

Diode Circuits Handbook

Back in the days, long ago, when diodes were plugged into sockets and required lots of space and heater power, they weren't very common. I guess that they seemed too expensive and wasteful of space to be popular. Rectifiers and detectors were about the only diodes you saw—and the detectors were usually combined with other tubes in common envelopes.

Things are different now. Even those who still build receivers with tubes use lots of diodes. But they're different diodes. Now they're usually tiny glass or plastic-cased silicon or germanium diodes which are soldered into equipment. And they're all over the place. The tube-type "Junior Miser's Dream" in the 1966 *ARRL Handbook* uses ten semiconductor diodes. The Davco DR-30 contains 15 and its power supply uses a few more. There's a good reason these receivers use so many diodes; diodes are very useful. One diode can often take the place of many other components, including such large, expensive, and cantankerous parts as relays, voltage-regulator tubes and switches.

I've often searched through dozens of references for a particular diode circuit and I suspect that many of you have done the same. I finally decided to try to get together all the practical ham diode circuits I could find and put them in a reference article for me—and all 73 readers. Most of the circuits I found seem to be fairly well known and have appeared in many places, so I haven't tried to give credit.

Take a look at these diode circuits. Chances are that some of them are unfamiliar to

you and could be useful in some of your projects. Some of the circuits are complete in themselves; many others are used with other devices.

Basic Diode Facts

Uses of readily available, well-known silicon and germanium diodes are the subject of this article. None of the applications are for tunnel diodes, four-layer diodes, or other specialized devices. The varactor circuits I've given will work with at least some common diodes, but work better with varactors, of course. Unless stated otherwise, the diodes shown are not critical.

To use this article, you should keep a few basic characteristics of diodes in mind. What makes a diode a diode is that for a given voltage, it will conduct more current when the voltage is connected across the diode in one way than in the other way. See Fig. 1. High current flows (the diode has low resistance) when the positive side of the power supply is connected to the anode of the diode. This is called forward biasing. When a diode is forward-biased, with adequate current flowing through it, it will have a fairly-constant voltage of about 0.7 V across it if it's a silicon diode, or about 0.3 V across it if it's germanium. This voltage is called the forward voltage drop. It will increase slowly with increasing current to a maximum of about 1.5 V for most diodes.

The reverse of forward bias is reverse bias. If you connect a voltage source across a diode so that the positive side of the supply is connected to the cathode of the diode, the diode is said to be reverse biased. A reverse-biased diode acts like a very high resistance so that almost no current flows through it. However, if you increase the voltage to a high enough value, the diode will "break down" and conduct current heavily. If there isn't enough resistance in the circuit to limit the current to a safe

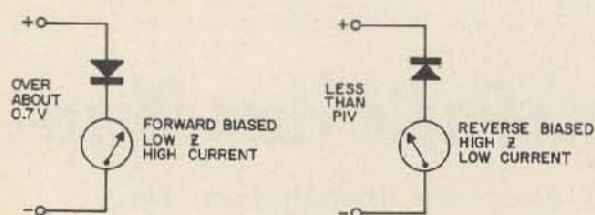

Fig. 1. The properties of a diode depend on whether it is forward biased or reverse biased.

value, the diode will be destroyed. If there is enough limiting resistance, the circuit will settle down with part of the total voltage across the diode and part of the voltage across the limiting resistance. As the voltage is increased further, the voltage across the diode remains fairly constant unless too much current flows and cooks the diode. The break-down point is called the avalanche voltage, for high-voltage diodes, and the zener voltage for low-voltage diodes. The maximum voltage that should be applied to a diode is called its peak inverse voltage (PIV). The PIV, as rated by the manufacturer, is always less than the avalanche or zener voltage.

As you can see from the above discussion, a high breakdown voltage—at least higher than any peak voltages in the circuit—is desirable for diodes used as rectifiers. However, diodes can be used as regulators, too; for this use, a low, and known breakdown voltage is needed. Thus, you can use a zener diode as a rectifier, or a rectifier as a zener, if you are able to pick the right diode.

Silicon diodes resist high temperature better than germanium ones, so are most useful for high power. On the other hand, germanium diodes have lower forward voltage drops (about $\frac{1}{2}$ V as against about $\frac{3}{4}$ V for silicon). Silicon diodes usually have lower leakage and higher reverse-biased resistances than germanium diodes.

Diodes have capacitance as well as resistance. This capacitance varies with the voltage applied. A reverse-biased diode is often used as a voltage-variable capacitor (varicap or varactor). Most silicon diodes can be used in this way, but diodes made and tested for this purpose are generally more predictable and satisfactory.

Power Supplies

Rectifiers

Say diode to the average ham, and he thinks of power-supply rectifiers. Diodes, and particularly silicon diodes, have so many overwhelming advantages over thermionic rectifiers that only the most conservative ham, or the ham with a junk box full of 5U4's, still uses tubes. Silicon diodes are cheaper, smaller, more versatile, etc., than tubes. However, semiconductor diodes are far more sensitive to voltage and current

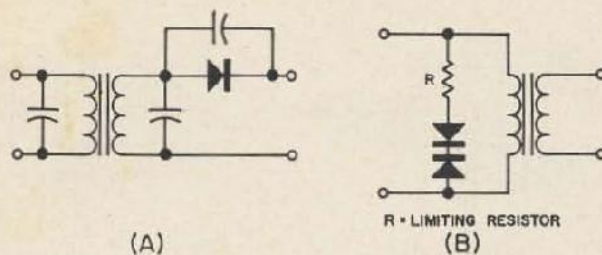
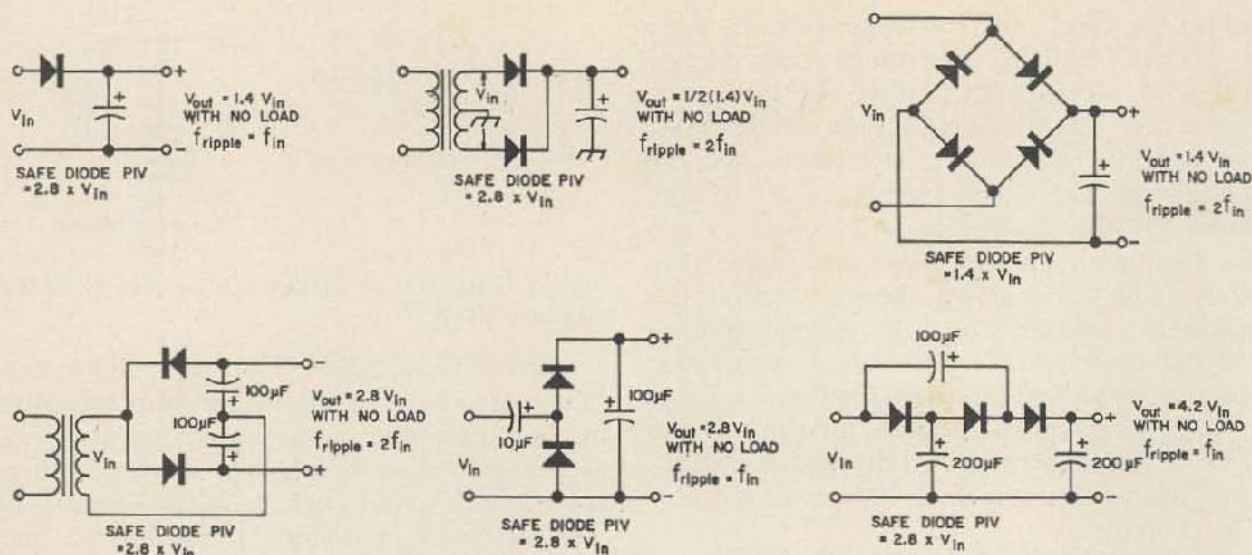

Fig. 2. Capacitors or diodes can be used to reduce transient peaks.

overloads than tubes. The very short transients generated on almost all ac power lines by lightning and large inductors, can ruin unprotected diodes instantly. However, there are ways to avoid such problems. One is to connect small capacitors across the ac line, across transformer secondaries, or across the diodes themselves. These capacitors tend to stretch the length of the voltage pulses while reducing their height. Special semiconductors can be connected across transformer primaries to clip off high peaks, or you can even connect two diodes, cathode-to-cathode, across the primary for the same effect. It's best to choose two diodes with roughly matched avalanche points a little higher than the peak value of the line. The peak value of the 117 V ac line is 170 V, so use 200-300 PIV diodes. See Fig. 2.

Another way to avoid blowing out diodes through accidental voltage transients (which may reach 4-5 kV), is to use special diodes designed to withstand such peaks. They're called controlled-avalanche diodes and in most cases cost more than regular diodes.

Of course, these suggestions can help take care of random voltage transients. But most hams who blow diodes, do it because they haven't been following good "engineering" practice. There's a lot of confusion about the ratings of diodes. The peak inverse voltage, or peak reverse voltage, of a diode, as rated by the manufacturer, is below the minimum peak voltage; which will cause the diode to conduct in the reverse direction. This is equivalent to the "zener" break of high voltage diodes. For instance, a diode with a 200-V PIV rating will not conduct current (over a few micro-amperes) for any dc voltage under 200 V applied across it in the reverse-biased direction (with the cathode connected to the positive voltage). But, if you increase the voltage over 200 V, at some voltage (its avalanche voltage) the diode suddenly starts conducting like mad, and quickly shorts (for diodes usually



Figs. 3-8. The most popular rectifier circuits with their output voltages and minimum safe diode PIV rating.

short, not open) unless there is enough resistance in the circuit to prevent excessive current flow.

For example, suppose the diode under discussion had an avalanche point of exactly 200 V. If it's a common epoxy-case diode, it can probably dissipate about $\frac{1}{2}$ W. That is 2.5 mA, so if more than 2.5 mA is flowing through that diode in the reverse direction, it's not going to stay healthy long. Note that this discussion is about direct current, as it's a little easier to follow than ac. If alternating current is applied across the diode, things are more complicated, but the same basic considerations apply.

If the diode is *forward* biased (positive voltage to the anode), about 0.7 volts will be dropped across the diode. If the diode can dissipate $\frac{1}{2}$ watt, that means (by $P=EI$) about 700 mA can flow through it.

Manufacturers rate their diodes by minimum PIV's, not actual avalanche voltages (except for regulators). You might do this same thing if you get \$10 worth of unmarked diodes from a surplus dealer. You could put out a series of cans labeled 0-100, 100-200, 200-300 and so forth. Then you could check the diodes and throw them in the proper can. Any in the 100-200 PIV can could be used for applications calling for a PIV under 200 V. The ratings on diodes are often conservative. A 1N2069 diode is listed at 200 PIV, so it will have an avalanche voltage of over 200 V, but could be quite a bit higher—I've found 1N2069's with avalanche voltages of over 1500 V.

The other diode problem is current overload. There should be enough resistance in

the circuit to limit current to the specified peak value, typically 25 A.

Enough theory. Figs. 3-8 show the most common types of rectifier circuits with the minimum PIV's that should be used for the diodes and the voltage outputs. The voltage "multipliers" (more correctly, "adders") can be carried on to ridiculous limits, but aren't very practical over about four diodes since you start needing so many big charging-filtering capacitors.

When you use discrete diodes in series to get a higher PIV than a single diode has, you should remember that the diodes you use are unlikely to be well matched. They probably have widely different avalanche voltages and back resistances, so that voltages applied across the series string will divide unequally across the diodes. This will likely blow out one of them, which will tend to blow out the others. A simple solution is to connect a 100-k Ω to 1 = M Ω resistor across each diode in the series, as shown in Fig. 9. Use the same value across each diode, though the value isn't critical. These equalizing diodes have saved a lot of diodes which otherwise would have blown. Incidentally, very high voltage rectifiers in one can are generally made from a number

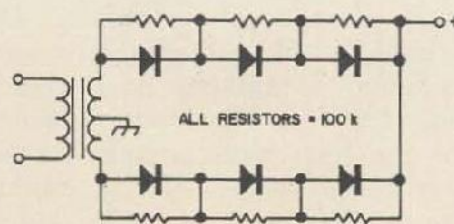
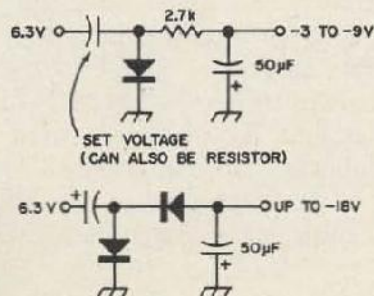

Fig. 9. Resistors are used across series diodes to equalize reverse voltage drop.

of individual junctions in series, but they don't require equalizing resistors since they're made from the same slice of silicon and are well matched.

Most modern transmitters and tube-type receivers require some negative voltage at low current for bias. Probably the easiest way to get this is by rectifying (with multiplying, if necessary) the filament line (See Figs. 10 and 11, or by tapping down resistively, or by a capacitor from the high voltage winding of the power supply. For low voltages, common germanium diodes, such as the 1N34, can be used for rectifiers. Shunt rectifiers work as well as series when they're being driven by a high-impedance source, such as a high-value resistor or low-value capacitor. A single diode can put out up to 9 V from a 6 V supply when it's loaded lightly.



Figs. 10 and 11. Simple shunt rectifiers can provide low bias voltages.

Fig. 12 is a simple bridge high voltage supply which can provide two high voltages at once. One voltage is about twice the other. This type of rectifier is often used with a junked TV power transformer for transmitters in the 100-200 watt range.

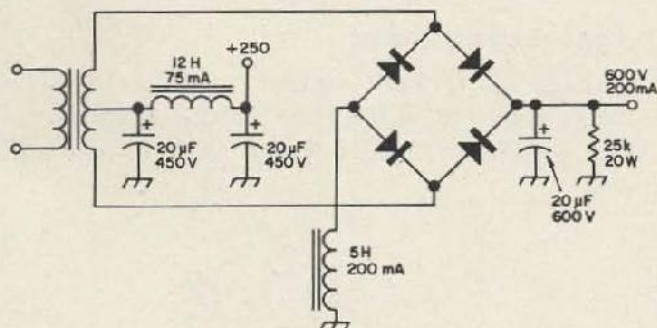

Fig. 12. This circuit gives two outputs, 600 V and 250 V.

Regulators

A zener diode regulator is shown in Fig. 13. It doesn't look very impressive, and the values of everything in it are dependent

on everything else. W2DXH's 12-page article on zenors in the October 1966 issue of 73, covers the subject thoroughly and succinctly, and there's little reason to go over it again.

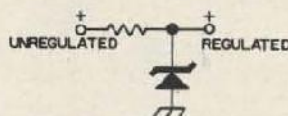

Fig. 13. A basic zener regulator. The values depend on input and output voltage, current, etc.

It's interesting that low-voltage zeners (under about 6 V) and forward-biased silicon diodes (equivalent to 0.7-V regulators) have thermal drifts opposite in direction from the drifts of avalanche diodes (zeners over about 6 V). So we can put one or more forward-biased diodes in series with a regular zener (as in Fig. 14) to decrease the total temperature-voltage drift. These diodes are also useful to boost a zener up a little amount. Remember that forward-biased silicon diodes act like 0.7-V regulators, and forward-biased germanium ones act like 0.2-0.3 V regulators.

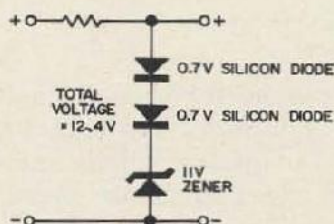

Fig. 14. Forward-biased silicon diodes can be used as low-voltage zeners. Their temperature drift is opposite that of regulators with breakdown voltages over 6 V, which is convenient for temperature stabilization.

An interesting use of a zener is shown in Fig. 15. Here the zener is used to increase the voltage rating of a low-voltage capacitor.

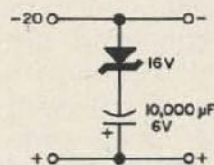

Fig. 15. A zener can be used as a ripple filter and to "increase" the voltage rating of a capacitor.

Fig. 16 shows the use of two different zeners to get a regulated low voltage. You can use a forward-biased diode in a similar manner to get a regulated voltage slightly lower than a given zener will provide. For instance, suppose you have a 10 V zener, but want a slightly lower voltage. A for-

ward-biased silicon diode (the reverse of the one shown) connected in place of the 8 V zener would give about 9.3 V.

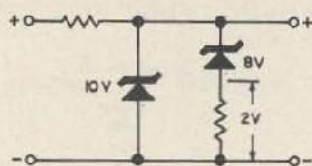

Fig. 16. Two zeners can furnish a regulated low voltage.

Zeners can also be used on ac. Fig. 17 shows this use to regulate at slightly less than 110 V.

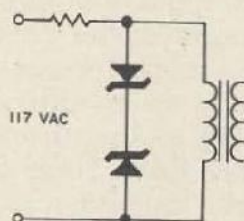

Fig. 17. Zener regulators can be used on ac, too.

Meters

AC meters

Since true ac meter movements are very frequency sensitive, most meters used by hams are dc meters. Diode circuits can be used with dc meters to make ac meters for many different uses. However, this can be tricky and it's a good idea to understand what's happening in the circuits. The most common and useful method for describing an ac voltage is in terms of RMS (root-mean-square), or effective, voltage. This voltage has the same heating effect as a dc voltage of the same value. The 117 we call the ac line is an RMS value. However, most ac meters made from a dc meter and a rectifier, read either peak or average value rather than RMS since these circuits are far simpler. The peak value is the difference between the 0 point of a wave and its highest peak, as measured on an oscilloscope. The average value, which should be called the average rectified value, is of very little use in radio and chances are you've never even seen an average value mentioned except in discussions of ac voltmeters. If you're curious, it's the area under the curve, divided by the time measured. There is a very simple relationship between these values—for perfect sine waves: peak is about 1.4 (or exactly $\sqrt{2}$) times RMS;

RMS is about 0.7 (exactly $1/\sqrt{2}$) times peak; average is about 0.6 (exactly $2/\pi$) times peak and so forth. However, for wave shapes other than perfect sine waves, the relations are not the same, and we must give some thought to the measurements we make under these conditions.

Average-reading meter

The most common type of ac voltmeter—the type used in virtually all VOM's, for example, is shown in Fig. 18. This circuit usually uses a copper-oxide bridge rectifier since this type of rectifier is linear at much lower levels than silicon or germanium diodes. Notice that there is no capacitor in this circuit. The reading on the meter will be the average value of the ac waveform. However, the scale is almost always calibrated in terms of RMS. As mentioned before, this is accurate only for true sine waves, but is generally satisfactory for other waveforms as even 10% second-harmonic energy causes only 3% error. This type of rectifier circuit is useful up to a few hundred kilohertz. It cannot be used higher because of the properties of the rectifier and the high stray capacitance of the circuit.

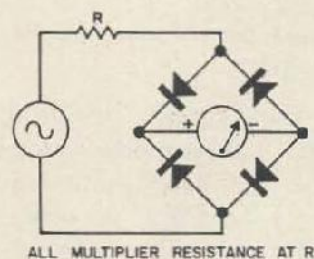

Fig. 18. A bridge average-reading ac meter.

Peak-reading meter

Fig. 19 is very similar to Fig. 18. The only apparent difference is the addition of the capacitor C. If C is very large and

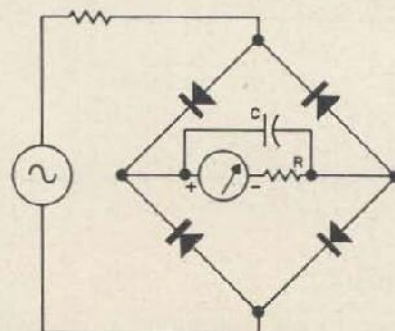

Fig. 19. A bridge peak-(or semi-RMS) reading ac meter.

the meter has a high resistance, the capacitor will stay charged up to a high level and the meter will read approximately the peak value of the waveform. For instance, with a 1-mA meter and 50- μ F capacitor, this makes an excellent peak meter for the value of fairly constant audio voltages. The time constant is too long to follow fast changes. This meter is excellent for aligning receivers with a modulated signal generator.

RMS-reading meter

If capacitor C in Fig. 19 is made small with regard to the period of the ac frequency being measured, the meter will read approximate RMS. Unfortunately, the optimum value for the capacitor will vary with frequency, so this type of meter has limited use. A combination of peak- and average-reading meters can provide a meter which reads closer to RMS.

Peak-to-peak-reading meter

Sometimes we need the peak-to-peak value of an ac voltage. This will be twice the peak value on a symmetrical wave, and it can be measured with the circuit of Fig. 20. This, of course, is a voltage "doubler." The capacitors must be large, and the meter resistance high, to keep the capacitors charged.

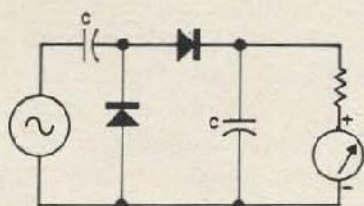

Fig. 20. A peak-to-peak reading ac meter is simply a voltage "doubler."

Variations of basic ac meters

Another type of peak reading voltmeter is shown in Fig. 21. It is a half-wave rectifier, unlike the full-wave bridge peak-reading voltmeter shown in Fig. 19. This circuit, or a variation of it, is used in rf probes

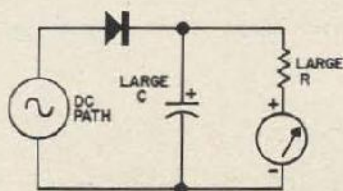

Fig. 21. A half-wave peak-reading ac meter.

where the rectifier must be close to the circuit being measured.

A similar peak reading circuit that requires no dc path is shown in Fig. 22. Another type of RMS-reading meter is shown in Fig. 23. This one is useful only over a limited frequency range.

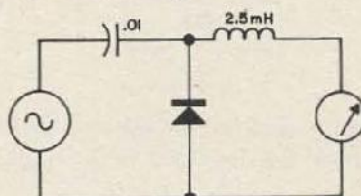

Fig. 22. A half-wave peak-reading ac meter that requires no dc path.

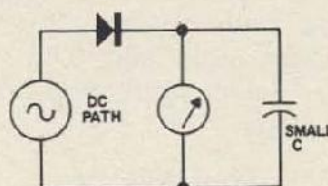

Fig. 23. A semi-RMS-reading ac meter.

Reversible-polarity meter

Fig. 24 looks like an ac voltmeter, but it can also be used for something else. Remember the last time you made a small transmitter and wanted to measure both the grid and plate currents? They are opposite in polarity, so it took a DPDT switch. This circuit gets around that. Voltages of either polarity may be applied to it and will always read upscale.

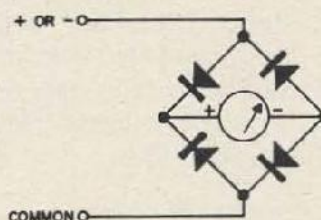

Fig. 24. A meter for ac, or either polarity dc.

Expanded and compressed scales

Zener diodes may be used to play some interesting tricks with dc-reading meters. For instance, suppose you want to meter the voltage in your car. It never goes below 12 V or above 15 V. If you use a 15-V meter, the variation will be a small part of the scale and hard to read. But if we expanded the 12 to 15 V range to fill the face of the meter, the variations would be very noticeable. A way to do this is shown in Fig. 25. A 12-V zener diode is placed in series with a 0 to 3 V meter.

The meter reads nothing until the voltage reaches 12 V, then reads normally from 13 to 15 V. This is called suppressing the low end of the scale.

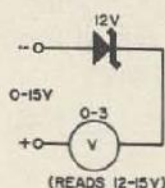

Fig. 25. A zener and a low-voltage meter can be used to suppress the low end of a range.

The last circuit for modifying meters is shown in Fig. 26. It partially suppresses the low end of the scale. For example, the meter can be made to read 0-9 V in the first half of the scale and 9-12 V in the second half. Values will depend on the voltages and meter.

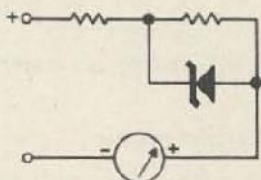

Fig. 26. This circuit partially suppresses the low end of a range.

Meter protection

You can also suppress the high end of the scale. If that sounds rather pointless, you can think of this operation as a meter protector. Fig. 27 shows the circuit. The resistors will depend on the voltage, etc. If the zener is picked to conduct at the high end of the scale, the meter will not be overloaded even by voltages much higher than should be applied to it.

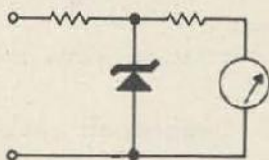

Fig. 27. This is a meter-protective circuit. The zener should be tapped on the resistor chain at a point that provides conduction when the meter pointer is pinned.

Fig. 28 is a simpler meter protector using a run-of-the-mill silicon power diode or two. A silicon diode acts like a 0.7-V zener when it's forward biased, so will conduct whenever the voltage across the meter goes over 0.7 V. It's best to use two diodes back-to-back for maximum protection. Hav-

ing the meter needle take off in the wrong direction with 0.7 V is better than with 400 V. As an example of the voltages involved, a 50- μ A, 4000-ohm meter has 0.2 V across it at full scale, so a 0.7-V silicon diode limits overloads to about 3½ times, which most good meters can handle. Incidentally, it's recommended that you also put a .01- μ F capacitor across the meter in parallel with the diode or the meter will be very susceptible to rf.

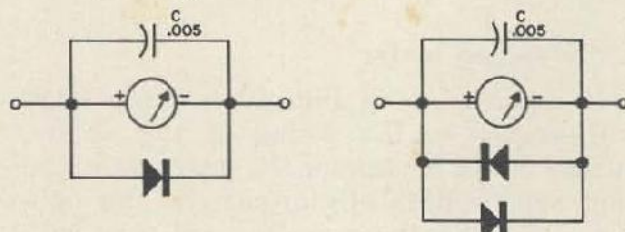

Fig. 28. Conventional silicon diodes can protect a meter movement, too. The 0.005- μ F capacitor bypasses rectified rf.

Receiver Circuits

Diode mixer

Diode mixers are rarely used in modern high-frequency or VHF receivers. Transistor mixers give better performance in every respect: gain, noise figure, selectivity, and versatility. However, diode mixers are still used almost universally at frequencies above about 500 MHz, where a diode can provide better results than a transistor—at least at present. A standard type of diode mixer suitable for any frequency is shown in Fig. 29. The antenna and local oscillator inputs can be low impedance (as shown) through taps or loops, or high impedance through capacitors connected to the top of the coil. The input coil can be a quarter-wave trough line at UHF frequencies.

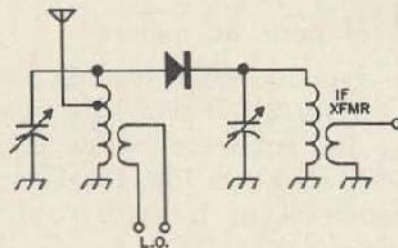

Fig. 29. A basic diode mixer as used at UHF and microwave.

AM detectors

The most popular receiver in the early days of radio was a crystal set. The typical

crystal set used a large coil, a crystal detector, and a set of headphones. The most common crystal detector was a piece of galena (lead sulfide) or some other semiconductor with a springy wire contact (cat's whisker) which had to be adjusted for best results. The modern equivalent of this circuit is shown in Fig. 30. It is the half-wave detector used in almost all AM receivers. This detector includes a resonant circuit tuned to the frequency of interest, a diode rectifier and a load. In the diagram, the load is a resistor suitable for transistor *if* use. The capacitor provides filtering and smoothing. The resistor can be replaced by a set of headphones, and a long antenna added to make a modern crystal receiver. A good ground will also be necessary in most places.

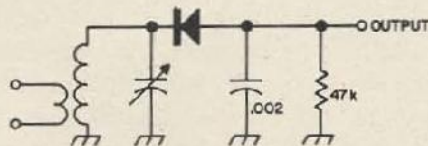

Fig. 30. A half-wave detector. This can be used as a crystal set, too.

The half-wave detector is very popular, but it's far from the best AM detector. The peak-to-peak or voltage-doubler detector in Fig. 13 provides much higher output with lower distortion and is highly recommended for all AM receiver applications.

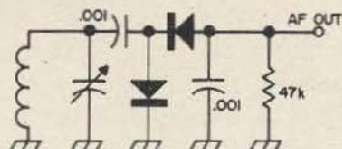

Fig. 31. This detector provides much better results than that in Fig. 30.

Ring modulator

Balanced mixers (or modulators) are becoming very popular in modern receivers as we face the problem of many strong signals in and out of the ham bands. Conventional mixers can easily be overloaded by these signals, while balanced mixers can handle more power and reduce spurious-causing frequencies. The balanced modulators used in SSB generators generally make excellent mixers, but many of them are inconvenient to use in equipment which must be tuned over a wide range. Nevertheless, we will likely be seeing more of them in the future. The balanced modulator shown

in Fig. 32 is a ring modulator which can be used in both receiving and transmitting equipment. The diodes should be matched, as described in the paragraphs in this article on SSB balanced modulators.

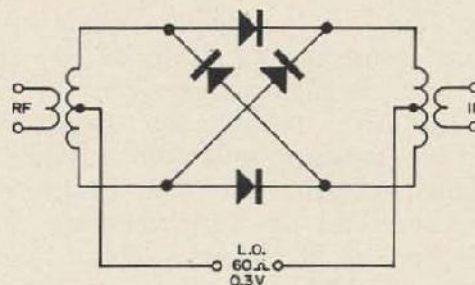

Fig. 32. A diode ring balanced modulator.

Product detectors

While any good AM detector can give excellent results on SSB signals if it has proper BFO injection, a number of circuits have been developed to make tuning and detecting SSB easier. One is the product detector shown in Fig. 33. This popular circuit has been used in many ham receivers. The BFO voltage should be 10 to 20 times that of the incoming signal for best results. The diodes should have high back resistance, but must have at least some leakage for the circuit to work properly (or a resistor must be added from the junction of the diodes to ground).

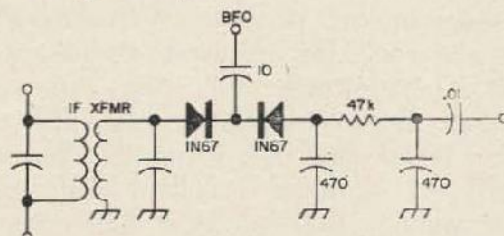

Fig. 33. A popular product detector for SSB.

Another product detector is illustrated in Fig. 34. Values are given for use at both 455 kHz and 9 MHz, the most popular SSB *if*s. For use at 2 or 3 MHz, the capacitors and inductors can be about half-way between the values given. Other balanced

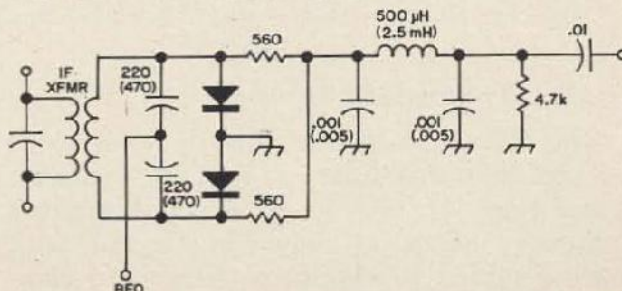

Fig. 34. A product detector for 9-MHz SSB. The values in parentheses are for 455 kHz.

modulator circuits that make excellent SSB detectors are given in the transmitter section of this article.

FM detectors

There are three excellent types of FM detectors using diodes. Two of these are well known to almost everyone in radio. The third isn't, though it's an excellent, inexpensive detector and easy to use. The well-known circuits are the Foster-Seeley discriminator and the ratio detector, shown in Figs. 35 and 36. They work on different principles, and the circuits are quite different. The discriminator is easier to align,

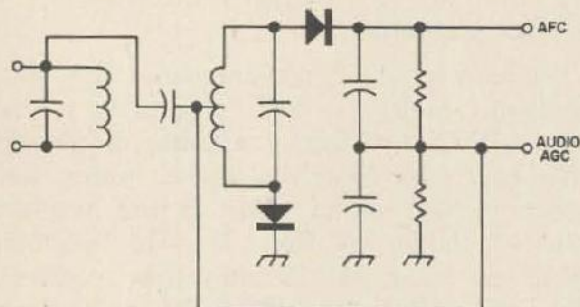

Fig. 35. Foster-Seeley FM discriminator.

but requires a separate limiter to remove AM. This can be a diode limiter or a more popular tube or transistor circuit. Otherwise it is simply a convenient AM and FM detector. While that might be useful for many experimental purposes, it is undesirable for most since the greatest advantage of FM is its suppression of noise and static, which are almost completely AM. The ratio detector is self limiting. When it is adjusted properly, it provides excellent suppression of AM signals. Both of these FM detectors require special transformers.

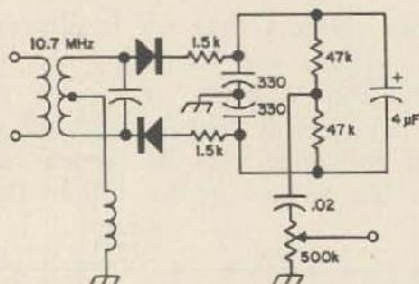

Fig. 36. 10.7-MHz FM ratio detector.

The other, less-common FM detector needs no special transformer; in fact, it needs no transformer at all. It is a pulse-counting frequency meter, as shown in Fig. 85, with a filter added to eliminate the carrier components. This is a very versatile circuit. It can be used as a frequency meter, tachom-

eter and FM detector. Unfortunately, the circuit cannot be used very easily at high frequencies (say, over 1 MHz) without a good bit of care. Nevertheless, it is becoming popular and we will probably see it in many FM and TV receivers in the future.

Noise limiters

Most AM communications systems suffer from electrical noise caused by atmospheric disturbances and man-made equipment. Many noise limiters have been developed to try to reduce the effects of this interference. Some noise limiters are effective against only very short, high-impulse noise, while others can reduce more difficult-to-handle, long-term, moderate-level interference. Because of the widely different characteristics of AM, SSB and CW signals, practical limiters are usually designed for optimum results on one type of modulation, and are less effective on others. In all cases, however, noise limiting should be performed before highly selective sections in a receiver, if that is possible. Sharp filters will lengthen noise pulses and make them more difficult to eliminate. The selectivity can also lead to ringing, a very unpleasant sound to human ears.

A very simple noise limiter which can be quite effective against high-impulse, fast pulses in a moderately unselective receiver is shown in Fig. 37. The two diodes clip any signals above 0.3 or 0.7 volts (depending on whether the diodes are silicon or germanium). Obviously, the performance of this limiter will be quite dependent on the output impedance and power of the receiver, and the characteristics of the speaker with which it is used. As a rough idea of the levels involved, suppose the diodes are germanium and the impedance is 4Ω (which is not too likely as the impedance of most speakers is very dependent on frequency). By Ohm's Law, $P = E^2/R$, $0.3^2/4 = 0.09/4 = 22$ mW. Thus the diodes will start clipping at 22 mW of output. This may well be plenty of audio. If more is desired,

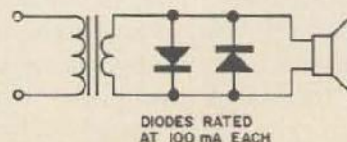

Fig. 37. Shunt diode noise limiter for use across a loudspeaker.

silicon diodes can be used. The volume control must be set for the proper level to clip noise peaks and leave any desired sound alone.

A simple shunt half-wave limiter can be installed at the second detector of the receiver, or at the input to an audio amplifier stage to accomplish much the same thing. Here a single diode may be sufficient because of the characteristics of the detector or the amplifier. Fig. 38 shows a typical limiter of this type.

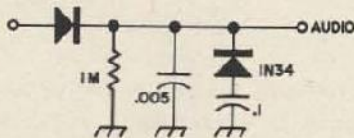

Fig. 38. Shunt diode noise limiter that can be easily added to the input of an audio amplifier.

Fig. 39 illustrates a simple half-wave series peak limiter. It requires a diode with high back resistance; the base-emitter junction of a transistor often makes an excellent diode of this type. This circuit must be adjusted to the proper clipping level for best results. Though there is no negative peak clipping in the circuit, it does a good

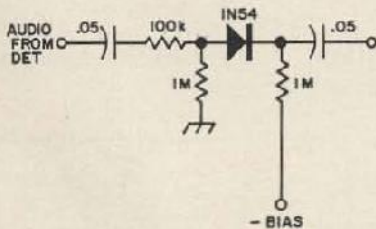

Fig. 39. Half-wave series noise limiter with adjustable clipping level.

job. A better circuit, though, is that in Fig. 40. This is a full-wave series peak limiter which clips both negative and positive peaks. This circuit, like the previous one, requires high back resistance diodes for best performance.

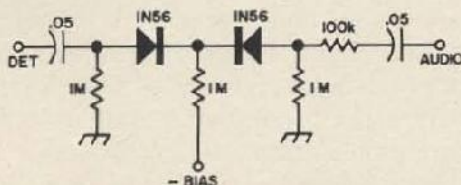

Fig. 40. Full-wave series noise limiter.

An excellent AM noise eliminator is the trough limiter in Fig. 41. This circuit will eliminate the background noise that can be very fatiguing, yet it permits most of the audio to pass. This limiter works on the low level signals rather than the high.

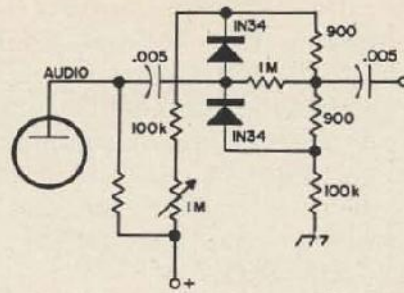

Fig. 41. This "trough" limiter will eliminate the background noise that is ignored by conventional limiters.

Perhaps the ultimate noise limiter for AM use is the rate-of-change noise limiter developed in England for use in the audio portion of TV sets. This detector works on the theory that most noise peaks have a much faster rise time than desirable modulation. The detector eliminates these peaks very effectively, as has been demonstrated by many testimonials. The limiter diode in this circuit, which is shown in Fig. 42 must have very high back resistance. Transistor junctions have been used for this diode by some hams with excellent results. The detector diode can be any conventional diode. This circuit has some loss, so an extra audio amplifier may be needed in some receivers. The clipping can be adjusted by changing the ratios of the 27k Ω and 18k Ω resistors.

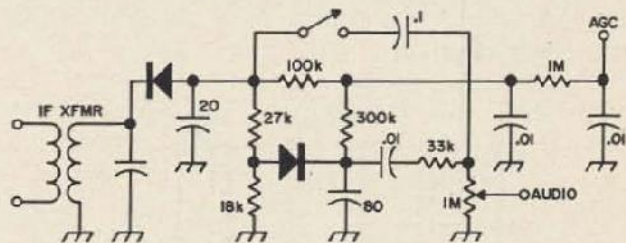

Fig. 42. One of the best noise limiters is the "rate-of-change" limiter designed for TV audio in England.

The next two circuits are installed in the *if* amplifier section of a receiver rather than in the audio section. They provide superior results on SSB and CW, but are not as ef-

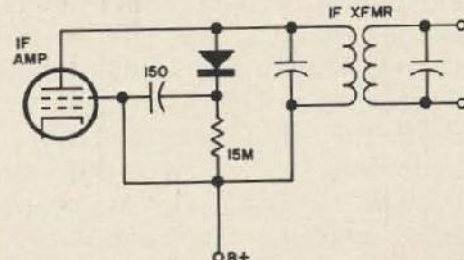

Fig. 43. This simple noise limiter is installed in an *if* stage for SSB and CW use. The diode must have high back resistance, low capacitance and short rise time.

fective as other limiters on AM. The first circuit, shown in Fig. 43, uses a fast diode to clip short interference pulses. It is very simple and could be installed in almost any receiver. A slightly more complex circuit is shown in Fig. 44. It is self-adjusting. Both of these *if* limiters use fast diodes. Among suitable ones are 1N903, 1N904, 1N916, and MA-4441.

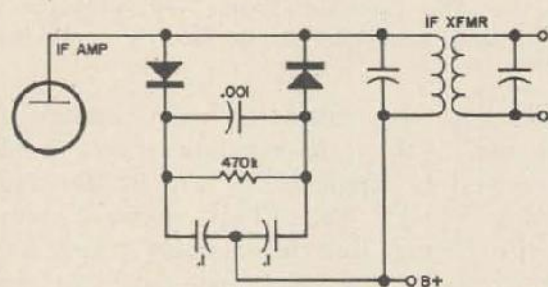

Fig. 44. This is an improved version of the SSB if noise limiter in Fig. 43.

Diode squelch

Diodes make excellent switches. This property can be used in the very simple squelch shown in Fig. 45. The diode detector is simply biased to the desired threshold with the potentiometer and signals weaker than this level will not be passed. There are two major problems with the circuit. It does not quiet the receiver completely, and it introduces distortion on weak signals. However, it is simple, cheap, and easy to add to almost any receiver.

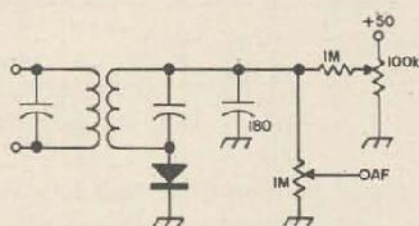

Fig. 45. Simple diode squelch.

Add-on BFO/Q-multiplier

It's very easy to add a simple beat frequency oscillator Q-multiplier to tube-type receivers, and many SWL's and others with receivers not designed for CW or SSB reception should find the circuit shown in Fig. 46 interesting. The principle is straightforward. If the suppressor grid of a high gain pentode is not connected to ground, the tube will oscillate. We can control the impedance between the suppressor and ground with a diode and make the tube regenerate. This will increase the Q and hence, the selectivity of the amplifier. If the regeneration is carried far enough, the

tube will oscillate and can be used for CW or SSB reception. The control potentiometer can be installed on the front panel of a receiver, with the diode and 1.5k Ω resistor near the tube.

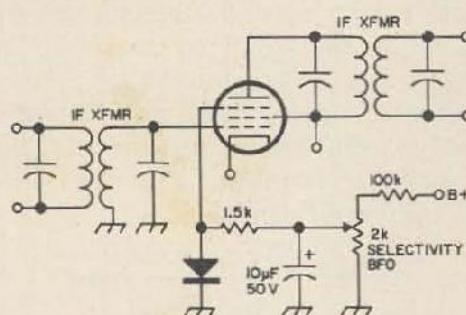

Fig. 46. Adaptor to provide SSB/CW reception and Q-multiplication in a receiver.

Oscillator limiter

It's often difficult to design an oscillator which provides a constant output as its frequency is varied. This is especially true of wide-range transistor oscillators. A circuit designed to stabilize the output of an oscillator of this type is shown in Fig. 47. The diode is reverse biased, so it doesn't normally conduct unless the voltage in the tuned circuit exceeds a certain level. Then it conducts on positive half cycles and damps the oscillation. The result is an output which is fairly constant across a band.

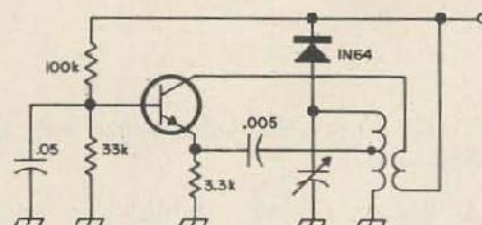

Fig. 47. This circuit uses a diode to limit the output of an oscillator.

Transistor protection

It's always discouraging to burn out transistors, even if they are about the cheapest components used in many projects. An rf amplifier, particularly a low-noise VHF one, is usually tightly coupled to an antenna for minimum noise figure and maximum power gain. Unfortunately, this tight coupling increases the chance that the transistor will be damaged by strong nearby transmitters which may inject too much voltage into the base of the transistor. A simple, effective way to reduce the likelihood that this will happen is to place two low-capacitance silicon diodes across the input coil of the

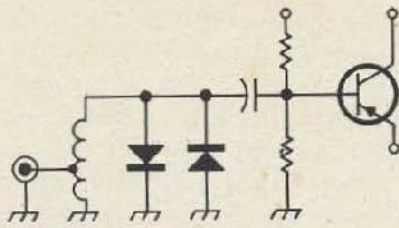

Fig. 48. Diodes can be used to protect a transistor rf amplifier from burnout.

amplifier (Fig. 48). These diodes will conduct if the voltage across the coil exceeds about 0.7 V, simultaneously shunting it through the diodes and causing the capacitance of the diodes to change drastically, which will detune the resonant circuit. This will often save the transistor. This pair of diodes will not cause too much signal loss as long as the diodes are suitable for the use. The easiest way to check them is to try the circuit with and without the diodes. Signal strength should be the same.

Automatic gain control

A circuit designed to adjust the amplification of a receiver for approximately constant output with varying input is called automatic gain control (AGC) or automatic volume control (AVC). The most common type of AGC for tube-type receivers is shown in Fig. 49. Its operation is simple. The amplification of a tube is dependent on the voltage of its grid. Up to a point, the higher the negative voltage, the lower the amplification. So we simply take a part of the negative voltage output from the receiver detector and apply it to the grid of one of the *if* amplifiers. Then the stronger the received signal, the more negative the output from the detector and the less amplification in the tube. This in turn reduces the negative voltage and the receiver tends to have a fairly constant output. Normally, the AGC voltage is applied to both *if* and rf amplifiers for best results.

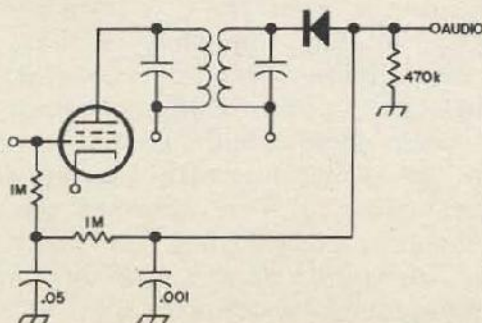

Fig. 49. The conventional AGC system used in tube-type receivers.

Of course, we really only want to reduce amplification on strong signals. The best AGC circuits should leave the weak signals alone. One way to do this is shown in Fig. 50. It is called delayed AGC. A separate diode is used to detect a voltage for AGC. This diode is connected to a point which is slightly positive, such as the cathode of an audio amplifier. Then the diode will not conduct until it reaches a point determined by the positive voltage. This prevents the AGC from reducing the amplification of any amplifiers on weak signals.

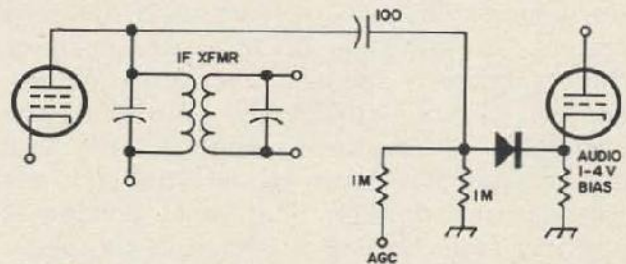

Fig. 50. Delayer AGC acts only on strong signals.

For reception of single-sideband signals, a special type of automatic gain control is needed. SSB comes in fast bunches with space between the bunches. Thus the AGC should act very quickly when a signal is received (fast attack), yet keep the receiver gain at about the same level for a short while after the burst in case another is coming (slow delay). The one-way conduction of a diode provides this action in the "hang" diode circuit shown in Fig. 51. The diode conducts when there is a negative voltage from the AGC detector on its cathode (in other words, when a signal is received). This charges the capacitor quickly and acts on the controlled stages. In the spaces between words or syllables, the capacitor supplies an AGC voltage to the controlled stages; there is no conduction from the capacitor back to the detector because the diode will not conduct in that direction. The size of the capacitor should be chosen for the desired AGC characteristics. In some receivers, a choice of values is available.

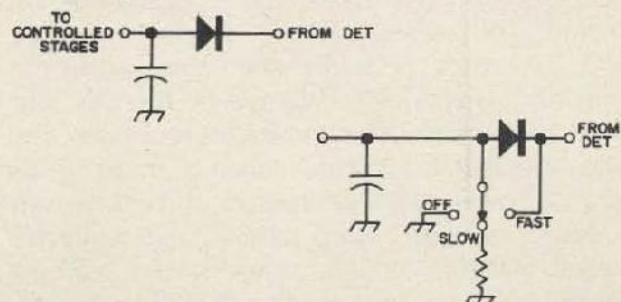

Fig. 51. "Hang" AGC for SSB/CW reception.

Fig. 51 also shows a simple type of switching to provide fast, slow or no AGC action.

Transistor AGC

Transistor automatic gain control is not as simple as tube AGC. Conventional transistors have a number of properties that complicate things slightly. There are three ways to arrange AGC in a transistorized receiver. Two are fairly common; the third is little used.

The simplest type of transistor AGC is shown in Fig. 52. It is called reverse AGC, since increased AGC voltage gives reduced current. In this type of AGC, the gain of the transistor is reduced by decreasing the emitter current, usually by controlling the base bias. As shown in Fig. 52, the bias of the transistor must be negative for the transistor to amplify. The AGC voltage is positive, so increasing it decreases the negative bias and hence the gain. As the current through the transistor decreases, the input and output impedances increase, resulting in greater selectivity with strong signals than weak. The transformer impedances can also be designed to be matched with weak signals so that the mismatch with strong signals will reduce the gain in addition to the transistor reduction.

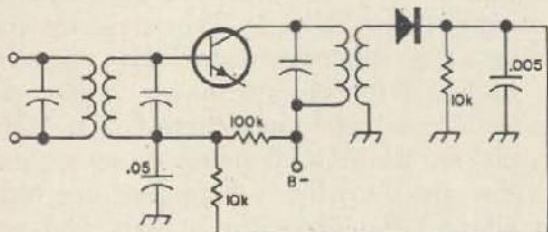

Fig. 52. Reverse AGC for a transistor-receiver.

In the other type of common AGC, called forward AGC, increased AGC voltage causes increased current to flow in the stage (though the reduction in gain is actually a result of decreased emitter voltage). The schematic of the forward AGC system shown in Fig. 53 is identical to that for reverse AGC except that the AGC voltage is reversed (by reversing the diode detector) and a resistor is added in series with the collector transformer winding. In this circuit, increasing AGC voltage increases the bias on the transistor, causing it to draw more current. This increased current causes a larger voltage drop across the collector series resistor, which reduces the voltage on the collector of the transistor. This results in less gain. Forward AGC offers greater

reduction in gain than reverse AGC and better strong-signal performance. As the current through a transistor increases, its impedances drop to low values which decreases the voltage across the transistor. Forward AGC has a few disadvantages: an amplifier may be needed to get adequate AGC voltage, the selectivity of the controlled stage is reduced, and the stage is detuned with strong signals. These last two problems may be minimized by delaying the AGC so that it does not act on weak or moderate signals.

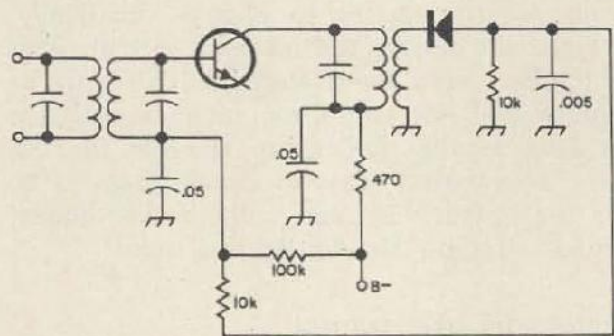

Fig. 53. Forward transistor AGC.

Reverse AGC is commonly used for inexpensive portable receivers where it's unlikely that an external antenna will be connected. Forward AGC is more suitable for receivers which are likely to have to handle strong signals. Both types of AGC may be used in some receivers. For example, forward AGC on the rf stage can be used to handle strong signals and reverse AGC could be used on the first if stages to maintain the proper bandwidth with strong signals. Incidentally, AGC should never be applied to the if amplifier feeding the detector; this stage usually needs to furnish quite a bit of power and it should be adjusted for best power-handling capability.

The other type of transistor AGC involves an attenuator rather than just reducing the gain of one or more of the amplifiers in the receiver. Diodes, transistors and other devices can be used for this purpose. The advantage of this approach is that each transistor amplifier can be designed for maximum gain, power-handling capacity, or lowest noise figure without any need to change the conditions with varying signal strengths. Most of these schemes are considerably more complicated than the simple circuits discussed above and are rarely needed in practical receivers.

A simple auxilliary AGC circuit used in most practical receivers is shown in Fig. 54.

The circuit is similar to conventional AGC circuits except that a diode is added as shown. The diode is reverse-biased under normal conditions (for weak or moderate signals) with its cathode more positive than its anode. However, at a certain point with a strong signal, the diode becomes forward biased and this causes it to have very low impedance. This low impedance is shunted across the transformer, causing a reduction in gain.

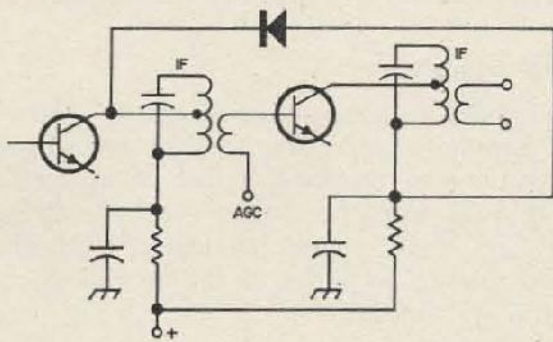

Fig. 54. An auxiliary AGC diode improves AGC action.

Many types of detectors, especially those used for SSB, FM and CW, make no provision for AGC output. A simple auxiliary AGC detector may be added in the *if* amplifier string to provide this voltage. Such a detector is shown in Fig. 55. It is arranged for positive output, but may easily be reversed for negative AGC voltage. The coupling capacitor should be very small to reduce the loading of the transformer.

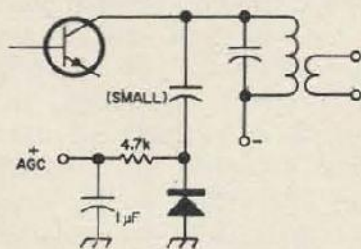

Fig. 55. An auxiliary AGC detector can be used with a product detector for SSB/CW.

AFC diode

Automatic frequency control circuits are used in many FM and TV sets as well as in commercial SSB and teletype receivers to keep locked on frequency even though the receiver or transmitter oscillator might drift slightly. The control voltage for AFC circuits is obtained from a phase detector, generally a discriminator, which provides a negative voltage if the drift is in one direction, a positive voltage if it's in the other

direction, and no voltage if there is no difference in frequency. (Of course, the circuit can also be offset so that 5 V, for example, is the voltage output if there is no difference.) This control voltage is applied to an oscillator in the receiver in such a way that it varies the frequency to keep in lock. Though the oscillator can be arranged so that the control voltage varies the transistor capacitance to keep in lock, it's usually easier to use a voltage-variable capacitor diode (varicap or varactor) as shown in Fig. 56. This schematic is designed

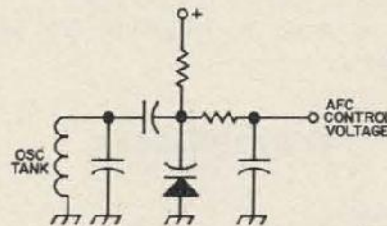

Fig. 56. A varicap is often used to provide automatic frequency control. The control voltage is provided by a discriminator.

for a conventional broadcast FM receiver; a simple filter is included to eliminate the FM deviation and a small amount of reverse bias on the diode for linear operation. The coupling capacitor should be as small as possible to simplify the adjustment of the system and prevent the characteristics of the diode from having too much effect on the oscillator—diodes have much lower Q than the other capacitors used in oscillator circuits. The diode can be a diode designed for this use (such as the Amperex 1N3182 at about 60c) or can be a small silicon diode or silicon transistor junction.

Varicap tuning

Tuning capacitors are large, expensive, fragile and hard to control remotely. But varicap diodes are small, cheap, rugged and give the amount of variation necessary for easy to control. There seems to be a pretty good future for varicaps in tuning applications. Only specially processed varicaps can use in broadcast receivers, but many others can be used for more restricted ranges. Special diode networks can be designed so that one potentiometer (which can be far from the rest of the equipment) can track both *rf* and oscillator stages. Varicaps, generally speaking, have lower Q 's than air capacitors, so will not provide quite the selectivity of conventional tuning capacitors in most cases. This is rarely a problem,

though. It's beyond the scope of this article to go into the design of wide-range, tracked tuning networks, but the manufacturers of variable capacitance diodes have published information for this purpose. Fig. 57 gives the basic type of circuit.

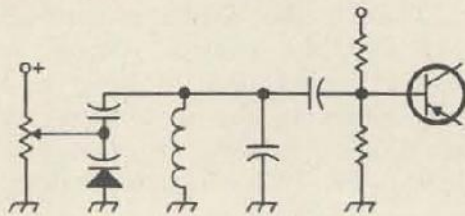

Fig. 57. An rf stage or oscillator can be tuned with a varicap.

Transmitters

Audio clippers

Many AM and FM transmitters contain audio compressors and clippers which increase the average level of modulation ("talk power") transmitted without causing overmodulation. Probably the simplest type of peak clipper is that shown in Fig. 58A. Here two low-voltage zener diodes are put in series across an audio amplifier stage where there is enough voltage to cause the zeners to clip. Alternately, as shown in the Fig. 58B, parallel-connected germanium or silicon diodes can be used. They have the advantage over the zeners that they will clip at lower voltages (0.3 or 0.6 volts). As this type of circuit simply clips off the tops of the signal, it generates many strong harmonics which must be filtered out after the clipping. A simple resistor-capacitor low-pass filter will be adequate in many cases, though a more selective L-C filter is better.

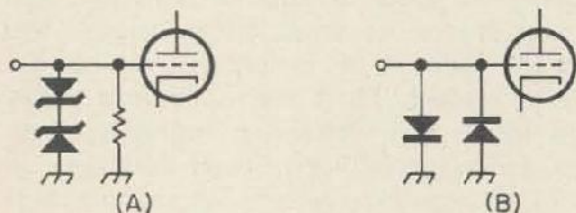

Fig. 58. Simple clippers can be made from zener diodes or silicon diodes.

A more satisfactory filter is shown in Fig. 59. The clipping level of this filter can be adjusted by changing the negative voltage applied to the anodes of the diodes. This circuit includes a low-pass filter.

Neither of the clipper circuits shown is useful for SSB in most cases. SSB clippers

must operate on the rf envelope rather than the audio.

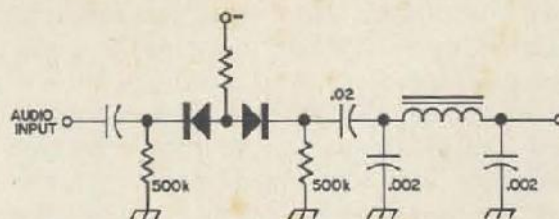

Fig. 59. A good clipper for AM or FM use includes adjustable clipping level and a harmonic filter.

Audio compressor

An audio compressor is shown in Fig. 60. This circuit is interesting, but it has a few disadvantages, including a loss of up to 60 dB. It does keep the output constant within 1 dB for 20-dB change in input. With the values shown, an input of 0.2 to 6 V gives about 5 mV output.

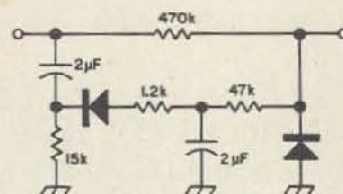

Fig. 60. The compressor can provide 25-dB compression, but at the expense of up to 60-dB loss.

Negative peak clipping

There has been a great deal of discussion among hams about negative peak clipping. Many who have tried it are very enthusiastic, but others have proved that, theoretically, it is neither necessary or desirable. Apparently a properly operating modulator well-matched to a correctly adjusted power amplifier has no need for negative peak clipping. On the other hand, simple gear which is not optimized can make good use of negative peak clipping to help reduce overmodulation and splattering. Two circuits are shown in Fig. 61. One uses series

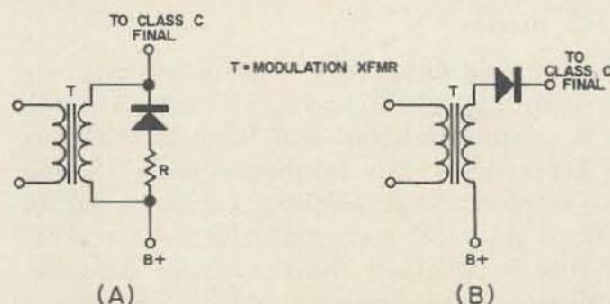

Fig. 61. The need for high-level negative-peak clipping is often debated, but its value is championed by many.

clipping and the other, parallel. The series circuit is obviously easier to install, and in view of the fact that this type of negative peak clipping is so cut-and-dry, it is recommended. Silicon power diodes suitable for the voltages encountered should be used.

FM modulator

While the battle between SSB and conventional AM has certainly been decided in favor of SSB at high frequencies, SSB hasn't threatened FM for commercial VHF use. FM has many overwhelming advantages over AM, and a number of advantages over SSB. FM has never been given a very fair test by hams, but it has been completely accepted for most VHF communications use. Narrow-band FM, as must be used on high frequencies, is not very attractive except in its simplicity and noise reduction, but wide-band VHF FM is an excellent communications medium and is becoming more and more popular for fixed-frequency net operation. FM is especially useful with transistor transmitters, as an FM transmitter can be much simpler and cheaper than an AM or SSB transmitter of equivalent power output. A simple direct FM modulator using a variable-capacitance diode is shown in Fig. 62. A regular varicap or varactor is best for this circuit, but almost any conventional silicon diode is usable. The audio signal input varies the bias on the diode causing a capacitance change, which varies the frequency of the oscillator. The oscillator is normally fairly low in frequency. Its output is multiplied to the VHF range to get sufficient deviation. The oscillator (including the diode) should be very stable so the only FM produced is intentional. Incidentally, the battery is used to set the bias of the diode to the most linear part of its voltage-versus-capacitance curve. It's interesting to experiment with this bias voltage; it is possible to produce greater deviation in one direction than the other. This may be desirable when the signal is being received by the slope-detection method on a receiver not designed for FM.

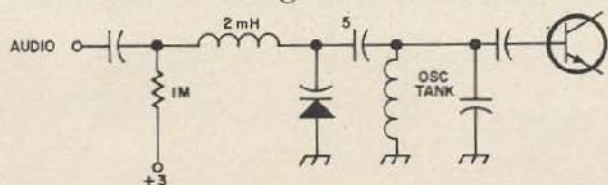

Fig. 62. A diode can be used for direct frequency modulation.

Balanced modulators

A fundamental circuit in an SSB transmitter is the balanced modulator. There are many different types of balanced modulators, and some must obviously work better than others. Unfortunately, exhaustive comparative tests on the circuits have not been published, as far as I know, and almost every SSB transmitter diagram published has used a different type of modulator. However, two which have been found excellent are shown in Fig. 63 and 64. One

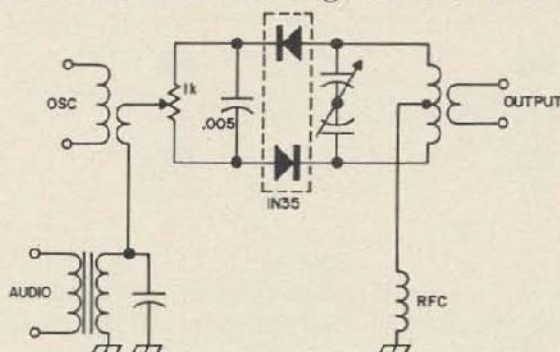

Fig. 63. This is a popular balanced modulator for generating DSB (and eventually SSB).

uses four diodes in a bridge, and the other uses two diodes. The diodes in these circuits should be matched if possible. Matched pairs of diodes are available (for instance, the 1N35 is a matched set of two 1N34's), or they can be matched by measuring the forward (low) resistance of a number of diodes with an ohmmeter and choosing the ones which have the closest values. Both of the circuits shown produce a carrierless double-sideband signal from an rf signal and audio.

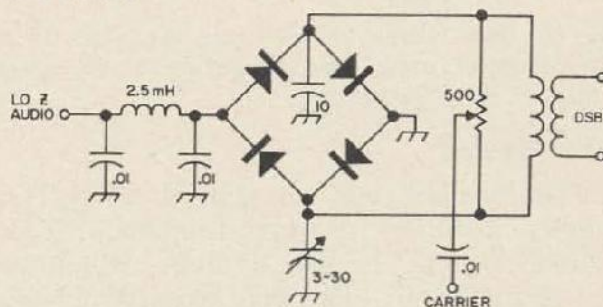

Fig. 64. This is a bridge balanced modulator for SSB.

Sideband switching

A sideband transmitter usually has some provision for operating on both upper and lower sidebands. There are a number of ways to do this, but one of the simplest is shown in Fig. 65. Here simple diode switches are used to select either the upper- or lower-sideband crystal by grounding the desired

crystal and presenting the other crystal with a very-high-impedance path to ground. As the circuit is shown, applying a positive voltage will select the lower-sideband crystal, and a negative voltage the upper. The voltage should be a little higher than the peak voltage across the crystal.

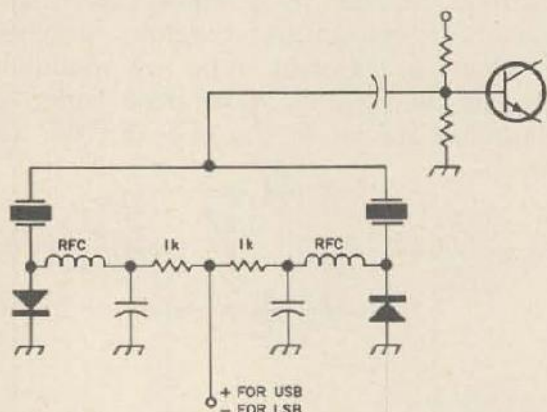

Fig. 65. A pair of diode switches can be used to select upper-or lower-sideband-generating crystals.

Another useful diode switch is shown in Fig. 66. This circuit is especially useful in transceivers. A positive bias voltage selects the first input and a negative one the second input. Here again, the bias voltage must exceed the peak voltage in the circuit.

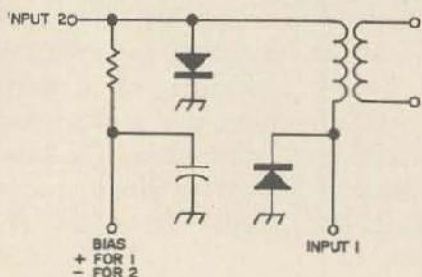

Fig. 66. These diode switches can be used in a transceiver or other type of equipment to select either of two inputs.

RTTY keying

The simplest way to shift a VFO frequency slightly for high-frequency FSK radioteletype is to use a diode switch as shown in Fig. 67. The shift required is only 850 Hz or less, which is easy to get in

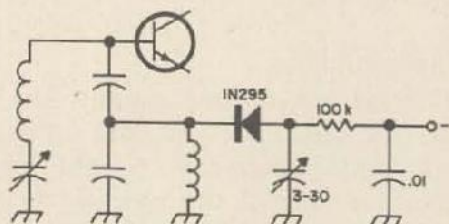

Fig. 67. A diode switch is used to connect a small capacitor to a VFO to shift its frequency slightly for radioteletype.

most high frequency VFO's. The trimmer capacitor is adjusted for the proper shift.

Varactor multipliers

Few components have simplified the work of the VHF engineer or ham more than the power varactor diode. Currently available varactors can produce as much as 30 watts or more at 450 MHz from a 40-watt 150 MHz source. These varactors are very efficient, too, with efficiencies of 75% fairly typical. Other varactors are excellent for generating power at 10 GHz or more. Step-recovery diodes are recently developed varactors that are even more remarkable in producing power at microwave frequencies from simple circuits. Many cheap, common diodes (and transistor junctions) make excellent low-power varactors. Silicon power diodes can be used at low frequencies, and fast silicon diodes such as the IN916 are excellent as high as 1GHz in many uses. A general varactor doubler is shown in Fig. 68. Notice that the input and output

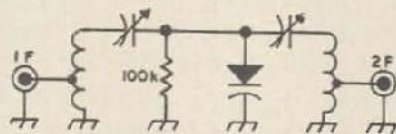

Fig. 68. This is a basic varactor doubler.

circuits are series tuned, with the diode in parallel. This is the most efficient and convenient type of varactor multiplier, since power varactors are generally designed for grounded cathode operation. The bias resistor is not usually critical, though in general, low values give the best linearity and high values the best efficiency. Applying a slight bias to the cold end of the resistor, instead of grounding it, often improves the efficiency slightly. While not shown, a varactor doubler can be built with two parallel tank circuits and a series diode. This is not as efficient as the parallel circuit, but it is often more convenient for low-power receiver multipliers and signal sources, especially if they use popular grounded quarter-wave coaxial or trough-line tanks. A varactor tripler or quadrupler

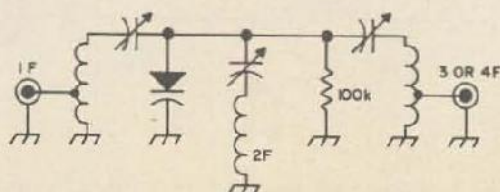

Fig. 69. "A" is a varactor tripler or doubler.

is shown in Fig. 69A. It requires an idler circuit tuned to the undesired second harmonic of the input. The tuning of this idler can be critical for best results, but it is often omitted in applications where low efficiency is satisfactory.

Fig. 69B shows a practical 144-to-432 MHz tripler using an Amperex 1N4885 diode (\$15). 25 W input at 144 gives 17 watts of output at 432 MHz.

Since varactor multipliers are such excellent generators of harmonics, they can cause severe interference in transmitters and spurious responses in receivers. They can not only multiply by whole numbers, but can mix these harmonics together to produce strong signals at 3/2, 4/3, 5/2 and other multiples of the fundamental. Consequently, varactors should always be used with selective filters except where these extra signals will cause no problems.

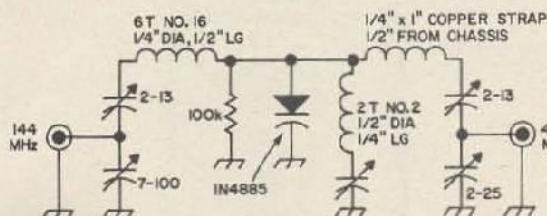

Fig. 69B is a practical high-power varactor tripler.

Transmitter spotting switch

Every CW transmitter should have some method of spotting its frequency without putting a signal on the air. Some of the schemes which have been published are quite involved; many even require stealing voltage from the receiver for spotting. A far simpler approach uses one diode along with one single-pole-single-throw switch. It's shown in Fig. 70. When the spot switch is thrown, the diode is reverse biased, so it does not conduct and only the oscillator can draw current. However, in normal transmission, when the key is depressed, the diode is forward biased, so all the stages in the transmitter can operate. The diode should have high back resistance. A silicon power diode is recommended.

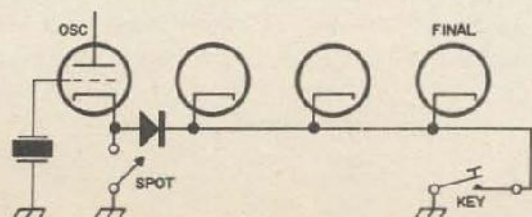

Fig. 70. A diode can be used for very simple spotting in a CW transmitter.

Test Applications

Field strength meters

One of the most useful pieces of equipment in any ham shack is a field strength meter. While FSM's can be bought for very little from any big radio supply house, they're so simple and easy to build that most hams make their own. The simplest type of FSM is untuned, and can be used at any frequency from below the broadcast band to UHF. Fig. 71 shows such an FSM. It uses only four components: a non-critical rf choke, a germanium diode of almost any type, a small capacitor, and a meter. This

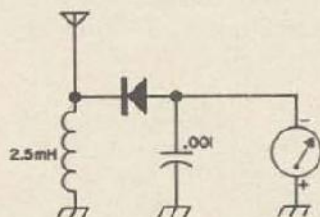

Fig. 71. A simple field-strength meter.

circuit gives a very nonlinear, relative reading. A slightly better FSM is shown in Fig. 72. It is less frequency-dependent than that in Fig. 71 at it doesn't contain an rf choke. It uses a resistor to help linearize the meter. This circuit uses a voltage-doubling detector for high sensitivity, a variable resistor for adjusting the deflection on the meter, and a choice of meter output for adjusting transmitters, or a pair of magnetic headphones for monitoring AM transmissions.

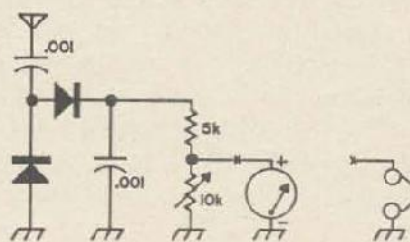

Fig. 72. This voltage-doubling field-strength meter-monitor is not frequency selective.

The mobiling ham has a special problem. He needs a good FSM to get the best performance from his usually inefficient antenna, but can't use a meter which is affected by other nearby transmitters. A solution to his problem is the mobile FSM shown in Fig. 73. It uses a silicon diode which doesn't conduct except on very close high power transmitters (his). This design also uses a normal BC antenna for pick-up, yet requires no switching.

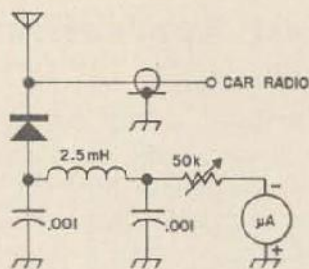

Fig. 73. A special type of FSM for use in a car.

Another simple rf detector-FSM is shown in Fig. 74. It's called an rf sniffer, and is especially useful for neutralizing transmitters and detecting the presence of small amounts of rf in both transmitters and receivers. The size and shape of the loop of wire is not critical, but it should be insulated for safety.

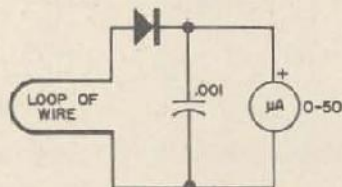

Fig. 74. The rf sniffer is a wide-range sensitive rf detector.

Wavemeters

A slightly more sophisticated rf detector is shown in Fig. 75. It includes a tuned circuit for differentiating between frequencies. This type of instrument is very useful in adjusting transmitters since it helps to prevent transmitting on the wrong harmonic of a crystal-controlled oscillator. The tuned circuit should tune the required range, and can be tapped as shown for the best selectivity. Bandswitching is necessary for ranges of more than about 3 to 1. This type of circuit is usually called a wavemeter. It can also be used as a field strength meter, of course.

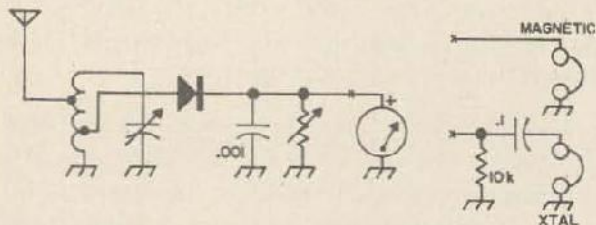

Fig. 75. A wavemeter is simply a FSM tunable to frequency. It is especially useful for checking transmitter harmonics.

A good wavemeter-FSM for the VHF man is the simple tunable, voltage-doubling six-and two-meter unit shown in Fig. 76. It can be used to make sure that he's trans-

mitting on the right frequency, help him adjust his transmitter for maximum output, and monitor his modulation if he's on AM.

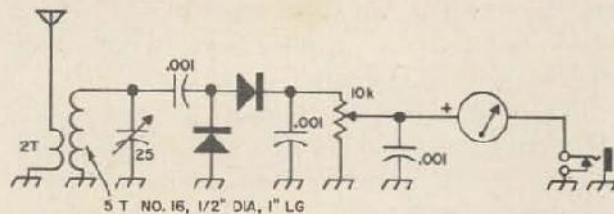

Fig. 76. This tunable VHF wavemeter-FSM-monitor covers six and two meters.

The Uhfite, shown in Fig. 77, is a FSM-monitor using a capacitively tuned, quarter-wave line. It tunes 215-450 MHz, covering both the 220 and 432 MHz bands. The Uhfite can be built from any type of solderable metal, or from copper-clad board.

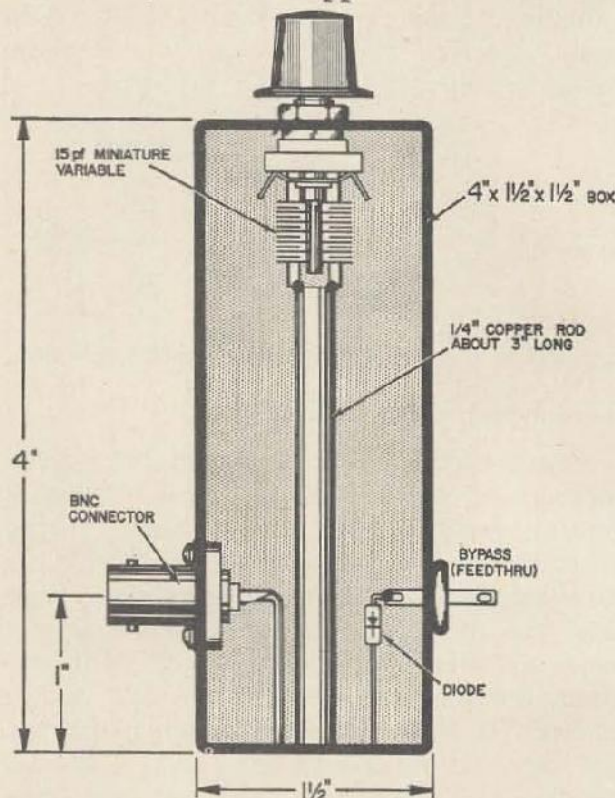

Fig. 77. The Uhfite is a general-purpose wavemeter and monitor.

RF probe

A necessity for the ham experimenter is an rf probe which can be used to detect and measure small rf voltages. This type of probe can be used with both voltmeters

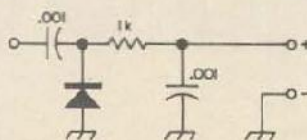

Fig. 78. A general-purpose rf detector probe for use with an oscilloscope or voltmeter.

and oscilloscopes for alignment, troubleshooting, signal tracing and many other jobs. A good rf probe for the HF and VHF ranges is shown in Fig. 78. The capacitors should be button or other good HF units for VHF use. They can be increased slightly in value for use down to 455 kHz or lower.

Dummy load

Every ham needs a dummy load for his transmitters. It can be used for tests to avoid transmitting a signal that could cause interference to other stations. A dummy load is simply a non-reactive resistor which matches the output of a transmitter, usually 50 ohms. A dummy load is most useful when it contains an rf voltmeter so it can be used for determining power by the familiar equation, $P = E^2/R$. See Fig. 79A. For low power, the diode can be connected directly across the resistor, but for higher power, enough voltage may be developed to damage the diode. For example, a typical 1N34 diode, which is often used for rf monitoring, has a PIV of only 60 volts. Assuming that the waveform applied to it is a perfect sine wave, which is unlikely, a voltage of about 20 RMS is the maximum it can take. However, that's only 8 W. Therefore, most dummy loads of this type use a voltage divider, such as shown in Fig. 79B.

This step-down in voltage subjects the diode to much lower voltage (about 1/100th in this case). Then, if the 50-ohm load can stand the power, the same diode could be used for up to 800 W. This type of divider is, unfortunately, quite sensitive to frequency, so cannot be trusted at high frequencies (say over 30 MHz) unless calibrated. It is possible to compensate for this by adding a small capacitor across either the large or small resistor in the voltage divider, and that will increase the maximum usable frequency somewhat. Here again, though, it must be checked against a reliable standard.

One thing to be very careful about with all of the rf voltmeters mentioned above is that they are peak-reading instruments. That means that on a perfect sine wave, they indicate about 1.4 times the RMS value of the rf if they're used with a high resistance dc voltmeter. The RMS value is what we usually use. However, it is easy to compensate for this by multiplying the value by 0.7. A more serious problem is that for wave shapes other than sine, the

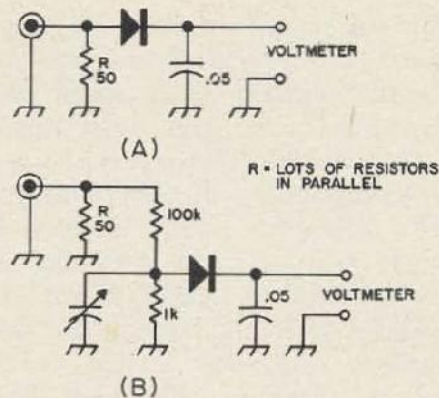

Fig. 79. A dummy load should be used for all possible transmitter testing. An rf voltmeter connected to the dummy load makes it a wattmeter. A single diode is limited in voltage rating, so a voltage divider must be used for high power.

relation between the peak value and the RMS value may be unknown, and some waves may have peak values which are very much higher than 1.4 times the RMS. For example, a wave with high out-of-phase third-harmonic content can read very high. This is often responsible for such statements as the 99% or even 75% efficiency sometimes claimed for two meter transmitters or varactor multipliers. There is no simple, universal solution to this problem.

SWR bridge

There are a number of instruments which can help you find out whether your antenna is matched properly to its feed line. Most hams use an SWR bridge, which measures the degree of mismatch in the line, but these SWR bridges really tell very little unless they're installed at the antenna feed point rather than at the transmitter. A basic and very popular type of SWR bridge is shown in Fig. 80. This device can be left in a transmission line when transmitting and can be used to tune a transmitter for maximum output. There are many variations on this type of bridge, using slightly different electrical or mechanical arrange-

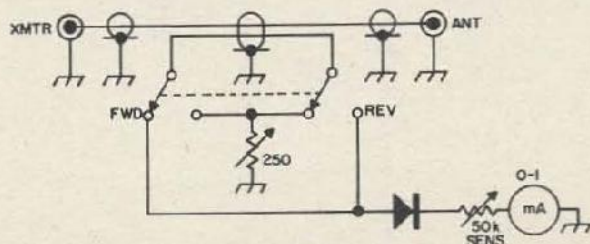

Fig. 80. An SWR bridge is invaluable for adjusting an antenna. The critical part of the bridge is a piece of coax cable with an extra wire inserted between the cable dielectric and the shield.

ments for easier construction or improved performance. The bridge shown uses a piece of coax cable with an extra small piece of wire slipped between the inner insulation and the coax shield. The piece of coax and the other components should be kept short for VHF operation, with a symmetrical arrangement of parts. In use, the bridge sensitivity control is adjusted for a full-scale reading with the switch in the forward position, then the switch is thrown to the reverse position. The lower the reading the better, and a zero reading indicates (at least in theory) a perfectly matched line with an SWR of 1.00:1. In practice, this type of bridge is not that trustworthy, but it still can be useful in helping you tell whether your antenna is close to 50 ohms.

Antennascope

Another type of bridge used for matching antennas is better in that it can tell you what your antenna impedance is instead of just indicating whether it is close to 50Ω. This is the simple impedance bridge, called the antennascope, shown in Fig. 81. This bridge is designed for low power operation—a grid dip meter usually gives plenty of power. It should be built very compactly with short leads. The potentiometer should be of high quality; an Allen-Bradley Type J is fine. The bridge can be calibrated with regular composition resistors. Simply connect the resistors in turn to the antenna terminal and adjust the pot until the meter reading dips to zero. Then mark the value of the resistor by the pot pointer. In use, the meter reading will not null completely except for resistive loads, so it will not read zero for reactive antennas. Nevertheless, the minimum reading will occur at the approximate impedance reading. Remember that all antenna bridges should be used between the antenna and the transmission line.

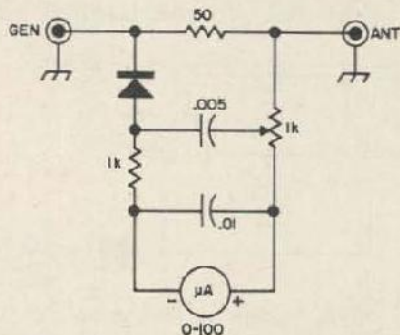

Fig. 81. This antennascope is a simple antenna impedance bridge. It should be constructed compactly for best high frequency use.

James Dandy Mixer

A little-known but very useful simple piece of test equipment is the untuned mixer, or James Dandy Mixer, as W2DXH calls it. This gadget, as shown in Fig. 82, has many uses. It can be used as an untuned detector or monitor, or for making an impromptu frequency meter, neutralizing transmitters, finding VHF parasitics. The James Dandy Mixer has two inputs of 50 ohms, which are fairly well isolated from each other. Shorting or opening one, has little effect on the other. This mixer is one of those instruments that finds many uses after it is built, and is so easy to build that it belongs in every lab or shack.

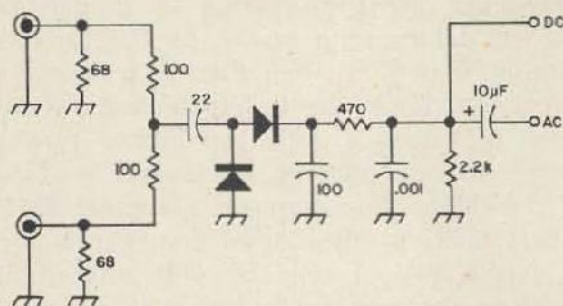

Fig. 82. The James Dandy Mixer is a general-purpose untuned mixer useful as an impromptu frequency meter, receiver, detector, etc.

Signal generator modulator

A simple diode AM modulator for an unmodulated signal generator is shown in Fig. 83. It can be used with an audio generator and early BC-221, for example, for receiver alignment.

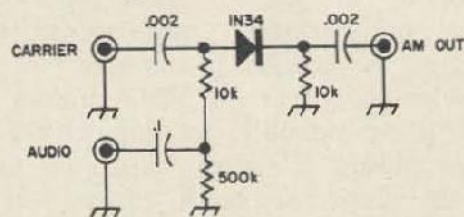

Fig. 83. This amplitude modulator can be used to modulate the output of any low-level CW source.

Tachometer/audio frequency meter

Diodes can be used to form a simple audio frequency meter. The circuit is shown in Fig. 84. This circuit requires a constant 10 V RMS input, which may be set by a

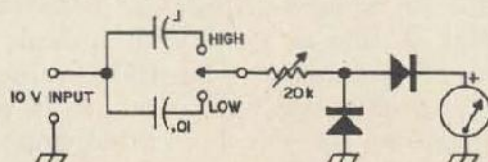

Fig. 84. This audio frequency meter must be calibrated before use. It requires an input of 10 V.

pair of zener diodes or with the help of an audio voltage meter. The circuit shown covers 20-5000 Hz; the scales are not linear, and must be calibrated before use.

A more satisfactory frequency meter for audio frequencies is shown in Fig. 85. Its scale is linear, and the input is automatically set to the right level by the zener diode or diode-battery clipper over quite a wide range. The same circuit can be used as an automobile tachometer. Simply connect the input to the high side of the points in the car. It can easily be calibrated on about 12 Vac. Remember that 1 Hz = 60 rpm, so 60 Hz = 3600 rpm.

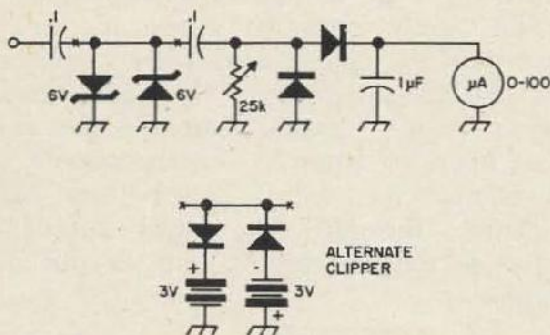

Fig. 85. This audio frequency meter-tachometer is self limiting and linear reading. Either two zeners or two conventional diodes and batteries can be used to set the proper input voltage.

Noise generator

A useful piece of equipment often used in aligning receivers is a noise generator. A noise generator is a source of controllable noise, more-or-less independent of frequency. For instance, the noise generator shown in Fig. 86 provides noise from below the broadcast band all the way to 500 MHz. It is adjustable in output by the potentiometer. The capacitor should be a UHF button mica or ceramic feedthrough for best results. Most surplus 1N21 silicon diodes can be used, but some generate more noise than others. The resistor across the output should have the same value as the input to the receiver under test. Leads should be as short as possible. This type of noise generator is useless for quantitative tests as there is no simple relation between the amount of current flowing through a diode and its noise output, but the generator is very useful for adjusting a receiver for lowest noise figure. The procedure is to adjust the receiver while turning the noise generator on and off. You should adjust for maximum rise in noise when the generator is turned on. Incidentally, the polarity of the diode must

be checked carefully. If it is reversed, it will be forward biased, and its impedance will be very low and in parallel with the 50-ohm resistor. Also, the impedance will change radically with varying current, making the output impedance of the device uncertain and consequently unreliable.

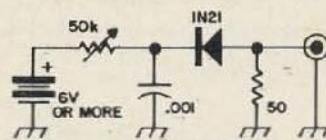

Fig. 86. A diode noise generator is very useful in aligning a receiver for lowest noise figure.

Square-wave generator

A simple square-wave generator is shown in Fig. 87. If a sine wave is applied to the input, an almost-square wave will appear across the two back-to-back zeners as they clip the top and bottom off the sine wave. Best waveform results when the input voltage is much higher than the output, for instance 50-V input and 5-V output. The limiting resistor must be picked for the voltage and current capabilities of the zeners.

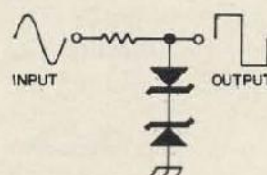

Fig. 87. Two zeners can be used to produce a highly clipped sine wave very similar to a square wave.

Sawtooth pulse generator

A simple sawtooth generator for use with simple monitor scopes is shown in Fig. 88. It works best with low frequency sine-wave input and very high impedance output.



Fig. 88. This simple sawtooth generator could be added to a monitor oscilloscope.

A relative of the sawtooth generator is shown in Fig. 89. It can be used for generating pulses for many applications. It, too, takes a sine wave input. Among the applications of a pulse generator are adjusting noise clippers and blankers, and providing marker pulses for the time base of a scope. For instance, a 1000 Hz sine wave can

provide a pulse every millisecond (1000 microseconds).

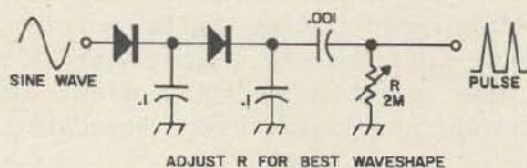

Fig. 89. A pulse generator is needed to adjust noise limiters for best results.

Miscellaneous Circuits

Dual battery supply

Many hams who operate mobile have had the embarrassing experience of running their battery down by talking a bit too long. One way to avoid this is to use two batteries, one for the ham gear and one for normal car needs. However, some way must be found to keep them both charged, yet make sure that the ham battery does not steal energy from the normal battery. Schemes to accomplish this used to be complex, with heavy relays and complicated switching, but as has happened in so many cases, semiconductors have simplified the problem to almost nothing. A couple of high-current, low-voltage silicon diodes can be used as one-way switches as shown in Fig. 90. The

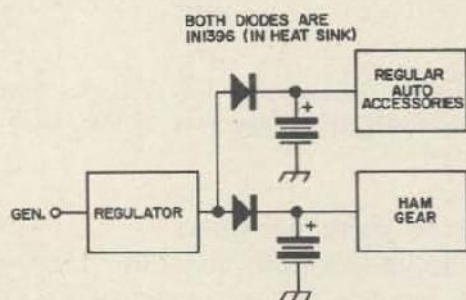

Fig. 90. Here's how to use two batteries in your car, one for ham gear and one for the rest of the car needs. The diodes act as one-way switches, keeping the batteries charged, yet preventing any power from flowing from one to the other.

diodes conduct when the generator voltage is higher than the batteries, charging the batteries, but current cannot flow in the other direction and cause one battery to charge the other. The diodes should be mounted on heat sinks in as cool a place as can be found near the batteries. Heavy wire is necessary as many amperes will flow at times. There is a voltage drop of about 0.6 V across the diodes, so it may be necessary to adjust the car voltage regulator for slightly higher output. Since charg-

ing voltage is usually 13.5 to 15 V or more, this may not be required.

Combination battery charger-power supply

It's often convenient to have an ac power supply included in equipment that is normally battery operated. Unfortunately, some switching must be provided between the two supplies so that the battery will not run down by mistake when the equipment is supposedly used on ac. One simple way to avoid this problem is to use a rechargeable battery which cannot be overcharged, and float it across the power supply as shown in Fig. 91. In this circuit, if the power supply is plugged into ac, the battery will be charged and the equipment can also be operated at the same time. If the ac supply is disconnected, the equipment operates from its battery supply with no manual switching. The battery cannot discharge through the power supply because of the one-way action of the diode bridge.

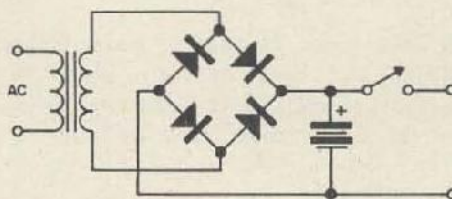

Fig. 91. A battery can be floated across a power supply, keeping it charged and providing automatic switching from ac to battery power.

Code transmission

The simplest way to transmit code for practice is to use a tape recorder to modulate a transmitter. However, this produces an AM or FM signal rather than CW (except possibly on SSB). It's generally better to transmit a CW signal as used in most communications. One way to do this is shown in Fig. 92. Here the rectified audio output from the recorder operates a relay which keys the transmitter. A high-speed relay and short capacitor-resistor time constant is necessary for high-speed operation.

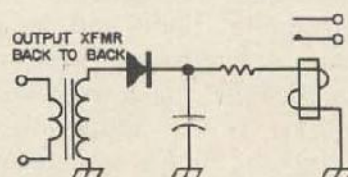

Fig. 92. A transmitter can be keyed by a tape recorder for automatic code practice with this circuit.

Code monitoring

Fig. 93 shows a simple method for monitoring the CW output of a transmitter. Antenna, choke and diode rectifier produce a dc voltage that operates a suitable code practice monitor. The monitor must be one which can operate from the keying voltage available and will turn on quickly. Some code practice oscillators operate from as little as $\frac{1}{2}$ V; they would obviously be more suitable for low-power applications than oscillators requiring higher voltage. However, if you live near a broadcast transmitter, a monitor which is too sensitive may be triggered by the BC signal.

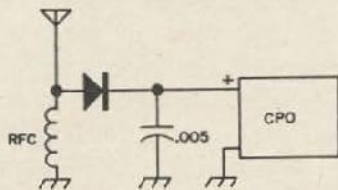

Fig. 93. A field strength meter can key a code oscillator to form a cw monitor.

Radar detector

Of limited practical use, but tremendous appeal, is a simple detector for police radar speed traps. These detectors, which consist of a diode detector in a tuned cavity and a high gain audio amplifier, are illegal in many states, but the laws forbidding them are really a waste of time because anyone who hears the police radar on his

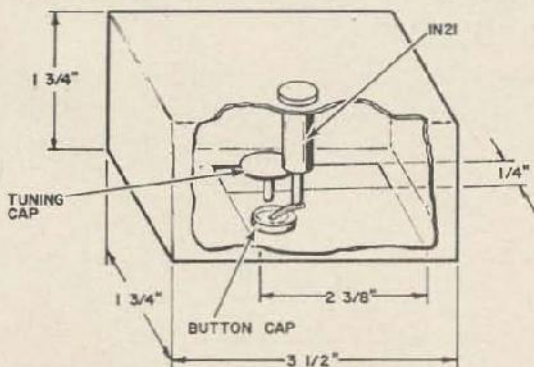

Fig. 94. This is a radar receiver; it covers a ham band as well as a police radar speed meter assignment.

receiver is already in its beam. Nevertheless, the radar detector is interesting. As a bonus, it covers some ham bands and other possibly interesting frequencies. A detector for 2.3 to 3.3 GHz, which includes some of the police radar assignments, is shown in Fig. 94. It can be built from brass or copper-clad circuit board. It should be followed by a very high-gain low-noise

amplifier for greatest sensitivity. This receiver will pick up many signals in almost any location, but don't count on it saving you from a speeding ticket.

Zener tricks

A zener diode can replace a large, high-capacitance coupling capacitor in an amplifier, and improve the frequency response of the amplifier in the process. The direct-coupled amplifier in Fig. 95 uses a 15-V zener in this way. High-voltage zeners can also be used in tube circuits.

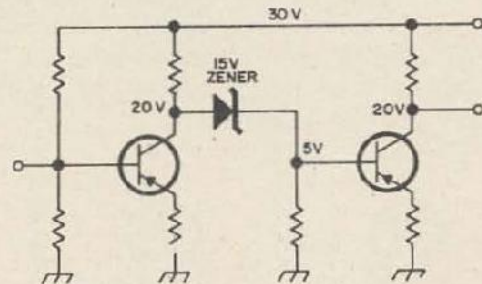

Fig. 95. Zeners can be used in dc-coupled amplifiers to replace coupling capacitors.

Fig. 96 shows a pair of diodes used to provide an artificial center tap in a push-pull transistor amplifier. This arrangement is more satisfactory than a resistive tap.

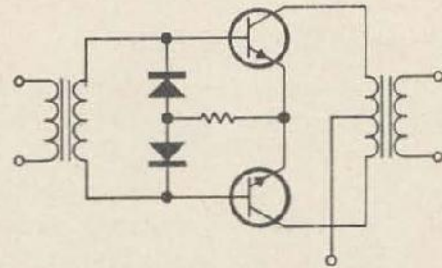

Fig. 96. Diodes can provide an artificial center tap for push-pull amplifiers.

Zeners can furnish low-impedance stable bias sources for vacuum tubes. A screen voltage zener is shown in Fig. 97A, and a zener in series with the tube to provide grid bias is shown in Fig. 97B. The resistor R may be necessary to keep the zener alive if

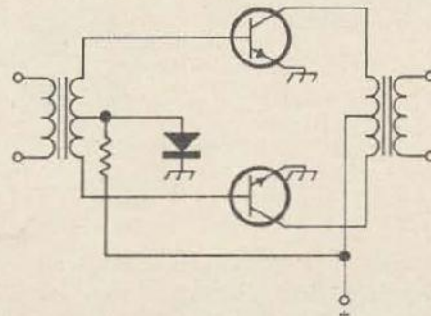

Fig. 97. A diode is often used to provide temperature-compensated bias for class B amplifiers.

the current of the tube drops to a low level or if the zener works best at a higher current than the tube.

Class B temperature stabilization

Class B transistor amplifiers are very sensitive to changes in temperature. A small resistor is generally used in the emitter circuits of these amplifiers to prevent excessive current flow at high temperatures, but resistors can waste a lot of power as well as provide varying bias. A better approach is to use a diode to maintain the bias as shown in Fig. 98. The diode will compensate for temperature changes because of its temperature coefficient, which is similar to that of the transistors.

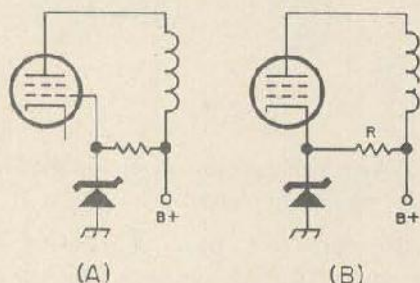

Fig. 98. A zener can furnish stable screen or grid bias for a vacuum tube.

Reverse polarity protection

Few things are as disheartening as connecting a piece of equipment to a reversed power supply and blowing out its transistors or other parts. Though this possibility has probably been over-emphasized in the past, it is true that some transistors in some circuits are very intolerant of incorrect polarity.

Fig. 99A shows a simple way to prevent this. If a diode is connected in series with the power lead, the wrong polarity will cause no problem as the equipment will simply not work. An even better arrangement is shown

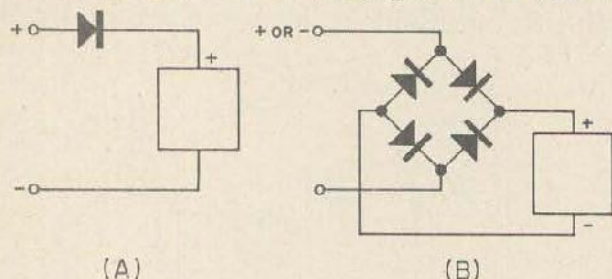

Fig. 99. These two circuits protect equipment from incorrectly polarized voltage. The single diode keeps the equipment from working when the polarity is wrong, while the bridge automatically selects the proper polarity.

in Fig. 99B. Here the equipment will work properly no matter how you connect the power supply. The diode bridge "chooses" the proper polarity from the input voltage. In fact, it will even work on alternating current, but a filter will probably be necessary. The diodes must be suitable for the current passing through them. There is a slight voltage drop across the diodes.

Under- and over-voltage protectors

Tubes are becoming unpopular for many applications, but many are still being used. They are often expensive and critical tubes are easily damaged by excessive filament or heater voltage, such as transmitting power amplifiers and cathode ray tubes. Zener diodes can be used to protect filaments from gross voltage overloads, and with care, can also protect them from small excessive voltages. The filament voltage of most tubes used by hams should be kept within 10% of the proper value for best results and longest service. Fig. 100 shows how a zener (or zeners) can be connected across a filament to eliminate the problem of high voltage.

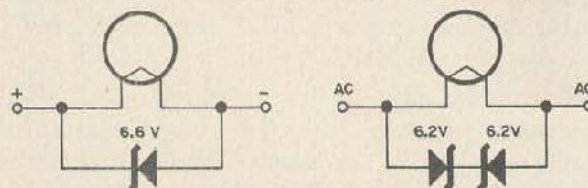

Fig. 100. Zeners can protect a delicate filament from overvoltage.

Fig. 101 shows a similar arrangement which will provide protection from high voltage for a piece of equipment of any type.

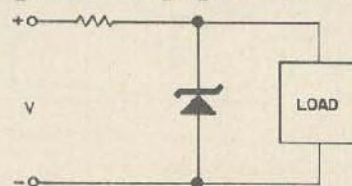

Fig. 101. A zener can protect any critical load from overvoltage.

Many pieces of equipment can be damaged from under-voltage as well as over-voltage. Many motors, for instance, will stall under low voltage, then draw excessive current and burn out. One way to prevent this is shown in Fig. 102. The relay disconnects the load when the input voltage drops to a value low enough to cause the zener to stop conducting. The resistor is necessary to limit zener current if the relay resistance is not high enough.

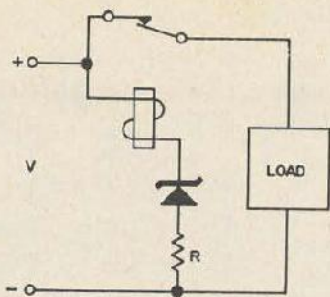

Fig. 102. This circuit will disconnect a load when voltage drops below a minimum.

Transient fields

Transformers, relays and other inductive components operating in dc circuits often generate large reverse transient voltages when their magnetic fields collapse as the dc voltage is removed. These transients can damage transistors, diodes and other polarity- and voltage-sensitive components if suitable precautions are not taken. A simple, inexpensive transient damper is shown in Fig. 103. A silicon diode is connected across the coil in the reverse direction. It conducts no current as long as the dc flows. When the dc is removed, the diode will short circuit any reverse-polarity voltage transient generated by the collapsing coil. The diode used must have a PIV rating greater than the voltage generated.

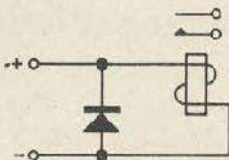

Fig. 103. A diode can damp the field generated by a coil when current through it is disconnected.

Transistor gain control

A vexing problem in transistor amplifiers is varying the gain of an amplifier without changing its dc conditions. One simple approach is shown in Fig. 104. Here the impedance of a diode in series with an emitter

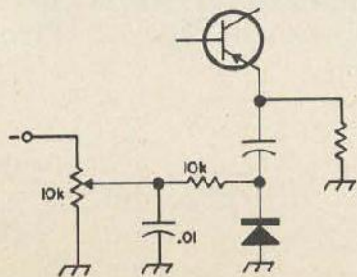

Fig. 104. A diode can control the bypassing of an emitter bypass capacitor to change an amplifier's gain.

bypass capacitor is varied to change the effectiveness of the bypassing, and hence the gain of the stage.

Lamp dimmer

Fig. 105 shows a simple non-dissipative lamp dimmer. It offers only two positions, full on and half on, but that is adequate for many uses. Its operation should be fairly obvious. The diode conducts ac in only one direction, so only half the current that normally would flow through the lamp is passed. The diode must be rated for the wattage of the lamp; a 750-mA diode is satisfactory for a 60-W lamp.

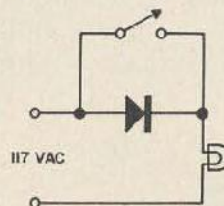

Fig. 105. This is a lamp dimmer providing two brilliance positions, half on and full on.

Control circuits

Diode control circuits are among the most interesting, yet least understood, diode circuits. Some of them smack of black magic when they're not well understood. Fig. 106 shows such a circuit. Here one switch and two wires serve to control two lamps. Do you see why it works? There is a small voltage

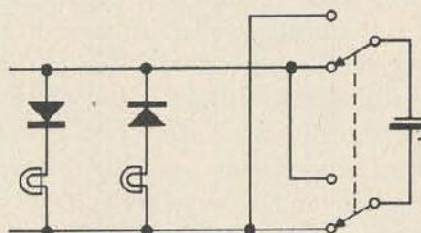

Fig. 106. Diodes can be used for mysterious switching of two lamps with one pair of wires.

drop across the diodes. Fig. 107 is a slightly more interesting version of the same type

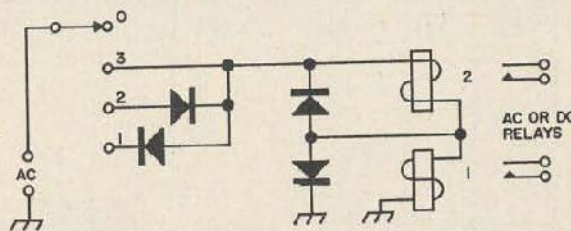

Fig. 107. This is an extension of Fig. 106. In position 0 neither relay is energized. In position 3 both are energized. In 2, relay 2 is on and in 1, relay 1 is on.

of circuit. One switch and two wires control two relays, turning them both on or off, or either one on or off, in turn.

Another interesting scheme is shown in Fig. 108. Here the relay receives current when the input voltage exceeds the zener

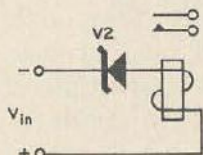

Fig. 108. An input voltage over the zener voltage energizes the relay.

voltage. Fig. 109 is an expansion of that idea in which increasing voltages turn on the relays in sequence. This could be used for various indicators such as antenna elevators or rotators.

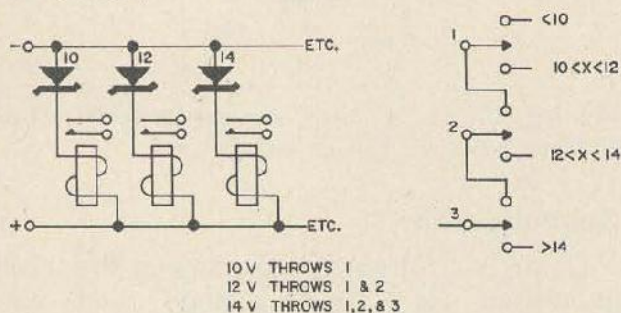

Fig. 109. In this scheme, a varying input voltage selects relay contacts in turn.

Transmit-receive switches

Diodes make excellent transmitter-relay switches. A number of manufacturers make diodes especially suited for this service. You can buy solid-state antenna switches for HF, VHF or microwave use, but they aren't cheap. For ham HF use, simple, cheap silicon power diodes make excellent T-R switches that switch very fast and provide excellent isolation and low loss. Such a circuit is shown in Fig. 110. It will handle quite a bit of power. Fig. 111 shows another semiconductor antenna switch. This one is a little more symmetrical than Fig. 110 and better for VHF. The diodes should be special mic-

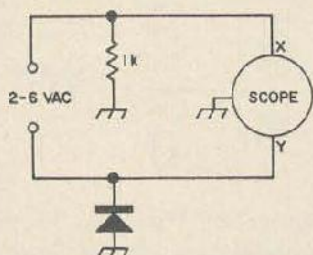

Fig. 112. One of the easiest types of diode checks for a person with a scope is this, but it tells nothing about a diode's high voltage performance.

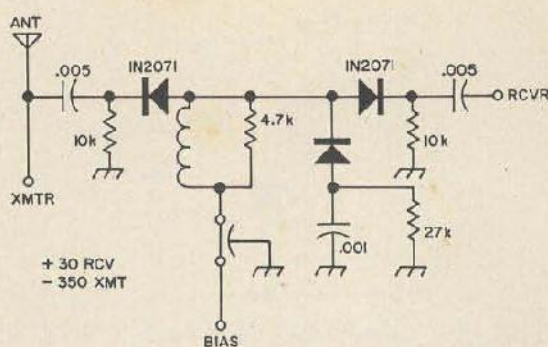

Fig. 110. This is a high-frequency antenna switch using diodes.

rowave varactors, but the circuit will likely work with common diodes such as the 1N21 if the diode ratings are not exceeded.

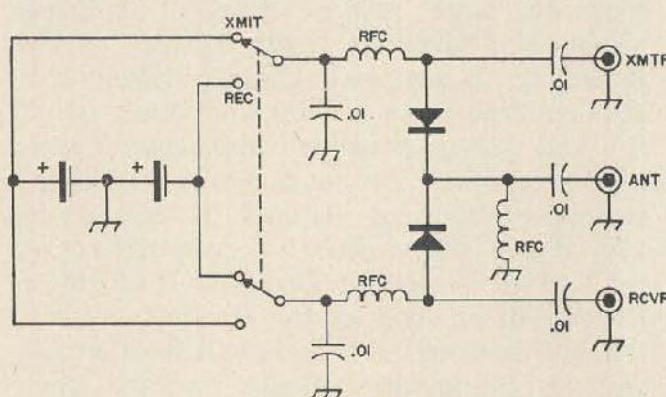

Fig. 111. This transmit-receive switch can be used at VHF if it is constructed carefully.

Testing Diodes

Probably the best way to check a diode is to display its characteristics on an oscilloscope, as described by W2DXH in the April 1967 73. Jim's checker puts a maximum of about 225 volts across the diode, so tells little about the properties of the diode under higher voltage. It is often desirable to test diodes at higher voltages. It's easy to modify Jim's circuit for this, but you have to be careful in using a higher voltage or the diode, the instrument, or you, may go up in air pollutants. On the other hand, you can test diodes at low voltages with the popular (It has appeared in almost all electronics magazines.) scheme shown in Fig. 112. This

arrangement works on the same principle as the more complex instruments mentioned above. It is interesting, and very simple. It makes an excellent diode rejector; any diode which doesn't pass this test should quickly be thrown away. Incidentally, silicon diodes seem to have sharper knees and straighter traces than germanium ones.

Another and even simpler, gadget that quickly tells whether a diode is hopeless, is shown in Fig. 113. It is also identifies the diode's cathode (if it has one). The principle of this one should be obvious if you've been paying attention. Use low current lamps to avoid cooking small diodes. Operation is very simple. Connect the diode. If lamp A lights, the diode is good. If B lights, the diode is good, but you've got it in backwards or the diode is mismarked. If both A and B light the diode is shorted. If neither lights, the diode is open.

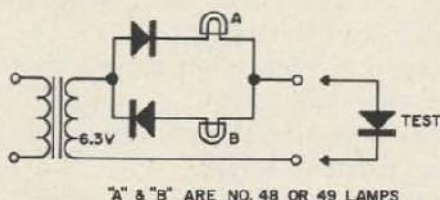

Fig. 113. This simple device gives a quick check of diodes. If lamp A lights, the diode is good. If B lights, the diode is good, but connected backwards. If neither lamp lights, the diode is open, and if both light, it is shorted.

A simple way to check diodes is with an ohmmeter, and a simple ohmmeter is shown in Fig. 114. If the diode is connected with its cathode to the positive terminal of the ohmmeter (reverse biased), no current flows (or at least very very little). Conversely, if the diode is connected with its anode to the positive voltage (forward biased), lots of current will flow. In simpler terms, the diode should have low resistance with the ohmmeter leads connected in one way, and high resistance if the leads are reversed. Almost any ohmmeter is usable. Be careful that your ohmmeter doesn't furnish enough current to damage the diode.

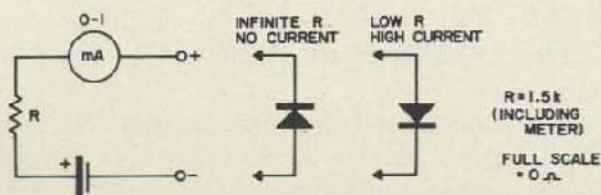

Fig. 114. This simple ohmmeter demonstrates how a diode can be checked with an ohmmeter.

An easy way to check zener diodes (incidentally, snobs call them zayners not zeeners) is shown in Fig. 115. Start with zero voltage, and increase it until the voltmeter stops rising. That's the zener voltage. If the voltmeter stops at about $\frac{1}{4}$ volt, you have a forward-biased germanium diode, and if it stops at about $\frac{3}{4}$ volt, it's a forward-biased silicon diode, instead of a reversed biased zener. Turn it around. It's a good idea to place a milliammeter in series with the diode to make sure that you don't exceed the power the zener can dissipate. You can figure the power input by Ohm's Law; power in watts equals voltage across the zener times the current flowing through it in am-

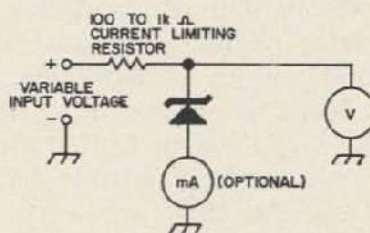

Fig. 115. Here's a simple way to find the breakdown voltage of zener diode.

peres. For example, if a 10-volt zener has 10 mA (0.01 amps) flowing through it, the power being dissipated by the zener is $\frac{1}{10}$ watt (100 mW), which isn't likely to cook it. Most of the small glass zeners are rated at 250 or 400 mW, the small metal cased ones 1 W and the studs (with heat sinks) 10 W. There's no need to push the ratings when you check the zener break, though. Diodes have almost the same zener point with maximum dissipation and $\frac{1}{10}$ dissipation.

You can check varicaps and varactors by the above methods, but that just tells whether they're diodes. You can also check them in practical circuits, or simplified test jigs. For instance, if you want to find a good frequency multiplier, make a multiplier and try diodes until you find a satisfactory one.

Transistors can be thought of as two diodes (emitter-base and base-collector), so you can check them for use as diodes by ignoring the unused lead. Silicon transistor emitter-base junctions often make excellent zeners, for example, while old germanium VHF transistor base-collector junctions can make good varactors, and old germanium power transistors make good low voltage rectifiers. Though it's a bit out of the scope of this article, you can even cut off the top of a transistor case and get a photocell.

... WA1CCH