



Xserve User's Guide

Includes setup, expansion,
and hardware specifications for Xserve

 **Apple Computer, Inc.**

© 2002 Apple Computer, Inc. All rights reserved.

Under the copyright laws, this manual may not be copied, in whole or in part, without the written consent of Apple. Your rights to the software are governed by the accompanying software license agreement.

The Apple logo is a trademark of Apple Computer, Inc., registered in the U.S. and other countries. Use of the “keyboard” Apple logo (Option-Shift-K) for commercial purposes without the prior written consent of Apple may constitute trademark infringement and unfair competition in violation of federal and state laws.

Every effort has been made to ensure that the information in this manual is accurate. Apple is not responsible for printing or clerical errors.

Apple Computer, Inc.
1 Infinite Loop
Cupertino, CA 95014-2084
408-996-1010
www.apple.com

Apple, the Apple logo, FireWire, the FireWire logo, Mac, Macintosh, and QuickTime are trademarks of Apple Computer, Inc., registered in the U.S. and other countries.

Xserve is a trademark of Apple Computer, Inc.

PowerPC and the PowerPC logo are trademarks of International Business Machines Corporation, used under license therefrom.

This product includes software developed by the University of California, Berkeley, and its contributors.

Other company and product names mentioned herein are trademarks of their respective companies. Mention of third-party products is for informational purposes only and constitutes neither an endorsement nor a recommendation. Apple assumes no responsibility with regard to the performance or use of these products.

Simultaneously published in the United States and Canada.



Contents

Preface **Introducing Xserve 7**

1 Xserve Overview 9

- Your Server at a Glance—Front Panel 10
- Your Server at a Glance—Back Panel 12
- Your Server at a Glance—Interior 14
- Your Server at a Glance—Mounting Hardware 16

2 Preparing to Install Your Server 19

- Guidelines for Server Installation 19
 - Choose the Server's Position in a Rack 19
 - Electrical Power 20
 - Operating Environment 21
 - Rack Stability 21
 - Considerations for Cables 21
 - Security 22

3 Installing Your Server in a Rack 23

- Installing the Server 24
 - Get Ready to Install 24
 - Prepare the Server for Installation 25
 - Install the Server in a Four-Post Rack or Cabinet 29
 - Install the Cable-Management Arm 33
 - Place the Server in the Rack 36
 - Install the Server in a Two-Post (Telco) Rack 37
 - Connect Cables to the Server 40

Preparing the Server for Software Setup 43

4 Using Your Server 45

Starting Up the Server 45

Monitoring Status Lights and Other Indicators on the Server 46

If the Server Has a Problem 46

 What to Do If . . . 47

5 Installing or Replacing Server Components 49

Installing or Replacing an Apple Drive Module 50

Opening and Closing the Server 52

Adding Memory 56

Installing a PCI Card 59

 About PCI Cards for the Server 59

 Install a PCI Card in a Long Card Slot 60

 Install a PCI Card in the PCI/AGP Card Slot 64

Replacing the Battery 67

Appendix A Specifications 69

Processor and Memory Specifications 69

Dimensions and Operating Environment 69

CD-ROM Specifications 70

Ethernet Specifications 70

FireWire Specifications 70

USB Specifications 70

Serial Port Specifications 71

Video Card Specifications 71

Power Supply 71

Power Requirements for Devices You Can Connect 72

System Clock and Battery 72

Appendix B Safety, Maintenance, and Ergonomics 73

Important Safety Information 73

Handling Your Computer Equipment 74

Protecting Your CD Drive 75

Power Supply	75
Cleaning Your Equipment	75
Cleaning the Server's Case	75
Apple and the Environment	76
For More Information	76
Health-Related Information About Computer Use	76

Introducing Xserve

Congratulations on purchasing your new server. This product is designed to be mounted in a rack. Once the server is installed in the rack, an administrator or other user can slide it open from the front to exchange or add components.

Among the distinctive hardware features of the server are

- one or two G4 processors with minimum operating speed of 1 gigahertz (GHz), with 256 kilobytes (K) of level 2 cache and 2 megabytes (MB) of double-data-rate (DDR) backside L3 cache
- up to 2 gigabytes (GB) of DDR Synchronous Dynamic Random-Access Memory (SDRAM)
- system bus speed 133 megahertz (MHz) (at minimum)
- four Apple Drive Module bays, supporting up to four hot-pluggable ATA 100 hard disks, accessible from the front, with status and activity lights
- front panel with CD-ROM drive; LED status lights; power and system identifier buttons and lights; FireWire port; and security lock for the enclosure
- back panel with one or two gigabit Ethernet ports (auto-negotiating 10/100/1000 megabits per second); two FireWire ports; two USB ports; serial port that supports RS-232 or RS-422 connection; and VGA monitor connection
- cable-management arm to allow the unit to be opened without disconnecting cables
- two internal expansion slots for PCI cards and one combination slot for either a PCI or an AGP card
- fault-sensing operation, with sensors to detect internal temperature, blower status or failure, power status or failure, and open enclosure

Among the services offered by Mac OS X Server, included with the standard configuration, are

- file and print services for Macintosh, Windows, and UNIX® clients
- high-performance Apache Web server, with integrated WebDAV and SSL
- World Wide Web application deployment platform
- QuickTime Streaming Server
- IP filtering, DHCP, DNS, and SLP networking services
- directory services
- mail service
- Macintosh Management service
- NetBoot server for Macintosh client computers that can start up from a server
- tools for remote server configuration and monitoring

For detailed information about Mac OS X Server and instructions for using it with Xserve, see the other documentation that came with the server. The booklet *Quick Start for Xserve* provides an overview of those materials and their contents.

Xserve Overview

The illustrations on the pages that follow provide a reference for the server. (Depending on the configuration of your server, it may look slightly different from the illustrations shown here.)

See Chapter 3, “Installing Your Server in a Rack,” on page 23 for details on the mounting hardware and the server’s enclosure and components.

See Chapter 4, “Using Your Server,” on page 45 for details on monitoring the lights and other indicators on the server’s front and back panels.

See Chapter 5, “Installing or Replacing Server Components,” on page 49 for details on working with the drive modules and internal components of the server.

Your Server at a Glance—Front Panel

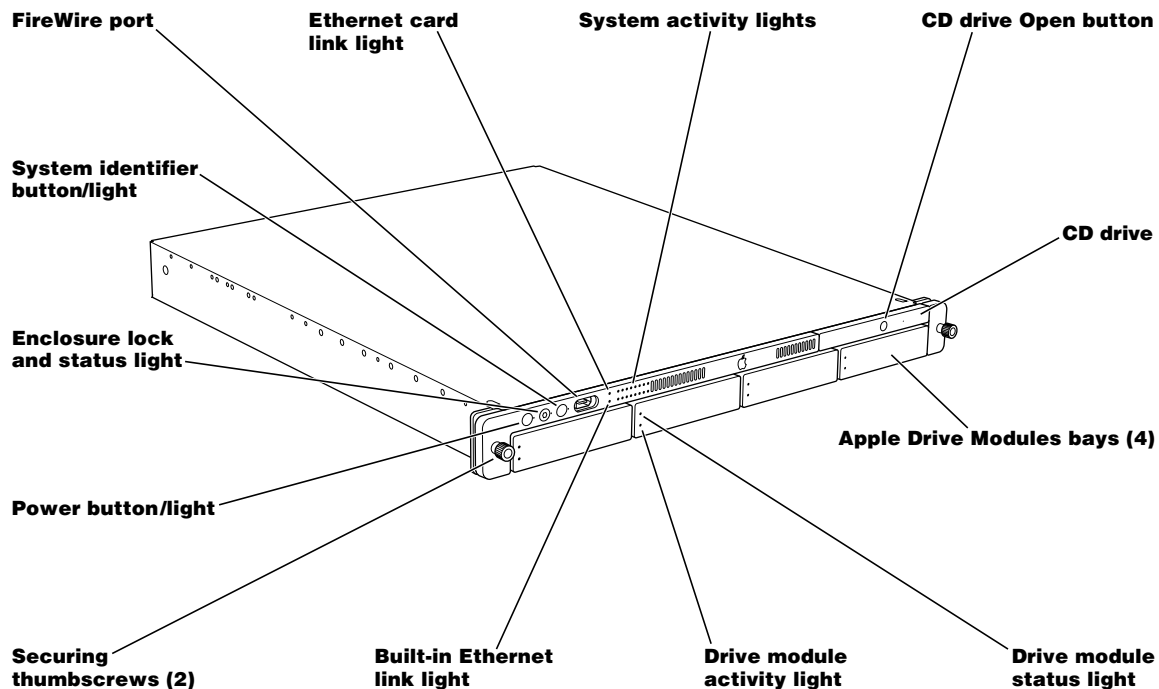

**Power button and light**

Press to turn on the server.

**Enclosure lock and lock status light**

The lock secures the enclosure and drive modules in the server. It can be locked and unlocked with the enclosure key supplied with the server.

**System identifier button and light**

The system identifier light turns on if a problem is detected. It also can be turned on manually by pressing the button. This indicator is useful for locating a particular unit in a rack with multiple servers. A duplicate system identifier button and light are on the back panel.

**FireWire port**

Provides a FireWire connection on the front of the server. There are also two FireWire ports on the back panel.

Ethernet link lights

Two lights indicate Ethernet links. The upper light represents a network card; the lower light represents built-in Ethernet.

System activity lights

Two rows of eight lights indicate system activity. In a server with a single processor, the rows of system activity lights operate in sync; in a dual-processor server, the rows of lights operate independently to show each processor's activity.

CD drive

You can use the tray-load CD-ROM optical drive to add or reinstall software on the server.

**CD drive Open button**

When the server is turned on, pressing this button opens the drive's tray.

Drive modules and lights

You can install up to four drive modules in the server. These modules can be removed and installed while the server is running. (See "Installing or Replacing an Apple Drive Module" on page 50 for more information.) Each drive module has lights showing operating status and disk activity.

Your Server at a Glance—Back Panel

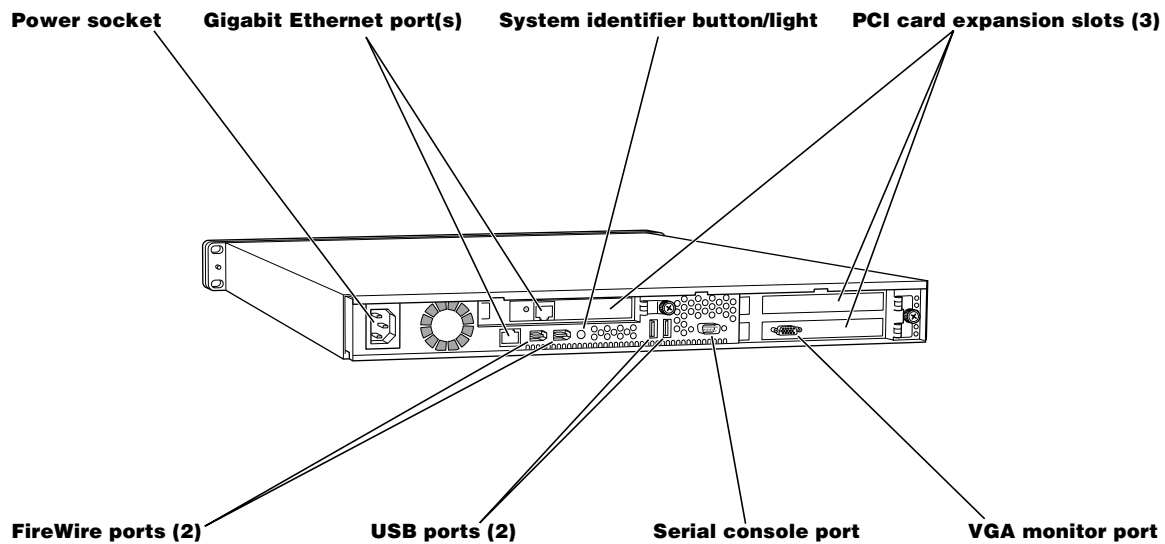

**Power socket**

The power cord connects here; it is held in place by a special clip so that it stays connected when the server is opened in the rack.

**System identifier button and light**

The system identifier light turns on if a problem is detected. It also can be turned on manually by pressing the button. This indicator is useful for locating a particular unit in a rack with multiple servers. A duplicate system identifier button and light are on the front panel.

**Gigabit Ethernet port**

Connect your server to a high-speed Ethernet network. Ethernet ports adjust automatically to the transmission speed supported by network components. One port is built in; some configurations also have an Ethernet card installed, providing a second port.

**FireWire ports**

Connect FireWire devices to the server. A third FireWire port is located on the front panel.

**USB ports**

Connect USB devices, such as a keyboard or mouse.

**Serial console port**

Connect a serial device or computer with a serial port. This console supports both RS-232 and RS-422 connections.

PCI card slots and PCI/AGP card slot

You can install two 12-inch PCI cards in the server to connect peripheral devices. See “About PCI Cards for the Server” on page 59 for details. One or two slots may come with cards installed at the factory. One additional slot takes a 7-inch PCI card or, in some configurations, an Accelerated Graphics Port (AGP) card. The AGP card requires a special adapter.

**VGA monitor port**

Connect a VGA monitor to the server for setup or monitoring tasks. The VGA port is on a card installed in the server. (In some configurations, the card may be in a different slot and may have a different connector.)

Your Server at a Glance—Interior

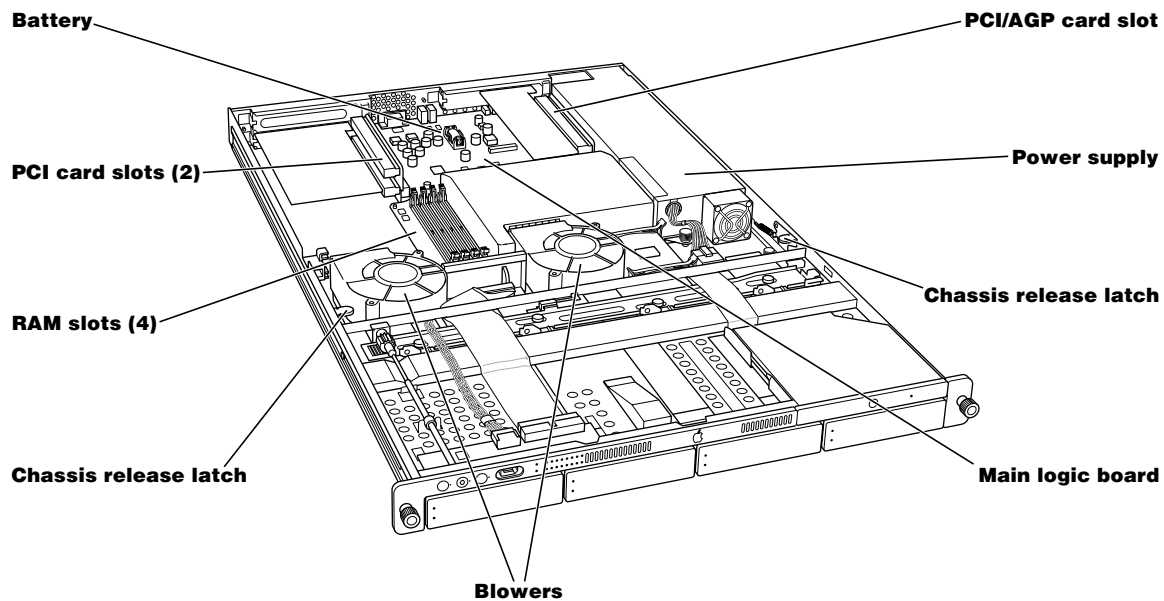

PCI card slots and PCI/AGP card slot

You can install PCI expansion cards in the three slots. The two slots on the left side of the server hold 12-inch cards; the slot on the right side holds a 7-inch card, and can also be configured to hold an AGP card, which requires a special adapter.

RAM expansion slots

You can expand DDR RAM up to 2 GB, using the four slots. (See “Adding Memory” on page 56 for more information.)

Power supply

The autoswitching power supply detects the voltage and adjusts for it. This component has a sensor that detects and reports if the power supply needs service.

Blowers

The blowers cool the server during operation. Sensors detect and report if a blower needs service.

Chassis release latches

Press these latches to slide the server to its full length when in the rack, or to remove it from the cover.

Your Server at a Glance—Mounting Hardware

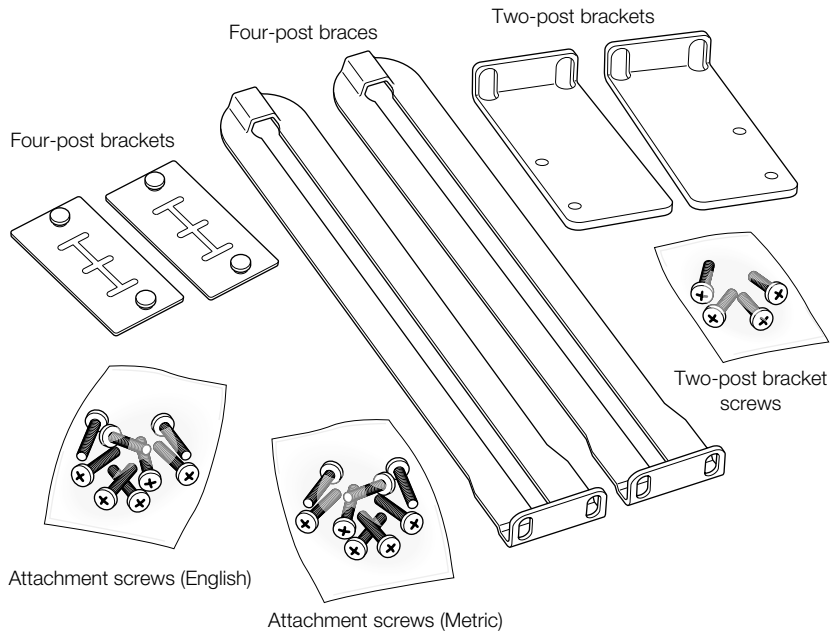

Four-post brackets

Two rivets on each bracket secure it to the brace and the server's cover.

Four-post braces

These two long, U-shaped pieces support the back of the server and attach it to the rack.

Two-post brackets

These two short, L-shaped brackets attach to the sides of the server's enclosure and to the rack.

Screws for attaching brackets and braces to the rack and server cover

Two sets of screws are provided; one set (English) has a diameter of 10/32 inches; the other is metric size M5.¹

¹ See Chapter 3, "Installing Your Server in a Rack," on page 23 for more information on mounting hardware.

Preparing to Install Your Server

Before you install the server in a rack, you should carefully consider the placement of the unit in its rack and several factors in the infrastructure that will keep the server operating efficiently.

Guidelines for Server Installation

To ensure safe and smooth operation of your server, it's essential that you plan for proper location of the server in its rack, adequate power to the components in the rack, and the appropriate operating environment for the rack.

As you plan for server installation, follow these guidelines to ensure that the server and its environment are safely and appropriately positioned for efficient operation and service.

Choose the Server's Position in a Rack

When determining the location for the server in a rack, be sure to allow adequate space for airflow and servicing from both the front and back.

- Air to cool the server flows from front to back. Do not cover the front or back of the server or any of the openings in the server's front and back panels and case.

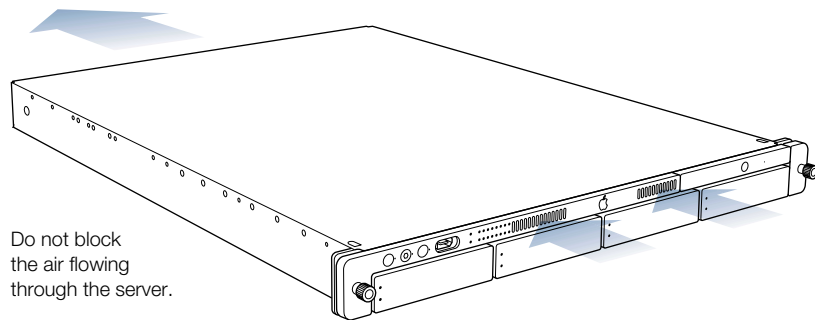

Do not block
the air flowing
through the server.

- The server slides out of the rack from the front. Be sure to leave a minimum of 36 inches clear in front of the server to allow room to open and service it.
- To provide access to the server's back panel and cables, leave at least 24 inches clear behind the server.
- If you are installing multiple servers or other components in the rack, place the server so that you can easily open and service it. For example, in a multiple-component installation, the heaviest items—such as an uninterruptible power supply—are usually placed at or near the bottom of a rack; servers are often located near the middle of the rack.
- For a rack with multiple components, you may want to prepare a list of all equipment in the rack and the requirements for each unit. Such a list should include the following information:

Component	Power needed	Clear area front/back	Height in rack	Temperature range	Other
Server 1					
Server 2					
Component 3					

Electrical Power

If you plan to install the server in a rack that contains other components, be sure that the circuitry and power connections are sufficient for the combined power needs of all components. To plan for safe and adequate power to the server, follow these guidelines:

- Check the documentation for all components in the rack to determine their power requirements. Also determine that the available power supply for the rack is sufficient for the planned components.
- If you need assistance in determining the power needs of the components in the rack, consult an electrical expert who is familiar with your facility.

Important When planning for electrical power, make sure you have more power than specified for all components. Also make certain that the power load is distributed evenly among circuits to the rack's location. Consult an electrician or other expert if you need assistance with planning for the power needs of your components.

- Make sure that the power connections for the server and all other components are grounded (according to local and national standards). Consult an electrician if you need assistance with grounding.
- See Appendix A, "Specifications," for more information about electrical power requirements for the server.

Operating Environment

The operating environment for the server's rack must meet certain requirements:

- Verify that the temperature range of the rack's location is within the limits established for the server and all other components.
- Make certain that the rack's location has adequate ventilation to maintain the necessary temperature range. This is particularly important for a rack that is enclosed in a cabinet.
- If multiple components are installed in the rack, consider additional cooling to assure efficient operation of the servers and other equipment.

Rack Stability

The rack must be stable and strong enough to hold the components installed.

- Check the documentation for the rack to make certain that it can carry the load of components.
- If you are using a two-post (telco) rack, verify that the rack is securely fastened to the building's structure at the top and bottom.
- Make certain that all components are secured in the rack.
- When working with components in the rack, never extend more than one at a time.

Considerations for Cables

For optimal efficiency in server operation and maintenance, follow these guidelines for handling cables connected to the server and other components in a rack.

- Plan to install the cable-management arm supplied with the server. If you don't install this device, you must disconnect all cables from the server's back panel before opening the server in the rack.
- Arrange all component cables so that they do not interfere with access to the rack. Ideally each component should have a cable-management option in place so that anyone servicing units in the rack can readily determine where each cable is connected.
- To ensure full signal strength for Ethernet, serial, and other connections, make sure cables do not exceed established length limits.

Security

Whatever the location of the server and rack, it should be secure.

- Determine that the rack's location is secure and that only authorized staff members or technicians can gain access to this site.
- If using a server cabinet that is not stored in a secure room, be sure that the cabinet has adequate locking and that access to it is limited to authorized staff.
- Develop a plan for distributing and controlling keys to the server environment and access codes that will allow others to manage servers over the network. Keep the plan updated with names of key staff and relevant emergency information and procedures.
- Store a copy of essential server access information in a safe location away from the server site.

Installing Your Server in a Rack

Xserve is specifically designed for rack mounting. It is not designed for use as a desktop machine.

Warning Do not place a monitor on the server or use the top of the server as a shelf in the rack. Any weight on the server's enclosure could damage the components inside.

You can install the server in several types of racks, including

- open four-post rack, 19 inches wide and 29–36 inches deep
- cabinet with four-post rack inside, 19 inches wide and 29–36 inches deep
- two-post (telecommunications, or “telco”) rack, 19 inches wide

The server is 1.75 inches (1U) high.

Important Any rack used for Xserve should meet the specifications of the American National Standards Institute (ANSI)/Electronic Industries Association (EIA) standard ANSI/EIA-310-D-92, International Electrotechnical Commission (IEC) 297, and Deutsche Industrie Norm (DIN) 41494. See the documentation for the rack to determine whether it is compatible with these standards.

The brackets and screws necessary to attach the server to any of these racks are included with your server. You need to supply medium-sized and very small Phillips screwdrivers for the installation.

Installing the Server

As noted previously, you can install the server in a four-post or a two-post rack. Instructions for both procedures are given below. Preparations for installing are the same, whichever type of rack you use.

Important Check the documentation for your rack for any special requirements.

Get Ready to Install

Before beginning work with the server and rack, make the following preparations.

- If possible, arrange to work with another person as you prepare the server and install it in a rack.
- Assemble the tools, brackets, and connectors you'll need for the installation. (All except the screwdrivers are provided with the server.)
 - A medium-sized Phillips screwdriver. If you have a power screwdriver, use it.
 - A very small Phillips screwdriver (needed for a four-post rack if you are attaching the cable-management arm).
 - For a four-post rack, you'll use two small brackets (each has two rivets), two long U-shaped braces, and eight mounting screws. Also get the cable-management arm and the two screws to attach it to the server.
 - For a two-post rack, you'll use two L-shaped brackets and eight screws.

Note: Two sets of screws are provided with the server. One set (English) is 10/32 inches in diameter; the other set is size M5 metric and fit racks with metric holes. Check the documentation for your rack and use the appropriate set of screws; most racks use one of the two sizes. If screws are provided with your rack, you can use those as well.

- To measure and mark the position of the server in the rack, you may want to use a straightedge, such as a yardstick. You'll also need a pen or pencil and some masking tape or similar tape.
- Clear a table, cart, or other flat surface near the rack. You'll need to put the server on it temporarily during installation, and you can use it to lay out the brackets and screws you'll use to attach the server to the rack.

Determine the Position for the Server in the Rack

Review the guidelines for positioning the server in the rack. Then follow these steps to measure and mark its specific location.

- 1 Determine the exact position where you want to attach the server and mark it on one side of the rack.

Some racks have marks at regular intervals (such as 1U) to aid in locating a server; others may provide a template to help place the server in the rack. If your rack does not have such aids, measure or count holes from an established point.

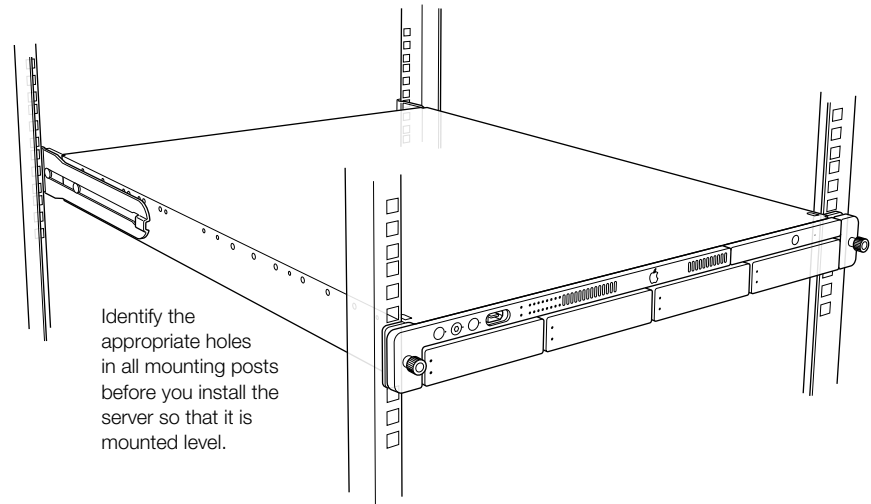

The distance between holes may vary somewhat on racks made by different manufacturers.

- 2 Use a straightedge to mark the same spot on the other side of the rack.
You can put a pencil mark or a piece of tape on each side of the rack to mark the correct spot. For a four-post rack, measure and mark the posts at the front and back.
- 3 To verify that the position is correct, measure 1.75 inches (the server's height) down from the hole you've marked on the rack.
You measure downward because you'll attach the cover of the server's enclosure to the rack, then slide the server into it.

Prepare the Server for Installation

If possible, work with another person as you prepare and install the server in a rack.

Follow these steps to prepare the server hardware for installation.

- 1 Unpack the server from its box and place it on the table
Follow the instructions in the booklet *Quick Start for Xserve* to unpack the server.
- 2 At the back of the server, write down the serial number from the server's back panel.
You will need the server's serial number to log in when you first set up the server software.

- 3 Remove the protective faceplate from the server's front panel by unscrewing the thumbscrews at each side of the faceplate and lifting it off.

Set the thumbscrews aside.

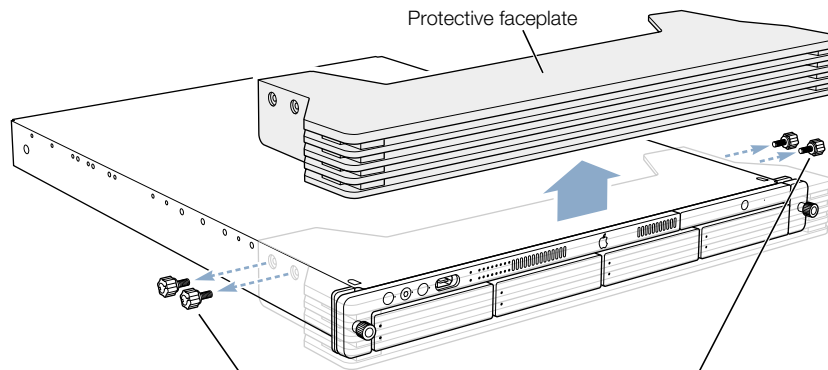

Remove the four thumbscrews that hold the protective faceplate in place, and remove the faceplate by lifting it straight up.

- 4 Loosen the two thumbscrews (one on each side) at the front of the server's enclosure.

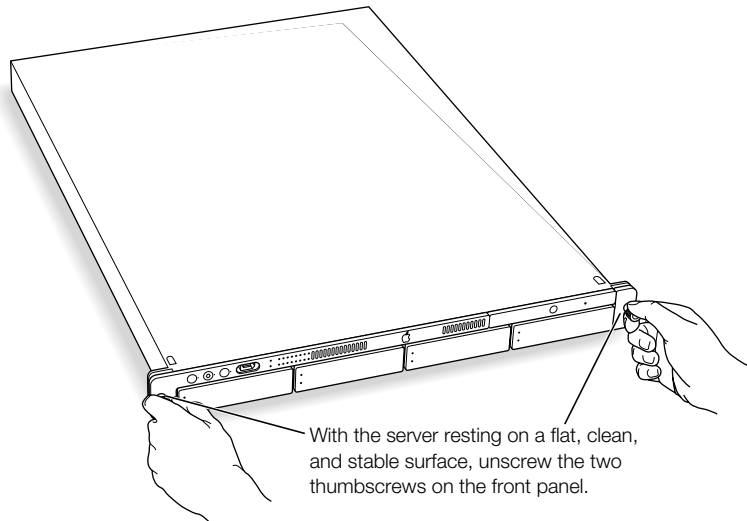

With the server resting on a flat, clean, and stable surface, unscrew the two thumbscrews on the front panel.

These thumbscrews are “captive” and do not separate from the enclosure.

- 5 Remove the cover of the server's enclosure by sliding it toward the back of the unit. Hold the front thumbscrews to keep the main part of the server in place as you slide the cover toward the back.

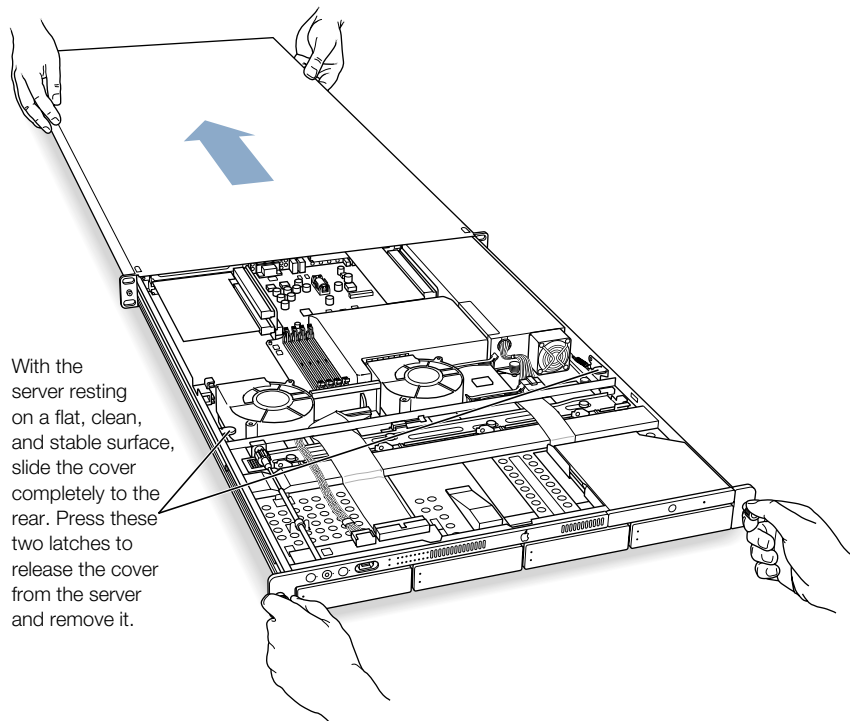

- 6 When the cover is almost off, press the yellow release latches at the sides of the server's interior to release the cover, then take the cover off. When you've removed the cover, set it aside.

- 7 If necessary, install any optional internal components, such as additional memory or a PCI card, in the server. Follow the appropriate instructions in Chapter 5, “Installing or Replacing Server Components,” on page 49.

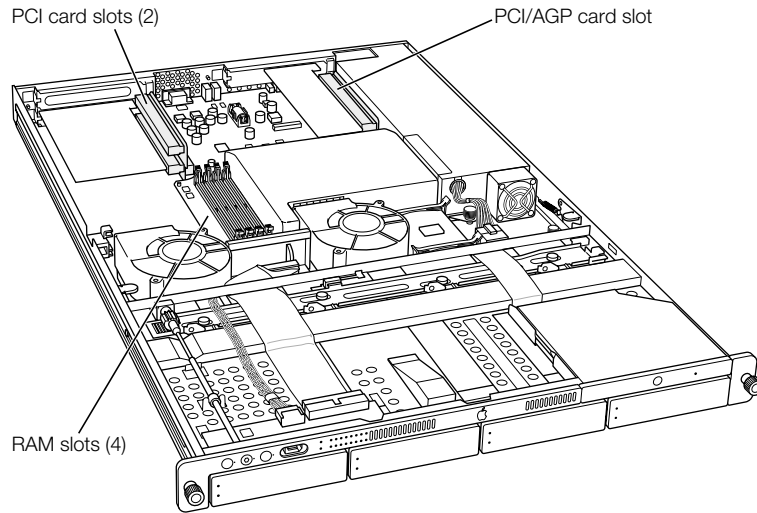

- 8 If necessary, install any additional Apple Drive Modules in the front panel of the server. Follow the instructions in “Installing or Replacing an Apple Drive Module” on page 50.

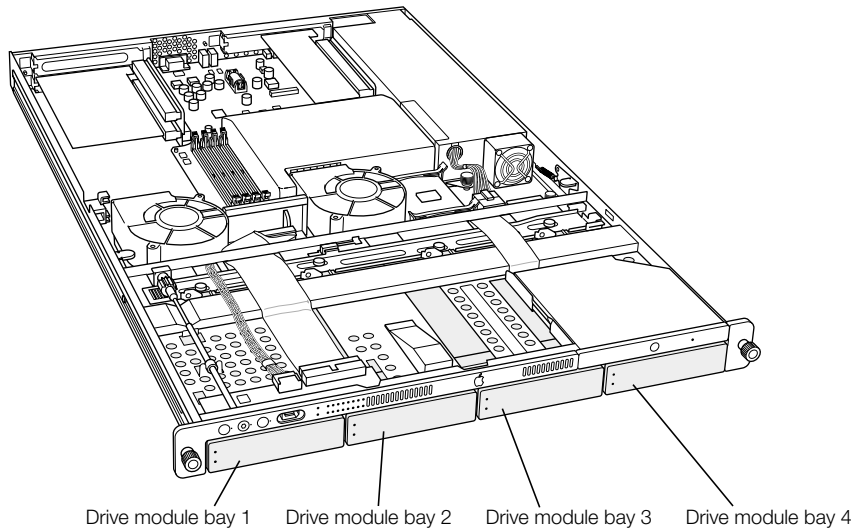

Note: When installing a drive module for the first time, remove the blank drive module and save it for possible future use. This unit is necessary for appropriate cooling of the server in a drive bay that has no drive module in it.

When you've installed optional items, you're ready to connect the server to the rack. If you have a four-post rack or cabinet, proceed to the next section, "Install the Server in a Four-Post Rack or Cabinet" on page 29. If you have a two-post rack, go to "Install the Server in a Two-Post (Telco) Rack" on page 37.

Install the Server in a Four-Post Rack or Cabinet

A four-post rack can be open or enclosed in a cabinet. Examples of both racks are shown below. You follow the same steps to attach the server to either of these racks. For a cabinet, however, you may have to remove the door before installing the server.

Important Be sure to check the documentation for your rack for any specific mounting instructions.

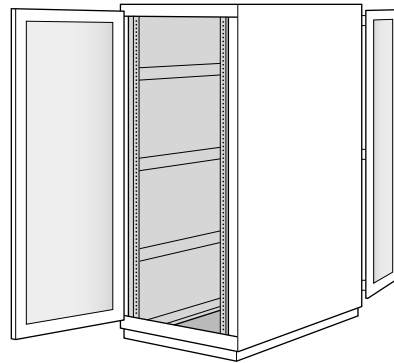

Four-post cabinet rack

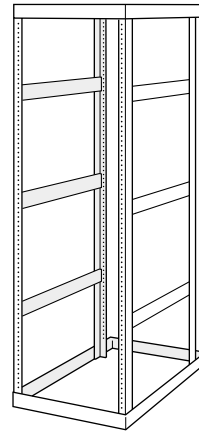

Four-post open rack

Once you've marked the exact position for the server on the rack, you're ready to attach the server. Here is an overview of the procedure.

- Connect the cover of the server to the front of the rack.
- Assemble the rear mounting hardware.
- Connect the rear mounting hardware to the server enclosure.
- In a four-post rack, install the cable-management arm.
- Slide the server into the cover and secure it.

Follow these steps to attach the server to the rack.

- 1 Keep the cover of the enclosure level and support it from the center as you slide it into the rack at the desired position.

Important Work with someone else to make sure the cover is supported and square to the rack. The cover must be installed level to avoid changing its shape before the screws are inserted to hold it in place.

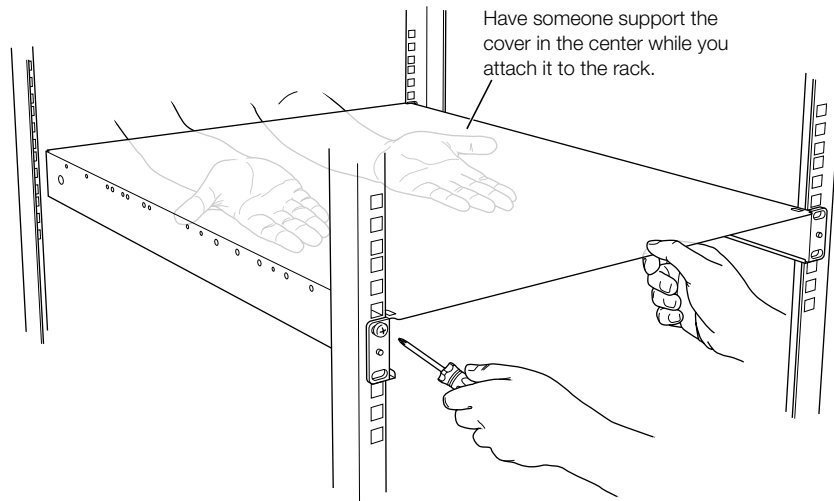

2 Screw the flanges at the front of the cover to the front rails of the rack

Be careful not to overtighten the flange screws. Doing so could change the shape of the cover slightly and make it difficult to slide the server into the cover.

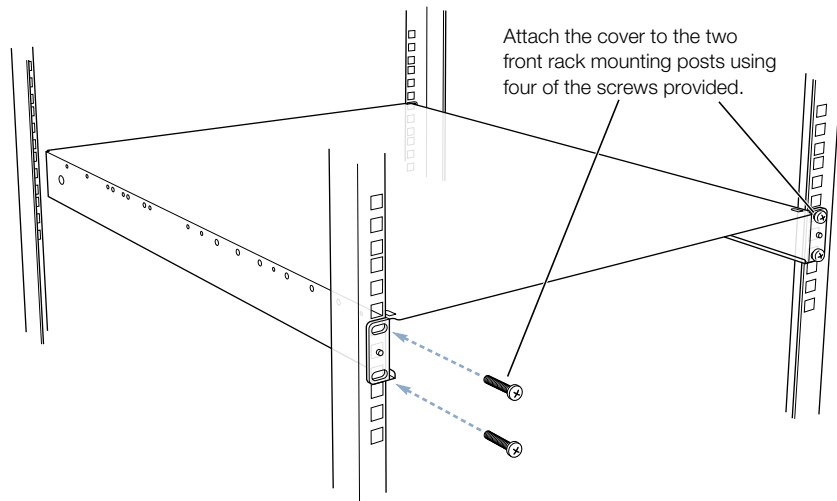

Some racks have prethreaded holes and some have square holes that take clips with attached nuts. You may need to insert a clip (not provided with the server) into the appropriate hole before attaching the screw.

Some racks have pre-threaded holes.

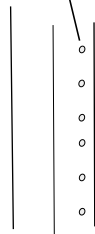

Other racks use various types of removable, captive nuts to secure equipment.

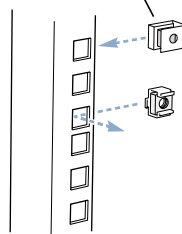

- 3 At the back of the server, position the small bracket inside the server's cover so that the head of one rivet is facing the side of the cover.

Note: Start on the left side of the server (when facing the back). This makes installing the cable-management arm more efficient.

- 4 Push the rivet head through the hole that's near the back on the side of the cover.

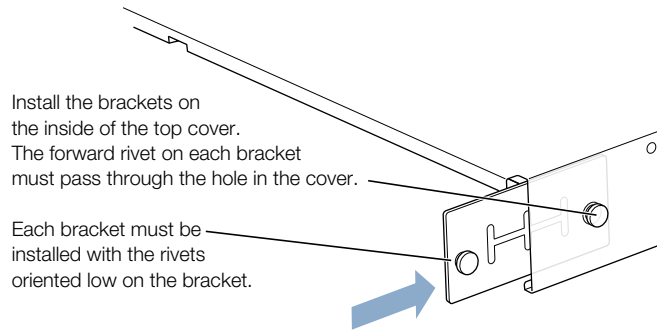

The head of the rivet protrudes through the cover.

- 5 Position the long, U-shaped brace on the outside of the server's cover, so that the curved end is near the protruding rivet. The indented lip at the curved end of the brace should face the rivet head.
- 6 Slide the lip at the end of the brace over both rivets on the small bracket and continue to slide the brace forward a few inches.

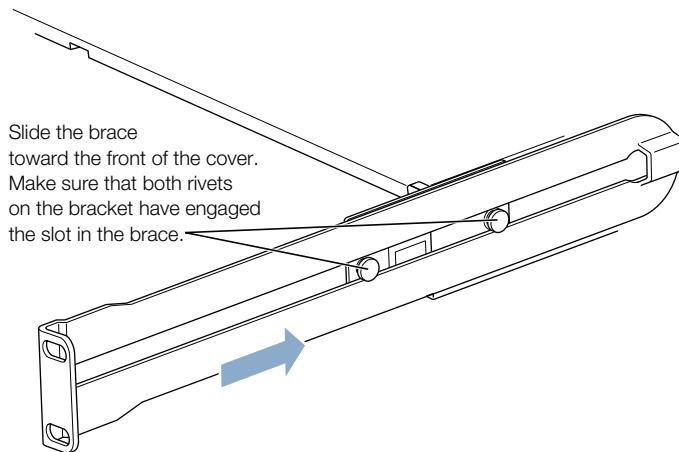

Make sure the brace is on the outside of the cover and that both rivets are captured in the center opening of the brace.

- 7 Slide the brace forward or backward so that the flat end of the brace is flush with the back rail of the rack and screw the brace's flange to the rail.

Note: If you are installing the cable-management arm and your server is the same depth as your rack (or within an inch of it), only attach the brace to the rail on the left side of the server (as you face the back panel). You attach the cable-management arm along with the brace at the right rear of the server.

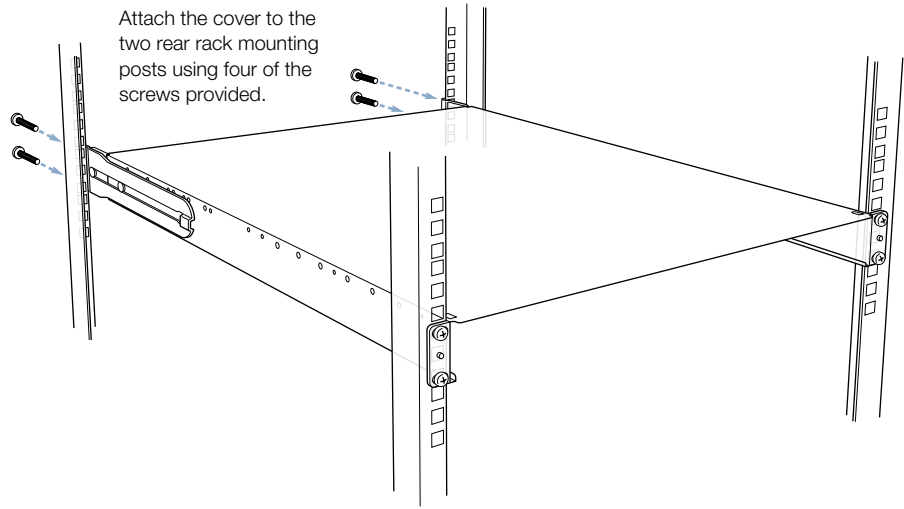

- 8 Attach the second bracket and brace, as described in steps 3 through 7.

Note: If your rack is deeper than the server, the braces and brackets extend beyond the server's back panel to the rack's rails.

Install the Cable-Management Arm

Xserve has a cable-management arm that allows you to open the server without disconnecting cables. In addition, this device supports the cables and relieves strain on the server's back-panel connectors.

Important To open the server with the cables attached, you must install and use the cable-management arm.

If your rack is the same depth as the server (or an inch or so deeper), you attach the cable-management arm to one rear post of the rack. If your rack is several inches deeper than the server, you attach the cable-management arm to one of the braces that supports the back of the server.

The steps that follow explain how to install the cable-management arm either to the rack or to the brace.

Attach the Cable-Management Arm to the Rack

- 1 If the rear rails of your rack are flush with the server's back panel or within an inch of it, position the cable-management arm so that the short side is closer to the server's back panel and the holes on the long side align with the holes on the brace on the right side.

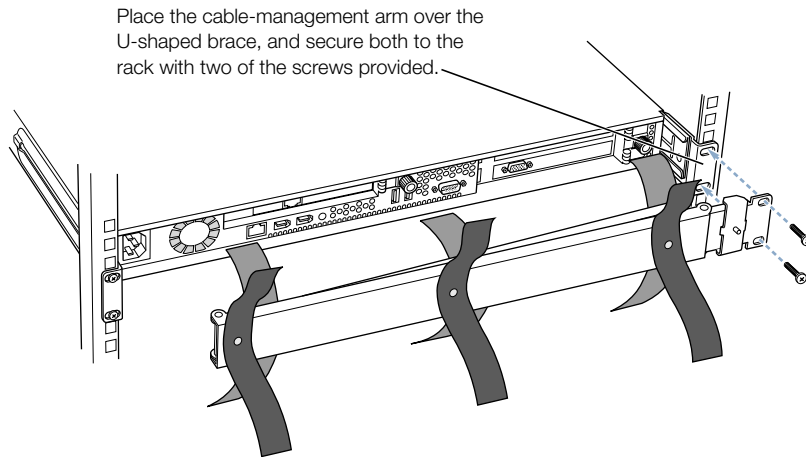

- 2 Thread the hook-and-loop straps through the holes in the cable-management arm.

If the straps are already attached, skip this step.

- 3 Attach the long side of the folding arm to the rear rail, using two of the mounting screws provided with the server.

The cable-management arm attaches on top of the right brace. The mounting screws hold both in place.

See “Connect Cables to the Server” on page 40 for details on connecting cables and using the cable-management arm.

Attach the Cable-Management Arm to the Support Brace

If the rear rails of your rack are more than an inch away from the server's back panel, you need to attach the cable-management arm to the support brace at the side of the server (not to the rear rail). Otherwise the arm will not extend properly when you open the server in the rack.

- 1 Use a very small Phillips screwdriver to disconnect the small clamp that wraps around the long end of the cable-management arm (next to the two oval holes).

You'll use this clamp and screw to attach the arm to the brace.

- 2 Hold the cable-management arm with the long end closer to you and fold the hinged section of the long end away from you.

The hinged section is the part from which you removed the clamp and screw. This section should be perpendicular to the main part of the arm, with the oval holes furthest from you.

Mount the cable-management arm as close to the back of the server as possible. Rotate the mounting plate on the arm so that it lies against the inside of the U-shaped bracket. The U-shaped bracket should be sandwiched between the arm and the small clamp. Secure the clamp with the screw that held it stored on the arm.

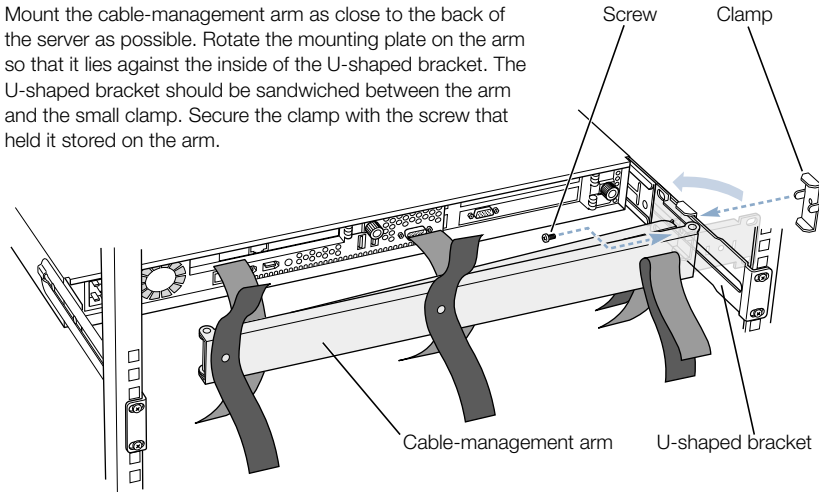

- 3 Position the cable-management arm so that the hinged section is on the inside of the right brace, about 2 inches behind the server's back panel.
- 4 Hold the arm in place and put the clamp you detached on the opposite side of the arm, so that the screw hole in the center shows through the open part of the brace.
- 5 Insert the screw into its hole and tighten it so that the arm is fastened to the brace.
- 6 Thread the hook-and-loop straps through the holes in the cable-management arm.

If the straps are already attached, skip this step.

See “Connect Cables to the Server” on page 40 for details on connecting cables and using the cable-management arm.

Place the Server in the Rack

Once you've attached the cable-management arm, you can put the server into the rack.

- 1 At the front of the rack, lift the server to the level where the enclosure's cover is installed and slide the server into the cover.

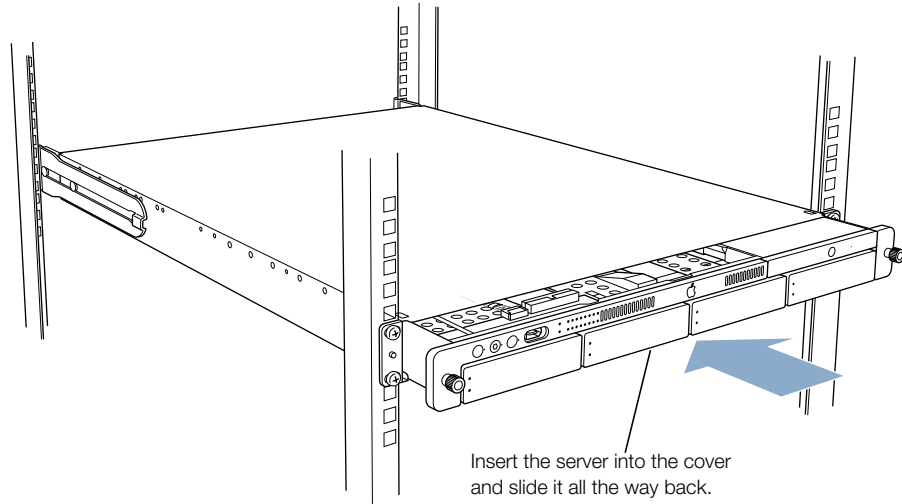

- 2 Secure the server in the rack by tightening the thumbscrews on the front.

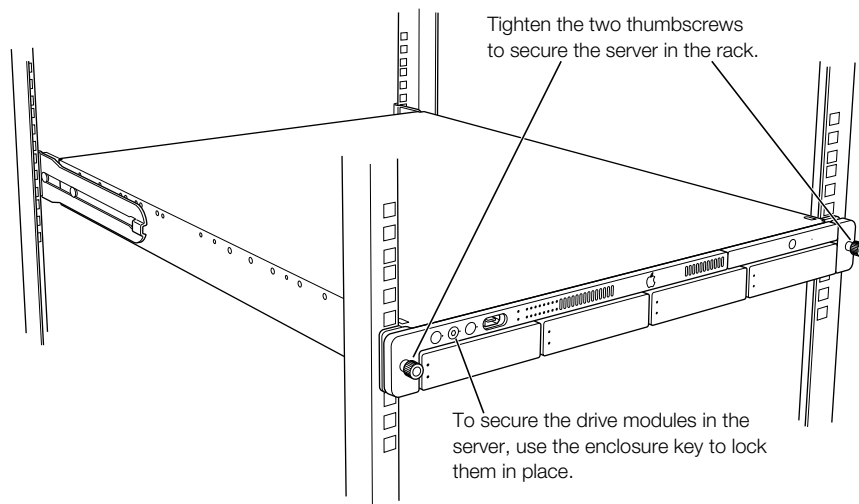

- 3 To further secure the server and prevent removal of the drive modules, use the enclosure key (supplied with the server) to fasten the security lock on the front panel. (See the illustration above.)

- 4 If you've installed the server in a cabinet, replace and close the cabinet door.

Once the server is secured in the rack or cabinet, you can attach cables for the server's connections.

See "Connect Cables to the Server" on page 40 for details of connecting cables and using the cable-management arm.

Install the Server in a Two-Post (Telco) Rack

The server attaches to a two-post rack at the center of the enclosure, so that the front and back of the server extend beyond the rack.

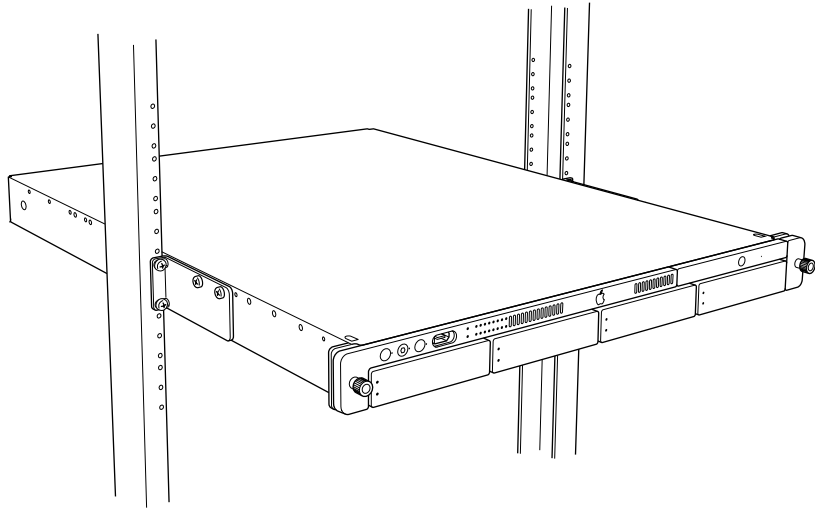

Important Before installing the server in a two-post rack, make certain that the rack is securely fastened to the floor. Also check the rack's documentation for any specific installation instructions.

Follow these steps to install the server in a two-post rack. (These instructions assume that you have previously taken the cover off the server; see "Prepare the Server for Installation" on page 25 for details.)

- 1 Attach the small L-shaped brackets to the sides of the server enclosure's cover with four of the screws provided.

Attach the two telco mounting brackets to the server's cover using the four screws provided.

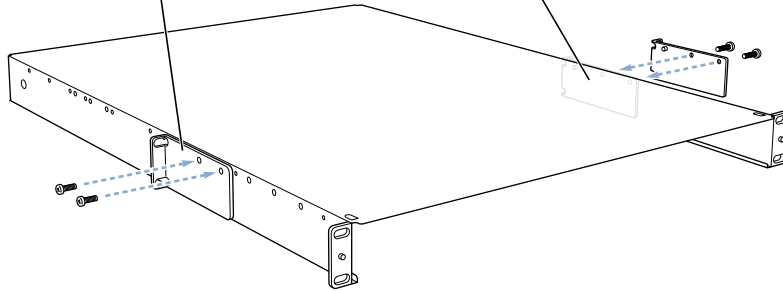

Orient the bracket so that the screws are at the top. Attach the brackets to holes that are about one-third of the way back from the front panel.

- 2 Position the cover in the rack at the desired location and screw the flange of the L-shaped bracket to the front of the rack on each side.

Important Be sure to work with another person for this part of the installation. The cover should be held level to avoid changing its shape before the screws are inserted to hold it in place.

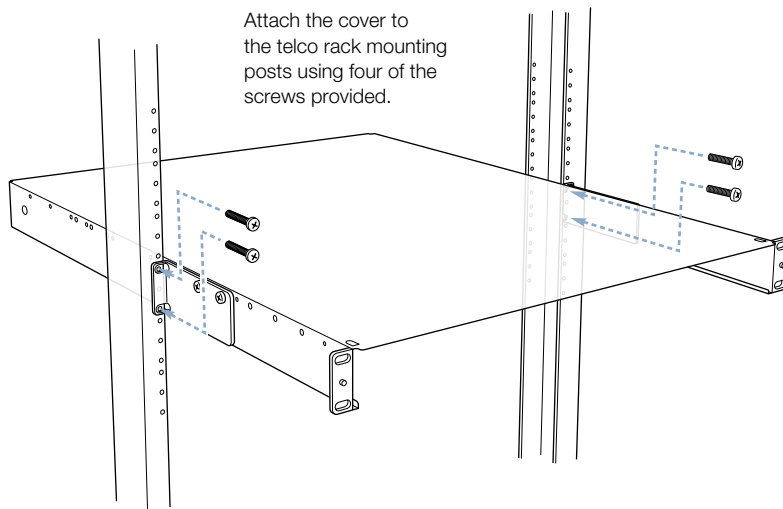

Be careful not to overtighten the flange screws. Doing so could change the shape of the cover slightly and make it difficult to slide the server into the cover.

- 3 Lift the server to the level where the cover is installed and slide the server into the cover.

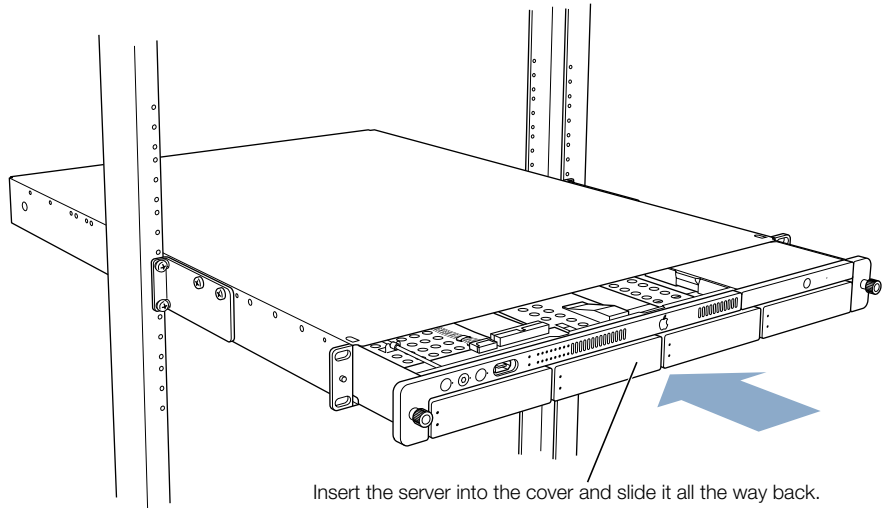

- 4 Secure the server in the rack by tightening the thumbscrews on the front.

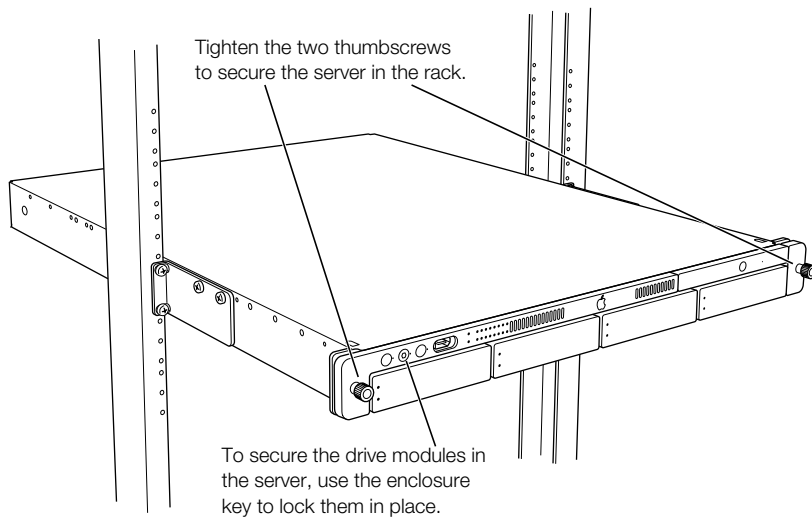

- 5 To further secure the server and prevent removal of the drive modules, use the enclosure key (supplied with the server) to fasten the security lock on the server's front panel. (See the illustration above.)

Note: You cannot use the cable-management arm on an Xserve system that is installed in a two-post rack.

Connect Cables to the Server

Once the server is secured in the rack, you can connect the cables and power cord to its back and front panels.

Important If you use the cable-management arm, your cables must be approximately 3 feet longer than the distance between the server and its peripheral devices. This extra length may not be feasible for some cables, such as SCSI cables. In this instance, you can bypass the cable-management arm with a shorter cable. But you must disconnect that cable when you open the server.

Follow these steps to connect cables for network connections and peripheral devices.

- 1 Assemble the cables and devices you will connect to the server's back panel. Make certain that each cable has the proper connector and that it is designed for use in a high-capacity server. (Check the documentation for each peripheral device or cable to determine that it can be used with the server.)
- 2 Attach an identifying label to each cable you are connecting.
The labels allow you to locate a specific cable quickly and avoid errors when disconnecting cables.
- 3 Beginning at one side of the server's back panel, connect each cable to its respective port.
Do not attach the power cord yet.

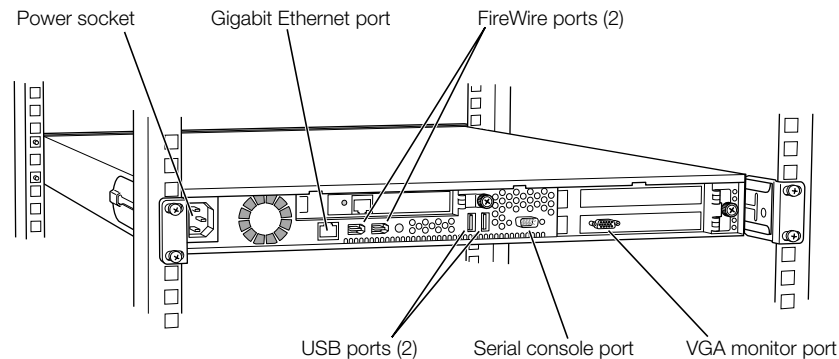

- 4 Arrange all the cables on the back panel in the cable-management arm and secure them with the straps provided with the cable-management arm.

The cable-management arm can only be used with a four-post rack or cabinet.

If you are not using the cable-management arm, skip this procedure. It's a good idea to group the cables and arrange them so that they don't cause any hazard and are easy to handle should you need to detach them when opening the server.

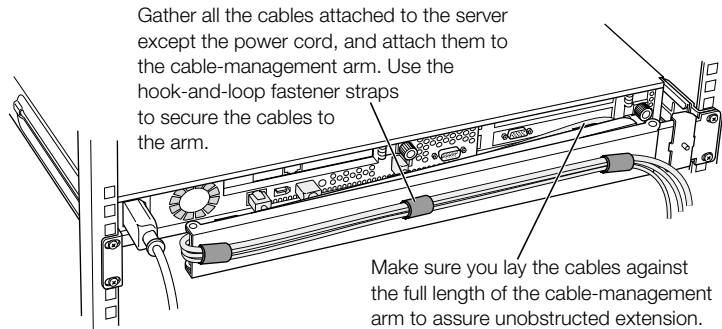

- a Group the cables together loosely and “fold” them to the right side of the back panel, until they are near the short (inner) end of the cable-management arm.
 - b Reverse the direction of the cables and lay them along the edge of the cable-management arm closest to the server's back panel.
 - c Attach the cables to the arm with the straps provided.
Wrap the cables so that the sides of facing straps do not stick to each other.
 - d Reverse the direction of the cables again and lay them along the edge of the cable-management arm furthest from the back panel.
 - e Attach the cables to the arm with the straps provided.
- 5 Connect the power cord to the back panel.

- 6 Attach the power cord's retainer clip to the back panel to keep the power cord in place when you open the server.

The ends of the clip fit into the small openings at either side of the power socket. Be sure that the rounded part of the clip goes under the cord, so that the cord is supported.

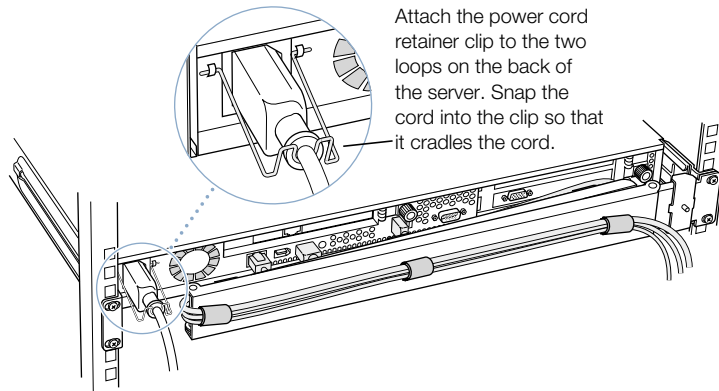

If more than one power cord came with your server, use the appropriate cord for the electrical service available at your location.

You can use the long power cord supplied with the server, or another cord, such as one already installed in the rack.

- 7 If you will be using the FireWire port on the front panel of the server, connect a cable to it.
- 8 When all cables are in place, connect each one to its intended device.

Important When connecting peripheral devices, be sure to allow adequate space at the front and back of the server for proper airflow and access to the rack for servicing.

- 9 After all connections are complete, plug the power cord into a power source.

Warning This equipment is intended to be electrically grounded. Your server is equipped with a three-wire grounding plug—a plug that has a third (grounding) pin. This plug will fit only a grounded AC outlet. This is a safety feature. If you are unable to insert the plug into the outlet because the outlet is not grounded, contact a licensed electrician to replace the outlet with a properly grounded outlet. Do not defeat the purpose of the grounding plug!

Because you are installing the server in a rack with other equipment, be certain that the power outlet and any other equipment, such as a power strip, used with the rack is designed to carry the electrical load of multiple devices. Check the documentation for your rack for any special instructions.

With the server in the rack and the cables in place, you can prepare to set up the Mac OS X Server software.

Preparing the Server for Software Setup

When the server is installed and secured, you are ready to set up the software.

You can configure the server locally or use the remote setup tools. If you want to configure the server software where the server and rack are located, you can do one of the following:

- Connect a monitor, keyboard, and mouse to the server.

You can connect the monitor to the VGA port and connect the keyboard and mouse to the USB ports on the server's back panel. If a KVM (keyboard-video-mouse) switch is installed in the rack, you can use it. See the documentation for the KVM switch for instructions.

- Connect a computer running Mac OS X to the server using an Ethernet connection on the same subnet as the server.

If you want to set up the software from another location, you can work at a computer on the server's network, using the remote server administration software and command-line tools. You need to install the administration software on the portable or network computer before you can set up the software.

See Chapter 4, "Using Your Server," on page 45 for more about software configuration.

Using Your Server

When you've connected the cables and peripheral devices you plan to use with your server, you can turn it on and set up the software and network services.

Starting Up the Server

Press the power button at the left side of the server's front panel to turn it on.

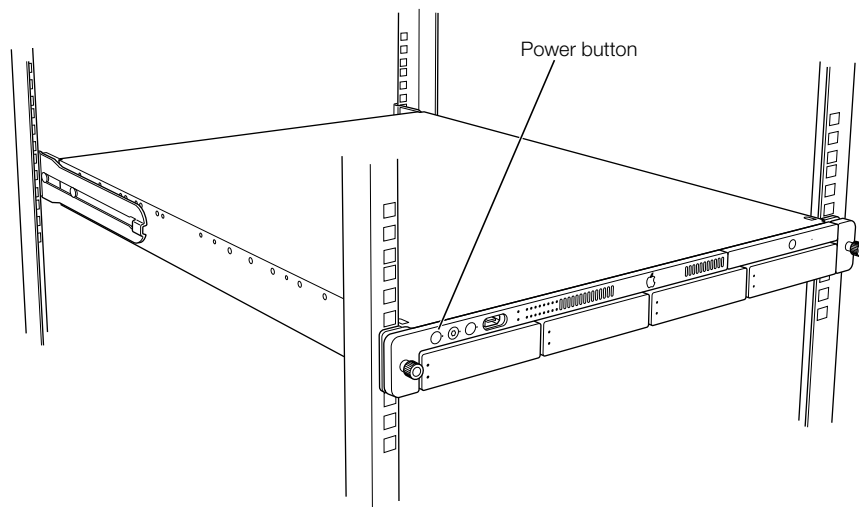

The power indicator light turns on, and the server starts up. Status lights on the front panel indicate network connection, system activity, and drive module use.

Detailed instructions for setting up all the services and options of the Mac OS X Server software are provided in the software documentation included with the server. See the *Quick Start for Xserve* booklet for a roadmap to the software documentation.

Monitoring Status Lights and Other Indicators on the Server

The server has a number of built-in sensors that detect and report essential operating factors, such as power, temperature, and condition of several key components. You can monitor the server's operation using the lights on the unit or using the remote monitoring tools.

The server's status lights are listed in the table below.

Indicator	Color	Description
Power	White	On and OK
Security lock	Yellow	Lock is engaged
System identifier	Yellow	Indicates that there is a hardware error in the server or that someone has turned on the light manually; check the server monitoring application for more information.
Ethernet (lower is built-in port; upper is network card, if installed)	Green No light	Link No connection
System activity	Blue	Two rows of eight LEDs; in server with one processor, rows of lights work in tandem; in dual-processor server, rows operate independently for each processor
Drive module (upper LED)	Green Yellow Red	Powered and running Warning condition Problem or failure
Drive module (lower LED)	No light Blinking blue	Drive module can be removed Disk activity; do not remove drive module

If the Server Has a Problem

If you discover a problem with the server, you can assess the situation and often solve the problem from a remote computer. The Mac OS X Server software documentation contains information about restarting the server and solving some other problems; see the *Quick Start for Xserve* booklet to learn which parts of the software documentation to consult.

If you have access to the server itself, you can use the buttons on the front panel to change the server's status. These buttons include

- **Power:** Press to turn the server on.
- **System identifier:** This light helps you determine which server in a multiple-server rack has a problem. The light turns on when the server has a problem; it can also be turned on manually. Pressing the button next to this light turns the light off when it's on. (Duplicates of the button and light are on the back panel.)

Should you need to open the server and exchange components, see Chapter 5, "Installing or Replacing Server Components," on page 49 for instructions. If you want to exchange or add a drive module, see "Installing or Replacing an Apple Drive Module" on page 50.

What to Do If . . .

If you detect trouble with the server, follow the guidelines below to solve the problem.

Problem	Try this
Server doesn't start up	Start up from the system CD that came with your server. <ol style="list-style-type: none">1. With the power off, hold in the system identifier button and press the power button.2. Continue holding in the system identifier button until the light next to this button begins to flash and the CD tray opens (about 5 seconds).3. Release the system identifier button and put the system CD in the open tray.4. Close the CD tray.
Hard disk is erased or server software is damaged	Reinstall system software from the system CD. (Start up from the CD and use the Installer to reinstall the software.)

If you can't solve the problem on your own, go to the Help for Mac OS X Server. Check the "News" section of Help for the latest information on server hardware.

Also go to the Apple Support Web site for the latest troubleshooting information and software updates:

www.apple.com/support

Installing or Replacing Server Components

Your server is designed so that you can install or exchange drive modules while the server is operating. The server should be turned off before opening it to install or exchange other key components.

When working with the server hardware, always guard against static electricity, which can damage electronic components. Touch a metal surface before handling RAM or an expansion card or working inside the server.

When installing components, it's wise to wear a wrist grounding strap that prevents static electricity from discharging into electronic components.

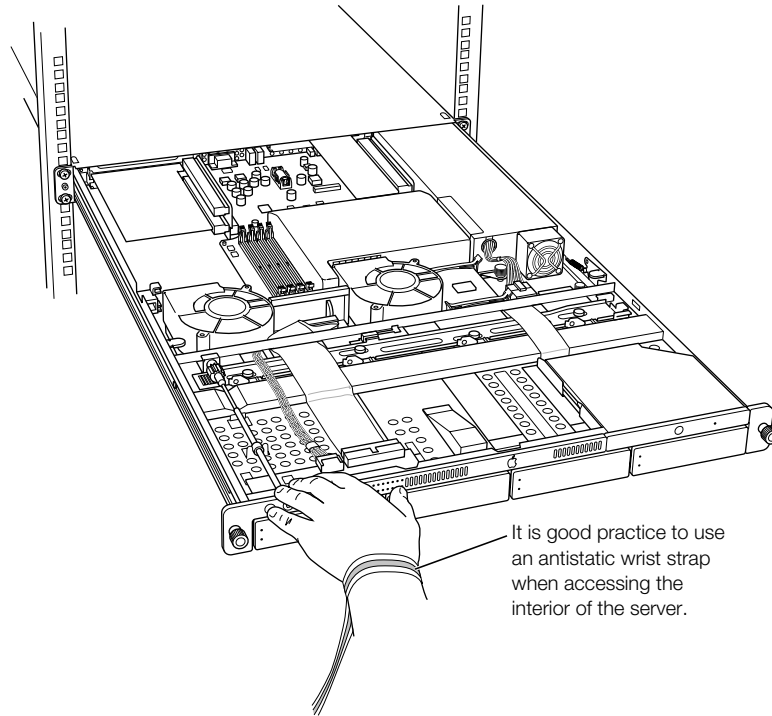

You can also arrange for an Apple-authorized service provider to install or replace components in the server. For details about this service, see the support information that came with your server. Additional support information is available at the Apple Support Web site: www.apple.com/support

Installing or Replacing an Apple Drive Module

The drive modules in the server are hot-pluggable; that is, you can remove one and replace it with another drive while the server is running. A status light on each drive indicates when it's safe to remove a drive without losing any information.

Follow these steps to install or replace a drive module.

- 1 If necessary, use the enclosure key to unlock the security lock on the server's front panel.

2 Remove the blank drive module or the drive currently installed.

- If there is no drive installed, press the handle on the front of the blank drive module so that the handle pops out, then pull the blank drive module out of the front panel.

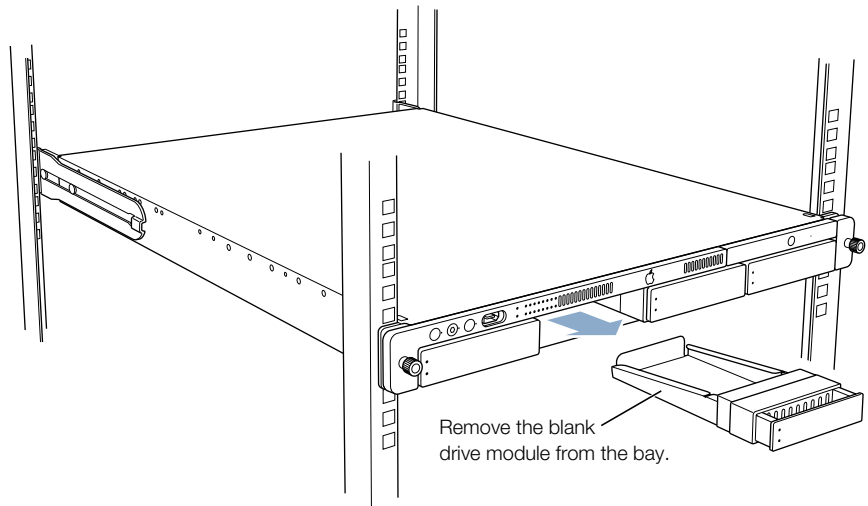

- If there is a drive module already in the bay:
 - a** Make sure the drive currently in the bay is not being used by any application and that the drive is not being shared by the server. (See the Mac OS X Server documentation for information about shared drives.)
 - b** Press the handle on the front of the drive module so that the handle pops out.

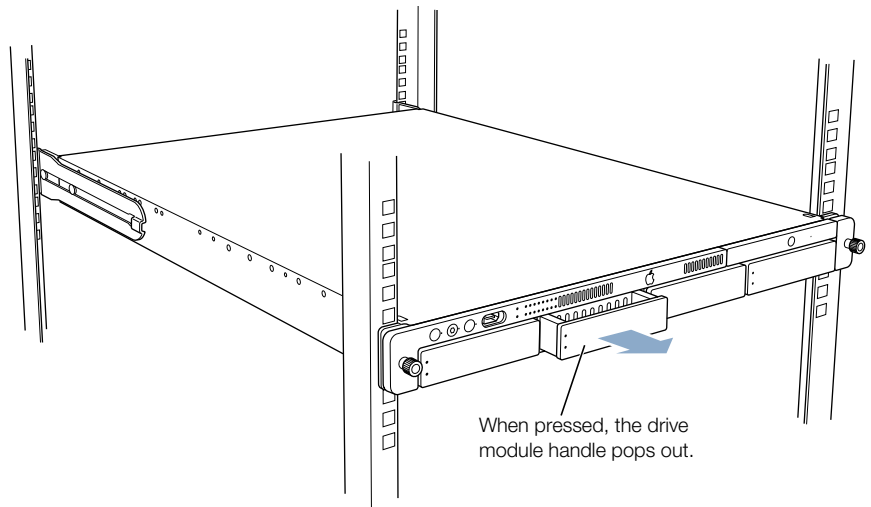

- c Wait for the upper disk light to go off, then grasp the handle and pull the drive module out of its bay and set it aside.

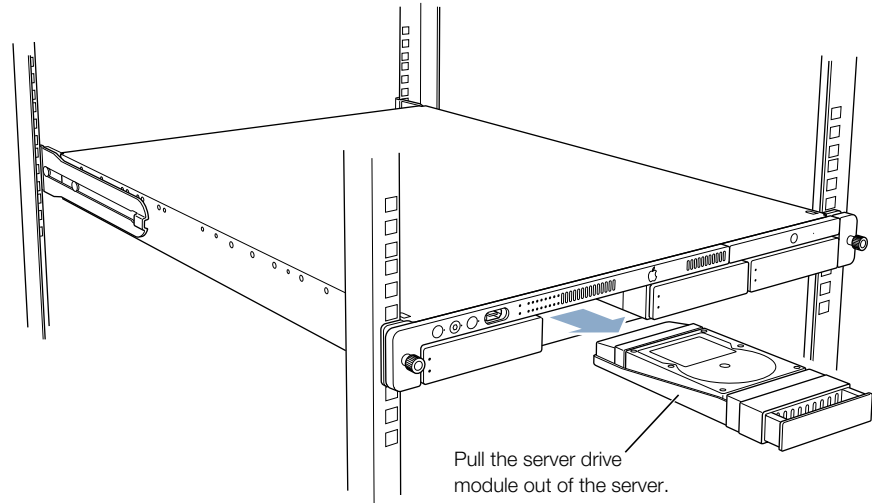

- 3 Press to open the handle of the replacement drive module and slide it into the empty bay until its connector clicks into place.
- 4 The disk status light turns green to indicate normal operation.

Important Be sure to save the blank drive module if you removed one. This module should always be placed in an empty drive bay to maintain proper airflow through the server.

Opening and Closing the Server

- 1 Shut down the server.

Be sure to wait a brief period to allow the server's internal components to cool.



Warning Always shut down your server before opening it to avoid damaging its internal components or the components you want to install. Do not open the server or attempt to install items inside it while it is turned on. After shutting down your server, the internal components can be very hot. Let the computer cool down before continuing.

- 2 If the cable-management arm is not in use for all cables, unplug all cables from the back panel except the power cord. (If necessary, also remove the FireWire cable from the front panel.)

- 3 Touch the metal enclosure to discharge any static electricity.

Important Always do this before you touch any parts, or install any components, inside the computer. To avoid generating static electricity, do not walk around the room until you have finished installing the expansion card, memory, or internal storage device and have closed the computer.

- 4 Unplug the power cord.

Warning The power supply in your computer is a high-voltage component and should not be opened for any reason, even when the computer is off. If the power supply needs service, contact your Apple-authorized dealer or service provider.

- 5 Loosen the thumbscrews at the front of the server's cover.

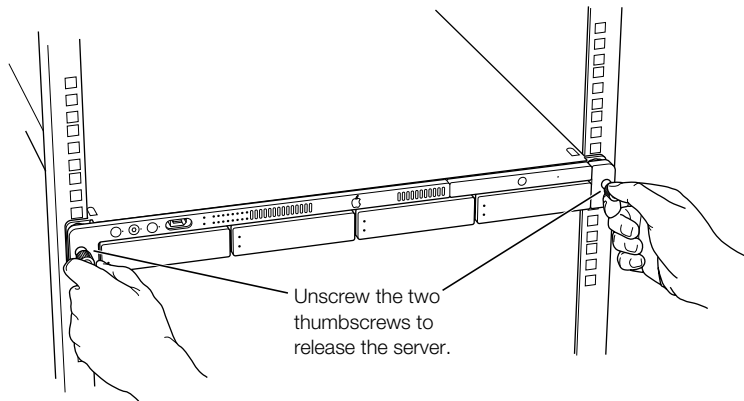

- 6 Grasp the thumbscrews and use them to slide the server forward.

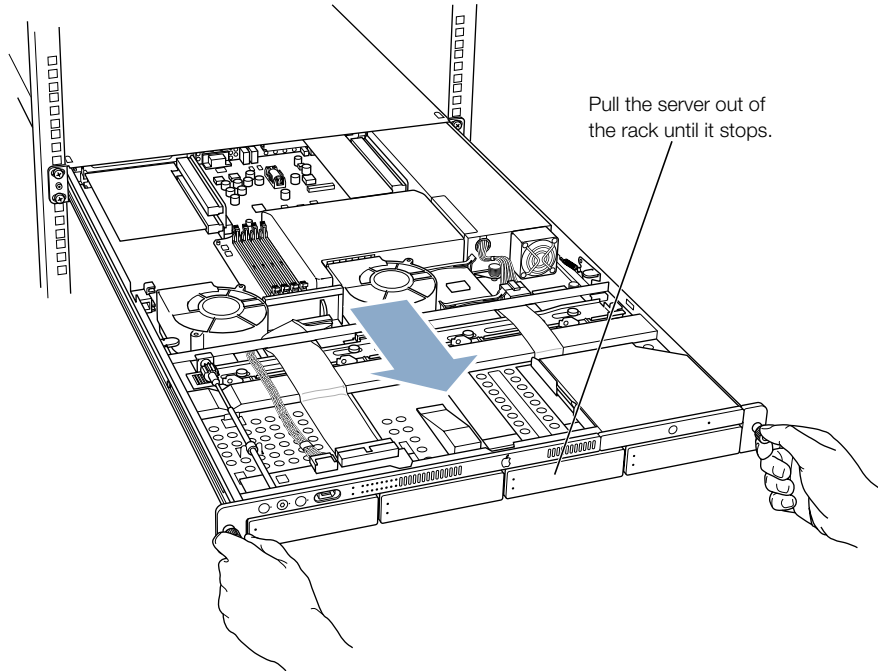

The server's cover remains in place. The enclosure and components slide forward until the interior is in view.

If you need to remove the server from the rack, press the release latches on each side of the server's interior, then carefully slide it forward and lift it out of the cover.

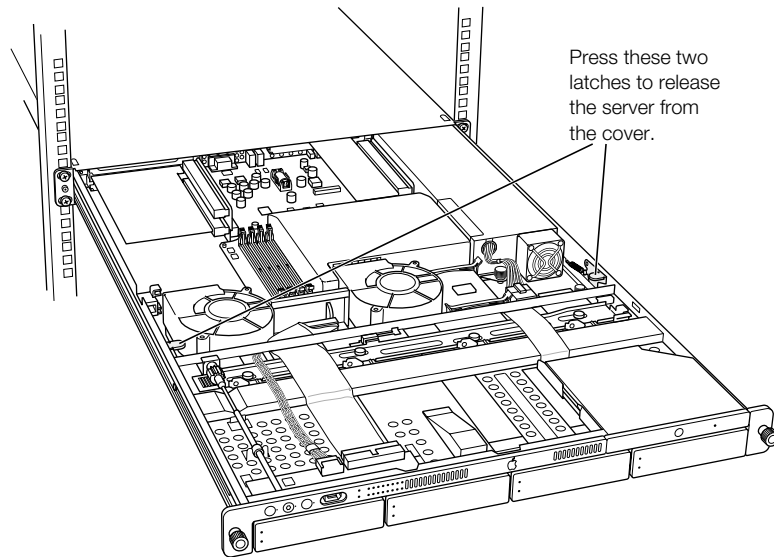

- 7 When you've completed your work inside the server, carefully slide it closed and tighten the front thumbscrews to secure it in the rack.

Adding Memory

The server has four memory slots, at least one of which is filled at the factory. Follow these steps to add memory to the server.

You can install additional dynamic random-access memory (DRAM) in packages called Dual Inline Memory Modules (DIMMs) in the four DRAM DIMM slots on the server's main logic board. You can expand your computer's DRAM to a maximum of 2 gigabytes (GB). To check the amounts of DRAM installed, use the Apple System Profiler (located in the Utilities folder, in your computer's Applications folder).

DIMMs must fit these specifications:

- PC2100 double-data-rate (DDR) Synchronous DRAM (SDRAM); also described as DDR-266
- 2.5 volt (V)
- 64-bit wide, 184-pin module
- Maximum number of memory devices on a DIMM is 16.
- Unbuffered; do not use registered or buffered DRAM.
- Height must not exceed 1.25 inches.

Important DIMMs from older Macintosh computers are not compatible with your server. Do not use older DIMMs even if they fit into the DIMM slots.

Note: When purchasing DRAM for use in the server, make sure that the memory conforms to the JEDEC specification. Check with your memory vendor to ensure that the DRAM DIMM supports the correct timing modes and that the Serial Presence Detect (SPD) feature has been programmed properly, as described in the JEDEC specification. You can purchase memory where you bought your server.

Follow these steps to install memory in the server.

- 1 Shut down the server.
Be sure to alert users of the server that it will be unavailable for a period of time.
- 2 Unplug the power cord from the back panel of the server. (If the cable-management arm is not attached, you also need to disconnect cables from the back panel.)

Warning The only way to disconnect power completely is to unplug the power cord. Make sure that the cord is disconnected before removing or installing any components inside the server.

- 3 Open the server to its full length.

See “Opening and Closing the Server” on page 52 for details.

You can also remove the server from the rack (leaving the cover in place) and do the installation with the server on a sturdy flat surface.

- 4 Locate the RAM slots at the rear center of the server.

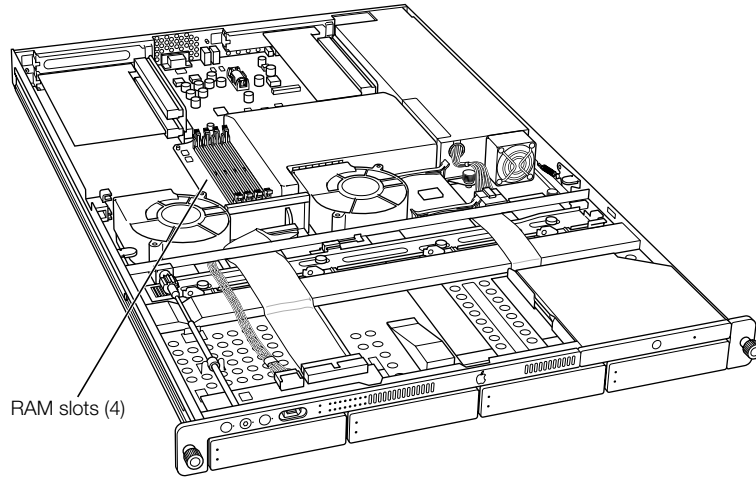

- 5 Open the ejectors on the DIMM slots you want to use by pushing down on them.

- Align the DIMM in the slot as pictured and push the DIMM down until the ejectors snap into place.

Important Do not touch the DIMM's connectors. Handle the DIMM only by the edges.

DRAM DIMM (Your DIMM's shape and components may vary.)

The DRAM DIMM is designed to fit into the slot only one way. Be sure to align the notch in the DIMM with the small rib inside the slot. With the ejectors in the open position (as shown), push down on the DIMM until it snaps into place. The ejectors will automatically close.

Ejectors
(They should be pushed outward and down to be in the open position, as shown.)

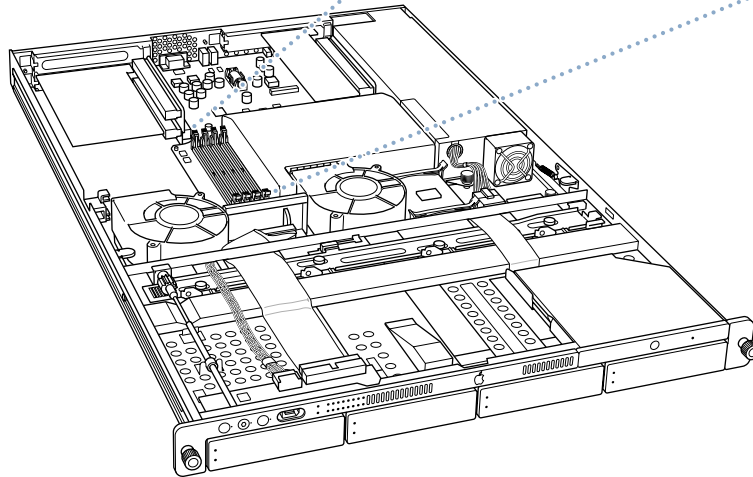
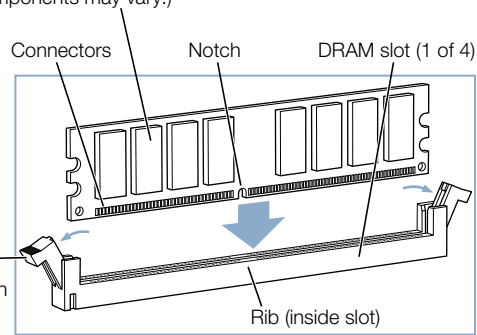

- Close the server and tighten its thumbscrews.
- Reconnect the power cord and any cables that you removed.

Installing a PCI Card

You can add to the capabilities of your server by installing cards in its expansion slots. The computer has three expansion slots, which accommodate Peripheral Component Interconnect (PCI) cards. In some models, the slot that takes a short (7-inch) PCI card can accept a 4x Accelerated Graphics Port (AGP) card.

About PCI Cards for the Server

Two of the server's slots accept PCI cards up to 12 inches long; the third slot accepts a 7-inch card. (Some models come with a card installed in one or two slots.) Install only expansion cards that are compatible with Mac OS X and that comply with the PCI 2.1 standard.

PCI Card Requirements

Criteria for PCI cards you can install in the Xserve server are summarized in the table below.

12-inch PCI card	7-inch PCI card
64-bit or 32-bit data width	32-bit data width
66 or 33 MHz frequency (If a 33 MHz card is used in one slot, both cards operate at 33 MHz.)	66 MHz frequency
3.3 volt (V)	3.3 V
12 or 7 inches long	7 inches long
	4x AGP card with an AGP adapter

Important The PCI card must have a 3.3 V connector or a universal connector to fit into the server's expansion slots. Cards with a 5 V connector will not work in this server.

Power Consumption of Cards

Maximum power consumption for all three expansion slots combined should not exceed 50 watts (W). Check the documentation that came with each card to be certain that the cards don't exceed this power consumption.

Install a PCI Card in a Long Card Slot

Follow these steps to install a PCI card in one of the long PCI slots.

- 1 Shut down the server.
Be sure to alert users of the server that it will be unavailable for a period of time.
- 2 Unplug the power cord from the back panel of the server. (If the cable-management arm is not attached, you will also have to disconnect cables from the back panel.)

Warning The only way to disconnect power completely is to unplug the power cord. Make sure that the cord is disconnected before removing or installing any components inside the server.

- 3 Loosen the thumbscrew on the back panel for the PCI slot that you want to use and swivel open the small metal piece that holds the thumbscrew.

Also grasp the slot cover and remove it through the slot opening, if possible.

You can skip this step if there is already a card in the slot you want to use.

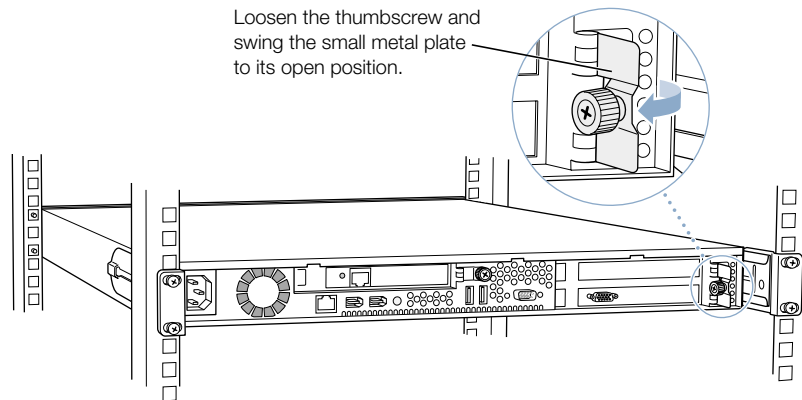

- 4 Move to the front of the server and open it to its full length.
See "Opening and Closing the Server" on page 52 for details.

You can also remove the server from the rack (leaving the cover in place) and do the installation with the server on a sturdy flat surface.

- 5 Locate the long PCI slots at the back left side of the server.

You can install a card in one or both slots. Cards are oriented horizontally in the server. The long PCI cards fit into an assembly unit that contains the sockets for both cards.

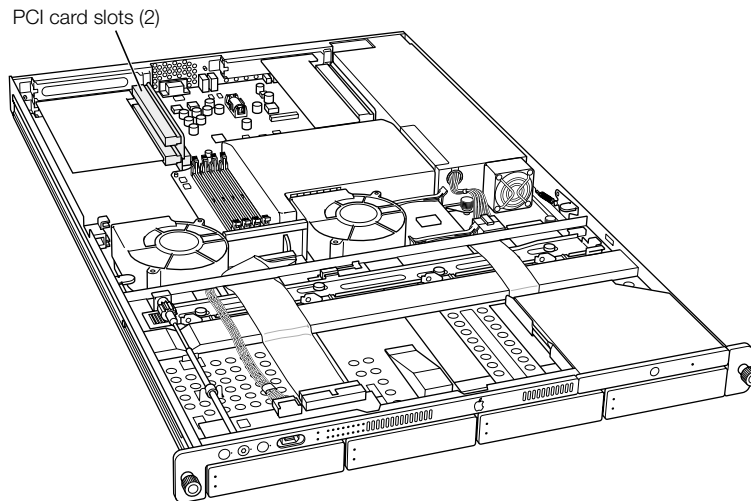

- 6 Grasp the PCI card assembly, which may contain one or two cards, gently pull it toward the left side of the server's enclosure, and then lift it out of the server.

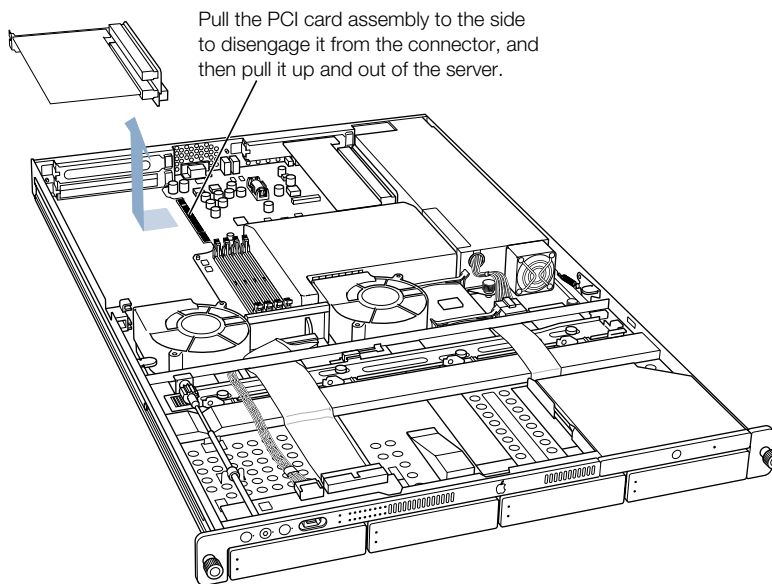

Set the card assembly on a cushioned surface.

- 7 Prepare the card slot by doing one of the following:
 - If a card is already in the slot you want to use, hold the assembly and remove the card, taking care not to touch its surface.
Store the card in static-proof packaging made to protect it.
 - If no card is in the slot, be sure to remove the slot cover (which came loose when you loosened the cover's thumbscrew on the back panel).
- 8 Remove the card you're installing from its packaging and hold it by its corners, taking care not to touch the gold connector or any of the components on the card.
- 9 Align the card's connector with the expansion slot in the assembly and carefully press it into the slot until the connector is inserted all the way into the slot.

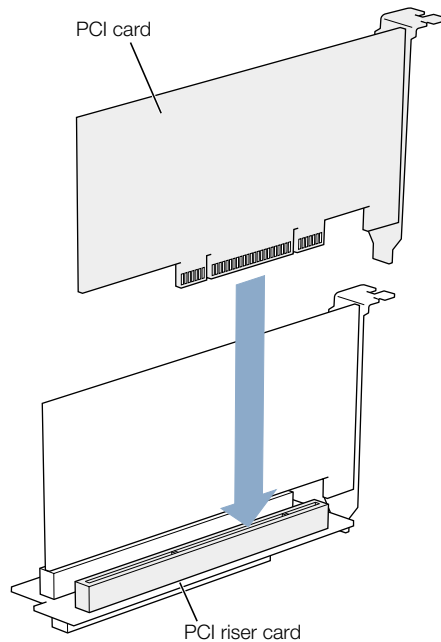

If you are installing a 12-inch card, align it with the card guide.

Press the card gently but firmly until the connector is fully inserted.

- Don't rock the card from side to side; instead, press the card straight into the slot.
- Don't force the card. If you meet a lot of resistance, pull the card out. Check the connector and the slot for damage or obstruction, then try inserting the card again.
- Pull the card gently to see if it is properly connected. If it resists and stays in place, and if its gold connectors are barely visible, the card is connected.

- 10 Replace the card assembly by aligning it with the connector and pressing it into place.

Attach the PCI card assembly to the connector on the logic board by pushing it in sideways. Be sure to engage the card in this slot on the back panel.

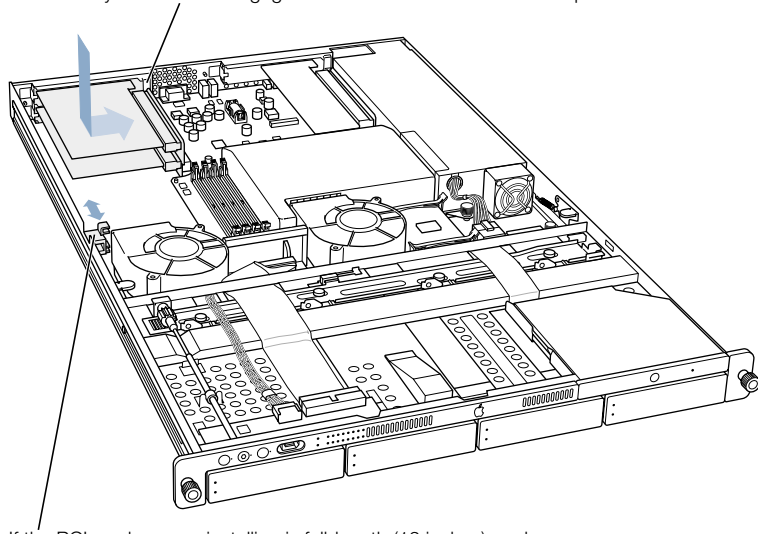

If the PCI card you are installing is full-length (12 inches), make sure it fits in one of these two card guides. The card guides snap forward and backward a short distance to help you position them on the cards.

- 11 Close the card retainer on the back panel and tighten its thumbscrew.

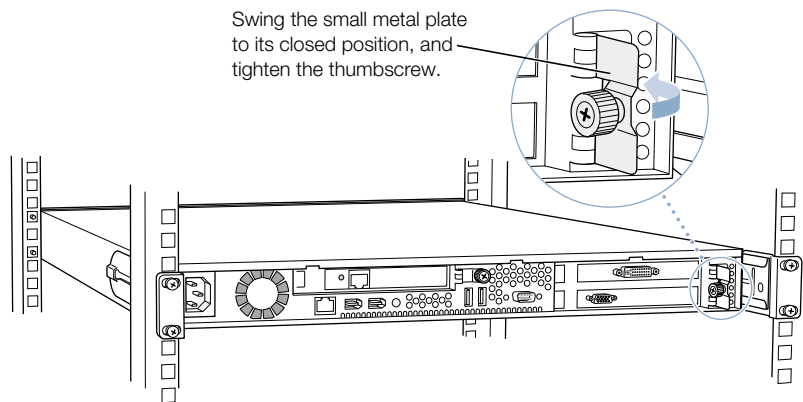

Warning If you removed a card from the server and did not install a replacement, be sure to place a port access cover over the empty slot in the back panel. Do not leave an empty slot without a cover. An uncovered slot can affect the air flow that cools the server's internal components and cause damage.

- 12 Close the server and reconnect any cords or cables that you detached.

Install a PCI Card in the PCI/AGP Card Slot

You can install a 7-inch PCI card in the PCI/AGP card slot.

Note: An AGP card requires a special adapter.

Follow these steps to install a PCI card in the PCI/AGP slot.

- 1 Shut down the server.

Be sure to alert users of the server that it will be unavailable for a period of time.

- 2 Unplug the power cord from the back panel of the server. (If the cable-management arm is not attached, you will also have to disconnect cables from the back panel.)

Warning The only way to disconnect power completely is to unplug the power cord. Make sure that the cord is disconnected before removing or installing any components inside the server.

- 3 Loosen the thumbscrew on the back panel for the PCI/AGP slot and swivel open the small metal piece that holds the thumbscrew.

If there is no card already in the slot, also grasp the slot cover and remove it through the slot opening, if possible.

You can skip this step if there is already a card in the slot.

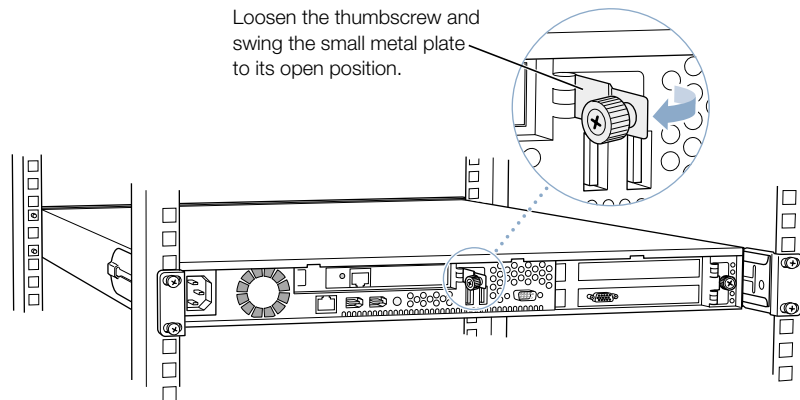

- 4 Move to the front of the server and open it to its full length.

See “Opening and Closing the Server” on page 52 for details.

You can also remove the server from the rack (leaving the cover in place) and do the installation with the server on a sturdy flat surface.

- 5 Locate the PCI/AGP slot at the back right side of the server.

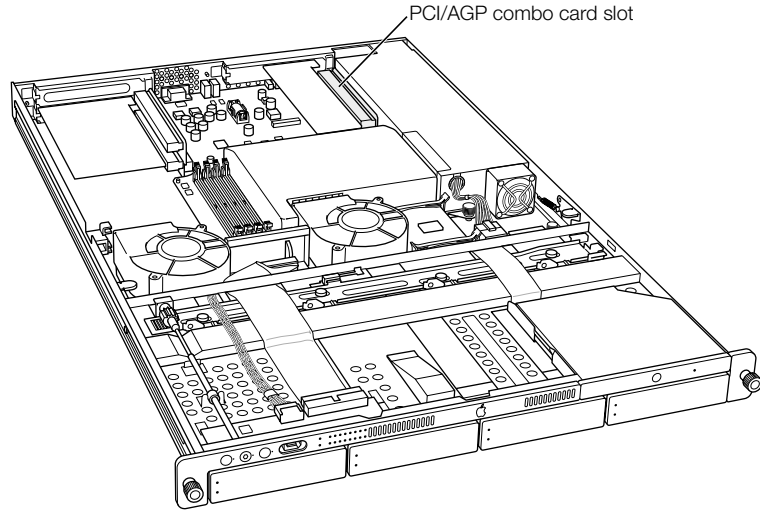

- 6 Prepare the card slot by doing one of the following:
- If a card is already in the slot, remove it by grasping the edges and gently pulling it toward the left side of the enclosure.
Store the card in static-proof packaging made to protect it.
 - If no card is in the slot, be sure to remove the slot cover (which came loose when you loosened the cover's thumbscrew on the back panel).

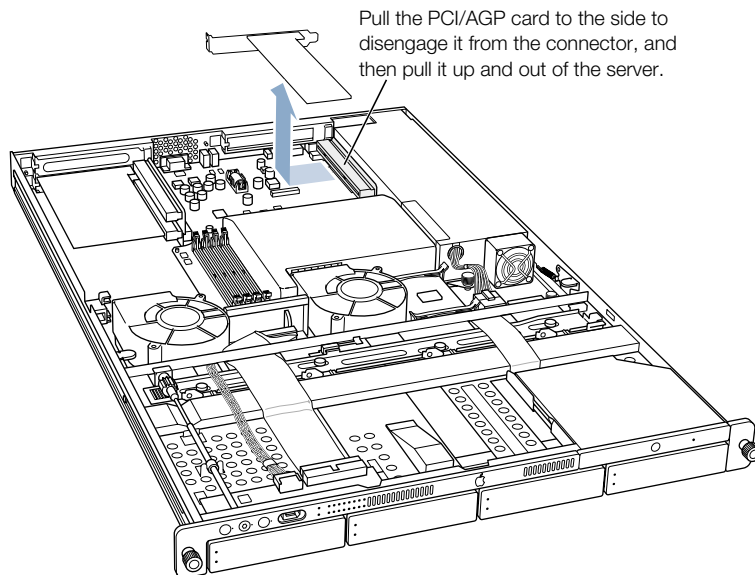

- 7 Remove the card you're installing from its packaging and hold it by its corners, taking care not to touch the gold connector or any of the components on the card.
- 8 Align the card's connector with the expansion slot and carefully press it to the right until the connector is inserted all the way into the slot.

Attach the PCI/AGP card to the connector by pushing it in sideways. Be sure to engage the card in this slot on the back panel.

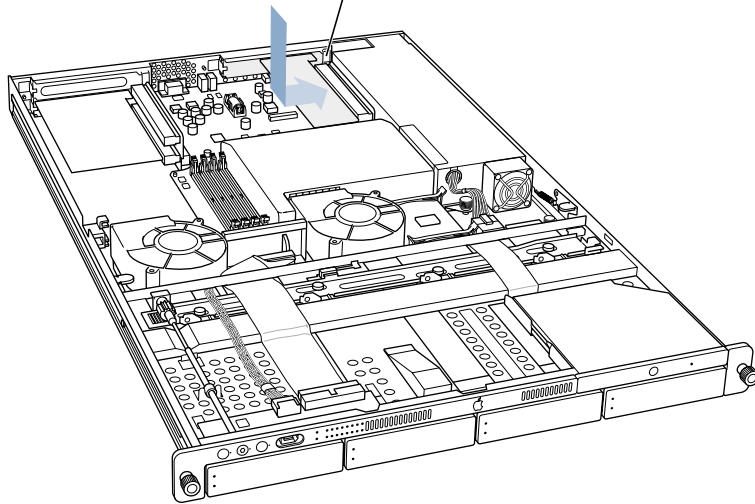

Press the card gently but firmly until the connector is fully inserted.

- Don't rock the card from side to side; instead, press the card straight into the slot.
- Don't force the card. If you meet a lot of resistance, pull the card out. Check the connector and the slot for damage or obstruction, then try inserting the card again.
- Pull the card gently to see if it is properly connected. If it resists and stays in place, and if its gold connectors are barely visible, the card is connected.

- 9 Close the card retainer on the back panel and tighten its thumbscrew.

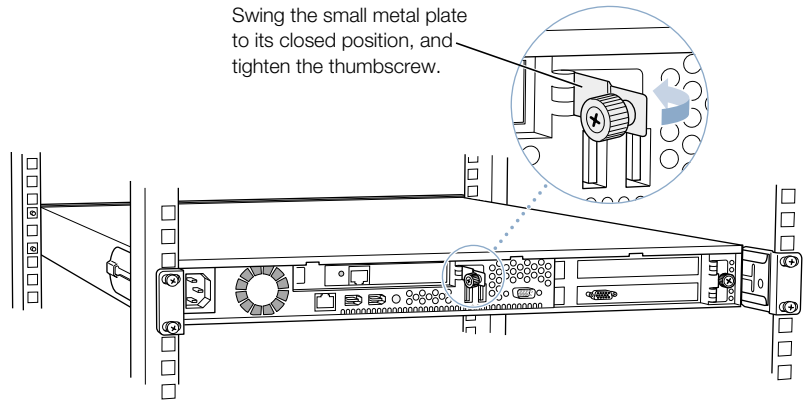

Warning If you removed a card from the server and did not install a replacement, be sure to place a port access cover over the empty slot in the back panel. Do not leave an empty slot without a cover. An uncovered slot can affect the air flow that cools the server's internal components and cause damage.

- 10 Close the server and reconnect any cords or cables that you detached.

Replacing the Battery

The server has a 3.6 V lithium battery installed on the main logic board. Some signs that you need to replace the battery are intermittent problems starting up the computer and random changes in its date and time settings. You can purchase a replacement battery from the dealer where you bought your server.

Warning There is a risk of explosion if the incorrect type of battery is installed.

- 1 Shut down the server.

Be sure to alert users of the server that it will be unavailable for a period of time.

- 2 Unplug the power cord from the back panel of the server. (If the cable-management arm is not attached, you will also have to disconnect cables from the back panel.)

Warning The only way to disconnect power completely is to unplug the power cord. Make sure that the cord is disconnected before removing or installing any components inside the server.

- 3 Open the server to its full length.

See “Opening and Closing the Server” on page 52 for details.

You can also remove the server from the rack (leaving the cover in place) and do the installation with the server on a sturdy flat surface.

- 4 Locate the battery holder near the back of the server.

Remove the battery by pulling it up and out of its holder. You may need to spread these two tabs slightly apart to release the battery. Spread the tabs gently so they don't break. Positive and negative symbols are molded inside the holder to help you orient the battery correctly.

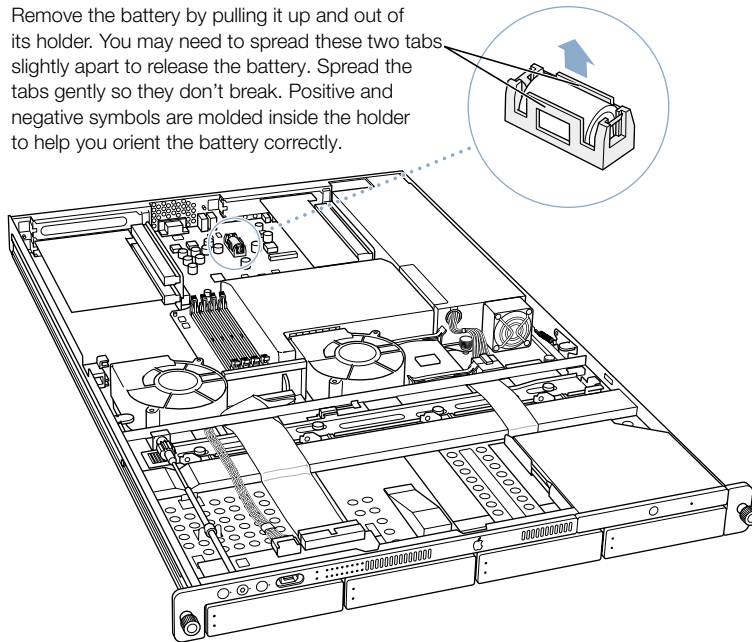

- 5 Remove the battery from its holder, noting the orientation of the battery's positive end. (A plus sign is marked on the holder.)
- 6 Insert the new battery in the holder, making sure the battery's positive end aligns with the positive symbol on the holder.
- 7 Close the server and tighten the thumbscrews to secure it.
- 8 Reconnect any cords or cables that you disconnected.

Important Batteries contain chemicals, some of which may be harmful to the environment. Please dispose of used batteries according to your local environmental laws and guidelines.

Specifications

Processor and Memory Specifications

Processor

- PowerPC G4 (single or dual), 1 GHz processor speed (at a minimum)
- 256K level 2 cache
- 2 MB backside DDR L3 cache

Random-access memory (RAM)

- Minimum of 256 MB of DDR RAM, maximum of 2 GB of RAM in four DIMM slots
- PC2100 double-data-rate (DDR) Synchronous DRAM (SDRAM); also described as DDR-266
- 2.5 volt (V) unbuffered, unregistered, 64-bit wide, 184-pin module
- 256 or 512 MB DIMMs; maximum number of memory devices on a DIMM is 16.
- Height must not exceed 1.25 inches.

Dimensions and Operating Environment

Dimensions

- *Height:* 1.75 in. (4.4 cm) (1U)
- *Width:* 19.0 in. (48.3 cm)
- *Depth:* 29.5 in. (74.9 cm)
- *Weight (with one drive module):* 26.6 lbs. (12.0 kg)
- *Drive module weight:* 2 lbs. (0.9 kg)

Weight depends on the number of drive modules installed in the server.

Operating environment

- *Operating temperature:* 10° to 35° C (50° to 95° F)
- *Storage temperature:* -40° to 47° C (-40° to 116.6° F)
- *Relative humidity:* 5% to 95% (noncondensing)
- *Altitude:* 0 to 3048 meters (0 to 10,000 feet)

CD-ROM Specifications

- *Disk dimensions supported:* 12 cm (4.7 in.)

Ethernet Specifications

- IEEE 802.3 compliant
- *Maximum cable length:* 100 meters (m)
- *Connectors:* RJ-45 for 10Base-T, 100Base-TX, and 1000Base-T
- *Media, 10Base-T:* Category 3 or higher UTP on 2 pairs up to 100 m
- *Media, 100Base-TX:* Category 5 UTP on 2 pairs up to 100 m
- *Media, 1000Base-T:* Category 5 and 6 UTP on 4 pairs up to 100 m
- *Channel speeds:* IEEE Auto Negotiation of 10Base-T, 100Base-TX, and 1000Base-T

FireWire Specifications

- *Data transfer speed:* 100, 200, and 400 megabits per second

USB Specifications

- Support for USB 1.1
- Two external Universal Serial Bus (USB) Type A ports
- Each port is on a separate 12 megabit per second (Mbps) USB channel.
- 500 milliamperes (mA) at 5 V are available per port for a total of 1 ampere (A).

Serial Port Specifications

- 9-pin D connector

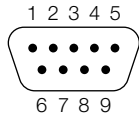

- Pin signals
 - 1: Received line signal detector (RLSD)
 - 2: Received data (RD)
 - 3: Transmitted data (TD)
 - 4: DTE ready (DRT CD)
 - 5: Signal ground (SGND)
 - 6: DCE ready (DCR CC)
 - 7: Request to send (RTS)
 - 8: Clear to send (CTS)
 - 9: Ring indicator (RI)

Video Card Specifications

- Standard VGA connection
- 32 MB of video memory
- Support for 33 and 66 MHz operation
- Support for startup without a monitor connected

Power Supply

AC line input

- *Line voltage/current:* 100–240 V alternating current (AC), 6 A maximum, single phase, set automatically
- *Frequency:* 50–60 hertz (Hz)

Power Requirements for Devices You Can Connect

Expansion cards

- Maximum power consumption by three PCI cards combined is 50 W (total for two 12-inch cards and one 7-inch card).
- 12-inch PCI card slots
 - *Data width:* 32 or 64 bits
 - *Frequency:* 33 or 66 MHz
 - *Power:* 3.3 V
 - *Length:* 7 or 12 in.
- PCI/AGP card slot (AGP card requires adapter)
 - *Data width:* 32 bits
 - *Frequency:* 66 MHz
 - *Power:* 3.3 V
 - *Length:* 7 inches

FireWire devices

- The computer can provide up to 15 W total to all FireWire ports combined.
- *Output voltage range:* Approximately 13 to 30 V
- *Output power range:* Up to 15 W

USB devices

- Each of the computer's built-in USB ports is allotted 500 mA.

System Clock and Battery

CMOS custom circuitry with long-life lithium battery. You can replace the computer's battery (see "Replacing the Battery" on page 67) with a new one purchased from an Apple-authorized dealer.

Safety, Maintenance, and Ergonomics

Important Safety Information

For your own safety and that of your equipment, always take the following precautions.

Important The only way to disconnect power completely is to unplug the power cord. Make sure at least one end of the power cord is within easy reach so that you can unplug the server when you need to.

Disconnect the power plug (by pulling the plug, not the cord) if any of the following conditions exists:

- you want to remove any parts (leave the cord disconnected as long as the cover is off)
- the power cord or plug becomes frayed or otherwise damaged
- you spill something into the case
- your server is exposed to rain or any other excess moisture
- your server has been dropped or the case has been otherwise damaged
- you suspect that your server needs service or repair
- you want to clean the case (use only the recommended procedure described later)

Be sure that you always do the following:

- Keep your server away from sources of liquids, such as washbasins, bathtubs, shower stalls, and so on.
- Protect your server from dampness or wet weather, such as rain, snow, and so on.
- Read all the installation instructions carefully before you plug your server into a wall socket or power strip.
- Keep these instructions handy for reference by you and others.
- Follow all instructions and warnings dealing with your system.

Electrical equipment may be hazardous if misused. Operation of this product, or similar products, must always be supervised by an adult. Do not allow children access to the interior of any electrical product and do not permit them to handle any cables.

Handling Your Computer Equipment

Follow these guidelines for handling your computer and its components:

- When the server is removed from its rack, set it on a sturdy, flat surface.

Important Do not put a monitor or any other device on top of the server. Essential components are installed in this low-profile server, and any weight on top of the case could damage these components.

- When connecting or disconnecting a cable, always hold the cable by its connector (the plug, not the cord).
- Turn off your server before connecting or disconnecting a cable for a monitor or a serial device. Failure to do so could damage your equipment or cause an interruption in the server's operation.

Certain components and cables—hard disks, a VGA monitor, FireWire, Ethernet, and USB devices—are designed to be installed or removed while the server is turned on and operating.

- Never force a connector into a port. If the connector and port do not join with reasonable ease, they probably don't match. Make sure that the connector matches the port and that you have positioned the connector correctly in relation to the port.
- Take care not to spill any food or liquid on the server or other components. If you do, turn your server off immediately and unplug it before cleaning up the spill. Depending on what you spilled and how much of it got into your equipment, you may have to arrange for an Apple-authorized service provider to inspect or repair the server.
- Protect the server and its components from direct sunlight and rain or other moisture.
- Keep all ventilation openings clear and unobstructed. Without proper air circulation, components can overheat, causing damage or unreliable operation.

Protecting Your CD Drive

To keep your CD drive working properly:

- Position your server so that when the tray opens, it doesn't bump into anything.
- Do not leave the disc tray open. If dust gets on the lens of the CD-ROM drive, the drive may have problems reading your discs.
- Do not put anything (for instance, a cup) on top of the tray when it is open.
- Do not force the tray open by hand. In an emergency, you can use an opened paper clip in the tiny hole near the drive to eject a disc.
- Do not wipe the lens with a paper towel or other abrasive surface. If you need to clean the lens, see an Apple-authorized service provider for a lens cleaner.

You may want to open the tray and take out your disc before shutting down.

Power Supply

The power supply in your computer is a high-voltage component and should not be opened for any reason, even when the computer is off. If the power supply needs service, contact your Apple-authorized dealer or service provider.

Cleaning Your Equipment

Follow these general rules when cleaning the outside of your server:

- Use a damp, soft, lint-free cloth to clean the computer's exterior. Avoid getting moisture in any openings.
- Don't use aerosol sprays, solvents, or abrasives.

Cleaning the Server's Case

To clean the case, do the following:

- 1 Turn off the computer completely and then disconnect the power plug. (Pull the plug, not the cord.)
- 2 Wipe the surfaces lightly with a clean, soft cloth dampened with water.

Apple and the Environment

At Apple, we recognize our responsibility to minimize the environmental impacts of our operations and products.

For More Information

Go to www.apple.com/about/environment

Health-Related Information About Computer Use

In most instances, you will probably set up and administer your server from a remote location, such as a computer on the server's network. If you work at the server rack for extended periods, be sure to following these guidelines for avoiding muscle soreness, eye fatigue, or other discomforts associated with computer use.

- If feasible in the server location, use an adjustable chair that provides firm, comfortable support. The back of the chair should support your lower back (lumbar region). Follow the manufacturer's instructions for adjusting the backrest to fit your body properly.
- When using a keyboard at the server location, your shoulders should be relaxed. Your upper arm and forearm should form an approximate right angle, with your wrist and hand in roughly a straight line. Depending on the location of the monitor and keyboard connected to the server, you may have to adjust the height of your chair so that you can maintain a comfortable position. Your feet should be flat on the floor or on a footrest.

Communications Regulation Information

FCC Statement

This equipment has been tested and found to comply with the limits for a Class A digital device, pursuant to Part 15 of FCC rules. These limits are designed to provide reasonable protection against harmful interference when the equipment is operated in a commercial environment. This equipment generates, uses, and can radiate radio-frequency energy, and if not installed and used in accordance with Apple's instructions, may cause harmful interference with radio communications. Operation of this equipment in a residential area is likely to cause harmful interference, in which case the user will be required to correct the interference at his or her own expense.

Important Changes or modifications to this product not authorized by Apple Computer, Inc., could void the EMC compliance and negate your authority to operate the product.

This product was tested for EMC compliance under conditions that included the use of Apple peripheral devices and Apple shielded cables and connectors between system components. It is important that you use Apple peripheral devices and shielded cables and connectors between system components to reduce the possibility of causing interference to radios, television sets, and other electronic devices. You can obtain Apple peripheral devices and the proper shielded cables and connectors through an Apple-authorized dealer. For non-Apple peripheral devices, contact the manufacturer or dealer for assistance.

The above model is certified only as a component for use with other equipment, where the suitability of the combination is to be determined by a Nationally Recognized Testing Laboratory.

Industry Canada Statement

Complies with the Canadian ICES-003 Class A specifications.

Cet appareil numérique de la classe A est conforme à la norme NMB-003 du Canada.

European Union Statement

Complies with European Directive 89/336/EEC.

CISPR 22 & EN55022 Statement

Warning This is a Class A product. In a domestic environment this product may cause radio interference, in which case the user may be required to take adequate measures.

VCCI Class A Statement

この装置は、情報処理装置等電波障害自主規制協議会（VCCI）の基準に基づくクラスA情報技術装置です。この装置を家庭環境で使用すると電波妨害を引き起こすことがあります。この場合には使用者が適切な対策を講ずるよう要求されることがあります。

Laser Information

If you have an internal Apple CD-ROM drive in your computer, your computer is a Class 1 laser product. The Class 1 label, located in a user-accessible area, indicates that the drive meets minimum safety requirements. A service warning label is located in a service-accessible area. The labels on your product may differ slightly from the ones shown here.



Class 1 label

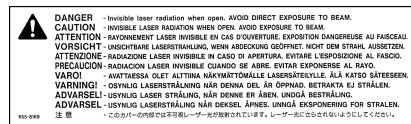

Service warning label

High-Risk Activities Warning

This computer system is not intended for use in the operation of nuclear facilities, aircraft navigation or communications systems, or air traffic control machines, or for any other uses where the failure of the computer system could lead to death, personal injury or severe environmental damage.