

**Lucent Technologies**  
Bell Labs Innovations



**DEFINITY<sup>®</sup>**

**Enterprise Communications Server**

Release 7

Maintenance for R7r

555-230-126  
Comcode 108343203  
Issue 4  
June 1999

## Notice

Every effort was made to ensure that the information in this book was complete and accurate at the time of printing. However, information is subject to change.

## Your Responsibility for Your System's Security

Toll fraud is the unauthorized use of your telecommunications system by an unauthorized party, for example, persons other than your company's employees, agents, subcontractors, or persons working on your company's behalf. Note that there may be a risk of toll fraud associated with your telecommunications system and, if toll fraud occurs, it can result in substantial additional charges for your telecommunications services.

You and your system manager are responsible for the security of your system, such as programming and configuring your equipment to prevent unauthorized use. The system manager is also responsible for reading all installation, instruction, and system administration documents provided with this product in order to fully understand the features that can introduce risk of toll fraud and the steps that can be taken to reduce that risk. Lucent Technologies does not warrant that this product is immune from or will prevent unauthorized use of common-carrier telecommunication services or facilities accessed through or connected to it. Lucent Technologies will not be responsible for any charges that result from such unauthorized use.

## Lucent Technologies Fraud Intervention

If you *suspect that you are being victimized* by toll fraud and you need technical support or assistance, call Technical Service Center Toll Fraud Intervention Hotline at 1 800 643-2353 or contact your local Lucent representative.

## Federal Communications Commission Statement

**Part 15: Class A Statement.** This equipment has been tested and found to comply with the limits for a Class A digital device, pursuant to Part 15 of the FCC Rules. These limits are designed to provide reasonable protection against harmful interference when the equipment is operated in a commercial environment. This equipment generates, uses, and can radiate radio-frequency energy and, if not installed and used in accordance with the instructions, may cause harmful interference to radio communications. Operation of this equipment in a residential area is likely to cause harmful interference, in which case the user will be required to correct the interference at his own expense.

**Part 68: Network Registration Number.** This equipment is registered with the FCC in accordance with Part 68 of the FCC Rules. It is identified by FCC registration number AS593M-13283-MF-E.

**Part 68: Answer-Supervision Signaling.** Allowing this equipment to be operated in a manner that does not provide proper answer-supervision signaling is in violation of Part 68 Rules. This equipment returns answer-supervision signals to the public switched network when:

- Answered by the called station
- Answered by the attendant
- Routed to a recorded announcement that can be administered by the CPE user

This equipment returns answer-supervision signals on all DID calls forwarded back to the public switched telephone network. Permissible exceptions are:

- A call is unanswered
- A busy tone is received
- A reorder tone is received

## Canadian Department of Communications (DOC)

### Interference Information

This digital apparatus does not exceed the Class A limits for radio noise emissions set out in the radio interference regulations of the Canadian Department of Communications.

Le Présent Appareil Numérique n'émet pas de bruits radioélectriques dépassant les limites applicables aux appareils numériques de la class A prescrites dans le règlement sur le brouillage radioélectrique édicté par le ministère des Communications du Canada.

### Trademarks

See the preface of this document.

### Ordering Information

**Call:** Lucent Technologies BCS Publications Center  
Voice 1 800 457-1235 International Voice 317 322-6416  
Fax 1 800 457-1764 International Fax 317 322-6699

**Write:** Lucent Technologies BCS Publications Center  
2855 N. Franklin Road  
Indianapolis, IN 46219

**Order:** Document No. 555-230-126  
Comcode 108343203  
Issue 4, June 1999

For additional documents, refer to the section in "About This Document" entitled "Related Resources."

You can be placed on a standing order list for this and other documents you may need. Standing order will enable you to automatically receive updated versions of individual documents or document sets, billed to account information that you provide. For more information on standing orders, or to be put on a list to receive future issues of this document, contact the Lucent Technologies Publications Center.

## European Union Declaration of Conformity

The "CE" mark affixed to the DEFINITY® equipment described in this book indicates that the equipment conforms to the following European Union (EU) Directives:

- Electromagnetic Compatibility (89/336/EEC)
- Low Voltage (73/23/EEC)
- Telecommunications Terminal Equipment (TTE) i-CTR3 BRI and i-CTR4 PRI

For more information on standards compliance, contact your local distributor.

## Comments

To comment on this document, return the comment card at the front of the document or email us at [document@drmail.lucent.com](mailto:document@drmail.lucent.com).

## Acknowledgment

This document was prepared by Product Documentation Development, Lucent Technologies, Denver, CO.

# Contents

<a href="#">Contents</a>	<a href="#">iii</a>
<a href="#">About this Book</a>	<a href="#">xvii</a>
<a href="#">Intended Use</a>	<a href="#">xvii</a>
<a href="#">How to Use this Document</a>	<a href="#">xviii</a>
<a href="#">Organization</a>	<a href="#">xviii</a>
<a href="#">Safety Precautions</a>	<a href="#">xix</a>
<a href="#">Electromagnetic Compatibility Standards</a>	<a href="#">xix</a>
<a href="#">Standards Compliance</a>	<a href="#">xxi</a>
<a href="#">Conventions Used in This Document</a>	<a href="#">xxi</a>
<a href="#">Trademarks and Service Marks</a>	<a href="#">xxiii</a>
<a href="#">Related Documents</a>	<a href="#">xxiii</a>
<a href="#">Federal Communications Commission Statement</a>	<a href="#">xxv</a>
<a href="#">How to Order Documentation</a>	<a href="#">xxvii</a>
<a href="#">How to Comment on This Document</a>	<a href="#">xxvii</a>
<a href="#">Where to Call for Technical Support</a>	<a href="#">xxvii</a>
<b><a href="#">1 Maintenance Architecture</a></b>	<b><a href="#">1-1</a></b>
<a href="#">What's new for R7r</a>	<a href="#">1-1</a>
<a href="#">How to use the Maintenance book</a>	<a href="#">1-5</a>
<a href="#">Maintenance Objects</a>	<a href="#">1-10</a>
<a href="#">Alarm and Error Reporting</a>	<a href="#">1-11</a>
<a href="#">Port Network Connectivity (PNC)</a>	<a href="#">1-12</a>
<a href="#">SPE Duplication</a>	<a href="#">1-16</a>
<a href="#">Power Interruptions</a>	<a href="#">1-26</a>
<a href="#">Protocols</a>	<a href="#">1-28</a>
<a href="#">Service Codes</a>	<a href="#">1-42</a>
<a href="#">Facility Interface Codes</a>	<a href="#">1-43</a>
<a href="#">Multimedia Interface (MMI)</a>	<a href="#">1-44</a>
<b><a href="#">2 Hardware Configurations</a></b>	<b><a href="#">2-1</a></b>
<a href="#">Multi-Carrier Cabinet</a>	<a href="#">2-1</a>
<a href="#">Carriers in Multi-Carrier Cabinets</a>	<a href="#">2-3</a>
<a href="#">PNC Cabling — Fiber Hardware</a>	<a href="#">2-8</a>
<a href="#">Circuit Packs</a>	<a href="#">2-12</a>
<a href="#">Duplication: Reliability Options</a>	<a href="#">2-17</a>

<b><u>3</u></b>	<b><u>Management Terminal</u></b>	<b><u>3-1</u></b>
	■ <u>Terminals Supported</u>	<u>3-1</u>
	■ <u>Multiple Access</u>	<u>3-1</u>
	■ <u>Switch-Based Bulletin Board</u>	<u>3-2</u>
	■ <u>Switch-Based Bulletin Board Message Notification</u>	<u>3-5</u>
	■ <u>Connecting the MT</u>	<u>3-24</u>
	■ <u>Logging On</u>	<u>3-26</u>
	■ <u>Logging Off</u>	<u>3-28</u>
<b><u>4</u></b>	<b><u>Initialization and Recovery</u></b>	<b><u>4-1</u></b>
	■ <u>Multiple Offer Categories</u>	<u>4-2</u>
	■ <u>Hot Restart</u>	<u>4-3</u>
	■ <u>Reset Level 1 (Warm Restart)</u>	<u>4-3</u>
	■ <u>Reset Level 2 (Cold-2 Restart)</u>	<u>4-5</u>
	■ <u>Reset Level 3 (Cold-1 Restart)</u>	<u>4-6</u>
	■ <u>Reset Level 4 (Reboot)</u>	<u>4-6</u>
	■ <u>Reset Level 5 (Extended Reboot)</u>	<u>4-7</u>
	■ <u>Initialization Diagnostics</u>	<u>4-7</u>
	■ <u>SPE-Down Command Interface</u>	<u>4-9</u>
<b><u>5</u></b>	<b><u>Alarms, Errors, and Troubleshooting</u></b>	<b><u>5-1</u></b>
	■ <u>Safety Precautions</u>	<u>5-1</u>
	■ <u>DEFINITY AUDIX System Power Procedures</u>	<u>5-2</u>
	■ <u>Electrostatic Discharge</u>	<u>5-3</u>
	■ <u>Suppress Alarm Origination [y]</u>	<u>5-4</u>
	■ <u>Reseating and Replacing Circuit Packs</u>	<u>5-5</u>
	■ <u>Replacing a BIU or Rectifier</u>	<u>5-6</u>
	■ <u>Replacing SPE Circuit Packs</u>	<u>5-7</u>
	■ <u>Troubleshooting a Duplicated SPE</u>	<u>5-10</u>
	■ <u>Executing a Planned SPE Interchange</u>	<u>5-15</u>
	■ <u>LA85 Port Tester</u>	<u>5-18</u>
	■ <u>Fiber Fault Isolation Procedure</u>	<u>5-21</u>
	■ <u>ATM Tips</u>	<u>5-27</u>
	■ <u>Unusual ATM trouble conditions</u>	<u>5-57</u>
	■ <u>Multimedia Call Handling (MMCH)</u>	<u>5-59</u>
	■ <u>Troubleshooting ISDN-PRI Problems</u>	<u>5-66</u>
	■ <u>Troubleshooting ISDN-PRI Endpoints (Wideband)</u>	<u>5-69</u>



■	<a href="#">Troubleshooting ISDN-BRI/ASAI Problems</a>	<a href="#">5-71</a>
■	<a href="#">Troubleshooting ISDN-PRI Test Call Problems</a>	<a href="#">5-75</a>
■	<a href="#">Troubleshooting the Outgoing ISDN-Testcall Command</a>	<a href="#">5-77</a>
■	<a href="#">Packet Bus Fault Isolation and Repair</a>	<a href="#">5-78</a>
<b>6</b>	<b><a href="#">Additional Maintenance Procedures</a></b>	<b><a href="#">6-1</a></b>
■	<a href="#">Software updates</a>	<a href="#">6-1</a>
■	<a href="#">DS1 CPE Loopback Jack (T1 Only)</a>	<a href="#">6-10</a>
■	<a href="#">Facility test calls</a>	<a href="#">6-23</a>
■	<a href="#">Preventive Maintenance</a>	<a href="#">6-31</a>
■	<a href="#">Analog Tie Trunk Back-to-Back Testing</a>	<a href="#">6-34</a>
■	<a href="#">Terminating Trunk Transmission Testing</a>	<a href="#">6-38</a>
■	<a href="#">Removing and Restoring Power</a>	<a href="#">6-39</a>
■	<a href="#">Automatic Transmission Measurement System (ATMS)</a>	<a href="#">6-40</a>
<b>7</b>	<b><a href="#">LED Interpretation</a></b>	<b><a href="#">7-1</a></b>
■	<a href="#">Terminal Alarm Notification</a>	<a href="#">7-1</a>
■	<a href="#">Attendant Console LEDs</a>	<a href="#">7-2</a>
■	<a href="#">Circuit Pack LEDs</a>	<a href="#">7-3</a>
■	<a href="#">Expansion Interface Circuit Pack LEDs</a>	<a href="#">7-4</a>
■	<a href="#">SYSAM and Maintenance Circuit Pack LEDs</a>	<a href="#">7-5</a>
■	<a href="#">Duplication Interface Circuit Pack LEDs</a>	<a href="#">7-7</a>
■	<a href="#">Switch Node Interface LEDs</a>	<a href="#">7-8</a>
■	<a href="#">DS1 CONV (TN574/TN1654) Circuit Pack LEDs</a>	<a href="#">7-9</a>
■	<a href="#">Tone-Clock Circuit Pack LEDs</a>	<a href="#">7-13</a>
■	<a href="#">Maintenance/Test Circuit Pack LEDs</a>	<a href="#">7-13</a>
■	<a href="#">LEDs on Standby Components</a>	<a href="#">7-14</a>
<b>8</b>	<b><a href="#">Maintenance Commands</a></b>	<b><a href="#">8-1</a></b>
■	<a href="#">Command Line Syntax</a>	<a href="#">8-1</a>
■	<a href="#">Common Input Parameters</a>	<a href="#">8-2</a>
■	<a href="#">Common Output Fields</a>	<a href="#">8-5</a>
■	<a href="#">Contention Between Simultaneous Commands</a>	<a href="#">8-7</a>
■	<a href="#">Busyout and Release Commands</a>	<a href="#">8-8</a>
■	<a href="#">Common Abort and Fail Codes</a>	<a href="#">8-10</a>
■	<a href="#">Alarm and Error Categories</a>	<a href="#">8-13</a>
■	<a href="#">add atm pnc</a>	<a href="#">8-36</a>

■ <a href="#">backup disk</a>	<a href="#">8-37</a>
■ <a href="#">busyout cdr-link</a>	<a href="#">8-38</a>
■ <a href="#">busyout data-module</a>	<a href="#">8-39</a>
■ <a href="#">busyout disk</a>	<a href="#">8-39</a>
■ <a href="#">busyout ds1-facility</a>	<a href="#">8-39</a>
■ <a href="#">busyout fiber-link</a>	<a href="#">8-40</a>
■ <a href="#">busyout host-adapter</a>	<a href="#">8-41</a>
■ <a href="#">busyout journal-printer</a>	<a href="#">8-42</a>
■ <a href="#">busyout link</a>	<a href="#">8-43</a>
■ <a href="#">busyout spe-standby</a>	<a href="#">8-43</a>
■ <a href="#">busyout sp-link</a>	<a href="#">8-44</a>
■ <a href="#">busyout tape</a>	<a href="#">8-44</a>
■ <a href="#">busyout trunk</a>	<a href="#">8-45</a>
■ <a href="#">cancel hardware-group</a>	<a href="#">8-45</a>
■ <a href="#">change atm pnc</a>	<a href="#">8-47</a>
■ <a href="#">change circuit packs</a>	<a href="#">8-47</a>
■ <a href="#">change fiber-link</a>	<a href="#">8-51</a>
■ <a href="#">change synchronization</a>	<a href="#">8-54</a>
■ <a href="#">change system-parameters maintenance</a>	<a href="#">8-55</a>
■ <a href="#">clear errors</a>	<a href="#">8-66</a>
■ <a href="#">clear firmware-counters</a>	<a href="#">8-66</a>
■ <a href="#">clear link n</a>	<a href="#">8-67</a>
■ <a href="#">clear pgate-port</a>	<a href="#">8-67</a>
■ <a href="#">disable suspend-alm-orig</a>	<a href="#">8-67</a>
■ <a href="#">display alarms</a>	<a href="#">8-69</a>
■ <a href="#">display atm pnc</a>	<a href="#">8-76</a>
■ <a href="#">display capacity</a>	<a href="#">8-77</a>
■ <a href="#">display communication-interface links</a>	<a href="#">8-87</a>
■ <a href="#">display errors</a>	<a href="#">8-89</a>
■ <a href="#">display events</a>	<a href="#">8-95</a>
■ <a href="#">display fiber-link</a>	<a href="#">8-97</a>
■ <a href="#">display initcauses</a>	<a href="#">8-98</a>
■ <a href="#">display system-parameters duplication</a>	<a href="#">8-100</a>
■ <a href="#">display node-names</a>	<a href="#">8-101</a>
■ <a href="#">display system-parameters maintenance</a>	<a href="#">8-103</a>

■ <a href="#">display test-schedule</a>	8-113
■ <a href="#">display time</a>	8-115
■ <a href="#">enable administered-connection</a>	8-116
■ <a href="#">enable suspend-alm-orig</a>	8-116
■ <a href="#">enable synchronization-switch</a>	8-118
■ <a href="#">enable test-number</a>	8-118
■ <a href="#">format card-mem</a>	8-119
■ <a href="#">get vector</a>	8-121
■ <a href="#">list atm pnc</a>	8-123
■ <a href="#">list cabinet</a>	8-124
■ <a href="#">list communication-interface processor-channel</a>	8-125
■ <a href="#">list configuration</a>	8-127
■ <a href="#">list configuration software-version</a>	8-131
■ <a href="#">list disabled-MOs</a>	8-137
■ <a href="#">list fiber-link</a>	8-138
■ <a href="#">list history</a>	8-139
■ <a href="#">list ip-route</a>	8-142
■ <a href="#">list isdn-testcall</a>	8-143
■ <a href="#">list marked-ports</a>	8-144
■ <a href="#">list measurements ds1</a>	8-145
■ <a href="#">list pms-down</a>	8-149
■ <a href="#">list suspend-alm-orig</a>	8-150
■ <a href="#">list sys-link</a>	8-152
■ <a href="#">mark port</a>	8-153
■ <a href="#">monitor bcms</a>	8-153
■ <a href="#">monitor health</a>	8-158
■ <a href="#">monitor security violations</a>	8-159
■ <a href="#">monitor system</a>	8-160
■ <a href="#">monitor traffic</a>	8-167
■ <a href="#">monitor trunk</a>	8-169
■ <a href="#">netstat ip-route</a>	8-170
■ <a href="#">ping ip-address</a>	8-171
■ <a href="#">ping node-name</a>	8-173
■ <a href="#">recycle carrier</a>	8-173
■ <a href="#">release commands</a>	8-174

■ <a href="#">reset board</a>	8-175
■ <a href="#">reset disk</a>	8-175
■ <a href="#">reset fiber-link</a>	8-176
■ <a href="#">reset host-adapter</a>	8-177
■ <a href="#">reset maintenance</a>	8-177
■ <a href="#">reset packet-interface</a>	8-178
■ <a href="#">reset interchange</a>	8-180
■ <a href="#">reset port-network</a>	8-183
■ <a href="#">reset spe-standby</a>	8-185
■ <a href="#">reset system</a>	8-186
■ <a href="#">reset system interchange</a>	8-188
■ <a href="#">reset tape</a>	8-190
■ <a href="#">restore announcements</a>	8-191
■ <a href="#">restore disk</a>	8-193
■ <a href="#">resume hardware-group</a>	8-195
■ <a href="#">save announcements</a>	8-196
■ <a href="#">save translation</a>	8-199
■ <a href="#">set options</a>	8-201
■ <a href="#">set pnc</a>	8-209
■ <a href="#">set signaling-group</a>	8-209
■ <a href="#">set snc</a>	8-210
■ <a href="#">set synchronization</a>	8-210
■ <a href="#">set tdm</a>	8-211
■ <a href="#">set time</a>	8-211
■ <a href="#">set tone-clock</a>	8-212
■ <a href="#">set vector</a>	8-213
■ <a href="#">status access-endpoint</a>	8-216
■ <a href="#">status administered-connection</a>	8-217
■ <a href="#">status attendant</a>	8-220
■ <a href="#">status bri-port</a>	8-220
■ <a href="#">status cabinet</a>	8-228
■ <a href="#">status cdr-link</a>	8-229
■ <a href="#">status cleared-alarm-notif</a>	8-230
■ <a href="#">status conference</a>	8-231
■ <a href="#">status data-module</a>	8-271

■ <a href="#">status hardware-group</a>	8-272
■ <a href="#">status health</a>	8-274
■ <a href="#">status isdn-testcall</a>	8-277
■ <a href="#">status journal-link</a>	8-279
■ <a href="#">status link n</a>	8-280
■ <a href="#">status link (with PGATE)</a>	8-284
■ <a href="#">status logins</a>	8-285
■ <a href="#">status packet-interface</a>	8-285
■ <a href="#">status periodic-scheduled</a>	8-287
■ <a href="#">status pgate-port</a>	8-288
■ <a href="#">status processor-channel 1</a>	8-289
■ <a href="#">status pms-link</a>	8-290
■ <a href="#">status pnc</a>	8-290
■ <a href="#">status port-network</a>	8-294
■ <a href="#">status processor-channel</a>	8-298
■ <a href="#">status signaling-group</a>	8-299
■ <a href="#">status spe</a>	8-302
■ <a href="#">status sp-link</a>	8-305
■ <a href="#">status station</a>	8-306
■ <a href="#">status switch-node</a>	8-308
■ <a href="#">status synchronization</a>	8-309
■ <a href="#">status sys-link</a>	8-310
■ <a href="#">status trunk</a>	8-312
■ <a href="#">status tsc-administered</a>	8-314
■ <a href="#">status tti</a>	8-315
■ <a href="#">test alarms</a>	8-317
■ <a href="#">test analog-testcall</a>	8-326
■ <a href="#">test board</a>	8-326
■ <a href="#">test cdr-link</a>	8-327
■ <a href="#">test customer-alarm</a>	8-327
■ <a href="#">test data-module</a>	8-328
■ <a href="#">test disk</a>	8-328
■ <a href="#">test ds1-facility</a>	8-328
■ <a href="#">test ds1-loop</a>	8-329
■ <a href="#">test duplication-interface</a>	8-334

■ <a href="#">test eda-external-device-alm</a>	<a href="#">8-335</a>
■ <a href="#">test environment</a>	<a href="#">8-338</a>
■ <a href="#">test fiber-link</a>	<a href="#">8-339</a>
■ <a href="#">test hardware-group</a>	<a href="#">8-341</a>
■ <a href="#">test host-adapter</a>	<a href="#">8-345</a>
■ <a href="#">test inads-link</a>	<a href="#">8-346</a>
■ <a href="#">test isdn-testcall</a>	<a href="#">8-348</a>
■ <a href="#">test journal-printer</a>	<a href="#">8-349</a>
■ <a href="#">test led</a>	<a href="#">8-350</a>
■ <a href="#">test link</a>	<a href="#">8-350</a>
■ <a href="#">test maintenance</a>	<a href="#">8-351</a>
■ <a href="#">test mass-storage</a>	<a href="#">8-352</a>
■ <a href="#">test memory</a>	<a href="#">8-353</a>
■ <a href="#">test mssnet</a>	<a href="#">8-354</a>
■ <a href="#">test packet-interface</a>	<a href="#">8-355</a>
■ <a href="#">test pkt</a>	<a href="#">8-356</a>
■ <a href="#">test processor</a>	<a href="#">8-357</a>
■ <a href="#">test signaling-group</a>	<a href="#">8-358</a>
■ <a href="#">test spe-standby</a>	<a href="#">8-358</a>
■ <a href="#">test stored-data</a>	<a href="#">8-360</a>
■ <a href="#">test switch-control</a>	<a href="#">8-361</a>
■ <a href="#">test synchronization</a>	<a href="#">8-361</a>
■ <a href="#">test sys-link</a>	<a href="#">8-362</a>
■ <a href="#">test tape</a>	<a href="#">8-363</a>
■ <a href="#">test tdm</a>	<a href="#">8-364</a>
■ <a href="#">test tone-clock</a>	<a href="#">8-364</a>
■ <a href="#">test trunk</a>	<a href="#">8-364</a>
■ <a href="#">test tsc-administered</a>	<a href="#">8-364</a>
■ <a href="#">upgrade software</a>	<a href="#">8-365</a>

**9 Maintenance Object Repair Procedures** **9-1**

■ <a href="#">Escalation Procedures</a>	<a href="#">9-1</a>
■ <a href="#">ABRI-PORT (ASAI ISDN-BRI Port)</a>	<a href="#">9-2</a>
■ <a href="#">AC-POWER</a>	<a href="#">9-3</a>
■ <a href="#">ADM-CONN (Administered Connection)</a>	<a href="#">9-11</a>
■ <a href="#">ADX8D-BD (AUDIX Circuit Pack)</a>	<a href="#">9-14</a>

■ <a href="#">ADX8D-PT (AUDIX Digital Port)</a>	<a href="#">9-15</a>
■ <a href="#">ADX16D-B (16 Port AUDIX Circuit Pack)</a>	<a href="#">9-23</a>
■ <a href="#">ADX16A-BD (AUDIX Circuit Pack)</a>	<a href="#">9-24</a>
■ <a href="#">ADX16D-P (16-Port AUDIX Digital Port)</a>	<a href="#">9-25</a>
■ <a href="#">ADX16A-PT (AUDIX Analog Line/Control Link)</a>	<a href="#">9-33</a>
■ <a href="#">ALARM-PT (ALARM PORT)</a>	<a href="#">9-40</a>
■ <a href="#">ANL-16-L (16-Port Analog Line)</a>	<a href="#">9-44</a>
■ <a href="#">ANL-24-L (24-Port Analog Line)</a>	<a href="#">9-60</a>
■ <a href="#">ANL-BD (Analog Line Circuit Pack)</a>	<a href="#">9-76</a>
■ <a href="#">ANL-LINE, ANL-NE-L (8-Port Analog Line)</a>	<a href="#">9-77</a>
■ <a href="#">ANN-BD (Announcement Circuit Pack)</a>	<a href="#">9-97</a>
■ <a href="#">ANN-PT (Announcement Port)</a>	<a href="#">9-113</a>
■ <a href="#">ANNOUNCE</a>	<a href="#">9-121</a>
■ <a href="#">ASAI-BD (Multi-Application Platform Board)</a>	<a href="#">9-124</a>
■ <a href="#">ASAI-EPT</a>	<a href="#">9-126</a>
■ <a href="#">ASAI-PT</a>	<a href="#">9-135</a>
■ <a href="#">ASAI-RES/E-DIG-RES (TN800 reserve slot)</a>	<a href="#">9-147</a>
■ <a href="#">ATM-BCH (ATM B-Channel Trunk)</a>	<a href="#">9-148</a>
■ <a href="#">ATM-DCH (ATM D-Channel Port)</a>	<a href="#">9-162</a>
■ <a href="#">ATM-EI (Expansion Interface Circuit Pack)</a>	<a href="#">9-165</a>
■ <a href="#">ATM-INTF (TN2305/6)</a>	<a href="#">9-215</a>
■ <a href="#">ATM-NTWK (ATM Network Error)</a>	<a href="#">9-218</a>
■ <a href="#">ATM PNC-DUP (ATM PNC Duplication)</a>	<a href="#">9-224</a>
■ <a href="#">ATM-SGRP (ATM Signaling Group)</a>	<a href="#">9-235</a>
■ <a href="#">ATM-SYNC (ATM Synchronization)</a>	<a href="#">9-246</a>
■ <a href="#">ATM-TRK (Circuit Emulation Service Circuit Pack)</a>	<a href="#">9-254</a>
■ <a href="#">AUDIX-BD (AUDIX Circuit Pack)</a>	<a href="#">9-285</a>
■ <a href="#">AUDIX-PT (AUDIX Port)</a>	<a href="#">9-286</a>
■ <a href="#">AUX-BD (Auxiliary Trunk Circuit Pack)</a>	<a href="#">9-287</a>
■ <a href="#">AUX-TRK (Auxiliary Trunk)</a>	<a href="#">9-288</a>
■ <a href="#">BRI-BD/LGATE-BD (ISDN-BRI Line Circuit Pack)</a>	<a href="#">9-297</a>
■ <a href="#">BRI-DAT (ISDN-BRI Data Module)</a>	<a href="#">9-305</a>
■ <a href="#">BRI-PORT (ISDN-BRI Port), ABRI-PORT (ASAI ISDN-BRI Port)]</a>	<a href="#">9-306</a>

■ <a href="#">BRI-SET, ASAI-ADJ, BRI-DAT</a>	<a href="#">9-331</a>
■ <a href="#">CABINET (Cabinet Sensors)</a>	<a href="#">9-361</a>
■ <a href="#">CARR-POW (Carrier Power Supply)</a>	<a href="#">9-370</a>
■ <a href="#">CDR-LNK (Call Detail Recording Link)</a>	<a href="#">9-387</a>
■ <a href="#">CLAN-BD (Control LAN Circuit Pack)</a>	<a href="#">9-388</a>
■ <a href="#">CLSFY-BD (Call Classifier Circuit Pack)</a>	<a href="#">9-404</a>
■ <a href="#">CLSFY-PT (Call Classifier Port)</a>	<a href="#">9-405</a>
■ <a href="#">CO-BD (Central Office Trunk Circuit Pack)</a>	<a href="#">9-410</a>
■ <a href="#">CO-DS1 (DS1 CO Trunk)</a>	<a href="#">9-411</a>
■ <a href="#">CO-TRK (Analog CO Trunk)</a>	<a href="#">9-427</a>
■ <a href="#">CONFIG (System Configuration)</a>	<a href="#">9-449</a>
■ <a href="#">CUST-ALM (Customer-Provided Alarming Device)</a>	<a href="#">9-455</a>
■ <a href="#">DAT-LINE (Data Line Port)</a>	<a href="#">9-457</a>
■ <a href="#">DC-POWER (Single Carrier Cabinet Environment)</a>	<a href="#">9-466</a>
■ <a href="#">DETR-BD (Tone Detector Circuit)</a>	<a href="#">9-471</a>
■ <a href="#">DID-BD (Direct Inward Dial Trunk Circuit Pack)</a>	<a href="#">9-472</a>
■ <a href="#">DID-DS1 (Direct Inward Dial Trunk)</a>	<a href="#">9-473</a>
■ <a href="#">DID-TRK (Direct Inward Dial Trunk)</a>	<a href="#">9-483</a>
■ <a href="#">DIG-BD (Digital Line Circuit Pack)</a>	<a href="#">9-496</a>
■ <a href="#">DIG-LINE (Digital Line)</a>	<a href="#">9-497</a>
■ <a href="#">DIOD-BD (DIOD Trunk Circuit Pack)</a>	<a href="#">9-518</a>
■ <a href="#">DIOD-DS1 (DS1 DIOD Trunk)</a>	<a href="#">9-519</a>
■ <a href="#">DIOD-TRK (DIOD Trunk)</a>	<a href="#">9-530</a>
■ <a href="#">DISK (MSS Disk Circuit Pack)</a>	<a href="#">9-540</a>
■ <a href="#">DLY-MTCE (MO-DAILY)</a>	<a href="#">9-563</a>
■ <a href="#">DS1-BD (DS1 Interface Circuit Pack)</a>	<a href="#">9-564</a>
■ <a href="#">DS1-FAC (DS1 Facility)</a>	<a href="#">9-636</a>
■ <a href="#">DS1 CONV-BD</a>	<a href="#">9-660</a>
■ <a href="#">DT-LN-BD (Data Line Circuit Pack)</a>	<a href="#">9-693</a>
■ <a href="#">DTMR-PT (Dual Tone Multi-Frequency Receiver Port)</a>	<a href="#">9-694</a>
■ <a href="#">DUP-CHL (Duplication Interface)</a>	<a href="#">9-699</a>
■ <a href="#">DUPINT (Duplication Interface Circuit Pack)</a>	<a href="#">9-731</a>
■ <a href="#">E-DIG-BD (Multi Application Platform Board)</a>	<a href="#">9-743</a>
■ <a href="#">E-DIG-RES (TN800 reserve slot)</a>	<a href="#">9-745</a>
■ <a href="#">E-DIG-STA (Emulated Digital Line)</a>	<a href="#">9-746</a>



■ <a href="#">EMG-XFER (Emergency Transfer)</a>	<a href="#">9-755</a>
■ <a href="#">EPN-SNTY (EPN Sanity Audit)</a>	<a href="#">9-760</a>
■ <a href="#">ERR-LOG (Error Log)</a>	<a href="#">9-762</a>
■ <a href="#">ETH-PT (Control LAN Ethernet)</a>	<a href="#">9-763</a>
■ <a href="#">ETR-PT (Enhanced Tone Receiver Port)</a>	<a href="#">9-773</a>
■ <a href="#">EXP-INTF (Expansion Interface Circuit Pack)</a>	<a href="#">9-780</a>
■ <a href="#">EXP-PN (Expansion Port Network)</a>	<a href="#">9-840</a>
■ <a href="#">EXT-DEV ADMIN? Y (External Device Alarm)</a>	<a href="#">9-845</a>
■ <a href="#">FIBER-LK (Fiber Link)</a>	<a href="#">9-848</a>
■ <a href="#">GPTD-PT (General Purpose Tone Detector Port)</a>	<a href="#">9-886</a>
■ <a href="#">H-ADAPTR (MSS Host Adapter)</a>	<a href="#">9-891</a>
■ <a href="#">HYB-BD (Hybrid Line Circuit Pack)</a>	<a href="#">9-906</a>
■ <a href="#">HYB-LINE (Hybrid Line)</a>	<a href="#">9-907</a>
■ <a href="#">INADS (INADS Link)</a>	<a href="#">9-928</a>
■ <a href="#">ISDN-PLK (ISDN-PRI Signaling Link Port)</a>	<a href="#">9-931</a>
■ <a href="#">ISDN-LNK (ISDN-PRI Signaling Link Port)</a>	<a href="#">9-936</a>
■ <a href="#">ISDN-SGR (ISDN-PRI Signaling Group)</a>	<a href="#">9-942</a>
■ <a href="#">ISDN-TRK (DS1 ISDN Trunk)</a>	<a href="#">9-955</a>
■ <a href="#">JNL-PRNT (Journal Printer Link)</a>	<a href="#">9-978</a>
■ <a href="#">LGATE-AJ</a>	<a href="#">9-979</a>
■ <a href="#">LGATE-BD</a>	<a href="#">9-979</a>
■ <a href="#">LGATE-PT</a>	<a href="#">9-979</a>
■ <a href="#">LOG-SVN (Login Security Violation)</a>	<a href="#">9-980</a>
■ <a href="#">MAINT (EPN Maintenance Circuit Pack)</a>	<a href="#">9-983</a>
■ <a href="#">MAPD-BD (MAPD Interface Circuit Pack TN802)</a>	<a href="#">9-996</a>
■ <a href="#">MEM-BD (32MB Memory Circuit Pack)</a>	<a href="#">9-1026</a>
■ <a href="#">MET-BD (MET Line Circuit Pack)</a>	<a href="#">9-1038</a>
■ <a href="#">MET-LINE (MET Line)</a>	<a href="#">9-1039</a>
■ <a href="#">MIS (Management Information System)</a>	<a href="#">9-1057</a>
■ <a href="#">MMI-BD</a>	<a href="#">9-1058</a>
■ <a href="#">MMI-LEV (Multimedia Interface Resource Level)</a>	<a href="#">9-1068</a>
■ <a href="#">MMI-PT</a>	<a href="#">9-1071</a>
■ <a href="#">MMI-SYNC</a>	<a href="#">9-1077</a>
■ <a href="#">MODEM-BD (Modem Pool Circuit Pack)</a>	<a href="#">9-1078</a>
■ <a href="#">MODEM-PT (Modem Pool Port)</a>	<a href="#">9-1079</a>

■ <a href="#">M/T-ANL (Maintenance/Test Analog Port)</a>	<a href="#">9-1095</a>
■ <a href="#">M/T-BD (Maintenance/Test Circuit Pack)</a>	<a href="#">9-1104</a>
■ <a href="#">M/T-DIG (Maintenance/Test Digital Port)</a>	<a href="#">9-1108</a>
■ <a href="#">M/T-PKT (Maintenance/Test Packet Bus Port)</a>	<a href="#">9-1120</a>
■ <a href="#">OPS-LINE (DS1 Off Premises Station Line)</a>	<a href="#">9-1125</a>
■ <a href="#">PDATA-BD (Packet Data Line Circuit Pack)</a>	<a href="#">9-1139</a>
■ <a href="#">PDATA-PT (Packet Data Line Port)</a>	<a href="#">9-1144</a>
■ <a href="#">PDMODULE (Processor Data Module)</a> <a href="#">TDMODULE (Trunk Data Module)</a>	<a href="#">9-1160</a>
■ <a href="#">PE-BCHL (PRI Endpoint Port)</a>	<a href="#">9-1177</a>
■ <a href="#">PGATE-BD (Packet Gateway Circuit Pack)</a>	<a href="#">9-1194</a>
■ <a href="#">PGATE-PT (Packet Gateway Port)</a>	<a href="#">9-1210</a>
■ <a href="#">PKT-BUS (Packet Bus)</a>	<a href="#">9-1235</a>
■ <a href="#">PKT-INT (Packet Interface Circuit Pack)</a>	<a href="#">9-1244</a>
■ <a href="#">PMS-LINK (Property Management System Link)</a>	<a href="#">9-1281</a>
■ <a href="#">PMS-PRNT/JNL-PRNT (PMS Printer Link)</a>	<a href="#">9-1289</a>
■ <a href="#">PNC-DUP (PNC Duplication)</a>	<a href="#">9-1294</a>
■ <a href="#">POWER</a>	<a href="#">9-1312</a>
■ <a href="#">PPP-PT (Control LAN Packet/Port)</a>	<a href="#">9-1325</a>
■ <a href="#">PRI-CDR/SEC-CDR (Call Detail Recording Link)</a>	<a href="#">9-1336</a>
■ <a href="#">PROC-SAN (Process Sanity Audits)</a>	<a href="#">9-1342</a>
■ <a href="#">PROCR (RISC Processor Circuit Pack)</a>	<a href="#">9-1343</a>
■ <a href="#">RING-GEN</a>	<a href="#">9-1354</a>
■ <a href="#">S-SYN-BD (Speech Synthesis Circuit Pack)</a>	<a href="#">9-1360</a>
■ <a href="#">S-SYN-PT (Speech Synthesis Port)</a>	<a href="#">9-1361</a>
■ <a href="#">SN-CONF (Switch Node Configuration)</a>	<a href="#">9-1373</a>
■ <a href="#">SNC-BD (Switch Node Clock Circuit Pack)</a>	<a href="#">9-1381</a>
■ <a href="#">SNC-LINK (Switch Node Clock Link)</a>	<a href="#">9-1418</a>
■ <a href="#">SNC-REF (Switch Node Clock Reference)</a>	<a href="#">9-1423</a>
■ <a href="#">SNI-BD (SNI Circuit Pack)</a>	<a href="#">9-1426</a>
■ <a href="#">SNI-PEER (SNI Peer Link)</a>	<a href="#">9-1487</a>
■ <a href="#">SPE-SELE (SPE Select Switch)</a>	<a href="#">9-1491</a>
■ <a href="#">STBY-SPE (Standby SPE Maintenance)</a>	<a href="#">9-1493</a>
■ <a href="#">STO-DATA (Stored Data)</a>	<a href="#">9-1515</a>
■ <a href="#">STRAT-3 (Stratum 3 Clock)</a>	<a href="#">9-1536</a>
■ <a href="#">SVC-SLOT (Service Slot)</a>	<a href="#">9-1548</a>

■ <a href="#">SW-CTL (Switch Control)</a>	<a href="#">9-1550</a>
■ <a href="#">SYNC (Synchronization)</a>	<a href="#">9-1562</a>
■ <a href="#">SYS-LINK (System Links)</a>	<a href="#">9-1589</a>
■ <a href="#">SYS-PRNT (System Printer)</a>	<a href="#">9-1595</a>
■ <a href="#">SYSAM (Circuit Pack)</a>	<a href="#">9-1600</a>
■ <a href="#">SYSTEM (System)</a>	<a href="#">9-1624</a>
■ <a href="#">TAPE</a>	<a href="#">9-1629</a>
■ <a href="#">TBRI-BD (TN2185 ISDN Trunk-Side BRI)</a>	<a href="#">9-1665</a>
■ <a href="#">TBRI-PT (TN2185 ISDN Trunk-Side BRI Port)</a>	<a href="#">9-1673</a>
■ <a href="#">TBRI-TRK (TN2185 ISDN Trunk-Side BRI)</a>	<a href="#">9-1693</a>
■ <a href="#">TDM-BUS (TDM Bus)</a>	<a href="#">9-1703</a>
■ <a href="#">TDM-CLK (TDM Bus Clock)</a>	<a href="#">9-1720</a>
■ <a href="#">TDMODULE (Trunk Data Module)</a>	<a href="#">9-1735</a>
■ <a href="#">TIE-BD (Tie Trunk Circuit Pack)</a>	<a href="#">9-1736</a>
■ <a href="#">TIE-DS1 (DS1 Tie Trunk)</a>	<a href="#">9-1737</a>
■ <a href="#">TIE-TRK (Analog Tie Trunk)</a>	<a href="#">9-1756</a>
■ <a href="#">TIME-DAY (Time of Day)</a>	<a href="#">9-1776</a>
■ <a href="#">TONE-BD (Tone-Clock Circuit Pack)</a>	<a href="#">9-1778</a>
■ <a href="#">TONE-PT (Tone Generator)</a>	<a href="#">9-1797</a>
■ <a href="#">TSC-ADM (Administered Temporary Signaling Connections)</a>	<a href="#">9-1807</a>
■ <a href="#">TTR-LEV (TTR Level)</a>	<a href="#">9-1813</a>
■ <a href="#">UDS1-BD (UDS1 Interface Circuit Pack)</a>	<a href="#">9-1818</a>
■ <a href="#">VC-BD</a>	<a href="#">9-1909</a>
■ <a href="#">VC-DSPPT</a>	<a href="#">9-1913</a>
■ <a href="#">VC-LEV (Voice Conditioner DSP Port Level)</a>	<a href="#">9-1922</a>
■ <a href="#">VC-SUMPT</a>	<a href="#">9-1925</a>
■ <a href="#">WAE-PORT (Wideband Access Endpoint Port)</a>	<a href="#">9-1930</a>
■ <a href="#">XXX-BD (Common Port Circuit Pack)</a>	<a href="#">9-1937</a>



## About this Book

---

This document provides instructions and supporting information needed to monitor, test, and maintain the hardware components of the DEFINITY Enterprise Communications Server Release 7 systems.

These system's extensive background testing and technician-demanded tests allow many problems to be addressed before they severely disrupt call processing. Duplication options further enhance this reliability, giving the technician an opportunity to provide a high level of service while resolving problems or performing routine maintenance.

This book provides the necessary information to make full use of these capabilities and introduces some new components and strategies found in R6r.

### NOTE:

This document is intended for Release 7 and later systems only. For previous DEFINITY systems (G3V5 and earlier), refer to *DEFINITY Enterprise Communications Server, Release 5 Maintenance for R5r, 555-230-122*.

## Intended Use

---

- As a guide to diagnosing and repairing the Release 7r system for use by field technicians, remote service personnel, and user-assigned maintenance personnel
- As a training manual for teaching technicians how to maintain the system
- As a reference source on the system's maintenance capabilities

This document assumes that the technician has a working knowledge of telecommunications fundamentals and PBX maintenance practices. This

document also assumes that the system was initially installed and tested properly and brought into service with all faults cleared. Adjuncts and other devices external to the switch are covered by their own service documentation.

## How to Use this Document

---

Most maintenance sessions involve analyzing the Alarm and Error Logs to diagnose a trouble source and replacing a component such as a circuit pack. The information in [Chapter 9, "Maintenance Object Repair Procedures"](#) will generally suffice to address these needs. Certain complex elements of the system, such as fiber links and the packet bus, require a more comprehensive approach. Special procedures for these elements appear in [Chapter 5, "Alarms, Errors, and Troubleshooting"](#).

This document is not intended to solve all levels of trouble. When the limits of these procedures have been reached and the problem has not been resolved, it is the technician's responsibility to escalate to a higher level of technical support. Escalation should conform to the procedures in the *Technical and Administration Plan*.

## Organization

---

- [Chapter 1, "Maintenance Architecture"](#), describes the system's design and maintenance strategy.
- [Chapter 2, "Hardware Configurations"](#), shows the locations and arrangements of the system's cabinets, carriers, circuit packs, and cabling.
- [Chapter 3, "Management Terminal"](#), describes how to set up and use the management terminal.
- [Chapter 4, "Initialization and Recovery"](#), describes the various reset and reboot processes and how these are used to perform maintenance and recover systems or subsystems that are out of service. Use of the terminal SPE-down interface on non-functional or standby Switch Processor Elements is included here.
- [Chapter 5, "Alarms, Errors, and Troubleshooting"](#), describes general repair procedures such as replacing circuit packs and special troubleshooting procedures such as those for fiber link and packet bus faults.
- [Chapter 6, "Additional Maintenance Procedures"](#), describes preventive maintenance, software updates and other procedures not associated with specific alarms or components.
- [Chapter 7, "LED Interpretation"](#), is a guide to interpreting indications given by circuit pack and attendant console LEDs.

- [Chapter 8, “Maintenance Commands”](#), contains a description of each maintenance command available through the management terminal. The commands are ordered alphabetically. A general description of command syntax and conventions appears at the beginning of the chapter.
- [Chapter 9, “Maintenance Object Repair Procedures”](#), contains specific troubleshooting and repair instructions for every component in the system. The maintenance objects are listed alphabetically by name as they appear in the Alarm and Error Logs. Under each maintenance object appears a description of the object’s function, tables for interpreting alarm and error logs, and instructions on how to use tests, commands, and replacements to resolve associated problems. Most of these procedures are complete and self-contained, while others rely upon procedures in [Chapter 5, “Alarms, Errors, and Troubleshooting”](#).

## Safety Precautions

---

Before working on a system, the technician must be thoroughly familiar with the precautions and practices described at the beginning of [Chapter 5, “Alarms, Errors, and Troubleshooting”](#).

### Class 1 Laser Device

The DEFINITY ECS contains a Class 1 LASER device if single-mode fiber optic cable is connected to a remote Expansion Port Network (EPN). The LASER device operates within the following parameters:

Power Output: -5 dBm  
Wavelength: 1310 nm  
Mode Field Diameter: 8.8 microns  
CLASS 1 LASER PRODUCT  
IEC825 1993

#### DANGER:

*Use of controls or adjustments or performance of procedures other than those specified herein may result in hazardous radiation exposure.*

Contact your Lucent Technologies representative for more information.

## Electromagnetic Compatibility Standards

---

This product complies with and conforms to the following:

- Limits and Methods of Measurements of Radio Interference Characteristics of Information Technology Equipment, EN55022 (CISPR22), 1993

- EN50082-1, European Generic Immunity Standard
- FCC Parts 15 and 68
- Australia AS3548



**NOTE:**

The system conforms to Class A (industrial) equipment. Voice terminals meet Class B requirements.

- Electrostatic Discharge (ESD) IEC 1000-4-2
- Radiated radio frequency field IEC 1000-4-3
- Electrical Fast Transient IEC 1000-4-4
- Lightning effects IEC 1000-4-5
- Conducted radio frequency IEC 1000-4-6
- Mains frequency magnetic field IEC 1000-4-8
- Low frequency mains disturbance

The system conforms to the following:

- Electromagnetic compatibility General Immunity Standard, part 1; residential, commercial, light industry, EN50082-1, CENELEC, 1991
- Issue 1 (1984) and Issue 2 (1992), Electrostatic discharge immunity requirements (EN55024, Part 2) IEC 1000-4-2
- Radiated radio frequency field immunity requirements IEC 1000-4-3
- Electrical fast transient/burst immunity requirements IEC 1000-4-4

## **European Union Standards**

---

Lucent Technologies Business Communications Systems declares that the DEFINITY equipment specified in this document bearing the “CE” mark conforms to the European Union Electromagnetic Compatibility Directives.

The “CE” (Conformité Européenne) mark indicates conformance to the European Union Electromagnetic Compatibility Directive (89/336/EEC) Low Voltage Directive (73/23/EEC) and Telecommunication Terminal Equipment (TTE) Directive (91/263/EEC) and with i-CTR3 Basic Rate Interface (BRI) and i-CTR4 Primary Rate Interface (PRI) as applicable.

The “CE” mark is applied to the following Release 7 products:

- Global AC powered Multi-Carrier Cabinet (MCC)
- DC powered Multi-Carrier Cabinet (MCC) with 25 Hz ring generator
- AC powered Single-Carrier Cabinet (SCC) with 25 Hz ring generator



- AC powered Compact Single-Carrier Cabinet (CSCC) with 25 Hz ring generator
- Enhanced DC Power System

## **Standards Compliance**

---

The equipment presented in this document complies with the following (as appropriate):

- ITU-T (Formerly CCITT)
- ECMA
- ETSI
- IPNS
- DPNSS
- National ISDN-1
- National ISDN-2
- ISO-9000
- ANSI
- FCC Part 15 and Part 68
- EN55022
- EN50081
- EN50082
- CISPR22
- Australia AS3548 (AS/NZ3548)
- Australia AS3260
- IEC 825
- IEC950
- UL 1459
- UL1950
- CSA C222 Number 225
- TS001

## **Conventions Used in This Document**

---

The following conventions are used in this document:

- DEFINITY Systems are called G3V4, G3 Release 5, G3vs, G3si, and G3r

- All occurrences of G3siV4, G3siV4+m, G3siV5, and G3siV5+m are called G3si unless a specific configuration is required to differentiate among product offerings
- All occurrences of G3 with out a suffix following the “3” refer to G3vs, G3si, and G3r
- A component of a DEFINITY System, such as a circuit pack, occurring without a reference to any specific system, is part of G3
- DEFINITY Communications Sever is abbreviated DEFINITY ECS
- All physical dimensions in this book are in English (Foot Pound Second) (FPS) followed by metric Centimeter Grams Second) (CGS) in parenthesis. Wire gauge measurements are in AWG followed by the diameter in millimeters in parenthesis.
- Information you type at the management terminal is shown in the following typeface: **list system-parameters maintenance**
- Information displayed on the management terminal screen is shown in the following typeface: `login`
- Keyboard keys are shown in the following typeface: Enter.
- Circuit pack codes (such as TN790 or TN2182B) are shown with the minimum acceptable alphabetic suffix (like the “B” in the code TN2182B).

Generally, an alphabetic suffix higher than that shown is also acceptable. However, not every *vintage* of either the minimum suffix or a higher suffix code is necessarily acceptable.

 **NOTE:**

Refer to *Technical Monthly: Reference Guide for Circuit Pack Vintages and Change Notices*, for current information about the usable vintages of specific circuit pack codes (including the suffix) in a Release 7 system.

- Admonishments used in this book are as follows:

 **CAUTION:**

*This sign is used to indicate possible harm to software, possible loss of data, or possible service interruptions.*

 **WARNING:**

*This sign is used where there is possible harm to hardware or equipment.*

 **DANGER:**

*This sign is used to indicate possible harm or injury to people.*

## Trademarks and Service Marks

---

The following are trademarks or registered trademarks of Lucent Technologies:

- 5ESS™, 4ESS™
- AUDIX®
- Callvisor®
- Callmaster®
- CentreVu™
- CONVERSANT®
- DEFINITY®
- DIMENSION®
- VOICE POWER®

The following are trademarks or registered trademarks of AT&T:

- ACCUNET®
- DATAPHONE®
- MEGACOM®
- MULTIQUEST®
- TELESEER®

The following are trademarks or registered trademarks of other companies:

- Ascend® (registered trademark of Ascend, Inc.)
- Audichron® (registered trademark of the Audichron Company)
- MS-DOS® (registered trademark of the Microsoft Corporation)
- MicroChannel® (registered trademark of IBM Systems)
- MULTIQUEST® (registered trademark of Telecommunications Service)
- PagePac® (trademark of the Dracon Division of the Harris Corporation)
- UNIX® (trademark of the Novell Corporation)

## Related Documents

---

The following documents are useful for system-related information:

### ***DEFINITY ECS Release 7.1 — Change Description, 555-233-405***

Gives a high-level overview of what is new in DEFINITY ECS Release 7. Describes the hardware and software enhancements and lists the problem corrections for this release.

***DEFINITY ECS Release 7— System Description Pocket Reference, 555-230-211***

Provides hardware descriptions, system parameters, listing of hardware required to use features, system configurations, and environmental requirements.

***DEFINITY ECS Release 7 — Administrator's Guide, 555-233-502***

Provides descriptions of system features. Also provides step-by-step procedures for preparing the screens that are required to implement the features, functions, and services of the system. Includes the applications and benefits, feature interactions, administration requirements, hardware requirements, and procedures for voice terminal, data module, and trunk group administration.

***DEFINITY ECS Release 7 — Reports, 555-230-511***

Formerly titled *System Monitoring and Reporting*, this book provides detailed descriptions of the measurement, status, security, and recent change history reports available in the system and is intended for administrators who validate traffic reports and evaluate system performance. Includes corrective actions for potential problems.

***DEFINITY ECS Release 7 — Installation and Test for Single-Carrier Cabinets, 555-230-894***

Provides procedures and information for hardware installation and initial testing of single-carrier cabinets. This document is available in the following languages: English, German (DE), Dutch (NL), Brazilian Portuguese (PTB), European French (FR), Castillian Spanish (SP), Italian (IT), Russian (RU), and Japanese (JA). To order, append the language suffix to the document number; for example, 555-230-894DE for German. No suffix is needed for the English version.

***DEFINITY ECS Release 7 — Installation and Test for Multi-Carrier Cabinets, 555-230-112***

Provides procedures and information for hardware installation and initial testing of multi-carrier cabinets.

***DEFINITY ECS Release 7 — Installation for Adjuncts and Peripherals, 555-230-125***

Provides procedures and information for hardware installation and initial testing of ECS adjunct and peripheral systems and equipment.

***DEFINITY ECS Release 7 — Upgrades and Additions for R7r, 555-230-121***

Provides procedures for an installation technician to convert an existing Generic 3 Version 4 DEFINITY Communications System to DEFINITY ECS and from DEFINITY ECS Release 5 to DEFINITY ECS Release 7. Included are upgrade considerations, lists of required hardware, and step-by-step upgrade procedures. Also included are procedures to add control carriers, switch node carriers, port carriers, circuit packs, auxiliary cabinets, and other equipment.

***BCS Products Security Handbook, 555-025-600***

Provides information about the risks of telecommunications fraud and measures for addressing those risks and preventing unauthorized use of BCS products. This document is intended for telecommunications managers, console operators, and security organizations within companies.

***DEFINITY Wireless Business System Users Guide, 555-232-105***

***DEFINITY Wireless Business System Installation and Test Guide,  
555-232-102***

***DEFINITY Wireless Business Systems System Interface, 555-232-108***

***AT&T Network and Data Connectivity Reference, 555-025-201***

## **Federal Communications Commission Statement**

---

### **Part 68: Statement**

---

Part 68: Answer-Supervision Signaling. Allowing this equipment to be operated in a manner that does not provide proper answer-supervision signaling is in violation of Part 68 rules. This equipment returns answer-supervision signals to the public switched network when:

- Answered by the called station
- Answered by the attendant
- Routed to a recorded announcement that can be administered by the CPE user

This equipment returns answer-supervision signals on all DID calls forwarded back to the public switched telephone network. Permissible exceptions are:

- A call is unanswered
- A busy tone is received
- A reorder tone is received

This equipment is capable of providing users access to interstate providers of operator services through the use of access codes. Modification of this equipment by call aggregators to block access dialing codes is a violation of the Telephone Operator Consumers Act of 1990.

This equipment complies with Part 68 of the FCC Rules. On the rear of this equipment is a label that contains, among other information, the FCC registration number and ringer equivalence number (REN) for this equipment. If requested, this information must be provided to the telephone company.

The REN is used to determine the quantity of devices which may be connected to the telephone line. Excessive RENs on the telephone line may result in devices not ringing in response to an incoming call. In most, but not all areas, the sum of RENs should not exceed 5.0. To be certain of the number of devices that may be connected to a line, as determined by the total RENs, contact the local telephone company.



**NOTE:**

REN is not required for some types of analog or digital facilities.

## Means of Connection

Connection of this equipment to the telephone network is shown in the following table.

<b>Manufacturer's Port Identifier</b>	<b>FIC Code</b>	<b>SOC/REN/ A.S. Code</b>	<b>Network Jacks</b>
Off/On Premises Station	OL13C	9.0F	RJ2GX, RJ21X, RJ11C
DID Trunk	02RV2-T	0.0B	RJ2GX, RJ21X
CO Trunk	02GS2	0.3A	RJ21X
CO Trunk	02LS2	0.3A	RJ21X
Tie Trunk	TL31M	9.0F	RJ2GX
1.544 Digital Interface	04DU9-B,C	6.0P	RJ48C, RJ48M
1.544 Digital Interface	04DU9-BN,KN	6.0P	RJ48C, RJ48M
120A2 Channel Service Unit	04DU9-DN	6.0P	RJ48C

If the terminal equipment (DEFINITY<sup>®</sup> System) causes harm to the telephone network, the telephone company will notify you in advance that temporary discontinuance of service may be required. But if advance notice is not practical, the telephone company will notify the customer as soon as possible. Also, you will be advised of your right to file a complaint with the FCC if you believe it is necessary.

The telephone company may make changes in its facilities, equipment, operations or procedures that could affect the operation of the equipment. If this happens, the telephone company will provide advance notice in order for you to make necessary modifications to maintain uninterrupted service.

If trouble is experienced with this equipment, for repair or warranty information, please contact the Technical Service Center at 1-800-248-1234. If the equipment is causing harm to the telephone network, the telephone company may request that you disconnect the equipment until the problem is resolved.

It is recommended that repairs be performed by Lucent Technologies certified technicians.

The equipment cannot be used on public coin phone service provided by the telephone company. Connection to party line service is subject to state tariffs. Contact the state public utility commission, public service commission or corporation for information.

This equipment, if it uses a telephone receiver, is hearing aid compatible.

## **How to Order Documentation**

---

In addition to this book, other description, installation and test, maintenance, and administration books are available. A complete list of DEFINITY books can be found in the *Business Communications System Publications Catalog*, 555-000-010.

This document and any other DEFINITY documentation can be ordered directly from the Lucent Technologies Business Communications System Publications Fulfillment Center toll free at 1-800-457-1235 (voice) and 1-800-457-1764 (fax). International customers should use 317-322-6791 (voice) and 317-322-6849 (fax).

## **How to Comment on This Document**

---

Lucent Technologies welcomes your feedback. Please fill out the reader comment card found at the front of this manual and return it. Your comments are of great value and help improve our documentation.

If the reader comment card is missing, FAX your comments to 1-303-538-1741 or to your Lucent Technologies representative, and mention this document's name and number, *DEFINITY Enterprise Communication Server Release 7, Maintenance for R7r, 555-230-126*.

## **Where to Call for Technical Support**

---

Use the following telephone number for the region in which the system is installed.

<b>Organization</b>	<b>Telephone Number</b>
Streamlined Implementaion (for missing equipment)	1-800-772-5409
USA/Canada Technical Service Center	1-800-248-1234

---

*Continued on next page*

<b>Organization</b>	<b>Telephone Number</b>
Technical Service Center (INADS Database Administration)	1-800-248-1111
Asia/Pacific Regional Support Center	65-872-8686
Western Europe/South Africa/Middle East	441-242-774-800
Business Communications Europe	441-242-391-789
Eastern/Central Europe	361-345-4334
ITAC	1-303-804-3777
Latin/Central America & Caribbean	1-303-804-3778
DEFINITY Helpline	1-800-225-7585
Lucent Technologies Toll Fraud Intervention	1-800-643-2353
Lucent Technologies Technical Service Center	1-800-242-2121
Lucent Technologies Corporate Security	1-800-822-9009



# Maintenance Architecture

# 1

---

The maintenance subsystem is that part of the software that is responsible for initializing and maintaining the system. This software continuously monitors system health and maintains a record of errors detected in the system. The maintenance subsystem also provides a user interface for on-demand testing.

This chapter provides a brief description of the R6r maintenance strategy, and presents background information on the system's overall functions. For detailed descriptions of components and subsystems, refer to related topics in [Chapter 9, "Maintenance Object Repair Procedures"](#). Sections on the following MOs are particularly useful for gaining an understanding of how the system works:

- STBY-SPE
- PNC-DUP
- EXP-PN
- SNI-BD
- DUP-INT
- SYNC

## What's new for R7r

---

- ["Access Security Gateway \(ASG\)"](#)
- [ATM](#)
- ["IP Trunking"](#)
- ["Japan 2Mbit service \(TN2242\)"](#)
- ["Definity over LAN services"](#)

## Access Security Gateway (ASG)

Access Security Gateway is *installed in the DEFINITY software base* and is a centralized access interface that uses a challenge/response protocol to verify the authenticity of a user and to reduce the opportunity for unauthorized access. Topics covered in this section are:

- [“Locking administered passwords”](#)

### Locking administered passwords

Page 2 of the Change System-parameters Customer-options form contains a ASG? field with a default of **n**, as shown in the screen below. *Do not* change this field.

```
change system-parameters customer-options                               Page 2 of 4
                                OPTIONAL FEATURES

OPERATIONS SUPPORT PARAMETERS
      ISDN-BRI trunks? n  Restrict Call Forward Off Net? y
            ISDN-PRI? y                Secondary Data Module? y
      ISDN-PRI over PACCON? y                ASG? n
      Malicious Call Trace? n                Station and Trunk MSP? n
      Mode Code Interface? n                Tenant Partitioning? n
      Multifrequency Signaling? y           Terminal Trans. Init. (TTI)? y
Multimedia Appl. Server Interface (MASI)? n  Time of Day Routing? n
      Multimedia Call Handling (Basic)? n     Uniform Dialing Plan? n
      Usage Allocation Enhancements? n
      Personal Station Access (PSA)? y
                                           Wideband Switching? n
                                           Wireless? n
      Processor and System MSP? n
      Private Networking? n

(NOTE: You must logoff and login to effect the permission changes.)
```

**Figure 1-1. Change system-parameters customer-options form**



#### **WARNING:**

*Do not* change the ASG? field to **y**, as it locks all administered passwords in the system.

Similarly, [Figure 1-2](#) shows page 2 of the Change System-parameters Security form containing the following ASG fields that *should not* be changed:

- SYSAM-LCL?
- SYSAM-RMT?
- MAINT?
- SYS-PORT?

These fields are shown in bold for reference only.

```

change system-parameters security                               Page 2 of 2

                SECURITY-RELATED SYSTEM-PARAMETERS

SECURITY VIOLATION NOTIFICATION PARAMETERS

    SVN Station Security Code Violation Notification Enabled? n
      Originating Extension: _____ Referral Destination? n
Station Security Code Threshold: 10           Time Interval: 0:03
      Announcement Extension: _____

STATION SECURITY CODE VERIFICATION PARAMETERS

                Minimum Station Security Code Length: 4
Security Code for Terminal Self-Administration Required? y

SOFTLOCK PARAMETERS

SYSAM-LCL? n          SYSAM-RMT? n
  MAINT? n           SYS-PORT? n
    
```

**Figure 1-2. Change system-parameters security form**



**WARNING:**

*Do not change any of these fields to y.*

**ATM**

---

The DEFINITY ECS can interface with an Asynchronous Transfer Mode (ATM) switch array to allow:

- Replacement of the G3r Center Stage Switch
- PNC-WAN
- Customers to merge voice and data networks
- See ATM-EI and related Maintenance Objects
- Circuit Emulation Service (CES) or ATM trunking

**IP Trunking**

---

The DEFINITY ECS interfaces through the new TN802 circuit pack to an Internet connection to provide Internet telephony services.

## Japan 2Mbit service (TN2242)

The TN2242 2Mbit, 30-port trunk circuit pack supports Japanese TTC private networking environments. This circuit pack interfaces only with network equipment or other circuit packs of the same model and is incompatible with all other digital trunk circuit packs.

## Definity over LAN services

The CLAN circuit pack (TN795) is the DEFINITY ECS interface to LAN services over which telephony can be distributed.

## International Consolidation (I-CON)

The Location field defaults to 1 for the United States and Canada. The Location field must be set to 2 for all other locations to allow the use of International Consolidation circuit packs and terminals in all DEFINITY ECS platform and International offers.

Page 1 of X

OPTIONAL FEATURES

G3 Version: V7	Maximum Ports: ____
Location: _	
Abbreviated Dialing Enhanced List? _	CAS Main? _
Access Security Gateway ? _	Cvg Of Calls Redirected Off-net? _
Analog Trunk Incoming Call ID? _	DCS (Basic)? _
A/D Grp/Sys List Dialing Start at 01? _	DCS Call Coverage? _
Answer Supervision by Call Classifier? _	DCS with Rerouting? _
ARS? _	DEFINITY Network Admin? _
ARS/AAR Partitioning? _	DS1 MSP? _
ASAI Interface? _	Emergency Access to Attendant? _
ASAI Proprietary Adjunct Links? _	Extended Cvg/Fwd Admin? _
	External Device Alarm Admin? _
Async. Transfer Mode (ATM) Trunking? _	Flexible Billing? _
ATMS? _	Forced Entry of Account Codes? _
Audible Message Waiting? _	Global Call Classification? _
Authorization Codes? _	Hospitality (Basic)? _
CAS Branch? _	Hospitality (G3V3 Enhancements)? _

## System Parameters Customer Options screen

### Circuit Packs

TN791, TN 2793, TN2214 and TN2215 are new TN codes assigned to International Consolidation circuit packs that are exported outside of the United States and Canada. These circuit packs are functionally identical to those described in [Table 1-1](#).

The International Consolidation circuit packs function properly only in Offer Category A systems outside of the US and Canada or in Offer Category B (DEFINITY BCS or Guestworks) systems in the US and Canada.

If an International Consolidation circuit pack is inserted into a Category A system with the Location field set to 1, the circuit pack cannot operate properly, and the system generates a major alarm (Error Code 276).

**Table 1-1. International Consolidation circuit packs**

<b>Standard - for use in the US and Canada (Offer A)</b>	<b>International Consolidation - For use in international offers and Offer B</b>	<b>Description</b>
TN746B	TN791	16 port analog line
TN793	TN2793	24 port analog line
TN2224	TN2214	24 port digital line
	TN2215	16 port analog line (used only in Australia, China, and Western Europe)
TN464F	TN2464	DS1

## **How to use the Maintenance book**

This procedure begins with the system raising an alarm against a Maintenance Object (MO), a software module that monitors the components of a circuit pack. These components can include:

- Hardware
- System (processor) availability and conditions
- Presence of and physical connections (copper, fiber) to other components
- Presence of certain signals (synchronization, DS1) within specific parameters
- Environment (power, cabinet temperature sensors)

**Table 3. Alarm levels, reporting conditions and action to take**

Alarm level	Description	Reported to INADS?	Reported to console?	What action to take?
MAJOR	Critical service degradation	Y	Yes, after 4 attempts to call INADS	Immediate attention
MINOR	Some service degradation but does not render the system inoperable.	Y	Same as above	Check to see what service is affected
WARNING	Failure that causes no significant service degradation	N <sup>1</sup>	N	Monitor the situation. May be service or equipment interruption or failure outside the switch.

1. Some system-downgraded Warning alarms are reported to INADS.

Alarms are further classified as:

- On-board problems originate in the circuitry on the alarmed circuit pack.
- Off-board problems originate in a process or component that is external to the circuit pack.

To clear system alarms using the appropriate maintenance book:

1. Type **display alarms** and press Enter.
2. A query screen displays next ([Screen 1-1](#)), asking you if you want to see all alarms or if you want to restrict the list to certain kinds of errors.

```

                                ALARM REPORT
The following options control which alarms will be displayed.
ALARM TYPES
      Active? y      Resolved? n
      Major? y      Minor? y      Warning? y
REPORT PERIOD
      Interval: m      From: / / :      To: / / :
EQUIPMENT TYPE ( Choose only one, if any, of the following )
      Cabinet:
      Port Network:
      Board Number:
      Port:
      Category:
    
```

**Screen 1-1. Alarm Report query screen**

a. The report can be restricted by typing either **y** (yes) or **n** (no) in these fields (shown above in bold):

- Active
- Major
- Minor
- Warning



**CAUTION:**

*If you choose **n** for major alarms and **y** for minor and warning alarms, you will not see the macro-level information that you may need to determine what is wrong with the system.*

b. The Cabinet, Port Network Board Number, Port and Category fields are described in the ["Field descriptions"](#) section.

3. After you have made your choices to tailor the report, press Enter.

4. The alarm log displays.

ALARM REPORT

Port	Maintenance On Name	Alt Brd? Name	Alarm Type	Svc State	Ack? 1 2	Date Alarmed	Date Resolved
01C1008	DID-TRK	y	MAJOR			03/09/00:30	00/00/00:00

**Screen 1-2. Alarm Report screen**

A DID trunk port in slot 10, carrier C has a MAJOR alarm.

5. Note the value in the `Port` field (01C1008). This is the alarmed port address.
6. Type **display errors** and press Enter.
7. A query screen displays next, asking if you want to see all the errors or if you want to restrict the list to certain kinds of errors. Except for warning levels (Major, Minor, Warning), the screen is the same as [Screen 1-1](#).

Generally, unless you suspect a problem occurred within a certain time frame or with a particular component of the system, simply pressing Enter at the query screen displays the accumulated system errors ([Screen 1-3](#)).

HARDWARE ERROR REPORT - ACTIVE ALARMS

Port	Mtce Name	Alt Name	Err Type	Aux Data	First Occur	Last Occur	Err Cnt	Err Rt	Rt/ Hr	Al St	Ac
01C1008	DID-TRK		1547		03/09/00:20	03/15/01:18	255	1	7	a	y

**Screen 1-3. Hardware Error Report - Active Alarms**

1 Maintenance Architecture

How to use the Maintenance book

1-8

8. Note the Error Type (Err Type field) value (1547) and the Aux Data value if present.
9. Find the DID-TRK MO in the Maintenance Object chapter of the appropriate maintenance book.
10. In the first table look up the initial command to run in the MAJOR row of the table (Step 4 indicated that a DID trunk in slot 10, carrier C has a MAJOR alarm).

MO Name (in Alarm Log)	Alarm Level	Initial Command to Run <sup>1</sup>	Full Name of MO
DID-TRK	MAJOR <sup>2</sup>	test port UUCSSpp long	DID Trunk
DID-TRK	MINOR	test port UUCSSpp long	DID Trunk
DID-TRK	WARNING	test port UUCSSpp	DID Trunk

1. *UU* is the universal cabinet number (1 for PPN, 2 - 44 for EPNs), *C* is the carrier designation (A, B, C, D, or E), *SS* is the number of the slot in which the circuit pack resides (01 to 21), and *pp* is the two digit port number (01, 02, ...).
2. A MAJOR alarm on a truk indicates that alarms on these trunks are downgraded by the set options command and that at least 75% of the trunks in this trunk group are alarmed.

11. Type **test port 01C1008 long** and press Enter.  
 "01C1008" is the address of the alarmed port (see [Screen 1-2](#) and [Screen 1-3](#))
12. While the port test is running, look up the Error Type (1537 from [Screen 1-3](#)) in the DID Trunk Error Log Entries table (example below).

Table 1-2. DID Trunk Error Log entries

Error Type	Aux Data	Associated Test	Alarm Level	On/Off Board	Test to Clear Value
1537		Port Diagnostic (#35)	MAJ/MIN/WRN	OFF	test port UUCSSpp sh r 1
3840 (k)	40965	None			

13. Since the Test to Clear Value (**test port 01C1008 sh r 1**) is very similar to the initial test you ran in Step 11, wait for the results of the port test.
14. When the port test finishes, the following display appears ([Screen 1-4](#)):



TEST RESULTS

Port	Maintenance Name	Alt. Name	Test No.	Result	Error Code
01C1008	DID-TRK		35	FAIL	61472

**Screen 1-4. Test Results screen**

- Find the Port Diagnostic Test (#35) [from the Test No. field] in the DID-TRK section of the Maintenance book. Note the Error Code (61472).
- Look in [Table 1-3](#) for Test #35 and then find "61472" in the Error Code column *and* "FAIL" in the Test Result column read the Description/Recommendation column.

**Table 1-3. TEST #35 Port Diagnostic Test**

Error Code	Test Result	Description/Recommendation
61472	FAIL	Battery feed test failed. A problem with the incoming CO line was detected. <ol style="list-style-type: none"> <li>Check the incoming CO line for proper operation. If warranted, refer the problem to the CO.</li> <li>If the CO line checks out Ok, the failure must be on the DID port. Replace the circuit pack.</li> </ol>

- Perform both steps in the Description/Recommendation column.
- Test the port (**test port 01C1008 long** and press Enter.) again after all of the recommendations are exhausted.
- If all tests pass, wait approximately 3-5 minutes for the Alarm and Error logs to clear.
- Type display alarms and press Enter twice.
- Check that the DID-TRK alarm does not appear in the log.

**Field descriptions**

Error type	Enter error type, or blank
Error List	active-alarms, errors, or cleared-errors
Interval	h(our), d(ay), w(eek), m(onth), a(II)
From: /To:	Specify time interval by date and time

1 Maintenance Architecture  
 Maintenance Objects

1-10

Cabinet	Enter cabinet number (1 - 44)
Port Network	Enter port network number (1 - 44)
Board Number	Enter 5-character board number in <b>UUCSS</b> format: cabinet (1-44), carrier (A-E), slot (0-20)
Port	Enter 7-character port address in <b>UUCSSss</b> format: cabinet (1-44), carrier (A-E), slot (0-20), circuit (01-31)
Category	Enter category name (choose 1 from the list below:  adm-conn   announce   bri/asai   cdr   data-mod detector   dup-spe   environ   exp-intf   ext-dev generatr   inads-link   infc   maint   mass-st mbus   memory   misc   mmi   mnt-test modem   mssnet   pkt   pms/jrnl   pnc pncmaint   pnc-peer   procr   quick-st   s-syn spe   stabd   stackrk   stations   sys-link sys-prnt   tape   tdm   tone   trkbd trkcrk   trunks   vc   vsp   wideband wireless
Extension	Enter assigned extension, or blank
Trunk	
Group	Enter group number between 1-666
Member	Enter group member between 1-255, or blank

## Maintenance Objects

The system is partitioned into separate entities called maintenance objects (MOs). Each MO is monitored by the system and has its own maintenance strategy. Most MOs are individual circuit packs such as the processor circuit pack (PROC) and expansion interface circuit pack (EXP-INTF). Some are hardware components that reside on part of a circuit pack. For example, the TDM bus clock (TDM-CLK) and tone generator (TONE-PT) circuits reside on the tone/clock circuit pack (TONE-BD). Others represent larger subsystems or sets of monitors, such as expansion port network (EXP-PN) and cabinet environmental sensors (CABINET).

Finally, some MOs represent processes or combinations of processes and hardware, such as synchronization (SYNC) and duplicated port network connectivity (PNC-DUP). The above abbreviations are *maintenance names* as recorded in the error and alarm logs. Individual copies of a given MO are further

distinguished with an address that defines its physical location in the system. These addresses are described in [Chapter 8, "Maintenance Commands"](#). Repair instructions and a description of each MO appear alphabetically in [Chapter 9, "Maintenance Object Repair Procedures"](#).

## **Alarm and Error Reporting**

---

During normal operations, software, hardware, or firmware may detect error conditions related to specific MOs. The system attempts to fix or circumvent these problems automatically, but if a hardware component incurs too many errors, an alarm is raised.

### **Alarm and Error Logs**

---

The system keeps a record of every alarm detected in the system. This record, the alarm log, and the error log can be displayed locally on the management terminal or remotely by Initialization and Administration System (INADS) personnel. An alarm is classified as MAJOR, MINOR, or WARNING, depending on its effect on system operation. Alarms are also classified as ON-BOARD or OFF-BOARD.

- MAJOR alarms identify failures that cause critical degradation of service and require immediate attention. On high and critical reliability systems, MAJOR alarms can occur on standby components without affecting service since their active counterparts continue to function.
- MINOR alarms identify failures that cause some service degradation but do not render a crucial portion of the system inoperable. The condition requires attention, but typically a MINOR alarm affects only a few trunks or stations or a single feature.
- WARNING alarms identify failures that cause no significant degradation of service or failures of equipment external to the system. These are not reported to INADS or the attendant console.
- ON-BOARD problems originate in circuitry on the alarmed circuit pack.
- OFF-BOARD problems originate in a process or component external to the circuit pack.

Multiple alarms against a given MO can change the level of a given alarm as it appears in the alarm log. If there is an active error against an MO that causes a MINOR alarm and an active error that causes a MAJOR alarm, then the alarm log would show two MAJOR alarms. If the MINOR alarm problem is resolved first, the error is still marked as alarmed until the MAJOR alarm problem is resolved, and the alarm log would still show two MAJOR alarms. If the MAJOR alarm problem is resolved first, the error is still marked as alarmed until the MINOR alarm problem is resolved, and the alarm log would now show two MINOR alarms. Similarly, the presence of an ON-BOARD alarm will cause all alarms against that MO to report as ON-BOARD.

**⇒ NOTE:**

To determine the actual level and origin of each alarm when there are more than one against the same MO, you must consult the *Hardware Error Log Entries* table for that MO.

The alarm log is restricted in size. If the log is full, a new entry overwrites the oldest resolved alarm. If there are no resolved alarms, the oldest error (which is not alarmed) is overwritten. If the log consists of only active alarms, the new alarm is dropped.

## **INADS Alarm Reporting**

---

All Major and Minor alarms and some downgraded Warning alarms are reported to INADS. (Some classes of alarms can be downgraded to lower levels by INADS at the customer's request). When the system raises one of these alarms, an attempt is made to call INADS. If the call to INADS fails, the call is retried in 7 minutes. This is repeated until four attempts have been made in a period of approximately 21 to 30 minutes. If all 4 attempts fail, the system waits 1 hour. Then it starts over again with 4 call attempts spaced 7 minutes apart. This cycle repeats until either the call to INADS successfully completes, or until the whole cycle is repeated 6 times. If, at any time during, a new alarm is raised by the system that should be reported to INADS, all timers and counts are reset and the strategy is repeated from the beginning.

During the 4 call attempts, the ACK lamp on the attendant console is turned off. Approximately 15 minutes into the hour interval between call attempts, the ACK lamp flashes, indicating the system is having trouble reporting alarms to INADS. At the end of the entire scenario described above, if the system could not report the alarm to INADS, the ACK lamp continues to flash.

## **Port Network Connectivity (PNC)**

---

Port network connectivity is the equipment and controlling software that allows building large systems comprised of multiple Port Networks (PNs). Each PN is composed of Time Division Multiplexing (TDM) and packet (PKT) busses, and the port circuit packs connecting to them. A multi-carrier cabinet can contain more than one PN.

**⇒ NOTE:**

The terms LAN bus and PKT bus are interchangeable on the Release 7r. This document uses the term PKT bus, but "LAN" appears marked on some hardware components.

This section describes the hardware, software and firmware components that support the PNC. Knowledge of the service and maintenance functions of these components will aid in diagnosing and resolving troubles. Troubleshooting

techniques for general PNC components such as busses appear in [Chapter 6, "Additional Maintenance Procedures"](#).

## PNC Configurations

The PNC is provided in one of two different configurations: Direct Connect and Center Stage Switch (CSS). In either configuration the TN570 Expansion Interface (EI) board provides the interface to the data on the TDM/PKT busses. In the direct connect configuration up to three PNs connect by hardware between each pair of PN EIs. See [Figure 1-4](#).

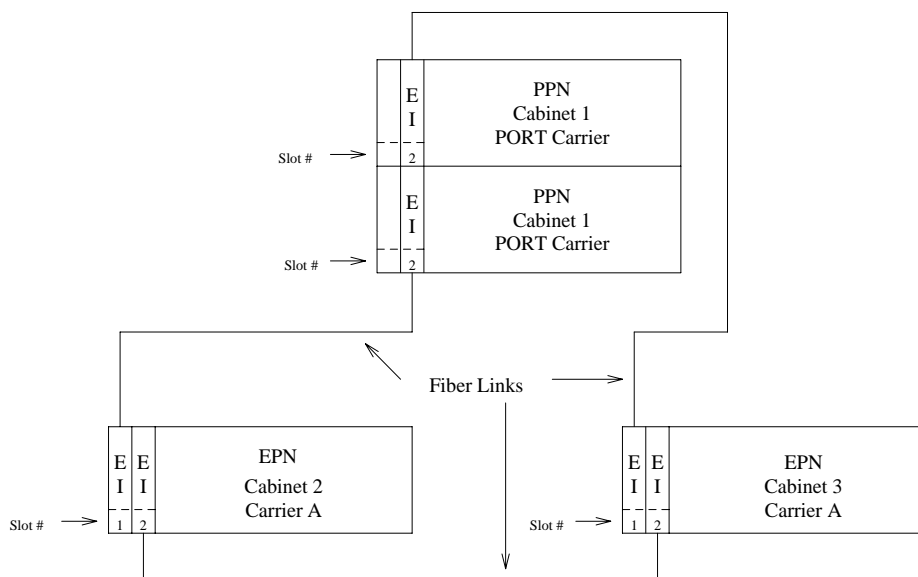

**Figure 1-4. Direct Connect PNC**

In the CSS configuration, up to 16 PNs (including the PPN) can connect to one switch node (SN). With two SNs, up to 22 PNs can be connected. Each SN consists of a carrier containing the following components (in critical reliability systems, each SN is duplicated on a second, identically configured carrier):

- 1 to 16 switch node interface (SNI) circuit packs (TN573)

Each SNI serves as the interface for TDM/PKT data to and from its associated PN EI or to and from an SNI in the other switch node.

- 1 or 2 switch node clock (SNC) circuit packs (TN572)

The SNCs provide timing for bit synchronized switching among the SNIs.

- Two power units  
Each power unit provides +5V to the circuit packs in its half of the SN and to both SNCs.
- Optionally in the PPN only, one Expansion Interface
- Optionally, 1 or 2 DS1 converter (DS1C) circuit packs  
The DS1 CONV circuit packs allow PNs to be located remotely up to 100 miles (161 km) between the two most distant PNs. The DS1 CONVs provide DS1 facility transport for a subset of the fiber timeslots between EIs in a direct connect system or between EIs and SNIs in CSS configurations. They can also be located on port carriers.
- TDM and PKT busses, and bus terminations  
There are 16 data busses in the SN. Each SNI has a slot dependent data bus on which it transmits data and has 16 inputs, one for each SN SNI slot, including its own. The data busses are terminated by 4 AHF105 paddle boards that mount on the backside of the backplane slots 2 and 20.
- Power distribution and control leads

[Figure 1-5](#) shows two examples of CSS configurations. Illustrations of the switch node carrier hardware appear in Chapter 2.

CSS with one switch node

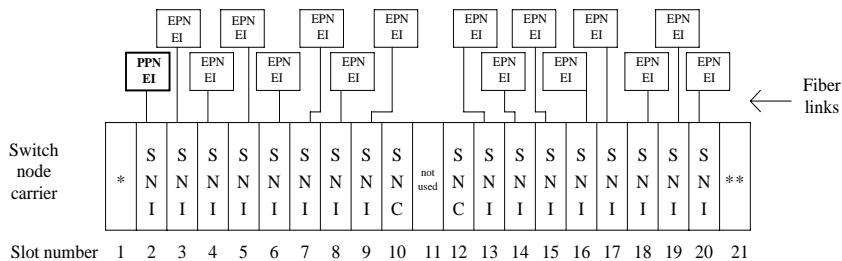

CSS with two switch nodes

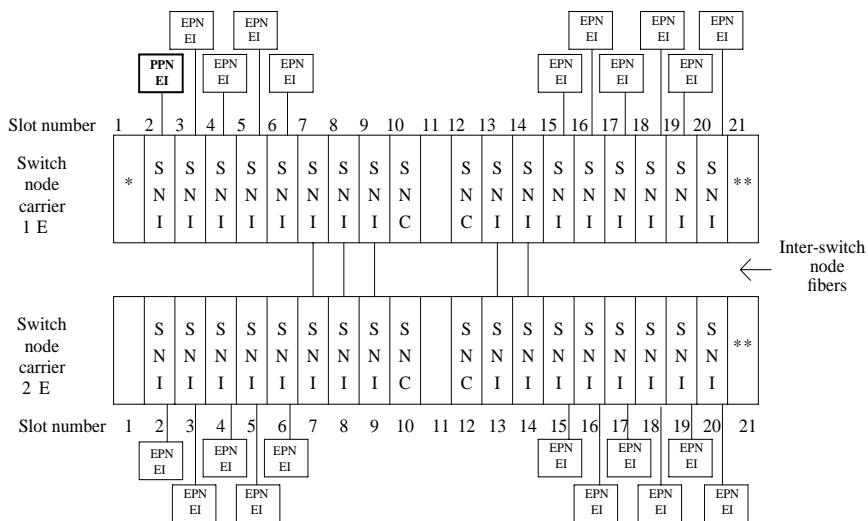

\* The PPN EI or a DS1C circuit pack may reside in this slot

\*\* A DS1C circuit pack may reside in this slot

Figure 1-5. Center Stage Switch Configurations (Simplex Examples)

## SPE Duplication

The Switch Processing Element (SPE) consists of the following circuit packs.

**Table 1-4. SPE Circuit Packs and Maintenance Objects**

<b>Apparatus Code</b>	<b>Circuit Pack Name</b>	<b>Associated Maintenance Objects</b>
TN1648	System Access and Maintenance	SYSAM
UN330B	Duplication Interface	DUPINT, DUP-CHL
UN331B	Processor	PROCR
TN1650B	Memory	MEM-BD
TN1655	Packet	PKT-INT
UN332	Mass Storage System/ Network Control (MSSNET)	H-ADAPTR, SW-CTL
TN1657	Disk Drive	DISK
TN1656	Tape Drive	TAPE STBY-SPE STO-DATA

These circuit packs reside on the A carrier (control carrier) of the PPN in all systems, except for the UN330B which is found only in high and critical reliability systems. In high and critical reliability systems, the PPN B carrier duplicates exactly the configuration of the A carrier, making two identical SPE complexes. This duplication allows the system to recover from many faults, and enables troubleshooting and repairing of SPE components without interrupting service.

The Tone-Clock circuit pack also resides on the control carrier, and is also duplicated. However, it is not considered a part of the SPE. Although the SPE-Select switches control Tone-Clock selection, its duplication strategy differs from that of the SPE. See the [“TDM-CLK \(TDM Bus Clock\)”](#) and [“TONE-BD \(Tone-Clock Circuit Pack\)”](#) sections in [Chapter 9, “Maintenance Object Repair Procedures”](#) for details.

Duplicated SPEs employ an active/standby strategy. At any one time, one SPE, A or B, is designated active and controls the switch services network. The other SPE, designated standby, is not required for switch service but remains ready to become active and resume control of service should a service-affecting failure occur in the active SPE. This action is termed an SPE interchange. It is important that the standby SPE be kept as available as possible to allow for a rapid interchange.



## Standby SPE Availability

The STBY-SPE maintenance object is responsible for testing of the standby SPE so that any faults that would prevent it from being available for service can be isolated and repaired. Various factors affect the availability of the standby SPE:

- The condition of the individual hardware components of the standby SPE, including circuit packs, power supplies, cables and other supporting components.

Loss of power in an SPE due to power supply or power delivery components is discussed under the condition SPE-Down. If a circuit pack in the standby SPE that is critical to call service has failed, the standby will not be able to become active. Maintenance testing of the standby SPE allows isolation and repair of component problems so that the standby can be made available again.

- Standby memory content

Each write operation in active memory is shadowed to the corresponding location in the standby SPE's memory. The standby memory should be in agreement with the active in order to support an interchange that will preserve call, feature and translation information. Maintenance software tracking the STBY-SPE MO aims to keep the two memories in agreement.

- Standby State-of-Health (SOH)

The Duplication Interface circuit packs maintain a state-of-health value which reflects the availability of the standby SPE. If the Standby SPE's state-of-health level is too poor, it cannot automatically be interchanged into (made active).

- Standby SPE-Down

If the standby SPE is completely dead and held reset by its SYSAM (in SPE-Down), or the standby SPE has no power, it is unavailable for service.

- System Time-of-Day

If the Time-of-Day clock of the standby SPE is substantially out of synch with the active, interchanges could be more disruptive to service than desirable.

System software running on both active and standby SPEs attempts to ensure that the standby SPE is kept fully available in terms of the above factors. The health of both the active and standby is tracked as a State-of-Health (SOH) value.

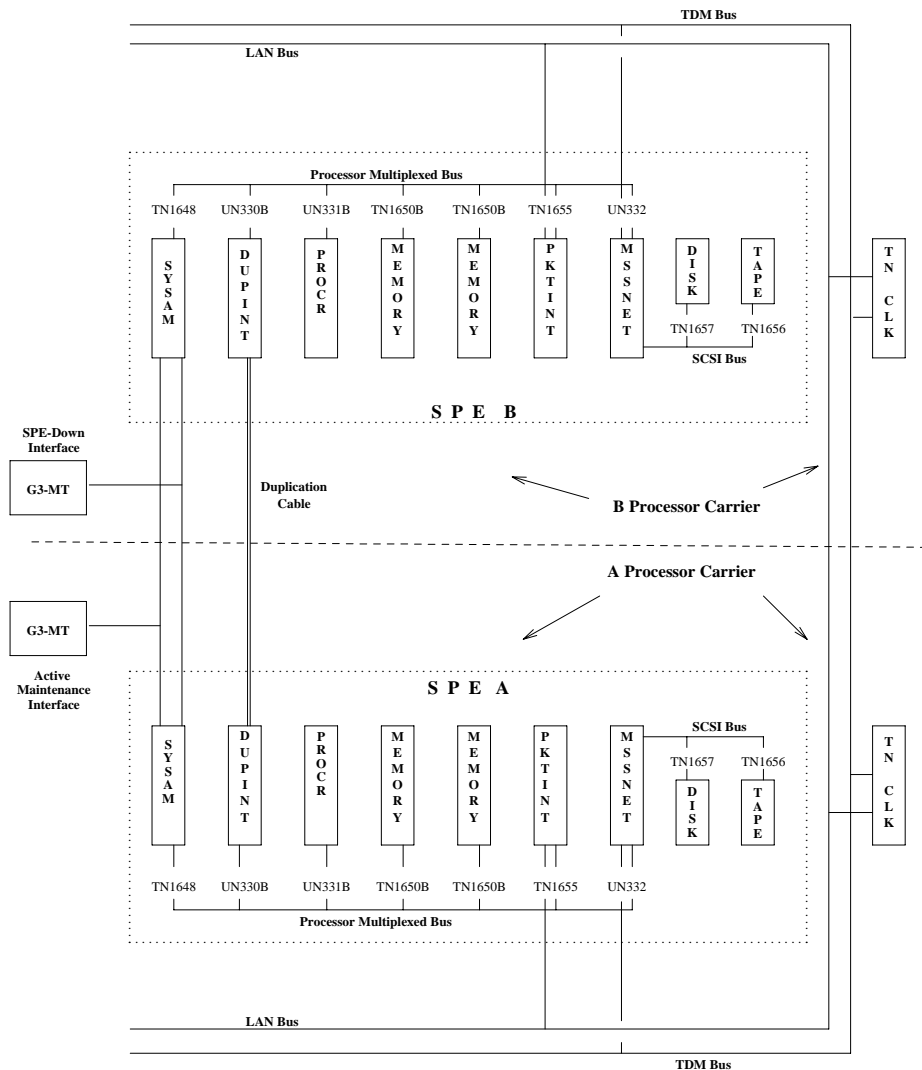

Figure 1-6. Duplicated SPEs — Hardware Configuration

### Standby SPE State of Health

The Duplication Interface circuit packs on each of the two SPEs keep track of the State of Health (SOH) of each of the two SPEs. This circuitry ensures that, at any time, unless the SPE-select switches are locked:

- If the two SPEs have the same SOH, the current active SPE remains active.

- If the two SPEs have different SOH, the SPE with the better SOH becomes or remains the active SPE.

These descriptions apply to SOH levels on the standby SPE. Four possible levels of SPE SOH are supported and maintained by system hardware and software.

functional	The standby SPE is fully healthy with up-to-date memory content identical to active SPE memory content. An interchange into this SPE will cause minimal service disruption.
not refreshed	The standby SPE's hardware and operational software are fully healthy but the standby memory content is not currently identical to active SPE memory content. Typically either memory shadowing is off or a memory refresh operation is in progress to bring the memories' contents into agreement. Interchange into an SPE of this health level will lead to calls dropping and a service outage of several minutes.
partially-functional	One of the following conditions is in effect: <ul style="list-style-type: none"><li>— A failure of a critical standby SPE component has occurred.</li><li>— The standby SPE has been busied out.</li><li>— The SPE is in recent interchange mode (see <a href="#">“STBY-SPE (Standby SPE Maintenance)”</a> in <a href="#">Chapter 9, “Maintenance Object Repair Procedures”</a>).</li></ul>
non-functional	This is the worst and most seriously disabled state of a standby SPE. The SPE has lost either power or basic sanity; the standby processor and its software are unable to cycle. Such an SPE cannot be made active by an interchange.

## Standby SPE Maintenance Architecture

The maintenance strategy for the standby SPE is based on several independent components.

- Maintenance of handshake communication so that software on the active SPE can control maintenance of the standby SPE and its components.
- Controlling memory shadowing and performing the standby memory refresh operation.
- Activities, independent of handshake communication and memory shadowing, used to allow tracking of the standby SPE's condition. This includes reading of hardware status to determine the actual state of standby SPE.

As shown in [Figure 1-7](#), all maintenance capabilities for the standby SPE are built upon these three strategies.

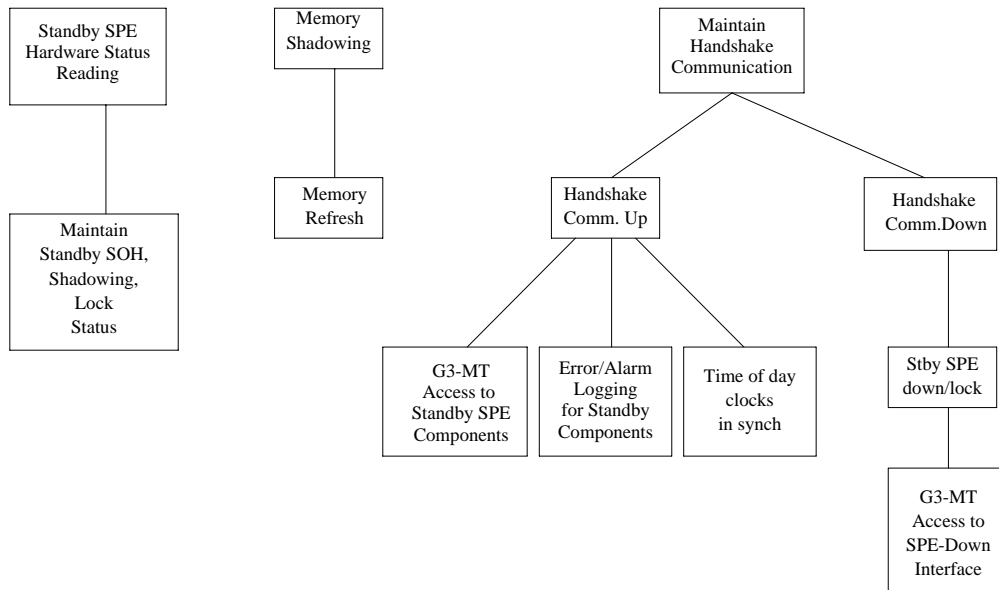

**Figure 1-7. Components of Standby Maintenance**

Standby SPE maintenance software is designed to attempt to self-correct problems. If a problem occurs, this software automatically tries to address the problem, bring the standby SPE back to a state of availability and clear all alarms which might have been raised. Typically, if a standby SPE problem has not cleared, it is of a hardware nature and some type of hardware component maintenance or replacement action is indicated. Once such corrections have been made, the system software will automatically bring the standby SPE back to full availability. There is no management terminal command to stimulate refresh of standby SPE memory; system software automatically accomplishes this itself when conditions are appropriate. The same is true of efforts to turn on shadowing where no explicit user interface command to turn on/off shadowing is available (note that busyout/release, below, can be used to indirectly accomplish this).

## **Standby Maintenance Monitor Software**

The Standby Maintenance Monitor (SMM) is a software package that is *always* running on key components of the standby SPE to verify its competence. SMM tests individual standby SPE components and reports back to the active SPE, by the handshake message, any failures of individual tests. Failure reports trigger enhanced maintenance attention to standby SPE component problems by active

SPE software. SMM also ensures that when handshake communication has been down for an extended period, the standby SPE will transition into the SPE-down state.

## Handshake Communication

---

Every 30 seconds, the active SPE sends a handshake request message to SMM and waits for SMM to respond with a handshake response message. This message transmission occurs across the Duplication Interface circuit packs and their interconnecting cable. As long as SMM responds to these regular handshake request messages, handshake communication is considered *up* as reported on the **status spe** screen.

The physical path of handshake communication is illustrated below. Hardware problems at any point in this route could interfere with handshake communication. If the standby SPE fails to respond to four successive handshake requests, handshake communication is considered down. A major alarm is logged against STBY-SPE with error type 1 logged. The **status spe** screen will indicate that handshake is down. It is then no longer possible to communicate with the standby SPE. Maintenance testing of the standby by the active SPE (or by command) is discontinued, and the error and alarm logs become outdated for standby components.

Handshake communication failure is a severe and rare condition. It is due to either a failure of Duplication Interface hardware or a catastrophic failure of the standby SPE. As long as the active SPE is not locked by the switches, software attempts every 30 seconds, to re-establish handshake communication.

When the SPEs are locked with the switches, handshake communication is physically impossible, but no alarm is raised. When the standby is busied out, handshake communication should remain up, but in any case, only the busyout WARNING alarm will be raised.

Whenever the active SPE has undergone a restart (levels 1-5), handshake is technically considered down during and just after the restart. After a level 1 (hot) restart, if there are no standby SPE problems, handshake communication should be restored within 30 seconds. After active-SPE restarts of levels 2 and up, handshake should be restored within 3 minutes of G3-MT re-enabling.

The active SPE keeps hardware configuration and vintage data about the components of the standby SPE. This data can be accessed with **list configuration control**. Whenever handshake is down, this data may be out of date. Whenever handshake has been down and is restored, the active SPE requests standby SPE software to transmit the current version of this data. The data is then stored in active SPE memory.

Failure to use the lock-and-power-down method for standby circuit pack replacement can lead to incorrect standby component hardware configuration and vintage data.

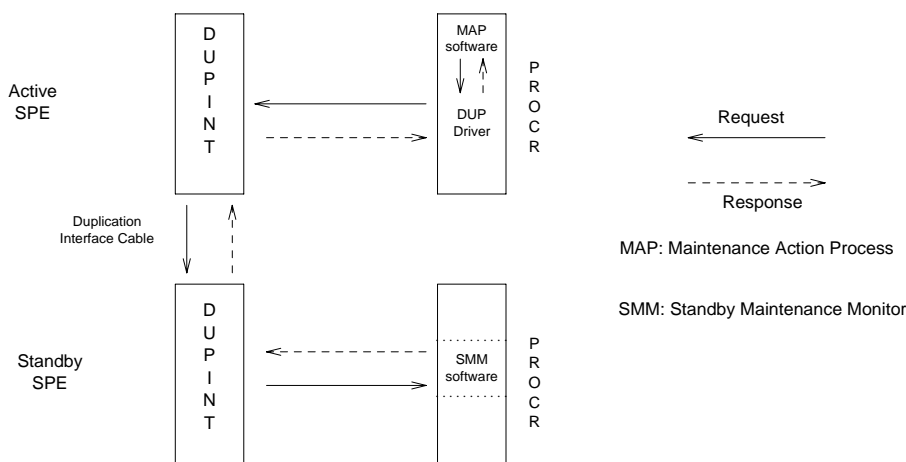

**Figure 1-8. Handshake Communication Path**

## Maintenance of Standby Components

When handshake communication is up, maintenance for individual components of the standby SPE is the same as that for the active (except in some details for PKT-INT). The same commands are used to test standby and active circuit packs, and the error and alarm logs maintained on the active side record data for both.

If a major on-board alarm is raised against a standby SYSAM, Processor, Memory, MSSNET, or Packet Interface board, the standby SPE's SOH is lowered to *partially-functional*. Once that board's problem is fixed and the alarm cleared, system software automatically raises the standby SPE's SOH to *not-refreshed* or *functional*, depending on whether its memory is up to date.

Standby component faults can also affect memory shadowing. Certain faults can have negative effects on system operation if memory shadowing is left on. When these components get major alarms, memory shadowing is automatically kept off by system software. These are referred to as *shadowing relevant* components. Roughly, these include the hardware that provide shadowing or the hardware into which shadowed writes occur.

[Table 1-5](#) below shows the effect often major on-board alarms against standby components on standby SOH and on memory shadowing. Note that off-board

alarms, minor alarms and warning alarms have no effect on memory shadowing or on the SOH of the standby SPE.

**Table 1-5. Effects of Major Alarms on Shadowing and Standby SOH**

Alarmed Component	SOH Effect	Shadowing Effect
PROCR	partially functional	no effect
MEM-BRD	partially functional	shadowing kept off
SW-CTL	partially functional	shadowing kept off
SYSAM	partially functional	no effect
PKT-INT	partially functional	shadowing kept off
DUPINT	no effect	shadowing kept off
DUP-CHL	no effect	shadowing kept off
HOST-ADAPTER	no effect	no effect
DISK	no effect	no effect
TAPE	no effect	no effect

When handshake communication is down, but the standby SPE is not in SPE-down mode (SOH is not *nonfunctional*), autonomous testing of standby SPE components by the SMM occurs on the standby SPE. If a component fails a test *while handshake is down*, its red LED is lit and the standby SOH is lowered to *partially-functional*.

A standby SPE component is considered to be testable if it can be tested with the usual maintenance commands from a management terminal connected to an ACTIVE connector on the SPE. In this condition, full maintenance software for it is running in the active SPE and the error/alarm data for it is up to date. [Table 1-6](#) gives testability requirements for the various SPE components.

**Table 1-6. Testability Requirements for Standby Components**

Component	Required Condition
PROCR	handshake up
MEM-BD	handshake up
SW-CTL	handshake up
SYSAM	handshake up
PKT-INT	handshake up and Stby Refreshed
DUPINT	handshake up
DUP-CHL	handshake up
HOST-ADAPTER	handshake up
DISK	handshake up and Stby Refreshed
TAPE	handshake up and Stby Refreshed

## Locking the Active SPE

Duplication Interface hardware supports the ability to lock the active SPE in active mode by means of the SPE-Select switches. The procedure for safely doing this is described in [Chapter 5, “Alarms, Errors, and Troubleshooting”](#), and in [“STBY-SPE \(Standby SPE Maintenance\)”](#) in [Chapter 9, “Maintenance Object Repair Procedures”](#). In locked mode, the system operates as if it is simplex:

- The standby SPE is inaccessible to the active SPE and active G3-MT login.
- No SPE-interchange is possible.
- Handshake is down and memory shadowing is off.

The locked state is intended for temporary use to prevent interchanges during maintenance sessions. No alarm is raised when the switches are locked. However, alarms against SPE-SELE are raised later if the switches are left out of the AUTO position for an extended length of time.

## Memory Shadowing

Memory shadowing is used to keep the standby SPE's memory content up-to-date relative to the active SPE's memory. Memory shadowing is turned on automatically when the standby SPE has booted up and completed its own memory testing. Each write operation in active memory is replicated in the corresponding location in standby memory.



When shadowing into the standby SPE has been off (as when the system first comes up), system software checks to see if it is safe to restore shadowing. Handshake communication must be up. Then software verifies (with Test #920) that the SPEs have identical hardware configurations. If this passes and there are no shadow-relevant component failures, system software turns on shadowing again.

Once shadowing is turned on, it is necessary to refresh the contents of standby memory to bring it into full agreement with the active's by copying every word of active SPE memory to the standby. This takes approximately 5 minutes, though traffic load can increase the duration. When completed, the standby SPE is said to be "refreshed". **status spe** or the *Standby SPE Status Query Test (#855)* in the STBY-SPE test sequence can be used to check the REFRESH status of the standby. Unless the standby SPE is refreshed, interchange into it can disrupt service for several minutes. Otherwise, interchanges are minimally disruptive. A standby SPE exiting lock mode or just released from busyout must undergo this full re-initialization.

System software tracks the operation and raises a major alarm when refresh failure occurs. If shadowing stays on, system software automatically tries to refresh again 5 minutes later.

Generally, memory shadowing should always remain on. But there are conditions when the system legitimately operates with shadowing off:

- The standby SPE is undergoing any restart.
- The active SPE is undergoing a restart level of 2 or greater.
- The active SPE is locked.
- The standby SPE is busied out.

In any other situation, it is an error condition for shadowing to be off. The first 2 situations are transitory and shadowing should automatically be restored within 10 minutes. If shadowing has been on for several minutes, it is an error condition for the standby not to be refreshed.

## Initialization: Bringing the Standby SPE Up

When the standby SPE has been out of service or is first coming up, SPE software executes the following steps:

1. Establishes handshake communication.
2. When SMM answers handshake, raises the standby SPE's SOH to *not refreshed* if it has no critical component alarms, or *partially functional* there are critical component alarms.
3. Tests for component mismatch (test number 920).
4. If there is no mismatch, and no major alarms against shadow-relevant components, and if SMM permits, turns on memory shadowing

5. If memory shadowing is successfully turned on, initiates the process of overall memory refresh
6. When refresh completes, if there are no critical component major alarms, raises the standby SPE's SOH to level *functional*

Standby SPE initialization is a lower priority than initializing the active SPE and is therefore "paced" to lower CPU consumption. The above steps are carried out at 10 second intervals. During system initialization, the above sequence begins about 2 minutes after the terminal login prompt becomes available. Normally, the standby SPE should be fully initialized about 5 minutes after the availability of the login prompt. You can follow the execution of this sequence by repeatedly entering the command "status spe."

Should a step of this initialization sequence fail, system software retries that step at 30 second intervals until it succeeds. It does not proceed to the next step until the current one has succeeded. The failed condition is alarmed.

A procedure for bringing up the standby SPE after being in the SPE-down or locked modes is described at the end of [Chapter 4, "Initialization and Recovery"](#).

## Power Interruptions

---

System cabinets and their associated power supplies can be powered by 110/208 volts AC either directly or from an Uninterruptible Power Supply (UPS) system. Alternatively, the cabinets and their power supplies may be powered by a -48 VDC battery power plant, which requires DC-to-DC conversion power units in the system.

If power is interrupted to a DC-powered cabinet or an AC-powered cabinet without optional backup batteries, the effect depends upon the decay time of the power distribution unit. If the interruption period is shorter than the decay time, there is no effect on service, though some -48V circuits may experience some impact. If the decay time is exceeded for a PPN, all service is dropped, emergency transfer is invoked and the system must reboot when power is restored. If the decay time is exceeded for an EPN, all service to that Port network is dropped and the EPN must be reset when power is restored. If the EPN contains a Switch Node carrier, all service to Port Networks connected to that Switch Node is dropped.

Single-carrier cabinets, which can be used for EPNs, also have no battery backup. If power is interrupted for more than 0.25 seconds, all service is dropped, and emergency transfer is invoked for the EPN.

In the above cases, the cabinet losing power is unable to log any alarms. However, in the case of an EPN going down while the PPN remains up, alarms associated with the EPN will be reported by the system.

## Nominal Power Holdover

---

AC-powered multicarrier cabinets are equipped with an internal battery, powered by its own charger, that provides a short term holdover to protect the system against brief power interruptions. This feature, known as the Nominal Power Holdover, is optional on cabinets supplied by a UPS and required on all other AC-powered cabinets. The battery is controlled in such a manner that it automatically provides power to the cabinet if the AC service fails. The duration of the holdover varies according to the type of carrier and whether or not the system has a duplicated SPE. See [Table 1-7](#) for duration times:

**Table 1-7. Nominal Power Holdover**

Cabinet Type	Control Carrier	Entire Cabinet
PPN, duplicated SPE	5 minutes	10 seconds
PPN, simplex SPE	10 minutes	10 seconds
EPN	10 minutes	15 seconds

---

## Effects of Power Interruptions

---

Power holdover is controlled by software in the above manner in order to allow the system to sustain multiple brief power interruptions without exhausting the batteries before they have time to recharge. After power is restored, the batteries are recharged by a circuit that monitors current and time. If the batteries take more than 30 hours to recharge, a minor alarm is raised, indicating that the batteries must be replaced or the charger replaced.

The 397 Battery Charger Circuit immediately detects loss of AC power and raises a warning alarm against AC-POWER that is not reported to INADS. Certain maintenance objects such as external DS1 timing will report major alarms in this situation. When power is restored, the AC-POWER alarm is resolved.

## PPN Cabinet with Power Holdover

When power is interrupted to a PPN cabinet, the effects depend upon the duration of the outage. Battery power is supplied to the whole cabinet for 10 seconds. If power is restored during that period, service is not affected. If the interruption exceeds the cabinet holdover period, but is restored before the control carrier holdover expires, all service is dropped and emergency transfer is invoked. The SPE is kept up allowing for a speedy restoration of service since a reboot is not required. All non-SPE circuit packs must be reinserted, taking about a minute, depending on the size of the system. If the interruption exceeds the control carrier holdover, all service is dropped and the system must reboot when

power is restored, taking up to 15 minutes, depending on the size of the system. Human intervention may be required if central office equipment has been busied out.

## EPN Cabinet with Power Holdover

When power is interrupted to an EPN MCC for less than 15 seconds, no service effect results. If the interruption exceeds 15 seconds, only the control carrier is kept up. Circuit packs on other carriers are powered down. Only calls and other services maintained by circuit packs on the control carrier are maintained. For this reason, critical services and those that require a long time to restore (for example, Announcement circuit packs) should be located on control carriers. All service to Port Networks connected to a Switch Node in the EPN is lost. When power is restored, all affected EPNs are reset by system software (see [“EXP-PN \(Expansion Port Network\)”](#) in [Chapter 9, “Maintenance Object Repair Procedures”](#)). As with the PPN, a warning alarm is raised against AC-POWER.

## External Alarm Leads

---

Each cabinet provides two leads for one major and one minor alarm contact closure that can be connected to external equipment. These are located on the SYSAM and Maintenance circuit packs. If the switch is under warranty or a maintenance agreement, EXT-DEV alarms are generated by the equipment connected to these leads and reported to INADS. These may be used to report failures of UPSs or battery reserves powering the switch. They are also commonly used to monitor adjuncts such as AUDIX.

## Protocols

---

This section describes the protocols handled by the system and the points where these protocols change. [Figure 1-9](#) is a pictorial guide through data-transmission state changes. [Figure 1-9](#) illustrates the flow of data from DTE equipment, like a terminal or host, through DCE equipment, like a modem or data module, into a communications port on the system. The data flow is shown by solid lines. Below these lines are the protocols used at particular points in the data stream.

Not shown in the [Figure 1-9](#) is the treatment of D-channels in ISDN-PRI and ISDN-BRI transmissions. PRI and BRI D-channels transport information elements that contain call-signaling and caller information. These elements conform to ISDN level-3 protocol. In the case of BRI, the elements are created by the terminal or data module; for the PRI, the elements are created by the system, which inserts them into the D-channel at the DS1 port.

For ISDN transmissions, therefore, BRI terminals and data modules, and DS1 ports insert, interpret, and strip both layer-2 DCE information and layer-3 elements. Also, the DS1 port passes layer-3 elements to the system for processing.

## Layers

---

The Open System Interconnect (OSI) model for data communications contains seven layers, each with a specific function. Communications to and through the system concern themselves only with layers 1 and 2 of the model.

Layer 1, or the *physical layer*, covers the physical interface between devices and the rules by which bits are passed. Among the physical layer protocols are RS-232, RS-449, X.21, DCP, DS1, and others.

Layer 2, or the *data-link layer*, refers to code created and interpreted by the DCE. The originating equipment can send blocks of data with the necessary codes for synchronization, error control, or flow control. With these codes, the destination equipment checks the physical-link reliability, corrects any transmission errors, and maintains the link. When a transmission reaches the destination equipment, it strips any layer-2 information the originating equipment may have inserted. The destination equipment only passes to the destination DTE equipment the information sent by the originating DTE equipment. The originating DTE equipment can also add layer-2 code to be analyzed by the destination DTE equipment. The DCE equipment treats this layer as data and passes it along to the destination DTE equipment as it would any other binary bits.

Layers 3 to 7 (and the DTE-created layer 2) are embedded in the transmission stream and are meaningful only at the destination DTE equipment. Therefore, they are shown in the figure as “user-defined,” with no state changes until the transmission stream reaches its destination.

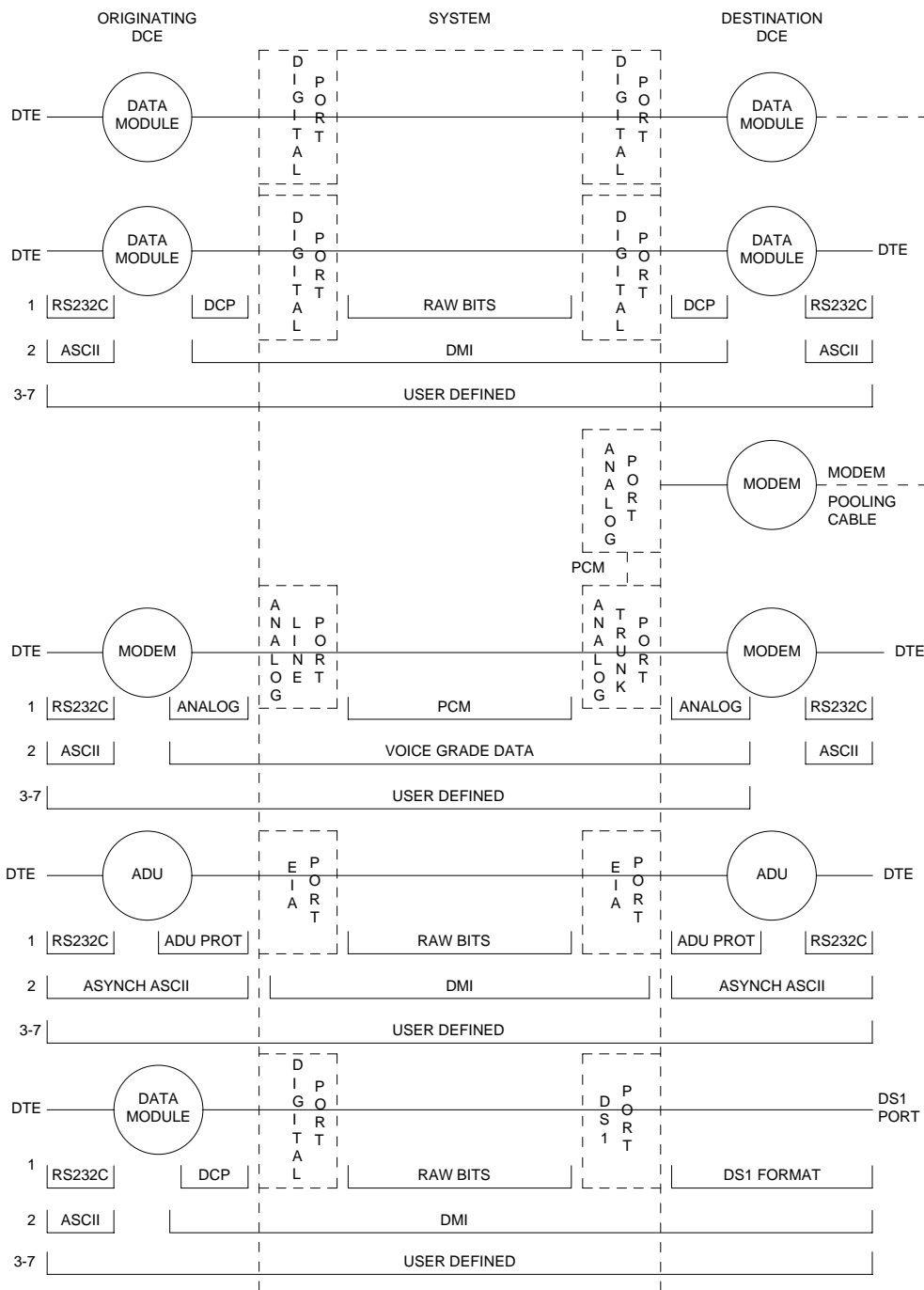

Figure 1-9. Data Transmission States

## Usage

---

The following is a list of the protocols when data is transmitted to and through the system. The list is organized by protocol layers. Refer to [Figure 1-9](#).

### Layer-1 Protocols

Layer-1 protocols are used between the terminal or host DTE and the DCE, used between the DCE equipment and the system port, and used inside the system.

The following layer-1 protocols are used between the DTE equipment and the DCE equipment. DCE equipment can be data modules, modems, or Data Service Units (DSUs). A DSU is a device that transmits digital data to a particular digital endpoint over the public network without processing the data through any intervening private network switches.

- *RS-232* — A common physical interface used to connect DTE to DCE. This protocol is typically used for communicating up to 19.2 kbps
- *RS-449* — Designed to overcome the RS-232 distance and speed restrictions and lack of modem control
- *V.35* — A physical interface used to connect DTE to a DCE. This protocol is typically used for transmissions at 56 or 64 kbps

The following protocols are used at layer 1 to govern communication between the DCE equipment and the port. These protocols consist of codes inserted at the originating DCE and stripped at the port. The DS1 protocol can be inserted at the originating, outgoing trunk port and stripped at the destination port.

- *Digital Communications Protocol (DCP)* — A standard for a 3-channel link. This protocol sends digitized voice and digital data in frames at 160 kbps. The channel structure consists of two information (I) channels and one signaling (S) channel. Each I-channel provides 64 kbps of voice and/or data communication and the S-channel provides 8 kbps of signaling communication between the system and DTE equipment. DCP is similar to ISDN-BRI
- *Basic Rate Interface (BRI)* — An ISDN standard for a 3-channel link, consisting of two 64-kbps bearer (B) channels and one 16-kbps signaling (D) channel. For the implementation of this standard, see *DEFINITY Communications System and System 75 and System 85 ISDN BRI Reference*, 555-025-103
- *Primary Rate Interface (PRI)* — An ISDN standard that sends digitized voice and digital data in T1 frames at 1.544-Mbps or, for countries outside the United States, in E1 frames at 2.048-Mbps. Layer 1 (physical), layer 2 (link), and layer 3 (network) ISDN PRI protocols are defined in *AT&T System 75 and 85 — DS1/DMI/ISDN-PRI — Reference Manual*, 555-025-101. At 1.544 Mbps, each frame consists of 24 64-kbps channels plus 8 kbps for framing. This represents 23 B-channels plus 1 D-channel.

The maximum user rate is 64 kbps for voice and data. The maximum distances are based on T1 limitations. At 2.048 Mbps, each E1 frame consists of 32 64-kbps channels

- *Analog* — A modulated voice-frequency carrier signal
- *ADU Proprietary* — A signal generated by an ADU. The signal is for communication over limited distances and can be understood only by a destination ADU or destination system port with a built-in ADU
- *Digital Signal Level 1 (DS1)* — A protocol defining the line coding, signaling, and framing used on a 24-channel line. Many types of trunk protocols (for example, PRI and 24th-channel signaling) use DS1 protocol at layer 1
- *European Conference of Postal and Telecommunications rate 1 (CEPT1)* — A protocol defining the line coding, signaling, and framing used on a 32-channel line. Countries outside the United States use CEPT1 protocol

Inside the system, data transmission appears in one of two forms:

1. Raw digital data, where the physical layer protocols, like DCP, are stripped at the incoming port and reinserted at the outgoing port.
2. Pulse Code Modulation (PCM)-encoded analog signals (analog transmission by a modem), the signal having been digitized by an analog-to-digital coder/decoder (CODEC) at the incoming port.

## Layer-2 Protocols

Layer-2 protocols are given below:

- *8-bit character code* — Between the DTE equipment and the DCE equipment. Depending on the type of equipment used, the code can be any proprietary code set.
- *Digital multiplexed interface proprietary* — Family of protocols between the originating DCE and the destination DCE for digital transmission. See *DEFINITY Communications System and System 75 and System 85 DS1/DMI/ISDN PRI Reference*, 555-025-101; and *Digital Multiplexed Interface [DMI] Technical Specification*, 555-025-204
- *Voice-grade data* — Between the originating DCE and the destination DCE for analog transmission



## Protocol States

---

[Table 1-8](#) summarizes the protocols used at various points in the data transmission stream. See [Figure 1-9](#).

**Table 1-8. Protocol States for Data Communication**

Transmission Type	Incoming DTE to DCE	OSI Layer	Protocols DTE to DCE	DCE to System Port	Inside System
Analog	Modem	1	RS-232, RS-449, or V.35	analog	PCM
		2	8- or 10-bit code	voice-grade data	voice-grade data
	ADU	1	RS-232	ADU proprietary	raw bits
		2	asynchronous 8-bit code	asynchronous 8-bit code	DMI
Digital	Data Module	1	RS-232, RS-449, or V.35	DCP or BRI	raw bits
		2	8-bit code	DMI	DMI
	Digital Signal Level 1 (DS1)	1	any	DS1	PCM or raw bits
		2	8-bit code	DMI or voice-grade data	DMI or voice-grade data



**NOTE:**

OSI means Open Systems Interconnect  
 PCM means Pulse Code Modulated  
 DMI means Digital Multiplexed Interface

---

Both the physical-layer protocol and the Digital Multiplexed Interface (DMI) mode used in the connection are dependent upon the type of 8-bit code used at layer 2 between the DTE equipment and DCE equipment, as listed in [Table 1-9](#) and [Table 1-10](#).

**Table 1-9. Physical-Layer Protocol Versus Character Code**

Protocol	Code
RS-232	Asynchronous 8-bit ASCII, and synchronous
RS-449	Asynchronous 8-bit ASCII, and synchronous
V.35	Synchronous

**Table 1-10. Digital Multiplexed Interface (DMI) Mode Versus Character Code**

DMI Mode	Code
0	Synchronous (64 kbps)
1	Synchronous (56 kbps)
2	Asynchronous 8-bit ASCII (up to 19.2 kbps), and synchronous
3	Asynchronous 8-bit ASCII, and private proprietary

## Connectivity Rules

[Figure 1-9](#) implies the following connectivity rules:

- Only the DS1 port and the analog trunk port are trunking facilities (all other ports are line ports). For communication over these facilities, the destination DCE equipment can be a hemisphere away from the system, and the signal can traverse any number of intervening switching systems before reaching the destination equipment.
- Data originating at any type of digital device, whether DCP or BRI, can exit the system at any type of digital port — BRI, digital-line, PRI, DS1, and others; as long as the call destination is equipped with a data module using the same DMI mode used at the call origin. This is because once the data enters the system through a digital port, its representation is uniform (raw bits at layer 1, and DMI at level 2), regardless of where it originated.

- Although data entering the system through an EIA port has not been processed through a data module, the port itself has a built-in data module. Inside the system, port data is identical to digital line data. Data entering the system at a DCP line port can exit at an EIA port. Conversely, data entering the system at an EIA port can exit at any DCP line port. The destination data module must be set for Mode-2 DMI communication.
- Voice-grade data can be carried over a DS1 facility as long as the destination equipment is a modem compatible with the originating modem
- If a mismatch exists between the types of signals used by the endpoints in a connection (for example, the equipment at one end is an analog modem, and the equipment at the other end is a digital data module), a modem-pool member must be inserted in the circuit. When the endpoints are on different switches, it is recommended that the modem-pool member be put on the origination or destination system. A modem-pool member is always inserted automatically for calls to off-premises sites via analog or voice-grade trunking. For internal calls, however, the systems are capable of automatically inserting a modem-pool member.
- Data cannot be carried over analog facilities unless inside the system it is represented as a Pulse Code Modulation (PCM)-encoded analog signal. To do this for data originating at a digital terminal, the signal enters the system at a digital port and exits the system at a digital port. The signal then reenters the system through a modem-pool connection (data-module to modem to analog-port) and exits the system again at an analog port.
- Although DS1 is commonly called a trunk speed, here it names the protocol used at layer 1 for digital trunks. Some trunks use different signaling methods but use DS1 protocol at layer 1 (for example, PRI and 24th-channel signaling trunks).

## **Disconnect Supervision**

---

Disconnect supervision means the CO has the ability to release a trunk when the party at the CO disconnects, and the system is able to recognize the release signal. In general, a CO in the United States provides disconnect supervision for incoming calls but not for outgoing calls. Many other countries do not provide disconnect supervision on either incoming or outgoing calls.

The system must provide the assurance that at least one party on the call can control the dropping of the call. This avoids locking up circuits on a call where no party is able to send a disconnect signal to the system. Internal operations must check to be sure one party can provide disconnect supervision. An incoming trunk that does not provide disconnect supervision is not allowed to terminate to an outgoing trunk that does not provide disconnect supervision.

In a DCS environment, an incoming trunk without disconnect supervision can terminate to an outgoing DCS trunk connecting two nodes. The incoming trunk is restricted from being transferred to a party without disconnect supervision on the terminating node.

This is because, through messaging, the terminating node knows the originating node cannot provide disconnect supervision. This messaging is not possible with non-DCS tie trunks, and the direct call is denied.

Some two-wire loop start trunks outside the United States provide busy tone disconnect in place of line signals. For these trunks, an adjunct can be attached to the trunk to listen for busy or other disconnect tone. When a tone is detected, the adjunct sends line signals for disconnect to the system.

Administration is provided for each trunk group to indicate whether it provides disconnect supervision for incoming calls and for outgoing calls.

## Transfer on Ringing

A station or attendant may conference in a ringing station or transfer a party to a ringing station. When a station conferences in a ringing station and then drops the call, the ringing station is treated like a party without disconnect supervision. However, when a station transfers a party to a ringing station, the ringing station party is treated like a party with disconnect supervision. Two timers (Attendant Return Call Timer and Wait Answer Supervision Timer) are provided to ensure the call is not locked to a ringing station.

## Conference, Transfer, and Call-Forwarding Denial

If a station or attendant attempts to connect parties without disconnect supervision together, the following is possible:

- *Digital Station or Local Attendant Transfer*: if a digital station attempts to transfer the two parties together, the call appearance lamp flutters, indicating a denial. If transferring to a DCS trunk, the denial may drop the call since the transfer is allowed and the other system is queried for disconnect supervision.
- *Analog Station Transfer*: if an analog station attempts to transfer two parties together by going on-hook, the analog station is no longer on the call and the transfer cannot be denied.
- *Centralized Attendant Service (CAS) Attendant Transfer*: if a CAS attempts to transfer two parties together by pressing the release key, the release link trunk is released and the branch attempts a transfer by going on-hook
- *Station Conference/Dropout*: if a station conferences all parties, the conference is allowed since the station has disconnect supervision. When the station is dropped from the call, the call is dropped since the other parties do not have disconnect supervision.
- *Station Call Forwarding*: if a station is call forwarded off-premise to a trunk without disconnect supervision, the calling party without disconnect supervision is routed to the attendant

[Table 1-11](#) lists the various protocols, with applications and maximum limitations.

**Table 1-11. Protocols Used in DEFINITY**

<b>Protocol</b>	<b>Applications</b>	<b>Maximum Data Rate</b>	<b>Maximum Distance</b>
DCP	Digital switch to data endpoints	64 kbps	5000 feet (1524 m) for data 3000 feet (915 m) for voice
RS-232	System to administration terminal. Data module to host computer	19.2 kbps	50 feet (15.2 m)
	Data module to printer	64 kbps	17 feet (5.9 m)
	Data module for downloading and high-speed data transfer	64 kbps	17 feet (5.9 m)
	EIA interface (Data line to ADU)	19.2 kbps	2000 feet (610 m)
		9.6 kbps	5000 feet (1524 m)
4.8 kbps		7000 feet (2130 m)	
2.4 kbps		12,000 feet (3654 m)	
1.2 kbps	20,000 feet (6100 m)		
0.3 kbps	40,000 feet (12200 m)		
RS-449	Processor Interface to Processor Interface	19.2 kbps	200 feet (61 m)
		9.6 kbps	400 feet (122 m)
		4.8 kbps	800 feet (244 m)
		2.4 kbps	1600 feet (488 m)
SSI	715 BCS-2 to Processor Interface 500 series printers to Processor Interface	56 kbps	5000 feet (1524 m)
BISYNC	Processor Interface line controller to host computer for terminal emulation (9.6 kbps)	2.4 kbps 4.8 kbps 9.6 kbps	
BX.25	Communication interface to MSA, DCS, ISDN, or AUDIX	9.6 kbps	
SDCPI	Data module to Processor Interface	64 kbps	17 feet (5.9 m)
RS-366	Host computer to ACU		50 feet (15.2 m)
	Data module to ACU	64 kbps	17 feet (5.9 m)
V.35	Data module to data endpoints	56 kbps	50 feet (15.2 m)

*Continued on next page*

**Table 1-11. Protocols Used in DEFINITY — Continued**

Protocol	Applications	Maximum Data Rate	Maximum Distance
Category A	Data modules to terminals or cluster controller	64 kbps	500 feet (152 m)
	Data module in ASCII emulation mode	9.6 kbps	
ISDN-BRI	Communication interface to ISDN-BRI S/T	64 kbps	655 feet (199.3 m) to network interface or repeater 1310 feet (399.3 m) system to system
	ISDN-BRI U	160 kbps	18,000 feet (5486.4 m) from system to network interface, and then ~2000 feet to phone
ISDN-PRI	Communication interface to ISDN-PRI	64 kbps	655 feet (199.3 m) to network interface or repeater 1310 feet (399.3 m) system to system

**NOTE:**

- ADU means Asynchronous Data Unit
- BCS means Business Communications System
- MSA means Message Servicing Adjunct
- ACU means Automatic Call Unit

**Transmission Characteristics**

The system transmission characteristics comply with the American National Standards Institute/Electronic Industries Association (ANSI/EIA) standard RS-464A (SP-1378A). The following tables list some general switch transmission characteristics.

## Frequency Response

---

[Table 1-12](#) lists the analog-to-analog frequency response for station-to-station or station-to-CO trunk, relative to loss at 1 kHz for the United States.

**Table 1-12. Analog-to-Analog Frequency Response**

---

Frequency (Hz)	Maximum Loss (dB)	Minimum Loss (dB)
60	—	20
200	5	0
300 to 3000	1	-0.5
3200	1.5	-0.5
3400	3	0

---

[Table 1-13](#) lists the analog-to-digital frequency response of the system for station or CO-trunk-to-digital interface (DS0), relative to loss at 1 kHz for the United States.

**Table 1-13. Analog-to-Digital Frequency Response**

---

Frequency (Hz)	Maximum Loss (dB)	Minimum Loss (dB)
60	—	20
200	3	0
300 to 3000	0.5	-0.25
3200	0.75	-0.25
3400	1.5	0

---

## Insertion Loss for Port-to-Port; Analog or Digital

[Table 1-14](#) lists the insertion loss in the system for different connection types for the United States. [Table 1-15](#) shows the overload and cross-talk characteristics.

**Table 1-14. Insertion Loss for the United States**

Typical Connections	Nominal Loss (dB) at 1 kHz
On-premises to on-premises station	6
On-premises to off-premises station	3
Off-premises to off-premises station	0
On-premises station to 4-wire trunk	3
Off-premises station to 4-wire trunk	2
Station-to-trunk	0
Trunk-to-trunk	0

**Table 1-15. Overload and Crosstalk**

Overload level	+3 dBm0
Crosstalk loss	>70 dB

## Intermodulation Distortion

[Table 1-16](#) lists the intermodulation distortion in the system for analog-to-analog and analog-to-digital, up to 9.6 kbps data

**Table 1-16. Intermodulation Distortion**

Four-Tone Method	Distortion
Second-order tone products	>46 dB
Third-order tone products	>56 dB



## Quantization Distortion Loss

---

[Table 1-17](#) lists the quantization distortion loss in the system for analog port to analog port.

**Table 1-17. Quantization Distortion Loss**

<b>Analog Port-to-Analog Port</b>	
Signal Level	Distortion Loss
0 to -30 dBm0	>33 dB
-40 dBm0	>27 dB
-45 dBm0	>22 dB

[Table 1-18](#) lists the quantization distortion loss in the system for analog port to digital port and digital port to analog port.

**Table 1-18. Quantization Distortion Loss**

<b>Analog Port-to-Digital Port or Digital Port-to-Analog Port</b>	
Signal Level	Distortion Loss
0 to -30 dBm0	>35 dB
-40 dBm0	>29 dB
-45 dBm0	>25 dB

Terminating Impedance: 600 Ohms nominal

Trunk balance impedance (selectable): 600 Ohms nominal or complex Z [350 Ohms + (1 k Ohms in parallel with 0.215uF)]

## Impulse Noise

---

On 95% or more of all connections, the impulse noise is 0 count (hits) in five minutes at +55 dB<sub>rnC</sub> (decibels above reference noise with C-filter) during the busy hour.

## **ERL and SFRL Talking State**

---

Echo-Return Loss (ERL) and Single-Frequency Return Loss (SFRL) performance is usually dominated by termination and/or loop input impedances. The system provides an acceptable level of echo performance if the ERL and SFRL are met.

Station-to-station	ERL should meet or exceed 18 dB SFRL should meet or exceed 12 dB
Station to 4-wire trunk connection	ERL should meet or exceed 24 dB SFRL should meet or exceed 14 dB
Station to 2-wire trunk connection	ERL should meet or exceed 18 dB SFRL should meet or exceed 12 dB
4-wire to 4-wire trunk connection	ERL should meet or exceed 27 dB SFRL should meet or exceed 20 dB

## **Peak Noise Level**

---

- Analog to analog — 20 dB<sub>BrnC</sub> (decibels above reference noise with C-filter)
- Analog to digital — 19 dB<sub>BrnC</sub>
- Digital to analog — 13 dB<sub>BrnC</sub>

## **Echo Path Delay**

---

- Analog port to analog port —  $\leq 3$  ms
- Digital interface port to digital interface port —  $\leq 2$  ms

## **Service Codes**

---

Service codes (for the United States only) are issued by the Federal Communications Commission (FCC) to equipment manufacturers and registrants. These codes denote the type of registered terminal equipment and the protective characteristics of the premises wiring of the terminal equipment ports.

Private line service codes are as follows:

- 7.0Y — Totally protected private communications (microwave) systems
- 7.0Z — Partially protected private communications (microwave) systems
- 8.0X — Port for ancillary equipment
- 9.0F — Fully protected terminal equipment
- 9.0P — Partially protected terminal equipment

- 9.0N — Unprotected terminal equipment
- 9.0Y — Totally protected terminal equipment

The product line service code is 9.0F indicating it is terminal equipment with fully protected premises wire at the private line ports.

## Facility Interface Codes

A Facility Interface Code (FIC) is a five-character code (United States only) that provides the technical information needed to order a specific port circuit pack for analog private lines, digital lines, MTS lines, and WATS lines.

[Table 1-19](#) through [Table 1-21](#) list the FICs. Included are service order codes, Ringer Equivalency Numbers (RENs), and types of network jacks that connect a line to a rear panel connector on a carrier.

**Table 1-19. Analog Private Line and Trunk Port Circuit Packs**

Circuit Pack	FIC	Service Order Code	Network Jack
TN742 and TN747B Off-Premises Station Port, and TN746B Off-Premises Station Port or On-Premises Station port	0L13C	9.0F	RJ21X
TN760/B/C/D Tie Trunk	TL31M	9.0F	RJ2GX

**Table 1-20. Digital Trunk Port Circuit Packs**

Circuit Pack	FIC	Service Order Code	Network Jack
TN1654 and TN574 DS1 Converter; TN722B DS1 Tie trunk; and TN767 and TN464 DS1 Interface	04DU9B,C	6.0P	RJ48C and RJ48M

**Table 1-21. MTS and WATS Port Circuit Packs**

<b>Circuit Pack</b>	<b>FIC</b>	<b>Ringer Equivalency Number (REN)</b>	<b>Network Jack</b>
TN742 and TN746B Analog Line	02LS2	None	RJ21 and RJ11C
TN747B Central Office Trunk	02GS2	1.0A	RJ21X
TN753 DID Trunk	02RV2-T	0,0B	RJ21X
TN790 Processor	02LS2	1.0A	RJ21X
TN1648 System Access and Maintenance	02LS2	0.5A	RJ21X

## **Multimedia Interface (MMI)**

The Multimedia Interface handles the following protocols:

- International Telecommunications Union (ITU) H.221 — Includes H.230, H.242, H.231, and H.243 protocol
- American National Standards Institute (ANSI) H.221 — Includes H.230, H.242, H.231, and H.243 protocol
- BONDING (Bandwidth On Demand INoperability Group) Mode 1
- ESM HLP HDLC Rate Adaptation

The Vistium Personal Conferencing System is supported either through the 8510T BRI terminal or directly through the Vistium TMBRI PC board.

Using the World Class Core (WCC) BRI interface, most desktop multimedia applications are supported through a personal computer's BRI interface.

## Hardware Configurations

# 2

---

The DEFINITY System supports a variety of configurations consisting of a PPN and up to 21 EPNs. In addition, the system may use a Center Stage Switch (CSS) consisting of one or two Switch Nodes. This chapter describes the PPN and EPN cabinets, and the configuration of carriers and circuit packs within these cabinets.

### **Multi-Carrier Cabinet**

---

The Multi-Carrier Cabinet (J58890A) accommodates from one to five circuit pack carriers, and is always used for the PPN. EPNs may use either multicarrier cabinets or single-carrier cabinets.

The power unit in the bottom of the MCC cabinet supplies AC voltage or DC voltage from an external source to the power supply in each carrier. The AC powered cabinet optionally contains a battery charger and backup batteries to provide temporary power to the cabinet if the external source fails. The backup unit is optional for systems powered from an Uninterruptible Power Supply (UPS). The fan unit in the middle of the cabinet cools the carriers. AC-powered cabinets have two 120V AC receptacles in the back for use as an AC power source. These can be used to power the G3-MT.

Each cabinet must be connected to one of the following dedicated power sources:

- 120V AC 60 Hz at 50A from a National Electrical Manufacturing Association (NEMA) 5-50R power outlet or equivalent
- Single phase 240V AC, or three phase 208V AC, 60 Hz at 30A from a NEMA L 14-30R power outlet or equivalent

- -48V DC battery plant
- Global MCC uses 50-60 Hz at 200-240 VAC power source

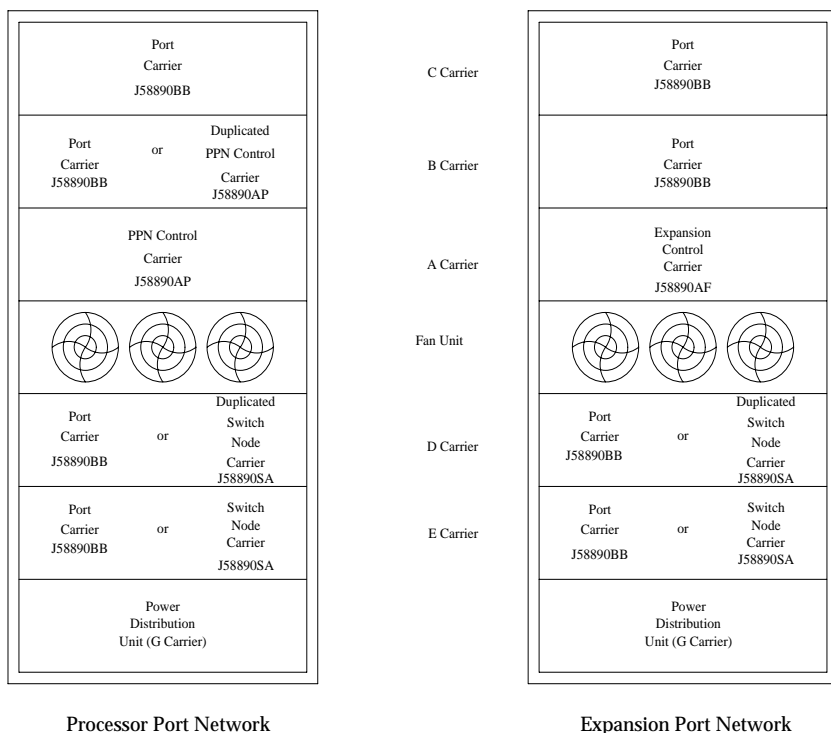

**Figure 2-1. Multicarrier Cabinet (J58890A) Configurations**

**Processor Port Network Cabinet**

The PPN cabinet, pictured above, is the primary cabinet in all G3r systems. It contains the Switch Processing Element (SPE) that controls the system and one Port Network that is interconnected by the daisy-chained TDM/LAN bus. If the system has a CSS, the PPN cabinet also contains a switch node. The individual carriers are described in following sections.

The A position always contains a PPN Control Carrier (J58890AP), also known as the Processor Carrier, which holds the SPE circuit packs. If the system has a duplicated SPE, the B position holds a second PPN Control Carrier. At least one, and up to four, Port Carriers (J58890BB) can be located in the other four carrier positions, depending on traffic needs and whether the system uses those positions for other types of carriers. In general, Port Carriers are added in the sequence, B-C-D-E, unless those positions are used otherwise, as follows.

If the system has a Center Stage Switch, the E position holds a Switch Node Carrier. In a CSS system with duplicated PNC, the D position holds a Switch Node Carrier that duplicates the one in E position. In large systems requiring a CSS with two Switch Nodes, the second SN is located in an EPN cabinet, for both simplex and duplicated systems. Systems that have added a CSS configuration after the original installation may have their first SN in an EPN cabinet.

## **Expansion Port Network Cabinets**

---

When used for an EPN, the multicarrier cabinet supports one Port Network with a daisy-chained TDM/LAN bus, or, optionally, two separate PNs if the cabinet does not contain a Switch Node. A cabinet with two PNs has two separate TDM/LAN bus daisy-chains. One TDM/LAN bus between carriers in positions A, B and C supports the first PN, and another TDM/LAN bus between positions D and E supports the second PN. [Figure 2-1](#) shows locations of carriers in EPN cabinets.

Each EPN cabinet contains one Expansion Control Carrier (J58890AF) located in the A position. In cabinets with one PN, up to four Port Carriers are added as needed in the sequence B-C-D-E, unless the D or E positions are used for a Switch Node. Cabinets with two PNs use optional Port Carriers in the B position, and then the C position for the first PN (above the fans). The second PN, (below the fans), is configured with the first Port Carrier in the E position and an optional second Port Carrier in D position.

In large systems with a CSS that requires two Switch Nodes, the second SN is located in an EPN cabinet (this is usually cabinet number 2, PN number 2). This EPN may not be remoted by a DS1CONV complex. An EPN with an SN has a Switch Node Carrier in E position. In systems with duplicated PNC, (Critical Reliability option), the D position holds another Switch Node Carrier that duplicates the one in E position.

## **Carriers in Multi-Carrier Cabinets**

---

### **PPN Control Carrier (J58890AP)**

---

The PPN Control Carrier contains dedicated slots used for circuit packs that compose the switch processing element (SPE). It does not contain port circuit pack slots. This carrier always resides in position A of the PPN cabinet. In a system with a duplicated SPE, a second PPN Control Carrier resides in the B position of the PPN cabinet.

[Table 2-1](#) describes the function of each slot in the PPN Control Carrier.

**Table 2-1. PPN Control Carrier Circuit Pack Slots**

Slot Name	Circuit Pack	Code	Notes
POWER UNIT (right side)	Power Unit (+5V)	649A	Required for DC-powered systems. TRI PLS OUTPUT DC-Powered cabinets
SYS ACCESS/ MAINTENANCE	System Access and Maintenance	TN1648	Required
DUP INTFC	Duplication Interface	UN330B	Required for systems with duplicated SPE
PROCR	RISC Processor	UN331B	Required
TEST INTFC			Used by field support to connect diagnostic equipment
MEMORY 1 to 4	32 Mbyte Memory	TN1650B	Two required, up to four optional, Release 5 and higher requires 3
PACKET INTFC 1 to 3	Packet Interface	TN1655	One required, two slots reserved for future use; with duplicated SPE, both carriers must use same slot
TONE-CLOCK	Tone-Clock	TN780 TN2182	Required; TN780 required for interface to external Stratum 3 Clock
MSS/ NET CON	Mass Storage System/ Network Control	UN332	Required
DISK DRIVE	Disk Drive	TN1657	Required
TAPE DRIVE	Tape Drive	TN1656	Required



**Port Carrier (J58890BB)**

[Table 2-2](#) describes the function of each carrier slot.

**Table 2-2. Port Carrier Circuit Pack Slots**

Slot Name	Circuit Pack	Code	Notes
POWER UNIT (right side)	Power Unit (+5V)	649A	Required for DC-powered systems. TRI PLS OUTPUT DC-Powered
POWER UNIT/ SERVICE	Power Unit, Neon	TN755B	This position is addressed as "00" in commands and displays. It does not provide tip and ring to the wall field. The following circuit packs are optional, depending on system features. One TN771D is required in all PPNs, and one in each EPN of Critical Reliability systems.
	Call Classifier	TN744	
	Integrated Announcement	TN750	
	Speech Synthesizer	TN725B, TN433, TN457	
	Tone Detector	TN748, TN420B	
	Maintenance/ Test	TN771D	
TONE- CLOCK 1	Tone-clock	TN768 TN2182	Required as follows: EPN with duplicated PNC: B carrier EPN cabinet with two PNs: D carrier E carrier of an EPN cabinet with two PNs and duplicated PNC; the Tone-clock slot is located with Port Slot #2. If the carrier does not contain a Tone-Clock board, any port board may be installed in this slot.
EXPN INTFC 2	Expansion Interface	TN570	Optional, depending on system's connectivity and duplication configuration; if not used for an EI board, this slot can accept any common port board.
3			If the system's connectivity and duplication configuration require a second EI on a port carrier, it resides in this slot; otherwise, this slot accepts any common port board.
4 to 20	Port Boards		Any common port board.

## Expansion Control Carrier (J58890AF)

The Expansion Control Carrier is located in position A of each EPN. [Table 2-3](#) describes the function of each carrier slot.

**Table 2-3. Expansion Control Carrier Slots**

Slot Name	Circuit Pack	Code	Notes
POWER UNIT (left side)	Power Unit (+5V)	631DA1	Required for AC-powered systems
		644A1	Required for DC-powered systems or empty
MAINTENANCE	Maintenance	TN775B	Required
TONE-CLOCK	Tone-Clock	TN2182	Required
EXPN INTFC	Expansion Interface	TN570	Required
2 to 19	Port Boards		Any common port board. Slot 2 may house a second EI if the configuration requires one.
POWER UNIT/ 18, 19	Power Unit, Neon	TN755B	Required for certain features; otherwise will accept any common port board.
POWER UNIT (right side)	Power Unit (-48V/-5V)	631DB1	Required for AC-powered systems
		645B1	Required for DC-powered systems
		649A	TRI PLS OUTPUT for DC-Powered cabinets

## Switch Node Carrier (J58890SA)

Switch Node carriers house the components of a Center Stage Switch (CSS). The first switch node is located in carrier E of the PPN. If duplicated in a Critical Reliability configuration, its duplicate is located in carrier D of the PPN. The second switch node is located in carrier E of a non-remoted EPN. If duplicated in a Critical Reliability configuration, its duplicate is located in carrier D of the same EPN.

**Table 2-4. Switch Node Carrier Circuit Pack Slots**

Slot Name	Circuit Pack	Code	Notes
POWER UNIT (right side)	Power Unit (+5V)	649A	Required for DC-powered systems
EXPN INTFC DS1 CONV/ 1	DS1 Converter	TN574	Provides fiber connectivity from DS1 facilities to a remote EPN; this slot used in conjunction with an SNI in one of slots 2 to 9.
	Expansion Interface	TN570	Used for an EI board only in the PPN cabinet in a system with duplicated PNC (Critical Reliability); used in conjunction with adjacent SNI
2 to 9, 13 to 20	Switch Node Interface	TN573	SNIs are added sequentially as needed beginning with slot 2. If a second switch node is needed, (for more than 16 EPNs), up to 5 SNIs (those in slots 7, 8, 9, 13 and 14) are connected to corresponding SNIs in the other SN.
SWITCH NODE CLOCK / 10	Switch Node Clock	TN572	Required
SWITCH NODE CLOCK / 12	Switch Node Clock	TN572	Used in High Reliability option only (duplicated SPE, simplex PNC)
DS1 CONV/ 21	DS1CONV	TN574	Used as above in conjunction with an SNI in one of slots 13 to 20

## PNC Cabling — Fiber Hardware

---

The term “fiber” is used to refer to all the hardware needed for the three basic types of connections used to form multi-PN systems. Fiber administration specifies the endpoints to be connected, optional DS1 CONV locations, and parameters for DS1 Facility Line encoding and equalization. The 3 connection types are:

1. EI-to-EI or EI-to-SNI Intercabinet hardware
2. EI-to-SNI or EI-to-EI intracabinet hardware
3. EI-DS1CONV or SNI-DS1CONV hardware

### EI-to-EI or EI-to-SNI Intercabinet Fiber Optic Cables

---

EI-to-EI or EI-to-SNI intercabinet connections are implemented by installing a lightwave transceiver on the I/O connector plate for each of the administered fiber endpoints. Each lightwave transceiver has a receive and a transmit connector for a 62.5 micron or 50 micron fiber connection. Standard fibers are available in various lengths up to 150 feet (46 m) for single-mode fiber and up to 200 feet (61 m) for multi-mode fiber. These fibers are used to connect lightwave transceivers to each other when they are close enough together, or to optical cross-connect facilities for greater distances.

The lightwave transceivers are powered from I/O connector plate leads attached to TN570 Expansion Interface circuit pack or a TN573 Switch Node Interface circuit pack. The transceivers include loop-around capabilities to support fiber fault isolation. Either of two different 9823-type multi-mode transceivers may be used, depending upon the length of the fiber (table below), or the 300A single mode fiber transceiver. The transceivers at each end of a given fiber should match. [Figure 2-2](#) illustrates the interconnection of fiber optic hardware.

Part Number	Maximum Fiber Length	Fiber Mode
9823A	4900 feet (1494 m)	Multi-mode
9823B	25,000 feet (7620 m)	Multi-mode
300A	22 miles (35.4 km)	Single mode

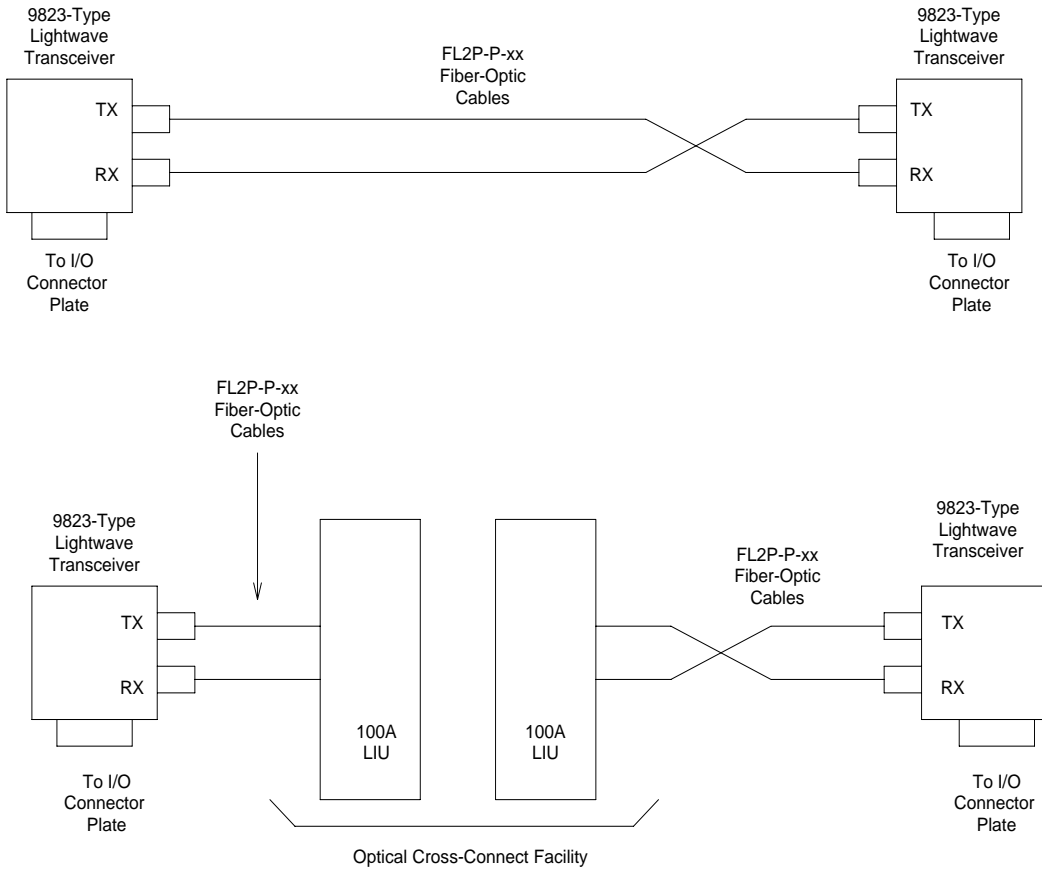

Figure 2-2. Fiber Link Connection Hardware

## EI-to-SNI or EI-to-EI Intracabinet Metallic Cabling

Metallic cable may be substituted for optical cable for “fiber” connections between EIs or between an EI and an SNI in the same MCC cabinet. The same I/O plate connectors are used. The metallic cables should not be used for intercabinet connections, since doing so violates system ground integrity. The metallic cable comes in two lengths.

Part No.	Length	Intended use
H600-278,G1	13 inches (33 cm)	From an EI in slot 1 of a switch node carrier to an SNI in the same half of the carrier (usually the adjacent slot)
H600-278,G2	66 inches (168 cm)	From an EI to an SNI in the same cabinet, but in a different carrier or different half of a carrier

## DS1 CONV Cabling

Digital services (DS1) can be used to connect PNs that are up to 100 miles (161 km) apart when fiber optic cabling is not practical. Multi-mode (fiber-connected PNs must be less than 25,000 feet (7620 m) and less than 22 miles (35.4 km) for single-mode fiber from the PPN.) A TN574 or TN1654 DS1 Converter (DS1 CONV) circuit pack serves as the interface between the network and an EI or SNI on the switch. DS1 cabling on a carrier consists of a Y-cable that connects a DS1 CONV to an EI or SNI and to the network. The following cables may be used, depending upon where the DS1 CONV and the EI or SNI are located:

Connection Type	Length	Comcode Number TN574	Comcode Number TN1654
On same half carrier	1 foot (30.48 cm)	846448637	847245750
On different half carriers in same cabinet	5.5 feet (1.68 m)	846448645	847245768
Between two adjacent cabinets	1 foot (30.48 cm), used with two 9823As, and 1 20-foot (6.1 m) fiber optic cable	846448652, and one 846885259 bracket	847245776 with one 846885259 bracket

The DS1 CONV to EI/SNI cable is a shielded metallic Y-cable held in place at the EI/SNI port connector by a 4B retainer and at the DS1 CONV port connector by a 4C retainer. The cable end with one 25-pair amphenol connector attaches to the I/O Plate connector for the EI or SNI. The end with two 25-pair amphenol connectors attaches to the DS1 CONV I/O Plate connector.

The 13-inch cable 846448652 or 847245776 connects the DS1 CONV to a fiber-optic cable, enabling the DS1 CONV to connect to an EI or SNI at a greater distance. The cable end with one 25-pair amphenol connector attaches to a lightwave transceiver using the 846885259 bracket. The end with two 25-pair amphenol connectors attaches to the DS1 CONV I/O Plate connector. The other end of the fiber-optic cable connects to a lightwave transceiver attached to the I/O plate connector of the EI or SNI.

An H600-348 cable connects the DS1 CONV cable to a Channel Service Unit (CSU), which connects to a wall field. (Alternatively, connection is sometimes made directly from the Y-cable to the wall field. See the pinout for the 50-pin connector at the end of the Fiber Fault Isolation Procedure in [Chapter 5, "Alarms, Errors, and Troubleshooting"](#).) This cable provides from one to four DS1 connections. One end of the H600-348 cable is plugged into the 50-pin amphenol piggy-back connector on the 8464486xx cable connected to the DS1CONV port connector. The other end of the H600-348 cable has four 15-pin sub-miniature D-type connectors that plug into the CSU. A pinout of this cable appears the end of the Fiber Fault Isolation Procedure in Chapter 5. H600-348 cables come in the following lengths:

Group No.	Length	Group No.	Length
G1	25 feet (7.62 m)	G5	125 feet (38.1 m)
G2	50 feet (15.24 m)	G6	200 feet (60.96 m)
G3	75 feet (22.86 m)	G7	400 feet (121.9 m)
G4	100 feet (30.48 m)	G8	650 feet (198 m)

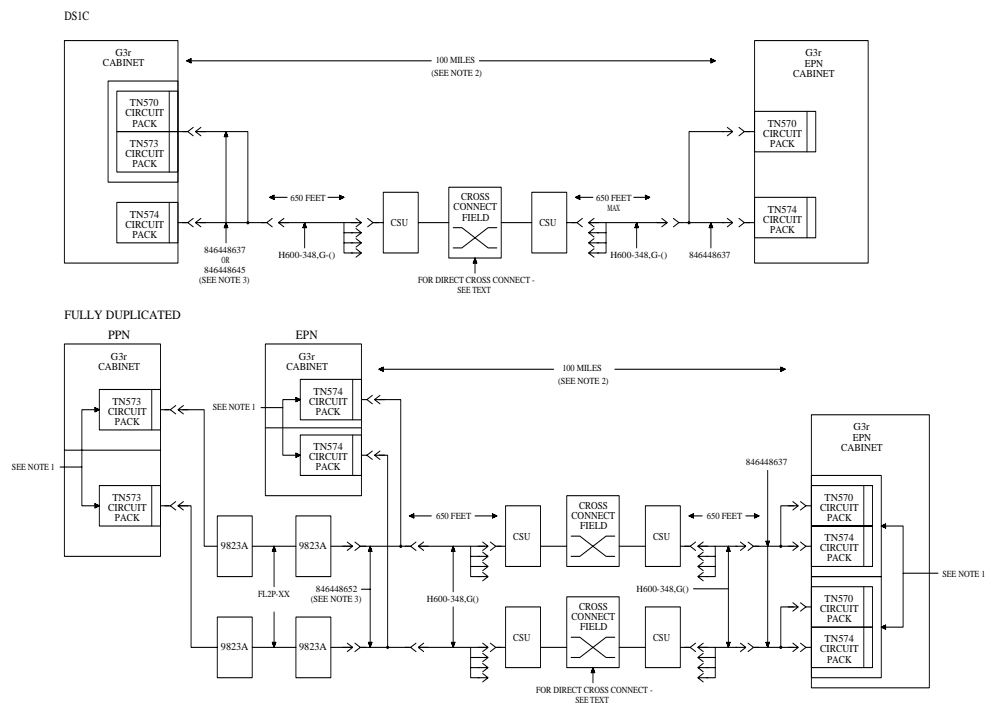

Figure 2-3. Typical DS1 CONV Connections to Remote EPNs

1. Place duplicate pairs in different carriers.
2. When removing two or more, the maximum cable distance between any two remoted end points is 100 miles (161 km). For example, if the EPN is 75 miles (121 km) from the PPN, then EPN 2 can only be 25 miles (40.2 km) from the PPN.
3. 846447637 is used within a carrier for a TN574, for TN1654 within a carrier use a 847245750.

846448645 is used within a cabinet between carriers for a TN574, for TN1654 within a cabinet between carriers use a 847245768.

## Circuit Packs

The following tables list all circuit packs supported by DEFINITY Systems. For information concerning vintages and current versions, see *Reference Guide for Circuit Pack Vintages and Change Notices* which is published periodically as a special edition of the *Lucent Technical Monthly*.



**Table 2-5. Circuit packs and modules supported by DEFINITY**

Apparatus Code	Name	Type
631DA1	AC Power Unit	Power
631DB1	AC Power Unit	Power
644A1	DC Power Unit	Power
645B1	DC Power Unit	Power
649A	DC Power Unit	Power
676B	DC Power Supply	Power
982LS	Current Limiter	Power
CFY1B	Current Limiter	Power
CPP1	Memory Expansion	Control
ED-1E546 (TN2169) (TN2170) (TN566) (TN567)	DEFINITY AUDIX R3 System	Port Assembly
ED-1E546 (TN2208) (TN2170)	Call Visor ASAI over the DEFINITY (LAN) Gateway R1	Port Assembly
J58890MAP (TN800)	CallVisor over the DEFINITY LAN Gateway R2	Port Assembly
TN417	Auxiliary Trunk	Port
TN419B	Tone-Clock	Control
TN420B/C	Tone Detector	Service
TN429	Direct Inward/Outward Dialing (DIOD) Trunk	Port
TN433	Speech Synthesizer	Service
TN436B	Direct Inward Dialing Trunk	Port
TN437	Tie Trunk	Port
TN438B	Central Office Trunk	Port
TN439	Tie Trunk	Port
TN447	Central Office Trunk	Port
TN457	Speech Synthesizer	Service
TN458	Tie Trunk	Port

*Continued on next page*

**Table 2-5. Circuit packs and modules supported by DEFINITY — Continued**

Apparatus Code	Name	Type
TN459B	Direct Inward Dialing Trunk	Port
TN464C/D/E/F	DS1 Interface - T1, 24 Channel - E1, 32 Channel	Port
TN465/B/C	Central Office Trunk	Port
TN467	Analog Line	Port
TN468B	Analog Line	Port
TN479	Analog Line	Port
TN497	Tie Trunk	Port
TN553	Packet Data Line	Port
TN556/B	ISDN-BRI 4-Wire S/T-NT Line (A-Law)	Port
TN570/B/C	Expansion Interface	Port
TN572	Switch Node Clock	Control
TN573/B	Switch Node Interface	Control
TN574	DS1 Converter - T1, 24 Channel	Port
TN577	Packet Gateway	Port
TN722B	DS1 Tie Trunk	Port
TN725B	Speech Synthesizer	Service
TN726/B	Data Line	Port
TN735	MET Line	Port
TN742	Analog Line	Port
TN744/B	Call Classifier	Service
TN744/C/D	Call Classifier - Detector	Service
TN746/B	Analog Line	Port
TN747B	Central Office Trunk	Port
TN748/B/C/D	Tone Detector	Service
TN750/B/C	Announcement	Service
TN753	Direct Inward Dialing Trunk	Port
TN754/B	Digital Line 4-Wire DCP	Port
TN755B	Neon Power Unit	Power
TN756	Tone Detector	Service

*Continued on next page*

**Table 2-5. Circuit packs and modules supported by DEFINITY — Continued**

Apparatus Code	Name	Type
TN758	Pooled Modem	Port
TN760B/C/D	Tie Trunk	Port
TN762B	Hybrid Line	Port
TN763B/C/D	Auxiliary Trunk	Port
TN765	Processor Interface	Control
TN767B/C/D/E	DS1 Interface - T1, 24 Channel	Port
TN768	Tone-Clock	Control
TN769	Analog Line	Port
TN771D	Maintenance/Test	Service
TN772	Duplication Interface	Control
TN773	Processor	Control
TN775/B	Maintenance	Service
TN776	Expansion Interface	Port
TN777/B	Network Control	Control
TN778	Packet Control	Control
TN780	Tone-Clock	Control
TN786	Processor	Control
TN786B	Processor	Control
TN787F/G	Multimedia Interface	Service
TN788B	Multimedia Voice Conditioner	Service
TN789	Radio Controller	Control
TN790	Processor	Control
TN793	Analog Line, 24-Port, 2-Wire	Port
TN796B	Processor	Control
TNPRI/BRI	PRI to BRI Converter	Port
TN1648	System Access/Maintenance	Control
TN1650B	Memory	Control
TN1654	DS1 Converter - T1, 24 Channel/E1, 32 Channel	Port
TN1655	Packet Interface	Control

*Continued on next page*

**Table 2-5. Circuit packs and modules supported by DEFINITY — Continued**

Apparatus Code	Name	Type
TN1656	Tape Drive	Control
TN1657	Disk Drive	Control
TN2135	Analog Line	Port
TN2136	Digital Line 2-Wire DCP	Port
TN2138	Central Office Trunk	Port
TN2139	Direct Inward Dialing Trunk	Port
TN2140/B	Tie Trunk	Port
TN2144	Analog Line	Port
TN2146	Direct Inward Dialing Trunk	Port
TN2147/C	Central Office Trunk	Port
TN2149	Analog Line	Port
TN2180	Analog Line	Port
TN2181	Digital Line 2-Wire DCP	Port
TN2182/B	Tone-Clock -Tone Detector and Call Classifier	Control
TN2183	Analog Line	Port
TN2184	DIOD Trunk	Port
TN2198	ISDN-BRI 2-Wire U Interface	Port
TN2199	Central Office Trunk	Port
TN2202	Ring Generator	Power
TN2224	Digital Line, 24-Port, 2-Wire DCP	Port
UN330B	Duplication Interface	Control
UN331B	Processor	Control
UN332	Mass Storage/Network Control	Control
WP-90510	AC Power Supply (Compact Single-Carrier Cabinet)	Power
WP-91153	AC Power Supply (Single-Carrier Cabinet)	Power

## **Duplication: Reliability Options**

---

### **Standard Reliability Option**

---

On Standard Reliability systems, the 512-time-slot TDM bus is divided into two duplicate 256-time-slot buses, A and B. Call traffic is shared between the two buses. The first 5 time slots on each bus are reserved for the control channel, which is active on only one of the two buses at a time. Likewise, the next 17 time slots are reserved for carrying system tones. The tone times slot are not necessarily on the same bus (A or B) as the control channel. If any failure takes place that affects the ability of the active control or tone time slots to function, the other bus becomes active for those time slots.

### **High Reliability Option**

---

High Reliability systems duplicate components that are critical to the viability of the system as a whole to prevent a single failure from dropping all service:

- PPN control carrier and carrier power units (OLSSs)
- All SPE circuit packs: Processor, Memory, MSSNET, Disk, Tape, SYSAM, Duplication Interface, and carrier power units (OLSSs)
- PPN Tone Clock circuit pack (EPN Tone-Clocks are not duplicated)
- TDM buses (described above)

In addition to the above, the following are duplicated in Center Stage Switch (CSS) configurations:

- The PPN to CSS fiber link (consisting of the PPN Expansion Interface circuit packs, the Switch Node Interface circuit packs that connect to the PPN EIs, and cabling from the PPN EI to the CSS)
- Switch Node Clocks (SNCs) (two; on each Switch Node carrier)

The duplicated SPEs operate in active/standby fashion. Interchanges of the SPE and of PPN Tone-Clocks operate independently unless induced by use of the SPE-select switches. The 2 SNCs on each Switch Node carrier also operate in an active/standby manner.

The duplicated fiber link between the PPN EIs and the CSS (the cable may actually be metallic) do not use an active/standby strategy. Instead, both links simultaneously carry active call traffic and control connectivity in an equally distributed load-sharing manner. If a component fails one of these fiber links, all connectivity over it on it is torn down, resulting in some dropped calls and control and application links. Links and subsequent call service is immediately re-established over the other EI fiber link.

## Critical Reliability Option

Critical Reliability systems include all of the features of the High Reliability option described above. Additionally, the duplicate components of Port Network Connectivity (PNC) and other components critical to the viability of each EPN.

- Switch Node carriers and carrier power supplies (OLSs)
- Switch Node Interface (SNI) circuit packs
- Switch Node Clock (SNC) circuit packs (one on each duplicated Switch Node carrier)
- PPN and EPN Tone-Clock circuit packs
- PPN and EPN Expansion Interface circuit packs
- Each EPN contains a TN771D Maintenance/Test circuit pack
- Inter-PN cabling
- DS1 Converter Complexes (circuit packs, cabling and DS1 facilities used to connect remote EPNs)

The entire PNC (whether direct connect or CSS connected) is duplicated as a whole, forming two identical sets which each function as a whole (A-PNC and B-PNC). The 2 PNCs operate in an active/standby manner with all inter-PN calls set up on both PNCs so that the active can assume control without disruption of service. Operation of PNC duplication is described under PNC-DUP in [Chapter 9, "Maintenance Object Repair Procedures"](#).

The Tone-Clocks in each EPN operate in an active/standby manner independently from other duplication strategies.

# Management Terminal

# 3

---

The management terminal is used to enter commands and monitor operations through the maintenance user interface. [Chapter 8, "Maintenance Commands"](#) describes the commands available to the maintenance user.

## Terminals Supported

Refer to *DEFINITY Enterprise Communications Server Installation and Test for Multi-Carrier Cabinets*, and the user manual on your terminal model for setup instructions.

## Multiple Access

Release 7r allows multiple users to perform maintenance and administration at the same time:

- This system has a security feature to allow the customer to define their own logins and passwords and to specify a set of commands for each login. It allows up to 11 customer and 4 services logins. Each login name can be customized.
- Login Security Violation Notification Following a Security Violation and Login Kill after "N" Attempts features notifies a referral point, and disables a login ID (Customer or Lucent Services logins) following a security violation (a user defined security violation threshold). The Login Kill after "N" Attempts feature will not disable the last remaining inads type login. Lucent Services logins require a Lucent init level login ID to re-enable logins that have been disabled by a security violation or the command disable login.

- **Logoff Notification** alerts system administrators, during log off from the system administration and maintenance interface, of possible system maintenance problems. This notification also alerts the system administrators that features that present a significant security risk are enabled. A message displays on the system administration/maintenance interface during logoff if a security risk feature is enabled. Additionally, the user can be required to acknowledge the notification before the logoff is completed.
- The system is delivered to the customer with one “super-user” login and password defined. The customer is required to administer any additional login and passwords. The super-user login has full customer permissions and can customize any login that they create. Login permissions are set by the super-user to allow or block any object that can affect the health of the switch. Up to 40 administration or maintenance objects (commands) can be blocked for a specified login.
- Two maintenance logins are reserved for the SYSAM-RMT and SYSAM-LCL ports on the TN1648 SYSAM circuit pack located on PPN control carriers. SYSAM-RMT is a dial-up remote access port reserved for use by INADS. SYSAM-LCL is accessed by RS232 connectors on the TN1648. Two other maintenance users can log in by dial-up System Access Ports (SAPs) or by connecting directly to EPN Maintenance circuit packs.
- Up to 5 maintenance and 5 administration commands can run concurrently. Some commands that use the same resources as others experience contention and cannot be run at the same time. For more information on contention, see [“Contention Between Simultaneous Commands”](#) in [Chapter 8, “Maintenance Commands”](#).

## Switch-Based Bulletin Board

---

This feature allows a System Access Terminal (SAT) user to leave messages in the system in order to communicate with other system users.

### NOTE:

This feature does not substitute for any existing procedures for escalating problems. It is only an aid to the existing process.

## Description

The bulletin board service provides an easy interface for the customer and Lucent to leave messages on the system.

The bulletin board feature makes it easy for the customer to communicate with Lucent (and vice versa). For example, when a new load is installed on a switch in the customer’s system, Lucent is able to leave the customer messages that describe any new functions. It also allow Lucent to keep you informed on the progress of trouble items. In addition, you can use this feature to provide



additional information concerning problems that have already been escalated by the normal procedure.

## Accessing the Bulletin Board

Any user with the appropriate permissions can log into the system and have access to the bulletin board. Users that have "Maintain System" or "Administer Features" permissions can enter, change, display, print, or schedule to print a message. Users that have "Display Admin" and "Maintain Data" permission can display the bulletin board. Any user who has "Display" permission can display, print, and schedule to print the contents of the bulletin board.

When a user logs on to the system they are notified of any messages on the bulletin board. The notification message indicates the last time the bulletin board was updated, if any "High-Priority" message exist, and if the bulletin board is 80% or more full. If a "High-Priority" message exists, the command prompt will change to the following message:

- High-Priority Bulletin Board Messages Entered:

After the next command is entered, the default command prompt returns to the screen.

## User Considerations

- Only one user at a time may edit a message on the bulletin board.
- The user must have the proper permissions to access the bulletin board.
- You, the user must maintain the information stored on the bulletin board. It is your responsibility to delete old messages. If the bulletin board is full any new messages overwrite old messages.

## System Considerations

- The Bulletin Board feature provides up to 3 pages of text for each message. Each page is limited to 20 lines of text and 40 characters per line. The first 10 lines of text on page 1 are reserved for Lucent Service's High-Priority messages.

## System Bulletin Board Commands

The system commands "**change bulletin board**", "**display bulletin board**," and existing commands in the user interface are provided for use in the Switch Based Bulletin Board.

To edit or enter a message on the Switch Based Bulletin Board you must:

1. Log into the system with "Maintain System or Administer Features" Permissions.
2. Enter the command **change bulletin-board**.

3. Follow system prompts.

To display messages on the Switch Based Bulletin Board you must:

1. Log into the system with "Maintain System", "Display Admin," or "Maint Data" permissions.
2. Enter the command **display bulletin board**.
3. Follow system prompts.

## Editing a Switch-Based Bulletin Board Message

As stated before, a message may contain up to three pages of information with the first 10 lines on page 1 reserved for Lucent Service's *High-Priority* messages (the "INIT", "INADS", and "craft" logins can edit the first 10 lines on page one). Pages 2 and 3 will allow up to 20 lines of 40 characters of text. Each line has a date field to show when the line is modified.

The control keys used to edit existing feature forms must be used to edit a message in the Switch Based Bulletin Board. The following characters are allowed for use in the text field:

- Uppercase/Lowercase letters, spaces, numerals, and !@#\$%^ &\*()\_ -+=[]{};"'<>./?.

### NOTE:

Tab characters are not allowed. The existing command line interface will cause the cursor to move to the next field if a Tab character is entered.

If a user changes any lines which cause 2 or more consecutive blank lines the bulletin board is automatically reorganized (upon submittal). Two or more blank lines are changed to a single blank line. A blank line at the top of a form is also deleted. This prevents holes in the bulletin board screens as old entries are deleted.

To save a message entered into the bulletin board text field, you must execute the **save translation** command.

The following screen, is an example of bulletin board messages between Lucent and a customer that is having trouble with trunk group translations:

### 3 Management Terminal

#### Switch-Based Bulletin Board Message Notification

3-5

```
display bulletin-board
```

```
Page 1 of 3
```

```
Messages (* indicates high-priority)           Date
* Lucent is in the process of                   02/02/95
* investigating your trunk lockup problem.      02/02/95
* The Bulletin Board will be updated as         02/02/95
* information is found.                         02/02/95
* We have identified the problem.               02/02/95
* The trunk you added does not provide          02/02/95
* disconnect supervision, however your trunk    02/02/95
* group was administered as such.              02/02/95
* Please call for details.                      02/02/95
*
We recently added a new trunk group (14)        02/03/95
and have had trunk group members locking up.   02/03/95
We see the error - Thanks for checking.        02/03/95
```

## Switch-Based Bulletin Board Message Notification

When a user logs on to the system they are notified of any messages on the bulletin board. The notification message indicates the last time the bulletin board was updated, if any "High-Priority" message exist and if the bulletin board is 80% or more full. If a "High-Priority" message exists, the command prompt changes to the following message:

```
High-Priority Bulletin Board Messages Entered:
```

After the next command is entered, the default command prompt returns to the screen.

## To Log In

To log in to the switch:

1. Enter your login name and password on the login and password screen.

If your password has expired you see the message:

```
Your password has expired, enter a new one.
```

The password aging screen ([Screen 3-1](#)) is displayed when a user logs in. If the user's password is expired, the user is prompted to enter a new password. If your password is within 7 days of the expiration date you see:

**3 Management Terminal***Switch-Based Bulletin Board Message Notification*

3-6

```
Login: telmgr
Password:
Your Password has expired, enter a new one.
Reenter Current Password:
  Old Password:
  New Password:
Reenter New Password:
```

**Screen 3-1. Password Aging Screen****Forced Password Aging and Administrable Logins**

---

G3V3 and later releases provide enhanced login/password security by adding a security feature that allows users to define their own logins/passwords and to specify a set of commands for each login. The system allows up to 11 customer logins. Each login name can be customized and must be made up of from 3 to 6 alphabetic/numeric characters, or a combination of both. A password must be from 4 to 11 characters in length and contain at least 1 alphabetic and 1 numeric symbol. Password aging is an optional feature that the super-user administering the logins can activate.

**⇒ NOTE:**

If several “users” are logging in and out at the same time, a user may see the message “Transient command conflict detected; please try later”. After the “users” have completed logging in or out, the System Access Terminal is available for use, try executing the command again.

The password for each login can be aged starting with the date the password was created, or changed, and continuing for a specified number of days (1 to 99). The user is notified at the login prompt, 7 days before the password expiration date, that his/her password is about to expire. When the password expires the user is required to enter a new password into the system before logging in. If a login is added or removed, the “Security Measurement” reports are not updated until the next hourly poll, or a **clear measurements security-violations** command is entered. Once a non-super-user has changed his/her password, the user must wait 24 hours to change the password again.

V4 security is enhanced by providing a logoff notification screen to a system administrator when he/she logs off while either the facility test call or remote access features are still administered. The administrator can be required to acknowledge the notification before completing the logoff process. Logoff notification is administered on the Login Administration screen.

The system is delivered to the customer with one customer “super-user” login/password defined. The customer is required to administer additional login/passwords as needed. The super-user login has full customer permissions and can customize any login that he/she creates.

Login permissions for a specified login can be set by the super-user to block any object that may compromise switch security. Up to 40 administration or maintenance objects commands can be blocked for a specified login in. When an object (administrative or maintenance command) is entered in the blocked object list on the Command Permissions Categories Restricted Object List form, the associated administrative or maintenance actions cannot be performed by the specified login.

There are 3 command categories. Each of the 3 command categories has a group of command subcategories listed under them, and each command subcategory has a list of command objects that the commands acts on. See Table 3-1 and Table 3-2 for a list of objects. A super-user can set a users permissions to restrict or block access to any command in these categories. The 3 categories are:

- Common Commands
  - Display Admin. and Maint. Data
  - System Measurements
- Administration Commands
  - Administer Stations
  - Administer Trunks
  - Additional Restrictions
  - Administer Features
  - Administer Permissions
- Maintenance Commands
  - Maintain Stations
  - Maintain Trunks
  - Maintain Systems
  - Maintain Switch Circuit Packs
  - Maintain Process Circuit Packs

These categories are displayed on the Command Permissions Categories form.

## To Log In

To log in to the switch:

1. Enter your login name and password on the login and password screen ([Screen 3-2](#)).

If your password has expired you see the message:

```
Login: telmgr

Password:
Your Password has expired, enter a new one.

Reenter Current Password:

        New Password:

Reenter New Password:
```

### Screen 3-2. Password Expiration Screen

The Password Expiration screen is displayed when you log in. If your password is expired you are prompted to enter a new password. If your password is within 7 days of the expiration date you see:

```
WARNING: Your password will expire in X days
```

### To Logoff

To logoff, enter **logoff** at the command prompt.

If facility test call notification or remote access notification are enabled for your login (see Adding Customer Logins and Assigning Initial Passwords, below), you receive a logoff screen. If either the facility test call or remote access acknowledgments are required, you need to respond to the `Proceed with Logoff?` prompt on the logoff screen. The response is defaulted to `n`; you will need to enter `y` to override the default.



**CAUTION:**

*To leave the facility test call administered after you logoff poses a significant security risk.*



**CAUTION:**

*To Leave Remote Access feature administered after logging off poses a significant security risk if you are using the feature in conjunction with the Facility Test Call feature.*

```
Facility Test Call Administered
Remote Access Administered

Proceed with Logoff? [n]
```

### Screen 3-3. Logoff Screen

## To Display a Login

To display a specified login:

1. Enter the command **display login [login name]** and press the Enter key.

The system displays the requested login's:

- Name
- Login type
- Service level
- Access to INADS Port value (V4)
- Password aging cycle length
- Facility test call notification and acknowledgment
- Remote access notification and acknowledgment

## To List Logins

To list all of the system logins and the status of each login:

2. Enter the command **list logins**.

The system displays the following information for all current logins:

- Name
- Service level
- Status (active, inactive, disabled, svn-disabled, void)
- Password aging cycle length

The system displays only those logins with the same, or lower, service level as the requestor.

## To Remove a Login

To remove a login from the system:

1. Enter the command **remove login [login name]**.  
The system displays the Login Administration form.
2. Press the Enter key to remove the login, or press Cancel to exit the remove login procedure without making a change.

## To Test a Login

1. Enter your login name at the login prompt.

```
Login: telmgr  
Password:vvvvvvvvcf
```

### Screen 3-4. Login Prompt Form

After the user enters the correct login name and password and the login is administered correctly, the system displays the command line interface.

## Administering Customer Logins and Forced Password Aging

### Adding Customer Logins and Assigning Initial Password

To add a customer login you must be a super-user, have administrative permissions, and:

1. Enter the **add login [name]** command to access the Login Administration form.
2. Enter your super-user password in the Password of Login Making Change field on the Login Administration form.

The 3- to 6-character login name (characters 0-9, a-z, A-Z) entered with the **add login [name]** command is displayed in the Login's Name field.

3. Enter **customer** in the Login Type field. The system default for the Login Type field is `customer`. The maximum number of customer logins of all types is 11.



## 3 Management Terminal

## Switch-Based Bulletin Board Message Notification

3-11

4. Enter super-user or non-super-user in the Service Level field. Default is non-super-user.
  - “super-user” gives access to the **add, change, display, list, and remove** commands for all customer logins and passwords. The super-user can administer any mix of super-user/non-super-user logins up to a total of ten additional system logins.
  - “non-super-user” permissions are limited by restrictions specified by the super-user when administering the non-super-user login. A non-super-user can change his/her password with permission set by the super-user, however once a password has been changed the non-super-user must wait 24 hours before changing the password again. A non-super-user cannot change other user passwords, login characteristics, or permissions.
5. Enter **y** in the `Disable Following a Security Violation` field to disable a login following a login security threshold violation. This field is a dynamic field and only appears on the Login Administration form when the SVN Login Violation Notification feature is enabled. The system default for the `Disable Following a Security Violation` field is **y**.
6. Enter **y** in the `Access to INADS Port?` field to allow access to the remote administration port. This field only displays if Acct. has first enabled customer super-user access to the INADS Remote Administration Port. Default is **n**. This step is valid for V4 and higher systems only.
7. Enter a password for the new login in the Login's Password field. A password must be from 4 to 11 characters in length and contain at least 1 alphabetic and 1 numeric symbol. Valid characters include numbers, and `!&*?;'^(),.-` (the system will not echo the password to the screen as you type).
8. Re-enter the password in the Login's Password field. The system will not echo the password to the screen as you type.
9. Enter the number of days (1 to 99) from the current day, that you want the password to expire, in the Password Aging Cycle Length field. If a you enter a blank in this field, password aging does not apply to the login.
10. Decide whether or not to leave the default of yes (“y”) in the `Facility Test Call Notification?` field. If you retain the default, the user receives notification at logoff that the facility test call feature access code is administered. If you do not want the notification to appear, set the field to **n**.

**CAUTION:**

*Leaving The facility Test Call administered after logging off poses a significant security risk.*

11. Decide whether or not to leave the default of yes (“y”) in the `Facility Test Call Notification Acknowledgment Required` field. If you retain the default, the user is required to acknowledge that they wish to logoff while Facility

Test Call is still administered. If you do not want to force the user to acknowledge, set the field to **n**. This field appears only if the Facility Test Call Notification field is set to **y**.

12. Decide whether or not to leave the default of yes (“y”) in the Remote Access Notification? field. If you retain the default, the user receives notification at logoff that remote access is still administered. If you do not want the notification to appear, set the field to **n**.

**CAUTION:**

*To Leave Remote Access feature administered after logging off poses a significant security risk if you are using the feature in conjunction with the Facility Test Call feature.*

13. Decide whether or not to leave the default of yes (“y”) in the Remote Access Acknowledgment Required? field. If you retain the default, the user is required to acknowledge that they wish to logoff while remote access is still administered. If you do not want to force the user to acknowledge, set the field to **n**. This field appears only if the Facility Test Call Notification field is set to **y**.

```

                LOGIN ADMINISTRATION

Password of Login Making Change:

LOGIN BEING ADMINISTERED
                Login's Name:xxxxxxx
                Login Type:
                Service Level:
Disable Following a Security Violation?
                Access to INADS Port?

LOGIN'S PASSWORD INFORMATION
                Login's Password:
                Reenter Login's Password:
                Password Aging Cycle Length:

LOGOFF NOTIFICATION
Facility Test Call Notification? y      Acknowledgment Required? y
Remote Access Notification? y        Acknowledgment Required? y
```

### Screen 3-5. Login Administration

#### Changing a Login's Attributes

To change a customer login's attributes you must be a super-user, have administrative permissions (specifically, the Administration Permission field must be set to **y** for the super-user), and:

1. Enter the **change login [name]** command to access the Login Administration form.

### 3 Management Terminal

#### Switch-Based Bulletin Board Message Notification

3-13

2. Enter your super-user password in the `Password` of `Login Making Change` field on the `Login Administration` form.

The 3- to 6-character login name (characters 0-9, a-z, A-Z) entered with the **change login [name]** command is displayed in the `Login's Name` field.

3. Enter **customer** in the `Login Type` field.
4. Enter super-user or non-super-user in the `Service Level` field.

#### NOTE:

You cannot change your own service level.

5. To disable a login following a login security threshold violation, enter **y** in the `Disable Following a Security Violation` field. This field is a dynamic field and only appears on the `Login Administration` form when the `SVN Login Violation Notification` feature is enabled.
6. To allow access to the remote administration port, enter **y** in the `Access to INADS Port?` field. This field only displays if Lucent has first enabled customer super-user access to the `INADS Remote Administration Port`.
7. Enter a password for the new login in the `Login's Password` field. A password must be from 4 to 11 characters in length and contain at least 1 alphabetic and 1 numeric symbol. Valid characters include numbers, and `!&*?;'^() ,.-` (the system will not echo the password to the screen as you type).
8. Re-enter the password in the `Login's Password` field. The system will not echo the password to the screen as you type.
9. Enter the number of days (1 to 99) from the current day, when you wish the password to expire, in the `Password Aging Cycle Length` field. If a blank is entered in this field, password aging does not apply to the login.

## Administering Login Command Permissions

To administer command permissions, log in as super-user and:

1. Access the `Command Permissions Categories` form by entering the command **change permissions login [login name]**. When the `Command Permission Categories` form is displayed for a login, the default permissions for that "login type" are shown on the form. The super-user administering the login can change a **y** to **n** for each subcategory field on the form.
2. Select a category for the login and enter **y** in each field where permission to perform a administrative or maintenance action is needed. The command object you select must be within the permissions for the login type you are administering.

If the `Maintenance` option is set to **y** on the `Customer Options` form, the super-user can enter **y** in the `Maintain Switch Circuit Packs?` or `Maintain Process Circuit Packs` fields.

3 Management Terminal

Switch-Based Bulletin Board Message Notification

3-14

3. A super-user with full super-user permissions (super-user administering the login cannot have the `Additional Restrictions` field set to `y` for his/her own login) can restrict additional administrative or maintenance actions for a specified login by entering `y` in the `Additional Restrictions` field on the `Command Permission Categories` form. Enter the additional restrictions for a login in the `Restricted object list` fields on the `Command Permission Categories Restricted Object List` form. You can enter up to 40 command names (object names) to block actions associated with a command category for a specified login.

Page 1 of 3

COMMAND PERMISSION CATEGORIES  
Login Name: Sup3ru

COMMON COMMANDS

Display Admin. and Maint. Data? y  
System Measurements? \_

ADMINISTRATION COMMANDS

Administer Stations? y	Administer Features? y
Administer Trunks? y	Administer Permissions? y
Additional Restrictions? n	

MAINTENANCE COMMANDS

Maintain Stations? n	Maintain Switch Circuit Packs? n
Maintain Trunks? n	Maintain Process Circuit Packs? n
Maintain Systems? n	

Screen 3-6. Command Permission Categories (Page 1 of 3)

Page 2 of 3

COMMAND PERMISSION CATEGORIES  
RESTRICTED OBJECT LIST

Screen 3-7. Command Permissions Categories (Page 2 of 3)

COMMAND PERMISSION CATEGORIES  
 RESTRICTED OBJECT LIST

_____	_____
_____	_____
_____	_____
_____	_____
_____	_____
_____	_____
_____	_____
_____	_____
_____	_____
_____	_____

Screen 3-8. Command Permissions Categories (Page 3 of 3)

Table 3-1. Command Permissions Form Entries — Display Administration and Maintenance

Object	Action						
	Change	Display	List	Monitor	Remove	Status	Test
aar analysis		X	X				
aar digit-conversion		X	X				
aar route-chosen			X				
abbreviated-dialing 7103A-buttons		X					
abbreviated-dialing enhanced		X					
abbreviated-dialing group		X	X				
abbreviated-dialing personal		X	X				
abbreviated-dialing system		X					
aca-parameters			X				
access-endpoint		X	X			X	X
adjunct-names		X					
adjunct-controlled-agents		X					
administered-connection		X	X			X	
agent-loginID		X	X				
alarms		X					X
alias-station		X					
alphanumeric-dial-table		X					
alternate-fri		X					

Continued on next page

**Table 3-1. Command Permissions Form Entries — Display Administration and Maintenance — Continued**

Object	Action						
	Change	Display	List	Monitor	Remove	Status	Test
analog -testcall							X
announcements		X					
ars analysis		X	X				
ars analysis			X				
ars digit-conversion		X					
ars digit-conversion			X				
ars route-chosen			X				
ars-toll		X					
attendant		X	X				
bcms agent			X				
bcms lignites			X				
bcms split			X				
bcms trunk			X				
bcms vdn			X				
board							X
bri-port						X	
bridged-extensions			X				
bulletin-board		X					
button-location-aca		X					
cabinet		X	X				
call-forwarding			X				
call-screening		X					
capacity		X					
card-mem*						X	X
cdr-link						X	X
circuit-packs		X					
communication-interface hop-channels		X				X	
communication-interface links		X					
communication-interface proc-channels		X				X	
configuration all			X				

*Continued on next page*

**Table 3-1. Command Permissions Form Entries — Display Administration and Maintenance — Continued**

Object	Action						
	Change	Display	List	Monitor	Remove	Status	Test
configuration board			X				
configuration carrier			X				
configuration control			X				
configuration network			X				
configuration software			X				
configuration station			X				
configuration trunk			X				
console-parameters		X					
cor		X	X				
cos		X					
coverage answer-group		X	X				
coverage groups		X					
coverage path		X	X				
customer-alarm							X
data-module		X	X			X	X
dappling		X					
digit-absorption		X					
display-format		X	X				
do-not-disturb group			X				
do-not-disturb station			X				
ds1		X					X
dsp-msg-auto-wakeup		X					
dsp-msg-call-identifier		X					
dsp-msg-date-time		X					
dsp-msg-lwc		X					
dsp-msg-mct		X					
dsp-msg-miscellaneous		X					
dsp-msg-property-mgmt		X					
dsp-msg-softkey-label		X					
dsp-msg-tod-routing		X					
emergency			X				

*Continued on next page*

**Table 3-1. Command Permissions Form Entries — Display Administration and Maintenance — Continued**

Object	Action						
	Change	Display	List	Monitor	Remove	Status	Test
enp-number-plan		X					
environment							X
errors		X					
events		X					
external-device-alarm							X
extension-type			X				
external-device-alarming							X
feature-access-code		X					
fiber-link <sup>†</sup>		X	X				
groups-of-extensions			X				
hardware-group						X	X
health						X	
history			X				
hunt-group		X	X				
inads-link							X
integrated-annc-boards		X	X				
intercom-group		X	X				
interface <sup>*</sup>						X	X
intra-switch-cdr		X	X				
isdn cpn-prefix		X					
isdn network-facilities		X					
isdn-testcall							X
isdn tsc-gateway		X					
ixc-codes		X					
journal-printer							X
led							X
link						X	X
listed-directory-numbers		X					
login						X	
login <sup>‡</sup>			X				
login-ids		X					

*Continued on next page*



**Table 3-1. Command Permissions Form Entries — Display Administration and Maintenance — Continued**

Object	Action						
	Change	Display	List	Monitor	Remove	Status	Test
maintenance							X
marked-port			X				
mct-group-extensions		X					
mct-history			X				
meas-selection coverage		X					
meas-selection principal		X					
meas-selection route-pattern		X					
meas-selection trunk-group		X					
meas-selection wideband-trunk-grp		X					
measurements security-violations detail			X				
measurements security-violations summary			X				
memory							X
MO							X
modem-pool		X	X				X
multi-frequency signaling		X					
network-control							X
node-routing		X	X				
packet-control <sup>*</sup>						X	X
packet-interface <sup>†</sup>						X	
paging code-calling-ids		X	X				
paging-loudspeaker		X					
password	X						
periodic-scheduled						X	
permissions		X					
personal-CO-line		X	X				
pgate		X	X				
pickup-group		X	X				
pkt							X
pms						X	
pms-down			X				

*Continued on next page*

**Table 3-1. Command Permissions Form Entries — Display Administration and Maintenance — Continued**

Object	Action						
	Change	Display	List	Monitor	Remove	Status	Test
pms-link							X
pms-log						X	
pnc						X	
port		X					X
port-network <sup>†</sup>						X	
pri-endpoint		X	X			X	X
processor							X
remote-call-coverage	X						
report-scheduler	X		X		X		
rhnpa		X					
route-pattern		X	X				
routing-table		X	X				
scr				X			
second-digit		X					
security-violations				X			
set-data			X				
signaling-group		X	X			X	X
sit-treatment		X					
site-data		X					
skill				X			
sp-link						X	X
spe						X	
stargate-port						X	
station		X	X				X
svn-button-location		X					
switch-node <sup>†</sup>						X	
synchronization		X				X	X
sys-link			X			X	
system				X			
system 1st-cabinet						X	
system 2nd-cabinet						X	

*Continued on next page*

**Table 3-1. Command Permissions Form Entries — Display Administration and Maintenance — Continued**

Object	Action						
	Change	Display	List	Monitor	Remove	Status	Test
system 3rd-cabinet						X	
system all-cabinets						X	
system conn				X			
system customer-options		X					
system features		X					
system-maintenance		X					
system-parameters cdr		X					
system-parameters country-options		X					
system-parameters duplication <sup>†</sup>		X					
system-parameters hospitality		X					
system-parameters security		X					
tdm							X
term-ext-group		X	X				
terminal-parameters 603/302B1		X					
terminal-parameters 8400		X					
test-schedule		X	X				
time		X					
time-of-day		X					
toll		X					
toll all			X				
toll restricted-call			X				
toll-list			X				
toll unrestricted-call			X				
tone-clock							X
trunk				X		X	X
trunk-group		X	X			X	
trunk-group-history			X				
trunk-group-members			X				
tsc-administered							X
tti						X	
udp		X	X				

*Continued on next page*

**Table 3-1. Command Permissions Form Entries — Display Administration and Maintenance — Continued**

Object	Action						
	Change	Display	List	Monitor	Remove	Status	Test
unstaffed-agents			X				
usage button-type hunt-ns			X				
usage button-type trunk-ns			X				
usage button-type night-service			X				
usage-extensions			X				
usage-hunt			X				
vdn		X	X	X			
vector		X	X				
wakeup incomplete			X				
wakeup requests			X				
wakeup station			X				
wakeup-log						X	

- \*. Intel only.
- †. MIPS only.
- ‡. Must be super-user.

**Table 3-2. Command Permissions Form Entries — Administer Permissions**

Object	Action				
	Add	Change	Display	Enable	Remove
login	X	X	X	X	X
permissions		X			

**Table 3-3. Command Permissions Form Entries — Administer Stations**

Object	Action			
	Add	Change	Duplicate	Remove
abbreviated-dialing 7103A-buttons	X	X		X
abbreviated-dialing enhanced	X	X		X
abbreviated-dialing group	X	X		X
abbreviated-dialing personal		X		X
abbreviated-dialing system	X	X		X
alias-station		X		
attendant	X	X		X
console-parameters				
data-module	X	X	X	X
routing-table	X	X		X
station	X	X	X	X
terminal-parameters 603/302B1		X		
terminal-parameters 8400		X		
vdn	X	X		X
vector		X		

**Table 3-4. Command Permissions Form Entries — Administer Trunks**

Object	Action				
	Add	Change	Display	Duplicate	Remove
aar analysis		X			
aar digit-conversion		X			
access-endpoint	X	X		X	X
announcements		X			
ars analysis		X			
ars digit-conversion		X			
ars toll		X			
digit-absorption		X			
meas-selection route-pattern		X			
meas-selection trunk-group		X			
meas-selection wideband-trunk-grp		X			
modem-pool	X	X			X
personal-CO-line	X	X			X
pri-endpoint	X	X		X	X
remote-access		X	X		
rhnpa		X			
route-pattern		X			
time-of-day		X			
toll		X			
trunk-group	X	X			X

## Connecting the MT

The management terminal can be connected to the system in the following ways:

- **SYSAM-LCL Port**

The management terminal can be connected directly to the SYSAM-LCL port of the TN1648 System Access and Maintenance (SYSAM) circuit pack in the PPN control carrier (or SPE). Two RS-232 connectors are located on the rear panel of the PPN control carrier beneath the label TERMINAL. To access the maintenance user interface running on the

active SPE, connect an M25B (EIA) cord to the connector labeled ACTIVE. Connect the other end to the connector on the 715 BCS labeled P2(DCE). On most other terminals, use the connector labeled MAIN PORT. A null modem is not required for these ports. More information on setting up the 715 BCS is given in following sections of this chapter.

On systems with duplicated SPEs, there are two PPN control carrier and two identical sets of connectors. Either connector labeled ACTIVE can be used, regardless of which SPE is active. The STANDBY connectors are described below.

- **SYSAM-RMT Port (RAP)**

One login can access the system by dialing in to the SYSAM-RMT port with a modem operating at either 1.2 or 2.4 kbps. This port is reserved for INADS (Initialization and Administration System) access.

## Logging In When The SPE Is In SPE Down Mode

If the system is in SPE down mode when the RAP Terminal displays `login`, enter **INADS** as the RAP login/name. Use the first INADS type password as your RAP password.

### **NOTE:**

You must identify the first INADS login before the system is in SPE down mode. The first INADS type login may be identified by entering the **list login** command and noting the first INADS login listed.

- **System Ports**

Terminals can log in via system ports (also known as system access ports or SAPs) if the system is so equipped. The connection is made by dialing in to a data port located on a data line circuit pack that is administered as a system port. This type of port is identified by the entry `Type: system port` on the data module form. These ports operate at 9.6 kbps. For more information on system ports, see [“PDATA-PT \(Packet Data Line Port\)”](#) in [Chapter 9, “Maintenance Object Repair Procedures”](#) and *DEFINITY Enterprise Communication Server Administrator’s Guide*.

- **EPN Maintenance Circuit Pack**

Terminals can log in to the system by directly connecting to the TN775 Maintenance circuit pack in each Expansion Port Network. Connect an M25B (EIA) cord to the RS-232 connector labeled TERM on the rear panel of the expansion control carrier. This connection operates at a slower speed because it communicates over system control links shared with call processing messages. The bit rate is limited to about 1 kbps. This type of connection is useful for performing maintenance on a remotely located EPN.

- Standby SPE Connection

With duplicated SPEs, there are two SYSAM connectors on each PPN control carrier (A and B). Either carrier's connectors may be used. Either ACTIVE connector always access the active SPE regardless of which carrier is active. Either STANDBY connector accesses the standby SPE through the SPE-Down interface. This interface is available when the SPEs are locked by the SPE-Select switches on a system with duplicated SPEs. Otherwise the STANDBY connection is inactive. (On a simplex SPE, this interface is accessed when the SPE is down through the ACTIVE connector). Separate terminals may be connected to the two connectors, or one terminal may be switched back and forth between connections. The unused connectors should be capped.

The SPE-down interface can only be accessed by SYSAM-LCL or SYSAM-RMT connections. This interface is described in *Initialization and Recovery*.

## **Serial Printer Connection**

---

For serial printer operation, connect the printer to the connector on the back of the 715 BCS terminal labeled P1(DCE). A null modem is not required. Set the printer for 9600 baud, 7 data bits and 1 stop bit. These are the default settings for the 715 BCS. If necessary, terminal settings for serial printer operations can be changed from the Communication Options sub-menu of the Setup menu.

## **Parallel Printer Connection**

For parallel printer operation, connect the printer to the connector labeled with the printer icon. To enable parallel printer operation, use the following series of keystrokes.

1. Cntl + F1 to access the Setup menu
2. F4 to select the User Preferences sub-menu
3. Down arrow to the Parallel Port field
4. F4 to enable the option
5. F1, F5, F1 to return to Setup, save selections, and exit

## **Logging On**

---

To log in to the system:

1. Connect and power up the MT; the screen displays `login:`
2. Enter your login name, and press the Return key. The screen displays `password:`
3. Enter your password, and press the Return key.



For security reasons, the password is not displayed as you type it. The system verifies that a valid login and password name were entered. If an invalid login or password name was entered, the screen displays `login incorrect:`

In this case you must repeat the procedure. If your password has expired or is within 7 days of the expiration day, you see a error message:

```
Your Password has expired; enter a new one
```

```
Old Password:
```

```
New Password:
```

```
WARNING: your password will expire in xx days
```

If the system recognizes the login and password name, the screen displays the software version number followed by the prompt:

```
Terminal Type (Enter 513, 4410, 4425, or VT220):  
[513]
```

4. Depending on your terminal type, enter one of the following:

Terminal Type	Entry
513 BCT	513 (default)
715 BCS	513 (default)
4410 Data Terminal	4410
4425 Data Terminal	4425
DEC VT220	VT220

5. You can deactivate INADS alarm origination whenever you log in as craft. After you supply the terminal type information requested, the system will display the following if alarm origination is activated on the Maintenance System-Parameters screen:

```
Suppress Alarm Origination: [y]
```

The default answer is yes. If you do NOT wish to suppress alarm origination, enter **no**. Any other entry will default to yes. The **test inads-link** command will work regardless of whether you have overridden INADS alarm origination.

6. The screen will display:

```
enter command:
```

The system is now ready to execute maintenance commands. Press the HELP key to display a list of all valid entries.

If you have a High-Priority Bulletin Board Message, the command line prompt will include the following notification to all users who are logged in:

```
-High-Priority Bulletin Board Messages Entered:
```

## Logging Off

---

The terminal should be logged off whenever it is not in use to avoid accidental or malicious entries that could corrupt translations or disrupt operations. This also re-enables INADS alarm origination so that alarms will not go unreported.

To log off, simply enter **logoff** at the command prompt. The screen should then display:

```
login:
```

If no entry is made for 30 minutes during a craft login, the system automatically times out and terminates the login. At that time, any unresolved alarms that have not been reported to INADS will be reported. If you are logged in at more than one G3-MT terminal, the system waits until the last terminal times out or logs off before reporting such alarms to INADS.

**Logoff Notification** alerts system administrators of enabled features that present a significant security risk. The user may be required to acknowledge the notification before the logoff is completed

# Initialization and Recovery

# 4

When the system is powered up, or when it experiences a catastrophic fault that interrupts its basic functions, it undergoes a reboot. In addition to reboot, there are several less severe resets available for the system to recover from less disrupting errors. The technician can also initiate these resets with a command.



## CAUTION:

*System resets can have wide-ranging disruptive effects. Unless you are familiar with resetting the system, follow normal escalation procedures before attempting a demand reset.*

If a reset fails to recover normal system operation, the firmware that controls reset will escalate to the next higher level, up to reboot if necessary. A failure to reboot results in SPE-down mode, which is described in later in this chapter.

This chapter describes the causes, effects, and duration of each reset level. In a system with duplicated SPE, the standby SPE can undergo a reset without disrupting service since the active SPE remains in control. These resets can also be requested with the corresponding **reset standby-spe level** commands. All standby resets turn off memory shadowing, leaving the standby SPE temporarily unavailable for service. Refresh of the standby typically takes several minutes.

When resets occur, including interchanges, an error is logged against the maintenance object "SYSTEM." The error code gives information about the cause of the reset. Information about the reset is also logged in the `initcauses` log. See **display initcauses** in [Chapter 8, "Maintenance Commands"](#).

The EPNs can also undergo individual resets. These are described in ["EXP-INTF \(Expansion Interface Circuit Pack\)"](#) and ["EXP-PN \(Expansion Port Network\)"](#) in [Chapter 9, "Maintenance Object Repair Procedures"](#). PNC interchanges are

described under PNC-DUP in Chapter 9, and under **reset pnc interchange** in [Chapter 8, "Maintenance Commands"](#).

## Multiple Offer Categories

When the system is initially powered up, or when it experiences a catastrophic fault that interrupts its basic functions, the system either initializes or reboots.

### Initialization

Upon initialization, no forms (not even Customer Options) are available until the Offer Category is set. (The remote INADS channel is available.) To set the customer options, do the following:

1. Enter **change system-parameters offer-options** (init and inads logins only) and the following form displays:

```
change system-parameters offer-options
```

```
OFFER OPTIONS FORM
```

```
Offer Category: _
```

```
Activate Offer? _
```

```
WARNING: Need to save translations and reboot to make the change permanent.
```

### Field descriptions

Offer category

Type either **A** or **B**.

Activate offer?

Type **y** if the entry for Offer category is correct and press Tab.  
Type **n** if there is an error in the Offer category field and press Tab. Re-enter the correct Offer Category.

2. After these two fields are filled and you press Enter, the system displays:

```
WARNING: Activating Offer Category may set unchangeable limits.
```

This is to let you know that the Offer Category along with the model determine the system capacities (limits) and allowable hardware.

3. Press the Submit key to submit the form.

4. Use the **save translations** command to make the changes permanent.



**CAUTION:**

*To avoid potential loss of service, ensure that your system's translations are protected by saving them to the PCM/CIA card.*

## Hot Restart

---

This reset occurs only on a duplicated SPE during a *planned* SPE interchange.

Duration Up to 1.5 minutes

Causes **reset system interchange** command

(use of the **contention-override** or **health-override** options causes a reset level 1 or higher)

SPE interchange requested by scheduled maintenance

Effects Call service is unaffected.

Yellow LEDs light on new active SPE and go out on the new standby.

Memory shadowing is turned off.

Remote access port (SYSAM-RMT) login is dropped.

## Reset Level 1 (Warm Restart)

---

Duration Up to 10 seconds, typically 2 seconds

Causes **reset system 1** command

Spontaneous SPE interchange (those caused by hardware faults)

Software faults that are non-service affecting

Abort of planned SPE interchange

Hardware bus errors

TN1655 Packet Interface faults

Effects      Stable calls are preserved.

System links, and stable feature and service state data are preserved.

Error and alarm logs are preserved, but all alarms are resolved except for STBY-SPE and busyouts.

Transient calls (not yet connected), and some user stimuli, are dropped.

New calls are not processed during the reset.

G3-MT logins, including remote access and system port logins, are dropped.

If the reset resulted from a spontaneous SPE interchange, memory shadowing is turned off, and the standby SPE will not be available for service until memory is refreshed (several minutes).

Application links such as those to AUDIX and CDR are dropped and reestablished in under 2 1/2 minutes. (BX.25 links are not dropped, and CDR data is buffered during the outage.)

MSS activity is aborted.

Translation data is preserved, but if translation changes were in progress, the reset is escalated to Reset Level 3 (Cold-1).

If core dump is enabled for this reset level, reset is delayed until the core dump is complete.

## Reset Level 2 (Cold-2 Restart)

---

Duration	Up to 3.75 minutes
Causes	<b>reset system 2</b> command Escalation from reset level 1 An attempted reset level 1 during a PNC interchange TDM-bus clock recovery on the PPN Spontaneous interchange into an unrefreshed standby SPE
Effects	<b>All system and application links are dropped.</b> All calls are dropped. Non-translation feature data, such as Automatic Wakeup calls, are lost and must be reentered. All G3-MT logins, including remote access and system port logins, are dropped. Initialization firmware runs diagnostics and displays results on the G3-MT screen. SPE memory shadowing is turned off, leaving the standby SPE unavailable for service for several minutes. All hardware components, except PNC components, are reset, including the EPNs. All standby Expansion Interfaces, and the active EI in the PPN are reset. SNIs, SNCs, DS1Cs and active EIs in the EPNs are not reset. If the PNC is duplicated, a global refresh of the standby PNC is performed after the reset. All busied out maintenance objects are released and must be rebusied, if so desired. Circuit packs are reinitialized, (translations are verified by comparison to physical board locations). If core dump is enabled for this reset level, reset is delayed until the core dump is complete. Error and alarm logs are preserved, but all alarms are resolved except for STBY-SPE and busyouts.

4 Initialization and Recovery

Reset Level 3 (Cold-1 Restart)

4-6

## Reset Level 3 (Cold-1 Restart)

---

Duration	Up to 6.5 minutes
Causes	<b>reset system 3</b> command Escalation from reset level 2 Translation loading fault Spontaneous interchange into an unrefreshed standby SPE
Effects	Actions and effects are the same as for reset level 2, plus the following:  Emergency transfer is invoked.  Translations are reloaded from disk or tape.  If core dump is enabled for this reset level, reset is delayed until the core dump is complete.  Translations entered by users since the last save translation was executed by command or by scheduled maintenance are lost.

## Reset Level 4 (Reboot)

---

Duration	Typically 8 to 11 minutes
Causes	<b>reset system 4</b> command Escalation from reset level 3 Power up Recovery attempt from SPE-down mode (requested by reboot command, or automatically every 20 minutes) Spontaneous interchange into an unrefreshed standby SPE
Effects	System software (boot image) is reloaded, and all processes are reinitialized  The disk, if present and healthy, is the default device from which the software is loaded. Otherwise, the reload is taken from tape  Before reboot, the system attempts to save the alarm and error logs to the disk on the active SPE  After reboot, error and alarm logs are restored from the SPE that is active coming out of the reboot. (Note that this means that some error and alarm information may be lost if the last save before the reboot save does not succeed or if an SPE interchange takes place)



Other effects are the same as those in reset level 3, except that more extensive diagnostics are performed.

If reboot fails, SPE-down mode is invoked.

If a core dump is enabled for this reset level via the **set vector** command, the reboot is delayed until the core dump has completed.

## Reset Level 5 (Extended Reboot)

---

Duration	Up to 25 minutes
Causes	<b>reset system 5</b> command  This reset is invoked only by command
Effects	Effects are the same as for a level 4 reboot except that more extensive diagnostics are performed.  This reset is used to diagnose SPE component failures not detected by level 4 reboot tests.

## Initialization Diagnostics

---

For each reset level, the system performs a series of diagnostic tests on components of the SPE to confirm that the system can be brought into service. The management terminal displays the result of each test as it occurs. If a reboot fails, and the system cannot bring itself up, SPE-down mode is invoked. A description of this mode, with troubleshooting procedures available to it, appears in the following section.

[Table 4-1](#) shows the diagnostic tests run during initializations. Level 1, 2 and 3 resets 4 perform the first 11 tests (through the Timer Test). Reboots complete all tests in the table except the last one. Only extended reboots execute the Memory Board Couple Test.

If a test fails, make the indicated repair. If more than one repair is indicated, perform them in the order shown until the problem is resolved. Follow procedures described in [“Replacing SPE Circuit Packs”](#) in [Chapter 5, “Alarms, Errors, and Troubleshooting”](#).

**Table 4-1. Initialization Diagnostics for All Reset Levels**

Test	Description/Recommendation
Internal Register Test	Replace processor.
Loop Data Test	Replace processor. Replace memory 1. Reseat all circuit packs in the processor carrier except SYSAM. The carrier may be defective. Follow normal escalation procedures.
Duart Test	Replace the processor board. Failure of this test will not prevent the system from running, but the processor is probably faulty.
Rom Checksum Test	Replace the processor.
Control Status Test	Replace the processor.
Dcache Test	Replace the processor. Failure of this test may not prevent the system from running, but degradation of service is probable.
Icache test	Replace the processor. Failure of this test may not prevent the system from running, but degradation of service is probable.
Write Buffer Test	Replace the processor. Replace the memory 1.
Bus Test	Replace processor. Replace memory 1. Reseat all circuit packs in the processor carrier except SYSAM. The carrier may be defective. Follow normal escalation procedures.
Parity Test	Replace the processor. Replace the SYSAM.
Timer Test	Replace the processor.
Bus Config Test	Replace processor.
Mem Config Test	Check memory boards for correct TN number and positioning on the carrier. Reseat memory boards.
Memory Functional Test	Replace memory boards one at a time until test passes.
Memory Board Stuck Bit Test	Replace memory board.
Memory Board EDC Test	Replace memory board.

*Continued on next page*

**Table 4-1. Initialization Diagnostics for All Reset Levels — Continued**

Test	Description/Recommendation
Memory Board Burst Test	Replace memory board Replace processor board The carrier may be defective. Follow normal escalation procedures.
Sysam Test	Replace the SYSAM board.
Vm Test	Replace the processor.
Exception Test	Replace the processor.
MSS Test	Replace the MSSNET board. Replace the processor.
Sanity Timer Test	Replace the SYSAM board.
Dupint Test	Replace the DUPINT board.
Disk Test	Replace the disk drive.
Loading Disk	Reformat disk. Replace the MSSNET board.
Ram Data Checksum Test	Reboot from whichever device (tape or disk) was <i>not</i> used for the failed reboot. Replace memory.
Ram Text Checksum Test	Reboot from whichever device (tape or disk) was <i>not</i> used for the failed reboot. Replace memory.
Tape Test	Replace the tape cartridge. Replace the tape drive. Replace the MSSNET board.
Pktint Reset Test	Replace the packet interface board.
Mem Board Couple Test (Extended reboot only)	Replace the indicated memory board.

## **SPE-Down Command Interface**

A limited command interface called the SPE-down interface can be used to communicate with low level firmware when system software is unavailable for executing the usual maintenance commands. This is useful in three situations.

- The SPE is down in a system without duplicated SPEs
- The standby SPE is down in a system with duplicated SPEs
- One SPE is locked standby in a system with duplicated SPEs

## SPE-Down Mode

Severe problems with components of the SPE may render a non-duplicated system incapable of call processing and other normal operations. When this happens, the system enters SPE-down mode and software is no longer in control. If the SPE is duplicated, this situation only occurs when *both* SPEs have fatal faults. Otherwise, if one SPE goes down, an interchange will occur and the system will run on the newly active SPE.

## SPE Locked Standby or Standby SPE-Down

The SPE-down interface can be useful when repairing a standby SPE on a duplicated system. For example, if handshake communication is down, this is the only way to communicate with the standby SPE. Or, if a circuit pack on the standby has been replaced, this interface allows you to test both that circuit pack and the rest of the standby SPE before unlocking.

When the standby SPE on a duplicated system is down, or locked by means of the SPE-Select switches, it is no longer in communication with the active side, and the system is functionally unduplicated. In this state, the normal Maintenance User Interface is unavailable to the standby SPE. You can use the SPE-down interface to test the standby SPE and verify its health before rebooting or unlocking. A test of all SPE boards takes only a short time and ensures that all problems have been fixed and the SPE is ready to return to service.

## Bringing Up the SPE-Down Interface

When SPE-down mode is in effect, the red LED will be lit on the Processor circuit pack and the system will present the following message:

```
***** SPE DOWN MODE *****
```

An alarm-notification call already in progress will preempt input from the terminal. When the call is completed or dropped, the system displays the results of the call and a welcome message with one of the following prompts, indicating which SPE is currently connected to the terminal.

SPE_A_DOWN>	If SPE-A was active when the system went down
SPE_B_DOWN>	If SPE-B was active when the system went down
SPE_DOWN>	If the SPE is unduplicated

You can now enter SPE-down interface commands as described in [“Using the SPE-Down Interface”](#). If the prompt does not appear, check the connections between the terminal and the control carrier. Make sure the cable is connected to the connector labeled *ACTIVE*. If possible, try a different cable and/or terminal. If the prompt is still not present, replace the SYSAM circuit pack. If the SPE remains down with no prompt, follow normal escalation procedures.

To return the standby SPE to service, see the following section on [“Bringing the SPE Back into Service”](#).

## SPE Locked Standby or Standby SPE-Down

To bring up the SPE-down interface on a functioning duplicated system, connect the terminal to the STANDBY terminal connector on the rear panel of either processor carrier. Assuming all cabling is intact, either connector will access the SPE which is standby. If the standby SPE is down, the message and prompt shown above are displayed. To enter SPE-locked-standby mode, carefully, and *one at a time*, move the SPE-Select switches to the position indicating the carrier of the currently active SPE. For example, if the SPE in carrier A is active, move the switches to position A. When the SPE is locked, SPE interchanges are prevented, memory shadowing is turned off, handshake is down, and maintenance activities normally controlled by software on the active SPE cease. The following message is printed, (in this example, A is locked standby):

```
*****SPE A locked standby*****
```

One of the following prompts will appear, indicating which SPE is locked *standby* and whether the SPE is down.

```
SPE_A_LOCKED>
```

```
SPE_B_LOCKED>
```

```
SPE_A_DOWN_LOCKED>
```

```
SPE_B_DOWN_LOCKED>
```

You can now enter the commands described in [“Using the SPE-Down Interface”](#). If the prompt fails to appear, check your connections. Try connecting to the connector labeled STANDBY on the other PPN control carrier (A or B). If possible, try using a different cable and/or terminal. If the above actions do not produce a prompt, replace the SYSAM circuit pack on the standby SPE. If the prompt is still not present, follow normal escalation procedures.

If an SPE was down and the SPE-Select switches are set to lock, the down-and-locked-standby mode *replaces* the SPE-down mode. Normally, when the standby SPE is up and cycling, the yellow LED on the Processor circuit pack flashes on and off. If the SPE is locked standby *and* a terminal is connected to the STANDBY connector, the Processor LED remains unlit.

To return the standby SPE to service, see the following section on [“Bringing the SPE Back into Service”](#).

**⇒ NOTE:**

The physical connection of the terminal to the STANDBY connector while the SPE is locked standby with the SPE-Select switches prevents the Standby Maintenance Monitor (SMM) from running. Any reboot command to the standby while it is in the locked state will abort.

## Using the SPE-Down Interface

When one of the above prompts appear, you may enter Spe-down interface commands. These are executed by the Low-level Maintenance Monitor (LMM), which is firmware resident on the processor board for controlling initialization and recovery actions, and processor and memory diagnostics.

Communications with the terminal are handled by the SYSAM board. If a remote access port (SYSAM-RMT) call is received while in this mode, it will preempt access by the local MT, and this message will be displayed:

```
Local Terminal session overridden by remote access  
KEYBOARD LOCKED, WAIT FOR SYSAM OR LOGIN PROMPT
```

When the call is completed or dropped, the prompt will return. Note that the SPE-down interface to an SPE that is locked standby is never available to the remote access port, because the standby SPE is isolated from the active SYSAM circuit pack.

A limited set of commands is available to the SPE-down interface, as follows.

**Table 4-2. SPE-Down Interface Commands**

<b>Keyboard Entry</b>	<b>Command</b>
<b>?</b>	Help
<b>r</b>	Reboot
<b>s</b>	Secondary reboot
<b>d</b>	display alarms
<b>t al</b> or <b>t</b>	Test all standby SPE circuit packs
<b>t sy</b>	Test SYSAM circuit pack
<b>t pr</b>	Test Processor circuit pack
<b>t m1</b>	Test Memory circuit pack 1
<b>t m2</b>	Test Memory circuit pack 2
<b>t m3</b>	Test Memory circuit pack 3
<b>t m4</b>	Test Memory circuit pack 4
<b>t ma</b>	Test all Memory circuit packs
<b>t du</b>	Test DUPINT circuit pack
<b>t ms</b>	Test MSSNET circuit pack
<b>t p1</b>	Test PKTINT circuit pack 1
<b>t p2</b>	Test PKTINT circuit pack 2
<b>t p3</b>	Test PKTINT circuit pack 3
<b>t pa</b>	Test all PKTINT circuit packs

The following qualifier can be used with the test commands:

**1 to 99**                      Number of repetitions (default is 1)

Enter *only* the characters which appear in bold type. For instance, to test all memory boards ten times, enter **t ma 10** Entering **t** results in testing all boards once. You can abort the execution of a command by pressing **ESC** 3 times.

## Test Commands

After a command is entered, various test result messages are printed on the terminal, indicating whether each test passes, fails or aborts. If any components fail, refer to the Maintenance Object documentation that applies. Additional information for interpreting these results can be found in the ["Troubleshooting a](#)

[Duplicated SPE](#)” and [“Testing the Standby SPE”](#) sections in [Chapter 5, “Alarms, Errors, and Troubleshooting”](#). Note that the test memory command performs exhaustive tests and can be very time-consuming.

When testing is complete, the system readies itself for another command and the prompt appears. If testing does not complete within 20 minutes, the following message is displayed:

```
LMM did not finish test in time.
```

This is a serious error indicating that the processor, bus, and/or LMM are not working properly. Normally you will see initial test result output within a few seconds. If not, you can abort the test request by pressing ESC 3 times, and the command prompt will be returned.

If the SPE-down mode is entered or re-entered as a result of the test request, the screen displays:

```
Can't continue - test aborted.
```

Again, this is a serious error, but at least the processor is able to handle SPE-down reporting. Likely fault locations are memory board number 1, processor board, or processor/memory bus.

## Display Alarms Command

The display alarms command asks for the alarms that caused the SPE to go down. It is valid only in the SPE-down or down-and-locked-standby mode. If **d** is entered while the SPE is in one of the down modes, the following header is displayed:

```
DISPLAY ALARMS:
```

Physical Name	Logical Name	On Board?	Alternate Name	Alarm Type	Date Alarmed	Date Resolved
------------------	-----------------	--------------	-------------------	---------------	-----------------	------------------



The header is followed by one and only one of the following lines (except that more than one Memory circuit pack failure may be displayed):

```

----      PROCR          y      -----  MAJOR      -----  -----
-----    MEM_BD_0      y      -----  MAJOR      -----  -----
-----    MEM_BD_1      y      -----  MAJOR      -----  -----
-----    MEM_BD_2      y      -----  MAJOR      -----  -----
-----    MEM_BD_3      y      -----  MAJOR      -----  -----
-----    MSS_NET       y      -----  MAJOR      -----  -----
-----    TAPE          y      -----  MAJOR      -----  -----
-----    DISK          y      -----  MAJOR      -----  -----
-----    NO_TAPE       y      -----  MAJOR      -----  -----
-----    BOOT_ERROR                    -----  MAJOR      -----  -----
-----    SPE_SAN                    -----  MAJOR      -----  -----
    
```

Note that the display is designed to approximate an alarm display from software maintenance, but is not populated with certain information, represented by dashed out fields. Only the first failed component detected is displayed.

In the absence of any other information about the cause of the failure, replace the indicated component using the procedures described in Replacing SPE Circuit Packs. After all tests pass, return the standby SPE to service, with procedures described in the following section on [“Bringing the SPE Back into Service”](#).

BOOT\_ERROR indicates that the LMM was not able to either load, start, or keep the SPE running following a reboot request. SPE\_SAN indicates that SYSAM detected enough sanity timeouts to exceed the threshold.

## Reboot Commands

After all SPE-down interface tests have passed, an SPE can be brought back up by using the reboot commands. The reboot command, **r** starts a reboot using the boot image loaded on the disk device. The secondary reboot command, **s**, starts a reboot using the boot image loaded on the tape device. The latter is useful if the boot image on the disk is corrupted, the disk device is faulty, or a different software load is desired. A reboot can be interrupted by pressing ESC 3 times.

As noted earlier, if an SPE is locked in the standby mode, the reboot commands cannot be entered and will abort.

## Bringing the SPE Back into Service

---



### **WARNING:**

*In a system with duplicated SPEs, a spontaneous SPE interchange may occur if the active SPE is not in good health and either*

- an unlocked SPE completes its reboot and handshake is reestablished
- a locked SPE in which the Standby Maintenance Monitor (SMM) is running is unlocked



### **WARNING:**

*Use the status spe command to determine the health of the active SPE and whether an interchange will occur.*

Once all tests pass using the SPE-down interface, the SPE should be competent to return to service. There are however certain problems which will not show up in testing that may prevent this. Follow the appropriate procedure below to bring the SPE back up.

## Simplex SPE

After the reboot command is entered, a series of diagnostics is run on the SPE. Results are displayed as they occur, as described in preceding sections. If all tests pass, the boot image is loaded and control is given to the operating system.

If you cannot get the SPE to reboot after replacing the components that failed SPE-down interface tests, follow normal escalation procedures.

## Duplicated SPE

The physical connection of the terminal to the STANDBY connector, while the SPE is locked standby with the SPE-Select switches, prevents the Standby Maintenance Monitor (SMM) from running. Thus, any reboot command to the standby while in this state will abort. To reboot an SPE that is locked standby and has a terminal connected to it, simply move the SPE-SELECT switches to the AUTO position one at a time. This will automatically cause the standby SPE to reboot and its progress is displayed on the terminal. Moving the switches back to the locked position will cause the reboot to abort.

To reboot the standby SPE and have it remain locked standby following the reboot, use the following procedure:

1. Start the reboot by moving the SPE-Select switches one at a time to the AUTO position.

2. As soon as initialization diagnostics begin to appear on the screen, disconnect the MT cable from the STANDBY connector on the control carrier.
3. Return the SPE-SELECT switches to their previous locked position.

When the standby is back up and cycling, the yellow LED on the Processor circuit pack will begin flashing. It is then safe to unlock the SPE-Select switches if they were relocked. At this point, the system should re-establish handshake communication, turn on memory shadowing (assuming the standby is not busied out), and perform a refresh of the standby SPE's memory. These steps can be monitored by using the **status spe** command at a terminal connected to the ACTIVE terminal connector. When these steps have been completed, the standby SPE should have a "functional" state of health and be fully in service.

If all tests pass, but the SPE does not return to service, there may still be problems on the standby which escaped detection by SPE-down testing. In this case, use the following steps, which describe a means of sequentially replacing circuit packs that are the most likely source of the problem.

1. First determine if memory shadowing is disabling handshake. With the standby locked, busyout the standby SPE; this prevents shadowing from turning on.
2. Bring up the standby as described above (unlock, unplug the STANDBY terminal and relock). If the yellow LED on the Processor fails to flash, follow normal escalation procedures. After the yellow LED begins flashing, unlock and monitor the recovery progress by repeatedly entering **status spe** on a terminal connected to the *active* SPE. If handshake is not established after 2 minutes, memory shadowing is not the problem. Proceed to step 4.
3. Release the standby and follow the progress of the refresh with **status spe**. If the refresh succeeds, the system should be fully functional. If the onset of shadowing or refresh coincides with handshake failure, replace the following circuit pack one at a time in the order shown and repeat this procedure from step 1 each time. (Use lock-and-power-down and DUP-CHL instructions).
  - a. Standby DUPINT
  - b. Standby PKT-INT
  - c. Standby MSSNET
  - d. Active DUPINT

If the problem persists, follow normal escalation procedures.

4. If handshake has not come up after 2 minutes, replace each of the following circuit packs one at a time, in the order shown, and repeat this procedure from step 1 each time:
  - a. Standby PKT-INT
  - b. Standby DUPINT

**4** Initialization and Recovery

*SPE-Down Command Interface*

4-18

- c. Standby SYSAM
- d. Standby PROCESSOR
- e. Standby MSSNET
- f. Standby MEMORY number 1
- g. Standby MEMORY number 2

If the problem persists, follow normal escalation procedures.

# Alarms, Errors, and Troubleshooting

# 5

## Safety Precautions

---

By observing the prescribed safety precautions when working on the system, you can avoid unnecessary disruption of service and damage to the equipment. The items on this list should be a regular part of your routine.



### **WARNING:**

*Failure to comply with these procedures can have catastrophic effects on system service and hardware. Read the explanations following the list to ensure a complete understanding of these necessary procedures.*

- Whenever touching any component inside the cabinet, ground yourself by means of the wrist strap attached to the cabinet, and avoid sources of static electricity.
- When logging on with the terminal, be aware that INADS alarm notification is normally disabled. Log off the terminal when leaving the system.
- Think carefully before moving SPE-SELECT switches. Always set them one at a time to the letter of the PPN control carrier that is *currently active* (unless a procedure specifically tells you to do otherwise).
- Never “hot plug” an SPE circuit pack, except for the tape and disk drives on a simplex SPE. Lock and power down the PPN control carrier first.
- Do *not* power down switch node or port carriers to replace a board.
- Handle fiber optic cables with care. Bending, piercing, or cutting the cable can sever communications between major subsystems.
- When disconnecting fiber optic cables, grasp of both the lightwave transceiver and the cable connector.

- Before powering down a cabinet or carrier that contains DEFINITY AUDIX circuit packs (TN566), first power down the AUDIX unit to avoid damaging the AUDIX software. Instructions for powering down this unit are in the [“DEFINITY AUDIX System Power Procedures”](#) below, on the circuit pack, and in DEFINITY AUDIX documentation.
- When you are finished working on a cabinet, replace and secure all panels and covers to avoid disseminating electromagnetic interference.

## DEFINITY AUDIX System Power Procedures

---

### Manually Power Down AUDIX System

A yellow caution sticker on the system's power unit notifies technicians to shut down the DEFINITY AUDIX System prior to powering down the system.

1. Using a pointed object, such as a paper clip or pen (do not use a pencil), press the Boot/shutdown button. The button is located at the top right portion of the front panel.
2. Hold the boot/Shutdown button in until the LCD display flashes the message MSHUT.
3. Release the Boot/Shutdown button.



#### NOTE:

The DEFINITY AUDIX System takes about five minutes to shut down. The “heartbeat” indication on the display continues to flash.

### Manually Power Up AUDIX System

1. Using a pointed object such as a paper clip or a pen (do not use a pencil), press the Boot/Shutdown button.
2. Hold the boot/Shutdown button in until the display indicates the message, BTEST, steady on.
3. Release the Boot/Shutdown button. the DEFINITY AUDIX system takes approximately 5 minutes to power up.
  - The display has the following sequence of steady on messages:
    - OSINIT
    - OS
    - AINIT
    - ADX

- The DEFINITY AUDIX System is now powered up. When the system is in the active state, the display indicates `ADX`, and the red LED is off.



**NOTE:**

When powering up, the DEFINITY ADUXI System automatically reboots. This sequence may show an `MD` or `MJ ADX` alarm in the display until the system has powered up. When the system has completed its power up sequence, the display reads: `ADX`.

## Electrostatic Discharge

Whenever a circuit pack is inserted or removed, the grounding wrist strap attached to the cabinet must be used to avoid damage or disruption from ESD. Use of the wrist strap is also required whenever touching any components inside the switch cabinet, including the SPE-SELECT and EMERGENCY TRANSFER switches. While such actions may not cause a problem in a highly controlled environment, disruption to the system could result when conditions are not ideal, (for example, when the air is very dry).

If you *must* proceed when a wrist strap is not available, grab the outside panel of the cabinet with one hand *before* touching any components, and keep your extra hand grounded throughout the procedure.

Handle a circuit pack only by the faceplate, latch, or top and bottom edges. Do not touch board components, leads or connector pins. Keep circuit packs away from plastic and other synthetic materials such as polyester clothing. Do not set a circuit pack on a non-conductive surface such as paper. Use the anti-static bag, if available.

Never hand a circuit pack to another person unless that person is also using a wrist ground strap.

The body collects potentially damaging amounts of static electricity from many ordinary activities. The smallest amount of ESD that can be felt is far above that which can damage a sensitive component or disrupt service!

[Figure 5-1](#) shows the location of the grounding jack.

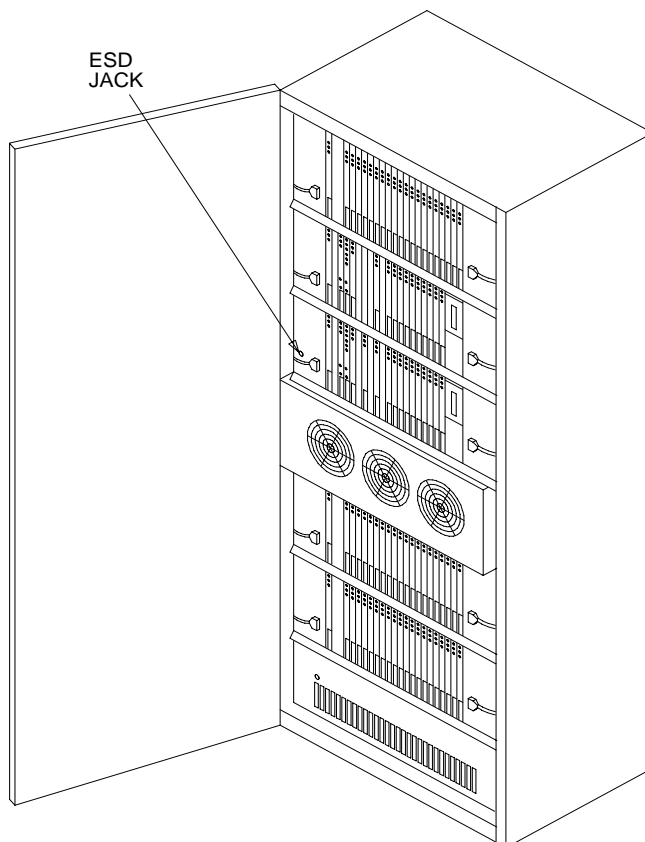

Figure 5-1. Multi-Carrier Cabinet ESD Grounding Wrist Strap Jack

## Suppress Alarm Origination [y]

When logged in as “craft,” no alarms are reported to INADS. After logging off, INADS automatically reactivates, and any unresolved alarms are reported to INADS.

Also, when logged in as “craft,” an automatic logoff of the terminal occurs after 30 minutes of non-use. At that time, any unresolved alarms are reported to INADS. If you are logged in as “craft” at 2 different terminals, the logoff occurs when the second terminal remains unused for 30 minutes.



**NOTE:**

The **test inads-link** command functions even if INADS Alarm Origination is overridden.



## Reseating and Replacing Circuit Packs

Most repair procedures involve replacing faulted circuit packs. In some cases, problems are resolved by reseating the existing circuit pack. Reseat a circuit pack *only* when explicitly instructed to do so by the documented procedures. Reseating is discouraged since it can put a faulty component back into service without addressing the cause, resulting in additional and unnecessary dispatches. After reseating a circuit pack, make sure the problem is really fixed by thorough testing and observing the component in operation.

When a port board is removed from the backplane, no alarm is logged for about 11 minutes to allow for maintenance activity to proceed. After that, a minor on-board alarm is logged. If the port board is not administered, no alarm is logged.



**WARNING:**

*This procedure can be destructive, resulting in a total or partial service outage.*



**WARNING:**

*Proceed only after consulting and understanding the applicable service documentation for the component.*



**WARNING:**

*Observe all Safety Precautions described above.*



**WARNING:**

*If the yellow LED on the circuit pack to be removed is lit, the circuit pack is active and services using it will be interrupted.*



**WARNING:**

*Follow special procedures for the circuit packs listed below.*

## Special Procedures

---

The following circuit packs require special procedures.

For components of the SPE, see “Replacing SPE Circuit Packs”.

- UN331B Processor (SPE)
- TN1650B Memory (SPE)
- TN1655 Packet Interface (SPE)
- TN1648 SYSAM (SPE)
- UN332 MSSNET (SPE)
- TN1657 Disk (SPE)
- TN1656 Tape (SPE)
- TN768/780 Tone/Clock
- UN330B Duplication Interface
- TN750 Expansion Interface
- TN573 Switch Node Interface
- TN572 Switch Node Clock
- DS1 CONV

## Replacing a BIU or Rectifier

---

To remove a Battery Interface Unit (BIU) or rectifier first attach a grounding strap from the cabinet to your bare wrist then follow the steps listed below:

1. Unlock the latch pin.
2. Pull down on the locking lever until the BUI or rectifier moves forward and disconnects from its socket.
3. Pull the BIU or rectifier out just enough to break contact with the backplane connector. Use steady even force to avoid disturbing the backplane.
4. Carefully slide the BIU or rectifier out of slot.

To install a BIU or rectifier first attach a grounding strap from the cabinet to your bare wrist then follow the steps listed below:

1. Insert the back edge of the BIU or rectifier making sure that it is horizontally aligned. Slide the unit in to the slot until it engages the backplane. Use extreme care in seating the backplane connectors.
2. Lift the locking lever until the latch pin engages.
3. Verify that the unit is seated correctly by observing the operation of the LED's.

## Replacing SPE Circuit Packs

---

All circuit packs on the processor carrier of the PPN except for the Tone/Clock board are components of the SPE. In addition to the customary MO documentation, there are additional diagnostic techniques for these boards described in the following section, [“Troubleshooting a Duplicated SPE”](#). Instructions for replacing the Tone/Clock circuit pack can be found in the TDM-CLK MO documentation.

**WARNING:**

**DO NOT “HOT PLUG” AN SPE BOARD.** *Before removing any SPE circuit pack you must power down the carrier in which it resides, (except in the case of a tape or disk drive in a simplex SPE). Powering down the processor carrier is destructive on a simplex system, causing a total service outage. Be sure you have consulted the appropriate documentation for the component you are replacing. Be sure you are familiar with the precautions at the beginning of this chapter.*

### Simplex SPE

---

This procedure is destructive, resulting in a total service outage except for lines administered with Emergency Transfer. The processor *must* be powered down to avoid hardware damage. Arrange to perform this procedure when a service outage will have the least impact on the customer.

1. Attach the grounding strap to your wrist.
2. Remove power to the processor carrier, (carrier A), by unplugging the power cords located on the front of the power units located at *both* ends of the carrier.
3. Remove or reseat the circuit pack using the procedure described previously in [“Reseating and Replacing Circuit Packs”](#).
4. Restore power to the carrier by plugging both power cords back in.
5. Monitor the system reboot by observing the LEDs and G3-MT output.  
These indicators are described in [Chapter 4, “Initialization and Recovery”](#).
6. Test the replaced component(s) using the appropriate MO documentation.
7. If the same problem persists, reinstall the original circuit pack to avoid confusing further troubleshooting.

## Replacing Circuit Packs on a Duplicated SPE: Lock-and-Power-Down

---

By following the lock-and-power-down procedure, components of a duplicated SPE can usually be replaced with no disruption of service.



### WARNING:

*In a system with duplicated SPEs, a spontaneous SPE interchange may occur if the active SPE is not in good health and either an unlocked SPE completes its reboot and handshake is reestablished, or a locked SPE in which the Standby Maintenance Monitor (SMM) is running is unlocked.*



### WARNING:

*Use the **status spe** command to determine the health of the active SPE and whether an interchange will occur.*

1. Enter **status spe** to verify that the component to be replaced is on the standby SPE. If it is, go to step 2.

If the component is on the active SPE, initiate a planned SPE interchange by entering **reset system interchange**. If the interchange fails, there may be faults on the standby SPE preventing the interchange. You must either repair the fault on the standby SPE first, or force an interchange by using **reset system interchange health-override**.



### WARNING:

*Forcing an interchange may disrupt service. Arrange to do so at a time suitable for the customer.*

2. Enter **status port-network 1** to check the health of the PPN Tone/Clocks.

The Tone/Clock in the same carrier as the active SPE should have a service state of "in." If not, repair it using "TDM-CLK" before proceeding.

3. Lock the active SPE.

After grounding yourself, move the SPE-SELECT switches on both DUPINT boards, 1 at a time, to the carrier designation of the active SPE. For example, if the A carrier SPE is currently active, move the switches to position "A."

4. Enter **status port-network 1** to verify that the active Tone/Clock is in the same carrier as the active SPE.

If not, repeat the command until this condition is met. If the active Tone/Clock has not migrated to the active carrier after 1 minute, there is a Tone/Clock problem. The Tone/Clock problem must be fixed first to avoid service disruption. See "TDM-CLK" maintenance object.

5. Power down the standby processor carrier by:
  - a. Remove the power plug from the **left side** of the carrier first.
  - b. Remove the second power plug from the **right side** of the carrier.
6. Remove the failed circuit pack and replace it with a new one of the same type.
7. Power up the standby processor carrier by:
  - a. Insert the power plug in the right side of the carrier first.
  - b. After inserting the first power plug in the right insert the second power plug in the left side of the carrier.

The red and green LEDs will light indicating restoration of power and testing of the boards. These LEDs will go out as tests pass.

8. This step is optional. Use a terminal and the SPE-down interface to test the standby SPE as follows.

If a terminal is connected to the STANDBY connector on the back of either PPN control carrier, the power-up reboot of the standby aborts and the SPE-Down interface can then be used to enter commands to the LMM firmware. Use **t al**, or the SPE-Down interface test command for the replaced component, to confirm that the problem is fixed. Repair any failures reported.

When testing is finished, move the SPE-Select switches to the AUTO position *one at a time*. This unlocks the standby and begin a reboot which can be monitored from the terminal.

9. Verify that the standby is up.

Regular flashing of the yellow LED on the Processor board indicates that the standby SPE is up and cycling. If the yellow LED is not flashing after five minutes, test the standby SPE as described in the above step. Relock the SPE standby, attach a terminal to the STANDBY connector on the back of either PPN control carrier and execute the SPE-down interface tests. All tests must pass before unlocking.

10. If the standby SPE is still locked, unlock it by returning both SPE-Select switches to the AUTO position *one at a time*.
11. Enter **status spe** to confirm that handshake is up. This should occur within 2 minutes. When it is, enter the **test long clear** command for the replaced component. If an alarm does not clear, consult the appropriate MO.
12. Verify that the standby SPE is brought into service.

Enter **status spe**. The standby SPE is fully operational when handshake is up, shadowing is on, and memory is refreshed. It can take up to 10 minutes after unlocking for the standby to be brought fully into service.

13. If the standby SPE does not fully return to service, consult [“STBY-SPE \(Standby SPE Maintenance\)”](#).

## Troubleshooting a Duplicated SPE

The section on maintenance object [“STBY-SPE \(Standby SPE Maintenance\)”](#) contains procedures for troubleshooting specific problems such as handshake failure, memory shadowing failure, and poor state of health. The following procedures describe a method for determining the cause of a spontaneous SPE interchange and resolving any related problems.

If a spontaneous SPE interchange has occurred, assume that a serious fault has occurred on the SPE that is currently the standby. The following symptoms indicate that a spontaneous SPE interchange has taken place:

- A MINOR alarm with error type 103 is logged against STBY-SPE.
- An interchange entry is recorded in the `initcauses` log.
- The system is put into *recent interchange mode*, which prevents further SPE interchanges from taking place.

The presence of recent interchange mode is displayed on the **status spe** screen. The system is released from this mode, and the minor alarm is cleared, after 1 hour, or upon the execution of **test spe-standby long**, regardless of whether all tests pass.

There are three possible causes of a spontaneous interchange:

- Major hardware failure
- Failed recovery that has been software escalated
- Switching both SPE-SELECT switches to the standby carrier (not a recommended procedure)

In the last case, the interchange is not fault-driven, and no specific repair action is required. To determine whether this is the case, enter **display initcauses**. If the interchange was initiated by the SPE-SELECT switches, the `Cause` field will appear as in the following example.

Cause	Action	Escalated	Carrier	Time
SPE-SELECT switch	1	no	1B	11/27 14:53

If the interchange was fault-driven, there are two ways of finding the cause.

1. Using alarm and error logs in conjunction with the timestamp described above. After a spontaneous SPE interchange has occurred, the Alarm Log retains a record of any MAJOR ON-BOARD alarm against an SPE component that took place before the interchange. This record is retained for three hours and may indicate the cause of the interchange when testing is not possible or conclusive. Other information in the Error Log may also be helpful.
2. Testing the standby SPE when the logs do not identify the problem.

Start by determining the time of the interchange. Then, examine the alarm and error logs as described in the following section. If that does not identify the problem, proceed to the next section, which describes a sequence of tests of the standby SPE.

## Determining the Time of a Spontaneous Interchange

---

There are 2 ways to tell at what time a spontaneous interchange has taken place:

- STBY-SPE Error 103

This error is logged with a minor alarm whenever a spontaneous interchange takes place. The time recorded for the *first occurrence* of the error is the approximate time of interchange. The error is logged against the carrier of the SPE that was active before the interchange. This should now be the standby SPE, assuming no further interchanges have taken place.

- Display initcauses

The **display initcauses** command displays a record of all system resets. In the following example, a spontaneous interchange *into* the B carrier SPE took place at 2:53 P.M. The standby SPE (B) transitioned into active mode with a WARM restart, (reset level 1).

Cause	Action	Escalated	Carrier	Time
Interchange	1	no	1B	11/27 14:53

## Examining the Alarm and Error Logs

The system may have had time to log alarms or errors against the fault the caused the interchange. Proceed through the steps summarized in [Figure 5-2](#). Examine only major alarms with a timestamp near the time of interchange, and whose carrier designation is the current standby SPE (the SPE interchanged out of). Include any resolved alarms meeting this description.

All relevant alarms must be timestamped at or near the time of interchange.

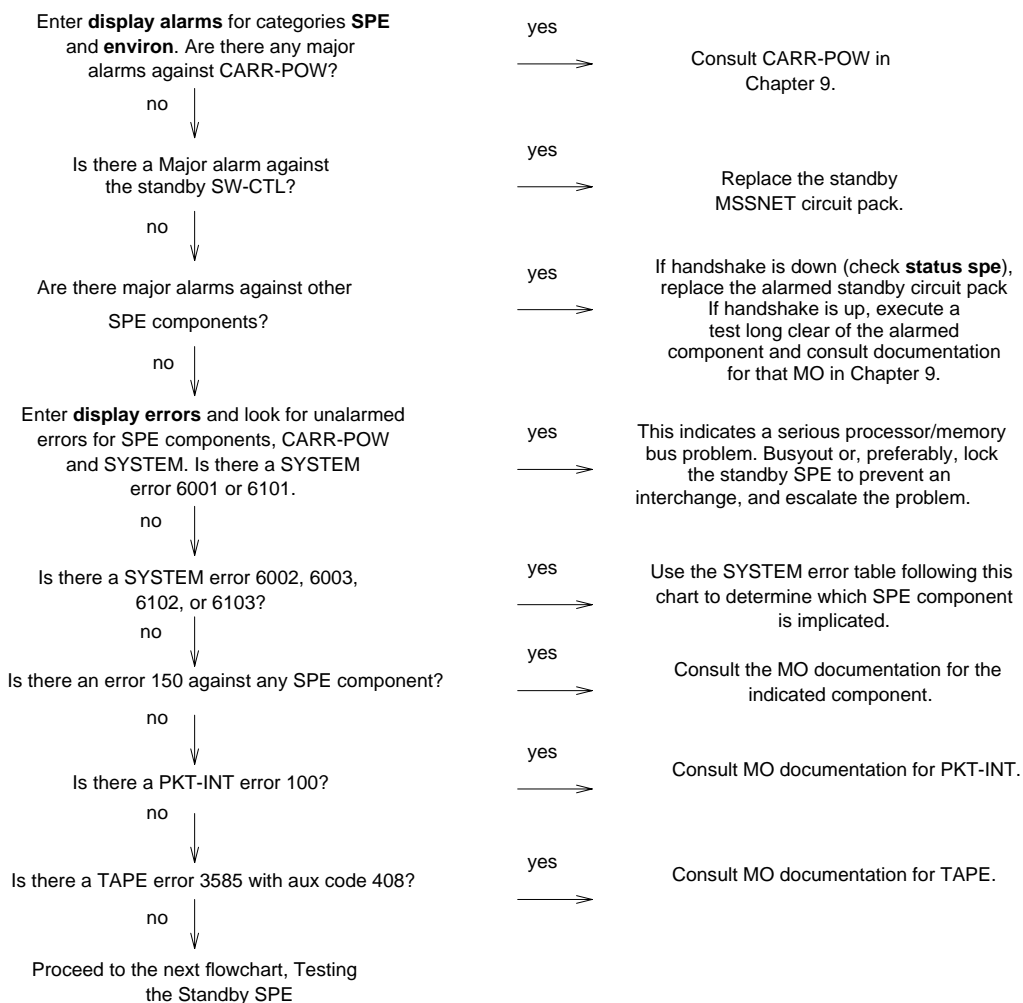

Figure 5-2. Determining the Cause of an SPE Interchange



## **Auxiliary Data for SYSTEM Errors 6002, 6003, 6102, and 6103**

---

The following table shows which components are indicted by the auxiliary error codes found by using the preceding flowchart ([Figure 5-2](#)). Once you have identified the faulted component, consult the section for that MO.

<b>Aux Data</b>	<b>Maintenance Object Implicated</b>
16384	PROCR
16385	MEM-BD
4137	PKT-INT
16391	SW-CTL
16386	SYSAM
16389	DUPINT
16392	HOST-ADAPTER
16397	TAPE
16398	DISK

## Testing the Standby SPE

The system may not have had time to log errors against the failed component that caused the spontaneous interchange. If you have progressed through the preceding flowchart without determining the cause of interchange, test the standby for faults by proceeding through the following steps shown in [Figure 5-3](#).

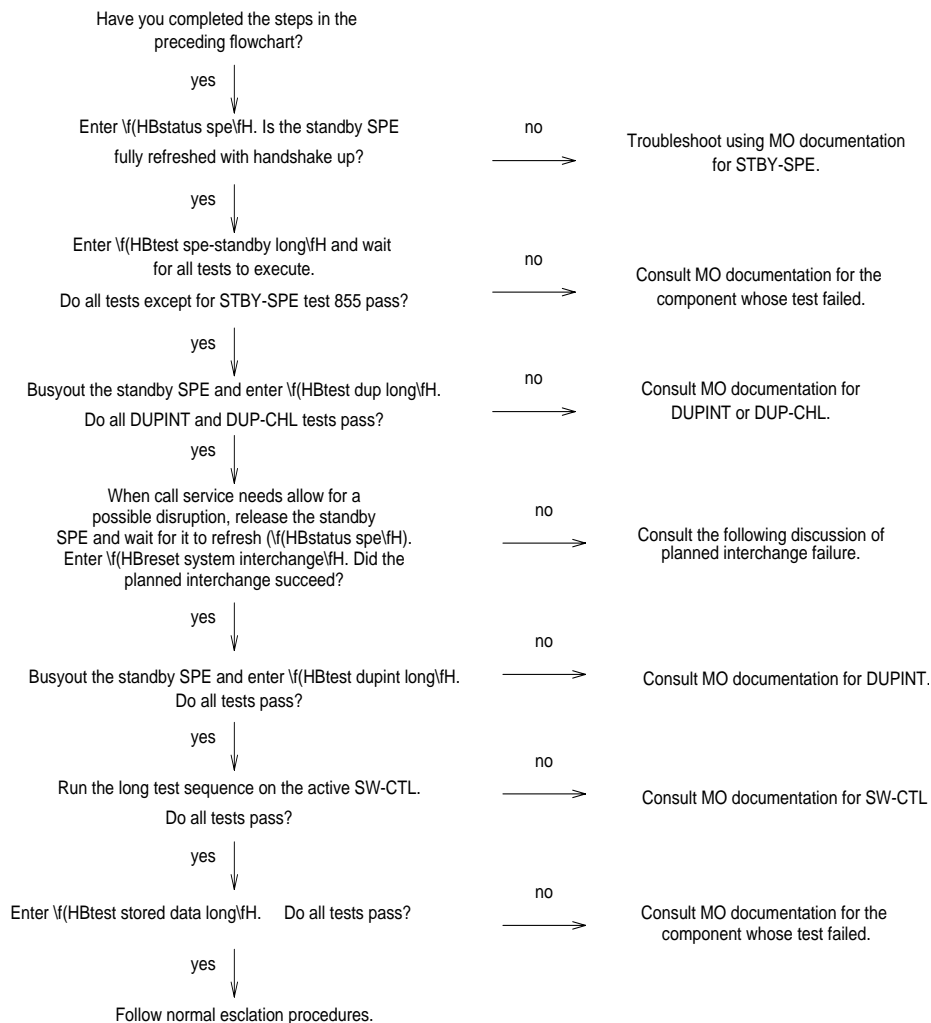

Figure 5-3. Testing the Standby SPE

## Executing a Planned SPE Interchange

---

Planned SPE interchanges are initiated on demand by the **reset system interchange** command, or automatically by scheduled daily maintenance. The latter is administered with the system-parameters maintenance screen. A planned interchange normally has no perceivable effect on service. All active calls, transient calls, system links and stimuli, and data transmission are preserved. The SYSAM-RMT port (also called the Remote Access Port) is dropped, necessitating a re-login. The duration of the interchange is approximately one minute.



### CAUTION:

*Switching the SPE-select switches to the standby carrier causes a spontaneous interchange, not a planned one. This can disrupt service and is not a recommended procedure.*

## Prerequisites

---

Several conditions must be met to guarantee a non-disruptive interchange. If these are not met the system will not execute the interchange. All of these conditions, listed below, are expected to be met during normal operation.

- The SPE must not be locked by the SPE-SELECT switches.
- The standby SPE must be fully in service.  
That is, handshake is up, shadowing is on, memory is refreshed, and standby SPE state-of-health is "functional". "[STBY-SPE \(Standby SPE Maintenance\)](#)" describes how to correct a failure of any of these.
- There can be no minor alarms against the standby's PKT-INT or SYSAM circuit packs.
- There can be no ongoing disk or tape operations on either active or standby MSS components.

Wait until all such operations, such as translation saves or backup restores, are complete before requesting an interchange.

## SPE Interchange Failures

---

If the above conditions are not met, or if any intermediate steps taken by the system in executing the interchange fail, the interchange is prevented. Usually, failure of a planned interchange has no effect on service.

If the interchange fails after the packet interface links have migrated, the system will require a reset level 1 (warm restart) to restore the links. In such a case, no calls are dropped, and new call service resumes within 5 seconds. However, it is probable that there is a severe system problem which predates the attempted interchange.

If the SPE is locked by means of the SPE-SELECT switches, error 607, auxiliary data 1153, is logged against SYSTEM. If the switches are not locked and the interchange fails, an unalarmed error 605 is logged against SYSTEM. The auxiliary code associated with this error indicates which aspect of the interchange failed. [Table 5-1](#) explains the meaning of the auxiliary codes and what corrective action to take.

**Table 5-1. SYSTEM Error 605 Planned Interchange Failure**

Aux Data	See Note	Explanation
1352	<a href="#">1</a>	Standby SOH "non-functional"
1353	<a href="#">1</a>	Standby SOH not "functional"
1355	<a href="#">1</a>	Handshake Communication with Standby SPE is down
1356	<a href="#">1</a>	Memory Shadowing not enabled
1357	<a href="#">1</a>	Standby memory not refreshed
1358	<a href="#">2</a>	Mass Storage System was in use
1359	<a href="#">3</a>	PKT-INT link migration failed
1360	<a href="#">1</a>	Interchange failed <sup>1</sup>
1361	<a href="#">4</a>	SW-CTL failure
1369	<a href="#">7</a>	Could not suspend G3-MT connectivity <sup>1</sup>
1370	<a href="#">4</a>	Could not freeze active SW-CTL <sup>1</sup>
1371	5	Internal Error associated with processor interrupts <sup>1</sup>
1372	<a href="#">6</a>	Minor alarm on standby SYSAM or PKT-INT
1395		SPE Duplication not administered
1396	<a href="#">3</a>	PKT-INT Link Migration failure in Begin Step <sup>1</sup>
1397	<a href="#">3</a>	PKT-INT Link Migration denied, (peer test in progress)
1398	<a href="#">3</a>	PKT-INT Link Migration failure in Completion Step <sup>1</sup>
1399	<a href="#">3</a>	PKT-INT Link Migration failure in Finish Step <sup>1</sup>
1400	<a href="#">4</a>	Could Not Idle SW-CTL dual port RAM <sup>1</sup>
1401	<a href="#">4</a>	Could Not Refresh SW-CTL dual port RAM <sup>1</sup>
1402	<a href="#">5</a>	Internal Error (could not get duplication status)
1403	5	Unable to inhibit Standby Maintenance Monitor
1404	<a href="#">5</a>	Failure to determine Standby SPE alarm status

*Continued on next page*

**Table 5-1. SYSTEM Error 605 Planned Interchange Failure — Continued**

Aux Data	See Note	Explanation
1406	<a href="#">3</a>	Active SPE's PKT-INT in held-reset state
1418	<a href="#">8</a>	Active Duplication Interface circuit pack is in a bad state and needs to be reset.
2500	<a href="#">5</a>	Internal Software failure <sup>1</sup> (sometimes)

1 A WARM restart is required.

Notes for SYSTEM Error 605 AUX Data:

1. Follow repair instructions in [“STBY-SPE \(Standby SPE Maintenance\)”](#) for the particular standby SPE problem. After fixing that problem, try the interchange again.
2. Mass Storage System is in use. Check Disk and Tape LEDs for activity. Wait until all MSS activity completes, then try the interchange again. If the problem persists, check for alarms and errors against MSS components and follow repair procedures for each Maintenance Object.
3. Test the PKT-INT on both carriers with the long test sequence. Follow procedures for [“PKT-INT \(Packet Interface Circuit Pack\)”](#). Once *all* tests of both PKT-INTs pass, try the interchange again.
4. Consult SW-CTL service documentation. Test SW-CTL on both carriers with the long test sequence. Follow repair instructions for any failures. Once *all* tests of both SW-CTLs pass, try the interchange again.
5. Make sure the standby SPE is refreshed. Then try the interchange again.
6. Examine alarm log to determine which of PKT-INT or SYSAM circuit packs has a minor alarm against it. Consult service documentation of whichever is alarm to clear.
7. Check for errors/alarms against active SPE's SYSAM. If you find any, consult the [“SYSAM \(Circuit Pack\)”](#) documentation. If you find none, and if all tests of the SYSAM long sequence pass, try the interchange again.
8. Run **test duplication-interface long** and follow instructions for any test that does not pass.

## LA85 Port Tester

The LA85 port tester (Comcode 105138424) is recommended for troubleshooting all DEFINITY station troubles involving analog, DCP, MFET, MFAT, or BRI configuration. The port tester detects the presence of voltage from equipment ports and is designed to indicate the status of the wiring at the:

- Wall field in the equipment room
- Wall field in any intermediate closet
- Wall jack at the station
- Terminal and terminal station cord

Use the information in [Table 5-2](#) to isolate problems with the port tester.

**Table 5-2. Port fault isolation using the LA85 Port Tester**

To begin the isolation procedure at the	You may need this preliminary information on equipment	And if	Then
Wall field in equipment room	Use <b>display errors</b> command	Off-board errors indicated	Verify wiring from switch to equipment room wall field.
Station (terminating end)			<ol style="list-style-type: none"> <li>1. Unplug station cord from terminal and plug it into the "BRI" or "Other" jack on the tester, as applicable.</li> <li>2. If the readings are OK, the terminal, handset, or handset cord may be faulty.</li> </ol>
Station wall jack	<ol style="list-style-type: none"> <li>1. Wrong or incorrect reading from the terminal end of the station cord (from Step 1 above)</li> <li>2. D8W line cord (Comcode 103786761) used at station wall jack</li> </ol>		<ol style="list-style-type: none"> <li>1. If the reading from the jack is OK, then the terminal cord may be faulty.</li> </ol>

**Table 5-2. Port fault isolation using the LA85 Port Tester — Continued**

To begin the isolation procedure at the	You may need this preliminary information or equipment	And if	Then
Intermediate closet wall field			1. Isolate part of the wiring span (either to the switch or to the terminal)

The port tester is equipped to check 110-type wall field hardware with the three 1-pair patch cords that are color-coded blue (1), orange (2), or green (3).



**NOTE:**

If the wall field has 66-type blocks, a 66-type block adapter (Comcode 405546474) is needed.



**DANGER:**

*The port tester should not be plugged into an active circuit for an extended period of time. Resistors in the tester can burn out.*

LED indications for the various port types are listed in [Table 5-3](#). Abbreviations are as follows:

- R = Red
- G = Green
- N = Not lighted
- N/A = Not applicable

**Table 5-3. LED indications for the LA85 Port Tester**

Port	W-BL Bl-W	W-O	O-W	W-G	G-W	Bl-W	W-BL
Analog	G <sup>1</sup>	N	N	N	N	N/A	N/A
DCP	N	G	G	G	G	N/A	N/A
DCP (2-wire)	G	N	N	N	N	N/A	N/A
MFET	G	G	G	G	G	N/A	N/A

*Continued on next page*

**Table 5-3. LED indications for the LA85 Port Tester — *Continued***

Port	W-BL Bl-W	W-O	O-W	W-G	G-W	Bl-W	W-BL
MFAT	N	R <sup>2</sup>	R	R	G <sup>3</sup>	N/A	N/A
BRI	N/A	N/A	N/A	G	G	G	G

- 1 The red LED lights on a reversal. If the analog set contains a polarity guard, the set is still operable. Determine whether an off-hook pulls a dial tone that can be broken by dialing.
- 2 Some LA85 port testers may indicate that W-O should appear green. Information in this chart is correct.
- 3 Some LA85 port testers may indicate that G-W should appear red. This chart is correct.



## Fiber Fault Isolation Procedure

Use the following procedure to isolate faults on a fiber-link. When troubleshooting a system with duplicated Port Network Connectivity (PNC), first **busyout pnc-standby** before busying out a standby Fiber-Link (FIBER-LK), Expansion Interface (EXP-INTF), Switch Node Interface (SNI) or DS1 Converter (DS1C). At the end of this section is a description of the loopback tests run and a pinout of the cable used to connect the DS1 C to DS1 facilities.

- A busyout of any of these components on a simplex PNC is destructive.
- Be sure to release all busied out components after completing the tests.

### Steps:

1. Enter **display alarms** with category **pnc**.

Are there any on-board alarms? If so, replace the circuit pack(s).

2. Enter **display errors** for category **pnc**.

Check for any of the following errors:

Maintenance Object	Error Type
FIBER-LK	Any
SNI-BD	513
EXP-INTF	257 769 770 1281 1537 3073 3074 3075 3076 3585 3841 3842

If *one or more* of the above errors are present go to step 3.

If *none* of the above errors are present, look for SNI-PEER errors.

- If there is one SNI circuit pack with many different SNI-PEER error types, replace the indicated SNI circuit pack
- If there are many SNI-PEER errors of the same error type, replace the indicted SNI circuit pack using the following table.

Error Type	SNI slot
1	2
257	3
513	4
769	5
1025	6
1281	7
1537	8
1793	9
2049	13
2305	14
2561	15
2817	16
3073	17
3329	18
3585	19
3841	20

- After replacing an SNI circuit pack, clear alarms by executing **test board UUCSSlong clear** for all alarmed EXP-INTF circuit packs. Wait 5 minutes for any SNI-BD or SNI-PEER alarms to clear. (You can speed this process with **clear firmware counters [a-pnc | b-pnc]** for the PNC that was repaired).
  - Exit this procedure.
3. Enter **list fiber-link** to get the physical location of the fiber-link endpoints. If a DS1 CONV is administered to the fiber-link (DS1 CONV is "y"), use the **display fiber-link** command to get the physical location of the DS1 CONV circuit packs on the fiber-link.
  4. Execute **bussyout fiber-link FP** followed by **test fiber-link FP long**.

*If any tests in the sequence fail, proceed with step 5.*

*If all of the tests pass, clear alarms by executing **test board UUCSS long clear** for all alarmed EXP-INTF circuit packs. Wait 5 minutes for any SNI-BD, SNI-PEER, FIBER-LK, or DS1C-BD alarms to clear. You can speed this process with **clear firmware counters [a-pnc | b-pnc]** for the PNC that was repaired. You are finished with this procedure.*

5. For each endpoint of the fiber-link, follow this flowchart:

**Busyout** and **test board UUCSS long** and record all test failures. When looking at test results, consult the explanations and illustrations of the tests, which appear at the end of this procedure.

Is **Board Not Assigned** displayed for an EXP-INTF in an EPN? If yes, **test maintenance long** to release an EXP-INTF that may be held reset by an EPN Maintenance circuit pack.

If No, did EXP-INTF test 242 fail? If yes, replace the EXP-INTF circuit pack and the lightwave transceiver (if present) and go back to Step 4. (EXP-INTF test 242 runs an on-board looparound if no lightwave transceiver is connected to the EXP-INTF.)

If No, did SNI test 757 fail? If yes, replace the SNI circuit pack and go back to step 4 of this procedure.

If No, did SNI test 756 fail? If yes, replace the SNI circuit pack and the lightwave transceiver (if present) and go back to Step 4.

If No, did EXP-INTF test 240 fail? If yes, replace the EXP-INTF circuit pack and go back to Step 4.

If No, did tests 238 (EXP-INTF) or 989 (SNI) fail? If yes, replace the lightwave transceivers and fiber-optic cable, or metallic cable, and go back to Step 4. The faulted component can be further isolated by using the Manual Loopback Procedure described at the end of this procedure.

**⇒ NOTE:**

If a fiber out of frame condition exists and lightwave transceivers are used, check that both lightwave transceivers are of the same type, (9823a or 9823b). If they are not both the same, replace one of the lightwave transceivers so that they match. (9823A is used for distances up to 4900 feet (1493 m) and 9823B is used for distances up to 25,000 feet (7620 m)).

If No, is a DS1 CONV administered on the fiber-link? If no, follow normal escalation procedures.

If Yes, is there an SNI-BD 513 alarmed error (**display errors** , `category = pnc`)? If yes, replace cabling between the SNI circuit pack and the DS1C circuit pack.

If the alarm persists, replace the DS1C and the SNI circuit packs. and go back to Step 4.

If No, if the connected circuit pack is an EXP-INTF, did Test #238 fail?

If Yes, replace cabling between the EXP-INTF circuit pack and the DS1C circuit pack. If Test #238 continues to fail, replace the DS1C and the EXP-INTF circuit packs and go back to Step 4.

If No, **busyout** and **test board UUCSS long** for both DS1C circuit packs and note all test failures and aborts.

Did the test return `Board not inserted` for the near-end circuit pack (nearest the SPE), or for the far-end circuit pack in a simplex PNC? If so, replace the cabling between the DS1C circuit pack and the SNI or EXP-INTF circuit pack.

Wait 1 minute and retest.

If the board is still not inserted, replace the DS1C circuit pack and the EXP-INTF or SNI connected to it and go back to Step 4.

If No, check to see if any of the CSU devices are looped back. **Busyout** and **test ds1-facility UUCSS external-loop** for each DS1 facility. The tests should fail.

If any test passes, the facility is looped back, and the loopback should be removed. If the DS1C Complex has only one DS1 facility, this test cannot be executed at the far-end circuit pack (farthest from the SPE).

Did test 788 pass and test 789 fail? If yes, replace the DS1C and lightwave transceiver (if present) at the other end of the DS1C complex. See [Figure 5-4](#) and [Figure 5-5](#). Go back to Step 4.

If No, did test 788 fail or abort and test 789 fail or abort? If yes, execute **test ds1-facility UUCSS long** command for each administered and equipped DS1 facility.

If No, did test 797 fail?

If Yes, run the **test ds1-facility UUCSS external-loopback** command for each administered and equipped DS1 facility.

This test requires manually altering the external connections of the DS1 facility. Place the loopbacks at as many points as your CSU capabilities will allow (see [Figure 5-5](#)).

- If Test #799 fails at LB1, problem is with DS1C #1, CSU #1, or the connections in between.
- If test 799 passes at LB1 and fails at LB2, the problem is with CSU #1.
- If test 799 passes at LB1 and at LB2, the problem is with the DS1 facility, CSU #2, connections to CSU #2, or DS1C #2.

## SNI/EI Manual Loop Back Procedure

Use this procedure to isolate a fault in the cables or lightwave transceivers of SNI/EI links. (Do not use this procedure on a connection with a DS1C as an endpoint.) By performing the loopback at both endpoints and, if applicable, at the cross-connect field, the failure point can be identified. If both endpoints pass, but the link remains inactive (with the boards not busied out), the fault should lie in the cabling in between. If the test passes at a transceiver, but fails at the cross-connect field, the cable or connectors in between are at fault.

A short optical fiber jumper with connectors is required for this procedure. If the link uses metallic cable, the metallic connector must be removed from the back of the carrier, and a lightwave transceiver connected in its place.

1. Note the condition of the yellow LED on the circuit pack.
2. Busyout the circuit pack.
3. Disconnect the transmit and receive fiber pair from the lightwave transceiver on the back of the circuit pack. Note which is the transmit fiber and which is the receive fiber for proper re-connection at the end of this procedure.
4. Connect the transmit and receive jacks of the lightwave transceiver with the jumper cable.

#### NOTE:

Make sure that the total length of the fiber jumper cable does not exceed the maximum length recommended for the fiber link connections between cabinets. Otherwise, test results may be influenced by violation of connectivity guidelines.

5. At the front of the cabinet, observe the yellow LED on the looped back circuit pack.
  - If the yellow LED flashes once per second, the circuit pack or transceiver should be replaced.
  - If the yellow LED flashes five times per second, the circuit pack or its lightwave transceiver may need replacement. This condition may also be due to a faulty system clock on the port network (for an EI) or the switch node carrier (for an SNI).
  - If the yellow LED was flashing before starting this procedure, and it is now either solid on or solid off, this circuit pack and its lightwave transceiver are functioning properly.
6. Replace the faulty component(s) and reconnect the original cables in their correct positions. Be sure to use a lightwave transceiver that matches the one at the opposite end.
7. Release the circuit pack.

## Loopback Tests for fiber fault isolation

[Figure 5-5](#) shows the loopbacks performed on the SNI circuit pack for test 756 and test 757. Test 756 reports the result of the off-board loopback; test 757 reports the result of the on-board loopback. Test 756 and test 757 can run individually or as part of the **test board UUCSS long** command for an SNI circuit pack.

Test 242 can be run as part of the **test board UUCSS long** command for an Expansion Interface circuit pack. Besides testing on-board components, this test is helpful for isolating problems between a circuit pack and the lightwave

transceiver. The loopback shown in this diagram shows only part what test 242 does. If no lightwave transceiver is connected to the Expansion Interface circuit pack, an on-board loopback is performed on the Expansion Interface circuit pack. For more information about test 242, see [“EXP-INTF \(Expansion Interface Circuit Pack\)”](#).

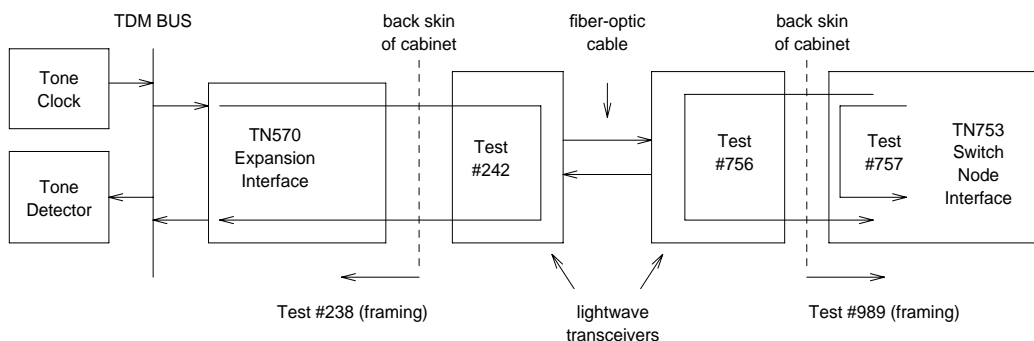

**Figure 5-4. Fiber fault isolation tests**

If DS1Cs exist on the fiber link (check with **list fiber-link**), then additional DS1CONV loopback tests can be run to further isolate the problem. The loopback tests are shown in [Figure 5-5](#). For more information about loopback tests 788 and 789, see the [“DS1 CONV-BD”](#) section in. For more information about DS1 facility loopback tests 797 and 799, see the [“DS1-FAC \(DS1 Facility\)”](#) section.

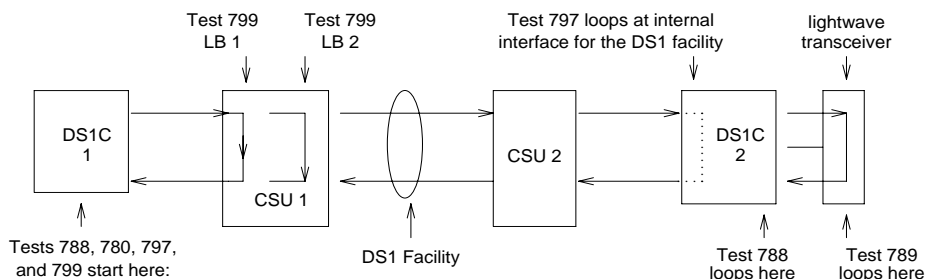

**Figure 5-5. DS1 CONV Loopbacks**

[Table 5-4](#) shows the pin assignments for the cable used to connect the TN574 DS1 CONV circuit pack to DS1 facilities.

**Table 5-4. DS1 Interface Cable Connectors**

Lead	Desig.	50-Pin Connector Pin	15-Pin Connector Color	Pin	Color
<b>Plug 04</b>					
Facility D Line In	LID	38	W-BL	11	W-BL
Facility D Line In	LID*	13	BL-W	03	BL-W
Facility D Line Out	LOD	39	W-O	09	W-O
Facility D Line Out	LOD*	14	O-W	01	O-W
<b>Plug 03</b>					
Facility C Line In	LIC	41	W-G	11	W-G
Facility C Line In	LIC*	16	G-W	03	G-W
Facility C Line Out	LOC	42	W-BR	09	W-BR
Facility C Line Out	LOC*	17	BR-W	01	BR-W
<b>Plug 02</b>					
Facility B Line In	LIB	44	W-S	11	W-S
Facility B Line In	LIB*	19	S-W	03	S-W
Facility B Line Out	LOB	45	R-BL	09	R-BL
Facility B Line Out	LOB*	20	BL-R	01	BL-R
<b>Plug 01</b>					
Facility A Line In	LIA	47	R-O	11	R-O
Facility A Line In	LIA*	22	O-R	03	O-R
Facility A Line Out	LOA	48	R-G	09	R-G
Facility A Line Out	LOA*	23	G-R	01	G-R

## ATM Tips

This section provides tips for DEFINITY ATM PNC when interfacing with the Cajun Networks A500 ATM switch. Throughout this section, refer to [Figure 5-6](#).

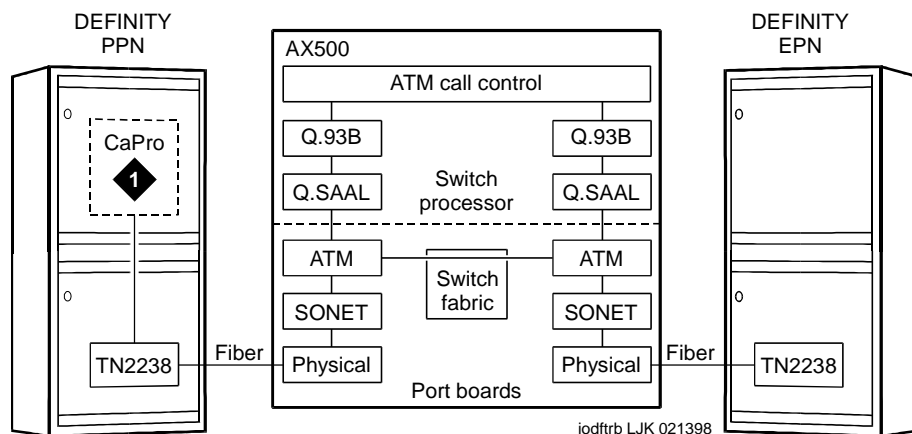

**Figure 5-6. ATM troubleshooting schematic**



**NOTE:**

The CaPro element (Note 1 in [Figure 5-6](#)) is a software module within the DEFINITY PPN.

**Initial LED inspection**

Visually inspect the LEDs on both the TN230X ([Table 5-5](#)) and the ATM switch ([Table 5-6](#)) for a high-level status of the system.

**Table 5-5. TN230X LED reference**

Red	LED color		Interpretation
	Green	Yellow	
Off	Off	Steady on	Normal state for active ATM EI board on PPN.
Off	Off	Off	Normal state for standby ATM EI board on PPN and EPN.
Off	Off	2 sec on / 2 sec off	Normal state for active PNC archangel ATM EI board on EPN.
-	-	100ms on / 100ms off	Loss of signal on the OC-3 fiber. Either the TN230X-receive (top) or TN230X-transmit (bottom) fibers are not working.
N/S	Fast blink	-	Running DSP diagnostics or downloading code to DSPs (typical during boot process).

*Continued on next page*



**Table 5-5. TN230X LED reference — Continued**

Red	LED color		Interpretation
	Green	Yellow	
-	Slow blink	-	Board insertion has not yet completed.
-	Steady on	-	Running maintenance tests. May appear to be blinking if several short tests are run one after another.
Steady on	-	-	Hardware alarm. Does not necessarily take the TN230X out of service, for example, if one of the 24 DSPs fails diagnostics.

[Table 5-6](#) shows the various LEDs on the A500 ATM switch and the meanings of the different states.

**Table 5-6. A500 LED Quick Reference**

Component	Label	Color	State	Meaning
Switch Processor Board	LK	Green	Intermittent blink	Normal state. Traffic is being sent or received over the Ethernet LAN link.
	RX	Green	Steady on	Normal state. Carrier is received over the Ethernet LAN link.
	DIAG	Green	Off	Normal state.
	NBOOT	Green	Off	Normal state.
	MGT	Green	Off	Normal state.
	RUN	Green	Steady on	Normal state. The switch processor is running.
	PWR	Green	Steady on	Normal state. The switch processor board is powered up.
	VOLT	Yellow	Off	Normal state
	TEMP	Yellow	Off	Normal state
	FAN	Yellow	Off	Normal state
	SYSERR	Yellow	Off	Normal state
FAULT	Yellow	Off	Normal state	
Switch Fabric Board	PWR	Green	Steady on	Normal state. The switch fabric board is powered up.

*Continued on next page*

**Table 5-6. A500 LED Quick Reference — Continued**

Component	Label	Color	State	Meaning
	FAULT	Yellow	Off	Normal state
Port Board	PWR	Green	Steady on	Normal state. The port board is powered up.
	FAULT	Yellow	Off	Normal state
Port Board Per Port	RX	Green	Off	No ATM cells are being received. This is not a normal state if the terminating port network is supposed to be up and running.
	RX	Green	Intermittent blink	ATM cells are being received intermittently. This is a typical pattern for DEFINITY if only Variable Bit Rate (VBR) signaling connections are present but no talk paths are up, perhaps because no calls are in progress.
	RX	Green	Steady on	ATM cells are being received frequently enough that the LED is lit constantly. This is a typical pattern for DEFINITY if Constant Bit Rate (CBR) talk paths are present.
	CD	Green	Off	Loss of carrier on the fiber. The A500 detects only if the A500-receive (right-hand) fiber is not working. The state of the A500-transmit (left hand) fiber is not detected.
	CD	Green	Steady on	Normal state. There is a optical carrier detected on the fiber from the TN230X.
	RPRD	Yellow	Off	Normal state
	Power Supply	AC OK	Green	Steady on
DC OK		Green	Steady on	Normal state. DC power is okay.

## **Cajun A500 Diagnostics**

The first step in any diagnostic procedure involving the A500 is to identify the OC-3 ports on the A500 that have DEFINITY port networks attached.

- Be aware that customers may use other ports on the A500 for applications unrelated to DEFINITY (LAN traffic or multimedia applications, for examples).
- These other applications may manifest themselves in the output of the troubleshooting commands you run on the A500. DEFINITY port networks must be identified by their A500 port numbers.

**NOTE:**

The following examples show DEFINITY port networks connected to A500 ports A1.1 and A1.2.

**Has the A500 been installed and configured correctly?****Diagnostics**

- Is the A500 powered up?
- If you are administering the A500 through a locally-attached console, is there a local console terminal connected to the console port on the A500 switch processor board with the correctly-pinned RS232 serial cable?
- If you are administering the A500 through telnet over the Ethernet, is there an 10BaseT Ethernet drop plugged into the Ethernet port on the A500 switch processor board? (Note that a few A500 commands are only permitted over the local console terminal.)
- Has the A500 been booted using either the recessed reset button or by turning the power off, then on again?
- Did the A500 go through a normal power up sequence, including testing all of the LEDs?
- Are any A500 yellow fault LEDs lit?
- Are the remaining A500 LEDs in a normal state ([Table 5-6](#) above)?
- Can you log into the A500 console using the diagnostic account **root** from the local console terminal or through telnet? (See [Figure 5-7](#) below.)

```
A500 System Console
(c) 1997 Lucent Technologies

login: root
password: XXXXXX

***** New System Alarms *****
[1] Failed to fetch configuration files
***** Hit any key to continue *****

A500:
```

**Figure 5-7. A500 login screen**

8. Enter **status** at the A500: prompt. [Figure 5-8](#) shows the output from the status command.

```
System Status

A500 System, Ace_200.01
Copyright 1996, 1997 Lucent Technologies
Built Tue Dec 2 08:45:26 EST 1997
by jdoe in view cm_ace_200

-----

System name           --
System time/date      -- Wednesday, December 3, 1997 15:59:07p
System Uptime         -- days 1,
                     -- hours 1,
                     -- minutes 1
Ethernet IP address   -- 123.1.123.12
Ethernet IP mask      -- 255.255.255.0
LEC IP address        -- 0.0.0.0
LEC IP mask           -- 0.0.0.0
IP default router     -- 123.1.123.123
TFTP server           -- 123.1.123.234
base MAC address      -- 12:34:56:78:9a:bc
ATM address           -- 45.0000.00000123456789abcdef.123456789abc.00
```

**Figure 5-8. A500 screen output for status command**

- a. If the customer is providing an Ethernet connection to the A500, does the `Ethernet IP address` field have the customer-provided Internet address (configured using the **admin address** command)?  

If you are administering the A500 through a telnet connection over the Ethernet, this works, but it is worthwhile making sure the Ethernet address is correct anyway.
- b. If the customer is providing an Ethernet connection to the A500, does the `Ethernet IP mask` field have the customer-provided mask (typically something like `255.255.255.0`, although other values are valid), as configured with the **admin address** command?
- c. If the customer is providing an Ethernet connection to the A500, does the `IP default router` field have the customer-provided Internet address, as configured using the **admin gateway** command?
- d. If the customer is providing an Ethernet connection to the A500 and intends to upload to or download from a TFTP server, does the `TFTP server` field have the customer-provided Internet address, as configured using the **tftp setserver** command?
- e. Does the `ATM address` field have the customer- or Lucent-provided network prefix (the first thirteen bytes and set by using the **modify atmprefix** command)?

## DEFINITY Administration

---

### Is ATM PNC administered correctly?

1. Enter **list atm pnc** on the DEFINITY SAT. The cabinet, carrier and slot positions of each administered TN230X board display as shown in [Figure 5-9](#). Ensure that each board's physical location matches the display.

```
list atm pnc                                     Page 1  SPE A
                                     ATM PNC
PNC                                     A-PNC                                     B-PNC
Connection #                           LOC                                     LOC
1                                       01B02
2                                       02A01
```

---

**Figure 5-9. Screen output for list atm pnc command**

Alternatively, use the **list configuration UUC** command (non-control cabinets) to confirm the PPN and EPN board locations and correct insertion.

2. Enter **status pnc** at the DEFINITY SAT. This display tells you which TN230X board is active in a duplicated system and how many alarms (if any) of each severity level have been logged for the board. [Figure 5-10](#) shows the output from this command.

```
status pnc

                                PORT NETWORK CONNECTIVITY

                                Duplicated? no
                                Software Locked?
                                Standby Busied?

                                Standby Refreshed?
                                Interchange Disabled?

                                A-PNC                                B-PNC

                                Mode: active                        Mode:
State of Health:                                State of Health:
Inter PN Index:                                Inter PN Index:

Major Alarms: 0                                Major Alarms:
Minor Alarms: 0                                Minor Alarms:
Warning Alarms: 0                              Warning Alarms:
```

**Figure 5-10. Screen output for status pnc command**

3. Enter either **list configuration UUC** (for the carrier in which the ATM-EI packs reside) or **display circuit-packs cabinet** (non-control cabinet) at the DEFINITY SAT. This command tells you in more detail what boards are in which slots in each cabinet and carrier. Verify that the TN230Xs are physically located in the slots indicated on the display. [Figure 5-11](#) shows the output for the **display circuit-packs 1** command; [Figure 5-12](#) shows the output for the **display circuit-packs 2** command.

```
display circuit-packs 1
```

CIRCUIT PACKS

```
Cabinet: 1 Carrier: A
Cabinet Layout: five-carrier Carrier Type: processor
```

\*\*\* PROCESSOR BOARDS NOT ADMINISTERABLE IN THIS SCREEN \*\*\*

CIRCUIT PACKS

```
Cabinet: 1 Carrier: B
Cabinet Layout: five-carrier Carrier Type: port
```

Slot Code	Sfx	Name	Slot Code	Sfx	Name
00:			11: TN464	C	DS1 INTERFACE
01:			12: TN464	F	DS1 INTERFACE
02: TN2305		ATM PNC EI	13: TN767	F	DS1 INTERFACE
03:			14: TN767	C	DS1 INTERFACE
04: TN754	C	DIGITAL LINE	15: TN760	D	TIE TRUNK
05: TN746	B	ANALOG LINE	16: TN760	D	TIE TRUNK
06: TN753		DID TRUNK	17:		
07: TN771	D	MAINTENANCE/TEST	18:		
08: TN747	B	CO TRUNK	19:		
09: TN556	B	BRI LINE	20:		
10: TN767	C	DS1 INTERFACE			

'#' indicates circuit pack conflict.

Figure 5-11. Screen output for display circuit-packs 1

```
display circuit-packs 2

                                CIRCUIT PACKS

      Cabinet: 2                      Carrier: A
Cabinet Layout: single-carrier-stack  Carrier Type: expansion-control

Slot Code  Sfx  Name                               Slot Code  Sfx  Name
      11: TN746  B   ANALOG LINE
01: TN2305 ATM PNC EI                               12:
02:
03:
04:
05:
06:
07:
08:
09: TN767  E   DS1 INTERFACE
10: TN754  B   DIGITAL LINE
17: TN754  C   DIGITAL LINE

'#' indicates circuit pack conflict.
```

**Figure 5-12. Screen output for display circuit-packs 2**

4. Enter **display atm pnc portnetwork** on the DEFINITY SAT.

This display tells you the ATM addresses that have been administered for each TN230X. Verify that each ATM address (the concatenation of the five displayed hexadecimal fields) is correct and match those administered in the A500. See [“A500 Administration”](#) for more information.

#### **Administered with hard coded PNNI routes**

If the port networks are addressed using *hard coded PNNI routes* in the A500, the display looks like [Figure 5-13](#) (pnc 1) and [Figure 5-14](#) (pnc 2).



```
display atm pnc 1

                                ATM PNC

                                Connection Number: 1

Location: 01B02
Name:

Address Format: ICD ATM

AFI: 47
ICD: 0005
HO-DSP: 80FFE1000000F2071B02
ESI: 000000000000
SEL: 00
```

**Figure 5-13. Screen output for display atm pnc 1**

```
display atm pnc 2

                                ATM PNC

                                Connection Number: 2

Location: 02A01
Name:

Address Format: ICD ATM

AFI: 47
ICD: 0005
HO-DSP: 80FFE1000000F2072A01
ESI: 000000000000
SEL: 00
```

**Figure 5-14. Screen output for display atm pnc 2**

### Administered with End System Identifiers

If the port networks are addressed using End System Identifiers, the display looks like [Figure 5-15](#) (pnc 1) and [Figure 5-16](#) (pnc 2).

```
display atm pnc 1

                                ATM PNC

                                Connection Number: 1

                                A - PNC
                                Location: 01B02
                                Name:

                                Address Format: E.164 ATM Private

                                AFI: 45
                                E.164: 0001013035381053
                                HO-DSP: 00000000
                                ESI: 000000000011
                                SEL: 00
```

Figure 5-15. Screen output for display atm pnc 1 with End System Identifiers

```
display atm pnc 2

                                ATM PNC

                                Connection Number: 2

                                A - PNC

                                Location: 02A01
                                Name:

                                Address Format: E.164 ATM Private

                                AFI: 45
                                E.164: 0001013035381053
                                HO-DSP: 00000000
                                ESI: 000000000012
                                SEL: 00
```

Figure 5-16. Screen output for display atm pnc 2 with End System Identifiers

## A500 Administration

### Is the A500 administered correctly?

1. Enter **show signaling summary** on the A500 console. [Figure 5-17](#) shows the screen output.

```
A500:show signaling summary
```

Port	loc VCI	SAP	IntType	Signaling	ILMI	SAP State	State
A1.1	1	1	Network	UNI3.1	No	UP	UP
A1.2	2	2	Network	UNI3.1	No	UP	UP

**Figure 5-17. Screen output for the show signaling summary command**

- a. If an A500 port to which a DEFINITY port network is attached is not listed in this display, it is likely that the port was administered incorrectly as having no UNI signaling (**admin link** command).

Ensure that fields listed have the values indicated below.

Field	Value
IntType	Network If it is User, links will not come up between the PPN and the EPN.
Signaling	UNI3.1 If it is UNI3.0, links will not come up between the PPN and the EPN.
ILMI	Preferred value of is No, however this alone does not prevent links from coming up between the PPN and an EPN.
SAP State	May or may not be UP. Their values depend on more than just whether the port was marked as UP. (See highlighted data for SAP State in <a href="#">Figure 5-17</a> .)

- 2. If the A500 was administered using hard-coded PNNI routes to identify each endpoint, enter **show signaling routes** on the A500 console. [Figure 5-18](#) shows the screen output from the command.

```
A500:show signaling routes

Number of Local Static Routes Allowed: 30
Current number of Local Static Routes: 2

Address: 47.00.05.80.ff.e1.00.00.00.f2.07.2a.01.00.00.00.00.00.00
mask:152 cost: 0 node:self port:A1.2 state:UP

Address: 47.00.05.80.ff.e1.00.00.00.f2.07.1b.02.00.00.00.00.00.00
mask:152 cost: 0 node:self port:A1.1 state:UP
```

**Figure 5-18. Screen output from the show signaling routes command**

Check that the `Address` field (administered using the **admin signaling route add** command) matches those administered in DEFINITY.

3. If the A500 was administered using End System Identifiers, enter **show signaling esi** on the A500 console. [Figure 5-19](#) shows the command output.

```
A500:show signaling esi
Addresses registered on A1.1
-----
* 45.0001.01303538105300000000.000000000011.00

Addresses registered on A1.2
-----
* 45.0001.01303538105300000000.000000000012.00

( * - configured )
```

**Figure 5-19. Screen output A500: show signaling esi command**

Check that the `Addresses registered` (use the **admin signaling esi add** command) match those administered in DEFINITY.

- If an address or End System Identifier is missing or incorrect on the A500 port associated with the PPN, the EAL and PACL links will come up, but one-way talk paths may result. (The ATM network can route from the PPN to the EPN, which creates the bidirectional EAL and PACL signaling channels and one side of the talk path.)
- If an address or End System Identifier is missing or incorrect on the A500 port associated with the EPN, the links will not come up between the PPN and the EPN.

4. Enter **show sys interfaces** on the A500 console. [Figure 5-20](#) shows the screen output.

Device	Oper Status	Admin Status	State	Type
A1.1	up	up	present	STS_3c (MultiMode)
A1.2	up	up	present	STS_3c (MultiMode)
A1.3	down	down	present	STS_3c (MultiMode)
A1.4	down	down	present	STS_3c (MultiMode)
A1.5	down	down	present	STS_3c (MultiMode)
A1.6	down	down	present	STS_3c (MultiMode)
A1.7	down	down	present	STS_3c (MultiMode)
A1.8	down	down	present	STS_3c (MultiMode)
A2.1	down	down	present	STS_3c (MultiMode)
A2.2	down	down	present	STS_3c (MultiMode)
A2.3	down	down	present	STS_3c (MultiMode)
A2.4	down	down	present	STS_3c (MultiMode)
A2.5	down	down	present	STS_3c (MultiMode)
A2.6	down	down	present	STS_3c (MultiMode)
A2.7	down	down	present	STS_3c (MultiMode)
A2.8	down	down	present	STS_3c (MultiMode)
A3.1	down	down	invalid	STS_3c (MultiMode)
A3.2	down	down	invalid	STS_3c (MultiMode)
A3.3	down	down	invalid	STS_3c (MultiMode)
A3.4	down	down	invalid	STS_3c (MultiMode)
A3.5	down	down	invalid	STS_3c (MultiMode)
A3.6	down	down	invalid	STS_3c (MultiMode)
A3.7	down	down	invalid	STS_3c (MultiMode)
A3.8	down	down	invalid	STS_3c (MultiMode)
A4.1	down	down	invalid	STS_3c (MultiMode)
A4.2	down	down	invalid	STS_3c (MultiMode)
A4.3	down	down	invalid	STS_3c (MultiMode)
A4.4	down	down	invalid	STS_3c (MultiMode)
A4.5	down	down	invalid	STS_3c (MultiMode)
A4.6	down	down	invalid	STS_3c (MultiMode)
A4.7	down	down	invalid	STS_3c (MultiMode)
A4.8	down	down	invalid	STS_3c (MultiMode)
Self	up	up	present	PROPVIRTUAL
Self	up	up	present	SAR
E1.1	up	up	present	TenBaseT

**Figure 5-20.** A500 screen output for **show sys interfaces** command

- For each administered port used by a DEFINITY port network, the `Admin Status` should be `up` (using the **admin up** command).
- The state of `Oper Status` is not pertinent to administration of the A500 and is discussed in a later section.
- `State` should be `present`, indicating that A500 port board insertion was successful. If `State` is `invalid`, then the A500 believes that the corresponding port board slot is empty or the port board is not recognized.

It may be necessary to re-administer the A500 port boards. Refer to the *Cajun A500 Quick Reference* for further information.

- If `Admin Status` or `State` is incorrect, the links will not come up between the PPN and the EPN.

## TN230X

---

### Did the TN230X come up correctly?

1. Review the LED conditions for the TN230X:
  - Do the TN230X LEDs (see [Table 5-5](#)) indicate a normal operational state (any of the following):
    - Active in the PPN
    - Standby in the PPN
    - Archangel mode in the EPN
    - Standby in the EPN?
2. If after board insertion or a demand reset:
  - Do the TN230X LEDs indicate that it is booting?
  - Do the TN230X LEDs indicate it is downloading its DSPs?
  - Do the TN230X LEDs indicate that board insertion has not yet occurred?
  - Do the TN230X LEDs indicate a maintenance alarm?
3. Enter **list configuration carrier *cabinetcarrier*** on the DEFINITY SAT. See [Figure 5-21](#) (1b) and [Figure 5-22](#) (2a) below.

```
list configuration carrier 1b

                                SYSTEM CONFIGURATION

Board                               Assigned Ports
Number  Board Type                Code    Vintage  u=unassigned t=tti p=psa

01B02   ATM PNC EI                 TN2305 000001
01B04   DIGITAL LINE                TN754C 000002   u u u u u u u u
01B05   ANALOG LINE                 TN746B 000010   u u u u u 06 u u
                                u u u u u u u u
01B06   DID TRUNK                   TN753  000021   u u u u u u u u
01B07   MAINTENANCE/TEST           TN771D 000006   u 02 03 04
01B08   CO TRUNK                    TN747B 000018   u u u u u u u u
01B09   BRI LINE                     TN556B 000003   u u u u u u u u
                                u u u u u u u u
                                u u u u u u u u

01B10   DS1 INTERFACE              TN767C 000003   u u u u u u u u
                                u u u u u u u u
                                u u u u u u u u
```

Figure 5-21. List configuration carrier 1b screen

```
list configuration carrier 2a

                                SYSTEM CONFIGURATION

Board                               Assigned Ports
Number  Board Type                Code    Vintage  u=unassigned t=tti p=psa

02A01   ATM PNC EI                 TN2305 000001
02A09   DS1 INTERFACE              TN767E 000004   u u u u u u u u
                                u u u u u u u u
                                u u u u u u u u
02A10   DIGITAL LINE                TN754B 000016   u u u u u u u u
02A11   ANALOG LINE                 TN746B 000010   01 u u u u u u u u
                                u u u u u u u u
02A17   DIGITAL LINE                TN754C 000002   u u u u u u u u
```

Figure 5-22. List configuration carrier 2a screen

- The TN230X board should be shown in the correct slot.
- Fields should have values as indicated below:

Field	Value
Board Type	ATM PNC EI
Vintage	The TN230X vintage. If Vintage is no board, then either the board is in the incorrect slot or board insertion was not completed correctly. Refer to <a href="#">“Reseating and Replacing Circuit Packs”</a> in this chapter.

4. If the TN230X is inserted and shows a vintage number, enter **test board cabinetcarrierslot** for this board on the DEFINITY SAT, as shown in [Figure 5-23](#) (1b02) and [Figure 5-24](#) (2a01).

```
test board 1b02
```

```
TEST RESULTS
```

Port	Maintenance Name	Alt. Name	Test No.	Result	Error Code
01B02	ATM-EI		316	PASS	
01B02	ATM-EI		598	PASS	
01B02	ATM-EI		1258	PASS	
01B02	ATM-EI		241	PASS	
01B02	ATM-EI		304	PASS	
01B02	ATM-EI		1259	PASS	

Figure 5-23. Screen output for the test board 1b02 command

```
test board 2a01
```

```
TEST RESULTS
```

Port	Maintenance Name	Alt. Name	Test No.	Result	Error Code
02A01	ATM-EI		316	PASS	
02A01	ATM-EI		598	PASS	
02A01	ATM-EI		1258	PASS	
02A01	ATM-EI		241	PASS	
02A01	ATM-EI		304	PASS	
02A01	ATM-EI		1259	PASS	

Figure 5-24. Screen output for the test board 2a01 command



- The `Result` should be `PASS` for each test number. If any of the tests fail, refer to [“ATM-BCH \(ATM B-Channel Trunk\)”](#) in [Chapter 9](#).

## Possible Causes

1. The TN230X board is in a slot different from the DEFINITY administration.
2. The TN230X did not complete board insertion.

## Physical Layer

---

### Is there an optical signal between the TN230X and the A500?

1. Does the TN230X's yellow LED flash 100ms on/100ms off, indicating a loss of signal on the fiber? Recall that the TN230X detects continuity problems with either the Transmit (bottom) or the Receive (top) fibers.

If there is loss of signal on the fiber, refer to the [“Fiber Fault Isolation Procedure”](#) in this chapter.

2. Is the A500 port's CD LED off, indicating a loss of signal on the fiber? Note that the A500 detects continuity problems only with the Receive (right-hand) fiber; the state of the Transmit (left-hand) fiber is not detected.
3. Enter **show signaling summary** on the A500 console. [Figure 5-25](#) shows the screen output.

```
A500:show signaling summary
```

Port	loc	VCI	SAP	IntType	Signaling	ILMI	SAP State	State
A1.1	1	1	1	Network	UNI3.1	No	UP	UP
A1.2	2	2	2	Network	UNI3.1	No	UP	UP

**Figure 5-25. A500: show signaling summary screen**

Ensure that the fields have the values indicated below.

SAP State Up

If it is `PHY_DOWN` or `DOWN`, then there is probably a loss of signal on the port in question. This command detects a continuity problem only with the Receive (right-hand) fiber; it does not detect the state of the Transmit (left-hand) fiber.

State

The value of `State` may be `UP` or `DOWN`, depending on the administration of the port. It may be necessary to re-administer the A500 port boards. Refer to the *Cajun A500 Quick Reference* for further information.

4. Enter **show system interfaces** on the A500 console. [Figure 5-26](#) shows an example of the screen output.

Device	Oper Status	Admin Status	State	Type
A1.1	up	up	present	STS_3c (MultiMode)
A1.2	up	up	present	STS_3c (MultiMode)
A1.3	down	down	present	STS_3c (MultiMode)
A1.4	down	down	present	STS_3c (MultiMode)
A1.5	down	down	present	STS_3c (MultiMode)
A1.6	down	down	present	STS_3c (MultiMode)
A1.7	down	down	present	STS_3c (MultiMode)
A1.8	down	down	present	STS_3c (MultiMode)
A2.1	down	down	present	STS_3c (MultiMode)
A2.2	down	down	present	STS_3c (MultiMode)
A2.3	down	down	present	STS_3c (MultiMode)
A2.4	down	down	present	STS_3c (MultiMode)
A2.5	down	down	present	STS_3c (MultiMode)
A2.6	down	down	present	STS_3c (MultiMode)
A2.7	down	down	present	STS_3c (MultiMode)
A2.8	down	down	present	STS_3c (MultiMode)
A3.1	down	down	invalid	STS_3c (MultiMode)
A3.2	down	down	invalid	STS_3c (MultiMode)
A3.3	down	down	invalid	STS_3c (MultiMode)
A3.4	down	down	invalid	STS_3c (MultiMode)
A3.5	down	down	invalid	STS_3c (MultiMode)
A3.6	down	down	invalid	STS_3c (MultiMode)
A3.7	down	down	invalid	STS_3c (MultiMode)
A3.8	down	down	invalid	STS_3c (MultiMode)
A4.1	down	down	invalid	STS_3c (MultiMode)
A4.2	down	down	invalid	STS_3c (MultiMode)
A4.3	down	down	invalid	STS_3c (MultiMode)
A4.4	down	down	invalid	STS_3c (MultiMode)
A4.5	down	down	invalid	STS_3c (MultiMode)
A4.6	down	down	invalid	STS_3c (MultiMode)
A4.7	down	down	invalid	STS_3c (MultiMode)
A4.8	down	down	invalid	STS_3c (MultiMode)
Self	up	up	present	PROPVIRTUAL
Self	up	up	present	SAR
E1.1	up	up	present	TenBaseT

**Figure 5-26. A500: show sys interfaces**

- Oper Status should be up. If it is down, there is likely a loss of signal on the port in question (State of present), or the A500 does not recognize the port board (State of invalid). This command detects a continuity problem only with the Receive (right-hand) fiber; it does not detect the state of the Transmit (left-hand) fiber.

## Possible Causes

- The fiber is disconnected from the A500 and/or the TN230Xs.
- The Transmit and Receive fibers are swapped at the A500 or the TN230X (but not both).
- There is a break in the fiber.
- The TN230X is not transmitting a carrier (not inserted, not powered, or not administered). See [“ATM-BCH \(ATM B-Channel Trunk\)”](#).
- Hardware safety interlocks on optical transceivers may cut transmitter power if no carrier is received, so lack of a receive carrier could indicate a transmitter problem at the same end.
- The A500 does not recognize that there is a port board in the slot. It may be necessary to re-administer the A500 port boards. Refer to the *Cajun A500 Quick Reference* for further information.

## Recommended Action

1. Plug in, swap, repair, or replace the fiber as necessary.
2. Verify that the port board is inserted.

## SONET Layer

### Are SONET frames reaching the A500?

### Is the A500 port's green RX LED solid off, indicating no cell traffic?

1. Enter **show stats sonet port** on the A500 console. [Figure 5-27](#) shows the screen output.



### NOTE:

The following examples point to port A1.2 as the port of interest.

## Sonet per Port Statistics

```
-----  
Receive Cell Count:      80654  
Transmit Cell Count:     79555  
  
Section Level Bit Err:   1  
Line Bit Err:           1  
Line FEB Err:           168  
Path Bit Err:           1  
Path FEB Err:           98  
Correctable HCS Err:    0  
Uncorrectable HCS Err:  0  
Loss of Frame Err:      1  
Loss of Signal Err:     0  
Out of Frame Err:       0  
  
Path Signal Label:      19
```

**Figure 5-27. A500: show stats sonet a1.2 screen**

Ensure that the fields have the values indicated below.

Receive Cell Count      Each field's values should be increasing if the TN230X is actively sending and receiving cells with the A500. (Even if a TN230X did not achieve board insertion, it will still try to talk to the A500.)

Transmit Cell Count      If neither field is increasing, the A500 port may have been marked down using the **admin down** command. Use the **show system interfaces** command to verify that the Admin Status is up.

If the Receive Cell Count is increasing but the Transmit Cell Count is not increasing, this may be because the port was administered with no UNI signaling (**admin link** command). Use the **show signaling summary** command to ensure that Signaling is UNI3.1.

The error counters may not be zero, but should not be large either compared to the receive and transmit cell counters. If the counters are large and increasing, check the fiber integrity. Make sure the fiber pairs are securely plugged into both the TN230X and the A500.

If the fiber has been pulled and reinserted as part of fault diagnosis, the non-zero Loss of Signal Err counter may be correct.

## Q.SAAL (Data Link) Layer

### Are ATM signaling messages reaching A500 Call Control?

1. Enter **show signaling stats port qsaal** on the A500 console. [Figure 5-28](#) shows the screen output.

```
A500: show signaling stats a1.2 qsaal

-----Q.SAAL Statistics-----
Port A1.2:
-----
Type: UNI3.1
VPI: 0x00, VCI: 0x05

          Tx          Rx
-----  -  -----  -
BGN PDUs:          0          1
BGAK PDUs:          1          0
END PDUs:           0          0
ENDAK PDUs:         0          0
RS PDUs:            0          0
RSAK PDUs:           0          0
BGREJ PDUs:         0          0
SD PDUs:           81          78
SDP PDUs:   Supported only for UNI 3.0
ER PDUs:            0          0
POLL PDUs:        6259        5720
STAT PDUs:        5720        6259
USTAT PDUs:         0          0
ERAK PDUs:          0          0
Discarded PDUs:    0          0
Errored PDUs:      0          0
Buffers in use:    0          0
High buffer mark:  3          0
```

**Figure 5-28.** A500: show signaling stats a1.2 qsaal screen

### ⇒ NOTE:

If there is no connection between the TN230X and the A500 at the Q.SAAL protocol layer, then no report is displayed.

- If Port A1.2 (or the port of interest) is not configured for UNI signaling, then the port was administered for no UNI signaling (**admin link** command). Use the **show signaling summary** command to verify that Signaling is UNI3.1.
- The Supported only for UNI 3.0 line for the SDP PDUs: field means that the port was administered for UNI3.0 signaling (**admin link** command). Use the **show signaling summary** command to verify that Signaling is UNI3.1.

- The POLL PDUs and STAT PDUs counters should be increasing if the TN230X is actively sending and receiving Q.SAAL Protocol Data Units with the A500. This occurs even if the TN230X did not achieve board insertion.

## Q.93B (Network) Layer

### Are connection requests being received by A500 Call Control?

1. Enter **show signaling stats port q93b** (or the port of interest) on the A500 console. [Figure 5-29](#) shows the screen output.

```
A500:show signaling stats a1.2 q93b
```

```
-----Q.93B Statistics-----
```

```
Port A1.2:
```

```
-----
```

	Tx	Rx
Connect Messages:	15	18
Setup Messages:	18	15
Release Messages:	17	13
Rel Cmplt Messages:	13	17
Add Party Messages:	0	0
Add Party Acks:	0	0
Add Party Rejects:	0	0
Drop Party Messages:	0	0
Drop Party Acks:	0	0
Last Cause Code:	31	31
Last Diag Code:	0. 0. 0	71. 0.29
Total Connections:	33	
Current Connections:	3	

**Figure 5-29. A500:show signaling stats A1.2 q93b**

### ⇒ NOTE:

If there is no connection between the TN230X and the A500 at the Q93B protocol layer, then no report displays.

Ensure that the fields have the values indicated below.

Port A1.2 (or the port of interest)	If this field is not configured for UNI signaling, then the port was administered for no UNI signaling ( <b>admin link</b> command). Use the <b>show signaling summary</b> command to verify that Signaling is UNI3.1.
---	--

Connect Messages	These counters should be non-zero if the A500 is handling Q.93B protocol layer messages sent by the PPN and EPN. They may not increase during troubleshooting unless calls are being made, since the PPN initially sets up control connections to the PPN and then sets up talk path connections as needed.
Setup Messages	
Release Messages	

2. If connections are being rejected, the `Last Cause Code` may give a clue to why. The Cause Code ([Table 5-7](#) below) indicating the error may be on the PPN port even though the EPN port is the one misbehaving, and vice versa.

Enter **show signaling cause *causecode*** on the A500 console. [Figure 5-30](#) shows the screen output for this command.

---

```
A500:show signaling cause 31
Cause 31: Normal, unspecified
```

---

**Figure 5-30. A500:show signaling cause 31**

3. At the DEFINITY SAT type **display errors** and press Enter.

Set the `Error List` to **errors** and `Category` to **PNC** on the input screen ([Figure 5-31](#)) and press Enter to display any Cause Codes (see [Table 5-7](#) below) returned from the ATM network to a TN230X on the PPN (and to a TN230X on an EPN). This is successful only if the links between the PPN and the EPN remain up so that the message from the EPN is logged.

Refer to "[ATM-BCH \(ATM B-Channel Trunk\)](#)" in [Chapter 9](#) for detailed information regarding Cause Codes for this Maintenance Object.

```

display errors                                     Page 1 of 1  SPE A
                                         ERROR REPORT

The following options control which errors will be displayed.
ERROR TYPES

Error Type:                                     Error List: errors

REPORT PERIOD

Interval: a      From: / / :      To: / / :

EQUIPMENT TYPE ( Choose only one, if any, of the following )

Cabinet:
Port Network:
Board Number:
Port:
Category: PNC
Extension:
Trunk ( group/member ): /
    
```

**Figure 5-31. DEFINITY display errors Input Screen**

[Figure 5-32](#) shows the screen output for the **display errors** command.

```

display errors                                     Page 9  SPE A
                                         HARDWARE ERROR REPORT

Port      Mtce      Alt      Err  Aux      First      Last      Err  Err  Rt/  Al  Ac
Name      Name      Name     Type Data      Occur      Occur      Cnt  Rt  Hr  St

AT01A    ATM-NTWK      41    1    11/12/16:59 12/09/15:10 14  0  0  n  n
AT01A    ATM-NTWK      31    0    11/13/18:27 11/20/20:02  5  0  0  n  n
AT02A    ATM-NTWK      0     0    11/13/18:45 11/13/18:45  1  0  0  n  n
AT02A    ATM-NTWK      31    0    11/15/14:40 11/15/14:41  2 120  0  n  n
AT01B    ATM-NTWK      31    0    11/16/17:39 11/16/17:39  1  0  0  n  n
AT01A    ATM-NTWK      3     1    11/16/18:19 11/26/13:13 12  0  0  n  n
    
```

**Figure 5-32. Screen output for display errors command**

In this example the errors that have ATM-NTWK for Name and 1 for Data indicate an error returned to the TN230X from the ATM network. In this case, Type indicates the Cause Code returned by the ATM network (see [Table 5-7](#) below). In the example above, two Cause Codes (41 and 3) are reported from the ATM network. For more information about these Cause Codes and repair information see [“ATM-NTWK \(ATM Network Error\)”](#) in [Chapter 9](#).



Table 5-7. Observed Cause Codes

Cause Code	Definition	Observed Cause
3	No route to destination	The ATM addresses administered in the ATM switch ( <b>show signaling routes</b> or <b>show signaling esi</b> ) or in DEFINITY ( <b>display atm pnc</b> ) are incorrect.
31	Normal, unspecified	This is a normal return.
41	Temporary failure	This "try again later" Cause Code has been observed when the source of the problem is on another port (for example, a routing problem on another port that displays Cause Code 3).
47	Resources unavailable, unspecified	DEFINITY call volume is too high for the available resources in the ATM network.
63	Service or option unavailable, unspecified	DEFINITY call volume is too high for the available resources in the ATM network.

## ATM Call Control

### Are ATM signaling connections being setup to A500 Call Control?

1. Enter **show switch circuittable** on the A500 console. [Figure 5-33](#) shows the screen output.

```
A500:show switch circuittable
```

Input			Output			Connection		
port	vpi	vci	port	vpi	vci	type	class	parameters
A1.1	0	5	Self	0	1	pp	UBR	ppd on
A1.1	0	32	A1.2	0	32	pp	VBRnrt	pcr=5729 /scr=5729 /mbs=17187
A1.1	0	35	A1.2	0	35	pmp	CBR	pcr=173
A1.2	0	5	Self	0	2	pp	UBR	ppd on
A1.2	0	32	A1.1	0	32	pp	VBRnrt	pcr=5729 /scr=5729 /mbs=17187
A1.2	0	34	A1.1	0	34	pmp	CBR	pcr=173
Self	0	1	A1.1	0	5	pp	UBR	ppd on
Self	0	2	A1.2	0	5	pp	UBR	ppd on

Figure 5-33. A500: show switch circuittable screen

- The `pp` UBR virtual circuits between A500 ports `A1.1` (PPN) and `Self` (A500) and between `A1.2` (EPN) and `Self` (A500) are ATM signaling channels between the port network and the A500.
- They are used to request connection setups and releases to other end points such as another port network.
- These are established by each TN230X when it comes up, independent of DEFINITY Call Processing.
- Other UBR virtual circuits may exist between A500 ports that are not associated with DEFINITY port networks and may be signaling channels for other applications (for example, data network traffic).

## CaPro Layer

---

### Are control channels being established from the PPN to the EPN?

## Diagnostics

- Do you get a dial tone on a set on the port network in question?
  - Can you ring a set on the EPN dialing from the PPN and vice versa?
1. Enter **list sys-link** on the DEFINITY SAT. [Figure 5-34](#) shows the screen output.

```
list sys-link
```

#### SYSTEM LINKS INFORMATION

Location	Link Type/ Channel	State	Current Path	Faulted Path	Last Fault Recorded
02A0101	EAL	up	present	present	12/06/1997 16:20
01B0202	PACL	up	present	present	12/06/1997 16:17
02A0102	PACL	up	present	present	12/06/1997 16:20

**Figure 5-34. List sys-link screen**

Ensure that the fields have the values indicated below.

Link Type/ Channel	One PACL to each TN230X in either a PPN or an EPN, and one EAL to each TN230X in an EPN.
State	up

2. Enter **show switch circuittable** on the A500 console. [Figure 5-35](#) shows the screen output.

```
A500:show switch circuit
```

Input			Output			Connection		
port	vpi	vci	port	vpi	vci	type	class	parameters
A1.1	0	5	Self	0	1	pp	UBR	ppd on
A1.1	0	32	A1.2	0	32	pp	VBRnrt	pcr=5729 /scr=5729 /mbs=17187
A1.1	0	35	A1.2	0	35	pmp	CBR	pcr=173
A1.2	0	5	Self	0	2	pp	UBR	ppd on
A1.2	0	32	A1.1	0	32	pp	VBRnrt	pcr=5729 /scr=5729 /mbs=17187
A1.2	0	34	A1.1	0	34	pmp	CBR	pcr=173
Self	0	1	A1.1	0	5	pp	UBR	ppd on
Self	0	2	A1.2	0	5	pp	UBR	ppd on

**Figure 5-35. A500: show switch circuit screen**

- The pp VBRnrt (Variable Bit Rate) virtual circuits between A500 ports A1.1 (PPN) and A1.2 (EPN) are used for signaling between the PPN and each EPN.
- These are established once upon initialization under control of DEFINITY Call Processing. They represent the ATM Control Link (ACL) and Expansion Archangel Link (EAL).
- VBRnrt virtual circuits are also be used for ISDN channels between Definity port networks.
- Other VBRnrt virtual circuits may exist between A500 ports that are not associated with DEFINITY port networks. A common use of VBRnrt circuits is multimedia and video-conferencing systems.

## CaPro Layer

### Are talk paths being established between port networks?

## Diagnostics

- Can you talk both ways on a set on one port network dialed from another port network and vice versa?
1. Enter **show switch circuit** on the A500 console. [Figure 5-36](#) shows the screen output.

```
A500:show switch circuit
```

Input			Output			Connection		
port	vpi	vci	port	vpi	vci	type	class	parameters
A1.1	0	5	Self	0	1	pp	UBR	ppd on
A1.1	0	32	A1.2	0	32	pp	VBRnrt	pcr=5729 /scr=5729 /mbs=17187
A1.1	0	35	A1.2	0	35	pmp	CBR	pcr=173
A1.2	0	5	Self	0	2	pp	UBR	ppd on
A1.2	0	32	A1.1	0	32	pp	VBRnrt	pcr=5729 /scr=5729 /mbs=17187
A1.2	0	34	A1.1	0	34	pmp	CBR	pcr=173
Self	0	1	A1.1	0	5	pp	UBR	ppd on
Self	0	2	A1.2	0	5	pp	UBR	ppd on

**Figure 5-36. A500:show switch circuit screen**

- The pmp CBR (Constant Bit Rate) virtual circuits (VCs) between A500 port A1.1 (PPN) and A500 port A1.2 (EPN) are used for talk paths between port networks (PPN to EPN, EPN to PPN, or EPN to EPN).
- They are established when calls are first setup between port networks. Each virtual circuit represents one party of a complete multiparty talk path.
- The report above shows one complete talk path: one unidirectional point-to-multipoint virtual circuit from A1.1 to A1.2, and another from A1.2 to A1.1.
- These virtual circuits may persist beyond the duration of a phone call. The DEFINITY Call Processing software saves virtual circuits for a few seconds after the end stations have hung up in case the VC can be used again for another call between the same two port networks.
- In early version of the Release 2 A500 firmware, these connections incorrectly identified as pmp UBR.
- There may be other CBR virtual circuits between A500 ports that are not associated with DEFINITY port networks. A common CBR application is Circuit Emulation, in which T-1, T-3, etc. circuits are carried over ATM.

## Unusual ATM trouble conditions

---

There are a few failure modes in the DEFINITY/A500 combination that are particularly difficult to diagnose. One example might be that you can't make a completely successful call, even though most indications from DEFINITY and the A500 look pretty good. This section documents some hints and clues that may help diagnose the following failure modes:

- [Incorrectly typed or omitted EPN Route or End System Identifier \(A500\)](#)
- [Swapped Routes, End System Identifiers, or Fiber between a PPN and an EPN](#)
- [Swapped Routes, End System Identifiers, or Fiber between A and B side TN230Xs on an EPN](#)
- [Swapped Routes, End System Identifiers, or Fiber between two EPNs](#)

### Incorrectly typed or omitted EPN Route or End System Identifier (A500)

---

#### Symptoms

Talk paths are one-way, from the PPN to the EPN: you can hear tones from the PPN end station to the EPN end station but not vice versa. Because the signaling channels are bidirectional virtual circuits (VCs) established from the PPN to the EPN, these can be routed correctly and come up just fine. Talk paths are two unidirectional virtual circuits, so a single call has one VC from the PPN to the EPN (which is routed correctly) and one VC from the EPN to the PPN (which cannot be routed).

#### Diagnostics

1. At the A500 use the **show signaling routes** or **show signaling esi** command(s) as appropriate to check the ATM addresses.
2. Use **show signaling stats port q93b** on the EPN port and look for Cause Code 3 (No route to destination).

#### Action

1. Correct the ATM address translations in the A500.

### Swapped Routes, End System Identifiers, or Fiber between a PPN and an EPN

---

#### Symptoms

- An incorrectly-connected EPN TN230X does not complete board insertion.

5 Alarms, Errors, and Troubleshooting  
*Unusual ATM trouble conditions*

5-58

- Dial tone is present on end stations on the PPN and on correctly-connected EPNs, but no dial tone is present on the affected EPN end stations.
- Calls cannot be made between the PPN and the correctly connected EPNs, because talk paths cannot be routed correctly.

## Diagnostics

1. The **show switch circuittable** command on the A500 shows VBR control channels from the A500 port intended for the incorrectly-connected EPN (but actually connected logically or physically to the PPN) that should not exist.

## Action

1. Correct the ATM addresses (or swap fibers) on the A500 between the incorrectly-connected PPN and EPN.

## Swapped Routes, End System Identifiers, or Fiber between two EPNs

### Symptoms

- All TN230Xs complete board insertion.
- The PPN cold starts both incorrectly connected EPNs as usual.
- Both EPNs log many `WRONG BOARD INSERTED` errors (use **list configuration all** or **display circuit-packs <carrier>**) providing the EPNs actually do have different boards configured in the same slots.
- Some end stations may work if they are connected to the correct board in the same slot on both EPNs. Otherwise, end stations on the PPN have dial tone, while end stations on the EPNs do not.
- All A500 diagnostic commands look good.

### Diagnostics

1. Check log for `WRONG BOARD INSERTED` errors (use **list configuration all** or **display circuit-packs <carrier>**).

### Action

1. Correct the ATM addresses (or swap fibers) on the A500 between the incorrectly connected EPNs.

## Swapped Routes, End System Identifiers, or Fiber between A and B side TN230Xs on an EPN

### Symptoms

- The PPN establishes links to what it thinks is the active TN230X on the EPN.
- As normal, it reboots this TN230X, and when complete, it resets the EPN. When this happens, the active (instead of the standby) TN230X reboots, dropping the links.
- To recover, the PPN re-establishes links to what it thinks is the active TN230X and the cycle repeats indefinitely.

### Diagnostics

1. The **status pnc** command on the DEFINITY SAT shows both the A-side and B-side State of Health field as partially functional.

### Action

1. Correct the ATM addresses (or swap fibers) on the A500 between the A and B side of the EPN.

## Multimedia Call Handling (MMCH)

### Expansion Services Module

The Expansion Services Module (ESM) provides T.120 data sharing capability on a MMCH multipoint H.320 video conference. Each conference participant must have endpoints administered and a personal computer with the H.320 video application installed. The DEFINITY ECS must have the expansion service module installed.

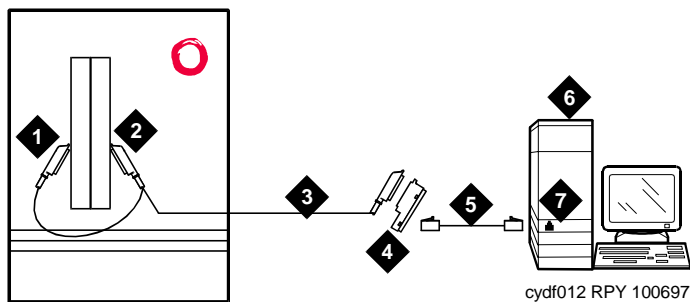

Figure 5-37. Typical ESM connections

## Figure Notes

1. Port B Y-cable connector to a TN787 Multimedia Interface (MMI) circuit pack
2. Port A Y-cable connector to a TN2207 PRI circuit pack
3. 25-pair Y-cable
4. 356A adapter
5. D8W cord connected to 356A adapter port 1
6. Expansion Service Module (ESM)
7. Port B on compatible primary rate interface (PRI) card



### CAUTION:

*The TN2207 circuit pack is the only pack allowing connection of an ESM to the DEFINITY ECS switch.*

## Troubleshooting

---

Before troubleshooting any problems associated with the DEFINITY MMCH, always be sure that the endpoint is operating correctly (audio, video, and data) by making point-to-point test calls. If possible, make the test calls over the network to test the connectivity and routing of network calls from the endpoint. This eliminates problems such as disconnected audio or video cables and network troubles.

### 64 Kbps Calls Terminate but Far End Receives 56 Kbps Indication

#### Description

Some 2x64 Kbps conferences on the DEFINITY MMCH do not establish because of framing, audio, or video problems.

For calls that are routed in the network through a Lucent Technologies/LEC interface, the originating equipment may launch a 64 Kbps call attempt, and the far end receives either a 56 Kbps or 64 Kbps indication. If the far end receives a 64 Kbps indication, the call may have used 56 Kbps facilities. If so, the call may exhibit any of the following conditions:

- No handshaking in one direction or both (call disconnects after timeouts)
- Call connects, but audio or video is corrupted (audio noise or no video)
- Call succeeds without disruption (this is the least likely since one endpoint must be aware that the call is really 56 Kbps to connect)

If any of the above conditions occur, then 64 Kbps calls from the site are blocked.

#### Solution

Administer the conference for connection at 56 Kbps.



## Calls Terminate with No Audio

### Description

To support endpoints that do not support Multipoint Command Conference (MCC), the DEFINITY MMCH changes its capability set and initiates a capability set exchange with the endpoint when the Selected Communications Mode (SCM) changes. If the endpoint does not follow the SCM audio mode, the MCU may include the endpoint as a secondary (audio only) endpoint. If the endpoint sends an unknown or unsupported audio mode, then the TN788B decoder port mutes the endpoint from the conference. The user may hear the conference but may not be heard by other parties in the conference.

### Solution

1. Use the Status Conference x form and check the Audio Mode field for the current operating mode of the conference.
2. Another indication of the audio modes is in the "Incoming Mode Commands from Endpoint and Outgoing Commands from MMI" on page 3 of the Status Conference x Endpoint y form. Check the `Audio` fields under the Mode Commands/Communication Modes section of the form.

## Some Parties Cannot Be Heard by Others (Audio Subsetting)

### Description

Problems where varying subsets of the conference hear different things may have problems with the various summing resources/groups that are in use. Traditionally these faults are caused by the SPE not cleaning up the connections properly. Isolation and diagnosis should focus on the VC resources in use by that conference.

### Solution

1. Use the **status conference** command to list the VC resources in use by this conference. Try a hot replacement of any VC boards in use, which refreshes the VC translations and move all of the audio connections to different VC ports.
2. If the problem still exists, try dropping the conference and then bringing the conference back up again. Not only does this refresh VC translations, but uses different timeslots as well.
3. If the problem still exists, suspect a hardware problem. If practical, wait for the DEFINITY MMCH to be idle (no active conferences), and then check the circuit packs for active (yellow) LEDs. If any of these are unexpected, such as on a VC board, try replacing the board and then bringing the conference up again.

## Calls Terminate with No Video

### Description

Generally, loss of video can be divided into 2 types. The first occurs when the DEFINITY MMCH switches to the endpoint, but nobody sees them. The receivers see either "black" video or a frozen image of the previous speaker depending on the codec of the manufacturer. The type occurs when the DEFINITY MMCH does not switch to an endpoint.

### Solution

In the first type described above, wiring problems, power to the camera, or video encoder circuit pack problems in the codec are typical causes.

In the second type, no video from an endpoint typically occurs because it is not a valid video source. This can be checked by looking at page 1 of the Status Conference x Endpoint y Vid form under the Capability section. In this section, a "y" or "c" suggests that the endpoint has video. An "e" means ept has not declared any video capability in cap set, "n" is audio only, and "blank" means audio add-on.

Also check page 1 of the Status Conference x Endpoint y Vs form for indication of the video state for the endpoint values.

## Calls Terminate Correctly but Are Unstable

A number of conditions will lead to some or all endpoints having stability problems during the course of a conference. A lack of stability from an endpoint is noticeable by a lack of a video switching while the party is the only talker or excessive disconnects from that endpoint.

### Synchronization

Generally, the most common problem is a mismatch in synchronization sources between the endpoint and the DEFINITY MMCH. This typically causes low-level (Px64) handshake problems that can trigger the endpoint/MMCH to disconnect the call. The MCCH's timers are set to sufficiently high values so that, normally, the endpoint will timeout and disconnect first. If installed in a customer network, it is a good idea to perform an audit of the path synchronization is being supplied. If there are different clock sources between endpoints and the DEFINITY MMCH, some problems are sure to occur. The severity of these problems can range from a handshake failure every few seconds to one per day. Depending on the type of endpoint, this can cause the endpoint to disconnect or just freeze video until the main problem is resolved.

Specifically, PictureTel System 4000 endpoints seem to be the most sensitive to instability. The Lucent Technologies Vistium also disconnects fairly infrequently. Last, the CLI Rembrandt II VP freezes video and waits for framing to be recovered.

## Network Configuration Concerns with Synchronization

When auditing a network for synchronization, avoid unnecessary hops. Thus, a switch providing star-configuration synchronization is preferred over a daisy-chain configuration. Additionally, if there are DEFINITY PBXs that have EPNs, synchronization should be provided to sub nodes from the same port network through which the PBX receives its synchronization. Passing synchronization through the PBX Expansion Interface adds an unnecessary hop to the path and creates another potential point of failure.

## Expansion Interface Duplication

If a customer's network uses PBX EPNs with duplicated Expansion Interfaces, scheduled switching of the Expansion Interface links should be disabled on the PBX via **change system-parameters maintenance**. When scheduled maintenance runs and switches the links, there is a brief corruption of the data path. If endpoints have active calls when the switch occurs, this corruption of the data path causes Px64 handshake problems, which lead to the endpoints losing video source status, and sometimes disconnecting as described above. Disabling the EI switching is in the customer's best interest to prevent the disruption of the Px64 data stream. The customer will get the same level of alarm indications and maintenance on the EI links, regardless of the status of scheduled switching.

## PRI D-Channel Backup

A somewhat unlikely source of call stability problems occur where the translations for PRI D-channel Backup between two non-MCU switches were incorrect. As an example, on switch A, DS1 1A10 was designated as the primary source, and on switch B, the corresponding DS1 was designated as the secondary source. When scheduled maintenance was run on the switch that had an active standby D-channel, an audit disconnected some calls using the link. The problem was corrected when the the D-channel primary/secondary assignments matched.

## Processor Duplication on the PBX

Do not enable the PI link switch on scheduled maintenance. This can cause link stability problems on the Accunet Bandwidth Controller (ABC).

## Voice-Activated Switching Problems

Voice-activated switching on the DEFINITY MMCH does not follow the loudest talker. The MMCH queues all speaking parties and selects a new video broadcaster (the second-oldest speaking party) when the oldest speaking party has stopped talking. The new broadcaster will see the last speaker as its video. The system can also "learn" about the noise coming from an endpoint to help prevent false switches, adapting both to noise level and repetitive sounds such as a fan. This adaptation occurs over approximately 10 seconds.

## No Switching, Full Motion Video

If a room is excessively noisy, the DEFINITY MMCH may receive sufficient audio signal to conclude that there is a speaker present. Use the Status Conference X form to determine if the MMCH thinks an endpoint is talking. The MMCH sets the `Ts` field to `t` for each endpoint if there is voice energy detected. This endpoint may have to mute when nobody at the site is speaking to allow the conference to proceed normally. Remind the customer that it may be necessary to mute if a side conversation is going on in the background, just as one would do in an audio conference. If the system does not switch broadcasters even after the current broadcaster has muted, check the conference administration using the **display conference X** command to ensure that the conference is in voice-activated mode. Also verify that parties who were speaking are valid video sources as described in the "[Calls Terminate with No Video](#)" section above.

The See-Me feature (MCV) can also cause VAS to "lock-up." An endpoint can activate MCV to force their site to become the broadcaster. If they do not disable the feature when finished, the system remains in this mode indefinitely. Beginning with Release 3.0, the **status conference X** command shows that MCV is in effect by displaying `av` in the Video Status (Vs) column. Page 3 of the Status Conference X Endpoint Y form also has a `Broadcaster` field that indicates MCV is in effect with (SEE-ME) as the broadcaster. The same scenario can occur in a CHAIR or UCC-controlled conference with a designated broadcaster. In this situation the CHAIR/UCC has not released the designated broadcaster and returned to VAS mode. If there is a UCC-designated broadcaster, **status conference X** indicates a Video Status of `u`. Also, for UCC rollcall the return video may appear to be stuck. Check the Video Status for an "R," indicating rollcall.

If none of the examples above appears to be the cause, and if the room was quiet, all speakers are valid video sources, the conference is voice-activated, and the speaker can be heard, then escalate the problem.

## Video Never Switches to a Particular Party

### Description

Verify that the endpoint is a valid video source as described in the "[Calls Terminate with No Video](#)" section above. If it is, then the audio from the endpoint may not have sufficient voice signal for the hardware to determine the parties at the endpoint are speaking. Check the `Talk` field on page three of the Status Conference X Endpoint Y form to see if the `talking bit` is `y`. Next, check the audio by standing adjacent to the microphone and speaking at a normal level.

### Solution

If the audio is not muffled:

1. Use the **status conference** command to determine which port on the TN788B (VC board) is connected to this endpoint.

2. Check the VC (TN788B) board using the **test board xxyy long** command.
3. Drop the call.
4. Find another available port, then:
  - a. Busyout the port to which the endpoint was connected.
  - b. Make another call to the same conference. If the problem corrects itself, then the previous port may be bad. If there are other VC boards with sufficient available ports to replace calls on the current VC, then pull the board that has the bad endpoint on it (the **status conference** command displays the encoder port associated with the call). The system will automatically reestablish the VC connections without dropping the call. If this fixes the problem, then replace the board, as it has at least one bad port. Reseating the board may temporarily fix the problem due to the hard reset done to the board.

## Audio Echo

Echo in conference calls, particularly those with large delay characteristics, is totally disruptive. When Voice Activated Switching is taken into account, the effects are disastrous. Various arrangements of the microphone(s) and room speaker(s) may be needed.

For some Lucent Technologies Vistium endpoints, if an external speaker is attached or was attached when the system was last rebooted, this endpoint will cause audio echo throughout the conference. First, isolate the offending endpoint by asking each endpoint to mute, one at a time, until the echo disappears.

If the input from an endpoint is located too close to the speakers of an endpoint, then acoustic echo is created. The microphone must be moved away from the speakers.

Normally, if any microphone in the room is moved relative to the speakers, that site will cause echo until the echo canceller in the codec retrains itself, some will require a manual reset. If a PictureTel keypad is configured with external microphones connected to the keypad, then the internal microphone and external microphone(s) "sing" to each other if the "ext mic" bat switch is set to "int mic" on the back of the keypad. In this configuration, VAS locked on that site, and the acoustic "singing" was inaudible.

## Rate Adaptation

Because of a lack of a clear explanation in standards, sometimes endpoints do not work well with each other and the DEFINITY MMCH. The MMCH will only allow a conference to downgrade from 64kbps to 56 kbps operation on conferences that have the `Rate Adaptation` flag set to `y`.

When a downgrade does occur, information on the Status Conference form indicates the success or failure of the 64kbps-endpoints that are participants to properly rate adapt to 56kbps. As a general indication that the conference has rate adapted, the `Conference Transfer Rate` and `Effective Transfer Rate` fields show initial and current transfer rates, respectively. For each 64-kbps endpoint the column that indicates `Rate Adapt` shows an `n` if the endpoint did not follow the procedures as specified by the H.221. If an endpoint shows `y`, it did successfully rate adapt. If an endpoint shows `c`, it joined the conference at 56kbps.

Once the conference rate adapts, the endpoints that do not properly follow suit, will become audio-only endpoints. A conference will not rate adapt from 56 kbps back to 64 kbps until all endpoints disconnect from the conference and it idles.

The PictureTel 1000 Release 1.1C, PictureTel 6.01 software, and the Vistium 2.0 software successfully rate adapt with the MCU. External rate adaptation techniques used by VTEL and CLI are known to cause problems with the endpoint when used with this feature.

## Endpoint or I-MUX in Loopback Mode

Some endpoints have a loopback enable feature. This makes DEFINITY MMCH data loopback at the MMCH when a connection is in progress. The loopback can be enabled prior to or during a connection.

The MMCH does not detect the loop and continues to VAS. In most scenarios, the switch occurs, but within a few seconds, the broadcaster's return video becomes its own image. Once the broadcaster stops speaking, the system "false" switches to an apparently random port that was not speaking.

## Troubleshooting ISDN-PRI Problems

The following flow chart defines a layered approach when troubleshooting ISDN-PRI problems. Since a problem at a lower layer affects upper layers, layers are investigated from low to high. In the flowchart, the DS1 facility is layer 1, the ISDN-PRI D-channel is layer 2, and the ISDN trunks are layer 3. Transient problems are diagnosed on Page 2 of the flowchart. For problems with PRI endpoints (wideband), see the following section.

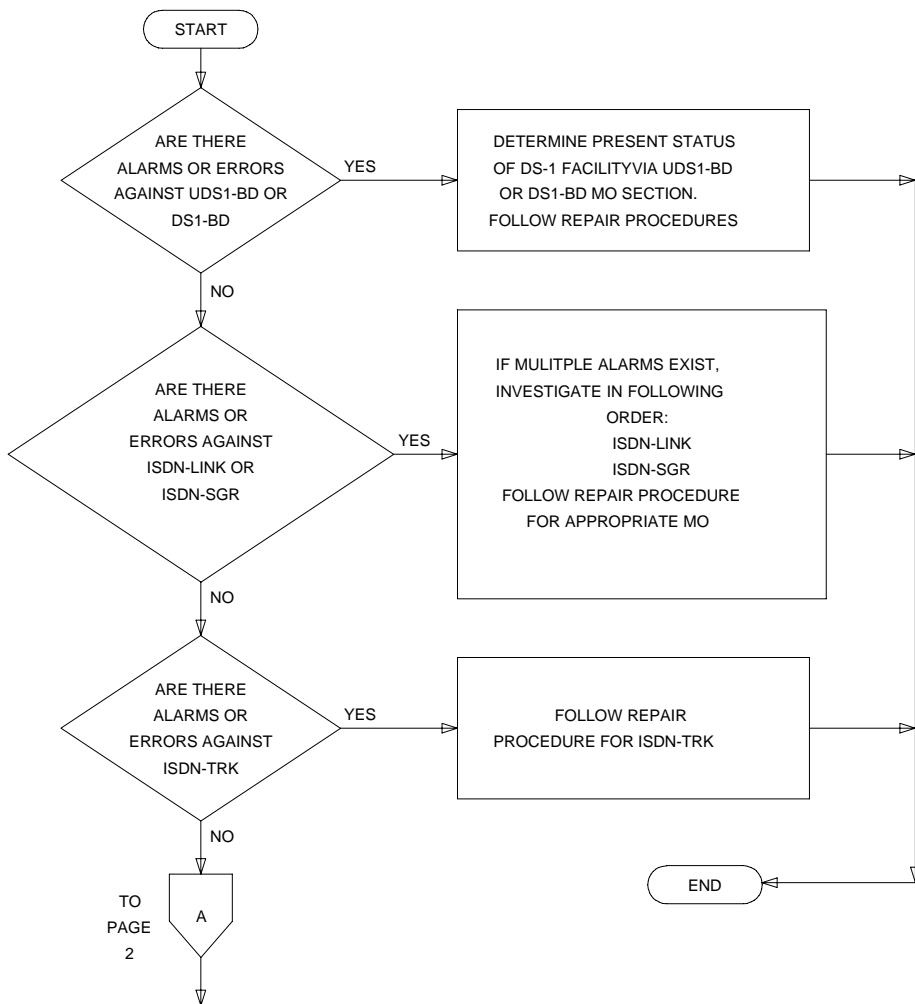

Figure 5-38. Troubleshooting ISDN-PRI (Page 1 of 2)

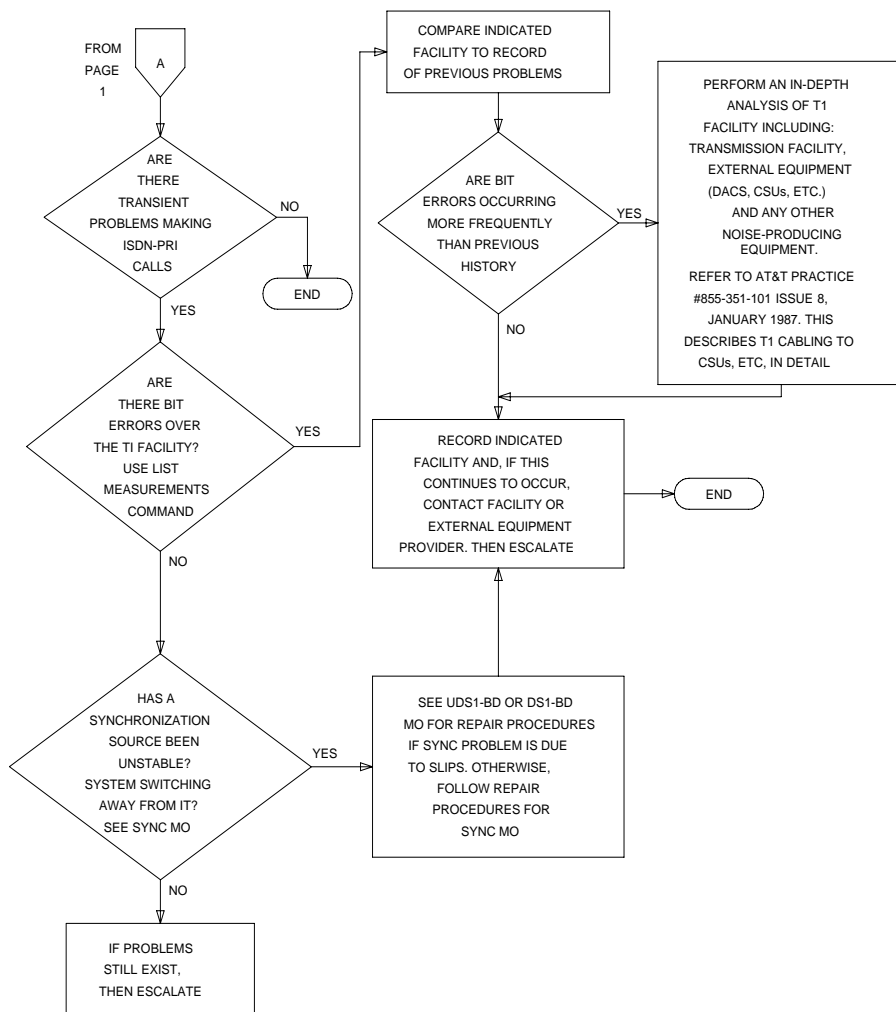

Figure 5-39. Troubleshooting ISDN-PRI (Page 2 of 2)



## **Troubleshooting ISDN-PRI Endpoints (Wideband)**

---

The following flow chart defines a layered approach when troubleshooting PRI endpoint problems. Because problems at lower layers affect upper layers, layers are investigated from low to high. In this procedure, the DS1 facility is layer 1, the TN1655 Packet Interface is layer 2, and the PRI endpoint ports are layer 3.

The troubleshooting procedure described here is limited to diagnosing faults between the switch and the line-side PRI terminal adapter or ISDN-PRI endpoint equipment. Problems encountered on the network-side of a wideband connection or problems with end-to-end equipment compatibility are beyond the scope of this section.

5 Alarms, Errors, and Troubleshooting

Troubleshooting ISDN-PRI Endpoints (Wideband)

5-70

START

↓

Are there alarms or errors against any of the following maintenance objects: UDS1-BD PKT-INT SYS-LINK ISDN-LNK ISDN-SGR PE-BCHL	YES →	Resolve those alarms or errors in the order listed at left by following procedures for the appropriate maintenance object in Chapter 9.
---	----------	---

↓ NO

Check out the status of the endpoint equipment or Terminal Adaptor. Do this at the endpoint, not at the G3-MT on the switch. Does the adaptor or endpoint indicate problems?	YES →	Follow repair procedures recommended by the provider of the Terminal Adaptor or endpoint equipment.
--	----------	---

↓ NO

Check administration at the endpoint and on the switch (for example, port boundary width). Are they inconsistent?	YES →	Correct the administration so that both ends match.
---	----------	---

↓ NO

Does every call fail or are the failures transient?	Always Fails →	Check the health of the application equipment (for example, the video codec) and that of the DEFINITY network. If constant failures persist, follow normal escalation procedures.
---	-------------------	---

↓ Transient Failures

Use <b>list measurements ds1</b> to check for bit errors over the DS1 interface between the switch and the terminal adaptor or endpoint equipment.	Bit Errors →	Perform an in-depth analysis of the DS1 interface including premises distribution wiring, endpoint equipment, and any other possible source of noise. If the problem cannot be isolated, follow normal escalation procedures.
--	-----------------	---

↓ No bit errors

Check for alarms and errors against SYNC. Has a synchronization source been unstable? Has the system switched synch sources?	YES →	Follow procedures described in SYNC in Chapter 9.
--	----------	---

↓ NO

Follow normal escalation procedures.

## Troubleshooting ISDN-BRI/ASAI Problems

Troubleshooting ISDN-BRI/ASAI problems can be a complex and involved procedure. The reason for this is that ISDN-BRI devices communicate with the SPE over the Packet Bus, as opposed to the TDM Bus. Therefore, it is possible for failures of other Packet Bus-related system components to cause problems with ISDN-BRI devices. [Figure 5-40](#) shows the connectivity of the Packet Bus as it applies to ISDN-BRI signaling.

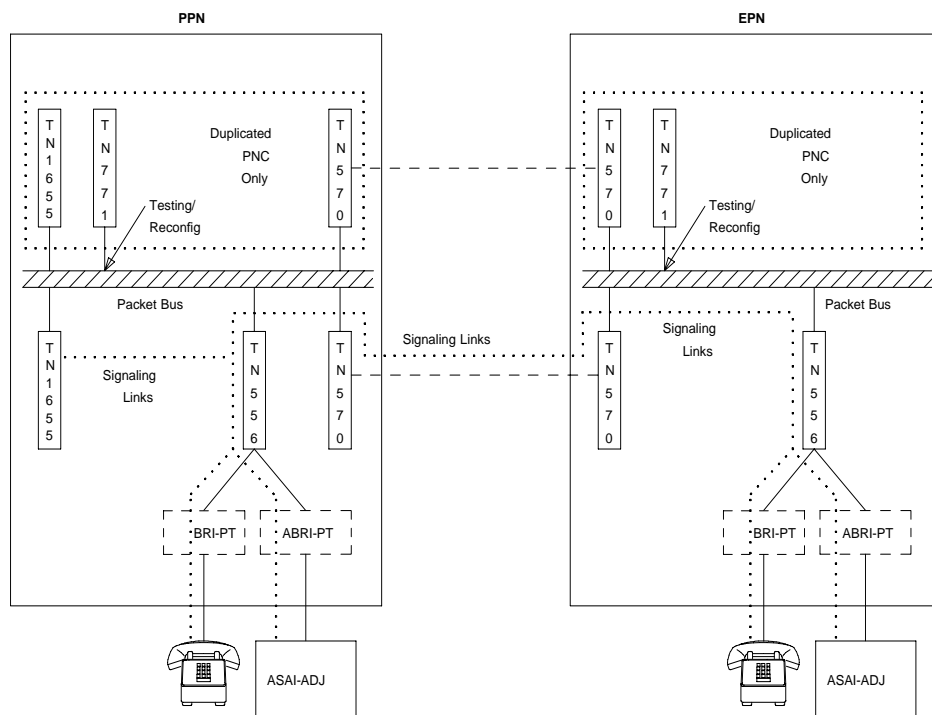

Figure 5-40. ISDN-BRI/ASAI Packet Bus Connectivity

The flowchart in [Figure 5-41](#) describes the steps needed to isolate and resolve ISDN-BRI problems. The order in which you should examine the maintenance objects is determined by looking at how widespread the failure is. For example, since all ISDN-BRI devices communicate with the TN1655 Packet Interface circuit pack, this MO should be examined early in the sequence. On the other hand, a failure of an Expansion Interface (TN570) circuit pack may cause ISDN-BRI failure in an EPN, but could not be the cause of a failure in the PPN.

 **NOTE:**

If the flowchart query “Is the problem affecting MOs on multiple BRI-BD circuit packs?” is reached and the port network in question has only one ISDN-BRI circuit pack, then assume that the answer is “Yes” and follow the repair procedure for PKT-BUS.

When directed by the flowchart to refer to the Maintenance documentation for a specific MO, keep in mind that the repair procedure for that MO may refer you to another MO’s repair procedure. The flowchart tries to coordinate these activities so that a logical flow is maintained if the ISDN-BRI problems are not resolved with the first set of repair procedures.

These following **status** commands may also be useful when diagnosing ISDN-BRI problems:

- **status port-network**
- **status packet-interface**
- **status bri-port**
- **status station**
- **status data-module**

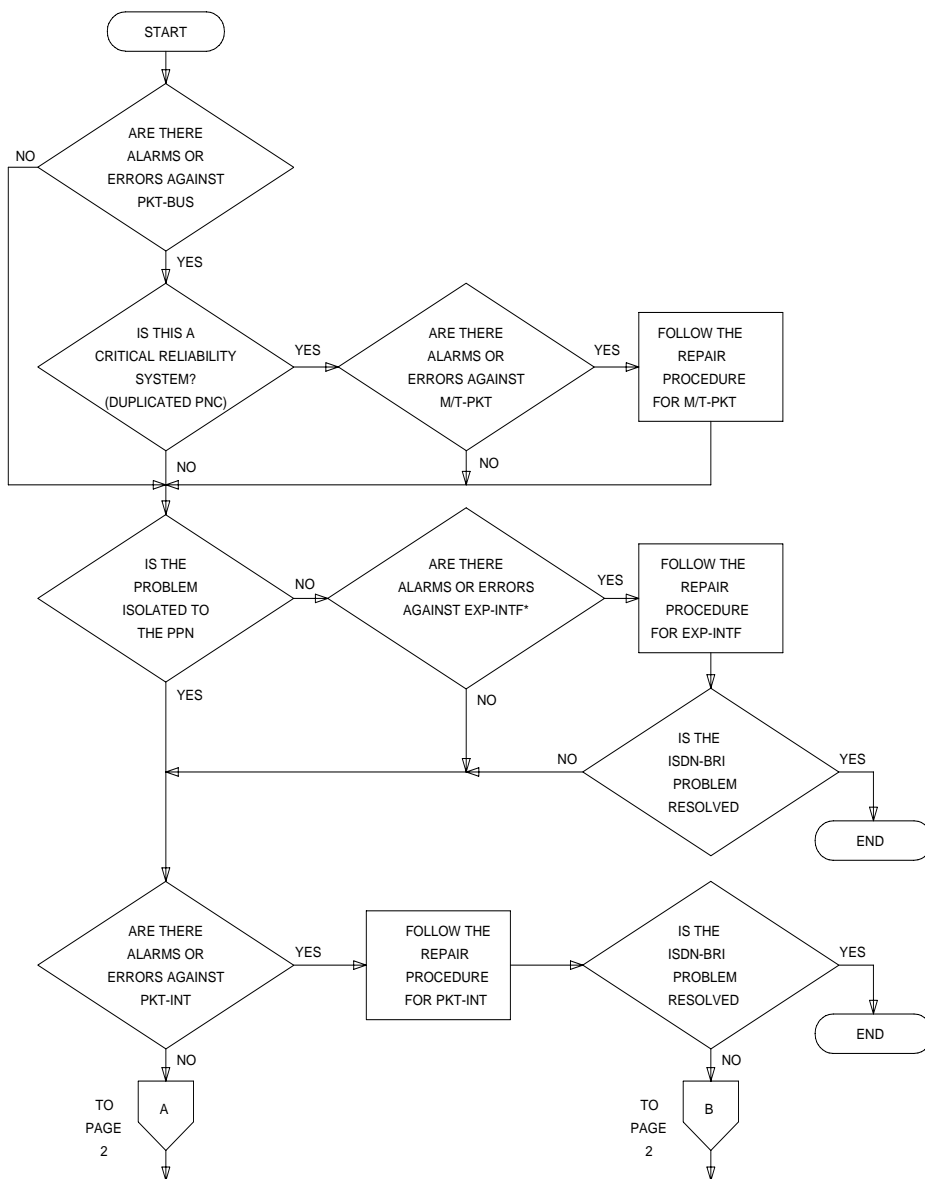
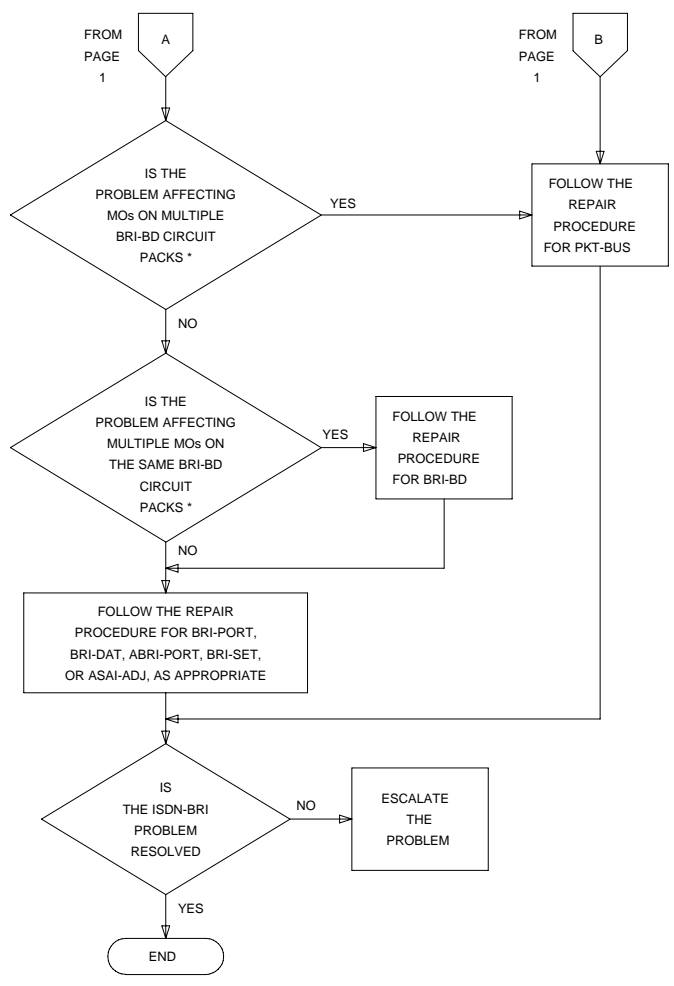

Figure 5-41. Troubleshooting ISDN-BRI Problems (Page 1 of 2)



\* THESE MOs WOULD BE BRI-PORT, ABRI-PORT, BRI-DAT, BRI-SET, OR ASAI-ADJ

Figure 5-42. Troubleshooting ISDN-BRI Problems (Page 2 of 2)

## Troubleshooting ISDN-PRI Test Call Problems

---

An ISDN-PRI test call is placed across an ISDN-PRI user-network interface to a previously designated number in order to test ISDN capabilities of the switch, the trunk and the far end. An ISDN-PRI test call is also a maintenance procedure concerned with the identification and verification ISDN-PRI user-network interface problems. The ISDN-PRI test call can access ISDN-PRI trunks only.

An ISDN-PRI test call can be placed only if the circuit translates to an ISDN-PRI trunk. An ISDN-PRI test call can be originated via either the *synchronous* or the *asynchronous* method. Each method is described below.

### NOTE:

Before attempting to make an ISDN-PRI test call to the public network (the far-end), make sure that test call service is provisioned by the network. The user must subscribe to Test Type 108 service and have the correct far-end test call number administered on the trunk group form for the call to be allowed.

## Synchronous Method

One command is used in this method to start, stop and query an ISDN-PRI test call. In the synchronous method, an outgoing ISDN-PRI test call may be part of one of the following *long* test sequences entered at the terminal:

- **test trunk grp/mbr long [repeat #]**
- **test port UUCSSpp long [repeat #]**
- **test board UUCSS long [repeat #]**

The **long** qualifier must be entered in the above commands in order for the ISDN test call to run. The repeat number (#) can be any number from 1 through 99 (default = 1).

The following information is displayed in response to the above commands:

- **Port:** The port address (UUCSSpp) is the port network number, carrier designation, slot, and circuit of the maintenance object under test.
- **Maintenance Name:** The type of maintenance object tested.
- **Test Number:** The actual test that was run.
- **Test Results:** Indicates whether the test passes, fails, or aborts.
- **Error Code:** Additional information about the results of the test (See the ISDN-TRK section of Chapter 9 for details).

## Asynchronous Method

---

The asynchronous method requires a Maintenance/Test circuit pack to be present in the system. In this method, 4 commands are used to start, stop, query, and list an outgoing ISDN-PRI test call:

Start:           **test isdn-testcall grp/mbr[minutes]**  
Stop:           **clear isdn-testcall grp/mbr**  
List:           **list isdn-testcall**  
Query:          **status isdn-testcall <grp>/<mbr>**

Before placing an outgoing ISDN-PRI test call, verify that the Feature Access Code has been administered on the System Features Form, and that the Far End Test Line Number and TestCall Bearer Capability Class (BCC) have been administered on the Trunk Group Administration Form. Furthermore, if the ISDN-PRI trunk is of the *cbc* (call by call) service type, then the Testcall Service field on Trunk Group Administration Form must have been administered also.

To initiate an outgoing ISDN-PRI test call with the asynchronous method, issue the start command listed above, which enables you to specify a specific the trunk on which to originate the ISDN-PRI test call. An optional qualifier can be used that specifies in minutes (1 to 120) the duration of the test call. If no duration is specified, the default is either 8.4 or 9.6 seconds.

[Screen 5-1](#) shows a typical response to the **test isdn-testcall** command:

```
test isdn-testcall

Port      Maintenance Name  Test Number  Test Result  Error Code
1B1501    ISDN-TRK          258          PASS
```

### Screen 5-1. Test ISDN-TestCall Response

The displayed fields have the following meanings:

Port	The port address (UUCSSpp) is the port network number, carrier designation, slot, and circuit of the maintenance object under test.
Maint. Name	The type of maintenance object tested.
Test Number	The actual test that was run.
Test Results	Indicates whether the test passes, fails, or aborts.
Error Code	Additional information about the results of the test (See the ISDN-TRK section in Chapter 9 for details).



The functions of the **clear**, **list**, and **status** commands associated with the ISDN Testcall are summarized below.

**clear isdn-testcall:** enables you to cancel an in-progress ISDN-PRI test call and allow another test call to start.

**list isdn-testcall:** enables you to list all the ISDN-PRI trunks in use for an ISDN-PRI test call in the system.

**status isdn-testcall:** enables you to check on the progress of an outgoing test call. When an outgoing ISDN-PRI test call completes in a specific port network, another ISDN-PRI trunk from the same port network is available for testing (regardless of whether the **status** information has been displayed).

## Troubleshooting the Outgoing ISDN-Testcall Command

---

If the TestCall BCC field appears on the Trunk Group Administration Form, make sure the TestCall BCC field indicates the correct BCC for the service provisioned on the ISDN-PRI trunk. The TestCall BCC values are defined as follows:

0	Voice
1	Digital Communications Protocol Mode 1
2	Mode 2 Asynchronous
3	Mode 3 Circuit
4	Digital Communications Protocol Mode 0 (that is usually the default).

If the ISDN-PRI trunk is of type `cbc` make sure the TestCall Service field on the Trunk Group Administration Form indicates the correct service so that a network facility message can be sent across the ISDN-PRI network.

If the outgoing ISDN-PRI test call keeps aborting, make sure that the far-end device can handle DCP Mode 0 or DCP Mode 1.

### NOTE:

Before attempting to make an ISDN-PRI test call to the public network (that is, the network is the far-end), make sure that test call service is provisioned by the network. The user must subscribe to Test Type 108 service and have the correct far-end test call number administered on the trunk group form for the call to be allowed.

## Packet Bus Fault Isolation and Repair

---

The following procedures provide a means of isolating and correcting faults on both the packet bus and the various maintenance objects that use the packet bus. The packet bus is shared by all circuit packs that communicate on it, and a fault on one of those can disrupt communications over the packet bus. Furthermore, a circuit pack that does not use the packet bus can also cause service disruptions by impinging on the backplane or otherwise modifying the configuration of the bus. (this is discussed in more detail later). For these reasons, isolating the cause of packet bus failure can be complicated. This discussion provides a flowchart and descriptions of the tools and procedures used to isolate and correct packet bus faults.

This discussion is organized into the following sections which provide background information and troubleshooting procedures. The Packet Bus Fault Isolation Flowchart is intended to be the normal starting point for isolating and resolving packet bus problems. Before using it you should familiarize yourself with packet bus maintenance by reading the introductory sections.

- [“Remote Maintenance versus On-Site Maintenance”](#) discusses the strategy and the requirements for performing remote maintenance and on-site maintenance for the packet bus.
- [“Tools for Packet Bus Fault Isolation and Correction”](#) discusses the tools that are needed to isolate and correct packet bus faults.
- [“What is the Packet Bus?”](#) describes the packet bus, its use in G3r, and the types of faults that can occur on the packet bus. A diagram shows the physical and logical connections between circuit packs connected to the packet bus.
- [“Circuit Packs That Use the Packet Bus”](#) describes the various circuit packs, ports, and endpoints that use the packet bus. The section discusses how these maintenance objects interact, how a failure of one maintenance object can affect another, and failure symptoms of these maintenance objects.
- [“Maintenance of the Packet Bus”](#) describes the strategy of maintenance software for packet bus. Similarities and differences between the packet bus and the TDM Bus are discussed. An overview of the Fault Isolation and Correction Procedures is also presented.
- [“The Maintenance/Test Circuit Pack \(TN771\)”](#) discusses the use of the Maintenance/Test circuit pack in both packet bus fault isolation and other switch maintenance. The standalone mode of the Maintenance/Test circuit pack, which is used to perform on-site packet bus fault isolation and correction, is discussed in detail.

- [“Packet Bus Fault Isolation Flowchart”](#) is the starting point for the troubleshooting process. It is used to determine if a failure of service is caused by the packet bus itself or by another maintenance object on the packet bus.
- [“Correcting Packet Bus Faults”](#) presents the procedures required to correct either a problem with the packet bus itself or one that is caused by a circuit pack connected to the Packet Bus.

## Remote Maintenance versus On-Site Maintenance

---

Most packet bus fault isolation and repair procedures require a technician to be on-site. This is because a packet bus failures are caused by a hardware failure of either the packet bus itself or a circuit pack that is connected to it. Initial diagnoses can be made via use of the Packet Bus Fault Isolation Flowchart, but the Maintenance/Test Standalone Mode Procedure and the Packet Bus Fault Correction Procedure require that a technician be on-site. These procedures are presented with this requirement in mind.

The flowchart refers to the repair procedures in [Chapter 9, “Maintenance Object Repair Procedures”](#) for various maintenance objects. When a decision point is reached, a remotely located technician can refer to the appropriate section and attempt to resolve any fault conditions. Some procedures require on-site repair action. Keep in mind that failure of a maintenance object appearing early in the flowchart can cause alarms with maintenance objects that appear later in the flowchart. Multiple dispatches can be prevented by remotely checking subsequent stages on the flowchart and preparing the on-site technician for replacement of several components if necessary.

The Maintenance/Test packet bus port described below provides status information that is accessed with the **status port-network P** command and the PKT-BUS test sequence. The Maintenance/Test circuit pack may or may not be present at a customer site, depending on the configuration of the switch. If a Maintenance/Test circuit pack is not present, one must be taken to the site for diagnosing packet bus problems.

In a system with duplicated SPEs, an SPE interchange may resolve the packet bus problem. This operation can be executed remotely, and is discussed in *Packet Bus Fault Correction Procedures* below.

## Tools for Packet Bus Fault Isolation and Correction

The following tools may be required on-site to perform packet bus fault isolation and correction.

- TN771D Maintenance/Test circuit pack for use in standalone mode, and the connectors and cables necessary to install it (see the *Maintenance/Test Circuit Pack* section).
- A replacement for the TN771D Maintenance/Test circuit pack in the system may be needed. See the *A Special Precaution Concerning the TN771D* section.
- A backplane pin-replacement kit may be required (see *Packet Bus Fault Correction*) If the kit is not available, replacement of a carrier may be required.

## What is the Packet Bus?

The packet bus is a set of 24 leads in the backplane of each Port Network. Twenty of these leads are data leads, three are control leads, and one lead is a spare. This distinction is important only for understanding why some circuit packs are able to detect only certain faults; the distinction does not affect fault isolation and repair. Each Port Network has its own packet bus and there is one packet bus maintenance object (PKT-BUS) in each port network. The packet bus is not duplicated as is the TDM Bus. There are however several spare leads on the packet bus and, in Critical Reliability systems (duplicated PNC), these spare leads are used to recover from some failures on the packet bus.

The packet bus carries various types of information:

- Signaling and data traffic destined for other port-networks and/or Center Stage Switches. The TN570 Expansion Interface circuit pack provides packet bus access for these connections.
- ISDN-BRI signaling information for ISDN-BRI stations, data modules and ASAI adjunct connections. The TN556 ISDN-BRI circuit pack provides packet bus access for these connections.
- X.25 signaling information and data traffic to support system adjunct applications. The TN577 Packet Gateway circuit pack provides packet bus access for these connections.
- ISDN-PRI signaling information carried in the D-channels of ISDN-PRI facilities connected to the switch. The TN464F Universal DS1 circuit pack provides packet bus access for these connections.
- System Port traffic to support various input/output devices such as dial-up modems and printers, as well as system adjunct applications. The TN553 Packet Data circuit pack provides packet bus access for these connections.

The SPE interface to the packet bus is the TN1655 Packet Interface circuit pack. When SPEs are duplicated, there is one TN1655 in each SPE. The TN771D Maintenance/Test Circuit Pack (discussed in detail later) provides packet bus maintenance testing and reconfiguration capabilities.

## Packet Bus Faults

Two types of packet bus faults occur:

- Shorts** A short occurs when different leads on the packet bus become electrically connected to each other. This can occur due to failures of circuit packs, cables between carriers, TDM/LAN terminators, or bent pins on the backplane. A fault occurring during normal operation is usually caused by a circuit pack. A fault that occurs while moving circuit packs or otherwise modifying the switch is usually due to bent pins on the backplane.
- Opens** An open occurs when there is a break on the packet bus such that the electrical path to the termination resistors is interrupted. Usually, this break is caused by a failed TDM/LAN cable or terminator. A less likely possibility is a failure in the backplane of a carrier.

Shorts are far more common than opens, since they can be caused by incorrect insertion of a circuit pack. It is possible for a circuit pack to be the cause of a packet bus fault but still operate trouble-free itself. For example, the insertion of a TDM-only circuit pack such as a TN754 Digital Line could bend the packet bus pins on the backplane, but remain unaffected since it does not communicate over the packet bus.

Packet bus faults do not necessarily cause service interruptions, but shorts on it usually do. Depending on what leads are defective, the system may be able to recover and continue to communicate. While this allows uninterrupted service, it makes isolating the fault difficult. The Maintenance/Test circuit pack provides the capability to detect, and, in some cases, correct packet bus faults.

## Packet Bus Connectivity

Various circuit packs communicate on the packet bus (see the next section). For more details, refer to [Chapter 9, "Maintenance Object Repair Procedures"](#) for the following circuit packs:

- TN1655 Packet Interface: PKT-INTF
- TN570 Expansion Interface: EXP-INTF
- TN556 ISDN-BRI: BRI-BD, BRI-PORT, ABRI-PORT, BRI-SET, BRI-DAT, ASAI-ADJ
- TN577 Packet Gateway: PGATE-BD, PGATE-PT
- TN553 Packet Data: PDATA-BD, PDATA-PT

- TN464F Universal DS1: UDS1-BD, ISDN-LNK
- TN771D Maintenance/Test: M/T-BD, M/T-DIG, M/T-PKT

## Circuit Packs That Use the Packet Bus

This section describes the circuit packs that use the packet bus and the effects of circuit pack and bus failures on each other.

Seven circuit packs can use the packet bus: The maintenance objects pertaining to each circuit pack, (described further in Chapter 9), are listed in brackets.

- **TN1655 Packet Interface** [PKT-INTF] provides the SPE interface to the packet bus (as the UN332 MSSNET does to the TDM Bus). All traffic on the packet bus passes through the Packet Interface. The Packet Interface can detect some control lead failures and many data lead failures via parity errors on received data.
- **TN570 Expansion Interface** [EXP-INTF] connects the Port Networks (PNs) in the system. (Only TN570s can be used in Release 5r). All Packet traffic between PNs passes through a pair of TN570s (one in each port network). The Expansion Interface can detect some control lead failures, and many data lead failures via parity errors on received data.
- **TN556, TN2198, and TN2208 ISDN-BRI circuit packs** [BRI-BD, BRI-PORT, ABRI-PORT, BRI-SET, BRI-DAT, ASAI-ADJ] carries signaling information for ISDN-BRI station sets and data modules, as well as signaling information and ASAI messages between the SPE and an ASAI adjunct. The ISDN-BRI circuit pack has the same fault detection capabilities as the TN570 Expansion Interface.
- **TN577 Packet Gateway circuit pack** [PGATE-BD, PGATE-PT] provides X.25 connectivity to support external system adjuncts such as Audix® and DCS. The packet bus carries both signaling and customer traffic. The Packet Gateway circuit pack has the same fault detection capabilities as the TN570 Expansion Interface.
- **TN553 Packet Data circuit pack** [PDATA-BD, PDATA-PT] connects via a backplane cable to a TN726B Data Line circuit pack in an adjacent carrier slot. Together, the two circuit packs perform a protocol conversion from mode 3 packet bus traffic originating in the SPE to mode 2 TDM Bus traffic destined for external system devices and adjuncts. This connectivity is referred to as a *System Port*. System Ports support devices and adjuncts such as the System Printer, the PMS Journal Printer, the PMS Wakeup Log Printer, data terminals, remote administration terminals, and equipment to support the Call Detail Recording (CDR) feature. System Ports are also used for saving and restoring System Announcements. The packet bus carries both signaling and data for the Packet Data circuit pack. The Packet Data circuit pack has the same fault detection capabilities as the TN570 Expansion Interface.

- **TN464F Universal DS1 circuit pack** [UDS1-BD, ISDN-LNK] supports ISDN-PRI communications over an attached DS1 facility. It transports of D-channel signaling information over the packet bus, and B-channel data over the TDM bus. The Universal DS1 circuit pack has the same fault detection capabilities as the TN570 Expansion Interface.
- **TN771D Maintenance/Test circuit pack** [M/T-BD, M/T-DIG, M/T-PKT, M/T-ANL] is the workhorse of packet bus maintenance. This circuit pack can detect all packet bus failures for the Port Network in which it resides. In Critical Reliability systems (duplicated PNC), this circuit pack enables the reconfiguring of the packet bus around a small number of failed leads. The TN771D circuit pack provides a standalone mode (one that does not involve communication with the SPE), for inspecting the packet bus for faults. Standalone mode is a critical tool for troubleshooting packet bus faults.

**⇒ NOTE:**

All Maintenance/Test circuit packs must be of vintage TN771D or later. This circuit pack is also used for ISDN-PRI trunk testing (M/T-DIG) and ATMS trunk testing (M/T-ANL).

## Effects of Circuit Pack Failures on the Packet Bus

Certain failures of any of the above circuit packs can disrupt traffic on the packet bus. Some failures cause packet bus failures with corresponding alarms, while others cause service outages without alarming the packet bus, (although the failed circuit pack should be alarmed).

Packet bus circuit pack failures affect the bus in the following ways:

- **TN1655 Packet Interface.** A failure of the Packet Interface typically causes all Packet traffic in the system to fail. As a result,
  - Expansion Port Networks and Center Stage Switches are disabled.
  - ISDN-BRI sets are not able to make or receive calls.
  - Communication with ASAI adjuncts fail
  - X.25 communications with external adjuncts fail.
  - System Ports are disabled.
  - ISDN-PRI D-channel signaling is disabled.

If the failure is on the packet bus interface, the packet bus may be alarmed as well.

In a system with duplicated SPEs, there is one TN1655 Packet Interface in each SPE. If a Packet Interface failure in the active SPE causes a packet bus disruption, an SPE interchange may restore service. In other cases, replacement of the circuit pack may be required before service is restored.

- **TN570 Expansion Interface.** A failure of the Expansion Interface typically causes all packet traffic in the connected EPN or Center Stage Switch to fail. If the failure is on the packet bus interface, the packet bus may be alarmed as well.

If an active Expansion Interface failure causes a packet bus disruption in a Critical Reliability system (duplicated PNC), a PNC Interchange may restore service. In other cases, replacement of the circuit pack may be required before service is restored.

- **TN556 ISDN-BRI Circuit Pack.** A failure of the ISDN-BRI circuit pack typically causes some or all ISDN-BRI sets and data modules and/or an ASAI adjunct connected to the circuit pack to stop functioning. If the failure is on the circuit pack's packet bus interface, the packet bus may be alarmed.
- **TN577 Packet Gateway Circuit Pack.** A failure of the Packet Gateway circuit pack disrupts communications with the adjunct (for example, Audix, DCS) connected to the far end of the X.25 link. If the failure is on the circuit pack's packet bus interface, the packet bus may be alarmed.
- **TN553 Packet Data Circuit Pack.** A failure of the Packet Data circuit pack disrupts System Port traffic. If the failure is on the circuit pack's packet bus interface, the packet bus may also be alarmed. Applications that use System Ports include:
  - Saving and restoring announcements
  - Call Detail Recording (CDR)
  - Journal Printer for the Property Management System (PMS)
  - Wakeup Log Printer for the Property Management System (PMS)
  - System Printer
  - Data Terminals
  - Remote administration terminals
- **TN464F Universal DS1 Circuit Pack.** A failure of the Universal DS1 Circuit Pack disrupts ISDN-PRI signaling traffic carried on the D-channel. The loss of that signaling may impact the pack's 23 B-channels. If the D-channel supports Non Facility Associated Signaling (NFAS), the B-channels of up to 20 other DS1 circuit packs may also be affected. In cases where all 24 channels of the circuit pack are B-channels, packet bus related failures may not affect the B-channels, since only D-channel signaling is carried on the packet bus. If the failure is on the circuit pack's packet bus interface, the packet bus may be alarmed as well.
- **TN771D Maintenance/Test.** A failure of the Maintenance/Test may cause an incorrect indication of a packet bus failure or the inability to detect such a failure. If the failure is on the packet bus interface, the packet bus may be alarmed as well.



Failure of any circuit pack's bus interface may alarm the packet bus due to shorting of the packet bus leads. This typically disrupts *all* packet bus traffic in the affected PN. A failure of the packet bus in the PPN affects packet traffic in the EPNs as well. Some packet bus failures do not affect all endpoints, so a packet bus failure cannot be ruled out just because some packet service is still available.

A circuit pack can fail in a manner such that it transmits bad data on the packet bus. If the Packet Interface so fails, all Packet traffic is disrupted. Such a failure on an Expansion Interface may disrupt all Packet traffic in that port network. If an ISDN-BRI circuit pack fails such that it transmits bad data, all devices connected to the circuit pack fail to function. This failure may also disrupt the entire packet bus whenever the circuit pack tries to transmit data. Such a disruption may be indicated by packet bus alarms that occur and go away, intermittent failures of other packet circuit packs, and/or interference with other connected endpoints. These failures are difficult to isolate because of their intermittent nature. In most cases, the failed circuit pack is alarmed, and all connected endpoints on the circuit pack are out of service until the circuit pack is replaced. These symptoms help in isolating the fault.

## Maintenance of the Packet Bus

The following topics are covered in this section:

- [“Packet Bus and TDM Bus: a Comparison”](#)
- [“Packet Bus Maintenance Software”](#)
- [“Fault Correction Procedures: Overview”](#)

### Packet Bus and TDM Bus: a Comparison

The packet and TDM busses have several similarities and differences. There are two physical TDM buses in each PN. One of the buses can fail without affecting the other, but half of the call-carrying capacity is lost. There is *one* packet bus in each PN. A failure of that bus can disrupt all packet traffic in that PN.

In critical reliability systems, the Maintenance/Test circuit pack provides packet bus reconfiguration capabilities. This allows the packet bus to remain in service with up to 3 lead failures. There is no corresponding facility on the TDM Bus. Instead, the second physical TDM Bus continues to carry traffic until repairs are completed.

System response varies according by type of bus failure and whether or not the failure occurs in the PPN or an EPN. In an EPN, a catastrophic TDM Bus failure (one that affects both TDM Buses) disables *all* traffic in the PN. A catastrophic packet bus failure affects only packet traffic, so that TDM traffic is unaffected, while all ISDN-BRI, ASAI, X.25, and ISDN-PRI signaling traffic is disrupted. The significance of this distinction depends on the customer's applications. A customer whose primary application requires ASAI would consider the switch to be out of service, while a customer with a large number of Digital/Analog/Hybrid sets and a small number of ISDN-BRI sets would probably not consider the

packet bus failure a catastrophic problem. The only way an EPN packet bus failure can affect TDM traffic is via possible impact on system response time in a large switch due to running of ISDN-BRI endpoint maintenance. This should rarely happen because the packet bus maintenance software is able to prevent this for most faults (see the next section).

If packet bus failure occurs in the PPN, the impact is much more widespread. Because the PPN packet bus carries the signaling and control links for all EPNs, PPN packet bus failure effectively removes all the EPNs from service, including both TDM and packet busses. Packet bus traffic in the PPN is also disrupted.

**CAUTION:**

*Packet bus fault correction and fault isolation often involve circuit pack removal, which is destructive to service. Minimize time devoted to destructive procedures by the use of non-destructive ones where possible.*

## Packet Bus Maintenance Software

Packet bus maintenance software involves the usual set of maintenance object error conditions, tests, and alarms. These are described in “PKT-BUS” in Chapter 9. Because a packet bus failure can cause all BRI/ASAI endpoints in the affected Port Network, and all their associated ports and circuit packs, to report failures, special care must be taken to ensure that the flood of error messages does not overload the system and interfere with TDM Bus traffic. *When such a failure occurs*, circuit pack maintenance is affected in the following manner:

- In-line errors for the following MOs which indicate possible packet bus failures are logged but *not acted upon*: BRI-BD, PGATE-BD, PDATA-BD, UDS1-BD.
- In-line errors for the following MOs which indicate possible packet bus failures are *neither logged nor acted upon*: BRI-PORT, ABRI-PORT, PGATE-PT, PDATA-PT, ISDN-LNK.
- All in-line errors for the following MOs are *neither logged nor acted upon*: BRI-SET, BRI-DAT, ASAI-ADJ.
- Circuit pack and port in-line errors that are not related to the packet bus, or that indicate a circuit pack failure, are acted upon in the normal fashion.
- Periodic and scheduled background maintenance is not affected.
- Foreground maintenance (for example, commands executed from the terminal) is not affected.

These interactions allow normal non-packet system traffic to continue unaffected, and they reduce the number of entries into the Error/Alarm Logs. If the packet bus failure is caused by a failed circuit pack, errors against the circuit pack should appear in the Error/Alarm Logs as an aid for fault isolation. The above strategy is implemented when:

- In-line errors indicate a possible packet bus failure reported by two or more Packet circuit packs.

- A packet bus Uncorrectable report is sent from the Maintenance/Test packet bus port (M/T-PKT).

When such a failure occurs, a PKT-BUS error is logged. Refer to the PKT-BUS section in Chapter 9 for more detailed information.

### **Fault Correction Procedures: Overview**

This section gives an overview of the procedures used to isolate the cause of and correct packet bus faults. Details are presented in following sections.

1. Procedure 1 attempts to determine if a circuit pack that interfaces to the packet bus is the cause of the packet bus problem. This involves examination of the Error and Alarm logs followed by the usual repair actions.
2. If the packet bus problem persists, remove port circuit packs (those in purple slots) to look for circuit packs that have failed and/or damaged the packet bus pins.
3. If the packet bus problem persists, perform the same procedure for control complex circuit packs.
4. If the problem persists, or if the packet bus faults are known to have open leads, replace bus terminators and cables. If this does not resolve the problem, reconfigure the carrier connectivity of the port network to attempt to isolate a faulty carrier.

### **The Maintenance/Test Circuit Pack (TN771)**

The TN771 Maintenance/Test circuit pack provides the following functions:

- Analog Trunk (ATMS) Testing
- Digital Port Loopback Testing
- ISDN-PRI Trunk Testing
- Packet Bus Testing
- Packet Bus Reconfiguration (Critical Reliability systems only)

The PPN always contains a TN771D. Critical Reliability systems have a TN771D in each EPN. A TN771D is optional in EPNs of other configurations. The ISDN-PRI Trunk Testing functions are discussed in the [“ISDN-PLK \(ISDN-PRI Signaling Link Port\)”](#) section in [Chapter 9, “Maintenance Object Repair Procedures”](#).

The Digital Port Testing functions are discussed in the [“DIG-LINE \(Digital Line\)”](#), [“DAT-LINE \(Data Line Port\)”](#), [“PDMODULE \(Processor Data Module\) TDMODULE \(Trunk Data Module\)”](#), [“TDMODULE \(Trunk Data Module\)”](#), [“PGATE-PT \(Packet Gateway Port\)”](#), [“PDATA-PT \(Packet Data Line Port\)”](#), and [“MODEM-PT \(Modem Pool Port\)”](#), sections in [Chapter 9, “Maintenance Object Repair Procedures”](#).

The Analog Trunk Testing functions are discussed in the [“TIE-TRK \(Analog Tie Trunk\)”](#), [“DID-TRK \(Direct Inward Dial Trunk\)”](#), [“CO-TRK \(Analog CO Trunk\)”](#), and [“AUX-TRK \(Auxiliary Trunk\)”](#), sections in [Chapter 9, “Maintenance Object Repair Procedures”](#).

 **NOTE:**

All Maintenance/Test circuit packs must be of TN771D vintage or later.

### TN771D Packet Functions

The Maintenance/Test packet bus port (M/T-PKT) provides the packet bus testing and reconfiguration capabilities. When the port is in service, it continuously monitors the packet bus for faults and fault recoveries, and reports results to PKT-BUS maintenance.

The yellow LED on the TN771D Maintenance/Test circuit pack provides a visual indication of the state of the packet bus:

- |           |   |
|-----------|---|
| Flashing  | Flashing of the yellow LED once per second indicates that there are too many faults for the Maintenance/Test packet bus port to recover by swapping leads. <i>The packet bus may be unusable.</i> If the failures detected are open lead failures, the packet bus may still be operating. |
| On steady | The Maintenance/Test packet bus port has swapped leads on the packet bus to correct a fault. <i>The packet bus is still operating.</i> Or, one of the other ports on the Maintenance/Test circuit pack is in use.   |

 **NOTE:**

First busy out the Maintenance/Test circuit pack ports used for other than packet bus testing before using the Maintenance/Test circuit pack to help resolve packet bus faults. This is done by entering **busyout port UUCSS01**, **busyout port UUCSS02**, and **busyout port UUCSS03**. Be sure to release these ports when the process is completed.

- |     |                                       |
|-----|---------------------------------------|
| Off | There is no packet bus fault present. |
|-----|---------------------------------------|

 **NOTE:**

It takes 5 to 10 seconds for the LED to respond to a change in the state of the packet bus.

During normal switch operation, the Maintenance/Test provides visual feedback of the packet bus state. When in standalone mode (see the next section), these visual indications are still present, but the packet bus is never reconfigured. The yellow LED either blinks or is off.

## TN771D in Standalone Mode

In TN771D standalone mode, a terminal is connected to the Maintenance/Test circuit pack with an Amphenol connector on the back of the cabinet. This setup allows direct inspection of the packet bus and identifies shorted or open leads. This mode does not use the usual MT Maintenance User Interface and is thus available even if switch is not in service. When in standalone mode, the TN771D does not reconfigure the packet bus.

### Required Hardware

- TN771D: Standard or High Reliability systems may not have a TN771D in each EPN. (Use **list configuration** to determine if this is so.) When this is the case, one must be taken to the site. See the following section, [“Special Precaution Concerning the TN771D”](#).
- Terminal or PC with terminal-emulation software: The EIA-232 (RS-232) port should be configured at 1200 baud, no parity, 8 data bits, and one stop bit. This is *not* the same configuration as for the G3-MT. If a terminal configured as a G3-MT is used, change the SPEED field from 9600 to 1200 on the terminal’s options setup menu. (This menu is accessed on most terminals by pressing the CTRL and F1 keys together. On the 513 BCT, press SHIFT/F5 followed by TERMINAL SET UP). Remember to restore the original settings before returning the G3-MT to service.
- 355A EIA-232 Adapter (Comcode 105 012 637).
- 258B Six-Port Male Amphenol Adapter (Comcode 103 923 025). A 258A Adapter and an extension cable can also be used.
- D8W 8-wire modular cable of an appropriate length to connect the 258A on the back of the cabinet to the 355A adapter. The relevant Comcode is determined by the length of the cable, as follows:
  - 103 786 786 (7 feet)(2.1 m)
  - 103 786 802 (14 feet)(4.3 m)
  - 103 786 828 (25 feet)(7.6 m)
  - 103 866 109 (50 feet)(15.2 m)

### Slot Selection for Standalone Mode

When selecting a carrier slot to use for standalone mode in a port network that does not already contain a TN771D, keep the following points in mind:

- A port circuit slot (indicated by a purple label) should be used. The service slot (slot 0) *cannot* be used for standalone mode, although a TN771D may normally be installed there.
- -5 volt power supply must be available in the carrier. (Refer to [“CARR-POW \(Carrier Power Supply\)”](#) in [Chapter 9, “Maintenance Object Repair Procedures”](#) for a description of carrier power supply units.)

- A slot in the A carrier is preferable for EPNs if the above conditions are met.

## Entering and Exiting Standalone Mode

When in standalone mode, the red LED on the TN771D is lit. This is normal and serves as a reminder to remove the TN771 from standalone mode.



### CAUTION:

*The TN771D in standalone must be the only TN771D in the port network. If a TN771D is already in the port network, place that TN771D in standalone mode. Do not insert a second TN771D. Otherwise, the system is not able to detect the extra circuit pack and will behave unpredictably.*



### CAUTION:

*If the TN771D packet bus port has reconfigured the packet bus in a Critical Reliability system (indicated by error type 2049 against PKT-BUS), placing the Maintenance/Test in standalone mode causes a loss of service to the packet bus. In this case, this procedure disrupts service.*

For port networks with a TN771D already installed:

1. Ensure that Alarm Origination is suppressed either at login or via **change system-parameters maintenance**.
2. Attach the 258A 6-Port Male Amphenol Adapter to the Amphenol connector on the back of the carrier corresponding to the TN771D's slot. Connect one end of a D8W 8-wire modular cable to port 1 of the 258A. Connect the other end of the cable to a 355A EIA-232 Adapter. Plug the EIA-232 Adapter into the terminal to be used, and turn the terminal on.
3. Reseat the TN771D circuit pack.



### NOTE:

On a Critical Reliability system, this causes a MINOR OFF-BOARD alarm to be raised against PKT-BUS. This alarm is not resolved until the TN771D's packet bus port (M/T-PKT) is returned to service. To ensure that PKT-BUS alarms have been cleared, it may be necessary to restore the TN771D to normal mode.

For port networks without a TN771D installed:

1. Attach the 258A 6-Port Male Amphenol Adapter to the Amphenol connector on the back of the carrier corresponding to the slot into which the TN771D is to be inserted. Connect one end of a D8W 8-wire modular cable to port 1 of the 258A. Connect the other end of the cable to a 355A EIA-232 Adapter. Plug the EIA-232 Adapter into the terminal to be used, and turn the terminal on.

2. Insert the TN771D circuit pack into the slot. The system will not recognize the presence of the circuit pack.

If the standalone mode is entered successfully, the following is displayed on the connected terminal:

```
TN771 STANDALONE MODE

(Type "?" at the prompt for help)

Command:
```



**CAUTION:**

*If the above display does not appear, check the wiring between the terminal and the TN771D, and the terminal parameters settings. If these are correct, the TN771D may be defective. In such a case, use the following procedures to exit standalone mode and then test the Maintenance/Test circuit pack. Refer to M/T-BD and M/T-PKT in [Chapter 9, "Maintenance Object Repair Procedures"](#). If the TN771D fails while in standalone mode, the message `TN771 circuit pack failed` is displayed, and no further input is accepted on the terminal. The circuit pack must be replaced.*

To exit standalone mode:

1. Remove the 258A Adapter from the Amphenol connector.
2. If the TN771D was installed for this procedure, remove it. Otherwise, reseat the TN771D.
3. If **change system-parameters maintenance** was used to disable alarm origination, re-enable it now.

## Using Standalone Mode in Packet Bus Fault Isolation and Correction

When the TN771D is in standalone mode, three commands are available:

- |     |  |
|-----|--|
| ds  | Displays the current state of the packet bus leads.  |
| dsa | Toggles auto-report mode on and off. In auto-report mode, the state of the packet bus leads are displayed and the terminal beeps whenever a change occurs. |
| ?   | Displays the available commands.   |

Below is an example of a standalone mode display. The symbols above the line represent specific leads on the backplane. The bottom line indicates the following:

```

L L L L L L L L L L H H H H H H H H S S S L
P 0 1 2 3 4 5 6 7 8 P 0 1 2 3 4 5 6 7 8 S F B F
-----
S S                               O

Command:
```

- O Open lead
- S Shorted lead
- blank No fault

**⇒ NOTE:**

This information is available only from the standalone mode. It is not available from the MT or a remote login.

[Figure 5-43](#) shows the location of the packet bus leads for a given slot as seen from the front and back of the carrier.



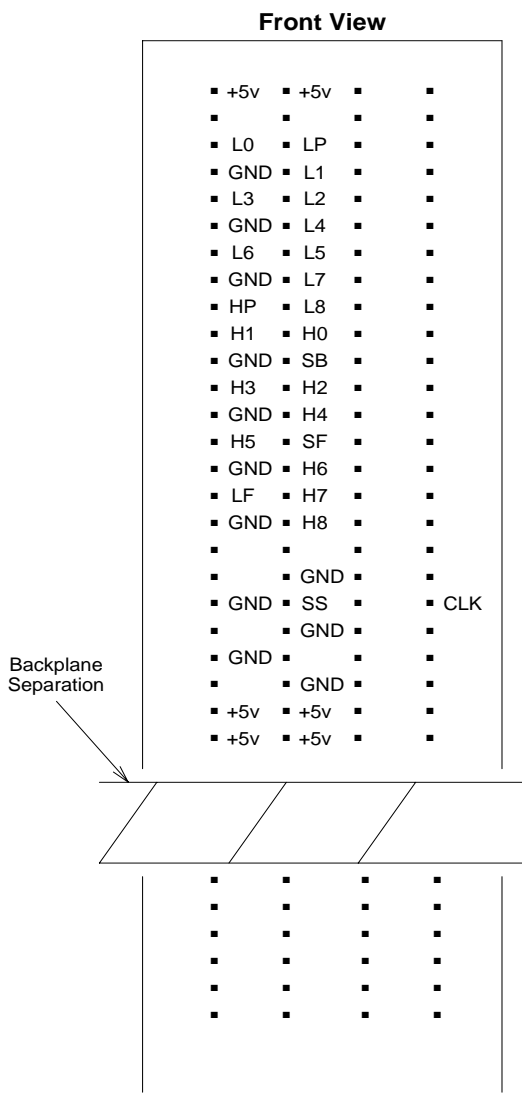

**Figure 5-43. Packet Bus Leads on the Backplane**

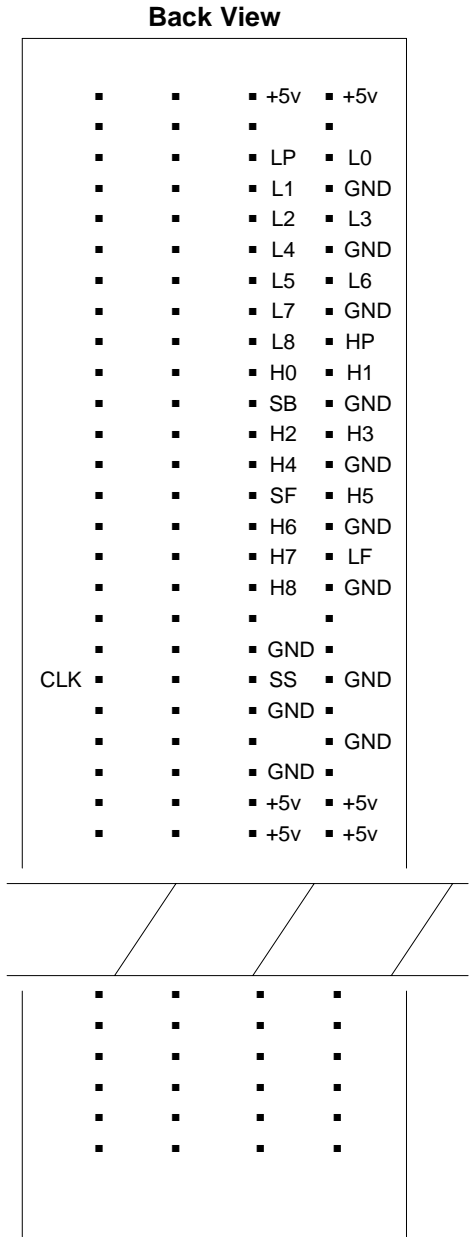

**Figure 5-44. Packet Bus Leads on the Backplane**

## Special Precaution Concerning the TN771D

A TN771D Maintenance/Test circuit pack must be taken to the customer site if:

- The Maintenance/Test packet bus port indicates that a Packet Bus fault is present by logging a Major or Minor alarm against PKT-BUS. A Major alarm is indicated in the error log by Error Type 513; a Minor alarm is indicated by Error Type 2049.
- Test #572 of the PKT-BUS test sequence is the only test that fails.

This precaution is taken because certain failures of the Maintenance/Test circuit pack can appear as packet bus failures. To ensure that the problem is indeed with the packet bus, proceed through the following steps:

1. If the TN771D Maintenance/Test circuit pack is replaced during this process, enter the **test pkt P long** command to determine if the packet bus faults have been resolved. If there are still packet bus problems, correct them by using the procedures in the sections that follow.
2. If the Maintenance/Test circuit pack was *not* replaced, enter **test pkt P**. Record the results (PASS/FAIL/ABORT) and error codes for Test #572.
3. Enter **status port-network P**. Record the information listed for PKT-BUS.
4. Busyout the Maintenance/Test circuit pack with **busyout board UUCSS**.
5. Replace the Maintenance/Test circuit pack with the new circuit pack.
6. Release the Maintenance/Test circuit pack with **release board UUCSS**.
7. Enter the **test pkt P** and **status port-network P** commands as described in Steps 2 and 3.
8. If the data matches the previously recorded data, a packet bus problem exists, and the original TN771D Maintenance/Test circuit pack is not defective. Reinsert the original TN771D, and correct the packet bus problem by using the procedures in the sections that follow.
9. If the data does *not* match the previously recorded data, the original TN771D circuit pack is defective. If there are still indications of packet bus problems, correct them by using the procedures in the following sections.

## Packet Bus Fault Isolation Flowchart

The flowchart below shows the steps to be taken for isolating and resolving packet bus problems. The order in which the maintenance objects should be examined can be determined by assessing how wide-spread the failure is. For example, since all ISDN-BRI devices communicate with the TN1655 Packet Interface circuit pack, this MO should be examined early in the sequence. On the other hand, a failure of a TN570 circuit pack in an EPN may cause ISDN-BRI failure in the EPN, but not in the PPN.

Whenever the flowchart refers to MO documentation, keep in mind that the repair procedure for that MO may in turn refer to another MO's repair procedure. The flowchart tries to coordinate these procedures so that a logical flow is maintained

if the packet bus problems are not resolved via the first set of repair procedures. However, a packet bus failure can lead to a somewhat haphazard referencing of various MO procedures that may result in taking steps that are repetitive or unnecessary. If this occurs, return to the flowchart at the step that follows the reference to [Chapter 9, "Maintenance Object Repair Procedures"](#), and continue from there. The following **status** commands can also help diagnose packet bus problems, especially when logged in remotely.

<b>status port-network P</b>	<b>status packet-interface</b>
<b>status pnc</b>	<b>status bri-port</b>
<b>status station</b>	<b>status data-module</b>
<b>status link</b>	<b>status pms-link</b>
<b>status sp-link</b>	<b>status cdr-link</b>
<b>status journal-link</b>	

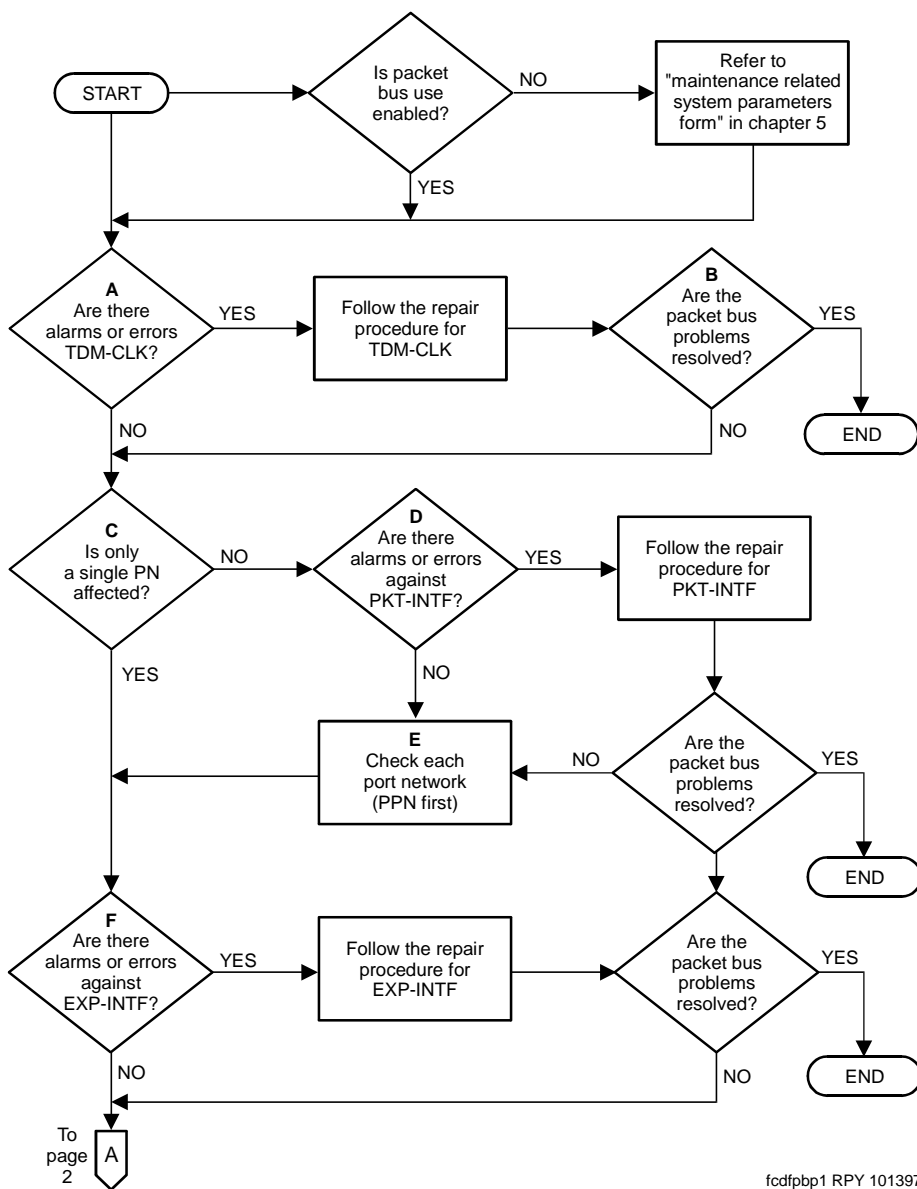

fcdfpbp1 RPY 101397

**Figure 5-45. Troubleshooting Packet Bus Problems (Page 1 of 2)**

Boldface letters in the flowchart refer to paragraphs in the explanatory section that follows.

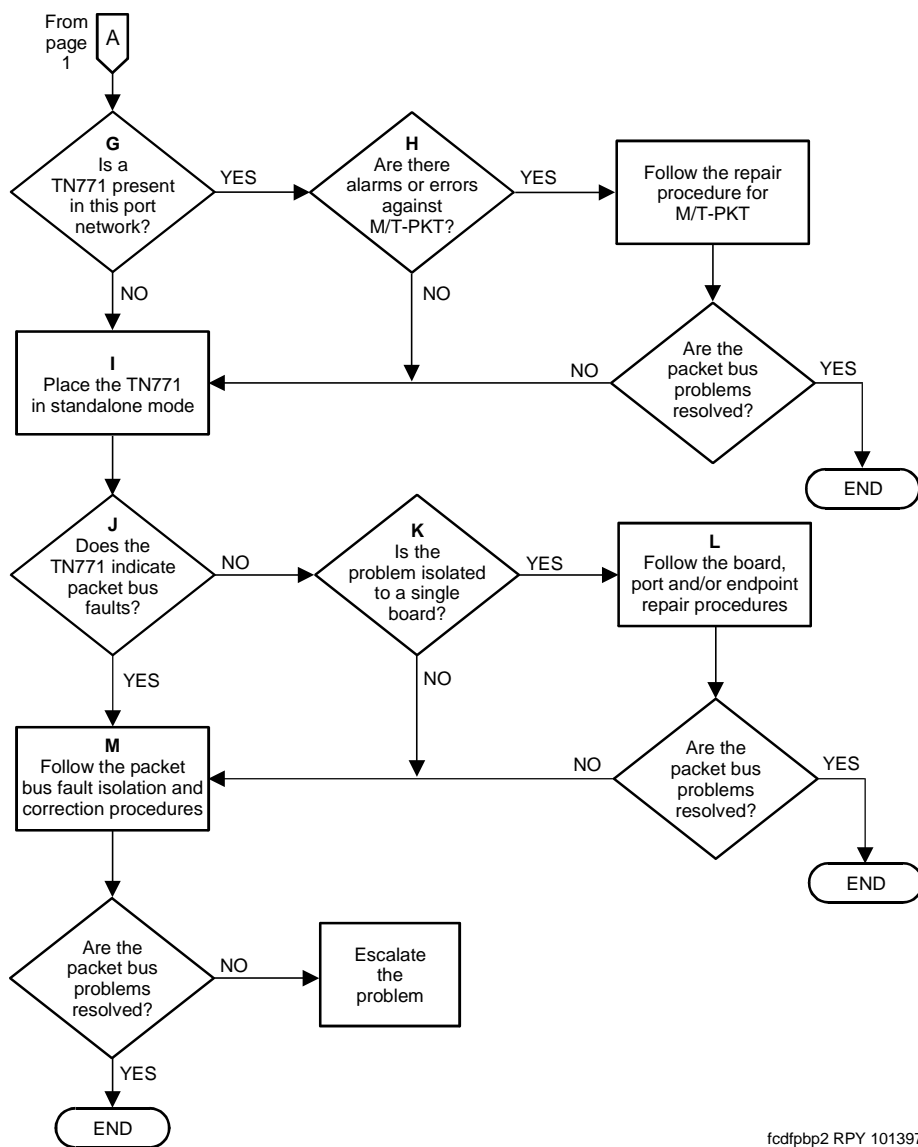

fcdfpbp2.RPY 101397

**Figure 5-46. Troubleshooting Packet Bus Problems (Page 2 of 2)**

Boldface letters in the flowchart refer to paragraphs in the explanatory section that follows.

### Flowchart Notes

The following paragraphs refer by letter to corresponding entries in the preceding flowchart. Individual errors and alarms are not detailed in the flowchart. When referring to explanations of these in [Chapter 9, "Maintenance](#)

[Object Repair Procedures](#)”, any that do not refer explicitly to the TDM bus (except TDM-CLK) should be considered a possible cause of packet bus problems.

- a. Problems with the system clock (TDM-CLK) can cause service disruptions on the packet bus. All alarms active against TDM-CLK should be resolved first, even if the explanation refers only to TDM bus. A packet bus problem cannot cause a TDM-CLK problem, but a TDM-CLK problem can cause a packet bus problem.
- b. Throughout the flowchart, the question, “Are the packet bus problems resolved?,” refers to the problems that led you to this chart, and can involve several checks, such as:
  - Are all packet bus alarms resolved?
  - Are all packet circuit pack port and endpoint alarms resolved?
  - Are all ISDN-BRI stations/data modules, ASAI adjuncts, System Port supported adjuncts, Packet Gateway supported adjuncts, and ISDN-PRI D-channel links in service?
  - Does the Maintenance/Test packet bus port (in normal or standalone mode) still indicate a packet bus fault?
- c. If only a single PN is affected, the Packet Interface is probably not the source of the problem. Nonetheless, if all of the ISDN-BRI, Packet Gateway, Packet Data, and Universal DS1 circuit packs are located in a single EPN, assume that the answer to this question is “No,” and check the Packet Interface.
- d. A packet problem that affects more than one port network is probably caused by either a Packet Interface failure or a PPN packet bus failure. The Packet Interface is checked before the packet bus.
- e. Because the packet bus in each port network is physically separate, each affected port network must be checked individually. The PPN should be checked first since any EPN packet problems are usually resolved once a PPN packet problem is resolved. After resolving the problem in one port network, make sure that problems in other port networks have also been resolved.
- f. This step applies only when attempting to resolve an EPN packet bus problem. When checking the Expansion Interfaces in an EPN, be sure to check the corresponding one(s) in the PPN. (G3r supports only the TN570 Expansion Interface, not the earlier TN776 Port Network Interface).
- g. If a TN771D is not present, one must be installed to accommodate the standalone mode. See the above section on standalone mode.
- h. If a TN771D is present, it can fail in such a way that it eventually disrupts the packet bus or misinterprets a packet bus problem.
- i. If work is being done on-site, follow the procedures described earlier in this discussion on standalone mode. If work is not being done on-site, go to the next step.

- j. The answer is yes if any of the following apply:
  - The TN771D in standalone mode indicates any faulty leads.
  - Test #572 in the PKT-BUS test sequence fails.
  - The **status port-network P** display indicates that faulty leads are present and the TN771D in the port network is known to be functioning correctly.
- k. If the non-functional endpoints are isolated to a single circuit pack, that circuit pack is probably the cause of the problem.
- l. Investigate errors and alarms in the following order:
  1. Circuit pack-level
  2. Ports
  3. Endpoints
- m. Follow the [“Troubleshooting Procedures”](#) outlined later in this discussion. If the packet bus problem cannot be resolved with these procedures, follow normal escalation procedures.

## Correcting Packet Bus Faults

### The Status Port-Network Command

**Status port-network P** displays include the service state, alarm status, and, if the Maintenance/Test packet bus port is present, the number of faulty and open leads for the packet bus in the specified port-network. This information can be used to determine the urgency of the repair. In general, a service state of “out” indicates extreme urgency, while a service state of “reconfig” indicates moderate urgency.

#### NOTE:

Ultimately, the urgency of a repair is determined by the customer’s requirements. A customer who uses ISDN-BRI for station sets, or who relies heavily on packet bus supported system adjunct features like DCS, Audix, or CDR, probably considers a packet bus failure critical. On the other hand, a customer with little ISDN-BRI service and no adjunct features may consider even an uncorrectable packet bus fault unimportant, and may prefer to delay repairs due to their disruptive nature.

If background maintenance is running on the packet bus when the **status port-network** command is issued, the data reported for the packet bus may be inconsistent due to updating by the tests. If the data seems inconsistent, enter the command again.



If test results or the results of the **status port-network** command indicate that there are 24 faults on the packet bus, the problem is probably caused by faulty cables between carriers, or by defective or missing bus terminators. However, before proceeding, make sure that the Maintenance/Test packet bus port is not generating a false report by looking for an M/T-PKT error in the error log. Then test the Maintenance/Test packet bus port with **test port UUCSSpp**. See [“Special Precaution Concerning the TN771D”](#) above if any problems are suspected.

### ➤ NOTE:

If the carrier into which a TN771D Maintenance/Test circuit pack is inserted does not have a -5V power supply, the Maintenance/Test packet bus port reports 24 open leads in response to **status port-network**, or Test #572 of the PKT-BUS test sequence. Refer to CARR-POW maintenance in Chapter 9 to ensure that a -5 volt power supply is available.

## Considerations for Duplicated Systems

Some packet bus-related components are duplicated in systems with one of the duplication options:

- In High Reliability systems (duplicated SPE, simplex PNC), Packet Interface circuit packs are duplicated with the SPEs, a Maintenance/Test circuit pack is required in the PPN, and Maintenance/Test packet bus reconfiguration is not enabled.
- In Critical Reliability Systems (duplicated SPE and PNC), the Packet Interface circuit packs are duplicated, Maintenance/Test circuit packs are required in all port networks, and packet bus reconfiguration by the Maintenance/Test circuit packs is enabled.

If a packet bus problem is caused by a duplicated component, switching to the standby component may alleviate the problem and isolate the faulty circuit pack. Start by executing the commands in the following list when they apply.

- **reset system interchange:** If this command resolves the packet bus problem, the problem is with the Packet Interface in the SPE which was just switched to standby. Refer to [“PKT-INT \(Packet Interface Circuit Pack\)”](#) in [Chapter 9, “Maintenance Object Repair Procedures”](#).
- **reset pnc interchange:** If this command resolves the packet bus problem, the problem is with the EIs or the link on the PNC (a or b) that just became the standby. Refer to [“EXP-INTF \(Expansion Interface Circuit Pack\)”](#) in [Chapter 9, “Maintenance Object Repair Procedures”](#).
- **set tone-clock:** If this command resolves the packet bus problem, the problem is with the Tone/Clock that just became the standby. Refer to [“TDM-CLK \(TDM Bus Clock\)”](#) in [Chapter 9, “Maintenance Object Repair Procedures”](#) of this document.

Continue with the procedures in the next section.

## Troubleshooting Procedures

Packet bus faults are usually caused by a defective circuit pack connected to the backplane, by bent pins on the backplane, or by defective cables or terminators that make up the packet bus. The first two faults cause shorts, while the third fault causes either shorts or opens.

There are four procedures for correcting packet bus faults. Which are used depends on the nature of the fault. For example:

- If the Maintenance/Test packet bus port is activated, and if there is an indication of open leads on the packet bus from **status port-network** or Test #572, go directly to Procedure 4. Procedures 1 through 3 try to locate faulty circuit packs or bent pins and these do not cause open faults.
- If there are both shorts and opens, start with Procedure 4, and return to Procedure 1 if shorts persist after the open leads are fixed.



### CAUTION:

*Packet bus fault isolation procedures involve removing circuit packs and possibly disconnecting entire carriers. These procedures are destructive. Whenever possible, implement these procedures during hours of minimum system use.*



### CAUTION:

*To replace the following circuit packs, follow instructions in the appropriate sections: Tone-Clock ([“TONE-BD \(Tone-Clock Circuit Pack\)”](#)), Expansion Interface ([“EXP-INTF \(Expansion Interface Circuit Pack\)”](#)), Packet Interface ([“Replacing SPE Circuit Packs”](#)).*

When the procedure asks whether the packet bus problem has been resolved, the following conditions should all be met:

- All faulty leads reported by the TN771D standalone mode should no longer be reported.
- All alarms against the packet bus and packet circuit packs have been resolved.
- All ISDN-BRI stations and data modules and all relevant ASAI, System Port, and Packet Gateway supported adjuncts are in service.

## Procedure 1

Procedure 1 determines whether any circuit packs that use the packet bus have faults. For each circuit pack type in [Table 5-8](#) proceed through the steps below. Check the circuit pack in the order presented by the flowchart which appears earlier in this discussion unless newly inserted circuit packs are involved. Newly added boards are the most likely cause of a problem.

1. **Display errors** and **display alarms** for the circuit pack.
2. For any errors or alarms, follow the repair actions recommended in [Chapter 9, "Maintenance Object Repair Procedures"](#).
3. After following the recommended repair actions, *whether they succeed or fail*, determine if the packet bus fault is resolved. If so, you are finished.
4. If the packet bus fault is still present, apply this procedure to the next circuit pack.
5. If there are no more circuit packs in the list, go to Procedure 2.

**Table 5-8. Packet Circuit Packs**

Circuit Pack Name	Circuit Pack Code	Associated Maintenance Objects
ISDN-BRI	TN556	BRI-BD, BRI-PORT, ABRI-PORT, BRI-SET, BRI-DAT, ASAI-ADJ
Maintenance/Test	TN771D	M/T-BD, M/T-PKT
Packet Gateway	TN577	PGATE-BD, PGATE-PT
Packet Data	TN553	PDATA-BD, PDATA-PT
Universal DS1	TN464F	UDS1-BD, ISDN-LNK
Packet Interface	TN1655	PKT-INTF
Expansion Interface	TN570	EXP-INTF

## Procedure 2

Procedure 2 removes and reinserts *port* circuit packs (purple slots), and the Expansion Interface one or several at a time. Use Procedure 2 for each port circuit pack in the port network until the problem is resolved *or* all port circuit packs have been tried.

### NOTE:

The Expansion Interface circuit pack should be the last one checked since removing it disconnects the EPN. To check an active Expansion Interface in a system with duplicated PNC, use **reset pnc interchange** to make it the standby. (Always check the status of the standby before executing an interchange.)

**⇒ NOTE:**

The Tone/Clock circuit pack should be the next-to-last one checked. (The TN771D must be reseated after the Tone/Clock is reinstalled.) Refer to Procedure 3 for the TN768 or TN780 Tone/Clock circuit pack in a PPN with duplicated SPEs.

If the packet bus problem is present when the circuit pack is inserted, but is resolved when the circuit pack is removed, either the circuit pack or the backplane pins in that slot caused the problem. If the backplane pins are intact, replace the circuit pack. Keep in mind that there may be more than one failure cause.

In Procedure 2, you may try one circuit pack at a time, or multiple circuit packs simultaneously. The allowable level of service disruption should guide this choice. If the entire port network can be disrupted, trying large groups of circuit packs will save time. If traffic is heavy, trying 1 circuit pack at a time is slow but will minimize outages.

If the TN771D Standalone mode does *not* indicate packet bus faults, perform Procedure 2 for *only the port* circuit packs (purple slots) listed in [Table 5-8](#) in Procedure 1. In this case, you need not check for problems with the backplane pins. It is sufficient to determine whether the problem is resolved by removing circuit packs.

If you decide to remove multiple circuit packs, consider working with an entire carrier at a time to more quickly and reliably determine which circuit packs are *not* the source of trouble. Any circuit packs, (packet or non-packet), that have been recently inserted should be checked first. Packet circuit packs should be checked before non-packet circuit packs.

1. Remove one or several circuit packs.
2. Determine if the packet bus fault is still present. If not, go to step 4.
3. If the packet bus fault is still present:
  - a. Determine if the backplane pins in the removed circuit pack's slot are bent using the output from the Maintenance/Test standalone mode and the backplane illustrations which appear earlier in this discussion.
  - b. If the backplane pins are bent:

Power down the carrier (see ["Replacing a BIU or Rectifier"](#)), straighten or replace the pins, reinsert the circuit pack and restore power. Repeat Step 2 for the same circuit pack.
  - c. If the backplane pins are not bent:

Reinsert the circuit pack(s), and repeat this procedure for the next set of circuit packs.

4. If the packet bus fault is not present:
  - a. Reinsert circuit packs one at a time and repeat the following substeps until all circuit packs have been reinserted.
  - b. Determine if the packet bus fault has returned.
  - c. If the packet bus fault has returned, the reinserted circuit pack is defective. Replace the circuit pack and then continue.
  - d. If the packet bus fault does not return when all of the circuit packs have been reinserted, you are finished.

Continue with Procedure 3 if all the port circuit packs have been checked, but the packet bus fault is still not resolved.

### Procedure 3

Procedure 3 removes and reinserts SPE and EPN control circuit packs one at a time. In the PPN, the following SPE circuit packs either use the packet bus or are connected to it in the backplane wiring:

- TN1655 Packet Interface
- TN768/TN780 Tone/Clock
- UN332 MSSNET

In the EPN, the following control circuit packs either use the packet bus for communication or are connected to it in the backplane wiring:

- TN775 EPN Maintenance Board
- TN768/TN780 Tone/Clock

These are the only SPE and EPN control circuit packs that are likely to cause a packet bus problem in a stable system. Perform this procedure on only these circuit packs.

If the TN771D Standalone mode does *not* indicate packet bus faults, perform Procedure 3 for *only* the Packet Interface and Tone/Clock circuit packs and do not check for problems with the backplane pins. Determining if the problem is resolved by removing circuit packs is sufficient.

#### For a system with simplex SPE:

1. Power down the control carrier. Refer to [“Replacing SPE Circuit Packs”](#).
2. Remove the suspect circuit pack.
3. Determine if the backplane pins in the removed circuit pack’s slot are bent.
4. If the backplane pins are bent:
  - a. Straighten or replace the pins.

- b. Insert the same circuit pack.
5. If the backplane pins are not bent:
  - a. Replace the circuit pack (reinsert the old one if a replacement is not available).
6. Turn the power back and allow the system to reboot. This may take up to 12 minutes. Log in at the terminal.
7. Determine if the packet bus fault is still present. If not, you are finished.

If the problem is still present,

- a. If the old circuit pack was reinserted in Step 5, replace the circuit pack, and repeat Procedure 3.
- b. If the circuit pack was replaced in Step 5, repeat Procedure 3 for the next SPE circuit pack.

If Procedure 3 fails to identify the cause of the problem, go to Procedure 4.

#### **For a system with duplicated SPEs:**

1. For SPE circuit packs, follow the [“Replacing Circuit Packs on a Duplicated SPE: Lock-and-Power-Down”](#) procedure within the [“Replacing SPE Circuit Packs”](#) section to remove and replace the circuit pack.
2. To remove an EPN Tone/Clock circuit pack, use **set tone-clock** if necessary to make the suspect circuit pack the standby. (Always check the status of the standby Tone/Clock with **status port network** before executing an interchange.)
3. Determine if the backplane pins in the removed circuit pack’s slot are bent.
4. If the pins are bent:
  - a. Power down the carrier if it is not already.
  - b. Straighten or replace the pins.
  - c. Insert the same circuit pack.
  - d. Restore power to the carrier.
5. If the backplane pins are not bent:

Insert or replace the circuit pack.
6. Determine if the packet bus fault is still present. If not you are finished.
7. If the packet bus fault is still present, do the following:
  - a. If the old circuit pack was reinserted in Step 5, replace the circuit pack and repeat Procedure 3 starting at Step 2.
  - b. If the circuit pack was replaced with a new one, proceed with the next step.

8. Repeat this procedure for the other SPE or Tone/Clock. If both have already been checked, go to the next step.
9. If all SPE and/or EPN control circuit packs have been checked and the problem is not resolved, continue with Procedure 4.

#### Procedure 4

Procedure 4 is used when the preceding procedures fail or when open leads are present. It is helpful in identifying multiple circuit pack faults and carrier hardware faults. It attempts to isolate the failure to a particular set of carriers and checks only the circuit packs in those carriers.

In Procedure 4, the TDM/LAN Cable Assemblies and TDM/LAN termination resistor packs are replaced. If this action does not resolve the packet bus fault, the carriers are reconfigured by moving the termination resistor packs on the carrier backplanes in such a manner that certain carriers are disconnected from the bus. To terminate the packet bus at the end of a particular carrier, unplug the cable that connects the carrier to the next carrier and replace the cable with a TDM/LAN terminator resistor pack (see [Figure 5-47](#)). When the length of the packet bus is modified with this procedure, circuit packs that are essential to system operation (and the TN771D Maintenance/Test in standalone mode) must still be connected to the new 'shortened' packet and TDM busses.



**DANGER:**

*Power must be removed from the entire port network before any cables or terminators are removed. Failure to do so can cause damage to circuit packs and power supplies, and can be hazardous to the technician.*



**DANGER:**

*Circuit packs in carriers that are not part of the shortened bus are not inserted. As a result, these circuit packs are not alarmed. Ignore alarm status for these circuit packs for now. All alarms should be resolved when the cabinet is restored to its original configuration.*

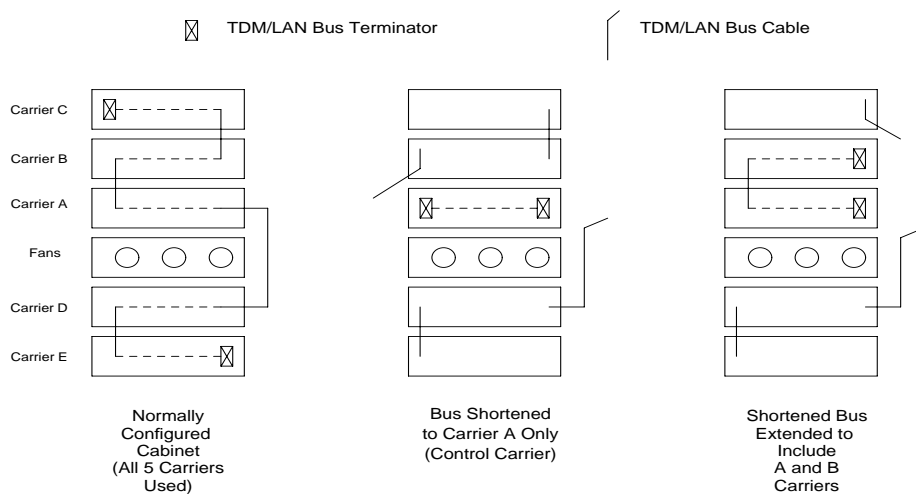

**Figure 5-47. Carrier Rewiring Example—Rear View of Multicarrier Cabinet**

Procedure 4 consists of two parts. Part 1 attempts to clear the packet bus fault by replacing all the bus cabling and terminators within a port-network. Part 2 attempts to isolate the fault to a particular carrier by extending the packet bus from the control carrier to additional carriers one at a time.

**Part 1:**

1. Power down the port network.
2. Replace all of the TDM/LAN Cable Assemblies and both TDM/LAN Terminators.
3. Restore power to the port network.
4. Determine if the packet bus fault is still present.
5. If the packet bus fault is resolved, the procedure is completed. Otherwise, go to Part 2.



### **Processor Port Network:**

1. Power down the cabinet and terminate the packet bus so that it extends only from the carrier that contains the active SPE (A or B) to the carrier that contains the Maintenance/Test circuit pack.
2. Power up the cabinet, allow the system to reboot, and determine if the packet bus fault is still present. If not, proceed to the next step.  
  
If there are shorts on the packet bus, perform Procedures 2 and/or 3 for the circuit packs in the active SPE and carriers connected to it on the shortened bus. (Procedure 2 is performed for port circuit packs, and Procedure 3 is performed for SPE circuit packs.)
3. If the packet bus fault is not present, extend the packet bus to another carrier, and repeat the procedure in the previous step. When the addition of a carrier causes the fault to recur, and if there are shorts, perform Procedure 2 and/or Procedure 3 for only the circuit packs in that carrier.
4. If the packet bus fault recurs when the packet bus is extended, and if there are no shorts, or Procedures 2 and 3 do not resolve the problem, the added carrier(s) that caused the problem to recur are defective and must be replaced.

### **Expansion Port Networks:**

1. Place the Maintenance/Test circuit pack into a carrier that contains the active Expansion Interface circuit pack to permit isolation of the failure to the smallest possible number of carriers.
2. Power down the cabinet and terminate the packet bus on the carrier with the M/T and active EI.
3. Determine if the packet bus fault is still present. If so, and if there are shorts on the packet bus, perform Procedure 2 and/or Procedure 3 for only the circuit packs in carriers connected to the "shortened" packet bus.
4. If the packet bus fault is not present, extend the packet bus to another carrier, and repeat the procedure in the previous step. When a carrier that causes the fault to recur is added, and if there are shorts, perform Procedure 2 and/or Procedure 3 for only the circuit packs in that carrier.
5. If the packet bus fault recurs as the packet bus is extended, and if there are no shorts, or Procedures 2 and 3) do not resolve the problem, the added carrier(s) that caused the problem to recur are defective and must be replaced.

# 6

## Additional Maintenance Procedures

---

### Software updates

---

A software update is the complete replacement of the software load running on a switch with a new version of software. Updates are used to provide new features and improved services, and to repair bugs discovered in the field. Note that the process is called a software update; the command used is **upgrade software**. A description of this command appears in [Chapter 8, "Maintenance Commands"](#).

Software *field updates* are partial replacements of a software load normally used for emergency bug fixes. Usually, a field update is transmitted electronically to the system from a remote site, but a technician must be on site to apply the update to backup tapes and insure that the system returns to normal operation. This procedure should be guided by the remote facility applying the update.

Refer to *DEFINITY Enterprise Communications Server Upgrades and Additions for R7r* for specific upgrade information.

### Software Version Number

---

Each software load is identified by a version number. The following are typical software version numbers displayed when **list configuration software-version** is entered:

```
SOFTWARE VERSION: DG3r01.06.1.00.0
```

```
SOFTWARE VERSION: G3r5.01.2.0.078
```

This identifier is also called the release number or the vintage number. Version numbers are interpreted as follows:

Release 7r loads:

G3r5	m	01	2	0	078
Product	Boot	Major	Minor	Unscheduled	Load
ID	Image	Release	Release	Release	Number

The `Boot Image` field contains "m" (mips) for Release 7r systems.

The system expects any software upgrade to be going from a lower, or older version number, to a higher, or newer version number. To install an older version (for example, when backing out a failed upgrade), follow normal escalation procedures to avoid putting the system into a corrupted state.

Each software version also has a compatibility index of the form:

8	1
Major Field	Minor Field

Differences between old and new version numbers and compatibility indexes can be used to determine what service effects can be expected from the update. See the "[Service effects of a software update](#)" section that follows.

## Service effects of a software update

### Simplex SPE

The **upgrade software** command executes a system reboot similar to a **reset system 4**. Emergency transfer is invoked and all calls drop. The MT login is terminated and error logs are cleared. The service outage lasts for a period of up to 15 minutes. Results of each step in the upgrade process and initialization diagnostics are displayed on the terminal screen. Screen output is described in *Maintenance Commands*, **upgrade software**. Failure of initialization will produce an SPE-down mode, described in *Initialization and Recovery*. Translations are reloaded from the primary storage device and reformatted for the new software if necessary.

### Duplicated SPE

On a system with a duplicated SPE, a software update may be either *call-preserving* or *call-dropping*. The compatibility of the old and new versions determines which type of update is performed. If the major fields of the compatibility indexes of the two versions are equal, then a call-preserving update is possible. The documentation accompanying the update tapes (Engineering Design Information, or EDI, and the Release Letter) should confirm this. With rare exceptions, this is the case when the Feature Version and Product ID numbers match.

If these conditions are not met, The **upgrade software call-override** option must be used, and the update will result in a system reset level 2 (cold-2 restart). An additional option, **preserve-calls**, can be added to force the system to attempt to preserve calls, but this must be used with care. If the incompatibility is great enough, this option may cause the system to escalate to a reboot (**reset system 4**). It is recommended that you escalate any such software update.

### Call-Preserving Update

During a call-preserving update, calls in which two or more parties are connected and talking are preserved. The following types of calls are dropped: wideband calls, held calls, dialing calls, and calls that are connected to announcements, speech synthesizers, or tones. Administered connections are dropped and automatically restored. Feature activation attempts are ignored. No new calls are processed for a brief period. This period usually lasts less than 5 seconds but can last up to 1 minute depending on traffic load during the SPE interchange. Conference calls that attempt a new connection are either ignored or dropped.

### Call-Dropping Update

During a call-dropping update, the effect will be similar to a cold-2 restart (**reset system 2**). All calls and system links drop, and the MT login is terminated. The service outage lasts up to 4 minutes.

## Preparing for a Software Update

1. Notify users of anticipated service effects described in the preceding section and arrange to do the update at a suitable time. Also advise appropriate users of the following feature interactions:
  - Administered connections are temporarily dropped.
  - Leave Word Calling messages stored in the SPE are lost. Those stored in a Message Server Adjunct or AUDIX system are saved.
  - Some feature settings will be lost and must be restored afterward. The effect is the same as a cold-2 restart. Features affected include night service, trunk/hunt group control, and manual/clock-manual override status on time of day routing. For example, hunt groups and attendant are put into night service after the update.
  - ACD queues will be lost. There is no mechanism to drain the queues. CMS or BCMS can be used to monitor the queue lengths. If it is important to empty all queues before the update, you must coordinate with the customer to redirect traffic away from ACD splits before the update. Changing vectors to temporarily route calls to a disconnect announcement is one way to accomplish this. ACD agents will need to log in again after the update and their status lamps may be incorrect for about an hour (until periodic background maintenance completes one cycle).

- CMS links are dropped and restored, resulting in a loss of incoming data during the upgrade. Data loss can be minimized by performing the update soon after the end of a CMS measurement interval.
  - Wideband calls are dropped.
2. Some information which is stored in system memory will be lost and must be manually recorded and then re-entered after the update:
- Record all busied out maintenance objects. Enter **display errors print**, and select error type 18 on the menu. All busyouts will be lost during the update and must be reentered afterward. Disabled maintenance objects will likewise be re-enabled by the update.
  - All measurement data stored in memory, including BCMS, is lost. Print any desired reports before the update.
  - Enter **list report-scheduler**. Reports that are currently printing or queued will be lost. Wait until reports are finished printing or notify the customer. Reports are printing if the Link State field displays `up` on the **status sp-link** screen.
  - Enter **list wakeup print** and **list do-not-disturb stations print**. These feature settings will be lost and must be re-entered afterwards.
3. Make sure that the system's health and activity can support a successful update:
- Enter **status spe** and verify that the state of health of the SPE is *functional*. This must hold true for active and standby SPEs when duplicated.
  - Enter **display alarms** and **display errors**. Resolve any active alarms or errors against SPE components or the PPN Tone-Clock.
  - Enter **status logins** and make sure that no other logins except yours are active.
  - Enter **status health** and look at the amount of load on the system. If call processing is greater than 50 percent, an update is not recommended due to increased customer impact.
  - Disable TTI changes by the **change system-parameters features**.
  - Enter **change system-parameters maintenance** and make sure that scheduled daily maintenance will not be running during the update. The Start Time field should be set to a time well after the session will end. If scheduled daily maintenance is running and needs to be shut off, set the Stop Time field to one minute after the current time. Be sure to restore the original settings when finished.

## Restoring the System after an Update

During software updates, including call-preserving updates, several feature settings are lost. These must be manually restored afterward.

- Re-enter all Maintenance Object busyouts.
- Re-enter wakeup calls and do-not-disturb stations.
- Restore attendant feature settings.
- Notify Administration and ACD users that the update is complete.
- Re-enable TTI changes by the **change system-parameters features**.
- On the **change system-parameters maintenance** form, restore Alarm Origination, Save Translations, CPE Alarm Level and SPE Interchange fields and Scheduled Daily Maintenance times to their original settings.
- Manually reset any speakerphones which derive power from the switch by pressing the button on the voice terminal.

## Backing Out of a Software Update

If fatal hardware errors or memory faults prevent the update from completing, the system must be recovered and the update backed out. If the update command has already been entered, follow normal escalation procedures. Backing out after this point is hazardous and may leave the system in a corrupted state.

## Software Update Procedure — Simplex SPE

After making the preparations described above, execute the following sequence of steps, entering the commands shown in bold type. This part of the procedure normally takes about 3 1/2 hours. Screen output for each command is described in [Chapter 8, "Maintenance Commands"](#). If errors are encountered after entering the *update software* command, follow normal escalation procedures. Avoid touching the keyboard while the save or upgrade commands are running since doing so may cause diagnostic messages to be lost.

Table 6-1. Software Update—Simplex SPE

Step	Time (min)	Remarks
<b>change sys-par maint</b>	2	Note the current settings of the Save Translation and Alarm Origination Activated fields and then set them to <b>n</b> . Set CPE Alarm Activation Level to <b>none</b> . Make sure scheduled daily maintenance is not set to run during the update.
<b>save announcements</b>	40	These steps create a backup tape in case the update fails and a backout is necessary. Saving announcements may be skipped if <b>display announcements</b> shows no administered announcements.
<b>save translation</b>	2	
<b>backup disk</b>	10	
Remove the backup tape and clean the tape drive	5	This procedure is described under " <b>TAPE</b> " in <a href="#">Chapter 9, "Maintenance Object Repair Procedures"</a> .
Insert the tape with the new software	2	Wait for the tape to retension itself.
<b>list config software-version</b>	5	Make sure the tape has the expected version number.
<b>restore disk install</b>	10	This copies files from the new tape to disk. If you are updating <i>from</i> a load earlier than 6.0, substitute for this step the following sequence: <b>copy announce tape, save translation tape</b> , then <b>restore disk full</b> .
The following step will result in the service effects described above.		
<b>upgrade software to-version</b>	10	Use the new software version number described above. The system will reboot and then reload translations. Results of each step in the upgrade process and initialization diagnostics will be displayed on the terminal. A full description of screen output appears in <b>upgrade software</b> in <a href="#">Chapter 8, "Maintenance Commands"</a> .   <b>NOTE:</b> Be careful not to touch the G3-MT keyboard while waiting for the command to execute, or the result messages may be lost.

Login on the G3-MT.

*Continued on next page*

**Table 6-1. Software Update—Simplex SPE — Continued**

Step	Time (min)	Remarks
<b>change sys-par maint</b>	2	Set the Save Translation, Alarm Origination Activated, CPE Alarm Level, and Daily Scheduled Maintenance times to the values that were in effect before starting this procedure.
<b>save translation</b>	2	This step stores the upgraded translations on disk.
<b>backup disk</b>	20	This step makes a backup copy of the new files. If a coredump from before the upgrade is on disk, this can take up to 50 minutes.
<b>test stored-data</b>	10	This step verifies that all MSS files are consistent. The next run of scheduled maintenance will also do this.
<b>list config soft long</b>	5	Verify that all files are correct.
<b>backup disk</b>	20	Make extra backup copies of the new files as needed. The next run of scheduled maintenance will also do this.
<b>set vector 8</b>	1	Sets the coredump vector to take a coredump when the system reboots.

Restore the system as described above.

## **Software Update Procedure — Duplicated SPE**

After making the preparations described above, execute the following sequence of steps, entering the commands shown in bold type. This part of the procedure normally takes about 3-1/2 hours. Screen output for each command is described in [Chapter 8, "Maintenance Commands"](#). If errors are encountered after entering the **update software** command, follow normal escalation procedures. Avoid touching the keyboard while the save or upgrade commands are running since doing so may cause diagnostic messages to be lost.



**Table 6-2. Software Update—Duplicated SPE**

Step	Time (min)	Remarks
<b>change sys-par maint</b>	2	Note the current settings of the Save Translation, SPE Interchange, and Alarm Origination Activated fields and then set them to n. Set CPE Alarm Activation Level to none. Make sure scheduled daily maintenance is not set to run during the update.
<b>save announcements</b>	40	These steps create a backup tape in case the update fails and a backout is necessary. Saving announcements may be skipped if <b>display announcements</b> shows no administered announcements.
<b>save translation</b>	2	
<b>backup disk</b>	10	
Remove tapes and clean tape drives.	5	This procedure is described under <a href="#">"TAPE"</a> in <a href="#">Chapter 9, "Maintenance Object Repair Procedures"</a> .
Insert the tapes containing the new software	2	Wait for the tape to retension itself.
<b>list config software-version long</b>	5	Make sure the tapes have the expected version number.
<b>restore disk install both</b>	10	Copies new tape files to disk. If updating <i>from</i> a load earlier than 6.0, substitute for this step the following sequence: <b>copy announce tape, save translation tape</b> , then <b>restore disk full both</b> .

*Continued on next page*

Table 6-2. Software Update—Duplicated SPE — *Continued*

Step	Time (min)	Remarks
The following step will result in the service effects described above. <b>upgrade software</b> to-version	10	Use the new software version number described above. The system will reboot the standby SPE, reload translations, and then execute an SPE interchange. Results of each step in the upgrade process and initialization diagnostics will be displayed on the terminal.   <b>NOTE:</b> Be careful not to touch the G3-MT keyboard while waiting for the command to execute, or the result messages may be lost.
Log in on the G3-MT.		
<b>status spe</b>	5	Repeat this command until the states of health of both SPEs are <i>functional</i> .
<b>reset spe-standby 4</b>	5	This step initiates a reboot of the standby SPE with the new software load.
<b>status spe</b>	15	Repeat this command until the states of health of both SPEs are <i>functional</i> .
<b>change sys-par maint</b>	2	Set the Save Translation, Alarm Origination Activated, CPE Alarm Level, SPE Interchange fields and Daily Scheduled Maintenance times to the values that were in effect before starting this procedure.
<b>save translation both</b>	2	This step stores the upgraded translations on both disks.
<b>backup disk</b>	20	This step makes a backup copy of the new files. The next run of scheduled maintenance will also do this. If a coredump from before the upgrade is on disk, this can take up to 50 minutes.
<b>test stored-data</b>	10	This step verifies that all MSS files are consistent. The next run of scheduled maintenance will also do this.
<b>list config soft long</b>	5	Verify that all files are correct.

*Continued on next page*

**Table 6-2. Software Update—Duplicated SPE — Continued**

Step	Time (min)	Remarks
backup disk	20	Make extra backup copies of the new files as needed.
set vector f spe-maint	1	Sets the coredump vector to take a coredump when the system reboots.

Restore the system as described above.

## **DS1 CPE Loopback Jack (T1 Only)**

Using the DS1 CPE Loopback Jack (apparatus code 700A, comcode 107988867), a technician can test the DS1 span between the system and the network interface point. The loopback jack is required when DC power appears at the interface to the ICSU. *The loopback jack isolates the ICSU from the DC power and properly loops the DC span power.*

### **⇒ NOTE:**

The loopback jack operates with any vintage of TN767E (or later) or TN464F (or later) DS1 circuit packs and with G3V3 EDI Release 3 (or later) software. The loopback jack operates with the 120A2 (or later) Integrated Channel Service Unit (ICSU) only; *not* the 31xx series of Channel Service Units or other external CSUs or earlier ICSUs.

## **Loopback Jack Installation**

### **Configurations Using a Smart Jack**

The preferred location of the loopback jack is at the interface to the Smart Jack. This provides maximum coverage of CPE wiring when remote tests are run using the loopback jack. If the Smart Jack is not accessible, install the loopback jack at the extended demarcation point.

1. If there is no extended demarcation point, install the loopback jack directly at the network interface point as shown in [Figure 6-1](#).
2. If there is an extended demarcation point and the Smart Jack is not accessible, install the loopback jack as shown in [Figure 6-2](#).
3. If there is an extended demarcation point, but the Smart Jack is accessible, install the loopback jack as shown in [Figure 6-3](#).

## Configurations without a Smart Jack

1. Install the loopback jack at the point where the cabling from the ICSU plugs into the “dumb” block. If there is more than one “dumb” block, choose the one that is closest to the Interface Termination feed or the fiber MUX. This provides maximum coverage for loopback jack tests. Refer to [Figure 6-4](#) and [Figure 6-5](#).

## Installation

1. To install the loopback jack, simply disconnect the RJ-48 (8-wide) connector (typically an H600-383 cable) at the appropriate interface point and connect the loopback jack in series with the DS1 span. See [Figure 6-1](#) through [Figure 6-5](#).
2. Plug the H600-383 cable from the ICSU into the female connector on the loopback jack.
3. Plug the male connector on the loopback jack cable into the network interface point.

### NOTE:

Do not remove the loopback jack after installation. This is not a test tool and should always be available to remotely test a DS1 span.

## Administration

---

1. At the management terminal, enter **change ds1 location** (the DS1 interface circuit pack for which the loopback jack was installed).
2. Be sure the `near-end CSU type` is set to **integrated**.
3. On page 2 of the form, change the `supply CPE loopback jack power` field to **y**.

### NOTE:

Setting this field to **y** informs the technician that a loopback jack is present on the facility. This allows a technician to determine that the facility is available for remote testing.

4. Enter **save translation** to save the new information.

## DS1 Span Test

---

This test should only be performed after the DS1 circuit pack and the 120A2 (or later) ICSU have been successfully tested using appropriate maintenance procedures. The DS1 span test consists of 2 sequential parts. Each part provides a result indicating if there is a problem in the CPE wiring. CPE wiring may be considered problem-free only if the results of both parts are successful.

The first part of the span test powers-up the loopback jack and attempts to send a simple code from the DS1 board, through the wiring and loopback jack, and back to the DS1 board. Maintenance software waits about 10 seconds for the loopback jack to loop, sends the indication of the test results to the management terminal, and proceeds to the second part of the test.

The second part of the test sends the standard DS1 3-in-24 stress testing pattern from the DS1 board, through the loopback jack, and back to a bit error detector and counter on the DS1 board. The bit error rate counter may be examined at will via the management terminal, and provides the results of the second part of the test. The test remains in this state until it is terminated so that the CPE wiring may be bit error rate tested for as long as desired.

1. Busy out the DS1 circuit pack by entering **busyout board UUCSS**.
2. At the management terminal, enter **change ds1 location** and verify the `near-end csu type` is set to **integrated**.
3. Change to page 2 of the DS1 administration form and confirm that the `TX LBO` field is **0** (dB). If not, record the current value and change it to 0 dB for testing. Press `Enter` to implement the changes or press `Cancel` to change nothing.
4. Enter **test ds1-loop location cpe-loopback-jack**. This turns on simplex power to the loopback jack and waits about 20 seconds for any active DS1 facility alarms to clear. A "PASS" or "FAIL" displays on the terminal. This is the first of the 2 results. A "FAIL" indicates a fault is present in the wiring between the ICSU and the loopback jack. The loopback jack may also be faulty. A "PASS" only indicates that the loopback jack looped successfully, not that the test data contains no errors. If a "PASS" is obtained, continue with the following steps.

**⇒ NOTE:**

The loss of signal (LOS) alarm (demand test #138) is not processed during this test while the 3-in-24 pattern is active.

5. Enter **clear meas ds1 loop <location>** to clear the bit error count.
6. Enter **clear meas ds1 log <location>** to clear the performance measurement counts.
7. Enter **clear meas ds1 esf <location>** to clear the ESF error count.
8. Enter **list meas ds1 sum <location>** to display the bit error count. Refer to [Table 6-3](#) for troubleshooting information.

**Table 6-3. DS1 Span Troubleshooting**

Displayed Field	Function	Indication
Test: cpe-loopback-jack	Pattern 3-in-24	The loopback jack test is active.
Synchronized	Y or N	If "y" displays, the DS1 circuit pack has synchronized to the looped 3-in-24 pattern and is accumulating a count of the bit errors detected in the pattern until the test has ended. If "n" displays, retry the test 5 times by ending the test per Step 11 and re-starting the test per Step 4. If the circuit pack never synchronizes, substantial bit errors in the 3-in-24 pattern are likely. This could be intermittent connections or a broken wire in a receive or transmit pair in the CPE wiring.
Bit Error Count	Cumulative count of detected errors	<p>If there are no wiring problems, the counter remains at 0. A count that pegs at 65535 or continues to increment by several hundred to several thousand on each <b>list meas</b> command execution indicates intermittent or corroded connections, severe crosstalk, or impedance imbalances between the two conductors of the receive pair or the transmit pair. Wiring may need replacement.</p> <p>Note that "ESF error events" counter and the ESF performance counter summaries ("errored seconds", "bursty errored seconds", and so forth) will also increment. These counters are not used with the loopback jack tests. However, they will increment if errors are occurring. Counters should be cleared following the test.</p>

9. Repeat Steps 5 through 8 as desired to observe bit error rate characteristics. Also, wait 1 to 10 minutes between Steps 5 through 7. One minute without errors translates to better than a 1 in 10 to the eighth error rate. Ten minutes without errors translates to better than a 1 in 10 to the ninth error rate.
10. If the test runs for 1 minute with an error count of 0, confirm that the 3-in-24 pattern error detector is operating properly by entering **test ds1-loop <location> inject-single-bit-error**. This causes the 3-in-24 pattern generator on the DS1 circuit pack to inject a single-bit error into the transmit pattern. A subsequent **list meas ds1 summary <location>** command displays the bit error count. If a count greater than 1 is displayed, replace the ICSU and retest. If the problem continues, replace the DS1 circuit pack.

11. Terminate the test by entering **test ds1-loop <location> end cpe-loopback-jack-test**. Wait about 30 seconds for the DS1 to re-frame on the incoming signal and clear DS1 facility alarms.

Loopback termination fails under the following conditions:

- a. The span is still looped somewhere. This could be at the loopback jack, at the ICSU, or somewhere in the network. This state is indicated by a fail code of 1313. If the red LED on the loopback jack is on, replace the ICSU. Re-run the test and verify that the loopback test terminates properly. If not, replace the DS1 circuit pack and repeat the test.
  - b. The DS1 cannot frame on the incoming span's signal after the loopback jack is powered down. This means that there is something wrong with the receive signal into the loopback jack from the "dumb" block or the Smart Jack. If the service provider successfully looped and tested the span, up to the Smart Jack, this condition isolates the problem to the wiring between the loopback jack and the Smart Jack. Refer to "Loopback Jack Fault Isolation Procedures" for information on how to proceed in this case. The test cannot be successfully terminated until a good signal is received. To properly terminate the test before a good receive signal is available, enter **reset board <location>**.
12. Restore the "TX LBO" field to the original value recorded in Step 2.
  13. Release the DS1 circuit pack using the **release board UCCSSpp** command.
  14. Leave the loopback jack connected to the DS1 span.

## Loopback Jack Fault Isolation Procedures

This section describes the possible DS1 configurations in which the loopback jack may be used. These configurations are: when the DS1 provider includes a Smart Jack, when no Smart Jack is provided at all, and when sites use fiber multiplexers. These configurations are separated into "Configurations Using a Smart Jack" and "Configurations Without a Smart Jack."

### Configurations Using a Smart Jack

The addition of the loopback jack and the presence of a Smart Jack divides the DS1 span into 3 separate sections for fault isolation. These sections are shown in [Figure 6-1](#) through [Figure 6-3](#) for the different span configurations. They are:

- Section 1: Between the 120A2 (or later) ICSU and the loopback jack.
- Section 2: Between the loopback jack and the Smart Jack (network interface point).
- Section 3: From the Smart Jack to the CO. It is necessary to contact the DS1 provider to run this test.

A problem can exist in 1 or more of the 3 sections. The field technician is responsible for finding and correcting problems in the first 2 sections. The DS1 service provider is responsible for finding and correcting problems in the third section. Testing is divided into 3 steps.

- Test customer premises wiring (section 1 in the following 3 figures) from the ICSU to the loopback jack as described in “DS1 Span Test.”
- Test the CO-to-network interface wiring (section 3 in [Figure 6-1](#)) using the Smart Jack loopback (CO responsibility). Coordinate this test with the DS1 provider.
- Test the short length of customer premises wiring (section 2 in the following 3 figures) between the loopback jack and the Smart Jack. This can be done using a loopback that “overlaps” section 2 of the cable. Any of the following loopbacks can do this:
  - a. The local ICSUs line loopback, which is typically activated, tested, and then deactivated by the DS1 service provider at the CO end.
  - b. The local DS1 interface’s payload loopback, activated and tested by the DS1 service provider at the CO end.
  - c. The far-end ICSU’s line loopback. This test is activated at the management terminal by entering **test ds1-loop <location> far-csu-loopback-test-begin**. The test is terminated by entering **test ds1-loop <location> end-loopback/span-test**. Bit error counts are examined as described in “DS1 Span Test.” This test method is the least preferable because it covers wiring that is not in the local portion of the span. This test only isolates problems to section 2 wiring if there are no problems in the wiring between the far-end CO and the far-end ICSU. Coordinate this test with the DS1 service provider.

If any of the above tests (a, b, or c) fail, a problem is indicated in section 2 as long as the tests for section 1 and section 3 pass. Since section 2 includes the network interface point, it is necessary to work with the service provider to isolate the fault to the loopback jack cable, the “dumb” block, or the Smart Jack.



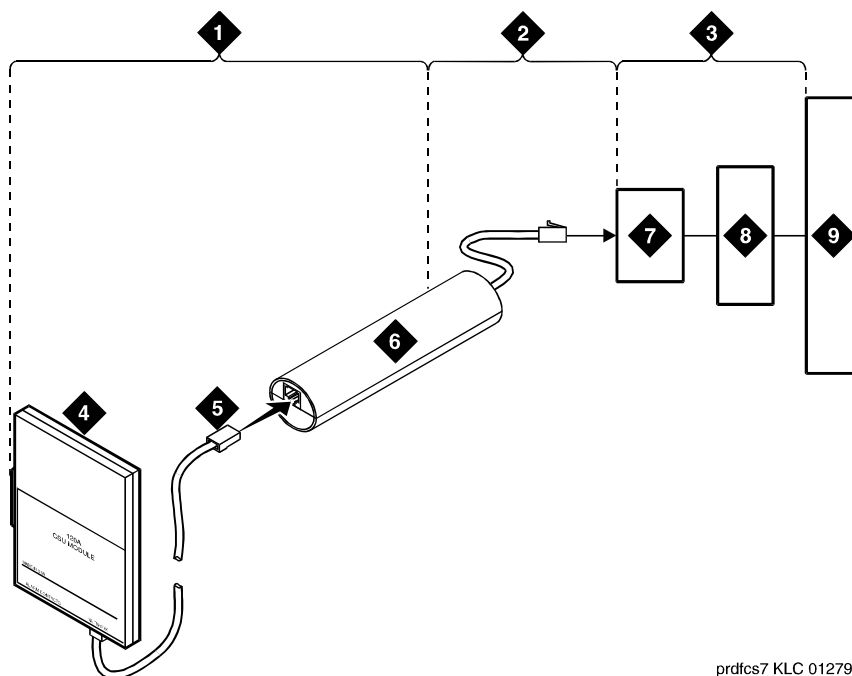

prdfcs7 KLC 012797

**Figure Notes:**

- |  |   |
|--|---|
| 1. Span Section 1  | 5. RJ-48 to Network Interface (Up to 1000 Feet) (305 m) |
| 2. Span Section 2  | 6. Loopback Jack  |
| 3. Span Section 3  | 7. Network Interface Smart Jack                         |
| 4. 120A2 (or later) Integrated Channel Service Unit (ICSU) | 8. Interface Termination or Fiber MUX                   |
|  | 9. Central Office                                       |

**Figure 6-1. Network Interface at Smart Jack**

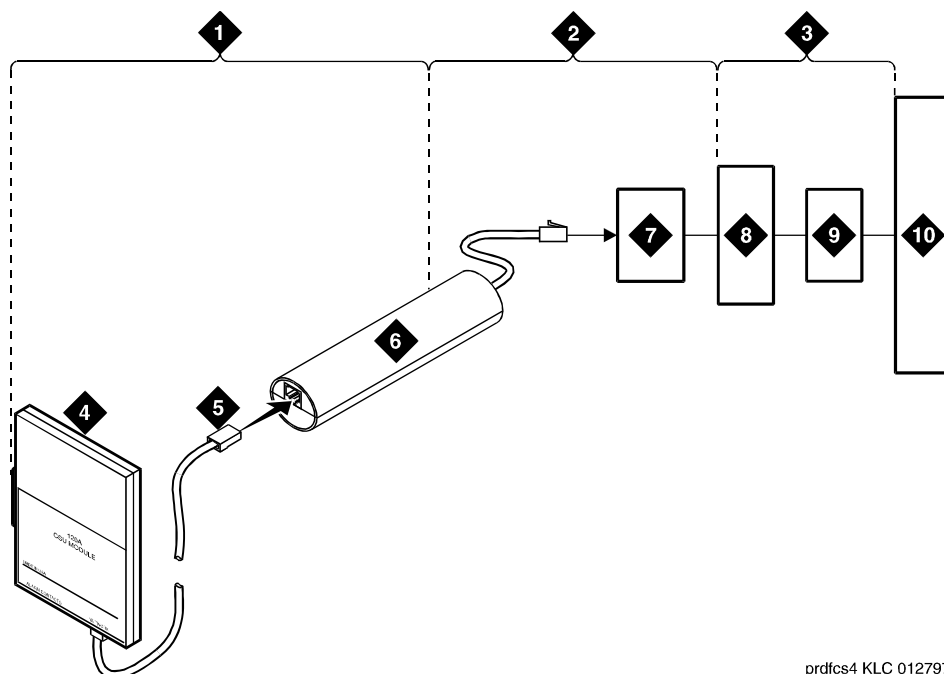

pdfcs4 KLC 012797

**Figure Notes:**

- |  |  |
|--|--|
| 1. Span Section 1  | 6. Loopback Jack                       |
| 2. Span Section 2  | 7. "Dumb" Block (Extended Demarcation) |
| 3. Span Section 3  | 8. Network Interface Smart Jack        |
| 4. 120A2 (or later) Integrated Channel Service Unit (ICPU) | 9. Interface Termination or Fiber MUX  |
| 5. RJ-48 to Network Interface (Up to 1000 Feet) (305 m)    | 10. Central Office                     |

**Figure 6-2. Network Interface at Extended Demarcation Point (Smart Jack Inaccessible)**

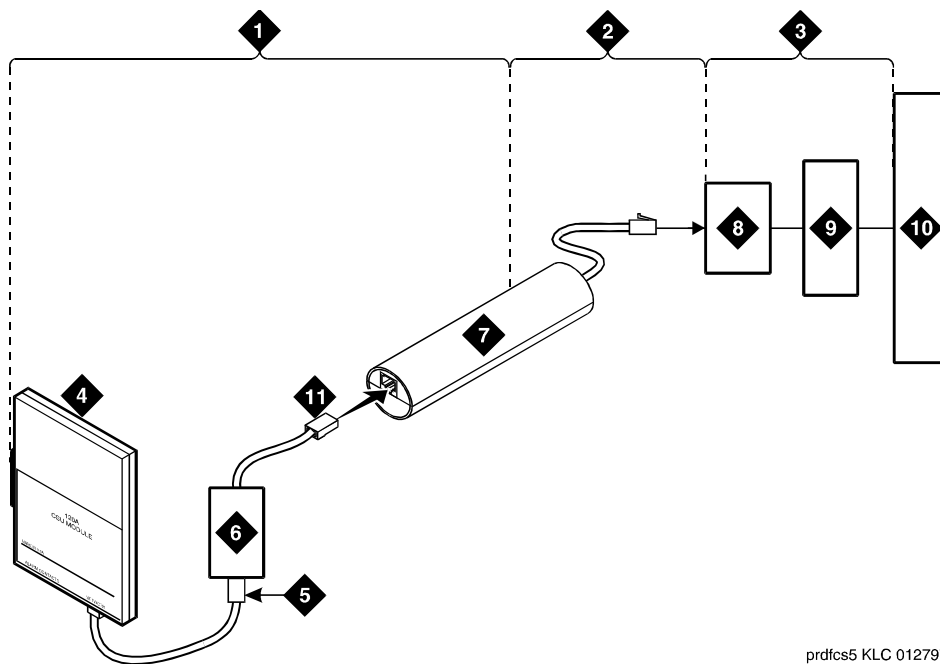

prdfcs5 KLC 012797

**Figure Notes:**

- |  |  |
|--|--|
| 1. Span Section 1  | 6. "Dumb" Block (Extended Demarcation) |
| 2. Span Section 2  | 7. Loopback Jack                       |
| 3. Span Section 3  | 8. Network Interface Smart Jack        |
| 4. 120A2 (or later) Integrated Channel Service Unit (ICSU) | 9. Interface Termination or Fiber MUX  |
| 5. RJ-48 to Network Interface (Up to 1000 Feet) (305 m)    | 10. Central Office                     |
|  | 11. "Dumb" Block to Smart Jack RJ-48   |

**Figure 6-3. Network Interface at Extended Demarcation Point (Smart Jack Accessible)**

## Configurations without a Smart Jack

When the loopback jack is added to a span that does not contain a Smart Jack, the span is divided into 2 sections. See [Figure 6-4](#) and [Figure 6-5](#).

1. ICSU to the loopback jack.
2. Loopback jack to the Central Office (CO).

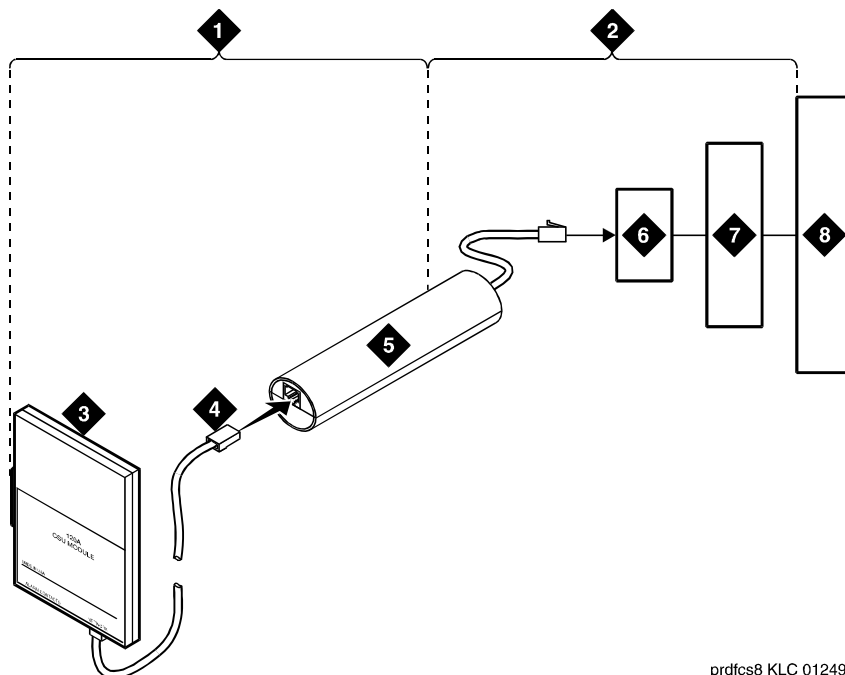

prdfcs8 KLC 012497

### Figure Notes:

- |  |                                       |
|--|---------------------------------------|
| 1. Span Section 1  | 5. Loopback Jack                      |
| 2. Span Section 2  | 6. "Dumb" Block (Demarcation Point)   |
| 3. 120A2 (or later) Integrated Channel Service Unit (ICSU) | 7. Interface Termination or Fiber MUX |
| 4. RJ-48 to Network Interface (Up to 1000 Feet) (305 m)    | 8. Central Office                     |

**Figure 6-4. Network Interface at "Dumb" Block**

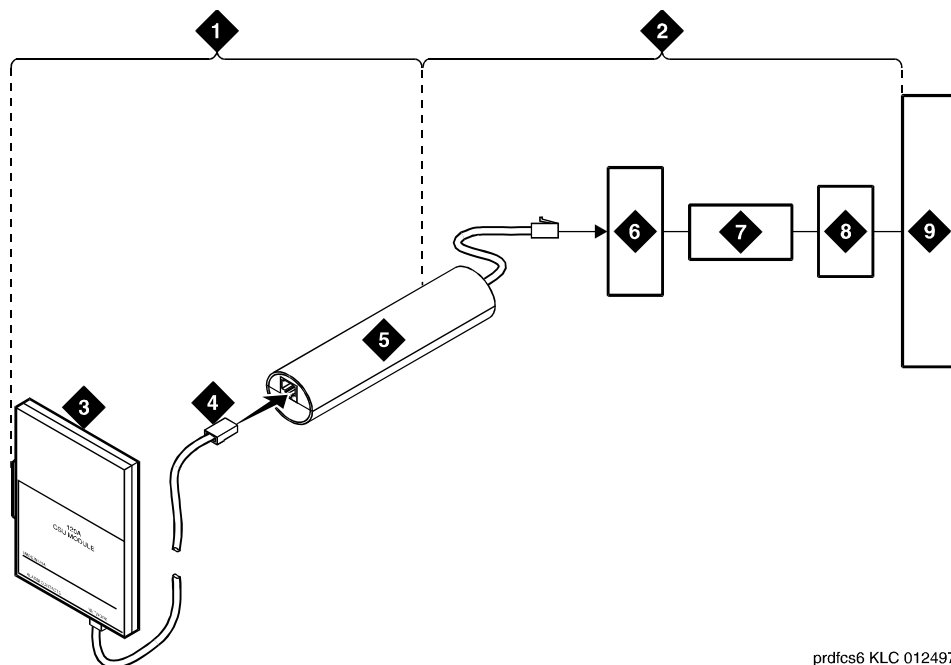

prdfcs6 KLC 012497

**Figure Notes:**

- |  |                                     |
|--|-------------------------------------|
| 1. Span Section 1  | 5. Loopback Jack                    |
| 2. Span Section 2  | 6. "Dumb" Block (Demarcation Point) |
| 3. 120A2 (or later) Integrated Channel Service Unit (ICSU) | 7. Repeater                         |
| 4. RJ-48 to Network Interface (Up to 1000 Feet) (305 m)    | 8. Fiber MUX                        |
|  | 9. Central Office                   |

**Figure 6-5. Network Interface at "Dumb" Block with Repeater Line to Fiber MUX**

Section 2 includes the short cable from the loopback jack to the "dumb" block demarcation point (part of the loopback jack). This is the only portion of section 2 that is part of customer premises wiring but is not covered in the loopback jack's loopback path.

A problem can exist in 1 or both of the 2 sections. The field technician is responsible for finding and correcting problems in section 1 and the loopback cable portion of section 2. The DS1 service provider is responsible for finding and correcting problems in the majority of section 2. Testing is divided into 2 steps.

1. Test customer premises wiring (section 1 in [Figure 6-4](#)) from the ICSU to the loopback jack as described in the “DS1 Span Test” section.
2. Test the loopback jack-to-”dumb” block and ”dumb” block-to-CO wiring (section 2 in [Figure 6-4](#)). This can be done using a loopback that “overlaps” the section of the span. Any of the following loopbacks can do this:
  - a. The local ICSUs line loopback, which is typically activated, tested, and then deactivated by the DS1 service provider at the CO end.
  - b. The local DS1 interface’s payload loopback, activated and tested by the DS1 service provider at the CO end.
  - c. The far-end ICSU’s line loopback. This test is activated at the management terminal by entering **test ds1-loop <location> far-csu-loopback-test-begin**. The test is terminated by entering **test ds1-loop <location> end-loopback/span-test**. Bit error counts are examined as described in the “DS1 Span Test” section. This test only isolates problems to section 2 wiring if there are no problems in the wiring between the far-end CO and the far-end ICSU. Coordinate this test with the DS1 service provider.

If any of the above tests (a, b, or c) fail, a problem is indicated in section 2. This could mean bad loopback jack -to-”dumb” block cabling, but is more likely to indicate a problem somewhere between the “dumb” block and the CO. This is the responsibility of the DS1 service provider. If the DS1 Span Test confirms that there are no problems in section 1, the technician should proceed as follows to avoid unnecessary dispatch.

- Identify and contact the DS1 service provider
- Inform the DS1 provider that loopback tests of the CPE wiring to the “dumb” block (section 1) showed no problems
- If the far-end ICSU line loopback test failed, inform the DS1 provider
- Request that the DS1 provider perform a loopback test of their portion of the section 2 wiring by sending someone out to loop section 2 back to the CO at the “dumb” block.

If this test fails, the problem is in the service provider’s wiring.

If the test passes, the problem is in the cable between the loopback jack and the “dumb” block. Replace the loopback jack.

## Configurations Using Fiber Multiplexers

Use the loopback jack when customer premises DS1 wiring connects to an on-site fiber multiplexer (MUX) and allows wiring to the network interface point on the MUX to be remotely tested. This requires that ICSUs be used on DS1 wiring to the MUX.

Fiber MUXes can take the place of Interface termination feeds as shown in [Figure 6-1](#), [Figure 6-2](#), [Figure 6-3](#), and [Figure 6-4](#). Test these spans using the same procedures as metallic spans. Note the following points:

1. Fiber MUXes may have loopback capabilities that can be activated by the service provider from the CO end. These may loop the signal back to the CO or back to the DS1 board. If the MUX provides the equivalent of a line loopback on the "problem" DS1 facility, this may be activated following a successful loopback jack test and used to isolate problems to the wiring between the loopback jack and the MUX.
2. Be aware that there are installations that use repeatered metallic lines between the MUX and the "dumb" block. These lines require DC power for the repeaters and this DC power is present at the "dumb" block interface to the CPE equipment. *A loopback jack is required in this configuration to properly isolate and terminate the DC power.*

To check for the presence of DC, make the following 4 measurements at the network interface jack:

1. From Transmit Tip (T, Pin 5) to Receive Tip (T1, Pin 2)
2. From Transmit Ring (R, Pin 4) to Receive Ring (R1, Pin 4)
3. From Transmit Tip (T, Pin 5) to Transmit Ring (R, Pin 4)
4. From Receive Tip (T1, Pin 2) to Receive Ring (R1, Pin 4)

All measurements should read 0 (zero) volts DC. For pin numbers and pin designations, refer to *Integrated Channel Service Unit (ICSU) Installation and Operation*, 555-230-193.

## Operating Characteristics

If a TN464F or TN767E and a 120A2 were installed in a system running pre-G3V3 software and the software is later upgraded to G3V3 Release 3 or later, reset the DS1 circuit pack so that the ICSU administration fields will appear on the DS1 administration form.

## Facility test calls

---

The Facility Test Calls feature allows you to use a voice terminal to make test calls to specific trunks, time slots, tones, and tone receivers within the system. The test call verifies that the accessed component is functioning properly. To use this feature, it must be enabled on the Class of Restriction form, and you must know the Facility Test Call Access Code. The code can be retrieved by entering **display feature-access-codes**. It appears on page one of the screen output.

### ⇒ NOTE:

For the ISDN-PRI Test Call feature see [“Troubleshooting ISDN-PRI Test Call Problems”](#) in [Chapter 5, “Alarms, Errors, and Troubleshooting”](#).

### ⇒ NOTE:

The following test call descriptions are for voice terminal users:

## Trunk test call

---

The trunk test call accesses specific Tie or CO trunks, including DS1 trunks. If the trunk is busied out by maintenance, it will be temporarily released for the test call and returned to busyout afterwards. Before making the test call, use **list configuration** to determine the location of the trunk ports that you which to test. DID trunks cannot be accessed.

### ⇒ NOTE:

Do not use this trunk test call procedure to test ISDN-PRI or ATM-CES trunks. For more information on testing ISDN-PRI or ATM CES trunks see ATM-BCH, Test #258.

To place a trunk test call:

1. Dial the FAC described above and listen for dial tone.
2. Dial the 7-digit port location UUCSSpp, where:  
UU= Cabinet number (01 for PPN, 02 -- 44 for EPNs)  
C = Carrier number (A=1, B=2, C=3, D=4, E=5)  
SS = Slot number (01--20)  
pp = Port circuit number (01--24)

The channels on a DS1 trunk are addressed by using the channel number for the port number.



## 3. Listen for one of the following tones:

Dial tone or Silence	The trunk is connected. Go to step 4.
Busy Tone	The trunk is either busy processing a call or is out of service. Check <b>status trunk</b> .
Reorder tone	The trunk requested is in a different port network from your station, and inter-PN resources are not available to access it.
Intercept Tone	The port addressed is not a trunk, or it is a DID trunk, or the trunk is not administered.
Confirmation Tone	The port is a tone receiver. See the <a href="#">“DTMR Test Call”</a> section.

## 4. Place a call. If the call does not go through (no ringing is heard) check to see if the circuit has been removed or if the trunk is a rotary trunk.

The dial tone heard is coming from the far-end. If the far end has been disabled, you will not hear dial tone. However, depending on far-end administration, you may still be able to dial digits. All digits dialed after the port number are transmitted using end-to-end DTMF signaling. If the trunk being tested is a rotary trunk, it is not possible to break dial tone.

## DSO Loop-Around Test Call

The DSO Loop Around feature provides a loop around connection for incoming Non-ISDN DS1 trunk data calls. This feature is similar to the far end loop around connection provided for the ISDN Test Call feature. This DSO loop around is provided primarily to allow a network service provider to perform facility testing at the DSO level before video teleconferencing terminals are installed at the PBX.

The feature is activated on a call-by-call basis by dialing a test call extension specified on the second page of the System Parameters Maintenance form. No special hardware is required. When the test call extension is received by the PBX, a non inverting 64 kbps connection is set up on the PBX's Time Division Multiplexed bus. More than one loop around call can be active at the same time.

For calls routed over the public network using the ACCUNET Switched Digital Service (SDS) or Software Defined Data Network (SDDN), the data transmission rate is 56 Kbps since robbed bit signaling is used. For calls established over a private network using common channel signaling, the full 64 kbps data rate is available.

When the incoming trunk group is used only for data calls (SDS), the Communications Type on the associated Trunk Group form should be set to “data”. When the incoming trunk group is used for robbed bit alternate voice and/or data (SDN/SDDN), the Communications Type on the Trunk Group form should be set to “rbavd” (robbed bit alternate voice data). For private network trunks using common channel signaling, the Communications Type on the associated Trunk Group form can be set to “avd”.

## DTMR Test Call

This call accesses and tests the dual tone multifrequency receivers (DTMR-PTs) located on TN420 and TN748 Tone Detector circuit packs. These tone receivers are also known as touch tone receivers (TTRs). Before making the test call, use **list configuration** to determine the location of the TN420 or TN748 that you wish to test.

To place a tone receiver test call:

1. Dial the FAC described in the introduction to this section and listen for dial tone.
2. Dial the seven-digit port location UUCSSpp of one of the four DTMR ports located on a Tone Detector circuit pack:

C = Carrier number (A=1, B=2, C=3, D=4, E=5)

SS = Slot number (00-20)

pp = Port circuit number (DTMR ports are numbered 01, 02, 05, and 06).

3. Listen for one of the following tones:

Confirmation tone	The DTMR is connected. Go to step 4.
Intercept tone	The port entered is not a TTR, (if a trunk, see above), or the board is not inserted.
Reorder tone	The DTMR is in use, (call processing), the board is busied out, or inter-PN resources are unavailable for the call.
Dial tone	The port is a trunk. See the preceding section.

4. Dial the sequence **1234567890\*#**.

If the sequence is entered and received correctly, dial tone is returned and another test call can be made. If the test fails, intercept tone is returned. A failure may indicate a faulty DTMR port or circuit pack, a faulty voice terminal, or an error in the entry of the sequence.

5. To test another DTMR, repeat steps 2 through 4.
6. To terminate the test call, hang up the station set used for testing.

## TDM Bus Time Slot Test Call

The time slot test call connects the voice terminal to a specified time slot on the A or B TDM Bus of a specified port network. To connect to any out-of-service time slots, refer to the [“Out-of-Service Time Slot Test Call”](#) section.

To test a specific time slot on the TDM bus of a specific port network:

1. Dial the FAC described in the introduction to this section and listen for dial tone.

2. Dial the 2-digit port network number followed by # and the 3-digit time slot number listed in the following table.
3. Listen for one of the following tones:

Reorder tone	The time slot is in use, the time slot is not addressable, or inter-PN resources are not available to make the call.
Confirmation tone	The time slot is idle or out-of-service. The time slot may be on the TDM bus (A or B) that is not currently carrying tones, or it may be busied out. The call is connected to the time slot so that any noise may be heard.
System tone	The time slot is carrying a system tone as listed in the following table.

## TDM Bus Time Slots

When you address a tone-carrying time slot on the TDM bus (A or B) that is currently carrying tones, you will be connected to that time slot and will hear the tone.

Time slots 005-021 and 261-277 are reserved to carry the system's dedicated tones. Time slots 000-004 and 256-260 carry control information and are not addressable. Time slots 254 and 510 are not addressable due to a hardware constraint. At any given time, only one of the TDM busses (A or B) carries the dedicated tones, with B being the default. Entering **status port-network** will display which TDM bus is currently carrying the dedicated tones. The corresponding time slots on the other bus are normally inactive and are used for call service only as a last resort when all other non-control channel time slots on both busses are busy. Bus A's tone time slots are numbered 005-021; bus B's tone time slots are numbered 261-277.

**Table 6-4. TDM Bus Time Slot Numbers**

<b>TDM Bus A time slot</b>	<b>TDM Bus B time slot</b>	<b>Tone Heard</b>
000	256	Reorder
001	257	Reorder
002	258	Reorder
003	259	Reorder
004	260	Reorder
005	261	Touch Tone 1 - 697Hz
006	262	Touch Tone 2 - 770 Hz
007	263	Touch Tone 3 - 852Hz
008	264	Touch Tone 4 - 941 Hz
009	265	Touch Tone 5 - 1209 Hz
010	266	Touch Tone 6 - 1336Hz
011	267	Touch Tone 7 - 1447 Hz
012	268	Touch Tone 8 - 1633 Hz
013	269	Dial Tone
014	270	Reorder Tone
015	271	Alert Tone
016	272	Busy Tone
017	273	Ringback Tone
018	274	Special Ringback Tone
019	275	2225 Hz Tone
020	276	Music
021	277	Tone on Hold
022-253	278-509	Confirmation (used for calls)
254	510	Reorder
255	511	Confirmation

## Out-of-Service Time Slot Test Call

This call can be used to determine if there are any out-of-service time slots on the TDM bus of a specified port network. If there are, you will be connected to one. By listening to noise on the time slot and selectively removing circuit packs, you may be able to isolate the source of interference.

To place the call:

1. Dial the FAC described above and listen for dial tone.
2. Dial the port network number followed by \*\*\*\* and listen for one of the following tones:

Reorder tone	There are no out-of-service time slots on the specified port network.
--------------	---

Confirmation tone	Connection is made to an out-of-service time slot.
-------------------	--

3. Repeated test calls will alternate between out-of-service time slots on TDM bus A and TDM bus B.

## System Tone Test Call

This test connects the voice terminal to a specific system tone.

To place the call:

1. Dial the FAC described above.
2. Dial the port network number followed by \* and the two-digit tone identification number from the following table.
3. Listen for one of the following tones:

Intercept tone	The number entered is not a valid tone number.
----------------	--

Reorder tone	Inter-PN resources are not available.
--------------	---------------------------------------

System tone	The specified tone will be heard if it is functioning.
-------------	--

### NOTE:

For a definition of Call Progress Tones see *DEFINITY Communications System Generic 3 System Descriptions and Specifications, 555-230-206*, Chapter 11.

**Table 6-5. System Tone Identification Numbers**

Number	Description
00	Null tone
01	Dial tone
02	Reorder tone
03	Alert tone
04	Busy tone
05	Recall dial tone
06	Confirmation tone
07	Internal call waiting tone
08	Ringback tone
09	Special ringback tone
10	Dedicated ringback tone
11	Dedicated special ringback tone
12	Touch tone 1
13	Touch tone 2
14	Touch tone 3
15	Touch tone 4
16	Touch tone 5
17	Touch tone 6
18	Touch tone 7
19	Touch tone 8
20	Chime
21	350 Hz
22	440 Hz
23	480 Hz
24	620 Hz
25	2025 Hz
26	2225 Hz
27	Counter

*Continued on next page*

**Table 6-5. System Tone Identification Numbers — Continued**

<b>Number</b>	<b>Description</b>
28	External call waiting
29	Priority call waiting
30	Busy verification
31	Executive override/intrusion tone
32	Incoming call identification
33	Dial zero
34	Attendant transfer
35	Test calls
36	Recall on don't answer
37	Audible ring
38	Camp-on recall
39	Camp-on confirmation
40	Hold recall
41	Hold confirmation
42	Zip tone
43	2804 Hz
44	1004 Hz (-16db)
45	1004 Hz (0 db)
46	404 Hz
47	Transmission test sequence 105
48	Redirect tone
49	Voice signaling tone
50	Digital milliwatt
51	440 Hz + 480 Hz
52	Music
53	Transmission test sequence 100
54	Transmission test sequence 102
55	Laboratory test tone 1

*Continued on next page*

**Table 6-5. System Tone Identification Numbers — Continued**

Number	Description
56	Laboratory test tone 2
57	Disable echo supervision dial tone
58	7 seconds of answer tone
59	4 seconds of answer tone
60	Restore music (or silence)
61	Warning tone
62	Forced music tone
63	Zip tone (first of 2 sent)
64	Incoming call ID (first of 2 sent)
65	Tone on hold
66	CO dial tone
67	Repetitive confirmation tone
68	Conference/bridging tone

## Preventive Maintenance

The following preventive maintenance procedures should be followed when visiting customer sites. The chart that follows shows a sample of the Preventive Maintenance Log. Whenever you complete a preventive maintenance procedure, be sure to fill in the information on the log form before you leave the customer's premises.

### Air Filters

Air filters should be inspected annually. If a filter is dirty or clogged, first tap it on the ground. If the filter is still dirty or clogged, then wash it with warm water and a mild detergent. A vacuum cleaner can be used if one is available. If there is no facility for washing or vacuuming the air filter, then replace the filter. Refer to "[CABINET \(Cabinet Sensors\)](#)" maintenance documentation for information on air filters and fans.



## **Tape Drive**

---

The head and capstan on the tape drive of the SPE should be cleaned every three months. Abrasive particles from worn tape and environmental debris can cause loss of information and services. The procedure for cleaning the tape drive is described in the section on TAPE in [Chapter 9, "ABRI-PORT \(ASAI ISDN-BRI Port\)"](#).

## **Batteries**

---

The backup batteries in the power distribution unit in the bottom of the cabinet should be replaced every four years or whenever a POWER alarm that indicates the condition of the batteries is logged. Systems with an uninterruptible power supply (UPS) may not be equipped with backup batteries.

**PREVENTIVE MAINTENANCE LOG  
DEFINITY ECS**

Date equipment installed: \_\_\_\_\_

<b>Air Filters<sup>1</sup></b>	<b>Scheduled Date</b>	<b>Date Completed</b>	<b>Completed By</b>
Single-carrier cabinet			
Multi-carrier cabinet			

<b>Scheduled Date</b>	<b>Date Completed</b>	<b>Completed By</b>

<b>Tape Head/Capstan<sup>2</sup></b>	<b>Scheduled Date</b>	<b>Date Completed</b>	<b>Completed By</b>

<b>Scheduled Date</b>	<b>Date Completed</b>	<b>Completed By</b>

<b>Battery Packs<sup>3</sup></b>	<b>Scheduled Date</b>	<b>Date Completed</b>	<b>Completed By</b>
Single-carrier cabinet			
Multi-carrier cabinet			

<b>Scheduled Date</b>	<b>Date Completed</b>	<b>Completed By</b>

- 1 Inspect annually; clean or replace
- 2 Clean every three months
- 3 Replace every 4 years

Post this form with the equipment.

## Analog Tie Trunk Back-to-Back Testing

The TN760 circuit pack can be configured for back-to-back testing (also known as connectivity testing) by making translation and cross-connect changes. This testing configuration allows for the connection of Tie Trunks back-to-back in the same switch to verify the operation of Tie Trunk ports. The tests can be performed in either the E&M or simplex modes. (Refer to *DEFINITY Communications System Generic 1 and Generic 3 Installation and Test*, 555-230-104, for instructions on how to make connections at the cross-connect field).

### E&M Mode Test Procedure

1. At the administration terminal, enter **list configuration trunks** to determine which ports are assigned on the Tie Trunk circuit pack.
2. Enter **display dialplan** command to determine the Trunk Access Code (TAC) format.
3. Enter **display port xxx** for all ports defined in Step 1. This displays the trunk groups of which the ports are members. See [Chapter 5, "Alarms, Errors, and Troubleshooting"](#) for details of how to remove and replace port circuit packs.
4. Insert the circuit pack back into the slot.
5. Enter **display trunk xxx p** for each trunk group identified in Step 3. This command displays the specified trunk group on the administration terminal screen and prints a hard copy on the printer. Save this data for later use.
6. Remove all members defined by these ports from the trunk group(s) using the **change trunk xxx** command.
7. Remove the Tie Trunk circuit pack from the carrier slot.
8. Set the dip (option) switches for each of the two ports to be tested on the Tie Trunk circuit pack to "E&M mode" and "unprotected."
9. Enter **add trunk n** to add a new (test) trunk group. Then enter information for the following fields:

Group Type	tie
TAC	Use trunk access code obtained from dial plan
Trunk Type (in/out)	wink/wink
Port	Assign two of the ports from the tie trunk.
Mode	E&M for both ports
Type	Specify one port as <b>t1 standard</b> and other port as <b>t1 compatible</b> .

10. Locate the Tie Trunk port terminal connections at the cross-connect field. Consult the appropriate table below for either 110-type or 66-type hardware.
11. At the cross-connect field, disconnect outside trunk facilities from the Tie Trunk ports and mark the disconnected wires for reconnecting the Tie Trunk ports to their normal configuration later. The D Impact Tool (AT-8762) is required to perform this step.
12. Use jumper wires (DT 24M-Y/BL/R/G and DT 24P-W/BRN) and the D Impact Tool to connect wiring between the two ports assigned in Step 9 at the cross-connect field. For example, if the two ports on the Analog Tie Trunk circuit pack are port 1 and 2, connect the wirings as shown below:

Port 1 (t1 stan) (E & M)	connected to	Port 2 (t1 comp) (E & M)
T1	connected to	T12
R1	“	R12
T11	“	T2
R11	“	R2
E1	“	M2
M1	“	E2

13. Check all wirings to verify good connections between the two test ports.
14. Place a call from one voice terminal to another voice terminal using the Tie Trunk ports assigned. Dial TAC and extension. For example, if TAC of Tie Trunk group is 110 and station number is 5012, then dial 110 5012. If the call cannot be made, either one of these ports could be defective. There are four ports on the TN760. Try different combinations to determine defective ports.
15. If there is a defective port on the circuit pack, try to switch to an unused port. If all ports are normally used, then replace the circuit pack.
16. Disconnect the jumpers between two ports. Then use administration terminal and trunk printouts to restore all trunk group changes to normal values.

**Table 6-6. Carrier Lead Appearances MDF**

110 Connecting Block Terminals	CO Trunk TN747	Tie Trunk TN760
1	T1	T1
2	R1	R1
3		T11
4		R11
5		E1
6		M1
7	T2	T2
8	R2	R2
9		T12
10		R12
11		E2
12		M2
13	T3	T3
14	R3	R3
15		T13
16		R13
17		E3
18		M3
19	T4	T4
20	R4	R4
21		T14
22		R14
23		E4
24		M4
25	T5	
26	R5	
27		
28		

*Continued on next page*

**Table 6-6. Carrier Lead Appearances MDF — Continued**

<b>110 Connecting Block Terminals</b>	<b>CO Trunk TN747</b>	<b>Tie Trunk TN760</b>
29		
30		
31	T6	
32	R6	
32		
33		
34		
36		
37	T7	
38	R7	
39		
40		
41		
42		
43	T8	
44	R8	
45		
46		
47		
48		
49		
50		

**Simplex Mode Test Procedure**

1. Repeat Steps 1 through 7 of the E&M Mode Test Procedure.
2. Set the dip (option) switches for each of the two ports to be tested on the Tie Trunk circuit pack to simplex mode.

3. Enter **add trunk n** to add a new (test) trunk group. Then enter information for the following fields:

Group Type	tie
TAC	Use trunk access code obtained from dial plan.
Trunk Type (in/out)	wink/wink
Port	Assign two of the ports from the tie trunk.
Mode	simplex
Type	type 5

4. Locate the Tie Trunk port terminal connections at the cross-connect field. Consult the appropriate table above for either 110-type or 66-type hardware.
5. At the cross-connect field, disconnect outside trunk facilities from the Analog Tie Trunk ports and mark the disconnected wires for later when the Tie Trunk ports are placed back into normal operation. The D Impact Tool (AT-8762) is required to perform this step.
6. Use jumper wires (DT 24M-Y/BL/R/G) and the D Impact Tool to connect wiring between the two ports assigned in Step 4 at the cross-connect field. For example, if the two ports on the Analog Tie Trunk circuit pack are ports 1 and 2, connect the wirings as shown below:

Port 1	connected to	Port 2
(type 5)		(type 5)
(simplex)		(simplex)

T1	connected to	T12
R1	"	R12
T11	"	T2
R11	"	R2

7. Repeat Steps 13 through 16 of the E & M Mode Test Procedure.

## Terminating Trunk Transmission Testing

---

The Terminating Trunk Transmission (TTT) (non-interactive) feature provides for extension number access to three tone sequences that can be used for trunk transmission testing from the far end of the trunks.

The three test types should have extension numbers assigned on the Maintenance-Related System Parameters Form.

Test Type 100:\_\_\_\_ Test Type 102:\_\_\_\_ Test Type 105:\_\_\_\_

Test Type 100 provides:

- 5.5 seconds of 1004 Hz tone at 0dB
- Quiet until disconnect; disconnect is forced after one minute

Test Type 102 provides:

- 9 seconds of 1004 Hz tone at 0dB
- 1 second of quiet
- This cycle is repeated until disconnect; disconnect is forced after 24 hours.

Test Type 105 provides:

- 9 seconds of 1004 Hz at -16dB
- 1 second of quiet
- 9 seconds of 404 Hz at -16dB
- 1 second of quiet
- 9 seconds of 2804 Hz at -16dB
- 30 seconds of quiet
- 1/2 second of Test Progress Tone (2225 Hz)
- Approximately five seconds of quiet
- Forced disconnect

## Removing and Restoring Power



### CAUTION:

*Error Log information is lost when the PPN cabinet is powered down. If this information is to be saved, enter the **reset system 4** command. The command will take several minutes to complete, and will result in saving of the Error Log to the MSS.*



### CAUTION:

*Before powering down a cabinet or carrier that contains DEFINITY AUDIX circuit packs (TN566 and TN2169), you must first power down the AUDIX unit to avoid damage to the AUDIX software. Instructions for powering down this unit appear on the circuit pack and in DEFINITY AUDIX documentation.*





**CAUTION:**

*If there is an alarm or problem suspected on the Tape or Disk Circuit packs do not save translations or announcements to the affected device. If there is an alarm or problem suspected with the Host Adapter circuit, do not save data to either MSS device. Saving data under these circumstances can destroy good copies of the file. If necessary, obtain a spare tape cartridge to save data.*

To remove power to the cabinet:

1. If the cabinet is the PPN, execute **save translation** and **save announcement** unless a tape drive problem is active.
2. Set the Emergency Transfer switch(es) in the affected cabinet to ON. In the PPN these are located on the SYSAM circuit pack(s). Set both in a system with duplicated SPE. In an EPN the switch is located on the EPN Maintenance circuit pack. This locks the system in the emergency transfer mode until the trouble is cleared.
3. Depending on which type of cabinet you are powering down, do one of the following:
  - In an AC-Powered multi-carrier cabinet, set the circuit breaker to OFF at the Power Distribution Unit.
  - In a DC-Powered multi-carrier cabinet, turn off the DC Power supply.
  - In an AC-Powered single-carrier cabinet stack, turn off the power in each affected carrier individually. The ON/OFF switch is located at the back of the carrier behind the WP-91153 Power Unit.
  - In a DC-Powered single-carrier cabinet stack, turn off the power in each affected carrier individually. The ON/OFF switch is located at the back of the carrier behind the 676B Power Unit.
4. Power is restored by reversing the action taken above.

When restoring power to a PPN, the system will reboot. When restoring power to an EPN, the EPN will under go a restart. This process is described under EXP-PN in [Chapter 9, "ABRI-PORT \(ASAI ISDN-BRI Port\)"](#).

If a powered down carrier contains a 676B Power Unit, the 676B must have been powered down for at least 10 seconds for the unit to restart.

## **Automatic Transmission Measurement System (ATMS)**

---

The ATMS performs transmission tests on analog trunks to determine whether they are performing satisfactorily. The switch automatically originates test calls from an Originating Test Line (OTL), over the trunks to be tested, to a Terminating

Trunk Line (TTL) on the switch at the far end of the trunk. Several different measurements of noise and attenuation are made and compared to administered thresholds. Test measurements can be viewed in the form of detailed or summary reports which are described below.

ATMS test calls can be initiated on demand from the management terminal, or automatically by ATMS Trunk Test Schedules. For complete details on how to set up ATMS Trunk Test Schedules, see Chapter 4 of *Generic 3 V2 Implementation*, 555-230-653. Demand tests are run with the **test analog-testcall** command which is described below.

Trunk groups can be administered to respond in different ways when a trunk fails to perform within the administered thresholds. Alarms and errors may be logged, and the trunk can be automatically busied out. When a trunk fails an unacceptable threshold twice, the system will busy it out if the trunk group is so administered and doing so will not exceed an administered limit (25, 50, 75, or 100% of the members in the group). This limit is not applied to later busyouts caused by other factors. Trunks can be manually returned to service by changing the thresholds and running a demand test or by using the release command.

## **ATMS Requirements**

---

ATMS tests utilize the analog port (port number 01) on a TN771 Maintenance/Test circuit pack. Each PPN contains one TN771. Depending on system configuration, each EPN may also contain one TN771. Multiple TN771s allow up to 3 concurrent test calls.

AMTS tests are designed to operate on the types of trunks found in the US, and the TN771 analog port is Mu-law companding only. The tests will not be useful in all environments.

For ATMS tests to run, several administrative prerequisites must be met. The following list shows the field entries necessary to enable testing.

**Table 6-7. ATMS Administration**

Form	Field	Entry/Remarks
System-parameters customer options	ATMS?	<b>y</b> (You must logoff/login in order for changes on this form to take effect.)
Station	Extension	At least one TN711 analog port must be assigned.
	Port Number	<b>UUCSS01</b> where UUCSS is the location of any TN771
	Port Type COR	<b>105TL</b> The number of a COR that has testing enabled (see next form)
Class of Restriction	Facility Access Trunk Test	<b>y</b>
Trunk Group	Maintenance Tests? ATMS Thresholds (page 4 of form)	<b>y</b> This page is used to specify performance thresholds, the type and access number of the far-end TTL, and system response to test failures.
Hunt Group		(Optional, for incoming test calls) If the system has several TN771s, you can use this form to make up a hunt group of TTLs so that one extension can be used for the whole pool.
ATMS Trunk Test Schedule		(Optional) To set up a test schedule, see Chapter 4 of <i>Generic 3 V2 Implementation</i> , 555-230-653.

**Running ATMS Tests  
 (Test Analog-Testcall Command)**

ATMS test calls can be originated either on demand or according to the ATMS Test Schedule. Test schedules are set up with **test-schedule** commands which are described in *DEFINITY Enterprise Communications Server Release 5.4 Administration and Feature Description*.

Demand test calls are originated by the **test analog-testcall** command. You can specify testing of an entire trunk group, an individual trunk, or all trunks on a single circuit pack. Trunks can be addressed by either group/member numbers or circuit pack/port locations. The type of test call, the number of the testing line on the far-end switch and various other parameters must be administered on the trunk group form before the command can execute.

Normally you should invoke only the full or supervision tests. The other options are provided mainly for use in setting up an ATMS schedule. Which tests are run depend on the type of TTL at the far end to which the test call is made. The following table shows which tests are run for each type of TTL. Command syntax is as follows:

### test analog-testcal

```
trunkgroup#| member#| port UUCSSpp | boardUUCSS  
[full | supervision | no-selftest | no-return-loss | no-st-or-rl]  
[repeat#][schedule]
```

## Input Parameters

trunk addresses	You can specify a single trunk or several trunks by using <b>trunk</b> , <b>port</b> , or <b>board</b> addresses. These parameters are described in the introduction to <a href="#">Chapter 8, "Maintenance Commands"</a> . If you enter a trunk group number without a member number, all members of the group are tested.
full	This executes the most comprehensive test call available using the administered test set type.  "Full" is the default.
supervision	This test takes about 10 seconds and simply confirms the presence of testing capability at the far end.
no-selftest	This executes the full test, but skips self test sequences. This saves about 20 seconds on the type 105 transmission test and has no effect on type 100 and 102 transmission tests.
no-return-loss	This executes the full test, but skips return loss sequences. This saves about 20 seconds on the type 105 transmission test and has no effect on type 100 or 102 transmission tests.
no-st-or-rl	This executes the full test, but skips the self test and the return loss sequences. This saves about 40 seconds on the type 105 transmission test and has no effect on type 100 or 102 transmission tests.
repeat #	This specifies repeating the tests up to 99 times. The default is a single run of the tests.
schedule	This qualifier brings up a form for scheduling execution of the test at a later time. This is not the same as setting up an ATMS Test Schedule, which is described above.

Different TTLs have different measurement capabilities and you will need the following information about specific TTL types. This table does not include the self-test nor does it distinguish between measurements for different test tone levels.

**Table 6-8. Measurement Capability by TTL Type**

Test	Terminating Test Line Type				
	105 Type with Return Loss	105 Type without Return Loss	High-level/ Low-level Tone Source	100 Type	102 Type
1004 Hz Loss Far-End to Near-End	x	x	x	x	x
1004 Hz Loss Near-End to Far-End	x	x			
404 Hz Loss Far-End to Near-End	x	x	x		
404 Hz Loss Near-End to Far-End	x	x			
2804 Hz Loss Far-End to Near-End	x	x	x		
2804 Hz Loss Near-End to Far-End	x	x			
C-Message Noise Near-End	x	x	x	x	
C-Message Noise Far-End	x	x			
C-Notched Noise Near-End	x	x			
C-Notched Noise Far-End	x	x			
Return Loss <sup>1</sup> Near-End	x	x	x	x	
Return Loss Far-End					

1 Return Loss includes Singing Return Loss High Frequency, Singing Return Loss Low Frequency, and Echo Return Loss.

## Test Call Results

If the test call successfully completes, and all trunks test within administered thresholds for marginal and unacceptable performance, then a PASS result is returned. If the test aborts or fails, an error code indicating the cause is returned. The error codes are explained in the CO-TRK and TIE-TRK sections of [Chapter 9, "ABRI-PORT \(ASAI ISDN-BRI Port\)"](#). When the trunk is being used for call

**6 Additional Maintenance Procedures***Automatic Transmission Measurement System (ATMS)*

6-45

processing, the test aborts. When the trunk is already being tested by maintenance software, the test is queued and run when the maintenance activity finishes.

Measurement data gathered by analog testcalls can be retrieved with the **list testcalls** command which is described below. Which measurements are made and recorded depends on which type of test is specified and the capabilities of the far-end TTL.

[Screen 6-1](#) shows a typical result for **test analog-testcall trunk 60**

```
test analog-testcall trunk 60                                SPE B

                                TEST RESULTS

Port      Maintenance Name  Alt. Name  Test No.  Result  Error Code
02B1901   TIE-TRK              060/001   845      PASS
02B1902   TIE-TRK              060/002   845      PASS
02B1903   TIE-TRK              060/003   845      PASS
02B1904   TIE-TRK              060/004   845      ABORT    1004
02B1905   TIE-TRK              060/005   845      PASS
02B1906   TIE-TRK              060/006   845      ABORT    1004
```

**Screen 6-1. Test Results for test analog-testcall trunk 60**

## Output Fields

Port	The physical location of the port supporting the trunk being tested. The format is UUCSSpp where UU is the cabinet number, C is the carrier letter, SS is the circuit pack slot, and pp is the port circuit number.
Maintenance Name	The name of the maintenance object tested, TIE-TRK or CO-TRK.
Alt. Name	The trunk group number and member number of the trunk being tested.
Test Number	ATMS tests are numbered 844 through 848.
Result	If the test call successfully completes, and all trunks test within administered thresholds for marginal and unacceptable performance, then a PASS result is returned. If measurements fall outside the thresholds, the test fails. The trunks group can be administered to log errors and alarms, and to busy out the failed trunk. If the test call cannot be completed, an ABORT is returned.

Error Code This numerical code indicates the reason for a failure or abort. The codes are explained in the CO-TRK and TIE-TRK sections of [Chapter 9, "ABRI-PORT \(ASAI ISDN-BRI Port\)"](#).

## ATMS Reports (List Testcall Command)

The **list testcalls** command produces detailed and summary reports of measurements made by the Automatic Transmission Measurement System (ATMS). Measurement reports contain data on trunk signal loss, noise, singing return loss, and echo return loss, and are used to determine the quality of trunk lines. The system maintains a database with the results of the last test for each trunk. System resets clear all transmission test data, and ATMS measurements are not backed up by the Mass Storage System.

ATMS parameters are administered on page 4 of the trunk group form. These include thresholds for marginal and unacceptable performance. On the screen display, measurements that exceed the marginal threshold are highlighted. Measurements that are exceed the unacceptable level appear flashing, indicating unusable trunks. Trunk groups can be administered to log errors and alarms, and busyout the failed trunk in response to such results.

The detailed report lists measurements for each trunk group member. The summary reports lists trunk groups as a whole. Which measurements are displayed depends on what type of test, if any, was last run on the trunk, and the capabilities of the TTL on the switch at the far end of the trunk. See the preceding description of the **test analog-testcall** command. A blank line indicates that no test data is available for that trunk or group.

The number of pages of each report is dependent upon the selection criteria and the number of outgoing trunks in the system. About 10 measurements can be listed on a page on the administration terminal, or about 50 measurements can be listed on a printer. By default, reports list all measurements. Filtering can be used to limit the output. For example, the report can be set up to print only failed measurements.

The syntax of the command is as follows:

```
list testcalls detail | summary  
    [port UUCSSpp]  
    [grp group#] [to-grpgroup#]  
    [mem member#] [to-memmember#]  
    [resultresultID> | not-resultresultID]  
    [count#] [print | schedule]
```

## Input Parameters - List Testcall Command

detail	This qualifier specifies a detailed report that shows each measurement made for each trunk.
summary	This qualifier specifies a report that shows totaled results of ATMS tests for trunk groups as a whole.
grp #	This qualifier specifies a report showing measurements for a specific trunk group. When used with <b>to-grp</b> , this option specifies the starting trunk group in a range.
to-grp	This qualifier specifies a report showing measurements for all trunk groups from 1 up to the trunk group number entered. When used with <b>grp</b> , this is the ending trunk group in a range.
mem	Used with <b>grp</b> , this qualifier specifies a report showing measurements for a specific trunk group member. When used with <b>to-mem</b> , this is starting trunk group member in a range.
to-mem	Used with <b>grp</b> , this qualifier specifies display of measurements for all trunk group members from 1 up to the specified trunk group member entered. When used with <b>mem</b> , this is the ending trunk group member in a range.
port	This qualifier specifies display of measurements for the trunk assigned to a specific port circuit.
result	Only measurements that match the specified result are displayed. Result IDs include <b>pass</b> , <b>marg</b> , <b>fail</b> , and numerical abort codes.
not-result	Only measurement results that do not match the specified result are displayed.
count number	This qualifier limits the total number of records displayed.
print	With this qualifier, the command executes immediately (if resources are available) and sends output both to the screen and to a printer connected to the terminal where the command was entered.
schedule	With this qualifier, a scheduling form is displayed which allows you to specify a start time for the command. The command is placed in the queue and, when executed, sends the output to the system printer.

## ATMS Summary Reports

The ATMS Summary Report summarizes, on a trunk group basis, the collective results of the latest ATMS tests performed on each trunk group. By interacting with the trunk group form, it highlights out-of-tolerance measurements. Marginal trunks are highlighted, and unusable trunks blink, allowing you to quickly identify out-of-tolerance or unusable trunks. [Screen 6-2](#) shows a typical summary report.



6 Additional Maintenance Procedures

Automatic Transmission Measurement System (ATMS)

6-48

ATMS MEASUREMENT SUMMARY REPORT

trk Grp	Num of Trks	Last Test Date	Last Test Time	Trunks Passed Transm Test	Trunks Failed Marginal Threshld	Trunks Failed Unaccept Threshld	Trks In- Use	Trks Not Test	Busied Out Trunks
1	10	10/04/91	15:15	10	0	0	0	0	0
10	10	10/04/91	15:40	10	0	0	0	0	0
20	5	10/04/91	16:00	5	0	0	0	0	0
30	30			0	0	0	0	30	0
40	20	10/04/91	16:15	20	0	0	0	0	0
50	10	10/04/91	16:40	10	0	0	0	0	0
60	3	10/04/91	16:55	0	0	0	0	0	3
78	10	10/04/91	17:05	8	0	0	1	0	1
83	15	10.04/91	17:20	15	0	0	0	0	0
105	100	10/04/91	17:40	100	0	0	0	0	0
125	2	10/04/91	19:30	0	0	0	0	0	2
350	10	10/04/91	19:40	10	0	0	0	0	0
500	55	10/04/91	19:55	55	0	0	0	0	0
650	1	10/04/91	21:00	1	0	0	0	0	0

Screen 6-2. Summary Report Screen

Output Fields - ATMS Summary Report

Trk Grp Num	Results for each trunk group are listed by trunk group number. Trunk group number Only outgoing or two-way analog trunks are listed.
Num Of Trks	The number of members in the trunk group.
Last Test Date	The date of the oldest measurement in the trunk group.
Last Test Time	The time of the oldest measurement in the trunk group.
Trunks Passed Transm Test	The number of trunks that have passed the trunk transmission tests.
Trunks Failed Marginal Threshld	The number of trunks that performed outside the marginal threshold, but not the unacceptable threshold, as defined on the trunk group form.
Trunks Failed Unaccept Threshld	The number of trunks that performed outside the unacceptable threshold, as defined on the trunk group form.
Trks In-Use	The number of trunks that were in use at the time of testing. Abort codes for trunk-in-use are 1000 and 1004.
Trks Not Test	The number of trunks that were not tested due to error conditions other than trunk-in-use. Abort codes are given in the detailed report.

6 Additional Maintenance Procedures

Automatic Transmission Measurement System (ATMS)

6-49

**Busied Out Trunks** The number of trunks that were busied out in response to test failures. These may be caused by hardware problems, incorrect threshold values, and so on.

**ATMS Detail Report**

This report is divided into two sections. The upper section lists the trunk group, trunk type, trunk vendor, TTL type, and the user-defined threshold values administered on page 4 of the trunk group form. The lower section lists the most recent set of measurements for each member of the trunk group selected for the report. Measurements that exceed the marginal threshold, but not the unacceptable threshold, are highlighted. Measurements that exceed the unacceptable threshold blink, identifying unusable trunks. When a marginal or unacceptable measurement is located, scan the top section to find out how far the measurement deviates from its defined threshold.

ATMS TRUNK MEASUREMENTS																					
Group: 78		Type: co		Vendor: AT&T								TTL Type: 105-w-r1									
THRESHOLD VALUES																					
				1004Hz-loss				Loss dev at				C-msg		C-ntch		SRL		SRL			
				Min	Max	-	+	-	+	Noise	Noise	LO	HI	ERL							
Marginal				-2	21	9	9	9	9	55	74	0	0	0							
Unacceptable				-2	21	9	9	9	9	55	74	0	0	0							
Trk	Test	Test	Test	-16dBm		OdBm															
Mem	Date	Time	Rslt	FE	NE	FE	NE	FE	NE	FE	NE	FE	NE	FE	NE	FE	NE				
1	10/04	14:25	pass	7	7	7	7	-2	-2	7	7	15	28	34	34	8	16	11	16	11	17
2	10/04	14:26	1920																		
3	10/04	14:27	1000																		
4	10/04	14:28	pass	7	7	7	7	-2	-2	6	6	15	29	38	34	8	16	11	15	11	16
5	10/04	14:29	pass	7	7	7	7	-2	-2	6	6	15	35	34	34	8	6	9	6	10	7
6	10/04	14:30	pass	7	7	7	7	-2	-2	6	6	15	26	34	34	8	16	9	13	10	16
7	10/04	14:31	pass	7	7	7	7	-2	-2	7	7	15	30	34	34	8	16	9	11	10	13
8	10/04	14:32	pass	6	6	6	6	-2	-2	6	6	15	25	34	34	10	17	11	16	12	17
9	10/04	14:33	pass	6	6	7	7	-1	-1	7	7	15	25	34	34	8	15	9	13	10	16
10	10/04	14:34	pass	6	6	7	6	-1	-1	7	7	15	36	34	35	8	6	9	6	10	7

**Output Fields - ATMS Detail Report**

Measurements are made in both directions, near to far end, and far to near end. For each measurement, there are 2 columns on the lower part of the report, "NE" for near end, and "FE" for far end. These refer to the destination end for that measurement.

- Group The trunk group number selected.
- Type The trunk group type.
- Vendor The vendor of this trunk group.

6 Additional Maintenance Procedures

Automatic Transmission Measurement System (ATMS)

6-50

TTL Type	The type of terminating test line on the switch at the far end of the trunk to which the test call was made.
Threshold Values	The list of marginal and unacceptable threshold values for each type of measurement. These are defined on the trunk group form.
Trk Mem	The trunk member number.
Test Date	The month and day this trunk was last tested.
Test Time	The time of day this trunk was last tested.
Tst Rslt	The results of the trunk transmission test as follows:  pass  The test call completed successfully and trunk performance was satisfactory  marg  Trunk measurements exceeded the marginal threshold, but not the unacceptable.  fail  Trunk measurements exceeded the unacceptable threshold.  xxxx  A numerical error code indicates the reason for an aborted test call. The codes are explained in the CO-TRK and TIE-TRK sections of <a href="#">Chapter 9, "ABRI-PORT (ASAI ISDN-BRI Port)"</a> .  blank  A blank line indicates that no measurements have been made on this trunk since the database was last initialized.
1004Hz-loss Min	Far-to-near and near-to-far measurements of 1004-Hz loss from low-level tone.
1004Hz-loss Max	Far-to-near and near-to-far measurements of 1004-Hz loss at 0 dBm.
Loss dev at 404Hz	These low-frequency transmission tests measure maximum positive and negative deviation of +9 and -9 dB from the 1004-Hz loss measurements.
Loss dev at 2804Hz	These high frequency transmission tests measure maximum positive and negative deviation of +9 and -9 dB from the 1004-Hz loss measurements.
C-msg Noise	Maximum noise interference noise) terminating on a voice terminal within the voice-band frequency range (500 to 2500 Hz). The measurement ranges from 15 to 55 dBnC (decibels above reference noise).
C-ntch Noise	Maximum signal-dependent noise interference on a line between 34 and 74 dBnC.

6 Additional Maintenance Procedures

*Automatic Transmission Measurement System (ATMS)*

6-51

SRL-LO	Singing return loss from 0 to 40 dB between the sum of the circuit (repeater) gains and the sum of the circuit losses. SRL-LO occurs most often in the frequency range of 200 to 500 Hz.
SRL-HI	Singing return loss from 0 to 40 dB between the sum of the circuit (repeater) gains on a circuit and the sum of the circuit losses. SRL-HI occurs most often in the frequency range of 2500 to 3200 Hz.
ERL	Echo return loss from 0 to 40 dB between the level of signal strength transmitted and the level of signal strength reflected. ERL occurs most often in the frequency range of 500 to 2500 Hz.

## ATMS Measurement Analysis

ATMS compares the results of the test measurements with threshold values to identify trunks that are out of tolerance or unusable. Once a defective circuit has been pinpointed, a proper analysis must be made to determine the appropriate action to take on the facility failures. Although there is no "right" procedure for every situation, the following items will help in troubleshooting problems:

- If a circuit fails an ATMS transmission test, it does not necessarily mean the trouble is in the facility itself. The problem could be caused by a faulty test line, bad switch path, or a variety of other reasons.
- If a circuit fails a transmission test but successfully passes a supervision test, some of the items mentioned above are probably not at fault, since proper call routing and circuit continuity are required for successful of a supervision test.
- If several circuits in the same group are failing, this could indicate the failure of some common equipment (such as a carrier system, test line, or cable) or erroneous information in the threshold tables.
- When a test call can be successfully made, but not completed, either the OTL or TTL is probably defective. For this failure type, further ATMS testing might be seriously impaired, but the system is not otherwise affected.
- If a test call cannot be successfully made, the wrong number might have been dialed, the far-end device might be busy, the far-end device is defective, or there is a serious trunk failure obstructing the call.

## LED Interpretation



---

If a maintenance object in the system begins to fail some of the periodic tests, the system automatically generates an alarm. This alarm indicates to maintenance personnel that action is required to restore the system to a normal condition. The system identifies three levels of alarms:

- Major Alarms — Failures that cause critical degradation of service and require immediate attention.
- Minor Alarms — Failures that cause some degradation of service, but do not render a crucial portion of the system inoperable. This condition requires action, but its consequences are not immediate. Problems might be impairing service to a few trunks or stations or interfering with one feature across the entire system.
- Warning Alarms — Failures that cause no significant degradation of service or failures in equipment external to the system. Warning alarms are not reported to the attendant console or INADS.

Alarms are communicated to the system users and technicians by entries in the Alarm Log and the lighting of LEDs located on the attendant console, on all circuit packs in the switch cabinets, and, optionally, on customer-designated voice terminals.

## Terminal Alarm Notification

Terminal Alarm Notification is an optional feature which displays several types of alarms on voice terminals with administered feature buttons or the attendant console. A maximum of ten digital and/or hybrid voice terminals may be used.

When an alarm occurs, the green status LED associated with the assigned button will be in a steady state. The lamp may be turned off by pressing the

button associated with the lighted alarm lamp. If the lamp is turned off, and the alarm has not been resolved by the time maintenance reschedules testing, the green status LED will resume its steady state. The following alarms are displayed:

ac-alarm	Administered Connection Alarm: a locally administered connection (ADM-CONN) has a Major, Minor, or Warning alarm active.
pr-awu-alm	Auto Wakeup Journal Printer Alarm: the automatic wakeup journal printer has a Major, Minor, or Warning alarm active.
ds1-alarm	DS1 Facility Alarm: a DS1-BD has an off-board Major, Minor, or Warning alarm active.
trk-ac-alm	Facility Access Alarm: The facility access trunk test feature is activated.
major-alm	Major Alarm: The system has logged a Major Alarm.
mj/mn-alm	Major/Minor Alarm: The system has logged a Major or Minor Alarm.
pr-pms-alm	PMS Printer: The Property Management System printer has a Major, Minor, or Warning alarm active.
rs-alert	Reset-Alert: <b>reset system 2</b> or <b>3</b> has been performed.
cdr1-alm	Call Detail Recording Alarm: The Primary CDR Link has a Major, Minor, or Warning alarm active.
cdr2-alm	Call Detail Recording Alarm: The Secondary Link has a Major, Minor, or Warning alarm active.
pr-sys-alm	System Printer Alarm: The System Printer (SYS-PRNT) has a Major, Minor, or Warning alarm active.
pms-alarm	The Property Management System has a Major, Minor or Warning alarm active.

## Attendant Console LEDs

The console has two red LEDs, labeled "ALM" and "ACK." The ALM LED lights steadily when there is a Major or Minor alarm at the switch cabinet. The ACK LED lights steadily if the alarm has been successfully reported to INADS. If the system is unable to report the alarm to INADS, the LED flashes; this signals the attendant to call INADS and report the alarm.

## Circuit Pack LEDs

---

Each circuit pack typically has three LEDs on the front panel visible at the front of the carrier, there are some exceptions to this (for example DS1CONV circuit pack) that are covered later in this section. On most circuit packs, the LEDs indicate the following when lit. Exceptions to these indications are explained in subsequent sections.

Red	Alarm	The system has detected a fault in this circuit pack. The Alarm Log should contain an on-board alarm for this circuit pack or one of the maintenance objects associated with it. The red LED is also lit briefly when a circuit pack is inserted or reset. If the circuit pack passes its initialization tests, the LED is extinguished. If a fault is detected, it remains lit.
Green	Testing	The system is currently running tests on this circuit pack as part of background maintenance or demand testing. This LED is also lit briefly during initialization tests when a circuit pack is inserted or reset.
Yellow	Busy	The circuit pack is currently in use by the system.

### LED Alarms without Alarm Log Entry or with Error Type 1

---

Whenever the system or a part of the system is reset, all affected circuit packs will briefly light their red and green LEDs as they are initialized. Upon power-up of a newly installed system, several alarm indicators may remain lit until the circuit packs are administered. These alarms should be ignored until administration is completed.

During routine or demand testing of Mass Storage System components, the red, green and yellow LEDs on the MSSNET, TAPE, and DISK circuit packs all light temporarily. This is normal and does not indicate a problem.

After a circuit pack has been initialized, a lit red LED should be accompanied by an alarm in the Alarm Log. A single fault can sometimes light alarm LEDs on several circuit packs, as in the following examples.

- A TDM bus problem may cause several port circuit packs to display red LEDs.
- An EPN Maintenance circuit pack can prevent an Expansion Interface circuit pack from initializing.
- Extensive interactions in the Center Stage Switch can cause multiple alarms from single faults in DS1C, SNI and SNC circuit packs and fiber links.
- Tone/clock problems may cause other circuit packs to report alarms.

- Misconnected optical fiber cables may cause several circuit packs to alarm.
- Packet bus faults can cause several port circuit packs to display red LEDs.

If a circuit pack has had at least five minutes to be initialized, and the red LED is lit without an associated alarm in the Alarm Log, the circuit pack may not be in communication with the system. This may also be the case when a circuit pack is properly administered and present in its slot, but there is an error type 1 logged against it. To determine if this is so, proceed as follows:

- Issue the **list configuration board** UUCSS command. If the system does not detect the circuit pack, this command will return

```
identifier not assigned
```

or

```
no board.
```

If the documentation for the associated maintenance object gives no special instructions for this situation, go to the next step.

- Check the Hardware Error Log for TONE-BD or TDM-BUS errors. Use the **test tdm** and **test tone-clock** commands and use the appropriate maintenance procedures to resolve any identified faults. If this does not resolve the problem, go to the next step
- Reseat the suspect circuit pack.

**CAUTION:**

*This procedure can cause a partial or total service outage. Consult thoroughly the documentation for the associated maintenance object before proceeding. Observe the precautions and procedures described above.*

- Inspect the backplane connectors for bent pins.
- If the system seems to be functioning correctly, but the circuit pack in question will not communicate with the system, replace the circuit pack.

## Expansion Interface Circuit Pack LEDs

The Expansion Interface (EI) TN570 circuit pack has the standard red, green and yellow LEDs. The red and green LEDs have the traditional meaning, where red indicates an alarm condition, and green indicates testing in progress.



The yellow LED displays various flashing patterns to provide status information useful in isolating faults in the fiber link and other components connected to the fiber link. [Table 7-1](#) illustrates the EI yellow LED states.

**Table 7-1. Expansion Interface Yellow Led Flashing Codes**

LED on	LED off	Condition
0.1 sec	0.1 sec	Fiber Out-of-Frame. This state indicates a failure of test #989. This may be caused by absence of the opposite end EI or Switch Node Interface, a broken or missing fiber, or a missing lightwave transceiver on either endpoint.
0.5 sec	0.5 sec	In Frame — No Neighbor. This state corresponds to a failure of test # 237, usually due to a failure of this EI or of the EI or SNI at the other end of the fiber.
2 sec	0.2 sec	Expansion Interface Active. This is the normal state of an active EI that is an archangel of an Expansion Port Network.
solid on		Expansion Interface Active. This is the normal state for an active EI that is not an EPN archangel. These include EPN EIs connected to other EPN EIs in Direct Connect Configurations, and EIs located in the Processor Port Network.
	solid off	Expansion Interface Standby. This is the normal state for a standby EI in systems with a duplication option.

## **SYSAM and Maintenance Circuit Pack LEDs**

TN1648 System Access-Maintenance (SYSAM) and TN775 EPN Maintenance circuit packs have seven LEDs on their front panels. The top three LEDs are the standard group of red, green and yellow, and indicate the status of the circuit pack. The green LED on TN775s blinks faintly once per second, indicating continual self-testing.

The second group of three LEDs, labeled “ALARMS”, reflect maintenance conditions throughout the system, and indicate alarms reported against other components, as shown in [Table 7-2](#).

### **⇒ NOTE:**

On systems with duplicated SPEs, disregard the Major, Minor, and Warning alarm LEDs on the standby SYSAM circuit pack. Only those on the active SYSAM (see yellow LED, third from the top) are updated with the current system status.

**Table 7-2. SYSAM and Maintenance circuit pack LED interpretation**

LED color	State	Level/Function	Interpretation
Red	flashing	MAJOR	Major alarm against a component in the same cabinet, (PPN for SYSAM, and EPN for MAINT).
	solid	MAJOR	Major alarm against a component in another cabinet.
	flashing	MINOR	Minor alarm against a component in the same cabinet.
Red	solid	MINOR	Minor alarm against a component in another cabinet.
Yellow	flashing	WARNING	Warning alarm against a component in the same cabinet.
	solid	WARNING	Warning alarm against a component in another cabinet.
Green	on	ACK	Acknowledged; alarm has been reported to INADS.
Red	on	EMERGENCY TRANSFER	Emergency transfer has been invoked. This occurs upon power-up as well as during disabling failures.

These LEDs are illustrated [Figure 7-1](#).

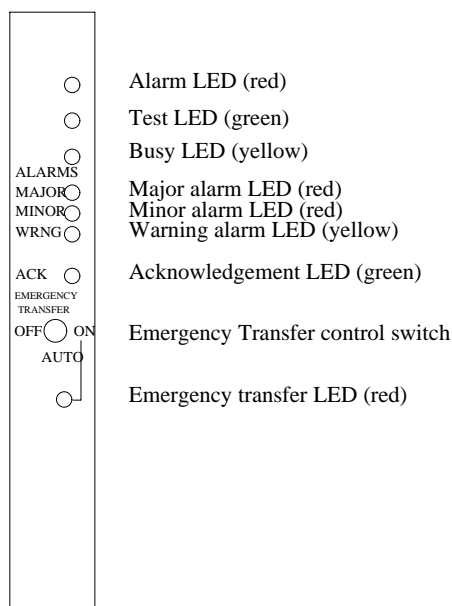

**Figure 7-1. SYSAM and EPN Maintenance Circuit Pack LEDs**

## Duplication Interface Circuit Pack LEDs

---

In systems with duplicated SPEs, (High Reliability and Critical Reliability), there are two Duplication Interface UN330B circuit packs. One is located in carrier A and one in carrier B of the PPN. Each circuit pack has four LEDs. The top three have the traditional function of indicating the status of the pack.

The LED located at the bottom of the faceplate directly beneath the SPE Select switch is labeled OVERRIDE. Under normal operating conditions, the SPE Select switch is in the AUTO (center) position, and the OVERRIDE LED remains unlit. This means that the system controls which SPE is active. System selection of the active SPE can be manually overridden by moving the SPE Select switches from the AUTO position to either the "A" position or the "B" position on both Duplication Interface circuit packs. At this time, the red OVERRIDE LEDs on both Duplication Interface circuit packs will light steadily to indicate that one SPE is locked Active and the system is not duplicated. If both SPE Select switches are not in the same position, the system software retains control of Active SPE selection, and the OVERRIDE LED remains unlit. When control of the SPE selection is returned to the system by returning the SPE Select switches on both Duplication Interface circuit packs to the AUTO position, the OVERRIDE LED will go dark. Forced SPE selection should be undertaken only after consulting the appropriate sections in [Chapter 9, "Maintenance Object Repair Procedures"](#).

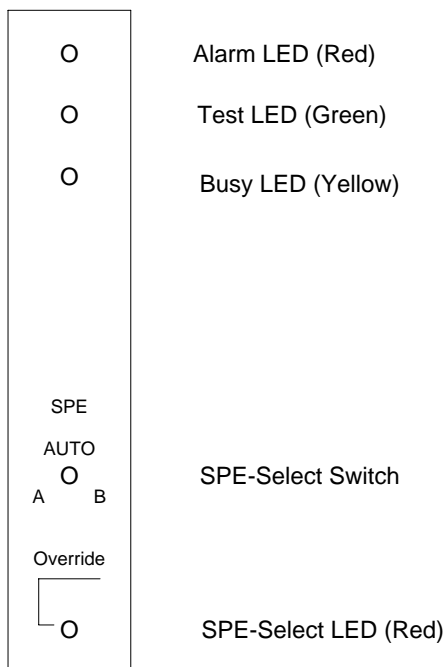

Figure 7-2. Duplication Interface Circuit Pack LEDs

## Switch Node Interface LEDs

The Switch Node Interface (SNI) TN573 circuit pack has the standard red, green, and yellow LEDs. The red and green LEDs have the traditional meaning, where red indicates an alarm condition, and green indicates testing in progress.

The yellow LED displays various flashing patterns to provide status information useful in isolating faults in the fiber link and other components connected to the fiber link. [Table 7-3](#) illustrates the SNI yellow LED states.

**Table 7-3. Switch Node Interface Yellow Led Flashing States**

LED on	LED off	Condition
0.1 sec	0.1 sec	Fiber Out-of-Frame. This state indicates a failure of test #238, which may be caused by absence of the opposite end EI or Switch Node Interface, a broken or missing fiber, or a missing lightwave transceiver on either endpoint.
0.5 sec	0.5 sec	In Frame — No Neighbor. This state corresponds to a failure of test # 237, usually due to a failure of this SNI, or the EI or SNI at the opposite of the fiber. This condition may also be due to a faulty Switch Node Clock.
solid on		SNI Active. This is the normal state for an active SNI.
	solid off	SNI Standby. This is the normal state for a standby SNI in systems with a duplication option.

## **DS1 CONV (TN574/TN1654) Circuit Pack LEDs**

The TN574 and the TN1654 LEDs provide an indication of the state of the DS1 Converter and facilities, and are covered in the following sections of this document.

### **TN574 Circuit Pack LEDs**

Seven LEDs provide an indication of the state of the DS1 Converter (DS1 CONV) TN574 circuit pack and the DS1 facilities. The top group has the standard red, green and yellow LEDs. The red and green LEDs have the traditional meaning, where red indicates an alarm condition, and green indicates testing in progress. The four green LEDs on the bottom indicate the status of the DS1 facilities (see following section).

The yellow LED is used to indicate the state of the Fiber Interface, the Fiber Channel, and the DS1 channel in the following manner and order of priority.

**Table 7-4. DS1C Yellow Led Flashing States**

LED on	LED off	Condition
0.1 sec	0.1 sec	Fiber Out-of-Frame or Fiber Loss of Signal
0.5 sec	0.5 sec	In Frame, fiber channel down. The fiber channel communicating between the DS1C and the other fiber endpoint (EI or SNI) is down.
1 sec	1 sec	In Frame, DS1 channel down. The channel between the two DS1Cs in the DS1C complex is down.
2 sec	0.2 sec	No response from SPE. The SPE is not acknowledging messages from the DS1C or the communications link to the SPR is down.
solid on		DS1C active. This is the normal state for an active DS1C.
	solid off	DS1C standby. This is the normal state for a standby DS1C in Critical Reliability Systems (duplicated PNC).

## DS1 Facility LEDs

Below the three standard LEDs on the DS1C circuit pack are four green LEDs used to indicate whether a receive signal is present for each of the four DS1 facilities. [Figure 7-3](#) shows which facility (A, B, C, or D) corresponds to each LED. If a green LED is off, there is a Loss of Signal condition on the DS1 facility associated with that LED. The presence of a signal does not guarantee that the signal is using the correct framing format or line coding; an Alarm Indication Signal indicating that the opposite end of the DS1C complex is out of service may be present.

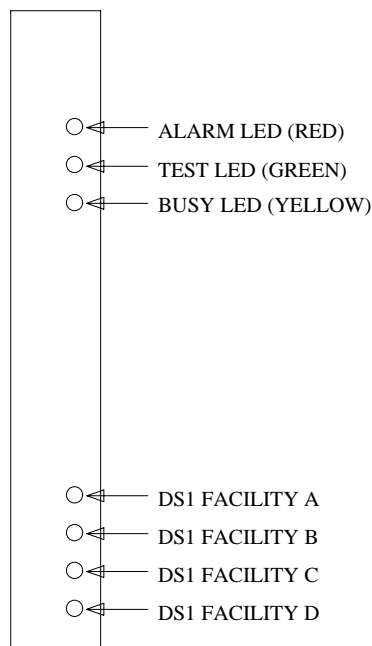

**Figure 7-3. TN574 DS1C Circuit Pack LEDs**

### TN1654 Circuit Pack LEDs

The TN1654 DS1CONV board has 11 LEDs on its faceplate. The top 3 system standard LEDs indicate the state of the DS1CONV board. These LEDs are under firmware control until the board has established a link to the SPE via the EI or SNI. Once the link is established, software controls the 3 LEDs. If the link breaks, the LEDs are again under firmware control.

The red and green LEDs have the traditional use: red means an alarm condition, and green indicates that maintenance testing is in progress. The red and green LEDs are also turned on during circuit pack initialization by firmware. When the control link to the circuit pack is lost, firmware controls the red LED to indicate an alarm condition.

The yellow LED under firmware control is used to indicate the state of the physical Fiber Interface, the Fiber Channel (link to EI or SNI), the DS1 Control Channel (link to opposite DS1CONV board), and the SPE communications link in the following manner and order of priority. (The yellow LED remains on for longer periods of time as the DS1CONV Complex becomes closer to being fully operational.)

1. If the Fiber is Out of Frame or if a Fiber Loss of Signal condition exists, the yellow LED will flicker at a 5 Hz rate (on for 100 mS, off for 100 mS).

## 7 LED Interpretation

### DS1 CONV (TN574/TN1654) Circuit Pack LEDs

7-12

2. If the Fiber Channel is down (DS1 Converter circuit pack/fiber endpoint communications), the yellow LED will flash at a 1 Hz rate (on for 500 ms, off for 500 ms).
3. If the DS1 Control Channel is down between the two DS1CONVs in the DS1CONV Complex, the yellow LED will pulse at a 0.5 Hz rate (on for 1 second, off for 1 second).
4. If the SPE communications link is down, the yellow LED will wink off every 2 seconds for 200 ms (2 seconds on, 200 ms off).
5. If all is well with the Fiber Interface and all communications channels, the yellow LED will remain on continuously in a Standard Reliability and High Reliability System configuration. In Critical Reliability systems (duplicated PNC), an active DS1CONV circuit pack will have its yellow LED on continuously, and a standby DS1CONV circuit pack will have its yellow LED off. The LED will then be under software control.

The bottom four green LEDs on the TN574 DS1CONV board are under hardware control. The four green LEDs indicate, for each DS1CONV facility, whether a receive signal is present for the DS1 facility

The next four LEDs on the TN1654 DS1CONV board are labeled STATUS LEDs and are for future use. These LEDs will not be lit.

The bottom four LEDs on the TN1654 board are labeled SPAN LEDs. These LEDs are under firmware control. If the facility is not administered, then the LED is not lit. The LED is lit amber if the facility is running alarm free. If the facility is detecting either a red alarm (loss-of-signal or loss-of-frame), a yellow alarm (remote frame alarm) or a blue alarm (AIS signal) then the LED is lit red. The SPAN SELECT Switch on the TN1654 faceplate is for future use. Pushing the switch will have no effect on the board. See [Figure 7-4](#) for a view of the face plate on the TN1654 DS1CONV circuit pack



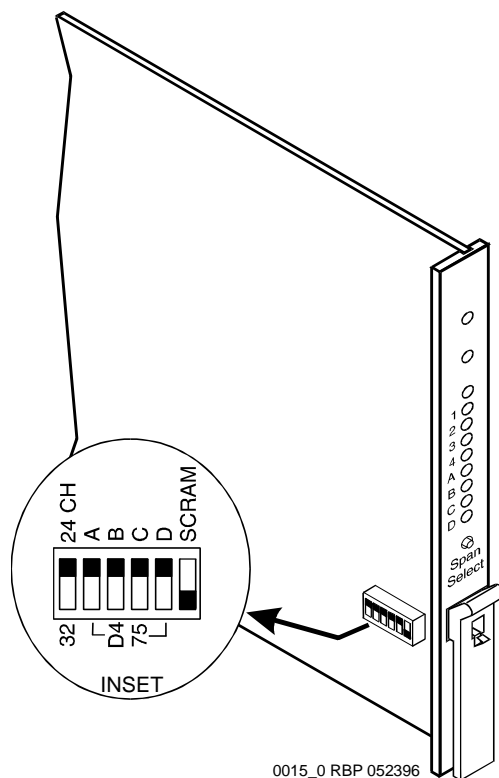

Figure 7-4. TN1654 DS1CONV Circuit Pack

## Tone-Clock Circuit Pack LEDs

The Tone-Clock circuit packs have the standard red, green and yellow LEDs. The red LED has the traditional meaning. The yellow and green LEDs flash in specific patterns to indicate the status of the circuit pack. The standby status applies only to systems with a duplication option.

## Maintenance/Test Circuit Pack LEDs

The TN771D Maintenance/Test circuit pack has the standard red, green, and yellow LEDs. The red and green LEDs have the traditional meaning, where red indicates an alarm condition, and green indicates testing in progress.

The yellow LED can be off or on continuously or flashing, depending on the mode of operation of the TN771D and whether or not it has detected errors. The yellow LED is on steady when the TN771D's analog test port or digital test ports are being used to test trunks or line circuits. The yellow LED is also used to indicate

Packet Bus status. [Table 7-5](#) illustrates the Maintenance/Test yellow LED states as they apply to Packet Bus activity.

**Table 7-5. TN771D Maintenance/Test Yellow LED States**

LED State*	TN771D Mode	Condition
Solid off	Normal	The Maintenance/Test circuit pack detects no Packet Bus faults.
Solid on <sup>†</sup>	Normal	The Maintenance/Test Packet Bus port has successfully reconfigured the Packet Bus around a fault.
Flashing (1 Hz)	Normal	The Maintenance/Test Packet Bus port is unable to reconfigure the Packet Bus around a fault.
Solid off	Standalone <sup>‡</sup>	The Maintenance/Test detects no Packet Bus faults.
Solid on	Standalone	This condition cannot normally occur. The LED is always either off or blinking in standalone mode.
Flashing (1 Hz)	Standalone	The Maintenance/Test Packet Bus port detects a Packet Bus fault.

- \*. It takes 5 to 10 seconds for the yellow LED to respond to a change in the state of the Packet Bus.
- †. Because the yellow LED on the Maintenance/Test circuit pack can also be on steady when the digital and analog test ports on the circuit pack are in use, exact interpretation of the yellow LED may require that the technician busy out the analog and digital test ports or examine the error and Alarm Logs for PKT-BUS errors and alarms.
- ‡. "Standalone" refers to the TN771D's capability to operate autonomously as a troubleshooting aid. A detailed description of the TN771D standalone mode is provided in the "[Packet Bus Fault Isolation and Repair](#)" section of [Chapter 5, "Alarms, Errors, and Troubleshooting"](#).

## LEDs on Standby Components

In high reliability and critical reliability option systems, duplicated components that are on standby will usually have their yellow LEDs unlit, with the following exceptions.

- The Major, Minor and Warning alarm LEDs on the SYSAM circuit pack on the standby SPE do not give reliable indications. Pay attention only to those LEDs that are on the active SYSAM circuit pack.
- The yellow LED will blink on and off when the standby Processor circuit pack is up and standby maintenance is running.

7 LED Interpretation

*LEDs on Standby Components*

7-15

- In high reliability systems with a Center Stage Switch, (duplicated SPE, simplex PNC), the standby Switch Node Clock's yellow LED is off. In critical reliability systems, the standby SNC is located on a separate carrier and normally remains lit.
- Yellow LEDs on Power Units on standby carriers normally remain lit.

When LED indications are not clear, use the **status pnc**, **status spe** and **status pn** commands to determine which components are active.

# Maintenance Commands

# 8

This chapter contains descriptions of commands available to the craft login. Introductory sections explain the meaning of common input parameters, or command line arguments, common output fields, and error codes for busyout, release and reset commands.

**CAUTION:**

*This document is intended for Release 5 and later systems only. For previous DEFINITY systems (G3V4 and earlier), refer to DEFINITY Enterprise Communications Server Release 5 Maintenance for R5r, 555-230-105.*

## Command Line Syntax

Each command consists of an action word, an object upon which the action is performed, and optional qualifiers that modify the execution of the command. In some cases the choice of a qualifier may be required. The syntax of the command appears under the heading at the beginning of each command description. The syntax is interpreted as follows:

Command	Object	Optional Qualifiers
<b>test station</b>	<i>extension</i>	[short long] [repeat number   clear] [schedule]
bold	bold italic if a variable, bold if entered literally	bracketed; either/or choices are separated by a vertical slash (/); bold italic if a variable, bold if entered literally

Command words can be abbreviated. A partially spelled word is recognized as long as enough letters are entered to distinguish it from other valid entries. Otherwise, the screen displays a selection of command words that match the

abbreviation. For example, **test alarms step short clear** can be entered as **t al st sh c**. Drop leading zeroes from numerical entries. For example, cabinet number 03 can be entered as 3.

Pressing the HELP key displays all available commands. If an incomplete command is entered, pressing HELP displays all valid qualifiers for the command.

**⇒ NOTE:**

When the successful execution of a command is prevented, an error message that is usually self-explanatory displays. If the following message appears, the software is most likely corrupt:

```
Error encountered; can't complete request
```

In this case, follow normal escalation procedures.

## Common Input Parameters

Characters in bold type are entered literally on the command line. Characters in italic bold type are variables. See [Table 8-1](#) for common test command parameters and their explanations and for explanations of less common parameters.

**Table 8-1. Common Test Command Parameters**

<b>Parameter</b>	<b>Range</b>	<b>Meaning</b>
<b>UU</b>	1-22	One or two-digit cabinet number For many commands this defaults to cabinet 1, the PPN
<b>C</b>	A-E	Letter designation of a carrier. For many commands relating to SPE or EPN control circuit packs, this defaults to A, the control carrier. For PPNs with duplicated SPEs, A or B is usually specified for SPE MOs.
<b>SS</b>	1-21	One or two-digit number identifying a circuit pack slot on a carrier For many commands relating to SPE or EPN control circuit packs, this usually defaults to the only possible slot number.
<b>pp</b>	1-24	One or two-digit number identifying an individual port circuit on circuit pack The range of this variable differs depending on the type of circuit pack.

For example, **display cabinet** requires only the entry of **UU**: **display cabinet 12**. **Test port** requires a location of the form **UUCSSpp**: **test port 05c1506** to test



port circuit 6 on the circuit pack in cabinet 5, carrier C, slot 6. The **list** and **display** commands are useful in relating MO locations to information such as PN number, extension, link numbers, and so forth. [Table 8-2](#) contains information about the less-common command parameters.

**Table 8-2. Less-Common Test Command Parameters**

Parameter	Range	Default	Meaning
<b>PN#</b>			One or two-digit port network number. EPN cabinets may contain one or two port networks. Use <b>list cabinet</b> to find which port networks are in each cabinet.
<b>print</b>			This command executes immediately (if resources are available) and sends output both to the screen and to a printer connected to the terminal where the command was entered. This option is available for <b>display</b> , <b>list</b> and <b>status</b> commands.
<b>schedule</b>			A scheduling form is displayed which allows you to specify a start time for the command. The command is placed in the queue and, when executed, sends the output to the system printer. The <b>schedule</b> option is available for <b>display</b> , <b>list</b> and <b>test</b> commands. When used with <b>display alarms</b> or <b>errors</b> , a full report is generated. The usual selection form for error and alarm reports is suppressed so that it will not interfere with the command's execution when it is issued from the queue.  You can see what commands are currently queued with the <b>list command-queue</b> command. A queued command can be canceled with <b>remove command-queue job#</b> . This option requires that the system printer be administered on page 4 of the Feature-Related System Parameters form.
<b>group#</b>	1-666		One to three-digit trunk group number; used to address trunk maintenance objects.
<b>group#/ member#</b>	1-255		Group number followed by a slash and the one to three-digit member number of an individual trunk; used to address trunk maintenance objects.

*Continued on next page*

**Table 8-2. Less-Common Test Command Parameters — Continued**

Parameter	Range	Default	Meaning
<b>extension</b>			<p>The extension number assigned to the port or other maintenance object.</p> <p>The number of digits in an extension is determined by the system dial plan. The <b>list</b> and <b>display</b> commands are useful in relating extension numbers, maintenance objects, and other components.</p>
<b>repeat #</b>	1-100	1	<p>Used with test commands, the number of times a test sequence is to be repeated. The word <b>repeat</b>, or simply the letter <b>r</b>, followed by the number.</p>
<b>short long</b>			<p>Used with <b>test</b> commands, these qualifiers determine either the long or short test sequence run for this maintenance object. The test sequence run varies for each maintenance object.</p> <p> <b>CAUTION:</b>  <i>For some maintenance objects, the long sequence is destructive, that is, disruptive to call service.</i></p> <p>The short sequence is always non-destructive.</p>
<b>clear</b>			<p>Used with <b>test</b> commands, this specifies that the test sequence is to be repeated until any active alarms against the maintenance object is cleared by the passing of tests or until any test in the sequence fails.</p> <p>If no such alarms are active, the sequence is run once. The <b>long clear</b> combination effects a clearing of all alarms against the maintenance object if no errors are encountered. The <b>short clear</b> combination clears only alarms pertinent to the tests in the short sequence.</p> <p> <b>CAUTION:</b>  <i>If all tests pass, the <b>long clear</b> combination clears all error counters. If firmware counters are cleared while actual problem exists, customer service may degrade due to calls being routed over faulty components.</i></p>

## Common Output Fields

- An indication that the command successfully completed or a self-explanatory message giving a reason for a failure or abort.
- An input form for entering additional information required to complete the command. These are described under each command that presents an input form.
- A form listing one or more lines of results with error codes that indicate the reason for a FAIL or ABORT result.

Many commands that use the last form display the fields listed in the table below. Some return one line of output. Other commands that run either one test on several objects or several different tests on one or more objects return several lines of output. In this case, each line represents one test result.

Variable	Range	Meaning
<b>UU</b>	1-22	One or two-digit cabinet number
<b>C</b>	A-E	Letter designation of a circuit pack carrier
<b>SS</b>	1-21	One or two-digit number identifying a circuit pack slot on a carrier
<b>pp</b>	1-24	One or two-digit number identifying an individual port circuit on circuit pack
<b>Port</b>		The address or physical location of the MO. Usually this is <b>UUCSSpp</b> .

The length of this variable differs for the various types of commands. A port circuit requires a full length address such as 11C1502, which indicates circuit number 2 on the circuit pack in cabinet 11, carrier C, slot 15. A control carrier component such as a SYSAM circuit pack is designated simply as **01B**, indicating the SYSAM in carrier B of cabinet 1, the PPN cabinet.

Some MOs such as TDM-BUS are addressed by PN number. In this case, the number is usually preceded by PN. For example, TDM bus A in port network 5 is designated as **PN 05A**.

In critical reliability systems, Port Network Connectivity is duplicated as two independent sets of PNC components. These are designated as A-PNC and B-PNC.



**Maintenance Name** The name of the MO as it appears in the alarm and error logs.

**Alt. Name** The output screens of many commands list an alternate name for certain MOs in addition to their port address (physical location). The meaning of the name depends upon the type of the object, as shown in the following table.

Maintenance Object	Alternate Name	Example
Station	extension	84140
Trunk	trunk group # / member # (001-666) / (001-255)	45/3
Personal CO line	P/ personal CO line group # (001-200)	P/23

**Test No.** The number of the test run on the MO as part of a test command. Descriptions of each test and its related error codes appear under the relevant MO. Other commands such as **clear firmware-counters** and **reset** also report a test number.

**Result** One of the following results:

**PASS:** The command successfully completed. For a test command this indicates that no errors were detected by the test.

**ABORT:** The command was prevented from completing. See Error Code below.

**FAIL:** Indicates that a serious error was detected by the test. See Error Code below.

**NO BOARD:** The system does not detect a circuit pack in the location specified on the command line.

**CONFLICT:** Another user was testing this maintenance object.

**EPN-DOWN:** The EPN holding the MO is inaccessible. The Expansion Archangel Link may be down.

**DISABLED:** The MO or test has been disabled by the Tier 3 disable command.

**NOT ASSIGNED:** The location specified does not have a circuit pack administered to it.

**EXTRA BOARD:** This result can appear for the Maintenance/Test, Call Classifier, Tone Detector, Announcement, and Speech Synthesis circuit packs. Each of these circuit packs has restrictions on how many can be in the system or a port network:

Maintenance/Test circuit pack: 1 per port network

Tone Detector circuit pack: up to 50 per system

Call Classifier circuit pack: up to 25 per system

Speech Synthesis circuit pack: 40 per system

Announcement circuit pack: 1 per system

Remove the extra circuit pack(s).

**Error Code** A number indicating the reason for a FAIL or ABORT result. For test commands and other commands that return a test result, consult the tables of test error codes under the relevant MO. For **busyout**, **release** and **reset** commands, see [“Common Abort and Fail Codes”](#) and Test Commands.

## Contention Between Simultaneous Commands

---

The following limits apply to simultaneous maintenance and administration activities:

- Up to 8 users can be logged into the system at the same time.
- Up to 5 maintenance commands can run concurrently.

- Up to 3 maintenance commands issued from system access port (SAP) or EPN Maintenance circuit pack logins can run concurrently. The other 2 are reserved for the SYSAM and INADS ports.
- Up to 5 administration commands can run concurrently.
- In general, a maintenance object or other system entity can be acted upon by only one command at a time. This restriction applies to such action commands as:
  - busyout
  - change
  - clear
  - recycle
  - release
  - set
  - test
- In general, only 1 SPE component can be acted upon at one time by commands such as those just mentioned.
- When an action command is acting on a circuit pack, that circuit pack and all maintenance objects located on it are unavailable for other commands.
- Display-only commands such as the following generally do not conflict with any other commands.
  - display
  - status
  - get
  - monitor
- Certain system-wide actions such as **reset system** and **upgrade software** cannot run concurrently with any other command.
- Most commands require the use of shared system resources in order to execute. When required resources are already in use, the command will abort. For example, **save**, **restore**, **backup**, and **test disk** commands all require the use of the Mass Storage System (MSS). Only one such command can run at one time.

## **Busyout and Release Commands**

The **busyout** command places the object of the command in a maintenance busy state. In this state, the object is removed from active service and is not available for use by call processing. Services dependent on the busied out component are dropped. If the component supports a link, the link is dropped. No scheduled or periodic background tests are run on the object while it is busied out. Demand maintenance tests can be run on the object, though some

tests require that the object be released to complete. A WARNING alarm with error type 18 is logged against each busied out object. All busied out MOs can be displayed by entering error type 18 in the Error Type field on the Hardware Errors Report Form (see **display errors**). The matching release command returns the maintenance object to service, providing the object is not otherwise incapacitated.

On systems with duplicated SPE, busyouts are preserved across planned SPE interchanges and level 1 system resets (Warm). System resets of level 2 or higher release the busied out objects.

A variety of self-explanatory error messages may be displayed if the command cannot be executed as entered. In addition to these there are a number of numerical error codes which may be displayed in the Error Code field if the command ABORTS or FAILS as indicated in the Result field. These are explained in the *Common Abort and Fail Codes* section of this chapter.

The following screen display shows a typical result for **busyout board 1c03** (analog line circuit pack in cabinet 1, carrier c, slot 7 with three administered ports):

```
busyout board 01C03
```

```
Command Results
```

Port	Maintenance Name	Alt. Name	Result	Error Code
01C03	ANL-BD		PASS	
01C0301	ANL-16-L	5409	PASS	
01C0302	ANL-16-L	5416	PASS	
01C0303	ANL-16-L	5421	PASS	
01C0304	ANL-16-L	5422	PASS	
01C0305	ANL-16-L	5411	PASS	

```
Command successfully completed
```

The following display shows a typical result for most maintenance objects. See ["Common Output Fields"](#) above for an explanation of the fields displayed.

```
busyout disk b
```

```
COMMAND RESULTS
```

Port	Maintenance Name	Alt. Name	Result	Error Code
01B	DISK		PASS	

```
Command successfully completed
```

## Common Abort and Fail Codes

[Table 8-3](#) lists common error codes associated with abort and fail results for busyout, release, test, and reset commands. In addition to these, many maintenance objects have other unique error codes.

**Table 8-3. Common Error Codes for Busyout, Release, Test, and Reset Commands**

Error Code	Command Result	Description/Recommendation
	ABORT	System resources are unavailable to run command. 1. Try the command again at 1-minute intervals up to 5 times.
0	ABORT	Internal system error. 1. Retry the command at 1-minute intervals up to 5 times.
1005	ABORT	A DS1 interface circuit pack could not be reset because it is currently supplying the on-line synchronization reference. 1. Use the <b>set sync</b> command to designate a new DS1 interface circuit pack as the on-line reference, then try the reset again.
1010	ABORT	Attempt was made to busyout an object that was already busied out.
1011	ABORT	Attempt was made to release an object that was not first busied out.
1015	ABORT	A reset of this circuit pack requires that all maintenance objects on it be in the out-of-service state. 1. Use the <b>busyout board</b> command to place all objects on the circuit pack in the out-of-service state, and try the reset again.
1026	ABORT	The specified TDM bus cannot be busied out because the control channel or system tones are being carried on it. You can use the <b>set tdm PC</b> command to switch the control channel and system tones to the other TDM bus.
1030	ABORT	This command is not allowed on a circuit pack on the standby SPE.

*Continued on next page*

**Table 8-3. Common Error Codes for Busyout, Release, Test, and Reset Commands — Continued**

Error Code	Command Result	Description/Recommendation
1338	ABORT	The system could not execute the command on a component on the Standby SPE because an interchange was pending. <ol style="list-style-type: none"><li>1. Refer to <a href="#">“STBY-SPE (Standby SPE Maintenance)”</a> in <a href="#">Chapter 9</a>.</li><li>2. Try the command again after the SPE interchange occurs.</li></ol>
1339	ABORT	The system could not execute the command on a component on the Standby SPE because an handshake communication was down. <ol style="list-style-type: none"><li>1. Refer to <a href="#">“STBY-SPE (Standby SPE Maintenance)”</a> in <a href="#">Chapter 9</a>.</li><li>2. Try the command again after the standby SPE is restored to service. Use <b>status spe</b> to determine state of standby SPE.</li></ol>
1347	ABORT	The system could not execute the command on a component on the Standby SPE because memory refresh was not complete. <ol style="list-style-type: none"><li>1. Refer to <a href="#">“STBY-SPE (Standby SPE Maintenance)”</a> in <a href="#">Chapter 9</a>.</li><li>2. Try the command again after the standby SPE is restored to service. Use <b>status spe</b> to determine state of standby SPE.</li></ol>
1350	ABORT	The system could not execute the command on a component on the Standby SPE because memory shadowing was not enabled. <ol style="list-style-type: none"><li>1. Refer to <a href="#">“STBY-SPE (Standby SPE Maintenance)”</a> in <a href="#">Chapter 9</a>.</li><li>2. Try the command again after the standby SPE is restored to service. Use <b>status spe</b> to determine state of standby SPE.</li></ol>
2012 2500	ABORT	Internal system error.
2100	ABORT	System resources to run this command were unavailable. <ol style="list-style-type: none"><li>1. Try the command again at 1-minute intervals up to 5 times.</li></ol>

*Continued on next page*

**Table 8-3. Common Error Codes for Busyout, Release, Test, and Reset Commands — Continued**

Error Code	Command Result	Description/Recommendation
62524 62525 62526	ABORT	Maintenance is currently active on the maximum number of maintenance objects that the system can support. This condition is commonly caused by the fact that the system contains a large number of stations or trunks that have been administered, and whose circuit packs are installed, but which are not physically connected.  1. Resolve as many alarms as possible on the station and trunk MOs, or busyout these MOs to prevent maintenance activity on them. Then try the command again.
	NO BOARD	The circuit pack is not physically installed.
	EXTRA BD	This result can appear for Maintenance/Test, Call Classifier, Tone Detector, Announcement and Speech Synthesis circuit packs. Each of these circuit packs has restrictions on how many can be installed in the system or in a port network. The restrictions are as follows:  TN771D Maintenance/Test: 1 /port network TN748 Tone Detector: 50 /system TN744 Call Classifier: 25 /system Speech Synthesizer: 40 /system TN750 Announcement: 1 /system Remove any extra circuit packs.
1	FAIL	For reset commands, the circuit pack was not successfully halted.
2	FAIL	For reset commands, the circuit pack was not successfully restarted after being halted. For both results, replace the circuit pack.
	FAIL	Refer to the applicable maintenance object in <a href="#">Chapter 9</a> .
	PASS	The requested action successfully completed. If the command was a reset, the circuit pack is now running and should be tested.

## Alarm and Error Categories

---

The **display alarms** and **display errors** commands allow you to generate reports for certain groups of maintenance objects. By entering a category from the [Table 8-4](#) into the `Category` field of the input form, you can restrict the report to only those maintenance objects included in that category. The report can be further narrowed down by using the other fields on the form.

[Table 8-4](#) is a list of the categories showing which MOs are included. [Table 8-5](#) is sorted by MO and shows the categories containing each MO.

**Table 8-4. Alarm and Error Categories**

Category	Maintenance Objects
<b>adm-conn</b>	ADM-CONN
<b>announce</b>	ANN-PT ANN-BD ANNOUNCE
<b>bri/asai</b>	ASAI-ADJ ASAI-BD ASAI-PT ASAI-RES ABRI-PORT BRI-BD BRI-PORT BRI-SET LGATE-AJ LGATE-BD LGATE-PT
<b>cdr</b>	CDR-LNK
<b>data-mod</b>	BRI-DAT DAT-LINE DT-LN-BD PDMODULE TDMODULE

---

*Continued on next page*



**Table 8-4. Alarm and Error Categories — Continued**

Category	Maintenance Objects
<b>detector</b>	DTMR-PT DETR-BD GPTD-PT TONE-BD
<b>dup-spe</b>	CARR-POW DUPINT MEM-BD PROCR SPE-SELEC STBY-SPE SW-CTL TAPE
<b>environ</b>	AC-POWER CABINET CARR-POW DC-POWER EMG-XFER EXT-DEV POWER RING-GEN
<b>exp-intf</b>	AC-POWER CARR-POW DC-POWER DUPINT EPN-SNTY EXP-INTF MAINT SYNC

*Continued on next page*

**Table 8-4. Alarm and Error Categories — Continued**

Category	Maintenance Objects
<b>ext-dev</b>	TDM-CLK TONE-BD
<b>generatr</b>	CUST-ALM  STRAT-3 SYNC TDM-CLK TONE-PT TONE-BD
<b>inads-link</b>	INADS
<b>infc</b>	EXP-INTF ISDN-LNK ISDN-SGRP PGATE-BD X25-PT
<b>maint</b>	MAINT
<b>mass-st</b>	DISK
	H-ADAPTR STO-DATA TAPE
<b>mbus</b>	DUPINT MEM-BD PROCR SW-CTL TAPE
<b>memory</b>	MEM-BD

*Continued on next page*

**Table 8-4. Alarm and Error Categories — Continued**

<b>Category</b>	<b>Maintenance Objects</b>
<b>misc</b>	CONFIG ERR-LOG MIS PROC-SAN SYSTEM TIME-DAY
<b>mmi</b>	MMI-BD MMI-LEV MMI--PT MMI-SYNC
<b>mnt-test</b>	M/T-ANL M/T-BD M/T-DIG M/T-PKT
<b>modem</b>	MODEM-BD MODEM-PT
<b>mssnet</b>	H-ADAPTR SW-CTL
<b>netcon</b>	SW-CTL
<b>pkt</b>	M/T-PKT PKT-BUS
<b>pms/jrnl</b>	JNL-PRNT PMS-LINK
<b>pnc</b>	DS1C-BD DS1-FAC EXP-INTF FIBER-LK PNC-DUP

---

*Continued on next page*

**Table 8-4. Alarm and Error Categories — Continued**

<b>Category</b>	<b>Maintenance Objects</b>
	SN-CONF SNC-BD SNC-LINK SNC-REF SNI-BD SNI-PEER
<b>pncmaint</b>	DS1C-BD DS1-FAC EXP-INTF FIBER-LK PNC-DUP SN-CONF SNC-BD SNC-LINK SNC-REF SNI-BD
<b>pnc-peer</b>	SNI-PEER
<b>procr</b>	PROCR
<b>quick-st</b>	ABRI-PT ADXDP-PT ANL-16-LINE ANL-LINE ANL-NE-LINE ANN-PT ANNOUNCE ASAI-ADJ AUDIX-PT AUX-TRK

---

*Continued on next page*

**Table 8-4. Alarm and Error Categories — Continued**

<b>Category</b>	<b>Maintenance Objects</b>
	BRI-PT
	BRI-SET
	CDR-LINK
	CLSFY-PT
	CO-DS1
	CO-TRK
	CONFIG
	DAT-LINE
	DID-DS1
	DID-TRK
	DIG-LINE
	DIOD-TRK
	DISK
	DS1-FAC
	DS1C-BD
	DTMR-PT
	EPN-SANITY
	EXP-INTF
	EXP-PN
	FIBER-LNK
	GPTD-PT
	HYB-LINE
	ISDN-LNK
	ISDN-TRK
	JNL-PRNT
	MAINT
	MEM-BD
	MET-LINE

---

*Continued on next page*

**Table 8-4. Alarm and Error Categories — Continued**

Category	Maintenance Objects
	MODEM-PT
	OPS-LINE
	PDATA-PT
	PDMODULE
	PGATE-PT
	PKT-BUS
	PKT-INT
	PMS-LINK
	PMS-PRNT
	PNC-DUP
	PRI-CDR
	PROCR
	S-SYN-PT
	SEC-CDR
	SN-CONF
	SNC-BD
	SNC-LNK
	SNC-REF
	SNI-BD
	SNI-PEER
	SW-CNTL
	SYS-PRNT
	SYSAM
	SYSLINK
	SYSTEM
	TAPE
	TDM-BUS
	TDM-CLK

---

*Continued on next page*

**Table 8-4. Alarm and Error Categories — Continued**

Category	Maintenance Objects
	TDMODULE TIE-DS1 TIE-TRK TONE-BD TTR-LEV
<b>spe</b>	DISK DUP-CHL DUPINT H-ADAPTR MEM-BD PKT-INT PROCR SPE-SELEC STBY-SPE STO-DATA SW-CTL SYSAM SYSTEM TAPE
<b>s-syn</b>	S-SYN-BD S-SYN-PT
<b>stabd</b>	ABRI-PORT ADXDP-BD ADXDP-PT ANL-16-LINE ANL-BD ANL-BD ANL-LINE

*Continued on next page*

**Table 8-4. Alarm and Error Categories — Continued**

Category	Maintenance Objects
	ANL-NE-LINE
	ASAI-ADJ
	AUDIX-BD
	AUDIX-PT
	BRI-BD
	BRI-PORT
	BRI-SET
	DIG-BD
	DIG-LINE
	HYB-BD
	HYB-LINE
	MET-BD
	MET-LINE
<b>stacrk</b>	ADXDP-PT
	ANL-LINE
	ANL-16-LINE
	ANL-NE-LINE
	AUDIX-PT
	DIG-LINE
	HYB-LINE
	MET-LINE
	OPS-LINE
<b>stations</b>	ABRI-PORT
	ADXDP-PT
	ANL-16-LINE
	ANL-LINE
	ANL-NE-LINE
	ASAI-ADJ

*Continued on next page*



**Table 8-4. Alarm and Error Categories — Continued**

Category	Maintenance Objects
	AUDIX-PT BRI-PORT BRI-SET DIG-LINE HYB-LINE MET-LINE OPS-LINE
<b>sys-link</b>	SYS-LINK
<b>sys-prnt</b>	SYS-PRNT
<b>tape</b>	TAPE
<b>tdm</b>	SW-CTL TDM-BUS
<b>tone</b>	CLSFY-BD CLSFY-PT DETR-BD DTMR-PT GPTD-PT STRAT-3 SYNC TDM-CLK TONE-BD TONE-PT TTR-LEV
<b>trkbd</b>	AUX-BD AUX-TRK CO-BD CO-DS1 CO-TRK

*Continued on next page*

**Table 8-4. Alarm and Error Categories — Continued**

Category	Maintenance Objects
	DID-BD
	DID-DS1
	DID-TRK
	DIOD-BD
	DIOD-TRK
	DS1-BD
	ISDN-TRK
	PE-BCHL
	TIE-BD
	TIE-DS1
	TIE-TRK
	UDS1-BD
	WAE-PT
<b>trkcrk</b>	AUX-TRK
	CO-DS1
	CO-TRK
	DID-DS1
	DID-TRK
	DIOD-TRK
	ISDN-LNK
	ISDN-TRK
	TIE-DS1
	TIE-TRK
<b>trunks</b>	CO-TRK
	AUX-TRK
	CO-DS1
	DID-DS1
	DID-TRK

*Continued on next page*

**Table 8-4. Alarm and Error Categories — Continued**

Category	Maintenance Objects
	DIOD-TRK ISDN-LNK ISDN-TRK PE-BCHL TIE-DS1 TIE-TRK WAE-PORT
<b>vc</b>	VC-BD VC-DSPPT VC-LEV VC-SUMPT
<b>wide-band</b>	PE-BCHL WAE-PORT

**Table 8-5. Alarm and Error Categories  
 (Sorted by MO)**

Maintenance Object	Categories
ABRI-PORT	bri/asai quick-st stabd stations
AC-POWER	environ exp-intf
ADM-CONN	adm-conn
ADXCL-BD	
ADXCL-PT	
ADXCL-RS	
ADXDP-BD	quick-st stabd
ADXDP-PT	quick-st stabd
ADXDP-RS	
ANL-16-L	quick-st sta-bd stackrk stations
ANL-BD	stabd
ANL-LINE	quick-st stabd stackrk stations
ANN-BD	announce
ANN-PT	announce quick-st
ANNOUNCE	quick-st

*Continued on next page*

**Table 8-5. Alarm and Error Categories  
 (Sorted by MO) — *Continued***

Maintenance Object	Categories
	announce
ASAI-ADJ	bri/asai quick-st sta-bd stations
AUDIX-BD	quick-st sta-bd
AUDIX-PT	quick-st stabd stacrk stations
AUDIX-RES	
AUX-BD	trkbd
AUX-TRK	quick-st trkbd trkcrk trunks
BRI-BD	bri/asai sta-bd
BRI-DAT	data-mod quick-st
BRI-PORT	bri/asai quick-st stabd stations
BRI-SET	bri/asai quick-st stabd

*Continued on next page*

**Table 8-5. Alarm and Error Categories  
 (Sorted by MO) — *Continued***

Maintenance Object	Categories
	stations
CABINET	environ
CARR-POW	environ exp-intf
CDR-LNK	cdr quick-st
CLSFY-BD	tone
CLSFY-PT	tone quick-st
CO-BD	trkbd
CO-DS1	quick-st trkbd trkcrk trunks
CO-TRK	quick-st trkbd trkcrk trunks
CONFIG	misc quick-st
CUST-ALM	ext-dev
DAT-LINE	data-mod quick-st
DC-POWER	environ exp-intf
DETR-BD	detector tone
DID-BD	trkbd

*Continued on next page*

**Table 8-5. Alarm and Error Categories  
 (Sorted by MO) — *Continued***

Maintenance Object	Categories
DID-DS1	quick-st trkbd trkcrk trunks
DID-TRK	quick-st trkbd trkcrk trunks
DIG-BD	sta-bd
DIG-LINE	quick-st stabd stacrk stations
DIOD-BD	trkbd
DIOD-TRK	quick-st trkbd trkcrk trunks
DISK	quick-st mass-st spe
DS1-BD	trkbd
DS1-FAC	pnc pncmaint quick-st
DS1C-BD	pnc pncmaint quick-st

*Continued on next page*

**Table 8-5. Alarm and Error Categories  
(Sorted by MO) — Continued**

Maintenance Object	Categories
DT-LN-BD	data-mod
DTMR-PT	detector tone quick-st
DUP-CHL	spe
DUPINT	dup-spe exp-intf mbus spe
EMG-XFER	environ
EPN-SNTY	exp-intf quick-st
ERR-LOG	misc
EXP-INTF	exp-intf infc pnc pncmaint quick-st
EXP-PN	quick-st
EXT-DEV	environ ext-dev
FIBER-LK	pnc pncmaint quick-st
GPTD-PT	detector quick-st tone
H-ADAPTR	mass-st

*Continued on next page*



**Table 8-5. Alarm and Error Categories  
(Sorted by MO) — Continued**

Maintenance Object	Categories
	mssnet spe
HYB-BD	stabd
HYB-LINE	quick-st stabd stacrk stations
INADS	inads
ISDN-LNK	infc quick-st trkcrk trunks
ISDN-SGR	infc
ISDN-TRK	quick-st trkbd trkcrk trunks
JNL-PRNT	quick-st
MAINT	exp-intf maint quick-st
MEM-BD	dup-spe mbus memory quick-st spe
MET-BD	stabd
MET-LINE	quick-st

*Continued on next page*

**Table 8-5. Alarm and Error Categories  
 (Sorted by MO) — *Continued***

Maintenance Object	Categories
	stabd stacrk stations
MIS	misc
MODEM-BD	modem
MODEM-PT	modem quick-st
M/T-ANL	mnt-test
M/T-BD	mnt-test
M/T-DIG	mnt-test
M/T-PKT	mnt-test pkt
OPS-LINE	quick-st stacrk stations
PDATA-BD	
PDATA-PT	quick-st
PDMODULE	data-mod quick-st
PE-BCHL	trunkbd trunks wideband
PGATE-BD	
PGATE-PT	quick-st
PKT-BUS	pkt quick-st
PKT-INT	quick-st spe

*Continued on next page*

**Table 8-5. Alarm and Error Categories  
 (Sorted by MO) — *Continued***

Maintenance Object	Categories
PMS-LINK	pms/jrnl quick-st
PMS-PRNT	quick-st
PNC-DUP	pnc pncmaint quick-st
POWER-AC	
POWER-DC	
PRI-CDR	quick-st
PROC-SAN	misc
PROCR	dup-spe mbus procr quick-st spe
RING-GEN	environ
S-SYN-BD	quick-st
S-SYN-PT	quick-st s-syn
SEC-CDR	quick-st
SN-CONF	pnc pncmaint quick-st
SNC-BD	pnc pncmaint quick-st
SNC-LINK	pnc pncmaint

*Continued on next page*

**Table 8-5. Alarm and Error Categories  
 (Sorted by MO) — Continued**

Maintenance Object	Categories
	quick-st
SNC-REF	pnc pncmaint quick-st
SNI-BD	pnc pncmaint quick-st
SNI-PEER	pnc pnc-peer quick-st
SPE-SELE	dup-spe spe
STBY-SPE	dup-spe spe
STO-DATA	mass-st spe
STRAT-3	generatr tone
SVC-SLOT	
SW-CTL	dup-spe mbus mssnet netcon quick-st spe tdm
SYNC	exp-intf generatr

*Continued on next page*

**Table 8-5. Alarm and Error Categories  
 (Sorted by MO) — *Continued***

Maintenance Object	Categories
	tone
SYS-LINK	sys-link
SYS-PRNT	quick-st sys-prnt
SYSAM	quick-st spe
SYSTEM	misc quick-st spe
TAPE	dup-spe mass-st mbus quick-st spe tape
TDM-BUS	quick-st tdm
TDM-CLK	exp-intf generatr quick-st tone
TDMODULE	data-mos quick-st
TIE-BD	trkbd
TIE-DS1	quick-st trkbd trkcrk trunks

*Continued on next page*

**Table 8-5. Alarm and Error Categories  
 (Sorted by MO) — *Continued***

Maintenance Object	Categories
TIE-TRK	quick-st trkbd trkcrk trunks
TIME-DAY	misc
TONE-BD	detector exp-intf generatr quick-st tone
TONE-PT	generatr tone
TSC-ADM	
TTR-LEV	quick-st tone
UDS1-BD	trkbd
WAE-PORT	trunkbd trunks wideband

## add atm pnc

This command adds a new atm pnc to the system configuration.

Action/Object	Qualifier	Qualifier Description	Permissions	Defaults	Feature Interactions
add atm pnc	<b>number</b>	Number to assign to new atm pnc	init inads craft	none	none
	<b>next</b>	Next number automatically assigned to new atm pnc.  Examples: <b>add atm pnc 23</b> <b>add atm pnc next</b>			

## Output

The following example shows the output for the **add atm pnc next** command.

```

add atm pnc next                                     Page 1 of 1   SPE A
                                                    ATM PNC
                                                    Connection Number: 17

Location:
  Name:
Address Format: E.164 ATM Private
  AFI: 39
  E.164:
HO-DSP:
  ESI:
  SEL:

Command Successfully Completed
    
```

## Field descriptions

Location	5-character board number <b>UUCSS</b> ; cabinet (1-44) carrier (A-E) slot (0-20)
Name	16-character alpha-numeric characters for identification
Address Format	DCC ATM, E.164 ATM Private, or ICD ATM
E.164	Up to 15 decimal digits (0-9)
HO-DSP	8 hexadecimal digits (0-9, a-f, A-F)
ESI	12 hexadecimal digits (0-9, a-f, A-F)
SEL	2 hexadecimal digits (0-9, a-f, A-F); currently "00"

## backup disk

---

**backup disk** [spe-a | spe-b | active | standby | both | either] [incremental | full]

This command copies all information from the disk drive in the specified processor carrier(s) to the tape system in the same carrier. This can take up to 40 minutes to complete.

On a simplex SPE, the default is to perform an incremental backup of SPE-A. On a duplex SPE, the default is to perform an incremental backup on both SPE-A and SPE-B.

### NOTE:

The backup command can take up to 10 minutes to complete. Avoid pressing the ENTER key on the keyboard during this time, since doing so will cause the result messages to be lost.

## Parameters

---

spe-a	Specifies a backup from the A processor carrier hard disk to the A SPE tape.
spe-b	This specifies a backup from the B processor carrier hard disk to the B SPE tape.
active	This specifies a backup of the active processor.
standby	This specifies a backup of the standby processor.
both	This specifies a backup of both processor carriers.
either	Specifies a backup of both SPE carriers. If the standby is not accessible, the command performs a backup of the active SPE.
incremental	Causes all data marked "good" that has been changed since the last backup to tape to be copied to the tape. That is, all files that have a date newer than the date on the tape file.
full	This causes all data to be copied from disk to tape regardless of the dates and the state of the data ("good" or "bad").

## Examples

---

**backup disk**  
**backup disk spe-b**  
**backup disk active incremental**



## Output

---

Processor	Identifies the processor carrier that was backed up (SPE-A, or SPE-B).
Command	Results of the command, and the reason for any failure are displayed.
Completion Status	

For the following output example, assume that the command, **backup disk** is entered on a duplex system.

```
backup disk
                                     BACKUP DISK

Processor Command Completion Status

SPE-A      Success
SPE-B      Success

Command Successfully Completed
```

## busyout cdr-link

---

### **busyout cdr-link [primary | secondary]**

The `busyout cdr-link` command puts a specified call detail recording link in a maintenance busy state. When busied out, the link is dropped and must be reestablished later when returned to service. See the description of **status link** for more information on links.

### Parameters

---

[primary | secondary] This qualifier is used to specify one of the two possible links to CDR output devices. Primary is the default.

### Examples

---

```
busyout cdr-link  
busy cdr secondary
```

For more information see the following sections at the beginning of this chapter: Busyout and Release Commands, Common Input Parameters, and Common Output Fields.

## **busyout data-module**

---

### **busyout data-module extension**

This command puts the specified data module in a maintenance busy state, whether or not it is installed. No call processing may be executed on the data modules or over the data channels. A list of all data-modules administered on the system can be displayed with **list data-module**. This form gives the extension, port, type and other data for each data-module. The following table gives the maintenance object name for each type of data-module listed in the "Type" field on the list data-module form.

Type	Maintenance Object
adm-t	BRI-SET
announcement	DAT-LINE
dtdm	DIG-LINE
pdm	PDMODULE
system-port	DAT-LINE
x.25	PGATE-PT

## **busyout disk**

---

### **busyout disk C**

This command puts the hard disk drive of the Mass Storage System (MSS) into a maintenance busy state. Placing the disk in a busyout state prevents read and write access to the disk except when performed by demand maintenance testing. This command and the release command abort if any other MSS operation has already begun.

When the **release** command is issued, all alarms against the disk are automatically resolved. If the host-adapter is busied out, it must be released before the disk can be released. When the host-adapter becomes out-of-service due to test or reset failures and becomes uninstalled, the disk also becomes uninstalled, and all access by system software and maintenance tests and commands is blocked.

The cabinet is always **1** and need not be entered. The carrier, **a** or **b**, must be entered only on systems with duplicated SPEs.

## **busyout ds1-facility**

---

### **busyout ds1-facility UUCSSf [override]**

This command puts a specified DS1 facility of a DS1C Complex into a maintenance busy state. Each DS1C complex uses from 1 to 4 DS1 facilities. One of the facilities, called the packet facility, carries the control channel for all facilities in the complex, all packet traffic, and some circuit connections. The other facilities carry circuit connections only. Whenever the circuit pack resets, the packet facility is set on the "a" facility. If system software detects a problem with this facility, it switches the packet and control traffic to another facility. The **busyout** command is not allowed on the packet facility unless the override qualifier is used. When the override is used, all packet and circuit traffic on the packet facility is switched to one of the other 3 facilities; all traffic that was on the destination facility before the switch is dropped. There is no way to tell which facility is carrying the packet and control traffic without attempting to busy it out. If there is only 1 facility left in service on the circuit pack, it cannot be busied out. In this case, the circuit pack must be busied.

**CAUTION:**

*Busying out a non-packet facility disrupts all traffic carried on that facility. Use of the override command to busy the packet facility disrupts all traffic on the facility to which the packet and control traffic is moved. Which facility this is cannot be determined in advance.*

On critical reliability systems (duplicated PNC) a facility on the active PNC cannot be busied out. To busyout a facility on the standby PNC, the standby PNC must first be busied out by **busyout pnc**.

## **busyout fiber-link**

---

### **busyout fiber-link fiber# [a-pnc | b-pnc]**

The **busyout fiber-link** command puts a specified fiber link into a maintenance busy state. (See **Busyout** and **Release** Commands at the beginning of this chapter). A fiber link is a connection carrying all circuit and packet traffic between two port networks, two switch nodes, or a port network and a switch node. A fiber link may contain a DS1 CONV complex used to provide connectivity to a remote EPN.

**CAUTION:**

*On systems with simplex PNC, the **busyout** command is destructive. All calls and application links carried on the busied out fiber link will be torn down, and new calls will not be established over the link.*

On systems with duplicated PNC, the command is allowed only on a fiber link on the standby PNC, does not impact service, and requires that the standby PNC be busied first.

For more information on fiber links, see FIBER-LNK in Chapter 9.

## Parameters

---

- fiber#** The administered number assigned to the fiber link. (In a system with duplicated PNC, this represents a fiber link pair.) **List fiber-link** displays a list of all fiber links with their numbers, endpoints, and other useful information.
- a-pnc** If PNC is duplicated, this identifier is used to distinguish between the two fibers of a duplicated pair. For non duplicated PNC "a-pnc" is the only valid qualifier.
- b-pnc** On a system with duplicated PNC, this identifier distinguishes between the two fibers of a duplicated fiber pair. This identifier is invalid on a system with simplex PNC.

If neither PNC is specified, the command defaults to **a-pnc**.

## Examples

---

Duplex PNC: **busyout fiber-link 01 b-pnc busyout fiber-link 03** (defaults to a-pnc)

## busyout host-adapter

---

### **busyout host-adapter C**

The **busyout host-adapter** command puts the host-adapter circuit on the MSSNET circuit pack into a maintenance busy state. When the host-adapter is busied out, the tape and disk devices on the same carrier are also busied out, and warning alarms with error type 526 are raised against DISK and TAPE. The tape and disk do remain available for maintenance testing. This command will abort if any other MSS operation has already begun.

When the host-adapter is out of service due to test failures, or uninstalled due to a reset failure, the related tape and disk devices are also placed in the uninstalled state. All access by system software, maintenance tests, and commands, including reset, are blocked from execution.

## Parameters

---

- C The cabinet is always **1** and need not be entered. On systems with duplicated SPEs only, carrier **a** or **b** must be entered.

## Examples

---

Simplex: **busyout host-adapter**

Duplicated: **busyout host-adapter b**

For more information see the following sections at the beginning of this chapter: **Busyout** and **Release** Commands, Common Input Parameters, and Common Output Fields.

## busyout journal-printer

---

### busyout journal-printer pms-log | wakeup-log

The **busyout journal-printer** command puts the link to the Property Management System log or wakeup log printers in a maintenance busy state. (See Busyout and Release Commands at the beginning of this chapter). When busied out, the link is dropped and no data transfer can take place over it.

This command can be used to prevent unwanted interference between different maintenance processes. Maintenance software may put a component that is part of a link in a busy state, causing link set-up to fail, and resulting in attempts by the system to reestablish the link. If a maintenance test requires that the component be idle, frequent attempts at re-setup may delay the recovery of a faulty component. Busying out the link will prevent re-setup attempts.

## Parameters

---

- pms-log Busies out the link to the Property Management System printer
- wakeup-log Busies out the link to the Wakeup Log printer

## Examples

---

**busyout journal-printer pms-log**  
**busyout journal-printer wakeup-log**

For more information see the following sections at the beginning of this chapter: **Busyout** and **Release** Commands, Common Input Parameters, and Common Output Fields.

## busyout link

---

### busyout link link#

The **busyout link** command puts a specified Packet Gateway link in a maintenance busy state. (See **Busyout** and **Release** Commands at the beginning of this chapter). A link may also be busied out with **busyout port** using the address of the PGATE port that supports the link.



#### CAUTION:

*Busyout of a link drops all calls and packet traffic dependent on that link. The application, adjunct, or switch connected to the link will be inaccessible and the link will have to be reestablished later when returned to service. See **status link** for more details on links.*

## Parameters

---

Link#     A number (1-16) assigned to the link on the Communication-Interface Links form.

For more information see the following sections at the beginning of this chapter: **Busyout** and **Release** Commands, Common Input Parameters, and Common Output Fields.

## busyout spe-standby

---

### busyout spe-standby

The **busyout spe-standby** command lowers the Software State Of Health of the standby Switch Processing Element (SPE) kept by the standby Duplication Interface (DUPINT) board to the lowest possible level above non-functional. This diminishes the chance that an interchange will occur, but does not guarantee that an interchange will not occur. This command also turns off memory shadowing. Periodic and scheduled testing *are not* turned off on busied out objects, but warning alarms with error 18 are generated.

Busyout of the standby SPE is allowed if communication to the standby is down (handshake failure), but the state of health may not be lowered. Use **status spe** to determine the condition of the SPE after the busyout has been entered.

When a busyout of the standby SPE is performed, the software state of health of the standby SPE is set to the lowest possible level and memory shadowing is turned off. This is done to lessen the probability that the system will switch to the standby SPE. However, in some cases a “spontaneous” (hard) interchange of the SPEs may still occur.

This command can be used as a mechanism to turn off memory shadowing of the standby SPE.

The busyout *will* execute even if the standby SPE state of health is less than “functional”, memory shadowing is already off, or handshake communication with the standby is down.

For more information see the following sections at the beginning of this chapter: Busyout and Release Commands, Common Input Parameters, and Common Output Fields.

## **busyout sp-link**

---

### **busyout sp-link**

The **busyout sp-link** command puts the system printer link into a maintenance busy state. Placing the system printer link in a busyout state prevents access to the system printer.

The system printer link is a link from the switch to an external printer. This link is created by administering the system printer extension and setting up a call to the system printer.

For more information, refer to the following sections: **Busyout** and **Release** Commands, Common Input Parameters, and Common Output Fields.

## **busyout tape**

---

### **busyout tape C**

The **busyout tape** command puts the tape into a maintenance busy state. Placing the tape in a busyout state prevents read and write access of the tape except for that requested by demand maintenance testing. This command aborts if the host adapter on the same carrier is already busied out.

When the host-adapter is busied out, only the demand maintenance busyout and test commands are permitted on the attached tape in the same carrier. Reset, release, scheduled and periodic testing and other system software access are blocked. In this case, the host-adapter must first be released before the tape can be released.

When the host-adapter is taken out-of-service due to maintenance test or reset failures, the tape is also placed in the uninstalled state and all access by system software, maintenance tests and commands, including reset, are blocked.

## Parameters

---

- C The cabinet is always **1** and need not be entered. On systems with duplicated SPEs only, the carrier, **a orb**, must be entered.

## Examples

---

Simplex: **busyout tape**

Duplicated: **busyout tape a**

For more information, refer to the following sections: **Busyout** and **Release** Commands, Common Input Parameters, and Common Output Fields. This command will abort if any other MSS operation has already begun.

## busyout trunk

---

**busyout trunk group# [/member#]**

The **busyout trunk** command puts an entire trunk group or a single trunk group member in a maintenance busy state whether it is installed or not. Entering only the group number busies out all members in the group. (Although not recommended, entering a group number and a slash (/) without a member number busies out the member with the lowest-numbered port location.)

## Examples

---

**busyout trunk 78**  
**busyout trunk 78/1**

For more information see the following sections at the beginning of this chapter: **Busyout** and **Release** Commands, Common Input Parameters, and Common Output Fields.

## cancel hardware-group

---

**cancel hardware-group**

In the course of executing **test hardware-group**, you may find it necessary to halt the test temporarily or permanently. This can be accomplished with **cancel hardware-group**. The canceled **test hardware-group** command may be restarted where it left off with **resume hardware-group**, or another test hardware-group test may be started. In addition to the cancel hardware-group command, pressing CANCEL will cancel a hardware-group test executing in the foreground.



The status of a canceled test hardware-group command will show up as “canceled” on the “status hardware-group” screen.

When a hardware-group test is executing in the foreground with the “continuously” option and CANCEL is pressed or the cancel hardware-group is entered, then the hardware-group test is canceled and for security reasons, the MT running the hardware-group test will be logged off. However, after logging back on the system, you can still restart the canceled hardware-group test command with resume hardware-group command.

## Scheduled and Periodic Maintenance

When a **test hardware-group** is entered, all activity related to scheduled background maintenance, periodic background maintenance, and data audits is suspended for the duration of the execution of the **test hardware-group** command. All activity related to scheduled background maintenance, periodic background maintenance, and data audits will restart if the “test hardware-group” command is canceled.

## Status Hardware-Group

The state of a canceled **test hardware-group** command is displayed by the **test hardware-group** command and the state shows up as canceled.

## All Ports Option

When **test hardware-group all-ports** is canceled, the internally generated port translations for ports that are otherwise untranslated are removed. If **resume hardware-group** is then entered, only customer-administered ports will subsequently be tested. **resume** does *not* reinstate the port translations that were removed by the **cancel**.

## Output

If a **test hardware-group** command started in the background is successfully canceled with **cancel hardware-group**, this response is displayed:

```
Hardware-group command successfully canceled
```

If a **test hardware-group** command executing in the foreground is successfully canceled with a **cancel hardware-group** command from another terminal, the following response will be displayed on the terminal where the **hardware-group** command was executing:

```
Hardware-group command aborted with cancel  
command entered from another terminal
```

## change atm pnc

This command only allows you to change the name of the ATM switch.

Action/ Object	Qualifier	Qualifier Description	Permissions	Defaults	Feature Interactions
<b>change atm pnc</b>	<b><i>number</i></b>	Number assigned to the atm pnc  Example: <b>change atm pnc 23</b>	init inads craft	none	none

## Output

The following example shows the output for the **change atm pnc 2** command.

```
change atm pnc 2                                     Page 1 of 1   SPE A
                                                    ATM PNC
                                                    Connection Number: 2
Location: 01D01
Name: dup atm pnc
Address Format: ICD ATM
AFI: 47
ICD: 0005
HO-DSP: 80FFE1000000F21C31D4
ESI: 000000010D01
SEL: 00
```

## Field descriptions

Name                      16-character alpha-numeric characters for identification

## change circuit packs

### **change circuit-packs UU**

This command allows the user to administratively add, change or remove circuit packs that are to be inserted into port, expansion control, and switch node carriers. It is used to configure the system when the circuit packs have not yet been physically inserted. This command does *not* support displaying or modifying the boards in the PPN control carrier.

## Parameters

---

UU The number of the cabinet containing the circuit packs to be modified. Default is 1.

## Output

---

An input form is displayed containing the following fields:

Cabinet	The administered number of the cabinet (1-22).
Cabinet Layout	Type of cabinet.
Carrier	Each page of this form reports the information for 1 carrier. This field indicates the letter designation of the carrier displayed on the current page.
Carrier Type	The function of the carrier: (port, processor, switch-node, dup-switch-node, or not-used).
Slot	The carrier slot numbers (00 - 21).
Code	The TN or UN part number of the circuit pack. This number identifies the circuit pack type to system software.
Sfx	The letter suffix of the circuit pack, if applicable.
Name	The name of the circuit pack. This field aids in entering the circuit pack codes.

The following display shows a typical result when **change circuit-packs 1** is entered on a system with simplex SPE and a Center Stage Switch (cabinet 1 is always 5-carrier).

```
change circuit-packs 1                               Page 1 of 5
                CIRCUIT PACKS
Cabinet: 1                                           Carrier: A
Cabinet Layout: five-carrier                         Carrier Type: processor

*** PROCESSOR BOARDS NOT ADMINISTERABLE IN THIS SCREEN ***
```

8 Maintenance Commands  
change circuit packs

8-49

change circuit-packs 1 Page 2 of 5

CIRCUIT PACKS

Cabinet: 1 Carrier: B  
Cabinet Layout: five-carrier Carrier Type: not-used

Slot Code	Sfx	Name	Slot Code	Sfx	Name
00:			11:		
01:			12:		
02:			13:		
03:			14:		
04:			15:		
05:			16:		
06:			17:		
07:			18:		
08:			19:		
09:			20:		
10:			21:		

'#' indicates circuit pack conflict.

change circuit-packs 1 Page 3 of 5

CIRCUIT PACKS

Cabinet: 1 Carrier: C  
Cabinet Layout: five-carrier Carrier Type: port

Slot Code	Sfx	Name	Slot Code	Sfx	Name
00:			11: TN754		DIGITAL LINE
01: TN748	C	TONE DETECTOR	12: TN753		DID TRUNK
02:			13: TN742		ANALOG LINE
03:			14: TN760	C	TIE TRUNK
04: TN771	C	MAINTENANCE/TEST	15: TN747	B	CO TRUNK
05: TN748	B	TONE DETECTOR	16: TN742		ANALOG LINE
06: TN767		DS1 INTERFACE	17: TN556		BRI LINE
07: TN742		ANALOG LINE	18: TN742		ANALOG LINE
08: TN762	B	HYBRID LINE	19:		
09: TN742		ANALOG LINE	20: TN754		DIGITAL LINE
10:					

'#' indicates circuit pack conflict.

8 Maintenance Commands  
 change circuit packs

8-50

change circuit-packs 1 Page 4 of 5

CIRCUIT PACKS

Cabinet: 1 Carrier: D  
 Cabinet Layout: five-carrier Carrier Type: port

Slot Code	Sfx	Name	Slot Code	Sfx	Name
00:			11:		
01:			12:	TN722 B	DS1 TIE TRUNK
02:			13:	TN760 C	TIE TRUNK
03:	TN750 B	ANNOUNCEMENT	14:		
04:			15:	TN754	DIGITAL LINE
05:			16:		
06:			17:	TN742	ANALOG LINE
07:	TN747 B	CO TRUNK	18:		
08:	TN753	DID TRUNK	19:		
09:	TN742	ANALOG LINE	20:		
10:			21:		

'#' indicates circuit pack conflict.

change circuit-packs 1 Page 5 of 5

CIRCUIT PACKS

Cabinet: 1 Carrier: E  
 Cabinet Layout: five-carrier Carrier Type: switch-node

Slot Code	Sfx	Name	Slot Code	Sfx	Name
01:	TN570	EXPANSION INTF	11:		
02:	TN573	SWITCH NODE INTF	12:		
03:	TN573	SWITCH NODE INTF	13:		
04:			14:		
05:			15:		
06:			16:		
07:			17:		
08:			18:		
09:			19:	TN573	SWITCH NODE INTF
10:			20:	TN573	SWITCH NODE INTF
11:	TN572	SWITCH NODE CLOCK	21:		

'#' indicates circuit pack conflict.

## **change fiber-link**

---

### **change fiber-link fiber#**

The **change fiber-link** command changes the translation data associated with an existing fiber link. On critical reliability systems (duplicated PNC), each fiber link is duplicated and exists as a pair. When PNC duplication is enabled, only the fields on pages 2 and 3 (the DS1 CONV complex attributes) can be changed.

Translation data is not changed until the Enter key is pressed. Pressing CANCEL any time before pressing Enter to enter the changes returns you to the command line without changing any translation data.

When you enter a command that changes translation data, two checks are made:

- You must have permission to administer the feature.
- No other user may be executing a **change, add, or remove fiber-link** command.

On a simplex PNC or fully operational duplex PNC, you must remove a fiber and add it again to change the endpoint board locations.

### **Parameters**

---

number     The administered number (1-27) associated with a fiber link or, on a duplicated PNC, with a fiber link pair.

### **Examples**

---

**change fiber-link 21**

## Output

---

Fiber Link #	This display-only field shows the identifying number of the fiber link entered on the command line.
Board Location	The physical address (cabinet-carrier-slot) of the circuit packs comprising the two endpoints (ENDPOINT-1 and ENDPOINT-2) of the fiber link.
Board Type	This display-only field shows the type of circuit pack administered at each endpoint ("ei" or "sni").
DS1 Converter?	<b>y</b> indicates that a DS1C Converter Complex is used on this link to remotely locate a port network. If this is the case, a second page displays for administration of the DS1C Complex attributes.

The following fields appear on Page 2 when a DS1 CONV complex is administered on the fiber link. Only the DS1 CONV complex *attributes* are administered here. The circuit pack itself is administered by **change circuit pack**. Entries on Page 2 represent the A-PNC. If the PNC is duplicated, these fields are repeated on Page 3 for the B-PNC. Page 3 fields are display-only, and can be changed only by changing their counterpoints on Page 2.

Board Location	This field under the heading DS1C-1 is used to define the physical location of the converter board connected to ENDPOINT-1. It is a data entry field consisting of the board's physical address by cabinet-carrier-slot. When the location is entered, validation is performed to ensure that the board has been administered and is of the correct type (DS1 CONV).
DS1 Converter Facilities	The fields under this heading define attributes of the four DS1 facilities (A, B, C, D) that can be connected to the DS1 CONV.
Facility Installed?	This specifies ( <b>y</b> or <b>n</b> ) whether the indicated facility has been provided and installed. Facility A is required for the DS1 CONV Complex.
Passes Far-end Clock?	This specifies whether the DS1 CONV can use the timing of the received signal as a clock source (as when passing timing from a master PN to a slave PN. If the DS1 signal does not come directly from the far-end DS1 CONV board or the network, <b>n</b> should be entered. (For example, when using a 'combined' facility in which the signal is converted from digital to analog and back to digital.)
Digital Data Compatible?	This specifies whether the facility is suitable for transmission of digital data. Facility A must be so and this field cannot be changed. If Customer Premises Equipment that alters digital data exists on this facility (for example, a channel expansion multiplexer or a combined DS1 facility), <b>n</b> should be entered. (Thus, a multiplexer cannot be installed on facility A).

DS1C-1 Line Compensation This specifies the type of line compensation or line equalization for each facility of the DS1 CONV connected to ENDPOINT-1. Valid entries are **1** to **5**. Meanings of these entries are shown in [Table 8-6](#).

**Table 8-6. DS1 Line Equalization Settings**

Equalizer Setting	Distance to DSX-1 Interface (feet)	
	22 AWG ABAM and 24 AWG PDS	26 AWG PDS
1	1 to 133	0 to 90
2	133 to 266	90 to 180
3	266 to 399	180 to 270
4	399 to 533	270 to 360
5	533 to 655	360 to 450

The line equalization setting defaults to the median value of 3. This setting remains in effect until changed by administration. Incorrect equalizer settings may cause a higher error rate on the DS1 facility.

DS1 CONV-2 Line Compensation: Same as the above for ENDPOINT-2 of the DS1 CONV Complex.

Zero Code Suppression: Specifies the line coding format for each facility. Valid entries are: **zcs** and **b8zs**. There are 2 line coding options supported by the DS1 Interfaces to meet ones-density requirements in the data stream. Zero Code Suppression (ZCS) line coding is the default and is in place following an initialization until changed by administration. Note that either line coding option may be used on the DS1 Interface that carries the packet time slots.

Framing Mode: Specifies the data framing format (**esf** or **d4**) used on the facility. It is initialized to ESF. In this mode, an automatic selection process is executed until either the DS1 Interface is brought into frame, or an Options CCMS message is received by the framing options master. Once options are set by administration, they remain fixed on the framing option master until the board is again initialized, reset, or sent new options. The framing option on the framing option slave Converter Board can change to track the framing option master's option.

The following display shows a typical result when **change fiber-link 1** is entered on a system with simplex PNC and Center Stage Switch.



```
change fiber-link 1                               Page 1 of 1

                FIBER LINK ADMINISTRATION

Fiber Link #: 1

    ENDPOINT-1                                ENDPOINT-2
    (A-PNC)                                    (A-PNC)

Board Location: 01E01                          Board Location: 01E02
Board Type: ei                                  Board Type: sni
```

Is one endpoint remoted via DS1 Converter Complex? n

## **change synchronization**

**This command is destructive.**

This command changes the synchronization source to the system.

Action/ Object	Qualifier	Qualifier Description	Permissions	Defaults	Feature Interactions
<b>change synchronization</b>			init inads craft	none	none

## **Output**

The following example shows the output for the **change synchronization** command.

8 Maintenance Commands

*change system-parameters maintenance*

8-55

change synchronization Page 1 of 6 SPE A

SYNCHRONIZATION PLAN  
 ATM SYNCHRONIZATION REFERENCE (circuit pack location)

Stratum: 4

Primary: ATM-SW Secondary: ATM-SW

Location	Name	Slip	Location	Name	Slip
44C20	uds1-tg12&13	n	03B20	uds1-tg23	n
44B20	uds1-tg18	n	03D20	uds1-tg23	n
44C18	DCS+ -> ST12	n	04E20	uds1-tg23	n
44C19	QSIG -> ST12	n	05D20	uds1-tg23	n
07D20	DCS+ -> ST11	n	06B20	uds1-tg23	n
02A19	QSIG -> ST11	n	04C20	uds1-tg22	n
07E19	uds1-tg8&9	n	05A19	uds1-tg22	n
02E20	uds1-tg23	n	06D20	uds1-tg21	n

NOTE: DS1 and BRI TRUNK sources result in stratum 4, type II synchronization

## Field descriptions

Primary Enter **ATM-SW** or 5-character board location

Secondary 16-character alpha-numeric characters for identification



**NOTE:**

Port Networks can only get synchronization from the ATM switch. Entering a circuit pack location only monitors that pack for errors.

## change system-parameters maintenance

---

### change system-parameters maintenance

The maintenance-related system parameters form specifies and displays scheduled maintenance operations and maintenance support functions.

This form activates and deactivates INADS alarm origination when performing repairs. To deactivate alarm origination:

1. Make a note of the current entries in the Alarm Origination and CPE fields so you can restore them when you are done.
2. Change the Alarm Origination to OSS Numbers field "neither."
3. Change the CPE Alarm Activation Level field to "none."

8 Maintenance Commands

*change system-parameters maintenance*

8-56

4. If daily scheduled maintenance must be prevented from starting during a maintenance procedure, set the `Start Time` field to a time after the session will end. If daily Scheduled Maintenance is already running and needs to be shut off, set the `Stop Time` field to one minute after the current time.
5. Press `Enter` and verify that the screen displays the message:

Command successfully completed

**⇒ NOTE:**

For earlier releases of system software, disable Cleared Alarm Notification and Restart Notification before submitting the form.

**⇒ NOTE:**

When finished working on the switch be sure to return all fields to their original settings.

## Examples

---

**change system-parameters maintenance**

## Output

---

An input form is displayed with the following fields. Defaults for data entry fields are listed in parentheses.

The following display shows a typical result when **change system-parameters maintenance** is entered.

8 Maintenance Commands

change system-parameters maintenance

8-57

change system-parameters maintenance Page 1 of 3

MAINTENANCE-RELATED SYSTEM PARAMETERS

OPERATIONS SUPPORT PARAMETERS

Product Identification: 1000000000  
First OSS Telephone Number: 5551212 Abbrev Alarm Report? y  
Second OSS Telephone Number: 5551213 Abbrev Alarm Report? n  
Alarm Origination to OSS Numbers: both  
Cleared Alarm Notification? y  
Restart Notification? y  
Test Remote Access Port? n  
CPE Alarm Activation Level: none  
  
Customer Access to INADS Port? n  
Repeat Dial Interval (mins): 7

SCHEDULED MAINTENANCE

Start Time: 22:00 Stop Time: 04:00  
Daily Maintenance: daily Save Translation: daily  
Control Channel Interchange: no System Clocks Interchange: no  
SPE Interchange: no

change system-parameters maintenance Page 2 of 3

MAINTENANCE-RELATED SYSTEM PARAMETERS

MAINTENANCE THRESHOLDS ( Before Notification )

Minimum Threshold for TTRs: 4 Minimum Threshold for CPTRs: 1  
Minimum Threshold for Call Classifier Ports: \_

TERMINATING TRUNK TRANSMISSION TEST (Extension)

Test Type 100: Test Type 102: Test Type 105:

ISDN MAINTENANCE

ISDN-PRI TEST CALL Extension: \_\_\_\_\_ ISDN BRI Service SPID: \_\_\_\_\_

DS1 MAINTENANCE

DSO Loop-Around Test Call Extension: \_\_\_\_\_

LOSS PLAN (Leave Blank if no Extra Loss is Required)

Minimum Number of Parties in a Conference Before Adding Extra Loss: \_\_\_\_\_

SPE OPTIONAL BOARDS

Disk? y Packet Intf1? y Packet Intf2? n Packet Intf3? n

8 Maintenance Commands

*change system-parameters maintenance*

8-58

change system-parameters maintenance

Page 3 of 3

MAINTENANCE-RELATED SYSTEM PARAMETERS

Modem Connection: external  
Data Bits: 8  
Parity: none

Modem Name: \_\_\_\_\_

RTS/CTS Enabled: &H1            Auto Answer Ring Count (rings): S0=10  
Asynchronous Data Mode: \_\_\_\_\_            Dial Type: T  
DTE Auto-Data Speed: \_\_\_\_\_            Adjustable Make/Break Ratio:  
Disable Data Compression: &K0            Dial Command: D  
Enable Error Control: \_\_\_\_\_            No Answer Time-out: S7=255  
Misc. Init. Param: \_\_\_\_\_

Help/Error Message Line

## Operations Support Parameters

Product Identification	This is a 10-digit number starting with 1 that identifies the switch to an Operations Support System (OSS), for example, INADS.
First OSS Telephone Number	The first telephone number that the switch uses to report alarms to, for example, INADS or Trouble Tracker. The number must be obtained from the National Customer Support Center (NCSC) or the TSC. # and * are not allowed in the telephone number.
Abbrev Alarm Report	Enables the Abbreviated Alarm Report feature for the first OSS. (yes)
Second OSS Telephone Number	The second telephone number that the switch uses to report alarms to, for example, INADS or DEFINITY SNMP. The number must be obtained from the National Customer Support Center (NCSC) or the TSC. # and * are not allowed in the telephone number.
Abbrev Alarm Report	Enables the Abbreviated Alarm Report feature for the second OSS. (no)

8 Maintenance Commands

*change system-parameters maintenance*

8-59

Alarm Origination to OSS Numbers

Indicates one of four options for alarm origination (neither):

- If this field is set to “both,” all Major and Minor alarms result in an automatic call to both OSS telephone numbers. Both OSS telephone numbers must be administered.
- If this field is set to “first-only,” all Major and Minor alarms result in an automatic call to the first OSS number only. The switch does not call the second OSS telephone number even if the number is administered. The first OSS telephone number must be administered
- If this field is set to “neither,” alarm origination does not take place. Warning alarms are not reported to either numbers.
- If this field is set to “second-as-backup,” all Major and Minor alarms result in an automatic call to the first OSS telephone number. If calling the first OSS telephone number fails four attempts, the switch starts to call the second OSS telephone number as a backup until calling the first OSS telephone number becomes successful. Both OSS telephone numbers must be administered.

Before Release 5, the name of this field is “Alarm Origination Activated.” If Alarm Origination is deactivated, both Cleared Alarm Notification and Restart Notification are disabled, even though they may still be activated in the administration.

Cleared Alarm Notification

Enables the switch to originate a call to the OSS and send an alarm resolution message whenever all previously reported Major and Minor alarms are resolved. Alarm Origination must be activated in order for Cleared Alarm Notification to work. (no)

Restart Notification

Enables the switch to originate a call to the OSS and report any system restarts caused by problems with the switch.

Suspension Threshold

The threshold for suspending Cleared Alarm Notification. Some problems may cause alarms to be generated and then resolved repeatedly. To detect these problems (by not sending additional Cleared Alarm notifications to indicate a problem-free system), the switch suspends Cleared Alarm Notification when it has reported this administrable number of Cleared Alarm notifications in a 24 hour period. A suspended Cleared Alarm Notification is only enabled again with a successfully completed “logoff” command, a system reset, or when the threshold is changed. This field is irrelevant if Cleared Alarm Notification or Alarm Origination is disabled. The possible range of threshold values is between 1 and 15.

8 Maintenance Commands

*change system-parameters maintenance*

8-60

Test Remote Access Port Specifies whether testing of the remote access port on the SYSAM circuit pack is enabled. This field should be set to "yes" whenever there is an INADS line connected to the switch and there is a maintenance contract in effect so that alarm origination capability is maintained.

If no equipment is connected to the remote access port, or if a trunk for remote access and alarm origination is not provided, running tests on the remote access port on the SYSAM results in test failures. This causes unnecessary maintenance alarms and allows potentially destructive tests to be run. Setting this field to "no" prevents this.

CPE Alarm Activation Level Indicates the minimum level (Major, Minor or Warning) at which the Customer-Provided Equipment (CPE) alarm is activated. If the level is "none," the CPE does is not activated for any alarm. (none)



**NOTE:**

The CPE alarm is always activated when the switch goes into Emergency Transfer, regardless of the CPE Alarm Activation Level setting.

Customer Access to INADS Port Provides the capability to prohibit access to system administration and maintenance interface, via the INADS port when using customer login ID's. This field can only be activated Lucent through system-parameters maintenance administration.(no)

**Scheduled Maintenance**

---

A series of maintenance tests and operations runs automatically every day according to the schedule and settings specified in [Table 8-7](#)

**Table 8-7. Schedules and Settings for Maintenance Tests**

---

Start Time	The hour and minute in 24-hour notation at which daily scheduled maintenance will begin running.
Stop Time	The hour and minute when scheduled daily maintenance will stop running. If any daily maintenance operations are not completed by this time, the system will note where in the sequence it stopped and perform those operations during the next scheduled daily maintenance.
Daily Maintenance	This display-only field simply represents the series of tests that are always run by maintenance software as part of daily maintenance.

---

*Continued on next page*

**Table 8-7. Schedules and Settings for Maintenance Tests — *Continued***

Save Translation	This field indicates on which days translation data in memory will automatically be saved to the Mass Storage System disk and/or tape devices during scheduled maintenance. The save operation is first made to disk, followed by a disk backup to tape. On systems with duplicated SPEs, translation data is saved on both SPEs. Valid entries are <b>daily</b> , days of the week, or <b>no</b> . "No" specifies that no automatic saves are to be executed. (daily)
Control Channel Interchange	Each port network has a pair of TDM busses called A and B, each of which has a set of time slots dedicated to use by the control channel. At any one time, the control channel in each PN is carried on only one of the two busses. This field indicates on which days the control channel in each port network will be switched from one of the paired TDM busses to the other. Valid entries are <b>daily</b> , days of the week, or <b>no</b> . "No" specifies that no interchange be executed. (no)
System Clocks Interchange	On High and Critical Reliability systems, this option causes a Tone-Clock interchange in each port network with duplicated Tone-Clock circuit packs. Each port network interchanges into the standby Tone-Clock for 20 seconds and then back to the Tone-Clock that was originally active. This field indicates on which days the interchanges are to take place. Valid entries are daily, days of the week, or no. "No" specifies that interchanges be executed. (no)  The system performs a Tone-Clock interchange, making the stand by Tone-Clock active. The newly active Tone-Clock circuit pack is tested and, while active, provides system clocks for the port network in which it resides. The system then interchanges back to the originally active Tone-Clock circuit pack.
SPE Interchange	On systems with duplicated SPEs, this field indicates on which days an SPE interchange will be executed during scheduled maintenance. Valid entries are <b>daily</b> , days of the week, or <b>no</b> . "No" specifies no scheduled interchanges. (no)
Minimum Threshold for TTRs	When the number of touch tone receivers (TTRs) in service falls below this number (4 to 200), a WARNING alarm is raised against TTR-LEV. These are also known as dual-tone multifrequency receivers (DTMRs). There are 4 TTRs on each TN748, TN718, TN420, or TN756; TN2182 and TN744 (suffix C or later) each have 8 TTRs. To alarm the first occurrence of a TTR being taken out of service, set this field to the total number of TTRs in the switch.

*Continued on next page*



**Table 8-7. Schedules and Settings for Maintenance Tests — *Continued***

Minimum Threshold for CPTRs	When the number of call progress tone receivers in service falls below this number (2 to 100), a WARNING alarm is raised against TTR-LEV. These are also known as general purpose tone detectors (GPTDs). There are 2 CPTRs on each TN748, TN718, TN420, or TN756; TN2182 and TN744 (suffix C or later) each have 8 CPTRs. To alarm the first occurrence of a CPTR being taken out of service, set this field to the total number of CPTRs in the switch.
Minimum Threshold for Call Classifier Ports	When the number of call classifier ports (CLSFY-PTs) in service falls below this number, a WARNING alarm is raised against TTR-LEV. Valid entries are 1 to 200. There are 8 ports on each TN744 or TN2182 circuit pack. To alarm the first occurrence of a CLSFY-PT being taken out of service, set this field to the total number of CLSFY-PTs. If there are no TN744 or TN2182 circuit packs in the system, leave this field blank.
Test Type 100, Test Type 102, Test Type 105	<p>An extension assigned to receive tie-trunk calls from other switches with test line origination capability. The system responds by sending a sequence of test tones. Test Type 100 tests far end to near end loss and C-message by sending:</p> <ul style="list-style-type: none"> <li>■ 5.5 seconds of 1004 Hz tone at 0dB</li> <li>■ Quiet until disconnect; disconnect is forced after one minute</li> </ul> <p>Test Type 102 tests far end to near end loss by sending:</p> <ul style="list-style-type: none"> <li>■ 9 seconds of 1004 Hz tone at 0dB</li> <li>■ 1 second of quiet</li> <li>■ This cycle is repeated until disconnect; disconnect is forced after 24 hours.</li> </ul> <p>Test Type 105 tests 2-way loss, gain slope, and C-message and C-notch noise by sending:</p> <ul style="list-style-type: none"> <li>■ nine seconds of 1004 Hz at -16dB</li> <li>■ one second of quiet</li> <li>■ nine seconds of 404 Hz at -16dB</li> <li>■ one second of quiet</li> <li>■ nine seconds of 2804 Hz at -16dB</li> <li>■ 30 seconds of quiet</li> <li>■ one half second of Test Progress Tone (2225 Hz)</li> <li>■ approximately 5 seconds of quiet</li> <li>■ forced disconnect</li> </ul>

8 Maintenance Commands

*change system-parameters maintenance*

8-63

**Table 8-7. Schedules and Settings for Maintenance Tests — Continued**

ISDN-PRI Test Call Extension	The extension used by a far-end ISDN node to place a call to the system to test the ISDN-PRI trunks between the far-end and the system.
ISDN-BRI Service SPID	This field shows whether or not the link is associated with the Service SPID. If the link is associated with the Service SPID, the field contains a number from "0 to 99999" this number is the test spid (See <i>SPID Facility Test</i> in <i>chapter 9</i> under <i>BRI-SETMO</i> ) otherwise, this field is blank. Service SPID is a feature used by the system technician to check building wiring between the switch and the BRI endpoint.
DSO Loop-Around Test Call Extension	<p>The extension used by the network service provider to set up a DSO loop around connection for testing non ISDN DS1 trunks</p> <p>The DSO Loop-Around Test Call feature is used primarily for testing DSO channels associated with non ISDN-PRI trunks. The loop-around is activated by dialing the test extension number. Multiple DSO Loop-Around connections can be set up by placing multiple calls to the loop-around extension.</p> <p>For more information see chapter 6 (Facility Test Calls).</p>
Loss Plan	Use only when extra loss is required to maintain quality of transmission on conference calls. Leave this field blank if no extra loss is required. If extra loss is required, enter digits as shown below.

Number Of Parties To Be Conferenced	Enter Digit
3	2
4	3
5	4
6	5
7	6

## 8 Maintenance Commands

*change system-parameters maintenance*

8-64

SPE  
Optional  
Boards:

These fields indicate whether a Disk circuit pack is present in the system, and which Packet Interface slots are administered. If a Packet Interface circuit pack is physically present, the corresponding Packet Interface field is set to y when the system boots, and no change to that field is allowed. If the system is equipped with duplicated SPEs, a Packet Interface field is set to y when either SPE carrier contains a Packet Interface circuit pack in the corresponding position. If a Packet Interface circuit pack is not present, then the value for the Packet Interface field is read from translation data stored on disk or tape. If the field is set to n, a Packet Interface circuit pack may be administered by changing the corresponding Packet Interface field to y.

## Modem Connection

On page 3 of the example forms shown below, there are 11 fields that are hidden when the `Modem Connection?` field is set to **internal**. In this example the `Modem Connection` field is set to **external**, and these additional 11 fields are visible.

The first 2 fields on page 3 help setup the data format for the serial data from the switch to the modem. There are only two valid combinations for these 2 fields:

- Data Bits = 8, Parity = None
- Data Bits = 7, Parity = (odd, even, mark, or space)

The remaining fields are listed below:

Modem Connection	Internal or external (internal)
Modem Name	This field is 20 characters long and will permit alpha-numeric characters to provide a unique qualifier for a given modem. ( )
RTS/CTS Enabled	This field will inform the modem that communication with the data source UART will be driven with RTS/CTS flow control. This field is 6 characters long and is case in-sensitive. (&H1)
Asynchronous Data Mode	This field will configure the modem as an asynchronous communications device. This field is 8 characters long and is case in-sensitive. ( )
DTE Auto-Data Speed	This option will adjust the speed of the data source (DTE) UART to the outgoing (modem-to-modem) data rate. So, at maximum this speed would be 9600 baud. This field is 6 characters long and is case in-sensitive.

Note that this field sets the link speed between the switch and the modem. It does not set the speed of the modem. It is not desirable to have the serial data fill the modem buffer faster than the outgoing data rate especially because data compression is disabled. ( )

8 Maintenance Commands

*change system-parameters maintenance*

8-65

Disable Data Compression	This field will turn off the default data compression algorithms that are in use by most consumer modems. This field is 6 characters long and is case in-sensitive. (&K0)
Enable Error Control	<p>This field will turn on the V.42 LAPM and MNP error control protocols, if available on the modem. This field is 6 characters long and is case in-sensitive.</p> <p>This V.42/MNP/Buffer mode first attempts to negotiate V.42 error control with the remote modem. If this fails, then the modem transitions to MNP, and if this fails then no error control is used. ( )</p>
Misc. Init. Param	This field supports any initialization parameters that are not already specified. The AT commands specified in this free-form field will be always the last initialization parameters to be sent to the external modem. This field is 20 characters long and is case in-sensitive. ( )
Auto-Answer Ring Count	<p>This field controls the number of rings required before the modem automatically answers an incoming call, if and only if the switch doesn't answer first. (If the switch is healthy, it answers an incoming within the first few rings.) This field is 6 characters long and is case insensitive. Typically, the maximum permissible value for this register is 255. The values 1-255 denote the number of incoming ring cycles. (S0=10)</p> <p><b>⇒ NOTE:</b> The number of rings is optimally set above 5, and if at all possible, keep the default of S0=10.</p>
Dial Type	This field controls the type of inter-register signaling to be used between the modem and the Central Office. Use "T" for tone dialing and "P" for pulse dialing. The field length is be 3 characters long and is case in-sensitive. This field will be concatenated with the dial string. (T)
Adjustable Make/Break Ratio	<p>This field can be of particular importance when using a modem that may be transferable from country to country. The intent of this field is to control the make/break ratios of pulses and DTMF dialing. The Intel product information has support for the different make/break options for pulse dialing only.</p> <p>Intel uses the option "&amp;P0" to select a ratio of 39% make and 61% break for communication within the U.S. and Canada. The option "&amp;P1" sets a ration of 33% make and 67% break for the U.K. and Hong Kong.</p> <p>This field is 5 characters long and is case in-sensitive. ( )</p>
Dial Command	This field simply denotes the dialing command of the modem. This is a fairly standard command. (D)

No Answer  
Time-Out

Most off-the-shelf external modems provide a timer that abandons any outbound data call after a predetermined interval. Some modems provide for this timer to be disabled, thus allowing an outbound call to ring indefinitely. AT&T Paradyne does not provide this capability with their modem line, because it is generally undesirable to have an outbound call attempt ring indefinitely.

The internal modem must have this parameter disabled or set to at least 255 seconds.

This is a non-administrable parameter. For the external modem connection, this parameter will be the first initialization string to be transmitted to the external modem. This field will be visible on the administration form in display mode only.

This hardcoded constant can be overridden for type approval applications, specifically in the U.K and other Western European nations, by the use of the "Misc. Init. Param." field. (S7=255)

## clear errors

---

### clear errors

The **clear errors** command moves all errors and resolved alarms to the cleared errors list, thereby making room for new incoming error messages which might otherwise be dropped. This command does not clear active alarms from the alarm log. Cleared error entries are the first entries overwritten when additional room is needed to log new entries. To retrieve cleared errors, use **display errors clear**.

#### ⇒ NOTE:

Use this command with care. Cleared data will be lost if the logs fill up.

## clear firmware-counters

---

### clear firmware-counters UUCSS | a-pnc | b-pnc

This command clears the firmware error counters on the specified circuit packs(s). This command is valid only for SNI, SNC, and DS1C board locations. When a- or b-pnc is specified, all such circuit packs in a single PNC can be cleared at once. On a Critical Reliability systems (duplicated PNC), only circuit packs on a standby PNC that is busied out can be cleared.

This command is useful for quickly clearing lingering alarms after a hardware problem has been fixed. (**Test clear** commands do not clear alarms on SNI, SNC, and DS1C circuit packs.)



**WARNING:**

*This command can mask actual hardware problems since firmware is cleared and appears as if no problems were ever encountered.*

## Parameters

---

**UUCSS** The specified location must be occupied by an SNI, SNC or DS1C circuit pack. All circuit packs on the standby PNC can be cleared at once by specifying a- or b-pnc. To do so, the standby PNC must first be busied out.

For more information see Common Output Fields at the beginning of this chapter.

## clear link n

---

This command clears the counters associated with a numbered PPP C-LAN link. The clear clan-port command accomplishes the same thing. The statistical counters cannot be cleared for an Ethernet C-LAN link.

## clear pgate-port

---

### clear pgate-port UUCSSpp

The **clear pgate-port** command clears the hardware error counters associated with the specified packet gateway port by performing a reset. If the number of the link assigned to the port is known, **clear link** accomplishes the same thing.

For more information see Common Input Parameters and Common Output Fields at the beginning of this chapter.

## disable suspend-alm-orig

---

This command disables one or more active Suspend Alarm Origination entries.

## Synopsis

---

disable suspend-alm-orig (board location).

## Examples

---

disable suspend-alm-orig 1C03  
disable suspend-alm-orig 1E07

## Description

---

This command disables one or more active Suspend Alarm Origination entries from the Suspend Alarm Origination table. This command disables all entries (boards and ports) matching the specified physical board location.

**NOTE:**

A port entry cannot be disabled with this command. Allowing for different ways to disable one or more entries greatly increases the complexity of updating and displaying the Suspend Alarm Origination table.

## Defaults

---

None.

## Parameter

---

board location	This parameter specifies the physical board location of the hardware component that has been replaced or corrected. A port location is not supported because of its complexities.
----------------	---

## Help Messages

---

N is the maximum number of cabinets in the switch:

```
Enter board location:[cabinet(1-N)];  
carrier(A-E);slot(0-20)
```

## Output

---

The command returns one of the following messages:

1. If the board specifier is not valid:

```
Board invalid
```

2. If no entries can be disabled in the Suspend Alarm Origination table:

```
Entry not found; no entries disabled
```

## Feature Interactions

---

None.

## display alarms

---

This command will display an options form which allows the technician to choose which alarms are to be displayed.

### Synopsis

---

`display alarms [print | schedule]`

### Permissions

---

The following default logins may execute this command: system technician, inads, cust, rcust, bcms, init, browse.

### Examples

---

**display alarms display alarms print display alarms schedule**

### Description

---

The **display alarms** command brings up a hardware alarm report. This screen allows the technician various different options to select which alarms will be displayed on the alarm report. There are no parameters entered on the command line, parameters are selected on the hardware alarm report form instead.

An alarm can occur for any hardware object when it has been determined by the maintenance subsystem that a problem definitely exists. The impact of the problem is indicated by the alarm type:

Warning alarm—A problem which has been deemed important enough to log, or may be external to the system, but not severe enough to cause a noticeable degradation of service.

Minor alarm—A problem which could disable a local area of the system and so noticeably degrade the system.

Major alarm—A problem which widely degrades the system and seriously impairs service. This would cause a call to be placed to INADS.

A resolved alarm is a problem which has been corrected, and the alarmed component of the system is functioning correctly again. The alarm will be stamped with a resolved date and time, indicating that it is no longer a concern (any errors associated with the alarms will also be considered resolved).



## Defaults

---

All alarms will be displayed.

## Parameters

---

- print** This will cause the report to be printed if a printer is linked to the SAT.
- schedule** When the “schedule” option is specified, the command is validated and then a scheduling form is displayed to allow the technician to schedule execution of the command. The command is then placed in the command queue and is executed at the specified time. The information displayed by the command is sent to the system printer instead of the screen. Refer to the Report Scheduler and System Printer feature specification [4] for more details.

There are no parameters entered on the command line, parameters are selected on the hardware alarm report form instead.

## Help Messages

---

If the technician presses HELP after entering “display alarms” the following message will be displayed:

```
[ 'print' or 'schedule' ]
```

## Error Messages

---

If during the execution of a command a resource problem occurs that requires the user to restart the command, then the following message will be displayed:

```
Command resources busy; Press CANCEL to clear, and then resubmit
```

If all of the available maintenance resources are currently in use, then the following message will be displayed:

```
All maintenance resources busy; try again later
```

## From Input

---

After entering the command **display alarms**, the system technician will be presented with an options form.

- Alarm Types** The type of alarm to be displayed is specified by placing a “y” or “n” in the alarm type fields. The technician can choose a combination of active alarms, major, minor, warning, or resolved alarms.
- Interval** Display alarm records for the last (m)onth, last (h)our, last (d)ay, last (w)eek, or (a)ll. The default is all.

8 Maintenance Commands  
*display alarms*

8-71

From	Display alarm records from the time specified by mm/dd/hh/mm, where mm is the month, dd is the day, hh is the hour and mm is the minute. If no "from" date is entered, then no checking is done. This will give the user all the alarms active since a month prior to the current time.
To	Display alarm record to the time specified by mm/dd/hh/mm, where mm is the month, dd is the day, hh is the hour and mm is the minute. If no "to" date is entered, any alarm which is active after the from date will be selected.
Equipment Type	<p>The technician can choose between seven different equipment types. If there is no input to any of these fields, the system will default to all the equipment. The user can select one of the following fields:</p> <ul style="list-style-type: none"><li>■ Cabinet: This allows the technician to display all alarms associated with a particular cabinet. Alarms for a cabinet are referenced by a number ranging from 1 to 3 which is assigned during cabinet administration.</li><li>■ Port Network: This allows the technician to display all alarms associated with a particular port network. Alarms for a port network are referenced by a number ranging from 1 to 3.</li><li>■ Board Number: This allows the technician to choose all alarms associated with a particular circuit pack for display. Alarms for a (cabinet-carrier-slot). If the cabinet number is omitted, the system will default to 1.</li><li>■ Port: This allows the technician to choose all alarms associated with a particular port on a circuit pack for display. Alarms for a port circuit are referenced by port location (cabinet-carrier-slot-circuit). If the cabinet number is omitted, the system will default to 1.</li><li>■ Category: Alarms for a particular equipment category.</li><li>■ Extension: Alarms associated with an extension number.</li><li>■ Trunk (group/member): The technician can choose to view all alarms associated with a particular trunk group or trunk group member. The group identifier should be entered to view all alarms associated with a trunk group XXX/__. The group identifier and member identifier should both be entered to view all alarms associated with a specific trunk group member XXX/XXX.</li></ul>

display alarms

Page 1 of 1

ALARM REPORTS

The following options control which alarms will be displayed.

ALARM TYPES

Active? y\_ Resolved? n\_  
 Major? y\_ Minor? y\_ Warning? y\_

REPORT PERIOD

Interval: m\_ From: \_\_/\_\_/\_\_:\_\_ To: \_\_/\_\_/\_\_:\_\_

EQUIPMENT TYPE ( Choose only one, if any, of the following )

Cabinet: \_\_\_\_  
 Port Network: \_\_  
 Board Number: \_\_\_\_  
 Port: \_\_\_\_  
 Category: \_\_\_\_  
 Extension: \_\_\_\_  
 Trunk ( group/member ): \_\_/\_\_

**Field Help**

Following are the help messages that the system technician will see upon tabbing to the specified field and pressing the HELP key.

Active?	n(o) y(es)
Resolved?	n(o) y(es)
Major?	n(o) y(es)
Minor?	n(o) y(es)
Warning?	n(o) y(es)
Interval:	The interval field help is a list of objects. This list includes: m(onth), h(our), d(ay), w(eek), a(11). From (month) "Enter month between 1-12
From (day)	Enter day between 0-31
From (hour)	Enter hour between 0-23
From (minute)	Enter minute between 0-59
To (month)	Enter month between 1-12
To (day)	Enter day between 0-31
To (hour)	Enter hour between 0-23
To (minute)	Enter minute between 0-59
Cabinet:	Enter cabinet number (1-3)
Port Network:	Enter port network number (1-3)

*Continued on next page*

Board Number:	Enter 5 character board number; cabinet(01-3):carrier(A-E):slot(00-20)
Port:	Enter port number; [cabinet(1-3)]: carrier(A-E): slot(0-20): circuit(01-31)
Category:	The category field help is a list of objects. This list includes the following: adm-conn, announce, bri/asai, card-mem, cdr, data-mod, detector, dup-spe, environ, exp-intf, ext-dev, generatr, inads-link, infc, maint, mbus, memory, misc, mnt-test, modem, netcon, pkt, pkt-ctrl pms/jrnl, procr, quick-st s-syn, stabd, stackr, stations, sys-prnt, tape, tdm, tone, trkbd, trkcrk, trunk, wideband. For a table describing the category entries in greater detail, see the <b>display errors</b> command.
Extension:	Enter assigned extension
Trunk (group)	Enter group number between 1-99
Trunk (member)	Enter group member between 1-99, or blank

## Field Error Messages

Following are the error messages that display on the screen. The messages display when the system technician tabs out of a field and the validation routines are executed. In the following messages, an "x" represents the character that was entered by the user.

8 Maintenance Commands  
*display alarms*

8-74

Body	
Active?	"x" is an invalid entry; please press HELP
Resolved?	"x" is an invalid entry; please press HELP
Major?	"x" is an invalid entry; please press HELP
Minor?	"x" is an invalid entry; please press HELP
Warning?	"x" is an invalid entry; please press HELP
Interval:	"x" is an invalid entry; please press HELP
From (month)	Entry must be all digits
From (day)	Entry must be all digits
From (hour)	Entry must be all digits
From (minute)	Entry must be all digits
To (month)	Entry must be all digits
To (day)	Entry must be all digits
To (hour)	Entry must be all digits
To (minute)	Entry must be all digits
Cabinet:	Entry invalid
Port Network:	Entry invalid
Board Number:	Board invalid
Port:	Port invalid
Category:	"xxxxxxx" is an invalid entry; please press HELP
Extension:	Entry must be all digits
Trunk (group)	Entry must be all digits
Trunk (member)	Entry must be all digits

## Output

---

After valid options are entered by the technician, an alarm report is displayed. The data displayed on this form will be:

Port	The location of the alarmed object. For installed circuit packs, the location is displayed as <b>cabinet-carrier-[slot]-[circuit]</b> . For Port Network-related objects, the location is displayed as <b>PN UUB</b> , where "UU" is the Port Network number and B is the bus (A or B). For Fiber Link-related objects, the location is displayed as <b>x a-PNC</b> where "x" is the Fiber Link number and "a" is the PNC side (A or B). This is the same identifier as used by the alarm log.
Maintenance Name	The logical name of the MO which has been alarmed.
On Brd	Whether the fault detected is on the associated circuit pack, or an off board element connected to the circuit pack.
Alt Name	The alternate means of identifying the MO. This field contains the extension when the object is a station, and it contains xxx/yyy when the object is a trunk, where xxx is the trunk group number and yyy is the member number. It contains P/xxx when the object is a private CO line, where xxx is the private CO line group number.
Alarm Type	MAJOR, MINOR, or WARNING. This is an indicator to the seriousness of the alarm raised.
Service State	RDY (ready for service), OUT (out of service), or IN (in service). This is the current service state of the station and trunk ports shown. If a blank is displayed in this field it means that no service state is associated with the MO.
Ack?	The columns under the "1" and "2" headings denote if the alarm has been acknowledged by the first and second OSS telephone numbers, respectively. A "y" in this field means that the alarm has been acknowledged. An "n" means that the alarm has not been acknowledged. A "c" means that the alarm resolved and cleared and the alarm notification was acknowledged. A blank means that there will be no attempt to report the alarm.
Date Alarmed	Day, hour, and minute of alarm.
Date Resolved	Day, hour, and minute of resolution. For active alarms this field is zero (0).

**8 Maintenance Commands**  
*display atm pnc*

8-76

For the following example, the ENTER key was pressed immediately after entering the **display alarms print** command.

```
display alarms
```

## ALARM REPORT

Port	Maintenance Name	On Brd?	Alt Name	Alarm Type	Svc State	Ack?		Date Alarmed	Date Resolved
						1	2		
02A	TONE-BD	y		MAJOR		y	n	05/22/20:34	00/00/00:00
01C07	ANL-BD	y		MINOR		n	n	05/22/20:26	00/00/00:00
01C0702	ANL-LINE	n	311	WARNING	IN			05/22/20:26	00/00/00:00
01C0701	ANL-LINE	n	1051	WARNING	IN			05/22/20:26	00/00/00:00
01C0703	ANL-LINE	n	1053	WARNING	IN			05/22/20:26	00/00/00:00
01C1505	CO-TRK	n	78/01	WARNING	OUT			05/22/20:26	00/00/00:00
01C1505	CO-TRK	n	78/01	WARNING	OUT			05/22/20:26	00/00/00:00
02A0201	TONE-PT	n		WARNING				05/22/20:34	00/00/00:00
02A	TDM-CLK	n		WARNING				05/23/13:43	00/00/00:00
PN 02B	TDM-BUS	n		WARNING				05/23/14:53	00/00/00:00

```
Command successfully completed
```

## Feature Interactions

If the alarm origination is disabled by “change system-parameters maintenance,” the Ack? field displays blanks no matter what the true acknowledge state is for the alarm.

If “second-as-backup” is administered in the Alarm Origination to OSS Numbers field, the column under the “2” heading will be blank for the alarms that the switch has not attempted to send to the second OSS telephone number. For the alarms that the switch has attempted to send to the second OSS telephone number, the column will be “y,” “n,” or “c,” depending on the acknowledgment status of the alarm. After calling the first OSS telephone number becomes successful, for the alarms that the switch has attempted to send to OSSN2, the column will be consistent with the column under the “1” heading.

## display atm pnc

This command displays specific atm pnc data.

Action/ Object	Qualifier	Qualifier Description	Permissions	Defaults	Feature Interactions
<b>display atm pnc</b>	<i>number</i>	The administered number of the atm pnc	init inads craft	none	none
	<i>print</i>				
	<i>schedule</i>				

## Output

The following example shows the output for the **display atm pnc 2** command.

```

display atm pnc 2                                     SPE A
                                                    ATM PNC
                                                    Connection Number: 2
Location: 01D01
Name: dup atm pnc
Address Format: ICD ATM
AFI: 47
ICD: 0005
HO-DSP: 80FFE1000000F21C31D4
ESI: 000000010D01
SEL: 00
    
```

## display capacity

This form describes how you have administered your system and provides a "snapshot" status of the switch resources.

Action/Object	Qualifier	Qualifier Description	Permissions	Defaults	Feature Interactions
<b>display capacity</b>	<i>print</i>	Report sent to printer	init inads craft cust rcust	none	none
	<i>schedule</i>	Command validated first, then a scheduling form displays to schedule execution of the command. The command is then placed in the command queue and is executed at the specified time. The information displayed is sent to the system printer instead of the screen. <sup>1</sup>			

1. Refer to the Report Scheduler and System Printer feature specification for more details.

The screen below shows the output from the **display capacity** command.





**NOTE:**

The capacities listed may not coincide with your system. The figures that follow are included to help explain the command and the field values, not to provide capacity information.

display capacity

Page 1 of 9

SYSTEM CAPACITY

Current System Memory Configuration: G3rV6

	Used	Available	System Limit
-----			
AAR/ARS			
AAR/ARS Patterns:	17	623	640
Inserted Digit Strings:	6	2994	3000
ABBREVIATED DIALING (AD)			
AD Entries Per System:	10	99990	100000
AD Personal Lists Per System:	1	4999	5000
ADJUNCT SWITCH APPLICATION INTERFACE (ASAI)			
Active Controlling Associations:	0	6000	6000
Notification Requests:	0	10000	10000
Simultaneous Active Adjunct Controlled Calls:	0	3000	3000

**Field descriptions (page 1)**

**AAR/ARS**

**AAR/ARS Patterns** The number of route patterns. For further information, see *DEFINITY Enterprise Communications Server Administration and Feature Description*.

**Inserted Digit Strings** Number of 12-character inserted-digit strings available for AAR/ARS preferences. For further information, see *DEFINITY Enterprise Communications Server Administration and Feature Description*.

**Abbreviated Dialing (AD)**

**AD Entries Per System** The number of abbreviated dialing entries (for both group and personal lists).

**AD Personal Lists Per System** The number of abbreviated dialing personal lists. For further information, see *DEFINITY Enterprise Communications Server Administration and Feature Description*.

### Adjunct Switch Application Interface (ASAI)

Active Controlling Associations	The number of station domain controls that ASAI adjuncts can request.
Notification Requests	The number of requests ASAI can make to monitor call activity at a split or VDN.
Simultaneous Active Adjunct Controlled Calls	The number of calls that can be controlled by ASAI adjuncts.

Page 2 of 9

SYSTEM CAPACITY

	Used	Available	System Limit
	---	---	---
ATTENDANT SERVICE			
Attendant Positions:	2	26	28
Queue Length:	0	300	300
Authorization Codes:	0	90000	90000
BASIC CALL MANAGEMENT SYSTEM (BCMS)			
Measured Agents Per System:	0	2000	2000
Measured Splits/Skills:	0	600	600
VDNs:	0	512	512

**Figure 8-1. System Capacity form (page 2 of 9)**

### Field descriptions (page 2)

#### Attendant Service

Attendant Positions	The number of administered attendants.
Queue Length	A <i>real-time</i> snapshot of the number of calls waiting for all attendants.
Authorization Codes	The number of authorization codes used for security purposes. For further information, see <i>DEFINITY Enterprise Communications Server Administration and Feature Description</i> .

**Basic Call Management System (BCMS)**

- Measured Agents Per System      The number of agents the Basic Call Management System (BCMS) is measuring.
- Measured Splits/Skills      The number of hunt groups BCMS is measuring.
- VDNs      The number of vector directory numbers BCMS is measuring.

SYSTEM CAPACITY		Page 3 of 9		
	Used	Available	System Limit	
	---	---	---	---
CALL COVERAGE				
Coverage Answer Groups:	0	750	750	
Coverage Paths:	7	9992	9999	
Call Pickup Groups:	0	5000	5000	
Call Records:	-	-	7712	
CALL VECTORING/CALL PROMPTING				
Vector Directory Numbers:	2	19998	20000	
Vectors Per System:	3	509	512	
BSR Application-Location Pairs Per System:	0	1000	1000	

**Figure 8-2. System Capacity form (page 3 of 9)**

**Field descriptions (page 3)**

**Call Coverage**

- Coverage Answer Groups      The number of Coverage Answer Groups. For further information, see *DEFINITY Enterprise Communications Server Administration and Feature Description*.
- Coverage Paths      Coverage Paths — The number of coverage paths which is a path taken when a call goes to coverage. For further information, see *DEFINITY Enterprise Communications Server Administration and Feature Description*.
- Call Pickup Groups      The number of call pickup groups have been administered. For further information, see *DEFINITY Enterprise Communications Server Administration and Feature Description*.

Call Records      The maximum number of active calls at a given time. This field does not display real-time data, just the system limit and is not administerable.

**Call Vectoring/Call Prompting**

Vector Directory Numbers      The number of system VDNs. For further information, see *DEFINITY Call Vectoring/Expert Agent Selection*.

Vectors Per System      The number of vectors per system. For further information, see *DEFINITY Call Vectoring/Expert Agent Selection*.

BSR Application - Location Pairs Per System      The number of mappings administered in a multisite network. The maximum number of application-location pairs per system is 1000. For example, for a network of 10 locations, you can assign 100 applications; with 50 locations, you can assign 20 applications. For further information, see *DEFINITY Call Vectoring/Expert Agent Selection*.

SYSTEM CAPACITY		Page 4 of 9		
		Used	Available	System Limit
		---	---	---
DATA PARAMETERS				
Administered Connections:		5	123	128
Alphanumeric Dialing Entries:		0	1250	1250
DIAL PLAN				
Extensions:		104	35961	36065
Miscellaneous Extensions:		25	20292	20317
UDP Extension Records:		15	49985	50000
Digital Data Endpoints:		50	7450	7500
Expansion Port Networks:		2	41	43
Facility Busy Indicators:		10	9990	10000

**Figure 8-3. System Capacity form (page 4 of 9)**

**Field descriptions (page 4)**

**Data Parameters**

Administered Connections      The number of connections between two access or data endpoints. For further information, see *DEFINITY Enterprise Communications Server Administration and Feature Description*.

Alphanumeric Dialing Entries For further information, see *DEFINITY Enterprise Communications Server Administration and Feature Description*.

**Dial Plan**

Extensions This includes stations, data endpoints, hunt groups, announcements, TEGs, VDNs, common shared extensions, and code calling IDs.

Miscellaneous Extensions Anything that is not a station, trunk, data module, or attendant. This includes, but is not limited to, PCOL groups, common shared extensions, access endpoints, administered TSCs, code calling IDs, VDNs, LDNs, hunt groups, announcements, and TEGs.

UDP Extension Records The number of 4- or 5-digit extension numbers that allow a user to call from one PBX to another using that number.

Digital Data Endpoints The number of digital serial communication devices that permit the asynchronous transfer of data. This also includes the number of analog adjuncts.

Expansion Port Networks The number of port networks connected to the TDM bus and packet bus of a process port network.

Facility Busy Indicators The number of visual indicators of the busy/idle status of any particular trunk group, hunt group member, or station user. For further information, see *DEFINITY Enterprise Communications Server Administration and Feature Description*.

Page 5 of 9

SYSTEM CAPACITY

	Used	Available	System Limit
	---	---	---
HUNT GROUPS, SPLITS, OR SKILLS			
Groups/Splits/Skills:	9	591	600
Logged-In ACD Agents:	0	5200	5200
Group Members Per System:	17	9983	10000
CMS Measured ACD Members:	0	10000	10000
Queue Slots Per System:	2	14998	15000
Queue Status Buttons:	0	2000	2000
Intercom Groups Per System:	0	256	256
Modem Pool Groups Per System:	0	63	63
Personal CO Line (PCOL) Trunk Groups:	0	200	200

Figure 8-4. System Capacity form (page 5 of 9)

## Field descriptions (page 5)

### Hunt Groups, Splits, or Skills

Groups/Splits/ Skills	The number of ACD hunt groups.
Logged-In ACD Agents	A <i>real-time</i> field displaying the number of agents actually logged in. For example, if an agent is logged into 4 skills (and there are no other agents), then the <code>Logged-In ACD Agents</code> field is 1 and the <code>Group Members Per System</code> field is 4.
Group Members Per System	The number of agent/group pairs.
CMS Measured ACD Members	The number of agent pairs being measured by CMS.
Queue Slots Per System	The number of hunt group queue positions.
Queue Status Buttons	The number of hunt group queue status buttons administered on stations. There are four types of queue status buttons; attendants use the last two queue status buttons: <ul style="list-style-type: none"><li>■ q-calls (Queue Calls)</li><li>■ q-time (Queue Time)</li><li>■ atd-qcalls (ATD - Queue Calls)</li><li>■ atd-qtime (ATD - Queue Time)</li></ul>
Intercom Groups Per System	The number of intercom groups set up within your organization.
Modem Pool Groups Per System	The number of modem pool groups. For further information, see <i>DEFINITY Enterprise Communications Server Administration and Feature Description</i> .
Personal CO Line (PCOL) Trunk Groups	The number of PCOL trunk groups. For further information, see <i>DEFINITY Enterprise Communications Server Administration and Feature Description</i> .

SYSTEM CAPACITY		Page 6 of 9		
	Used	Available	System Limit	
				-----
Recorded Announcement Analog Queue Slots:	0	1256	1256	
<b>TEMPORARY SIGNALING CONNECTIONS (TSC)</b>				
Administered TSCs:	0	128	128	
NCA-TSC Calls:	0	256	256	
<b>TRUNKS</b>				
DS1 Circuit Packs:	9	157	166	
ICHT For ISDN Trunks:	0	576	576	
ISDN CBC Service Selection Trunks:	1	199	200	
Trunks Groups:	29	637	666	
Trunks Ports:	86	3914	4000	

**Figure 8-5. System Capacity form (page 6 of 9)**

**Field descriptions (page 6)**

Recorded Announcement Analog Queue Slots      The number of calls in queue for the system's analog announcements.

**Temporary Signaling Connections (TSC)**

Administered TSCs      The number of allowed Temporary Signaling Connections (TSCs).  
 NCA-TSC Calls      The number of allowed Non-Call Associated TSCs.

**Trunks**

DS1 Circuit Packs      The number of allowed DS1 circuit packs.  
 ICHT For ISDN Trunks      The number of Incoming Call Handling Table (ICHT) entries administered for trunk groups.  
 ISDN CBC Service Selection Trunks      The number of call-by-call trunk groups.  
 Trunk Groups      The number of trunk groups administered.





Station and Trunk Ports      The number of stations with ports and assigned trunk ports.

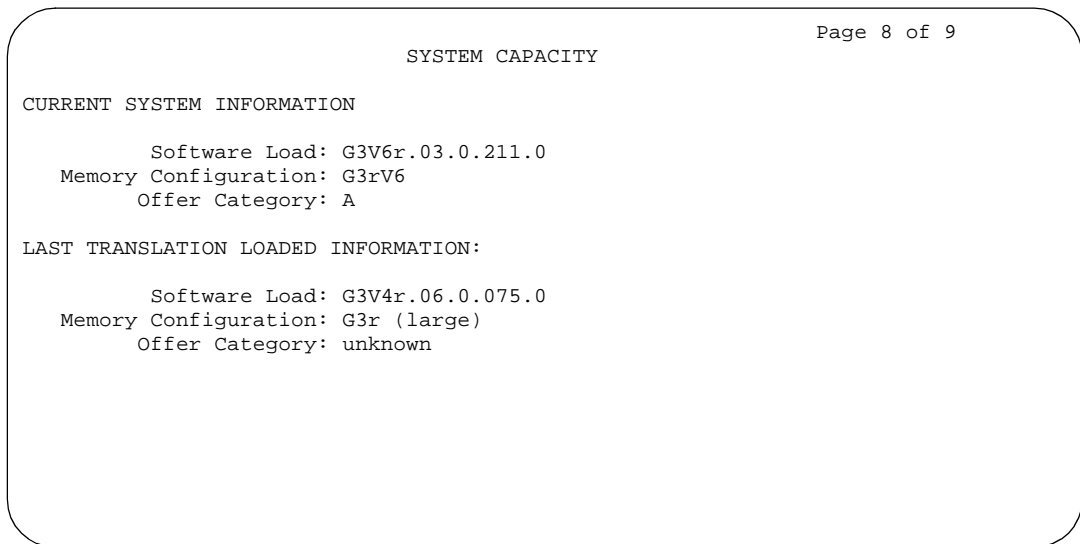

**Figure 8-7. System Capacity form (page 8 of 9)**

**Field descriptions (page 8)**

**Current System Information**

- Software Load      The current software load on which the system is running.
- Memory Configuration      The system platform.
- Offer Category      The system's offer category.

**Last Translation Loaded Information**

- Software Load      The software load translations saved before upgrade or reboot. Can also be unknown/no trans if no flash card is present. Also, if load translations were upgraded from one prior to G3V4 load 71 or early G3V5 loads, unknown/no trans displays.
- Memory Configuration      The platform on which the translations were saved. Can also be unknown if no flash card is present or translations made on old load. This is important because platforms are not always compatible.

8 Maintenance Commands

*display communication-interface links*

8-87

Offer Category The offer category that was set when the last save translation was done before upgrade or reboot. Can also be unknown if no flash card is present or translations made on old load.

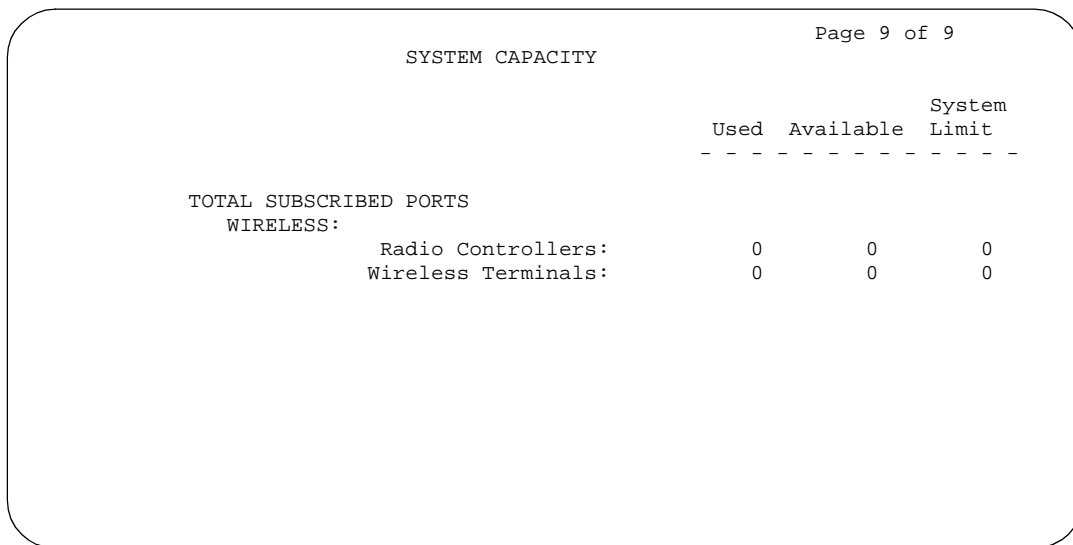

Figure 8-8. System Capacity form (page 9 of 9)

Field descriptions (page 9)

**Total Subscribed Ports**

Radio Controllers The number of subscribed radio controller circuit packs.

Wireless Terminals The number of subscribed wireless terminals.

**display communication-interface links**

Action/ Object	Qualifier	Qualifier Description	Permissions	Defaults	Feature Interactions
list communication-interface	links	Example: list communication-interface links	init inads craft	none	None

## 8 Maintenance Commands

*display communication-interface links*

8-88

**Output**

The following example shows the output from the **list/display communication-interface links** command.

```

display communication-interface links                               Page 1 of 2
                                INTERFACE LINKS
Link Enable Est Ext  Type      Destination DTE Conn  Name
          Conn                Number      DCE Mod.
1: y      n   2991  ETHERNET                ethernet on link 1
2: n      n
3: n      n
4: n      n
5: n      n
6: n      n
7: n      n
8: n      n
9: n      n
10: n     n
11: n     n
12: n     n
13: n     n
14: n     n
15: n     n
16: n     n
17: n     n

```

**Screen 8-1. Interface links screen****Field descriptions**

Link	Number of the administered link (data module form).
Enable	Yes (y) or no (n) depending upon data module administration (Processor Interface, X.25, Ethernet, and PPP).
Est. Conn.	Establish Connection data from the data module forms (Processor Interface, X.25, and PPP).
Ext	Extension number of the local data module for this link.
Type	Protocol for this link: <ul style="list-style-type: none"> <li>■ bx.25 (Processor Interface and X.25)</li> <li>■ ppp</li> <li>■ ethernet</li> </ul>
Destination Number	Destination of the link as administered on the data module forms (Processor Interface, X.25 and PPP).
DTE/DCE	Processor Interface administration from data module form (Processor Interface only).
Conn. Mod.	Connected Data Module administration from data module form (Processor Interface and X.25 only)

Name Administered name from the data module forms (Processor Interface, X.25, Ethernet, and PPP)

## **display errors**

---

### **display errors [high-resolution] [print | schedule]**

The **display errors** command brings up an input form that allows you to select which errors will be displayed on the hardware error report.

Errors can result from in-line firmware errors, periodic tests, failures detected while executing a test command, software inconsistency, or a data audit discrepancy. The Error Log is restricted in size. A new entry overwrites the oldest unalarmed entry. The overwritten entry must be at least six minutes old, or the new entry is dropped.

## **Help Messages**

---

The following help message will be displayed when the first page of a multiple page list of alarms/errors or after the Prev Page key is pressed:

```
Press CANCEL to abort or NEXT PAGE for next page
```

The following help message will be displayed after the Next Page key is pressed and there are more pages of alarms/errors to be displayed:

```
Press CANCEL to abort, NEXT PAGE for next page, PREV PAGE for previous page
```

The following help message will be displayed after the Next Page key is pressed and there are no more alarms/errors to be displayed:

```
Press CANCEL to abort, NEXT PAGE to complete, PREV PAGE for previous page
```

## **Actions**

The following command will display the next page of alarms/errors or echo "Command successfully completed" and exit if there are no more pages of alarms/errors to display:

```
Next Page
```

The following command will display the previous page of alarms/errors and the "press CANCEL to abort or NEXT PAGE for next page" help message:

```
Prev Page
```

The following display command will be cancelled and echo "Command aborted" and exit.

```
Cancel
```

## System Reboots and the Error and Alarm Logs

The system attempts to save the error and alarm logs to the disk on the *active* SPE when any of the following events take place:

- The **save translation** command is executed.
- Translations are saved as part of scheduled maintenance (as administered on the maintenance-related system parameters form).
- A demand or software-escalated system reboot takes place.
- The PPN is about to lose all power after having been on battery backup.

Conditions such as unavailability of the MSS can prevent this attempt from succeeding.

Whenever the system reboots, the error log is restored from the disk on the SPE that becomes active with the reboot. Since the logs are saved to the disk on the SPE that was active before the reboot, the versions restored at reboot time may not be current. This occurs when either:

- The attempt to save at reboot did not succeed.
- The SPE that is active coming out of the reboot is not the same one to which the logs were last saved.

In such a case, the logs will not show the errors and alarms that have been logged since the last time a save was made to the SPE that became active with the reboot. When looking at errors that precede the last reboot, look for indications preceding the reboot to determine whether the logs restored at reboot are complete.

System resets less severe than a reboot rarely affect the error and alarm logs.

### NOTE:

If there are SYSTEM errors in the Error Log, use **display initcauses** to obtain additional information. Information that could not be logged during a system reset may be found here.

## Parameters

- |                 |   |
|-----------------|---|
| high-resolution | This option specifies an error report with high resolution time stamps for the first occurrence and last occurrence of the error. The high resolution time stamp includes seconds and a sequence count within a second. The sequence count starts over for each second. |
|-----------------|---|

For more information see [“Common Input Parameters”](#) at the beginning of this chapter.

## Input Form

---

This form specifies which errors display on the report. When all selections have been made, press ENTER. If no selections are made, or if the schedule option is specified, all errors from the last day that are associated with active alarms display (or print).

Error Type	The report can be restricted to specific error codes. This field defaults to all errors.
Error List	The report can be restricted to errors from one of three lists described below: active-alarms, errors, or cleared-errors. Default is active-alarms.
Interval	Specifies error records for the last month, hour, day, week, or all errors (m, h, d, w, a). The default is all.
From	Specifies error records starting from the time specified by mm/dd/hh/mm (month/day/hour/minute). If no “from” date is entered, errors from the earliest record in the log are displayed.
To	Specifies all error records up to the time specified by mm/dd/hh/mm. If no “to” date is entered, all errors up to the current date are displayed.
Equipment Type	<p>To limit the report to a specific group of components, enter the location of a type of equipment in one of the following fields. If no entry is made, errors for the entire system are displayed.</p> <ul style="list-style-type: none"><li>■ Cabinet: Enter the cabinet number (1-22).</li><li>■ Port Network Number: 1-22</li><li>■ Board Number: Enter the cabinet-carrier-slot address of the circuit pack (for example, 11c04). If the cabinet number is omitted, it defaults to 1.</li><li>■ Port: Enter the cabinet-carrier-slot-circuit address of the port (for example, 11c0408). If the cabinet number is omitted, the system will default to 1.</li><li>■ Category: errors for a particular equipment category. See the list of alarm and error categories at the beginning of this chapter. The HELP key displays a list of categories.</li><li>■ Extension: Enter the extension number of a port.</li><li>■ Trunk (group/member): Enter a trunk group number, or a trunk group and member number separated by a slash (for example, 78 or 78/1).</li></ul>

## Output

```
display errors                               Page 1 of 1
```

### ERROR REPORT

The following options control which errors will be displayed.

#### ERROR TYPES

Error Type: \_\_\_\_ Error List: active-alarms

#### REPORT PERIOD

Interval: \_ From: \_\_/\_\_/\_\_:\_\_ To: \_\_/\_\_/\_\_:\_\_

EQUIPMENT TYPE ( Choose only one, if any, of the following )

Cabinet: \_\_\_\_  
 Port Network: \_\_\_\_  
 Board Number: \_\_\_\_  
 Port: \_\_\_\_  
 Category: \_\_\_\_\_  
 Extension: \_\_\_\_\_  
 Trunk ( group/member ): \_\_/\_\_\_\_

## Error Log Report Standard Resolution

Port	The physical location of the alarmed object. For circuit pack based MOs, the location is cabinet-carrier-[slot]-[circuit]. For PN-based objects, such as TDM-BUS, the location displays as 3PN xx, where xx is the PN number. For Fiber Link-based objects, the location displays as x a,b-PNC where x is the Fiber Link number and a- or b-pnc indicates one of the PNC pair. (Always a-pnc on systems with simplex PNC.)
Maintenance Name	The abbreviated name of the MO that encountered the error.
Alt Name	An alternate means of identifying the MO.
Error Type	Numerical error code that identifies the type of problem. The meanings of these codes are explained under the name of the MO in Chapter 9.
Aux Data	Additional numerical information about the error type. Only the most recent auxiliary data for each error type is displayed.
First Occur	Month, day, hour, and minute (and second if the high-resolution command line option is used) that the error was first recorded.

Seq Cnt	Sequence Count. These numbers give the order in which the errors were logged. Each sequence covers a period of one second. Sequence numbers are assigned to the first and last occurrences of a given error within the one second period given in the time stamp. There may be gaps in the sequence numbers within a given second because the last occurrence of an error may replace an existing entry and because sequence numbers are also assigned to software events not shown in the hardware error log. This information is displayed only if the high-resolution option is specified on the command line.
Last Occur	The month, day, hour, and minute (and second if the high-resolution command line option is used) of the most recent error. If the system is unable to retrieve the time of day when the error occurred, a "dummy" date will be stamped in the log so as to distinguish it from reliable data. It appears as "00/00/01:07"
Err Cnt	The total number of times that the error type has occurred. The maximum entry displayed is 999.
Err Rt	Average hourly rate at which the error has occurred from the first occurrence to the present. The maximum entry displayed is 999.
Rt/Hr	An approximation of the rate at which this error occurred in the last hour. The maximum entry displayed is 999.
Al St	Alarm Status - A character indicating the status of this MO in the error and alarm logs. The allowed values are: <ul style="list-style-type: none"><li>■ a — Active alarm entry</li><li>■ r — Resolved alarm entry</li><li>■ c — Resolved alarm entry as a result of the long "clear" option of the test command.</li><li>■ s — Resolved alarm entry as a result of a software requested (non-demand) system restart.</li><li>■ t — Resolved alarm entry as a result of a technician requested system restart.</li><li>■ n — Not alarmed.</li></ul>
Ac	A flag (yes or no) indicating whether or not the maintenance object is still under active consideration by the maintenance subsystem.

The following display shows a typical result when **disp errors** is entered with the default input settings.



8 Maintenance Commands  
*display errors*

8-94

display errors

Page 1

HARDWARE ERROR REPORT - ACTIVE ALARMS

Port	Mtce Name	Alt Name	Err Type	Aux Data	First Occur	Last Occur	Err Cnt	Err Rt	Rt/ Hr	Al St	Ac
01C0702	ANL-LINE	311	257		01/31/09:20	01/31/20:26	255	999	255	a	y
01C0701	ANL-LINE	1051	257		01/31/20:26	01/31/20:26	4	0	4	a	y
01C0703	ANL-LINE	1053	257		01/31/20:26	01/31/20:26	4	0	4	a	y
01A	TDM-CLK		0	0	01/31/20:34	01/31/20:34	1	0	1	a	n
01C1505	CO-TRK	078/001	3329	57408	01/31/20:26	01/31/20:27	5	300	5	a	y
01C1505	CO-TRK	078/001	1537		01/31/20:26	01/31/20:28	5	150	5	a	y
02A0201	TONE-PT		0		01/31/20:34	01/31/20:34	1	0	1	a	y
PN 02B	TDM-BUS		18	0	01/31/14:53	01/31/21:12	1	0	1	a	n
1 A-PNC	FIBER-LK		18	0	01/31/21:55	01/31/21:55	1	0	1	a	y

Command successfully completed

## Error Log Report High Resolution

The following display shows a typical result when **display errors high-res** is entered with the default input settings.

```

display errors high-resolution                                     Page 1
HIGH RESOLUTION HARDWARE ERROR REPORT - ACTIVE ALARMS

Port      Mtce      Alt      Err      Aux      First      Seq      Last      Seq  Err  Al
Name      Name      Type     Data     Occur     Cnt      Occur    Cnt  Cnt  St
01C0702  ANL-LINE  311      257      01/31/09:20:21 1 01/31/20:26:05 1 255 a
01C0701  ANL-LINE  1051     257      01/31/20:26:18 1 01/31/20:26:18 7 4 a
01C0703  ANL-LINE  1053     257      01/31/20:26:18 2 01/31/20:26:18 8 4 a
01A      TDM-CLK  0        0        01/31/20:34:35 1 01/31/20:34:35 1 1 a
01C1505  CO-TRK   078/001 3329    57408    01/31/20:26:07 1 01/31/20:27:28 1 5 a
01C1505  CO-TRK   078/001 1537    01/31/20:26:52 1 01/31/20:28:41 1 5 a
02A0201  TONE-PT  0        0        01/31/20:34:28 1 01/31/20:34:28 1 1 a
PN 02B   TDM-BUS  18      0        01/31/14:53:03 1 01/31/21:12:22 1 1 a
1 A-PNC  FIBER-LK 18      0        01/31/21:55:24 1 01/31/21:55:24 1 1 a

Command successfully completed

```

## display events

### display events [print]

A vector event is the occurrence of something unexpected during a vector-routed call due to resource exhaustion or faulty vector programming. (For example, route-step failures are typically due to the programming of an invalid extension.) These types of failures are not due to faulty hardware or system software error and do not constitute incorrect feature operation. This command allows you to diagnose and correct vectoring problems due to the above-mentioned causes. See *DEFINITY Communications System Generic 3 Call Vectoring and Expert Agent Selection (EAS) Guide*, 555-230-520, for information on how to interpret this report.

## Input Form

The following entry form is displayed to allow limiting the report to events of a certain type or from a certain time period. Enter the desired parameters and press ENTER.

Category      "Vector" specifies the type of event report to display and is the only valid entry.

8 Maintenance Commands  
*display events*

8-96

Report Period	The fields in this section allow you to view only those vector events that occurred within a specific time period. If these are left blank, all vector events recorded are displayed.
Interval:	This field specifies a display of all events within the last time period of the type. Enter the first letter of one of the following selections: <i>all</i> , <i>month</i> , <i>day</i> , <i>hour</i> , <i>minute</i> .
Start/Stop Time	The starting and ending times, in 24-hour notation, of the interval to be reported.
Vector Number	The number of the vector (1-256) for which events will be reported. If this field is left blank, events for all vectors will be reported.
Event Type	Specific types of vector events are associated with numbers from 50000 to 50999. Entering one of these numbers will limit the report to events of this type. If this field is left blank, events for all types of vectors will be reported.

## Output

---

See *DEFINITY Communications System Generic 3 Call Vectoring and Expert Agent Selection (EAS) Guide*, 555-230-520, for more information on how to interpret this report. In particular, the Event Data 2 field will be associated with possible causes and repair strategies for the event.

Event Type	A number from 50000 to 50999 that identifies what type of vector event occurred.
Event Description	A text string describing the event.
Event Data 1	If in the format <i>number/number</i> such as "200/10", this indicates the vector number and step number associated with the event. If in the format "Split <i>number</i> " such as "Split 2", this indicates the split number.
Event Data 2	Additional data concerning the event encoded as a hex number.
First Occur	The date and time when the vector event first occurred.
Last Occur	The date and time when the vector event last occurred.
Evnt Cnt	The total number of times, up to 255, that vector events of this type have occurred.

The following example shows the input form for **display events**:

```

display events                               Page 1 of 1   SPE B

                                EVENT REPORT

The following options control which events will be displayed.

EVENT CATEGORY

    Category: vector

REPORT PERIOD

    Interval: _a_   From: __/__/__:__ To: __/__/__:__

SEARCH OPTIONS

                                Vector Number: ___
                                Event Type:  ___
    
```

The following example shows a typical vector event report.

```

display events                               Page 1   SPE B

                                EVENTS REPORT

Event Event          Event   Event   First   Last   Evnt
Type  Description     Data 1  Data 2  Occur   Occur  Cnt

50020 Call not queued   256/5   B   09/28/13:43 09/28/13:43 1
50541 Not a messaging split Split 89 4C 09/28/13:43 09/28/13:43 1
    
```

## **display fiber-link**

**display fiber-link fiber# [print | schedule]**

The **display fiber-link** command displays the translation data associated with an existing fiber link.

The output for this command is the same as that for **change fiber-link**.

## Parameters

---

fiber# The administered number (1 to 27) associated with a fiber link (or fiber link pair in a duplicated PNC).

## display initcauses

---

### display initcauses [print | schedule]

The **display initcauses** command displays a history of recovery steps taken by the system. *This command displays information for restarts of the active processor only.* Whenever the processor resets and the system is restarted, whether initiated by a technician command or by system software, information about the recovery is stored. If the reset is escalated, only the reset that successfully completes is recorded. Information about the reset may also be found in the Error Log. When a reset 4 (reboot) occurs, the Error Log is saved on the Mass Storage System.

Records of the last 16 restarts are retained in the initcauses log in chronological order. A power failure results in loss of all records in the initcauses log.

## Output

---

The entire initcauses log, consisting of 16 resets, fills one screen.

Cause This gives the reason for the system reset, as follows:

**Agent Request:** The restart was requested through the Agent/GEMINI debugger interface (not available to craft login).

**Craft Request:** The reset was initiated using **reset system**. This includes restarts requested through the SPE-Down interface.

**Initialized:** This represents a power-up, and is always the first entry in the log unless more than 15 restarts have occurred since the last power up.

**Interchange:** A spontaneous interchange was executed by the system usually in response to a major hardware fault on the active SPE.

**Maintenance Reset:** The SPE was reset by maintenance software on the SYSAM circuit pack. This includes periodic resets initiated by the SYSAM during SPE-Down mode.

Cause	<p><b>mon:</b> A restart was initiated from the system monitor (not available to craft login).</p> <p><b>Sanity Timer Reset:</b> The sanity timer on the processor timed out and reset the system. This usually indicates corrupted software.</p> <p><b>Scheduled Interchange:</b> An interchange was performed as part of scheduled daily maintenance.</p> <p><b>Software Request:</b> System software detected problems and executed a restart to recover.</p> <p><b>SPE-Select Lead Change:</b> On systems with duplicated SPEs, the SPE select lead changed and reset the processor.</p> <p><b>SPE-Select Switch:</b> The SPE select switches on the DUPINT circuit packs were manually set to lock the standby SPE active, causing a spontaneous interchange. This is <b>not</b> a recommended procedure.</p> <p><b>Unknown:</b> The restart could not be classified. The Error Log may contain more information about the restart.</p> <p><b>Upgrade Software:</b> The indicated SPE was reset as part of the execution of the upgrade software command. If this precedes a Software Requested level 2 reset, both are probably associated and indicate a non-call preserving upgrade took place.</p>
Action	<p>The level of recovery performed by the system.</p> <ol style="list-style-type: none"> <li>1 Reset system 1 (Warm)</li> <li>2 Reset system 2 (Cold-2)</li> <li>3 Reset system 3 (Cold-1)</li> <li>4 Reset system 4 (Reboot)</li> <li>5 Reset system 5 (Extended Reboot)</li> </ol> <p>Planned SPE Interchange (requested by <b>reset system</b> command or scheduled maintenance)</p>
Escalated	<p>Whether the restart was escalated to a higher level than originally attempted. The system's software escalation strategy can perform a higher level restart than the one initiated if problems prevent or conditions interfere with normal execution.</p>
Carrier	<p>The carrier (always A in a simplex system) on which the restart took place. If an interchange took place, this indicates the carrier of the newly active SPE that was switched into.</p>
Time	<p>The month, day and time of the restart.</p>

The following display shows a typical result when **dis init** is entered.

## 8 Maintenance Commands

*display system-parameters duplication*

8-100

display initcauses

## INITIALIZATION CAUSES

Cause	Action	Escalated	Carrier	Time
Initialized	4	no	1A	06/01 7:14
Scheduled Interchange	i	no	1B	06/02 2:00
Scheduled Interchange	i	no	1A	06/03 2:00
Scheduled Interchange	i	no	1B	06/04 2:00
Scheduled Interchange	i	no	1A	06/05 2:00
Scheduled Interchange	i	no	1B	06/06 2:00
Scheduled Interchange	i	no	1A	06/07 2:00
Scheduled Interchange	i	no	1B	06/08 2:00
Scheduled Interchange	i	no	1A	06/09 2:00
Scheduled Interchange	i	no	1B	06/10 2:00
Scheduled Interchange	i	no	1A	06/11 2:00
Interchange	l	no	1B	06/11 12:14
Craft Request	i	no	1A	06/11 15:40
Craft Request	i	no	1B	06/11 16:33
Scheduled Interchange	i	no	1A	06/12 2:00
Scheduled Interchange	i	no	1B	06/13 2:00

Command successfully completed

## display system-parameters duplication

This command displays the status (enabled or disabled) of Switch Processing Element (SPE) and Port Network Connectivity (PNC) duplication. The following must be duplicated:

- Each switch node record and every switch node with its duplicate (cabinet administration is a prerequisite)
- Every fiber link containing either an expansion interface circuit pack as an endpoint, or a DS1-C (fiber link administration is a prerequisite; circuit pack administration then follows duplication administration)

All nonduplicated switch node interfaces (SNI) to SNI fiber links are automatically duplicated.

### ⇒ NOTE:

You must enable (y) the PNC Duplication field on the customer options form (**change system-parameters customer-options**) before you can do any duplication administration.

PNC Duplication cannot be enabled until all pnc-a and pnc-b boards are released from the "busyout" state.

Action/Object	Qualifier	Qualifier Description	Permissions	Defaults	Feature Interactions
<b>display system-parameters</b>	<b>duplication</b>	SPE or PNC duplication Examples: <b>display system-parameters duplication</b>	init inads craft	none	none

## Output

The following example shows the output from the **display system-parameters duplication** command.

```

Page 1 of 1
DUPLICATION-RELATED SYSTEM PARAMETERS
Enable Operation of SPE Duplication? y
Enable Operation of PNC Duplication? y
    
```

Screen 8-2. Duplication-Related System Parameters form (page 1 of 1)

## Field descriptions

Enable Operation of SPE Duplication?

Status of SPE duplication: **y** is enabled; **n** (default) is disabled

Enable Operation of PNC Duplication?

Status of PNC duplication: **y** is enabled; **n** (default) id disabled.  
 This field appears only if PNC Duplication has been enabled on the System-Parameters Customer-Options form.

## display node-names

This command displays a list of the administered node names.

Action/ Object	Qualifier	Qualifier Description	Permissions	Defaults	Feature Interactions
<b>display node-names</b>	<b>print schedule</b>	Example: <b>display node-names</b>	init inads craft	none	none

## Output

The following example shows the output from the **display node-names** command.



**Page 1**

page 1 of 6

NODE NAMES

Audix Name	IP address	MSA Names	IP Address
1. _____	____.____.____.____	1. _____	____.____.____.____
2. _____	____.____.____.____	2. _____	____.____.____.____
3. _____	____.____.____.____	3. _____	____.____.____.____
4. _____	____.____.____.____	4. _____	____.____.____.____
5. _____	____.____.____.____	5. _____	____.____.____.____
6. _____	____.____.____.____	6. _____	____.____.____.____
7. _____	____.____.____.____	7. _____	____.____.____.____
8. _____	____.____.____.____		

**Field descriptions (page 1)**

- Audix Name      Identifies the name of the adjunct or switch node. Enter 1-7 characters for audix or msa; 1-20 characters for others. Default is blank.
- IP Address      IP address for the adjunct or switch. Enter **0 - 255** or leave blank (default).
- MSA Names      MSA node name (up to 7 characters)
- IP Address      IP address for the adjunct or switch. Enter **0 - 255** or leave blank (default).

**Page 2**

Page 2 of 6

NODE NAMES

Name	IP Address	Name	IP Address
1. Default	0. 0. 0. 0.	17. _____	____.____.____.____
2. _____	____.____.____.____	18. _____	____.____.____.____
3. _____	____.____.____.____	19. _____	____.____.____.____
4. _____	____.____.____.____	20. _____	____.____.____.____
5. _____	____.____.____.____	21. _____	____.____.____.____
6. _____	____.____.____.____	22. _____	____.____.____.____
7. _____	____.____.____.____	23. _____	____.____.____.____
8. _____	____.____.____.____	24. _____	____.____.____.____
9. _____	____.____.____.____	25. _____	____.____.____.____
10. _____	____.____.____.____	26. _____	____.____.____.____
11. _____	____.____.____.____	27. _____	____.____.____.____
12. _____	____.____.____.____	28. _____	____.____.____.____
13. _____	____.____.____.____	29. _____	____.____.____.____
14. _____	____.____.____.____	30. _____	____.____.____.____
15. _____	____.____.____.____	31. _____	____.____.____.____
16. _____	____.____.____.____	32. _____	____.____.____.____

## Field descriptions (page 2)

Name	Non-specific node name (up to 15 characters each) for CMS nodes, DCS nodes, and so forth. Valid entries are alpha-numeric and/or special characters for identification.
IP Address	IP address for the adjunct or switch. Enter <b>0 - 255</b> or leave blank (default).

## **display system-parameters maintenance**

---

This command displays existing maintenance-related system parameters.

### **Synopsis**

---

**display system-parameters maintenance [high-resolution] [print | schedule]**

### **Permissions**

---

Logins with the following service levels may execute this command: craft, inads, init, super-user, or logins with Maintain Switch Circuit Packs permissions enabled.

### **Examples**

---

**display system-parameters maintenance**  
**display system-parameters maintenance print**  
**display system-parameters maintenance schedule**

### **Description**

---

The **display system-parameters maintenance** command displays the translation data for maintenance related system parameters.

## Parameters

---

Print	This option causes the report to be printed if a printer is linked to the SAT.
Schedule	When the schedule option is specified, the command is validated and a schedule form is displayed to allow the technician to schedule execution of the command at a specified time. The information displayed by the command will be sent to the system printer instead of the screen.

For more information see [“Common Input Parameters”](#) at the beginning of this chapter.

## Help Messages

---

The following help message will be displayed when the system technician presses the help key after entering the **display system-parameters maintenance** command:

```
[ 'Print' or 'schedule' ]
```

## Output

---

An input form is displayed with the following fields. Defaults for data entry fields are listed in parentheses.

8 Maintenance Commands

*display system-parameters maintenance*

8-105

The following display shows a typical result when **display system-parameters maintenance** is entered.

```

display system-parameters maintenance                               Page 1 of 3
                MAINTENANCE-RELATED SYSTEM PARAMETERS

OPERATIONS SUPPORT PARAMETERS
    Product Identification: 1000000000
    First OSS Telephone Number: 5551212           Abbrev Alarm Report? y
    Second OSS Telephone Number: 5551213         Abbrev Alarm Report? n
    Alarm Origination to OSS Numbers: both
    Cleared Alarm Notification? y
    Restart Notification? y
    Test Remote Access Port? n
    CPE Alarm Activation Level: none
    Packet Bus Activated? n
    Customer Access to INADS Port? n
    Repeat Dial Interval (mins): 7

SCHEDULED MAINTENANCE
    Start Time: 22: 00                               Stop Time: 04: 00
    Daily Maintenance: daily                         Save Translation: daily
    Control Channel Interchange: no                   System Clocks Interchange: no
    SPE Interchange: no                               EXP-LINK Interchange: no
    
```

```

display system-parameters maintenance                               Page 2 of 3
    
```

MAINTENANCE-RELATED SYSTEM PARAMETERS

MAINTENANCE THRESHOLDS ( Before Notification )

Minimum Threshold for TTRs: 4 Minimum Threshold for CPTRs: 1  
 Minimum Threshold for Call Classifier Ports: \_

TERMINATING TRUNK TRANSMISSION TEST (Extension)

Test Type 100: Test Type 102: Test Type 105:

ISDN MAINTENANCE

ISDN-PRI TEST CALL Extension: \_\_\_\_\_ ISDN BRI Service SPID: \_\_\_\_\_

DS1 MAINTENANCE

DSO Loop-Around Test Call Extension: 1001

LOSS PLAN (Leave Blank if no Extra Loss is Required)

Minimum Number of Parties in a Conference Before Adding Extra Loss: \_\_\_\_\_

SPE OPTIONAL BOARDS

Disk? y Packet Intf1? y Packet Intf2? n Packet Intf3? n

8 Maintenance Commands

*display system-parameters maintenance*

8-106

display system-parameters maintenance

Page 3 of 3

MAINTENANCE-RELATED SYSTEM PARAMETERS

Modem Connection: external

Data Bits: 8

Parity: none

Modem Name:

RTS/CTS Enabled: &H1

Auto Answer Ring Count (rings): S0=10

Asynchronous Data Mode:

Dial Type: T

DTE Auto-Data Speed:

Adjustable Make/Break Ratio:

Disable Data Compression: &K0

Dial Command: D

Enable Error Control:

No Answer Time-out: S7=255

Misc. Init. Param:

Help/Error Message Line

Product  
Identification

This is a 10-digit number starting with 1 that identifies the switch to an Operations Support System (OSS), for example, INADS.

First OSS  
Telephone  
Number

The first telephone number that the switch uses to report alarms to, for example, INADS or Trouble Tracker. The number must be obtained from the National Customer Support Center (NCSC) or the TSC. # and \* are not allowed in the telephone number.

Abbrev Alarm  
Report

Enables the Abbreviated Alarm Report feature for the first OSS. (yes)

Second OSS  
Telephone  
Number

The second telephone number that the switch uses to report alarms to, for example, INADS or DEFINITY SNMP. The number must be obtained from the National Customer Support Center (NCSC) or the TSC. # and \* are not allowed in the telephone number.

Abbrev Alarm  
Report

Enables the Abbreviated Alarm Report feature for the second OSS. (no)

8 Maintenance Commands

*display system-parameters maintenance*

8-107

Alarm Origination to OSS Numbers

Indicates one of four options for alarm origination (neither):

- If “both,” all Major and Minor alarms result in an automatic call to both OSS telephone numbers. Both OSS telephone numbers must be administered.
- If “first-only,” all Major and Minor alarms result in an automatic call to the first OSS number only. The switch does not call the second OSS telephone number even if the number is administered. The first OSS telephone number must be administered
- If “neither,” alarm origination does not take place. Warning alarms are not reported to either numbers.
- If “second-as-backup,” all Major and Minor alarms result in an automatic call to the first OSS telephone number. If calling the first OSS telephone number fails four attempts, the switch starts to call the second OSS telephone number as a backup until calling the first OSS telephone number becomes successful. Both OSS telephone numbers must be administered.

Before Release 5, the name of this field is “Alarm Origination Activated.” If Alarm Origination is deactivated, both Cleared Alarm Notification and Restart Notification are disabled, even though they may still be activated in the administration.

Cleared Alarm Notification

Enables the switch to originate a call to the OSS and send an alarm resolution message whenever all previously reported Major and Minor alarms are resolved. Alarm Origination must be activated in order for Cleared Alarm Notification to work. (no)

Restart Notification

Enables the switch to originate a call to the OSS and report any system restarts caused by problems with the switch.

Suspension Threshold

The threshold for suspending Cleared Alarm Notification. Some problems may cause alarms to be generated and then resolved repeatedly. To detect these problems (by not sending additional Cleared Alarm notifications to indicate a problem-free system), the switch suspends Cleared Alarm Notification when it has reported this administrable number of Cleared Alarm notifications in a 24 hour period. A suspended Cleared Alarm Notification is only enabled again with a successfully completed “logoff” command, a system reset, or when the threshold is changed. This field is irrelevant if Cleared Alarm Notification or Alarm Origination is disabled. The possible range of threshold values is between 1 and 15.

Test Remote Access Port

Specifies whether testing of the remote access port on the SYSAM circuit pack is enabled. This field should be set to “yes” whenever there is an INADS line connected to the switch and there is a maintenance contract in effect so that alarm origination capability is maintained.

## 8 Maintenance Commands

*display system-parameters maintenance*

8-108

CPE Alarm Activation Level Indicates the minimum level (Major, Minor or Warning) at which the Customer-Provided Equipment (CPE) alarm is activated. If the level is "none," the CPE does is not activated for any alarm. (none)

**NOTE:**

The CPE alarm is always activated when the switch goes into Emergency Transfer, regardless of the CPE Alarm Activation Level setting.

## Scheduled Maintenance

---

A series of maintenance tests and operations runs automatically every day according to the schedule and settings specified in the following fields.

Start Time	The hour and minute in 24-hour notation at which daily scheduled maintenance will begin running. (22:00)
Stop Time	The hour and minute when scheduled daily maintenance will stop running. If any daily maintenance operations are not completed by this time, the system will note where in the sequence it stopped and perform those operations during the next scheduled daily maintenance.
Daily Maintenance	This display-only field simply represents the series of tests that are always run by maintenance software as part of daily maintenance.
Save Translation	This field indicates on which days translation data in memory will automatically be saved to the Mass Storage System disk and/or tape devices during scheduled maintenance. The save operation is first made to disk, followed by a disk backup to tape. On systems with duplicated SPEs, translation data is saved on both SPEs. Valid entries are <b>daily</b> , days of the week, or <b>no</b> . "No" specifies that no automatic saves are to be executed. (daily)
Control Channel Interchange	Each port network has a pair of TDM busses called A and B, each of which has a set of time slots dedicated to use by the control channel. At any one time, the control channel in each PN is carried on only one of the two busses. This field indicates on which days the control channel in each port network will be switched from one of the paired TDM busses to the other. Valid entries are <b>daily</b> , days of the week, or <b>no</b> . "No" specifies that no interchange be executed. (no)

8 Maintenance Commands

*display system-parameters maintenance*

8-109

System Clocks Interchange	On High and Critical Reliability systems, this option causes a Tone-Clock interchange in each port network with duplicated Tone-Clock circuit packs. Each port network interchanges into the standby Tone-Clock for 20 seconds and then back to the Tone-Clock that was originally active. This field indicates on which days the interchanges are to take place. Valid entries are <b>daily</b> , days of the week, or <b>no</b> ."No" specifies that interchanges be executed. (no)
SPE Interchange	On systems with duplicated SPEs, this field indicates on which days an SPE interchange will be executed during scheduled maintenance. Valid entries are <b>daily</b> , days of the week, or <b>no</b> ."No" specifies no scheduled interchanges. (no)
Minimum Threshold for TTRs	When the number of touch tone receivers (TTRs) in service falls below this number (4 to 200), a WARNING alarm is raised against TTR-LEV. These are also known as dual-tone multifrequency receivers (DTMRs). There are 4 TTRs on each TN748, TN718, TN420, or TN756; TN2182 and TN744 (suffix C or later) each have 8 TTRs. To alarm the first occurrence of a TTR being taken out of service, set this field to the total number of TTRs in the switch.
Minimum Threshold for CPTRs	When the number of call progress tone receivers in service falls below this number (2 to 100), a WARNING alarm is raised against TTR-LEV. These are also known as general purpose tone detectors (GPTDs). There are 2 CPTRs on each TN748, TN718, TN420, or TN756; TN2182 and TN744 (suffix C or later) each have 8 CPTRs. To alarm the first occurrence of a CPTR being taken out of service, set this field to the total number of CPTRs in the switch.
Minimum Threshold for Call Classifier Ports	When the number of call classifier ports (CLSFY-PTs) in service falls below this number, a WARNING alarm is raised against TTR-LEV. Valid entries are 1 to 200. There are 8 ports on each TN744 or TN2182 circuit pack. To alarm the first occurrence of a CLSFY-PT being taken out of service, set this field to the total number of CLSFY-PTs. If there are no TN744 or TN2182 circuit packs in the system, leave this field blank.
Test Type 100, Test Type 102, Test Type 105	An extension assigned to receive tie-trunk calls from other switches with test line origination capability. The system responds by sending a sequence of test tones. Test Type 100 tests far-end to near-end loss and C-message by sending: <ul style="list-style-type: none"> <li>■ 5.5 seconds of 1004 Hz tone at 0dB</li> <li>■ Quiet until disconnect; disconnect is forced after 1 minute</li> </ul>
ISDN-PRI Test Call Extension	The extension used by a far-end ISDN node to place a call to the system to test the ISDN-PRI trunks between the far-end and the system.



8 Maintenance Commands

*display system-parameters maintenance*

8-110

ISDN-BRI  
 Service SPID

This field shows whether or not the link is associated with the Service SPID. If the link is associated with the Service SPID, this field contains a "yes" and the extension field is blank; otherwise, this field is blank. Service SPID is a feature used by the system technician to check building wiring between the switch and the BRI endpoint.

DSO Loop-Around  
 Test Call  
 Extension

This field contains the extension number for the test call extension number. This test extension number will be used to establish a loop-around connection on the selected trunk.

The DSO Loop-Around Test Call feature is used primarily for testing DSO channels associated with non-ISDN-PRI trunks. The loop-around is activated by dialing the test extension number. Multiple DSO Loop-Around connections can be set up by placing multiple calls to the loop-around extension.

DSO Loop-Around  
 Test Call  
 Extension

The DSO Loop Around feature provides a loop around connection for incoming non-ISDN DS1 trunk data calls. This feature is similar to the far-end loop around connection provided for the ISDN Test Call feature. This DSO loop around is provided primarily to allow a network service provider to perform facility testing at the DSO level before video teleconferencing terminals are installed at the PBX.

The feature is activated on a call-by-call basis by dialing a test call extension specified on the second page of the System Parameters Maintenance form. No special hardware is required. When the test call extension is received by the PBX, a non-inverting, 64 kbps connection is set up on the PBX's Time Division Multiplexed bus. More than one loop around call can be active at the same time.

*More information follows.*

DSO Loop-Around  
 Test Call  
 Extension

(cont'd.)

For calls routed over the public network using the ACCUNET Switched Digital Service (SDS) or Software Defined Data Network (SDDN), the data transmission rate is 56 kbps, since robbed bit signaling is used. For calls established over a private network using common channel signaling, the full 64 kbps data rate is available.

When the incoming trunk group is used only for data calls (SDS), the Communications Type on the associated Trunk Group form should be set to "data." When the incoming trunk group is used for robbed bit alternate voice and/or data (SDN/SDDN), the Communications Type on the Trunk Group form should be set to "rbavd" (robbed bit alternate voice data). For private network trunks using common channel signaling, the Communications Type on the associated Trunk Group form can be set to "avd."

Loss Plan

Use only when extra loss is required to maintain quality of transmission on conference calls. Leave this field blank if no extra loss is required. If extra loss is required, enter digits as shown below.

No. Of Parties To Be Conferenced	Enter Digit
3	2
4	3
5	4
6	5
7	6

SPE Optional Boards:

These fields indicate whether a Disk circuit pack is present in the system, and which Packet Interface slots are administered. If a Packet Interface circuit pack is physically present, the corresponding Packet Interface field is set to y when the system boots, and no change to that field is allowed. If the system is equipped with duplicated SPEs, a Packet Interface field is set to y when either SPE carrier contains a Packet Interface circuit pack in the corresponding position. If a Packet Interface circuit pack is not present, then the value for the Packet Interface field is read from translation data stored on disk or tape. If the field is set to n, a Packet Interface circuit pack may be administered by changing the corresponding Packet Interface field to y.

## Modem Connection

On page 3 of the example forms shown below, there are 11 fields that are hidden when the `Modem Connection?` field is set to **internal**. In this example the `Modem Connection` field is set to **external**, and these additional 11 fields are visible.

The first 2 fields on page 3 help setup the data format for the serial data from the switch to the modem. There are only two valid combinations for these 2 fields:

- Data Bits = 8, Parity = None
- Data Bits = 7, Parity = (odd, even, mark, or space)

The remaining fields are listed below:

Modem Connection Internal or external (internal)

Modem Name This field is 20 characters long and will permit alpha-numeric characters to provide a unique qualifier for a given modem. ( )

8 Maintenance Commands

*display system-parameters maintenance*

8-112

RTS/CTS Enabled	This field will inform the modem that communication with the data source UART will be driven with RTS/CTS flow control. This field is 6 characters long and is case in-sensitive. (&H1)
Asynchronous Data Mode	This field will configure the modem as an asynchronous communications device. This field is 8 characters long and is case in-sensitive. ( )
DTE Auto-Data Speed	This option will adjust the speed of the data source (DTE) UART to the outgoing (modem-to-modem) data rate. So, at maximum this speed would be 9600 baud. This field is 6 characters long and is case in-sensitive.  Note that this field sets the link speed between the switch and the modem. It does not set the speed of the modem. It is not desirable to have the serial data fill the modem buffer faster than the outgoing data rate especially because data compression is disabled. ( )
Disable Data Compression	This field will turn off the default data compression algorithms that are in use by most consumer modems. This field is 6 characters long and is case in-sensitive. (&K0)
Enable Error Control	This field will turn on the V.42 LAPM and MNP error control protocols, if available on the modem. This field is 6 characters long and is case in-sensitive.  This V.42/MNP/Buffer mode first attempts to negotiate V.42 error control with the remote modem. If this fails, then the modem transitions to MNP, and if this fails then no error control is used. ( )
Misc. Init. Param	This field supports any initialization parameters that are not already specified. The AT commands specified in this free-form field will be always the last initialization parameters to be sent to the external modem. This field is 20 characters long and is case in-sensitive. ( )
Auto-Answer Ring Count	This field controls the number of rings required before the modem automatically answers an incoming call, if and only if the switch doesn't answer first. (If the switch is healthy, it answers an incoming within the first few rings.) This field is 6 characters long and is case insensitive. Typically, the maximum permissible value for this register is 255. The values 1-255 denote the number of incoming ring cycles. (S0=10)

**⇒ NOTE:**

The number of rings is optimally set above 5, and if at all possible, keep the default of S0=10.

Dial Type	This field controls the type of inter-register signaling to be used between the modem and the Central Office. Use "T" for tone dialing and "P" for pulse dialing. The field length is be 3 characters long and is case in-sensitive. This field will be concatenated with the dial string. (T)
-----------	--

8 Maintenance Commands  
*display test-schedule*

8-113

Adjustable Make/Break Ratio	<p>This field can be of particular importance when using a modem that may be transferable from country to country. The intent of this field is to control the make/break ratios of pulses and DTMF dialing. The Intel product information has support for the different make/break options for pulse dialing only.</p> <p>Intel uses the option "&amp;P0" to select a ratio of 39% make and 61% break for communication within the U.S. and Canada. The option "&amp;P1" sets a ration of 33% make and 67% break for the U.K. and Hong Kong.</p> <p>This field is 5 characters long and is case in-sensitive. ( )</p>
Dial Command	<p>This field simply denotes the dialing command of the modem. This is a fairly standard command. (D)</p>
No Answer Time-Out	<p>Most off-the-shelf external modems provide a timer that abandons any outbound data call after a predetermined interval. Some modems provide for this timer to be disabled, thus allowing an outbound call to ring indefinitely. AT&amp;T Paradyne does not provide this capability with their modem line, because it is generally undesirable to have an outbound call attempt ring indefinitely.</p> <p>The internal modem must have this parameter disabled or set to at least 255 seconds.</p> <p>This is a non-administrable parameter. For the external modem connection, this parameter will be the first initialization string to be transmitted to the external modem. This field will be visible on the administration form in display mode only.</p> <p>This hardcoded constant can be overridden for type approval applications, specifically in the U.K and other Western European nations, by the use of the "Misc. Init. Param:" field. (S7=255)</p>

## display test-schedule

Automatic Transmission Measurement System (ATMS) provides advanced maintenance procedures for monitoring system trunk facilities. This system performs transmission tests on system trunks to determine if trunks are performing satisfactorily. These tests can be initiated in two ways:

demand	user enters command at the System Administration Terminal (SAT) to initiate a test immediately
scheduled	schedules tests through a schedule form to automatically initiate tests at a predetermined time



Test Type	<p>One of the following types of test to be performed on the trunk group/members in this schedule:</p> <ul style="list-style-type: none"><li>■ <b>full</b> (default) runs the most comprehensive test and collects all associated measurements for each TTL type.</li><li>■ <b>supv</b> performs a supervision test and only confirms the presence of the test set at the far end. No measurements are taken for this test.</li><li>■ <b>no-st</b> runs the "full" test, but skips any self-test sequences. This saves about 20 seconds on the type 105 test and does not have any effect on type 100 or 102 tests.</li><li>■ <b>no-rl</b> runs the "full" test, but skips any return loss sequences. This saves about 20 seconds on the type 105 test and does not have any effect on type 100 or 102 tests.</li><li>■ <b>no-st/rl</b> runs the "full" test, but skips all self-test and return loss sequences. This saves about 40 seconds on the type 105 test and does not have any effect on type 100 or 102 tests.</li></ul>
Duration	<p>The maximum number of hours (<b>1 to 24</b>) a schedule can remain active. Schedules continue to run until all trunk group/members for that particular schedule are tested or until the schedule duration is reached. If the duration is reached before all trunk groups/members can be tested, the schedule stops.</p>
Trk Trp	<p>The trunk group numbers to be tested when this schedule runs. There is no limit to the number of times that a trunk group can appear on any particular schedule, or to the number of different schedules in which a trunk group can appear. Default is blank.</p>
Bgn Mbr	<p>The beginning member number of the trunk group to be tested; default is <b>1</b>.</p>
End Mbr	<p>The ending member number of the trunk group to be tested. This value must be greater than or equal to the value of the beginning member field.</p>

## display time

**display time [print | schedule]**

This command displays the system date and time that is used by software processes for scheduling and so on.

## Output

---

```
display time
                                     DATE AND TIME

      DATE
          Day of the Week: Sunday      Month: January
          Day of the Month: 1          Year: 1992

      TIME
          Hour: 6                      Second: 20
          Minute: 8
```

## enable administered-connection

---

**enable administered-connection [adm-conn# | all**

This command re-enables scheduled and periodic testing and in-line error processing on a specified administered connection (AC) or all ACs. It is used after previously disabling maintenance via the **disable administered-connection** command. These commands can be useful in isolating results of certain maintenance processes by preventing interference from others.

## Parameters

---

- adm-conn#** The number (1-128) of the administered connection as assigned during administration.
- all** This qualifier causes all ACs in the system to be enabled.

## enable suspend-alm-orig

---

This command suspends Alarm Origination for alarms generated from a specified hardware component over a time-out duration.

## Synopsis

---

**enable suspend-alm-orig (board or port location) [off-board-only]**  
**expires-in-hrs(1-72).**

## Examples

---

```
enable suspend-alm-orig 1C03 expires-in-hrs 3  
enable suspend-alm-orig 1E0701 expires-in-hrs 72  
enable suspend-alm-orig 1E07 off-board-only expires-in-hrs 24
```

## Description

---

This command enables Suspend Alarm Origination for a board (which also includes all ports and endpoints on the board) or for a port (which includes all endpoints on the port), and either for both on- and off-board alarms or for off-board alarms only. Many control circuit packs do not have a board location, so this command cannot support all circuit packs.

On the command line, specify a time-out duration between one and 72 hours. The “off-board-only” keyword is optional; if the keyword is not specified, the entry suspends Alarm Origination for both on-and off-board alarms. Each enable command becomes a new entry or replaces an existing entry in the Suspend Alarm Origination table. A new entry that matches both the physical location and off-only/on- and off-board specifications of an active entry replaces the active entry in the Suspend Alarm Origination table.

This command may be useful for improving control over situations such as the following:

- Improved control over customer requests. For example, to suspend off-board DS1 alarms temporarily for customers that periodically disconnect DS1 trunks for testing or other business related purposes.
- Improved control over external (non-Lucent) problems. For example, to suspend off-board DS1 alarms before a customer resolves facility problems (such as working with the vendor of a T1 trunk that has developed an off-board condition).
- Improved control over internal (Lucent) problems that cannot be resolved right away. For example, to suspend Alarm Origination for a bad circuit pack detected late Friday night and personnel cannot be dispatched until Monday.

### NOTE:

Also see other Suspend Alarm Origination related commands, including “disable suspend-alm-orig” and “list suspend-alm-orig”.

## Defaults

---

This command enables Suspend Alarm Origination for both on- and off-board alarms if the “off-board-only” keyword is not specified.



**8 Maintenance Commands***enable synchronization-switch*

8-118

**Parameter**

board or port location	This parameter specifies the physical location of the hardware component for suspending Alarm Origination.
off-board-only	This option enables Suspend Alarm Origination for off-board alarms only.
expires-in-hrs	This parameter specifies the time-out duration for a Suspend Alarm Origination entry. Expired entries are removed automatically.

**Help Messages**

---

```
Enter board or port location,  
[ 'off-board-only' ], expires-in-hrs(1-72)
```

**Output**

---

The command returns one of the following messages:

1. If the time-out duration is not between one and 72:

```
XX is an invalid identifier; please press HELP
```

2. If the port or board specifier is not valid:

```
Port/Board invalid
```

3. If the Suspend Alarm Origination table is full:

```
Table full; cannot enable a new entry
```

**Feature Interactions**

---

None.

**enable synchronization-switch****enable synchronization-switch**

This command returns control of the selection of synchronization source to the maintenance subsystem and tone-clock after being previously turned off by the **disable synch** command. See "SYNCH" in Chapter 9 for details.

**enable test-number****enable test-number test#**

## Examples

---

### **enable test-number 102**

This command will re-enable a specified test that was previously turned off with the **disable test** command. (The **disable test** command is not available to the craft login.) While disabled a test cannot be run by background or demand maintenance. Before enabling a test, ascertain why it was disabled, and inform INADS that it has been turned back on.

## Parameters

---

test# The number of the test to be re-enabled

Descriptions of each test appear under the relevant MO in Chapter 9. See the Index for a numerical list of all demand maintenance tests.

## format card-mem

---

This command formats the active and standby processor Flash Read-Only Memory.

## Synopsis

---

format card-mem [translation] [announcements] [coredump]

## Permissions

---

The following default logins may execute this command: browse, system technician, cust, inads, init.

## Examples

---

**format card-mem translation**  
**format card-mem announcements**  
**format card-mem coredump**

## Description

---

The maintenance command, “format card-mem translation” will erase and format the memory card for translations only. The maintenance command **format card-mem announcement** will erase and format the memory card for translations and announcements. The maintenance command **format card-mem coredump** will erase and format the memory card for translations, announcements and coredump.

## Defaults

---

No defaults.

## Parameters

---

print	This parameter causes the information displayed by this command to be sent to the printer attached to the terminal as well as to the screen.
schedule	When the "schedule" option is specified, the command is validated and then a scheduling form is displayed to allow the technician to schedule execution of the command. The command is then placed in the command queue and is executed at the specified time. The information displayed by the command is sent to the system printer instead of the screen. Refer to the Report Scheduler and System Printer feature specification [1] for more details.

## Help Messages

---

If the system technician presses help after entering **displaymemory-configuration** the following message will be displayed:

## Error Messages

---

If the format memory [translation] [announcements] [coredump] maintenance command is executed and errors occur, one of the following error messages will be displayed:

- flash card to small for operation requested
- card is bad (reformat failed)
- card is write protected
- command cannot be executed due to command contention
- NETCON 12V programming power failure

## Output

---

For the following output example the command **format card-mem** was entered.

```
Enter 'translation' or 'announcements' or 'coredump' or 'firmware'  
  'translation' option includes translation only  
  'announcements' option includes translation and announcements  
  'core-dump' option includes translation, announcements, and code-dump  
  'firmware' option includes translation, announcements, and firmware  
Or press CANCEL to cancel the command
```

```
-----  
Identifier command word(s) omitted; please press HELP PREV-FIELD to edit  
-----
```

```
Command: format card-mem <Help>
```

```
Command:
```

## Feature Interactions

---

None

## get vector

---

### get vector [long] [print]

This command displays the triggering conditions and the SPE associated with a core dump of memory to the tape or disk device. The vector is a set of system reset levels which will cause the contents of memory to be saved on tape. When the core dump occurs, the vector settings are cleared. The vector is set with the **set vector** command (not available to craft logins). If no core dump has taken place since the vector was set, the settings are displayed. If a core dump has taken place, the time and location of the core dump files is displayed.

### NOTE:

When a system reset of a level that is set to trigger a core dump takes place, the vector is cleared regardless of whether the core dump is successful.

## Parameters

**long** Specifies display of the timestamps for the core dump. If SPEs are duplicated, timestamps are printed for both SPEs (or a message stating why the timestamp cannot be printed is displayed).

**Core Dump Vector** The conditions which are enabled to initiate a core dump to tape or disk, as represented by a hexadecimal value. The hexadecimal value represents a combination of four system reset levels: warm restart (reset level 1), cold 2 restart (2), cold 1 restart (3), and reboot (4). The table below shows which reset levels will initiate a core dump for each value of the vector.

Vector Value	Reset Levels	Vector Value	Reset Levels
0	none	8	4
1	1	9	1, 4
2	2	a	2, 4
3	1, 2	b	1, 2, 4
4	3	c	3, 4
5	1, 3	d	1, 3, 4
6	2, 3	e	2, 3, 4
7	1, 2, 3	f	1, 2, 3, 4

**Set Vector Command Option** This indicates from which SPE the core dump is to be taken as specified with the **set vector command**. This is always spe-active for simplex systems. Additional options for systems with duplicated SPEs are spe-standby and spe-smm. If the vector has been cleared or not set, blanks are displayed.

**Core Dump Time** For each SPE, the date and time at which the core dump took place, or on of the following:

Blank: No core dump has been stored.

Cannot access: The system cannot currently access the core dump file. (For example, a standby SPE may not be refreshed).

Non-duplicated SPE: This SPE does not exist (as in a simplex system).

Device busy: the MSS device on which the core dump is stored is busy with another operation.

The following display shows a typical result when **get vic** is entered and no core dump has taken place.

```
get vector

                                GET RESULTS

Core Dump Vector                Set Vector Command Option
                                spe-standby
                                F

Core Dump Time

SPE_A
SPE_B

Command successfully completed
```

The following display shows a typical result when **get vec long** is entered and a core dump has taken place, clearing the vector.

```
get vector

                                GET RESULTS

Core Dump Vector                Set Vector Command Option
                                spe-standby
                                F

Core Dump Time

SPE_A    JUN 5 14:31
SPE_B    device busy

Command successfully completed
```

## **list atm pnc**

---

This command lists the administered atm-pnc equipment in the system.

Action/ Object	Qualifier	Qualifier Description	Permissions	Defaults	Feature Interactions
<b>list atm pnc</b>	<i>print</i> <i>schedule</i>		init inads craft	none	none

## Output

The following example shows the output for the **list atm pnc** command.

```
list atm pnc                                     Page 1  SPE A
                                     ATM PNC
PNC                                     A-PNC                                     B-PNC
Connection #                           LOC                                     LOC
1                                       01C01
2                                       01D01
3                                       02A01
4                                       02E01
5                                       03A01
6                                       03E01
7                                       04A01
8                                       04E01
9                                       05A01
10                                      05E01
11                                      06A01
12                                      06E01
13                                      07A01
14                                      07E01

press CANCEL to quit --  press NEXT PAGE to continue
```

## list cabinet

### list cabinet [*print* | *schedule*]

The `list cabinet` command displays the type, layout, room, floor, building, operational carriers and port network number for each cabinet in the system. This command is useful when the port network number is needed for another command entry and only the cabinet number is known.

8 Maintenance Commands

*list communication-interface processor-channel*

8-125

## Output

Number	The administered number of the cabinet.
Type	The type of cabinet (PPN or EPN).
Layout	The layout of the cabinet .
Room	Room where cabinet is located, if administered on the cabinet form.
Floor	Floor where cabinet is located, if administered on the cabinet form.
Building	Building where cabinet is located, if administered on the cabinet form.
A B C D E	The letter designation of each carrier. For each carrier the port network number is given (PN #). If the carrier is a switch node this number is preceded by SN.

The following display shows a typical result when **list cabinet** is entered on a system with four port networks. In this example there are two port networks in cabinet 2.

```
list cabinet                               Page 1  SPE A
                                           CABINET REPORT
Number Type Layout Room  Floor  Building  A      B      C      D      E
  1    PPN 5-car
  2    EPN 5-car    PN 01  PN 01  PN 01  PN 01  SN 01
  3    EPN 5-car    PN 02  PN 02  PN 02  PN 05  PN 05
  4    EPN 5-car    PN 03  PN 03  PN 03  PN 03  PN 03
  5    EPN stack    PN 04  PN 04  PN 04  PN 04  PN 04
```

Command Successfully Completed

## list communication-interface processor-channel

Action/ Object	Qualifier	Qualifier Description	Permissions	Defaults	Feature Interactions
list communication-interface processor-channel	<i>number</i>	Example: <b>list communication-interface processor channel 125</b>	init inads craft	none	none



## Output

The following example shows the output from the **list/display communication-interface processor-channel** command.

PROCESSOR CHANNEL ASSIGNMENT										Page 1 of X	
Proc Chan	Enable	Appl.	Gtwy		Interface		Destination		Session		Mach ID
			To	Mode	Link/Chan	Node	Port	Local/Remote			
1:	-	_____	_____	-	_____	_____	_____	_____	_____	_____	_____
2:	-	_____	_____	-	_____	_____	_____	_____	_____	_____	_____
3:	-	_____	_____	-	_____	_____	_____	_____	_____	_____	_____
4:	-	_____	_____	-	_____	_____	_____	_____	_____	_____	_____
5:	-	_____	_____	-	_____	_____	_____	_____	_____	_____	_____
6:	-	_____	_____	-	_____	_____	_____	_____	_____	_____	_____
7:	-	_____	_____	-	_____	_____	_____	_____	_____	_____	_____
8:	-	_____	_____	-	_____	_____	_____	_____	_____	_____	_____
9:	-	_____	_____	-	_____	_____	_____	_____	_____	_____	_____
10:	-	_____	_____	-	_____	_____	_____	_____	_____	_____	_____
11:	-	_____	_____	-	_____	_____	_____	_____	_____	_____	_____
12:	-	_____	_____	-	_____	_____	_____	_____	_____	_____	_____
13:	-	_____	_____	-	_____	_____	_____	_____	_____	_____	_____
14:	-	_____	_____	-	_____	_____	_____	_____	_____	_____	_____
15:	-	_____	_____	-	_____	_____	_____	_____	_____	_____	_____
16:	-	_____	_____	-	_____	_____	_____	_____	_____	_____	_____

Screen 8-3. Processor Channel Assignment

### Field descriptions

- Proc Chan** Displays the BX.25 virtual channel number or the TCP/IP listen port channel to carry this processor (virtual) channel.
- Enable** Type **y** to enable a processor channel. Type **n** (default) to disable a processor channel.
- Appl.** Identifies the switch application used over this link. The application gateway is used for conversion between ISDN and either TCP/IP or BX.25. Use the **gtwy-tcp** entry for conversion between BX.25 and TCP/IP. Valid entries are: audix, dcs, fp-mwi, gateway, gtwy-tcp, mis, msaamwl, msackl, msahlwc, msallwc, msamcs, qs-mwi, blank (default)
- Gtwy To** Identifies which processor channel the given processor channel is serving as a gateway to. Valid entries are a number between 1-(maximum number of processor channels), or blank (default).
- Mode** Identifies whether the IP session is passive (client) or active (server). This field must be blank if the type of interface link is **x.25** (r model) or **procr-intf** (si model). This field cannot be blank if the type of interface link is **ehternet** or **ppp**. Valid entries are **client**, **server**, or blank (default).

Interface Link	Identifies the physical link carrying this processor (virtual) channel. Links numbered 1 through (4 times the number of PI circuit packs) for the si model can be either <b>x.25</b> or <b>tcp/ip</b> . The rest of the links (up to 25) must be <b>tcp/ip</b> .
Interface Chan	Identifies the BX.25 virtual channel number or the TCP/IP listen port channel to carry this processor (virtual) channel. The channel number 0 means any port can be used. Valid entries for link type x.25 are <b>1-64</b> ; for Ethernet or ppp, <b>0, 5000-64500</b> .
Destination Node	Identifies the switch or adjunct at the far end of this link. Enter an adjunct name, switch name, far end IP address, node ID, or leave blank (default) for services local to this switch.
Destination Port	Identifies the port number of the destination. The number 0 means any port can be used. Valid entries are <b>0</b> (default), <b>5000-64500</b> .
Session Local	Field ported forward from R6.
Session Remote	Field ported forward from R6.
Mach ID	Field ported forward from R6.

## list configuration

---

### list configuration hardware-group [print | schedule]



#### NOTE:

The **list configuration software-version** command is discussed separately under its own heading.

Hardware configuration reports list, for each circuit pack in the group specified, the type, code, suffix, and vintage of the requested circuit packs as installed in the switch, and all ports assigned to the circuit pack.

## Parameters

---

Enter one of the following hardware groups.

- **all**—Specifies the display of all circuit packs administered and/or physically inserted in port, switch node and control carriers on the entire system.
- **board UUCSS**—Specifies the display of all assigned ports on the circuit pack specified by cabinet, carrier and slot.
- **carrier c**—Specifies the display of all circuit packs and assigned ports on a specified carrier.
- **control**—Specifies the display of all circuit packs located in the control complex.

- **ds1**—Specifies the display of all the DS1 (TN722, TN767 and TN464) circuit packs administered and/or physically inserted in port carriers on the entire system.
- **port-network pn#**—Specifies the display of all circuit packs located in a specified port network. **List cabinet** gives the port network number(s) associated with a particular cabinet. Circuit packs on switch node carriers are not displayed when the port-network qualifier is entered. To display SN circuit packs, use the **all**, **carrier** or **board** qualifiers.
- **stations**—Specifies the display of all circuit packs that can be assigned stations (including DS1 circuit packs for remote stations). All assigned ports are displayed.
- **trunks**—Specifies the display of all circuit packs that can be used for administering trunks. All assigned ports are displayed.

## Examples

---

```
list configuration carrier 2c schedule
list configuration port-network 5
list configuration stations print
```

## Output

---

Assigned Ports:

- **Board Number**—The functional name of the circuit pack
- **Code**—The TN or UN code and suffix of the circuit packs are displayed.
- **Vintage 00000000-065535 KKKKKK**—The vintage number of the circuit pack.
- **no board**—The circuit pack is administered but not physically installed.
- **conflict**—The circuit pack administered to the slot differs from the circuit pack that is physically installed.
- **no link**—The T1 link is down to a DS1 circuit pack.

### Field definitions:

- **Signaling**—This field is displayed only when "list configuration ds1" option is selected. The contents of the field are the same as the signaling mode administered for the ds1 circuit pack (via **add/change ds1** command) or "none" if the circuit pack is not administered.
- **Name**—This field is displayed only when "list configuration ds1" option is selected. The contents of the field are the same as the name administered for the ds1 circuit pack (by the **add/change ds1 command**) or "blank" if the circuit pack is not administered.

- **CSU MOD**—This field is displayed only when “list configuration ds1” option is selected. The field contains the identification number of the Integrated CSU module present on the ds1 circuit pack (TN767E or later / TN464F or later) or “none”. If the circuit pack is a TN464E or TN767D, “unknown” will be displayed. If the circuit pack is a TN464D or TN767C or earlier suffix DS1 board, then “n/a” will be displayed.

## Assigned Ports

Each port on the circuit pack is represented by a position corresponding to its circuit number in ascending order from left to right. The assigned ports are not displayed for **list configuration ds1**. Two rows are required for circuit packs with more than 8 ports. The position displays one of the following values depending on its administered status:

- **01-16**—The circuit number of an assigned port.
- **u**—The port corresponding to this position exists but is unassigned.
- **t**—The port is not currently assigned and is supported by the Terminal Translation Initialization feature. Ports in this state can be activated by the TTI association sequence.
- **mj**—The port corresponding to this position is currently assigned as an external device (mj) alarm port.
- **mn**—The port corresponding to this position is currently assigned as an external device (mn) alarm port.

Each port on a TN556 ISDN-BRI circuit pack can have two BRI endpoints. BRI ports are displayed once when assigned only one endpoint and twice when fully configured with two endpoints.

The following display shows a typical result when **list configuration all** is entered.

```
list configuration all                                     Page 1

                                SYSTEM CONFIGURATION

Board
Number   Board Type           Code      Vintage      Assigned Ports
                                u=unassigned t=tti

01C00    MAINTENANCE/TEST          TN771C    000003      u 02 03 04
01C01    AUXILIARY TRUNK           TN748C    conflict    u u u u
01C02    EXPANSION INTRFC         no board
01C03    PGATE BOARD               TN577     000003      u u u u
01C05    TONE DETECTOR             TN748B    000002      01 02 03 u 05 06 07
01C06    DS1 INTERFACE             TN767     000011      u u u u u u u
                                u u u u u u u
                                u u u u u u u

01C07    ANALOG LINE               TN742     000010      u u u u u u u
01C08    HYBRID LINE               TN762B    000004      u u u u u u u
01C09    ANALOG LINE               TN742     000010      u u u u u u u
01C11    DIGITAL LINE              TN754     000004      u u u u u u u
01C12    DID TRUNK                 TN753     000006      u u u u u u u
01C13    ANALOG LINE               TN742     000010      u u u u u u u
01A14    SYS ACCESS-MAINT         TN1648    000002      mj mn
01A15    Maintenance                TN775B    000002      mj u

press CANCEL to quit -- press NEXT PAGE to continue
```

The following display shows a typical result when **list configuration ds1** is entered.

```
list configuration ds1

                                SYSTEM CONFIGURATION - DS1 Circuit Packs

Location  Code      Vintage      Signaling      Name              CSU MOD
01B05    TN464F    000002      isdn-pri      120A1
01B06    TN464D    000002      isdn-pri      n/a
01B10    TN767C    000003      none          n/a
01B11    TN767E    000003      robbed-bit    120A1
01B12    TN767E    conflict    none          <blank>
01C06    no board  none          none          <blank>
01C13    TN464E    000003      common-channel unknown
01C16    TN767D    000024      robbed-bit    unkonwn
01C18    TN464F    000002      isdn-pri      none
```

## list configuration software-version

---

**list configuration software-version [memory-resident | long] [print | schedule]**

This command displays

- Software version numbers and compatibility indexes of the software load modules stored in system memory (RAM) and on the Mass Storage System devices (tape and disk).
- The dates and times when translation and announcement data were last saved to the MSS.
- Information about any software update files that have been applied to the system. See [“Software updates”](#) in [Chapter 6, “Additional Maintenance Procedures”](#) for an explanation of software versions and compatibility indexes.

### Parameters

---

long	Specifies display of data for both SPEs in a high or critical reliability. If not used, only data for the active SPE is shown.
memory-resident	Specifies display of RAM-resident files only. Fields for tape and disk data will contain n/a

### Output

---

If the tape contains a core dump file, fields for tape data display `coredump`. When a core dump is present, all other files on the device are marked invalid. If the tape or disk files cannot be read at the time the command is entered, the relevant fields display `no tape` or `no disk`. (This does not indicate that the system does not recognize the presence of the device.)

Fields in the SPE-B column are blank for standard reliability systems. On high and critical reliability systems, only fields for the active SPE are displayed unless the **long** option is specified.

### Tape and Disk Second Copy Fields

Many of the files on disk and tape are duplicated: a second copy of the file is stored on the same device. The Second Copy fields indicate whether the two copies are consistent using the following entries:

Good	The second copy is considered usable. The time stamp and/or vintage of the second copy matches the first, and its status bits mark it as a good file.
------	---

- |              |   |
|--------------|---|
| Inconsistent | The time stamp or vintage of the file is inconsistent with the first copy, or the status bits mark it as a bad file. Follow normal escalation procedures. |
| Inaccessible | The second copy of the file could not be accessed. Media failure is the most probable cause.  |

## Update File Section

The top half of page 1 of the form displays information pertaining to software field-update files ("patches").

- |                                    |  |
|------------------------------------|--|
| Creation (GMT)<br>Tape and<br>Disk | When the update file was originally created, in Greenwich Mean Time (GMT). Note that this is <i>not</i> the time at which the update file was written to the MSS device. |
| Old-Version<br>Tape and Disk       | The software version for which the update was created.   |
| Old-Identifier<br>Tape and Disk    | Which previous update file this update file expected to find stored in the MSS when it was applied.  |
| New-Identifier<br>Tape and Disk    | Uniquely identifies the current update file.   |

## Software Version Section

This section at the bottom of page 1 of the output form displays information related to the current software-load module stored in memory and in the MSS.

- |                   |  |
|-------------------|--|
| Memory Resident   | Version number of the RAM-resident load module.                                    |
| Tape Resident     | Version number of the tape-resident load module.                                   |
| Tape Second Copy  | See Second Copy remarks above.   |
| Disk Resident     | Version number of the disk-resident load module.                                   |
| Disk Second Copy  | See Second Copy remarks above.   |
| Update-identifier | This uniquely identifies the update file, if any, that has been applied to memory. |

Update-state            The status of the software field-update ("patch") file:

                         none in memory

                         No software update has been applied to memory.

                         immediate partially applied

                         A software update failed in the process of being applied. Check the validity of the update file that was sent. Check also the hardware error log for tape errors, and follow standard maintenance procedures.

                         all immediate applied deferred pending

                         A valid update file was received by the switch, and all update files marked for immediate application were applied. This message indicates that there are additional files in the update file whose application has been deferred until a system reset of a required level takes place.

                         deferred partially applied

                         Application of the deferred files of a software update was attempted and failed. Check the validity of the update file that was sent. Check also the hardware error log for tape errors, and follow standard maintenance procedures.

                         entirely applied to memory

                         All files in a software update have been successfully applied.

## Translation Date Section

This section at the top of page 2 displays information related to the translation files as stored in memory and the MSS.

Memory Resident        Date and time marked on the tape or disk when translation data was last read from the MSS into memory. This is stored in SPE memory and is not modified by changes to translation data. A save translation will update this date. If "Date invalid" is displayed, the timestamp does not contain the expected information.

Tape Resident          The last date and time that translation data was saved to tape. This date is read from tape and appears blank if the tape is not installed.

Tape Second Copy        See Second Copy remarks above.

Disk Resident          The last date and time that translation data was saved to disk. This date is read from disk and appears blank if the disk is not installed.

Disk Second Copy        See Second Copy remarks above.



## System Configuration Section

This section of page 2 pertains to size of the memory configuration. All fields should display large except when the tape indicates the presence of a coredump.

## Announcement Date Section

This section at the bottom of page 2 displays data pertaining to the recorded announcement files.

Tape Resident	The last date and time that announcement data was saved to tape. This date is read from the tape.
Tape Second Copy	The last date and time that announcement data was saved to tape. This date is read from the second copy of the file on the tape.
Disk Resident	The last date and time that announcement data was saved to disk. This date is read from disk and appears blank if the disk is not installed.
Disk Second Copy	The last date and time that announcement data was saved to disk. This date is read from the second copy of the file on the disk.

## Compatibility Index Section

This section on page 3 displays data pertaining to the compatibility index, which is used to determine what types of software updates can be applied to a system running this software load.

Memory Resident	The compatibility index of the software version in memory.
Tape Resident	The compatibility index of the software version on tape.
Disk Resident	The compatibility index of the software version on disk.

The following display shows a typical result when **list configuration software-version** is entered on a simplex system. On a duplicated system the

fields under SPE-B should display the same entries as the SPE-A fields if all files are consistent.

```
list configuration software-version                               Page 1
```

```
                SOFTWARE VERSIONS
```

```
                SPE-A                               SPE-B
    UPDATE FILE
Creation (GMT) Tape: none
    (GMT) Disk: none
    Old Version Tape: none
                Disk: none
Old Identifier Tape: none
                Disk: none
New Identifier Tape: none
                Disk: none
```

```
    SOFTWARE VERSION
```

```
Memory Resident: DG3r01.06.0.01.0
Tape Resident: DG3r01.06.0.01.0
Tape Second Copy: good
Disk Resident: DG3r01.06.0.01.0
Disk Second Copy: good
Update Identifier: none
Update State: none in memory
```

```
press CANCEL to quit -- press NEXT PAGE to continue
```

```
list configuration software-version                               Page 2
```

```
                SOFTWARE VERSIONS
```

```
                SPE-A                               SPE-B
    TRANSLATION DATE
Memory Resident: 10:00 pm SAT APR 11, 1992
Tape Resident: 2:00 am SAT APR 11, 1992
Tape Second Copy: good
Disk Resident: 10:00 pm SAT APR 11, 1992
Disk Second Copy: good
```

```
    SYSTEM CONFIGURATION
```

```
Memory Resident: large
Tape Resident: large
Disk Resident: large
```

```
    ANNOUNCEMENT DATE
```

```
Tape Resident: 11:38 am FRI MAR 27, 1992
Tape Second Copy: 11:38 am FRI MAR 27, 1992
Disk Resident: 10:09 pm SAT APR 11, 1992
Disk Second Copy: 10:09 pm SAT APR 11, 1992
```

8 Maintenance Commands

*list configuration software-version*

8-136

```

                                SOFTWARE VERSIONS
                                SPE-A                SPE-B
COMPATIBILITY INDEX
Memory Resident: 8.3
Tape Resident: 8.3
Disk Resident: 8.3
    
```

The following display shows a typical result when **list config soft mem** is entered on a system with duplicated SPE while the B carrier SPE is active.

```

list configuration software-version memory-resident   Page 1   SPE B

                                SOFTWARE VERSIONS
                                SPE_A                SPE_B
UPDATE FILE
Creation (GMT) Tape:                n/a
(GMT) Disk:                        n/a
Old Version Tape:                  n/a
Disk:                              n/a
Old Identifier Tape:              n/a
Disk:                              n/a
New Identifier Tape:              n/a
Disk:                              n/a
SOFTWARE VERSION
Memory Resident:                   DG3r01.06.1.00.0
Tape Resident:                     n/a
Tape Second Copy:                  n/a
Disk Resident:                     none
Disk Second Copy:                  n/a
Update Identifier:                 none
Update State:                      none in memory

press CANCEL to quit -- press NEXT PAGE to continue
    
```

```
list configuration software-version memory-resident    Page 2    SPE B

                                SOFTWARE VERSIONS
                                SPE_A                SPE_B
TRANSLATION DATE
Memory Resident:                12:10 pm THU JUN 4, 1992
Tape Resident:                  n/a
Tape Second Copy:               n/a
Disk Resident:                  n/a
Disk Second Copy:               n/a

SYSTEM CONFIGURATION
Memory Resident:                large
Tape Resident:                  n/a
Disk Resident:                  n/a

ANNOUNCEMENT DATE
Tape Resident:                  n/a
Tape Second Copy:               none
Disk Resident:                  n/a
Disk Second Copy:               none

press CANCEL to quit --  press NEXT PAGE to continue
```

```
list configuration software-version memory-resident    Page 3    SPE B

                                SOFTWARE VERSIONS
                                SPE_A                SPE_B
COMPATIBILITY INDEX
Memory Resident:                8.4
Tape Resident:                  n/a
Disk Resident:                  n/a

Command successfully completed
```

## list disabled-MOs

---

### list disabled-MOs [print | schedule]

This command displays a list of the maintenance objects that have been disabled with the **disable MO**, **disable all**, or **disable MO-all** command (not available to craft logins), as well as whether or not the command has been run. Use **display disabled-tests** for numbers of tests that have been disabled.

## Output

---

Maintenance Name	Type of maintenance object(s) disabled. "ALL" is displayed if all MOs are either enabled or disabled.
Location	The physical location (cabinet-carrier-[slot-circuit]) of the maintenance objects. Blank when "ALL" is displayed under Maintenance Name.
Status	Whether the MOs displayed are enabled or disabled.

The following display shows a typical result when **list disabled-MOs** is entered and no MOs are currently disabled.

```
list disabled-MOs

                DISABLED MAINTENANCE OBJECT INFORMATION

Maintenance Name      Location      Status
ALL                   Enabled

Command successfully completed
```

## list fiber-link

---

### **list fiber-link [print | schedule]**

This command displays a list of all fiber links in the system. The list is a summary of data entered on the fiber link form (**add**, **display**, **change**, or **remove fiber-link**).

## Output

FIBER LINK #	The administered number used to identify the fiber link (1 to 27).
TYPE	The types of circuit packs that constitute endpoint 1 and endpoint 2 of the fiber link. (ei or sni).
A-PNC LOC	The physical locations (cabinet-carrier-slot number) of the circuit packs that constitute the endpoints.
B-PNC LOC	In a system with duplicated PNC, the physical location (cabinet-carrier-slot number) of the circuit packs that constitute the endpoints of the link in the B-PNC.
DS1 CONV	Whether or not an endpoint of the link is remotely located by means of a DS1C Converter Complex.

The following display shows a typical result when **list fiber** is entered on a system with duplicated PNC and 5 EPNs, one of which is DS1C remoted.

```
list fiber-link                               SPE A
                                           FIBER LINK ADMINISTRATION
FIBER   - - - ENDPOINT 1- -   - - -ENDPOINT 1- -   DS1
LINK #   TYPE  A-PNC   B-PNC   TYPE  A-PNC   B-PNC   CONV
          LOC    LOC      LOC    LOC    LOC
1        ei    01E01   01D01   sni   01E02   01D02   n
2        ei    02A01   02B02   sni   02E02   02D02   n
3        ei    03A01   03B02   sni   01E20   01D20   n
4        ei    04A01   04B02   sni   02E02   02D20   n
5        ei    05A01   05B02   sni   02E03   02D03   y
6        sni   01E13   01D13   sni   02E13   02D13   n
7        sni   01E09   01D09   sni   02E09   02D09   n
8        sni   01E14   01D14   sni   02E14   02D14   n
9        ei    06A01   06B02   sni   01E03   01D03   n

Command Successfully Completed
```

## list history

### list history [print | schedule]

The **list history** command generates a log listing of the most recent data-affecting administration and maintenance commands successfully completed.

Administration data commands change translation data. Maintenance data commands change state information. For example, **change station** would be classed as a data command, whereas **display station** would not.

All information in the transaction log is saved on tape as translation data when the **save translation** command is performed (LIFO order). A system reset of level 3 or higher (COLD 1 and reboots) saved translations and the transaction log are read from tape. In this way, the translation data and the data in the transaction log will remain compatible.

The translation log is written to tape as translation data when the save translation command is executed.

Translation data is time stamped when saved on tape. This time stamp is noted when translation is loaded from tape and included in all recent change history reports.

When a user requests a recent change history report, there could be other users concurrently issuing data commands and altering the contents of the transaction log. Therefore, if the user pages the entire way through the report, the oldest entries in the transaction log may have been overwritten by data commands issued by these other users. Should this occur, the final entries of the report will show the data commands which have been issued by these other users since the recent change history report was originally requested.

Use of the maintenance command "set time" to alter the system clock could make it look as if the recent change history report is not in true LIFO order.

A maximum of 250 commands are stored in the transaction log.

## Output

---

### NOTE:

The date listed in the header, refers to the last date on which a reset level 3 (COLD-1 restart) or greater took place. *This date is not updated* when translation is saved manually by command, or automatically by scheduled daily maintenance. Thus, it is usually *not* the date of the current translations.

Date of Loaded Translation:

Date	The date the command was issued. Format "mm/dd" where "mm" is the month and "dd" is the day.
Time	The time the command was issued. Format "hh:mm" where "hh" is the hour and "mm" is the minute.
Port	The port field indicates the port type to which the user was connected when the command was issued.

<b>Port Type</b>	<b>List History Display</b>
EPN Maintenance Board Port	MAINT
System Access Port	SYS-PORT
Maintenance Board Port	SYSAM-LCL
Remote Maintenance Board Port	SYSAM-RMT

**Login** The login of the user performing the data command; for example "craft."

**Actn** The first word (verb) of the command, specifying the operation to be performed. This field is truncated after four characters to allow enough space for objects and qualifiers. Four characters is enough to uniquely identify each action.

**Object** The second phrase of the command specifying the particular thing being acted upon by the command.

**⇒ NOTE:**

Where the object is multiple words in length, only the first word will be displayed in the object field. All succeeding words will be treated as qualifiers. This field is truncated after twelve characters to allow enough space for qualifiers. 12 characters is enough to uniquely identify each object.

**Qualifier** One or more qualifiers which specify the characteristics of the action/object pair. This field is truncated after 31 characters to keep information for a command on a single line.



The following display shows a typical result when **list history** is entered.

```
list history                               Page 1      SPE A

                                HISTORY

                Date of Loaded Translation: 12:10pm Thu Jun 4, 1992

Date  Time  Port      Login  Actn  Object      Qualifier

6/05 14:55 SYSAM-LCL craft  enab  test-number 5
6/05 14:54 SYSAM-LCL craft  set   vector      f
6/05 14:31 SYSAM-LCL craft  rese  system      1
6/05 14:29 SYSAM-LCL craft  set   vector      f
6/05 14:27 SYSAM-LCL craft  disa  synchronizat
6/05 14:26 SYSAM-LCL craft  enab  synchronizat
6/05 14:20 SYSAM-LCL craft  enab  synchronizat
6/05 14:19 SYSAM-LCL craft  disa  synchronizat
6/05 14:19 SYSAM-LCL craft  clea  port        1c0308
6/05 14:19 SYSAM-LCL craft  mark  port        1c0308
6/05 14:18 SYSAM-LCL craft  clea  firmware-cou 3d21
6/05 14:18 SYSAM-LCL craft  busy  pnc-standby
6/05 14:16 SYSAM-LCL craft  clea  errors
6/05 14:08 SYSAM-LCL craft  rel   trunk       1

press CANCEL to quit -- press NEXT PAGE to continue
```

## **list ip-route**

This command displays a list of the IP route from DEFINITY ECS out to the LAN. You can enter the “board” parameter and specify which C-LAN's circuit pack to show the IP routes for that circuit pack (for example, **list ip-route board UUCss**).

Action/ Object	Qualifier	Qualifier Description	Permissions	Defaults	Feature Interactions
<b>list ip-route</b>	<i>n</i> <i>board</i> <i>UUCss</i>	Route number Location Example: <b>list ip-route board 01A03</b>	init inads craft	none	none

## **Output**

The following example shows the output from the **list ip-route n** command.

```
list ip-route 1
                                     IP ROUTING
                                     Page 1 of 1

Route   Destination
Number  Node
Gateway
C-LAN   Board
Metric
Accepted by C-LAN?

xxx     xxxxxxxxxxxxxxxxxxxx  xxxxxxxxxxxxxxxxxxxx  xxxxxx  x    x
xxx     xxxxxxxxxxxxxxxxxxxx  xxxxxxxxxxxxxxxxxxxx  xxxxxx  x    x
xxx     xxxxxxxxxxxxxxxxxxxx  xxxxxxxxxxxxxxxxxxxx  xxxxxx  x    x
```

## Field descriptions

Route Number	IP-route number
Destination Node	Destination of the route. The destination is a name administered on the Node Name form that can include the keyword <b>DEFAULT</b> indicating the default route. Default is blank.
Gateway	The node name of the Gateway through which the destination is to be reached. The Gateway is a name administered on the Node Name form. Default is blank.
C-LAN Board	Indicates the giving circuit pack location for the circuit pack that provides the interface for the route. Default is blank.
Metric	Specifies the hop count metric which gives an indication of how many hops are involved on this route in order to reach the destination from the given C-LAN circuit pack. Valid entry is <b>0</b> (a simple route), <b>1</b> (a complex route), or blank (default).
Accepted by CLAN	Indicates whether a C-LAN circuit pack has accepted the administered IP-route. This is initialized to <b>no</b> by the system when a new route is administered and then set to <b>yes</b> after the C-LAN has accepted the given routing information and is displayed as an "x."

## list isdn-testcall

**list isdn-testcall [print | schedule]**

The **list isdn-testcall** command displays the ISDN-PRI trunks that are currently in use for outgoing ISDN test calls.

## Output

---

B-Channel	The trunk group number and member number of the trunk in use.
Start Time	Day of the month, hour and minute when the test call began.
Duration	Expected duration, in minutes, of the test call.
M/T Port	Cabinet, carrier, slot and circuit number of the port on the Maintenance/Test circuit pack in use for the outgoing test call.

The following display shows a typical result when **list isdn-testcall** is entered.

```
list isdn-testcall
```

```
ISDN-PRI TESTCALLS
```

B-Channel	Start Time	Duration	M/T Port
078/001	25/14:36	120	1B1102

```
Command successfully completed
```

## list marked-ports

**list marked-ports [print | schedule]**

The list marked-ports command displays all of the ports that have been marked unusable with the mark port command.

## Output

---

Port The physical location (cabinet-carrier-slot-port circuit) of the marked port.  
Board-Type The type of circuit pack with the marked port.

```
list marked-ports

                                MARKED-PORT INFORMATION

      Port      Board-Type
      1C0101    DIG-BD
      1C0102    DIG-BD

Command successfully completed
```

## list measurements ds1

---

**list measurements ds1 UUCSS [print | schedule]**  
**list measurements ds1-log UUCSS [print | schedule]**  
**list measurements ds1-fac UUCSSf [log | summary] [print | schedule]**

The **list measurements ds1** and **list measurements ds1-log** commands provide performance measurements on a DS-1 link. The **ds1** option provides a summary report while the **ds1-log** option provides a detailed report.

The performance measurements of a DS-1 link indicate the quality of the DS-1 physical interface between the system and a far-end system.

The **list measurements ds1-fac** command provides link performance measurements on a DS1 Converter facility.

The DS1 Converter Complex consists of two DS1Cs connected by one to four DS1 facilities. This complex allows the distance between two port networks to extend up to 100 miles, thereby extending the range of the optical fiber link within limited bandwidth (96 channels). A DS1C Complex can be used in a direct connectivity configuration or a Center Stage Switch configuration. The DS1 converters may be connected to an Expansion Interface(EI) or a Switch Node Interface(SNI) via a metallic connection.

## Parameters

---

UUCSS	The location of a DS1 circuit pack.
UUCSS	The location of a DS1 converter facility where <i>UUCSS</i> is the location of the circuit pack and <i>f</i> is a letter (a-d) designating one of the four DS1 facilities.

## Examples

---

```
list measurements ds1 2a18
list measurements ds1-log 2e01a
list measurements ds1-facility summary 2e01d schedule
```

## Output

---

The following field descriptions pertain to the summary reports accessed by **list measurements ds1** and **list measurements ds1-facility summary**.

Counted Since:	The start time and date when the associated measurement counters were cleared, or when the DS1C circuit pack or facility was administered.
Number of Seconds Elapsed Into Current 15-min Interval:	The number of seconds from the beginning of the current 15-minute interval. This field has a value from 0 to 900.
Total of Valid 15-min Intervals in Past 24-hr Period:	The total number of 15-minute intervals in the past 24-hour period that contain valid data. This field has a value from 0 to 96.
Category	The following four fields report data form the error counters.
Errored Seconds	The value of the errored seconds counter for the specified 15-minute interval. This field has a value from 0 to 900 or N/A if the data for the 15-minute interval is invalid.
Bursty Err Secs	The value of the bursty errored seconds counter for the specified 15-minute interval. This field has a value from 0 to 900 or N/A if the data for the 15-minute interval is invalid.
Severely Err Secs	The value of the severely errored seconds counter for the specified 15-minute interval. This field has a value from 0 to 900 or N/A if the data for the 15-minute interval is invalid.

**8** Maintenance Commands  
*list measurements ds1*

8-147

Failed Seconds	The value of the failed seconds counter for the specified 15-minute interval. This field has a value from 0 to 900 or N/A if the data for the 15-minute interval is invalid.
Worst 15-Min Interval	The date(Date), end time(Time), and error count (Count; from 0 to 900 in increments of four) of the 15-minute interval in the previous 24-hour period that contains the maximum value for each of the four error categories (errored seconds, bursty errored seconds, severely errored seconds, and failed seconds).
Total of 24-Hour Count	The sum of all valid 15-minute counts for the previous 24-hour period for each of the four error categories. This field has a value from 0 to 65535.
Current 15-Minute Interval	The error count for the current (incomplete) 15-minute interval for each of the four error categories. This field has a value from 0 to 899 or N/A if the data for the current 15-minute interval is invalid.

The following field descriptions pertain to the detailed reports accessed by the **list measurements ds1-log** and **list measurements ds1-facility log** commands.

Counted Since:	The start time and date when the associated measurement counters were cleared or the DS1C circuit pack was administered.
Date	The date of the 15-minute interval.
Time	The time of the 15-minute interval.
Errored seconds	The value of the errored seconds counter for the specified 15-minute interval. This field has a value from 0 to 900 or N/A if the data for the 15-minute interval is invalid.
Bursty err secs	The value of the bursty errored seconds counter for the specified 15-minute interval. This field has a value from 0 to 900 or N/A if the data for the 15-minute interval is invalid.
Valid interval	This field indicates whether the data for the specified 15-minute interval is valid. Data is considered valid when a count for that 15-minute interval. If the field has a value of "y", the data for the four error categories is valid; otherwise, the data is invalid. Data is considered valid when a count for that 15-minute interval is retrieved and none of the following invalid conditions occur. Data is invalid if a system warm start or a system cold start occurred during the interval, if the DS1C circuit pack was not inserted during the interval, if the system time was changed during the interval, or if the system was too busy to respond to a poll request for the interval.

The following output examples show all of the four different DS1 reports.

```
list measurements ds1 2a19                                SPE A
Switch Name:                                             Date: 1:25 pm THU APR 16, 1992

DS-1 Link Performance Measurements Summary Report

Counted Since: 1:20 pm THU APR 16, 1992
Number of Seconds Elapsed Into Current 15-min Interval: 323
Total of Valid 15-min Intervals in Past 24-hr Period: 0
```

Category	Worst 15-Min Interval			Total of	Current
	Date	Time	Count	24-hr	15-Min Int
Errored Seconds	4/16	13:20	0	0	4
Bursty Err Secs	4/16	13:20	0	0	4
Severely Err Secs	4/16	13:20	0	0	0
Failed Seconds	4/16	13:20	0	0	0

Command successfully completed

```
list measurements dsl-facility summary 2e01a            SPE A
Switch Name:                                             Date: 1:26 pm THU APR 16, 1992

DS1C Link Performance Measurements Summary Report

Counted Since: 10:50 am THU APR 16, 1992
Number of Seconds Elapsed Into Current 15-min Interval: 375
Total of Valid 15-min Intervals in Past 24-hr Period: 10
```

Category	Worst 15-Min Interval			Total of	Current
	Date	Time	Count	24-hr	15-Min Int
Errored Seconds	4/16	10:50	0	0	0
Bursty Err Secs	4/16	10:50	0	0	0
Severely Err Secs	4/16	10:50	0	0	0
Failed Seconds	4/16	10:50	0	0	0

Command successfully completed

```
list measurements dsl-log 2a19                                SPE A
Switch Name:                                                Date: 1:26 pm  THU APR 16, 1992
```

DS-1 Link Performance Measurements Detailed Log Report

Counted Since: 1:20 pm THU APR 16, 1992

DATE	TIME	ERRORED SECOND	BURSTY ERR SECS	SEVERELY ERR SECS	FAILED SECONDS	VALID INTERVAL
4/16	13:05	0	0	0	0	y
4/16	13:20	0	0	0	0	y

Command successfully completed

```
list measurements dsl-facility log 2e01a                    SPE A
Switch Name:                                                Date: 1:26 pm  THU APR 16, 1992
```

DS1C Link Performance Measurements Detailed Log Report

Counted Since: 10:50 am THU APR 16, 1992

DATE	TIME	ERRORED SECOND	BURSTY ERR SECS	SEVERELY ERR SECS	FAILED SECONDS	VALID INTERVAL
4/16	11:05	0	0	0	0	Y
4/16	11:20	0	0	0	0	Y
4/16	11:35	0	0	0	0	Y
4/16	11:50	0	0	0	0	Y
4/16	12:05	0	0	0	0	Y
4/16	12:20	0	0	0	0	Y
4/16	12:35	0	0	0	0	Y
4/16	12:50	0	0	0	0	Y
4/16	13:05	0	0	0	0	Y
4/16	13:20	0	0	0	0	Y

Command successfully completed

## **list pms-down**

**list pms-down [start-time][stop-time][print]**



This command lists all events that have meaning to the Property Management System (PMS) that have occurred while the link between the switch and the PMS was down. For example, any room status codes entered by hotel housekeeping staff during a time of PMS outage would be shown in this report.

## Parameters

---

- start-time** The starting time in 24-hour notation from which events are to be listed.
- stop-time** The time in 24-hour notation up to which events are to be listed.

## Output

---

- Extension** The extension associated with the reported event.
- Event** The PMS event that was reported to the switch, but which could not be sent to the PMS.
- Reason** The reason that the event could not be reported by the switch to the PMS.
- Time** The time at which the event was reported.

The following example shows a typical result when **list pms-down** is entered.

```
list pms-down
```

### PROPERTY MANAGEMENT SYSTEM ACTIVITY

Extension	Event	Reason	Time
402	from room, code 1	PMS link out of service	7:00am
405	from stn, code 1	PMS link out of service	9:00am
411	check in, complete	PMS link out of service	9:30am
411	PBX enabled MWL	PMS link out of service	12:00am
450	from room, code 1	PMS reject	12:05am

## list suspend-alm-orig

---

This command lists entries in the Suspend Alarm Origination table.

## Synopsis

---

**list suspend-alm-orig [print | schedule]**

## Examples

---

```
list suspend-alm-orig
list suspend-alm-orig print
list suspend-alm-orig schedule
```

## Description

---

This command lists active entries in the Suspend Alarm Origination table. Even though this command only lists active entries, an entry that expires during the list process still appears in the output. If the Suspend Alarm Origination table is empty, the output would only contain the title and field headings.

## Parameters

---

- Print** This option causes the report to be printed if a printer is linked to the SAT.
- Schedule** When the schedule option is specified, the command validates and a schedule form displays to allow the technician to schedule execution of the command at a specified time. The information displayed by the command is sent to the system printer instead of the screen.

## Help Messages

---

```
['print' or 'help']
```

## Output

---

```
list suspend-alm-orig

                Suspend Alarm Origination Entries
Physical      Board           Expires At
01C03         off-only          06/11/15:06
01E0407       on-and-off       06/11/17:26
01E0406       on-and-off       06/12/45:34
```

## Feature Interactions

---

None.

## list sys-link

---

### list sys-link [print | schedule]

The list sys-link displays all of the system links. The location, link type and channel number, link state, current path status, faulted path status, and last recorded fault, if any, are displayed for each system link. See [SYS-LINK in Chapter 9, "ABRI-PORT \(ASAI ISDN-BRI Port\)"](#) for details.

## Output

---

Location	The physical location of the far endpoint associated with the system link (cabinet-carrier-slot-circuit).
Link Type/Channel	The type of system-link and the processor channel number of the link (if there is one). System links include the following (see MO SYS-LINK):  Expansion Archangel Links (EAL), Indirect Neighbor Links (INL), Processor Gate Control links (PGC), PRI signaling links (PRI), System Port links (SAP), Remote Neighbor links (RNL), Local Neighbor links (LNL), X25 adjunct links. Processor channel numbers range from 1 to 128.
State	Whether the system link is "up" or "down."
Current Path	This field specifies the status of the current path. This field displays "none" if the link is down or "present" if the current path is functional.
Faulted Path	This field shows whether the link has experienced a fault and been switched to another path. "Present" indicates that the link has been faulted at least once. "None" is displayed if the link has not gone down. "Default" is displayed if the default faulted path is being used.
Last Fault Recorded	The date and time that the most recent fault on the link took place.

The following display shows a typical result when **list sys-link** is entered on a system with 5 PNs and PNC duplication.

```
list sys-link                                     Page 1  SPE A

                                SYSTEM LINKS INFORMATION

Location  Link Type/  State  Current  Faulted  Last Fault
          Channel   State  Path     Path     Recorded

02A0101  EAL           up     present  present  12/30/1991 14:18
02B0201  EAL           up     present  none     12/30/1991 12:56
03A0101  EAL           up     present  present  12/30/1991 14:18
03B0201  EAL           up     present  none     12/30/1991 12:56
04A0101  EAL           up     present  present  12/30/1991 14:18
04B0201  EAL           up     present  none     12/30/1991 12:56
05A0101  EAL           up     present  present  12/30/1991 14:18
05B0201  EAL           up     present  none     12/30/1991 12:56
01E0201  LNL           up     present  none     12/30/1991 14:18
01D0201  LNL           up     present  none     12/30/1991 14:18
01E2001  RNL           up     present  none     12/30/1991 14:18
02E0201  RNL           up     present  present  12/30/1991 14:18
02E0301  RNL           up     present  present  12/30/1991 14:18
02E2001  RNL           up     present  none     12/30/1991 14:18

press CANCEL to quit -- press NEXT PAGE to continue
```

## mark port

### mark port UUCSSpp

The **mark port** command will identify a port as unusable by normal call processing. The port will be able to be tested, etc. but calls will not be attempted through the port. The marking of a port is saved as part of translation. The port can be restored to service by using the clear port command.

For more information see [“Common Input Parameters”](#) and [“Common Output Fields”](#) at the beginning of this chapter.

## monitor bcms

### monitor bcms split split# | system system# | skill skill#

The **monitor bcms** command displays output for agents and splits summarizing the Basic Call Management System (BCMS) condition. This on-line status report is automatically updated every 30 seconds or on demand by pressing UPDATE. The command is canceled by pressing CANCEL which results in termination of the login. Three display options are available: split, system and skill.

## Parameters

---

- split** This specifies display of status information for one particular split (ACD hunt group). The qualifier is followed by an ACD hunt group number (split number) that identifies the split to the switch.
- system** This specifies display of split queue status as well as cumulative split information for all splits measured by BCMS. The qualifier is followed by ACD hunt group numbers (split numbers) separated by spaces and/or split number ranges separated by a hyphen ("-").
- skill** This specifies display of status information for one particular skill group. The qualifier is followed by a skill number that identifies the group.

## Examples

---

```
monitor bcms split 1  
monitor bcms system 1 5 7 8 9  
monitor bcms system 1-15
```

## Output for the System Option

---

Date	The current date and time which is updated every 30 seconds or when the UPDATE key is pressed.
SPLIT	The name of the split being reported, if no name is administered then the split extension is displayed in the form "EXTxxxx". Splits are displayed in split number order. This field is translation data.
CALLS WAIT	The number of calls currently waiting in this split's queue. If any of these calls are Direct Agent Calls, the field will be preceded by an asterisk. This field is real-time status data.
OLDEST CALL	The amount of time that the oldest call has waited in queue. This field is real-time status data.
AVG ANSW SPEED	The average time required for an answer in this split during the current period, including time in queue and time ringing at the agent's voice terminal. Intraflow calls (those that overflow from one ACD split to another split) will not have queue time from previous splits included in the average. The calculation is Total Answer Time/Total Automatic Call Distribution (ACD) Calls. This is measurement data and includes only those calls that have completed.
AVAIL AGENT	The number of agents in this split currently available to receive an Automatic Call Distribution (ACD) call from this split. This field is real-time status data.
# ABAND	The number of calls that have abandoned during the current period. This field is measurement data.
AVG ABAND TIME	The average time abandoned calls waited in queue before abandoning during the current period. The calculation is Total Abandon Time/Total Calls Abandoned. This field is measurement data and includes only those calls that have completed (terminated).
# ACD	The number of Automatic Call Distribution (ACD) calls handled by this split during the current period. This includes calls that intraflow into the split. This field is measurement data.
AVG TALK	The average talk time for Automatic Call Distribution (ACD) calls handled by this split during the current period. This does not include ring time at the agents' voice terminal. The calculation is Total ACD Talk Time/Number of ACD Calls. This field is measurement data and includes only those calls that have completed (terminated).
AVG AFTER CALL	The average After Call Work (ACW) time for Automatic Call Distribution (ACD) calls handled by this split during the current period. ACD calls with no ACW time are included in the average. Time spent on direct incoming or outgoing calls while in ACW will not be included in the average. The calculation is (Total ACW Time - Total ACW Incoming Time - Total ACW Outgoing Time)/Total ACD Calls. This field is measurement data and includes only those calls that have completed (terminated).

The following display shows a typical result when **monitor bcms system** is entered.

```
monitor bcms system                                     Page 1 of 1
                                     BCMS SYSTEM STATUS
                                     Date: 14:02 THU OCT 17 1991
                                     AVG
SPLIT  CALLS  OLDEST  ANSW  AVAIL  #  AVG  #  AVG  AVG
       WAIT  CALL   SPEED AGENT ABAND TIME ACD TALK AFTER
Service 3  1:03   :45   0     3    :30  20  2:30  1:25
Sales  5  :33   :15   0    11   :45  36  1:32  :35
```

## Output for the Split Option

---

Split:	The number of the split requested. This field is translation data.
Split Name:	The name of the split requested. If no name exists the split extension is displayed in the form "EXT xxxxx". This field is translation data.
Date:	The current date and time which is updated every 30 seconds or when the UPDATE key is pressed.
Calls Waiting:	The number of calls currently waiting in this split's queue. If any of these calls are Direct Agent Calls, the field will be preceded by an asterisk. This field is real-time status data.
Oldest Call:	The time in minutes:seconds that the current oldest call has waited in this split's queue. This field is real-time status data.
Staffed:	The number of agents currently logged into this split. This field is real-time status data.
Avail	The number of agents currently available to receive an Automatic Call Distribution (ACD) call in this split. Agents are in either the Auto-in or Manual-in work modes and are not currently on a call. If the agent is on another split's call or in After Call Work (ACW) for another split, this agent is not considered available and will not be recorded here. This field is real-time status data.
ACD	The number of agents in this split currently on an Automatic Call Distribution (ACD) call for this split. This includes ACD calls that are being handled by this split that arrive as coverage from another split. This field also includes outbound calls (Outgoing Call Manager) that are distributed through the ACD. Note that if an agent puts an ACD call on hold, but does not enter another state (for example, the agent does not enter the AVAIL state), the agent will still be seen as in the ACD state. This field is real-time status data.
ACW	The number of agents in this split currently in After Call Work (ACW) split. This field is real-time status data.
AUX	The number of agents in this split currently in AUX work for this split. If an agent is on another split's call or in After Call Work (ACW) for another split, this agent is not considered in AUX work and will not be recorded here. This field is real-time status data.
Extn	The number of agents in this split currently on non-ACD (Automatic Call Distribution) calls, either incoming or outgoing directly to/from their extensions. If the agents are also in After Call Work (ACW) or AUX they will be recorded as Extn rather than ACW or AUX. This field is real-time status data.
OtherSplit	The number of agents in this split on another split's call or in After Call Work (ACW) for another split. Only used if agents belong to multiple splits. This field is real-time status data.



AGENT	The name of the agent associated with the extension. If no name exists this field will be left blank. This field is translation data.
EXT	The agent's extension. This field is translation data.
STATE	The current state of the agent for this split. This possible states are Avail, ACD, ACW, AUX, Extn In, Extn Out, OtherSplit, and Unstaff. If an agent is staffed, the agent must also be in one of the above states. This field is real-time status data.
TIME	The clock time at which the agent entered the current state. This field is real-time status data.
ACD CALLS	The number of Automatic Call Distribution (ACD) calls (inbound and outbound), that the agent has completed for this split during the current period (half hour or hour). The maximum number of calls is 255, and if this maximum is exceeded, 255 is displayed. This field is measurement data.
EXTN IN CALLS	The number of non-ACD incoming calls that the agent has received and completed during the current period. The maximum number of calls displayed is 255. This field is measurement data.
EXTN OUT CALLS	The number of outgoing non-ACD (Automatic Call Distribution) calls that the agent has completed during the current period. The maximum number displayed is 255. This field is measurement data.

The following display shows a typical result when **mon bcms spl 1** is entered.

```
monitor bcms split 1                               Page 1 of 1   SPE A
              BCMS SPLIT (AGENT) STATUS

      Split: 1
      Split Name: hunt group 1                     Date: 9:02 TUE OCT 22 1991
      Calls Waiting: 0
      Oldest Call: 0:00

0=Staffed  0=Avail  0=ACD  0=ACW  0=AUX  0=Extn      0=OtherSplit

AGENT      EXT      STATE      TIME      ACD      EXTN IN  EXTN OUT
          CALLS      CALLS      CALLS
```

## monitor health

### monitor health

The **monitor health** command displays the same information as the **status health** command and updates the display automatically every minute. The command is terminated by pressing Cancel. When the command is canceled, the

management terminal login is dropped. See **status health** for a description of the fields displayed.

## **monitor security violations**

---

### **monitor security-violations [print]**

The **monitor security-violations** command displays the following information about failed attempts to access the system: the time of the violation, the login entered, and the port accessed during the failed login attempt. For remote access violations, the trunk group number, member, and extension are also shown. A total of 16 entries are maintained for each type of access. The report is automatically updated every 30 seconds until the command is canceled by pressing CANCEL. Unlike some other monitor commands, canceling does not cause the terminal to be logged off.

## **Output**

---

Date	The date of the security violation given as MM/DD.
Time	The time of the logged security violation given as HH:MM.
Login	The login ID that was entered as part of the violation attempt.

## System Management Violations

---

Port Type	The type of port through which the login violation was attempted:  SYS-PORT  A dial-in connection to a system port.  MAINT  A physical connection to the G3-MT terminal connector on an EPN maintenance circuit pack.  SYSAM-LCL  A physical connection to the ACTIVE terminal connector on the SYSAM circuit pack in a PPN control carrier.  SYSAM-RMT  A connection to the Remote Access Port (RAP) on the SYSAM circuit pack. This port is usually accessed by dialing in and is reserved for use by INADS.
Ext	The extension assigned to the data module that was used to attempt the failed login. If a data module was not used (as in the case of dedicated EIA connections, for example) the field is blank.

## Remote Access Violations

---

TG No.	The trunk group that carried the incoming remote access attempt (remote access violations only).
Mbr	The trunk group member number associated with the trunk from which the remote access attempt terminated (remote access violations only).
Ext	The extension used to access the RAP (remote access violations only).

## monitor system

---

This command with the **view1** or **view2** option displays one screen page of output summarizing the overall condition of the system. With the **connection** option, the command displays the real-time status for time slots and buses. Additionally, there are other miscellaneous parameters displayed that show call rates, intervals, etc.

## Synopsis

---

**monitor system [ view1 | view2 | conn [ pnn pnn number 1 pnn number 2 pnn number 3 ] ]**

## Permissions

---

The following default logins may execute this command: system technician, inads, cust, init, nms, browse.

## Examples

---

```
monitor system view1  
monitor system view2  
monitor system conn  
monitor system conn pnn 1 5 7
```

## Description

---

The **monitor system view1** and **view2** commands display a page of output summarizing the condition of the system. This on-line status report is automatically updated until the command is canceled by pressing the CANCEL key. Two display options are available: view1 and view2.

The current overall system status is available with either of the view options. "View1" displays attendant, maintenance, and traffic status. Attendant and maintenance status are updated every minute and traffic status is updated on an hourly basis. When the command is canceled, the technician will be automatically logged off for security reasons. The "view2" report contains everything the "view1" report does, except the hunt group measurements are omitted from the traffic status portion of the "view2" report. These forms contain simplified high-level information from which a basic picture of the system's health can be drawn. The **monitor system conn** command displays output that shows the status of connections in the connection manager process. Data is collected frequently in the connection manager for certain key information items. It is from this database that this report is drawn. This on-line status report is automatically updated every minute (or by pressing the UPDATE key) until the command is canceled by pressing the CANCEL key. Pressing the CANCEL keys forces a logout of the current login id.

There is one option to the command line entry, **monitor system conn**. That parameter is *pnn*. On the *gaz target*, there are only 3 possible pnn's. On the *mips target*, however, up to 22 pnn can be administered. The command line parameter *pnn* is used to indicate which 3 pnn's the user wishes to see.

## Defaults

---

No defaults.

## Parameters

---

<b>view1</b>	This specifies a form that will include the attendant status, the maintenance status, the last hour's measurement of trunk groups, hunt groups, and the attendant group, and finally, the time of day.
<b>view2</b>	This specifies a form that will display a subset of the view1 form entries. This form will include all of the view1 form except the last hour's hunt group measurements.
<b>conn</b>	This option will bring up the connection monitor output for key information.
entering no options	Omitting the "pnn # # #" argument on the command line will cause the default configuration of Pnn's 1, 2 and 3 to be displayed.
<b>pnn # # #</b>	Entering "pnn # # #", where "#" is replaced by a pnn number from 1 to 3, will cause data for the specified pnn's to be displayed.

## Help Messages

---

If the system technician presses HELP after entering "monitor system", the following object command word choices will be displayed:

```
conn          view1      view2
              scr
```

If the system technician presses HELP after entering "monitor system conn" the following message will be displayed:

```
Enter 3 port network numbers (xx-xx) ['pnn' x x x]
```

## Error Messages

---

If the pnn number entered is non numeric, not administered, or invalid in any other way, one of following messages will be displayed:

```
Object command word omitted; please press HELP
"xx" is an invalid identifier; press RETURN to execute modified command
```

If during the execution of a command a resource problem occurs that requires the user to restart the command, then the following message will be displayed:

```
Command resources busy; Press CANCEL to clear, and then resubmit
```

If all of the available maintenance resources are currently in use, then the following message will be displayed:

```
All maintenance resources busy; try again later
```

## Output

---

The following output fields are for the **monitor system view1** and **monitor system view2** commands.

Console #	A list of console numbers that are either activated or deactivated.
Activated:	The attendant console is in service. An attendant console is considered activated if its handset/headset is plugged in, it is not busied out, and the system is in day service and the console is a day or day/night or principle console, or the system is in night service and the console is a night or day/night console.
Deactivated:	The attendant console is not in service. The attendant console is considered deactivated if it does not meet the previous activated conditions.
# of alarms for trunks	The total number of existing minor and major alarms on trunk ports.
# of alarms for other resources	The total number of existing minor and major alarms on all maintainable objects in the system except trunks and stations.
First OSS number has been informed?	Has all the alarm been reported and acknowledged by the first OSS telephone number. If the "Alarm Origination" is not enable or there are no active alarm, the field will be "n".
Measurement hour	The starting time of the period for which the measurement was taken. For example, if the measurement hour is shown as 1800, it means the traffic status data displayed is for the time period from 6 PM to 7 PM (The measurement is taken on an hourly basis).
Grp no	A number between 1 and the maximum trunk group number or maximum hunt group number in the system.
Grp dir	Group direction: incoming, outgoing or two way.
Calls queued	Total calls that arrived and were placed in the queue for trunk groups.
Calls aban	Total calls that were abandoned by the caller.
%Out blkg:	The ratio of outgoing calls that are not carried (due to overload conditions) on a trunk group to the outgoing calls offered.
% Time ATB:	The percentage of time within the polling interval that all trunks in the trunk group were unavailable for use.
Time of day	The current time of day acquired from the system.

For the following output example, the command `monitor system view1` was entered.

```

monitor system view1
      ATTENDANT STATUS                                MAINTENANCE STATUS

      Console no.                                     # of alarms for trunks: 4
Activated: 1 2 3 4 5 6                               # of alarms for stations: 2
                                                    # of alarms for other res: 1
Deactivated: 7 8                                     First OSS number has been informed? n

      TRAFFIC STATUS
      Measurement Hour: 1800

      Trunk Group Measurement                         Hunt groups Measurement
(4 grps with highest %time ATB)                    (4 grps with highest # of qued calls)
  Grp no: 78                                         Grp no: 16
  Grp dir:                                           Calls qued: 2
Calls qued: 1                                       Calls aban: 1
%Out blkg:                                           Attendant Group Measurement
%Time ATB:                                           Calls qued: 1    Calls aban: 0

                                                    16:06 WED MAR 6 1996

      - press CANCEL to quit -
    
```

For the following output example, the command monitor system view2 was entered.

```

monitor system view2
      ATTENDANT STATUS                                MAINTENANCE STATUS

      Console no.                                     # of alarms for trunks: 4
Activated: 1 2 3 4 5 6                               # of alarms for stations: 2
                                                    # of alarms for other res: 1
Deactivated: 7 8                                     First OSS number has been informed? n

      TRAFFIC STATUS Measurement Hour: 1800

      Trunk Group Measurement
(4 grps with highest %time ATB)
  Grp no: 78
  Grp dir:
Calls qued: 1
%Out blkg:
%Time ATB:

      Attendant Group Measurement
Calls qued: 1    Calls aban: 0

                                                    16:08 WED MAR 6 1996

      - press CANCEL to quit -
    
```

## Output

---

The following output fields are for the **monitor system conn** command.

Time Slot Status	There are 4 numbers associated with the time slot status for each specified pnn; for each of the two buses (0 and 1) there is a maintenance and a normal state. The first row is the pnn, the second specifies the bus while the third specifies the bus's state while the last column represents the number of idle counts. These fields represent real-time status data.
Bus Status	For the bus status fields, there are two numbers associated with each of the two buses for each pnn. Shown are the pnn number; the bus associated with it, i.e., 0 or 1; and the state of the bus, i.e., "avail" or "unavail". These fields represent real-time status data.
Callrate	The callrate field represents the call rate being experienced currently on the switch. This is a counter which is bumped each time a call attempt is made. This field represents real-time status data.
Interval	This field is related to the above field in that it represents the interval being applied with which the call rate is applicable. It is normally set to a 36 second time period. This field represents a constant status data.
Max_callrate	This field represents the maximum call rate which has been hit during the time since the last hour has passed. If, for example, at 20 minutes past 12:00 this command is executed, this field will represent the maximum call rate obtained during the past 20 minutes. This field represents real-time status data.
Next_hour	This field will contain a value of 0 or 1 depending upon if the measurements being taken are for this hour or the next. It is related to the previous field in that the maximum call rate is reflected for this hour. When this flag is set, then statistics begin to accumulate for the next hour and shortly thereafter, the maximum call rate will become zero and accumulations will begin anew.
tot_ts_req	This field holds the total time slots in use during the time period elapsed since the top of the last hour. Data is internally collected every 100 seconds. When the timer fires and the data collection occurs, a check is made as to how many time slots are currently in use. That's where the total comes from. There are three numbers displayed for this field on the form; one for each of the pnn's requested. This field represents real-time status data.
ts_denied	This field holds the total time slots requests that were denied during the time period elapsed since the top of the last hour. Data is internally collected every 100 seconds. There are three numbers displayed for this field on the form; one for each of the pnn's requested. This field represents real-time status data.



<code>tot_fts_req</code>	This field represents the total fiber time slots that have been requested. This field is incremented each time a fiber time slots that have been allocated since the last top of the hour measurements polling. There are three values shown on the form; one for each of the requested pnns. This field represents real-time status data.
<code>ts_count</code>	This field indicates how many time slots are in use during the last 100 second poling period. An internal timer causing polling to occur every 100 seconds. The value in this field represents the requests for time slots during that 100 second interim. There are three numbers displayed for this field on the form; one for each of the pnns requested. This field represents real-time status data.
<code>ts_total</code>	This field gets it's value from the time slots count field discussed above every 100 seconds. It represents the total number of time slots requested since the top of the last hour and is real-time status data.
<code>fts_count</code>	This field indicates how many fiber time slots are in use during the last 100 second poling period. An internal timer causing polling to occur every 100 seconds. The value in this field represents the requests for fiber time slots during that 100 second interim. There are three numbers displayed for this field on the form; one for each of the pnns requested. This field represents real-time status data.
<code>fts_total</code>	This field indicates the total number of fiber time slots. This field gets it's value from the fiber time slots count field discussed above every 100 seconds. It represents the total number of fiber time slots requested since the top of the last hour and is real-time status data.
Requests-TN748 TTRs	The total number of touch tone receivers requested is reflected in this field. It is a running count of currently active requests. It is decremented when a tone receiver is freed and incremented when they are requested. Note that this field applies strictly to the TN748 board. This field represents real-time status data.
Requests-TN748 CPTRs	The total number of call progress tone receivers requested is reflected in this field. It is a running count of currently active requests. It is decremented when a call progress tone receiver is freed and incremented when they are requested. Note that this field applies strictly to the TN748 board. This field represents real-time status data.
Requests-TN744 CPTRs	The total number of call progress tone receivers requested is reflected in this field. It is a running count of currently active requests. It is decremented when a call progress tone receiver is freed and incremented when they are requested. Note that this field applies strictly to the TN744 board. This field represents real-time status data.

Requests-TN744 TTRs The total number of touch tone receivers requested is reflected in this field. It is a running count of currently active requests. It is decremented when a tone receiver is freed and incremented when they are requested. Note that this field applies strictly to the TN744 board. This field represents real-time status data.

Requests-TN744 MFC The total number of multi-frequency receivers requested is reflected in this field. It is a running count of currently active requests. It is decremented when a multi-frequency receiver is freed and incremented when they are requested. Note that this field applies strictly to the TN744 board. This field represents real-time status data.

The following display was produced by entering **monitor system conn**.

```

Time Slot Status
Pnn Bus State *Idle Count Pnn Bus State
10 0 Maint 0 10 0 Avail
10 1 Normal 233 10 1 Avail
10 0 Maint 0 22 0 Avail
10 1 Normal 233 22 1 Avail
22 0 Maint 0 1 0 Avail
22 1 Normal 233 1 1 Avail
22 0 Maint 0
22 1 Normal 233 *Callrate: 20
1 0 Maint 0 *Interval: 60
1 1 Normal 233 *Max_callrate:45
1 0 Maint 0 *Next_hour: 70
1 1 Normal 233
tot_ts_req :0F24 0000 3CE2 ts_count :0010 0920 0200 Requests-TN748 TTRs :0014
ts_denied :0E46 3CE2 0000 ts_total :0000 0090 0028 Requests-TN748 CPTRs:0041
tot_fts_req:0000 53D2 2231 fts_count:02E0 0910 0784 Requests-TN744 CPTRs:0082
fts_total:0320 0192 7048 Requests-TN744 TTRs :0082
Requests-TN744 MFCs :0082
Note: * Denotes Base 10, All Other Figures are in Base 16
    
```

## Feature Interactions

None.

## monitor traffic

**monitor traffic trunk-groups [group#]**  
**monitor traffic hunt-groups**

The monitor traffic command shows the current load on specified trunk and hunt groups and the length of time that the oldest call in the group has been waiting.

## Parameters

---

**trunk-groups** The trunk group report displays the number of calls in the queue waiting to be serviced for each trunk group. The total number of members in the group and the number of members active on calls are displayed for comparative analysis. Only administered trunk groups up to a maximum of 60 are displayed.

You can specify the starting trunk group. For example, if you enter 5, trunk groups from group 5 up are displayed.

**hunt-groups** The hunt-group report is similar to the trunk-group report. In addition to the information contained in the trunk-group report, this report displays how long the oldest call in each group's queue has been waiting. The display is updated every minute. refreshed. Fields are blank for unadministered hunt groups.

## Output

---

- # Group number for the trunk or hunt group.
- S The size (number of members administered) of each trunk or hunt group.
- A The number of members in a group that are active on a call. This does not include members which have been busied out.
- Q The length of the queue administered for a group.
- W The number of calls waiting in the group queue to be serviced.
- LCIQ The longest call in queue (LCIQ) indicates the time in seconds the oldest call in the hunt group queue has been waiting to be serviced.

The following display shows a typical result when **mon tr hu** is entered.

```
monitor traffic hunt-groups

                HUNT GROUP STATUS          22:49 G3-MT DEC 31 1988
      #   S   A   Q   W   LCIQ           #   S   A   Q   W   LCIQ
      1   15  10  10  0   20             17
      2                                     18
      3                                     19
      4                                     20
      5                                     21
      6                                     22
      7                                     23
      8                                     24  10  5  0  0  10
      9                                     25
     10                                     26
     11                                     27
     12                                     28
     13                                     29
     14                                     30
     15                                     31
     16                                     32
( #: Group; S: Grp Size; A: Active Members; Q: Q Length; W: Calls Waiting)
(LCIQ: Longest Call In Queue in seconds)
```

The following display shows a typical result when **mon tr tr** is entered.

```
monitor traffic trunk-groups

                TRUNK GROUP STATUS          22:49 G3-MT DEC 311988
      #   S   A   Q   W   #   S   A   Q   W   #   S   A   Q   W   #   S   A   Q   W
      1   15  10  0  0
      2   22  21  10  10
      9   31  12  20  0
     65   5   5  10  8
     99  12  0  0  0

( #: Group; S: Grp Size; A: Active Members; Q: Q Length; W: Calls Waiting)
```

## monitor trunk

### monitor trunk group# / member#

This command displays the same information as the **status trunk** command and updates the data automatically every minute or on demand. To manually update the display, press UPDATE (f6 on most terminals). Press CANCEL to cancel the

command. Unlike some monitor commands, the terminal login is not dropped when you cancel the command.

## netstat ip-route

This command displays the routing tables that are resident in the C-LAN circuit pack. With the “board” option, the command **netstat ip-route board UUCss** displays the routing tables that are resident on the specified C-LAN circuit pack.

Action/ Object	Qualifier	Qualifier Description	Permissions	Defaults	Feature Interactions
netstat ip-route	<i>board UUCss</i>	Example: <b>netstat ip-route board 01A03</b>	init inads craft	none	none

## Output

The following example shows the output from the **netstat ip-route** command.

```

netstat ip-route                               page 1 of xxx
                IP ROUTING - C-LAN

  Destination      Gateway                C-LAN Bd/Pt      Interface
1: . . . . .      . . . . .             01C0514           ppp13
2: . . . . .      . . . . .             01C0517           cmp0
3: . . . . .      . . . . .             01C0518           lo03

```

## Field descriptions

Destination	Fixed field giving the destination of the route. The destination is a name administered on the Node Name form which can include the keyword “Default,” indicating the default route.
Gateway	The node name of the Gateway by which the Destination can be reached. The Gateway must be a name administered on the Node Name form.
C-LAN Board/Pt	The circuit pack location for the circuit pack that provides the interface for the route.
Interface	<ul style="list-style-type: none"> <li>■ pppn represents one of the PPP interfaces on the C-LAN, which is administered as port n+1.</li> <li>■ cpm0 represents the ethernet interface on the C-LAN which is administered as port 17.</li> <li>■ lo00 represents the loopback interface on the C-LAN which does not need to be administered.</li> </ul>

## ping ip-address

---

This command sends a “ping” to the given IP address and returns the port used to perform the test, the pass/fail results of the test, the round-trip delay time for successful tests, and the error code on tests that failed. You can also specify which circuit pack that is used to perform the test in the case of multiple C-LAN circuit packs.

If the command fails (for example, if the port or far end is not responding etc.), the system returns one of the following messages ([Table 8-8](#)):

**Table 8-8. Ping command error messages**

Message	Interpretation
www.xxx.yyy.zzz Internet address not assigned	The system cannot find the IP address.
Internet address not reachable from this board	The IP address is not in the route table of the specified board.
More than one default route exists, specify board	The IP address is not in the route table, and more than 1 C-LAN circuit pack has a default route.
Invalid internet address	Invalid Internet address parameter
"CCcss" is an invalid identifier; please press HELP	Invalid board location (when using the “board” option).
Error encountered, could not complete request	The internal error of not being able to find the port through which the IP address is reached.

---

Action/ Object	Qualifier	Qualifier Description	Permissions <sup>1</sup>	Defaults	Feature Interactions
ping ip-address	ipadd	The IP address of the device to ping  Example: <b>ping ip-address 192.68.3.26</b>	init inads craft	none	none

1. The ping ip-address command is restricted to the init, inads, and craft logins. You can place additional restrictions on the command by selecting the object "ip-address" on the Restricted Object List:

Enter **change permissions loginid**, where loginid is an administered login such as inads) and press Enter.

Set the Additional Restrictions to **y** in the Administration Commands section of the form.

Go to the second or third page of the form.

Enter **ip-address** in the list of Restricted Objects and press Enter.

## Output

The following example shows the output from the **ping ip-address 192.68.3.26** command.

PING RESULTS					
End-pt IP	Port	Port Type	Result	Time(ms)	Error Code
192.68.3.26	01C0202	PPP-PT	PASS	221	

Screen 8-4. Ping results

## Field descriptions

End-pt IP	The actual TCP/IP destination address of the ping command.
Port	Location of the C-LAN circuit pack.
Port Type	Can be either PPP-PT for PPP ports (ports 1-16) or ETH-PT for the Ethernet port (port 17).
Result	PASS or FAIL
Time (ms)	The round-trip time (in milliseconds) of the ping.
Error Code	

## **ping node-name**

This command performs a ping test exactly like the **ping ip-address** command, except you enter an administered node-name (**display node-names**).

Action/ Object	Qualifier	Qualifier Description	Permissions	Defaults	Feature Interactions
ping node-name	<i>board</i> <i>repeat</i>	Example: ping node-name <i>nname</i>	init inads craft	none	none

## **Output**

The command output looks the same as [Screen 8-4](#).

## **recycle carrier**

### **recycle carrier UUC**

The recycle carrier command turns power off, then back on, on a specific carrier. When a power unit is replaced in a carrier, this command must be entered to restart the power on that carrier. The following carriers cannot be recycled:

- PPN Control Carrier (active or standby)
- Switch Node Carrier
- EPN Control Carrier
- Any carrier holding an active Tone-Clock or an active Expansion Interface circuit pack



#### **CAUTION:**

*When a port carrier is recycled, all ports and adjuncts supported by circuit packs on that carrier undergo a service outage.*



#### **CAUTION:**

*Never recycle power to a carrier containing DEFINITY AUDIX TN566/TN2169 circuit packs without first shutting down the AUDIX system. Doing so can damage AUDIX software. Follow instructions on the TN566/TN2169 faceplate (these also appear under ADXDP-PT in [Chapter 9, "ABRI-PORT \(ASAI ISDN-BRI Port\)"](#)). On G3r V1 systems, the TN566/TN2169 may appear as a TN746 with a vintage greater than 50.*

For more information see Common Input Parameters and Common Output Fields at the beginning of this chapter.



## release commands

---

### **release board UUCSS**

#### **release maintenance-name [address]**

Release commands release specified maintenance objects from the maintenance busyout state and puts them back into service, assuming the health of the component(s) permits. Hardware tests specific to the maintenance object are performed to verify that it is functioning.

For each maintenance object, the release command is entered in the same fashion as the associated busyout command, except that the word **release** is entered instead of **busyout**. See the description of the related busyout command for details of command syntax.

If a release command is entered for an object that is not busied out, the command will abort. Some release commands trigger recovery actions by the system, such as the refresh of a standby PNC or SPE. See the description of the related busyout command for details of command execution and interactions.

## Parameters

---

Input parameters consist of specifying the location, if required, of the given maintenance object. Use the same format as that used for the related busyout command.

## Examples

---

```
release board 01c11  
release data-module 310  
release tone-clock 2a  
release ds1-fac 02e01a  
release fiber-link 13  
release standby-spe
```

## Output

---

The identity of the maintenance object and the result of command execution is displayed on a screen form similar to the related busyout screen. When the command aborts or fails, an error code indicating the reason is displayed. See Common Abort and Fail Codes at the beginning of this chapter.

The following display shows a typical result when **release board 01c07** is entered.

```
release board 01C07
```

```
COMMAND RESULTS
```

Port	Maintenance Name	Alt. Name	Result	Error Code
01C07	ANL-BD		PASS	
01C0701	ANL-LINE	5409	PASS	
01C0702	ANL-LINE	5416	PASS	
01C0703	ANL-LINE	5421	PASS	

```
Command successfully completed
```

## reset board

---

**reset board UUCSS [repeat #]**



**CAUTION:**

*This command can be service disrupting and may cause extraneous alarms. Effects of a reset vary depending upon the type of object being reset and upon whether the component is duplicated. Consult the section in [Chapter 9, "ABRI-PORT \(ASAI ISDN-BRI Port\)"](#) on the relevant maintenance object for details.*

When a port circuit pack is specified, the reset board command performs a software reset of every administered port on the circuit pack. All ports must be busied out before the port circuit pack is reset.

On Critical Reliability systems (duplicated PNC), reset of an Expansion Interface, Switch Node Interface, Switch Node Clock, or DS1 Converter circuit pack on the active PNC is not permitted. Standby components must first be busied out before entering the reset.

Cabinet number and repeat both default to 1. For more information see Common Input Parameters and Common Output Fields at the beginning of this chapter.

## reset disk

---

**reset disk [C]**

This command resets the disk device, queries the device for ID, size and other information, and initiates self-testing by the device. Upon successful completion, all alarms on that disk are cleared and the device is returned to service.

The cabinet is always **1** and need not be entered. On systems with duplicated SPEs only, carrier **a** or **b** must be entered.

Failure of the reset command places the disk in the uninstalled state. All system access to the disk, including demand testing, is prevented except for demand resets.

When the host-adapter is busied out, only the demand busyout and test commands are permitted on the attached disk. Reset, release, scheduled and periodic testing and other system software access are blocked. In this case, the host-adapter must first be released before the disk can be released.

When the host-adapter is taken out of service due to test or reset failures, and becomes uninstalled, the disk is also placed in the uninstalled state and all access by system software, including resets, is blocked.

## reset fiber-link

---

**reset fiber-link fiber# [a-pnc | b-pnc]**



### CAUTION:

*The reset fiber-link command is destructive on standard and high reliability systems (simplex PNC), and may cause an entire port network to be removed from service.*

This command resets the Expansion Interface and/or Switch Node Interface circuit packs that are endpoints of a specified fiber link, dropping the link in the process.

A fiber link must be busied out before being reset. To busyout a fiber on critical reliability systems, the fiber must be on the standby PNC and the standby PNC must first be busied out. See **busyout fiber-link** for associated interactions.

The **list fiber-link** command displays a list of fiber links and their locations.

## Parameters

---

- fiber#** The administered number of the fiber link (1-27). On critical reliability systems (duplicated PNC), this number designates a fiber link pair; the following qualifier specifies which fiber in the pair is to be reset.
- a-pnc, b-pnc** On critical reliability systems (duplicated PNC), this distinguishes between the two fibers in a duplicated pair. On systems with simplex PNC this is always a-pnc and need not be specified.

## Examples

---

**Simplex PNC: reset fiber-link 1**

**Duplex PNC: reset fiber-link 1**

## reset host-adapter

---

### reset host-adapter C

This command resets and initializes the host-adapter circuit on the MSSNET circuit pack. Upon successful completion, the host-adapter is put into service and all alarms active for that host-adapter circuit are cleared.

The cabinet is always 1 and need not be specified. Carrier a or b must be specified only on systems with duplicated SPEs.

This command will abort if any other MSS operation has already begun.

Failure of this command will place the host-adapter in the uninstalled state, preventing all maintenance testing, including demand testing, of the failed host-adapter. The reset must pass to put the host-adapter back into service.

When the host-adapter is taken out of service due to failures of its tests, or fails a reset and becomes uninstalled, the attached tape and disk are also placed in the uninstalled state and all access by system software, maintenance tests and commands including reset are blocked from execution.

## reset maintenance

---

### reset maintenance UUC

This command performs a reset on a specified maintenance circuit pack. Specifying cabinet 1 resets the PPN SYSAM circuit pack on the selected carrier, dropping any remote or local logins. Specifying cabinets 2 through 22 resets the EPN maintenance circuit pack in the 'a' carrier of the specified cabinet, dropping any local login to that circuit pack.

The cabinet number defaults to 1. The carrier must be specified only for PPNs with duplicated SPEs.

## **reset packet-interface**

---

### **reset packet-interface C [S]**



#### **CAUTION:**

*Resetting a packet interface is disruptive under the following conditions:*

- On all standard reliability systems (simplex SPE)
- When SPEs in a duplicated system are locked, or handshake is down, and the active packet interface is reset.
- When the standby SPE in a duplicated system has a state of health lower than the active, and the active packet interface is reset.



#### **CAUTION:**

*In the above cases, call service throughout the system is disrupted, the terminal is logged off and all EPNs are unavailable during the reset interval. A minor alarm is logged against the circuit pack to be reset. This lowers the state of health of the associated SPE and may cause a spontaneous SPE interchange in duplicated systems.*

This command resets and initializes the packet interface circuit pack hardware and firmware. The actual sequence of operation depends on the type and status of the SPEs.

When an active packet interface is reset, its links are dropped and reassigned to the remaining in-service packet interface circuit packs. These links are not migrated back to the packet interface after the reset. A level 2 (Cold-2) or greater system restart is required to redistribute the links equally among all active packet interfaces, including the one that was reset.

## **Simplex SPE**

---

For standard reliability systems the specified packet interface circuit pack is simply reset. Failure of the reset can lead to the circuit pack being placed in the out-of-service state. When a packet interface is out of service, scheduled, periodic, error and demand testing of the circuit pack is prevented and it is not used for links. The circuit pack returns to the in-service state upon passing the reset. A level 2 (Cold-2) or greater system restart is then performed to distribute the links equally among the available packet interface circuit packs.

## **Duplicated SPE Standby Packet Interface**

Reset of a packet interface on the standby SPE does not disrupt service and results in a reset of all packet interfaces on the standby SPE. The following conditions are necessary:

- Handshake communication is up.
- The SPE carriers are not locked with the SPE-Select switches.

The following sequence occurs:

1. Memory shadowing is turned off.
2. All standby packet interfaces are reset.
3. If the reset succeeds, shadowing is turned on, memory refresh initiated, and the packet is put into the standby state.
4. If the reset fails, the circuit pack is put into the out-of-service state, lowering the standby SPE's state-of-health.

## **Duplicated SPE Active Packet Interface**

### **Standby SPE available**

When a packet interface on the active SPE of a duplicated system is specified, a spontaneous SPE interchange is first performed by the system, assuming that:

- The SPE carriers are not locked with the SPE-Select switches.
- Handshake communication is up.
- The state of health of the standby SPE is not lower than that of the active.

If these conditions are met, the interchange places the active SPE into the standby state, and then all standby packet interfaces are reset as in the above case. Links are not disrupted, but due to the interchange transient calls are dropped and the terminal is logged off.

### **Standby SPE Not Available**

If any of the three conditions listed above are not met, an SPE interchange is prevented and the active packet interface is reset, resulting in disruption of all links associated with the circuit pack (see the Caution above). When the interchange is prevented by lower state of health of the standby, the standby packet interfaces are also reset according to the sequence listed above.

## Parameters

---

- C, CS** The cabinet is always 1 and need not be specified. Carrier a or b must be specified only for duplicated SPEs. The slot number (1-3) designates one of the dedicated PKT-INTFC slots on the PPN control carrier and defaults to the lowest-numbered slot with a packet interface installed in it.

## reset interchange

---

### reset pnc interchange [override-and-lock]

#### ⇒ NOTE:

This command does not work like other reset commands. Instead of resetting or initializing hardware, a PNC interchange is executed. Before entering this command, look at the states of health of the two PNCs with **status pnc**.

This command executes a PNC interchange on a Critical Reliability system (duplicated PNC). The standby PNC becomes active and assumes control of active call processing, and the active goes to standby. If the health of the standby PNC is the same as or better than that of the active, no service disruption takes place; all stable calls and links are preserved. Some unstable calls may drop.

Both demand and spontaneous PNC interchanges are prevented by the following conditions:

- The standby PNC is busied out.
- The PNCs are locked by means of the **set pnc lock** or **reset PNC override-and-lock** commands.
- For 5 minutes after a spontaneous PNC interchange, or for 30 seconds after a demand interchange, an anti-thrashing mechanism prevents subsequent interchanges unless the override-and-lock option is used.
- If the state of health of the standby PNC is worse than that of the active, the command will abort unless the override-and-lock option is used.
- If the standby PNC has not completed a global refresh since it was last initialized or released, the reset will abort unless the override-and-lock option is used.

Note the following caution regarding the use of the **override-and-lock** option.

See **status pnc** for details of how to obtain and interpret the states of health and other current information about the PNCs. For a more complete explanation of PNC duplication and interchanges, see PNC-DUP in Chapter 9.

## Parameters

---

- interchange** "interchange" (without a preceding hyphen) must be specified on the command line.
- override-and-lock** This option is also used to override the anti-thrashing mechanism. Subsequent PNC interchanges are prevented, regardless of changes in the states health of the PNCs. Double call setup still takes place; each call is set up on both PNCs. To unlock the PNCs, use **set pnc unlock**.



### CAUTION:

*This option forces execution of the interchange regardless of the state of health of the standby, possibly disrupting service.*

## Output

---

One of the following messages is displayed:

```
Command successfully completed
```

If the reset pnc interchange command is unsuccessful due to the state of health of the standby Port Network Connectivity, operation of anti-thrashing, or the following message will be displayed:

```
Interchange of pnc failed;  
try again using the 'override-and-lock' identifier
```

See the preceding caution regarding use of the override-and-lock option. If the reset pnc interchange command is unsuccessful due to a busyout of the standby PNC, the following message will be displayed:

```
Must release port network connectivity first
```

### reset pnc interchange [override-and-lock]



### NOTE:

This command does not work like other reset commands. Instead of resetting or initializing hardware, a PNC interchange is executed. Before entering this command, look at the states of health of the two PNCs with **status pnc**.

This command executes a PNC interchange on a Critical Reliability system (duplicated PNC). The standby PNC becomes active and assumes control of active call processing, and the active goes to standby. If the health of the standby PNC is the same as or better than that of the active, no service disruption takes place; all stable calls and links are preserved. Some unstable calls may drop.



Both demand and spontaneous PNC interchanges are prevented by the following conditions:

- The standby PNC is busied out.
- The PNCs are locked by means of the **set pnc lock** or **reset PNC override-and-lock** commands.
- For five minutes after a spontaneous PNC interchange, or for 30 seconds after a demand interchange, an anti-thrashing mechanism prevents subsequent interchanges unless the override-and-lock option is used.
- If the state of health of the standby PNC is worse than that of the active, the command will abort unless the override-and-lock option is used.
- If the standby PNC has not completed a global refresh since it was last initialized or released, the reset will abort unless the override-and-lock option is used.

Note the following caution regarding the use of the override-and-lock option.

See **status pnc** for details of how to obtain and interpret the states of health and other current information about the PNCs. For a more complete explanation of PNC duplication and interchanges, see PNC-DUP in Chapter 9.

## Parameters

---

<b>interchange</b>	"interchange" (without a preceding hyphen) must be specified on the command line.
<b>override-and-lock</b>	This option is also used to override the anti-thrashing mechanism. Subsequent PNC interchanges are prevented, regardless of changes in the states health of the PNCs. Double call setup still takes place; each call is set up on both PNCs. To unlock the PNCs, use <b>set pnc unlock</b> .



### CAUTION:

*This option forces execution of the interchange regardless of the state of health of the standby, possibly disrupting service.*

## Output

---

One of the following messages is displayed:

```
Command successfully completed
```

If the `reset pnc interchange` command is unsuccessful due to the state of health of the standby Port Network Connectivity, operation of anti-thrashing, or the following message will be displayed:

```
Interchange of pnc failed;  
try again using the 'override-and-lock' identifier
```

See the preceding caution regarding use of the `override-and-lock` option. If the `reset pnc interchange` command is unsuccessful due to a busyout of the standby PNC, the following message will be displayed:

```
Must release port network connectivity first
```

## reset port-network

**reset port-network PN# level [1 | 2]**



**CAUTION:**

*A reset of level 2 is destructive, causing all calls and application links on the specified EPN to drop. EPN resets are described under EXP-PN in [Chapter 9](#).*

This command resets a specified port network to a specified level. This does not cause an interchange on a system with duplicated PNC. The command will not execute on the PPN, or on an EPN whose fiber link to the PPN or CSS is down.

## Parameters

---

- PN#** Port network number
- Use **list cabinet** to find the PN number(s) associated with a given cabinet.
- level 1 | 2** Reset level 1 (WARM restart) is used to restart an EPN that is still fully or partially in service. All stable calls are preserved, and full service is restored within 35 seconds.
- Reset level 2 (COLD restart) results in reset, removal, and reinsertion of all EPN circuit packs. It is used to recover an EPN that has been taken out of service. Level 2 restarts should take less than 2 minutes. All calls and application links with an endpoint in the EPN are dropped. If two level 2 resets within an hour fail to return the EPN to service, EPN Emergency Transfer is invoked. (EPN Emergency Transfer will already be in effect if the link to the EPN has been down for more than 1 minute).

## Examples

---

**reset port-network 10 level 2**

## Output

---

Port The PN number of the reset EPN.

For more information, see [“Common Output Fields”](#) and [“Common Abort and Fail Codes”](#) at the beginning of this chapter. The following display shows a typical result when **reset port-network 4 lev 1** is entered.

```
reset port-network 4 level 1

                                TEST RESULTS

Port      Maintenance Name  Alt. Name  Test No.  Result  Error Code
-----
04        EXP-PN                956       PASS

Command Successfully Completed
```

## reset spe-standby

---

### reset spe-standby level# [tape]

This resets the standby SPE on a system with duplicated SPEs to a specified level. The command is increasingly destructive as the reset level increases. On a system with disk and tape devices, the reset is executed using the boot image stored on disk unless a reset of level 4 (reboot) with the “tape” qualifier is requested. During the reset, the standby SPE is taken out of service for several minutes. Reset status can be monitored with the **status spe** command.

During a reset of any level, memory shadowing is turned off. After the reset completes, memory shadowing is automatically restored and a memory refresh of the standby takes place. The standby is not fully in service until the refresh is complete. **Reset spe-standby** invokes initialization of the standby in the same fashion as low level maintenance. The reset level requested will not be escalated by software. The level requested will always be the level that is performed.

Any reset of the standby SPE turns off shadowing, leaving the standby SPE unrefreshed. It may take several minutes before the standby is available for service.

## Parameters

---

**level#** This specifies the level of reset to be executed, from 1 to 5:

Tape	Recovery
1	Warm Restart
2	Cold-2
3	Cold-1
4	Reboot
5	Extended Reboot

**Tape** Valid only for a reset of level 4, this specifies a reboot using the boot image stored on tape instead of disk.

## Output

---

The message: `Command successfully completed` indicates that the reset has been initiated. Execution and recovery can take several minutes.

## reset system

---

**reset system [level# | interchange] [disk | tape] [contention-override]**



### CAUTION:

*All system resets (except planned interchanges) are service affecting, with higher levels being increasingly destructive. Some resets may take up to one half hour to complete. Certain conditions may result in a higher reset level than the one requested. Unless you are experienced with resetting a system, follow normal escalation procedures.*



### NOTE:

**reset system interchange**, used to switch control of the system from an active SPE to the standby, is discussed separately under its own heading.

This command resets a Switch Processing Element (SPE) at a specified level that is increasingly disruptive as the reset level increases. *All system resets (except reset system interchange) are disruptive and terminate the G3-MT login.*

When the command is entered, the MSS devices are checked to see if they are currently in use. If any command or maintenance process that accesses the MSS is in progress, the reset is denied and a message is displayed. In this case, the **contention-override** option is required to force the reset. This check prevents aborting of a **save translation** or other MSS process.

If the vector bit is set to trigger a core dump for the specified reset level, a copy of system memory is first written to the primary MSS device. The system then clears the vector and proceeds with the request. If the vector is set for an active SPE core dump for reset level 1 a reset level 2 will be performed to recover the Packet Interface links. See the **get vector** command.

System software will generally not escalate a demand system reset to a higher level. There are certain conditions that result in a higher level reset than that requested. These include the following:

- The vector is set to trigger a core dump on the active SPE in the event of a level 1 reset.
- A PNC interchange is already in progress.
- A change in translation administration is in progress.

Reset levels greater than 1 turn off shadowing in a duplicated system, and leave the standby SPE in an unrefreshed condition for several minutes.

## Parameters

**Level** Reset levels are numbered as shown in [Table 8-9](#). The execution times listed are approximations.

**Table 8-9. Approximate Recovery Time for System Resets (min:sec)**

Level	Recovery	2,400 lines		5,000 lines		15,000 lines	
		Tape	Disk	Tape	Disk	Tape	Disk
1	Warm Restart	:10	:10	:10	:10	:10	:10
2	Cold-2	1:00	1:00	2:00	2:00	4:00	4:00
3	Cold-1	3:00	2:00	5:00	3:00	11:00	7:00
4	Reboot	12:00	4:00	15:00	6:30	23:00	11:00
5	Extended Reboot	15:00	7:00	18:00	10:00	25:00	15:00

<b>Interchange</b>	See <b>reset system interchange</b>
<b>Health-override</b>	See <b>reset system interchange</b>
<b>Disk</b>	Valid only for reset level 4, this specifies use of the boot image stored on disk for the reboot. Disk is the default device.
<b>Tape</b>	Valid only for reset level 4, this specifies use of the boot image stored on tape for the reboot.
<b>Contention-override</b>	Contention control aborts the reset system command if any other command is currently running. The <b>contention-override</b> option forces other processes to abort, allowing the reset to proceed.

## Examples

```
reset system 1
reset system 4 tape contention-override
```

## Output

Once this command is entered, it may not be canceled. The screen will display the results of various initialization tests. If the reset command is successful the user will be logged off (except for **reset system interchange**). Several

conditions may prevent a requested reset. If the reset fails and the message displayed is not self-explanatory, use **status spe** to determine what caused the failure.

## reset system interchange

**reset system interchange [health-override][contention-override]**



### CAUTION:

*Although this command is normally not disruptive, certain conditions may escalate the interchange to a higher reset level.*

This command is used to switch control from the currently active SPE to the standby. This type of interchange is called a planned, soft, demand or requested interchange. Interchanges caused by hardware faults or the SPE-Select hardware switches are called spontaneous or hard interchanges. Planned interchanges are discussed under:

- SPE Duplication in [Chapter 1, “Maintenance Architecture”](#)
- Executing a Planned Interchange in [Chapter 5, “Alarms, Errors, and Troubleshooting”](#)
- STBY-SPE in [Chapter 9](#)

This operation is not disruptive if the state of health of the standby SPE is “functional.” If this condition is not met, system software will normally abort a requested interchange. When this is the case, the **health-override** option can be specified to try to force a *spontaneous* (hard) interchange.



### CAUTION:

*Use of health-override may cause serious service disruption.*

Once a planned interchange has been initiated, it cannot be aborted with the CANCEL key. A **reset system interchange** command will abort for the following reasons:

- If the standby SPE is down
- If the SPEs are locked by means of the SPE-Select switches
- If communication to the standby SPE is not possible (handshake is down)
- If shadowing to the standby SPE is not turned on
- If the standby SPE is not fully refreshed
- If the State-of-Health of the standby is not “functional”
- There is an SCD dual-port RAM failure
- If there is any Mass Storage System activity

- If Packet Interface link migration fails
- If a minor or major alarm is logged against the standby SPE's SYSAM or Packet Interface circuit packs
- If the standby SPE is busied out

The destructiveness of an interchange that fails depends on how far the interchange proceeds before it fails. A non-destructive recovery should occur if an interchange is aborted before link migration has started. If the interchange fails after link migration has started, the system will perform a WARM restart to recover.

The SPE-Select switches located on the Duplication Interface circuit packs override any demand maintenance activities. If the SPEs are locked by means of these hardware switches, an interchange cannot take place until the switches are unlocked.

If a planned interchange aborts or fails, an error will be logged against SYSTEM, signaling that the expected interchange has not occurred. In this case, the reset may be escalated by software. This condition is described in [Failure of Planned Interchange in Chapter 5, "Alarms, Errors, and Troubleshooting"](#).

If **reset system interchange override** is specified while a PNC interchange is occurring, a spontaneous (hard) SPE interchange will occur which results in a Cold restart. After the restart, the active PNC will be the one that was being switched into before the restart.

If a requested SPE interchange fails, an error conveying additional information about the failure will be logged against the SYSTEM maintenance object.



## Parameters

---

- health-override** If a planned (demand) interchange fails for any of the previously listed reasons, this option can be specified to try to force a switch to occur. This option causes the active SPE's state of health to be downgraded as much as possible in order to allow a spontaneous (hard) switch to occur. However, if the standby SPE's state of health is still not better than that of the active, or if the SPEs are locked, the interchange will still not occur.
- contention-override** Due to contention control, **reset system interchange** aborts if any other command is currently running. Use of this option overrides contention control and forces the command to execute regardless of whether other commands are currently running.

## Output

---

Once this command is entered, it may not be canceled. The screen will display the results of various initialization tests. Several conditions can prevent a requested interchange. If the interchange fails and the message displayed is not self-explanatory, use **status spe** to determine what caused the failure. Executing a Planned SPE Interchange in [Chapter 5, "Alarms, Errors, and Troubleshooting"](#) and STBY-SPE in [Chapter 9](#) contain useful information for troubleshooting interchange failures. The following display shows a typical result when **reset sys int** is entered while a save operation is currently running.

```
reset system interchange                               SPE A

Unable to interchange due to MSS activity.
```

## reset tape

---

### reset tape [C]

This command resets the tape circuit pack, queries the device for ID, size and other information, initiates self testing of the device, and rewinds the tape. If successful, all alarms active for the tape device are cleared and the device is put back in service.

This command will abort if any other MSS operation has already begun.

Failure of the reset command will place the tape in the uninstalled state, preventing all maintenance testing including demand testing of the failed tape as well as all system access to the failed tape except for this reset command.

When the host-adapter is busied out, only the busyout and test commands are permitted on the tape in that carrier. Reset, release, scheduled and periodic testing and other system software access are blocked. The host-adapter must be released before the tape can be released.

When the host-adapter is taken out-of-service due to test failures, or fails a reset and becomes uninstalled, the tape on the same carrier is also placed in the uninstalled state. All access to that tape by system software, including maintenance tests, resets and other commands are blocked from execution.

## Parameters

---

- C** The cabinet is always 1 and need not be entered. Carrier a or b must be specified only for systems with duplicated SPE.

## Examples

---

Simplex SPE:     **reset tape**

Duplicated SPE: **reset tape a**

For more information see [“Common Output Fields”](#) at the beginning of this chapter.

## restore announcements

---

### **restore announcements [disk | tape]**

This command copies stored announcement data from the specified MSS device to the announcement board. On a duplicated system, data is always copied from the device on the active SPE.

#### **NOTE:**

The restore command can take up to 40 minutes to complete. Avoid pressing the ENTER key on the keyboard during this time, since doing so will cause the result messages to be lost.

The command is not executed if any of the following conditions is present:

- An announcement data module and a system port data module have not been administered.
- The announcement data module port is out of service or already in use (for example, performing an announcement playback).

- An integrated announcements session is in progress or the circuit pack is currently being uploaded or downloaded. Announcements cannot be save or restored after the restore announcements command has started. Tape is specified and a tape cartridge is not in the tape drive.
- A system port is not available.
- The MSS is in use by either another user or by maintenance.
- An announcement file does not exist on the specified device, or is corrupted.

In case of a failure of the restore command, you must make sure the announcement file is completely copied to the announcement circuit pack. The system will continually attempt to download the circuit pack at 10 minute intervals until either a download is successful, announcements are recorded, or a download is initiated from the terminal. In case of a hardware or firmware error, an error will be logged, pointing to the source of trouble. Maintenance software will invoke tests to diagnose and attempt to correct the problem. If maintenance software fails to correct the problem, an alarm is raised.

If a system crash or spontaneous SPE interchange takes place, the restore operation will fail, leaving the announcement circuit pack without a valid announcement file. To remedy this, repeat the restore command on the newly active SPE.

 **NOTE:**

Until announcements are completely copied to the announcement circuit pack, calls will not be connected to any announcements on the announcement circuit pack.

When the announcement circuit pack is inserted or reset, an automatic download of the announcement file is performed.

## Parameters

---

- disk** This specifies copying the announcement data stored on the disk device. Disk is the default device.
- tape** This specifies copying the announcement data stored on the tape device.

## Output

---

- Processor** The SPE from whose MSS device the announcement data was copied.
- Command Completion Status** This field indicates the results of the command execution and gives a self-explanatory reason for any failures.
- Error Code** A number indicating whether the announcement file was successfully restored to the announcement board:
- 0 = The restore was successful.
  - 1 = The restore failed.

The following display shows a typical result when **restore announcements** is entered.

```
restore announcements                Page 1 of 1   SPE A
                                     RESTORE ANNOUNCEMENTS
Processor  Command Completion Status          Error Code
SPE-A     Success                          0
```

## restore disk

---

**restore disk** [active | standby] [spe-a | spe-b] [both | either]  
[incremental | full]

This command copies all information from the tape device in the specified SPE to the disk device on the same carrier. Defaults are a full restore and, if the SPE is duplicated, both SPEs.



### NOTE:

The restore command can take up to 1 hour to complete. Avoid pressing the ENTER key on the keyboard during this time, since doing so will cause the result messages to be lost.

## Parameters

---

<b>spe-a</b>	This specifies a restore from the A carrier tape device to the A carrier disk device.
<b>spe-b</b>	This specifies a restore from the B carrier tape device to the B carrier disk device.
<b>active</b>	This specifies a restore on the active SPE.
<b>standby</b>	This specifies a restore on the standby SPE.
<b>both</b>	This specifies a restore on both SPEs. If the MSS on either SPE is inaccessible, the restore will abort on both SPEs.
<b>either</b>	This specifies a restore on both SPEs. If the standby SPE is inaccessible, the active SPE only will be restored.
<b>incremental</b>	This specifies that all data on tape marked "good" that has a date newer than the date on the disk be copied to the disk from the tape.
<b>full</b>	This specifies that all data be copied to the disk regardless of the dates and the status of the data (e.g., "good" or "bad").

## Examples

---

```
restore disk
restore disk active incremental
```

## Output

---

The outcomes are displayed for each SPE.

Processor	This identifies the processor carrier that was backed up (SPE-A or SPE-B).
Command Completion Status	This field displays one of various self-explanatory messages indicating the success or failure of the command.

The following display shows a typical result when **restore disk** is entered.

```
restore disk

                                RESTORE DISK

Processor      Command Completion Status

SPE-A         Success
SPE-B         Success

Command Successfully Completed
```

## **resume hardware-group**

---

### **resume hardware-group**

In the course of execution of a **test hardware-group** command, it may be desirable to halt the test temporarily or permanently. This is accomplished by either the **cancel hardware-group** command for a background test, or by pressing **Cancel** for a foreground test. **Resume hardware-group** enables you to restart the hardware group test at the point where it was canceled. This capability is not available if another hardware group test has been started. The status of a hardware group test can be obtained with **status hardware-group**.

When **test hardware-group all-ports** is canceled, the internally generated port translations for previously untranslated ports are removed. If **resume hardware-group** is then entered, only customer-administered ports will then be tested. **resume** does *not* reinstate the port translations that were removed by cancellation of the test.

## **Output**

---

When a test that was executing in the background is resumed, a success message is displayed. When a test that was executing in the foreground is resumed, test results are displayed.

## save announcements

---

**save announcements** [active | standby | spe-a | spe-b | both | either]  
[disk | tape]



### CAUTION:

*Do not execute **save announcements** if there is an unresolved problem with the HOST-ADAPTR maintenance object. Save translations should not be done to a tape or disk device with unresolved problems. Doing so may destroy a good copy of the files.*



### CAUTION:

*The option to save announcements to only one SPE in a duplicated system should be used with care since it causes two inconsistent versions to exist in storage.*



### CAUTION:

*The save command can take up to 40 minutes to complete. Avoid pressing ENTER during this time since doing so will cause the result messages to be lost.*

The save announcements command copies announcement data from the TN750B Integrated Announcement circuit pack to the Mass Storage System (MSS). Default devices are the disk in a disk/tape system, and the devices in both SPEs in a duplicated system. Other options are available as described below.

**Save announcements** writes two identical copies of the announcement data to each specified device. Each copy bears the same time-stamp, (the time at which the first copy was written). Each copy is also marked with the state of the copy ("good" or "bad").

Execution of this command requires the presence of a TN750B circuit pack and an administered announcement data module and associated system port.

The command is disallowed or aborts if:

- An announcement data module and system port data module are not administered.
- The announcement data module port is out of service or already in use.
- No announcements are on the board.
- An integrated announcements session is in progress.
- The board is currently being uploaded or downloaded.

- The tape drive is specified and no tape is in the tape drive or the tape is write-protected.
- No system access port is available.
- The MSS is in use by another user or by maintenance.
- The specified device or SPE is not in service.
- The standby SPE is specified and shadowing is not enabled.

A user cannot record announcements while a save announcements command is in progress. However, 15 channels are still available for announcement playback (one is reserved for uploading and downloading).

When MSS devices on both SPEs in a duplicated system are specified, **save announcements** will save data from the announcement board to the active and standby devices in parallel. The status of each save operation is reported separately. If one save operation fails, the save to the other device continues. Thus, the data is not lost. In this case, announcement date is inconsistent between the two devices. In case of a failure due to hardware faults or spontaneous SPE interchange, the user must make the announcement files on the two MSS devices consistent.

If a hardware failure occurs during a save announcements operation, software will log a hardware error. Maintenance software will invoke tests to diagnose and attempt to correct the problem. If corrective action fails, an alarm is raised against the ANNOUNCE maintenance object. Follow procedures recommended under ANNOUNCE in [Chapter 9, "ABRI-PORT \(ASAI ISDN-BRI Port\)"](#).

If a good copy of the announcement file is not available on the MSS, the **restore announcements** command can not be executed until after a successful **save announcements** is completed. The announcements on the board are still accessible and usable.



## Parameters

---

<b>active</b>	This option specifies writing to the specified device in the currently active SPE.
<b>standby</b>	This option specifies writing to the specified device in the standby SPE.
<b>spe-a</b>	This option specifies writing to the specified device in the SPE on the A carrier.
<b>spe-b</b>	This option specifies writing to the specified device in the SPE on the B carrier.
<b>both</b>	This option specifies writing to the specified device in each SPE concurrently. A failure in accessing either device causes the entire operation to fail and neither device is written to.
<b>either</b>	This option specifies writing to the specified device in both SPEs concurrently. If there is a failure in accessing one of the devices, the announcement data will still be written to the other one.
<b>disk</b>	This option specifies writing to the disk drive. Disk is the default device.
<b>tape</b>	This option specifies writing to the tape drive.

## Examples

---

```
save announcements
save announcements active disk
save announcements standby tape
save announcements spe-a disk
```

## Output

---

Processor	The SPE(s) to which announcement data was written (SPE-A or SPE-B).
Command Completion Status	The result of command execution, with a self-explanatory message explaining any failure or abort.
Error Code	Each device holds two copies of the announcements file. This field indicates whether both copies on the device were successfully stored:  0 = save was successful 1 = unable to save to the active spe device 2 = unable to save to the standby spe device

The following display shows a typical result when **save announcements** is entered on a system with simplex SPE.

```
save announcements                               Page 1 of 1   SPE A
                                                SAVE ANNOUNCEMENTS
Processor  Command Completion Status           Error Code
SPE-A     Success                               0
```

## save translation

**save translation** [active | standby | spe-a | spe-b | both | either]  
[disk | tape]

### ⇒ NOTE:

The save command can take up to 15 minutes to complete. Avoid pressing the ENTER key on the keyboard during this time, since doing so will cause the result messages to be lost.

All translation data is kept in volatile system memory during normal operation. In the event of a power outage or certain system failures, data in memory is lost. The save translation command allows the user to store on disk or tape the translation data currently in memory. This operation can be executed as part of scheduled background maintenance or on demand. The defaults are to save to disk and, on a system with duplicated SPEs, to both SPEs.

### ⚠ CAUTION:

*Save translation should not be executed if there is an unresolved problem with the HOST-ADAPTR maintenance object. Save translations should not be done to a TAPE or DISK device with unresolved problems. Doing so may destroy a good copy of the files.*

### ⚠ CAUTION:

*On systems with duplicated SPEs, the capability to save translation to only one SPE should be used with extreme caution since it results in the two SPEs having inconsistent translation data in storage.*

The save translation cannot be executed if translation data is being changed by an administration command.

### Parameters

- spe-a** This specifies saving translation data to the MSS device on the SPE in carrier A only.
- spe-b** This specifies saving translation data to the MSS device on the SPE in carrier B only.

- active** This specifies saving translation data on the active SPE only.
- standby** This specifies saving translation data on the standby SPE only.
- both** This specifies saving translation data on both SPEs concurrently (the default). The command will fail if the specified device on either SPE is inaccessible, and neither device will be saved to.
- either** This specifies saving translation data on both SPEs. If the standby is inaccessible, the save will still be done on the active SPE.
- disk** This specifies saving translation data to the disk drive. Disk is the default device.
- tape** This specifies saving translation data to the tape drive.

## Examples

---

**save translation disk**  
**save translation either tape**

## Output

---

Results are displayed for each SPE.

Processor	This identifies the SPE to which translation data was saved (SPE-A or SPE-B).
Command Completion Status	One of the following results is displayed: Success Disk device is out of service Tape device is out of service

The following display shows a typical result of entering **save translation** on a duplex system.

```

save translation

                                SAVE TRANSLATION

Processor      Command      Completion Status

SPE-A         Success
SPE-A         Success

Command Successfully Completed
```

## set options

---

This command allows the user to administer whether certain alarms are reported to INADS or whether they are downgraded to a minor alarm, warning alarm, or no alarm.

### Synopsis

---

**set options**

### Permissions

---

The following default logins may execute this command: **inads**, **init**.

### Examples

---

**set options**

### Description

---

This special command enables the technician (that is, remote user with INADS permission) to select which types of maintenance categories report alarms automatically and which types require the customer to call in. Judicious use of this command can reduce the number of ineffective alarms to the TSC. For the **set options** command to be effective, the default settings specified in this section should always be used. These settings are not intended to be changed on a per-system basis. Special circumstances (for example, special studies) may require temporary changes under the guidance of Tiers 3 and 4.

NOTE: Alarms can't be upgraded.

### Defaults

---

Initially, the alarm reporting options for On-board Trunk Alarms (Alarm Group 1), both Major and Minor, are set to "yes" (y); all others are set to "warning" (w). All trunk groups are associated with alarm severity group 1 by default.

### Parameters

---

None.

## Help Messages

If the user presses HELP after entering **set options**, the following message is displayed:

```
Entry is not required
```

## Error Messages

If the command entered is in conflict with another currently executing command, then a message is displayed showing the login id of the conflicting user and the conflicting command. The message is as follows:

```
'login id': 'command' has a command conflict
```

If during the execution of a command a resource problem occurs that requires the user to restart the command, then the following message is displayed:

```
Command resources busy;  

Press CANCEL to clear, and then resubmit
```

If all of the available maintenance resources are currently in use, then the following message is displayed:

```
All maintenance resources busy; try again later
```

## Form Input

After entering the command **set options**, the user is presented with the following form.

```
set options
```

```
Page 1 of 8
```

```
ALARM REPORTING OPTIONS
```

	Major	Minor
On-board Station Alarms:	w	w
Off-board Station Alarms:	w	w
On-board Trunk Alarms (Alarm Group 1):	y	y
Off-board Trunk Alarms (Alarm Group 1):	w	w
On-board Trunk Alarms (Alarm Group 2):	w	w
Off-board Trunk Alarms (Alarm Group 2):	w	w
On-board Trunk Alarms (Alarm Group 3):	w	w
Off-board Trunk Alarms (Alarm Group 3):	w	w
On-board Trunk Alarms (Alarm Group 4):	w	w
Off-board Trunk Alarms (Alarm Group 4):	w	w
On-board Adjunct Alarms:	w	w
Off-board Adjunct Alarms:	w	w
Off-board DS1 Alarms:	w	w
Off-board PGATE-PT Alarms:	w	w
Off-board Alarms (Other):	w	w

set options

Page 2 of 8

TRUNK GROUP ALARM OPTIONS  
(Alarm Group)

01: 1	11: 1	21: 1	31: 1	41: 1	51: 1	61: 1	71: 1	81: 1	91: 1
02: 1	12: 1	22: 1	32: 1	42: 1	52: 1	62: 1	72: 1	82: 1	92: 1
03: 1	13: 1	23: 1	33: 1	43: 1	53: 1	63: 1	73: 1	83: 1	93: 1
04: 1	14: 1	24: 1	34: 1	44: 1	54: 1	64: 1	74: 1	84: 1	94: 1
05: 1	15: 1	25: 1	35: 1	45: 1	55: 1	65: 1	75: 1	85: 1	95: 1
06: 1	16: 1	26: 1	36: 1	46: 1	56: 1	66: 1	76: 1	86: 1	96: 1
07: 1	17: 1	27: 1	37: 1	47: 1	57: 1	67: 1	77: 1	87: 1	97: 1
08: 1	18: 1	28: 1	38: 1	48: 1	58: 1	68: 1	78: 1	88: 1	98: 1
09: 1	19: 1	29: 1	39: 1	49: 1	59: 1	69: 1	79: 1	89: 1	99: 1
10: 1	20: 1	30: 1	40: 1	50: 1	60: 1	70: 1	80: 1	90: 1	100: 1

 **NOTE:**

The remaining Trunk Group information is shown on the next 6 pages and is not documented in this Manual.

On the first page of the Alarm Reporting Options Form, the user selects the alarm severity options for station alarms, the four trunk alarm severity groups, the adjunct alarms, off-board DS1 alarms, off board PGATE-PT alarms, and other off-board alarms. On the second page, known as the Alarm Reporting Options Form, the user assigns an alarm severity group to each trunk group. This feature enables the technician to reduce the level of alarms reported for on-board or off-board trouble conditions.

The following alarm options are available:

- Minor

Alarms are raised as maintenance testing discovers them but the severity of the alarm is downgraded to a minor. Alarmed resources that would have normally been taken out of service are still taken out of service. LEDs on the port board and maintenance board follow the normal Minor alarm LED strategy and there is a call to the receiving OSS.

- Warning

Alarms are raised as maintenance testing discovers them, but the severity of the alarm is downgraded to a warning. The advantage to the technician here is that the Alarm Log can still be used to pinpoint trunk or station problems reported by the customer. Alarmed resources that would normally have been taken out-of-service are still taken out-of-service. Alarm LEDs light on the port circuit pack and Maintenance circuit pack as before, but no attendant LEDs or stations reporting alarms are affected. There is no call to INADS.

- Report

This option treats the alarms in the same way as the warning category with one exception: alarms are reported to INADS using a special WARNING category. When an alarm of this type is received, INADS logs the occurrence and either creates a trouble ticket or closes it immediately. The retry strategy for a call of this type is similar to normal Major or Minor alarm reports. However, the acknowledgment LED on the attendant console or alarm reporting station does not reflect the status of the call.

- Yes

Alarms are raised in the normal manner. There is no filtering of alarm data.

- No

Alarms raised on a trunk, station, or adjunct in this category are dropped. Error information is provided as before, but there is no trace of an alarm. There is no LED activity and no call to INADS. Because resources are taken out-of-service without any record, this option is recommended only when other options do not provide the desired result.

The alarm options can be administered only on a system-wide basis for the following alarm categories:

- Major on-board station alarms
- Minor on-board station alarms
- Major off-board station alarms
- Minor off-board station alarms

Four alarm severity groups are provided for trunk alarms. You can administer the alarm options for the categories listed below in each alarm severity group. However, in G1, the alarm options can be administered only on a system-wide basis for the following categories:

- Major on-board trunk alarms
- Minor on-board trunk alarms
- Major off-board trunk alarms
- Minor off-board trunk alarms

For Adjuncts, an alarm severity option is assigned to each of the following categories:

- Major on-board adjunct alarms
- Major off-board adjunct alarms
- Minor on-board adjunct alarms
- Minor off-board adjunct alarms

You can also administer the options on a system-wide basis for Minor off-board DS1 Interface circuit pack alarms.

Alarm reporting options information in the Alarm Reporting Options Form is considered translation data and, thus, is preserved through all levels of restart.

This feature affects the alarming of the MOs listed below. Neither the trunk nor the station category applies to alarms raised on the common portion of the circuit pack.

In all cases, if the option associated with the alarm type is set to “n,” the alarm report is dropped. All error information about the alarm is intact, but there is no record of an alarm and no LEDs light on the port circuit pack, the Maintenance circuit pack, the attendant console, or alarm reporting station to indicate a problem.

If the option is set to “warning” or “report,” port circuit pack LEDs and LEDs on the Maintenance circuit pack are affected the same as normal warning alarms.

The default parameters are as follows:

- Downgrade all station, trunk (except on-board trunk alarms), and Minor DS1-BD alarms to warning alarms.
- On-board Major and Minor trunk alarms, should continue to raise alarms and report to INADS.

## Station MOs Affected By This Command

### NOTE:

Although alarms on these MOs may appear as warnings, the alarms should be investigated with user-reported problems.

- Analog Lines (ANL-LINE, ANL-NE-L, ANL-16-L)
- Digital Lines (DIG-LINE)
- Hybrid Lines (HYB-LINE)
- MET Lines (MET-LINE)
- ISDN-BRI Lines (BRI-PORT, BRI-SET)

Trunk maintenance is characterized by an escalation of a Minor alarm to a Major alarm if more than 75 percent of the members of the trunk group are alarmed. If the option for the trunk category is set to “warning,” “minor,” “report,” or “no,” this no longer happens. Maintenance removes an individual trunk member out-of-service according to the normal criteria used for Major and Minor alarms.



## Trunk MOs Affected By This Command:

### ⇒ NOTE:

Although alarms on these MOs may appear as warnings, the alarms should be investigated with user-reported problems.

- Auxiliary Trunks (AUX-TRK)
- Central Office Trunks (CO-TRK)
- Direct Inward Dialing Trunks (DID-TRK)
- Direct Inward and Outward Dial Trunks (DIOD-TRK)[G1.2SE only]
- DS1 Central Office Trunks (CO-DS1)
- DS1 Direct Inward Dialing Trunks (DID-DS1)
- DS1 Tie Trunks (TIE-DS1)
- ISDN Trunks (ISDN-TRK)
- Tie Trunks (TIE-TRK)

## Circuit Pack MOs Affected By This Command

### ⇒ NOTE:

Although alarms on these MOs may appear as warnings, the alarms should be investigated with user-reported problems.

### ⇒ NOTE:

Trunks that are not members of Trunk Groups, (e.g. PCOLs) are downgraded according to the alarm severity of group one.

- DS1 Interface Circuit Pack (DS1-BD)

## Adjunct-Related MOs Affected by this Command

### ⇒ NOTE:

Although alarms on these MOs may appear as warnings, the alarms should be investigated with user-reported problems.

- ASAI Adjunct (ASAI-ADJ)
- Lucent Adjunct Port (ATT-PORT)
- Ethernet ASAI Port (LGATE-PT)
- Ethernet ASAI Adjunct (LGATE-AJ)
- Ethernet Lucent Port (ATTE-PT)
- Ethernet Lucent Adjunct (ATTE\_AJ)
- ISDN-BRI Ports connected to Adjuncts (ABRI-PORT)

Although adjuncts are administered as stations, the administration of alarm severity for the station alarm group does not affect the alarm severity levels of the adjuncts. Similarly, the administration of alarm severity for the adjunct alarm group does not affect the alarm severity levels for other types of stations.

## PGATE-PT and associated Link MOs Affected by this Command

### ⇒ NOTE:

Although alarms on these MOs may appear as warnings, the alarms should be investigated with user-related problems.

- See Packet Gateway Port (PGATE-PT) for other Link associated MOs affected by this Command

### ⇒ NOTE:

Although alarms on these MOs may appear as warnings, the alarms should be investigated with user-related problems.

- EPN Maintenance Circuit Pack (MAINT)
- Expansion Interface (EXP-INTF)
- ISDN-PRI Signaling Group (ISN-SGR)
- Journal Printer (JNL-PRNT)
- PMS Link (PMS-LINK)
- PMS log printer (PMS-LOG)
- Primary CDR Link (PRI-CDR)
- Secondary CDR Link (SEC-CDR)
- SPE Select Switches (SPE-SELEC)
- Synchronization (SYNC)
- Packet Gateway Port (PGATE-PT)
- System Printer (SYS-PRNT)
- TDM Clock (TDM-CLK)
- Tone Generator Circuit Pack (TONE-BD)

## Field Help

---

Since all fields on the first page may have the same values, then pressing HELP in any field on the first page presents the following field help message:

```
m(inor) n(o) r(eport) w(arning) y(es)
```

The following is a description of the values:

m(inor)	Downgrade the major alarm to a minor alarm and report the alarm to INADS.
n(o)	Do not log the alarm or report it to INADS.
r(eport)	Downgrade the alarm to a warning and report the warning to INADS.
w(arning)	Downgrade the alarm to a warning, log it but do not report the alarm to INADS.
y(es)	Log and report the alarm to INADS.

All fields on page 2 may have the same values. Pressing HELP in any field on page 2 gives the following field help message:

```
Enter alarm group number: 1 to 4
```

The alarm group number is a way of distinguishing four different groups of alarms. These alarm groups allow the user to specify that alarms in different groups are handled differently from those in other groups.

## Field Error Messages

---

All of the fields on the first page allow the same values. Only one error message is printed for all first page fields. If the value is not one of the listed characters (m,n,r,w,or y) then the following message is displayed:

```
"X" is an invalid entry; please press HELP key
```

All of the fields on page 2 allow the same values. If the value in one of these fields is not numeric, the following message is displayed:

```
Entry must be all digits
```

All of the fields on pages page 2 allow the same values. If the value in one of these fields is a digit other than 1, 2, 3, or 4, the following message is displayed:

```
Entry out of range
```

## Output

---

After the user has entered in the changes to the options and pressed SUBMIT, the following message appears at the bottom of the screen:

```
Command successfully completed
```

## Feature Interactions

---

None.

## set pnc

---

### set pnc lock | unlock

On Critical Reliability systems (duplicated PNC), **set pnc lock** locks the active port network connectivity in the active state. PNC interchanges will be prevented and the active port network connectivity will remain active regardless of its state of health. Duplicate call setup will still take place, though the standby is not available for service. This condition can also be initiated by the **reset pnc interchange override-and-lock** command. You can tell if the PNC is locked by looking at the `Software Locked?` field on the **status pnc** screen. (The `Interchange Disabled?` field refers to the antithrashing mechanism.)

**Set pnc unlock** releases the lock and enables subsequent interchanges to take place.

If the health of the active pnc has degraded to worse than that of the standby pnc, unlocking the active port network connectivity can cause an immediate PNC interchange. This condition can be foreseen by use of **status pnc**.

System restarts remove a PNC lock.



#### **CAUTION:**

*If the active PNC experiences problems while in the locked state, service disruptions may occur that would ordinarily be avoided by PNC interchange.*

## Parameters

---

- lock** PNC interchanges will be prevented, and the active port network connectivity will be locked on-line.
- unlock** Releases the PNC lock.

## set signaling-group

---

### set signaling-group group#

The `set signaling-group` command sets the secondary D-Channel in the specified signaling group to be the primary D-Channel. The primary D-Channel becomes the secondary D-Channel. A signaling group is a collection of B-channels signaled for by a designated single D-channel or set of D-channels over an ISDN-PRI link.

## Parameters

---

**group#** The signaling group identifier is an administered number assigned to each signaling group.

## set snc

---

### set snc UUCSS [override]

This command sets which switch node clock (SNC) circuit pack in a given switch node carrier is active.



**NOTE:**

This command is valid only on a High Reliability system with a Center Stage Switch (duplicated SPE, simplex PNC). In this configuration, SNCs are duplicated on each switch node carrier.

## Parameters

---

**override** This qualifier will force execution of the set command regardless of the health of the standby SNC circuit pack.

## set synchronization

---

This command sets a specific DS1 trunk, tone-clock circuit pack, or ATM switch as the reference source for system synchronization signals. It is permitted only after synchronization has been disabled with **disable synch**. Any administered DS1 trunk or *active* tone-clock may be entered with the set command. The DS1 or tone-clock will remain the synchronization reference until either the set command specifies another circuit pack, or **enable synchronization** is entered.

After an **enable synchronization**, the administered primary or secondary synchronization source will become the synchronization reference. If no primary or secondary source is administered, the active tone-clock is used as the synchronization reference.



**NOTE:**

This command is not supported when ATM-PNC is enabled.

Action/ Object	Qualifier	Qualifier Description	Permissions	Defaults	Feature Interactions
set synchronization	<i>print</i>		init inads craft	none	none

## set tdm

---

### set tdm port-network PN# bus a | b [override]

This command determines which of the paired TDM buses (A or B) on a port network will carry the control channel and dedicated tone time slots. Each port network has a 512 time-slot TDM bus configured as two separate 256 time-slot buses. This division allows for duplication of control channels and time slots dedicated for use by system tones. On power-up, the control channel is carried on the A bus, and the tone time slots are carried on the B bus. Execution of this command puts both the control channel and the tone time slots on the specified bus.

Under extremely heavy traffic load, tone time slots on the bus that is not currently carrying the tones may be used for call processing. Use of the override command under these conditions will cause calls to be dropped.

See TDM-BUS in [Chapter 9](#) for details.

## Parameters

---

- PN#** The Port Network number of the TDM bus to be set. **List cabinet** displays port network numbers for a given cabinet.
- bus** One of the paired TDM buses, a or b.
- override** This option forces the setting of a bus which is out of service or a bus whose dedicated tone time slots are in use by call processing.

**CAUTION:**

*Use of this option disrupts service.*

## Examples

---

```
set tdm port-network 2 bus a
```

## set time

---

### set time

This command brings up a form showing the current day, date, month, year and time kept by the system clock. These entries can be edited to update the system time. The second field is set to zero whenever the time on the clock is altered. If no new entries are made, system time remains unchanged.

## Input Form

---

An input form with the following fields is displayed. The current time, or default time will be displayed in the fields.

Day of the Week:	Valid entries are Monday through Sunday.
Day of the Month:	1-31 are valid entries. A check for leap year is also made.
Month:	January through December.
Year:	The year must be saved as translation data and passed to the kernel whenever kernel memory is corrupted (system reboot or cold I restart), or the data is changed.
Hour:	0-23 are valid entries.
Minute:	0-59 are valid entries.
Second:	This field is reset automatically and cannot be altered.

```
set time                                     Page 1 of 1
                                     DATE AND TIME
DATE
    Day of the Week: _____ Month: _____
    Day of the Month:  __   Year:  ____
TIME
    Hour:  __   Second:
    Minute:  __
```

## set tone-clock

---

### set tone-clock UUC [override]

On port networks with duplicated Tone-Clocks, this command is used to select which of the two Tone-Clock circuit packs is to be active.

In EPNs, the A-carrier Tone Clock is the *preferred* Tone-Clock. It is always active unless a failure, maintenance testing, or use of this set command has caused an interchange to the B-carrier Tone-Clock. If you have used this command during a maintenance session, set the EPN Tone-Clock back to the A carrier when you are finished, assuming it is healthy. Tone-Clock interchanges executed by scheduled daily maintenance cause the standby to become active for 20 seconds and then interchange back to whichever Tone-Clock was originally active.

Cabinet number defaults to 1.

## Parameters

---

**override** This qualifier forces execution of the set command regardless of the health of the Tone-Clock circuit pack.

**CAUTION:**

*Use of this option is destructive to an entire port network for EPNs and for the entire system for PPN Tone-Clocks.*

## Examples

---

```
set tone-clock 01c override
set tone-clock a
```

## set vector

---

```
set vector reset-level# [spe-standby | spe-active | spe-maint | spe-smm]
```

The set vector command specifies the reset levels which will activate a core dump. When a designated reset occurs, a current copy of the system's memory is stored on the disk device, allowing the information to be examined later for troubleshooting purposes.

To force an immediate core dump, set the appropriate bit using this command and then execute **reset system** of the corresponding level, *but* be aware of possible disruption as a result of the reset.

**CAUTION:**

*Note that level 1 (WARM) resets may result in a more destructive level 2 (COLD2) reset for certain settings of the vector.*

**CAUTION:**

*Service is disrupted whenever an active SPE is performing a core dump.*

## Execution

---

The following actions are taken in response to the vector settings listed below when a designated reset takes place. In all cases after a core dump has been performed, the vector will be cleared.



## Simplex SPE

---

When a system restart occurs on a system with simplex (SPE) with the corresponding vector bit set, the core dump is written to the primary MSS device. Once the core dump is written, the vector is cleared and the restart is performed. When a WARM restart (reset system 1) is performed and the vector is set for WARM restarts, a COLDII is executed after the WARM restart in order to recover the packet interface circuit pack. Packet interface recovery is necessary due to delays of writing the core dump.

## Duplicated SPE Options

- spe-active** The active SPE will perform a core dump. When a WARM restart (reset system 1) is performed and the vector is set for WARM restarts, a COLDII is executed after the WARM restart in order to recover the packet interface circuit pack. This packet interface recovery is necessary due to the delays of writing the core dump
- spe-standby** The standby SPE will perform a core dump after its memory has been refreshed. When a WARM restart (reset system 1) is performed and the vector is set for WARM restarts, a COLDII is executed after the WARM restart in order to recover the packet interface circuit pack. This packet interface recovery is necessary due to the delays of refreshing the standby processor.
- spe-maint** The standby SPE will perform a core dump without refreshing its memory first. This option is the default on a duplicated system.
- spe-smm** The standby SPE will perform a core dump. This allows a dump of the Standby Maintenance Monitor (SMM) when the standby SPE is experiencing problems. If an interchange occurs after the standby (spe-smm) SPE vector has been set, a core dump will not be performed on either the new active SPE or the new standby SPE regardless of the level of restart that occurs. However, if another interchange occurs making the new active SPE the standby SPE once again, a core dump on the standby SPE will occur if the standby restarts at the appropriate level.

## Feature Interactions

---

In a simplex SPE system, service will be disrupted while a core dump is being written to the primary Mass Storage System device. In addition, service will continue to be disrupted until the software is restarted at an appropriate level. These “disruption” times will vary depending upon the particular switch configuration.

If a core dump file already exists, a subsequent core dump will overwrite it.

If the disk is not accessible, a core dump cannot be executed.

A core dump file can overwrite other files on tape. Caution must be exercised when generating a core dump on tape.

The vector will be cleared when a system restart of the proper level is performed regardless of whether the core is actually dumped.

If handshake is down in a duplicated system, while *spe-active*, *spe-standby*, or *spe-maint* is set, the active vector will be set, but the standby vector will retain its former value. This could lead to different vectors on the active and standby SPEs. **Set vector** should be reentered after handshake is back up. (Setting *spe-smm* while handshake is down returns an error message.) If handshake is up, the selected vector (active or standby) will be set and the other cleared.

If an interchange occurs after the *spe-smm* vector has been set, a subsequent restart will not trigger a core dump. However, if *another* interchange occurs, a core dump on the standby SPE will take place in response to a reset of the appropriate level on the standby.

## Parameters

**condition** A hexadecimal value representing the combination of reset levels (1= warm restart, 2= cold-2 restart, 3=cold-1 restart, and 4=reboot) that are enabled to initiate a core dump, as illustrated in the following table.

Vector Value	Reset Levels	Vector Value	Reset Levels
0	none	8	4
1	1	9	1, 4
2	2	a	2, 4
3	1, 2	b	1, 2, 4
4	3	c	3, 4
5	1, 3	d	1, 3, 4
6	2, 3	e	2, 3, 4
7	1, 2, 3	f	1, 2, 3, 4

**spe-standby** This is the default for duplicated systems. If a restart of a designated level occurs on the active SPE and the corresponding vector bit is set, a core dump will be taken on the standby SPE after the standby SPE has performed a refresh of memory.

**spe-active** On duplicated systems, a restart on the active SPE will cause a core dump to be taken on the active SPE.



**CAUTION:**

*A core dump performed with the **spe-active** option causes a service disruption.*

**spe-maint** On a duplicated system, if a restart of a designated level occurs on the active SPE, a core dump will be taken on the standby SPE without a refresh of its memory first.

**spe-smm** On a duplicated system, if a restart of a designated level occurs on the standby SPE, a core dump will be taken on the standby SPE. This can be useful to debug Standby Maintenance Monitor (SMM) problems.

## **status access-endpoint**

---

### **status access-endpoint extension [print]**

This command displays the operational of a non-signaling port on a DS1 interface or on an analog tie trunk circuit pack.

## Output

---

Extension	The extension number of the specified port.
Port	The physical location (cabinet-carrier-slot-circuit) of the port.
Communication Type	The type of communication supported by the channel: 56k-data, 64k-data, or voice-band-data.
Service State	The operational status of the access-endpoint channel: in-service/idle, out-of-service, maintenance-busy or disconnected.
Connected Ports	The location of any facility/endpoint to which this access-endpoint is connected.

The following display shows a typical result when **status access-endpoint 2300** is entered.

```
status access-endpoint 2300                                SPE A
                                     ACCESS END-POINT STATUS
                                     Extension: 2300
                                     Port: 02B0905
                                     Communication Type: 56k-data
                                     Service State: disconnected
                                     Connected Ports:
```

## status administered-connection

---

### **status administered-connection adm-conn# [print]**

This commands displays the operational status of an administered connection. To view administrative information for administered connections, use **list administered-connection** and **display administered-connection**.

## Parameters

---

**adm-conn#** The number (1-128) of the administered connection as assigned during administration.

## Output

---

Connection Number: The number assigned to the administered connection.

Enabled?: Whether the administered connection is enabled.

Originator: The extension of the access or data endpoint that originates the connection.

Destination: The destination address used to route the administered connection.

Connection State: The current status of the administered connection as follows:

*connected* = A connection between the originating and destination endpoints is currently active.

*restored* = The connection has been restored. The session may or may not have been preserved.

*failed* = The connection failed due to either an administrative error such as a wrong number or a service-blocking condition such as barring of outgoing calls.

Recovering from such a failure requires manual intervention. No further attempt is made by the system to re-establish the administered connection until the **change administered-connection** command is executed. If the failure was caused by a transient condition, you may be able to re-establish the connection by first disabling and then enabling the connection via the "Enable?" field on the **change administered connection** form. (The **enable admin** and **disable admin** *commands* affect only maintenance processes).

8 Maintenance Commands

*status administered-connection*

8-219

Connection State: (cont'd.)	<p>The cause of the failure is reported as an ISDN cause value that is recorded in the error log. Refer to the Hardware Error Log Table for ADM-CONN in <a href="#">Chapter 9</a> to identify failure causes.</p> <p><code>waiting to retry</code> = The system is waiting between attempts to restore the connection. The amount of time between attempts to restore is administered on the administered connections form. Check the contents of the Failure Cause field for information about why the administered connection failed.</p> <p><code>attempting to connect/attempting to restore</code> = These are transitional states during which an attempt is made to connect or restore the administered connection. If an administered connection remains in this state for longer than 1 minute, disable and then re-enable the connection. If the problem still persists, or if the administered connection has retried a number of times with <code>administered connection origination attempt timed out</code> reported in the Failure Cause field, then make sure that the originating data module is connected and the destination access endpoint is not out-of-service.</p> <p><code>not scheduled</code> = The administered connection is enabled but is not scheduled to be active at the current time.</p>
Failure Cause:	<p>This field displays a self-explanatory message indicating the reason for a current state of <code>attempting to connect</code>, <code>attempting to restore</code>, or <code>failed</code>. If the administered connection should be active but is not connected, then this field shows the most recent reason for failure. See also the above description of "Connection State: failed."</p>
Number of Retries:	<p>The number of consecutive failed attempts to establish the connection.</p>
Auto Restorable?	<p>When an administered connection fails, the system can automatically attempt to restore the connection. This field indicates whether this capability is activated on the administered connections administration form.</p>

The following display shows a typical result when **status administered-conn 3** is entered. In this example, destination is another switch, and the destination number consists of a trunk access code (512) and extension (26001).

```
status administered-connection 3                               page 1 of 1

      ADMINISTERED-CONNECTION STATUS

      Connection Number: 3
                Enabled? y
                Originator: 71001
                Destination: 51226001

      Connection State: connected
                Failure Cause:
      Number of Retries:
                Auto Restorable? y
```

## **status attendant**

---

### **status attendant console# [print]**

The status attendant command displays the operational state of the specified attendant console. This information can help in trouble diagnosis and in locating facilities to which the attendant console is connected.

## **status bri-port**

---

### **status bri-port UUCSSpp [print]**

The status bri-port command displays the service state, maintenance state and layer 1 state of an ISDN-BRI port. Also displayed on this form is information on the point-to-point signaling links carried over the port. For more information, see BRI-PORT in [Chapter 9, "ABRI-PORT \(ASAI ISDN-BRI Port\)"](#).

## **Output**

---

An extra section describing how to interpret the results of this command follows the screen display.

Port	The location of the ISDN-BRI port.
Service State	Whether the ISDN-BRI port is "in-service" or "out-of-service."
Maintenance Busy?	Whether maintenance testing is currently being performed on the port.

**8** Maintenance Commands  
*status bri-port*

8-221

Layer 1 State	<p>The operational state of the physical connection (Layer 1) of the ISDN link carried over the port:</p> <p><i>activated</i> = Layer 1 frames are being passed between the port and BRI endpoints.</p> <p><i>pend-activation</i> = The port is in service, the layer 1 interface device is turned on and layer 1 frames are being sent from the port, but the BRI endpoints are not responding.</p> <p><i>deactivated</i> = The layer 1 interface device on the BRI has been turned off due to the port being out of service.</p>
TEI Value	<p>The Terminal Endpoint Identifier (TEI) is a layer 2 addressing parameter used by the switch to exchange information with BRI endpoints over the point-to-point signaling link. The TEI is a number from 1 to 127.</p>
Layer2 State	<p>The operational state of the point-to-point signaling link (Layer 2):</p> <p><i>assigned</i> = The link is currently in the <i>AWAIT_EST</i> (Await Establish) state at layer 2. If the BRI endpoint supports TEI allocation procedures, those procedures have been successfully executed and a TEI has been assigned to the endpoint by the switch.</p> <p><i>established</i> = The link is in the <i>MF_EST_NORM</i> (Multi-Frame Established Normal) state at layer 2. The switch has successfully started the link and is now capable of exchanging layer 3 frames with the endpoint. If the endpoint does not support SPID initialization procedures, the voice extension of the endpoint associated with the link is also displayed. This is the normal state for a link in a point-to-point wiring configuration.</p> <p><i>L3-established</i> = The link is in the <i>MF_EST_NORM</i> state at layer 2 and SPID initialization procedures have been successfully completed. The voice extension of the endpoint associated with the link is also displayed. This is the normal state for a link in a multi-point wiring configuration.</p> <p><i>hyperactive</i> = Traffic on this link has exceeded the threshold and the link has been suspended.</p>
Endpt Extension	<p>The extension of the voice/data endpoint associated with the link. This field is blank if the link is not in the <i>established</i> or <i>L3-established</i> state.</p>
Endpt SPID	<p>The SPID (Service Profile Identifier) administered for the voice/data endpoint. This field is blank if the link is not in the <i>established</i> or <i>L3-established</i> state.</p>
Service SPID?	<p>If the link is associated with the Service SPID this field displays <i>yes</i> and the Endpoint Extension field is blank. Otherwise this field is blank. Service SPID is a feature used by service technicians to check building wiring between the switch and the BRI endpoint.</p>

The following display shows a typical result when **status bri-port** is entered.



**Table 8-10. Interpreting BRI-Port Status Reports**

Error Type	Aux Data	Associated Test	Alarm Level	On/Off Board	Test to Clear Value
ASAI, BRI	0-126	Assigned	blank	blank	<p>This is a transitory state for BRI endpoints and ASAI adjuncts. The switch is attempting to establish the link.</p> <ol style="list-style-type: none"> <li>1. Check the endpoint and wiring by following the SPID Facility Test Procedure described in the BRI-SET section of <a href="#">Chapter 9</a>.</li> <li>2. Repeat <b>status bri-port</b> to determine that the Layer 2 state of the signaling link is either <code>L3-Established</code> (for ASAI adjuncts and BRI endpoints supporting MIM initialization) or <code>Established</code> (for fixed TEI BRI endpoints and automatic TEI BRI endpoints not supporting MIM initialization). If it is not, follow normal escalation procedures. (A MIM or management information message is a level-3 message that conveys management and maintenance information between a communications system and a BRI terminal.)</li> </ol>
ASAI	0-63	Established	blank	blank	<p>This is a transitory state for ASAI adjuncts. ASAI signaling is connected at Layer 2 but the Layer 3 Restart procedure has not been completed between switch and adjunct.</p> <ol style="list-style-type: none"> <li>1. Check the adjunct by following the recommended repair procedures of the manufacturer.</li> <li>2. Repeat <b>status bri-port</b> and determine whether the L2 state of the signaling link is <code>L3-Established</code>. If it is not, follow normal escalation procedures.</li> </ol>
BRI	0-126	Established	ext#	blank	<p>This is the normal state for non-MIM initializing, fixed, and automatic TEI BRI endpoints.</p>

*Continued on next page*

**Table 8-10. Interpreting BRI-Port Status Reports — Continued**

Error Type	Aux Data	Associated Test	Alarm Level	On/Off Board	Test to Clear Value
BRI, ASAI	64-126	Established	blank	blank	This is a transitory state for automatic TEI BRI endpoints that support MIM initialization. <ol style="list-style-type: none"> <li>1. Verify that SPID administration on the switch and the endpoint are consistent. Repeat <b>status bri-port</b> to determine whether the Layer 2 state of the signaling link is L3-Established.</li> <li>2. Try replacing the endpoint. Repeat <b>status bri-port</b> to determine whether the Layer 2 state of the signaling link is L3-Established. If it is not, follow normal escalation procedures.</li> </ol>
BRI	64-126	L3-Established	ext#	blank	This is the normal state for automatic TEI BRI endpoints that support MIM initialization.
BRI, ASAI	64-126	L3-Established	blank	yes	A demand SPID Facility Test is in progress on the port, and the link is not currently associated with a BRI endpoint. See SPID Facility Test Procedures described in the BRI-SET section of <a href="#">Chapter 9, "ABRI-PORT (ASAI ISDN-BRI Port)"</a> .
BRI	64-126	L3-Established	ext#	yes	A demand SPID Facility Test is in progress on the port, and the link is associated with an endpoint on the port. See SPID Facility Test Procedures described in the BRI-SET section of <a href="#">Chapter 9</a> .
BRI	0-126	L3-Established	blank	blank	An invalid SPID is assigned to link. <ol style="list-style-type: none"> <li>1. Change the SPID value in the BRI endpoint to match the SPID administered to the BRI endpoint on the port. Repeat <b>status bri-port</b> to determine whether the Layer 2 state of the signaling link is L3-Established. If it is not, follow normal escalation procedures.</li> </ol>

*Continued on next page*

**Table 8-10. Interpreting BRI-Port Status Reports — Continued**

Error Type	Aux Data	Associated Test	Alarm Level	On/Off Board	Test to Clear Value
BRI	0-126	L3-Assigned	ext#	blank	<p>This is a transitory state for BRI endpoints that support MIM initialization.</p> <ol style="list-style-type: none"> <li>1. Wait 5 seconds and repeat the command. If the state has not changed, continue with Step 2.</li> <li>2. Make sure SPID administration on the switch and endpoint are consistent. Repeat <b>status bri-port</b> to determine whether the Layer 2 state of the signaling link is <i>L3-Established</i>. If it is not, go to Step 3.</li> <li>3. Try replacing the endpoint. Repeat <b>status bri-port</b> to determine whether the Layer 2 state of the signaling link is <i>L3-Established</i>. If it is not, follow normal escalation procedures.</li> </ol>
BRI	0-126	L3-Assigned	ext#	yes	<p>This is a transitory state for BRI endpoints that support MIM initialization when a SPID Facility Test has been used to initialize the station.</p> <ol style="list-style-type: none"> <li>1. Wait 5 seconds and repeat the command. If the state has not changed continue with Step 2.</li> <li>2. Make sure SPID administration on the switch and endpoints are consistent. Repeat <b>status bri-port</b> to determine whether the Layer 2 state of the signaling link is <i>L3-Established</i>. If it is not, go to Step 3.</li> <li>3. Try replacing the endpoint. Repeat <b>status bri-port</b> to determine whether the Layer 2 state of the signaling link is <i>L3-Established</i>. If it is not, follow normal escalation procedures.</li> </ol>

*Continued on next page*

**Table 8-10. Interpreting BRI-Port Status Reports — Continued**

Error Type	Aux Data	Associated Test	Alarm Level	On/Off Board	Test to Clear Value
ASAI BRI	0-126	Hyperactive	ignore	ignore	Link has sent too many messages per unit time. Signaling has been suspended. After 60 seconds, the system attempts to put the link into service. If a link remains in this state while there is no activity at the BRI endpoint, take the following steps: <ol style="list-style-type: none"> <li>1. Make sure SPID administration on the switch and endpoints are consistent. Repeat <b>status bri-port</b> to determine whether the Layer 2 state of the signaling link is L3-Established. If it is not, go to Step 2.</li> <li>2. Try replacing the endpoint. Repeat <b>status bri-port</b> to determine whether the Layer 2 state of the signaling link is L3-Established. If it is not, follow normal escalation procedures.</li> </ol>
ASAI	0-126	L3-Restarting	ext#		The switch has sent a Restart message to the adjunct but has not yet received a Restart Acknowledgment message from the adjunct.
ASAI	0-126	L3-Restarted	ext#		After receiving a Restart Acknowledgment message, the switch has sent a Heartbeat message to the adjunct and is waiting for a response.
ASAI	0-126	L3-Established	ext#		This is the normal state for ASAI adjunct.

```
status bri-port 1c1701                               Page 1 of 1   SPE A
                                                    STATUS BRI-PORT

                Port: 01C1701
            Service State: in-service
Maintenance Busy?: no
            Layer 1 State: activated

    TEI Value  Layer2 State  Endpt Extension  Endpt SPID  Service SPID?
Link1    64      13-established    1010          1010
Link2
Link3
```

## Interpreting Results of BRI-Port Status Reports

[Table 8-10](#) will help to interpret results of the **status bri-port** command. Find the combination of output field values contained in your report and follow the recommendations for the type of endpoint connected to the portStatus Cabinet

### **status cabinet UU [print]**

This command displays the operational status and attributes of the specified cabinet. The output screen displays configuration information for each carrier, connectivity and alarm information for each port network or switch node, and the emergency transfer status of the cabinet.

The cabinet number defaults to 1.

## Output

Carrier Location	The cabinet number and carrier letter of each carrier in the cabinet.
PN/SN Number	The Port Network number (1-22) or Switch Node number (1 or 2) of the indicated carrier.
Carrier Type	The type of the indicated carrier: processor, port, expansion-control, switch-node, dup-sw-node or not-used.
Cabinet Type	One of the following types: <ul style="list-style-type: none"><li>MCC Multicarrier cabinet</li><li>SCC Single carrier cabinet</li><li>S75XE System 75 (pre-R1V4) single carrier XE cabinet</li><li>blank The cabinet type could not be determined.</li></ul>

PN/SN Each Port Network and Switch Node located in the cabinet is identified by its PN number or its SN number and PNC designation (A or B).

Connectivity Status **For PNs** connectivity status refers to the availability of the Expansion Archangel Link (EAL) and Indirect Neighbor Link (INL) to the carrier for both active and standby PNCs (if duplicated). Possible values are:

- up EAL and INL are both available.
- down EAL and INL are both unavailable.
- near-end The EAL is available and the INL is unavailable.
- far-end The INL is available and the EAL is unavailable.
- blank In the standby column, this means PNC is not duplicated.

**For SNs** connectivity status indicates circuit pack insertion on the Switch Node as follows:

- up At least one switch node interface circuit pack in the Switch Node is inserted.
- down There are no switch node interface circuit packs inserted on the Switch Node.
- blank In the active column, this indicates that the Switch Node carrier is currently the standby in a critical reliability system. In the standby column, this indicates that the Switch Node carrier is currently active (whether or not PNC is duplicated).

Emergency Transfer The location of the circuit pack containing the emergency transfer select switch (EPN maintenance or SYSAM). In PPN cabinets with duplicated SPEs, there are two such circuit packs. In this case, if the standby Emergency Transfer Select switch is changed while handshake is down, switch setting displayed will be incorrect until handshake comes back up.

Select Switch The current setting of the emergency transfer switch:

- on Emergency transfer has been manually activated.
- off Emergency transfer is being manually prevented.
- auto+ The cabinet is controlling emergency transfer and it is currently activated.
- auto- The cabinet is controlling emergency transfer it is not currently activated.
- unavail The current setting of the emergency transfer switch is not available.

PN/SN Each Port Network and Switch Node located in the cabinet is identified by its PN number or its SN number and PNC designation (A or B).

Mj, Mn, Wn The number of major, minor and warning alarms currently logged against the Port Network or Switch Node.

The following display shows a typical result when **status cabinet 1** is entered.

```

status cabinet 1

CABINET CONFIGURATION STATUS                CABINET CONNECTIVITY STATUS

Carrier  PN/SN  Carrier  Cabinet  PN/SN      Connectivity Status
Location Number Type      Type     Type      Active      Standby

01A      PN 1    processor MCC      PN 1      up         up
01B      PN 1    processor SN 1      B-PNC    up         up
01C      PN 1    port     SN 1      A-PNC    up
01D      SN 1    dup-sw-node
01E      SN 1    switch-node

CABINET EMERGENCY TRANSFER                CABINET ALARM STATUS

Emergency  Select  PN/SN      Mj  Mn  Wn
Transfer   Switch

01A      off    SN 1  B-PNC  0  0  0
01B      off    SN 1  A-PNC  0  0  0
    
```

## status cabinet

This command lists the administered cabinets in the system.

Action/ Object	Qualifier	Qualifier Description	Permissions	Defaults	Feature Interactions
status cabinet			init inads craft	none	none

## Output

The following example shows the output for the **status cabinet** command.

```

status cabinet
                                                    SPE B

CABINET CONFIGURATION STATUS
Carrier  PN/SN  Carrier      Cabinet  PN/SN
Location Number Type          Type

01A     PN 1   processor    MCC      PN 1
01B     PN 1   processor
01C     PN 1   port
01D     PN 1   port
01E     PN 1   not-used

CABINET EMERGENCY TRANSFER
Emergency Select
Transfer      Switch

01B          auto-
01A          auto-

CABINET ALARM STATUS
PN/SN      Mj      Mn      Wn

PN 1       0       1       19

```

## status cdr-link

### status cdr-link [print]

The status cdr-link command displays the status of the call detail recording (CDR) links. If a link is down, the report includes the number of times the switch has tried to re-establish the link.

The CDR link is the physical link that the SPE uses to send call detail records to an output device such as a Call Detail Recording Utility (CDRU). CDR links use System Ports which are described in the PDATA-PT section of [Chapter 9](#). A system may have up to two CDR links, a primary and a secondary. See PRI-CDR in [Chapter 9](#).

## Output

The following information is displayed for both the Primary and Secondary CDR links, whether or not both are used.

Link State	The operational status of the link as follows:  up The link is established and is capable of supporting the application. This is the normal operational state.  down The link is physically down.  extension not administered An extension number for the output device has not been assigned on the CDR system parameters form.
Number of Retries	The number of times the switch has tried to set up the link.



Maintenance Whether the link is busied out for testing.  
Busy

The following is an example of the fields contained on the output form.

```
status cdr-link                               SPE A
                                             CDR LINK STATUS
                                             Primary           Secondary
Links state: up                             extension not administered
Maintenance Busy? no
```

## **status cleared-alarm-notif**

---

This command returns the status of Cleared Alarm Notification.

### **Synopsis**

---

```
status cleared-alarm-notif [1 | 2]
```

### **Examples**

---

```
status cleared-alarm-notif
status cleared-alarm-notif 1
status cleared alarm-notif 2
```

### **Description**

---

This command is intended to be used by Expert System to detect a chronic alarming condition. If this command returns Feature is suspended, Expert System can then identify an open trouble ticket as a chronic problem for special considerations.

### **Defaults**

---

The test defaults to return the status of Cleared Alarm Notification of the first OSS telephone number.

## Parameter

- 1 This option returns the status of Cleared Alarm Notification of the first OSS telephone number.
- 2 This option returns the status of Cleared Alarm Notification of the second OSS telephone number.

## Help Messages

[ '1' or '2' ]

## Output

---

The command returns one of the following messages:

1. If Cleared Alarm Notification is enabled and has not been suspended:

Feature is enabled

2. If Cleared Alarm Notification is disabled:

Feature is disabled

3. If Cleared Alarm Notification is enabled and has been suspended:

Feature is suspended

## Feature Interactions

---

None.

## **status conference**

---

This command is a troubleshooting aid to help identify problems with a multimedia conference and can help solve more complex problems.

## Synopsis

---

The first screen appears when **status conference** is entered and at least 1 valid conference is found.

## Permissions

---

The following default logins may execute this command: system technician, inads, init.

## Examples

---

**status conference**

**status conference 2 print**

**status conference [all \ conference-ID] [print \ schedule]**

**status conference [all \ conference-ID] [endpoint \ endpoint id]**

(see [“Field Descriptions \(status conference endpoint\)”](#) on page 8-246)

## Description

---

Use the **status conference** command to solve the following multimedia problems:

1. A user unable to join or remain joined to a conference.
2. A conference having poor video quality due to it being downgraded because of the automatic algorithms - audio AUTO mode and the Px64 video picture specifications.
3. A user not receiving full service, such as being an audio-only endpoint (no video).
4. An audio add-on user unable to join or remain joined to a conference.
5. A conferee not being seen by other users due to interworking problems.
6. A user not able to participate in the Multipoint Communications Service conference.
7. A continuous conference not switching endpoints in or out of quadrants.

## Defaults

---

The default for the conference-ID is **all** (all stored data).

## Parameters

---

<b>status conference</b>	Displays all stored conference data.
<b>status conference 2 print</b>	Displays data on conference 2 (current or last completed), and sends it to the SAT printer.

## Feature Interactions

---

None.

## Output

Depending on the command entered, it is possible to have many records display. Active conferences display first (in order of conference-ID), followed by completed conferences (most recently completed first). There is no data or information about conferences not yet begun.

The data for each conference displays in 2 parts: the first screen describes the status of the conference and indicates the modes and levels of the conference. It also shows certain endpoint information such as which endpoints are in use and which endpoint caused the conference operating mode to change. This screen is similar to the administration screens. The remainder of the screens display endpoint level data (up to 8 endpoints per screen), displaying the ports and drop reasons.

[Screen 8-5](#) shows page 1 of a typical administration screen. The first screen appears when **status conference** is entered and at least 1 valid conference is found.

```

status 50                                     Page 1 of 2
                                     STATUS OF CONFERENCE: 50 Status: in-use
Conference Name: MMCH DYNAMIC           Conference Mode: voice-activated
Password Scope:
  Password:                               Cascade Mode:
    Class: dedicated                       Audio Mode: G.728
Start Time/Date: 09:08 OCT 28           Data Mode: none       MLP Rate:
Stop Time/Date: 00:00 000 00           Admin Bandwidth: 64k   No of Channels: 2
  Chair:                               Conf Bandwidth: 64k   Rate Adaptation? y
Format (in/out): CIF                   FPS: 7.5 QFPS: 7.5   Lo/Hi Interworking? n

      Type Ext Meet-Me Number   Dial In  ----Capability---- Rate Bond
1: P64                          in  c    y  y  c      e
2: AUD                          out y           y
3:
4:
5:
6:
    
```

sdfsoc KLC 010397

**Screen 8-5. status conference: page 1 of 2**

### Field Descriptions (status conference, page 1)

status	The current status of the conference - active, in-use, complete
conference name	Always set as MMCH DYNAMIC

**8** Maintenance Commands  
*status conference*

8-234

conference mode	Always set as voice-activated
password	Not Applicable
password scope	Not Applicable
cascade mode	Conference cascade mode - blank
audio mode	The current operating audio mode - G.711-A, G.711-mu, G.728, G.722
class	The type of conference - dedicated
data mode	Data mode capability for this conference - none, any-mlp, ww-pcs
MLP rate	MLP Data Rate for this conference - blank.
start time/date	Conference start time in 24-hour notation with month and day.
stop time/date	End of conference in 24-hour notation with month and day. It is the actual end time if Status is complete; otherwise it is blank.
admin bandwidth	The channel bandwidth as administered on the Conference Record form - 64k.
no of channels	The number of channels (transfer rate) required for each Px64 endpoint - 2.
Chair	Identifies the current chair token holder. This field is always blank.
conf bandwidth	The current operating channel conference bandwidth. This can be different from the administered bandwidth because of Rate Adaptation.
Rate adaptation	Does this conference support Rate Adaptation? - n, y.
Format (in/out)	For single-screen conference, the video format of the conference, CIF, QCIF, QCIF/CIF, H.CTS, H.CTX+, and SG4. For conferences other than H.261, the input and output formats are always symmetric and the mode is the same for input and output. These display as H.CTX, H.CTX+, and SG4. For H.261 mode non-continuous presence conferences, the format is always symmetric and displays as CIF and QCIF. The same is true for the non-presentation, continuous presence conference in single-screen. For presentation mode H.261 single screen continuous presence capable conferences, the input and output formats may be symmetric QCIF/CIF (displayed as CIF) or asymmetric QCIF/CIF, depending on if the format is administered as upgradeable. For quad-screen conferences, the format is QCIF/CIF to reflect the input of QCIF from all participants and output of CIF to all participants. For presentation mode quad-screen conference, the format is also QCIF/CIF to reflect the input/output of all participants except the presenter. In quad-screen mode, the input from the presenter is always CIF.

8 Maintenance Commands  
*status conference*

8-235

FPS	The CIF frame rate (frames per second) - ' - ', 30, 15, 10, 7.5. FPS indicates the rate that an endpoint is capable of receiving frames. Note that there is no indication of the maximum transmit frame rate nor the current frame rate that the MCU can detect. The frame rate changes as a function of the amount of motion in the input image.
QFPS	<p>The ACIF frame rate (frames per second) - ' - ', 30, 15, 10, 7.5. QFPS indicates the rate that an endpoint is capable of generating/receiving frames.</p> <p>For quad-screen VAS conferences, QFPS reflects the highest common QCIF frame rate of all endpoints and the rate of the video mixer board, which may be lower than the rest of the participants. Note that QCIF calculation takes into account the highest common CIF frame rate declared by all conference participants, since QCIF rate cannot be greater than that of the highest common CIF rate.</p> <p>For quad-screen presentation conferences, QFPS reflects the highest common QCIF frame rate of all participants and the rate of the video mixer board. Note that the QFPS cannot be greater than the CIF frame rate announced by the presenter.</p> <p>QFPS field is blank for proprietary modes.</p>
lo/hi interworking	Does this conference support Low Speed/High Speed Interworking? - This field will always have a value of n.
Type	The type of conferee, either Audio/Video (P64), Audio Add-on (AUD), Cascade Link (CAS), BONDing Call (BOND), BONDing Cascade Link (BCAS), UCC Controller (UCC), or Dedicated Access (DA). BONDing calls use up to 12 channels to form a single multimedia pipe.
Ext	Endpoint extension chosen at administration. This field is blank.
Meet-me number	The Meet-Me Number administered for the Meet-Me Extension. This field is blank.
Dial Type	Indicates whether dial-in or dial-out is used to join the endpoint to the conference - in, out. The value in is for dial-in, and out is for dial-out.

In Use	<p>Is the endpoint currently participating in the conference or in process of connecting to the conference? - <i>y, c, e, f, n, blank</i>.</p> <p><i>y</i> means that the endpoint is in use and is fully connected on all media in an active conference.</p> <p><i>c</i> means that the endpoint is in use and is fully connected, however the endpoint has changed the conference audio or video capability or has changed the rate of the conference because of rate adaptation. This condition requires analysis of this endpoint's capabilities and mode fields to identify which capability was reduced.</p> <p><i>e</i> means that the endpoint is in use but the endpoint had capability problems. The endpoint does not have one of the required capabilities (Vid, Bhl, MLP) to be a full participant. For MLP capabilities, see the "T120" field. This condition requires analysis of this endpoint's capabilities and mode field to identify the missing capability.</p> <p><i>f</i> means that the endpoint is in use but is not connected to all media. This indicates that the endpoint has declared all the required capabilities (channel/video/ audio/data) but is not fully connected to all conference media at this time. This endpoint may be in the process of connecting, has failed to connect, or is not a valid video source. This condition requires analysis of this endpoint's capabilities and mode fields to identify the problem.</p> <p><i>n</i> means that the endpoint was connected in a conference but has/was disconnected or attempted to connect to a conference but was unsuccessful.</p> <p><i>blank</i> means the field is blank until the first call is made from/to the endpoint.</p>
Ch1	<p>Data on the quantify and quality of channels (transfer rate)? - <i>y, e, n, blank</i></p> <p><i>y</i> the endpoint has the required number of channels.</p> <p><i>e</i> means that the endpoint has not declared support for the correct number of channels and cannot participate fully in the conference.</p> <p><i>n</i> means that the endpoint has declared the correct number of channels, but all the channels have not yet joined the conference, due to either a network or endpoint problem.</p> <p><i>blank</i> Audio add-on endpoints always have the <i>Ch1</i> field set to <i>blank</i>.</p>

- Aud** Does it have the required audio capability? - *y, c, e, blank*
- y* the endpoint has the required audio capability. Audio add-on endpoint always have the Aud field set to *y* once the endpoint has joined the conference.
- c* this endpoint is PCM only and it changed the video quality of the conference by changing the operating audio from G.728 to G.711. If the administered audio mode is auto and the administered bandwidth is 112 kbps (56 k/channel) or 128 kbps (64 k/channel), the system starts out with the highest common audio of G.728. When the administered bandwidth is greater than 128 kbps, the system starts out with the highest common bandwidth of 7 kHz.
- e* A PCM-only endpoint that did not have the capability of supporting the administered audio mode of G.728 (such as a data conference), or G. 278/G.711 endpoint that did not have the capability of supporting the administered audio mode of 7 kHz. Such endpoints operate with PCM audio and interwork with the current operating audio mode.
- blank* the field is blank until the first call is made from/to the endpoint.
- Vid** Does it have the required video capability and is receiving video? - *y, c, e, n, blank*
- y* the endpoint has the required video capability and should be receiving video if the Chl, Aud, and Dat fields are *y*.
- c* means it downgraded the conference's video quality - either from CIF to ACIF or by decreasing the frame rate. The conference video mode is set by default to CIF and if a QCIF-only endpoint joins the conference, then the entire conference is made to operate in QCIF, with the video clarity downgraded. Also, the conference frame rate is initially set to the highest frame rate that can then be reduced by any endpoint. If the conference video mode is not administered with upgrade capability, then if the video parameters for a conference have been "downgraded," they are not "upgraded" until all endpoints disconnect from the conference.
- e* means that the endpoint has not declared any video capability in its cap-set.
- n* means audio only, not receiving video, possibly due to an audio or data problem.
- blank* Audio add-on endpoint always have the Vid field set to *blank*.
- Mlp** The state of the Control Link to the ESM (T.120 stack terminator), the endpoint MLP data capability, and the state of the data connection in the T.120 stack. This field value is always *blank*, indicating that the Data Mode for the conference is *none*, and therefore, the data does not apply, or the endpoint has never joined the conference.



Gx	<p>Does it have the Still Frame Graphics capability? - y, e, blank</p> <p>y This endpoint has this capability.</p> <p>e This endpoint did not declare this capability. The conference retains the still frame graphics capability when a non-compliant endpoint joins the conference.</p> <p>blank This endpoint has never joined the conference.</p>
Rate Adpt	<p>Rate adaptation/Interworking indicator - 5, 6, y, c, e, n, blank. Values of 5 and 6 apply only to Low Speed/High Speed Interworking. All other values apply only to Rate Adaptation.</p> <p>5 A 56-kbps (Low Speed) endpoint has joined a High Speed (128 kbps or above) conference. This endpoint is connected with audio only capability but is not a valid video source and destination.</p> <p>6 A 64-kbps (Low Speed) endpoint has joined a High Speed (128 kbps or above) conference. This endpoint is connected with audio only capability but is not a valid video source and destination.</p> <p>y This endpoint has joined the conference at the administered rate of 64 kbps, but because rate adaptation to 56 kbps was triggered by another endpoint, this endpoint has successfully rate adapted to 56 kbps.</p> <p>c The administered bandwidth of the conference is 64 kbps and this endpoint has joined the conference at 56 kbps. The first 56 kbps endpoint that joins 64 kbps rate adaptable conference triggers rate adaptation (see <code>Join Time</code> below).</p> <p>n A 64-kbps conference was triggered to rate adapt to 56 kbps by some other endpoint. This endpoint joined the conference at the bandwidth of 64 kbps, but encountered problems in rate adapting down to 56 kbps. This endpoint may have the audio and may be receiving video, but is not a valid video source.</p> <p>blank Rate adaptation was never triggered by any endpoint, and if this endpoint is in use and connected, then it has joined the conference at the administered bandwidth.</p>
Bond Mode	<p>BONDing Mode - blank. This field is blank for calls that are not related to bonding.</p>

- Ts** Indication of the talking state of the endpoint - *t, m, M, S, blank*.
- t* At the time the command was invoked, voice energy (talking) was detected from the endpoint.
- m* At the time the command was invoked, the endpoint indicated to the MCU that it was muted. It is possible that an endpoint may mute, but not send any indication to the MCU. In this situation the MCU does not display a mute indication.
- M* At the time the command was invoked, the endpoint's audio was muted via UDD/CRCS Agent interface. *M* displays when both the endpoint and the UCC/CRCS Agent have muted the endpoint audio.
- S* At the time the command was invoked, the endpoint's audio was muted because of solo-audio state set by UCC/CRCS Agent. While in solo-audio state, new endpoints joining the conference are automatically muted.
- blank* At the time the command was invoked voice energy (talking) was not being detected from the endpoint.
- Vs** Indication of the MCU video state for this endpoint - *a, b, B, c, i, r, R, s, S, u, U, v, blank*.
- For quad-screen conferences an *\** is affixed before the value of *Vs* to indicate that an endpoint is currently part of the mixed image. A *#* may be affixed before the value of *Vs* to indicate that an endpoint was fixed to be in the mixed image (via administration or UCC/CRCS Agent), but instead, a *Fill* video is shown in its place. This occurs when the video of an endpoint that is fixed in a quadrant cannot be used as a video source because the endpoint is currently not joined to the conference, has suppressed its video, or has invalid video to be the video source. Notice that at most four endpoints have an *\** or *#* affixed before the *Vs* field value.
- For quad-screen conference in VAS mode, the mixed image is broadcast to all endpoints. For quad-screen conference in presentation mode, the mixed image is return video to the presenter.

- Vs  
(cont'd.)
- a This value applies only to quad-screen conferences. \*a indicates that an endpoint is part of the current mixed image and is fixed in one of the quadrants via administration. A value of \*a indicates that the endpoint is fixed in a quadrant but is not currently connected (Fill image displays).
  - b For full-screen conference it indicates that at the time the command was invoked, this endpoint's video was being broadcast to other sites. This conference was in VAS, broadcast, or presentation mode. For quad-screen VAS conference it is prefixed with an asterisk (\*) and indicates that this endpoint's video is part of the mixed image because of VAS. For quad-screen presentation conferences, b (without an asterisk) identifies the presenter as the broadcaster.
  - B At the time the command was invoked the endpoint's video was being broadcast to other sites because of the UCC roll call feature. UCC roll call feature can only be performed in full-screen mode.
  - c At the time the command was invoked this endpoint's video was being broadcast to other sites. The conference was in chair mode and the broadcaster was designated by the chair. Chair features can only be performed in full-screen mode.
  - i At the time the command was invoked the endpoint was not a valid video source. For continuous presence conference, if this endpoint is fixed in a particular quadrant, an asterisk (#) is affixed before i.
  - r For full-screen conferences, at the time the command was invoked the endpoint's video was the return video to the broadcaster. For continuous presence conference in presentation mode, \*r represents a VAS quadrant that is part of the mixed image.
  - R At the time the command was invoked, the endpoint's video was the return video to the broadcaster because of the UCC browse feature. UCC Browse feature can only be performed in full-screen mode.
  - s At the time the command was invoked this endpoint's video was suppressed at the request of the endpoint. For continuous presence conference with fixed quadrant participants, if this endpoint is fixed in a particular quadrant a # is affixed before s.

- Vs*  
(*cont'd*)
- S** At the time the command was invoked this endpoint's video was suppressed via UCC/CRCS Agent interface. For continuous presence conference with fixed quadrant participants, if this endpoint is fixed in a particular quadrant, # is affixed before S. S displays when both the endpoint and the UCC/CRCS Agent have suppressed the endpoint video.
  - u** For full-screen conferences, at the time the command was invoked this endpoint's video was being broadcast to other sites. The conference was in VAS mode and the broadcaster was designated by the UCC/CRCS Agent interface. For quad-screen conferences, it indicates that UCC/CRCS Agent designated this endpoint as fixed in a quadrant. An asterisk (\*) is affixed before u if the endpoint is currently part of the quad image, and # is affixed if the endpoint is not currently joined.
  - U** Applies only to quad-screen conference and indicates that UCC/CRCS Agent designated a quadrant as VAS. An asterisk (\*) is affixed before U to indicate that this endpoint is part of the current quad image.
  - v** At the time the command was invoked this endpoint's video was being broadcast to other sites. The conference was in VAS mode but the endpoint has asked to be a broadcaster via "See-Me" request and was granted a MCV (Multipoint Command Visualize) token. The See-Me feature is only performed in full-screen mode.
  - blank** At the time of the request the endpoint's video was not broadcast, return, video, or part of the mixed-image, but it is a valid video source.

```

status conference                                     page 2 of 2

                STATUS OF CONFERENCE:

                Sum Grp: Group1  Group2  Group3  Group 4
                  L1:
                  L2:

    Ext   Join   Drop   Drop   AC   -----Ports-----   Sum
    Time  Time  Time  Reason Num Trunk   Video   Aud/Esm Grp   Software

1:
2:
3:
4:
5:
6:
    
```

**Screen 8-6. status conference: page 2 of 2**

**Field Descriptions (status conference, page 2)**

- Sum Grp**                    The VD audio Level 1 (L1) and Level 2 (L2) summer group parts for each assigned group (1-4). Summer parts are assigned only for conferences with over 6 participants. When a conference operates at an audio mode of 7 kHz (administered audio mode is 7 kHz, or auto with the bandwidth greater than 128 kbps), the system allocates “primary” and “secondary” L1 and L2 summer parts. These primary and secondary parts are allocated as adjacent port slots on the same board. Status conference only displays the primary summer ports. The secondary summer ports are always one slot higher than the displayed primary summer port.
- Join Time**                Time (in 24-hour notation) when the channel joined the conference.
- Drop Time**                Time (in 24-hour notation) when the channel disconnected. If the first channel has a drop time, then it means that the endpoint is not in use. If there is a drop time without a join time, it means that the call disconnected without being joined to the conference.

Drop Reason	<p>The reason for the channel's disconnect:</p> <p><b>2-pri</b> This drop reason occurs when an administration error causes a mismatch in primary-secondary designation for a cascade link. This mismatch shows that both MCUs are administered as primaries (see "Cascading" for a description of primary-secondary compatibility).</p> <p><b>2-sec</b> This drop reason occurs when an administration error causes a mismatch in primary-secondary designation for a cascade link. This mismatch shows that both MCUs are administered as secondaries (see "Cascading" for a description of primary-secondary compatibility).</p> <p><b>Agent</b> The reservation agent has caused the call to disconnect (for example, the agent has changed a connected dial-out destination number).</p> <p><b>Bandwidth</b> mismatch between a call and the conference it attempted to join. For example, a 56-kbps call attempted to join a 64-kbps conference that does not allow rate adaptation.</p> <p><b>BondHshake</b> BONDing handshake drop reason can be caused due to the following reasons: information channel parameter not supported or invalid, parameter negotiation terminated out of sequence, timer expired because of the secondary channels did not establish, or BONDing framing was not detected for one of the other channels.</p> <p><b>Busy</b> This dial-out drop reason occurs when the MCU detects that the conferee's terminal equipment is busy. This drop reason is detected by an ISDN cause value (for example h0). See "Dial-out" for a description of CPTR usage.</p> <p><b>Chair</b> disconnected the endpoint, using either Chair Command Disconnect (CCD) or Chair Command Kill (CCK) signals.</p> <p><b>Conf End</b> The conference was ended due to reaching stop time for a reserved conference or due to an active conference being converted to file.</p>
-------------	--

Drop Reason  
(*cont'd*)

**Endpoint** Clearing received from DS1 - the disconnect came from the endpoint. The endpoint notified the MCU that it intended to disconnect.

**Far-end** Clearing received from DS1 - the disconnect came from either the network or the endpoint.

**Handshake** Either framing was never found (the endpoint could not complete initialization - problems finding Frame Alignment Signal (FAS), Multi Frame Alignment (MFA) and getting a corrected coded cap-set) or framing was lost for some time (over 40 seconds) and the endpoint was disconnected.

**IDtimeout** The MCU has not received response to the UIN/password Query from the H.320 user after three attempts. Each attempt has a system administered timeout period.

**Internal** MCU has a problem allocating trunk resources necessary to route the dial-out call for the specified dial-numbers. This problem can be associated with routing pattern or trunk associated translation (for example, TAC specified in the dial-out number or routing pattern points to a trunk group without members), or it can indicate a lack of trunk resources (for example, all trunk members are maintenance busy or all in-service members are busy on a call).

**Network** Clearing received from DS1 - the disconnect came from the network. The endpoint that had the disconnect notification capability disconnected without notifying the MCU.

**Not-MCU** The dial-out destination number(s) of the "CAS" extension has terminated to a number that is not a dial-in cascade MCU extension.

**No-ring** This dial-out drop reason occurs when the call has been up for 30 seconds and no ringing is detected.

**Reorder** This dial-out drop reason occurs when the MCU detects that there are no available trunks in the network to place the call. This drop reason is detected by MCU CPTR resources. See "Dial-out" for a description of CPTR usage.

Drop Reason (cont'd)	<p><b>Pre-AnsDrop</b> The call disconnected before answer by an endpoint. The cause of the disconnect may be the network, an endpoint, or a terminal adapter. This drop reason is different from 'No-answer,' which indicates that a 60-second timeout occurred while alerting. In this case, the call drops before the 60-second timer has expired. Some busy endpoints connected through terminal adapters display this behavior.</p> <p><b>Resource</b> MCU could not provide resources (VC or MMI) when the call arrived or lost the resources during the call. This could be due to them being Out of Service, busied out by craft, or being used by system maintenance. This drop reason could also occur if the DS1/MMI cable is disconnected. If there was a resource problem when the call arrived, it would get reorder (fast busy) and not get disconnected by the MCU.</p> <p><b>Password</b> Either the user entered the wrong password or the audio add-on user did not enter it within the specified time period. Note that the audio add-on user gets one attempt to enter a correct password and inter-digit timing for each digit (that is, about 10 seconds between digits).</p> <p><b>System</b> An MCU restart (level 2) disconnected all calls.</p> <p><b>UIN-Inv</b> The user entered an invalid User Identification Number.</p> <p><b>Unknown</b> The system could not determine the cause of the disconnect.</p> <p><b>Wrong-num</b> This dial-out drop reason occurs when the MCU detects the wrong destination number was dialed. This drop reason is detected by MCU CPTR resources SDN cause value. See "Dial-out" for details.</p> <p><b>UCC</b> controller intentionally disconnected the endpoint.</p>
AC Num	Administered Connection Number - from 1 to 128. AC number can be used to further diagnose a problem by combining status conference information with the <b>status administered connection</b> command and data stored in the error and alarm logs.
Ports Trunk	The data endpoint that the channel is using.
Ports Video	The MMI port for the channel.
Ports Aud	If the endpoint type is not "UCC," the VC audio encoder port (which is always paired to a decoder port) for the channel (only the first channel). Because only one audio encoder port is allocated per endpoint, it appears together with the ESM data port in the endpoint's channel 1 port slot position of the <code>Port Aud/ESM</code> column. For "UCC" endpoint type, the channel 1 port slot position displays the allocated Call Classifier resource.
Ports ESM	The Expansion Service Module MMI data port. This field is always blank.
Sum Grp	Endpoint's assigned summer group number. The summer group port assignments are on screen 1.
software	For Lucent Technologies use only.



## Field Descriptions (status conference endpoint)

### status conference x endpoint y

The first screen appears when **status conference x endpoint y** is entered and the specified conference is found. Data relevant for each endpoint displays in 6 pages. If the endpoint-ID of **all** is used, all possible endpoints associated with the specified conference display.

### Page 1 - Status Conference Endpoint

```

status conference endpoint                                     page 1 of 6
      STATUS OF CONFERENCE ___  ENDPOINT: ___  Status: _____
Ext: ___  Type: ___  Manufacturer/Country: ___/___  Product: _____
Terminal Name: _____  Data Mode: _____  MLP Rate: _____
Admin Bandwidth: _____  Rate Adaptation: _
Conf Bandwidth: _____  Lo/Hi Interworking: _
Meet-Me Number: _____  Dial Out #1: _____
Sum Grp: _  L1: _____  L2: _____  #2: _____
Quadrature: _____  _____

      ENDPOINT STATES/CAPABILITIES/MODES
In  Enh  ----Capability----  Rate  Bond
Use  BAS  Chl  Aud  Vid  Mlp  Gx  Adpt  Mode  Ts  Vs
-  -  -  -  -  -  -  -  -  -  -

Help line
enter command:
    
```

### Screen 8-7. Page 1 of 6: status conference x endpoint y

Endpoint	Endpoint-ID is a slot number associated with the endpoint entered on the conference forms.
Product	Product identification number obtained from the endpoint.
Manufacturer/ Country	Manufacturer identification number and manufacturer's country code obtained from the endpoint.
Terminal Name	This field is always blank.
Sum Grp	Summer group number to which this endpoint belongs and the VC Audio Level (L1) and Level 2 (L2) summer ports for this group. These fields have an entry only for conferences with over 6 participants.
Dial Out #1	Blank
Dial Out #2	Blank

In Use	<p>Is the endpoint currently participating in the conference or in process of connecting to the conference? - <i>y, c, e, f, n, blank</i>.</p> <p><i>y</i> means that the endpoint is in use and is fully connected on all media in an active conference.</p> <p><i>c</i> means that the endpoint is in use and is fully connected, however the endpoint has changed the conference audio or video capability or has changed the rate of the conference because of rate adaptation. This condition requires analysis of this endpoint's capabilities and mode fields to identify which capability was reduced.</p> <p><i>e</i> means that the endpoint is in use but the endpoint had capability problems. The endpoint does not have one of the required capabilities (Vid, Bhl, MLP) to be a full participant. For MLP capabilities, see the "T120" field. This condition requires analysis of this endpoint's capabilities and mode field to identify the missing capability.</p> <p><i>f</i> means that the endpoint is in use but is not connected to all media. This indicates that the endpoint has declared all the required capabilities (channel/video/ audio/data) but is not fully connected to all conference media at this time. This endpoint may be in the process of connecting, has failed to connect, or is not a valid video source. This condition requires analysis of this endpoint's capabilities and mode fields to identify the problem.</p> <p><i>n</i> means that the endpoint was connected in a conference but has/was disconnected or attempted to connect to a conference but was unsuccessful.</p> <p><i>blank</i> means the field is blank until the first call is made from/to the endpoint.</p>
Enh BAS	<p>EnhancedBasic Service Flag - <i>n, y</i></p> <p><i>y</i> means that the endpoint supports the enhanced BAS commands/caps; <i>n</i> means that the endpoint only supports the basic BAS commands/caps.</p>
Ch1	<p>Data on the quantify and quality of channels (transfer rate)? - <i>y, e, n, blank</i></p> <p><i>y</i> the endpoint has the required number of channels.</p> <p><i>e</i> means that the endpoint has not declared support for the correct number of channels and cannot participate fully in the conference.</p> <p><i>n</i> means that the endpoint has declared the correct number of channels, but all the channels have not yet joined the conference, due to either a network or endpoint problem.</p> <p><i>blank</i> Audio add-on endpoints always have the <i>Ch1</i> field set to <i>blank</i>.</p>

- Aud** Does it have the required audio capability? - *y*, *c*, *e*, *blank*
- y* the endpoint has the required audio capability. Audio add-on endpoint always have the Aud field set to *y* once the endpoint has joined the conference.
- c* this endpoint is PCM only and it changed the video quality of the conference by changing the operating audio from G.728 to G.711. If the administered audio mode is auto and the administered bandwidth is 112 kbps (56 k/channel) or 128 kbps (64 k/channel), the system starts out with the highest common audio of G.728. When the administered bandwidth is greater than 128 kbps, the system starts out with the highest common bandwidth of 7 kHz.
- e* A PCM-only endpoint that did not have the capability of supporting the administered audio mode of G.728 (such as a data conference), or G. 278/G.711 endpoint that did not have the capability of supporting the administered audio mode of 7 kHz. Such endpoints operate with PCM audio and interwork with the current operating audio mode.
- blank* the field is blank until the first call is made from/to the endpoint.
- Vid** Does it have the required video capability and is receiving video? - *y*, *c*, *e*, *n*, *blank*
- y* the endpoint has the required video capability and should be receiving video if the Chl, Aud, and Dat fields are *y*.
- c* means it downgraded the conference's video quality - either from CIF to ACIF or by decreasing the frame rate. The conference video mode is set by default to CIF and if a QCIF-only endpoint joins the conference, then the entire conference is made to operate in QCIF, with the video clarity downgraded. Also, the conference frame rate is initially set to the highest frame rate that can then be reduced by any endpoint. If the conference video mode is not administered with upgrade capability, then if the video parameters for a conference have been "downgraded," they are not "upgraded" until all endpoints disconnect from the conference.
- e* means that the endpoint has not declared any video capability in its cap-set.
- n* means audio only, not receiving video, possibly due to an audio or data problem.
- blank* Audio add-on endpoint always have the Vid field set to *blank*.
- Mlp** The state of the Control Link to the ESM (T.120 stack terminator), the endpoint MLP data capability, and the state of the data connection in the T.120 stack. This field value is always *blank*, indicating that the Data Mode for the conference is *none*, and therefore, the data does not apply, or the endpoint has never joined the conference.

Gx	<p>Does it have the Still Frame Graphics capability? - y, e, blank</p> <p>y This endpoint has this capability.</p> <p>e This endpoint did not declare this capability. The conference retains the still frame graphics capability when a non-compliant endpoint joins the conference.</p> <p>blank This endpoint has never joined the conference.</p>
Rate Adpt	<p>Rate adaptation/Interworking indicator - 5, 6, y, c, e, n, blank.</p> <p>Values of 5 and 6 apply only to Low Speed/High Speed Interworking. All other values apply only to Rate Adaptation.</p> <p>5 A 56-kbps (Low Speed) endpoint has joined a High Speed (128 kbps or above) conference. This endpoint is connected with audio only capability but is not a valid video source and destination.</p> <p>6 A 64-kbps (Low Speed) endpoint has joined a High Speed (128 kbps or above) conference. This endpoint is connected with audio only capability but is not a valid video source and destination.</p> <p>y This endpoint has joined the conference at the administered rate of 64 kbps, but because rate adaptation to 56 kbps was triggered by another endpoint, this endpoint has successfully rate adapted to 56 kbps.</p> <p>c The administered bandwidth of the conference is 64 kbps and this endpoint has joined the conference at 56 kbps. The first 56 kbps endpoint that joins 64 kbps rate adaptable conference triggers rate adaptation (see <code>Join Time</code> below).</p> <p>n A 64-kbps conference was triggered to rate adapt to 56 kbps by some other endpoint. This endpoint joined the conference at the bandwidth of 64 kbps, but encountered problems in rate adapting down to 56 kbps. This endpoint may have the audio and may be receiving video, but is not a valid video source.</p> <p>blank Rate adaptation was never triggered by any endpoint, and if this endpoint is in use and connected, then it has joined the conference at the administered bandwidth.</p>
Bond Mode	<p>BONDing Mode - blank. This field is blank for calls that are not related to bonding.</p>

Ts                    Indication of the talking state of the endpoint - t, m, M, S, blank.

t    At the time the command was invoked, voice energy (talking) was detected from the endpoint.

m    At the time the command was invoked, the endpoint indicated to the MCU that it was muted. It is possible that an endpoint may mute, but not send any indication to the MCU. In this situation the MCU does not display a mute indication.

M    At the time the command was invoked, the endpoint's audio was muted via UDD/CRCS Agent interface. M displays when both the endpoint and the UCC/CRCS Agent have muted the endpoint audio.

S    At the time the command was invoked, the endpoint's audio was muted because of solo-audio state set by UCC/CRCS Agent. While in solo-audio state, new endpoints joining the conference are automatically muted.

blank    At the time the command was invoked voice energy (talking) was not being detected from the endpoint.

Vs Indication of the MCU video state for this endpoint - a, b, B, c, i, r, R, s, S, u, U, v, blank.

For quad-screen conferences an \* is affixed before the value of Vs to indicate that an endpoint is currently part of the mixed image. A # may be affixed before the value of Vs to indicate that an endpoint was fixed to be in the mixed image (via administration or UCC/CRCS Agent), but instead, a Fill video is shown in its place. This occurs when the video of an endpoint that is fixed in a quadrant cannot be used as a video source because the endpoint is currently not joined to the conference, has suppressed its video, or has invalid video to be the video source. Notice that at most four endpoints have an \* or # affixed before the Vs field value.

For quad-screen conference in VAS mode, the mixed image is broadcast to all endpoints. For quad-screen conference in presentation mode, the mixed image is return video to the presenter.

a This value applies only to quad-screen conferences. \*a indicates that an endpoint is part of the current mixed image and is fixed in one of the quadrants via administration. A value of \*a indicates that the endpoint is fixed in a quadrant but is not currently connected (Fill image displays).

b For full-screen conference it indicates that at the time the command was invoked, this endpoint's video was being broadcast to other sites. This conference was in VAS, broadcast, or presentation mode. For quad-screen VAS conference it is prefixed with an asterisk (\*) and indicates that this endpoint's video is part of the mixed image because of VAS. For quad-screen presentation conferences, b (without an asterisk) identifies the presenter as the broadcaster.

B At the time the command was invoked the endpoint's video was being broadcast to other sites because of the UCC roll call feature. UCC roll call feature can only be performed in full-screen mode.

c At the time the command was invoked this endpoint's video was being broadcast to other sites. The conference was in chair mode and the broadcaster was designated by the chair. Chair features can only be performed in full-screen mode.

- Vs  
(cont'd.)
- i At the time the command was invoked the endpoint was not a valid video source. For continuous presence conference, if this endpoint is fixed in a particular quadrant, an asterisk (#) is affixed before i.
  - r For full-screen conferences, at the time the command was invoked the endpoint's video was the return video to the broadcaster. For continuous presence conference in presentation mode, \*r represents a VAS quadrant that is part of the mixed image.
  - R At the time the command was invoked, the endpoint's video was the return video to the broadcaster because of the UCC browse feature. UCC Browse feature can only be performed in full-screen mode.
  - s At the time the command was invoked this endpoint's video was suppressed at the request of the endpoint. For continuous presence conference with fixed quadrant participants, if this endpoint is fixed in a particular quadrant a # is affixed before s.
  - S At the time the command was invoked this endpoint's video was suppressed via UCC/CRCS Agent interface. For continuous presence conference with fixed quadrant participants, if this endpoint is fixed in a particular quadrant, # is affixed before S. S displays when both the endpoint and the UCC/CRCS Agent have suppressed the endpoint video.
  - u For full-screen conferences, at the time the command was invoked this endpoint's video was being broadcast to other sites. The conference was in VAS mode and the broadcaster was designated by the UCC/CRCS Agent interface. For quad-screen conferences, it indicates that UCC/CRCS Agent designated this endpoint as fixed in a quadrant. An asterisk (\*) is affixed before u if the endpoint is currently part of the quad image, and # is affixed if the endpoint is not currently joined.
  - U Applies only to quad-screen conference and indicates that UCC/CRCS Agent designated a quadrant as VAS. An asterisk (\*) is affixed before U to indicate that this endpoint is part of the current quad image.
  - v At the time the command was invoked this endpoint's video was being broadcast to other sites. The conference was in VAS mode but the endpoint has asked to be a broadcaster via "See-Me" request and was granted a MCV (Multipoint Command Visualize) token. The See-Me feature is only performed in full-screen mode.
  - blank At the time of the request the endpoint's video was not broadcast, return, video, or part of the mixed-image, but it is a valid video source.

## Page 2 - Endpoint Channel Information

This section only describes the fields that are specific to the endpoint-level command output.

```

status conference endpoint                                     page 2 of 6

                                ENDPOINT CHANNEL INFORMATION

Chan. Join  Drop  ----Drop----  AC  -----Ports-----  Fr
No.   Time  Time  Reason  Code  Num  Trunk  Video  Aud/ESM  BONDng  Err  Software
1:    _____  _____  _____  _____  _____  _____  _____  _____  _____  _____  _____
2:    _____  _____  _____  _____  _____  _____  _____  _____  _____  _____  _____
3:    _____  _____  _____  _____  _____  _____  _____  _____  _____  _____  _____
4:    _____  _____  _____  _____  _____  _____  _____  _____  _____  _____  _____
5:    _____  _____  _____  _____  _____  _____  _____  _____  _____  _____  _____
6:    _____  _____  _____  _____  _____  _____  _____  _____  _____  _____  _____
7:    _____  _____  _____  _____  _____  _____  _____  _____  _____  _____  _____
8:    _____  _____  _____  _____  _____  _____  _____  _____  _____  _____  _____
9:    _____  _____  _____  _____  _____  _____  _____  _____  _____  _____  _____
10:   _____  _____  _____  _____  _____  _____  _____  _____  _____  _____  _____
11:   _____  _____  _____  _____  _____  _____  _____  _____  _____  _____  _____
12:   _____  _____  _____  _____  _____  _____  _____  _____  _____  _____  _____

Help line
enter command:
    
```

**Screen 8-8. Page 2 of 6: status conference x endpoint y**

- Join Time            Time (in 24-hour notation) when the channel joined the conference.
- Drop Time           Time (in 24-hour notation) when the channel disconnected. If the first channel has a drop time, then it means that the endpoint is not in use. If there is a drop time without a join time, it means that the call disconnected without being joined to the conference.



Drop Reason

The reason for the channel's disconnect:

**2-pri** This drop reason occurs when an administration error causes a mismatch in primary-secondary designation for a cascade link. This mismatch shows that both MCUs are administered as primaries (see "Cascading" for a description of primary-secondary compatibility).

**2-sec** This drop reason occurs when an administration error causes a mismatch in primary-secondary designation for a cascade link. This mismatch shows that both MCUs are administered as secondaries (see "Cascading" for a description of primary-secondary compatibility).

**Agent** The reservation agent has caused the call to disconnect (for example, the agent has changed a connected dial-out destination number).

**Bandwidth** mismatch between a call and the conference it attempted to join. For example, a 56-kbps call attempted to join a 64-kbps conference that does not allow rate adaptation.

**BondHshake** BONDing handshake drop reason can be caused due to the following reasons: information channel parameter not supported or invalid, parameter negotiation terminated out of sequence, timer expired because of the secondary channels did not establish, or BONDing framing was not detected for one of the other channels.

**Busy** This dial-out drop reason occurs when the MCU detects that the conferee's terminal equipment is busy. This drop reason is detected by an ISDN cause value (for example h0). See "Dial-out" for a description of CPTR usage.

**Chair** disconnected the endpoint, using either Chair Command Disconnect (CCD) or Chair Command Kill (CCK) signals.

**Conf End** The conference was ended due to reaching stop time for a reserved conference or due to an active conference being converted to file.

Drop Reason  
(cont'd)

**Endpoint** Clearing received from DS1 - the disconnect came from the endpoint. The endpoint notified the MCU that it intended to disconnect.

**Far-end** Clearing received from DS1 - the disconnect came from either the network or the endpoint.

**Handshake** Either framing was never found (the endpoint could not complete initialization - problems finding Frame Alignment Signal (FAS), Multi Frame Alignment (MFA) and getting a corrected coded cap-set) or framing was lost for some time (over 40 seconds) and the endpoint was disconnected.

**IDtimeout** The MCU has not received response to the UIN/password Query from the H.320 user after three attempts. Each attempt has a system administered timeout period.

**Internal** MCU has a problem allocating trunk resources necessary to route the dial-out call for the specified dial-numbers. This problem can be associated with routing pattern or trunk associated translation (for example, TAC specified in the dial-out number or routing pattern points to a trunk group without members), or it can indicate a lack of trunk resources (for example, all trunk members are maintenance busy or all in-service members are busy on a call).

**Network** Clearing received from DS1 - the disconnect came from the network. The endpoint that had the disconnect notification capability disconnected without notifying the MCU.

**Not-MCU** The dial-out destination number(s) of the "CAS" extension has terminated to a number that is not a dial-in cascade MCU extension.

**No-ring** This dial-out drop reason occurs when the call has been up for 30 seconds and no ringing is detected.

**Reorder** This dial-out drop reason occurs when the MCU detects that there are no available trunks in the network to place the call. This drop reason is detected by MCU CPTR resources. See "Dial-out" for a description of CPTR usage.

Drop Reason <i>(cont'd)</i>	<p><b>Pre-AnsDrop</b> The call disconnected before answer by an endpoint. The cause of the disconnect may be the network, an endpoint, or a terminal adapter. This drop reason is different from 'No-answer,' which indicates that a 60-second timeout occurred while alerting. In this case, the call drops before the 60-second timer has expired. Some busy endpoints connected through terminal adapters display this behavior.</p> <p><b>Resource</b> MCU could not provide resources (VC or MMI) when the call arrived or lost the resources during the call. This could be due to them being Out of Service, busied out by craft, or being used by system maintenance. This drop reason could also occur if the DS1/MMI cable is disconnected. If there was a resource problem when the call arrived, it would get reorder (fast busy) and not get disconnected by the MCU.</p> <p><b>Password</b> Either the user entered the wrong password or the audio add-on user did not enter it within the specified time period. Note that the audio add-on user gets one attempt to enter a correct password and inter-digit timing for each digit (that is, about 10 seconds between digits).</p> <p><b>System</b> An MCU restart (level 2) disconnected all calls.</p> <p><b>UIN-Inv</b> The user entered an invalid User Identification Number.</p> <p><b>Unknown</b> The system could not determine the cause of the disconnect.</p> <p><b>Wrong-num</b> This dial-out drop reason occurs when the MCU detects the wrong destination number was dialed. This drop reason is detected by MCU CPTR resources SDN cause value. See "Dial-out" for details.</p> <p><b>UCC controller intentionally disconnected the endpoint.</b></p>
Drop Code	<p>A detail code complementing the Drop Reason (see above). Additional bonding related information may be obtained from supplementary BONDing Drop Codes described above.</p>
AC Num	<p>Administered Connection Number - from 1 to 128. AC number can be used to further diagnose a problem by combining status conference information with the <b>status administered connection</b> command and data stored in the error and alarm logs.</p>
Ports Trunk	<p>The data endpoint that the channel is using.</p>
Ports Video	<p>The MMI port for the channel.</p>

- Ports Aud            If the endpoint type is not "UCC," the VC audio encoder port (which is always paired to a decoder port) for the channel (only the first channel). Because only one audio encoder port is allocated per endpoint, it appears together with the ESM data port in the endpoint's channel 1 port slot position of the Port Aud/ESM column. For "UCC" endpoint type, the channel 1 port slot position displays the allocated Call Classifier resource.
- Ports ESM            The Expansion Service Module MMI data port. This field is always blank.
- Ports BONDng        The MMI port used for BONDing for the channel.
- Fr Err                Frame error counter. A circular hex counter (0-FF) to indicate the occurrence of framing errors.

### Page 3 - Conference Information

This section only describes the fields that are specific to the endpoint-level command output.

```

status conference endpoint page 3 of 6
CONFERENCE INFO:  Broadcaster: xx (See-Me)
                    Return Vid: xx

----- MODE COMMANDS/COMMUNICATION MODES -----
  CMD  STAT   CONF          EPT-IN          EPT-OUT          EPT MISC          FAW --
                   |          |          |          |          | I  O          | CH1 CH2
                   |          |          |          |          |-----|
XRATE: y   384          384          384          AIM: y n          A-OUT: y n
AUDIO: n   G728      neutral      G728          MIS: n n          A-IN: y n
56/64: y   derestrict derestrict   derestrict     MCV: n n          M-FRM: y n
VIDEO: n   H.261      H.261        H.261          |-----|          MFA: y n
MLP: y     MLP-off    MLP-off       MLP-off        TALK: y 05       MFN: y n
H-MLP: y   H-MLP-off  H-MLP-off    H-MLP-off     VFCV: y 01       FAS: y n
LSD: y     LSD-off    LSD-off       LSD-off        BCTK: n 02       MUFAL: 00 00
HSD: y     HSD-off    HSD-off       HSD-off        RTTK: y 01       FEFAL: 00 00
CRYPT: y   encrypt-off encrypt-off   encrypt-off    BCLS: n
S/M: y     N-comp-6B-H0 N-comp-6B-H0 N-comp-6B-H0  RTLS: n
                                           HYPR: n 00
                                           DMUTE: n 00
                                           H.261: n 00
                                           VFMT: n 00

Help line
enter command:
    
```

Screen 8-9. Page 3 of 6: status conference x endpoint y

**Conference Info.** This information applies mostly to full-screen conferences. The *Broadcaster* field also applies to quad-screen presentation mode conferences.

Broadcaster	<p>Indicates the endpoint number that is the current broadcaster. The Broadcaster can be qualified with the following keywords:</p> <ol style="list-style-type: none"> <li>1. <code>Broadcast</code> - indicates a broadcast mode broadcaster.</li> <li>2. <code>Chair</code> - indicates that the broadcaster was designated by the chair.</li> <li>3. <code>See-Me</code> - indicates that the broadcaster is a result of MCV request from an endpoint.</li> <li>4. <code>Presenter</code> - indicates a presentation mode broadcaster.</li> <li>5. <code>Rollcall</code> - indicates that the broadcaster was designated by the UCC via the Rollcall feature.</li> <li>6. <code>UCC</code> - indicates that the broadcaster was designated by the UCC.</li> <li>7. <code>VAS</code> - indicates a Voice Activated Switching broadcaster.</li> </ol>
Next Broadcaster	<p>Indicates the endpoint number that is selected to be the next broadcaster.</p>
Return Vid	<p>Indicates the endpoint number that is the current return video. The return video can be qualified with the following keywords:</p> <ol style="list-style-type: none"> <li>1. <code>blank</code> - indicates that the return video is the previous broadcaster forced to be return video because of VAS, action by Chair, action by UCC, or endpoint MCV request. The broadcaster qualifier identifies which action forced this endpoint to become return video.</li> <li>2. <code>Autoscan</code> - indicates auto scan return video. This is true only when conference mode is broadcast with auto scan.</li> <li>3. <code>Browse</code> - indicates that the return video was designated by the UCC via the Browse feature.</li> <li>4. <code>VAS</code> - indicates a Voice Activated Switching return video.</li> </ol>
Next Return Vid	<p>Indicates the endpoint number that is selected to be the next return video.</p>

**Mode Commands/Communication Modes.** This is a collection of both incoming and outgoing bandwidth allocations for the multiplex. The Incoming data is the rate at which the MCU thinks the endpoint is communicating based on the Bit-rate Allocation Signal (BAS) codes received from the endpoint/codec and the capabilities the MCU has declared. The Outgoing data is the rate from the MCU toward the endpoint. The following are column definitions for this section of page 3.

CONF	<p>The desired conference operating mode. This may be different from the endpoint in (<code>EPT-IN</code>) or endpoint out (<code>EPT-OUT</code>) modes.</p>
CMD	<p>labels for the various types of mode commands</p>

- STAT indicates if the conference and the incoming modes are compatible. A value of *y* indicates mode compatibility; a value of *n* indicates that the modes are not compatible.
- EPT-IN defines the communication modes coming in from an endpoint.
- EPT-OUT defines the communication modes sent out to an endpoint based on the number of channels connected and the capabilities of the endpoint.

The following are field definitions for the Mode Commands/Communication Modes section of Page 3.

XRATE One of the supported rates in [Table 8-11](#):

**Table 8-11. Supported Transfer Rates**

XRATE	Bandwidth of the Call
2x64	2B (2x56 or 2x64)
128	112kbps or 128kbps
196	168kbps or 196kbps
256	224kbps or 256kbps
320	280kbps or 320kbps
384	336kbps or 384kbps
512	512kbps
768	768kbps
1472	1472kbps
1536	1536kbps'
1920	1920kbps

XRATE *(cont'd.)* XRATE may be 64 when the endpoint is just dialing in, or in the event of problems. It implies that only one B channel is being used.

AUDIO Audio rate (kbps bandwidth) of the conference and the endpoint must be the same but not necessarily their mode. When the audio rate of the conference and the endpoint are different the endpoint's audio will interwork but the endpoint's video will be invalid. MCU may or may not send video to such an endpoint.

[Table 8-12](#) summarizes expected endpoint audio mode with different configurations of transfer rate, facility bandwidth, conference mode, and whether or not all endpoints support the highest common audio mode (HC audio) when the administered mode is `auto`. The highest common conference mode is dependent on the administered bandwidth. A '-' in the table indicates 'does not apply.'

**Table 8-12. Audio Mode Configurations**

Admin Mode (HC Audio)	All Support HC Audio	Xfer Rate	Facility BW	Conf Mode	Expected Endpoint Mode
auto (G.728)	yes	<=128k	-	G.728	G.728
auto (G.728)	no	<=128k	64k	G.711-A-56k	G.711-A-56k B.711-Mu-56k
auto (G.728)	no	<=128k	56k	G.711-A-48k	G.711-A-48k G.711-MU-48k
auto (G.722)	-	>128k	64k	G.722-56k	G.722-56k G.711-A-56k G.711-Mu-56k
auto (G.722)	-	>128k	56k	G.722-48k	G.722-48k G.711-A-48k G.711-Mu-48k
G.728	-	-		G.728	G.728
G.711	-	-	64k	G.711-A-56k	G.711-A-56k G.711-Mu-56k
G.711	-	-	56k	G.711-A-48k	G.711-A-48k G.711-Mu-48k
G.722	-	-	64k	G.722-56k	G.722-56k G.711-A-56k G.711-mu-56k
G.722	-	-	56k	G.722-48k	G.722-48k G.711-A-48k G.711-Mu-48k

AUDIO Other possible AUDIO mode values include `neutral` (neutralized I-channel) and `Au-off, Frm` (no audio signal) which never match conference mode and are not supported by MCU.

(cont'd.)

56/64	<p>The 65/64 field is <code>derestrict</code> when operating at per-channel speeds of 64kbps, 128kbps, 192kbps, 256kbps, 320kbps, 384kbps, 512kbps, 768 kbps, 1472kbps, 1536kbps, or 1920kbps; it is <code>restrict</code> when operating at 56kbps, 112kbps, 168kbps, 224kbps, 280kbps, 336kbps, 448kbps, and 672kbps.</p> <p>Note that if the conference is configured for Nx56kbs operation, the endpoint may signal either via capabilities or modes that is operating at the proper rate. In such a case, even when we receive <code>derestrict</code> command which does not match the conference communication mode of <code>restrict</code>, if the capability indicates <code>restrict</code> (MISC capability has <code>restrict</code> displayed on Page 4) the STAT 56/64 is set to <code>y</code> to indicate 56/64 compatibility between the conference and the endpoint.</p>
VIDEO	<p>The Video mode: <code>H.261</code> (recommended), <code>H.CTX</code> (proprietary), <code>H.CTX+</code> (proprietary), or <code>SG4</code> (proprietary) indicate that video is on in the direction indicated; <code>video-off</code> when the video is off.</p>
MLP	<p>Multi Layer Protocol data mode. When Data Mode is administered as <code>any-mlp</code> or <code>ww-pcs</code>, the MLP mode should be <code>var-MLP</code>. Other values will affect video status.</p> <p>The MLP mode should be <code>MLP-off</code> when Data Mode is administered as <code>none</code>. Again, other values in this mode will affect video status.</p>
H_MLP	<p>The High Speed MLP mode. The HMLP mode should be <code>H-MLP-off</code>. Other values in this mode will affect video status.</p>
LSD	<p>Low Speed Data mode. The LSD mode should be <code>LSD-off</code>. Other values in this mode will affect video status.</p>
HSD	<p>High Speed Data mode. The HSD mode should be <code>HSD-off</code>. Other values in this mode will affect video status.</p>
CRYPT	<p>Encryption mode. The CRYPT mode should be <code>encrypt-off</code>. Other values in this mode will affect video status.</p>
S/M	<p>Single/Multi channel interoperability mode. <code>6B-H0-comp</code> indicates that the sender is interoperating multiple channels and a single channel (for example, 6B and H0). <code>Not-comp-6B-H0</code> indicates that the sender is not interoperating between 6B and H0. Normally this value is <code>Not-comp-6B-H0</code>. Other values in this mode will affect video status.</p>

**Endpoint Miscellaneous (EPT MISC) Information.** EPT MISC contains miscellaneous states and counters for an endpoint. The flags can be a value of `y` or `n`. The counters start with initial value of `0x00`, they increment to `0xff`, and then



wrap around to 0x01. AIM and VIS are BAS commands which can be sent as input (I) to MCU from an endpoint or as output (O) from MCU to an endpoint.

AIM	Audio Indicate Muted. Value of <i>y</i> on input (I) indicates that this endpoint has muted its audio. MCU will not VAS to an endpoint displaying mute indicate. Value of <i>n</i> on input indicates that this endpoint has not muted (only if endpoint audio mode is turned on). Value of <i>y</i> on output (O) indicates that all other endpoints in the conference have muted their audio (have sent AIM to MCU). MCU in turn tells this endpoint (by sending it AIM) that there is no audio output from MCU. A value of <i>n</i> on output indicates that there is an audio path open across the bridge.
VIS	Video Indicate Suppressed. Value of <i>y</i> on input (I) indicates that this endpoint has suppressed its video (indicated video is muted). Value of <i>y</i> on output (O) indicates that the MCU is not sending video to this endpoint because there is no video broadcaster (broadcaster has not joined or broadcaster's video is not valid).
MIS	Multipoint Indicate Secondary-status. This command is only sent as output (O) to an endpoint. A value of <i>n</i> indicates that the endpoint is viewed as capable of being a valid source (although not necessarily at this moment). A value of <i>n</i> is the correct state to be in for video. A value of <i>y</i> indicates that MIS was sent to an endpoint and that this endpoint is viewed as a secondary endpoint. The endpoint is included in the audio portion of the conference but not the video portion. Video will not be sent.
MCV	Multipoint Command Visualize. This command is only sent as input (I) from an endpoint. A value of <i>y</i> indicates that an endpoint has requested to become a broadcaster. This is used during Still Frame Graphics and to force "presentation" mode.
TALK	A value of <i>y</i> indicates that the VC board is detecting voice energy from the endpoint. The TALK counter indicates the number of times a start/stop was detected.
VRCV	Value of <i>y</i> indicates if the endpoint is receiving video (MMCH is sending video to the endpoint). The VRCV counter indicates the number of times video was sent/not sent to this endpoint.
BCTK	Applies to single screen and quad-screen presentation mode conferences. A value of <i>y</i> indicates that the endpoint is the video broadcast source. The BCTK counter indicates the number of times this endpoint was the video broadcast source.
RTTK	Applies only to single screen conferences. A value of <i>y</i> indicates that the endpoint is the return video source. The RTTK counter indicates the number of times this endpoint was the return video source.
BCLS	Applies to single screen and quad-screen presentation mode conferences. A value of <i>y</i> indicates that the endpoint is watching the video of the broadcast source.

RTLS	Applies only to single screen conferences. A value of $y$ indicates that the endpoint is watching the video of the return source.
HYPR	A value of $y$ indicates hyperactivity from an endpoint (MCU isolated endpoint from the MCU conference due to “thrashing” behavior) and affects endpoint’s status as a video source (for 5 seconds of hyperactivity timer). The HYPR counter indicates the number of times this endpoint was hyperactive.
DMUTE	A value of $y$ indicates that the decoder was muted by the VC board or the software in the MCU. VC board mutes the decoder when it loses MMI or endpoint framing is lost, when it receives an invalid audio code word, and when endpoint is hyperactive. The only time that the MCU software mutes the decoder of an endpoint is to mute all endpoints, other than the broadcaster, when a mode of a conference is “broadcastw/scan” (broadcast with auto scan). The DMUTE counter indicates the number of times this endpoint’s decoder was muted by the VC board.
VFMT	The video format applicable only to quad-screen conferences. This field always has a value of $n$ , indicating QCIF format.
H. 261	A value of $y$ indicates video framing loss. The H.261 counter indicates the number of times the framing was lost.

**Frame Alignment Word (FAW) Information.** The FAW section of page 3 provides the channel Frame Alignment Word information for the communication paths labeled CHL 1 and 2. For 2B calls, both CHL 1 and 2 are used. For 1-channel calls (112, kbps, 128 kbps, 168 kbps, 196 kbps, 224 kbps, 256 kbps, 280 kbps, 320 kbps, 336 kbps, 384 kbps, 768 kbps, 1472 kbps, 1536 kbps, and 1920 kbps) only CHL 1 is used. A-OUT, A-IN, M-FRM, MFA, and MFN are flags with values of  $y$  or  $n$ .

A-OUT	MCU has endpoint framing.
A-IN	Endpoint has MCU framing
M-FRM	Multichannel frame alignment is present (alignment of both channels in 2B).
MFA	Multiframe alignment word is present (required in 2B call).
MFN	Multiframe numbering is present (required in 2B call).
FAS	Frame Alignment Signal (FAS) channel number (1 or 2). This number should match the column header.
MCUFAL	MCU Frame Alignment Loss (MCUFAL). A counter of the number of times the MCU indicates to the endpoint that it has lost endpoint FAW or multichannel synchronization (M-FRM). The MCU a-bit toggles when the MCU gains or loses endpoint multichannel synchronization. This counter starts with an initial value of 0x00, increments to 0xff, then wraps around to 0x01. The MCUFAL count is also shown in the Fr Err field on Page 2

**FEFAL** Far End Frame Alignment Loss (FEFAL). A counter of the number of changes the MCU detects in the endpoint's a-bit (A-OUT). The endpoint a-bit toggles when an endpoint gains or loses MCU framing. This counter starts with an initial value of 0x00, increments to 0xff, then wraps around to 0x01.

### Page 4 - Endpoint Capability Information

This section only describes the fields that are specific to the endpoint-level command output.

```

status conference endpoint                                     page 4 of 6
-----
                                ENDPOINT CAPABILITY INFORMATION
-----
VID | vfmt: QCIF   cfps: 30      H.CTX   SG4     imp
    | da_sfg      qfps: 7.5     H.CTX+  SG4_sfg
-----
MISC | derestrict  S/M  mbe  dcomp   cic
-----
XR  | 64 64x2 64x3 64x4 64x5 64x6      384 384x2 384x3 384x4 384x5
    |    128 192 256 320 512 768 1152 1472 1536 1920
-----
AUD | ntrl      711m 711a g728 g722_64 g722_48
-----
LSD | var 300 1200 4800 6400 8000 9600 14.4k 16k 24k 32k 40k 48k 56k 62.4k 64k
-----
HSD | var 64k 128k 192k 256k 320k 348k 512k 768k 1152k 1536k
-----
MLP | var 4k 6.4k 14.4k 16k 22.4k 24k 30.4k 32k 38.4k 40k 46.4k 62.4k
-----
HMLP | var 62.4k 68k 128k 192k 256k 320k 384k
-----
    
```

Screen 8-10. Page 4 of 6: status conference x endpoint y

**Endpoint Capability Information.** Fields on this page will only be displayed if an endpoint declares the specific capability. For example, if an endpoint does not declare the VID H.CTX capability, the H.CTX field will not be displayed.

VID	<p>Provides information about the type of video and frame rate the endpoint supports.</p> <p><code>vfmt</code> - does not display if the endpoint has no video capability. All values are blank if there is an active call or this is an audio-only endpoint. Otherwise, values for this field include:</p> <ul style="list-style-type: none"><li>■ <code>FCIF</code> for full CIF</li><li>■ <code>QCIF</code> for quarter CIF. Support of CIF implies support of QCIF. In general, for larger screens, CIF displays sharper resolution video, which ZCIF is blocked, but may run at higher frame rates and less clear. The differences are less observable on very small displays.</li><li>■ <code>cfps</code> and <code>qfps</code> are the maximum frame rate (frames/second) at which the endpoint can receive video for CIF and QCIF operating modes. CIF frame rate values are 30fps, 15fps, 10fps, and 7.4fps. If the endpoint does not support CIF (that is, the <code>vfmt</code> field is QCIF), the <code>cfps</code> value should be blank.</li><li>■ <code>da_sfg</code> indicates support for H.261 Still Frame Graphics transfers.</li><li>■ <code>H.CTX</code>, <code>H.CTX+</code> and <code>SG4</code> are proprietary video format capabilities.</li><li>■ <code>SG4_sfg</code> indicates support for SG4 Still Frame Graphics</li></ul>
MISC	<p>The <code>restrict</code> field is 1 way for an endpoint to indicate that it is operating at 56 kbps per channel, the other way is the <code>56/64</code> command mode with a value of <code>restrict</code>. An endpoint on a 56 kbps conference must send one or both of the 2 indications that they are operating at 56 kbps before they become a video source in a 56 kbps conference. If they signal either way that they are operating at 56 kbps in a 64 kbps or 384 kbps conference, they are an audio-only source, but the MCU continues to send Selected Communication Mode (SCM) toward them when possible.</p> <p>A MISC capability of <code>derestrict</code> and a <code>56/64</code> command of <code>derestrict</code> together indicate that an endpoint is operating at 64 kbps. If either is <code>restrict</code>, the conference operates at 56 kbps. Other field values include:</p> <ul style="list-style-type: none"><li>■ <code>dcomp</code> indicates support for WorldWorx PCS data compliance.</li><li>■ <code>mbe</code> indicates support for Multi Byte Extension. MBE capability is used for the exchange of passwords, terminal names, and other special capabilities, such as, support of WorldWorx PCS specific features.</li><li>■ <code>cic</code> (Chair Indicate Capability) indicates chair control capability.</li></ul>

XR	<p>Transfer rate capabilities are statement about the speeds at which the endpoint can operate over the current connection and operate a Px64 Multiplex.</p> <p>For a 384 kbps (H0) call, the endpoint sends its capabilities to indicate 384 kbps support, which displays as 384. On a 336 kbps call, the endpoint must signal 384 kbps support. If an endpoint does not indicate support for 384 kbps on a 384/336 kbps conference, the MCU provides Audio Only Communications Mode (ACOM). For a 2B conference, the MCU sets the rate to 2x64, expecting the endpoints to do likewise (64x2 is displayed; if this is not displayed, there is no 64x2 capability). Endpoints may occasionally take 2x64 (or the current channel rate: 384, 768, 1472, 1536) out of their capability. This is Mode 0 forcing and is part of normal procedures. The MCU will provide AOCM if the endpoint does not signal support matching the configuration of the conference.</p>
AUD	<p>The audio fields are statements of the audio protocols that the endpoint supports. 711m and 711a are PCM (G.711) and support Mu and A-law, respectively, and at least one is required of endpoints. The g728 field indicates whether G.728 is supported (LB_CELP). This value depends upon the type of the endpoint and how that endpoint is currently configured. The g722_48 field indicates endpoint support for G.722 (7 kHz) at both 48 kbps and 56 kbps. Therefore, g722_48 indicates that the endpoint supports G.722 audio at both rates. The g722_64 field indicates endpoint support for G.722 at 64 kbps in an unframed (not supported by the MCU) mode.</p>
LSD	<p>The LSD fields indicate the capabilities for Low Speed Data conferencing.</p>
HSD	<p>The HSD fields indicate the capabilities for High speed Data conferencing.</p>
MLP	<p>The MLP fields indicate the capabilities for Multi Layer Protocol Data capabilities.</p>
HMLP	<p>The HMLP fields indicate the conference's capability for High Speed MLP data conferencing.</p>

## Page 5 - Endpoint Call Status Information

This page summarizes such call-related status as per-channel join counts, join/drop time, drop reason, drop code, and auxiliary bonding drop code. In addition, it contains a drop code and software fields from the previous call. The data on the page is always retained. The Endpoint Call Status Information section groups together all call-related fields. The only new field in this section is Join Count; all other fields are described in [Screen 8-7](#) and [Screen 8-8](#).

```

status conference endpoint                                     page 5 of 6

                                ENDPOINT CALL STATUS INFORMATION

Chan  Join  Join  Drop  ----- Drop  -----  --- Previous  -----
      Count Time  Time Reason          Code    BondCode  DropCode  Software
1:    ---  ---  ---  -----  ---    ---      ---      ---
2:    ---  ---  ---  -----  ---    ---      ---      ---
3:    ---  ---  ---  -----  ---    ---      ---      ---
4:    ---  ---  ---  -----  ---    ---      ---      ---
5:    ---  ---  ---  -----  ---    ---      ---      ---
6:    ---  ---  ---  -----  ---    ---      ---      ---
7:    ---  ---  ---  -----  ---    ---      ---      ---
8:    ---  ---  ---  -----  ---    ---      ---      ---
9:    ---  ---  ---  -----  ---    ---      ---      ---
10:   ---  ---  ---  -----  ---    ---      ---      ---
11:   ---  ---  ---  -----  ---    ---      ---      ---
12:   ---  ---  ---  -----  ---    ---      ---      ---
    
```

**Screen 8-11. Page 5 of 6: status conference x endpoint y**

**Join Count**      This field displays a count of the number of times this endpoint joined this conference during this conference session. This counter starts with an initial value of 0, can increment to 64, and wraps around back to 1.

**Page 6 - Administered Connections**

This page summarizes information on the administered connections associated with this endpoint. This data can only be viewed while the conference is active.

```

status conference endpoint                                     page 6 of 6
    
```

ADMINISTERED CONNECTIONS INFORMATION

AC				
Chan Num	Dial-out Number	Connection State	Retry Count	Failure Cause
1:	_____	_____	—	—
2:	_____	_____	—	—
3:	_____	_____	—	—
4:	_____	_____	—	—
5:	_____	_____	—	—
6:	_____	_____	—	—
7:	_____	_____	—	—
8:	_____	_____	—	—
9:	_____	_____	—	—
10:	_____	_____	—	—
11:	_____	_____	—	—
12:	_____	_____	—	—

**Screen 8-12. Page 6 of 6: status conference x endpoint y**

Dial-out  
 number

The actual numbers that are dialed out by the administered connections for each channel in the call. Note that the dial Out #1 and #2 on page 1 of the forms display the DCP endpoint number. This is particularly useful with bonding dial-out calls.

Connection State	<p>Indicates the current call state of the AC. The following are connection states associated with dial-out ACs:</p> <ul style="list-style-type: none"><li>■ <code>enabled</code> - is transient in nature and indicates that an AC is about to enter the attempting to connect state.</li><li>■ <code>disabled</code> - this may mean one of three things:<ul style="list-style-type: none"><li>— The AC has reached an administered retry threshold, and all retries are stopped. Verify this by checking the Error Log and checking whether an error type of 9 is logged against the AC.</li><li>— The AC was in a connected state and the far end disconnected.</li><li>— The initial channel call has not yet connected. No dial out call attempt is made for the additional channel(s) until the initial channel has reached a connected state.</li></ul></li><li>■ <code>not scheduled</code> - is transient in nature and indicates that an AC is about to enter the “attempting to connect” state.</li><li>■ <code>waiting to retry</code> - means that the AC is inactive (sleeping) and waiting for the retry timer to expire. Once the timer expires, the AC sends a dial out call and enters the “attempting to connect” state. ACs in this state indicate that the dial out call has failed at least once.</li><li>■ <code>attempting to connect</code> - means that the AC is active on a call, but the call has not yet connected.</li><li>■ <code>connected</code> - means that the call associated with the AC has been answered and join cut-thru to the conference.</li></ul>
Retry Count	<p>This field indicates how many retries have been attempted for this AC during this join attempt. This field does not clear when the AC connects. However, it clears when a new join attempt is made via a Redial feature. Note that this is different from the <code>Join Count</code> which counts the number of times the channel joined the conference during this conference session.</p>
Failure Cause	<p>This field shows an ISDN or CPTR cause value (values lower than 0x7f) recorded when the last dial out call was dropped. Values above 0x7f are generated internally. <a href="#">Table 8-13</a> lists all possible failure cause values displayed by this field and its associated description. The <code>Failure Cause</code> value is logged in the Error Log and can be displayed via the <code>display errors</code> command. (<code>Err Type</code> is normally displayed as a decimal.)</p>



**Table 8-13. Status AC - Failure Cause Values**

<b>Failure Cause (hexadecimal)</b>	<b>Description</b>
0x00 (0t0)	N/A
0x01 (0t1)	Incorrect destination address
0x02 (0t2)	Reason unknown
0x06 (0t6)	Reason unknown
0x10 (0t16)	Normal call clearing
0x11 (0t17)	Endpoint not available
0x12 (0t18)	ISDN timer expired
0x15 (0t21)	Reason unknown
0x12 (0t22)	Destination address changed
0x1C (0t28)	Bad destination or access denied
0x1D (0t29)	Access denied
0x1F (0t31)	Reason unknown
0x22 (0t34)	Trunks unavailable
0x26 (0t38)	Temporary or facility failure
0x29 (0t41)	Temporary or facility failure
0x2A (0t42)	Resources unavailable
0x2C (0t44)	Resources unavailable
0x32 (0t50)	Access denied
0x34 (0t52)	Access denied
0x36 (0t54)	Access denied
0x3A (0t58)	Resources unavailable
0x41 (0t65)	Required capability not implemented
0x42 (0t66)	Required capability not implemented
0x45 (0t69)	Required capability not implemented
0x51 (0t81)	ISDN protocol error
0x52 (0t82)	Required capability not implemented
0x58 (0t88)	Incorrect destination number
0x60 (0t96)	ISDN protocol error
0x61 (0t97)	ISDN protocol error
0x62 (0t98)	ISDN protocol error

*Continued on next page*

**Table 8-13. Status AC - Failure Cause Values — Continued**

<b>Failure Cause (hexadecimal)</b>	<b>Description</b>
0x64 (0t100)	ISDN protocol error
0x66 (0t102)	ISDN timer expired
0x7f (0t127)	Reason unknown
0xC2 (0t194)	Ring no answer
0xC8 (0t200)	Hi and dry - no feedback detected
0xC9 (0t201)	Cascade link administered wrong
0xCA (0t202)	CPTR not available to detect failure

## **status data-module**

### **status data-module extension [print]**

This command displays internal software states of a specified data-module port. It is useful for diagnosis and locating facilities to which the data module is connected.

```
DATA-MODULE STATUS
Data Ext/Stn Ext for Stn DM: 301           Service State: out-of-service
Port/Channel Number: 01C1103           Maintenance Busy? no
CF Destination Ext:
Connected Ports:

Associated C-LAN Modem: 1
Connect speed: 9600
V42? yes
V42bis? no
```

## Output

---

Data Ext/Sta Ext for Stn DM	The data module's extension number. For DTDMs, the connected station extension is shown instead.
Port/Channel Number	The location of the port connected to the data module. For data channels, the channel number is shown instead.
Service State	The operational state of the data-module:  in-service/idle The data module is connected but not in use. in-service/active The data module is connected and in use. out-of-service The data module has been removed from service.

If the specified port is administered as a system port, the following fields will be displayed at the bottom of the screen. See PDATA-PT in [Chapter 9](#) for more information.

CF Destination Ext	The call-forwarding destination, if any, of the port.
Maintenance Busy	Whether the port is busied out for testing.
Connected Ports	Locations of ports to which the data module is currently connected.
Associated PDATA Port	The location of a port on a TN553 Packet Data Line circuit pack to which this data-module port is connected.
Service State	The operational state of the associated PDATA port.
Maintenance Busy	Whether the PDATA port is busied out for testing.

## status hardware-group

---

### status hardware-group [print]

Summary information on the active or last hardware group tests will be displayed. This display includes the number and percentage of maintenance objects tested, the percentage of tests passed/failed/aborted, the time elapsed since initiating the hardware group test, the specific hardware group test command (see test hardware-group command) initiated, and the state (active/canceled/complete) of the hardware-group test.

## Output

---

Hardware Group Command State:	The state of a hardware-group command: active: testing is in progress; canceled: testing has been canceled; complete the command has completed and there is no testing going on.
Number of MOs Tested:	The number of MOs in the specified group (refer to test hardware-group command) that have had been tested by the current hardware-group command. This includes all MOs that were either actually tested or were aborted due to resource contention.
Total Number of MOs to be Tested:	The total number of MOs in the group that was specified in the "test hardware-group" command.
Percent Complete:	A ratio of the number of MOs completed and the total number of MOs to test in the command.
Elapsed Test Time:	The duration of the hardware-group test. If a test was canceled and then restarted this time excludes the cancel period. If the hardware-group command has finished it will indicate the length of time it took to complete the command. The time is displayed in the HH:MM:SS format where HH is hours, MM is minutes, and SS is seconds.
Repetition Number	The number of iterations that have been completed corresponding to the 'repeat' or the 'continuously' option.
Percentage of Tests Passed:	The percentage of tests that passed.
Percentage of Tests Failed:	The percentage of tests that failed.
Percentage of Tests Aborted:	The percentage of tests that were aborted.
Command:	The hardware-group action object and qualifiers that were entered.
Test sequence:	This will display either short or long.
Test repetition:	This will display either continuously or the keyword repeat along with the repeat value entered.
Output options:	This will display the selections that were chosen on the input form: auto-page, background, or failures.
Hardware options:	This will display the selections that were chosen on the input form, (all-ports or SPE-interchange).

The following display shows a typical result when **status hardware-group** is entered.

```

status hardware-group                                page 1 of 1
                                     HARDWARE GROUP STATUS

Hardware Group Command State:    active
Number of MOs Tested:           11070
Total Number of MOs to be Tested: 12300
Percent Complete:                90%
Elapsed Test Time (hr:min:sec): 4:15:30
Repetition Number:              1
Percentage of Tests Passed:      82%
Percentage of Tests Failed:      11%
Percentage of Tests Aborted:     7%

ENTERED HARDWARE GROUP Command

Command: test hardware-group system
Test sequence: short
Test repetition: repeat 3
Output Options: failures
Hardware Options: SPE-interchange
    
```

## status health

This command lists various performance measurements in the system.

Action/ Object	Qualifier	Qualifier Description	Permissions	Defaults	Feature Interactions
<b>status health</b>	<i>print</i>		init inads craft	none	none

## Output

The following example shows the output for the **status health** command.

```

status health                                        SPE B

PNC: Simplex                                ALARMS:Maj: 2 Min: 3 Wrn: 54
Pwr: comm Sync:ATM SW  Logins:2  BUSYOUT:Trk: 0 Stn: 0 Oth: 0

Cab EmTr  Mj Mn Wn PNC          Cab EmTr  Mj Mn Wn PNC          Cab EmTr  Mj Mn Wn PNC
1 auto-  0| 1|19 up
2 auto-  0| 0| 1 up/up
3 auto-  0| 0| 1 up/up
4 auto-  2| 2| 0 dn/up
5 auto-  0| 0| 2 up/up
6 auto-  0| 0|25 up/up
7 auto-  0| 0| 0 up/up
44 auto- 0| 0| 6 up/up
    
```

## Field descriptions

Major	Number of major alarms logged up to 2000
Minor	Number of minor alarms logged up to 2000
Warning	Number of warning alarms logged up to 2000
Trunks	Number of busied-out trunks
Stations	Number of busied-out stations
Others	Number of busied-out maintenance objects, excluding trunks and stations
Static	Percentage of CPU time currently dedicated to high priority items such as the operating system, rounded to the nearest whole number
SM	Percentage of CPU time currently dedicated to system management or periodic and scheduled maintenance, rounded to the nearest whole number  If a large amount of periodic or scheduled maintenance testing is being performed, this number can be high without affecting service.
CP	Percentage of CPU time currently dedicated to call processing, rounded to the nearest whole number  Call processing has priority over system management and will draw occupancy from the SM or IDLE categories.
Idle	Percentage of CPU time currently idle and available for use, rounded to the nearest whole number
Active SPE	Always A for a simplex SPE, otherwise:  A or B The currently active SPE  locked The SPE is locked by the SPE-Select switches on the Duplication Interface circuit packs.  auto The switches are set to allow the system control of active SPE selection.
Active PNC	Always A for a simplex PNC, otherwise:  A-PNC The currently active PNC or B-PNC  locked The PNC is locked via the <b>set pnc</b> command.  auto The system is controlling selection of the active PNC.
Duplicated?	Whether the SPE and PNC are duplicated

SPE Power	<p>Current source of power to the PPN</p> <p>commercialThe SPE is currently powered by the normal external power source.</p> <p>backupThe SPE is currently powered by the backup batteries. This is usually due to a failure of the external power source.</p>
Time Source	<p>The current source of timing signals used for system synchronization</p> <p>For systems with a Stratum 3 clock:</p> <p>externalNormal operating condition</p> <p>internalAnother source besides the Stratum 3 clock, such as a Tone-Clock circuit pack, is providing the master timing signal.</p> <p>For systems with Stratum 4 timing:</p> <p>primaryThe primary administered timing source</p> <p>secondaryThe secondary administered timing source</p> <p>localAnother source besides the administered ones, such as a Tone-Clock circuit pack, is providing the master timing signal.</p>
# Logins	Number of current users
Cab	<p>Cabinet number</p> <p>Cabinet numbers can be related to port network numbers with the <b>list cabinet</b> command.</p>
Emerg Trans	<p>The current setting of the switches on the SYSAM and EPN Maintenance circuit packs that control Emergency Transfer</p> <p>See EMG-XFER in <a href="#">Chapter 9</a>. For a PPN cabinet with duplicated SPEs, settings for both SYSAM circuit packs are displayed; <code>auto</code> is then abbreviated to <code>a</code>, and <code>off</code> to <code>of</code>. If the Emergency Transfer switch setting on a standby SYSAM is changed while handshake is down, this field will display the prior value until handshake is restored.</p> <p><code>auto</code> - Emergency Transfer is under system control and is not currently activated (normal operating state).</p> <p><code>auto</code> + Emergency Transfer is under system control and is in effect.</p> <p><code>on</code> Emergency Transfer has been manually activated. This setting should only be in effect during an emergency.</p> <p><code>off</code>Emergency Transfer is manually prevented from occurring. This setting should only be in effect when a technician is on site.</p> <p><code>n.a.</code> The setting of the switch in this EPN is not available to the switch. The Expansion Archangel Link may be down.</p>
Mj, Mn, Wn	<p>Number of Major, Minor or Warning alarms associated with the cabinet</p> <p>An asterisk indicates that the number exceeds 99.</p>

PNC	<p>Current Port Network Connectivity (PNC) status for each of the port networks in the cabinet</p> <p>When multiple port networks exist within a cabinet, Carriers A, B, and C are listed first and separated from Carriers D and E by a slash (e.g. up/up).</p> <p><i>up</i> Both the Expansion Archangel Link (EAL) and the Indirect Neighbor Link (INL, if applicable) are available.</p> <p><i>dn</i> Both EAL and INL (if applicable) are not available.</p> <p><i>ne</i> (Near End) The EAL is available but the INL is not available.</p> <p><i>fe</i> (Far End) The INL is available but the EAL is not available.</p> <p><i>up/up</i> When two port networks share a cabinet, the port network in carriers A, B, and C is listed first and separated from the one in carriers D and E by a slash.</p>
Time of Day	Current system time

## Feature Interactions

---

In a High or Critical Reliability System, if the standby SPE Emergency Transfer Select Switch is changed and the handshake is down, the displayed Emerg Trans field will be incorrect until the handshake comes up again.

## status isdn-testcall

---

**status isdn-testcall group# / member# [print]**

## Examples

---

**status isdn-testcall 78/1 print**

This command displays the progress of an outgoing ISDN-PRI test call on the trunk specified. The tested ISDN-PRI B-channel port number, bit error rate, number of bits transmitted, block error rate, number of blocks transmitted, start time, duration specified, duration of test call and reason of termination are displayed on the status form.

If the bit error rate or block error rate is greater than zero, the ISDN-PRI trunk “may” be in a troubled state. Based on the statistical information displayed on the terminal, it can be decided to take the ISDN trunk out of service. This is subjective data because the ISDN trunk may be used for data or voice. If the trunk is used for data and the rates are high, the trunk should be taken out of service. If the trunk is used for voice, the trunk may not have to be taken out of service. High rates may also be due to some type of power hit on the line.



## Output

---

Port	This field specifies the physical address of the ISDN-PRI B-channel.
Bit Error Rate	The measured bit error count according to the comparison of the sent and received bit pattern. The number is displayed in scientific notation.
Number of Bits	The number of bits generated. The number is displayed in scientific notation.
Block error Rate	The measured block error count according to the comparison of the sent and received bit pattern. The number is displayed in scientific notation.
Number of Blocks	The number of blocks generated. The number is displayed in scientific notation.
Start Time	The time the test call started (dd/hh:mm).
Duration Specified	The duration specified in minutes for how long the test call should run. Valid durations are 1-120 (minutes) or blank (to indicate the default amount of minutes was used to run the test).
Duration of Test	The duration specified in minutes for how long the test call has been running. A blank indicates that the default amount of time was used to run the test.
Reason of Termination	The reason of termination indicates why the test call has terminated. Valid reasons of termination are "finished," "canceled," "overflow," "no bits," "transmission," "internal fail," "data corrupt," and "in progress." A termination reason of "finished" means the test finished in the specified time. A termination reason of "canceled" means the test call has been canceled with the "clear isdn-testcall" command. A reason of "overflow" denotes that the bits transmitted have overflowed buffer allocation. A reason of "no bits" means that no bits have been received because the ISDN-PRI test call circuit connection is bad. A reason of "transmission" means there has been a data transmission interruption, probably caused from a power hit. A termination reason of "internal fail" specifies that there is an internal error on the Maintenance/Test circuit pack. A reason of "in progress" means the test is still running and a reason of "data corrupt" is used for any other error condition.

The following display shows a typical result when **status isdn-t 80/1** is entered.

```
status isdn-testcall 80/1                               Page 1 of 1   SPE A
                                     ISDN TESTCALL STATUS

      Bit   Number Block Number          Duration Reason
      Error Of Error Of Start      Duration Of      Of
Port   Rate  Bits   Rate  Blocks Time   Specified Test   Termination
-----
1B1401 0EE0 4EE7  0EE0 6EE2  25/12:36  120    100    in progress
```

## **status journal-link**

---

### **status journal-link wakeup-log | pms-log [print]**

This command displays the operational status of a wakeup-log or a pms-log printer link. If the link is down, the number of times the switch has tried to re-establish the link will be shown.

A journal printer is used to document automatic wake-up events, emergency access to attendant events and, if the Property Management System is not functional, housekeeping events. When the system includes two printers, one is for the housekeeping events and the other is used for automatic wake-up events and emergency access events.

## **Parameters**

---

- wakeup-log** The printer that handles automatic wakeup events, emergency access events and scheduled reports.
- pms-log** The printer that handles housekeeping events while the PMS is down.
- print** This qualifier sends output to a printer connected to the terminal and to the screen.

## **Examples**

---

```
status journal-link wakeup-log
status journal-link pms-log print
```

## Output

---

Link State	The operational status of the link as follows:  up The link is established and is capable of supporting the application. This is the normal operational state.  down The link is physically down.  extension not administered An extension number for the printer administered has not been assigned on the hospitality system parameters.
Maintenance Busy	Whether there is any maintenance testing being performed upon the link.

The following display shows a typical result when **status journal-link wakeup-log** is entered.

```
status journal-link wakeup-log                               SPE A
                                                                JOURNAL LINK STATUS
Link State: down
Number of retries: 1
Maintenance Busy? no
```

## status link n

---

(csi, si, r models with C-LAN circuit pack - Ethernet connection)

This command displays:

- static information about the link
- the modem used, connect speed, and protocol information
- a counter of CHAP failures for PPP links
- time information for PPP and Ethernet links (includes the time of the last reset, the last hour start time, and end time for the error counter statistics).

The same information that is displayed by the status link command can also be invoked with:

- **status pgate-port** for PGATE links
- **status clan-port** or **netstat link n** for C-LAN links.

Action/Object	Qualifier	Qualifier Description	Permissions	Defaults	Feature Interactions
status link	n	Number of the administered link. Example: status link 1	init inads craft	none	none

## Output

The following example shows page 1 of the output from the **status link n** command (si w/ TN794 Net Packet/Packet Interface circuit pack).

### Link/Port Status form (page 1)

Example below from Berlin (4-15-99):

```

status link 1                                     Page 1 of 3
                                     LINK/PORT STATUS
Link Number: 1
Link Status: connected
Link Type: ethernet
Link Name: ethernet on link 1
Service Port Location: 01A0917
Service Port Data Extension: 2991
Service State: in-service/idle
Node Name: berl
Source IP Address: 192.168.10.11
Subnet Mask: 255.255.255.0
Broadcast Address: 255.255.255.255
Physical Address: 00:00:00:00:00:00
Enabled? yes
Maintenance Busy? no
Active Channels: 0
    
```

### Field descriptions (page 1)

- Link Number                      Administered link number (assigned by **add/change data-module** command)
- Link Status                      Displays no, yes, unavail, connected, disconnected, enabled, out-of-service, or restarting
- Link Type                        The type of interface according to the physical/link protocol(s) immediately "below" the network layer in the protocol stack (ethernet, ppp, bx.25)
- Link Name                        Administered link name (assigned by **add/change data-module** command)
- Service Port Location           Administered port location (assigned by **add/change data-module** command)

**8** Maintenance Commands  
*status link n*

8-282

Service Port Data Extension	Administered extension number (assigned by <b>add/change data-module</b> command)
Service State	Displays: in-service/idle, in-service/active, disconnected, out-of-service, maintenance busy, in-service, inactive, active, idle
Node Name	Administered node name (assigned by <b>add/change data-module</b> command)
Source IP Address	Administered IP address (assigned with <b>change node-name</b> or <b>add/change data-module</b> commands)
Subnet Mask	Administered subnet mask address (assigned by <b>add/change data-module</b> command)
Broadcast Address	Administered broadcast address (assigned by <b>add/change data-module</b> command)
Physical Address	The interface's address (CLAN circuit pack) at the protocol layer immediately "below" the network layer in the protocol stack.
Enabled	y (yes) or n (no)
Maintenance Busy?	y (yes) or n (no)
Active Channels	Number of active channels

**Error Counters form (page 2)**

```

status link 1                                     Page 2 of 3
          ERROR COUNTERS
Reset Time: 04/08 14:46
Last Hour Start Time:                               End Time:
Incoming Received:  Unicast Pkts  Multicast Pkts  Octets
    Since Reset
    Last Hour
Incoming Dropped:   Error Pkts    Discard Pkts
    Since Reset
    Last Hour
Outgoing Transmitted: Unicast Pkts  Multicast Pkts  Octets
    Since Reset
    Last Hour
Outgoing Dropped:   Error Pkts    Discard Pkts
    Since Reset
    Last Hour
CRC Check: 0          Collision Count: 0
    
```

**Field descriptions, page 2**

Incoming received Unicast packets      The number of subnetwork-unicast packets delivered to a higher-layer protocol.

Incoming received multicast packets	The number of non-unicast (subnetwork-broadcast or subnetwork-multicast) packets delivered to a higher-layer protocol.
Incoming dropped octets	The total number of octets received on the interface, including framing characters.
Incoming errored packets	The number of inbound packets that contained errors preventing them from being deliverable to a higher-layer protocol.
Incoming packets discarded	The number of inbound packets which were chosen to be discarded even though no errors had been detected to prevent their being deliverable to a higher-layer protocol. One possible reason for discarding such a packet could be to free up buffer space.
Outgoing Transmitted unicast packets	The total number of packets that higher-level protocols requested be transmitted to a subnetwork-unicast address, including those that were discarded or not sent.
Outgoing multicast packets	The total number of packets that higher-level protocols requested be transmitted to a non- unicast (subnetwork-broadcast or subnetwork-multicast) address, including those that were discarded or not sent.
Outgoing transmitted octets	The total number of octets transmitted out of the interface, including framing characters.
Outgoing errored packets	The number of outbound packets that could not be transmitted because of errors.
Outgoing packets discarded	The number of outbound packets which were chosen to be discarded even though no errors had been detected to prevent their being transmitted. One possible reason for discarding such a packet could be to free up buffer space.

### Processor Channel Status form (page 3)

The example below is for processor channels (page 3 of the form). Information about administered hop channels displays on page 4 of the form.

The processor or hop channel status information can take either 1 or 2 pages on this form, depending on the number of links being reported and their condition. Hop channel information (shown only for BX.25 links using the Processor Interface or PGATE circuit packs) uses only 1 page.

```
status link 1
                                Page 3 of 3
                                PROCESSOR CHANNEL STATUS

UP: 001, 007, 010-115
    199, 300:310

DN: 001-002

PND: 003, 216-220, 299
```

### Field descriptions, page 3



**NOTE:**

A dash (-) or a colon (:) between numbers indicates all numbers including and between the indicated numbers.

- UP: Channels are up.
- DN: Channels are down.
- PND: Channels are in a pending state from the down to the up state (processor channels only)

### status link (with PGATE)

(r model with PGATE circuit pack)

Action/ Object	Qualifier	Qualifier Description	Permissions	Defaults	Feature Interactions
<b>status link</b>	<i>n</i>	Number of the administered link.  Example: <b>status link 1</b>	init inads craft	none	none

### Output

The following example shows the output from the **status link 1** command.

Page 1 of 4

```
LINK / PORT STATUS

Link Number: 1
Link Status: disconnected
Link Type: x.25
Link Name: audixa
Service Port Location: 01C0301
Service Port Data Extension: 4011
Service State: in service/idle
Enabled: y
Maintenance Busy? n
Active Channels: 0

CONNECTED TO:

Destination: TDMODULE           Destination Port: 1C0303
Destination Status: in-service/active Destination Extension: 4002
```

## status logins

---

### status logins [print]

This command will display information about all of the users that are currently logged into the system. This information will contain their login names, location of physical access, and their currently executing command.

The screen does not automatically update, and is a reflection of the system at the time the request was made. Users may have logged off, or on, or the command may have finished executing while the information is being displayed. These updates will not be reflected until the next execution of the command.

The command will take a snapshot of the commands that the users on the system are currently executing. Because of timing, the command could be terminated by the time this command finishes displaying the list (i.e. the active command may not be accurate).

## status packet-interface

---

### status packet-interface [print]

The status packet-interface command displays the status of all packet-interface circuit packs in the system along with link information. The service state is displayed for both active and standby packet-interface circuit packs. Link status information including total, active and failed links are displayed for active packet-interface circuit packs only.



If there are no standby packet interface circuit packs, or if the standby is inaccessible (due to handshake failure, incomplete memory refresh, or locking of the SPEs) the standby packet-interface circuit packs will be in the uninstalled state.

When a packet-interface circuit pack is out-of-service or uninstalled, it is not used to establish and maintain links. When the circuit pack returns to in-service status, new links are again assigned to it.

For simplex SPE systems, information for only the A carrier packet-interface is displayed. For duplicated SPE systems, if the standby is inaccessible because of handshake failure or locking of carriers, the standby packet-interface circuit packs will be in the uninstalled state.

## Output

---

Separate columns identify each packet interface circuit pack slot. Service state is displayed for both active and standby packet-interface circuit packs. Dashes in output fields for the standby SPE indicate that link information is not applicable to standby packet-interface circuit packs.

Location	The packet-interface cabinet, carrier and circuit pack position number.
Service State	One of the following states is displayed: "in-service", "out-of-service" or "uninstalled". The "standby" state is used in place of "in-service" for standby packet-interface circuit packs.
Total links	The total number of links.
Active links	The number of links that are in use.
Failed links	The number of links that failed to be established. These links are in a recovery state and not active. The failures can arise from problems in the packet-interface, EI or center stage hardware. The number of failed links is the number of total links minus the number of active links.

The following display shows a typical result when **status packet-interface** is entered.

```
status packet-interface

                                PACKET INTERFACE STATUS

      Location:      01A1          01A2          01A3
Service State:      in-service    uninstalled    uninstalled

      Total Links:   32           -           -
      Active Links:  32           -           -
      Failed Links:  0            -           -

      Location:      01B1          01B2          01B3
Service State:      standby       uninstalled    uninstalled

      Total Links:   -            -           -
      Active Links:  -            -           -
      Failed Links:  -            -           -
```

## **status periodic-scheduled**

### **status periodic-scheduled [print]**

The **status periodic-scheduled** command displays summary information on currently active and recently completed background testing. Periodic tests are run every hour, and scheduled tests are run daily. Starting and stopping times, and other parameters for daily scheduled testing are administered on the **change system parameters maintenance** form.

## Output

Percentage Complete	The ratio of the number of maintenance objects tested to the total number of maintenance objects tested during a cycle. For periodic tests, the ratio is for the current cycle, if active; or for the last completed cycle if not. For scheduled tests, the ratio is for the last completed cycle.
System Critical	System critical resources are those whose health affects the entire system such as the processor. These are always tested first.
Shared Resource	Shared resources are those that are used by many users, such as trunks. These are tested after system critical resources.
Single User	Single User resources are those whose health affects only one user, such as voice stations.
Pre- SCHEDULED MAINTENANCE	The system can be administered to perform interchanges of duplicated components and backup of data to disk before daily scheduled maintenance begins. This is pre-scheduled maintenance and is administered on the <b>change system-parameters maintenance</b> form.

The following display shows a typical result when **status periodic-scheduled** is entered.

```
status periodic-scheduled
```

	MO Type	Current Cycle % Complete	Current Cycle Active?	Previous Cycle Duration (hr:min:sec)	Rate of Completed Cycles
PERIODIC MAINTENANCE	System Critical	80%	y	00:00:48	1.0/hr
	Shared Resource	100%	n	00:00:43	1.0/hr
	Single User	100%	n	00:00:48	1.0/hr

```
Total 00:01:57
```

```
Start Time of Current or Previous Cycle: 11/19/13:34:36
```

```
Pre-SCHEDULED MAINTENANCE n 00:08:15
```

SCHEDULED MAINTENANCE	System Critical	100%	n	00:02:15	1.0/day
	Shared Resource	100%	n	00:03:16	1.0/day
	Single User	100%	n	00:20:05	1.0/day

```
Total 00:25:36
```

```
Start Time of Current or Previous Cycle: 11/18/22:00
```

## status pgate-port

The status pgate-port command displays the operational status of a specified Packet Gateway port. Such ports support the connection of X.25 adjunct applications to the system. If the technician knows the X.25 link number associated with the connection, but not the port number, then the "status link" command may be used to access exactly the same information.

Adjunct Applications supported over X.25 connections include:

- AUDIX
- Calling Party Billing Number (CPN/BN or ISDN Gateway)
- CMS
- DCS
- Gateway Channels for DCS over ISDN-PRI
- Message Server

See *DEFINITY Communications System Generic 3 V2 Implementation*, 555-230-653, for details. Status information provided by the command is restricted to the switch hardware and extends no further than the Packet Gateway circuit pack port.

The screen output for this command is the same as that for the **status link** command.

## **status processor-channel 1**

The following screen applies to processor channels carried over link type of Ethernet or ppp (using the TCP/IP protocol).

```
PROCESSOR CHANNEL STATUS

Channel Number: 1

Channel Status: Administered but not connected

Link Number: 3

Link Type: ethernet

Message Buffer Number: 0

Reset Count: 0

Retransmission Count: 0
```

## **status pms-link**

---

### **status pms-link [print]**

The `status pms-link` command displays the status of the property management system interface link. If the link is up, whether or not a data base swap is taking place between the switch and PMS, will be shown. If the link is down, the number of times the switch has tried to set up the link will be shown.

A property management system (PMS) is a stand alone computer system which can be integrated with the switch to enhance the service capability for a hotel/motel.

## **Output**

---

Physical Link State	Up, down, or extension not administered will be displayed. The PMS link is considered administered only if an extension is given in the system hospitality form.
Protocol State	
Maintenance Busy	Whether there is any maintenance testing being performed upon the link.

The following display shows a typical result when **status pms-link** is entered.

```
status pms-link

                                PMS LINK STATUS

Physical Link State: extension not administered
Protocol State:

Maintenance Busy?
```

## **status pnc**

---

### **status pnc [print]**

The `status pnc` command displays a summary of conditions on the active and standby Port Network Connectivities. If the PNC is not duplicated, the screen displays blanks in the PNC-B and other duplication-related fields.

## Output

---

Most fields on this screen display blanks when the PNC is not duplicated.

Duplicated?	Whether or not the system has a duplicated PNC (Critical Reliability option).
Software Locked?	On a system with duplicated PNC, whether the PNCs are locked by means of the <b>set pnc lock</b> or <b>reset pnc override-and-lock</b> commands. When this field displays "yes", spontaneous or demand PNC interchanges are not possible. To enable interchanges, use the <b>set pnc unlock</b> command.
Standby Busied?	On a system with duplicated PNC, whether or not the standby PNC is busied out with the <b>busy pnc</b> command. Interchanges are prevented when the standby is busied out.
Direct Connect?	Whether the system uses direct-connect connectivity or a center stage switch.
Standby Refreshed?	On a duplicated system, this field indicates whether the standby PNC has completed a global refresh of duplicated call setup after being released from a busyout, or after a system reset.

### ⇒ NOTE:

This field does not indicate if a partial unrefresh has taken place in response to a problem on the standby. Only a "functional" state of health on the standby (all zeros in the state of health vector) guarantees that the standby's call setup matches completely that of the active.

Interchange Disabled?	This field displays "yes" when the anti-thrashing mechanism is in effect, preventing PNC interchanges. This is the case for 5 minutes after a spontaneous PNC interchange, and for 30 seconds after a demand interchange. The <b>reset pnc interchange override-and-lock</b> command overrides antithrashing. This field does not indicate whether a PNC interchange is currently prevented by a software lock, by insufficient state of health of the standby, or by busyout of the standby.
-----------------------	---

In a duplicated system, each PNC has a separate entry for the following fields, representing conditions for only that particular PNC.

Mode	This field displays "active" or "standby", depending on whether or not that PNC controls active call processing.
------	--

State of  
Health

On a system with duplicated PNC, the state of health of each PNC. For the standby PNC, service effects mentioned below are those that would occur if that PNC were to become active via an interchange.

Functional: the indicated PNC has no service disrupting alarms against it. The state of health vector is all zeros, and call setup on the standby PNC matches that of the active.

Partially functional: the health of the PNC is less than perfect. The source and severity of the problem is indicated by the state of health vector (Inter-PN and Inter-SN Indexes). Whenever the standby's state of health is partially functional, duplicated call setup on the standby probably does not match that on the active.

Not functional: Expansion Archangel Links to all EPNs are down on this PNC. No service is possible to any EPNs via this PNC.

Inter PN  
Index,  
Inter SN  
Index

The Inter-PN and Inter-SN Indexes form the state of health vector, which is used to track and compare the states of health of both PNCs. The fields making up the indexes are two digit numbers separated by periods (.), with each field representing a different class of faults. The fault class fields are arranged in order of decreasing importance from left to right. In other words, each field in the index supersedes the following fields in determining which PNC is healthiest. The Inter-PN Index contains five fields (XX.XX.XX.XX.XX), and the Inter-SN Index has two (XX.XX). The Inter-PN Index reports faults in connectivity between port networks and supersedes the Inter-SN Index, which reports faults in connectivity between switch nodes. (The Inter-SN Index is only meaningful for systems with a center stage switch having 2 switch nodes, each of which is duplicated).

The meaning of each fault class field is given in [Table 8-14](#) below. A zero entry indicates that there are no such faults reported. Higher numbers indicate increasing number of faults. All zeros indicates perfect state of health. Unless the PNCs are locked, the active PNC's state of health should always be equal to or better than the standby's. (Otherwise, the system would perform a spontaneous interchange.)

After a PNC-related alarm is cleared, the system performs a partial refresh of the standby PNC. The corresponding fault class field is not updated to reflect the improved state of health until the refresh is done. The state of health indexes will not agree with the current alarm status during this period.

**Table 8-14. Fault Class Field Descriptions**

Fault Class	Priority	Description	MOs
FC_EAL	1	Number of PNs with EALs down	EXP-PN
FC_INL	2	Number of PNs with LINL, RINL, or EI-SNI neighbor link faults	EXP-PN SN-CONF
FC_HW	3	Number of PNs affected by hardware faults in a link having an EI as an endpoint (Endpoints can be determined with <b>list fiber-link</b> .)	EXP-INTF SN-CONF FIBER-LK SNI-BD DS1C-BD
FC_PER	4	Number of PNs affected by SNI peer link faults for SNIs connected to EIs	SNI-PEER
FC_DS1	5	Number of PNs affected by DS1C facility faults	DS1FAC
FC_SNIL	6	Number of inter-switch-node fibers affected by peer or neighbor link faults	SNI-PEER
FC_SNIHW	7	Number of inter-switch-node fibers affected by hardware faults	SN-CONF SNI-BD FIBER-LK

Major Alarms,  
 Minor Alarms,  
 Warning Alarms

The number of major, minor, or warning alarms logged against DS1C-BD, SNI-BD, SNC-BD, EXP-INTF, FIBER-LK, DS1C-FAC, SNC-LINK, SN-CONF, SNC-REF, SYNCH, and SNI-PEER on the indicated PNC.

Switch Node  
 Locations

The locations of all Switch Nodes comprising the indicated PNC.



The following display shows a typical result when **status pnc** is entered on a system with a single switch node CSS and duplicated PNC.

```

status pnc

                                PORT NETWORK CONNECTIVITY

                                Duplicated? yes
                                Software Locked? no
                                Standby Busied? no
                                Direct Connect? no
                                Standby Refreshed? yes
                                Interchange Disabled? no

                                A-PNC                                B-PNC

                                Mode: active                        Mode: standby
                                State of Health: functional        State of Health: functional
                                Inter PN Index: 00.00.00.00.00    Inter PN Index: 00.00.00.00.00
                                Inter SN Index: 00.00              Inter SN Index: 00.00
                                Major Alarms: 0                    Major Alarms: 0
                                Minor Alarms: 0                    Minor Alarms: 0
                                Warning Alarms: 0                  Warning Alarms: 0
                                SN Locations: 01E                   SN Locations: 01D
    
```

## **status port-network**

This command lists port network(s) in the system.

Action/ Object	Qualifier	Qualifier Description	Permissions	Defaults	Feature Interactions
<b>status port-network</b>	<i>print</i>		init inads craft	none	none

## **Output**

The following example shows the output for the **status port-network** command.

status port-network SPE B

PORT NETWORK STATUS

PN	Major Alarms	Minor Alarms	Warning Alarms	Carrier Locs	PNC Status	ATM PNC Conn	PNC Standby	Endpoints	Mode
1	0	1	19	01A 01B 01C 01D	up	2 1	A-PNC A-PNC	01D01-AT02A 01C01-AT01A	active active

TDM Bus	Service State	Control Channel	Dedicated Tones	TONE/CLOCK	Service State	System Clock	System Tones
A	in	n	n	01A	in	standby	standby
B	in	y	y	01B	in	active	active

PKT	Service State	Major Alarms	Minor Alarms	Bus Faults	Open Bus Leads
1	in	n	n	0	0

status port-network 4 SPE B

PORT NETWORK STATUS

PN	Major Alarms	Minor Alarms	Warning Alarms	Carrier Locs	PNC Status	ATM PNC Conn	PNC Standby	Endpoints	Mode
4	0	0	1	03A 03B 03C	up	5	A-PNC	03A01-AT05A	active

TDM Bus	Service State	Control Channel	Dedicated Tones	TONE/CLOCK	Service State	System Clock	System Tones
A	in	n	n	03A	in	active	active
B	in	y	y				

PKT	Service State	Major Alarms	Minor Alarms	Bus Faults	Open Bus Leads
4	in	n	n	0	0

## Field descriptions

- PN            The Port Network number associated with the Port Network for which status is being displayed.
- Major Alarms    The number of major alarms logged against the Port Network that is being displayed.
- Minor Alarms    The number of minor alarms logged against the Port Network that is being displayed.

**8** Maintenance Commands  
*status port-network*

8-296

Warning Alarms	The number of warning alarms logged against the Port Network that is being displayed.
Carrier Locs	The cabinet and carrier locations of each carrier in the Port Network.
PNC Status	Active (and Standby if PNC is duplicated) Port Network Connectivity (PNC) status for the specified port network is displayed. The PNC Status of a port network is determined by the availability of the Expansion Archangel Link (EAL) and Indirect Neighbor Link (INL) to the port network. A status of "up" denotes that the EAL and INL are both available. A status of "down" is displayed when the EAL and INL are both unavailable. When the EAL is available, but the INL is unavailable, a status of "near-end" is displayed. A status of "far-end" is displayed when the INL is available and the EAL is unavailable. When the EAL is unavailable (far-end), tone clock, tdm bus, and packet bus information will be blank.
FIBER-LINK	This field displays the fiber-link number associated with all fiber links having an Expansion Interface circuit pack endpoint residing in the specified Port Network. The fiber connectivity side will also be displayed (i.e. "A-PNC" or "B-PNC").
Endpoints	The physical position of each Expansion Interface board that is an endpoint for a fiber link in the specified Port Network is displayed as "UUcSS." "UU" represents the cabinet number, "c" represents the carrier, and "SS" represents the slot position. The simplex PNC configuration will display only one Expansion Interface pair, while the duplex PNC configuration will display two Expansion Interface pairs separated by a hyphen (-). If blanks are displayed it means the endpoints could not be retrieved by software.
Mode	The mode is the current role of the link. A mode of "active" means the link is providing normal circuit and control functions for the Port Network. A mode of "standby" means the link is part of a duplicated system and is ready to perform its functions but is not active. If blanks are displayed it means that PNC is not duplicated, or the mode could not be retrieved from software.
TDM Bus	The TDM bus identifier associated with the Port Network is displayed. The TDM bus ("a" or "b") specifies which half of the TDM bus is being displayed.
Service State	The operational state of the TDM bus. A TDM bus service state of "in" means the bus is in normal operation. A TDM bus service state of "out" means the bus has failed certain maintenance tests and has been taken out of service, or the maintenance object has been demand busied out.
Control Channel	This field shows whether the TDM bus has the control channel on it ("y"/"n"). Only one TDM bus of a TDM bus pair on each Port Network can have the control channel on it at a given time. If the system does not contain an EPN, blanks appear in this field.

8 Maintenance Commands  
*status port-network*

8-297

Dedicated Tones	This field shows whether the TDM bus has the system tones on it ("y"/"n"). Only one TDM bus of a TDM bus pair can have system tones on it at a given time. If the system does not contain an EPN, blanks appear in this field.
TONE/CLOCK	The location of the tone-clock circuit packs in the specified Port Network. The location is represented using the cabinet and carrier where the tone-clock resides (e.g. 1a, 1b, 2a, 2b, etc.).
Service State	This field represents the operational state of the tone-clock circuit pack. A service state of "in" means the tone-clock has been installed and is in normal operation. A service state of "out" means that the tone-clock is out of service and has failed certain maintenance tests.
System Clock	This field shows which tone-clock circuit pack supplies the system clock for that port network by displaying the mode of the tone-clock. An "active" mode means that the tone-clock supplies the system clock. Only one tone-clock in each Port Network can have a mode of "active" at any given time. A "standby" mode means the tone-clock is part of a duplicated clock system and is ready to supply the system clock, but is not currently "active." A "down" mode means the tone-clock is not operational.
System Tones	This field shows which tone-clock circuit pack supplies the system tones for that port network by displaying the mode of the tone-clock. An "active" mode means that the tone-clock supplies the system tones. Only one tone-clock in each Port Network can have a mode of "active" at any given time. A "standby" mode means the tone-clock is part of a duplicated clock system and is ready to supply system tones, but is not currently "active." A "down" mode means the tone-clock is not operational.
PKT	This field contains the Packet Bus identifier, which is the same as the Port Network number.
Service State	This field represents the operational state of the packet bus. A service state of "in" means the packet bus has been installed and is in normal operation. A service state of "out" means that the packet bus is out of service and has failed certain maintenance tests, or the maintenance object has been demand busied out. A service state of "reconfig" means that the Maintenance/Test circuit pack has swapped one or more signal leads because of lead faults detected during testing (Duplex System Only). A service state of "open lds" means the Maintenance/Test circuit pack query was run and open bus leads were found. A service state of Blanks in this field means the system does not have the Packet Bus feature optioned.
Major Alarms	Whether major alarms are logged against the packet bus that is being displayed ("y" or "n").
Minor Alarms	Whether minor alarms are logged against the packet bus that is being displayed ("y" or "n").

Bus Faults	This field indicates the number of faulty bus leads, where a fault is defined as either shorted to another lead or stuck at some value. This field may take on any integer value between 0 and 24. The field contains a blank if the Maintenance/Test circuit pack is not present or has been taken out of service.
Open Bus Leads	This field indicates the number of bus leads that have an open circuit between the Maintenance/Test circuit pack and bus terminator. This information is determined by testing performed on the bus leads; bus leads test open as a result of physical damage to the backplane or the backplane's connectors, or because a bus terminator is missing. This field may contain integer values between 0 and 24. This field contains a blank if the Maintenance/Test circuit pack is not present or has been taken out of service.

## **status processor-channel**

---

### **status processor-channel channel# [print]**

The status processor-channel command displays the status of the specified processor channel and the values of its various counters. A processor channel is one of 128 logical channels associated with an SCI link. Each processor channel terminates in the switch processing element with a session.

## **Parameters**

---

**channel number** The processor channel number (1-128).

## **Output**

---

Channel Number	The processor channel number 1-128.
Channel Status	The state that the channel is in: 1-16. The following describes the various channel states:
Reset Count	The number of times that the reset has been issued for this channel.
Message Buffer Number	The number of message buffers currently allocated for communications on this channel.
Link Number	The physical BX.25 interface link, 1-16, associated with the channel.
Retransmission Count	The number of times that message retransmission has occurred.

The following display shows a typical result when **status processor-channels 1** is entered.

```
status processor-channels 1
```

```
PROCESSOR CHANNEL STATUS
```

```
Channel Number: 1  
Channel Status: 11: Administered but not connected  
Reset Count: 0  
Message Buffer Number: 0  
Link Number: 3  
Retransmission Count: 0
```

## **status signaling-group**

---

### **status signaling-group group# [print]**

This command displays the service state, type, port location, and of the primary and secondary D-Channels within an ISDN-PRI signaling group. A signaling group is a set of B-channels signaled for by a designated single D-channel or combination of D-channels.

## Parameters

---

**group#** An administered number associated with each signaling group.

## Output

---

**Group ID:** An administered number from 1 to 666 that identifies the signaling group.

**Type:** See “ISDN-SGR (ISDN-PRI Signaling Group)” in Chapter 9 for more information about group types.

**facility** All members are carried on a single DS-1 associated facility. Facility-associated signaling groups support only simplex D-channel configuration.

**non-facility** Members can include trunks on several different associated DS-1 facilities. The DS-1 facility is identified signaling across the ISDN-PRI using an explicit facility identifier. A single D-channel on one of the facilities is used to signal for all members. In a duplex configuration, a second D-channel is assigned to act as a backup in case the primary signaling channel fails.

**Group State:** The operational state of D-channel providing signaling for the group: *in-service* or *out-of-service*. In duplex configurations, this field displays *in-service* if either D-channel is functioning.

The following information is given for both primary and secondary D-channels, if any.

**Link:** The number of the link carrying the D-channel.

**Port:** The location of the port carrying the D-channel.

Level 3 The operational state of the primary and secondary D-channels:

State: *in-service* The D-channel is functioning.

*standby* the link is established but the D-channel is not currently being used for layer 3 signaling.

*wait* This is a transitional state in the process of progressing to the *in-service* state. The switch has sent an ISDN SERVICE message requesting establishment of layer 3 communications, and is awaiting a SERVICE ACKNOWLEDGE message from the far end to put the D-channel into service.

*maintenance busy* The D-channel is no longer in the multiple-frame-established state at layer 2. When an active D-channel in a duplex signaling group fails, it is placed into this state and an interchange to the standby D-channel takes place. When layer 3 signaling is re-established over the new D-channel, the failed D-channel is moved from this state to *out-of-service* and restarted. If the link is successfully re-established, it is put into the *standby* state.

*manual-out-of-service* The link carrying the D-channel has been busied-out by command.

*out-of-service* The D-channel is down.

*no-link* A link has not been administered for this D-channel on the signaling-group form.

The following display shows a typical result when **status signaling-group 1** is entered.

```

status signaling-group 1                               Page 1 of 1   SPE A
              STATUS SIGNALING-GROUP

      Group ID: 1
      Type: facility associated signaling
      Group State: in-service

              Primary D-Channel

Link: 1      Port: 01C1924   Level 3 State: in-service

              Secondary D-Channel

Link:      Port:      Level 3 State:
    
```



## status spe

---

### status spe [print]

The `status spe` command displays a page of output summarizing the condition of the active and standby (if the system is duplicated) SPE(s) in the system. If the SPEs are not duplicated, the fields in the standby SPE column will be blank.

## Output

---

Duplicated?	This field specifies whether the system is a duplex SPE system ("yes" or "no").
SPE Selected:	If the system is a duplex SPE system, this field displays which SPE is locked active by the position of the duplication interface circuit pack Select-switches. If "spe a locked active" is displayed, then the SPE in cabinet 1 and carrier A has been locked active (both duplication interface circuit pack switches are switched left). If "spe b locked active" is displayed, then the SPE in cabinet 1 and carrier B has been locked active (both duplication interface circuit pack switches are switched right). If "auto" is displayed, it means the switches are in any other combination of positions besides both left or both right. If blanks are displayed, the system is not a duplex SPE system (there are no duplication interface boards).
Standby Busied?	This field specifies whether the standby SPE is busied out ("yes" or "no"). Blanks are displayed if the system is not a duplex SPE system.
Standby Refreshed?	This field specifies whether the standby SPE's memory has been completely refreshed ("yes" or "no"). Blanks are displayed if the system is not a duplex SPE system.
Standby Shadowing:	This field specifies whether the standby SPE's memory is currently being updated when changes are made to the active SPE's memory ("on" or "off"). Blanks are displayed if the system is not a duplex SPE system.
Standby Handshake:	This field specifies whether the software running on the standby SPE's duplication interface board is communicating to the software on the active SPE's duplication interface board ("up" or "down"). Blanks are displayed if the system is not a duplex SPE system.

8 Maintenance Commands  
*status spe*

8-303

Recent Spontaneous Interchange?	This field specifies whether a spontaneous interchange has occurred within the last hour. If this field displays "yes," a spontaneous interchanges has occurred within the last hour. If the field displays "no" a spontaneous interchange has not occurred within the last hour, or a technician has purposely reset this field in the software. Immediately following a spontaneous interchange, the field is set to "yes." While the field displays "yes," the health of the standby SPE can never be better than "partially functional," and an interchange can not occur unless the health of the active SPE drops below "partially functional." Recent interchange mode can be cleared by either <b>test spe-standby long</b> or <b>busyout spe-standby</b> . This condition clears automatically one hour after the interchange occurred.
	This field will be blank in a simplex SPE system.
Mode:	The mode is the current role of the SPE. "active" indicates that this SPE is controlling the network and providing services for the system. <i>standby</i> indicates that this SPE is part of a duplicated system and is not currently active. Blanks indicate that the system has a simplex SPE.
Select Switch:	This field shows the position of the SPE Select-switch on the duplication interface circuit pack. The Select-switch can be in three different positions. A position of "spe a" means the switch is switched left. A position of "spe b" means the switch is switched right. A position of "auto" means the switch is in the center position. "unavail" means the duplication interface circuit pack has been removed (the board has been unseated). Blanks mean that the system is not duplicated and there is no Select-switch due to there being no duplication interface boards.
Major Alarms:	The number of major alarms logged against the SPE are displayed in this field. Blanks in the standby fields mean that the system is not duplicated and a standby SPE does not exist. The category <b>spe</b> may be entered on the <b>display alarms</b> or <b>display errors</b> forms to view all alarms or errors logged against SPE maintenance objects.
Minor Alarms:	The number of minor alarms logged against the SPE are displayed in this field. Blanks in the standby side mean that the system is not duplicated and a standby SPE does not exist. The category <b>spe</b> may be entered on the <b>display alarms</b> or <b>display errors</b> forms to view all alarms or errors logged against SPE maintenance objects.
Warning Alarms:	The number of warning alarms logged against the SPE are displayed in this field. Blanks in the standby side mean that the system is not duplicated and a standby SPE does not exist. The category <b>spe</b> may be entered on the <b>display alarms</b> or <b>display errors</b> forms to view all alarms or errors logged against SPE maintenance objects.

State of Health:	On a duplicated SPE system, these fields each display one of the following states of health for each SPE: "functional," "partially functional," "not refreshed," or "not functional". If the system has a simplex SPE, the state of health fields for both the active and the standby SPEs will display nothing. A health of "functional" means that the SPE has no service disrupting alarms. A health of "partially functional" means that the health of the SPE has been degraded (possibly service disrupting). A health of "not functional" means that the associated SPE is not cycling at all (no service). A health of "not refreshed" means that the standby SPE's memory has not been refreshed with the active SPE's memory, but it is otherwise healthy and cycling correctly.
Tape State:	This field represents the operational state of the tape device. A service state of "in-service" means the tape has been installed and is in normal operation. A service state of "out-of-service" means that the tape is out of service and has failed certain maintenance tests. A state of "maintenance-busy" means the tape is busied out. Blanks mean the tape device is not installed or the system has a simplex SPE.
Disk Present?	If a disk device resides on the SPE this field will display "yes," otherwise, the field will display "no." A blank in the SPE-B side indicates the system has a simplex SPE.
Disk State:	This field represents the operational state of the disk device. A service state of "in-service" means the disk has been installed and is in normal operation. A service state of "out-of-service" means that the disk is out of service and has failed certain maintenance tests. A state of "maintenance-busy" means the disk is busied out. Blanks are displayed on the SPE-B side when the system is not duplicated.

The following display shows a typical result when **status spe** is entered on a duplicated system.

```
status spe                                     page 1 of 1
                                           PROCESSOR COMPLEX
                                           Duplicated? yes
                                           SPE Selected: auto
                                           Standby Busied? no
                                           Standby Refreshed? yes
                                           Standby Shadowing: on
                                           Standby Handshake: up
                                           Recent Spontaneous Interchange? no
                                           SPE-A                                     SPE-B
                                           Mode: active                               Mode: standby
                                           Select Switch: auto                       Select Switch: auto
                                           Major Alarms: 0                           Major Alarms: 0
                                           Minor Alarms: 0                           Minor Alarms: 0
                                           Warning Alarms: 0                         Warning Alarms: 0
                                           State of Health: functional                State of Health: functional
                                           Tape State: in-service                     Tape State: in-service
                                           Disk Present? yes                          Disk Present? yes
                                           Disk State: in-service                     Disk State: in-service
```

## **status sp-link**

---

### **status sp-link [print]**

This command displays a summary of the operational state of the system printer link.

## Output

---

Link State:	The operational state of the link:  up A call is currently set up to the system printer.  down The link is administered but a call is not currently set up to the printer.  extension not administered An extension has not been administered for the system printer on the features-related system parameters form.
Number of Retries:	The number of times the switch has tried to establish the link since a request to set it up has been received. This field is displayed only when the link is down. The maximum value displayed is 999.
Maintenance Busy?	Whether maintenance testing is being performed on the system printer link. A blank is displayed if the system printer link is not administered.

The following display shows a typical result when **status sp-link** is entered.

```
status sp-link                               SPE A
                                             SYSTEM PRINTER LINK STATUS
Link State: down
Number of Retries: 0
Maintenance Busy? no
```

## status station

---

### status station extension [print]

The status station command displays internal software state information for diagnosis. This command can help locate facilities to which the station is communicating.

## Output

---

Type	The type of equipment administered for the extension.
Extension	The extension number specified on the command line.
Port	The location of the port assigned to the station.
Call Park	Whether the station has a call parked.

8 Maintenance Commands  
*status station*

8-307

Ring Cut Off Activated	Whether ring cut-off is activated.
CF Destination Ext	The extension of the call forwarding destination.
Message Waiting	The location of any active messages for the station: AUDIX, PMS or AP-SPE. The field is blank if no messages are waiting.
Connected Ports	Locations of ports currently connected to the station.
Agent Logged In	Numbers of hunt groups that the agent is currently logged into. A maximum of three groups is displayed.
On ACD Call?	Whether the agent is currently on an ACD call.
Work Mode	Work mode of each hunt group that an agent is logged into.
Service State	The service state of the station: in-service/on-hook, in-service/off-hook, in-service/in-tsa (Terminal Self Administration - see DEFINITY ECS Release 6, <i>Administration and Feature Description</i> , 555-230-522), out-of-service, or disconnected.
Maintenance Busy?	Whether maintenance is currently testing the object.
SAC Activated	Whether send-all-calls is activated.
User Cntrl Restr	Which, if any, restrictions are placed on the individual terminal: total The station cannot originate or receive calls. stat-stat The station cannot originate or receive calls to other stations. outward The station cannot originate calls to the public network. terminate The station cannot receive calls. none
Group Cntrl Restr	Whether the station is restricted as part of a restricted group. Values are the same as for the above field, User Cntrl Restr.
AWU Call at	If an automatic wakeup call is scheduled, this field displays the time scheduled for the call.
DND	Status of the do not disturb feature.
Room Status	Whether a room is occupied, vacant, or a non-guest room.

The following display shows a typical result when **status station 1002** is entered.

```
status station 1002
```

```
GENERAL STATUS
```

```
      Type: 7405D           Service State: in-service/on-hook
      Extension: 1002       Maintenance Busy? no
      Port: 01C0702        SAC Activated? no
      Call Parked? no      User Cntrl Restr: none
      Ring Cut Off Act? no Group Cntrl Restr: none
      CF Destination Ext:
      Message Waiting:
      Connected Ports:
```

```
ACD STATUS
```

```
Agent Logged In   Work Mode
```

```
HOSPITALITY STATUS
```

```
AWU Call At:
      DND: not activated
Room Status: non-guest room
```

```
On ACD Call? no
```

## status switch-node

---

### status switch-node SN# [print]

This command displays the operational status and attributes of the user specified switch node. The operational status of the active and standby switch node Clock(SNC) circuit packs for the switch node are displayed along with any alarms logged against the specified switch node.

### Parameters

---

**SN number** Normally switch node 1 is located in the PPN cabinet, and switch node 2, if present, is located in the nearest EPN cabinet. The switch node number defaults to 1.

### Output

---

A line of information is displayed for each switch node carrier.

**Switch Node** The switch node number, 1 or 2. If the PNC is duplicated, the A and B PNCs are each reported separately.

**Location** The physical position of the switch node carrier represented as "UUc". Where "UU" represents the cabinet number and "c" represents the carrier. The simplex PNC configuration will display only one switch node location, while the duplex PNC configuration will display the active and standby switch node locations.

Mode	The mode is the current role of the switch node carrier. A mode of "active" means the SN is providing normal circuit and control functions for PNC. A mode of "standby" means the SN is ready to become active, but is currently not active. If blanks are displayed it means that PNC is not duplicated.
Major Alarms	The number of major alarms logged against the switch node carrier that is being displayed.
Minor Alarms	The number of minor alarms logged against the switch node carrier that is being displayed.
Warning Alarms	The number of warning alarms logged against the switch node carrier that is being displayed.
Active SNC Location	The physical position of the active switch node Clock circuit pack, per administration, represented as "UUcSS." "UU" represents the cabinet number, "c" represents the carrier, and "SS" represents the slot position. If an SNC is administered but not inserted, "no board" will be displayed.
Standby SNC Location	The physical position of the standby switch node Clock circuit pack, per administration, represented as "UUcSS." "UU" represents the cabinet number, "c" represents the carrier, and "SS" represents the slot position. Blanks will be displayed if there is no standby switch node Clock for a given switch node. If an SNC is administered but not inserted, "no board" will be displayed.

The following display shows a typical result when **status switch-node** is entered.

```

status switch-node 1                                     page 1 of 1

                                     switch node STATUS

Switch Node  Location  Mode      Major   Minor   Warning  Active SNC  Standby SNC
              Alarms    Alarms   Alarms   Location  Location
1  A-PNC      01E      active   0        0        0        01E10      01E12
1  B-PNC      01D      standby  0        1        2        01D10      01D12
    
```

## status synchronization

This command lists the synchronization source for the system.

Action/ Object	Qualifier	Qualifier Description	Permissions	Defaults	Feature Interactions
status synchronization	<i>print</i>		init inads craft	none	none



## Output

---

The following example shows the output for the **status synchronization** command.

```
status synchronization                               SPE B
                                                    SYNCHRONIZATION STATUS
                Stratum Level: 4
    Inferred Sync Reference: UDS1-BD      Location: 01C20
    Excessive Reference Switching: No
```

## status sys-link

---

**status sys-link UUCSSpp [ channel channel# ] [print]**

The **status sys-link** command displays status data for a specified system link. The report includes the type and operational state of the link, the associated processor channel, if any, active alarms and path status, and a list of all hardware components making up the link's path. If in addition to the current path a faulted path exists, the components making up the faulted path are displayed on page 2 of the report.

## Parameters

---

- UUCSSpp** The link is specified by giving the location of the port associated with the link.
- channel#** If the link is an X.25 link (to an adjunct or another switch), you must specify a processor channel number (1-128) associated with the link.

## Examples

---

```
status sys-link 1e0201
status sys-link 1c17 channel 2
```

## Output

---

- Location** The location of the port associated with the system link (cabinet-carrier-slot-circuit).

Type/Chan	The type of system-link and the channel number of the link (for X.25 links) as follows:  EAExpansion Archangel Link INLIndirect Neighbor Link (Center Stage Switch) PGCPacket Gateway Call-Control Link PRIISDN-PRI signaling Link SAPSystem Access Port Link X25X.25 Link to an adjunct or DCS
Alarms	The highest level of alarm currently logged against the components making up the link.
Current Path	The operational status of the current path:  noneThe link is down.  presentThe current path displayed below is valid.
Faulted Path	The status of the faulted path, if any:  presentThe path of the link has been faulted at least once.  noneThere is no record of the link having gone down.  defaultThe default faulted path is being used.
Last Fault	The date and time at which the most recent fault occurred.
State	Whether the system link is "up" or "down."
Current Hardware Path	The location, maintenance name, and alarm information for each hardware component making up the current path of the link. The path begins at the Packet Interface in the SPE and terminates at the circuit path that terminates the other end of the link.
Faulted Hardware Path	If the link encounters a fault, the system will reroute it if possible over an alternate route. If this has taken place, the faulted path is displayed on page 2 of the report. The location, maintenance name, and alarm information for each hardware component making up the most recent faulted path is shown.

The following display shows a typical result when **status sys-link 2a0101** is entered. In the following case, the link encountered a fault and recovered by switching to a different inter-switch-node fiber.

8 Maintenance Commands  
*status trunk*

8-312

```
status sys-link 2a0101                               Page 1 of 2   SPE A
Location: 02A0101      Type/Chan: EAL              Alarms: none
Current Path: present  Faulted Path: present        Last Fault: 12/30/1991 14:18
State: up
```

Current Hardware Path

Maintenance			Maintenance		
Location	Name	Alarms	Location	Name	Alarms
01A1	PKT-INT	none			
PN 01	PKT-BUS	none			
01E01	EXP-INTF	none			
1 A-PNC	FIBER-LK	none			
01E02	SNI-BD	none			
01E09	SNI-BD	none			
7 A-PNC	FIBER-LK	none			
02E09	SNI-BD	none			
02E02	SNI-BD	none			
2 A-PNC	FIBER-LK	none			
02A01	EXP-INTF	none			

```
status sys-link 2a0101                               Page 2 of 2   SPE A
Location: 02A0101      Type/Chan: EAL              Alarms: none
Current Path: present  Faulted Path: present        Last Fault: 12/30/1991 14:18
State: up
```

Faulted Hardware Path

Maintenance			Maintenance		
Location	Name	Alarms	Location	Name	Alarms
01A1	PKT-INT	none			
PN 01	PKT-BUS	none			
01E01	EXP-INTF	none			
1 A-PNC	FIBER-LK	none			
01E02	SNI-BD	none			
01E13	SNI-BD	none			
6 A-PNC	FIBER-LK	none			
02E13	SNI-BD	none			
02E02	SNI-BD	none			
2 A-PNC	FIBER-LK	none			
02A01	EXP-INTF	none			

## **status trunk**

**status trunk group# [/ member#] [print]**

The status trunk command displays information about the operational status of a single trunk or of all members of a trunk group. You can also use it to locate facilities with which the trunk is communicating.

The **monitor trunk** command displays the same information and updates the screen automatically every minute or on demand.

## Parameters

---

**group#/member#** If you enter a trunk group number without a member number, then information for all members of that group is displayed as shown in the second screen shown below. If you enter a trunk group and a member number separated by a slash (/), then information for only that member, including some additional fields, is displayed as shown in the first screen shown below. If you enter a group number followed by only a slash (/), then the system defaults to member number 1 and displays the member report.

## Examples

---

```
status trunk 78
status trunk 80/2 print
```

## Output

---

Trunk Group/Member	Group and member numbers of specified trunks.
Port	The location of the port associated with the trunk.
Signaling Group ID	For ISDN trunks, the number of the signaling group to which the trunk group belongs. For other trunk types, the field is blank.
Connected Ports	Locations of ports currently connected to the trunk.
Service State	One of the following states is displayed: in-service/active, in-service/idle, out-of-service, out-of-service-NE (Near End), out-of-service-FE (Far End), maint-NE/active, maint-FE/active, maint-NE/idle, maint-FE/idle, pending-in-service, pending-maint, or disconnected. NE (Near End) and FE (Far End) refer to which end of the trunk has placed the facility in its current state. Explanations of these service states for each type of trunk appear in the maintenance object descriptions in <a href="#">Chapter 9, "ABRI-PORT (ASAI ISDN-BRI Port)"</a> .
Maintenance Busy	Whether maintenance testing is currently being performed upon the trunk.
CA-TSC State	The status of the call-associated temporary signaling connection, if any. A TSC is a temporary connection set up to pass call information over ISDN-PRI signaling links.

The following display shows a typical result when **status trunk 20/1** is entered.

```
status trunk 20/1

                                TRUNK STATUS

Trunk Group/Member: 020/001          Service State: in-service/idle
      Port: 01D0801                Maintenance Busy? no
Signaling Group ID: 1                CA-TSC State: none
      Connected Ports:
```

The following display shows a typical result when **status trunk 1** is entered for a trunk group with two members.

```
status trunk 1

                                TRUNK GROUP STATUS

Member  Port      Service State  Mtce Busy  Connectd Ports
01/01   01A0101  in-service/idle  no         01A0501 02B0607
01/02   04A0702  in-service/idle  no         04C0604
```

## **status tsc-administered**

**status tsc-administered signaling-group# [ /tsc-index] [print]**

This command displays the operational status of temporary signaling connections (TSCs) administered for a specified signaling group.

### **Examples**

```
status tsc-administered 1
status tsc-administered 1/2 print
```

### **Parameters**

- signaling-group#** An administered number associated with each signaling group.
- tsc-index** A number associated with each TSC in a signaling group.

### **Output**

TSC Index The administered TSC index (1-759).

TSC State	A state of "inactive" means that the administered TSC is not functioning (i.e. D-Channel out-of-service, or disabled, etc.). A state of "active" indicates that the administered TSC is up and user information can be exchanged end-to-end. A state of "pending-inactive" shows that the TSC is being released. A state of "pending-active" means that the TSC is about to come up.
Establish	This field pertains to the switch responsible for the origination of the administered TSC. A state of "as-needed" shows that the TSC is established on an as needed basis. A state of "permanent" shows that the TSC is permanently established.
Enabled	"Y" indicates that the administered TSCs have been enabled.
Congested	A congested state indicates that the network cannot handle the receipt of USER INFORMATION messages for the administered TSC. "Yes" indicates that the administered TSC is congested. "No" indicates that the administered TSC is not congested. "Clear" indicates that TSC was congested during its active period and the congestion has been cleared.

The following display shows a typical result when **status tsc-administered 1/1** is entered.

```
status tsc-administered 1/1
                        ADMINISTERED NON-CALL-ASSOCIATED TSC STATUS

TSC      TSC
Index    State          Establish   Enabled    Congested
1        inactive       as-needed  yes        no
```

## **status tti**

---

### **status tti [print]**

This command displays the operational status of the Terminal Translation Initialization (TTI) background maintenance task. The TTI Background maintenance task is activated by enabling the TTI feature on the system-parameters features administration form.

## Output

---

TTI	One of the following:
Background	generating TTI ports
Task State:	removing TTI ports
	suspended
	not active
	completed - all ports translated
	The last execution of the background task completed normally.
	completed - some ports not trans
	The task completed due to resource exhaustion with some ports left untranslated.
TTI State:	offThe TTI feature is not enabled.
	voice, dataThe type of TTI ports that are being generated or removed
# of Boards	Number of TTI-supported circuit packs that have been processed by the
Completed:	background maintenance task.
	A "completed" circuit pack has either had all its unadministered ports translated as TTI ports or its TTI ports have been removed and are now unadministered ports.
# of Boards	Number of TTI-supported circuit packs that have not yet been processed
Left to	by the background maintenance task.
Process:	
Percent	A ratio of the of number of circuit packs completed to the total number.
Complete:	
Elapsed	Elapsed time in hours:minutes:seconds since the TTI background task
Time Since	was started.
Task	
Started:	This field is blank if the task is not active. If the task is completed or suspended, this field displays the elapsed time up to when the job finished or was suspended.

The following display shows a typical result when **status tti** is entered.

```
status tti

                               TTI STATUS
TTI Background Task State:  completed - all ports translated
                               TTI State:  voice
# of Boards Completed:      30
# of Boards Left to Process: 0
                               Percent Complete: 100
Elapsed Time since Task Started: 0 :0 :1
```

## test alarms

---

This command tests the hardware associated with selected alarms

### Synopsis

---

**test alarms *auto-page failures step [short | long][repeat number | clear]***

### Permissions

---

The following default logins may execute this command: system technician, inads, init, nms.

### Examples

---

**test alarms**  
**test alarms step failures**  
**test alarms long clear auto-page**  
**test alarms long failures**

### Description

---

This command allows the technician to automatically test all of the hardware that is associated with the active alarms in the alarm log. This command provides a query form to help the user narrow the selection of alarmed objects. Once the form is filled out, the user presses ENTER and the hardware associated with the selected alarm log entries is tested. The results will be displayed in standard test output and status information will be displayed on the message line as the command progresses.

Several alarms may be logged against a single maintenance object, each alarm representing a different problem. Even if there are multiple entries in the alarm



log for a single object, the test alarms command will only test each physical object once.

## Defaults

The default options for this command are: short, repeat of 1.

## Parameters

**auto-page** This option provides the ability to continue testing and displaying test results, by providing a new screen every time the SAT screen is filled with test results. The screen does not scroll to accommodate new results; instead a new screen is provided after the current screen fills up.

If the auto-page option is not specified, the SAT screen will not be refreshed once it is filled with test results and testing will stop until the user enters the "PAGE" key to continue or the "CANCEL" key to halt the testing.

**failures** This requests that only the failures be displayed on the screen. All passes will not be displayed on the output screen. Hardware failures as well as aborts, conflicts and EPN-down failures will be displayed.

**step** This option will allow the user to step to the next or previous alarm and not have the current alarm tested. When this option is specified, the user is presented with the alarm information and prompted for a keypress. The user may enter CANCEL to abort the command, ENTER to test the currently displayed alarm, NEXT ALARM (function key) to move to the next alarm, PREV ALARM (function key) to move to the previous alarm without testing the currently displayed alarm. If this option is given, then the NEXT ALARM (function key) or PREV ALARM (function key) may be pressed at any time during the command (even during test results). If the NEXT ALARM or PREV ALARM is pressed during a test, the test is aborted, testing of the current alarm stops, and the next alarm or previous alarm is displayed. If the first alarms is displayed, and the PREV ALARM is pressed, then the last alarm is displayed. Also, if the last alarm is currently displayed, and the NEXT ALARM is requested, then the first alarm will be shown.

### NOTE:

When this option is given the only way to terminate this command is to press CANCEL.

**short** This will cause the command to execute a series of nondestructive diagnostic tests.

**long** This will execute a more comprehensive and longer version of the diagnostic tests. This may involve both destructive and nondestructive tests.

**repeat number** The "number" specifies how many times each test in the sequence is to be repeated. "Number" may be any integer between 1 and 100.

**clear** This option causes the test sequence (short or long) to repeat until the alarm is cleared or a single test in the sequence fails. The long clear option forces a clear of all alarms if no errors are encountered during testing. The short clear option only clears alarms pertinent to tests in the short sequence.

 **WARNING:**  
*Executing a clear with short option, may not clear all alarms even if all tests pass.*

 **WARNING:**  
*Since the "clear long" options clear all counters if tests pass, it is possible for firmware counters to be cleared even when a problem exists. In some cases customer service might degrade since calls may be routed over defective equipment.*

## Help Messages

If the technician presses HELP after entering "test alarms" the following message will be displayed:

```
Enter ['auto-page'], ['failures'], ['step'],  
['short' or 'long'], ['repeat' (1-100) or 'clear']
```

## Error Messages

If the command entered is in conflict with another currently executing command, then a message will be displayed showing the login id of the conflicting user and the conflicting command. The message is as follows:

```
'login id':'command' has a command conflict
```

If during the execution of a command a resource problem occurs that requires the user to restart the command, then the following message will be displayed:

```
Command resources busy;  
Press CANCEL to clear, and then resubmit
```

If all of the available maintenance resources are currently in use, then the following message will be displayed:

```
All maintenance resources busy; try again later
```

## Query From Input

---

After entering the command **test alarms**, the system technician will be presented with an options form for alarm selection.

Alarm Types	The type of alarm to be tested is specified by placing a 'y' or 'n' in the alarm type fields. The technician can choose a combination of active alarms: major, minor, and/or warning.
Interval	Test alarms for records for the last hour (h), last day (d), last week (w) or all (a). The default is all.
From	Test alarm associated with records from the time specified by mm/dd/hh/mm, where mm month, dd is the day, hh is the hour and mm is the minute. If no "from" date is entered, then no checking is done. This will give the user all the alarms active since a month prior to the current time.
To	Test alarms associated with records to the time specified by mm/dd/hh/mm, where mm is the month, dd is the day, hh is the hour and mm is the minute. If no "to" date is entered, any alarm which is active after the from date will be selected.

- Equipment Type
- The technician can choose between five different equipment types. If there is no input to any of these fields, the system will default to all the equipment. The user can select one of the following fields:
- Cabinet: This allows the technician to test all alarms associated with a particular cabinet. Alarms for a cabinet are referenced by a number ranging from 1 to 3 which is assigned during cabinet administration.
  - Port Network: This allows the technician to test all alarms associated with a particular port network. Alarms for a port network are referenced by a number ranging from 1 to 3.
  - Board Number: This allows the technician to choose all alarms associated with a particular circuit pack for testing. Alarms for a circuit pack are referenced by circuit pack location (cabinet-carrier-slot). If the cabinet number is omitted, the system will default to 1.
  - Port: This allows the technician to choose all alarms associated with a particular port on a circuit pack for testing. Alarms for a port circuit are referenced by port location (cabinet-carrier-slot-circuit). If the cabinet number is omitted, the system will default to 1.
  - Category: Alarms for a particular equipment category.
  - Extension: Alarms associated with an extension number.
  - Trunk (group/member): The technician can choose to test all alarms associated with a particular trunk group or trunk group member. The group identifier should be entered to test all alarms associated with a trunk group (XX/\_\_). The group identifier and member identifier should both be entered to test all alarms associated with a specific trunk group member (XX/XX).

```
test alarms repeat 1
```

```
HARDWARE TEST ALARM QUERY
```

```
The following options control which alarms will be tested.
```

```
ALARM TYPES
```

```
Major? y_      Minor? y_      Warning? y_
```

```
REPORT PERIOD
```

```
Interval: m_  From: __/__/__:__  To: __/__/__:__
```

```
EQUIPMENT TYPE ( Choose only one, if any, of the following )
```

```
    Cabinet:  __
```

```
    Port Network:  __
```

```
    Board Number:  ____
```

```
    Port:  _____
```

```
    Category:  _____
```

```
    Extension:  _____
```

```
    Trunk ( group/member ):  __/__
```

## Field Help

---

Following are the help messages that the system technician will see upon tabbing to the specified field and pressing the HELP key.

Major?	"n(o) y(es)"
Minor?	"n(o) y(es)"
Warning?	"n(o) y(es)"
Interval:	"m(onth), h(our), d(ay), w(eek), a(ll)"
From month	"Enter month between 1-12"
From (day)	"Enter day between 0-31"
From (hour)	"Enter hour between 0-23"
From (minute)	"Enter minute between 0-59"
To (month)	"Enter month between 1-12"
To (day)	"Enter day between 0-31"
To (hour)	"Enter hour between 0-23"
To (minute)	"Enter minute between 0-59"
Cabinet:	"Enter cabinet number (1-3)"
Port Network:	"Enter port network number (1-3)"
Board Number:	"Enter 4 character board number; [cabinet(1-3)]:carrier(A-E):slot(0-21)"
Port:	"Enter port number; [cabinet(1-3)]:carrier(A-E):slot(0-21):circuit(1-24)"
Category:	"adm-conn, announce, bri/asai, card-mem, cdr, data-mod, detector, dup-spe, environ, ext-intf, ext-dev, generatr, inads-link, infc, maint, mbus, memory, misc, mnt-test, modem, netcon, pkt, pkt_ctrl, quick-st, pms/jrnl, procr, s-syn, stabd, stacrk, stations, sys-prnt, tape, tdm, tone, trkbd, trkcrk, trunks and wideband" (For a table describing the category entries in greater detail, see the "display errors" command.)
Extension:	"Enter assigned extension, or blank"
Trunk (group)	"Enter group number between 1-99"
Trunk (member)	"Enter group member between 1-99, or blank"

## Field Error Messages

---

Following are the error messages that will be displayed on the screen. The messages are displayed when the system technician tabs out of a field and the validation routines are executed. In the following messages, an "x" represents the character that was entered by the user.

Major?	"x" is an invalid entry; please press HELP"
Minor?	"x" is an invalid entry; please press HELP"
Warning?	"x" is an invalid entry; please press HELP"
Interval:	"x" is an invalid entry; please press HELP key"
From (month)	"Entry must be all digits"
From (day)	"Entry must be all digits" "Day invalid"
From (hour)	"Entry must be all digits" "Hour invalid"
From (minute)	"Entry must be all digits" "Minute invalid"
To (month)	"Entry must be all digits"
To (day)	"Entry must be all digits" "Day invalid"
To (hour)	"Entry must be all digits" "Hour invalid"
To (minute)	"Entry must be all digits" "Minute invalid"
Cabinet:	"Invalid entry"
Port Network:	"Port Network invalid"
Board Number:	"Invalid entry"
Port:	"Port invalid"
Category:	"xxxxxxxx" is an invalid entry; please press HELP"
Extension:	"Entry must be all digits" "Extension not assigned"

Trunk (group)	"Entry must be all digits" "Group not assigned, or group assigned but with no member"
Trunk (member)	"Entry must be all digits" "Number invalid" "Group member not assigned" "Trunk or trunk group invalid"

## Output

---

The responses, with normal output, will be displayed on a test-by-test basis with one line of data displayed for each test result. With the failures option only the tests that have failed will be displayed.

The following output fields are for the ALARM ENTRY section:

Port	The location of the alarmed object (cabinet-carrier-slot-circuit). This is the same identifier as used by the alarm log.
Maintenance Name	The logical name of the maintenance object which has been alarmed.
On Board	Whether the fault detected is on the associated circuit pack, or an off board element connected to the circuit pack.
Alt Name	Terminal extension numbers or trunk group numbers.
Alarm Type	Major, Minor, or Warning. This is an indicator to the seriousness of the alarm raised.
Service State	RDY (ready for service), OUT (out of service), or IN (in service). This is the current service state of the station and trunk ports shown.
Ack	The columns under the "1" and "2" headings denote if the alarm has been acknowledged by the first and second OSS telephone numbers, respectively.
Date Alarmed	Day, hour, and minute of alarm.
Alarm Count	This field contains the count of the current alarm entry verses the total number of alarms to be tested.

The following fields are displayed for the test results:

Port	The port address (cabinet-carrier-slot-circuit) of the maintenance object that is being tested.
Maintenance Name	The type of maintenance object that is being tested.

- Alt. Name      The alternate means of identifying the maintenance object. This field contains the extension when the object is a station, and it contains xxx/yyy when the object is a trunk, where xxx is the trunk group number and yyy is the member number. It contains P/xxx when the object is a private CO line, where xxx is the private CO line group number.
- Test No        The actual test that is being executed.
- Result         An indicator as to whether the test failed, passed, aborted or no hardware was available (no board). If this field has conflict, this means that another user was testing this hardware. If this field has epn-down it means that the epn is inaccessible at this time.
- Error Code     A numerical description of why the test failed or was aborted.

When errors are encountered preparing a particular object to be tested (not inserted, contention, etc.) the an error message will be displayed. This error message will be displayed in the TEST RESULTS data.

For the following output example, assume that only one alarm was in the alarm log and it is on the board in cabinet 1, carrier c, slot 7. The command that was entered was "test alarms" and the query form was left empty by just pressing ENTER.

```

test alarms Page 1

                ALARM ENTRY
Port      Maintenance On  Alt   Alarm  Svc  Ack?  Date      Alarm
Name      Brd?  Name  Type   State 1 2   Alarmed   Count
01C03     UDS1-BD  n           WARNING                03/06/16:48 1/4

                TEST RESULTS
Port      Maintenance Name  Alt. Name  Test No.  Result      Error Code
01C03     UDS1-BD                138       NO BOARD
01C03     UDS1-BD                139       NO BOARD
01C03     UDS1-BD                140       NO BOARD
01C03     UDS1-BD                141       NO BOARD
01C03     UDS1-BD                142       NO BOARD
01C03     UDS1-BD                143       NO BOARD
01C03     UDS1-BD                144       NO BOARD
01C03     UDS1-BD                145       NO BOARD
01C03     UDS1-BD                146       NO BOARD
Testing completed for this object.
    
```

## Feature Interactions

With the enhancement of multiple maintenance users, there may be a possibility of two users attempting to test the same physical hardware (e.g. one via the test alarms command and another through the test board command). If this command should attempt to test a board that is currently being tested by another user, an error message is displayed.



## test analog-testcall

---

<b>test analog-testcall</b>	<b>trunk group# / member#   port UUCSSpp   board UUCSS</b> <b>[full   supervision   no-selftest   no-return-loss   no-st-or-rl]</b> <b>[repeat #] [schedule]</b>
-----------------------------	--

The **test analog-testcall** command causes the Automatic Transmission Measurement System (ATMS) to originate a test calls over analog trunks. ATMS collects performance measurements on the test call and compares them to administered thresholds. Detail and summary reports of these measurements are generated with the **list testcalls** command.

You can specify testing of an entire trunk group or an individual trunk using either group/member addresses or port and circuit pack location. The type of test call, the number of the testing line on the far-end switch and various other parameters must be administered on the trunk group form before the command can execute.

ATMS, the operation of this command, and the measurement reports are described in Automatic Transmission Measurement System (ATMS) in [Chapter 6, "Additional Maintenance Procedures"](#).

## test board

---

**test board UUCSS [short | long] [repeat # | clear] [schedule]**

The **test board** command will validate that the board exists at the specified location. Based on the logical type (e.g., Analog, Digital, Hybrid, etc.) of board a series of tests will be executed. Each individual test will exercise diagnostics on the board and then return results of the test along with any possible error codes.

Destructive long tests on a Switch Node Interface (SNI) board are not allowed unless the board has been busied out.

For more information see Common Input Parameters and Common Output Fields at the beginning of this chapter.

The following display shows a typical result when **test board 1D07** is entered and slot 1D07 holds a Digital Line circuit pack with 7 ports administered.

```
test board 1d07 short                               SPE B

                                TEST RESULTS

Port      Maintenance Name  Alt. Name Test No. Result  Error Code
01D07     DIG-BD                 52        PASS
01D0701   DIG-LINE               5401      16      PASS
01D0701   DIG-LINE               5401      17      PASS
01D0702   PDMODULE               5460      17      PASS
01D0703   PDMODULE               5461      17      ABORT    5
01D0704   PDMODULE               5444      17      ABORT    5
01D0705   DIG-LINE                16      ABORT   1392
01D0705   DIG-LINE                17      ABORT   1392
01D0706   DIG-LINE               Attd2     16      PASS
01D0706   DIG-LINE               Attd2     17      PASS
01D0707   DIG-LINE               Attd1     16      PASS
01D0707   DIG-LINE               Attd1     17      PASS

Command Successfully Completed
```

## test cdr-link

**test cdr-link**    **primary | secondary**  
**[short | long] [repeat number | clear] [schedule]**

The **test cdr-link** command validates that a call detail recording link has been administered and established.

### Parameters

**[primary | secondary]**    A system may have up to two CDR links: a primary that is normally used and a secondary that serves as a backup in case the primary fails. This qualifier specifies which link to test. Primary is the default.

For more information see [“Common Input Parameters”](#) and [“Common Output Fields”](#) at the beginning of this chapter.

## test customer-alarm

**test customer-alarm UUC [short | long] [repeat # | clear] [schedule]**

The **test customer-alarm** command performs hardware diagnostic tests on the leads of the SYSAM or EPN Maintenance circuit pack in a specified cabinet. These leads are connected to customer equipment and provide a means of alerting the system administrator and INADS when that equipment fails. The alarm is activated when a relay on the connected equipment is closed for 1 minute.

The cabinet default is 1. The carrier needs be specified only for PPNs with duplicated SPEs.

## **test data-module**

---

**test data-module extension [short | long] [repeat # | clear] [schedule]**

The **test data-module** command performs hardware diagnostic tests on a data module or a data channel. Test results are determined by the interface to the digital switch-data line port, digital line port, or network control data channel.

## **test disk**

---

**test disk [C] [short | long] [repeat # | clear] [schedule]**

The **test disk** command performs a series of tests on the disk circuit pack and the disk media itself. The cabinet is always 1 and need not be entered. Carrier a or b must be specified only for duplicated SPEs. This command will abort if any other MSS operation has already begun.

Failure of the disk test may result in the disk being taken out of service. In this state, access to the disk by all system software except maintenance is blocked. When the host-adaptor is taken out of service due to test or reset failures and becomes uninstalled, the disk is also placed in the uninstalled state and all access by system software, maintenance tests, commands (including resets) is blocked.

## **test ds1-facility**

---

**test ds1-facility UUCSSf [short | long | external loopback] [repeat #] [schedule]**

The **test ds1-facility** command performs a series of tests on the specified facility. Each individual test will exercise diagnostics on the facility and then return results of the test along with any possible error codes. The **long** test is destructive and is not allowed unless the facility has been busied out.

## Parameters

---

- UUCSSf** A DS1 facility is specified by the location of the DS1 Converter circuit pack and a letter from **a** to **d** corresponding to the four facilities connected to the circuit pack.
- external loopback** This specifies a destructive test that sends a test pattern to an external device and returns it for comparison to the original. Configure the external device to loop back the signal. See “DS1-FAC (DS1 Facility)” and “DS1C-BD (DS1 Converter)” in Chapter 9.

## Examples

---

```
test ds1-facility 04a01d
test ds1-facility 03a01a sh c
```

## test ds1-loop

---

**test ds1-loop** - For TN464F or TN767E or later suffix DS1 Interface circuit packs. This command is used for loopback and one-way span testing of the DS1 span.

## Synopsis

---

```
test ds1-loop location [cpe-loopback-jack-test-begin [number-of-bits
bit-pattern] | far-csu-loopback-test-begin | one-way-span-test-begin |
end-loopback/span-test | inject-single-bit-error | ds1/csu-loopback-tests]
```

## Permissions

---

Logins with the following service levels may execute this command: system technician, inads, init, super-user, or logins with Maintain Switch Circuit Packs permissions enabled.

## Examples

---

```
test ds1-loop 01c08
test ds1-loop 1-3c03 cpe-loopback-jack
test ds1-loop 1-3c03 cpe
test ds1-loop 10c03 end
test ds1-loop 02d12 fa
test ds1-loop 02d12 inj
```

## Description

---

The **test ds1-loop** command will validate that the board exists at the specified location, that the board is a TN464F or TN767E or later suffix DS1 Interface board. Based on the command parameter, a long-duration loopback/span test or series of short-duration loopback tests will be executed.

Long-duration loopback tests execute for an extended period of time until the system technician terminates it. Short-duration loopback tests return the result of the test to the screen when finished executing. The **list measurements ds1 summary** command should be used to monitor the status of a long-duration loopback/span test.

## Defaults

The default for the command is ds1/csu-loopback-tests.

## Parameters

---

<b>location</b>	A [location] represents the physical position of the board to be tested. For Standard cabinets a location is entered as [UUcSS] where "UU" represents the cabinet number, "c" represents the carrier, and "SS" represents the slot position. A single digit cabinet (1-3) are entered with or without a leading zero (0).
<b>cpe-loopback-jack-test-begin<sup>1</sup></b>	For TN464F or TN767E or later suffix DS1 boards, this causes a long-duration loopback test to be setup through the Customer Premises Equipment (CPE) Loopback Jack. The command allows you to specify a loop-up code for the CPE loopback jack if it differs from the default of 0x47F. Specify the number of bits in the loop-up code as well as the actual bit-pattern (in hexadecimal).
<b>far-csu-loopback-test-begin<sup>1</sup></b>	For TN464F or TN767E or later suffix DS1 boards, this causes a long-duration loopback test to be setup through the far-end Channel Service Unit (CSU).
<b>one-way-span-test-begin<sup>1</sup></b>	For TN464F or TN767E or later suffix DS1 boards, this begins execution of a long-duration one-way span test.
<b>end-loopback/span-test</b>	For TN464F or TN767E or later suffix DS1 boards, this parameter terminates long-duration one-way span and loopback testing.
<b>inject-single-bit-error</b>	For TN464F or TN767E or later suffix DS1 boards, this parameter causes a single bit error to be sent within an active framed 3-in-24 test pattern used in long-duration loopback and span testing.
<b>ds1/csu-loopback-tests</b>	For TN464F or TN767E or later suffix DS1 boards, this parameter executes the following loopback tests: DS1 Board LoopBack, CSU Module Equipment LoopBack, and CSU Module Repeater LoopBack. These tests are performed sequentially for a short duration each, and individual PASS/FAIL/ABORT test results are reported following each test.

---

1. The test will abort if the busyout command has not been set

---

## Help Messages

---

If the system technician presses HELP after entering “test ds1-loop” the following message will be displayed:

```
Enter DS1 board location,  
[ 'cpe-loopback-jack-test-begin [number-of-bits bit-pattern]' or  
  'far-csu-loopback-test-begin' or 'one-way-span-test-begin' or  
  'end-loopback/span-test' or 'inject-single-bit-error' or  
  'ds1/csu-loopback-tests' ]
```

## Error Messages

---

If the format for the board location is incorrect, the following error message will be displayed:

```
Port/Board invalid
```

If the EPN in which the specified board resides is not available, the following message will be displayed:

```
EPN is not available
```

If the specified board is not inserted in the system, the following message will be displayed:

```
Board not inserted
```

If the command entered is in conflict with another currently executing command, then a message will be displayed showing the login id of the conflicting user and the conflicting command. The message is as follows:

```
'login id':'command' has a command conflict
```

If during the execution of a command a resource problem occurs that requires the user to restart the command, then the following message will be displayed:

```
Command resources busy; Press CANCEL to clear, and then resubmit
```

If all of the available maintenance resources are currently in use, then the following message will be displayed:

```
All maintenance resources busy; try again later
```

If the **test ds1-loop** command is executed and the “G3 Version” field on the “system-parameters customer-options” form is not V3 or later, then the following message will be displayed:

```
G3 Version must be V3 or later
```

If the **test ds1-loop** command is executed on a circuit pack other than TN464F or TN767E or later DS1 board, then the following message will be displayed:

```
Command valid for TN464F or TN767E or  
later release DS1 circuit packs
```

If the [inject-single-bit-error] parameter is selected, but no CPE Loopback Jack, far-end CSU, or one-way span test is active on the DS1 circuit pack, then the following message will be displayed:

Parameter valid only if a loopback/span test is active on the DS1

## Output

---

The responses will be displayed on a test-by-test basis with one line of data displayed for each test result.

Port	The port address (cabinet-carrier-slot-circuit) of the maintenance object that is being tested.
Maintenance Name	The type of maintenance object that is being tested.
Alt. Name	The alternate means of identifying the maintenance object.
Test No	The actual test that is being executed.
Result	The result of the individual test - PASS, ABORT, FAIL, NO BOARD, DISABLED, EXTRA BD.
Error Code	A system-generated number that tells why the release failed or aborted. A detailed list of the codes according to "Test No." is provided for each MO.

For the following output example, assume that the board in cabinet 1, carrier c, slot 7 is a TN767E DS1 board. The command that was entered was **test ds1-loop 1c07**.

```
test ds1-loop 01C07 ds1/csu-loopback-tests
```

### TEST RESULTS

Port	Maintenance Name	Alt. Name	Test No.	Result	Error Code
01C07	DS1-BD		1209	PASS	
01C07	DS1-BD		1210	PASS	
01C07	DS1-BD		1211	PASS	

```
Command Successfully Completed
```

## Feature Interactions

---

Loopback or span tests will not be allowed on DS1 boards unless the board has been busied out.



Only one of the CPE Loopback Jack, far-end CSU, one-way span, or DS1/CSU loopback tests may be active at any given time on a DS1 span.

## **test duplication-interface**

---

**test duplication-interface [short | long] [repeat # | clear] [schedule]**

The **test duplication-interface** command performs hardware diagnostic tests on the system's dupint circuit packs and interconnecting cable (DUPINT and DUP-CHL maintenance objects). Testing is under control of the active SPE. See descriptions of these maintenance objects in Chapter 9 for more details.

The DUP-CHL maintenance object is associated with both active and standby DUPINT boards and the interconnecting cable. The DUPINT maintenance object is associated with the active dupint board. There are five tests for the DUPINT maintenance object and an additional eight tests for the DUP-CHL maintenance object.

When testing the active and standby dupint circuit packs and the interconnection cable for an active SPE carrier, duplication channel components are only tested in one direction. By performing an SPE interchange, the duplication channel components can be tested in the other direction for complete testing. Further testing of the standby dupint board can also be done through the SPE-down Command Interface with carriers locked. This interface can be used for general testing of the standby SPE when the SPE handshake is not functioning.

The duplication-interface test is invalid for an SPE simplex system. For SPE duplex systems, the presence of both DUPINT boards is assumed. In duplex SPE systems, any DUPINT communication failures will give FAIL or ABORT results on the output screen.

Loss of handshake between active and standby SPEs prevents testing of standby SPE components unless the SPE-down interface is used.

The **long** test sequence is destructive and requires that **busyout spe-standby** be executed first.

## **Output**

---

Port	The physical address of the maintenance object that is being tested. For DUPINT the address is the cabinet (1) and carrier (A or B) of the active SPE. For DUP-CHL, the address is the cabinet and carrier of the standby SPE.
Maintenance Name	The type of maintenance object that is being tested.
Alt. Name	Not applicable.

**8 Maintenance Commands***test eda-external-device-alm*

8-335

Test No.	The number of the test being executed.
Result	An indicator as to whether the test failed, passed or was aborted.
Error Code	A numerical description of why the test failed or was aborted.

The following display shows a typical result when **test duplication-interface** is entered and A is the active carrier of a duplicated SPE system.

```
test duplication-interface

                                TEST RESULTS

Port  Maintenance Name  Alt. Name  Test No.   Result  Error Code
-----
01B   DUPINT              979        PASS
01A   DUP-CHL              980        PASS
01A   DUP-CHL              874        PASS
01A   DUP-CHL              875        PASS
01A   DUP-CHL              876        PASS

Command Successfully Completed
```

## **test eda-external-device-alm**

---

**test eda-external-device-alm all | physical location [repeat number | clear][schedule]**

This test will perform hardware diagnostic tests on an individual external-device-alarm port or on all external-device-alarm ports.

The **test eda-external-device-alm** command performs a hardware diagnostic test on all administered external device alarms if all is entered. If an administered external device alarm port is entered, the test external-device-alarm command performs a hardware diagnostic test on that port. The test PASSES if the external device is not reporting an external device alarm and FAILS if the external device is reporting an external device alarm. If the technician specifies the port it must be administered as an external device alarm port on a maintenance board or on an analog line port carrier board.

## **Defaults**

---

The default for this command is a repeat of 1.

## Parameters

---

**physical location** In addition to entering the word “physical” the system technician must specify the physical location. For an administered external device alarm analog line port, a “physical location” represents the physical position of the port to be tested and is entered as **UUcSSpp** where “**UU**” represents the cabinet number (1-MAX\_CABS), “**c**” represents the carrier, “**SS**” represents the slot position, and “**pp**” represents the circuit.

Since the “maintenance board” alarm connections connect to control carrier boards that are in unnumbered slots, the standard port format cannot be used to designate these alarm connections. The special ports **UUmajor** and **UUminor** are used designate the major or minor maintenance board alarm connection for cabinet UU.

### NOTE:

The special locations **UUmajor** and **UUminor** designate the name of the major or minor maintenance circuit pack alarm connection for cabinet UU (depends upon the auxiliary connector of the Port Network). Thus, both a “major” and “minor” port can be administered with major, minor, or warning alarms.

The “all” location is used to test all administered external device alarm ports on analog line boards and maintenance boards.

**repeat number** The “number” specifies how many times the “test physical location” is to be repeated. “Number” may be any integer between 1 and 100.

**clear** This option causes the test sequence (short or long) to repeat until the alarm (if one exists against the MO) is cleared or a single test in the sequence fails. If no alarms are registered against the maintenance object then the test sequence will be exercised only once.

**schedule** When the “schedule” option is specified, the command is validated and then a scheduling form is displayed to allow the technician to schedule execution of the command. The command is then placed in the command queue and is executed at the specified time. The information displayed by the command is sent to the system printer instead of the screen. Refer to the Report Scheduler and System Printer feature specifications [1] for more details.

## Examples

---

```
test eda-external-device-alm all
test eda-external-device-alm all schedule
test eda-external-device-alm physical 1major r 10
test eda-external-device-alm physical 2c1101 c
```

## Output

---

For the following output example the command that was entered was **test external-device-alm all**:

```
test eda-external-device-alm all
```

TEST RESULTS

Port	Maintenance Name	Alt. Name	Test No.	Result	Error Code
03major	EXT-DEV	CMS1	120	PASS	
03A2102	EXT_DEV	CMS2	120	FAIL	
01major	EXT-DEV	UPS1	120	PASS	
01minor	EXT-DEV	UPS1	120	PASS	
01c1201	EXT-DEV	UPS1	120	PASS	
03A2101	EXT_DEV	CC temp	120	PASS	
01c1202	EXT-DEV	Audix1	120	PASS	
03minor	EXT-DEV	Audix2	120	FAIL	
04major	EXT-DEV	unknown	120	FAIL	

```
Command successfully completed
```

The responses are displayed on a test-by-test basis with one line of data displayed for each test result.

## Field definitions:

---

Port	The port address (cabinet-carrier-slot-circuit) of the maintenance object that is being tested.
Maintenance Name	The type of maintenance object that is being tested.
Alt. Name	The alternate means of identifying the MO. This is an administered more descriptive name of the external device alarm
Test No	The actual test that is being executed.
Result	The result of the individual test -PASS, ABORT, FAIL,NO BOARD, DISABLED, EXTRA BD.

Error Code      A system-generated number that tells why the release failed or aborted. A detailed list of the codes according to "Test No." is provided for each MO.

## **test environment**

---

**test environment UU [short | long] [repeat # | clear] [schedule]**

The **test environment** command performs hardware diagnostic tests of the environment monitoring and control, and emergency transfer functions of a specified cabinet. This command tests both PPN and EPN cabinets. Circuit packs involved are the SYSAM (PPN) EPN Maintenance, and tone/clock (for the ring generator test).



### **CAUTION:**

*The **long** test recycles power on all port circuit pack carriers and is destructive. It does not recycle power on active or standby PPN or EPN control carriers or switch node carriers. When a port carrier is recycled, all service and links to ports on the carrier are dropped. If a carrier containing an active EI or tone-clock is recycled, all service to that cabinet will be disrupted.*

There are nine Maintenance Objects involved in this test:

EMG-XFER	POWER	RING-GEN
AC-POWER	DC-POWER	CUST-ALARM
CARR-POW	CABINET	EXT-DEV

Note that although the CUST-ALARM maintenance object is part of the environment functionality, it is not actually tested using the 'test maintenance' command. See 'test customer-alarm' for details on testing this particular MO.

## **Output**

---

The following display shows a typical result when **test environment 1** is entered in order to test the PPN cabinet.

```
test environment 1
```

```
TEST RESULTS
```

Port	Maintenance Name	Alt. Name	Test No.	Result	Error Code
01	POWER		5	PASS	
01	AC-POWER		78	PASS	
01E	CARR-POW		127	PASS	
01D	CARR-POW		127	PASS	
01A	CARR-POW		127	PASS	
01B	CARR-POW		127	PASS	
01C	CARR-POW		127	PASS	
01	EMG-XFER		124	PASS	
01	CABINET		122	PASS	
01	EXT-DEV		120	PASS	
01	RING-GEN		117	PASS	
01	RING-GEN		118	PASS	

```
Command Successfully Completed
```

The following display shows a typical result when **test environment 2** is entered and cabinet 2 is a single carrier cabinet.

```
test environment 2
```

```
TEST RESULTS
```

Port	Maintenance Name	Alt. Name	Test No.	Result	Error Code
04	DC-POWER		79	PASS	
04	EMG-XFER		124	PASS	
04	EXT-DEV		120	PASS	
04	RING-GEN		117	PASS	
04	RING-GEN		118	PASS	

```
Command Successfully Completed
```

## test fiber-link

**test fiber-link#**

**[a-pnc | b-pnc] [short | long]  
[repeat # | clear] [schedule]**

The **test fiber-link** command validates that the optical fiber connection between switch node interfaces (SNI) and expansion interfaces (EI), or a combination thereof, are administered. If the fiber link is administered, a series of hardware diagnostic tests are performed on the specified fiber link. The test results along with any possible error codes are displayed on the MT. The long test sequence

includes destructive tests. All destructive tests abort unless the fiber link is first busied out. The short test sequence is non-destructive and can be performed regardless of whether the fiber link is busied out.

A fiber link is a connection between port networks (PNs), switch nodes (SNs), or between a PN and the Center Stage Switch (CSS). This connection is comprised of a bi-directional optical fiber connection (optionally extended via a DS1 Converter Complex), with each end terminated on either an Expansion Interface (EI) or a Switch Node Interface (SNI). Fiber links provide the medium for circuit and packet connections between PNs and for communication between the SPE and Expansion PNs (EPNs) for the CSS.

The **long** sequence includes destructive tests and requires that the fiber link be busied out first. When a fiber is busied out, all calls over that fiber are dropped.

**clear firmware-counters** clears the firmware counters of specified SNI, SNC or DS1C circuit packs, or of an the entire PNC (A or B).

## Parameters

---

<b>link#</b>	The number associated with a fiber link or fiber link pair (on duplicated PNCs). <b>List fiber-link</b> displays the location of endpoints for each fiber link.
<b>a-pnc   b-pnc</b>	On Critical Reliability systems (duplicated PNC) this identifier is used to distinguish between the two fibers of a duplicated fiber pair.

## Examples

---

Simplex PNC:

```
test fiber-link 1 l schedule  
test fiber-link 10 sh r 25 sch
```

Duplicated PNC:

```
test fiber-link 1 a-pnc schedule  
test fiber-link 03 b-pnc sh r 3
```

## Output

---

Port	On Critical Reliability systems (duplicated PNC) there are two fibers associated with every fiber link number. A-PNC and B-PNC distinguish one from the other.
------	--

The following display shows a typical result when **test fiber-link 1 b-pnc** is entered.

```

test fiber-link 1 b-pnc                               SPE B

                                TEST RESULTS

Port      Maintenance Name  Alt. Name  Test No.  Result  Error Code
-----
1 B-PNC   FIBER-LK           777        PASS
1 B-PNC   FIBER-LK           759        PASS
1 B-PNC   FIBER-LK           989        PASS
1 B-PNC   FIBER-LK           237        PASS
1 B-PNC   FIBER-LK           238        PASS

```

```
Command Successfully Completed
```

## test hardware-group

**test hardware-group** [system | carrier UUC | cabinet UU | port-network PN# |  
pnc a-pnc | b-pnc | board UUCSS | spe]  
[print | schedule]

This command runs a series of demand maintenance tests on all hardware in a specified group: a carrier, cabinet, port network, PNC (A or B), SPE, circuit pack or the entire system. The tests executed vary depending on the options chosen and types of hardware in the group. Some tests are run concurrently to speed execution, so test results for several maintenance objects may be intermixed.

A hardware-group command running in the foreground can be aborted by pressing **Cancel** or by entering **cancel hardware-group** at another terminal. The cancel command must be used for a test running in the background. You can restart a canceled hardware-group test at the point it left off by entering **resume hardware-group**. Hardware group tests started with the all-ports or spe-interchange options can be resumed, but they will not always test every port that originally would have been tested.

## Feature Interactions

Test hardware-group	Only one "test hardware-group" command can be active at any given time.
TTI	If the test hardware-group command is issued with the all-ports option while the TTI background task is active, some unadministered ports may not be tested. In addition, active alarms on line ports may be cleared by this task. The status tti command may be used to determine the state of the TTI background task.



Add Station	<p>If the add station command is entered for an untranslated port at the same time as it is being tested by the test hardware-group command with the all-ports option, the request to add station will fail and the following message will be displayed:</p> <p>Object in use; please try later</p>
Trunk Administration	<p>If an attempt is made to add an unadministered trunk port to a trunk group at the same time as it is being tested because of the test hardware-group command with the all-ports option, the request will fail and the following message will be displayed:</p> <p>Object in use; please try later</p>
Save Translation	<p>If the test hardware-group command is issued with the all-ports option when a translation save operation is active, some unadministered ports may not be tested. All other hardware will be tested normally.</p>
Hardware Alarms	<p>When a hardware error is detected by the test hardware-group command the hardware goes through the standard escalation strategy. Alarms will be raised on hardware that manifest hard errors. This alarming strategy is the same, regardless of whether the ports are translated or not.</p>
System Interaction	<p>The performance of test hardware-group is affected by call processing traffic, administration activity, choice of the short or long option, whether the all-ports option was chosen, whether the spe-interchange option was chosen, and other demand maintenance activity.</p>
Scheduled and Periodic Maintenance	<p>When a test hardware-group command is entered, all activity related to scheduled background maintenance, periodic background maintenance, and data audits is suspended for the duration of the execution of the test hardware-group command. When a test hardware-group command is canceled or when the test hardware-group command completes, all suspended periodic, scheduled, and data audits background maintenance activity will be restarted where it left off.</p>
Demand Testing of SPE Components	<p>When a test hardware-group command is entered with the SPE-interchange option, demand tests of SPE components may abort while the interchange is in progress.</p>

## Parameters

---

All maintenance objects included in the specified hardware group are tested, including all circuit packs and ports. When a cabinet or larger entity is specified, environmental MOs are tested (see **test environment**).

## Examples

---

```
test hardware-group system
test hardware-group port-network 11
test hardware-group pnc a-pnc
test hardware-group board 01c07
test hardware-group spe
```

## Form Input

---

When you enter the command, an input form is displayed upon which you can specify certain options.

Test sequence	Specify the short or long test sequence. The <b>long</b> sequence is more comprehensive and is not destructive.
Test Repetition	Specify <b>repeat</b> to enter a number of times that the entire test sequence is to be repeated. Specify <b>continuously</b> to cause the test sequence to be repeated until the command is canceled.
count	When the previous field is set to <b>repeat</b> , specify the number of repetitions here.
Auto-page?	Specifying <b>y</b> causes a whole new screen to be displayed automatically whenever the screen fills up with results. This option is incompatible with the background option. If you do not specify the auto-page option, once the screen fills with results, testing will stop until you press Page or Cancel. Specifying <b>print</b> on the command line automatically engages auto-page.
Background?	Specifying <b>y</b> causes the tests to run in the background, freeing up the terminal for other tasks. Error results are logged in the error log but not displayed on the screen. This option is incompatible with the auto-page and "continuously" options.
Failures?	Specifying <b>y</b> causes only failure results to be displayed on the screen.
All-ports?	Specifying <b>y</b> causes testing of all customer-translated line and trunk ports and, for the following circuit packs, untranslated ports as well:

TN#	Description	TN#	Description
TN413	Digital Line [G3r V2]	TN753	Direct-Inward-Dial Trunk
TN417	Auxiliary Trunk [G3r V2]	TN754	Digital Line
TN429	DIOD Trunk [G3r V2]	TN754	Digital Line
TN436	DID Trunk [G3r V2]	TN760C	Tie Trunk
TN437	Tie Trunk [G3r V2]	TN762	Hybrid Line
TN438	Central Office Trunk [G3r V2]	TN762B	Data Line

TN#	Description	TN#	Description
TN439	Tie Trunk [G3r V2]	TN763C	Auxiliary Trunk
TN447	Central Office Trunk [G3r V2]	TN769	Analog Line with Message Waiting
TN458	Tie Trunk [G3r V2]	TN784	Digital Line
TN459	DID Trunk [G3r V2]	TN785	16 Port Analog Line
TN465	Central Office Trunk [G3r V2]	TN2135	Italian 16 Port Analog Line [G3r V2]
TN467	8 port Analog line [G3r V2]	TN2136	Digital Line [G3r V2]
TN468	16 port Analog line [G3r V2]	TN2138	Central Office Trunk [G3r V2]
TN479	16 port Analog line [G3r V2]	TN2139	Direct Inward Dialing Trunk [G3r V2]
TN497	Tie Trunk [G3r V2]	TN2140	Tie Trunk [G3r V2]
TN556	ISDN BRI Line	TN2144	Analog Line [G3r V2]
TN735	MET Line	TN2146	Direct Inward Dialing Trunk [G3r V2]
TN742	8 port Analog Line	TN2147	Central Office Trunk [G3r V2]
TN746	16 port Analog line	TN2149	Analog Line [G3r V2]
TN747B	Central Office Trunk	TN2180	16 port Analog line [G3r V2]

SPE-interchange?    Specifying **y** causes the system to perform a planned SPE interchange so that both SPEs can be fully tested.

```

test hardware-group system                                     Page 1 of 1

TEST HARDWARE-GROUP SELECTIONS

Select the desired options for the specified test.

Test sequence: short
Test repetition: repeat count: 1

Output OPTIONS:                                           HARDWARE OPTIONS:

Auto-page? n                                           All-ports? n
Background? n                                           SPE-interchange? n
Failures? n
    
```

## Output

---

When the test is run in the foreground, test results are displayed in the normal format. In addition, the message line displays a running count of the number of maintenance objects already tested, the total number included in the tests, percent completed and repetition count.

The following display shows a typical result when **test hardware-group system** is entered.

```
test hardware-group system
```

### TEST RESULTS

Port	Maintenance Name	Alt. Name	Test No.	Result	Error Code
01C07	ANL-BD		51	PASS	
01C07	ANL-BD		52	PASS	
01C0703	ANL-LINE	5444	35	PASS	
01C0702	ANL-LINE	5447	35	PASS	
01C0703	ANL-LINE	5444	48	PASS	
01C0701	ANL-LINE	5401	35	FAIL	1000
01C0702	ANL-LINE	5447	48	PASS	
01C0703	ANL-LINE	5444	36	PASS	
01C0702	ANL-LINE	5447	36	PASS	
01C0701	ANL-LINE	5401	48	FAIL	1000
01C0701	ANL-LINE	5401	36	PASS	

```
Testing system, 68 of 342 (19%) MOs tested for repetition 1
```

## test host-adapter

---

**test host-adapter [C] [short | long] [repeat # | clear] [schedule]**

The test host-adapter command performs a series of tests on the host-adapter portion of the specified MSSNET circuit pack. This command will abort if any other MSS operation has already begun.

Failure of the host-adapter test may result in disabling access to the host-adapter by all system software except maintenance. Such a failure of the host-adapter also denies access to the related tape and disk until the host-adapter is fully in service.

The cabinet is always **1** and need not be entered. Carrier **a** or **b** must be specified only for systems with duplicated SPEs.

## test inads-link

---

This command will perform hardware diagnostic tests from the inads port that is accessible through the maintenance board to an OSS telephone number.

### Synopsis

---

**test inads-link [1 | 2]**

### Permissions

---

The following default logins may execute this command: system technician, inads, init, nms.

### Examples

---

```
test inads-link
test inads-link 1
test inads-link 2
```

### Description

---

The test inads-link command attempts to make a call over the inads port on the maintenance board to verify the INADS alarm notification process. By default, the link to the first OSS telephone number is tested. If there is an alarm pending to be reported or the call is in progress or up, then the test will be aborted. If the alarm origination to the OSS telephone number to be tested is disabled, the test generates an informative error and the test continues. The test will wait 2 minutes before executing to allow the remote maintenance technician to logoff freeing the line. The line must be free so the system can place a call to INADS. A local SAT user entering the **test inads-link** command need not log off for the system to place a call to INADS, but the 2 minute delay still exists.

Once the call is answered by INADS, the system will send a message with a test alarm type. INADS acknowledges receipt of the message and creates a trouble ticket. The trouble ticket will be closed immediately and have a "INADS LINK TEST" message entered in the description field. If an alarm is raised while the test call is up, the system will not send an alarm message over the existing link. The normal retry mechanism will be followed, which means an attempt to make a call to INADS to report the error will take place 7 minutes later. An INADS trouble ticket will be created only if the connection is successfully established, and a message is sent to the system acknowledging that INADS received the system message.

The "Maintain Process Circuit Packs" field must be set to yes on the inads and technician permission forms. This will provide permissions to execute the **test**

**inads-link** command. The field can be changed by executing a **change permission login** command.

There will be no alarms raised on the system as a result of the “test inads-link” command. Attendant alarm and acknowledgment lamp states will not be changed as a result of the command. The test will not be run during periodic or scheduled maintenance.

## Defaults

---

The test will default to test the link to the first OSS telephone number.

## Parameter

---

- 1 This option will cause testing of the link to the first OSS telephone number.
- 2 This option will cause testing of the link to the second OSS telephone number.

## Help Messages

---

If the system technician presses HELP after entering test **inads-link** the following message will be displayed:

```
[ '1' or '2' ]
```

Or press CANCEL to cancel the command

If the command entered is in conflict with another currently executing command, then a message will be displayed showing the login id of the conflicting user and the conflicting command. The message is as follows:

```
'login id':'command' has a command conflict
```

If during the execution of a command a resource problem occurs that requires the user to restart the command, then the following message will be displayed:

```
Command resources busy;  
Press CANCEL to clear, and then resubmit
```

If all of the available maintenance resources are currently in use, then the following message will be displayed:

```
All maintenance resources busy; try again later
```

## Output

---

If the test passed then the following message will be displayed:

```
Command successfully completed
```

If the test failed, because the link was up or because there was an active alarm that the switch needs to report or there was a problem with the call, the following message will be displayed:

```
Command failed
```

**NOTE:**

An entry is made in the error log describing why the inads-link test failed.

## Feature Interactions

---

None

## test isdn-testcall

---

**test isdn-testcall group#/member# [minutes #] [schedule]**

The **test isdn-testcall** command starts an outgoing ISDN-PRI test call using the asynchronous method.

Only 1 ISDN trunk in each port network can be tested at one time. The maximum number of asynchronous outgoing test calls that can be run simultaneously depends on the number of Maintenance/Test circuit packs in the system.

For more information, see Test #258 under “ISDN-TRK (DS1 ISDN Trunk)” in Chapter 9.

## Parameters

---

- |                       |  |
|-----------------------|--|
| <b>group#/member#</b> | Specify the trunk over which to originate the test call.   |
| <b>minutes #</b>      | Specify the duration of the test call in minutes from 1 to 120. The duration defaults to 8.4 or 9.6 seconds. |

For more information, see [“Common Input Parameters”](#) at the beginning of this chapter.

## Examples

---

**test isdn-testcall 78/2 minutes 10**

## Output

---

Result            PASS - The test call was successfully initiated.

                  ABORT - Resources were not available (for example, a B-channel or Maintenance/Test circuit pack).

                  FAIL - An outgoing test call could not be initiated.

## test journal-printer

---

**test journal-printer pms-log | wakeup-log**  
**[short | long] [repeat number| clear] [schedule]**

The test journal-printer command performs hardware diagnostics on the link between the switch and a specified journal printer link to either the PMS-log printer or the wakeup-log printer.

## Parameters

---

One of the 2 journal printers must be specified:

**pms-log**            This specifies the link to the Property Management System printer, whose maintenance name is PMS-PRNT.

**wakeup-log**        This specifies the wakeup-log printer, whose maintenance name is JNL-PRNT.

## Output

---

Maintenance      PMS-PRNT designates the PMS-log printer. JNL-PRNT designates the  
Name              wakeup-log printer.

Background maintenance activity on a link can interfere with testing and recovery of a particular component of the link. For example, as part of a test, maintenance software may busy out a component of the link, causing the link to drop. The system may then perform frequent attempts to re-establish the link. This can delay recovery of the component, since it must be idle for certain tests to take place. Busying out the link will prevent the system from these attempts to set up the link. Remember that a busyout will tear down a link if it is not already down.



## test led

---

**test led** [**all** | **cabinet UU** | **port-network PN#** | **switch-node SN#** | **a-pnc** | **b-pnc**] [**repeat #**]

This command verifies that a specified cabinet, port network, PNC or switch node is recognized by the system. It is also useful for identifying a port network, cabinet, or PNC (A or B).

When **test led** is entered, the red, green and yellow circuit pack LEDs are turned on until all administered carriers in the specified group have been lit for 2 seconds. They are then turned off in the same order in which they came on. The cycle can be repeated a number of times with the **repeat** option. Once all of the repeat cycles are completed, all affected LEDs are restored to reflect their current status.

## test link

---

**test link link** [**short** | **long**] [**repeat** | **clear**] [**schedule**]

This command verifies that the specified link is administered and performs a series of tests on the link.

### Parameters

---

**Port** Each link is identified by a number (1-16) assigned on the Communication-Interface Links form. **Display communication-interface links** shows the location and identification of each link.

### Output

---

**Port** The location of the port on a Packet Gateway circuit pack associated with the link being tested.

The following display shows a typical result when **test link 1 long** is entered.

```
test link 1 long                                     SPE B

                                TEST RESULTS

Port      Maintenance Name  Alt. Name  Test No.  Result  Error Code
-----
01C2001   PGATE-PT                5464      610      ABORT   1000
01C2001   PGATE-PT                5464      611      ABORT   1000
01C2001   PGATE-PT                5464      599      ABORT   1005
01C2001   PGATE-PT                5464      613      PASS
01C2001   PGATE-PT                5464      614      ABORT   1
01C2001   PGATE-PT                5464      976      FAIL    2
01C2001   PGATE-PT                5464      977      FAIL

Command Successfully Completed
```

## test maintenance

**test maintenance [C] [short | long] [repeat # | clear] [schedule]**

The test maintenance command performs hardware diagnostic tests on a the SYSAM (PPN) and EPN Maintenance circuit packs.

On the SYSAM, this command tests system maintenance, ACTIVE and STANDBY terminal ports, and the SYSAM refresh, dual port RAM, system reset and sanity timer functions. On the SYSAM, the long test sequence resets the circuit pack, terminating any local or remote SYSAM logins. To see if the last 2 tests pass, you must log in again. The Outputpulse Relay Test and the Analog Loop Around Test are not run on the standby SYSAM in a duplicated SPE.

On EPN Maintenance circuit packs, the MT interface, EI link, reset and sanity functions are tested. The long test resets the EPN Maintenance circuit pack, causing a local EPN Maintenance login to drop.

The cabinet number defaults to 1. Carrier **a** or **b** must be specified only for PPN cabinets with duplicated SPEs.

## Output

The following display shows a typical result when **test maintenance a** is entered.

```
test maintenance
```

```
TEST RESULTS
```

Port	Maintenance Name	Alt. Name	Test No.	Result	Error Code
01A	SYSAM		911	PASS	
01A	SYSAM		913	PASS	
01A	SYSAM		915	PASS	

```
Command Successfully Completed
```

The following display shows a typical result when **test maintenance 2** is entered.

```
test maintenance 2
```

```
TEST RESULTS
```

Port	Maintenance Name	Alt. Name	Test No.	Result	Error Code
02A	MAINT		106	PASS	
02A	MAINT		229	PASS	
02A	MAINT		303	PASS	
02A	MAINT		854	PASS	
02A	MAINT		337	PASS	

```
Command Successfully Completed
```

## **test mass-storage**

**test mass-storage [C] [short | long] [repeat | clear] [schedule]**

This command performs tests on each of the 3 components of the Mass Storage System (MSS): the host adapter circuit on the MSSNET circuit pack, the tape circuit pack and the disk circuit pack. Each of the 3 objects is tested using the same sequence used when individual components are tested separately.

This command aborts if any other mass-storage operation has already begun.

Failure of the host-adapter test may result in the disabling of periodic and scheduled testing of the failed host-adapter and the related tape and disk. Failure of a tape or disk test may result in the disabling of periodic and scheduled testing of the component.

The cabinet is always **1** and need not be entered. Carrier **a** or **b** must be specified only for systems with duplicated SPEs.

The following display shows a typical result when **test mass-storage a** is entered.

```
test mass-storage
```

TEST RESULTS

Port	Maintenance Name	Alt. Name	Test No.	Result	Error Code
01A	H-ADAPTR		822	PASS	
01A	H-ADAPTR		823	PASS	
01A	H-ADAPTR		824	PASS	
01A	H-ADAPTR		825	PASS	
01A	TAPE		809	PASS	
01A	TAPE		812	PASS	
01A	TAPE		813	PASS	
01A	TAPE		814	PASS	
01A	TAPE		815	PASS	
01A	DISK		809	PASS	
01A	DISK		812	PASS	
01A	DISK		813	PASS	
01A	DISK		814	PASS	
01A	DISK		815	PASS	

```
Command Successfully Completed
```

## test memory

**test memory CSS [short | long] [repeat # | clear] [schedule]**

This command performs hardware diagnostic tests on any or all Memory circuit packs in the specified carrier. All tests in both sequences are non-destructive.

The short test takes about 2 minutes to complete. The long test on a single circuit pack takes about 2.5 minutes. The long test takes an additional 2 minutes on circuit pack 1 for the Checksum Test.

### Parameters

**CSS** The cabinet is always 1 and need not be specified. Carrier a or b must be specified only for duplicated SPEs. You can specify one of the Memory circuit pack slots (1-4) on the PPN control carrier. If the slot is not specified, all memory circuit packs are tested.

### Output

NOT ASSIGNED indicates that the specified slot is not administered.

## test mssnet

---

**test mssnet C** [short | long][repeat |clear][schedule]

The **test mssnet** command runs a series of diagnostic tests on the MSSNET circuit pack. Tests are run on both maintenance objects located on the MSSNET circuit pack: host-adaptor (H-ADAPTR) and switch control (SW-CTL).

### Parameters

---

- C** The cabinet is always 1 and need not be entered. The carrier, **a** or **b**, must be specified in a duplicated SPE system.
- clear** The clear option does not provide a useful function for this command. MSSNET is used only as a command object to run tests of the MSSNET circuit pack. Failures of circuits on the MSSNET board cause alarms against H-ADAPTR and SW-CTL. Individual demand tests of those maintenance objects should be used to clear associated alarms.

### Output

---

The following display shows a typical result when **test mssnet 1a** is entered.

```
test mssnet 1a                                     SPE A

                                TEST RESULTS

Port      Maintenance Name  Alt. Name  Test No.  Result      Error Code
-----
01A      H-ADAPTR              822       PASS
01A      H-ADAPTR              823       PASS
01A      H-ADAPTR              824       PASS
01A      H-ADAPTR              825       PASS
01A      SW-CTL                 92        PASS

Command Successfully Completed
```

## test packet-interface

---

**test packet-interface [CSS] [short | long] [repeat # |clear] [schedule]**

This command performs hardware diagnostic tests on any or all of the packet interface circuit packs in a specified carrier. Tests performed include local memory checksum tests, loop-around tests, and checks of failure counters.

The Maintenance Loop-Around Test (#886) is included in the test sequences of *active* packet-interface circuit packs only. The Active-Standby Peer Link Test (#888) is included in the test sequences of the *standby* packet-interface circuit packs only.

If the packet-interface circuit pack is in the “out-of-service” or “uninstalled” states, no demand tests as well as scheduled, periodic and error tests will run. See also **reset packet-interface** and **status packet-interface**.

### Parameters

---

**CSS** The cabinet is always 1 and need not be entered. The carrier, **a** or **b**, must be entered only for duplicated SPEs. Slot number ranges from 1 to 3, corresponding to the dedicated PKT-INTFC slots on the control carrier. If omitted, all Packet Interface circuit packs on the specified carrier are tested.

## test pkt

The test runs a series of tests on the Packet bus of the specified PPN or EPN.

Action/Object	Qualifier	Qualifier Description	Permissions	Defaults	Feature Interactions
<b>test pkt port-network</b>	pn number	The Packet bus to be tested: <i>nn</i> (1-44)	init inads craft	Test Sequence = short; Repeat = 1	none
	short	Option for a brief series of nondestructive diagnostic tests.			
	long	Option for a longer, more comprehensive series of both destructive and nondestructive diagnostic tests.			
	repeat number	How many times each test in the sequence is repeated (1-100)			
	clear	This option causes the test sequence (short or long) to repeat until the alarm (if any) is cleared or a single test in the sequence fails. <sup>1</sup>			
	schedule	Command is validated and then a scheduling form displays to schedule execution of the command. The command is then placed in the command queue and is executed at the specified time. The information displayed by the command is sent to the system printer instead of the screen. <sup>2</sup>  Examples: <b>test pkt port-network 1 l</b> <b>test pkt port-network 2 sh r 2</b> <b>test pkt port-network 2 sh schedule</b> <b>test pkt port-network 1 l r 25</b> <b>test pkt port-network 2</b> <b>test pkt port-network 1 c</b>			

1. If no alarms are registered against the maintenance object, then the test sequence is run only once. The **long clear** option forces a clear of all alarms if no errors are encountered during testing. The **short clear** option only clears alarms pertinent to tests in the short sequence. SEE WARNING BELOW.
2. Refer to the Report Scheduler and System Printer feature specification for more details.



### WARNING:

Since the **clear long** options clear all counters if tests pass, it is possible for firmware counters to be cleared even when a problem exists. In some cases customer service might degrade since calls may be routed over defective equipment.

## Output

---

The following example shows the output for the **test pkt port-network 1** command. The responses display on a test-by-test basis with one line of data for each test result.

```
test pkt port-network 1
```

TEST RESULTS

Port	Maintenance Name	Alt. Name	Test No.	Result	Error Code
PN 01	PKT-BUS		571	PASS	
PN 01	PKT-BUS		572	PASS	
PN 01	PKT-BUS		573	PASS	

```
Command successfully completed
```

## Field descriptions

Port	A port network number (1-44).
Maintenance Name	The name of maintenance object being tested.
Alt. Name	Not applicable.
Test No	The test being executed.
Result	Test result: Pass, Abort, Fail, No Board, Disabled, Extra Bd.
Error Code	Numeric code explaining why the release failed or aborted. Refer to the detailed list of the codes by test number for each MO.

## test processor

---

**test processor [C] [short | long] [repeat # | clear] [schedule]**

The test processor command performs hardware diagnostic tests on a specified processor circuit pack.



## test signaling-group

---

**test signaling-group group#[short | long] [repeat# | clear][schedule]**

The test signaling-group validates the administration of a signaling group and runs a series of diagnostic tests on it.

An ISDN-PRI signaling group is a set of B-channels whose signaling messages are carried together on a designated D-channel or set of D-channels.

### Parameters

---

**group#** An administered number associated with each signaling group.

## test spe-standby

---

**test spe-standby [short | long] [repeat # | clear][schedule]**

This command is valid only on systems with duplicated SPE. The test spe-standby command performs hardware diagnostic tests on each component of the standby Switch Processing Element (SPE). This command is also used with the long option to remove a standby from recent interchange mode. The sequence begins with testing of the STBY-SPE maintenance object to determine the availability of the standby SPE. The following tests are run on STBY-SPE:

1. Standby SPE status query
2. Standby SPE handshake test
3. Standby SPE time of day comparison (standby in synch with active)
4. Standby SPE configuration matchup test

The last test is run only in the long sequence. After the above sequence, tests of each component on the standby SPE are run.

Testing the standby SPE does not affect the availability of the standby SPE for service only in that execution of the long sequence takes the standby out of recent interchange mode.

## Output

The following display shows a typical result when **test spe-standby** is entered.

```
test spe-standby                               Page 1  SPE B
TEST RESULTS
Port      Maintenance Name  Alt. Name  Test No.  Result  Error Code
01A      STBY-SPE           855        PASS
01A      STBY-SPE           919        PASS
01A      STBY-SPE           858        PASS
01A      DISK                809        PASS
01A      DISK                812        PASS
01A      DISK                813        PASS
01A      DISK                814        PASS
01A      DISK                815        PASS
01A      TAPE                809        PASS
01A      TAPE                812        PASS
01A      TAPE                813        PASS
01A      TAPE                814        PASS
01A      TAPE                815        PASS
01A      H-ADAPTR           822        PASS
01A      H-ADAPTR           823        PASS
press CANCEL to quit -- press NEXT PAGE to continue
```

```
test spe-standby                               Page 2  SPE B
TEST RESULTS
Port      Maintenance Name  Alt. Name  Test No.  Result  Error Code
01A      H-ADAPTR           824        PASS
01A      H-ADAPTR           825        PASS
01A      PROCR              896        PASS
01A      PROCR              897        PASS
01A      PROCR              899        PASS
01A      PROCR              900        PASS
01A      SYSAM              911        PASS
01A      SYSAM              913        PASS
01A      SYSAM              912        PASS
01A      SYSAM              915        PASS
01A2     MEM-BD             906        PASS
01A2     MEM-BD             907        PASS
01A2     MEM-BD             908        PASS
01A1     MEM-BD             906        PASS
01A1     MEM-BD             907        PASS
press CANCEL to quit -- press NEXT PAGE to continue
```

```
test spe-standby                                PAGE 3      SPE B
TEST RESULTS
Port      Maintenance Name  Alt. Name  Test No.  Result    Error Code
01A1     MEM-BD                908        PASS
01A      SW-CTL                92         PASS
01A1     PKT-INT              887        PASS
01A1     PKT-INT              888        PASS

Command Successfully Completed
```

## test stored-data

### **test stored-data [short | long] [repeat # | clear] [schedule]**

The **test stored-data** command performs a set of consistency checks of the boot images and translation data on tape and disk. In particular, software vintage numbers and translation time stamps are compared.

The short test sequence includes only inter-device tests. These include a tape-to-tape, disk-to-disk and two tape-to-disk tests for SPE duplex systems with tape and disk devices on both carriers. The long test sequence includes up to four intra-device consistency checks, one for each device. Another check of the system boot source is included in the long sequence.

For SPE simplex systems, only one tape-to-disk inter-device test and two intra-device consistency checks along with the boot source check are run. The other tests simply do not appear in the short or long test sequences.

The lack of the optional disks does not affect which tests are run. For both SPE simplex systems and SPE duplex systems, aborts are returned for those tests which require a disk.

This command will abort if any other MSS operation has already begun.

If translations have been saved to disk since the last time the disk was backed up to tape (a normal situation during work sessions), tests executed by this command will fail.

## test switch-control

---

**test switch-control [C] [short | long] [repeat # | clear] [schedule]**

The **test switch-control** command performs hardware diagnostic tests of the PPN Archangel, or SW-CTL circuit, on a specified MSSNET circuit pack. The PPN Archangel is responsible for transmitting messages back and forth between the SPE and the port circuit packs. For the short test of the active PPN Archangel, a loop-around test and a Control Channel test are performed. For the short test of the standby PPN Archangel, only the loop-around test is performed.

The long test includes a reset. When applied to the active PPN Archangel, this momentarily prevents call origination from stations or trunks connected to ports in the PPN. It is non-destructive for existing calls.

### Parameters

---

- C** The cabinet is always **1** and need not be entered. Carrier **a** or **b** must be specified only for systems with duplicated SPEs.
- long** This will execute a more comprehensive and longer version of the diagnostic tests. When applied to the active PPN Archangel, this momentarily prevents call origination from stations or trunks connected to ports in the PPN. It is non-destructive for existing calls.

## test synchronization

---

**test synchronization [short | long] [repeat # | clear] [schedule]**

The **test synchronization** command checks the timing synchronization source and updates circuit packs with the correct synchronization parameters. The tone-clocks, DS1s, and EIs are sent down-link messages to place them in the correct synchronization configuration given the current on-line synchronization reference.

The synchronization subsystem provides error-free digital communication between the switch and other PBXs, COs, or customer premises equipment. The subsystem is made up of the TDM bus clock, DS1 trunk circuit packs, and maintenance and administration software resident in the SPE.

## Parameters

---

**long** Both long and short sequences run Test #417. If Stratum 3 synchronization is administered, an additional non-destructive test (#649) is run by the long sequence.

## test sys-link

---

**test sys-link UUCSSpp [channel # ] [current | faulted]  
[short | long][repeat # | clear] [schedule]**

The **test sys-link** command will validate the existence of the specified link and run diagnostic tests on the hardware path that comprises the system link. If the "current" or "faulted" option is specified, tests are run on all hardware objects that comprise the specified link. If "current" or "faulted" is not specified, only the end-to-end sys-link connection will be tested.

The hardware path that comprises a system link consists of up to 21 hardware components that affect the behavior of the link. The number of components of a given system link hardware path depends on the system configuration and type of system link. The following links are examples of system links: Expansion Archangel Links (EAL), Indirect Neighbor Links (INL), Processor Gate Control links (PGC), PRI signaling links (PRI), System Access Port links (SAP), X.25 adjunct links (X25).

## Parameters

---

**UUCSSpp** The location of the port associated with the system link.

**channel number** The processor channel (1 to 128) associated with an X.25 adjunct link to be tested.

**current** This specifies testing of the current hardware path of the system link.

**faulted** This specifies testing of the hardware path of the system link as it was constituted when a fault last caused the link to go down. For more information, see "[Common Input Parameters](#)" at the beginning of this chapter.

## Examples

---

```
test sys-link 2e0201 current l schedule
test sys-link 2e0201 faulted r 10
test sys-link 1c1701 channel 3 r 10
```

## Output

The following display shows a typical result when **test sys-link 1e0201 current** is entered.

```
test sys-link 1e0201 current                               Page 1  SPE A
```

```
TEST RESULTS
```

Port	Maintenance Name	Alt. Name	Test No.	Result	Error Code
01E0201	SYS-LINK	LNL	985	PASS	
01A1	PKT-INT		886	PASS	
01A1	PKT-INT		887	PASS	
PN 01	PKT-BUS		572	PASS	
PN 01	PKT-BUS		573	PASS	
01E01	EXP-INTF		237	PASS	
01E01	EXP-INTF		238	PASS	
01E01	EXP-INTF		240	PASS	
01E01	EXP-INTF		241	PASS	
01E01	EXP-INTF		589	PASS	
01E01	EXP-INTF		316	PASS	
1 A-PNC	FIBER-LK		777	PASS	
1 A-PNC	FIBER-LK		759	PASS	
1 A-PNC	FIBER-LK		237	PASS	
1 A-PNC	FIBER-LK		238	PASS	

```
press CANCEL to quit -- press NEXT PAGE to continue
```

## test tape

**test tape [C] [short | long] [repeat # | clear] [schedule]**

The **test tape** command performs a series of tests on the tape circuit pack and tape cartridge. The standard cartridge used for backups of the disk is compatible with this test. The tape cartridge is rewound and a specific portion of the tape is used for test reads and writes. Tapes used for core dumps have an incompatible file system and should not be used for this test.

The cabinet is always **1** and need not be entered. Carrier **a** or **b** must be specified only for systems with duplicated SPEs.

This command aborts if any other MSS operation has already begun.

Failure of the tape test may result in the tape being placed in an out-of-service state. In this state, access to the tape by all system software except maintenance is blocked.

When the host-adaptor is taken out of service due to failures of its tests, or fails a reset and becomes uninstalled, the tape is also placed in the uninstalled state

and all access by system software, maintenance tests and commands including reset are blocked from execution.

Tapes used for core dumps have an incompatible file systems and cannot be tested by this command.

## **test tdm**

---

**test tdm port-network PN# [short | long] [repeat # | clear] [schedule]**

The **test tdm** command performs hardware diagnostic tests on the time slots of the specified TDM bus. Both halves ("a" and "b") of the TDM bus are tested.

## **test tone-clock**

---

**test tone-clock UUC [short | long] [repeat # | clear] [schedule]**

The **test tone/clock** command performs hardware diagnostic tests on the 3 maintenance objects on a specified tone/clock circuit pack: TONE-BD, TONE-GEN, TDM-CLK.

## **test trunk**

---

**test trunk group# [/ member#] [short | long] [repeat # | clear] [schedule]**

The **test trunk** command performs hardware diagnostic tests on an entire trunk group or an individual trunk group member, depending on the options entered.

## **test tsc-administered**

---

**test tsc-administered signaling-group# / tsc-index [repeat#] [schedule]**

The **test tsc-administered** command runs diagnostic tests on any type of administered Temporary Signaling Connections (TSCs) on a signaling group. A switched services request to run the TSC heartbeat test is also performed.

## **upgrade software**

---

Simplex:

**upgrade software to-version [version-override] [save-translation | no-translation]**

Duplex:

**upgrade software to-version [call-override] [no-interchange] [version-override] [preserve-calls | no-calls] [save-translation | no-translation]**

This command is a single user command; that only **status** commands may be executed while this command is running; all other commands will be blocked.

**Simplex:** In a simplex system this command will result in translation being saved to the primary device, followed by a reboot of the processor with loading of the new software and translation data, and any field updates from the primary MSS device. When completed, service is restored.

**Duplex:** In a duplicated SPE system, the upgrade software command will save translation, reboot the standby SPE with new software from its primary MSS device, load translations, apply any field updates, initiate an interchange of the SPE's, and begin providing service to the system. Normally the interchange of the SPEs will result in minimal service disruption. In cases where the new software load is incompatible with the existing load, the system may perform a service-disrupting reboot.

### **Parameters**

---

- |                       |   |
|-----------------------|---|
| <b>to-version</b>     | This qualifier identifies the software version. This qualifier is checked against the data on the MSS device to verify that the correct software version is being loaded and that the software version is the same or newer that the version in memory.   |
| <b>no-interchange</b> | <p>This option is only available in duplicated systems and provides the technician the ability to reboot the standby processor with the software on the standby primary MSS device, apply any field-updates and yet have the standby SPE remain the standby.</p> <p>The duplex default is to interchange the processors, upon a successful boot of the standby SPE.</p> |
| <b>call-override</b>  | This option is only available in duplicated systems and allows the command to continue, even if the command will result in a reset level 2 of the processor. Normally, the command would print an error message if it was able to determine if the reset was necessary. This reset would cause all calls in the system to be dropped.                                   |



- version-override** This option allows the command to continue if the version specified is older than the version in memory. This would normally result in the command aborting because the upgrade is not moving to a newer version of the software. If the version-override option is used and the version on the primary MSS device is older than the current version in memory then the save translation step will be skipped.
- save-translation** This option will override the internal system and save translation. The switch will not save translation if the version in memory is newer than the version to be booted. With this option the translation will be saved regardless of the software version.
- no-translation** This option will cause the system not to save translation. When the upgrade is from an older to a newer release, the system will save translation, even if the translation is incompatible between the two particular releases. There may be rare occasions when there may be this incompatibility and therefore this option will keep the translation from being saved on the new version.
- preserve-calls** The system may automatically not preserve calls because of the compatibility index, which signals a potential memory mismatch across the processors. Compatibility index major numbers must be identical, and the minor must either be identical or greater going forward for the upgrade to automatically be call preserving. This option will override the software determination of call preservation, and force the memory from the active to be sent to standby processor in an attempt to preserve calls. This option should be used with care, because attempting to preserve calls when the internal memory layout is not compatible will result in processor escalation to an eventual reboot.

## Examples

---

Duplex

**upgrade software DG3v02.03.0.01.0**

**upgrade software DG3v02.03.0.01.0 no-interchange no-translation**

**upgrade software DG3v02.03.0.01.0 call-override version-override**

## Input

---

Due to the complexity of this command and the options available, the system will display the following screen and ask for input (ENTER or CANCEL) from the user to either proceed with the command or to cancel the request.

The following display shows a typical result when **upgrade software DGv01.02.1.13.0** is entered on a system with simplex SPE:

```
upgrade software DG3v01.02.1.13.0
```

This upgrade software command will result in the following actions:

```
From software version: DG3v01.02.1.13.0  
To software version: DG3v01.03.4.13.0
```

```
Save CURRENT translation to MSS? yes
```

Press ENTER to continue or CANCEL to abort the command

The following display shows a typical result when **upgrade software DG3v01.02.1.13.0** is entered on a system with duplicated SPE.

```
upgrade software DG3v01.02.1.13.0
```

This upgrade software command will result in the following actions:

```
From software version: DG3v01.02.1.13.0  
To software version: DG3v01.03.4.13.0
```

```
From compatibility index: 2.2  
To compatibility index: 2.2
```

```
Save CURRENT translation to both active and standby MSS? yes
```

```
Attempt to preserve calls across interchange? yes
```

Press ENTER to continue or CANCEL to abort the command

If the user presses ENTER, then the command will proceed. If, however, the user presses the CANCEL key then the command will be terminated.

## Output

---

### NOTE:

After initiating an **upgrade software**, do not touch the keyboard while waiting for the command to execute. Entering a carriage return will cause the progress and diagnostic messages to be lost. If the upgrade is successful, Command successfully completed is *not* displayed. Instead, the terminal is logged off the system and must be logged in again.

As the command progresses, results of each step are displayed with corresponding error codes. The entire process takes about 10 minutes. While the system is saving translations the following progress message is displayed and updated every 10 seconds:

```
Maximum remaining translation save time: 03 mins 20 secs
```

A success or failure result is displayed. If the following message appears, system software is corrupted; follow normal escalation procedures.

```
Error encountered; can't complete request
```

## Simplex SPE

The following display shows a typical result when **upgrade software** is executed on a system with a simplex SPE.

```
upgrade software
```

### UPGRADE RESULTS

Upgrade Step	Results	Error Code
disable maintenance	PASS	
save translation	PASS	
reboot processor	PASS	

#### Upgrade Step

Each step in the upgrade execution is displayed after it occurs:

1. **disable maintenance**: This step prevents periodic maintenance from interfering with the upgrade (similar to the **disable all** command).
2. **save translation**: Saves a copy of the current translation to the primary MSS device
3. **reboot processor**: Reboots the processor, causing a temporary service outage.
4. If the upgrade is successful, `Command successfully completed` is *not* displayed. Instead, the terminal is logged off the system and must be logged in again.

#### Results

This displays whether the step was successful or not. Possible values are: PASS, FAIL, or SKIPPED. SKIPPED only occurs for the save translation step when the current version is newer than the version on the primary MSS device, causing this step to be bypassed.

#### Error Code

If a step fails, this field displays a code indicating the reason. See the following table.

Upgrade Step	Error Code	Description
Disable maintenance	6	Internal software error
Save translation	6	Internal software error
	7	Storage device currently in use
	8	Tape/disk access failure
	9	Internal translation data is corrupted
	10	Storage device has corrupted translation
	2000	The save was not completed in the allotted time
	6	Internal software error
Reboot processor	11	Could not load the boot image from the storage device
	12	Could not reboot the processor

### Duplicated SPE

The following display shows a typical result when **upgrade software** is entered on a system with duplicated SPE.

```

upgrade software

                                UPGRADE RESULTS

Upgrade Step                      Results      Error Code

disable maintenance                PASS
save translation                   PASS
busyout standby processor          PASS
translation load and reboot standby PASS
change memory shadow bounds       PASS
release standby processor          PASS
refresh standby memory             PASS
request an SPE interchange         PASS
    
```

Upgrade Step	<p>Each step in the upgrade execution is displayed after it occurs:</p> <ol style="list-style-type: none"><li>1. disable maintenance: This prevents periodic maintenance from interfering with the upgrade (similar to the <b>disable all</b> command).</li><li>2. save translation: save a copy of the current translation to the primary MSS device</li><li>3. busyout standby processor: This busies out the standby SPE, preventing spontaneous interchanges while the new software load is booted on the standby processor. This also turns off memory shadowing from active memory to the standby.</li><li>4. translation load and reboot standby: This causes the standby processor to load the boot image and translation on its primary device. The SPE remains standby, and starts running the Standby Maintenance Monitor (SMM).</li><li>5. change memory shadow bounds: This adjusts the range of memory transmitted from the active to the standby SPE to include only the information pertaining to active calls so as to preserve stable calls across the interchange.</li><li>6. release standby processor: This releases the standby SPE from busyout, allowing resumption of handshake and memory shadowing, with transfer of active call status to the standby.</li><li>7. refresh standby memory: The system waits for refresh to complete and reports the result.</li><li>8. request an SPE interchange: An interchange is executed into the standby SPE with the new load. If this step succeeds, the terminal is logged off. Otherwise, a failure code is returned.</li><li>9. If the upgrade is successful, <code>Command successfully completed</code> is <i>not</i> displayed. Instead, the terminal is logged off the system and must be logged in again.</li></ol>
Results	Result of the execution of the corresponding step: PASS, FAIL, or SKIPPED. SKIPPED occurs only for the save translation step when the current version is newer than the version on the primary MSS device.
Error Code	If a step fails, this field displays a code indicating the reason according to <a href="#">Table 8-15</a> :

**Table 8-15. Upgrade Software Error Codes—Duplicated SPE**

Upgrade Step	Error Code	Description
disable maintenance	6	Internal software error
save translation	6	Internal software error
	7	Storage device currently in use
	8	Tape/disk access failure
	9	Internal translation data is corrupted
	10	Storage device has corrupted translation
	2000	The save was not completed in the allotted time
busyout standby processor	6	Internal software error
	2010	Standby is already busied out
translation load and reboot standby	1	Could not create software processes on the standby
	2	Not all processes on the standby were able to start
	3	Standby LMM detected hardware failures on processor complex
	4	Software update file on standby corrupted
	5	Translation on standby was not able to load correctly
	6	Internal software error
	2000	The load and reboot was not completed in the allotted time, or communication with the standby was corrupted
	2500	Internal software error with standby communication
change memory shadow bounds	6	Internal software error
	2500	Internal software error with standby communication
release standby processor	6	Internal software error
	2011	Standby processor was not busied out.
refresh standby memory	6	Internal software error
	2000	The refresh of the standby was not completed in the allotted time

*Continued on next page*

**Table 8-15. Upgrade Software Error Codes—Duplicated SPE — Continued**

Upgrade Step	Error Code	Description
request an SPE interchange	6	Internal software error
	2000	The load and reboot was not completed in the allotted time, or communication with the standby was corrupted
	2300	Communication failure with standby resulted in interchange failure
	2360	LMM attempt to interchange processors failed
	2500	Internal software error with standby communication

## Feature Interactions

### System Restarts

An upgrade causes in a system restart. For a complete description of effects, see “Software Updates” in [Chapter 6](#).

### Error and Alarm Log

Error and alarm logs are cleared.

### Busyouts

Maintenance objects that have been busied out by command are released during the reboot or interchange. If the upgrade command is canceled, all busyouts are preserved.

### Multi-User Contention

While the upgrade command is executing, all other administration and maintenance commands except **status** reports are blocked.

### Periodic and Scheduled Maintenance

Periodic and scheduled maintenance are suspended while the upgrade command is processing.

## Command History Log

Unlike other commands, the upgrade software command is logged into the history log *before* it completes, prior to the save translation step. A record of the upgrade is saved on the new active SPE.

## Alarm Origination

To prevent reporting of alarms generated by the upgrade, alarm origination is suspended during the execution of the command. After a successful interchange on a system with duplicated SPE, alarm origination remains suspended for approximately 5 minutes, or until the newly active SPE is ready to begin normal maintenance.

## Enable All

All previously disabled maintenance objects are re-enabled following the upgrade. If the command is canceled, disables are preserved.

## Parameters

---

- UUCSSf** The location of a DS1 Converter facility. F represents a letter (a-d) used to identify the separate DS1 facilities connected to the DS1 Converter.
- override** This option must be used to busyout the facility on a DS1 Converter that is carrying the packet traffic and control messages. See the caution note above.

## Output

---

Port The DS1 facility as described above in UUCSSf.

The following display shows a typical result when **busyout ds1-facility 2e1a** is entered.

```
busyout dsl-facility 02e01a
```

COMMAND RESULTS

Port	Maintenance Name	Alt. Name	Result	Error Code
02E01A	DS1-FAC		PASS	

```
Command successfully completed
```

For more information see the following sections at the beginning of this chapter: [“Busyout and Release Commands”](#) and [“Common Output Fields”](#).



# Maintenance Object Repair Procedures

# 9

## ⇒ NOTE:

This chapter does not contain maintenance objects for the DEFINITY Wireless Business System (DWBS). Refer to the appropriate maintenance documentation that accompanies DWBS products.

## Escalation Procedures

This document is not intended to solve all levels of trouble. When the limits of these procedures have been reached and the problem has not been resolved, it is the technician's responsibility to escalate to a higher level of technical support.

Escalation should conform to the procedures in the *Technical and Administration Plan*.

## **ABRI-PORT (ASAI ISDN-BRI Port)**

---

<b>MO Name (in Alarm Log)</b>	<b>Alarm Level</b>	<b>Initial Command to Run</b>	<b>Full Name of MO</b>
ABRI-PORT <sup>1</sup>	MAJ/MIN/WRN	test port UUCSSpp l <sup>2</sup>	ASAI ISDN-BRI Port

- 
1. The alarm level for ABRI ports may be administered using the **set options** command. The alarm level can be set independently for off-board and on-board alarms to WARNING, MINOR, or MAJOR for all ABRI ports in the system.
  2. UU is the universal cabinet number (1 for PPN, 2 - 44 for EPNs). C is the carrier designation (A, B, C, D, or E). SS is the number of the slot in which the circuit pack resides (01 to 21). pp is the two digit port number (01, 02, ...).
- 

Refer to BRI-PORT (ISDN-BRI Port) information for repair procedures.

## AC-POWER

---

### AC Power for AC-Powered Systems

---

MO Name (in Alarm Log)	Alarm Level	Initial Command to Run	Full Name of MO
AC-POWER	WARNING	test environment UU <sup>1</sup>	AC Power

- 
1. UU is the universal cabinet number (1 for PPN, 2 - 44 for EPNs).
- 

DEFINITY systems support two different cabinet types: Multi-Carrier Cabinets and Single-Carrier Cabinets. Single-Carrier Cabinets are used only for EPNs. Both cabinet types may be powered by either AC or DC power source. Environmental maintenance differs according to cabinet type and power supply.

#### CAUTION:

*Before powering down a cabinet or carrier that contains DEFINITY AUDIX circuit packs (TN566), first power down the AUDIX unit to avoid damaging the AUDIX software. Instructions for powering down this unit are in the [“DEFINITY AUDIX System Power Procedures”](#) in [Chapter 5, “Alarms, Errors, and Troubleshooting”](#), on the circuit pack, and in DEFINITY AUDIX documentation.*

### Single-Carrier Cabinet Power Systems

Each Single-Carrier Cabinet has one power supply that distributes DC power and AC ringing voltage to the circuit pack slots in the cabinet.

#### AC Power Supply (WP-91153)

In an AC-powered cabinet, a single, plug-in, multi-output AC power supply is in the power supply slot. A power cord, with a three-prong plug on one end and an appliance connector on the other end, connects the supply to a dedicated AC power source. The inputs to the power supply can be (depending on list version):

- 120 VAC, 60 Hz, 15 Amp to 20 Amp; three wires in the power cord: one hot wire, one neutral wire, and one ground wire
- 220 VAC or 240 VAC, 50 Hz, 10 Amp; three wires in the power cord: one hot wire, one neutral wire, and one ground wire

The AC power supply produces the following DC outputs: +5 VDC, -5 VDC, -48 VDC, +12 VDC, and a battery-charging voltage. The DC outputs distribute power on the cabinet backplane to the circuit pack slots.

The AC power supply also produces AC ringing voltage. The AC ringing voltage output value and frequency depend on the country of use. The power supply has a circuit breaker and EMI filtering.

## Nominal Power Holdover

### Multi-Carrier Cabinets

Two types of battery holdover are available:

- The small battery assembly provides short-term battery holdover. If AC power fails, 48 VDC batteries power the system for 10 seconds in a PPN cabinet, for 15 seconds in an EPN cabinet, and for 10 minutes in the control carrier in a Standard Reliability system. The batteries also provide system power for 5 minutes in the control carrier in High and Critical Reliability systems, and for 10 minutes in the expansion control carrier in the "A" position of an EPN cabinet (Release 5r and higher).
- Some AC-powered Multi-Carrier Cabinets contain three 48V batteries and a battery charger (397C) to provide backup power in case power is interrupted. The holdover times are identical to those above.

### Single-Carrier Cabinets

A holdover circuit in the power supply allows a system to operate normally during AC power interruptions. When AC input power fails, reserve batteries supply power to the memory and processor circuit packs and fans for two minutes. All port circuit packs are inactive during this time. The power supply contains a battery charger to charge the holdover batteries.

## Error Log Entries and Test to Clear Values

**Table 9-1. AC Power Error Log Entries**

Error Type	Aux Data	Associated Test	Alarm Level	On/Off Board	Test to Clear Value
0 <sup>1</sup>	0	Any	Any	Any	test environment UU sh r 1
513	Any	AC Power Query Test (#78)	WARNING	OFF	test environment UU sh r 1

1. Run the Short Test Sequence first. If all tests pass, run the Long Test Sequence. Refer to the appropriate test description and follow the recommended procedures.

## System Technician-Demanded Tests: Descriptions and Error Codes

Always investigate tests in the order shown in the table below. By clearing error codes associated with the *Battery and Battery Charger Query Test*, for example, you may also clear errors from other tests in the testing sequence. Refer to the appropriate sections of this chapter for descriptions of each test.



**NOTE:**

The following tests apply to J58890CE, J58890CF, and J58890CH.

Order of Investigation	Short Test Sequence	Long Test Sequence	D/ND <sup>1</sup>
Battery & Battery Charger Query Test (#5)	X	X	ND
AC Power Query Test (#78)	X	X	ND
Power Unit Query Test (carrier E) (#127)	X	X	ND
Power Unit Query Test (carrier D) (#127)	X	X	ND
Power Unit Query Test (carrier A) (#127)	X	X	ND
Power Unit Query Test (carrier B) (#127)	X	X	ND
Power Unit Query Test (carrier C) (#127)	X	X	ND
Emergency Transfer Query Test (#124)	X	X	ND
Cabinet Temperature Query Test (#122)	X	X	ND
External Alarm Lead Query Test (#120)	X	X	ND
Analog Ring Generator Initialization Test (#117)	X	X	ND
Analog Ring Generator Query Test (#118)	X	X	ND

---

1. D = Destructive; ND = Nondestructive

### AC Power Query Test (#78)

This test queries the SYSAM in the PPN or the EPN maintenance circuit pack in an EPN Multi-Carrier Cabinet system for the status of AC power to the cabinet.

**Table 9-2. TEST #78 Power Query Test**

Error Code	Test Result	Description/Recommendation
1000	ABORT	System resources required to run test are not available. 1. Retry the command at 1-minute intervals for a maximum of 5 times.
100 2000	ABORT	Response to the test request was not received within the allowable time period. 1. Retry the command at 1-minute intervals for a maximum of 5 times. 2. If the test continues to ABORT with error code 2000, check for system powering problems with the A carrier (PPN or EPN). Resolve all AC-POWER and CARR-POW alarms. Then, repeat the test. 3. If the test continues to ABORT with a 2000 error code, check for and resolve all SYSAM errors in a PPN or MAINT errors (EPN maintenance circuit pack) in an EPN. Then, repeat the test.
2029 2319 2320 2500	ABORT	Internal system error
1	FAIL	<p> <b>NOTE:</b>                      For a J58890CE, skip to step 2.</p> <p>1. Procedures for a Global MCC (J58890CH):</p> <ol style="list-style-type: none"> <li>a. For a nominal holdover system if there is no AC power at the wall outlet, have a qualified electrician restore power to the outlet. Power should range from 170 to 264 VAC.</li> <li>b. If there is AC power at the wall outlet, then there could be a problem with the RM0850 Rectifiers, BU3200A Battery Interface Unit (BIU), or battery. Resolve all alarms logged against the POWER maintenance object, and rerun the test. If the test still fails, the BIU may be defective. Check the BIU. If the BOD alarm LED is on, replace the BIU.                      If the BOD LED is off and the BOK LED is on, then the SYSAM or the EPN maintenance circuit pack may be incorrectly reporting the problem. Resolve all alarms against these MOs and rerun the test.</li> </ol>

*Continued on next page*

Table 9-2. TEST #78 Power Query Test — Continued

Error Code	Test Result	Description/Recommendation
1 (Continued)	FAIL	<p>2. Procedures for a J58890CE:                      The cabinet is currently without AC power.</p> <p>1. Check for AC at the wall outlet (99-127 VAC, or 200 - 250 VAC).</p> <p>a. If there is no AC power at the wall outlet, then the problem is not with the system itself. Power must be restored to the wall outlet.</p> <p>b. If there is AC power at the wall outlet, then there could be a problem with the Battery or Battery chargers. Resolve all alarms logged against POWER (Battery &amp; Battery Charger), and rerun the test. If the test still fails, the fuse F5 may have opened.</p> <p style="text-align: center;"><b>⚠ WARNING:</b>  <i>Turn off the 397C Battery Charger before inserting or removing Fuse F5.</i></p> <p>Replace fuse F5 and rerun the test. If the test still fails, then the SYSAM or the EPN Maintenance circuit pack may be incorrectly reporting the problem. Resolve all alarms against these MOs, and rerun the test. There are failures that can occur on the SYSAM and EPN Maintenance circuit pack that <i>will not</i> be detected by their respective maintenance, but which will cause many, if not all, environment tests to fail. If more than two environment tests are failing, the suspect circuit pack, depending on the system configuration, should be replaced and the test rerun.</p>
100	FAIL	<p>The cabinet is currently without AC power, and AC power maintenance is in the middle of timing the NPH interval.</p> <p>1. Follow the repair steps for error code 1.</p>
	PASS	<p>The SYSAM in the PPN or the EPN MAINT (maintenance) circuit pack in an EPN has reported that the cabinet has AC power. If there is no AC power at the wall outlet, then look for and resolve all alarms against the appropriate MO listed.</p>

## AC-POWER for DC-Powered Systems

MO Name (in Alarm Log)	Alarm Level	Initial Command to Run	Full Name of MO
AC-POWER	WARNING	test environment UU <sup>1</sup>	AC Power

1. UU is the universal cabinet number (1 for PPN, 2 - 44 for EPNs).

### ⇒ NOTE:

In a DC-powered Multi-Carrier Cabinet, the AC-POWER maintenance object exists, but serves no functional purpose. Because the system cannot determine the type of power used, the AC-POWER test should always pass or abort. The maintenance strategy for power components in DC cabinets is described in the [“CARR-POW \(Carrier Power Supply\)”](#) section.

DEFINITY supports two different cabinet types: Multi-Carrier Cabinets and Single-Carrier Cabinets. Single-Carrier Cabinets are used only for EPNs. Both cabinet types may be powered by either AC or DC power source. Environmental maintenance differs according to cabinet type and external power supply.

## Error Log Entries and Test to Clear Values

**Table 9-3. AC Power Error Log Entries**

Error Type	Aux Data	Associated Test	Alarm Level	On/Off Board	Test to Clear Value
0 <sup>1</sup>	0	Any	Any	Any	test environment UU sh r 1
513	Any	AC Power Query Test (#78)	WARNING	OFF	test environment UU sh r 1

1. Run the Short Test Sequence first. If all tests pass, run the Long Test Sequence. Refer to the appropriate test description and follow the recommended procedures.



## System Technician-Demanded Tests: Descriptions and Error Codes

Always investigate tests in the order presented in the table below. By clearing error codes associated with the *AC Power Query Test*, for example, you may also clear errors generated from other tests in the testing sequence. Refer to the appropriate sections of this chapter for descriptions of each test.

Order of Investigation	Short Test Sequence	Long Test Sequence	D/ND <sup>1</sup>
Battery & Battery Charger Query Test (#5)	X	X	ND
AC Power Query Test (#78)	X	X	ND
Power Unit Query Test (carrier E) (#127)	X	X	ND
Power Unit Query Test (carrier D) (#127)	X	X	ND
Power Unit Query Test (carrier A) (#127)	X	X	ND
Power Unit Query Test (carrier B) (#127)	X	X	ND
Power Unit Query Test (carrier C) (#127)	X	X	ND
Emergency Transfer Query Test (#124)	X	X	ND
Cabinet Temperature Query Test (#122)	X	X	ND
External Alarm Lead Query Test (#120)	X	X	ND
Analog Ring Generator Initialization Test (#117)	X	X	ND
Analog Ring Generator Query Test (#118)	X	X	ND

---

1. D = Destructive; ND = Nondestructive

---

## AC Power Query Test (#78)

This test is not valid for DC-powered cabinets and should always abort or pass.

**Table 9-4. TEST #78 Power Query Test**

Error Code	Test Result	Description/Recommendation
1000	ABORT	System resources required to run test are not available.
100 2000	ABORT	Response to the test request was not received within the allowable time period.
2029 2319 2320 2500	ABORT	Internal system error.  1. Retry the command at 1-minute intervals for a maximum of 5 times.
Any	FAIL	The SYSAM in a PPN or the EPN Maintenance circuit pack in an EPN is incorrectly reporting an AC power problem. If this test fails, there is a problem with the SYSAM OR EPN Maintenance circuit pack. Replace the suspect circuit pack and run the test again. (b)
	PASS	Since this test is invalid for DC-powered cabinets, this result simply indicates that the SYSAM or EPN Maintenance circuit pack is handling this test properly

## ADM-CONN (Administered Connection)

MO Name (in Alarm Log)	Alarm Level	Initial Command to Run	Full Name of MO
ADM-CONN	MAJOR, MINOR, or WARNING	status administered-connection N <sup>1</sup>	Administered Connection

1. Where N is an administered connection number indicated in the PORT field of the Alarm or Error Log.

An administered connection provides an end-to-end connection between two access endpoints or data modules on either the same or different switches. The connection is automatically established when it is administered and scheduled to be active.

An error is logged whenever an administered connection fails or cannot be established. Failures to establish a connection generate an error whether they occur on an initial try, a retry, a fast retry, a redial or an auto-restoration. A failed connection generates an error whether or not the connection is subsequently reestablished by fast retry, redial, or auto restoration.

An alarm is logged when an administered connection cannot be established either initially or after failure of a connection. Both the alarm level (none to major) and a failure threshold can be administered for each administered connection. An alarm is raised when either of the following occurs:

- The number of consecutive failed attempts to establish a connection reaches the administered threshold.
- Software determines that failure to establish a connection is due to a mistake in administration. See [Table 9-5](#).

### Error Log Entries and Test to Clear Values

Table 9-5. Administered Connection Error Log Entries

Error Type	Aux Data	Associated Test	Alarm Level	On/Off Board	Test to Clear Value
0, or 29	Any	None	Any	OFF	None
1, or 28 (a,b)	Any	None	Any	OFF	None
2 (c)	Any	None	Any	OFF	None
6,21,31, or 127(d)	Any	None	Any	OFF	None

*Continued on next page*

**Table 9-5. Administered Connection Error Log Entries — Continued**

<b>Error Type</b>	<b>Aux Data</b>	<b>Associated Test</b>	<b>Alarm Level</b>	<b>On/Off Board</b>	<b>Test to Clear Value</b>
16 (a)	Any	None	Any	OFF	None
17 (e)	Any	None	Any	OFF	None
18, or 102 (f)	Any	None	Any	OFF	None
22 (a,g)	Any	None	Any	OFF	None
34,42,44, or 58 (h)	Any	None	Any	OFF	None
38, or 41 (i)	Any	None	Any	OFF	None
43, or 81	Any	None	Any	OFF	None
50 (a)	Any	None	Any	OFF	None
52 (a)	Any	None	Any	OFF	None
54	Any	None	Any	OFF	None
65,66, or 69 (a)	Any	None	Any	OFF	None
82	Any	None	Any	OFF	None
88 (a)	Any	None	Any	OFF	None
91,95,96,97,98,99,100, or 111	Any	None	Any	OFF	None

**For all ADM-CONN errors:**

All of the above errors have no specific test associated with them and, except for errors 17 and 127, are valid only for administered connections established over ISDN-PRI facilities. Error 127 is valid for administered connections established over non-ISDN facilities or between two endpoints on the same switch.

**Notes:**

- These errors are typically associated with administration problems and are not expected to be of a temporary nature. The administered connection is not retried and the failure is alarmed immediately. The alarm threshold specified by the customer is ignored.
- The address of the destination endpoint is: an unassigned number (1), has an invalid number format (28), or is restricted from terminating calls due to Class of Restriction (“Access Denied”). Verify that the destination address is correct and that the destination endpoint is administered. The destination endpoint is not administered on the switch where this error is logged.
- A request has been made to use a transit network or common carrier that cannot be accessed. Check the routing pattern used by this administered connection and verify that the inter-exchange carrier specified is correct.

- d. The exact failure cause is unknown or has been mapped to one of these values. If this is not a temporary condition, try reversing the direction of the Administered Connection (originate the administered connection from the destination switch). This may yield another failure cause.
  - e. The destination endpoint is not available. Check the status of the destination endpoint at the far-end switch. The status for the destination endpoint will not be available on the switch where this error is logged. At the far end, use **status access-endpoint** or **status data-module** to see whether the endpoint is busy, out-of-service or otherwise unavailable.
  - f. This switch sent an ISDN message to another switch, which either did not respond (18) or did not respond within the allotted time (102). This could be due to link failure or congestion or outage at the other switch.
  - g. The address of the destination endpoint has changed. Change the administered connection accordingly. The destination endpoint will not be administered on the switch where this error is logged.
  - h. These errors indicate that a resource (for example, a circuit or bearer capability) required by the administered connection is not presently available.
  - i. A network failure (38) or temporary failure (41) has occurred. Error Log entries for other MOs (for example, DS1-BD) may indicate a local problem.
-

## ADX8D-BD (AUDIX Circuit Pack)

MO Name (in Alarm Log)	Alarm Level	Initial Command to Run <sup>1</sup>	Full Name of MO
ADX8D-BD	MINOR or WARNING	test board UUCSS sh	AUDIX Circuit Pack

- 
1. UU is the universal cabinet number (1 for PPN, 2 - 44 for EPNs). C is the carrier designation (A, B, C, D, or E). SS is the number of the slot in which the circuit pack resides (01 to 21).
- 

The ADX8D-BD maintenance object represents a TN566/TN2169 DEFINITY AUDIX circuit pack (sometimes called Embedded AUDIX) operating in digital-port (DP) mode. For circuit-pack-level problems, see “XXX-BD (Common Port Circuit Pack)”. Port-level problems are covered by ADX8D-PT.

DEFINITY AUDIX consists of two circuit packs that occupy 5 slots on a port carrier. The tests described in this manual apply only to switch-side maintenance which tests circuit pack components related to the TDM bus interface. The AUDIX system has an extensive maintenance strategy that is described in *DEFINITY AUDIX System Maintenance*, 585-300-110.

## ADX8D-PT (AUDIX Digital Port)

MO Name (in Alarm Log)	Alarm Level	Initial Command to Run <sup>1</sup>	Full Name of MO
ADX8D-PT	MINOR	test port UUCSSpp l	AUDIX Digital Port
ADX8D-PT	WARNING	test port UUCSSpp sh	AUDIX Digital Port

1. UU is the universal cabinet number (1 for PPN, 2 - 44 for EPNs). C is the carrier designation (A, B, C, D, or E). SS is the number of the slot in which the circuit pack resides (01 to 21). pp is the two digit port number (01, 02, ...).

The ADX8D-PT maintenance object represents a port on a TN566/TN2169 DEFINITY AUDIX circuit pack (sometimes called Embedded AUDIX) operating in digital-port (DP) mode. The maintenance strategy for ports on the TN566 operating in control-link mode is described in ADX16A-PT.

The tests described in this section apply only to switch-side maintenance which tests circuit pack components related to the TDM bus interface. The AUDIX system has an extensive maintenance strategy that is described in *DEFINITY AUDIX System Maintenance*, 585-300-110.

AUDIX resides on a combined pair of circuit packs: the TN566 Multifunction Board (MFB) and the TN2169 Alarm Board (ALB). Because of its size this combination occupies 5 slots, but only 1 slot is functional as far as the switch is concerned. The other 4 slots are seen by the switch as "AUDIX-reserved" slots (or ADXDP-RS/ADX8D-RS.)

In DP mode the TN566 pack supports up to 8 voice ports, each with a primary information channel and a secondary information channel. Ports are administered in increments of two. When a call to a station with an AUDIX login is not answered, AUDIX answers the call using one of the available voice ports.

Unlike other AUDIX systems, DEFINITY AUDIX is not an adjunct.

### CAUTION:

*Never do any of the following without first shutting down AUDIX. Follow instructions on the TN566/TN2169 faceplate:*

- Remove DEFINITY AUDIX circuit packs
- Cycle power to a carrier containing DEFINITY AUDIX circuit packs
- Remove power to a carrier containing DEFINITY AUDIX circuit packs

## Error Log Entries and Test to Clear Values

**Table 9-6. DEFINITY AUDIX Digital Port Error Log Entries**

Error Type	Aux Data	Associated Test	Alarm Level	On/Off Board	Test to Clear Value
0 <sup>1</sup>	0	Any	Any	Any	test port UUCSSpp sh r 1
1(a)	40987	None	WARNING	OFF	
1(b)	1 to 20	None	WARNING	OFF	
15(c)	Any	None			
18(d)	0	busyout port UUCSSpp	WARNING	OFF	release port UUCSSpp
23(e)	0	None	WARNING	OFF	
130(f)		None	WARNING	ON	test port UUCSSpp sh
257(g)	40971	None			
513(h)	Any	None			
1537(i)	40968	None	WARNING	OFF	
1793		Voice & Ctrl. Local Loop Test (#13)	MIN/WRN <sup>2</sup>	ON	test port UUCSSpp l r 3
2049		NPE Crosstalk Test (#9)	MIN/WRN <sup>2</sup>	ON	test port UUCSSpp l r 3
2305(j)	40967	None			
3840(k)	40965	None			
3840(l)	41029	None			

1. Run the Short Test Sequence first. If all tests pass, run the Long Test Sequence. Refer to the appropriate test description and follow the recommended procedures.
2. Minor alarms on this MO may be downgraded to Warning alarms based on the values used in the **set options** command.

### Notes:

- a. The user may experience a noisy port or link. This is an off-board problem that is detected by the port circuit. If this problem exists, replace the circuit pack (see caution at the beginning of this section). Once the problem is resolved, the alarm is retired after a predetermined time.
- b. At least 15 off-board problems have been detected with the link to the voice port. When an error with the link is detected, an on-board counter is incremented. Also see Note (a).
- c. This is an internal type error that occurs when an audit request fails.
- d. The port is busied-out by command. You can release the port via the **release port UUCSSpp** command.



- e. The circuit pack is administered but not physically installed. The alarm will clear when a circuit pack is inserted.
- f. The circuit pack has been removed or has been insane for more than 21-minutes. To clear the error, reinsert or replace the AUDIX circuit pack (see precaution at the beginning of this section).
- g. Something is interfering with transmitting to the voice port. This is usually an on-board problem and can be ignored if no user complaints are received.
- h. AUDIX is not available to the switch, possibly due to a busyout on the AUDIX system. Check out the AUDIX system referring *DEFINITY AUDIX System Maintenance*, 585-300-110, if necessary.
- i. An in-line maintenance error has generated an off-board warning due to some problem with the link to the voice port. This can be ignored if no user complaints are received. If the problem persists, replace the circuit pack (see precaution at the beginning of this section). Once the problem is resolved, the alarm is retired after a certain period of time.
- j. The link between the circuit pack and the voice port is successfully reset. No craft action is necessary.
- k. No voice ports are connected to the DEFINITY AUDIX circuit pack. No maintenance action is required.
- l. The message buffer in the circuit pack is full.

### **System Technician-Demanded Tests: Descriptions and Error Codes**

Always investigate tests in the order presented in the table below when you are inspecting errors in the system. By clearing error codes associated with the *Voice and Control Channel Local Looparound Test* for example, you may also clear errors generated from other tests in the testing sequence.

<b>Order of Investigation</b>	<b>Short Test Sequence</b>	<b>Long Test Sequence</b>	<b>D/ND<sup>1</sup></b>
Voice and Control Channel Local Looparound Test (#13)		X	ND
NPE Crosstalk Test (#9)		X	ND

1. D = Destructive; ND = Nondestructive

## NO-OP Tests

The maintenance strategy for DEFINITY AUDIX emulates the one for DIG-LINE. The tests listed below apply only to DIG-LINE and not to DEFINITY AUDIX. These are referred to as *NO-OP* tests, and they always return PASS.

- Electronic Power Feed Test (#11)
- Station Lamp Updates Test (#16)
- Station (Digital) Audits Test (#17)

## NPE Crosstalk Test (#9)

This test verifies that this port's NPE channel talks on the selected time slot and that it never crosses over to time slots reserved for other connections. If the NPE is not working correctly, one-way and noisy connections may be observed. This test is part of a port's Long Test Sequence, and it takes about 20 to 30 seconds to complete.

Crosstalk testing is performed on both the primary information channel (voice) and on the secondary information channel (data) associated with each DEFINITY AUDIX port. If this test fails on either channel, the voice port is taken out-of-service.

**Table 9-7. TEST #9 NPE Crosstalk Test**

Error Code	Test Result	Description/Recommendation
1	ABORT	During testing of the primary information channel, system resources may not have been available. Also, the port may have been busy during the test. <ol style="list-style-type: none"> <li>1. Check the port status.</li> <li>2. Use the <b>display port UUCSSpp</b> command to determine the voice port extension of the port. Use the <b>status station</b> command to determine the service state of the port. If the service state indicates that the port is in use, you must wait until the port is idle.</li> <li>3. Retry the command at 1-minute intervals for a maximum of 5 times.</li> </ol>
2	ABORT	System resources may not have been available, or the port may have been busy during the test. <ol style="list-style-type: none"> <li>1. Retry the command at 1-minute intervals for a maximum of 5 times.</li> </ol>
1000	ABORT	System resources required to run this test are not available. The port may be in use. <ol style="list-style-type: none"> <li>1. Use the <b>display port UUCSSpp</b> command to determine the voice port extension of the port. Use the <b>status station</b> command to determine the service state of the port. If the service state indicates that the port is in use, you must wait until the port is idle before retesting.</li> <li>2. Retry the command at 1-minute intervals for a maximum of 5 times.</li> </ol>
1001	ABORT	System resources required to run this test are not available. <ol style="list-style-type: none"> <li>1. Retry the command at 1-minute intervals for a maximum of 5 times.</li> </ol>
1002	ABORT	The system could not allocate time slots for the test. The system may be under heavy traffic conditions, or it may have time slots out-of-service due to TDM-BUS errors. <ol style="list-style-type: none"> <li>1. If system has no TDM-BUS errors, and if it is not handling heavy traffic, retry the command at 1-minute intervals for a maximum of 5 times.</li> </ol>
1003	ABORT	The system could not allocate a tone receiver for the test. The system may be oversized for the number of Tone Detectors present, or some Tone Detectors may be out-of-service. <ol style="list-style-type: none"> <li>1. Resolve any TTR-LEV errors.</li> <li>2. Resolve any TONE-PT errors.</li> <li>3. Retry the command at 1-minute intervals for a maximum of 5 times.</li> </ol>
1004	ABORT	The port was put in use during the test. The test has been aborted. <ol style="list-style-type: none"> <li>1. Use the <b>display port UUCSSpp</b> command to determine the voice port extension of the port. Use the <b>status station</b> command to determine the service state of the port. If the port is in use, wait until the port is idle before testing.</li> </ol>

*Continued on next page*

Table 9-7. TEST #9 NPE Crosstalk Test — *Continued*

Error Code	Test Result	Description/Recommendation
1020	ABORT	Test disabled by background testing. Use the <b>status station</b> command to determine when the voice port is available for testing.
2000	ABORT	Response to the test request was not received within the allowable time period. <ol style="list-style-type: none"><li>1. Retry the command at 1-minute intervals for a maximum of 5 times.</li></ol>
1 2	FAIL	The NPE of the tested port is transmitting in error. This causes noisy and unreliable connections. Failure code 1 indicates that the Crosstalk test failed on the primary channel. Failure code 2 indicates that the Crosstalk test failed on the secondary channel. <ol style="list-style-type: none"><li>1. Replace the circuit pack .</li></ol>
	PASS	The port is using its allocated time slots correctly. <ol style="list-style-type: none"><li>1. To be sure that this is not an intermittent problem, repeat this test up to a maximum of 10 times to make sure it continues to pass.</li><li>2. If complaints still exist, examine the connections.</li></ol>

### Voice and Control Channel Local Loop Test (#13)

This test checks the information and control channels between the Switch Processing Element (SPE) and the DEFINITY AUDIX port circuit. First, the primary information (voice) channel loop back test is run.

While the primary information channel is still looped around, the Control Channel Looparound Test is performed. The Looparound Test for the secondary information (data) channel is then performed. This test is the same as the primary information channel loop around test.

Next, a Conference Test is implemented for the primary information channel. This test is the same as Conference Test #6.

Only one value (Pass, Fail, or Abort) is generated as a result of the four tests run. If any test fails or aborts, the sequence is stopped.

**Table 9-8. TEST #13 Voice and Control Channel Local Loop Test**

Error Code	Test Result	Description/Recommendation
	ABORT	Internal system error. 1. Retry the command at 1-minute intervals for a maximum of 5 times. Then try (b).
1000	ABORT	System resources required to run this test are not available. The port may be in use. 1. Use the <b>display port UUCSSpp</b> command to determine the voice port extension of the port. Use the <b>status station</b> command to determine the service state of the port. If the service state indicates that the port is in use, you must wait until the port is idle before retesting. 2. Retry the command at 1-minute intervals for a maximum of 5 times.
1001	ABORT	System resources required for this test are not available. 1. Retry the command at 1-minute intervals for a maximum of 5 times.
1002	ABORT	The system could not allocate time slots for the test. The system may be under heavy traffic conditions, or may have time slots that are out-of-service due to TDM-BUS errors. 1. If the system has no TDM-BUS errors, and is not handling heavy traffic, retry the command at 1-minute intervals for a maximum of 5 times.
1003	ABORT	The system could not allocate a tone receiver for the test. The system may be oversized for the number of Tone Detectors present, or some Tone Detectors may be out-of-service. 1. Resolve any TTR-LEV errors. 2. Resolve any TONE-PT errors. 3. If neither condition exists, retry the command at 1-minute intervals for a maximum of 5 times.
1004	ABORT	The port was put in use during the test. 1. Use the <b>display port UUCSSpp</b> to determine the voice port extension of the port. Use the <b>status station</b> command to determine the service state of the port. If the service state indicates that the port is in use, you must wait until the port is idle before retesting. 2. Retry the command at 1-minute intervals for a maximum of 5 times.
2000	ABORT	Response to the test request was not received within the allowable time period. 1. Retry the command at 1-minute intervals for a maximum of 5 times.
2100	ABORT	Could not allocate the necessary system resources to run this test. 1. Retry the command at 1-minute intervals for a maximum of 5 times.

*Continued on next page*

**Table 9-8. TEST #13 Voice and Control Channel Local Loop Test — Continued**

Error Code	Test Result	Description/Recommendation
7	FAIL	Conference Test failed on the primary channel. Some users may not notice a disruption in service. In extreme cases, the conferencing feature may not work at all.
14	FAIL	The primary voice channel is not transmitting properly. User impact may range from no noticeable effect to loss of use of this port.
15	FAIL	The control channel between the processor and DEFINITY AUDIX circuit pack is not transmitting properly. User impact may range from no noticeable effect to loss of use of this port. This failure could also be disruptive to other users.
16	FAIL	The secondary voice channel is not transmitting properly. User impact may range from no noticeable effect to loss of use of this port.
None	FAIL	The test failed for reasons external to the DEFINITY AUDIX circuit pack. <ol style="list-style-type: none"> <li>1. Run circuit pack tests to check the Tone Generator circuit pack and the Tone Detector circuit pack by using the <b>test board UUCSS s</b> command.</li> <li>2. Resolve any problems that are detected on the Tone Generator circuit pack or Tone Detector circuit pack.</li> <li>3. If the Tone Generator and Tone Detector circuit packs are functioning properly, and if the test still fails, replace the DEFINITY AUDIX circuit pack (see precaution at the beginning of this section).</li> </ol>
	PASS	Voice and Control Channel Local Loop test passed. All channels are transmitting properly. <ol style="list-style-type: none"> <li>1. To be sure that this is not an intermittent problem, repeat this test up to 10 times and see if it continues to pass.</li> <li>2. If complaints still exist, examine the connections.</li> </ol>

## ADX16D-B (16 Port AUDIX Circuit Pack)

---

MO Name (in Alarm Log)	Alarm Level	Initial Command to Run <sup>1</sup>	Full Name of MO
ADX16D-B	MINOR	test board UUCSS sh	AUDIX Circuit Pack
ADX16D-B	WARNING	test board UUCSS sh	AUDIX Circuit Pack

- 
1. UU is the universal cabinet number (1 for PPN, 2 - 44 for EPNs). C is the carrier designation (A, B, C, D, or E). SS is the number of the slot in which the circuit pack resides (01 to 21).
- 

The ADX16D-BD maintenance object represents a TN566/TN2169 DEFINITY AUDIX circuit pack combination operating in 16 port mode digital (DP). For circuit-pack-level problems, see “XXX-BD (Common Port Circuit Pack)”. Port-level maintenance is covered by ADX16D-PT.

DEFINITY AUDIX consists of 2 circuit packs that occupy 5 slots on a port carrier. The tests described in this manual apply only to switch-side maintenance which tests circuit pack components related to the TDM bus interface. The AUDIX system has an extensive maintenance strategy of its own that is described in *DEFINITY AUDIX System Maintenance*, 585-300-110.

## **ADX16A-BD (AUDIX Circuit Pack)**

---

<b>MO Name (in Alarm Log)</b>	<b>Alarm Level</b>	<b>Initial Command to Run<sup>1</sup></b>	<b>Full Name of MO</b>
ADXCL-BD or VADX16A-BD	MINOR, or WARNINGS	test board UUCSS sh	AUDIX Circuit Pack

- 
1. UU is the universal cabinet number (1 for PPN, 2 - 44 for EPNs). C is the carrier designation (A, B, C, D, or E). SS is the number of the slot in which the circuit pack resides (01 to 21).
- 

The ADX16A-BD maintenance object represents a TN566/TN2169 DEFINITY AUDIX circuit pack combination operating in control-link (CL) mode. For circuit-pack-level problems, see “XXX-BD (Common Port Circuit Pack)”. Port-level maintenance is covered by ADX16A-PT.

DEFINITY AUDIX consists of 2 circuit packs that occupy 5 slots on a port carrier. The tests described in this manual apply only to switch-side maintenance which tests circuit pack components related to the TDM bus interface. The AUDIX system has an extensive maintenance strategy that is described in *DEFINITY AUDIX System Maintenance*, 585-300-110.



## ADX16D-P (16-Port AUDIX Digital Port)

MO Name (in Alarm Log)	Alarm Level	Initial Command to Run <sup>1</sup>	Full Name of MO
ADX16D-P	MINOR or WARNINGS	test port UUCSSpp I	AUDIX Digital Port

1. UU is the universal cabinet number (1 for PPN, 2-44 for EPNs). C is the carrier designation (A, B, C, D, or E). SS is the number of the slot in which the circuit pack resides (01 to 21). pp is the two digit port number (01, 02, ...).

### CAUTION:

*Never do any of the following without first shutting down AUDIX. Follow the instructions on the TN566/TN2169 faceplate:*

- *Remove DEFINITY AUDIX circuit packs*
- *Cycle power to a carrier containing DEFINITY AUDIX circuit packs*
- *Remove power to a carrier or cabinet containing DEFINITY AUDIX circuit pack.*

The ADX16D-P maintenance object represents a port on a TN566/TN2169 DEFINITY AUDIX circuit pack operating in digital-port (DP) mode. The maintenance strategy for ports on the TN566 operating in control-link mode is described in ADX16A-PT.

The tests described in this section apply only to switch-side maintenance which tests circuit pack components related to the TDM bus interface. The AUDIX system has an extensive maintenance strategy that is described in *DEFINITY AUDIX System Maintenance*, 585-300-110.

AUDIX resides on a combined pair of circuit packs: the TN566 Multifunction Board (MFB) and the TN2169 Alarm Board (ALB). Because of its size this combination occupies 5 slots, but only 1 slot is functional as far as the system is concerned. The other 4 slots are seen by the switch as "AUDIX-reserved" slots (or ADX16-RES/ADX16D-RS).

In 16 Port DP mode, the TN566 pack supports up to 16 voice ports, each with a primary information channel and a secondary information channel. Ports are administered in increments of two. When a call to a station with an AUDIX login is not answered, AUDIX answers the call using one of the available voice ports.

Unlike other AUDIX systems, DEFINITY AUDIX is not an adjunct.

## Error Log Entries and Test to Clear Values

**Table 9-9. DEFINITY AUDIX Digital Port Error Log Entries**

Error Type	Aux Data	Associated Test	Alarm Level	On/Off Board	Test to Clear Value
0 <sup>1</sup>	0	Any	Any	Any	test port UUCSSpp sh r 1
1(a)	40987	None	WARNING	OFF	
1(b)	1 to 20	None	WARNING	OFF	
15(c)	Any	None			
18(d)	0	busyout port UUCSSpp	WARNING	OFF	release port UUCSSpp
23(e)	0	None	WARNING	OFF	
130(f)		None	WARNING	ON	test port UUCSSpp sh
257(g)	40971	None			
513(h)	Any	None			
1537(i)	40968	None	WARNING	OFF	
1793		Voice and Control Local Loop TEST (#13)	MIN/ WRN <sup>2</sup>	ON	test port UUCSSpp l r 3
2049		NPE Crosstalk Test (#9)	MIN/ WRN <sup>2</sup>	ON	test port UUCSSpp l r 3
2305(j)	40967	None			
3840(k)	40965	None			
3840(l)	41029	None			

1. Run the Short Test Sequence first. If all tests pass, run the Long Test Sequence. Refer to the appropriate test description and follow the recommended procedures.
2. Minor alarms may be downgraded to Warning alarms based on the values used in the **set options** command.

### Notes:

- a. The user may experience a noisy port or link. This is an off-board problem that is detected by the port circuit. If this problem exists, replace the circuit pack (see caution at the beginning of this section). Once the problem is resolved, the alarm is retired after a predetermined time.
- b. At least 15 off-board problems have been detected with the link to the voice port. When an error with the link is detected, an on-board counter is incremented. Also see Note a, above.
- c. This is an internal type error that occurs when an audit request fails.

- d. The port is busied-out by command. Release the port with the **release port UUCSSpp** command.
- e. The circuit pack is administered but not physically installed. The alarm will clear when a circuit pack is inserted.
- f. The circuit pack has been removed or has been insane for more than 21-minutes. To clear the error, reseal or replace the AUDIX circuit pack (see caution at the beginning of this section).
- g. Something is interfering with transmitting to the voice port. This is usually an on-board problem and can be ignored if no user complaints are received.
- h. AUDIX is not available to the switch, possibly due to a busyout on the AUDIX system. Refer to *DEFINITY AUDIX System Maintenance*, 585-300-110, if necessary.
- i. An in-line maintenance error has generated an off-board warning due to some problem with the link to the voice port. This can be ignored if no user complaints are received. If the problem persists, replace the circuit pack (see caution at the beginning of this section). Once the problem is resolved, the alarm is retired after a certain period of time.
- j. The link between the circuit pack and the voice port is successfully reset. No craft action is necessary.
- k. No voice ports are connected to the DEFINITY AUDIX circuit pack. No maintenance action is required.
- l. The message buffer in the circuit pack is full.

## System Technician-Demanded Tests: Descriptions and Error Codes

Always investigate tests in the order presented in the table below. By clearing error codes associated with the *Voice and Control Channel Local Looparound Test* for example, you may also clear errors generated from other tests in the testing sequence.

Order of Investigation	Short Test Sequence	Long Test Sequence	D/ND <sup>1</sup>
Voice and Control Channel Local Looparound Test (#13)		X	ND
NPE Crosstalk Test (#9)		X	ND

1. D = Destructive; ND = Nondestructive

## NO-OP Tests

The maintenance strategy for DEFINITY AUDIX emulates the one for DIG-LINE. The tests listed below apply only to DIG-LINE and not to DEFINITY AUDIX. These tests always return PASS.

- Electronic Power Feed Test (#11)
- Station Lamp Updates Test (#16)
- Station (Digital) Audits Test (#17)
- Digital Terminal Remote Looparound Test (1201)

## NPE Crosstalk Test (#9)

This test verifies that this port's NPE channel talks on the selected time slot and that it never crosses over to time slots reserved for other connections. If the NPE is not working correctly, one-way and noisy connections may be observed. This test is part of a port's Long Test Sequence, and it takes about 20 to 30 seconds to complete.

Crosstalk testing is performed on both the primary information channel (voice) and on the secondary information channel (data) associated with each DEFINITY AUDIX port. If this test fails on either channel, the voice port is taken out-of-service.

**Table 9-10. TEST #9 NPE Crosstalk Test**

Error Code	Test Result	Description/Recommendation
1	ABORT	During testing of the primary information channel, system resources may not have been available. Also, the port may have been busy during the test. <ol style="list-style-type: none"> <li>1. Check the port status.</li> <li>2. Use the <b>display port UUCSSpp</b> command to determine the voice port extension of the port. Use the <b>status station</b> command to determine the service state of the port. If the port is in use, it is unavailable for this test. Wait until the port is idle.</li> <li>3. Retry the command at 1-minute intervals for a maximum of 5 times.</li> </ol>
2	ABORT	System resources may not have been available, or the port may have been busy during the test. <ol style="list-style-type: none"> <li>1. Check if port is being used.</li> <li>2. Retry the command at 1-minute intervals for a maximum of 5 times.</li> </ol>

*Continued on next page*

**Table 9-10. TEST #9 NPE Crosstalk Test — Continued**

Error Code	Test Result	Description/Recommendation
1000	ABORT	System resources required to run this test are not available. The port may be in use. <ol style="list-style-type: none"> <li>1. Use the <b>display port UUCSSpp</b> command to determine the voice port extension of the port. Use the <b>status station</b> command to determine the service state of the port. If the port is in use, it is unavailable for certain tests. Refer to "Status" commands in Chapter 8, for a full description of all possible states. Wait until the port is idle before testing.</li> <li>2. If the port status is idle, retry the command at 1-minute intervals for a maximum of 5 times.</li> </ol>
1001	ABORT	System resources required to run this test are not available. <ol style="list-style-type: none"> <li>1. Retry the command at 1-minute intervals for a maximum of 5 times.</li> </ol>
1002	ABORT	The system could not allocate time slots for the test. The system may be under heavy traffic conditions, or it may have time slots out-of-service due to TDM-BUS errors. <ol style="list-style-type: none"> <li>1. If system has no TDM-BUS errors, and if it is not handling heavy traffic, retry the command at 1-minute intervals for a maximum of 5 times.</li> </ol>
1003	ABORT	The system could not allocate a tone receiver for the test. The system may be oversized for the number of tone detectors present, or some tone detectors may be out-of-service. <ol style="list-style-type: none"> <li>1. Resolve any TTR-LEV errors.</li> <li>2. Resolve any TONE-PT errors.</li> </ol>
1004	ABORT	The port was put in use during the test. The test has been aborted. <ol style="list-style-type: none"> <li>1. Use the <b>display port UUCSSpp</b> command to determine the voice port extension of the port. Use the <b>status station</b> command to determine the service state of the port. If the port is in use, it is unavailable for certain tests. Refer to "Status" commands in <a href="#">Chapter 8, "Maintenance Commands"</a> for explanations of all possible states. Wait until the port is idle before testing.</li> </ol>
1020	ABORT	Test disabled via background testing. Use the <b>status station</b> command to determine when the voice port is available for testing.
2000	ABORT	Response to the test request was not received within the allowable time period <ol style="list-style-type: none"> <li>1. Retry the command at 1-minute intervals for a maximum of 5 times.</li> </ol>
1 2	FAIL	The NPE of the tested port was found to be transmitting in error. This causes noisy and unreliable connections. Failure code 1 indicates that the Crosstalk test failed on the primary channel. Failure code 2 indicates that the Crosstalk test failed on the secondary channel. <ol style="list-style-type: none"> <li>1. Replace the circuit pack (see caution at the beginning of this section).</li> </ol>

**Table 9-10. TEST #9 NPE Crosstalk Test — Continued**

Error Code	Test Result	Description/Recommendation
	PASS	The port is using its allocated time slots correctly. <ol style="list-style-type: none"> <li>1. To be sure that this is not an intermittent problem, repeat this test up to a maximum of 10 times to make sure it continues to pass.</li> <li>2. If complaints still exist, examine the connections.</li> </ol>

### Voice and Control Channel Local Loop Test (#13)

This test checks the information and control channels between the Switch Processing Element (SPE) and the DEFINITY AUDIX port circuit. The SPE sends a message to loop around both the information and control channels for the port. First, the primary information (voice) channel loop back test is run.

While the primary information channel is still looped around, the Control Channel Looparound Test is performed. The Looparound Test for the secondary information (data) channel is then performed. This test is the same as the primary information channel loop around test.

Next, a Conference Test is implemented for the primary information channel. This test is the same as Conference Test #6.

Only one value (Pass, Fail, or Abort) is generated as a result of the four tests run. If any test fails or aborts, the sequence is stopped.

**Table 9-11. TEST #13 Voice and Control Channel Local Loop Test**

Error Code	Test Result	Description/Recommendation
	ABORT	Internal system error <ol style="list-style-type: none"> <li>1. Retry the command at 1-minute intervals for a maximum of 5 times.</li> </ol>
1000	ABORT	System resources required to run this test are not available. The port may be in use. <ol style="list-style-type: none"> <li>1. Use <b>display port UUCSSpp</b> command to determine the voice port extension of the port. Use <b>status station</b> command to determine the service state of the port. Wait until the port is idle before testing.</li> <li>2. Retry the command at 1-minute intervals for a maximum of 5 times.</li> </ol>
1001	ABORT	System resources required to run this test are not available. <ol style="list-style-type: none"> <li>1. Retry the command at 1-minute intervals for a maximum of 5 times.</li> </ol>

*Continued on next page*

**Table 9-11. TEST #13 Voice and Control Channel Local Loop Test — Continued**

Error Code	Test Result	Description/Recommendation
1002	ABORT	The system could not allocate time slots for the test. The system may be under heavy traffic conditions, or it may have time slots that are out-of-service due to TDM-BUS errors. <ol style="list-style-type: none"> <li data-bbox="274 413 1091 467">1. If the system has no TDM-BUS errors and if it is not handling heavy traffic, retry the command at 1-minute intervals for a maximum of 5 times.</li> </ol>
1003	ABORT	The system could not allocate a tone receiver for the test. The system may be oversized for the number of tone detectors present, or some tone detectors may be out-of-service. <ol style="list-style-type: none"> <li data-bbox="274 584 612 611">1. Resolve any TTR-LEV errors.</li> <li data-bbox="274 620 612 646">2. Resolve any TONE-PT errors.</li> <li data-bbox="274 664 1015 691">3. Retry the command at 1-minute intervals for a maximum of 5 times.</li> </ol>
1004	ABORT	The port was put in use during the test. The test has been aborted. <ol style="list-style-type: none"> <li data-bbox="274 754 1078 835">1. Use <b>display port UUCSSpp</b> to determine the voice port extension of the port. Use <b>status station</b> command to determine the service state of the port. If the port is in use, wait until the port is idle before retesting.</li> </ol>
2000	ABORT	Response to the test request was not received within the allowable time period. <ol style="list-style-type: none"> <li data-bbox="274 888 1015 915">1. Retry the command at 1-minute intervals for a maximum of 5 times.</li> </ol>
2100	ABORT	Could not allocate the necessary system resources for this test. <ol style="list-style-type: none"> <li data-bbox="274 978 1015 1005">1. Retry the command at 1-minute intervals for a maximum of 5 times.</li> </ol>

*Continued on next page*

**Table 9-11. TEST #13 Voice and Control Channel Local Loop Test — Continued**

Error Code	Test Result	Description/Recommendation
7	FAIL	Conference Test failed on the primary channel. In some cases, users may not notice a disruption in service. In extreme cases, the conferencing feature may not work at all.
14	FAIL	The primary voice channel is not transmitting properly. User impact may range from no noticeable effect to loss of use of this port.
15	FAIL	The control channel between the processor and AUDIX is not transmitting properly. User impact may range from no noticeable effect to loss of use of this port. This failure could also be disruptive to other users.
16	FAIL	The secondary voice channel is not transmitting properly. User impact may range from no noticeable effect to loss of use of this port.
None	FAIL	The test failed for reasons external to the AUDIX. <ol style="list-style-type: none"> <li>1. Run circuit pack tests to check the tone generator circuit pack and the tone detector circuit pack using <b>test board UUCSS s</b>.</li> <li>2. Resolve any problems detected on the tone generator circuit pack or tone detector circuit pack.</li> <li>3. If the tone generator and tone detector circuit packs are functioning properly, and if the test still fails, replace the AUDIX (see caution at the beginning of this section).</li> </ol>
	PASS	Voice and Control Channel Local Loop test passed. All channels are transmitting properly. <ol style="list-style-type: none"> <li>1. To be sure that this is not an intermittent problem, repeat this test up to 10 times and see if it continues to pass.</li> <li>2. If complaints still exist, examine the connections.</li> </ol>



## ADX16A-PT (AUDIX Analog Line/Control Link)

MO Name (in Alarm Log)	Alarm Level	Initial Command to Run <sup>1</sup>	Full Name of MO
ADXCL-PT or ADX16A-PT	MINOR	test port UUCSSpp l	AUDIX Analog Line/ Control Link
ADXCL-PT or ADX16A-PT	WARNING	test port UUCSSpp sh	AUDIX Analog Line/ Control Link

1. UU is the universal cabinet number (1 for PPN, 2 - 44 for EPNs). C is the carrier designation (A, B, C, D, or E). SS is the number of the slot in which the circuit pack resides (01 to 21). pp is the two digit port number (01, 02, ...).

### CAUTION:

*Never do any of the following without first shutting down AUDIX. Follow the instructions on the TN566/TN2169 faceplate:*

- Remove DEFINITY AUDIX circuit packs
- Cycle power to a carrier containing DEFINITY AUDIX circuit packs
- Remove power to a carrier containing DEFINITY AUDIX circuit packs

The ADX16A-PT maintenance object represents a port on a TN566/TN2169 DEFINITY AUDIX circuit pack that is operating in control-link (CL) mode. For circuit-pack-level problems (ADX16A-BD or ANL-16-BD), see “XXX-BD (Common Port Circuit Pack)”. For port-level problems with AUDIX operating in digital-port mode, see ADXDP-PT/ADX8D-PT.

The tests described in this section apply only to switch-side maintenance which tests circuit pack components related to the TDM bus interface. The AUDIX system has an extensive maintenance strategy that is described in *DEFINITY AUDIX System Maintenance*, 585-300-110.

AUDIX resides on a combined pair of circuit packs: the TN566 Multifunction Board (MFB) and the TN2169 Alarm Board (ALB). Because of its size this combination occupies 5 slots, but only 1 slot is functional as far as the switch is concerned. The other 4 slots are seen by the switch as “AUDIX-reserved” slots.

In CL mode the TN566 pack supports up to 16 voice ports. When a call to a station with an AUDIX login is not answered, AUDIX answers the call using one of the available voice ports.

Unlike other AUDIX systems, DEFINITY AUDIX is not an adjunct.

## Error Log Entries and Test to Clear Values

**Table 9-12. DEFINITY AUDIX Analog Line/Control Link Error Log Entries**

Error Type	Aux Data	Associated Test	Alarm Level	On/Off Board	Test to Clear Value
0 <sup>1</sup>	0	Any	Any	Any	test port UUCSSpp sh r 1
1 (a)	40977	None			
18	0	busyout station <extension>	WRN	ON	release station <extension>
23 (b)	0	None	WRN	OFF	
130 (c)		None	WRN	ON	test port UUCSSpp sh
257 (d)	40973	None			
513 (e)	Any	None			
1025 (f)		Looparound Test (#161)	MIN/ WRN <sup>2</sup>	ON	test port UUCSSpp l r 2
1281		Conference Test (#7)	MIN/ WRN <sup>2</sup>	ON	test port UUCSSpp l r 2
1537		NPE Crosstalk Test (#6)	MIN/ WRN <sup>2</sup>	ON	test port UUCSSpp l r 2

1. Run the Short Test Sequence first. If all tests pass, run the Long Test Sequence. Refer to the appropriate test description and follow the recommended procedures.
2. Minor alarms on this MO may be downgraded to Warning alarms based on the values used in the **set options** command.

### Notes:

- a. This is an in-line error and can only be resolved over time. This indicates that no terminal equipment was present when ringing was attempted. Execute the short **test port UUCSSpp** command.
- b. The circuit pack has been logically administered but not physically installed. The alarm will be cleared when the circuit pack is installed.
- c. The circuit pack has been removed or has been insane for more than 11-minutes. To clear the error, reseal or replace the circuit pack.
- d. This is an in-line error and can only be resolved over time. This error indicates that ringing voltage is absent. If only one analog circuit pack in the system has this problem, then replace the circuit pack. If only analog circuit packs on a particular carrier have this error, then the ringing generator may not be connected to this carrier. If analog circuit packs on many carriers have this error, check the ringing generator.
- e. AUDIX is not available to the switch. Check the AUDIX system, referring to *DEFINITY AUDIX System Maintenance*, 585-300-110.
- f. The TDM bus is out of service. See the "TDM-BUS" section.

## System Technician-Demanded Tests: Descriptions and Error Codes

Always investigate tests in the order presented in the table below. By clearing error codes associated with the *Looparound Test #161* for example, you may also clear errors generated from other tests in the testing sequence.

Order of Investigation	Short Test Sequence	Long Test Sequence	D/ND <sup>1</sup>
Looparound Test (#161)		X	ND
Conference Test (#7)		X	ND
NPE Crosstalk Test (#6)		X	ND

1. D = Destructive; ND = Nondestructive

### NO-OP Tests

The maintenance strategy for DEFINITY AUDIX emulates the one for ANL-16-L. The tests listed below apply only to ANL-16-L and not to DEFINITY AUDIX. These tests always return PASS.

- Battery Feed Test (#35)
- Audits and Updates Test (#36)
- Station Present Test (#48)

Tests 36 and 48 ABORT when AUDIX is not running.

### NPE Crosstalk Test (#6)

This test verifies that this port's NPE channel talks on the selected time slot and never crosses over to time slots reserved for other connections. If the NPE is not working correctly, one-way and noisy connections may be observed. This test is part of the long test sequence and takes about 25 seconds to complete.

Table 9-13. TEST #6 NPE Crosstalk Test

Error Code	Test Result	Description/ Recommendation
	ABORT	Could not allocate the necessary system resources to run this test. 1. Retry the command at 1-minute intervals for a maximum of 5 times.

*Continued on next page*

**Table 9-13. TEST #6 NPE Crosstalk Test — Continued**

Error Code	Test Result	Description/ Recommendation
1000	ABORT	System resources required to run this test are not available. The port may be busy with a valid call.  1. Use the <b>display port UUCSSpp</b> command to determine the station extension. Use the <b>status station</b> command to determine the service state of the port. If the port is in use, it is unavailable for certain tests. Wait until the port is idle before testing.  2. Retry the command at 1-minute intervals for a maximum of 5 times.
1001	ABORT	Could not allocate the necessary system resources to run this test. <sup>1</sup>
1002	ABORT	The system could not allocate time slots for the test. The system may be under heavy traffic conditions or it may have time slots out-of-service due to TDM-BUS errors.  1. If system has no TDM-BUS errors and is not handling heavy traffic, then retry the command at 1-minute intervals for a maximum of 5 times.
1003	ABORT	The system could not allocate a tone receiver for the test. The system may be oversized for the number of tone detectors present or some tone detectors may be out-of-service.  1. Resolve any TTR-LEV errors. 2. Resolve any TONE-PT errors. 3. Retry the command at 1-minute intervals for a maximum of 5 times.
1004	ABORT	The port was seized by a valid call during the test. The test has been aborted.  1. Use the <b>display port UUCSSpp</b> command to determine the station extension. Use the <b>status station</b> command to determine the service state of the port. If the port is in use, it is unavailable for certain tests. Wait until the port is idle before testing.  2. Retry the command at 1-minute intervals for a maximum of 5 times.
1005	ABORT	This condition indicates that the test is not applicable when the analog port is used in a combined modem pool. This error can be ignored.
1018	ABORT	Test disabled via administration.  1. To enable the test for the particular analog station being tested, enter the <b>change station extension</b> command and change the Test? field on the Station Form to <b>y</b> .
2000	ABORT	Response to the test request was not received within the allowable time period.
2012	ABORT	System could not respond to this request.
2100	ABORT	Could not allocate the necessary system resources to run this test.  1. Retry the command at 1-minute intervals for a maximum of 5 times.

*Continued on next page*

**Table 9-13. TEST #6 NPE Crosstalk Test — Continued**

Error Code	Test Result	Description/ Recommendation
Any	FAIL	The NPE of the tested port was found to be transmitting in error. This causes noisy and unreliable connections.  1. Replace the circuit pack.
	PASS	The port is correctly using its allocated time slots. User-reported troubles on this port should be investigated by using other port tests, by examining station wiring, or by examining the station.

### Conference Circuit Test (#7)

This test verifies that the NPE channel for the port being tested can correctly perform the conferencing function.

**Table 9-14. TEST #7 Conference Circuit Test**

Error Code	Test Result	Description/Recommendation
	ABORT	Could not allocate the necessary system resources to run this test.  1. Retry the command at 1-minute intervals for a maximum of 5 times.
1000	ABORT	System resources required to run test are not available. The port may be busy with a valid call.  1. Use the <b>display port UUCSSpp</b> command to determine the station extension. Use the <b>status station</b> command to determine the service state of the port. If the port is in use, wait until it is idle before retesting.  2. Retry the command at 1-minute intervals for a maximum of 5 times.
1004	ABORT	The port was seized by a valid call during the test. The test has been aborted.  1. Use the <b>display port UUCSSpp</b> command to determine the station extension. Use the <b>status station</b> command to determine the service state of the port. If the port is in use, wait until it is idle before testing.  2. Retry the command at 1-minute intervals for a maximum of 5 times.
1018	ABORT	Test disabled by administration. This only applies to analog stations.  1. To enable the test for the analog station being tested, enter the <b>change station &lt;extension&gt;</b> command and change the Test? field on the Station Form from to <b>y</b> .

*Continued on next page*

**Table 9-14. TEST #7 Conference Circuit Test — Continued**

Error Code	Test Result	Description/Recommendation
2000	ABORT	Response to the test request was not received within the allowable time period.
2100	ABORT	Could not allocate the necessary system resources for this test. 1. Retry the command at 1-minute intervals for a maximum of 5 times.
Any	FAIL	The NPE of the tested port did not conference the tones correctly. This causes noisy and unreliable connections. 1. Replace the circuit pack.
	PASS	The port can correctly conference multiple connections. User-reported troubles on this port should be investigated by using other port tests and by examining station, trunk, or external wiring.

**Looparound Test (#161)**

This test is designed to check the on-board transmission capabilities of the NPE on the analog port.

**Table 9-15. TEST #161 Looparound Test**

Error Code	Test Result	Description/ Recommendation
	ABORT	Could not allocate the necessary system resources for this test. 1. Retry the command at 1-minute intervals for a maximum of 5 times.
1000	ABORT	System resources required to run this test are not available. The port may be busy with a valid call. 1. Use the <b>display port UUCSSpp</b> command to determine the station extension. Use the <b>status station</b> command to determine the service state of the port. If the port is in use, wait until it is idle before testing. 2. If the port status is idle, retry the command at 1-minute intervals for a maximum of 5 times.
1002	ABORT	The system could not allocate time slots for the test. The system may be under heavy traffic conditions or it may have time slots out-of-service due to TDM-BUS errors. 1. If system has no TDM-BUS errors and is not handling heavy traffic, retry the command at 1-minute intervals for a maximum of 5 times.

*Continued on next page*

**Table 9-15. TEST #161 Looparound Test — Continued**

Error Code	Test Result	Description/ Recommendation
1003	ABORT	The system could not allocate a tone receiver for the test. The system may be oversized for the number of tone detectors present or some tone detectors may be out-of-service. <ol style="list-style-type: none"> <li>1. Resolve any TTR-LEV errors.</li> <li>2. Resolve any TONE-PT errors.</li> <li>3. If neither condition exists, retry the command at 1-minute intervals for a maximum of 5 times.</li> </ol>
1004	ABORT	The port was seized by a valid call during the test. The test has been aborted. <ol style="list-style-type: none"> <li>1. Use the <b>display port UUCSSpp</b> command to determine the station extension. Use the <b>status station</b> command to determine the service state of the port. If the port is in use, wait until the port is idle before testing.</li> <li>2. Retry the command at 1-minute intervals for a maximum of 5 times.</li> </ol>
1018	ABORT	Test disabled by administration. To enable the test for the particular analog station, enter the <b>change station &lt;extension&gt;</b> command and change the "Test?" field on the Station Form from "n" to "y."
2000	ABORT	Response to the test was not received within the allowable time period.
2100	ABORT	Could not allocate the necessary system resources to run this test. <ol style="list-style-type: none"> <li>1. Retry the command at 1-minute intervals for a maximum of 5 times.</li> </ol>
	FAIL	The reflective Looparound Test failed. This causes noisy or unreliable connections or other users calling this port may hear an echo. <ol style="list-style-type: none"> <li>1. Replace the circuit pack.</li> </ol>
	PASS	The port is able to provide an analog transmission path to the station equipment. User-reported troubles on this port should be investigated by using other port tests, by examining station wiring, or by examining the station.

## ALARM-PT (ALARM PORT)

MO Name (in Alarm Log)	Alarm Level	Initial Command to Run <sup>1</sup>	Full Name of MO
ALARM-PT	MIN	test port UUCSSpp l	Alarm-Port
ALARM-PT	WRN	test port UUCSSpp sh	Alarm-Port

1. UU is the universal cabinet number (1 for PPN, 2 -44 for EPNs). C is the carrier designation (A, B, C, D, or E). SS is the number of the slot in which the circuit pack resides (01 to 21). pp is the two digit port number (01, 02, ...).

The Alarm Port MO provides on-board maintenance for an analog line port that is administered as an external device alarm port. Test are provided to verify the analog line ports ability to detect an external device alarm. The external device alarm (EXT-DEV) MO is used for the off-board external device alarm.

### Error Log Entries and Test to Clear Values

**Table 9-16. 8-Port Analog Line Error Log Entries**

Error Type	Aux Data	Associated Test	Alarm Level	On/Off Board	Test to Clear Value
0 <sup>1</sup>	0	Any	Any	Any	test port UUCSSpp sh r 1
15 (a)	Any	Audits and Updates Test (#36)			
18	0	busy-out station <i>extension</i>	WARNIN G	OFF	release station <i>extension</i>
130 (b)		None	WARNIN G	ON	test port UUCSSpp sh
769		Battery Feed Test (#35)	MINIOR	ON	test port UUCSSpp sh r 2

1. Run the Short Test Sequence first. If all tests pass, run the Long Test Sequence. Refer to the appropriate test description and follow the recommended procedures

Notes:

- a. This is a software audit error that does not indicate any hardware malfunction. Run Short Test Sequence and investigate errors.



- b. Indicates that the circuit pack has been removed or has been insane for more than 11-minutes. To clear the error, reseal or replace the circuit pack.

## System Technician-Demanded Tests: Descriptions and Error Codes

---

Always investigate tests in the order presented in the table below. By clearing error codes associated with the *Battery Feed Test*, for example, you may also clear errors generated from other tests in the testing sequence.

Order of Investigation	Short Test Sequence	Long Test Sequence	D/ND <sup>1</sup>
Battery Feed Test (#35)	X	X	ND
Station Status and Translation Audits and Updates Test (#36)	X	X	ND

---

1. D = Destructive; ND = Nondestructive

### Battery Feed Test (also called Port Diagnostic Test) (#35)

The battery feed chip provides power to the telephone equipment, signaling, rotary dial pulsing, transmission, and balance. This test checks the signaling and switchhook capabilities of the battery feed chip by terminating the port, applying battery, and trying to detect a current.

**Table 9-17. TEST #35 Battery Feed Test**

Error Code	Test Result	Description/Recommendation
	ABORT	Could not allocate the necessary system resources to run this test. 1. Retry the command at 1-minute intervals for a maximum of 5 times.
1000	ABORT	System resources required to run this test are not available. The port may be reporting an external device alarm. 1. Enter <b>test external-device-alarm port UUCSSpp</b> to determine if the port is reporting an EXT-DEV failure before retesting. 2. When the port has no EXT-DEV failure, retry the command at 1-minute intervals for a maximum of 5 times.
1004	ABORT	The port received an EXT-DEV failure during the test. The test has been aborted. 1. Enter <b>test external-device-alarm port UUCSSpp</b> to determine if the port is reporting an EXT-DEV failure before retesting. 2. If the port has no EXT-DEV failure, retry the command at 1-minute intervals for a maximum of 5 times.
2000	ABORT	Response to the test request was not received within the allowable time period.
2100	ABORT	Could not allocate the necessary system resources to run this test. 1. Retry the command at 1-minute intervals for a maximum of 5 times.
	FAIL	The port's battery feed chip is unable to supply sufficient power to sense the external device alarm. This may occur when the test is performed at the same time that the external device contact closure occurred. 1. Enter <b>test external-device-alarm port UUCSSpp</b> to determine if the port is reporting an EXT-DEV failure before retesting. Wait until the port has no EXT-DEV failure before retesting. 2. Retry the command at 1-minute intervals for a maximum of 5 times.
	PASS	The port's battery feed chip is able to provide power to the external device alarm to detect contact closure.

**Station Status and Translation Audits and Updates Test (#36)**

For an analog line port that is administered as an external alarm, this test is limited to updating the software with the switchhook state.

**Table 9-18. TEST #36 Station Status and Translation Audits and Updates**

Error Code	Test Result	Description/Recommendation
	ABORT	Could not allocate the necessary system resources to run this test. 1. Retry the command at 1-minute intervals for a maximum of 5 times.
1004	ABORT	The port received an EXT-DEV failure during the test. The test has been aborted. 1. Enter <b>test external-device-alarm port UUCSSpp</b> to determine if the port is reporting an EXT-DEV failure before retesting. 2. If the port has no EXT-DEV failure, retry the command at 1-minute intervals for a maximum of 5 times.
1006	ABORT	This port has been busied out by command. 1. Check Error Log for Error Type 18 (port busied out). If present, release the port with the <b>release port UUCSSpp</b> command and run the test again.
2000	ABORT	Response to the test request was not received within the allowable time period.
2100	ABORT	Could not allocate the necessary system resources to run this test. 1. Retry the command at 1-minute intervals for a maximum of 5 times.
1	FAIL	This failure does not indicate a hardware problem. The switchhook audit failed, this condition may occur when the audit is performed at the same time that the terminal equipment goes off-hook. 1. Enter <b>test external-device-alarm port UUCSSpp</b> to determine if the port is reporting an EXT-DEV failure before retesting. Wait until the port has no EXT-DEV failure before retesting 2. If the port has no EXT-DEV failure, retry the command at 1-minute intervals for a maximum of 5 times.
7	FAIL	The translation update failed. This does not indicate a hardware problem but may be an internal software error.
	PASS	The software and the port processor have the same status.

## ANL-16-L (16-Port Analog Line)

MO Name (in Alarm Log)	Alarm Level	Initial Command to Run <sup>1</sup>	Full Name of MO
ANL-16-L	MIN	test port UUCSSpp l	16-Port Analog Line
ANL-16-L	WRN	test port UUCSSpp sh	16-Port Analog Line

1. UU is the universal cabinet number (1 for PPN, 2 -44 for EPNs). C is the carrier designation (A, B, C, D, or E). SS is the number of the slot in which the circuit pack resides (01 to 21). pp is the two digit port number (01, 02, ...).

The circuit packs listed below provide 16 analog line ports for single-line voice terminals. The table below indicates which circuit packs are equipped with lightning protection (for off-premises, out-of -building stations), and which ones support the neon message waiting lamp feature.

Circuit Pack	Off-Premises	Neon
TN468B	y	
TN479		
TN746		y
TN746B	y	y
TN2135	y	
TN2144	y	
TN2149	y	
TN2180	y	

No maintenance of the terminal connected to the 16-Port Neon Analog Line circuit pack is performed, except to determine whether or not the terminal is connected. Failures of the neon message waiting lamp power and the common ringing application circuitry are reported as part of common port circuit pack errors; see errors 1281 and 1793 in the "XXX-BD (Common Port Circuit Pack)" section.

### Ringling Caused by Maintenance Testing

Test #48 may cause some terminal equipment to ring briefly during daily maintenance. If this ringing is disturbing the customer or the terminal equipment, it should be disabled in the Tests field of the **change station** extension form. Be aware that this action will also disable Tests #6, 7, 161 and 35.

## Error Log Entries and Test to Clear Values

**Table 9-19. 16-Port Analog Line Error Log Entries**

Error Type	Aux Data	Associated Test	Alarm Level	On/Off Board	Test to Clear Value
0 <sup>1</sup>	0	Any	Any	Any	test port UUCSSpp sh r 1
1(a)	40960 40975 40977	none			
15(b)	Any	Audits and Updates Test (#36)			
18	0	busy-out station extension	WRN	ON	release station extension
130(c)		None	WRN	ON	test port UUCSSpp sh
257(d)	40973	none			
513(e)		Station Present Test (#48)	WRN	OFF	test port UUCSSpp sh r 2
769		Battery Feed Test (#35)	MIN/ WRN <sup>2</sup>	ON	test port UUCSSpp sh r 2
1025		Looparound Test (#161)	MIN/ WRN <sup>2</sup>	ON	test port UUCSSpp l r 2
1281		Conference Test (#7)	MIN/ WRN <sup>2</sup>	ON	test port UUCSSpp l r 2
1537		NPE Crosstalk Test (#6)	MIN/ WRN <sup>2</sup>	ON	test port UUCSSpp l r 2

1. Run the Short Test Sequence first. If all tests pass, run the Long Test Sequence. Refer to the appropriate test description and follow the recommended procedures.
2. Minor alarms on this MO may be downgraded to Warning alarms based on the values used in the **set options** command.

### Notes:

- a. These are in-line errors and can only be resolved over time.

Aux Data 40960 indicates that too many simultaneous incoming ringing attempts were made on this board. Only 4 ports on a board may ring simultaneously. A 5th incoming call causes an inline error from the board.

Aux Data 40975 indicates that the terminal equipment was on-hook when ring-tip was detected during ringing. This usually indicates a failure in the terminal equipment or the type of terminal has a low ringer impedance. Call the terminal equipment and verify that the terminal rings. If the terminal does not ring, then replace it. Otherwise, issue the **test port UUCSSpp** command, and follow the procedure for Test #48.

Aux Data 40977 indicates that no terminal equipment was connected when ringing was attempted. Run the short test via the **test port UUCSSpp** command, and follow the procedure for the results of Test #48.

- b. This is a software audit error that does not indicate any hardware malfunction. Run Short Test Sequence and investigate associated errors.
- c. This error type indicates that the circuit pack has been removed or has been insane for more than 11-minutes. To clear the error, reseal or replace the circuit pack.
- d. This is an in-line error and can only be resolved over time. This error indicates that ringing voltage is absent. If only 1 analog circuit pack in the system has this problem, then replace the circuit pack. If only analog circuit packs on a particular carrier have this error, then the ringing generator may not be connected to this carrier. If analog circuit packs on many carriers have this error, then it is probably a problem with the ringing generator.
- e. Test #48 may cause some terminal equipment to ring briefly during daily maintenance. If this disturbs the customer or the terminal equipment, disable it by setting the `Tests` field on the **change station** extension form to `n`. On some software releases, this will also disable Tests #6, 7, 161, and 35.

## System Technician-Demanded Tests: Descriptions and Error Codes

Always investigate tests in the order presented in the table below when inspecting errors in the system. By clearing error codes associated with the *Battery Feed Test*, for example, you may also clear errors generated from other tests in the testing sequence.

Order of Investigation	Short Test Sequence	Long Test Sequence	D/ND <sup>1</sup>
Battery Feed Test (#35)	X	X	ND
Station Present Test (#48)	X	X	ND
Looparound Test (#161)		X	ND
Conference Test (#7)		X	ND
NPE Crosstalk Test (#6)		X	ND
Station Status and Translation Audits and Updates Test (#36)	X	X	ND

1. D = Destructive; ND = Nondestructive

### NPE Crosstalk Test (#6)

This test verifies that this port's NPE channel talks on the selected time slot and never crosses over to time slots reserved for other connections. If the NPE is not working correctly, one-way and noisy connections may be observed. This test is usually part of the long test sequence and takes about 20 to 30 seconds to complete.

**Table 9-20. TEST #6 NPE Crosstalk Test**

Error Code	Test Result	Description/Recommendation
	ABORT	Could not allocate the necessary system resources to run this test. 1. Retry the command at 1-minute intervals for a maximum of 5 times.
1000	ABORT	System resources required to run test are not available. The port may be busy with a valid call. This result is also reported for the system's Music-On-Hold port when it is off-hook, which it usually is. 1. Enter <b>display port UUCSSpp</b> to determine the station's extension. Enter <b>status station</b> extension to determine the service state of the port. If the port is in use, wait until the port is idle. 2. Retry the command at 1-minute intervals for a maximum of 5 times.
1001	ABORT	System resources required to run test are not available. This could be due to a failure to seize the port. 1. Retry the command at 1-minute intervals for a maximum of 5 times.

*Continued on next page*

**Table 9-20. TEST #6 NPE Crosstalk Test — Continued**

Error Code	Test Result	Description/Recommendation
1002	ABORT	The system could not allocate time slots for the test. The system may be under heavy traffic conditions or have time slots out-of-service due to TDM-BUS errors. <ol style="list-style-type: none"> <li data-bbox="303 408 1043 467">1. If system has no TDM-BUS errors and is not handling heavy traffic, retry the command at 1-minute intervals for a maximum of 5 times.</li> </ol>
1003	ABORT	The system could not allocate a tone receiver for the test. The system may be oversized for the number of tone detectors present or some tone detectors may be out-of-service. <ol style="list-style-type: none"> <li data-bbox="303 578 640 605">1. Resolve any TTR-LEV errors.</li> <li data-bbox="303 623 647 650">2. Resolve any TONE-PT errors.</li> <li data-bbox="303 668 1084 723">3. If neither condition exists, retry the command at 1-minute intervals for a maximum of 5 times.</li> </ol>
1004	ABORT	The port was seized by a valid call during the test. The test has been aborted. <ol style="list-style-type: none"> <li data-bbox="303 808 1072 924">1. Use the <b>display port UUCSSpp</b> command to determine the station extension. Use the <b>status station</b> command to determine the service state of the port. If the port is in use, wait until the port is idle before testing.</li> <li data-bbox="303 942 1047 969">2. Retry the command at 1-minute intervals for a maximum of 5 times.</li> </ol>
1005	ABORT	The test was aborted due to a configuration problem. This test may not be applicable, or it may be disruptive to terminal equipment other than a voice terminal (for example, the modem pool member or Music On Hold).
1018	ABORT	The test has been disabled by administration. The default for the <code>Test</code> field on the station form is <code>y</code> . Determine why this field has been set to "no" on this station (this may be due to the ringing application Test #48, that can be customer or terminal disturbing). <ol style="list-style-type: none"> <li data-bbox="303 1207 1063 1297">1. To enable the test for a particular station being tested, enter <b>change station extension</b> and set the "Test?" field on the station from "n" to "y."</li> </ol>
2000	ABORT	Response to the test request was not received within the allowable time period.
2100	ABORT	System resources required to run test are not available. This could be due to a failure to seize the port. <ol style="list-style-type: none"> <li data-bbox="303 1447 1047 1474">1. Retry the command at 1-minute intervals for a maximum of 5 times.</li> </ol>

*Continued on next page*



**Table 9-20. TEST #6 NPE Crosstalk Test — Continued**

Error Code	Test Result	Description/Recommendation
Any	FAIL	<p>This test can fail due to on-board or off-board problems. Off-board problems include EXP-PN and EXP-INTF faults, TDM-BUS faults, and faults associated with the tone detectors/tone generators. Clear all off-board problems before replacing the board. A TDM-BUS problem is usually the result of a faulty board connected to the backplane, or bent pins on the backplane.</p> <ol style="list-style-type: none"> <li>1. Resolve any EXP-PN or EXP-INTF errors.</li> <li>2. Resolve any TDM-BUS errors.</li> <li>3. Resolve any TONE-BD or TONE-PT errors.</li> <li>4. Test the board when the faults from Steps 1, 2, and 3 are cleared. Replace the board only if the test fails.</li> </ol>
	PASS	<p>The port is correctly using its allocated time slots. User-reported troubles on this port should be investigated by using other port tests, by examining station wiring, or by examining the station.</p>
0	NO BOARD	<p>The test could not relate the internal ID to the port (no board). This could be due to incorrect translations, no board is inserted, an incorrect board is inserted, or an insane board is inserted.</p> <ol style="list-style-type: none"> <li>1. Check to ensure that the board translations are correct. Use the <b>list config</b> command, and resolve any problems.</li> <li>2. If the board was found to be correctly inserted in step 1, issue the <b>busyout board</b> command.</li> <li>3. Issue the <b>reset board</b> command.</li> <li>4. Issue the <b>release busy board</b> command.</li> <li>5. Issue the <b>test board long</b> command. This should re-establish the linkage between the internal ID and the port. If this is not the case, check to ensure that there is a valid board inserted.</li> </ol>

### Conference Circuit Test (#7)

This test verifies that the NPE channel for the port being tested can correctly perform the conferencing function.

**Table 9-21. TEST #7 Conference Circuit Test**

Error Code	Test Result	Description/Recommendation
	ABORT	Could not allocate the necessary system resources to run this test. 1. Retry the command at 1-minute intervals for a maximum of 5 times.
1000	ABORT	System resources required to run this test are not available. The port may be busy with a valid call. This result is also reported for the system's Music-On-Hold port when it is off-hook, which it usually is. 1. Enter <b>display port UUCSSpp</b> to determine the station's extension. Enter <b>status station</b> extension to determine the service state of the port. If the port is in use, wait until the port is idle. 2. Retry the command at 1-minute intervals for a maximum of 5 times.
1004	ABORT	The port was seized by a valid call during the test. The test has been aborted. 1. Use the <b>display port UUCSSpp</b> command to determine the station extension. Use the <b>status station</b> command to determine the service state of the port. If the port is in use, wait until the port is idle. 2. Retry the command at 1-minute intervals for a maximum of 5 times.
1005	ABORT	The test was aborted due to a configuration problem. This test may not be applicable, or it may be disruptive to terminal equipment other than a voice terminal (for example, the modem pool member or Music On Hold).
1018	ABORT	The test has been disabled via administration. The default for the <code>Test</code> field on the station form is <code>y</code> . Determine why this field has been set to "n" on this station (this may be due to the ringing application Test #48, which can be customer or terminal disturbing). 1. To enable the test for the particular analog station being tested, enter <b>change station extension</b> and set the <code>Test?</code> field on the station to <code>y</code> .
2000	ABORT	Response to the test request was not received within the allowable time period.
2100	ABORT	System resources required to run this test are not available. 1. Resolve any TONE-PT errors. 2. Resolve any TONE-PT errors.

*Continued on next page*

**Table 9-21. TEST #7 Conference Circuit Test — Continued**

Error Code	Test Result	Description/Recommendation
Any	FAIL	The NPE of the tested port did not conference the tones correctly. This will cause noisy and unreliable connections. <ol style="list-style-type: none"> <li>1. Issue the <b>display port</b> and the <b>status station</b> commands to determine if the station is idle. If the station is idle, issue the <b>test port</b> command for this port.</li> <li>2. If the test continues to fail, issue the <b>busyout port</b> and the <b>release port</b> commands, and then retest.</li> <li>3. If the test still fails, replace the board.</li> </ol>
	PASS	The port can correctly conference multiple connections. User-reported troubles on this port should be investigated by using other port tests and by examining station, trunk, or external wiring.
0	NO BOARD	The test could not relate the internal ID to the port (no board). This could be due to incorrect translations, no board is inserted, an incorrect board is inserted, or an insane board is inserted. <ol style="list-style-type: none"> <li>1. Check to ensure that the board translations are correct. Use the <b>list config</b> command, and resolve any problems.</li> <li>2. If the board was found to be correctly inserted in step 1, issue the <b>busyout board</b> command.</li> <li>3. Issue the <b>reset board</b> command.</li> <li>4. Issue the <b>release busy board</b> command.</li> <li>5. Issue the <b>test board long</b> command. This should re-establish the linkage between the internal ID and the port. If this is not the case, check to ensure that there is a valid board inserted.</li> </ol>

**Battery Feed Test (also called Port Diagnostic Test) (#35)**

The battery feed chip provides power to the telephone equipment, signaling, rotary dial pulsing, transmission, and balance. This test checks the signaling and switchhook capabilities of the battery feed chip by terminating the port, applying battery and detecting the resulting current.

For the TN746B, Test #35 does not actually run and instead always returns PASS. Test #35 operates in the normal manner for TN746.

**Table 9-22. TEST #35 Battery Feed Test**

Error Code	Test Result	Description/Recommendation
	ABORT	Could not allocate the necessary system resources to run this test. 1. Retry the command at 1-minute intervals for a maximum of 5 times.
1000	ABORT	System resources required to run this test are not available. The port may be busy with a valid call. This result is also reported for the system's Music-On-Hold port when it is off-hook, which it usually is. 1. Enter <b>display port UUCSSpp</b> to determine the station's extension. Enter <b>status station</b> extension to determine the service state of the port. If the port is in use, wait until the port is idle. 2. Retry the command at 1-minute intervals for a maximum of 5 times.
1004	ABORT	The port was seized by a valid call during the test. 1. Use the <b>display port UUCSSpp</b> command to determine the station extension. Use the <b>status station</b> command to determine the service state of the port. If the port is in use, wait until the port is idle. 2. Retry the command at 1-minute intervals for a maximum of 5 times.
1005	ABORT	The test was aborted due to a configuration problem. This test may not be applicable, or it may be disruptive to terminal equipment other than a voice terminal (for example, the modem pool member or Music On Hold).
1018	ABORT	The test has been disabled via administration. The default for the "Test" field on the station form is <b>y</b> . Determine why this field has been set to "n" on this station (this may be due to the ringing application Test #48, which can be customer or terminal disturbing). 1. To enable the test for the particular analog station being tested, enter <b>change station extension</b> and set the <code>Test?</code> field on the station to <b>y</b> .
1392	ABORT	This port is currently a TTI port and the test will not execute on it. 1. Verify that the port is a TTI port using either the <b>display port</b> command (the display shows that the port is a TTI port) or the <b>list config</b> command (the display shows a <code>t</code> for the port). 2. If the port is <i>not</i> a TTI port, escalate the problem. If both commands indicate that the port is a TTI port, the abort is correct for the test, and no action is necessary.
2000	ABORT	Response to the test request was not received within the allowable time period.
2100	ABORT	Could not allocate the necessary system resources to run this test. 1. Retry the command at 1-minute intervals for a maximum of 5 times.

*Continued on next page*

**Table 9-22. TEST #35 Battery Feed Test — Continued**

Error Code	Test Result	Description/Recommendation
	FAIL	<p>The port's battery feed chip is unable to supply sufficient power to the terminal equipment. This could be a marginal test, and the terminal equipment may be operating satisfactorily.</p> <ol style="list-style-type: none"> <li>1. Retry the command at 1-minute intervals for a maximum of 5 times.</li> <li>2. If the test continues to fail, determine whether the customer is experiencing problems on this line. Replace the circuit pack only if the customer is experiencing problems.</li> </ol>
	PASS	<p>The port's battery feed chip is able to provide power to the station equipment to detect on-/off-hook, but may not be able to supply power for touch-tones. If touch-tones are inoperative on this station, then replace the circuit pack because this port is inoperative. User-reported troubles on this port should be investigated by using other port tests, by examining station wiring, or by examining the station.</p>
0	NO BOARD	<p>The test could not relate the internal ID to the port (no board). This could be due to incorrect translations, no board is inserted, an incorrect board is inserted, or an insane board is inserted.</p> <ol style="list-style-type: none"> <li>1. Check to ensure that the board translations are correct. Use the <b>list config</b> command, and resolve any problems.</li> <li>2. If the board was found to be correctly inserted in step 1, issue the <b>busyout board</b> command.</li> <li>3. Issue the <b>reset board</b> command.</li> <li>4. Issue the <b>release busy board</b> command.</li> <li>5. Issue the <b>test board long</b> command. This should re-establish the linkage between the internal ID and the port. If this is not the case, check to ensure that there is a valid board inserted.</li> </ol>

### Station Status and Translation Audits and Updates Test (#36)

This test updates the analog port's message lamp state (if it has one) and translations with information in the software.

**Table 9-23. Test #36 Station Status and Translation Audits and Updates**

Error Code	Test Result	Description/ Recommendation
	ABORT	Could not allocate the necessary system resources to run this test. 1. Retry the command at 1-minute intervals for a maximum of 5 times.
1004	ABORT	The port was seized by a valid call during the test. The test has been aborted. 1. Use the <b>display port UUCSSpp</b> command to determine the station extension. Use the <b>status station</b> command to determine the service state of the port. If the port is in use, wait until port is idle. 2. Retry the command at 1-minute intervals for a maximum of 5 times.
1005	ABORT	The test was aborted due to a configuration problem. This test may not be applicable, or it may be disruptive to terminal equipment other than a voice terminal (for example, the modem pool member or Music On Hold).
1006	ABORT	This port has been busied out by command, or taken out-of-service by the failure of the NPE Crosstalk Test. 1. Look in the error log for error type 18 (port busied out) for this port. If this error is present, release the port with the <b>release station extension</b> command, and run the test again. 2. Check the error log for error type 1025 (NPE crosstalk test failed) for this port. If this error is present, investigate the errors associated with the NPE Crosstalk Test 6. 3. Make sure that the terminal is connected and in service, and then retest.
2000	ABORT	Response to the test request was not received within the allowable time period.
2100	ABORT	Could not allocate the necessary system resources to run this test. 1. Retry the command at 1-minute intervals for a maximum of 5 times.
1	FAIL	This does not indicate a hardware problem. The switchhook audit failed. The other updates were not performed because of this failure. This may occur when the audit is performed at the same time the terminal equipment goes off-hook. 1. Use the <b>status station</b> command to determine when the port is available. 2. Retry the command at 1-minute intervals for a maximum of 5 times.
5	FAIL	This may be an internal software error. The message waiting lamp update failed. The translation and ringer updates were not performed because of this failure.
7	FAIL	The translation update failed. There may be an internal software error. The ringer update was not performed because of this failure.

*Continued on next page*

Table 9-23. Test #36 Station Status and Translation Audits and Updates — *Continued*

Error Code	Test Result	Description/ Recommendation
8	FAIL	This does not indicate a hardware problem. There may be an internal software error. The ringer update failed. <ol style="list-style-type: none"><li>1. Retry the command at 1-minute intervals for a maximum of 5 times.</li></ol>
	PASS	The software and the port processor have the same status. User-reported troubles on this port should be investigated by using other port tests, by examining station wiring, or by examining the station.
0	NO BOARD	The test could not relate the internal ID to the port (no board). This could be due to incorrect translations, no board is inserted, an incorrect board is inserted, or an insane board is inserted. <ol style="list-style-type: none"><li>1. Check to ensure the board translations are correct. Use the <b>list config</b> command and resolve problems.</li><li>2. If the board was found to be correctly inserted in step 1, issue the <b>busyout board</b> command.</li><li>3. Issue the <b>reset board</b> command.</li><li>4. Issue the <b>release busy board</b> command.</li><li>5. Issue the <b>test board long</b> command. This should re-establish the linkage between the internal ID and the port. If this is not the case, check to ensure that there is a valid board inserted.</li></ol>

### Station Present Test (also called Ringing Application Test) (#48)

This test applies momentary ringing voltage to the terminal equipment and monitors resulting current flow to determine whether terminal equipment is connected to the port. This test may cause some terminal equipment to ring briefly during daily maintenance. If this ringing disturbs the customer or the terminal equipment, you can disable it via the Tests field on the **change station** form. However, on some software releases, Tests #6, 7, 161, and 35 are disabled.

**Table 9-24. TEST #48 Station Present Test**

Error Code	Test Result	Description/Recommendation
	ABORT	Could not allocate the necessary system resources to run this test. 1. Retry the command at 1-minute intervals for a maximum of 5 times.
1000	ABORT	System resources required to run this test are not available. The port may be busy with a valid call.
1004	ABORT	The port was seized by a valid call during the test. The test has been aborted. 1. Use the <b>display port UUCSSpp</b> command to determine the station extension. 2. Use the <b>status station</b> command to determine the service state of the port. If the service state indicates that the port is in use, wait until the port is idle. 3. Retry the command at 1-minute intervals for a maximum of 5 times.
1005	ABORT	The test was aborted due to a configuration problem. This test may not be applicable, or it may be disruptive to terminal equipment other than a voice terminal (for example, the modem pool member or Music On Hold).
1008	ABORT	Could not allocate a ringing circuit. Either all the ringing circuits are in use or the ringing generator is defective or it is not wired correctly. Retry the command at 1-minute intervals for a maximum of 5 times. 1. If the test continues to abort, look for RING-GEN errors in the Error Log. If an ABORT 1008 occurs for this test on other circuit packs as well, then the ringing generator may be defective or is not wired correctly. If it does not occur on other ports, then all four ring phases are in use.
1018	ABORT	The test has been disabled by administration. The default for the <code>Test?</code> field on the station form is <b>y</b> . Determine why this field has been set to "n" on this station (this may be due to the brief ringing disturbance that this test may cause). 1. To enable the test for the particular analog station being tested, enter <b>change station extension</b> and set the <code>Test?</code> field on the station to <b>y</b> .
2000	ABORT	Response to the test request was not received within the allowable time period.
2100	ABORT	Could not allocate necessary system resources to run this test. 1. Retry the command at 1-minute intervals for a maximum of 5 times.

*Continued on next page*



**Table 9-24. TEST #48 Station Present Test — Continued**

Error Code	Test Result	Description/Recommendation
	FAIL	<p>The terminal equipment is not connected to the circuit pack. Some terminal equipment, such as modems, may fail even when connected properly.</p> <ol style="list-style-type: none"> <li>1. Remotely test the equipment.</li> <li>2. If the test fails again, look for RING-GEN errors in the Error Log.</li> <li>3. Check all of the wiring between the station equipment and the switch. Then, run the test again.</li> <li>4. If the test still fails, the set may be defective. Check the set, and replace it, if necessary.</li> <li>5. Some terminal equipment could fail even when it is connected properly. If this is the case, disable the test using the <b>change station extension</b> command (enter <b>n</b> into the <code>Test?</code> field). Note that this action also disables Tests 6, 7, 161, and 35 on this port.</li> </ol>
	PASS	<p>The station is connected properly to the switch. This test may also pass if no terminal equipment is connected and the terminal is located very far from the switch. User-reported troubles on this port should be investigated by using other port tests, by examining station wiring, or by examining the station.</p>
0	NO BOARD	<p>The test could not relate the internal ID to the port (no board). This could be due to incorrect translations, no board is inserted, an incorrect board is inserted, or an insane board is inserted.</p> <ol style="list-style-type: none"> <li>1. Check to ensure that the board translations are correct. Use the <b>list config</b> command, and resolve any problems.</li> <li>2. If the board was found to be correctly inserted in step 1, issue the <b>busyout board</b> command.</li> <li>3. Issue the <b>reset board</b> command.</li> <li>4. Issue the <b>release busy board</b> command.</li> <li>5. Issue the <b>test board long</b> command. This should re-establish the linkage between the internal ID and the port. If this is not the case, check to ensure that there is a valid board inserted.</li> </ol>

### Looparound Test (#161)

This test checks the on-board transmission capabilities of the NPE, the codec, and the battery feed chip of the analog port. The test passes if the signal measured by the tone detector is within acceptable limits.

**Table 9-25. TEST #161 Looparound Test**

Error Code	Test Result	Description/Recommendation
	ABORT	Could not allocate the necessary system resources to run this test. 1. Retry the command at 1-minute intervals for a maximum of 5 times.
1000	ABORT	System resources required to run this test are not available. The port may be busy with a valid call. 1. Use the <b>display port UUCSSpp</b> command to determine the station extension. 2. Use the <b>status station</b> command to determine the service state of the port. If the port is in use, wait until the port is idle. 3. Retry the command at 1-minute intervals for a maximum of 5 times.
1002	ABORT	The system could not allocate time slots for the test. The system may be under heavy traffic conditions or it may have time slots out-of-service due to TDM-BUS errors. 1. If system has no TDM-BUS errors and is not handling heavy traffic, retry the command at 1-minute intervals for a maximum of 5 times.
1003	ABORT	The system could not allocate a tone receiver for the test. The system may be oversized for the number of tone detectors present or some tone detectors may be out-of-service. 1. Resolve any TTR-LEV errors. 2. Resolve any TONE-PT errors. 3. If neither condition exists, retry the command at 1-minute intervals for a maximum of 5 times.
1004	ABORT	The port was seized by a valid call during the test. The test has been aborted. 1. Use the <b>display port UUCSSpp</b> command to determine the station extension. Use the <b>status station</b> command to determine the service state of the port. If the port is in use, wait until the port is idle. 2. Retry the command at 1-minute intervals for a maximum of 5 times.
1005	ABORT	This test is not run on ports administered as External Alert, Announcement or combined modem pool ports. This error can be ignored.
1018	ABORT	The test has been disabled by administration. The default for the Test? field on the station form is <b>y</b> . Determine why this field has been set to "n" on this station (this may be due to the ringing application Test #48, which can be customer or terminal disturbing). 1. To enable the test for the particular analog station being tested, enter <b>change station extension</b> and set the Test? field on the station to <b>y</b> .

*Continued on next page*

**Table 9-25. TEST #161 Looparound Test — Continued**

Error Code	Test Result	Description/Recommendation
2000	ABORT	Response to the test request was not received within the allowable time period.
2100	ABORT	<p>Could not allocate the necessary system resources to run this test. This could be due to a failure to seize the port.</p> <ol style="list-style-type: none"> <li>1. Retry the command at 1-minute intervals for a maximum of 5 times.</li> </ol>
	FAIL	<p>The reflective loop around test failed. This could cause noisy or unreliable connections, or users calling this port may hear an echo. The problem can also be off-board.</p> <ol style="list-style-type: none"> <li>1. Since the test may be affected by a line seizure, repeat the test at 1-minute intervals for a maximum of 5 times.</li> <li>2. Run circuit pack tests to check the tone generator circuit pack and the tone detector circuit pack by using the <b>test board UUCSS short</b> command.</li> <li>3. Resolve any problems on the tone generator circuit pack or the tone detector circuit pack.</li> <li>4. If the tone generator and tone detector circuit packs are functioning properly and the test still fails and a voice terminal is connected and wired properly, replace the analog line circuit pack.</li> </ol>
	PASS	The port is able to provide an analog transmission path to the station equipment. User-reported troubles on this port should be investigated by using other port tests, by examining station wiring, or by examining the station.
0	NO BOARD	<p>The test could not relate the internal ID to the port (no board). This could be due to incorrect translations, no board is inserted, an incorrect board is inserted, or an insane board is inserted.</p> <ol style="list-style-type: none"> <li>1. Check to ensure that the board translations are correct. Use the <b>list config</b> command, and resolve any problems.</li> <li>2. If the board was found to be correctly inserted in step 1, issue the <b>busyout board</b> command.</li> <li>3. Issue the <b>reset board</b> command.</li> <li>4. Issue the <b>release busy board</b> command.</li> <li>5. Issue the <b>test board long</b> command. This should re-establish the linkage between the internal ID and the port. If this is not the case, check to ensure that there is a valid board inserted.</li> </ol>

## ANL-24-L (24-Port Analog Line)

---

MO Name (in Alarm Log)	Alarm Level	Initial Command to Run <sup>1</sup>	Full Name of MO
ANL-24-L	MIN	test port UUCSSpp l	24-Port Analog Line
ANL-24-L	WRN	test port UUCSSpp sh	24-Port Analog Line

- 
1. UU is the universal cabinet number (1 for PPN, 2 -44 for EPNs); C is the carrier designation (A, B, C, D, or E); SS is the number of the slot in which the circuit pack resides (01 to 21); and pp is the two digit port number (01, 02, ...).
- 

The 24-Port Analog Line circuit pack (TN793) provides 24 ports for voice terminals and supports both on-premises and off-premises analog voice terminals.

No maintenance of the terminal connected to the 24-Port Neon Analog Line circuit pack is performed, except to determine whether or not the terminal is connected. Failures of the neon message waiting lamp power and the common ringing application circuitry are reported as part of common port circuit pack errors. See errors 1281 and 1793 in the "XXX-BD (Common Port Circuit Pack)" section.

### NOTE:

This analog line circuit pack supports analog data modules. When assigned, analog data modules provide access to the Net Pkt (TN794) data ports. To activate an analog data module you must assign the port location on the data form and connect a modem to the port. (The analog data module may be used for connection to a CDR output or other adjuncts as needed.) These ports are tested the same as all other analog ports on the circuit pack.

## Ringling Caused by Maintenance Testing

---

Test #48 may cause some terminal equipment to ring briefly during daily maintenance. If this ringing is disturbing the customer or the terminal equipment, it should be disabled in the Test? field of the **change station** extension form. Be aware that this action also disables Tests #6, 7, 161, and 35.

## Error Log Entries and Test to Clear Values

Table 9-26. 24-Port Analog Line Error Log Entries

Error Type	Aux Data	Associated Test	Alarm Level	On/Off Board	Test to Clear Value
0 <sup>1</sup>	0	Any	Any	Any	test port UUCSSpp sh r 1
1(a)	40960 40975 40977	none			
15(b)	Any	Audits and Updates Test (#36)			
18	0	busy-out station <i>extension</i>	WRN	ON	release station <extension>
130(c)		None	WRN	ON	test port UUCSSpp sh
257(d)	40973	none			
513(e)		Station Present Test (#48)	WRN	OFF	test port UUCSSpp sh r 2
769		Battery Feed Test (#35)	MIN/ WRN <sup>2</sup>	ON	test port UUCSSpp sh r 2
1025		Looparound Test (#161)	MIN/ WRN <sup>2</sup>	ON	test port UUCSSpp l r 2
1281		Conference Test (#7)	MIN/ WRN <sup>2</sup>	ON	test port UUCSSpp l r 2
1537		NPE Crosstalk Test (#6)	MIN/ WRN <sup>2</sup>	ON	test port UUCSSpp l r 2

1. Run the Short Test Sequence first. If all tests pass, run the Long Test Sequence. Refer to the appropriate test description and follow the recommended procedures.
2. Minor alarms on this MO may be downgraded to Warning alarms based on the values used in the **set options** command.

### Notes:

- a. These are in-line errors and can only be resolved over time.

Aux Data 40960 indicates that too many simultaneous incoming ringing attempts were made on this board. Only 4 ports on a board may ring simultaneously. A 5th incoming call will cause an inline error from the board.

Aux Data 40975 indicates that the terminal equipment was on-hook when ring-tip was detected during ringing. This usually indicates a failure in the terminal equipment or the type of terminal has a low ringer impedance.

Call the terminal equipment and verify that the terminal rings. If the terminal does not ring, then replace it. Otherwise, issue the **test port UUCSSpp** command, and follow the procedure for Test #48.

Aux Data 40977 indicates that no terminal equipment was connected when ringing was attempted. Run the short test via the **test port UUCSSpp** command, and follow the procedure for the results of Test #48.

- b. This is a software audit error that does not indicate any hardware malfunction. Run Short Test Sequence and investigate associated errors.
- c. This error type indicates that the circuit pack has been removed or has been insane for more than 11-minutes. To clear the error, reseal or replace the circuit pack.
- d. This is an in-line error and can only be resolved over time. This error indicates that ringing voltage is absent. If only 1 analog circuit pack in the system has this problem, then replace the circuit pack. If only analog circuit packs on a particular carrier have this error, then the ringing generator may not be connected to this carrier. If analog circuit packs on many carriers have this error, then it is probably a problem with the ringing generator.
- e. Test #48 may cause some terminal equipment to ring briefly during daily maintenance. If this disturbs the customer or the terminal equipment, disable it by setting the `Tests` field on the **change station** extension form to `n`. On some software releases, this also disables Tests #6, 7, 161, and 35.

---

## System Technician-Demanded Tests: Descriptions and Error Codes

---

Always investigate tests in the order presented in the table below when inspecting errors in the system. By clearing error codes associated with the *Battery Feed Test*, for example, you may also clear errors generated from other tests in the testing sequence.

Order of Investigation	Short Test Sequence	Long Test Sequence	D/ND <sup>1</sup>
Battery Feed Test (#35)	X	X	ND
Station Present Test (#48)	X	X	ND
Looparound Test (#161)		X	ND
Conference Test (#7)		X	ND
NPE Crosstalk Test (#6)		X	ND
Station Status and Translation Audits and Updates Test (#36)	X	X	ND

1. D = Destructive; ND = Nondestructive

### NPE Crosstalk Test (#6)

This test verifies that this port's NPE channel talks on the selected time slot and never crosses over to time slots reserved for other connections. If the NPE is not working correctly, one-way and noisy connections may be observed. This test is usually part of the long test sequence and takes about 20 to 30 seconds to complete.

Table 9-27. TEST #6 NPE Crosstalk Test

Error Code	Test Result	Description/Recommendation
	ABORT	Could not allocate the necessary system resources to run this test. 1. Retry the command at 1-minute intervals for a maximum of 5 times.
1000	ABORT	System resources required to run test are not available. The port may be busy with a valid call. This result is also reported for the system's Music-On-Hold port when it is off-hook, which it usually is. 1. Enter <b>display port UUCSSpp</b> to determine the station's extension. 2. Enter <b>status station</b> extension to determine the service state of the port. 3. If the port is in use, wait until the port is idle. Retry the command at 1-minute intervals for a maximum of 5 times.
1001	ABORT	System resources required to run test are not available. This could be due to a failure to seize the port. 1. Retry the command at 1-minute intervals for a maximum of 5 times.

*Continued on next page*

**Table 9-27. TEST #6 NPE Crosstalk Test — Continued**

Error Code	Test Result	Description/Recommendation
1002	ABORT	The system could not allocate time slots for the test. The system may be under heavy traffic conditions or have time slots out-of-service due to TDM-BUS errors. <ol style="list-style-type: none"> <li data-bbox="303 426 1043 480">1. If system has no TDM-BUS errors and is not handling heavy traffic, retry the command at 1-minute intervals for a maximum of 5 times.</li> </ol>
1003	ABORT	The system could not allocate a tone receiver for the test. The system may be oversized for the number of tone detectors present or some tone detectors may be out-of-service. <ol style="list-style-type: none"> <li data-bbox="303 598 640 625">1. Resolve any TTR-LEV errors.</li> <li data-bbox="303 639 647 666">2. Resolve any TONE-PT errors.</li> <li data-bbox="303 680 1047 707">3. Retry the command at 1-minute intervals for a maximum of 5 times.</li> </ol>
1004	ABORT	The port was seized by a valid call during the test. <ol style="list-style-type: none"> <li data-bbox="303 766 1050 820">1. Use the <b>display port UUCSSpp</b> command to determine the station extension.</li> <li data-bbox="303 835 1081 888">2. Use the <b>status station</b> command to determine the service state of the port. If the port is in use, wait until the port is idle before testing.</li> <li data-bbox="303 903 1047 930">3. Retry the command at 1-minute intervals for a maximum of 5 times.</li> </ol>
1005	ABORT	The test was aborted due to a configuration problem. This test may not be applicable, or it may be disruptive to terminal equipment other than a voice terminal (for example, the modem pool member or Music On Hold).
1018	ABORT	The test has been disabled by administration. The default for the <code>Test</code> field on the station form is <code>y</code> . Determine why this field has been set to <code>n</code> on this station (this may be due to the ringing application Test #48, that can be customer or terminal disturbing). <ol style="list-style-type: none"> <li data-bbox="303 1179 1063 1232">1. To enable the test for a particular station being tested, enter <b>change station extension</b> and set the <code>Test?</code> field on the station from <code>n</code> to <code>y</code>.</li> </ol>
2000	ABORT	Response to the test request was not received within the allowable time period.
2100	ABORT	System resources required to run test are not available. This could be due to a failure to seize the port. <ol style="list-style-type: none"> <li data-bbox="303 1387 1047 1413">1. Retry the command at 1-minute intervals for a maximum of 5 times.</li> </ol>

*Continued on next page*



**Table 9-27. TEST #6 NPE Crosstalk Test — Continued**

Error Code	Test Result	Description/Recommendation
Any	FAIL	<p>This test can fail due to on-board or off-board problems. Off-board problems include EXP-PN and EXP-INTF faults, TDM-BUS faults, and faults associated with the tone detectors/tone generators. Clear all off-board problems before replacing the board. A TDM-BUS problem is usually the result of a faulty board connected to the backplane, or bent pins on the backplane.</p> <ol style="list-style-type: none"> <li>1. Resolve any EXP-PN or EXP-INTF errors.</li> <li>2. Resolve any TDM-BUS.</li> <li>3. Resolve any TONE-BD or TONE-PT errors.</li> <li>4. Test the board when the faults from Steps 1, 2, and 3 are cleared. Replace the board only if the test fails.</li> </ol>
	PASS	<p>The port is correctly using its allocated time slots. User-reported troubles on this port should be investigated by using other port tests, by examining station wiring, or by examining the station.</p>
0	NO BOARD	<p>The test could not relate the internal ID to the port (no board). This could be due to incorrect translations, no board is inserted, an incorrect board is inserted, or an insane board is inserted.</p> <ol style="list-style-type: none"> <li>1. Check to ensure that the board translations are correct. Use the <b>list config</b> command, and resolve any problems.</li> <li>2. If the board was found to be correctly inserted in step 1, issue the <b>busyout board</b> command.</li> <li>3. Issue the <b>reset board</b> command.</li> <li>4. Issue the <b>release busy board</b> command.</li> <li>5. Issue the <b>test board long</b> command. This should re-establish the linkage between the internal ID and the port. If this is not the case, check to ensure that there is a valid board inserted.</li> </ol>

### Conference Circuit Test (#7)

This test verifies that the NPE channel for the port being tested can correctly perform the conferencing function.

**Table 9-28. TEST #7 Conference Circuit Test**

Error Code	Test Result	Description/Recommendation
	ABORT	Could not allocate the necessary system resources to run this test. 1. Retry the command at 1-minute intervals for a maximum of 5 times.
1000	ABORT	System resources required to run this test are not available. The port may be busy with a valid call. This result is also reported for the system's Music-On-Hold port when it is off-hook, which it usually is. 1. Enter <b>display port UUCSSpp</b> to determine the station's extension. 2. Enter <b>status station</b> extension to determine the service state of the port. 3. If the port is in use, wait until the port is idle and retry the command at 1-minute intervals for a maximum of 5 times.
1004	ABORT	The port was seized by a valid call during the test. The test has been aborted. 1. Use the <b>display port UUCSSpp</b> command to determine the station extension. 2. Use the <b>status station</b> command to determine the service state of the port. 3. If the port is in use, wait until the port is idle and retry the command at 1-minute intervals for a maximum of 5 times.
1005	ABORT	The test was aborted due to a configuration problem. This test may not be applicable, or it may be disruptive to terminal equipment other than a voice terminal (for example, the modem pool member or Music On Hold).
1018	ABORT	The test has been disabled via administration. The default for the <code>Test</code> field on the station form is <code>y</code> . Determine why this field has been set to <code>n</code> on this station (this may be due to the ringing application Test #48, that can be customer or terminal disturbing). 1. To enable the test for a particular station being tested, enter <b>change station extension</b> and set the <code>Test?</code> field on the station from <code>n</code> to <code>y</code> .
2000	ABORT	Response to the test request was not received within the allowable time period.
2100	ABORT	System resources required to run this test are not available. 1. Resolve TONE-PT errors. 2. Retry the command at 1-minute intervals for a maximum of 5 times.

*Continued on next page*

**Table 9-28. TEST #7 Conference Circuit Test — Continued**

Error Code	Test Result	Description/Recommendation
Any	FAIL	<p>The NPE of the tested port did not conference the tones correctly. This will cause noisy and unreliable connections.</p> <ol style="list-style-type: none"> <li>1. Issue the <b>display port</b> and the <b>status station</b> commands to determine if the station is idle. If the station is idle, issue the <b>test port</b> command for this port.</li> <li>2. If the test continues to fail, issue the <b>busyout port</b> and the <b>release port</b> commands, and then retest.</li> <li>3. If the test still fails, replace the board.</li> </ol>
	PASS	<p>The port can correctly conference multiple connections. User-reported troubles on this port should be investigated by using other port tests and by examining station, trunk, or external wiring.</p>
0	NO BOARD	<p>The test could not relate the internal ID to the port (no board). This could be due to incorrect translations, no board is inserted, an incorrect board is inserted, or an insane board is inserted.</p> <ol style="list-style-type: none"> <li>1. Check to ensure that the board translations are correct. Use the <b>list config</b> command, and resolve any problems.</li> <li>2. If the board was found to be correctly inserted in step 1, issue the <b>busyout board</b> command.</li> <li>3. Issue the <b>reset board</b> command.</li> <li>4. Issue the <b>release busy board</b> command.</li> <li>5. Issue the <b>test board long</b> command. This should re-establish the linkage between the internal ID and the port. If this is not the case, check to ensure that there is a valid board inserted.</li> </ol>

### Battery Feed Test (also called Port Diagnostic Test) (#35)

The battery feed chip provides power to the telephone equipment, signaling, rotary dial pulsing, transmission, and balance. This test checks the signaling and switchhook capabilities of the battery feed chip by terminating the port, applying battery and detecting the resulting current.

For the TN746B, Test #35 does not actually run and instead always returns PASS. Test #35 operates in the normal manner for TN746.

**Table 9-29. TEST #35 Battery Feed Test**

Error Code	Test Result	Description/Recommendation
	ABORT	Could not allocate the necessary system resources to run this test. 1. Retry the command at 1-minute intervals for a maximum of 5 times.
1000	ABORT	System resources required to run this test are not available. The port may be busy with a valid call. This result is also reported for the system's Music-On-Hold port when it is off-hook, which it usually is.
1004	ABORT	The port was seized by a valid call during the test. The test has been aborted. 1. Use the <b>display port UUCSSpp</b> command to determine the station extension. 2. Use the <b>status station</b> command to determine the service state of the port. 3. If the port is in use, wait until the port is idle and retry the command at 1-minute intervals for a maximum of 5 times.
1005	ABORT	The test was aborted due to a configuration problem. This test may not be applicable, or it may be disruptive to terminal equipment other than a voice terminal (for example, the modem pool member or Music On Hold).
1018	ABORT	The test has been disabled via administration. The default for the <code>Test</code> field on the station form is <b>y</b> . Determine why this field has been set to <b>n</b> on this station (this may be due to the ringing application test 48, that can be customer or terminal disturbing). 1. To enable the test for a particular station being tested, enter <b>change station extension</b> and set the <code>Test?</code> field on the station from <b>n</b> to <b>y</b> .
1392	ABORT	This port is currently a TTI port and the test will not execute on it. 1. Verify that the port is a TTI port using either the <b>display port</b> command (the display shows that the port is a TTI port) or the <b>list config</b> command (the display shows a <b>t</b> for the port). 2. If the port is <i>not</i> a TTI port, escalate the problem. If both commands indicate that the port is a TTI port, the abort is correct for the test, and no action is necessary.
2000	ABORT	Response to the test request was not received within the allowable time period.
2100	ABORT	Could not allocate the necessary system resources to run this test. 1. Retry the command at 1-minute intervals for a maximum of 5 times.

*Continued on next page*

**Table 9-29. TEST #35 Battery Feed Test — Continued**

Error Code	Test Result	Description/Recommendation
	FAIL	<p>The port's battery feed chip is unable to supply sufficient power to the terminal equipment. This could be a marginal test, and the terminal equipment may be operating satisfactorily.</p> <ol style="list-style-type: none"> <li>1. Retry the command at 1-minute intervals for a maximum of 5 times.</li> <li>2. If the test continues to fail, determine whether the customer is experiencing problems on this line. Replace the circuit pack only if the customer is experiencing problems.</li> </ol>
	PASS	<p>The port's battery feed chip is able to provide power to the station equipment to detect on-/off-hook, but may not be able to supply power for touch-tones. If touch-tones are inoperative on this station, then replace the circuit pack because this port is inoperative. User-reported troubles on this port should be investigated by using other port tests, by examining station wiring, or by examining the station.</p>
0	NO BOARD	<p>The test could not relate the internal ID to the port (no board). This could be due to incorrect translations, no board is inserted, an incorrect board is inserted, or an insane board is inserted.</p> <ol style="list-style-type: none"> <li>1. Check to ensure that the board translations are correct. Use the <b>list config</b> command, and resolve any problems.</li> <li>2. If the board was found to be correctly inserted in step 1, issue the <b>busyout board</b> command.</li> <li>3. Issue the <b>reset board</b> command.</li> <li>4. Issue the <b>release busy board</b> command.</li> <li>5. Issue the <b>test board long</b> command. This should re-establish the linkage between the internal ID and the port. If this is not the case, check to ensure that there is a valid board inserted.</li> </ol>

### Station Status and Translation Audits and Updates Test (#36)

This test updates the analog port's message lamp state (if it has one) and translations with information in the software.

**Table 9-30. Test #36 Station Status and Translation Audits and Updates**

Error Code	Test Result	Description/ Recommendation
	ABORT	Could not allocate the necessary system resources to run this test. 1. Retry the command at 1-minute intervals for a maximum of 5 times.
1004	ABORT	The port was seized by a valid call during the test. The test has been aborted. 1. Use the <b>display port UUCSSpp</b> command to determine the station extension. 2. Use the <b>status station</b> command to determine the service state of the port. 3. If the port is in use, wait until port is idle and retry the command at 1-minute intervals for a maximum of 5 times.
1005	ABORT	The test was aborted due to a configuration problem. This test may not be applicable, or it may be disruptive to terminal equipment other than a voice terminal (for example, the modem pool member or Music On Hold).
1006	ABORT	This port has been busied out by command, or taken out-of-service by the failure of the NPE Crosstalk Test. 1. Look in the Error Log for error type 18 (port busied out) for this port. If this error is present, release the port with the <b>release station extension</b> command, and run the test again. 2. Check the Error Log for error type 1025 (NPE crosstalk test failed) for this port. If this error is present, investigate the errors associated with the NPE Crosstalk Test #6. 3. Make sure that the terminal is connected and in service, and then retest.
2000	ABORT	Response to the test request was not received within the allowable time period.
2100	ABORT	Could not allocate the necessary system resources to run this test. 1. Retry the command at 1-minute intervals for a maximum of 5 times.
1	FAIL	This does not indicate a hardware problem. The switchhook audit failed. The other updates were not performed because of this failure. This may occur when the audit is performed at the same time the terminal equipment goes off-hook. 1. Use the <b>status station</b> command to determine when the port is available and retry the command at 1-minute intervals for a maximum of 5 times.

*Continued on next page*

**Table 9-30. Test #36 Station Status and Translation Audits and Updates — Continued**

Error Code	Test Result	Description/ Recommendation
5	FAIL	This may be an internal software error. The message waiting lamp update failed. The translation and ringer updates were not performed because of this failure.
7	FAIL	The translation update failed. There may be an internal software error. The ringer update was not performed because of this failure.
8	FAIL	This does not indicate a hardware problem. There may be an internal software error. The ringer update failed.  1. Retry the command at 1-minute intervals for a maximum of 5 times.
	PASS	The software and the port processor have the same status. User-reported troubles on this port should be investigated by using other port tests, by examining station wiring, or by examining the station.
0	NO BOARD	The test could not relate the internal ID to the port (no board). This could be due to incorrect translations, no board is inserted, an incorrect board is inserted, or an insane board is inserted.  1. Check to ensure the board translations are correct. Use the <b>list config</b> command and resolve problems.  2. If the board was found to be correctly inserted in step 1, issue the <b>busyout board</b> command.  3. Issue the <b>reset board</b> command.  4. Issue the <b>release busy board</b> command.  5. Issue the <b>test board long</b> command. This should re-establish the linkage between the internal ID and the port. If this is not the case, check to ensure that there is a valid board inserted.

### Station Present Test (also called Ringing Application Test) (#48)

This test applies momentary ringing voltage to the terminal equipment and monitors resulting current flow to determine whether terminal equipment is connected to the port. This test may cause some terminal equipment to ring briefly during daily maintenance. If this ringing disturbs the customer or the terminal equipment, you can disable it via the Tests field on the **change station** form. However, on some software releases, Tests #6, 7, 161, and 35 are disabled.

**Table 9-31. TEST #48 Station Present Test**

Error Code	Test Result	Description/Recommendation
	ABORT	Could not allocate the necessary system resources to run this test. 1. Retry the command at 1-minute intervals for a maximum of 5 times.
1000 1004	ABORT ABORT	System resources required to run this test are not available. The port may be busy with a valid call.  The port was seized by a valid call during the test. The test has been aborted.  1. Use the <b>display port UUCSSpp</b> command to determine the station extension.  2. Use the <b>status station</b> command to determine the service state of the port.  3. If the port is in use, wait until the port is idle and retry the command at 1-minute intervals for a maximum of 5 times.
1005	ABORT	The test was aborted due to a configuration problem. This test may not be applicable or it may be disruptive to terminal equipment other than a voice terminal (for example, the modem pool member or Music On Hold).
1008	ABORT	Could not allocate a ringing circuit. Either all the ringing circuits are in use or the ringing generator is defective or it is not wired correctly.  1. Retry the command at 1-minute intervals for a maximum of 5 times.  2. If the test continues to abort, look for RING-GEN errors in the Error Log. If an ABORT 1008 occurs for this test on other circuit packs as well, then the ringing generator may be defective or is not wired correctly (see errors for RING-GEN). If it does not occur on other ports, then all four ring phases are in use.
1018	ABORT	The test has been disabled by administration. The default for the <code>Test</code> field on the station form is <b>y</b> . Determine why this field has been set to <b>n</b> on this station (this may be due to the brief ringing disturbance that this test may cause).  1. To enable the test for a particular station being tested, enter <b>change station extension</b> and set the <code>Test?</code> field on the station from <b>n</b> to <b>y</b> .
2000	ABORT	Response to the test request was not received within the allowable time period.
2100	ABORT	Could not allocate necessary system resources to run this test.  1. Retry the command at 1-minute intervals for a maximum of 5 times.

*Continued on next page*



**Table 9-31. TEST #48 Station Present Test — Continued**

Error Code	Test Result	Description/Recommendation
	FAIL	<p>The terminal equipment is not connected to the circuit pack. Some terminal equipment, such as modems, may fail even when connected properly.</p> <ol style="list-style-type: none"> <li>1. Remotely test the equipment.</li> <li>2. If the test fails again, look for RING-GEN errors in the error log. If present, refer to "RING-GEN".</li> <li>3. Check all of the wiring between the station equipment and the switch. Refer to "<a href="#">LA85 Port Tester</a>" in <a href="#">Chapter 5</a> for instructions on using the port tester. Then, run the test again.</li> <li>4. If the test still fails, the set may be defective. Check the set, and replace it, if necessary.</li> <li>5. Some terminal equipment could fail even when it is connected properly. If this is the case, disable the test using the <b>change station extension</b> command (enter <b>n</b> into the <code>Test</code> field). Note that this action also disables Tests 6, 7, 161, and 35 on this port.</li> </ol>
	PASS	<p>The station is connected properly to the switch. This test may also pass if no terminal equipment is connected and the terminal is located very far from the switch. User-reported troubles on this port should be investigated by using other port tests, by examining station wiring, or by examining the station.</p>
0	NO BOARD	<p>The test could not relate the internal ID to the port (no board). This could be due to incorrect translations, no board is inserted, an incorrect board is inserted, or an insane board is inserted.</p> <ol style="list-style-type: none"> <li>1. Check to ensure that the board translations are correct. Use the <b>list config</b> command, and resolve any problems.</li> <li>2. If the board was found to be correctly inserted in step 1, issue the <b>busyout board</b> command.</li> <li>3. Issue the <b>reset board</b> command.</li> <li>4. Issue the <b>release busy board</b> command.</li> <li>5. Issue the <b>test board long</b> command. This should re-establish the linkage between the internal ID and the port. If this is not the case, check to ensure that there is a valid board inserted.</li> </ol>

### Looparound Test (#161)

This test checks the on-board transmission capabilities of the NPE, the codec, and the battery feed chip of the analog port. The test passes if the signal measured by the tone detector is within acceptable limits.

**Table 9-32. TEST #161 Looparound Test**

Error Code	Test Result	Description/Recommendation
	ABORT	Could not allocate the necessary system resources to run this test. 1. Retry the command at 1-minute intervals for a maximum of 5 times.
1000	ABORT	System resources required to run this test are not available. The port may be busy with a valid call. 1. Use the <b>display port UUCSSpp</b> command to determine the station extension. 2. Use the <b>status station</b> command to determine the service state of the port. 3. If the port is in use, wait until the port is idle and retry the command at 1-minute intervals for a maximum of 5 times.
1002	ABORT	The system could not allocate time slots for the test. The system may be under heavy traffic conditions or it may have time slots out-of-service due to TDM-BUS errors. 1. If system has no TDM-BUS errors and is not handling heavy traffic, retry the command at 1-minute intervals for a maximum of 5 times.
1003	ABORT	The system could not allocate a tone receiver for the test. The system may be oversized for the number of tone detectors present or some tone detectors may be out-of-service. 1. Resolve any TTR-LEV errors. 2. Resolve any TONE-PT errors. 3. If neither condition exists, retry the command at 1-minute intervals for a maximum of 5 times.
1004	ABORT	The port was seized by a valid call during the test. The test has been aborted. 1. Use the <b>display port UUCSSpp</b> command to determine the station extension. 2. Use the <b>status station</b> command to determine the service state of the port. 3. If the port is in use, wait until the port is idle and retry the command at 1-minute intervals for a maximum of 5 times.
1005	ABORT	This test is not run on ports administered as External Alert, Announcement or combined modem pool ports. This error can be ignored.
1018	ABORT	The test has been disabled by administration. The default for the <code>Test</code> field on the station form is <code>y</code> . Determine why this field has been set to <code>n</code> on this station (this may be due to the ringing application test 48, that can be customer or terminal disturbing). 1. To enable the test for a particular station being tested, enter <b>change station extension</b> and set the <code>Test?</code> field on the station from <code>n</code> to <code>y</code> .

**Table 9-32. TEST #161 Looparound Test — Continued**

Error Code	Test Result	Description/Recommendation
2000	ABORT	Response to the test request was not received within the allowable time period.
2100	ABORT	<p>Could not allocate the necessary system resources to run this test. This could be due to a failure to seize the port.</p> <ol style="list-style-type: none"> <li>1. Retry the command at 1-minute intervals for a maximum of 5 times.</li> </ol>
	FAIL	<p>The reflective loop around test failed. This could cause noisy or unreliable connections, or users calling this port may hear an echo. The problem can also be off-board.</p> <ol style="list-style-type: none"> <li>1. Since the test may be affected by a line seizure, repeat the test at 1-minute intervals for a maximum of 5 times.</li> <li>2. Run circuit pack tests to check the tone generator circuit pack and the tone detector circuit pack by using the <b>test board UUCSS short</b> command.</li> <li>3. Resolve any problems on the tone generator circuit pack or the tone detector circuit pack.</li> <li>4. If the tone generator and tone detector circuit packs are functioning properly and the test still fails and a voice terminal is connected and wired properly, replace the analog line circuit pack.</li> </ol>
	PASS	<p>The port is able to provide an analog transmission path to the station equipment. User-reported troubles on this port should be investigated by using other port tests, by examining station wiring, or by examining the station. Refer to "<a href="#">LA85 Port Tester</a>" in <a href="#">Chapter 5</a> for instructions on using the port tester.</p>
0	NO BOARD	<p>The test could not relate the internal ID to the port (no board). This could be due to incorrect translations, no board is inserted, an incorrect board is inserted, or an insane board is inserted.</p> <ol style="list-style-type: none"> <li>1. Check to ensure that the board translations are correct. Use the <b>list config</b> command and resolve any problems.</li> <li>2. If the board was found to be correctly inserted in step 1, issue the <b>busyout board</b> command.</li> <li>3. Issue the <b>reset board</b> command.</li> <li>4. Issue the <b>release busy board</b> command.</li> <li>5. Issue the <b>test board long</b> command. This should re-establish the linkage between the internal ID and the port. If this is not the case, check to ensure that there is a valid board inserted.</li> </ol>

## **ANL-BD (Analog Line Circuit Pack)**

---

<b>MO Name (in Alarm Log)</b>	<b>Alarm Level</b>	<b>Initial Command to Run<sup>1</sup></b>	<b>Full Name Of MO</b>
ANL-BD	MIN/WRN	test board UUCSS sh	16-Port Neon Analog Line Circuit Pack

- 
1. UU is the universal cabinet number (1 for PPN, 2 - 44 for EPNs). C is the carrier designation (A, B, C, D, or E). SS is the number of the slot in which the circuit pack resides (01 to 21).
- 

Refer to "XXX-BD (Common Port Circuit Pack)" for circuit pack level errors. See also ANL-16-L (16-Port Neon Analog Line) maintenance information for related line information.

## ANL-LINE, ANL-NE-L (8-Port Analog Line)

MO Name (in Alarm Log)	Alarm Level	Initial Command To Run <sup>1</sup>	Full Name of MO
ANL-LINE	MIN	test port UUCSSpp l	8-Port Analog Line
ANL-LINE	WRN	test port UUCSSpp sh	8-Port Analog Line
ANL-NE-L	MIN	test port UUCSSpp l	8-Port Neon Analog Line
ANL-NE-L	WRN	test port UUCSSpp sh	8-Port Neon Analog Line

1. UU is the universal cabinet number (1 for PPN, 2 -44 for EPNs). C is the carrier designation (A, B, C, D, or E). SS is the number of the slot in which the circuit pack resides (01 to 21). pp is the two digit port number (01, 02, ...).

The 8-port Analog Line circuit packs,

TN712 TN467 [G3r V2] TN411 [G3rV2]

TN742 TN443 [G3r V2]

TN769 TN443 [G3r V2]

each provide eight ports for single-line, on or off-premises analog endpoints such as analog voice terminals, queue warning level lamps, recorded announcements, dictation machines, PAGEPAC paging equipment, external alerting devices, modems, fax machines, and AUDIX voice ports. Only the TN769 supports a neon message waiting lamp.<sup>1</sup>

Test #48 may cause some terminal equipment to ring briefly during daily maintenance, which may disturb the customer or the terminal equipment. Test #47 may cause a false alarm when the port is connected to certain off-premises equipment, non-voice terminal equipment, or loop equipment. In either case, the tests can be disabled by entering **n** in the "Tests" field on the **change station <extension>** form. Be aware that this will disable Tests 6, 35, 47 and 48.

No maintenance of the terminal connected to the 8-Port Analog Line circuit pack or 8-Port Neon Analog Line circuit pack is performed, except to determine whether or not the terminal is connected. Failures of the common ringing application circuitry and the neon message waiting lamp power (ANL-NE-L only) are reported as errors 1281 and 1793 against XXX-BD (Common Port Circuit Pack).

## Hardware Error Log Entries and Test to Clear Values

### 8-Port Analog Line Error Log Entries

Error Type	Aux Data	Associated Test	Alarm Level	On/Off Board	Test to Clear Value
0 <sup>1</sup>	0	Any	Any	Any	test port UUCSSpp sh r 1
1 (a)	40960 40977 40975	None			
15 (b)	Any	Audits and Updates Test (#36)			
18	0	busy-out station <i>extension</i>	WARNING	OFF	release station <i>extension</i>
130 (c)		None	WARNING	ON	test port UUCSSpp sh
257 (d)		Station Present Test (#48)	WARNING	OFF	test port UUCSSpp sh r 3
513		Battery Feed Test (#35)	MIN/WRN <sup>2</sup>	ON	test port UUCSSpp sh r 2
769 (e)		Loop Around and Conference Test (#47)			test port UUCSSpp l r 3
1025		NPE Crosstalk Test (#6)	MIN/WRN <sup>2</sup>	ON	test port UUCSSpp l r 3
1281 (f)					
1793 (f)					

1. Run the Short Test Sequence first. If all tests pass, run the Long Test Sequence. Refer to the appropriate test description and follow the recommended procedures.
2. Minor alarms on this MO may be downgraded to Warning alarms based on the values used in the **set options** command.

#### Notes:

- a. These are in-line errors that can only be resolved over time.

Aux Data 40960 Indicates that too many simultaneous incoming ringing attempts were made on this board. Only 4 ports on a board may ring simultaneously. A 5th incoming call will cause an inline error from the board.

Aux Data 40975 indicates that the terminal equipment was on-hook when ring-tip was detected during ringing. This usually indicates a failure in the terminal equipment or the type of terminal has a low ringer impedance. Call the terminal equipment and verify that the terminal rings. If the terminal doesn't ring, then replace it. Otherwise, issue the **test port UUCSSpp** command, and follow the procedure for Test #48.

Aux Data 40977 indicates that no terminal equipment was connected when ringing was attempted. Run the short test via the **test port UUCSSpp** command, and follow the procedure for the results of Test #48.

- b. This is a software audit error that does not indicate any hardware malfunction. Run Short Test Sequence and investigate errors (if any).
- c. This error type indicates that the circuit pack has been removed or has been insane for more than 11-minutes. To clear the error, reinsert or replace the circuit pack.
- d. Test #48 may cause some terminal equipment to ring briefly during daily maintenance. If this ringing is disturbing the customer or the terminal equipment, it should be disabled via the **change station** extension command. However, on some releases of the software, this will disable Tests #6, 47, and 35 as well as Test #48.
- e. Test #47 may cause a false alarm when the port is connected to off-premises equipment, some non-voice terminal equipment, and some loop equipment. If this causes a false alarm, then disable the test by changing the Tests field of the **change station** command to "no."
- f. Refer to "XXX-BD (Common Port Circuit Pack)" Maintenance documentation.

## System Technician-Demanded Tests: Descriptions and Error Codes

Always investigate tests in the order presented in the table below when inspecting errors in the system. By clearing error codes associated with the *Battery Feed Test*, for example, you may also clear errors generated from other tests in the testing sequence.

Order of Investigation	Short Test Sequence	Long Test Sequence	D/ND <sup>1</sup>
Battery Feed Test (#35)	X	X	ND
Station Present Test (#48)	X	X	ND
NPE Crosstalk Test (#6)		X	ND
Loop Around and Conference Test (#47)		X	ND
Station Status and Translation Audits and Updates Test (#36)	X	X	ND

1. D = Destructive; ND = Nondestructive

## NPE Crosstalk Test (#6)

One or more Network Processing Elements (NPEs) reside on each circuit pack with a TDM Bus interface. The NPE controls port connectivity and gain, and provides conferencing functions on a per-port basis. The NPE Crosstalk Test verifies that this port's NPE channel talks on the selected time slot and never crosses over to time slots reserved for other connections. If the NPE is not working correctly, one-way and noisy connections may be observed. This test is usually only part of a port's Long Test Sequence and takes about 20 to 30 seconds to complete

**Table 9-33. TEST #6 NPE Crosstalk Test**

Error Code	Test Result	Description/ Recommendation
1000	ABORT	System resources required to run this test are not available. The port may be busy with a valid call. This result is also reported for the system's Music-on-Hold port when it is off-hook, which it usually is. <ol style="list-style-type: none"> <li>1. Enter <b>display port UUCSSpp</b> to determine the station's extension. Enter <b>status station</b> extension to determine the service state of the port. If the port is in use, it will be unavailable for certain tests. Wait until the port is idle before retesting.</li> <li>2. When the port is idle, retry the command at 1-minute intervals up to 5 times.</li> </ol>
1001	ABORT	Could not allocate the necessary system resources to run this test. <ol style="list-style-type: none"> <li>1. Retry the command at 1-minute intervals for a maximum of 5 times.</li> </ol>
1002	ABORT	The system could not allocate time slots for the test. The system may be under heavy traffic conditions or it may have time slots out-of-service due to TDM-BUS errors. <ol style="list-style-type: none"> <li>1. If system has no TDM-BUS errors and is not handling heavy traffic, repeat test at 1-minute intervals for a maximum of 5 times.</li> <li>2. If the test continues to abort, escalate the problem.</li> </ol>
1003	ABORT	The system could not allocate a tone receiver for the test. The system may be oversized for the number of Tone Detectors present or some Tone Detectors may be out-of-service. <ol style="list-style-type: none"> <li>1. Resolve TTR-LEV errors.</li> <li>2. Resolve TONE-PT errors.</li> <li>3. Retry the test at 1-minute intervals for a maximum of 5 times.</li> </ol>

*Continued on next page*



**Table 9-33. TEST #6 NPE Crosstalk Test — Continued**

Error Code	Test Result	Description/ Recommendation
1004	ABORT	<p>The port was seized by a valid call during the test. The test has been aborted.</p> <ol style="list-style-type: none"> <li>1. Use the <b>display port UUCSSpp</b> command to determine the station extension. Use the <b>status station</b> command to determine the service state of the port. If the service state indicates that the port is in use, then the port is unavailable for certain tests. You must wait until the port is idle before retesting.</li> <li>2. Retry the command at 1-minute intervals for a maximum of 5 times.</li> <li>3. If the test continues to abort and the port is not in use, escalate the problem.</li> </ol>
1005	ABORT	<p>The test was aborted due to a configuration problem. This code will result under either of the following conditions:</p> <ol style="list-style-type: none"> <li>1. This test may not be applicable, or it may be disruptive to terminal equipment other than a voice terminal (for example, the modem pool member or music on hold).</li> <li>2. The circuit pack is one of the following:                         <ul style="list-style-type: none"> <li>— TN742 vintages 13,14 and 15</li> <li>— TN769 vintages 3,4 and 5</li> </ul> </li> </ol>
1018	ABORT	<p>Test disabled via administration. The default for the Test? field on the station form is <b>y</b>; thus, you may want to determine why this field has been set to 'n' on this station (this may be due to the ringing application test 48, which can be customer or terminal disturbing).</p> <ol style="list-style-type: none"> <li>1. To enable the test for a particular station, enter <b>change station extension</b> and set the Test? field to <b>y</b>.</li> </ol>
1020	ABORT	<p>The test did not run due to a previously existing error on the specific port or a more general circuit pack error.</p> <ol style="list-style-type: none"> <li>1. Examine Error Log for existing errors against this port or the circuit pack and attempt to diagnose the previously existing error.</li> </ol>
2000	ABORT	<p>Response to the test request was not received within the allowable time period.</p>
2100	ABORT	<p>System resources required to run this test are not available. Either a system allocation to get information about the port or to put the port into a service state failed or the attempt to put the port in connection with a tone source failed (this could be a tone-clock problem). The tone-clock and tone detectors could be having a communication problem, for example, the companding modes could be out of synchronization.</p> <ol style="list-style-type: none"> <li>1. Retry the command at 1-minute intervals for a maximum of 5 times.</li> </ol>

*Continued on next page*

Table 9-33. TEST #6 NPE Crosstalk Test — Continued

Error Code	Test Result	Description/ Recommendation
Any	FAIL	<p>This test can fail due to on-board or off-board problems. Off-board problems of concern include EXP-PN and EXP-INTF faults, TDM-BUS faults, and faults associated with the tone detectors/tone generators. Clear all off-board problems before replacing the board. Keep in mind that a TDM-BUS problem is usually the result of a faulty board connected to the backplane or bent pins on the backplane.</p> <ol style="list-style-type: none"> <li>1. Resolve EXP-PN or EXP-INTF errors.</li> <li>2. Resolve TDM-BUS errors.</li> <li>3. Resolve TONE-BD or TONE-PT errors.</li> <li>4. Test the board when the faults from steps 1, 2, and 3 are cleared. Replace the board only if the test fails.</li> </ol>
	PASS	<p>The port is correctly using its allocated time slots. User-reported troubles on this port should be investigated by using other port tests, by examining station wiring, by examining the station, and by ensuring that the terminal is correctly translated as off-premises or on-premises.</p> <p> <b>NOTE:</b>                      This test always passes for circuit packs TN712 prior to Vintage 14 and TN742 prior to Vintage 6.</p>
0	NO BOARD	<p>The test could not relate the internal ID to the port (no board). This could be due to incorrect translations, no board is inserted, an incorrect board is inserted, or an insane board is inserted.</p> <ol style="list-style-type: none"> <li>1. Check to ensure that the board translations are correct. Use the <b>list config</b> command, and resolve any problems that are found.</li> <li>2. If the board was found to be correctly inserted in step 1, issue the <b>busyout board</b> command.</li> <li>3. Issue the <b>reset board</b> command.</li> <li>4. Issue the <b>release busy board</b> command.</li> <li>5. Issue the <b>test board long</b> command. This should re-establish the linkage between the internal ID and the port. If this is not the case, dispatch to check to ensure that there is a valid board inserted.</li> </ol>

## Battery Feed Test (also called Port Diagnostic Test) (#35)

The battery feed chip provides power to the telephone equipment, signaling, rotary dial pulsing, transmission, and balance. This test checks the signaling and switchhook capabilities of the battery feed chip by terminating the port, applying battery, and trying to detect a current.

**Table 9-34. TEST #35 Battery Feed Test Results**

Error Code	Test Result	Description/ Recommendation
	ABORT	Could not allocate the necessary system resources to run this test. <ol style="list-style-type: none"> <li>1. Retry the command at 1-minute intervals for a maximum of 5 times.</li> </ol>
1000	ABORT	System resources required to run this test are not available. The port may be busy with a valid call. This result is also reported for the system's Music-on-Hold port when it is off-hook, which it usually is. <ol style="list-style-type: none"> <li>1. Enter <b>display port UUCSSpp</b> to determine the station's extension. Enter <b>status station</b> extension to determine the service state of the port. If the port is in use, it will be unavailable for certain tests. Wait until the port is idle before retesting.</li> <li>2. When the port is idle, retry the command at 1-minute intervals up to 5 times.</li> </ol>
1004	ABORT	System resources required to run this test are not available. The port may be busy with a valid call. <ol style="list-style-type: none"> <li>1. Use the <b>display port UUCSSpp</b> command to determine the station extension. Use the <b>status station</b> command to determine the service state of the port. If the service state indicates that the port is in use, then the port is unavailable for certain tests. (Refer to <a href="#">Chapter 8, "Maintenance Commands"</a>, for a full description of all possible states.) You must wait until the port is idle before retesting.</li> <li>2. Retry the command at 1-minute intervals for a maximum of 5 times.</li> <li>3. If the test continues to abort and the port is not in use, escalate the problem.</li> </ol>
1005	ABORT	The test was aborted due to a configuration problem. This code results under either of the following conditions: <ol style="list-style-type: none"> <li>1. This test may not be applicable, or it may be disruptive to terminal equipment other than a voice terminal (for example, the modem pool member or music on hold).</li> <li>2. The circuit pack is one of the following:                             <ul style="list-style-type: none"> <li>— TN742 vintages 13,14 and 15</li> <li>— TN769 vintages 3,4 and 5</li> </ul> </li> </ol>

**Table 9-34. TEST #35 Battery Feed Test Results — Continued**

Error Code	Test Result	Description/ Recommendation
1018	ABORT	Test disabled via administration. The default for the <code>Test?</code> field on the <code>y</code> ; thus, you may want to determine why this field has been set to "n" on this station (this may be due to the ringing application Test E48, which can be customer or terminal disturbing). <ol style="list-style-type: none"> <li>To enable the test for a particular station, enter <b>change station extension</b> and set the <code>Test?</code> field to <code>y</code>.</li> </ol>
1392	ABORT	This port is currently a TTI port and the test will not execute on it. <ol style="list-style-type: none"> <li>Verify that the port is a TTI port using either the <b>display port</b> command (the display shows that the port is a TTI port) or the <b>list config</b> command (the display shows a <code>t</code> for the port).</li> <li>If either <b>list config</b> or <b>display port</b> indicate that the port is <i>not</i> a TTI port, escalate the problem. If both commands indicate that the port is a TTI port, the abort is correct for the test, and no action is necessary.</li> </ol>
2000	ABORT	Response to the test request was not received within the allowable time period.
2100	ABORT	System resources required to run this test are not available. Either a system allocation to get information about the port or to put the port into a service state failed or the attempt to put the port in connection with a tone source failed (this could be a tone-clock problem). The tone-clock and tone detectors could be having a communication problem, for example, the companding modes could be out of synchronization. <ol style="list-style-type: none"> <li>Retry the command at 1-minute intervals for a maximum of 5 times.</li> </ol>
	FAIL	The port's battery feed chip is unable to supply sufficient power to the terminal equipment. This may occur when the test is performed at the same time that the terminal equipment goes off-hook. <ol style="list-style-type: none"> <li>Use <b>status station</b> to determine when the port is available for testing. When the port becomes available for testing, retry the command at 1-minute intervals a minimum of five times.</li> <li>If the test continues to fail, determine whether the customer is experiencing problems on this line. Replace the circuit pack only if the customer is experiencing problems.</li> </ol>

*Continued on next page*

**Table 9-34. TEST #35 Battery Feed Test Results — Continued**

Error Code	Test Result	Description/ Recommendation
	PASS	<p>The port's battery feed chip is able to provide power to the station equipment to detect on-/off-hook. However, the battery feed chip may still be unable to provide power for touch-tones. If tones are heard when buttons are pressed, then the battery feed chip is functioning correctly; otherwise, replace the circuit pack because this port is defective. User-reported troubles on this port should be investigated by using other port tests, by examining station wiring, by examining the station, and by ensuring that the terminal is correctly translated as off-premises or on-premises.</p> <p> <b>NOTE:</b>                      This test always passes for circuit packs TN712 prior to Vintage 14 and TN742 prior to Vintage 6.</p>
0	NO BOARD	<p>The test could not relate the internal ID to the port (no board). This could be due to incorrect translations, no board is inserted, an incorrect board is inserted, or an insane board is inserted.</p> <ol style="list-style-type: none"> <li>1. Check to ensure that the board translations are correct. Use the <b>list config</b> command, and resolve any problems that are found.</li> <li>2. If the board was found to be correctly inserted in step 1, issue the <b>busyout board</b> command.</li> <li>3. Issue the <b>reset board</b> command.</li> <li>4. Issue the <b>release busy board</b> command.</li> <li>5. Issue the <b>test board long</b> command. This should re-establish the linkage between the internal ID and the port. If this is not the case, dispatch to check to ensure that there is a valid board inserted.</li> </ol>

### Station Status and Translation Audits and Updates Test (#36)

This test updates the analog port's message lamp state (if it has one) and translations (such as station type, dial type, network connection) with information kept in the software. The software is updated with the switchhook state reported by the port processor. When the ringer is in the off state, this test also turns off the station's ringer to prevent constant ringing caused by defective hardware.

**Table 9-35. TEST #36 Station Status and Translation Audits and Updates Test**

Error Code	Test Result	Description/ Recommendation
1004	ABORT ABORT	<p>Could not allocate the necessary system resources to run this test.</p> <p>System resources required to run this test are not available. The port may be busy with a valid call.</p> <ol style="list-style-type: none"> <li>1. Use the <b>display port UUCSSpp</b> command to determine the station extension. Use the <b>status station</b> command to determine the service state of the port. If the service state indicates that the port is in use, then the port is unavailable for certain tests. You must wait until the port is idle before retesting.</li> <li>2. Retry the command at 1-minute intervals for a maximum of 5 times.</li> <li>3. If the test continues to abort and the port is not in use, escalate the problem.</li> </ol>
1005	ABORT	<p>The test was aborted due to a configuration problem. This code results under either of the following conditions:</p> <ol style="list-style-type: none"> <li>1. This test may not be applicable, or it may be disruptive to terminal equipment other than a voice terminal (for example, the modem pool member or music on hold).</li> <li>2. The circuit pack is one of the following:                         <ul style="list-style-type: none"> <li>— TN742 vintages 13,14 and 15</li> <li>— TN769 vintages 3,4 and 5</li> </ul> </li> </ol>
1006	ABORT	<p>This port has been busied out by command or taken out-of-service by the failure of the NPE Crosstalk Test.</p> <ol style="list-style-type: none"> <li>1. Look in the Error Log for Error Type 18 (port busied out) for this port. If this error is present, then release the port with the <b>release station extension</b> command and run the test again.</li> <li>2. Look in the Error Log for Error Type 1025 (NPE Crosstalk Test failed) for this port. If this error is present, then investigate the errors associated with the NPE Crosstalk Test (#6) first.</li> <li>3. Make sure that the terminal is connected and in service, and then retest.</li> </ol>
2000	ABORT	<p>Response to the test request was not received within the allowable time period.</p>
2100	ABORT	<p>Could not allocate the necessary system resources to run this test.</p> <ol style="list-style-type: none"> <li>1. Retry the command at 1-minute intervals for a maximum of 5 times.</li> </ol>

*Continued on next page*

**Table 9-35. TEST #36 Station Status and Translation  
 Audits and Updates Test — Continued**

Error Code	Test Result	Description/ Recommendation
1	FAIL	<p>This does not indicate a hardware problem. The switchhook audit failed, and the other updates were not performed because of this failure. This condition may occur when the audit is performed at the same time that the terminal equipment goes off-hook. Use the <b>status station</b> command to determine when the port is available for testing.</p> <ol style="list-style-type: none"> <li>1. When the port becomes available for testing, retry the command at 1-minute intervals for a maximum of 5 times.</li> </ol>
5	FAIL	<p>This does not indicate a hardware problem but may indicate an internal software error. The message waiting lamp update failed. The translation and ringer updates were not performed because of this failure.</p>
7	FAIL	<p>The translation update failed. The ringer update was not performed because of this failure. This does not indicate a hardware problem but may be an internal software error.</p>
8	FAIL	<p>This does not indicate a hardware problem but may be an internal software error. The ringer update failed.</p> <ol style="list-style-type: none"> <li>1. Retry the command at 1-minute intervals for a maximum of 5 times.</li> </ol>
	PASS	<p>The software and the port processor have the same status. User-reported troubles on this port should be investigated by using other port tests, by examining station wiring, by examining the station, and by ensuring that the terminal is correctly translated as off-premises or on-premises.</p> <p><b>⇒ NOTE:</b>                      This test always passes for circuit packs TN712 prior to vintage 14 and TN742 prior to vintage 6.</p>
0	NO BOARD	<p>The test could not relate the internal ID to the port (no board). This could be due to incorrect translations, no board is inserted, an incorrect board is inserted, or an insane board is inserted.</p> <ol style="list-style-type: none"> <li>1. Check to ensure that the board translations are correct. Use the <b>list config</b> command, and resolve any problems that are found.</li> <li>2. If the board was found to be correctly inserted in step 1, issue the <b>busyout board</b> command.</li> <li>3. Issue the <b>reset board</b> command.</li> <li>4. Issue the <b>release busy board</b> command.</li> <li>5. Issue the <b>test board long</b> command. This should re-establish the linkage between the internal ID and the port. If this is not the case, dispatch to check to ensure that there is a valid board inserted.</li> </ol>

## Looparound and Conference Test (#47)

Each Analog Port consists of

- A Network Processing Element (NPE) for port connectivity and gain, and conferencing functionality
- A codec which converts TDM Bus digital signals to analog
- A battery feed chip that provides power to the telephone set for signaling, dial pulsing, transmission, and balance.

This test is designed to check the on-board transmission capabilities of the NPE, the codec, and the battery feed chip of the Analog Port. A Tone Detector and a Tone Generator talk and listen on the same pair of time slots as the Analog Port. The Analog Port is then instructed to go into loop around mode (see [Figure 9-1](#)). The test passes if the signal measured by the Tone Detector is within acceptable limits.

The Conference Circuit Test verifies that the NPE channel for the port being tested can correctly perform the conferencing function. Test #47 also tests the operation of the port conference circuits in the NPE for three and four parties. In addition, a test is run to measure noise. The NPE is instructed to listen to several different tones and conference the tones together. The resulting signal is then measured by a Tone Detector port. If the level of the tone is within a certain range, the test passes.

The noise test is performed by filtering out the tone, and then measuring inherent port noise.

### NOTE:

This Looparound Test is sensitive to the length of the loop, the equipment in the loop, or the equipment terminating the loop, such as off-premises stations. If this test is causing a false alarm, then disable the test by changing the Tests field to "no" using the **change station** command for this station.



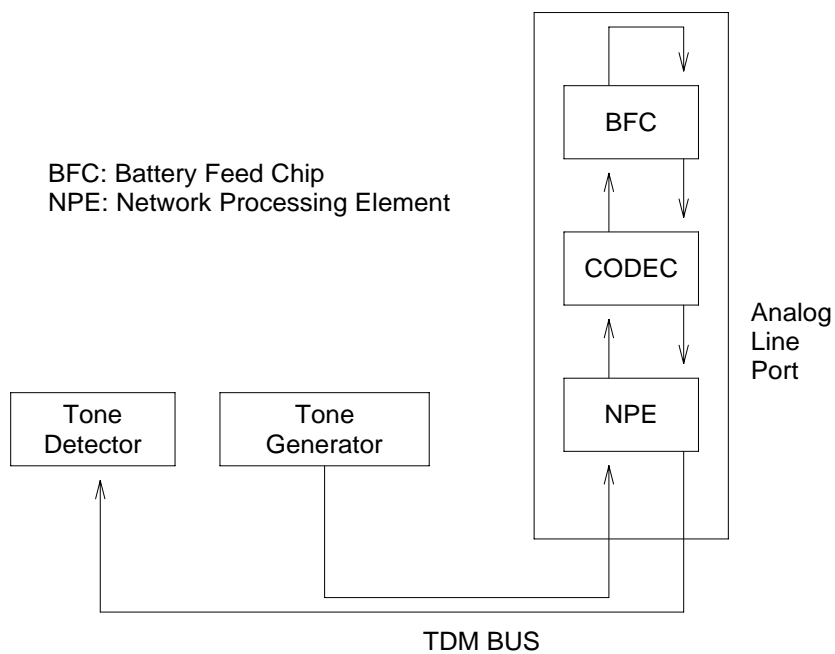

Figure 9-1. Analog Looparound and Conference Test

**Table 9-36. TEST #47 Loop Around and Conference Test**

Error Code	Test Result	Description/ Recommendation
	ABORT	Could not allocate the necessary system resources to run this test. 1. Retry the command at 1-minute intervals for a maximum of 5 times.
7	ABORT	The port was seized by a user for a valid call. 1. Enter <b>display port UUCSSpp</b> to determine the station's extension. Enter <b>status station extension</b> to determine the service state of the port. If the port is in use, it will be unavailable for certain tests. Wait until the port is idle before retesting. 2. If the port is idle, retry the command at 1-minute intervals up to 5 times.
1000	ABORT	System resources required to run this test were not available. The port may be busy with a valid call. (This could be a Music-on-Hold port.) 1. Enter <b>display port UUCSSpp</b> to determine the station's extension. Enter <b>status station extension</b> to determine the service state of the port. If the port is in use, it will be unavailable for certain tests. Wait until the port is idle before retesting. 2. If the port is idle, retry the command at 1-minute intervals up to 5 times.
1002	ABORT	The system could not allocate time slots for the test. The system may be under heavy traffic conditions or it may have time slots out-of-service due to TDM-BUS errors. 1. If system has no TDM-BUS errors and is not handling heavy traffic, repeat test at 1-minute intervals for a maximum of 5 times.
1003	ABORT	The system could not allocate a tone receiver for the test. The system may be oversized for the number of Tone Detectors present or some Tone Detectors may be out-of-service. 1. Resolve TTR-LEV errors. 2. Resolve TONE-PT errors. 3. If neither condition exists, retry the test at 1-minute intervals for a maximum of 5 times.
1004	ABORT	The port has been seized for a valid call during the conference or noise test. 1. If the circuit pack is a TN742 of Vintage 10 or less, this test is not valid. Otherwise, proceed with step 2. 2. When the port is available for testing, retry the command at 1-minute intervals for a maximum of 5 times.

*Continued on next page*

Table 9-36. TEST #47 Loop Around and Conference Test — *Continued*

Error Code	Test Result	Description/ Recommendation
1005	ABORT	<p>The test was aborted due to a configuration problem. This code will result under either of the following conditions:</p> <ol style="list-style-type: none"><li>1. This test may not be applicable, or it may be disruptive to terminal equipment other than a voice terminal (for example, the modem pool member or music on hold).</li><li>2. The circuit pack is one of the following:<ul style="list-style-type: none"><li>— TN742 vintages 13,14 and 15</li><li>— TN769 vintages 3,4 and 5</li></ul></li></ol>
1018	ABORT	<p>Test disabled via administration. The default for the <code>Test?</code> field on the is <code>y</code>; thus, you may want to determine why this field has been set to "n" on this station (this may be due to the ringing application test 48, which can be customer or terminal disturbing).</p> <ol style="list-style-type: none"><li>1. To enable the test for a particular station, enter <b>change station</b> extension and set the 'Test?' field on the 'Station Form' to 'y.'</li></ol>
1392	ABORT	<p>This port is currently a TTI port and the test will not execute on it.</p> <ol style="list-style-type: none"><li>1. Verify that the port is a TTI port using either the <b>display port</b> command (the display shows that the port is a TTI port) or the <b>list config</b> command (the display shows a <code>t</code> for the port).</li><li>2. If either <b>list config</b> or <b>display port</b> indicate that the port is <i>not</i> a TTI port, escalate the problem. If both commands indicate that the port is a TTI port, the abort is correct for the test, and no action is necessary.</li></ol>
2000	ABORT	<p>Response to the test request was not received within the allowable time period.</p>
2100	ABORT	<p>System resources required to run this test are not available. Either a system allocation to get information about the port or to put the port into a service state failed or the attempt to put the port in connection with a tone source failed (this could be a tone-clock problem). The tone-clock and tone detectors could be having a communication problem, for example, the companding modes could be out of synchronization.</p> <ol style="list-style-type: none"><li>1. Retry the command at 1-minute intervals for a maximum of 5 times.</li></ol>

*Continued on next page*

**Table 9-36. TEST #47 Loop Around and Conference Test — Continued**

Error Code	Test Result	Description/ Recommendation
7	FAIL	The conference test or the noise test failed. This could cause noisy or unreliable connections, or users calling this port may hear an echo. The problem can also be off-board, as described below.
13		The reflective loop around with gain set to low and the 600-ohm balance failed. This will cause noisy or unreliable connections.
14		The reflective loop around test (with the gain set to high, using RC balance) failed. This could cause noisy or unreliable connections. The problem can also be off-board, as described below.
15		<p>The nonreflective looparound test failed. This could cause noisy or unreliable connections, or users calling this port may hear an echo. The problem can also be off-board as described below.</p> <ol style="list-style-type: none"> <li>1. Disconnect the terminal equipment from the circuit pack at the cross-connect and run the test again.</li> <li>2. If the test fails again, replace the circuit pack and reconnect the terminal equipment. If the test passes the second time, then the test results were affected by the terminal equipment connected to the port; in this case, ignore the results of this test if all other tests pass or abort and the station is operating properly. Failure of test 47 does not cause an alarm. If there are failures of other tests, then investigate those errors. User reported troubles with this port should be investigated by using other port tests, by examining station wiring, and by examining the station to ensure that it is correctly translated as off-premises or on-premises.</li> </ol> <p><b>➡ NOTE:</b></p> <p>If the looparound and conference circuit test fails for all ports on a circuit pack, a -5 volt power problem is indicated. If a TN736 or TN752 power unit circuit pack is present, either the 631DB AC power unit or the 676B DC power unit may be defective. (The 631DB power unit is used in a medium cabinet powered by an AC source. The 645B power unit is used in a medium cabinet powered by a DC power source.) The system may contain a TN736 or TN752 power unit circuit pack or a 631DB AC power unit, but not both types of power units. To investigate problems with a 631DB AC power unit, refer to the "<a href="#">CARR-POW (Carrier Power Supply)</a>" Maintenance documentation. To investigate problems with a 645B DC power unit, refer to the "<a href="#">CARR-POW (Carrier Power Supply)</a>" Maintenance documentation. If a red LED on TN736 or TN752 power unit circuit pack is on, replace the pack. If the test fails on more than 1 port, check for errors on the TONE-BD or the TONE-PT. If errors, take appropriate actions. When the tone errors are cleared, rerun the test.</p>

**Table 9-36. TEST #47 Loop Around and Conference Test — Continued**

Error Code	Test Result	Description/ Recommendation
	PASS	<p>The port is able to provide an analog transmission path to the station equipment. User-reported troubles on this port should be investigated by using other port tests, by examining station wiring, by examining the station, and by ensuring that the terminal is correctly translated as off-premises or on-premises.</p> <p><b>⇒ NOTE:</b>                      This test always passes for circuit packs TN712 prior to vintage 14 and TN742 prior to vintage 6.</p>
0	NO BOARD	<p>The test could not relate the internal ID to the port (no board). This could be due to incorrect translations, no board is inserted, an incorrect board is inserted, or an insane board is inserted.</p> <ol style="list-style-type: none"> <li>1. Check to ensure that the board translations are correct. Use the <b>list config</b> command, and resolve any problems that are found.</li> <li>2. If the board was found to be correctly inserted in step 1, issue the <b>busyout board</b> command.</li> <li>3. Issue the <b>reset board</b> command.</li> <li>4. Issue the <b>release busy board</b> command.</li> <li>5. Issue the <b>test board long</b> command. This should re-establish the linkage between the internal ID and the port. If this is not the case, dispatch to check to ensure that there is a valid board inserted.</li> </ol>

### Station Present Test (also called Ringing Application Test) (#48)

This test provides a burst of ringing current to the terminal equipment and detects that current flows. This test is to ascertain whether or not terminal equipment is connected to the port.

This test may cause some terminal equipment to ring briefly during daily maintenance. If this ringing is disturbing the customer or the terminal equipment, it should be disabled using the Tests field of the station administration screen. However, on some releases of the software, this action disables Tests #6, 47, and 35, as well as Test #48.

**Table 9-37. TEST #48 Station Present Test**

Error Code	Test Result	Description/ Recommendation
	ABORT	Could not allocate the necessary system resources to run this test. 1. Retry the command at 1-minute intervals for a maximum of 5 times.
1000	ABORT	System resources required to run this test were not available. The port may be busy with a valid call. 1. Use the <b>display port UUCSSpp</b> to determine the station's extension. Enter <b>status station</b> extension to determine the service state of the port. If the port is in use, it will be unavailable for certain tests. Wait until the port is idle before retesting. 2. If the port is idle, retry the command at 1-minute intervals up to 5 times. 3. Check for phone left off-hook or for wiring problems.
1004	ABORT	System resources required to run this test are not available. The port may be busy with a valid call. 1. Use the <b>display port UUCSSpp</b> command to determine the station extension. Use the <b>status station</b> command to determine the service state of the port. If the service state indicates that the port is in use, then the port is unavailable for certain tests. You must wait until the port is idle before retesting. 2. Retry the command at 1-minute intervals for a maximum of 5 times. 3. If the test continues to abort and the port is not in use, escalate the problem.
1005	ABORT	The test was aborted due to a configuration problem. This code will result under either of the following conditions: 1. This test may not be applicable, or it may be disruptive to terminal equipment other than a voice terminal (for example, the modem pool member or music on hold). 2. The circuit pack is one of the following: — TN742 vintages 13,14 and 15 — TN769 vintages 3,4 and 5
1008	ABORT	Could not allocate a ringing circuit for one of the following reasons: (1) all the ringing circuits are in use, or (2) the ringing generator is defective, or (3) it is not wired correctly. 1. Retry the command at 1-minute intervals for a maximum of 5 times. 2. If the test continues to abort, look for RING-GEN errors in the Error Log. If an ABORT 1008 occurs for Test #48 on other circuit packs as well, then the ringing generator may be defective or not wired correctly. If it does not occur on other ports, then that circuit pack is currently using all four ringing phases.

*Continued on next page*

**Table 9-37. TEST #48 Station Present Test — Continued**

Error Code	Test Result	Description/ Recommendation
1018	ABORT	The test was disabled via administration. The default for the <code>Test?</code> field is <b>y</b> ; thus, you may want to determine why this field has been set to "n" on this station (this may be due to the ringing application Test #48, which can be customer or terminal disturbing). <ol style="list-style-type: none"> <li>To enable the test for a particular station, enter <b>change station extension</b> and set the <code>Test?</code> field to <b>y</b>.</li> </ol>
2000	ABORT	Response to the test request was not received within the allowable time period.
2100	ABORT	System resources required to run this test are not available. Either a system allocation to get information about the port or to put the port into a service state failed or the attempt to put the port in connection with a tone source failed (this could be a tone-clock problem). The tone-clock and tone detectors could be having a communication problem, for example, the companding modes could be out of synchronization. <ol style="list-style-type: none"> <li>Retry the command at 1-minute intervals for a maximum of 5 times.</li> <li>If the test continues to abort, escalate the problem.</li> </ol>
	FAIL	The terminal equipment is not connected to the circuit pack or the ringing generator may have failed. <ol style="list-style-type: none"> <li>Remotely test the equipment.</li> <li>If the test fails again, look for RING-GEN errors in the error log. If present, refer to the RING-GEN (analog ring generator) Maintenance documentation.</li> <li>Check all of the wiring between the station equipment and the switch. Then, run the test again.</li> <li>If the test still fails, the set may be defective. Check the set, and replace it, if necessary.</li> <li>Some terminal equipment (such as a modem) could fail even when it is connected properly. If this is the case, disable the test using the <b>change station extension</b> command (enter <b>n</b> into the <code>Test?</code> field). Note that this action also disables Tests 6, 7, 161, and 35 on this port.</li> </ol>
	PASS	The station is connected properly to the switch. This test may also pass if no terminal equipment is connected and the terminal is located very far from the switch. User-reported troubles on this port should be investigated by using other port tests, by examining station wiring, or by examining the station.

*Continued on next page*

**Table 9-37. TEST #48 Station Present Test — Continued**

Error Code	Test Result	Description/ Recommendation
0	NO BOARD	<p>The test could not relate the internal ID to the port (no board). This could be due to incorrect translations, no board is inserted, an incorrect board is inserted, or an insane board is inserted.</p> <ol style="list-style-type: none"> <li>1. Check to ensure that the board translations are correct. Use the <b>list config</b> command, and resolve any problems that are found.</li> <li>2. If the board was found to be correctly inserted in step 1, issue the <b>busyout board</b> command.</li> <li>3. Issue the <b>reset board</b> command.</li> <li>4. Issue the <b>release busy board</b> command.</li> <li>5. Issue the <b>test board long</b> command. This should re-establish the linkage between the internal ID and the port. If this is not the case, dispatch to check to ensure that there is a valid board inserted.</li> </ol>



## ANN-BD (Announcement Circuit Pack)

---

MO Name (in Alarm Log)	Alarm Level	Initial Command to Run <sup>1</sup>	Full Name of MO
ANN-BD	MINOR	test board UUCSS I	Announcement Circuit Pack
ANN-BD	WARNING	test board UUCSS I	Announcement Circuit Pack

- 
1. UU is the universal cabinet number (1 for PPN, 2 - 44 for EPNs). C is the carrier designation (A, B, C, D, or E). SS is the number of the slot in which the circuit pack resides (01 to 21).
- 

The TN750 contains 16 announcement ports each of which can play any recorded announcement. The circuit pack also has one data line circuit port (port 17) for uploading and downloading announcement files to and from the system's disk and tape devices. For errors associated with port 17, refer to DAT-LINE. For errors associated with ports 1-16 refer to ANN-PT.

### ⇒ NOTE:

TN750C is required if the system has multiple announcement boards. To use multiple announcement boards, you must have V4 or later software, and at least one TN750C (up to ten are allowed). Only one TN750A/B may be present in the system when a TN750C is used. The announcements from a TN750A/B can be saved and restored to a TN750C — but once the announcements are recorded onto a TN750C, they are not backward compatible with the TN750A/B.

## Essential Service Information

---

You should have an understanding of the following principles before attempting work on the TN750/B Announcement circuit pack.

### ⇒ NOTE:

The TN750C Announcement circuit pack has on-board non-volatile storage and does not need to be saved to disk.

- The announcement circuit pack retains all integrated announcements *as long as the circuit pack has power*. Announcements are preserved through a software reset (**reset board** command), but they are lost when the circuit pack is unseated. (Unseating is generally not recommended unless replacement is necessary.)

- Whenever new announcements are recorded on the circuit pack, save them on disk as soon as possible to ensure that they will not be lost due to a disruption. Periodic saves to tape provide further backup if the disk files are lost or corrupted. This is also accomplished when the entire disk is backed up.

 **NOTE:**

Unlike translations, announcements are never saved automatically by the system. so you must do it manually.

- The **save announcements** command replaces the announcement files on disk or tape with those in Announcement circuit pack speech memory. Take care not to inadvertently destroy a valid file on tape or disk with this command.
- The **restore announcements** command replaces announcement circuit pack speech memory with announcement files on the disk or tape. Take care not to inadvertently destroy valid announcements on the circuit pack by restoring from a device that does not contain a current announcement file.
- Whenever the announcement circuit pack is replaced, you must re-record announcements or restore them from disk or tape. Otherwise, the circuit pack will be unavailable to call processing service.
- If the circuit pack's speech memory is corrupted, announcements should *not* be saved (for example, when the Announcement Checksum Test (#209) fails or announcements sound corrupted when played back). This can ruin a good announcement file on disk or tape, and potentially cause errors and alarms on any circuit pack to which the saved file is downloaded. If, however, the customer does not have a valid announcement file on tape or disk, You may wish to save announcements in an effort to try to retain those which are not corrupted.

## Announcement Session

The recording, playing back, and deleting of announcements is called an announcement session. The station used must have a class of service (COS) that includes console permissions.

1. To enter an announcement session, go off-hook on the station and enter the announcement Feature Access Code (FAC) administered on the Feature Access Codes form.
2. You should now hear dial tone. Enter the extension of the announcement to be recorded, deleted, or played back.
3. You should again hear dial tone. To record an announcement, press 1, record after the tone, and hang up when finished.
4. To play back an announcement, press 2. Announcements can also be played back by simply calling the announcement extension associated with them.

5. To delete an announcement, press 3, and confirmation tone will be given if the delete was successful.

## Saving and Restoring Announcements

Integrated announcements on the announcement circuit pack can be uploaded to the system tape or disk with the **save announcements** command. Likewise, integrated announcements can be downloaded to the announcement circuit pack with the **restore announcements** command. Both commands require a free system port, an announcement data module administered on the announcement circuit pack and, if saving to tape, a non-write protected tape cartridge in the tape drive. Typical announcement uploads or downloads take 30 to 45 minutes, depending on system traffic.

The system automatically attempts to download to the announcement circuit pack 5 minutes after it is inserted. This automatic download procedure may be aborted or preempted by any of the following:

- An announcement is recorded within 10 minutes of circuit pack insertion.
- An announcement download is invoked sooner with the **restore announcements** command.
- An announcement data module is not administered or is busy.
- A system access port is not available.
- There is no tape in the system when saving to tape.
- The tape or disk does not have a valid announcement file.

### NOTE:

If the announcement file becomes corrupted, the only solution is to re-record all announcements.

### WARNING:

*All alarms are upgraded to MAJOR when the BASE Tone Generator is set to 12. (France).*

## Error Log Entries and Test to Clear Values

**Table 9-38. Announcement Circuit Pack Error Log Entries**

Error Type	Aux Data	Associated Test	Alarm Level	On/Off Board	Test to Clear Value
0 <sup>1</sup>	0	Any	Any	Any	test board UUCSS sh r 1
1(a)	0	Circuit pack removed or SAKI Test (#53)	MINOR	ON	
2(n)		None			
14(b)	1-128	Announcement Checksum Test (#209)			
18	0	busy-out board UUCSS	WARNING	OFF	release board UUCSS
23(c)	0	None	WARNING	OFF	
125(d)		None	MINOR	ON	
217(m)	0	None	WARNING	OFF	
257	65535	Control Channel Test (#52)	MINOR	ON	test board UUCSS l r 20
257(e)	Any	None			
267(m)	0	None	WARNING	OFF	
513(f)	Any	None			
1025(g)	4363	NPE Audit Test (#50)			test board UUCSS l
1281(h)	17699	None			
1538(i)	Any	None	MINOR	ON	
1793		Angel-SP Handshake Test (#208)	MINOR	ON	test board UUCSS l r 3
	17680	In-line Error			
2049(j)(k)		Clock Match Inquiry Test (#212)	MINOR	ON	test board UUCSS sh r 3
	17674	In-line Error			
2305		140AY Looparound Test (#210)	MINOR	ON	test board UUCSS sh r 3
2561		Super Frame Match Inquiry Test (#211)	MINOR	ON	test board UUCSS sh r 3

*Continued on next page*

**Table 9-38. Announcement Circuit Pack Error Log Entries — Continued**

Error Type	Aux Data	Associated Test	Alarm Level	On/Off Board	Test to Clear Value
	17676	In-line Error			
2817(j)		Announcement Checksum Test (#209)	MINOR	ON	test board UUCSS sh r 3
	17682	In-line Error			
	17699(j)	In-line Error			
3840(l)	Any	None			
3999 (o)	Any	None			

1. Run the Short Test Sequence first. If all tests pass, run the Long Test Sequence. Refer to the appropriate test description and follow the recommended procedures.

**Notes:**

- a. Error Type 1—This error indicates the circuit pack totally stopped functioning or it was physically removed from the system.

**⇒ NOTE:**

The alarm is logged about 11-minutes after the circuit pack has been removed or when the SAKI Test (#53) fails.

If the circuit pack is not in the system, insert a circuit pack (in the same slot as the error indicates) to resolve this error. If the circuit pack is in the system and the red LED is on, refer to [“LED Alarms without Alarm Log Entry or with Error Type 1”](#) in [Chapter 7, “LED Interpretation”](#).

- b. Error Type 14—This error is logged whenever the Announcement Checksum Test (#209) fails. The Aux Data indicates the identifying number of the first defective announcement found. This number corresponds to the announcement numbers on the announcement administration form. The extension associated with the announcement can be determined with the **display announcement** command. This error always appears in conjunction with Error Type 2817. Follow the procedures for Error Type 2817 to troubleshoot Error Type 14.
- c. Error Type 23—The circuit pack has been logically administered but not physically installed. The alarm clears when the circuit pack is installed.

- d. Error Type 125—A wrong circuit pack is inserted in the slot where this circuit pack is logically administered. To resolve this problem, either remove the wrong circuit pack and insert the logically administered circuit pack OR use the **change circuit-pack** command to readminister this slot to match the circuit pack inserted.
- e. Error Type 257—This error indicates transient communication problems with this circuit pack. This error is not service-affecting and no action is required.
- f. Error Type 513—This error, when reported with Aux Data in the range of 4352 to 4358, indicates the circuit pack has reported a hardware failure on the circuit pack. The circuit pack should be replaced.



**WARNING:**

*Replacing the circuit pack will result in loss of integrated announcements. See Essential Service Information above.*

- g. Error Type 1025—This error is not service-affecting and no action is required.
- h. Error Type 1281—The Speech Processor (SP) found one or more faulty memory locations in the speech main memory (SMM). Whenever this error is logged, error 2817 will also be logged (Note j), causing maintenance to run the Announcement Checksum Test (#209) to determine if the bad memory location is used by an announcement.
- i. Error Type 1538—The hyperactive circuit pack is out-of-service and may exhibit one or more of the following symptoms:
  - 1. The tests run on the ports of this circuit pack are returning with a NO-BOARD.
  - 2. A busy-out/release of the circuit pack has no affect on test results.
  - 3. A **list configuration** command shows that the circuit pack and ports are properly installed.

The system will try to restore the circuit pack within 15 minutes. If the error recurs after 15 minutes, then replace the circuit pack.

- j. Error Type 2049 and 2817—These errors or logged in conjunction with Error Type 1281, Aux Data 17699 (Note h). Since that error means that a defective speech memory location was found, the announcement checksum error is also logged, causing the Announcement Checksum Test (#209) to run. This test determines whether the defective memory location has corrupted any recorded announcements. If the Checksum Test passes, the faulty memory location is not currently being used; the Speech Processor will then mark the location as faulty to prevent future announcements from using it.

 **NOTE:**

As memory locations are marked faulty, the amount of available memory decreases, lowering the amount of announcement time available on the circuit pack.

- k. A transient error that does not cause an alarm can occasionally occur during a SPE, TDM BUS, or Tone Clock interchange. Error Type 2049—It is possible for a marginal Tone-Clock circuit pack to cause this error against the ANN-BD without alarming the TONE-BD. If this error occurs again, replacing the Tone-Clock circuit pack may clear up this error. See the FAIL case in the Clock Match Inquiry Test (#212).
- l. Error Type 3840—This error is not service-affecting and no action is required.
- m. Error Type 217 and 267—Indicate that there is more than one TN750 Announcement circuit pack inserted in the system. Remove the alarmed circuit pack.
- n. Error Type 2—Check the Class of Restriction (COR) administered for the Data Line extension assigned to the TN750 for uploading and downloading announcements. The extension can be found by using **list data-module**.
- o. Error Type 3999—Indicates that the circuit pack sent a large number of control channel messages to the switch within a short period of time. If error type 1538 is also present, then the circuit pack was taken out-of-service due to hyperactivity. If error type 1538 is not present, then the circuit pack has not been taken out-of-service, but it has generated 50% of the messages necessary to be considered hyperactive. This may be completely normal during heavy traffic periods. However, if this error type is logged when the circuit pack is being lightly used, it may indicate a problem with the circuit pack or the equipment attached to it.

## **System Technician-Demanded Tests: Descriptions and Error Codes**

---

Always investigate tests in the order presented in the table below when inspecting errors in the system. By clearing error codes associated with the *Control Channel Looparound Test*, for example, you may also clear errors generated from other tests in the testing sequence.

Order of Investigation	Short Test Sequence	Long Test Sequence	D/ND <sup>1</sup>
Control Channel Looparound Test (#52) <sup>2</sup>		X	ND
Angel-Speech Processor (SP) Handshake Test (#208)		X	ND
Clock Match Inquiry (#212)	X	X	ND
Super Frame Match Inquiry (#211)	X	X	ND
140AY Looparound Test (#210)	X	X	ND
Announcement Checksum Test (#209)	X	X	ND
Network Processor Element (NPE) Audit Test (#50) <sup>2</sup>		X	ND
SAKI Test (#53) <sup>2</sup>		X	D

1. D = Destructive; ND = Nondestructive
2. For results of these tests, see the "XXX-BD (Common Port Circuit Pack)" section.

### Angel-Speech Processor Handshake Test (#208)

This test checks the integrity of the communication link between the two processors on the Announcement circuit pack.

 **CAUTION:**

*Failure of this test indicates that the Speech Processor is insane and results in the loss of all integrated announcements on the circuit pack.*

**Table 9-39. TEST #208 Angel-Speech Processor (SP) Handshake Test**

Error Code	Test Result	Description/ Recommendation
2000	ABORT	Response to the test request was not received within the allowable time period. If Error Type 1538 is present in the Error Log, follow the maintenance strategy recommended for this Error Type.
2100	ABORT	Could not allocate the necessary system resources to run this test.
	ABORT	Internal system error. 1. Retry the command at 1-minute intervals for a maximum of 5 times.

*Continued on next page*



**Table 9-39. TEST #208 Angel-Speech Processor (SP) Handshake Test — Continued**

Error Code	Test Result	Description/ Recommendation
	FAIL	<p>The circuit pack cannot be used. Announcement speech memory is cleared when this test fails. When the problem has been resolved, announcements must be re-recorded or downloaded to the circuit pack. Refer to <i>Essential Service Information</i> earlier.</p> <ol style="list-style-type: none"> <li>1. Reset the circuit pack by the <b>reset board UUCSS</b> command and then run this test again. If the test continues to fail, replace the circuit pack.</li> <li>2. If there are recurring alarms on this circuit pack caused by this test failing, replace the circuit pack, <i>even if step 1 works</i>.</li> </ol> <p> <b>CAUTION:</b>  <i>Replacing the circuit pack will result in loss of integrated announcements. See Essential Service Information.</i></p>
	PASS	<p>The communications link between the two processors on the announcement circuit pack is functioning properly. User-reported troubles on this circuit pack should be investigated using other circuit pack and port tests. Refer to "ANN-PT" for a description of the port tests.</p>

### Announcement Checksum Test (#209)

In this test, the Speech Processor calculates a global checksum covering the entire announcements file and compares it to a stored one. If the comparison of any announcement's checksum fails, then the total number of defective announcements found is reported. The test failure is associated with an error type 14 in the Error Log. The aux data gives the identifying number of the first defective announcement found. This number and the extension assigned to the announcement are listed on the **display announcement** command.

**Table 9-40. TEST #209 Announcement Checksum Test**

Error Code	Test Result	Description/ Recommendation
1023	ABORT	There are no announcements currently recorded on the circuit pack.



*Continued on next page*

**Table 9-40. TEST #209 Announcement Checksum Test — Continued**

Error Code	Test Result	Description/ Recommendation
1024	ABORT	This abort code indicates any of the following: <ul style="list-style-type: none"> <li>■ An announcement upload or download is in progress.</li> <li>■ An announcement upload or download was requested while the test was running.</li> <li>■ A recording session was in progress.</li> <li>■ A recording session was initiated in while this test was running.</li> </ul>
		If an announcement upload or download is in progress, <b>status data-module</b> extension should show that the announcement data port (17) is connected to a data line port that is part of a system port, and the tape or disk should be active. (To determine the extension of the announcement data module, use the <b>list data-module</b> command.) See also <i>Locked Announcement Circuit Pack</i> at the end of this table. <ol style="list-style-type: none"> <li>1. Wait until the cause of the abort finishes and run the test again. Upload or download can take up to 45 minutes to complete. A recording session is finished as soon as the station that was making the recording is placed on-hook.</li> <li>2. If the test continues to abort, and a recording session or upload/download is not in progress, escalate the problem.</li> </ol>
2000	ABORT	Response to the test request was not received within the allowable time period. If Error Type 1538 is present in the Error Log, follow the maintenance strategy recommended for this Error Type.
2100	ABORT ABORT	Could not allocate the necessary system resources to run test. Internal system error. <ol style="list-style-type: none"> <li>1. Retry the command at 1-minute intervals for a maximum of 5 times.</li> </ol>

*Continued on next page*

**Table 9-40. TEST #209 Announcement Checksum Test — Continued**

Error Code	Test Result	Description/ Recommendation
0-256	FAIL	<p>The error code for this result gives the total number of defective announcements found in speech memory.</p> <p>When TEST #209 fails with error code 0, the global checksum failed on the board, but no individual checksum failed.</p> <p> <b>NOTE:</b>                      Since announcements are stored digitally, it is possible for the announcement checksum test to fail and still have all announcements sound uncorrupted. When an individual announcement fails the checksum test, always listen to the announcement before taking any action. If the announcement sounds corrupted, then re-record it or delete it. An announcement can be played back by dialing the extension associated with the announcement number. Use the <b>display announcement</b> command to find identifying numbers and extensions of announcements.</p> <ol style="list-style-type: none"> <li>1. Check the aux data for error type 14 in the Error Log to determine the number of the first defective announcement encountered. Play back the announcement and re-record or delete it if it sounds corrupted. If the FAIL code for this test was greater than 1, there is more than one corrupted announcement. To get the numbers of the others, you must re-record or delete the first one and then rerun this test.</li> <li>2. If, after deleting and re-recording all defective announcements, the checksum test still fails, then reset the circuit pack using the <b>reset board UUCSS</b> command and run this test again.</li> <li>3. If the test continues to fail, reseal the circuit pack and restore announcements (this can take up to 40 minutes). Any announcements recorded since the last <b>save announcements</b> will be lost, and must be re-recorded. Then run this test again.</li> <li>4. If the test continues to fail, replace the circuit pack.</li> </ol> <p> <b>CAUTION:</b>                      Replacing the circuit pack will result in loss of integrated announcements. See <i>Essential Service Information</i>.</p>
	PASS	<p>All recorded announcements checksum correctly, indicating that the speech main memory is functioning properly. User-reported troubles on this circuit pack should be investigated using other circuit pack and port tests. Refer to ANN-PT (Announcement Port) Maintenance documentation for a description of the port tests.</p>

## Locked Announcement Circuit Pack

The announcement circuit pack can exhibit a rare “locked” condition that renders two of its ports unusable by software. One of these ports is the record port, thus preventing any recording of announcements or execution of the **save/restore announcements** commands. Software does not have any way of detecting this condition and will attempt to use the ports.

When the circuit pack is in this state, the following symptoms is observed:

- When attempting to record an announcement, you will hear the proper record tone, but the announcement will not record. This will not be apparent until an attempt is made to play the announcement back.
- Performing a **test board long** will yield the following abort codes:
  - Test #206 aborts on ports 1 and 9 with code 1024.
  - Test #205 aborts on ports 1 and 9 with code 2000.
  - Tests #209 and #210 abort with code 1024.
- The **save/restore announcements** commands will time out with: `Error encountered, can't complete request`

The announcement circuit pack lock-up can be cleared remotely by performing a soft reset to the circuit pack with the following sequence of commands:

1. **busy-out board UUCSS** (this command will drop all calls to the Announcement circuit pack)
2. **reset board UUCSS**
3. **release board UUCSS**

## 140AY Looparound Test (#210)

This test checks the integrity of the record channel on the Announcement circuit pack (announcement port 1). The main function of the 140AY device is to accept Pulse Code Modulation (PCM)/Adaptive Differential Pulse Code Modulation (ADPCM) samples and compress/expand the samples using ADPCM. This test connects a tone generator to one port (announcement port 1, the recording port), and a tone detector to another port (announcement port 9). A tone is generated by the tone generator on the first port and looped through the 140AY device to the second port. The tone detector then responds with a tone present/absent message. The 140AY Looparound Test is repeated at three different speech compression rates.

Since this test involves sending a tone through two different ports, the Playback Speech Memory Array (PSMA) Test (#206) [see “ANN-PT” for a description of this test] is run on the two ports first to make sure that they are working properly.

**Table 9-41. TEST #210 140AY Looparound Test**

Error Code	Test Result	Description/Recommendation
1-3	ABORT	Response to the test request was not received within the allowable time period. The error code indicates at which speech compression rate the test aborted (1 being the first rate tested, 3 being the last).  1. Retry the command at 1-minute intervals for a maximum of 5 times.
10  90	ABORT  ABORT	The Playback Speech Memory Array (PSMA) Test (#206) failed on Announcement Port 1.  The Playback Speech Memory Array (PSMA) Test (#206) failed on Announcement Port 9.  1. Refer to "ANN-PT", Test #206.
1000	ABORT	System resources required to run this test are not available. This test needs Announcement Ports 1 and 9 to run. One of the ports may be in use on a valid call.  If Ports 1 and 9 are not in use, retry the command at 1-minute intervals for a maximum of 5 times.
1002	ABORT	The system could not allocate time slots for the test. The system may be under heavy traffic conditions or it may have time slots out-of-service due to TDM-BUS errors.  1. If system has no TDM-BUS errors and is not handling heavy traffic, retry the command at 1-minute intervals for a maximum of 5 times.
1003	ABORT	The system could not allocate a tone receiver for the test. The system may be oversized for the number of tone detectors present or some tone detectors may be out-of-service.  1. Resolve any TTR-LEV errors. 2. Resolve any TONE-PT errors. 3. If neither condition exists, retry the command at 1-minute intervals for a maximum of 5 times.
1007	ABORT	The announcement circuit pack thinks that Port 1 or Port 9 is busy.
1024	ABORT	Announcement circuit pack blocked the test because an announcement download is in progress. If a download is in progress, a <b>status data-module</b> announcement data extension command should show that the announcement data port is connected to a data line port that is part of a system access port, and the tape drive should be active (to determine the extension of the announcement data module, use the <b>list data-module</b> command). See the " <a href="#">Locked Announcement Circuit Pack</a> " at the end of the table for Test #209.  1. Wait until download is finished (up to 45 minutes), and then run the test again.

*Continued on next page*

**Table 9-41. TEST #210 140AY Looparound Test — Continued**

Error Code	Test Result	Description/Recommendation
2000	ABORT	Response to the test request was not received within the allowable time period. If Error Type 1538 is present in the Error Log, follow the maintenance strategy recommended for this error type.
2007	ABORT	The Announcement circuit pack thinks that Port 1 or Port 9 is busy. <ol style="list-style-type: none"> <li>1. Retry the command at 1-minute intervals for a maximum of 5 times.</li> <li>2. If the test continues to abort, follow the Announcement Port maintenance procedures for Ports 1 and 9.</li> </ol>
2100	ABORT ABORT	Could not allocate the necessary system resources to run this test. Internal system error. Retry the command at 1-minute intervals for a maximum of 5 times.
1-3	FAIL	Test failed. The error code indicates at which speech compression rate the test actually failed (1 being the first rate tested, 3 being the last). <ol style="list-style-type: none"> <li>1. Reset the circuit pack using the <b>reset board UUCSS</b> command and then run this test again. If the test continues to fail, replace the circuit pack.</li> <li>2. If there are recurring alarms on this circuit pack caused by this test failing, replace the circuit pack even if step 1 works.</li> </ol> <p> <b>CAUTION:</b>  <i>Replacing the circuit pack will result in loss of integrated announcements. See <a href="#">"Essential Service Information"</a> above.</i></p>
	PASS	The record channel on the announcement circuit pack is functioning properly. User-reported troubles on this circuit pack should be investigated using other circuit pack and port tests. Refer to "ANN-PT" for a description of the port tests.

### Super Frame Match Inquiry Test (#211)

The super frame is a means by which the Speech Processor (SP) synchronizes with the 140AY device on the announcement circuit pack. If the super frame is not synchronized, the SP will not be able to properly process record/playback requests. Both the SP and the hardware generate a super frame pulse. When these two pulses are out of synch, the SP sets a flag to indicate the mismatch. When this test is run, the state of this flag is returned.

**Table 9-42. TEST #211 Super Frame Match Inquiry**

Error Code	Test Result	Description/ Recommendation
2000	ABORT	Response to the test request was not received within the allowable time period. If Error Type 1538 is present in the Error Log, follow the maintenance strategy recommended for this Error Type.
2100	ABORT ABORT	Could not allocate the necessary system resources to run this test. Internal system error. 1. Retry the command at 1-minute intervals for a maximum of 5 times.
	FAIL	Test failed. Announcement playbacks should sound corrupted. 1. Reset the circuit pack via the <b>reset board UUCSS</b> command and then run this test again. If the test continues to fail, replace the circuit pack (see Warning). 2. If there are recurring alarms on this circuit pack caused by this test failing, replace the circuit pack even if step 1 works.   <b>WARNING:</b> <i>Replacing the circuit pack will result in loss of integrated announcements. See Essential Service Information.</i>
	PASS	The speech processor can properly process record/playback requests. User-reported troubles on this circuit pack should be investigated using other circuit pack and port tests. Refer to “ANN-PT” for a description of the port tests.

**Clock Match Inquiry Test (#212)**

This test determines the state of the clock-generating circuitry on the Announcement circuit pack. This circuitry is used to synchronize the announcement board with the TDM clock carried on the PN’s backplane.

**Table 9-43. TEST #212 Clock Match Inquiry Test**

Error Code	Test Result	Description/ Recommendation
2000	ABORT	Response to the test was not received within the allowable time period. If Error Type 1538 is present in the Error Log, follow the procedure for that error.
2100	ABORT ABORT	Could not allocate the necessary system resources to run this test. Internal system error. 1. Retry the command at 1-minute intervals for a maximum of 5 times.

**Table 9-43. TEST #212 Clock Match Inquiry Test — Continued**

Error Code	Test Result	Description/ Recommendation
	FAIL	<p>The ANN-BD may be defective or the active tone-clock circuit pack in the same PN may be bad. Announcements recorded or played back while the clock circuitry is not functioning properly sound distorted.</p> <ol style="list-style-type: none"> <li>1. Reset the Announcement circuit pack via the <b>reset board UUCSS</b> command and then run this test again. If the test continues to fail, proceed to Step 2 or 3, whichever applies.</li> <li>2. If this PN has duplicated Tone-Clocks: Determine the Active TONE-BD in this PN via the <b>status port-network 1</b> command. Make the Standby Tone-Clock circuit pack active via the <b>set tone-clock UUC</b> command. Rerun the test. If the test passes, then replace the now Standby Tone-Clock circuit pack. If the test continues to fail, replace the ANN-BD circuit pack.</li> </ol> <p><b>⚠ CAUTION:</b>  <i>Replacing the announcement circuit pack results in loss of integrated announcements. See Essential Service Information. See "TONE-BD" for Tone-Clock replacement instructions.</i></p> <ol style="list-style-type: none"> <li>3. If the PN has a single tone-clock: Replace the ANN-BD. Rerun the test. If the test continues to fail, replace the Tone-Clock circuit pack located in the same PN as the ANN-BD.</li> </ol> <p><b>⚠ CAUTION:</b>  <i>Replacing the PPN Tone-Clock circuit pack in a Standard Reliability system (simplex SPE) will cause COLD 2 reset (service outage). Replacing a simplex EPN Tone-Clock will cause an EPN reset with service outage to that EPN. See How to Replace a Tone-Clock Circuit Pack in the "TONE-BD" section of this chapter. Replacing the ANN-BD will result in loss of integrated announcements. See Essential Service Information.</i></p> <ol style="list-style-type: none"> <li>4. If failures of this test continue to raise alarms, replace the circuit pack even if the previous steps were successful.</li> </ol>
	PASS	<p>Announcement playbacks must have clear sound quality. Investigate user-reported troubles on this circuit pack using the other circuit pack and port tests. Refer to "ANN-PT" for descriptions of the port tests.</p>



## ANN-PT (Announcement Port)

---

MO Name (in Alarm Log)	Alarm Level	Initial Command to Run <sup>1</sup>	Full Name of MO
ANN-PT	MINOR	test port UUCSSpp I	Announcement Port
ANN-PT	WARNING	test port UUCSSpp I	Announcement Port

- 
1. UU is the universal cabinet number (1 for PPN, 2 - 44 for EPNs), C is the carrier designation (A, B, C, D, or E), and SS is the number of the slot in which the circuit pack resides (01 to 21). pp is the two digit port number (01, 02, ...).
- 

There are 16 announcement ports on the announcement circuit pack. Each port can play any integrated announcement, independently of the other ports. In addition to the 16 ports, the announcement circuit pack also has one data line circuit port (Port 17). The data line circuit port is used for uploading/downloading the announcement memory to/from the system tape or disk devices. If there are any errors associated with Port 17, refer to DAT-LINE maintenance information. If there are any errors associated with the circuit pack, refer to "ANN-BD" maintenance information.

### Essential Service Information

---

There are a number of important basic principles that should be understood before undertaking work on the announcement circuit pack. These are described in *Essential Service Information* at the beginning of the "ANN-BD" section of this chapter.

Although announcement port 5 and data line circuit port 17 on the announcement circuit pack are logically two separate ports, they are physically the same port. Therefore, if one of the ports is in use, the other one will be busy. Also, if announcement port 5 is out-of-service, the data line circuit port will be taken out-of-service. However, if the data line circuit port is out-of-service, the announcement port will remain in-service.

## Error Log Entries and Test to Clear Values

**Table 9-44. Announcement Port Error Log Entries**

Error Type	Aux Data	Associated Test	Alarm Level	On/Off Board	Test to Clear Value
0 <sup>1</sup>	0	Any	Any	Any	test port UUCSSpp sh r 1
1		Playback Speech Memory Array (PSMA) Test (#206)	MINOR	ON	test port UUCSSpp sh r 3
18	0	The port was busied out.	WARNING	OFF	release port UUCSSpp
130(a)		None	WARNING	ON	test port UUCSSpp sh
257		Channel Administration Memory Array (CAMA) Test (#205)	MINOR	ON	test port UUCSSpp l r 3
	17667	In-line error			
513		140AY Channel Sanity Inquiry Test (#222)	MINOR	ON	test port UUCSSpp sh r 3
	17684	In-line error			
769(b)		None			

1. Run the Short Test Sequence first. If all tests pass, run the Long Test Sequence. Refer to the appropriate test description and follow the recommended procedures.

### Notes:

- a. This error type indicates that the circuit pack has been removed or has been insane for more than 11-minutes. To clear the error, reinsert or replace the circuit pack.
- b. This error is logged and the port is alarmed when an alarm is raised on the announcement circuit pack because of a faulty condition with a common circuit pack resource. Any one of the following alarmed errors on the announcement circuit pack causes this error to be logged against the Announcement Port: 1793, 2049, 2305, 2561. See "[ANN-BD \(Announcement Circuit Pack\)](#)" to resolve these alarms. When the corresponding circuit pack alarm is cleared, this alarm will clear.

## System Technician-Demanded Tests: Descriptions and Error Codes

Always investigate tests in the order presented in the table below. By clearing error codes associated with the *Channel Administration Memory Array (CAMA) Test*, for example, you may also clear errors generated from other tests in the testing sequence.

Order of Investigation	Short Test Sequence	Long Test Sequence	D/ND <sup>1</sup>
Channel Administration Memory Array (CAMA) Test (#205)		X	ND
Playback Speech Memory Array (PSMA) Test (#206)	X	X	ND
140AY Channel Sanity Inquiry Test (#222)	X	X	ND

1. D = Destructive; ND = Nondestructive

### Channel Administration Memory Array (CAMA) Test (#205)

This test is a memory device that stores information used to control the 140AY device. The Angel asynchronously feeds the CAMA with the control information.

Table 9-45. TEST #205 Channel Administration Memory Array (CAMA) Test

Error Code	Test Result	Description/Recommendation
1000	ABORT	System resources required to run test are not available. The port may be in use on a valid call.  1. If the circuit pack is not in use, retry the command at 1-minute intervals for a maximum of 5 times.
2000	ABORT	Response to the test request was not received within the allowable time period. See <i>Announcement Board Locked Condition</i> at the end of this section.
2100	ABORT	Could not allocate the necessary system resources to run this test.

*Continued on next page*

**Table 9-45. TEST #205 Channel Administration Memory Array (CAMA) Test**

Error Code	Test Result	Description/Recommendation
	ABORT	Internal system error. <ol style="list-style-type: none"><li>1. Retry the command at 1-minute intervals for a maximum of 5 times.</li></ol>
	FAIL	Test failed. Announcements played back on this port may sound corrupted. <ol style="list-style-type: none"><li>1. Reset the circuit pack using the <b>reset board UUCSS</b> command and then run this test again. If the test continues to fail, replace the circuit pack.</li><li>2. If there are recurring alarms on this port caused by this test failing, replace the circuit pack even if Step 1 works.</li></ol> <p> <b>CAUTION:</b> <i>Replacing the circuit pack results in loss of integrated announcements. Refer to Essential Service Information at the beginning of "<a href="#">ANN-BD (Announcement Circuit Pack)</a>" in this chapter.</i></p>
	PASS	This test verifies that the Angel processor can properly set up this port for playbacks. User-reported troubles on this circuit pack should be investigated using other port and circuit pack tests. (Refer to " <a href="#">ANN-BD (Announcement Circuit Pack)</a> " for a description of the circuit pack tests.)

## Playback Speech Memory Array (PSMA) Test (#206)

The PSMA test checks the integrity of a playback channel's interface to the speech memory and the TDM Bus. *This test is very important.* It is the only test that actually checks an announcement port's ability to play back an announcement on the TDM Bus. If the test fails, the tone detector returns the number of bytes that did not match the expected sequence. The larger the number, the more severe the problem is with that port. If this test fails, announcements played over this port sound corrupted.

**Table 9-46. TEST #206 Playback Speech Memory Array (PSMA) Test**

Error Code	Test Result	Description/Recommendation
1000	ABORT	System resources required to run this test are not available. The port may be in use on a valid call. When the port is not in use, retry the command at 1-minute intervals for a maximum of 5 times.
1002	ABORT	<p>The system could not allocate time slots for the test. The system may be under heavy traffic conditions or it may have time slots out-of-service due to TDM-BUS errors.</p> <ol style="list-style-type: none"> <li>1. If system has no TDM-BUS errors and is not handling heavy traffic, retry the command at 1-minute intervals for a maximum of 5 times.</li> </ol>
1003	ABORT	<p>The system could not allocate a tone receiver for the test. The system may be oversized for the number of tone detectors present or some tone detectors may be out-of-service.</p> <ol style="list-style-type: none"> <li>1. Resolve any TTR-LEV errors.</li> <li>2. Resolve any TONE-PT errors.</li> <li>3. If neither condition exists, retry the command at 1-minute intervals for a maximum of 5 times.</li> </ol>
1024	ABORT	<p>Announcement circuit pack blocked the test because an announcement download is in progress. If an announcement download is in progress, a <b>status data-module announcement data extension</b> command shows that the announcement data port is connected to a system access port, and the tape drive should be active. (To determine the extension of the announcement data module, use the <b>list data-module</b> command.) See <i>Announcement Board Locked Condition</i> at the end of this section.</p> <ol style="list-style-type: none"> <li>1. Wait until download is finished (maximum of 45 minutes), and then run the test again.</li> </ol>
2000	ABORT	Response to the test request was not received within the allowable time period.
2100	ABORT ABORT	<p>Could not allocate the necessary system resources to run this test.</p> <p>Internal system error.</p> <ol style="list-style-type: none"> <li>1. Retry the command at 1-minute intervals for a maximum of 5 times.</li> </ol>

*Continued on next page*

**Table 9-46. TEST #206 Playback Speech Memory Array (PSMA) Test — Continued**

Error Code	Test Result	Description/Recommendation
1 to 254	FAIL	<p>Test failed. The error code indicates the number of byte count errors found by the Tone Detector.</p> <ol style="list-style-type: none"> <li>1. Reset the circuit pack via the <b>reset board UUCSS</b> command and then run this test again. If the test continues to fail, replace the circuit pack.</li> <li>2. If there are recurring alarms on this port caused by this test failing, replace the circuit pack even if Step 1 works.</li> </ol> <p><b>⚠ CAUTION:</b>  <i>Replacing the circuit pack results in loss of integrated announcements. Refer to Essential Service Information at the beginning of <a href="#">“ANN-BD (Announcement Circuit Pack)”</a> in this chapter.</i></p>
255	FAIL	<p>Test failed. The announcement port and the tone detector never synchronized. Check for active GPTD-PT errors, and refer to “GPTD-PT (General Purpose Tone Detector Port)” to diagnose them first.</p> <ol style="list-style-type: none"> <li>1. If there are no active GPTD-PT errors, reset the circuit pack using the <b>reset board UUCSS</b> command and then run this test again. If the test continues to fail, replace the circuit pack.</li> <li>2. If there are recurring alarms on this port caused by this test failing, replace the circuit pack even if Step 1 works. See Caution, above.</li> </ol>
	PASS	<p>This port can cleanly play announcements. User-reported troubles on this pack should be investigated using other port and circuit pack tests. Refer to <a href="#">“ANN-BD (Announcement Circuit Pack)”</a> for a description of the circuit pack tests.</p>

**140AY Channel Sanity Inquiry Test (#222)**

The Angel keeps a sanity status bit for each of the 16 channels on the 140AY device. This test queries the Angel to determine the status for a particular channel. If a channel is insane, that implies that announcements cannot be played back on that channel.

**Table 9-47. TEST #222 140AY Channel Sanity Inquiry Test**

Error Code	Test Result	Description/Recommendation
2000	ABORT	Response to the test request was not received within the allowable time period.
2100	ABORT ABORT	Could not allocate the necessary system resources to run this test.  Internal system error  1. Retry the command at 1-minute intervals for a maximum of 5 times.
	FAIL	Test failed. Announcements cannot be played back over this port.  1. Reset the circuit pack via the <b>reset board UUCSS</b> command and then run this test again. If the test continues to fail, replace the circuit pack (see Warning).  2. If there are recurring alarms on this port caused by this test failing, replace the circuit pack even if Step 1 works.   <b>CAUTION:</b> <i>Replacing the circuit pack will result in loss of integrated announcements. Refer to Essential Service Information at the beginning of "ANN-BD" in this chapter.</i>
	PASS	Announcements can be played back over this port. User-reported troubles on this pack should be investigated using other port and circuit pack tests. Refer to the <a href="#">"ANN-BD (Announcement Circuit Pack)"</a> for a description of the circuit pack tests.

## Announcement Board Locked Condition

The announcement circuit pack can exhibit a condition that does not allow recording.

If the circuit pack gets locked into this state (this is an extremely rare condition), two of the announcement ports on the circuit pack (one of which is the record port) will be unusable by software. Also, **save/restore announcements** will not work since the record port looks busy to the circuit pack. Note that software does not have any way of knowing this and will attempt to use the ports.

If the circuit pack is locked into this state, the following symptoms will be observed:

1. When attempting to record an announcement, users will hear the proper record tone, but the announcement will not record (they will not know it until the announcement is played back).

2. Performing a **test board long** when the circuit pack is in this state will yield the following abort codes:
  - Ports 1 AND 9 abort Test 206 with code 1024.
  - Ports 1 AND 9 abort Test 205 with code 2000.
  - Board level Tests 209 and 210 abort with code 1024.
3. The **save/restore announcements** command will time out with:  
`Error encountered, can't complete request`

The Announcement circuit pack lock-up can be cleared remotely by performing a soft reset to the circuit pack:

- **busy-out board UUCSS** (this command drops all calls in progress on the Announcement circuit pack).
- Reset circuit pack using the **reset board UUCSS** command.
- Release board using the **release board UUCSS** command.



## ANNOUNCE

---

MO Name (in Alarm Log)	Alarm Level	Initial Command to Run	Full Name of MO
ANNOUNCE	none	none	ANNOUNCEMENT

The ANNOUNCE maintenance object logs an error in the hardware error log when either of the following occurs:

- A **save announcement** or **restore announcement** command does not complete successfully.
- The system fails to restore announcements from tape or disk at boot time.

## Hardware Error Log Entries

---

**Table 9-48. ANNOUNCE Error Log Entries**

Error Type	Aux Data	Associated Test	Alarm Level	On/Off Board	Test to Clear Value
1(a)(f)	any	None			
257(b)(f)	any	None			
513(c)(f)	0	None			
769(d)(f)	0	None			
1025(e)(f)	any	None			

Notes:

- a. Error occurred while saving announcements. See [Table 9-49](#) for an explanation of aux data and recommended repair actions.
  - b. Error occurred while saving announcements to the standby SPE. (See the table in the next section for an explanation of aux data and recommended repair actions.)
  - c. User pressed the CANCEL key while announcement was being saved by the active SPE.
  - d. User pressed the CANCEL key while announcement was being saved by the standby SPE.
  - e. Error occurred while restoring announcements. See [Table 9-49](#) for an explanation of aux data and recommended repair actions.
  - f. The `PORT` field for this error displays which SPE was active when the error occurred.
-

## ANNOUNCE Error Code Aux Data

**Table 9-49. ANNOUNCE Aux Data and Repair Actions**

Aux Data	Description/Recommendation
30001 through 30054	Disk/Tape errors Check and resolve errors and alarms
32001	Internal system error Check other ANNOUNCE errors and take corrective action. If there are no other ANNOUNCE errors: 1. Retry the command at 3 minute intervals a maximum of 3 times. 2. Try the <b>save/restore announcement</b> command.
32002	Announcement circuit pack in use. 1. Retry the command at 2-minute intervals a maximum of 3 times. 2. Try the <b>save/restore announcement</b> command.
32003	Announcement port in use. 1. Wait for all Announcement ports to become available. 2. Enter the <b>save/restore announcement</b> command.
32004	No announcements on board. There are no announcements recorded on the announcement circuit pack. The <b>save announcement</b> command is not allowed to prevent the destroying of the announcement file on tape.
32005	Integrated announcement board not present. The announcement circuit pack is not inserted, or it is defective. 1. Enter the <b>list config</b> command to check for the presence of the board in the system. 2. If the Announcement circuit pack is present, use the <b>test board UUCSS</b> command to check the status of the Announcement circuit pack.
32006	Announcement data module not available. 1. Use the <b>status data-module</b> command to check the status of the announcement data module.
32007	Announcement data module out of service. 1. Use the <b>status data-module</b> command to check the status of the announcement data module.
32008	Announcement data being saved or loaded. 1. Retry the command at two-minute intervals a maximum of three times. 2. If the <b>save/restore announcement</b> command fails, escalate the problem.

*Continued on next page*

**Table 9-49. ANNOUNCE Aux Data and Repair Actions — Continued**

Aux Data	Description/Recommendation
32009	<p>No system port is available (none are administered, or all are busy). A system port is required to save or restore announcements.</p> <ol style="list-style-type: none"> <li>1. Use <b>add data-module</b> to administer a System Port if none is administered.</li> <li>2. If system ports are administered, use the <b>status data-module</b> command to check the status of all system ports. At least one system port should be in the in-service/idle state.</li> </ol>
32010 32013	<p>System port not administered or unavailable. A system port is required to save or restore announcements.)</p> <ol style="list-style-type: none"> <li>1. Use <b>add data-module</b> to administer a system port if none is administered.</li> <li>2. If system ports are administered, use the <b>status data-module</b> command to check the status of all system ports. At least one system port should be in the in-service/idle state.</li> </ol>
32012	<p>Required announcement data module not administered.</p> <ol style="list-style-type: none"> <li>1. Add an announcement data module and repeat the command.</li> </ol>

## ASAI-BD (Multi-Application Platform Board)

MO Name (in Alarm Log)	Alarm Level	Initial Command to Run <sup>1</sup>	Full Name of MO
ASAI-BD	MIN	test board UUCSS pp	ASAI-BD
ASAI-BD	WRN	test board UUCSS pp	ASAI-BD

1. Where UU is the universal cabinet number (1 for PPN and 2-44 for EPN); C is the carrier designation (for example, A, B, C, D, or E); SS is the address of the slot in the carrier where the circuit pack is located (for example, 01, 02, ..., and so forth); and pp is the two digit port number (01, 02, 03, ...).

Maintenance testing of the common circuit pack is handled by on-board firmware and SPE-controlled tests. Maintenance software queries the firmware for error and alarm information, status, and test results. Firmware automatically reports error conditions that result in SPE-controlled testing.

For MAPD board insertion, the switch makes an additional board query if any of the following circuit packs are inserted:

Circuit Pack	Vintage
TN754	49
TN556	49, 80 or greater
TN800	any

For any of the above initial board uplinks, the switch queries the board for administration data as well as reporting the switch software release and the system type.

For the native mode, the response to the board query downlink messages consists of several CCMS uplink messages that identify the true board code, vintage, suffix, emulation type, and number of reserved slots needed.

### NOTE:

See also ASAI-PT/ASAI-EPT (BRI Line) maintenance documentation for related line information. See the following exceptions listed below:

- **Hyperactivity:** currently, the common circuit pack is considered "hyperactive" if the Service Dispatcher receives 200 uplink messages from the circuit pack in a 10-second period. Since MAPD has 32 ports, the hyperactivity limit increases to 500 uplink

messages per 10 seconds. The switch issues an alarm when the limit reaches 400; when it reaches 500 up-link messages in 10 seconds, the board is taken out of service.

- LED use: the LED Control Message 038x requests the Angel to drive the red, yellow, and green LEDs on the face plate of a typical port board on or off. On the MAPD, only the red LED is controlled by this message. Yellow and green change requests received from the switch by the MAPD drive LCD behavior rather than LED behavior. The DEFINITY switch continues to send the same LED control messages to the MAPD that the DEFINITY switch currently sends to all other port boards. The MAPD handles proper interpretation of these messages. You should note that the PC on the MAPD and the switch itself control the LEDs and the LCD on the MAPD.
- Port Administration: in Administration Without Hardware (AWOH), the switch allows administration of up to 8 ports in any of the first 12 ports. If the port type later reported by the board does not match the existing type, the switch assumes it to be a MAPD board with a different configuration and rejects the board.

 **NOTE:**

Refer to the LAN-BD documentation for circuit pack level errors. For related information, see ASAI-PT and ASAI-EPT maintenance documentation.

## ASAI-EPT

---

MO Name (in Alarm Log)	Alarm Level	Initial Command to Run	Full Name of MO
ASAI-EPT	MAJOR <sup>1</sup>	test station extension	ASAI-Adjunct

- 
1. The alarm level for ASAI adjuncts is administered using the **set options** command. The alarm level can be set independently for off-board and on-board alarms to WARNING, MINOR, or MAJOR for all ASAI adjuncts in the system.
- 

The maintenance strategy for this endpoint MO is built on maintenance facilities offered in the Lucent ISDN-BRI protocol and in the ASAI adjuncts. Currently there are no facilities in the protocol that provide for maintenance of set data features.

The TN800 is a PC-based platform that allows interaction of multiple applications with DEFINITY at any time. DEFINITY Release 5 software (Native mode) supports emulation of three types of port MOs on this board. The type of ports to be emulated is defined by the applications running on the TN800.

### NOTE:

If the TN800 is emulating BRI, the software/firmware supports a maximum of 12 ports, but only 8 of the 12 ports can be administered at any one time.

## Error Log Entries and Test to Clear Values

Table 9-50. ASAI-EPT Error Log Entries

Error Type	Aux Data	Associated Test	Alarm Level ASAI-EPT	On/ Off Board	Test to Clear Value
0 <sup>1</sup>	0	Any	Any	Any	test ASAI-ADJ
2 (a)	2-102	None			
257 (b)	Any	BRI Layer 3 Query	MAJ/WNG <sup>2</sup>	OFF	test station ext r 2 test data-module ext r 2
351 (c)	0	none	WARNING	OFF	busyout and release station
513 (d)	0	None			
769 (e)	0	None	MAJOR	OFF	
2561 (f)	0	None			
2562-2566 (g)	0	None			
2567 (h)	0	None			
2568 (i)	0	None			
3329 (j)	Any	Signaling Link Status (626)	MAJ/WNG <sup>†</sup>	OFF	
3584-3839 (k)	Any	None			
3841 (l) 4095	Any	None			

1. Run the Short Test Sequence first. If all tests pass, run the Long Test Sequence. Refer to the appropriate test description and follow the recommended procedures.
2. Major alarms on this MO may be downgraded to Warning alarms based on the value used in the **set options** command.

Notes:

- a. Errors of this type indicate violations of the ISDN-BRI signaling protocol. Timers associated with certain Layer 3 messages have expired before a required response was received. In the following table, the aux data column indicates which timer has just expired. For more information, refer to the Lucent ISDN-BRI Specification.

Aux Data	Timer Type
2	First T303 (SETUP timer)
3	Second T303 (SETUP timer)
4	T305 (DISConnect timer)
5	First T308 (RELease timer)
6	Second T308 (RELease timer)
10	T316 (REStart timer)
12	T309 (Layer 2 Failure timer)
16	TM100 (Management Information Message timer 1)
17	TM200 (Management Information Message timer 2)
102	TASAI (ASAI Routing Timer)

The switch sent a message to an endpoint that did not respond in the allotted time. This may be due to failure of the point-to-point signaling link or because of a problem in the ASAI adjunct. To repair:

- Execute the **test station extension** command and perform the associated repair procedures for those tests.
- b. An endpoint is not responding to the service state query message sent to the adjunct or to the endpoint. This error causes an alarm to be raised. The alarm is retired when the switch receives a response to the service state query to the endpoint or to the adjunct.

When this error occurs for an ASAI adjunct, the Aux Data field indicates the state of the ASAI link and whether an invalid response or no response was received to the query from the switch, as shown in the following table:

Aux Data	ASAI Link State	Error
102	13-restarting	No response to RESTART message
104	13-restarting	Invalid response to RESTART message
152	13-restarted	No response to Layer 3 query
154	13-restarted	Invalid response to Layer 3 query
202	13-established	No response to Layer 3 query
204	13-established	Invalid response to Layer 3 query

See "[status bri-port](#)" in [Chapter 8, "Maintenance Commands"](#) for an explanation of the ASAI link states.

For ASAI or Lucent adjuncts, the switch queries the adjunct every two minutes. The Layer 3 Query Test is not executed for ASAI or Lucent adjuncts through a command issued from the management terminal. While alarmed for this error, the switch takes the associated port out-of-service for five seconds every 15 minutes. This action attempts to stimulate recovery actions to be taken by the adjunct.



When this error occurs for an ASAI or Lucent adjunct, the service technician should:

1. Execute the **test station extension** command and perform the associated repair procedures for those tests.
  2. Check the health of the adjunct by following the recommended repair procedures of the manufacturer of the adjunct if the preceding step does not resolve the problem.
- c. This error and associated warning alarm are logged against an ASAI endpoint when the adjunct has asked the switch to suspend maintenance on the ASAI endpoint. Busing out and releasing the ASAI station clears this alarm.
- d. This error occurs when the endpoint sends more messages than the switch can handle. The switch suspends the reception of messages from the endpoint for a short period of time. There is no repair procedure for this error. If the condition persists, replace the endpoint.
- e. This error occurs when the signaling link associated with the ASAI endpoint has too much link-establishment related traffic. This occurs if the signaling link is alternating between assigned and established states. If this problem persists, replace the endpoint.
- f. This error occurs when the ASAI-EPT message is not transmitted because the PKT-CTRL (packet control circuit pack) transmit buffers are exhausted. Frequent or persistent occurrence of these events may indicate a hardware problem or traffic overload on the PKT-CTRL, the signaling link, or the ASAI adjunct. Resolve the problem by following the repair procedures for the PKT-CTRL. If these attempts fail, re-engineering the traffic on the PKT-CTRL, signaling link, or adjunct may be necessary.
- g. The ASAI message is not transmitted because the transmit buffer for the ASAI link is full, causing the link to be flow-controlled. Frequent or persistent occurrence of these events may indicate a hardware problem or traffic overload on the PKT-CTRL, the signaling link, or the ASAI adjunct. Resolve the problem by following the repair procedures issued by the manufacturer of the adjunct. If these attempts fail, re-engineering of the traffic on the PKT-CTRL, signaling link, or adjunct may be necessary.
- h. This version of ASAI is not supported. Check the software version that is running on the ASAI adjunct.
- i. The adjunct identification is invalid. Check the vendor ID or software running on the ASAI adjunct.
- j. This occurs when the point-to-point signaling link to the endpoint goes down, except when the link goes down because either a system technician has busied out the PKT-CTRL or the PKT-BUS, or they have failed. This error raises an alarm against the endpoint or adjunct. Execute the **test station extension short** command and note the results of the Signaling Link Status Test (#626). If this test fails, follow the repair procedure for Test #626. The alarm is retired when the signaling link is re-established to the endpoint or adjunct.

- k. The switch software logs certain ASAI cause values. The cause value is determined from the following formulas:
- If the error type is greater than 3712, then the ASAI cause value is equal to the error type minus 3712. The switch sent this value to the adjunct.
  - If the error type is less than 3712, then the ASAI cause value is equal to the error type minus 3584. The adjunct sent this value to the switch.
- [Table 9-51](#) contains a description of the various ASAI cause values and recommended system technician actions associated with the cause value. The *ISDN-BRI Specification* contains further information.
- l. The switch software logs certain ASAI cause values. The cause value is determined from the following formula:
- If the error type is greater than 3968, then the ASAI cause value is equal to the error type minus 3968. The switch sent this value to the endpoint.
  - If the error type is less than 3968, then the ASAI cause code is equal to the error type minus 3840. The endpoint sent this value to the switch.

**Table 9-51. ASAI Cause Values**

Code	Explanation	Recommendation
0	Unrecognized ASAI Protocol Operation.	Requested ASAI protocol is not implemented by switch or adjunct. <i>Aux Data</i> field of error log entry contains protocol identifier for unrecognized operation. <ol style="list-style-type: none"> <li>1. Consult switch and adjunct documentation to determine which set of operations is supported by switch and the adjunct. Turning off adjunct operations not implemented by the switch may resolve the problem.</li> </ol>
34	No circuit or channel available	A resource on the switch is unavailable for a call. For BRI endpoints, this cause value is not logged. For ASAI, this condition means that there are no available trunks for an outgoing call request. <ol style="list-style-type: none"> <li>1. Verify that the adjunct is administered to support the trunk capabilities of the switch.</li> <li>2. Investigate trunk group status by issuing the <b>status trunk</b> command from the SAT or by requesting trunk group query(ies) from the adjunct.</li> <li>3. Perform trunk diagnostic procedures outlined in this manual.</li> </ol>
40	Resources not available.	No available internal resources to service switch or adjunct request. Exceeds system transaction capacity for adjunct or switch. <ol style="list-style-type: none"> <li>1. May require re-engineering of adjunct services.</li> </ol>

**Table 9-51. ASAI Cause Values — Continued**

Code	Explanation	Recommendation
50	Requested facility not subscribed	<p>Requested facility is implemented, but not administered. Potential administration problem with endpoint or adjunct.</p> <p>For BRI endpoints:</p> <ol style="list-style-type: none"> <li>1. Verify the switch administration of endpoint using either the <b>display station</b> or <b>display data-module</b> commands.</li> <li>2. If Step 1 does not resolve the problem, refer to the endpoint's service manual and verify administration on the endpoint.</li> </ol> <p>For ASAI adjuncts:</p> <ol style="list-style-type: none"> <li>1. Display the Customer Optional Features Form (administration screen) on the switch to determine which ASAI capabilities are turned on in the switch.</li> <li>2. Verify that the adjunct is administered to support the identical capabilities as the switch. If there is a mismatch in the administered capabilities, then readminister the switch and/or the adjunct to establish a consistent set of desired capabilities on both the switch and the adjunct.</li> </ol>
58	Bearer capability not presently available	Requested bearer capability is implemented, but not administered. No B-channel administered. See code 50 above.
63	Service or option not available	<p>Requested ASAI capability or resource is not available on the switch or adjunct. More than one adjunct may be contending for the same switch resource. Potential administration mismatch between the resource domains administered on the switch and those administered on the adjunct.</p> <ol style="list-style-type: none"> <li>1. Verify that no overlapping administration of switch resources (for example, requesting notifications on a single domain by multiple adjuncts attempting to control a single call) exists across all adjuncts connected to the switch. If overlaps exist, then re-administer the adjuncts to ensure that each adjunct is associated with a unique set of switch resources.</li> </ol>
65	Bearer service not implemented	Requested service not implemented in switch or endpoint.
69	Requested facility not implemented	<p>Requested service not supported in switch or endpoint.</p> <ol style="list-style-type: none"> <li>1. Consult switch and endpoint documentation to determine service support.</li> </ol>

*Continued on next page*

**Table 9-51. ASAI Cause Values — Continued**

Code	Explanation	Recommendation
79	Service or option not implemented	Requested service or option (or combination of selected options) is not supported (implemented) in switch or the adjunct.  1. Consult switch and adjunct documentation to determine ASAI service and options supported by both switch and adjunct. Re-administration of the switch-administered capabilities (see Customer Optional Feature Form) or those of the adjunct may be necessary to correct the problem.
81	Invalid CRV	An invalid CRV was sent by the adjunct.  1. This may indicate a CRV inconsistency between the switch and the adjunct. See the CallVisor protocol reference manual.
87	Internal switch audit	There is an inconsistency in switch data records.  1. There is no action needed, since the switch has corrected the data inconsistency.

**System Technician-Demanded Tests:  
 Descriptions and Error Codes**

When inspecting errors in the system, always investigate errors associated with the circuit pack and port first. Clearing these error codes first may also clear errors generated against the endpoint. When all circuit pack and port errors have been cleared, but errors still exist against the endpoint, investigate errors in the table below. By clearing error codes associated with the Signaling Link Status Test, for example, you may also clear errors generated from other tests in the testing sequence.

Order of Investigation	Short Test Sequence	Long Test Sequence	D/ND <sup>1</sup>
Signaling Link Status Test (#626)	X	X	ND

1. D = Destructive; ND = Nondestructive

**BRI Layer 3 Query Test (#629)**

This test is not used by the ASAI-ADJ maintenance object. For information about this test, see BRI-SET in the maintenance documentation.

## Signaling Link Status Test (#626)

This test determines the current status of the signaling link. This test passes if the link is "bound" to an endpoint and fails if the link is "not bound."

The definition of the term "bound" for a link depends upon the type of endpoint and may depend on the successful completion of procedures at both Layers 2 and 3 of the protocol. The definition of "bound" for ASAI type of endpoint is:

- ASAI adjuncts and BRI endpoints not administered for MIM initialization (point-to-point):

For endpoints of this type, the signaling link is "bound" when the link is connected at Layer 2 (L2 established).

**Table 9-52. TEST #626 Signaling Link Status Test**

Error Code	Test Result	Description/ Recommendation
1139	ABORT	The Packet Bus in the port network is out-of-service. <ol style="list-style-type: none"><li>1. Follow the repair procedures for the Packet Bus.</li><li>2. After completing Step 1, execute the <b>test port long UUCSSpp</b> command and review the results of the BRI Port Local LAN Looparound Test to verify the repair.</li></ol>
1141	ABORT	The PKT-CTRL is out-of-service. <ol style="list-style-type: none"><li>1. Refer to PKT-CTRL maintenance documentation.</li></ol>
1144	ABORT	The PPN Packet Bus is out-of-service. <ol style="list-style-type: none"><li>1. Follow the repair procedures for the Packet Bus in the PPN.</li><li>2. Execute the <b>test port long UUCSSpp</b> command and review the results of the BRI Port Local LAN Looparound Test to verify the repair.</li></ol>
1187	ABORT	The circuit pack, port, or station may have been busied out. <ol style="list-style-type: none"><li>1. Look in the Error Log for Error Type 18 (busied out) for ASAI-BD, ASAI-PT, or ASAI-EPT.</li><li>2. If this Error Type is present for ASAI-EPT only, then use the <b>release station</b> command and run the test again.</li><li>3. If this Error Type is present for ASAI-PT and ASAI-EPT, then use the <b>release port</b> command and run the test again.</li><li>4. If this Error Type is present for ASAI-BD, ASAI-PT, and ASAI-EPT, then use the <b>release board</b> command and run the test again.</li></ol>

*Continued on next page*

**Table 9-52. TEST #626 Signaling Link Status Test — Continued**

<b>Error Code</b>	<b>Test Result</b>	<b>Description/ Recommendation</b>
2012 2100	ABORT ABORT	Internal system error Could not allocate the necessary system resources to run this test. 1. Retry the command at 1-minute intervals for a maximum of 5 times.
1113	FAIL	The signaling link is not "bound" to the adjunct. For ASAI adjuncts this error indicates that the link is disconnected at Layer 2. Since the signaling link associated with the endpoint has been identified by administration, the link is only "unbound" from the endpoint when it is disconnected. 1. Execute the <b>status bri-port UUCSSpp</b> command and refer to the associated procedures for this command contained in "BRI-PORT".
	PASS	The signaling link is connected at Layer 2 and "bound" to the ASAI adjunct.

## ASAI-PT

---

MO Name (in Alarm Log)	Alarm Level	Initial Command to Run <sup>1</sup>	Full Name of MO
ASAI-PT	MAJOR <sup>2,3</sup>	test port UUCSSpp I	ASAI ISDN BRI Port
ASAI-PT	WARNING	test port UUCSSpp I	ASAI ISDN BRI Port

1. Where UU is the universal cabinet number (1 for PPN and 2-44 for EPN); C is the carrier designation (for example, A, B, C, D, or E); SS is the address of the slot in the carrier where the circuit pack is located (for example, 01, 02, ..., and so forth); and pp is the two digit port number (01, 02, 03, ...).
2. The alarm level for ASAI adjunct ports may be administered using the **set options** command. The alarm level can be set independently for off-board and on-board alarms to WARNING, MINOR, or MAJOR for all ASAI adjunct ports in the system.
3. All alarming for an ASAI adjunct and off-board alarming for an ASAI port is disabled if the ASAI adjunct asks the switch to suspend maintenance. When this occurs, an error and a WARNING alarm is logged against the ASAI adjunct. Check the Hardware Error and Alarm Logs to see if the adjunct has disabled alarming.

Unless otherwise stated, all maintenance actions contained in this section apply to ASAI-PT and ISDN-BRI ports connected to ASAI adjuncts. This port type is administered as an ASAI-BD on the TN800 circuit pack.

The TN800 circuit pack is a PC-based platform that allows interaction of multiple applications with DEFINITY. DEFINITY software (Native mode) supports emulation of three types of port MOs on this board. The type of ports to be emulated are defined by the applications running on the TN800. The TN800 can support a maximum of 32 ports (time slots) at a time.

The TN800 connects to the switch through a single slot in the backplane, however its width is not limited to one slot. The number of slots occupied by the TN800 is supplied by the board during its insertion. The TN800 (Release 5 and higher) is 3 slots wide. The blank (reserve) slots are to the left of the functional slot.

In non-native mode the TN800 is recognized as TN556, TN2181, TN754, or TN746 based on the switch software and the application running on the TN800. In non-native mode only one type of port MO runs at any time, and the port type depends on the application running on the TN800. If the TN800 fails diagnostics in non-native mode, the system's alarm and error logs would show a failure for the board type the TN800 is emulating.

## Error Log Entries and Test to Clear Values

Table 9-53. ASAI-PT Port Error Log Entries

Error Type	Aux Data	Associated Test	Alarm Level ASAI-PORT	On/Off Board	Test to Clear Value
0 <sup>1</sup>	0	Any	Any	Any	test port UUCSSpp sh r 1
1 (a)	(a)	Level 1 Status Inquiry (#621)	MAJ <sup>2</sup>	OFF	test port UUCSSpp sh r 2
513 (b)	0	none	(b)	ON	
1537 (c)	46210	CRC Error Counter (#623)	MAJ <sup>2</sup>	OFF	
3841 (d)	46208	None			
3844 (e)	46223	None			
3845 (f)	46211	None			
3846 (g)	TEI	None			

1. Run the Short Test Sequence first. If all tests pass, run the Long Test Sequence. Refer to the appropriate test description and follow the recommended procedures.
2. Major and Minor alarms may be downgraded to warning alarms based on the value used in the **set options** command.

### Notes:

- a. This error occurs when the Level 1 Status Inquiry fails or when the BRI circuit pack detects that Level 1 has been deactivated on the port. The `Aux Data` field contains one of the following values:

Blank This indicates that the Level 1 Status Inquiry failed.

32773 This is a message from the ASAI-Line circuit pack indicating Level 1 has been deactivated.

Refer to the repair procedures for Test #621.

- b. The circuit pack is having problems transmitting data to the Packet Bus, thus affecting the conveyance of signalling information over D-channel. This error occurs when the Packet Bus transmit FIFO buffer overflows. This condition probably indicates a hardware problem as well. The ASAI-PORT alarm level is MAJOR with aux data 0. Use troubleshooting procedures for both on-board hardware problems and potential off-board Packet Bus problems.



- c. The port received an invalid frame over the D-channel. When the Cyclical Redundancy Check (CRC) errors exceed 5 within 15 minutes, the port is taken out of service for 5 seconds. If 5 more CRC errors are received within 15 minutes of the first set of 5 errors, the port is taken out of service for one minute. If 5 more CRC errors are received within 15 minutes of the last 5, the port is taken out of service for 15 minutes.

This error is most likely due to a problem with the wiring to the set or adjunct, interference on the wiring due to a noise source, or no termination (an open circuit). It usually does not indicate a problem with the circuit pack.

- Check the wiring to the endpoints or the adjunct.
  - If the problem persists, replace the endpoints or adjuncts.
- d. This error occurs when a Layer 1 Transmission error is detected for the port. Run the Long Test Sequence and note the results of the Layer 1 Transmission Error Counter Test (#624).
- e. This error occurs when the circuit pack detects an overflow of its receive buffers. Run the Long Test Sequence and note the results of the Receive FIFO Overflow Counter Test (#625).
- f. This error occurs when the BRI Port Local LAN Looparound Test (#618) fails. Run the Long Test Sequence and note the results of Test (#618).
- g. The Terminal Endpoint Identifier (TEI) administered for the ASAI endpoint most likely does not match the TEI administered in the ASAI adjunct. Check the switch administration of the TEI against that of the adjunct, and make sure that both are using the same TEI.

### System Technician-Demanded Tests: Descriptions and Error Codes

Always investigate tests in the order presented in the following tables when inspecting errors in the system. For example, by clearing error codes associated with the NPE Crosstalk Test, you may also clear errors generated from other tests in the testing sequence.

**Table 9-54. System Technician-Demanded Tests: ASAI-PT**

Order of Investigation	Short Test Sequence	Long Test Sequence	D/ND <sup>1</sup>
ASAI Port Local LAN Looparound Test (#618)		X	D
Level 1 Status Inquiry Test (#621)	X	X	ND
CRC Error Counter Test (#623)		X	ND

*Continued on next page*

**Table 9-54. System Technician-Demanded Tests: ASAI-PT — Continued**

Order of Investigation	Short Test Sequence	Long Test Sequence	D/ND <sup>1</sup>
Layer 1 Transmission Error Counter Test (#624)		X	ND
Receive FIFO Overflow Error Counter Test (#625)		X	ND
Clear Error Counters (#270)	X	X	ND

1. D = Destructive, ND = Non-destructive

### **BRI Port Local LAN Looparound Test (#618)**

**This test is destructive.**

This test verifies the connectivity of a BRI port across the LAN Bus and executes only if the port is out-of-service. The test aborts if calls associated with the port are in-progress. Failures of this test indicate either on-board faults associated with the ASAI-PT hardware on the circuit pack or problems with the LAN Bus, which is used to form connectivity between the switch and the ASAI-PT.

The dotted lines in [Figure 9-2](#) show how a Looparound Test is performed across the Packet Bus for the D-channel.

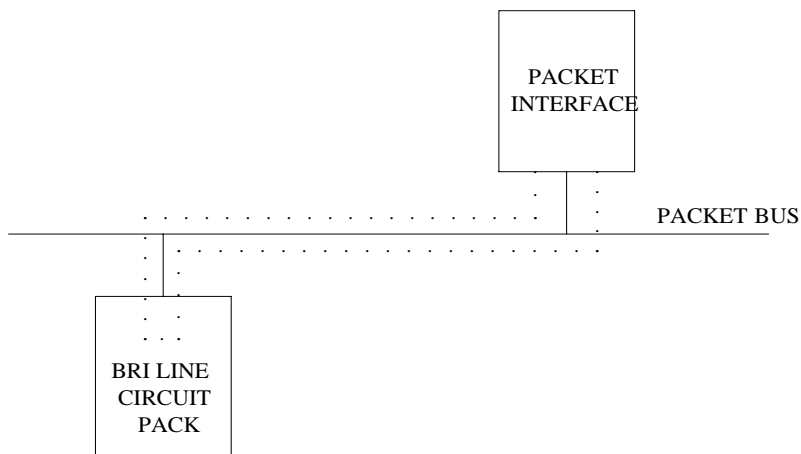

**Figure 9-2. BRI Port Local LAN Looparound Path**

**Table 9-55. TEST #618 BRI Port Local LAN Looparound**

Error Code	Test Result	Description/Recommendation
1015	ABORT	<p>The port is not in the out-of-service state.</p> <ol style="list-style-type: none"> <li>1. Display the Port Status form using the <b>status bri-port UUCSSpp</b> command to determine which stations or adjuncts are on this port.</li> <li>2. Use the extension shown on this form in the <b>status station</b> command to determine if the station or adjunct is in use.</li> <li>3. If the port is in use, wait until it is idle, and use the <b>busyout port UUCSSpp</b> command to place it in the out-of-service state and repeat this test.</li> </ol> <p><b>⚠ WARNING:</b>  <i>Since the "busyout" command is destructive, using this command prior to the port being idle causes all transactions associated with the ASAI on the port to be torn down. Note that third party calls established by an ASAI adjunct remain connected even though the port is taken out-of-service.</i></p>

*Continued on next page*

**Table 9-55. TEST #618 BRI Port Local LAN Looparound — Continued**

Error Code	Test Result	Description/Recommendation
1139	ABORT	The Packet Bus in the port network is out-of-service. <ol style="list-style-type: none"> <li>Follow the repair procedures for the Packet Bus.</li> <li>After completing Step 1, execute the <b>test port long UUCSSpp</b> command and review the results of the BRI Port Local LAN Looparound Test to verify the repair.</li> </ol>
1141	ABORT	The PKT-CTRL is out-of-service. <ol style="list-style-type: none"> <li>Follow the repair procedures for the PKT-CTRL.</li> <li>Issue the <b>test port long UUCSSpp</b> command and review the results of the BRI Port Local LAN Looparound Test to verify the repair.</li> </ol>
1144	ABORT	The PPN Packet Bus is out-of-service. <ol style="list-style-type: none"> <li>Follow the repair procedures for the Packet Bus.</li> <li>Issue the <b>test port long UUCSSpp</b> command and review the results of the BRI Port Local LAN Looparound Test to verify the repair.</li> </ol>
2012	ABORT	Internal system error
2100	ABORT	Could not allocate the necessary system resources to run this test. <ol style="list-style-type: none"> <li>Retry the command at 1-minute intervals for a maximum of 5 times.</li> </ol>
	FAIL	The Looparound test has failed. <ol style="list-style-type: none"> <li>If the test fails repeatedly, attempt to reset the circuit pack if the other ports on the board are not in use. Reset the circuit pack by issuing the <b>busyout board UUCSS</b> and the <b>reset board UUCSS</b> commands.</li> <li>If the test fails again, execute <b>test pkt P</b> on the management terminal. If this fails, follow the failure procedures the in PKT-BUS section.</li> <li>If the tests executed in Step 2 pass, the problem is local to the BRI board. Replace the circuit pack.</li> </ol>
	PASS	The BRI Port Local LAN Looparound test has passed.

**Level 1 Status Inquiry Test (#621)**

This test determines the state of the transmission facility of a BRI port at the Level 1 (L1) or physical layer. L1 can be in one of two possible states: Activated or Deactivated.

The Activated state is the correct state for an ISDN-BRI port. In this state the Level 1 interface can communicate with the BRI endpoint or ASAI adjunct administered on this port. This test passes if the state of L1 is activated. This test also passes if software has taken this port out of service.

The Deactivated state indicates a problem with the ASAI circuit pack. When in this state, the Level 1 interface is idle and is not trying to communicate with the BRI endpoints or adjunct. When an ASAI port is placed in the out-of-service state, Level 1 is also put into the deactivated state. This could be due either to the system detecting a fault with the port or in response to a **busyout port UUCSSpp** request.

**Table 9-56. TEST #621 Level 1 Status Inquiry**

Error Code	Test Result	Description/Recommendation
1187	ABORT	<p>The board, port, or station may have been busied-out by a technician.</p> <ol style="list-style-type: none"> <li>1. Look in the Error Log for Error Type 18 (port busied out) for this port and ASAI-BD (board busied out). If this error type is present for ASAI-PT only, then release the port using the <b>release port pp</b> command and run the test again. If the error is present for both ASAI-BD and ASAI-PT, then release the board with the <b>release port UUCSS</b> command and run the test again.</li> </ol> <p><b>⇒ NOTE:</b>                      When you release a port, you release all ports associated with it. If certain ports still need to be busied out, use the <b>release port UUCSSpp</b> command to busy them out.</p> <ol style="list-style-type: none"> <li>2. Make sure the terminal is connected.</li> <li>3. Retry the command at 1-minute intervals for a maximum of 5 times.</li> </ol>
2000	ABORT	<p>Response was not received from the circuit pack within the allowable time period.</p> <ol style="list-style-type: none"> <li>1. If the test aborts repeatedly a maximum of 5 times, reset the circuit pack using the <b>busyout board UUCSS</b> and <b>reset board UUCSS</b> commands.</li> <li>2. If the test aborts again, replace the circuit pack.</li> </ol>
2012	ABORT	<p>Internal system error</p>
2100	ABORT	<p>Could not allocate the necessary system resources to run this test.</p> <ol style="list-style-type: none"> <li>1. Retry the command at 1-minute intervals for a maximum of 5 times.</li> </ol>

*Continued on next page*

Table 9-56. TEST #621 Level 1 Status Inquiry — Continued

Error Code	Test Result	Description/Recommendation
3	FAIL	<p>Received a status of Level 1 Deactivated; the port is out-of-service.</p> <ol style="list-style-type: none"><li>1. Issue the <b>status bri-port UUCSSpp</b> command to verify that the service state of the port is out-of-service. If the port is not out-of-service, escalate the problem, or else proceed to Step 2.</li><li>2. If the port has been placed out-of-service using the <b>busyout port UUCSSpp</b> command, try releasing the port by executing the <b>release port UUCSSpp</b> command. Then issue the <b>test port long UUCSSpp</b> command, and review the results of Level 1 Status Inquiry test. If this test is still failing, proceed to Step 3.</li><li>3. After executing the <b>test port long UUCSSpp</b> command, review the results of all the tests. Follow the repair procedures for any tests that fail. Verify repair of the problem by executing the <b>test port UUCSSpp</b> command and by determining that the Level 1 Status test passes.</li><li>4. If the test continues to fail for this reason, escalate the problem.</li></ol>
	PASS	<p>This test indicates that Level 1 is activated, or that software has taken the port out of service.</p>

### CRC Error Counter Test (#623)

This test reads and clears the BRI port's CRC error counter maintained on the BRI-LINE circuit pack. This counter is incremented by the circuit pack when it receives a frame from the endpoint or adjunct with a bad CRC over the D-channel. The test passes if the value of the counter is 0 (the error is cleared). If the counter is not 0, the test will fail and the value of the counter is displayed in the `Error Code` field. A CRC error is most likely due to a problem with the wiring to the set or adjunct, interference on the wiring due to a noise source (for example, electrical motors or generators), or no termination (open circuit). It usually does not indicate a problem with the BRI circuit pack. This test is used for verifying the repair of the problem.

**Table 9-57. TEST #623 CRC Error Counter Test**

Error Code	Test Result	Description/Recommendation
2000	ABORT	Response was not received from the circuit pack within the allowable time period. <ol style="list-style-type: none"> <li>1. If the test aborts repeatedly a maximum of 5 times, reset the circuit pack using the <b>busyout board UUCSS</b> and <b>reset board UUCSS</b> commands.</li> <li>2. If the test aborts again, replace the circuit pack.</li> </ol> <p> <b>CAUTION:</b>  <i>Do not leave the circuit pack busied out.</i></p>
2012	ABORT	Internal system error <ol style="list-style-type: none"> <li>1. Retry the command at 1-minute intervals for a maximum of 5 times.</li> </ol>
Any	FAIL	The BRI circuit pack is still detecting CRC errors. The <code>ERROR_CODE</code> field contains the value of the counter. <ol style="list-style-type: none"> <li>1. Retry the command at 1-minute intervals for a maximum of 5 times.</li> <li>2. If the test continues to fail, review the results of other tests in the long test sequence. Pay particular attention to the results of the Level 1 Status Inquiry test. Follow the repair procedures for any of the executed tests if they fail; otherwise, proceed to Step 3.</li> <li>3. If the tests for the endpoints or adjunct pass and the CRC error counter test continues to fail, check the wiring to the endpoints or adjunct. If the wiring appears to be OK, escalate the problem.</li> </ol>

**Layer 1 Transmission Error Counter Test (#624)**

This test reads and clears the BRI port's Layer 1 Transmission error counter maintained on the ASAI circuit pack. This counter is incremented by the circuit pack when it detects a Layer 1 transmission problem. The test passes if the value of the counter is 0 (that is, the error is cleared). If the counter is not zero, the test fails, and the value of the counter is displayed in the Error Code field.

This error is most likely due to a problem with the wiring or adjunct (verify that the wiring meets the configuration rules defined in *DEFINITY Communications System Generic 1 and Generic 3i Wiring*, 555-204-111). It does not indicate a problem with the TN800 circuit pack. This test is useful for verifying the repair of the problem.

**Table 9-58. TEST #624 Layer 1 Transmission Error Counter Test**

Error Code	Test Result	Description/Recommendation
2000	ABORT	Response was not received from the circuit pack within the allowable time period. <ol style="list-style-type: none"> <li>1. If the test aborts repeatedly a maximum of 5 times, reset the circuit pack using the <b>busyout board UUCSS</b> and <b>reset board UUCSS</b> commands.</li> <li>2. If the test aborts again, replace the circuit pack.</li> </ol>
2012 2100	ABORT ABORT	Internal system error Could not allocate necessary system resources to run test. <ol style="list-style-type: none"> <li>1. Retry the command at 1-minute intervals for a maximum of 5 times.</li> </ol>
Any	FAIL	The TN800 circuit pack is still detecting errors of this type. The Error Code field contains the value of this counter. <ol style="list-style-type: none"> <li>1. Retry the command at 1-minute intervals for a maximum of 5 times.</li> <li>2. If the test continues to fail, review the results of other tests in the Long Test Sequence. Note the results of the Level 1 Status Inquiry test. Follow the repair procedures for any of the executed tests if they fail. Otherwise, go to the next step.</li> <li>3. Replace the circuit pack.</li> </ol>
	PASS	The Layer 1 Transmission error counter was read correctly and has a value of 0.

**Receive FIFO Error Counter Test (#625)**

This test reads and clears the BRI port's Receive FIFO error counter maintained on the TN800 circuit pack. This counter is incremented by the circuit pack when it detects an overflow of its receive buffers. The test passes if the value of the counter is 0 (that is, the error is cleared). If the counter is not zero, the test fails, and the value of the counter is displayed in the Error Code field.

This error can occur if signaling frames are being received from a Packet Bus at a rate sufficient to overflow the receive buffers on the circuit pack for a port or if hardware fault is causing the receive buffers not to be emptied properly. This test is useful for verifying the repair of the problem.



**Table 9-59. TEST #625 Receive FIFO Error Counter Test**

Error Code	Test Result	Description/Recommendation
2000	ABORT	Response was not received from the circuit pack within the allowable time period. <ol style="list-style-type: none"> <li>1. If the test aborts repeatedly a maximum of 5 times, reset the circuit pack via the <b>busyout board UUCSS</b> and <b>reset board UUCSS</b> commands.</li> <li>2. If the test aborts again, replace the circuit pack.</li> </ol>
2012	ABORT	Internal system error
2100	ABORT	Could not allocate necessary system resources to run test. <ol style="list-style-type: none"> <li>1. Retry the command at 1-minute intervals for a maximum of 5 times.</li> </ol>
Any	FAIL	The TN800 circuit pack is still detecting errors of this type. The Error Code field contains the value of this counter. <ol style="list-style-type: none"> <li>1. Retry the command at 1-minute intervals for a maximum of 5 times.</li> <li>2. If the test continues to fail, review the results of other tests in the Long Test Sequence. Note the results of the Level 1 Status Inquiry test. Follow repair procedures for any of the tests that fail. Otherwise, go to the next step.</li> <li>3. If the tests for the endpoints or adjunct pass and the Layer 1 Transmission Error Counter Test continues to fail, check the wiring to the endpoints or adjunct.</li> </ol>
	PASS	The Layer 1 Transmission error counter was read correctly and has a value of 0.

**Clear Error Counters Test (#270)**

There are various error counters associated with each ASAI-PT. This test clears those counters and triggers the auditing of Layer 3 reinitialization. This test is used only to send messages to the ASAI-PT and, therefore, should neither abort nor fail. ASAI uses a fixed TEI value of 1.

**Table 9-60. TEST #270 Clear Error Counters**

<b>Error Code</b>	<b>Test Result</b>	<b>Description/Recommendation</b>
Any	ABORT	This test should never abort.
Any	FAIL	This test should never fail. 1. Retry the command at 1-minute intervals for a maximum of 5 times.
	PASS	The message to clear the error counters of the ASAI-PT has been sent.

## ASAI-RES/E-DIG-RES (TN800 reserve slot)

---

MO Name (in Alarm Log)	Alarm Level	Initial Command to Run	Full Name of MO
ASAI-RES	NONE	NONE	TN800 ASAI reserve slot
E-DIG-RES	NONE	NONE	TN800 DIG reserve slot

There are no tests associated with these MOs. Both the **test board** and **busy out board** commands abort when either is attempted on a reserved slot. An error message indicates the slot is associated with the circuit pack that the TN800 is emulating, but the requested operation is not valid.

The TN800 MAPD (Multi-Application Platform for DEFINITY) circuit pack connects to the switch through a single slot in the backplane. The number of slots occupied by the MAPD pack is supplied by the board when inserted. The TN800 in R5EM is 3 slots wide. The TN800 requires 2 reserve slots to its left. The reserve (blank) slots are to left of the functional slot and are place holders on the switch, and do not have any interaction with the switch.

Each instance of these MOs represents a reserve slot associated with respective circuit pack mode in which the MAPD is working.

## ATM-BCH (ATM B-Channel Trunk)

MO Name (in Alarm Log)	Alarm Level	Initial Command to Run <sup>1</sup>	Full Name of MO
ATM-BCH <sup>2</sup>	MAJOR <sup>3</sup>	test port UUCSSppp l	ATM B-Channel Trunk
ATM-BCH	MINOR	test port UUCSSppp l	ATM B-Channel Trunk
ATM-BCH	WARNING	test port UUCSSppp sh	ATM B-Channel Trunk

1. UU is the universal cabinet number (1 for PPN, 2-44 for EPNs). C is the carrier designation (A, B, C, D, or E). SS is the number of the slot where the circuit pack resides (01-21). ppp is the 3-digit port number (9-256).
2. For additional repair information, see also [“ATM-DCH \(ATM D-Channel Port\)”](#), [“ATM-SGRP \(ATM Signaling Group\)”](#) and PKT-BUS.
3. A MAJOR alarm on a trunk means that alarms on these trunks are not downgraded by the **set options** command, and at least 75% of the trunks in this trunk group are alarmed.

This maintenance object explains how you test and repair TN230x ATM Interface circuit packs (TN2305 and TN2306) that have ATM B-channel trunks administered for ATM Circuit Emulation Service (CES).

For maintenance instructions for TN230x circuit packs that are administered as Expansion Interfaces for ATM network connectivity, see the [“ATM-EI \(Expansion Interface Circuit Pack\)”](#) maintenance object.

## ATM Circuit Emulation Service

Under ATM Circuit Emulation Service, you simulate ISDN-PRI circuits by assigning ATM ports to *signaling groups*. Each signaling group represents a PRI circuit, and the ports in the group represent the D-channel and B-channels of that circuit. B-channels must also be assigned to ISDN-PRI trunk groups. TN230x circuit packs support up to 248 ports per circuit pack.

### Signaling group components

Bearer (B) channels (ATM-BCH) transmit digitized voice or data, while a separate D-channel (ATM-DCH) handles call-control signaling. One D-channel handles signaling for a group of B-channels that combine to form a signaling group (ATM-SGRP).

### B-channel service states

The ISDN specification defines 2 service state categories for B-channels as listed in [Table 9-61](#).

**Table 9-61. ATM ISDN service states**

Category	Description		
<b>Service states</b>			
In-Service (INS)	B-channel is in normal operating state	Active	A call is connected over the B-channel.
		Idle	There is no call on the B-channel.
Out-of-Service/Far-end (OOS/FE)	<p>The switch has not successfully negotiated B-channel connection as of yet. Calls cannot be placed or received.</p> <p>When you first administer a B-channel, the switch initializes the B-channel to this state while it tries to negotiate a connection to the far end. If the request times out with no response from the far end, the switch leaves the B-channel in the OOS/FE state.</p>		
Out-of-Service/Near-End (OOS/NE)	The NPE Crosstalk Test has failed or the trunk is busied out. Calls cannot be placed or received.		
Maintenance/Far-End (MTC/FE)	A request has timed out with no response from the far end after signaling is in place and B-channels are in service. Calls can be received but not placed, and stable calls are unaffected.		
Maintenance/Near-End (MTC/NE)	The signaling channel (ISDN-LNK) has been busied out, possibly after a <b>test trunk grp#/mbr# long</b> command. Calls cannot be placed or received, but stable calls are unaffected.		
<b>Pending states<sup>1</sup></b>			
Pending-in-Service	The near-end is waiting for a response to a transition-to-service request.		
Pending-Maintenance	The near-end is waiting for a transition-to-maintenance-service request (US and other country-protocol-1 systems).		

1. The switch is waiting for a reply from the far-end. Pending service states remain in effect until the near end receives a response or times out.

**B-channel alarms**

The Maintenance/Far-End and Out-Of-Service/Far-End states generate warning alarms displayed with **status trunk grp#/mbr#**.

**Table 9-62. ATM-BCH alarms by service state**

Service state	Alarm <sup>1</sup>	Possible cause	Possible solution
Out-of-Service/NE	Warning	Trunk busied out	Release the port ( <b>release trunk grp#mbr#</b> ).
	Minor	NPE Crosstalk Test (#6) failed	Replace ATM circuit pack.
	None	ATM circuit pack lost signal or there is a circuit pack problem.	Install circuit pack or cable. Check circuit pack using procedures in ATM-BCH. Check far-end switch status.
Out-of-Service/FE	Warning	Unadministered far-end	Administer the corresponding trunk on the far-end switch.
	Warning	Far-end busied out	Check the status of the far-end switch.
Pending/In-Service Pending/Maint	None	Maintenance message timed out waiting for reply	Wait 2 minutes after the pending state clears, and check the service state.
Maint/NE	None	ISDN test call in progress ( <b>test trunk long</b> )	Wait for the test to finish and recheck.
	None	System link busied out	Check link status. Run <b>release link link#</b> .
Maint/FE	Warning	Signaling channel down for over 90 sec.	See <a href="#">ATM-SGRP</a> or <a href="#">ATM-DCH</a> .
	Warning	Repeated lack of response to messages sent to the far end	Wait. Maintenance software resends messages periodically. Or run <b>test trunk grp#mb#</b> or <b>test signaling-grp grp#</b> .
	Warning	The far-end trunk is being tested.	Check status of the far-end switch. Wait for testing to finish.
In-Service	None	Normal operating state	

1. ATM-BCH alarms; alarms against other maintenance objects may also be present.

## Error Log Entries and Test to Clear Values

**Table 9-63. ATM-BCH Error Log entries**

Error Type	Aux Data	Associated Test	Alarm Level	On/Off Board	Test to Clear Value
0 <sup>1</sup>	0	Any	Any	Any	test port UUCSSppp
1(a)	Any	None			test port UUCSSppp
18	0	busyout trunk <i>grp/mbr</i>			release trunk <i>grp/mbr</i>
129 (b)		None	WNG	OFF	test port UUCSSppp
130 (c)					test port UUCSSppp
257(d)	Any	Service State Audit (Test #256)			test port UUCSSppp
513(e)	Any	None	WNG	OFF	test port UUCSSppp
769(f)	Any	Service State Audit (Test #256)			test port UUCSSppp
1793(g)	Any	None			test port UUCSSppp
3073(h)	Any	Service State Audit (#256)			test port UUCSSppp
3585(i)	Any	None			none
3841(j)	Any	None	WNG	OFF	none

1. Run the Short Test Sequence first. If all tests pass, run the Long Test Sequence. Refer to the appropriate test description and follow the recommended procedures.

### Notes:

- a. Error Type 1: the two ends of the ATM trunk do not agree on the ISDN call state. Possible causes:
  - Received a DISConnect or RELease COMplete message with cause value 52 (outgoing calls barred)
  - Received a DISConnect or RELease COMplete message with cause value 54 (incoming calls barred)
  - Outgoing call renegotiated by the far end to another B-channel in the absence of SETUP message glare
  - Near end attempted a call on a B-channel that the far end has marked OOS

When running the Short Test Sequence, pay close attention to the results of the Call State Audit Test (#257).

- b. Error Type 129: the far-end switch changed its ISDN service state to either out-of-service or maintenance. This may be a temporary condition because the far-end is testing that trunk or a hardware problem with the trunk. Outgoing calls may not be allowed over that trunk.
  1. Investigate the trunk status (**status trunk grp#/mbr#**).
- c. Error Type 130: the circuit pack has been removed or has been insane for more than 11 minutes.
  1. Reinsert or replace the circuit pack to clear the error.
- d. Error Type 257: SETUP received for a B-channel that is in an invalid service state. Service states may be incompatible at the two ends of the trunk. A normal call was received while the B-channel was MTC/FE, MTC/NE, OOS/FE, or OOS/NE or a test call was received while the B-channel was OOS/FE or OOS/NE.
- e. Error Type 513: RELEase COMplete message received with cause value 82 (nonexistent channel). The B-channel may not be administered at the far end. The trunk has been placed in the OOS/FE state.
- f. Error Type 769: inconsistent SERvice or SERvice ACKnowledge message. Possible causes:
  - SERvice or SERvice ACKnowledge message received containing a change status that is more available than the previously-transmitted SERvice message.
  - Unsolicited SERvice ACKnowledge message received containing a change status that does not match the current B-channel state.

ISDN-PRI service-state negotiation rules have been violated and may indicate that a pending service-state audit is failing. The system

- cancels the maintenance timer
- increments the Service State Audit counter
- attempts a Service State Audit

When running the Short Test Sequence, pay close attention to the results of the Service State Audit Test (#256).

- g. Error Type 1793: TN230x circuit pack has failed. The maintenance system
  - places the trunk in the OOS/NE state
  - sends a SERvice message to the far-end (if possible) containing a change status of OOS for the B-channel
  - returns the trunk to service when the ATM trunk circuit pack reports the failure cleared
- h. Error Type 3073: Service State Audit attempt failed (see Test #256). Calls can be received but not placed until the test passes and the trunk state returns to In-Service.
  1. Check the trunk status (**status trunk grp#/mbr#**).



- i. Error Type 3585: ISDN RESTART message received. Active calls have been dropped.

The following Aux Data values (Error Type 3585 only) below represent the trunk's ISDN call state at the time Error 3585 occurred. This information can be useful if users report dropped calls on the ISDN-PRI trunks.

Aux Data	Description
0	An idle trunk received a restart.
10	An ISDN RESTART from the far-end has unexpectedly cleared a call in the ACTIVE state (call stable, parties talking).
4 7 8 260 263	An ISDN RESTART from the far-end has unexpectedly cleared a RINGING call.
1 3 6 9 265	An ISDN RESTART from the far-end has unexpectedly cleared a call before the call entered the RINGING state.
11 12 19 531 267 268	An ISDN RESTART from the far-end has unexpectedly cleared a call that was already in the process of clearing. If this condition occurs frequently, the far-end may be trying to clear trunks that appear to be in the "hung" state.

- j. Error Type 3841: the far-end rejected an ATM CES trunk selected by the near-end 10 times. The ATM CES trunk may not be administered on the far-end.

1. Get the physical name of the ATM trunk by noting the decimal number in the Aux Data field.
2. Check administration for the named trunk on the far-end.
3. If problems persist, then busyout the ATM trunk to take it out of the hunt group.

The WARNING alarm retires automatically whenever a called endpoint answers an outgoing or incoming call that uses the alarmed trunk.

## System Technician-Demanded Tests: Descriptions and Error Codes

---

Always investigate problems in the order presented in the table below. When you clear one of the error codes associated with a given test, you clear errors generated by other tests in the testing sequence. If you clear errors out of order, you can lose important information.

**Table 9-64. System Technician-Demanded Tests: ATM-BCH**

Order of Investigation	Short Test Sequence	Long Test Sequence	Destructive or Non-destructive
Signaling Link State Check Test (#255)	X	X	ND
Service State Audit Test (#256)	X	X	ND
Call State Audit Test (#257)	X	X	ND
ISDN Test Call Test (#258)		X	ND

---

### Signaling Link State Audit Test (#255)

This non-destructive test checks the status of the TN230x ATM-CES Interface circuit pack and the ATM D-channel (ATM-DCH) trunk, which are both important elements to the health of the ATM-BCH trunk.

**Table 9-65. TEST #255 Signaling Link State Audit Test**

Error Code	Test Result	Description/ Recommendation
None	ABORT	Internal system error
0	ABORT	
1114	ABORT	Signaling link in transitional state 1. Retry the command up to 5 times at 1-minute intervals.
1018	ABORT	Maintenance disabled 1. Enable maintenance. Enter <b>y</b> in the <code>Maintenance Tests?</code> field on page 2 of the <b>change trunk-group</b> form.

---

*Continued on next page*

Table 9-65. TEST #255 Signaling Link State Audit Test — Continued

Error Code	Test Result	Description/ Recommendation
4	FAIL	Signaling channel problem 1. Look for errors or alarms against the “ <a href="#">ATM-SGRP (ATM Signaling Group)</a> ” and “ <a href="#">ATM-DCH (ATM D-Channel Port)</a> ” maintenance objects.
8	FAIL	TN230x circuit pack failed 1. See the “ <a href="#">ATM-INTF (TN2305/6)</a> ” maintenance object.
	PASS	Signaling link OK.

## Service State Audit (#256)

This test checks the service state of the trunk.

**Country protocol 1.** If the interface uses country protocol 1 (includes USA), the service-state audit executes in all trunk service states. It queries the service state on the far end and waits 2 minutes for a reply. If the first request times out, the service-state audit asks again. If the request times out again, it logs error 3073 and resends the request every 15 minutes. It places in-service trunks in the MAINTENANCE/FAR-END state (outgoing calls blocked, incoming calls accepted). Incoming calls trigger an immediate service-state audit without waiting for the end of a 15-minute cycle.

**Any other country protocol.** If the interface uses some other country protocol, the service-state audit executes only on trunks that are in the OUT-OF-SERVICE/FAR-END state. It asks the far-end switch to bring the trunk back into the IN-SERVICE state and waits 2 minutes for a reply. If the first request times out, the service-state audit asks again. If the request times out again, it leaves the trunk in the OUT-OF-SERVICE/FAR-END state and tries again in 1 hour.



### NOTE:

PASS for this test only means that a message to the far-end was successfully sent.

To check the service state of the ATM-BCH trunk, run **status trunk grp#mbr#**.

**Table 9-66. TEST #256 Service State Audit Test**

Error Code	Test Result	Description/ Recommendation
1000	ABORT	Needed resources not available, port on a call or initializing 1. Run <b>status trunk grp#mbr#</b> . 1. Check the results of Test #255.
1018	ABORT	Maintenance disabled 1. Enable maintenance by entering <b>y</b> in the <code>Maintenance Tests?</code> field on page 2 of the <b>change trunk-group</b> form.
1113	ABORT	Signaling link failed 1. Run <b>status trunk grp#mbr#</b> . 2. Check the results of Test #255. 3. See the " <a href="#">ATM-SGRP (ATM Signaling Group)</a> " maintenance object.
1114	ABORT	Signaling link in transitional state 1. Retry the command up to 5 times at 1-minute intervals.
1116	ABORT	Trunk not in Out-of-Service/Far-end state and country protocol other than 1
1117	ABORT	Service-state audit message outstanding 1. Wait 2 minutes, then try again.
2100	ABORT	Could not allocate needed resources 1. Retry the command up to 5 times at 1-minute intervals.
1113	FAIL	Signaling link failed 1. See the " <a href="#">ATM-SGRP (ATM Signaling Group)</a> " and ISDN-LNK (ISDN Signaling Link Port) maintenance objects.
	FAIL	Internal system error 1. Retry the command up to 5 times at 1-minute intervals.
	PASS	1. Wait 4 minutes, then check the Error Log for any new Error Type 3073. <ul style="list-style-type: none"> <li>■ If there are none, both sides of the ISDN connection agree on the service state. The negotiation succeeded.</li> <li>■ If there is a new 3073 error, then the negotiation failed (the request timed out).</li> </ul>

## Call State Audit Test (#257)

This test audits the internal call state by asking the far-end switch for the ISDN call state. The test is particularly useful when you are trying to clear a hung call. If the internal call state on the near-end differs from that on the far-end, the call is torn down.

The ISDN specification allows up to 2 minutes for a reply. If a reply is not received within the 2 minute window, the test logs a protocol time-out violation against the associated signaling channel (ATM-DCH, Error Type 1).

**NOTE:**

PASS simply means that an appropriate message was composed and sent to the far-end switch.

**Table 9-67. TEST #257 Call State Audit Test**

Error Code	Test Result	Description/ Recommendation
1018	ABORT	Maintenance disabled 1. Enable maintenance by entering <b>y</b> in the <i>Maintenance Tests?</i> field on page 2 of the <b>change trunk-group</b> form.
1019	ABORT	Audit already in progress 1. Wait 2 minutes, and try again.
1113	ABORT	Signaling link failed 1. Check the results of Test #255 (Signaling Link State Check).
1114	ABORT	Signaling link in transitional state 1. Retry the command up to 5 times at 1-minute intervals.
1116	ABORT	Trunk out-of-service 1. Check the trunk service state ( <b>status trunk grp#mbr#</b> ).
2100	ABORT	Could not allocate needed resources 1. Retry the command up to 5 times at 1-minute intervals.
	FAIL	Internal system error 1. Retry the command up to 5 times at 1-minute intervals.
	PASS	1. Wait 4 minutes, then check the Error Log for call-state mismatches. If a call state mismatch is found, the call is torn down.

## ISDN Test Call Test (#258)

This non-destructive test performs a far-end looparound test over an ATM-BCH trunk if

- the trunk is IN-SERVICE, MAINTENANCE/NEAR-END, or OUT-OF-SERVICE/NEAR-END
- no calls are active on the trunk
- the system uses country protocol 1 (including US) or the far-end has looparound capability

The test sets up a call to a far-end switch over the ATM-BCH trunk. Then the digital port on a TN711D Maintenance/Test circuit pack sends a bit pattern to the far-end and back. If the received pattern matches that sent, the test passes. If there are differences, it fails.

### Synchronous Test Calls

You can initiate a synchronous outgoing test call (including a test call for ISDN-PRI trunks) with these commands:

- **test trunk** *grp#/mbr# long* [repeat #]
- **test board** *UUCSS long* [repeat #]
- **test port** *UUCSSpp long* [repeat #]

Table 9-68. TEST #258 ISDN Test Call

Error Code	Test Result	Description/ Recommendation
4	ABORT	Signaling channel problem <ol style="list-style-type: none"><li>1. Look for errors or alarms against the <a href="#">“ATM-SGRP (ATM Signaling Group)”</a> and <a href="#">“ATM-DCH (ATM D-Channel Port)”</a> maintenance objects.</li></ol>
8	ABORT	TN230x circuit-pack problem <ol style="list-style-type: none"><li>1. See the <a href="#">“ATM-INTF (TN2305/6)”</a> maintenance object.</li></ol>
1004	ABORT	B-channel in use. <ol style="list-style-type: none"><li>1. See if a call is active. Run <b>status trunk</b> <i>grp#/mbr#</i> command.</li><li>2. If the service state is In-Service/Idle, retry the test.</li></ol>
1005	ABORT	Bad configuration (for example, no Maintenance/Test circuit pack) <ol style="list-style-type: none"><li>1. Make sure that the Maintenance/Test Circuit Pack is inserted.</li><li>2. Repeat the test.</li></ol>
1018	ABORT	Test call disabled <ol style="list-style-type: none"><li>1. Enable Maintenance on the Trunk Group form.</li></ol>

**Table 9-68. TEST #258 ISDN Test Call — Continued**

Error Code	Test Result	Description/ Recommendation
1020	ABORT	TN230x circuit-pack problem 1. See the <a href="#">“ATM-INTF (TN2305/6)”</a> maintenance object.
1024	ABORT	Maintenance/Test Digital Port in use 1. Wait until yellow and green LEDs on the Maintenance/Test circuit pack are OFF. 2. Rerun the test. 3. If the problem persists, see the M/T-DIG (Maintenance/Test Digital Port) maintenance object.
1113	ABORT	Signaling link failed 1. Check the results of Test #255 (Signaling Link State Check Test).
1116	ABORT	Switch could not change the service state 1. See if calls are active. Run <b>status trunk grp#/mbr#</b> . 2. If a call is active. proceed as for Error Code 1119. 3. If not, check the Error and Alarm Logs and refer to the ATM-TRK (Circuit Emulation Service Circuit Pack) maintenance object.
1117	ABORT	ISDN service message outstanding 1. Wait 2 minutes. Then try again.
1118	ABORT	Far-end not administered 1. Check the administration of the far-end of the ATM trunk. Run <b>status trunk grp#/mbr#</b> . 2. Try the test again.
1119	ABORT	Test call aborted, normal call attempted 1. Wait for the call to terminate normally or drop it by running <b>busyout trunk grp#/mbr#</b> . 2. When the trunk is idle, retry the test.
1120	ABORT	Trunk OUT-OF-SERVICE/FAR-END 1. Try to change the service state via Test #256 (Service State Audit Test). 2. Try the test again.
1122	ABORT	No test-line number for the far-end switch 1. Check the Trunk Group Administration form.
1123	ABORT	No Feature Access Code administration for this Facility Test 1. Check the Dial Plan and Feature Administration forms.

*Continued on next page*

**Table 9-68. TEST #258 ISDN Test Call — Continued**

Error Code	Test Result	Description/ Recommendation
2000 2012 None	ABORT	Internal system error 1. Retry the command up to 5 times at 1-minute intervals.
2035	ABORT	Call timed out 1. Wait 1 minute, and try again.
2036- 2037	ABORT	Internal system error 1. Retry the command up to 5 times at 1-minute intervals.
2038- 2039	ABORT	Problem reading test data 1. Wait 1 minute, and then try again. 2. If the test aborts again, there is a serious internal problem.
2040	ABORT	Internal system error 1. Retry the command up to 5 times at 1-minute intervals.
2041	ABORT	Call timed out 1. Wait 1 minute, and try again.
2066	ABORT	Could not establish test call 1. Retry the command up to 5 times at 1-minute intervals.
2067	ABORT	Call timed out 1. Wait 1 minute, and try again.
2074	ABORT	Bit and Block Error query failed 1. Retry the command up to 5 times at 1-minute intervals. 2. If the test continues to abort, there may be a serious internal problem in the Maintenance/Test Digital Port. See the M/T-DIG (Maintenance/Test Digital Port) maintenance object.
2075	ABORT	Internal system error 1. Retry the command up to 5 times at 1-minute intervals.
2100	ABORT	Could not allocate the necessary system resources to run this test. 1. Retry the command at 1-minute intervals a maximum of 5 times.
2201- 2205	ABORT	Internal system error 1. Retry the command up to 5 times at 1-minute intervals.
2206	ABORT	Could not allocate needed resources 1. Retry the command at 1-minute intervals a maximum of 5 times.

*Continued on next page*



**Table 9-68. TEST #258 ISDN Test Call — Continued**

<b>Error Code</b>	<b>Test Result</b>	<b>Description/ Recommendation</b>
2208	ABORT	Internal system error 1. Retry the command at 1-minute intervals a maximum of 5 times.
2209-2210	ABORT	Could not allocate needed resources 1. Follow recommendations for ABORT code 2100.
2211	ABORT	Internal system error. 1. Retry the command at 1-minute intervals a maximum of 5 times.
2212	ABORT	Call terminated by unexpected disconnect 1. Wait 1 minute and then try again.
2213	ABORT	Call timed out 1. Wait 1 minute, and try again.
2214	ABORT	Call terminated by unexpected disconnect 1. Wait 1 minute and then try again.
2215-2219	ABORT	Internal system error 1. Retry the command at 1-minute intervals a maximum of 5 times.
2220	ABORT	Call terminated prematurely 1. Wait 1 minute, and try again.
2221-2226	ABORT	Internal system error 1. Retry the command at 1-minute intervals a maximum of 5 times.
2227	ABORT	Could not allocate needed resources 1. Retry the command at 1-minute intervals a maximum of 5 times.
2042	FAIL	Test data corrupt
	PASS	Test pattern intact. If the synchronous test call was performed (long test sequence), the communications path is operating properly.

## ATM-DCH (ATM D-Channel Port)

MO Name (in Alarm Log)	Alarm Level	Initial System Technician Command to Run <sup>1</sup>	Full Name of MO
ATM-DCH <sup>2</sup>	MINOR	test port <i>UUCSSpp l</i>	ATM D-Channel
ATM-DCH	WARNING	test port <i>UUCSSpp sh</i>	ATM D-Channel

1. pp is administered as a port in the range of 9 through 32.
2. For additional related information, see [“ATM-TRK \(Circuit Emulation Service Circuit Pack\)”](#).

### ⇒ NOTE:

TN230x circuit packs are not interchangeable. Always replace an ATM circuit pack with the same type.

This MO (ATM-DCH) utilizes the existing ISDN-PLK or D-channel maintenance strategy with modifications. The ATM circuit pack can be administered for up to 8 Circuit Emulation Service (CES) or signaling groups, each with its own D-channel, as opposed to one D-channel for an entire DS1 circuit pack.

### ⇒ NOTE:

Due to the dual personalities and the number of D channels the ATM board can possess, the in-line errors and signaling port LAN loopback test have been moved to the maintenance object ATM-TRK. When an in-line error is sent due to PACKET BUS errors, the ATM circuit pack maintenance object receives the error, not ATM-DCH.

The D-channel ISDN-PRI interface, which is emulated for ATM-CES, uses out-of-band signaling to transmit control messages between two endpoints. User information or bearer channels (B-channels) carry digitized voice and digital data and are assigned to DS1 ISDN trunks or PRI endpoints. Call control signaling for the B-channels is combined and carried over the separate ISDN-PRI Signaling Link Port D-channel.

Problems with ATM-DCH affects all of the associated B-channels, since call control signaling cannot reach the far-end switch or terminal adapter. Stable calls may remain operational, but no new calls can be made. ATM-DCH in turn depends on the TN230X ATM Trunk circuit pack it resides on and the packet bus which provides the link to the processor.

When working ATM-DCH alarms or errors, also investigate

- [“ATM-TRK \(Circuit Emulation Service Circuit Pack\)”](#)
- PKT-BUS

## Hardware Error Log Entries and Test to Clear Values

---

**Table 9-69. ATM D-channel Error Log entries**

Error Type	Aux Data	Associated Test	Alarm Level	On/Off Board	Test to Clear Value
0 <sup>1</sup>	0	Any	Any	Any	test port UUCSSpp <sup>2</sup>
18 (a)	0	busyout port <i>UUCSSpp</i>	WARNING	OFF	release port UUCSSpp
130 (b)		None	WARNING	ON	test port UUCSSpp
1793 (c)		Signaling Link Board Check (#643)			test board UUCSS I

---

1. Run the Short Test Sequence first. If all tests pass, run the Long Test Sequence. Refer to the appropriate test description and follow the recommended procedures.
2. pp is for ports 9-32.

**Notes:**

- a. Error Type 18: D-channel busied out; no calls possible over this D-channel.
  - b. Error Type 130: circuit pack removed or has been insane for more than 11 minutes. To clear the error, reinsert or replace the circuit pack.
  - c. Error Type 1793: ATM Trunk circuit pack failed the Signaling Link Board Check (#643). Resolve any ATM-TRK errors in the Error Log.
-

## System Technician-Demanded Tests: Descriptions and Error Codes

The command to test the ATM-DCH maintenance object is **test port UUCSSpp**, where pp is for ports 9-32.

**Table 9-70. System Technician-Demanded Tests: ATM-DCHL**

Order of Investigation	Short Test Sequence	Long Test Sequence	D/ND <sup>1</sup>
Signaling Link Board Check (#643)	X	X	ND

1. D = Destructive, ND = Non-destructive

### Signaling Link Board Check (#643)

This nondestructive test checks the health of the ATM TN230X Trunk circuit pack hardware. The test runs on a periodic or scheduled basis, during initialization testing, and upon demand.

**⇒ NOTE:**

The board-level maintenance is handled independently of the ATM-CES signaling link maintenance, raising the possibility of inconsistent states.

**Table 9-71. TEST #643 Signaling Link Board Check**

Error Code	Test Result	Description/ Recommendation
	ABORT	Internal System Error 1. Retry the command at 1-minute intervals for a maximum of 5 times.
8	FAIL	The TN230X circuit pack is not in-service. 1. Check the Error Log for ATM-TRK errors and resolve any using <a href="#">“ATM-TRK (Circuit Emulation Service Circuit Pack)”</a> .
	PASS	The ATM TN230X circuit pack is in-service.

## ATM-EI (Expansion Interface Circuit Pack)

MO Name (in Alarm Log)	Alarm Level	Initial Command to Run <sup>1</sup>	Full Name of MO
ATM-EI	MAJOR	test board UUCSS	ATM Expansion Interface Circuit Pack
ATM-EI	MINOR	test board UUCSS	ATM Expansion Interface Circuit Pack
ATM-EI	WARNING	test board UUCSS	ATM Expansion Interface Circuit Pack

1. UU is the universal cabinet number (1 for PPN, 2 - 44 for EPNs). C is the carrier designation (A, B, C, D, or E). SS is the number of the slot in which the circuit pack resides (01 to 21).

This maintenance object covers the ATM circuit pack administered as an ATM-Port Network Connectivity (PNC) Expansion Interface (ATM-EI). The ATM-EI provides PNC between a DEFINITY PPN and all the EPNs through the ATM switch.

The circuit packs listed in [Table 9-72](#) are ATM-EI boards *if they are administered to serve the ATM Port Network Connectivity (ATM-PNC) for DEFINITY.*

**Table 9-72. ATM-EI circuit packs for R7 ATM-PNC**

Circuit pack	Fiber	Echo cancellation	Release
TN2305	Multi mode	Y	7.1
TN2306	Single mode	Y	7.1
TN2238	Multi mode	N	6.3

### ⇒ NOTE:

TN230x circuit packs are not interchangeable. Always replace an ATM circuit pack with the same type.

### ⇒ NOTE:

ATM switch maintenance is not covered in this section. When DEFINITY ECS maintenance software suspects the ATM switch connections, it raises appropriate DEFINITY alarms.

To clear any ATM switch faults, refer to the particular ATM switch's documentation.

## LEDs

---

The ATM-EI circuit pack has three LEDs:

- red indicates some alarm condition
- green indicates maintenance testing in progress
- yellow provides useful visual information regarding the operating mode of the ATM-EI and possible error conditions.

The possible LED states are in [Table 9-73](#).

**Table 9-73. ATM-EI LED codes**

LED	LED status	Condition
Red	Steady on	Board is not healthy
	Never on	Normal conditions
Red and Green	Red LED solid on Green LED 200 ms on; 200 ms off	Board is in the processes of booting
Green	Steady on <sup>1</sup>	Maintenance is running tests on the board
	100 ms on - 100 ms off	No links to the board
Yellow	100 ms on -100 ms off	Fiber Loss of Signal (LOS), LOF, MS_RDI, MS_AIS, LCD, HP_RDI, HP_AIS, LOP, PSC (See <a href="#">Table 9-77</a> )
Yellow	500 ms on; 500 ms off	Signal to the ATM switch is down
Yellow	2 s on; 0.2 s off	ATM-EI is Expansion Archangel (EAA)
Yellow	Steady on	ATM-EI active (PPN)
Yellow	Never on	ATM-EI standby

---

1. The green LED flashes between tests.

---

## ATM-EI-related commands

---

The following commands may be helpful in resolving ATM-EI problems:

add atm pnc	list measurements atm
busyout/release atm pnc	remove atm pnc
busyout/release board	reset board
change system-parameters customer-options (atm pnc)	status atm-pnc
change atm pnc (pnc duplication)	status cabinet
display atm pnc	status port-network
list atm oam-statistics	test board
list atm pnc	

## Replacing an ATM-EI circuit pack

---

### Standard Reliability

1. Enter **busyout atm-pnc** at the DEFINITY SAT.
2. Replace the ATM-PNC circuit pack.
3. Enter **release atm-pnc**.
4. Wait 2.5 minutes for board insertion (firmware download).
5. Enter **list sys-link** to verify that the links are up.
6. Enter **test board UUCSS** and verify that all tests pass.

### High Reliability

There are 2 ATM-EI circuit packs in the PPN, 1 in the EPN.

1. Enter **busyout atm pnc** at the DEFINITY SAT.
2. Replace the circuit pack.
3. Enter **release atm pnc**.
4. Wait 2.5 minutes for board insertion (firmware download).
5. Enter **list sys-link** to verify that the links are up.
6. Enter **test board UUCSS** and verify that all tests pass.

## Critical Reliability

There are 2 ATM-EI circuit packs in the PPN, 2 in the EPN.

1. Enter **status pnc** at the DEFINITY SAT. If the board is on the active side, enter **reset pnc interchange** to switch the active ATM-EI board to the standby side.
2. Enter **busyout pnc-standby**.
3. Enter **busyout atm-pnc a-pnc** or **b-pnc**.
4. Replace the circuit pack.
5. Enter **release atm pnc**.
6. Enter **release pnc-standby**.
7. Wait 2.5 minutes for board insertion (firmware download).
8. Enter **test board UUCSS** and verify that all tests pass.

## Basic ATM PNC administration

---



### NOTE:

This section contains basic administration information only. Refer to *DEFINITY ECS Installation, Upgrade, and Administration for ATM* for more detailed information.

ATM PNC connections involve administering

- 1 ATM-EI board in each Port Network (Standard Reliability)
- 2 ATM-EI boards in the PPN; 1 in each EPN (High Reliability)
- 2 ATM-EI boards in every Port Network; 1 in each EPN (Critical Reliability)

## Adding ATM PNC connections

### Standard Reliability

1. If the ATM PNC EI circuit pack is not present or if the circuit pack is present but is in an EPN, use the **change circuit-pack** command to add circuit pack translation.
2. Enter **add atm pnc n** (connection number), and administer the circuit pack location and ATM address.

### Critical Reliability

1. Enter **change system-parameters duplication** and change the Enable Operation of PNC Duplication field to **n**.



2. If the ATM PNC EI circuit pack is not present or is present but it is in an EPN that does not yet have PNC connectivity to it, use the **change circuit-pack** command to add circuit pack translation for the missing circuit pack.
3. Enter **add atm pnc n** (connection number), and administer the circuit pack location and ATM address.
4. Enter **change system-parameters duplication** and change the Enable Operation of PNC Duplication field to **y**.

## Removing ATM PNC connections

### Standard Reliability



**NOTE:**

Standard Reliability systems are *not* equipped with PNC duplication.

1. Enter **busyout atm-pnc n** (connection number)
2. Enter **remove atm-pnc n** (connection number)

### Critical Reliability

1. Enter **status pnc** and ensure that the A-PNC is active. If it is not active, request a PNC interchange using the **reset pnc interchange** command.
2. Enter **busyout pnc-standby**.
3. Enter **change system-parameters duplication** and change the Enable Operation of PNC Duplication field to **n**.
4. Enter **busyout atm-pnc n** (port network number).
5. Enter **remove atm pnc n** (port network number) to remove both ATM PNC EI boards, or enter **change atm pnc** to remove the B-side ATM PNC EI board.
6. Enter **change system-parameters duplication** and change the Enable Operation of PNC Duplication field to **y**.

## Changing circuit pack location or ATM address

### Standard Reliability



**NOTE:**

Standard Reliability systems are *not* equipped with PNC duplication.

1. Remove the ATM PNC connection (see [“Removing ATM PNC connections”](#) above).
2. Add an ATM PNC connection (see [“Adding ATM PNC connections”](#) above).

### A-side ATM PNC EI — Critical Reliability

1. Remove the ATM PNC connection (see [“Removing ATM PNC connections”](#) above).
2. Add an ATM PNC connection (see [“Adding ATM PNC connections”](#) above).

### B-side ATM PNC EI — Critical Reliability

1. Enter **status pnc** and ensure that the A-PNC is active.  
 If it is not active, request a pnc interchange using the **reset pnc interchange** command.
2. Enter **busyout pnc-standby**.
3. Enter **list config car** and verify that an ATM circuit pack is administered for the new location. If it is not, add the ATM circuit pack translations.
4. Enter **busyout atm pnc n** (connection number) **b-pnc**.
5. Enter **change atm pnc n** (connection number) and change circuit pack location for the B side.
6. Enter **release pnc-standby**.

### Changing ATM address of a B-side ATM-PNC EI — Critical Reliability

1. Enter **busy pnc-standby**.
2. Enter **change atm pnc n** (connection number) and change the ATM address for the B side.
3. Enter **release pnc-standby**.

## Error Log Entries and Test to Clear Values

Table 9-74. ATM-EI Error Log Entries

Error Type	Aux Data <sup>1</sup>	Associated Test	Alarm Level	On/Off Board	Test to Clear Value
0 <sup>2</sup>	0	Any	Any	Any	test board UUCSS
2 (a)		None	MIN	ON	
18 (b)	0	busy out board UUCSS	WAR	OFF	release board UUCSS
23 (c)	0	None	WAR	OFF	
125 (d)		None	MIN	ON	
131 (e)		None	MIN	ON	

*Continued on next page*

**Table 9-74. ATM-EI Error Log Entries — Continued**

<b>Error Type</b>	<b>Aux Data<sup>1</sup></b>	<b>Associated Test</b>	<b>Alarm Level</b>	<b>On/Off Board</b>	<b>Test to Clear Value</b>
257-9 (f)	Any	Expansion Interface Control Channel Test (#316)	MAJ	ON	test board UUCSS r 2
513 (g)	Any	NPE Cross talk Test (#6)	MIN	ON	test board UUCSS l r 3
769 (h)	34, 35	None	WRN	OFF	
770 (h)	31	None	WRN	OFF	
771 (h)	26	None	WRN	OFF	
1024 - 1151 (i)			WRN	ON	test board UUCSS
1153 (j)		None	WRN	ON	test board UUCSS
1281 (k)		ATM Board Error Query test (#1259)	MAJ	OFF	test board UUCSS r 1
1537 (l)	12	None	MIN	ON	
1538 (m)	0	None	MIN	ON	
1793 (n)	13	None	MIN	ON	
2049 (o)	15	None	MIN	OFF	test board UUCSS r 4
2050 (o)		Expansion Interface Lock Query test (#304)	MIN	OFF	test board UUCSS r 4
2305 (p)		None	MIN	ON	
2309 (p)		Packet interface test (#598)	MIN	ON	test board UUCSS r 2
2561 (q)		Expansion Interface 2-way Transmission test (#241)	MAJ	OFF	test board UUCSS r 3
2817 (r)	Any	ATM Board DSP test (#1258 or #1293) <sup>3</sup>	MIN	ON	test board UUCSS
2818 (r)	Any	None	MIN	ON	test board UUCSS
3329 (s)	3	LANHO critical error	MAJ	OFF	
3585 (t)		ATM Framer Looparound Test (#1259)	MAJ	ON	test board UUCSS l
3586 (t)		ATM Board Error Query Test (#1260)	MAJ	ON	test board UUCSS l

*Continued on next page*

**Table 9-74. ATM-EI Error Log Entries — Continued**

Error Type	Aux Data <sup>1</sup>	Associated Test	Alarm Level	On/Off Board	Test to Clear Value
3841 (u)					
3842 (v)					
3999 (w)	Any	None			

1. Aux Data 32767 for any error log entry indicates that an alarmed ATM-EI was busied out and then released. When this occurs, existing service-affecting alarms must be preserved. Typically, all alarms are resolved when the ATM-EI is released. Therefore, the Alarm and Error Logs must be repopulated with the alarms present at time of busyout. This Error Code indicates that existing Aux Data and Error Log time stamps are no longer valid because they were lost when the circuit pack was released.
2. Run the Short Test Sequence first. If all tests pass, run the Long Test Sequence. Refer to the appropriate test description and follow the recommended procedures.
3. Test # 1258 applies to TN2238 (R6.3); Test #1293 applies to TN2305 and TN2306.

Notes:

- a. Error Type 2: on-board DUART chip failed. This results in communication failure between the port network's maintenance board and the ATM-EI board. The Maintenance circuit pack should have a red LED lit, because the link to the ATM-EI is down in this EPN.
  1. Reset the board with the **reset board UUCSS** command.
  2. If the board does not recover, replace the board.
- b. Error Type 18: the ATM-EI circuit pack has been busied out.
  1. Release the circuit pack (**release board UUCSS**).
- c. Error Type 23: an ATM-EI circuit pack has been administered with the **add atm-pnc n** command, but the circuit pack has not been inserted into the system.
  1. Insert an ATM-EI circuit pack at this location.
- d. Error Type 125: a wrong circuit pack is located in the slot where the ATM-EI circuit pack is logically administered.
  1. Either remove the wrong circuit pack and insert the ATM-EI circuit pack or remove the ATM-EI administration (see ["Basic ATM PNC administration"](#)).
  2. Remove the ATM-INTF administration and re-administer the slot (**change circuit-pack**) to match the circuit-pack that is physically present in this slot.

- e. Error Type 131: an ATM-EI circuit pack has been removed from the slot for 5 minutes.
  1. Insert the ATM-EI circuit pack into its administered slot.
  2. Another way to resolve or prevent this alarm is to remove the ATM-EI administration (see [“Basic ATM PNC administration”](#)), then remove the ATM-INTF administration (**change circuit-pack**).

It is possible that the ATM-EI could be held in reset by the EPN Maintenance board and is not inserted in the system.

- 1. Try issuing the **test maint P long** command on the maintenance board in the same port network.
- f. Error Type 257: Expansion Interface Control Channel Test #316 failed (board cannot communicate on the TDM bus control channel). Follow the suggested test procedures.

Error Type 258: The archangel is out of sequence (Aux Data indicates angel number).

Error type 259: the expansion archangel link (EAL) to the active ATM-EI board is down. See SYS-LINK.

- g. Error Type 513: NPE Crosstalk test failed. The board is either writing to or reading from a TDM time slot that is not allocated to the board.
  1. Test the board (**test board UUCSS**) and follow the test procedures suggested for this test. In random tests of a single DSP during low or high traffic, the same DSP may be tested more than once.
- h. Error Type 769 and 770 (Error Type 771 below): board-degraded alarm errors that result when the ATM switch is sending corrupted cells or excessive AAL/LAPD retransmissions (off-board ATM cell corruption errors). These errors indicate the detection of a problem in handling ATM cells that are received from the fiber interface.

Aux Data:

Error Type	Aux Data	Description
769	34	AAL5 Excessive: retransmission requests
769	35	LAPD Excessive: retransmission requests
770	25	ATM Uncorrectable cell headers - threshold
771	26	VPI,VCI pair unknown

The problem is most likely *not* on the ATM-EI circuit pack reporting the errors, but it could be due to one or more of the following reasons:

- The fiber is not snugly connected to either the board or the ATM switch.
- The PN packet bus is corrupting the cells. See Packet maintenance objects (Aux Data 35 only).

- The fiber between the ATM switch and the ATM-EI is too long (greater than 2km for multimode fiber). Use loopback to see if the fiber is corrupting the cells.
- Some other ATM-EI board is not receiving the cells properly.
- The intervening ATM switch is dropping the ATM cells due to a shortage of bandwidth, or the DEFINITY is using more than the subscribed bandwidth.

Error Type 771: the ATM switch is sending cells with unknown VPI and VCI address (wrong connection).

1. Ensure that the ATM-EI board address on the ATM switch matches the ATM-EI (ATM) address on the DEFINITY side.
- i. Error Type 1024-1151: These errors represent problems detected by the ATM-EI board in response to SETUP and ADDPARTY requests from software.
- The Error Types and descriptions are in [Table 9-75](#):
  - Aux Data values represent port network and angel numbers and are in [Table 9-76](#).

**Table 9-75. ATM Error Types 1024 - 1151**

Error Type	Description	General problem
1024	Next node unreachable	ATM protocol stack on ATM-EI circuit pack
1056	DTL Transit not my node ID	

*Continued on next page*

**Table 9-75. ATM Error Types 1024 - 1151 — Continued**

Error Type	Description	General problem
1088	ATM-EI circuit pack received a request with an invalid connection identifier.	Firmware-detected problems on the ATM-EI circuit pack
1089	ATM-EI circuit pack received a request with a reference to an unknown VC token.	
1090	ATM-EI circuit pack did not have enough resources (memory) for the requested operation.	
1091	Internal failure in the local protocol stack. This can occur when the connection to the ATM switch failed, perhaps because the: <ul style="list-style-type: none"> <li>■ ATM switch rebooted</li> <li>■ fiber between the ATM switch and the ATM-EI circuit pack disconnected</li> </ul>	
1092	ATM-EI circuit pack received a request for which the referenced VC was in the wrong call state.	
1093	ATM-EI circuit pack received a request for which the VPI/VCI pair was invalid or out of range.	
1094	ATM-EI circuit pack received a request to add a party to an existing VC. The add party request failed, and a retry was not possible.	
1095	ATM-EI circuit pack in link recovery after the lower ATM layer (Q.SAAL portion of the protocol stack) failed. This can occur when the connection to the ATM switch failed, perhaps because the: <ul style="list-style-type: none"> <li>■ ATM switch rebooted</li> <li>■ fiber between the ATM switch and the ATM-EI circuit pack disconnected</li> </ul>	
1096	ATM-EI circuit pack received an error from the local protocol stack for which no more detailed cause was specified.	
1102	ATM-EI circuit pack asked to create more connections that it was capable of creating.	
1103	ATM-EI circuit pack detected an illegal message from software. <ol style="list-style-type: none"> <li>1. Check the Error Log for CONN-M proc errors for more information.</li> </ol>	
1113	Far-end circuit pack detected a problem of some kind. Further details not available.	Problems detected by the board terminating the connection

1. Test the ATM-EI circuit pack (**test board UUCSS**) and investigate further based on each test's results. If all tests pass, the error was a transient problem.

Aux Data values: For each connection request failure type, the port network and the angel number of the destination ATM-EI circuit pack are logged Aux Data values in the form XXYYY, where

- port network number = XX
- angel number = YYY

Since you need to know the slot number also, [Table 9-76](#) converts the Aux Data to slot numbers.

**Table 9-76. Error Type 1024-1151 Aux Data values (XXYYY) converted to slot number**

Slot	Carrier									
	A		B		C		D		E	
	Failure type		Failure type		Failure type		Failure type		Failure type	
	Setup	Add Party	Setup	Add Party	Setup	Add Party	Setup	Add Party	Setup	Add Party
1	28	528	66	566	98	598	34	534	02	502
2	29	529	67	567	99	599	35	535	03	503
3	30	530	68	568	100	600	36	536	04	504
4	31	531	69	569	101	601	37	537	05	505
5	56	556	70	570	102	602	38	538	06	506
6	57	557	71	571	103	603	39	539	07	507
7	58	558	72	572	104	604	40	540	08	508
8	59	559	73	573	105	605	41	541	09	509
9	60	560	74	574	106	606	42	542	10	510
10	61	561	75	575	107	607	43	543	11	511
11	62	562	76	576	108	608	44	544	12	512
12	63	563	77	577	109	609	45	545	13	513
13	88	588	78	578	110	610	46	546	14	514
14	89	589	79	579	111	611	47	547	15	515
15	90	590	80	580	112	612	48	548	16	516
16	91	591	81	581	113	613	49	549	17	517
17	92	592	82	582	114	614	50	550	18	518
18	93	593	83	583	115	615	51	551	19	519
19	94	594	84	584	116	616	52	552	20	520
20	95	595	85	585	117	617	53	553	21	521
21	NA	NA	86	586	118	618	54	554	22	522
22	NA	NA	87	587	119	619	55	555	23	523



- j. Error type 1153: the ATM connection audit found some discrepancy in the firmware's VC token numbers and live VCs. The problem is rectified in firmware and no action is needed.
- k. Error Type 1281: loss of high-level signal indicating operational problems of equipment located outside of the circuit pack and the fiber connected to the board. Aux Data values are listed in [Table 9-77](#).

**Table 9-77. Error type 1281 Aux Data and repair procedures**

Aux Data	Alarm Description	Repair procedure
15	SYSCLOCK failed	The board is not locked to the TDM backplane clock signal. This is probably due to a Tone Clock problem. <ol style="list-style-type: none"> <li>1. Check for TDM-BUS or TONE-BD errors in the Error Log.</li> <li>2. If no other problems are present, reset the circuit pack (<b>reset board UUCSS</b>)</li> </ol>
16	Loss of Signal: LOS	The fiber is not connected properly to the ATM-TRK board or ATM switch (or to the multiplexer section [MUX] if present).It is possible that the board transceivers are not functioning properly. <ol style="list-style-type: none"> <li>1. Run <b>test board UUCSS</b> command.</li> <li>2. If Test #1259 fails, connect a fiber back-to-back in a looped mode (one strand of fiber connecting the transmit transceiver to the receive transceiver of the board) and see if the yellow LED flash goes away. If it does the problem is off-board.</li> <li>3. If the yellow LED continues to flash, replace the circuit pack.</li> </ol>
17	Loss of Frame: LOF	The fiber signal cannot obtain or maintain STM-1/OC-3 framing. <ol style="list-style-type: none"> <li>1. Try to more the fiber on the ATM switch side to a different port.</li> <li>2. If the problem persists, reset the circuit pack (<b>reset board UUCSS</b>).</li> </ol>

*Continued on next page*

**Table 9-77. Error type 1281 Aux Data and repair procedures — Continued**

Aux Data	Alarm Description	Repair procedure
18	Multiplexer Section Alarm Indication Signal: MS_AIS	<p>There is a major problem on the far end (between multiplexer section [MUX] and the switch) that prohibits the circuit pack from sending a valid signal.</p> <ol style="list-style-type: none"> <li>1. See if the ports at the MUX and/or the ATM switch are connected snugly.</li> <li>2. Run <b>test board UUCSS</b> command</li> <li>3. If Test #1259 fails with Error Code 18, connect a fiber back-to-back in a looped mode (one strand of fiber connecting the transmit transceiver to the receive transceiver of the board) and see if the yellow LED flash goes away.</li> <li>4. If it does the problem is off-board.</li> <li>5. If the yellow LED continues to flash, replace the circuit pack; if the error persists, escalate the problem.</li> </ol>
19	Multiplexer Section Remote Defect Indicator: MS_RDI	<p>The far-end is detecting a major problem with the signal that this board is transmitting.</p> <ol style="list-style-type: none"> <li>1. Make sure the ATM switch port (or a MUX port, if present between ATM switch and the ATM-TRK board) is the same as the ATM-TRK circuit pack's cable interface</li> <li>2. Run <b>test board UUCSS</b> command.</li> <li>3. If Test #1259 fails with Error Code 19, connect a fiber back-to-back in a looped mode (one strand of fiber connecting the transmit transceiver to the receive transceiver of the board) and see if the yellow LED flash goes away.</li> <li>4. If it does the problem is off-board.</li> <li>5. If the yellow LED continues to flash, replace the circuit pack; if the error persists, escalate the problem.</li> </ol>
20	Loss of pointer: LOP	<p>ATM framer chip is unable to access the payload part of the signal.</p> <ol style="list-style-type: none"> <li>1. Reset the board (<b>reset board UUCSS</b>).</li> <li>2. If the error persists replace the board.</li> </ol>
21	Path Signal Error (PSL) (STM1/SONET)	<p>The incoming signal payload is not set up for transmission of ATM data.</p> <ol style="list-style-type: none"> <li>1. Make sure the ATM switch port (or a MUX port, if present between ATM switch and the ATM-TRK board) is the same as the ATM-TRK circuit pack's cable interface.</li> </ol>

*Continued on next page*

**Table 9-77. Error type 1281 Aux Data and repair procedures — Continued**

Aux Data	Alarm Description	Repair procedure
22	High-level Path Alarm Indication Signal: HP_AIS	The payload is invalid. <ol style="list-style-type: none"> <li>1. Make sure the ATM switch port (or a MUX port, if present between ATM switch and the ATM-TRK board) is the same as the ATM-TRK circuit pack's cable interface.</li> <li>2. Run <b>test board UUCSS</b>.</li> <li>3. If Test #1259 fails with Error Code 22, connect a fiber back-to-back in a looped mode (one strand of fiber connecting the transmit transceiver to the receive transceiver of the board) and see if the yellow LED flash goes away.</li> <li>4. If it does the problem is off-board.</li> <li>5. If the yellow LED continues to flash, replace the circuit pack.</li> </ol>
23	High-level path Remote defect Indicator: HP_RDI	The far-end is detecting a major problem with the signal that this board is transmitting. The transmitted payload is invalid. <ol style="list-style-type: none"> <li>1. Make sure the ATM switch port (or a MUX port, if present between ATM switch and the ATM-TRK board) is the same as the ATM-TRK circuit pack's cable interface.</li> <li>2. Run <b>test board UUCSS</b> command; if the Test #1259 fails with Error Code 23, connect a fiber back-to-back in a looped mode (one strand of fiber connecting the transmit transceiver to the receive transceiver of the board) and see if the yellow LED flash goes away.</li> <li>3. If it does the problem is off-board.</li> <li>4. If the yellow LED continues to flash, replace the circuit pack.</li> </ol>
24	Loss of cell delineation (LCD)	On board ATM framer chip is not able to frame cells based on the cell header. <ol style="list-style-type: none"> <li>1. Reset the board (<b>reset board UUCSS</b>).</li> <li>2. If the error persists, replace the board.</li> </ol>
27	SIGCON_DOWN ATM switch high level signal.	The board cannot communicate with the ATM switch. <ol style="list-style-type: none"> <li>1. Busyout the board (busyout board UUCSS).</li> <li>2. Test the board (<b>test board long UUCSS</b>).</li> <li>3. If Test #1260 fails, replace the board.</li> <li>4. If Test #1260 passes, make sure the ATM address on both the DEFINITY and the ATM switch sides are the same for this board.</li> <li>5. If the address is the same, change the port on the ATM switch side.</li> <li>6. If the error is resolved, the problem is on the ATM switch port.</li> </ol>

- l. Error Type 1537: LAN bus time out. The circuit pack is transmitting a packet larger than 1,024 bytes. Replace the circuit pack.
- m. Error Type 1538: A hyperactive ATM-EI circuit pack is generating an abnormal amount of control messages to the processor. When this error is generated, the system automatically resets the ATM-EI.

Duplicated PNC?	Then:
Y	service to the EPN is disrupted
N	the system switches to the standby PNC

- 1. Enter the **reset board UUCSS** command for this ATM-EI circuit pack.
  - 2. If the same error persists, replace the ATM-EI circuit pack.
- n. Error Type 1793: LANHO transmit FIFO overflow error (the transmit FIFO RAM buffers on the circuit pack overflowed). This most likely indicates a hardware problem on the circuit pack, because the speed of the LAN/Package Bus is much higher than the speed of the link connected to the port.
  - 1. Test this ATM-EI circuit pack (**test board UUCSS**).
  - 2. If Test #598 fails again, replace the ATM-EI circuit pack.
- o. Error Type 2049, 2050: the ATM-EI is out of lock with the backplane system clock.
  - 1. Test this ATM-EI circuit pack (**test board UUCSS**).
  - 2. If Test #304 fails, follow the repair procedures suggested for this test.
- p. Error Type 2305: too many parity errors on data received from the LAN/Package Bus (could be due to packet bus problems).
  - 1. Test the ATM-EI circuit pack (**test board UUCSS**).
  - 2. If Test #598 fails, follow the repair procedures suggested for this test.
  - 3. If the test passes, look for and resolve any PKT-BUS (Packet Bus) alarms/errors.
  - 4. If there are no PKT-BUS errors and the problem persists, escalate the problem.
- Error Type 2309: packet interface chip (LANHO) malfunctioning.
  - 1. Test the ATM-EI circuit pack (**test board UUCSS**).
  - 2. If Test #598 fails, follow the repair procedures suggested for this test.

- q. Error Type 2561: ATM-EI 2-way Transmission Failure (circuit pack is having problems creating connections to other port networks in the system).
  - 1. Test the ATM-EI circuit pack (**test board UUCSS**).
  - 2. Follow the repair procedures suggested for Test #241.
- r. Error Type 2817, 2818: DSP test failure detected along the circuit path of the ATM-EI circuit pack.

Error Type	Description	Aux Data indicates
2817	DSP test failure	The Aux Data field contains the following information about the failed DSPs: <ul style="list-style-type: none"> <li>■ X is the number of talker DSPs</li> <li>■ Y is the number of listener DSPs</li> <li>■ Z is the number of echo-cancelling DSPs</li> </ul>
2818	One or more DSPs failed	DSP number that has failed

- 1. Test the ATM-EI circuit pack (**test board UUCSS**).
  - 2. Follow the repair procedures suggested for Test #1258.
- s. Error Type 3329: on-board LANHO chip is insane, possibly due to a problem in Packet Bus arbitration, the transmission line frame, or the circuit pack itself. The circuit pack cannot talk to the packet bus.

If the packet bus is alarmed:

- 1. Resolve PKT-BUS errors, if any. The probability of this error being related to Packet bus problem increases with the number of other circuit packs using the Packet bus that are also displaying this error.

If the Packet Bus is *not* alarmed:

- 1. Reset the circuit pack (**reset board UUCSS**).
- 2. If the problem persists, replace the ATM-EI circuit pack.

If the system has a duplicated PNC, and the in-line error received is from an active ATM-EI, the system switches to the standby PNC.



**CAUTION:**

*If the system does not have duplicated PNC, services to the EPN could be disrupted.*

- t. Error Type 3585, 3586 (Major board alarm): failure of critical components involved in the operation of the circuit pack, and the switch may no longer recognize the circuit pack. If the system has a duplicated PNC and the in-line error received is from an active ATM-EI, the system switches to standby PNC.



**CAUTION:**

*If the system does not have duplicated PNC, services to the EPN could be disrupted.*

Error Type 3585:

Aux Data (Error Type 3585 only):

Aux Data	Description
1	ATM framer failure
2	NCE failed (only from ATM-EIs in EPN)
4	TDM_PLD_FAILED
5	DSP_ALL FAILED
6	Receive Network Processor (RNP) failure
7	Transmit Network Processor (TNP) failure
8	MEMORY read/write failure

1. If the board is in a PPN, or if the system has duplicated PNC:
  - a. Test the ATM-EI (**test board UUCSS I**).
  - b. If Error 3585 is detected again, or if the board is not recognized anymore, replace the ATM-EI circuit pack.
2. If the system does *not* have duplicated PNC, and the circuit pack is in an EPN:
  - a. Replace the ATM-EI circuit pack.

Error Type 3586: Framer Looparound Test #1260 failed.

Aux Data (Error Code 3586 only):

Aux Data	Description
2	Packet path failed
3	Circuit path failed
4	TDM loop cannot be created
5	Packet loop cannot be created

1. If Error Type 3586 is detected again, replace the circuit pack.
- u. Error Type 3841: the board received a message from the switch that it does not recognize, and the board responded with an inconsistent down link error message. This error does not affect service, and no action is required.
  - v. Error type 3842: the circuit pack received data from the Packet Bus faster than it could distribute the data to its endpoint. This circuit pack should be able to recover by itself, and no action is necessary.
  - w. Error Type 3999: circuit pack sent a large number of control channel messages to the switch within a short period of time.

If	Then
Error Type 1538 is also present	Circuit pack is taken out of service
If Error Type 1538 is not present	Circuit pack is <i>not</i> taken out of service, but has generated 50% of the messages necessary to be considered hyperactive. <ul style="list-style-type: none"> <li>■ This may be normal during heavy traffic.</li> <li>■ If the error is logged during light traffic, it may indicate a problem with the circuit pack or the equipment attached to it.</li> </ul>

### System Technician-Demanded Tests: Descriptions and Error Codes

Always investigate tests in the order presented in [Table 9-78](#) when inspecting the errors in the system. By clearing error codes associated with the Control Channel Test, for example, you may also clear errors generated from other tests in the testing sequence.

**Table 9-78. System Technician-Demanded Tests: ATM-EI**

Order of Investigation	Short Test Sequence	Long Test Sequence	Reset Board Sequence	D/ND <sup>1</sup>
ATM Board DSP Test (#1258) for TN2238 circuit packs	X	X		ND
Expansion Interface 2way-Transmission Test (#241)	X	X		ND
ATM Board Framer Looparound Test (#1260)		X		D
NPE Cross Talk-Test (#6) for TN2238 circuit packs		X		ND
Expansion Interface Lock Query Test (#304)	X	X		ND
ATM Board Error Query Test (#1259)	X	X		ND
ATM Expansion Interface Reset (#1256)			X	D
ATM board DSP test(#1293) for TN2305 and TN2306 circuit packs.	X	X		ND
ATM Cross Talk test(#1298) for TN2305 and TN2306 circuit packs		X		ND

1. D = Destructive, ND = Non-destructive

**⇒ NOTE:**

To get a better indication of a problem's location, test both ATM-EI circuit packs on the associated fiber link, whether the circuit packs are both ATM-EI circuit packs or not.

**NPE Cross Talk Test (#6) (TN2238 only)**

This test is non-destructive. The NPE Cross Talk test verifies that the selected TDM bus time slot never crosses over to time slots reserved for other connections. The test also checks for cross connections, where the board talks/listens to time slots other than those specified. Since this test uses many system resources (TDM time slots, tone generator, tone detector, and others), it runs as a part of a demand test only.

This test fails if either the TDM programmable logic and/or the interface to the DSP is not operating properly. Failure of these components may result in one-way or noisy connections. Refer to [Figure 9-3](#) for a schematic of this test.



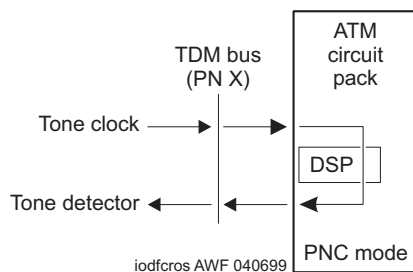

**Figure 9-3. NPE Cross Talk Test #6 schematic**

**Table 9-79. NPE Crosstalk Test (#6)**

Error Code	Test Result	Description/ Recommendation
	ABORT	Could not allocate the necessary system resources to run this test. 1. Retry the command at 1-minute intervals for a maximum of 5 times.
2	ABORT	All DSPs are busy (an unlikely event) 1. Retry the command at 1-minute intervals for a maximum of 3 times.
1002	ABORT	The system could not allocate time slots for the test. The system may be under heavy traffic conditions or it may have time slots out-of-service due to TDM-Bus errors. 1. If system has no TDM-Bus errors and is not handling heavy traffic, repeat test at 1-minute intervals for a maximum of 5 times.
1003	ABORT	The system could not allocate a tone receiver for the test. The system may be oversized for the number of tone detectors present or some tone detectors may be out-of-service. 1. Resolve any TTR-LEV errors. 2. Resolve any TONE-PT errors. 3. If neither condition exists, retry the test at 1-minute intervals for a maximum of 5 times.
2000	ABORT	Response to the test was not received within the allowable time period.
2100	ABORT	Could not allocate the necessary system resources to run this test. 1. Retry the command at 1-minute intervals for a maximum of 5 times.
2752	ABORT	The circuit pack in this location is not an ATM pack.

*Continued on next page*

**Table 9-79. NPE Crosstalk Test (#6) — Continued**

Error Code	Test Result	Description/ Recommendation
1	FAIL	One (or more) DSP on the circuit pack is defective. Because of the above condition maintenance software could not allocate a DSP for this test: <ol style="list-style-type: none"> <li>1. Test the circuit pack (<b>test board UUCSS</b>) and see if the DSP Test #1258 passes.</li> <li>2. If the DSP Test #1258 fails, replace the circuit pack.</li> <li>3. If the DSP Test #1258 passes, retry the command at 1-minute intervals a maximum of 3 times.</li> </ol>
6	FAIL	Cannot establish a looparound because the previously-established looparound was not removed. <ol style="list-style-type: none"> <li>1. Retry the command at 1-minute intervals a maximum of 3 times.</li> <li>2. If the test fails with the same error code, replace the circuit pack.</li> </ol>
	FAIL	The board is writing on unauthorized TDM time slots. <ol style="list-style-type: none"> <li>1. Retry the command at 1-minute intervals a maximum of 3 times.</li> <li>2. If the failure persists, replace the circuit pack.</li> </ol>
	PASS	The board is not talking to unauthorized time slots on the TDM Bus.

### Expansion Interface 2-way Transmission Test (#241)

This test is non-destructive and applies to all ATM-EIs, both active and standby. It is run as part of craft short and long testing, periodic, scheduled, initialization, and error analysis testing. The test sets up a connection between a Tone/Clock in one cabinet and a Tone Detector in a separate cabinet and transmits a digital test count between the port networks. The ATM-EIs used to set up this connection are chosen by maintenance, not call processing. After the connection is checked for dial-tone, the connection is torn down and re-established in the opposite direction.

In this test the second ATM-EI may be in any port network outside the port network of the ATM-EI under test. Therefore if the test should fail in any direction, the test is repeated with a different port network, if available, which aids the fault isolation procedure.

The test results indicate if the test failed in one or both directions. The test aborts if the ATM-EIs do not exist on both ends (for example, the EIs are not administered correctly). If the test passes, the TDM and ATM framer interfaces of both ATM-EIs are functioning properly. If the test fails, a series of tests are run on the board. [Figure 9-4](#) shows a schematic of this test.

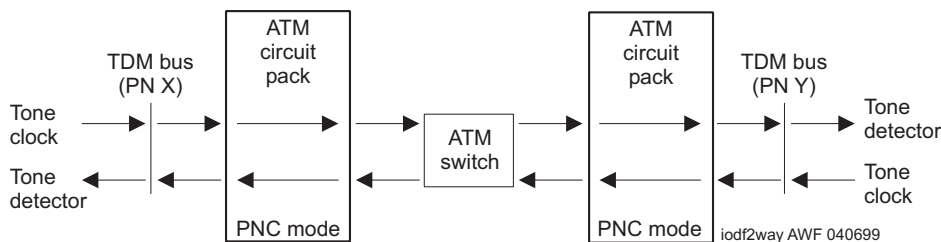

**Figure 9-4. Expansion Interface 2-Way Transmit Test #241**  
 PN X and PN Y represent any of 43 possible port networks.

**Table 9-80. Expansion Interface 2-way Transmission Test (#241)**

Error Code	Test Result	Description/ Recommendation
	ABORT	Could not allocate the necessary system resources to run this test. 1. Retry the command at 1-minute intervals for a maximum of 5 times.
1002	ABORT	The system could not allocate time slots for the test. The system may be under heavy traffic conditions or it may have time slots out of service due to TDM-BUS errors. 1. If system has no TDM-BUS errors and is not handling heavy traffic, retry the command at 1-minute intervals a maximum of 3 times.
1003	ABORT	The system could not allocate a tone receiver for the test. The system may be oversized for the number of tone detectors present, or some tone detectors may be out of service. 1. Resolve any TTR-LEV errors. Even if there are not TTR-LEV errors, there may not be a tone detector available on the network that contains the circuit pack being tested. Verify that there is at least one tone detector on this network. If not, this test always aborts for this ATM-EI circuit pack, but does not harm the system. <b>➡ NOTE:</b> DEFINITY Systems require that Tone Clock circuit packs (TN2182) must be of vintage "B" or newer. If older Tone Detector circuit packs are installed in the system, this test always aborts with this abort code. 2. Resolve any TONE-PT errors. 3. If neither condition exists, retry the command at 1-minute intervals a maximum of 3 times.

**Table 9-80. Expansion Interface 2-way Transmission Test (#241) — Continued**

Error Code	Test Result	Description/ Recommendation
1033	ABORT	<p>The test cannot run because either the ATM-EI board is not administered, or there were no other PNs administered that had its ATM-EI board in-service.</p> <ol style="list-style-type: none"> <li>1. Ensure that the board is administered as ATM PNC Expansion Interface circuit pack.  If the board is administered as ATM-EI circuit pack, then there has been some change in the ability of the ATM-EI circuit pack in the other PNs to communicate with the ATM-EI on the other end of its connection.</li> <li>2. Using <b>status port x</b> (the port-network number in which the board is administered), see if both ACL and EAL are up to this board. If they are not, see the service procedure for SYS-LINK.</li> <li>3. Check the Error Log for Error Type 1281 with Aux Data 27 (board cannot talk to the ATM switch). See <a href="#">Table 9-77</a> for repair procedures.  If present, check both the ATM switch and the DEFINITY administrations for consistent ATM addresses. Reset the board and see if the problem resolves.</li> <li>4. Repeat Test #241. If it continues to abort with this abort code, replace the board.</li> </ol>
1394	ABORT	<ol style="list-style-type: none"> <li>1. See <a href="#">Table 9-77</a> (Error Type 1281) with Aux Data 27 (board cannot talk to the ATM switch), and if present, check both the ATM switch and the DEFINITY administrations for consistent ATM addresses.</li> <li>2. Reset the board and see if the problem resolves.</li> <li>3. Repeat the test.</li> </ol>
1395	ABORT	<p>This test cannot run on an ATM-EI circuit pack if it is part of the B-side PNC and Duplicated PNC is not enabled.</p> <ol style="list-style-type: none"> <li>1. If this test needs to run on this ATM-EI circuit pack, enable PNC with the <b>change system-parameters duplication</b> command.</li> <li>2. Prevent the system from doing a PNC interchange by executing the <b>set PNC lock</b> command.</li> <li>3. Repeat this test.</li> </ol>
1413	ABORT	<p>This test requires the use of a Tone/Clock circuit pack in each of the port networks (PN) used in this test. This abort code indicates that a Tone/Clock circuit pack is not present in one of the PNs.</p> <ol style="list-style-type: none"> <li>1. Make sure that there is a Tone/Clock circuit pack located in the PN in which the ATM PNC Expansion Interface circuit pack under test is located.</li> <li>2. In ATM PNC configurations, make sure that there is at least one other PN besides the PN where the ATM-EI circuit pack under test resides that contains a Tone/Clock circuit pack.</li> </ol>

*Continued on next page*

Table 9-80. Expansion Interface 2-way Transmission Test (#241) — Continued

Error Code	Test Result	Description/ Recommendation
1414	ABORT	The active Tone/Clock circuit pack in one of the port networks being used for the test has a MAJOR or MINOR alarm logged against it. <ol style="list-style-type: none"><li>1. Enter <b>display alarms</b> and resolve any TONE-BD and TONE-PT alarms.</li></ol>
1956	ABORT	ACL to the board is not up. See ACL status with the <b>list sys-link</b> command and follow the repair procedures for SYS-LINK.
2000	ABORT	Response to the test request was not received within the allowable time period.
2100	ABORT	System resources required to run this test are not available.
2500	ABORT	Internal system error <ol style="list-style-type: none"><li>1. Retry the command at 1-minute intervals a maximum of 3 times.</li></ol>
	FAIL	The test tone was not detected correctly in either direction. <ol style="list-style-type: none"><li>1. Use the <b>status system all</b> command to determine the active Tone/Clock.</li><li>2. Test the active Tone/Clocks on the Port Networks for which the ATM-EI circuit pack under test provides a link. This determines if the dial tone is supplied.</li></ol>
10MM	FAIL	The failure codes only apply to a system equipped with an ATM Switch. The letters "MM" refer to the distant or far-end port network (PN), and "NN" to the near-end ATM-EI under test.  The test tone was detected correctly in forward direction (data sent from the PN in which the circuit pack under test resides and detected correctly in port network MM), but not the opposite direction. <ol style="list-style-type: none"><li>1. Use the <b>status system all</b> command to determine the active Tone/Clock.</li><li>2. Test the active Tone/Clocks on the "MM" PN and the PN in which the ATM-EI under test resides (<b>test tone-clock UUCSS</b>). This determines if dial tone is supplied.</li><li>3. Ensure that the ATM address of the ATM-EI circuit pack under test matches the ATM address on the ATM switch for the port to which this circuit pack is connected. Refer to the "<a href="#">ATM Tips</a>" section in Chapter 5 for the procedure to check the ATM port address on the ATM switch.</li><li>4. Run this Test #241 on the active ATM-EI in port network MM. If this test fails with Error Code 10NN or 30NN, go back to Step 2.</li></ol> <p>If the address was the same, replace the active ATM-EI circuit pack on port network MM.</p> <p>If this test fails with Error Code 20NN or 40NN, replace ATM-EI circuit pack that had the initial problem.</p>

*Continued on next page*

**Table 9-80. Expansion Interface 2-way Transmission Test (#241) — Continued**

Error Code	Test Result	Description/ Recommendation
20MM	FAIL	<p>The failure codes only apply to a system equipped with an ATM Switch. The letters "MM" refer to the distant or far-end port network (PN), and "NN" to the near-end ATM-EI under test.</p> <p>The test tone was detected correctly in reverse direction (data sent from the MM port network was detected correctly in the port network in which the circuit pack under test resides, but not the opposite direction).</p> <ol style="list-style-type: none"> <li>1. Use the <b>status system all</b> command to determine the active Tone/Clock.</li> <li>2. Test the active Tone/Clock on the "MM" PN and the PN in which the ATM-EI under test resides (<b>test tone-clock UUCSS</b>). This determines if dial tone is supplied.</li> <li>3. Ensure that the ATM address of the active ATM-EI circuit pack under test matches the ATM address on the ATM switch for the port to which this circuit pack is connected. Refer to the <a href="#">"ATM Tips"</a> section in Chapter 5 for the procedure to check the ATM port address on the ATM switch.</li> <li>4. Run this Test #241 on the active ATM-EI in port network MM. If this test fails with Error Code 20NN or 40NN, go back to Step 2.</li> </ol> <p>If the address was the same, replace the active ATM-EI circuit pack on port network MM.</p> <p>If this test fails with Error Code 10NN or 30NN, replace ATM-EI circuit pack with the initial problem.</p>

*Continued on next page*

**Table 9-80. Expansion Interface 2-way Transmission Test (#241) — Continued**

Error Code	Test Result	Description/ Recommendation
30MM	FAIL	<p>The failure codes only apply to a system equipped with an ATM Switch. The letters "MM" refer to the distant or far-end port network (PN), and "NN" to the near-end ATM-EI under test.</p> <p>The test failed for the first connection from the ATM-EI board under test to another EPN, and the test tone was detected correctly in the forward direction (data sent from the port network in which the circuit pack under test resides was detected correctly in port network MM, but not the opposite direction).</p> <ol style="list-style-type: none"> <li>1. Use the <b>status system all</b> command to determine the active Tone/Clock.</li> <li>2. Test the active Tone/Clock on the "MM" PN and the PN in which the ATM-EI under test resides (<b>test tone-clock UUCSS</b>). This determines if dial tone is supplied.</li> <li>3. Ensure that the ATM address of the ATM-EI circuit pack under test matches the ATM address on the ATM switch for the port to which this circuit pack is connected. Refer to the "<a href="#">ATM Tips</a>" section in Chapter 5 for the procedure to check the ATM port address on the ATM switch.</li> <li>4. Run this Test #241 on the active ATM-EI in port network MM. If this test fails with Error Code 10NN or 30NN, go back to Step 2.</li> </ol> <p>If the address was the same, replace the active ATM-EI circuit pack on port network MM.</p> <p>If this test fails with Error Code 20NN or 40NN, replace ATM-EI circuit pack with the initial problem.</p>

*Continued on next page*

**Table 9-80. Expansion Interface 2-way Transmission Test (#241) — Continued**

Error Code	Test Result	Description/ Recommendation
40MM	FAIL	<p>Failure code only applies to a system equipped with an ATM Switch. The letters "MM" refer to the distant or far-end port network (PN), and "NN" to the near-end ATM-EI under test.</p> <p>The test failed for the first connection from the ATM-EI board under test to another EPN, and the test tone was detected correctly in the reverse direction (data sent from the MM port network was detected correctly in the port network in which the circuit pack under test resides), but not the opposite direction.</p> <ol style="list-style-type: none"> <li>1. Test for the Active Tone-Clocks on the MM PN and the PN in which the ATM-EI under test resides. This determines if dial tone is supplied.</li> <li>2. Ensure that the ATM address of the active ATM-EI circuit pack in port network MM matches the ATM address on the ATM switch for the port to which this circuit pack is connected. Refer to the <a href="#">"ATM Tips"</a> section in Chapter 5 for the procedure to check the ATM port address on the ATM switch.</li> <li>3. Run this Test #241 on the active ATM-EI in port network MM. If this test fails with Error Code 20NN or 40NN, go back to Step 2.</li> </ol> <p>If the address was the same, replace the active ATM-EI circuit pack on port network MM.</p> <p>If this test fails with Error Code 10NN or 30NN, replace ATM-EI circuit pack with the initial problem.</p>
	PASS	<p>Tone successfully transmitted in both directions. Both ATM-EI boards and their lightwave transceivers are functioning properly.</p>
0	NO BOARD	<p>No board was detected by the test.</p> <ol style="list-style-type: none"> <li>1. Resolve either wrong board (Error 125) or no board (Error 131) issues.</li> <li>2. Check that the board is properly translated and inserted. If so, check for hyperactivity (Error 1538). If hyperactive, use the <b>reset board UUCSS</b> command.</li> <li>3. Run the test again. If it fails, the ID chip on board may be bad. Replace the board and retest.</li> </ol>

**Expansion Interface Lock Query Test (#304)**

This test is non-destructive and is used to query the ATM and EI circuit packs (both active and standby) for its status concerning lock to the backplane system clock. It is run as part of periodic, scheduled, initialization, and error analysis



testing. When an in-line, “out-of-lock” report comes in, this test is run to check the circuit pack’s status. The ATM-EI responds with “in lock” or “out of lock.” If the response is “in lock,” the test passes; if the response is “out of lock,” the test fails.

**Table 9-81. TEST #304 Expansion Interface Lock Query Test (#304)**

Error Code	Test Result	Description/ Recommendation
2000	ABORT	Response to the test request was not received within the allowable time period.
2100	ABORT	Could not allocate the necessary system resources to run this test.
2500	ABORT	Internal system error 1. Retry the command at 1-minute intervals a maximum of 3 times.
	FAIL	The ATM-EI circuit pack responded incorrectly or if it is the EPN active ATM-EI circuit pack, it could not talk to EPN circuit packs. 1. If the active ATM-EI circuit pack in the EPN is failing and duplicated PNC is enabled, attempt to switch to the standby PNC using the <b>reset PNC interchange</b> command. 2. Repeat the short test sequence. 3. If test continues to fail, reset the ATM-EI circuit pack with the <b>reset board UUCSS</b> command. 4. If the ATM-EI circuit pack in the EPN is failing, enter <b>display errors</b> and <b>display alarms</b> and follow the associated repair procedures for TDM-CLK, TONE-BD, or SYNC alarms/errors and repeat the Short Test Sequence. 5. If test continues to fail, replace the circuit pack or transceiver.
	PASS	Communication from software to the ATM-EI circuit pack is functioning correctly.
0	NO BOARD	No board was detected by the test. 1. Check the error log for wrong board (error 125) or no board (error 131). Resolve either of these issues. 2. Check that the board is properly translated and inserted. If so, check for hyperactivity (error 1538). If hyperactive, use the <b>reset board UUCSS</b> command. 3. Run the test again. If it fails, the NCE chip on board may be bad. Replace the board and retest.

## Expansion Interface Control Channel Test (#316)

This test is non-destructive. If an ATM-EI circuit pack is an *active* ATM-EI in the EPN (yellow LED on long/off short), the Expansion Interface Control Channel test checks to see if the ATM-EI circuit pack can communicate with other circuit packs in the EPN using the EPN TDM bus.

If the circuit pack is a *standby* ATM-EI (yellow LED off) or if the ATM PNC Expansion Interface is in the PPN (yellow LED on), this test queries the ATM PNC Expansion Interface circuit pack for its circuit pack type and vintage information.

**Table 9-82. Expansion Interface Control Channel Test #316**

Error Code	Test Result	Description/ Recommendation
2000	ABORT	Response to the test request was not received within the allowable time period.
2100	ABORT	Could not allocate the necessary system resources to run this test.
2500	ABORT	Internal system error 1. Retry the command at 1-minute intervals a maximum of 3 times.
	FAIL	The ATM-EI circuit pack responded incorrectly or if it is the EPN active ATM-EI circuit pack, it could not talk to EPN circuit packs. 1. If the active ATM-EI circuit pack in the EPN is failing and duplicated PNC is enabled, attempt to switch to the standby PNC using the <b>reset PNC interchange</b> command. 2. Repeat the short test sequence. 3. If test continues to fail, reset the ATM-EI circuit pack with the <b>reset board UUCSS</b> command. 4. If the ATM-EI circuit pack in the EPN is failing, enter <b>display errors</b> and <b>display alarms</b> and resolve any TDM-CLK, TONE-BD, or SYNC alarms/errors and repeat the Short Test Sequence. 5. If test continues to fail, replace the circuit pack or transceiver.
	PASS	The ATM-EI circuit pack did respond correctly to test. Communication from software to the ATM-EI circuit pack is functioning. 1. Refer to other ATM-EI circuit pack tests if the link is not functioning correctly.

**Table 9-82. Expansion Interface Control Channel Test #316 — Continued**

Error Code	Test Result	Description/ Recommendation
0	NO BOARD	No board was detected by the test. <ol style="list-style-type: none"> <li>1. Resolve any wrong board (Error 125) or no board (Error 131) issues.</li> <li>2. Check that the board is properly translated and inserted. If so, check for hyperactivity (Error 1538). If hyperactive, use the <b>reset board UUCSS</b> command.</li> <li>3. Run the test again. If it fails, the NCE chip on board may be bad. Replace the board and retest.</li> </ol>

**Packet Interface Test (#598)**

This test is non-destructive and attempts to send a data packet from the TN1655 Packet Interface circuit pack through any ATM PNC Expansion Interface circuit packs. The path the data packet takes depends on the location of the ATM-PNC Expansion Interface circuit pack being tested and whether the system has duplicate Port Network Connectivity.

The Packet Interface Looparound test checks the Packet Bus interface circuitry on this board. The on-board LANHO chip sends a data stream to the bus, retrieves it back, and checks for its consistency. If the data is consistent, the test passes; otherwise, it fails. The test aborts if the Packet Bus in the specified port network has a minor alarm active, is out of service, or if the Packet Bus in the PPN is out of service. This test runs as a part of initialization, periodic, scheduled, error analysis, and demand test sequences. [Figure 9-5](#) shows a schematic of the test.

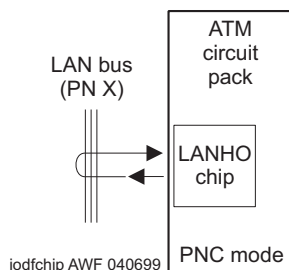

**Figure 9-5. Packet Interface Test (#598)**

**Table 9-83. Packet Interface Test (#598)**

Error Code	Test Result	Description/ Recommendation
2000	ABORT	Response to the test request was not received within the allowable time period. <ol style="list-style-type: none"><li>1. Retry the command at 1-minute intervals for a maximum of 3 retries.</li><li>2. If the test fails repeatedly, attempt to reset the circuit pack.</li><li>3. If the test continues to fail, replace the circuit pack.</li></ol>
2012	ABORT	Internal system error
2100	ABORT	Could not allocate the necessary system resources to run this test. <ol style="list-style-type: none"><li>1. Retry the command at 1-minute intervals a maximum of 5 times.</li></ol>
ANY	FAIL	The transmitted data packet was not received correctly by the Packet Interface circuit pack. The failure may be in the ATM-EI under test, the DS1 CONV circuit packs, or the intervening Center Stage components. <ol style="list-style-type: none"><li>1. Retry the command at 1-minute intervals a maximum of five times</li><li>2. If the test continues to fail, replace the circuit pack.</li></ol>
	PASS	The Packet Interface Test passed.

### ATM Board DSP Test #1258 (TN2238 only)

This test is non-destructive and is designed to test the board's interface to the TDM bus and the functions of all 24 on-board DSPs (Digital Signal Processors). This looparound test is completely on-board, and the results for each DSP are saved until all DSPs are tested.

If the test fails for all DSPs, a MAJOR alarm is raised against the board. If the test fails for one or more DSPs, the test fails and a MINOR alarm is raised. If a DSP is "busy," the test for that particular DSP is considered passed. The test aborts if the system resources (for example, the TDM time slots, tone generator, and others) are not available. This test applies to all ATM-EIs, both active and standby, and is run as part of craft short and long testing, periodic, scheduled, initialization, and error analysis testing. Refer to [Figure 9-6](#) for a diagram of this looparound test.

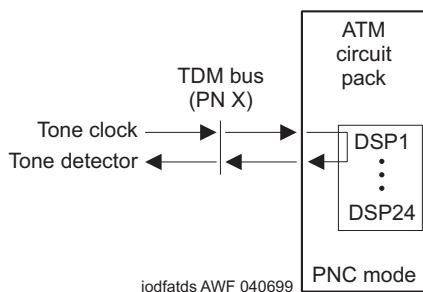

**Figure 9-6. ATM Board DSP Test (#1258)**

**Table 9-84. ATM Board DSP Test (#1258)**

Error Code	Test Result	Description/ Recommendation
1002	ABORT	<p>The system could not allocate timeslots for the test. The system may be under heavy traffic conditions or it may have timeslots out of service due to TDM-BUS errors.</p> <ol style="list-style-type: none"> <li>1. If system has no TDM-BUS errors and is not handling heavy traffic, retry the command at 1-minute intervals a maximum of 3 times.</li> </ol>
1003	ABORT	<p>The system could not allocate a tone receiver for the test. The system may be oversized for the number of tone detectors present, or some tone detectors may be out of service.</p> <ol style="list-style-type: none"> <li>1. Enter <b>display errors</b> and resolve any TTR-LEV errors. Even if there are not TTR-LEV errors, there may not be a tone detector available on the network that contains the circuit pack being tested. Verify that there is at least one tone detector on the network. If not, this test always aborts for this ATM-EI circuit pack and does not harm the system.</li> <li>2. Resolve any TONE-PT errors.</li> <li>3. If neither condition exists, retry the command at 1-minute intervals a maximum of 3 times.</li> </ol>

*Continued on next page*

**Table 9-84. ATM Board DSP Test (#1258) — Continued**

Error Code	Test Result	Description/ Recommendation
1395	ABORT	This test cannot be run on an ATM-EI circuit pack if it is part of the B-side PNC, and the duplicated PNC is not enabled. <ol style="list-style-type: none"> <li>1. If this test needs to run on this ATM-EI circuit pack, enable PNC with the <b>change system-parameters duplication</b> command.</li> <li>2. Prevent the system from doing a PNC interchange (<b>set PNC lock</b>).</li> <li>3. Repeat this test.</li> </ol>
2000	ABORT	Response to the test was not received within the allowable time period for some of the DSPs. <ol style="list-style-type: none"> <li>1. If the board is in standby, reset the board and run the test again once the board is inserted.</li> <li>2. Check the Error Log for Error Type 1218 (bad DSP). If Error Type 1218 is not logged against this board, run the DSP test again and see if the error persists.</li> </ol>
2100	ABORT	Could not allocate the necessary system resources to run this test.
2500	ABORT	Internal system error
2751	ABORT	All DSPs are busy (very unlikely). <ol style="list-style-type: none"> <li>1. Retry the command at 1-minute intervals a maximum of 3 times.</li> </ol>
2752	ABORT	The circuit pack in this location is not an ATM pack.
10XX, where XX = DSP# 01-24	FAIL	There is at least one bad DSP on the board. The 10XX value indicates the DSP number that has failed the test. However, the failure of these DSPs does not indicate that all of the DSPs failed. <ol style="list-style-type: none"> <li>1. Retry the command at 1-minute intervals a maximum of 3 times.</li> <li>2. If the test fails with the same error code, replace the board.</li> </ol>
30XX, where XX = DSP# 01-24	FAIL	At least one DSP has failed because the test tone was not detected correctly after being looped through the DSP. The 30XX value indicates the DSP number that has failed the test. The failure of these DSPs does not indicate that all of the DSP failed due to incorrect tone detection. <ol style="list-style-type: none"> <li>1. Run the tests for the Active Tone-Clock on the PN that contains the indicted ATM-EI circuit pack to verify that dial-tone is supplied.</li> <li>2. If the tone-clock is healthy, repeat the short test on the ATM-EI board.</li> <li>3. If this test continues to fail, replace the ATM-EI circuit pack.</li> </ol>

*Continued on next page*

**Table 9-84. ATM Board DSP Test (#1258) — Continued**

Error Code	Test Result	Description/ Recommendation
60XX, where XX = DSP# 01-24	FAIL	Cannot establish a looparound, because the previously established looparound was not removed. The 60XX value indicates the DSP number that has failed the test. <ol style="list-style-type: none"> <li>1. Retry the command at 1-minute intervals a maximum of 3 times.</li> <li>2. If the test fails with the same error code replace the board.</li> </ol>
	PASS	Test tone was correctly detected on both TDM Busses. <ol style="list-style-type: none"> <li>1. Refer to other ATM-EI circuit pack tests if the links between this ATM-EI circuit pack and the ATM-EI or Switch Node Interface circuit pack on the other end of the fiber are not functioning correctly.</li> </ol>
0	NO BOARD	No board was detected by the test. <ol style="list-style-type: none"> <li>1. Check the Error Log for wrong board (Error Type 125) or no board (Error Type 131). Resolve either of these issues, if applicable.</li> <li>2. Check that the board is properly translated and inserted. If so, check for hyperactivity (Error Type 1538). If hyperactive, use the <b>reset board UUCSS</b> command.</li> <li>3. Run the test again. If it fails, the NCE chip on the circuit pack may be bad. Replace the circuit pack and retest.</li> </ol>

### ATM Board Error Query Test (#1259)

This test is non-destructive. The ATM circuit pack firmware maintains counters for some of the on-board and off-board errors. The maintenance software queries the board for its health information to do error analysis. These alarms have assigned priority: if a higher priority alarm occurs, the remaining alarms are not reported to the software (through the inline errors), avoiding unnecessary up-link, in-line error message traffic. This is run as a part of a craft demand test sequence periodic testing, initialization, and error analysis.

**Table 9-85. ATM Board Error Query Test (#1259)**

Error Code	Test Result	Description/ Recommendation
2000	ABORT	Response to the test was not received within the allowable time period.
2100	ABORT	System resources required to run this test are not available.
2500	ABORT	Internal system error 1. Retry the command at 1-minute intervals a maximum of 3 times.
XXYY	FAIL	On-board hardware or off-board signalling errors on the board. XX indicates the on-board hardware error, and YY indicates the off-board errors on the as shown in <a href="#">Table 9-86</a> . 1. Resolve any errors in error logs.
	PASS	No service effecting errors or alarms were detected on the circuit pack.
0	NO BOARD	No board was detected by the test. 1. Check the Error Log for wrong board (Error Type 125) or no board (Error Type 131). Resolve either of these issues, if applicable. 2. Check that the board is properly translated and inserted. If so, check for hyperactivity (Error Type 1538). If hyperactive, use the <b>reset board UUCSS</b> command. 3. Run the test again. If it fails, the NCE chip on board may be bad. Replace the board and retest.

**Table 9-86. XXYY Aux Data for Test #1259 (ATM Board Error Query Test)**

XX Aux Data	Description
1	ATM framer chip failed
2	NCE chip failed
3	LANHO critical error
4	TDM Prog. logic device failed
5	All on-board DSPs failed
6	Receive network processor failed
7	Transmit network processor failed
8	Memory read failed



**Table 9-86. XXYY Aux Data for Test #1259  
(ATM Board Error Query Test) — Continued**

<b>XX Aux Data</b>	<b>Description</b>
9	Dual UART chip failed
10	LANHO receive parity error
11	LANHO FIFO overflow error
12	LAN Bus timeout
13	LANHO Xmit FIFO overflow
14	One or more on-board DSPs failed
<b>YY Aux Data</b>	<b>Description</b>
15	Backplane clock failed
16	Loss of signal
17	Loss of frame
18	Multiplexer Section Alarm indication signal error
19	Multiplexer Section remote defect indicator error
20	Loss of pointer
21	Path signal level mismatch
22	High level path alarm indication signal
23	High level path remote defect indicator
24	Loss of cell delineation
25	Uncorrectable headers sent by the ATM switch
26	Too many cells with invalid Virtual Path Indicator (VPI)/Virtual Circuit Indicator (VCI) combination
27	The signalling link between the board and the ATM switch is down.
28	Board to the ATM switch connection is down
34	AAL5 (ATM signalling protocol) excessive retransmission requests
35	LAPD excessive retransmission requests

**ATM Board Framer Looparound Test (#1260)**

**This test is destructive.**

**NOTE:**

This test can be run on the standby PNC only if the board is busied out.

This test places the ATM circuit pack in ATM framer looparound mode. Once the board receives this message, it creates a dummy virtual circuit that originates and ends on the same board, without leaving the board. This test verifies both the TDM path and the Packet Path. If the TDM test path passes, then the packet path is tested. Definitions of each test path are:

- **The circuit (TDM) path:** one of the tone generators sends a bit pattern is through a TDM bus time slot to the ATM framer. The pattern is converted into ATM cells and looped back to the ATM-EI board, which converts the cell back into the bit pattern and puts it on a pre-determined time slot. A tone detector tests for the bit pattern and reports the test result. This test verifies that a large portion of the ATM-EIs circuit paths are functioning correctly. [Figure 9-7](#) shows a diagram of the test.

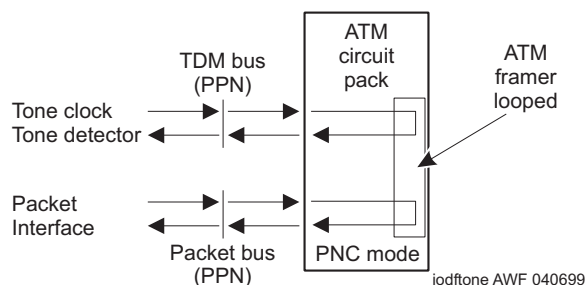

**Figure 9-7. ATM Board Framer Looparound Test (#1260)**

- **Packet path:** the Packet Interface circuit pack sends packet data to the ATM framer interface, where it is mapped into ATM cells and then looped around internally. The cells are converted back to packet data after it has been looped. This portion of the test verifies correct operation of the ATM-EI's Packet bus interface and a large portion of the ATM-EI's packet paths. [Figure 9-8](#) shows the packet switched signal path for the ATM circuit pack.

This test verifies the operation of a large portion of the ATM-EI circuit and packet paths, but does not verify the optical portion of the lightwave transceiver. If this test passes, the ATM-EI circuit pack is functioning correctly, but faults may exist in the lightwave transceiver. If the test fails, the fault may lie on the board. After the test results are reported, the ATM framer is taken out of loopback.

**NOTE:**

This test may be run on active or standby ATM-EIs, but it is *not* allowed if an ATM-EI is the Expansion Archangel.

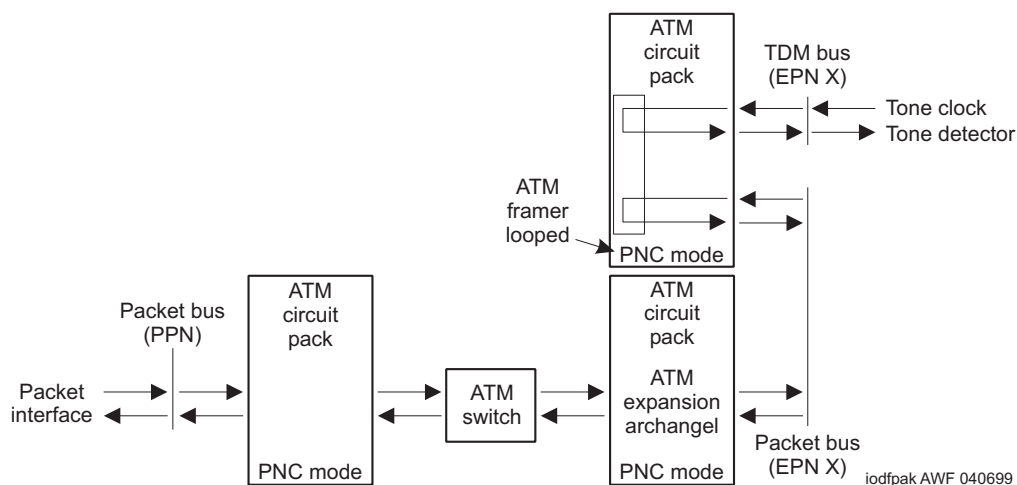

**Figure 9-8. ATM Board Framer Looparound Test (#1260) (non-EAA, Packet Path)**

**Table 9-87. ATM Board Framer Looparound Test (#1260)**

Error Code	Test Result	Description/ Recommendation
1002	ABORT	<p>The system could not allocate timeslots for the test. The system may be under heavy traffic conditions or it may have timeslots out of service due to TDM-BUS errors.</p> <ol style="list-style-type: none"> <li>If system has no TDM-BUS errors and is not handling heavy traffic, retry the command at 1-minute intervals a maximum of 3 times.</li> </ol>

*Continued on next page*

**Table 9-87. ATM Board Framer Looparound Test (#1260) — Continued**

Error Code	Test Result	Description/ Recommendation
1003	ABORT	<p>The system could not allocate a tone receiver for the test. The system may be oversized for the number of Tone Detectors present or some Tone Detectors may be out of service.</p> <ol style="list-style-type: none"> <li>1. Resolve any TTR-LEV errors. Even if there are no TTR-LEV errors, there may not be a Tone Detector available on the network that contains the circuit pack being tested. Verify that there is at least one Tone Detector on this network. If there is not at least one Tone Detector, this test always aborts for this ATM-EI board. This will not harm the system.</li> </ol> <p><b>⇒ NOTE:</b>                      DEFINITY Systems require that Tone Clock circuit packs (TN2182) must be of vintage "B" or newer. If older Tone Detector circuit packs are installed in the system, this test always aborts with this abort code.</p> <ol style="list-style-type: none"> <li>2. Resolve any TONE-PT errors.</li> <li>3. If neither condition exists, retry the command at 1-minute intervals a maximum of 3 times.</li> </ol>
1015	ABORT	<p>The ATM-EI circuit pack has not been busied out.</p> <ol style="list-style-type: none"> <li>1. Busyout the ATM-Expansion Interface circuit pack, then repeat the <b>test board UUCSS long</b> command.</li> </ol>
1031	ABORT	<p>If the ATM Expansion Interface circuit pack is in an EPN and is on the active PNC, this test cannot be executed.</p> <ol style="list-style-type: none"> <li>1. If PNC Duplication is enabled, attempt to make the standby PNC active with the <b>reset pnc interchange</b> command.</li> <li>2. If the PNC Interchange is successful, rerun the test.</li> </ol>
1033	ABORT	<p>The ATM-EI circuit pack is not present.</p> <ol style="list-style-type: none"> <li>1. Issue the <b>list atm-pnc</b> command to verify that switch recognizes the circuit pack.</li> <li>2. Retry the command.</li> </ol>
1139	ABORT	<p>The packet bus in the EPN where this ATM-EI board is located has a major alarm against it. This test needs to use the alarmed port network's Packet Bus.</p> <ol style="list-style-type: none"> <li>1. Resolve any PKT-BUS problems.</li> <li>2. Retry the command.</li> </ol>
1141	ABORT	<p>The Packet Interface circuit pack is out of service.</p> <ol style="list-style-type: none"> <li>1. Resolve any PKT-INTF problems.</li> </ol>

*Continued on next page*

**Table 9-87. ATM Board Framer Looparound Test (#1260) — Continued**

Error Code	Test Result	Description/ Recommendation
1144	ABORT	The Packet Bus in the PPN has a major alarm against it. This test needs to use the alarmed PPN packet bus. <ol style="list-style-type: none"> <li>1. Resolve any PKT-BUS problems.</li> <li>2. Retry the command.</li> </ol>
1394	ABORT	The ATM-EI board is out of service and the test cannot be run. This condition is due to a change in the ATM-EI board's ability to communicate with the ATM switch. <ol style="list-style-type: none"> <li>1. Run Test #241. If it does not pass, refer to repair procedures for <a href="#">"Expansion Interface 2-way Transmission Test (#241)"</a>.</li> </ol>
1395	ABORT	This test cannot be run on an ATM-EI circuit pack if it is part of the B-side PNC and duplicated PNC is not enabled. <ol style="list-style-type: none"> <li>1. If this test needs to run on this ATM-EI circuit pack, enable PNC duplication with the <b>change system-parameters duplication</b> command.</li> <li>2. Prevent the system from doing a PNC interchange by executing the <b>set PNC lock</b> command.</li> <li>3. Repeat this test.</li> </ol>
1407	ABORT	This test cannot be run on an ATM-EI board that is on the active PNC because it cannot be busied out. This error code indicates that PNC duplication is enabled. <ol style="list-style-type: none"> <li>1. Attempt to perform a PNC interchange with the <b>reset pnc interchange</b> command.</li> <li>2. If the PNC interchange is successful, busy out the original ATM-Expansion Interface circuit pack with the <b>busyout board UUCSS</b> (address of the original ATM-EI board) command.</li> <li>3. Retry the command.</li> </ol>
2000	ABORT	Response to the test was not received in the allowable time period. <ol style="list-style-type: none"> <li>1. Retry the command at 1-minute intervals a maximum of 3 times.</li> </ol>
2060	ABORT	The link on the packet bus being used to perform the test has failed. <ol style="list-style-type: none"> <li>1. Retry the command at 1-minute intervals a maximum of 3 times.</li> <li>2. If the test continues to abort, resolve any PKT-INTF errors.</li> </ol>
2100	ABORT	Could not allocate the necessary system resources to run this test.
2500	ABORT	Internal system error. <ol style="list-style-type: none"> <li>1. Retry the command at 1-minute intervals a maximum of 3 times.</li> </ol>

*Continued on next page*

**Table 9-87. ATM Board Framer Looparound Test (#1260) — Continued**

Error Code	Test Result	Description/ Recommendation
1	FAIL	<p>The test did not detect the test tone through the looparound connection.</p> <p> <b>NOTE:</b>                      The packet portion of this test was not run since the circuit portion failed.</p> <ol style="list-style-type: none"> <li>1. Test the active Tone/Clock (<b>test tone-clock UUCSS</b>) on the PN that contains the defective ATM-EI circuit pack to verify that dial tone is being supplied.</li> <li>2. If the Tone/Clock is healthy, test the ATM-EI circuit pack (<b>test board UUCSS long</b>).</li> <li>3. If this test continues to fail, replace the ATM-EI circuit pack or transceiver.</li> <li>4. Test the new ATM-EI circuit pack (<b>test board UUCSS long</b>).</li> </ol>
2	FAIL	<p>The test tone was transmitted and detected correctly, but the correct data packet was not detected by the Packet Interface circuit pack.</p> <ol style="list-style-type: none"> <li>1. Test the Packet Interface circuit pack to verify that it is functioning properly. If any tests fail, investigate those tests and repair the Packet Interface circuit pack.</li> <li>2. If the Packet Interface circuit pack is OK, resolve any DS1 CONV-BD alarms or errors (if so equipped).</li> <li>3. Test the ATM-EI circuit pack (<b>test board UUCSS long</b>).</li> <li>4. If this test continues to fail, replace the ATM-EI board.</li> <li>5. Test the new ATM-EI circuit pack (<b>test board UUCSS long</b>).</li> </ol>
3	FAIL	<p>The test tone was transmitted correctly, but the returned tone was distorted.</p> <ol style="list-style-type: none"> <li>1. If the Tone/Clock is healthy, test the ATM-EI circuit pack (<b>test board UUCSS long</b>).</li> <li>2. If this test continues to fail, replace the ATM-EI circuit pack.</li> <li>3. Test the new ATM-EI circuit pack (<b>test board UUCSS long</b>).</li> </ol>
4	FAIL	<p>Unable to create loop for TDM path for this test.</p> <ol style="list-style-type: none"> <li>1. Retry the command at 1-minute intervals a maximum of 3 times.</li> <li>2. If this test continues to fail, replace the ATM-EI circuit pack.</li> <li>3. Test the new ATM-EI circuit pack (<b>test board UUCSS long</b>).</li> </ol>

*Continued on next page*

**Table 9-87. ATM Board Framer Looparound Test (#1260) — Continued**

Error Code	Test Result	Description/ Recommendation
5	FAIL	Unable to create loop for packet path for this test. <ol style="list-style-type: none"> <li>1. Retry the command at 1-minute intervals a maximum of 3 times.</li> <li>2. If this test continues to fail, replace the ATM-EI circuit pack.</li> <li>3. Test the new ATM-EI circuit pack (<b>test board UUCSS long</b>).</li> </ol>
6	FAIL	A previously-established looparound was not released. <ol style="list-style-type: none"> <li>1. Issue the <b>reset board UUCSS</b> command.</li> <li>2. Retry the command at 1-minute intervals a maximum of 3 times.</li> <li>3. If this test continues to fail, replace the ATM-EI circuit pack.</li> <li>4. Test the new ATM-EI circuit pack (<b>test board UUCSS long</b>).</li> </ol>
	PASS	The ATM-EI board is functioning properly, however this test does not verify that the optical portion of the lightwave transceiver is functioning.
0	NO BOARD	No board was detected by the test. <ol style="list-style-type: none"> <li>1. Resolve either wrong board (Error 125) or no board (Error 131) issues, if applicable.</li> <li>2. Check that the board is properly translated and inserted. If so, check for hyperactivity (Error 1538). If hyperactive, use the <b>reset board UUCSS</b> command.</li> <li>3. Run the test again. If it fails, the NCE chip on board may be bad. Replace the board and retest.</li> </ol>

### ATM Board Time Of Day Update (#1261)

This test is non-destructive. The ATM circuit pack requires a reference time to do SDH/SONET performance monitoring. This test updates the system time to the board and synchronizes the board with the DEFINITY system clock during initialization, scheduled maintenance, and craft long test.

**Table 9-88. ATM Board Time Of Day Update (#1261)**

Error Code	Test Result	Description/ Recommendation
2031	FAIL	The attempt to send the message to the ATM-EI circuit pack was not successful.
2500	FAIL	Did not send the time of day information to the board. 1. Retry the command at 1-minute intervals a maximum of 3 times.
	PASS	The ATM-EI circuit pack is successfully updated with system time. 1. If the <b>status port-network</b> command still indicates that this link is down, it is possible that one or both of the ATM-EI circuit packs have been busied out. 2. If the link still does not come up, reset one or both ATM-EI circuit packs on the link.
0	NO BOARD	No board detected. 1. Resolve either wrong board (Error 125) or no board (Error 131) issues, if applicable. 2. Check that the board is properly translated and inserted. If so, check for hyperactivity (Error 1538). If hyperactive, use the <b>reset board UUCSS</b> command. 3. Run the test again. If it fails, the NCE chip on the circuit pack may be bad. Replace the pack and retest.

**ATM Board Reset (#1256)**

This test is destructive. If the ATM-EI board is in the PPN or is a standby in the EPN, the reset is done through the SAKI reset interface. If the ATM-EI is an Expansion Arch Angel (active ATM-EI board in the EPN) a special message is sent to the board over the EAL if the EAL is present.

**Table 9-89. ATM Board Reset (#1256)**

Error Code	Test Result	Description/ Recommendation
1386	ABORT	No Active EAL to the board. This error applies only if the board under test is in EPN. Check the error logs for SYS-LINK errors against the port network in which the ATM-EI is residing and take appropriate diagnostic action for the SYS-LINK.



**Table 9-89. ATM Board Reset (#1256) — Continued**

Error Code	Test Result	Description/ Recommendation
1015	ABORT	This test cannot be run because the ATM-TRK circuit pack has not been busied out. 1. Busyout the ATM circuit pack, then repeat the <b>test board UUCSS long</b> command.
1407	ABORT	1. Perform a PNC Interchange 2. Try to reset the board again.
None	ABORT	Could not allocate the necessary system resources to run this test. 1. Retry the command at 1-minute intervals a maximum of 5 times. 2. If the test continues to abort escalate the problem.
2000	ABORT	Did not receive the SANITY response in the given time. 1. Wait for 5 minutes and see if board is visible to the system by using list config all command. 2. If the board is visible, run the test again. If same abort code results, escalate the problem. 3. If the board is not visible to the system via list config all command, re-seat the board. 4. If the board is still not recognized by the system, replace the board.
2100	ABORT	Could not allocate the necessary system resources to run this test. 1. Retry the command at 1-minute intervals a maximum of 5 times.
2500	ABORT	Internal system error 1. Try to reset the board again.
1	FAIL	The circuit pack failed to reset
2	FAIL	The circuit pack failed to restart. 1. Execute command again. 2. If the problem persists, replace the circuit pack.
	PASS	The ATM-EI circuit pack is successfully reset. 1. If the <b>status port-network</b> command still indicates that this link is down, it is possible that one or both of the ATM-EI circuit packs are busied out. 2. If the links do not come up after reset, review the error logs and take appropriate diagnostic action.

### ATM Cross Talk Test (#1298) (TN2305/6 only)

This test is non-destructive. The ATM board Cross Talk test verifies that the selected TDM bus time slot never crosses over to time slots reserved for other connections. The test also checks for cross connections, where the board talks to time slots other than those specified. Since this test uses many system resources (TDM time slots, tone generator, tone detector, and others), it runs as a part of demand test only.

This test fails if either the TDM programmable logic and/or the interface to the DSP is not operating properly. Failure of these components may result in one-way or noisy connections. Refer to [Figure 9-9](#) for a schematic of this test.

**⇒ NOTE:**

Note: This test applies only to TN2305 and TN2306 circuit packs.

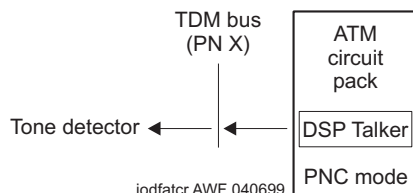

**Figure 9-9. ATM Cross Talk Test #1298 schematic**

**Table 9-90. ATM Crosstalk Test (#1298)**

Error Code	Test Result	Description/ Recommendation
	ABORT	Could not allocate the necessary system resources to run this test. 1. Retry the command at 1-minute intervals for a maximum of 5 times.
1002	ABORT	The system could not allocate time slots for the test. The system may be under heavy traffic conditions or it may have time slots out-of-service due to TDM-Bus errors. Refer to TDM-BUS to diagnose these errors. 1. If system has no TDM-Bus errors and is not handling heavy traffic, repeat test at 1-minute intervals for a maximum of 5 times.

*Continued on next page*

**Table 9-90. ATM Crosstalk Test (#1298) — Continued**

Error Code	Test Result	Description/ Recommendation
1003	ABORT	The system could not allocate a tone receiver for the test. The system may be oversized for the number of tone detectors present or some tone detectors may be out-of-service. <ol style="list-style-type: none"> <li>1. Resolve any TTR-LEV errors in the Error Log.</li> <li>2. Resolve any TONE-PT errors in the Error Log.</li> <li>3. If neither condition exists, retry the test at 1-minute intervals for a maximum of 5 times.</li> </ol>
2000	ABORT	Response to the test was not received within the allowable time period.
2100	ABORT	Could not allocate the necessary system resources to run this test. <ol style="list-style-type: none"> <li>1. Retry the command at 1-minute intervals for a maximum of 5 times.</li> </ol>
1962	ABORT	All the TALKER DSPs are busy (an unlikely event). <ol style="list-style-type: none"> <li>1. Retry the command at 1-minute intervals a maximum of 3 times.</li> </ol>
2302	ABORT	Inconsistent uplink message from the ATM-EI board. This is a very unlikely event. <ol style="list-style-type: none"> <li>1. Retry the command at 1-minute intervals a maximum of 3 times.</li> </ol>
2752	ABORT	The circuit pack in this location is not a TN2305/TN2306.
1-8, None	FAIL	The board is writing to unauthorized TDM time slots. The error code indicates the number of faulted TALKER DSPs. <ol style="list-style-type: none"> <li>1. Retry the command at 1-minute intervals a maximum of 3 times.</li> <li>2. If the failure persists, replace the circuit pack.</li> </ol>
1-8	PASS	The board is not talking to unauthorized time slots on the TDM Bus. The error code indicates the number of TALKER DSPs that were tested.

### ATM Board DSP Test (#1293)

This test is non-destructive and is designed to test the board's interface to the TDM bus and the functions of all 24 on-board DSPs (Digital Signal Processors). There are three functional types of DSPs:

- talkers - put data on the TDM bus
- listeners - take data off the TDM bus
- echo cancelers - as implied

Listener and echo cancelers are tightly coupled because firmware allocates *sets* of DSPs. Since there are a total of 24 DSPs on the board, there may be up to 8 triplets allocated.

If the test fails for all DSPs, a MAJOR alarm is raised against the board. If the test fails for one or more DSPs, a MINOR alarm is raised. If a DSP is "busy," the test for that particular DSP is considered passed. The test aborts if the system resources (for example, the TDM time slots, tone generator, and others) are not available.

This test applies to TN2305 and TN2306 ATM-EIs, both active and standby, and is run as part of craft short and long testing, periodic, scheduled, initialization, and error analysis testing. Refer to [Figure 9-10](#) for a diagram of this looparound test.

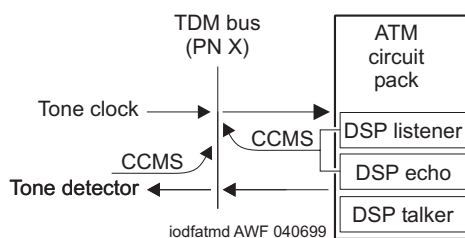

**Figure 9-10. ATM Board DSP Test (#1293)**

**Table 9-91. ATM Board DSP Test (#1293)**

Error Code	Test Result	Description/ Recommendation
1002	ABORT	<p>The system could not allocate time slots for the test. The system may be under heavy traffic conditions or it may have time slots out of service due to TDM-BUS errors.</p> <ol style="list-style-type: none"> <li>If system has no TDM-BUS errors and is not handling heavy traffic, retry the command at 1-minute intervals a maximum of 3 times.</li> </ol>

*Continued on next page*

**Table 9-91. ATM Board DSP Test (#1293) — Continued**

Error Code	Test Result	Description/ Recommendation
1003	ABORT	<p>The system could not allocate a tone receiver for the test. The system may be oversized for the number of tone detectors present, or some tone detectors may be out of service.</p> <ol style="list-style-type: none"> <li>1. Resolve any TTR-LEV errors.</li> </ol> <p>Even if there are no TTR-LEV errors, there may not be a tone detector available on the network that contains the circuit pack being tested. Verify that there is at least one tone detector on the network. If not, this test always aborts for this ATM-EI circuit pack and does not harm the system.</p> <ol style="list-style-type: none"> <li>2. Resolve any TONE-PT errors.</li> <li>3. If neither condition exists, retry the command at 1-minute intervals a maximum of 3 times.</li> </ol>
1962	ABORT	<p>All DSPs are busy (an unlikely event).</p> <ol style="list-style-type: none"> <li>1. Retry the command at 1-minute intervals a maximum of 3 times.</li> </ol>
2000	ABORT	<p>Response to the test was not received within the allowable time period for some of the DSPs.</p> <ol style="list-style-type: none"> <li>1. If the board is in standby, reset the board and run the test again once the board is inserted.</li> <li>2. Look into the Error Log for Error Type 1218 (bad DSP). If Error Type 1218 is not logged against this board, run the DSP test again and see if the error persists.</li> </ol>
2100	ABORT	<p>Could not allocate the necessary system resources to run this test.</p>
2302	ABORT	<p>Inconsistent uplink message from the ATM-EI board (an unlikely event).</p> <ol style="list-style-type: none"> <li>1. Retry the command at 1-minute intervals a maximum of 3 times.</li> </ol>
2500	ABORT	<p>Internal system error</p>
2752	ABORT	<p>The circuit pack in this location is not a TN2305/6.</p>

*Continued on next page*

**Table 9-91. ATM Board DSP Test (#1293) — Continued**

Error Code	Test Result	Description/ Recommendation
XYZ	FAIL	<p>A device on the circuit pack is failing. There is at least one bad DSP on the board. Values are as follows:</p> <ul style="list-style-type: none"> <li>■ The X value indicates the number of talker DSPs</li> <li>■ Y indicates the number of listener DSPs</li> <li>■ Z indicates the number of Echo Canceler DSPs that have failed the test.</li> </ul> <ol style="list-style-type: none"> <li>1. Run the tests for the active Tone-Clock on the PN that contains the indicted ATM-EI circuit pack to verify that dial-tone is supplied.</li> <li>2. If the tone-clock is healthy, repeat the short test on the ATM-EI board.</li> <li>3. If this test continues to fail, replace the ATM-EI circuit pack.</li> </ol>
XYZ	PASS	<p>The test passed for some or all DSPs depending on XYZ values. XYZ indicates the number of talker, listener and echo-canceler DSPs for which the test passed, respectively. In the DSPs that passed the test, the test tone was correctly detected by the DSP Listener and by tone-detector for the DSP Talkers on both busses, and the Echo Canceler DSPs are working properly.</p>
0	NO BOARD	<p>No board was detected by the test.</p> <ol style="list-style-type: none"> <li>1. Check the Error Log for wrong board (Error Type 125) or no board (Error Type 131). Resolve either of these issues, if applicable.</li> <li>2. Check that the board is properly translated and inserted. If so, check for hyperactivity (Error Type 1538). If hyperactive, use the <b>reset board UUCSS</b> command.</li> <li>3. Run the test again. If it fails, the circuit pack may be bad. Replace the circuit pack and retest.</li> </ol>

## ATM-INTF (TN2305/6)

MO Name (in Alarm Log)	Alarm Level	Initial Command to Run	Full Name of MO
ATM-INTF	WARNING	test board UUCSSpp	ATM interface board

The TN2305/6 is recognized by the system as an ATM Interface board (ATM-INTF) if it has not been assigned a personality through the **add atm-pnc** command or **add atm trunk** command. ATM-INTF does not have a maintenance strategy associated with it, although the Control Channel test can be run on demand by using the **test board** command, and the board can be reset by using the **reset board** command. The board is visible through the **list config** and **change circuit-pack** commands.

The circuit packs listed in [Table 9-92](#) are ATM-EI boards if they are administered to serve the ATM Port Network Connectivity (ATM-PNC).

**Table 9-92. ATM-EI circuit packs for ATM-PNC**

Circuit pack	Fiber	Echo cancellation	Release
TN2238	Multi mode	N	6.3
TN2305	Multi mode	Y	7.1
TN2306	Single mode	Y	7.1



**NOTE:**

Always replace an ATM-EI circuit pack with the same type.

### LED states

The ATM-INTF circuit pack has the standard red, green and yellow LEDs. The red and green LEDs have the traditional use: red indicates an alarm condition, green means maintenance testing in progress. The yellow LED is not used. The possible LED states are listed below:

LED	Condition	LED
Red	Board is not healthy	Solid on never off
Red Green	Board is in the processes of booting	Red: solid on Green: 200 ms on 200 ms off
Green	Maintenance is running tests on the board	Solid on (off when maintenance completed)
Yellow	Fiber LOS	100 ms on, 100ms off
Yellow	Signal to the ATM switch is down	500 ms on, 500 ms off

## Error Log Entries and Test to Clear Values

**Table 9-93. ATM-INTF Error Log Entries**

Error Type	Aux Data	Associated Test	Alarm Level	On/Off Board	Test to Clear Value
23(a)	0	None	WAR	OFF	
125(b)		None	MIN	ON	
217(c)	0	None	WAR	OFF	

Notes:

- a. Error Type 23: ATM Expansion Interface circuit pack is administered through a **change circuit-pack** command, but has not been inserted into the system. Insert the circuit pack.
- b. Error Type 125: A wrong circuit pack is located in the slot where this circuit pack is logically administered. To resolve this problem, either remove the wrong circuit pack or insert the logically administered circuit pack.
- c. Error Type 217: The ATM circuit pack is physically present but has not been given a personality. Remove the circuit pack or administer it using the **add atm pnc** command or **add atm trunk** command.



## System Technician-Demanded Tests: Descriptions and Error Codes

Failure of this test is not logged in the Error Log.

Order of Investigation	Short Test Sequence	Long Test Sequence	D/ND <sup>1</sup>
Control Channel Loop Around Test (#52)	X	X	N

1. D = Destructive, ND = Non-destructive

### Control Channel Loop-Around Test (#52)

This test is non-destructive. This test queries the circuit pack for its circuit pack code and vintage and verifies its records.

**Table 9-94. TEST #52 Control Channel Loop-Around Test**

Error Code	Test Result	Description/ Recommendation
2000	ABORT	Response to the test request was not received within the allowable time period.
2100	ABORT	System resources required to run this test are not available.
2500	ABORT	Internal system error <ol style="list-style-type: none"> <li>1. Retry the command at 1-minute intervals for a maximum of 5 times.</li> </ol>
	FAIL	The circuit pack failed to return the circuit pack code or vintage. <ol style="list-style-type: none"> <li>1. Retry the command a few times for a maximum of 5 times.</li> <li>2. If the problem continues to fail, reset the circuit pack.</li> <li>3. Retry the command a few times for a maximum of 5 times.</li> </ol>
	PASS	Communication with this circuit pack is successful.
Any	NO BOARD	This is normal if the test is being done when: <ul style="list-style-type: none"> <li>■ the board is not physically in the system.</li> <li>■ the system is booting up.</li> </ul> Otherwise, there is some inconsistency in the data kept in the system. <ol style="list-style-type: none"> <li>1. Verify that the board is physically in the system.</li> <li>2. Verify that the system is not in the process of booting up.</li> <li>3. Retry the command at 1-minute intervals for a maximum of 5 times.</li> </ol>

## ATM-NTWK (ATM Network Error)

---

MO Name (in Alarm Log)	Physical Name in Error Logs <sup>1</sup>	Alarm Level	Full Name of MO
ATM-NTWK	ATUUP	WARNING	ATM Network Error

1. *AT* indicates it is an ATM switch related address, *UU* is the connection number. The connection number can be converted into a board location by the command **display atm pnc UU**, which shows the translations for the board that reported the ATM network error. *P* indicates if the ATM-EI board (reporting the ATM network error) is the A side or the B side of the PNC. If the system is simplex, only A is valid.

In the ATM PNC configuration, the proprietary Center Stage Switch (CSS) is replaced by the ATM switch. Since the CSS switch nodes are replaced by the ATM switch in the ATM PNC configuration, the SNI boards are no longer needed. In place of SNI board, the ATM\_EI boards are connected to an ATM switch port over a fiber optic cable. The port on the ATM switch is under the control of ATM switch maintenance software. Refer to [Figure 5-6](#) in the “[ATM Tips](#)” section in Chapter 5 for a schematic of these connections.

An error against this MO indicates a problem in the ATM network (including the ATM switch) that is affecting the service quality. These error events are reported by the ATM network to the ATM-EI board. Since these errors are *not* related to the ATM-EI board, these errors are not reported against ATM-EI Maintenance Object. These log-only errors require no action by DEFINITY maintenance software.

### Error Codes and Aux Data values

---

The Cause Code and Error Type information from the ATM network is shown in [Table 9-95](#). These are the errors that are logged when the Cause Code or Error Type is received from the network. Six-digit codes against the ATM-NTWK maintenance object are possible:

- The first two characters represent ATM
- The next two characters stand for the connection number
- The last character indicates if it is A or B side of the PNC.

If the ATM-NTWK Maintenance Object receives more than 6 errors, the oldest errors are overwritten unless it has been less than 6 minutes since the oldest reported error.

**Table 9-95. Error Codes and Aux Data values ATM-NTWK**

Cause Code/ Error Type	Aux Data	Cause Codes Description
<b>NORMAL EVENTS</b>		
0	(a)	Network unreachable
1	(a)	Unallocated (unassigned) number. This cause indicates that the called party cannot be reached because, although the number is in a valid format, it is not currently assigned (allocated).
2	(a)	No route to specified transit network. This cause indicates that the equipment sending this cause has received a request to route the call through a particular network which it does not recognize, either because the transit network does not exist or because that particular transit network does not serve the equipment which is sending this cause. This cause is supported on a network-dependent basis.
3	(a)	No route to destination. This cause indicates that the called party cannot be reached because the network through which the call has been routed does not serve the destination desired. This cause is supported on a network-dependent basis.
10	(a)	VPCI/VCI unacceptable. This cause indicates that the virtual channel most recently identified is not acceptable to the sending entity for use in this call.
16	(a)	Normal call clearing. This cause indicates that the call is being cleared because one of the users involved in the call has requested that the call be cleared. Under normal situations, the source of this cause is not the network.
17	(a)	User busy. This cause indicates that the called party is unable to accept another call because the user busy condition has been encountered. This cause value may be generated by the called user or by the network.
18	(a)	No user responding. This cause is used when a called party does not respond to a call establishment message with a connect indication within the prescribed period of time allocated.
21	(a)	Call rejected. This cause indicates that the equipment sending this cause does not wish to accept this call, although it could have accepted the call because the equipment sending this cause is neither busy nor incompatible.
22	(a)	Number changed. This cause is returned to a calling party when the called party number indicated by the calling user is no longer assigned. The new called party number may optionally be included in the diagnostic field. If a network does not support this capability, cause number 1 "unassigned (unallocated) number" is used.

**Table 9-95. Error Codes and Aux Data values ATM-NTWK — Continued**

Cause Code/ Error Type	Aux Data	Cause Codes Description
23	(a)	User rejects all calls with calling line identification restriction (CLIR). This cause is returned by the called party when the call is offered without calling party number information and the called party requires this information.
27	(a)	Destination out of order. This cause indicates that the destination indicated by the user cannot be reached because the interface to the destination is not functioning correctly. The term "not functioning correctly" indicates that a signalling message was unable to be delivered to the remote user; for example, a physical layer or SAAL failure at the remote user or user equipment off-line.
28	(a)	Invalid number format (address incomplete). This cause indicates that the called user cannot be reached because the called party number is not in a valid format or is not complete.
30	(a)	Response to STATUS ENQUIRY. This cause is included in the STATUS message when the reason for generating the STATUS message was the prior receipt of a STATUS ENQUIRY message.
31	(a)	Normal, unspecified. This cause is used to report a normal event only when no other cause in the normal class applies.
32	(a)	DTL transit not-my-node ID
<b>RESOURCE UNAVAILABLE</b>		
35	(a)	Requested VPCI/VCI not available. This cause indicates that the requested VPCI/VCI is not available.
36	(a)	VPCI/VCI assignment failure
37	(a)	User Cell Rate not available
38	(a)	Network out of order. This cause indicates that the network is not functioning correctly and that the condition is likely to last a relatively long period of time; for example, immediately re-attempting the call is not likely to be successful.
41	(a)	Temporary failure. This cause indicates that the network is not functioning correctly and that the condition is not likely to last a long period of time; for example, the user may wish to try another call attempt immediately.
43	(a)	Access information discarded. This cause indicates that the network could not deliver access information to the remote user as requested; that is, ATM adaptation layer parameters, Broadband low layer information, Broadband high layer information, or sub-address as indicated in the diagnostic.
45	(a)	No VPCI/VCI available. This cause indicates that there is no appropriate VPCI/VCI presently available to handle the call.

**Table 9-95. Error Codes and Aux Data values ATM-NTWK — Continued**

<b>Cause Code/ Error Type</b>	<b>Aux Data</b>	<b>Cause Codes Description</b>
47	(a)	Resource unavailable, unspecified. This cause is used to report a resource unavailable event only when no other cause in the resource unavailable class applies.
<b>SERVICE OR OPTION UNAVAILABLE</b>		
49	(a)	Quality of Service unavailable. This cause is used to report that the requested Quality of Service cannot be provided.
51	(a)	User cell rate not available. This cause is used to report that the requested ATM Traffic Descriptor is unobtainable.
57	(a)	Bearer capability not authorized. This cause indicates that the user has requested a bearer capability which is implemented by the equipment which generated this cause but the user is not authorized to use.
58	(a)	Bearer capability not presently available. This cause indicates that the user requested a bearer capability implemented by the equipment that generated the cause but is not available at this time.
63	(a)	Service or option not available, unspecified. This cause is used to report a service or option not available event only when no other cause in the service or option not available class applies.
65	(a)	Bearer capability not implemented. This cause indicates that the equipment sending this cause does not support the bearer capability requested.
73	(a)	Unsupported combination of traffic parameters. This cause indicates that the combination of traffic parameters contained in the ATM traffic descriptor information element is not supported.
78	(a)	AAL parameters cannot be supported.
<b>INVALID MESSAGES</b>		
81	(a)	Invalid call reference value. This cause indicates that the equipment sending this cause has received a message with a call reference which is not currently in use on the user-network interface.
82	(a)	Identified channel does not exist. This cause indicates that the equipment sending this cause has received a request to use a channel not activated on the interface for a call.
88	(a)	Incompatible destination. This cause indicates that the equipment sending this cause has received a request to establish a call which has Broadband low layer information, Broadband high layer information, or other compatibility attributes which cannot be accommodated.

**Table 9-95. Error Codes and Aux Data values ATM-NTWK — Continued**

Cause Code/ Error Type	Aux Data	Cause Codes Description
89	(a)	Invalid endpoint reference value. This cause indicates that the equipment sending this cause has received a message with an endpoint reference that is currently not in use on the user-network interface.
91	(a)	Invalid transit network selection. This cause indicates that a transit network identification was received in an incorrect format as defined in Annex D.
92	(a)	Too many pending add party requests. This cause indicates a temporary condition when the calling party sends an add party message, but the network is unable to accept another add party message because its queues are full.
93	(a)	AAL parameters cannot be supported. This cause indicates that the equipment sending this cause has received a request to establish a call with ATM adaptation layer parameters that cannot be accommodated.

**PROTOCOL ERROR**

96	(a)	Mandatory information element is missing. This cause indicates that the equipment sending this cause has received a message that is missing an information element.
97	(a)	Message type non-existent or not implemented. This cause indicates that the equipment sending this cause has received a message with a message type it does not recognize either because this is a message not defined or defined but not implemented by the equipment sending this cause.
99	(a)	Information element non-existent or not implemented. This cause indicates that the equipment sending this cause has received a message that includes information element(s) not recognized because the information element identifier(s) are not defined or are defined but not implemented by the equipment sending the cause. This cause indicates that the information element was discarded. However, the information element is not required to be present in the message in order for the equipment sending this cause to process the message.
100	(a)	Invalid information element contents. This cause indicates that the equipment sending this cause has received and implemented an information element. However, one or more of the fields in the information element are coded in such a way that has not been implemented by the equipment sending this cause.
101	(a)	Message not compatible with call state. This cause indicates receipt of a message that is incompatible with the call state.

**Table 9-95. Error Codes and Aux Data values ATM-NTWK — Continued**

Cause Code/ Error Type	Aux Data	Cause Codes Description
102	(a)	Recovery on timer expiration. This cause indicates that a procedure has been initiated by the expiration of a timer in association with error handling procedures.
104	(a)	Incorrect message length
111	(a)	Protocol error, unspecified. This cause is used to report a protocol error event only when no other cause in the protocol error class applies.

Note:

- a. Aux Data values (XX = Port Network, YYY = location code).

[Table 9-96](#) is a list of UNI 3.1 location codes:

**Table 9-96. Location codes from Aux Data values**

Setup (Location Code)	Add Party (Location Code)	Location Code Meaning
0	500	User
1	501	Private network serving the local user
2	502	Public network serving the local user
3	503	Transit network
4	504	Public network serving the remote user
5	505	Private network serving the remote user
6	506	International network
7	507	Network beyond interworking point



**NOTE:**

Under certain circumstances network errors can be against the ATM-EI board.

## ATM PNC-DUP (ATM PNC Duplication)

---

MO Name (in Alarm Log)	Alarm Level	Initial Command to Run	Full Name of MO
PNC-DUP	NA	status pnc	PNC duplication

The PNC-DUP maintenance object tracks the health of the active and standby PNCs, controls planned and spontaneous interchanges, and manages related functions such as double call refresh and unrefresh, antithrashing, and so on. The main responsibility of PNC-DUP is to recover the system to full service in the event of a fault. In the event of multiple faults, PNC-DUP does its best to maximize service continuity.

In systems with the Critical Reliability option, the following components, which together comprise the Port Network Connectivity (PNC), are duplicated:

- ATM-Expansion Interface (ATM-EI) circuit packs in the port networks (PNs)
- Fiber-optic cables connecting the above circuit packs to the ATM Switch Interface Modules
- ATM Switch

Although not part of the PNC, Tone-Clock circuit packs are also duplicated in each PN. All systems have one Processor Port Network (PPN). ATM PNC systems can have up to 43 EPNs.

PNC duplication architecture utilizes an active/standby duplication scheme in which one complete set of PNC components supports call processing, while the duplicate PNC is held in reserve. All calls on the active PNC are simultaneously set up, or shadowed, on the standby PNC in order for it to be capable of instantly assuming active status when necessary, allowing for interchanges without service disruption (in the case of single faults).

PNC duplication does not introduce any additional types of hardware or hardware faults, and there are no tests associated with the PNC-DUP MO. Instead, its error log entries contain useful information about the occurrence and causes of interchanges in order to facilitate diagnosis of problems, which can then be addressed by using the documentation for the individual maintenance object involved.

### PNC-DUP Related Commands

The following commands and their output screens are fully described in [Chapter 8](#).



<b>status pnc</b>	Displays information about the operational status of both PNCs including state of health, alarms, busyouts and locks, and so on.
<b>reset pnc interchange</b>	Used to initiate a demand PNC interchange. If the standby is healthy (state of health indexes all zero), there is no effect on service. Otherwise, calls may be dropped.
<b>set pnc</b>	Used to lock or unlock the active PNC, preventing interchanges. It does not interfere with double call setup.
<b>busyout pnc</b>	Removes the standby PNC from service. See also the following section on busyout of PNC components.

## Busyouts and PNC-DUP

**Busyout pnc** puts the standby PNC in the busyout state. In this condition:

- Double call set up is turned off.
- The standby PNC is unrefreshed; existing duplicate call connections are removed.
- PNC interchanges are prevented.

Upon release, interchanges are re-enabled and a global refresh of double call setup on the standby is performed.

When PNC duplication is in effect:

- An active PNC component cannot be busied-out.
- A standby PNC component can only be busied-out when the standby PNC is first busied-out.
- The standby PNC cannot be released unless all standby PNC components are released.

## Enabling and removing PNC Duplication

To enable PNC duplication, perform the following sequence of steps:

1. Enable administration of PNC-DUP on the **change system-parameters customer-options** form.
2. Fully administer duplicate fiber link connectivity. Verify by **list atm-pnc**.
3. Activate PNC-DUP through the **change system-parameters duplication** form. This is not allowed if any component of either PNC (A or B) is busied out.

4. The system must insert all connectivity-related components for both standby and active PNC, a process that takes up to 5 minutes, depending upon circuit pack insertion. The process is complete when the first terminal login prompt appears.
5. The PNC-DUP initialization anti-thrashing timer must expire (this occurs 5 minutes after completion of board insertion, PNC interchange, or system reset of level 2 or higher).

To disable PNC duplication perform the following sequence of steps:

1. Verify that the A-PNC is active. A forced interchange may be required. See **reset pnc** in [Chapter 8](#).
2. Busyout the standby PNC (B-PNC).
3. Turn off the system parameter for PNC-DUP through **change system-parameters duplication**.
4. Remove the B-PNC connectivity by removing the Board Locations on the **change fiber** form for ATM-PNC.
5. Remove the B-PNC circuit packs (ATM-EI boards). Use **change circuit pack UUC**.
6. Disable administration of PNC duplication on the **change system-parameters customer-options** form by changing the `PNC Duplication` field to `n`.



**NOTE:**

Alterations to PNC that involve only the *addition* of connectivity can be done with PNC-DUP operational.  
Alterations requiring the *removal* of connectivity must be done with PNC-DUP removed.  
PNC-DUP must be removed and translations should be saved before making any hardware changes.

## Steady State LEDs

The LEDs of PNC components in a stable duplicated system should appear as follows:

- The *active* ATM-EIs in the EPNs are functioning as Archangels. Their yellow LED flash pattern is 2 seconds on/200 ms off.
- The EPN standby EIs yellow LEDs are off.
- The PPN active EI yellow LED is on steady.
- The PPN standby EI yellow LED is off.

## PNC state of health

PNC-DUP software monitors the health of the two PNCs as determined by their state of health (SOH) vectors, and initiates an interchange when the health of the active falls below that of the standby (unless prevented from doing so by a PNC lock, busyout, or antithrashing mechanism). Potentially service-disrupting faults that occur in PNC components are reported to PNC-DUP and incorporated in the state of health for the affected PNC. The SOHs of both PNCs are displayed on the **status pnc** screen, as shown in [Figure 9-11](#).

```

status pnc                                     page 1 of 1

                                PORT NETWORK CONNECTIVITY

                                Duplicated? yes
                                Software Locked? no
                                Standby Busied? no
                                Direct Connect? no
                                Standby Refreshed? yes
                                Interchange Disabled? no

                                A-PNC                                B-PNC

                                Mode: active                        Mode: standby
                                State of Health: functional        State of Health: functional
                                Inter PN Index: 00.00.00            Inter PN Index: 00.00.00
                                Major Alarms: 0                    Major Alarms: 0
                                Minor Alarms: 0                    Minor Alarms: 0
                                Warning Alarms: 0                  Warning Alarms: 0
    
```

**Figure 9-11. Status PNC screen with standby PNC fully In-Service**

## PNC state of health indexes

The Inter-PN Index from the state of health vector is used to track and compare the states of health of both PNCs. The fields making up the indexes are two-digit numbers separated by periods (.), with each field representing a different class of faults. The fault class fields are arranged in order of decreasing importance from left to right. In other words, each field in the index supersedes the following fields in determining which PNC is healthiest. A fault class drives an interchange only when all of the higher priority fault classes are equal. A zero entry indicates no faults present for that class. Increasing numbers indicate increasingly higher numbers of faults present in that class.

The Inter-PN Index contains five fields (XX.XX.XX). The Inter-PN Index reports faults in connectivity between port networks.

- The meaning of each fault class field is given in [Table 9-97](#).

- A zero entry indicates that there are no faults reported.
- Higher numbers indicate increasing number of faults.
- All zeros indicates perfect state of health.
- Unless the PNCs are locked, the active PNC's state of health should always be equal to or better than the standby's, otherwise, the system performs a spontaneous interchange.

After a PNC-related alarm is cleared, the system performs a partial refresh of the standby PNC. The corresponding fault class field is not updated to reflect the improved state of health until the refresh is done. The state of health indexes do not agree with the current alarm status during this period.

**Table 9-97. PNC State of Health Fault Classes**

Fault Class	Priority	Description	MOs
FC_EAL	1	Number of PNs with EALs down	EXP-PN
FC_PACL	2	Number of PNs with LINL, RINL, or EI-SNI neighbor link faults	EXP-PN
FC_HW	3	Number of PNs affected by hardware faults in a link having an EI as an endpoint. (Endpoints can be determined with <b>list fiber-link</b> .)	ATM-EI

### Resolving poor state of health

When the SOHs for both PNCs are not all zeros (perfect health), use the following steps to identify and repair the problem.

1. Look for PNC component alarms (major or minor) for the PNC side whose SOH is not all zero. The standby PNC should be repaired first.
2. Busy-out the standby PNC.
3. Follow the appropriate diagnostic and repair procedures for the alarmed PNC components just as with a simplex PNC. Both the alarm and error logs should be examined to isolate the fault.
4. Verify that the related PNC SOH is restored to all zeros.
5. Release the standby PNC.

### Refresh and unrefresh of the standby PNC

In a fully-functional PNC with healthy standby and active sides, the standby PNC has a complete set of call connections corresponding to those in the active PNC. If, however, the state of health of the standby PNC degrades, a selective

unrefresh of those connections that utilize the faulted component(s) is performed. If the health of the standby PNC improves, a selective refresh of connections on the affected route is performed so that call setup is consistent between the active PNC and the healthy parts of the standby PNC.

The `Standby Refreshed?` field on the **status pnc** screen does *not* refer to the selective type of refresh. It refers only to a global refresh that is performed when:

- The system is initialized and PNC duplication is enabled.
- There has been a spontaneous PNC interchange.
- The standby PNC has been released from busy-out.
- A system reset of level 2 or higher has taken place.

The refreshed field may display yes when in fact the standby is partially unrefreshed. An interchange into an incompletely refreshed standby results in dropped calls. This can happen when a more severe fault occurs on the active PNC or when **reset pnc interchange** is used with the override option.

## PNC interchanges

PNC spontaneous interchanges occur when PNC duplication software determines that the State of Health (SOH) of the standby PNC is better than that of the active PNC.

- PNC-DUP executes a spontaneous interchange in response to a message from a PNC component maintenance object indicating that either a fault has occurred on the active PNC or a fault has been resolved on the standby PNC.
- The PNC SOH is compared to the standby PNC, and an interchange occurs if the state of health of the standby PNC is now better than that of the active PNC.
- A corresponding Major or Minor alarm is logged by the reporting MO, stimulating an alarm report.

When the resolution of a fault on the standby renders it more healthy than a simultaneously-faulted active PNC, the error message indicates the type and location of the *improved* component.

Once the interchange completes, the failed component is on the standby PNC. A demand interchange can be requested in the presence or absence of standby PNC faults. The following sequence of actions can be observed during a fault-free interchange:

1. The ATM-Expansion Interfaces currently acting as archangels in the EPNs are deactivated as indicated by the yellow LEDs going from flashing to on solid.

2. The PPN ATM-EIs are interchanged, indicated by the new standby ATM-EI yellow LED off and the new active ATM-EI yellow LED on steady.
3. One by one the EPN ATM-EIs are interchanged as indicated by new standby ATM-EI yellow LED turning off and the new active ATM-EI yellow LED flashing (2 seconds on/200 milliseconds off). At this point the interchange is functionally complete.

Certain conditions may interfere with the normal execution of the interchange:

1. In a faulted spontaneous interchange, it is possible the EPN/EPNs directly affected by the fault will be the last to interchange.
2. A user directly affected by the single fault instigating a PNC interchange can experience a momentary voice path outage during the switch.
3. If faults exist on both the standby and active PNC, it is possible to have some EPNs go out of service while others are returned to service.

In any multifault situation, rely on **status pnc** to determine which is the active PNC.

PNC duplication informs Timing Synchronization maintenance when a PNC interchange has been completed and indicates which PNC is active. This causes Synchronization to audit and ensure that the primary source for synchronization of Tone-Clocks in each PN is supplied by a path associated with the active PNC.

## Antithrashing and PNC interchanges

Following a spontaneous PNC interchange, subsequent PNC interchanges are prevented for 5 minutes. This condition is indicated by *y* in the *Interchange Disabled?* field of the **status pnc** screen. After 5 minutes, the antithrashing, timer expires, interchange decisions are re-enabled, and the field displays *n*. *Should a catastrophic failure occur on the active PNC during the period when the Interchange Disabled? field is set to "yes," there will be no spontaneous PNC interchange.*

Demand PNC interchanges also invoke anti-thrashing, but only for a period of 30 seconds. During antithrashing mode, demand interchanges are also prevented unless the override option is specified.



### **CAUTION:**

*Use of this option may cause a service disruption.*

## Repairs on the standby PNC components



### **CAUTION:**

*If there is a TDM-CLK alarm, system timing may be routed through part of the standby PNC, and circuit switched data may be affected by the*

following repair procedures. This can happen, for example, when a slave tone/clock circuit pack experiences a loss of signal and switches to receive timing from the standby ATM-EI. In this case TDM-CLK 2305 error is logged, and the clock problem should be addressed first, if possible.

To repair PNC components in a duplicated PNC proceed as follows:

1. Most repairs involve fixing a single fault on the standby PNC. Use **set pnc lock** or **busy-out pnc** to prevent an interchange into the PNC being repaired.
2. If a faulty component exists on the active PNC, this also means that the standby PNC is more severely faulted. Normally, the *standby* PNC is repaired first, since it is the most severely impaired.

To repair the active PNC (standby is already repaired), issue the **set pnc unlock** command, which generates a spontaneous interchange. In a PNC demand interchange with **reset pnc interchange** use the **override-and-lock** qualifier for the active PNC. The *override-and-lock* option ensures that no subsequent interchange can occur during the repair of the standby PNC. A demand interchange may not be necessary if the following conditions drive a spontaneous interchange:

- The anti-thrashing period from the last interchange has expired.
- The global refresh from releasing the standby PNC has completed.
- The standby PNC State of Health is better than the active PNC.

At this point, the faulty component is on the standby PNC, and the PNCs are locked in their current active/standby state.

3. Busyout the PNC with the **busyout pnc** command.
4. Use fault isolation and component testing procedures for the individual PNC components, just as for a simplex PNC. Replacement of components does disrupt operation of the active PNC.
5. Once the failed component is replaced, use the **status pnc** command to check the health standby PNC component.
6. When confident that the problem has been resolved, as indicated by a state of health with all zeros, unlock (**set pnc unlock**) and release (**release pnc**) the PNC. Note that no further PNC interchange is required since you can test the standby PNC as thoroughly as the active.

### Interactions: SPE resets and PNC interchanges

- After a **reset system 4** (reboot), the A PNC is always the active.
- A system reset of level 1 (warm), 2 (cold2) or 3 (cold1) does not change which PNC is active. If a PNC interchange was in progress when the reset took place, the PNC interchange continued until completion.

- If a **reset system 1** (warm) takes place during a PNC interchange, the reset is escalated to level 2 (cold2).

## Fault isolation using Duplicated PNC

In some cases, PNC duplication can aid in the fault isolation procedure. PNC interchanges can be used to help isolate the faulty hardware. Two examples demonstrating this technique follow:

1. There is a fault that can occur in either the PPN ATM-EI or the PKT-INT which cannot be readily attributed to one board or the other. If the packet bus transceivers on either the PKT-INT or ATM-EI fail, the two boards cannot communicate, but it will not be clear which board is at fault. In this case, a planned interchange of the PNC can be used to indicate which of the two boards.
  - If the interchange cures the problem, the ATM-EI was at fault.
  - If the interchange does not cure the problem, the PKT-INT is suspect, provided there are no PKT-BUS faults.
2. A similar relationship exists for the EPN Archangel (EAA - the active ATM-EI) and certain TDM bus problems. If the EAA is unable to communicate with a port board over the TDM bus, either the EAA has a fault, the port board has a fault, or there is a problem with the TDM bus itself. If TDM bus maintenance tests find no problems with the bus, then it is either the port board or the EAA. It may be simpler to replace the port board than to request a PNC interchange. However, if it is not clear which port board may be at fault or maintenance is being performed remotely, verify that the EAA is not at fault by executing a PNC interchange. If the interchange solves the problem, then the EAA is faulty. If the problem persists after the interchange, but TDM bus maintenance finds no problem, then the port board is faulty.

## Error Log entries

Whenever a PNC interchange takes place, an error is logged against PNC-DUP with a code that conveys information about the cause of the interchange and which PNC became active. There are no alarms associated with PNC-DUP errors, but there should be an alarm against the PNC component that caused the interchange. There are no PNC-DUP test sequences, but **status pnc** provides information regarding the status of the PNCs. The information in [Table 9-98](#) and [Table 9-99](#) can help to identify which areas of the Alarm Log to investigate to find the source of the problem.



**Table 9-98. Error Code descriptions and Aux Data correlations**

Error Code	Description	Aux Data <sup>1</sup>
00000	Error in generating error code	None
1cxpp	Spontaneous Interchange in response to a constraint for A-PNC	Active PNC
2cxpp	Spontaneous Interchange in response to a constraint for B-PNC	Active PNC
51000	Spontaneous Interchange at expiration of SOH validation timer	Active PNC
52000	Spontaneous Interchange upon PNC UNLOCK	Active PNC
53000	Spontaneous Interchange at completion of Global Refresh	Active PNC
60801	PNC Demand Interchange	Active PNC
60800	PNC Demand Interchange with override	Active PNC

- The Aux Data indicates which PNC became active after the PNC interchange: "0" denotes PNC-A; "1" denotes PNC-B.

**Table 9-99. Error Log Encode Field Decoding**

Field	Variable Name	Values	Description
c	Alarm Type	0 1	Alarm retired MAJOR or MINOR alarm on any PNC component
x	Fault class; see description for contributing MOs	0	EAL (Expansion Archangel Link - EXP-PN) carries CCMS messages
		1	PAEL (ATM-EI) carries ATM signaling commands from Call Processing to the remote ATM-EI circuit packs.
		2	PNC hardware (providing connectivity of PPN or EPN to EPN or ATM-EI)
pp	Port Network number	0-44	0-2 for constraint class (this is an internal number; add 1 for external port number)

## Error Log Entries and Test to Clear Values

Error Type	Aux Data	Associated Test	Alarm Level	On/Off Board	Test to Clear Value
18	None	busy PNC-DUP	WARNING	ON	release pnc-dup



**NOTE:**

The **list config port-network** command gives the cabinet number associated with a port network.

## ATM-SGRP (ATM Signaling Group)

MO Name (in Alarm Log)	Alarm Level	Initial Command to Run <sup>1</sup>	Full Name of MO
ATM-SGRP	MINOR	test sig-group <i>grp#</i>	ATM-CES Signaling Group
ATM-SGRP	WARNING	test sig-group <i>grp#</i>	ATM-CES Signaling Group

1. *grp#* is the signaling group number (1-166); the test sequence can be either short or long.

This Maintenance Object (ATM-SGRP) applies when ATM signaling groups have been administered on an ATM circuit pack as ATM Trunks.

[Table 9-100](#) outlines the differences between ATM interface circuit packs:

**Table 9-100. R7 ATM-SGR circuit packs**

Circuit pack	Channel types	Interface	Fiber	Echo cancellation
TN2305	B and D channels	24 or 32 channel	Multimode	Y
TN2306	B and D channels	24 or 32 channel	Single mode	Y

The TN2305 and TN2306 ATM Interface circuit boards are referred to as TN230X for the remainder of this MO.

An ATM Signaling Group is a collection of B-channels for which a given ISDN-PRI Signaling Channel Port (ATM D-channel) carries signaling information. ATM B-channels (ATM-BCH) carry voice or data and are assigned to ISDN trunks. For more information see [“ATM-TRK \(Circuit Emulation Service Circuit Pack\)”](#).

The operation of the entire ATM signaling group depends on several other entities:

- the ATM-DCH signaling channel port
- the TN230X Interface circuit pack on which the D-channels reside
- the system link that is carried over the packet bus to the processor

When there are problems with ATM-SGRP (ATM signaling group), also investigate:

- [“ATM-DCH \(ATM D-Channel Port\)”](#)
- [“ATM-BCH \(ATM B-Channel Trunk\)”](#)
- SYS-LINK
- PKT-BUS

## Error Log Entries and Test to Clear Values

Table 9-101. ATM-SGRP Signaling Group Error Log Entries

Error Type	Aux Data	Associated Test	Alarm Level	On/Off Board	Test to Clear Value
0	0	Any	Any		test sig-group <i>grp#</i>
1 (a)	Any	None			
18 (b)		MO busied out			
257 (c)	Any	None			test sig-group <i>grp#</i>
769 (d)	Any	Primary Signaling Link Hardware Check (#636)			test sig-group <i>grp#</i>
1281 (e)	Any	Secondary Signaling Link Hardware Check (#639)			test sig-group <i>grp#</i>
1793 (f)	Any	Layer 2 Status (Test #647)	WNG	OFF	test sig-group <i>grp#</i>
2305 (g)	Any	Remote Layer 3 Query (Test #637)	MINOR	OFF	test sig-group <i>grp#</i>
3585 (h)	Port number	None			
3840 - 3928 (i)	Port number	None			

Notes:

- a. Error Type 1: switch sent a message to the far-end switch or terminal adapter, and the far-end did not respond in the allotted time. Possible causes include link failure and congestion or outage at the far-end. The Aux Data field contains Layer 3 protocol information used by internal counters.

If no other symptoms are present, no action is required. If Layer 3 communication is down:

- a. Check for alarms and errors against link components

- b. Check out other errors against ATM-SGRP, ATM-TRK, and other hardware components on the link.

There is no test to clear these errors. The error counter is decremented by 1 every 15 minutes.

- b. Error Type 18: the ATM circuit pack has been busied out (either **busyout atm sig-grp** or **busyout board UUCSS**).
  1. Release the ATM signaling group (**release atm sig-grp**) or the circuit pack (**release board UUCSS**).
- c. Error Type 257: the primary signaling channel connection has been lost for more than 90 seconds.
  - The associated B-channels are placed in the ISDN Maintenance/Far-End state.
  - The B-channels are not usable for outgoing calls, although incoming calls can be accepted.
  - The switch automatically attempts to recover the signaling link.
  - 1. Pay particular attention to the results of Test #636 (Primary Signaling Link Hardware Check) in the test sequence.
    - When the link does recover, the B-channels are negotiated back to the In-Service state and their alarms are retired.
  - 2. When this error occurs, the state of the Signaling Group is changed to out-of-service (verify using the **status sig-group** command).
- d. Error Type 769: signaling link hardware error.

Service-affecting failures of the hardware used to transport the D-Channel are reported to the ATM CES Signaling Group MO. Maintenance logs this error, places the D-Channel into the OOS state, and raises a board-level alarm. The D-Channel is returned to service and the alarm is retired once the hardware failure condition clears.
- e. Error Type 1281: Degraded PVC Alarms indicate that a particular Permanent Virtual Circuit, or signaling group, has encountered sufficient errors to exceed firmware thresholds. Operations can continue but at a lower level of reliability or performance. Firmware filters these alarms so that only one is reported active at a given time. The following in-line error is considered a Degraded PVC Alarm:
  - Excessive AAL - The AAL layer is experiencing an excessive number of errors in trying to reconstruct Service Data Unit (SDUs). Possible causes:
    - Something may be wrong with the ATM switch.
    - The communication paths on the other side of the ATM switch may be noisy.
    - The sending node might not be healthy.
    - Could be a problem with congestion on the ATM switch.

- f. Error Type 1793: failure of the Layer 2 Query Test for the primary signaling channel.
- Excessive AAL - The AAL layer is experiencing an excessive number of errors in trying to reconstruct Service Data Unit (SDUs). Possible causes:
    - Something may be wrong with the ATM switch.
    - The communication paths on the other side of the ATM switch may be noisy.
    - The sending node might not be healthy. It could also be a problem with congestion on the ATM switch.

- g. Error Type 2305: the Remote Layer 3 Query Test (#637) failed. A specific message was sent to the far-end switch, and it did not respond within the allotted time.
1. Investigate elements of the ATM D-channel(s) (ATM-DCH) for both this switch and the Far-end switch.

If Test #637 fails twice in a row, the B-channels are alarmed and made unavailable for outgoing calls (although incoming calls are still accepted). When Test #637 succeeds and the Far-end switch starts responding properly, the ATM Trunk (B-channels) are placed back into normal operation and their alarms retired.

- h. Error Type 3585: A SERV or SERV ACK ISDN D-channel message has been received by a non-US-type interface (country option other than 1 on the DS1 administration form). However, these messages are used only for duplex NFAS signaling, which is supported by country protocol 1.

Thus, there may be a mismatch in administration between the local and far-end switches.

1. Consult with the customer's network provider to determine whether the D-channel is set up correctly on the far-end switch.

- i. Error Type 3840-3928: These error types are used to report certain error messages received by the ATM-SGRP Signaling Group for one of its associated B-channels. The Aux Data field is the port number of the B-channel from which the message was received.

The error code generated equals 3840+x, where x is a Cause Value defined by the ISDN PRI Specification. Note that there is no Test to Clear Value for these error types; selected ISDN cause values are placed in the log when they are received, but no direct action or alarming is performed solely in response to receiving them. They provide added data that may prove useful when tracking down obscure networking and routing problems. [Table 9-102](#) provides more information about this range of Error Codes:

**Table 9-102. Descriptions and repair recommendations (Error Types 3840-3928)**

Error Code	Description	Recommendation
3842	A request has been made to use a transit network or common carrier that cannot be accessed.	From the circuit pack and port number (in the Aux Data field), determine the trunk group against which the error was reported. <ol style="list-style-type: none"> <li>1. Check all routing patterns containing this trunk group for validity of interexchange carriers requested (IXC field).</li> </ol>
3846	The far-end switch has indicated that the B-channel (trunk) is not acceptable for use in the call for which it was requested.	This could indicate <ul style="list-style-type: none"> <li>■ an administration problem (for example, the local switch and the far-end switch have different B-channels administered)</li> <li>■ a normal race condition (for example, the local switch has requested use of a B-channel which the far-end switch had just reserved for use on another call).</li> </ul> <ol style="list-style-type: none"> <li>1. From the circuit pack and port number (in the Aux Data field), determine the trunk group against which the error was reported.</li> <li>2. Issue the <b>status trunk</b> command for the indicated trunk.</li> <li>3. Refer to <a href="#">Table 9-61</a> in "<a href="#">ATM-BCH (ATM B-Channel Trunk)</a>" for recovery suggestions.</li> </ol>
3858	Similar to Error Type 1. The switch sent an ISDN message to the far-end switch or terminal adapter which did not respond in the allotted time.	<ol style="list-style-type: none"> <li>1. Check for alarms and errors against link components</li> <li>2. Check out other errors against "<a href="#">ATM-SGRP (ATM Signaling Group)</a>", "<a href="#">ATM-TRK (Circuit Emulation Service Circuit Pack)</a>", and other hardware components on the link.</li> </ol>
3878	The far-end switch has indicated that the network is not functioning correctly and that the condition may last a relatively long period of time (for example, immediately re-attempting the call may not be successful).	<ol style="list-style-type: none"> <li>1. From the circuit pack and port number (in the Aux Data field), determine the trunk group against which the error was reported.</li> <li>2. Consult with the network provider to determine the nature and expected duration of the out of service condition.</li> <li>3. Consider modifying all routing patterns containing this trunk group, to route calls around the network which is out of service.</li> </ol>

*Continued on next page*

**Table 9-102. Descriptions and repair recommendations (Error Types 3840-3928) — Continued**

Error Code	Description	Recommendation
3890	<p>A request to use a network service (for example, SDN) has been denied. Administration somewhere on the network has indicated that the requested service has not been subscribed to or purchased for this trunk.</p>	<p>This could indicate</p> <ul style="list-style-type: none"> <li>■ a local administration problem</li> <li>■ a mismatch between the local administration and that of the network provider.</li> </ul> <ol style="list-style-type: none"> <li>1. From the circuit pack and port number (in the Aux Data field), determine the trunk group against which the error was reported.</li> <li>2. Display the trunk group form.                     <p>If the trunk group is Call-by-Call (the <i>Service Type</i> field is <i>cbc</i>), check all routing pattern forms containing this trunk group to see if the <i>Service/Feature</i> fields contain the correct network services purchased for this trunk.</p> <p>If the trunk group is not Call-by-Call, check that the <i>Service Type</i> field contains the single network service purchased for this trunk.</p> </li> <li>3. If local administration appears correct, consult with the customer and/or the network provider to determine the services that the customer has subscribed to for this trunk group.</li> </ol>
3892	<p>Protocol detail; may offer a clue if customer is having ISDN calls denied with an unexpected intercept tone.</p>	<ol style="list-style-type: none"> <li>1. If customer is complaining of unexpected intercept tones when accessing ISDN trunks or PRI endpoints and no other cause can be found, escalate the problem and provide the next tier with this Error Log information.</li> </ol>
3894	<p>Protocol detail; may offer a clue if customer is having ISDN calls denied with an unexpected intercept tone.</p>	<ol style="list-style-type: none"> <li>1. Eliminate any transitory state mismatch problems (<b>test port UUCSSpp</b> for the trunk port shown in the Aux Data field). Test #256 (Service State Audit) is the important test in the sequence.</li> <li>2. If Test #256 passes yet the customer continues to complain of unexpected intercept tones when accessing ISDN trunks or PRI endpoints and no other cause can be found, escalate the problem and provide the next tier with this Error Log information.</li> </ol>
3905	<p>Protocol detail; may offer a clue if customer is having ISDN calls denied with an unexpected intercept tone.</p>	<ol style="list-style-type: none"> <li>1. If customer is complaining of unexpected intercept tones when accessing ISDN trunks or PRI endpoints and no other cause can be found, escalate the problem and provide the next tier with this Error Log information.</li> </ol>

*Continued on next page*



**Table 9-102. Descriptions and repair recommendations (Error Types 3840-3928) — Continued**

Error Code	Description	Recommendation
3906	Protocol detail; may offer a clue if customer is having ISDN calls denied with an unexpected intercept tone.	<ol style="list-style-type: none"> <li>1. If customer is complaining of unexpected intercept tones when accessing ISDN trunks or PRI endpoints and no other cause can be found, escalate to the problem and provide the next tier with this Error Log information.</li> </ol>
3909	A request to use a network service has been made, but the network has rejected the request because the requested service is not implemented.	<ol style="list-style-type: none"> <li>1. Follow the recommendations listed above for Error Type 3890.</li> </ol>
3928	A call was denied because of a basic incompatibility between the type of call and either the facilities selected by the routing pattern or the called user itself.	<p>This error might be helpful as a clue if the customer complains of receiving unexpected intercept tone after accessing ISDN trunks or PRI endpoints.</p> <ol style="list-style-type: none"> <li>1. Determine the trunk group from the circuit pack and port number (in the aux data field)</li> <li>2. check the BCC fields of the pertinent routing patterns.</li> <li>3. Also, investigate whether or not the calling and called endpoints are compatible (for example, some ISDN switches may not allow a voice station to call a data extension).</li> </ol>

## **System Technician-Demanded Tests: Descriptions and Error Codes**

Always investigate tests in the order presented in the table below when inspecting errors in the system. By clearing error codes associated with the Primary Signaling Link Hardware Check, for example, you may also clear errors generated from other tests in the testing sequence.

**Table 9-103. System Technician-Demanded Tests: ATM-SGRP**

Order of Investigation	Short Test Sequence	Long Test Sequence	D/ND <sup>1</sup>
Primary Signaling Link Hardware Check (#636)	X	X	ND
Layer 2 Status Test (#647)	X	X	ND
Remote Layer 3 Query Test (#1291)	X	X	ND

1. D = Destructive, ND = Non-destructive

### Primary Signaling Link Hardware Check (#636)

The ATM-SGRP Signaling Group D-Channel port depends on the health of the TN230X interface circuit pack on which it resides. This test fails if there are problems with either the ATM-DCH (D-channel port) maintenance object or the TN230X circuit pack. Investigate the ATM TN230X circuit pack (ATM-TRK) anytime there are problems with the ATM D-channel port (ATM-DCH).

**Table 9-104. Primary Signaling Link Hardware Check (#636)**

Error Code	Test Result	Description/ Recommendation
	ABORT	Internal system error Retry the command at 1-minute intervals a maximum of 5 times.
8	FAIL	There is a problem with the ATM TN230X Circuit Pack or the ATM Signaling Channel (D-Channel), preventing any ISDN trunk calls until the problem is resolved. 1. Consult the procedures for the TN230X Circuit Pack (ATM-TRK) and the ATM D-channel (ATM-DCH).
	PASS	The basic physical connectivity of the D-channel is intact and functional. 1. Try this test repeatedly to ensure the link is up and to uncover any transitory problems.

## Layer 2 Status Test (#647)

The Layer 2 Status Test checks the layer 2 status of the ATM-SRG Signaling Channel (D-channel). This test fails when:

- there is a hardware failure
- there is a facility problem
- the D-channels are not administered correctly

The Signaling Link Hardware Check (Test #637) and the Remote Layer 3 Query Test (#1291) detects most problems caused by hardware failures or incorrect administration.

**Table 9-105. TEST #647 Layer 2 Status Query Test**

Error Code	Test Result	Description/ Recommendation
1132	ABORT	Internal system error. The port location for the D-channel is not known. This condition should not be possible since an administered ATM circuit pack must be specified when a Signaling Group is administered: <ol style="list-style-type: none"> <li>1. Retry the command at one minute intervals a maximum of five times.</li> </ol>
1134	ABORT	Internal system error. The associated ATM circuit pack is not administered. This condition should not be possible, since an administered ATM circuit pack must be specified when administering a Signaling Group. <ol style="list-style-type: none"> <li>1. Retry the command at one minute intervals a maximum of three times.</li> </ol>
2500	ABORT	Internal system error <ol style="list-style-type: none"> <li>1. Retry the command at one minute intervals a maximum of five times.</li> </ol>
1	FAIL	Layer 2 of the signaling channel is down <ol style="list-style-type: none"> <li>1. Examine the results of the Signaling Test (#636) and follow recommendations provided there.</li> <li>2. If Test #636 (Primary Signaling Link Hardware Check) passes, the Layer 2 Query test may still fail if the Signaling Channel at the far end has not been administered correctly or if the Signaling Channel has been busied out.</li> <li>3. Verify that the Signaling Channel (D-channel) at the far end has been administered correctly.</li> <li>4. Verify that the ATM-DCH port used for the D-channel has not been busied out at the far end.</li> </ol>

*Continued on next page*

Table 9-105. TEST #647 Layer 2 Status Query Test — Continued

Error Code	Test Result	Description/ Recommendation
3	FAIL	The D-Channel is down. <ol style="list-style-type: none"><li>1. Examine the results of the Primary Signaling Link Hardware Check (#636) and follow recommendations provided there.</li><li>2. If Test #636 (Primary Signaling Link Hardware Check) passes, the Layer 2 Query test may still fail if the Signaling Channel at the far end has not been administered correctly or if the Signaling Channel has been busied out.</li><li>3. Verify that the Signaling Channel (D-channel) at the far end has been administered correctly.</li><li>4. Verify that the ATM-DCH port used for the Primary and Secondary D-channels has not been busied out at the far end.</li></ol>
	PASS	The Primary Signaling Channel is up.

### Remote Layer 3 Query (#1291)

This test queries the far-end switch or terminal adapter to determine if the signaling connection is functioning properly at Layer 3. It selects a B-channel in the in-service or maintenance service state and sends an ISDN Layer 3 SERVICE message, which requires a response from the far end (similar to performing Test #256 on an ISDN trunk). The test is not performed if there are no B-channels in an appropriate ISDN service state (for example, when none are administered or they are all out of service).

#### ⇒ NOTE:

The service state can be displayed by using the **status trunk <trunk group/trunk member>** or **status pri-endpoint** command.

As is the case with Test #256 for an ISDN trunk, a PASS only indicates that a message was composed and sent to the far-end switch or terminal adapter. The ISDN PRI Specification allows up to 2 minutes for a response. Check the Error Log for ATM-SGRP errors of type 2305 for evidence of a Remote Layer 3 Query failure.

Test #636 checks the health of the D-channels and ATM Interface Circuit Packs. This test goes one step further by checking the communication path from the processor, through the TDM/Packet Bus and ATM Interface circuit pack, and on to the far-end switch or terminal adapter. A special ISDN message is sent to the far-end switch or terminal adapter, which must respond within a specified amount of time. This test is designed to ensure that the communication path

between the switch and the far-end is up and operational, and that the two endpoints can properly exchange ISDN control messages.

**Table 9-106. TEST #1291 Remote Layer 3 Query**

Error Code	Test Result	Description/ Recommendation
1006	ABORT	There are no associated B-channels in an ISDN "in-service" or "maintenance" service state. This is a NORMAL ABORT. <ol style="list-style-type: none"> <li>1. Administer or release an ISDN trunk or PRI endpoint before retrying the test. For an ATM trunk, use the <b>status trunk grp#/mbr#</b> command to verify the ISDN trunk state.</li> <li>2. Retry this test when at least one B-channel is in the "in-service" or "maintenance" states.</li> </ol>
1113	ABORT	The signaling channel is down. Therefore, no messages can be sent to the far-end switch or terminal adapter. <ol style="list-style-type: none"> <li>1. Examine the results of Tests #636 and follow recommendations provided there.</li> </ol>
2100	ABORT	Could not allocate the necessary system resources to run this test. <ol style="list-style-type: none"> <li>1. Retry the command at 1-minute intervals a maximum of 5 times.</li> </ol>
2500 or none	ABORT	Internal system error or administration problem <ol style="list-style-type: none"> <li>1. Determine if any B-channels are administered.</li> <li>2. If there are none, then this is a normal ABORT, since this test cannot run unless at least one B-channel is administered.</li> <li>3. If at least one B-channels is administered, there is an internal system error. Retry the command at 1-minute intervals a maximum of 5 times.</li> </ol>
	FAIL	Internal system error <ol style="list-style-type: none"> <li>1. See description of ABORT with Error Code 2500.</li> </ol>
	PASS	A message was sent to the far-end switch or terminal adapter. The ISDN PRI specification allows up to 2 minutes for a reply. <ol style="list-style-type: none"> <li>1. Check the Error Log for ATM-SGRP errors of type 2305 for evidence of a Remote Layer 3 Query failure.</li> <li>2. If no new errors were logged since this test was run, then this switch and the far-end switch can exchange call control messages.</li> <li>3. If there is still a problem with a particular ATM trunk, busyout the trunk and run the long test sequence, paying particular attention to the results of Test #258 (ISDN Test Call).</li> </ol>

## ATM-SYNC (ATM Synchronization)

---

MO Name (in Alarm Log)	Alarm Level	Initial Command to Run	Full Name of MO
ATM-SYNC	MINOR	display errors	ATM Synchronization
ATM-SYNC	WARNING	test synchronization	ATM Synchronization

This section discusses intra-switch synchronization maintenance and the hardware and software components that provide a common reference frequency for reliable digital communication among the G3r system, the ATM switch, and other PBXs, Central Offices (COs) or Customer-Premises Equipment (CPE). Circuit packs involved in synchronization include:

- TN768, TN780, or TN2182 Tone/Clock
- TN722, TN767, and TN464 DS1 Interfaces (all suffixes)
- TN2305/6 (R7.1) and TN2238 (R6.3) ATM Expansion Interface (multimode fiber)

Synchronization is achieved between the Processor Port Network (PPN) and the Expansion Port Networks (EPNs) through the ATM port network connectivity (ATM PNC) between the networks. Depending on the network synchronization plan and the status of synchronization sources, the system timing reference may be:

- The clock circuit pack on the ATM switch
- A DS1 or UDS1 interface circuit pack-tapped T1 input signal connected to the ATM switch clock circuit
- An OC-3 interface circuit pack on the ATM switch

Stratum 4 synchronization extracts timing information directly from

- A DS1 or UDS1 reference
- An OC3 reference
- The ATM switch clock

For further information about synchronization including network synchronization, see *AT&T Network and Data Connectivity*.

### Stratum 4 Synchronization

---

Systems may have primary and secondary synchronization references (DS1/UDS1 interface circuit packs or ATM-Switch) when using Stratum 4 synchronization.

If the primary synchronization reference in [Figure 9-12](#) is providing a valid timing signal, then the flow of system synchronization would travel from the DS1 interface circuit pack in the EPN to the ATM switch. The primary DS1 interface

circuit pack provides a timing signal for the ATM switch clock circuitry. This synchronization source is then distributed to all of its OC3 Interface Modules. Each ATM Expansion Interface circuit pack uses the received data stream from the ATM switch to generate a timing signal. The Tone-Clock circuit packs in the EPNs use this signal to generate timing for all the circuit packs in their respective EPNs. All PNs, in the above mentioned scenario are designated the *slave* port networks. The ATM switch is the *master* that contains the system synchronization source. If the primary synchronization reference does not provide a valid timing signal, ATM synchronization maintenance infers a switch to the secondary reference.

If the primary synchronization reference is not providing a valid timing signal, the system automatically switches to the secondary synchronization reference. If the primary synchronization reference is invalid, and if the secondary reference does not provide a valid timing signal or is not administered as a synchronization reference, the switch infers that the local oscillator of the ATM switch provides the system timing source. If the system is using the local oscillator of the ATM switch as the system timing source because the primary and secondary references are providing invalid timing signals, when either the primary or secondary reference becomes valid again, the system switches back to the primary or secondary source. When both the primary and secondary source become valid, the system switches to the primary source, since the primary source is always preferred over the secondary source when both sources are equally healthy.

[Figure 9-12](#) depicts a simplex ATM PNC with T1/OC3 synchronization reference into the ATM switch.

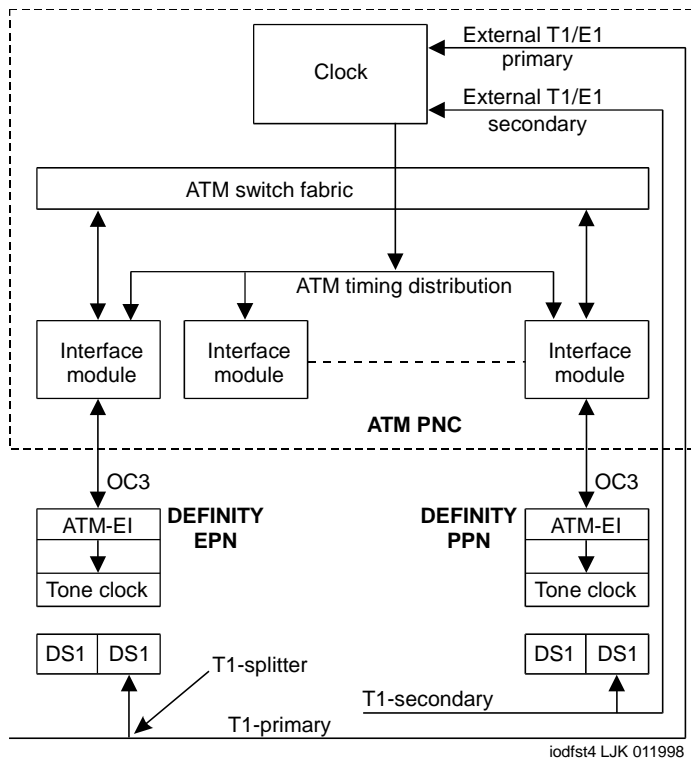

**Figure 9-12. Stratum 4 synchronization with simplex ATM PNC**



**NOTE:**

The TN722 DS1 Interface circuit pack does not provide a synchronization reference as reliably as the TN767 or TN464C circuit packs. Therefore, administer the TN767 or TN464C circuit packs as the primary or secondary sources.

**Stratum 3 Synchronization**

Stratum 3 synchronization is not supported in DEFINITY with ATM PNC.

**Synchronization troubleshooting**

A significant part of the Synchronization Recovery Strategy for a DEFINITY with ATM PNC resides in the ATM switch's clock hardware, firmware, and software. DEFINITY monitors synchronization performance and alarms faulty components within DEFINITY. Refer to "[SYNC \(Synchronization\)](#)".



## ATM-SYNC commands

Use the following commands to help troubleshoot ATM-SYNC problems:

change synchronization	Allows primary and secondary references to be administered for the Stratum 4 option, or <code>ATM-Switch</code> , indicating that the synchronization references are input directly to the ATM switch
status synchronization	Shows the current inferred synchronization reference
status synchronization	Shows the administered primary and secondary synchronization references
list timing-source	Displays all DS1 and UDS1 locations that are allowed to be administered as primary or secondary references with the <b>change synchronization</b> command
disable/enable synchronization-switch	Prevents or allows switching to another synchronization source
test synchronization	Tests the administered synchronization source

## Error Log Entries and Test to Clear Values

Table 9-107. Synchronization Error Log Entries

Error Type	Aux Data	Associated Test	Alarm Level	On/Off Board	Test to Clear Value
0 <sup>1</sup>	0	Any	Any	Any	test synchronization
1 (a) (g)		None	WARNING/ MINOR	OFF	None
257 (b) (g)		None	WARNING/ MINOR	OFF	None
513 (c) (g)		None	WARNING/ MAJOR	OFF	None
1537 (d) <sup>2</sup>		None	WARNING	OFF	None
1793 (e) <sup>2</sup>	0-50	None	NONE	OFF	None
2049 (f) <sup>2</sup>	0	None	WARNING	OFF	None

1. Run the Short Test Sequence first. If all tests pass, run the Long Test Sequence. Refer to the appropriate test description and follow the recommended procedures.
2. It may take up to 1 hour for these alarms to clear via the "leaky bucket" strategy.

Notes:

- a. Error Type 1: problem with the primary DS1 reference. It is cleared when the primary reference is restored. The following steps should give an indication of the source of the problem:
  1. Check if the primary DS1 interface circuit pack is inserted in the carrier with the **list configuration board UUCSS** command.
  2. Verify that the administered primary reference matches the DS1 reference from the network synchronization plan.
  3. Test the primary DS1 interface circuit pack with the **test board UUCSS long** command. Check the Error Log for DS1-BD or UDS1-BD errors and refer to the DS1-BD or UDS1-BD (DS1 Interface Circuit Pack or UDS1 Interface Circuit Pack) Maintenance documentation to resolve any errors associated with the primary DS1 (DS1 or UDS1) interface circuit pack. If the only errors against DS1-BD or UDS1-BD are slip errors, then follow the procedures described in the troubleshooting section above. If no errors are listed in the Error Log for the primary DS1 interface circuit pack, continue with the following steps.
  4. Test the active Tone-Clock circuit pack in the master port network with the **test tone-clock UUC long** command. Check the Error Log for TDM-CLK errors and verify that TDM Bus Clock Test #148 (TDM Bus Clock Circuit Status Inquiry Test) passes successfully. If Test #148 fails with an Error Code 2 through 32, refer to the TDM-CLK (TDM Bus Clock) Maintenance documentation to resolve the problem.
- b. Error Type 257: problem with the secondary DS1 reference. It is cleared when the secondary reference is restored. Refer to note (a) to resolve this error substituting **secondary** for **primary** in the preceding resolution steps.
- c. Error Type 513: the ATM switch clock is inferred to be providing the timing source for the system. The primary and secondary (if administered) are not providing a valid timing signal. Investigate errors 1 and 257 to resolve this error.
- d. Error Type 1537: over half of the DS1s that are administered with slip detection enabled through the `Slip Detection?` field set to **y** are experiencing slips.
- e. Error Type 1793: inferred excessive switching of system synchronization references has occurred. When this error occurs, it is inferred that the ATM switch clock has become the synchronization reference for the system.
  1. Check for timing loops and resolve any loops that exist.
  2. Test the active Tone-Clock circuit pack in the master port network with the **test tone-clock UUC long** command. Check the Error Log for TDM-CLK errors and verify that TDM Bus Clock Test #148 (TDM

Bus Clock Circuit Status Inquiry test) passes successfully. If Test #148 fails with an Error Code 2 through 32, refer to TDM-CLK to resolve the problem. If not, continue with the following steps.

3. *For Duplicated Tone-Clock circuit packs in the master port network:* Switch Tone-Clock circuit packs on the master port network with the **set tone-clock UUC** command.

*For Simplex Tone-Clock circuit packs in the master port network:* replace the primary and secondary (if administered) DS1 Interface circuit packs.

4. Investigate any other SYNC errors.
- f. Error Type 2049: the ATM Expansion Interface circuit packs are errors that affect synchronization. Test the ATM Expansion Interface circuit pack with the **test board UUCSS** command.

This error is cleared by a “leaky bucket” strategy and takes up to one hour to clear (leak away) the error counter once it is cleared.

- g. Error Types 1, 257, and 513: noise on the DS1 line can cause transient alarms on synchronization. Therefore, when a synchronization problem occurs on Error Types 1, 257, or 513, a WARNING alarm is first raised for 15 to 20 minutes before the alarm is upgraded to a MINOR or MAJOR alarm.

## System Technician-Demanded Tests: Descriptions and Error Codes

Always investigate tests in the order presented below when inspecting errors in the system.

Order of Investigation	Short Test Sequence	Long Test Sequence	D/ND <sup>1</sup>
Test Synchronization Test (#417)	X	X	ND

1. D = Destructive, ND = Non-destructive

### Test Synchronization Test (#417)

This test updates all the Synchronization Maintenance component circuit packs with the correct information regarding their role in providing synchronization for the system. All the Tone-Clock, ATM Expansion Interface, DS1 Interface, and UDS1 Interface circuit packs in the system are updated through this test. This test either passes or aborts.

**Table 9-108. TEST #417 Test Synchronization Test**

Error Code	Test Result	Description/ Recommendation
1000	ABORT	System resources required to run this test are not available. 1. Retry the command at 1-minute intervals a maximum of 3 times.
1115	ABORT	Could not allocate the necessary system resources to run this test.
2500	ABORT	Internal system error
	PASS	The synchronization maintenance component circuit pack parameters have been successfully updated. The system should be synchronized after successful execution of this test. 1. If synchronization problems still exist, refer to the Error Log to obtain information regarding the source of the problem.

**Session Restart Test (#1287)**

**This test is destructive.**

This test attempts to restart those sessions that are down on the PPP link. The test runs only on demand as a part of **test port UUCSSpp long** command.

**Table 9-109. TEST #1287 Session Restart Test**

Error Code	Test Result	Description/ Recommendation
1125	ABORT	PPP Link is not in service. 1. Check if the PPP link is in-service or not. If the link is not in service, release the link ( <b>release link n</b> or the <b>release port UUCSSpp</b> ) and repeat the test. This is a normal abort.
2000	ABORT	Response to the test was not received from the C-LAN circuit pack within the allowable time period. 1. If this result occurs repeatedly, attempt to reset the circuit pack if the other ports on the board are not in use (Yellow LED is off). Reset the circuit pack by issuing the <b>busyout board UUCSS</b> and the <b>reset board UUCSS</b> commands. 2. If this result occurs again, replace the circuit pack.
2100	ABORT	The necessary system resources to execute the test could not be allocated. 1. Retry the command at 1-minute intervals a maximum of 5 times.

**Table 9-109. TEST #1287 Session Restart Test — Continued**

Error Code	Test Result	Description/ Recommendation
2500	ABORT	Internal system Error. 1. Retry the command at 1-minute intervals a maximum of 3 times
	FAIL	All sessions on PPP link are down. 1. Test the port (test port UUCSSpp long) and verify the result of the SCOTCH Synchronous Local Loop Around Test (#1275). 2. If the test fails, escalate the problem. 3. If the test passes wait for the sessions to come up.
	PASS	All sessions on PPP link are up.

**PPP Link Status Inquiry Test (#1279)**

This non-destructive test determines the state of the PPP link. If the link is connected, this test passes. The test fails if the PPP link is disconnected.

**Table 9-110. TEST #1279 PPP Link Status Inquiry Test**

Error Code	Test Result	Description/ Recommendation
1125	ABORT	PPP Link is not in service. 1. Check if the PPP link is in-service or not. If the link is not in service, release the link ( <b>release link n</b> or <b>release port UUCSSpp</b> ) and repeat the test. This is a normal abort.
2100	ABORT	The necessary system resources to execute the test could not be allocated. 1. Retry the command at 1-minute intervals a maximum of 5 times.
2500	ABORT	Internal system Error. 1. Retry the command at 1-minute intervals a maximum of 3 times
	FAIL	PPP link is down. 1. Test the port ( <b>test port UUCSSpp long</b> ) and verify the result of the SCOTCH Synchronous Local Loop Around Test (#1275). 2. If the test passes wait for the link to come up.
	PASS	PPP link is up.

## ATM-TRK (Circuit Emulation Service Circuit Pack)

---

MO Name (in Alarm Log)	Alarm Level	Initial Command to Run <sup>1</sup>	Full Name of MO
ATM-TRK	MAJOR	test board UUCSS	ATM TRUNK (ATM Circuit Emulation Service)
ATM-TRK	MINOR	test board UUCSS	ATM TRUNK (ATM Circuit Emulation Service)
ATM-TRK	WARNING	test board UUCSS	ATM TRUNK (ATM Circuit Emulation Service)

- 
1. UU is the universal cabinet number (1 for PPN, 2 - 44 for EPNs). C is the carrier designation (A, B, C, D, or E). SS is the number of the slot in which the circuit pack resides (01 to 21).
- 

This maintenance object explains how you test and repair TN230x ATM Interface circuit packs (TN2305 and TN2306) that have been administered as virtual ISDN-PRI trunks for ATM Circuit Emulation Service (CES). The maintenance instructions for TN230x circuit packs that have been administered as Expansion Interfaces for WAN connectivity are in the [ATM-EI \(Expansion Interface Circuit Pack\)](#) maintenance object.

### Description

---

The TN2305 and TN2306 ([Table 9-111](#)) are dual-purpose ATM circuit packs that can be administered as either personality:

- [“ATM Circuit Emulation Service”](#) or virtual ISDN-PRI signaling trunks.
- Expansion Interfaces (ATM-EI) for Port Network Connectivity (ATM-PNC) between the PPN and the EPNs.

Either circuit pack “personality” requires SONET OC-3 or SDH STM-1 fiber cable connections between the circuit pack and the ATM switch. As a trunk board, it supports direct connection between ATM CES circuit packs without an intervening ATM switch.

**Table 9-111. R7 ATM-TRK circuit packs**

Circuit pack	Channel types	Interface	Fiber	Echo cancellation
TN2305	B and D channels	24 or 32 channel	Multi mode	Y
TN2306	B and D channels	24 or 32 channel	Single mode	Y

**⇒ NOTE:**

TN230x circuit packs are not interchangeable.

**ATM Circuit Emulation Service**

Under ATM Circuit Emulation Service (CES), you simulate ISDN-PRI circuits by assigning ports to *signaling groups*. Each signaling group represents a PRI circuit, and the ports in the group represent the D-channel and B-channels of that circuit. TN230x circuit packs support up to 248 ports per circuit pack.

**Virtual D-channels.** Non-facility associated signaling is not supported under ATM-CES, so you must reserve one port in each signaling group for use as a D-channel (channel 24 when emulating a T-1 ISDN facility, channel 16 when emulating an E-1 facility). The D-channel can be any physical port from 9 to 32.

**Virtual circuits.** The TN230x can support a varied number of virtual circuits, depending on the switch and the administration of the circuit pack. [Table 9-112](#) lists the possibilities for various G3V4 models.

**Table 9-112. Circuit and channel capacities, for each DEFINITY model**

Model	Ports	Emulated circuits (signaling groups)	Channels/circuit	Virtual D-channels	Virtual B-channels
R6csi	248	1 to 8	24 (T1), 31 (E1)	1-8	6-240
R6si	248	1 to 8	24 (T1), 31 (E1)	1-8	6-240
R6r	248	1 to 8	24 (T1), 31 (E1)	1-8	6-240

**Virtual trunk groups.** You cannot bundle physical DS1 ISDN-PRI circuits and virtual ATM-CES circuits into the same trunk groups. Virtual circuits can only be assigned to all-virtual, all-ATM trunk groups. [Table 9-113](#) lists the possible trunk-group capacities.

**Table 9-113. ATM CES capacities by DEFINITY model**

Model	Ports per trunk group (max)	Trunk groups per switch (max)	Trunks per switch (max)
R6csi	99	99	400
R6si	99	99	400
R6r	255	666	400

[Table 9-114](#) shows the ATM CES capacities for both T1 and E1 circuits.

**Table 9-114. Ports available for trunking, for each ISDN facility type**

Type	Channels per signaling group (trunk)	Max. signaling groups (trunks) per circuit pack	Max. available ports	Reserved ports	Total ports
T1:	24	8	192	ports 1-8	256
E1:	31	8	248	ports 1-8	256

## LEDs

The ATM circuit pack LEDs give you a visual indication of the condition of the TN230x circuit pack ([Table 9-115](#)).



**Table 9-115. ATM-TRK LED interpretation**

LEDs	Condition	LED status
Red	Error (alarm logged)	On
Red and Green	Booting (LEDs being tested)	Blinking (on 200 ms, off 200 ms)
Green	Test/maintenance in progress	On
Yellow	Fiber Loss of Signal (LOS), LOF, MS_RDI, MS_AIS, LCD, HP_RDI, HP_AIS, LOP, PSC	Blinking fast (100 ms on, 100 ms off)
Yellow	Signal to ATM switch down	Blinking slowly (500 ms on, 500 ms off)
Yellow	One or more CES signaling groups administered	On
Yellow	CES signaling group not administered or not reporting to firmware	Off

## ATM-TRK-related commands

[Table 9-116](#) lists some commands that can be useful in troubleshooting ATM errors and alarms.

**Table 9-116. ATM CES troubleshooting commands**

Command	Description
<b>display circuit-packs cabinet</b>	Displays the circuit packs in the cabinet, identifying ATM Trunk as well as ATM PNC EI boards. "ATM Interface" boards have not been administered as CES or PNC.
<b>display atm ports UUCSSppp</b>	Displays the 256 ports on the ATM board with the corresponding signaling and trunk group.
<b>list configuration atm</b>	Lists the ATM boards, identifying equipment location, board code, type, and vintage.
<b>list configuration trunks</b>	Lists boards identifying assigned ports. While the ATM board is listed, the 256 ports are not.

*Continued on next page*

**Table 9-116. ATM CES troubleshooting commands — Continued**

Command	Description
<b>busyout/release atm signaling-group</b>	Busyout or release of an ATM signaling group within a trunk group.
<b>status atm signaling-group</b>	Show current status of an ATM signaling group.
<b>status trunk-group</b>	Shows status of the trunk group (ATM signaling groups are part of trunk groups).

**Error Log Entries and Test to Clear Values**

**Table 9-117. ATM-TRK Error Log entries**

Error Type	Aux Data	Associated Test	Alarm Level	On/Off Board	Test to Clear Value
0	0	Any	Any		test board UUCSS
1(a)		None	MIN	ON	
18(b)	0	busy out board UUCSS	MIN	ON	release board UUCSS
23(c)	0	None	MIN	ON	
125(d)		None	MIN	ON	
257(e)	Any	Control Channel Loop Test (#52)	MIN	ON	test board UUCSS r 2
513(f)	Any	ATM Cross talk Test (#1298)	MIN	ON	test board UUCSS l r 1
769(g)	35	ATM Error Query Test #1259	WRN	OFF	test board UUCSS
770(g)	25	ATM Error Query Test #1259	WRN	OFF	test board UUCSS
771(h)	26	ATM Error Query Test #1259	WRN	OFF	test board UUCSS
1281(i)		ATM Board Error Query Test (#1259)	WRN/ MIN	OFF	test board UUCSS r 1
1537(j)	12	None	WRN/ MIN	ON	
1538(k)	0	None	WRN/ MIN	ON	reset board UUCSS

*Continued on next page*

Table 9-117. ATM-TRK Error Log entries — *Continued*

Error Type	Aux Data	Associated Test	Alarm Level	On/Off Board	Test to Clear Value
1794(l)	13	None	MIN	ON	
2049(m)	15	None	WRN	OFF	test board UUCSS
2306(n)		None			
2561(o)		Packet interface test (#598)	MIN	ON	test board UUCSS r 2
2817(p)	1-24	ATM Board DSP test (#1293)	WRN/ MIN	ON	test board UUCSS
2818(p)	1-24		WRN/ MIN	ON	test board UUCSS
3330(q)	3		MIN	OFF	
3585(r)		ATM Board Error Query test (#1259)	WRN/ MIN	ON	test board UUCSS I
3841(s)	Any	None			
3842(t)	11	None			
3999(v)	Any	None			

## Notes:

- a. Error Type 1: the ATM-TRK circuit pack does not appear to be in its assigned slot.
  1. Make sure that the ATM-TRK circuit pack is installed correctly seated in the slot administered for the ATM trunk.
- b. Error Type 18: the ATM circuit pack is busied out.
  1. Run **release board UUCSS**.
- c. Error Type 23: an ATM trunk is administered, but the corresponding ATM-TRK circuit pack does not appear to be physically installed.
  1. Make sure the ATM-TRK circuit pack is installed and correctly seated in the slot.
- d. Error Type 125: an ATM trunk is administered but a non-ATM-TRK circuit pack is installed in the corresponding slot. You have two options:
  - Replace the incorrect circuit pack with an ATM-TRK circuit pack.
  - Or re-administer the slot for the circuit pack that is physically present, locate the slot where the ATM-TRK circuit pack is actually installed, and re-administer the ATM trunk.

- e. Error Type 257: Control Channel Loop Test #52 failed. The circuit pack is not properly connected with the control channel on the TDM bus.
  - 1. Take the corrective action specified by Test #52.
- f. Error Type 513: ATM Crosstalk Test (#1298) failed. The board is writing to or reading from a TDM time slot that is not allocated to the board, or the Digital Signal Processor (DSP) selected for this test has malfunctioned.
  - 1. Run **test board UUCSS**.
  - 2. Take the corrective action specified for Test #1298.
- g. Error Type 769, 770: the ATM switch is requesting too many LAPD retransmissions (off-board ATM cell corruption errors).

Error Type	Aux Data	Description
769	35	LAPD excessive retransmission requests
770	25	ATM uncorrectable cell headers - threshold

- 1. Check the connections between the fiber cable, the ATM-TRK circuit pack, and the ATM switch.
- 2. See [PKT-BUS](#) for test and corrective procedures.
- 3. Determine what type of fiber is installed between the ATM-TRK circuit pack and the ATM switch.

If	Then
There is multimode fiber	Check the length of the fiber. If the cable is longer than 2 km, it is probably causing the errors.
There is single-mode fiber or the length of the multimode fiber is less than 2 km	The source of the errors may lie in the ATM facility, the ATM-TRK circuit pack, or the far-end circuit pack.

- 4. Perform ATM loopback tests on the near-end ATM-TRK circuit pack and on the far-end circuit pack or ATM switch.

If	Then
The ATM-TRK circuit pack fails the loopback test.	The problem is in the ATM-TRK circuit pack. Replace the circuit pack.
The far-end circuit pack or ATM switch fails the loopback test.	The problem is in the far-end circuit pack or ATM switch. Consult the circuit-pack or ATM switch documentation for advice.
The equipment at each end of the ATM span passes the loopback test	The problem is somewhere in the ATM span. Lack of bandwidth may be forcing an intermediate ATM switch to drop cells.

5. Check capacity and peak bandwidth consumption for the ATM span.

If	Then
The capacity of the span is inadequate or bandwidth consumption is too high.	Reduce traffic on the G3V4 switch to ensure that it is using no more than its subscribed bandwidth.

- h. Error Type 771: the ATM switch is sending cells with unknown Virtual Path-Identifier (VPI) and Virtual Channel-Identifier (VCI) addresses.
  1. Make sure that the ATM-TRK circuit-pack address is administered identically on the ATM switch and the DEFINITY ECS.
- i. Error Type 1281: Board major signals error (loss of high-level signal). The far-end has detected a major problem in transmissions originating from the ATM-TRK circuit pack. The possible Aux Data values for this software counter are listed in [Table 9-118](#).

**Table 9-118. Error type 1281 Aux Data and repair procedures**

Aux Data	Alarm Description	Repair procedure
15	SYSCLOCK failed	The board is not locked to the TDM backplane clock signal. This is probably due to a Tone Clock problem. <ol style="list-style-type: none"> <li>1. Check for TDM-BUS or TONE-BD errors in the Error Log.</li> <li>2. If no other problems are present, reset the circuit pack (<b>reset board UUCSS</b>)</li> </ol>

*Continued on next page*

**Table 9-118. Error type 1281 Aux Data and repair procedures — Continued**

Aux Data	Alarm Description	Repair procedure
16	Loss of Signal: LOS	<p>The fiber is not connected properly to the ATM-TRK board or ATM switch (or to the multiplexer section [MUX] if present). It is possible that the board transceivers are not functioning properly.</p> <ol style="list-style-type: none"> <li>1. Run <b>test board UUCSS</b> command.</li> <li>2. If Test #1259 fails with Error Code 16, connect a fiber back-to-back in a looped mode (one strand of fiber connecting the transmit transceiver to the receive transceiver of the board) and see if the yellow LED flash goes away. If it does the problem is off-board.</li> <li>3. If the yellow LED continues to flash, replace the circuit pack.</li> </ol>
17	Loss of Frame: LOF	<p>The fiber signal cannot obtain or maintain STM-1/OC-3 framing.</p> <ol style="list-style-type: none"> <li>1. Try to move the fiber on the ATM switch side to a different port.</li> <li>2. If the problem persists, reset the circuit pack (<b>reset board UUCSS</b>).</li> </ol>
18	Multiplexer Section Alarm Indication Signal: MS_AIS	<p>There is a major problem on the far end (between multiplexer section [MUX] and the switch) that prohibits the circuit pack from sending a valid signal.</p> <ol style="list-style-type: none"> <li>1. See if the ports at the MUX and/or the ATM switch are connected snugly.</li> <li>2. Run <b>test board UUCSS</b> command</li> <li>3. If Test #1259 fails with Error Code 18, connect a fiber back-to-back in a looped mode (one strand of fiber connecting the transmit transceiver to the receive transceiver of the board) and see if the yellow LED flash goes away.</li> <li>4. If it does the problem is off-board.</li> <li>5. If the yellow LED continues to flash, replace the circuit pack; if the error persists, escalate the problem.</li> </ol>

*Continued on next page*

**Table 9-118. Error type 1281 Aux Data and repair procedures — Continued**

Aux Data	Alarm Description	Repair procedure
19	Multiplexer Section Remote Defect Indicator: MS_RDI	The far-end is detecting a major problem with the signal that this board is transmitting. <ol style="list-style-type: none"> <li>1. Make sure the ATM switch port (or a MUX port, if present between ATM switch and the ATM-TRK board) is the same as the ATM-TRK circuit pack's cable interface</li> <li>2. Run <b>test board UUCSS</b> command.</li> <li>3. If Test #1259 fails with Error Code 19, connect a fiber back-to-back in a looped mode (one strand of fiber connecting the transmit transceiver to the receive transceiver of the board) and see if the yellow LED flash goes away.</li> <li>4. If it does the problem is off-board.</li> <li>5. If the yellow LED continues to flash, replace the circuit pack; if the error persists, escalate the problem.</li> </ol>
20	Loss of pointer: LOP	ATM framer chip is unable to access the payload part of the signal. <ol style="list-style-type: none"> <li>1. Reset the board (<b>reset board UUCSS</b>).</li> <li>2. If the error persists replace the board.</li> </ol>
21	Path Signal Error (PSL) (STM1/SONET)	The incoming signal payload is not set up for transmission of ATM data. <ol style="list-style-type: none"> <li>1. Make sure the ATM switch port (or a MUX port, if present between ATM switch and the ATM-TRK board) is the same as the ATM-TRK circuit pack's cable interface.</li> </ol>
22	High-level Path Alarm Indication Signal: HP_AIS	The payload is invalid. <ol style="list-style-type: none"> <li>1. Make sure the ATM switch port (or a MUX port, if present between ATM switch and the ATM-TRK board) is the same as the ATM-TRK circuit pack's cable interface.</li> <li>2. Run <b>test board UUCSS</b>.</li> <li>3. If Test #1259 fails with Error Code 22, connect a fiber back-to-back in a looped mode (one strand of fiber connecting the transmit transceiver to the receive transceiver of the board) and see if the yellow LED flash goes away.</li> <li>4. If it does the problem is off-board.</li> <li>5. If the yellow LED continues to flash, replace the circuit pack.</li> </ol>

*Continued on next page*

**Table 9-118. Error type 1281 Aux Data and repair procedures — Continued**

Aux Data	Alarm Description	Repair procedure
23	High-level path Remote defect Indicator: HP_RDI	The far-end is detecting a major problem with the signal that this board is transmitting. The transmitted payload is invalid. <ol style="list-style-type: none"> <li>1. Make sure the ATM switch port (or a MUX port, if present between ATM switch and the ATM-TRK board) is the same as the ATM-TRK circuit pack's cable interface.</li> <li>2. Run <b>test board UUCSS</b> command; if the Test #1259 fails with Error Code 23, connect a fiber back-to-back in a looped mode (one strand of fiber connecting the transmit transceiver to the receive transceiver of the board) and see if the yellow LED flash goes away.</li> <li>3. If it does the problem is off-board.</li> <li>4. If the yellow LED continues to flash, replace the circuit pack.</li> </ol>
24	Loss of cell delineation (LCD)	On board ATM framer chip is not able to frame cells based on the cell header. <ol style="list-style-type: none"> <li>1. Reset the board (<b>reset board UUCSS</b>).</li> <li>2. If the error persists, replace the board.</li> </ol>
27	SIGCON_DOWN ATM switch high level signal.	The board cannot communicate with the ATM switch. <ol style="list-style-type: none"> <li>1. Busyout the board (busyout board UUCSS).</li> <li>2. Test the board (<b>test board long UUCSS</b>).</li> <li>3. If Test #1260 fails, replace the board.</li> <li>4. If Test #1260 passes, make sure the ATM address on both the DEFINITY and the ATM switch sides are the same for this board.</li> <li>5. If the address is the same, change the port on the ATM switch side.</li> <li>6. If the error is resolved, the problem is on the ATM switch port.</li> </ol>

j. Error Type 1537: LANHO bus timeout. The circuit pack is transmitting too many bytes on the LAN bus for a single frame. This may be due to:

- on-board fault
- faulty data received on one of the circuit pack's external ports

If the error occurs 3 times in 10 minutes, the board is isolated from the Packet Bus and the board is alarmed. To clear the alarm:

1. Restore this circuit pack to the Packet Bus with this command sequence:

**a. busyout board UUCSS**



- b. **reset board UUCSS**
- c. **test board UUCSS long**
- d. **release board UUCSS**

- 2. If the problem persists and there are no PKT-BUS or port alarms, replace the circuit pack.
- k. Error Type 1538: The ATM-TRK circuit pack is hyperactive (sending an abnormal number of control messages to the processor). Use the following command sequence for this ATM-TRK circuit pack:
  - 1. **busyout board UUCSS**
  - 2. **reset board UUCSS**
  - 3. **test board UUCSS long**
  - 4. **release board UUCSS**
  - 5. If this error persists, replace the circuit pack.
- l. Error Type 1794: LANHO transmit FIFO overflow. The circuit pack's transmit buffers have overflowed.
  - 1. Run **test board UUCSS r 5**.

If	Then
Test #598 fails	Replace the circuit pack.

- m. Error Type 2049: ACL Link Failure (link is down). The ATM Control Link (ACL) has failed, communication has been interrupted between the SPE and the ATM-TRK circuit packs on the system, and signaling-group parameters are not communicated across the packet bus.
  - 1. Check the [PKT-BUS \(Packet Bus\)](#) and SYS-LINK (System Link) maintenance objects, and follow the repair procedures indicated.
  - 2. Run **test board UUCSS** against the ATM-TRK circuit pack.

If	Then
Test 598 fails.	Follow the repair procedures suggested for that test.

- n. Error Type 2306: too many parity errors in data received from the LAN/packet bus.

1. Run **test board UUCSS**.

If	Then
Test 598 fails.	Follow the repair procedures suggested for that test
Test 598 passes.	See the <a href="#">PKT-BUS (Packet Bus)</a> maintenance object, and perform the specified repair.
There are no errors against the packet bus maintenance object.	This may be a transient condition. Do nothing now, but escalate if the error occurs repeatedly.

- o. Error Type 2561: Packet Interface Loop Around Test (598) Failure. The ATM-TRK circuit pack has failed, the packet bus has a minor alarm active, or the packet bus is out of service.

1. Run **test board UUCSS**.

If	Then
Test 598 fails.	Follow the repair procedures suggested for that test
Test 598 passes.	See the <a href="#">PKT-BUS (Packet Bus)</a> maintenance object, and perform the specified repair.
There are no errors against the packet bus maintenance object.	This may be a transient condition. Do nothing now, but escalate if the error occurs repeatedly.

- p. Error Type 2817, 2818: DSP failure detected along the circuit path.

1. Run **test board UUCSS**.

2. Follow the repair procedures suggested for Test #1293.

Error Type	Description
2818	One or more DSPs failed. The <code>Aux Data</code> field contains the ID number of DSP that failed
2817	DSP test failure. The <code>Aux Data</code> field contains the following information about the failed DSPs: <ul style="list-style-type: none"> <li>■ X is the number of talker DSPs</li> <li>■ Y is the number of listener DSPs</li> <li>■ Z is the number of echo-cancelling DSPs</li> </ul>

- q. Error Type 3330: LANHO critical error. The circuit pack reports that the on-board LANHO chip is insane (possibly due to a problem in Packet Bus arbitration, in the transmission line frame, or in the circuit pack itself). The circuit pack cannot talk to the Packet Bus.

1. Check for PKT-BUS alarms.

If	Then
There is a packet-bus alarm.	There is probably a packet-bus problem, particularly if other circuit packs on the packet bus report the same error. See the <a href="#">PKT-BUS (Packet Bus)</a> maintenance object and the <a href="#">packet-bus fault-isolation and recovery</a> sections of the maintenance manual for repair procedures.
There are no packet-bus alarms.	Run the following command sequence: <b>busyout board UUCSS</b> <b>reset board UUCSS.</b> <b>test board UUCSS long</b> <b>release board UUCSS</b>
The problem persists.	Replace the ATM-TRK circuit pack.

- r. Error Type 3585: Major board alarm; failure of critical components involved in the operation of the circuit pack. The circuit pack has failed, and the switch may no longer recognize it.

Aux Data	Description
1	ATM framer chip failure
2	NCE failed
4	TDM PLD failed
5	All DSPs on the circuit pack have failed
6	Receive Network Processor (RNP) failed
7	Transmit Network Processor (TNP) failed
8	MEMORY read/write failure
9	DUART failure

1. Run **test board UUCSS long**.

If	Then
Test #1259 fails with Error Code XYYY and XX is an AUX value in the preceding table	Replace the ATM-TRK circuit pack.
The system does not recognize the circuit pack	Replace the ATM-TRK circuit pack.

- s. Error Type 3841: the ATM-TRK circuit pack received an unrecognized message from the switch and responded with an inconsistent down-link error message.
  - 1. Do nothing. This error does not affect service.
- t. Error Type 3842: LANHO Receive FIFO Overflow error; the packet bus is delivering data to the ATM-TRK circuit pack faster than the circuit pack can distribute it to the endpoint.
  - 1. Do nothing. The circuit pack can recover by itself.
- u. Error Type 3999: circuit pack sent a large number of control channel messages to the switch within a short period of time.

If	Then
Error Type 1538 is also present	Circuit pack is taken out of service
If Error Type 1538 is not present	Circuit pack is <i>not</i> taken out of service, but has generated 50% of the messages necessary to be considered hyperactive. <ul style="list-style-type: none"> <li>■ This may be normal during heavy traffic.</li> <li>■ If the error is logged during light traffic, it may indicate a problem with the circuit pack or the equipment attached to it.</li> </ul>

## System Technician-Demanded Tests: Descriptions and error codes

Always investigate problems in the order presented. When you clear one of the error codes associated with a given test, you clear errors generated by other tests in the testing sequence. If you clear errors out of order, you can lose important information.

**Table 9-119. System Technician-Demanded Tests: ATM-TRK**

Order of Investigation	Short Test Sequence	Long Test Sequence	Reset Board Sequence	D/ND <sup>1</sup>
ATM Board Time Of Day Update (#1261)		X		ND
Connection Audit Test (#50)		X		ND
Control Channel Loop Test (#52)		X		ND

*Continued on next page*

**Table 9-119. System Technician-Demanded Tests: ATM-TRK — Continued**

Order of Investigation	Short Test Sequence	Long Test Sequence	Reset Board Sequence	D/ND <sup>1</sup>
Packet Interface Loop Around Test (#598)	X	X		ND
ATM DSP Test (#1293)	X	X		ND
ATM Board Framer Looparound Test (#1260)		X		D
ATM Board Error Query Test (#1259)	X	X		ND
ATM Cross Talk Test (#1298)		X		ND
ATM Board Reset (#1256)			X	D

1. D = Destructive, ND = Non-destructive

### Connection Audit Test (#50)

Non-destructive (in a sane switch environment).

The Connection Audit test updates TDM time slots. It sends network-update Control Channel Message Set (CCMS) messages that tell the ATM-TRK circuit pack to listen to, talk to, or disconnect particular time slots.

The test passes if software successfully sends the downlink network-update messages. It aborts otherwise.

 **CAUTION:**

*Though normally non-destructive, this test might unintentionally tear down an active call if the connection-manager software's tables are corrupt.*

**Table 9-120. TEST #50 Connection Audit Test**

Error Code	Test Result	Description/ Recommendation
None 2100	ABORT	System resources required for this test are not available. 1. Retry the command up to 5 times at 1-minute intervals.
1019	ABORT	The test aborted because a test was already running on the port. 1. Retry the command up to 5 times at 1-minute intervals.
	FAIL	Internal system error 1. Retry the command up to 5 times at 1-minute intervals.
	PASS	The circuit pack has been updated with its translation.
0	NO BOARD	The test could not relate the internal ID to the port (no board). This could be due to incorrect translations, no board is inserted, an incorrect board is inserted, or an insane board is inserted.  1. Check the board translations. 2. If the ATM-TRK circuit pack is not administered, run <b>add atm trunk UUCSS</b> . 3. If the ATM-TRK circuit pack is administered correctly, check the error log. 4. If ATM-TRK circuit pack is hyperactive, shut down, and reseal the circuit pack to force re-initialization. 5. If the ATM-TRK circuit pack is correctly inserted, run <b>busyout board</b> . 6. Run <b>reset board</b> . 7. Run <b>release busy board</b> . 8. Run <b>test board long</b> to re-establish the linkage between the internal ID and the port.

### Control Channel Loop Test (#52)

The non-destructive Control Channel Loop Test is part of the maintenance subsystem's [Common Port Board Testing](#) feature. The Common Port Board test sends board vintage queries to a port circuit pack and checks the responses. CCMS downlink notifications tell the circuit pack which TDM Bus (A or B) carries the control channel and which carries the touch tones.

The test passes if the port circuit pack responds. The test aborts if the circuit pack does not respond. The test fails otherwise.

**Table 9-121. Control Channel Test #52**

Error Code	Test Result	Description/ Recommendation
2000	ABORT	Test request timed out.
2100	ABORT	Could not allocate needed system resources.
2500	ABORT	Internal system error 1. Retry the command up to 3 times at 1-minute intervals.
	FAIL	The ATM circuit pack responded incorrectly. 1. Retry the command up to 3 times at 1-minute intervals. 2. If the test continues to fail, reset the ATM-TRK circuit pack ( <b>reset board UUCSS</b> ). 3. If test continues to fail, replace the circuit pack or transceiver.
	PASS	The ATM-TRK circuit pack is communicating correctly with the software.
0	NO BOARD	Circuit pack not detected. 1. Check the error log for Error 125 (wrong board) or Error 131 (no board), and correct any errors found. 2. Make sure that the ATM-TRK circuit pack is properly translated and inserted. 3. Check for Error 1538 (hyperactivity). If hyperactive, run <b>reset board UUCSS</b> . 4. Run the test again. If it fails, replace the ATM-TRK circuit pack, and retest.

**Packet Interface Loop Around Test (#598)**

This nondestructive test checks the ATM-TRK circuit pack’s packet-bus interface. The LANHO chip sends data through the bus and back to itself. [Figure 9-195](#) describes this test, substituting “CES mode” for “PNC mode.”

If the data received is consistent with the data sent, the test passes. The test does not run if the packet bus in the specified port network has a minor alarm, or is out of service, or if the packet bus in the PPN is out of service.

**Table 9-122. Packet Interface Loop Around Test (#598)**

<b>Error Code</b>	<b>Test Result</b>	<b>Description/ Recommendation</b>
1144	ABORT	The packet bus in the PPN has a major alarm against it. <ol style="list-style-type: none"><li>1. Run <b>display alarms</b> and <b>display errors</b>.</li><li>2. Perform the PKT-BUS repair procedures associated with the alarms.</li><li>3. Retry the command.</li></ol>
2000	ABORT	Test request timed out. <ol style="list-style-type: none"><li>1. Retry the command up to 3 times at 1-minute intervals.</li><li>2. If the test fails repeatedly, run <b>reset board UUCSS</b>.</li><li>3. If the test continues to fail, replace the ATM-TRK circuit pack.</li></ol>
2012	ABORT	Internal system error.
2100	ABORT	Could not allocate needed system resources. <ol style="list-style-type: none"><li>1. Retry the command up to 5 times at 1-minute intervals.</li></ol>
ANY	FAIL	Data packet not received correctly by the ATM Interface circuit pack. <ol style="list-style-type: none"><li>1. Retry the command up to 5 times at 1-minute intervals.</li><li>2. If the test continues to fail, replace the ATM-TRK circuit pack.</li></ol>
	PASS	The Packet Interface Test passed.

## ATM Board Reset (#1256)

**This test is destructive.**

This test checks the sanity of the angel processor using the Sanity and Control Interface (SAKI) test (Common Port Board test #53). It resets the circuit pack if the SAKI test fails and runs the test again. The ATM Board Reset test passes if SAKI can successfully reset and retest the board.

Before running the SAKI test, you must:

- Move synchronization off the ATM-TRK circuit pack
- Busyout the ATM-TRK circuit pack

The test aborts if the ATM-TRK circuit pack is supplying synchronization.



**Table 9-123. ATM Board Reset (#1256)**

Error Code	Test Result	Description/ Recommendation
1005	ABORT	Wrong circuit pack configuration to run this test. The ATM CES Trunk Interface circuit pack provides timing for the system and cannot be reset without major system disruptions. <ol style="list-style-type: none"> <li>1. Set synchronization to another ATM CES trunk circuit pack or to the Tone-Clock circuit pack and test again.</li> </ol>
1015	ABORT	Test cannot be run because the ATM-TRK circuit pack has not been busied out. <ol style="list-style-type: none"> <li>1. Busyout out the circuit pack (<b>busyout board UUCSS</b>).</li> <li>2. Repeat the test (<b>test board UUCSS long</b>).</li> </ol>
None	ABORT	Could not allocate the required system resources <ol style="list-style-type: none"> <li>1. Retry the command up to 5 times at 1-minute intervals.</li> <li>2. If the test continues to abort escalate the problem.</li> </ol>
2000	ABORT	Sanity test timed out. <ol style="list-style-type: none"> <li>1. Wait 5 minutes. Then see if ATM-TRK circuit pack is visible to the system by running <b>list config all</b>.</li> <li>2. If the ATM-TRK circuit pack is visible (<b>list configuration all</b>), run the test again, and escalate if the problem recurs.</li> <li>3. If the ATM-TRK circuit pack is not visible to the system (<b>list configuration all</b>), re-seat the ATM-TRK circuit pack, and retest.</li> <li>4. If the ATM-TRK circuit pack is still not recognized by the system, replace the board.</li> </ol>
2100	ABORT	Could not allocate required system resources <ol style="list-style-type: none"> <li>1. Retry the command up to 5 times at 1-minute intervals.</li> </ol>
2500	ABORT	Internal system error. <ol style="list-style-type: none"> <li>1. Try to reset the circuit pack (<b>reset board UUCSS</b>).</li> </ol>

*Continued on next page*

**Table 9-123. ATM Board Reset (#1256) — Continued**

Error Code	Test Result	Description/ Recommendation
1	FAIL	The circuit pack failed to reset
2	FAIL	The circuit pack failed to restart. 1. Retry command. 2. If the problem persists, replace the ATM-TRK circuit pack.
	PASS	The ATM-TRK circuit pack is successfully reset.
0	NO BOARD	No board detected. 1. Check the error log for Error 125 (wrong board) or Error 131 (no board), and perform the appropriate repair, if needed. 2. Ensure that the board is properly translated and inserted. 3. Check for Error 1538 (hyperactivity). If hyperactive, run <b>reset board UUCSS</b> . 4. Run the test again. If it fails, replace the ATM-TRK circuit pack, and retest.

### ATM Board Error Query Test (#1259)

This non-destructive ATM Error Query Test retrieves the most severe, active, on- and off-board problem from the ATM-TRK circuit pack's firmware and increments error counts in the Error Log.

The test passes if there are no errors and fails otherwise. A passing test clears the software counters; a failure increments the counter associated with the problem that caused the failure and clears the others.

**Table 9-124. ATM Board Error Query Test (#1259)**

Error Code	Test Result	Description/ Recommendation
2000	ABORT	Test request timed out.
2031	ABORT	SCD failure. Unable to sent down-link message.
2100	ABORT	Could not allocate needed system resources.
2500	ABORT	Internal system error 1. Retry the command up to 3 times at 1-minute intervals.

*Continued on next page*

**Table 9-124. ATM Board Error Query Test (#1259) — Continued**

Error Code	Test Result	Description/ Recommendation
XXYY	FAIL	On-board error XX ( <a href="#">Table 9-125</a> ) and/or off-board error YY ( <a href="#">Table 9-126</a> ). 1. Examine the error logs and repair any errors found.
	PASS	The ATM circuit pack has passed this test. No service effecting errors/alarms have been detected on board.
0	NO BOARD	ATM-TRK circuit pack not found 1. Check the error log, and correct Error 125 (wrong board) or Error 131 (no board), if found. 2. Make sure that the board is properly translated and inserted. 3. Check for hyperactivity (Error 1538). Run <b>reset board UUCSS</b> if hyperactive. 4. Run the test again. If it fails, replace the board, and retest.

## Aux Data XX

**Table 9-125. Aux Data XX for ATM Board Error Query Test (#1259)**

If XX=	Then
1	ATM framer chip failed
2	NCE chip failed
3	LANHO critical error
4	TDM Programmable Logic Device Failed
5	All on-board DSPs failed
6	Receive Network Processor failed
7	Transmit Network Processor failed
8	Memory read failed
9	Dual UART chip failed
10	LANHO receive parity error
11	LANHO FIFO over flow error

*Continued on next page*

**Table 9-125. Aux Data XX for ATM Board Error Query Test (#1259) —  
 Continued**

<b>If XX=</b>	<b>Then</b>
12	LAN bus time out.
13	LANHO Xmit FIFO overflow error
14	One or more on-board DSPs failed

## Aux Data YY

**Table 9-126. Aux Data YY for ATM Board Error Query Test (#1259)**

<b>If YY=</b>	<b>Then</b>
15	Back plane clock failed
16	Loss of signal
17	Loss of frame
18	MS alarm indication signal error
19	MS remote defect indicator error
20	Loss of Pointer
21	Path Signal Level mismatch
22	High-level Path alarm indication signal
23	High-level Path remote defect indicator
24	Loss of Cell Delineation
25	Uncorrectable headers sent by the ATM switch.
26	Too may cells with invalid VPI/VCI combination.
27	The signalling link between the board and the ATM switch is down.
34	AAL5 Excessive retransmission requests -per VC
35	LAPD Excessive retransmission requests - per VC

## ATM Board Framer Looparound Test (#1260)

### Destructive

This test verifies the board's circuit (Time Division Multiplexing) and packet paths using an on-board, dummy virtual circuit. Before running the test, you must

- busyout the ATM-TRK circuit pack (**busyout board UUCSS**) and
- switch synchronization (**change synchronization**) from the ATM-TRK circuit pack

If the ATM-TRK circuit pack is supplying synchronization, the test aborts.

The test sends a digital counter from one of the tone generators via one of the TDM bus time slots. The ATM framer interface converts this digital counter to ATM cells and loops them back internally. The ATM-TRK circuit pack converts the cells back to a digital counter and sends it to the tone receiver for verification. If the circuit pack passes the circuit check, the software checks the packet path by sending a packet from the packet-interface circuit pack to the ATM-TRK circuit pack via the ATM protocol stack.

[Figure 9-202](#) and [Figure 9-203](#) show a diagrams of this two-part test, substituting "CES mode" for "PNC mode."

**Table 9-127. ATM Board Framer Looparound Test (#1260)**

Error Code	Test Result	Description/ Recommendation
1002	ABORT	Time slots could not be allocated. Traffic may be heavy or time slots may be out-of-service. 1. Run <b>display errors</b> , and perform repairs associated with TDM-BUS errors. 2. Retry the command up to 3 times at 1-minute intervals.
1003	ABORT	Tone receiver could not be allocated. 1. Run <b>display errors</b> , and perform the repairs associated with TTR-LEV and TONE-PT errors. The test cannot run unless there is at least one Tone Detector available on the network that holds the ATM-TRK circuit pack. 2. Retry the command up to 3 times at 1-minute intervals.
1015	ABORT	ATM-TRK circuit pack not busied out 1. Busyout the ATM circuit pack. 2. Rerun the command.

*Continued on next page*

**Table 9-127. ATM Board Framer Looparound Test (#1260) — Continued**

Error Code	Test Result	Description/ Recommendation
1033	ABORT	ATM-TRK circuit pack not found 1. See if the switch can see the circuit pack. Run status Trunk Group. 2. Retry the command.
1139	ABORT	Major alarm on the EPN packet bus 1. Run <b>display alarms</b> , and perform the repairs associated with PKT-BUS errors. 2. Run <b>display errors</b> , and perform the repairs associated with PKT-BUS errors. 3. Retry the command.
1141	ABORT	Packet-interface circuit pack out of service 1. See <a href="#">PKT-INTE</a> .
1144	ABORT	Major alarm on the PPN packet bus 1. Run <b>display alarms</b> , and perform the repairs associated with PKT-BUS. 2. Run <b>display errors</b> , and perform the repairs associated with PKT-BUS. 3. Retry the command.
1394	ABORT	ATM-TRK circuit pack out of service 1. Run ATM Board Reset Test #1256.
2000	ABORT	Request timed out. 1. Retry the command up to 3 times at 1-minute intervals.
2060	ABORT	Packet-bus link has failed. 1. Retry the command up to 3 times at 1-minute intervals. 2. If the test continues to abort, run <b>display errors</b> , and perform the repairs associated with PKT-INT errors.
2100	ABORT	Could not allocate the necessary system resources to run this test.
2500	ABORT	Internal system error 1. Retry the command up to 3 times at 1-minute intervals.

*Continued on next page*

**Table 9-127. ATM Board Framer Looparound Test (#1260) — Continued**

Error Code	Test Result	Description/ Recommendation
1	FAIL	Test tone not detected over the looparound; packet-path test aborted. <ol style="list-style-type: none"> <li>1. Test the active tone clock on the port network, and verify that a tone is reaching the ATM-TRK circuit pack. If not, correct the condition.</li> <li>2. Run <b>test board UUCSS long</b>.</li> <li>3. If the test continues to fail, replace the ATM-TRK circuit pack or transceiver.</li> <li>4. Rerun <b>test board UUCSS long</b>.</li> </ol>
2	FAIL	TN1655 Packet Interface circuit pack could not detect the correct data packet. <ol style="list-style-type: none"> <li>1. Test the TN1655 Packet Interface circuit pack to verify that it is functioning properly. If not, correct the condition.</li> <li>2. Run <b>display errors</b>, and perform the repairs associated with DS1 CONV-BD errors, if applicable.</li> <li>3. Run <b>display alarms</b>, and perform the repairs associated with DS1 CONV-BD alarms, if applicable.</li> <li>4. Run <b>test board UUCSS long</b>.</li> <li>5. If this test continues to fail, replace the ATM-TRK circuit pack.</li> <li>6. Run <b>test board UUCSS long</b>.</li> </ol>
3	FAIL	Distorted tone returned <ol style="list-style-type: none"> <li>1. Test the active tone clock on the port network, and verify that a tone is reaching the ATM-TRK circuit pack. If not, correct the condition.</li> <li>2. Run <b>test board UUCSS long</b>.</li> <li>3. If the test continues to fail, replace the ATM-TRK circuit pack.</li> <li>4. Run <b>test board UUCSS long</b>.</li> </ol>
4	FAIL	Unable to create TDM-path loop. <ol style="list-style-type: none"> <li>1. Retry the command up to 3 times at 1-minute intervals.</li> <li>2. If this test continues to fail, replace the ATM-TRK circuit pack.</li> <li>3. Run <b>test board UUCSS long</b>.</li> </ol>
5	FAIL	Unable to create packet-path loop. <ol style="list-style-type: none"> <li>1. Retry the command up to 3 times at 1-minute intervals.</li> <li>2. If this test continues to fail, replace the ATM-TRK circuit pack.</li> <li>3. Rerun <b>test board UUCSS long</b>.</li> </ol>

*Continued on next page*

Table 9-127. ATM Board Framer Looparound Test (#1260) — Continued

Error Code	Test Result	Description/ Recommendation
6	FAIL	A previously established looparound was not released. <ol style="list-style-type: none"><li>1. Run <b>reset board UUCSS</b>.</li><li>2. Retry the command up to 3 times at 1-minute intervals.</li><li>3. If this test continues to fail, replace the ATM-TRK circuit pack.</li><li>4. Rerun <b>test board UUCSS long</b>.</li></ol>
	PASS	The non-optical parts of the ATM-TRK circuit pack are functioning properly.
0	NO BOARD	ATM-TRK circuit pack not found <ol style="list-style-type: none"><li>1. Check the error log for Error 125 (wrong board) or Error 131 (no board), and correct as necessary.</li><li>2. Check that the board is properly translated and inserted.</li><li>3. Check for Error 1538 (hyperactivity), and run <b>reset board UUCSS</b> if necessary.</li><li>4. Rerun <b>test board UUCSS long</b>.</li><li>5. If the test fails, replace the board, and rerun <b>test board UUCSS long</b>.</li></ol>

### ATM Board Time Of Day Update (#1261)

The non-destructive ATM-TOD-UPD test updates the system time that the ATM-TRK circuit pack uses for SDH/SONET performance monitoring and synchronizes the ATM-TRK circuit pack with the DEFINITY system clock. This test is run during initialization, scheduled maintenance, and craft long test.



**Table 9-128. ATM Board Time Of Day Update (#1261)**

Error Code	Test Result	Description/ Recommendation
2031	FAIL	The attempt to send the message to the ATM-TRK circuit pack was not successful.
2500	FAIL	Internal system error. Did not send the time of day information to the board. 1. Retry the command up to 3 times at 1-minute intervals. 2. If the test aborts with the same error code, escalate the problem.
	PASS	The ATM-TRK circuit pack is successfully updated with system time. 1. If the <b>status port-network</b> command still indicates that this link is down, it is possible that one or both of the ATM-TRK circuit packs have been busied out. 2. If the link still does not come up, reset one or both ATM-TRK circuit packs on the link.
0	NO BOARD	No board detected. 1. Check the error log for wrong board (Error 125) or no board (Error 131). Resolve either of these issues, if applicable. 2. Check that the board is properly translated and inserted. If so, check for hyperactivity (Error 1538). If hyperactive, use the <b>reset board UUCSS</b> command. 3. Run the test again. If it fails, the board may be bad. Replace the board and retest.

**ATM Board DSP Test (#1293)**

Non-destructive

There are three kinds of digital signal processors (DSPs): talkers, listeners, and echo cancelers. Talkers put data on the TDM bus, listeners take data off the TDM bus, and echo cancelers filter out echoes of the main transmission. Firmware allocates DSPs in sets of three (one of each type), up to a maximum of 8 sets. This has three parts, one for each type of DSP. If the test fails for all DSPs, a MAJOR alarm is raised. If the test fails for one or more DSPs, a MINOR alarm is raised. If a DSP is busy, the test passes for that DSP. The test aborts if system resources are not available. Each part of the test returns the number of DSPs that passed or failed. This test run during initialization, error analysis testing, periodic, scheduled, and craft short and long testing.

**Table 9-129. ATM Board DSP Test (#1293)**

Error Code	Test Result	Description/ Recommendation
1002	ABORT	Could not allocate time slots. Traffic may be heavy or time slots may be out-of-service <ol style="list-style-type: none"> <li>1. Run <b>display errors</b>, and follow associated repair procedures for TDM-BUS.</li> <li>2. Retry the command up to 3 times at 1-minute intervals.</li> </ol>
1003	ABORT	Could not allocate a tone detector. Too few tone detectors present or tone detectors out-of-service. <ol style="list-style-type: none"> <li>1. Run <b>display errors</b>, and follow the repair procedures associated with any <a href="#">TTR-LEV</a> errors that appear.</li> <li>2. Make sure that there is at least one tone detector on the network that holds the ATM-TRK circuit pack.</li> <li>3. Resolve any <a href="#">TONE-PT</a> errors listed in the Error Log.</li> <li>4. Retry the command up to 3 times at 1-minute intervals.</li> </ol>
1962	ABORT	All DSPs are busy. This is a very unlikely event. <ol style="list-style-type: none"> <li>1. Retry the command up to 3 times at 1-minute intervals.</li> </ol>
2000	ABORT	Test timed out. <ol style="list-style-type: none"> <li>1. If the ATM-TRK circuit pack is in standby, reset the board and run the test again after the ATM-TRK circuit pack is inserted.</li> <li>2. Examine the Error Log for Error 1218 (bad DSP).</li> <li>3. Run the test again.</li> </ol>
2100	ABORT	Could not allocate required system resources.
2302	ABORT	Inconsistent uplink message from the ATM-TRK circuit pack.
2500	ABORT	Internal system error <ol style="list-style-type: none"> <li>1. Retry the command up to 5 times at 1-minute intervals.</li> </ol>
2752	ABORT	Circuit pack not a TN230x.

*Continued on next page*

Table 9-129. ATM Board DSP Test (#1293) — Continued

Error Code	Test Result	Description/ Recommendation
XYZ	FAIL	<p>There is at least one bad DSP on the board. The <b>X</b> value indicates the number of bad talker DSPs, <b>Y</b> indicates the number of bad listener DSPs and <b>Z</b> indicates the number of bad echo canceler DSPs.</p> <ol style="list-style-type: none"><li>1. Test the Active Tone-Clock on the port network that contains the ATM-TRK circuit pack for dial-tone. Repair as needed.</li><li>2. Repeat the short test on the ATM-TRK circuit pack.</li><li>3. If the test continues to fail, check for service-affecting MINOR alarms. If a MINOR alarm is raised for Error Type 2817 or 1818, replace the circuit pack.</li><li>4. If a WARNING alarm is raised, this is a non-service-affecting error, and the circuit pack can still process calls.</li></ol>
XY8	PASS	<p>The test passed for some or all DSPs. XY8 indicates the number of talker, listener, and echo-canceler DSPs for which the test passed (the rest of the DSPs were skipped). The <b>X</b> value indicates the number of good talker DSPs, <b>Y</b> indicates the number of good listener DSPs and <b>Z</b> indicates the number of good echo canceler DSPs.</p>
0	NO BOARD	<p>No board detected.</p> <ol style="list-style-type: none"><li>1. Check the Error Log for wrong board Error 125 (wrong board) or Error 131 (no board). Replace or insert the circuit pack if necessary.</li><li>2. Check that the board is properly translated and inserted.</li><li>3. If Error 1538 (hyperactivity) is listed in the Error Log, and run <b>reset board UUCSS</b>.</li><li>4. Run the test again, and, if it fails, replace the ATM-TRK circuit pack.</li><li>5. Retest.</li></ol>

### ATM Cross Talk Test (#1298)

This nondestructive ATM Cross Talk test makes sure that TDM time slots are correctly allocated to connections. It is useful for diagnosing one-way or noisy connections. The test fails if the TDM programmable logic and/or the interface to the DSP is not operating properly. The test can take more than 10 minutes.

[Figure 9-210](#) shows a diagram of this test, substituting “CES mode” for “PNC mode.”

**Table 9-130. ATM Crosstalk Test (#1298)**

Error Code	Test Result	Description/ Recommendation
	ABORT	Could not allocate required system resources. 1. Retry the command up to 5 times at 1-minute intervals.
1002	ABORT	Could not allocate time slots. Traffic may be heavy or time slots may be out-of-service. 1. Identify and correct TDM-bus errors (if any) using the procedures in the <a href="#">TDM-BUS</a> maintenance object. 2. Repeat the test up to 5 times at 1-minute intervals.
1003	ABORT	Could not allocate a tone receiver. Too few tone detectors installed or tone detectors out-of-service. 1. Identify and correct any <a href="#">TTR-LEV</a> errors listed in the Error Log. 2. Resolve any <a href="#">TONE-PT</a> errors listed in the Error Log. 3. Retry the test up to 5 times at 1-minute intervals a maximum.
2000	ABORT	Test timed out.
2100	ABORT	Could not allocate required system resources 1. Retry the command 5 times at 1-minute intervals.
1962	ABORT	All TALKER DSPs are busy.
2302	ABORT	Inconsistent uplink message from the ATM-TRK circuit pack. 1. Retry the command up to 3 times at 1-minute intervals.
2752	ABORT	The circuit pack in this location is not a TN230x.
1-8, None	FAIL	ATM-TRK circuit pack writing on unauthorized TDM time slots. The error code indicates the number of TALKER DSPs that are at fault. These DSPs cannot be used again until this test of the ATM DSP Test (#1293) tells the circuit pack to use them again. 1. Retry the command up to 3 times at 1-minute intervals. 2. If the failure persists, replace the circuit pack.
1-8	PASS	ATM-TRK circuit pack not talking to un-authorized time slots on the TDM bus. The error code indicates the number of TALKER DSPs tested.

## AUDIX-BD (AUDIX Circuit Pack)

MO Name (in Alarm Log)	Alarm Level	Initial Command to Run <sup>1</sup>	Full Name of MO
AUDIX-BD	MINOR	test board UUCSS sh	AUDIX Circuit Pack
AUDIX-BD	WARNING	test board UUCSS sh	AUDIX Circuit Pack

1. *UU* is the universal cabinet number (1 for PPN, 2 - 44 for EPNs). *C* is the carrier designation (A, B, C, D, or E). *SS* is the number of the slot in which the circuit pack resides (01 to 21).

The AUDIX-BD maintenance object represents a TN566/TN2169 DEFINITY AUDIX circuit pack combination. For circuit-pack-level problems, see “XXX-BD (Common Port Circuit Pack)”.

DEFINITY AUDIX consists of a combination of 2 circuit packs that occupy 5 slots on a port carrier. The tests described in this manual apply only to switch-side maintenance which tests circuit pack components related to the TDM bus interface. The AUDIX system has an extensive maintenance strategy that is described in *DEFINITY AUDIX System Maintenance*, 585-300-110.

## AUDIX-PT (AUDIX Port)

---

MO Name (in Alarm Log)	Alarm Level	Initial Command to Run <sup>1</sup>	Full Name of MO
AUDIX-PT	MINOR	test port UUCSSpp l	AUDIX Port
AUDIX-PT	WARNING	test port UUCSSpp sh	AUDIX Port

- 
1. *UU* is the universal cabinet number (1 for PPN, 2 - 44 for EPNs). *C* is the carrier designation (A, B, C, D, or E). *SS* is the number of the slot in which the circuit pack resides (01 to 21). *pp* is the two digit port number (01, 02, ...).
- 

The AUDIX-PT maintenance object represents a port on a TN566/TN2169 DEFINITY AUDIX circuit pack operating in digital-port (DP) mode. For circuit-pack-level problems (AUDIX-BD), see “XXX-BD (Common Port Circuit Pack)”.

The maintenance strategy for ports on the TN566 operating in control-link mode is described in ADX16A-PT.

## AUX-BD (Auxiliary Trunk Circuit Pack)

---

MO Name (in Alarm Log)	Alarm Level	Initial Command to Run <sup>1</sup>	Full Name of MO
AUX-BD	MIN	test board UUCSS sh	Auxiliary Trunk Circuit Pack
AUX-BD	WRN	test board UUCSS sh	Auxiliary Trunk Circuit Pack

- 
1. *UU* is the universal cabinet number (1 for PPN, 2 - 44 for EPNs). *C* is the carrier designation (A, B, C, D, or E). *SS* is the number of the slot in which the circuit pack resides (01 to 21).
- 

Refer to “XXX-BD (Common Port Circuit Pack)” maintenance information for circuit pack level errors. See also AUX-TRK (Auxiliary Trunk) Maintenance documentation for related trunk information.

## AUX-TRK (Auxiliary Trunk)

---

MO Name (in Alarm Log)	Alarm Level	Initial Command to Run <sup>1</sup>	Full Name of MO
AUX-TRK	MAJOR <sup>2</sup>	test port UUCSSpp l	Auxiliary Trunk
AUX-TRK	MINOR	test port UUCSSpp l	Auxiliary Trunk
AUX-TRK	WARNING	test port UUCSSpp sh	Auxiliary Trunk

- 
1. *UU* is the universal cabinet number (1 for PPN, 2 - 44 for EPNs). *C* is the carrier designation (A, B, C, D, or E). *SS* is the number of the slot in which the circuit pack resides (01 to 21). *pp* is the two digit port number (01, 02, ...).
  2. A Major alarm on a trunk indicates that alarms on these trunks are not downgraded by the **set options** command and that at least 75 % of the trunks in this trunk group are alarmed.
- 

The TN763B/C/D and TN417 Auxiliary Trunk circuit packs are used to provide ports for the following features: Music-On-Hold, loudspeaker paging (voice and coded chimes), dictation, automated wake-up with AUDICHRON.

Recorder/Announcer, and recorded announcements. TN763C circuit packs support Mu-law companding. TN417 circuit packs support A-law companding. TN763D can support either companding mode and defaults to mu-law on initialization. Companding modes are administered on the country-options system-parameters screen. See *DEFINITY Enterprise Communications Server Release 5.4 Administration and Feature Description*.

Music-On-Hold is administered via the Feature-Related System Parameters Form. Loudspeaker paging can be administered via the **change paging loudspeaker** or **add trunk-group** [Customer-Provided Equipment (CPE)] commands. The **change paging loudspeaker** command is used for system-provided paging; the **add trunk group** command is used for access to otherwise-provided (CPE) paging. The translation for code chiming is administered by the **change paging code-calling-ids** command. Recorded announcement and dictation are administered by the **add trunk-group** (CPE) command. Automatic wake-up is administered by the **change system-parameters hospitality** command and uses all four ports on a TN763B Auxiliary Trunk circuit pack.

Music-On-Hold provides audible feedback to a held, parked, or otherwise split-away party indicating that the call is still connected. The feedback can be customer-provided music, a recorded message, or other audible indication. Since the Music-On-Hold port is always busy, some of its port tests always abort.

The Loudspeaker Paging feature provides voice and/or code calling chime paging. If multiple paging zones are provided at a customer's premises, the Loudspeaker Paging feature gives a user the option of paging to a particular



zone or to all zones. If a zone is being used for one type of page, it may not be used at that time for the other one.

An Auxiliary Trunk circuit pack contains four ports and uses DTMF signaling. A different hardware interface between the switch and the auxiliary equipment is used for the four types of signaling that the auxiliary trunk circuit pack supports.

The interface used for the DEFINITY System loudspeaker paging consists of the following three pairs:

- The Tip-Ring (T-R) pair used for voice transmission.
- The S (S-S1) pair that carries answer supervision and/or make busy information.
- The SZ (SZ-SZ1) pair that provides the external equipment with a seizure indication.

The interface used for recorded announcement, dictation, and other loudspeaker paging consists of the following two pairs:

- The Tip-Ring (T-R) pair used for voice transmission.
- The S (S-S1) pair that carries answer supervision and/or make busy information.

The interface used for Music-On-Hold consists of one pair:

- The Tip-Ring (T-R) pair used for voice transmission.

The interface, used for automatic wake-up using an Audichron recorder/announcer unit, consists of the following two pairs:

- The Tip-Ring (T-R) pair used for voice transmission.
- The S (S-S1) pair that carries the synchronization signal.

## Error Log Entries and Test to Clear Values

Table 9-131. Auxiliary Trunk Error Log Entries

Error Type	Aux Data	Associated Test	Alarm Level	On/Off Board	Test to Clear Value
0 <sup>1</sup>	0	Any	Any	Any	test port UUCSSpp sh r 1
1(a)	57481	None			
1(b)	57782				
15(c)	Any	Audit Update Test (#36)			
18	0	busyout port UUCSSpp	WARNING	OFF	release port UUCSSpp
130(d)		None	WARNING	ON	test trunk <grp>/<mbr> sh
769(b)	57482	None			
257		Hybrid/Conference Circuit Test (#33)	MIN/WRN <sup>2</sup>	ON	test port UUCSSpp l r 3
513		NPE Crosstalk Test (#6)	MIN/WRN <sup>2</sup>	ON	test port UUCSSpp l r 3
1025		Diagnostic Test— Auxiliary Trunk Test (#114)	WARNING	ON	test port UUCSSpp sh r 3

1. Run the Short Test Sequence first. If all tests pass, run the Long Test Sequence. Refer to the appropriate test description and follow the recommended procedures.
2. Major or Minor alarms may be downgraded to Warning alarms based on the values used in the **set options** command.

### Notes:

- a. Error Type 1 with Aux Data 57481 indicates a port fault. Use an empty port if one is available until the circuit pack can be replaced.
- b. Error Type 1 or 769 with Aux Data 57482 indicates a fault on signaling lead, which is an off-board error. This error should only occur with loudspeaker paging. If the trunk is being used for another application, check that the administration is correct. Otherwise, check the wiring to the external equipment connected to the Auxiliary Trunk and check the external equipment.
- c. This is a software audit error that does not indicate any hardware malfunction. Run Short Test Sequence and investigate associated errors.
- d. Indicates the circuit pack has been removed or has been insane for more than 11-minutes. To clear the error, reseal or replace the circuit pack.

## System Technician-Demanded Tests: Descriptions and Error Codes

Always investigate tests in the order presented in the table below when inspecting errors in the system. By clearing error codes associated with the *Looparound and Conference Test*, for example, you may also clear errors generated from other tests in the testing sequence.

Order of Investigation	Short Test Sequence	Long Test Sequence	D/ND <sup>1</sup>
Looparound and Conference Test (#33)		X	ND
NPE Crosstalk Test (#6)		X	ND
Diagnostic Test (#114)	X	X	ND
Audit Update Test (#36)	X	X	ND

1. D = Destructive; ND = Nondestructive

### NPE Crosstalk Test (#6)

The NPE Crosstalk Test verifies that this port's NPE channel talks on the selected time slot and never crosses over to time slots reserved for other connections. If the NPE is not working correctly, one-way and noisy connections may be observed. This test is part of a port's Long Test Sequence and takes about 20 to 30 seconds to complete.

Table 9-132. TEST #6 NPE Crosstalk Test

Error Code	Test Result	Description/Recommendation
	ABORT	Could not allocate the necessary system resources to run this test. 1. Retry the command at 1-minute intervals for a maximum of 5 times
1000	ABORT	System resources required to run test are not available. The port may be busy with a valid call. 1. Use the <b>display port UUCSSpp</b> command to determine the trunk group/member number of the port. Use the <b>status trunk</b> command to determine the service state of the port. If the port is in use, wait until the port is idle. 2. Retry the command at 1-minute intervals for a maximum of 5 times.
1001	ABORT	Could not allocate the necessary system resources to run this test. 1. Retry the command at 1-minute intervals for a maximum of 5 times.

*Continued on next page*

**Table 9-132. TEST #6 NPE Crosstalk Test — Continued**

Error Code	Test Result	Description/Recommendation
1002	ABORT	The system could not allocate time slots for the test. The system may be under heavy traffic conditions or it may have time slots out-of-service due to TDM-BUS errors. <ol style="list-style-type: none"> <li data-bbox="303 410 1084 467">1. If system has no TDM-BUS errors and is not handling heavy traffic, retry the command at 1-minute intervals for a maximum of 5 times.</li> </ol>
1003	ABORT	The system could not allocate a tone receiver for the test. The system may be oversized for the number of Tone Detectors present or some Tone Detectors may be out-of-service. <ol style="list-style-type: none"> <li data-bbox="303 580 593 607">1. Resolve TTR-LEV errors.</li> <li data-bbox="303 623 599 650">2. Resolve TONE-PT errors.</li> <li data-bbox="303 666 1084 723">3. If neither condition exists, retry the command at 1-minute intervals for a maximum of 5 times.</li> </ol>
1004	ABORT	The port was seized by a valid call during the test. The test has been aborted. <ol style="list-style-type: none"> <li data-bbox="303 808 1084 924">1. Use the <b>display port UUCSSpp</b> command to determine the trunk group/member number of the port. Use the <b>status trunk</b> command to determine the service state of the port. If the port is in use, wait until the port is idle.</li> <li data-bbox="303 940 1047 969">2. Retry the command at 1-minute intervals for a maximum of 5 times.</li> </ol>
2000	ABORT	Response to the test request was not received within the allowable time period. <ol style="list-style-type: none"> <li data-bbox="303 1050 1047 1082">1. Retry the command at 1-minute intervals for a maximum of 5 times.</li> </ol>
2020	ABORT	The test did not run due to a previously existing error on the specific port or a more general circuit pack error. <ol style="list-style-type: none"> <li data-bbox="303 1163 1084 1225">1. Examine Error Log for existing errors against this port or the circuit pack and attempt to diagnose the previously existing error.</li> </ol>
2100	ABORT	Could not allocate the necessary system resources to run this test. <ol style="list-style-type: none"> <li data-bbox="303 1279 1047 1306">1. Retry the command at 1-minute intervals for a maximum of 5 times.</li> </ol>
Any	FAIL	The Network Processing Element (NPE) of the tested port was found to be transmitting in error. This will cause noisy and unreliable connections. This problem may be caused by defective tone detectors. <ol style="list-style-type: none"> <li data-bbox="303 1422 1084 1503">1. Test all tone-clock circuit packs, and resolve any errors on these circuit packs before any action is taken on the auxiliary trunk circuit pack. Then, repeat the test.</li> <li data-bbox="303 1519 971 1548">2. If the test fails again, replace the auxiliary trunk circuit pack.</li> </ol>
	PASS	The port is correctly using its allocated time slots. User-reported troubles on this port should be investigated using other port tests and examining station, trunk, or external wiring.

## Looparound and Conference Test (#33)

This test checks the reflective loop around and conference capabilities of an auxiliary trunk port circuit. The test uses 404-Hz, 1004-Hz, and 2804-Hz tones. Each tone is separately transmitted through the loop and checked. All of these tests are performed on-board.

**Table 9-133. TEST #33 Looparound and Conference Test**

Error Code	Test Result	Description/Recommendation
	ABORT	Could not allocate the necessary system resources to run this test. 1. Retry the command at 1-minute intervals for a maximum of 5 times.
1000	ABORT	System resources required to run this test are not available. The port may be busy with a valid call. 1. Use the <b>display port UUCSSpp</b> command to determine the trunk group/member number of the port. Use the <b>status trunk</b> command to determine the service state of the port. If the port is in use, wait until the port is idle. 2. Retry the command at 1-minute intervals for a maximum of 5 times.
1004	ABORT	The port was seized by a valid call during the test. The test has been aborted. 1. Use the <b>display port UUCSSpp</b> command to determine the trunk group/member number of the port. Use the <b>status trunk</b> command to determine the service state of the port. If the port is in use, wait until the port is idle. 2. Retry the command at 1-minute intervals for a maximum of 5 times.
2100	ABORT	Could not allocate the necessary system resources to run this test. 1. Retry the command at 1-minute intervals for a maximum of 5 times.
7	FAIL	The conference capabilities of the port failed. 1. If no service problems exist on the port, continue to use the port until the circuit pack can be replaced.

**Table 9-133. TEST #33 Looparound and Conference Test — Continued**

Error Code	Test Result	Description/Recommendation
129	FAIL	The reflective 404-Hz tone test failed, no transmission was detected to or from the port. The problem may be off-board.
131	FAIL	The reflective 1004-Hz tone test failed. No transmission was detected to or from the port. The problem may be off-board.
133	FAIL	<p>The reflective 2804-Hz tone test failed. No transmission was detected to or from the port. The problem may be off-board.</p> <ol style="list-style-type: none"> <li>1. To make sure the problem is on-board, disconnect the port from the auxiliary equipment and retry test.</li> <li>2. If the test fails, replace the circuit pack. Otherwise, if the test passed after disconnecting the port from the auxiliary equipment, the problem is off-board. Check the wiring and connections to the auxiliary equipment and retry the test after reconnecting the port to the auxiliary equipment. If the test fails, check the auxiliary equipment. See the preceding procedure for a failure with Error Code 7.</li> </ol> <p><b>⇒ NOTE:</b>                      If the Looparound and Conference Test fails for all ports on a circuit pack, a -5 volt power problem is indicated. If a TN736 or TN752 power unit circuit pack is present, the 631DB AC power unit or the 676B power unit may be defective. The system may contain either a TN736 or a TN752 power unit circuit pack OR a 631DB power unit, <i>but not both types of power units</i>. To investigate power problems, refer to "CARR-POW".</p>
	PASS	Looparound and Conference Test is successful. This port is functioning properly.

### Audit Update Test (#36)

This test will send updates of the auxiliary trunk port translation for all ports on the Auxiliary Trunk circuit pack that have been translated. The update is non-disruptive and guards against possible corruption of translation data contained on the circuit pack. No response message is expected from the circuit pack once it receives translation updates. The port translation data includes:

- Trunk type
- DTMF time slot
- Termination R/RC
- Gain, high/low
- End-to-end signaling, tone, and pause duration

- Trunk state, idle/active/unavailable
- Companding mode (A-law or mu-law) [G3r V2]

**Table 9-134. TEST #36 Audit Update Test**

Error Code	Test Result	Description/Recommendation
	ABORT	Could not allocate the necessary system resources to run this test. 1. Retry the command at 1-minute intervals for a maximum of 5 times.
1006	ABORT	Port is in out-of-service state as a result of being busied out. This audit cannot be run. 1. Retry the command once the port is in service ( <b>Release port UUCSSpp</b> command has been run).
2100	ABORT	Could not allocate the necessary system resources to run this test.
	FAIL	Internal system error. 1. Retry the command at 1-minute intervals for a maximum of 5 times.
	PASS	This test passed. Translation information was successfully updated on the circuit pack.

**Diagnostic Test—Auxiliary Trunk Test (#114)**

The system software sends a message to the on-board microprocessor to operate a relay in the port circuit. If ground is detected, the test passes.

**Table 9-135. TEST #114 Diagnostic Test—Auxiliary Trunk Test**

Error Code	Test Result	Description/Recommendation
	ABORT	Could not allocate the necessary system resources to run this test. 1. Retry the command at 1-minute intervals for a maximum of 5 times.
1000	ABORT	System resources required to run this test are not available. The port may be busy with a valid call. 1. Use the <b>display port UUCSSpp</b> command to determine the trunk group/member number of the port. Use the <b>status trunk</b> command to determine the service state of the port. If the port is in use, wait until the port is idle. 2. Retry the command at 1-minute intervals for a maximum of 5 times.
1004	ABORT	The port was seized by a valid call during the test. The test has been aborted. 1. Use the <b>display port UUCSSpp</b> command to determine the trunk group/member number of the port. Use the <b>status trunk</b> command to determine the service state of the port. If the port is in use, wait until the port is idle. 2. Retry the command at 1-minute intervals for a maximum of 5 times.
2100	ABORT	Could not allocate the necessary system resources to run this test. 1. Retry the command at 1-minute intervals for a maximum of 5 times.
	FAIL	This test failed to detect ground. 1. Try the test once more. 2. If the test fails again, replace the circuit pack.
	PASS	This test passed. Ground was detected.



## BRI-BD/LGATE-BD (ISDN-BRI Line Circuit Pack)

MO Name in Alarm Log	Alarm Level	Initial Command to Run <sup>1</sup>	Full Name of MO
BRI-BD	MAJOR	test board UUCSS I	ISDN-BRI Line Circuit Pack
BRI-BD	MINOR	test board UUCSS I	ISDN-BRI Line Circuit Pack
BRI-BD	WARNING	test board UUCSS sh	ISDN-BRI Line Circuit Pack
LGATE-BD	MAJOR	test board UUCSS I	DEFINITY Lan Gateway
LGATE-BD	MINOR	test board UUCSS I	DEFINITY Lan Gateway
LGATE-BD	WARNING - (See Caution)	test board UUCSS sh	DEFINITY Lan Gateway

1. UU is the universal cabinet number (1 for PPN, 2 -44 for EPNs). C is the carrier designation (A, B, C, D, or E). SS is the number of the slot in which the circuit pack resides (01 to 21). pp is the two digit port number (01, 02, ...).

### CAUTION:

The [“Packet Bus Fault Isolation and Repair”](#) for isolating and resolving Packet Bus faults is included in [Chapter 5, “Alarms, Errors, and Troubleshooting”](#). This flowchart, along with the other information presented in the chapter, can help resolve problems that involve more than a single station or circuit pack. Refer to this section whenever the repair procedures for this Maintenance Object refer to Packet Bus and/or Packet Control maintenance.

This section relates to the TN556 ISDN BRI, TN2198 ISDN BRIU, TN2208 Ethernet, (LGATE)-Ethernet Multi-Function (MFB) boards.

The TN2208 LGATE MFB provides DEFINITY with the interface to Adjunct-Switch Application Interface (ASAI) and Lucent adjuncts (for example, CONVERSANT® Voice System). This circuit pack contains 12 ports for line circuit interface (although only 8 are usable by the switch), each of which operates with 2 B-Channels and 1 D-Channel as specified in the Lucent ISDN-BRI Specification. In this context, the term “ISDN-BRI port” is used to refer to ports on the TN2208 MFB circuit pack which are connected to ASAI or Lucent adjuncts. The TN2208 LGATE MFB is handled by the switch software as if it is an ISDN BRI compatible

board and all maintenance actions referring to ASAI and Lucent adjunct Links in this section apply.

The TN556, TN2198, and TN2208 ISDN-BRI Lines are packet port circuit packs that provides access to ISDN-BRI endpoints. The ISDN-BRI Line circuit packs supports 12 ports, each of which provides access to ISDN stations. Voice and circuit-switched data from the ISDN stations are carried on the Time Division Multiplex (TDM) Bus. Signaling is carried over the Packet Bus.

## LEDS

The ISDN-BRI Line circuit pack performs extensive initialization tests and lights both the red and green LEDS during the initialization testing. See [Chapter 7, "LED Interpretation"](#), for more details on circuit pack status LEDS.

## Hardware Error Log Entries and Test to Clear Values

Table 9-136. BRI-BD Error Log Entries

Error Type	Aux Data	Associated Test	Alarm Level	On/Off Board	Test to Clear Value
0 <sup>1</sup>	0	Any	Any	Any	test board UUCSS sh r 1
1(a)	Any	None	MINOR	ON	
18(b)	0	busyout board UUCSS	WARNING	OFF	release board UUCSS
23(c)	0	None	WARNING	OFF	
257(d)	65535	Control Channel Loop Test (#52)	MINOR	ON	test board UUCSS r 20
513(e)	4352 to 4357				
769(f)	4358				
1025(g)	4363	NPE Audit Test (#50)			
1293 to 1294 (h)	46088 to 46096	SAKI Sanity Test (#534)	MINOR	ON	See footnote (h)
1537 to 1538 (i)	46082		MINOR	ON	

*Continued on next page*

**Table 9-136. BRI-BD Error Log Entries — Continued**

Error Type	Aux Data	Associated Test	Alarm Level	On/Off Board	Test to Clear Value
1793 (j)	46080		MINOR	ON	
1794 (j)	46094		MINOR	ON	
1795 (j)	46085		MINOR	ON	
2306 (j)		LANBIC Receive Parity Error Counter Test (#595)			
3330 (k)	46083		MINOR	OFF	
3840 (l)	4096 to 4101				
3843 (m)	46097				
3999 (n)	Any	None			

1. Run the Short Test Sequence first. If all tests pass, run the Long Test Sequence. Refer to the appropriate test description and follow the recommended procedures.

Notes:

- a. This error indicates the circuit pack totally stopped functioning or it was physically removed from the system.

**⇒ NOTE:**

The alarm is logged approximately 11 minutes after the circuit pack has been removed and/or SAKI Sanity Test (#53) fails.

If the circuit pack is not in the system, insert a circuit pack (in the same slot as the error indicates) to resolve this error. Or, if the circuit pack is in the system and the red LED is on, then follow the instructions for “Red (alarm)” in [Chapter 7, “LED Interpretation”](#).

- b. This circuit pack has been busied out via the **busyout board UUCSS** command.
- c. Port(s) has(have) been administered on this circuit pack but the circuit pack is not physically present.
- d. This error indicates transient communication problems between the switch and this circuit pack. Execute the **test board UUCSS** command and refer to the repair procedures for the Control Channel Loop Around Test (#52).

- e. An on-board hardware failure has been detected by the circuit pack.

The reported aux data values correspond to the following detected errors:

4352	External RAM error
4353	Internal RAM error
4355	ROM Checksum error
4357	Instruction set error

Reset the circuit pack by executing the **busyout board UUCSS** and **reset board UUCSS** commands. When it is reset, the circuit pack executes a set of tests to detect the presence of any of the above faults. The detection of one of these errors during initialization causes the circuit pack to lock-up and appear insane to the system. See the repair procedure in footnote (a) for error type 1.

- f. This error is reported by the circuit pack when it detects a program logic error. While no action is required, this error may lead to errors of other types being reported against this circuit pack.
- g. This error is reported by the circuit pack when it cannot update NPE memory and read it back. This error type can be ignored, but may lead to errors of other types being reported against this circuit pack.
- h. A critical hardware failure has been detected on the circuit pack. Reset the circuit pack via the **busyout board UUCSS** and **reset board UUCSS** commands. If the Circuit Pack Restart Test (#594) passes, then the on-board circuitry is healthy. Retire the alarm via the **test board UUCSS long clear** command. If the Circuit Pack Restart Test (#594) fails, replace the circuit pack.

The reported error types correspond to the following detected errors:

1293	On-board auxiliary processor insane
1294	Internal memory access error

i. These error types are reported when the following errors are detected:

- 1537 Frame overrun at Packet Bus interface. This condition may be caused by an on-board fault or by faulty data received on one of the circuit pack's external ports. If any of the ports on this circuit pack are alarmed, refer to the repair procedures for those maintenance objects.
- 1538 Circuit packet is hyperactive; that is, it is flooding the switch with messages sent over the control channel. The circuit pack is taken out-of-service when a threshold number of these errors is reported to the switch. Clear the alarm via the following commands: **busyout board UUCSS, reset board UUCSS, test board UUCSS long clear, release board UUCSS**. If the error recurs within 10 minutes, then replace the circuit pack.

j. These errors indicate that the circuit pack is having problems transmitting data to the Packet Bus.

- 1793 Parity errors are detected when transmitting data to the Packet Bus.
- 1794 Overflow of Packet Bus transmit buffers has occurred.
- 1795 Circuit pack cannot find end of frame when transmitting to Packet Bus. Clear the alarm via the following commands: **busyout board UUCSS, reset board UUCSS, test board UUCSS long clear, release board UUCSS**. If the error recurs within 10 minutes, then replace the circuit pack.
- 2306 This error occurs when the circuit pack detects an error in a received frame from the packet bus. These errors are most likely caused by a packet bus problem, but may be due to a circuit pack fault. An invalid Link Access Procedure Data (LAPD) frame error occurs if the frame contains a bad Cyclical Redundancy Checking (CRC), is greater than the maximum length, or violates the link level protocol. When bus parity errors are reported, the LANBIC Receive Parity Error Counter Test (#595) should be performed to determine if the condition had cleared. Refer to the "PKT-BUS (Packet Bus)" Maintenance documentation to determine if the problem is isolated to this circuit pack or if the problem is caused by Packet Bus faults.

k. A critical failure has been detected in the Packet Bus interface of the circuit pack. This failure may be due to either a Packet Bus fault or an on-board fault. If the Packet Bus is alarmed, refer to the "PKT-BUS (Packet Bus)" section and the Packet Bus Fault Isolation and Recovery section of

the Maintenance documentation for recommended repair procedures. The probability of this error being related to Packet bus problems increases with the number of ISDN-BRI circuit packs displaying this error.

If the Packet Bus is not alarmed, reset the circuit pack via the **busyout board UUCSS** and **reset board UUCSS** commands. If the Circuit Pack Restart Test (#594) passes, then the on-board circuitry is healthy. Retire the alarm via the **test board UUCSS long clear** command. If the Circuit Pack Restart Test (#594) fails, replace the circuit pack. If the problem persists after complying with the above instructions, then follow normal escalation procedures.

- l. These errors are not service-affecting. No action is required. These errors are reported by the circuit pack when it receives a bad control channel message from the switch. The auxiliary data identifies the following error events:

4096	Bad major heading
4097	Bad port number
4098	Bad data
4099	Bad sub-qualifier
4100	State inconsistency
4101	Inconsistent downlink message

- m. This error is not service-affecting. No action is required.

3843	Bad translation RAM detected, but call continues by using another translation location.
------	---

- n. This error indicates that the circuit pack sent a large number of control channel messages to the switch in a short period of time.

3999	If error type 1538 is also present, then the circuit pack was taken out-of-service due to hyperactivity.  If error type 1538 was not present, then the circuit pack has not been taken out-of-service, but has generated 50% of the messages necessary to be considered hyperactive. This may be normal during heavy traffic periods. If traffic is light it may indicate a problem with the circuit pack or the equipment attached to it.
------	--

---

## System Technician-Demanded Tests: Descriptions and Error Codes

---

Always investigate tests in the order presented in the following tables when inspecting errors in the system. By clearing error codes associated with the *Control Channel Loop Around Test*, for example, you may also clear errors generated from other tests in the testing sequence.

Order of Investigation	Short Test Sequence	Long Test Sequence	D/ND <sup>1</sup>
Control Channel Loop-Around Test (#52)	X	X	ND
NPE Audit Test (#50)		X	ND
LANBIC Receive Parity Error Counter Test (#595)		X	ND

---

1. D = Destructive; ND = Nondestructive

### NPE Audit Test (#50)

Refer to the repair procedure described in the XXX-BD (Common Port Circuit Pack) Maintenance documentation as NPE Audit Test (#50).

### Control Channel Loop Around Test (#52)

Refer to the repair procedure described in the XXX-BD (Common Port Circuit Pack) Maintenance documentation as Control Channel Loop Around Test (#52).

### SAKI Sanity Test (#53)

Refer to the repair procedure described in the XXX-BD (Common Port Circuit Pack) Maintenance documentation as SAKI Sanity Test (#53).

### LANBIC Receive Parity Error Counter Test (#595)

**This test is destructive.**

The test reads and clears the LANBIC Receive Parity Error Counter on the circuit pack. This counter is incremented by the circuit pack when it detects a parity error in data received from the Packet Bus.

These errors may be indicative of a circuit pack problem, Packet Bus problem, or a problem with another circuit pack on the bus. This test is useful for verifying the repair of the problem.

**Table 9-137. TEST #595 LANBIC Receive Parity Error Counter Test**

Error Code	Test Result	Description/ Recommendation
2000	ABORT	Response to the test was not received from the circuit pack within the allowable time period. <ol style="list-style-type: none"> <li>1. If the test aborts repeatedly a maximum of five times, reset the circuit pack via the <b>busyout board UUCSS</b> and <b>reset board UUCSS</b> commands.</li> <li>2. If the test aborts again, replace the circuit pack.</li> </ol>
2100	ABORT	Could not allocate the necessary system resources to run this test.
2012	ABORT	Internal System Error. <ol style="list-style-type: none"> <li>1. Retry the command at one-minute intervals a maximum of five times.</li> <li>2. If the test continues to fail, escalate the problem.</li> </ol>
1-10	FAIL	The circuit pack is still detecting errors of this type. The error code indicates the value of the on-board error counter. <ol style="list-style-type: none"> <li>1. Retry the command at one-minute intervals a maximum of five times.</li> <li>2. If the test continues to fail, verify the validity of the Packet Bus. Run the Packet Bus maintenance test with the <b>test pkt P long</b> command. If any Packet Bus tests fail, refer to the "PKT-BUS (Packet Bus)" Maintenance documentation for recommended repair procedures.</li> <li>3. If the Packet Bus test passes, check the validity of the circuit pack. Execute a test that involves data transmission onto the Packet Bus. For example, the BRI may use the connectivity tests of the port-level maintenance object (BRI-PORT) by executing the <b>test port UUCSSpp</b> command. Refer to the repair procedures for the executed test if it fails. Otherwise, proceed to the next step.</li> <li>4. Other circuit packs on the Packet Bus may be the cause of the parity error. Use the <b>display errors</b> command to check the Error Log for other circuit packs that are alarmed. If any alarms are present for the other circuit packs, retire those alarms also. Then, rerun the LANBIC Receive Parity Error Counter Test (#595) on this circuit pack.</li> </ol>
	PASS	No errors detected by circuit pack.



## **BRI-DAT (ISDN-BRI Data Module)**

---

<b>MO Name (in Alarm Log)</b>	<b>Alarm Level</b>	<b>Initial Command to Run</b>	<b>Full Name of MO</b>
BRI-DAT	WARNING <sup>1</sup>	test data-module	ISDN-BRI Stand-alone Data Module

- 
1. The alarm level for ASAI or Lucent adjuncts may be administered using the **set options** command. The alarm level can be set independently for Off-Board and On-Board alarms to WARNING, MINOR, or MAJOR for all ASAI adjuncts in the system.
- 

Refer to the BRI-SET (ISDN-BRI Set) section of this chapter.

## **BRI-PORT (ISDN-BRI Port), ABRI-PORT (ASAI ISDN-BRI Port)]**

MO Name (in Alarm Log)	Alarm Level	InitialCommand to Run <sup>1</sup>	Full Name of MO
BRI-PORT	MINOR	test port PCSSpp l	ISDN-BRI Port
BRI-PORT	WARNING	test port PCSSpp sh	ISDN-BRI Port
ABRI-PORT	MAJOR <sup>2, 3</sup>	test port PCSSpp l	ASAI ISDN-BRI Port
ABRI-PORT	WARNING <sup>2, 3</sup>	test port PCSSpp l	ASAI ISDN-BRI Port
ATT-PORT	MAJOR <sup>2, 3</sup>	test port PCSSpp l	Lucent Adjunct ISDN-BRI Port
ATT-PORT	WARNING <sup>2, 3</sup>	test port PCSSpp l	Lucent Adjunct ISDN-BRI Port
LGATE-PT	MAJOR <sup>2, 3</sup>	test port PCSSpp l	Ethernet ASAI Port
LGATE-PT	WARNING <sup>2, 3</sup>	test port PCSSpp l	Ethernet ASAI Port
ATTE-PT	MAJOR <sup>2, 3</sup>	test port PCSSpp l	Ethernet Lucent Adjunct Port
ATTE-PT	WARNING <sup>2, 3</sup>	test port PCSSpp l	Ethernet Lucent Adjunct Port

1. UU is the universal cabinet number (1 for PPN, 2 -44 for EPNs). C is the carrier designation (A, B, C, D, or E). SS is the number of the slot in which the circuit pack resides (01 to 21). pp is the two digit port number (01, 02, ...).
2. The alarm level for ASAI and Lucent adjunct ports may be administered using the **set options** command. The alarm level can be set independently for Off-Board and On-Board alarms to WARNING, MINOR, or MAJOR for all ASAI and Lucent adjunct ports in the system.
3. All alarming for an ASAI and Lucent adjunct and OFF-BOARD alarming for an ASAI or Lucent port is disabled if the ASAI or Lucent adjunct asks the switch to suspend maintenance. When this occurs, an error and a WARNING alarm is logged against the ASAI or Lucent adjunct. The Hardware Error and Alarm Logs should be checked to see if the adjunct has disabled alarming.

 **NOTE:**

Some of the information in this section is reserved for future use.

 **CAUTION:**

The [“Packet Bus Fault Isolation and Repair”](#) for isolating and resolving Packet Bus faults is included in [Chapter 5, “Alarms, Errors, and Troubleshooting”](#). This flowchart, along with the other information presented in the chapter, can help resolve problems that involve more than a single station or circuit pack. Refer to this section whenever the repair procedures for this Maintenance Object refer to Packet Bus and/or Packet Control maintenance.

**⚠ WARNING:**

*If a significant Packet Bus failure occurs, errors and alarms may not be logged as expected for BRI-PORT/ABRI-POR/ATT-PORT/ LGATE-PT/ ATTE-PT. Conditions under which this occurs are detailed in the ["Maintenance of the Packet Bus"](#) section of [Chapter 5, "Alarms, Errors, and Troubleshooting"](#).*

The TN2208 LGATE MFB provides DEFINITY with the interface to Adjunct-Switch Application Interface (ASAI) and Lucent adjuncts (for example, CONVERSANT<sup>®</sup>. Voice System). The circuit pack contains 12 ports of line circuit interface (although only 8 are usable by the switch), each of which operates with two B-channels (referred to as B1 and B2 throughout this section) and one D-channel as specified in the Lucent ISDN-BRI Specification. In this context, the term "ISDN-BRI port" is used to refer collectively to ports on the TN2208 circuit pack which are connected to ASAI or Lucent adjuncts.

The TN556 and TN2198 ISDN-BRI Line circuit packs provide DEFINITY with the interface to ISDN-BRI end points, Adjunct-Switch Application Interface (ASAI) and Lucent adjuncts (for example, CONVERSANT<sup>®</sup>. Voice System). The circuit packs contain 12 ports of line circuit interface, each of which operates with two B-channels (referred to as B1 and B2 throughout this section) and one D-channel as specified in the Lucent ISDN-BRI Specification. In this context, the term "ISDN-BRI port" is used to refer collectively to ports on the TN556 an TN2198 circuit packs which are connected to either BRI endpoints, ASAI or Lucent adjuncts.

For BRI endpoints, each B-channel may support voice or circuit-switched data and may be circuit-switched simultaneously. The B-channels are not used on ports connected to ASAI or Lucent adjuncts. The D-channel is used for conveying signaling between the switch and a BRI endpoint(s), ASAI or Lucent adjunct. Each ISDN-BRI D-channel is connected to the switch processor and the ISDN-BRI port through the Packet Control circuit pack and the Packet Bus.

ISDN-BRI endpoints are available in various configurations. All endpoints require the D-channel to convey signaling information to the switch. Only one B-channel is required for a voice-only set or a stand-alone data module (BRI-DAT). A voice and data-capable set requires both B-channels (one for voice and one for data). Therefore, each TN556 or TN2198 port can support either two voice-only sets, two stand-alone data modules (BRI-DAT), or one voice and data-capable set. Only a single ASAI or Lucent adjunct may be connected to an ISDN-BRI port. Multiple adjuncts per line are not supported.

[Figure 9-13](#) illustrates the physical connection (solid line) between an ISDN-BRI Port and its associated ISDN-BRI set(s). Each physical connection allows for two B-channels and one D-channel. Each ISDN-BRI circuit pack can support up to 12 of these *physical* connections to different voice and voice/data sets or ASAI or Lucent adjuncts. On a TN2198 each ISDN-BRI circuit pack can support up to 12 *physical* connections to a NT1 which in turn connects to 2 terminals.

This section covers the maintenance documentation for ISDN-BRI ports. Some of the results of maintenance testing of ISDN-BRI ports may be affected by the health of the ISDN-BRI Line circuit pack (BRI-BD), BRI endpoint (BRI-SET), or ASAI adjunct (ASAI-ADJ/LGATE-AJ/LGATE-AJ) or Lucent adjunct (ATT-ADJ/ATTE-AJ). These interactions should be kept in mind when investigating the cause of ISDN-BRI port problems. For more information on the circuit pack and endpoints, refer to the BRI-BD (ISDN-BRI Line Circuit Pack) Maintenance documentation, the BRI-SET (ISDN-BRI Endpoint) Maintenance documentation, and ASAI-ADJ (Adjunct-Switch Application Interface) Maintenance documentation, ATT-ADJ (Lucent Adjunct) Maintenance documentation, LGATE-AJ (Ethernet Adjunct-Switch Application Interface) Maintenance documentation, ATTE-AJ (Ethernet Lucent Adjunct) Maintenance documentation.

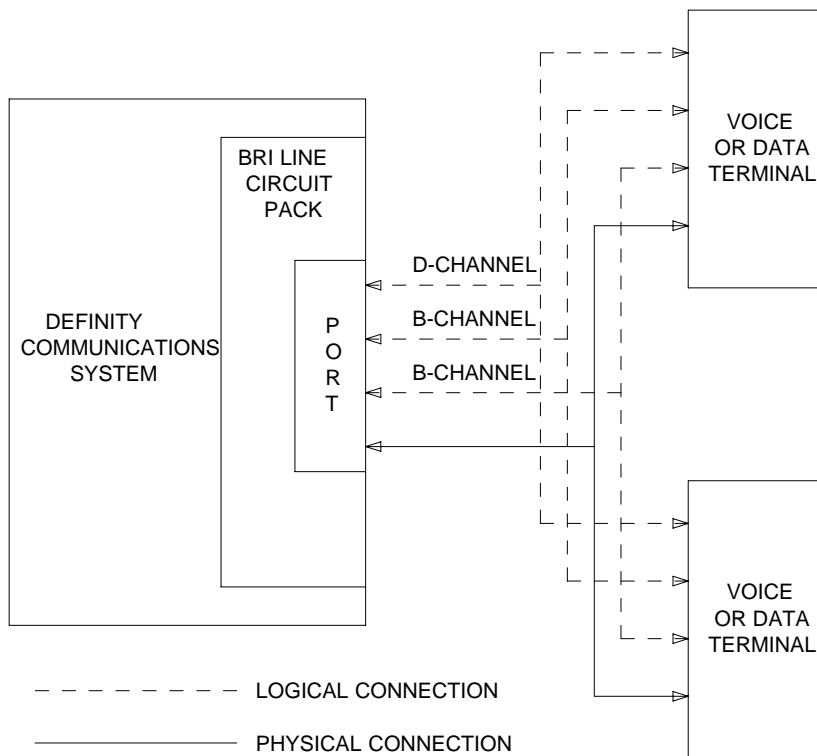

**Figure 9-13. ISDN-BRI Port Interactions**

## Hardware Error Log Entries and Test to Clear Values

**Table 9-138. ISDN-BRI Port Error Log Entries**

Error Type	Aux Data	Associated Test	Alarm Level BRI-PORT	Alarm Level ABRI-PORT ATT-PORT LGATE-PT ATTE-PT	On/Off Board	Test to Clear Value
0 <sup>1</sup>	0	Any	Any	Any	Any	test port PCSSpp sh r 1
1(a)	(a)	Level 1 Status Inquiry (#621)	WRN	MAJ/MIN/WRN <sup>2</sup>	OFF	test port PCSSpp sh r 2
18		busyout port PCSSpp	WRN		OFF	release port PCSSpp
130(b)			WRN		ON	test port PCSS sh
257(c)	(c)	EPF Inquiry (#622)	WRN	MAJ/MIN/WRN <sup>2</sup>	OFF	test port PCSSpp sh r 1
513(d)	(d) 46222	none	(d)	(d)	ON	
769(e)	0	none	WRN	MAJ	OFF	
1281(f)		NPE Crosstalk (#617)	MIN/ WRN <sup>2</sup>		ON	test port PCSSpp l r 2
1537(g)	46210	CRC Error Counter (#623)	WRN	MAJ/MIN/WRN <sup>2</sup>	OFF	
1793(h)		BRI Port Local TDM Loop Around (#619)	MIN/ WRN <sup>2</sup>		ON	test port PCSSpp l r 2
3841(i)	46208	None				
3842(j)	0	None				
3843(k)	0	None				
3844(l)	46223	None				
3845(m)		None				

*Continued on next page*

**Table 9-138. ISDN-BRI Port Error Log Entries — Continued**

<b>Error Type</b>	<b>Aux Data</b>	<b>Associated Test</b>	<b>Alarm Level BRI-PORT</b>	<b>Alarm Level ABRI-PORT ATT-PORT LGATE-PT ATTE-PT</b>	<b>On/Off Board</b>	<b>Test to Clear Value</b>
3846(n)	TEI	None				
3847(o)	0	None				

1. Run the Short Test Sequence first. If all tests pass, run the Long Test Sequence. Refer to the appropriate test description and follow the recommended procedures.
2. Major and Minor alarms on this MO may be downgraded to Warning alarms based on the value used in the set options command.

**Notes:**

- a. This error occurs when the Level 1 Status Inquiry fails or when the BRI circuit pack detects that Level 1 has been deactivated on the port. The aux data field contains one of the following values:
  - blank - this indicates that the Level 1 Status Inquiry failed.
  - 32773 - this is a message from the BRI-LINE circuit pack indicating Level 1 has been deactivated.

Refer to the repair procedures for Test #621.

- b. This error type indicates that the circuit pack has been removed or has been insane for more than 11 minutes. To clear the error, replace or reinsert the circuit pack.
- c. This error occurs when the EPF Status Inquiry fails due to an overcurrent condition or when the BRI-LINE circuit pack detects that the EPF is in an over current condition. The aux data field contains one of the following values:
  - blank - this indicates that the EPF Status Inquiry failed due to an overcurrent condition.
  - 40988 - this indicates that the BRI-LINE circuit pack has detected an overcurrent condition and has turned the EPF off.

Execute the Short Test Sequence and see the repair procedures for Test #622.

- d. This error indicates that the circuit pack is having problems transmitting data to the Packet Bus, thus affecting the conveyance of signaling information over the D-channel. With Aux Data 46222, this error occurs

## 9 Maintenance Object Repair Procedures

BRI-PORT (ISDN-BRI Port), ABRI-PORT (ASAI ISDN-BRI Port)]

9-311

when the Packet Bus transmit buffers overflow. This condition probably indicates a hardware problem. The BRI-PORT Alarm Level for the error with Aux Data 46222 is "MIN/WRN," and the ABRI-PORT/ATT-PORT/LGATE-PT/ATTE-PT Alarm Level is "MAJ/MIN/WNR." With Aux Data 0, this error occurs whenever the Packet Bus transmit FIFO buffers overflow. This condition can be caused by an on-board hardware problem as well as by problems on the Packet Bus that disrupt the BRI circuit pack's ability to transmit data onto the Packet Bus. Use troubleshooting procedures for both on-board hardware problems and potential off-board Packet Bus problems. See the "PKT-BUS (Packet Bus)" section in this chapter as well as "[Packet Bus Fault Isolation and Repair](#)" in [Chapter 5, "Alarms, Errors, and Troubleshooting"](#) for more details on Packet Bus troubleshooting procedures. The BRI-PORT Alarm Level for the error with Aux Data 0 is "MINOR," and the ABRI-PORT/ATT-PORT/LGATE-PT/ATTE-PT Alarm Level is "MAJOR."

- e. This error occurs when the NPE Crosstalk Test (#617) fails. Run the Long Test Sequence and pay particular attention to the results of Test #617.
- f. This error occurs when broadcast signaling links associated with this port have too much link establishment related traffic. This could occur if an endpoint on this port is sending link establishment traffic on a port level broadcast link or if there are Level 1 problems on the port. Check the error logs for Level 1 errors. If Level 1 problems exist, follow the repair procedures listed for test #621. Software will suspend activity to this port for 75 minutes when the port is alarmed due to this error (note that service suspension does not occur if the port is an ABRI-PORT/LGATE-PT/ATTE-PT/ATT-PORT). If this problem persists, replace the endpoint or endpoints associated with this port. If replacing the endpoints does not fix the problem, follow normal escalation procedures.
- g. This error occurs when the port receives an invalid frame over the D-channel. When CRC errors exceed five within 15 minutes, the port is taken out of service for five seconds. If five more CRC errors are received within 15 minutes of the first set of five errors, the port is taken out of service for one minute. If five more CRC errors are received within 15 minutes of the last five, the port is taken out of service for 15 minutes.

This error is most likely due to a problem with the wiring to the set or adjunct, interference on the wiring due to a noise source, or no termination (an open circuit). It usually does not indicate a problem with the circuit pack.

- Check the wiring to the endpoints or the adjunct.
  - If the problem persists, replace the endpoints or adjuncts, or escalate the problem.
- h. This error occurs when the BRI Port Local TDM Loop Around Test (#619) fails. Run the Long Test Sequence and pay particular attention to the results of Test #619.

There are no Test to Clear Values for the following error types. The error types are simply provided as additional data that may prove useful while troubleshooting.

- i. This error occurs when a Layer 1 Transmission error is detected for the port. Run the Long Test Sequence and pay particular attention to the results of the Layer 1 Transmission Error Counter Test (#624).
  - j. A BRI port supports up to three Terminal Endpoint Identifiers (TEIs). This error occurs when the switch receives a request for a fourth TEI on a port. Check the number of endpoints administered for this port.
  - k. This error occurs when an SPID initialization request is made from an endpoint and the switch determines that the SPID value is invalid or is a duplicate of another SPID that is already initialized at Layer 3 on the port. Check the administration of the endpoints.
  - l. This error occurs when the circuit pack detects an overflow of its receive buffers. Run the Long Test Sequence and pay particular attention to the results of the Receive First In First Out (FIFO) Overflow Error Counter Test (#625).
  - m. This error occurs when the BRI Port Local LAN Loop Around Test (#618) fails. Run the Long Test Sequence and pay particular attention to the results of Test #618.
  - n. This error most likely occurs when the Terminal Endpoint Identifier (TEI) administered for the ASAI or Lucent endpoint does not match the TEI administered in the ASAI or Lucent adjunct. Check the switch administration of the TEI against that of the adjunct and make sure that both are using the same TEI.
  - o. Indicates that sets on the port do not support Layer 3 initialization. Consult the Service Set documentation.
-



## System Technician-Demanded Tests: Descriptions and Error Codes

---

Always investigate tests in the order presented in the following tables when inspecting errors in the system. By clearing error codes associated with the *NPE Crosstalk Test*, for example, you may also clear errors generated from other tests in the testing sequence.

Order of Investigation	Short Test Sequence	Long Test Sequence	D/ND <sup>1</sup>
NPE Crosstalk Test (#617)		X	D
BRI Port Local LAN Loop Around Test (#618)		X	D
BRI Port Local TDM Loop Around Test (#619)		X	D
Electronic Power Feed Restoral Test (#620)	X	X	ND
Level 1 Status Inquiry Test (#621)	X	X	ND
Electronic Power Feed Inquiry Test (#622)	X	X	ND
CRC Error Counter Test (#623)		X	ND
Layer 1 Transmission Error Counter Test (#624)		X	ND
Receive FIFO Overflow Error Counter Test (#625)		X	ND
Clear Error Counters (#270)	X	X	ND

1. D = Destructive; ND = Nondestructive

### NOTE:

The NPE Crosstalk Test and the BRI Port Local TDM Loop Around Test are not executed for ABRI-PORT/ATT-PORT/LGATE-PT/ATTE-PT.

## NPE Crosstalk Test (#617)

**This test is destructive.**

One or more NPEs reside on each circuit pack with a TDM Bus interface. The NPE controls port connectivity and gain, and provides conferencing functions on a per port basis. The NPE Crosstalk Test verifies that this port's NPE channel talks on the selected time slot and never crosses over to time slots reserved for other connections. If the NPE is not working correctly, one-way and noisy connections may be observed. This test is part of a port's Long Test Sequence and takes approximately 20 to 30 seconds to complete. Crosstalk testing is

performed on both B-channels (B1 and B2) associated with a BRI port. If this test fails on either channel, any endpoints connected to the port are taken out-of-service.

This test is not executed for ABRI-PORT/ATT-PORT/LGATE-PT/ATTE-PT because the B-channels associated with the port are not used by ASAI or Lucent adjuncts

**Table 9-139. TEST #617 NPE Crosstalk Test**

Error Code	Test Result	Description/ Recommendation
1000	ABORT	System resources required to run this test are not available. The port may be busy with a valid call. 1. Use the <b>display port PCSSpp</b> command to determine the station extension or trunk group/member number of the port. Use the <b>status bri-port PCSSpp</b> command to determine the service state of the port. If the service state indicates that the port is in use, then the port is unavailable for certain tests. (Refer to the "Status Commands" section in <a href="#">Chapter 8, "Maintenance Commands"</a> , for a full description of all possible states.) Wait until the port is idle before retesting. 2. If the port status is idle, then retry the command at one-minute intervals a maximum of five times. 3. If the test continues to abort, escalate the problem.
1004	ABORT	The port has been seized by a user for a valid call. 1. Use the <b>status station</b> command for the station associated with this port and determine when the port is available for testing. 2. Retry the command at one-minute intervals a maximum of five times. 3. If the test continues to abort and the port is not in use, escalate the problem.
1005	ABORT	This test is not valid for this type of translation. Ports administered as "ASAI" or "ADJK" can not run this test, because the B channels associated with the port are not used by ASAI or Lucent Adjunct Links. This is a normal condition.
2012	ABORT	Internal System Error.
2100	ABORT	Could not allocate the necessary resources to run this test. 1. Retry the command at 1-minute intervals for a maximum of 5 times.
1 2	FAIL	The NPE of the tested port was found to be transmitting in error. This causes noisy and unreliable connections. Error code 1 indicates that the NPE Crosstalk Test failed on Channel B1. Error code 2 indicates that the NPE Crosstalk Test failed on Channel B1. 1. Replace the circuit pack.

Table 9-139. TEST #617 NPE Crosstalk Test — *Continued*

Error Code	Test Result	Description/ Recommendation
	PASS	The port is correctly using its allocated time slots. <ol style="list-style-type: none"><li>1. To be sure that this is not an intermittent problem, repeat this test a maximum of 10 times to make sure it continues to pass.</li><li>2. If complaints still exist, examine the station, connections, and wiring.</li></ol>

### BRI Port Local LAN Loop Around Test (#618)

**This test is destructive.**

This test, which verifies the connectivity of a BRI port across the LAN Bus, executes only if the port is out-of-service. The test aborts if calls associated with the port are in-progress. Failures of this test indicate either on-board faults associated with the BRI-PORT hardware on the circuit pack, or problems with the LAN Bus, which is used to form connectivity between the switch and the BRI-PORT.

The dotted lines in [Figure 9-14](#) show how a Loop Around Test is performed across the Packet Bus for the D-channel.

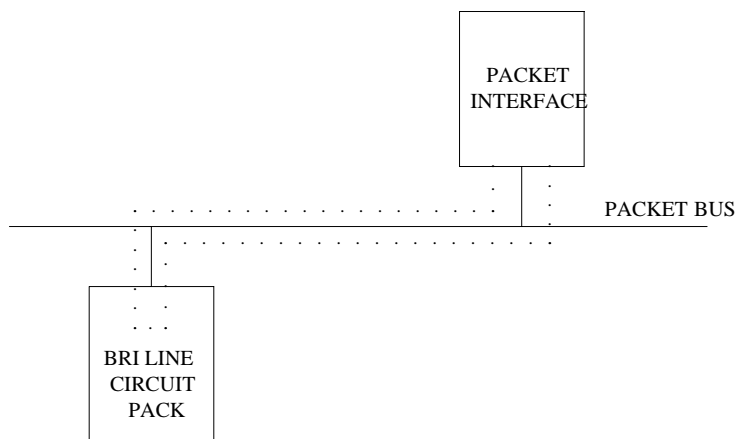

**Figure 9-14. Path of the BRI Port Local LAN Loop Around**

**Table 9-140. Test #618 BRI Port Local LAN Loop Around**

Error Code	Test Result	Description/ Recommendation
1015	ABORT	<p>The port is not in the out-of-service state.</p> <ol style="list-style-type: none"> <li>1. Display the BRI Port Status form via the <b>status bri-port PCSSpp</b> command to determine which stations or adjuncts are on this port.</li> <li>2. Use the extension shown on this form in the <b>status station</b> command to determine if the station or adjunct is in use.</li> <li>3. If it is in use, wait until it is idle, and then busyout the port (using the <b>busyout port PCSSpp</b> command) to place it in the out-of-service state and repeat this test.</li> </ol> <p><b>⚠ WARNING:</b></p> <p><i>Since the "busyout" command is destructive, execution of this command prior to the port being idle causes all calls associated with BRI endpoints and all transactions associated with ASAI or Lucent adjuncts on the port to be torn down. Note that third party calls established by an ASAI or Lucent adjunct remain connected even though the port is taken out-of-service.</i></p>

*Continued on next page*

**Table 9-140. Test #618 BRI Port Local LAN Loop Around — Continued**

Error Code	Test Result	Description/ Recommendation
1139	ABORT	The Packet Bus in the port network is out-of-service. <ol style="list-style-type: none"> <li>1. Follow the repair procedures for the Packet Bus.</li> <li>2. After completing Step 1, execute the <b>test port long PCSSpp</b> command, and review the results of the BRI Port Local LAN Loop Around Test to verify the repair.</li> </ol>
1141	ABORT	The PKT-CTRL is out-of-service. <ol style="list-style-type: none"> <li>1. Follow the repair procedures for the PKT-CTRL.</li> <li>2. After completing Step 1, execute the <b>test port long PCSSpp</b> command, and review the results of the BRI Port Local LAN Loop Around Test to verify the repair.</li> </ol>
1144	ABORT	The PPN Packet Bus is out-of-service. <ol style="list-style-type: none"> <li>1. Follow the repair procedures for the Packet Bus.</li> <li>2. After completing Step 1, execute the <b>test port long PCSSpp</b> command, and review the results of the BRI Port Local LAN Loop Around Test to verify the repair.</li> </ol>
2012	ABORT	Internal System Error.
2100	ABORT	Could not allocate the necessary system resources to run this test. <ol style="list-style-type: none"> <li>1. Retry the command at one-minute intervals a maximum of five times.</li> <li>2. If the test continues to abort, escalate the problem.</li> </ol>
	FAIL	The Loop Around Test has failed. <ol style="list-style-type: none"> <li>1. If the test fails repeatedly, attempt to reset the circuit pack if the other ports on the board are not in use. Reset the circuit pack by issuing the <b>busyout board PCSS</b> and the <b>reset board PCSS</b> commands.</li> <li>2. If the test fails again, execute <b>test port-network &lt;pn#&gt;</b>. If this fails, follow failure procedures in "PKT-BUS (Packet Bus)" section.</li> <li>3. If tests executed in Step 2 pass, the problem is local to the BRI board. Replace the circuit pack.</li> </ol>
	PASS	The BRI Port Local LAN Loop Around Test has passed.

## BRI Port Local TDM Loop Around Test (#619)

**This test is destructive.**

This test verifies the connectivity of a BRI port across the TDM Bus. It aborts if calls associated with the port are in progress. Failure of this test indicates an on-board fault associated with the port hardware on the circuit pack.

This Loop Around Test runs a series of individual tests on the two B-channels (B1 and B2) associated with the port. It is a collection of the following:

- A Loop Around Test across the TDM Bus for B1.
- A Conference Circuit Test for B1.
- A Loop Around Test across the TDM Bus for B2.
- A Conference Circuit Test for B2.

The tests are run in the above order. If one fails, the remaining tests in the sequence are not executed. An error code is returned at that point.

This test is not executed for ABRI-PORT/ATT-PORT/LGATE-PT/ATTE-PT because the B-channels associated with the port are not used by ASAI or Lucent adjuncts.

The dotted lines in [Figure 9-15](#) show how a Loop Around Test is performed for the B-channels. The figure shows a terminal connected to a BRI line board using a TN556. If a TN2198 is used the terminal would be connected to a NT1, and the NT1 to the BRI board.

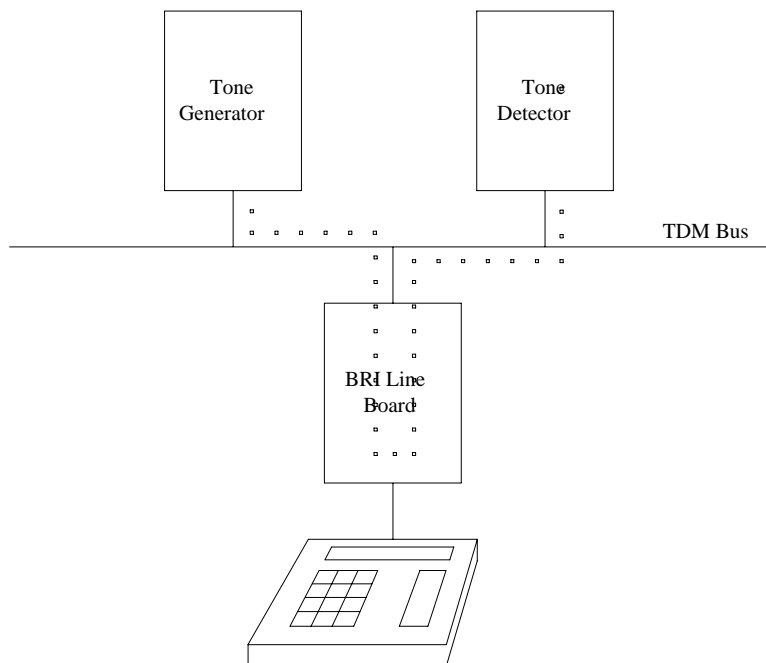

---

**Figure 9-15. Path of the BRI Port Local TDM Loop Around**

Table 9-141. Test #619 BRI Port Local TDM Loop Around

Error Code	Test Result	Description/ Recommendation
1000	ABORT	<p>The system resources required to run this test are not available. The port may be busy with a valid call.</p> <ol style="list-style-type: none"><li>1. Use the <b>display port PCSSpp</b> command to determine the station extension or trunk group/member number of the port. Use the <b>status bri-port PCSSpp</b> command to determine the service state of the port. If the service state indicates that the port is in use, then the port is unavailable for certain tests. (Refer to the "Status Commands" section in <a href="#">Chapter 8, "Maintenance Commands"</a>, for a full description of all possible states.) Wait until the port is idle before retesting.</li><li>2. If the port is idle, then retry the command at one-minute intervals a maximum of five times.</li><li>3. If the test continues to abort, escalate the problem.</li></ol>
1002	ABORT	<p>The system could not allocate time slots for the test. The system may be under heavy traffic conditions or it may have time slots out-of-service due to TDM-BUS errors.</p> <ol style="list-style-type: none"><li>1. If the system has no TDM-BUS errors and is not handling heavy traffic, repeat test at one-minute intervals a maximum of five times.</li><li>2. If the test continues to abort, escalate the problem.</li></ol>
1003	ABORT	<p>The system could not allocate a tone receiver for the test. The system may be oversized for the number of Tone Detectors present or some Tone Detectors may be out-of-service.</p> <ol style="list-style-type: none"><li>1. Resolve any TTR-LEV errors</li><li>2. Resolve any TONE-PT errors.</li><li>3. If neither condition exists, retry the test at one-minute intervals a maximum of five times.</li><li>4. If the test continues to abort, escalate the problem.</li></ol>
1004	ABORT	<p>The port has been seized by a user for a valid call. Use the <b>status station</b> command for the station associated with this port and determine when the port is available for testing.</p> <ol style="list-style-type: none"><li>1. Retry the command at one-minute intervals a maximum of five times.</li><li>2. If the test continues to abort and the port is not in use, escalate the problem.</li></ol>
1005	ABORT	<p>This test is not valid for this type of translation. Ports administered as "ASAI" or "ADJK" can not run this test, because the B channels associated with the port are not used by ASAI or Lucent Adjunct Links. This is a normal condition.</p>

*Continued on next page*



**Table 9-141. Test #619 BRI Port Local TDM Loop Around — Continued**

Error Code	Test Result	Description/ Recommendation
2000	ABORT	Response to the test was not received from the BRI-LINE circuit pack within the allowable time period.  1. If this result occurs repeatedly, attempt to reset the circuit pack if the other ports are not in use. Reset the circuit pack by issuing the <b>busyout board PCSS</b> and the <b>reset board PCSS</b> commands.  2. If this result occurs again, replace the circuit pack.
2012	ABORT	Internal System Error.
2100	ABORT	Could not allocate the necessary resources to run this test.  1. Retry the command at one-minute intervals a maximum of five times.  2. If the test continues to abort, escalate the problem.
2103	ABORT	The system could not make the conference connection for the test.  1. Retry the command at one-minute intervals a maximum of five times.  2. If the test continues to abort, escalate the problem.
1 2	FAIL	As stated previously, this test runs a TDM Loop Around Test on each B-channel. This indicates that the loop around failed on one of the channels. Error Code 1 indicates that the TDM Loop Around Test failed on B1. Error Code 2 indicates that the TDM Loop Around Test failed on B2.
7 8	FAIL	As stated previously, this test runs a Conference Circuit Test on each B-channel. A failure here indicates that one of these conference tests failed; Error Code 7 means that the test failed on B1; Error Code 8 means that the test failed on B2.  1. If the test fails repeatedly, attempt to reset the circuit pack if the other ports on the circuit pack are not in use. Reset the circuit pack by issuing the <b>busyout board PCSS</b> and the <b>reset board PCSS</b> commands.  2. If the test fails again, replace the circuit pack.
	PASS	The BRI Port Local TDM Loop Around Test has passed.

### Electronic Power Feed Restoral Test (#620)

This test attempts to restore the Electronic Power Feed (EPF) on an ISDN-BRI port twice. In this test, the processor requests that the EPF be turned on for a given port. An attempt is made to turn on the power unit to the station or adjunct. If no current is being drawn by a station, this probably indicates that the station is not connected. No current being drawn by an adjunct is the normal condition. If an overcurrent condition is sensed (that is, too much current is being drawn), this condition may indicate a short in the wiring to the endpoint or adjunct.

Depending on what condition is sensed, a message is returned stating that either the EPF was turned on successfully with no problems or that an overcurrent condition is sensed. This response is reported by the Electronic Power Feed Inquiry (#622), which follows in the testing sequence. EPF Restoral is attempted again by this test five seconds later. This test always passes for the TN2198 because it has no EPF. This test will always abort when run on the TN2208.

**Table 9-142. TEST #620 Electronic Power Feed Restoral**

Error Code	Test Result	Description/ Recommendation
1005	ABORT	This test is not valid for this port type. The TN2208 does not have an electronic power feed, and the test will abort.
2012	ABORT	Internal System Error. 1. Retry the command at one-minute intervals a maximum of five times. 2. If the test continues to abort, escalate the problem.
	PASS	The EPF Test passed. The message to turn on the power feed to the station or the adjunct was successfully sent to the port. 1. Although this test should not return a fail result, after running this test, the Error Log should be checked for any entries with error type 257 to examine the real results of this test. 2. An error type of 257 in the Error Log indicates some problem with the power to the station or the adjunct. Check for a short in the wiring, a damaged jack, a defective voice terminal or adjunct, or an incorrect type of terminal.

### Level 1 Status Inquiry Test (#621)

This test determines the state of the transmission facility of a BRI port at the physical layer (that is, Level 1). Level 1 can be in one of three possible states: Activated, Pending Activation, or Deactivated.

The Activated state is the correct state for an ISDN-BRI port. In this state the Level 1 interface can communicate with the BRI endpoint or ASAI or Lucent adjunct administered on this port. This test passes if the state of Level 1 (L1) is Activated. This test also passes if software has taken this port out of service. See the description of the Level 1 "Deactivated State" below for more details.

The Pending Activation state indicates a problem with the endpoints or adjunct, the wiring to the sets or adjunct, or the BRI-LINE circuit pack. When in this state, the Level 1 interface is either not receiving any L1 framing from the endpoint or adjunct (Endpoint Idle), or it is communicating with the endpoint or adjunct but cannot transition to the Activated state (Endpoint Active).

The Deactivated state indicates a problem with the BRI-LINE circuit pack. When in this state, the Level 1 interface is idle and is not trying to communicate with the BRI endpoints or adjunct. When an ISDN-BRI port is placed in the out-of-service state, Level 1 is also put into the Deactivated state. This could be due either to the system detecting a fault with the port or to a **busyout port PCSSpp** request. This could be due either to the system detecting a fault with the port or to a **busyout port PCSSpp** request.

**Table 9-143. TEST #621 Level 1 Status Inquiry**

Error Code	Test Result	Description/ Recommendation
1187	ABORT	<p>The board, port or station may have been busied out by a technician.</p> <ol style="list-style-type: none"> <li>1. Look in the Error Log for Error Type 18 (port busied out) for this port and BRI-BD (board busied out). If this error type is present for BRI-PORT only, then release the port via the <b>release port pp</b> command and run the test again. If the error is present for both BRI-BD and BRI-PORT, then release the board via the <b>release port PCSS</b> command and run the test again.</li> </ol> <p><b>⇒ NOTE:</b>                      When you release a port, you release all ports associated with it. If certain ports still need to be busied out, use the <b>release port PCSSpp</b> command to busy them out.</p> <ol style="list-style-type: none"> <li>2. Make sure the terminal is connected.</li> <li>3. Retry the command at one-minute intervals a maximum of five times.</li> <li>4. If the test continues to abort, escalate the problem.</li> </ol>
2000	ABORT	<p>Response to the test was not received from the circuit pack within the allowable time period.</p> <ol style="list-style-type: none"> <li>1. If the test aborts repeatedly a maximum of five times, reset the circuit pack via the <b>busyout board PCSS</b> and <b>reset board PCSS</b> commands.</li> <li>2. If the test aborts again, replace the circuit pack.</li> </ol>
2012	ABORT	<p>Internal System Error.</p>
2100	ABORT	<p>Could not allocate the necessary system resources to run this test.</p> <ol style="list-style-type: none"> <li>1. Retry the command at one-minute intervals a maximum of five times.</li> <li>2. If the test continues to fail, escalate the problem.</li> </ol>

*Continued on next page*

**Table 9-143. TEST #621 Level 1 Status Inquiry — Continued**

Error Code	Test Result	Description/ Recommendation
1	FAIL	<p>Received a status of Level 1 Pending Activation-Endpoint Idle which indicates a problem with the BRI endpoint or ASAI or Lucent adjunct, the wiring to the endpoint or adjunct, or the ISDN-BRI port.</p> <p>For the TN2198, received a status of Level 1 Pending Activation. U interface down, which indicates a problem with a connection between the switch and the NT1.</p> <p><b>⇒ NOTE:</b>                      An NT1 is a 2-to-4 wire converter that is used to connect 4-wire Lucent terminals to a 2-wire TN2198 circuit pack. The NT1 also has status lamps to determine the health of the unit.</p> <ol style="list-style-type: none"> <li>1. For the TN556, verify that an end point is connected to the port. If an endpoint is connected to the port then proceed to step 2. For the TN2198 verify that the connections are good between the switch and the NT1. Verify that the NT1 has power.</li> <li>2. As necessary, check and repair the wiring between the circuit pack and the endpoint or adjunct. If a TN2198 is used the set must have been plugged in for at least 15 seconds before it will stabilize. Execute the <b>test port PCSSpp</b> command, and review the results of the Level 1 Status Inquiry Test to verify the repair. If this test is still failing, proceed to Step 3.</li> <li>3. For BRI endpoints, replace the BRI endpoint(s) connected to the port or the NT1 if a TN2198 is used. For ASAI or Lucent adjuncts, follow the recommended repair procedures of the manufacturer for link communication problems. For the NT1, follow the manufacturers repair procedures. Then execute the <b>test port PCSSpp</b> command and review the results of the Level 1 Status Inquiry Test to verify repair. If this test is still failing, proceed to Step 4.</li> <li>4. Escalate the problem to the next tier.</li> </ol>

*Continued on next page*

Table 9-143. TEST #621 Level 1 Status Inquiry — Continued

Error Code	Test Result	Description/ Recommendation
2	FAIL	<p>For the TN556 or TN2208, received a status of Level 1 Pending Activation-Endpoint Active which indicates a problem with the BRI endpoint or ASAI or Lucent adjunct, the wiring to the endpoint or adjunct, or the ISDN-BRI port.</p> <p>For the TN2198, received a status of Level 1 Pending Activation. U interface up S/T interface down, which indicates a problem with the NT1 or the wiring between the NT1 and the BRI endpoint (S/T interface).</p> <ol style="list-style-type: none"> <li>1. As necessary, check and repair the wiring between the circuit pack and the endpoint or adjunct. Execute the <b>test port PCSSpp</b> command, and review the results of the Level 1 Status Inquiry test to verify the repair. If this test is still failing, proceed to Step 2.</li> <li>2. For BRI endpoints, try replacing the BRI endpoint(s) connected to the port. For ASAI or Lucent adjuncts, follow the recommended repair procedures of the manufacturer for link communication problems. For the NT1, follow the recommended repair procedures of the manufacturer. Then execute the <b>test port PCSSpp</b> command, and review the results of the Level 1 Status Inquiry test to verify repair. If this test is still failing, proceed to Step 3.</li> <li>3. Escalate the problem to the next tier.</li> </ol>
3	FAIL	<p>Received a status of Level 1 Deactivated; the port is out-of-service.</p> <ol style="list-style-type: none"> <li>1. Issue the <b>status bri-port PCSSpp</b> command to verify that the service state of the port is out-of-service. If the service state of the port is not out-of-service, escalate the problem to the next tier. Otherwise, proceed to Step 2.</li> <li>2. If the port has been placed out-of-service via the <b>busyout port PCSSpp</b> command, try releasing the port by executing the <b>release port PCSSpp</b> command. Then issue the <b>test port long PCSSpp</b> command, and review the results of Level 1 Status Inquiry test. If this test is still failing, proceed to Step 3.</li> <li>3. After executing the <b>test port long PCSSpp</b> command, review the results of all the tests. Follow the repair procedures for any tests that fail. Verify repair of the problem by executing the <b>test port PCSSpp</b> command and by determining that the Level 1 Status test passes. If the test continues to fail for this reason, proceed to Step 4.</li> <li>4. Escalate the problem to the next tier.</li> </ol>

Continued on next page

**Table 9-143. TEST #621 Level 1 Status Inquiry — Continued**

Error Code	Test Result	Description/ Recommendation
4	FAIL	For the TN2198 only: Received a status of Level 1 Pending Activation, the NT1 has a loss of power indicating a problem with the NT1. 1. For the NT1 follow the manufacturers recommended repair procedures. 2. Execute the <b>test port PCSSpp</b> command, and review the results of the Level 1 Status Inquiry test to verify the repair. If the test is still failing proceed to Step 3. 3. Escalate the problem to the next tier.
	PASS	This test indicates that Level 1 is activated, or that software has taken the port out of service.

### Electronic Power Feed Inquiry (#622)

This test queries the BRI-LINE circuit pack for the status of the Electronic Power Feed (EPF) supplied to a BRI endpoint or an ASAI or Lucent adjunct. If the EPF is on and no overcurrent condition exists, this test passes. All other states are not normal and indicate a problem with the endpoint or adjunct, the wiring to the endpoint or adjunct, or the BRI-LINE circuit pack. This test is not run on the TN2208 circuit pack or the TN2198 and will always return a pass for the TN2198. The TN2208 has no power feeds.

**Table 9-144. TEST #622 Electronic Power Feed Inquiry**

Error Code	Test Result	Description/ Recommendation
1005	ABORT	This test is not valid for this port type. Ports on the TN2208 can not run this test because this board does not have an electronic power feed.
2000	ABORT	Response to the test was not received from the circuit pack within the allowable time period. 1. If the test aborts repeatedly a maximum of five times, reset the circuit pack via the <b>busyout board PCSS</b> and <b>reset board PCSS</b> commands. 2. If the test aborts again, replace the circuit pack.

*Continued on next page*

Table 9-144. TEST #622 Electronic Power Feed Inquiry — Continued

Error Code	Test Result	Description/ Recommendation
2012	ABORT	Internal System Error.
2100	ABORT	Could not allocate the necessary system resources to run this test. <ol style="list-style-type: none"><li>1. Retry the command at one-minute intervals a maximum of five times.</li><li>2. If the test continues to abort, escalate the problem.</li></ol>
1	FAIL	The BRI-LINE circuit pack reports that it has detected an overcurrent condition and has turned off the EPF. <ol style="list-style-type: none"><li>1. As necessary, check and repair the wiring between the circuit pack and the endpoint or adjunct. Check the endpoints and replace one or both sets if the sets are drawing too much current. Execute the <b>test port PCSSpp</b> command and review the results of the EPF Inquiry Test to verify the repair. If this test is still failing, proceed to Step 2.</li><li>2. Execute the <b>test port PCSSpp</b> command, and review the results of the Level 1 Status Inquiry Test. If this test is also failing, then follow the repair procedure for the Level 1 Status Inquiry Test. Otherwise, escalate this problem to the next tier.</li></ol>
	PASS	The Electronic Power Feed Inquiry Test reports that the EPF is on.

### Layer 1 Transmission Error Counter Test (#624)

This test reads and clears the BRI port's Layer 1 Transmission error counter maintained on the BRI-LINE circuit pack. This counter is incremented by the circuit pack when it detects a Layer 1 transmission problem. The test passes if the value of the counter is 0 (that is, the error is cleared). If the counter is not zero, the test fails, and the value of the counter is displayed in the Error Code field.

This error is most likely due to a problem with the wiring or the endpoint or adjunct (verify that the wiring meets the configuration rules defined in *DEFINITY Communications System Generic 1 and Generic 3i Wiring*, 555-204-111. It does not indicate a problem with the ISDN-BRI circuit pack. This test is useful for verifying the repair of the problem.

**Table 9-145. TEST #624 Layer 1 Transmission Error Counter Test**

Error Code	Test Result	Description/ Recommendation
2000	ABORT	Response to the test was not received from the circuit pack within the allowable time period. <ol style="list-style-type: none"> <li>1. If the test aborts repeatedly a maximum of five times, reset the circuit pack via the <b>busyout board PCSS</b> and <b>reset board PCSS</b> commands.</li> <li>2. If the test aborts again, replace the circuit pack.</li> </ol>
2012	ABORT	Internal System Error.
2100	ABORT	Could not allocate necessary system resources to run test. <ol style="list-style-type: none"> <li>1. Retry the command at one-minute intervals a maximum of five times.</li> <li>2. If the test continues to fail, escalate the problem.</li> </ol>
value	FAIL	The BRI-LINE circuit pack is still detecting errors of this type. The Error Code field contains the value of this counter. <ol style="list-style-type: none"> <li>1. Retry the command at one-minute intervals a maximum of five times.</li> <li>2. If the test continues to fail, review the results of other tests in the Long Test Sequence. Pay particular attention to the results of the Level 1 Status Inquiry test. Follow repair procedures for any of the executed tests if they fail. Otherwise, go to the next step.</li> <li>3. If the tests for the endpoints or adjunct pass and the Layer 1 Transmission Error Counter Test continues to fail, check the wiring to the endpoints or adjunct. If the wiring appears to be fine, escalate the problem.</li> </ol>
	PASS	The Layer 1 Transmission error counter was read correctly and has a value of 0.

### Receive FIFO Overflow Error Counter Test (#625)

This test reads and clears the BRI port's Receive FIFO Overflow error counter maintained on the BRI-LINE circuit pack. This counter is incremented by the circuit pack when it detects an overflow of its receive buffers. The test passes if the value of the counter is 0 (that is, the error is cleared). If the counter is non-zero, the test fails, and the value of the counter is displayed in the Error Code field.

This error can occur if signaling frames are being received from the Packet Bus at a rate sufficient to overflow the receive buffers on the circuit pack for a port OR if a hardware fault is causing the receive buffers not to be emptied properly by the circuit pack. This test is useful for verifying the repair of the problem.



**Table 9-146. TEST #625 Receive FIFO Overflow Error Counter Test**

Error Code	Test Result	Description/ Recommendation
2000	ABORT	Response to the test was not received from the circuit pack within the allowable time period. <ol style="list-style-type: none"> <li>1. If the test aborts repeatedly a maximum of five times, reset the circuit pack via the <b>busyout board PCSS</b> and <b>reset board PCSS</b> commands.</li> <li>2. If the test aborts again, replace the circuit pack.</li> </ol>
2012	ABORT	Internal System Error.
2100	ABORT	Could not allocate the necessary system resources to run this test. <ol style="list-style-type: none"> <li>1. Retry the command at one-minute intervals a maximum of five times.</li> <li>2. If the test continues to fail, escalate the problem.</li> </ol>
value	FAIL	The BRI-LINE circuit pack is still detecting errors of this type. The Error Code field contains the value of this counter. <ol style="list-style-type: none"> <li>1. Retry the command at one-minute intervals a maximum of five times.</li> <li>2. If the test continues to fail, run the Long Test Sequence and pay particular attention to the Loop Around Tests (#618 and #619). See the repair procedures for the executed test if it fails. Otherwise, go to the next step.</li> <li>3. Replace the circuit pack.</li> </ol>
	PASS	The Receive FIFO Overflow error counter was read correctly and has a value of 0.

### Clear Error Counters Test (#270)

This test is not an actual test in the strict sense of the word. There are various error counters associated with each BRI-PORT/ABRI-PORT/ATT-PORT/LGATE-PT/ATTE-PT. This test clears those counters and triggers the auditing of Terminal Endpoint Identifier (TEI) values and layer 3 reinitialization. This test is used only to send messages to the BRI-PORT/ABRI-PORT/ATT-PORT/LGATE-PT/ATTE-PT and, therefore, should neither abort nor fail

**Table 9-147. TEST #270 Clear Error Counters**

Error Code	Test Result	Description/ Recommendation
Any	ABORT	This test should never abort.
Any	FAIL	This test should never fail. 1. Retry the command at one-minute intervals a maximum of five times. 2. If the test continues to fail, escalate the problem.
	PASS	The message to clear the error counters of the BRI-Port/ABRI-Port/ATT-PORT/LGATE-PT/ATTE-PT has been sent.

## BRI-SET, ASAI-ADJ, BRI-DAT

MO Name As It Appears in Alarm Log	Alarm Level	Initial System Technician Command to Run <sup>1</sup>	Full Name of MO
BRI-SET BRI-DAT	WARNING <sup>2</sup>	test station extension I, test data-module extension	ISDN-BRI Set
ASAI-ADJ	MAJOR <sup>2</sup>	test station extension	ASAI-Adjunct
ASAI-ADJ	MAJOR <sup>2</sup>	test data-module extension	ASAI-Adjunct
ASAI-ADJ	WARNING <sup>3</sup>	test data-module extension	ASAI-Adjunct
ATT-ADJ	MAJOR <sup>2</sup>	test station extension	Lucent-Adjunct
ATT-ADJ	MAJOR <sup>2</sup>	test station extension	Lucent-Adjunct
ATT-ADJ	WARNING <sup>3</sup>	test station extension	Lucent-Adjunct
LGATE-AJ	MAJOR <sup>2</sup>	test station extension	Ethernet ASAI-Adjunct
LGATE-AJ	MAJOR <sup>2</sup>	test station extension	Ethernet ASAI-Adjunct
LGATE-AJ	WARNING <sup>3</sup>	test station extension	Ethernet ASAI-Adjunct
ATTE-AJ	MAJOR <sup>2</sup>	test station extension	Ethernet Lucent-Adjunct
ATTE-AJ	MAJOR <sup>2</sup>	test station extension	Ethernet Lucent-Adjunct
ATTE-AJ	WARNING <sup>3</sup>	test station extension	Ethernet Lucent-Adjunct

1. UU is the universal cabinet number (1 for PPN, 2 -44 for EPNs). C is the carrier designation (A, B, C, D, or E). SS is the number of the slot in which the circuit pack resides (01 to 21). pp is the two digit port number (01, 02, ...).
2. The alarm level for ASAI and Lucent adjuncts may be administered using the **set options** command. The alarm level can be set independently for Off-Board and On-Board alarms to WARNING, MINOR, or MAJOR for all ASAI and Lucent adjuncts in the system.
3. Alarming for an ASAI and Lucent adjuncts is disabled if the adjunct asks the switch to suspend maintenance. When this occurs, an error and a WARNING alarm are logged against the endpoint. Busing out and releasing the ASAI station or ADJLK station will clear the alarm.

### CAUTION:

The [“Packet Bus Fault Isolation and Repair”](#) for isolating and resolving Packet Bus faults is included in [Chapter 5, “Alarms, Errors, and Troubleshooting”](#). This flowchart, along with the other information presented in the chapter, can help resolve problems that involve more than a single station or circuit pack. Refer to this section whenever the repair procedures for this Maintenance Object refer to Packet Bus and/or Packet Control maintenance.

**WARNING:**

*If a significant Packet Bus failure occurs, errors and alarms may not be logged as expected for BRI-PORT/ABRI-POR/ATT-PORT/ LGATE-PT/ ATTE-PT. Conditions under which this occurs are detailed in the ["Maintenance of the Packet Bus"](#) section of [Chapter 5, "Alarms, Errors, and Troubleshooting"](#).*

The TN2208 ESAI MFB provides DEFINITY with an Ethernet interface to Adjunct-Switch Application Interface (ASAI) and Lucent adjuncts (for example, CONVERSANT<sup>®</sup> Voice System). This circuit pack contains 8 ports of line circuit interface, each of which operates with two B-channels (referred to as B1 and B2 throughout this section) and one D-channel as specified in the Lucent ISDN-BRI Specification. In this context, the term "ISDN-BRI port" is used to refer collectively to ports on the TN2208 MFB circuit pack which is connected to ASAI or Lucent adjuncts. The TN2208 ESAI MFB is handled by switch software as it is an ISDN BRI compatible board and all maintenance actions referring to ASAI and Lucent Adjunct Links in this section apply.

In G3iV1.1-286 and G3iV2-386, two types of ISDN-BRI endpoints may be connected to ISDN-BRI (ISDN Basic Rate Interface Line) TN556 and TN2198 circuit packs: ISDN-BRI station endpoints, ASAI (Adjunct-Switch Application Interface) and Lucent adjuncts (for example CONVERSANT<sup>®</sup> Voice System). These circuit packs contain 12 ports of line circuit interfaces, each of which operates at 192 kilobits per second (kbps) with two B-channels and one D-channel as specified in the Lucent ISDN-BRI specification (PUB 801-802-100). For BRI endpoints, each B-channel may support voice or circuit-switched data and may be circuit-switched simultaneously. The B-channels are not used by ASAI or Lucent adjuncts. The D-channel is used for conveying signaling between the switch and a BRI endpoint(s) or ASAI or Lucent adjuncts. Each ISDN-BRI D-channel is connected to the switch processor and the ISDN-BRI port through the PKT-CTRL (Packet Control) and the PKT-BUS (Packet Bus).

ISDN-BRI endpoints come in a number of configurations. All endpoints require the D-channel to convey signaling information to the switch. A voice-only set requires only one B-channel. A voice and data-capable set requires both

B-channels (one for voice and one for data). Therefore, each TN556 port can support either two voice-only sets or one voice and data-capable set. Only a single ASAI or Lucent adjunct may be connected to an ISDN-BRI port. Multiple adjuncts per line are not supported.

[Figure 9-16](#) illustrates the physical connection (solid line) between an ISDN-BRI Circuit Pack and a voice or voice/data set. Each physical connection allows for two B-channels, as stated above, plus one D-channel. Each ISDN-BRI circuit pack can support up to 12 of these PHYSICAL connections to different voice and voice/data sets or ASAI and Lucent adjuncts.

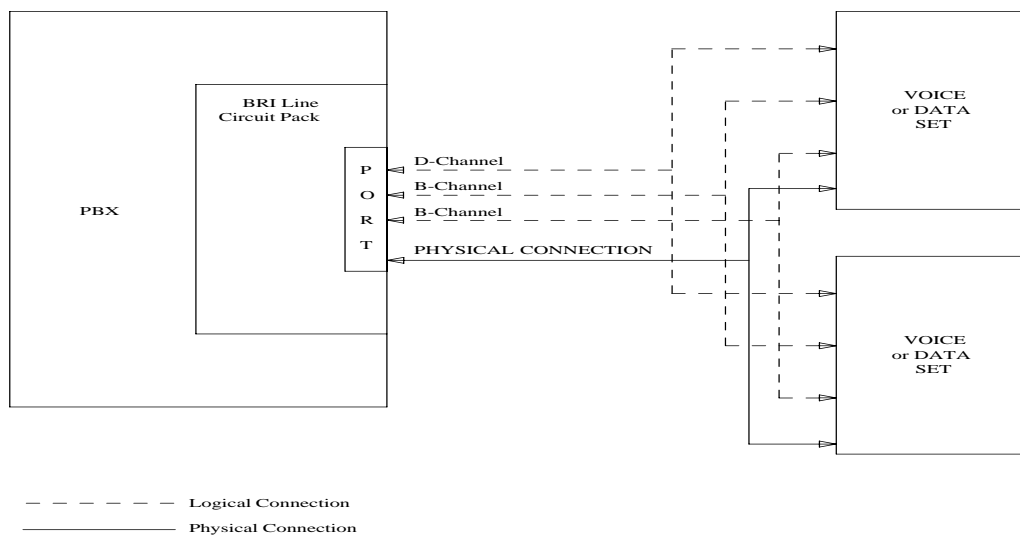

**Figure 9-16. ISDN-BRI Set Interactions**

This section contains the ISDN-BRI Set, ASAI Adjunct and Lucent Adjunct Maintenance documentation. Some of the results of maintenance testing of the ISDN-BRI Set or the ASAI and Lucent Adjunct may be affected by the health of the ISDN-BRI circuit pack and Port. These interactions should be kept in mind when investigating the cause of ISDN-BRI Set problems.

## Hardware Error Log Entries and Test to Clear Values

Table 9-148. BRI-SET/ASAI-ADJ Error Log Entries

Error Type	Aux Data	Associated Test	Alarm Level BBRI-SET	Alarm Level ASAI-ADJ ASAI-ADJ ATT-ADJ LGATE-AJ ATTE-AJ	On/Off Board	Test to Clear Value
0 <sup>1</sup>	0	Any	Any	Any	Any	test BRI-SET or ASAI-ADJ ATT-ADJ ESIA-ADJ EATT_ADJ
2(a)	2-10 2	None				
18	0	busyout station ext	WARNING	MAJOR/ WARNING <sup>2</sup>	OFF	release station <ext>
130(b)			WRN		ON	test port PCSS sh
257(c)	Any	BRI Layer 3 Query (#629)	WARNING	MAJOR/ WARNING <sup>2</sup>	OFF	test station ext r 2 test data-module ext r 2
351(d)	0	None		WARNING	OFF	busyout and release station
513(e)	0	None				
769(f)	0	None	WARNING	MAJOR	OFF	
2561 (g)	0	None				
2562- 2566(h)	0	None				
2567 (o)	0	None				
2568 (p)	0	None				

Continued on next page

**Table 9-148. BRI-SET/ASAI-ADJ Error Log Entries — Continued**

<b>Error Type</b>	<b>Aux Data</b>	<b>Associated Test</b>	<b>Alarm Level BBRI-SET</b>	<b>Alarm Level ASAI-ADJ ASAI-ADJ ATT-ADJ LGATE-AJ ATTE-AJ</b>	<b>On/Off Board</b>	<b>Test to Clear Value</b>
2817(i)	0	XID Test (#628)	WARNING	MAJOR/ WARNING <sup>2</sup>	OFF	test station ext r 2 test data-module ext r 2
3073(j)	0	BRI Remote Loop Back (#627)	WARNING		OFF	test station ext l r 2 test data-module ext l r 2
3329 (k)	Any	Signaling Link Status (626)	WARNING	MAJOR/ WARNING <sup>2</sup>	OFF	
3584	0,1	None				
3585-3839(i)	0	None				
3840-4095 (m) (n)	0	None				

1. Run the Short Test Sequence first. If all tests pass, run the Long Test Sequence. Refer to the appropriate test description and follow the recommended procedures.
2. Major alarms on this MO may be downgraded to Warning alarms based on the value used in the set options command.

**Notes:**

- a. Errors of this type indicate violations of the ISDN-BRI signaling protocol; timers associated with certain Layer 3 messages have expired before a required response was received. In the following table, the aux data field indicates which timer has just expired. (For more information, refer to the Lucent ISDN-BRI Specification.

Aux Data	Timer Type
2	First T303 (SETUP timer)
3	Second T303 (SETUP timer)
4	T305 (DISConnect timer)
5	First T308 (RELease timer)
6	Second T308 (RELease timer)
10	T316 (REStart timer)
12	T309 (Layer 2 Failure timer)
16	TM100 (Management Information Message timer 1)
17	TM200 (Management Information Message timer 2)
102	TASAI (ASAI Routing Timer)

The switch sent a message to the endpoint which did not respond in the allotted time. This can happen occasionally due to failure of the point-to-point signaling link or because of a problem in the BRI endpoint or ASAI adjunct or Lucent adjunct. Execute the **test station extension sh** command and pay particular attention to the results of the BRI Layer 3 Query Test (#629). If this test fails, follow the repair procedure for Test #629.

- b. This error type indicates that the circuit pack has been removed or has been insane for more than 11 minutes. To clear the error, replace or reinsert the circuit pack.
- c. This error occurs when the endpoint does not respond to the service state query message sent to the adjunct or the endpoint. This error causes an alarm to be raised. The alarm is retired when the switch receives a response to the service state query to the endpoint or the adjunct.

For BRI endpoints, the Aux Data field for this error contains "0." When it occurs, execute the **test station extension sh** command and pay particular attention to the results of the BRI Layer 3 Query Test (#629). If this test fails, follow the repair procedure for Test #629.



When this error occurs for an ASAI or Lucent adjunct, the Aux Data field indicates the state of the ASAI link or Lucent link and whether an invalid response or no response was received to the query from the switch, as shown in the following table:

Aux Data	ASAI Link State	Error
102	13-restarting	No response to RESTART message
104	13-restarting	Invalid response to RESTART message
152	13-restarted	No response to Layer 3 query
154	13-restarted	Invalid response to Layer 3 query
202	13-established	No response to Layer 3 query
204	13-established	Invalid response to Layer 3 query

(See "Status BRI-Port" in [Chapter 8, "Maintenance Commands"](#), for an explanation of the ASAI link states.)

For ASAI or Lucent adjuncts, the switch automatically queries the adjunct every two minutes (and therefore the Layer 3 Query Test is not executed for ASAI or Lucent adjuncts via a command issued from the G3MT terminal). While alarmed for this error, the switch momentarily (for five seconds) takes the associated port out-of-service every 15 minutes. This action is taken in an attempt to stimulate recovery actions to be taken by the adjunct.

When this error occurs for an ASAI or Lucent adjunct, the service technician should:

1. Execute the **test station extension** command and pay particular attention to any tests which fail and perform the associated repair procedures for those tests.
  2. Check the health of the adjunct by following the recommended repair procedures of the manufacturer of the adjunct if the preceding step does not resolve the problem.
  3. The alarm condition persists and, if the above steps do not resolve the problem, follow normal escalation procedures.
- d. This error and associated WARNING alarm are logged against an ASAI or Lucent endpoint when the adjunct has asked the switch to suspend Maintenance on the ASAI or Lucent endpoint. Busying out and releasing the ASAI station or ADJLK station will clear this alarm.
- e. This error occurs when the endpoint sends more messages than the switch can handle. The switch suspends the reception of messages from the endpoint for a short period of time. There is no repair procedure for this error. If the condition persists, replace the endpoint.

- f. This error occurs when the signaling link associated with a BRI endpoint has too much link establishment related traffic. This could occur if the signaling link is bouncing between assigned and established states. Software will suspend activity to this endpoint for 75 minutes when the endpoint is alarmed due to this problem (note that service suspension does not occur if the endpoint is an ASAI or Lucent adjunct). If this problem persists, replace the endpoint. If replacing the endpoint does not fix the problem, follow normal escalation procedures.
- g. This error occurs when the ASAI-ADJ or ATT-ADJ or LGATE-AJ or ATTE-AJ message is not transmitted because the PKT-CTRL (Packet Control Circuit Pack) transmit buffers are exhausted. Frequent or persistent occurrence of these events may indicate a hardware problem or traffic overload on the PKT-CTRL, the signaling link, or the ASAI or Lucent adjunct. Attempt to resolve the problem by following the repair procedures for the PKT-CTRL. If these attempts fail, the problem should be escalated because re-engineering of the traffic on the PKT-CTRL, signaling link, or adjunct may be necessary.
- h. This error occurs when the ASAI message is not transmitted because the transmit buffer for the ASAI link is full, causing the link to be flow controlled. Frequent or persistent occurrence of these events may indicate a hardware problem or traffic overload on the PKT-CTRL, the signaling link, or the ASAI or Lucent adjunct. Attempt to resolve the problem by following the repair procedures issued by the manufacturer of the adjunct. If these attempts fail, the problem should be escalated because re-engineering of the traffic on the PKT-CTRL, signaling link, or adjunct may be necessary.
- i. This error indicates a problem with Layer 2 over the D-channel between the switch and the endpoint. When this error occurs, an alarm is raised against the station or adjunct. Execute the **test station extension short** command and pay particular attention to the results of the BRI XID Test (#628). If this test fails, follow the repair procedure for Test #628.
- j. This error indicates a problem with the B-channel connection between the switch and the endpoint. When this error occurs, a warning alarm is raised against the endpoint. Execute the **test station <extension> long** command and pay particular attention to the results of the BRI Remote Loop Back Test (#627). If this test fails, follow the repair procedure for Test #627.
- k. This error occurs whenever the point-to-point signaling link to the endpoint goes down (except when it goes down because either the PKT-CTRL or the PKT-BUS has failed or has been busied out by system technician). When this error occurs, an alarm is raised against the endpoint or adjunct. Execute the **test station <extension> short** command and pay particular attention to the results of the Signaling Link Status Test (#626). If this test fails, follow the repair procedure for Test #626. The alarm is retired when the signaling link is reestablished to the endpoint or adjunct.
- l. Certain ASAI protocol-specific cause codes are logged by switch software. The cause code can be determined from the following formula:

If the error type is greater than 3712, then the ASAI cause code is equal to the error type minus 3712. This code was sent to the adjunct by the switch.

If the error type is less than 3712, then the ASAI cause code is equal to the error type minus 3584. This code was sent to the switch by the adjunct.

A description of the various ASAI cause values is contained in the [Table 9-149](#). This table also contains recommended system technician actions associated with the cause value. Further information can also be found in the Lucent ASAI Specification (288-500-03). In addition, the Aux Data field of the Error Log entry contains additional diagnostic information additional diagnostic.

**Table 9-149. ASAI CAUSE VALUES**

Error Code	Test Result	Description/ Recommendation
0	Unrecognized ASAIProtocol Operation	Requested ASAI protocol operation is not implemented by the switch or adjunct. Aux Data field of Error Log entry contains protocol identifier for unrecognized operation. <ol style="list-style-type: none"> <li>1. Consult switch and adjunct documentation to determine which set of operations is supported by the switch and the adjunct. Adjunct administration turning off operations not implemented by the switch may resolve the problem.</li> <li>2. If Step 1 does not resolve the problem, escalate to the next tier.</li> </ol>
40	Resources not available	No available internal resources to service switch or adjunct request. System transaction capacity for adjunct or switch is exceeded. <ol style="list-style-type: none"> <li>1. Re-engineering of adjunct services may be required. If problem persists, escalate problem to the next tier.</li> </ol>

*Continued on next page*

**Table 9-149. ASAI CAUSE VALUES — Continued**

Error Code	Test Result	Description/ Recommendation
63	SERVICE OR OPTION NOT AVAILABLE	<p>Requested ASAI capability or resource is not available on the switch or adjunct. More than one adjunct may be contending for the same switch resources. Potential administration mismatch between the resource domains administered on the switch and those administered on the adjunct.</p> <ol style="list-style-type: none"> <li>1. Verify that no overlapping administration of switch resources (e.g., requesting notifications on a single domain by multiple adjuncts or multiple adjuncts attempting to control a single call) exists across all adjuncts connected to the switch. If overlaps exist, then readminister the adjuncts to guarantee that each adjunct is associated with a unique set of switch resources.</li> <li>2. If Step 1 does not resolve the problem, escalate to the next tier.</li> </ol>
79	SERVICE OR OPTION NOT IMPLEMENTED	<p>Requested service or option (or combination of selected options) is not supported (implemented) in switch or the adjunct.</p> <ol style="list-style-type: none"> <li>1. Consult switch and adjunct documentation to determine ASAI service and options supported by both switch and adjunct. Readministration of the switch-administered capabilities (see Customer Optional Feature Form) or those of the adjunct may be necessary to correct the problem.</li> <li>2. If Step 1 does not provide the set of desired services due to deficient implementation, escalate the problem to the next tier.</li> </ol>

*Continued on next page*

**Table 9-149. ASAI CAUSE VALUES — Continued**

<b>Error Code</b>	<b>Test Result</b>	<b>Description/ Recommendation</b>
87	Internal switch audit	There is an inconsistency in switch data records.  1. There is no action needed since the switch has corrected the data inconsistency.  2. If a number of these errors continue to occur, then escalate to next tier.

- m. Certain ISDN-BRI cause codes are logged by switch software. The cause code can be determined from the following formula:

If the error type is greater than 3968, then the ISDN-BRI cause code is equal to the error type minus 3968. This code was sent to the endpoint by the switch.

If the error type is less than 3968, then the ISDN-BRI cause code is equal to the error type minus 3840. This code was sent to the switch by the endpoint.

A description of the various ISDN-BRI cause values is contained in [Table 9-150](#). This table also contains recommended system technician actions associated with the cause value. Further information can also be found in the Lucent ISDN-BRI Specification (801-802-100). In addition, the Aux Data field of the Error Log entry contains additional diagnostic information.

- n. Error 3847 indicates that sets on the port do not support level 3 initialization. Consult the Set Service documentation
- o. For the Error 2567 indicates that the version of ASAI is not supported, check version of the software running on the ASAI or Lucent adjunct.

**Table 9-150. ISDN-BRI CAUSE VALUES**

Error Code	Test Result	Description/ Recommendation
1		<p>Requested channel is in use by another station on the BRI-PORT. (Not applicable for ASAI or Lucent adjuncts.)</p> <p>For BRI endpoints:</p> <ol style="list-style-type: none"> <li>1. Try to originate a call to or from this port.</li> <li>2. If the error persists, busy out and release the port.</li> <li>3. If the problem still persists, replace stations on the port.</li> <li>4. If the problem still persists, escalate to the next tier.</li> </ol>
34	No circuit or channel available	<p>A resource on the switch is unavailable for a call. For BRI endpoints: This cause value is not logged. For ASAI or Lucent Adjuncts: This condition means that there are no available trunks for an outgoing call request.</p> <ol style="list-style-type: none"> <li>1. Verify that the adjunct is administered to support the trunk capabilities of the switch.</li> <li>2. Investigate trunk group status by issuing <b>status trunk</b> commands from the SAT or by requesting a trunk group query or queries from the adjunct.</li> <li>3. Perform trunk diagnostic procedures outlined in this manual.</li> <li>4. If step 3 does not resolve the problem, escalate to the next tier.</li> </ol>
42	Switch Equipment Congestion	<p>Switch takes control to limit received traffic. For BRI endpoints: This cause value is not logged. For ASAI or Lucent Adjuncts:</p> <ol style="list-style-type: none"> <li>1. See CallVisor protocol reference manual.</li> <li>2. If step 1 does not resolve the problem, escalate to the next tier.</li> </ol>

*Continued on next page*

Table 9-150. ISDN-BRI CAUSE VALUES — *Continued*

Error Code	Test Result	Description/ Recommendation
50	Requested Facility Not Subscribed	<p>Requested facility is implemented, but not administered. Potential administration problem with endpoint or adjunct. For BRI endpoints:</p> <ol style="list-style-type: none"> <li>1. Verify the switch administration of endpoint using either the <b>display station</b> or <b>display data-module</b> commands.</li> <li>2. If Step 1 does not resolve the problem, refer to the endpoint's service manual and verify administration on the endpoint.</li> <li>3. If Step 2 does not resolve the problem, escalate to the next tier.</li> </ol> <p>For ASAI adjuncts:</p> <ol style="list-style-type: none"> <li>1. Display the Customer Optional Features Form (administration screen) on the switch to determine which ASAI capabilities are turned on in the switch.</li> <li>2. Verify that the adjunct is administered to support the identical capabilities as the switch. If there is a mismatch in the administered capabilities, then readminister the switch and/or the adjunct to establish a consistent set of desired capabilities on both the switch and the adjunct.</li> <li>3. If Step 2 does not resolve the problem, escalate to the next tier.</li> </ol> <p>For Lucent adjuncts:</p> <ol style="list-style-type: none"> <li>1. Display the Customer Optional Features Form (administration screen) on the switch to determine if the Lucent adjunct is set enabled on in the switch.</li> <li>2. If error type 2567 or 2568, verify the Lucent adjunct version, and readminister if needed.</li> <li>3. If step 2 does not fix the problem, escalate to the next tier of support</li> </ol>

*Continued on next page*

**Table 9-150. ISDN-BRI CAUSE VALUES — Continued**

<b>Error Code</b>	<b>Test Result</b>	<b>Description/ Recommendation</b>
58	Bearer Capability Not Presently Available	Requested bearer capability is implemented, but not administered. No B-channel administered. See recommendation 50 above.
65	Bearer Service Not Implemented	Requested service not implemented in switch or endpoint.
69	Requested Facility Not Implemented	Requested service not supported in switch or endpoint.  1. Consult switch and endpoint documentation to determine service support.  2. If Step 1 does not resolve the problem, escalate to the next tier.
81	Invalid CRV	An invalid CRV was sent by the adjunct.  1. This may indicate a CRV inconsistency between the switch and the adjunct. See the CallVisor protocol reference manual.  2. If step 1 does not resolve the problem, escalate to the next tier.

- p. For Error 2568 indicates that the adjunct id is invalid, check the vender id or software running on the Lucent adjunct

### **System Technician-Demanded Tests: Descriptions and Error Codes**

When inspecting errors in the system and deciding which ones to address, always investigate errors associated with the circuit pack and port first. Clearing these error codes first may also clear errors generated against the endpoint. When all circuit pack and port errors have been cleared, and errors still exist against the endpoint, always investigate errors in the order they are presented in



the table below. By clearing error codes associated with the *Signaling Link Status Test*, for example, you may also clear errors generated from other tests in the testing sequence.

Order of Investigation	Short Test Sequence	Long Test Sequence	D/ND <sup>1</sup>
Signaling Link Status Test (#626)	X	X	ND
BRI XID Test (#628)	X	X	ND
BRI Layer 3 Query (#629)	X(a)	X(a)	ND
BRI Remote Loop Back (#627)		X(a)	ND
BRI Set Audits (#630)	X(a)	X(a)	ND
BRI Vendor ID Test (#631)		X(a)	ND
BRI Model/Vintage ID Test (#632)		X(a)	ND

---

1. D = Destructive; ND = Nondestructive

Note:

- a. Will execute the **test port long PCSSpp** command, and review the results of the BRI Port Local LAN Loop Around Test to verify the repair.
- 

## Signaling Link Status Test (#626)

This test determines the current status of the signaling link. This test passes if the link is “bound” to an endpoint and fails if the link is “not bound.”

The definition of the term “bound” for a link depends upon the type of endpoint and may depend on the successful completion of procedures at both Layers 2 and 3 of the protocol. The definition of “bound” for each type of endpoint is as follows:

- **BRI endpoints administered for MIM (management information messages) initialization (multipoint):**



### NOTE:

An MIM is a level 3 message that conveys management and maintenance information between a communications system and a BRI terminal.

For endpoints of this type, the signaling link is “bound” when the link is connected at Layer 2 and the link has been associated with an endpoint, [that is, the endpoint has completed SPID initialization (L3 established)].

■ **ASAI adjuncts and BRI endpoints not administered for MIM initialization (point-to-point):**

For endpoints of this type, the signaling link is “bound” when the link is connected at Layer 2 (L2 established).

For all endpoint types, a signaling link becomes “unbound” when it is disconnected at Layer 2. For BRI endpoints supporting MIM initialization, a signaling link may also become “unbound” if a subsequent attempt to perform SPID initialization on a “bound” link fails, (that is, wrong SPID is entered into the endpoint by the user)

**Table 9-151. TEST #626 Signaling Link Status Test**

Error Code	Test Result	Description/ Recommendation
1139	ABORT	The Packet Bus in the port network is out-of-service. 1. Follow the repair procedures for the Packet Bus. 2. After completing Step 1, execute the <b>test port long PCSSpp</b> command, and review the results of the BRI Port Local LAN Loop Around Test to verify the repair.
1141	ABORT	The PKT-CTRL is out-of-service. 1. Refer to PKT-CTRL (Packet Control Circuit Pack) Maintenance documentation. 2. If Step 1 does not resolve the problem, escalate to the next tier.
1144	ABORT	The PPN Packet Bus is out-of-service. 1. Follow the repair procedures for the Packet Bus in the PPN. 2. After completing Step 1, execute the <b>test port long PCSSpp</b> command, and review the results of the BRI Port Local LAN Loop Around Test to verify the repair.

*Continued on next page*

Table 9-151. TEST #626 Signaling Link Status Test — Continued

Error Code	Test Result	Description/ Recommendation
1187	ABORT	<p>The circuit pack, port or station may have been busied out by a technician.</p> <ol style="list-style-type: none"> <li>1. Look in the Error Log for Error Type 18 (busied out ) for BRI-BD, BRI-PORT, or BRI-SET.                             <ol style="list-style-type: none"> <li>a. If this error type is present for BRI-SET only, then release the station via the <b>release station</b></li> <li>b. If this error type is present for BRI-PORT and BRI-SET, then release the port via the <b>release port PCSSpp</b> command and run the test again.</li> <li>c. If the error is present for BRI-BD, BRI-PORT, and BRI-SET, then release the circuit pack via the <b>release port PCSSpp</b> command and run the test again. If the error is present for BRI-SET only, then release the circuit pack via the <b>release port PPCSS</b> command and run the test again. If the error is present for both BRI-BD and BRI-PORT, then release the circuit pack via the <b>release board PPCSS</b> command and run the test again.</li> </ol> </li> </ol> <p> <b>NOTE:</b>                      When you release the circuit pack, you release all ports associated with it. If certain ports still need to be busied out, use the <b>release port PCSSpp</b> command to busy them out.</p> <ol style="list-style-type: none"> <li>2. Make sure the terminal is connected.</li> <li>3. Retry the command at one-minute intervals a maximum of five times.</li> <li>4. If the test continues to abort, escalate the problem.</li> </ol>
2012	ABORT	Internal System Error.
2100	ABORT	<p>Could not allocate the necessary system resources to run this test.</p> <ol style="list-style-type: none"> <li>1. Retry the command at one-minute intervals a maximum of five times.</li> <li>2. If the test continues to abort, escalate the problem.</li> </ol>

*Continued on next page*

Table 9-151. TEST #626 Signaling Link Status Test — Continued

Error Code	Test Result	Description/ Recommendation
1113	FAIL	<p>The signaling link is not “bound” to the adjunct or endpoint. For BRI endpoints supporting MIM initialization, this error indicates that the endpoint has not been bound to a signaling link (that is, SPID initialization has not been completed). Since the signaling link associated with the endpoint is not identified until SPID initialization completes, this error does not imply that the signaling link is connected or disconnected at Layer 2 nor does it provide the status of TEI assignment for the endpoint. For ASAI adjuncts and BRI endpoints not supporting MIM initialization, this error indicates that the link is disconnected at Layer 2. Since the signaling link associated with the endpoint has been identified via administration, the link is only “unbound” from the endpoint when it is disconnected.</p> <ol style="list-style-type: none"><li>1. Execute the <b>status bri-port PCSSpp</b> command and refer to the associated procedures for this command contained in the BRI-PORT (ISDN-BRI Port) Maintenance documentation.</li></ol>
	PASS	<p>The signaling link is connected at Layer 2 and “bound” to the BRI endpoint or ASAI adjunct.</p>

### BRI Remote Loop Back Test (#627)

This test checks the integrity of a circuit switched B-channel connection between the switch and the endpoint.

In this test, the endpoint is put in the “maintenance busy” state to prevent the switch from issuing calls to the endpoint during the test. An application message containing a loop back activate request for the appropriate B-channel is sent to the endpoint. The endpoint responds with a loop back activated response. Maintenance then sends data to the endpoint over the B-channel under test. Since the B-channel is looped back at the endpoint, maintenance should receive the data that it sent. If no data is detected, the test fails. An application message containing a loop back deactivate request is then sent to the endpoint to terminate the remote loop back test. The endpoint responds with an MIM message containing a loop back deactivate response. Maintenance then releases the endpoint so that it is available to terminate calls.

This test is not executed for ASAI adjuncts because adjuncts do not support MIMs upon which this test is based.

**Table 9-152. TEST #627 BRI Remote Loop Back**

Error Code	Test Result	Description/ Recommendation
1000	ABORT	Could not seize the endpoint or B-channels for test. <ol style="list-style-type: none"> <li>1. Retry the command at one-minute intervals a maximum of five times.</li> <li>2. If the test continues to abort, escalate the problem.</li> </ol>
1005	ABORT	The endpoint's MIMs Supported field is administered to "no." <ol style="list-style-type: none"> <li>1. Use the <b>change station extension</b> command to change parameter only if the endpoint documentation reflects support for ISDN-BRI Management and Maintenance Procedures.</li> </ol>
1113	ABORT	The signaling link between the switch and the endpoint is down. <ol style="list-style-type: none"> <li>1. Use the <b>test port PCSSpp long</b> command to clear any errors which prevent establishment of the signaling link.</li> <li>2. Examine the results of the Signaling Link Status Test (#626) which is run as part of this command. If this test aborts or fails, follow the repair procedure for Test #626.</li> <li>3. If the XID Test #628 continues to abort, escalate the problem.</li> </ol>
1139	ABORT	The Packet Bus in the port network is out-of-service. <ol style="list-style-type: none"> <li>1. Follow the repair procedures for the Packet Bus.</li> <li>2. After completing Step 1, execute the <b>test port long PCSSpp</b> command, and review the results of the BRI Port Local LAN Loop Around Test to verify the repair.</li> </ol>
1141	ABORT	The PKT-CTRL is out-of-service. <ol style="list-style-type: none"> <li>1. Refer to PKT-CTRL (Packet Control Circuit Pack) Maintenance documentation.</li> <li>2. If Step 1 does not resolve the problem, escalate to the next tier.</li> </ol>
1144	ABORT	The PPN Packet Bus is out-of-service. <ol style="list-style-type: none"> <li>1. Follow the repair procedures for the Packet Bus in the PPN.</li> <li>2. After completing Step 1, execute the <b>test port long PCSSpp</b> command, and review the results of the BRI Port Local LAN Loop Around Test to verify the repair.</li> </ol>

*Continued on next page*

**Table 9-152. TEST #627 BRI Remote Loop Back — Continued**

Error Code	Test Result	Description/ Recommendation
1187	ABORT	<p>The circuit pack, port or station may have been busied out by a technician.</p> <ol style="list-style-type: none"> <li>1. Look in the Error Log for Error Type 18 (busied out ) for BRI-BD, BRI-PORT, or BRI-SET.                             <ol style="list-style-type: none"> <li>a. If this error type is present for BRI-SET only, then release the station via the <b>release station</b></li> <li>b. If this error type is present for BRI-PORT and BRI-SET, then release the port via <b>release port PCSSpp</b> command and run the test again.</li> <li>c. If the error is present for BRI-BD, BRI-PORT, and BRI-SET, then release the circuit pack via the <b>release port PCSSpp</b> command and run the test again. If the error is present for both BRI-BD and BRI-PORT, then release the circuit pack via the <b>release board PPCSS</b> command and run the test again. If the error is present for BRI-SET only, then release the circuit pack via the <b>release port PPCSS</b> command and run the test again.</li> </ol> </li> </ol> <p><b>⇒ NOTE:</b>                      When you release the circuit pack, you release all ports associated with it. If certain ports still need to be busied out, use the <b>release port PCSSpp</b> command to busy them out.</p> <ol style="list-style-type: none"> <li>2. Make sure the terminal is connected.</li> <li>3. Retry the command at one-minute intervals a maximum of five times.</li> </ol>
2012	ABORT	<p>Internal System Error.</p> <ol style="list-style-type: none"> <li>1. Retry the command at one-minute intervals a maximum of five times.</li> <li>2. If the test continues to abort, escalate the problem.</li> </ol>
2068	ABORT	<p>The endpoint has rejected the switch sent application message. This indicates that the endpoint does not support the ISDN-BRI Management and Maintenance Procedure for Loop Back Testing.</p> <ol style="list-style-type: none"> <li>1. Use the <b>change station extension</b> command and change the <i>MIMs Supported</i> field to <b>n</b>.</li> </ol>
2069	ABORT	<p>The endpoint has returned an error response to the application message sent by the switch.</p>
2100	ABORT	<p>Could not allocate the necessary system resources to run this test.</p> <ol style="list-style-type: none"> <li>1. Retry the command at one-minute intervals a maximum of five times.</li> <li>2. If the test continues to abort, escalate the problem.</li> </ol>

## BRI XID Test (#628)

This test checks the D-channel connection between the SPE and the endpoint or adjunct.

In this test, a D-channel XID frame is sent to the endpoint or adjunct over the point-to-point signaling link. The test passes if the endpoint or adjunct responds with a Layer 2 XID-RESPONSE frame

This test must be administered to not run in the station administration form for ports on a TN2208.

Table 9-153. TEST #628 BRI XID

Error Code	Test Result	Description/ Recommendation
1000	ABORT	<p>The BRI-SET, ASAI-ADJ, ATT-ADJ, LGATE-AJ, ATTE-AJ is busy. The test cannot be executed at this time:</p> <ol style="list-style-type: none"> <li>1. Pause momentarily (30 seconds) and re-execute at this time.</li> <li>2. If this problem persists, escalate this problem.</li> </ol> <p><b>⇒ NOTE:</b>                      A BRI-PORT can also be busy. When using this for BRI-PORT/ABRI-PORT tests, the words "BRI-SET, ASAI-ADJ, ATT-ADJ," can be changed to "BRI-PORT, ABRI-PORT, ATT-ADJ."</p>
1005	ABORT	<p>The endpoint is not administered to support XID Testing.</p> <ol style="list-style-type: none"> <li>1. If the endpoint documentation reflects support XID testing, use the <b>change station extension</b> command to change the <i>XID Testing?</i> field on the form to <b>y</b>.</li> </ol>
1113	ABORT	<p>The signaling link between the switch and the endpoint is down.</p> <ol style="list-style-type: none"> <li>1. Use the <b>test port PCSSpp long</b> command to clear any errors which prevent establishment of the signaling link.</li> <li>2. Examine the results of the Signaling Link Status Test (#626) which is run as part of this command. If this test aborts or fails, follow the repair procedure for Test #626.</li> <li>3. If the XID Test #628 continues to abort, escalate the problem.</li> </ol>
1139	ABORT	<p>The Packet Bus in the port network is out-of-service.</p> <ol style="list-style-type: none"> <li>1. Follow the repair procedures for the Packet Bus.</li> <li>2. After completing Step 1, execute the <b>test port long PCSSpp</b> command, and review the results of the BRI Port Local LAN Loop Around Test to verify the repair.</li> </ol>

*Continued on next page*

**Table 9-153. TEST #628 BRI XID — Continued**

Error Code	Test Result	Description/ Recommendation
1141	ABORT	The PKT-CTRL is out-of-service. <ol style="list-style-type: none"> <li>1. Refer to PKT-CTRL (Packet Control Circuit Pack) Maintenance documentation.</li> <li>2. If Step 1 does not resolve the problem, escalate to the next tier.</li> </ol>
1144	ABORT	The PPN Packet Bus is out-of-service. <ol style="list-style-type: none"> <li>1. Follow the repair procedures for the Packet Bus in the PPN.</li> <li>2. After completing Step 1, execute the <b>test port long PCSSpp</b> command, and review the results of the BRI Port Local LAN Loop Around Test to verify the repair.</li> </ol>
1187	ABORT	The circuit pack, port or station may have been busied out by a technician. <ol style="list-style-type: none"> <li>1. Look in the Error Log for Error Type 18 (busied out ) for BRI-BD, BRI-PORT, or BRI-SET.                             <ol style="list-style-type: none"> <li>a. If this error type is present for BRI-SET only, then release the station via the <b>release station</b></li> <li>b. If this error type is present for BRI-PORT and BRI-SET, then release the port via <b>release port PCSSpp</b> command and run the test again.</li> <li>c. If the error is present for BRI-BD, BRI-PORT, and BRI-SET, then release the circuit pack via the <b>release port PCSSpp</b> command and run the test again. If the error is present for BRI-SET only, then release the circuit pack via the <b>release port PCSSpp</b> command and run the test again. If the error is present for both BRI-BD and BRI-PORT, then release the circuit pack via the <b>release board PPCSS</b> command and run the test again.</li> </ol> </li> </ol> <p><b>⇒ NOTE:</b>                      When you release the circuit pack, you release all ports associated with it. If certain ports still need to be busied out, use the <b>release port PCSSpp</b> command to busy them out.</p> <ol style="list-style-type: none"> <li>2. Make sure the terminal is connected.</li> <li>3. Retry the command at one-minute intervals a maximum of five times.</li> <li>4. If the test continues to abort, escalate the problem.</li> </ol>
2012	ABORT	Internal System Error.
2100	ABORT	Could not allocate the necessary system resources to run this test. <ol style="list-style-type: none"> <li>1. Retry the command at one-minute intervals a maximum of five times.</li> <li>2. If the test continues to abort, escalate the problem.</li> </ol>



Table 9-153. TEST #628 BRI XID — Continued

Error Code	Test Result	Description/ Recommendation
2000	FAIL	The XID-RESPONSE message was not received from the endpoint. <ol style="list-style-type: none"><li>1. Consult the endpoint documentation to determine if the Layer 2 XID and XID-RESPONSE messages are supported. If the documentation reflects no support for these messages, change XID Testing? field to "no" using the <b>change station extension</b> command.</li><li>2. If the endpoint supports these Layer 2 messages and the test continues to fail, assume the endpoint is defective and replace it.</li><li>3. If the test continues to fail, escalate the problem.</li></ol>
	PASS	The switch can successfully pass messages over the D-channel to the BRI endpoint.

### BRI Layer 3 Query Test (#629)

This test is used to check the application layer communications between the switch and the endpoint or adjunct.

For BRI endpoints, an application message containing the appropriate endpoint service state is sent by the switch to the endpoint. The endpoint responds with an acknowledgment to the application message.

For ASAI and Lucent adjuncts, this test is not executed from the administration terminal. Rather, a query message is automatically sent by the switch every two minutes. Failure of the switch to receive a response to a query from the adjunct is logged in the Hardware Error Log

Table 9-154. TEST #629 BRI Layer 3 Query

Error Code	Test Result	Description/ Recommendation
1005	ABORT	The endpoint's MIMs Supported? field is administered to "no." <ol style="list-style-type: none"><li>1. Use the <b>change station extension</b> command to change the parameter only if the endpoint documentation reflects support for ISDN-BRI Management and Maintenance Procedures.</li></ol>

*Continued on next page*

**Table 9-154. TEST #629 BRI Layer 3 Query — Continued**

Error Code	Test Result	Description/ Recommendation
1113	ABORT	The signaling link between the switch and the endpoint or adjunct is down. <ol style="list-style-type: none"> <li>1. Use the <b>test port PCSSpp long</b> command to clear any errors which prevent establishment of the signaling link.</li> <li>2. Examine the results of Test #626, which is executed with the command. If this test aborts or fails, follow the repair procedure for the Signaling Link Status Test.</li> <li>3. Escalate problem if BRI Layer 3 Query Test continues to abort.</li> </ol>
1139	ABORT	The Packet Bus in the port network is out-of-service. <ol style="list-style-type: none"> <li>1. Follow the repair procedures for the Packet Bus.</li> <li>2. After completing Step 1, execute the <b>test port long PCSSpp</b> command, and review the results of the BRI Port Local LAN Loop Around Test to verify the repair.</li> </ol>
1141	ABORT	The PKT-CTRL is out-of-service. <ol style="list-style-type: none"> <li>1. Consult the repair procedure for PKT-CTRL (Packet Control Circuit Pack) Maintenance documentation.</li> <li>2. If Step 1 does not resolve the problem, escalate to the next tier.</li> </ol>
1144	ABORT	The PPN Packet Bus is out-of-service. <ol style="list-style-type: none"> <li>1. Follow the repair procedures for the Packet Bus in the PPN.</li> <li>2. After completing Step 1, execute the <b>test port long PCSSpp</b> command, and review the results of the BRI Port Local LAN Loop Around Test to verify the repair.</li> </ol>

*Continued on next page*

Table 9-154. TEST #629 BRI Layer 3 Query — Continued

Error Code	Test Result	Description/ Recommendation
1187	ABORT	<p>The circuit pack, port or station may have been busied out by a technician.</p> <ol style="list-style-type: none"> <li>1. Look in the Error Log for Error Type 18 (busied out ) for BRI-BD, BRI-PORT, or BRI-SET.                             <ol style="list-style-type: none"> <li>a. If this error type is present for BRI-SET only, then release the station via the <b>release station</b></li> <li>b. If this error type is present for BRI-PORT and BRI-SET, then release the port via the <b>release port PCSSpp</b> command and run the test again.</li> <li>c. If the error is present for BRI-BD, BRI-PORT, and BRI-SET, then release the circuit pack via the <b>release port PCSSpp</b> command and run the test again. If the error is present for BRI-SET only, then release the circuit pack via the <b>release port PPCSS</b> command and run the test again. If the error is present for both BRI-BD and BRI-PORT, then release the circuit pack via the <b>release board PPCSS</b> command and run the test again.</li> </ol> </li> </ol> <p> <b>NOTE:</b>                      When you release the circuit pack, you release all ports associated with it. If certain ports still need to be busied out, use the <b>release port PCSSpp</b> command to busy them out.</p> <ol style="list-style-type: none"> <li>2. Make sure the terminal is connected.</li> <li>3. Retry the command at one-minute intervals a maximum of five times.</li> <li>4. If the test continues to abort, escalate the problem.</li> </ol>
2012	ABORT	Internal System Error.
2100	ABORT	<p>Could not allocate the necessary system resources to run this test.</p> <ol style="list-style-type: none"> <li>1. Retry the command at one-minute intervals a maximum of five times.</li> <li>2. If the test continues to abort, escalate the problem.</li> </ol>
2068	ABORT	<p>The endpoint has rejected the switch sent application message. This indicates that the endpoint does not support the ISDN-BRI Management and Maintenance Procedure for Endpoint Service Messages.</p> <ol style="list-style-type: none"> <li>1. Use the <b>change station extension</b> command and change the MIMs Supported? field to “no.”</li> </ol>
2069	ABORT	<p>The endpoint has returned an error response to the switch sent application message.</p> <ol style="list-style-type: none"> <li>1. Retry the command at one-minute intervals a maximum of five times.</li> <li>2. If the test continues to abort, escalate the problem.</li> </ol>

Table 9-154. TEST #629 BRI Layer 3 Query — Continued

Error Code	Test Result	Description/ Recommendation
2000	FAIL	No response is received from the endpoint or the adjunct. For BRI endpoints: <ol style="list-style-type: none"><li>1. Consult the endpoint documentation to determine if ISDN-BRI Management and Maintenance Procedures are supported. If not supported, use the <b>change station extension</b> command to change the "MIMs Supported?" field to "no." Use the <b>busyout station extension</b> and <b>release station extension</b> commands to busyout and release the endpoint to resolve any endpoint alarms resulting from failure of this test.</li><li>2. If the endpoint supports these procedures and the test continues to fail, assume the endpoint is defective and replace it.</li></ol>
	PASS	The endpoint has successfully responded to the switch's application message.

### BRI Set Audits Test (#630)

This is a series of two tests which are classified as audits. The switch sends messages to the BRI endpoint to perform the following tests:

- Ringer Audit - This audit insures that both the switch and the endpoint agree as to the current state of the endpoint's ringer.
- Lamps Audit - This audit insures that both the switch and the endpoint agree as to the current state of the endpoint's lamps.
- Call Activity Audit - This audit insures that the state of calls is consistent between the switch and the endpoint.

This test is not executed for ASAI or Lucent adjunct because adjuncts do not employ ringers or lamps, or establish calls on the B-channels associated with the BRI interface.

**Table 9-155. TEST #630 BRI Set Audits**

Error Code	Test Result	Description/ Recommendation
1113	ABORT	The signaling link between the switch and the endpoint is down. <ol style="list-style-type: none"> <li>1. Use the <b>test port PCSSpp long</b> command to clear any errors which prevent establishment of the signaling link.</li> <li>2. Examine the results of the Signaling Link Status Test (#626) which is run as part of this command. If this test aborts or fails, follow the repair procedure for Test #626.</li> <li>3. If the BRI Set Audits test continues to abort, escalate the problem.</li> </ol>
1139	ABORT	The Packet Bus in the port network is out-of-service. <ol style="list-style-type: none"> <li>1. Follow the repair procedures for the Packet Bus.</li> <li>2. After completing Step 1, execute the <b>test port long PCSSpp</b> command, and review the results of the BRI Port Local LAN Loop Around Test to verify the repair.</li> </ol>
1141	ABORT	The PKT-CTRL is out-of-service. <ol style="list-style-type: none"> <li>1. Refer to PKT-CTRL (Packet Control Circuit Pack) Maintenance documentation.</li> <li>2. If Step 1 does not resolve the problem, escalate to the next tier.</li> </ol>
1144	ABORT	The PPN Packet Bus is out-of-service. <ol style="list-style-type: none"> <li>1. Follow the repair procedures for the Packet Bus in the PPN.</li> <li>2. After completing Step 1, execute the <b>test port long PCSSpp</b> command, and review the results of the BRI Port Local LAN Loop Around Test to verify the repair.</li> </ol>

*Continued on next page*

Table 9-155. TEST #630 BRI Set Audits — *Continued*

Error Code	Test Result	Description/ Recommendation
1187	ABORT	<p>The circuit pack, port or station may have been busied out by a technician.</p> <ol style="list-style-type: none"> <li>1. Look in the Error Log for Error Type 18 (busied out ) for BRI-BD, BRI-PORT, or BRI-SET.                             <ol style="list-style-type: none"> <li>a. If this error type is present for BRI-SET only, then release the station via the <b>release station</b></li> <li>b. If this error type is present for BRI-PORT and BRI-SET, then release the port via the <b>release port PCSSpp</b> command and run the test again.</li> <li>c. If the error is present for BRI-BD, BRI-PORT, and BRI-SET, then release the circuit pack via the <b>release port PCSSpp</b> command and run the test again. If the error is present for both BRI-BD and BRI-PORT, then release the circuit pack via the <b>release board PPCSS</b> command and run the test again.</li> </ol> </li> </ol> <p><b>⇒ NOTE:</b>                      When you release the circuit pack, you release all ports associated with it. If certain ports still need to be busied out, use the <b>release port PCSSpp</b> command to busy them out.</p> <ol style="list-style-type: none"> <li>2. Make sure the terminal is connected.</li> <li>3. Retry the command at one-minute intervals a maximum of five times.</li> <li>4. If the test continues to abort, escalate the problem.</li> </ol>
2012	ABORT	Internal System Error.
2100	ABORT	<p>Could not allocate the necessary system resources to run this test.</p> <ol style="list-style-type: none"> <li>1. Retry the command at one-minute intervals a maximum of five times.</li> <li>2. If the test continues to abort, escalate the problem.</li> </ol>
	PASS	The switch has successfully executed the BRI station audits.

## SPID Facility Test

This test is used to verify the wiring and operation of the signaling link between the switch and a endpoint or adjunct on a BRI interface. **This test is not executed from the administration terminal, but rather is executed by using a BRI test set equipped with a display.** The test set may replace the BRI set, ASAI or Lucent adjunct under test by plugging it into the same jack or by bridging it onto the wiring at some point between the switch and the endpoint (or adjunct), thereby creating a pseudo-BRI multipoint configuration.

When plugged into the port in this manner, the test set establishes a signaling link connection with the switch and attempts to complete SPID initialization by using the Service SPID administered for the system (see the System Maintenance Administration Form). If the test set displays the correct administered port address for the endpoint or adjunct under test, the test passes (see Service SPID Display, which follows). If after one-minute nothing is displayed on the test set, the test fails.

### SPID Facility Test

Test Result	Description / Recommendation
FAIL	No response is received from the endpoint. <ol style="list-style-type: none"> <li>1. Check the physical wiring between the switch and the endpoint or adjunct.</li> <li>2. If test continues to fail, escalate to the next tier.</li> </ol>
FAIL	Display does not match administered port address for the endpoint or adjunct. <ol style="list-style-type: none"> <li>1. Change station administration for endpoint or adjunct to match displayed port address.</li> <li>2. If test continues to fail, escalate the problem.</li> </ol>
PASS	Display matches administered port address for the endpoint or adjunct. <p>For BRI endpoints:</p> <ol style="list-style-type: none"> <li>1. Verify that the SPID values administered in the switch and the endpoint are consistent.</li> <li>2. If the SPID values are correct, replace the endpoint.</li> <li>3. If test continues to fail, escalate the problem.</li> </ol> <p>For ASAI adjuncts:</p> <ol style="list-style-type: none"> <li>1. Verify that the TEI values administered in the switch and the adjunct are consistent.</li> <li>2. If the TEI values are correct, consult the recommended repair procedures of the manufacturer for the adjunct.</li> <li>3. If test continues to fail, escalate the problem.</li> </ol>

The abbreviations used in (Service SPID Display) have the following meanings:

- UU      Universal Cabinet number  
 (1 for PPN, 2 - 44 for EPN)
- C        Carrier (A,B,C, ...)
- SS      Slot (01, 02, ...)

pp      port (01-12)  
 ext     extension one and two (one through 99999)  
 SPID    service order profile identifier

**Table 9-156. Service SPID Display**

Restricted Service starting display column		8		14		25		31
UUCSSpp	-	ext1	-	SPID111111	-	ext2	-	SPID222222
starting display column		8		14		25		31
UUCSSpp	*	ext1	*	SPID111111	-	ext2	-	SPID222222
Bound to Second Endpoint Translation starting display column		8		14		25		31
UUCSSpp	-	ext1	-	SPID111111	*	ext2	*	SPID222222



## CABINET (Cabinet Sensors)

---

MO Name (in Alarm Log)	Alarm Level	Initial Command to Run <sup>1</sup>	Full Name of MO
CABINET	MAJOR	test environment UU	Cabinet Sensors
CABINET	MINOR	test environment UU	Cabinet Sensors

---

1. UU is the universal cabinet number (1 for PPN, 2 -44 for EPNs).

---

**NOTE:**

The CABINET maintenance object is valid only for multi-carrier cabinets. For information about environmental maintenance on single-carrier cabinets, refer to DC-POWER.

The cabinet sensors monitor cabinet temperature and fan rotation. Variable-speed fans are used extensively in DEFINITY Systems.

The SYSAM circuit pack in the PPN cabinet and the EPN Maintenance circuit pack in a multi-carrier EPN cabinet monitor a temperature sensor (S1) at the top of the cabinet and generate a major alarm if the exit air temperature exceeds 65 degrees Celsius (149 degrees Fahrenheit). Another temperature sensor in the top of the cabinet (S2) also monitors exit air temperature. If it exceeds 70 degrees Celsius (158 degrees Fahrenheit), the power distribution unit turns off all cabinet power and invokes emergency transfer. Other sensors monitor fan performance.

The repair procedures that follow rely on your ability to distinguish between high and low fan speeds by the sound of the fans. Experience will allow you to distinguish between the high and low pitches generated by high and low speeds. A thermometer is also required for some of the procedures that follow.

In making replacements, observe the following rules:

- New fan assemblies accept *only* variable-speed fans.
- Old fan assemblies accept either variable-speed or nonvariable-speed fans.
- Replace a fan assembly (carrier) *only* with a fan assembly of the same type (new for new, old for old).

### Variable-Speed Fans

---

A variable-speed fan is identified by the following features:

- A fan and air filter assembly with product code ED-67077-30, Group 4 or greater, labeled on the front of the carrier

- A five-pin white connector mounted next to each fan on the fan assembly cover plate for speed control and alarm circuitry
- A two-pin black -48 V power connector to each fan
- A power filter (ED-1E554-30, G1 or G2) located in a metal box mounted behind the fans on the right-hand cable trough as you face the rear of the cabinet
- The AHD1 circuit pack and the two S4 sensors used with older fan assemblies are *not* present.

Alarm leads from each fan are tied together into a single lead that registers a minor alarm against CABINET whenever a fan's speed drops below a preset limit or fails altogether.



**NOTE:**

The front fans may run at a different speed than the rear fans since they are controlled by different sensors.

## Replacing Variable-Speed Fans

This procedure applies to replacement of a variable-speed fan (KS-23912, L3) in a new type fan assembly (ED-67707-30, G4 or greater). Do *not* use a nonvariable-speed fan in this assembly.

1. If replacing a fan in the front of the cabinet, remove the white plastic fan assembly cover by pulling it outward. There is no cover on the rear fans; they are accessible simply by opening the rear cabinet doors.
2. *Connect the grounding wrist strap to yourself and the cabinet.* The fan alarm circuit can be damaged by ESD.
3. Disconnect the white 5-pin connector on the fan assembly.
4. Loosen and remove the retaining screw nearest the power connector on the defective fan.
5. Disconnect the 2-pin black power plug on the fan.
6. Loosen and remove the other retaining screw on the fan.
7. Remove the fan from the fan assembly.
8. Position the new fan and insert the screw that is opposite the power connector.
9. Connect the 2-pin black power plug on the fan.
10. Connect the white 5-pin connector on the fan assembly. Insert and tighten the retaining screws.
11. Replace the front fan cover, if removed.

## Replacing the Fan Power Filter

---

The fan power filter (ED-1E554-30) is a metal box located behind the fans on the right-hand cable trough as you face the rear of the cabinet. It is not present with nonvariable-speed fan assemblies.

### CAUTION:

*The fan power filter can be replaced without powering down the cabinet. To avoid damage, you must use the following steps in the order shown. Note that the J2F/P2F connectors on the power filter must not be connected whenever connecting or disconnecting the J2/P2 connectors on the fan assembly.*

1. Access the power filter through the rear cabinet doors.
2. *Connect the grounding wrist strap to yourself and the cabinet.* The fan alarm circuit can be damaged by ESD.

### CAUTION:

*Failure to disconnect the J2F connector on the filter before the J2 connector on the fan assembly can damage the fan alarm circuits.*

3. Disconnect cabinet local cable connector J2F from the P2F connector on top of the power filter.
4. Disconnect cable connector J2 from the P2 connector on the fan assembly.
5. Loosen the power filter mounting screws using a 5/16" nut driver and remove the filter.

### CAUTION:

*Failure to connect the J2 connector on the fan assembly can damage the fan alarm circuits.*

6. Connect the J2 cable connector of the replacement power filter to the P2 connector on the fan assembly.
7. Mount the new power filter on the screws and tighten.
8. Connect cabinet local cable connector J2F to the P2F connector on the top of the power filter.
9. The fans should start rotating after a 4 second delay.

## Replacing the Top Temperature Sensor

The top temperature sensors are located at the top rear of the cabinet in some cabinets. On these cabinets, the tape shelf is located on the rear door, at the bottom.

1. From the rear of the cabinet, remove the screws holding the top temperature sensor.
2. Replace the sensor with a new one using the screws removed above.
3. Route the cable along the path of the existing sensor cable.
4. Unplug the cable on the defective sensor and replace with the plug on the new sensor.
5. Remove the old sensor from the cabinet.

## Error Log Entries and Test to Clear Values

**Table 9-157. Cabinet Sensors Error Log Entries**

Error Type	Aux Data	Associated Test	Alarm Level	On/Off Board	Test to Clear Value
0	0	Any	Any	Any	test environment UU
1	0 or 1	Cabinet Temperature Query (#122)	MINOR	ON	test environment UU s r 3
257	0 or 1	Cabinet Temperature Query (#122)	MAJOR	ON	test environment UU s r 3

## System Technician-Demanded Tests: Descriptions and Error Codes

Always investigate tests in the order presented in the table below. By clearing error codes associated with one test, you may also clear errors generated from later tests in the sequence.

Order of Investigation	Short Test Sequence	Long Test Sequence	D/ND*
Battery & Battery Charger Query Test (#5) <sup>1</sup>	X	X	ND
AC Power Query Test (#78) <sup>2</sup>	X	X	ND
OLS Query Test (carrier E) (#127) <sup>3</sup>	X	X	ND
OLS Query Test (carrier D) (#127) <sup>3</sup>	X	X	ND
OLS Query Test (carrier A) (#127) <sup>3</sup>	X	X	ND
OLS Query Test (carrier B) (#127) <sup>3</sup>	X	X	ND
OLS Query Test (carrier C) (#127) <sup>3</sup>	X	X	ND

Order of Investigation	Short Test Sequence	Long Test Sequence	D/ND*
Emergency Transfer Query Test (#124) <sup>4</sup>	X	X	ND
Cabinet Temperature Query Test (#122)	X	X	ND
External Alarm Lead Query Test (#120) <sup>5</sup>	X	X	ND
Analog Ring Generator Initial Test (#117) <sup>6</sup>	X	X	ND
Analog Ring Generator Query Test (#118) <sup>6</sup>	X	X	ND

1. See the POWER section in this chapter.
2. See the AC-POWER section in this chapter.
3. See the CARR-POW section in this chapter.
4. See the EMG-XFER section in this chapter.
5. See the EXT-DEV section in this chapter.
6. See the RING-GEN section in this chapter.

### Cabinet Temperature Query Test (#122)

This test queries the SYSAM in a PPN or the EPN Maintenance circuit pack in an EPN for the status of the temperature and fan sensors in the cabinet.

**Table 9-158. TEST #122 Cabinet Temperature Query Test**

Error Code	Test Result	Description/ Recommendation
1000	ABORT	System resources required to run test are not available. 1. Retry the command at 1-minute intervals for a maximum of 5 times.
2000	ABORT	Response to the test request was not received within the allowable time period. 1. Retry the command at 1-minute intervals for a maximum of 5 times. 2. If the test continues to abort with error code 2000, check for power problems with the A carrier (PPN or EPN). Look for and resolve all AC-POWER and CARR-POW alarms in a multi-carrier cabinet or DC-POWER alarms in a single-carrier cabinet. Repeat the test. 3. If the test continues to abort with error code 2000, check for and resolve all SYSAM errors in a PPN or MAINT errors in an EPN. Repeat the test.
2029 2319 2500	ABORT	Internal system error 1. Retry the command at 1-minute intervals for a maximum of 5 times.

**Table 9-158. TEST #122 Cabinet Temperature Query Test — Continued**

Error Code	Test Result	Description/ Recommendation
1	FAIL	<p><b>VARIABLE-SPEED FAN ASSEMBLIES:</b> One or more fans have stopped. <i>If none of the fans are running:</i></p> <ol style="list-style-type: none"> <li>1. Resolve all alarms against "<a href="#">CARR-POW (Carrier Power Supply)</a>".</li> <li>2. Verify that 48 VDC is available to the fan power filter at the J2F local cable connector. The voltage range is -42.5 V to -52.5 V. There should be 48 VDC between the following pin pairs: 2/3, 8/9, 10/11. If -48 VDC is not present, replace the CFY1B current limiter card.</li> <li>3. If there is 48 VDC at the power filter input, verify that there is 48 VDC at the power filter output using the following procedure exactly to avoid damage to the fan alarm circuit. Note that the J2F/P2F connectors on the power filter must be disconnected whenever connecting or disconnecting the J2/P2 connectors on the fan assembly. <i>First</i> disconnect connector J2F from P2F on the top of the filter. <i>Then</i> disconnect J2 from P2 on the fan assembly. Reconnect J2F to P2F on the filter. There should be 48 VDC between the following pin pairs on the J2 connector: 2/3, 8/9, 10/11. If not, replace the fan power filter using the procedure described previously. <i>Be sure to disconnect the J2F/P2F connector again before reconnecting the J2/P2.</i> If 48 VDC is present, the fans should have power. Make sure all power connectors are sound and making good contact. <i>Be sure to disconnect the J2F/P2F connector again before reconnecting the J2/P2.</i></li> </ol>
1 (Cont'd.)	FAIL (Cont'd.)	<p><i>If some of the fans are running and some are not:</i></p> <ol style="list-style-type: none"> <li>1. Replace the defective fans. If all fans can then be started, wait 5 minutes and rerun the test. If the test fails again, proceed to the next step below.</li> <li>2. Remove all 6 white 5-pin connectors on the front and back of the fan assembly. This will cause all fans to run at high speed and the alarm to be cleared. If the alarm does not clear, the SYSAM (in a PPN) or EPN Maintenance circuit pack is incorrectly reporting the problem. Check for and resolve all errors against SYSAM or MAINT, and then rerun the test.</li> <li>3. One at a time, replace the 5-pin connectors and check to see if the alarm recurs. Replace each fan whose reconnection causes a recurrence of the alarm.</li> </ol>

*Continued on next page*

**Table 9-158. TEST #122 Cabinet Temperature Query Test — Continued**

Error Code	Test Result	Description/ Recommendation
1 (Cont'd.)	FAIL (Cont'd.)	<p><b>NONVARIABLE-SPEEDFAN ASSEMBLIES</b> (older or upgraded cabinets): The AHD1 circuit pack has reported an air flow problem. The temperature difference between the air intake and the air exhaust is at least 15<sup>0</sup>C (59<sup>0</sup>F) and the absolute temperature at the top of the cabinet is at least 50<sup>0</sup>C (122<sup>0</sup>F). The fans should be running at high speed. If none of the fans are running then:</p> <ol style="list-style-type: none"> <li>1. Look for an resolve all alarms against CARR-POW.</li> <li>2. Verify that 48 VDC is available to the fan wiring harness connector between pin pairs 2/3, 8/9, and 10/11. The tolerable range for this measurement is -42.5 V to -52.5 V.  If 48 VDC is present and the fans are not running, replace the AHD1 circuit pack.</li> <li>3. If the fans still do not run, escalate the problem.</li> <li>4. If 48 VDC is not present, replace the CFY1B current limiter card.  If the fans still do not run, escalate the problem. If some fans are running and some not, replace the defective fans.</li> <li>5. If all fans can then be started, wait 5 minutes and rerun the test. If the test fails again, proceed to the next step.</li> <li>6. If all fans are running but not at high speed, measure the cabinet temperature at the air intake and the air exhaust at the top of the cabinet.             <ol style="list-style-type: none"> <li>a. If the 15<sup>0</sup>C/50<sup>0</sup>C criteria is met, there is a problem with the AHD1 circuit pack or the fans. Replace the AHD1 circuit pack and/or fans. If the fans run at high speed, wait 5 minutes for the cabinet to cool, then retest. If the test fails, escalate the problem.</li> <li>b. If the 15<sup>0</sup>C/50<sup>0</sup>C criteria is not met, the SYSAM (in a PPN) or EPN Maintenance circuit pack is incorrectly reporting this condition. Resolve all SYSAM or MAINT errors and retest. If the test fails, escalate the problem.</li> </ol> </li> </ol>

*Continued on next page*

**Table 9-158. TEST #122 Cabinet Temperature Query Test — Continued**

Error Code	Test Result	Description/ Recommendation
1 <i>(Cont'd.)</i>	FAIL <i>(Cont'd.)</i>	<p><b>NONVARIABLE-SPEEDFAN ASSEMBLIES</b> (continued): If the fans are running at high speed, check the following items, any of which can restrict or redirect airflow within the cabinet.</p> <ol style="list-style-type: none"> <li>1. Check both filters. If a filter is dirty or clogged, clean with soapy water or a vacuum.</li> <li>2. Ensure that there is nothing other than circuit packs in the carrier slots that could be restricting the airflow.</li> <li>3. Ensure that there are no missing circuit pack faceplates or blanks.</li> <li>4. The cabinet door must be closed for proper cooling.</li> <li>5. Wait 5 minutes for the cabinet to cool and rerun the test.</li> <li>6. If the test fails, check temperatures for the 15<sup>0</sup>C/50<sup>0</sup>C criteria. If the 15<sup>0</sup>C/50<sup>0</sup>C criteria is present, then the fans should be running at high speed.</li> <li>7. Wait 5 minutes and rerun the test.</li> <li>8. If the test still fails, then the ambient room temperature is probably too high. Cool the room.</li> <li>9. If the 15<sup>0</sup>C/50<sup>0</sup>C criteria does not exist, one of the following components is defective:                         <ul style="list-style-type: none"> <li>■ AHD1 circuit pack</li> <li>■ fans</li> <li>■ S3 sensors</li> <li>■ S4 sensors</li> </ul> </li> </ol> <p>Replace these items one at a time in the order listed, running the test after each replacement. If many environmental tests are failing, it can be a problem that is undetected by maintenance on the SYSAM or EPN Maintenance circuit packs, depending on the cabinet type. Replace the circuit pack. Escalate if the problem persists.</p>

*Continued on next page*



**Table 9-158. TEST #122 Cabinet Temperature Query Test — Continued**

Error Code	Test Result	Description/ Recommendation
2	FAIL	<p>The SYAM or the EPN Maintenance circuit pack has reported a temperature problem due to the S1 sensor detecting a temperature of at least 65<sup>0</sup>C (149<sup>0</sup>F). The entire cabinet is in danger of power-down if the temperature reaches 70<sup>0</sup>C (158<sup>0</sup>F).</p> <ol style="list-style-type: none"> <li>1. If any of the fans are not running, there should be a FAIL with Error Code 1 present. Follow the procedures for that Error Code, noting the differences for variable and nonvariable-speed fan assemblies.</li> <li>2. If the fans are running, check the temperature at the top of the cabinet.                         <ol style="list-style-type: none"> <li>a. If the temperature is at least 65<sup>0</sup>C (149<sup>0</sup>F), the ambient room temperature is too high and the fans cannot cool the system. Unless the room temperature is reduced, the system will shut down soon.</li> </ol> </li> <li>3. If the temperature at the top of the cabinet is less than 65<sup>0</sup>C (149<sup>0</sup>F), either the S1 sensor or the SYSAM or EPN Maintenance circuit packs are incorrectly reporting the problem.                         <ol style="list-style-type: none"> <li>a. Resolve any errors against SYSAM or MAINT, then rerun the test.</li> <li>b. If there are errors, replace the S1 sensor and retest. If the test fails, escalate.</li> </ol> </li> </ol>
3	FAIL	<p>Fan failures and temperature alarms have been reported.</p> <ol style="list-style-type: none"> <li>1. Resolve the fan failure (Error Code 1). This should also resolve the temperature alarm. (With nonvariable-speed fan assemblies, fan failures correspond to air flow problems.)</li> </ol>
	PASS	<p>Temperature measurements and fan performance are satisfactory.</p>

## CARR-POW (Carrier Power Supply)

MO Name (in Alarm Log)	Alarm Level	Initial Command to Run <sup>1</sup>	Full Name of MO
CARR-POW	MAJOR	Cycle carrier <i>UUC</i>	Carrier Port Power Supply

- UU* is the universal cabinet number (1 for PPN, 2-44 for EPNs), *C* is the carrier designation (A, B, C, D, or E). Cycle the carrier indicated by the PORT field in the alarm log.

DEFINITY systems support two different cabinet types: multi-carrier and single-carrier. Single-carrier cabinets are used only for EPNs. Both cabinet types may be powered by either AC or DC external power source. Environmental maintenance differs according to cabinet type and external power supply.

### CAUTION:

*Before powering down a cabinet or carrier that contains DEFINITY AUDIX circuit packs (TN566), first power down the AUDIX unit to avoid damaging the AUDIX software. Instructions for powering down this unit are in the [“DEFINITY AUDIX System Power Procedures”](#) in [Chapter 5, “Alarms, Errors, and Troubleshooting”](#), on the circuit pack, and in DEFINITY AUDIX documentation.*

The CARR-POW maintenance object represents the pair of power supplies that supply +5V, -48V and -5 VDC power to each carrier in a multi-carrier cabinet. In AC-powered cabinets, these are called Off Line Switches (OLS); in DC-powered cabinets, they are DC/DC converters.

## Cycling Power Supplies

When a port carrier power supply problem is reported by hardware, the system can cycle the power supplies in that carrier. When a carrier is cycled, the power supplies are turned off for 2 seconds and then turned back on. The system cannot cycle the power supplies on any of the following types carriers even if they are duplicated:

- PPN control carrier
- Expansion control carrier
- Switch node carrier
- Single-carrier cabinet

### WARNING:

*When port carrier power is cycled, all service dependent upon circuit packs in that carrier are disrupted.*

**Carrier Port Power Supplies—Multi-Carrier Cabinets**

<b>Code</b>	<b>System Power</b>	<b>Output (VDC)</b>	<b>Location</b>
631DA	AC	+5	Left side
631DB	AC	-48/-5	Right side
644A	DC	+5	Left side
645B	DC	-48/-5	Right Side
TN755B		165	Slots 17 and 18
631WA/AR	AC	+5	Left side
631WB/BR	AC	-48	Right side
TN736	AC	-5	Used with 631
TN752	AC	165/-5	WA/WB or AR/AB
649A	AC	-48 at 10 Amps +5 VDC and -5 VDC at 6 Amps	Right side on control and port carriers. Left and right side on switch node carriers.

**AC-Powered Cabinets**

---

**AC Power Distribution Unit and Battery Charger  
 (J58890CE-2)**

[Figure 9-17](#) shows an AC Power Distribution Unit (List 9 or List 10). This unit sits at the bottom of some Multi-Carrier Cabinets.

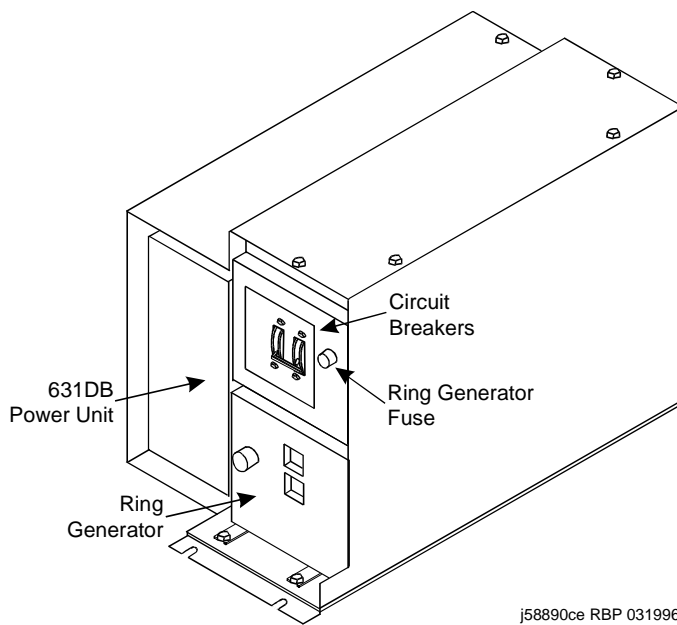

---

**Figure 9-17. AC Power Distribution Unit (J58890CE-2) — Front**

The AC Power Distribution Unit contains the following components:

- Circuit breaker
- Electromagnetic Interference (EMI) filter
- Ring generator
- AC input fuse
- 20 Amp fuses
- Signal connector
- -48 VDC fan power

The optional battery charger (List 11) sits at the bottom of some Multi-Carrier Cabinets. See [Figure 9-18](#).

---

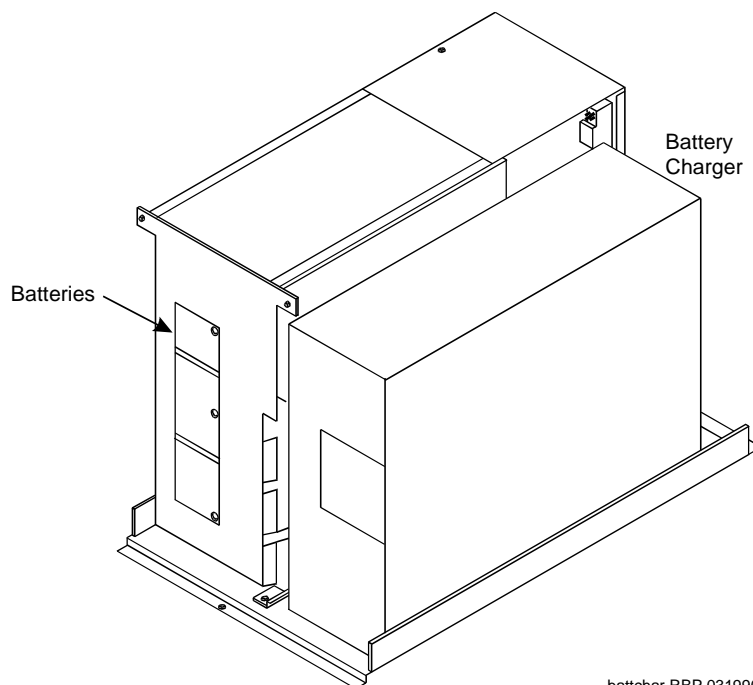

battchar RBP 031996

---

**Figure 9-18. Battery Charger (Optional Part of J58890CE-2) — Front**

The charger is used only without an Uninterruptible Power Supply (UPS). The charger contains:

- Three 48 VDC batteries for backup power to the cabinet
- A DC power relay to automatically switch the batteries into the power circuit if a main power failure is detected

Figure 9-19 shows AC power distribution in some Multi-Carrier Cabinets. The DC power distribution cables are on both sides of the cabinet. These cables supply power to each of the carriers. The optional battery charger is at the right side of the power distribution unit.

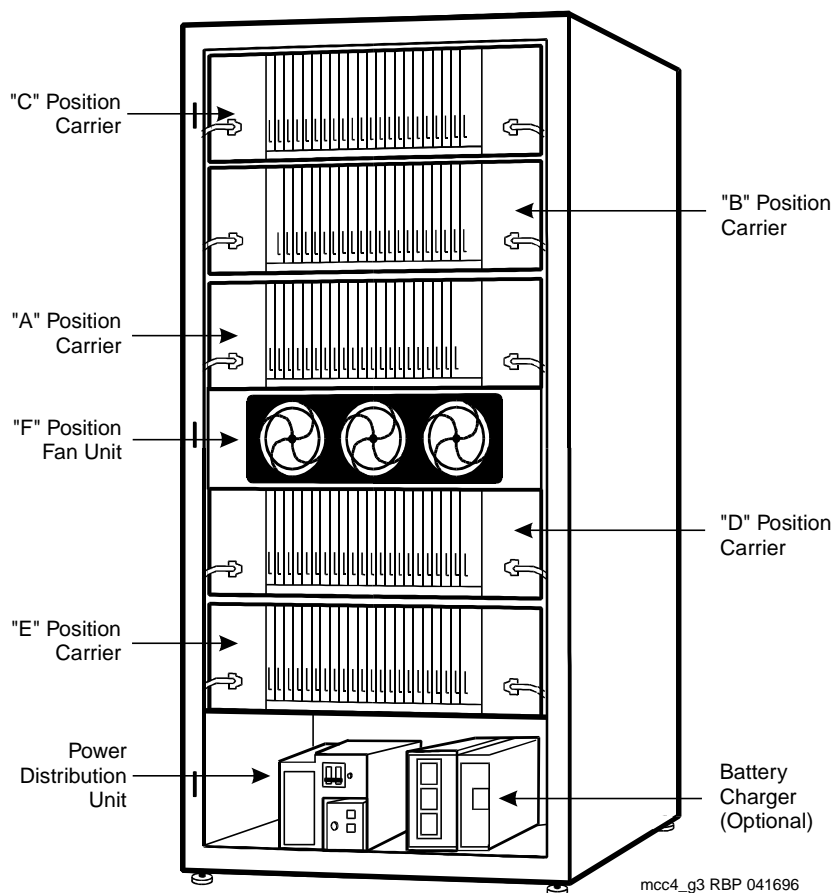

Figure 9-19. AC Power Distribution in Multi-Carrier Cabinets

## Power Backup

If AC power fails, three 48 VDC batteries power the system for 10 seconds in a PPN cabinet, for 15 seconds in an EPN cabinet, and for 10 minutes in the control carrier in a standard reliability system. The batteries also supply system power for five minutes in the control carrier in high and critical reliability systems, and for 10 minutes in the expansion control carrier in the "A" position of an EPN cabinet (Release 5r only).

## Uninterruptible Power Supply

An external UPS provides a longer backup time than holdover batteries and can replace the batteries and battery charger. The unit connects from the AC power source to a cabinet's AC power cord. If AC power fails, the unit supplies its own AC power to the cabinet.

### J58890CH-1

In AC powered cabinets, the power distribution unit (J58890CH-1), distributes 170 to 264 VAC from a wall outlet to a set of BU3200A Battery Interface Units (BIU). See [Figure 9-20](#) and [Figure 9-21](#).

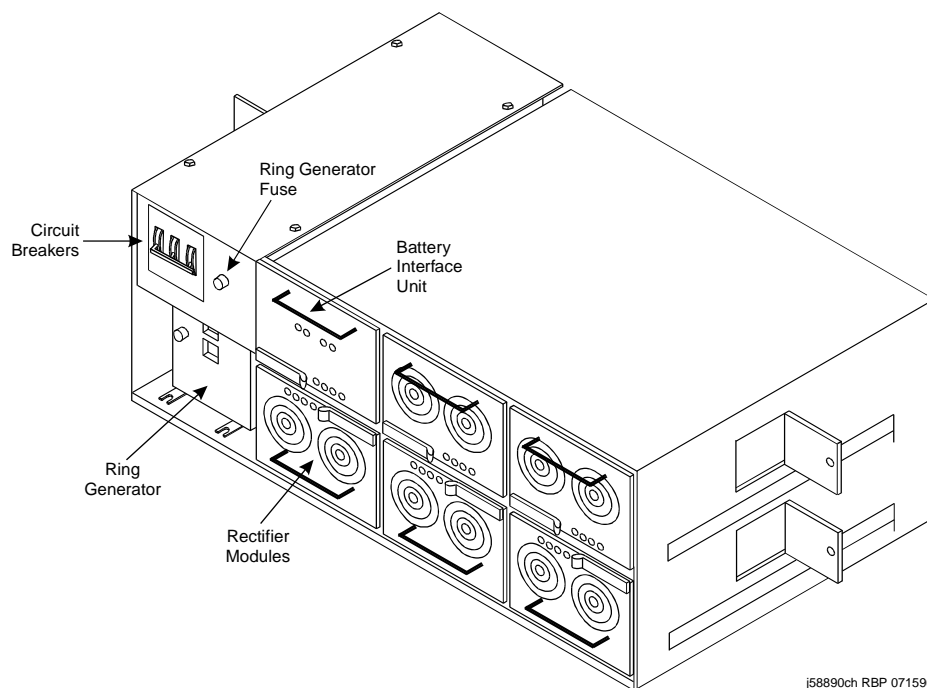

j58890ch RBP 071596

Figure 9-20. AC Power Distribution Unit (J58890CH-1) — Front

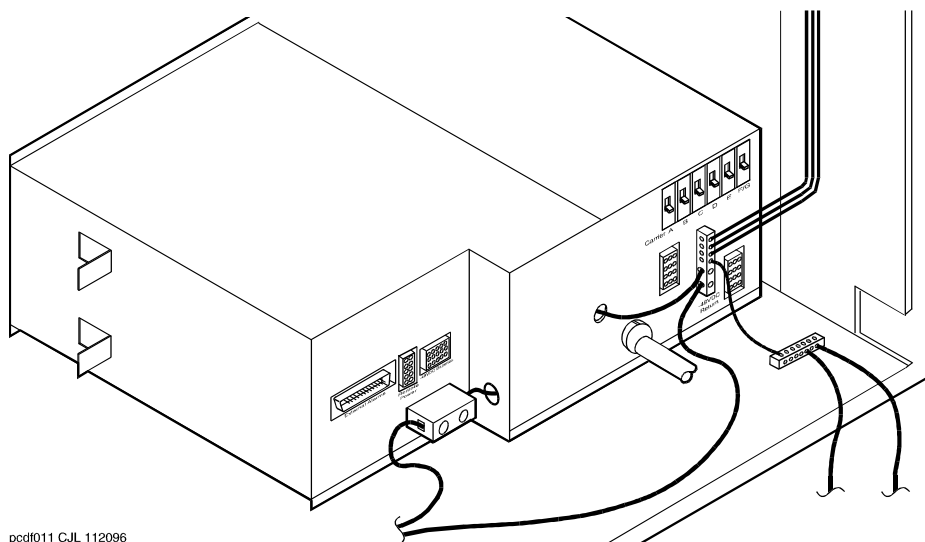

**Figure 9-21. Power Distribution Unit (J58890CH-1)**

## Power Backup

The small battery is at the center rear of the Multi-Carrier Cabinet. This eight Amp Hour (AH) battery is fused for short circuit protection and is charged by the J58890CH-1. The batteries also contain a thermal sensor that changes the charging voltage depending on battery temperature.

The small batteries provide short-term battery holdover. If AC power fails, 48 VDC batteries power the system for 10 seconds in a PPN cabinet, for 15 seconds in an EPN cabinet, and for 10 minutes in the control carrier in a standard reliability system. The batteries also provide system power for five minutes in the control carrier in high and critical reliability systems, and for 10 minutes in the expansion control carrier in the "A" position of an EPN cabinet (Release 5r only).

[Figure 9-22](#) shows the small battery assembly.



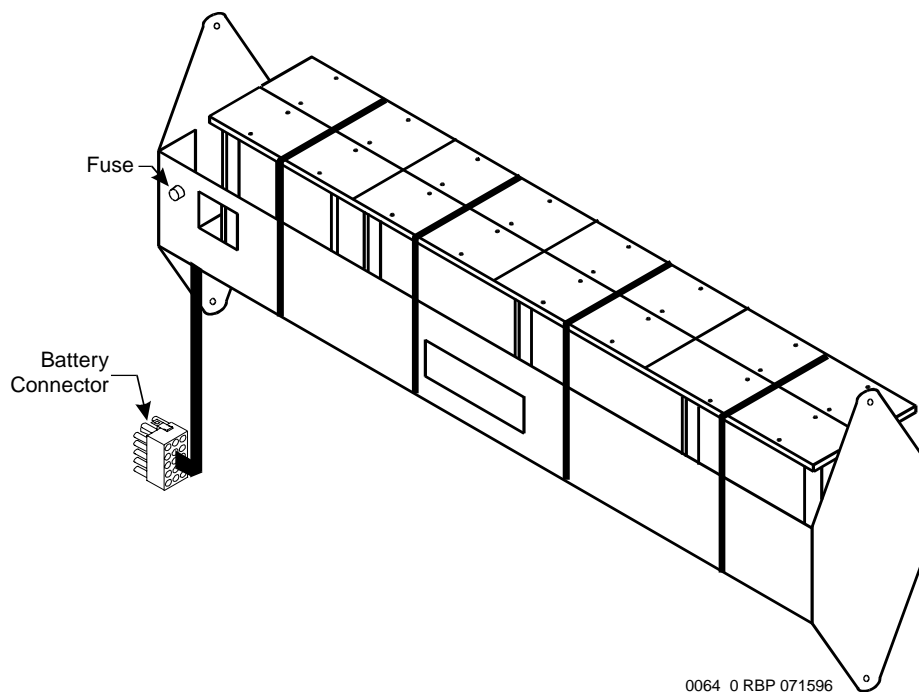
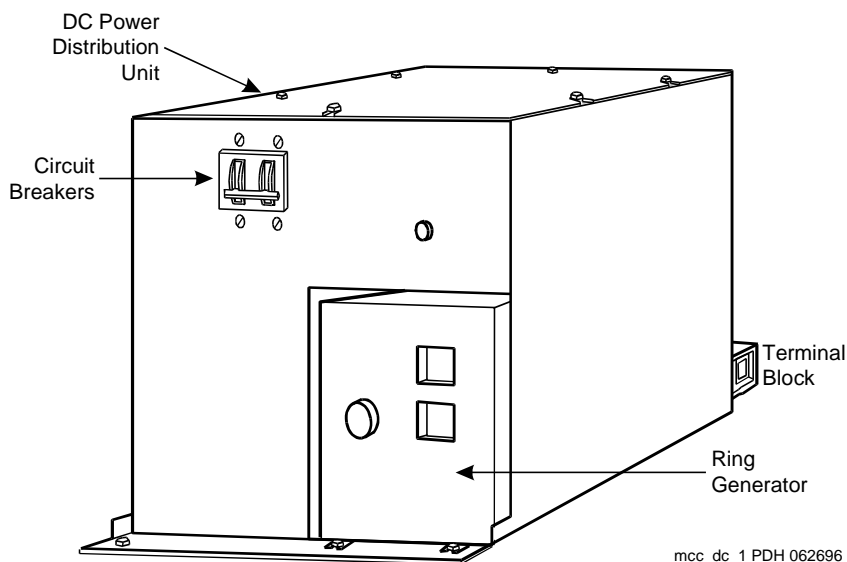

Figure 9-22. Small Battery Assembly

## DC-Powered Cabinets

### DC Power Distribution Unit (J58890CF-2)

[Figure 9-23](#) shows a power distribution unit in some DC-powered Multi-Carrier Cabinets. The unit sits at the bottom of the cabinet and contains the ring generator, 20 Amp circuit breakers, terminal blocks, and system fan power.



mcc\_dc\_1 PDH 062696

**Figure 9-23. DC Power Distribution Unit (J58890CF-2) — Front**

Some carriers may contain two power supplies, the 644A and the 645B, which together supply the required voltages to the carrier. Other carriers may contain one 649A power supply located on the right side of the carrier. In these systems, an additional 649A is located on the right of the optional switch node carriers.

Loss of the 645B Carrier Port Power Supply in the active PPN control carrier causes the management terminal login to drop. In a system with duplicated SPEs CARR-POW alarms do not cause an interchange, but loss of power to PROC, MEM-BD, SW-CTL, SYSAM, and PKT-INT maintenance objects (powered from the left side of the active control carrier) reduces the SPE state of health, possibly causing an interchange. Loss of power on the right side of the active control carrier causes the HOST-ADAPTER, DISK, and TAPE maintenance objects to fail, these failures do not cause an SPE interchange.

[Figure 9-24](#) shows a typical AC powered Multi-Carrier Cabinet.

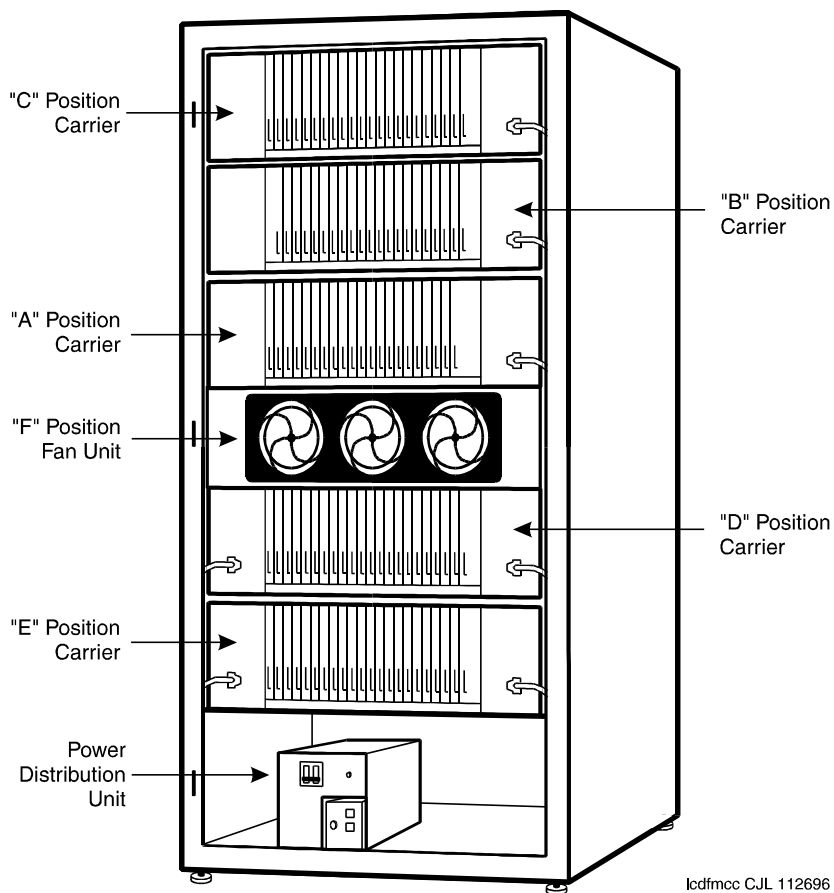

**Figure 9-24. Typical Multi-Carrier Cabinet with 649A Power Units**

The table below shows which carriers are protected by each circuit breaker on the J58890CF-1. The ring generator is protected by a fuse located next to the main circuit breaker on the front of the unit.

<b>Circuit Breaker</b>	<b>Associated Carriers</b>
CB1	Carrier A, both sides
CB2	Carrier B, both sides
CB3	Carrier C, both sides
CB4	Carrier D, both sides
CB5	Carrier E, both sides
CB6	Level F (Fans) and Level G (Ring Generator)

The table below shows which carriers are protected by each circuit breaker on the J58890CH-1. The ring generator is protected by a fuse located next to the main circuit breaker on the front of the unit.

<b>Circuit Breaker</b>	<b>Associated Carriers</b>
CB1	Carrier A, both sides
CB2	Carrier B, both sides
CB3	Carrier C, both sides
CB4	Carrier D, both sides
CB5	Carrier E, both sides
CB6	Level F (Fans) and Level G (Ring Generator)

## **Neon Lamp Power**

---

The system can also support neon message waiting lamps on analog telephones. Any carrier containing a TN769 Neon Analog Line circuit packs must also be supplied with 150 Volts from a TN755B power supply circuit pack. See the table above for other supported neon power circuit packs.

## Error Log Entries and Test to Clear Values

---

**Table 9-159. Carrier Port Power Supply Error Log Entries**

Error Type	Aux Data	Associated Test	Alarm Level	On/Off Board	Test to Clear Value
1 <sup>1</sup>	0 or 1	OLS Query Test (#127)	MAJOR	ON	test environment <i>UU r 2</i> recycle carrier <i>UUC</i>

1. Run the OLS Query Test (#127) first using the **test environment** *UU r 2* command. Then, if a carrier must be recycled to clear the CARR-POW alarm, use the **recycle carrier** *UUC* command to run the OLS Recycle Test (#126). The OLS Recycle Test (#126) is not included in either the long or short test sequences.



**WARNING:**

*The OLS Recycle Test (#126) is destructive. For more information, refer to the description of this test.*

## System Technician-Demanded Tests: Descriptions and Error Codes

---

Always investigate tests in the order presented in the table below. By clearing error codes associated with the *Battery & Battery Charger Query Test*, for example, you may also clear errors generated from other tests in the testing sequence.

Order of Investigation	Short Test Sequence	Long Test Sequence	D/ND <sup>1</sup>
Battery & Battery Charger Query Test (#5) (a)	X	X	ND
AC Power Query Test (#78) (b)	X	X	ND
OLS Query Test (carrier E) (#127)	X	X	ND
OLS Query Test (carrier D) (#127)	X	X	ND
OLS Query Test (carrier A) (#127)	X	X	ND
OLS Query Test (carrier B) (#127)	X	X	ND
OLS Query Test (carrier C) (#127)	X	X	ND
OLS Recycle Carrier Test (#126)			D
Emergency Transfer Query Test (#124) (c)	X	X	ND
Cabinet Temperature Query Test (#122) (d)	X	X	ND
External Alarm Lead Query Test (#120) (e)	X	X	ND
Analog Ring Generator Initialization Test (#117) (f)	X	X	ND
Analog Ring Generator Query Test (#118) (f)	X	X	ND

1. D = Destructive; ND = Nondestructive

Notes:

- a. Refer to "POWER" section for a description of this test.
- b. Refer to "AC-POWER" section for a description of this test.
- c. Refer to "EMG-XFER" section for a description of this test.
- d. Refer to "CABINET" section for a description of this test.
- e. Refer to "EXT-DEV" section for a description of this test.
- f. Refer to "RING-GEN" section for a description of this test.

**OLS Recycle Test (#126)**

**This test is destructive.**

This test removes power from the specified carrier and causes all circuit packs in the recycled carrier to be removed and inserted. These actions cause all calls originating or terminating on circuit packs in this carrier to be dropped. The pair of OLSs in the specified carrier is recycled. Both OLSs in the carrier are turned off for 2 seconds and then back on again. After the OLSs have been turned back on, the test queries the SYSAM in a PPN or the EPN Maintenance circuit pack in an EPN for the status of the pair of OLSs in the specified carrier. If both OLSs are on and functioning, then the test passes. If both OLSs are not on and functioning, the test fails, and BOTH OLSs are turned off.

**Table 9-160. TEST #126 OLS Recycle Test**

Error Code	Test Result	Description/ Recommendation
1000	ABORT	System resources required for this test are not available. 1. Retry the command at 1-minute intervals for a maximum of 5 times.
1366	ABORT	Indicates that the active Tone/Clock for the EPN is in requested carrier. 1. If duplicated Tone/Clock boards exist, issue the <b>set tone-clock</b> command to switch Tone/Clocks, otherwise the power cannot be cycled. 2. If the switch succeeds, rerun the test.
1367	ABORT	Indicates that the active Expansion Interface link for the EPN is in requested carrier. 1. If duplicated EIs exist, issue the <b>reset pnc interchange</b> command to switch EIs, otherwise the power cannot be cycled. 2. If the switch succeeds, rerun the test.
2000	ABORT	Response to the test request was not received within the allowable time period. 1. Retry the command at 1-minute intervals for a maximum of 5 times.
2029 2319 2320 2500	ABORT	Internal system error 1. Retry the command at 1-minute intervals for a maximum of 5 times.
	FAIL	There is a problem with one or both OLSs on the cycled carrier. 1. Since the OLS Recycle Test failed, both OLSs in the cycled carrier should have been powered off by the system software. Both OLSs should be showing a red status LED, instead of a yellow one. Since the OLS Query Test is a subset of the OLS Recycle Test, the OLS Query Test (#127) should also fail. Run the OLS Query Test by using the <b>test environment UU</b> command where UU is the appropriate cabinet number. 2. If test #127 fails, follow the repair procedures described for Test #127.
	PASS	Both OLSs in the recycled carrier were found to be healthy by the SYSAM in a PPN or the EPN Maintenance circuit pack in an EPN after the OLSs were powered down and back up. If the status LEDs on both OLSs are not showing yellow, then the SYSAM or the EPN MAINT (Maintenance) circuit pack may have incorrectly reported the state of the OLSs. Resolve any alarms on these MOs.

## Off-Line Switcher (OLS) Query Test (#127)

This test queries the SYSAM in a PPN or the EPN Maintenance circuit pack in an EPN for the status of the pair of OLSs in the specified carrier. If both OLSs are on and functioning, then the test passes. If both are not on and functioning, it fails.

**Table 9-161. TEST #127 OLS Query Test**

Error Code	Test Result	Description/ Recommendation
1000	ABORT	System resources required for this test are not available. 1. Retry the command at 1-minute intervals for a maximum of 5 times.
2000	ABORT	Response to the test request was not received within the allowable time period. 1. Retry the command at 1-minute intervals for a maximum of 5 times. 2. If the test continues to ABORT with error code 2000, check for system powering problems with the A carrier (PPN or EPN). Resolve all AC-POWER and CARR-POW alarms in a multi-carrier cabinet system or DC-POWER alarms in a single-carrier cabinet system. Then, repeat the test. 3. If the test continues to ABORT with a 2000 error code, resolve all SYSAM errors in the PPN or MAINT (EPN Maintenance circuit pack) errors in an EPN. Then, repeat the test.
2029 2500	ABORT	Internal system error 1. Retry the command at 1-minute intervals for a maximum of 5 times.
	FAIL	<p><b>AC POWERED SYSTEMS</b></p> <p>There is a problem with one or both OLSs on the tested carrier.</p> 1. For each OLS that has all status LEDs OFF, check the AC input to the OLS at the OLS outlet. If there is no AC, then check the appropriate fuses for the affected OLS. Replace open fuses. If the fuses open again or AC does not show up at the OLS outlet, then there is probably a power wiring problem in the cabinet. 2. At this point, AC should be present at the OLS outlet. Use the <b>recycle carrier UUC</b> command (where <i>UUC</i> is the appropriate cabinet and carrier) in an attempt to bring back the OLSs for this carrier. If the test passes, the trouble is cleared. If the test does not pass, one OLS or both, in the tested carrier is defective. If only one OLS is defective, then the status LEDs on the healthy OLS will light green for a moment. When the recycle test determines that both OLSs are defective, the software will turn off power to both the good and defective OLSs. This will cause the status LED(s) on the good OLS to light red. 3. Unplug both OLSs, and wait approximately 1-minute to allow the OLSs to cool down. Plug in the OLSs. If either OLS is operating properly (the status LEDs show green), then replace the defective OLS(s). See OLS Replacement Procedures in this section.



Table 9-161. TEST #127 OLS Query Test — Continued

Error Code	Test Result	Description/ Recommendation
	FAIL (cont'd.)	<ol style="list-style-type: none"> <li data-bbox="303 311 1068 455">4. If the replaced OLS(s) still do not operate properly, then a circuit pack or a defective telephone connected to a circuit pack in the affected carrier could be causing an electrical load which is preventing the OLS from operating properly. Unseat all the circuit packs in the carrier, and reissue the <b>recycle carrier</b> command.                         <ol style="list-style-type: none"> <li data-bbox="335 473 1068 731">a. If the recycle passes, then the OLSs are healthy, and the problem is with one of the circuit packs. Reinsert the circuit packs one at a time. If the status LED shows red after reinserting a circuit pack, then replace the defective circuit pack. If the status LED still shows red, then remove the amphenol connector on the back of the slot containing this circuit pack and reissue the <b>recycle carrier</b> command. If the status LED shows green, then the problem is with one of the telephones or the wiring to one of the telephones on this slot.</li> <li data-bbox="335 749 1068 974">b. If either OLS still shows a red status LED, then check for bent pins and cable placement in the affected carrier. There are failures that can occur on the SYSAM and EPN Maintenance circuit pack that <i>will not</i> be detected by their respective maintenance, but which will cause many, if not all, environment tests to fail. If many environment tests are failing, the suspect circuit pack, depending on the system configuration, should be replaced and the test rerun.</li> </ol> </li> </ol>
	FAIL	<p data-bbox="287 992 577 1017"><b>DC POWERED SYSTEMS</b></p> <p data-bbox="287 1023 1034 1076">There is a problem with one or both port carrier power supplies on the tested carrier.</p> <ol style="list-style-type: none"> <li data-bbox="303 1094 1068 1297">1. For each port carrier power supply that has all status LEDs OFF, check the DC input to the port carrier power supply at the port carrier power supply outlet. If there is no DC, then check the appropriate circuit breakers for the affected port carrier power supply. If the circuit breaker has tripped, reset the circuit breaker. If the circuit breaker trips again or DC is not present at the port carrier power supply outlet, then there is probably a power wiring problem in the cabinet.</li> <li data-bbox="303 1315 1068 1655">2. At this point, DC should be present at the port carrier power supply outlet. Use the <b>recycle carrier UUC</b> command (where <i>UUC</i> is the appropriate cabinet and carrier) in an attempt to bring back the port carrier power supplies for this carrier. If the test passes, the trouble is cleared. If the test does not pass, one port carrier power supply, or both, in the tested carrier is defective. If only one port carrier power supply is defective, then the status LEDs on the healthy port carrier power supply will light green for a moment. When the recycle test determines that both port carrier power supplies are defective, the software will turn off power to both the good and defective port carrier power supplies. This will cause the status LED(s) on the good port carrier power supply to light red.</li> </ol>

Table 9-161. TEST #127 OLS Query Test — Continued

Error Code	Test Result	Description/ Recommendation
	FAIL (cont'd.)	<ol style="list-style-type: none"> <li>3. Unplug both port carrier power supplies, and wait approximately 1-minute to allow the power supplies to cool down. Plug in the power supplies. If either power supply is operating properly (the status LEDs show green), then replace the defective power supply(s). See "Port Carrier Power Supply Replacement Procedures" above.</li> <li>4. If the replaced port carrier power supply(s) still do not operate properly, then a circuit pack or a defective telephone connected to a circuit pack in the affected carrier could be causing an electrical load which is preventing the power supply from operating properly. Unseat all the circuit packs in the carrier, and reissue the <b>recycle carrier</b> command.                         <ol style="list-style-type: none"> <li>a. If the recycle passes, then the port carrier power supplies are healthy, and the problem is with one of the circuit packs. Reinsert the circuit packs one at a time. If the status LED shows red after reinserting a circuit pack, then replace the defective circuit pack. If the status LED still shows red, then remove the amphenol connector on the back of the slot containing this circuit pack and reissue the <b>recycle carrier</b> command. If the status LED shows green, then the problem is with one of the telephones or the wiring to one of the telephones on this slot.</li> <li>b. If either port carrier power supply still shows a red status LED, then check for bent pins and cable placement in the affected carrier. There are failures that can occur on the SYSAM and EPN Maintenance circuit pack that <i>will not</i> be detected by their respective maintenance, but which will cause many, if not all, environment tests to fail. If many environment tests are failing, the suspect circuit pack, depending on the system configuration, should be replaced and the test rerun.</li> </ol> </li> </ol>
	PASS	<p>AC POWERED SYSTEMS</p> <p>Both OLSs in the tested carrier were found to be healthy by the SYSAM in a PPN or the EPN Maintenance circuit pack in an EPN. If the status LEDs on both OLSs are not showing green, then the SYSAM or the EPN MAINT circuit pack may have incorrectly reported the state of the OLSs. Resolve any alarms on these MOs.</p> <p>DC POWERED SYSTEMS</p> <p>Both port carrier power supplies in the tested carrier were found to be healthy by the SYSAM in a PPN or the EPN Maintenance circuit pack in an EPN. If the status LEDs on both port carrier power supplies are not showing green, then the SYSAM or EPN MAINT circuit pack may have incorrectly reported the state of the port carrier power supplies. Resolve any alarms on these MOs.</p>

## CDR-LNK (Call Detail Recording Link)

---

MO Name (in Alarm Log)	Alarm Level	Initial Command to Run	Full Name of MO
CDR-LINK	MINOR	test cdr [primary/secondary] l	CDR Link
CDR-LINK	WARNING	test cdr [primary/secondary]	CDR Link

Refer to the PRI-CDR/SEC-CDR (Primary and Secondary CDR Links) section for Call Detail Recording Link problems.

## CLAN-BD (Control LAN Circuit Pack)

MO Name (in Alarm Log)	Alarm Level	Initial Command to Run <sup>1</sup>	Full Name of MO
CLAN-BD	MINOR	test board UUCSS long	Control LAN Circuit Pack
CLAN-BD	WARNING	test board UUCSS short	Control LAN Circuit Pack

1. UU is the universal cabinet number (1 for PPN, 2 - 44 for EPNs). C is the carrier designation (A, B, C, D, or E). SS is the number of the slot in which the circuit pack resides (01 to 21).

### Control LAN Circuit Pack

The TN799 Control LAN (CLAN) packet port circuit pack provides TCP/IP connection to adjuncts applications such as CMS, Intuity, and DCS Networking. The CLAN circuit pack has 1 10baseT Ethernet connection and up to 16 DS0 physical interfaces for PPP connections. Two integrated modems provide remote PPP connectivity over analog facilities. Putting multiple CLAN circuit packs into a system gives additional TCP/IP capacity. In addition to the TCP/IP functionality, CLAN extends the ISDN capabilities for csi models by providing Packet bus access.

A remote socket control link (RSCL) links the CLAN and the SPE to pass call control and other management information. Since one link serves all the ports on the circuit pack, maintenance of the RSCL is part of the CLAN circuit pack maintenance.

### Control LAN Congestion Controls

The switch activates congestion controls on CLAN when it detects buffers exceeding the threshold. The switch releases the congestion controls when the CLAN reports that its buffer level has returned to normal levels.

If congestion:	Then the switch:
Persists for a 14-minute interval,	Raises MINOR alarm.
Exhausts buffers,	Raises MINOR alarm.
Ceases for 12 minutes,	Retires MINOR alarm.

## Error Log Entries and Test to Clear Values

**Table 9-162. CLAN-BD Error Log Entries**

Error Type	Aux Data	Associated Test	Alarm Level	On/Off Board	Test to Clear Value
1(a)	0		MINOR	ON	
18 (b)			WARNING	OFF	release board UUCSS
217 (c)	0	None	WARNING	ON	
257	65535	Control Channel Loop Test (#52)	MINOR	ON	test board UUCSS l r 20
257 (d)					
513 (e)	4352-4357		MINOR	ON	
769 (f)	4358				
1291 to 1296 (g)			MINOR	ON	reset board UUCSS
1537(h)	Any		MINOR	ON	
1793-1795 (i)			MINOR	ON	
2049 (j)		Packet Interface Test (#598)	MINOR	ON	test board UUCSS l r 3
2305 2306 (k)					
2561 to 2668 (l)	Any	Socket Error			
2817 2819 (m)		Congestion Query Test (#600)	MINOR	ON	test board UUCSS s r 3
3073 (n)		PPP Link Status Inquiry Test (#1279)	MINOR	ON	test board UUCSS s
3330 (o)			MINOR	ON	reset board UUCSS
3586 (p)					
3840 (q)	4096-4100				
3841 3843 (r)					

*Continued on next page*

**Table 9-162. CLAN-BD Error Log Entries**

Error Type	Aux Data	Associated Test	Alarm Level	On/Off Board	Test to Clear Value
3842 (s)					
3844 (t)	Any				
3999 (p)	Any	None			

Notes:

- a. **Error Type 1:** Circuit pack stopped functioning or is not physically present.
  - 1. Verify that the circuit pack is present.
  - 2. If circuit pack is present, reset the circuit pack (**reset board UUCSS**).
  - 3. If the error persists, replace the circuit pack.
- b. **Error Type 18:** The CLAN circuit pack busied out.
- c. **Error Type 217:** applies to 3 circuit packs:

Circuit pack	Description
Maintenance/Test	More than one Maintenance/Test circuit pack in the port network
Tone Detector Call Classifier	More than 10 circuit packs in the system. 1. Remove the circuit pack(s) against which the error is logged.

- d. **Error Type 257:** Transient communication problem between switch and circuit pack; does not affect service and can be ignored.
  - 1. Ignore this error.

Repetitive failures of the Control Channel Loop Test indicate circuit pack hardware failure.
- e. **Error Type 513:** Circuit pack detected and reported hardware failure.
  - 1. Reset the circuit pack (**reset board UUCSS**).

Aux Data:

- 4352 External RAM error
- 4353 Internal RAM error
- 4355 ROM Checksum error
- 4356 Angel Message Corruption error
- 4357 Instruction set error

- f. **Error Type 769:** Logic error. By itself this error may be ignored, but it may report other error types.
- g. **Error Type 1291-1296:** Critical hardware or firmware error.

If the switch detects:	Then the switch:
1 error,	Resets circuit pack.
3 errors in 15 minutes,	Raises MINOR alarm.

Error Type descriptions are as follows:

- 1292 Internal hardware component failed
- 1293 Insane on-board auxiliary processor

1. Attempt to clear the alarm (**reset board UUCSS**).
  2. If alarm persists, replace circuit pack.
- h. **Error Type 1537:** Switch removed hyperactive circuit pack that reported threshold number of errors.
    1. Attempt to clear the alarm (**reset board UUCSS**).
    2. If the error recurs within 15 minutes, replace the circuit pack.
  - i. **Error Type 1793-1795:** Informational frame errors.

If the switch:	Then it:
Receives errors at defined rate.	Raises MINOR alarm on circuit pack.

Error Type descriptions are as follows:

- 1794 Packet bus transmit buffers has overflowed.

1. Attempt to clear the alarm (**reset board UUCSS**).
  2. If the error recurs within 15 minutes, replace the circuit pack.
- j. **Error Type 2049:** Packet Interface Test (#598) failed.
    1. Attempt to clear the alarm (**test board UUCSS I r 3**).

2. If alarm does not clear, reset the circuit pack (**reset board UUCSS**).
  3. If circuit pack resets, execute Packet Interface Test (#598) several times.
  4. If Packet Interface Test (#598) continues to fail, replace the circuit pack.
- k. **Error Type 2305-2306:** Error in received frame from packet bus.

Error Type:	Description
2305	Received invalid LAPD frame.
2306	Detected parity error on received frame.

Most likely cause—packet bus problem.  
 Other cause—circuit pack fault.

Invalid LAPD frame errors occur when the frame

- contains a bad Cyclic Redundancy Check (CRC),
  - is greater than the maximum length,
  - violates the link level protocol.
1. Retry the command (**test board UUCSS**) and see if the condition clears.
  2. If condition persists, execute PPE/LANBIC Receive Parity Error Counter Test (# 597) and determine if the condition clears.
  3. If condition persists, execute Packet Interface Test (# 598) to verify circuit pack integrity.
  4. If Packet Interface Test (# 598) fails, consult repair procedure for the packet bus.
- l. **Error Type 2561-2668:** System software received an indication that the socket was closed due to an error. Errors are reported as log only. Errors logged here are for the sockets that had *no* processor channels associated with them, for example, sockets to read SNMP data. The counter base is offset by the application type of the application associated with this socket that is down. The Aux Data field of the log entry contains this application's number, for example, a SNMP application would have its application number in the Aux Data field.
- m. **Error Type 2817-2819:** Congestion Query Test (#600) failed.

Below, Error Types correspond to descriptions.

- |      |                                    |
|------|------------------------------------|
| 2817 | All buffers exhausted.             |
| 2819 | Utilized buffers exceed threshold. |



If:	Then:
Active buffers exceed threshold,	CLAN enters congested state.

1. Refer to Congestion Query Test (# 600) for Abort and Fail Error Codes.
- n. **Error Type 3073:** Remote Socket Control Link (RSCL) or Link Status Test (#1279) failed. This failure may be due to the
- circuit pack
  - packet bus
  - packet interface circuit pack .

If:	Then:
RSCL disconnects at link level	Link fails
Link cannot be reconnected quickly	Switch raises MINOR alarm

- o. **Error Type 3330:** Critical failure in Packet Bus interface.

Below, Error Types correspond to descriptions.

- 1292 Internal hardware component failed
- 1293 Insane on-board auxiliary processor

If the switch detects:	Then it:
1 error,	Resets circuit pack.
2 errors in 15 minutes,	Raises MINOR alarm.

1. Attempt to clear the alarm (**reset board UUCSS**).
  2. If alarm persists, replace circuit pack.
- p. **Error Type 3586 and 3999:** Switch removed hyperactive circuit pack that reported threshold number of errors. One or more of the following symptoms may be present:
- Circuit pack port tests return NO BOARD.
  - List configuration command shows circuit pack and ports are installed properly

If Error Type 3999:	And traffic volume is:	Then:
Does not accompany Error Type 3586,	Heavy	Circuit pack is in service, but sent at least half hyperactive threshold. With heavy traffic, this is normal.
Does not accompany Error Type 3586,	Light	Circuit pack is in service, but sent at least half hyperactive threshold. With light traffic, this error indicates problem with circuit pack or its links.
Accompanies Error Type 3586,	Either Light or Heavy	Switch removed hyperactive circuit pack.

1. Busyout (**busyout board UUCSS**) and release (**release board UUCSS**) circuit pack
2. Allow 30 minutes for condition to clear itself.
3. To re-establish circuit pack into service manually, busyout (**busyout board UUCSS**), reset (**reset board UUCSS**), and release (**release board UUCSS**) the circuit pack.
4. If error recurs within 15 minutes, replace the circuit pack.
5. If the same error occurs on a different circuit pack, follow normal escalation procedures.

q. **Error Type 3840:** Bad control channel message from switch.

Aux Data:

- 4096 Bad major heading
- 4097 Bad port number
- 4098 Bad data
- 4099 Bad sub-qualifier
- 4100 State inconsistency
- 4101 Bad logical link
- 4102 Bad application identifier

r. **Error Type 3841-3843:** errors do not affect service.

Below, Error Types correspond to descriptions.

- 3841 Internal firmware error.
- 3843 Bad translation RAM. Call uses another translation location.

These errors do not affect service, however, they may cause reports of other errors that do affect service.

If Error Type 3843 begins to affect service, it escalates to Error Type 1296.

- s. **Error Type 3842:** Packet interface receive buffers overflowed.

If this error occurs frequently, the overflow may be congesting the circuit pack.

- 1. Refer to Receive FIFO Overflow Error Counter Test (#596).

- t. **Error Type 3844:** LAPD frame contains LAPD Protocol Error.

By themselves, these errors do not affect service.

## System Technician-Demanded Tests: Descriptions and Error Codes

---

Investigate errors in the order they appear in the table below.

Order of Investigation	Short Test Sequence	Long Test Sequence	D/ND <sup>1</sup>
Control Channel Loop-Around Test #52	X	X	ND
Invalid LAPD Frame Error Counter Test #597		X	ND
PPE/LANBIC Receive Parity Error Counter Test #595		X	ND
Receive FIFO Overflow Error Counter Test #596		X	ND
Packet Interface Test #598	X	X	ND
Congestion Query Test #600	X	X	ND
PPP Link Status Inquiry Test #1279	X	X	ND

---

1. D = Destructive; ND = Nondestructive

### Circuit Pack Restart Test (#252)

**This test is destructive.**

Use this test (not part of either short or long demand test sequence) to reset the circuit pack only if there are PPCPU errors. The circuit pack resets through the SAKI Sanity Test (#53).

## Control Channel Loop-Around Test (#52)

This non-destructive test fails if the circuit pack does not return to a sane state after being reset. This test queries the circuit pack for its code and vintage, and verifies its records.

**Table 9-163. TEST #52 Control Channel Loop-Around Test**

Error Code	Test Result	Description/ Recommendation
None 2100	ABORT	Could not allocate the necessary system resources to run test. 1. Retry the command at 1-minute intervals, up to 5 times.
	FAIL	The circuit pack failed to return the code or vintage. 1. Retry command at 1-minute intervals, up to 5 times. 2. a. If the test continues to fail with a Port circuit pack, reseal the circuit pack; otherwise, b. If the test continues to fail on SPE Processor Complex circuit packs, refer to <i>Replacing SPE Circuit Packs</i> in Chapter 5 (Responding to Alarms and Errors) to remove and reinsert the circuit pack.
	PASS	Test successful.

## Circuit Pack Restart Test (#252)

**This test is destructive.**

Execute this test (not part of either short or long demand test sequence) to reset the circuit pack, only if there are PPCPU errors. This test fails if the circuit pack does not return to a sane state after being reset. The circuit pack resets through the SAKI Sanity Test (#53).

**Table 9-164. Test #252 Circuit Pack Restart Test**

Error Code	Test Result	Description/ Recommendation
None	ABORT	Could not allocate the necessary system resources to run test. 1. Retry the command at 1-minute intervals, up to 5 times.
1015	ABORT	Port is not out-of-service. 1. Busyout the circuit pack ( <b>busyout board UUCSS</b> ). 2. Retry the command at 1-minute intervals, up to 5 times.
2100	ABORT	Could not allocate the necessary system resources to run test. 1. Retry the command at 1-minute intervals, up to 5 times.

**Table 9-164. Test #252 Circuit Pack Restart Test — Continued**

Error Code	Test Result	Description/ Recommendation
1, 2	FAIL	The circuit pack failed to reset. <ol style="list-style-type: none"> <li>1. Retry command at 1-minute intervals, up to 5 times.</li> <li>2. If the problem persists, pull out and reseal the circuit pack.</li> <li>3. If the problem persists, replace the circuit pack.</li> </ol>
	PASS	The circuit pack initialized correctly.

**PPE/LANBIC Receive Parity Error Counter Test (#595)**

This test is non-destructive. When the CLAN circuit pack detects a parity error with a received frame, it increments the PPE/LANBIC Receive Parity error counter. This test reads and clears the counter, and may verify repair of problem.

Errors may indicate a problem with

- a circuit pack
- a packet bus
- another circuit pack on the bus

**Table 9-165. TEST #595 PPE/LANBIC Receive Parity Error Counter Test**

Error Code	Test Result	Description/ Recommendation
2000	ABORT	Did not receive circuit pack test response within the allowable time period. <ol style="list-style-type: none"> <li>1. Retry command at 1-minute intervals, up to 5 times.</li> <li>2. If the problem persists, reset the circuit pack (<b>reset board UUCSS</b>).</li> <li>3. If the problem persists, replace the circuit pack.</li> </ol>
2100	ABORT	Could not allocate the necessary system resources to run test.
2500	ABORT	Internal system error. <ol style="list-style-type: none"> <li>1. Retry the command at 1-minute intervals, up to 5 times.</li> </ol>

*Continued on next page*

**Table 9-165. TEST #595 PPE/LANBIC Receive Parity Error Counter Test — Continued**

Error Code	Test Result	Description/ Recommendation
1-10	FAIL	Circuit pack detects parity errors. The Error Code indicates the value of the on-board error counter. <ol style="list-style-type: none"> <li>1. Retry the command at 1-minute intervals, up to 5 times.</li> <li>2. If the test continues to fail, execute the Packet Interface Test (#598) (<b>test board UUCSS</b>).</li> <li>3. If Packet Interface Test (#598) fails, see Packet Bus repair procedures.</li> </ol>
	PASS	Circuit pack detects no errors.

**Receive FIFO Overflow Error Counter Test (#596)**

This test is non-destructive. When the CLAN circuit pack detects packet bus buffer overflow, it increments the error on the FIFO Overflow error counter. This test reads and clears the counter.

If errors are:	Then they may be due to:
Occasional	Statistical buffer sizing
Persistent	Circuit pack congestion that requires redistribution of traffic load

**Table 9-166. TEST #596 Receive FIFO Overflow Error Counter Test**

Error Code	Test Result	Description/ Recommendation
2000	ABORT	Did not receive circuit pack test response within the allowable time period. <ol style="list-style-type: none"> <li>1. Retry command at 1-minute intervals, up to 5 times.</li> <li>2. If the problem persists, reset the circuit pack (<b>reset board UUCSS</b>).</li> <li>3. If the problem persists, replace the circuit pack.</li> </ol>
2100	ABORT	Could not allocate the necessary system resources to run test.
2500	ABORT	Internal system error. <ol style="list-style-type: none"> <li>1. Retry the command at 1-minute intervals, up to 5 times.</li> </ol>

*Continued on next page*

**Table 9-166. TEST #596 Receive FIFO Overflow Error Counter Test**

Error Code	Test Result	Description/ Recommendation
1-10	FAIL	Circuit pack detects overflow errors. The error code indicates the value of the on-board error counter. <ol style="list-style-type: none"> <li>1. Retry the command at 1-minute intervals, up to 5 times.</li> <li>2. If the test continues to fail, execute the Packet Interface Test (#598) (<b>test board UUCSS</b>).</li> <li>3. If Packet Interface Test (#598) fails, refer to Packet Bus repair procedures.</li> </ol>
	PASS	Circuit pack detects no errors.

### Invalid LAPD Frame Error Counter Test (#597)

This test is non-destructive.

CLAN detects invalid frames when it receives

- a frame with a CRC error
- an unrecognizable frame
- a recognizable frame in an unexpected state

When the CLAN circuit pack detects an invalid LAPD frame, it increments the Invalid LAPD Frame error counter. This test reads and clears the counter, and verifies the repair of the problem.

Errors may indicate a

- circuit pack problem
- packet bus problem
- problem with another circuit pack on the bus

**Table 9-167. TEST #597 Invalid LAPD Frame Error Counter Test**

Error Code	Test Result	Description/ Recommendation
2000	ABORT	Did not receive circuit pack test response within the allowable time period. <ol style="list-style-type: none"> <li>1. Retry command at 1-minute intervals, up to 5 times.</li> <li>2. If the problem persists, reset the circuit pack (<b>reset board UUCSS</b>).</li> <li>3. If the test fails again, replace the circuit pack.</li> </ol>
2100	ABORT	Could not allocate the necessary system resources to run this test.
2500	ABORT	Internal system error. <ol style="list-style-type: none"> <li>1. Retry the command at 1-minute intervals, up to 5 times.</li> </ol>
1-10	FAIL	The circuit pack detects LAPD frame errors. The error code indicates the value of the on-board error counter. <ol style="list-style-type: none"> <li>1. Retry the command at 1-minute intervals, up to 5 times.</li> <li>2. If the test continues to fail, execute the Packet Interface Test (#598) (<b>test board UUCSS long</b>).</li> <li>3. If Packet Interface Test (#598) fails, refer to Packet Bus repair procedures.</li> </ol>
	PASS	Circuit pack detects no errors.

**Packet Interface Test (#598)**

This non-destructive test checks the packet bus interface circuitry on the CLAN circuit pack. Test failure indicates faulty circuit pack.

**Table 9-168. TEST #598 Packet Interface Test**

Error Code	Test Result	Description/ Recommendation
2000	ABORT	Did not receive circuit pack test response within the allowable time period. <ol style="list-style-type: none"> <li>1. Retry command at 1-minute intervals, up to 5 times.</li> <li>2. If the problem persists, reset the circuit pack (<b>reset board UUCSS</b>).</li> <li>3. If the test fails again, replace the circuit pack.</li> </ol>

*Continued on next page*



**Table 9-168. TEST #598 Packet Interface Test — Continued**

Error Code	Test Result	Description/ Recommendation
2012	ABORT	Could not allocate the necessary system resources to run test.
2100	ABORT	Internal system error. 1. Retry the command at 1-minute intervals, up to 5 times.
	FAIL	Circuit pack has detected a failure of the Packet Interface Test (#598). 1. Retry command at 1-minute intervals, up to 5 times. 2. If the problem persists, reset the circuit pack ( <b>reset board UUCSS</b> ). 3. If the test continues to fail, replace the circuit pack.
	PASS	The Packet Interface Test (#598) passed.

### Congestion Query Test (#600)

This non-destructive test queries the number of used buffers to determine if the CLAN circuit pack is congested.

If:	Then:
Used buffers are, or are nearly, exhausted,	The test fails
The test fails,	The switch redirects outgoing calls to another available CLAN, and denies new incoming calls

Normal call handling resumes when the CLAN circuit pack has recovered from congestion.

**Table 9-169. TEST #600 Congestion Query Test**

Error Code	Test Result	Description/ Recommendation
2000	ABORT	Did not receive circuit pack test response within the allowable time period. 1. Retry command at 1-minute intervals, up to 5 times. 2. If the problem persists, reset the circuit pack ( <b>reset board UUCSS</b> ). 3. If the test fails again, replace the circuit pack.

**Table 9-169. TEST #600 Congestion Query Test — Continued**

Error Code	Test Result	Description/ Recommendation
2012	ABORT	Could not allocate the necessary system resources to run test.
2100	ABORT	Internal system error. 1. Retry the command at 1-minute intervals, up to 5 times.
1	FAIL	The buffer level is nearly exhausted.
2	FAIL	The CLAN is congested, and no buffers are available. 1. Retry command at 1-minute intervals, up to 5 times. 2. If command continues to fail, examine the CLAN port measurements to determine which ports are heavily utilized and the processor occupancy of the circuit pack. <i>Low processor occupancy</i> when CLAN congested indicates circuit pack failure. 1. If the problem persists, reset the circuit pack ( <b>reset board UUCSS</b> ). 2. If congestion recurs, replace the circuit pack. <i>High processor occupancy</i> indicates the CLAN is congested due to traffic load. 1. Busyout the circuit pack ( <b>busyout board UUCSS</b> ) to relieve congestion selectively. 2. Consider replacing affected CLAN ports with new ports.
3	FAIL	The CLAN circuit pack is operating normally and is not congested.
	PASS	Hardware setting and attached cable type match CLAN circuit pack administration.

## Link Status Test (#601)

This non-destructive test sends a test frame over the signaling link to determine whether the CLAN call control signaling link is connected.

**Table 9-170. TEST #601 Link Status Test**

Error Code	Test Result	Description/ Recommendation
2012 2100	ABORT ABORT	Could not allocate the necessary system resources to run this test.  Internal system error. 1. Retry command at 1-minute intervals, up to 5 times.
2	FAIL	The RSCL control link disconnected. 1. Retry command at 1-minute intervals, up to 5 times. 2. If the test continues to fail, execute the Packet Interface Test (#598) to determine if the problem is due to the circuit pack. 3. If the Packet Interface Test (#598) fails, refer to Packet Interface Test repair procedures. 4. If the Packet Interface Test (#598) fails, refer to Packet Control Circuit Pack and Packet Bus repair procedures.
3	FAIL	Received no response to RSCL control link test frame. 1. Retry command at 1-minute intervals, up to 5 times. 2. If the problem persists, reset the circuit pack ( <b>reset board UUCSS</b> ). 3. If test continues to fail, replace the circuit pack.
	PASS	RSCL control link connected.

## CLSFY-BD (Call Classifier Circuit Pack)

---

MO Name (in Alarm Log)	Alarm Level	Initial Command to Run <sup>1</sup>	Full Name of MO
CLSFY-BD	MIN	test board UUCSS sh	Call Classifier Circuit Pack
CLSFY-BD	WRN	test board UUCSS sh	Call Classifier Circuit Pack

- 
1. 4UU is the universal cabinet number (1 for PPN, 2 -44 for EPNs). C is the carrier designation (A, B, C, D, or E). SS is the number of the slot in which the circuit pack resides (01 to 21).

Refer to "XXX-BD (Common Port Circuit Pack)" for circuit pack level errors. See also "Call Classifier Port (CLSFY-PT)" for related port information.

## CLSFY-PT (Call Classifier Port)

MO Name (in Alarm Log)	Alarm Level	Initial Command to Run <sup>1</sup>	Full Name of MO
CLSFY-PT <sup>1</sup>	MAJOR	test port UUCSSpp sh	Call Classifier Port
CLSFY-PT	MINOR	test port UUCSSpp sh	Call Classifier Port
CLSFY-PT	WARNING	test port UUCSSpp sh	Call Classifier Port

1. UU is the universal cabinet number (1 for PPN, 2 -44 for EPNs). C is the carrier designation (A, B, C, D, or E). SS is the number of the slot in which the circuit pack resides (01 to 21). pp is the two digit port number (01, 02, ...).

The TN744 Call Classifier is a service circuit pack that provides specialized tone detection capabilities to support the Outbound Call Management (OCM) and Inbound Call Management (ICM) features. The TN744 supports both A-law and Mu-law companding.

The TN744 has eight ports (CLSFY-PTs), each capable of supporting call classification, touch-tone reception and MFC-tone generation and detection. The CLSFY-PT maintenance object implements a set of tests designed to ensure proper operation of the Call Classifier.

### Error Log Entries and Test to Clear Values

Table 9-171. Call Classifier Port (CLSFY-PT) Error Log Entries

Error Type	Aux Data	Associated Test	Alarm Level	On/Off Board	Test to Clear Value
1	any	Tone Detector Audit/Update Test (#43)	MAJOR/ MINOR(a)	ON	test port UUCSSpp r 2
18		busyout port	WARNING	OFF	release port UUCSSpp
257(b)	17666	Tone Detection Audit Update Test (#43)	MAJOR/ MINOR(a)	ON	test port UUCSSpp r 3
513(c)	any	Tone Detection Verification Test (#42)	MAJOR/ MINOR(a)	ON	test port UUCSSpp r 3

Notes:

- a. There are two possible alarm levels for this error type: MAJOR and MINOR. A major alarm is raised if the total number of call classifier ports currently in-service is less than or equal to 1/2 of the administered

threshold number. Otherwise, a minor alarm is raised. In either case, run the short test sequence on the alarmed port and follow the error code procedures for the individual tests.

The in-service threshold number for alarming call classifier ports is administered using the **change system-parameters maintenance** command. For details, refer to [Chapter 8, "Maintenance Commands"](#).

1. Issue these commands in order: **busyout board**, **reset board**, **release board**. The board reset is required to reload on-board RAM associated with the TN744's DSPs. This takes all 8 tone detector ports out of service for a few seconds. Only 4 of the 8 would be out of service due to the alarm. (There are 5 tone detectors on each of the two DSPs.) Other than the unlikely potential of running out of tone detector resources in the switch, there is no other effect when the board is reset.
  2. Test the board (**test board UUCSS long**).
  3. If the test still fails, replace the board.
- b. The CLSFY-PT lost its translation. Testing the CLSFY-PT is sufficient to reload its translation. If testing the call classifier port does not clear the error, then the call classifier circuit pack containing the defective call classifier port should be replaced.
- c. This error indicates the call classifier port is having problems detecting call classification tones or detecting and generating R2-MFC tones. This is usually accompanied by failures of some incoming or outgoing calls. If this error type is persistently logged, then replace the call classifier circuit pack containing the defective CLSFY-PT.

## System Technician-Demanded Tests: Descriptions and Error Codes

---

Always investigate tests in the order presented in the following tables. By clearing error codes associated with the *Tone Detection Verification Test*, for example, you may also clear errors generated from other tests in the testing sequence.

Order of Investigation	Short Test Sequence	Long Test Sequence	D/ND <sup>1</sup>
Tone Detection Verification Test(#42)	X	X	ND
Tone Detection Audit/Update Test(#43)	X	X	ND

---

1. D = Destructive; ND = Nondestructive

## Tone Detection Verification Test (#42)

This test checks the operation of the TN744 in touch-tone receiver, call classifier and R2-MFC modes. It verifies the circuit pack's ability to detect DTMF, ring back, busy reorder and modem answer tones and to generate and detect forward and backward MFC tones.

**Table 9-172. TEST #42 Tone Detection Verification Test**

Error Code	Test Result	Description/ Recommendation
none	ABORT	The system was not able to allocate all the resources needed for this test OR there was an internal system error.
1	ABORT	The system could not allocate all the resources needed to test the tones.
1001	ABORT	The system was unable to put the call classifier port in the appropriate mode to test it.
1002	ABORT	The system could not allocate time slots for the test connection. This situation could occur when the system is heavily loaded. If the system is not heavily loaded, then test the TDM-BUS via the <b>test tdm</b> command. 1. Retry the command at 1-minute intervals for a maximum of 5 times.
1003	ABORT	The system could not allocate a Tone-Clock for the test connection. This may be caused by a heavy load on the system or by a faulted Tone-Clock. 1. Check to see if there are any alarms against the Tone-Clock in the port network where the test aborted. If so refer to the recommended procedures for TONE-BD or TONE-PT. 2. If a new Tone-Clock has been inserted, allow about 1-minute for maintenance to run on the newly inserted circuit pack. 3. Retry the command at 1-minute intervals for a maximum of 5 times.
2000	ABORT	Call classifier circuit pack's response to the test request was not received within the allowable time period. 1. Retry the command at 1-minute intervals for a maximum of 5 times.
2006	ABORT	Indicates that the active Tone-Clock circuit pack or a Tone Detector circuit pack may not be functioning properly. 1. Test the <i>active</i> Tone-Clock circuit pack in the port network with the <b>test tone-clock</b> UUC command and refer to the TONE-BD section for failures. 2. Retry the command at 1-minute intervals for a maximum of 5 times.
2100	ABORT	Could not allocate the necessary system resources to run this test. 1. Retry the command at 1-minute intervals for a maximum of 5 times.

*Continued on next page*

**Table 9-172. TEST #42 Tone Detection Verification Test — Continued**

Error Code	Test Result	Description/ Recommendation
1-3	FAIL	DTMF digits were not detected correctly. This may or may not impact reception of R2-MFC calls. <ol style="list-style-type: none"> <li>1. Run the short test sequence via the <b>test port UUCSSpp sh r 1</b> command.</li> <li>2. If the problem persists, the system is still operating properly but capacity will be reduced. To restore performance to normal, replace the call classifier circuit pack containing the defective CLSFY-PT (Call Classifier Port).</li> </ol>
102	FAIL	2225 Hz Modem Answer Tone was not detected correctly. This will impact call-classification operation. <ol style="list-style-type: none"> <li>1. Run the short test sequence via the <b>test port UUCSSpp sh r 1</b> command.</li> <li>2. If the problem persists, the system can still operate properly but capacity will be reduced. In order to restore performance to normal, replace the call classifier circuit pack containing the defective port.</li> </ol>
130	FAIL	Forward or backward R2-MFC signals were not correctly generated or detected. This will impact R2-MFC calls. <ol style="list-style-type: none"> <li>1. Run the short test sequence via the <b>test port UUCSSpp sh r 1</b> command.</li> <li>2. If the problem persists, the system can still operate properly but capacity will be reduced. In order to restore performance to normal, replace the call classifier circuit pack containing the defective port.</li> </ol>
	PASS	Tone detection verification is successful. The call classifier port is able to detect and generate all necessary tones.

### Tone Detector Audit/Update Test (#43)

This test performs a sanity audit on the CLSFY-PT (Call Classifier Port).

**Table 9-173. TEST #43 Tone Detector Audit/Update Test**

Error Code	Test Result	Description/ Recommendation
none	ABORT	The system was not able to allocate the resources for this test. <ol style="list-style-type: none"> <li>1. Retry the command at 1-minute intervals for a maximum of 5 times.</li> </ol>

*Continued on next page*



**Table 9-173. TEST #43 Tone Detector Audit/Update Test — Continued**

Error Code	Test Result	Description/ Recommendation
2000	ABORT	Response to the test request was not received within the allowable time period.
2100	ABORT	Could not allocate the necessary system resources to run this test. 1. Retry the command at 1-minute intervals for a maximum of 5 times.
	FAIL	Hardware audit failed. 1. Issue these commands in order: <b>busyout board, reset board, release board</b> . The board reset is required to reload on-board RAM associated with the TN744's DSPs. This takes all 8 tone detector ports out of service for a few seconds. Only 4 of the 8 would be out of service due to the alarm. (There are 5 tone detectors on each of the two DSPs.) Other than the unlikely potential of running out of tone detector resources in the switch, there is no other effect when the board is reset. 2. Test the board ( <b>test board UUCSS long</b> ). 3. If the test still fails, replace the board.
	PASS	The call classifier port has passed the sanity inquiry.

## CO-BD (Central Office Trunk Circuit Pack)

---

MO Name (in Alarm Log)	Alarm Level	Initial Command to Run <sup>1</sup>	Full Name of MO
CO-BD	MIN	test board UUCSS sh	Central Office Trunk Circuit Pack
CO-BD	WRN	test board UUCSS sh	Central Office Trunk Circuit Pack

- 
1. UU is the universal cabinet number (1 for PPN, 2 -44 for EPNs). C is the carrier designation (A, B, C, D, or E). SS is the number of the slot in which the circuit pack resides (01 to 21).

Refer to "XXX-BD (Common Port Circuit Pack)" for circuit pack level errors. See also "CO-TRK (CO Trunk)" for related trunk information.

## CO-DS1 (DS1 CO Trunk)

---

MO Name (in Alarm Log)	Alarm Level	Initial Command to Run <sup>1</sup>	Full Name of MO
CO-DS1	MAJOR <sup>2</sup>	test trunk <i>group# member#</i> l	DS1 CO Trunk
CO-DS1	MINOR	test trunk <i>group# member#</i> l	DS1 CO Trunk
CO-DS1	WARNING	test trunk <i>group# member#</i>	DS1 CO Trunk

1. UU is the universal cabinet number (1 for PPN, 2 -44 for EPNs). C is the carrier designation (A, B, C, D, or E). SS is the number of the slot in which the circuit pack resides (01 to 21). pp is the two digit port number (01, 02, ...).
2. A Major alarm on a trunk indicates that alarms on these trunks are not downgraded by the **set options** command and that at least 75 percent of the trunks in this trunk group are alarmed. For more information on the **set options** command, see [Chapter 8, "Maintenance Commands"](#).

### ⇒ NOTE:

Many trunk problems are caused by incorrect settings of parameters on the trunk group administration form. Settings must be compatible with the local environment and with parameter settings on the far-end. Refer to *DEFINITY Enterprise Communications Server Release 5.4 Administration and Feature Description*, for information on how to administer trunks. The Application Notes section of that book shows the correct settings for administrable timers and other parameters on a country-by-country basis.

A DS1 CO (central office) trunk provides a link for digitized voice or data communications between the system and a central office switch. There are two types of DS1 interfaces:

- 24 DS0 channels on a 1.544 Mbps link
- 31 DS0 channels + 1 framing channel on a 2.048 Mbps link

### ⇒ NOTE:

32-channel mode is supported only on TN464 circuit packs and on G3r V2 systems.

The DS1-CO maintenance object monitors and maintains a CO trunk port on either a TN767 DS1 Interface circuit pack or a TN464 UDS1 Interface circuit pack. Throughout this discussion, the term DS1 circuit pack applies to both. See “DS1-BD (DS1 Interface Circuit Pack)” and “UDS1-BD (UDS1 Interface Circuit Pack)” in this chapter for more information about these circuit packs. The DS1 circuit pack supports low level CO trunk signaling interfaces for both ground-start and loop-start trunks. This maintenance strategy covers the in-line errors log, initialization tests, periodic tests, scheduled tests, demand tests, and alarm resolution.

Three trunk service states are specified by DS1 CO trunk maintenance:

- out-of-service                      The trunk is in a deactivated state and cannot be used for either incoming or outgoing calls.
- in-service                              The trunk is in an activated state and can be used for both incoming and outgoing calls.
- disconnect (ready-for-service)      The trunk is in an activated state but can only be used for an incoming call.

## Error Log Entries and Test to Clear Values

**Table 9-174. DS1 CO Trunk Error Log Entries**

Error Type	Aux Data	Associated Test	Alarm Level	On/Off Board	Test to Clear Value
0 <sup>1</sup>	0	Any	Any	Any	test trunk <grp>/<mbr>
1(a)	57408				
1(a)	57487				
15(b)	Any	Port Audit and Update Test (#36)			
18(c)	0	busyout trunk <grp>/<mbr>	WARNING	OFF	release trunk <grp>/<mbr>
130(d)		None	WARNING	ON	test trunk <grp>/<mbr>
257(e)	57392	DS1 CO Dial Tone Seizure Test (#314)	MIN/MAJ <sup>2</sup>	OFF	
513(f)	57393	DS1 CO Dial Tone Seizure Test (#314)	MIN/MAJ <sup>2</sup>	OFF	
769(g)	57484				
1025		DS1 CO Dial Tone Seizure Test (#314)	MIN/WRN <sup>3</sup>	OFF	test trunk <grp>/<mbr> r 2

**Table 9-174. DS1 CO Trunk Error Log Entries**

Error Type	Aux Data	Associated Test	Alarm Level	On/Off Board	Test to Clear Value
1281		Conference Circuit Test (#7)	MIN/ WRN <sup>3</sup>	ON	test trunk <grp>/<mbr> l r 4
1537		NPE Crosstalk Test (#6)	MIN/ WRN <sup>3</sup>	ON	test trunk <grp>/<mbr> l r 3
1793(h)					test board UUCSS I
2562(i))	16665				
2817(j)	52992				
3840(k)		Port Audit and Update Test (#36)			

1. Run the Short Test Sequence first. If all tests pass, run the Long Test Sequence. Refer to the appropriate test description and follow the recommended procedures.
2. This alarm will only be raised when the System-Parameter Country form has the Base Tone Generator field set to 4 (Italy). This alarm will be a MINOR alarm unless 75% or more trunks in this trunk group are out of service, then the alarm will be upgraded to a MAJOR alarm.
3. Major alarms MO may be downgraded to Warning alarms based on the value used in the set options command.

**Notes:**

- a. Error Type 1—Aux Data 57408—No tip ground is detected on an outgoing call.

Aux Data 57487—PBX could not get "loop close" signal.

The DS1 Interface circuit pack detected a hardware fault. These errors will cause the Dial Tone Test (#314) to run and are only considered a problem if the Dial Tone Test fails (in which case Error Type 1025 will also show up). In this case, the trunk may be put in the ready-for-service state (shown as "disconnected" by the status command), which allows only incoming calls. Run the Dial Tone Test (#314) and follow the procedures.

- b. Error Type 15—This is a software audit error that does not indicate any hardware malfunction. Run Short Test Sequence and investigate associated errors (if any).
- c. Error Type 18—System Technician has busied out the trunk to the out-of-service state. No calls can be made on this trunk except the Facility Access Test Call. For details on this feature, refer to "[Facility test calls](#)" section in [Chapter 6, "Additional Maintenance Procedures"](#).
- d. Error Type 130—This error type indicates that the circuit pack has been removed or has been insane for more than 11-minutes. To clear the error, reinsert or replace the circuit pack.
- e. Error Type 257—The DS1 Interface circuit pack detects a hardware fault. Aux Data 57392 indicates no external release on PBX disconnect.

- f. Error Type 513—The DS1 Interface circuit pack detects a hardware fault. Aux Data 57393 indicates belated external release on PBX disconnect.
- g. Error Type 769—The DS1 Interface circuit pack detects a hardware fault. The Aux Data field contains the following error type:—57484, fault is detected on tip/ring.
- h. Error Type 1793—DS1 Interface circuit pack is out-of-service. Look for DS1-BD errors in the Hardware Error Log if the port is on a TN767 DS1 board. Look for UDS1-BD errors in the Hardware Error Log if the port is on a TN464 UDS1 board. Refer to the DS1-BD or UDS1-BD (DS1 Trunk Circuit Pack) Maintenance documentation for details
- i. Error Type 2562—Retry Failure error. This error is logged only. It is not a hardware failure and hence does not start any testing or generate any alarms. This error comes from call processing and is generated when a second attempt (retry) to seize an outgoing trunk fails.
- j. Error Type 2817—Glare error. This error is logged only. It is not a hardware failure and hence does not start any testing or generate any alarms. This error is the result of a simultaneous seizure of a two-way trunk from both the near-end and the far-end. Attempt to place the call again. If the error persists, execute the Dial Tone Seizure Test (#314) and follow those procedures.
- k. Error Type 3840—Port Audit and Update Test (#36) failed due to an internal system error. Enter the **status trunk** command to verify the status of the trunk. If the trunk is out-of-service, then enter the **release trunk** command to put it back into in-service. Retry the test command.

## System Technician-Demanded Tests: Descriptions and Error Codes

Always investigate tests in the order they are presented in the table below when inspecting errors in the system. By clearing error codes associated with the *NPE Crosstalk Test*, for example, you may also clear errors generated from other tests in the testing sequence.

Order of Investigation	Short Test Sequence	Long Test Sequence	D/ND <sup>1</sup>
NPE Crosstalk Test (#6)		X	ND
Conference Circuit Test (#7)		X	ND
DS1 CO Trunk Seizure Test (#314)	X	X	ND
Port Audit and Update Test (#36)	X	X	ND

1. D = Destructive; ND = Nondestructive

## NPE Crosstalk Test (#6)

The NPE Crosstalk Test verifies that this port's NPE channel talks on the selected time slot and never crosses over to time slots reserved for other connections. If the NPE is not working correctly, one-way and noisy connections may be observed. This test is usually only part of a port's Long Test Sequence and takes about 20 to 30 seconds to complete.

**Table 9-175. TEST #6 NPE Crosstalk Test**

Error Code	Test Result	Description/ Recommendation
	ABORT	System resources required for this test are not available. 1. Retry the command at 1-minute intervals for a maximum of 5 times.
1000	ABORT	System resources required to run this test were not available. The port may be busy with a valid call. 1. Use the <b>display port UUCSSpp</b> command to determine the trunk group/member number of the port. Use the <b>status trunk</b> command to determine the service state of the port. If the port is in use, wait until the port is idle before testing. 2. If the port status is active but the port is not in use (no calls), check the error log for error type 1025 (see the error log table for a description of this error and required actions). The port may be locked up. 3. If the port status is idle, retry the command at 1-minute intervals for a maximum of 5 times.
1001	ABORT	System resources required for this test are not available. 1. Retry the command at 1-minute intervals for a maximum of 5 times.
1002	ABORT	The system could not allocate time slots for the test. The system may be under heavy traffic conditions or it may have time slots out-of-service due to TDM-BUS errors. The <b>status health</b> command can be used to determine if the system is experiencing heavy traffic. 1. If system has no TDM-BUS errors and is not handling heavy traffic, retry the command at 1-minute intervals for a maximum of 5 times.
1003	ABORT	The system could not allocate a tone receiver for the test. The system may be oversized for the number of Tone Detectors present or some tone detectors may be out-of-service. The <b>list measurements tone-receiver</b> command will display information on the system's tone receivers. 1. Resolve any TTR-LEV errors. 2. Resolve any TONE-PT errors. 3. If neither condition exists, retry the command at 1-minute intervals for a maximum of 5 times.

*Continued on next page*

**Table 9-175. TEST #6 NPE Crosstalk Test — Continued**

Error Code	Test Result	Description/ Recommendation
1004	ABORT	The port was seized by a user for a valid call. <ol style="list-style-type: none"> <li>1. Use the <b>display port UUCSSpp</b> command to determine the trunk group/member number of the port. Use the <b>status trunk</b> command to determine the service state of the port. If the port is in use, wait until the port is idle before testing.</li> <li>2. If the port status is idle, retry the command at 1-minute intervals for a maximum of 5 times.</li> </ol>
1020	ABORT	The test did not run due to a previously existing error on the specific port or a more general circuit pack error. <ol style="list-style-type: none"> <li>1. Examine Error Log for existing errors against this port or the circuit pack and attempt to diagnose the already existing error.</li> </ol>
2000	ABORT	Response to the test request was not received within the allowable time period.
2100	ABORT	System resources required for this test are not available. <ol style="list-style-type: none"> <li>1. Retry the command at 1-minute intervals for a maximum of 5 times.</li> </ol>
2053	ABORT	At least one of the following errors was found on the DS1 circuit pack: loss of signal (1281), blue alarm (1793), red alarm (2049), yellow alarm (2305), or hyperactivity (1537). <ol style="list-style-type: none"> <li>1. Look for the above error types in the Hardware Error Log and follow the procedures given in the appropriate DS1-BD or UDS1-BD maintenance documentation for the listed error types.</li> </ol>

*Continued on next page*



Table 9-175. TEST #6 NPE Crosstalk Test — *Continued*

Error Code	Test Result	Description/ Recommendation
	FAIL	The NPE of the tested port was found to be transmitting in error. This will cause noisy and unreliable connections.  1. Replace the circuit pack.
	PASS	The port is correctly using its allocated time slots. User-reported troubles on this port should be investigated using other port tests and examining station, trunk, or external wiring.
0	NO BOARD	The test could not relate the internal ID to the port (no board). This could be due to incorrect translations, no board is inserted, an incorrect board is inserted, an insane board is inserted, or the board is hyperactive.  1. Check to ensure that the board translations are correct. Use the <b>list config</b> command, and resolve any problems that are found. 2. If the board was found to be correctly inserted in step 1, issue the <b>busyout board</b> command. 3. Issue the <b>reset board</b> command. 4. Issue the <b>release busy board</b> command. 5. Issue the <b>test board long</b> command. This should re-establish the linkage between the internal ID and the port. If this is not the case, dispatch to check to ensure that there is a valid board inserted.  <b>⇒ NOTE:</b> Hyperactivity causes some special problems with the sequence suggested above. If the ports are translated after issuing the <b>list config</b> command but the 'Vintage' field reports that there is no board (when there really is a board), then the <b>busyout board</b> and the <b>release busy board</b> commands will not work (even though the <b>reset board</b> command will work). The software will put the hyperactive board back in service after the hyperactivity clears.

### Conference Circuit Test (#7)

The Conference Circuit Test verifies that the NPE channel for the port being tested can correctly perform the conferencing function. The NPE is instructed to listen to several different tones and conference the tones together. The resulting signal is then measured by a tone detector port. If the level of the tone is within a certain range, the test passes.

**Table 9-176. TEST #7 Conference Circuit Test**

Error Code	Test Result	Description/ Recommendation
	ABORT	System resources required for this test are not available. 1. Retry the command at 1-minute intervals for a maximum of 5 times.
1000	ABORT	The test was aborted. System resources required to run this test were not available. The port may be busy with a valid call. 1. Use the <b>display port UUCSSpp</b> command to determine the trunk group/member number of the port. Use the <b>status trunk</b> command to determine the service state of the port. If the port is in use, wait until the port is idle before testing. 2. If the port status is active but the port is not in use (no calls), check the error log for error type 1025 (see the error log table for a description of this error and required actions). The port may be locked up. 3. If the port status is idle, retry the command at 1-minute intervals for a maximum of 5 times.
1002	ABORT	The system could not allocate time slots for the test. The system may be under heavy traffic conditions, or it may have time slots out of service due to TDM-BUS errors. 1. If the system has no TDM-BUS errors and is not handling heavy traffic and the port status is idle, retry the command at 1-minute intervals for a maximum of 5 times.
1003	ABORT	The system could not allocate a tone receiver for the test. The system may be oversized for the number of tone detectors present or some of the tone detectors may be out of service. Issue the <b>list measurements tone-receiver</b> command to display basic information about the system's tone receivers. 1. Resolve any TTR-LEV errors. 2. Resolve any TONE-PT errors. 3. If neither condition exists, retry the command at 1-minute intervals for a maximum of 5 times.
1004	ABORT	The port has been seized by a user for a valid call. 1. Use the <b>status station</b> or <b>status trunk</b> command to determine when the port is available for testing. 2. Retry the command at 1-minute intervals for a maximum of 5 times.
1018	ABORT	The test was disabled via translation. You may want to determine why the test has been disabled before you enable it. 1. Verify that the 'Maintenance Test' field on the 'Trunk Administration' screen is set to 'n.' To enable the test, change the trunk administration and enter 'y' into the 'Maintenance Test' field. 2. Repeat the test.

**Table 9-176. TEST #7 Conference Circuit Test — Continued**

Error Code	Test Result	Description/ Recommendation
1020	ABORT	The test did not run due to a previously existing error on the specific port or a more general circuit pack error.  1. Examine Error Log for existing errors against this port or the circuit pack and attempt to diagnose the previously existing error.
2000	ABORT	Response to the test request was not received within the allowable time period.
2100	ABORT	System resources required for this test are not available.  1. Retry the command at 1-minute intervals for a maximum of 5 times.
2053	ABORT	At least one of the following errors was found on the DS1 circuit pack: loss of signal (1281), blue alarm (1793), red alarm (2049), yellow alarm (2305), or hyperactivity (1537).  Look for the above error types in the Hardware Error Log and follow the procedures given in the appropriate DS1-BD or UDS1-BD maintenance documentation for the listed error types.

*Continued on next page*

**Table 9-176. TEST #7 Conference Circuit Test — Continued**

Error Code	Test Result	Description/ Recommendation
	FAIL	<p>The NPE of the tested port did not conference the tones correctly. This will cause noisy and unreliable connections.</p> <ol style="list-style-type: none"> <li>1. Enter the <b>list configuration board UUCSS</b> command. If the circuit pack is a TN767B vintage 8 or 9, replace the circuit pack with a TN767C V3 or later. The error log may have error type 1281 entries.</li> <li>2. Test all administered trunks on the board. If one fails, this could be an off-board problem (such as an incoming seizure or an off-hook port seizure during the test). Retest the board.</li> <li>3. If all of the ports fail, check the CARR-POW.</li> <li>4. If several ports fail, check the error log for TONE-BD or TONE-PT errors. If there are such errors, take the appropriate action. When the TONE errors have cleared, rerun the test.</li> <li>5. If the retry passes and troubles have been reported, coordinate isolation with the CO. Make sure that the switch, the CO, and any NTCE equipment (the CSU's) have the correct administration.</li> <li>6. Replace the circuit pack.</li> </ol> <p><b>⇒ NOTE:</b>                      If the conference circuit test fails for all ports on a circuit pack, a -5 volt power problem is indicated. To investigate problems with a power unit, refer to "CARR-POW". If a red LED on a TN736 or TN752 power unit circuit pack is on, replace the pack.</p>
	PASS	<p>The port can correctly conference multiple connections. User-reported troubles on this port should be investigated by using other port tests and by examining station, trunk, or external wiring.</p>

*Continued on next page*

**Table 9-176. TEST #7 Conference Circuit Test — Continued**

Error Code	Test Result	Description/ Recommendation
0	NO BOARD	<p>The test could not relate the internal ID to the port (no board).</p> <p>This result could be due to incorrect translations, no board is inserted, an incorrect board is inserted, an insane board is inserted, or the board is hyperactive.</p> <ol style="list-style-type: none"> <li>1. Check to ensure that the board translations are correct. Use the <b>list config</b> command, and resolve any problems that are found.</li> <li>2. If the board was found to be correctly inserted in step 1, issue the <b>busyout board</b> command.</li> <li>3. Issue the <b>reset board</b> command.</li> <li>4. Issue the <b>release busy board</b> command.</li> <li>5. Issue the <b>test board long</b> command.</li> </ol> <p>This should re-establish the linkage between the internal ID and the port. If this is not the case, dispatch to check to ensure that there is a valid board inserted.</p> <p><b>⇒ NOTE:</b>                      Hyperactivity causes some special problems with the sequence suggested above. If the ports are translated after issuing the <b>list config</b> command but the 'Vintage' field reports that there is no board (when there really is a board), then the <b>busyout board</b> and the <b>release busy board</b> commands will not work (even though the <b>reset board</b> command will work). The software will put the hyperactive board back in service after the hyperactivity clears.</p>

### Port Audit and Update Test (#36)

This test sends port level translation data from switch processor to the DS1 Interface circuit pack to assure that the trunk's translation is correct. Translation updates include the following data: trunk type (in/out), dial type, timing parameters, and signaling bits enabled. The port audit operation verifies the consistency of the current state of trunk.

**Table 9-177. TEST #36 Port Audit and Update Test**

Error Code	Test Result	Description/ Recommendation
	ABORT	Internal system error 1. Retry the command at 1-minute intervals for a maximum of 5 times.
1000	ABORT	System resources required to run this test were not available. The port may be busy with a valid call. 1. Issue <b>display port UUCSSpp</b> to determine the trunk group/member number of the port. Use the <b>status trunk</b> command to determine the service state of the port. If the port is in use, wait until the port is idle before testing. 2. If the port status is active but the port is not in use (no calls), check the error log for error type 1025. The port may be locked up. 3. If the port status is idle, retry the command at 1-minute intervals for a maximum of 5 times.
1006	ABORT	The DS1 CO trunk is out of service. 1. Use <b>status trunk</b> to verify that the trunk is out of service. 2. If the trunk is out of service, determine why. 3. If it is OK to put the trunk back in service, issue the <b>release trunk</b> command to put the trunk back in service, and then retry the test.
2000	ABORT	Response to the test was not received within the allowable time period.
2100	ABORT	Could not allocate the necessary system resources to run this test.
	FAIL	Test failed due to internal system error. 1. Retry the command at 1-minute intervals for a maximum of 5 times.
	PASS	Trunk translation has been updated successfully. The current trunk states kept in the DS1 Interface circuit pack and switch software are consistent. If the trunk is busied out, the test will not run but will return PASS. To verify that the trunk is in-service: 1. Enter <b>status trunk</b> to verify that the trunk is in-service. If the trunk is in-service, no further action is necessary. If the trunk is out-of-service. 2. Enter <b>release trunk</b> to put the trunk back into in-service. 3. Retry the test command.

Table 9-177. TEST #36 Port Audit and Update Test — Continued

Error Code	Test Result	Description/ Recommendation
0	NO BOARD	<p>The test could not relate the internal ID to the port. This result could be due to incorrect translations, no board inserted, an incorrect board inserted, an insane board inserted, or the board is hyperactive.</p> <ol style="list-style-type: none"><li>1. Check to ensure that the board translations are correct. Use the <b>list config</b> command, and resolve any problems that are found.</li><li>2. Issue the <b>busyout board</b> command.</li><li>3. Issue the <b>reset board</b> command.</li><li>4. Issue the <b>release busy board</b> command.</li><li>5. Issue the <b>test board long</b> command.</li></ol> <p>This should re-establish the linkage between the internal ID and the port. If not, to check that there is a valid board inserted.</p> <p>Hyperactivity causes some special problems with the sequence suggested above. If the ports are translated after issuing the <b>list config</b> command but the 'Vintage' field reports that there is no board (when there really is a board), then the <b>busyout board</b> and the <b>release busy board</b> commands do not work (even though the <b>reset board</b> command does work). The software puts the hyperactive board back in service after the hyperactivity clears.</p>

### DS1 CO Dial Tone Seizure Test (#314)

DS1 CO Dial Tone Seizure Test checks the trunk's signaling capability provided by the DS1 Interface circuit pack. The maintenance software initiates the test by sending a "seizure" message to the DS1 Interface circuit pack and expects an "active" reply from the DS1 interface circuit pack. If the "active" message is received, then the test passes. If no message is received and the timer expires, the test is aborted. If the DS1 Interface circuit pack sends a "reorder" message back to maintenance software, then the test fails.

This test cannot be run on a trunk in any of the following conditions:

- a. The trunk direction is administered as an incoming only trunk.
- b. The trunk has been seized by a normal trunk call.
- c. The trunk is administered with maintenance test disabled.

**Table 9-178. TEST #314 DS1 CO Dial Tone Seizure Test**

Error Code	Test Result	Description/ Recommendation
	ABORT	Internal system error 1. Retry the command at 1-minute intervals for a maximum of 5 times.
1000	ABORT	The test was aborted because system resources required to run this test were not available. The port may be busy with a valid call. 1. Use the <b>display port UUCSSpp</b> command to determine the trunk group/member number of the port. Use the <b>status trunk</b> command to determine the service state of the port. If the port is in use, wait until the port is idle before testing. 2. If the port status is active but the port is not in use (no calls), check the error log for error type 1025. The port may be locked up. 3. If the port status is idle, retry the command at 1-minute intervals for a maximum of 5 times.
1004	ABORT	The test was aborted because the port was seized by a user for a valid call. 1. Use the <b>display port UUCSSpp</b> command to determine the trunk group/member number of the port. Use the <b>status trunk</b> command to determine the service state of the port. If the port is in use, wait until the port is idle before testing. 2. If the port status is idle, retry the command at 1-minute intervals for a maximum of 5 times.
1005	ABORT	Test failed due to incompatible configuration administered in trunk group form. 1. Look at the trunk group administration form and see whether the trunk is incoming only, port 24 on a DS1 Interface with common control channel signaling, or an automatic CO type such as FX. Under any of these conditions this is a normal abort.
1018	ABORT	Test is disabled via translation. You may want to determine why the test has been disabled before you enable it. 1. Verify that the 'Maintenance Test' field on the 'Trunk Group' form is set to 'n'. To enable the test, issue the <b>change trunk-group x</b> command (x equals the number of the trunk group to be tested). Then, change the entry in the 'Maintenance Test' field on the form to 'y'. 2. Repeat the test.
1040	ABORT	The test was aborted because this port may be an access endpoint. 1. Verify that this port is an access endpoint by issuing the <b>display port</b> command. 2. If the port has been administered as an access endpoint, then this is a normal abort.

*Continued on next page*



**Table 9-178. TEST #314 DS1 CO Dial Tone Seizure Test — Continued**

Error Code	Test Result	Description/ Recommendation
1020	ABORT	The DS1 Interface circuit pack is out-of-service. 1. Look for DS1-BD/UDS1-BD errors in the Hardware Error Log. If present, refer to the appropriate DS1-BD/UDS1-BD (DS1/UDS1 Trunk Circuit Pack). 2. Retry the command.
2012	ABORT	The test was aborted due to an internal system error. 1. Retry the command at 1-minute intervals for a maximum of 5 times.
2100	ABORT	Could not allocate the necessary system resources for this test. 1. Retry the command at 1-minute intervals for a maximum of 5 times.
2000	FAIL	Response to the seizure message was not received within the allowable time period. 1. Enter the <b>list configuration board UUCSS</b> command. If the circuit pack is a TN767B vintage 8 or 9, a failure of test 314 causes a subsequent failure of test 7 due to a firmware bug. Eventually, the board and all of its ports will be taken out of service and extraneous on-board alarms will be generated. Replace the circuit pack with a TN767C V3 or later. 2. Verify that the 'Trunk Type' field on the 'Trunk Administration' screen matches the trunk type administered on far-end switch. 3. Look for DS1-BD or UDS1-BD errors in the hardware error log. If present, refer to the DS1-BD (DS1 trunk circuit pack) maintenance documentation or to the UDS1-BD (UDS1 trunk circuit pack) maintenance documentation. 4. Retry the command at 1-minute intervals for a maximum of 5 times.
2053	FAIL	At least one of the following errors was found on the DS1 circuit pack: loss of signal (1281), blue alarm (1793), red alarm (2049), yellow alarm (2305), or hyperactivity (1537). 1. Look for these error types in the hardware error log and then follow the procedures given in the maintenance documentation that is appropriate for the error type that was found.
	FAIL	The trunk cannot be seized for an outgoing call. This could cause in-line failures to be reported against the trunk (no answer would report error type 257 with auxiliary data 57487 in the error log). 1. Verify the Trunk Type field on the trunk administration screen form matches the trunk type administered on far end switch. 2. Look for DS1-BD/UDS1-BD errors in Error Log. If present, refer to DS1-BD/UDS1-BD (DS1/UDS1 Trunk Circuit Pack). 3. Retry the command at 1-minute intervals for a maximum of 5 times.

*Continued on next page*

**Table 9-178. TEST #314 DS1 CO Dial Tone Seizure Test — Continued**

Error Code	Test Result	Description/ Recommendation
	PASS	The trunk can be seized for an outgoing call.
0	NO BOARD	<p>The test could not relate the internal ID to the port (no board).</p> <p>This could be due to incorrect translations, no board is inserted, an incorrect board is inserted, an insane board is inserted, or the board is hyperactive.</p> <ol style="list-style-type: none"> <li>1. Check to ensure that the board translations are correct. Use the <b>list config</b> command, and resolve any problems that are found.</li> <li>2. Issue the <b>busyout board</b> command.</li> <li>3. Issue the <b>reset board</b> command.</li> <li>4. Issue the <b>release busy board</b> command.</li> <li>5. Issue the <b>test board long</b> command. This should re-establish the linkage between the internal ID and the port. If this is not the case, dispatch to check to ensure that there is a valid board inserted.</li> </ol> <p>Hyperactivity causes some special problems with the sequence suggested above. If the ports are translated after issuing the <b>list config</b> command but the 'Vintage' field reports that there is no board (when there really is a board), then the <b>busyout board</b> and the <b>release busy board</b> commands will not work (even though the <b>reset board</b> command will work). The software will put the hyperactive board back in service after the hyperactivity clears.</p>

## CO-TRK (Analog CO Trunk)

MO Name (in Alarm Log)	Alarm Level	Initial Command to Run <sup>1</sup>	Full Name of MO
CO-TRK	MAJOR <sup>2</sup>	test port UUCSSpp l	Analog CO Trunk
CO-TRK	MINOR	test port UUCSSpp l	Analog CO Trunk
CO-TRK	WARNING	test port UUCSSpp l	Analog CO Trunk

1. UU is the universal cabinet number (1 for PPN, 2 -44 for EPNs). C is the carrier designation (A, B, C, D, or E). SS is the number of the slot in which the circuit pack resides (01 to 21). pp is the two digit port number (01, 02, ...).
2. A MAJOR alarm on a trunk indicates that alarms on these trunks are not downgraded by the **set options** command and that at least 75% of the trunks in this trunk group are alarmed.

If ATMS testing is enabled, check the error log for ATMS errors 3840 and 3841. If the error log indicates that measurements exceeded acceptable thresholds, and no other trouble is found with **test trunk**, run the ATMS test call with **test analog-testcall port UUCSSpp full**.

### ⇒ NOTE:

Many trunk problems are caused by incorrect settings of parameters on the trunk group administration form. Settings must be compatible with the local environment and with parameter settings on the far-end. Refer to *DEFINITY Enterprise Communications Server Release 5.4 Administration and Feature Description*. The Application Notes section of that book shows the correct settings for administrable timers and other parameters on a country-by-country basis.

Analog CO trunks are 2-wire analog lines to the CO which support both incoming and outgoing calls. CO trunk circuit packs have eight ports, each of which provides an interface between the 2-wire CO line and the 4-wire TDM bus. The system supports the following CO trunk circuit packs:

TN438	TN2138
TN447	TN2147
TN465	TN2148
TN747	

The following sequences show the interactions between the switch and the CO during call setup for both loop-start and ground-start trunks.

## Loop Start Operation

**Idle State:** Tip = ground, Ring = CO Battery **Outgoing Call:**

1. PBX Off-Hook (Seize Message): Closes the Tip-Ring Loop  
CO Response: DC loop current + Dial tone
2. PBX On-Hook (Drop Message): Open Tip-Ring loop, no loop current  
CO Response: CO goes to idle state (see Note)

**Incoming Call:**

1. CO Applies Ringing Voltage  
PBX Response: Detect ringing current
2. PBX Off-Hook (Answer Message): Close loop  
CO Response: Trip ringing, provide loop current
3. PBX On-Hook (Drop Message): Open Tip-Ring loop, no loop current  
CO Response: CO goes to idle state (see Note)



**NOTE:**

CO does not normally provide an On-Hook (Disconnect) signal. Exceptions to this rule include Netherlands loop start and UK loop-calling guarded-clearing.

## Ground Start Operation

**Idle state:** Tip = open, Ring = CO Battery **Outgoing Call:**

1. PBX Off-Hook (Seize Message): Places ground on Ring  
CO Response: Places ground on Tip  
PBX Response: Close the loop  
CO Response: Provide loop current  
PBX response: Dial out digits
2. PBX On-Hook first (Drop Message): Open the Tip-Ring Loop, no loop current  
CO Response: Open circuit on Tip
3. CO On-Hook first (Disconnect): Open circuit on Tip, no loop current  
PBX Response: Open Tip-Ring loop

**Incoming Call:**

1. CO Off-Hook (Seizure): CO applies ground on Tip and applies ringing voltage  
 PBX Response: Make trunk busy for outgoing calls
2. CO Ringing: CO applies ringing voltage  
 PBX Response: Detect ringing, ring destination
3. PBX Off-Hook (Answer Message): Close loop  
 CO Response: Trip ringing, provide loop current
4. PBX On-Hook first (Drop Message): Open the Tip-Ring Loop, no loop current  
 CO Response: Open circuit on Tip
5. CO On-Hook first (Disconnect): Open circuit on Tip, no loop current

**Error Log Entries and Test to Clear Values**

**Table 9-179. CO Trunk Error Log Entries**

Error Type	Aux Data	Associated Test	Alarm Level	On/Off Board	Test to Clear Value
0 <sup>1</sup>	0	Any	Any	Any	test port UUCSSpp sh r 1
1 (a)	57347	None			
15 (b)	any	Port Audit Update Test (#36)			
18	0	busyout trunk	WARNING	OFF	release trunk grp#/mbr#
130(c)		None	WARNING	ON	test port UUCSSpp sh r 2
257 (a)	50176	None			
513 (a)	57364	None	MAJ/MIN/ WRN <sup>2</sup>	ON	
769 (a)	57392	None	MAJ/MIN/ WRN <sup>2</sup>	OFF	
1025 (e)	Any	Demand Diagnostic Test (#3)	MAJ/MIN/ WRN <sup>2</sup>	OFF	test port UUCSSpp sh r 2
1281 (e)	Any	Demand Diagnostic Test (#3)	MAJ/MIN/ WRN <sup>2</sup>	ON	test port UUCSSpp sh r 3
1537		Dial Tone Test (#0)	MAJ/MIN/ WRN <sup>2</sup>	OFF	test port UUCSSpp l r 2

*Continued on next page*

**Table 9-179. CO Trunk Error Log Entries — Continued**

Error Type	Aux Data	Associated Test	Alarm Level	On/Off Board	Test to Clear Value
1793		Looparound and Conference Test (#33)	MAJ/MIN/WRN <sup>2</sup>	ON	test port UUCSSpp   r 3
2049		NPE Cross Talk Test (#6)	MAJ/MIN/WRN <sup>2</sup>	ON	test port UUCSSpp   r 3
2561 (d)	57345	None			
2817 (a)	57360	None			
2817 (a)	57393	None			
2817 (d)	57484	Dial Tone Test(#0)	MAJ/MIN/WRN	OFF	test port UUCSSpp   r 1
3073 (d)	57376	None			
3329 (d)	57408	None			
3329 (d)	57484	Dial Tone Test(#0)	MAJ/MIN/WRN	OFF	test port UUCSSpp   r 1
3585 (d)	57424	None			
3840 (f)	8000	Transmission Tests (ATMS)(#844-848)		OFF	test analog-testcall
3841 (f)		Transmission Tests (ATMS)(#844-848)	MINOR	OFF	test analog-testcall

1. Run the Short Test Sequence first. If all tests pass, run the Long Test Sequence. Refer to the appropriate test description and follow the recommended procedures.
2. Major alarms may be downgraded to Warning alarms based on the value used in the set options command.

**Notes:**

- a. These are in-line errors that have no specific test associated with them. Refer to the following table for an explanation and appropriate action.
- b. This is a software audit error that does not indicate any hardware malfunction. Run Short Test Sequence and investigate associated errors.
- c. This error type indicates that the circuit pack has been removed or has been insane for at least 11-minutes. To clear the error, reinsert or replace the circuit pack.
- d. Aux data 57345 — Single polarity ringing current  
 Aux data 57376 — No loop current on incoming call  
 Aux data 57408 — No tip ground detected on outgoing call

Aux data 57424 — No loop current on outgoing call

Aux data 57484 — No dial tone on outgoing call

These errors will cause the Dial Tone Test (#0) to run and are only considered a problem if the Dial Tone Test fails (in which case Error Type 1537 will also show up). In this case, the trunk may be put in "Ready-for-Service" state (shown as "disconnected" by status command), which allows only incoming calls. Run the Dial Tone Test (#0) and follow its outlined procedures.

If error count associated with this error type is very high (i.e., 255) and if Alarm Status on the Hardware Error Report is "n" (not alarmed), then the existence of this error type indicates that, despite the fact that many in-line error messages have been received, all Call Seizure Tests have passed. Problems at the CO may cause this condition rather than problems with the PBX.

- e. These errors will be logged for all versions of the CO-TRK/CO-BD. However, no MINOR alarms will be generated for Central Office Trunks [TN747B] with vintages V8 or greater. Any failures received by this test will still be logged as Error type 1025/1281.

Check for the use of MFT/Range extenders. If there are extenders present, and there are no other complaints or maintenance errors against this trunk, then there is a good chance that Test #3 failed due to excessive loop current and may be ignored.

- f. Error 3840 indicates that test calls made by the Automatic Transmission Measurement System (ATMS) returned measurements in the unacceptable range. Error 3841 indicates measurements were in the marginal range. Use **list testcall detail** to examine the specific transmission parameters which are out of spec, and investigate the trunk for that kind of noise. If the noise is acceptable, then the AMTS thresholds administered on page 4 of the trunk group form should be changed.

**Table 9-180. CO Trunk Errors with No Tests**

Error Type	Aux Data	Error Description and Repair Action
1	57347	Port error. Ringing without ground. This error is detected on an incoming call on a ground-start CO trunk. The CO trunk circuit pack has not detected a Tip ground before ringing current is detected. This may indicate that the ground detector is not working. However, the call will be accepted. Busyout the affected port, and run a long test. Observe the test results. If any tests fail, refer to the description of the tests and the associated error codes. Release the port. If users continue to report troubles, check for other errors and make test calls to determine whether the problem should be referred to the CO.

**Table 9-180. CO Trunk Errors with No Tests — Continued**

Error Type	Aux Data	Error Description and Repair Action
257	50176	Battery reversal detected. This is usually caused by the CO (often seen with step-by-step and cross-bar offices in connection with outgoing calls). This is detected if the direction of the loop current changes from normal to reverse for at least 40 msec. Could occur if the trunk was just installed and for some reason the Tip and Ring wires were reversed at the PBX. If battery reversals occur during dialing, wrong numbers may result. Refer problem to CO. Ask them to remove the battery reversal option.
513	57364	Ground detector stuck active. After several occurrences, an on-board minor alarm is generated. Run the short test sequence. If test aborts with Error Code 1000, disconnect Tip and Ring and repeat short test. If test still aborts, replace circuit pack. If test passes, refer problem to CO. If any other error code is received, pursue that problem.
769	57392	CO not releasing after call is dropped from PBX end (TN747B), or the loop is not open after a disconnect (TN765). After several occurrences, an off-board (TN747B) or on-board (TN465) warning alarm is generated. Refer problem to CO.
2561	57345	Single polarity ringing current. This error results from abnormal ringing current, but does not prevent the incoming call from being accepted. One cause could be that the reverse current detector associated with the port is failing. (Will not be detected by any tests.) Another cause could be that normal current is not detected. In this case, neither incoming nor outgoing calls can be completed, and the dial tone test will also fail. The last cause could be that certain types of noise are present on the CO line during the silent period of ringing. First check for other errors. If the count for this error is very high (255), and all tests pass, then either the reverse current detector is defective or the CO line is noisy. If the CO line is suspect, make Tip and Ring observations. If the line is determined to be noisy, refer the problem to the CO. If the reverse current detector is defective, ignore this error.
2817	57360	Ground but no ringing. This error occurs on an incoming call on a ground-start trunk. If ringing is not detected within 5 seconds of the Tip being grounded, the call is still accepted. If the CO is of the No. 5ESS switch type, ringing delays of more than 5 seconds during heavy traffic are fairly common. Check for other errors.
2817	57393	On the TN465, the loop is opening too slowly after a disconnect. This error indicates an on-board problem, although the trunk may be functional. Check for other errors.
3073	57376	No loop current on incoming call. The incoming destination has already answered and no loop current has been detected. If this is a hard fault, the dial tone test and all outgoing calls should also fail. Check for other errors.

*Continued on next page*



**Table 9-180. CO Trunk Errors with No Tests — Continued**

Error Type	Aux Data	Error Description and Repair Action
3329	57408	Trunk error. No Tip ground detected on outgoing call. This error occurs when an attempt is made to seize a ground-start CO trunk for an outgoing call and Tip ground is not detected or the caller hangs up before Tip ground is detected. <ol style="list-style-type: none"> <li>1. Busyout the affected port, and run a long test. Observe the test results. If any tests fail, refer to the description of the tests and the associated error codes. Release the port.</li> <li>2. If users continue to report troubles, check for other errors and make test calls to determine whether the problem should be referred to the CO. Busyout the affected port, and run a long test. If Dial Tone Test #0 passes, ignore this error. Release the port.</li> </ol>
3585	57424	No loop current on outgoing call. This error occurs on attempt to seize a loop or ground-start trunk for an outgoing call. An error occurs if loop current is not detected or the caller hangs up before it is detected. Busyout the affected port, and run a long test. If CO Demand Diagnostic Test #3 passes and this error keeps occurring, refer problems to CO. Release the port.

### System Technician-Demanded Tests: Descriptions and Error Codes

Always investigate tests in the order they are presented in the table below when inspecting errors in the system. By clearing error codes associated with the *NPE Crosstalk Test*, for example, you may also clear errors generated from other tests in the testing sequence.

Order of Investigation	Short Test Sequence	Long Test Sequence	D/ND <sup>1</sup>
NPE Crosstalk Test (#6)		X	ND
Dial Tone Test (#0)		X	ND
CO Demand Diagnostic Test (#3) (a)	X	X	ND
Looparound and Conference Test (#33)		X	ND
Audit Update Test (#36)	X	X	ND
Transmission Test - ATMS (#844-848)	(b)	(b)	ND

1. D = Destructive; ND = Nondestructive

Notes:

- a. A demand test of Diagnostic Test (#3) will always return a PASS indication for CO-TRK/CO-BD [TN747B] version 8 or greater. However, any errors produced as a result of this test will be logged and produce no alarms.

If errors logged by test #3 are the only complaints against this trunk, then the system technician should check if MFT/Range Extenders are being used. If extenders are present, then there is a good chance that there is excessive loop current, which will cause Test #3 to log errors.

However, all else being normal, these errors should not affect the customer.

- b. The ATMS tests are not part of either test sequence. They are run either on demand with **test analog-testcall** or by the ATMS schedule.

### Dial Tone Test (#0)

This test attempts to seize a port and checks for the return of a dial tone.

Table 9-181. TEST #0 Dial Tone Test

Error Code	Test Result	Description/ Recommendation
	ABORT	Could not allocate system resources to run this test. 1. Retry the command at 1-minute intervals for a maximum of 5 times.
1000	ABORT	System resources required to run this test are not available. The port may be busy with a valid call. 1. Use the command <b>display port UUCSSpp</b> to determine the trunk group/member number of the port. Use the <b>status trunk</b> command to determine the service state of the port. If the service state indicates that the port is in use, then the port is unavailable for certain tests. You must wait until the port is idle before retesting. 2. Retry the command at 1-minute intervals for a maximum of 5 times.
1001	ABORT	System resources required to run this test were not available. This could be due to a failure to seize the port. 1. Retry the command at 1-minute intervals for a maximum of 5 times.
1002	ABORT	The system could not allocate time slots for the test. The system may be under heavy traffic conditions or it may have time slots out-of-service due to TDM-BUS errors. 1. If the system has no TDM-BUS errors and is not handling heavy traffic, retry the command at 1-minute intervals for a maximum of 5 times.

*Continued on next page*

**Table 9-181. TEST #0 Dial Tone Test — Continued**

Error Code	Test Result	Description/ Recommendation
1004	ABORT	The port was seized by a user for a valid call. <ol style="list-style-type: none"> <li>1. Use the <b>display port UUCSSpp</b> command to determine the trunk group/member number of the port. Use the <b>status trunk</b> command to determine the service state of the port. If the service state indicates that the port is in use, then the port is unavailable for certain tests. You must wait until the port is idle before retesting.</li> <li>2. If the port status is idle, retry the command at 1-minute intervals for a maximum of 5 times.</li> </ol>
1005	ABORT	Trunk has been administered as incoming-only; dial tone can only be obtained on outgoing trunks. This is a normal condition.
1018	ABORT	Test has been disabled via administration. <ol style="list-style-type: none"> <li>1. Verify that the "Maintenance Tests?" field on the Trunk Group Form is set to "n." To enable the test, issue the <b>change trunk-group x</b> command where "x" equals the number of the trunk group to be tested. Then change the entry in the "Maintenance Tests?" field on the form to "y."</li> </ol>
2000	ABORT	Response to the test was not received within the allowable time period. <ol style="list-style-type: none"> <li>1. Retry the command at 1-minute intervals for a maximum of 5 times.</li> </ol>
	FAIL	Trunk was seized, but dial tone could not be detected. <ol style="list-style-type: none"> <li>1. Test all administered outgoing ports on the board. Failure of 1 indicates a problem toward the CO.</li> <li>2. If all fail, see note below.</li> <li>3. Check for errors on the TONE-BD or TONE-PT. Clear any errors found, and repeat the test.</li> <li>4. If the error has still not cleared, refer the problem to the CO.</li> <li>5. If no service problems exist on the port, continue to use the port until the circuit pack can be replaced (as a last resort). Perform a trunk test call to see if the trunk is operable.</li> </ol> <p><b>⇒ NOTE:</b>                      If the dial tone test fails for all ports on a circuit pack, a -5 volt power problem is indicated. To investigate problems with a power unit, refer to "CARR-POW".</p>

*Continued on next page*

Table 9-181. TEST #0 Dial Tone Test — *Continued*

Error Code	Test Result	Description/ Recommendation
2002	FAIL	<p>Seizure portion of test failed due to hardware problem. Fault is usually caused by a disconnected trunk.</p> <ol style="list-style-type: none"><li>1. If the CO Demand Diagnostic Test (#3) also failed, display the Hardware Error Log. If the CO Demand Diagnostic Test failed because it could not detect ground (indicated by Error Type 1281 in the Hardware Error Log) AND Error Type 3329 or 3585 appears in the Hardware Error Log (with the same last occurred time as Error Type 1281 and 1537), replace the circuit pack.</li><li>2. Check trunk wiring to ensure good connection; repeat test if wiring correction made.</li><li>3. Locate another identical CO trunk and swap its wiring with one under test. Repeat test on both trunks and determine if problem follows trunk or remains at original port. If problem follows trunk, refer problem to CO. If problem remains at port, replace circuit pack and repeat test.</li></ol>
1009	PASS	Detected tone was not pure dial tone. No action required.
	PASS	Trunk was seized, and dial tone was detected. User-reported troubles on this port should be investigated by using other port tests and by examining trunk or external wiring.
0	NO BOARD	<p>The test could not relate the internal ID to the port.</p> <ol style="list-style-type: none"><li>1. Check to ensure that the board translations are correct. Translate the board, if necessary.</li><li>2. Issue the <b>busyout board</b> command.</li><li>3. Issue the <b>reset board</b> command.</li><li>4. Issue the <b>release busy board</b> command.</li><li>5. Issue the <b>test board</b> command. This should re-establish the linkage between the internal ID and the port.</li></ol>

### CO Demand Diagnostic Test (#3)

For ground start trunks, port circuit pack relays are operated and checks are made to see if the port can detect and apply ground on the Tip lead. This test also verifies that there is no external ground on the Ring lead. In the absence of other failures, the circuit pack should be replaced only if this test fails with the CO line disconnected.

For the TN2147, this test also checks the on-board programmable transmission circuits that allow the circuit pack to support transmission characteristics of several different countries.

**Table 9-182. TEST #3 CO Demand Diagnostic Test**

Error Code	Test Result	Description/ Recommendation
	ABORT	Could not allocate system resources to run this test. 1. Retry the command at 1-minute intervals for a maximum of 5 times.
1000	ABORT	System resources required to run this test are not available. The port may be busy with a valid call. 1. Use the <b>display port UUCSSpp</b> command to determine the trunk group/member number of the port. Use the <b>status trunk</b> command to determine the service state of the port. If the service state indicates that the port is in use, then the port is unavailable for certain tests. You must wait until the port is idle before retesting. 2. If the port status is idle, retry the command at 1-minute intervals for a maximum of 5 times.
1004	ABORT	The port was seized by a user for a valid call. 1. Use the <b>display port UUCSSpp</b> command to determine the trunk group/member number of the port. Use the <b>status trunk</b> command to determine the service state of the port. If the service state indicates that the port is in use, then the port is unavailable for certain tests. You must wait until the port is idle before retesting. 2. If the port status is idle, retry the command at 1-minute intervals for a maximum of 5 times.
1005	ABORT	Test inapplicable to present configuration. This is a normal condition.
1018	ABORT	Test has been disabled via administration. 1. For this test to run, the <code>Maintenance Tests?</code> field on the trunk group form must be set to <code>n</code> . The form is accessed with the <code>change trunk-group grp#</code> command.
2000	ABORT	Response to the test was not received within the allowable time period. 1. Retry the command at 1-minute intervals for a maximum of 5 times.

*Continued on next page*

Table 9-182. TEST #3 CO Demand Diagnostic Test — Continued

Error Code	Test Result	Description/ Recommendation
	FAIL	<p>Failure to detect ground or faulty ground detected on Ring lead. Display the hardware errors for this trunk, to determine if the fault was on- or-off board. Look for Error Type 1025 or 1281 (if both appear in the Hardware Error Log, pick the most recent error). Error Type 1025 indicates a faulty ground detected on Ring lead (an off-board fault) and Error Type 1281 indicates failure to detect (internally generated) ground (an on-board fault).</p> <p>Faulty ground detected on Ring lead (Error Type 1025):</p> <p> <b>NOTE:</b>                      On TN747B vintage 8 and greater circuit packs, an incoming seizure during this test may cause it to fail with an off-board fault.</p> <ol style="list-style-type: none"> <li>1. Repeat test. If test passes, ignore the original failure. If test aborts, follow the recommended procedures.</li> <li>2. Repeat test with CO line removed.</li> <li>3. If test fails, replace the circuit pack.</li> <li>4. If test passes, refer problem to CO.</li> </ol> <p>Failure to detect ground (Error Type 1281):</p> <ol style="list-style-type: none"> <li>1. Run the long test sequence. If the CO Demand Diagnostic Test fails, the Dial Tone Test (#0) fails with Error Code 2002, AND Error Type 3329 or 3585 appears in the Hardware Error Log (with the same last occurred time as Error Type 1281 and 1537), replace the circuit pack.</li> <li>2. Repeat test with CO line removed.</li> <li>3. If test fails, replace the circuit pack.</li> <li>4. If test passes, the CO may be drawing too much current. Refer problem to CO.</li> </ol>
	PASS	<p>This test verifies that the port is able to apply ground for outgoing calls and detect ground for incoming calls; however, it does not provide information on whether a CO line is actually connected. User-reported troubles on this port should be investigated by using other port tests and by examining trunk or external wiring.</p>
0	NO BOARD	<p>The test could not relate the internal ID to the port (no board).</p> <ol style="list-style-type: none"> <li>1. Check to ensure that the board translations are correct. Translate the board, if necessary.</li> <li>2. Issue the <b>busyout board</b> command.</li> <li>3. Issue the <b>reset board</b> command.</li> <li>4. Issue the <b>release busy board</b> command.</li> <li>5. Issue the <b>test board</b> command. This should re-establish the linkage between the internal ID and the port.</li> </ol>

## NPE Crosstalk Test (#6)

The NPE Crosstalk Test verifies that this port's NPE channel talks on the selected time slot and never crosses over to time slots reserved for other connections. If the NPE is not working correctly, one way and noisy connections may be observed. This test is usually only part of a port's long test sequence and takes approximately 20 to 30 seconds to complete.

**Table 9-183. TEST #6 NPE Crosstalk Test**

Error Code	Test Result	Description/ Recommendation
	ABORT	Could not allocate the necessary system resources to run this test. 1. Retry the command at 1-minute intervals for a maximum of 5 times.
1000	ABORT	The port was seized by a user for a valid call. 1. Use the <b>display port UUCSSpp</b> command to determine the trunk group/member number of the port. Use the <b>status trunk</b> command to determine the service state of the port. If the port is in use, wait until the port is idle before testing. 2. If the port status is active but the port is not in use (no calls), check the error log for error type 1025 (see the error log table for a description of this error and required actions). The port may be locked up. Check the CO wiring, check for excessive loop current, and check the trunk translations. (If the trunk is translated incorrectly, this test will abort.) 3. If the port status is idle, busyout and release the trunk, and retry the command at 1-minute intervals for a maximum of 5 times. 4. If the test still aborts, replace the circuit pack.
1001	ABORT	Could not allocate the necessary system resources to run this test. 1. Retry the command at 1-minute intervals for a maximum of 5 times.
1002	ABORT	The system could not allocate time slots for the test. The system may be under heavy traffic conditions or it may have time slots out-of-service due to TDM-BUS errors. 1. If system has no TDM-BUS errors and is not handling heavy traffic, retry the command at 1-minute intervals for a maximum of 5 times..
1003	ABORT	The system could not allocate a tone receiver for the test. The system may be oversized for the number of tone detectors present or some tone detectors may be out-of-service. 1. Resolve any TTR-LEV errors. 2. Resolve any TONE-PT errors. 3. If neither condition exists, retry the command at 1-minute intervals for a maximum of 5 times.

*Continued on next page*

Table 9-183. TEST #6 NPE Crosstalk Test — Continued

Error Code	Test Result	Description/ Recommendation
1004	ABORT	The port was seized by a valid call during the test. The test has been aborted. <ol style="list-style-type: none"><li>1. Use the <b>display port UUCSSpp</b> command to determine the trunk group/member number of the port. Use the <b>status trunk</b> command to determine the service state of the port. If the port is in use, wait until the port is idle before testing.</li></ol>
2000	ABORT	Response to the test request was not received within the allowable time period.
2100	ABORT	Could not allocate the necessary system resources to run this test. <ol style="list-style-type: none"><li>1. Retry the command at 1-minute intervals for a maximum of 5 times.</li></ol>
Any	FAIL	The NPE of the tested port was found to be transmitting in error. This will cause noisy and unreliable connections. <ol style="list-style-type: none"><li>1. Replace the circuit pack.</li></ol>
	PASS	The port is correctly using its allocated time slots. User-reported troubles on this port should be investigated by using other port tests and by examining trunk or external wiring.
0	NO BOARD	The test could not relate the internal ID to the port (no board). <ol style="list-style-type: none"><li>1. Check to ensure that the board translations are correct. Translate the board, if necessary.</li><li>2. Issue the <b>busyout board</b> command.</li><li>3. Issue the <b>reset board</b> command.</li><li>4. Issue the <b>release busy board</b> command.</li><li>5. Issue the <b>test board</b> command. This should re-establish the linkage between the internal ID and the port.</li></ol>

### Looparound and Conference Circuit Test (#33)

This test checks the reflective loop around and conference capabilities of a CO port circuit. The test uses 404-Hz, 1004-Hz, and 2804-Hz tones. Each tone is transmitted separately through the loop and checked.



**Table 9-184. TEST #33 Looparound and Conference  
 Circuit Test**

Error Code	Test Result	Description/ Recommendation
7 129 131 133	ABORT ABORT ABORT	<p>Could not allocate the necessary system resources to run this test.</p> <p>Conference Circuit Test aborted.</p> <p>The 404-Hz reflective loop around test aborted. Response to the test request was not received within the allowable time period.</p> <p>The 1004-Hz reflective loop around test aborted. Response to the test request was not received within the allowable time period.</p> <p>The 2804-Hz reflective loop around test aborted. Response to the test request was not received within the allowable time period.</p> <ol style="list-style-type: none"> <li>1. Retry the command at 1-minute intervals for a maximum of 5 times.</li> </ol>
1000	ABORT	<p>System resources required to run this test are not available. The port may be busy with a valid call.</p> <ol style="list-style-type: none"> <li>1. Use the <b>display port UUCSSpp</b> command to determine the trunk group/member number of the port. Use the <b>status trunk</b> command to determine the service state of the port. If the port is in use, wait until the port is idle before testing.</li> <li>2. If the port status is active but the port is not in use (no calls), check the error log for error type 769 (see the error log table for a description of this error and required actions). The port may be locked up.</li> <li>3. If the port status is idle, retry the command at 1-minute intervals for a maximum of 5 times.</li> </ol>
1002	ABORT	<p>The system could not allocate time slots for the test. The system may be under heavy traffic conditions or it may have time slots out-of-service due to TDM-BUS errors.</p> <ol style="list-style-type: none"> <li>1. If system has no TDM-BUS errors and is not handling heavy traffic, retry the command at 1-minute intervals for a maximum of 5 times.</li> </ol>
1003	ABORT	<p>The system could not allocate a tone receiver for the test. The system may be oversized force.</p> <ol style="list-style-type: none"> <li>1. Resolve any TTR-LEV errors.</li> <li>2. Resolve any TONE-PT errors.</li> <li>3. If neither condition exists, retry the command at 1-minute intervals for a maximum of 5 times.</li> </ol>

*Continued on next page*

**Table 9-184. TEST #33 Looparound and Conference  
 Circuit Test — Continued**

Error Code	Test Result	Description/ Recommendation
1004	ABORT	System resources required to run this test are not available. The port may be busy with a valid call. <ol style="list-style-type: none"> <li>1. Use the <b>display port UUCSSpp</b> command to determine the trunk group/member number of the port. Use the <b>status trunk</b> command to determine the service state of the port. If the port is in use, wait until the port is idle before testing.</li> <li>2. If the port status is idle, retry the command at 1-minute intervals for a maximum of 5 times..</li> </ol>
1018	ABORT	The test was disabled via administration. Verify that the 'Maintenance Test' field on the 'Trunk Group' form is set to 'n'. To enable the test, issue the 'change trunk-group x' command (x equals the number of the trunk group to be tested). Then, change the entry in the 'Maintenance Test' field on the form to 'y'. <ol style="list-style-type: none"> <li>1. Retry the command at 1-minute intervals for a maximum of 5 times.</li> </ol>
2000	ABORT	Response to the test was not received within the allowable time period. <ol style="list-style-type: none"> <li>1. Retry the command at 1-minute intervals for a maximum of 5 times.</li> </ol>
2100	ABORT	Could not allocate the necessary system resources to run this test. <ol style="list-style-type: none"> <li>1. Retry the command at 1-minute intervals for a maximum of 5 times.</li> </ol>
7 129 131 133	FAIL	The conference capabilities of the port failed (Error Code 7). The reflective 404-Hz Tone Test failed. No transmission was detected to or from the port (Error Code 129). The reflective 1004-Hz Tone Test failed. No transmission was detected to or from the port (Error Code 131). The reflective 2804-Hz Tone Test failed. No transmission was detected to or from the port (Error Code 133). FAULT ISOLATION: Proceed as follows unless power or tone problems are suspected (see notes on the next page). <ol style="list-style-type: none"> <li>1. To make sure the problem is on-board, disconnect the port from the CO and retry the test. Coordinate this with the CO, or do it after busy hours; otherwise, the CO may put the connection out of service.</li> <li>2. If the retry fails, replace the circuit pack.</li> <li>3. If the retry passes and no troubles have been reported, disable the test. If the retry passes and troubles have been reported, refer the problem to the CO.</li> </ol>

*Continued on next page*

**Table 9-184. TEST #33 Looparound and Conference  
 Circuit Test — Continued**

Error Code	Test Result	Description/ Recommendation
7, 129, 131, or 133	FAIL	<p><b>⇒ NOTE:</b>                      If the loop around and conference circuit test fails for all ports on a circuit pack, a -5 volt power problem is indicated. To investigate problems with a power unit, refer to "CARR-POW". If a red LED on TN736 or TN752 power unit circuit pack is on, replace the pack. If the test fails on more than 1 port, check for errors on the TONE-BD or the TONE-PT. If errors, take appropriate actions. When the tone errors are cleared, rerun the test. If the test fails again, see FAULT ISOLATION above.</p>
	PASS	CO Trunk Looparound and Conference Test is successful. User-reported troubles on this port should be investigated by using other port tests and by examining trunk or external wiring.
0	NO BOARD	<p>The test could not relate the internal ID to the port (no board).</p> <ol style="list-style-type: none"> <li>1. Check to ensure that the board translations are correct. Translate the board, if necessary.</li> <li>2. Issue the <b>busyout board</b> command.</li> <li>3. Issue the <b>reset board</b> command.</li> <li>4. Issue the <b>release busy board</b> command.</li> <li>5. Issue the <b>test board</b> command. This should re-establish the linkage between the internal ID and the port.</li> </ol>

### Port Audit Update Test (#36)

This test will send updates of the CO port translation for all ports on the circuit pack which have been translated. The update is non-disruptive and guards against possible corruption of translation data contained on the circuit pack. No response message is expected from the circuit pack once it receives translation updates. The port translation data includes: ground or loop start trunk, tone or rotary dialing trunk, rotary dialing inter-digit timing, network balance R/RC, and disconnect timing.

**Table 9-185. TEST #36 Port Audit Update Test**

Error Code	Test Result	Description/ Recommendation
	ABORT	Could not allocate the necessary system resources to run this test. 1. Retry the command at 1-minute intervals for a maximum of 5 times.
1006	ABORT	The port has been placed out of service, perhaps by craft busyout. 1. Use the <b>display port UUCSSpp</b> command to determine the trunk group/member number of the port. Use the <b>status trunk</b> command to determine the service state of the port. If the service state indicates that the port is in use, wait until the port is idle before testing. 2. If the port status is idle, retry the command at 1-minute intervals for a maximum of 5 times.
2100	ABORT	System resources required to run this test were not available. 1. If the port status is idle, retry the command at 1-minute intervals for a maximum of 5 times.
	FAIL	Internal system error 1. Retry the command at 1-minute intervals for a maximum of 5 times.
	PASS	This test passed. Translation information was successfully updated on the circuit pack. User-reported troubles on this port should be investigated by using other port tests and by examining trunk or external wiring. If the trunk is busied out, the test will not run, but will return PASS. To verify that the trunk is in-service: 1. Enter <b>status trunk</b> to verify that the trunk is in-service. If the trunk is in-service, no further action is necessary. If the trunk is out-of-service, continue to Step 2. 2. Enter <b>release trunk</b> command to put trunk back into in-service. 3. Retry the test command.
0	NO BOARD	The test could not relate the internal ID to the port (no board). 1. Check to ensure that the board translations are correct. Translate the board, if necessary. 2. Issue the <b>busyout board</b> command. 3. Issue the <b>reset board</b> command. 4. Issue the <b>release busy board</b> command. 5. Issue the <b>test board</b> command. This should re-establish the linkage between the internal ID and the port.

**Transmission Test (#844-848)**

This test is non-destructive.

**⇒ NOTE:**

Tests #844-848 are not supported on a International switch.

These tests are run by the Automatic Transmission Measurement System (ATMS). They are not part of the long or short trunk test sequences. Instead, they are run on demand with the **test analog-testcall** command or as part of ATMS scheduled testing. For more information, see [“Automatic Transmission Measurement System \(ATMS\)”](#) in [Chapter 6, “Additional Maintenance Procedures”](#).

The test call is run from an analog port on a TN771 Maintenance/Test circuit pack. It attempts to seize a port and make a call to a terminating test line (TTL) on the trunk's far end. Transmission performance measurements are made and compared to administered thresholds. Errors are generated when results fall outside of "marginal" or "unacceptable" thresholds. Detail and summary measurement reports are obtainable via the **list testcalls** command.

**Table 9-186. TEST #844-848 Transmission Test**

Error Code	Test Result	Description/ Recommendation
1000	ABORT	System resources required to run this test are not available. The port may be busy with a valid call. <ol style="list-style-type: none"><li>1. Use <b>display port UUCSSpp</b> to determine the trunk group/member number of the port. Use the "status trunk" command to determine the service state of the port. If the port is in use, wait until the port is idle before testing.</li><li>2. If the port status is idle, then retry the command at 1-minute intervals for a maximum of 5 times.</li></ol>
1001	ABORT	Could not allocate the necessary system resources to run this test. <ol style="list-style-type: none"><li>1. Retry the command at 1-minute intervals for a maximum of 5 times.</li></ol>
1002	ABORT	The system could not allocate timeslots for the test. The system may be under heavy traffic conditions or it may have timeslots out of service due to TDM bus errors. <ol style="list-style-type: none"><li>1. If system has no TDM bus errors and is not handling heavy traffic, retry the command at 1-minute intervals for a maximum of 5 times.</li></ol>
1004	ABORT	The port has been seized by a user for a valid call. Use status trunk to determine when the port is available for testing. <ol style="list-style-type: none"><li>2. Retry the command at 1-minute intervals for a maximum of 5 times.</li></ol>
1005	ABORT	Trunk has been administered as incoming-only; transmission tests can only be run on outgoing trunks.

*Continued on next page*

**Table 9-186. TEST #844-848 Transmission Test — Continued**

Error Code	Test Result	Description/ Recommendation
1115	ABORT	The near end test line on the TN771 circuit pack could not be allocated. 1. Verify that the TN771 circuit pack is in service and that port 1 is administered and in service with the <b>status port</b> command. 2. Retry the command at 1-minute intervals for a maximum of 5 times.
1900	ABORT	The test completion message was not received from the TN771 circuit pack. 1. Test the TN771 circuit packs.
1901	ABORT	This error occurs when the TN771 circuit pack uplinks a message that is not the proper response for this test. The anticipated uplink messages are seize, ring or answer. 1. Verify that the Trunk is administered properly.
1905	ABORT	Intercept tone detected from far end. 1. Get the test line data from theand verify it with the far end. Dial the test number manually to see if the TTL is reached. If it is not, then either the number is wrong, or the far end is administered incorrectly.
1906	ABORT	Reorder tone detected from far end. 1. See actions for error code 1905.
1907	ABORT	Other unexpected tone detected from far end. 1. See actions for error code 1905.
1913	ABORT	Audible Ring detected from far end. 1. See actions for error code 1905.
1914	ABORT	Unidentified interrupted tone detected from far end. 1. See actions for error code 1905
1915	ABORT	Busy tone detected from far end. 1. Since the test line at the far end was busy. Try the test again. 2. If the test continues to abort, the problem is with the far end system.
1918	ABORT	Test progress tone not removed from far end (type 105 test line only). 1. The problem is with the far end system; a technician at the far end should test the test line (TN771 or ADFTC).
1919	ABORT	Unexpected far end release 1. The problem is with the far end system; a technician at the far end should test the test line (TN771 or ADFTC).
1920	ABORT	No response from far end. 1. The problem is with the far end system; a technician at the far end should test the test line (TN771 or ADFTC).

*Continued on next page*

**Table 9-186. TEST #844-848 Transmission Test — Continued**

Error Code	Test Result	Description/ Recommendation
1921	ABORT	No data returned from far end. 1. The problem is with the far end system; a technician at the far end should test the test line (TN771 or ADFTC).
1922	ABORT	Steady, unidentifiable tone from far end 1. See actions for error code 1905.
1923	ABORT	Broadband energy detected from far end (such as voice or announcement). 1. See actions for error code 1905.
1924	ABORT	No test tone from far end 1. See actions for error code 1905.
1938	ABORT	Near-end self test failed. 1. Test the TN771 circuit packs.
1939	ABORT	Loss self check at 0dBm at 1004 Hz failed. 1. Test the TN771 circuit packs.
1940	ABORT	Far end noise self check failed. 1. The problem is with the far end system; a technician at the far end should test the test line (TN771 or ADFTC).
1941	ABORT	High frequency singing return loss self check failed. 1. Test the TN771 circuit packs.
1942	ABORT	Echo return loss self check failed. 1. Test the TN771 circuit packs.
1943	ABORT	Singing return loss self check failed. 1. Test the TN771 circuit packs.
1944	ABORT	Loss self check at -16 dBm at 1004 Hz failed. 1. Test the TN771 circuit packs
1945	ABORT	Loss self check at -16 dBm at 404 Hz failed. 1. Test the TN771 circuit packs.
1946	ABORT	Loss self check at -16 dBm at 2804 Hz failed. 1. Test the TN771 circuit packs.
1947	ABORT	Noise with tone self check failed. 1. Test the TN771 circuit packs.
2000	ABORT	The test timed out while waiting for a response from the TN771 circuit pack. 1. Retry the command at 1-minute intervals for a maximum of 5 times.

*Continued on next page*

Table 9-186. TEST #844-848 Transmission Test — *Continued*

Error Code	Test Result	Description/ Recommendation
2012	ABORT	An internal software error occurred. 1. Retry the command at 1-minute intervals for a maximum of 5 times.
2053	ABORT	The test call could not be established, but no information on why is available. 1. Retry the command at 1-minute intervals for a maximum of 5 times.
2056	ABORT	An error occurred while trying to obtain results from the TN771 circuit pack. 1. Test the TN771 circuit packs.
	FAIL	Measured transmission performance was in the unacceptable range as administered on the trunk group form. Retrieve a measurement report via the <b>list testcalls</b> command. Make sure that ATMS thresholds are set properly on page 4 of the trunk group form. Besides the facility, test failures can be caused by faulty test lines or switch paths. If the measurements point to a facility problem, report the results to the trunk vendor.
8000	FAIL	Measured transmission performance was in the marginal range as administered on the trunk group form. This generally means that the trunk is usable but has an undesirable amount of noise or loss. If the user does not report unacceptable effects, it may not be necessary to take any action. Retrieve a measurement report via the <b>list testcalls</b> command. Make sure that ATMS thresholds are set properly on page 4 of the trunk group form.



## CONFIG (System Configuration)

MO Name (in Alarm Log)	Alarm Level	Initial Command to Run	Full Name of MO
CONFIG	none	none	System Configuration

The System Configuration maintenance object (MO) oversees logical insertion and removal of circuit packs in the system. When Switch Control detects that a circuit pack is present in a port slot, it informs System Configuration and System Configuration queries the circuit pack to determine the type and vintage of the circuit pack. Similarly, when Switch Control detects that a circuit pack has been removed from a port slot, it informs System Configuration.

There are no alarms or tests for System Configuration, but three types of errors are logged to the Hardware Error Log.

### Error Log Entries and Test to Clear Values

**Table 9-187. System Configuration Error Log Entries**

Error Type	Aux Data	Associated Test	Alarm Level	On/Off Board	Test to Clear Value
0 <sup>1</sup>	0	none	none	N/A	none
1-119 (a)	0-21	none	MAJOR		
257(b)		none			
1001-1119 (c)	0-21	none			

1. This error should not occur. It indicates that an attempt was made by software to raise an alarm against CONFIG without first logging a CONFIG error.

Notes:

- a. This error indicates that a port circuit pack in the system did not respond to a circuit pack type inquiry. Follow the procedures outlined in (b) to determine if there is an error.
- b. This error indicates that less than 25% of Trunk Group is available.
- c. This error indicates that a port circuit pack in the system did not respond to a vintage inquiry.

As a result of either of these errors, a port circuit pack may be physically inserted in a port slot, but the system may not recognize its existence. The Aux Data field specifies the circuit pack's port-network number as indicated in the following table.

Converting Aux Data to Port-Network Number

Aux Data	Port-Network Number
0	1
1	2
2	3
3	4
4	5
5	6
6	7
7	8
8	9
9	10
10	11
11	12
12	13
13	14
14	15
15	16
16	17
17	18
18	19
19	20
20	21
21	22

The Error Type field specifies the carrier and slot location of the circuit pack that caused the error as indicated in [Table 9-188](#). If the Error Type field is greater than 1000, subtract 1000 from the Error Type field before consulting the table.

If more than one CONFIG error is logged with an Aux Data of 1 at the same time, investigate any EXP-INTF (Expansion Interface) errors before proceeding. Once the port circuit pack location has been determined from [Table 9-188](#), use the **list configuration all** command to determine if the circuit pack is inserted. If not, insert the pack. If the circuit pack has already been inserted but the error persists, replace the circuit pack.

**Table 9-188. Converting Error Types  
 To Carrier Locations**

Error Type	Carrier Location
1	a)
2	E01
3	E02
4	E03
5	E04
6	E05
7	E06
8	E07
9	E08
10	E09
11	E10
12	E11
13	E12
14	E13
15	E14
16	E15
17	E16
18	E17
19	E18
20	E19
21	E20
22	E00 (d)
23	a)
24	a)
25	(a)
26	(a)
27	A00 (e)
28	A01 (b)
29	A02
30	A03
31	A04
32	(a)
33	(a)
34	D01

*Continued on next page*

**Table 9-188. Converting Error Types  
 To Carrier Locations — Continued**

Error Type	Carrier Location
35	D02
36	D03
37	D04
38	D05
39	D06
40	D07
41	D08
42	D09
43	D10
44	D11
45	D12
46	D13
47	D14
48	D15
49	D16
50	D17
51	D18
52	D19
53	D20
54	D00 (d)
55	(a)
56	A05
57	A06
58	A07
59	A08
60	A09
61	A10 (c)
62	A11
63	A12
64	(a)
65	(a)
66	B01
67	B02
68	B03

*Continued on next page*

**Table 9-188. Converting Error Types  
 To Carrier Locations — Continued**

Error Type	Carrier Location
69	B04
70	B05
71	B06
72	B07
73	B08
74	B09
75	B10
76	B11
77	B12
78	B13
79	B14
80	B15
81	B16
82	B17
83	B18
84	B19
85	B20
86	B00 (d)
87	(a)
88	A13
89	A14
90	A15
91	A16
92	A17
93	A18
94	A19
95	A20
96	(a)
97	(a)
98	C01
99	C02
100	C03
101	C04
102	C05

*Continued on next page*

**Table 9-188. Converting Error Types  
To Carrier Locations — Continued**

Error Type	Carrier Location
103	C06
104	C07
105	C08
106	C09
107	C10
108	C11
109	C12
110	C13
111	C14
112	C15
113	C16
114	C17
115	C18
116	C19
117	C20
118	C00 (d)
119	(a)

**Notes:**

- a. These error types do not represent physical port circuit pack slots and are not logged against CONFIG.
- b. If this error type occurs in the PPN, it refers to the A-Carrier Tone Generator circuit pack. If it occurs in any EPN, it refers to the circuit pack in slot A01.
- c. If this error type occurs in the PPN, it refers to the B-Carrier Tone Generator circuit pack. If it occurs in any EPN, it refers to the circuit pack in slot A10.
- d. Slots B00, C00, D00, and E00 refer to the *Service Slots* in the B, C, D, And E carriers.
- e. In EPN A-Carriers, slot A00 is the Tone Generator slot.

## CUST-ALM (Customer-Provided Alarming Device)

---

MO Name (in Alarm Log)	Alarm Level	Initial Command to Run <sup>1</sup>	Full Name of MO
CUST-ALM	none	test customer-alarm UUC	Customer-Provided Alarming Device

1. where UUC is an appropriate cabinet number and carrier (duplicated SPE system only, that is, can be 1a or 1b).

The system provides customers a way to connect their own alarm indication device to a switch. The CUST-ALM maintenance object represents this customer-provided alarming device (CPAD).

The customer administers the level of alarm for which the CPAD will be activated via the **change system-parameter maintenance** form (CPE Alarm Activation Level field). The customer sets this field to: **none**, **warning**, **minor**, or **major** depending on the level of alarm at which the CPAD should be activated. When an alarm occurs of at least the level to which the CPAD is administered, the CPAD in the PPN and the EPN will be activated. The CPAD will also be activated within a cabinet whenever Emergency Transfer is invoked within that cabinet.

The CPAD is connected to the SYSAM in the PPN (in a duplicated SPE system, the CPAD is connected to both SYSAMs), and to the EPN Maintenance circuit pack in the EPN. The CUST-ALM maintenance object is not maintained by the system, and will not generate any alarms. If a problem is suspected with the CPAD, it may be tested using the **test customer-alarm** command, which will activate the device by closing the relay on either the SYSAM or the EPN Maintenance circuit pack (whichever is specified) for 1-minute. In a duplicated SPE system the CPAD on the PPN is connected to the SYSAM on both carrier A and carrier B, and the **test customer-alarm** command will close the relay on the active SYSAM. The repeat parameter may be used to close the relay for a longer length of time where the number of the repeat is the number of minutes for which the device will be activated (5 minutes is the suggested repeat value).

### System Technician-Demanded Tests: Descriptions and Error Codes

---

The **test customer-alarm UUC** command is provided to allow a technician to check that the customer-provided alarming device is correctly installed and functional. It is recommended that this test be run at least once after both the switch and the customer alarm have been installed.

## Customer-Provided Alarming Device Test (#115)

The Customer-Provided Alarming Device (CPAD) Test closes the relay that activates the CPAD for 1-minute only within the port network specified. If it takes longer than 1-minute to check that the CPAD has been activated, the Repeat field on the **test customer-alarm UUC** command can be used to close the relay for up to 99 minutes. Note that when the repeat option is used, the results for Test #115 come back immediately and, for each test that passed, the CPAD is kept on for that many minutes. The CPAD does not go off after 1-minute and then come back on. Instead, the CPAD is kept on continuously for the entire time. If the CPAD is being activated and deactivated in a flickering fashion, there is a problem with either the CPAD, or the SYSAM, or the EPN Maintenance circuit pack.

**Table 9-189. TEST #115 Customer-Provided Alarming Device Test**

Error Code	Test Result	Description/ Recommendation
Any	ABORT	Internal system error <ol style="list-style-type: none"><li>1. Retry the command at 1-minute intervals for a maximum of 5 times.</li></ol>
	PASS	The switch software successfully sent the request to the SYSAM or EPN Maintenance circuit pack to turn on the CPAD. The CPAD must be physically inspected to verify that it is working. If the CPAD is working but the customer has complained that the CPAD did not indicate a system alarm when it occurred, then check the administered alarm level for turning on the CPAD. This is on the <b>display system-parameter maintenance</b> form. Compare this level with the customer's specifications. If the level does not match the customer's specifications, change it using the <b>change system-parameter maintenance</b> form. If Test #115 passes, and the CPAD is not being activated, check the connection of the CPAD to the SYSAM or EPN Maintenance circuit pack. If the CPAD can be activated but cannot be deactivated, first check to make sure Emergency Transfer is not activated in the affected port network via the <b>status port-network</b> command. Emergency Transfer can be forced to manual OFF via the Emergency Transfer switch on the SYSAM or EPN Maintenance circuit pack. If Emergency Transfer is OFF and the CPAD still cannot be deactivated, check the administered levels for the CPAD via the <b>display system-parameter maintenance</b> form and compare against the alarm levels currently present in the system ( <b>display alarms</b> command).



## DAT-LINE (Data Line Port)

---

MO Name (in Alarm Log)	Alarm Level	Initial Command to Run <sup>1</sup>	Full Name of MO
DAT-LINE	MINOR	test port UUCSSpp l	Data Line Port
DAT-LINE	WARNING	test port UUCSSpp l	Data Line Port

- 
1. UU is the universal cabinet number (1 for PPN, 2 -44 for EPNs). C is the carrier designation (A, B, C, D, or E). SS is the number of the slot in which the circuit pack resides (01 to 21). pp is the two digit port number (01, 02, ...).
- 

The TN726 Data Line circuit pack has 8 ports, each of which supports an RS-232 interface to asynchronous Customer Premises Equipment (CPE). Each of these ports and the equipment connected to it constitute a data line. For DT-LN-BD (Data Line Circuit Pack) errors, refer to "XXX-BD (Common Port Circuit Pack)". Check circuit pack-level errors first since the usability of the ports depend on the health of the circuit pack.

Data line ports are administered at the terminal with the **add data-module** command. The data module type is *data-line*. The **list data-module** command will list all administered data modules in the system. See "PDATA-PT" for details on how data lines are used as system ports.

The TN750 Announcement circuit pack also has one data line-type port on it. This data line port is used for saving and restoring announcements. For a description of this feature and repair instructions for the TN750, refer to "ANN-BD".

### NOTE:

If the tests for the data line port in question pass, and user-reported complaints persist, there is probably an external problem. Test the asynchronous data unit (ADU), following the procedures outlined in *User Manual Z3A Asynchronous Data Unit*, 555-401-701. If the ADU appears to be working properly, check the external wiring, and then check the customer equipment.

## Error Log Entries and Test to Clear Values

**Table 9-190. Data Line Port Error Log Entries**

Error Type	Aux Data	Associated Test	Alarm Level	On/Off Board	Test to Clear Value
0 <sup>1</sup>	0	Any	Any	Any	test port UUCSSpp sh r 1
1		Digital Looparound Test (#171)	MINOR	ON	test port UUCSSpp s r 2
15(a)	Any	Audit Update Test (#36)			
18	0	Busyout port UUCSSpp	WARNING	OFF	rel port UUCSSpp
130 (b)		None	WARNING	ON	test port UUCSSpp sh
257		Conference Circuit Test (#7)	MINOR	ON	test port UUCSSpp l r 2
513		NPE Crosstalk Test (#6)	MINOR	ON	test port UUCSSpp l r 2
769(c)	40983	None			

1. Run the Short Test Sequence first. If all tests pass, run the Long Test Sequence. Refer to the appropriate test description and follow the recommended procedures.

### Notes:

- a. This is a software audit error that does not indicate any hardware malfunction. Run the Short Test Sequence and investigate errors.
- b. Indicates the circuit pack has been removed or has been insane for more than 11-minutes. To clear the error, reseal or replace the circuit pack.
- c. Error type 769 indicates that the data line circuit pack found an error in the transmit/receive circuitry of an administered data line when the circuit pack was inserted. Perform the following:

1. Enter **busyout board UUCSS** for the circuit pack on which the port resides.
2. Enter **reset board UUCSS**. Check the Error Log to determine if Error Type 769 is logged again for DAT-LINE. Make sure that the `Active Alarms Only` field is set to `n`.

If error type 769 reappears, replace the data line circuit pack. If Error Type 769 does not reappear, proceed to Step 3.

3. Enter **release board UUCSS**.

## System Technician-Demanded Tests: Descriptions and Error Codes

Always investigate tests in the order presented in the table below. By clearing error codes associated with the *Digital Looparound Test*, for example, you may also clear errors generated from other tests in the testing sequence. For example, you may also clear errors generated from other tests in the testing sequence.

Order of Investigation	Short Test Sequence	Long Test Sequence	D/ND <sup>1</sup>
Digital Looparound Test (#171)	X	X	ND
NPE Crosstalk Test (#6)		X	ND
Conference Circuit Test (#7)		X	ND
Audit Update Test (#36)	X	X	ND

1. D = Destructive; ND = Nondestructive

### NPE Crosstalk Test (#6)

The NPE Crosstalk Test verifies that this port's NPE channel talks on the selected time slot and never crosses over to time slots reserved for other connections. If the NPE is not working correctly, one-way and noisy connections may be observed. This test is usually part of a port's long test sequence and takes about 20 to 30 seconds to complete.

Table 9-191. TEST #6 NPE Crosstalk Test

Error Code	Test Result	Description/ Recommendation
	ABORT	Could not allocate the necessary system resources to run this test. 1. Retry the command at 1-minute intervals a maximum of 5 times.
1000	ABORT	System resources required to run test are not available. The port may be in use on a valid call. Use <b>status data-module</b> to determine when the port is available for testing. 1. Retry the command at 1-minute intervals a maximum of 5 times.
1001	ABORT	Could not allocate the necessary system resources to run this test. 1. Retry the command at 1-minute intervals a maximum of 5 times.

*Continued on next page*

Table 9-191. TEST #6 NPE Crosstalk Test — *Continued*

Error Code	Test Result	Description/ Recommendation
1002	ABORT	The system could not allocate time slots for the test. The system may be under heavy traffic conditions or it may have time slots out-of-service due to TDM-BUS errors. <ol style="list-style-type: none"><li>1. Resolve TDM-BUS errors, if any.</li><li>2. If the system is not handling heavy traffic, retry the command at 1-minute intervals a maximum of 5 times.</li></ol>
1003	ABORT	The system could not allocate a tone receiver for the test. The system may be oversized for the number of tone detectors present, or some tone detectors may be out-of-service. <ol style="list-style-type: none"><li>1. Resolve TTR-LEV and TONE-PT errors, if any.</li><li>2. If neither condition exists, retry the command at 1-minute intervals a maximum of 5 times.</li></ol>
1004	ABORT	The port was in use on a valid call. <ol style="list-style-type: none"><li>1. Determine whether the port is available for testing (<b>status data-module</b>).</li><li>2. When available, retry the command at 1-minute intervals a maximum of 5 times.</li></ol>
1020	ABORT	An existing Error Type 769 on this port prevented the test from running. <ol style="list-style-type: none"><li>1. Follow the procedures for Error Type 769.</li></ol>
2000	ABORT	Response to the test command was not received within the allowable time period.
2100	ABORT	Could not allocate the necessary system resources to run this test. <ol style="list-style-type: none"><li>1. Retry the command at 1-minute intervals a maximum of 5 times.</li></ol>
Any	FAIL	The NPE of the tested port was transmitting in error, which can cause noisy and unreliable connections. <ol style="list-style-type: none"><li>1. Replace the circuit pack.</li></ol>
	PASS	The port is correctly using its allocated time slots. <ol style="list-style-type: none"><li>1. Investigate user-reported troubles on this port using other port tests and examining the ADU, external wiring, and customer equipment.</li></ol>

### Conference Circuit Test (#7)

The Conference Circuit Test verifies that the NPE channel for the port being tested can correctly perform the conferencing function. The NPE is instructed to listen to several different tones and conference the tones together. The resulting signal is then measured by a tone detector port. If the level of the tone is within a certain range, the test passes.

**Table 9-192. TEST #7 Conference Circuit Test**

Error Code	Test Result	Description/ Recommendation
	ABORT	Could not allocate the necessary system resources to run this test. 1. Retry the command at 1-minute intervals a maximum of 5 times.
1000	ABORT	System resources required to run this test are not available. The port may be in use on a valid call. Use <b>status data-module</b> to determine when the port is available for testing.
1004	ABORT	The port has been seized by a user for a valid call. Use <b>status data-module</b> to determine when the port is available for testing. 1. Retry the command at 1-minute intervals a maximum of 5 times.
1020	ABORT	An existing error type 769 on this port prevented the test from running. 1. Follow the procedure following the Error Log Table for error type 769.
2000	ABORT	Response to the test request was not received within the allowable time period.
2100	ABORT	Could not allocate the necessary system resources to run this test. 1. Retry the command at 1-minute intervals a maximum of 5 times.
Any	FAIL	The conference circuit test failed (possible off-board problem). 1. Busyout and release the port (data line), and then retest. 2. Replace the circuit pack if the test continues to fail.
	PASS	The port can correctly conference multiple connections. Investigate user-reported troubles on this port using other port tests and examining the ADU, external wiring, and customer equipment.

### Audit Update Test (#36)

This audit verifies that the hardware state of the data line is consistent with the system translations. The audit queries the port for the switchhook state, the software state is updated according to the returned value. Also, the audit data line options down to the port.

**Table 9-193. TEST #36 Audit Update Test**

Error Code	Test Result	Description/ Recommendation
1006	ABORT	An existing error type 769 on this port prevented the test from running. 1. Follow the procedure following the Error Log Table for error type 769.

*Continued on next page*

**Table 9-193. TEST #36 Audit Update Test — Continued**

Error Code	Test Result	Description/ Recommendation
2000	ABORT	Response to the test request was not received within the allowable time period.
2100	ABORT ABORT	Could not allocate the necessary system resources to run this test. Internal system error 1. Try the command again at 1-minute intervals up to 5 times.
7	FAIL	Internal system error 1. Try the command again at 1-minute intervals up to 5 times.
	PASS	The hardware port state is consistent with the software state. Investigate user-reported troubles on this port using other port tests and examining the ADU, external wiring, and customer equipment.

### Digital Looparound Test (#171)

The Digital Looparound Test checks the data line port's ability to transmit and receive data on the TDM Bus. Data is sent through an available Maintenance/Test digital port over the TDM Bus, internally looped through the data line port back onto the TDM Bus, and received again by the same Maintenance/Test digital port.

Note that only one of the two digital ports on a Maintenance/Test circuit pack is used for this test, and that port must be the **first** such port; such as port 02. If port 02 is in use, out-of-service, or not present, the test aborts. This test may fail if the Maintenance/Test digital port used by the test is not functioning properly. If there are any M/T-DIG errors in the Error Log, refer to the "M/T-BD" to clear them first. This test will pass regardless of any customer equipment that might be connected to the port, as long as the port is not in use by the equipment.

**Table 9-194. TEST #171 Digital Looparound Test**

Error Code	Test Result	Description/ Recommendation
1000	ABORT ABORT	Internal system error System resources required to run test are not available. The port may be in use on a valid call. Use <b>status data-module</b> to determine when the port is available for testing. 1. Retry the command at 1-minute intervals a maximum of 5 times.

*Continued on next page*

**Table 9-194. TEST #171 Digital Looparound Test — Continued**

Error Code	Test Result	Description/ Recommendation
1020	ABORT	An existing error type 769 on this port prevented the test from running. 1. Follow the procedure following the Error Log Table for error type 769.
1042	ABORT	Port under test is a TTI port and has only default translations with no assigned extension. The executed test requires an assigned extension associated with the port being tested. Therefore, this test cannot successfully execute. 1. If there is a need to execute the test on this particular port then the tester must insure that the port is fully translated such that the port has an assigned extension.
1180	ABORT	There is no Maintenance/Test circuit pack digital port available to carry out the test. 1. Check to see if the Maintenance/Test digital ports are present. (Enter <b>list config</b> command; ports 02 and 03 should show). 2. If the digital ports (02 and 03) on the Maintenance/ Test circuit pack are not present, refer to "M/T-BD". 3. If the digital ports are present, retry the command at 1-minute intervals a maximum of 5 times.
1181	ABORT	No time-slots available to connect digital ports for the test.
1182	ABORT	Internal system error. Failed to connect the digital ports with time-slots. 1. Retry the command at 1-minute intervals a maximum of 5 times.
1340	ABORT	No Maintenance/Test digital port is currently available to perform this test. 1. Use <b>list config</b> to determine whether any Maintenance/Test digital ports (ports 02 and 03 on the Maintenance/Test circuit pack) are present in the system. At least one Maintenance/Test circuit pack must be present in the PPN of a Release 5r system. There should be at least two such ports present. If the ports are present, proceed to step 2. Otherwise, determine why no ports appear in the <b>list config</b> display. Refer to "M/T-DIG" and "M/T-BD". 2. Look for M/T-DIG errors in the Error Log. If present, refer to "M/T-DIG". 3. If the ports are present and no errors are logged against them, retry the command at 1-minute intervals a maximum of 5 times. 4. If the test continues to abort, replace the Maintenance/Test circuit pack.

*Continued on next page*

**Table 9-194. TEST #171 Digital Looparound Test — Continued**

Error Code	Test Result	Description/ Recommendation
1392	ABORT	This port is currently a TTI port and the test will not execute on it. <ol style="list-style-type: none"> <li>1. Verify that the port is a TTI port using either the <b>display port</b> command (the display shows that the port is a TTI port) or the <b>list config</b> command (the display shows a "t" for the port).</li> <li>2. If either <b>list config</b> or <b>display port</b> indicate that the port is <b>not</b> a TTI port, escalate the problem. If both commands indicate that the port is a TTI port, the abort is correct for the test, and no action is necessary.</li> </ol>
2004	ABORT	Off hook was not received from the data line device. <ol style="list-style-type: none"> <li>1. Busyout the digital port being tested on the data line circuit pack. Retry the command at 1-minute intervals a maximum of 5 times.</li> <li>2. If the test still aborts, replace the circuit pack.</li> </ol>
2005	ABORT	The handshake between the Maintenance/Test circuit pack digital port and the data line port failed. <ol style="list-style-type: none"> <li>1. Resolve M/T-DIG errors, if any.</li> <li>2. Retry the command at 1-minute intervals a maximum of 5 times.</li> <li>3. If the test still aborts, replace the data line circuit pack.</li> </ol>
2312	ABORT	Test did not complete, did not receive loop back data. <ol style="list-style-type: none"> <li>1. Resolve M/T-DIG errors, if any.</li> <li>2. Retry the test, if still aborts, replace the Data Line circuit pack.</li> </ol>
2313	ABORT	Failed to receive a response from the Maintenance/Test digital port. <ol style="list-style-type: none"> <li>1. Resolve M/T-DIG errors, if any.</li> <li>2. Retry the command at 1-minute intervals a maximum of 5 times.</li> <li>3. If the test continues to abort, replace the Maintenance/Test circuit pack.</li> </ol>
2314	ABORT	Data line port did not respond to downlinked message. <ol style="list-style-type: none"> <li>1. Busyout the digital port being tested on the data line circuit pack. Retry the command at 1-minute intervals a maximum of 5 times.</li> <li>2. If the test still aborts, replace the circuit pack.</li> </ol>
2500	ABORT	Internal system error. <ol style="list-style-type: none"> <li>1. Retry the command at 1-minute intervals a maximum of 5 times.</li> </ol>

*Continued on next page*



**Table 9-194. TEST #171 Digital Looparound Test — Continued**

Error Code	Test Result	Description/ Recommendation
	FAIL	<p>The test failed because the data received did not match the data sent. This would indicate that there is a fault somewhere in the transmit/receive path to the TDM Bus, which will probably result in data corruption over this port. This test may fail if the Maintenance/Test digital port used by the test is not functioning properly.</p> <ol style="list-style-type: none"> <li>1. Resolve M/T-DIG errors, if any.</li> <li>2. Repeat Test #171.</li> <li>3. If the test fails again, replace the data line circuit pack.</li> </ol>
	PASS	<p>The port can correctly transmit/receive data. Investigate user-reported troubles on this port using other port tests and examining the ADU, external wiring, and customer equipment.</p>

## DC-POWER (Single Carrier Cabinet Environment)

MO Name As It Appears in Alarm Log	Alarm Level	Initial System Technician Command to Run <sup>1</sup>	Full Name of MO
DC-POWER	MAJOR	test environment UU	Single Carrier Cabinet Environment

1. UU is the universal cabinet number indicated in the PORT field of the alarm log.

DEFINITY Generic 3r systems support two different cabinet types: multicarrier and single carrier. Single carrier cabinets are used only for EPNs. Both cabinet types may be powered by either AC or DC external power source. Environmental maintenance differs according to cabinet type and external power supply. Refer to the following table to determine which maintenance object documentation to use for environmental maintenance.

Cabinet Type	Power Source	Environmental Maintenance Objects
Single carrier (EPN)	AC or DC	DC-POWER (all environmental maintenance)
Multicarrier	AC	AC-POWER for AC-powered systems (external power source) POWER for AC-powered systems (battery backup) CARR-POW (carrier port power supply) CABINET (temperature and fan sensors)
Multicarrier	DC	CARR-POW (carrier port power supply) CABINET (temperature and fan sensors)

The DC-POWER maintenance object represents all environmental maintenance for single-carrier cabinets, whether the external power supply is AC or DC. This includes the external power supply and all Carrier Port Power Supplies in a port network composed of a single-carrier cabinet stack. The Carrier Port Power Supplies provide +5/-5/-48V DC to the circuit packs on the carrier. The following power supplies are used:

WP-91153	Accepts AC power input
676B	Accepts DC power input

Each power unit has one yellow LED. A lit LED signifies normal operation. An unlit LED signifies a loss of external power to the cabinet, or a fault in the power unit. When hardware detects a problem with any of these components, it reports the information to the system software through a single lead. System software does not differentiate between different environmental failures. Since several environmental elements of single-carrier cabinets are logged against the DC-POWER maintenance object, it is possible to have a DC-POWER alarm while there is still power to the system.

If a Carrier Port Power Supply is physically removed from a carrier in a single-carrier cabinet, there will not be a DC-POWER alarm. DC-POWER maintenance cannot distinguish between removal of the power supply and the physical absence of the cabinet.

There is a nominal power holdover of .25 second in an EPN single carrier cabinet.

## Hardware Error Log Entries and Test to Clear Values

### Single Carrier Cabinet Power Error Log Entries

Error Type	Aux Data	Associated Test	Alarm Level	On/Off Board	Test to Clear Value <sup>1</sup>
0 <sup>2</sup>	0	Any	Any	Any	test environment UU
513	0 or 1	Single Carrier Cabinet Power Query (#79)	MAJOR	ON	test environment UU r 2

1. UU is the universal cabinet number indicated in the PORT field of the Alarm Log.
2. Run the Short Test Sequence first. If all tests pass, run the Long Test Sequence. Refer to the appropriate test description and follow the recommended procedures.

## System Technician-Demanded Tests: Descriptions and Error Codes

Always investigate tests in the order presented in the following table when inspecting errors in the system. By clearing error codes associated with the *Single Carrier Cabinet Power Query Test*, for example, you may also clear errors generated from other tests in the testing sequence. Test description(s) and recommended maintenance procedures follow for all errors that can occur during system technician-demanded testing.

Order of Investigation	Short Test Sequence	Long Test Sequence	D/ND <sup>1</sup>
Single Carrier Cabinet Power Query Test (#79)	X	X	ND
Emergency Transfer Query Test (#124) (a)	X	X	ND
External Alarm Lead Query Test (#120) (b)	X	X	ND
Analog Ring Generator Initialization Test (#117) (c)	X	X	ND
Analog Ring Generator Query Test (#118) (c)	X	X	ND

1. D = Destructive; ND = Nondestructive

### Notes:

- a. Refer to EMG-XFER (Emergency Transfer) Maintenance documentation for a description of this test.
- b. Refer to EXT-DEV (External Alarm Lead) Maintenance documentation for a description of this test.
- c. Refer to RING-GEN (Analog Ring Generator) Maintenance documentation for a description of this test.

## Single Carrier Cabinet Power Query Test (#79)

This test queries the EPN Maintenance circuit pack (in an EPN) about the status of the power in a single carrier cabinet system. This test can only detect power problems in carriers in the Port Network for which the Carrier Port Power Supply is physically present.

**Table 9-195. TEST #79 Single Carrier Cabinet Power Query Test**

Error Code	Test Result	Description/ Recommendation
1000	ABORT	System resources required to run this test are not available. 1. Retry the command at 1-minute intervals a maximum of 5 times.
2000	ABORT	Response to the test request was not received within the allowable time period. 1. Retry the command at 1-minute intervals a maximum of 5 times. 2. If the test continues to ABORT with a 2000 error code, check for and resolve all MAINT (EPN Maintenance circuit pack) errors. Then, repeat the test. 3. If the test continues to ABORT with a 2000 error code, then escalate the problem.
2029 2319 2320 2500	ABORT	Internal System Error 1. Retry the command at 1-minute intervals a maximum of 5 times.

*Continued on next page*

**Table 9-195. TEST #79 Single Carrier Cabinet Power Query Test — Continued**

Error Code	Test Result	Description/ Recommendation
1	FAIL	<p>There is currently a problem with the environment of the power system.</p> <ol style="list-style-type: none"> <li>1. The power supply to any one of the carriers may have been lost.                             <ol style="list-style-type: none"> <li>a. Verify, and if necessary restore, AC power at the wall outlet for each carrier.</li> <li>b. Rerun the test. If the test still fails, proceed to Step 2.</li> </ol> </li> <li>2. One of the WP-91153 or 676-B power units for one of the carriers could be defective.                             <ol style="list-style-type: none"> <li>a. If a WP-91153 or 676-B power unit does not have its yellow status LED on, then replace the power unit (procedure in <a href="#">Chapter 5, "Alarms, Errors, and Troubleshooting"</a>).</li> <li>b. Rerun the test. If the test still fails, proceed with Step 3.</li> </ol> </li> <li>3. The MAINT (EPN Maintenance Circuit Pack) could be incorrectly reporting this error. Resolve all alarms on these MOs, and rerun the test. There are failures that can occur on the EPN Maintenance circuit pack that <i>will not</i> be detected by their respective maintenance, but which will cause many, if not all, environment tests to fail. If more than two environment tests are failing, the suspect circuit pack, depending on the system configuration, should be replaced and the test rerun. If the test still fails, follow normal escalation procedures.</li> </ol>
	PASS	<p>The MAINT (EPN Maintenance Circuit Pack) has reported no problem with the power.</p>

## **DETR-BD (Tone Detector Circuit)**

---

<b>MO Name (in Alarm Log)</b>	<b>Alarm Level</b>	<b>Initial Command to Run<sup>1</sup></b>	<b>Full Name of MO</b>
DETR-BD	MINOR	test board UUCSS	Tone Detector Circuit Pack
DETR-BD	WARNING	test board UUCSS	Tone Detector Circuit Pack

1. UU is the universal cabinet number (1 for PPN, 2 -44 for EPNs). C is the carrier designation (A, B, C, D, or E). SS is the number of the slot in which the circuit pack resides (01 to 21).

For proper tone detection, the companding mode administered for the system must match that of the DETR-BD circuit pack. The companding mode is administered on the system-parameters country-options form. Refer to *DEFINITY Enterprise Communications Server Release 5.4 Administration and Feature Description*.

For all DETR-BD (Tone Detector Circuit Pack) errors, refer to "XXX-BD (Common Port Circuit Pack)".

## DID-BD (Direct Inward Dial Trunk Circuit Pack)

---

MO Name (in Alarm Log)	Alarm Level	Initial Command to Run <sup>1</sup>	Full Name of MO
DID-BD	MIN	test board UUCSS sh	Direct Inward Dial Trunk Circuit Pack
DID-BD	WRN	test board UUCSS sh	Direct Inward Dial Trunk Circuit Pack

- 
1. UU is the universal cabinet number (1 for PPN, 2 -44 for EPNs). C is the carrier designation (A, B, C, D, or E). SS is the number of the slot in which the circuit pack resides (01 to 21). pp is the two digit port number (01, 02, ...).

Refer to "XXX-BD (Common Port Circuit Pack)" for circuit pack level errors. See also "DID-TRK" (DID Trunk) for related trunk information.



## DID-DS1 (Direct Inward Dial Trunk)

MO Name (in Alarm Log)	Alarm Level	Initial Command to Run	Full Name of MO
DID-DS1	MAJOR <sup>1</sup>	test trunk <i>grp/mbr l</i>	Direct Inward Dial Trunk
DID-DS1	MINOR	test trunk <i>grp/mbr l</i>	Direct Inward Dial Trunk
DID-DS1	WARNING	test trunk <i>grp/mbr</i>	Direct Inward Dial Trunk

1. A Major alarm on a trunk indicates that alarms on these trunks are not downgraded by the **set options** command and that at least 75 percent of the trunks in this trunk group are alarmed. For more information on the **set options** command.

The DID-DS1 trunk provides a digital Direct Inward Dial (DID) trunk from a CO switch to the system through a DS1 link. A 24-channel DS1 link can support up to 24 DID-DS1 trunk calls simultaneously. A 32-channel link can support up to 30. A DID-DS1 trunk can be used for digitized voice and data communications with appropriate DS1 signaling mode (for example, common channel signaling). The TN767 and TN464 series circuit packs support wink-start and immediate-start trunks and call processing signaling. See "[DS1-BD \(DS1 Interface Circuit Pack\)](#)" and "UDS1-BD (UDS1 Interface Circuit Pack)" for more information. Throughout this section, the term DS1 applies to both the DS1 or UDS1 circuit packs.

Information included in this section covers the in-line errors log, initialization tests, periodic tests, scheduled tests, system technician demand tests, and alarms escalation and elimination. Two trunk service states are specified in the DID-DS1 trunk maintenance:

<code>out-of-service</code>	The trunk is in a deactivated state and cannot be used for incoming calls.
<code>in-service</code>	The trunk is in an activated state and can be used for incoming calls.

If the DS1 circuit pack is out-of-service, then all trunks on the DS1 Interface circuit pack are put into the out-of-service state and a Warning alarm is raised.

## Error Log Entries and Test to Clear Values

### DID-DS1 Trunk Error Log Entries

Error Type	Aux Data	Associated Test	Alarm Level	On/Off Board	Test to Clear Value
0 <sup>1</sup>	0	Any	Any	Any	test trunk <i>grp#/mbr#</i>
1(a)	Any				
15(b)	Any	Port Audit and Update Test (#36)			
18(c)			WARNING	OFF	release trunk <i>grp#/mbr#</i>
130(d)		None	WARNING	ON	test trunk <i>grp#/mbr#</i>
257(e)	57474 57473				
513(f)	57392		MIN/MAJ <sup>2</sup>		
769(g)	57393		MIN/MAJ <sup>2</sup>		
1281		Conference Circuit Test (#7)	MIN/ WRN <sup>3</sup>	ON	test trunk <i>grp#/mbr#</i>   r 4
1537		NPE Crosstalk Test (#6)	MIN/ WRN <sup>3</sup>	ON	test trunk <i>grp#/mbr#</i>   r 3
1793(h)					test board <i>UUCSSI</i>
2305(i)	50944	None	MIN/MAJ <sup>2</sup>	OFF	
3840(j)		Port Audit and Update Test (#36)			

1. Run the Short Test Sequence first. If all tests pass, run the Long Test Sequence. Refer to the appropriate test description and follow the recommended procedures.
2. This alarm will only be raised when the System-Parameter Country form has the Base Tone Generator field set to 4 (Italy). This alarm will be a MINOR alarm unless 75% or more trunks in this trunk group are out of service, then the alarm will be upgraded to a MAJOR alarm.
3. Major alarms may be downgraded to Warning alarms based on the value used in the set options command.

#### Notes:

- a. Error Type 1—DS1 Interface circuit pack detects a hardware error on the DS1 DID trunk. The Aux Data field indicates the following:

57476	On-hook before wink
57477	On-hook before ready to receive digits
57485	Wink too short for valid signal

Maintenance does not start any testing or generate any alarms in response to these errors.

- b. Error Type 15—This is a software audit error that does not indicate any hardware malfunction. Run Short Test Sequence and investigate errors (if any).
- c. Error Type 18—The trunk has been taken out of service by a demand busyout. No calls can be made on this trunk.
- d. Error Type 130—This error type indicates that the circuit pack has been removed or has been insane for more than 11 minutes. To clear the error, reinsert or replace the circuit pack.
- e. Error Type 257—DS1 Interface circuit pack detects a hardware error on the DS1 DID trunk. The Aux Data field indicate the source of the error:
  - 57474 Rotary dial rate above 12 pulses per second
  - 57473 Rotary dial rate below 8 pulses per second
- f. Error Type 513—DS1 Interface circuit pack detects a hardware error on the DS1 DID trunk. Aux Data 57392 indicates no external release on PBX disconnect.
- g. Error Type 769—DS1 Interface circuit pack detects a hardware error on the DS1 DID trunk. Aux Data 57393 indicates belated external release on PBX disconnect.
- h. Error Type 1793—DS1 Interface circuit pack is out-of-service. Look for DS1-BD/UDS1-BD errors in Hardware Error Log. Refer to the appropriate “DS1-BD/UDS1-BD” information for details.
- i. Error Type 2305—This error indicates that a signaling change was detected by the PBX trunk circuit pack which is inconsistent with the present state of the trunk.
- j. Error Type 3840—Port Audit and Update Test (#36) failed due to an internal system error. Enter **status trunk** command to verify the status of the trunk. If the trunk is out-of-service, then enter the **release trunk** command to put it back to in-service. Retry the test command.

## System Technician-Demanded Tests: Descriptions and Error Codes

Always investigate tests in the order they are presented in the table below. By clearing error codes associated with the *NPE Crosstalk Test*, for example, you may also clear errors generated from other tests in the testing sequence.

Order of Investigation	Short Test Sequence	Long Test Sequence	D/ND <sup>1</sup>
NPE Crosstalk Test (#6)		X	ND
Conference Circuit Test (#7)		X	ND
Port Audit and Update Test (#36)	X	X	ND

1. D = Destructive; ND = Nondestructive

### NPE Crosstalk Test (#6)

The NPE Crosstalk Test verifies that this port's NPE channel talks on the selected time slot and never crosses over to time slots reserved for other connections. If the NPE is not working correctly, one-way and noisy connections may be observed. This test is usually only part of a port's Long Test Sequence and takes about 20 to 30 seconds to complete.

Table 9-196. TEST #6 NPE Crosstalk Test

Error Code	Test Result	Description/ Recommendation
	ABORT	System resources required for this test are not available. 1. Retry the command at 1-minute intervals a maximum of 5 times.
1000	ABORT	System resources required for this test are not available. The port may be busy with a valid call. 1. Use <b>display port UUCSSpp</b> to determine the trunk group/ member number of the port. Use the <b>status trunk</b> command to determine the service state of the port. If the port is in use, wait until the port is idle before testing. 2. If the port status is active but the port is not in use (no calls), check the error log for error type 1025. The port may be locked up. 3. If the port status is idle, retry the command at 1-minute intervals a maximum of 5 times.

*Continued on next page*

**Table 9-196. TEST #6 NPE Crosstalk Test — Continued**

Error Code	Test Result	Description/ Recommendation
1001	ABORT	System resources required for this test are not available. 1. Retry the command at 1-minute intervals a maximum of 5 times.
1002	ABORT	The system could not allocate time slots for the test. The system may be under heavy traffic conditions or it may have time slots out-of- service due to TDM BUS error. Use <b>status health</b> to determine if the system is experiencing heavy traffic. 1. If the system has no TDM-BUS errors and is not handling heavy traffic, retry the command at 1-minute intervals a maximum of 5 times.
1003	ABORT	The system could not allocate a tone receiver for the test. The system may be oversized for the number of tone detectors present or some tone detectors may be out-of-service. Use <b>list measurements tone-receiver</b> to display information on the tone receivers. 1. Resolve any TTR-LEV errors. 2. Resolve any TONE-PT errors. 3. If neither condition exists, retry the command at 1-minute intervals a maximum of 5 times.
1004	ABORT	The port was seized by a user for a valid call. 1. Use <b>display port UUCSSpp</b> to determine the trunk group/member number of the port. Use <b>status trunk</b> to determine the service state of the port. If the port is in use, wait until the port is idle before testing. 2. If the port status is idle, retry the command at 1-minute intervals a maximum of 5 times.
1020	ABORT	The test did not run due to a previously existing error on the specific port or a more general circuit pack error. 1. Examine Error Log for existing errors against this port or circuit pack and attempt to diagnose the previously existing error.
2000	ABORT	Response to the test was not received within the allowable time period.
2100	ABORT	System resources required for this test are not available. 1. Retry the command at 1-minute intervals a maximum of 5 times.
2053	ABORT	At least one of the following errors is found on the DS1 circuit pack (DS1-BD or UDS1-BD): 1281—Loss of signal, 1793—Blue Alarm, 2049—Red Alarm, 2305—Yellow Alarm, or 1537—Hyperactivity 1. Resolve any of the above error types.

*Continued on next page*

**Table 9-196. TEST #6 NPE Crosstalk Test — Continued**

Error Code	Test Result	Description/ Recommendation
ANY	FAIL	This can be due to off-board problems, including EXP-PN and EXP-INTF faults, TDM-BUS faults, and tone detectors/tone generators. Clear all off-board problems before replacing the board. A TDM-BUS problem is usually a faulty board or bent pins on the backplane. <ol style="list-style-type: none"> <li>1. Resolve any EXP-PN, EXP-INTF, TDM-BUS, TONE-BD, and TONE-PT errors in the error log.</li> <li>2. Retest when errors are cleared. Replace the board if the test fails.</li> </ol>
	PASS	The port is correctly using its allocated time slots. Investigate user-reported troubles on this port using other port tests and by examining station, trunk, or external wiring.
0	NO BOARD	The test could not relate the internal ID to the port. This could be due to incorrect translations, no board is inserted, an incorrect board is inserted, or an insane board is inserted. <ol style="list-style-type: none"> <li>1. Check to ensure that the board translations are correct. Use <b>llst config</b> and resolve any problems that are found.</li> <li>2. Issue the <b>busyout board</b> command. Issue the <b>reset board</b> command. Issue the <b>release busy board</b> command.</li> <li>3. Issue the <b>test board long</b> command. This should re-establish the link between the internal ID and the port. If not, check to see that there is a valid board inserted.</li> </ol>

### Conference Circuit Test (#7)

The Conference Circuit Test verifies that the NPE channel for the port being tested can correctly perform the conferencing function. The NPE is instructed to listen to several different tones and conference the tones together.

**Table 9-197. TEST #7 Conference Circuit Test**

Error Code	Test Result	Description/ Recommendation
	ABORT	Could not allocate the necessary system resources for this test. <ol style="list-style-type: none"> <li>1. Retry the command at 1-minute intervals a maximum of 5 times.</li> </ol>

*Continued on next page*

**Table 9-197. TEST #7 Conference Circuit Test — Continued**

Error Code	Test Result	Description/ Recommendation
1000	ABORT	<p>System resources required for this test were not available. The port may be busy with a valid call.</p> <ol style="list-style-type: none"> <li>1. Use <b>display port UUCSSpp</b> to determine the trunk group/member number of the port. Use <b>status trunk</b> to determine the service state of the port. If the port is in use, wait until the port is idle before testing.</li> <li>2. If the port status is active but the port is not in use (no calls), check the error log for error type 1025. The port may be locked up.</li> <li>3. If the port status is idle, retry the command at 1-minute intervals a maximum of 5 times.</li> </ol>
1002	ABORT	<p>The system could not allocate time slots for the test. The system may be under heavy traffic conditions, or it may have time slots out of service due to TDM-BUS errors.</p> <ol style="list-style-type: none"> <li>1. If the system has no TDM-BUS errors and is not handling heavy traffic and the port status is idle, retry the command at 1-minute intervals a maximum of 5 times.</li> </ol>
1003	ABORT	<p>The system could not allocate a tone receiver for the test. The system may be oversized for the number of tone detectors present or some of the tone detectors may be out of service. Use <b>list measurements tone-receiver</b> to display information about the tone receivers.</p> <ol style="list-style-type: none"> <li>1. Resolve any TTR-LEV errors.</li> <li>2. Resolve any TONE-PT errors.</li> <li>3. If neither condition exists, retry the command at 1-minute intervals a maximum of 5 times.</li> </ol>
1004	ABORT	<p>The port was seized by a user for a valid call.</p> <ol style="list-style-type: none"> <li>1. Use <b>display port UUCSSpp</b> to determine the trunk group/member number of the port. Issue the <b>status trunk</b> command to determine the service state of the port. If the port is in use, wait until the port is idle before testing.</li> <li>2. If the port status is idle, retry the command at 1-minute intervals a maximum of 5 times.</li> </ol>
1018	ABORT	<p>The test was disabled via translation. Determine why the test has been disabled before you enable it.</p> <ol style="list-style-type: none"> <li>1. Verify that the <code>Maintenance Test</code> field on the Trunk Administration screen is set to <code>n</code>. To enable the test, change the trunk administration and enter <code>y</code> for this field.</li> <li>2. Repeat the test.</li> </ol>

*Continued on next page*

**Table 9-197. TEST #7 Conference Circuit Test — Continued**

Error Code	Test Result	Description/ Recommendation
1020	ABORT	The test did not run due to a previously existing error on the specific port or a more general circuit pack error.  1. Examine Error Log for existing errors against this port or the circuit pack and attempt to diagnose the previously existing error.
2000	ABORT	Response to the test was not received within the allowable time period.
2100	ABORT	Could not allocate the necessary system resources to run this test.  1. Retry the command at 1-minute intervals a maximum of 5 times.
2053	ABORT	At least one of the following errors is found on the DS1 circuit pack (DS1-BD or UDS1-BD):  1281—Loss of signal, 1793—Blue Alarm, 2049—Red Alarm, 2305—Yellow Alarm, 1537—Hyperactivity  1. Resolve any of the above error types.
	FAIL	The NPE of the tested port did not conference the tones correctly. This can cause noisy and unreliable connections.  1. Enter <b>list configuration board UUCSS</b> . The circuit pack must be a TN767C V3 or later. The error log may have error type 1281. 2. Test all administered trunks on the board. If one fails, this could be an off-board problem (such as an incoming seizure or an off-hook port seizure during the test). Retest the board. 3. If all of the ports fail, a -5 volt power problem is indicated. Check "CARR-POW". 4. If several ports fail, resolve any "TONE-BD" or "TONE-PT" errors and rerun the test. 5. If the retry passes and troubles are reported, coordinate isolation with the CO. Make sure that the switch, the CO, and any NTCE equipment (the CSUs) have the correct administration. 6. Replace the circuit pack.
	PASS	The port can correctly conference multiple connections. Investigate user-reported troubles on this port using other port tests and by examining station, trunk, or external wiring.

*Continued on next page*



Table 9-197. TEST #7 Conference Circuit Test — Continued

Error Code	Test Result	Description/ Recommendation
0	NO BOARD	<p>The test could not relate the internal ID to the port. This could be due to incorrect translations, no board is inserted, an incorrect board is inserted, or an insane board is inserted.</p> <ol style="list-style-type: none"><li>1. Check to ensure that the board translations are correct. Use the <b>llst config</b> command and resolve any problems that are found.</li><li>2. If the board was found to be correctly inserted in step 1, issue the <b>busyout board</b> command.</li><li>3. Issue the <b>reset board</b> command.</li><li>4. Issue the <b>release busy board</b> command.</li><li>5. Issue the <b>test board long</b> command. This should re-establish the link between the internal ID and the port. If not, check to see that there is a valid board inserted.</li></ol>

### Port Audit and Update Test (#36)

This test sends port level translation data from the switch processor to the DS1 Interface circuit pack to assure that the trunk's translation is correct. The port audit operation verifies the consistency of the current state of the trunk as kept in the DS1 Interface circuit pack and in the switch software.

Table 9-198. TEST #36 Port Audit and Update Test

Error Code	Test Result	Description/ Recommendation
	ABORT	<p>Internal system error</p> <ol style="list-style-type: none"><li>1. Retry the command at 1-minute intervals a maximum of 5 times.</li></ol>
1000	ABORT	<p>The port may be busy with a valid call.</p> <ol style="list-style-type: none"><li>1. Issue <b>display port UUCSSpp</b> to determine the trunk group/member number of the port. Use the <b>status trunk</b> command to determine the service state of the port. If the port is in use, wait until the port is idle before testing.</li><li>2. If the port status is active but the port is not in use (no calls), check the error log for error type 1025. The port may be locked up.</li><li>3. If the port status is idle, retry the command at 1-minute intervals a maximum of 5 times.</li></ol>

*Continued on next page*

**Table 9-198. TEST #36 Port Audit and Update Test — Continued**

Error Code	Test Result	Description/ Recommendation
1006	ABORT	The test was aborted because the trunk is out of service. <ol style="list-style-type: none"> <li>1. Use <b>status trunk</b> to verify that the trunk is out of service.</li> <li>2. If the trunk is out of service, determine why.</li> <li>3. To put the trunk back in service, issue the <b>release trunk</b> command. Retry the test.</li> </ol>
2000	ABORT	Response to the test was not received in the allowable time period.
2100	ABORT	Could not allocate resources to run this test. <ol style="list-style-type: none"> <li>1. Retry the command at 1-minute intervals a maximum of 5 times.</li> </ol>
	FAIL	Test failed due to internal system error. <ol style="list-style-type: none"> <li>1. Retry the command at 1-minute intervals a maximum of 5 times.</li> </ol>
	PASS	Trunk translation has been updated successfully. The current trunk states kept in the DS1 Interface circuit pack and switch software are consistent. If the trunk is busied out, the test will not run but will return PASS. To verify that the trunk is in-service: <ol style="list-style-type: none"> <li>1. Enter <b>status trunk</b> to verify that the trunk is in-service. If the trunk is in-service, no further action is necessary. If the trunk is out-of-service.</li> <li>2. Enter <b>release trunk</b> to put the trunk back into in-service.</li> <li>3. Retry the test command.</li> </ol>
0	NO BOARD	The test could not relate the internal ID to the port (no board). This could be due to incorrect translations, no board is inserted, an incorrect board is inserted, or an insane board is inserted. <ol style="list-style-type: none"> <li>1. Check to ensure that the board translations are correct. Use the <b>list config</b> command, and resolve any problems that are found.</li> <li>2. If the board was found to be correctly inserted in step 1, issue the <b>busyout board</b> command.</li> <li>3. Issue the <b>reset board</b> command.</li> <li>4. Issue the <b>release busy board</b> command.</li> <li>5. Issue the <b>test board long</b> command. This should re-establish the linkage between the internal ID and the port. If this is not the case, check to see that there is a valid board inserted.</li> </ol>

## DID-TRK (Direct Inward Dial Trunk)

---

MO Name (in Alarm Log)	Alarm Level	Initial Command to Run <sup>1</sup>	Full Name of MO
DID-TRK	MAJOR <sup>2</sup>	test port <i>UUCSSpp l</i>	DID Trunk
DID-TRK	MINOR	test port <i>UUCSSpp l</i>	DID Trunk
DID-TRK	WARNING	None	DID Trunk

1. UU is the universal cabinet number (1 for PPN, 2 -44 for EPNs). C is the carrier designation (A, B, C, D, or E). SS is the number of the slot in which the circuit pack resides (01 to 21). pp is the two digit port number (01, 02, ...).
2. A MAJOR alarm on a trunk indicates that alarms on these trunks are not downgraded by the **set options** command and that at least 75 percent of the trunks in this trunk group are alarmed.

### ⇒ NOTE:

Many trunk problems are caused by incorrect settings of parameters on the trunk group administration form. Settings must be compatible with the local environment and with parameter settings on the far-end. Refer to *DEFINITY. Enterprise Communications Server Release 5.4 Administration and Feature Description*, for information on how to administer trunks. The Application Notes section of that book shows the correct settings for administrable timers and other parameters on a country-by-country basis.

Direct Inward Dial trunks connect the switch to the CO, and allow outside parties to call directly to an extension in the system. DID trunk circuit packs support eight incoming-only ports. Each port provides an interface between the 2-wire analog CO line and the 4-wire TDM bus on the switch.

## DID Trunk Operation

---

The DID port receives three to five digits from the CO that are used to directly connect an outside caller to the called station without assistance from an attendant. For each call, the CO switch signals the system by opening and closing individual DID loops (one of the eight ports), causing the starting or stopping of loop current.

## DID Trunk Testing

---

The system uses four tests of on-board circuitry to diagnose the health of the trunk. These are described in the following sections. Additionally, in-line testing which can generate errors, is performed while a call is in progress. See the Error Log table for a description of these errors. These errors may be reproduced by placing a call on the trunk and checking the Hardware Error Log.

Problems detected during signaling may be caused by off-board faults in the CO switch or connections for which a Warning alarm is raised.

Before a maintenance test can be run on a port, the port must be idle. If an incoming call seizes a port that is being tested, the test will abort and the incoming call will proceed.

For transmission and signaling standard specification, refer to *Digital PBX Standards*, RS4648.

## Ports Out-of-Service without Errors or Alarms

A common trouble on DID trunks that produces no errors or alarms occurs when the CO busies out (disconnects) the port. This situation occurs when the CO thinks there are problems with the DID port. In this case, no incoming calls will be possible through this port. This may result in complaints from outside callers trying unsuccessfully to call in. This problem can be diagnosed by listing measurements on lightly used trunks. If a particular port is detected as not in use, a call to the CO will be necessary to get the connection back in service.

## Error Log Entries and Test to Clear Values

Table 9-199. DID Trunk Error Log Entries

Error Type	Aux Data	Associated Test	Alarm Level	On/Off Board	Test to Clear Value
0 <sup>1</sup>	0	Any	Any	Any	test port <i>UUCSSpp</i> sh r 1
1(a)	Any	None	WRN	OFF	
1(b)	57476	None	WRN	OFF	
1(c)	57477	None	WRN	OFF	
1(d)	57483	None	WRN	OFF	
15(e)	Any	Port Audit Update (#36)			
18	0	busyout trunk <i>grp/mbr</i>	WRN	OFF	release trunk <i>grp/mbr</i>
130(f)		None	WRN	ON	test trunk <i>grp/mbr</i>
257(g)	57472	None	WRN	OFF	
257(h)	57473	None	WRN	OFF	
257(i)	57474	None	WRN	OFF	
257(j)	57475	None	WRN	OFF	
513(k)	57392	None	MIN/ WRN <sup>2</sup>	OFF	
510(l)	57393	None			

Continued on next page

**Table 9-199. DID Trunk Error Log Entries — Continued**

Error Type	Aux Data	Associated Test	Alarm Level	On/Off Board	Test to Clear Value
769	Any	Port Diagnostic (#35)	MIN/ WRN <sup>2</sup>	ON	test port UUCSSpp r 3
1025		Looparound and Conference (#33)	MIN/ WRN <sup>2</sup>	ON	test port UUCSSpp l r 3
1281		NPE Crosstalk (#6)	MIN/ WRN <sup>2</sup>	ON	test port UUCSSpp l r 3
1537	Any	Port Diagnostic (#35)	MAJ/ MIN/ WRN <sup>2</sup>	OFF	test port UUCSSpp r 3
1793(m)	57489	None	None		

1. Run the Short Test Sequence first. If all tests pass, run the Long Test Sequence. Refer to the appropriate test description and follow the recommended procedures.
2. Major alarms may be downgraded to Warning alarms based on the value used in the set options command.

**Notes:**

See also the preceding section on trunk problems without errors or alarms.

- a. This condition occurs when the tone detector times out waiting for digits. Change wink/immediate-start parameter to wink/immediate-start and rotary/tone-dial parameters.
  1. Verify trunk administered wink/immediate-start parameter.
  2. Test trunk using BUTT set.
  3. Refer problem to CO.
- b. Rotary dial before wink — This condition occurs when the CO starts dialing before the PBX sends wink on a wink-start trunk.
  1. Verify trunk administered wink/immediate-start parameter.
  2. Refer problem to CO.
- c. Rotary dial too early — This condition occurs when the CO starts dialing too soon after seizure on an immediate-start trunk.
  1. Verify trunk administered wink/immediate-start parameter.
  2. Refer problem to CO.
- d. Rotary dial pulse during wink — This condition occurs when the CO sends rotary dial digits too soon after seizure on a wink-start trunk.
  1. Verify trunk administered wink/immediate-start parameter.

2. Refer problem to CO.
- e. This is a software audit error that does not indicate any hardware malfunction. Run Short Test Sequence and investigate associated errors (if any).
- f. This error type indicates that the circuit pack has been removed or has been insane for more than 11 minutes. To clear the error, reinsert or replace the circuit pack.
- g. Rotary dial pulse on-hook longer than 105 msec — Break between rotary pulses is too long.
  1. Test trunk by performing an incoming test call.
  2. Refer problem to CO.
- h. Rotary dial rate below 8 pulses/sec — More than 135 msec between two successive breaks.
  1. Verify trunk administered interdigit-timing parameters.
  2. Refer problem to CO.
- i. Rotary dial rate above 12 pulses/sec — Less than 75 msec between two successive breaks.
  1. Verify trunk administered interdigit-timing parameters.
  2. Refer problem to CO.
- j. Digit detection — CO is starting new rotary dial digit within 150 msec of previous digit.
  1. Verify trunk administered interdigit timing parameters.
  2. Refer problem to CO.
- k. Loop current active — CO not releasing trunk after PBX disconnect. Occurs when the PBX end drops first and the CO does not release the trunk within 4 minutes.
  1. Verify the interface to the network with a hand telephone set. If calls are placed correctly, then refer problem to the CO.
  2. If unable to place calls or this equipment is not available, check the status on port using the **status trunk** command. If active but not connected, disconnect bridging clips at the network interface. Check status on the trunk. If trunk went idle, then replace clips. If trunk is still active but unable to place calls, refer problem to the CO.
- l. Late CO trunk release — This event only occurs after the occurrence of Error Type 513. The CO released the trunk 4 minutes after the PBX dropped the call. This event decrements the severity (error count) of Error Type 513, or may mean the problem related to Error Type 513 has been fixed.

Verify that Error Type 513 does not occur again. Refer to Error 513.

- m. Incomplete Dial timer expired. This error only applies to the TN459 and indicates a problem with incoming dialing stream. Refer the problem to the CO.

## System Technician-Demanded Tests: Descriptions and Error Codes

---

Always investigate tests in the order presented in the table below. By clearing error codes associated with the *NPE Crosstalk Test* for example, you may also clear errors generated from subsequent tests in the testing sequence..

Order of Investigation	Short Test Sequence	Long Test Sequence	D/ND <sup>1</sup>
NPE Crosstalk Test (#6)		X	ND
Port Diagnostic Test (#35)	X	X	ND
Looparound and Conference Circuit Test (#33)		X	ND
Port Audit Update Test (#36)	X	X	ND

1. D = Destructive; ND = Nondestructive

### NPE Crosstalk Test (#6)

The NPE Crosstalk Test verifies that this port's NPE channel talks on the selected time slot on the TDM bus and never crosses over to time slots reserved for other connections. If the NPE is not working correctly, one-way and noisy connections may be observed. This test is usually only part of a port's Long Test Sequence and takes about 20 to 30 seconds to complete.

**Table 9-200. TEST #6 NPE Crosstalk Test**

Error Code	Test Result	Description/ Recommendation
	ABORT	Could not allocate the necessary system resources for this test. This could be due to a failure to seize the port.  1. Retry the command at 1-minute intervals a maximum of 5 times.

*Continued on next page*

**Table 9-200. TEST #6 NPE Crosstalk Test — Continued**

Error Code	Test Result	Description/ Recommendation
1000	ABORT	<p>System resources required to run this test are not available. The port may be busy with a valid call.</p> <ol style="list-style-type: none"> <li>1. Enter <b>display port UUCSSpp</b> to determine the station extension, attendant number, or trunk group/member number of the port. Enter <b>status station</b>, <b>status attendant</b>, or <b>status trunk</b> to determine the service state of the port. If the port is in use, wait until the port is idle before testing. Attendants are always in use (off-hook) if the handset is plugged in and the port is not busied out.</li> <li>2. If the port status is active but the port is not in use (no calls), check the Error Log for Error Type 513. The port may be locked up.</li> <li>3. If the port status is idle, retry the command at 1-minute intervals a maximum of 5 times.</li> </ol>
1001	ABORT	<p>Could not allocate the necessary system resources to run this test.</p> <ol style="list-style-type: none"> <li>1. Retry the command at 1-minute intervals a maximum of 5 times.</li> </ol>
1002	ABORT	<p>The system could not allocate time slots for the test. The system may be under heavy traffic conditions or it may have time slots out-of-service due to TDM-BUS errors.</p> <ol style="list-style-type: none"> <li>1. If system has no TDM-BUS errors and is not handling heavy traffic, retry the command at 1-minute intervals a maximum of 5 times.</li> </ol>
1003	ABORT	<p>The system could not allocate a tone receiver for the test. The system may be oversized for the number of Tone Detectors present or some Tone Detectors may be out-of-service.</p> <ol style="list-style-type: none"> <li>1. Resolve any TTR-LEV errors.</li> <li>2. Resolve any TONE-PT errors.</li> <li>3. If neither condition exists, retry the command at 1-minute intervals a maximum of 5 times.</li> </ol>
1004	ABORT	<p>The port was seized by a valid call during the test.</p> <ol style="list-style-type: none"> <li>1. Enter <b>display port UUCSSpp</b> to determine the station extension, attendant number, or trunk group/member number of the port. Enter <b>status station</b>, <b>status attendant</b>, or <b>status trunk</b> to determine the service state of the port. If the the port is in use, wait until the port is idle before testing. Attendants are always in use (off-hook) if the handset is plugged in and the port is not busied out.</li> <li>2. Retry the command at 1-minute intervals a maximum of 5 times.</li> </ol>

*Continued on next page*



**Table 9-200. TEST #6 NPE Crosstalk Test — Continued**

Error Code	Test Result	Description/ Recommendation
2000	ABORT	Response to the test was not received within the allowable time period.
2100	ABORT	Could not allocate the necessary system resources for this test. This could be due to a failure to seize the port.  1. Retry the command at 1-minute intervals a maximum of 5 times.
Any	FAIL	This test can fail due to off-board problems, including EXP-PN and EXP-INTF faults, TDM-BUS faults, and tone detectors/tone generators. Clear all off-board problems before replacing the board. A TDM-BUS problem is usually a faulty board or bent pins on the backplane.  1. Resolve any EXP-PN, EXP-INTF, TDM-BUS, TONE-BD, and TONE-PT errors in the error log.  2. Retest the board. Replace the board if the test fails.
	PASS	The port is correctly using its allocated time slots. User-reported troubles on this port should be investigated using other port tests and by examining station, trunk, or external wiring.
0	NO BOARD	The test could not relate the internal ID to the port (no board).  1. Check to ensure that the board translations are correct. Translate the board, if necessary.  2. Issue the <b>busyout board</b> command.  3. Issue the <b>reset board</b> command.  4. Issue the <b>release busy board</b> command.  5. Issue the <b>test board</b> command. This should re-establish the linkage between the internal ID and the port.

### Looparound and Conference Circuit Test (#33)

This test checks the reflective and non-reflective loop around and conference capabilities of a DID port circuit. The test that uses 404-Hz, 1004-Hz, and 2804-Hz tones is an on-board test only. Each tone is separately transmitted to and from the port (loop around within the port) and verified.

This test may fail due to noise induced by adjacent electric power lines. Customers having this problem should resolve it with their local power company. To temporarily alleviate the alarm caused by the failure of this test, the test may be disabled from trunk administration Test field. (This also disables the port diagnostic test.)

**Table 9-201. TEST #33 Looparound and Conference Circuit Test**

Error Code	Test Result	Description/ Recommendation
	ABORT	Could not allocate the necessary system resources to run this test. This could be due to a failure to seize the port.  1. Retry the command at 1-minute intervals a maximum of 5 times.
1000	ABORT	System resources required to run this test are not available. The port may be busy with a valid call.  1. Enter <b>display port UUCSSpp</b> to determine the station extension, attendant number, or trunk group/member number of the port. Use <b>status station</b> , <b>status attendant</b> , or <b>status trunk</b> to determine the service state of the port. If the port is in use, wait until the port is idle before testing. Attendants are always in use (off-hook) if the handset is plugged in and the port is not busied out.  2. If the port status is active but the port is not in use (no calls), check the Error Log for Error Type 513. The port may be locked up.  3. If the port status is idle, retry the command at 1-minute intervals a maximum of 5 times.
1004	ABORT	The port was seized by a valid call during the test.  1. Enter <b>display port UUCSSpp</b> to determine the station extension, attendant number, or trunk group/member number of the port. Use <b>status station</b> , <b>status attendant</b> , or <b>status trunk</b> to determine the service state of the port. If the port is in use, wait until the port is idle before testing. Attendants are always in use (off-hook), if the handset is plugged in and the port is not busied out.  2. Retry the command at 1-minute intervals a maximum of 5 times.
1018	ABORT	Test disabled via administration. Verify that the <code>Maintenance Tests?</code> field on the Trunk Group Form is set to <code>n</code> . To enable the test, issue the <b>change trunk-group x</b> command (x is the trunk group number). Then change the entry in the <code>Maintenance Tests?</code> field to <code>y</code> .
2000	ABORT	Response to the test was not received within the allowable time period.  1. Retry the command at 1-minute intervals a maximum of 5 times.
2100	ABORT	System resources required to run this test are not available. This may be due to the port being seized.  1. This abort code is usually associated with tone-clock (TONE-BD, TONE-PT, and TDM-CLK) resources. Clear any tone errors in the error log.  2. Retry the command at 1-minute intervals a maximum of 5 times.

*Continued on next page*

**Table 9-201. TEST #33 Looparound and Conference Circuit Test — Continued**

Error Code	Test Result	Description/ Recommendation
3	FAIL	The nonreflective 1004 Hz tone test of the port failed. An echo was detected from the port. Poor quality transmission was detected to or from the port. The problem may be off-board.
7		The conference capabilities of the port failed. Poor quality transmission was detected to or from the port. The problem may be off-board.
129		The reflective 404-Hz tone test failed. Poor quality transmission was detected to or from the port. The problem may be off-board.
131		The reflective 1004-Hz tone test failed. Poor quality transmission was detected to or from the port. The problem may be off-board.
133		The reflective 2804-Hz tone test failed. Poor quality transmission was detected to or from the port. The problem may be off-board.
		<p><b>⚠ CAUTION:</b>  <i>The port may still be operational, or the fault may be off-board (connections or CO). Off-board problems include incoming seizures or off-hook port seizures during the test and, perhaps, noise induced by adjacent electric power lines. The test may be disabled from trunk administration 'Test' field. This turns off all testing for that trunk group except for tests 6 and 36.</i></p>
3 7 129 131 133 (cont'd.)	FAIL (cont'd.)	<p>Proceed as follows unless power or tone problems are suspected (see note below).</p> <ol style="list-style-type: none"> <li>To see if the problem is on-board, disconnect the port from the far-end and retry the test. Coordinate this with the CO, or do it after busy hours.</li> <li>If the retry fails, replace the circuit pack.</li> <li>If the retry passes and no troubles have been reported, disable the test in the trunk group administration. If the retry passes and troubles are reported, coordinate isolation with the CO.</li> </ol>
		<p><b>⇒ NOTE:</b>                      If the loop around and conference circuit test fails for all ports on a circuit pack, a -5 volt power problem is indicated. A power unit may be defective (CARR-POW). If the test fails on more than 1 port, check for errors on the TONE-BD or the TONE-PT maintenance objects.</p> <ol style="list-style-type: none"> <li>Rerun the test.</li> </ol>
	PASS	<p>DID Trunk Looparound and Conference Test is successful. This port is functioning properly.</p> <ol style="list-style-type: none"> <li>If users are reporting troubles, examine loop connections to the port and refer problem to the CO.</li> </ol>

**Table 9-201. TEST #33 Looparound and Conference Circuit Test — Continued**

Error Code	Test Result	Description/ Recommendation
0	NO BOARD	The test could not relate the internal ID to the port (no board). <ol style="list-style-type: none"> <li>1. Check to ensure that the board translations are correct.</li> <li>2. Issue the <b>busyout board</b> command.</li> <li>3. Issue the <b>reset board</b> command.</li> <li>4. Issue the <b>release busy board</b> command.</li> <li>5. Issue the <b>test board</b> command. This should establish the link between the internal ID and the port.</li> </ol>

### Port Diagnostic Test (#35)

This test checks a port's battery feed circuitry for on-/off-hook detection, battery shutdown, and battery reversal (wink) capabilities.

**Table 9-202. TEST #35 Port Diagnostic Test**

Error Code	Test Result	Description/ Recommendation
	ABORT	System resources required to run this test were not available. <ol style="list-style-type: none"> <li>1. Retry the command at 1-minute intervals a maximum of 5 times.</li> </ol>
1000	ABORT	System resources required to run this test were not available. The port may be busy with a valid call. <ol style="list-style-type: none"> <li>1. Enter <b>display port UUCSSpp</b> to determine the trunk group/member number of the port. Use the <b>status trunk</b> command to determine the service state of the port. If the port is in use, wait until the port is idle before testing.</li> <li>2. If the port status is active but the port is not in use (no calls), check the error log for Error Type 513. The port may be locked up.</li> <li>3. If the port status is idle, busyout and release the trunk, and retry the command at 1-minute intervals a maximum of 5 times.</li> <li>4. If the test continues to abort, check for wiring errors toward the CO which may cause the trunk to lock up.</li> <li>5. If the wiring is good and the test continues to abort, replace the TN753.</li> </ol>

*Continued on next page*

**Table 9-202. TEST #35 Port Diagnostic Test — Continued**

Error Code	Test Result	Description/ Recommendation
1004	ABORT	The port was seized by a valid call during the test. <ol style="list-style-type: none"> <li>1. Enter <b>display port UUCSSpp</b> to determine the station extension, attendant number, or trunk group/member number of the port. Use the <b>status station</b>, <b>status attendant</b>, or <b>status trunk</b> command to determine the service state of the port. If the port is in use, wait until the port is idle before testing. Attendants are always in use (off-hook) if the handset is plugged in and the port is not busied out.</li> <li>2. Retry the command at 1-minute intervals a maximum of 5 times.</li> </ol>
1018	ABORT	Test disabled via administration. Verify that the <code>Maintenance Tests?</code> field on the Trunk Group Form is set to <code>n</code> . To enable the test, issue the <b>change trunk-group x</b> command (x is the trunk group number). Then change the entry in the <code>Maintenance Tests?</code> field to <code>y</code> .
2000 2100	ABORT ABORT	Response to the test was not received within the allowable time period. Could not allocate the necessary system resources to run this test. <ol style="list-style-type: none"> <li>1. Retry the command at 1-minute intervals a maximum of 5 times.</li> </ol>
61446	FAIL	Battery feed test failed. A loop current fault was detected. This is most probably an incoming CO-line problem. This failure code is only reported by the TN2139 Italian DID circuit pack. <ol style="list-style-type: none"> <li>1. Check the incoming CO-line for loop current. If none is detected refer the problem to the CO.</li> <li>2. If the CO-line checks out OK, the failure must be on the DID port. Replace the circuit pack.</li> </ol>
61456	FAIL	Battery feed test failed. An on-board problem was detected. This port is out-of-service. <ol style="list-style-type: none"> <li>1. Replace circuit pack.</li> </ol>
61472	FAIL	Battery feed test failed. A problem with the incoming CO-line was detected. <ol style="list-style-type: none"> <li>1. Check the incoming CO-line for proper operation. If warranted, refer the problem to the CO.</li> <li>2. If the CO-line is not at fault, the failure must be on the DID port. Replace the circuit pack.</li> </ol>
	PASS	Current flow was detected for this port. <ol style="list-style-type: none"> <li>1. User-reported troubles on this port should be investigated using other port tests and by examining connections.</li> <li>2. Refer problem to the CO.</li> </ol>

*Continued on next page*

**Table 9-202. TEST #35 Port Diagnostic Test — Continued**

Error Code	Test Result	Description/ Recommendation
0	NO BOARD	The test could not relate the internal ID to the port (no board). <ol style="list-style-type: none"> <li>1. Check to ensure that the board translations are correct. Translate the board, if necessary.</li> <li>2. Issue the <b>busyout board</b> command.</li> <li>3. Issue the <b>reset board</b> command.</li> <li>4. Issue the <b>release busy board</b> command.</li> <li>5. Issue the <b>test board</b> command. This should re-establish the linkage between the internal ID and the port.</li> </ol>

**Port Audit Update Test (#36)**

This test sends updates of the DID port translation for all ports on the circuit pack that have been translated. The update is non-disruptive and guards against possible corruption of translation data contained on the circuit pack. No response message is expected from the circuit pack once it receives translation updates. The port translation data includes:

- Wink or immediate start trunk
- Dial tone or rotary dialing trunk
- Rotary dialing inter-digit timing
- Network balance R/RC
- Disconnect timing

**Table 9-203. TEST #36 Port Audit Update Test**

Error Code	Test Result	Description/ Recommendation
	ABORT	Could not allocate the necessary system resources to run this test. <ol style="list-style-type: none"> <li>1. Retry the command at 1-minute intervals a maximum of 5 times.</li> </ol>

*Continued on next page*

**Table 9-203. TEST #36 Port Audit Update Test — Continued**

Error Code	Test Result	Description/ Recommendation
1006	ABORT	The port is out of service, perhaps busied out. <ol style="list-style-type: none"> <li>1. Use <b>display port UUCSSpp</b> to determine the trunk group/member number of the port. Use <b>status trunk</b> to determine the service state of the port. If the port is out of service, wait until the port is in service and idle before testing.</li> <li>2. If the port status is in service and idle, then retry the command at 1-minute intervals a maximum of 5 times.</li> </ol>
2100	ABORT	Could not allocate the necessary system resources to run the test. <ol style="list-style-type: none"> <li>1. Retry the command at 1-minute intervals a maximum of 5 times.</li> </ol>
	FAIL	Internal system error <ol style="list-style-type: none"> <li>1. Retry the command at 1-minute intervals a maximum of 5 times.</li> </ol>
	PASS	This test passed. Translation information was successfully updated on the circuit pack. <ol style="list-style-type: none"> <li>1. If signaling troubles are reported (Error Types 1, 257, or 513), verify translation for this port.</li> <li>2. Refer problem to the CO.</li> </ol>
0	NO BOARD	The test could not relate the internal ID to the port. <ol style="list-style-type: none"> <li>1. Check to ensure that the board translations are correct. Translate the board, if necessary.</li> <li>2. Issue the <b>busyout board</b> command.</li> <li>3. Issue the <b>reset board</b> command.</li> <li>4. Issue the <b>release busy board</b> command.</li> <li>5. Issue the <b>test board</b> command. This should re-establish the linkage between the internal ID and the port.</li> </ol>

## **DIG-BD (Digital Line Circuit Pack)**

---

<b>MO Name (in Alarm Log)</b>	<b>Alarm Level</b>	<b>Initial Command to Run<sup>1</sup></b>	<b>Full Name of MO</b>
DIG-BD	MIN	test board UUCSS sh	Digital Line Circuit Pack
DIG-BD	WRN	test board UUCSS sh	Digital Line Circuit Pack

- 
1. UU is the universal cabinet number (1 for PPN, 2 -44 for EPNs). C is the carrier designation (A, B, C, D, or E). SS is the number of the slot in which the circuit pack resides (01 to 21).

Refer to "XXX-BD (Common Port Circuit Pack)" for circuit pack level errors. See also "DIG-LINE" for related line information.



## DIG-LINE (Digital Line)

MO Name (in Alarm Log)	Alarm Level	Initial Command to Run <sup>1</sup>	Full Name of MO
DIG-LINE	MINOR	test port UUCSSpp l	Digital Line
DIG-LINE	WARNING	test port UUCSSpp sh	Digital Line

1. UU is the universal cabinet number (1 for PPN, 2 -44 for EPNs). C is the carrier designation (A, B, C, D, or E). SS is the number of the slot in which the circuit pack resides (01 to 21). pp is the two digit port number (01, 02, ...).

DIG-LINE maintenance monitors and tests ports on digital line circuit packs and the hardware connected to those ports for lines administered as a digital station. These include stations with just a digital voice terminal and stations with a digital voice terminal and a linked data module. Stand-alone data modules, and data adaptors in stand-alone mode, are covered by the PDMODULE and TDMODULE maintenance objects. Circuit pack-level maintenance is covered by "DIG-BD" whose strategy is described in the "XXX-BD (Common Port Circuit Pack)" section.

Only the TN754B or TN2136 should be used in out-of-building applications. For important information pertaining to protection required for out-of-building digital voice terminals, see *DEFINITY Enterprise Communications Server Release 5.4 Installation and Test for Multi-Carrier Cabinets*.

Only 2-wire Italtel Digital Telephone Models 1 and 2 (IDT1/2) or DAs can directly connect to a TN2136. Lucent DCP (4-wire) digital voice terminals and data modules can connect to these circuit packs via Italtel's 2/4-wire adapter. DAs can operate in either of two modes which are covered by different MOs:

DA Mode	Administered as:	Endpoint	MO
Stand-alone	PDM	Data endpoint only	PDMODULE
Linked	DTDM	IDT1/2 and optional data terminal	DIG-LINE

Digital line maintenance interacts with digital line circuit pack (DIG-BD) maintenance, and results of DIG-LINE testing can be affected by the health of the digital line circuit pack. Keep this in mind when investigating digital line problems.

There are instances where the service state of a station is mentioned. It is helpful to understand what is meant by the different service states that may exist. The different service states which apply to digital line station are explained as follows:

Out-of-Service	The port, and thus the station, have been removed from service. Busyout puts the port in the out-of-service state.
Ready-for-Service	The port on the circuit pack has been put into service, but the voice terminal has not yet established signaling communications with the port.
In-Service	The voice terminal has established signaling communications with the port, and the system is ready to process calls to and from that station. A terminal in the ready-for-service state will progress to the in-service state if it is functioning normally. It can also be forced into the in-service state by going off-hook.

## Downloading of Terminal Parameters

### Programmable Terminals

The following information is presented to help you understand how maintenance software interacts with terminal parameter downloading.

#### Terminal Types:

- 84xx multibutton digital voice terminals (8403D01A, 8410B, 8410D02A, 8434D01A) with optional expansion module.
- 603A1 and 603D1 Callmaster terminals for telemarketing applications.
- 302B1 and 302C1 attendant console.

#### Circuit Packs:

- 8400x, 302B1 Terminals
  - TN754 (4-wire, mu-law)  
**Minimum usable vintage for 8410D and 8434D terminals - V11**
  - TN413 (4-wire, A-law)
  - TN754B (4-wire, A-law/mu-law selectable)
  - TN2177 (2-wire, 16-port, A-law/mu-law selectable)
  - TN2181 (2-wire, 16-port, A-law/mu-law selectable)
  - TN2224 (2-wire, 24-port, A-law/mu-law selectable)
- 603A1/D1 Terminals
  - TN754 (4-wire, mu-law),
  - TN413 (4-wire, A-law)
  - TN754B (4-wire, A-law/mu-law selectable)

## Downloadable Terminal Parameters

The following parameters are downloaded to programmable terminals:

**Table 9-204. Parameters Downloadable to Programmable Terminals**

Parameter	Scope	Terminal
International Flags (A-law/mu-law, Display Mode, DLI Voltage level)	System level	84xx, 603x, 302B1
Primary Levels (Transmission & Sidetone)	System level	84xx, 603x, 302B1
Adjunct Levels (Transmission & Sidetone)	System level	84xx
Handset Expander Option	System level	84xx
Administrable Options (Speakerphone & Mute Button)	Per-terminal	84xx
Administrable Softkeys	Per-terminal, System level	8410D, 8434D

## Nonvolatile Memory

Nonvolatile memory stores downloadable parameters in programmable terminals. Once the terminal is downloaded, it is not necessary to download it again, even if power is removed from the terminal. If nonvolatile memory fails with power still present, the terminal reverts to its default factory settings except for its A-law/mu-law companding settings which are stored in RAM. If power is removed after the nonvolatile memory fails, the terminal reverts to its factory default settings.

### NOTE:

The mu-law companding mode is assigned as a default setting at the factory. For the United States, a programmable terminal can place calls even though it has not been downloaded from the system.

## Download Actions

There are several different scenarios that cause a terminal to be downloaded. These can occur as part of background maintenance activity or on demand from the System Access Terminal or from a station.

For the background actions described below, the terminal downloads automatically if a download retry flag for the terminal is set in software. This flag is set at the time translation is loaded at boot time, when translation which affects the parameters of a terminal is changed as part of system administration actions, and when a port is inserted in software as a result of board insertion or translation change.

## Automatic Download Actions

### 1. System Reboot/Restart

A global download action is started when periodic maintenance tests start after a system reboot/restart regardless of whether the parameters have been downloaded previously.

### 2. Periodic Tests

If the download flag is still set when periodic tests are run on a terminal, a download action will occur. This operation is required in case a terminal could not be downloaded previously because it was off-hook at the time the system first booted or because the terminal was off-hook at the time translation associated with downloadable parameters was changed.

Note that it may take more than an hour for periodic tests to reach the terminal that needs to be downloaded.

### 3. Terminal Administration

A downloadable terminal is automatically downloaded when translation changes associated with downloadable parameters are made as part of system administration. As shown in the previous table, these changes can be for a specified terminal or may be system-wide. If the change is for system-level parameter, a background global update request is made to download all programmable terminals.

This global update may take more than an hour for a system with several thousand programmable terminals.

### 4. Port Insertion

Whenever maintenance software initiates a request to place a port into service, a terminal download action is started on that terminal if that terminal is programmable. This port insertion action occurs under the following circumstances:

- a. A digital line circuit pack that is physically inserted into the system has ports currently administered for programmable terminals.

If more than 20 port insertion requests are received within a few seconds, a global download request is started up as a background task. This action updates all programmable terminals instead of just those being inserted. This is done to avoid system overload for situations where there is massive board insertion. This could occur when connectivity to an EPN is reestablished after that EPN was down.

- b. A station port is added to the system by a "**add station**" or "**change station**" command.
- c. A TTI port is activated.

## 5. Audits

As part of periodic maintenance, the hardware status audit test queries programmable terminals to determine which levels and/or options are being used. If the reported values are not equal to the administered values, the system will initiate a terminal download action. This audit does NOT check the parameters used for softkeys.

## 6. Activation of TTI

A terminal is downloaded automatically when it is activated using the Terminal Translation Initialization feature. Therefore, no special user actions are required for TTI.

### NOTE:

Plugging the station cord into a terminal does not automatically cause the terminal to be downloaded. If this terminal has factory defaults or if the terminal has been previously downloaded with parameters different than those desired, use one of the demand download actions described below to download the terminal.

## Demand Download Actions

### 1. Busyout/Release Command

A maintenance demand busyout/release request for a station will cause the terminal to be downloaded regardless of its previous download status.

### 2. Feature Access Code

A Refresh Terminal Parameters Feature Access Code can be used to request a terminal download action. When this code is followed by a "#", the programmable parameters for the current terminal are downloaded when the terminal goes on hook. When this code is followed by an extension, the programmable parameters for the specified station are downloaded.

This Refresh Terminal Parameters Feature Access Code is assigned on the second page of the "feature-access-codes" screen.

A confirmation is returned if the download request is accepted. A busy tone is returned if the request is made from a different station when the target station is off-hook.

The first three green call appearance LEDs on the 84xx 603x terminal will be turned on for three seconds if the station was successfully downloaded as a result of an entry of a Refresh Terminal Parameters Facility Access Code. This is not true for the 302B1 terminal.

There is no visible display on a station for the other background or demand download actions. As described below, the "status station" and "status attendant" screens can be used to check the download status of a specified terminal.

## Status of Parameter Downloads

The "status station" and "status attendant" screens display the current download status of individual 84xx, 603, and 301B1 terminals in the Download Status field. The possible download states are:

Status	Explanation
Complete	Terminal successfully downloaded sometime in the past.
Pending	System waiting to download the terminal. This may require the execution of a background periodic test which could take more than an hour. A demand download as described above may also be used to initiate an immediate download.
Not Applicable	Not a programmable terminal.

Possible reasons for terminal being not downloaded include:

- Terminal is off-hook.
- Terminal detected a bad checksum.
- Terminal detected a bad or missing EEPROM (refer to hardware error log).
- Terminal is busy programming data from a previous PROGRAM message.
- Terminal is in the Programming Disabled state.
- Terminal is in the Local Program Options Mode.
- Terminal is disconnected or out of service (use **status station** command).

## Error Log Entries and Test to Clear Values

Table 9-205. Digital Line Error Log Entries

Error Type	Aux Data	Associated Test	Alarm Level	On/Off Board	Test to Clear Value
0 <sup>1</sup>	0	Any	Any	Any	test port <i>UUCSSpp</i> sh r 1
1 (a)	40987	None	WARNING	OFF	
1 (b)	1 to 20	None	WARNING	OFF	
18 (c)	0	busyout port <i>UUCSSpp</i>	WARNING	OFF	rel port <i>UUCSSpp</i>
130 (d)		None	WARNING	ON	test port <i>UUCSSpp</i> sh
257 (e)	40971	None			
513	0	Station (Digital) Audits Test (#17)	WARNING( o)	OFF	test port <i>UUCSSpp</i> sh r 6
767 (f)	40964	None	WARNING	OFF	
769 (g)	40963 40988	None	WARNING	OFF	

Table 9-205. Digital Line Error Log Entries — Continued

Error Type	Aux Data	Associated Test	Alarm Level	On/Off Board	Test to Clear Value
1026(o)		NONE	WARNING	OFF	
1281	Any	Station (Digital) Audits Test (#17)	WARNING	OFF	test port UUCSSpp sh r 4
1537 (h)	40968	None	WARNING	OFF	
1793		Voice & Ctrl. Local Loop Test (#13)	MINOR/ WARNING <sup>2</sup>	ON	test port UUCSSpp l r 3
2049		NPE Crosstalk Test (#9)	MINOR/ WARNING <sup>2</sup>	ON	test port UUCSSpp l r 3
2304 (n)		None			
2305 (i)	32770	None			
2305 (h)	40967	None			
3840 (k)	40965	None			
3840 (l)	40989	None			
3841 (m)	41029	None			

1. Run the Short Test Sequence first. If all tests pass, run the Long Test Sequence. Refer to the appropriate test description and follow the recommended procedures.
2. Major alarms may be downgraded to Warning alarms based on the value used in the set options command.

## Notes:

- a. Could experience a noisy port or link. This is an off-board problem detected by the port circuit. Check for defective wiring, a defective voice terminal, or move voice terminal closer to the switch (in terms of feet of wire from the jack to the switch). If the problem still exists, replace the circuit pack. Once the problem has been resolved, the alarm will be retired after a predetermined amount of time.
- b. This Error Type and Aux Data will occur when at least 15 off-board problems have been detected with the link to the terminal. When an error with the link is detected, an on-board counter is incremented.

The user could experience a noisy port or link. This is an off-board problem detected by the port circuit. Check for defective wiring, a defective voice terminal, or move voice terminal closer to the switch (in terms of feet of wire from the jack to the switch). If the problem still exists, replace the circuit pack. Once the problem has been resolved, the alarm will be retired after a predetermined amount of time.

- c. This error type is logged when the port in question is busied out by maintenance personnel. Make sure port is released from busyout via the **release port UUCSS pp/PCSSpp** command.
- d. This error type indicates that the circuit pack has been removed or has been insane for more than 21 minutes. To clear the error, reinsert or replace the circuit pack.
- e. Problems transmitting to the voice terminal. This problem can be caused by defective wiring. Defective wiring can cause varying degrees of problems on different types of sets. Sets such as the 7410 appear to be more susceptible to wiring problems than other sets. This is usually an on-board problem and can be ignored if no user complaints are received.
- f. This is an in-line event that produces this error type when a favorable response is received from running the Digital Line Electronic Power Feed Test (#11). No craft action is necessary. This alarm will be resolved with the passing of time.
- g. With Aux Data 40963, this error type is a result of an unfavorable response to the Electronic Power Feed/ Positive Temperature Coefficient Test (#11). With Aux Data 40988, this error type indicates that the EPF/PTC circuit has been turned off due to an overcurrent condition.

For TN754 vintage 13 or earlier and TN413, the EPF circuit senses an overcurrent condition at the voice terminal. Check for a short in the wiring, a damaged jack, an incorrect type of voice terminal, or a defective voice terminal.

For TN754 vintage 14 or later, TN754B and TN2136, the PTC will open if there is a short on the power line for 1/2 second or longer. The voice terminal is probably not operating properly. Unplug the voice terminal for 30 seconds and then plug it back in. If the voice terminal still does not operate, then check for a short in the wiring, a damaged jack, an incorrect type of voice terminal, or a defective voice terminal.

Once the problem has been resolved, it may take up to 1 hour for the alarm to clear due to "leaky bucket" strategy. If the problem cannot be resolved by one of the steps above, then replace the circuit pack.

- h. An in-line maintenance error has generated an off-board warning due to some problem with the link to the voice terminal. This can be ignored if no user complaints are received. Otherwise, make sure the voice terminal is connected, check for defective wiring, check for a defective voice terminal, and move voice terminal to a jack that is closer to the switch (in terms of feet of wiring between the jack and the switch). If the problem still exists, replace the circuit pack. Once the problem has been resolved, the alarm will be retired after a predetermined amount of time.
- i. This indicates that the station went off-hook while it was in the ready-for-service state. Use the **status station** command to determine the state of the station. The off-hook should have moved the station to ready-for-service. No craft action is necessary.



- j. This is the code that is generated when the link between the circuit pack and the voice terminal is successfully reset. No craft action is necessary.
- k. No terminal is connected to the Digital Line board. No maintenance action is required.
- l. An uplink message has been logged indicating that the Electric Power Feed (EPF) is on with no load on it. No action is necessary.
- m. The circuit pack's message buffer is full. This may be caused by having many display phones with heavy traffic connected to the circuit pack. No action is necessary.
- n. Internal system error. No action is necessary.
- o. There is a problem with the voice terminal EEPROM. When the voice terminal is repaired the alarm will be resolved with the passing of time.

### System Technician-Demanded Tests: Descriptions and Error Codes

Always investigate tests in the order presented in the table below. By clearing error codes associated with the *Voice and Control Channel Local Looparound Test*, for example, you may also clear errors generated from other tests in the testing sequence.

Order of Investigation	Short Test Sequence	Long Test Sequence	D/ND <sup>1</sup>
Digital Terminal Remote Looparound Test (#1201)		X	D
Voice and Control Channel Local Looparound Test (#13)		X	ND
Digital Line NPE Crosstalk Test (#9)		X	ND
Digital Line Electronic Power Feed Test (#11)		X	ND
DIG-LINE Station Lamp Updates Test (#16)	X	X	ND
Station (Digital) Audits Test (#17)	X	X	ND

1. D = Destructive; ND = Nondestructive

### Digital Terminal Remote Looparound Test (#1201)

This test checks the connection between the SPE and the digital terminal and the ability of the terminal and the associated port to send and receive data. This test is based on procedure 622 to isolate digital terminal problems.

A request is presented to the terminal to go into loopback mode. Data is sent to the terminal and when received back, checked for consistency. This test is run as a part of the "test long" procedure. It is not included in any error recovery strategy

and generates no Error Log entries or alarms. To begin the test, Maintenance will ask call processing to make the associated endpoint and port "Maintenance Busy". This test succeeds if the endpoint is "idle". If the reserve request fails then the test aborts. If the request succeeds then the SPE sends a message to loop around both information channels for the digital terminal. First the primary information (voice, Information Channel 1 or I1) channel loopback test is run. The test is performed by sending a digital count from the Tone/Clock circuit pack on the primary information channel time slot and receiving the same digital count with a general purpose tone detector.

If the primary information channel test is successful, the loop around test for the secondary information (data, Information Channel 2 or I2) channel is then performed. This test is the same as the primary information channel loop around test and is performed only if a DTDM is administered. This is also the case for a linked DA.

Only one value (Pass, Fail, or Abort) is generated as a result of the two tests run. If any test fails aborts, the sequence is stopped. Upon completion of this test the associated endpoint and port are moved back into the previous service state.

**Table 9-206. TEST #1201 Digital Terminal Remote Looparound Test**

Error Code	Test Result	Description/ Recommendation
	ABORT	Internal system error 1. Retry the command at 1-minute intervals a maximum of 5 times.
1000	ABORT	System resources required to run this test are not available. The port may be busy with a valid call. 1. Use the <b>display port UUCSSpp</b> command to determine the station extension or attendant number of the port. Use <b>status station</b> or <b>status attendant</b> to determine the service state of the port. If the port is in use, wait until the port is idle before testing. Attendants are always in use (off-hook) if the handset is plugged in and the port is not busied out. 2. If the port status is idle, then retry the command at 1-minute intervals a maximum of 5 times.
1001	ABORT	System resources required to run this test are not available. 1. If the port status is idle, then retry the command at 1-minute intervals a maximum of 5 times.
1002	ABORT	The system could not allocate time slots for the test. The system may be under heavy traffic conditions or it may have time slots out-of-service due to TDM-BUS errors. 1. If the system has no TDM-BUS errors and is not handling heavy traffic, retry the command at 1-minute intervals a maximum of 5 times.

**Table 9-206. TEST #1201 Digital Terminal Remote Looparound Test — Continued**

Error Code	Test Result	Description/ Recommendation
1003	ABORT	The system could not allocate a tone receiver for the test. The system may be oversized for the number of Tone Detectors present or some Tone Detectors may be out of service. <ol style="list-style-type: none"> <li>1. Resolve any TTR-LEV errors.</li> <li>2. Resolve any TONE-PT errors.</li> <li>3. If neither condition exist, retry the command at 1-minute intervals a maximum of 5 times.</li> </ol>
1004	ABORT	The port was seized by a valid call during the test. <ol style="list-style-type: none"> <li>1. Enter <b>display port UUCSSpp</b> to determine the station extension or attendant number of the port. Use <b>status station</b> or <b>status attendant</b> to determine the service state of the port. If the port is in use, wait until the port is idle before resetting. Attendants are always in use (off-hook) if the handset is plugged in and the port is not busied out.</li> <li>2. Retry the command at 1-minute intervals a maximum of 5 times.</li> </ol>
1005 2000	ABORT ABORT	The installed circuit pack does not support this operation. Response to the test was not received within the allowable time period. <ol style="list-style-type: none"> <li>1. Retry the command at 1-minute intervals a maximum of 5 times.</li> </ol>
2100	ABORT	System resources required to run this test are not available. <ol style="list-style-type: none"> <li>1. Make sure terminal is connected and repeat test.</li> <li>2. If test fails replace terminal and repeat test.</li> <li>3. Retry the command at 1-minute intervals a maximum of 5 times.</li> </ol>
14	FAIL	The primary channel is not operating properly. User impact may range from noticing nothing to not being able to use the port. Check the results of "Voice and Control Channel Local Loop Test (#13). If that test fails, suspect the Digital Line circuit pack. If that test passes then replace the terminal. If both tests fail, and component replacement does not change the results, then: <ol style="list-style-type: none"> <li>1. Run circuit pack tests to check the tone generator circuit pack and the Tone Detector circuit pack using <b>test board UUCSS</b> .</li> <li>2. Resolve any problems that are detected on the Tone Generator circuit pack or Tone Detector circuit pack.</li> </ol>
1015	ABORT	The station is not busied out ( <b>busyout station</b> ).

*Continued on next page*

**Table 9-206. TEST #1201 Digital Terminal Remote Looparound Test — Continued**

Error Code	Test Result	Description/ Recommendation
16	FAIL	The secondary channel is not operating properly. User impact may range from noticing nothing to not being able to use this terminal. Check the results of Voice and Control Channel Local Loop Test (#13). If that test fails, suspect the Digital Line circuit pack. If that test passes then replace the terminal. If both test fail, and component replacement does not change the results, then: <ol style="list-style-type: none"> <li>1. Run circuit pack tests to check the tone generator circuit pack and the Tone Detector circuit pack using <b>test board UUCSS</b> .</li> <li>2. Resolve any problems that are detected on the Tone Generator circuit pack or Tone Detector circuit pack.</li> </ol>
	PASS	Voice and Control Channel Local Loop test passed. All channels are transmitting properly. <ol style="list-style-type: none"> <li>1. To be sure that this is not an intermittent problem, repeat this test up to a maximum of ten times to make sure it continues to pass.</li> <li>2. If complaints persist (noisy connections for voice. corrupted data transfer for data), examine the station, connections, and wiring.</li> </ol>

### Digital Line NPE Crosstalk Test (#9)

The NPE Crosstalk Test verifies that this port's NPE channel talks on the selected time slot and never crosses over to time slots reserved for other connections. If the NPE is not working correctly, one-way and noisy connections may be observed. This test is part of a port's Long Test Sequence and takes about 20 to 30 seconds to complete.

**Table 9-207. TEST #9 Digital Line NPE Crosstalk Test**

Error Code	Test Result	Description/ Recommendation
1	ABORT	During testing of the primary information channel, system resources were not available. Also, the port may have been busy during the test. <ol style="list-style-type: none"> <li>1. Enter <b>display port UUCSSpp</b> to determine the station extension of the port. Use <b>status station</b> to determine the service state of the port. If the port is in use, wait until the port is idle before testing.</li> <li>2. If the port status is idle, retry the command at 1-minute intervals a maximum of 5 times.</li> </ol>

*Continued on next page*

**Table 9-207. TEST #9 Digital Line NPE Crosstalk Test — Continued**

Error Code	Test Result	Description/ Recommendation
2	ABORT	<p>During testing of DTDM, system resources may not have been available. Also, the port may have been busy during the test.</p> <ol style="list-style-type: none"> <li>1. Check if port is being used. If possible, disconnect by toggling disconnect button on DTDM. Retry command after 1 minute.</li> </ol> <p> <b>WARNING:</b>  <i>This action will drop the call in progress.</i></p>
1000	ABORT	<p>System resources required to run this test are not available. The port may be busy with a valid call.</p> <ol style="list-style-type: none"> <li>1. Enter <b>display port UUCSSpp</b> to determine the station extension or attendant number of the port. Use <b>status station</b> or <b>status attendant</b> to determine the service state of the port. If the port is in use, wait until the port is idle before testing. Attendants are always in use (off-hook) if the handset is plugged in and the port is not busied out.</li> <li>2. If the port status is idle, retry the command at 1-minute intervals a maximum of 5 times.</li> </ol>
1001	ABORT	<p>System resources required to run this test are not available.</p> <ol style="list-style-type: none"> <li>1. Retry the command at 1-minute intervals a maximum of 5 times.</li> </ol>
1002	ABORT	<p>The system could not allocate time slots for the test. The system may be under heavy traffic conditions or it may have time slots out-of-service due to TDM-BUS errors.</p> <ol style="list-style-type: none"> <li>1. If system has no TDM-BUS errors and is not handling heavy traffic. Retry the command at 1-minute intervals a maximum of 5 times.</li> </ol>
1003	ABORT	<p>The system could not allocate a tone receiver for the test. The system may be oversized for the number of Tone Detectors present or some Tone Detectors may be out-of-service.</p> <ol style="list-style-type: none"> <li>1. Resolve any TTR-LEV errors.</li> <li>2. Resolve any TONE-PT errors.</li> <li>3. If neither condition exists, retry the command at 1-minute intervals a maximum of 5 times.</li> </ol>
1004	ABORT	<p>The port was seized by a valid call during the test. The test has been aborted.</p> <ol style="list-style-type: none"> <li>1. Enter <b>display port UUCSSpp</b> to determine the station extension or attendant number of the port. Use <b>status station</b> or <b>status attendant</b> to determine the service state of the port. If the port is in use, wait until the port is idle before testing. Attendants are always in use (off-hook) if the handset is plugged in and the port is not busied out.</li> </ol>

*Continued on next page*

**Table 9-207. TEST #9 Digital Line NPE Crosstalk Test — Continued**

Error Code	Test Result	Description/ Recommendation
1020	ABORT	Test disabled via background testing. Use <b>status station</b> command to determine when station is available for testing.
2000	ABORT	Response to the test request was not received within the allowable time period.  1. Retry the command at 1-minute intervals a maximum of 5 times.
1 2	FAIL	The Network Processing Element (NPE) of the tested port was transmitting in error. Error code 1 = Crosstalk test failed on the primary channel. Error code 2 = Crosstalk test failed on the secondary channel.  1. Replace circuit pack.
	PASS	The port is correctly using its allocated time slots.  1. To be sure that this is not an intermittent problem, repeat this test up to a maximum of 10 times to make sure it continues to pass.  2. If complaints persist, examine the station, connections, and wiring.

### Digital Line Electronic Power Feed/Positive Temperature Coefficient/PPF Test(#11)

For TN413, and TN754 vintage 13 or earlier, this is an Electronic Power Feed (EPF) restoral test. In this test, the processor requests that the EPF be turned on for a given port, and an attempt is made to turn on the power supply to the station. If no current is drawn, the station is probably not connected. If an overcurrent condition is sensed, there may be a short in the loop. A message is returned reporting that either the EPF was successfully turned on, or that an overcurrent condition was sensed. This test is repeated again 5 seconds later.

For TN754 vintage 14 or later, TN754B and TN2136 this is a Positive Temperature Coefficient (PTC) restoral test. In this test, the processor requests that the PTC be turned on for a given port, and an attempt is made to turn on the power supply to the station. If an overcurrent condition is sensed, there is probably a short on the power line that causing the PTC to open and disconnect the voice terminal. Since the PTC does not have self-restoral capability, the voice terminal must be manually unplugged for 30 seconds and then plugged back in to restore the PTC. A message is returned reporting that either the PTC was successfully turned on successfully with no problem or an overcurrent condition was sensed. This test is repeated again 5 seconds later.

TN2181 and TN2224 boards carry a Protected Power Feed (PPF) relays, one for each port. Therefore this will be a Protected Power Feed restoral test. The test

procedure and its response is same as that of EPF. One of differences between EFP and PPF is that, if the port goes into a overcurrent state, PPF does not report this change of state because it is a transient state which will not last more than 50ms. If the over current persists the power will be shut off automatically and an EPF\_off\_overcurrent message is sent uplink.

**Table 9-208. TEST #11 Digital Line Electronic Power Feed Test**

Error Code	Test Result	Description/ Recommendation
	ABORT	Internal system error 1. Retry the command at 1-minute intervals a maximum of 5 times.
1000	ABORT	System resources required to run this test are not available. The port may be busy with a valid call. 1. Enter <b>display port UUCSSpp</b> to determine the station extension or attendant number of the port. Use <b>status station</b> or <b>status attendant</b> to determine the service state of the port. If the port is in use, wait until the port is idle before testing. Attendants are always in use (off-hook) if the handset is plugged in and the port is not busied out. 2. If the port status is idle, then retry the command at 1-minute intervals a maximum of 5 times.
	FAIL	Internal system error 1. Retry the command at 1-minute intervals a maximum of 5 times.
	PASS	Electronic Power Feed Test passed. The message to turn on the power to the station was successfully sent to the port. 1. Although this test will never actually return a FAIL result except for the <b>Internal system error</b> described above, it will log an error indicating the real results of the test. Check the Error Log for any entries with Error Types 767 or 769 after the test completes. 2. If Error Type 767 appears in the Error Log, this indicates that the test sensed no problems with the power to the station. To verify that the station is powered up correctly, run a self-test on the station and check that all the feature buttons are operating. 3. If Error Type 769 appears in the Error Log, this indicates some problem with the power to the station. Check for a short in the wiring, a damaged jack, a defective voice terminal, or an incorrect type of terminal.

### Voice and Control Channel Local Loop Test (#13)

These tests check the information and control channels between the Switch Processing Element (SPE) and the Digital Line port circuit. The SPE sends a message to loop around both the information and control channels for the port. First, the primary information (voice) channel loop back test is run. The test is

performed by sending a digital count from the Tone-Clock circuit pack on the primary information channel time slot and receiving the same digital count with a general purpose Tone Detector.

While the primary information channel is still looped around, the Control Channel Looparound Test is performed. This test consists of sending four different transparent patterns to the on-board microprocessor, receiving them back, and comparing them.

The Looparound Test for the secondary information (data) channel is then performed. This test is the same as the primary information channel loop around test and is performed only if a DTDM is administered.

A Conference Test is done next for the primary information channel. This test is the same as Conference Test #6. Only one value (Pass, Fail, or Abort) is generated as a result of four tests run. If any test fails or aborts, the sequence is stopped.

**Table 9-209. TEST #13 Voice and Control Channel Local Loop Test**

Error Code	Test Result	Description/ Recommendation
	ABORT	Internal system error 1. Retry the command at 1-minute intervals a maximum of 5 times.
1000	ABORT	System resources required to run this test are not available. The port may be busy with a valid call. 1. Use <b>display port UUCSSpp</b> to determine the station extension or attendant number of the port. Use <b>status station</b> or <b>status attendant</b> to determine the service state of the port. If the port is in use, wait until the port is idle before testing. Attendants are always in use (off-hook) if the handset is plugged in and the port is not busied out. 2. If the port status is idle, retry the command at 1-minute intervals a maximum of 5 times.
1001	ABORT	System resources required for this test are not available. 1. Retry the command at 1-minute intervals a maximum of 5 times.
1002	ABORT	The system could not allocate time slots for the test. The system may be under heavy traffic conditions or it may have time slots out-of-service due to TDM-BUS errors. 1. If system has no TDM-BUS errors and is not handling heavy traffic, repeat test at 1-minute intervals a maximum of 5 times.

*Continued on next page*



**Table 9-209. TEST #13 Voice and Control Channel Local Loop Test — Continued**

Error Code	Test Result	Description/ Recommendation
1003	ABORT	The system could not allocate a tone receiver for the test. The system may be oversized for the number of Tone Detectors present or some Tone Detectors may be out-of-service. <ol style="list-style-type: none"> <li>1. Resolve any TTR-LEV errors.</li> <li>2. Resolve any TONE-PT errors.</li> <li>3. If neither condition exists, retry the command at 1-minute intervals a maximum of 5 times.</li> </ol>
1004	ABORT	The port was seized by a valid call during the test. The test has been aborted. <ol style="list-style-type: none"> <li>1. Use <b>display port UUCSSpp</b> to determine the station extension or attendant number of the port. Use <b>status station</b> or <b>status attendant</b> to determine the service state of the port. If the port is in use, wait until the port is idle before testing. Attendants are always in use (off-hook) if the handset is plugged in and the port is not busied out.</li> <li>2. Retry the command at 1-minute intervals a maximum of 5 times.</li> </ol>
2000	ABORT	Response to the test was not received within the allowable time period. <ol style="list-style-type: none"> <li>1. Retry the command at 1-minute intervals a maximum of 5 times.</li> </ol>
2100	ABORT	Could not allocate the necessary system resources to run this test. <ol style="list-style-type: none"> <li>1. Rerun the test at 1-minute intervals a maximum of 5 times.</li> </ol>
7	FAIL	Conference Test failed on primary channel. In some cases, users may not notice disruption in service. In extreme cases, conferencing feature may not work at all.
14	FAIL	The primary voice channel is not transmitting properly. User impact may range from noticing nothing to not being able to use this port.
15	FAIL	The control channel between the processor and digital circuit pack is not transmitting properly. User impact may range from noticing nothing to not being able to use the port. Could also be disruptive to other users.
16	FAIL	The secondary voice channel is not transmitting properly. User impact may range from noticing nothing to not being able to use this port. <ol style="list-style-type: none"> <li>1. Run circuit pack tests to check the Tone Generator circuit pack and the Tone Detector circuit pack using <b>test board UUCSS</b>.</li> <li>2. Resolve any problems that are detected on the Tone Generator circuit pack or Tone Detector circuit pack.</li> <li>3. If the Tone Generator and Tone Detector circuit packs are functioning properly, and the test still fails, replace the Digital Line circuit pack.</li> </ol>

*Continued on next page*

**Table 9-209. TEST #13 Voice and Control Channel Local Loop Test — Continued**

Error Code	Test Result	Description/ Recommendation
	PASS	Voice and Control Channel Local Loop test passed. All channels are transmitting properly. <ol style="list-style-type: none"> <li>1. To be sure that this is not an intermittent problem, repeat this test up to a maximum of 10 times to make sure it continues to pass.</li> <li>2. If complaints persist (noisy connections for voice, corrupted data for data transfer), examine the station, connections, and wiring.</li> </ol>

### DIG-LINE Station Lamp Updates Test (#16)

This test lights all lamps on the terminal as specified. The lamp updates will run only if the station is in-service. The status of the station is checked and the lamp updates are blocked from taking place if the station is not in the in-service state. This test does not affect the status of the Message Waiting lamp.

**Table 9-210. TEST #16 DIG-LINE Station Lamp Updates Test**

Error Code	Test Result	Description/ Recommendation
	ABORT	Internal system error <ol style="list-style-type: none"> <li>1. Retry the command at 1-minute intervals a maximum of 5 times.</li> </ol>
1	ABORT	This port may have been busied out by system technician. <ol style="list-style-type: none"> <li>1. Look in the Error Log for Error Type 18 (port busied out) for this port. If this error type is present, then release the port via the <b>release station &lt;extension&gt;</b> command and run the test again.</li> <li>2. Make sure that the terminal is connected.</li> <li>3. Retry the command at 1-minute intervals a maximum of 5 times.</li> </ol>
3	ABORT	Station may be in ready-for-service or out-of-service state. <ol style="list-style-type: none"> <li>1. Use <b>status station</b> command to verify state of station.</li> <li>2. Make sure the terminal is connected.</li> <li>3. Retry the command at 1-minute intervals a maximum of 5 times.</li> </ol>

*Continued on next page*

**Table 9-210. TEST #16 DIG-LINE Station Lamp Updates Test — Continued**

Error Code	Test Result	Description/ Recommendation
1000	ABORT	System resources required to run this test are not available. The port may be busy with a valid call. <ol style="list-style-type: none"> <li>1. Use <b>display port UUCSSpp</b> to determine the station extension or attendant number of the port. Use <b>status station</b> or <b>status attendant</b> to determine the service state of the port. If the port is in use, wait until the port is idle before testing. Attendants are always in use (off-hook) if the handset is plugged in and the port is not busied out.</li> <li>2. If the port status is idle, then retry the command at 1-minute intervals a maximum of 5 times.</li> </ol>
1392	ABORT	This port is currently a TTI port and the test will not execute on it. <ol style="list-style-type: none"> <li>1. Verify that the port is a TTI port using either the <b>display port</b> command (the display shows that the port is a TTI port) or the <b>list config</b> command (the display shows a "t" for the port).</li> <li>2. If either <b>list config</b> or <b>display port</b> indicates that the port is <i>not</i> a TTI port, escalate the problem. If both commands indicate that the port is a TTI port, the abort is correct, and no action is necessary.</li> </ol>
	FAIL	Internal system error <ol style="list-style-type: none"> <li>1. Retry the command at 1-minute intervals a maximum of 5 times.</li> </ol>
	PASS	The message to light all of the station lamps was sent successfully to the port. <ol style="list-style-type: none"> <li>1. Observe the station lamps being lit when running the test. If all lamps do not light, the other Digital Line test results may indicate related problems that do not allow the lamps to light.</li> <li>2. Investigate by using other Digital Line port tests, and by examining the station, wiring, and connections.</li> </ol>

### Digital Station Audits Test (#17)

This is a series of six tests that are classified as audits. The SPE sends messages to the on-board microprocessor to perform the following tests. These audits run only if the station is in-service.

- Switchhook Inquiry Test — This is an update of the SPE records according to the circuit pack's records. This inquiry is sent all the way to the voice terminal.
- Bad Scan Inquiry Test — A message is sent uplink which contains a count that is generated due to certain events relating to the link conditions. This can be an indication of communications problems between the Processor and Digital Port circuit pack.

- EPF/PTC Inquiry Test — For a TN413 or a TN754 vintage 13 or earlier, the status of the Electronic Power Feed (EPF) is sent uplink. Possible conditions are: EPF-on-ok, EPF-off, and EPF-no-load. For TN754 vintage 14 or later, TN754B or TN2136, TN2181, TN2224, the status of the PTC is sent uplink. Possible conditions are: PTC-on-ok, PTC-off, and PTC-no-load.
- ID Request Test — A request is made to the station for its status. The station sends its configuration information and health information back. This information is checked and a pass/fail result is provided.
- Ringer Update Test — This updates the digital telephone ringer state according to the processor records.
- DTMF Administration Update Test — This is a message to the digital station to refresh the default value that causes the station to send touch-tones only in the primary information channel. This value is set initially when the station is put in-service and every time the station's state changes from other states to in-service.

**Table 9-211. TEST #17 Station (Digital) Audits Test**

Error Code	Test Result	Description/ Recommendation
1	ABORT	Switchhook audit timed out.
2	ABORT	ID request fails, health bit returned from voice terminal is bad. 1. Make sure voice terminal is connected and repeat test. 2. If test fails, replace voice terminal and repeat test.
3	ABORT	The EPF/PTC has detected an overcurrent condition. 1. For a TN754 vintage 13 or earlier Digital Line circuit pack, use <b>test UUCSSpp long</b> . If Test #11 passes, then the EPF/PTC condition was cleared. Rerun the Short Test Sequence. If Test #11 does not pass, follow the repair procedures described for Test #11. 2. Look for Error Type 769 logged against DIG-LINE and follow the procedures in the associated footnote. If any additional problems are found, rerun the test.
4	ABORT	Internal system error 1. Resolve any outstanding circuit pack maintenance problems. 2. Retry the command at 1-minute intervals a maximum of 5 times.
5	ABORT	Ringer update aborted due to station being in ready-for-service or out-of-service state.

*Continued on next page*

**Table 9-211. TEST #17 Station (Digital) Audits Test — Continued**

Error Code	Test Result	Description/ Recommendation
6	ABORT	This port may have been busied out by system technician. <ol style="list-style-type: none"> <li>1. Look in the Error Log for Error Type 18 (port busied out) for this port. If this error is present, the release the port via <b>release station</b></li> <li>2. Make sure that the terminal is connected.</li> <li>3. Retry the command at 1-minute intervals a maximum of 5 times.</li> </ol>
1000	ABORT	System resources required for this test are not available.
1392	ABORT	This port is currently a TTI port and the test will not execute on it. <ol style="list-style-type: none"> <li>1. Verify that the port is a TTI port using either the <b>display port</b> command (the display shows that the port is a TTI port) or the <b>list config</b> command (the display shows a "t" for the port).</li> <li>2. If either <b>list config</b> or <b>display port</b> indicate that the port is <i>not</i> a TTI port, escalate the problem. If both commands indicate that the port is a TTI port, the abort is correct, and no action is necessary.</li> </ol>
2000	ABORT FAIL	Response to the test was not received in the allowable time period. Internal system error <ol style="list-style-type: none"> <li>1. Retry the command at 1-minute intervals a maximum of 5 times.</li> </ol>
	PASS	Station Audits passed. This Digital Port circuit pack is functioning properly. <ol style="list-style-type: none"> <li>1. If complaints persist, investigate by using other port tests, and by examining the station, wiring, and connections.</li> </ol>

## DIOD-BD (DIOD Trunk Circuit Pack)

MO Name (in Alarm Log)	Alarm Level	Initial Command to Run <sup>1</sup>	Full Name of MO
DIOD-BD	MINOR	test port <i>UUCSSpp s</i>	DIOD Circuit Pack

1. *UU* is the universal cabinet number (1 for PPN, 2 -44 for EPNs). *C* is the carrier designation (A, B, C, D, or E). *SS* is the number of the slot in which the circuit pack resides (01 to 21). *pp* is the two digit port number (01, 02, ...).

Refer to the "XXX-BD (Common Port Circuit Pack)" section at the end of this chapter.

## DIOD-DS1 (DS1 DIOD Trunk)

---

MO Name (in Alarm Log)	Alarm Level	Initial Command to Run	Full Name of MO
DIOD-DS1	MAJOR <sup>1</sup>	test trunk <i>group# member# l</i>	DS1 DIOD Trunk
DIOD-DS1	MINOR	test trunk <i>group# member# l</i>	DS1 DIOD Trunk
DIOD-DS1	WARNING	test trunk <i>group# member#</i>	DS1 DIOD Trunk

1. A Major alarm on a trunk indicates that alarms on these trunks are not downgraded by the **set options** command and that at least 75 percent of the trunks in this trunk group are alarmed. For more information on the **set options** command.

### NOTE:

Many trunk problems are caused by incorrect settings of parameters on the trunk group administration form. Settings must be compatible with the local environment and with parameter settings on the far-end. Refer to *DEFINITY Enterprise Communications Server Release 5.4 Administration and Feature Description*, for information on how to administer trunks. The Application Notes section of that book shows the correct settings for administrable timers and other parameters on a country-by-country basis.

A DS1 DIOD trunk provides a link for digitized voice or data communications between the system and a central office switch. There are two types of DS1 interfaces:

- 24 DS0 channels on a 1.544 Mbps link
- 31 DS0 channels + 1 framing channel on a 2.048 Mbps link
- 32-channel mode is supported only on TN464 circuit packs and on G3r V2 systems.

The DS1-DIOD maintenance object monitors and maintains a DIOD trunk port on a TN464 UDS1 Interface circuit pack. See "UDS1-BD (UDS1 Interface Circuit Pack)" in this chapter for more information about this circuit pack. The DS1 circuit pack supports low level CO trunk signaling interfaces for both ground-start and loop-start trunks. This maintenance strategy covers the in-line errors log, initialization tests, periodic tests, scheduled tests, demand tests, and alarm resolution and escalation.

Three trunk service states are specified by DS1 DIOD trunk maintenance:

- out-of-service            The trunk is in a deactivated state and cannot be used for either incoming or outgoing calls.
- in-service                The trunk is in an activated state and can be used for both incoming and outgoing calls.
- disconnect  
(ready-for-service)      The trunk is in an activated state but can only be used for an incoming call.

## Error Log Entries and Test to Clear Values

DS1 DIOD Trunk Error Log Entries

Error Type	Aux Data	Associated Test	Alarm Level	On/Off Board	Test to Clear Value
0 <sup>1</sup>	0	Any	Any	Any	test trunk <grp>/<mbr>
1(a)	57408				
1(a)	57487 57476 57477 57485				
15(b)	Any	Port Audit and Update Test (#36)			
18(c)	0	busyout trunk <grp>/<mbr>	WARNING	OFF	release trunk <grp>/<mbr>
130(d)		None	WARNING	ON	test trunk <grp>/<mbr>
257(e)	57392	DS1 CO Dial Tone Seizure Test (#314)	MIN/MAJ <sup>2</sup>	OFF	
513(f)	57393	DS1 CO Dial Tone Seizure Test (#314)	MIN/MAJ <sup>2</sup>	OFF	
769(g)	57484				
1025(h)	51200				
1025		DS1 CO Dial Tone Seizure Test (#314)	MIN/WRN <sup>3</sup>	OFF	test trunk <grp>/<mbr> r 2
1281		Conference Circuit Test (#7)	MIN/WRN <sup>3</sup>	ON	test trunk <grp>/<mbr> l r 4
1537		NPE Crosstalk Test (#6)	MIN/WRN <sup>3</sup>	ON	test trunk <grp>/<mbr> l r 3
1793(i)					test board UUCSS I
2049(j)	57473 57474 57475				



**DS1 DIOD Trunk Error Log Entries**

<b>Error Type</b>	<b>Aux Data</b>	<b>Associated Test</b>	<b>Alarm Level</b>	<b>On/Off Board</b>	<b>Test to Clear Value</b>
2305(k)	50944				
2562(l)	16665				
2817(m)	52992				
3840(n)		Port Audit and Update Test (#36)			

1. Run the Short Test Sequence first. If all tests pass, run the Long Test Sequence. Refer to the appropriate test description and follow the recommended procedures.
2. This alarm is only raised when the System-Parameter Country form has the Base Tone Generator field set to 4 (Italy). This alarm will be a MINOR alarm unless 75% or more trunks in this trunk group are out of service, then the alarm will be upgraded to a MAJOR alarm.
3. Major alarms may be downgraded to Warning alarms based on the value used in the set options command.

**Notes:**

- a. Error Type 1—Aux Data 57408—No tip ground is detected on an outgoing call.

Aux Data 57476—Rotary Dial before Wink.

Aux Data 57477—Rotary Dial pulse too early.

Aux Data 57485—Wink too short for a valid signal.

Aux Data 57487—PBX could not get “loop close” signal.

The DS1 Interface circuit pack detected a hardware fault. These errors will cause the Dial Tone Test (#314) to run and are only considered a problem if the Dial Tone Test fails (in which case Error Type 1025 will also show up). In this case, the trunk may be put in the ready-for-service state (shown as “disconnected” by the status command), which allows only incoming calls. Run the Dial Tone Test (#314) and follow the procedures.

- b. Error Type 15—This is a software audit error that does not indicate any hardware malfunction. Run Short Test Sequence and investigate associated errors (if any).
- c. Error Type 18—System Technician has busied out the trunk to the out-of-service state. No calls can be made on this trunk except the Facility Access Test Call. For details on this feature, refer to “Facility Test Calls” section in Chapter 6.
- d. Error Type 130—This error type indicates that the circuit pack has been removed or has been insane for more than 11 minutes. To clear the error, reinsert or replace the circuit pack.
- e. Error Type 257—The DS1 Interface circuit pack detects a hardware fault. Aux Data 57392 indicates no external release on PBX disconnect.

- f. Error Type 513—The DS1 Interface circuit pack detects a hardware fault. Aux Data 57393 indicates belated external release on PBX disconnect.
- g. Error Type 769—The DS1 Interface circuit pack detects a hardware fault. The Aux Data field contains the following error type:—57484, fault is detected on tip/ring.
- h. The DS1 Interface circuit pack detects a hardware fault, and the Aux Data field contains the following error type: 51200, port is unavailable. Run the Dial Tone Test (#314) and follow procedures.
- i. Error Type 1793—DS1 Interface circuit pack is out-of-service. Look for UDS1-BD errors in the Hardware Error Log if the port is on a TN464 UDS1 board. Refer to "UDS1-BD (UDS1 Interface Circuit Pack)" (DS1 Trunk Circuit Pack) for details
- j. Error Type 2049—With the following Aux Data:
  - Aux Data 57473—Rotary dial rate below 8 pulses per second.
  - Aux Data 57474—Rotary dial rate above 12 pulses per second.
  - Aux Data 57475—Rotary Dial interdigit time is too short.

The DS1 interface circuit pack detects a hardware error on the DS1 DIOD trunk. The trunk can not communicate with the far-end because it is unable to interpret digits sent from the far-end switch. Check with the far-end switch or Operating Company for proper trunk connection.

- k. Error Type 2305—Recorder message, trunk could not be seized (Aux Data 50944). Run Test #314 and follow the outlined procedures.
- l. Error Type 2562—Retry Failure error. This error is logged only. It is not a hardware failure and hence does not start any testing or generate any alarms. This error comes from call processing and is generated when a second attempt (retry) to seize an outgoing trunk fails.
- m. Error Type 2817—Glare error. This error is logged only. It is not a hardware failure and hence does not start any testing or generate any alarms. This error is the result of a simultaneous seizure of a two-way trunk from both the near-end and the far-end. Attempt to place the call again. If the error persists, execute the Dial Tone Seizure Test (#314) and follow those procedures.
- n. Error Type 3840—Port Audit and Update Test (#36) failed due to an internal system error. Enter the **status trunk** command to verify the status of the trunk. If the trunk is out-of-service, then enter the **release trunk** command to put it back into in-service. Retry the test command.

## System Technician-Demanded Tests: Descriptions and Error Codes

Always investigate tests in the order they are presented in the table below. By clearing error codes associated with the *NPE Crosstalk Test*, for example, you may also clear errors generated from other tests in the testing sequence.

Table 9-212. System Technician-Demanded Tests: DS1-BD

Order of Investigation	Short Test Sequence	Long Test Sequence	D/ND <sup>1</sup>
NPE Crosstalk Test (#6)		X	ND
Conference Circuit Test (#7)		X	ND
DS1 Dial Tone Test (#314)	X	X	ND
Port Audit and Update Test (#36)	X	X	ND

1. D = Destructive, ND = Non-destructive

### NPE Crosstalk Test (#6)

The NPE Crosstalk Test verifies that this port's NPE channel talks on the selected time slot and never crosses over to time slots reserved for other connections. If the NPE is not working correctly, one-way and noisy connections may be observed. This test is usually only part of a port's Long Test Sequence and takes about 20 to 30 seconds to complete.

Table 9-213. TEST #6 NPE Crosstalk Test

Error Code	Test Result	Description/ Recommendation
	ABORT	System resources required for this test are not available. 1. Retry the command at 1-minute intervals a maximum of 5 times.
1000	ABORT	System resources required to run this test are not available. The port may be in use on a valid call. 1. Use the <b>status station</b> or <b>status trunk</b> command to determine when the port is available for testing. 2. Retry the command at 1-minute intervals a maximum of 5 times.
1001	ABORT	System resources required for this test are not available. 1. Retry the command at 1-minute intervals a maximum of 5 times.

*Continued on next page*

**Table 9-213. TEST #6 NPE Crosstalk Test — Continued**

Error Code	Test Result	Description/ Recommendation
1002	ABORT	<p>The system could not allocate time slots for the test. The system may be under heavy traffic conditions or it may have time slots out-of-service due to TDM-BUS errors. The <b>status health</b> command can be used to determine if the system is experiencing heavy traffic.</p> <ol style="list-style-type: none"> <li>1. If system has no TDM-BUS errors and is not handling heavy traffic, repeat test at 1-minute intervals a maximum of 5 times.</li> </ol>
1003	ABORT	<p>The system could not allocate a tone receiver for the test. The system may be oversized for the number of Tone Detectors present or some tone detectors may be out-of-service. The <b>list measurements tone-receiver</b> command will display information on the system's tone receivers.</p> <ol style="list-style-type: none"> <li>1. Resolve any TTR-LEV errors.</li> <li>2. Resolve any TONE-PT errors.</li> <li>3. If neither condition exists, retry the test at 1-minute intervals a maximum of 5 times.</li> </ol>
1004	ABORT	<p>The port has been seized by a user for a valid call. Use the <b>status trunk</b> command to determine when the port is available for testing.</p> <ol style="list-style-type: none"> <li>1. Retry the command at 1-minute intervals a maximum of 5 times.</li> </ol>
1020	ABORT	<p>The test did not run due to a previously existing error on the specific port or a more general circuit pack error.</p> <ol style="list-style-type: none"> <li>1. Examine Error Log for existing errors against this port or the circuit pack and attempt to diagnose the already existing error.</li> </ol>
2000	ABORT	<p>Response to the test request was not received within the allowable time period.</p>
2100	ABORT	<p>System resources required for this test are not available.</p> <ol style="list-style-type: none"> <li>1. Retry the command at 1-minute intervals a maximum of 5 times.</li> </ol>
2053	ABORT	<p>At least one of the following errors is found on the DS1 circuit pack:</p> <ul style="list-style-type: none"> <li>■ 1281—Loss of signal</li> <li>■ 1793—Blue Alarm</li> <li>■ 2049—Red Alarm</li> <li>■ 2305—Yellow Alarm</li> <li>■ 1537—Hyperactivity</li> </ul> <p>Look for the above error types in the Hardware Error Log and follow the procedures given in the appropriate DS1-BD or UDS1-BD maintenance documentation for the listed error types.</p>

*Continued on next page*

**Table 9-213. TEST #6 NPE Crosstalk Test — Continued**

Error Code	Test Result	Description/ Recommendation
	FAIL	The NPE of the tested port was found to be transmitting in error. This will cause noisy and unreliable connections.  1. Replace the circuit pack.
	PASS	The port is correctly using its allocated time slots. User-reported troubles on this port should be investigated using other port tests and examining station, trunk, or external wiring.

### Conference Circuit Test (#7)

The Conference Circuit Test verifies that the NPE channel for the port being tested can correctly perform the conferencing function. The NPE is instructed to listen to several different tones and conference the tones together. The resulting signal is then measured by a tone detector port. If the level of the tone is within a certain range, the test passes.

**Table 9-214. TEST #7 Conference Circuit Test**

Error Code	Test Result	Description/ Recommendation
	ABORT	System resources required for this test are not available.  1. Retry the command at 1-minute intervals a maximum of 5 times.
1000	ABORT	System resources required to run this test are not available. The port may be in use on a valid call.  1. Use the <b>status station</b> or <b>status trunk</b> command to determine when the port is available for testing.
1004	ABORT	The port has been seized by a user for a valid call.  1. Use the <b>status station</b> or <b>status trunk</b> command to determine when the port is available for testing.  2. Retry the command at 1-minute intervals a maximum of 5 times.
1018	ABORT	Test disabled via administration. This only applies to analog stations.  1. To enable test, set the <code>Test</code> field ( <b>change station extension</b> ) to <b>y</b> . Use the command.

*Continued on next page*

**Table 9-214. TEST #7 Conference Circuit Test — Continued**

Error Code	Test Result	Description/ Recommendation
1020	ABORT	The test did not run due to a previously existing error on the specific port or a more general circuit pack error.  1. Examine Error Log for existing errors against this port or the circuit pack and attempt to diagnose the previously existing error.
2000 2100	ABORT ABORT	Response to the test request was not received within the allowable time period.  System resources required for this test are not available.  1. Retry the command at 1-minute intervals a maximum of 5 times.
2053	ABORT          FAIL	At least one of the following errors is found on the DS1 circuit pack:  <ul style="list-style-type: none"> <li>■ 1281—Loss of signal</li> <li>■ 1793—Blue Alarm</li> <li>■ 2049—Red Alarm</li> <li>■ 2305—Yellow Alarm</li> <li>■ 1537—Hyperactivity</li> </ul> Look for the above error types in the Hardware Error Log and follow the procedures given in the appropriate DS1-BD or UDS1-BD maintenance documentation for the listed error types.  The NPE of the tested port did not conference the tones correctly. This will cause noisy and unreliable connections.  1. Replace the circuit pack.
	PASS	The port can correctly conference multiple connections. User-reported troubles on this port should be investigated by using other port tests and by examining station, trunk, or external wiring.

**Port Audit and Update Test (#36)**

This test sends port level translation data from switch processor to the DS1 Interface circuit pack to assure that the trunk's translation is correct. Translation updates include the following data: trunk type (in/out), dial type, timing parameters, and signaling bits enabled. The port audit operation verifies the consistency of the current state of trunk kept in the DS1 Interface circuit pack and in the switch software.

**Table 9-215. TEST #36 Port Audit and Update Test**

Error Code	Test Result	Description/ Recommendation
	ABORT	Internal system error 1. Retry the command at 1-minute intervals a maximum of 5 times.
2000	ABORT	Response to the test request was not received within the allowable time period.
2100	ABORT	Could not allocate the necessary system resources to run this test.
	FAIL	Test failed due to internal system error. 1. Retry the command at 1-minute intervals a maximum of 5 times.
	PASS	Trunk translation has been updated successfully. The current trunk states kept in the DS1 Interface circuit pack and switch software are consistent. If the trunk is busied out, the test will not run but will return PASS. To verify that the trunk is in-service: 1. Enter the <b>status trunk</b> command to verify that the trunk is in-service. If the trunk is in-service, no further action is necessary. If the trunk is out-of-service, continue to step 2. 2. Enter the <b>release trunk</b> command to put the trunk back into in-service. 3. Retry the test command.

### DS1 CO Dial Tone Seizure Test (#314)

DS1 CO Dial Tone Seizure Test checks the trunk's signaling capability provided by the DS1 Interface circuit pack. The maintenance software initiates the test by sending a "seizure" message to the DS1 Interface circuit pack and expects an "active" reply from the DS1 interface circuit pack. If the "active" message is received, then the test passes. If no message is received and the timer expires, the test is aborted. If the DS1 Interface circuit pack sends a "reorder" message back to maintenance software, then the test fails.

This test cannot be run on a trunk in any of the following conditions:

- a. The trunk direction is administered as an incoming only trunk.
- b. The trunk has been seized by a normal trunk call.
- c. The trunk is administered with maintenance test disabled.

**Table 9-216. TEST #314 DS1 CO Dial Tone Seizure Test**

Error Code	Test Result	Description/ Recommendation
	ABORT	Internal system error 1. Retry the command at 1-minute intervals a maximum of 5 times.
1000	ABORT	System resources required to run this test are not available. The port may be in use on a valid call. Use the <b>status trunk</b> command to determine when the port is available for testing.
1004	ABORT	The port has been seized by a user for a valid call. Use the <b>status trunk</b> command to determine when the port is available for testing. 1. Retry the command at 1-minute intervals a maximum of 5 times.
1005	ABORT	Test failed due to incompatible configuration administered in trunk group form. 1. Look at the trunk group administration form and see if the trunk is incoming only, port 24 on a DS1 Interface with common control channel signaling, or an automatic CO type such as FX. Under any of these conditions this is a normal abort.
1018	ABORT	Test has been disabled via administration. 1. Verify that the "Maintenance Tests" field on the Trunk Group Form is set to "n." To enable the test, issue the <b>change trunk-group x</b> command where "x" equals the number of the trunk group to be tested. Then change the entry in the "Maintenance Tests" field on the form to "y." 2. Repeat the test.
1020	ABORT	The DS1 Interface circuit pack is out-of-service. 1. Look for UDS1-BD errors in the Hardware Error Log. If present, refer to "UDS1-BD (UDS1 Interface Circuit Pack)" (DS1/UDS1 Trunk Circuit Pack). 2. Retry the command.
2000	ABORT	Response to the test request was not received within the allowable time period.
2100	ABORT	Could not allocate the necessary system resources to run this test. 1. Retry the command at 1-minute intervals for a maximum of 5 times.

*Continued on next page*



**Table 9-216. TEST #314 DS1 CO Dial Tone Seizure Test — Continued**

Error Code	Test Result	Description/ Recommendation
2053	ABORT	At least one of the following errors is found on the DS1 circuit pack: <ul style="list-style-type: none"> <li>■ 1281—Loss of signal</li> <li>■ 1793—Blue Alarm</li> <li>■ 2049—Red Alarm</li> <li>■ 2305—Yellow Alarm</li> <li>■ 1537—Hyperactivity</li> </ul> Look for the above error types in the Hardware Error Log and follow the procedures given in the appropriate DS1-BD or UDS1-BD maintenance documentation for the listed error types.
	FAIL	The trunk cannot be seized for an outgoing call. <ol style="list-style-type: none"> <li>1. Verify that the Trunk Type field on the trunk administration screen form matches the trunk type administered on far end switch.</li> <li>2. Look for UDS1-BD errors in Hardware Error Log. If present, refer to the UDS1-BD (DS1/UDS1 Trunk Circuit Pack) Maintenance documentation.</li> <li>3. Retry the test at 1-minute intervals for a maximum of 5 times.</li> </ol>
	PASS	The trunk can be seized for an outgoing call.

## DIOD-TRK (DIOD Trunk)

MO Name (in Alarm Log)	Alarm Level	Initial Command to Run <sup>1</sup>	Full Name of MO
DIOD-TRK	MAJOR <sup>2</sup>	test port <i>UUCSSpp l</i>	DIOD Trunk
DIOD-TRK	MINOR	test port <i>UUCSSpp l</i>	DIOD Trunk
DIOD-TRK	WARNING	test port <i>UUCSSpp l</i>	DIOD Trunk

- UU* is the universal cabinet number (1 for PPN, 2-44 for EPNs). *C* is the carrier designation (A, B, C, D, or E). *SS* is the number of the slot in which the circuit pack resides (01 to 21). *pp* is the two digit port number (01, 02, ...).
- A MAJOR alarm on a trunk indicates that alarms on these trunks are not downgraded by the **set options** command and that at least 75 percent of the trunks in this trunk group are alarmed.

### ⇒ NOTE:

Many trunk problems are caused by incorrect settings of parameters on the trunk group administration form. Settings must be compatible with the local environment and with parameter settings on the far-end. Refer to DEFINITY Communications System Generic 3 V2 Implementation, 555-230-653 for information on how to administer trunks. The Application Notes section of that book shows the correct settings for administrable timers and other parameters on a country-by-country basis.

Direct inward and outward dial (DIOD) trunks are 2-wire analog lines to the CO which support the following services:

- Both incoming and outgoing CO calls
- DID trunk
- DID trunk and 1-way outgoing DIOD

TN429 DIOD trunk circuit packs provide eight ports for loop-start CO trunks and serve as an interface between the 2-wire analog CO line and the 4-wire TDM bus on the switch.

## Loop Start Operation

Idle State: Tip = ground, Ring = CO Battery

## Outgoing Call

- PBX Off-Hook (Seize Message): Closes the Tip-Ring Loop CO Response: DC loop current + Dial tone

2. PBX On-Hook (Drop Message): Open Tip-Ring loop, no loop current CO Response: CO goes to idle state (see Note)

## Incoming Call

1. CO Applies Ringing Voltage PBX Response: Detect ringing current
2. PBX Off-Hook (Answer Message): Close loop CO Response: Trip ringing, provide loop current
3. PBX On-Hook (Drop Message): Open Tip-Ring loop, no loop current CO Response: CO goes to idle state (see Note)

## Direct Inward Dialing (DID)

1. CO Applies Ringing Voltage  
PBX Response: Detect ringing current and close loop  
CO Response: Send DTMF digits  
PBX Response: Acknowledge of Number dialed and open loop
2. PBX Off-Hook (Answer Message): Close loop CO Response: Trip ringing, provide loop current
3. PBX On-Hook (Drop Message): Open Tip-Ring loop, no loop current CO Response: CO goes to idle state (see Note)



### NOTE:

CO does not normally provide an On-Hook (Disconnect) signal.

## Error Log Entries and Test to Clear Values

**Table 9-217. DIOD Trunk Error Log Entries**

Error Type	Aux Data	Associated Test	Alarm Level	On/Off Board	Test to Clear Value
0 <sup>1</sup>	0	Any	Any	Any	test port sh
15 (b)	any	Port Audit Update Test (#36)			
18	0	Busyout trunk <i>grp/mbr</i>	WARNING		release trunk
769 (a)	57392	None	MAJ/MIN/WRN <sup>2</sup>	ON	
1537		Dial Tone Test (#0)	MAJ/MIN/WRN <sup>2</sup>	ON	test port long r 2
1793		Looparound and Conference Test (#33)	MAJ/MIN/WRN <sup>2</sup>	ON	test port long r 3
2049		NPE Cross Talk Test (#6)	MAJ/MIN/WRN <sup>2</sup>	ON	test port long r 3
2561 (a,d)	57345	None			
2817 (a,e)	57393	None			
3073 (a,c)	57376	None			
3073 (a,c)	57424	None			
3585 (a,c)	57424	None			

1. Run the Short Test Sequence first. If all tests pass, run the Long Test Sequence. Refer to the appropriate test description and follow the recommended procedures.
2. Major alarms on this MO may be downgraded to Warning alarms based on the value used in the set options command. If the Minor alarm is not downgraded by the **set-options** values, the Minor alarm is upgraded to a Major alarm if 75 percent of the trunks in this trunk group are alarmed.

### Notes:

- a. These are in-line errors that have no specific test associated with them. Refer to the following table for an explanation and appropriate action.
- b. This is a software audit error and does not indicate any hardware malfunction. Run the Short Test Sequence and investigate associated errors.
- c. Aux data 57376—No loop current on incoming call  
Aux data 57424—No loop current on outgoing call

These errors cause the Dial Tone Test (#0) to run and are only considered a problem if the Dial Tone Test fails (in which case Error Type 1537 also appears). In this case, the trunk may be put in "Ready-for-Service" state (shown as "disconnected" by status command), which allows only incoming calls. Run the Dial Tone Test (#0) and follow its procedures.

- d. Single polarity ringing current—This error results from abnormal ringing current, but does not prevent the incoming call from being accepted. This error code is logged for information purposes only and does not cause additional testing to occur.
- e. Late CO Trunk release—This indicates that the CO releases the trunk at least four minutes after the PBX dropped the call. This error code is only logged as an informational event and causes no other testing to occur.

**Table 9-218. DIOD Trunk Errors without Associated Tests**

Error Type	Aux Data	Description and Recommendation
769	57392	CO not releasing after call is dropped from PBX end (TN747B), or the loop is not open after a disconnect (TN765). After several occurrences, an off-board (TN747B) or on-board (TN465) warning alarm is generated. Refer problem to CO.
2561	57345	Single polarity ringing current. This error results from abnormal ringing current, but does not prevent the incoming call from being accepted. One cause could be that the reverse current detector associated with the port is failing. (Will not be detected by any tests.) The other cause could be that normal current is not detected. In this case, neither incoming nor outgoing calls can be completed, and the dial tone test also fails. Check for other errors.
2817	57393	CO released the trunk at least four minutes after the PBX dropped the call. This error code is log only and causes no other testing to occur. No alarm is generated. Check for other errors.
3073	57376	No loop current on incoming call. The incoming destination has already answered and no loop current has been detected. If this is a hard fault, the dial tone test and all outgoing calls should also fail. Check for other errors.
3585	57424	No loop current on outgoing call. This error occurs on attempt to seize a loop or ground-start trunk for an outgoing call. An error occurs if loop current is not detected or the caller hangs up before it is detected. Busyout the affected port, and run a Long test. If Dial Tone Test #0 passes, ignore this error. Release the port.

## System Technician-Demanded Tests: Descriptions and Error Codes

Always investigate tests in the order they are presented in the table below. By clearing error codes associated with the *NPE Crosstalk Test*, for example, you may also clear errors generated from other tests in the testing sequence.

Order of Investigation	Short Test Sequence	Long Test Sequence	D/ND <sup>1</sup>
NPE Crosstalk Test (#6)		X	ND
Dial Tone Test (#0)		X	ND
Looparound and Conference Test (#33)		X	ND
Audit Update Test (#36)	X	X	ND

1. D = Destructive; ND = Nondestructive

### Dial Tone Test (#0)

This test attempts to seize a port and checks for the return of a dial tone.

**Table 9-219. TEST #0 Dial Tone Test**

Error Code	Test Result	Description/ Recommendation
	ABORT	Could not allocate system resources to run this test. 1. Retry the command at 1-minute intervals a maximum of 5 times.
1000	ABORT	System resources required to run this test are not available. The port may be busy with a valid call. 1. Use the command <b>display port</b> UUCSSpp to determine the trunk group/member number of the port. Use the <b>status trunk</b> command to determine the service state of the port. If the service state indicates that the port is in use, then the port is unavailable for certain tests. You must wait until the port is idle before retesting. 2. If the port status is idle, then retry the command at 1-minute intervals a maximum of 5 times.
1001	ABORT	Could not allocate the necessary system resources to run this test. 1. Retry the command at 1-minute intervals a maximum of 5 times.

*Continued on next page*

Table 9-219. TEST #0 Dial Tone Test — *Continued*

Error Code	Test Result	Description/ Recommendation
1002	ABORT	The system could not allocate time slots for the test. The system may be under heavy traffic conditions or it may have time slots out-of-service due to TDM-BUS errors. <ol style="list-style-type: none"> <li data-bbox="278 419 1055 473">1. If the system has no TDM-BUS errors and is not handling heavy traffic, repeat test at 1-minute intervals a maximum of 5 times.</li> </ol>
1004	ABORT	The port has been seized by a user for a valid call. Use the <b>status trunk</b> command to determine when the port is available for testing. <ol style="list-style-type: none"> <li data-bbox="278 562 984 591">1. Retry the command at 1-minute intervals a maximum of 5 times.</li> </ol>
1018	ABORT	Test has been disabled via administration. <ol style="list-style-type: none"> <li data-bbox="278 652 1093 741">1. The <code>Maintenance Tests?</code> field must be set to <code>y</code> on the trunk group form for this test to run. This form is accessed with the <b>change trunk-group grp#</b> command.</li> </ol>
1005	ABORT	Trunk has been administered as incoming-only; or DID trunk group type; dial tone can only be obtained on outgoing trunks. This is a normal condition.
2000	ABORT	Response to the test was not received within the allowable time period. <ol style="list-style-type: none"> <li data-bbox="278 876 1009 904">1. Retry the command at 1-minute intervals a maximum of five times.</li> </ol>
	FAIL	Trunk was seized, but dial tone could not be detected. <ol style="list-style-type: none"> <li data-bbox="278 965 1068 1019">1. Check for errors on TONE-BD or TONE-PT. Clear any errors and repeat test.</li> <li data-bbox="278 1037 820 1066">2. If error has still not cleared, refer problem to CO.</li> </ol>
2002	FAIL	Seizure portion of test failed due to hardware problem. Fault is usually caused by a disconnected trunk. <ol style="list-style-type: none"> <li data-bbox="278 1154 1015 1207">1. Check trunk wiring to ensure good connection; repeat test if wiring correction made.</li> <li data-bbox="278 1225 1093 1342">2. Locate another identical CO trunk and swap its wiring with one under test. Repeat test on both trunks and determine if problem follows trunk or remains at original port. If problem follows trunk, refer problem to CO. If problem remains at port, replace circuit pack and repeat test.</li> </ol>
1009	PASS	Detected tone was not pure dial tone. No action required.
	PASS	Trunk was seized, and dial tone was detected. User-reported troubles on this port should be investigated by using other port tests and by examining trunk or external wiring.

## NPE Crosstalk Test (#6)

The NPE Crosstalk Test verifies that this port's NPE channel talks on the selected time slot and never crosses over to time slots reserved for other connections. If the NPE is not working correctly, one way and noisy connections may be observed. This test is usually only part of a port's long test sequence and takes approximately 20 to 30 seconds to complete.

**Table 9-220. TEST #6 NPE Crosstalk Test**

Error Code	Test Result	Description/ Recommendation
	ABORT	Could not allocate the necessary system resources to run this test. 1. Retry the command at 1-minute intervals a maximum of 5 times.
1000	ABORT	System resources required to run this test are not available. The port may be busy with a valid call. 1. Enter <b>display port UUCSSpp</b> to determine the trunk group/member number of the port. Use the <b>status trunk</b> command to determine the service state of the port. If the port is in use, wait until the port is idle before testing. 2. If the port status is idle, then retry the command at 1-minute intervals a maximum of 5 times.
1001	ABORT	Could not allocate the necessary system resources to run this test. 1. Retry the command at 1-minute intervals a maximum of 5 times.
1002	ABORT	The system could not allocate time slots for the test. The system may be under heavy traffic conditions or it may have time slots out-of-service due to TDM-BUS errors. 1. If system has no TDM-BUS errors and is not handling heavy traffic, repeat test at 1-minute intervals a maximum of 5 times.
1003	ABORT	The system could not allocate a tone receiver for the test. The system may be oversized for the number of tone detectors present or some tone detectors may be out-of-service. 1. Resolve any TTR-LEV errors. 2. Resolve any TONE-PT errors. 3. If neither condition exists, retry the test at 1-minute intervals a maximum of 5 times.
1004	ABORT	The port was seized by a valid call during the test. The test has been aborted. 1. Enter <b>display port UUCSSpp</b> to determine the trunk group/member number of the port. Use the <b>status trunk</b> command to determine the service state of the port. If the port is in use, wait until the port is idle before retesting.
2000	ABORT	Response to the test was not received within the allowable time period.



**Table 9-220. TEST #6 NPE Crosstalk Test — Continued**

Error Code	Test Result	Description/ Recommendation
2100	ABORT	Could not allocate the necessary system resources to run this test. 1. Retry the command at 1-minute intervals a maximum of 5 times.
Any	FAIL	The NPE of the tested port was found to be transmitting in error. This causes noisy and unreliable connections. 1. Replace the circuit pack.
	PASS	The port is correctly using its allocated time slots. User-reported troubles on this port should be investigated by using other port tests and by examining trunk or external wiring.

**Looparound and Conference Circuit Test (#33)**

This test checks the reflective loop and conference abilities of a CO port circuit. The test uses 404 Hz, 1004 Hz, and 2804 Hz tones. Each tone is transmitted separately through the loop and checked.

**Table 9-221. TEST #33 Looparound and Conference Circuit Test**

Error Code	Test Result	Description/ Recommendation
	ABORT	Could not allocate system resources to run this test.
7	ABORT	Conference Circuit Test aborted.
1000	ABORT	System resources required to run this test are not available. The port may be busy with a valid call. L 1. Enter <b>display port UUCSSpp</b> to determine the trunk group/member number of the port. Use the <b>status trunk</b> command to determine the service state of the port. If the port is unavailable, wait until the port is idle before testing. 2. If the port status is idle, then retry the command at 1-minute intervals a maximum of 5 times.
1004	ABORT	The port has been seized by a user for a valid call. Use the <b>status trunk</b> command to determine when the port is available for testing. 1. Retry the command at 1-minute intervals a maximum of 5 times.
2100	ABORT	Could not allocate the necessary system resources to run this test. 1. Retry the command at 1-minute intervals a maximum of five times.

*Continued on next page*

**Table 9-221. TEST #33 Looparound and Conference Circuit Test — Continued**

Error Code	Test Result	Description/ Recommendation
7	FAIL	<ol style="list-style-type: none"> <li>1. Check for errors on TONE-BD or TONE-PT.</li> <li>2. If the Reflective Looparound Test fails for all ports on a circuit pack, a -5 volt power problem is indicated. If a TN736 or TN752 power unit circuit pack is present, check the circuit pack for a red LED. If the red LED is on, then replace the appropriate power unit circuit pack. If neither the TN736 nor the TN752 power unit circuit pack is present, then the OLS631DB AC power unit may be defective. The system may contain a TN736 or TN752 power unit circuit pack <i>or</i> an OLS631DB AC power unit, <i>but not both</i>. Refer to "CARR-POW".</li> <li>3. Rerun the test.</li> <li>4. If the test fails again, replace the circuit pack.</li> </ol>
	PASS	CO Trunk Looparound and Conference Test is successful. User-reported troubles on this port should be investigated by using other port tests and by examining trunk or external wiring.

**Port Audit Update Test (#36)**

This test sends updates of the CO port translation for all ports on the circuit pack which have been translated. The update is non-disruptive and guards against possible corruption of translation data contained on the circuit pack. No response message is expected from the circuit pack once it receives translation updates. The port translation data includes: ground or loop start trunk, tone or rotary dialing trunk, rotary dialing inter-digit timing, network balance R/RC, and disconnect timing.

**Table 9-222. TEST #36 Port Audit Update Test**

Error Code	Test Result	Description/ Recommendation
	ABORT	Could not allocate the necessary system resources to run this test. <ol style="list-style-type: none"> <li>1. Retry the command at 1-minute intervals a maximum of 5 times.</li> </ol>
2100	ABORT FAIL	Could not allocate the necessary system resources to run the test. Internal system error. <ol style="list-style-type: none"> <li>1. Retry the command at 1-minute intervals a maximum of 5 times.</li> </ol>

Table 9-222. TEST #36 Port Audit Update Test — Continued

Error Code	Test Result	Description/ Recommendation
	PASS	<p>This test passed. Translation information was successfully updated on the circuit pack. User-reported troubles on this port should be investigated by using other port tests and by examining trunk or external wiring. If the trunk is busied out, the test does not run, but returns PASS. To verify that the trunk is in-service:</p> <ol style="list-style-type: none"><li data-bbox="282 480 1077 562">1. Enter <b>status-command</b> to verify that the trunk is in-service. If the trunk is in-service, no further action is necessary. If the trunk is out-of-service, continue to Step 2.</li><li data-bbox="282 580 980 605">2. Enter <b>release-trunk</b> command to put trunk back into in-service.</li><li data-bbox="282 623 568 648">3. Retry the test command.</li></ol>

## DISK (MSS Disk Circuit Pack)

MO Name (in Alarm Log)	Alarm Level	Initial Command to Run <sup>1</sup>	Full Name of MO
DISK	WARNING	test disk al b long	MSS Disk Circuit Pack
DISK	MINOR	test disk al b long	MSS Disk Circuit Pack

1. In a system with a simplex SPE, the carrier does not have to be specified. In a system configured with duplicated SPEs, the carrier (a or b) must be specified.

The TN1657 Disk circuit pack is part of the Generic 3r Mass Storage System (MSS). The MSS provides non-volatile storage for system software, translation data, announcement data and program update data. As shown in [Figure 9-25](#), the MSS consists of a Host Adapter circuit on the UN332 MSS-Network Control circuit pack (MSSNET), a Small Computer System Interface (SCSI) bus, a TN1656 Tape circuit pack and the TN1657 Disk Drive circuit pack. The Disk Drive acts as the primary storage device and the Tape Drive serves as a backup device.

The system is usually booted from the bootimage stored on disk. The **save translation** and **save announcements** commands save to disk the memory-resident translation data and TN750-resident announcement data, respectively. The **backup disk** command copies data from the disk to the tape for backup storage. The **restore disk** command copies data from the tape back to disk. All MSS components reside in the SPE, or PPN control carrier (carrier A for a simplex SPE, carriers A and B for a duplicated SPE).

The Disk Drive circuit pack contains SCSI bus terminators, an industry standard SCSI-based Disk Drive, and interface circuitry to the private bus to control the LEDs, detect the presence of the circuit pack, and identify the vintage of the hardware.

A -48V to +12V converter circuit on the Tape circuit pack provides power for both the Tape Drive and the Disk Drive. The presence of +12V on these circuit packs is monitored separately by maintenance software so that a failure of the +12V converter on the Tape circuit pack can be identified or ruled out as the source of the problem when the Disk Drive loses +12V power.

The Host Adapter Circuit, Tape circuit pack, and Disk circuit pack are treated as separate, but related, maintenance objects (H-ADAPTER, TAPE, and DISK). Since the Disk circuit pack is controlled by SCSI commands which are generated by the Host Adapter, problems with the Host Adapter can prevent communications with the Disk. Whenever the Host Adapter is taken out of service by the **busy-out host-adapter** command, or due to failure of a critical Host Adapter test, the Tape and Disk maintenance objects are also placed in a maintenance busyout state.

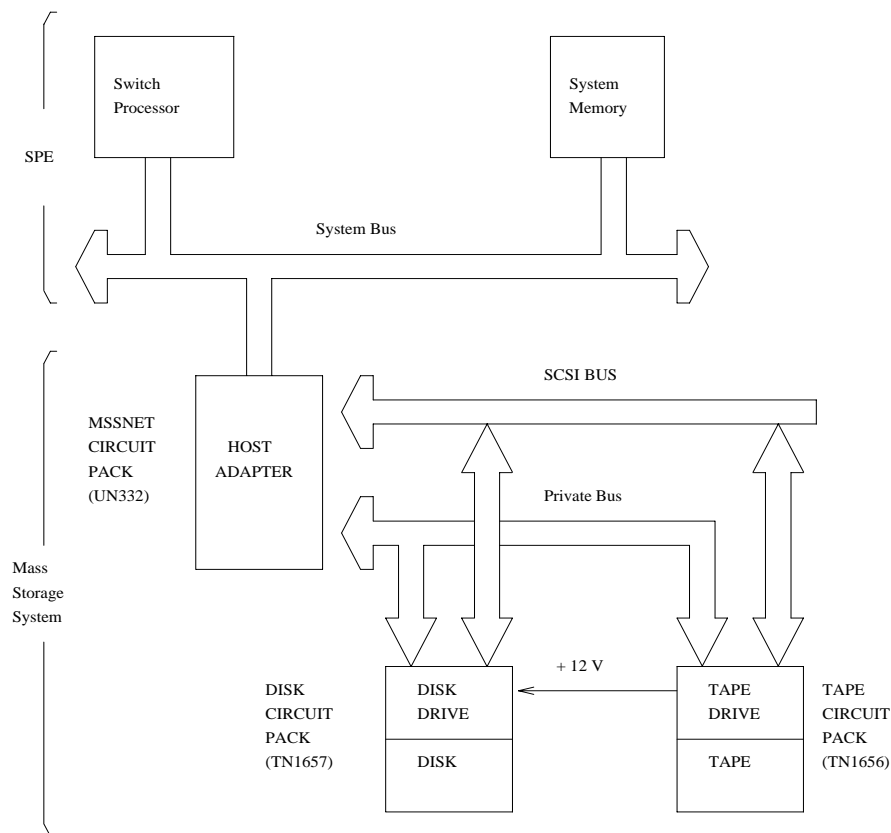

**Figure 9-25. Mass Storage System Interactions**

## General Troubleshooting Information

Keep the following points in mind when troubleshooting disk problems.

1. *Do not save translations or announcements on the disk if unresolved Disk Drive or Host Adapter problems are present.*

If there is something wrong with the MSS, any attempt to save translations or announcements could destroy a good copy of the files on disk.

2. When multiple error conditions are present, check for Host Adapter and Tape errors first.

Maintenance software cannot always distinguish between errors caused by the Disk Drive, and errors caused by the Host Adapter or Tape Drive.

3. In a system with duplex SPEs, the tests run on the standby Disk circuit pack are identical to those run on the active Disk circuit pack. The DUPINT circuit pack handles communications between the active and standby SPEs for the control channel and memory shadowing. Therefore, problems with the DUPINT circuit pack may affect maintenance testing of the standby Disk circuit pack.
4. The *disk data will likely be destroyed* if:
  - a. Power is removed from the Disk circuit pack while its yellow LED is on.
  - b. The Disk circuit pack is removed while its yellow LED is on.
5. *Tape data may be destroyed* if the Disk circuit pack is removed while the yellow LED on the Tape Drive is on.

## Replacing the Disk Circuit Pack

- If the SPE is not duplicated:
  1. Issue the **busyout host-adapter** command.

The Host Adapter should be "busied out" to prevent other applications from trying to access the disk or tape.
  2. Replace the Disk circuit pack.
  3. Issue the **reset host-adapter** command.

This allows the disk to "spin up."
  4. Issue the **release host-adapter** command.
  5. Issue the **status spe** command and verify that the disk is now in service.
  6. Issue the **restore disk** command to copy the boot image files, translation files, announcement files, and program update files from the tape to the disk. This may take up to an hour to complete.
  7. Issue the **test stored-data** command to verify that the files on all storage devices are consistent.
- If the SPE is duplicated:
  1. To replace the Disk circuit pack on a system equipped with duplicated SPEs, use the lock-and power-down procedure described in *Replacing SPE Circuit Packs* in Chapter 5.
  2. After the standby SPE is powered up and fully refreshed, enter the **restore disk** command to copy the bootimage files, translation files, announcement files, and program update files from the tape to the disk.
  3. Test the standby Disk using the **test disk long** command.

- Verify that the files on all storage devices are consistent by issuing the **test stored-data** command.

## Error Log Entries and Test to Clear Values

Table 9-223. DISK Error Log Entries

Error Type	Aux Data	Associated Test	Alarm Level	On/Off Board	Test to Clear Value
1 (a)	any	Disk Reset (#809)	MINOR	OFF	reset disk a b <sup>1</sup>
18 (b)	0	Busyout Disk (#817)	WARNING	OFF	release disk a b <sup>1</sup>
250 (c)	0	Reset Disk (#894)	WARNING	OFF	reset disk a b <sup>1</sup>
257 (d)	any	Disk Looparound (#814)	WARNING	OFF	test disk a b <sup>1</sup> sh r 2
258 (e)	any	Disk Looparound (#814)	WARNING	OFF	test disk a b <sup>1</sup> sh r 2
513 (f)	any	Disk Diagnostics (#813)	MINOR	ON	test disk a b <sup>1</sup> sh r 2
526 (g)	0	Busyout Host-adaptor	WARNING	OFF	rel host-ad a b <sup>1</sup>
528 (h)	0		WARNING	OFF	
529 (i)	0		WARNING	OFF	reset disk a b <sup>1</sup>
769 (j)	any	Disk Looparound (#814)	MINOR	ON	test disk a b <sup>1</sup> sh r 2
1025 (k)	any	Disk Write-Read (#810)	MINOR	OFF	test disk a b <sup>1</sup> l r 2
1281 (l)	any	Disk Diagnostics (#813)	MINOR	ON	test disk a b <sup>1</sup> sh r 2
1793 (m)	any	Disk Looparound (#814)	MINOR	OFF	test disk a b <sup>1</sup> sh r 2
2049 (n)	any	Disk Looparound (#814)	MINOR	OFF	test disk a b <sup>1</sup> sh r 2
2305 (o)	any	Disk Status (#815)	MINOR	ON	test disk a b <sup>1</sup> sh r 1
2306 (p)	5504	Disk Frmwr Counters (#812)	MINOR	ON	test disk a b <sup>1</sup> sh
2561 (q)	any	Disk Write-Read (#810)	MINOR	OFF	test disk a b <sup>1</sup> l r 2
2817 (r)	any	Disk Status (#815)	WARNING	ON	test disk a b <sup>1</sup> sh r 2
3073 (s)	any	In-line	MINOR	ON	test disk a b <sup>1</sup> l r 2
3329 (t)	any	Disk Audit (#811)	MINOR	OFF	test disk a b <sup>1</sup> sh r 2
3841 (u)	<sup>2</sup>	Miscellaneous	MINOR	OFF	test disk a b <sup>1</sup> l r 1

- In a system with simplex SPE, the carrier need not be specified. With duplicated SPEs, carrier a or b must be specified.
- If error type 1 with aux data of 123 is present, this field will indicate the cause of the out-of-service condition. See the *MSS Error Actions* table at the end of the section on TAPE

The *Service State* field in the Alarm Log refers to the accessibility of the device. IN (in service) means that users can access the device and all maintenance tests

run. MTC (maintenance busy) means that the device is busied out; users cannot access it, but all demand maintenance tests run. OUT (out of service) means that users cannot access the device, but background and demand testing may run.

Notes:

- a. Error type 1 means that the device is out of service as a result of maintenance tests detecting a critical failure of the disk drive.
- b. Error type 18 means that the disk was busied out on demand from the System Access Terminal.
- c. Error type 250 means that the Reset Test (#809 or #894) failed.
- d. Error type 257 means that the device could not be accessed.
- e. Error type 258 means an attempt was made to remove a disk that was physically present or failure during remove occurred.
- f. Error type 513 means that on-board disk drive diagnostics tests requested by the Disk Diagnostic Test (#813) failed.
- g. Error type 526 means that the Host Adapter was busied out. This also causes the disk to be busied out.
- h. Error type 528 means that there was a failure to insert the disk at system initialization time. This is a software problem.
- i. Error type 529 means that there was a failure to put the disk in service or to take it out of service. Execute the **reset disk** command and then execute the **status spe** command to verify that the disk is in service. If the disk is not in the expected state, first clear any other alarms against other MSS components and then execute the **reset disk** command.
- j. Error type 769 means that the disk Loop-around Test (#814) failed.
- k. Error type 1025 means that a disk medium error was detected when the disk was read or written. The Disk circuit pack should be replaced if this error continues to be reported.
- l. Error type 1281 indicates that a hardware failure condition was detected by the Firmware Error Counters Read and Clear Test (#812). See the *MSS Error Actions* table at the end of the section on TAPE.
- m. Error type 1793 is an in-line error from the disk control software that indicates there was a problem with the SCSI Bus Access Failure or Memory Access Failure between the Host Adapter and the Disk Drive. See the *MSS Error Actions* table at the end of the section on TAPE.
- n. Error type 2049 indicates that a bad command was sent to the disk drive. This may be caused by a software error or a hardware failure. Execute the **test disk long** command and fix any failures associated with those tests. Error type 2305 means that the system is equipped with more than 2 memory circuit packs and the disk is either not large enough or has not been configured correctly to support the larger memory size.



1. If the value in the Auxiliary Data field is 5513, the vintage of the TN1657 Disk circuit pack is less than V4. This may be verified by executing the **list configuration control** command.
  2. If the value in the Auxiliary Data field is 5514, the disk capacity is adequate but the file system on the disk has not been configured for the large coredump file required when greater than 2 memory circuit packs are used.
- o. Error Type 2305 indicates a mismatch between memory size and disk size
- AUX Data 5513 indicates the system is equipped with 3 memory circuit packs but the capacity of the disk is not large enough for the coredump file.
- AUX Data 5514 indicates the system is equipped with 3 memory circuit packs but the disk has not been configured for a large coredump file. The tape and disk should have been configured for the larger memory size as part of the procedures for installing 3 memory circuit packs as described in the Installation Manual.
- p. Error type 2306 means that a block has been reassigned on the disk or an attempt to reassign a block has failed. The Minor alarm may clear after executing the Status test (#815) but the data block will remain reassigned as a result of a medium error. The disk drive should be replaced if this Error Type is generated more than 3 times within an hour.
- q. Error type 2561 indicates that the Data Write-Read Test (#810) failed.
- r. Error 2817 indicates that the Disk Status Test (#815) detected a fault. See the *MSS Error Actions* table at the end of the section on TAPE.
- s. Error type 3073 indicates in-line errors reported by the disk control software. See the *MSS Error Actions* table at the end of the section on TAPE.
- t. Error type 3329 indicates that the Disk Audit Test (#811) detected a corrupted directory file. This is a serious failure of the disk so the disk should be restored from tape.
- u. Error type 3841 is used to record miscellaneous data when an out-of-service condition occurs. See the *MSS Error Actions* table at the end of the section on TAPE.

## System Technician-Demanded Tests: Descriptions and Error Codes

---

Always investigate tests in the order presented in the table below when inspecting errors in the system. By clearing error codes associated with the *Disk Reset Test*, for example, you may also clear errors generated from other tests in the testing sequence.

Order of Investigation	Short Test Sequence	Long Test Sequence	Reset Board Sequence	D/ND <sup>1</sup>
Disk Reset Test (#809)	X	X		ND
Disk Diagnostic Test (#813)	X	X		ND
Disk Looparound Test (#814)	X	X		ND
Disk Status Test (#815)	X	X		ND
Disk Firmware Error Counters Read and Clear Test (#812)	X	X		ND
Disk Write-Read Test (#810)		X		ND
Disk Audit Test (#811)		X		ND
Disk Reset Test (#894)			X	ND

1. D = Destructive; ND = Nondestructive

### Disk Reset Test (#809 and #894)

The Disk Reset Test consists of the following steps controlled by firmware on the Host Adapter Circuit (located on the MSSNET circuit pack):

- Disk Drive reset: A SCSI BUS DEVICE RESET message is transmitted to the Disk circuit pack to reset it.
- Presence test: A SCSI INQUIRY command is sent to the Disk Drive to attempt to query it. If the Disk Drive is present, it will return information about the device type, whether or not its medium is removable, compatibility with established standards, vendor and product IDs, and other miscellaneous information.
- Start unit: This starts the disk drive spinning.
- Capacity test: A SCSI READ CAPACITY command is sent to the Disk Drive. It returns with the logical block address and the block length of the last logical block on the medium. This is necessary to restore the information lost after the reset and verify that the device can be accessed.

A SCSI READ DATA BUFFERS command is sent to the Disk Drive. This returns the size of the controller memory data buffers.

A SCSI READ DEFECT DATA command is sent to the Disk Drive. This returns the addresses of bad blocks on the disk that must be mapped around.

- **Device Diagnostic Tests:** A SCSI SEND DIAGNOSTICS command is sent to the Disk Drive to initiate a set of device-dependent self-tests that run as a unit. Failures can be for multiple reasons and the return code that indicates the cause of failure is vendor unique. A failure condition reports as single failure type since the only repair action is to replace the Disk Drive circuit pack

**Table 9-224. TEST #809 Disk Reset Test**

Error Code	Test Result	Description/ Recommendation
526	ABORT	The Host Adapter has been busied out. 1. Issue the <b>release host-adapter</b> command.
1316	ABORT	Could not get access to the MSS. Other application software may be using it or background maintenance tests may be running. 1. Retry the command at 1-minute intervals a maximum of 5 times. 2. If the test continues to abort, verify that the daily translation-save operation is not in progress (use <b>display system-parameters maintenance</b> to display the time for scheduled maintenance and the "y/n" option for saving translation daily).
1335	ABORT	Could not run the test on the Standby SPE—Duplication not administered. 1. Refer to "STBY-SPE". 2. Administer standby present.
1338	ABORT	Could not run the test on the Standby SPE—Interchange pending. 1. Refer to "STBY-SPE". 2. After interchange occurs, run test on new active SPE.
1339	ABORT	Could not run the test on the Standby SPE—Handshake down. 1. Refer to "STBY-SPE". 2. When the standby is restored to service (use <b>status spe</b> to determine state of standby) retry the command.
1347	ABORT	Could not run the test on the Standby SPE—Refresh not complete. 1. When the standby is restored to service (use <b>status spe</b> to determine state of standby) retry the command.
1350	ABORT	Could not run the test on the Standby SPE—Shadowing not enabled. 1. When the standby is restored to service (use <b>status spe</b> to determine state of standby) retry the command.

*Continued on next page*

Table 9-224. TEST #809 Disk Reset Test — Continued

Error Code	Test Result	Description/ Recommendation
2000	ABORT	Response to the test was not received within the allowable time period. <ol style="list-style-type: none"><li>1. Retry the command at 1-minute intervals a maximum of 5 times.</li></ol>
2500	ABORT	Could not run the test on the Standby SPE—Internal software error. <ol style="list-style-type: none"><li>1. Retry the command at 1-minute intervals a maximum of 5 times.</li></ol>
5102	ABORT	Could not allocate the Mass Storage System to run test <ol style="list-style-type: none"><li>1. Retry the command at 1-minute intervals a maximum of 5 times.</li><li>2. If the test continues to abort, verify that the daily translation-save operation is not in progress (use the <b>display system-parameters maintenance</b> command to display the time for scheduled maintenance and the "y/n" option for saving translation daily).</li></ol>
	NO BOARD	The disk has been placed in the "uninstalled" state. <ol style="list-style-type: none"><li>1. Verify that the disk drive is fully inserted and powered up.</li><li>2. Attempt a demand reset of the disk.</li></ol>
5513	FAIL	The system contains 3 memory boards but the capacity of the disk is not large enough for the coredump file. <ol style="list-style-type: none"><li>1. Issue the <b>list configuration control</b> command and check if the carrier is equipped with 3 memory boards and the vintage of the TN1657 Disk circuit pack is less than Vintage 4.</li><li>2. Replace the Disk circuit pack with one of Vintage 4 or greater, issue the <b>reset disk</b> command, and perform the <b>restore disk</b> command. The restore operation may take up to 1 hour to complete.</li></ol>
5514	FAIL	The system contains 3 memory boards but the disk has not been configured for a large coredump file. The tape and disk should have been configured for the larger memory size as part of the procedures for installing 3 memory circuit packs. <ol style="list-style-type: none"><li>1. Issue the <b>configure tape 3-mem</b> command to ensure that the file system on the tape is configured for the large core dump file. This command cannot execute if the tape is already configured.</li><li>2. Issue the <b>restore disk</b> command. This step may take up to 1 hour for a complete restore.</li><li>3. Execute the <b>test disk</b> command to clear the alarm.</li></ol>

Continued on next page

Table 9-224. TEST #809 Disk Reset Test — *Continued*

Error Code	Test Result	Description/ Recommendation
Any Other <sup>1</sup>	FAIL	The disk configuration information shows the disk is missing or the disk LED test failed. <ol style="list-style-type: none"><li>1. Retry the command for a maximum of 5 retries.</li><li>2. If the command continues to fail, replace the Disk circuit pack, issue the <b>reset disk</b> command and perform the <b>restore disk</b> command. This will take up to 1 hour for a complete restore.</li><li>3. Replace the MSSNET circuit pack.</li></ol>
	PASS	The Disk status test passed successfully. Look at the results of other tests to see if it is operating correctly.

1. See the MSS Error Actions Table at the end of the TAPE section.

### Disk Write-Read Test (#810)

The Disk Write-Read Test verifies that data can be written to the disk and read back successfully. This test consists of the following steps:

1. Maintenance software in the SPE issues a request to the Host Adapter for a transfer of data between SPE memory and a specified block on the disk. The Host Adapter firmware issues a SCSI **WRITE** command to the Disk Drive which results in a transfer of data between the SPE memory and the disk.
2. Maintenance software in the SPE issues a request to the Host Adapter to run a checksum on the data previously written to the disk. The Host Adapter reads the data off the disk and computes a checksum which is returned to the SPE maintenance software.
3. Maintenance software compares the value of the checksum from the Host Adapter with the checksum it previously calculated on the data it stored on the disk.

Multiple failure conditions can occur during this test since it uses both the software and hardware functions used during normal operations

**Table 9-225. TEST #810 Disk Write-Read Test**

Error Code	Test Result	Description/ Recommendation
1301 1302	ABORT	Could not run the test—internal MSS error 1. Retry the command.
1304	ABORT	Could not allocate the Mass Storage System to run this test. Other application software may be using it or background maintenance tests may be running. 1. Retry the command at 1-minute intervals for a maximum of 5 retries. 2. If the test continues to abort, verify that the daily translation-save operation is not in progress (Use the <b>display system-parameters maintenance</b> command to display the start time for scheduled maintenance and the "y/n" option for saving translation daily).
1316	ABORT	Could not get access to the Mass Storage System. Other application software may be using it or background maintenance tests may be running. 1. Retry the command at 1-minute intervals a maximum of 5 times. 2. If the test continues to abort, verify that the daily translation-save operation is not in progress (issue the <b>display system-parameters maintenance</b> command to display the time for scheduled maintenance and the "y/n" option for saving translation daily).
1335	ABORT	Could not run the test on the Standby SPE—Duplication not administered. 1. Refer to "STBY-SPE". 2. Administer standby present.
1338	ABORT	Could not run the test on the Standby SPE—Interchange pending. 1. Refer to "STBY-SPE". 2. After interchange occurs, run test on new active SPE.
1339	ABORT	Could not run the test on the Standby SPE—Handshake down. 1. Refer to "STBY-SPE". 2. When the standby is restored to service (use <b>status spe</b> to determine state of standby) retry the command.
1347	ABORT	Could not run the test on the Standby SPE—Refresh not complete. 1. When the standby is restored to service (use <b>status spe</b> to determine state of standby) retry the command.
1350	ABORT	Could not run the test on the Standby SPE—Shadowing not enabled. 1. When the standby is restored to service (use <b>status spe</b> to determine state of standby) retry the command.
2000	ABORT	Response to the test was not received within the allowable time period. 1. Retry the command at 1-minute intervals a maximum of 5 retries.

*Continued on next page*

**Table 9-225. TEST #810 Disk Write-Read Test — Continued**

Error Code	Test Result	Description/ Recommendation
2500	ABORT	Could not run the test on the Standby SPE—Internal software error. 1. Retry the command at 1-minute intervals a maximum of 5 times.
5102	ABORT	Could not allocate the Mass Storage System to run this test 1. Retry the command at 1-minute intervals a maximum of 5 times. 2. If the test continues to abort, verify that the daily translation-save operation is not in progress (issue the <b>display system-parameters maintenance</b> command to display the time for scheduled maintenance and the "y/n" option for saving translation daily).
	NO BOARD	The disk has been placed in the "uninstalled" state. 1. Verify that the disk drive is fully inserted and powered up. 2. Attempt a demand reset of the disk.
1	FAIL	The disk could not be accessed, the checksum on the data written did not match the checksum in memory or the data read did not match the data written. 1. Retry the command for a maximum of 5 retries. 2. If the command continues to fail, replace the Disk circuit pack, issue the <b>reset disk</b> command and perform the <b>restore disk</b> command. This will take up to 1 hour for a complete restore. 3. If the test continues to fail, replace the MSSNET circuit pack.
	PASS	The Disk write read test executed successfully. Look at the results of other tests to see if it is operating correctly.

1. See the MSS Error Actions Table at the end of the TAPE section.

### Disk Audit Test (#811)

The Disk Audit Test verifies the following Disk Medium conditions.

- The directory can be read.
- There are no "dirty" files. What is meant by "dirty" is that the data in the file may not be complete or the directory entry was never updated after the data was written to the device

**Table 9-226. TEST #811 Disk Audit Test**

Error Code	Test Result	Description/ Recommendation
1316	ABORT	Could not get access to the Mass Storage System. Other software may be using it or background maintenance tests may be running. <ol style="list-style-type: none"> <li>1. Retry the command at 1-minute intervals a maximum of 5 times.</li> <li>2. If the test continues to abort, verify that the daily translation-save operation is not in progress (issue the <b>display system-parameters maintenance</b> command to display the time for scheduled maintenance and the "y/n" option for saving translation daily).</li> </ol>
1335	ABORT	Could not run the test on the Standby SPE—Duplication not administered. <ol style="list-style-type: none"> <li>1. Refer to "STBY-SPE".</li> <li>2. Administer standby present.</li> </ol>
1338	ABORT	Could not run the test on the Standby SPE—Interchange pending. <ol style="list-style-type: none"> <li>1. Refer to "STBY-SPE".</li> <li>2. After interchange occurs, run test on new active SPE.</li> </ol>
1339	ABORT	Could not run the test on the Standby SPE—Handshake down. <ol style="list-style-type: none"> <li>1. Refer to "STBY-SPE".</li> <li>2. When the standby is restored to service (use <b>status spe</b> to determine state of standby) retry the command.</li> </ol>
1347	ABORT	Could not run the test on the Standby SPE—Refresh not complete. <ol style="list-style-type: none"> <li>1. When the standby is restored to service (use <b>status spe</b> to determine state of standby) retry the command.</li> </ol>
1350	ABORT	Could not run the test on the Standby SPE—Shadowing not enabled. <ol style="list-style-type: none"> <li>1. When the standby is restored to service (use <b>status spe</b> to determine state of standby) retry the command.</li> </ol>
2000	ABORT	Response to the test was not received within the allowable time period. <ol style="list-style-type: none"> <li>1. Retry the command at 1-minute intervals a maximum of 5 times.</li> </ol>
2500	ABORT	Could not run the test on the Standby SPE—Internal software error. <ol style="list-style-type: none"> <li>1. Retry the command at 1-minute intervals a maximum of 5 times.</li> </ol>
5102	ABORT	Could not allocate the Mass Storage System to run this test <ol style="list-style-type: none"> <li>1. Retry the command at 1-minute intervals for a maximum of 5 retries.</li> <li>2. If the test continues to abort, verify that the daily translation-save operation is not in progress (issue the <b>display system-parameters maintenance</b> command to display the time for scheduled maintenance and the "y/n" option for saving translation daily).</li> </ol>

*Continued on next page*



**Table 9-226. TEST #811 Disk Audit Test — Continued**

Error Code	Test Result	Description/ Recommendation
	NO BOARD	The disk has been placed in the "uninstalled" state. 1. Verify that the disk drive is fully inserted and powered up. 2. Attempt a demand reset of the disk.
1	FAIL	The audit of the disk directory failed. 1. Perform a <b>restore disk full</b> command. This will take up to 1 hour for a complete restore (G3V3 full disk restore + or - 30 minutes). 2. If the test continues to fail, replace the Disk circuit pack, issue the <b>reset disk</b> command and perform the <b>restore disk</b> command. 3. If the test continues to fail, replace the MSSNET circuit pack.
	PASS	The disk directory audit passed successfully. Look at the results of other tests to see if it is operating correctly.

1. See the MSS Error Actions Table at the end of the TAPE section.

### Disk Firmware Error Counters Read and Clear Test (#812)

The Host Adapter firmware is constantly running background tests on each of its devices. When an error is detected by one of these background tests, the appropriate counter in the host adapter dual port RAM is incremented. The Disk Firmware Error Counters Read and Clear Test requests that the firmware return these errors to the software and clear the area in dual port RAM. If any counter is non-zero, the software then increments the appropriate software counter. The 16 errors reported by the firmware are:

- Unexpected interrupt from the SCSI Bus Interface Controller Chip (SBICC)
- SBICC timed out during SCSI command
- Error interrupt from the Direct Memory Access Controller (DMAC)
- DMAC timeout without issuing interrupt
- Disk self-test failed
- Disk external looparound test failed
- Command failed with bad sense key
- Disk could not be accessed
- Flaw detected in disk medium

- Unrecoverable hardware error on disk
- Invalid parameter in SCSI command
- Media removed or device reset
- Disk is write protected
- Disk reached end of medium
- Block reassigned on disk
- Block reassignment on disk failed

**Table 9-227. TEST #812 Disk Firmware Error Counters Read and Clear Test**

Error Code	Test Result	Description/ Recommendation
1305	ABORT	Could not read firmware error counters. 1. Retry the command at 1-minute intervals a maximum of 5 times.
1306	ABORT	Could not read configuration area for defect information. 1. Retry the command at 1-minute intervals a maximum of 5 times.
1316	ABORT	Could not get access to the Mass Storage System. Other software may be using it or background maintenance tests may be running. 1. Retry the command at 1-minute intervals a maximum of 5 times. 2. If the test continues to abort, verify that the daily translation-save operation is not in progress (issue the <b>display system-parameters maintenance</b> command to display the time for scheduled maintenance and the "y/n" option for saving translation daily).
1335	ABORT	Could not run the test on the Standby SPE—Duplication not administered. 1. Refer to "STBY-SPE". 2. Administer standby present.
1338	ABORT	Could not run the test on the Standby SPE—Interchange pending. 1. Refer to the documentation for STBY-SPE maintenance. 2. After interchange occurs, run test on new active SPE.
1339	ABORT	Could not run the test on the Standby SPE—Handshake down. 1. Refer to "STBY-SPE". 2. When the standby is restored to service (use <b>status spe</b> to determine state of standby) retry the command.
1347	ABORT	Could not run the test on the Standby SPE—Refresh not complete. 1. When the standby is restored to service (use <b>status spe</b> to determine state of standby) retry the command.

**Table 9-227. TEST #812 Disk Firmware Error  
 Counters Read and Clear Test — Continued**

Error Code	Test Result	Description/ Recommendation
1350	ABORT	Could not run the test on the Standby SPE—Shadowing not enabled. 1. When the standby is restored to service (use <b>status spe</b> to determine state of standby) retry the command.
2000	ABORT	Response to the test request was not received within the allowable time period. 1. Retry the command at 1-minute intervals a maximum of 5 times.
2500	ABORT	Could not run the test on the Standby SPE—Internal software error. 1. Retry the command at 1-minute intervals a maximum of 5 times.
5102	ABORT	Could not allocate the Mass Storage System to run this test 1. Retry the command at 1-minute intervals a maximum of 5 times. 2. If the test continues to abort, verify that the daily translation-save operation is not in progress (issue the <b>display system-parameters maintenance</b> command to display the time for scheduled maintenance and the "y/n" option for saving translation daily).
	NO BOARD	The disk has been placed in the "uninstalled" state. 1. Verify that the disk drive is fully inserted and powered up. 2. Attempt a demand reset of the disk.
1	FAIL	At least one of the firmware error counters was non-zero. 1. Retry the command at 1-minute intervals a maximum of 5 times. 2. If the test continues to fail, replace the Disk circuit pack, issue the <b>reset disk</b> command and perform the <b>restore disk</b> command. This will take up to 1 hour for a complete restore. 3. If the test continues to fail, replace the MSSNET circuit pack.
	PASS	All of the firmware error counters were zero. Look at the results of other tests to see if it is operating correctly.

1. See the MSS Error Actions Table at the end of the TAPE section.

### Disk Diagnostic Test (#813)

The Disk Diagnostic test causes the Host Adapter to send a SCSI **send diagnostics** command to the DISK Drive circuit pack. This initiates a set of device-dependent self-tests that are run as a unit. Failures can be for multiple

reasons. The return code which indicates the cause of failure is vendor unique. A failure condition will be reported as single failure type since the only repair action is to replace the Disk Drive circuit pack

**Table 9-228. TEST #813 Disk Diagnostic Test**

Error Code	Test Result	Description/ Recommendation
1316	ABORT	Could not get access to the Mass Storage System. Other application software may be using it or background maintenance tests may be running. <ol style="list-style-type: none"> <li>1. Retry the command at 1-minute intervals a maximum of 5 times.</li> <li>2. If the test continues to abort, verify that the daily translation-save operation is not in progress (issue the <b>display system-parameters maintenance</b> command to display the time for scheduled maintenance and the "y/n" option for saving translation daily).</li> </ol>
1335	ABORT	Could not run the test on the Standby SPE—Duplication not administered. <ol style="list-style-type: none"> <li>1. Refer to "STBY-SPE".</li> <li>2. Administer standby present.</li> </ol>
1338	ABORT	Could not run the test on the Standby SPE—Interchange pending. <ol style="list-style-type: none"> <li>1. Refer to the documentation for STBY-SPE maintenance.</li> <li>2. After interchange occurs, run test on new active SPE.</li> </ol>
1339	ABORT	Could not run the test on the Standby SPE—Handshake down. <ol style="list-style-type: none"> <li>1. Refer to the documentation for STBY-SPE maintenance.</li> <li>2. When the standby is restored to service (use <b>status spe</b> to determine state of standby) retry the command.</li> </ol>
1347	ABORT	Could not run the test on the Standby SPE—Refresh not complete. <ol style="list-style-type: none"> <li>1. When the standby is restored to service (use <b>status spe</b> to determine state of standby) retry the command.</li> </ol>
1350	ABORT	Could not run the test on the Standby SPE—Shadowing not enabled. <ol style="list-style-type: none"> <li>1. When the standby is restored to service (use <b>status spe</b> to determine state of standby) retry the command.</li> </ol>
2000	ABORT	Response to the test was not received within the allowable time period. <ol style="list-style-type: none"> <li>1. Retry the command at 1-minute intervals a maximum of 5 times.</li> </ol>
2500	ABORT	Could not run the test on the Standby SPE—Internal software error. <ol style="list-style-type: none"> <li>1. Retry the command at 1-minute intervals a maximum of 5 times.</li> </ol>

*Continued on next page*

Table 9-228. TEST #813 Disk Diagnostic Test — Continued

Error Code	Test Result	Description/ Recommendation
5102	ABORT	Could not allocate the Mass Storage System to run this test. <ol style="list-style-type: none"><li>1. Retry the command at 1-minute intervals a maximum of 5 times.</li><li>2. If the test continues to abort, verify that the daily translation-save operation is not in progress (issue the <b>display system-parameters maintenance</b> command to display the time for scheduled maintenance and the "y/n" option for saving translation daily).</li></ol>
	NO BOARD	The disk has been placed in the "uninstalled" state. <ol style="list-style-type: none"><li>1. Verify that the disk drive is fully inserted and powered up.</li><li>2. Attempt a demand reset of the disk.</li></ol>
1	FAIL	A Disk diagnostic test failed. <ol style="list-style-type: none"><li>1. Retry the command a maximum of 5 times.</li><li>2. If the command continues to fail, replace the Disk circuit pack, issue the <b>reset disk</b> command and perform the <b>restore disk</b> command. This will take up to 1 hour for a complete restore.</li><li>3. If the test continues to fail, replace the MSSNET circuit pack.</li></ol>
	PASS	The Disk passed all diagnostic tests. Look at the results of other tests to see if it is operating correctly.

1. See the MSS Error Actions Table at the end of the TAPE section.

## Disk Loop-Around Tests (#814)

This test extends the Host Adapter Loop-Around test to send data from the Host Adapter to buffers on the Disk Drive circuit pack and back to the Host Adapter. It may detect errors related to the Host Adapter, SCSI bus, and the Disk Drive circuit pack. It is intended to functionally test the Disk Drive circuit pack to the extent possible without actually writing data to the disk.

This test consists of two sets of tests:

- Disk Internal Loop-Around

Data is generated in the RAM of the Host Adapter and transferred to its SCSI Data Memory. A SCSI **WRITE DATA BUFFERS** command is sent to the Disk Drive circuit pack which causes the Disk Drive circuit pack to copy the data to its buffers. A SCSI **READ DATA BUFFERS** command is then sent by the Host Adapter to the Disk Drive circuit pack which causes

the Disk Drive circuit pack to transfer the data from its buffers back to the Host Adapter's SCSI Data Memory. The Host Adapter then copies the data back to its private RAM where it compares it with the original test data.

- Disk External Loop-Around

This test is similar to the Internal Loop-around test except that the data originates in the Host Adapter's Dual Port RAM and it is transferred to and from the SCSI Data Memory using SPE system bus accesses. Only a small amount of data is sent to the Disk Drive circuit pack in order to keep system bus access to a minimum.

**Table 9-229. TEST #814 Disk Loop-Around Test**

Error Code	Test Result	Description/ Recommendation
1316	ABORT	Could not get access to the Mass Storage System. Other application software may be using it or background maintenance tests may be running. <ol style="list-style-type: none"> <li>1. Retry the command at 1-minute intervals a maximum of 5 times.</li> <li>2. If the test continues to abort, verify that the daily translation-save operation is not in progress (issue the <b>display system-parameters maintenance</b> command to display the time for scheduled maintenance and the "y/n" option for saving translation daily).</li> </ol>
1335	ABORT	Could not run the test on the Standby SPE—Duplication not administered. <ol style="list-style-type: none"> <li>1. Refer to the documentation for STBY-SPE maintenance.</li> <li>2. Administer standby present.</li> </ol>
1338	ABORT	Could not run the test on the Standby SPE—Interchange pending. <ol style="list-style-type: none"> <li>1. Refer to the documentation for STBY-SPE maintenance.</li> <li>2. After interchange occurs, run test on new active SPE.</li> </ol>
1339	ABORT	Could not run the test on the Standby SPE—Handshake down. <ol style="list-style-type: none"> <li>1. Refer to the documentation for STBY-SPE maintenance.</li> <li>2. When the standby is restored to service (use <b>status spe</b> to determine state of standby) retry the command.</li> </ol>
1347	ABORT	Could not run the test on the Standby SPE—Refresh not complete. <ol style="list-style-type: none"> <li>1. When the standby is restored to service (use <b>status spe</b> to determine state of standby) retry the command.</li> </ol>
1350	ABORT	Could not run the test on the Standby SPE—Shadowing not enabled. <ol style="list-style-type: none"> <li>1. When the standby is restored to service (use <b>status spe</b> to determine state of standby) retry the command.</li> </ol>
2000	ABORT	Response to the test request was not received within the allowable time period. <ol style="list-style-type: none"> <li>1. Retry the command at 1-minute intervals a maximum of 5 times.</li> </ol>

**Table 9-229. TEST #814 Disk Loop-Around Test — Continued**

Error Code	Test Result	Description/ Recommendation
2500	ABORT	Could not run the test on the Standby SPE—Internal software error. 1. Retry the command at 1-minute intervals a maximum of 5 times.
5102	ABORT	Could not allocate the Mass Storage System to run this test 1. Retry the command at 1-minute intervals a maximum of 5 times. 2. If the test continues to abort, verify that the daily translation-save operation is not in progress (issue the <b>display system-parameters maintenance</b> command to display the time for scheduled maintenance and the "y/n" option for saving translation daily).
	NO BOARD	The disk has been placed in the "uninstalled" state. 1. Verify that the disk drive is fully inserted and powered up. 2. Attempt a demand reset of the disk.
1	FAIL	The Disk loop-around test failed. 1. Retry the command a maximum of 5 times. 2. If the command continues to fail, replace the Disk circuit pack, issue the <b>reset disk</b> command and perform the <b>restore disk</b> command. This will take up to 1 hour for a complete restore. 3. If the test continues to fail, replace the MSSNET circuit pack.
	PASS	The Disk loop-around test passed. Look at the results of other tests to see if it is operating correctly.

1. See the MSS Error Actions Table at the end of the TAPE section.

## Disk Status Test (#815)

The Disk Status Test verifies the following:

- The Host Adapter knows about the existence of the Disk Drive.
- The LEDs on the faceplate can be turned on and off correctly. This verifies only that the LED control and status logic is operating correctly. LED operation may also be tested visually with **test led**.
- The presence of +5V and +12V

**Table 9-230. TEST #815 Disk Status Test**

Error Code	Test Result	Description/ Recommendation
1306 1307 1308	ABORT	Internal software error between maintenance software and MSS driver. 1. Retry the command at 1-minute intervals a maximum of 5 times.
1316	ABORT	Could not get access to the Mass Storage System. Other application software may be using it or background maintenance tests may be running. 1. Retry the command at 1-minute intervals a maximum of 5 times. 2. If the test continues to abort, verify that the daily translation-save operation is not in progress (issue the <b>display system-parameters maintenance</b> command to display the time for scheduled maintenance and the "y/n" option for saving translation daily).
1335	ABORT	Could not run the test on the Standby SPE—Duplication not administered. 1. Refer to the documentation for STBY-SPE maintenance. 2. Administer standby present.
1338	ABORT	Could not run the test on the Standby SPE—Interchange pending. 1. Refer to the documentation for STBY-SPE maintenance. 2. After interchange occurs, run test on new active SPE.
1339	ABORT	Could not run the test on the Standby SPE—Handshake down. 1. Refer to the documentation for STBY-SPE maintenance. 2. When the standby is restored to service (use <b>status spe</b> to determine state of standby) retry the command.
1347	ABORT	Could not run the test on the Standby SPE—Refresh not complete. 1. When the standby is restored to service (use <b>status spe</b> to determine state of standby) retry the command.
1350	ABORT	Could not run the test on the Standby SPE—Shadowing not enabled. 1. When the standby is restored to service (use <b>status spe</b> to determine state of standby) retry the command.

*Continued on next page*



Table 9-230. TEST #815 Disk Status Test — Continued

Error Code	Test Result	Description/ Recommendation
2000	ABORT	Response to the test request was not received within the allowable time period. 1. Retry the command at 1-minute intervals a maximum of 5 times.
2500	ABORT	Could not run the test on the Standby SPE—Internal software error. 1. Retry the command at 1-minute intervals for a maximum of 5 retries.
5102	ABORT	Could not allocate the Mass Storage System to run this test 1. Retry the command at 1-minute intervals a maximum of 5 times. 2. If the test continues to abort, verify that the daily translation-save operation is not in progress (issue the <b>display system-parameters maintenance</b> command to display the time for scheduled maintenance and the "y/n" option for saving translation daily).
	NO BOARD	The disk has been placed in the "uninstalled" state. 1. Verify that the disk drive is fully inserted and powered up. 2. Attempt a demand reset of the disk.
5513	FAIL	The system is equipped with 3 memory circuit packs but the capacity of the disk is not large enough for the coredump file. 1. Use <b>list configuration control</b> and verify that the control carrier is equipped with 3 memory boards. Also check the vintage of the TN1657 Disk Drive circuit pack. 2. Replace the Disk Drive circuit pack with Vintage 4 or greater, issue the <b>reset disk</b> command, and perform the <b>restore disk</b> command. The restore operation may take up to 1 hour to complete.
5514	FAIL	The system is equipped with 3 memory circuit packs but the disk has not been configured for a large coredump file. The tape and disk should be configured for the larger memory size as part of the procedures for installing 3 memory circuit packs. 1. Use <b>configure tape 3-mem</b> to ensure that the file system on the tape has been configured for the large core dump file. This command will not execute if the tape has already been configured. 2. Use <b>restore disk</b> . This step may take up to 1 hour for a complete restore. 3. Execute the <b>test disk R</b> command to clear the alarm.

Continued on next page

**Table 9-230. TEST #815 Disk Status Test — Continued**

Error Code	Test Result	Description/ Recommendation
Any Other <sup>1</sup>	FAIL	The disk configuration information shows the disk is missing or the disk LED test failed. <ol style="list-style-type: none"> <li>1. Retry the command a maximum of 5 times.</li> <li>2. If the command continues to fail, replace the Disk Drive circuit pack, issue the <b>reset disk</b> command and perform the <b>restore disk</b> command. This will take up to 1 hour for a complete restore.</li> <li>3. If the test continues to fail, replace the MSSNET circuit pack.</li> </ol>
	PASS	The Disk status test passed successfully. Look at the results of other tests to see if it is operating correctly.

---

1. See the MSS Error Actions Table at the end of the TAPE section.

---

### Disk Reset Test (#894)

The Disk Reset Test is executed when the **reset disk** command is entered at the terminal. The test results for Test 894 are the same as those for Test 809. The only difference between Test 809, which is run as part of the test sequence for the **test disk** command, and Test 894 which is run in response to the **reset disk** command is that all disk alarms are resolved when Test 894 passes while only some disk alarms may be resolved when Test 809 passes.

Refer to the results for Test #809 for the appropriate repair procedures.

## **DLY-MTCE (MO-DAILY)**

---

<b>MO Name (in Alarm Log)</b>	<b>Alarm Level</b>	<b>Initial Command to Run</b>	<b>Full Name of MO</b>
DLY-MTCE	MINOR	NONE	DLY-MTCE
DLY-MTCE	MAJOR	NONE	DLY-MTCE

The DLY-MTCE maintenance object monitors daily translation saves. If a translation save times out or fails to run, an error is logged against this maintenance object. If the save fails three times in a row, a MINOR alarm is raised; if the save fails for seven consecutive attempts, a MAJOR alarm is raised.

## DS1-BD (DS1 Interface Circuit Pack)

MO Name (in Alarm Log)	Alarm Level	Initial Command to Run <sup>1</sup>	Full Name of MO
DS1-BD	MAJOR	test board UUCSS sh	DS1 Interface Circuit Pack
DS1-BD	MINOR	test board UUCSS I	DS1 Interface Circuit Pack
DS1-BD	WARNING	test board UUCSS sh	DS1 Interface Circuit Pack

1. UU is the universal cabinet number (1 for PPN, 2 - 44 for EPNs). C is the carrier designation (A, B, C, D, or E). SS is the number of the slot in which the circuit pack resides (01 to 21).

The DS1 Interface circuit pack provides an interface to an external DS1 facility and supports 24 DS0 channels carried on a 1.544 Mbps DS1 link. These DS0 channels can be administered as either trunks to other switches or lines to off-premises stations. The TN464C and later suffix Universal DS1 Interface also supports a 32-channel interface on a 2.048Mbps link. The functions and maintenance strategy for the TN464 circuit packs are covered under a separate maintenance object, UDS1-BD.

DS1-BD maintenance logs in-line errors reported by the DS1 Interface circuit pack, runs tests for error diagnosis and recovery, and raises and clears alarms. The following table shows the capabilities of each DS1 circuit pack. The TN722 and TN722B are not supported on G3r V1 or later systems.

Circuit Pack Code	24 Channel	32 Channel	Tie Trunk Signaling	CO Trunk Signaling	DID Trunk Signaling	OPS Line Signaling
TN722/B	x		x			
TN767/B/C/D/E	x		x	x	x	x
TN464C/D/E/F	x	x	x	x	x	x (24-chl only)

ISDN-PRI Trunk signaling (for example, Q.921, Q.931) requires a TN464D and is handled by system software. The TN464 is covered in the "UDS1-BD (UDS1 Interface Circuit Pack)" section of Chapter 9.

Each trunk and line have their own maintenance strategies. However, they all depend on the health of the DS1 Interface circuit pack. Refer to the following sections for details: TIE-DS1, CO-DS1, DID-DS1, OPS-LINE, ISDN-TRK, and ISDN-PLK. Signaling over the DS1 link must be synchronized between the transmitting and receiving ends to ensure error-free communication. Refer to "SYNC (Synchronization)" for details.

The TN767E circuit pack combined with Lucent's new 120A1 CSU Module forms an Enhanced Integrated CSU. The new 120A1 CSU Module, when combined with the functionality provided by the TN767E hardware and firmware, and new switch software, provides functionality equivalent to an external stand-alone Lucent ESF T1 CSU. The 120A1 CSU Module connects to the TN767E circuit pack on the I/O connector panel on the back of the port carrier. The new CSU Module, thus becomes an integrated part of the DEFINITY. system. Throughout the document, the term 120A1 will mean a 120A1 or later suffix CSU Module.

The Enhanced Integrated CSU is for use in the United States of America with 1.544 Mbps DS1 service. For further details on the 120A1 CSU Module see *DEFINITY. Communications System Generic 1, Generic 2, and Generic 3 V1 and V2 - Integrated CSU Module Installation and Operation, 555-230-193.*

The TN767E and 120A1 CSU Module support on-demand loopback tests that assist in the detection of faults between the TN767E circuit pack and the CSU Module, between the Integrated CSU and the optional Customer Premises Loopback Jack, or between the Integrated CSU and remote CSU. These loopback tests are explained in detail later in this DS1-BD section, but [Figure 9-26](#) gives a high level overview of the loopback points.

The following list of acronym definitions are for [Figure 9-26](#):

- PLB = Payload Loopback
- BLB = Board Loopback
- ELB = Equipment Loopback
- LLB = Line Loopback
- RLB = Repeater Loopback
- CLJ = Loopback Jack Loopback
- R-LLB = Remote Line Loopback
- SMRT = Smart Jack
- LPBK = Loopback

For more information about DS1 interfaces, see the *DEFINITY Communications System DS1/CEPT1/ISDN-PRI Reference, 555-025-107.*

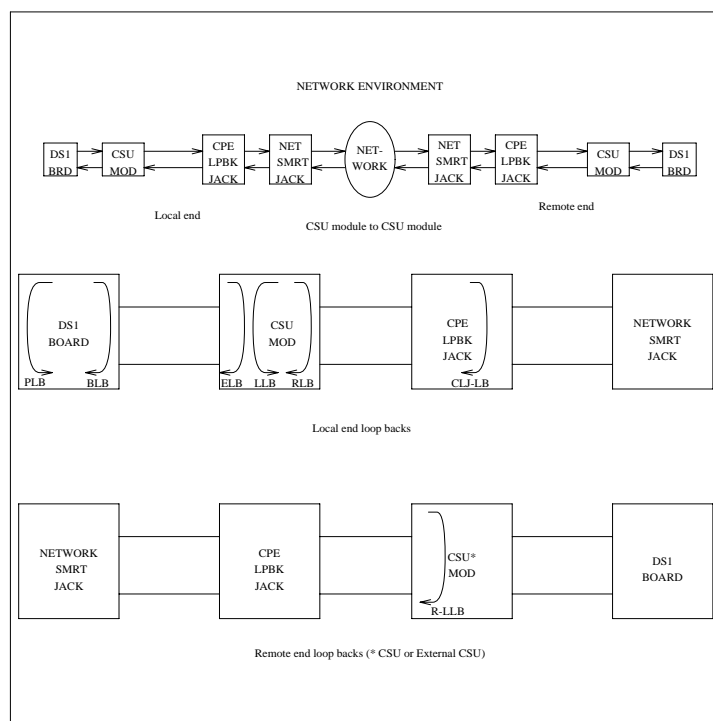

Figure 9-26. High Level Overview Of Loopback Points

## Error Log Entries and Test to Clear Values

Table 9-231. DS1 Interface Circuit Pack Maintenance Error Log Entries

Error Type	Aux Data	Associated Test	Alarm Level	On/Off Board	Test to Clear Value
0 <sup>1</sup>	0	Any	Any	Any	test board UUCSS
1 (a)	0	Circuit pack removed or SAKI Test (#53)	MIN/WRN‡	ON	
18 (b)	0	busy-out board UUCSS	WARNING	OFF	release board UUCSS
23 (c)	0		WARNING	OFF	add ds1 UUCSS

**Table 9-231. DS1 Interface Circuit Pack Maintenance Error Log Entries — Continued**

Error Type	Aux Data	Associated Test	Alarm Level	On/Off Board	Test to Clear Value
12 5(d)		None	MINOR	ON	
257	65535	Control Channel Loop Test (#52)	MINOR	ON	test board UUCSS l r 20
257 (e)	Any	None			
513 (f)	Any		MINOR	ON	
769 (g)	4358				
1025 (e)	4363	NPE Audit Test (#50)			
1281	Any	Loss of Signal Alarm Inquiry Test (#138)	MIN/WRN†	OFF	test board UUCSS
1300 (h)	Any	Loss Of Signal Alarm Inquiry Test (#138)	WARNING	OFF	test board UUCSS
1301 (i)	Any	Loss Of Signal Alarm Inquiry Test (#138)	WARNING	OFF	test board UUCSS
1302 (j)	Any	Loss Of Signal Alarm Inquiry Test (#138)	MIN/WRN†	OFF	test board UUCSS
1303 (k)	Any	Loss Of Signal Alarm Inquiry Test (#138)	MIN/WRN†	ON	test board UUCSS
1310 (l)	Any	Board Loopback Test (#1209)	MINOR	ON	test ds1-loop UUCSS ds1/csu-loopback-tests
1311 (m)	Any	Equipment Loopback Test (#1210)	MIN/WRN†	OFF	test ds1-loop UUCSS ds1/csu-loopback-test
1312 (n)	Any	Repeater Loopback Test (#1211)	MIN/WRN†	OFF	test ds1-loop UUCSS ds1/csu-loopback-tests
1313 (o)	Any	CPE Loopback Jack Test (#1212)	MIN/WRN†	OFF	test ds1-loop UUCSS end-loopback/span-test
1314 (p)	Any	Far CSU Loopback Test (#1213)	MIN/WRN†	OFF	test ds1-loop UUCSS end-loopback/span-test
1320	Any	Loss of Signal Alarm Inquiry Test (#138)	MIN/WRN†	OFF	test board UUCSS
1321	Any	Loss of Signal Alarm Inquiry Test (#138)	MIN/WRN†	OFF	test board UUCSS
1322	Any	Loss of Signal Alarm Inquiry Test (#138)	MINOR	ON	test board UUCSS
1323	Any	Loss of Signal Alarm Inquiry Test (#138)	MIN/WRN†	OFF	test board UUCSS

*Continued on next page*

**Table 9-231. DS1 Interface Circuit Pack Maintenance Error Log Entries — Continued**

Error Type	Aux Data	Associated Test	Alarm Level	On/Off Board	Test to Clear Value
1324	Any	Loss of Signal Alarm Inquiry Test (#138)	WARNING	OFF	test board UUCSS
1538 (q)	Any		MINOR	ON	
1793	Any	Blue Alarm Inquiry Test (#139)	MAJ/MIN/WRN **	OFF	test board UUCSS
1794	Any	Blue Alarm Inquiry Test (#139)	MAJ/MIN/WRN **	OFF	test board UUCSS
1795	Any	Blue Alarm Inquiry Test (#139)	MAJ/MIN/WRN **	OFF	test board UUCSS
2049	Any	Red Alarm Inquiry Test (#140)	MIN/WRN†	OFF	test board UUCSS
2305	Any	Yellow Alarm Inquiry Test (#141)	MINOR	OFF	test board UUCSS
2306	Any	Yellow Alarm Inquiry Test (#141)	MINOR	OFF	test board UUCSS
2561	Any	Major Alarm Inquiry Test (#142)	MIN/WRN†	OFF	test board UUCSS
2817		Minor Alarm Inquiry Test (#143)	MIN/WRN†	OFF	test board UUCSS
3073 to 3160 (r)	Any	Slip Alarm Inquiry Test (#144)	MIN/WRN†	OFF	test board UUCSS r 6
3329 to 3345 (s)	Any	Misframe Alarm Inquiry Test (#145)	MIN/WRN†	OFF	test board UUCSS r 6
3840(t)	Any	None			
3900(u)	Any	CPE Loopback Jack Test (#1212)			
3901(v)	Any	Far CSU Loopback Test (#1213)			
3902(w)	Any	One-Way Span Test (#1214)			
3999 (x)	Any	None			

1. Run the Short Test Sequence first. If all tests pass, run the Long Test Sequence. Refer to the appropriate test description and follow the recommended procedures.



Notes:

- a. This error indicates that the circuit pack has stopped functioning or is not completely administered. The alarm is logged about 15 minutes after the circuit pack has been removed or 11 minutes after the SAKI Test (#53) fails.

To be completely administered, a DS1 circuit pack must meet all 3 of the following conditions:

1. Have an entry in the circuit plan via the **change circuit pack** command
2. Be administered via the **add ds1 UUCSS** command
3. Be physically inserted in the appropriate slot

If the circuit pack has an entry in the circuit plan and either of the other two conditions are *not* met, a MINOR alarm is logged. To resolve the error either

1. Make sure all conditions for administration are met and that a functioning DS1 circuit pack is inserted in the correct slot.
2. Completely remove the DS1-BD from the system using the following steps:
  - a. Remove any administered DS1 trunks or access endpoints associated with the circuit pack from their trunk groups.
  - b. Execute the **remove ds1 UUCSS** and **change circuit pack UUCSS** commands.

If all the administration conditions are met for this circuit pack and the red LED is still on, follow the instructions for *LED Alarms with Error Type 1* in Chapter 7.

- b. The DS1 Interface circuit pack has been busied out by a **busy-out board UUCSS** command.
- c. The DS1-BD circuit pack is not completely administered. A completely administered DS1-BD circuit pack should have an entry in the circuit plan via the **change circuit pack** command, should have been administered via the **add ds1 UUCSS** command, and should have been inserted into the appropriate port slot.
- d. The circuit pack in the slot does not match the type administered to that position. Either replace the circuit pack with one of the type administered, or use **change circuit-pack** to readminister the slot. This error may also indicate that the 24/32-channel selection on the DS1 administration form does not match the configuration of the circuit pack.
- e. This error is associated with the Common Port Circuit Pack Maintenance Test. Refer to "XXX-BD (Common Port Circuit Pack)" for details.
- f. The DS1 Interface circuit pack has detected a transient hardware problem (for example, external RAM failure, internal RAM failure, internal ROM failure, or instruction set failure). This error will disappear when no faults

are detected for 30 minutes. The value in the Aux Data field indicates the type of hardware problem. However, when this error is reported with Aux Data in the range of 4352 to 4358, it indicates the circuit pack has reported a hardware failure such that the circuit pack should be replaced.

- g. The DS1 Interface circuit pack has detected a transient hardware logic error (for example, program logic inconsistency). This error will disappear when no faults are detected for 100 minutes. The value in Aux Data field indicates the type of hardware problem.
- h. CSU Module missing. The *Near-End CSU Type* field on the **add ds1** form has been administered as *integrated* but the 120A1 CSU Module is not physically connected (or is improperly connected) to the TN767E board on the back of the port carrier.

If using the 120A1 CSU Module, plug (or replug) the CSU Module into the TN767E circuit pack's connector on the I/O connector panel on back of the carrier. Otherwise, change the *Near-End CSU Type* field using the **change ds1** form to *other*.

If this error remains after plugging the CSU Module into the board's connector, there could be a problem with the I/O connector panel.

- i. CSU Module not expected. The 120A1 CSU Module is physically connected to the TN767E board on the back of the port carrier but the *Near-End CSU Type* field on the **add ds1** form has not been administered as *integrated*.

If the 120A1 CSU Module is to be used, use the **change ds1** command to change the *Near-End CSU Type* field to *integrated*. Otherwise, physically remove the 120A1 CSU Module from the back of the port carrier.

- j. DS1 configuration error. Attempting to use the 120A1 CSU Module with a TN767E circuit pack that is configured for 32-channel (2.048 Mbps) operation. The CSU Module only works with a DS1 board configured for 24-channel (1.544 Mbps) operation in the United States of America.
- k. DS1 circuit pack suffix incorrect for CSU Module. The *Near-End CSU Type* field on the **add ds1** form has been administered as *integrated* but the DS1 circuit pack is not a TN767E or later suffix DS1 board.

If the 120A1 CSU Module is to be used, remove the circuit pack and replace it with a TN767E or later suffix board. Otherwise, use the **change ds1** command to change the *Near-End CSU Type* field to *other*.

- l. BLB failure. This error occurs when the DS1 Board Loopback (BLB) demand test fails. Repeat the test using the following commands: **busyout board UUCSS, test ds1-loop UUCSS ds1/csu-loopback-tests, release board UUCSS**. If the BLB test continues to fail, then the TN767E circuit pack needs to be replaced.
- m. ELB failure. This error occurs when the Integrated CSU (I-CSU) Module Equipment Loopback (ELB) test fails. This test is executed by the I-CSU during I-CSU power-up/reset (i.e., TN767E board physically inserted and

120A1 CSU Module already installed) or when the 120A1 CSU Module is plugged on to an already initialized DS1 board. The ELB test is also executed as part of the command **test ds1-loop UUCSS ds1/csu-loopback-tests**.

Attempt to clear the alarm via the following commands: **busyout board UUCSS**, **test ds1-loop UUCSS ds1/csu-loopback-tests**, and **release board UUCSS**. If the ELB test continues to fail, then either the TN767E board, the CSU Module, or the I/O cable between the backplane and the CSU module (or any combination thereof) has failed. Attempt to isolate where the failure is occurring by re-executing the test by replacing one piece of hardware at a time.

- n. RLB failure. This error occurs when the Integrated CSU (I-CSU) Module Repeater Loopback (RLB) test fails. This test is executed by the I-CSU during I-CSU power-up/reset (i.e., TN767E board physically inserted and 120A1 CSU Module already installed) or when the 120A1 CSU Module is plugged on to an already initialized DS1 board. The RLB test is also executed as part of the command **test ds1-loop UUCSS ds1/csu-loopback-tests**.

Attempt to clear the alarm via the following commands: **busyout board UUCSS**, **test ds1-loop UUCSS ds1/csu-loopback-tests**, and **release board UUCSS**. If the RLB test continues to fail, then the CSU Module needs to be replaced.

- o. CPE Loopback Jack deactivation error. This error occurs when the TN767E circuit pack could not deactivate a CPE Loopback Jack loopback.

Attempt to clear the alarm via the following commands: **busyout board UUCSS**, **test ds1-loop UUCSS end-loopback/span-test**, and **release board UUCSS**. If the attempt to deactivate the CPE Loopback Jack loopback continues to fail, other steps must be taken to deactivate the loopback.

- p. Far CSU Loopback deactivation error. This error occurs when the TN767E circuit pack could not deactivate a far-end CSU loopback on power-up/reset or upon software request.

Attempt to clear the alarm via the following commands: *busyout board UUCSS*, *test ds1-loop UUCSS end-loopback/span-test*, *release board UUCSS*. If the attempt to deactivate the Far CSU loopback continues to fail, then escalate the problem.

- q. The hyperactive circuit pack is out-of-service and may exhibit one or more of the following symptoms:
  - 1. The common circuit pack level tests such as Test #51 and/or Test #220 are aborting with error code 2000.
  - 2. The tests run on the ports of this circuit pack are returning NO BOARD.
  - 3. A busy-out/release of the circuit pack has no affect on test results.

4. A **list configuration** command shows that the circuit pack and ports are properly installed.

The circuit pack is isolated from the system and all trunks of this circuit pack are placed into the out-of-service state. The system will try to restore the circuit pack within 15 minutes. When no faults are detected for 15 minutes, the DS1 Interface circuit pack is restored to normal operation. All trunks of the DS1 Interface circuit pack are then returned to the in-service state. If the error recurs after 15 minutes, then replace the circuit pack.

- r. For later releases of G3V4 and beyond, only error 3073 will show that this board is receiving Slips and the AUX data shows the last Slip count that was reported.
- s. For later releases of G3V4 and beyond, only error 3329 will show that this board is receiving misframes and the AUX data shows the last misframe count that was reported.
- t. This error is not service-affecting and can be ignored.
- u. Error 3900 is used to give status information on a CPE Loopback Jack Test. The value in the Aux Data field indicates the status of the loopback test.

1 — Test is currently running.

2 — Test failed because loopback could not be activated.

3 — Test failed because test pattern could not be detected.

4 — Test has been terminated.

- v. Error 3901 is used to give status information on a Far CSU Loopback Test. The value in the Aux Data field indicates the status of the loopback test.

1 — Test is currently running.

2 — Test failed because loopback could not be activated.

3 — Test failed because test pattern could not be detected.

4 — Test has been terminated.

- w. Error 3902 is used to give status information on a One-Way Span Test. The value in the Aux Data field indicates the status of the span test.

1 — Test is currently running.

2 — Test has failed because test could not be activated.

3 — Test pattern was not received from the far end.

4 — Test has been terminated.

- x. Error type 3999 indicates that the circuit pack sent a large number of control channel messages to the switch within a short period of time. If error type 1538 is also present, then the circuit pack was taken out-of-service due to hyperactivity. If error type 1538 is not present, then

the circuit pack has not been taken out-of-service, but it has generated 50% of the messages necessary to be considered hyperactive. This may be completely normal during heavy traffic periods. However, if this error type is logged when the circuit pack is being lightly used, it may indicate a problem with the circuit pack or the equipment attached to it.

## System Technician-Demanded Tests: Descriptions and Error Codes

Always investigate tests in the order they are presented in [Table 9-232](#). By clearing error codes associated with the *NPE Connection Audit Test*, for example, you may also clear errors generated from other tests in the testing sequence

**Table 9-232. System Technician-Demanded Tests: DS1-BD**

Order of Investigation	Short Test Sequence	Long Test Sequence	Reset Board Sequence	test ds1-loop Command	D/ND <sup>1</sup>
NPE Connection Audit Test (#50)		X			ND
Control Channel Loop Test (#52)		X			ND
Loss of Signal Alarm Inquiry Test (#138)	X	X			ND
Blue Alarm Inquiry Test (#139)	X	X			ND
Red Alarm Inquiry Test (#140)	X	X			ND
Yellow Alarm Inquiry Test (#141)	X	X			ND
Major Alarm Inquiry Test (#142)	X	X			ND
Minor Alarm Inquiry Test (#143)	X	X			ND
Slip Alarm Inquiry Test (#144)	X	X			ND
Misframe Alarm Inquiry Test (#145)	X	X			ND
Translation Update Test (#146)	X	X			ND
ICSU Status LEDs Test (#1227)	X	X			ND
SAKI Sanity Test (#53)			X		D
Internal Looparound Test (#135)			X		D
DS1/CSU Loopback Tests				X	D
DS1 Board Loopback Test (#1209)				X	D

*Continued on next page*

**Table 9-232. System Technician-Demanded Tests: DS1-BD — Continued**

Order of Investigation	Short Test Sequence	Long Test Sequence	Reset Board Sequence	test ds1-loop Command	D/ND <sup>1</sup>
CSU Equipment Loopback Test (#1210)				X	D
CSU Repeater Loopback Test (#1211)				X	D
CPE Loopback Jack Test (#1212)				X	D
Far CSU Loopback Test (#1213)				X	D
One-Way Span Test (#1214)				X	D
Inject Single Bit Error (#1215)				X	D
End Loopback/Span Test (#1216)				X	D

1. D = Destructive, ND = Non-destructive

**NPE Connection Audit Test (#50):**

The system sends a message to the on-board microprocessor to update the network connectivity translation for all the Network Processing Elements (NPEs) on the circuit pack.

**Table 9-233. TEST #50 NPE Connection Audit Test**

Error Code	Test Result	Description/ Recommendation
None 2100	ABORT	System resources required for this test are not available.
1019	ABORT	Test already in progress.
	FAIL	Internal system error 1. Retry the command at 1-minute intervals a maximum of 5 times.
	PASS	The circuit pack's NPEs have been updated with their translation.

**Table 9-233. TEST #50 NPE Connection Audit Test — Continued**

Error Code	Test Result	Description/ Recommendation
0	NO BOARD	<p>The test could not relate the internal ID to the port (no board).</p> <p>This could be due to incorrect translations, no board is inserted, an incorrect board is inserted, or an insane board is inserted.</p> <ol style="list-style-type: none"> <li>1. Check to ensure that the board translations are correct. Use the <b>add ds1 UUCSS</b> command to administer the DS1 interface if it is not already administered.</li> <li>2. If board was already administered correctly, check the error log to determine if the board is hyperactive. If this is the case, the board is shut down. Reseating the board will re-initialize the board.</li> <li>3. Issue the <b>busyout board</b> command.</li> <li>4. Issue the <b>reset board</b> command.</li> <li>5. Issue the <b>release busy board</b> command.</li> <li>6. Issue the <b>test board long</b> command.</li> </ol> <p>This should re-establish the linkage between the internal ID and the port.</p>

### Control Channel Looparound Test (#52)

This test queries the circuit pack for its circuit pack code and vintage and verifies its records.

**Table 9-234. TEST #52 Control Channel Looparound Test**

Error Code	Test Result	Description/ Recommendation
None 2100	ABORT	<p>System resources required for this test are not available.</p> <ol style="list-style-type: none"> <li>1. Retry the command at 1-minute intervals a maximum of 5 times.</li> </ol>

*Continued on next page*

**Table 9-234. TEST #52 Control Channel Looparound Test — Continued**

Error Code	Test Result	Description/ Recommendation
	FAIL	<p>The test failed because the circuit pack did not return the circuit pack code or vintage.</p> <p><b>⇒ NOTE:</b>                      Error type 1538 in the error log indicates hyperactivity. The hyperactive circuit pack is out of service and one or more of the following symptoms may be exhibited.</p> <ol style="list-style-type: none"> <li>1. The DS1-BD tests (such as Test 138 and Test 139) are aborting with error code 2000.</li> <li>2. The tests run on the ports of this circuit pack are returning a no board result.</li> <li>3. A <b>busyout</b> or a <b>release</b> command has no affect on the test result.</li> <li>4. A <b>list config</b> command shows that the circuit pack and the ports are properly installed.</li> </ol> <p>When hyperactivity occurs, the circuit pack is isolated from the system, and all of the trunks for this circuit pack are placed into the out of service state. The system will try to restore the circuit pack within 15 minutes. When no faults are detected for 15 minutes, the DS1 interface circuit pack is restored to normal operation. All of the trunks for the DS1 interface circuit pack are then returned to the in service state. Hyperactivity is often caused by the associated facility. In such a case, faults (such as slips, misframes, or blue alarms) would be entered in the error log. In addition, many hardware errors would be logged against the associated trunk circuits. If the facility is OK and the error occurs again after 15 minutes, replace the circuit pack.</p> <ol style="list-style-type: none"> <li>1. Retry the command for a maximum of 5 times.</li> <li>2. If the problem continues, check for hyperactivity. Resolve the problem, as appropriate.</li> <li>3. If there is no longer hyperactivity, retry the command for a maximum of 5 times.</li> <li>4. If the test continues to fail, replace the circuit pack.</li> </ol>
	PASS	Communication with this circuit pack is successful.

*Continued on next page*



**Table 9-234. TEST #52 Control Channel Looparound Test — Continued**

Error Code	Test Result	Description/ Recommendation
0	NO BOARD	<p>The test could not relate the internal ID to the port (no board).</p> <p>This could be due to incorrect translations, no board is inserted, an incorrect board is inserted, or an insane board is inserted.</p> <ol style="list-style-type: none"> <li>1. Check to ensure that the board translations are correct. Use the <b>add ds1 UUCSS</b> command to administer the DS1 interface if it is not already administered.</li> <li>2. If board was already administered correctly, check the error log to determine if the board is hyperactive. If this is the case, the board is shut down. Reseating the board will re-initialize the board.</li> <li>3. If the board was found to be correctly inserted in step 1, issue the <b>busyout board</b> command.</li> <li>4. Issue the <b>reset board</b> command.</li> <li>5. Issue the <b>release busy board</b> command.</li> <li>6. Issue the <b>test board long</b> command.</li> </ol> <p>This should re-establish the linkage between the internal ID and the port.</p>

**SAKI Sanity Test (#53)**

**This test is destructive. This test resets the circuit pack.**

**Table 9-235. TEST #53 SAKI Sanity Test**

Error Code	Test Result	Description/ Recommendation
None	ABORT	<p>System resources required for this test are not available.</p> <ol style="list-style-type: none"> <li>1. Retry the command at 1-minute intervals a maximum of 5 times.</li> </ol>
1005	ABORT	<p>Wrong circuit pack configuration to run this test. This error applies only to DS1 Interface circuit packs. It means the DS1 Interface circuit pack is providing timing for the system and, therefore, it cannot be reset without major system disruptions.</p> <ol style="list-style-type: none"> <li>1. If the circuit pack needs to be reset, then set synchronization to another DS1 Interface circuit pack or to the Tone-Clock circuit pack and try again. Refer to "SYNC (Synchronization)".</li> </ol>

*Continued on next page*

**Table 9-235. TEST #53 SAKI Sanity Test — Continued**

Error Code	Test Result	Description/ Recommendation
1015	ABORT	Port is not out-of-service. 1. Busyout the circuit pack. 2. Execute the command again.
2100	ABORT	System resources required for this test are not available. 1. Retry the command at 1-minute intervals a maximum of 5 times.
1	FAIL	The circuit pack failed to reset.
2	FAIL	The circuit pack failed to restart. 1. Execute the command again. 2. If the problem persists, replace the circuit pack.
	PASS	The circuit pack initializes correctly. 1. Run the Short Test Sequence.
0	NO BOARD	The test could not relate the internal ID to the port (no board). This could be due to incorrect translations, no board is inserted, an incorrect board is inserted, or an insane board is inserted. 1. Check to ensure that the board translations are correct. Use the <b>add ds1 UUCSS</b> command to administer the DS1 interface if it is not already administered. 2. If board was already administered correctly, check the error log to determine if the board is hyperactive. If this is the case, the board is shut down. Reseating the board will re-initialize the board. 3. If the board was found to be correctly inserted in step 1, issue the <b>busyout board</b> command. 4. Issue the <b>reset board</b> command. 5. Issue the <b>release busy board</b> command. 6. Issue the <b>test board long</b> command. This should re-establish the linkage between the internal ID and the port.

### Internal Looparound Test (#135)

**This test is destructive.**

The Internal Looparound Test is run by looping the transmitted DS1 bit stream back into the DS1's board receiver. The loop occurs just before the DS1 facility

interface. The test is highly destructive and can only be initiated by a system technician-demanded **reset board UUCSS** command.

All trunks on the DS1 Interface circuit pack must be busied out via the system technician **busy-out board** command before running the Internal Looparound Test. When the Internal Looparound Test is initiated, maintenance software sends appropriate messages to the DS1 Interface circuit pack to start the test. The test uses the Tone Generator and Tone Detector to exercise a bit pattern consistency test for all ports. If the transmitted and received bit patterns on a trunk are different, the test fails.

When the test is complete, the maintenance software sends a stop loop around message to the DS1 Interface circuit pack to put the circuit pack back into the normal operation mode. All trunks of the DS1 Interface circuit pack are restored to the in-service state after the **release board** command is entered

**Table 9-236. TEST #135 Internal Looparound Test**

Error Code	Test Result	Description/ Recommendation
2012	ABORT	Internal system error 1. Retry the command at 1-minute intervals a maximum of 5 times.
1002	ABORT	The system could not allocate time slots for the test. The system may be under heavy traffic conditions or it may have time slots out-of-service due to TDM-BUS errors. 1. If system has no TDM-BUS errors and is not handling heavy traffic, repeat test at 1-minute intervals a maximum of 5 times.
1003	ABORT	The system could not allocate a tone receiver for the test. The system may be oversized for the number of Tone Detectors present or some Tone Detectors may be out-of-service. 1. Resolve any TTR-LEV errors. 2. Resolve any TONE-PT errors. 3. If neither condition exists, retry the test at 1-minute intervals a maximum of 5 times.
1004	ABORT	Received an incoming call on a port of the DS1 circuit pack during the test. 1. Enter the <b>busy-out board UUCSS</b> command to put all trunks of DS1 Interface circuit pack to out-of-service state. 2. Retry the command at 1-minute intervals a maximum of 5 times.
1015	ABORT	Ports on DS1 Interface circuit pack have not been busied out. 1. Enter the <b>busy-out board UUCSS</b> command to put all trunks of the DS1 Interface circuit pack into out-of-service state. 2. Retry the command.

**Table 9-236. TEST #135 Internal Looparound Test — Continued**

Error Code	Test Result	Description/ Recommendation
1039	ABORT	<p>The DS1 Interface circuit pack is providing timing for the system. Therefore, it cannot be reset without major system disruption.</p> <ol style="list-style-type: none"> <li>1. If the DS1 Interface circuit pack needs to be tested, set the synchronization reference to another DS1 Interface circuit pack or to the Tone-Clock circuit pack via the following command sequence:                             <ul style="list-style-type: none"> <li>■ Issue the <b>disable synchronization-switch</b> command.</li> <li>■ Next, issue the <b>set synchronization UUCSS</b> command.</li> <li>■ Lastly, issue the <b>enable synchronization-switch</b> command.</li> </ul> </li> </ol>
2000	ABORT	<p>The test was aborted. Response to the test was not received within the allowable time period. This may be due to hyperactivity. Error type 1538 in the error log indicates hyperactivity. The hyperactive circuit pack is out of service and one or more of the following symptoms may be exhibited.</p> <ol style="list-style-type: none"> <li>1. The DS1-BD tests (such as Test 139 and Test 140) are aborting with error code 2000.</li> <li>2. The tests run on the ports of this circuit pack are returning a no board result.</li> <li>3. A <b>busyout</b> or a <b>release</b> command has no affect on the test results.</li> <li>4. A <b>list config</b> command shows that the circuit pack and the ports are properly installed.</li> </ol> <p><b>⇒ NOTE:</b></p> <p>When hyperactivity occurs, the circuit pack is isolated from the system, and all of the trunks for this circuit pack are placed into the out of service state. The system will try to restore the circuit pack within 15 minutes. When no faults are detected for 15 minutes, the DS1 interface circuit pack is restored to normal operation. All of the trunks for the DS1 interface circuit pack are then returned to the in service state. Hyperactivity is often caused by the associated facility. In such a case, faults (such as slips, misframes, or blue alarms) would be entered in the error log. In addition, many hardware errors would be logged against the associated trunk circuits. If the facility is OK and the error occurs again after 15 minutes, replace the circuit pack.</p>
2100	ABORT	<p>Could not allocate the necessary system resources to run this test.</p> <ol style="list-style-type: none"> <li>1. Retry the command at 1-minute intervals for a maximum of 5 times.</li> </ol>

*Continued on next page*

**Table 9-236. TEST #135 Internal Looparound Test — Continued**

Error Code	Test Result	Description/ Recommendation
	FAIL	<p>DS1 Interface circuit pack failed in the Internal Looparound Test.</p> <ol style="list-style-type: none"> <li>1. Retry the command at 1-minute intervals a maximum of 5 times.</li> <li>2. If the DS1 Interface circuit pack is TN767, enter the <b>list measurement ds1-log UUCSS</b> command to read the error seconds measurement. Otherwise, skip this step.</li> <li>3. Verify that both endpoints of the DS1 link are administered using the same signaling mode, framing mode, and line coding.</li> <li>4. Check the physical connectivity of DS1 Interface circuit packs and cable.</li> <li>5. If all of the above are OK, replace the local DS1 Interface circuit pack and repeat the test.</li> <li>6. Contact T1 Network Service to diagnose remote DS1 endpoint.</li> </ol>
	PASS	<p>All administered trunks of DS1 Interface circuit pack pass the Internal Looparound Test. The bit pattern consistency test is executed successfully over the path that covers a DS1 port, cable, and the external NCTE device.</p>
0	NO BOARD	<p>The test could not relate the internal ID to the port (no board).                      This could be due to incorrect translations, no board is inserted, an incorrect board is inserted, or an insane board is inserted.</p> <ol style="list-style-type: none"> <li>1. Check to ensure that the board translations are correct. Use the <b>add ds1 UUCSS</b> command to administer the DS1 interface if it is not already administered.</li> <li>2. If board was already administered correctly, check the error log to determine if the board is hyperactive. If this is the case, the board is shut down. Reseating the board will re-initialize the board.</li> <li>3. If the board was found to be correctly inserted in step 1, issue the <b>busyout board</b> command.</li> <li>4. Issue the <b>reset board</b> command.</li> <li>5. Issue the <b>release busy board</b> command.</li> <li>6. Issue the <b>test board long</b> command.</li> </ol> <p>This should re-establish the linkage between the internal ID and the port.</p>

### Loss of Signal Alarm Inquiry Test (#138)

This test verifies the synchronization status and continuity of the DS1 link. The Loss of Signal alarm indicates that the DS1 Interface circuit pack is unable to derive the synchronization clock from the DS1 facility. When the DS1 Interface

circuit pack detects a Loss of Signal alarm, it stops providing the synchronization clock for the system if it is administered as a timing source and transmits a Yellow alarm to the remote DS1 endpoint.

When the Loss of Signal alarm is confirmed, the maintenance software places all trunks or ports of the DS1 Interface circuit pack into the out-of-service state. The inquiry test will run every 10 minutes until the loss of signal has been restored. The DS1 Interface circuit pack raises a Loss of Signal alarm after the signal has been lost for about 1second. It will not retire the alarm until the signal has returned for about 10 seconds.

This test is also used to maintain the new 120A CSU Module. This Module, when combined with the functionality provided by the TN767E circuit pack, provides functionality equivalent to an external standalone ESF T1 CSU.

If a TN767E circuit pack detects certain ICSU hardware errors, it will notify maintenance. When the maintenance subsystem receives notification of the I-CSU error, it will execute this Loss of Signal Inquiry test. The test, in addition to querying for a Loss Of Signal alarm condition, will also query the TN767E board to confirm the I-CSU error. A Minor or Warning alarm will be raised depending on the severity of the ICSU error. The trunks on the board may be taken out of service if the ICSU error is deemed serious.

If a Loss Of Signal alarm and an ICSU error co-exist, the Loss Of Signal alarm condition will take priority and the board and all trunks on the board will be put in the out-of-service state. Errors will be logged, however, for both.

When the maintenance subsystem receives notification that the ICSU hardware error condition no longer exists, maintenance will restore the board and all trunks to their previous service state if the alarm can be cleared (no other ICSU errors or Loss Of Signal alarm exist)

**Table 9-237. TEST #138 Loss of Signal Alarm Inquiry Test**

Error Code	Test Result	Description/ Recommendation
2100	ABORT	Internal system error
	ABORT	Could not allocate the necessary system resources to run this test. 1. Retry the command at 1-minute intervals a maximum of 5 times.

*Continued on next page*

Table 9-237. TEST #138 Loss of Signal Alarm Inquiry Test — Continued

Error Code	Test Result	Description/ Recommendation
2000	ABORT	<p>Response to the test was not received within the allowable time period. This may be due to hyperactivity. Error type 1538 in the error log indicates hyperactivity. The hyperactive circuit pack is out of service and one or more of the following symptoms may be exhibited.</p> <ol style="list-style-type: none"> <li>1. The DS1-BD tests (such as test 138 and test 139) are aborting with error code 2000.</li> <li>2. The tests run on the ports of this circuit pack are returning a no board result.</li> <li>3. A <b>busyout</b> or a <b>release</b> command has no affect on the test results.</li> <li>4. A <b>list config</b> command shows that the circuit pack and the ports are properly installed.</li> </ol> <p><b>⇒ NOTE:</b>                      When hyperactivity occurs, the circuit pack is isolated from the system, and all of the trunks for this circuit pack are placed into the out of service state. The system will try to restore the circuit pack within 15 minutes. When no faults are detected for 15 minutes, the DS1 interface circuit pack is restored to normal operation. All of the trunks for the DS1 interface circuit pack are then returned to the in service state. Hyperactivity is often caused by the associated facility. In such a case, faults (such as slips, misframes, or blue alarms) would be entered in the error log. In addition, many hardware errors would be logged against the associated trunk circuits. If the facility is OK and the error occurs again after 15 minutes, replace the circuit pack.</p>
	FAIL	<p>DS1 Interface circuit pack detects a Loss of Signal alarm. The physical link is broken or the remote DS1 endpoint is down. All trunks or ports of this DS1 interface circuit pack are out-of-service. If the DS1 Interface circuit pack is designated as the supplier of the system synchronization source, then the system synchronization maintenance will adopt a source elsewhere. Refer to "SYNC (Synchronization)" section for details.</p> <ol style="list-style-type: none"> <li>1. If the DS1 Interface circuit pack connects to a T1 facility, call the vendor of the T1 carrier to diagnose the remote DS1 endpoint. If the DS1 Interface circuit pack connects directly to a switch, call the system technician of the remote switch to diagnose the DS1 endpoint.</li> <li>2. Check the physical connection of the DS1 Interface circuit pack and the cable. If a 120A1 CSU Module is physically connected to a TN767E board on the back of the port carrier, check the physical connection of the CSU Module and make sure the Network Interface cable is plugged into the CSU Module's NETWORK jack.</li> </ol>

Continued on next page

**Table 9-237. TEST #138 Loss of Signal Alarm Inquiry Test — Continued**

Error Code	Test Result	Description/ Recommendation
1300	FAIL	<p>The CSU Module is missing. The <i>Near-End CSU Type</i> field on the <i>add ds1</i> form has been administered as <i>integrated</i> but the 120A1 CSU Module is not physically connected to the TN767E board on the back of the port carrier.</p> <ol style="list-style-type: none"> <li>1. If using the 120A1 CSU Module, plug the CSU Module into the TN767E circuit pack's connector on the I/O connector panel on back of the carrier. Otherwise, change the <i>Near-End CSU Type</i> field using the <i>change ds1</i> form to <i>other</i>.</li> <li>2. Run the test again.</li> </ol>
1301	FAIL	<p>The 120A1 CSU Module is physically connected to the TN767E board on the back of the port carrier but the <i>Near-End CSU Type</i> field on the <i>add ds1</i> form has not been administered as <i>integrated</i>.</p> <ol style="list-style-type: none"> <li>1. If the 120A1 CSU Module is to be used, use the <i>change ds1</i> command to change the <i>Near-End CSU Type</i> field to <i>integrated</i>. Otherwise, physically remove the 120A1 CSU Module from the back of the port carrier.</li> <li>2. Run the test again.</li> </ol>
1302	FAIL	<p>Attempting to use the 120A1 CSU Module with a TN767E circuit pack that is configured for 32-channel (2.048 Mbps) operation. The CSU Module only works with a DS1 board configured for 24-channel (1.544 Mbps) operation in the United States of America.</p> <ol style="list-style-type: none"> <li>1. If the 120A1 CSU Module is to be used, physically remove the TN767E circuit pack and reconfigure for 24-channel (1.544 Mbps) operation.</li> <li>2. Reinsert the circuit pack and run the test again.</li> </ol>
1303	FAIL	<p>The DS1 circuit pack Suffix is incorrect for CSU Module administration. The <i>Near-End CSU Type</i> field on the <i>add ds1</i> form has been administered as <i>integrated</i> but the DS1 circuit pack is not a TN767E or later suffix DS1 board.</p> <ol style="list-style-type: none"> <li>1. If the CSU Module is to be used, and the <i>Near-End CSU Type</i> field is set to <i>integrated</i>, to allow for CSU module administration, remove the circuit pack and replace it with a TN767E or later suffix board. Otherwise use the <i>change ds1</i> command to change the <i>Near-End CSU Type</i> field to <i>other</i>.</li> </ol>
1310	FAIL	<p>The DS1 Board Loopback (BLB) demand test (#1209) failed.</p> <ol style="list-style-type: none"> <li>1. Repeat the test using the <i>test ds1-loop UUCSS ds1/csu-loopback-tests</i> command.</li> <li>2. If the BLB test continues to fail, then replace the TN767E circuit pack.</li> <li>3. Run this test again.</li> </ol>

*Continued on next page*



**Table 9-237. TEST #138 Loss of Signal Alarm Inquiry Test — Continued**

Error Code	Test Result	Description/ Recommendation
1311	FAIL	<p>The Integrated CSU (I-CSU) Module Equipment Loopback (ELB) test (#1210) failed. This test is executed by the ICSU during ICSU power-up/reset (TN767E board physically inserted and 120A CSU Module already installed) or when the 120A CSU Module is plugged on to an already initialized DS1 board. The ELB test is also executed as part of the command <b>test ds1-loop UUCSS ds1/csu-loopback-tests</b>.</p> <ol style="list-style-type: none"> <li>1. Execute <b>test ds1-loop UUCSS ds1/csu-loopback-tests</b>.</li> <li>2. If the ELB test continues to fail, then either the TN767E board, the CSU Module, or the I/O cable between the backplane and the CSU module (or any combination thereof) has failed. Attempt to isolate the problem to one of these areas. Begin by replacing the CSU Module and running the <b>test ds1-loop UUCSS ds1/csu-loopback-tests</b> command again.</li> <li>3. If the ELB test continues to fail, then replace the TN767E board and run <b>test ds1-loop UUCSS ds1/csu-loopback-tests</b> again.</li> <li>4. If the ELB test continues to fail, the problem could be in the I/O cable between the backplane and the CSU module.</li> </ol>
1312	FAIL	<p>The Integrated CSU (I-CSU) Module Repeater Loopback (RLB) test (#1211) failed. This test is executed by the ICSU during ICSU power-up/reset (TN767E board physically inserted and 120A CSU Module already installed) or when the 120A1 CSU Module is plugged on to an already initialized DS1 board. The RLB test is also executed as part of the command <b>test ds1-loop UUCSS ds1/csu-loopback-tests</b>.</p> <ol style="list-style-type: none"> <li>1. Execute <b>test ds1-loop UUCSS ds1/csu-loopback-tests</b>.</li> <li>2. If the RLB test continues to fail, then replace the CSU Module.</li> <li>3. Run this test again.</li> </ol>
1313	FAIL	<p>The TN767E circuit pack could not deactivate a CPE Loopback Jack loopback.</p> <ol style="list-style-type: none"> <li>1. Execute <b>test ds1-loop UUCSS end-loopback/span-test</b>.</li> <li>2. If the attempt to deactivate the CPE Loopback Jack is not successful, check the cabling and investigate the problem at the CPE Loopback Jack.</li> <li>3. Run the test again.</li> </ol>
1314	FAIL	<p>The TN767E circuit pack could not deactivate a far-end CSU loopback.</p> <ol style="list-style-type: none"> <li>1. Execute <b>test ds1-loop UUCSS end-loopback/span-test</b>.</li> </ol>

*Continued on next page*

**Table 9-237. TEST #138 Loss of Signal Alarm Inquiry Test — Continued**

Error Code	Test Result	Description/ Recommendation
1320	FAIL	<p>A 120A1 CSU module hardware failure or an ICSU serial interface audit failure was detected by the TN767E DS1 circuit pack.</p> <ol style="list-style-type: none"> <li>1. Replace the CSU module, and then run the test again.</li> <li>2. If the test continues to fail with this error code, replace the TN767E and run the test again.</li> <li>3. If the test continues to fail with this error code, the problem could be in the I/O cable between the backplane and the CSU module.</li> </ol>
1321	FAIL	<p>DTE LOS (loss of signal) was detected between the TN767E DS1 board and the 120A1 CSU Module. Either the TN767E board, the 120A1 CSU Module, or the I/O cable between the backplane and the CSU module (or any combination thereof) has failed. Attempt to isolate the problem to one of these areas.</p> <ol style="list-style-type: none"> <li>1. Replace the CSU Module and run the test again.</li> <li>2. If the test continues to fail with this error code, then replace the TN767E board and run the test again.</li> <li>3. If the test continues to fail with this error code, the problem could be in the I/O cable between the backplane and the CSU module.</li> </ol>
1322	FAIL	<p>No 5 volts power detected from the TN767E circuit pack to the 120A1 CSU Module. Problem probably due to an open fuse on the DS1 board or a faulty ICSU. <b>NOTE</b> <i>Do not swap DS1 boards as this may open the fuse on the new board.</i></p> <ol style="list-style-type: none"> <li>1. Remove the TN767E from the system and reinsert.</li> <li>2. Run the test again once the board has finished its reset.</li> <li>3. If the test continues to fail with this error code, then replace the CSU Module and run the test again.</li> <li>4. If the test continues to fail with this error code, then replace the TN767E board and run the test again.</li> <li>5. If the test continues to fail with this error code, the problem could be in the I/O cable between the backplane and the CSU module.</li> </ol>
1323	FAIL	<p>A service affecting CSU Module audit failure was detected by the TN767E DS1 circuit pack. All administered ports on the DS1 circuit pack are affected and maintenance software will place the ports into the out-of-service state.</p> <ol style="list-style-type: none"> <li>1. Replace the 120A1 CSU Module.</li> </ol>
1324	FAIL	<p>A non-service affecting CSU Module audit failure was detected by the TN767E DS1 circuit pack. No ports should be affected. No immediate action is required. These errors indicate that the CSU Module hardware may have a problem, and that it should be replaced when practical to avoid further deterioration.</p>

*Continued on next page*

**Table 9-237. TEST #138 Loss of Signal Alarm Inquiry Test — Continued**

Error Code	Test Result	Description/ Recommendation
	PASS	DS1 signal is present and the physical link is healthy. In addition, no Integrated CSU errors are detected.
0	NO BOARD	<p>The test could not relate the internal ID to the port (no board).</p> <p>This could be due to incorrect translations, no board is inserted, an incorrect board is inserted, or an insane board is inserted.</p> <ol style="list-style-type: none"> <li>1. Check to ensure that the board translations are correct. Use the <b>add ds1 UUCSS</b> command to administer the DS1 interface if it is not already administered.</li> <li>2. If board was already administered correctly, check the error log to determine if the board is hyperactive. If this is the case, the board is shut down. Reseating the board will re-initialize the board.</li> <li>3. If the board was found to be correctly inserted in step 1, issue the <b>busyout board</b> command.</li> <li>4. Issue the <b>reset board</b> command.</li> <li>5. Issue the <b>release busy board</b> command.</li> <li>6. Issue the <b>test board long</b> command.</li> </ol> <p>This should re-establish the link between the internal ID and the port.</p>

### Blue Alarm Inquiry Test (#139)

The Blue Alarm is a signal sent by the remote DS1 endpoint when it is out-of-service. The Blue Alarm Inquiry Test checks the blue alarm status of the remote DS1 endpoint.

When the DS1 Interface circuit pack detects a Blue Alarm signal from the remote DS1 endpoint, the circuit pack will transmit a Yellow alarm to the remote DS1 endpoint and send a BLUE ALARM message to the maintenance software. When the Blue alarm is confirmed, the maintenance software places all trunks of the DS1 Interface circuit pack into the out-of-service state. The inquiry test will be run every 10 minutes until the Blue alarm is cleared.

The DS1 Interface circuit pack takes 2 seconds to recognize and report a Blue alarm and 16 seconds to recognize and report the resolution of a Blue alarm. When the Blue alarm is cleared, the DS1 Interface circuit pack stops transmitting the Yellow alarm and places the trunks back into the service state before the Blue alarm occurs.

### Line Loopback Alarm

The Line Loopback (LLB) is used by the remote DS1 endpoint to put the ICSU or DS1 into a loopback mode. When the ICSU or DS1 Board is in the LLB mode, the arriving bit pattern is regenerated and sent back. Line Loopback (LLB) Alarm is activated when the in-band activate LLB bit pattern has been arriving continuously for 5 seconds on the DS1 line. LLB is deactivated when the in-band deactivate LLB bit pattern has been arriving continuously for 5 seconds on the DS1 line.

Since LLB is a maintenance condition rendering all DS0 channels unavailable for signaling or bearer traffic, maintenance software treats this the same as a Blue Alarm.

### Payload Loopback Alarm

The Payload Loopback (PLB) is used by the remote DS1 endpoint to put the switch DS1 into a loopback mode. PLB Alarm is activated when a network protocol activate bit pattern arrives over the 4-Kbps ESF data link on the DS1 line. PLB is deactivated when a network protocol deactivate bit pattern arrives over the 4-Kbps ESF data link on the DS1 line.

Since PLB is a maintenance condition rendering all DS0 channels unavailable for signaling or bearer traffic, maintenance software treats this the same as a Blue Alarm

**Table 9-238. TEST #139 Blue Alarm Inquiry Test**

Error Code	Test Result	Description/ Recommendation
2100	ABORT	Internal system error
	ABORT	Could not allocate the necessary system resources to run this test. 1. Retry the command at 1-minute intervals a maximum of 5 times.

*Continued on next page*

**Table 9-238. TEST #139 Blue Alarm Inquiry Test — Continued**

Error Code	Test Result	Description/ Recommendation
2000	ABORT	<p>Response to the test was not received within the allowable time period. This may be due to hyperactivity. Error type 1538 in the error log indicates hyperactivity. The hyperactive circuit pack is out of service and one or more of the following symptoms may be exhibited.</p> <ol style="list-style-type: none"> <li>1. The DS1-BD tests (such as test 138 and test 139) are aborting with error code 2000.</li> <li>2. The tests run on the ports of this circuit pack are returning a no board result.</li> <li>3. A <b>busyout</b> or a <b>release</b> command has no affect on the test results.</li> <li>4. A <b>list config</b> command shows that the circuit pack and the ports are properly installed.</li> </ol> <p><b>⇒ NOTE:</b>                      When hyperactivity occurs, the circuit pack is isolated from the system, and all of the trunks for this circuit pack are placed into the out of service state. The system will try to restore the circuit pack within 15 minutes. When no faults are detected for 15 minutes, the DS1 interface circuit pack is restored to normal operation. All of the trunks for the DS1 interface circuit pack are then returned to the in service state. Hyperactivity is often caused by the associated facility. In such a case, faults (such as slips, misframes, or blue alarms) would be entered in the error log. In addition, many hardware errors would be logged against the associated trunk circuits. If the facility is OK and the error occurs again after 15 minutes, replace the circuit pack.</p>
	FAIL	<p>The remote DS1 endpoint is out-of-service.</p> <ol style="list-style-type: none"> <li>1. If the DS1 interface circuit pack connects to a T1 facility, call the vendor of the T1 carrier to diagnose the remote endpoint.</li> <li>2. If the DS1 interface circuit pack connects directly to a switch, call the system technician of the remote switch to diagnose the DS1 endpoint.</li> </ol>
1794	FAIL	<p>The DS1 Interface circuit pack detects a Line Loopback Alarm (LLB).</p> <ol style="list-style-type: none"> <li>1. If the DS1 interface circuit pack connects to a T1 facility, call the vendor of the T1 carrier to diagnose the remote DS1 endpoint.</li> <li>2. If the DS1 interface circuit pack connects directly to a switch, call the system technician of the remote switch to diagnose the DS1 endpoint.</li> <li>3. If the DS1 interface circuit pack connects directly to a line-side terminating device (for example, a PRI terminal adapter), call the vendor of the terminating device to diagnose the equipment.</li> </ol>

*Continued on next page*

**Table 9-238. TEST #139 Blue Alarm Inquiry Test — Continued**

Error Code	Test Result	Description/ Recommendation
1795	FAIL	The DS1 Interface circuit pack detects a Payload Loopback Alarm (PLB). If the DS1 Interface circuit pack connects to a leased T1 facility, call the vendor of the T1 carrier to diagnose the remote DS1 endpoint. If the DS1 Interface circuit pack connects directly to another DS1 board, call the system technician of the remote switch to diagnose the DS1 endpoint.
	PASS	Remote DS1 endpoint is in-service. Neither a Blue alarm nor a Line Loopback alarm nor a Payload Loopback alarm is detected in the DS1 Interface circuit pack.
0	NO BOARD	<p>The test could not relate the internal ID to the port (no board).</p> <p>This could be due to incorrect translations, no board is inserted, an incorrect board is inserted, or an insane board is inserted.</p> <ol style="list-style-type: none"> <li>1. Check to ensure that the board translations are correct. Use the <b>add ds1 UUCSS</b> command to administer the DS1 interface if it is not already administered.</li> <li>2. If board was already administered correctly, check the error log to determine if the board is hyperactive. If this is the case, the board is shut down. Reseating the board will re-initialize the board.</li> <li>3. If the board was found to be correctly inserted in step 1, issue the <b>busyout board</b> command.</li> <li>4. Issue the <b>reset board</b> command.</li> <li>5. Issue the <b>release busy board</b> command.</li> <li>6. Issue the <b>test board long</b> command.</li> </ol> <p>This should re-establish the link between the internal ID and the port.</p>

### Red Alarm Inquiry Test (#140)

DS1 Interface circuit pack raises a Red alarm when the framing pattern of the incoming DS1 bit stream has been lost. The Red Alarm Inquiry Test checks the framing status of a DS1 Interface circuit pack. DS1 Interface circuit pack takes 3 seconds to recognize and report a Red alarm and 10 seconds to recognize and report the resolution of a Red alarm.

When the DS1 Interface circuit pack detects a Red alarm, the circuit pack will transmit a Yellow alarm to the remote DS1 endpoint and send a RED ALARM message to the maintenance software. After the Red alarm is confirmed, the maintenance software places all trunks of the circuit pack into the out-of-service state. The inquiry test will be run every 10 minutes until the Red alarm is cleared.

When the Red alarm is cleared, the DS1 Interface circuit pack will stop transmitting the Yellow alarm to the remote DS1 endpoint. The maintenance software restores all trunks of the DS1 Interface circuit pack to the service state before the Red alarm occurs.

Loss of Multiframe Alarm: If the DS1 Interface circuit pack is administered using DMI-BOS signaling, the DS1 Interface circuit pack raises a Loss of Multiframe Alarm (LMA) when it cannot interpret the incoming signaling bits to synchronize to the multiframe pattern received in the 24th channel. Once DS1 Interface circuit pack detects an LMA, the circuit pack will transmit a Remote Multiframe Alarm (RMA) to the remote DS1 endpoint. Maintenance software handles both Red alarm and LMA alarm(s) using the same mechanism.

**Table 9-239. TEST #140 Red Alarm Inquiry Test**

Error Code	Test Result	Description/ Recommendation
2100	ABORT ABORT	Internal system error  Could not allocate the necessary system resources to run this test.  1. Retry the command at 1-minute intervals a maximum of 5 times.
2000	ABORT	Response to the test was not received within the allowable time period. This may be due to hyperactivity. Error type 1538 in the error log indicates hyperactivity. The hyperactive circuit pack is out of service and one or more of the following symptoms may be exhibited.  1. The DS1-BD tests (such as test 138 and test 139) are aborting with error code 2000.  2. The tests run on the ports of this circuit pack are returning a no board result.  3. A <b>busyout</b> or a <b>release</b> command has no affect on the test results.  4. A <b>list config</b> command shows that the circuit pack and the ports are properly installed.   <b>NOTE:</b> When hyperactivity occurs, the circuit pack is isolated from the system, and all of the trunks for this circuit pack are placed into the out of service state. The system will try to restore the circuit pack within 15 minutes. When no faults are detected for 15 minutes, the DS1 interface circuit pack is restored to normal operation. All of the trunks for the DS1 interface circuit pack are then returned to the in service state. Hyperactivity is often caused by the associated facility. In such a case, faults (such as slips, misframes, or blue alarms) would be entered in the error log. In addition, many hardware errors would be logged against the associated trunk circuits. If the facility is OK and the error occurs again after 15 minutes, replace the circuit pack.

**Table 9-239. TEST #140 Red Alarm Inquiry Test — Continued**

Error Code	Test Result	Description/ Recommendation
	FAIL	<p>The DS1 Interface circuit pack detects a Red alarm. An out-of-frame condition occurs on the DS1 Interface circuit pack. DS1 Interface circuit pack will transmit a Yellow alarm to the remote DS1 endpoint until the Red alarm is retired.</p> <ol style="list-style-type: none"> <li>1. Verify that both endpoints of the DS1 link are administered using the same signaling mode, framing mode, and line coding. Likewise, verify that any intermediate CSU's are administered correctly.</li> <li>2. If the DS1 interface circuit pack connects to a T1 facility, call the vendor of the T1 carrier to diagnose the remote DS1 endpoint. If the DS1 interface circuit pack connects directly to a switch, call the system technician of the remote switch to diagnose the DS1 endpoint.</li> <li>3. Check the physical connectivity of the DS1 pack and of the cable.</li> <li>4. Replace the local DS1 interface circuit pack, and repeat the test.</li> </ol>
1	FAIL	<p>The DS1 interface circuit pack detected a loss of multiframe alarm (LMA). An out of frame condition occurred on the DS1 interface circuit pack. The DS1 interface circuit pack will transmit a remote multiframe alarm (RMA) to the remote DS1 endpoint until the LMA is retired.</p> <ol style="list-style-type: none"> <li>1. Verify that both endpoints of the DS1 link are administered using the same signaling mode, framing mode, and line coding. Likewise, verify that any intermediate CSU's are administered correctly.</li> <li>2. If the DS1 interface circuit pack connects to a T1 facility, call the vendor of the T1 carrier to diagnose the remote DS1 endpoint. If the DS1 interface circuit pack connects directly to a switch, call the system technician of the remote switch to diagnose the DS1 endpoint.</li> <li>3. Check the physical connectivity of the DS1 pack and of the cable.</li> <li>4. Replace the local DS1 interface circuit pack, and repeat the test.</li> </ol>
	PASS	No Red alarm is detected on DS1 Interface circuit pack.

*Continued on next page*



Table 9-239. TEST #140 Red Alarm Inquiry Test — Continued

Error Code	Test Result	Description/ Recommendation
0	NO BOARD	<p>The test could not relate the internal ID to the port (no board).</p> <p>This could be due to incorrect translations, no board is inserted, an incorrect board is inserted, or an insane board is inserted.</p> <ol style="list-style-type: none"><li>1. Check to ensure that the board translations are correct. Use the <b>add ds1 UUCSS</b> command to administer the DS1 interface if it is not already administered.</li><li>2. If board was already administered correctly, check the error log to determine if the board is hyperactive. If this is the case, the board is shut down. Reseating the board will re-initialize the board.</li><li>3. If the board was found to be correctly inserted in step 1, issue the <b>busyout board</b> command.</li><li>4. Issue the <b>reset board</b> command.</li><li>5. Issue the <b>release busy board</b> command.</li><li>6. Issue the <b>test board long</b> command.</li></ol> <p>This should re-establish the linkage between the internal ID and the port.</p>

### Yellow Alarm Inquiry Test (#141)

Receiving a Yellow alarm from remote DS1 endpoint indicates that the remote DS1 endpoint has an out-of-frame condition. The Yellow Alarm Inquiry Test is used to determine whether the remote DS1 endpoint is transmitting a Yellow alarm. The DS1 Interface circuit pack takes 500 msec to recognize and report a Yellow alarm and 500 msec to recognize and report that a Yellow alarm condition is cleared.

When the DS1 Interface circuit pack detects a Yellow alarm from the remote DS1 endpoint, it will send a YELLOW-ALARM uplink message to the maintenance software. After the maintenance software receives the YELLOW-ALARM message, the Yellow Alarm Inquiry Test is run to confirm the Yellow alarm. Once the Yellow alarm is confirmed, the maintenance software places all trunks on the circuit pack into the out-of-service state. The Inquiry Test will be run every 10 minutes until the Yellow alarm is cleared.

When the Yellow alarm is cleared, the maintenance software restores all trunks on the DS1 Interface circuit pack back to their previous service state before the Yellow alarm is raised.

This Yellow Alarm corresponds to the yellow F2 state documented in CCITT recommendation I.431.

Remote Multiframe Alarm: Remote Multiframe Alarm (RMA) indicates that the remote DS1 endpoint is in a Loss of Multiframe Alarm condition while the DS1 Interface circuit pack is administered using the DMI-BOS common channel signaling. The RMA is handled as a Yellow alarm.

Yellow F5 State Alarm: For 32-channel E1 operation with CRC4 on, the F5 fault state is defined as a fault in the user-network interface, specifically in the direction from the user (PBX) to the network. Refer to CCITT recommendation I.431

**Table 9-240. TEST #141 Yellow Alarm Inquiry Test**

Error Code	Test Result	Description/ Recommendation
2100	ABORT	Internal system error
	ABORT	Could not allocate the necessary system resources to run this test. 1. Retry the command at 1-minute intervals a maximum of 5 times.
2000	ABORT	Response to the test was not received within the allowable time period. This may be due to hyperactivity. Error type 1538 in the error log indicates hyperactivity. The hyperactive circuit pack is out of service and one or more of the following symptoms may appear. 1. The DS1-BD tests (such as test 138 and test 139) are aborting with error code 2000. 2. The tests run on the ports of this circuit pack are returning a no board result. 3. A <b>busyout</b> or a <b>release</b> command has no affect on the test results. 4. A <b>list config</b> command shows that the circuit pack and the ports are properly installed.   <b>NOTE:</b> When hyperactivity occurs, the circuit pack is isolated from the system, and all of the trunks for this circuit pack are placed into the out of service state. The system will try to restore the circuit pack within 15 minutes. When no faults are detected for 15 minutes, the DS1 interface circuit pack is restored to normal operation. All of the trunks for the DS1 interface circuit pack are then returned to the in service state. Hyperactivity is often caused by the associated facility. In such a case, faults (such as slips, misframes, or blue alarms) would be entered in the error log. In addition, many hardware errors would be logged against the associated trunk circuits. If the facility is OK and the error occurs again after 15 minutes, replace the circuit pack.

*Continued on next page*

Table 9-240. TEST #141 Yellow Alarm Inquiry Test — *Continued*

Error Code	Test Result	Description/ Recommendation
1	FAIL	The DS1 interface circuit pack detected a yellow alarm sent by the remote DS1 endpoint. An out of frame condition occurred at the DS1 endpoint.
	FAIL	The DS1 Interface circuit pack detects a Remote Multiframe Alarm sent by the remote DS1 endpoint. An out-of-frame condition occurs on the remote DS1 endpoint.
2	FAIL	<p>The DS1 Interface circuit pack is reporting a yellow F5 State alarm. There is a fault in the user-network interface from the user (PBX) to the network.</p> <ol style="list-style-type: none"> <li>1. Verify that both endpoints of the DS1 link are administered using the same signaling mode, framing mode, and line coding. Likewise, verify that any intermediate CSUs are administered correctly.</li> <li>2. If the DS1 interface circuit pack connects to a T1 facility, call the vendor of the T1 carrier to diagnose the remote DS1 endpoint. If the DS1 interface circuit pack connects directly to a switch, call the system technician of the remote switch to diagnose the DS1 endpoint.</li> <li>3. Check the physical connectivity of the DS1 pack and of the cable.</li> <li>4. Replace the local DS1 interface circuit pack, and repeat the test.</li> </ol>
	PASS	No Yellow alarm nor Remote Multiframe Alarm nor F5 State Alarm is received from the remote DS1 endpoint.
0	NO BOARD	<p>The test could not relate the internal ID to the port (no board).                      This could be due to incorrect translations, no board is inserted, an incorrect board is inserted, or an insane board is inserted.</p> <ol style="list-style-type: none"> <li>1. Check to ensure that the board translations are correct. Use the <b>add ds1 UUCSS</b> command to administer the DS1 interface if it is not already administered.</li> <li>2. If board was already administered correctly, check the error log to determine if the board is hyperactive. If this is the case, the board is shut down. Reseating the board will re-initialize the board.</li> <li>3. If the board was found to be correctly inserted in step 1, issue the <b>busyout board</b> command.</li> <li>4. Issue the <b>reset board</b> command.</li> <li>5. Issue the <b>release busy board</b> command.</li> <li>6. Issue the <b>test board long</b> command.</li> </ol> <p>This should re-establish the linkage between the internal ID and the port.</p>

## Major Alarm Inquiry Test (#142)

The Major alarm raised by a DS1 Interface circuit pack indicates that the average bit error rate on the DS1 facility is greater than 1/1000. The Major Alarm Inquiry Test is used to determine that the received DS1 bit error rate is greater than 1/1000. When D4 framing mode is selected, the DS1 Interface circuit pack takes 16 seconds to recognize and report a Major alarm and 16 seconds to recognize and report that a Major alarm condition is cleared. If ESF framing mode is selected, the DS1 Interface circuit pack takes 10 seconds to recognize and report a Major alarm and 10 seconds to recognize and report that a Major alarm condition is cleared.

When the DS1 Interface circuit pack detects a Major alarm, it will send a MAJOR-ALARM message to the maintenance software. After the maintenance software receives a MAJOR-ALARM message, the Major Alarm Inquiry Test is initiated to confirm the Major alarm on the DS1 Interface circuit pack. The Inquiry Test will be run every 10 minutes until the Major alarm is cleared. The maintenance software places all trunks on the circuit pack in the out-of-service state if the Major alarm persists for more than 20 minutes.

When the Major alarm is cleared, the maintenance software restores all trunks on the circuit pack to their previous service state before a Major alarm occurs.

**Table 9-241. TEST #142 Major Alarm Inquiry Test**

Error Code	Test Result	Description/ Recommendation
2100	ABORT ABORT	Internal system error Could not allocate the necessary system resources to run this test. 1. Retry the command at 1-minute intervals a maximum of 5 times.

*Continued on next page*

**Table 9-241. TEST #142 Major Alarm Inquiry Test — Continued**

Error Code	Test Result	Description/ Recommendation
2000	ABORT	<p>Response to the test was not received within the allowable time period. This may be due to hyperactivity. Error type 1538 in the error log indicates hyperactivity. The hyperactive circuit pack is out of service and one or more of the following symptoms may be exhibited.</p> <ol style="list-style-type: none"> <li>1. The DS1-BD tests (such as test 138 and test 139) are aborting with error code 2000.</li> <li>2. The tests run on the ports of this circuit pack are returning a no board result.</li> <li>3. A <b>busyout</b> or a <b>release</b> command has no affect on the test results.</li> <li>4. A <b>list config</b> command shows that the circuit pack and the ports are properly installed.</li> </ol> <p><b>⇒ NOTE:</b>                      When hyperactivity occurs, the circuit pack is isolated from the system, and all of the trunks for this circuit pack are placed into the out of service state. The system will try to restore the circuit pack within 15 minutes. When no faults are detected for 15 minutes, the DS1 interface circuit pack is restored to normal operation. All of the trunks for the DS1 interface circuit pack are then returned to the in service state. Hyperactivity is often caused by the associated facility. In such a case, faults (such as slips, misframes, or blue alarms) would be entered in the error log. In addition, many hardware errors would be logged against the associated trunk circuits. If the facility is OK and the error occurs again after 15 minutes, replace the circuit pack.</p>
	FAIL	<p>The DS1 Interface circuit pack detects a Major alarm. The DS1 bit error rate is greater than 1/1000.</p> <ol style="list-style-type: none"> <li>1. The performance of DS1 link between DS1 Interface circuit pack and remote DS1 endpoint is very poor. If the DS1 Interface circuit pack is TN767, enter <b>list measurement ds1-log UUCSS</b> command to read the error seconds measurement.</li> <li>2. Verify that both endpoints of the DS1 link are administered using the same signaling mode, framing mode, and line coding.</li> <li>3. If the DS1 interface circuit pack connects to a T1 facility, call the vendor of the T1 carrier to diagnose the remote DS1 endpoint. If the DS1 interface circuit pack connects directly to a switch, call the system technician of the remote switch to diagnose the DS1 endpoint.</li> <li>4. Check the physical connectivity of the DS1 pack and of the cable.</li> <li>5. Replace the local DS1 interface circuit pack, and repeat the test.</li> </ol>
	PASS	<p>No Major alarm is detected in DS1 Interface circuit pack.</p>

*Continued on next page*

Table 9-241. TEST #142 Major Alarm Inquiry Test — *Continued*

Error Code	Test Result	Description/ Recommendation
0	NO BOARD	<p>The test could not relate the internal ID to the port (no board).</p> <p>This could be due to incorrect translations, no board is inserted, an incorrect board is inserted, or an insane board is inserted.</p> <ol style="list-style-type: none"> <li>1. Check to ensure that the board translations are correct. Use the <b>add ds1 UUCSS</b> command to administer the DS1 interface if it is not already administered.</li> <li>2. If board was already administered correctly, check the error log to determine if the board is hyperactive. If this is the case, the board is shut down. Reseating the board will re-initialize the board.</li> <li>3. If the board was found to be correctly inserted in step 1, issue the <b>busyout board</b> command.</li> <li>4. Issue the <b>reset board</b> command.</li> <li>5. Issue the <b>release busy board</b> command.</li> <li>6. Issue the <b>test board long</b> command.</li> </ol> <p>This should re-establish the link between the internal ID and the port.</p>

### Minor Alarm Inquiry Test (#143)

The Minor alarm raised by a DS1 Interface circuit pack indicates that the average bit error rate on the DS1 facility is greater than 1/1,000,000, but less than 1/1000. The Minor Alarm Inquiry Test is used to determine that the received DS1 bit error rate is greater than 1/1,000,000 and less than 1/1000. When D4 framing mode is selected, the DS1 Interface circuit pack takes 41 minutes to recognize and report a Minor alarm and 41 minutes to recognize and report that a Minor alarm condition is cleared. If ESF framing mode is selected, the DS1 Interface circuit pack takes 10 minutes to recognize and report a Minor alarm and 10 minutes to recognize and report that a Minor alarm condition is cleared.

When the DS1 Interface circuit pack detects a Minor alarm condition, it will send a MINOR-ALARM message to the maintenance software. After the maintenance software receives a MINOR-ALARM message, the Minor Alarm Inquiry Test is initiated to confirm the Minor alarm. All trunks on the circuit pack are kept in the in-service state after the Minor alarm is confirmed. The Minor Alarm Inquiry Test is run every 10 minutes until the Minor alarm is cleared.

**Table 9-242. TEST #143 Minor Alarm Inquiry Test**

Error Code	Test Result	Description/ Recommendation
2100	ABORT ABORT	Internal system error Could not allocate the necessary system resources to run this test. 1. Retry the command at 1-minute intervals a maximum of 5 times.
2000	ABORT	Response to the test was not received within the allowable time period. This may be due to hyperactivity. Error type 1538 in the error log indicates hyperactivity. The hyperactive circuit pack is out of service and one or more of the following symptoms may be exhibited. 1. The DS1-BD tests (such as test 138 and test 139) are aborting with error code 2000. 2. The tests run on the ports of this circuit pack are returning a no board result. 3. A <b>busyout</b> or a <b>release</b> command has no affect on the test results. 4. A <b>list config</b> command shows that the circuit pack and the ports are properly installed.  <b>⇒ NOTE:</b> When hyperactivity occurs, the circuit pack is isolated from the system, and all of the trunks for this circuit pack are placed into the out of service state. The system will try to restore the circuit pack within 15 minutes. When no faults are detected for 15 minutes, the DS1 interface circuit pack is restored to normal operation. All of the trunks for the DS1 interface circuit pack are then returned to the in service state. Hyperactivity is often caused by the associated facility. In such a case, faults (such as slips, misframes, or blue alarms) would be entered in the error log. In addition, many hardware errors would be logged against the associated trunk circuits. If the facility is OK and the error occurs again after 15 minutes, replace the circuit pack.

*Continued on next page*

Table 9-242. TEST #143 Minor Alarm Inquiry Test — *Continued*

Error Code	Test Result	Description/ Recommendation
	FAIL	<p>The DS1 Interface circuit pack detects a Minor alarm. The DS1 bit error rate is greater than 1/1,000,000 and less than 1/1000.</p> <ol style="list-style-type: none"> <li>The performance of DS1 link between DS1 Interface circuit pack and remote DS1 endpoint is poor. If DS1 Interface circuit pack is TN767, enter <b>list measurement ds1-log UUCSS</b> command to read the error seconds measurement.</li> <li>Verify that both endpoints of the DS1 link are administered using the same signaling mode, framing mode, and line coding.</li> <li>If the DS1 interface circuit pack connects to a T1 facility, call the vendor of the T1 carrier to diagnose the remote DS1 endpoint. If the DS1 interface circuit pack connects directly to a switch, call the system technician of the remote switch to diagnose the DS1 endpoint.</li> <li>Check the physical connection of the DS1 pack and of the cable.</li> <li>Replace the local DS1 interface circuit pack, and repeat the test.</li> </ol>
	PASS	<p>No Minor alarm is detected in DS1 Interface circuit pack.</p>
0	NO BOARD	<p>The test could not relate the internal ID to the port (no board).</p> <p>This could be due to incorrect translations, no board is inserted, an incorrect board is inserted, or an insane board is inserted.</p> <ol style="list-style-type: none"> <li>Check to ensure that the board translations are correct. Use the <b>add ds1 UUCSS</b> command to administer the DS1 interface if it is not already administered.</li> <li>If board was already administered correctly, check the error log to determine if the board is hyperactive. If this is the case, the board is shut down. Reseating the board will re-initialize the board.</li> <li>If the board was found to be correctly inserted in step 1, issue the <b>busyout board</b> command.</li> <li>Issue the <b>reset board</b> command.</li> <li>Issue the <b>release busy board</b> command.</li> <li>Issue the <b>test board long</b> command.</li> </ol> <p>This should re-establish the link between the internal ID and the port.</p>

### Slip Alarm Inquiry Test (144)

Slips occur when transmitter and receiver are not running at precisely the same clock rate. The DS1 Interface circuit pack can detect both positive and negative slips on the DS1 facility. The Slip Alarm Inquiry Test is used to acquire the total number of slips occurred on a DS1 link.



When the DS1 Interface circuit pack detects a slip condition, the circuit pack will increase the on-board slip counter by 1. A SLIP-COUNT message is spontaneously sent to the system software after the counter reaches a threshold (for example, 88). When the maintenance software receives the SLIP-COUNT message, the Slip Alarm Inquiry Test is initiated to query the slip counters on DS1 Interface circuit pack and total the slip counts in the maintenance software.

If the count of slips is over the threshold, a Minor alarm is raised against the DS1 Interface circuit pack. All trunks of the DS1 Interface circuit pack are still in the in-service state. If the DS1 Interface circuit pack is used to supply the system synchronization source, the MINOR alarm will initiate a synchronization source switch. See "TDM-BUS" and "SYNC (Synchronization)" for details.

**Table 9-243. TEST #144 Slip Alarm Inquiry Test**

Error Code	Test Result	Description/ Recommendation
2100	ABORT ABORT	Internal system error Could not allocate the necessary system resources to run this test. 1. Retry the command at 1-minute intervals a maximum of 5 times.
2000	ABORT	Response to the test was not received within the allowable time period. This may be due to hyperactivity. Error type 1538 in the error log indicates hyperactivity. The hyperactive circuit pack is out of service and one or more of the following symptoms may be exhibited. 1. The DS1-BD tests (such as test 138 and test 139) are aborting with error code 2000. 2. The tests run on the ports of this circuit pack are returning a no board result. 3. A <b>busyout</b> or a <b>release</b> command has no affect on the test results. 4. A <b>list config</b> command shows that the circuit pack and the ports are properly installed.   <b>NOTE:</b> When hyperactivity occurs, the circuit pack is isolated from the system, and all of the trunks for this circuit pack are placed into the out of service state. The system will try to restore the circuit pack within 15 minutes. When no faults are detected for 15 minutes, the DS1 interface circuit pack is restored to normal operation. All of the trunks for the DS1 interface circuit pack are then returned to the in service state. Hyperactivity is often caused by the associated facility. In such a case, faults (such as slips, misframes, or blue alarms) would be entered in the error log. In addition, many hardware errors would be logged against the associated trunk circuits. If the facility is OK and the error occurs again after 15 minutes, replace the circuit pack.

Table 9-243. TEST #144 Slip Alarm Inquiry Test — Continued

Error Code	Test Result	Description/ Recommendation
1 to 88	FAIL	<p>The DS1 interface circuit pack detected a slip alarm. The error code equals the number of slips detected by the DS1 interface circuit pack since the last slip alarm inquiry test.</p> <ol style="list-style-type: none"> <li>1. Retry the command at 1-minute intervals a maximum of 5 times.</li> <li>2. If the DS1 interface circuit pack is a TN767, enter the <b>list measurement ds1-log UUCSS</b> command to read the error seconds measurement.</li> <li>3. Verify that both endpoints and all intermediate equipment of the DS1 link are administered using the same signaling mode, framing mode, and line coding.</li> <li>4. If the DS1 interface circuit pack connects to a T1 facility, call the vendor of the T1 carrier to diagnose the remote DS1 endpoint. If the DS1 interface circuit pack connects directly to a switch, call the system technician of the remote switch to diagnose the DS1 endpoint.</li> <li>5. Check the active alarm and error logs for recent alarms and errors against the synchronization (SYNC). Follow the suggested repair procedure for these errors.</li> <li>6. Check the physical connectivity of the DS1 pack and of the cable.</li> <li>7. Replace the local DS1 interface circuit pack and repeat the test.</li> </ol>
	PASS	No Slip alarm is detected on the DS1 Interface circuit pack.
0	NO BOARD	<p>The test could not relate the internal ID to the port (no board).</p> <p>This could be due to incorrect translations, no board is inserted, an incorrect board is inserted, or an insane board is inserted.</p> <ol style="list-style-type: none"> <li>1. Check to ensure that the board translations are correct. Use the <b>add ds1 UUCSS</b> command to administer the DS1 interface if it is not already administered.</li> <li>2. If board was already administered correctly, check the error log to determine if the board is hyperactive. If this is the case, the board is shut down. Reseating the board will re-initialize the board.</li> <li>3. If the board was found to be correctly inserted in step 1, issue the <b>busyout board</b> command.</li> <li>4. Issue the <b>reset board</b> command.</li> <li>5. Issue the <b>release busy board</b> command.</li> <li>6. Issue the <b>test board long</b> command.</li> </ol> <p>This should re-establish the link between the internal ID and the port.</p>

## Misframe Alarm Inquiry Test (#145)

Misframe Alarm indicates that framing bits observed on a DS1 Interface circuit pack are in error. Misframe Alarm Inquiry Test queries the total number of misframes that occurred on a DS1 Interface circuit pack since the last inquiry.

When the DS1 Interface circuit pack detects a misframe error, it will increase its misframe counter by 1. If the counter reaches the threshold, a MISFRAME-COUNT message is automatically sent to the switch maintenance software. After the maintenance software receives the MISFRAME-COUNT message, the Misframe Alarm Inquiry Test is initiated to collect the misframe counts from the DS1 Interface circuit pack.

When the threshold of misframes is reached, if the DS1 Interface circuit pack is supplying the system synchronization source, then a switching synchronization source message is sent to the TDM Bus Clock. See TDM-BUS (TDM Bus) Maintenance documentation for details. A Minor alarm against the DS1 Interface circuit pack is raised, but all trunks of the DS1 Interface circuit pack are still in the in-service state.

**Table 9-244. TEST #145 Misframe Alarm Inquiry Test**

Error Code	Test Result	Description/ Recommendation
2100	ABORT	Internal system error
	ABORT	Could not allocate the necessary system resources to run this test. 1. Retry the command at 1-minute intervals a maximum of 5 times.

*Continued on next page*

**Table 9-244. TEST #145 Misframe Alarm Inquiry Test — Continued**

Error Code	Test Result	Description/ Recommendation
2000	ABORT	<p>Response to the test was not received within the allowable time period. This may be due to hyperactivity. Error type 1538 in the error log indicates hyperactivity. The hyperactive circuit pack is out of service and one or more of the following symptoms may appear.</p> <ol style="list-style-type: none"> <li>1. The DS1-BD tests (such as test 138 and test 139) are aborting with error code 2000.</li> <li>2. The tests run on the ports of this circuit pack are returning a no board result.</li> <li>3. A <b>busyout</b> or a <b>release</b> command has no affect on the test results.</li> <li>4. A <b>list config</b> command shows that the circuit pack and the ports are properly installed.</li> </ol> <p><b>⇒ NOTE:</b>                      When hyperactivity occurs, the circuit pack is isolated from the system, and all of the trunks for this circuit pack are placed into the out of service state. The system will try to restore the circuit pack within 15 minutes. When no faults are detected for 15 minutes, the DS1 interface circuit pack is restored to normal operation. All of the trunks for the DS1 interface circuit pack are then returned to the in service state. Hyperactivity is often caused by the associated facility. In such a case, faults (such as slips, misframes, or blue alarms) would be entered in the error log. In addition, many hardware errors would be logged against the associated trunk circuits. If the facility is OK and the error occurs again after 15 minutes, replace the circuit pack.</p>

*Continued on next page*

**Table 9-244. TEST #145 Misframe Alarm Inquiry Test — Continued**

Error Code	Test Result	Description/ Recommendation
ANY	FAIL	<p>The test failed because the DS1 interface circuit pack detected errors in the received framing bits pattern. The error code equals the number of misframes detected by the DS1 interface circuit pack since the last misframe alarm inquiry test. Major bit and minor bit error rate (error types 2561 and 2817) error logs often accompany misframe alarms. Clearing the cause of these error logs may clear the misframes which are occurring.</p> <ol style="list-style-type: none"> <li>1. Retry the command at 1-minute intervals a maximum of 5 times.</li> <li>2. If the DS1 interface circuit pack is a TN767, enter the <b>list measurement ds1-log UUCSS</b> command to read the error seconds measurement.</li> <li>3. Verify that both endpoints and all intermediate equipment of the DS1 link are administered using the same signaling mode, framing mode, and line coding.</li> <li>4. If the DS1 interface circuit pack connects to a T1 facility, call the vendor of the T1 carrier to diagnose the remote DS1 endpoint. If the DS1 interface circuit pack connects directly to a switch, call the system technician of the remote switch to diagnose the DS1 endpoint.</li> <li>5. Check the active alarm and error logs for recent alarms and errors against the synchronization (SYNC). Follow the suggested repair procedure for these errors.</li> <li>6. Check the physical connection of the DS1 pack and of the cable.</li> <li>7. Replace the local DS1 interface circuit pack, and repeat the test.</li> </ol>
	PASS	No Misframe alarm is detected on the DS1 Interface circuit pack.
0	NO BOARD	<p>The test could not relate the internal ID to the port (no board).</p> <p>This could be due to incorrect translations, no board is inserted, an incorrect board is inserted, or an insane board is inserted.</p> <ol style="list-style-type: none"> <li>1. Check to ensure that the board translations are correct. Use the <b>add ds1 UUCSS</b> command to administer the DS1 interface if it is not already administered.</li> <li>2. If board was already administered correctly, check the error log to determine if the board is hyperactive. If this is the case, the board is shut down. Reseating the board will re-initialize the board.</li> <li>3. If the board was found to be correctly inserted in step 1, issue the <b>busyout board</b> command.</li> <li>4. Issue the <b>reset board</b> command.</li> <li>5. Issue the <b>release busy board</b> command.</li> <li>6. Issue the <b>test board long</b> command.</li> </ol> <p>This should re-establish the link between the internal ID and the port.</p>

## Translation Update Test (#146)

The Translation Update Test sends the circuit-pack-level information specified by System Administration to the DS1 Interface circuit pack. Translation includes the following data administered for a DS1 Interface circuit pack (see output of **display ds1 UUCSS** command): DS1 Link Length between two DS1 endpoints, Synchronization Source Control, All Zero Suppression, Framing Mode, Signaling Mode, Time Slot Number of 697-Hz Tone, Time Slot Number of 700-Hz Tone, etc.

If a TN767E or later DS1 circuit pack is combined with a 120A CSU Module to form an Integrated CSU Module, this test will also send the administration for this Integrated CSU to the circuit pack to assure the board's translations are correct. The administration of the CSU Module is done using the DS1 circuit pack administration form. Translation for the CSU Module includes the following data: Transmit LBO, Receive ALBO, Supply CPE Loopback Jack Power?, and so forth.

**Table 9-245. TEST #146 Translation Update Test**

Error Code	Test Result	Description/ Recommendation
	ABORT	Internal system error 1. Retry the command at 1-minute intervals a maximum of 5 times.
	FAIL	Internal system software error. 1. Enter the <b>display ds1 UUCSS</b> command to verify the DS1 Interface circuit pack translation.
	PASS	Translation data has been downloaded to the DS1 Interface circuit pack successfully.
0	NO BOARD	The test could not relate the internal ID to the port (no board). This could be due to incorrect translations, no board is inserted, an incorrect board is inserted, or an insane board is inserted. 1. Check to ensure that the board translations are correct. Use the <b>add ds1 UUCSS</b> command to administer the DS1 interface if it is not already administered. 2. If board was already administered correctly, check the error log to determine if the board is hyperactive. If this is the case, the board is shut down. Reseating the board will re-initialize the board. 3. If the board was found to be correctly inserted in step 1, issue the <b>busyout board</b> command. 4. Issue the <b>reset board</b> command. 5. Issue the <b>release busy board</b> command. 6. Issue the <b>test board long</b> command. This should re-establish the link between the internal ID and the port.

## DS1 Board Loopback Test (#1209)

**This test is destructive.**

The DS1 Board Loopback (BLB) Test causes a loopback at the TN767E DS1 board edge and tests DS1 board internal circuitry.

The test is destructive and can only be initiated by a system technician demanded **test ds1-loop UUCSS ds1/csu-loopback-tests** command.

All trunks or ports on the DS1 Interface circuit pack must be busied out via the system technician **busyout board** command before running the BLB Test.

When the BLB Test is initiated, maintenance software sends an appropriate message to the TN767E DS1 Interface circuit pack to start the test. The board will set up the BLB loopback, transmit a test pattern, and verify that the pattern is received unaltered through the loopback. If the transmitted and received pattern is different, the test fails.

When the test is complete, all trunks or ports on the TN767E DS1 Interface circuit pack are restored to the in-service state after the **release board** command is entered

**Table 9-246. TEST #1209 DS1 Board Loopback Test**

Error Code	Test Result	Description/ Recommendation
	ABORT	Internal system error 1. Retry <b>test ds1-loop UUCSS ds1/csu-loopback-tests</b> at 1-minute intervals a maximum of 5 times.
1005	ABORT	DS1 Board Loopback Test cannot be executed in the current configuration. To run this Test, the TN767E or later suffix DS1 must be administered for 24-channel operation. The "Bit Rate" field on the DS1 circuit pack administration form must be set to "1.544" for 24-channel operation.
1015	ABORT	Ports on the DS1 Interface circuit pack have not been busied out to out-of-service. 1. Enter <b>busyout board UUCSS</b> to put all trunks or ports of the DS1 Interface circuit pack into the out-of-service state. 2. Retry the command.

*Continued on next page*

**Table 9-246. TEST #1209 DS1 Board Loopback Test — Continued**

Error Code	Test Result	Description/ Recommendation
1039	ABORT	<p>The DS1 Interface circuit pack is providing timing for the system. Executing this test could cause major system disruption.</p> <p>If the DS1 Interface circuit pack needs to be tested, set the synchronization reference to another DS1 Interface circuit pack or to the Tone-Clock circuit pack via the following command sequence:</p> <ol style="list-style-type: none"> <li>1. Issue the <b>disable synchronization-switch</b> command.</li> <li>2. Next, issue the <b>set synchronization UUCSS</b> command.</li> <li>3. Lastly, issue the <b>enable synchronization-switch</b> command.</li> </ol>
1950	ABORT	<p>Another loopback/span test is already executing on the DS1 board or the board is in a network requested loopback mode (Line loopback or Payload loopback). The hardware error log will indicate whether a Customer Loopback Jack Test, Far CSU Loopback Test, or the One-Way Span Test is executing or if the board is in line loopback or payload loopback mode. Only one long-duration loopback/span test can be active at a given time. Thus, if a loopback/span test is already active, that test must be terminated via the <i>test ds1-loop UUCSS end-loopback/span-test</i> command in order to execute this test.</p>
2100	ABORT ABORT	<p>Internal system error</p> <p>Could not allocate the necessary system resources to run this test.</p> <ol style="list-style-type: none"> <li>1. Retry the command at 1-minute intervals for a maximum of 5 times.</li> </ol>

*Continued on next page*



**Table 9-246. TEST #1209 DS1 Board Loopback Test — Continued**

Error Code	Test Result	Description/ Recommendation
2000	ABORT	<p>Response to the test was not received within the allowable time period. This may be due to hyperactivity. Error type 1538 in the error log indicates hyperactivity. The hyperactive circuit pack is out of service and one or more of the following symptoms may be exhibited.</p> <ol style="list-style-type: none"> <li>1. The DS1-BD tests (such as test 138 and test 139) are aborting with error code 2000.</li> <li>2. The tests run on the ports of this circuit pack are returning a no board result.</li> <li>3. A <b>busyout</b> or a <b>release</b> command has no affect on the test results.</li> <li>4. A <b>list config</b> command shows that the circuit pack and the ports are properly installed.</li> </ol> <p><b>⇒ NOTE:</b>                      When hyperactivity occurs, the circuit pack is isolated from the system, and all of the trunks for this circuit pack are placed into the out of service state. The system will try to restore the circuit pack within 15 minutes. When no faults are detected for 15 minutes, the DS1 interface circuit pack is restored to normal operation. All of the trunks for the DS1 interface circuit pack are then returned to the in service state. Hyperactivity is often caused by the associated facility. In such a case, faults (such as slips, misframes, or blue alarms) would be entered in the error log. In addition, many hardware errors would be logged against the associated trunk circuits. If the facility is OK and the error occurs again after 15 minutes, replace the circuit pack.</p>
	FAIL	<p>DS1 Interface circuit pack failed the DS1 Board Loopback Test.</p> <ol style="list-style-type: none"> <li>1. Retry <b>test ds1-loop UUCSS ds1/csu-loopback-tests</b>.</li> <li>2. If the BLB test continues to fail, then replace the DS1 circuit pack.</li> </ol>
	PASS	<p>The BLB test executed successfully. The test pattern was transmitted and received successfully up to the TN767E DS1 board edge.</p>

*Continued on next page*

**Table 9-246. TEST #1209 DS1 Board Loopback Test — Continued**

Error Code	Test Result	Description/ Recommendation
0	NO BOARD	<p>The test could not relate the internal ID to the port (no board).</p> <p>This could be due to incorrect translations, no board is inserted, an incorrect board is inserted, or an insane board is inserted.</p> <ol style="list-style-type: none"> <li>1. Check to ensure that the board translations are correct. Use the <b>add ds1 UUCSS</b> command to administer the DS1 interface if it is not already administered.</li> <li>2. If board was already administered correctly, check the error log to determine if the board is hyperactive. If this is the case, the board is shut down. Reseating the board will re-initialize the board.</li> <li>3. If the board was found to be correctly inserted in step 1, issue the <b>busyout board</b> command.</li> <li>4. Issue the <b>reset board</b> command.</li> <li>5. Issue the <b>release busy board</b> command.</li> <li>6. Issue the <b>test board long</b> command.</li> </ol> <p>This should re-establish the link between the internal ID and the port.</p>

### CSU Equipment Loopback Test (#1210)

**This test is destructive.**

The CSU Equipment Loopback (ELB) Test causes a loopback at the near-edge of the local 120A CSU Module and tests the connection from the TN767E DS1 board to the CSU Module (DS1 board edge interconnecting cable, and CSU Module edge). This test will only be performed if the 120A CSU Module is present, administered, and connected to a 1.544Mbps TN767E DS1 circuit pack on the back of the port carrier.

The test is destructive and can only be initiated by a system technician demanded **test ds1-loop UUCSS ds1/csu-loopback-tests** command.

All trunks or ports on the DS1 Interface circuit pack must be busied out via the system technician **busyout board** command before running the ELB Test.

When the ELB Test is initiated, maintenance software sends an appropriate message to the TN767E DS1 Interface circuit pack to start the test. The board sets up the ELB loopback, transmit a test pattern, and verify that the pattern is received unaltered through the loopback. If the transmitted and received pattern is different, the test fails.

In addition, the DS1 circuit pack hardware applies a DC current while the test is running in order to detect any broken wires which may not be detected by the loopback pattern.

When the test is complete, all trunks or ports on the TN767E DS1 Interface circuit pack are restored to the in-service state after the **release board** command is entered.

**Table 9-247. TEST #1210 CSU Equipment Loopback Test**

Error Code	Test Result	Description/ Recommendation
	ABORT	Internal system error <ol style="list-style-type: none"><li>1. Retry <b>test ds1-loop UUCSS ds1/csu-loopback-tests</b> at 1-minute intervals a maximum of 5 times.</li></ol>
1005	ABORT	CSU Equipment Loopback Test cannot be executed in the current configuration. To run this test, the <i>Near-End CSU Type</i> field on the DS1 circuit pack administration form must be set to <i>integrated</i> and the "Bit Rate" field must be set to "1.544" (24-channel operation). <ol style="list-style-type: none"><li>1. Use the <b>change ds1 UUCSS</b> command to set the <i>Near-End CSU Type</i> field on the DS1 circuit pack administration form to <i>integrated</i>, and/or change the "Bit Rate" field to "1.544" if the board is to be used in the 24-channel configuration.</li><li>2. Retry <b>test ds1-loop UUCSS ds1/csu-loopback-tests</b>.</li></ol>
1015	ABORT	Ports on the DS1 Interface circuit pack have not been busied out to out-of-service. <ol style="list-style-type: none"><li>1. Enter the <b>busyout board UUCSS</b> command to put all trunks or ports of the DS1 Interface circuit pack into the out-of-service state.</li><li>2. Retry the command.</li></ol>
1039	ABORT	The DS1 Interface circuit pack is providing timing for the system. Executing this test could cause major system disruption. If the DS1 Interface circuit pack needs to be tested, set the synchronization reference to another DS1 Interface circuit pack or to the Tone-Clock circuit pack via the following command sequence: <ol style="list-style-type: none"><li>1. Issue the <b>disable synchronization-switch</b> command.</li><li>2. Next, issue the <b>set synchronization UUCSS</b> command.</li><li>3. Lastly, issue the <b>enable synchronization-switch</b> command.</li></ol>

*Continued on next page*

**Table 9-247. TEST #1210 CSU Equipment Loopback Test — Continued**

Error Code	Test Result	Description/ Recommendation
1950	ABORT	Another loopback/span test is already executing on the DS1 board or the board is in a network requested loopback mode (Line loopback or Payload loopback). The hardware error log will indicate whether a Customer Loopback Jack Test, Far CSU Loopback Test, or the One-Way Span Test is executing or if the board is in line loopback or payload loopback mode. Only one long-duration loopback/span test can be active at a given time. Thus, if a loopback/span test is already active, that test must be terminated via the <b>test ds1-loop UUCSS end-loopback/span-test</b> command in order to execute this test.
1951	ABORT	The CSU Equipment Loopback Test could not be executed because the 120A CSU Module was not physically installed. Physically connect the 120A CSU Module to the TN767E board on the back of the port carrier.
2100	ABORT	Internal system error Could not allocate the necessary system resources to run this test. <ol style="list-style-type: none"> <li>1. Retry the command at 1-minute intervals a maximum of 5 times.</li> </ol>
2000	ABORT	Response to the test was not received within the allowable time period. This may be due to hyperactivity. Error type 1538 in the error log indicates hyperactivity. The hyperactive circuit pack is out of service and one or more of the following symptoms may be exhibited. <ol style="list-style-type: none"> <li>1. The DS1-BD tests (such as test 138 and test 139) are aborting with error code 2000.</li> <li>2. The tests run on the ports of this circuit pack are returning a no board result.</li> <li>3. A <b>busyout</b> or a <b>release</b> command has no affect on the test results.</li> <li>4. A <b>list config</b> command shows that the circuit pack and the ports are properly installed.</li> </ol> <p><b>⇒ NOTE:</b>                      When hyperactivity occurs, the circuit pack is isolated from the system, and all of the trunks for this circuit pack are placed into the out of service state. The system will try to restore the circuit pack within 15 minutes. When no faults are detected for 15 minutes, the DS1 interface circuit pack is restored to normal operation. All of the trunks for the DS1 interface circuit pack are then returned to the in service state. Hyperactivity is often caused by the associated facility. In such a case, faults (such as slips, misframes, or blue alarms) would be entered in the error log. In addition, many hardware errors would be logged against the associated trunk circuits. If the facility is OK and the error occurs again after 15 minutes, replace the circuit pack.</p>

*Continued on next page*

**Table 9-247. TEST #1210 CSU Equipment Loopback Test — Continued**

Error Code	Test Result	Description/ Recommendation
	FAIL	<p>DS1 Interface circuit pack failed the CSU Equipment Loopback Test.</p> <ol style="list-style-type: none"> <li>1. Retry <b>test ds1-loop UUCSS ds1/csu-loopback-tests</b>.</li> <li>2. If the ELB test continues to fail, then either the TN767E board, the CSU Module, or the I/O cable between the backplane and the CSU module (or any combination thereof) has failed. Attempt to isolate the problem to one of these areas. Replace the CSU Module and running <b>test ds1-loop UUCSS ds1/csu-loopback-tests</b> again.</li> <li>3. If the ELB test continues to fail, then replace the TN767E board and run <b>test ds1-loop UUCSS ds1/csu-loopback-tests</b> again.</li> <li>4. If the ELB test continues to fail, the problem could be in the I/O cable between the backplane and the CSU module.</li> </ol>
	PASS	<p>The ELB test executed successfully. The test pattern was transmitted and received successfully over the connection from the TN767E DS1 board to the near-edge of the 120A1 CSU Module.</p>
0	NO BOARD	<p>The test could not relate the internal ID to the port (no board). This could be due to incorrect translations, no board is inserted, an incorrect board is inserted, or an insane board is inserted.</p> <ol style="list-style-type: none"> <li>1. Check to ensure that the board translations are correct. Use the <b>add ds1 UUCSS</b> command to administer the DS1 interface if it is not already administered.</li> <li>2. If board was already administered correctly, check the error log to determine if the board is hyperactive. If this is the case, the board is shut down. Reseating the board will re-initialize the board.</li> <li>3. If the board was found to be correctly inserted in step 1, issue the <b>busyout board</b> command.</li> <li>4. Issue the <b>reset board</b> command.</li> <li>5. Issue the <b>release busy board</b> command.</li> <li>6. Issue the <b>test board long</b> command.</li> </ol> <p>This should re-establish the link between the internal ID and the port.</p>

### CSU Repeater Loopback Test (#1211)

**This test is destructive.**

The CSU Repeater Loopback (RLB) Test causes a loopback at the far-edge of the local 120A CSU Module and tests the connection from the TN767E DS1 board to and including the CSU Module circuitry. This test will only be performed

if the 120A CSU Module is present, administered, and connected to a 1.544 Mbps TN767E DS1 circuit pack on the back of the port carrier.

The test is destructive and can only be initiated by a system technician demanded **test ds1-loop UUCSS ds1/csu-loopback-tests** command.

All trunks or ports on the DS1 Interface circuit pack must be busied out via the system technician **busyout board** command before running the RLB Test.

When the RLB Test is initiated, maintenance software sends an appropriate message to the TN767E DS1 Interface circuit pack to start the test. The board will set up the RLB loopback, transmit a test pattern, and verify that the pattern is received unaltered through the loopback. If the transmitted and received pattern is different, the test fails.

In addition, the DS1 circuit pack hardware applies a DC current while the test is running in order to detect any broken wires which may not be detected by the loopback pattern.

When the test is complete, all trunks or ports on the TN767E DS1 Interface circuit pack are restored to the in-service state after the **release board** command is entered

**Table 9-248. TEST #1211 CSU Repeater Loopback Test**

Error Code	Test Result	Description/ Recommendation
	ABORT	Internal system error 1. Retry <b>test ds1-loop UUCSS ds1/csu-loopback-tests</b> at 1-minute intervals a maximum of 5 times.
1005	ABORT	CSU Repeater Loopback Test cannot be executed in the current configuration. To run this test, the <i>Near-End CSU Type</i> field on the DS1 circuit pack administration form must be set to <i>integrated</i> and the "Bit Rate" field on the DS1 circuit pack administration form must be set to "1.544" (24-channel configuration). 1. Use the <b>change ds1 UUCSS</b> command to set the <i>Near-End CSU Type</i> field on the DS1 circuit pack administration form to <i>integrated</i> , and/or change the "Bit Rate" field to "1.544" if the board is to be used in 24-channel configuration. 2. Retry <b>test ds1-loop UUCSS ds1/csu-loopback-tests</b> .

*Continued on next page*

**Table 9-248. TEST #1211 CSU Repeater Loopback Test — Continued**

Error Code	Test Result	Description/ Recommendation
1015	ABORT	<p>Ports on the DS1 Interface circuit pack have not been busied out to out-of-service.</p> <ol style="list-style-type: none"> <li>1. Enter the <b>busyout board UUCSS</b> command to put all trunks or ports of the DS1 Interface circuit pack into the out-of-service state.</li> <li>2. Retry the command.</li> </ol>
1039	ABORT	<p>The DS1 Interface circuit pack is providing timing for the system. Executing this test could cause major system disruption.</p> <p>If the DS1 Interface circuit pack needs to be tested, set the synchronization reference to another DS1 Interface circuit pack or to the Tone-Clock circuit pack via the following command sequence:</p> <ol style="list-style-type: none"> <li>1. Issue the <b>disable synchronization-switch</b> command.</li> <li>2. Next, issue the <b>set synchronization UUCSS</b> command.</li> <li>3. Lastly, issue the <b>enable synchronization-switch</b> command.</li> </ol>
1950	ABORT	<p>Another loopback/span test is already executing on the DS1 board or the board is in a network requested loopback mode (Line loopback or Payload loopback). The hardware error log indicates whether a Customer Loopback Jack Test, Far CSU Loopback Test, or the One-Way Span Test is executing or if the board is in line loopback or payload loopback mode. Only one long-duration loopback/span test can be active at a given time. Thus, if a loopback/span test is already active, that test must be terminated via the <b>test ds1-loop UUCSS end-loopback/span-test</b> command in order to execute this test.</p>
1951	ABORT	<p>The CSU Repeater Loopback Test could not be executed because the 120A CSU Module was not physically installed. Physically connect the 120A1 CSU Module to the TN767E board on the back of the port carrier.</p>

*Continued on next page*

**Table 9-248. TEST #1211 CSU Repeater Loopback Test — Continued**

Error Code	Test Result	Description/ Recommendation
2100	ABORT	Internal system error
	ABORT	Could not allocate the necessary system resources to run this test. 1. Retry the command at 1-minute intervals a maximum of 5 times.
2000	ABORT	Response to the test was not received within the allowable time period. This may be due to hyperactivity. Error type 1538 in the error log indicates hyperactivity. The hyperactive circuit pack is out of service and one or more of the following symptoms may be exhibited. 1. The DS1-BD tests (such as test 138 and test 139) are aborting with error code 2000. 2. The tests run on the ports of this circuit pack are returning a no board result. 3. A <b>busyout</b> or a <b>release</b> command has no affect on the test results. 4. A <b>list config</b> command shows that the circuit pack and the ports are properly installed.  <b>⇒ NOTE:</b> When hyperactivity occurs, the circuit pack is isolated from the system, and all of the trunks for this circuit pack are placed into the out of service state. The system will try to restore the circuit pack within 15 minutes. When no faults are detected for 15 minutes, the DS1 interface circuit pack is restored to normal operation. All of the trunks for the DS1 interface circuit pack are then returned to the in service state. Hyperactivity is often caused by the associated facility. In such a case, faults (such as slips, misframes, or blue alarms) would be entered in the error log. In addition, many hardware errors would be logged against the associated trunk circuits. If the facility is OK and the error occurs again after 15 minutes, replace the circuit pack.
FAIL		DS1 Interface circuit pack failed the CSU Repeater Loopback Test. 1. Retry <b>test ds1-loop UUCSS ds1/csu-loopback-tests</b> . 2. If the RLB test continues to fail, and the CSU Equipment Loopback Test (#1210) passed, then replace the CSU Module.
PASS		The RLB test executed successfully. The test pattern was transmitted and received successfully over the connection from the TN767E DS1 board to the far-edge of the 120A1 CSU Module.

*Continued on next page*



**Table 9-248. TEST #1211 CSU Repeater Loopback Test — Continued**

Error Code	Test Result	Description/ Recommendation
0	NO BOARD	<p>The test could not relate the internal ID to the port (no board).</p> <p>This could be due to incorrect translations, no board is inserted, an incorrect board is inserted, or an insane board is inserted.</p> <ol style="list-style-type: none"> <li>1. Check to ensure that the board translations are correct. Use the <b>add ds1 UUCSS</b> command to administer the DS1 interface if it is not already administered.</li> <li>2. If board was already administered correctly, check the error log to determine if the board is hyperactive. If this is the case, the board is shut down. Reseating the board will re-initialize the board.</li> <li>3. If the board was found to be correctly inserted in step 1, issue the <b>busyout board</b> command.</li> <li>4. Issue the <b>reset board</b> command.</li> <li>5. Issue the <b>release busy board</b> command.</li> <li>6. Issue the <b>test board long</b> command.</li> </ol> <p>This should re-establish the link between the internal ID and the port.</p>

### CPE Loopback Jack Test (#1212)

**This test is destructive.**

The CPE Loopback Jack (CLJ-LB) Test causes a loopback at the CPE Loopback Jack and tests the building wiring connection between the TN767E DS1 board and the CPE Loopback Jack.

The test is highly destructive and can only be initiated by a system technician demanded **test ds1-loop UUCSS cpe-loopback-jack-test-begin [number-of-bits bit-pattern]** command. The System technician has the choice of entering a loopback activation code on the command line or using the default code (0x47F).

All trunks or ports on the DS1 Interface circuit pack must be busied out via the system technician **busyout board** command before running the CPE Loopback Jack Test.

The CPE Loopback Jack Test has the TN767E DS1 Interface circuit pack transmit a loopback activation code to the CPE Loopback Jack, waits up to 10 seconds for return of the code to verify the loopback has been established, transmits a framed 3-in-24 test pattern, begins counting bit errors in the received test pattern, and returns a PASS result to indicate that the pattern was successfully

sent. If the loopback is not established within the 10 seconds, the test returns FAIL.

The status of the CPE Loopback Jack test will be available in the hardware error log via error type 3900. Several distinct aux values will be used to give the user information of the status of the test.

The *list measurements ds1 summary* command will display the length of time the test has been running (*Test Duration* field) and number of bit errors detected (*Loopback/Span Test Bit-Error Count* field). If the test pattern is being passed through the loopback cleanly, the number of bit errors should be very low. The command will also display the type of loopback/span test executing (*Test* field), the type of pattern generated for the loopback/span test (*Pattern* field), and whether the pattern (*3-in-24 Pattern*) is synchronized (*Synchronized Field*).

To terminate the test, enter **test ds1-loop UUCSS end-loopback/span-test** command or the **release board**. Using the **release board** command restores all trunks or ports on the TN767E DS1 Interface circuit pack to the in-service state.

**Table 9-249. TEST #1212 CPE Loopback Jack Test**

Error Code	Test Result	Description/ Recommendation
	ABORT	Internal system error 1. Retry <b>test ds1-loop UUCSS cpe-loopback-jack-test-begin</b> at 1-minute intervals a maximum of 5 times.
1005	ABORT	CPE Loopback Jack Test cannot be executed in the current configuration. To run this Test, the TN767E or later suffix DS1 must be administered for 24-channel operation. The "Bit Rate" field on the DS1 circuit pack administration form must be set to "1.544" for 24-channel operation.
1015	ABORT	Ports on the DS1 Interface circuit pack have not been busied out to out-of-service. 1. Enter the <b>busyout board UUCSS</b> command to put all trunks or ports of the DS1 Interface circuit pack into the out-of-service state. 2. Retry the command.
1039	ABORT	The DS1 Interface circuit pack is providing timing for the system. Executing this test could cause major system disruption. If the DS1 Interface circuit pack needs to be tested, set the synchronization reference to another DS1 Interface circuit pack or to the Tone-Clock circuit pack via the following command sequence: 1. Issue the <b>disable synchronization-switch</b> command. 2. Next, issue the <b>set synchronization UUCSS</b> command. 3. Lastly, issue the <b>enable synchronization-switch</b> command.

**Table 9-249. TEST #1212 CPE Loopback Jack Test — Continued**

Error Code	Test Result	Description/ Recommendation
1950	ABORT	Another loopback/span test is already executing on the DS1 board or the board is in a network requested loopback mode (Line loopback or Payload loopback). The hardware error log will indicate whether a Customer Loopback Jack Test, Far CSU Loopback Test, or the One-Way Span Test is executing or if the board is in line loopback or payload loopback mode. Only one long-duration loopback/span test can be active at a given time. Thus, if a loopback/span test is already active, that test must be terminated via the <i>test ds1-loop UUCSS end-loopback/span-test</i> command in order to execute this test.
2100	ABORT ABORT	Internal system error Could not allocate the necessary system resources to run this test. <ol style="list-style-type: none"> <li>1. Retry the command at 1-minute intervals for a maximum of 5 times.</li> </ol>
2000	ABORT	Response to the test was not received within the allowable time period. This may be due to hyperactivity. Error type 1538 in the error log indicates hyperactivity. The hyperactive circuit pack is out of service and one or more of the following symptoms may be exhibited. <ol style="list-style-type: none"> <li>1. The DS1-BD tests (such as test 138 and test 139) are aborting with error code 2000.</li> <li>2. The tests run on the ports of this circuit pack are returning a no board result.</li> <li>3. A <b>busyout</b> or a <b>release</b> command has no affect on the test results.</li> <li>4. A <b>list config</b> command shows that the circuit pack and the ports are properly installed.</li> </ol> <p><b>⇒ NOTE:</b>                      When hyperactivity occurs, the circuit pack is isolated from the system, and all of the trunks for this circuit pack are placed into the out of service state. The system will try to restore the circuit pack within 15 minutes. When no faults are detected for 15 minutes, the DS1 interface circuit pack is restored to normal operation. All of the trunks for the DS1 interface circuit pack are then returned to the in service state. Hyperactivity is often caused by the associated facility. In such a case, faults (such as slips, misframes, or blue alarms) would be entered in the error log. In addition, many hardware errors would be logged against the associated trunk circuits. If the facility is OK and the error occurs again after 15 minutes, replace the circuit pack.</p>

*Continued on next page*

**Table 9-249. TEST #1212 CPE Loopback Jack Test — Continued**

Error Code	Test Result	Description/ Recommendation
2	FAIL	<p>The CLJ-LB test failed because it was not set up properly. The DS1 interface pack could not successfully put the CPE loopback jack into loopback mode.</p> <ol style="list-style-type: none"> <li>1. Rerun the <b>test ds1-loop UUCSS cpe-loopback-jack-test-begin</b> command.</li> <li>2. If the test continues to fail, the problem could be with the TN767E board, the CPE loopback jack equipment, or somewhere between. Run the <b>test ds1-loop UUCSS ds1/csu-loopback-tests</b> command to determine if the loopback tests that are closer to the TN767E board are successful. If any of these tests fail, follow the maintenance strategy that is associated with the test that fails.</li> </ol>
3	FAIL	<p>The CPE Loopback Jack Test was not set up properly. The framed 3-in-24 test pattern, generated by the DS1 Interface circuit pack and looped back through the CPE Loopback Jack, could not be detected properly by the DS1 circuit pack.</p> <ol style="list-style-type: none"> <li>1. Retry <b>test ds1-loop UUCSS cpe-loopback-jack-test-begin</b>.</li> <li>2. If the CPE Loopback test continues to fail, the problem could be with the TN767E board, the CPE Loopback Jack equipment, or somewhere in between. Run <b>test ds1-loop UUCSS ds1/csu-loopback-tests</b> to see if the loopback tests closer to the TN767E board are successful. If any of those loopback tests fail, follow the maintenance strategy associated with those loopbacks.</li> </ol>
	PASS	<p>The CPE Loopback Jack test has successfully began executing. The test will continue to run until the system technician enters the <b>test ds1-loop UUCSS end-loopback/span-test</b> command or the <b>release board UUCSS</b> command.</p>

*Continued on next page*

**Table 9-249. TEST #1212 CPE Loopback Jack Test — Continued**

Error Code	Test Result	Description/ Recommendation
0	NO BOARD	<p>The test could not relate the internal ID to the port (no board).</p> <p>This could be due to incorrect translations, no board is inserted, an incorrect board is inserted, or an insane board is inserted.</p> <ol style="list-style-type: none"> <li>1. Check to ensure that the board translations are correct. Use the <b>add ds1 UUCSS</b> command to administer the DS1 interface if it is not already administered.</li> <li>2. If board was already administered correctly, check the error log to determine if the board is hyperactive. If this is the case, the board is shut down. Reseating the board will re-initialize the board.</li> <li>3. If the board was found to be correctly inserted in step 1, issue the <b>busyout board</b> command.</li> <li>4. Issue the <b>reset board</b> command.</li> <li>5. Issue the <b>release busy board</b> command.</li> <li>6. Issue the <b>test board long</b> command.</li> </ol> <p>This should re-establish the link between the internal ID and the port.</p>

### Far CSU Loopback Test (#1213)

**This test is destructive.**

The Far CSU Loopback (R-LLB) Test causes a loopback at the far-end CSU and tests all circuitry and facilities from the local TN767E DS1 board to the far-end CSU.

The test is destructive and can only be initiated by a system technician demanded **test ds1-loop UUCSS far-csu-loopback-test-begin** command.

All trunks or ports on the DS1 Interface circuit pack must be busied out via the system technician **busyout board** command before running the Far CSU Loopback Test.

If the far-end CSU is not a 120A CSU Module, and the DS1 is administered for ami-zcs line coding, one's density protection must be disabled on the CSU during the test due to the large number of zero's in the 3-in-24 test pattern.

The Far CSU Loopback Test has the TN767E DS1 Interface circuit pack transmit a loopback activation code to the remote CSU, waits up to 15 seconds for return of the code to verify the loopback has been established, transmits a framed 3-in-24 test pattern, begins counting bit errors in the received test pattern, and

returns a PASS result. If the loopback is not established within the 15 seconds, the test fails.

The status of the Far CSU Loopback test will be available in the hardware error log via error type 3901. Several distinct aux values will be used to give the user information of the status of the test.

The *list measurements ds1 summary* command will display the length of time the test has been running (*Test Duration* field) and number of bit errors detected (*Loopback/Span Test Bit-Error Count* field). If the test pattern is being passed through the loopback cleanly, the number of bit errors should be very low. The command will also display the type of loopback/span test executing (*Test* field), the type of pattern generated for the loopback/span test (*Pattern* field), and whether the pattern (*i.e. 3-in-24 Pattern*) is synchronized (*Synchronized* field).

To terminate the test, enter **test ds1-loop UUCSS end-loopback/span-test** or the **release board** command. Using the **release board** command will restore all trunks or ports on the TN767E DS1 Interface circuit pack to the in-service state.

**Table 9-250. TEST #1213 Far CSU Loopback Test**

Error Code	Test Result	Description/ Recommendation
	ABORT	Internal system error  1. Retry <b>test ds1-loop UUCSS far-csu-loopback-test-begin</b> at 1-minute intervals a maximum of 5 times.
1005	ABORT	Far CSU Loopback Test cannot be executed in the current configuration. To run this, the TN767E or later suffix DS1 must be administered for 24-channel operation. The "Bit Rate" field on the DS1 circuit pack administration form must be set to "1.544" for 24-channel operation.
1015	ABORT	Ports on the DS1 Interface circuit pack have not been busied out to out-of-service.  1. Enter the <b>busyout board UUCSS</b> command to put all trunks or ports of the DS1 Interface circuit pack into the out-of-service state.  2. Retry the command.
1039	ABORT	The DS1 Interface circuit pack is providing timing for the system. Executing this test could cause major system disruption.  If the DS1 Interface circuit pack needs to be tested, set the synchronization reference to another DS1 Interface circuit pack or to the Tone-Clock circuit pack via the following command sequence:  1. Issue the <b>disable synchronization-switch</b> command.  2. Next, issue the <b>set synchronization UUCSS</b> command.  3. Lastly, issue the <b>enable synchronization-switch</b> command.

*Continued on next page*

**Table 9-250. TEST #1213 Far CSU Loopback Test — Continued**

Error Code	Test Result	Description/ Recommendation
1950	ABORT	Another loopback/span test is already executing on the DS1 board or the board is in a network requested loopback mode (Line loopback or Payload loopback). The hardware error log will indicate whether a Customer Loopback Jack Test, Far CSU Loopback Test, or the One-Way Span Test is executing or if the board is in line loopback or payload loopback mode. Only one long-duration loopback/span test can be active at a given time. Thus, if a loopback/span test is already active, that test must be terminated via the <i>test ds1-loop UUCSS end-loopback/span-test</i> command in order to execute this test.
2100	ABORT ABORT	Internal system error Could not allocate the necessary system resources to run this test. 1. Retry the command at 1-minute intervals for a maximum of 5 times.
2000	ABORT	Response to the test was not received within the allowable time period. This may be due to hyperactivity. Error type 1538 in the error log indicates hyperactivity. The hyperactive circuit pack is out of service and one or more of the following symptoms may be exhibited. 1. The DS1-BD tests (such as test 138 and test 139) are aborting with error code 2000. 2. The tests run on the ports of this circuit pack are returning a no board result. 3. A <b>busyout</b> or a <b>release</b> command has no affect on the test results. 4. A <b>list config</b> command shows that the circuit pack and the ports are properly installed.   <b>NOTE:</b> When hyperactivity occurs, the circuit pack is isolated from the system, and all of the trunks for this circuit pack are placed into the out of service state. The system will try to restore the circuit pack within 15 minutes. When no faults are detected for 15 minutes, the DS1 interface circuit pack is restored to normal operation. All of the trunks for the DS1 interface circuit pack are then returned to the in service state. Hyperactivity is often caused by the associated facility. In such a case, faults (such as slips, misframes, or blue alarms) would be entered in the error log. In addition, many hardware errors would be logged against the associated trunk circuits. If the facility is OK and the error occurs again after 15 minutes, replace the circuit pack.

*Continued on next page*

Table 9-250. TEST #1213 Far CSU Loopback Test — Continued

Error Code	Test Result	Description/ Recommendation
2	FAIL	The far CSU Loopback Test was not set up properly. The DS1 Interface circuit pack could not put the far-end CSU into loopback mode.
3	FAIL	<p>The far CSU Loopback Test was not set up properly. The framed 3-in-24 test pattern, generated by the DS1 Interface circuit pack and looped back through the far-end CSU, could not be detected by the DS1 circuit pack.</p> <ol style="list-style-type: none"> <li>1. Retry <b>test ds1-loop UUCSS far-csu-loopback-test-begin</b>.</li> <li>2. If the Far CSU Loopback test continues to fail with this error code, the problem could be with the TN767E board, the far-end CSU equipment, or somewhere in between. Run <b>test ds1-loop UUCSS cpe-loopback-jack-test-begin</b> to see if the CPE Loopback Jack test which is closer to the TN767E board is successful. (If a CPE Loopback Jack device is not being used, then run <b>test ds1-loop UUCSS ds1/csu-loopback-tests</b> to see if these even closer loopback tests succeed). If the closer loopback test fails, follow the maintenance strategy associated with that loopback</li> </ol>
	PASS	The Far CSU Loopback test has successfully began executing. The test will continue to run until the system technician enters <b>test ds1-loop UUCSS end-loopback/span-test</b> or the <b>release board UUCSS</b> .
0	NO BOARD	<p>The test could not relate the internal ID to the port (no board).</p> <p>This could be due to incorrect translations, no board is inserted, an incorrect board is inserted, or an insane board is inserted.</p> <ol style="list-style-type: none"> <li>1. Check to ensure that the board translations are correct. Use the <b>add ds1 UUCSS</b> command to administer the DS1 interface if it is not already administered.</li> <li>2. If board was already administered correctly, check the error log to determine if the board is hyperactive. If this is the case, the board is shut down. Reseating the board will re-initialize the board.</li> <li>3. If the board was found to be correctly inserted in step 1, issue the <b>busyout board</b> command.</li> <li>4. Issue the <b>reset board</b> command.</li> <li>5. Issue the <b>release busy board</b> command.</li> <li>6. Issue the <b>test board long</b> command.</li> </ol> <p>This should re-establish the link between the internal ID and the port.</p>

## One-Way Span Test (#1214)

This test is destructive.



The One-Way Span Test allows one-way span testing to and from remote test equipment or another DEFINITY communications system. This will test all circuitry and facilities from the local TN767E DS1 board to the remote test equipment or other DEFINITY communications system.

The test is destructive and can only be initiated by a system technician demanded *test ds1-loop UUCSS one-way-span-test-begin* command.

All trunks or ports on the DS1 Interface circuit pack must be busied out via the system technician **busyout board** command before running the One-Way Span Test.

The One-Way Span Test has the TN767E DS1 Interface circuit pack transmit a framed 3-in-24 test pattern and attempt to receive and verify the pattern. If the TN767E board receives a framed 3-in-24 test pattern sent from another DEFINITY G3V3 or test equipment at the far-end of the DS1, it will begin counting bit errors within the received pattern.

The status of the One-Way Span test will be available in the hardware error log via error type 3902. Several distinct aux values will be used to give the user information of the status of the test.

The *list measurements ds1 summary* command will display the length of time the test has been running (*Test Duration* field) and number of bit errors detected (*Loopback/Span Test Bit-Error Count* field). If the test pattern is being sent cleanly over the span from the far-end, the number of bit errors should be very low. The *Test Duration* field will show 0 until the test pattern is received from the far-end. Upon receiving the test pattern, the board will begin calculating the test duration and number of bit errors. The command will also display the type of loopback/span test executing (*Test* field), the type of pattern generated for the loopback/span test (*Pattern* field), and whether the pattern (*i.e. 3-in-24 Pattern*) is synchronized (*Synchronized* field).

To terminate the test, enter the *test ds1-loop UUCSS end-loopback/span-test* command or the **release board** command. Using the **release board** command will restore all trunks or ports on the TN767E DS1 Interface circuit pack to the in-service state.

Table 9-251. TEST #1214 One-Way Span Test

Error Code	Test Result	Description/ Recommendation
	ABORT	Internal system error  1. Retry the <b>test ds1-loop UUCSS one-way-span-test-begin</b> command at 1-minute intervals a maximum of 5 times.

**Table 9-251. TEST #1214 One-Way Span Test — Continued**

Error Code	Test Result	Description/ Recommendation
1005	ABORT	One-Way Span Test cannot be executed in the current configuration. To run this, the TN767E or later suffix DS1 must be administered for 24-channel operation. The "Bit Rate" field on the DS1 circuit pack administration form must be set to "1.544" for 24-channel operation.
1015	ABORT	<p>Ports on the DS1 Interface circuit pack have not been busied out to out-of-service.</p> <ol style="list-style-type: none"> <li>1. Enter the <b>busyout board UUCSS</b> command to put all trunks or ports of the DS1 Interface circuit pack into the out-of-service state.</li> <li>2. Retry the command.</li> </ol>
1039	ABORT	<p>The DS1 Interface circuit pack is providing timing for the system. Executing this test could cause major system disruption.</p> <p>If the DS1 Interface circuit pack needs to be tested, set the synchronization reference to another DS1 Interface circuit pack or to the Tone-Clock circuit pack via the following command sequence:</p> <ol style="list-style-type: none"> <li>1. Issue the <b>disable synchronization-switch</b> command.</li> <li>2. Next, issue the <b>set synchronization UUCSS</b> command.</li> <li>3. Lastly, issue the <b>enable synchronization-switch</b> command.</li> </ol>
1950	ABORT	Another loopback/span test is already executing on the DS1 board or the board is in a network requested loopback mode (Line loopback or Payload loopback). The hardware error log will indicate whether a Customer Loopback Jack Test, Far CSU Loopback Test, or the One-Way Span Test is executing or if the board is in line loopback or payload loopback mode. Only one long-duration loopback/span test can be active at a given time. Thus, if a loopback/span test is already active, that test must be terminated via the <b>test ds1-loop UUCSS end-loopback/span-test</b> command in order to execute this test.
2100	ABORT ABORT	<p>Internal system error</p> <p>Could not allocate the necessary system resources to run this test.</p> <ol style="list-style-type: none"> <li>1. Retry the command at 1-minute intervals for a maximum of 5 times.</li> </ol>

*Continued on next page*

**Table 9-251. TEST #1214 One-Way Span Test — Continued**

Error Code	Test Result	Description/ Recommendation
2000	ABORT	<p>Response to the test was not received within the allowable time period. This may be due to hyperactivity. Error type 1538 in the error log indicates hyperactivity. The hyperactive circuit pack is out of service and one or more of the following symptoms may be exhibited.</p> <ol style="list-style-type: none"> <li>1. The DS1-BD tests (such as test 138 and test 139) are aborting with error code 2000.</li> <li>2. The tests run on the ports of this circuit pack are returning a no board result.</li> <li>3. A <b>busyout</b> or a <b>release</b> command has no affect on the test results.</li> <li>4. A <b>list config</b> command shows that the circuit pack and the ports are properly installed.</li> </ol> <p><b>⇒ NOTE:</b>                      When hyperactivity occurs, the circuit pack is isolated from the system, and all of the trunks for this circuit pack are placed into the out of service state. The system will try to restore the circuit pack within 15 minutes. When no faults are detected for 15 minutes, the DS1 interface circuit pack is restored to normal operation. All of the trunks for the DS1 interface circuit pack are then returned to the in service state. Hyperactivity is often caused by the associated facility. In such a case, faults (such as slips, misframes, or blue alarms) would be entered in the error log. In addition, many hardware errors would be logged against the associated trunk circuits. If the facility is OK and the error occurs again after 15 minutes, replace the circuit pack.</p>
	PASS	<p>The One-Way Span test has successfully began transmitting a framed 3-in-24 test pattern. The test will continue to run until the system technician enters the <i>test ds1-loop UUCSS end-loopback/span-test</i> command or the <i>release board UUCSS</i> command.</p>

*Continued on next page*

Table 9-251. TEST #1214 One-Way Span Test — Continued

Error Code	Test Result	Description/ Recommendation
0	NO BOARD	<p>The test could not relate the internal ID to the port (no board).</p> <p>This could be due to incorrect translations, no board is inserted, an incorrect board is inserted, or an insane board is inserted.</p> <ol style="list-style-type: none"> <li>1. Check to ensure that the board translations are correct. Use the <b>add ds1 UUCSS</b> command to administer the DS1 interface if it is not already administered.</li> <li>2. If board was already administered correctly, check the error log to determine if the board is hyperactive. If this is the case, the board is shut down. Reseating the board will re-initialize the board.</li> <li>3. If the board was found to be correctly inserted in step 1, issue the <b>busyout board</b> command.</li> <li>4. Issue the <b>reset board</b> command.</li> <li>5. Issue the <b>release busy board</b> command.</li> <li>6. Issue the <b>test board long</b> command.</li> </ol> <p>This should re-establish the link between the internal ID and the port.</p>

### Inject Single Bit Error Test (#1215)

**This test is destructive.**

The Inject Single Bit Error Test will cause a single bit error to be sent within an active framed 3-in-24 test pattern.

The test is highly destructive and can only be initiated by a system technician demanded *test ds1-loop UUCSS inject-single-bit-error* command. An attempt to use this command will be rejected if none of the three long-duration DS1 loopback/span tests (CPE Loopback Jack Test, Far CSU Loopback Test, One-Way Span Test) are active on a TN767E circuit pack.

All trunks or ports on the DS1 Interface circuit pack must be busied out via the system technician **busyout board** command before running the Inject Single Bit Error Test.

The *list measurements ds1 summary* command displays the number of bit errors detected (*Loopback/Span Test Bit-Error Count* field). Injecting this single bit error should increment the bit error count of the loopback/span test by one.

**Table 9-252. TEST #1215 Inject Single Bit Error Test**

Error Code	Test Result	Description/ Recommendation
ABORT	Internal system error	1. Retry the test <i>ds1-loop UUCSS inject-single-bit-error</i> command at 1-minute intervals a maximum of 5 times.
1015	ABORT	Ports on the DS1 interface circuit pack have not been busied out to out-of-service.  1. Enter the <b>busyout board UUCSS</b> command to put all trunks or ports of the DS1 Interface circuit pack into the out-of-service state.  2. Retry the command.
2100	ABORT	Internal system error  Could not allocate the necessary system resources to run this test.  1. Retry the command at 1-minute intervals for a maximum of 5 times.
2000	ABORT	Response to the test was not received within the allowable time period. This may be due to hyperactivity. Error type 1538 in the error log indicates hyperactivity. The hyperactive circuit pack is out of service and one or more of the following symptoms may be exhibited.  1. The DS1-BD tests (such as test 138 and test 139) are aborting with error code 2000.  2. The tests run on the ports of this circuit pack are returning a no board result.  3. A <b>busyout</b> or a <b>release</b> command has no affect on the test results.  4. A <b>list config</b> command shows that the circuit pack and the ports are properly installed.
 <b>NOTE:</b>		When hyperactivity occurs, the circuit pack is isolated from the system, and all of the trunks for this circuit pack are placed into the out of service state. The system will try to restore the circuit pack within 15 minutes. When no faults are detected for 15 minutes, the DS1 interface circuit pack is restored to normal operation. All of the trunks for the DS1 interface circuit pack are then returned to the in service state. Hyperactivity is often caused by the associated facility. In such a case, faults (such as slips, misframes, or blue alarms) would be entered in the error log. In addition, many hardware errors would be logged against the associated trunk circuits. If the facility is OK and the error occurs again after 15 minutes, replace the circuit pack.
PASS	A single bit error has been successfully injected into an active framed 3-in-24 test pattern.	

**Table 9-252. TEST #1215 Inject Single Bit Error Test — Continued**

Error Code	Test Result	Description/ Recommendation
0	NO BOARD	<p>The test could not relate the internal ID to the port (no board).</p> <p>This could be due to incorrect translations, no board is inserted, an incorrect board is inserted, or an insane board is inserted.</p> <ol style="list-style-type: none"> <li>1. Check to ensure that the board translations are correct. Use the <b>add ds1 UUCSS</b> command to administer the DS1 interface if it is not already administered.</li> <li>2. If board was already administered correctly, check the error log to determine if the board is hyperactive. If this is the case, the board is shut down. Reseating the board will re-initialize the board.</li> <li>3. If the board was found to be correctly inserted in step 1, issue the <b>busyout board</b> command.</li> <li>4. Issue the <b>reset board</b> command.</li> <li>5. Issue the <b>release busy board</b> command.</li> <li>6. Issue the <b>test board long</b> command.</li> </ol> <p>This should re-establish the link between the internal ID and the port.</p>

## End Loopback/Span Test (#1216)

**This test is destructive.**

The End Loopback/Span Test will terminate an active loopback or span test on a TN767E DS1 circuit pack. Bit error counting against the received test pattern stream is terminated and sending of the framed 3-in-24 test pattern is halted. If either the CPE Loopback Jack or the far-end CSU is looped, the appropriate loopback deactivate code is sent. If the loopback could not be deactivated, then the test will FAIL and a MINOR alarm will be noted in the alarm log until the loopback is cleared.

The test is highly destructive and can only be initiated by a system technician demanded *test ds1-loop UUCSS end-loopback/span-test* command. Since only one of these three different long-duration loopback/span tests can be active at a time, the TN767E circuit pack knows which loopback/span test to terminate.

All trunks or ports on the DS1 Interface circuit pack must be busied out via the system technician **busyout board** command before running this End Loopback/Span Test.

The *list measurements ds1 summary* command will display the length of time the test ran (*Test Duration* field) and number of bit errors detected (*Loopback/Span Test Bit-Error Count* field).

To restore the trunks or ports on the TN767E DS1 Interface circuit pack to the in-service state, execute the **release board** command.

**Table 9-253. TEST #1216 End Loopback/Span Test**

Error Code	Test Result	Description/ Recommendation
	ABORT	Internal system error 1. Retry the <i>test ds1-loop UUCSS end-loopback/span-test</i> command at 1-minute intervals a maximum of 5 times.
1005	ABORT	End Loopback/Span Test cannot be executed in the current configuration. To run this, the TN767E or later suffix DS1 must be administered for 24-channel operation. The "Bit Rate" field on the DS1 circuit pack administration form must be set to "1.544" for 24-channel operation.
1015	ABORT	Ports on the DS1 Interface circuit pack have not been busied out to out-of-service. 1. Enter the <b>busyout board UUCSS</b> command to put all trunks or ports of the DS1 Interface circuit pack into the out-of-service state. 2. Retry the command.
2100	ABORT ABORT	Internal system error Could not allocate the necessary system resources to run this test. 1. Retry the command at 1-minute intervals for a maximum of 5 times.

*Continued on next page*

**Table 9-253. TEST #1216 End Loopback/Span Test — Continued**

Error Code	Test Result	Description/ Recommendation
2000	ABORT	<p>Response to the test was not received within the allowable time period. This may be due to hyperactivity. Error type 1538 in the error log indicates hyperactivity. The hyperactive circuit pack is out of service and one or more of the following symptoms may be exhibited.</p> <ol style="list-style-type: none"> <li>1. The DS1-BD tests (such as test 138 and test 139) are aborting with error code 2000.</li> <li>2. The tests run on the ports of this circuit pack are returning a no board result.</li> <li>3. A <b>busyout</b> or a <b>release</b> command has no affect on the test results.</li> <li>4. A <b>list config</b> command shows that the circuit pack and the ports are properly installed.</li> </ol> <p><b>⇒ NOTE:</b>                      When hyperactivity occurs, the circuit pack is isolated from the system, and all of the trunks for this circuit pack are placed into the out of service state. The system will try to restore the circuit pack within 15 minutes. When no faults are detected for 15 minutes, the DS1 interface circuit pack is restored to normal operation. All of the trunks for the DS1 interface circuit pack are then returned to the in service state. Hyperactivity is often caused by the associated facility. In such a case, faults (such as slips, misframes, or blue alarms) would be entered in the error log. In addition, many hardware errors would be logged against the associated trunk circuits. If the facility is OK and the error occurs again after 15 minutes, replace the circuit pack.</p>
1313	FAIL	<p>The TN767E DS1 circuit pack could not deactivate the loopback through the Customer Loopback Jack.</p> <ol style="list-style-type: none"> <li>1. Retry the <i>test ds1-loop UUCSS end-loopback/span-test</i> command at 1-minute intervals for a maximum of 5 times.</li> </ol>
1314	FAIL	<p>The TN767E DS1 circuit pack could not deactivate the loopback through the far-end CSU.</p> <ol style="list-style-type: none"> <li>1. Make sure that the far-end DS1 is installed if the far-end CSU is a 120A CSU Module.</li> <li>2. Retry the <i>test ds1-loop UUCSS end-loopback/span-test</i> command at 1-minute intervals for a maximum of 5 times.</li> </ol>
	PASS	<p>The active long-duration loopback or span test on the TN767E circuit pack was successfully terminated.</p>

*Continued on next page*



**Table 9-253. TEST #1216 End Loopback/Span Test — Continued**

Error Code	Test Result	Description/ Recommendation
0	NO BOARD	<p>The test could not relate the internal ID to the port (no board).</p> <p>This could be due to incorrect translations, no board is inserted, an incorrect board is inserted, or an insane board is inserted.</p> <ol style="list-style-type: none"> <li>1. Check to ensure that the board translations are correct. Use the <b>add ds1 UUCSS</b> command to administer the DS1 interface if it is not already administered.</li> <li>2. If board was already administered correctly, check the error log to determine if the board is hyperactive. If this is the case, the board is shut down. Reseating the board will re-initialize the board.</li> <li>3. If the board was found to be correctly inserted in step 1, issue the <b>busyout board</b> command.</li> <li>4. Issue the <b>reset board</b> command.</li> <li>5. Issue the <b>release busy board</b> command.</li> <li>6. Issue the <b>test board long</b> command.</li> </ol> <p>This should re-establish the link between the internal ID and the port.</p>

**ICSU Status LEDs Test (#1227)**

The TN767E DS1 circuit pack has four status LEDs on the faceplate in addition to the three standard faceplate LEDs. These four status LEDs are associated with the 120A1 Channel Service Unit (CSU) Module that can be connected to the TN767E board via the I/O connector panel on the back of the port carrier.

This test is a visual test. It will light the four status LEDs red for 5 seconds, then light them green for 5 seconds, then light them yellow for 5 seconds, then turn the LEDs off and returns control of the status LEDs to the circuit pack.

This test will only be executed on TN767E or later suffix DS1 circuit packs administered for 24-channel operation (1.544 bit rate).

If the 1201 CSU Module is not installed, the status LEDs are always off and this test aborts.

**Table 9-254. TEST #1227 ICSU Status LEDs Test**

Error Code	Test Result	Description/ Recommendation
	ABORT	Internal system error 1. Retry the command at 1-minute intervals a maximum of 5 times.
1005	ABORT	The ICSU Status LEDs test can not be executed for the current configuration. The test applies only to TN767E or later DS1 circuit packs administered for 24-channel operation (1.544 bit rate). 1. If the circuit pack is a TN767E or later suffix DS1 circuit pack, then retry the command.
1951	ABORT	The ICSU Status LEDs Test can not be executed because a 120A1 or later suffix CSU Module is not physically installed. If using a 120A1 CSU Module, physically connect it to the TN767E board on the back of the port carrier otherwise, ignore this abort.
2100	ABORT	Could not allocate the necessary system resources to run this test. 1. Retry the command at 1-minute intervals for a maximum of 5 times.
2500	ABORT	Internal system error. 1. Retry the command.
	PASS	The ICSU Status LEDs test executed successfully. A PASS result, however, does not necessarily mean that the status LEDs behaved properly. It only means that the software successfully attempted to light the status LEDs. This is a visual test. The service technician must visually exam the behavior of the LEDs while the test is running. The LEDs are functioning properly if the four status LEDs are lit red for 5 seconds, then lit green for 5 seconds, then lit yellow for 5 seconds. If the LEDs behave differently, the board should be replaced at the customer's convenience.

Table 9-254. TEST #1227 ICSU Status LEDs Test — Continued

Error Code	Test Result	Description/ Recommendation
0	NO BOARD	<p>The test could not relate the internal ID to the port (no board).</p> <p>This could be due to incorrect translations, no board is inserted, an incorrect board is inserted, or an insane board is inserted.</p> <ol style="list-style-type: none"><li>1. Check to ensure that the board translations are correct. Use the <b>add ds1 UUCSS</b> command to administer the DS1 interface if it is not already administered.</li><li>2. If board was already administered correctly, check the error log to determine if the board is hyperactive. If this is the case, the board is shut down. Reseating the board will re-initialize the board.</li><li>3. If the board was found to be correctly inserted in step 1, issue the <b>busyout board</b> command.</li><li>4. Issue the <b>reset board</b> command.</li><li>5. Issue the <b>release busy board</b> command.</li><li>6. Issue the <b>test board long</b> command.</li></ol> <p>This should re-establish the linkage between the internal ID and the port.</p>

## DS1-FAC (DS1 Facility)

MO Name (in Alarm Log)	Alarm Level	Initial Command to Run <sup>1</sup>	Full Name of MO
DS1-FAC	MAJOR	test board UUCSS sh r 1	DS1 Facility
DS1-FAC	MINOR	test board UUCSS sh r 1	DS1 Facility
DS1-FAC	WARNING	test board UUCSS sh r 1	DS1 Facility

1. UU is the universal cabinet number (1 for PPN, 2-44 for EPNs). C is the carrier designation (A, B, C, D, or E). SS is the number of the slot in which the circuit pack resides (01 to 21). f is the DS1 facility (a, b, c, or d). See Chapter 7, or the DS1C-BD section, for identification of DS1 facility LEDs.

The DS1-FAC is a part of the DS1 Converter (DS1 CONV) Complex. The DS1 CONV Complex consists of two TN574 DS1 CONV circuit packs or two TN1654 DS1 CONV circuit packs connected by one to four DS1 facilities. The maintenance object name for the DS1 CONV circuit pack is DS1C-BD, and the maintenance object name for the connected DS1 facilities is DS1-FAC.

The TN1654 DS1 Converter Circuit pack is a redesign of the TN574 DS1 Converter board. The TN1654 provides functionality equivalent to the TN574 but also adds a 32-Channel E1 interface for international support as well as circuit-switched wideband connections (NxDS0).

The TN1654 DS1 CONV circuit pack is not compatible with the TN574 DS1 CONV board or the Y-cable used to interface to the TN574 DS1 CONV. A TN573B or later suffix SNI board must also be used when connecting to the TN1654 DS1 CONV board. See section DS1C-BD for information on both DS1 CONV circuit packs.

The DS1 CONV Complex is a part of the Port Network Connectivity (PNC). The DS1 CONV Complex is used to extend the range of the 32 Mbps fiber links that connect EPNs to either the PPN or the Center Stage Switch, allowing EPNs to be located at remote sites.

The DS1 CONV circuit pack contains on-board firmware that detects DS1 facility alarms and errors, communicates status to maintenance software, and runs tests in the background or on demand from maintenance software. The overall maintenance software strategy includes demand tests, recovery strategies, error logging and alarm logging, and periodic audits.

Every error condition reported by the firmware is associated with the background tests that the firmware runs autonomously. Demand tests that are executed by the maintenance software do not have any functionality that would effect any additional error manipulation by the firmware. However, the Failure Audit test

#949 effects auditing of the software error log by forcing the firmware to report the pending errors again.

DS1 CONV circuit packs are connected to the Expansion Interface (EI) circuit packs (TN570) and the Switch Node Interface (SNI) circuit packs (TN573) as shown in [Figure 9-27](#).

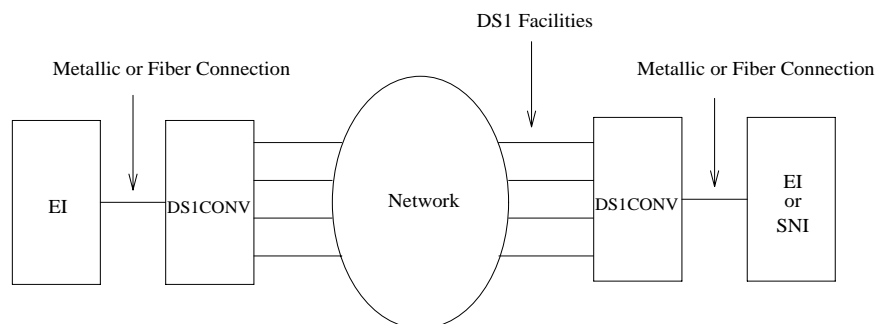

---

**Figure 9-27. DS1 CONV Complex and the DS1 Facilities**

The DS1 CONV Complex can replace fiber links between two EIs and fiber links between an EPN EI and an SNI. Fiber links between two SNIs and fiber links between the Processor Port Network (PPN) and the Center Stage Switch (CSS) cannot be replaced by a DS1 CONV Complex.

On the TN574 DS1 CONV circuit pack, one of the four DS1 facilities is used as the primary facility (or packet facility), and it is the only facility that can carry packet traffic besides providing circuit connections. The primary facility has 22 channels available for circuit and packet connections. Other facilities each have 24 channels available for circuit connections. On the TN574 primary facility, channels 1 and 24 are not available for packet or for circuit connections. Channel 1 is used for excess packets traffic to prevent packet overflow that might result from zero code substitutions. Channel 24 is the DS1 Control Channel that carries control link data between the two DS1 CONV circuit packs.

The primary facility on the TN1654 DS1 CONV circuit pack is restricted to facility A or facility B. The TN1654 provides fixed packet bandwidth of 192 Kbps while the TN574 provides packet bandwidth of up to 1408 Kbps with a dynamic allocation mechanism that could change packet/circuit use of individual channels. The first three 64 Kbps channels on the primary facility of the TN1654 are reserved as the packet channels. The DS1 Control Channel will be Channel 24 in T1 mode and Channel 31 in E1 mode. In T1 format the TN1654 provides 24 circuit channels for use on non-primary facilities and 20 circuit channels on the primary facility. E1 format provides 31 circuit channels for use on non-primary facilities and 27 circuit channels on the primary facility.

When there are alarms on the packet facility, DS1 CONV circuit pack firmware changes the mapping of the DS1 channels to move the packet traffic to another facility. On TN574 DS1 CONV boards, the packet traffic will be moved to another "Digital Data Compatible" facility (as indicated on the fiber link administration screen). On TN1654 DS1 CONV boards, the packet traffic will be moved to either facility A or B if available. This mapping is done to keep the packet service operational at all times as the system control links are carried on these packet connections. When packet traffic is moved to another facility, circuit connections on the new facility are torn down and circuit connections on the old (faulty) facility are re-mapped to the new packet facility.

After firmware initialization, facility A, the first facility, is chosen as the default primary facility for both DS1 CONV boards.

The TN574 DS1 CONV has seven LEDs which provide an indication of the state of the DS1 CONV circuit pack and the DS1 facilities. There is a yellow, a green, and a red LED under software and/or firmware control. There are four Green LEDs under hardware control that indicate, for each DS1 facility, whether a receive signal is present for the DS1 facility. From top to bottom these green LEDs correspond to DS1 facilities A, B, C, and D respectively. If one of the four green LED is on, it indicates a signal is present, but it does not imply that the signal is using the correct framing format (ESF or D4) or line coding (ZCS or B8ZS). See section DS1C-BD for the description of the red, the green, and the yellow LEDs on the DS1 CONV circuit pack.

The TN1654 DS1 CONV board has eleven LEDs on its faceplate. The top three system standard LEDs (yellow, green and red) are used to provide an indication of the state of the DS1 CONV board. The bottom four LEDs on the TN1654 board are labeled SPAN LEDs. These LEDs are under firmware control. If the facility is not administered, then the LED is not lit. The LED is lit amber if the facility is running alarm free. If the facility is detecting either a red alarm (loss-of-signal or loss-of-frame), a yellow alarm (remote frame alarm) or a blue alarm (AIS signal) then the LED is lit red. See section DS1C-BD for a complete description off all the LEDs.

The TN1654 DS1 CONV circuit pack supports the Wideband Switching feature. The TN574 DS1 CONV does not.

## DS1 Facility Busyout

Busying out a maintenance object allows service to be disconnected gracefully. Busyout puts the object out-of-service until the repair procedures are completed.

DS1 facilities are busied out via the **busyout ds1-facility** command. When an attempt is made to busyout the packet facility (or primary facility), system will print a warning message indicating that the **override** option must be used to busyout the packet facility. Busying out the packet facility will result in moving the packet traffic to another facility and disconnecting circuit connections on that new facility.

The system will not allow the last packet DS1 facility to be busied out. In this case, the DS1 CONV circuit pack must be busied out instead.

When the **busyout ds1-facility** command is executed, software communicates with both DS1 CONV circuit packs in the DS1 CONV Complex. If the board at which the facility is being busied out is not accessible, then the abort code 2100 will be returned, if the board at the other end of the DS1 CONV Complex is not accessible, then the abort code 105 will be returned.

## **DS1 Facility Administration**

---

DS1 facility administration is a part of the fiber link administration. DS1 options are set on the second page of the fiber link administration screen. In Critical Reliability systems, the third page of the fiber link administration screen contains the DS1 facility options for the B side of the PNC.

DS1 facility administration is explained in the following sections. Descriptions given here do not provide complete coverage of fiber link administration. See the DEFINITY ECS Release 5 Implementation Manual (555-230-302).

## **Replacing a DS1 Facility**

Disconnecting a DS1 facility is service disrupting except on Critical Reliability Systems since they have PNC duplication.

On a Standard Reliability or High Reliability System (no PNC Duplication):

**This procedure is destructive.**

1. Busyout the DS1 facility via the **busyout ds1-facility** command.
2. Replace the DS1 facility.
3. Release the DS1 facility via the **release ds1-facility** command.

On a Critical Reliability System (PNC Duplication):

This procedure is non-destructive.

1. If the DS1 facility to be replaced is on the active PNC (its yellow LED will be on solid), first do a PNC demand interchange via the **reset pnc interchange** command. (The **status pnc** command can also be used to determine the active PNC.)
2. When the DS1 facility to be replaced is on the standby PNC (if the DS1 facility was originally on the standby PNC or after the PNC interchange has finished), busyout the DS1 facility via the **busyout ds1-facility** command.
3. Replace the DS1 facility.
4. Release the DS1 facility via the **release ds1-facility** command.

## Installing a DS1 Facility

Installing a DS1 facility is done in the following sequence:

1. Connect the facility.
2. Check the fiber link number via the **list fibers** command. Administer the DS1 facility via the **change fiber-link** command. Change the **Facility Installed** field from "no" to "yes" for the facility that is being installed.
3. Busyout the DS1 CONV circuit pack via the **busyout board** command.
4. Run the DS1 Facilities Connectivity test #790 via the **test board UUCSS long** command to make sure that the facilities are connected correctly.
5. Release the DS1 CONV circuit pack via the **release board** command.

## Removing a DS1 Facility

Removing a DS1 facility is service disrupting in any system configuration (because the DS1 facility administration is similar on both sides of the PNC on Critical Reliability Systems).

**This procedure is destructive.**

1. Busyout the DS1 facility via the **busyout ds1-facility** command.
2. Check the fiber link number via the **list fibers** command. De-administer the DS1 facility via the **change fiber-link** command. Change the **Facility Installed** field from "yes" to "no" for the facility that is being removed.
3. Disconnect the DS1 facility (or facilities in Critical Reliability System configuration).

## DS1 Interface Options

The following DS1 Interface options must be set with fiber link administration. To set the values, check the number of the fiber link via the **list fibers** command. Execute the **change fiber-link** command and set the following fields:

### Facility Installed

This field determines if the DS1 facility is installed. The field is set to yes if the facility is installed.

For TN574 DS1 CONV boards, facility A must be installed before the others. Facilities B, C and D can then be installed in any order desired since the primary facility can reside on any of the four facilities.

For TN1654 DS1 CONV boards, facility A must be installed first, then B, then C or D. This is required since the primary facility can only reside on facilities A or B.



## Passes Far-end Clock

This field determines if the DS1 facility can be used as a clock reference for the receive fiber signal. The field is set to *yes* unless the DS1 facility cannot be used as clock reference signal.

*This field appears on the fiber-link form only for TN574 DS1 CONV circuit packs. On the TN1654 DS1 CONV board, none of the facilities can be used as a clock reference for the receive fiber signal thus administration of this field is not applicable.*

DS1 facilities cannot be used as system synchronization sources.

## Digital Data Compatible

This field determines if the DS1 facility is suitable for carrying packet traffic. The field is set to *yes* unless the DS1 facility is not digital data compatible.

*This field appears on the fiber-link form only for TN574 DS1 CONV circuit packs. The TN574 circuit pack allows any of the four facilities to be used as the primary facility which carries the packet traffic. The TN1654 DS1 CONV board, however, allows packet traffic only on facilities A and B. Thus there is no need to administer this information as it is already predetermined.*

## Bit Rate

This field is used to select domestic T1 operation or international E1 operation for all facilities in the TN1654 DS1 CONV Complex. The field is set to *1.544* Mbps for T1 operation and *2.048* Mbps for E1 operation.

*This field appears on the fiber-link form only for TN1654 DS1 CONV circuit packs.*

### NOTE:

The TN1654 DS1 CONV circuit pack is also field configurable for T1 or E1 operation. All four DS1 facilities are configured to either T1 or E1 as a group via an option switch located on the component side of the circuit pack. An error will be logged and an alarm will be raised if there is a T1/E1 inconsistency between the administered bit rate and the board option switch setting.

## Idle Code

This field is used to set the idle code for all facilities on the TN1654 DS1 CONV board. This field can accept any combination of ones (1) and zeros (0) with the exception that the second left-most digit must be set to one (1) at all times.

*This field appears on the fiber-link form only for TN1654 DS1 CONV circuit packs.*

## CRC

This field determines if CRC is enabled for all facilities on the TN1654 circuit pack. The field is set to *yes* if a cyclic redundancy check (CRC) is to be performed on transmissions that the board receives.

*CRC is applicable only to E1 operation. Thus, this field appears on the fiber-link form only for TN1654 DS1 CONV circuit packs whose bit rate is administered to 2.048 Mbps.*

## DS1 CONV-1 and DS1 CONV-2 Line Compensation

The DS1 facility line signal is pre-equalized at the transmitter on the DS1 CONV circuit pack so that DS1 line pulses have correct amplitude and shape when they reach the Network Interface (see [Figure 9-28](#)). The amount of equalization necessary is determined by the distance to the Network Interface and also by the type of wiring used to connect to the Network Interface. If the equalization is not set to the correct value, potentially high error rates (errored seconds) will be observed on the DS1 facility. Equalization values are determined as follows:

Equalizer Setting	Distance to Network Interface (feet)	
	Cable type 22 AWG ABAM & 24 AWG PDS	Cable type 26 AWG PDS
1	1 to 133	0 to 90
2	133 to 266	90 to 180
3	266 to 399	180 to 270
4	399 to 533	270 to 360
5	533 to 655	360 to 450

*Line compensation is applicable only to T1 operation, thus these fields will not appear on the fiber-link form if the TN1654 DS1 CONV is administered for a bit rate of 2.048 Mbps.*

## Line Coding

This field is used to administer the line coding for the DS1 facility. For the TN574 board and the TN1654 board in T1 mode, the field may be set to *ami-zcs* or *b8zs*. If the TN1654 board is set for E1 operation, the line coding may be set to either *ami-basic* or *hdb3*. The line coding must be the same at each end of the DS1 CONV Complex.

## Framing Mode

Either *esf* or *d4* framing mode can be selected for the DS1 facility. The same framing mode must be used at each end of the DS1 CONV Complex

For TN574 DS1 CONV boards, the framing mode field is administrable.

For TN1654 DS1 CONV boards, this field is display only. It can not be administered. The TN1654 has option switches located on the component side of the circuit pack. If T1 operation is selected via the first switch, four additional switches are used to select the framing mode for each facility. Each facility can be set to either D4 or ESF framing. The framing mode field will display what the switch is set to for the DS1 facility.

*Framing Mode is applicable only to T1 operation, thus this field will not appear on the fiber-link form if the TN1654 DS1 CONV is administered for a bit rate of 2.048 Mbps.*

### **Line Termination**

This field displays the line termination for the DS1 facility on the TN1654 DS1 Converter circuit pack. This field is display only. It can not be administered. The TN1654 has option switches located on the component side of the circuit pack. If E1 operation is selected via the first switch, four additional switches are used to select the line termination for each facility. Each facility can be set to either CEPT 75 ohm coaxial or 120 ohm CEPT twisted pair. This line termination field will display what the switch is set to for the DS1 facility.

*Line Termination is applicable only to E1 operation, thus this field will not appear on the fiber-link form if the TN1654 DS1 CONV is administered for a bit rate of 1.544 Mbps*

### **Facility Circuit ID**

These fields are used to specify a unique alpha-numeric name up to 40 characters long for each DS1 facility. This field will be displayed for each facility whose *Facility Installed?* field is set to *yes*.

## DS1 Converter Performance Measurements Report

---

The DS1 Converter Performance Measurements provide link performance measurements for the DS1 facilities.

When no facility alarms exist on the DS1 facility, events that indicate a degradation in the performance of the DS1 facility are monitored and recorded. These events will generate appropriate alarms when performance of the DS1 facility has degraded below acceptable levels. These measurements include errored seconds, bursty seconds, severely errored seconds, and failed seconds.

There are two DS1 Converter Performance Measurements Sub-reports. The first sub-report, DS1 Converter Performance Measurements Summary Report, provides information on the worst 15 minute interval of data, the total for 24 hours of data and the current 15 minute counter for each of the above mentioned counters.

The second sub-report, DS1 Converter Performance Measurements Detailed Report displays a detailed log for the last 96 15-minute intervals for each of the above mentioned counters.

The DS1 Converter Performance Measurements Summary Report can be accessed with **list measurements ds1-facility summary UUCSSf [print/schedule]**. A more detailed version of the report is accessed with **list measurements ds1-facility log UUCSSf [print/schedule]**.

The user can reset all hardware and software measurement counters for a given facility with **clear measurements ds1-facility UUCSSf**. The *Counted Since* time is also reset and the *Number of Valid Intervals* count is set to zero.

The reports are printed on the screen or, by using the *print* option, on a printer attached to the terminal.

## Clearing Firmware Errors

DS1 CONV error reports are generated by firmware autonomously, they are not associated with system technician demanded tests. Therefore, **test board clear** command does not affect the error status known by the DS1 CONV firmware. To clear all the on-board firmware-detected errors unconditionally, execute the **clear firmware-counters** command.

**Error Log Entries and Test to Clear Values****Table 9-255. DS1 Facility Error Log Entries**

Error Type	Aux Data	Associated Test	Alarm Level	On/Off Board	Test to Clear Value
0 <sup>1</sup>	0	Any	Any	Any	test ds1-facility UUCSSf sh r 1
1(a)		Failure Audit #949	MAJOR	ON	test board UUCSS sh r 1
18(b)	0	busyout ds1-facility UUCSSf	WARNING	OFF	release ds1-facility UUCSS
257(c)		Failure Audit #949	MINOR	ON	test board UUCSS sh r 1
513(d)	1	Failure Audit #949	MINOR	OFF	test board UUCSS sh r 1
513(d)	2	Failure Audit #949	MINOR	OFF	test board UUCSS sh r 1
856(e)		DS1 Facility Query for Slips/Misframes #972	MINOR	OFF	none
1025(f)		Failure Audit #949	MAJOR <sup>2</sup>	OFF	test board UUCSS sh r 1
1281(g)	None	Failure Audit #949	MAJOR <sup>2</sup>	OFF	test board UUCSS sh r 1
1281(g)	1	Failure Audit #949	MAJOR <sup>2</sup>	OFF	test board UUCSS sh r 1
1281(g)	2	Failure Audit #949	MAJOR <sup>2</sup>	OFF	test board UUCSS sh r 1
1537(h)		Failure Audit #949	MAJOR <sup>2</sup>	OFF	test board UUCSS sh r 1
1793(i)		Failure Audit #949	MAJOR <sup>2</sup>	OFF	test board UUCSS sh r 1
2065(j)		DS1 Facility Query for Slips/Misframes #972	MINOR	OFF	none
2305(k)		Failure Audit #949	MAJOR	OFF	test board UUCSS sh r 1
2561(l)		Failure Audit #949	MINOR <sup>3</sup>	OFF	test board UUCSS sh r 1

1. Run the Short Test Sequence first. If all tests pass, run the Long Test Sequence. Refer to the appropriate test description and follow the recommended procedures.
2. These failures are logged as a WARNING alarm when the error is first reported. The alarm severity is raised to a MAJOR in 15 minutes if the problem persists.
3. This failure is logged as a WARNING alarm when the error is first reported. The alarm severity is raised to a MINOR in 15 minutes if the problem persists.

**Notes:**

When problems persist, resetting the DS1 CONV circuit pack via the **reset board** command may temporarily resolve the error condition and restore service until further assistance is provided.

- a. A major failure occurred on the DS1 interface hardware on the DS1 CONV circuit pack associated with this DS1 facility. Replace the DS1 CONV circuit pack.

- b. This error indicates that the DS1 facility has been busied out via the **busyout ds1-facility** command. To resolve this error, release the DS1 facility via the **release ds1-facility** command.
- c. A minor failure occurred on the DS1 interface hardware on the DS1 CONV circuit pack associated with this DS1 facility. Replace the DS1 CONV circuit pack.
- d. DS1 CONV circuit packs in this DS1 CONV Complex do not match in their framing formats or line coding formats.

*Aux Data 1* indicates that the framing formats (ESF or D4) do not match. For TN574 DS1 CONV boards, the framing mode is administered on the fiber-link form. The TN1654 DS1 CONV has option switches located on the component side of the circuit pack. If T1 operation is selected via the first switch, four additional switches are used to select the framing mode for each facility. The Framing Mode field on the fiber-link form is display-only for the TN1654 boards. It displays what the switch is set to for the DS1 facility. It can not be administered.

*Aux Data 2* indicates that the line coding formats do not match. Line Coding is an administrable value on the fiber-link form. The line coding options are *ami-zcs* or *b8zs* for TN574 boards and TN1654 boards in T1 mode. For TN1654 boards in E1 mode, the line coding options are *ami-basic* or *hdb3*.

This error should clear in 15 minutes.

- 1. Verify that DS1 facility and the network is using the same line coding (*ami-zcs*, *b8zs*, *ami-basic*, *hdb3*) and framing mode (ESF, D4). Use **list fibers** and **display fiber-link** commands to check the values for this DS1 facility. Contact T1 Network Service to check the modes used by the network.  
  
If the framing mode format differs on boards in a TN1654 DS1 CONV Complex, the DS1 CONV board that has its option switch set incorrectly will have to be physically removed from the system in order to set the facility framing mode switch properly.
  - 2. If the problem persists, reset both DS1 CONV circuit packs via the **reset board** command.
  - 3. If the problem still persists, replace this DS1 CONV circuit pack.
  - 4. If the problem still persists, replace the DS1 CONV circuit pack at the other end of the DS1 CONV Complex.
- e. More than 88 negative and/or positive slip errors occurred. This error will clear when there are no slips for 1 hour.
    - 1. Enter **display errors** and follow the associated repair procedures for any SYNC, TDM-CLK, and SNC-BD errors.
    - 2. Verify that the DS1 facility and the network are using the same Line Coding. For TN574 boards and TN1654 boards in T1 mode, also verify that the Framing Mode used is the same. Use **list fibers** and

**display fiber-link** commands to check the values for this DS1 facility. Contact T1 Network Service to check the modes used by the network. See the above sections, “Line Coding” and “Framing Mode” for details on how these options apply to the TN574 and TN1654 DS1 CONV boards.

3. For TN574 boards and TN1654 boards in T1 mode, check line equalization settings as described in the above section, “DS1 CONV-1 and DS1 CONV-2 Line Compensation.”
  4. Enter **display errors** and follow the associated repair procedures for any EXP-INTF, and SNI-BD errors for the Fiber Endpoints. Enter **display errors** and follow the associated repair procedures for any FIBER-LK errors for this fiber link.
  5. If the problem still persists, replace this DS1 CONV circuit pack.
  6. If the problem still persists, replace the DS1 CONV circuit pack at the other end of the DS1 CONV Complex.
- f. Loss of Frame Alignment (LFA) Alarm, the RED alarm: This alarm indicates that the DS1 interface associated with the DS1 facility cannot frame up on the received data.

For the following repair procedure, refer to [Figure 9-28](#) and the diagrams in the related test descriptions.

1. If the network is used instead of private T1 lines, check that the DS1 facility and the network are using the same line coding. For TN574 boards and TN1654 boards in T1 mode, also verify that the Framing Mode used is the same. For TN1654 boards, verify that the two boards in the DS1 CONV Complex are using the same bit rate. Use **list fibers** and **display fiber-link** commands to check the values for this DS1 facility. Contact T1 Network Service to verify the modes set for the network. See the above sections, “Line Coding”, “Framing Mode” and “Bit Rate” for details on how these options apply to the TN574 and TN1654 DS1 CONV boards
2. Run the Near-end External Loopback test #799 via the **test ds1-facility UUCSSf external-loopback** command by setting up a loopback at CPE side of CSU towards DS1 CONV circuit pack shown as loopback point **LB 1** in the test description diagram. If the test fails, replace connectors and the cables between CSU and the DS1 CONV circuit pack.
3. If the test passes, run the Near-end External Loopback test #799 via the **test ds1-facility UUCSSf external-loopback** command by setting up a loopback at DS1 facility side of CSU towards the DS1 CONV circuit pack shown as loopback point **LB 2** in the test description diagram. If the test fails, replace the CSU.
4. If the test #799 passes, run the Far-end Internal Loopback test #797 via the **test ds1-facility UUCSSf long** command. If the test #797 passes, go to step 6. If the test fails, then run the Near-end

External Loopback test #799 via the **test ds1-facility UUCSSf external-loopback** command at the other end of the DS1 CONV Complex, and repeat steps 2 and 3 for the other end-point.

If the system is not configured as a Critical Reliability System and if there is only one DS1 facility, then the test #799 can only be executed at the end which is closer to the SPE relative to the DS1 CONV circuit pack at the end of the DS1 CONV Complex. If the test cannot be executed for this reason, then replace the cables, connectors and the CSU at the other end of the DS1 CONV Complex.

5. If the problem could not be isolated by the near-end external loopback tests, then the fault should be between CSU A and CSU B. Contact T1 Network Service to resolve the problem(\*).
6. If the problem still persists, check for excessive slips and synchronization problems. Enter **display errors** and follow the associated repair procedures for any SYNC, TDM-CLK, or SNC-BD errors. For TN574 boards and TN1654 boards in T1 mode, check line equalization settings as described in the above section, *DS1 CONV-1 and DS1 CONV-2 Line Compensation*.
7. Enter **display errors** and follow the associated repair procedures for any EXP-INTF, and SNI-BD errors for the Fiber Endpoints. Enter **display errors** and follow the associated repair procedures for any FIBER-LK errors for this fiber link.
8. If the problem still persists, replace this DS1 CONV circuit pack.
9. If the problem still persists, replace the DS1 CONV circuit pack at the other end of the DS1 CONV Complex.

If D4 framing mode is used, an in-band alarm signal (RFA) will be transmitted that will corrupt the transmit data on this facility.

- g. *Aux Data None* This entry in the DS1 Facility Error Log will only occur prior to release V5. The DS1 CONV circuit pack's neighbor (the DS1 CONV circuit pack at the other end of the DS1 CONV complex) is unable to frame up on the signal being sent to it by this DS1 CONV circuit pack on this DS1 facility. The far-end facility will be in LFA state. To isolate faults for this case, follow the repair procedure for error type 1025 for the other end of the DS1 facility. Note that references to the near-end and far-end are reversed, for example, the neighbor is now the near-end. If D4 framing is used, received data will be corrupted as well as transmitted data.

*Aux Data 1* indicates that the facility is detecting a Remote Frame Alarm (RFA), also known as the YELLOW alarm, being sent by the remote DS1 endpoint. This Yellow alarm corresponds to the yellow F2 state documented in CCITT Recommendation I.431. If D4 framing is used, received data will be corrupted in addition to transmitted data.



*Aux Data 2* indicates that the facility is detecting a yellow F5 state alarm. This error only applies to TN1654 DS1 CONV boards in 32-channel E1 operation with CRC enabled via the fiber-link form. The F5 fault state is defined as a fault in the user-network interface, specifically in the direction from the user (PBX) to the network. Refer to CCITT recommendation I.431.

The far-end facility will be in LFA state. To isolate faults for this case, follow the same repair procedure as in error type #1025 (Loss of Frame Alignment) for the other end of the DS1 facility.

- h. Alarm Indication Signal (AIS), the BLUE alarm. This alarm indicates that the far end of the facility is out of service. This means that the other end of the DS1 facility is undergoing maintenance testing or has a LOS condition and the CSU is providing a **Keep Alive** signal. If the **Keep Alive** signal is not supplied by the CSU, a LOS condition will exist on the facility instead of the AIS. If a LOS condition exists on the facility, the green LED on the TN574 DS1 CONV circuit pack that is associated with the facility will be off; if an AIS condition exists on the facility, the green LED that is associated with the facility that has the AIS will be on. For TN1654 DS1 CONV boards, the LED associated with the facility will be lit red if either the LOS or AIS conditions exist.

To isolate faults for this case, follow the same repair procedure as in error type #1793 (Loss of Signal) for the other end of this DS1 facility.

An RFA alarm indication (YELLOW alarm) is transmitted in response to this BLUE alarm. If D4 framing is used, transmitted data is corrupted.

- i. Loss of Signal (LOS) alarm. This alarm indicates that no signal is present at the DS1 interface associated with the facility. On TN574 DS1 CONV boards, the green LED that is associated with the facility will be off. For TN1654 DS1 CONV boards, the LED that is associated with the facility will be lit red. If the LED behavior differs, replace the DS1 CONV circuit pack.

Fault isolation for this problem may be different depending on the capabilities of the CSU device that is being used. Typically, CSUs provides an LED that is useful for fault isolation (see [Figure 9-29](#)). This is the "16 Zeros" LED. This LED is momentarily lit when a string of 16 consecutive zeros is detected in the DS1 signal from the DS1 CONV. Zeros on a DS1 link are represented by an absence of a pulse. Thus, an active 16 Zeros LED indicates a LOS alarm from the DS1 CONV.

For the following repair procedure, refer to [Figure 9-28](#) and the diagrams in the related test descriptions.

1. If the DS1 facility side LOS indication on CSU A is off (inactive), check for a problem between the DS1 CONV A circuit pack and the CPE side of CSU A. Connectors, cables, and the CSU may need to be replaced.
2. If the DS1 facility side LOS indication on CSU A is on (active), check for a problem between the CSU A and the CSU B. Contact T1 Network Service to resolve the problem. <sup>1</sup>

3. If the CPE side LOS indication on CSU B is on (active), check for a problem between the CPE side of CSU B and the DS1 CONV B circuit pack. Connectors, cables, and the CSU B may need to be replaced.
4. If the CSU A and the CSU B do not provide visual CPE side and DS1 facility side LOS indications, follow the repair procedure that is given for error type #1025 (Loss of Frame Alignment). Apply the procedure first to the DS1 CONV B side instead of the DS1 CONV A where the error is reported (external loopback test is not expected to pass if we execute it at this end as long as we have the LOS indication).

Repair procedure for error type #1025 (Loss of Frame Alignment) includes execution of Near-end External Loopback test #799. If the system is not configured as a Critical Reliability System and if there is only one DS1 facility, then the test #799 can only be executed at the end which is closer to the SPE relative to the DS1 CONV circuit pack at the end of the DS1 CONV Complex. If the test cannot be executed for that reason, then still make the external loopback as if the test was going to be executed, but instead of executing the test, check the green LED at the face plate of the DS1 CONV B that is associated with this DS1 facility. If the green LED is off, then replace the connectors, cables, and the CSU B.

5. If the problem still persists, replace the DS1 CONV circuit pack at the other end of the DS1 CONV Complex.
6. If the problem still persists, replace this DS1 CONV circuit pack.

If D4 framing is used, an in-band alarm signal (RFA) is transmitted that corrupts transmit data in response to this alarm.

- j. More than 17 misframe errors occurred. This error will clear when there are no misframes for 1 hour.
  1. Enter **display errors** and follow the associated repair procedures for any SYNC, TDM-CLK, or SNC-BD errors.
  2. Verify that the DS1 facility and the network are using the same Line Coding. For TN574 boards and TN1654 boards in T1 mode, also verify that the Framing Mode used is the same. Use **list fibers** and **display fiber-link** commands to check the values for this DS1 facility. Contact T1 Network Service to check the modes used by

- 
1. ;DS1 facility may be a private line or it may be connected to the Network. Network Interface (NI) point is where the customer's maintenance responsibility ends and the DS1 facility vendor's maintenance responsibility begins. This point ideally is the T, R, T1, and R1 terminals on the rear of the CSU to which the wires of the DS1 facility vendor's DS1 facility is attached. If the NI does not occur at this point, then any cabling between the CSU terminals and the NI is also considered to be part of the CPE. This cable typically runs between the DS1 facility terminals of the CSU and a cross-connect field where the DS1 facility vendor has terminated the DS1 facility. Maintenance responsibility for this portion of the DS1 facility resides with the customer unless other arrangements are made.

- the network. See the above sections, “Line Coding” and “Framing Mode” for details on how these options apply to the TN574 and TN1654 DS1 CONV boards.
3. For TN574 boards and TN1654 boards in T1 mode, check line equalization settings as described in the above section *DS1 CONV-1 and DS1 CONV-2 Line Compensation*.
  4. Enter **display errors** and follow the associated repair procedures for any EXP-INTF, and SNI-BD errors for the Fiber Endpoints. Enter **display errors** and follow the associated repair procedures for any FIBER-LK errors for this fiber link.
  5. If the problem still persists, replace this DS1 CONV circuit pack.
  6. If the problem still persists, replace the DS1 CONV circuit pack at the other end of the DS1 CONV Complex.
- k. Facility Packet Channel Loopback Error. This error indicates that the DS1 CONV primary facility which carries the packet timeslots and DS1 control channel is looped to itself. This error applies only to facilities A and B on TN1654 DS1 CONV boards. If both facilities A and B are being used and firmware detects a loopback condition an attempt will be made to switch the primary facility to the other facility. If the other facility is looped, down or not being used, the EPN will be down until this loopback is removed.
1. Check the loopback LEDs on both CSU A and CSU B as shown in [Figure 9-28](#) to see if a CSU is in a loopback mode. Also check to see if the CSUs have been manually hard-wired into a loopback mode. Remove detected loopbacks.
  2. If the CSUs are not in loopback mode, reset both DS1 CONV boards via the **reset board** command.
- l. Facility Jitter Alarm. This alarm indicates excessive receive jitter on the DS1 facility. This error only applies to TN1654 DS1 CONV boards. The problem is external to the DS1 CONV board. It could be caused by bad wiring, a bad device (CSU or repeater) or a bad signal coming in at the Network Interface.

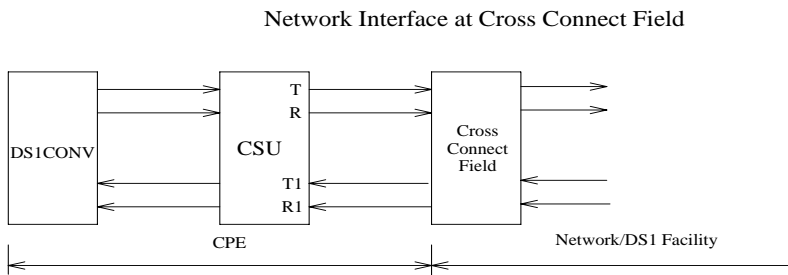
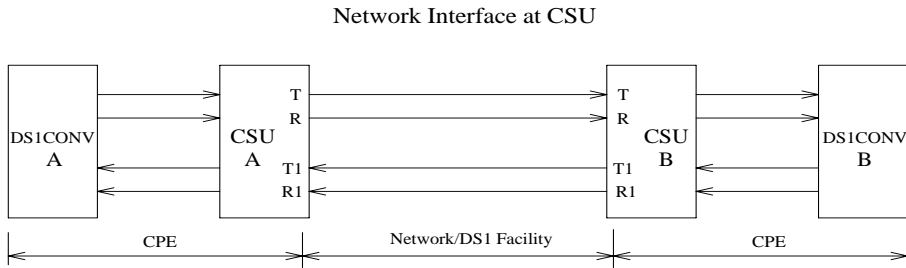

Figure 9-28. DS1 Facility Connections

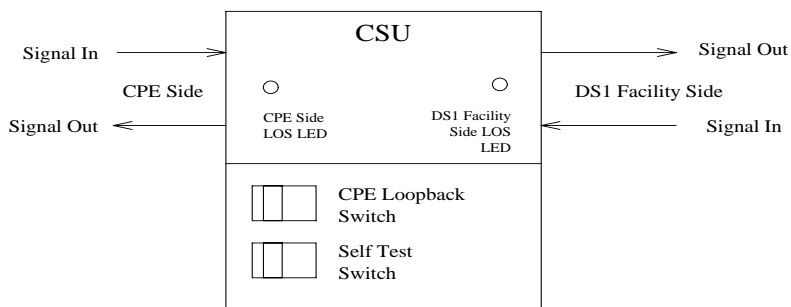

Figure 9-29. Typical CSU Maintenance Capabilities

## System Technician-Demanded Tests: Descriptions And Error Codes

Always investigate tests in the order presented in the table below. By clearing error codes associated with the *Failure Audit* for example, you may also clear errors generated from other tests in the testing sequence. The *Failure Audit* test is executed via the test board command.

Order of Investigation	Short Test Sequence	Long Test Sequence	External Loopback	Reset Sequence	D/ND <sup>1</sup>
Failure Audit (#949)					ND
DS1 Interface Options Audit (#798)	X	X			ND
Far-End Internal Loopback Test (#797)		X			D
Near-end External Loopback Test (#799)			X		D

1. D = Destructive; ND = Nondestructive

### Far-End Internal Loopback Test (#797)

**This test is destructive.**

This test starts at the DS1 CONV circuit pack whose equipment location was entered and traverses over the specified facility and loops at the internal facility interface on the other DS1 CONV circuit pack in the DS1 CONV Complex. See diagram below.

Every part of this test is executed under firmware control and the result is sent back to the maintenance software. The test is executed by sending digital data through every DS1 channel on this facility. For TN574 DS1 Converter facilities, test patterns are sent through all DS1 channels. For TN1654 DS1 Converter facilities, test patterns are sent through one DS1 channel.

If there is only one DS1 facility available, the system will not allow that last facility to be busied out. In that case, the DS1 CONV circuit pack must be busied out before executing this test.

On a Standard Reliability and High Reliability System (no PNC duplication), if there is only one DS1 facility available, then this test can only be executed at the end-point which is closer to the SPE relative to the neighbor DS1 CONV circuit pack because of its impacts on the system control links. For TN574 DS1 CONV boards, the completion of the test will be delayed in this configuration to wait for the recovery of the system control links. On a Critical Reliability System (PNC Duplication), or when there are multiple DS1 facilities, the test can be executed at any DS1 CONV circuit pack.

If the test passes on a TN1654 DS1 facility, the *round trip delay time* will be displayed in milliseconds in the *Error Code* field. The round trip delay time is defined as the length of time in milliseconds it takes for the firmware to receive the test pattern after it has been sent.

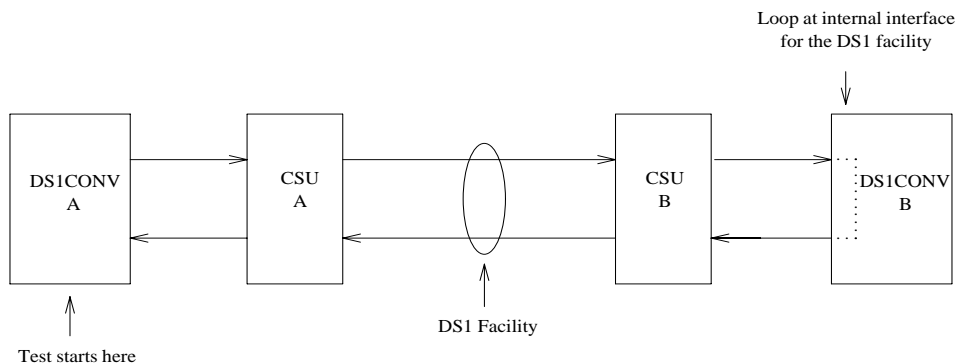

**Figure 9-30. Far-End Internal Loopback Test (#797)**

**Table 9-256. TEST #797 Far-End Internal Loopback Test**

Error Code	Test Result	Description/ Recommendation
2000	ABORT	Timed out while waiting for a response from the circuit pack.
2100	ABORT	Could not allocate the necessary system resources to run this test.
2300	ABORT	The downlink message necessary to run this test could not be sent.
2301	ABORT	The timer could not be set before sending the downlink message necessary to run this test. 1. Retry the command at 1-minute intervals a maximum of 3 times.
2316	ABORT	Fiber link is not administered. Administer the DS1 CONV fiber link via the <b>add fiber-link</b> command.
2321	ABORT	DS1 facility is not busied out. Busyout the DS1 facility via the <b>busyout ds1-facility</b> command. If there is only one DS1 facility, then busyout the DS1 CONV circuit pack via the <b>busyout board</b> command.
2332	ABORT	Test is not allowed to execute at the far end with this system configuration when there is only one DS1 facility available. Execute the test at the other end of the DS1 CONV Complex.

**Table 9-256. TEST #797 Far-End Internal Loopback Test — Continued**

Error Code	Test Result	Description/ Recommendation
2500	ABORT	Internal system error 1. Retry the command at 1-minute intervals a maximum of 3 times.
	FAIL	Far-End Internal loopback failed. A problem exists between DS1 CONV A and the internal interface for DS1 facility on the DS1 CONV B (see diagram above). 1. If the test is executed as a part of an error analysis, then return back to the related section. 2. Enter <b>display errors</b> and follow the associated repair procedures for any on-board DS1 CONV-BD errors on this DS1 CONV circuit pack and the DS1 CONV circuit pack at the other end of the DS1 CONV Complex. 3. If the network is used instead of private T1 lines, verify that the DS1 facility and the network are using the same Line Coding. For TN574 boards and TN1654 boards in T1 mode, also verify that the Framing Mode used is the same. Use <b>list fibers</b> and <b>display fiber-link</b> commands to check the values for this DS1 facility. Contact T1 Network Service to check the modes used by the network. See the above sections, "Line Coding" and "Framing Mode" for details on how these options apply to the TN574 and TN1654 DS1 CONV boards. 4. Isolate the problem by running the Near-end External Loopback test #799 via the <b>test ds1-facility UUCSSf external-loopback</b> command, first at this end and then at the other end of the DS1 CONV Complex. Setup loopbacks at different points as shown in the description diagram for test #799, and follow repair procedures described for test #799. 5. If the problem could not be found by near-end external loopback tests, then the fault should be between the CSU A and the CSU B. Contact T1 Network Service to resolve the problem, also see the repair procedures for error type #1025 (Loss of Frame Alignment).
Any	PASS	Transmission through the path of the loopback is successful. TN1654 DS1 facilities will display the round trip delay time in milliseconds in the Error Code field. The round trip delay time is defined as the length of time in milliseconds it takes for the firmware to receive the test pattern after it has been sent.

### DS1 Interface Options Audit Test (#798)

This test is non-destructive.

This test sends the administered DS1 Interface options to the DS1 CONV circuit pack. Options are sent to both DS1 CONV circuit packs at the same time to prevent any transitional mismatch of options.

The following DS1 facility options are sent to the TN574 DS1 CONV circuit pack: Framing Mode, Line Coding and DS1 CONV-1 and DS1 CONV-2 Line Compensation.

The following DS1 facility options are sent to the TN1654 DS1 CONV circuit pack: Line Coding and DS1 CONV-1 and DS1 CONV-2 Line Compensation (T1 only). These option fields are given in the fiber link administration screen.

**Table 9-257. TEST #798 DS1 Interface Options Audit**

Error Code	Test Result	Description/ Recommendation
105	ABORT	The neighbor DS1 CONV circuit pack at the other end of the DS1 CONV Complex is not accessible.
2100	ABORT	Could not allocate the necessary system resources to run this test.
2000	ABORT	Timed out while waiting for a response from the circuit pack.
2300	ABORT	The downlink message necessary to run this test could not be sent.
2301	ABORT	The timer could not be set before sending the downlink message necessary to run this test.  1. Retry the command at 1-minute intervals a maximum of 3 times.
2316	ABORT	Fiber link is not administered. Administer the DS1 CONV fiber link via the <b>add fiber-link</b> command.
2500	ABORT	Internal system error  1. Retry the command at 1-minute intervals a maximum of 3 times.
	PASS	The DS1 Interface options are sent to the circuit pack.

## Near-end External Loopback Test (#799)

### This test is destructive

This test starts at the DS1 CONV circuit pack whose equipment location was entered and traverses over the specified facility and loops back at the manually hard-wired external loopback device. Depending on the type of physical connectivity of the DS1 facility, special tools, cables or connectors may be required to make the hard-wired loopbacks.

To isolate a problem, set the loopback first at the loopback point **LB 1**, and then at the loopback point **LB 2**, see [Figure 9-31](#) and [Figure 9-28](#). Place the loopbacks at as many points as your CSU capabilities will allow. Hard-wired loopbacks at the far end are not desirable, because the equalization level adjustments may cause problems.



Every part of this test is executed under firmware control and the result is sent back to the maintenance software. The test is executed by sending digital data through every DS1 channel on this DS1 facility.

This test is executed via the **test ds1-facility UUCSSf external-loopback** command. It is not part of the Long Test Sequence because it requires modifications to the physical connectivity of the DS1 facility.

If there is only one DS1 facility available, system will not allow the last facility to be busied out. In that case, the DS1 CONV circuit pack must be busied out before executing this test.

On a Standard Reliability and High Reliability System (no PNC duplication), if there is only one DS1 facility available, then this test can only be executed at the end-point which is closer to the SPE relative to the neighbor DS1 CONV circuit pack because of its impacts on the system control links. On a Critical Reliability System (PNC Duplication), or when there are multiple DS1 facilities, the test can be executed at any DS1 CONV circuit pack.

If the test passes on a TN1654 DS1 facility, the *round trip delay time* will be displayed in milliseconds in the *Error Code* field. The round trip delay time is defined as the length of time in milliseconds it takes for the firmware to receive the test pattern after it has been sent. This measurement is taken on the last DS1 channel tested.

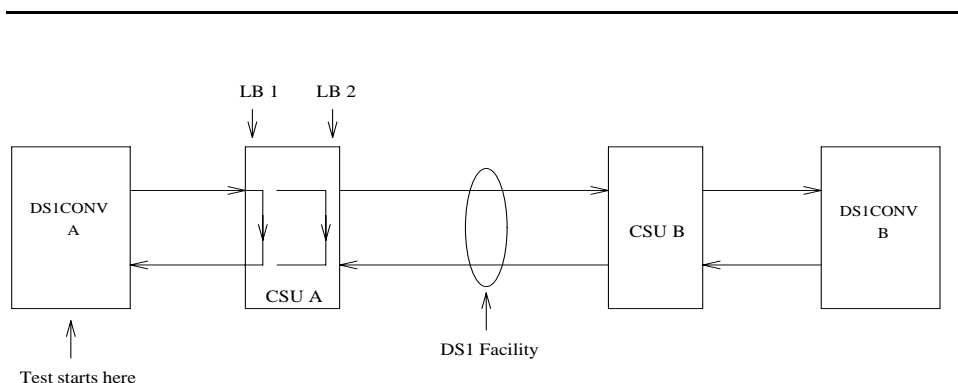

**Figure 9-31. Loopback Points for Test #799**

**Table 9-258. TEST #799 Near-end External Loopback Test**

Error Code	Test Result	Description/ Recommendation
2100	ABORT	Could not allocate the necessary system resources to run this test.
2000	ABORT	Timed out while waiting for a response from the circuit pack.
2300	ABORT	The downlink message necessary to run this test could not be sent.
2301	ABORT	The timer could not be set before sending the downlink message necessary to run this test.  1. Retry the command at 1-minute intervals a maximum of 3 times.
2316	ABORT	Fiber link is not administered. Administer the DS1 CONV fiber link via the <b>add fiber-link</b> command.
2321	ABORT	DS1 facility is not busied out. Busyout the DS1 facility via the <b>busyout ds1-facility</b> command. If there is only one DS1 facility, then busyout the DS1 CONV circuit pack via the <b>busyout board</b> command.
2332	ABORT	Test is not allowed to execute at the far end with this system configuration when there is only one DS1 facility available. Check the green LED at the face plate of the DS1 CONV circuit pack. The green LED should be on if the loop is complete.
2500	ABORT	Internal system error  1. Retry the command at 1-minute intervals a maximum of 3 times.
	FAIL	Near-end external loopback failed. A problem exists in the path of the loopback.  1. If the test is executed as a part of an error analysis, then return back to the related section.  2. Enter <b>display errors</b> and follow the associated repair procedures for any on-board DS1C-BD errors.  3. If the loopback point is <b>LB 1</b> , replace connectors and cables between the DS1 CONV A and the CSU A. If the loopback point is <b>LB 2</b> , replace CSU A. Also see the repair procedure for error type #1025 (Loss of Frame Alignment).  4. If the test still fails, replace DS1 CONV A circuit pack.
Any	PASS	Transmission through the path of the loopback is successful. TN1654 DS1 facilities will display the round trip delay time in milliseconds in the Error Code field. The round trip delay time is defined as the length of time in milliseconds it takes for the firmware to receive the test pattern after it has been sent. This measurement is taken on the last DS1 channel tested.

## Failure Audit (#949)

This test is non-destructive.

This test queries the DS1 CONV circuit pack for any existing circuit pack or facility failures and any unacknowledged cleared failure messages. Upon receiving the query request, DS1 CONV firmware sends failure reports to the maintenance software for every error in its failure database.

This test operates on both maintenance objects DS1C-BD and DS1-FAC. Error counts of both MOs (DS1C-BD and DS1-FAC) that are displayed in the error log will be incremented when this test is executed. This test is executed via the **test board** command. The test is also executed internally by the maintenance software when an alarm is resolved

**Table 9-259. TEST #949 Failure Audit**

Error Code	Test Result	Description/ Recommendation
2100	ABORT	Could not allocate the necessary system resources to run this test.
2000	ABORT	Timed out while waiting for a response from the circuit pack.
2300	ABORT	The downlink message necessary to run this test could not be sent.
2301	ABORT	The timer could not be set before sending the downlink message necessary to run this test.  1. Retry the command at 1-minute intervals a maximum of 3 times.
2316	ABORT	Fiber link is not administered. Administer the DS1 CONV fiber link via the <b>add fiber-link</b> command.
2500	ABORT	Internal system error  1. Retry the command at 1-minute intervals a maximum of 3 times.
	FAIL	The DS1 CONV circuit pack reported failures or retransmitted a cleared failure message.  1. Enter <b>display errors</b> and follow the associated repair procedures for any DS1C-BD and DS1-FAC errors.
	PASS	The DS1 CONV circuit pack has no failures.

## DS1 CONV-BD

---

### DS1 Converter (Also called DS1 CONV)

---

MO Name (in Alarm Log)	Alarm Level	Initial Command to Run <sup>1</sup>	Full Name of MO
DS1 CONV-BD	MAJOR	test board UUCSS sh r 1	DS1 CONV Circuit Pack
DS1 CONV-BD	MINOR	test board UUCSS sh r 1	DS1 CONV Circuit Pack
DS1 CONV-BD	WARNING	test board UUCSS sh r 1	DS1 CONV Circuit Pack

1. UU is the universal cabinet number (1 for PPN, 2-44 for EPNs). C is the carrier designation (A, B, C, D, or E). SS is the number of the slot in which the circuit pack resides (01 to 21).

The DS1 CONV Complex is part of the Port Network Connectivity (PNC) consisting of two TN574 DS1 Converter or two TN1654 DS1 Converter circuit packs connected by one to four DS1 facilities. It is used to extend the range of the 32 Mbps fiber links that connect EPNs to either the PPN or the Center Stage Switch, allowing EPNs to be located at remote sites.

The TN1654 DS1 Converter Circuit pack is a redesign of the TN574 DS1 Converter board. The TN1654 provides functionality equivalent to the TN574 but also adds a 32-Channel E1 interface for international support as well as circuit-switched wideband connections (NxDS0). The TN1654 is supported beginning with DEFINITY Release 5r.

Every error condition reported by the firmware is associated with background tests that the firmware runs autonomously. Demand tests that are executed by the maintenance software do not cause any new error generation by the firmware. However, the Failure Audit test #949 effects auditing of the software error log by forcing the firmware to report the pending errors again.

Maintenance of the DS1 facilities themselves is covered under the "DS1-FAC" maintenance object.

The DS1 CONV Complex can extend a fiber link between two EIs or between an EPN EI and an SNI. Fiber links between two SNIs or between the Processor Port Network (PPN) and the Center Stage Switch (CSS) cannot be extended.

The TN1654 board is not compatible with the TN574 board. A DS1 CONV Complex may consist of two TN574 boards or two TN1654 boards but a TN574 cannot be combined with a TN1654 in the same complex. A system with multiple DS1 CONV-remoted EPNs may contain DS1 CONV Complexes of both types,

TN1654 board-pairs and TN574 board-pairs. Critical reliability configurations with a pair of DS1 CONV Complexes serving an EPN require identical board pairs and facilities. For example, a TN574 Complex and a TN1654 Complex may not be used together to serve the same EPN in a critical reliability configuration.

DS1 CONV circuit packs connect to TN570 Expansion Interface (EI) circuit packs and TN573 Switch Node Interface (SNI) circuit packs via metallic cables as shown in [Figure 9-32](#). A fiber link cable can be used instead of the metallic cable if it is necessary to locate the DS1 CONV far from the connected EI or SNI circuit pack, for example, in an adjacent cabinet.

The DS1 CONV circuit pack can be placed in any regular slot in a PN carrier. However, the DS1 CONV circuit pack can only be placed in slots 1 and 21 in a Switch Node (SN) carrier. The DS1 CONV circuit pack is not connected to the TDM bus or the SN backplane. Communication to the circuit pack is done through the connected EI or the SNI circuit packs. Therefore, there is considerable interaction between the DS1 CONVs and the connected EIs and the SNIs. A special "Y" cable connects the DS1 CONV circuit pack to the Fiber Endpoint and to the facilities.

**⇒ NOTE:**

The two DS1 CONV boards, TN1654 and TN574, use unique "Y" cables that are incompatible with each other.

The TN573 SNI circuit pack is incompatible with the TN1654 board. A TN573B or later suffix SNI board must be used when connecting to a TN1654 board. The TN573B SNI board is fully backward compatible with the TN573 board and can be connected to either TN1654 or TN574 boards.

**⇒ NOTE:**

A TN573B or later suffix board must be used when connecting a SNI board to a TN1654 board. Error 125 will be logged and an on-board minor alarm will be generated against the SNI board if it is incompatible with the TN1654 circuit pack.

[Figure 9-33](#) and [Figure 9-34](#) show DS1 CONV connections in a direct connect PNC configuration and between the CSS and an EPN in a Critical Reliability System configuration (duplicated PNC).

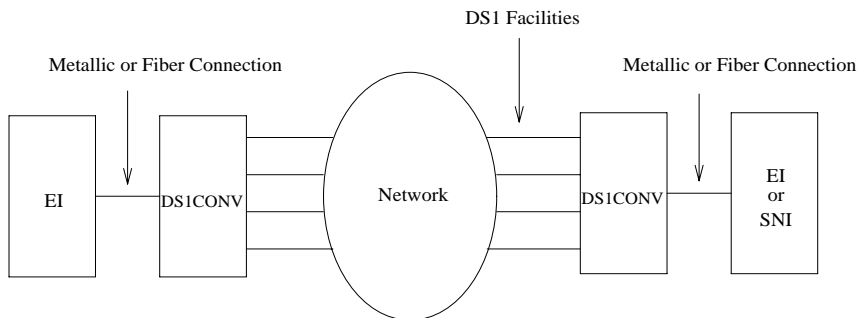

Figure 9-32. DS1 CONV connection to EIs and SNIs

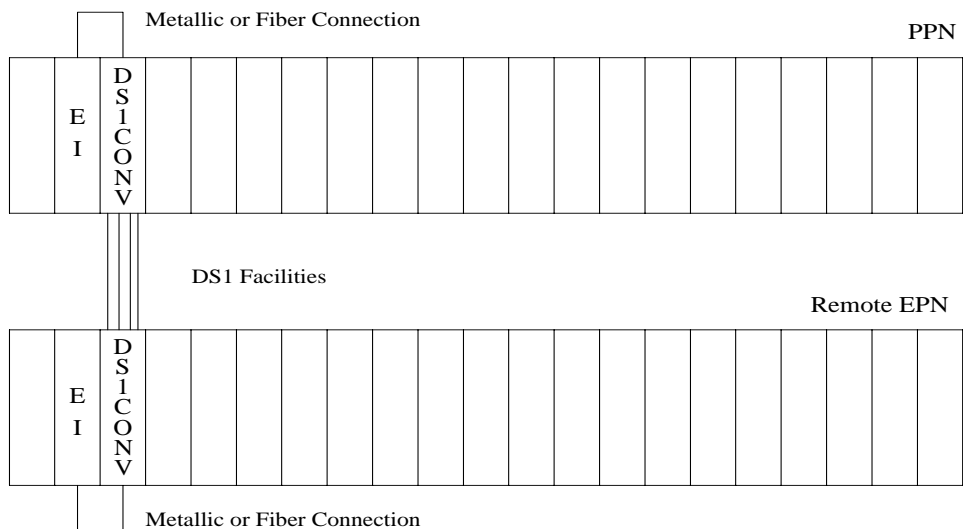

Figure 9-33. DS1 CONV Complex in Direct Connect PNC

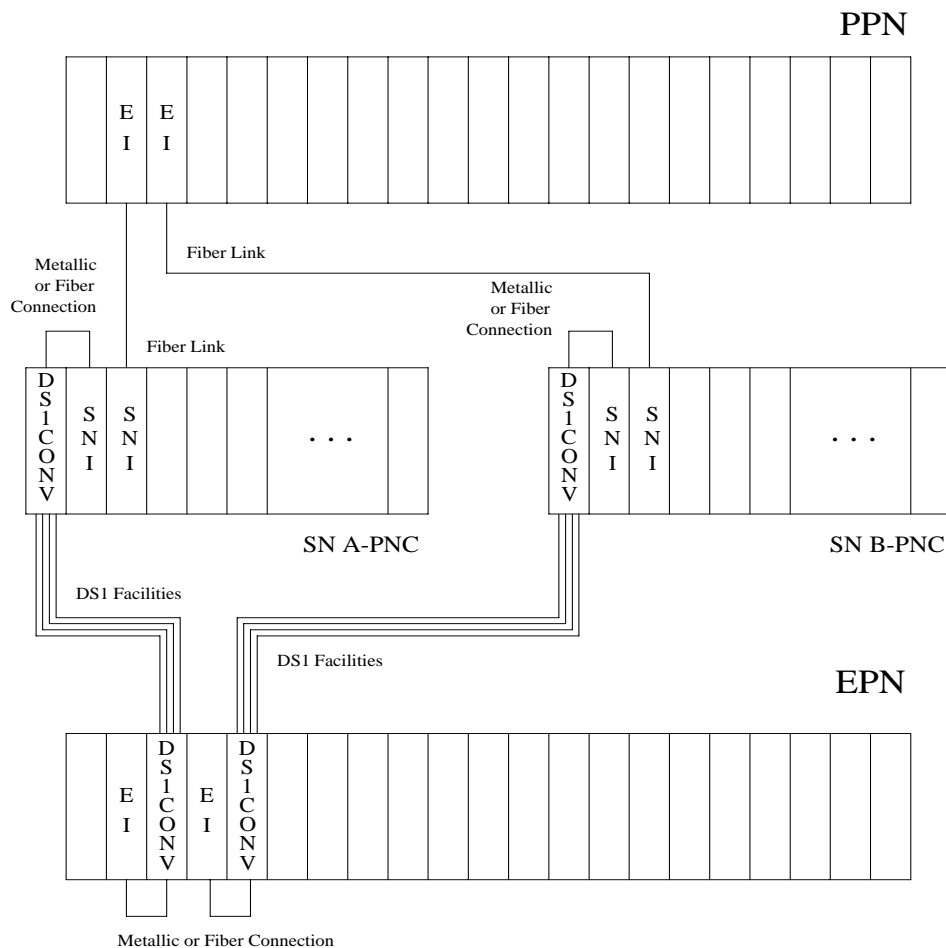

Figure 9-34. DS1 CONV Complex in Duplicated PNC with 1 SN

### DS1 CONV Administration and Board Insertion

Board insertion is the detection of a circuit pack by the system. The DS1 CONV circuit pack will not be inserted unless the circuit pack type, TN574 or TN1654, is entered into the associated field in circuit pack administration screen. The Fiber Endpoint (the EI or the SNI) must also be inserted and be operational for the DS1 CONV circuit pack to function.

Fiber link administration must be completed before the DS1 CONV maintenance can be operational. Fiber links are administered via the **add fiber-link** command. Fiber Endpoints, DS1 CONV circuit pack locations and DS1 facility options are entered as a part of the fiber link administration.

Administration steps for a Standard Reliability and High Reliability System (no PNC Duplication) are as follows:

1. Administer carriers via the **add/change cabinet** command
2. Administer circuit packs via the **change circuit-pack** command
3. Administer connectivity and the facility options of the DS1 CONV Complex via the **add/change fiber-link** command

Administration steps for a Critical Reliability System (PNC duplication) are as follows:

1. Enable PNC duplication feature using **change system-parameter customer-option** command
2. Administer carriers via the **add/change cabinet** command
3. Administer circuit packs via the **change circuit-pack** command
4. Administer connectivity and the DS1 facility options of each DS1 CONV Complex via the **add/change fiber-link** command
5. Turn on PNC duplication via the **change system-parameter duplication** command

## TN1654 Board Configuration Switch Settings

The TN1654 DS1 CONV circuit pack is field configurable for T1 or E1 operation so that a single board serves worldwide application. All four DS1 facilities are configured to either T1 or E1 as a group via an option switch located on the component side of the circuit pack. If T1 operation is selected, four additional switches are used to select the framing mode for each facility. Each facility can be set to either D4 or ESF framing. If E1 operation is selected, the same four switches are used to select the E1 facility line termination impedance. The E1 line termination impedance for each facility can be set to either 120Ω for twisted-pair or 75Ω for coaxial wiring.

T1 or E1 operation must also be administered for the TN1654 DS1 CONV board on the fiber-link form via the Bit Rate field. An error will be logged and an alarm will be raised if there is a T1/E1 inconsistency between the administered bit rate and the board option switch setting.

The T1 facility framing mode and the E1 facility line termination impedance are defined by the option switch settings only. Administration of these values is not allowed. The fiber-link form will display the selected option switch settings for each facility.

## DS1 CONV LEDs

The TN574 board has seven LEDs on its faceplate. The TN1654 board has eleven LEDs on its faceplate. The top three system standard LEDs are used to provide an indication of the state of the DS1 CONV board. These LEDs are under



firmware control until the board has established a link to the SPE via the EI or SNI. Once the link is established, software controls the three LEDs. If the link breaks, the LEDs are again under firmware control.

The red and green LEDs have the traditional use where red means an alarm condition and green indicates that maintenance testing is in progress. The red and green LED is also turned on during circuit pack initialization by firmware. When the control link to the circuit pack is lost, firmware controls the red LED to indicate an alarm condition.

The yellow LED under firmware control is used to indicate the state of the physical Fiber Interface, the Fiber Channel (link to EI or SNI), the DS1 Control Channel (link to opposite DS1 CONV board) and the SPE communications link in the following manner and order of priority. (The yellow LED remains on for longer periods of time as the DS1 CONV Complex becomes closer to being fully operational.)

1. If the Fiber is Out of Frame or if a Fiber Loss of Signal condition exists, the yellow LED will flicker at a 5 Hz rate (on for 100 ms, off for 100 ms).
2. If the Fiber Channel is down (DS1 Converter circuit pack/fiber endpoint communications), the yellow LED will flash at a 1 Hz rate (on for 500 ms, off for 500 ms).
3. If the DS1 Control Channel is down between the two DS1 CONVs in the DS1 CONV Complex, the yellow LED will pulse at a 1/2 Hz rate (on for 1 second, off for 1 second).
4. If the SPE communications link is down, the yellow LED will wink off every 2 seconds for 200 ms (2 seconds on, 200 ms off).
5. If all is well with the Fiber Interface and all communications channels, the yellow LED will remain on continuously in a Standard Reliability and High Reliability System configuration. In Critical Reliability systems (duplicated PNC), an active DS1 CONV circuit pack will have its yellow LED on continuously, and a standby DS1 CONV circuit pack will have its yellow LED off. The LED will then be under software control.

The bottom four green LEDs on the TN574 DS1 CONV board are under hardware control. The four green LEDs indicate, for each DS1 CONV facility, whether a receive signal is present for the DS1 facility

The next four LEDs on the TN1654 DS1 CONV board are labeled STATUS LEDs and are for future use. These LEDs will not be lit.

The bottom four LEDs on the TN1654 board are labeled SPAN LEDs. These LEDs are under firmware control. If the facility is not administered, then the LED is not lit. The LED is lit amber if the facility is running alarm free. If the facility is detecting either a red alarm (loss-of-signal or loss-of-frame), a yellow alarm (remote frame alarm) or a blue alarm (AIS signal) then the LED is lit red. The SPAN SELECT Switch on the TN1654 faceplate is for future use. Pushing the switch will have no effect on the board.

## Clear Firmware-Counters Command

---

DS1 CONV firmware generates error reports autonomously. This takes place independently of technician-demanded tests. Therefore, the **test board UUCSS** clear command will not affect the error status reported by firmware. The **clear firmware-counters command will clear all on-board firmware-detected errors unconditionally.**

The **clear firmware-counters UUCSS** command sends a downlink message to the DS1 CONV circuit packs, causing them to clear out their firmware error counters and failure databases. Once the firmware failure database is cleared, the failure audit test (#949) will pass. If problems still exist, the firmware will increment its error counters and the failure audit test will begin failing again.

This command should not be used as a replacement for the repair procedures associated with the hardware error log entries. This command may be useful if a problem has been fixed and off-board alarms associated with the problem are still active.

## Downtime required when upgrading to TN1654 DS1 CONV Circuit Packs

---

### **WARNING:**

*Upgrading from TN574 DS1 CONV circuit packs to TN1654 DS1 CONV circuit packs will require down time for the affected EPN.*

The TN1654 DS1 Converter circuit pack is not compatible with the TN573 SNI circuit pack, the TN574 DS1 CONV board, the Y-cable used to connect to the TN574 DS1 CONV board or pre-G3V5 software. All DS1 CONV boards and Y-cables must be upgraded. If the EPN is remoted via a Center-Stage Switch, the connected SNI must also be upgraded. A TN573B or later suffix SNI board must be used when connecting to a TN1654 DS1 CONV board.

The fiber-link administration for the TN574 DS1 CONV Complex must be removed via the remove fiber-link command. The change circuit-pack form must be updated to reflect that TN1654 boards are now being used. The TN1654 DS1 CONV Complex can then be administered via the add fiber-link command.

## Replacing a DS1 CONV Circuit Pack with the same type DS1 CONV circuit pack—Simplex PNC

---

### **WARNING:**

*Do not power down a Switch Node carrier to replace a circuit pack.*



**WARNING:**

*Replacing a Switch Node Interface, Switch Node Clock, Expansion Interface or DS1 Converter circuit pack on a simplex system disrupts service. The service effect can range from outage of a single EPN to outage of the entire system.*



**WARNING:**

*A DS1 Converter Complex must consist of two TN574 boards or two TN1654 boards. A TN574 cannot be combined with a TN1654 in the same DS1 CONV Complex.*

Steps	Comments
Enter <b>busyout board UUCSS</b>	UUCSS represents the cabinet-carrier-slot address of the circuit pack to be replaced. A G3-MT logged in at the EPN Maintenance circuit pack will remain active in spite of the busyout.
Replace the circuit pack with the same DS1 CONV board type.	
Wait for the circuit pack to reset	Red and green LEDs will light and then go out.
Enter <b>release board UUCSS</b>	<b>CAUTION:</b> <i>Do not busyout any Expansion Interface circuit pack after this point.</i>
Enter <b>test alarms long clear</b> for category <b>exp-intf</b> .	
Wait 5 minutes for SNI-BD, FIBER-LK AND DS1C-BD alarms to clear, or enter <b>clear firmware counters a-pnc</b>	

**Replacing a DS1 CONV Circuit Pack with the same type DS1 CONV circuit pack—Duplicated PNC**

---



**WARNING:**

*On a system with duplicated PNC, synchronization may be provided over a combination of active and standby components. This condition is indicated by an OFF-BOARD WARNING alarm against TDM-CLK with error type 2305. Repairs to standby PNC in this state may disrupt service. Otherwise, if the active PNC is functional, replacement of a standby component will not disrupt service.*

Steps	Comments
Enter <b>status pnc</b>	Verify that the component to be replaced is on the standby PNC.
Enter <b>busyout pnc</b>	
Enter <b>busyout board UUCSS</b>	UUCSS represents the cabinet-carrier-slot address of the circuit pack to be replaced.
Replace the circuit pack with the same DS1 CONV board type.	
Enter <b>release board UUCSS</b>	<b>CAUTION:</b> <i>Do not busyout any Expansion Interface circuit pack after this point.</i>
Enter <b>test alarms long clear</b> for category <b>exp-intf</b>	
Wait 5 minutes for SNI-BD, SNI-PEER, FIBER-LK, and DS1C-BD alarms to clear, or enter <b>clear firmware counters &lt;a-pnc or b-pnc&gt;</b>	Use the letter designation of the pnc which holds the replaced component (the standby pnc).
Enter <b>status pnc</b>	If either PNC state-of-health is not "functional", consult the PNC-DUP section of the Maintenance Manual.
Enter <b>release pnc</b>	



**WARNING:**

*Do not power down a Switch Node carrier to replace a circuit pack.*



**WARNING:**

*Replacing a Switch Node Interface, Switch Node Clock, Expansion Interface or DS1 Converter circuit pack on a simplex system disrupts service. The service effect can range from outage of a single EPN to outage of the entire system.*



**WARNING:**

*A DS1 Converter Complex must consist of two TN574 boards or two TN1654 boards. A TN574 cannot be combined with a TN1654 in the same DS1 CONV Complex.*



**WARNING:**

*The two DS1 CONV boards, TN1654 and TN574, use unique "Y" cables that are incompatible with each other.*



**WARNING:**

A TN573B or later suffix board must be used when connecting a SNI board to a TN1654 DS1 Converter board.

Steps	Comments
Enter <b>list fiber-link</b>	Determine the fiber-link number associated with the two TN574 circuit packs to be upgraded.
Enter <b>busyout fiber-link</b> <fiber #>	fiber # represents the fiber-link number associated with the TN574 DS1 CONV Complex that is being upgraded to a TN1654 DS1 CONV Complex.
Enter <b>remove fiber-link</b> <fiber #>	
Remove the TN574 DS1 CONV circuit packs from the system.	
Replace the TN574 Y-cables with appropriate TN1654 Y-cables.	
Replace the removed TN574 DS1 CONV circuit packs with TN1654 DS1 CONV circuit packs. Prior to installing the TN1654 boards, review the prior section, <i>TN1654 Board Configuration Switch Settings</i> .	
If a TN1654 DS1 CONV board is connected to an SNI board, upgrade the SNI to a TN573B or greater.	
Wait for the circuit packs to reset	Red and green LEDs will light and then go out.
Enter <b>change circuit-packs</b> < cabinet #>. Update the form to show that TN1654 boards are now being used instead of TN574 boards. Also update the connected SNI, if applicable, to suffix B.	cabinet # represents the cabinet associated with a DS1 CONV board. The appropriate <i>change circuit-packs</i> form needs to be updated for both DS1 CONV boards. Also, if needed, re-add translations for connected EI boards.
Enter <b>add fiber-link</b> <fiber #> to re-add the fiber-link using TN1654 DS1 CONV circuit packs. See the <i>Definity Enterprise Communications Server, Release 5, Implementation Manual, 555-230-302</i> , for details on TN1654 administration.	fiber # represents the fiber-link number associated with the TN574 DS1 CONV Complex that is being upgraded to a TN1654 DS1 CONV Complex
Enter <b>test alarms long clear</b> for category <b>exp-intf</b> .	

Steps	Comments
Wait 5 minutes for SNI-BD, FIBER-LK AND DS1C-BD alarms to clear, or enter <b>clear firmware-counters a-pnc</b>	

**Upgrading TN574 DS1 CONV Circuit Packs in a fiber-link to TN1654s—Duplicated PNC**



**WARNING:**

*Do not power down a Switch Node carrier to replace a circuit pack.*



**WARNING:**

*In duplicated PNC configurations, one DS1 CONV complex in the fiber-link serves as the active and the second DS1 CONV complex serves as the standby. Each DS1 Converter Complex consists of two TN574 boards or two TN1654 boards. A TN574 cannot be combined with a TN1654 in the same DS1 CONV Complex. It is also required that all four DS1 CONV boards and interconnecting facilities that serve an EPN be of the same type. Note, however, that TN574 and TN1654 boards can coexist within the same system, they just cannot be in the same fiber-link.*



**WARNING:**

*The two DS1 CONV boards, TN1654 and TN574, use unique “Y” cables that are incompatible with each other.*



**WARNING:**

*A TN573B or later suffix board must be used when connecting a SNI board to a TN1654 DS1 Converter board.*

**Table 9-260. Upgrading TN574 DS1 CONV Circuit Packs in a fiber-link to TN1654s—Duplicated PNC**

Steps	Comments
Enter <b>status pnc</b>	Verify that the A-PNC is active. If the B-PNC is active, enter the reset pnc interchange command to cause the A-PNC to go active.

*Continued on next page*

**Table 9-260. Upgrading TN574 DS1 CONV Circuit Packs in a fiber-link to TN1654s—Duplicated PNC — Continued**

Steps	Comments
Enter <b>busyout pnc-standby</b>	Fiber link can not be removed if PNC duplication is operational. Must busyout the standby PNC first.
Enter change system-parameters duplication. Change the Enable Operation of PNC Duplication? field to n.	Disable PNC duplication.
Enter <b>list fiber-link</b>	Determine the fiber-link number that the four TN574 circuit packs to be upgraded are associated with.
Enter <b>busyout fiber-link</b> <fiber #>	fiber # represents the fiber-link number associated with the TN574 DS1 CONV Complexes that are being upgraded to TN1654 DS1 CONV Complexes.
Enter <b>remove fiber-link</b> <fiber #>	
Remove the four TN574 DS1 CONV circuit packs from the system.	
Replace the TN574 Y-cables with appropriate TN1654 Y-cables.	
Replace the removed TN574 DS1 CONV circuit packs with TN1654 DS1 CONV circuit packs. Prior to installing the TN1654 boards, review the prior section, <i>TN1654 Board Configuration Switch Settings</i> .	
If a TN1654 DS1 CONV board is connected to an SNI board, upgrade the SNI to a TN573B or greater.	
Wait for the circuit packs to reset	Red and green LEDs will light and then go out.
Enter <b>change circuit-packs</b> <cabinet #>. Update the form to show that TN1654 boards are now being used instead of TN574 boards. Also update the connected SNI, if applicable, to suffix B.	cabinet # represents the cabinet associated with a DS1 CONV board. The appropriate <i>change circuit-packs</i> form needs to be updated for all four DS1 CONV boards. Also, if needed, re-add translations for connected EI boards.

*Continued on next page*

**Table 9-260. Upgrading TN574 DS1 CONV Circuit Packs in a fiber-link to TN1654s—Duplicated PNC — Continued**

Steps	Comments
Enter <b>change system-parameters duplication</b> . Change the Enable Operation of PNC Duplication? field to y.	Enable PNC duplication.
Enter <b>add fiber-link</b> <fiber #> to re-add the fiber-link using TN1654 DS1 CONV circuit packs. See the <i>Definity Enterprise Communications Server, Release 5, Implementation Manual, 555-230-302</i> , for details on TN1654 administration.	fiber # represents the fiber-link number associated with the TN574 DS1 CONV Complexes that are being upgraded to TN1654 DS1 CONV Complexes.
Enter <b>test alarms long clear</b> for category <b>exp-intf</b> .	
Wait 5 minutes for SNI-BD, SNI-PEER, FIBER-LK and DS1C-BD alarms to clear, or enter <b>clear-firmware counters</b> <a-pnc or b-pnc>	
Enter <b>status pnc</b>	If either PNC State of Health is not "functional", consult the PNC-DUP section of the Maintenance Manual.

**Converting DS1-CONV complex to direct-connect fiber (duplicated PNC)**



**NOTE:**

The procedure below is generic in its scope. Check the customer's switch configuration for EI/SNI structures.



**WARNING:**

Do not power down a Switch Node carrier to replace a circuit pack.



**WARNING:**

In duplicated PNC configurations, one DS1-CONV complex in the fiber-link serves as the active and the second DS1-CONV complex serves as the



*standby. Each DS1 Converter Complex consists of two TN574 or TN1654 circuit packs.*

**Table 9-261. Convert from DS1-CONV to direct-connect fiber in a duplicated PNC**

√	#	Command/Step	Description
	1.	<b>status pnc</b>	Verify that the A-side is active. 1. If the B-PNC is active, enter <b>reset pnc-interchange</b> and press Enter. 2. Then verify that the A-side is active ( <b>status pnc</b> ).
	3.	<b>busyout spe-standby</b>	Busyout the duplicated switch side.
	4.	<b>disable pnc-interchange</b>	Ensures that system does not switch to the duplicated side.
	5.	<b>change system-parameters duplication</b>	Disable PNC duplication by changing the Enable Operation of PNC Duplication? field to <b>n</b> .
	6.	<b>list fiber-link</b>	Lists administered fiber connections by number. Select the link number associated with the appropriate DS1-CONV complex that you are removing.
	7.	<b>busyout fiber link n</b>	Busyout the fiber link of interest. The fiber link number (Step 6) is <b>n</b> for this command.
	8.	<b>remove fiber link n</b>	Remove the link administration for this link.
	9.	<b>change circuit-pack cabinet</b>	Remove the DS1-CONV administration ("Cabinet" is the cabinet number where these DS1-CONV complexes reside).   <b>NOTE:</b> If you have to upgrade the TN573 SNI circuit packs to TN573B (see Step 9), remove the SNI administration for those circuit packs only at this time.  Press Enter.
	10.	If necessary upgrade the older TN573 SNI circuit pack to the TN573B.	<ul style="list-style-type: none"> <li>■ Remove the TN573 SNI circuit packs and replace each with a TN573B.</li> <li>■ Wait for the circuit packs to reset (both red and green LEDs are out).</li> </ul>

*Continued on next page*

**Table 9-261. Convert from DS1-CONV to direct-connect fiber in a duplicated PNC — Continued**

√	#	Command/Step	Description
	11.	Replace the DS1- CONV hardware	Remove the 4 TN574 or TN1654 DS1-CONV circuit packs and Y-cables and replace with Expansion Interface circuit packs.   <b>NOTE:</b> The TN1654 and TN574 DS1-CONV boards use unique “Y” cables that are incompatible with each other. Reuse these cables only with the proper circuit pack.
	12.	Wait for circuit packs to reset	Red and Green LEDs light then go out.
	13.	<b>change circuit-pack cabinet</b>	Re-administer the slots formerly occupied with DS1-CONV circuit packs: <ul style="list-style-type: none"> <li>■ Remove the DS1-CONV administration for the 4 designated circuit packs and add Expansion Interface (EI) administration for those slots.</li> <li>■ Change the SNI administration if you upgraded those circuit packs to TN573B in Step 9.</li> <li>■ Press Enter.</li> </ul>
	14.	Check fiberoptic cable connections	Ensure that the fiberoptic cables are securely connected to the lightwave transceivers that are attached to the designated circuit packs through the connections on the back of the cabinet.
	15.	<b>add fiber-link n</b>	Administer the new EI/SNI fiber connection
	16.	<b>change system-parameters duplication</b>	Enable PNC duplication by changing the Enable Operation of PNC Duplication? field to <b>y</b> .
	17.	Enter <b>test alarms long clear</b> for category <b>exp-intf</b> .	
	18.	Wait 5 minutes	SNI-BD, SNI-PEER, FIBER-LK and EXP-INTF maintenance objects need time to clear (or enter <b>clear firmware-counters a-pnc</b> or <b>b-pnc</b> )
	19.	Enter <b>status pnc</b>	Check: <ul style="list-style-type: none"> <li>■ if the A-PNC State of Health is not functional, consult the PNC-DUP maintenance object.</li> <li>■ that the links are up.</li> </ul>

*Continued on next page*

**Table 9-261. Convert from DS1-CONV to direct-connect fiber in a duplicated PNC — Continued**

√	#	Command/Step	Description
	20.	<b>reset pnc-interchange</b>	Force the system to the B-PNC while you change hardware, cables, and administration.
	21.	<b>status pnc</b>	Verify that the B-PNC is active.
	22.	Go back to Step #2	Use Steps #2 through 18, this time for the B-PNC.

## Error Log Entries and Test to Clear Values

**Table 9-262. DS1 CONV Board Error Log Entries**

Error Type	Aux Data	Associated Test	Alarm Level	On/Off Board	Test to Clear Value
0 <sup>1</sup>	0	Any	Any	Any	test board UUCSS sh r 1
1(a)		Failure Audit Test #949	MAJOR	ON/OFF	test board UUCSS sh r 1
18(b)	0	busyout board UCSS	WNG	OFF	release board UCSS
125(c)	3	None	MINOR	ON	
218(d) 257(e)	any	None Failure Audit Test #949	MAJOR MINOR	ON ON	test board UUCSS sh r 1
513(f)	1	Failure Audit Test #949	MAJOR	ON	test board UUCSS sh r 1
513(g)	2	Failure Audit Test #949	MAJOR	ON	test board UUCSS sh r 1
513(h)	3	Failure Audit Test #949	MAJOR	ON	test board UUCSS sh r 1
513(i)	4	Failure Audit Test #949	MAJOR	ON	test board UUCSS sh r 1
513(j)	5	Failure Audit Test #949	MAJOR	ON	test board UUCSS sh r 1
769(k)	1	Failure Audit Test #949	MINOR	ON/OFF	test board UUCSS sh r 1
769(l)	2	Failure Audit Test #949	MINOR	ON/OFF	test board UUCSS sh r 1

*Continued on next page*

Table 9-262. DS1 CONV Board Error Log Entries — Continued

Error Type	Aux Data	Associated Test	Alarm Level	On/Off Board	Test to Clear Value
769(m)	3	Failure Audit Test #949	MINOR	ON/OFF	test board UUCSS sh r 1
769(n)	5	Failure Audit Test #949	MINOR	ON/OFF	test board UUCSS sh r 1
769(o)	6	Failure Audit Test #949	MINOR	ON	test board UUCSS sh r 1
769(p)	7	Failure Audit Test #949	MINOR	ON	test board UUCSS sh r 1
1281(q)		Failure Audit Test #949	MINOR	OFF	test board UUCSS sh r 1
1537(r)		Failure Audit Test #949	MAJOR	OFF	test board UUCSS sh r 1
1793(s)		Failure Audit Test #949	MAJOR	OFF	test board UUCSS sh r 1
2049(t)		Failure Audit Test #949	MAJOR	OFF	test board UUCSS sh r 1
3329(u)		Failure Audit Test #949	WNG	OFF	test board UUCSS sh r 1

1. Run the Short Test Sequence first. If all tests pass, run the Long Test Sequence. Refer to the appropriate test description and follow the recommended procedures.

**Notes:**

When problems persist, resetting the DS1 CONV circuit pack via the **reset board** command may temporarily resolve the error condition and restore service until further assistance is provided.

- a. If the alarm is on board, then a major hardware error has occurred in a common part of the circuit pack, not circuit or packet specific. Replace the DS1 CONV circuit pack.

If the alarm is off board, then either a major hardware error has occurred in a common part of the circuit pack, or a good clock signal cannot be recovered from the synchronization source. The synchronization source can be the fiber link or any one of the DS1 facilities.

1. Enter **display errors** and follow the associated repair procedures for any SYNC, TDM-CLK, and SNC-BD errors.

2. Enter **display errors** and follow the associated repair procedures for any FIBER-LK and DS1-FAC errors.
  3. If the problem persists, replace the DS1 CONV circuit pack.
- b. This error indicates that the DS1 CONV circuit pack has been busied out via the **busyout board** command. To resolve this error, release the DS1 CONV circuit pack via the **release board** command.
  - c. The 24/32-channel option switch setting on the TN1654 circuit pack does not match the administered Bit Rate on the fiber-link form. If the on-board switch setting is wrong, the circuit pack must be physically removed to change the setting of the board option switch. If the administered bit rate is wrong, use the change fiber-link command to correct it.
  - d. The DS1 CONV board is physically installed in a slot different than its administered slot. Remove the DS1 CONV board and install it in its administered slot or execute the remove fiber-link command followed by the add fiber-link command to re-add the fiber-link setting the DS1 CONV board's administered location to the physically installed slot.
  - e. A minor hardware error has occurred in a common part of the circuit pack, not circuit or packet specific. Replace the DS1 CONV circuit pack.
  - f. A major hardware problem has occurred that affects only circuit data being received from the DS1 CONV circuit pack. Replace the DS1 CONV circuit pack.
  - g. A major hardware problem has occurred that affects only circuit data being transmitted from the DS1 CONV circuit pack. Replace the DS1 CONV circuit pack.
  - h. A major hardware problem has occurred that affects only packet data being received from the DS1 CONV circuit pack. Replace the DS1 CONV circuit pack.
  - i. A major hardware problem has occurred that affects only packet data being transmitted from the DS1 CONV circuit pack. Replace the DS1 CONV circuit pack.
  - j. A major lightwave transceiver transmit error occurred that affects data transmitted from the fiber link to the DS1 facility. Replace the DS1 CONV circuit pack.
  - k. *This error only applies to TN574 DS1 CONV circuit packs.*

If the alarm is on board, then a minor hardware problem has occurred that affects only circuit data being received from the DS1 CONV circuit pack. Replace the DS1 CONV circuit pack.

If the alarm is off board, then either a minor hardware problem has occurred that affects only circuit data being received into the DS1 CONV circuit pack or a good clock signal cannot be recovered from one of the DS1 facilities.

1. Enter **display errors** and follow the associated repair procedures for any SYNC, TDM-CLK, and SNC-BD errors.

2. Enter **display errors** and follow the associated repair procedures for any DS1-FAC errors.
3. If the problem persists, replace the DS1 CONV circuit pack.

*l. This error only applies to TN574 DS1 CONV circuit packs.*

If the alarm is on board, then a minor hardware problem has occurred that affects only circuit data being transmitted from the DS1 CONV circuit pack. Replace the DS1 CONV circuit pack.

If the alarm is off board, then either a minor hardware problem has occurred that affects only circuit data being transmitted from the DS1 CONV circuit pack or a good clock signal cannot be recovered from the fiber channel.

1. Enter **display errors** and follow the associated repair procedures for any SYNC, TDM-CLK, and SNC-BD errors.
2. Enter **display errors** and follow the associated repair procedures for any EXP-INTF, SNI-BD, and FIBER-LK errors.
3. If the problem persists, replace the DS1 CONV circuit pack.

*m. This error only applies to TN574 DS1 CONV circuit packs.*

If the alarm is on board, then a minor hardware problem has occurred that affects only packet data being received from the DS1 CONV circuit pack. Replace the DS1 CONV circuit pack.

If the alarm is off board, then either a minor hardware problem has occurred that affects only packet data being received from the DS1 CONV circuit pack or corrupted packets are being received from the packet facility.

1. Enter **display errors** and follow the associated repair procedures for any EXP-INTF, SNI-BD, and DS1-FAC errors.
2. If the problem persists enter **display errors** and follow the associated repair procedures for any SYNC, TDM-CLK, and SNC-BD errors.
3. If the problem still persists, replace the DS1 CONV circuit pack.

*n. If the alarm is on board, then a minor FOI transmit error occurred that affects data transmitted from the fiber link to the DS1 facility. Replace the DS1 CONV circuit pack.*

If the alarm is off board, then either a minor FOI transmit error occurred that affects data transmitted from the fiber link to the DS1 facility. or corrupted packets are being received from the packet facility.

1. Enter **display errors** and follow the associated repair procedures for any EXP-INTF, SNI-BD, and DS1-FAC errors.
2. If the problem persists enter **display errors** and follow the associated repair procedures for any SYNC, TDM-CLK, and SNC-BD errors.

3. If the problem still persists, replace the DS1 CONV circuit pack.
- o. A minor FOI receive error occurred that affects data received from the DS1 facility and transmitted to the fiber link. Replace the DS1 CONV circuit pack.
- p. A minor on-board hardware failure exists on the processor/control hardware on the DS1 CONV circuit pack. Replace the DS1 CONV circuit pack.
- q. For TN574 DS1 CONV boards, this error indicates that the facility masks or the clock reference masks do not match between the two DS1 CONV circuit packs in the DS1 CONV Complex.

For TN1654 DS1 CONV boards, this error indicates that the facility masks do not match between the two DS1 CONV circuit packs in the DS1 CONV Complex.

Alarm should clear in 15 minutes.

1. If the problem persists, reset both DS1 CONV circuit packs in the DS1 CONV Complex via the **reset board** command.
  2. If the problem persists, replace this DS1 CONV circuit pack.
  3. If the problem persists, replace the DS1 CONV circuit pack at the other end of the DS1 CONV Complex.
- r. The two TN574 DS1 CONV circuit packs in the DS1 CONV complex do not have the same firmware vintage. The TN574 DS1 CONV with the older vintage should be replaced. This error does not apply to TN1654 boards.
  - s. Fiber Loss of Frame Alignment (LFA) alarm occurred at the other end of the DS1 CONV Complex. The DS1 CONV circuit pack at the other end of the DS1 CONV Complex cannot frame up on the signal coming into the circuit pack from the fiber. (The neighbor DS1 CONV circuit pack detected the LFA and relayed this information to this DS1 CONV circuit pack via the DS1 Control Channel.) The yellow LED will flicker at a 5 Hz rate (on for 100 mS, off for 100 mS).
    1. Execute the **list fibers** command to determine the Fiber Endpoint that is connected to the DS1 CONV circuit pack. Enter **display errors** and follow the associated repair procedures for any EXP-INTF, and SNI-BD errors for the Fiber Endpoints. Enter **display errors** and follow the associated repair procedures for any FIBER-LK errors for this fiber link.
    2. If the problem still persists, check for excessive slips and synchronization problems. Enter **display errors** and follow the associated repair procedures for any SYNC, TDM-CLK, and SNC-BD errors.
    3. If the problem still persists, run the Far-end DS1 CONV Circuit Pack Loopback test #788 on this DS1 CONV circuit pack via the **test board UUCSS long** command. This test will indicate if the neighbor

- DS1 CONV circuit pack hardware is functioning. If this test fails, replace the DS1 CONV circuit pack at the other end of the DS1 CONV Complex.
4. If the problem still persists, run the Far-end Fiber Optic Terminator (lightwave transceiver) Loopback test #789 on this DS1 CONV circuit pack via the **test board UUCSS long** command. If this test fails, replace the lightwave transceiver that is connected to the neighbor DS1 CONV circuit pack at the other end of the DS1 CONV Complex. (If the neighbor board is connected to the Fiber Endpoint via metallic cable, then this test will abort.)
  5. If the problem still persists, replace connectors and the cable between the neighbor DS1 CONV circuit pack and the Fiber Endpoint at the other end of the DS1 CONV Complex. The cable may be a fiber or a metallic cable.
- t. Fiber Loss of Signal (LOS) alarm occurred at the other end of the DS1 CONV Complex. The DS1 CONV circuit pack at the other end of the DS1 CONV Complex does not detect a signal coming into the circuit pack from the fiber. (The neighbor DS1 CONV circuit pack detected the LOS and relayed this information to this DS1 CONV circuit pack via the DS1 Channel.) The yellow LED will flicker at a 5 Hz rate (on for 100 mS, off for 100 mS).
1. Execute the **list fibers** command to determine the Fiber Endpoints that are connected to both ends of this DS1 CONV Complex. Enter **display errors** and follow the associated repair procedures for any EXP-INTF, and SNI-BD errors for the Fiber Endpoints that are administered on this fiber link, and Enter **display errors** and follow the associated repair procedures for any FIBER-LK errors for this fiber link.
  2. If the problem still persists, run the Far-end DS1 CONV Circuit Pack Loopback test #788 on this DS1 CONV circuit pack via the **test board UUCSS long** command. This test will show if the neighbor DS1 CONV circuit pack hardware is functioning. If this test fails, replace the DS1 CONV circuit pack at the other end of the DS1 CONV Complex.
  3. If the problem still persists, run the Far-end Fiber Optic Terminator (lightwave transceiver) Loopback test #789 on this DS1 CONV circuit pack via the **test board UUCSS long** command. If this test fails, replace the lightwave transceiver that is connected to the neighbor DS1 CONV circuit pack. (If the neighbor board is connected to the Fiber Endpoint via metallic cable, then this test will abort.)
  4. If the problem persists, replace connectors and the cable between the neighbor DS1 CONV circuit pack and the Fiber Endpoint at the other end of the DS1 CONV Complex. The cable may be fiber or metallic.



- u. This error indicates that excessive slips have occurred on the fiber link between the DS1 CONV board and the Fiber Endpoint. See MO SYNC for diagnosing slip problems.

## System Technician-Demanded Tests: Descriptions And Error Codes

---

Always investigate tests in the order presented in the table below. By clearing error codes associated with the *Failure Audit* for example, you may also clear errors generated from other tests in the testing sequence. Tests 788 and 789 are executed by the TN574 DS1 Converter circuit pack only.

Order of Investigation	Short Test Sequence	Long Test Sequence	Reset Board Sequence	D/ND <sup>1</sup>
Failure Audit (#949)	X	X		ND
DS1 Facilities Connectivity Test (#790)		X		D
Far-end DS1 CONV Circuit Pack Loopback Test (#788) (Executed by TN574 only)		X		D
Far-end Lightwave Transceiver Loopback Test (#789) (Executed by TN574 only)		X		D
Board Options Audit (#795)	X	X		ND
Reset Test (#787)			X	D

1. D = Destructive; ND = Nondestructive

### NOTE:

Test #984 is not an actual demand maintenance test. This test number is used to report results of the **clear firmware-counters** command. Refer to the table for Test #949 to interpret ABORT codes for Test #984.

## Reset Test (#787)

**This test is destructive.**

DS1 CONV circuit pack is reset via the **reset board** command. When the circuit pack is reset, firmware executes a series of diagnostic tests on the circuit pack. The results of these tests are queried from the board when the board is inserted after completion of the reset sequence. If any one of the diagnostic test fails, the error log will have an entry of error type 1 for this circuit pack location, and the alarm log will have an entry of ON-BOARD MAJOR alarm.

The reset sequence will take about one minute to complete.

Table 9-263. TEST #787 Reset Board

Error Code	Test Result	Description/ Recommendation
2100	ABORT	Could not allocate the necessary system resources to run this test.
2300	ABORT	The downlink message necessary to run this test could not be sent.
2301	ABORT	The timer could not be set before sending the downlink message necessary to run this test. <ol style="list-style-type: none"><li>1. Retry the command at 1-minute intervals a maximum of 3 times.</li></ol>
2316	ABORT	Fiber link is not administered. Administer the DS1 CONV fiber link via the <b>add fiber-link</b> command.
2321	ABORT	DS1 CONV circuit pack is not busied out. Busyout the DS1 CONV circuit pack via the <b>busyout board</b> command.
2500	ABORT	Internal system error <ol style="list-style-type: none"><li>1. Retry the command at 1-minute intervals a maximum of 3 times.</li></ol>
	PASS	Reset sequence was executed successfully. This test result does not indicate if the firmware diagnostic tests have passed. Display error log via the <b>display errors</b> command to see if any one of the diagnostic firmware test have failed, this will be indicated by an entry of error type 1 for this circuit pack location, and the alarm log will have an entry of ON-BOARD MAJOR alarm, display the alarm log via the <b>display alarms</b> command.
0	NO BOARD	The system software found no board. <ol style="list-style-type: none"><li>1. Reset the board.</li><li>2. Remotely retry the command.</li></ol>

## Far-end DS1 Converter Circuit Pack Loopback Test (#788)

**This test is destructive.**

This test is executed by the TN574 DS1 Converter circuit pack only. Test #790 covers this testing for the TN1654 DS1 Converter.

This test starts at the DS1 CONV circuit pack whose equipment location was entered and loops all fiber timeslots at the far edge Fiber Optic Interface of the DS1 CONV circuit pack at the other end of the DS1 CONV Complex. See diagram below.

Every part of this test is executed under firmware control and the result is sent back to the maintenance software. Test is executed by sending digital data

through every administered DS1 facility channel. Two different test patterns are used, these are hexadecimal values 55 and AA.

On a Standard Reliability and High Reliability System (no PNC duplication), this test can only be executed at the end-point which is closer to the SPE relative to the neighbor DS1 CONV circuit pack because of its impacts on the system control links, also the completion of the test will be delayed in this configuration to wait for the recovery of the system control links. On a Critical Reliability System (PNC Duplication), test can be executed at any DS1 CONV circuit pack.

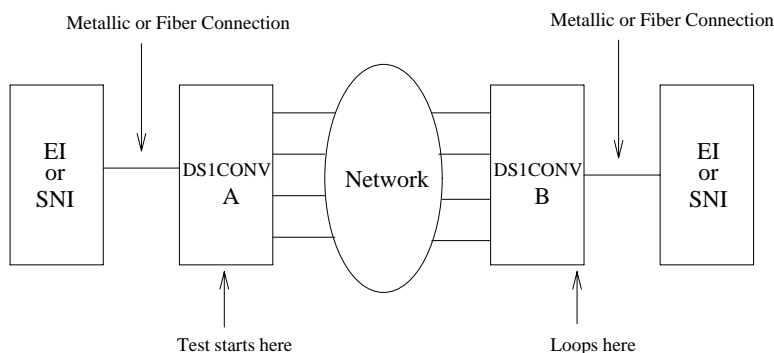

Figure 9-35. Far-end DS1 CONV Loopback Test (#788)

Table 9-264. TEST #788 Far-end DS1 Converter Board Loopback Test

Error Code	Test Result	Description/ Recommendation
2000	ABORT	Timed out while waiting for a response from the circuit pack.
2100	ABORT	Could not allocate the necessary system resources to run this test.
2300	ABORT	The downlink message necessary to run this test could not be sent to the selected DS1C board.
2301	ABORT	The timer could not be set before sending the downlink message necessary to run this test. 1. Retry the command at 1-minute intervals a maximum of 3 times.
2316	ABORT	Fiber link is not administered. Administer the DS1 CONV fiber link via the <b>add fiber-link</b> command.

Continued on next page

**Table 9-264. TEST #788 Far-end DS1 Converter Board  
 Loopback Test — Continued**

Error Code	Test Result	Description/ Recommendation
2321	ABORT	DS1 CONV circuit pack is not busied out. Busyout the DS1 CONV circuit pack via the <b>busyout board</b> command.
2332	ABORT	The test was aborted because it cannot be run at the far-end with this system configuration (PNC simplex) when there is only one DS1-FAC available (the link would be lost and no test results would be seen at the SPE). Run the test at the other end of the DS1C complex.
2500	ABORT	Internal system error 1. Retry the command at 1-minute intervals a maximum of 3 times.
	FAIL	Far-end DS1 CONV loopback failed. A problem exists between the DS1 CONV A and the DS1 CONV B (see diagram above). 1. If there are facilities that are not <b>digital data compatible</b> , then busyout those facilities via the <b>busyout ds1-facility</b> command. 2. If the test is executed as a part of an error analysis, then return back to the related section. 3. Enter <b>display errors</b> and follow the associated repair procedures for any on-board DS1C-BD errors on this DS1 CONV circuit pack and the DS1 CONV circuit pack at the other end of the DS1 CONV Complex. Enter <b>display errors</b> and follow the associated repair procedures for any DS1-FAC errors on the DS1 facilities. 4. Check the DS1 Converter Measurements Report to see if there are facilities with excessive errors, execute command <b>list measurements ds1-facility summary</b> . If there are facilities with excessive errors, execute Far-end Internal Loopback test #797 on those facilities, and follow repair procedures described for the test. 5. If the test still fails, replace the DS1 CONV circuit pack at the other end of the DS1 CONV Complex. 6. If the test still fails, replace this DS1 CONV circuit pack.
	PASS	Transmission through the path of the loopback is successful.
0	NO BOARD	The system software found no board. 1. Reset the board. 2. Remotely retry the command.

**Far-end Lightwave Transceiver Loopback Test  
 (#789)**

**This test is destructive.**

This test is executed by the TN574 DS1 Converter circuit pack only. Test #790 covers this testing for the TN1654 DS1 Converter.

This test starts at the DS1 CONV circuit pack whose equipment location was entered and loops at the Fiber Optic Terminator (lightwave transceiver) that is connected to the DS1 CONV circuit pack at the other end of the DS1 CONV Complex. See diagram below.

Every part of this test is executed under firmware control and the result is sent back to the maintenance software. Test is executed by sending digital data through every DS1 facility channel. Two different test patterns are used, these are hexadecimal values 55 and AA.

On a Standard and High Reliability System (no PNC duplication), this test can only be executed at the end-point which is closer to the SPE relative to the neighbor DS1 CONV circuit pack because of its impacts on the system control links, also the completion of the test will be delayed in this configuration to wait for the recovery of the system control links. On a Critical Reliability System (PNC Duplication), test can be executed at any DS1 CONV circuit pack.

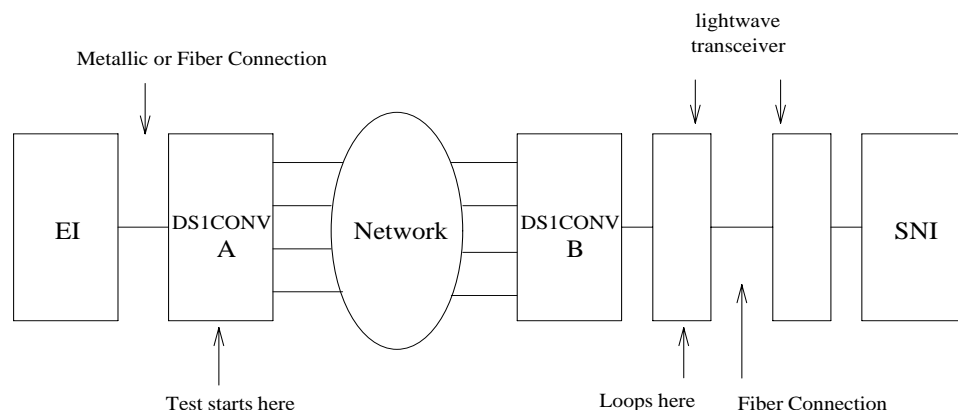

Figure 9-36. Far-end Lightwave Transceiver Loopback Test

**Table 9-265. TEST #789 Far-end FOT (Lightwave Transceiver) Loopback Test**

Error Code	Test Result	Description/ Recommendation
1410	ABORT	The test aborted because no lightwave transceiver is present. The neighbor DS1 CONV circuit pack and the fiber endpoint are connected via metallic cable. This abort may be ignored.
2000	ABORT	Timed out while waiting for a response from the circuit pack.
2100	ABORT	Could not allocate the necessary system resources to run this test.
2300	ABORT	The downlink message necessary to run this test could not be sent.
2301	ABORT	The timer could not be set before sending the downlink message necessary to run this test. 1. Retry the command at 1-minute intervals a maximum of 3 times.
2316	ABORT	Fiber link is not administered. Administer the DS1 CONV fiber link via the <b>add fiber-link</b> command.
2321	ABORT	DS1 CONV circuit pack is not busied out. Busyout the DS1 CONV circuit pack via the <b>busyout board</b> command.
2332	ABORT	The test was aborted because it cannot be run at the far-end with this system configuration (PNC simplex) when there is only one DS1-FAC available (the link would be lost and no test results would be seen at the SPE). Run the test at the other end of the DS1C complex.
2500	ABORT	Internal system error 1. Retry the command at 1-minute intervals a maximum of 3 times.

*Continued on next page*

**Table 9-265. TEST #789 Far-end FOT (Lightwave Transceiver) Loopback Test — Continued**

Error Code	Test Result	Description/ Recommendation
	FAIL	<p>Far-end lightwave transceiver loopback failed. A problem exists between the DS1 CONV A and the lightwave transceiver connected to the DS1 CONV B (see diagram above).</p> <ol style="list-style-type: none"> <li>1. If there are facilities that are not <b>digital data compatible</b>, then busyout those facilities via the <b>busyout ds1-facility</b> command.</li> <li>2. If the test is executed as a part of an error analysis, then return back to the related section.</li> <li>3. Enter <b>display errors</b> and follow the associated repair procedures for any on-board DS1 CONV-BD errors on this DS1 CONV circuit pack and the DS1 CONV circuit pack at the other end of the DS1 CONV Complex. Enter <b>display errors</b> and follow the associated repair procedures for any DS1-FAC errors on the DS1 facilities.</li> <li>4. Check the DS1 Converter Measurements Report to see if there are facilities with excessive errors, execute command <b>list measurements ds1-facility summary</b>. If there are facilities with excessive errors, execute Far-end Internal Loopback test #797 on those facilities, and follow repair procedures described for the test.</li> <li>5. If the test still fails, replace the lightwave transceiver device that is connected to the DS1 CONV circuit pack at the other end of the DS1 CONV Complex.</li> <li>6. If the test still fails, replace the DS1 CONV circuit pack at the other end of the DS1 CONV Complex.</li> <li>7. If the test still fails, replace this DS1 CONV circuit pack.</li> </ol>
	PASS	Transmission through the path of the loopback is successful.
0	NO BOARD	<p>The system software found no board.</p> <ol style="list-style-type: none"> <li>1. Reset the board.</li> <li>2. Remotely retry the command.</li> </ol>

### DS1 Facilities Connectivity Test (#790)

**This test is destructive.**

The DS1 facilities connectivity test will check the correct connectivity of the DS1 facilities at opposite ends of the DS1 CONV Complex. Every part of this test is executed under firmware control and the result is sent back to the maintenance software.

For TN574 DS1 Converter circuit packs, this test is executed by sending digital data through each timeslot of every DS1 facility channel. Two different test patterns are used, these are hexadecimal values 55 and AA.

For TN1654 DS1 Converter circuit packs, this test has been enhanced to provide error codes that point to the exact fault. Rather than simply reporting a failure of the connectivity test, the TN1654 test specifically identifies the two DS1 facilities that are cross-connected at the near and far ends of the DS1 converter complex. In addition, a fault code will indicate the condition of not being able to loop-up the far-end as required to run the test due to the packet DS1 facility being down.

The TN1654 connectivity test sends digital data through only one timeslot. Instead of looping back the facility to itself, the TN1654 version of the test loops-up the other three facilities. If the test pattern comes back, the firmware fails the test due to an incorrect connection between DS1 facilities. It should be noted that this test will pass and give no indication of problems if the non-packet facilities are down.

On a Standard and High Reliability System (no PNC duplication), this test can only be executed at the end-point which is closer to the SPE relative to the neighbor DS1 CONV circuit pack because of its impacts on the system control links. In addition, for TN574 DS1 CONV boards, the completion of the test will be delayed in this configuration to wait for the recovery of the system control links. On a Critical Reliability System (PNC Duplication), test can be executed at any DS1 CONV circuit pack.

**Table 9-266. TEST #790 DS1 Facilities Connectivity Loopback Test**

Error Code	Test Result	Description/ Recommendation
2000	ABORT	Timed out while waiting for a response from the circuit pack.
2100	ABORT	Could not allocate the necessary system resources to run this test.
2300	ABORT	The downlink message necessary to run this test could not be sent.
2301	ABORT	The timer could not be set before sending the downlink message necessary to run this test.  1. Retry the command at 1-minute intervals a maximum of 3 times.
2316	ABORT	Fiber link is not administered. Administer the DS1 CONV fiber link via the <b>add fiber-link</b> command.
2321	ABORT	DS1 CONV circuit pack is not busied out. Busyout the DS1 CONV circuit pack via the <b>busyout board</b> command.
2332	ABORT	The test was aborted because it cannot be run at the far-end with this system configuration (PNC simplex) when there is only one DS1-FAC available (the link would be lost and no test results would be seen at the SPE). Run the test at the other end of the DS1C complex.



**Table 9-266. TEST #790 DS1 Facilities Connectivity Loopback Test — Continued**

Error Code	Test Result	Description/ Recommendation
2500	ABORT	Internal system error 1. Retry the command at 1-minute intervals a maximum of 3 times.
1	FAIL	TN574 DS1 facilities connectivity loopback test failed.
2	FAIL	TN1654 Near-end DS1 facility A is connected to far-end DS1 facility B.
3	FAIL	TN1654 Near-end DS1 facility A is connected to far-end DS1 facility C.
10	FAIL	TN1654 Near-end DS1 facility A is connected to far-end DS1 facility D.
12	FAIL	TN1654 Near-end DS1 facility B is connected to far-end DS1 facility A.
13	FAIL	TN1654 Near-end DS1 facility B is connected to far-end DS1 facility C.
20	FAIL	TN1654 Near-end DS1 facility B is connected to far-end DS1 facility D.
21	FAIL	TN1654 Near-end DS1 facility C is connected to far-end DS1 facility A.
23	FAIL	TN1654 Near-end DS1 facility C is connected to far-end DS1 facility B.
30	FAIL	TN1654 Near-end DS1 facility C is connected to far-end DS1 facility D.
31	FAIL	TN1654 Near-end DS1 facility D is connected to far-end DS1 facility A.
32	FAIL	TN1654 Near-end DS1 facility D is connected to far-end DS1 facility B.
55	FAIL	TN1654 DS1 CONV packet facility is down and can't send loop-up message to the far-end.  1. Enter <b>display errors</b> and follow the associated repair procedures for any DS1-FAC errors on the DS1 facilities at both ends of the DS1 CONV Complex. If an alarm exists on a DS1 facility, then this test will fail.  2. Check the DS1 connections, both circuit packs should have their DS1 facilities connected identically.  3. Check the DS1 Converter Measurements Report to see if there are facilities with excessive errors, execute command <b>list measurements ds1-facility summary</b> . If there are facilities with excessive errors, execute Far-end Internal Loopback test #797 via the <b>test ds1-facility UUCSSf long</b> command on those facilities, and follow repair procedures described for the test.  4. Both circuit packs may not have the same translation information. Run the Board Options Audit test #795 via the <b>test board UUCSS short</b> command for both circuit packs in the DS1 CONV Complex to send the options, and check the results of this audit test. This test will not pass until the audit test problems are resolved.
PASS	DS1 facility connections are correct.	

*Continued on next page*

**Table 9-266. TEST #790 DS1 Facilities Connectivity Loopback Test — Continued**

Error Code	Test Result	Description/ Recommendation
0	NO BOARD	The system software found no board. 1. Reset the board. 2. Remotely retry the command.

*Continued on next page*

### Board Options Audit (#795)

**This test is non-destructive.**

This test sends the administered circuit pack options to the DS1 CONV circuit pack. Options are sent to both DS1 CONV circuit packs at the same time to prevent any transitional mismatch of options.

The following data is sent to the TN574 DS1 CONV circuit pack: system reliability configuration, master and slave end-points for framing (this is determined by the relative position of the circuit pack to the SPE), the facility mask (if each facility is installed), clock reference mask (whether each facility can be used as a clock reference source and whether the board is being used as a Network Timing Source), packet compatible mask (whether each facility is packet compatible) and facility information for line coding, framing mode, and line compensation.

The following data is sent to the TN1654 DS1 CONV circuit pack: system reliability configuration, master and slave end-points for framing (this is determined by the relative position of the circuit pack to the SPE), the facility mask (whether each facility is installed), idle code, CRC enabled/disabled flag (sent in E1 mode only) and facility information for line coding and line compensation (sent in T1 mode only).

**Table 9-267. TEST #795 Board Options Audit**

Error Code	Test Result	Description/ Recommendation
105	ABORT	The neighbor DS1 CONV circuit pack at the other end of the DS1 CONV Complex is not accessible (only applies to TN574 boards with vintage less than 7).  1. Retry the command at 1-minute intervals a maximum of 3 times.  2. The link to the other end of the DS1 CONV Complex may be down. Enter <b>display errors</b> and follow the associated repair procedures for any DS1C-BD and DS1-FAC errors.
2000	ABORT	Timed out while waiting for a response from the circuit pack.
2100	ABORT	Could not allocate the necessary system resources to run this test.
2300	ABORT	The downlink message necessary to run this test could not be sent.
2301	ABORT	The timer could not be set before sending the downlink message necessary to run this test.  1. Retry the command at 1-minute intervals a maximum of 3 times.
2316	ABORT	Fiber link is not administered. Administer the DS1 CONV fiber link via the <b>add fiber-link</b> command.
2500	ABORT	Internal system error  1. Retry the command at 1-minute intervals a maximum of 3 times.
	PASS	The options are sent to the circuit pack.
0	NO BOARD	The system software found no board.  1. Reset the board.  2. Remotely retry the command.

**Failure Audit (#949)**

This test is non-destructive.

This test queries the DS1 CONV circuit pack for any existing circuit pack or facility failures and any unacknowledged cleared failure messages for auditing purposes. Upon receiving the query request, DS1 CONV firmware sends failure reports to the maintenance software for every error in its failure database.

This test operates on both maintenance objects DS1C-BD and DS1-FAC. Error counts of both maintenance objects (DS1C-BD and DS1-FAC) that are displayed in the error log will be incremented when this test is executed. This test is also executed internally by the maintenance software when an alarm is resolved

**Table 9-268. TEST #949 Failure Audit**

Error Code	Test Result	Description/ Recommendation
2000	ABORT	Timed out while waiting for a response from the circuit pack.
2100	ABORT	Could not allocate the necessary system resources to run this test.
2300	ABORT	The downlink message necessary to run this test could not be sent.
2301	ABORT	The timer could not be set before sending the downlink message necessary to run this test.  1. Retry the command at 1-minute intervals a maximum of 3 times.
2316	ABORT	Fiber link is not administered. Administer the DS1 CONV fiber link via the <b>add fiber-link</b> command.
2500	ABORT	Internal system error  1. Retry the command at 1-minute intervals a maximum of 3 times.
	FAIL	The DS1 CONV circuit pack reported failures or retransmitted a cleared failure message.  1. Enter <b>display errors</b> and follow the associated repair procedures for any DS1C-BD and DS1-FAC errors.
	PASS	The DS1 CONV circuit pack has no failures.
0	NO BOARD	The system software found no board.  1. Reset the board. 2. Remotely retry the command.

## **DT-LN-BD (Data Line Circuit Pack)**

---

<b>MO Name (In Alarm Log)</b>	<b>Alarm Level</b>	<b>Initial Command to Run<sup>1</sup></b>	<b>Full Name of MO</b>
DT-LN-BD	MIN	test board UUCSS sh	Data Line Circuit Pack
DT-LN-BD	WRN	test board UUCSS sh	Data Line Circuit Pack

- 
1. UU is the universal cabinet number (1 for PPN, 2 -44 for EPNs). C is the carrier designation (A, B, C, D, or E). SS is the number of the slot in which the circuit pack resides (01 to 21).

Refer to "XXX-BD (Common Port Circuit Pack)" for circuit pack level errors. See also DAT-LINE (Data Line Circuit Port) for related line information.

## DTMR-PT (Dual Tone Multi-Frequency Receiver Port)

---

MO Name (in Alarm Log)	Alarm Level	Initial Command to Run <sup>1</sup>	Full Name of MO
DTMR-PT	MAJOR	test port UUCSSpp sh	Dual Tone Multi-Frequency Receiver Port (TTR)
DTMR-PT	MINOR	test port UUCSSpp sh	Dual Tone Multi-Frequency Receiver Port (TTR)
DTMR-PT	WARNING	release port UUCSSpp	Dual Tone Multi-Frequency Receiver Port (TTR)

1. UU is the universal cabinet number (1 for PPN, 2 -44 for EPNs). C is the carrier designation (A, B, C, D, or E). SS is the number of the slot in which the circuit pack resides (01 to 21). pp is the two digit port number (01, 02, ...).

Dual Tone Multi-Frequency Receiver Ports (DTMR), also known as Touch-Tone Receivers (TTR), reside on the following circuit packs:

- TN748 (mu-law companding)
- TN420 (A-law companding) [G3r V2]

There are four Dual Tone Multi-Frequency Receiver (DTMR-PT) ports and two General Purpose Tone Detector (GPTD-PT) ports on each Tone Detector circuit pack. The DTMR port is used to detect touch-tone digits that are placed on the Time Division Multiplex (TDM) bus. Examples of touch-tone digits are digits 0 through 9, digit #, and digit \*. The ability of the DTMR port to detect touch-tone digits is essential for maintenance of other circuit packs (for example, Tone-Clock circuit pack) and in placing a station-to-station call. Calls originating from a hybrid station *do not* require a DTMR port.

The DTMR-PT maintenance object implements a set of tests to ensure that detection of touch tone digits by the DTMR port is functioning properly. For all Tone Detector circuit pack level errors (DETR-BD), refer to the "XXX-BD (Common Port Circuit Pack)".

## Error Log Entries and Test to Clear Values

**Table 9-269. Dual Tone Multi-Frequency Receiver Port (TTR) Error Log Entries**

Error Type	Aux Data	Associated Test	Alarm Level	On/Off Board	Test to Clear Value
0 <sup>1</sup>	0	Any	Any	Any	test port UUCSSpp sh r 1
1	17664	Tone Detector Audit/ Update Test (#43)	MAJOR/ MINOR(a)	ON	test port UUCSSpp r 2
18	0	busyout port UUCSSpp	WARNING	ON	release port UUCSSpp
130 (d)		None	WARNING	ON	test port UUCSSpp sh r 2
257 (b)	17666	Tone Detector Audit/ Update Test (#43)	MAJOR/ MINOR(a)	ON	test port UUCSSpp r 3
513 (c)	Any	Tone Detection Verification Test (#42)	MAJOR/ MINOR(a)	ON	test port UUCSSpp r 3

1. Run the Short Test Sequence first. If all tests pass, run the Long Test Sequence. Refer to the appropriate test description and follow the recommended procedures.

### Notes:

- a. There are two possible alarm levels for this error: Major alarm and Minor alarm. A Major alarm is raised if the total number of DTMR ports currently in service is less than or equal to 1/2 of the administered threshold number. Otherwise, a Minor alarm is raised. In either case, run the Short Test Sequence against the DTMR port and follow the error code procedures for the individual tests.  
  
The threshold number of DTMR ports for service is administered using the **change system-parameters maintenance** command.
- b. The DTMR port lost its translation. Testing the DTMR port is sufficient to reload its translation. If testing the DTMR port does not clear the error, then the Tone Detector circuit pack containing the defective DTMR port should be replaced.
- c. This error indicates the DTMR port is having problems detecting touch-tone digits. If this error is being constantly logged, then the Tone Detector circuit pack containing the defective DTMR port should be replaced.
- d. This error type indicates that the circuit pack has been removed or has been insane for at least 11 minutes. To clear the error, reinsert or replace the circuit pack.

## System Technician-Demanded Tests: Descriptions and Error Codes

Always investigate tests in the order presented in the table below. By clearing error codes associated with the *Tone Detection Verification Test*, for example, you may also clear errors generated from other tests in the testing sequence.

Order of Investigation	Short Test Sequence	Long Test Sequence	D/ND <sup>1</sup>
Tone Detection Verification Test (#42)	X	X	ND
Tone Detector Audit/Update Test (#43)	X	X	ND

1. D = Destructive; ND = Nondestructive

### Tone Detection Verification Test (#42)

This test checks the touch-tone digits detection capability of the DTMR port.

Table 9-270. TEST #42 Tone Detection Verification Test

Error Code	Test Result	Description/ Recommendation
	ABORT	The system was not able to allocate all the resources needed for this test or there was an Internal system error.
1	ABORT	The system could not allocate all the resources needed to test the DTMR port.
1001	ABORT	The system was unable to put the DTMR port in the appropriate mode to test it.
1002	ABORT	The system could not allocate time slots for the test connection. This could happen when the system is heavily loaded. If the system is not heavily loaded, then test the TDM Bus via the <b>test tdm [a]b</b> command. <ol style="list-style-type: none"> <li>1. Retry the command at 1-minute intervals a maximum of 5 times.</li> </ol>
1003	ABORT	The system could not allocate a Tone Generator for the test connection. This may be caused by a heavy load on the system or by a faulted Tone-Clock. <ol style="list-style-type: none"> <li>1. Check to see if there are any alarms against the Tone-Clock in the port network where the test aborted. If so refer to the recommended procedures for TONE-BD or TONE-PT.</li> <li>2. If a new Tone-Clock has been inserted, allow about 1 minute for maintenance to run on the newly inserted circuit pack.</li> <li>3. Retry the command at 1-minute intervals a maximum of 5 times.</li> </ol>

*Continued on next page*



**Table 9-270. TEST #42 Tone Detection Verification Test — Continued**

Error Code	Test Result	Description/ Recommendation
2000	ABORT	Response to the test was not received within the allowable time period. 1. Retry the command at 1-minute intervals a maximum of 5 times.
2100	ABORT	Could not allocate the necessary system resources to run this test 1. Retry the command at one-minute intervals a maximum of five times.
2006	ABORT	DTMF detection failed. Make sure that the companding mode administered for the system matches that of the Tone Detector: mu-law for TN748, A-law for TN420.
1-3	FAIL	DTMF digits were not correctly detected. 1. Run the Short Test Sequence: <b>test port UUCSSpp sh r 1</b> . 2. If the problem persists, the system is still operating properly but system capacity will be reduced. In order to restore the system performance to normal, replace the Tone Detector circuit pack containing the defective DTMR port.
	PASS	The DTMR port is able to detect all the touch-tone digits.

### Tone Detector Audit/Update Test (#43)

The DTMR port is refreshed with all time slot information and sanity audit is performed on the DTMR port.

**Table 9-271. TEST #43 Tone Detector Audit/Update Test**

Error Code	Test Result	Description/ Recommendation
None	ABORT	The system was not able to allocate all the resources needed for this test. 1. Wait 1 minute and try again.
2000	ABORT	Response to the test request was not received within the allowable time period.
2100	ABORT	Could not allocate the necessary system resources to run this test. 1. Retry the command at 1-minute intervals for a maximum of 5 times.

**Table 9-271. TEST #43 Tone Detector Audit/Update Test — Continued**

Error Code	Test Result	Description/ Recommendation
	FAIL	Hardware audit failed. 1. Run the Short Test Sequence: <b>test port UUCSSpp sh r 1</b> . 2. If the problem persists, the system is still operating properly but system capacity will be reduced. In order to restore the system performance to normal, replace the Tone Detector circuit pack containing the defective DTMR port.
	PASS	The DTMR port has been successfully refreshed with its translation.

## DUP-CHL (Duplication Interface)

---

MO Name (in Alarm Log)	Alarm Level	Initial Command to Run	Full Name of MO
DUP-CHL	MAJOR	test duplication-interface l c	Duplication-Interface
DUP-CHL	MINOR	test duplication-interface l c	Duplication-Interface

The Duplication Channel (DUP-CHL) maintenance object tests both UN330B Duplication Interface circuit packs and the interconnecting cable. These tests, as a group, test end-to-end functionality. That is to say, software on the standby and the active as well as both duplication circuit packs and their cabling must be operational to some degree for these tests to PASS or FAIL. Otherwise, they will ABORT. Tests that fail are recorded in the error and alarm log as errors/alarms against the standby SPE. No errors/alarms are recorded against the active SPE for this maintenance object.

### Duplication Interface Functions

---

The Duplication Interface is comprised of two UN330B circuit packs, one in each of the duplicate SPE carriers, connected by a single Duplication Interface cable. The circuit packs and cable provide the following functions to support SPE duplication.

- Memory Shadowing

Every write to memory made by the active SPE is also written into the standby SPE memory. Only those memory writes to addresses that lie within certain address boundaries, as defined by memory bounds registers on the Duplication Interface circuit packs, and other qualified writes are shadowed.

- SPE Communication

Software running on the active SPE communicates with software on the standby SPE by sending and receiving information via the two way, general purpose mailbox mechanism provided by the circuit packs.

- Manual SPE Locking

The Duplication Interface Circuit packs monitor the relative states-of-health of the two SPEs, and control selection of active/standby status for them.

- SPE Selection

The SPE-Select switches on the Duplication Interface circuit packs can be used to lock the active SPE and prevent interchanges. See STBY-SPE for instructions.

Three Maintenance Objects are involved in the maintenance of the Duplication Interface circuit packs and their cabling: DUPINT, DUP-CHL, and SPE-SELE. DUPINT runs tests that check the operation of the active Duplication Interface circuit pack. DUP-CHL tests overall functionality of the circuit packs. This utilizes both circuit packs, their cabling, and communication with the standby software. SPE-SELE monitors the position of the select switches located on the front of the Duplication Interface circuit packs.

Testing is directional from the active Duplication Interface circuit pack to the standby Duplication Interface circuit pack. If an interchange has occurred with alarms raised against DUPINT or DUP-CHL, testing cannot resolve or clear these alarms because they are against the wrong circuit packs in the active to standby directional configuration. An interchange is needed to allow testing to resolve or clear these directional alarms.

## DUP-CHL tests

---

Eight tests run under this MO. Four of these (Status Register Comparison, SMM Channel, Remote SPE Error, and Memory Shadowing) are run at system initialization, during short and long demand testing, and during periodic and scheduled testing. Three other tests (Remote Loop-Around, State-of-Health, and Memory Shadowing Disable) are run only at initialization time (reset system 2 or higher) and during long demand testing. The FIFO Full destructive test is run only as a long demand test.

For long demand testing use **test duplication-interface long clear**. The clear option is needed to clear alarms for error types that don't have an associated test. Since these tests require the turning on and off of memory shadowing, you must enter the command **busyout spe** before the long sequence can be run. Busying out the SPE turns off memory shadowing but handshake communication continues between the SPEs. After testing of DUP-CHL is complete, **release spe** must be entered before memory shadowing is turned on and refresh completes. Memory shadowing is not turned back on if DUPINT, DUP-CHL or other MAJOR alarms pertinent to memory shadowing are not retired. See Chapter 1 and STBY-SPE for details.

**test dup** and **test dup long** run DUPINT *and* DUP-CHL tests. This is the only command that runs short and long test sequences for these maintenance objects.

Replacement procedures for the standby Duplication Interface circuit pack, the active Duplication Interface circuit pack, and the interconnecting cable appear at the end of this section (DUP-CHL). These procedures are designed to prevent disruption of customer service (except when the active Duplication Interface circuit pack must be replaced due to shadowing failure). Each procedure also describes testing after replacement to verify duplication operation when either SPE carrier is active. Test failures in a procedure may direct you to another maintenance object for repairs.

## Administration

No **add** or **remove** commands are associated with the Duplication Interface circuit packs.

## In-line errors

If standby SPE software detects problems with the standby Duplication Interface circuit pack, it will report these via the handshake to the active. The report will indicate one of the following:

- An error in reading or writing one or more of the registers on the circuit pack
- A problem with local loop around test
- A problem with the HFAIL bit being set

The last error is a bit set by the Duplication Interface circuit pack's hardware indicating a possible problem with the multiplexing of address and data during memory shadowing. No tests can retire these alarms reported by standby software. If the software stops reporting the errors, the alarms will be retired in about 15 minutes.

Other types of in-line errors are catastrophic ones resulting from FIFO overflow or Remote SPE Error interrupts. If these errors cause an alarm, shadowing will be turned off until the alarm is resolved. Alarms from these errors and the other in-line errors can be resolved by executing **test duplication-interface long clear** with no tests failing.

## MAJOR vs. MINOR alarms

DUP-CHL may have MAJOR or MINOR alarms. MAJOR alarms cause memory shadowing to be turned off. MINOR Alarms do not. DUP-CHL alarms do not lower the Standby State of Health and do not cause an SPE interchange.

Tests run by DUP-CHL are directional in nature: they are run by the active SPE on the standby SPE. Failures of these tests are logged against the standby Duplication Interface circuit pack. Consequently, should an interchange occur, alarms logged against DUP-CHL associated with the formerly standby, now active SPE can not be resolved. An interchange is required to allow testing to resolve or clear these directional alarms.

## MO interactions

**test duplication-interface** runs DUPINT and DUP-CHL non-destructive tests. **test duplication-interface long clear** runs DUPINT and DUP-CHL destructive and non-destructive tests, and requires that the standby SPE be busied out. Busying out the standby SPE turns off memory shadowing and lowers the health of the standby to *partially-functional*. This prevents an SPE interchange.

Once all DUPINT, DUP-CHL and any other alarms pertinent to shadowing are retired, a release of the standby will allow shadowing to be turned back on and refresh to complete. See STBY-SPE for more details.

DUP-CHL tests can also fail because shadowing is prevented by of a fault with MO: PKT-INT or MEM-BD. Use the command **status spe** to observe the presence of active alarms and display the alarm log to determine if alarms exist against these related maintenance objects that could cause memory shadowing to fail. MAJOR alarms from these other maintenance objects that cause memory shadowing failures must be resolved before attempting to resolve DUP-CHL alarms. A memory shadowing failure that is caused by another maintenance object such as PKT-INT can also cause a DUP-CHL alarm due to a test failure or in-line errors. Executing the **test duplication-interface long clear** command after repairing the underlying cause of the memory shadowing failure can also resolve a DUP-CHL alarm.

## Error Log Entries and Test to Clear Values

Table 9-272. Duplication Channel Error Log Entries

Error Type	Aux Data	Associated Test	Alarm Level <sup>1</sup>	On/Off Board	Test to Clear Value
0 <sup>2</sup>		Any	Any	Any	
001		State-of-Health (#873)	MINOR	ON	test dupl l
257		Memory Shadow Disable Interrupt test (#872)	MINOR	ON	test dupl l
513	any	SMM Channel test (#874)	MINOR	ON	test dupl l
769		Remote Error Interrupt test (#875)	MAJOR	ON	test dupl l
1025		Memory Shadowing test (#876)	MAJOR	ON	test dupl l
1281(a)		none	MAJOR	ON	test dupl l c
1537(b)		none	MINOR	ON	test dupl l c
1793(c)		none	MAJOR	ON	test dupl l c
2049		Remote Loop-Around test (#869)	MAJOR	ON	test dupl l
2305		FIFO Full Interrupt test (#871)	MINOR	ON	test dupl l

*Continued on next page*

**Table 9-272. Duplication Channel Error Log Entries — Continued**

Error Type	Aux Data	Associated Test	Alarm Level <sup>1</sup>	On/Off Board	Test to Clear Value
2561(d)	any	Status Register Comparison Test (#980)	MAJOR	ON	test dupl l
2817(e)	any	none	MAJOR	OFF	test dupl l c

1. DUP-CHL alarms can be resolved only when the alarmed Duplication Interface circuit pack is in the standby SPE carrier.
2. Run the Short Test Sequence first. If all tests pass, run the Long Test Sequence. Refer to the appropriate test description and follow the recommended procedures.

Notes:

- a. Reported by software on the standby via the handshake mechanism. This error indicates that software on the standby has seen the HFAIL bit become set on the standby Duplication Interface circuit pack. The setting of the HFAIL bit is an indication that an error in the multiplexing of the address and data by the Duplication Interface circuit packs has occurred. Three reports of this bit being set will result in a MAJOR alarm that can only be cleared over time (i.e. within 15 minutes of the final report) or by using **test duplication interface long clear**. Recommendation for repair (only if an alarm is raised): Replace Duplication Interface components starting with the standby Duplication Interface circuit pack. Use SPE Duplication Channel Component Replacement procedures at the end of this DUP-CHL section.
- b. Reported by the software on the standby via the handshake. This error indicates that the software on the standby failed tests with one or more of the registers located on the standby Duplication Interface circuit pack. The following Error Types are used to specify the register tests that failed:
  - 1 Control Register Test
  - 2 Shadowing Bounds Register Test
  - 4 Type/Suffix/Vintage Register Test
  - 3, 5, 6, 7 Additive combinations of the above

Three reports of this error will result in a MINOR alarm that can only be cleared over time (within 15 minutes of the final report) or by using **test duplication interface long clear**. Follow the repair procedures listed in note a above.

- c. Reported by the software on the standby the handshake mechanism. This error indicates that the software on the standby failed the Local Loop-Around test on the standby Duplication Interface circuit pack. Three

reports of this error will result in a MAJOR alarm that can only be cleared over time (within 15 minutes of the final report) or by using **test duplication interface long clear**. Follow the repair procedures listed in note a above.

d. Error Type 2561

- Aux Data 1032 or 2032 (SPE A); Aux Data 1016 or 2016 (SPE B): indicates a discrepancy between the SPE select switch settings and the **status spe** command screen display. Do not replace any circuit packs. Call Tier 3.

e. Catastrophic in-line error failure.

- Aux Data 1: Remote SPE shadowing bus error

Possible false alarms can be caused by pulling a standby SPE circuit pack (other than TAPE or DISK) while carrier power is on. Use the following repair procedure for this off circuit pack alarm.

1. Use the **display alarms** command and select Category **spe**. If any maintenance objects other than DUPINT or DUP-CHL have MAJOR alarms, fix these problems. Problems causing MAJOR alarms for MEM-BD, PKT-INT, SYSAM, H-ADAPTR, and SW-CTL, should be repaired first.
2. Execute the **test duplication-interface long clear** command to clear this alarm. If any DUPINT or DUP-CHL test fails or aborts, use the repair strategy for that test.
3. If no DUPINT nor DUP-CHL tests failed, the DUPINT and DUP-CHL alarms are resolved or cleared in this active to standby direction so release the standby SPE from the busyout condition using the **release spe-standby** command and wait (about 10 minutes) for the standby SPE to be refreshed as observed with the **status spe** command.
4. If the standby SPE is refreshed, and fully functional, with no DUPINT or DUP-CHL alarms in the other active to standby direction, this procedure is finished.
5. If the standby SPE is refreshed, and fully functional, with DUPINT or DUP-CHL alarms in the other active to standby direction, use the **reset system interchange** command. Go to step 8.
6. If the standby SPE is not refreshed, and fully functional, with DUPINT or DUP-CHL alarms in the other active to standby direction, arrange a time with the customer to interchange the SPE carriers because this interchange will disrupt service. If the standby SPE is not cycling as indicated by the flashing yellow LED on the standby Processor circuit pack, use the lock-and-power-down procedure described in Chapter 5 to power down and power up the standby SPE. If the standby SPE is still not cycling, escalate the problem.



7. Hard switch into the standby SPE by moving both SPE Select switches to the position that selects the standby SPE as active.
8. After the interchange, use the **busyout spe-standby** command. If the SPE Select switches are not in the auto position, move the switches to the auto position. Use the **test duplication-interface long clear** command to resolve the DUPINT and DUP-CHL alarms. If any DUPINT or DUP-CHL test fails, use the repair strategy for that test.
9. If no DUPINT nor DUP-CHL tests fail, the DUPINT and DUP-CHL alarms are resolved or cleared in both directions so release the standby SPE from the busyout condition using the **release spe-standby** command and wait (about 10 minutes) for the standby SPE to be refreshed as observed with the **status spe** command.
  - Aux Data 3: Remote Duplication Interface circuit pack FIFO overflow

Execute the **test duplication-interface long clear** command to resolve this alarm. If any DUPINT or DUP-CHL test fails, use the repair strategy for that test.

## System Technician-Demanded Tests: Descriptions and Error Codes

---

Always investigate tests in the order presented in the table below. By clearing error codes associated with the *SMM Channel test* for example, you may also clear errors generated from other tests in the testing sequence.

Order of Investigation	Short Test Sequence	Long Test Sequence	Reset Board Sequence	D/ND <sup>1</sup>
Status Register Comparison Test (#980)	X	X		ND
Remote Loop-Around Test (#869)		X		D
Dup Mailbox Test (#874)	X	X		ND
Remote Error Interrupt Test (#875)	X	X		ND
Memory Shadowing Test (#876)	X	X		ND
State-of-Health Test (#873)		X		D
Memory Shadowing Disable Test (#872)		X		D
FIFO Full Interrupt Test (#871)		X		D

---

1. D = Destructive; ND = Nondestructive

## Remote Loop-Around Test (#869)

**This test is destructive.**

This test writes a word to a memory address on the active SPE that is inverted and is looped back by the standby Duplication Interface circuit.

**Table 9-273. TEST #869 Remote Loop-Around Test**

Error Code	Test Result	Description/ Recommendation
1321	ABORT	<p>The faceplate switches on the Duplication Interface circuit packs are not set to <b>auto</b>.</p> <ol style="list-style-type: none"> <li>1. If the switches are locked because you are using a replacement procedure, continue with this procedure to the step that directs you to unlock the active SPE by moving both switches to <b>auto</b>. The next step using the <b>test duplication-interface long clear</b> should not abort with this error code.</li> <li>2. If the switches are locked and a replacement procedure is not being used, start with step 6 of the SPE Duplication Channel Component Replacement procedure for the standby</li> <li>3. Duplication Interface Circuit pack at the end of this DUP-CHL section to avoid an undesired interchange when unlocking the active SPE. If this same abort is received with both switches in auto, Replace Duplication Interface components starting with the standby Duplication Interface circuit pack. Use SPE Duplication Channel Component Replacement procedures at the end of this DUP-CHL section. In addition to looking for failures, also check for the absence of this 1321 abort code when testing after the procedure directs setting the switches to <b>auto</b> after a component replacement.</li> </ol>
1405	ABORT	<p>This test did not run because the Duplication Channel was busy.</p> <ol style="list-style-type: none"> <li>1. Retry the command at 1-minute intervals a maximum of 5 times.</li> </ol>
1411	ABORT	<p>This test did not run because the standby Duplication Interface circuit pack cannot be detected as being plugged in by the software.</p> <ol style="list-style-type: none"> <li>1. If this abort continues to occur, the standby SPE may not have initialized properly. Use the lock-and-power-down procedure described in Chapter 5 to power down and power up the standby SPE, but don't replace any circuit packs.</li> </ol>
2500	ABORT	<p>Internal system error</p> <ol style="list-style-type: none"> <li>1. Retry the command at 1-minute intervals a maximum of 5 times.</li> </ol>

*Continued on next page*

**Table 9-273. TEST #869 Remote Loop-Around Test — Continued**

Error Code	Test Result	Description/ Recommendation
	FAIL	The Remote Loop-Around Test has failed to loop a data word from the active to the standby and back to the active Duplication Interface circuit pack. <ol style="list-style-type: none"> <li>1. The standby SPE may not have initialized properly. Use the lock-and-power-down procedure described in Chapter 5 to power down and power up the standby SPE, but don't replace any circuit packs.</li> <li>2. Replace Duplication Interface components starting with the standby Duplication Interface circuit pack. Use SPE Duplication Channel Component Replacement procedures at the end of this DUP-CHL section.</li> </ol>
55	FAIL	The attempt to turn off memory shadowing in this DUPINT circuit pack could not be verified in the DUPINT hardware status register. <ol style="list-style-type: none"> <li>1. Replace Duplication Interface components starting with the standby Duplication Interface circuit pack. Use SPE Duplication Channel Component Replacement procedures at the end of this DUP-CHL section.</li> </ol>
	PASS	A data word was successfully looped around from the active to the standby and back to the active Duplication Interface circuit pack.

### FIFO Full Interrupt Test (#871)

**This test is destructive.**

This test effectively checks the correct operation of the FIFO located on the standby Duplication Interface circuit pack.

**Table 9-274. TEST #871 FIFO Full Interrupt Test**

Error Code	Test Result	Description/ Recommendation
1321	ABORT	<p>The faceplate switches on the Duplication Interface circuit packs are not set to <b>auto</b>.</p> <ol style="list-style-type: none"> <li>1. If the switches are locked because you are using a replacement procedure, continue with this procedure to the step that directs you to unlock the active SPE by moving both switches to <b>auto</b>. The next step using the <b>test duplication-interface long clear</b> should not abort with this error code.</li> <li>2. If the switches are locked and a replacement procedure is not being used, start with step 6 of the SPE Duplication Channel Component Replacement procedure for the standby Duplication Interface Circuit pack at the end of this DUP-CHL section to avoid an undesired interchange when unlocking the active SPE.</li> <li>3. If this same abort is received with both switches in auto, Replace Duplication Interface components starting with the standby Duplication Interface circuit pack. Use SPE Duplication Channel Component Replacement procedures at the end of this DUP-CHL section. In addition to looking for failures, also check for the absence of this 1321 abort code when testing after the procedure directs setting the switches to <b>auto</b> after a component replacement.</li> </ol>
1325	ABORT	<p>Memory shadowing is inhibited from the standby SPE.</p> <ol style="list-style-type: none"> <li>1. Shadowing may not be turned on yet, so wait 5 minutes and run the test again.</li> <li>2. Rerun the test; if the same 1325 abort occurs again, use the <b>display alarms</b> command and select Category <b>spe</b>. If any maintenance objects other than DUPINT or DUP-CHL have MAJOR alarms, fix these problems. Problems causing MAJOR alarms for MEM-BD, PKT-INT, SYSAM, H-ADAPTR, and SW-CTL should be repaired first.</li> <li>3. Rerun the test; if the same 1325 abort occurs again, look for other DUPINT or DUP-CHL test failures by using the <b>busyout spe-standby</b> if not already busied out and the <b>test duplication-interface long clear</b> commands. Fix these problems according to the service documentation for these packs.</li> <li>4. If this 1325 abort continues to occur, the standby SPE may not have initialized properly. Use the lock-and-power-down procedure described in Chapter 5 to power down and power up the standby SPE, but don't replace any circuit packs.</li> </ol>
1411	ABORT	<p>This test did not run because the standby Duplication Interface circuit pack cannot be detected as being plugged in by the software.</p> <ol style="list-style-type: none"> <li>1. If this abort continues to occur, the standby SPE may not have initialized properly. Use the lock-and-power-down procedure described in Chapter 5 to power down and power up the standby SPE, but don't replace any circuit packs.</li> </ol>

**Table 9-274. TEST #871 FIFO Full Interrupt Test — Continued**

Error Code	Test Result	Description/ Recommendation
1418	ABORT	The HFAIL bit being set in the active Duplication Interface circuit pack prevented this test from running.  1. Run this long demand test sequence and verify that test #870 passes or follow the repair strategy for test #870 until it passes.
2000	ABORT	This test did not run because communication with the standby timed out while waiting for a reply to a maintenance message.  1. Retry the command at 1-minute intervals a maximum of 5 times.  2. If this abort continues to occur, the standby SPE may not have initialized properly. Use the lock-and-power-down procedure described in Chapter 5 to power down and power up the standby SPE, but do not replace any circuit packs.
2334	ABORT	The hardware mailbox in the standby Duplication Interface circuit pack is not ready to receive messages.  1. Retry the command at 1-minute intervals a maximum of 5 times.  2. If this abort continues to occur, the standby SPE may not have initialized properly. Use the lock-and-power-down procedure described in Chapter 5 to power down and power up the standby SPE, but don't replace any circuit packs.
2500	ABORT	Internal system error  1. Retry the command at 1-minute intervals a maximum of 5 times.
	FAIL	The expected interrupt was not received from the standby Duplication Interface circuit pack when the FIFO was filled to overflowing with test data.  1. Replace Duplication Interface components starting with the standby Duplication Interface circuit pack. Use SPE Duplication Channel Component Replacement procedures at the end of this DUP-CHL section.
53	FAIL	The Duplication Interface circuit pack FIFO flow control flag was not set during this FIFO Full Interrupt Test.  1. Replace Duplication Interface components starting with the standby Duplication Interface circuit pack. Use SPE Duplication Channel Component Replacement procedures at the end of this DUP-CHL section.
54	FAIL	The attempt to turn on memory shadowing in this DUPINT circuit pack could not be verified in the DUPINT hardware status register.  1. Replace Duplication Interface components starting with the standby Duplication Interface circuit pack. Use SPE Duplication Channel Component Replacement procedures at the end of this DUP-CHL section.
	PASS	The FIFO full interrupt was received from the standby Duplication Interface circuit pack when the FIFO was filled to overflowing with test data.

## Memory Shadowing Disable Test (#872)

**This test is destructive.**

This test verifies the correct operation of the interrupt that indicate when shadowing has been turned off (disallowed) by the standby Processor

**Table 9-275. Test #872 Memory Shadowing Disable Test**

Error Code	Test Result	Description/ Recommendation
1321	ABORT	<p>The faceplate switches on the Duplication Interface circuit packs are not set to <b>auto</b>.</p> <ol style="list-style-type: none"> <li>1. If the switches are locked because you are using a replacement procedure, continue with this procedure to the step that directs you to unlock the active SPE by moving both switches to <b>auto</b>. The next step using the <b>test duplication-interface long clear</b> should not abort with this error code.</li> <li>2. If the switches are locked and a replacement procedure is not being used, start with step 6 of the SPE Duplication Channel Component Replacement procedure for the standby Duplication Interface Circuit pack at the end of this DUP-CHL section to avoid an undesired interchange when unlocking the active SPE.</li> <li>3. If this same abort is received with both switches in auto, Replace Duplication Interface components starting with the standby Duplication Interface circuit pack. Use SPE Duplication Channel Component Replacement procedures at the end of this DUP-CHL section. In addition to looking for failures, also check for the absence of this 1321 abort code when testing after the procedure directs setting the switches to <b>auto</b> after a component replacement.</li> </ol>

*Continued on next page*

Table 9-275. Test #872 Memory Shadowing Disable Test — *Continued*

Error Code	Test Result	Description/ Recommendation
1322	ABORT	<p>Memory shadowing is off, but not inhibited by the standby SPE.</p> <ol style="list-style-type: none"> <li>Shadowing may not be turned on yet, so use <b>release spe-standby</b> if the standby is busied out, wait 5 minutes and run the test again. If the long duplication-interface demand test was being used, investigate any failure or abort from test #872 because this test is expected to turn on shadowing.</li> <li>Rerun the test; if the same 1322 abort occurs again, use the <b>display alarms</b> command and select Category <b>spe</b>. If any maintenance objects other than DUPINT or DUP-CHL have MAJOR alarms, fix these problems. Problems causing MAJOR alarms for MEM-BD, PKT-INT, SYSAM, H-ADAPTR, and SW-CTL should be repaired first.</li> <li>Rerun the test; if the same 1322 abort occurs again, look for other DUPINT or DUP-CHL test failures by using the <b>busyout spe-standby</b> if not already busied out and the <b>test duplication-interface long clear</b> commands. Fix these problems according to the service documentation for these packs.</li> <li>If this abort continues to occur, the standby SPE may not have initialized properly. Use the lock-and-power-down procedure described in Chapter 5 to power down and power up the standby SPE, but don't replace any circuit packs.</li> </ol>
1325	ABORT	<p>Memory shadowing is inhibited from the standby SPE.</p> <ol style="list-style-type: none"> <li>Shadowing may not be turned on yet, so wait 5 minutes and run the test again.</li> <li>Rerun the test; if the same 1325 abort occurs again, use the <b>display alarms</b> command and select Category <b>spe</b>. If any maintenance objects other than DUPINT or DUP-CHL have MAJOR alarms, fix these problems. Problems causing MAJOR alarms for MEM-BD, PKT-INT, SYSAM, H-ADAPTR, and SW-CTL should be repaired first.</li> <li>Rerun the test; if the same 1325 abort occurs again, look for other DUPINT or DUP-CHL test failures by using the <b>busyout spe-standby</b> if not already busied out and the <b>test duplication-interface long clear</b> commands. Fix these problems according to the service documentation for these packs.</li> <li>If this 1325 abort continues to occur, the standby SPE may not have initialized properly. Use the lock-and-power-down procedure described in Chapter 5 to power down and power up the standby SPE, but don't replace any circuit packs.</li> </ol>
1405	ABORT	<p>This test did not run because the Duplication Channel was busy.</p> <ol style="list-style-type: none"> <li>Retry the command at 1-minute intervals a maximum of 5 times.</li> </ol>

*Continued on next page*

**Table 9-275. Test #872 Memory Shadowing Disable Test — Continued**

Error Code	Test Result	Description/ Recommendation
1411	ABORT	This test did not run because the standby Duplication Interface circuit pack cannot be detected as being plugged in by the software. <ol style="list-style-type: none"> <li data-bbox="274 390 1111 507">1. If this abort continues to occur, the standby SPE may not have initialized properly. Use the lock-and-power-down procedure described in Chapter 5 to power down and power up the standby SPE, but don't replace any circuit packs.</li> </ol>
2000	ABORT	This test did not run because communication with the standby timed out while waiting for a reply to a maintenance message instructing it to disallow memory shadowing. <ol style="list-style-type: none"> <li data-bbox="274 623 1111 650">1. Retry the command at 1-minute intervals a maximum of 5 times.</li> <li data-bbox="274 668 1111 784">2. If this abort continues to occur, the standby SPE may not have initialized properly. Use the lock-and-power-down procedure described in Chapter 5 to power down and power up the standby SPE, but don't replace any circuit packs.</li> </ol>
2334	ABORT	The hardware mailbox in the standby Duplication Interface circuit pack is not ready to receive messages. <ol style="list-style-type: none"> <li data-bbox="274 874 1111 901">1. Retry the command at 1-minute intervals a maximum of 5 times.</li> <li data-bbox="274 919 1111 1035">2. If this abort continues to occur, the standby SPE may not have initialized properly. Use the lock-and-power-down procedure described in Chapter 5. to power down and power up the standby SPE, but don't replace any circuit packs.</li> </ol>
2500	ABORT	Internal system error <ol style="list-style-type: none"> <li data-bbox="274 1089 1111 1116">1. Retry the command at 1-minute intervals a maximum of 5 times.</li> </ol>
	FAIL	The expected interrupt that indicates shadowing has been turned off in the standby SPE was not received after this test had instructed the standby SPE to turn off shadowing. <ol style="list-style-type: none"> <li data-bbox="274 1241 1111 1331">1. Replace Duplication Interface components starting with the standby Duplication Interface circuit pack. Use SPE Duplication Channel Component Replacement procedures at the end of this DUP-CHL section.</li> </ol>
54	FAIL	The attempt to turn on memory shadowing in this DUPINT circuit pack could not be verified in the DUPINT hardware status register. <ol style="list-style-type: none"> <li data-bbox="274 1421 1111 1510">1. Replace Duplication Interface components starting with the standby Duplication Interface circuit pack. Use SPE Duplication Channel Component Replacement procedures at the end of this DUP-CHL section.</li> </ol>
	PASS	The interrupt that indicates shadowing has been turned off in the standby SPE was received after this test had instructed the standby SPE to turn off shadowing.



## State-of-Health (#873)

**This test is destructive.**

This test verifies the correct operation of the State-of-Health interrupt

**Table 9-276. TEST #873 State-Of-Health Test**

Error Code	Test Result	Description/ Recommendation
1321	ABORT	<p>The faceplate switches on the Duplication Interface circuit packs are not set to <b>auto</b>.</p> <ol style="list-style-type: none"> <li>1. If the switches are locked because you are using a replacement procedure, continue with this procedure to the step that directs you to unlock the active SPE by moving both switches to <b>auto</b>. The next step using the <b>test duplication-interface long clear</b> should not abort with this error code.</li> <li>2. If the switches are locked and a replacement procedure is not being used, start with step 6 of the SPE Duplication Channel Component Replacement procedure for the standby Duplication Interface Circuit pack at the end of this DUP-CHL section to avoid an undesired interchange when unlocking the active SPE.</li> <li>3. If this same abort is received with both switches in auto, replace Duplication Interface components starting with the standby Duplication Interface circuit pack. Use SPE Duplication Channel Component Replacement procedures at the end of this section. In addition to looking for failures, also check for the absence of this 1321 abort code when testing after the procedure directs setting the switches to <b>auto</b> after a component replacement.</li> </ol>
1405	ABORT	<p>This test did not run because the Duplication Channel was busy.</p> <ol style="list-style-type: none"> <li>1. Retry the command at 1-minute intervals a maximum of 5 times.</li> </ol>
1411	ABORT	<p>This test did not run because the standby Duplication Interface circuit pack cannot be detected as being plugged in by the software.</p> <ol style="list-style-type: none"> <li>1. If this abort continues to occur, the standby SPE may not have initialized properly. Use the lock-and-power-down procedure described in Chapter 5 to power down and power up the standby SPE, but don't replace any circuit packs.</li> </ol>

*Continued on next page*

**Table 9-276. TEST #873 State-Of-Health Test — Continued**

Error Code	Test Result	Description/ Recommendation
1420	ABORT	<p>The state-of-health of the active SPE is <b>partially functional</b>.</p> <ol style="list-style-type: none"> <li>1. Use the <b>display alarms</b> command selecting the SPE category to determine which alarms have caused the active SPE to have a lower state-of-health. Problems causing MAJOR alarms for MEM-BD, PKT-INT, SYSAM, H-ADAPTR, and SW-CTL should be repaired first.</li> <li>2. If this abort continues to occur, the standby SPE may not have initialized properly. Use the lock-and-power-down procedure described in Chapter 5 to power down and power up the standby SPE, but don't replace any circuit packs. Try this test again.</li> </ol>
2000	FAIL	<p>This test did not run because communication with the standby timed out while waiting for a reply to a maintenance message instructing it to lower it's state-of-health.</p> <ol style="list-style-type: none"> <li>1. Replace Duplication Interface components starting with the standby Duplication Interface circuit pack. Use SPE Duplication Channel Component Replacement procedures at the end of this section.</li> </ol>
2334	ABORT	<p>The hardware mailbox in the standby Duplication Interface circuit pack is not ready to receive messages.</p> <ol style="list-style-type: none"> <li>1. Retry the command at 1-minute intervals a maximum of 5 times.</li> <li>2. If this abort continues to occur, the standby SPE may not have initialized properly. Use the lock-and-power-down procedure described in Chapter 5 to power down and power up the standby SPE, but do not replace any circuit packs.</li> </ol>
2500	ABORT	<p>Internal system error</p> <ol style="list-style-type: none"> <li>1. Retry the command at 1-minute intervals a maximum of 5 times.</li> </ol>
	FAIL	<p>The standby state-of-health was lowered but no interrupt was received after the test had instructed the standby SPE to lower its state of health.</p> <ol style="list-style-type: none"> <li>1. Replace Duplication Interface components starting with the standby Duplication Interface circuit pack. Use SPE Duplication Channel Component Replacement procedures at the end of this DUP-CHL section.</li> </ol>
	PASS	<p>The test successfully received the lowered state-of-health interrupt from the standby Duplication Interface circuit pack.</p>

### Duplication Channel Test (#874)

This test verifies the correct transmission of a message sent from the active SPE to the standby SPE via the Duplication Interface circuit pack mailbox

**Table 9-277. TEST #874 Duplication Channel Test**

Error Code	Test Result	Description/ Recommendation
1321	ABORT	<p>The faceplate switches on the Duplication Interface circuit packs are not set to <b>auto</b>.</p> <ol style="list-style-type: none"> <li>1. If the switches are locked because you are using a replacement procedure, continue with this procedure to the step that directs you to unlock the active SPE by moving both switches to <b>auto</b>. The next step using the <b>test duplication-interface long clear</b> should not abort with this error code.</li> <li>2. If the switches are locked and a replacement procedure is not being used, start with step 6 of the SPE Duplication Channel Component Replacement procedure for the standby Duplication Interface Circuit pack at the end of this DUP-CHL section to avoid an undesired interchange when unlocking the active SPE.</li> <li>3. If this same abort is received with both switches in auto, Replace Duplication Interface components starting with the standby Duplication Interface circuit pack. Use SPE Duplication Channel Component Replacement procedures at the end of this DUP-CHL section. In addition to looking for failures, also check for the absence of this 1321 abort code when testing after the procedure directs setting the switches to <b>auto</b> after a component replacement.</li> </ol>
1411	ABORT	<p>This test did not run because the standby Duplication Interface circuit pack cannot be detected as being plugged in by the software.</p> <ol style="list-style-type: none"> <li>1. If this abort continues to occur, the standby SPE may not have initialized properly. Use the lock-and-power-down procedure described in Chapter 5 to power down and power up the standby SPE, but don't replace any circuit packs.</li> </ol>
2000	ABORT	<p>This test did not run because communication with the standby timed out while waiting for a reply to a maintenance message.</p> <ol style="list-style-type: none"> <li>1. Retry the command at 1-minute intervals a maximum of 5 times.</li> <li>2. If this abort continues to occur, the standby SPE may not have initialized properly. Use the lock-and-power-down procedure described in Chapter 5 to power down and power up the standby SPE, but do not replace any circuit packs.</li> </ol>
2500	ABORT	<p>Internal system error</p> <ol style="list-style-type: none"> <li>1. Retry the command at 1-minute intervals a maximum of 5 times.</li> </ol>
	FAIL	<p>The standby software did not return the test message sent from the active SPE to the standby SPE via the Duplication Interface circuit pack mailbox.</p> <ol style="list-style-type: none"> <li>1. Replace Duplication Interface components starting with the standby Duplication Interface circuit pack. Use SPE Duplication Channel Component Replacement procedures at the end of this DUP-CHL section.</li> </ol>

**Table 9-277. TEST #874 Duplication Channel Test — Continued**

Error Code	Test Result	Description/ Recommendation
2334	FAIL	The hardware mailbox in the standby Duplication Interface circuit pack is not ready to receive messages. <ol style="list-style-type: none"> <li>1. Retry the command at 1-minute intervals a maximum of 5 times.</li> <li>2. If this failure continues to occur, the standby SPE may not have initialized properly. Use the lock-and-power-down procedure described in Chapter 5 to power down and power up the standby SPE, but do not replace any circuit packs.</li> <li>3. Replace Duplication Interface components starting with the standby Duplication Interface circuit pack. Use SPE Duplication Channel Component Replacement procedures at the end of this section.</li> </ol>
	PASS	The standby software returned the test message sent from the active SPE to the standby SPE via the Duplication Interface circuit pack mailbox.

**Remote SPE Error Interrupt Test (#875)**

This test is used to check for the correct operation of the Remote SPE Error interrupt

**Table 9-278. TEST #875 Remote SPE Error Interrupt Test**

Error Code	Test Result	Description/ Recommendation
1321	ABORT	<p>The faceplate switches on the Duplication Interface circuit packs are not set to <b>auto</b>.</p> <ol style="list-style-type: none"> <li>1. If the switches are locked because you are using a replacement procedure, continue with this procedure to the step that directs you to unlock the active SPE by moving both switches to <b>auto</b>. The next step using the <b>test duplication-interface long clear</b> should not abort with this error code.</li> <li>2. If the switches are locked and a replacement procedure is not being used, start with step 6 of the SPE Duplication Channel Component Replacement procedure for the standby Duplication Interface Circuit pack at the end of this DUP-CHL section to avoid an undesired interchange when unlocking the active SPE.</li> <li>3. If this same abort is received with both switches in auto, Replace Duplication Interface components starting with the standby Duplication Interface circuit pack. Use SPE Duplication Channel Component Replacement procedures at the end of this DUP-CHL section. In addition to looking for failures, also check for the absence of this 1321 abort code when testing after the procedure directs setting the switches to <b>auto</b> after a component replacement.</li> </ol>
1322	ABORT	<p>Memory shadowing is off, but not inhibited by the standby SPE.</p> <ol style="list-style-type: none"> <li>1. Shadowing may not be turned on yet, so use <b>release spe-standby</b> if the standby is busied out, wait 5 minutes and run the test again. If the long duplication-interface demand test was being used, investigate any failure or abort from test #872 because this test is expected to turn on shadowing.</li> <li>2. Rerun the test; if the same 1322 abort occurs again, use the <b>display alarms</b> command and select Category <b>spe</b>. If any maintenance objects other than DUPINT or DUP-CHL have MAJOR alarms, fix these problems. Problems causing MAJOR alarms for MEM-BD, PKT-INT, SYSAM, H-ADAPTR, and SW-CTL should be repaired first.</li> <li>3. Rerun the test; if the same 1322 abort occurs again, look for other DUPINT or DUP-CHL test failures by using the <b>busyout spe-standby</b> if not already busied out and the <b>test duplication-interface long clear</b> commands. Fix these problems according to the service documentation for these packs.</li> <li>4. If this abort continues to occur, the standby SPE may not have initialized properly. Use the lock-and-power-down procedure described in Chapter 5 to power down and power up the standby SPE, but don't replace any circuit packs.</li> </ol>

*Continued on next page*

**Table 9-278. TEST #875 Remote SPE Error Interrupt Test — Continued**

Error Code	Test Result	Description/ Recommendation
1325	ABORT	<p>Memory shadowing is inhibited from the standby SPE.</p> <ol style="list-style-type: none"> <li>1. Shadowing may not be turned on yet, so wait 5 minutes and run the test again.</li> <li>2. Rerun the test; if the same 1325 abort occurs again, use the <b>display alarms</b> command and select Category <b>spe</b>. If any maintenance objects other than DUPINT or DUP-CHL have MAJOR alarms, fix these problems. Problems causing MAJOR alarms for MEM-BD, PKT-INT, SYSAM, H-ADAPTR, and SW-CTL should be repaired first.</li> <li>3. Rerun the test; if the same 1325 abort occurs again, look for other DUPINT or DUP-CHL test failures by using the <b>busyout spe-standby</b> if not already busied out and the <b>test duplication-interface long clear</b> commands. Fix these problems according to the service documentation for these packs.</li> <li>4. If this 1325 abort continues to occur, the standby SPE may not have initialized properly. Use the lock-and-power-down procedure described in Chapter 5 to power down and power up the standby SPE, but don't replace any circuit packs.</li> </ol>
1411	ABORT	<p>This test did not run because the standby Duplication Interface circuit pack cannot be detected as being plugged in by the software.</p> <ol style="list-style-type: none"> <li>1. If this abort continues to occur, the standby SPE may not have initialized properly. Use the lock-and-power-down procedure described in Chapter 5 to power down and power up the standby SPE, but don't replace any circuit packs.</li> </ol>
2000	ABORT	<p>This test did not run because communication with the standby timed out while waiting for a reply to a maintenance message.</p> <ol style="list-style-type: none"> <li>1. Retry the command at 1-minute intervals a maximum of 5 times.</li> <li>2. If this abort continues to occur, the standby SPE may not have initialized properly. Use the lock-and-power-down procedure described in Chapter 5 to power down and power up the standby SPE, but do not replace any circuit packs.</li> </ol>
2334	ABORT	<p>The hardware mailbox in the standby Duplication Interface circuit pack is not ready to receive messages.</p> <ol style="list-style-type: none"> <li>1. Retry the command at 1-minute intervals a maximum of 5 times.</li> <li>2. If this abort continues to occur, the standby SPE may not have initialized properly. Use the lock-and-power-down procedure described in Chapter 5 to power down and power up the standby SPE, but don't replace any circuit packs.</li> </ol>
2500	ABORT	<p>Internal system error</p> <ol style="list-style-type: none"> <li>1. Retry the command at 1-minute intervals a maximum of 5 times.</li> </ol>

*Continued on next page*

**Table 9-278. TEST #875 Remote SPE Error Interrupt Test — Continued**

Error Code	Test Result	Description/ Recommendation
	FAIL	This test attempted to shadow a word with bad parity from the active SPE into the standby SPE memory, but the expected remote SPE error interrupt from detecting this bad parity word was not received in the active SPE.  1. Replace Duplication Interface components starting with the standby Duplication Interface circuit pack. Use SPE Duplication Channel Component Replacement procedures at the end of this DUP-CHL section.
54	FAIL	The attempt to turn on memory shadowing in this DUPINT circuit pack could not be verified in the DUPINT hardware status register.  1. Replace Duplication Interface components starting with the standby Duplication Interface circuit pack. Use SPE Duplication Channel Component Replacement procedures at the end of this DUP-CHL section.
	PASS	The test successfully created an Remote SPE Error interrupt.

### Memory Shadowing Test (#876)

This test checks to see if memory writes in the active SPE that occur within shadowed address space, can be successfully shadowed into the standby SPEs memory

Table 9-279. TEST #876 Memory Shadowing Test

Error Code	Test Result	Description/ Recommendation
1321	ABORT	<p>The faceplate switches on the Duplication Interface circuit packs are not set to <b>auto</b>.</p> <ol style="list-style-type: none"> <li>1. If the switches are locked because you are using a replacement procedure, continue with this procedure to the step that directs you to unlock the active SPE by moving both switches to <b>auto</b>. The next step using the <b>test duplication-interface long clear</b> should not abort with this error code.</li> <li>2. If the switches are locked and a replacement procedure is not being used, start with step 6 of the SPE Duplication Channel Component Replacement procedure for the standby Duplication Interface Circuit pack at the end of this DUP-CHL section to avoid an undesired interchange when unlocking the active SPE.</li> <li>3. If this same abort is received with both switches in auto, Replace Duplication Interface components starting with the standby Duplication Interface circuit pack. Use SPE Duplication Channel Component Replacement procedures at the end of this DUP-CHL section. In addition to looking for failures, also check for the absence of this 1321 abort code when testing after the procedure directs setting the switches to <b>auto</b> after a component replacement.</li> </ol>
1322	ABORT	<p>Memory shadowing is off, but not inhibited by the standby SPE.</p> <ol style="list-style-type: none"> <li>1. Shadowing may not be turned on yet, so use <b>release spe-standby</b> if the standby is busied out, wait 5 minutes and run the test again. If the long duplication-interface demand test was being used, investigate any failure or abort from test #872 because this test is expected to turn on shadowing.</li> <li>2. Rerun the test; if the same 1322 abort occurs again, use the <b>display alarms</b> command and select Category <b>spe</b>. If any maintenance objects other than DUPINT or DUP-CHL have MAJOR alarms, fix these problems. Problems causing MAJOR alarms for MEM-BD, PKT-INT, SYSAM, H-ADAPTR, and SW-CTL should be repaired first.</li> <li>3. Rerun the test; if the same 1322 abort occurs again, look for other DUPINT or DUP-CHL test failures by using the <b>busyout spe-standby</b> if not already busied out and the <b>test duplication-interface long clear</b> commands. Fix these problems according to the service documentation for these packs.</li> <li>4. If this abort continues to occur, the standby SPE may not have initialized properly. Use the lock-and-power-down procedure described in Chapter 5 to power down and power up the standby SPE, but do not replace any circuit packs.</li> </ol>

Continued on next page



**Table 9-279. TEST #876 Memory Shadowing Test — Continued**

Error Code	Test Result	Description/ Recommendation
1325	ABORT	<p>Memory shadowing is inhibited from the standby SPE.</p> <ol style="list-style-type: none"> <li>Shadowing may not be turned on yet, so wait 5 minutes and run the test again.</li> <li>Rerun the test; if the same 1325 abort occurs again, use the <b>display alarms</b> command and select Category <b>spe</b>. If any maintenance objects other than DUPINT or DUP-CHL have MAJOR alarms, fix these problems. Problems causing MAJOR alarms for MEM-BD, PKT-INT, SYSAM, H-ADAPTR, and SW-CTL should be repaired first.</li> <li>Rerun the test; if the same 1325 abort occurs again, look for other DUPINT or DUP-CHL test failures by using the <b>busyout spe-standby</b> if not already busied out and the <b>test duplication-interface long clear</b> commands. Fix these problems according to the service documentation for these packs.</li> <li>If this 1325 abort continues to occur, the standby SPE may not have initialized properly. Use the lock-and-power-down procedure described in Chapter 5 to power down and power up the standby SPE, but do not replace any circuit packs.</li> </ol>
1411	ABORT	<p>This test did not run because the standby Duplication Interface circuit pack cannot be detected as being plugged in by the software.</p> <ol style="list-style-type: none"> <li>If this abort continues to occur, the standby SPE may not have initialized properly. Use the lock-and-power-down procedure described in Chapter 5 to power down and power up the standby SPE, but don't replace any circuit packs.</li> </ol>
2000	ABORT	<p>This test did not run because communication with the standby timed out while waiting for a reply to a maintenance message.</p> <ol style="list-style-type: none"> <li>Retry the command at 1-minute intervals a maximum of 5 times.</li> <li>If this abort continues to occur, the standby SPE may not have initialized properly. Use the lock-and-power-down procedure described in Chapter 5 to power down and power up the standby SPE, but do not replace any circuit packs.</li> </ol>
2500	ABORT	<p>Internal system error</p> <ol style="list-style-type: none"> <li>Retry the command at 1-minute intervals a maximum of 5 times.</li> </ol>
	FAIL	<p>Test data retrieved from the standby SPE memory didn't match test data written into the active SPE memory and shadowed to the standby SPE memory.</p> <ol style="list-style-type: none"> <li>Replace Duplication Interface components starting with the standby Duplication Interface circuit pack. Use SPE Duplication Channel Component Replacement procedures at the end of this section.</li> </ol>

*Continued on next page*

**Table 9-279. TEST #876 Memory Shadowing Test — Continued**

Error Code	Test Result	Description/ Recommendation
54	FAIL	The attempt to turn on memory shadowing in this DUPINT circuit pack could not be verified in the DUPINT hardware status register.  1. Replace Duplication Interface components starting with the standby Duplication Interface circuit pack. Use SPE Duplication Channel Component Replacement procedures at the end of this DUP-CHL section.
	PASS	The test was able to successfully shadow, within shadowed address space, writes in the active SPE into the standby SPE memory.

### Status Register Comparison Test (#980)

The Status Register Comparison Test compares active Duplication Interface circuit pack remote status with standby Duplication Interface circuit pack local status.

**Table 9-280. TEST #980 Status Register Comparison Test**

Error Code	Test Result	Description/ Recommendation
1321	ABORT	The faceplate switches on the Duplication Interface circuit packs are not set to <b>auto</b> .  1. If the switches are locked because you are using a replacement procedure, continue with this procedure to the step that directs you to unlock the active SPE by moving both switches to <b>auto</b> . The next step using the <b>test duplication-interface long clear</b> should not abort with this error code.  2. If the switches are locked and a replacement procedure is not being used, start with step 6 of the SPE Duplication Channel Component Replacement procedure for the standby Duplication Interface Circuit pack at the end of this DUP-CHL section to avoid an undesired interchange when unlocking the active SPE.  3. If this same abort is received with both switches in auto, Replace Duplication Interface components starting with the standby Duplication Interface circuit pack. Use SPE Duplication Channel Component Replacement procedures at the end of this DUP-CHL section. In addition to looking for failures, also check for the absence of this 1321 abort code when testing after the procedure directs setting the switches to <b>auto</b> after a component replacement.

*Continued on next page*

**Table 9-280. TEST #980 Status Register Comparison Test — Continued**

Error Code	Test Result	Description/ Recommendation
1411	ABORT	<p>This test did not run because the standby Duplication Interface circuit pack cannot be detected as being plugged in by the software.</p> <ol style="list-style-type: none"> <li>1. If this abort continues to occur, the standby SPE may not have initialized properly. Use the lock-and-power-down procedure described in Chapter 5 to power down and power up the standby SPE, but do not replace any circuit packs.</li> </ol>
2000	ABORT	<p>This test did not run because communication with the standby timed out while waiting for a reply to a maintenance message requesting the standby status.</p> <ol style="list-style-type: none"> <li>1. Retry the command at 1-minute intervals a maximum of 5 times.</li> <li>2. If this abort continues to occur, the standby SPE may not have initialized properly. Use the lock-and-power-down procedure described in Chapter 5 to power down and power up the standby SPE, but do not replace any circuit packs.</li> </ol>
2334	ABORT	<p>The hardware mailbox in the standby Duplication Interface circuit pack is not ready to receive messages.</p> <ol style="list-style-type: none"> <li>1. Retry the command at 1-minute intervals a maximum of 5 times.</li> <li>2. If this abort continues to occur, the standby SPE may not have initialized properly. Use the lock-and-power-down procedure described in Chapter 5 to power down and power up the standby SPE, but do not replace any circuit packs.</li> </ol>
2500	ABORT	<p>Internal system error</p> <ol style="list-style-type: none"> <li>1. Retry the command at 1-minute intervals a maximum of 5 times.</li> </ol>
Any	FAIL	<p>The remote status in the active did not match the local status in the standby Duplication Interface circuit pack, or the remote status in the standby did not match the local status in the active Duplication Interface circuit pack.</p> <ol style="list-style-type: none"> <li>1. Replace Duplication Interface components starting with the standby Duplication Interface circuit pack. Use SPE Duplication Channel Component Replacement procedures at the end of this section.</li> </ol>
	PASS	<p>The comparison of remote with local status matched in both directions for the pair of Duplication Interface circuit packs.</p>

## Replacing Duplication Channel Components

The SPE Duplication Channel consists of a Duplication Interface circuit pack (DUPINT) in the active SPE, a DUPINT in the standby SPE, and an interconnecting cable. The following sections contain step-by-step procedures for replacing each of these components. DUPINT replacement must be done on the standby SPE to prevent loss of service.

If replacement of standby DUPINT circuit pack does not repair the Duplication Channel, replace the DUPINT circuit pack on the active SPE. If replacement of both of these circuit packs does not repair the Duplication Channel, replace the interconnecting cable.

## Replacing the STANDBY Duplication Interface (DUPINT) Circuit Pack

This procedure is used after a **test duplication-interface long** displays a failure for at least one of the tests that indict the standby DUPINT. The procedure to interchange the active DUPINT to the standby mode also uses this procedure.

1. Use the **busyout spe-standby** command to lower the standby State of Health to **partially functional** to prevent an unwanted interchange during replacement and testing of the standby DUPINT.
2. Manually lock the active SPE. by moving the SPE select switches located on the front of the DUPINT circuit packs to positions where they are both selecting the current active SPE.
3. Whenever locking the SPE, *always* verify that the active PPN Tone/Clock is in the active SPE carrier *before* doing any repair activity on the standby SPE carrier such as powering down. Enter **status port-network 1** to check which clock is active. Remove power from the standby SPE carrier by pulling the power cords located on both sides of the carrier. *Power must be removed from the standby carrier in order for the replacement DUPINT to initialize properly.*
4. Set the SPE-select switch on the new DUPINT circuit pack to the same position as the circuit pack you are going to replace. Then remove and replace the defective circuit pack.



### **CAUTION:**

*The new standby DUPINT must have its SPE Select switch set to lock the currently active carrier. The switch should be in the same position as the removed circuit pack.*

5. Apply power to the standby SPE carrier.

6. Verify that the standby is up. Regular flashing of the yellow LED on the Processor circuit pack indicates that the standby SPE is up and cycling. If the yellow LED is not flashing after 5 minutes test the standby SPE by using the lock-and-power-down procedure described in Chapter 5.
7. With the standby SPE still busied out to prevent an interchange, unlock the active SPE by moving the SPE Select Switches back to the Auto position.
8. Use the **status spe** command to verify that handshake is up. Wait up to 10 minutes for handshake to come up.
9. If **status spe** shows MAJOR alarms, enter the **display alarms** command for category **spe**. Resolve alarms for maintenance objects other than STBY-SPE, DUPINT and DUP-CHL first.
10. Execute the **test duplication-interface long clear** command to resolve the DUPINT and DUP-CHL alarms. If any test aborts, but none fail, run this test again at 1-minute intervals up to a maximum of 5 times, until all tests pass.
  - If no DUPINT or DUP-CHL tests failed, the DUPINT and DUP-CHL alarms are resolved or cleared in this active to standby direction. Continue with step 11.
  - If any DUPINT or DUP-CHL tests failed, and the standby DUPINT has been replaced, but the active DUPINT pack has *not* been replaced, replace the active DUPINT using the procedure in the following section.
  - If any DUPINT or DUP-CHL tests failed, and *both* DUPINTs have been replaced, but the DUPINT interconnecting cable has not been replaced, replace the DUPINT interconnecting cable using the replacement procedure for the DUPINT interconnecting cable.
  - If any DUPINT or DUP-CHL tests failed, and both DUPINT circuit packs and the interconnecting cable have been replaced, escalate the problem.
11. Release the standby SPE from the busyout using the **release spe-standby** command and wait about 10 minutes for the standby SPE to be refreshed. If the standby SPE fails to refresh, as observed with **status spe**, follow normal escalation procedures.
12. If the SPE Standby State-of-Health is functional as observed with **status spe**, enter the **reset system interchange** command. With this SPE now active, execute **busyout spe-standby** and use **test duplication-interface long clear** to test the Duplication Channel in the other direction.
  - If all tests pass, continue with step 13.
  - If any test fails, and the currently *standby* DUPINT circuit pack has not already been replaced, replace it now by starting at the beginning of this procedure. This circuit pack has passed tests while on the active carrier, but is still the most likely circuit pack to be faulted, especially if DUP-CHL tests are failing.

- If any test fails, and the currently *active* DUPINT circuit pack has not already been replaced, replace it now by starting at the beginning of the replacement procedure for the *active* DUPINT. This circuit pack has passed tests while on the standby carrier, but failed when on the active carrier, especially if DUPINT tests are failing.
  - If any test fails, and *both* DUPINTs have been replaced, replace the DUPINT interconnecting cable by using the procedure on the following pages.
13. Execute the **release spe-standby** command and wait for memory shadowing and standby refreshed to occur as verified with the **status spe** command.
    - If the standby is refreshed within 10 minutes, this replacement procedure is successfully finished.
    - If the standby is not refreshed within 10 minutes, continue with step 14.
  14. Use the **status spe** command. If the status shows MAJOR alarms, use the **display alarms** command with the **spe** category selection. Resolve alarms for maintenance objects other than DUPINT and DUP-CHL.
    - If the standby is refreshed within 10 minutes, and the DUPINT and DUP-CHL alarms are resolved, this replacement procedure is successfully finished.
    - If the DUPINT and DUP-CHL alarms are not resolved, and the standby DUPINT has been replaced, but the *active* DUPINT has *not* been replaced, replace the active DUPINT using the procedure in the following section.
    - If the DUPINT and DUP-CHL alarms are not resolved, and both DUPINTs have been replaced, but the DUPINT interconnecting cable has *not* been replaced during this repair activity, replace the DUPINT interconnecting cable using the procedure for interconnecting cable.

## Replacing the ACTIVE Duplication Interface (DUPINT) Circuit Pack

---

This procedure is used after a **test duplication-interface (long)** displays a failure for at least one of the tests that indict the active DUPINT, or when replacement of the active DUPINT is otherwise recommended. The active SPE must be interchanged to the standby mode before replacing this DUPINT to minimize disruption of customer service. Replacement of the DUPINT in the standby SPE carrier is described in the previous section.

1. If the **status spe** command displays `Standby Busied? yes`, release the standby SPE by using the **release spe-standby** command. If the System was recently interchanged, or if the standby SPE was busied out

and released, or if some other recent maintenance was performed on the standby SPE, it may take up to 10 minutes for the standby SPE to be refreshed. Use **status spe** to determine if `State of Health: functional` for the `Mode: standby` side is displayed.

- If handshake is down, continue with step 5.
  - If the Standby State of Health is other than functional, continue with step 2.
  - If the Standby State of Health is functional, enter the command **reset system interchange**.
    - *If the SPE interchange occurred*, replace the standby DUPINT using the replacement procedure for the standby DUPINT.
    - *If the SPE interchange did not occur* continue with step 2.
2. If there are no major alarms against MEM-BD, PKT-INT, SYSAM, H-ADAPTR, or SW-CTL, continue with step 5 in this procedure.
  3. If MAJOR alarms cannot be resolved for MEM-BD, PKT-INT, SYSAM, H-ADAPTR, or SW-CTL using their associated maintenance procedures, escalate the problem. These MAJOR alarms must be resolved before continuing with DUPINT and DUP-CHL Maintenance.
  4. If any MAJOR alarms were resolved for MEM-BD, PKT-INT, SYSAM, H-ADAPTR, or SW-CTL using their associated maintenance procedures, test DUPINT and DUP-CHL again: use **busyout spe-standby** followed by **test duplication-interface long clear** and see if any tests fail. Enter **release spe-standby**.

- If any test fails, continue with step 5 in this procedure.
- If all tests pass, wait up to 10 minutes and enter **status spe** to determine whether `Standby Refreshed? yes` and `State of Health: functional` are displayed for the standby SPE.

*If the above are not displayed*, go to Step 5 of this procedure.

*If the above are displayed*, enter the command **reset system interchange**.

- If this interchange was not successful, continue with step 5 in this procedure.
- If this interchange was successful, use the **busyout spe-standby** command followed by the **test duplication-interface long clear** command and see if any tests fail. Execute **release spe-standby**.

*If all tests pass*, the duplication channel has been successfully tested in both directions and this procedure is finished.

*If any test fails*, replace the standby DUPINT using the previous replacement procedure for the standby DUPINT.

5. Use the **status spe** command to determine if Standby Refreshed?  
yes for Mode: standby is displayed.
  - *If the standby is refreshed*, a hard switch will not affect customer service. Continue with step 6.
  - *If the standby is not refreshed*, you will need to execute a hard switch that *will* affect customer service (by at least dropping current calls). Notify the customer and establish a time to perform this disruptive maintenance.
6. Hard switch into the standby SPE by moving both SPE Select switches to the position that selects the standby SPE as active.
  - If the interchange was successful, replace the standby DUPINT using the replacement procedure for the standby DUPINT.

## Replacing the Duplication Interface Interconnecting Cable

---

This procedure is used after replacing both DUPINT circuit packs has failed to resolve the duplication channel failure.

1. Use the **busyout spe-standby** command to lower the standby State of Health to partially functional to prevent an unwanted interchange during the Duplication Interconnecting cable replacement and testing.
2. Manually lock the active SPE. This is done by moving the SPE select switches located on the front of the DUPINTs to positions where they are both selecting the current active SPE.
3. Whenever locking the SPE, *always* verify that the active PPN Tone/Clock is in the active SPE carrier *before* doing any repair activity on the standby SPE carrier such as powering down. Enter **status port-network 1** to check which clock is active. Remove power from the standby SPE carrier by pulling the power cords located on both sides of the carrier. **Power must be removed from the standby carrier. If power is not removed from the standby SPE carrier before the interconnecting cable is disconnected, an interchange to the standby SPE will occur, causing disruption of customer service.**
4. Examine the cable and associated connectors for obvious problems. Check for broken or bent pins, and repair or replace before installing the new cable.



### CAUTION:

*This cable interconnects the powered down standby and the active carriers. Use extreme caution. Shorting pins can cause the active SPE to fail. Consider replacing this cable during periods of light traffic or, ideally, when both carriers are powered down (system out of service).*



- Replace the cable observing proper connector location and orientation.
5. Apply power to the standby SPE carrier.
  6. Verify that the standby is up. Regular flashing of the yellow LED on the Processor circuit pack indicates that the standby SPE is up and cycling. If the yellow LED is not flashing after 5 minutes test the standby SPE by using the lock-and-power-down procedure described in Chapter 5.
  7. With the standby SPE still busied out to prevent an interchange, unlock the active SPE by moving the SPE Select Switches back to the Auto position.
  8. Use the **status spe** command to verify that handshake is up. Wait up to 10 minutes for handshake to come up.
  9. If the status shows MAJOR alarms, use the **display alarms** command for category **spe**. Resolve alarms for maintenance objects other than DUPINT and DUP-CHL first.
  10. Execute the **test duplication-interface long clear** command to resolve the DUPINT and DUP-CHL alarms. If any tests abort, but no tests fail, run the test again at 1-minute intervals up to a maximum of 5 times with the goal of observing all tests passing.
    - If no DUPINT nor DUP-CHL tests fail, the DUPINT and DUP-CHL alarms are resolved or cleared in this active to standby direction. Continue with step 11.
    - You should by now have replaced both DUPINT circuit packs and the interconnecting cable.
  11. Release the standby SPE from the busyout condition using the **release spe-standby** command and wait (about 10 minutes) for the standby SPE to be refreshed as observed with the **status spe** command.

12. If the SPE Standby State-of-Health is functional as observed with the **status spe** command, use the **reset system interchange** command. With the other SPE now active, execute the **busyout spe-standby** command and use the **test duplication-interface long clear** command to test the Duplication Channel in the other direction, resolving any outstanding alarms against DUPINT and DUP-CHL.
  - If these tests pass, continue with step 13.
13. Execute the **release spe-standby** command and wait for memory shadowing and standby refreshed to complete as verified with the **status spe** command.
  - If the standby is not refreshed within 10 minutes, continue with step 14.
  - If the standby is refreshed within 10 minutes, this replacement procedure is successfully finished.
14. Use the **status spe** command. If the status shows MAJOR alarms, use the **display alarms** command with the **spe** category selection. Resolve alarms for maintenance objects other than DUPINT and DUP-CHL.
  - If the standby is not refreshed within 10 minutes, or the DUPINT and DUP-CHL alarms are not resolved, escalate the problem.
  - If the standby is refreshed within 10 minutes, and the DUPINT and DUP-CHL alarms are resolved, this replacement procedure is successfully finished.

## DUPINT (Duplication Interface Circuit Pack)

---

MO Name (in Alarm Log)	Alarm Level	Initial Command to Run	Full Name of MO
DUPINT	MAJOR	test duplication-interface l c	Duplication Interface circuit pack
DUPINT	MINOR	test duplication-interface l c	Duplication Interface circuit pack

The Duplication Interface (DUPINT) maintenance object tests the active UN330B Duplication Interface circuit pack. Tests that fail are recorded in the error and alarm log as errors/alarms against the active Duplication Interface circuit pack. No errors/alarms are recorded against the standby Duplication Interface circuit pack by this maintenance object.

Three Maintenance Objects are utilized in the maintenance of the Duplication Interface circuit pack and their cabling. These are DUPINT, DUP-CHL, and SPE-SELE. The first of these, DUPINT, is composed of tests that check the operation of the active Duplication Interface circuit pack. The second maintenance object, DUP-CHL, test overall functionality of the circuit pack. This requires both circuit pack, their cabling, and communication with the standby software. The third and final MO is SPE-SELE. SPE-SELE monitors the position of the select switches located on the front of the Duplication Interface circuit pack.

Testing is directional from the active Duplication Interface circuit pack to the standby Duplication Interface circuit pack. If an interchange has occurred with alarms raised against DUPINT or DUP-CHL, testing cannot resolve or clear these alarms because they are against the wrong circuit pack in the active to standby directional configuration. An interchange is needed to allow testing to resolve or clear these directional alarms.

### Duplication Interface Maintenance Operation

---

There are six tests that comprise DUPINT. The not-destructive Active DUPINT HFAIL test is run as scheduled, periodic and demand short. The Active DUPINT Reset test is the destructive version of the HFAIL test and is only run at initialization time and on demand long. They are not run as part of periodic or scheduled maintenance. Test failures or in-line errors for this maintenance object are logged against the active Duplication Interface circuit pack.

The five destructive tests run by DUPINT are only run during initialization (reset system 2 or worse) and on demand with the command line of **test duplication-interface long**. The clear option is needed to clear alarms for error types that don't have an associated test when all of the tests pass or abort. Since these tests require the turning on and off of memory shadowing, you must enter the command **busyout spe** before the long sequence may be run. The busying out of the SPE turns off memory shadowing but handshaking continues between

the active and standby SPEs. After testing of DUPINT is complete, the command **release spe** must be entered before memory shadowing is allowed to be turned on and memory refresh to complete. Memory shadowing is not turned back on if DUPINT, DUP-CHL or other MAJOR alarms pertinent to memory shadowing are not retired. See STBY-SPE for more details as to how the turning on/off of shadowing is controlled.

The **test duplication-interface** and **test duplication-interface long** commands run DUPINT and DUP-CHL tests. This is the only command that can run short and long test sequences for these maintenance objects.

Replacement procedures are provided for the standby Duplication Interface circuit pack, the active Duplication Interface circuit pack, and the interconnecting cable. These procedures are designed to prevent disruption of customer service except when the active Duplication Interface circuit pack must be replaced because of a failure that prevents memory shadowing. Each procedure also describes testing after replacement to verify duplication operation when SPE carrier A is active and when SPE carrier B is active. Test failures in a procedure can direct you to another procedure for the replacement and testing of a related component.

## Administration

No **add** or **remove** commands are associated with the Duplication Interface circuit pack.

## In-line Errors

The Local FIFO Full Failure and DUPINT Driver Failure error types can raise alarms when in-line errors are received. There are no tests that can retire these reported alarms. The command line option of **test duplication-interface long clear** with the long test sequence and the clear option is needed to clear alarms for these in-line errors. The in-line error types are cleared by this command only if no tests fail.

## MAJOR vs. MINOR Alarms

DUPINT may have MAJOR or MINOR alarms. Whenever a MAJOR alarm is raised, memory shadowing to the standby is turned off. A MINOR alarm does not turn off shadowing. Neither type of alarm causes an SPE interchange.

## Maintenance Object Interactions

The command **test duplication-interface** runs both DUPINT and DUP-CHL non-destructive tests. The command **test duplication-interface long** runs both DUPINT and DUP-CHL destructive and non-destructive tests. The second command can only be run if the standby SPE is busied out. This busy out of the standby SPE turns off memory shadowing, and lowers the health of the standby to partially-functional; thereby preventing a possible interchange between the

active and standby SPE carriers. Then, if all DUPINT and DUP-CHL alarms are retired, a release of the standby SPE will allow memory shadowing to be turned back on (if no further alarms pertinent to memory shadowing are present) and refresh to complete. See STBY-SPE for more details as to how the turning on/off of shadowing is controlled.

## Error Log Entries and Test to Clear Values

**Table 9-281. Duplication Interface Circuit Pack Error Log Entries**

Error Type	Aux Data	Associated Test	Alarm Level <sup>1</sup>	On/Off Board	Test to Clear Value
0	0	Any	Any	Any	
1		Control Register test (#865)	MAJOR	ON	test dupl l
257	Any	Mailbox Loop-around test (#866)	MAJOR	ON	test dupl l
513	Any	Local Loop-around test (#867)	MAJOR	ON	test dupl l
769	Any	Memory Shadowing Bounds Test (#868)	MAJOR	ON	test dupl l
2049 (a)	Any	Active DUPINT Reset Test (#870) Active DUPINT STDONE/ HFAIL Check Test (#979)	MINOR	ON	test dupl l
3073 (b)	2	None	MINOR	ON	test dupl l c
3329 (c)	Any	None	MAJOR	ON	test dupl l c

1. DUPINT alarms can be resolved only when the alarmed Duplication Interface circuit pack is in the active SPE carrier.

### Notes:

- a. Indicates either a failure during a reset of the Duplication Interface circuit pack, or a report that either or both of the HFAIL and STDONE bits are in the wrong state. These errors cause a MINOR alarm that does not affect memory shadowing. The Aux Data indicates which error occurred.

Aux Data	Cause of Error
None	The active DUPINT Reset Test failed because the reset was unsuccessful.
1	The STDONE bit is in the wrong state.
2	The HFAIL bit is in the wrong state.
3	The STDONE and HFAIL bits are both in the wrong state.

Aux Data	Cause of Error
51	The Active DUPINT Reset Test failed because the HFAIL bit stayed set after reset.
52	The Active DUPINT Reset Test failed because the state of health could not be restored after the reset.
55	The Active DUPINT Reset Test failed because shadowing could not be turned off after the board was successfully reset.

- b. A local DUPINT FIFO overflow condition has been reported. If this alarm cannot be cleared by replacing the active Duplication Interface circuit pack, escalate the problem.
- c. In-line errors have been reported from the DUPINT driver. If this alarm cannot be cleared by replacing the active Duplication Interface circuit pack, escalate the problem.

Aux Data	Cause of Error
23	DUPINT driver suicide
24	DUPINT driver loss of interrupt path
27	DUPINT driver no handshake path for processes
28	DUPINT driver no handshake path for drivers
29	DUPINT driver no control path
30	DUPINT driver main receive failed

### **System Technician-Demanded Tests: Descriptions and Error Codes**

Always investigate tests in the order presented in the table below. By clearing error codes associated with the *Control Register Test* for example, you may also clear errors generated from other tests in the testing sequence.

Tests listed as *destructive* are so designated because they require shadowing to be turned off. For testing to resolve DUPINT alarms, the alarmed circuit pack must be on the Active SPE carrier.

Order of Investigation	Short Test Sequence	Long Test Sequence	D/ND <sup>1</sup>
Active DUPINT HFAIL Check Test (#979)	X	X	ND
Active DUPINT Reset Test (#870)		X	D
Control Register Test (#865)		X	ND
Mailbox Loop-around Test (#866)		X	D
Local Loop-around Test (#867)		X	D
Memory Shadow Bounds Test (#868)		X	D

1. D = Destructive, ND = Non-destructive

### Control Register Test (#865)

This test checks the operation of the control register located on the Duplication Interface circuit pack.

Table 9-282. Test #865 Control Register Test

Error Code	Test Result	Description/ Recommendation
1418	ABORT	The HFAIL bit and/or the STDONE bit is in the wrong state. The active Duplication Interface circuit pack needs to be reset. 1. Run the <b>test duplication-interface long</b> command and follow instructions for the Active DUPINT Reset Test (#870). 2. If test #870 passes and this test still aborts, escalate the problem.
2500	ABORT	Internal system error 1. Retry the command at 1-minute intervals a maximum of 5 times.
	FAIL	The Control Register test bit was not set in the Status Register and the Type/Suffix/Vintage Register after this bit was written into the Control Register. 1. Replace Duplication Interface components starting with the active Duplication Interface circuit pack. Use SPE Duplication Channel Component Replacement procedures at the end of this section.
	PASS	The Control Register test bit was set in the Status Register and the Type/Suffix/Vintage Register after this bit was written into the Control Register.

## Mailbox Loop-around Test (#866)

**This test is destructive.**

This test checks the functionality of the mailbox mechanism provided by the Duplication Interface circuit pack

**Table 9-283. TEST #866 Mailbox Loop-around Test**

Error Code	Test Result	Description/ Recommendation
1405	ABORT	This test did not run because the Duplication Channel was busy. 1. Retry the command at 1-minute intervals a maximum of 5 times.
1418	ABORT	The HFAIL bit and/or the STDONE bit is in the wrong state. The active Duplication Interface circuit pack needs to be reset. 1. Run the <b>test duplication-interface long</b> command and follow instructions for the Active DUPINT Reset Test (#870). 2. If test #870 passes and this test still aborts, escalate the problem.
2500	ABORT	Internal system error 1. Retry the command at 1-minute intervals a maximum of 5 times.
	FAIL	The test message written into the active Duplication Interface circuit pack mailbox did not cause an interrupt to notify the software to retrieve it from the receive mailbox; or if retrieved, the looped back message did not match the message written into the mailbox. 1. Replace Duplication Interface components starting with the active Duplication Interface circuit pack. Use SPE Duplication Channel Component Replacement procedures at the end of the DUP-CHL section.
55	FAIL	The attempt to turn off memory shadowing in this Duplication Interface circuit pack could not be verified in the Duplication Interface circuit pack hardware status register. 1. Replace Duplication Interface components starting with the active Duplication Interface circuit pack. Use SPE Duplication Channel Component Replacement procedures at the end of the DUP-CHL section.
	PASS	The test message written into the active Duplication Interface circuit pack mailbox successfully caused an interrupt to notify the software to retrieve it from the receive mailbox and the retrieved looped back message matched the message written into the mailbox.

## Local Loop-around Test (#867)

**This test is destructive.**



This test checks the ability of the active Duplication Interface circuit pack to shadow writes that are within the shadowed address boundaries

**Table 9-284. TEST #867 Local Loop-around Test**

Error Code	Test Result	Description/ Recommendation
1321	ABORT	<p>The faceplate switches on the Duplication Interface circuit packs are not set to <b>auto</b>.</p> <ol style="list-style-type: none"> <li data-bbox="282 473 1067 616">1. If the switches are locked because you are using a replacement procedure, continue with this procedure to the step that directs you to unlock the active SPE by moving both switches to <b>auto</b>. The next step using the <b>test duplication-interface long clear</b> should not abort with this error code.</li> <li data-bbox="282 634 1067 777">2. If the switches are locked and a replacement procedure is not being used, start with step 6 of the SPE Duplication Channel Component Replacement procedure for the standby Duplication Interface Circuit pack at the end of the DUP-CHL section to avoid an undesired interchange when unlocking the active SPE.</li> <li data-bbox="282 795 1067 992">3. If this same abort is received with both switches in auto, Replace Duplication Interface components starting with the standby Duplication Interface circuit pack. Use SPE Duplication Channel Component Replacement procedures at the end of the DUP-CHL section. In addition to looking for failures, also check for the absence of this 1321 abort code when testing after the procedure directs setting the switches to <b>auto</b> after a component replacement.</li> </ol>
1405	ABORT	<p>This test did not run because the Duplication Channel was busy.</p> <ol style="list-style-type: none"> <li data-bbox="282 1059 987 1082">1. Retry the command at 1-minute intervals a maximum of 5 times.</li> </ol>
1418	ABORT	<p>The HFAIL bit and/or the STDONE bit is in the wrong state. The active Duplication Interface circuit pack needs to be reset.</p> <ol style="list-style-type: none"> <li data-bbox="282 1171 971 1231">1. Run the <b>test duplication-interface long</b> command and follow instructions for the Active DUPINT Reset Test (#870).</li> <li data-bbox="282 1249 1009 1272">2. If test #870 passes and this test still aborts, escalate the problem.</li> </ol>
2500	ABORT	<p>Internal system error</p> <ol style="list-style-type: none"> <li data-bbox="282 1333 987 1356">1. Retry the command at 1-minute intervals a maximum of 5 times.</li> </ol>
	FAIL	<p>The retrieved test data word that was looped around in the active Duplication Interface circuit pack did not match the inversion of the written test data word.</p> <ol style="list-style-type: none"> <li data-bbox="282 1481 1013 1594">1. Replace Duplication Interface components starting with the active Duplication Interface circuit pack. Use SPE Duplication Channel Component Replacement procedures at the end of the DUP-CHL section.</li> </ol>

*Continued on next page*

**Table 9-284. TEST #867 Local Loop-around Test — Continued**

Error Code	Test Result	Description/ Recommendation
55	FAIL	The attempt to turn off memory shadowing in this Duplication Interface circuit pack could not be verified in the hardware status register.  1. Replace Duplication Interface components starting with the active Duplication Interface circuit pack. Use SPE Duplication Channel Component Replacement procedures at the end of the DUP-CHL section.
	PASS	The retrieved test data word that was looped around in the active Duplication Interface circuit pack matched the inversion of the written test data word.

### Memory Shadowing Bounds Test (#868)

**This test is destructive.**

This test is used to check the memory shadowing bounds register located on the Duplication Interface circuit pack

**Table 9-285. TEST #868 Memory Shadowing Bounds Test**

Error Code	Test Result	Description/ Recommendation
1321	ABORT	<p>The faceplate switches on the Duplication Interface circuit packs are not set to <b>auto</b>.</p> <ol style="list-style-type: none"> <li>1. If the switches are locked because you are using a replacement procedure, continue with this procedure to the step that directs you to unlock the active SPE by moving both switches to <b>auto</b>. The next step using the <b>test duplication-interface long clear</b> should not abort with this error code.</li> <li>2. If the switches are locked and a replacement procedure is not being used, start with step 6 of the SPE Duplication Channel Component Replacement procedure for the standby Duplication Interface Circuit pack at the end of the DUP-CHL section to avoid an undesired interchange when unlocking the active SPE.</li> <li>3. If this same abort is received with both switches in auto, Replace Duplication Interface components starting with the standby Duplication Interface circuit pack. Use SPE Duplication Channel Component Replacement procedures at the end of the DUP-CHL section. In addition to looking for failures, also check for the absence of this 1321 abort code when testing after the procedure directs setting the switches to <b>auto</b> after a component replacement.</li> </ol>
1405	ABORT	<p>This test did not run because the Duplication Channel was busy.</p> <ol style="list-style-type: none"> <li>1. Retry the command at 1-minute intervals a maximum of 5 times.</li> </ol>
1418	ABORT	<p>The HFAIL bit and/or the STDONE bit is in the wrong state. The active Duplication Interface circuit pack needs to be reset.</p> <ol style="list-style-type: none"> <li>1. Run the <b>test duplication-interface long</b> command and follow instructions for the Active DUPINT Reset Test (#870).</li> <li>2. If test #870 passes and this test still aborts, escalate the problem.</li> </ol>
2500	ABORT	<p>Internal system error</p> <ol style="list-style-type: none"> <li>1. Retry the command at 1-minute intervals a maximum of 5 times.</li> </ol>
	FAIL	<p>The looped around test word within the shadowing bounds did not match the inversion of the written test word or the looped around test word outside the shadowing bounds matched the inversion of the written test word. The test words are looped within the active Duplication Interface circuit pack.</p> <ol style="list-style-type: none"> <li>1. Replace Duplication Interface components starting with the active Duplication Interface circuit pack. Use SPE Duplication Channel Component Replacement procedures at the end of the DUP-CHL section.</li> </ol>

*Continued on next page*

**Table 9-285. TEST #868 Memory Shadowing Bounds Test — Continued**

Error Code	Test Result	Description/ Recommendation
55	FAIL	The attempt to turn off memory shadowing in this Duplication Interface circuit pack could not be verified in the hardware status register.  1. Replace Duplication Interface components starting with the active Duplication Interface circuit pack. Use SPE Duplication Channel Component Replacement procedures at the end of the DUP-CHL section.
	PASS	The looped around test word within the shadowing bounds matched the inversion of the written test word and the retrieved test word outside the shadowing bounds did not match the inversion of the written test word. The test words are looped within the active Duplication Interface circuit pack.

### Active DUPINT Reset Test (#870)

**This test is destructive.**

This test checks the HFAIL bit in the active Duplication Interface circuit pack and attempts to reset the circuit pack if the HFAIL bit is set. The state-of-health of the standby SPE must be *partially functional* for this test to run.

**Table 9-286. Test #870 Active DUPINT Reset Test**

Error Code	Test Result	Description/ Recommendation
1419	ABORT	A standby state-of-health of <i>functional</i> or <i>not refreshed</i> prevented the test from running.  1. Manually lock the active SPE by moving the SPE-select switches located on the front of the DUPINT circuit pack to positions where they are both selecting the currently active SPE.  2. Rerun the test.  3. If the test passes, then unlock the active SPE by moving both SPE select switches to the Auto position and rerun the <b>test duplication-interface long</b> command.  4. If the test fails or aborts, replace the active DUPINT circuit pack. Use procedures described in <i>Replacing Duplication Channel Components</i> in the DUP-CHL section.

*Continued on next page*

**Table 9-286. Test #870 Active DUPINT Reset Test — Continued**

Error Code	Test Result	Description/ Recommendation
1321 2500	ABORT	Internal system error  1. Retry the command at 1-minute intervals a maximum of 5 times.
	FAIL	The Active Duplication Interface circuit pack hardware did not initialize.  1. Replace Duplication Interface components starting with the active Duplication Interface circuit pack. Use SPE Duplication Channel Component Replacement procedures at the end of the DUP-CHL section.
51	FAIL	After the active Duplication Interface circuit pack reset attempt, the HFAIL was still set.  1. Replace Duplication Interface components starting with the active Duplication Interface circuit pack. Use SPE Duplication Channel Component Replacement procedures at the end of the DUP-CHL section.
52	FAIL	After the active Duplication Interface circuit pack was reset, an attempt to set the software state-of-health to its value that existed before running this reset test failed.  1. Replace Duplication Interface components starting with the active Duplication Interface circuit pack. Use SPE Duplication Channel Component Replacement procedures at the end of the DUP-CHL section.
55	FAIL	The attempt to turn off memory shadowing in this Duplication Interface circuit pack could not be verified in the Duplication Interface hardware status register.  1. Replace Duplication Interface components starting with the active Duplication Interface circuit pack. Use SPE Duplication Channel Component Replacement procedures at the end of the DUP-CHL section.
	PASS	The Active Duplication Interface circuit pack HFAIL bit was not set, or the HFAIL bit was set and successfully cleared by this test.

*Continued on next page*

**Active DUPINT HFAIL/STDONE Check Test (#979)**

This test checks the HFAIL and STDONE bits on the active Duplication Interface circuit pack. This test is used only for periodic or scheduled testing

**Table 9-287. Test #979 Active DUPINT HFAIL/STDONE Check Test**

Error Code	Test Result	Description/ Recommendation
2500	ABORT	Internal system error 1. Retry the command at 1-minute intervals a maximum of 5 times.
1	FAIL	The STDONE bit on the active Duplication Interface circuit pack is in the wrong state.
2	FAIL	The STDONE bit on the active Duplication Interface circuit pack is in the wrong state.
3	FAIL	The STDONE and HFAIL bits on the active Duplication Interface circuit pack are in the wrong state. 1. Run the <b>test duplication-interface long</b> command and follow instructions for the Active DUPINT Reset Test (#870).
	PASS	The STDONE and HFAIL bits on the active Duplication Interface circuit pack are in the correct state.

## E-DIG-BD (Multi Application Platform Board)

---

MO Name (in Alarm Log)	Alarm Level	Initial Command to Run <sup>1</sup>	Full Name of MO
DIG800-BD	MIN	test board UUCSS sh	MO800DIG-BD
DIG800-BD	WRN	test board UUCSS sh	MO800DIG-BD

- Where UU is the universal cabinet number (1 for PPN and 2-44 for EPN); C is the carrier designation (for example, A, B, C, D, or E); SS is the address of the slot in the carrier where the circuit pack is located (for example, 01, 02, ...); and pp is the two digit port number (01, 02, 03, ...).

The maintenance strategy for DIG800-BD is the same as the one described for MO-COMBD (MO-XXX-BD). Maintenance testing of the common circuit pack is handled by on-board firmware and SPE controlled tests. Maintenance software queries the firmware for error and alarm information, status, and test results. The firmware automatically reports error conditions that will result in SPE-controlled testing.

### Board Insertion

The switch makes an additional board query if any of the following circuit packs are inserted:

Circuit Pack	Vintage
TN754	49
TN556	49, 80 or greater
TN800	any

For any of the above initial board up-links, the switch sends queries requesting additional data from the board for administration purposes, while also telling the board the switch software release and the system type.

For the native mode, the response to the board query downlink messages consists of several CCMS uplink messages that identify the true board code, vintage, suffix, emulation type, and the number of reserved slots it needs.

## Hyperactivity

The common circuit pack is considered “hyperactive” if the service dispatcher receives 200 up-link messages from the circuit pack in a 10-second period. Since MAPD has 32 ports, the hyperactivity limit is increased to 500 up-link messages per 10seconds. An alarm is issued and the board taken out of service when the limit reaches 400 or when it hits 500 up-link messages in 10 seconds.

## LED Use

The LED Control message 038x requests the Angel to drive the Red, Yellow, and Green LEDs on the face plate of typical port board on or off. On the MAPD, only the Red LED is controlled by this message. Yellow and Green change requests received from the switch by the MAPD drive LCD behavior rather than LED behavior. The switch continues to send the same LED control messages to the MAPD that it currently sends to all other port boards. The MAPD handles proper interpretation of these messages. You should note that the PC on the MAPD, as well as the switch itself, can control the LEDs and the LCD on the MAPD.

## Port Administration

In administration without hardware, the switch allows administration of up to 32 MAPD ports of any port type. If the port type later reported by the board does not match the existing type, the switch assumes the board is a MAPD board with a different configuration and rejects the board. MAPD\_DCP\_STA and MAPD\_ASAL\_STA are the only two types of terminals are allowed on a MAPD board. Therefore, while administering ports on MAPD using **add station form**, it will allow only the terminals mentioned above.

### NOTE:

Refer to XXX-BD (Common Port Circuit Pack) maintenance documentation for circuit pack level errors. See also DIG-LINE maintenance documentation for related line information.



- 9** Maintenance Object Repair Procedures  
*E-DIG-RES (TN800 reserve slot)*

9-745

## **E-DIG-RES (TN800 reserve slot)**

See ASAI-RES.

## E-DIG-STA (Emulated Digital Line)

MO Name (in Alarm Log)	Alarm Level	Initial Command to Run <sup>1</sup> (a) (b)	Full Name of MO
E-DIG-STA	MINOR	test port UUCSSpp l	Emulated Digital St.
E-DIG-STA	WARNING	test port UUCSSpp sh	Emulated Digital St.

- Where UU is the universal cabinet number (1 for PPN and 2-44 for EPN); C is the carrier designation (for example, A, B, C, D, or E); SS is the address of the slot in the carrier where the circuit pack is located (for example, 01, 02, ...); and pp is the two digit port number (01, 02, 03, ...).

There are 4 tests in the Emulated Digital Line station maintenance test sequence and only one test path in the test sequence. Once the test sequence is started, all tests in the test sequence are executed.

E-DIG-ST maintenance monitors and tests ports on the TN800 MAPD circuit pack and the hardware connected to those ports for lines administered as a digital station. These include stations with an emulated digital voice terminal and stations with an emulated digital voice terminal and a linked data module. Stand-alone data modules and data adaptors in stand-alone mode are not supported by the TN800 circuit pack. Circuit pack maintenance is covered by E-DIG-BD.

## Hardware Error Log Entries and Test to Clear Values

**Table 9-288. Digital Line Error Log Entries - E-DIG-STA**

Error Type	Aux Data	Associated Test	Alarm Level	On/Off Board	Test to Clear Value
0 <sup>1</sup>	0	Any	Any	Any	test port UUCSSpp sh r 1
18 (a)	0	busyout port UUCSSpp	WNG	OFF	rel port UUCSSpp
130 (b)		None	WNG	ON	test port UUCSSpp sh
257 (c)	40971	None			
1537 (d)	40968	None	WNG	OFF	
1793 (e)		Voice and Control Local Loop Test (#13)	MIN/ WNG <sup>2</sup>	ON	test port UUCSSpp l r 3
2049 (f)		NPE Crosstalk Test (#9)	MIN/ WNG <sup>2</sup>	ON	test port UUCSSpp l r 3

*Continued on next page*

Table 9-288. Digital Line Error Log Entries - E-DIG-STA — Continued

Error Type	Aux Data	Associated Test	Alarm Level	On/Off Board	Test to Clear Value
2305 (g)	32770	None			
3840 (h)	40965	None			
3841 (i)	41029	None			
2304 (j)		None			

1. Run the Short Test Sequence first. If all tests pass, run the Long Test Sequence. Refer to the appropriate test description and follow the recommended procedures.
2. Major alarms may be downgraded to Warning alarms based on the value used in the **set options** command.

## Notes:

- a. Maintenance personnel have busied out the port in question. Make sure that the port is released from busyout by using the **release port UUCSSpp** command.
- b. The circuit pack has been removed or has been insane for more than 21 minutes. To clear the error, reinsert or replace the circuit pack.
- c. Problems transmitting to the voice terminal. This problem can be caused by defective wiring, which can cause varying degrees of problems on different types of sets. Sets such as the 7410 appear to be more susceptible to wiring problems than others.
- d. An in-link maintenance error has generated an off-board warning due to some problem with the link to the voice terminal. This can be ignored if no user complaints are received. Otherwise, make sure the voice terminal is connected, check for defective wiring, check for a defective voice terminal, and move voice terminal to a jack that is closer to the switch (number of feet of wiring between the jack and the switch). If the problem still exists, replace the circuit pack. Once the problem has been resolved, the alarm is retired after a predetermined amount of time.
- e. The local loop test failed. Each failure increments the counter by 1 when the local loop test fails. The counter is decremented when the loop test passes. When the counter reaches a threshold of 3, an on-board MINOR alarm is raised.
- f. The NPE Crosstalk test failed. The counter is incremented by 1 when the NPE Crosstalk test fails. The counter is decremented by 1 when the NPE Crosstalk test passes. When the counter reaches a threshold of 3, an on-board MINOR alarm is raised and the board is taken out of service.

- g. The station went off-hook while it was in the ready-for-service state. Use the **status station** command to determine the state of the station. The off-hook should have moved the station to ready-for-service. No technician action is necessary.
- h. No terminal is connected to the Digital Line board. No maintenance action is required.
- i. The circuit pack's message buffer is full. This may be caused by having many display phones with heavy traffic connected to the circuit pack. No action is necessary.
- j. Internal system error; no action is necessary. The error counters 1, 2, 3, 4, 5, 6, 10, 11, 12, 13, 14, 15, and 16 do not have any significance for this MO.

## System Technician-Demanded Tests: Descriptions and Error Codes

Always investigate tests in the order presented in the table below when inspecting errors in the system. By clearing error codes associated with the Voice and Control Channel Local Loop Around Test, for example, you may also clear errors generated from other tests in the testing sequence.

Order of Investigation	Short Test Sequence	Long Test Sequence	D/ND <sup>1</sup>
Voice and Control Channel Local Loop Around Test (#13)		X	D
NPE Crosstalk Test (#9)		X	ND
Station Lamp Updates Test (#16)		X	ND

1. D = Destructive; ND = Nondestructive

### Digital Line NPE Crosstalk Test (#9)

One or more Network Processing Elements (NPEs) reside on each circuit pack with a TDM Bus interface. The NPE controls port connectivity and gain and provides conferencing functions on a per-port basis. The NPE Crosstalk Test verifies that this port's NPE channel talks on the selected time slot and never crosses over to time slots reserved for other connections. If the NPE is not working correctly, one-way and noisy connections may be observed. This test is part of a port's Long Test Sequence and takes about 20 to 30 seconds to complete. Crosstalk testing occurs on both the primary information channel (voice) and the secondary information channel (data) associated with each digital station port. If this test fails on either channel, the station and the DTDM are taken out-of-service.

**Table 9-289. TEST #9 Digital Line NPE Crosstalk Test**

Error Code	Test Result	Description/Recommendation
1	ABORT	<p>During testing of the primary information channel, system resources may not have been available or the port was busy during the test.</p> <ol style="list-style-type: none"> <li>1. Check the port status.</li> <li>2. Use the <b>display port UUCSSpp</b> command to determine the station extension of the port. Use the <b>status station</b> command to determine the service state of the port. If the port is in use, wait until the port is idle before retesting.</li> <li>3. If the port status is idle, then retry the command at 1-minute intervals a maximum of 5 times.</li> </ol>
2	ABORT	<p>During testing of DTDM, system resources may not have been available or he port was busy during the test.</p> <ol style="list-style-type: none"> <li>1. Check if port is being used. If possible, disconnect by toggling the disconnect button on DTDM. Retry the command after 1 minute.</li> </ol> <p> <b>CAUTION:</b>  <i>This action drops the call in progress.</i></p>
1000	ABORT	<p>System resources required to run this test are not available. The port may be busy with a valid call.</p> <ol style="list-style-type: none"> <li>1. Use <b>display port UUCSSpp</b> to determine the station extension or attendant number of the port. Use <b>status station</b> or <b>status attendant</b> to determine the service state of the port. If the port is in use, wait until it is idle before retesting. Attendants are always in use (off-hook) if the handset is plugged in and the port is not busied out.</li> <li>2. If the port status is idle, then retry the command at 1-minute intervals a maximum of 5 times.</li> </ol>
1001	ABORT	<p>System resources required to run this test are not available.</p> <ol style="list-style-type: none"> <li>1. Retry the command at 1-minute intervals a maximum of 5 times.</li> </ol>
1002	ABORT	<p>The system could not allocate time slots for the test. The system is under heavy traffic conditions or has time slots out-of-service due to TDM-BUS errors.</p> <ol style="list-style-type: none"> <li>1. If system has no TDM-BUS errors and is not handling heavy traffic, repeat test at 1-minute intervals a maximum of 5 times.</li> </ol>

*Continued on next page*

Table 9-289. TEST #9 Digital Line NPE Crosstalk Test — *Continued*

Error Code	Test Result	Description/Recommendation
1003	ABORT	The system could not allocate a tone receiver for the test. The system is oversized for the number of Tone Detectors present, or some Tone Detectors are out-of-service. <ol style="list-style-type: none"><li>1. Resolve any TTR-LEV errors.</li><li>2. Resolve any TONE-PT errors.</li><li>3. If neither condition exists, retry the command at 1-minute intervals a maximum of 5 times.</li></ol>
1004	ABORT	The port was seized by a valid call during the test. <ol style="list-style-type: none"><li>1. Use <b>display port UUCSSpp</b> to determine the station extension or attendant number of the port.</li><li>2. Use <b>status station</b> or <b>status attendant</b> to determine the service state of the port.</li><li>3. If the service state indicates that the port is in use, then the port is unavailable for certain tests. Wait until the port is idle before retesting. Attendants are always in use (off-hook) if the handset is plugged in and the port is not busied out.</li></ol>
1020	ABORT	Test disabled by background testing. Use the <b>status station</b> command to determine when the station is available for testing.
2000	ABORT	Response to the test request was not received within the allowable time period. <ol style="list-style-type: none"><li>1. Retry the command at 1-minute intervals a maximum of 5 times.</li></ol>
1 2	FAIL	The Network Processing Element (NPE) of the tested port is transmitting in error. This causes noisy and unreliable connections. Error code 1 = Crosstalk test failed on the primary channel. Error code 2 = Crosstalk test failed on the secondary channel. <ol style="list-style-type: none"><li>1. Replace the circuit pack.</li></ol>
	PASS	The port is correctly using its allocated time slots. <ol style="list-style-type: none"><li>1. To ensure that this is not an intermittent problem, repeat this test a maximum of 10 times.</li><li>2. If complaints persist, examine the station, connections, and wiring.</li></ol>

### Voice and Control Channel Local Loop Test (#13)

These tests check the information and control channels between the Switch Processing Element (SPE) and the Digital Line port circuit. The SPE sends a message to loop around both the information and control channels for the port.

First, the primary information (voice) channel loopback test sends a digital count from the Tone-Clock circuit pack on the primary information channel time slot and receives the same digital count with a general purpose tone detector.

While the primary information channel is still looped around, the Control Channel Loop Around Test sends four different transparent patterns to the on-board microprocessor, receives them back, and compares them.

The Loop Around Test for the secondary information (data) channel is the same as the primary information channel loop around test and is performed only if a DTDM is administered.

Next, a Conference Test checks the primary information channel. This test is the same as Conference Test #6.

The four tests generate only one result: Pass, Fail, or Abort. If any test fails or aborts, the test sequence stops.

**Table 9-290. TEST #13 Voice and Control Channel  
 Local Loop Test**

Error Code	Test Result	Description/ Recommendation
	ABORT	Internal system error 1. Retry the command at 1-minute intervals a maximum of 5 times.
1000	ABORT	System resources required to run this test are not available. The port may be busy with a valid call. 1. Use <b>display port UUCSSpp</b> to determine the station extension or attendant number of the port. Use <b>status station</b> or <b>status attendant</b> to determine the service state of the port. If the port is in use, wait until it is idle before retesting. Attendants are always in use (off-hook) if the handset is plugged in and the port is not busied out. 2. If the port status is idle, then retry the command at 1-minute intervals a maximum of 5 times.
1001	ABORT	System resources required to run this test are not available. 1. Retry the command at 1-minute intervals a maximum of 5 times.
1002	ABORT	The system could not allocate time slots for the test. The system is under heavy traffic conditions or it has time slots out-of-service due to TDM-BUS errors. 1. If system has no TDM-BUS errors and is not handling heavy traffic, repeat test at 1-minute intervals a maximum of 5 times.

*Continued on next page*

**Table 9-290. TEST #13 Voice and Control Channel  
 Local Loop Test — Continued**

Error Code	Test Result	Description/ Recommendation
1003	ABORT	The system could not allocate a tone receiver for the test. The system is oversized for the number of Tone Detectors present, or some Tone Detectors are out-of-service. <ol style="list-style-type: none"> <li>1. Resolve any TTR-LEV errors.</li> <li>2. Resolve any TONE-PT errors.</li> <li>3. If neither condition exists, retry the command at 1-minute intervals a maximum of 5 times.</li> </ol>
1004	ABORT	The port was seized by a valid call during the test. <ol style="list-style-type: none"> <li>1. Use <b>display port UUCSSpp</b> to determine the station extension or attendant number of the port.</li> <li>2. Use <b>status station</b> or <b>status attendant</b> to determine the service state of the port. If the port is in use, wait until it is idle before retesting. Attendants are always in use (off-hook) if the handset is plugged in and the port is not busied out.</li> <li>3. Retry the command at 1-minute intervals a maximum of 5 times.</li> </ol>
2000	ABORT	Response to the test request was not received within the allowable time period.
2100	ABORT	Could not allocate the necessary system resources to run this test. <ol style="list-style-type: none"> <li>1. Rerun the test at 1-minute intervals a maximum of 5 times.</li> </ol>
7	FAIL	Conference Test failed on primary channel. In some cases, users may not notice disruption in service. In extreme cases, conferencing feature may not work at all.
14	FAIL	The primary voice channel is not transmitting properly. User impact may range from noticing nothing to not being able to use this port.
15	FAIL	The control channel between the processor and digital circuit pack is not transmitting properly. User impact may range from noticing nothing to not being able to use the port. This could disrupt other users.
16	FAIL	The secondary voice channel is not transmitting properly. User impact may range from noticing nothing to not being able to use this port. <ol style="list-style-type: none"> <li>1. Run circuit pack tests to check the Tone Generator circuit pack and the Tone Detector circuit pack using the <b>test board UUCSSpp</b> command.</li> <li>2. Resolve any problems that are detected on the Tone Generator circuit pack or Tone Detector circuit pack.</li> <li>3. If the test still fails, replace the Digital Line circuit pack.</li> </ol>

*Continued on next page*



**Table 9-290. TEST #13 Voice and Control Channel  
 Local Loop Test — Continued**

Error Code	Test Result	Description/ Recommendation
	PASS	The test passed, and all channels are transmitting properly. <ol style="list-style-type: none"> <li>1. To ensure that this is not an intermittent problem, repeat this test up to 10 times.</li> <li>2. If noisy connections for voice or corrupted data for data transfer persist, examine the station, connections, and wiring.</li> </ol>

### Station Lamp Updates Test (#16)

This test lights all lamps on the terminal as specified. The lamp updates will run only if the station is in-service. The status of the station is checked and the lamp updates are blocked from taking place if the station is not in the in-service state. This test does not affect the status of the Message Waiting lamp.

**Table 9-291. TEST #16 DIG-LINE Station Lamp Updates Test**

Error Code	Test Result	Description/ Recommendation
	ABORT	Internal system error <ol style="list-style-type: none"> <li>1. Retry the command at 1-minute intervals a maximum of 5 times.</li> </ol>
1	ABORT	System technician may have busied out the port. <ol style="list-style-type: none"> <li>1. Look for Error Type 18 (port busied out) for this port. If this error type is present, then release the port (<b>release station extension</b>) and run the test again.</li> <li>2. Make sure that the terminal is connected.</li> <li>3. Retry the command at 1-minute intervals a maximum of 5 times.</li> </ol>
3	ABORT	Station may be in ready-for-service or out-of-service state. <ol style="list-style-type: none"> <li>1. Use the <b>status station</b> command to verify state of station.</li> <li>2. Make sure the terminal is connected.</li> <li>3. Retry the command at 1-minute intervals a maximum of 5 times.</li> </ol>

*Continued on next page*

**Table 9-291. TEST #16 DIG-LINE Station Lamp Updates Test — Continued**

Error Code	Test Result	Description/ Recommendation
1000	ABORT	System resources required to run this test are not available. The port is busy with a valid call. <ol style="list-style-type: none"> <li>1. Use <b>display port UUCSSpp</b> to determine the station extension or attendant number of the port.</li> <li>2. Use <b>status station</b> or <b>status attendant</b> to determine the service state of the port. If the port is in use, wait until it is idle before retesting. Attendants are always in use (off-hook) if the handset is plugged in and the port is not busied out.</li> <li>3. Retry the command at 1-minute intervals a maximum of 5 times</li> </ol>
1392	ABORT	This is currently a TTI port, and the test cannot execute on it. <ol style="list-style-type: none"> <li>1. Verify that the port is a TTI port using either the <b>display port</b> command (the display shows that the port is a TTI port) or the <b>list config</b> command (the display shows a <math>\tau</math> for the port).</li> <li>2. If either <b>list config</b> or <b>display port</b> indicates that the port is <i>not</i> a TTI port, escalate the problem. If both commands indicate that the port is a TTI port, the abort is correct, and no action is necessary.</li> </ol>
	FAIL	Internal system error. <ol style="list-style-type: none"> <li>1. Retry the command at 1-minute intervals a maximum of 5 times.</li> </ol>
	PASS	The message to light all of the station lamps was sent successfully to the port. <ol style="list-style-type: none"> <li>1. Observe the station lamps being lit when running the test. If all lamps do not light successfully, the other Digital Line test results may indicate related problems that will not allow the lamps to light.</li> <li>2. Investigate by using other Digital Line port tests and by examining the station, wiring, and connections.</li> </ol>

## **EMG-XFER (Emergency Transfer)**

<b>MO Name (in Alarm Log)</b>	<b>Alarm Level</b>	<b>Initial Command to Run<sup>1</sup></b>	<b>Full Name of MO</b>
EMG-XFER	MAJOR	test environment UU	Emergency Transfer
EMG-XFER	WARNING	test environment UU	Emergency Transfer

1. UU is the universal cabinet number as listed in the PORT field of the Alarm or Error Log.

The Emergency Transfer maintenance object monitors the position of the Emergency Transfer switch(es) on the SYSAM circuit pack(s) in a PPN and the EPN Maintenance circuit packs in an EPN. It does not monitor whether or not the system is actually in Emergency Transfer.

Emergency Transfer (ET) provides the ability to connect designated analog phones to CO trunks when the switch cannot provide minimal phone service. Each cabinet (PPN and EPNs) has its own ET capability, and there is one EMG-XFER maintenance object for each cabinet or stack of single-carrier cabinets.

ET is controlled either automatically by the system, or manually, depending on the setting of the ET switches as described below.

### **Emergency Transfer Switches: EPNs and Simplex SPE**

In a simplex SPE PPN cabinet, or in an EPN cabinet, if the ET switch is in the “on” position, ET is manually invoked and the system has no control of ET. This will generate a major alarm. In a simplex SPE PPN cabinet or in an EPN cabinet, if the ET switch is in the “off” position, ET cannot be invoked even if the system requests it. This will generate a warning alarm. Unless a technician is currently working on the cabinet, the switches should be left in the auto position, giving control of ET to the system.

### **Emergency Transfer Switches: Duplicated SPEs**

On a system with duplicated SPE, the switches on both SYSAMs must be in the manual “on” position to manually invoke ET, generating a major alarm. If the switch on either SYSAM is in the manual “off” position, ET cannot be invoked, generating a warning alarm. Other settings give control to the system.

## Emergency Transfer Status

The **status cabinet** UU command shows the location of the ET switches and the current status of ET in the designated cabinet as follows:

on	ET is manually invoked.
off	ET is manually prevented.
auto+	ET is invoked and under system control.
auto-	ET is not in effect and is under system control (normal operating state).
unavailable	The switch setting(s) is not available.

## Error Log Entries and Test to Clear Values

Error Type	Aux Data	Associated Test	Alarm Level	On/Off Board	Test to Clear Value
0 <sup>1</sup>	0	Any	Any	Any	test environment UU
1	0	Emergency Transfer Query (#124)	MAJOR	ON	test environment UU r 3
257	0	Emergency Transfer Query (#124)	WARNING	ON	test environment UU r 3

1. Run the Short Test Sequence first. If all tests pass, run the Long Test Sequence. Refer to the appropriate test description and follow the recommended procedures.

## System Technician-Demanded Tests: Descriptions and Error Codes (Multi-Carrier)

Always investigate tests in the order presented in the table below. By clearing error codes associated with the *Battery & Battery Charger Query Test*, for example, you may also clear errors generated from other tests in the testing sequence.

**Table 9-292. System Technician-Demanded Tests: EMG-XFER (Multi-Carrier Cabinets)**

Order of Investigation	Short Test Sequence	Long Test Sequence	D/ND <sup>1</sup>
Battery & Battery Charger Query Test (#5) (a)	X	X	ND

*Continued on next page*

**Table 9-292. System Technician-Demanded Tests: EMG-XFER (Multi-Carrier Cabinets) — Continued**

Order of Investigation	Short Test Sequence	Long Test Sequence	D/ND <sup>1</sup>
AC Power Query Test (#78) (b)	X	X	ND
OLS Query Test (Carrier E) (#127) (c)	X	X	ND
OLS Query Test (Carrier D) (#127) (c)	X	X	ND
OLS Query Test (Carrier A) (#127) (c)	X	X	ND
OLS Query Test (Carrier B) (#127) (c)	X	X	ND
OLS Query Test (Carrier C) (#127) (c)	X	X	ND
Emergency Transfer Query Test (#124)	X	X	ND
Cabinet Sensors Query Test (#122) (d)	X	X	ND
External Alarm Lead Query Test (#120) (e)	X	X	ND
Analog Ring Generator Initialization Test			
Analog Ring Generator Initialization Test (#117) (f)	X	X	ND
Analog Ring Generator Query Test (#118) (f)	X	X	ND

1. D = Destructive, ND = Non-destructive

Notes:

- a. Refer to [“POWER”](#) section for a description of this test.
- b. Refer to AC-POWER section for a description of this test.
- c. Refer to CARR-POW section for a description of this test.
- d. Refer to CABINET section for a description of this test.
- e. Refer to [“EXT-DEV ADMIN? Y \(External Device Alarm\)”](#) section for a description of this test.
- f. Refer to [“RING-GEN”](#) section for a description of this test. These tests show up in the test sequence only if there is a TN768 or TN780 Tone/Clock circuit pack in the port network being tested.

## System Technician-Demanded Tests: Descriptions and Error Codes (Single-Carrier)

Always investigate tests in the order presented in the following table. By clearing error codes associated with the *Battery & Battery Charger Query Test*, for example, you may also clear errors generated from other tests in the testing sequence. For example, you may also clear errors generated from other tests in the testing sequence.

### Single-Carrier System

Order of Investigation	Short Test Sequence	Long Test Sequence	D/ND <sup>1</sup>
Power Query Test (#79) (a)	X	X	ND
Emergency Transfer Query Test (#124)	X	X	ND
External Alarm Lead Query Test (#120) (b)	X	X	ND
Analog Ring Generator Initialization Test (#117) (c)	X	X	ND
Analog Ring Generator Query Test (#118) (c)	X	X	ND

1. D = Destructive; ND = Nondestructive

#### Notes:

- a. Refer to "DC-POWER" for a description of this test.
- b. Refer to ["EXT-DEV ADMIN? Y \(External Device Alarm\)"](#) for a description of this test.
- c. Refer to ["RING-GEN"](#) for a description of this test.

#### NOTE:

These tests only show up in the test sequence if there is a TN768 Tone-Clock Board in the port network being tested.

## Emergency Transfer Query Test (#124)

The Emergency Transfer Query Test queries the hardware for the state of the Emergency Transfer switch (or switches in a duplicated SPE system) and reports the result. If the position of the switch in a single SPE cabinet or EPN cabinet, or switches in a duplicated SPE cabinet, is such that the system software can control Emergency Transfer (auto), then the test passes. If the position of the switch or switches is such that the system software cannot control Emergency Transfer (manual "on" or manual "off"), then the test fails. In the PPN the SYSAM controls Emergency Transfer, and in the EPN, the EPN Maintenance circuit pack controls Emergency Transfer

**Table 9-293. TEST #124 Emergency Transfer Query Test**

Error Code	Test Result	Description/ Recommendation
1000	ABORT	System resources required to run this test are not available. 1. Retry the command at 1-minute intervals a maximum of 5 times.
2000	ABORT	Response to the test was not received within the allowable time period. 1. Retry the command at 1-minute intervals a maximum of 5 times. 2. If the test continues to ABORT with Error Code 2000, check for system powering problems with the A carrier (PPN or EPN). Resolve all AC-POWER and CARR-POW alarms in a multi-carrier cabinet system or DC-POWER alarms in a single-carrier cabinet system. Then, repeat the test. 3. If the test continues to ABORT with a 2000 Error Code, resolve all SYSAM errors in a PPN, or MAINT (EPN Maintenance circuit pack) errors in an EPN. Then, repeat the test.
2029 2319 2320 2500	ABORT	Internal system error 1. Retry the command at 1-minute intervals a maximum of 5 times.
17 18 20 33 65 289	FAIL	Emergency Transfer is manually turned OFF (Emergency Transfer switch off). 1. Place the switch (or switches in a PPN with duplicated SPE) in the AUTO position.
34 290	FAIL	Emergency Transfer is manually turned ON (Emergency Transfer switch on). 1. Place the switch (or switches in a PPN with duplicated SPE) in the AUTO position.
	PASS	System software has control of Emergency Transfer within this cabinet. If Emergency Transfer is currently invoked (the emergency transfer LED is on), the cause could be a major alarm. 1. The following list shows the error types that can cause Emergency Transfer. If any of these errors appear in the log, then refer to the appropriate section and resolve those problems first. TAPE SW-CTL TONE-BD, Error Type 3585 Aux Data 121; Error Type 2305, Aux Data 40800 2. If none of the above errors appear in the log, then check the Emergency Transfer hardware. 3. On an EPN, if Emergency Transfer is invoked while call processing is permitted, verify that the current limiter card (982LS) is in the correct slot on the backplane. If the current limiter card is not in the correct slot, move it to the correct location and rerun Test #124.

## EPN-SNTY (EPN Sanity Audit)

MO Name (in Alarm Log)	Alarm Level	Initial Command to Run	Full Name of MO
EPN-SNTY	None	None	EPN Sanity Audit

The EPN Sanity Audit feature enhances the system's ability to recover from failure conditions that disable an entire EPN. In such situations, not only is the affected EPN unable to provide service to the system, but the system itself has not detected the condition. The EPN Sanity Audit feature recognizes an EPN as unable to provide service when the software cannot receive control messages from EPN circuit packs. When such a failure is detected by the EPN Sanity Audit, a sequence of recovery actions is triggered to restore the EPN to service.

For a Standard Reliability system (simplex SPE), the recovery sequence is:

1. TDM Bus Switch
2. EPN WARM Reset
3. EPN COLD Reset

For a High or Critical Reliability system (duplicated SPE), the recovery sequence is:

1. TDM Bus Switch
2. Tone/Clock Switch within the EPN
3. PNC Interchange
4. EPN WARM Reset
5. EPN COLD Reset

The EPN Sanity Audit feature activates only when all existing maintenance operations have failed to detect the EPN problem. The EPN Sanity Audit serves as a safety net for the EPN.

### NOTE:

It is not clear why certain types of EPN problems activate this feature. Thus, error log entries related to these problems do not specify which hardware to replace. The error log entries only indicate that some drastic recovery action occurred due to an unknown problem. However, clues as to the root cause of the EPN outage may be present in the Error Logs and the Alarm Logs of the following MOs: Switch Control (SW-CTL), TDM Bus (TDM-BUS), Expansion Interface (EXP-INTF), TDM Bus Clock (TDM-CLK), EXP-PN, and PNC-DUP. You should refer to these maintenance sections during troubleshooting operations.



## Error Log Entries and Test to Clear Values

**Table 9-294. EPN-SNTY Error Log Entries**

Error Type	Aux Data	Associated Test	Alarm Level	On/Off Board	Test to Clear Value
0 <sup>1</sup>	0	Any			None
8801 (a)	Any	None			
8803 (b)	Any	None			
9901 (c)	Any	None			
9902 (d)	Any	None			
9903 (e)	Any	None			
9904 (f)	Any	None			
9905 (g)	Any	None			

1. Run the Short Test Sequence first. If all tests pass, run the Long Test Sequence. Refer to the appropriate test description and follow the recommended procedures.

### Notes:

- a. Error 8801 occurs whenever the EPN is unable to send up-link control messages and the control channel of the TDM Bus in the EPN has been switched as part of the recovery procedure.
- b. Error 8803 occurs each time whenever the EPN is unable to send up-link control messages and the EPN Tone-Clock has been switched as part of the recovery procedure.
- c. Error 9901 occurs whenever the EPN is unable to send up-link control messages, but recovers after the control channels of the TDM Bus in the EPN are switched.
- d. Error 9902 occurs whenever the EPN is unable to send up-link control messages, but recovers after the active Tone-Clock in the EPN is switched.
- e. Error 9903 occurs whenever the EPN is unable to send up-link control messages, but recovers after a PNC interchange has taken place.
- f. Error 9904 occurs whenever the EPN is unable to send up-link control messages, but recovers after an EPN WARM reset.
- g. Error 9905 occurs whenever the EPN is unable to send up-link control messages, but recovers after an EPN COLD reset.

## ERR-LOG (Error Log)

MO Name (in Alarm Log)	Alarm Level	Initial Command to Run	Full Name of MO
ERR-LOG	none	none	Error Log

The ERR-LOG maintenance object (MO) is responsible for the sanity of the Alarm Log, the Hardware Error Log, and the Software Error Log. If an inconsistency is detected in any one of these logs, all logs will be re-initialized and a hardware error will be logged against ERR-LOG indicating the time of inconsistency. There are no tests and no alarms for the Error Log MO. This MO exists solely for the purpose of allowing errors to be logged against it.

### Hardware Error Log Entries

Error Type	Aux Data	Associated Test	Alarm Level	On/Off Board	Test to Clear Value
510 (a)	See below	none	none	none	none

Notes:

- a. Indicates that an inconsistency was detected in either the Alarm Log, the Hardware Error Log, or the Software Error Log. The system attempts to recover the logs but, depending on the extent of the corruption, some or all entries in the logs may be lost. Any alarms that were active at the time of this error have been cleared. There is no associated test for this error.

The Aux Data value indicates when the inconsistency was found:

0	During a periodic audit of the Error Log
1	After an extended reboot
2	After a reboot
4	After a Level-3 System Reset (COLD_1)
8	After a Level-2 System Reset (COLD_2)
16	After a Level-1 System Reset (Warm Start)
100	After an internal software audit
2500	After a single-process (MDM) restart

## ETH-PT (Control LAN Ethernet)

MO Name (in Alarm Log)	Alarm Level	Initial Command to Run <sup>1</sup>	Full Name of MO
ETH-PT	MAJOR	test port UUCSSpp long	MO_ETH_PT
ETH-PT	MINOR	test port UUCSSpp long	MO_ETH_PT
ETH-PT	WARNING	test port UUCSSpp	MO_ETH_PT

1. *UU* is the universal cabinet number (1 for PPN, 2 - 44 for EPNs). *C* is the carrier designation (A, B, C, D, or E). *SS* is the number of the slot in which the circuit pack resides (01 to 21). *pp* is the two digit port number (01, 02, ...).

The TN799 Control LAN (CLAN) packet port circuit pack provides TCP/IP connection to adjuncts applications such as CMS, Intuity, and DCS Networking. The CLAN circuit pack has one 10baseT Ethernet connection and up to 16 DS0 physical interfaces for PPP connections. Multiple CLAN circuit packs (maximum 2 per switch) in a system gives additional TCP/IP capacity.

A remote socket control link (RSCL) links the CLAN and the SPE to pass call control and other management information. Since one link serves all the ports on the circuit pack, maintenance of the RSCL is part of the CLAN circuit pack maintenance.

### NOTE:

The CLAN TN799 circuit pack replaces the PGATE and PI circuit packs in the G3r and G3si/G3vs systems, respectively. The PGATE or PI can be used with the CLAN to create an X.25-to-TCP/IP bridge for adjunct and DCS connections.

## Control LAN Congestion Controls

The switch activates congestion controls on CLAN when it detects buffers exceeding the threshold. The switch releases the congestion controls when the CLAN reports that its buffer level has returned to normal levels.

If congestion:	Then the switch:
Persists for a 14-minute interval,	Raises MINOR alarm.
Exhausts buffers,	Raises MINOR alarm.
Ceases for 12 minutes,	Retires MINOR alarm.

## Error Log Entries and Test to Clear Value

Table 9-295. ETH-PT Error Log Entries

Error Type	Aux Data	Associated Test	Alarm Level	On/Off Board	Test to Clear Value
0 <sup>1</sup>	0	Any	Any	Any	test port UUCSSpp s
1 (a)	0	Ethernet Local Looparound Test (#1278)	MINOR	ON	test port UUCSSpp l r 3
513 (b)	0	Link Integrity Inquiry (#1282)	MINOR	OFF	test port UUCSSpp r 2
769 (c)	0	Invalid Frame Error	WNG	OFF	
1281 (d)	0	Far-end Disconnect			
1537, 1538 (e)	See note	Session Status Test (#1286)	MINOR	OFF	
1793-1920 (f)	See note	Socket failure			
2305-2560 (g)	See note	Session Down error Session #s 1-256			
2561-2816 (g)	See note	Session Down error Session #s 257-512			
3329 (h)	See note	TCP/IP Ping Test (#1281)	WNG	OFF	

1. Run the Short Test Sequence first. If all tests pass, run the Long Test Sequence. Refer to the appropriate test description and follow the recommended procedures.

Notes:

- a. **Error Type 1:** Ethernet Local Looparound Test (#1278) failed.
  1. Test the port (**test port UUCSSpp long**).
  2. Refer to repair procedures for Test #1278.

- b. **Error Type 513:** Link Integrity Inquiry Test (#1282) failed or CLAN port detected loss of Ethernet link integrity.

Possible causes:

- Cabling
  - Ethernet transceiver
1. Test the port (**test port UUCSSpp long**).

- c. **Error Type 769:** Port received invalid frame.

Invalid Ethernet frame errors occur when the frame

- contains a bad Cyclic Redundancy Check (CRC)
- is misaligned

If the switch:	Then it:
Receives threshold failure rate	Raises WARNING alarm

1. Isolate the problem with the Ethernet Local Looparound Test (#1278).
2. Test the port (**test port UUCSSpp long**).
3. Verify the repair with the Ethernet Local Looparound Test (#1278).
4. Clear the alarm (**test port UUCSSpp long clear**).

- d. **Error Type 1281:** System software received an indication that the far-end has requested a disconnect of a session on this link. This is a log-only error.

- e. **Error Type 1537-1538:** Some or all sessions on a port are down.

If:	Then the switch:
Some sessions are down	Raises WARNING alarm on circuit pack
All sessions are down	Raises MINOR alarm on circuit pack

- f. **Error Type 1793-1920:** system software received an indication that a socket was closed due to an error. Error Type indicates the application of the application associated with this socket.

Error Type	Application
1794	DCS
1795	AUDIX
1796	CMS
1797	ISDN Gateway

Aux Data indicates the internal application number.

- g. **Error Type 2305-2816:** System software detected a session is down. Aux Data indicates the session number.
- h. **Error Type 3329:** TCP/IP Ping Test failed.

If the switch:	Then it:
Exceeds threshold failure rate	Raises off-board WARNING alarm on circuit pack

### System Technician-Demanded Tests: Descriptions and Error Codes

Investigate errors in the order they appear in the table below.

**Table 9-296. System Technician-Demanded Tests: ETH-PT**

Order of Investigation	Short Test Sequence	Long Test Sequence	D/ND <sup>1</sup>
Ethernet Local Loop-Around Test (#1278)		X	D
TCP/IP Ping Test (#1281)	X	X	ND
Session Status Test (#1286)	X	X	ND
Link Integrity Inquiry Test (#1282)	X	X	ND

1. D = Destructive, ND = Non-destructive

### Ethernet Local Looparound Test (#1278)

**This test is destructive.**

Use this test to check circuitry in the data path for an Ethernet call (from the MPC860 to the Ethernet Transceiver). This test fails if the data it receives does not match the data it transmits.

**Table 9-297. TEST #1278 Ether Local Looparound Test**

Error Code	Test Result	Description/ Recommendation
1000	ABORT	The port is in use. 1. Determine status of port ( <b>status clan-port UUCSSpp</b> ). 2. If port is idle, retry the Looparound Test (#1278). 3. If port is not idle, busyout the circuit pack ( <b>busyout port UUCSSpp</b> ).
2000	ABORT	Did not receive circuit pack test response within the allowable time period. 1. If the problem persists, reset the circuit pack ( <b>busyout port UUCSSpp</b> and <b>reset board UUCSS</b> ). 2. If the problem persists, replace the circuit pack.
2012	ABORT	Internal system error. 1. Retry the command at 1-minute intervals, up to 3 times.
2100	ABORT	Could not allocate the necessary resources to run test. 1. Retry the command at 1-minute intervals, up to 5 times.
1	FAIL	Circuit pack detected failure in the Ethernet Local Looparound Test (#1278). 1. If the problem persists, reset the circuit pack ( <b>busyout port UUCSSpp</b> and <b>reset board UUCSS</b> ). 2. If the problem persists, replace the circuit pack.
	PASS	The circuitry tests properly.

### TCP/IP PING Test (#1281)

This non-destructive test fails if all the endpoints fail to respond. Use this test to check the circuitry in the data path for a peer-to-peer IP layer connection.

System software launches a ping on a maximum of 3 endpoints reachable on this port. The test fails if all of the pings fail. The test passes if even 1 of the pings is successful.

**Table 9-298. TEST #1281 TCP/IP PING Test**

Error Code	Test Result	Description/ Recommendation
1, 2	ABORT	Internal error 1. Retry the command at 1-minute intervals a maximum of 3 times
7	ABORT	Destination unreachable. 1. Verify that at least one destination reachable through this port is up. Once verified, test the port again ( <b>test port UUCSS</b> ) verify that the TCP/IP Ping Test (#1281) passes.
1005	ABORT	Incorrect test configuration. 1. Verify Ethernet link is in service ( <b>status port UUCSSpp</b> or <b>status link n</b> ). 2. Verify that Ethernet link is enabled ( <b>status port UUCSSpp</b> or <b>status link n</b> or <b>display data-module</b> ). 3. Verify routing table has reachable destinations. 4. Repeat the test. 5. If problem persists while the Ethernet link is in service and enabled, escalate the problem.
1124	ABORT	Ethernet link is not enabled. 1. Verify that the Ethernet link is enabled ( <b>status port UUCSSpp</b> , <b>status link n</b> , or <b>display data-module</b> ). 2. If the link is not enabled, enable the link ( <b>change data-module</b> ). 3. Repeat the test.
1125	ABORT	Ethernet link not in service. 1. Verify Ethernet link is in service ( <b>status port UUCSSpp</b> or <b>status link n</b> ). 2. If the link is not in service, release the link using ( <b>release link n</b> or <b>release port UUCSSpp</b> ). 3. Repeat the test.
2000	ABORT	Did not receive circuit pack test response within the allowable time period. 1. Reset the circuit pack ( <b>busyout port UUCSSpp</b> and <b>reset board UUCSS</b> ). 2. If the test fails again, replace the circuit pack.
2012	ABORT	Internal system error. 1. Retry the command at 1-minute intervals, up to 3 times.
2100	ABORT	Could not locate the necessary system resources to run this test. 1. Retry the command at 1-minute intervals, up to 5 times.



**Table 9-298. TEST #1281 TCP/IP PING Test — Continued**

Error Code	Test Result	Description/ Recommendation
2500	ABORT	Internal system error. 1. Retry the command at 1-minute intervals, up to 3 times.
1003	FAIL	Ping to the destination failed due to on-board problem. 1. Test the port ( <b>test port UUCSSpp</b> ) and verify Session Status Test (#1286) result. 2. If this test indicates that all sessions on the port are down, escalate the problem.
1007	FAIL	Ping to the destination failed due to the destination down. 1. Verify that at least one destination reachable through this port is up. 2. Once verified, test the port ( <b>test port UUCSSpp</b> ) and verify TCP/IP Ping Test (#1281) passes.
	PASS	TCP/IP Ping Test (#1281) is successful.

**Link Integrity Inquiry Test (#1282)**

This non-destructive test queries the CLAN Ethernet port's physical connections.

If:	Then the test:
CLAN connection is present,	Passes.
CLAN connection is absent,	Fails.
There is no response,	Aborts.

**Table 9-299. TEST #1282 Link Integrity Inquiry Test**

Error Code	Test Result	Description/ Recommendation
1124	ABORT	Ethernet link is not enabled. 1. Verify that the Ethernet link is enabled ( <b>status port UUCSSpp, status link n, or display data-module</b> ). 2. If the link is not enabled, enable the link ( <b>change data-module</b> ). 3. Repeat the test.

*Continued on next page*

**Table 9-299. TEST #1282 Link Integrity Inquiry Test — Continued**

Error Code	Test Result	Description/ Recommendation
1125	ABORT	Ethernet link not in service. <ol style="list-style-type: none"> <li>1. Verify whether Ethernet link is in service (<b>status port UUCSSpp</b> or <b>status link n</b>).</li> <li>2. If the Ethernet link is not in service, release the link (<b>release link n</b> or <b>release port UUCSSpp</b>).</li> <li>3. Repeat the test.</li> </ol>
1959	ABORT	Downlink message error. <ol style="list-style-type: none"> <li>1. Retry the command at 1-minute intervals, up to 3 times.</li> </ol>
2012	ABORT	Internal system error. <ol style="list-style-type: none"> <li>1. Retry the command at 1-minute intervals, up to 3 times.</li> </ol>
2100	ABORT	Could not locate the necessary system resources to run this test. <ol style="list-style-type: none"> <li>1. Retry the command at 1-minute intervals, up to 5 times.</li> </ol>
2500	ABORT	Internal system error. <ol style="list-style-type: none"> <li>1. Retry the command at 1-minute intervals, up to 3 times.</li> </ol>
	FAIL	Link integrity lost due to problem with attachment of Ethernet cable to the port. <ol style="list-style-type: none"> <li>1. Repeat the test.</li> <li>2. If the test fails, verify that the cable properly is secured to Ethernet port and to the bus.</li> <li>3. Verify the CLAN circuit pack link integrity LED is glowing.</li> <li>4. Retry the test.</li> <li>5. If problem persists, refer to Ethernet Local Looparound Test (#1278) repair procedures.</li> </ol>
	PASS	The Ethernet Link Integrity Test (#1282) detects good connections.

## Session Status Test (#1286)

This non-destructive test determines the status of all Ethernet port sessions. This test queries the system software on port session status.

If the system software indicates that:	Then the switch:
All port sessions are up (ALL UP)	Raises no alarm, or retires alarm
Some port sessions are up (SOME UP)	Raises WARNING alarm
All port sessions are down (ALL DOWN)	Raises MINOR alarm

**Table 9-300. TEST #1286 Session Status Test**

Error Code	Test Result	Description/ Recommendation
1124	ABORT	Ethernet link is not enabled. <ol style="list-style-type: none"> <li>1. Verify that the Ethernet link is enabled (<b>status port UUCSSpp</b>, <b>status link n</b>, or <b>display data-module</b>).</li> <li>2. If the link is not enabled, enable the link (<b>change data-module</b>).</li> <li>3. Repeat the test.</li> </ol>
1125	ABORT	Ethernet link not in service. <ol style="list-style-type: none"> <li>1. Verify whether Ethernet link is in service (<b>status port UUCSSpp</b> or <b>status link n</b>).</li> <li>2. If the Ethernet link is not in service, release the link (<b>release link n</b> or <b>release port UUCSSpp</b>).</li> <li>3. Repeat the test.</li> </ol>
2000	ABORT	Did not receive circuit pack test response within the allowable time period. <ol style="list-style-type: none"> <li>1. If the problem persists, reset the circuit pack (<b>busyout port UUCSSpp</b> and <b>reset board UUCSS</b>).</li> <li>2. If the problem persists, replace the circuit pack.</li> </ol>
2100	ABORT	Could not locate the necessary system resources to run this test. <ol style="list-style-type: none"> <li>1. Retry the command at 1-minute intervals, up to 5 times.</li> </ol>
2500	ABORT	Internal system error. <ol style="list-style-type: none"> <li>1. Retry the command at 1-minute intervals, up to 3 times.</li> </ol>
1	FAIL	System software indicates at least one Ethernet link session is down (SOME UP). <ol style="list-style-type: none"> <li>1. Isolate downed sessions (<b>status port UUCSSpp</b> or <b>status link n</b>).</li> <li>2. Follow actions based on session information.</li> </ol>

*Continued on next page*

**Table 9-300. TEST #1286 Session Status Test — Continued**

Error Code	Test Result	Description/ Recommendation
2	FAIL	System software indicates all Ethernet sessions are down (ALL DOWN). 1. Test the port ( <b>test port UUCSSpp</b> ) to verify the Ethernet Local Looparound Test (#1278) result. 2. If test passes, wait for system software to indicate ALL UP.
	PASS	All sessions are up.

## ETR-PT (Enhanced Tone Receiver Port)

MO Name (in Alarm Log)	Alarm Level	Initial Command to Run <sup>1</sup>	Full Name of MO
ETR-PT	MAJOR	test port UUCSSpp sh	Enhanced Tone Receiver Port
ETR-PT	MINOR	test port UUCSSpp sh	Enhanced Tone Receiver Port
ETR-PT	WARNING	test port UUCSSpp sh	Enhanced Tone Receiver Port

1. UU is the universal cabinet number (1 for PPN, 2 - 44 for EPNs). C is the carrier designation (A, B, C, D, or E). SS is the number of the slot in which the circuit pack resides (01 to 21). pp is the two digit port number (01, 02, ...).

### NOTE:

Replacing the tone/clock circuit pack requires a special procedure which is described in "TONE-BD (Tone-Clock Circuit Pack)". That section also describes the LED display for this board.

The TN2182 is a combined Tone Generator/Tone Detector board. It provides 8 Enhanced Tone receiver (ETR) ports. Each of these ports provides the functions previously found individually on DTMR-PTs, GPTD-PTs and CLAS-PTs ports. Thus each port on the TN2182 may be used for any tone detection function that was previously done by TN748, TN420 or TN744 Tone detection boards.

The TN2182 provides Mu-law or A-law tone detection capability.

Since the TN2182 also provides Tone/Clock function only one (or two if your system is duplicated) TN2182 circuit packs may be present in a port network. Thus if more tone detection resources are needed, the additional resources must be provided by TN748, TN420 or TN744 circuit packs.

## Error Log Entries and Test to Clear Values

**Table 9-301. ETR-PT Error Log Entries**

Error Type	Aux Data	Associated Test	Alarm Level	On/Off Board	Test to Clear Value
1 (a)	any	Tone Detector Audit/Update Test (#43)	MAJ/ MIN	ON	test port UUCSSpp r 2
18		busyout port	WARNING	OFF	release port UUCSSpp

*Continued on next page*

**Table 9-301. ETR-PT Error Log Entries — Continued**

Error Type	Aux Data	Associated Test	Alarm Level	On/Off Board	Test to Clear Value
257 (a)(b)	17666	Tone Detection Audit Update Test (#43)	MAJ/ MIN	ON	test port UUCSSpp r 3
513 (a)(c)	any	Tone Detection Verification Test (#42)	MAJ/ MIN	ON	test port UUCSSpp r 3

Notes:

- a. There are two possible alarm levels for this error type: major alarm and minor alarm. These alarm levels are dependent on the administered thresholds for TTR, CPTR and CCTR. Each ETR port is capable of operating any of these.

A major alarm is raised if the total number of ports capable of TTR, CPTR or CCTR detection currently in-service is less than or equal to 1/2 of the administered TTR, CPTR or CCTR threshold number.

Otherwise, a minor alarm is raised. In either case, run the short test sequence against the port (ETR-PT) and follow the error code procedures for the individual tests.

The threshold number of ports for service is administered using the **change system-parameters maintenance** command.

1. Use **list configuration carrier** to get the board type and location. If the board is TN744, then do Steps 2-4; if it is TN2182, do Steps 5-12.
2. Execute 3 commands: **busyout board UUCSS**, **reset board UUCSS**, and **release board UUCSS**. Reset is required to reload RAM associated with the TN744's DSPs. This will take all 8 tone detector ports out of service for a few seconds. Only 4 of the 8 would be out of service due to the alarm. (There are 4 tone detectors on each of the two DSPs.) Other than the unlikely potential of running out of tone detector resources in the switch, there is no other effect when the board is reset.
3. Test the board (**test board UUCSS long**).
4. If the test passes, terminate the repair process. If the test fails, replace the board.
5. Check to see if the board is duplicated (**list cabinet** and **status port-network** on the affected port network.)

6. If the board is not duplicated, use test tone UUCSS long to resolve the error. The long test resets the board and is required to reload on-board RAM associated with the TN2182's DSPs. The effect is that tone detectors are taken out of service momentarily and tones are removed from the TDM bus for about 10 seconds. This means no dial or touch tones during this interval, which probably will not affect calls in progress, but could cause a call origination to abort or cause a user to not get dial tone when going off hook.
  7. If all tests pass and the alarm does not resolve, retest (**test tone UUCSS long clear**).
  8. If the test passes, terminate the repair process. If it fails, replace the circuit pack at the customer's convenience.
  9. If the board is duplicated, switch to the standby side (**set tone**).
  10. Test the alarmed board (test tone UUCSS long). This resets the board and is required to reload on-board RAM associated with the TN2182's DSPs.
  11. If all tests pass and the alarm does not resolve, retest with **test tone UUCSS long clear**.
  12. If the test passes, terminate the repair process. If it fails, replace the board.
- b. The ETR-PT lost its translation. Testing the ETR-PT is sufficient to reload its translation. If testing the ETR port does not clear the error, then the circuit pack containing the defective ETR port should be replaced at a time when it is convenient to remove a clock board from the system. Follow the procedures described in "TONE-BD (Tone-Clock Circuit Pack)" for replacing a tone/clock circuit pack.
- c. This error indicates the (ETR-PT) Enhanced Tone Receiver is having problems detecting touch tones, call progress or MFC tones. If this error type is persistently logged, then the circuit pack containing the defective ETR-PT should be replaced at a time it is convenient to remove a clock board from the board from the system. Follow the procedures described in the "TONE-BD (Tone-Clock Circuit Pack)" section for replacing a tone/clock circuit pack.

## System Technician-Demanded Tests: Descriptions and Error Codes

Always investigate tests in the order presented in the following table. By clearing error codes associated with the *Tone Detection Verification Test*, for example, you may also clear errors generated from other tests in the testing sequence.

Order of Investigation	Short Test Sequence	Long Test Sequence	D/ND <sup>1</sup>
Tone Detection Verification Test(#42)	X	X	ND
Tone Detection Audit/Update Test(#43)	X	X	ND

1. D = Destructive; ND = Nondestructive

### Tone Detection Verification Test (#42)

This test checks out a single ETR port in the touch-tone receiver mode MFC tone detection/generation mode and general purpose tone detection mode. During the first portion of the test, the touch-tone receiver mode is tested. Then general purpose call progress and maintenance tones are tested and lastly MFC tones are tested

**Table 9-302. TEST #42 Tone Detection Verification Test**

Error Code	Test Result	Description/ Recommendation
none	ABORT	The system was not able to allocate all the resources needed for this test OR there was an Internal system error.
1	ABORT	The system could not allocate all the resources needed to test the tones.
1001	ABORT	The system was unable to put the ETR-PT in the appropriate mode to test it.
1002	ABORT	The system could not allocate time slots for the test connection. This situation could occur when the system is heavily loaded. If the system is not heavily loaded, then test the TDM-BUS with the <b>test tdm</b> command. 1. Retry the command at 1-minute intervals a maximum of 5 times.
1003	ABORT	The system could not allocate a Tone-Clock for the test connection. This may be caused by a heavy load on the system or by a faulted Tone-Clock. 1. Check to see if there are any alarms against the TONE-BD or TONE-PT in the port network where the test aborted. 2. If a new Tone-Clock has been inserted, allow about 1 minute for maintenance to run on the newly inserted circuit pack. 3. Retry the command at 1-minute intervals a maximum of 5 times.

*Continued on next page*



**Table 9-302. TEST #42 Tone Detection Verification Test — Continued**

Error Code	Test Result	Description/ Recommendation
2000	ABORT	Circuit Pack's response to the test request was not received within the allowable time period. <ol style="list-style-type: none"> <li>1. Retry the command at 1-minute intervals a maximum of 5 times.</li> </ol>
2006	ABORT	This abort code indicates that the active Tone-Clock circuit pack or a Tone Detector circuit pack may not be functioning properly. <ol style="list-style-type: none"> <li>1. Test the <i>active</i> Tone-Clock circuit pack in the port network with the <b>test tone-clock UUC</b> command.</li> <li>2. Retry the command at 1-minute intervals a maximum of 5 times.</li> </ol>
2100	ABORT	Could not allocate the necessary system resources to run this test. <ol style="list-style-type: none"> <li>1. Retry the command at 1-minute intervals a maximum of 5 times.</li> </ol>
1-122	FAIL	DTMF digits were not detected correctly. <ol style="list-style-type: none"> <li>1. Run the short test sequence with the <b>test port UUCSSpp sh r 1</b> command.</li> <li>2. If the problem persists, the system is still operating properly but capacity is reduced. To restore performance to normal, replace the circuit pack with the defective ETR-PT.</li> </ol>
102	FAIL	2225-Hz Modem Answer Tone was not detected correctly. This impacts call-classification operation. <ol style="list-style-type: none"> <li>1. Run the short test sequence via the <b>test port UUCSSpp sh r 1</b> command.</li> <li>2. If the problem persists, the system can still operate properly but capacity is reduced. In order to restore performance to normal, replace the circuit pack containing the defective port. Follow the procedures described in the <a href="#">"TONE-BD (Tone-Clock Circuit Pack)"</a> section for replacing a tone/clock circuit pack.</li> </ol>
130	FAIL	Forward or Backward MFC signals were not correctly generated or detected. This will impact MFC calls. <ol style="list-style-type: none"> <li>1. Run the short test sequence via <b>test port UUCSSpp sh r 1</b>.</li> <li>2. If the problem persists, the system can still operate properly but capacity will be reduced. In order to restore performance to normal, replace the TN2182 circuit pack containing the defective ETR-PT. Follow the procedures described in the <a href="#">"TONE-BD (Tone-Clock Circuit Pack)"</a> section for replacing a tone/clock circuit pack.</li> </ol>
	PASS	Tone Detection Verification is successful. The ETR Port is able to detect/generate all necessary tones.

## Tone Detector Audit/Update Test (#43)

A Digital Signal Processor sanity audit is performed on the ETR-PT.

**Table 9-303. TEST #43 Tone Detector Audit/Update Test**

<b>Error Code</b>	<b>Test Result</b>	<b>Description/ Recommendation</b>
none	ABORT	The system could not allocate all the resources needed for this test.
2000	ABORT	Response to the test request was not received within the allowable time period.
2100	ABORT	Could not allocate the necessary system resources to run this test. <ol style="list-style-type: none"><li>1. Retry the command at 1-minute intervals a maximum of 5 times.</li></ol>

*Continued on next page*

Table 9-303. TEST #43 Tone Detector Audit/Update Test — *Continued*

Error Code	Test Result	Description/ Recommendation
	FAIL	<p>Hardware audit failed.</p> <ol style="list-style-type: none"> <li>1. Use <b>list configuration carrier</b> to get the board type and location. If the board is TN744, then do Steps 2-4; if it is TN2182, do Steps 5-12.</li> <li>2. Execute 3 commands: <b>busyout board UUCSS</b>, <b>reset board UUCSS</b>, and <b>release board UUCSS</b>. Reset is required to reload RAM associated with the TN744's DSPs. This will take all 8 tone detector ports out of service for a few seconds. Only 4 of the 8 would be out of service due to the alarm. (There are 4 tone detectors on each of the two DSPs.) Other than the unlikely potential of running out of tone detector resources in the switch, there is no other effect when the board is reset.</li> <li>3. Test the board (<b>test board UUCSS long</b>).</li> <li>4. If the test passes, terminate the repair process. If the test fails, replace the board. Follow the procedures in TONE-BD.</li> <li>5. Check to see if the board is duplicated (<b>list cabinet</b> and <b>status port-network</b> on the affected port network.)</li> <li>6. If the board is not duplicated, use test tone UUCSS long to resolve the error. The long test resets the board and is required to reload on-board RAM associated with the TN2182's DSPs. The effect is that tone detectors are taken out of service momentarily and tones are removed from the TDM bus for about 10 seconds. This means no dial or touch tones during this interval, which probably will not affect calls in progress, but could cause a call origination to abort or cause a user to not get dial tone when going off hook.</li> <li>7. If all tests pass and the alarm does not resolve, retest (<b>test tone UUCSS long clear</b>).</li> <li>8. If the test passes, terminate the repair process. If it fails, replace the circuit pack at the customer's convenience. Follow the procedures in TONE-BD.</li> <li>9. If the board is duplicated, switch to the standby side (<b>set tone</b>).</li> <li>10. Test the alarmed board (test tone UUCSS long). This resets the board and is required to reload on-board RAM associated with the TN2182's DSPs.</li> <li>11. If all tests pass and the alarm does not resolve, retest with <b>test tone UUCSS long clear</b>.</li> <li>12. If the test passes, terminate the repair process. If it fails, replace the board. Follow the procedures in TONE-BD.</li> </ol>
	PASS	The ETR Port has passed the sanity inquiry.

## EXP-INTF (Expansion Interface Circuit Pack)

MO Name (in Alarm Log)	Alarm Level	Initial Command to Run <sup>1</sup>	Full Name of MO
EXP-INTF	MAJOR	test board UUCSS s	Expansion Interface Circuit Pack
EXP-INTF	MINOR	test board UUCSS s	Expansion Interface Circuit Pack
EXP-INTF	WARNING	test board UUCSS s	Expansion Interface Circuit Pack

1. *UU* is the universal cabinet number (1 for PPN, 2 - 44 for EPNs). *C* is the carrier designation (A, B, C, D, or E). *SS* is the number of the slot in which the circuit pack resides (01 to 21).

### WARNING:

*If the Expansion Interface (EI) circuit pack you are troubleshooting is associated with a Survivable Remote EPN (SREPN), before the SREPN can be returned to normal service, all LAPD EI link problems must be cleared, and the SREPN slide switch on the TN2301 (located in the SRPPN carrier) must be **manually** set to the normal position. See [“Restoring Normal Service to the SREPN”](#) on page 9-788 in this section.*

Refer also to *DEFINITY ECS Installation and Maintenance for Survivable Remote EPN, Issue 1, 555-230-102*.

Following this introductory description of the Expansion Interface (EI) circuit pack are sections on the following topics:

- [“EI In-Service Mechanism”](#)
- [“Survivable Remote EPN”](#)
- [“LEDs”](#)
- [“EI and Tone-Clock Interactions”](#)
- [“Replacing an EI Circuit Pack—Simplex PNC”](#)
- [“Replacing an EI Circuit Pack— Duplicated PNC”](#)
- [“Expansion Interface Manual Loopback Procedure”](#)

The TN570 or the TN776 Expansion Interface (EI) Circuit Pack provides a TDM and Packet bus to fiber interface for the communication of signaling information, circuit switched connections, and packet switch connections between endpoints residing in separate port networks. EI Circuit Packs are located in the Processor Port Network (PPN) or in Expansion Port Networks (EPNs) and are connected via optical fiber links. An EI can be connected to:

- Another EI (direct-connect configuration)

- A DS1 Converter in a DS1 CONV Complex used to remote an EPN
- A Switch Node Interface (center stage switch configuration)
- A SREPN (Survivable Remote EPN)

In a Center Stage Switch configuration with duplicated Port Network Connectivity, the PPN Expansion Interface circuit pack may be located in the Switch Node Carrier (see [Figure 9-40](#)). In these cases, the Expansion Interface circuit pack and Switch Node Interface circuit pack may be connected via a metallic cable instead of an optical fiber link. Metallic cable should be tested and replaced in the same manner as the optical fiber.

A PPN-EPN connection can be extended through a DS1 CONV Complex. (See [Figure 9-41](#)). When discussing problems that may be related to fiber link problems, the DS1 CONV will be considered part of the fiber link. If diagnosis of the problem points to the fiber connectivity, and a DS1 CONV circuit pack is part of this connectivity, problems with the DS1 CONV circuit pack should be investigated (See DS1 CONV-BD Maintenance documentation). The DS1 CONV circuit pack enters into diagnostics for the Expansion Interface circuit pack via such tests as the Neighbor Query Test (#237), the Fiber Out-of-frame Test (#238), the Two-way Transmission Test (#241), and the Packet Transmission Test (#589).

In critical reliability systems, the fiber link connections are duplicated as part of Port Network Connectivity (PNC) duplication. In high reliability systems with a Center Stage Switch and simplex Port Network Connectivity, a single point of failure between the PPN and the Center Stage Switch is eliminated by duplicating PPN EIs, the SNI s to which they connect in the Center Stage Switch, and the fiber or metallic connections between them. These two connections normally share the call processing load. In the event of the failure of one of these connections, the load can be shifted to the operational link.

[Figure 9-37](#) shows the location of the EI circuit packs in a typical simplex PNC, direct connect configuration.

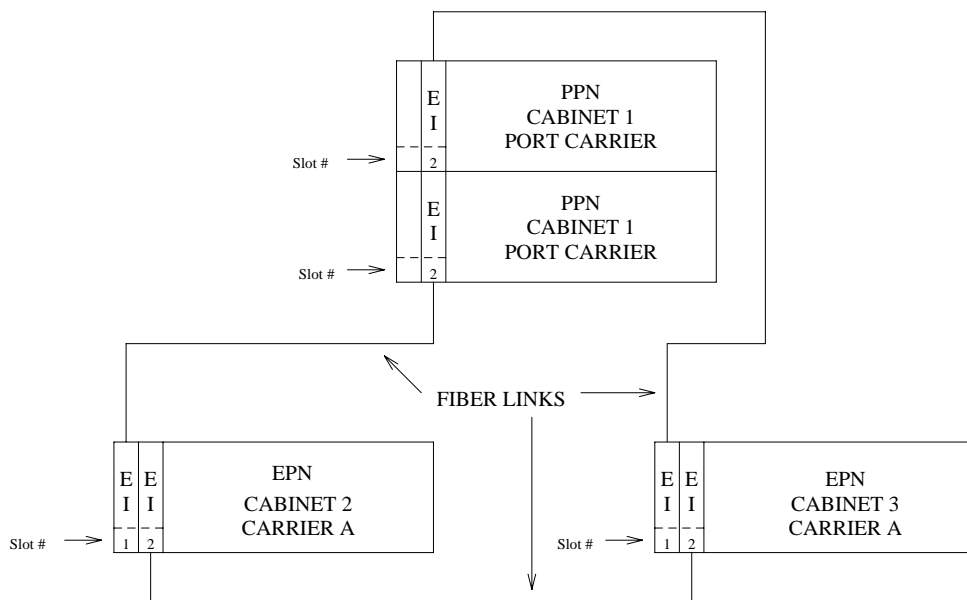

**Figure 9-37. Direct Connect Configuration with Simplex PNC**

Each Port Network in direct connect configurations must be connected to each other port network through a fiber link. Each EPN has one EI that functions as an archangel. This EI must be connected with fiber to an EI located in the PPN. If an EI is functioning as an archangel (bus master), its yellow led will be flashing at a rate of 2 seconds on and 200 ms off.

[Figure 9-38](#) shows the location of EI circuit packs in a typical duplicated PNC, direct-connect configuration.

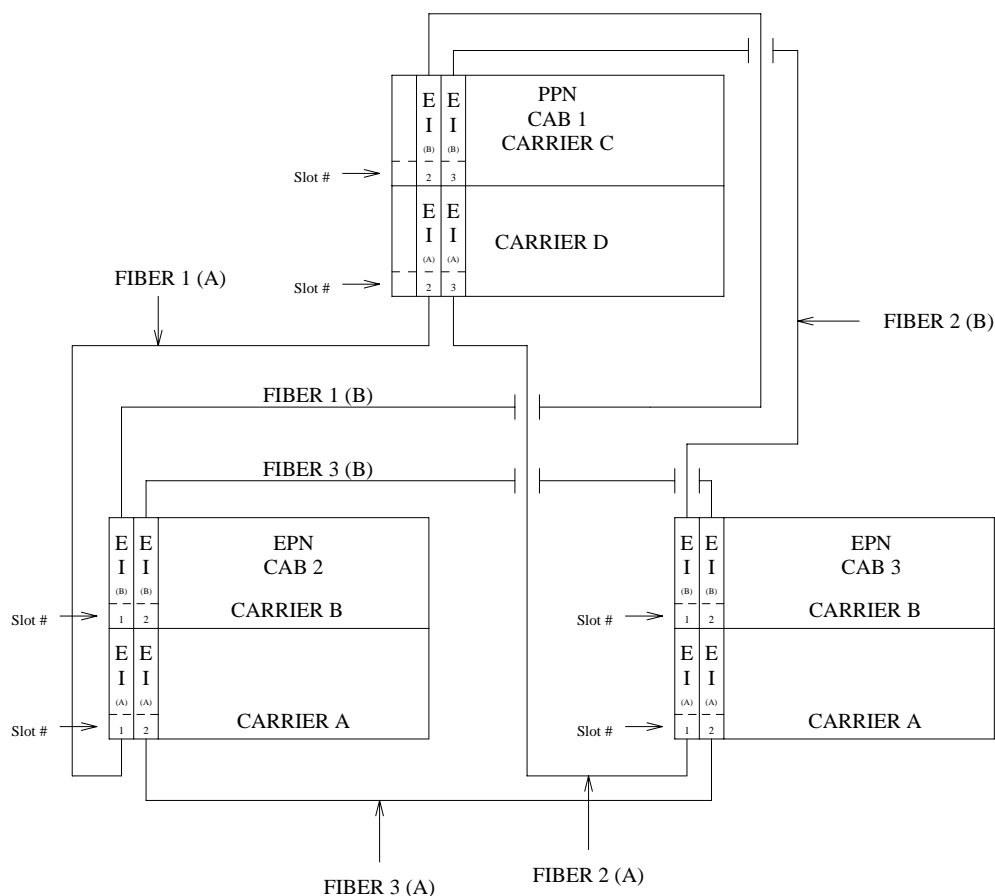

**Figure 9-38. Direct Connect Configuration with Duplicated PNC**

In a duplicated PNC there is an A-side PNC and a B-side PNC. All EIs in this diagram are labeled with an A or a B to designate which PNC they are a part of. Note that the PNC designation (A or B) does not relate directly to carrier location. Again, only one of the EIs in an EPN can function as an archangel (TDM Bus Master). The EI that is on the active PNC and that is connected to the PPN is the only one that can function in this mode. In normal operation, its yellow LED should be blinking at a rate of 2 seconds on and 200 ms. off.

[Figure 9-39](#) shows the location of EIs in a typical center stage switch configuration with simplex PNC.

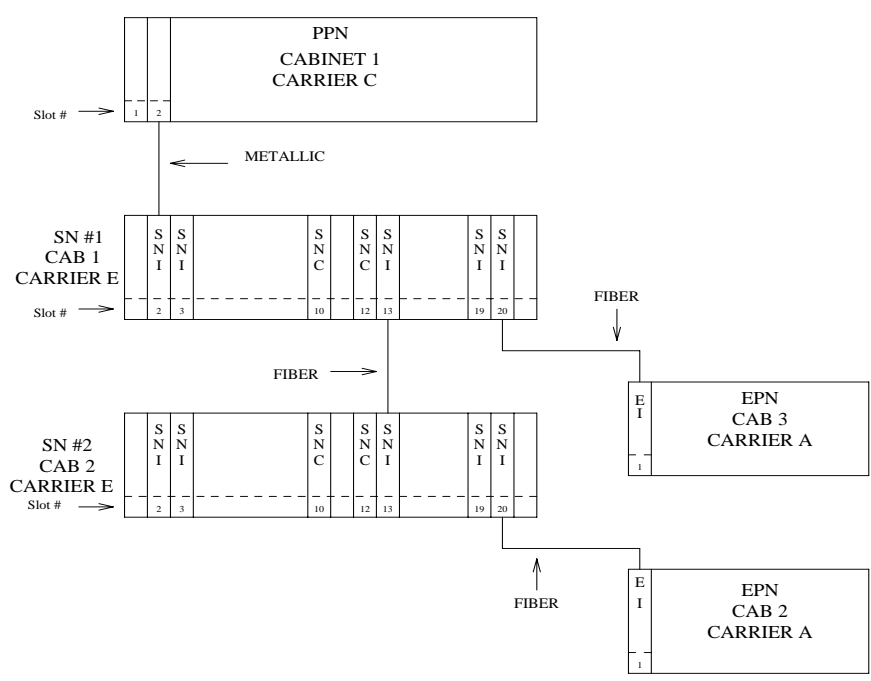
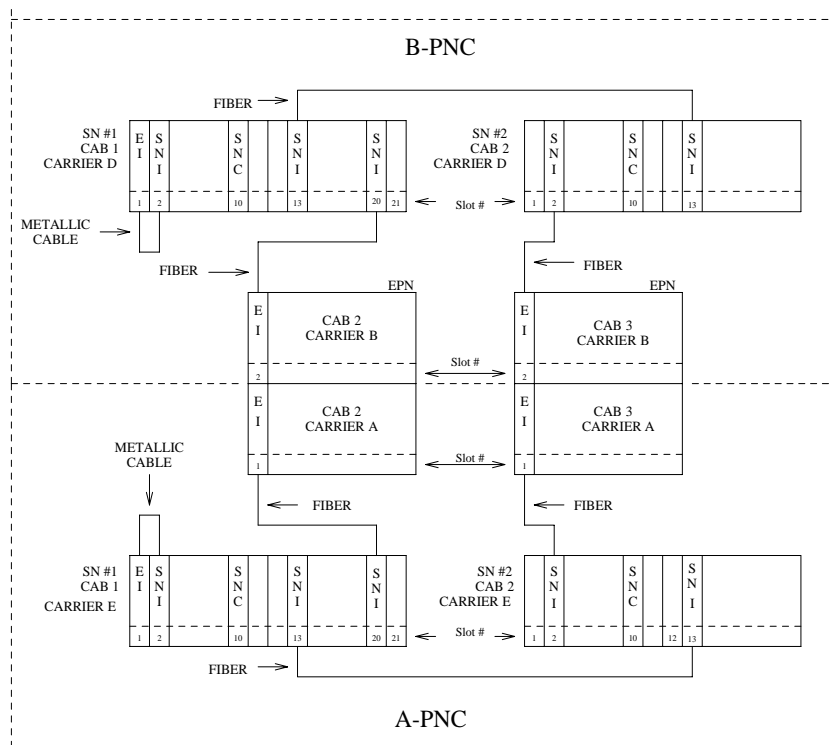

**Figure 9-39. Center Stage Switch Configuration with Simplex PNC**

In a simplex stage switch configuration, only one EI is needed in each port network. Notice that there is no direct connection between the EPNs, rather all inter-EPN connections are made through the stage switch. Each SNI in the switch node carriers can be connected to an EPN through an EI circuit pack.

[Figure 9-40](#) shows the location of EIs in a typical two Switch Node Center Stage Switch configuration with duplicated PNC.

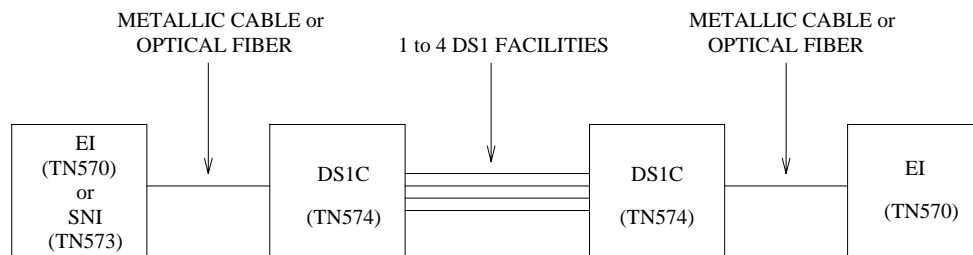



**Figure 9-40. Center Stage Switch Configuration with Duplicated PNC**

In a duplicated center stage switch configuration, two EIs are needed in each port network. One is located on the A-side PNC and the second one is located on the B-side PNC. Note that PNC designation (A or B) does not relate directly to carrier location. The EI that is on the active PNC is the one that is acting as the Archangel (TDM Bus Master) for the EPN. This is the EI that should have its yellow led blinking at a rate of 2 seconds on and 200 ms. off. The standby PNC EI should have its yellow led off. The PPN EI circuit packs are located in the first slot of the switch node carriers, although they may be located in port carriers.

An EPN (and thus, the EIs contained in that EPN) can be removed via a DS1 converter complex. This requires that the associated fiber link which provides connectivity to the remoted EPN, be administered with a DS1 converter complex. The DS1 converter complex consists of two TN574 DS1 converter (DS1 CONV) circuit packs connected by from 1 to 4 DS1 facilities. [Figure 9-41](#) shows where the DS1 converter complex fits into an EI to SNI, or EI to EI fiber link. For more information, refer to the DS1 CONV circuit pack Maintenance documentation.



**Figure 9-41. Fiber Link with DS1 Converter Complex**

## EI In-Service Mechanism

In order for calls to be routed through a given EPN, the EI that is part of the connectivity to that EPN must be put into service. In order for an EI to be put into service, the following criteria must be met:

1. The EI must be recognized by software (inserted). Use the **list config carrier** command to determine if the board is recognized by software.
2. The EI must have a fiber link administered to it. Use the **list fiber-link** command to determine if this EI circuit pack has a fiber administered to it.
3. The EI must have established a LAPD link to its neighbor (the circuit pack on the “other end” of the fiber link). This neighbor can be another EI or an SNI (Switch Node Interface).

### ⚠ CAUTION:

*If requirements 1 and 2, above, have been met, and the yellow LED s are flashing in a manner that appears to confirm that the Expansion Interface circuit pack has established a LAPD link to its neighbor, the circuit pack still may not be “in-service”. The requirement is that it must have the CORRECT neighbor on the other end of the fiber. Care must be taken when connecting the fibers to the back of the carriers so that fibers are connected to the correct circuit packs. In a Center Stage Switch configuration, run the “configuration audit” test against the Switch Node Interface circuit pack that is the neighbor of the Expansion Interface circuit pack in question (see SNI-BD Maintenance Documentation for more details).*

Once an EI has been put into service, if any of the above listed “in-service” criteria become untrue, the EI is taken out of service, and service to that port network is not available.

In a system that is configured with PNC duplication active, taking an EI out of service that is on the active PNC will, if all other things on the active and standby PNC are equal (i.e. both PNCs are equally healthy, the standby PNC is not busied out, the PNC is not locked by software), result in a PNC interchange.

## Survivable Remote EPN

---

The Survivable Remote EPN (SREPN) feature allows a DEFINITY R6r EPN (either MCC or SCC) to provide service to the customer when:

- The fiber (or T1/E1 Expansion Interface link to the main R6r processor) fails or is severed
- The R6r processor or center stage fails.

### NOTE:

This feature is viewed as a “disaster recovery operation” capability rather than as an additional reliability option.

The SREPN requires remote EPN cabinet to provide processor (SPE) capabilities to the EPN in the event of a failure. A logic switch circuit pack (TN2301) located in the SRPPN detects when the link to the R6r is down and switches to a link from the local SRPPN (TN790-based processor). When the links to the R6r are restored and verified to be stable, the logic switch is **manually reset**, and the EPN is reconnected to the links from the R6r.

### NOTE:

The SREPN feature is not available when an ATM-PNC/EI circuit pack is used to replace the TN570 EI circuit pack in a direct-connect configuration, or an ATM Switch is providing the Center Stage (PNC) connectivity.

### NOTE:

If you suspect a problem with the TN790B-based R6si SRPPN use the R6si maintenance documentation supplied with the SREPN feature to resolve any alarms/errors associated with the SRPPN carrier.

## SREPN Feature Active

### WARNING:

*All calls within the SREPN are terminated when the SREPN feature is activated, and the R6si SRPPN takes control of the SREPN.*

The SREPN feature is activated when the maintenance circuit pack (TN775C or later and located in the SREPN) detects a problem with the SREPN’s EI (TN570B) LAPD link to its counterpart in the R6r PPN. The TN775C maintenance circuit pack notifies the co-located SRPPN of the problem, and the TN2301 SRSwitch circuit pack in the SRPPN carrier switches the EI LAPD link connection from the

R6r PPN to its new counterpart in the R6si SRPPN. The SREPN is now in the Survivable Remote mode and has the capabilities of an R6si EPN that has been pre-translated with a *Disaster Recovery* configuration.

 **NOTE:**

When SREPN feature is active, the EI circuit pack that is assigned to the SREPN and located in the R6r PPN is put in loopback mode.

## Restoring Normal Service to the SREPN

 **WARNING:**

*All calls within the SREPN are terminated when the SREPN feature is returned to normal service.*

To restore normal connections to the SREPN Expansion Interface (EI) circuit pack in the R6r PPN you must:

1. Clear all errors logged against the R6r SREPN Expansion Interface (EI) circuit pack by using the suggested repair procedures outlined in this maintenance object.
2. At the SRP flip the 3-position switch on the TN2301 to the RSTR (restore) or top position for at least 1 second and return the switch to the AUTO, or middle position.
3. After the SREPN slide switch has been restored to the normal position, test the connectivity to R6r EI LAPD link, by using the suggested procedures outlined in this maintenance object.
4. After normal service is returned to the SREPN, the R6si SRPPN will be in an *alarmed state*. This is *normal* for a R6si SRPPN and indicates the SRSwitch (TN2301) has disconnected it from its neighbor (EI in the SREPN), and the R6si SRPPN is no longer in control. Connectivity has been reestablished between the EI in the SREPN and its counterpart EI circuit pack in the R6r PPN. The system is now in a normal R6r EI configuration.

## LEDs

---

### SREPN Expansion Interface

The Expansion Interface circuit pack has red, green, and yellow LEDs. The red and green LEDs show the standard conditions:

- Red indicates an alarm condition
- Green indicates maintenance testing in progress

The yellow LED is used to provide useful visual status information:

- Active EI circuit packs:
  - Have their yellow LED on solid (for an inter-EPN EI in a direct connect system) o
  - Blink a pattern of 2 seconds on and 200 ms off.
- The standby PNC EI circuit packs should have their yellow LEDs off.

Another way to determine which PNC (and therefore, which EI(s) in a port network) is active and which is standby, use the **status port-network** and **status PNC** commands.

See [Table 9-304](#) for the possible EI yellow LED states.

**Table 9-304. Expansion Interface Circuit Pack Yellow LED Flashing States**

Condition	LED On	LED Off
Fiber Out-of-Frame (a)	0.1 second	0.1 second
In frame-No Neighbor (b)	0.5 second	0.5 second
Expansion Interface Active (c)	2 second	0.2 second
Expansion Interface Active (d)	solid on	never off
Expansion Interface Standby (e)	never on	solid off

Notes:

- a. This flashing state corresponds to error codes 769 and 770 from the Hardware Error Log and indicates a failure of Test #238. These error codes are usually accompanied by error code 1281 (no Expansion Interface or Switch Node Interface detected on opposite end of fiber). This condition may be caused by the absence of the neighbor Expansion Interface or Switch Node Interface circuit pack, a broken or missing fiber, or a missing lightwave transceiver on either endpoint (Expansion Interface or Switch Node Interface circuit packs).
- b. This corresponds to error code 1281 from the Hardware Error Log and indicates a failure of Test #237. This condition is usually due to the failure of this Expansion Interface circuit pack or a failed Expansion Interface or Switch Node Interface circuit pack counterpart.
- c. This is the normal state for an Active EPN Expansion Interface circuit pack that is also the bus master (Expansion Archangel) in the EPN.
- d. This is the normal state for an Active Expansion Interface circuit pack that is not the bus master (Expansion Archangel) for an EPN. This applies only in the direct-connect configuration where the Expansion Interface circuit pack in an EPN is connected via a fiber link to an Expansion Interface circuit pack in the other EPN. This state also applies for an active Expansion Interface circuit pack located in the PPN.

- e. This is the normal state for a Standby Expansion Interface circuit pack in both the PPN and EPNs.

 **NOTE:**

In an EPN the TN775C EPN Maintenance (MAINT) circuit pack monitors the sanity of the Expansion Interface circuit pack. If the Expansion Interface circuit pack should cycle between sane and insane several times, the Maintenance circuit pack will hold the Expansion Interface circuit pack reset. If a new Expansion Interface circuit pack is installed in the EPN, and the red LED remains lit, the EPN Maintenance circuit pack should be removed because it may be holding the new Expansion Interface circuit pack reset. This condition could present itself if there is a link problem to the EPN, and the EPN experiences several EPN restarts. The Maintenance circuit pack may be reinstalled after the Expansion Interface circuit pack has been physically inserted and the Expansion Interface circuit pack's red LED has gone off.

The link between two Active Expansion Interface circuit packs or between an Active Expansion Interface circuit pack and an Active Switch Node Interface circuit pack is involved in synchronization. The Expansion Interface circuit pack reports slip errors if synchronization is not operating properly. When diagnosing synchronization problems, the Expansion Interface circuit packs should be examined as a possible cause.

## Expansion Interface LEDs

The Expansion Interface circuit pack has the standard red, green, and yellow LEDs. The red and green LEDs have the traditional uses: red means some alarm condition and green indicates maintenance testing in progress. The yellow LED is used to provide useful visual status information. The state of the yellow LED is very important when executing the Expansion Interface Manual Loopback Procedure. The possible yellow LED states are shown in [Table 9-305](#).

Upon power-up, the red and green LEDs turn on and off. The yellow LED goes to its appropriate state.

To determine which PNC (and which EI(s) in a port network) is active and which is standby, use the **status port-network** and **status PNC** commands. Alternately, visual inspection will show that the active EI circuit packs will have their yellow LED on solid (for an inter-EPN EI in a direct connect system) or blink a pattern of 2 seconds on and 200 ms off. The standby PNC EI circuit packs will have their yellow LED s off. See [Table 9-305](#) for the possible EI yellow LED states.

**Table 9-305. Expansion Interface Circuit Pack Yellow LED Flashing States**

Condition	LED On	LED Off
Fiber Out-of-Frame (a)	0.1 second	0.1 second
In frame-No Neighbor (b)	0.5 second	0.5 second
Expansion Interface Active (c)	2 second	0.2 second
Expansion Interface Active (d)	solid on	never off
Expansion Interface Standby (e)	never on	solid off

Notes:

- a. This flashing state corresponds to error codes 769 and 770 from the Hardware Error Log and indicates a failure of Test #238. These error codes will usually be accompanied by error code 1281 (no Expansion Interface or Switch Node Interface detected on opposite end of fiber). This condition may be caused by the absence of the neighbor Expansion Interface or Switch Node Interface circuit pack, a broken or missing fiber, or a missing lightwave transceiver on either endpoint (Expansion Interface or Switch Node Interface circuit pack).
- b. This flashing state corresponds to error code 1281 from the Hardware Error Log and indicates a failure of Test #237. This condition is usually due to the failure of this Expansion Interface circuit pack or a failed Expansion Interface or Switch Node Interface circuit pack neighbor.
- c. This is the normal state for an Active EPN Expansion Interface circuit pack that is also the bus master (Expansion Archangel) in the EPN.
- d. This is the normal state for an Active Expansion Interface circuit pack that is not the bus master (Expansion Archangel) for an EPN. This applies only in the Direct Connect Configuration where the Expansion Interface circuit pack in an EPN is connected via a fiber link to an Expansion Interface circuit pack in the other EPN. This state also applies for an active Expansion Interface circuit pack located in the PPN.
- e. This is the normal state for a Standby Expansion Interface circuit pack in both the PPN and EPNs.

**⇒ NOTE:**

In an EPN the TN775 EPN Maintenance (MAINT) circuit pack monitors the sanity of the Expansion Interface circuit pack. If the Expansion Interface circuit pack should cycle between sane and insane several times, the Maintenance circuit pack will hold the Expansion Interface circuit pack reset. If a new Expansion Interface circuit pack is installed in the EPN, and the red LED remains lit, the EPN Maintenance circuit pack should be removed because it may be holding the new Expansion Interface circuit

pack reset. This condition could present itself if there is a link problem to the EPN, and the EPN experiences several EPN restarts. The Maintenance circuit pack may be reinstalled after the Expansion Interface circuit pack has been physically inserted and the Expansion Interface circuit pack's red LED has gone off.

The link between two Active Expansion Interface circuit packs or between an Active Expansion Interface circuit pack and an Active Switch Node Interface circuit pack is involved in synchronization. The Expansion Interface circuit pack will report slip errors if synchronization is not operating properly. When diagnosing synchronization problems, the Expansion Interface circuit packs should be examined as a possible cause.

## **EI and Tone-Clock Interactions**

---

The viability of the EI fiber link depends upon the system clock that is provided by the active Tone-Clock circuit pack on each network (see "TDM-CLK" and "TONE-BD" documentation). Each Expansion Interface circuit pack transmits over the fiber at a rate derived from the system clock on its network. If the Active Tone-Clock is defective in such a way that the frequency of system clock it produces is out of the specified range ("out of spec"), an Expansion Interface fiber link might go down. This affects an Expansion Archangel Link (EAL), a Remote Neighbor Link (RNL), and/or a Local Neighbor Link (LNL), even though the Expansion Interface circuit packs are healthy. When the PNC is duplicated, both fiber links could go down if there is a defective Active Tone-Clock. Whether or not a fiber link goes down, depends on certain characteristics of the Expansion Interface circuit packs. An Expansion Interface circuit pack should not be replaced if the fiber link on which it resides goes down because of a defective Active Tone-Clock circuit pack. The defective Tone-Clock circuit pack should be replaced instead. The Expansion Interface circuit packs are more sensitive to a defective system clock than the rest of the components of the system. Therefore, testing of the Tone-Clock circuit pack might not reveal a problem.

The symptoms of the problem in which an invalid system clock causes an Expansion Link to go down are as follows:

- If the Tone-Clock in the PPN, or in an EPN that provides the current on-line synchronization reference (see **status synchronization**), is providing an invalid system clock:

Any Expansion Interface or SNI circuit pack has a Fiber Out-of-Frame condition or a No Neighbor condition.

An Expansion Interface circuit pack yellow LED blinks quickly when a Fiber Out-of-Frame condition exists (0.1 seconds on, 0.1 seconds off) and Test #238 fails on the Expansion Interface circuit pack that is out-of-frame.

An SNI circuit pack with a Fiber Out-of-Frame condition blinks its yellow LED quickly (0.1 seconds on, 0.1 seconds off) and Test #989 fails on the SNI circuit pack that is out-of-frame.



An Expansion Interface circuit pack yellow LED blinks slowly when a No Neighbor condition exists (0.5 seconds on, 0.5 seconds off) and Test #237 fails on this Expansion Interface circuit pack, but Test #238 passes.

An SNI circuit pack with a no neighbor condition blinks its yellow LED slowly (0.5 seconds on, 0.5 seconds off) and Test #759 fails on this SNI circuit pack, but Test #989 passes.

- If a Tone-Clock in an EPN that does not provide the current on-line synchronization reference (see **status synchronization**) is providing an invalid system clock:

*In a direct connect configuration*, the PPN Expansion Interface circuit pack yellow LED will blink quickly (Fiber Out-of-Frame condition - 0.1 seconds on, 0.1 seconds off).

Test #238 fails on this Expansion Interface circuit pack.

*In a CSS configuration*, the SNI connected to the EPN Expansion Interface circuit pack blinks its yellow LED quickly (Fiber Out-of-Frame condition - 0.1 seconds on, 0.1 seconds off).

The EPN Expansion Interface circuit pack yellow LED blinks slowly (In-frame, No Neighbor condition - 0.5 seconds on, 0.5 seconds off).

If the EPN is in-service, Test #237 fails on this Expansion Interface circuit pack, but Test #238 passes.

These symptoms can also be the result of other problems (for example, one half of the fiber being unable to transmit data). If the system exhibits these symptoms, execute the following procedure:

1. Verify that the EPN stays down for at least 1 minute.

If the EAL comes back in service after a short time, without switching the Active Tone-Clock, the problem was probably that the on-line synchronization source became invalid (See SYNC Maintenance documentation for more information).

However, if the EAL (s) have not come back into service after a minute, the synchronization source is not the cause of the problem. Proceed to Step 2.

2. Check for errors via the **display errors** command with the `Category` field set to **tone** and the Active alarms field set to **n**. Some of the alarms on EPN objects might have been resolved if the EPN went down. Refer to the appropriate MO Maintenance documentation for descriptions of any of the errors occurring at about the same time as the EXP-PN errors, SYS-LINK errors against EAL s, RNLs, or LNLs, or FIBER-LK (769, 1025, or 1281) errors. Resolve any active alarms. Also, if Error Type 18 was logged against the SYNC MO when the EPN went down, the problem was probably that the synchronization on-line reference became invalid. Since reference switching was disabled, the Tone-Clock did not switch from the invalid reference. Therefore, the Tone-Clock circuit pack put out a system

clock that was “out of spec.” Issue the **enable synchronization-switch** command. If the EPN is down, reseal the Tone-Clock circuit packs on the EPN. This action should restore the EPN to service.

Execute Steps 3 and 4 in the order most convenient to you and least destructive to the customer.

3. Check to see if the fiber optic cable is transmitting properly via the following procedure on one of the out-of-service links, or use the “Fiber Fault Isolation Procedure” in Chapter 5.
  - a. Carefully record the symptoms (yellow LED pattern and test failing) that were occurring on the PPN Expansion Interface circuit pack and the EPN Expansion Interface circuit pack or the connected Switch Node Interface circuit pack in the case of a Center Stage system. Clearly indicate which symptoms are occurring on which Expansion Interface/Switch Node Interface circuit pack.



**CAUTION:**

*Before proceeding, note which is the current transmit fiber and which is the current receive fiber for proper reconnection.*

- b. Disconnect the transmit and receive fiber pair from the lightwave transceiver on the back of one of the Expansion Interface circuit pack slots that is exhibiting symptoms.
  - c. Connect what was formerly the transmit fiber to the receive jack.
  - d. Connect what was formerly the receive fiber to the transmit jack.
  - e. Perform Steps b, c, and d on the opposite end of the fiber and the lightwave transceiver on the back of the connected Expansion Interface or Switch Node Interface circuit pack slot.
  - f. If the symptoms which were formerly occurring on the Expansion Interface circuit pack that was exhibiting these symptoms are now occurring on the connected Expansion Interface or Switch Node Interface circuit pack and vice versa, the fiber is defective and should be replaced.
4. Determine if the problem is due to a defective Active Tone-Clock circuit pack. Refer to the preceding list of symptoms to decide which network contains the suspect Active Tone-Clock.



**CAUTION:**

*If you remove the EPN Expansion Interface circuit pack that is active or that was active when the EPN was last in-service, the Tone-Clock lead will revert to the default value which will cause the Tone-Clock circuit pack located in the A carrier to become the Active Tone-Clock. This characteristic can be deceiving. Replacing or reseating the Active EPN Expansion Interface circuit pack might restore the link(s) temporarily. However, if the Tone-Clock circuit pack*

located in the B carrier was really the source of the problem and not the Expansion Interface circuit pack, then the link(s) will go down again the next time a Tone-Clock switch to the Tone-Clock in the B carrier is attempted (probably when the scheduled Tone-Clock switch occurs).

 **CAUTION:**

*If, after all the links are restored, you suspect the problem might have been due to a defective Tone-Clock circuit pack, switch to this Tone-Clock at an appropriate time. If the Tone-Clock circuit pack was the cause of the problem and the same Expansion Interface circuit packs are in place, the same link(s) will go down again.*

- a. On a system in which the network containing the suspect Tone-Clock circuit pack has duplicated Tone-Clock circuit packs and the network is in-service:

Switch to the Standby Tone-Clock on this network. If the suspect Tone-Clock circuit pack is defective, link(s) should be restored at this point. Switching back to the defective Tone-Clock should make the same link(s) go out-of-service. Such a Tone-Clock is defective and should be replaced as soon as possible. If switching Tone-Clocks does not bring up the EPN, then this Tone-Clock is not the source of the problem. Make sure to switch back to the original Tone-Clock.

 **CAUTION:**

*If the defective Tone-Clock circuit pack is left as the Standby Tone-Clock, then a scheduled Tone-Clock switch will cause the same link(s) go out-of-service again.*

- b. On a system in which the EPN containing the suspect Tone-Clock circuit pack is out-of-service:

Replace the Active Tone-Clock circuit pack on this network. In a network with duplicated Tone-Clock circuit packs, the Active Tone-Clock will be the Tone-Clock circuit pack whose yellow LED is flashing: if both are flashing, it is the one that is blinking slower. If the link(s) comes up after replacing this Tone-Clock circuit pack, then this Tone-Clock circuit pack should be replaced as soon as possible.

 **CAUTION:**

*If the defective Tone-Clock circuit pack is left as the Standby Tone-Clock, then a scheduled Tone-Clock switch will cause the same EPN to go out-of-service again.*

If replacing the Active Tone-Clock did not bring up the link(s), then this Tone-Clock circuit pack is not the source of the problem.

- c. On a Standard Reliability system in which the PPN contains the suspect Tone-Clock circuit pack:

Replace the PPN Tone-Clock circuit pack at a time when bringing down the system is most convenient to the customer.



**CAUTION:**

*Replacing the PPN Tone-Clock circuit pack will stop call processing on that network and also bring down stable calls. This action will eventually cause a Reset System 2 (Cold\_2 restart).*

If replacing the Tone-Clock circuit pack restores the link(s), then the Tone-Clock circuit pack is defective and should be replaced. Otherwise, the problem is not with the PPN Tone-Clock circuit pack.

**Replacing an EI Circuit Pack—Simplex PNC**



**WARNING:**

*Do not power down a Switch Node carrier to replace a circuit pack.*



**WARNING:**

*Replacing a Switch Node Interface, Switch Node Clock, Expansion Interface or DS1 Converter circuit pack on a simplex system disrupts service. The service effect can range from outage of a single EPN to outage of the entire system.*

Step	Action	Explanation/Caution
1.	Enter <b>busyout board UUCSS</b>	UUCSS = cabinet-carrier-slot address of the circuit pack to be replaced.
2.	Replace the circuit pack	
3.	Wait for the circuit pack to reset	Red and green LEDs light and then go out. If the red LED remains lit, see the Note under <a href="#">“Expansion Interface LEDs”</a> above.
4.	Enter <b>release board UUCSS</b>	<b>CAUTION:</b> Do not busyout any Expansion Interface circuit pack after this point.
5.	Enter <b>test alarms long clear</b> for category <b>exp-intf</b>	

Step	Action	Explanation/Caution
6.	Wait 5 minutes for SNI-BD, FIBER-LK AND DS1 CONV-BD alarms to clear, or enter <b>clear firmware counters a-pnc</b>	

## Replacing an EI Circuit Pack— Duplicated PNC

### WARNING:

*On a system with duplicated PNC, synchronization may be provided over a combination of active and standby components. This condition is indicated by an OFF-BOARD WARNING alarm against TDM-CLK with error type 2305. Repairs to standby PNC in this state may disrupt service. Otherwise, if the active PNC is functional, replacement of a standby component will not disrupt service.*

Step	Action	Explanation/Caution
1.	Enter <b>status pnc</b>	Verify that the component to be replaced is on the standby PNC.
2.	Enter <b>busyout pnc</b>	
3.	Enter <b>busyout board UUCSS</b>	UUCSS represents the cabinet-carrier-slot address of the circuit pack to be replaced.
4.	Replace the circuit pack	
5.	Enter <b>release board UUCSS</b>	<b>CAUTION:</b> Do not busyout any Expansion Interface circuit pack after this point.
6.	Enter <b>test alarms long clear</b> for category <b>exp-intf</b>	
7.	Wait 5 minutes for SNI-BD, SNI-PEER, FIBER-LK, and DS1 CONV alarms to clear, or enter <b>clear firmware counters &lt;a-pnc or b-pnc&gt;</b>	Use the letter designation of the pnc that holds the replaced component (the standby pnc).
8.	Enter <b>status pnc</b>	If either PNC state-of-health is not "functional," consult the <a href="#">"PNC-DUP (PNC Duplication)"</a> section.
9.	Enter <b>release pnc</b>	

If the red LED remains lit, see the Note under [“Expansion Interface LEDs”](#) above.

## Expansion Interface Manual Loopback Procedure

This procedure is to be used when an Expansion Interface circuit pack cannot be tested by software. This is usually when the Expansion Interface circuit pack is in the EPN and the EPN is down. When the connection to the Expansion Interface circuit pack is via fiber, a short length of optical fiber is required for this procedure. If a metallic cable is used in the connection, the metallic connector must be removed from the back of the carrier, and a lightwave transceiver connected in its place. The short length of optical fiber can then be used.

If this procedure is run on both endpoints of a fiber link (Expansion Interface circuit packs or Switch Node Interface circuit packs), and both check out fine, then the failure is most likely in the fiber itself, assuming neither endpoint circuit pack is busied out and the link remains inactive.

1. Busyout the circuit pack (Expansion Interface or Switch Node Interface) using the **busyout board UUCSS** command.
2. Disconnect the transmit and receive fiber pair from the lightwave transceiver on the back of the circuit pack (Expansion Interface or Switch Node Interface) slot.

### NOTE:

The fiber connected to the transmit side of the lightwave transceiver on one Expansion Interface circuit pack should be connected to the receive side of the lightwave transceiver on the circuit pack on the opposite end of the fiber.

3. Using a fiber jumper cable, interconnect the transmit and receive jacks of the lightwave transceiver as shown in [Figure 9-42](#).

### NOTE:

Make sure that the total length of the fiber jumper cable does not exceed the maximum length recommended for the fiber link connections between cabinets. Using cable lengths not within connectivity guidelines can adversely affect test results.

4. Go to the front of the cabinet and inspect the yellow LED.
  - If the yellow LED flashes on at a rate of once per second, the (Expansion Interface or Switch Node Interface) circuit pack or transceiver should be replaced.
  - If the yellow LED flashes on at a rate of five times per second, the circuit pack (Expansion Interface or Switch Node Interface) or the lightwave transceiver may need replacement. This condition may also be due to a faulty system clock on the network containing this Expansion Interface circuit pack.

- If the yellow LED is not blinking, this circuit pack (Expansion Interface or Switch Node Interface) and the lightwave transceiver are functioning properly.
5. Replace faulty components and reconnect the original fiber. Be sure to reconnect the fibers properly as noted in Step 3. If there is a problem with the port network after re-connecting the fiber, and the port network is connected to a Center Stage Switch, run the Configuration Audit via the **test board** command on the Switch Node Interface circuit pack to which the intervening fiber is connected. See the SNI-BD section for instructions on interpreting results.
  6. Release Expansion Interface circuit pack or Switch Node Interface circuit pack with the **release board UUCSS** command.
- 

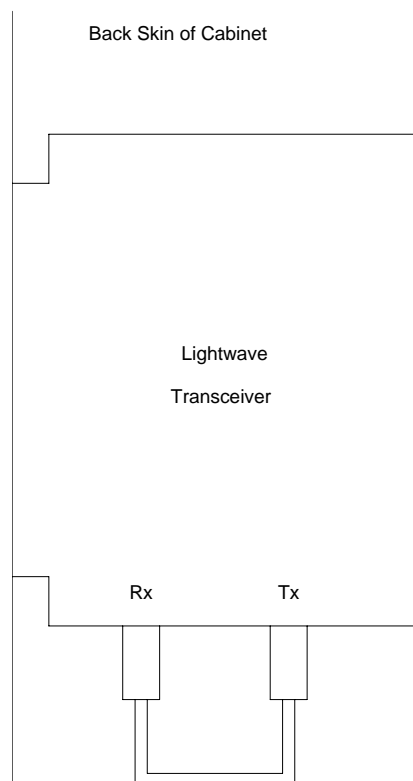

---

Figure 9-42. Interconnection of Lightwave Transceiver Transmit/Receive Jacks

## Error Log Entries and Test to Clear Values

**Table 9-306. EXP-INTF Error Log Entries**

Error Type	Aux Data <sup>1</sup>	Associated Test	Alarm Level	On/Off Board	Test to Clear Value
0 <sup>2</sup>	0	Any	Any	Any	test board UUCSS
1	Any	Expansion Interface Local TDM Looparound Test (#240)	MAJ	ON	test board UUCSS r 2
2		Expansion Interface Local TDM Looparound Test (#240)	MAJ	ON	test board UUCSS r 2
18(a)	0	busyout board UUCSS	WRN	OFF	release board UUCSS
23(b)	0	None	WRN	OFF	
125(c)		None	MIN	ON	
131(d)		None	MIN	ON	
257(e)	Any	None	MIN	OFF	
513(f)	5-7	None	MAJ	ON	
769(g)	113	Expansion Interface FOOF Query Test (#238)	WRN	OFF	test board UUCSS r 1
770		Expansion Interface FOOF Query Test (#238)	WRN	OFF	test board UUCSS r 1
1025	Any	Expansion Interface Control Channel Test (#316)	MAJ	ON	test board UUCSS r 1
1281(h)		Expansion Interface Neighbor Query Test (#237)	MIN	OFF	test board UUCSS r 1
1537		Expansion Interface 2-way Transmission Test (#241)	MAJ	OFF	test board UUCSS r 4
1538(i)		None	MIN	ON	
1793		Expansion Interface Lightwave Transceiver Looparound Test (#242)	MAJ	ON	test board UUCSS l r 3
2305(j)	118	None	WRN	OFF	
2306(j)	3	None	WRN	OFF	
	112				
2561(k)	Any	None	MIN	ON	
2817(l)	Any	None	MIN	ON	
3073(m)	Any	Expansion Interface Packet Interface Test(#589)	MAJ	OFF	test board UUCSS r 3

*Continued on next page*



**Table 9-306. EXP-INTF Error Log Entries — Continued**

Error Type	Aux Data <sup>1</sup>	Associated Test	Alarm Level	On/Off Board	Test to Clear Value
3074(n)	2	Expansion Interface Packet Interface Test(#589)	MAJ	OFF	test board UUCSS r 3
3075(n)	1	Expansion Interface Packet Interface Test(#589)	MAJ	OFF	test board UUCSS r 3
3076		Expansion Interface Packet Interface Test(#589)	MAJ	OFF	test board UUCSS r 3
3330(o)	Any	None	WRN	ON	
3585(p)	0	None	WRN	OFF	
3841(q)	Any	None	MIN	OFF	(s)
3842(r)	Any	None	MIN	OFF	(s)
10001(t)	0	None			

1. Aux Data 32767 for any error log entry indicates that an alarmed EI was busied out and then released. When this occurs, existing service affecting alarms must be preserved. As is typical, when the EI is released all alarms are resolved. Therefore the alarm and error logs must be repopulated with the alarms present at time of busy out. This error code is an indication that existing aux data and error log time stamps are no longer valid because they were lost when the alarms were resolved upon release of the circuit pack.
2. Run the Short Test Sequence first. If all tests pass, run the Long Test Sequence. Refer to the appropriate test description and follow the recommended procedures.

**Notes:**

- a. This error indicates that the Expansion Interface circuit pack has been busied out via the **busyout board UCSS** command. To resolve this error, release the Expansion Interface circuit pack via the **release board UCSS** command.
- b. Expansion Interface circuit pack has been administered on the Circuit Pack form, but has not been physically inserted into the system. Insert the circuit pack.
- c. A wrong circuit pack is located in the slot where this circuit pack is logically administered. To resolve this problem, either remove the wrong circuit pack and insert the logically administered circuit pack OR use the **change circuit-pack** command to readminister this slot to match the circuit pack that is physically inserted in this slot. If a fiber is administered to this circuit pack the fiber must be removed via administration before the circuit pack can be removed from administration.

- d. This alarm is raised after an Expansion Interface circuit pack has been removed from a slot for 5 minutes. The alarm will be resolved when the Expansion Interface circuit pack is physically inserted into this slot and becomes recognized by software.

Another way to resolve or prevent this alarm is to use the **change circuit pack** command to remove the Expansion Interface circuit pack administrative entry for this slot after the Expansion Interface circuit pack has been removed from the slot.

It is also possible that the EI could be held in reset by the EPN Maintenance Board (MAINT) and is not inserted in the system. Try issuing the **test maint P long** command on the maintenance board in the same port network.

- e. Error Type 257 indicates that this Expansion Interface circuit pack is detecting incorrect data on the incoming fiber bit stream. The data is originating at the connected circuit pack (DS1 CONV circuit pack, Expansion Interface circuit pack, or Switch Node Interface circuit pack).
  1. Enter **display errors** and save a copy of the error log for use in later steps. Intervening repair procedures are likely to alter the contents of the error log and this information may be needed in later steps.
  2. Perform the "Fiber Fault Isolation Procedure" described in Chapter 5.
  3. If errors are still present or if this error occurs intermittently, replace the Expansion Interface circuit packs, Switch Node Interface circuit packs, DS1 CONV circuit packs, or the transceivers on this link.
  4. These errors could result from a bad timing reference on the network or switch node which contains the DS1 CONV circuit pack, the Expansion Interface circuit pack or Switch Node Interface circuit pack on the opposite end of the fiber. Refer to the error log that was saved in step 1 and follow the associated repair procedure for EXP-INTF error 2305 to resolve this error. If there are any TONE-BD, TDM-CLK, or SYNC errors, resolve these errors as well.
- f. Error Type 513 with Aux Data 5-7 indicates an ON BOARD hardware failure of the circuit packs RAM or ROM.
  1. Replace the Expansion Interface circuit pack.
- g. Besides running the test sequence and following procedures outlined for test #238, perform the "Fiber Fault Isolation Procedure" described in Chapter 5.
- h. Error type 1281 means that the link to the neighbor circuit pack is broken or that the fibers have been connected incorrectly. Enter **test board UUCSS** and follow repair procedures for the tests.
- i. Error Type 1538 indicates a hyperactive Expansion Interface circuit pack that is generating an abnormal amount of control messages to the Processor. When this error was generated, the Expansion Interface was automatically reset by the system. If this system does not have duplicated

Port Network Connectivity, service to the EPN will have been disrupted. If this system does have duplicated Port Network Connectivity, the system should have switched to the Standby Port Network Connectivity.

1. Enter the **reset board UUCSS** command for this Expansion Interface circuit pack.
  2. If error 1538 is detected again, replace the Expansion Interface circuit pack.
- j. Error Type 2305 with Aux Data 118 indicates that the Expansion Interface circuit pack has detected slips on the incoming fiber data stream. That is, an EPN and the PPN in a Direct Connect configuration, or a Port Network and a Switch Node in a Center Stage Switch configuration, are not synchronized.
1. Enter **display errors** and follow the repair procedures for *non-slip* errors against any SYNC , TDM-CLK, TONE-BD, DS1 CONV-BD, EXP-INTF, SNC-BD, and SNI-BD. Non-slip errors are those *not* listed below:

Circuit Pack Name	Error Log Name	Error Log Entry for Slips
DS1 Interface	DS1-BD	3073 to 3160
Expansion Interface	EXP-INTF	2305
Switch Node Interface	SNI-BD	1537
Tone-Clock	TDM-CLK	1025
UDS1 Interface	UDS1-BD	3073 to 3160
DS1 CONV Circuit Pack	DS1 CONV-BD	3329

2. For slip errors, refer to the SYNC section.

Error type 2306 indicates on-board failures related to system timing and synchronization. Perform the [“Fiber Fault Isolation Procedure”](#) described in [Chapter 5, “Alarms, Errors, and Troubleshooting”](#).

- k. Error Type 2561 indicates an on-board failure of Expansion Interface circuitry related to handling packet data from the fiber interface and from the Packet bus interface.
1. If this error has generated a minor alarm, the Expansion Interface circuit pack should be replaced.
- l. Error type 2817 indicates an on-board failure of Expansion Interface circuitry related to transmission of data to the fiber interface.
1. If this error has generated a minor alarm, the Expansion Interface circuit pack or transceiver should be replaced.
- m. Perform the following steps for error type 3073:
1. Execute the **display errors** command and resolve any errors on the following: PKT-BUS, PKTINT, PDATA-BD, PGATE-BD, BRI-BD, BRI-PT, BRI-SET/ASAI, UDS1-BD.

2. Enter the **test board UUCSS r3** command for this circuit pack. If this error continues to appear, replace the EI circuit pack.
- n. Error Types 3074 and 3075 indicate failures of the Expansion Interface Circuit Pack Packet Path Test. This packet path test exercises circuitry on the Expansion Interface circuit pack, the neighbor Expansion Interface or Switch Node Interface circuit pack, and any intervening DS1 CONV circuit packs (if the EPN is remoted).
1. Certain packet bus faults can cause these errors without the EI being defective. Check to see if PKT-BUS errors are also present. If they are, use the PKT-BUS section of this chapter and *Packet Bus Fault Isolation and Repair* in Chapter 6 to diagnose the problem.
  2. If Error Type 3075 is present without Error Type 3074, replace the Expansion Interface circuit pack.
  3. If Error Type 3074 exists with or without 3075, run **test board UUCSS** on the EI and follow the repair procedures for any test that does not pass.
  4. If PKT-BUS errors are not present, and replacing the Expansion Interface does not resolve the problem, there is still the possibility of a packet bus fault. See *Packet Bus Fault Isolation and Repair* in Chapter 6.
- o. Error Type 3330 indicates a failure of a diagnostic component on the Expansion Interface circuit pack. The failed component will not impair service, but it may leave the Expansion Interface circuit pack in a state where the Expansion Interface circuit pack cannot detect errors.
1. Replace the Expansion Interface circuit pack at a time when it is most convenient for the customer (this may cause service outages).
- p. Error Type 3585 indicates that the Expansion Interface circuit pack experienced a series of very short out of frame conditions within several minutes. This may indicate transmission difficulties over the fiber link. If this condition ceases, the warning alarm should be resolved within 15 minutes.
1. Enter **display errors** and resolve any SNC-BD, TDM-BUS, TDM-CLK or SYNC errors.
  2. Perform the "Fiber Fault Isolation Procedure" described in Chapter 5.
  3. If the alarm is not resolved within the next 15 minutes, replace the lightwave transceiver on the Expansion Interface circuit pack reporting the problem and on the connected Expansion Interface circuit pack, Switch Node Interface circuit pack, or DS1 CONV circuit pack.
  4. If the alarm is not resolved within the next 15 minutes, replace the Expansion Interface circuit pack reporting the alarm.

5. If the alarm is not resolved within the next 15 minutes, replace the connected Expansion Interface circuit pack, Switch Node Interface circuit pack or DS1 CONV circuit pack.
- q. Error Type 3841 indicates the EI has reported a loss of lock with the backplane system clock.
- r. Error Type 3842 indicates that the test that queries the EI for the state of the lock to the system clock has failed. This means that a loss of lock condition is present.
- s. The counter associated with Error Types 3841 and 3842 is cleared when the query for the state of the clock-to-system-clock passes. Once the alarm is raised, this test is run every five minutes. However, the test is not part of any sequence that can be run on demand. See Note “p” above for repair procedure.
- t. Error type 10001 is a report that the Expansion Interface circuit pack dropped one control message to the EPN. This condition may have been observed as a call that did not complete correctly. No system technician action is required.

## System Technician-Demanded Tests: Descriptions and Error Codes

Always investigate tests in the order presented in [Table 9-307](#) below. By clearing error codes associated with the *Expansion Interface Reset Test*, for example, you may also clear errors generated from other tests in the testing sequence.

**Table 9-307. System Technician-Demanded Tests: EXP-INTF**

Order of Investigation	Short Test Sequence	Long Test Sequence	Reset Board Sequence	D/ND <sup>1</sup>
Expansion Interface Reset Test (#336)			X	D
Expansion Interface Fiber Out-of-Frame Query Test (#238)	X	X		ND
Expansion Interface Lightwave Transceiver Looparound Test (#242)		X		D
Expansion Interface Control Channel Test (#316)	X	X		ND
Expansion Interface Neighbor Query Test (#237)	X	X		ND
Expansion Interface Local Looparound Test (#240)	X	X		ND
Expansion Interface 2-way Transmission Test (#241)	X	X		ND

**Table 9-307. System Technician-Demanded Tests: EXP-INTF — Continued**

Order of Investigation	Short Test Sequence	Long Test Sequence	Reset Board Sequence	D/ND <sup>1</sup>
Expansion Interface Packet Interface Test (#589)	X	X		ND

1. D = Destructive, ND = Non-destructive

When testing Expansion Interface circuit packs to investigate problems, tests should always be run on both circuit packs on the associated fiber link, whether the circuit packs are both Expansion Interface circuit packs, or one is a Switch Node Interface circuit pack. This will provide a better indication of where a problem is located.

When testing of the EI is not possible, (for example, when the EPN is down), see the EI Manual Loopback Procedure above.

### Expansion Interface Neighbor Query Test (#237)

This test is non-destructive.

The Expansion Interface Neighbor Query Test is a request to an Expansion Interface circuit pack to determine if it has established communication with its neighbor Expansion Interface or Switch Node Interface circuit pack.

**Table 9-308. TEST #237 Expansion Interface Neighbor Query Test**

Error Code	Test Result	Description/ Recommendation
1033	ABORT	<p>The Expansion Interface circuit pack does not have a fiber link administered to it. There is not sufficient data to run test.</p> <ol style="list-style-type: none"> <li>1. Issue the <b>list fiber-link</b> command to verify that there is no fiber link administered to this circuit pack.</li> <li>2. If there is no fiber administered to this circuit pack, but there should be add the correct fiber using the <b>add fiber-link</b> command.</li> <li>3. Retry the command.</li> </ol>

*Continued on next page*

**Table 9-308. TEST #237 Expansion Interface Neighbor Query Test — Continued**

Error Code	Test Result	Description/ Recommendation
2000	ABORT	Response to the test was not received within the allowable time period.
2031	ABORT	The attempt to send the message to the Expansion Interface circuit pack, asking it who it's neighbor is, was not successful.
2100	ABORT	System resources required to run this test are not available. Someone may be doing something on this Port Network Interface.
2500	ABORT	Internal system error 1. Retry the command at 1-minute intervals a maximum of 3 times.
1033	FAIL	The EI circuit pack under test cannot make contact with its neighbor EI or Switch Node Interface circuit pack.  Perform the <a href="#">"Fiber Fault Isolation Procedure"</a> in <a href="#">"Alarms, Errors, and Troubleshooting"</a> .
2027	FAIL	The EI circuit pack has contact with the neighboring EI or Switch Node Interface circuit pack, but it is the incorrect EI or Switch Node Interface circuit pack.  1. Enter <b>list fiber-links</b> and verify that all fiber link cables are installed as they are administered.  2. Repeat the command.
	PASS	The EI circuit pack has successfully established a link with the neighbor EI or Switch Node Interface circuit pack.  If the <b>status port-network</b> command still indicates that this link is down, it is possible that one or both of the EI and/or Switch Node Interface circuit packs have been busied out.  1. If the link still does not come up, reset one or both EI and/or Switch Node Interface circuit packs on the link.
0	NO BOARD	No board was detected by the test.  1. Check the error log for wrong board (Error 125) or no board (error 131). Resolve either of these issues, if applicable.  2. Check that the board is properly translated and inserted. If so, check for hyperactivity (Error 1538). If hyperactive, use the <b>reset board UUCSS</b> command.  3. Run the test again. If it fails, the ID chip on board may be bad. Replace the board and retest.

## Expansion Interface Fiber Out-of-Frame (FOOF) Query Test (#238)

This test is nondestructive. This test is a request to an Expansion Interface circuit pack to determine if it is currently detecting the framing sequence on the incoming fiber data stream. If it cannot detect this framing signal, the Expansion Interface circuit pack will not be able to establish a link with the neighbor Expansion Interface or Switch Node Interface circuit pack.

**Table 9-309. TEST #238 Expansion Interface Fiber Out-of-Frame Query Test**

Error Code	Test Result	Description/ Recommendation
1033	ABORT	<p>The EI circuit pack does not have a fiber link administered to it. There is not sufficient data to run test.</p> <ol style="list-style-type: none"> <li>1. Issue the <b>list fiber-link</b> command to verify that there is no fiber link administered to this circuit pack.</li> <li>2. If there is no fiber administered to this circuit pack, but there should be add the correct fiber using the <b>add fiber-link</b> command.</li> <li>3. Retry the command.</li> </ol>
2000	ABORT	Response to the test was not received within the allowable time period.
2100	ABORT	System resources required to run this test are not available.
2500	ABORT	<p>Internal system error</p> <ol style="list-style-type: none"> <li>1. Retry the command at 1-minute intervals a maximum of 3 times.</li> </ol>
	FAIL	<p>Expansion Interface circuit pack could not detect framing sequence.</p> <ol style="list-style-type: none"> <li>1. If the Expansion Interface circuit pack that is failing Test #238 is in the EPN, and the red LEDs are ON on a large number of circuit packs, then reseal any Tone-Clock circuit packs in the EPN.</li> <li>2. Perform the <a href="#">"Fiber Fault Isolation Procedure"</a> in <a href="#">"Alarms, Errors, and Troubleshooting"</a>.</li> <li>3. Enter <b>display errors</b> and resolve any SNC-BD, TDM-BUS, TDM-CLK, or SYNC errors.</li> </ol>
	PASS	<p>The Expansion Interface circuit pack has detected the valid framing signal on the fiber.</p> <ol style="list-style-type: none"> <li>1. Refer to errors from other Expansion Interface circuit pack, Switch Node Interface tests, or DS1 CONV tests (if present) if the link is still not functioning.</li> </ol>



**Table 9-309. TEST #238 Expansion Interface Fiber Out-of-Frame  
Query Test — Continued**

Error Code	Test Result	Description/ Recommendation
0	NO BOARD	No board was detected by the test. <ol style="list-style-type: none"><li>1. Check the error log for wrong board (error 125) or no board (error 131). Resolve either of these issues, if applicable.</li><li>2. Check that the board is properly translated and inserted. If so, check for hyperactivity (error 1538). If hyperactive, use the <b>reset board UUCSS</b> command.</li><li>3. Run the test again. If it fails, the ID chip on board may be bad. Replace the board and retest.</li></ol>

### Expansion Interface Local Looparound (#240)

This test is nondestructive. The EI local looparound is similar to the Lightwave Transceiver looparound described in test #242. A test tone is received by the EI being tested, but is not transmitted out to the fiber interface before being looped back. The loopback is internal to the circuit pack. Thus, this test does not interfere with the normal fiber data stream.

**Table 9-310. TEST #240 Expansion Interface Local Looparound**

Error Code	Test Result	Description/ Recommendation
1	ABORT	Could not allocate time slot on TDM Bus A. Loopback passed on TDM Bus B.
2	ABORT	<p>Could not allocate time slot on TDM Bus B. Loopback passed on TDM Bus A.</p> <ol style="list-style-type: none"> <li>1. If there is no reason to doubt that the EI circuit pack can transfer data to or from a TDM Bus, then since the test passed on one bus, assume that the test passes on the other bus.</li> <li>2. If this test continues to abort with the same error, rerun test at 1-minute intervals a maximum of 3 times.</li> <li>3. If the test still does not pass on the other TDM Bus, follow the procedure for ABORT Error Code 3.</li> </ol>
3	ABORT	<p>The system could not allocate time slots for the test on either TDM Bus. The system may be under heavy traffic conditions or it may have time slots out-of-service due to TDM-BUS errors.</p> <ol style="list-style-type: none"> <li>1. If system has no TDM-BUS errors and is not handling heavy traffic, retry the command at 1-minute intervals a maximum of 3 times.</li> </ol>
1003	ABORT	<p>The system could not allocate a tone receiver for the test. The system may be oversized for the number of tone detectors present or some tone detectors may be out of service.</p> <ol style="list-style-type: none"> <li>1. Enter <b>display errors</b> and follow associated repair procedures for TTR-LEV errors in the error log. Even if there are not TTR-LEV errors, there may not be a tone detector available on the network that contains the circuit pack being tested. Verify that there is at least one tone detector on the network. If not, this test always aborts for this EI circuit pack. This does not harm the system.</li> <li>2. Resolve any TONE-PT errors.</li> <li>3. If neither condition exists, retry the command at 1-minute intervals a maximum of 3 times.</li> </ol>
1031	ABORT	<p>A query of the EI circuit pack aborted. The purpose of this query was to see if the EI circuit pack could detect the framing signal.</p> <ol style="list-style-type: none"> <li>1. If Test #238 aborted, follow the procedure associated with this abort code.</li> <li>2. If Test #238 did not abort, rerun Test #240 at 1-minute intervals a maximum of 3 times.</li> </ol>
1032	ABORT	<p>The EI cannot detect the framing signal and cannot run the test.</p> <ol style="list-style-type: none"> <li>1. Refer to the errors for Test #238 to determine why the EI circuit pack is out of frame.</li> </ol>

*Continued on next page*

**Table 9-310. TEST #240 Expansion Interface Local Looparound — Continued**

Error Code	Test Result	Description/ Recommendation
1033	ABORT	<p>The EI circuit pack does not have a fiber link administered to it. There is not sufficient data to run test.</p> <ol style="list-style-type: none"> <li>1. Issue the <b>list fiber-link</b> command to verify that there is no fiber link administered to this circuit pack.</li> <li>2. If there is no fiber administered to this circuit pack, but there should be add the correct fiber using the <b>add fiber-link</b> command.</li> <li>3. Retry the command.</li> </ol>
1394	ABORT	<p>The EI circuit pack is out of service and the test cannot be run. This condition is due to a change in the EI circuit pack's ability to communicate with the EI or Switch Node Interface circuit pack on the other end of the fiber.</p> <ol style="list-style-type: none"> <li>1. Run Test #237 and check the Error Log for EXP-INTF error type 1281. If error type 1281 is present or if Test #237 does not pass, refer to repair procedures for Test #237.</li> </ol>
1395	ABORT	<p>This test cannot be run on an EI circuit pack if it is part of the B-side PNC and Duplicated PNC is not enabled.</p> <ol style="list-style-type: none"> <li>1. If this test needs to run on this EI circuit pack, enable PNC with the <b>change system-parameters duplication</b> command.</li> <li>2. Prevent the system from doing a PNC interchange by executing the <b>set PNC lock</b> command.</li> <li>3. Repeat this test.</li> </ol>
2000	ABORT	<p>Response to the test was not received within the allowable time period.</p>
2100	ABORT	<p>Could not allocate the necessary system resources to run this test.</p>
2500	ABORT	<p>Internal system error</p> <ol style="list-style-type: none"> <li>1. Retry the command at 1-minute intervals a maximum of 3 times.</li> </ol>

*Continued on next page*

**Table 9-310. TEST #240 Expansion Interface Local Looparound — Continued**

Error Code	Test Result	Description/ Recommendation
1	FAIL	Loopback on TDM Bus A failed. Loopback on TDM Bus B passed.
2	FAIL	Loopback on TDM Bus B failed. Loopback on TDM Bus A passed.
3	FAIL	Loopback on both TDM Buses failed.
12	FAIL	Loopback on TDM Bus B failed. Loopback on TDM Bus A aborted because the system could not allocate time slots.
21	FAIL	Loopback on TDM Bus A failed. Loopback on TDM Bus B aborted because the system could not allocate time slots.
None	FAIL	<p data-bbox="265 607 1053 657">The test tone was not detected correctly after being looped through the EI circuit pack.</p> <ol data-bbox="282 677 1093 915" style="list-style-type: none"> <li data-bbox="282 677 1093 759">1. If Error Type 2305 has been logged against the EI circuit pack in the last 5 minutes, this test could have failed due to the associated slips. If so, first resolve the 2305 error, and then repeat the test.</li> <li data-bbox="282 779 1018 829">2. Run the tests for the Active Tone-Clock on the PN that contains the indicted EI circuit pack to verify that dial-tone is supplied.</li> <li data-bbox="282 849 990 870">3. If the tone-clock is healthy, repeat the short test on the EI board.</li> <li data-bbox="282 890 883 915">4. If this test continues to fail, replace the EI circuit pack.</li> </ol>
	PASS	<p data-bbox="265 940 1031 990">Test tone was correctly detected after internal EI loopback on both TDM Busses.</p> <ol data-bbox="282 1010 1084 1091" style="list-style-type: none"> <li data-bbox="282 1010 1084 1091">1. Refer to other EI circuit pack tests if the links between this EI circuit pack and the EI or Switch Node Interface circuit pack on the other end of the fiber is not functioning correctly.</li> </ol>
0	NO BOARD	<p data-bbox="265 1116 643 1137">No board was detected by the test.</p> <ol data-bbox="282 1157 1093 1381" style="list-style-type: none"> <li data-bbox="282 1157 1068 1207">1. Check the error log for wrong board (error 125) or no board (error 131). Resolve either of these issues, if applicable.</li> <li data-bbox="282 1227 1081 1309">2. Check that the board is properly translated and inserted. If so, check for hyperactivity (error 1538). If hyperactive, use the <b>reset board UUCSS</b> command.</li> <li data-bbox="282 1329 1093 1381">3. Run the test again. If it fails, the ID chip on board may be bad. Replace the board and retest.</li> </ol>

### Expansion Interface 2-way Transmission Test (#241)

This test is nondestructive. The EI 2-way transmission test is a basic connectivity test between two PNs. The test first sends dialtone from the cabinet of the EI circuit pack under test through the Center Stage Switch, through the DS1 CONV

circuit packs, and through another EI circuit pack to a tone detector in the other cabinet. The connections are then reversed and the tone is passed in the opposite direction. If the system is equipped with a Center Stage Switch, and this test either fails or aborts with the above connection, a second PN is chosen (if one is available and the EI circuit pack is In-Service) and the same test is run on this new connection. This helps in the isolation of the fault. Since two EI circuit packs are involved in the connection, either one of them could be at fault and this repeated test can help determine which is actually at fault.

The path used in this test is represented in [Figure 9-43](#).

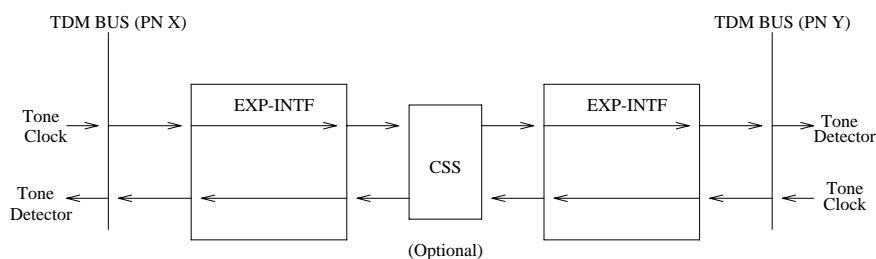

**Figure 9-43. Two-Way Circuit Switch Transmission Test**

**Table 9-311. TEST #241 Expansion Interface 2-way Transmission Test**

Error Code	Test Result	Description/ Recommendation
1002	ABORT	<p>The system could not allocate time slots for the test. The system may be under heavy traffic conditions or it may have time slots out of service due to TDM-BUS errors. Enter <b>display errors</b> and follow associated repair procedures for TDM-BUS errors.</p> <ol style="list-style-type: none"> <li>If system has no TDM-BUS errors and is not handling heavy traffic, retry the command at 1-minute intervals a maximum of 3 times.</li> </ol>

*Continued on next page*

**Table 9-311. TEST #241 Expansion Interface 2-way Transmission Test — Continued**

Error Code	Test Result	Description/ Recommendation
1003	ABORT	<p>The system could not allocate a tone receiver for the test. The system may be oversized for the number of tone detectors present or some tone detectors may be out of service.</p> <ol style="list-style-type: none"> <li>1. Enter <b>display errors</b> and follow associated repair procedures for TTR-LEV errors in the error log. Even if there are not TTR-LEV errors, there may not be a tone detector available on the network that contains the circuit pack being tested. Verify that there is at least one tone detector on this network. If not, this test will always abort for this EI circuit pack. This will not harm the system in any way.</li> </ol> <p><b>⇒ NOTE:</b>                      DEFINITY Systems require that Tone Detector circuit packs (TN768) must be of vintage “B” or newer. If older Tone Detector circuit packs are installed in the system, this test will always abort with this code.</p> <ol style="list-style-type: none"> <li>2. Enter <b>display errors</b> and follow associated repair procedures for TONE-PT errors.</li> <li>3. If neither condition exists, retry the command at 1-minute intervals a maximum of 3 times.</li> </ol>
1033	ABORT	<p>The test cannot run because either the EI board does not have a fiber link administered to it and there is not sufficient data to run the test, or there were no other PNs administered that had its EI board In-Service.</p> <ol style="list-style-type: none"> <li>1. Check fiber administration to insure that there is a fiber link administered to this Expansion Interface circuit pack.</li> <li>2. If there is a fiber administered to this EI circuit pack, then some change in the status of the ability of the EI circuit pack in the other PNs to communicate with the EI or Switch Node Interface circuit pack on the other end of its fiber has occurred.</li> <li>3. Test #237 and check for EXP-INTF circuit pack Error Type 1281 in the Error Log for the EI circuit packs in these other PNs. If Error Type 1281 is present and/or Test #237 does not pass, refer to repair procedures for Test #237.</li> <li>4. If Test #237 passes, reseal the EI circuit pack. This is not destructive since the circuit pack cannot be serving as the Expansion Archangel if it is not in service.</li> </ol>
1394	ABORT	<p>The Expansion Interface circuit pack is out of service and the test cannot be run. This condition is due to a change in the EI circuit pack’s ability to communicate with the EI or Switch Node Interface circuit pack on the other end of the fiber.</p> <ol style="list-style-type: none"> <li>1. Run Test #237 and check the Error Log for EXP-INTF Error Type 1281. If Error Type 1281 is present or if Test #237 does not pass, refer to repair procedures for Test #237.</li> </ol>

*Continued on next page*

**Table 9-311. TEST #241 Expansion Interface 2-way Transmission Test — Continued**

Error Code	Test Result	Description/ Recommendation
1395	ABORT	This test cannot be run on an EI circuit pack if it is part of the B-side PNC and Duplicated PNC is not enabled. <ol style="list-style-type: none"> <li data-bbox="274 390 1093 444">1. If this test needs to run on this EI circuit pack, enable PNC with the <b>change system-parameters duplication</b> command.</li> <li data-bbox="274 462 1093 516">2. Prevent the system from doing a PNC interchange by executing the <b>set PNC lock</b> command.</li> <li data-bbox="274 534 488 564">3. Repeat this test.</li> </ol>
1413	ABORT	This test requires the use of a Tone/Clock circuit pack in each of the port networks used in this test. This abort code indicates that there are none of these circuit packs located in one of the PNs. <ol style="list-style-type: none"> <li data-bbox="274 677 1093 731">1. Make sure that there is a Tone/Clock circuit pack located in the PN in which the Expansion Interface circuit pack under test is located.</li> <li data-bbox="274 749 1093 838">2. In Direct Connect configurations, make sure that there is a Tone/Clock circuit pack located in the PN where the neighbor Expansion Interface circuit pack is located.</li> <li data-bbox="274 856 1093 946">3. In Center Stage Switch configurations, make sure that there is at least one other PN, besides the PN where the EI circuit pack under test resides, that contains a Tone/Clock circuit pack.</li> </ol>
1414	ABORT	This test requires the use of an active Tone/Clock circuit pack in each of the port networks used in this test that does not have a MAJOR or MINOR alarm logged against it. This abort code indicates that the active Tone/Clock circuit pack in one of the port networks being used for the test has a MAJOR or MINOR alarm logged against it. <ol style="list-style-type: none"> <li data-bbox="274 1112 1093 1148">1. Enter <b>display alarms</b> and resolve all TONE-BD and TONE-PT alarms.</li> </ol>
2000	ABORT	Response to the test request was not received within the allowable time period.
2100	ABORT	System resources required to run this test are not available.
2500	ABORT	Internal system error <ol style="list-style-type: none"> <li data-bbox="274 1292 1093 1327">1. Retry the command at 1-minute intervals a maximum of 3 times.</li> </ol>
	FAIL	The test tone was not detected correctly in either direction. <ol style="list-style-type: none"> <li data-bbox="274 1381 1093 1471">1. Run the test for the Active Tone-Clocks on the Port Networks for which the Expansion Interface circuit pack under test provides a link. This will determine if the dial tone is being supplied.</li> <li data-bbox="274 1489 1093 1544">2. Perform the "<a href="#">Fiber Fault Isolation Procedure</a>" in <a href="#">Chapter 5, "Alarms, Errors, and Troubleshooting"</a>.</li> </ol>

*Continued on next page*

**Table 9-311. TEST #241 Expansion Interface 2-way Transmission Test — Continued**

Error Code	Test Result	Description/ Recommendation
1 or 2	FAIL	<p>The test tone was detected correctly in one direction, but not the opposite direction.</p> <ol style="list-style-type: none"> <li>1. Test for the Active Tone-Clocks on the PNs for which the defective EI board provides a link. This determines if the dial tone is supplied.</li> <li>2. Perform the <a href="#">“Fiber Fault Isolation Procedure”</a> in <a href="#">Chapter 5, “Alarms, Errors, and Troubleshooting”</a>.</li> </ol> <p><b>Center Stage:</b> These failure codes are possible on a Center Stage Switch configuration only when there is just one other PN available for looping back the test tone.</p> <ol style="list-style-type: none"> <li>1. Perform the <a href="#">“Fiber Fault Isolation Procedure”</a> in <a href="#">Chapter 5, “Alarms, Errors, and Troubleshooting”</a>.</li> </ol>
3 or 4	FAIL	<p>The failure codes only apply to a system equipped with a Center Stage Switch. They indicate that the test aborted or failed for the first connection from the EI board under test to another EPN, and that the test tone was detected correctly in one direction, but not the opposite direction when the connection was between the EI board under test and a different EPN than was used in the first connection.</p> <ol style="list-style-type: none"> <li>1. Run the test for the Active Tone-Clocks on the PNs for which the defective EI board provides a link. This determines if the dial tone is being supplied.</li> <li>2. Perform the <a href="#">“Fiber Fault Isolation Procedure”</a> in <a href="#">Chapter 5, “Alarms, Errors, and Troubleshooting”</a>.</li> </ol>
	PASS	<p>The tone was successfully transmitted in both directions. Both EI boards, Switch Node Interface boards, DS1 CONV circuit packs, and their lightwave transceivers are functioning properly.</p>
0	NO BOARD	<p>No board was detected by the test.</p> <ol style="list-style-type: none"> <li>1. Check the error log for wrong board (error 125) or no board (error 131). Resolve either of these issues, if applicable.</li> <li>2. Check that the board is properly translated and inserted. If so, check for hyperactivity (error 1538). If hyperactive, use the <b>reset board UUCSS</b> command.</li> <li>3. Run the test again. If it fails, the ID chip on board may be bad. Replace the board and retest.</li> </ol>

**Expansion Interface Lightwave Transceiver Looparound Test (#242)**

**This test is destructive.**



This test requires that the Expansion Interface circuit pack first be busied out. If the system has a duplicated Port Network Connectivity, this test cannot be run on an Expansion Interface circuit pack that resides on the current active PNC due to restrictions that prohibit the busying-out of certain components that are part of the active PNC. If this test is run on an Expansion Interface circuit pack that is part of the Standby PNC, this test is not destructive and no service outages will take place.

In a system without duplicated Port Network Connectivity, where this Expansion Interface circuit pack supports a PPN to EPN link, this test will disrupt service to one EPN (Direct Connect) or all EPN s (Center Stage). If the Expansion Interface circuit pack is part of an EPN to EPN link in a Direct Connect system, service between the two EPN s will be disrupted.

This is a two part connectivity test. In the first part of the test, a digital count is transmitted from the cabinet of the Expansion Interface circuit pack under test, through the Expansion Interface circuit pack under test, out to its lightwave transceiver. The connection then loops back into the lightwave transceiver through the same Expansion Interface circuit pack again and into the originating cabinet. If the test tone is detected by a tone detector, the first part of the test passes. The path used for this part of the test is represented in [Figure 9-44](#).

In the second part of the test, a data packet is sent from the TN1655 Packet Interface circuit pack to the Expansion Interface circuit pack under test, the packet is looped back through the lightwave transceiver and is sent back to the Packet Interface circuit pack. If the Packet Interface circuit pack receives the same packet it transmitted, the second part of the test passes. If the entire test has passed, the Expansion Interface circuit pack, its backplane wiring and the electrical portion of the lightwave transceiver are healthy.

The path used for this test if the Expansion Interface is located in the PPN is represented in [Figure 9-45](#). The path used for this test if the Expansion Interface is located in an EPN is represented in [Figure 9-46](#).

When the Expansion Interface circuit pack under test is in an EPN, the data packet must also pass through the Active Expansion Interface circuit packs and the Active DS1 CONV circuit packs (and the Active Switch Node Interface circuit pack(s) in a Center Stage Switch system) of the Active PNC link connecting the EPN to the PPN.

This test requires the Expansion Interface circuit pack to ignore incoming data from its neighbor Expansion Interface circuit pack or Switch Node Interface circuit pack. Thus this test will disturb any inter-port network connections that currently exist over the link provided by the Expansion Interface under test and its neighbor and disrupt signaling between the two circuit packs.

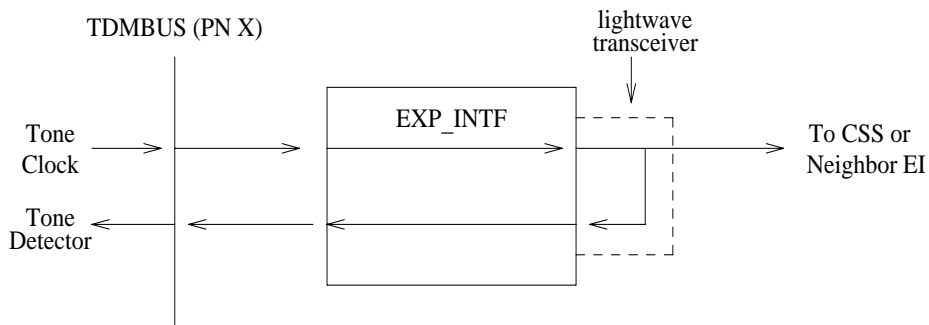

Figure 9-44. TDM BUS Lightwave Transceiver Looparound

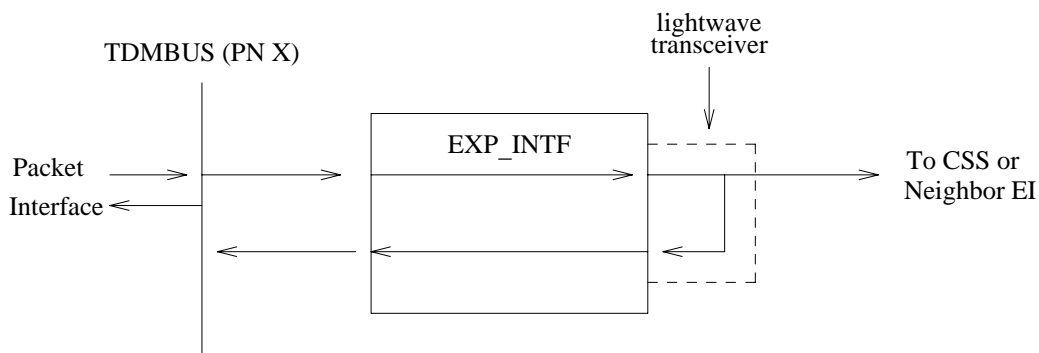
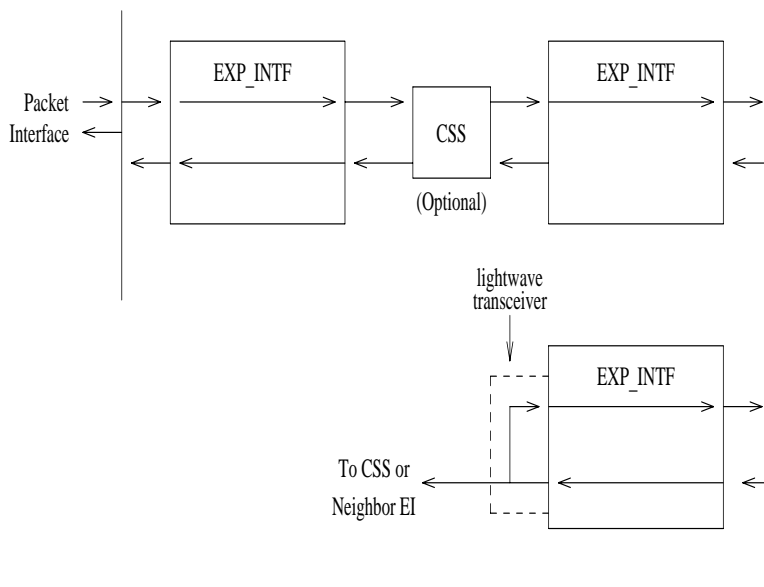

Figure 9-45. Packet BUS Lightwave Transceiver Looparound—PPN only



**Figure 9-46. Packet BUS Lightwave Transceiver Looparound—EPN only**

**Table 9-312. TEST #242 Expansion Interface Lightwave Transceiver Looparound**

Error Code	Test Result	Description/ Recommendation
1002	ABORT	<p>The system could not allocate timeslots for the test. The system may be under heavy traffic conditions or it may have timeslots out of service due to TDM-BUS errors. Enter <b>display errors</b> and resolve any TDM-BUS errors.</p> <ol style="list-style-type: none"> <li>1. If system has no TDM-BUS errors and is not handling heavy traffic, retry the command at 1-minute intervals a maximum of 3 times.</li> </ol>

*Continued on next page*

**Table 9-312. TEST #242 Expansion Interface Lightwave Transceiver Looparound — Continued**

Error Code	Test Result	Description/ Recommendation
1003	ABORT	<p>The system could not allocate a tone receiver for the test. The system may be oversized for the number of Tone Detectors present or some Tone Detectors may be out of service.</p> <ol style="list-style-type: none"> <li>1. Enter <b>display errors</b> and follow associated repair procedures for TTR-LEV. Even if there are no TTR-LEV errors, there may not be a Tone Detector available on the network that contains the circuit pack being tested. Verify that there is at least one Tone Detector on this network. If there is not at least one Tone Detector, this test always aborts for this EI board. This will not harm the system.</li> <li>2. Enter <b>display errors</b> and follow associated repair procedures for TONE-PT.</li> <li>3. If neither condition exists, retry the command at 1-minute intervals a maximum of 3 times.</li> </ol>
1015	ABORT	<p>The system will not allow this test to be run because the EI circuit pack has not been busied out.</p> <ol style="list-style-type: none"> <li>1. Busyout the Expansion Interface circuit pack. Then, repeat the <b>test board UUCSS long</b> command.</li> </ol>
1031	ABORT	<p>If the Expansion Interface circuit pack is in an EPN and is on the active PNC, and is not part of an EPN to EPN link, this test <i>cannot</i> be executed. If the lightwave transceiver looparound is activated, it is impossible to deactivate it.</p> <ol style="list-style-type: none"> <li>1. If PNC Duplication is enabled, attempt to make the Standby PNC active through the <b>reset pnc interchange</b> command.</li> <li>2. If the PNC Interchange is successful, the lightwave transceiver looparound test may now be executed on the original Expansion Interface circuit pack.</li> </ol>
1033	ABORT	<p>The test cannot run because the EI circuit pack does not have a fiber link administered to it and there is not sufficient data to run the test.</p> <ol style="list-style-type: none"> <li>1. Issue the <b>list fiber-link</b> command to verify that there is no fiber link administered to this circuit pack.</li> <li>2. If there is no fiber administered to this circuit pack (but should be), add the correct fiber using the <b>add fiber-link</b> command.</li> <li>3. Retry the command.</li> </ol>
1139	ABORT	<p>The packet bus in the EPN where this EI board is located has a major alarm against it. This test needs to use the alarmed PN's packet bus.</p> <ol style="list-style-type: none"> <li>1. Enter <b>display alarms</b> and <b>display errors</b> and resolve any PKT-BUS alarms.</li> <li>2. Retry the command.</li> </ol>
1141	ABORT	<p>The Packet Interface circuit pack is out of service.</p> <ol style="list-style-type: none"> <li>1. Refer to <a href="#">“PKT-INT (Packet Interface Circuit Pack)”</a>.</li> </ol>

**Table 9-312. TEST #242 Expansion Interface Lightwave Transceiver Looparound — Continued**

Error Code	Test Result	Description/ Recommendation
1144	ABORT	The packet bus in the PPN has a major alarm against it. This test needs to use the alarmed PPN packet bus. <ol style="list-style-type: none"> <li>1. Enter <b>display alarms</b> and <b>display errors</b> and resolve any PKT-BUS alarms.</li> <li>2. Retry the command.</li> </ol>
1394	ABORT	The EI board is out of service and the test cannot be run. This condition is due to a change in the EI board's ability to communicate with the EI or Switch Node Interface circuit pack on the other end of the fiber. <ol style="list-style-type: none"> <li>1. Run Test #237 and check the Error Log for EXP-INTF Error Type 1281. If Error Type 1281 is present or if Test #237 does not pass, refer to repair procedures for Test #237.</li> </ol>
1395	ABORT	This test cannot be run on an EI circuit pack if it is part of the B-side PNC and Duplicated PNC is not enabled. <ol style="list-style-type: none"> <li>1. If this test needs to run on this EI circuit pack, enable PNC with the <b>change system-parameters duplication</b> command.</li> <li>2. Prevent the system from doing a PNC interchange by executing the <b>set PNC lock</b> command.</li> <li>3. Repeat this test.</li> </ol>
1407	ABORT	This test cannot be run on an EI board that is on the active PNC because it cannot be busied out. This error code indicates that PNC duplication is enabled. <ol style="list-style-type: none"> <li>1. Attempt to perform a PNC interchange via the <b>reset pnc interchange</b> command.</li> <li>2. If the PNC interchange is successful, busy out the original Expansion Interface circuit pack via the <b>busyout board UUCSS</b> (address of the original EI board).</li> <li>3. Retry the command.</li> </ol>
2000	ABORT	Response to the test was not received in the allowable time period. <ol style="list-style-type: none"> <li>1. Retry the command at 1-minute intervals a maximum of 3 times.</li> </ol>
2060	ABORT	The link on the packet bus being used to perform the test has failed. <ol style="list-style-type: none"> <li>1. Retry the command at 1-minute intervals a maximum of 3 times.</li> <li>2. If the test continue to abort, enter <b>display errors</b> and resolve any PKTINT errors.</li> </ol>
2100	ABORT	Could not allocate the necessary system resources to run this test.
2500	ABORT	Internal system error <ol style="list-style-type: none"> <li>1. Retry the command at 1-minute intervals a maximum of 3 times.</li> </ol>

**Table 9-312. TEST #242 Expansion Interface Lightwave Transceiver Looparound — Continued**

Error Code	Test Result	Description/ Recommendation
1	FAIL	<p>The test did not detect the test tone through the looparound connection.</p> <p> <b>NOTE:</b>                      The packet portion of this test was not run since the circuit portion failed.</p> <ol style="list-style-type: none"> <li>1. Test the Active Tone-Clock on the PN that contains the defective EI circuit pack to verify that dial tone is being supplied.</li> <li>2. If the Tone-Clock is healthy, issue the <b>test board UUCSS long</b> on the EI circuit pack.</li> <li>3. If this test continues to fail, replace the EI circuit pack or transceiver. Then reissue the <b>test board UUCSS long</b> on the new EI circuit pack.</li> </ol>
2	FAIL	<p>The test tone was transmitted and detected correctly, but the correct data packet was not detected by the TN1655 Packet Interface circuit pack.</p> <ol style="list-style-type: none"> <li>1. Test the TN1655 Packet Interface circuit pack to verify that it is functioning properly. If any tests fail, investigate those tests and repair the Packet Interface circuit pack.</li> <li>2. If the Packet Interface circuit pack checks out OK, enter <b>display errors</b> and <b>display alarms</b> and resolve any SNI-BD and FIBER-LK alarms or errors (Center Stage Switch only) and DS1 CONV-BD alarms or errors (if present).</li> <li>3. Issue the <b>test board UUCSS long</b> command on the EI board.</li> <li>4. If test #242 continues to fail, replace the EI board. Then issue the <b>test board UUCSS long</b> command on the new EI board.</li> <li>5. If test #242 continues to fail, replace the lightwave transceiver, reset the circuit pack and issue the <b>test board UUCSS long</b> command on the EI circuit pack.</li> </ol>

*Continued on next page*

**Table 9-312. TEST #242 Expansion Interface Lightwave Transceiver Looparound — Continued**

Error Code	Test Result	Description/ Recommendation
	PASS	<p>When this test (#242) and the EI Local Looparound Test #240 pass, this indicates that the EI board is functioning properly, but it does not verify that the optical portion of the lightwave transceiver is functioning.</p> <ol style="list-style-type: none"> <li>Issue the <b>test board UUCSS</b> command on the EI board on both ends of fiber. If this test passes from both sides, but other tests fail, such as #241, this condition indicates either a faulty lightwave transceiver or the fiber itself has failed. To determine if either a lightwave transceiver or the fiber itself has failed, execute the EI Manual Loopback procedure described in a previous section.</li> </ol> <p><b>⇒ NOTE:</b>                      Test #242 can only be run from both EI s if they are the standby pair and the active pair is working properly.</p> <ol style="list-style-type: none"> <li>If this EI board is failing other tests, execute the EI Manual Loopback Test.</li> <li>If problems still exist after the EI Manual Loopback Procedure indicates both EI boards and both lightwave transceivers are healthy, manually check out the building fiber. Verify that each optical fiber connects to a transmitter at one end and a receiver at the other.</li> </ol>
0	NO BOARD	<p>No board was detected by the test.</p> <ol style="list-style-type: none"> <li>Check the error log for wrong board (Error 125) or no board (Error 131). Resolve either of these issues, if applicable.</li> <li>Check that the board is properly translated and inserted. If so, check for hyperactivity (Error 1538). If hyperactive, use the <b>reset board UUCSS</b> command.</li> <li>Run the test again. If it fails, the ID chip on board may be bad. Replace the board and retest.</li> </ol>

### Expansion Interface Control Channel Test (#316)

This test is nondestructive. If an Expansion Interface circuit pack is a standby Expansion Interface circuit pack (yellow LED off) or if the Expansion Interface is active in the PPN (yellow LED on), this test queries the Expansion Interface circuit pack for its circuit pack type and vintage information. If the Expansion Interface circuit pack is an active Expansion Interface circuit pack in the EPN (yellow LED on long off short) the Expansion Interface Control Channel test checks to see if the Expansion Interface circuit pack can communicate with other circuit packs in the EPN using the EPN TDM bus.

**Table 9-313. TEST #316 Expansion Interface Control Channel Test**

Error Code	Test Result	Description/ Recommendation
2000	ABORT	Response to the test request was not received within the allowable time period.
2100	ABORT	Could not allocate the necessary system resources to run this test.
2500	ABORT	Internal system error 1. Retry the command at 1-minute intervals a maximum of 3 times.
	FAIL	The EI circuit pack responded incorrectly or if it is the EPN active EI circuit pack, it could not talk to EPN circuit packs. 1. If the active EI circuit pack in the EPN is failing and duplicated Port Network Connectivity is enabled, attempt to switch to the standby PNC using the <b>reset PNC interchange</b> command. 2. Repeat the short test sequence. 3. If test continues to fail, reset the EI circuit pack via the <b>reset board UUCSS</b> command. 4. If the EI circuit pack in the EPN is failing, enter <b>display errors</b> and <b>display alarms</b> and resolve any TDM-CLK, TONE-BD, or SYNC alarms or errors and repeat the Short Test Sequence. 5. If test continues to fail, replace the circuit pack or transceiver.
	PASS	The EI circuit pack did respond correctly to test. Communication from software to the EI circuit pack is functioning. 1. Refer to other EI circuit pack tests if the link is not functioning correctly.
0	NO BOARD	No board was detected by the test. 1. Resolve either wrong board (Error 125) or no board (Error 131) issues. 2. Check that the board is properly translated and inserted. If so, check for hyperactivity (Error 1538). If hyperactive, use the <b>reset board UUCSS</b> command. 3. Run the test again. If it fails, the ID chip on board may be bad. Replace the board and retest.

### Expansion Interface Reset Test (#336)

**This test is destructive.**

This test is potentially very destructive and requires the Expansion Interface circuit pack to be busied out prior to execution of this test.



The Expansion Interface Reset test, which is not part of either the Short or the Long test sequences test is executed via the **reset board UUCSS** command where UUCSS is the address of the Expansion Interface circuit pack to be reset.

If the system does not have Duplicated Port Network Connectivity, and is a Direct Connect system, and one of the Expansion Interface circuit packs must be reset, the action of busying out the desired Expansion Interface circuit pack will deny calls to the EPN until the Expansion Interface circuit pack is released from the busyout state. If the Expansion Interface circuit pack is part of a PPN to EPN link, new connections to the EPN will be denied. If the Expansion Interface circuit pack is part of an EPN to EPN link, calls between the two EPN s will be denied.

In a non-duplicated PNC system with a Center Stage Switch, if the Expansion Interface circuit pack in the EPN is busied out, new service to that EPN only will be denied. However, if the Expansion Interface circuit pack is located in the PPN, new service to all EPN s will be denied until the Expansion Interface circuit pack is released from the busyout state.

If the system does not have duplicated PNC, the reset of any EI is allowed, but it will result in the resetting of all EPN boards and loss of service to the EPN (s) for a few minutes.

If the system does have duplicated PNC, and the Expansion Interface circuit pack to be reset is part of the Active PNC, the system will not allow the busyout and the system technician will be required to interchange the PNCs via the **reset PNC interchange** command. After executing the PNC interchange, it will be possible to busyout and then reset the original Expansion Interface circuit pack.

If the EPN Maintenance (MAINT) circuit pack determines that the Expansion Interface (EXP-INTF) circuit pack is cycling between sane and insane several times within several minutes, MAINT may inhibit operation of the EXP-INTF by holding the Expansion Interface circuit pack in a reset state. This condition may result in an unsuccessful reset of the Expansion Interface circuit pack.

If the reset command returns "EPN is unavailable," execute the following steps:

1. Use the **change circuit-pack P** (port network number of the EPN) command.
2. For the Expansion Interface circuit pack you wish to reset, add an entry to the Circuit Pack form for the TN570 Expansion Interface circuit pack. Be sure to enter the appropriate carrier and slot.
3. Enter the form.
4. Issue the **busyout board UUCSS** command.
5. Repeat the **reset board** command

**Table 9-314. TEST #336 Expansion Interface Reset Test**

Error Code	Test Result	Description/ Recommendation
4	ABORT	Could not reset the EPN Expansion Interface circuit pack over the optical fiber since the neighbor Expansion Interface circuit pack or Switch Node Interface circuit pack is not recognized by software (inserted). <ol style="list-style-type: none"> <li>1. Insert neighbor Expansion Interface circuit pack or Switch Node Interface circuit pack and perform reset again.</li> </ol>
1015	ABORT	The system will not allow this test to be run because the EI circuit pack has not been busied out.  Busyout the EI circuit pack. Repeat the <b>reset board UUCSS</b> command.
2000	ABORT	Response to the test request was not received within the allowable time period.
2100	ABORT	Could not allocate the necessary system resources to run this test.
2500	ABORT	Internal system error <ol style="list-style-type: none"> <li>1. Retry the command at 1-minute intervals a maximum of 3 times.</li> </ol>
1	FAIL	The Expansion Interface did not successfully reset. <ol style="list-style-type: none"> <li>1. If the EI circuit pack is in the EPN, the EPN Maintenance Board may be holding the EI circuit pack reset. Attempt to rectify this condition by executing the <b>test maint P long</b> command on the maintenance board in the same EPN.</li> <li>2. If Step #1 was not successful in releasing the Expansion Interface circuit pack, temporarily remove the EPN maintenance circuit pack.</li> <li>3. Repeat the <b>reset board UUCSS</b> command.</li> <li>4. If reset continues to fail, replace circuit pack.</li> <li>5. Insert EPN maintenance circuit pack if it was removed.</li> </ol>
2	FAIL	The Expansion Interface circuit pack was successfully reset, but it did not begin running after the reset. <ol style="list-style-type: none"> <li>1. If the Expansion Interface circuit pack is in the EPN, temporarily remove the EPN maintenance circuit pack.</li> <li>2. Repeat the <b>reset board UUCSS</b> command.</li> <li>3. Reinsert the EPN maintenance circuit pack if it was removed.</li> </ol>

*Continued on next page*

**Table 9-314. TEST #336 Expansion Interface Reset Test — Continued**

Error Code	Test Result	Description/ Recommendation
3	FAIL	<p>The reset over the optical fiber failed.</p> <ol style="list-style-type: none"> <li>1. Execute the <b>test board UUCSS</b> command on the PPN neighbor EI circuit pack located on the opposite end of the fiber from this EI circuit pack. If Test #238 does not pass, follow the maintenance procedure associated with this test result. Then perform the reset again.</li> <li>2. If the EI circuit pack is in the EPN, temporarily remove the EPN Maintenance circuit pack.</li> <li>3. Repeat the <b>reset board UUCSS</b> command.</li> <li>4. Reinsert EPN Maintenance circuit pack if it was removed.</li> <li>5. If the symptoms match those described in the <a href="#">“EI and Tone-Clock Interactions”</a> section, follow those guidelines.</li> <li>6. Check the Error Log for the EPN Tone-Clock errors that were resolved when the EPN went down. These errors may have been resolved BECAUSE the EPN went down. When there is no Tone-Clock generating the system clock on an EPN, then an Expansion Interface (EI) circuit pack can only be reset once. All subsequent reset attempts fail. It is also possible that the system itself may have already tried to reset the EI circuit pack. Refer to <a href="#">“TONE-BD (Tone-Clock Circuit Pack)”</a> for Tone-Clock problems.</li> <li>7. If the reset still fails, execute the Manual Loop Back Procedure on the opposite PPN EI circuit pack. This procedure is described in the section preceding the Error Log Entries and Test to Clear Values table for this MO. If the EI circuit pack and the lightwave transceiver are healthy, the problem is the EI circuit pack and its lightwave transceiver on the EPN end of the fiber or the fiber itself. Test the EPN EI circuit pack with the manual loop back procedure and investigate the test results.</li> </ol>
	PASS	<p>The EI was successfully reset. Remove the Expansion Interface circuit pack from the busyout state by using the <b>release board UUCSS</b> command.</p> <ol style="list-style-type: none"> <li>1. Execute <b>test board UUCSS short</b> command. Refer to errors for each test.</li> </ol>
0	NO BOARD	<p>No board was detected by the test.</p> <ol style="list-style-type: none"> <li>1. Resolve either wrong board (error 125) or no board (error 131) issues.</li> <li>2. Check that the board is properly translated and inserted. If so, check for hyperactivity (error 1538). If hyperactive, use the <b>reset board UUCSS</b> command.</li> <li>3. Run the test again. If it fails, the ID chip on board may be bad. Replace the board and retest.</li> </ol>

### Expansion Interface Packet Interface Test (#589)

This test is nondestructive. This test attempts to send a data packet from the TN1655 Packet Interface circuit pack through any intervening Expansion Interface circuit packs and/or Switch Node Interface circuit packs and through the Expansion Interface circuit pack to be tested. The path the data packet takes is dependent on the location of the Expansion Interface circuit pack to be tested and whether the system has duplicate Port Network Connectivity. The following diagrams and short discussion of each describe the different paths the test uses.

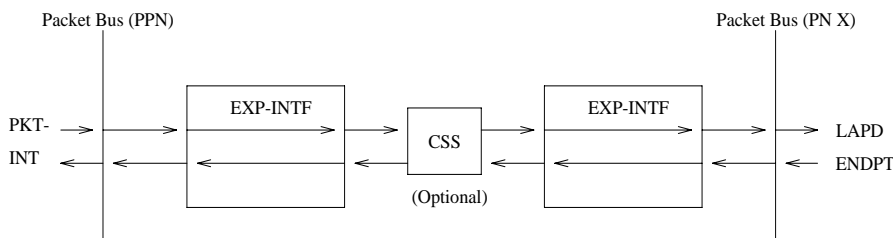

**Figure 9-47. Expansion Interface Packet Interface Test—Packet Endpoint Loop**

The path shown in [Figure 9-47](#) is used when testing an EPN EI that is on the active PNC.

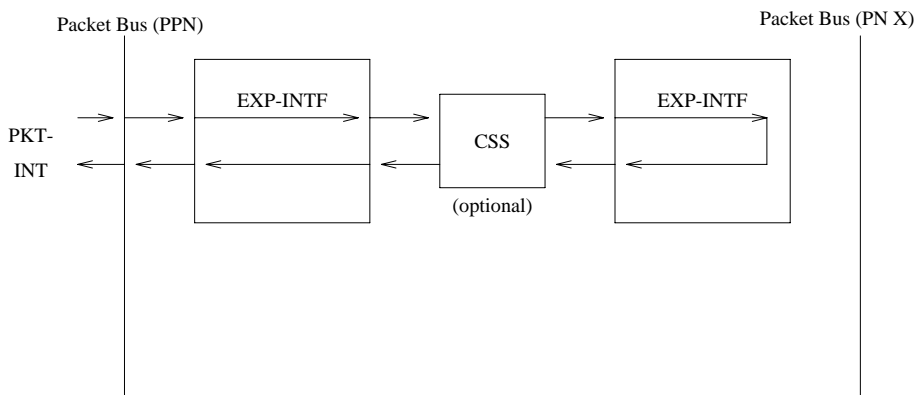

**Figure 9-48. Expansion Interface Packet Interface Test—PPN to EPN loop**

In a Center Stage configuration the path shown in [Figure 9-48](#) is used when testing an EPN EI that is on the standby PNC. In a Direct Connect configuration, this path is used on any PPN EI or on an EPN EI that is on the standby PNC.

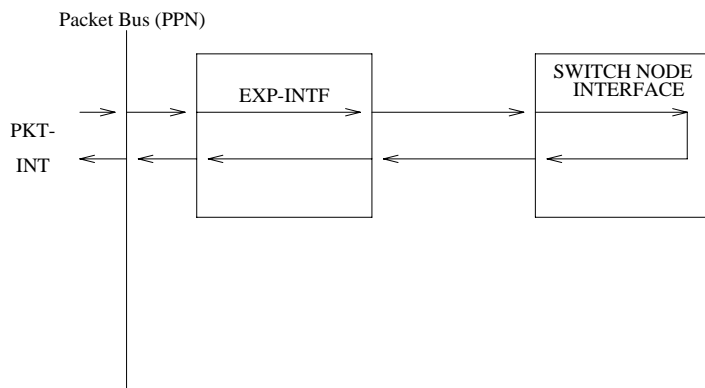

**Figure 9-49. Expansion Interface Packet Interface Test—PPN to CSS Loop**

The path shown in [Figure 9-49](#) is used when running the test on a PPN EI in a Center Stage configuration.

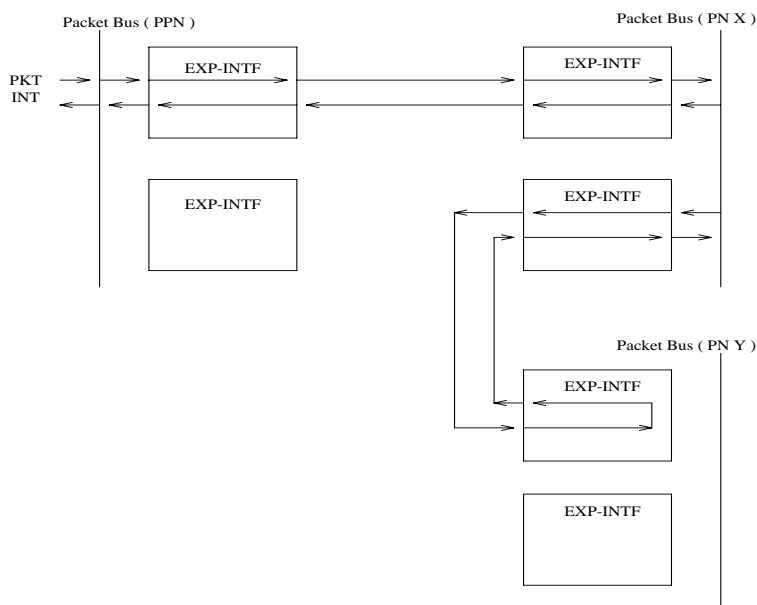

**Figure 9-50. Expansion Interface Packet Interface Test-EPN to EPN link**

The path shown in [Figure 9-50](#) is used when the EI under test is one that provides connectivity between the two EPN s in a Direct Connect configuration.

**Table 9-315. TEST #589 Expansion Interface Packet  
 Interface Test**

Error Code	Test Result	Description/ Recommendation
1033	ABORT	<p>The test cannot run because the Expansion Interface circuit pack does not have a fiber link administered to it and there is not sufficient data to run the test or because Expansion Interface circuit packs on other port networks needed for this test are out of service.</p> <ol style="list-style-type: none"> <li>1. Execute the <b>list fiber-link</b> command and determine if the Expansion Interface circuit pack under test is an endpoint of one of the administered fiber links. If it is one of the administered endpoints of a fiber link, proceed to Step 2. If it is not an administered endpoint, then this is considered to be a spare board and the test should not be attempted on this Expansion Interface circuit pack.</li> <li>2. Follow procedures for applicable configuration:</li> </ol> <p><b>DIRECT CONNECT</b></p> <ol style="list-style-type: none"> <li>1. Issue the <b>list config</b> command for the cabinet and carrier where the neighbor EI circuit pack is located. If the results reveal that the board is not recognized by software, the board is out of service because of this condition. Perform the following steps:                     <ol style="list-style-type: none"> <li>a. If this test is being executed on an Expansion Interface circuit pack located in the PPN, enter <b>display errors</b> and resolve any EXP-PN errors for the port network where the neighbor Expansion Interface circuit pack is located. Re-execute this test.</li> <li>b. If this test continues to abort with this abort code reset the DS1 CONV circuit pack (if so equipped) or the neighbor Expansion Interface circuit pack. This will not be destructive since the circuit pack cannot be serving as the Expansion Archangel if it is not in service.</li> </ol> </li> <li>2. Run Test #237 and check for EXP-INTF circuit pack Error Type 1281 in the Error Log. If Error Type 1281 is present and/or Test #237 does not pass, refer to repair procedures for Test #237.</li> </ol>

*Continued on next page*

**Table 9-315. TEST #589 Expansion Interface Packet  
 Interface Test — Continued**

Error Code	Test Result	Description/ Recommendation
1033 (cont'd )	ABORT (cont'd.)	<p>3. If Test #237 passes, reseal the Expansion Interface circuit pack. This will not be destructive since the circuit pack cannot be serving as the Expansion Archangel if it is not in service.</p> <p>4. Repeat test #237.</p> <p><b>CENTER STAGE</b></p> <p><i>If the Expansion Interface circuit pack under test is located in the PPN:</i></p> <p>None of the Expansion Interface circuit packs located in the EPNs (on the same PNC side) are in service (for EPN EIs see the next case).</p> <ol style="list-style-type: none"> <li>1. Issue the <b>list fiber-link</b> command and determine if any of the Expansion Interface circuit packs located in the EPNs are administered as endpoints of a fiber link. If none of them are then ignore the results of this test.</li> <li>2. Issue the <b>list conf</b> command for the cabinets and carriers where the Expansion Interface circuit packs are located in all other EPNs. If the results returned indicated that the circuit packs are not recognized by software, they are out of service for this reason.</li> <li>3. Issue the <b>display errors</b> command and resolve any EXP-PN errors. Re-execute this test.</li> <li>4. If the test continues to abort with this error code reseal the Expansion Interface circuit packs (or DS1 CONV circuit pack if so equipped) on the EPNs. This will not be destructive since the circuit pack cannot be serving as the Expansion Archangel if it is not in service.</li> <li>5. Run Test #237 on each of the EPN Expansion Interface circuit packs and check for EXP-INTF circuit pack Error Type 1281 in the error log. If Error Type is present and/or Test #237 does not pass, refer to repair procedures for Test #237.</li> <li>6. Repeat this test.</li> </ol>
1033 (cont'd )	ABORT (cont'd.)	<p><i>If the Expansion Interface circuit pack under test is located in the EPN:</i></p> <p>The Expansion Interface circuit located in the PPN is out of service.</p> <ol style="list-style-type: none"> <li>1. Run Test #237 on each of the EPN Expansion Interface circuit packs and check for EXP-INTF circuit pack Error Type 1281 in the error log. If Error Type is present and/or Test #237 does not pass, refer to repair procedures for Test #237.</li> <li>2. Repeat this test.</li> </ol>

*Continued on next page*

**Table 9-315. TEST #589 Expansion Interface Packet  
 Interface Test — Continued**

Error Code	Test Result	Description/ Recommendation
1139	ABORT	The Packet Bus in the Expansion Port Network where this Expansion Interface circuit pack is located has a major alarm against it. This test needs to use the alarmed port network's Packet Bus. <ol style="list-style-type: none"> <li>1. Enter <b>display alarms</b> and resolve any PKT-BUS alarms.</li> <li>2. Retry the command.</li> </ol>
1141	ABORT	The Packet Interface circuit pack is out of service. <ol style="list-style-type: none"> <li>1. Refer to "<a href="#">PKT-INT (Packet Interface Circuit Pack)</a>" for the recommended repair procedure.</li> </ol>
1144	ABORT	The Packet Bus in the PPN has a major alarm against it. This test needs to use the alarmed PPN Packet Bus. <ol style="list-style-type: none"> <li>1. Enter <b>display alarms</b> and resolve any PKT-BUS alarms.</li> <li>2. Retry the command.</li> </ol>
1394	ABORT	The Expansion Interface circuit pack is out of service and the test cannot be run. This condition is due to a change in the Expansion Interface circuit pack's ability to communicate with the Expansion Interface or Switch Node Interface circuit pack on the other end of the fiber. <ol style="list-style-type: none"> <li>1. Run Test #237 and check the Error Log for EXP-INTF Error Type 1281. If Error Type 1281 is present or if Test #237 does not pass, refer to the repair procedures for Test #237.</li> <li>2. If Test #237 passes, rest the Expansion Interface pack. Note that this will not be destructive to the port network that the Expansion Interface circuit pack is located in because it will not be serving as the expansion archangel if it is not in service.</li> <li>3. Repeat this test.</li> </ol>
1395	ABORT	This test cannot be run on an Expansion Interface circuit pack if it is part of the B-side Port Network Connectivity and Duplicated Port Network Connectivity is not enabled. <ol style="list-style-type: none"> <li>1. If this test needs to run on this Expansion Interface circuit pack, enable Port Network Connectivity with the <b>change system-parameters duplication</b> command.</li> <li>2. Prevent the system from doing a PNC interchange by executing the <b>set PNC lock</b> command.</li> <li>3. Repeat this test.</li> </ol>

*Continued on next page*



**Table 9-315. TEST #589 Expansion Interface Packet  
 Interface Test — Continued**

Error Code	Test Result	Description/ Recommendation
1421	ABORT	<p>This abort code appears only when the Expansion Interface circuit pack addressed in the test command is one that terminates a fiber link between two EPNs in a direct connect system. It indicates that the test failed, but that this test was run on the EPN EI board that is: a) in the same EPN as the board under test b) on the active PNC (if duplicated) c) terminates the fiber from the PPN. The EI tested is probably not at fault.</p> <ol style="list-style-type: none"> <li>1. Enter <b>display alarms</b> and follow the EXP-INTF repair procedures for any alarms against the EPN EI that is:                             <ol style="list-style-type: none"> <li>a. In the same EPN as the board just tested</li> <li>b. On the active PNC</li> <li>c. Terminates the fiber link from the PPN</li> </ol> </li> <li>2. If there are no alarms logged against that EI, run Test #589 on it and follow procedures for this test.</li> <li>3. Try this command again.</li> </ol>
1422	ABORT	<p>This abort code is valid and will only appear when the EI circuit pack under test is one which is located in an EPN in a system that is configured with a Center Stage Switch. It means that the test failed, but that this test was then run on the PPN EI on the same PNC as the EI under test and that test failed. This means that the EI originally tested is probably not at fault.</p> <ol style="list-style-type: none"> <li>1. Resolve any alarms that are logged against the PPN EI that is on the same PNC as the EI under test.</li> <li>2. If there are no alarms logged against the PPN EI, run Test #589 against the PPN EI and follow procedures for this test.</li> <li>3. Try this command again.</li> </ol>
2000	ABORT	<p>Response to the test request was not received within the allowable time period.</p> <ol style="list-style-type: none"> <li>1. Retry the command at 1-minute intervals for a maximum of 3 retries.</li> </ol>
2060	ABORT	<p>The link on the Packet Bus being used to perform the test has failed.</p> <ol style="list-style-type: none"> <li>1. Retry the command at 1-minute intervals a maximum of 3 times.</li> <li>2. If the test continues to abort, enter <b>display errors</b> and resolve any PKT-INT errors.</li> </ol>
2100	ABORT	<p>Could not allocate the necessary system resources to run this test.</p>
2500	ABORT	<p>Internal system error</p> <ol style="list-style-type: none"> <li>1. Retry the command at 1-minute intervals a maximum of 3 times.</li> </ol>

*Continued on next page*

**Table 9-315. TEST #589 Expansion Interface Packet  
 Interface Test — Continued**

Error Code	Test Result	Description/ Recommendation
ANY	FAIL	<p>The transmitted data packet was not received correctly by the Packet Interface circuit pack. The failure may be in the EI under test, the DS1 CONV circuit packs, or the intervening Center Stage components.</p> <ol style="list-style-type: none"> <li>1. Test the Packet Interface circuit pack with the <b>test packet- interface 1CS</b> command where C is the SPE carrier in a duplicated processor, and S is the slot number the Packet Interface is located in. If the Packet Interface circuit pack fails any tests, refer to "PKT-INTF".</li> <li>2. If the EI under test is located in an EPN in a high reliability system (2 PPN-to-CSS fibers in a simplex PNC), run the short test sequence on both of the PPN EI boards and follow procedures for test #589.</li> <li>3. Enter <b>display errors</b> and resolve any PKT-BUS errors.</li> <li>4. Perform the <a href="#">"Fiber Fault Isolation Procedure"</a>.</li> </ol>
	PASS	<p>Although this test has passed, there may be related problems on other EI s used in connectivity to and from this EI. Software may have conducted tests on these other components and determined that this board was functioning properly and any problems were probably due to a problem with some other connectivity component. Check the error and alarm logs for problems with other EI circuit packs and resolve these errors.</p> <ol style="list-style-type: none"> <li>1. Refer to other EI board tests if the link is not functioning correctly.</li> </ol>
0	NO BOARD	<p>No board was detected by the test.</p> <ol style="list-style-type: none"> <li>1. Resolve either wrong board (Error 125) or no board (Error 131) issues.</li> <li>2. Check that the board is properly translated and inserted. If so, check for hyperactivity (Error 1538). If hyperactive, use the <b>reset board UUCSS</b> command.</li> <li>3. Run the test again. If it fails, the ID chip on board may be bad. Replace the board and retest.</li> </ol>

### Expansion Interface Test (#244)

**This test is potentially very destructive and requires the Expansion Interface circuit pack to be busied out prior to execution of this test.**

The Expansion Interface Test, which is not a part of either the Short or the Long Test Sequences, is executed via the **reset board PCSS** command where PCSS is the address of the Expansion Interface circuit pack to be reset.

If the system only has one working Expansion Interface (EI) link between a pair of port networks and one of the EI circuit packs must be reset, the action of busying

out the desired Expansion Interface circuit pack WILL DISRUPT SERVICE TO THE EPN until the circuit pack is released from the busyout state. If the circuit pack is part of a PPN to EPN link, the EPN WILL BE WITHOUT SERVICE. If the circuit pack is part of an EPN to EPN link CALLS BETWEEN THE TWO EPNs WILL BE DENIED.

If the system has working duplicate EI links, and the EI circuit pack to be reset is part of the active EI link, the system does not allow the busyout and instructs system technician to switch EI links via the **set expansion-link PCSS** command where PCSS is the address of either Standby Expansion Interface circuit pack on the Standby link. After executing the EI link switch, it is possible to busyout and then reset the original EI circuit pack.

However, if the EPN Maintenance (MAINT) circuit pack determines that the Expansion Interface (EXP-INTF) circuit pack is cycling between sane and insane several times within several minutes, MAINT may inhibit operation of the EXP-INTF by holding the EI circuit pack in a reset state. This condition may result in an unsuccessful reset of the EI circuit pack.

If the reset command returns with `EPN is unavailable`, execute the following:

1. Use the **change circuit-pack P** command, where P is the port network number of the EPN.
2. For the EI circuit pack you wish to reset, add an entry to the Circuit Pack form for the TN776 Expansion Interface circuit pack. Be sure to enter the appropriate carrier and slot (that is, A01 or B02).
3. Repeat the **reset board** command.

**Table 9-316. TEST #224 Expansion Interface Test**

Error Code	Test Result	Description/ Recommendation
	ABORT	Internal system error. 1. Retry the command at 1-minute intervals a maximum of 3 times.
4	ABORT	Could not reset EPN Expansion Interface circuit pack over optical fiber since PPN Expansion Interface circuit pack on opposite end of fiber is not inserted. 1. Insert opposite EI circuit pack and perform reset again.
1015	ABORT	The system does not allow this test to be run because the EI circuit pack has not been busied out. 1. Busyout the Expansion Interface circuit pack. Repeat the <b>reset board PCSS</b> command.

*Continued on next page*

**Table 9-316. TEST #224 Expansion Interface Test — Continued**

Error Code	Test Result	Description/ Recommendation
2000 2100	ABORT ABORT	Response to the test request was not received within the allowable time period.  System resources required to run this test are not available.  1. Retry the command at 1-minute intervals a maximum of 3 times.
9999	ABORT	EI circuit pack reset successfully. Could not perform initialization test results query because link to EPN is not up.  1. Execute <b>release board PCSS</b> . Wait one minute. Issue the <b>display error</b> command. If you see Error Type 2049 logged against this EI circuit pack, then the EI Test has failed with an error code equal to the aux data of this entry. Otherwise, the initialization tests have passed.
12000 12100	ABORT ABORT	EI circuit pack reset successfully. Response to the initialization test results query was not received within the allowable time period.  EI circuit pack reset successfully. System resources required to run initialization test are not available.  1. Retry the command at 1-minute intervals a maximum of 3 times.
12026	ABORT	EI circuit pack reset successfully. It responded with an unknown reply to the query for the results of its initialization tests.  1. Retry the command at 1-minute intervals a maximum of 3 times.  2. If the test continues to abort, replace the circuit pack or transceiver.
1	FAIL	The EI did not successfully reset.  1. If the EI circuit pack is in the EPN, the EPN Maintenance Board may be holding the EI circuit pack reset. Attempt to rectify this condition by executing the <b>test maint P long</b> command on the maintenance board in the same EPN.  2. If Step #1 was not successful in releasing the EI circuit pack, temporarily remove the EPN maintenance circuit pack.  3. Repeat the <b>reset board PCSS</b> command.  4. If reset continues to fail, replace circuit pack.  5. Insert EPN maintenance circuit pack if it was removed.
2	FAIL	The EI circuit pack was successfully reset, but it did not begin running after the reset.  1. If the EI circuit pack is in the EPN, temporarily remove the EPN maintenance circuit pack.  2. Repeat the <b>reset board PCSS</b> command.  3. Re-insert the EPN maintenance circuit pack if it was removed.

*Continued on next page*

**Table 9-316. TEST #224 Expansion Interface Test — Continued**

Error Code	Test Result	Description/ Recommendation
3	FAIL	<p>The reset over the optical fiber failed.</p> <ol style="list-style-type: none"> <li>1. Execute the <b>test board PCSS</b> command on the PPN neighbor EI circuit pack located on the opposite end of the fiber from this EI circuit pack. If Test #238 does not pass, follow the maintenance procedure associated with this test result. Then perform the reset again.</li> <li>2. If the EI circuit pack is in the EPN, temporarily remove the EPN Maintenance circuit pack.</li> <li>3. Repeat the <b>reset board PCSS</b> command.</li> <li>4. Reinsert EPN Maintenance circuit pack if it was removed.</li> <li>5. Follow the procedure described in the “Relationship Between Expansion Interface and Tone-Clock Circuit Packs” section if the symptoms match those described there.</li> <li>6. Check the Error Log for the EPN Tone-Clock errors that were resolved about the same time when the EPN went down. These EPN Tone-Clock errors may have been resolved <i>because</i> the EPN went down. When there is no Tone-Clock generating the system clock on an EPN, then an EI circuit pack can only be reset once. All subsequent reset attempts fail. It is also possible that the system itself may have already tried to reset the EI circuit pack. Refer to the TONE-BD (Tone-Clock) Maintenance documentation for recommended maintenance strategy for Tone-Clock problems.</li> </ol>
		<ol style="list-style-type: none"> <li>7. If the reset still fails, execute the Manual Loop Back Procedure on the opposite PPN EI circuit pack. This procedure is described in the section preceding the Hardware Error Log Entries and Test to Clear Values table for this MO. If the EI circuit pack and the lightwave transceiver are healthy, the problem must lie with the EI circuit pack and its lightwave transceiver on the EPN end of the fiber or with the fiber itself. Test the EPN EI circuit pack with the manual loop back procedure and investigate the test results.</li> </ol>

*Continued on next page*

**Table 9-316. TEST #224 Expansion Interface Test — Continued**

Error Code	Test Result	Description/ Recommendation
5001	FAIL	<p>Initialization failure: the Expansion Interface circuit pack reset successfully and restarted execution, but the Expansion Interface circuit pack could not synchronize itself during hardware initialization.</p> <ol style="list-style-type: none"> <li>1. Issue the <b>reset board PCSS</b> command. If the circuit pack is on the Active link, this procedure can be very destructive. If a <b>test board PCSS</b> shows all the tests passing, and there is no Standby link to which you can switch, perform this reset at a time when service is least disrupted by losing use of the EPN.</li> <li>2. If the reset fails with the same error code, execute the <b>test tone-clock PC</b> command where P is the network that contains this Expansion Interface circuit pack and C is the carrier that contains the Active Tone-Clock on network P. Also look for SYNC and TONE-BD errors. Resolve any SYNC and TONE-BD errors by following the Maintenance documentation for these MOs. Then reissue the <b>reset board PCSS</b> command.</li> <li>3. If the Expansion Interface circuit pack still fails to reset with the same error code, replace the Expansion Interface circuit pack.</li> </ol>
5002	FAIL	<p><b>Initialization failure:</b> EI circuit pack reset successfully and restarted execution. But the EI circuit pack has determined that a lightwave transceiver was not attached to the backplane connector when the EI circuit pack was last reset. If this system does not have duplicate EI links, all users in the EPN will be without service until this problem is resolved. If this system does have duplicate links, the backup EI link is unavailable until this problem is resolved.</p> <ol style="list-style-type: none"> <li>1. Attach lightwave transceiver to 25-pair backplane connector <b>in slot belonging to Expansion Interface circuit pack</b>.</li> <li>2. Reset the circuit pack again.</li> <li>3. If the reset fails with an Error Code other than 5002, refer to the appropriate maintenance section.</li> <li>4. If the reset fails again with Error Code 5002, replace the lightwave transceiver, reset the circuit pack, and execute the <b>reset board PCSS</b> command again.</li> <li>5. If the reset fails again with Error Code 5002, the new lightwave transceiver may be defective, or the EI circuit pack may need to be replaced.</li> </ol>

*Continued on next page*

**Table 9-316. TEST #224 Expansion Interface Test — Continued**

Error Code	Test Result	Description/ Recommendation
5016 5017 5018 5019 5032 5033 5048 5064 5080 5096 5112	FAIL	Initialization failure: the EI circuit pack reset successfully and restarted execution, but the EI circuit pack detected communication errors during hardware initialization. The nature of the failure may prevent the EI circuit pack from communicating with its neighbor EI circuit pack on the opposite end of the fiber. The fault itself may be either on the EI circuit pack or on the lightwave transceiver. <ol style="list-style-type: none"> <li>1. If all other tests on this EI circuit pack are passing and no other errors have been logged against this circuit pack, replacement of the lightwave transceiver or the circuit pack are recommended, but not critical.</li> <li>2. If all other tests on this EI circuit pack are not passing or other errors have been logged against this circuit pack, replace the lightwave transceiver and/or the EI circuit pack.</li> </ol>
	PASS	The EI was successfully reset, and it did restart execution. Also, it passed all its initialization tests and detected a lightwave transceiver. Remove the EI circuit pack from the busyout state by using the <b>release board PCSS</b> command. <ol style="list-style-type: none"> <li>1. Execute <b>test board PCSS short</b> command. Refer to errors for each test.</li> </ol>
0	NO BOARD	No board was detected by the test. <ol style="list-style-type: none"> <li>1. Resolve either wrong board (Error 125) or no board (Error 131) issues.</li> <li>2. Check that the board is properly translated and inserted. If so, check for hyperactivity (Error 1538). If hyperactive, use the <b>reset board UUCSS</b> command.</li> <li>3. Run the test again. If it fails, the ID chip on board may be bad. Replace the board and retest.</li> </ol>

## EXP-PN (Expansion Port Network)

---

MO Name (in Alarm Log)	Alarm Level	Initial Command to Run <sup>1</sup>	Full Name of MO
EXP-PN	MAJOR	display errors <sup>1</sup>	Expansion Port Network

1. Investigate errors against EXP-PN and EXP-INTF.

The EXP-PN maintenance object is responsible for overall maintenance of an Expansion Port Network (EPN). The focus of EPN maintenance is on the Expansion Interface or on the ATM Expansion Interface circuit pack that is acting as the Expansion Archangel in an EPN. EXP-INTF or ATM-EI covers maintenance of the Expansion Interface or ATM Expansion Interface circuit pack, while EXP-PN covers a much broader area of activities and problems on an EPN. The alarming strategy for EXP-PN is fairly simple and does not make use of any failure analysis routine for spawning maintenance actions. EXP-PN alarming is based on the availability of an EPN for service and the EPN's response to various recovery actions.

When investigating alarms logged against an EPN, problems involving the Expansion Interface, an ATM Expansion Interface circuit pack acting as the Expansion Archangel, and problems that may involve loss of communication between the EPN and the SPE should be investigated. This could ultimately include fiber links (FIBER-LK), DS1 CONV circuit packs (DS1 CONV-BD), Switch Node Interface circuit packs (SNI-BD) and Switch Node Configurations (SN-CONF) for CSS. For ATM, this could include the PPN ATM Expansion Interface (ATM-EI) circuit pack, the ATM switch (ATM-NTWK), and EPN ATM Expansion Interface (ATM-EI) circuit pack.

### EPN Restarts

---

While not an exhaustive discussion of EPN recovery actions, this section describes at a high level the causes and effects of EPN restarts so that these Error Log events can be understood.

### EPN Warm Restarts

EPN Warm Restart (EPN Reset Level 1) is generally performed on an EPN when the recovery of that EPN can be accomplished in less than 30 seconds. When possible, Warm Restart minimizes the work required to reinitialize an EPN, and reduces the impact of an EPN failure by avoiding the longer and highly destructive EPN Cold Restart. The primary cause of EPN restarts is failure of the link from the SPE to the EPN due to a hardware fault in the link's path. For most hardware failures, this link, and thus the EPN, cannot be recovered until the failed hardware is replaced. However, several failures modes exist for which hardware redundancy allows the link to be recovered quickly. For instance, in a duplex SPE



system, a Packet Interface circuit pack failure causes an SPE interchange, which allows the link to be recovered quickly over the newly active Packet Interface. Or on a Center Stage Switch, a link carried on one of the multiple fibers interconnecting the switch nodes may be rerouted over an alternate fiber.

If the EAL is recovered quickly, the EPN Warm Restart returns the EPN to service with minimal effects on user service. If the EAL cannot be recovered quickly, the EPN is taken out-of-service and an EPN Reset Level 2 (EPN Cold Restart) is required to return it to service.

## EPN Cold Restarts

If the PPN to EPN link has failed and has not been recovered within 30 seconds, the EPN is taken out of service and can be brought back into service only with an EPN Reset Level 2 (EPN Cold Restart). Effects of an EPN Cold Restart include a reset of all circuit packs in the EPN, and the disconnection of all calls to or from the EPN. Calls with both endpoints within the EPN are dropped upon recovery.

## EPN Restart Escalation

EPN restarts follow an escalation strategy controlled by maintenance software. Whenever a request for an EPN Reset Level 1 (EPN Warm Restart) is made, software checks to see if the restart should be escalated to an EPN Reset Level 2 (EPN Cold Restart). If any of the following are true, the restart is escalated:

- At least two level 1 restarts have occurred and less than two hours has elapsed since the last occurrence.
- Current EPN conditions do not allow a level 1 restart, such as when the EPN is out-of-service.
- Less than 3 minutes has elapsed since the last EPN Cold Restart, indicating that the EPN is unstable.

If two EPN Cold Restarts have been executed in less than an hour and the link is functional, but the EPN has not recovered to an in-service state, a MAJOR alarm is raised against EXP-PN, and the EPN is put into Emergency Transfer by system software. (Software can invoke EPN Emergency Transfer only when the link to the EPN is up. If the link is down, the hardware automatically invokes Emergency Transfer 1 minute after it detects a link failure).

## Connectivity Alarming

When an EPN is out of service, a MAJOR EXP-PN alarm is raised against that EPN. An EPN can only be alarmed if it is out of service *and* the fiber between the PPN and EPN is up. If the fiber from the PPN to the Center Stage Switch is down (by removing it from administration, for example), all EPNs are lost but not alarmed, since they are not the cause of the problem. If, however, connectivity is restored and the EPN fails to recover, the EPN is alarmed.

For ATM, an EPN can only be alarmed if it is out of service and the connections to the PPN, ATM switch, and EPN are up. If the connection from the PPN to the ATM switch is down (by removing it from administration, for example), all EPNs are lost but not alarmed, since they are not the cause of the problem. As for CSS, if connectivity is restored and the EPN fails to recover, the EPN is alarmed.

## Error Log Entries and Test to Clear Values

**Table 9-317. Expansion Port Network (EXP-PN) Error Log Entries**

Error Type	Aux Data	Associated Test	Alarm Level	On/Off Board	Test to Clear Value
1(a)	0	None	None		
257(b)	0	None	None		
513(c)	0	None	MAJOR	OFF	
769(d)	0	None	MAJOR	OFF	

### Notes:

- This is an informational entry only, indicating that an EPN Reset Level 1 (EPN Warm Restart) has been executed on this EPN.
- This is an informational entry only, indicating that an EPN Reset Level 2 (EPN Cold Restart) has been executed on this EPN. This does not include restarts done at system initialization time.
- Indicates that an EPN is not in-service when it is expected to be. The value specified in the port field of the error log, is the PN number of the affected PN. When this condition occurs, examine all system link errors and EXP-INTF or ATM-PNC errors to aid in resolving the alarm (examples of system link errors are errors logged against PKT-INTF, EXP-INTF, SNI-BD, FIBER-LK, and PKT-BUS and for ATM, PKT-BUS, ATM-EI, ATM-NTWK). Also check that all fiber connectivity matches that which has been administered for the system. This alarm and error is resolved and removed from the logs only when the EPN comes back into service, or after fiber administration is changed to remove a fiber such that there is no connectivity from the PPN to this EPN.
- This alarm is raised when EPN maintenance has attempted to execute a Cold Restart recovery action two times, and both restarts failed. This will cause the EPN to be placed in Emergency Transfer. Examine all EXP-INTF or ATM-EI errors which, when cleared, may aid in resolving this alarm. Also check for any SNI-BD, SNI-PEER, FIBER-LK, SN-CONF, or DS1 CONV-BD errors or for ATM, ATM-EI or ATM-NTWK errors that may indicate a communication problem between the processor and the EPN. Make sure that the physical fiber connectivity matches that of system administration.

## System Technician-Demanded Tests: Descriptions And Error Codes

---

EXP-PN does not support demand testing. A demand reset can be executed to perform a demand reset on an EPN by using the **reset port-network P level [1 | 2]** command (P is the port network number, and 1 or 2 specifies the reset level).

### EPN Cold Restart (#955)

EPN Cold Restart, or EPN Reset Level 2, using the command **reset port-network P level 2** is used as a recovery mechanism for an EPN that has been taken out-of-service. It is executed as a result of EPN recovery escalation when a Warm Restart is not possible, or as a result of a system technician demanded EPN restart. Once an EPN has gone out-of-service, an EPN Cold Restart is required to bring it back into service.

This is the most severe of the EPN restarts, and users will experience a service outage. For the first 30 seconds after the occurrence of an event that requires a restart, all stable calls are preserved (although new calls will be denied). All calls terminating in the EPN are then dropped, and EPN users are not able to place new phone calls during the restart. All EPN hardware will also be re-initialized during this restart. The restart takes no longer than 2 minutes with service being restored much quicker in a typical restart situation.

**Table 9-318. TEST #955 EPN Cold Restart**

Error Code	Test Result	Description/ Recommendation
1386	ABORT	The system link to this EPN is unavailable and cannot be used. This reset cannot be executed without the link being operational.  1. Refer to SYS-LINK and resolve the link problem.
2100	ABORT	Could not allocate the necessary system resources to execute this reset.
2000	ABORT	Response to a request made in the internal portion of this reset procedure was not received within the allowable time period.
2500	ABORT	Internal system error  1. Retry the command at 1-minute intervals a maximum of 3 times.
	FAIL	Internal system error  1. Retry the command at 1-minute intervals a maximum of 3 times.
	PASS	The EPN Cold Restart procedure completed successfully.

**EPN Warm Restart (#956)**

The EPN Warm Restart, or EPN Reset Level 1, using the command **reset port-network P level 1** is used to restart an EPN that has not been taken out-of-service. It is the least severe of the EPN restart levels and is used in an attempt to preserve the state of the system as much as possible, thereby reducing user impact. This restart is attempted on a EPN if it is still in-service, or as a result of a system technician-demanded EPN Warm Restart.

During an EPN Warm Restart all calls are preserved including voice, data, and packet calls. Once an event has occurred that requires a warm restart, service is fully restored within 35 seconds.

**Table 9-319. TEST #956 EPN Warm Restart**

<b>Error Code</b>	<b>Test Result</b>	<b>Description/ Recommendation</b>
2100	ABORT	Could not allocate the necessary system resources to execute this reset. 1. Retry the command at 1-minute intervals for a maximum of 3 times.
1386	ABORT	The system link to this EPN is unavailable and cannot be used. This reset cannot be executed without the link being operational. 1. Refer to SYS-LINK and resolve the link problem.
1387	ABORT	This EPN is not in a state where it is possible to perform a Warm Restart on the EPN. It is necessary to perform an EPN Cold Restart (EPN Reset Level 2) because of one of the following reasons: <ul style="list-style-type: none"><li>■ The EPN is in an out-of-service state.</li><li>■ Insufficient time has elapsed since the last EPN Cold Restart was performed on this EPN.</li></ul>
2000	ABORT	Response to a request made in the internal portion of this reset procedure was not received within the allowable time period.
2500	ABORT	Internal system error 1. Retry the command at 1-minute intervals for a maximum of 3 times.
	FAIL	Internal system error 1. Retry the reset command at 1-minute intervals for a maximum of 3 times.
	PASS	The EPN Warm Restart procedure completed successfully.

## EXT-DEV ADMIN? Y (External Device Alarm)

---

MO Name (in Alarm Log)	Alarm Level	Initial Command to Run <sup>1</sup>	Full Name of MO
EXT-DEV	MAJOR	test eda-external-device-alm physical location	External Device Alarm
EXT-DEV	MINOR	test eda-external-device-alm physical location	External Device Alarm
EXT-DEV	WARNING	test eda-external-device-alm physical location	External Device Alarm

1. UU is a cabinet number determined in the `Port` field of the Alarm or Error Log.

### NOTE:

Use this MO when the *External Device Alarm Admin?* field on the *change system-parameters customer-options* form is set to **(y)**. You must have INADS or INIT login permission to administer EXT-DEV Alarm.

Generic 3r SYSAM and EPN Maintenance circuit packs each have two alarm ports that connect to such external devices as Uninterruptible Power Supplies (UPS) or adjuncts (AUDIX).

Certain conditions on the external device close the contacts on the alarm leads to notify the switch which in turn originates an EXT-DEV alarm. One set of leads generates a major alarm; the other set generates a minor alarm.

The special locations UUmajor and UUminor are used to designate the major or minor maintenance board alarm connection for cabinet UU. The major/minor designation specifies the port, not the alarm level associated with the connection; *for example*, the "major" port can be administered as a major, minor, or warning alarm, and the "minor" port can be administered as a major, minor, or warning alarm. In addition Analog line ports can also be administered as external device alarms.

### NOTE:

An unadministered maintenance board external device alarm port, that is sensing a contact closure will have an entry in the Error Log and in the Alarm Log. INADS will not receive warning alarms.

## Error Log Entries and Test to Clear Values

Error Type	Aux Data	Associated Test	Alarm Level	On/Off Board	Test to Clear Value
0	0	Any	Any	Any	test eda-external-device-alm physical location r 2 or 6
1 or 5	Any	External Device Alarm Test (#120)	Any	OFF	test eda-external-device-alm physical location r 2 or 6

### ⇒ NOTE:

The loss of -48 volt power prevents detection of an external device alarm. AC-POWER, CARR-POW, and DC-POWER alarms could indicate the loss of the external device alarm -48 volt power source. ALARM-PT alarms may also indicate a loss of power. When analog line ports are administered as analog line external device alarms loss of -48 volts prevents detection of an external device alarm.

## System Technician-Demanded Tests: Descriptions and Error Codes

Always investigate tests in the order presented in the table below when inspecting errors in the system. By clearing error codes associated with the *Battery & Battery Charger Query Test*, you may also clear errors generated from other tests in the testing sequence.

Order of Investigation	Short Test Sequence	Long Test Sequence	D/ND <sup>1</sup>
External Device Alarm Test (MAJOR port) (#120)	X	X	ND
External Device Alarm Test (MINOR port) (#120)	X	X	ND
External Device Alarm Test (WARNING port) (#120)	X	X	ND

1. D = Destructive; ND = Nondestructive

### External Device Alarm Test (#120)

The External Device Alarm Test requests the state of the External Device Alarm from a Maintenance circuit pack and reports the results. The test has no effect on the external device itself

**Table 9-320. TEST #120 External Device Alarm Test**

Error Code	Test Result	Description/ Recommendation
1000	ABORT	System resources required to run this test are not available. 1. Retry the command at 1-minute intervals a maximum of 5 times.
1035	ABORT	The EPN containing this equipment is not available. Resolve all EPN problems with this cabinet.
2000	ABORT	Response to the test request was not received within the allowable time period. 1. Retry the command at 1-minute intervals a maximum of 5 times. 2. (Maintenance Board) If the test continues to ABORT with Error Code 2000, check for system powering problems with the A carrier. Resolve all AC-POWER and CARR-POW alarms in a multi-carrier cabinet or DC-POWER alarms in a single-carrier cabinet. Then, repeat the test. 3. (Maintenance Board) If the test continues to ABORT with a 2000 Error Code, resolve all maintenance circuit pack errors. Then, repeat the test.
2029 2100 2319 2320 2500	ABORT	Internal system error 1. Retry the command at 1-minute intervals a maximum of 5 times.
ANY	FAIL	The External Device Alarm has been activated by the external device. 1. Clear the major alarm on the external device, and rerun the test. 2. If the test still fails, then disconnect the External Device Alarm Leads from the Maintenance circuit pack and rerun the test. 3. If the test still fails, then there is a problem with the analog external device alarm port or the Maintenance circuit pack that is reporting the alarm. This circuit pack should be replaced. There are failures that can occur on the Maintenance circuit pack that <i>will not</i> be detected by their respective maintenance, but which will cause many environment tests to fail. If many environment tests are failing, the suspect circuit pack should be replaced and the test rerun.
	PASS	If there is a problem with the external device, but the administered analog line external device alarm, or the administered Maintenance circuit pack connected to the device reports no alarm, then the External Device may not be properly reporting the problems or the External Device may not be properly connected to the External Device Alarm Leads.

## FIBER-LK (Fiber Link)

MO Name (in Alarm Log)	Alarm Level	Initial Command to Run <sup>1</sup>	Full Name of MO
FIBER-LK	MAJOR	test fiber <i>F pnc s</i>	Fiber Link
FIBER-LK	MINOR	test fiber <i>F pnc s</i>	Fiber Link
FIBER-LK	WARNING	test fiber <i>F pnc s</i>	Fiber Link

1. F is the fiber link number; pnc is "a-pnc" or "b-pnc" (always "a-pnc" in simplex systems).

A fiber link consists of the endpoint boards that are connected via the optical fiber, the lightwave transceivers or metallic connections on the endpoint boards, and, if administered, the DS1 Converter (DS1 CONV) complex that exists between the two fiber endpoints. The fiber endpoints are Expansion Interface (EI) circuit packs and/or Switch Node Interface (SNI) circuit packs.

Three types of fiber links exist in G3r systems:

- EI-EI fiber This type of fiber is an EI to EI connection and is only used in direct connect port network connectivity (PNC).
- EI-SNI fiber This type of fiber is an EI to SNI connection and is only used in Center Stage Switch (CSS) PNC.
- SNI-SNI fiber This type of fiber is an SNI to SNI connection and is only used in CSS PNC when two switch node carriers are connected in a two or three switch node configuration.

Fiber link errors and alarms are generated only on fibers that have at least one SNI endpoint. Fiber errors for fibers that have EI s as both endpoints are detected by the EI circuit pack, thus generating off-board EXP-INTF errors and alarms. Fiber errors and alarms on EI-SNI fiber links generate FIBER-LK and/or off-board EXP-INTF errors and alarms.

Fiber links are administered via **add fiber-link F** or **add fiber-link next**, where F is the fiber-link number. The 2 endpoints of the fiber are administered (EI and EI, EI and SNI, or SNI and SNI). In duplicated PNC configurations, both the a-pnc fiber-link and the b-pnc fiber-link are administered to the same fiber link number. The fiber links are designated by F P, where F is the fiber-link number and P is the pnc, a-pnc or b-pnc. In addition, a DS1 converter complex may be administered on the fiber link. In duplicated PNC configuration, the a-pnc and b-pnc DS1 converter complexes are administered to the same fiber-link number. DS1 facilities and parameters can be modified via **change fiber-link F P**.

An individual fiber link can be displayed with the **display fiber-link F** command. All fiber links can be listed via the **list fiber-link** command.



The following terms are used in the error descriptions:

Control Path	The path between the two fiber endpoints that is necessary for the two endpoint circuit packs to communicate.
Circuit Path	The path between the two fiber endpoints that is necessary for circuit switched phone calls to work.
Neighbor	The circuit pack on the other end of the fiber.
Out of Frame	A circuit pack reports fiber out of frame if it cannot detect valid data coming from the fiber.
Packet Path	The path between the two fiber endpoints that is necessary for packet switched messages to be sent between the two fiber endpoints.

## LEDs for Circuit Packs on a Fiber Link

---

The yellow LEDs on the three types of boards, SNI (TN573), EI (TN570), and DS1 Converter (TN574 or TN1654), that may be a part of the fiber link can help in diagnosing problems with the fiber link. The yellow LED states are as follows. The flashing LED patterns take precedence over the active or standby LED patterns.

If both endpoints of a fiber link (EI and/or SNI) are flashing with a fiber out of frame pattern, a fast yellow LED pattern (0.1 second on and 0.1 second off), check the lightwave transceivers (if present). Both lightwave transceivers on the fiber link must be of the same type. The 9823a shortwave transceiver and the 9823b longwave transceiver must never be combined on the same fiber link because a fiber out of frame condition will exist. The 9823a lightwave transceiver should be used for distances up to 4900 feet and the 9823b lightwave transceiver should be used for distances up to 25,000 feet.

**Table 9-321. Switch Node Interface Yellow LED Flashing Codes**

---

Condition	LED on	LED off
Fiber out of Frame	0.1 second	0.1 second
In Frame, No Neighbor <sup>1</sup>	0.5 second	0.5 second
SNI active	Solid on	Never off
SNI standby	Never on	Solid off

---

1. The fiber is in frame, but no communication exists to the neighbor

---

**Table 9-322. Expansion Interface Circuit Pack Yellow LED Flashing Codes**

Condition	LED on	LED off
Fiber Out-of-Frame	0.1 second	0.1 second
(a) In frame-No Neighbor	0.5 second	0.5 second
(b) Expansion Interface Active	2 second	0.2 second
(c) Expansion Interface Active	Solid on	Never off
(d) Expansion Interface Standby	Never on	Solid off

Notes:

- a. The fiber is in frame, but no communication exists to the neighbor.
- b. This is the normal state for an active EPN EI circuit pack that is also the bus master (expansion archangel) in the EPN.
- c. This is the normal state for an active EI circuit pack that is not the bus master (expansion archangel) for an EPN. This applies only in the direct connect configuration where the EI circuit pack in an EPN connects via a fiber link to an EI circuit pack in the other EPN. This state also applies for an active EI circuit pack located in the PPN.
- d. This is the normal state for a standby expansion Interface circuit pack in both the PPN and EPNs.

For more details about how the Expansion Interface circuit pack error codes relate to the LED states, see the EXP-INTF section.

**Table 9-323. DS1 CONV Yellow LED Flashing Codes**

Condition	LED on	LED off
(a) Fiber out of Frame	0.1 second	0.1 second
(b) In frame, fiber channel is down	0.5 second	0.5 second
(c) In frame, DS1 channel down	1 second	1 second
(d) DS1 CONV no response from SPE	2 second	0.2 second
DS1 CONV active	Solid on	Never off
DS1 CONV standby	Never on	Solid off

Notes:

- a. A Fiber is out of frame or a fiber loss of signal condition exists.
- b. DS1 CONV/fiber endpoint communication is down.

- c. The DS1 channel is down between the two DS1 CONVs in the DS1 converter complex.
- d. The SPE is not acknowledging messages from the DS1 CONV circuit pack or the DS1 CONV circuit pack does not have a processor route. This pattern indicates a probable software problem.

In addition to the traditional red, green, and yellow LEDs, the DS1 CONV circuit pack has four green LEDs that indicate whether a receive signal is present for each DS1 facility.

## Error Log Entries and Test to Clear Values

Table 9-324. Fiber Link Error Log Entries

Error Type	Aux Data	Associated Test	Alarm Level	On/Off Board	Test to Clear Value
0 <sup>1</sup>	0	Any	Any	Any	test fiber-link F P r 1
1 (b)	any	failure audit (#777) (a)	WAR/MIN/MAJ	OFF	test fiber-link F P r 1
18 (c)	0	busyout fiber F P	WARNING	OFF	release fiber F P
257 (d)	any	failure audit (#777) (a)	WAR/MIN/MAJ	OFF	test fiber-link F P r 1
513 (e)	any	failure audit (#777) (a)	WAR/MIN/MAJ	OFF	test fiber-link F P r 1
76 9(f)	any	failure audit (#777) (a)	WAR/MIN/MAJ	OFF	test fiber-link F P r 1
1025 (g)	any	failure audit (#777) (a)	WAR/MIN/MAJ	OFF	test fiber-link F P r 1
1281 (h)	any	failure audit (#777) (a)	WAR/MIN/MAJ	OFF	test fiber-link F P r 1

1. Run the Short Test Sequence first. If all tests pass, run the Long Test Sequence. Refer to the appropriate test description and follow the recommended procedures.

### Notes:

- a. The failure audit test (#777) should be run to confirm whether the error still exists.
- b. This error indicates problem with the control path to the neighbor.
- c. This error indicates that the fiber link has been busied out via the **busyout fiber F P** command. To resolve this error, release the fiber link with the **release fiber F P** command.
- d. This error indicates problem with the circuit path to the neighbor.
- e. This error indicates problem with the packet path to the neighbor.
- f. This error indicates problem with the control path from the neighbor.
- g. This error indicates problem with the circuit path from the neighbor.

h. This error indicates problem with the packet path from the neighbor.

For note b and notes d through h, perform the following steps:

1. Perform the [“Fiber Fault Isolation Procedure”](#).
2. Enter **display errors** and if any of the slip errors listed below exist, follow the associated repair procedures in the SYNC section for slip errors.

**Table 9-325. Error Log Entries for Slip Errors**

Circuit Pack Name	Error Log Name	Error Log Entry for Slips
DS1 Interface	DS1-BD	3073 to 3160
Expansion Interface	EXP-INTF	2305
Switch Node Interface	SNI-BD	1537
Tone-Clock	TDM-CLK	1025
UDS1 Interface	UDS1-BD	3073 to 3160

## System Technician-Demanded Tests: Descriptions and Error Codes

Always investigate tests in the order presented in the table below when inspecting errors in the system. By clearing error codes associated with one test, you may also clear errors generated by other tests later in the sequence.

**Table 9-326. Tests Run for an EI-to-EI Fiber Link**

Order of Investigation	Short Test Sequence	Long Test Sequence	Reset Fiber Sequence	D/ND <sup>1</sup>
EI Out-of-Frame Query Test(#238)	X	X		ND
EI Neighbor Query Test(#237)	X	X		ND
Fiber Link Reset Test(#768)			X	D

1. D = Destructive; ND = Nondestructive

**Table 9-327. Tests Run for an EI-to-SNI Fiber Link**

Order of Investigation	Short Test Sequence	Long Test Sequence	Reset Fiber Sequence	D/ND <sup>1</sup>
EI Out-of-Frame Query Test(#238)	X	X		ND
EI Neighbor Query Test(#237)	X	X		ND
Configuration Audit(#759)	X	X		ND
Failure Audit(#777)	X	X		ND
Fiber Out of Frame Query(#989)	X	X		ND
Destructive Facility Test(#757)		X		D
Off-Board Destructive Facility Test(#756)		X		D
Fiber Link Reset Test(#768)			X	D

1. D = Destructive, ND = Non-destructive

**Table 9-328. Tests Run for an SNI-to-SNI Fiber Link**

Order of Investigation	Short Test Sequence	Long Test Sequence	Reset Fiber Sequence	D/ND <sup>1</sup>
Configuration Audit(#759)	X	X		ND
Failure Audit(#777)	X	X		ND
Fiber Out of Frame Query(#989)	X	X		ND
Destructive Facility Test(#757)		X		D
Off-Board Destructive Facility Test (#756)		X		D
Fiber Link Reset Test(#768)			X	D

1. D = Destructive; ND = Nondestructive

### Expansion Interface Neighbor Query Test (#237)

This test is non-destructive. The Expansion Interface Neighbor Query Test is a request to an EI circuit pack to determine if it has established communication with the EI or Switch Node Interface circuit pack on the opposite end of the fiber.

For EI-EI fiber links, this test is run on both EI circuit pack endpoints of the fiber link.

**Table 9-329. TEST #237 Expansion Interface Neighbor Query Test**

Error Code	Test Result	Description/ Recommendation
1033	ABORT	The EI circuit pack does not have a fiber link administered to it. There is not sufficient data to run test. Since the <b>test fiber-link</b> command was run, the expansion interface should be administered on a fiber link, therefore this must be a software problem.
2000	ABORT	Response to the test request was not received within the allowable time period.  1. Run the <b>test board UUCSS</b> test separately for each EI endpoint on this fiber link and follow the procedures for this test in the <a href="#">“EXP-INTF (Expansion Interface Circuit Pack)”</a> section.
2031	ABORT	The attempt to send the message to the Expansion Interface circuit pack, asking it who it's neighbor is, was not successful.  1. Run the <b>test board UUCSS</b> test separately for each Expansion Interface endpoint on this fiber link and follow the procedures for this test in the <a href="#">“EXP-INTF (Expansion Interface Circuit Pack)”</a> section.
2100	ABORT	System resources required to run this test are not available.  1. Run the <b>test board UUCSS</b> test separately for each Expansion Interface endpoint on this fiber link and follow the procedures in the EXP-INTF section.
2500	ABORT	Internal system error  1. Run the <b>test board UUCSS</b> test separately for each Expansion Interface endpoint on this fiber link and follow the procedures in the EXP-INTF section.
1033	FAIL	The Expansion Interface circuit pack under test cannot make contact with opposite end Expansion Interface or Switch Node Interface circuit pack.  1. Run the <b>test board UUCSS</b> test separately for each Expansion Interface endpoint on this fiber link and follow the procedures in the <a href="#">“EXP-INTF (Expansion Interface Circuit Pack)”</a> section.
2027	FAIL	The Expansion Interface circuit pack has contact with the opposite Expansion Interface or Switch Node Interface circuit pack, but it is the incorrect Expansion Interface or Switch Node Interface circuit pack.  1. Run the <b>test board UUCSS</b> test separately for each Expansion Interface endpoint on this fiber link and follow the procedures in the <a href="#">“EXP-INTF (Expansion Interface Circuit Pack)”</a> section.

**Table 9-329. TEST #237 Expansion Interface Neighbor Query Test — Continued**

Error Code	Test Result	Description/ Recommendation
	PASS	The EI circuit pack(s) have successfully established a link with the opposite Expansion Interface or Switch Node Interface circuit pack. <ol style="list-style-type: none"> <li>1. If the <b>status port-network</b> command still indicates that this link is down, it is possible that one or both of the EI and/or Switch Node Interface circuit packs have been busied out.</li> <li>2. If the link still does not come up, reset one or both EI and/or Switch Node Interface circuit packs on the link.</li> </ol>

### Expansion Interface Fiber Out-of-Frame (FOOF) Query Test (#238)

This test is non-destructive.

This test is a request to an EI circuit pack to determine if it is currently detecting the framing sequence on the incoming fiber data stream. If it cannot detect this framing signal, the EI circuit pack will not be able to establish a link with the opposite EI or Switch Node Interface circuit pack.

For EI-EI fiber links, this test is run on both EI circuit pack endpoints of the fiber link.

**Table 9-330. TEST #238 Expansion Interface Fiber Out-of-Frame Query Test**

Error Code	Test Result	Description/ Recommendation
1033	ABORT	The Expansion Interface circuit pack does not have a fiber link administered to it. There is not sufficient data to run test. Since the <b>test fiber-link</b> command was run, the expansion interface should be administered on a fiber link, therefore this must be a software problem.
2000	ABORT	Response to the test request was not received within the allowable time period. <ol style="list-style-type: none"> <li>1. Run the <b>test board UUCSS</b> test separately for each Expansion Interface endpoint on this fiber link and follow the procedures in the EXP-INTF section.</li> </ol>

*Continued on next page*

**Table 9-330. TEST #238 Expansion Interface Fiber Out-of-Frame Query Test — Continued**

Error Code	Test Result	Description/ Recommendation
2100	ABORT	System resources required to run this test are not available. 1. Run the <b>test board UUCSS</b> test separately for each Expansion Interface endpoint on this fiber link and follow the procedures in the EXP-INTF section.
2500	ABORT	Internal system error 1. Run the <b>test board UUCSS</b> test separately for each Expansion Interface endpoint on this fiber link and follow the procedures in the EXP-INTF section.
	FAIL	Expansion Interface circuit pack could not detect framing sequence. 1. Run the <b>test board UUCSS</b> test separately for each Expansion Interface endpoint on this fiber link and follow the procedures in the EXP-INTF section.
	PASS	The Expansion Interface circuit pack(s) have detected the valid framing signal on the fiber. 1. Refer to errors from other EI circuit packs, Switch Node Interface tests, or DS1 Converter tests (if present) if the link is still not functioning.

### SNI Off-Board Destructive Facility Test (#756)

**This test is destructive.**

The SNI runs a destructive looparound of the off-board and on-board looparounds. This test returns the result of the off-board looparound, while test 757 returns the result of the on-board looparound. For SNI-SNI fiber links, this test is run on both SNI circuit pack endpoints of the fiber link.

**Table 9-331. TEST #756 SNI Off-Board Destructive Facility Test**

Error Code	Test Result	Description/ Recommendation
1015	ABORT	The system will not allow this test to be run because the fiber link has not been busied out. Busy out the fiber link with <b>busyout fiber-link</b> F P. Repeat the <b>test fiber-link</b> F P long command.

*Continued on next page*



**Table 9-331. TEST #756 SNI Off-Board Destructive Facility Test — Continued**

Error Code	Test Result	Description/ Recommendation
2100	ABORT	Could not allocate the necessary system resources to run this test.
2300	ABORT	The downlink message necessary to run this test could not be sent.
2301	ABORT	The software timer could not be set before sending the downlink message necessary to run this test.
2304	ABORT	<p>SNI circuit pack responded that it is not able to run the test requested by software.</p> <ol style="list-style-type: none"> <li>1. Retry the command at 1-minute intervals a maximum of 3 times.</li> </ol>
2306	ABORT	<p>An SNI circuit pack on the fiber link is not responding to test requests sent by software.</p> <ol style="list-style-type: none"> <li>1. Run the <b>test led switch-node</b> for the switch node(s) that the SNI (s) reside in to verify whether the LED s on the board(s) light. Follow the steps below for the SNI (s) from step 1 that had no LED s light.</li> <li>2. If the LED s on the other boards in the carrier light, but the LED s on this board do not light, run test 760 via <b>test board UUCSS I</b> for the active SNC in this carrier. Wait 5 minutes and then try step 1 one more time. If the LED s on this board still do not light, replace this board. Replacing an SNI may be service interrupting. Refer to the SNI-BD section for the procedure for replacing an SNI.</li> <li>3. If none of the LED s light for the boards in the same carrier as this board, fix any problems associated with the connectivity of this carrier to the SPE. Use <b>list fiber-link</b> to determine the fiber connections to this carrier. Check the LED s on all SNI s and EI s and fix any fiber problems. Enter <b>display errors</b> and resolve any EXP-INTF error entries associated with the PPN. Also, resolve any SYNC, SNI-BD, SNC-BD, FIBER-LK, or SNI-PEER error entries.</li> </ol>
1415	ABORT	<p>The lightwave transceiver is not present for endpoint 1 of the fiber link (<b>list fiber-link</b> can be used to display fiber link endpoints).</p> <ol style="list-style-type: none"> <li>1. If a lightwave transceiver is not supposed to be present, do nothing. For example, an SNI connected to a DS1 CONV circuit pack or an SNI with a metallic connection does not have a lightwave transceiver. This test can only be run when a lightwave transceiver exists.</li> <li>2. Otherwise, continue with the following steps.</li> <li>3. Check the lightwave transceiver connections.</li> <li>4. Replace the lightwave transceiver. If a fiber out of frame condition exists and lightwave transceivers are used, check that the lightwave transceivers are of the same type (both are 9823a or both are 9823b). If they are not the same type, replace one of the lightwave transceivers.</li> <li>5. Replace the SNI circuit pack.</li> </ol>

*Continued on next page*

**Table 9-331. TEST #756 SNI Off-Board Destructive Facility Test — Continued**

Error Code	Test Result	Description/ Recommendation
1416	ABORT	<p>The lightwave transceiver is not present for endpoint 2 of the fiber link (<b>list fiber-link</b> can be used to display fiber link endpoints).</p> <ol style="list-style-type: none"> <li>1. If a lightwave transceiver is not supposed to be present, do nothing. For example, an SNI connected to a DS1 CONV circuit pack or an SNI with a metallic connection does not have a lightwave transceiver. This test can only be run when a lightwave transceiver exists.</li> <li>2. Check the lightwave transceiver connections.</li> <li>3. Replace the lightwave transceiver. If a fiber out of frame condition exists and lightwave transceivers are used, check that the lightwave transceivers are of the same type (both are 9823a or both are 9823b). If they are not the same type, replace one of the lightwave transceivers.</li> <li>4. Replace the SNI circuit pack.</li> </ol>
127	FAIL	<p>The data is not correctly looped around on endpoint 1 of the fiber link (<b>list fiber-link</b> can be used to display fiber link endpoints).</p> <ol style="list-style-type: none"> <li>1. Check the lightwave transceiver.</li> <li>2. Replace the lightwave transceiver. If a fiber out of frame condition exists and lightwave transceivers are used, check that the lightwave transceivers are of the same type (both are 9823a or both are 9823b). If they are not the same type, replace one of the lightwave transceivers.</li> <li>3. Replace the SNI circuit pack.</li> </ol>
227	FAIL	<p>The data is not correctly looped around on endpoint 2 of the fiber link (<b>list fiber-link</b> can be used to display fiber link endpoints).</p> <ol style="list-style-type: none"> <li>1. Check the lightwave transceiver.</li> <li>2. Replace the lightwave transceiver. If a fiber out of frame condition exists and lightwave transceivers are used, check that the lightwave transceivers are of the same type (both are 9823a or both are 9823b). If they are not the same type, replace one of the lightwave transceivers.</li> <li>3. Replace the SNI circuit pack.</li> </ol>
	PASS	<p>No problems associated with this test are detected on the SNI (s).</p>

### SNI Destructive Facility Test (#757)

**This test is destructive.**

The SNI runs a destructive looparound of the off-board and on-board looparounds. This test returns the result of the on-board looparound, while test 756 returns the result of the off-board looparound.

For SNI-SNI fiber links, this test is run on both SNI circuit pack endpoints of the fiber link.

**Table 9-332. TEST #757 SNI Destructive Facility Test**

Error Code	Test Result	Description/ Recommendation
1015	ABORT	The system will not allow this test to be run because the fiber link has not been busied out. Busy out the fiber link with <b>busyout fiber-link</b> F P. Repeat the <b>test fiber-link F P long</b> command.
2100	ABORT	Could not allocate the necessary system resources to run this test.
2300	ABORT	The downlink message necessary to run this test could not be sent.
2301	ABORT	The software timer could not be set before sending the downlink message necessary to run this test.
2304	ABORT	SNI circuit pack responded that it is not able to run the test requested by software.  1. Retry the command at 1-minute intervals a maximum of 3 times.
2306	ABORT	An SNI circuit pack on the fiber link is not responding to test requests sent by software.  1. Run the <b>test led switch-node</b> for the switch node(s) that the SNI (s) reside in to verify whether the LEDs on the board(s) light. Follow the steps below for the SNI(s) that had no LEDs light.  2. If the LEDs on the other boards in the carrier light, but the LEDs on this board do not light, run test 760 via <b>test board UUCSS I</b> for the active SNC in this carrier. Wait 5 minutes and then try step 1 one more time. If the LEDs on this board still do not light, replace this board. Replacing an SNI may be service interrupting. Refer to the SNI-BD section for the procedure for replacing an SNI.  3. If no LEDs light for the boards in the same carrier as this board, fix any problems associated with the connectivity of this carrier to the SPE. Use <b>list fiber-link</b> to determine the fiber connections to this carrier. Check the LEDs on all SNIs and EIs and fix any fiber problems. Enter <b>display errors</b> and resolve any EXP-INTF error entries associated with the PPN. Also, resolve any SYNC, SNI-BD, SNC-BD, FIBER-LK, or SNI-PEER error entries.
127	FAIL	The data is not correctly looped around on endpoint 1 of the fiber link ( <b>list fiber-link</b> can be used to display fiber link endpoints).  1. Replace the SNI circuit pack.
227	FAIL	The data is not correctly looped around on endpoint 2 of the fiber link ( <b>list fiber-link</b> can be used to display fiber link endpoints).  1. Replace the SNI circuit pack.
	PASS	No problems associated with this test are detected on the SNI(s).

## Configuration Audit (#759)

This test is non-destructive.

This test is run via the **test board short** or **test board long** command for SNI circuit packs or via **test fiber-link** for fiber links with SNI endpoint(s).

This test queries the SNI for SNC s in the same switch node carrier, SNI peers, DS1 CONV s, and EI or SNI neighbors that the SNI can communicate with and compares this data to the administered data.

Failures of this test cause entries in the error and alarm logs against Switch Node Configuration (SN-CONF) with the board location of the SNI.

This test is unable to detect the case where an SNI is connected to the same type of board (EI or SNI) as administered but located in a different cabinet but the same carrier and same slot as the administered fiber endpoint. The administered fiber endpoint can be viewed with the **list fiber-link** command. This test can only detect if the fiber endpoint connected to the SNI is in a different carrier, slot location than the administered fiber endpoint.

If the SNI is connected to the same type of fiber endpoint as the administered fiber endpoint, but the location is the same as administered except for the cabinet, all phone calls will not work correctly; some phone calls will not go through and some phone calls will ring the wrong phone.

The **test led** command can be used in this case to check connectivity.

1. First, run the **test led port-network** command on each administered port network and verify that the LEDs on the correct port network are lit.
2. If not, check that the fiber connections to the port network are consistent with the administered fibers (**list fiber-link**) that does not light the LEDs as expected.
3. Then run the test led switch-node command on each administered switch node carrier and verify that the LEDs on the correct switch node carrier are lit.
4. If not, check the connectivity to the switch node carrier that does not light the LEDs as expected.

**Table 9-333. TEST #759 Configuration Audit**

Error Code	Test Result	Description/ Recommendation
2100	ABORT	Could not allocate the necessary system resources to run this test for endpoint 1 of the fiber link ( <b>list fiber-link</b> can be used to display fiber link endpoints). If this fiber link has two SNI endpoints, run the <b>test board UUCSS</b> test separately for each SNI and follow the repair procedures in section SNI-BD.
2300	ABORT	The downlink message necessary to run this test could not be sent. If this fiber link has two SNI endpoints, run the <b>test board UUCSS</b> test separately for each SNI and follow the repair procedures in section SNI-BD ( <b>list fiber-link</b> can be used to display fiber link endpoints).
2301	ABORT	The software timer could not be set before sending the downlink message necessary to run this test. If this fiber link has two SNI endpoints, run the <b>test board UUCSS</b> test separately for each SNI and follow the repair procedures in section SNI-BD ( <b>list fiber-link</b> can be used to display fiber link endpoints). <ol style="list-style-type: none"> <li>1. Retry the command at 1-minute intervals a maximum of 3 times.</li> </ol>
2306	ABORT	An SNI circuit pack on the fiber link is not responding to test requests sent by software. <ol style="list-style-type: none"> <li>1. Run the <b>test led switch-node</b> for the switch node(s) that the SNI(s) reside in to verify whether the LEDs on the board(s) light. Follow the steps below for the SNI(s) that had no LEDs light.</li> <li>2. If the LEDs on the other boards in the carrier light, but the LEDs on this board do not light, run test 760 via <b>test board UUCSS I</b> for the active SNC in this carrier. Wait 5 minutes and then try step 1 one more time. If the LEDs on this board still do not light, replace this board. Replacing an SNI may be service interrupting. Refer to the SNI-BD section for the procedure for replacing an SNI.</li> <li>3. If none of the LEDs light for the boards in the same carrier as this board, fix any problems associated with the connectivity of this carrier to the SPE. Use <b>list fiber-link</b> to determine the fiber connections to this carrier. Check the LEDs on all SNI s and EI s and fix any fiber problems. Enter <b>display errors</b> and resolve any EXP-INTF error entries associated with the PPN. Also, resolve any SYNC, SNI-BD, SNC-BD, FIBER-LK, or SNI-PEER error entries.</li> </ol>
2500	ABORT	Internal system error If this fiber link has two SNI endpoints, run the <b>test board UUCSS</b> test separately for each SNI and follow the repair procedures in section SNI-BD ( <b>list fiber-link</b> can be used to display fiber link endpoints). Otherwise: <ol style="list-style-type: none"> <li>1. Retry the command at 1-minute intervals a maximum of 3 times.</li> </ol>

*Continued on next page*

**Table 9-333. TEST #759 Configuration Audit — Continued**

Error Code	Test Result	Description/ Recommendation
102	FAIL	<p>The SNI circuit pack (endpoint 1) cannot communicate with the equipped SNI in slot 2 (<b>list fiber-link</b> can be used to display fiber link endpoints).</p> <ol style="list-style-type: none"> <li>1. Perform the "<a href="#">Fiber Fault Isolation Procedure</a>". This should resolve multiple SNI-PEER errors.</li> <li>2. If the SNI being tested has SNI-PEER Error Type 1, replace the SNI being tested. Replacing an SNI may be service interrupting. Refer to the SNI-BD section for the procedure for replacing an SNI. To view SNI-PEER errors, use the <b>display errors</b> command with category PNC-PEER. Retry the command.</li> <li>3. If the SNI being tested still has SNI-PEER Error Type 1, replace the SNI in slot 2.</li> </ol>
103	FAIL	<p>The SNI circuit pack (endpoint 1) cannot communicate with the equipped SNI in slot 3 (<b>list fiber-link</b> can be used to display fiber link endpoints).</p> <ol style="list-style-type: none"> <li>1. Perform the "<a href="#">Fiber Fault Isolation Procedure</a>". This should resolve multiple SNI-PEER errors.</li> <li>2. If the SNI being tested has SNI-PEER Error Type 257, replace the SNI being tested. Replacing an SNI may be service interrupting. Refer to the SNI-BD section for the procedure for replacing an SNI. To view SNI-PEER errors, use the <b>display errors</b> command with category PNC-PEER. Retry the command.</li> <li>3. If the SNI being tested still has SNI-PEER Error Type 257, replace the SNI in slot 3.</li> </ol>
104	FAIL	<p>The SNI circuit pack (endpoint 1) cannot communicate with the equipped SNI in slot 4 (use <b>list fiber-link</b> to display fiber link endpoints).</p> <ol style="list-style-type: none"> <li>1. Perform the "<a href="#">Fiber Fault Isolation Procedure</a>". This should resolve multiple SNI-PEER errors.</li> <li>2. If the SNI being tested has SNI-PEER Error Type 513, replace the SNI being tested. Replacing an SNI may be service interrupting. Refer to the SNI-BD section for the procedure for replacing an SNI. To view SNI-PEER errors, use the <b>display errors</b> command with category PNC-PEER. Retry the command.</li> <li>3. If the SNI being tested has SNI-PEER Error Type 513, replace the SNI in slot 4.</li> </ol>

*Continued on next page*

**Table 9-333. TEST #759 Configuration Audit — Continued**

Error Code	Test Result	Description/ Recommendation
105	FAIL	<p>The SNI circuit pack (endpoint 1) cannot communicate with the equipped SNI in slot 5 (<b>list fiber-link</b> can be used to display fiber link endpoints).</p> <ol style="list-style-type: none"> <li>1. Perform the <a href="#">“Fiber Fault Isolation Procedure”</a>. This should resolve multiple SNI-PEER errors.</li> <li>2. If the SNI being tested has SNI-PEER Error Type 769, replace the SNI being tested. Replacing an SNI may be service interrupting. Refer to the SNI-BD section for the procedure for replacing an SNI. To view SNI-PEER errors, use the <b>display errors</b> command with category PNC-PEER. Retry the command.</li> <li>3. If the SNI being tested has SNI-PEER Error Type 769, replace the SNI in slot 5.</li> </ol>
106	FAIL	<p>The SNI circuit pack (endpoint 1) cannot communicate with the equipped SNI in slot 6 (<b>list fiber-link</b> can be used to display fiber link endpoints).</p> <ol style="list-style-type: none"> <li>1. Perform the <a href="#">“Fiber Fault Isolation Procedure”</a>. This should resolve multiple SNI-PEER errors.</li> <li>2. If the SNI being tested has SNI-PEER Error Type 1025, replace the SNI being tested. Replacing an SNI may be service interrupting. Refer to the SNI-BD section for the procedure for replacing an SNI. To view SNI-PEER errors, use the <b>display errors</b> command with category PNC-PEER. Retry the command.</li> <li>3. If the SNI being tested still has SNI-PEER Error Type 1025, replace the SNI in slot 6.</li> </ol>
107	FAIL	<p>The SNI circuit pack (endpoint 1) cannot communicate with the equipped SNI in slot 7 (<b>list fiber-link</b> can be used to display fiber link endpoints).</p> <ol style="list-style-type: none"> <li>1. Perform the <a href="#">“Fiber Fault Isolation Procedure”</a>. This should resolve multiple SNI-PEER errors.</li> <li>2. If the SNI being tested has SNI-PEER Error Type 1281, replace the SNI being tested. Replacing an SNI may be service interrupting. Refer to the SNI-BD section for the procedure for replacing an SNI. To view SNI-PEER errors, use the <b>display errors</b> command with category PNC-PEER. Retry the command.</li> <li>3. If the SNI being tested still has SNI-PEER Error Type 1281, replace the SNI in slot 7.</li> </ol>

*Continued on next page*

**Table 9-333. TEST #759 Configuration Audit — Continued**

Error Code	Test Result	Description/ Recommendation
108	FAIL	<p>The SNI circuit pack (endpoint 1) cannot communicate with the equipped SNI in slot 8 (<b>list fiber-link</b> can be used to display fiber link endpoints).</p> <ol style="list-style-type: none"> <li>1. Perform the <a href="#">“Fiber Fault Isolation Procedure”</a>. This should resolve multiple SNI-PEER errors..</li> <li>2. If the SNI being tested has SNI-PEER Error Type 1537, replace the SNI being tested. Replacing an SNI may be service interrupting. Refer to the SNI-BD section for the procedure for replacing an SNI. To view SNI-PEER errors, use the <b>display errors</b> command with category PNC-PEER. Retry the command.</li> <li>3. If the SNI being tested still has SNI-PEER Error Type 1537, replace the SNI in slot 8.</li> </ol>
109	FAIL	<p>The SNI circuit pack (endpoint 1) cannot communicate with the equipped SNI in slot 9 (<b>list fiber-link</b> can be used to display fiber link endpoints).</p> <ol style="list-style-type: none"> <li>1. Perform the <a href="#">“Fiber Fault Isolation Procedure”</a>. This should resolve multiple SNI-PEER errors.</li> <li>2. If the SNI being tested has SNI-PEER Error Type 1793, replace the SNI being tested. Replacing an SNI may be service interrupting. Refer to the SNI-BD section for the procedure for replacing an SNI. To view SNI-PEER errors, use the <b>display errors</b> command with category PNC-PEER. Retry the command.</li> <li>3. If the SNI being tested still has SNI-PEER Error Type 1793, replace the SNI in slot 9.</li> </ol>
112	FAIL	<p>The SNI circuit pack (endpoint 1) cannot communicate with the active SNC (<b>list fiber-link</b> can be used to display fiber link endpoints).</p> <ol style="list-style-type: none"> <li>1. Check the error log for other SNI circuit packs in the same carrier with a 257 SNI-BD error. Use <b>display errors</b> with category PNC to view SNI-BD errors. If other SNI circuit packs in the same switch node carrier have error 257, then replace the active SNC in this switch node carrier. Replacing an SNC may be service interrupting. Refer to the SNC-BD section for the procedure for replacing an SNC.</li> <li>2. Replace this SNI.</li> <li>3. Replace the active SNC in the same switch node carrier.</li> </ol>

*Continued on next page*



**Table 9-333. TEST #759 Configuration Audit — Continued**

Error Code	Test Result	Description/ Recommendation
113	FAIL	<p>The SNI circuit pack (endpoint 1) cannot communicate with the equipped SNI in slot 13 (<b>list fiber-link</b> can be used to display fiber link endpoints).</p> <ol style="list-style-type: none"> <li>1. Perform the <a href="#">“Fiber Fault Isolation Procedure”</a>. This should resolve multiple SNI-PEER errors.</li> <li>2. If the SNI being tested has SNI-PEER Error Type 2049, replace the SNI being tested. Replacing an SNI may be service interrupting. Refer to the SNI-BD section for the procedure for replacing an SNI. To view SNI-PEER errors, use the <b>display errors</b> command with category PNC-PEER. Retry the command.</li> <li>3. If the SNI being tested still has SNI-PEER Error Type 2049, replace the SNI in slot 13.</li> </ol>
114	FAIL	<p>The SNI circuit pack (endpoint 1) cannot communicate with the equipped SNI in slot 14 (<b>list fiber-link</b> can be used to display fiber link endpoints).</p> <ol style="list-style-type: none"> <li>1. Perform the <a href="#">“Fiber Fault Isolation Procedure”</a>. This should resolve multiple SNI-PEER errors.</li> <li>2. If the SNI being tested has SNI-PEER Error Type 2305, replace the SNI being tested. Replacing an SNI may be service interrupting. Refer to the SNI-BD section for the procedure for replacing an SNI. To view SNI-PEER errors, use the <b>display errors</b> command with category PNC-PEER. Retry the command.</li> <li>3. If the SNI being tested still has SNI-PEER Error Type 2305, replace the SNI in slot 14.</li> </ol>
115	FAIL	<p>The SNI circuit pack (endpoint 1) cannot communicate with the equipped SNI in slot 15 (<b>list fiber-link</b> can be used to display fiber link endpoints).</p> <ol style="list-style-type: none"> <li>1. Perform the <a href="#">“Fiber Fault Isolation Procedure”</a>. This should resolve multiple SNI-PEER errors.</li> <li>2. If the SNI being tested has SNI-PEER Error Type 2561, replace the SNI being tested. Replacing an SNI may be service interrupting. Refer to the SNI-BD section for the procedure for replacing an SNI. To view SNI-PEER errors, use the <b>display errors</b> command with category PNC-PEER. Retry the command.</li> <li>3. If the SNI being tested still has SNI-PEER Error Type 2561, replace the SNI in slot 15.</li> </ol>

*Continued on next page*

**Table 9-333. TEST #759 Configuration Audit — Continued**

Error Code	Test Result	Description/ Recommendation
116	FAIL	<p>The SNI circuit pack (endpoint 1) cannot communicate with the equipped SNI in slot 16 (<b>list fiber-link</b> can be used to display fiber link endpoints).</p> <ol style="list-style-type: none"> <li>1. Perform the <a href="#">“Fiber Fault Isolation Procedure”</a>. This should resolve multiple SNI-PEER errors.</li> <li>2. If the SNI being tested has SNI-PEER Error Type 2817, replace the SNI being tested. Replacing an SNI may be service interrupting. Refer to the SNI-BD section for the procedure for replacing an SNI. To view SNI-PEER errors, use the <b>display errors</b> command with category PNC-PEER. Retry the command.</li> <li>3. If the SNI being tested still has SNI-PEER Error Type 2817, replace the SNI in slot 16.</li> </ol>
117	FAIL	<p>The SNI circuit pack (endpoint 1) cannot communicate with the equipped SNI in slot 17 (<b>list fiber-link</b> can be used to display fiber link endpoints).</p> <ol style="list-style-type: none"> <li>1. Perform the <a href="#">“Fiber Fault Isolation Procedure”</a>. This should resolve multiple SNI-PEER errors.</li> <li>2. If the SNI being tested has SNI-PEER Error Type 3073, replace the SNI being tested. Replacing an SNI may be service interrupting. Refer to the SNI-BD section for the procedure for replacing an SNI. To view SNI-PEER errors, use the <b>display errors</b> command with category PNC-PEER. Retry the command.</li> <li>3. If the SNI being tested still has SNI-PEER Error Type 3073, replace the SNI in slot 17.</li> </ol>
118	FAIL	<p>The SNI circuit pack (endpoint 1) cannot communicate with the equipped SNI in slot 18 (<b>list fiber-link</b> can be used to display fiber link endpoints).</p> <ol style="list-style-type: none"> <li>1. Perform the <a href="#">“Fiber Fault Isolation Procedure”</a>. This should resolve multiple SNI-PEER errors.</li> <li>2. If the SNI being tested has SNI-PEER Error Type 3329, replace the SNI being tested. Replacing an SNI may be service interrupting. Refer to the SNI-BD section for the procedure for replacing an SNI. To view SNI-PEER errors, use the <b>display errors</b> command with category PNC-PEER. Retry the command.</li> <li>3. If the SNI being tested still has SNI-PEER Error Type 3329, replace the SNI in slot 18.</li> </ol>

*Continued on next page*

Table 9-333. TEST #759 Configuration Audit — Continued

Error Code	Test Result	Description/ Recommendation
119	FAIL	<p>The SNI circuit pack (endpoint 1) cannot communicate with the equipped SNI in slot 19 (<b>list fiber-link</b> can be used to display fiber link endpoints).</p> <ol style="list-style-type: none"><li>1. Perform the "<a href="#">Fiber Fault Isolation Procedure</a>". This should resolve multiple SNI-PEER errors.</li><li>2. If the SNI being tested has SNI-PEER Error Type 3585, replace the SNI being tested. Replacing an SNI may be service interrupting. Refer to the SNI-BD section for the procedure for replacing an SNI. To view SNI-PEER errors, use the <b>display errors</b> command with category PNC-PEER. Retry the command.</li><li>3. If the SNI being tested still has SNI-PEER Error Type 3585, replace the SNI in slot 19.</li></ol>
120	FAIL	<p>The SNI circuit pack (endpoint 1) cannot communicate with the equipped SNI in slot 20 (<b>list fiber-link</b> can be used to display fiber link endpoints).</p> <ol style="list-style-type: none"><li>1. Perform the "<a href="#">Fiber Fault Isolation Procedure</a>". This should resolve multiple SNI-PEER errors.</li><li>2. If the SNI being tested has SNI-PEER Error Type 3841, replace the SNI being tested. Replacing an SNI may be service interrupting. Refer to the SNI-BD section for the procedure for replacing an SNI. To view SNI-PEER errors, use the <b>display errors</b> command with category PNC-PEER. Retry the command.</li><li>3. If the SNI being tested still has SNI-PEER Error Type 3841, replace the SNI in slot 20.</li></ol>
133	FAIL	<p>No neighbor link is administered, but the SNI (endpoint 1) has an EI neighbor (<b>list fiber-link</b> can be used to display fiber link endpoints).</p> <ol style="list-style-type: none"><li>1. Administer the SNI on a fiber link to the EI neighbor it is connected to via the <b>add fiber-link next</b> command. Or remove both fiber endpoints (i.e., this SNI and its EI neighbor) and remove the fiber endpoints from circuit pack administration via <b>change circuit-pack</b>.</li></ol>
134	FAIL	<p>No neighbor link is administered, but the SNI (endpoint 1) has an SNI neighbor (<b>list fiber-link</b> can be used to display fiber link endpoints).</p> <ol style="list-style-type: none"><li>1. Administer the SNI on a fiber link to the SNI neighbor it is connected to via the <b>add fiber-link next</b> command. Or remove both fiber endpoints (i.e., this SNI and its SNI neighbor) and remove the fiber endpoints from circuit pack administration via <b>change circuit-pack</b>.</li></ol>

*Continued on next page*

Table 9-333. TEST #759 Configuration Audit — Continued

Error Code	Test Result	Description/ Recommendation
135	FAIL	<p>The SNI circuit pack (endpoint 1) cannot communicate with its neighbor (<b>list fiber-link</b> can be used to display fiber link endpoints). The SNI has an administered neighbor, but cannot communicate with its neighbor.</p> <ol style="list-style-type: none"><li>1. Check if the administered neighbor is inserted. If not, insert the neighbor circuit pack.</li><li>2. Perform the <a href="#">“Fiber Fault Isolation Procedure”</a>.</li></ol>
136	FAIL	<p>The endpoint 1 SNI's administered neighbor does not match the physical neighbor connected (<b>list fiber-link</b> can be used to display fiber link endpoints). The type of neighbor administered is an SNI and the type of neighbor physically connected is an EI. Enter <b>list fiber-link</b> and verify that the fiber optic cable and metallic cable connections are installed as administered.</p>
137	FAIL	<p>The endpoint 1 SNI's administered neighbor does not match the physical neighbor connected (<b>list fiber-link</b> can be used to display fiber link endpoints). The type of neighbor administered is an EI and the type of neighbor physically connected is an SNI. Enter <b>list fiber-link</b> and verify that the fiber optic cable and metallic cable connections are installed as administered.</p>
138	FAIL	<p>The physical neighbor location of endpoint 1 SNI does not match administered neighbor location (<b>list fiber-link</b> can be used to display fiber link endpoints). The carrier and slot of the administered neighbor do not match the carrier and slot of the physical neighbor. Enter <b>list fiber-link</b> and verify that the fiber optic cable and metallic cable connections are installed as administered. If the problem does not seem to be caused by a physical connection problem or an administration problem, replace the neighbor circuit pack. It is possible for the neighbor circuit pack to have a hardware problem that causes it to report a wrong angel address (physical carrier/slot address) to software.</p>
139	FAIL	<p>The endpoint 1 SNI is administered to be connected to a DS1 CONV but is not physically connected to a DS1 CONV (<b>list fiber-link</b> can be used to display fiber link endpoints). If a DS1 CONV is not supposed to be connected to this SNI, change administration to remove the DS1 converter complex from the fiber link associated with this SNI by:</p> <ol style="list-style-type: none"><li>1. Check for the fiber that this SNI is an endpoint of by checking <b>list fiber-link</b></li><li>2. <b>Remove fiber-link</b> for the fiber that this SNI is an endpoint of.</li><li>3. Add the fiber back via <b>add fiber-link</b> and this time do not administer the DS1 converter complex. If a DS1 CONV should be connected to this SNI, enter <b>list fiber-link</b> and verify that the fiber optic cable and/or metallic cable connections are installed as administered.</li></ol>

*Continued on next page*

Table 9-333. TEST #759 Configuration Audit — *Continued*

Error Code	Test Result	Description/ Recommendation
140	FAIL	<p>The endpoint 1 SNI is physically connected to a DS1 CONV but is not administered to be connected to a DS1 CONV (<b>list fiber-link</b> can be used to display fiber link endpoints). Either add the DS1 converter complex to the fiber that this SNI is associated with by:</p> <ol style="list-style-type: none"><li>1. Check for the fiber that this SNI is an endpoint of by checking <b>list fiber-link</b>.</li><li>2. <b>Remove fiber-link</b> for the fiber that this SNI is an endpoint of.</li><li>3. Add the fiber back via <b>add fiber-link</b> and this time administer the DS1 converter complex also. Or, remove the DS1 CONV connection and connect the SNI directly to its administered fiber endpoint by entering <b>list fiber-link</b> and verifying that the fiber optic cable and metallic cable connections are installed as administered.</li></ol>
202	FAIL	<p>The SNI circuit pack (endpoint 2) cannot communicate with the equipped SNI in slot 2 (<b>list fiber-link</b> can be used to display fiber link endpoints).</p> <ol style="list-style-type: none"><li>1. Perform the <a href="#">"Fiber Fault Isolation Procedure"</a>. This should resolve multiple SNI-PEER errors.</li><li>2. If the SNI being tested has SNI-PEER Error Type 1, replace the SNI being tested. Replacing an SNI may be service interrupting. Refer to the SNI-BD section for the procedure for replacing an SNI. To view SNI-PEER errors, use the <b>display errors</b> command with category PNC-PEER. Retry the command.</li><li>3. If the SNI being tested still has SNI-PEER Error Type 1, replace the SNI in slot 2.</li></ol>
203	FAIL	<p>The SNI circuit pack (endpoint 2) cannot communicate with the equipped SNI in slot 3 (<b>list fiber-link</b> can be used to display fiber link endpoints).</p> <ol style="list-style-type: none"><li>1. Perform the <a href="#">"Fiber Fault Isolation Procedure"</a>. This should resolve multiple SNI-PEER errors.</li><li>2. If the SNI being tested has SNI-PEER Error Type 257, replace the SNI being tested. Replacing an SNI may be service interrupting. Refer to the SNI-BD section for the procedure for replacing an SNI. To view SNI-PEER errors, use the <b>display errors</b> command with category PNC-PEER. Retry the command.</li><li>3. If the SNI being tested still has SNI-PEER Error Type 257, replace the SNI in slot 3.</li></ol>

*Continued on next page*

**Table 9-333. TEST #759 Configuration Audit — Continued**

Error Code	Test Result	Description/ Recommendation
204	FAIL	<p>The SNI circuit pack (endpoint 2) cannot communicate with the equipped SNI in slot 4 (<b>list fiber-link</b> can be used to display fiber link endpoints).</p> <ol style="list-style-type: none"> <li>1. Perform the <a href="#">“Fiber Fault Isolation Procedure”</a>. This should resolve multiple SNI-PEER errors.</li> <li>2. If the SNI being tested has SNI-PEER Error Type 513, replace the SNI being tested. Replacing an SNI may be service interrupting. Refer to the SNI-BD section for the procedure for replacing an SNI. To view SNI-PEER errors, use the <b>display errors</b> command with category PNC-PEER. Retry the command.</li> <li>3. If the SNI being tested still has SNI-PEER Error Type 513, replace the SNI in slot 4.</li> </ol>
205	FAIL	<p>The SNI circuit pack (endpoint 2) cannot communicate with the equipped SNI in slot 5 (<b>list fiber-link</b> can be used to display fiber link endpoints).</p> <ol style="list-style-type: none"> <li>1. Perform the <a href="#">“Fiber Fault Isolation Procedure”</a>. This should resolve multiple SNI-PEER errors.</li> <li>2. If the SNI being tested has SNI-PEER Error Type 769, replace the SNI being tested. Replacing an SNI may be service interrupting. Refer to the SNI-BD section for the procedure for replacing an SNI. To view SNI-PEER errors, use the <b>display errors</b> command with category PNC-PEER. Retry the command.</li> <li>3. If the SNI being tested still has SNI-PEER Error Type 769, replace the SNI in slot 5.</li> </ol>
206	FAIL	<p>The SNI circuit pack (endpoint 2) cannot communicate with the equipped SNI in slot 6 (<b>list fiber-link</b> can be used to display fiber link endpoints).</p> <ol style="list-style-type: none"> <li>1. Perform the <a href="#">“Fiber Fault Isolation Procedure”</a>. This should resolve multiple SNI-PEER errors.</li> <li>2. If the SNI being tested has SNI-PEER Error Type 1025, replace the SNI being tested. Replacing an SNI may be service interrupting. Refer to the SNI-BD section for the procedure for replacing an SNI. To view SNI-PEER errors, use the <b>display errors</b> command with category PNC-PEER. Retry the command.</li> <li>3. If the SNI being tested still has SNI-PEER Error Type 1025, replace the SNI in slot 6.</li> </ol>

*Continued on next page*

**Table 9-333. TEST #759 Configuration Audit — Continued**

Error Code	Test Result	Description/ Recommendation
207	FAIL	<p>The SNI circuit pack (endpoint 2) cannot communicate with the equipped SNI in slot 7 (<b>list fiber-link</b> can be used to display fiber link endpoints).</p> <ol style="list-style-type: none"> <li>1. Perform the <a href="#">“Fiber Fault Isolation Procedure”</a>. This should resolve multiple SNI-PEER errors.</li> <li>2. If the SNI being tested has SNI-PEER Error Type 1281, replace the SNI being tested. Replacing an SNI may be service interrupting. Refer to the SNI-BD section for the procedure for replacing an SNI. To view SNI-PEER errors, use the <b>display errors</b> command with category PNC-PEER. Retry the command.</li> <li>3. If the SNI being tested still has SNI-PEER Error Type 1281, replace the SNI in slot 7.</li> </ol>
208	FAIL	<p>The SNI circuit pack (endpoint 2) cannot communicate with the equipped SNI in slot 8 (<b>list fiber-link</b> can be used to display fiber link endpoints).</p> <ol style="list-style-type: none"> <li>1. Perform the <a href="#">“Fiber Fault Isolation Procedure”</a>. This should resolve multiple SNI-PEER errors.</li> <li>2. If the SNI being tested has SNI-PEER Error Type 1537, replace the SNI being tested. Replacing an SNI may be service interrupting. Refer to the SNI-BD section for the procedure for replacing an SNI. To view SNI-PEER errors, use the <b>display errors</b> command with category PNC-PEER. Retry the command.</li> <li>3. If the SNI being tested still has SNI-PEER Error Type 1537, replace the SNI in slot 8.</li> </ol>
209	FAIL	<p>The SNI circuit pack (endpoint 2) cannot communicate with the equipped SNI in slot 9 (<b>list fiber-link</b> can be used to display fiber link endpoints).</p> <ol style="list-style-type: none"> <li>1. Perform the <a href="#">“Fiber Fault Isolation Procedure”</a>. This should resolve multiple SNI-PEER errors.</li> <li>2. If the SNI being tested has SNI-PEER Error Type 1793, replace the SNI being tested. Replacing an SNI may be service interrupting. Refer to the SNI-BD section for the procedure for replacing an SNI. To view SNI-PEER errors, use the <b>display errors</b> command with category PNC-PEER. Retry the command.</li> <li>3. If the SNI being tested still has SNI-PEER Error Type 1793, replace the SNI in slot 9.</li> </ol>

*Continued on next page*

**Table 9-333. TEST #759 Configuration Audit — Continued**

Error Code	Test Result	Description/ Recommendation
212	FAIL	<p>The SNI circuit pack (endpoint 2) cannot communicate with the active SNC (<b>list fiber-link</b> can be used to display fiber link endpoints).</p> <ol style="list-style-type: none"> <li>1. Check the error log for other SNI circuit packs in the same carrier with a 257 SNI-BD error. Use <b>display errors</b> with category PNC to view SNI-BD errors. If other SNI circuit packs in the same switch node carrier have error 257, then replace the active SNC in this switch node carrier. Replacing an SNC may be service interrupting. Refer to the SNC-BD section for the procedure for replacing an SNC.</li> <li>2. Replace this SNI.</li> <li>3. Replace the active SNC in the same switch node carrier.</li> </ol>
213	FAIL	<p>The SNI circuit pack (endpoint 2) cannot communicate with the equipped SNI in slot 13 (<b>list fiber-link</b> can be used to display fiber link endpoints).</p> <ol style="list-style-type: none"> <li>1. Perform the <a href="#">“Fiber Fault Isolation Procedure”</a>. This should resolve multiple SNI-PEER errors.</li> <li>2. If the SNI being tested has SNI-PEER Error Type 2049, replace the SNI being tested. Replacing an SNI may be service interrupting. Refer to the SNI-BD section for the procedure for replacing an SNI. To view SNI-PEER errors, use the <b>display errors</b> command with category PNC-PEER. Retry the command.</li> <li>3. If the SNI being tested still has SNI-PEER Error Type 2049, replace the SNI in slot 13.</li> </ol>
214	FAIL	<p>The SNI circuit pack (endpoint 2) cannot communicate with the equipped SNI in slot 14 (<b>list fiber-link</b> can be used to display fiber link endpoints).</p> <ol style="list-style-type: none"> <li>1. Perform the <a href="#">“Fiber Fault Isolation Procedure”</a>. This should resolve multiple SNI-PEER errors.</li> <li>2. If the SNI being tested has SNI-PEER Error Type 2305, replace the SNI being tested. Replacing an SNI may be service interrupting. Refer to the SNI-BD section for the procedure for replacing an SNI. To view SNI-PEER errors, use the <b>display errors</b> command with category PNC-PEER. Retry the command.</li> <li>3. If the SNI being tested still has SNI-PEER Error Type 2305, replace the SNI in slot 14.</li> </ol>

*Continued on next page*



**Table 9-333. TEST #759 Configuration Audit — Continued**

Error Code	Test Result	Description/ Recommendation
215	FAIL	<p>The SNI circuit pack (endpoint 2) cannot communicate with the equipped SNI in slot 15 (<b>list fiber-link</b> can be used to display fiber link endpoints).</p> <ol style="list-style-type: none"> <li>1. Perform the <a href="#">“Fiber Fault Isolation Procedure”</a>. This should resolve multiple SNI-PEER errors.</li> <li>2. If the SNI being tested has SNI-PEER Error Type 2561, replace the SNI being tested. Replacing an SNI may be service interrupting. Refer to the SNI-BD section for the procedure for replacing an SNI. To view SNI-PEER errors, use the <b>display errors</b> command with category PNC-PEER. Retry the command.</li> <li>3. If the SNI being tested still has SNI-PEER Error Type 2561, replace the SNI in slot 15.</li> </ol>
216	FAIL	<p>The SNI circuit pack (endpoint 2) cannot communicate with the equipped SNI in slot 16 (<b>list fiber-link</b> can be used to display fiber link endpoints).</p> <ol style="list-style-type: none"> <li>1. Perform the <a href="#">“Fiber Fault Isolation Procedure”</a>. This should resolve multiple SNI-PEER errors.</li> <li>2. If the SNI being tested has SNI-PEER Error Type 2817, replace the SNI being tested. Replacing an SNI may be service interrupting. Refer to the SNI-BD section for the procedure for replacing an SNI. To view SNI-PEER errors, use the <b>display errors</b> command with category PNC-PEER. Retry the command.</li> <li>3. If the SNI being tested still has SNI-PEER Error Type 2817, replace the SNI in slot 16.</li> </ol>
217	FAIL	<p>The SNI circuit pack (endpoint 2) cannot communicate with the equipped SNI in slot 17 (<b>list fiber-link</b> can be used to display fiber link endpoints).</p> <ol style="list-style-type: none"> <li>1. Perform the <a href="#">“Fiber Fault Isolation Procedure”</a>. This should resolve multiple SNI-PEER errors.</li> <li>2. If the SNI being tested has SNI-PEER Error Type 3073, replace the SNI being tested. Replacing an SNI may be service interrupting. Refer to the SNI-BD section for the procedure for replacing an SNI. To view SNI-PEER errors, use the <b>display errors</b> command with category PNC-PEER. Retry the command.</li> <li>3. If the SNI being tested still has SNI-PEER Error Type 3073, replace the SNI in slot 17.</li> </ol>

*Continued on next page*

**Table 9-333. TEST #759 Configuration Audit — Continued**

Error Code	Test Result	Description/ Recommendation
218	FAIL	<p>The SNI circuit pack (endpoint 2) cannot communicate with the equipped SNI in slot 18 (<b>list fiber-link</b> can be used to display fiber link endpoints).</p> <ol style="list-style-type: none"> <li>1. Perform the <a href="#">“Fiber Fault Isolation Procedure”</a>. This should resolve multiple SNI-PEER errors.</li> <li>2. If the SNI being tested has SNI-PEER Error Type 3329, replace the SNI being tested. Replacing an SNI may be service interrupting. Refer to the SNI-BD section for the procedure for replacing an SNI. To view SNI-PEER errors, use the <b>display errors</b> command with category PNC-PEER. Retry the command.</li> <li>3. If the SNI being tested still has SNI-PEER Error Type 3329, replace the SNI in slot 18.</li> </ol>
219	FAIL	<p>The SNI circuit pack (endpoint 2) cannot communicate with the equipped SNI in slot 19 (<b>list fiber-link</b> can be used to display fiber link endpoints).</p> <ol style="list-style-type: none"> <li>1. Perform the <a href="#">“Fiber Fault Isolation Procedure”</a>. This should resolve multiple SNI-PEER errors.</li> <li>2. If the SNI being tested has SNI-PEER Error Type 3585, replace the SNI being tested. Replacing an SNI may be service interrupting. Refer to the SNI-BD section for the procedure for replacing an SNI. To view SNI-PEER errors, use the <b>display errors</b> command with category PNC-PEER. Retry the command.</li> <li>3. If the SNI being tested still has SNI-PEER Error Type 3585, replace the SNI in slot 19.</li> </ol>
220	FAIL	<p>The SNI circuit pack (endpoint 2) cannot communicate with the equipped SNI in slot 20 (<b>list fiber-link</b> can be used to display fiber link endpoints).</p> <ol style="list-style-type: none"> <li>1. Perform the <a href="#">“Fiber Fault Isolation Procedure”</a>. This should resolve multiple SNI-PEER errors.</li> <li>2. If the SNI being tested has SNI-PEER Error Type 3841, replace the SNI being tested. Replacing an SNI may be service interrupting. Refer to the SNI-BD section for the procedure for replacing an SNI. To view SNI-PEER errors, use the <b>display errors</b> command with category PNC-PEER. Retry the command.</li> <li>3. If the SNI being tested still has SNI-PEER Error Type 3841, replace the SNI in slot 20.</li> </ol>
233	FAIL	<p>No neighbor link is administered, but the SNI (endpoint 2) has an EI neighbor (<b>list fiber-link</b> can be used to display fiber link endpoints).</p> <ol style="list-style-type: none"> <li>1. Administer the SNI on a fiber link to the EI neighbor it is connected to via the <b>add fiber-link next</b> command. Or remove both fiber endpoints (i.e., this SNI and its EI neighbor) and remove the fiber endpoints from circuit pack administration via <b>change circuit-pack</b>.</li> </ol>

Table 9-333. TEST #759 Configuration Audit — Continued

Error Code	Test Result	Description/ Recommendation
234	FAIL	<p>No neighbor link is administered, but the SNI (endpoint 2) has an SNI neighbor (<b>list fiber-link</b> can be used to display fiber link endpoints).</p> <ol style="list-style-type: none"><li>1. Administer the SNI on a fiber link to the SNI neighbor it is connected to via the <b>add fiber-link next</b> command. Or remove both fiber endpoints (i.e., this SNI and its SNI neighbor) and remove the fiber endpoints from circuit pack administration via <b>change circuit-pack</b>.</li></ol>
235	FAIL	<p>The SNI circuit pack (endpoint 2) cannot communicate with its neighbor (<b>list fiber-link</b> can be used to display fiber link endpoints). The SNI has an administered neighbor, but cannot communicate with its neighbor.</p> <ol style="list-style-type: none"><li>1. Check if the administered neighbor is inserted. If not, insert the neighbor circuit pack.</li><li>2. Perform the "<a href="#">Fiber Fault Isolation Procedure</a>".</li></ol>
236	FAIL	<p>The endpoint 2 SNI's administered neighbor does not match the physical neighbor connected (<b>list fiber-link</b> can be used to display fiber link endpoints). The type of neighbor administered is an SNI and the type of neighbor physically connected is an EI. Enter <b>list fiber-link</b> and verify that the fiber optic cable and metallic cable connections are installed as administered.</p>
237	FAIL	<p>The endpoint 2 SNI's administered neighbor does not match the physical neighbor connected (<b>list fiber-link</b> can be used to display fiber link endpoints). The type of neighbor administered is an EI and the type of neighbor physically connected is an SNI. Enter <b>list fiber-link</b> and verify that the fiber optic cable and metallic cable connections are installed as administered.</p>
238	FAIL	<p>The physical neighbor location of endpoint 2 SNI does not match administered neighbor location (<b>list fiber-link</b> can be used to display fiber link endpoints). The carrier and slot of the administered neighbor do not match the carrier and slot of the physical neighbor. Enter <b>list fiber-link</b> and verify that the fiber optic cable and metallic cable connections are installed as administered. If the problem does not seem to be caused by a physical connection problem or an administration problem, replace the neighbor circuit pack. It is possible for the neighbor circuit pack to have a hardware problem that causes it to report a wrong angel address (physical carrier/slot address) to software.</p>

Continued on next page

Table 9-333. TEST #759 Configuration Audit — Continued

Error Code	Test Result	Description/ Recommendation
239	FAIL	<p>The endpoint 2 SNI is administered to be connected to a DS1 CONV but is not physically connected to a DS1 CONV (<b>list fiber-link</b> can be used to display fiber link endpoints). If a DS1 CONV is not supposed to be connected to this SNI, change administration to remove the DS1 converter complex from the fiber link associated with this SNI by:</p> <ol style="list-style-type: none"><li>1. Check for the fiber that this SNI is an endpoint of by checking <b>list fiber-link</b></li><li>2. <b>Remove fiber-link</b> for the fiber that this SNI is an endpoint of.</li><li>3. Add the fiber back via <b>add fiber-link</b> and this time do not administer the DS1 converter complex. If a DS1 CONV should be connected to this SNI, enter <b>list fiber-link</b> and verify that the fiber optic cable and/or metallic cable connections are installed as administered.</li></ol>
240	FAIL	<p>The endpoint 2 SNI is physically connected to a DS1 CONV but is not administered to be connected to a DS1 CONV (<b>list fiber-link</b> can be used to display fiber link endpoints). Either add the DS1 converter complex to the fiber that this SNI is associated with by:</p> <ol style="list-style-type: none"><li>1. Check for the fiber that this SNI is an endpoint of by checking <b>list fiber-link</b>.</li><li>2. <b>Remove fiber-link</b> for the fiber that this SNI is an endpoint of.</li><li>3. Add the fiber back via <b>add fiber-link</b> and this time administer the DS1 converter complex also. Or, remove the DS1 CONV connection and connect the SNI directly to its administered fiber endpoint by entering <b>list fiber-link</b> and verifying that the fiber optic cable and metallic cable connections are installed as administered.</li></ol>
	PASS	<p>The administered data and the circuit packs the SNI (s) can communicate with match.</p>

## Fiber Link Reset Test (#768)

**This test is destructive.**

This test resets both endpoints of the fiber link and is executed via the **reset fiber-link F P** command. Any DS1 CONV circuit packs on the fiber link are not reset. The **reset fiber-link** command should almost never be used. It may be necessary to use it when the endpoint circuit packs enter a mode in which they cannot communicate with software. When necessary, always reset fiber endpoints with the command instead of reseating the endpoint circuit packs.

For EI-EI fibers that connect an EPN to the PPN, the EI on the EPN is reset first followed by the EI on the PPN. For EI-EI fiber links that connect two EPN s, one EI is reset first followed by the other.

For an EI-SNI fiber link in which the EI is on the PPN, the SNI is reset first followed by the EI.

For an EI-SNI fiber link in which the EI is on an EPN, the SNI is reset first followed by the EI.

For an SNI-SNI fiber link, the SNI farthest from the PPN is reset first followed by the SNI nearest to the PPN.

When an EI endpoint is reset, the Expansion Interface Reset Test (#336) is executed. When an SNI endpoint is reset, the SNI Reset Test (#761) is executed. These tests are described in the EXP-INTF and SNI-BD sections.

This test starts the other reset test mentioned above and returns PASS without waiting for the results of the other reset test. For a better indication of how the other reset tests are running, use the **reset board UUCSS** command on each individual fiber link endpoint.

**Table 9-334. TEST #768 Fiber Link Reset Test**

Error Code	Test Result	Description/ Recommendation
1703	ABORT	Both fiber endpoints are in the hardware path for INLs to their respective switch node carriers and, thus, cannot get a response from this test because the INLs response should come on will go down as a result of the reset. 1. Reset the individual fiber-link endpoints via the <b>reset board</b> command.
2500	ABORT	Internal system error 1. Retry the command at 1-minute intervals a maximum of 3 times.
	PASS	The reset of both fiber endpoints successfully completed.

### Failure Audit (#777)

This test is non-destructive.

This test queries the SNI (s) on the fiber link for any existing failures and any unacknowledged cleared failure messages. Each failure generates an error and alarm entry against SNI-BD, SNI-PEER, or FIBER-LK. An unacknowledged cleared failure message is a message the SNI circuit pack sent to software indicating a previous failure is now gone and the SNI circuit pack did not receive

a message from software indicating that the failure message was received by software.

If no failures are detected by the SNI circuit pack, this test will pass.

If this test reports failures, the results screen for the **test fiber-link** command will show **FAIL** with no FAIL code. The error log must then be displayed via **display errors** with category PNC to view SNI-BD and FIBER-LK errors and **display errors** with category PNC-PEER to view SNI-PEER errors.

For EI-EI fiber links, this test is not run. For EI-SNI fiber links, this test is run on the SNI circuit pack endpoint of the fiber link. For SNI-SNI fiber links, this test is run on both SNI circuit pack endpoints of the fiber link.

**Table 9-335. TEST #777 Failure Audit**

Error Code	Test Result	Description/ Recommendation
2100	ABORT	Could not allocate the necessary system resources to run this test.
2300	ABORT	The downlink message necessary to run this test could not be sent.
2301	ABORT	The software timer could not be set before sending the downlink message necessary to run this test.
2302	ABORT	The SNI circuit pack claims that it received a bad message from software.
2303	ABORT	The SNI circuit pack claims that the test requested by software is invalid.
2304	ABORT	SNI firmware is not able to run the test. 1. Retry the command at 1-minute intervals a maximum of 3 times.

*Continued on next page*

Table 9-335. TEST #777 Failure Audit — Continued

Error Code	Test Result	Description/ Recommendation
2306	ABORT	<p>An SNI circuit pack on the fiber link is not responding to test requests sent by software.</p> <ol style="list-style-type: none"> <li>1. Run the <b>test led switch-node</b> for the switch node(s) that the SNI (s) reside in to verify whether the LED s on the board(s) light. Follow the steps below for the SNI (s) from step 1 that had no LED s light.</li> <li>2. If the LED s on the other boards in the carrier light, but the LED s on this board do not light, run test 760 via <b>test board UUCSS I</b> for the active SNC in this carrier. Wait 5 minutes and then try step 1 one more time. If the LED s on this board still do not light, replace this board. Replacing an SNI may be service interrupting. Refer to the SNI-BD section for the procedure for replacing an SNI.</li> <li>3. If none of the LED s light for the boards in the same carrier as this board, fix any problems associated with the connectivity of this carrier to the SPE. Use <b>list fiber-link</b> to determine the fiber connections to this carrier. Check the LED s on all SNI s and EI s and fix any fiber problems. Enter <b>display errors</b> and resolve any EXP-INTF error entries associated with the PPN. Also, resolve any SYNC, SNI-BD, SNC-BD, FIBER-LK, or SNI-PEER error entries.</li> </ol>
	FAIL	<p>The SNI circuit pack reported failures or retransmitted a cleared failure message.</p> <ol style="list-style-type: none"> <li>1. If this is the first time this test was run, run the test again. If there were any previous failure messages that software did not acknowledge, this test will FAIL even if the failure messages indicate a FAIL to PASS transition, i.e., a problem has gone away. If this test is run twice and FAILs both times, then at least one problem still exists.</li> <li>2. Resolve any errors or alarms (<b>display errors</b> and <b>display alarms</b>) for SNI-BD, SNI-PEER, and FIBER-LK entries.</li> <li>3. If no SNI-BD, SNI-PEER, or FIBER-LK entries exist in the error and alarm logs, retry the command.</li> </ol>
	PASS	No problems are detected on the board.

### SNI Fiber Out of Frame Query (#989)

This test is non-destructive.

The SNI circuit pack reports whether a fiber out of frame condition exists, whether a loss of signal condition exists, and whether the lightwave transceiver is present.

**Table 9-336. TEST #989 SNI Fiber Out of Frame Query**

Error Code	Test Result	Description/ Recommendation
1415	ABORT	<p>The lightwave transceiver is not present for endpoint 1 of the fiber link (<b>list fiber-link</b> can be used to display fiber link endpoints).</p> <ol style="list-style-type: none"> <li>1. If a lightwave transceiver is not supposed to be present, do nothing. For example, an SNI connected to a DS1 CONV circuit pack or an SNI with a metallic connection does not have a lightwave transceiver.</li> <li>2. Otherwise, continue with the following steps.</li> <li>3. Check the lightwave transceiver connections.</li> <li>4. Replace the lightwave transceiver.</li> <li>5. Replace the SNI circuit pack.</li> </ol>
1416	ABORT	<p>The lightwave transceiver is not present for endpoint 2 of the fiber link (<b>list fiber-link</b> can be used to display fiber link endpoints).</p> <ol style="list-style-type: none"> <li>1. If a lightwave transceiver is not supposed to be present, do nothing. For example, an SNI connected to a DS1 CONV circuit pack or an SNI with a metallic connection does not have a lightwave transceiver.</li> <li>2. Otherwise, continue with the following steps.</li> <li>3. Check the lightwave transceiver connections.</li> <li>4. Replace the lightwave transceiver.</li> <li>5. Replace the SNI circuit pack.</li> </ol>
2100	ABORT	<p>Could not allocate the necessary system resources to run this test.</p> <ol style="list-style-type: none"> <li>1. Retry the command at 1-minute intervals a maximum of 3 times.</li> </ol>
2300	ABORT	<p>The downlink message necessary to run this test could not be sent.</p> <ol style="list-style-type: none"> <li>1. Retry the command at 1-minute intervals a maximum of 3 times.</li> </ol>
2301	ABORT	<p>The software timer could not be set before sending the downlink message necessary to run this test.</p> <ol style="list-style-type: none"> <li>1. Retry the command at 1-minute intervals a maximum of 3 times.</li> </ol>
2304	ABORT	<p>The SNI circuit pack responded that it is not able to run the test requested by software.</p> <ol style="list-style-type: none"> <li>1. Retry the command at 1-minute intervals a maximum of 3 times.</li> </ol>

*Continued on next page*



**Table 9-336. TEST #989 SNI Fiber Out of Frame Query — Continued**

Error Code	Test Result	Description/ Recommendation
2306	ABORT	<p>An SNI circuit pack on the fiber link is not responding to test requests sent by software.</p> <ol style="list-style-type: none"> <li>1. Run the <b>test led switch-node</b> for the switch node(s) that the SNI (s) reside in to verify whether the LED s on the board(s) light. Follow the steps below for the SNI (s) from step 1 that had no LED s light.</li> <li>2. If the LED s on the other boards in the carrier light, but the LED s on this board do not light, run test 760 via <b>test board UUCSS I</b> for the active SNC in this carrier. Wait 5 minutes and then try step 1 one more time. If the LED s on this board still do not light, replace this board. Replacing an SNI may be service interrupting. Refer to the SNI-BD section for the procedure for replacing an SNI.</li> <li>3. If none of the LED s light for the boards in the same carrier as this board, fix any problems associated with the connectivity of this carrier to the SPE. Use <b>list fiber-link</b> to determine the fiber connections to this carrier. Check the LED s on all SNI s and EI s and fix any fiber problems. Enter <b>display errors</b> and resolve any EXP-INTF error entries associated with the PPN. Also, resolve any SYNC, SNI-BD, SNC-BD, FIBER-LK, or SNI-PEER error entries.</li> </ol>
2500	ABORT	<p>Internal system error</p> <ol style="list-style-type: none"> <li>1. Retry the command at 1-minute intervals a maximum of 3 times.</li> </ol>
141	FAIL	<p>The SNI circuit pack (endpoint 1 of the fiber-link) has a fiber out of frame condition, but no loss of signal condition. Also, a lightwave transceiver is connected to the SNI circuit pack.</p> <ol style="list-style-type: none"> <li>1. Check that the connected circuit pack is physically installed. The connected circuit pack is the other endpoint of the fiber-link if no DS1 CONV complex is administered (check via <b>list fiber-link</b>). Otherwise, if a DS1 CONV complex is administered, the connected circuit pack is the DS1 CONV circuit pack connected to the SNI circuit pack.</li> <li>2. Perform the Fiber Fault Isolation Procedure described in Chapter 5.</li> <li>3. Replace this SNI circuit pack.</li> <li>4. Replace the connected circuit pack.</li> </ol>

*Continued on next page*

**Table 9-336. TEST #989 SNI Fiber Out of Frame Query — Continued**

Error Code	Test Result	Description/ Recommendation
142	FAIL	<p>The SNI circuit pack (endpoint 1 of the fiber-link) has a fiber out of frame condition, but no loss of signal condition. Also, no lightwave transceiver is connected to the SNI circuit pack.</p> <ol style="list-style-type: none"> <li>1. Check that the connected circuit pack is physically installed. The connected circuit pack is the other endpoint of the fiber-link if no DS1 CONV complex is administered (check via <b>list fiber-link</b>). Otherwise, if a DS1 CONV complex is administered, the connected circuit pack is the DS1 CONV circuit pack connected to the SNI circuit pack.</li> <li>2. Perform the Fiber Fault Isolation Procedure described in Chapter 5.</li> <li>3. Replace this SNI circuit pack.</li> <li>4. Replace the connected circuit pack.</li> </ol>
143	FAIL	<p>The SNI circuit pack (endpoint 1 of the fiber-link) has a loss of signal condition, but no fiber out of frame condition. Also, a lightwave transceiver is connected to the SNI circuit pack.</p> <ol style="list-style-type: none"> <li>1. Check that the connected circuit pack is physically installed. The connected circuit pack is the other endpoint of the fiber-link if no DS1 CONV complex is administered (check via <b>list fiber-link</b>). Otherwise, if a DS1 CONV complex is administered, the connected circuit pack is the DS1 CONV circuit pack connected to the SNI circuit pack.</li> <li>2. Perform the Fiber Fault Isolation Procedure described in Chapter 5.</li> <li>3. Replace this SNI circuit pack.</li> <li>4. Replace the connected circuit pack.</li> </ol>
144	FAIL	<p>The SNI circuit pack (endpoint 1 of the fiber-link) has a loss of signal condition, but no fiber out of frame condition. Also, no lightwave transceiver is connected to the SNI circuit pack.</p> <ol style="list-style-type: none"> <li>1. Check that the connected circuit pack is physically installed. The connected circuit pack is the other endpoint of the fiber-link if no DS1 CONV complex is administered (check via <b>list fiber-link</b>). Otherwise, if a DS1 CONV complex is administered, the connected circuit pack is the DS1 CONV circuit pack connected to the SNI circuit pack.</li> <li>2. Perform the Fiber Fault Isolation Procedure described in Chapter 5.</li> <li>3. Replace this SNI circuit pack.</li> <li>4. Replace the connected circuit pack.</li> </ol>

*Continued on next page*

**Table 9-336. TEST #989 SNI Fiber Out of Frame Query — Continued**

Error Code	Test Result	Description/ Recommendation
145	FAIL	<p>The SNI circuit pack (endpoint 1 of the fiber-link) has a fiber out of frame condition and a loss of signal condition. Also, a lightwave transceiver is connected to the SNI circuit pack.</p> <ol style="list-style-type: none"> <li>1. Check that the connected circuit pack is physically installed. The connected circuit pack is the other endpoint of the fiber-link if no DS1 CONV complex is administered (check via <b>list fiber-link</b>). Otherwise, if a DS1 CONV complex is administered, the connected circuit pack is the DS1 CONV circuit pack connected to the SNI circuit pack.</li> <li>2. Perform the Fiber Fault Isolation Procedure described in Chapter 5.</li> <li>3. Replace this SNI circuit pack.</li> <li>4. Replace the connected circuit pack.</li> </ol>
146	FAIL	<p>The SNI circuit pack (endpoint 1 of the fiber-link) has a fiber out of frame condition, and a loss of signal condition. Also, no lightwave transceiver is connected to the SNI circuit pack.</p> <ol style="list-style-type: none"> <li>1. Check that the connected circuit pack is physically installed. The connected circuit pack is the other endpoint of the fiber-link if no DS1 CONV complex is administered (check via <b>list fiber-link</b>). Otherwise, if a DS1 CONV complex is administered, the connected circuit pack is the DS1 CONV circuit pack connected to the SNI circuit pack.</li> <li>2. Perform the Fiber Fault Isolation Procedure described in Chapter 5.</li> <li>3. Replace this SNI circuit pack.</li> <li>4. Replace the connected circuit pack.</li> </ol>
241	FAIL	<p>The SNI circuit pack (endpoint 2 of the fiber-link) has a fiber out of frame condition, but no loss of signal condition. Also, a lightwave transceiver is connected to the SNI circuit pack.</p> <ol style="list-style-type: none"> <li>1. Check that the connected circuit pack is physically installed. The connected circuit pack is the other endpoint of the fiber-link if no DS1 CONV complex is administered (check via <b>list fiber-link</b>). Otherwise, if a DS1 CONV complex is administered, the connected circuit pack is the DS1 CONV circuit pack connected to the SNI circuit pack.</li> <li>2. Perform the Fiber Fault Isolation Procedure described in Chapter 5.</li> <li>3. Replace this SNI circuit pack.</li> <li>4. Replace the connected circuit pack.</li> </ol>

*Continued on next page*

**Table 9-336. TEST #989 SNI Fiber Out of Frame Query — Continued**

Error Code	Test Result	Description/ Recommendation
242	FAIL	<p>The SNI circuit pack (endpoint 2 of the fiber-link) has a fiber out of frame condition, but no loss of signal condition. Also, no lightwave transceiver is connected to the SNI circuit pack.</p> <ol style="list-style-type: none"> <li>1. Check that the connected circuit pack is physically installed. The connected circuit pack is the other endpoint of the fiber-link if no DS1 CONV complex is administered (check via <b>list fiber-link</b>). Otherwise, if a DS1 CONV complex is administered, the connected circuit pack is the DS1 CONV circuit pack connected to the SNI circuit pack.</li> <li>2. Perform the Fiber Fault Isolation Procedure described in Chapter 5.</li> <li>3. Replace this SNI circuit pack.</li> <li>4. Replace the connected circuit pack.</li> </ol>
243	FAIL	<p>The SNI circuit pack (endpoint 2 of the fiber-link) has a loss of signal condition, but no fiber out of frame condition. Also, a lightwave transceiver is connected to the SNI circuit pack.</p> <ol style="list-style-type: none"> <li>1. Check that the connected circuit pack is physically installed. The connected circuit pack is the other endpoint of the fiber-link if no DS1 CONV complex is administered (check via <b>list fiber-link</b>). Otherwise, if a DS1 CONV complex is administered, the connected circuit pack is the DS1 CONV circuit pack connected to the SNI circuit pack.</li> <li>2. Perform the Fiber Fault Isolation Procedure described in Chapter 5.</li> <li>3. Replace this SNI circuit pack.</li> <li>4. Replace the connected circuit pack.</li> </ol>
244	FAIL	<p>The SNI circuit pack (endpoint 2 of the fiber-link) has a loss of signal condition, but no fiber out of frame condition. Also, no lightwave transceiver is connected to the SNI circuit pack.</p> <ol style="list-style-type: none"> <li>1. Check that the connected circuit pack is physically installed. The connected circuit pack is the other endpoint of the fiber-link if no DS1 CONV complex is administered (check via <b>list fiber-link</b>). Otherwise, if a DS1 CONV complex is administered, the connected circuit pack is the DS1 CONV circuit pack connected to the SNI circuit pack.</li> <li>2. Perform the Fiber Fault Isolation Procedure described in Chapter 5.</li> <li>3. Replace this SNI circuit pack.</li> <li>4. Replace the connected circuit pack.</li> </ol>

*Continued on next page*

**Table 9-336. TEST #989 SNI Fiber Out of Frame Query — Continued**

Error Code	Test Result	Description/ Recommendation
245	FAIL	<p>The SNI circuit pack (endpoint 2 of the fiber-link) has a fiber out of frame condition and a loss of signal condition. Also, a lightwave transceiver is connected to the SNI circuit pack.</p> <ol style="list-style-type: none"> <li>1. Check that the connected circuit pack is physically installed. The connected circuit pack is the other endpoint of the fiber-link if no DS1 CONV complex is administered (check via <b>list fiber-link</b>). Otherwise, if a DS1 CONV complex is administered, the connected circuit pack is the DS1 CONV circuit pack connected to the SNI circuit pack.</li> <li>2. Perform the Fiber Fault Isolation Procedure described in Chapter 5.</li> <li>3. Replace this SNI circuit pack.</li> <li>4. Replace the connected circuit pack.</li> </ol>
246	FAIL	<p>The SNI circuit pack (endpoint 2 of the fiber-link) has a fiber out of frame condition, and a loss of signal condition. Also, no lightwave transceiver is connected to the SNI circuit pack.</p> <ol style="list-style-type: none"> <li>1. Check that the connected circuit pack is physically installed. The connected circuit pack is the other endpoint of the fiber-link if no DS1 CONV complex is administered (check via <b>list fiber-link</b>). Otherwise, if a DS1 CONV complex is administered, the connected circuit pack is the DS1 CONV circuit pack connected to the SNI circuit pack.</li> <li>2. Perform the Fiber Fault Isolation Procedure described in Chapter 5.</li> <li>3. Replace this SNI circuit pack.</li> <li>4. Replace the connected circuit pack.</li> </ol>
PASS	No problems associated with this test are detected on the SNI.	

## GPTD-PT (General Purpose Tone Detector Port)

MO Name (in Alarm Log)	Alarm Level	Initial Command to Run <sup>1</sup>	Full Name of MO
GPTD-PT	MAJOR	test port UUCSSpp sh	General Purpose Tone Detector Port
GPTD-PT	MINOR	test port UUCSSpp sh	General Purpose Tone Detector Port
GPTD-PT	WARNING	release port UUCSSpp	General Purpose Tone Detector Port

1. UU is the universal cabinet number (1 for PPN, 2 -44 for EPN s). C is the carrier designation (A, B, C, D, or E). SS is the number of the slot in which the circuit pack resides (01 to 21). pp is the two digit port number (01, 02, ...).

The General Purpose Tone Detector (GPTD) Ports, also known as Call Progress Tone Receivers (CPTR), reside on the following circuit packs:

- TN748 all suffixes (mu-law companding)

The GPTD port performs level measurements of test tones and to detect call progress tones. Examples of call progress tones are dial tone, ring back, busy, alert, confirmation, and recall dial. The abilities of the GPTD port to perform level measurements of test tones and to detect call progress tones are essential for maintenance of other circuit packs (for example, Tone-Clock).

The GPTD maintenance object defines a set of tests to ensure that the general purpose tone detection capability of the GPTD port is functioning properly. For all Tone Detector circuit pack level errors (DETR-BD), refer to “XXX-BD (Common Port Circuit Pack)”.

### Error Log Entries and Test to Clear Values

Table 9-337. General Purpose Tone Detector Port (CPTR) Error Log Entries

Error Type	Aux Data	Associated Test	Alarm Level	On/Off Board	Test to Clear Value
0 <sup>1</sup>	0	Any	Any	Any	test port UUCSSpp sh r 1
1	17664	Tone Detector Audit/ Update Test (#43)	MAJOR/ MINOR (a)	ON	test port UUCSSpp r 2
18	0	busyout port UUCSSpp	WARNING	ON	release port UUCSSpp
130 (d)		None	WARNING	ON	test port UUCSSpp sh r 2

Continued on next page

Table 9-337. General Purpose Tone Detector Port (CPTR) Error Log Entries — Continued

Error Type	Aux Data	Associated Test	Alarm Level	On/Off Board	Test to Clear Value
257 (b)	17666	Tone Detector Audit/ Update Test (#43)	MAJOR/ MINOR (a)	ON	test port UUCSSpp r 3
513 (c)	Any	Tone Detection Verification Test (#42)	MAJOR/ MINOR (a)	ON	test port UUCSSpp r 3

1. Run the Short Test Sequence first. If all tests pass, run the Long Test Sequence. Refer to the appropriate test description and follow the recommended procedures.

## Notes:

- a. A Major or a Minor alarm may be logged with this error. A Major alarm is raised when the total number of GPTD ports currently in service is less than or equal to 1/2 of the threshold number administered via the **change system-parameters maintenance** command. Otherwise a Minor alarm is raised. In either case, run the Short Test Sequence on the alarmed GPTD port and follow procedures for the individual test results.
- b. The GPTD port lost its translation. Testing the GPTD port is sufficient to reload its translation. If testing the GPTD port does not clear the error, then replace the Tone Detector circuit pack containing the defective GPTD port.
- c. This error indicates the GPTD port is having problems detecting call progress tones. If this error is logged constantly, replace the Tone Detector circuit pack containing the defective GPTD port.
- d. This Error Type indicates that the circuit pack has been removed or has been insane for at least 11 minutes. To clear the error, reinsert or replace the circuit pack.

## Technician-Demand Tests: Descriptions and Error Codes

Always investigate tests in the order presented below when inspecting errors in the system. By clearing error codes associated with the *Tone Detection Verification Test*, for example, you may also clear errors generated from other tests in the testing sequence.

Order of Investigation	Short Test Sequence	Long Test Sequence	D/ND <sup>1</sup>
Tone Detection Verification Test (#42)	X	X	ND
Tone Detector Audit/Update Test (#43)	X	X	ND

1. D = Destructive; ND = Nondestructive

### Tone Detection Verification Test (#42)

This test verifies that the call progress tones detection and the tone level measurement capabilities of the GPTD port are functioning properly.

**Table 9-338. TEST #42 Tone Detection Verification Test**

Error Code	Test Result	Description/ Recommendation
	ABORT	The system was not able to allocate all the resources needed for this test or there was an Internal system error.
1	ABORT	The system could not allocate all the resources needed to test the call progress tones.
1001	ABORT	The system was unable to put the GPTD port in the appropriate mode to test it.
1002	ABORT	The system could not allocate time slots for the test connection. This can happen when the system is heavily loaded. If the system is not heavily loaded, then test the TDM-BUS via the <b>test tdm [1 2]</b> command. 1. Retry the command at 1-minute intervals a maximum of 5 times.

*Continued on next page*



Table 9-338. TEST #42 Tone Detection Verification Test — Continued

Error Code	Test Result	Description/ Recommendation
1003	ABORT	<p>The system could not allocate a Tone-Clock for the test connection. This may be caused by a heavy load on the system or by a faulted Tone-Clock.</p> <ol style="list-style-type: none"> <li>1. Check to see if there are any alarms against the Tone-Clock in the port network where the test aborted. If so refer to the recommended procedures for TONE-BD or TONE-PT.</li> <li>2. If a new Tone-Clock has been inserted, allow about 1 minute for maintenance to run on the newly inserted circuit pack.</li> <li>3. Retry the command at 1-minute intervals a maximum of 5 times.</li> </ol>
2000	ABORT	<p>Response to the test request was not received within the allowable time period.</p> <ol style="list-style-type: none"> <li>1. Retry the command at 1-minute intervals a maximum of 5 times.</li> </ol>
2006	ABORT	<p>The active Tone-Clock circuit pack or a Tone Detector circuit pack may not be functioning properly.</p> <ol style="list-style-type: none"> <li>1. Test the <i>active</i> Tone-Clock circuit pack in the port network with the <b>test tone-clock</b> UUC command and refer to the "TONE-BD (Tone-Clock Circuit Pack)" section for failures.</li> <li>2. Retry the command at 1-minute intervals up to 5 times.</li> </ol>
2100	ABORT	<p>Could not allocate the necessary system resources to run this test.</p> <p>Retry the command at 1-minute intervals a maximum of 5 times.</p>
101-1 22	FAIL	<ol style="list-style-type: none"> <li>1. Run the Short Test Sequence: <b>test port UUCSSpp sh r 1</b>.</li> <li>2. If the problem persists, the system is still operating properly but system capacity will be reduced. In order to restore the system performance to normal, replace the tone detector circuit pack containing the defective GPTD port.</li> </ol>
1022	FAIL	<p>Tone detection for the system is administered as part of a wideband configuration, and the tone detector is not a TN420C (the only circuit pack with this capability). GPTD ports on other types of tone detector circuit packs are taken out of service since they cannot provide the administered function.</p> <ol style="list-style-type: none"> <li>1. Change the tone-detection mode administered on the system-parameters country-options form (see <i>DEFINITY Enterprise Communications Server Release 5.4 Administration and Feature Description</i>) or remove all non-TN420C tone detector circuit packs from the system.</li> </ol>
	PASS	<p>Tone Detection Verification is successful. The GPTD port is able to detect all call progress tones and perform level measurements of test tones.</p>

### Tone Detector Audit/Update Test (#43)

The GPTD port is refreshed with all time slot information and sanity audit is performed on the GPTD port

**Table 9-339. TEST #43 Tone Detector Audit/Update Test**

Error Code	Test Result	Description/ Recommendation
	ABORT	The system was not able to allocate the resources needed for this test. 1. Wait 1 minute and try again.
2000	ABORT	Response to the test request was not received within the allowable time period.
2100	ABORT	Could not allocate the necessary system resources to run this test. 1. Retry the command at 1-minute intervals a maximum of 5 times.
	FAIL	Hardware audit failed. 1. Run the Short Test Sequence: <b>test port UUCSSpp short repeat 1</b> . 2. If the problem persists, the system is still operating properly but system capacity will be reduced. To restore the system performance to normal, replace the Tone Detector circuit pack containing the defective GPTD port.
	PASS	The GPTD port has been successfully refreshed with its translation.

## H-ADAPTR (MSS Host Adapter)

---

MO Name (in Alarm Log)	Alarm Level	Initial Command to Run <sup>1</sup>	Full Name of MO
H-ADAPTR	MINOR	test host-adapter a b long	MSS Host Adapter
H-ADAPTR	WARNING	test host-adapter a b long	MSS Host Adapter

1. In a system with a simplex SPE, the carrier need not be specified. In a system with duplicated SPE s, carrier a or b must be specified.

The Host Adapter circuit is located on the UN332 Mass Storage System/Network Control circuit pack (MSSNET) and is part of the Mass Storage System (MSS) which also contains the Switch Control (SW-CTL) circuit. The MSS provides non-volatile tape and disk storage for booting the PBX system and for saving system translation data.

The Host Adapter circuit provides the interface between the Switch Processing Element (SPE) system bus and the Small Computer System Interface (SCSI) bus. The SCSI bus is an industry standard bus that connects a tape drive and disk drive to the PBX.

Note that the red LED on the MSSNET board is shared by both the switch control and host adapter circuits. A failure of either circuit will cause the LED to light. A reset of the host adapter also causes this LED to light. A separate MO (SW-CTL) and its associated tests are used for maintenance of the switch control circuit.

The tape and disk drives are treated as separate, but related, maintenance objects (TAPE and DISK). Problems with the host adapter may affect the operation of the tape and disk circuit packs.

When the host adapter is taken out of service because of a failure of a critical host adapter test, or by use of the **busyout** command, the TAPE and DISK maintenance objects are also placed in an out-of-service state.

In a system with duplicated SPEs, the tests run on the standby host adapter circuit are identical to those run on the active host adapter circuit. The DUPINT circuit pack handles communications between the active and standby SPEs for both the control channel and memory shadowing. Therefore, problems with the DUPINT circuit pack may affect maintenance tests of the standby host adapter circuit pack.

### Circuit Pack Replacement Procedures

---

If the MSSNET circuit pack needs to be replaced:

1. If the SPE is not duplicated:

2. Power down the SPE carrier by:
  - a. Remove the power plug from the **left side** of the carrier first.
  - b. Remove the second power plug from the **right side** of the carrier.
3. Replace the MSSNET circuit pack.
4. Power up the SPE carrier by:
  - a. Insert the power plug in the right side of the carrier first.
  - b. After inserting the first power plug in the right insert the second power plug in the left side of the carrier.
5. Wait for the system to reboot.
  - c. Test the MSSNET circuit pack using the **test mssnet long** command.
  - d. Verify that the tape and disk are in service by issuing the **status spe** command.
6. If the SPE is duplicated:
  - a. Refer to “Replacing SPE Circuit Packs” in Chapter 5.
  - b. After the standby SPE is powered up and fully refreshed, test the standby MSSNET circuit pack using the **test mssnet long command**.

## Error Log Entries and Test to Clear Values

Table 9-340. Host Adapter Error Log Entries

Error Type	Aux Data <sup>1</sup>	Associated Test	Alarm Level	On/Off Board	Test to Clear Value
1(a)	any	Host Adapter Hdwr Reset (#820)	MINOR	ON	test host-ad a b <sup>2</sup> l
18 (b)	0	Busyout host-ad	WARNING	OFF	rel host-ad a b <sup>2</sup>
257(c)	any	Host Adapter Diag (#823)	WARNING	ON	test host-ad a b <sup>2</sup> l r 3
513(d)	any	Host Adapter Diag (#823)	MINOR	ON	test host-ad a b <sup>2</sup> l r 3
529(e)	0	Host Adapter Reset (#893)	WARNING	ON	reset host-ad a b <sup>2</sup>
769(f)	any	Host Adapter Looparound (#824)	MINOR	OFF	test host-ad a b <sup>2</sup> sh r 2
1281(g)	any	Host Adapter Diag (#823)	MINOR	OFF	test host-ad a b <sup>2</sup> l r 2

Continued on next page

**Table 9-340. Host Adapter Error Log Entries — Continued**

Error Type	Aux Data <sup>1</sup>	Associated Test	Alarm Level	On/Off Board	Test to Clear Value
1793(h)	any	Host Adapter Diag (#823)	MINOR	OFF	test host-ad a b <sup>2</sup>   r 2
2049(i)	any	Host Adapter Diag (#823)	MINOR	ON	test host-ad a b <sup>2</sup>   r 2
2305(j)	any	Host Adapter Diag (#823)	MINOR	ON	test host-ad a b <sup>2</sup>   r 2
2561(k)	any	Host Adapter Diag (#823)	MINOR	ON	test host-ad a b <sup>2</sup>   r 2
2817(l)	any	Host Adapter Hdwr Reset (#820)	MINOR	ON	test host-ad a b <sup>2</sup>   2
3073(m)	any	Host Adapter Status (#825)	WARNING	OFF	test host-ad a b <sup>2</sup> sh 2
3329(n)	any	Host Adapter Hdwr Reset (#820)	WARNING	OFF	test host-ad a b   r 4
3585(o)	any	In line errors	MINOR	ON	test host-ad a b <sup>2</sup>   r 2
3841(p)	<sup>3</sup>	Miscellaneous	WARNING	OFF	test host-ad a b <sup>2</sup>   r 1

1. If Error Type 3585 with aux data of 5302 is present, this field will have the out of service cause data. See the *MSS Error Actions* table at the end of the section on TAPE.
2. In a system with a simplex SPE, the carrier does not have to be specified. In a system with duplicated SPE, the carrier (a or b) must be specified.
3. See the *MSS Error Actions* table at the end of the section on TAPE.

The *Service State* field in the alarm log refers to the accessibility of the device. IN (in service) means that users can access the device and all maintenance tests will run. MTC (maintenance busy) means the device is busied out; users cannot access it, but all maintenance tests will run. OUT (out of service) means that users cannot access the device and background testing will not run. Demand testing may or may not run depending on the severity of the error.

**Notes:**

- a. Indicates that the host adapter hardware is in a “held reset” state.
- b. Indicates that the host adapter has been “busied out.”
- c. Indicates that non-critical host adapter diagnostics failed.
- d. Indicates that critical host adapter diagnostics failed.

- e. Indicates that the Host Adapter Reset (#820 or #893) failed or that the hardware is in a “held reset” state.
- f. Indicates that the Host Adapter Looparound Test (#824) failed.
- g. Indicates that the host adapter detected a processor bus error.
- h. Indicates that the host adapter could not access SCSI memory.
- i. Indicates that the host adapter detected an illegal command or a command was aborted.
- j. Indicates that the host adapter detected an internal firmware or OS software error.
- k. Indicates that the host adapter detected an interrupt or exception.
- l. Indicates that the host adapter detected a flash prom programming error.
- m. Indicates that the Host Adapter Status Test (#825) detected an error in the host adapter configuration status or in the LED status test. See the *MSS Error Actions* table at the end of the section on TAPE.
- n. Indicates internal host adapter software errors.
- o. Indicates in-line errors reported by the host adapter firmware. See the *MSS Error Actions* table at the end of the section on TAPE.
- p. This is used to record miscellaneous data when an out-of-service condition occurs. See the *MSS Error Actions* table at the end of the section on TAPE.

### System Technician-Demanded Tests: Descriptions and Error Codes

Always investigate tests in the order presented in the table below. By clearing error codes associated with the *Host Adapter Diagnostic Test*, for example, you may also clear errors generated from other tests in the testing sequence.

**Table 9-341. System Technician-Demanded Tests: DS1-BD**

Order of Investigation	Short Test Sequence	Long Test Sequence	Reset Board Sequence	D/ND <sup>1</sup>
Host Adapter Reset Test (#820)		X		ND
Host Adapter Diagnostic Test (#823)	X	X		ND
Host Adapter Looparound Test (#824)	X	X		ND
Host Adapter Status Test (#825)	X	X		ND
Host Adapter Firmware Error Counters	X	X		ND

**Table 9-341. System Technician-Demanded Tests: DS1-BD — Continued**

Order of Investigation	Short Test Sequence	Long Test Sequence	Reset Board Sequence	D/ND <sup>1</sup>
Read and Clear Test (#822)				
Host Adapter Reset (#893)			X	ND

1. D = Destructive, ND = Non-destructive

### Host Adapter Reset Test (#820 and #893)

The Reset Test #820 resets the host adapter circuit on the MSSNET circuit pack and runs an initialization test. The initialization test is similar to the Diagnostic Test #823 with two exceptions: a test is run on the host adapter dual port RAM during the reset test and a test involving system bus mastership is run during the diagnostic test.

The reset test can be run in two ways: as a part of the long host adapter test sequence (**test host-adapter long**) or as a result of the reset host adapter command (**reset host-adapter**). Failure of the reset command cause the host adapter to be placed in an internal "held reset" state. In this state the host adapter will not run any background maintenance and will not respond to any commands except a reset command. The only way to restore the host adapter to service is for it to pass the reset command. Demand tests will not run until then.

If the reset test is requested as part of the long host adapter test sequence, failure of the test causes the host adapter to be placed in a software "out-of-service" state. From this state the host adapter can be restored to service by either passing the long host adapter test sequence the proper number of times or by passing the reset command. Refer to the Diagnostic Test #823 for a more complete description of the test coverage.

**Table 9-342. TEST #820/#893 Host Adapter Reset Test**

Error Code	Test Result	Description/ Recommendation
1316	ABORT	Could not allocate the Mass Storage System to run this test. Other application software may be using it or background maintenance tests may be running. <ol style="list-style-type: none"> <li>1. Retry the command at 1-minute intervals for a maximum of 5 retries.</li> <li>2. If the test continues to abort, verify that the daily translation-save operation is not in progress (issue the <b>display system-parameters maintenance</b> command to display the time for scheduled maintenance and the "y/n" option for saving translation daily).</li> </ol>
1335	ABORT	Could not run the test on the Standby SPE—Duplication not administered. <ol style="list-style-type: none"> <li>1. Refer to "STBY-SPE".</li> <li>2. Administer standby present.</li> </ol>
1338	ABORT	Could not run the test on the Standby SPE—Interchange pending. <ol style="list-style-type: none"> <li>1. Refer to "STBY-SPE".</li> <li>2. After interchange occurs, run test on new active SPE.</li> </ol>
1339	ABORT	Could not run the test on the Standby SPE—Handshake down. <ol style="list-style-type: none"> <li>1. Refer to "STBY-SPE".</li> <li>2. When the standby is restored to service (use <b>status spe</b> to determine state of standby) retry the command.</li> </ol>
1347	ABORT	Could not run the test on the Standby SPE—Refresh not complete. <ol style="list-style-type: none"> <li>1. When the standby is restored to service (use <b>status spe</b> to determine state of standby) retry the command.</li> </ol>
1350	ABORT	Could not run the test on the Standby SPE—Shadowing not enabled. <ol style="list-style-type: none"> <li>1. When the standby is restored to service (use <b>status spe</b> to determine state of standby) retry the command.</li> </ol>
2000	ABORT	Response to the test request was not received within the allowable time period. <ol style="list-style-type: none"> <li>1. Retry the command at 1-minute intervals a maximum of 5 times.</li> </ol>
2500	ABORT	Could not run the test on the Standby SPE—Internal software error. <ol style="list-style-type: none"> <li>1. Retry the command at 1-minute intervals a maximum of 5 times.</li> </ol>
5102	ABORT	Could not allocate the Mass Storage System to run this test <ol style="list-style-type: none"> <li>1. Retry the command at 1-minute intervals a maximum of 5 times.</li> <li>2. If the test continues to abort, verify that the daily translation-save operation is not in progress (issue the <b>display system-parameters maintenance</b> command to display the time for scheduled maintenance and the "y/n" option for saving translation daily).</li> </ol>



**Table 9-342. TEST #820/#893 Host Adapter Reset Test — Continued**

Error Code	Test Result	Description/ Recommendation
	NO BOARD	The host adapter has been placed in the "uninstalled" state. 1. Verify that the host adapter is fully inserted and powered up. 2. Attempt a demand reset of the host adapter.
1	FAIL	The host adapter could not be reset successfully. 1. Retry the command after 1 minute. 2. If the test fails, issue the <b>reset host-adapter</b> command. 3. If the command fails, replace the MSSNET circuit pack (see the circuit pack replacement section above) and issue the <b>test mssnet long</b> command.
	PASS	The host adapter was reset correctly. Check results of other tests to see if it is operating correctly.

1. See the MSS Error Actions table at the end of the section on TAPE.

### Host Adapter Read and Clear Firmware Error Counters Test (#822)

The host adapter firmware constantly executes background testing of the host adapter hardware. If any irregularities are detected, counters in dual port RAM are incremented. The Read and Clear Firmware Error Counters test reads these counters from the host adapter dual port RAM and increments the appropriate software counters based on which ones are non-zero. The dual port RAM counters are then cleared.

The firmware maintains sixteen counters that record the following errors:

- Unexpected interrupt from the SCSI Bus Interface Controller Chip (SBICC).
- SBICC timed out during SCSI command.
- Direct Memory Access Controller (DMAC) generated error interrupt.
- DMAC timed out without interrupt.
- Universal Synchronous/Asynchronous Receiver/Transmitter (USART) diagnostics failed.
- Host adapter LED test failed.
- Tape LED test failed.

- Disk LED test failed.
- Processor bus dual port RAM test failed.
- Processor bus IO registers test failed.
- External host adapter loop around failed.
- Illegal SCSI target controller requested.
- Interrupt during processor bus access.
- Bus timeout during processor bus access.
- Parity error during processor bus access.
- Error Detection and Correction (EDC) error during processor bus access.

**Table 9-343. TEST #822 Host Adapter Read and Clear Firmware Error Counters Test**

Error Code	Test Result	Description/ Recommendation
1311	ABORT	Could not read the firmware error counters 1. Retry the command at 1-minute intervals a maximum of 5 retries.
1316	ABORT	Could not allocate the Mass Storage System to run this test. Other application software may be using it or background maintenance tests may be running. 1. Retry the command at 1-minute intervals for a maximum of 5 retries. 2. If the test continues to abort, verify that the daily translation-save operation is not in progress (issue the <b>display system-parameters maintenance</b> command to display the time for scheduled maintenance and the "y/n" option for saving translation daily).
1335	ABORT	Could not run the test on the Standby SPE—Duplication not administered. 1. Refer to "STBY-SPE". 2. Administer standby present.
1338	ABORT	Could not run the test on the Standby SPE—Interchange pending. 1. Refer to "STBY-SPE". 2. After interchange occurs, run test on new active SPE.
1339	ABORT	Could not run the test on the Standby SPE—Handshake down. 1. Refer to "STBY-SPE". 2. When the standby is restored to service (use <b>status spe</b> to determine state of standby) retry the command.
1347	ABORT	Could not run the test on the Standby SPE—Refresh not complete. 1. When the standby is restored to service (use <b>status spe</b> to determine state of standby) retry the command.

**Table 9-343. TEST #822 Host Adapter Read and Clear Firmware Error Counters Test — Continued**

Error Code	Test Result	Description/ Recommendation
1350	ABORT	Could not run the test on the Standby SPE—Shadowing not enabled. 1. When the standby is restored to service (use <b>status spe</b> to determine state of standby) retry the command.
2000	ABORT	Response to the test request was not received within the allowable time period. 1. Retry the command at 1-minute intervals a maximum of 5 retries.
2500	ABORT	Could not run the test on the Standby SPE—Internal software error. 1. Retry the command at 1-minute intervals a maximum of 5 retries.
5102	ABORT	Could not allocate the Mass Storage System to run this test 1. Retry the command at 1-minute intervals for a maximum of 5 retries. 2. If the test continues to abort, verify that the daily translation-save operation is not in progress (issue the <b>display system-parameters maintenance</b> command to display the time for scheduled maintenance and the "y/n" option for saving translation daily).
	NO BOARD	The host adapter has been placed in the "uninstalled" state. 1. Verify that the host adapter is fully inserted and powered up. 2. Attempt a demand reset of the host adapter.
1	FAIL	The Read and Clear Firmware Error Counters test detected a non-zero firmware error counter. 1. Retry the command at 1-minute intervals a maximum of 5 retries. 2. If the command continues to fail, replace the MSSNET circuit pack (see the circuit pack replacement section above) and issue the <b>test mssnet long</b> command.
	PASS	The Read and Clear Firmware Error Counters test completed successfully without detecting a non-zero firmware error counter. Look at the results of other tests to see if it is operating correctly.

1. See the MSS Error Actions table at the end of the section on TAPE.

### Host Adapter Diagnostic Test (#823)

The Host Adapter Diagnostic test runs a set of non-destructive diagnostic tests for the Host Adapter. This includes tests requiring system bus mastership. Specific tests include:

- Micro processor testing including exception processing
- Private RAM test
- EPROM and FLASHROM checksum test
- SPE side Dual Port RAM test
- Control and status register test
- System memory access test
- SCSI bus access test
- SCSI memory access test
- Sanity timer test
- SCSI side Dual Port RAM test

A more complete test of the access to the disk and tape drives over the SCSI bus is provided by the DISK and TAPE tests.

**Table 9-344. TEST #823 Host Adapter Diagnostic Test**

Error Code	Test Result	Description/ Recommendation
1316	ABORT	Could not allocate the Mass Storage System to run this test. Other application software may be using it or background maintenance tests may be running. <ol style="list-style-type: none"> <li>1. Retry the command at 1-minute intervals for a maximum of 5 retries.</li> <li>2. If the test continues to abort, verify that the daily translation-save operation is not in progress (issue the <b>display system-parameters maintenance</b> command to display the time for scheduled maintenance and the "y/n" option for saving translation daily).</li> </ol>
1335	ABORT	Could not run the test on the Standby SPE—Duplication not administered. <ol style="list-style-type: none"> <li>1. Refer to "STBY-SPE".</li> <li>2. Administer standby present.</li> </ol>
1338	ABORT	Could not run the test on the Standby SPE—Interchange pending. <ol style="list-style-type: none"> <li>1. Refer to "STBY-SPE".</li> <li>2. After interchange occurs, run test on new active SPE.</li> </ol>
1339	ABORT	Could not run the test on the Standby SPE—Handshake down. <ol style="list-style-type: none"> <li>1. Refer to "STBY-SPE".</li> <li>2. When the standby is restored to service (use <b>status spe</b> to determine state of standby) retry the command.</li> </ol>

*Continued on next page*

**Table 9-344. TEST #823 Host Adapter Diagnostic Test — Continued**

Error Code	Test Result	Description/ Recommendation
1347	ABORT	Could not run the test on the Standby SPE—Refresh not complete. 1. When the standby is restored to service (use <b>status spe</b> to determine state of standby) retry the command.
1350	ABORT	Could not run the test on the Standby SPE—Shadowing not enabled. 1. When the standby is restored to service (use <b>status spe</b> to determine state of standby) retry the command.
2000	ABORT	Response to the test was not received within the allowable time period. 1. Retry the command at 1-minute intervals for a maximum of 5 retries.
2500	ABORT	Could not run the test on the Standby SPE—Internal software error. 1. Retry the command at 1-minute intervals a maximum of 5 retries.
5102	ABORT	Could not allocate the Mass Storage System to run this test 1. Retry the command at 1-minute intervals a maximum of 5 retries. 2. If the test continues to abort, verify that the daily translation-save operation is not in progress (issue the <b>display system-parameters maintenance</b> command to display the time for scheduled maintenance and the "y/n" option for saving translation daily).
	NO BOARD	The host adapter has been placed in the "uninstalled" state. 1. Verify that the host adapter is fully inserted and powered up. 2. Attempt a demand reset of the host adapter.
1	FAIL	The Host Adapter Diagnostic test could not be run successfully. 1. Replace the MSSNET circuit pack (see the circuit pack replacement section above) and issue the <b>test mssnet long</b> command.
	PASS	The Host Adapter Diagnostic Test completed successfully. Look at the results of other tests to see if it is operating correctly.

1. See the MSS Error Actions table at the end of the section on TAPE.

### Host Adapter Looparound Test (#824)

The Host Adapter Looparound test provides a partial functional test which verifies that the host adapter can perform data transfer functions.

This test performs two subtests:

- Internal loop-around test
- External loop-around test

Note that this test is entirely contained in the host adapter and does not test access to the system.

**Table 9-345. TEST #824 Host Adapter Looparound Test**

Error Code	Test Result	Description/ Recommendation
1316	ABORT	Could not allocate the Mass Storage System to run this test. Other application software may be using it or background maintenance tests may be running. <ol style="list-style-type: none"> <li>1. Retry the command at 1-minute intervals a maximum of 5 retries.</li> <li>2. If the test continues to abort, verify that the daily translation-save operation is not in progress (issue the <b>display system-parameters maintenance</b> command to display the time for scheduled maintenance and the "y/n" option for saving translation daily).</li> </ol>
1335	ABORT	Could not run the test on the Standby SPE—Duplication not administered. <ol style="list-style-type: none"> <li>1. Refer to "STBY-SPE".</li> <li>2. Administer standby present.</li> </ol>
1338	ABORT	Could not run the test on the Standby SPE—Interchange pending. <ol style="list-style-type: none"> <li>1. Refer to "STBY-SPE".</li> <li>2. After interchange occurs, run test on new active SPE.</li> </ol>
1339	ABORT	Could not run the test on the Standby SPE—Handshake down. <ol style="list-style-type: none"> <li>1. Refer to "STBY-SPE".</li> <li>2. When the standby is restored to service (use <b>status spe</b> to determine state of standby) retry the command.</li> </ol>
1347	ABORT	Could not run the test on the Standby SPE—Refresh not complete. <ol style="list-style-type: none"> <li>1. When the standby is restored to service (use <b>status spe</b> to determine state of standby) retry the command.</li> </ol>
1350	ABORT	Could not run the test on the Standby SPE—Shadowing not enabled. <ol style="list-style-type: none"> <li>1. When the standby is restored to service (use <b>status spe</b> to determine state of standby) retry the command.</li> </ol>
2000	ABORT	Response to the test was not received within the allowable time period. <ol style="list-style-type: none"> <li>1. Retry the command at 1-minute intervals a maximum of 5 retries.</li> </ol>
2500	ABORT	Could not run the test on the Standby SPE—Internal software error. <ol style="list-style-type: none"> <li>1. Retry the command at 1-minute intervals for a maximum of 5 retries.</li> </ol>

Table 9-345. TEST #824 Host Adapter Looparound Test — *Continued*

Error Code	Test Result	Description/ Recommendation
5102	ABORT	Could not allocate the Mass Storage System to run this test <ol style="list-style-type: none"><li>1. Retry the command at 1-minute intervals a maximum of 5 retries.</li><li>2. If the test continues to abort, verify that the daily translation-save operation is not in progress (issue the <b>display system-parameters maintenance</b> command to display the time for scheduled maintenance and the "y/n" option for saving translation daily).</li></ol>
	NO BOARD	The host adapter has been placed in the "uninstalled" state. <ol style="list-style-type: none"><li>1. Verify that the host adapter is fully inserted and powered up.</li><li>2. Attempt a demand reset of the host adapter.</li></ol>
1	FAIL	The host adapter loop around test could not be run successfully. <ol style="list-style-type: none"><li>1. Replace the MSSNET circuit pack (see the circuit pack replacement section above) and issue the <b>test mssnet long</b> command.</li></ol>
	PASS	The host adapter loop around Test completed successfully. Look at the results of other tests to see if it is operating correctly.

---

1. See the MSS Error Actions table at the end of the section on TAPE.

---

## Host Adapter Status Test (#825)

This test verifies the following host adapter circuit operations:

- The LED s on the MSSNET circuit pack can be turned on and off correctly.  
Note that this only verifies that the control and status logic for the LED s is operating correctly. The operation of the LED s may be tested visually by using the **test led** command.
- The MSS configuration information is correct (the host adapter is not in the "held reset" state).

**Table 9-346. TEST #825 Host Adapter Status Test**

Error Code	Test Result	Description/ Recommendation
1312 1313 1314	ABORT	Internal software error between maintenance software and mss driver. 1. Retry the command at 1-minute intervals for a maximum of 5 retries.
1316	ABORT	Could not allocate the Mass Storage System to run this test. Other application software may be using it or background maintenance tests may be running. 1. Retry the command at 1-minute intervals for a maximum of 5 retries. 2. If the test continues to abort, verify that the daily translation-save operation is not in progress (issue the <b>display system-parameters maintenance</b> command to display the time for scheduled maintenance and the "y/n" option for saving translation daily).
1335	ABORT	Could not run the test on the Standby SPE—Duplication not administered. 1. Refer to "STBY-SPE". 2. Administer standby present.
1338	ABORT	Could not run the test on the Standby SPE—Interchange pending. 1. Refer to "STBY-SPE". 2. After interchange occurs, run test on new active SPE.
1339	ABORT	Could not run the test on the Standby SPE—Handshake down. 1. Refer to "STBY-SPE". 2. When the standby is restored to service (use <b>status spe</b> to determine state of standby) retry the command.
1347	ABORT	Could not run the test on the Standby SPE—Refresh not complete. 1. When the standby is restored to service (use <b>status spe</b> to determine state of standby) retry the command.
1350	ABORT	Could not run the test on the Standby SPE—Shadowing not enabled. 1. When the standby is restored to service (use <b>status spe</b> to determine state of standby) retry the command.
2000	ABORT	Response to the test request was not received within the allowable time period. 1. Retry the command at 1-minute intervals for a maximum of 5 retries.
2500	ABORT	Could not run the test on the Standby SPE—Internal software error 1. Retry the command at 1-minute intervals for a maximum of 5 retries.

*Continued on next page*



Table 9-346. TEST #825 Host Adapter Status Test — Continued

Error Code	Test Result	Description/ Recommendation
5102	ABORT	Could not allocate the Mass Storage System to run this test <ol style="list-style-type: none"><li>1. Retry the command at 1-minute intervals for a maximum of 5 retries.</li><li>2. If the test continues to abort, verify that the daily translation-save operation is not in progress (issue the <b>display system-parameters maintenance</b> command to display the time for scheduled maintenance and the "y/n" option for saving translation daily).</li></ol>
	NO BOARD	The host adapter has been placed in the "uninstalled" state. <ol style="list-style-type: none"><li>1. Verify that the host adapter is fully inserted and powered up.</li><li>2. Attempt a demand reset of the host adapter.</li></ol>
<sup>1</sup>	FAIL	The host adapter status test could not be run successfully. <ol style="list-style-type: none"><li>1. Replace the MSSNET circuit pack (see the circuit pack replacement section above) and issue the <b>test mssnet long</b> command.</li></ol>
	PASS	The host adapter status test completed successfully. Look at the results of other tests to see if it is operating correctly.

---

1. See the MSS Error Actions table at the end of the section on TAPE.

---

### Host Adapter Reset Test (#893)

The Host Adapter Reset Test #893 is run on demand in response to the **reset host-adapter** command. This test resets the host adapter circuit on the MSSNET circuit pack and runs an initialization test.

Failure of the reset command will cause the host adapter to be placed in an internal "held reset" state. In this state the host adapter will not run any background maintenance and will not respond to any commands except a reset command. The only way to restore the host adapter to service is for it to pass the reset command. Demand tests will not run until then.

The test results for Test 893 are the same as those for Test 820. Refer to the information presented for Test 820 for the appropriate repair procedures.

## **HYB-BD (Hybrid Line Circuit Pack)**

---

<b>MO Name (in Alarm Log)</b>	<b>Alarm Level</b>	<b>Initial Command to Run<sup>1</sup></b>	<b>Full Name of MO</b>
HYB-BD	MIN	test board UUCSS sh	Hybrid Line Circuit Pack
HYB-BD	WRN	test board UUCSS sh	Hybrid Line Circuit Pack

- 
1. UU is the universal cabinet number (1 for PPN, 2 - 44 for EPN s). C is the carrier designation (A, B, C, D, or E). SS is the number of the slot in which the circuit pack resides (01 to 21).

Refer to XXX-BD (Common Port Circuit Pack) Maintenance documentation for circuit pack level errors. See also HYB-LINE (Hybrid Line) Maintenance documentation for related line information.

## HYB-LINE (Hybrid Line)

MO Name (in Alarm Log)	Alarm Level	Initial Command to Run <sup>1</sup>	Full Name of MO
HYB-LINE	Minor	test port UUCSSpp l	Hybrid Line
HYB-LINE	Warning	test port UUCSSpp l	Hybrid Line

1. UU is the universal cabinet number (1 for PPN, 2 - 44 for EPN s). C is the carrier designation (A, B, C, D, or E). SS is the number of the slot in which the circuit pack resides (01 to 21). pp is the two digit port number (01, 02, ...).

Hybrid Line is another term for the Multi-Function Analog Telephone (MFAT). The Hybrid Line set is also known as an SCS (Small Communications System).

The TN762B Hybrid Line circuit pack supports eight of these multifunction analog telephone sets. The Hybrid Line sets use three pairs of wires: an analog voice pair, a transmit/receive pair, and a power pair.

This section describes HYB-LINE (Hybrid Line) maintenance. HYB-LINE maintenance is closely related to, and sometimes interacts with, HYB-BD (Hybrid Line circuit pack) maintenance. This interaction should be kept in mind when troubleshooting Hybrid Line problems.

This section occasionally refers to a station's service state. These service states are defined as follows:

Out-of-Service	The port, and thus the station, have been removed from service. A busyout of a port will cause it to be out-of-service.
Ready-for-Service	The port on the circuit pack has been put into service, but the voice terminal has not yet established signaling communications with the port.
In-Service	The voice terminal has established signaling communications with the port, and the system is ready to process calls to and from that station. A terminal in the ready-for-service state will progress to the in-service state if it is functioning normally, but it can also be forced into the in-service state if it goes off-hook.

Use **status station** to determine terminal service state. Status is reported as either out-of-service, in-service, or disconnect. The latter is equivalent to the ready-for-service state.

**Error Log Entries and Test to Clear Values****Table 9-347. Hybrid Line Error Log Entries**

Error Type	Aux Data	Associated Test	Alarm Level	On/Off Board	Test to Clear Value
0 <sup>1</sup>	0	Any	Any	Any	test port UUCSSpp sh r 1
1(a)	40987	None	WARNING	OFF	
15(j)	Any	Hybrid Line Audits Test(#161)			
18(b)	0	busyout port UUCSSpp	WARNING	OFF	release port UUCSSpp
130(c)		None	WARNING	ON	test port UUCSSpp sh
257(d)	40988	None	MIN/WRN	OFF	
513(e)	40965	Hybrid Line Audits Test (#61)	WARNING	OFF	test port UUCSSpp sh r 4
769(f)		Remote Dig Looparound Test (#59)	WARNING	OFF	test port UUCSSpp sh r 3
1025		Hybrid & Conf. Circuits Test (#57)	MIN/WRN	ON	test port UUCSSpp l r 3
1281(f)		Local Digital Looparound Test (#58)	WARNING	ON	test port UUCSSpp l r 3
1537(g)	40968	None	WARNING	OFF	
1793		TDM NPE Crosstalk Test (#6)	MIN/WRN <sup>2</sup>	ON	test port UUCSSpp l r 3
2049(h)	32770	None			
2049(i)	40967	None			

1. Run the Short Test Sequence first. If all tests pass, run the Long Test Sequence. Refer to the appropriate test description and follow the recommended procedures.
2. Major or minor alarms may be downgraded to Warning alarms based on the value used in the set options command.

**Notes:**

- a. The data link between the port and the terminal is not operational. (An off-board problem was detected by port circuit). Verify that the Hybrid set is connected and that the Electronic Power Feed (EPF) test passes. If data transmission problems are experienced, check for defective wiring or a defective voice terminal, or move terminal closer to the switch (reduce the

length of the wiring between the terminal and the switch). If the problem persists, replace the circuit pack. Once the problem has been resolved, the alarm will be retired after a predetermined delay.

- b. Error type 18 indicates the port is busied out. The port is released with **release port** UUCSSpp.
- c. The circuit pack has been removed or has been insane for more than 11 minutes. To clear the error, reinsert or replace the circuit pack.
- d. The EPF has been turned off due to an overcurrent condition at the voice terminal. Check for defective wiring or a damaged jack, and make sure the voice terminal is a Hybrid set. Once the problem has been resolved, the alarm will be retired after a predetermined delay.
- e. The voice terminal has been disconnected or there is a problem in the wiring to the terminal. Make sure that the voice terminal is connected or check for defective wiring to the voice terminal.
- f. Note that Error Types 769 and 1281 by themselves create Warning alarms only, but if both are present, a Minor alarm will be logged.
- g. The port has reported a problem with the data link to the voice terminal. Ignore this error if there are no complaints about the voice terminal. Otherwise, make sure the voice terminal is connected, check for defective wiring, check for a defective voice terminal, and decrease the length of the wiring between the voice terminal and the switch. If the problem persists, replace the circuit pack.
- h. The voice terminal went off-hook while in the disconnect state. Use the **status station** command to determine the state of the terminal. The off-hook should have moved the terminal to in-service. No repair action is necessary.
- i. The link between the circuit pack and the voice terminal has been successfully reset. No repair action is necessary.
- j. Error 15 indicates a software audit error that does not indicate any hardware malfunction. Run the short test sequence and investigate any errors.

## System Technician-Demanded Tests: Descriptions and Error Codes

Always investigate tests in the order presented in the table below. By clearing error codes associated with the *Local Digital Looparound Test*, for example, you may also clear errors generated from other tests in the testing sequence.

**Table 9-348. System Technician-Demanded Tests: DS1-BD**

Order of Investigation	Short Test Sequence	Long Test Sequence	D/ND <sup>1</sup>
NPE Crosstalk Test (#6)		X	ND
Hybrid Electronic Power Feed Test (#56)		X	ND
Hybrid Circuit and Conference Circuit Test (#57)		X	ND
Local Digital Looparound Test (#58)		X	ND
Remote Digital Looparound Test (#59)	X	X	ND
Station Lamp Update Test (#60)	X	X	ND
Station Audits Test (#61)	X	X	ND
Ringer Update Test (#62)	X	X	ND

1. D = Destructive, ND = Non-destructive

### NPE Crosstalk Test (#6)

The NPE Crosstalk Test verifies that this port's NPE channel talks on the selected time slot and never crosses over to time slots reserved for other connections. If the NPE is not working correctly, one-way and noisy connections may be observed. This test is part of a port's Long Test Sequence and takes about 20 to 30 seconds to complete.

**Table 9-349. TEST #6 NPE Crosstalk Test**

Error Code	Test Result	Description/ Recommendation
	ABORT	Could not allocate the necessary system resources to run this test. 1. Retry the command at 1-minute intervals a maximum of 5 times.

*Continued on next page*

**Table 9-349. TEST #6 NPE Crosstalk Test — Continued**

Error Code	Test Result	Description/ Recommendation
1000	ABORT	System resources required to run this test are not available. The port may be busy with a valid call. <ol style="list-style-type: none"> <li>1. Use the <b>display port UUCSSpp</b> command to determine the station extension number of the port. Use the <b>status station</b> command to determine the service state of the port. If the port is in use, wait until the port is idle before testing.</li> <li>2. If the port status is idle, then retry the command at 1-minute intervals a maximum of 5 times.</li> </ol>
1001	ABORT	Could not allocate the necessary system resources to run this test. This could be a failure to seize the port. <ol style="list-style-type: none"> <li>1. Retry the command at 1-minute intervals a maximum of 5 times.</li> </ol>
1002	ABORT	The system could not allocate time slots for the test. The system may be under heavy traffic conditions or it may have time slots out-of-service due to TDM-BUS errors. <ol style="list-style-type: none"> <li>1. If system has no TDM-BUS errors and is not handling heavy traffic, repeat test at 1-minute intervals a maximum of 5 times.</li> </ol>
1003	ABORT	The system could not allocate a tone receiver for the test. The system may be oversized for the number of Tone Detectors present or some Tone Detectors may be out-of-service. <ol style="list-style-type: none"> <li>1. Resolve any TTR-LEV errors.</li> <li>2. Resolve any TONE-PT errors.</li> <li>3. If neither condition exists, retry the test at 1-minute intervals a maximum of 5 times.</li> </ol>
1004	ABORT	The port was seized by a valid call during the test. The test has been aborted. <ol style="list-style-type: none"> <li>1. Use the <b>display port UUCSSpp</b> command to determine the station extension number of the port. Use the <b>status station</b> command to determine the service state of the port. If the port is in use, wait until the port is idle before testing.</li> <li>2. Retry the command at 1-minute intervals a maximum of 5 times.</li> </ol>
1018	ABORT	Test disabled via administration. This only applies to analog stations.  The default for this field is 'y,' so you may want to determine why it has been turned off for this station. <ol style="list-style-type: none"> <li>1. To enable test, set the Test field on the station administration screen for the particular analog station being tested to 'y.' Use the <b>change station &lt;extension&gt;</b> command.</li> </ol>
2000	ABORT	Response to the test request was not received within the allowable time period. <ol style="list-style-type: none"> <li>1. Retry the command at 1-minute intervals a maximum of 5 times.</li> </ol>

*Continued on next page*

**Table 9-349. TEST #6 NPE Crosstalk Test — Continued**

Error Code	Test Result	Description/ Recommendation
2020	ABORT	The test did not run due to an already existing error on the specific port or a more general circuit pack error. <ol style="list-style-type: none"> <li>1. Examine Error Log for existing errors against this port or the circuit pack and attempt to diagnose the already existing error.</li> </ol>
2100	ABORT	Could not allocate the necessary system resources to run this test. This could be due to a failure to seize the port. <ol style="list-style-type: none"> <li>1. Retry the command at 1-minute intervals a maximum of 5 times.</li> </ol>
Any	FAIL	This test can fail due to on-board or off-board problems. Off-board problems of concern include EXP-PN and EXP-INTF faults, TDM-BUS faults, and faults associated with the tone detectors/tone generators. Clear all off-board problems before replacing the board. Keep in mind that a TDM-BUS problem is usually the result of a faulty board connected to the backplane or bent pins on the backplane. <ol style="list-style-type: none"> <li>1. Resolve any "EXP-PN" and "EXP-INTF" errors in the error log.</li> <li>2. Resolve any "TDM-BUS" errors in the error log.</li> <li>3. Retest the board when the faults from steps 1 and 2 are cleared.</li> </ol>
	PASS	The port is correctly using its allocated time slots. User-reported troubles on this port should be investigated using other port tests and by examining station, trunk, or external wiring.
0	NO BOARD	The test could not relate the internal ID to the port (no board). This could be due to incorrect translations, no board is inserted, an incorrect board is inserted, or an insane board is inserted. <ol style="list-style-type: none"> <li>1. Check to ensure that the board translations are correct. Use the <b>list config</b> command, and resolve any problems that are found.</li> <li>2. If the board was found to be correctly inserted in step 1, issue the <b>busyout board</b> command.</li> <li>3. Issue the <b>reset board</b> command.</li> <li>4. Issue the <b>release busy board</b> command.</li> <li>5. Issue the <b>test board long</b> command. This should re-establish the linkage between the internal ID and the port. If this is not the case, dispatch to check to ensure that there is a valid board inserted.</li> </ol>

### Hybrid Electronic Power Feed Test (#56)

In this test, the software requests that the EPF be turned on for a given port. Then hardware attempts to turn on the power unit from the station. If no current is drawn, the station is probably not connected. If an overcurrent condition is



sensed (that is, too much current is being drawn), this may indicate a short in the loop or a defective voice terminal. A message is returned stating that either the EPF was turned on successfully, or that an overcurrent condition exists. This test is repeated once more 5 seconds later. If either test is not successful, the test will abort (see first ABORT entry in [Table 9-350](#)).

**Table 9-350. TEST #56 Hybrid Electronic Power Feed Test**

Error Code	Test Result	Description/ Recommendation
	ABORT	Internal system error 1. Retry the command at 1-minute intervals a maximum of 5 times.
1000	ABORT	System resources required to run this test are not available. The port may be busy with a valid call. 1. Use the <b>display port UUCSSpp</b> command to determine the station extension number of the port. Use the <b>status station</b> command to determine the service state of the port. If the port is in use, wait until the port is idle before testing. 2. If the port status is idle, then retry the command at 1-minute intervals a maximum of 5 times.
	FAIL	Internal system error 1. Retry the command at 1-minute intervals a maximum of 5 times.
	PASS	Electronic Power Feed test passed. The message to turn on the power to the station was successfully sent to the port. 1. Although this test will never actually return a FAIL result except for the <b>Internal system error</b> described above, it will log an error if the overcurrent case is detected by the hardware. Check the Error Log for any entries with Error Type 257 when the test has completed. 2. If Error Type 257 does not appear in the Error Log within 10 seconds after completion of this test, it is safe to assume that the test sensed no problems with the power to the station. To verify that the station is powered up correctly, run a self-test on the station, if available, and check that all the feature buttons are operating. 3. If Error Type 257 appears in the Error Log, this indicates some problem with the power to the station. Check for a short in the wiring, a damaged jack, a defective voice terminal, or an incorrect type of terminal.

**Table 9-350. TEST #56 Hybrid Electronic Power Feed Test — Continued**

Error Code	Test Result	Description/ Recommendation
0	NO BOARD	<p>The test could not relate the internal ID to the port (no board). This could be due to incorrect translations, no board is inserted, an incorrect board is inserted, or an insane board is inserted.</p> <ol style="list-style-type: none"> <li>1. Check to ensure that the board translations are correct. Use the <b>list config</b> command, and resolve any problems that are found.</li> <li>2. If the board was found to be correctly inserted in step 1, issue the <b>busyout board</b> command.</li> <li>3. Issue the <b>reset board</b> command.</li> <li>4. Issue the <b>release busy board</b> command.</li> <li>5. Issue the <b>test board long</b> command. This should re-establish the linkage between the internal ID and the port. If this is not the case, dispatch to check to ensure that there is a valid board inserted.</li> </ol>

### Hybrid Circuit and Conference Circuit Test (#57)

This test checks two different port circuit functions. The Hybrid Circuit test performs an analog reflective looparound measurement on the port's hybrid circuitry. The conference circuit test performs a conference test on the port's NPE.

For the *Hybrid Circuit Test* results to be valid, a voice terminal must be connected to the port being tested. The test instructs the on-board microprocessor to put the port in analog reflective looparound mode.

The *Conference Test* is performed only if the Hybrid Test passes. The Conference Circuit Test verifies that the Network Processing Element (NPE) is able to correctly conference several test tones together.

**Table 9-351. TEST #57 Hybrid Circuit and Conference Circuit Test**

Error Code	Test Result	Description/ Recommendation
	ABORT	<p>Could not allocate the necessary system resources to run this test.</p> <ol style="list-style-type: none"> <li>1. Retry the command at 1-minute intervals a maximum of 5 times.</li> </ol>

*Continued on next page*

Table 9-351. TEST #57 Hybrid Circuit and Conference Circuit Test — *Continued*

Error Code	Test Result	Description/ Recommendation
1000	ABORT	<p>System resources required to run this test are not available. The port may be busy with a valid call.</p> <ol style="list-style-type: none"> <li>1. Use the <b>display port UUCSSpp</b> command to determine the station extension number of the port. Use the <b>status station</b> command to determine the service state of the port. If the port is in use, wait until the port is idle before testing.</li> <li>2. If the port status is idle, then retry the command at 1-minute intervals a maximum of 5 times.</li> </ol>
1001	ABORT	<p>Could not allocate the necessary system resources to run this test. This could be a failure to seize the port.</p> <ol style="list-style-type: none"> <li>1. Retry the command at 1-minute intervals a maximum of 5 times.</li> </ol>
1002	ABORT	<p>The system could not allocate time slots for the test. The system may be under heavy traffic conditions or it may have time slots out-of-service due to TDM-BUS errors.</p> <ol style="list-style-type: none"> <li>1. If system has no TDM-BUS errors and is not handling heavy traffic, repeat test at 1-minute intervals a maximum of 5 times.</li> </ol>
1003	ABORT	<p>The system could not allocate a tone receiver for the test. The system may be oversized for the number of Tone Detectors present or some Tone Detectors may be out-of-service.</p> <ol style="list-style-type: none"> <li>1. Resolve any TTR-LEV errors.</li> <li>2. Resolve any TONE-PT errors.</li> <li>3. If neither condition exists, retry the test at 1-minute intervals a maximum of 5 times.</li> </ol>
1004	ABORT	<p>The port was seized by a valid call during the test. The test has been aborted.</p> <ol style="list-style-type: none"> <li>1. Use the <b>display port UUCSSpp</b> command to determine the station extension number of the port. Use the <b>status station</b> command to determine the service state of the port. If the port is in use, wait until the port is idle before testing.</li> <li>2. Retry the command at 1-minute intervals a maximum of 5 times.</li> </ol>
1392	ABORT	<p>This port is currently a TTI port and the test will not execute on it.</p> <ol style="list-style-type: none"> <li>1. Verify that the port is a TTI port using either the <b>display port</b> command (the display shows that the port is a TTI port) or the <b>list config</b> command (the display shows a <math>\tau</math> for the port).</li> <li>2. If either <b>list config</b> or <b>display port</b> indicate that the port is <i>not</i> a TTI port, escalate the problem. If both commands indicate that the port is a TTI port, the abort is correct, and no action is necessary.</li> </ol>

*Continued on next page*

**Table 9-351. TEST #57 Hybrid Circuit and Conference Circuit Test — Continued**

Error Code	Test Result	Description/ Recommendation
2000	ABORT	Response to the test request was not received within the allowable time period. 1. Retry the command at 1-minute intervals a maximum of 5 times.
2012	ABORT	Internal system error. 1. Retry the command at 1-minute intervals a maximum of 5 times.
2100	ABORT	The system could not allocate a tone generator for the test. 1. Resolve any TONE-PT errors. 2. If no TONE-PT errors appear in the Error Log, retry the test at 1-minute intervals a maximum of 5 times.
2103	ABORT	The system could not make the conference connection for the test. 1. Retry the command at 1-minute intervals a maximum of 5 times.
7	FAIL	Conference Test failed. User may be able to use conference circuit without difficulty in some cases. In other extreme cases, conference calling will be totally restricted.  The failure may be due to off-board circumstances, the most common of which is an off-hook occurring during the test. Also, check the error logs against the GPTD-BD, the TONE-BD, and the TONE-PT. 1. This error can be caused by a disconnected terminal. First, ensure that the terminal is connected and the wiring is OK. 2. Then, issue the <b>display port</b> and the <b>status station</b> commands to determine if the station is idle. If it is idle, issue the <b>test port</b> command for this port. 3. If test continues to fail, issue the <b>busyout port</b> and the <b>release port</b> commands, and then retest the port. 4. It is possible that the port may still be functional from a user's point of view.

*Continued on next page*

Table 9-351. TEST #57 Hybrid Circuit and Conference Circuit Test — *Continued*

Error Code	Test Result	Description/ Recommendation
57	FAIL	<p>Hybrid Circuit Test failed. This could result in noisy or bad connections.</p> <ol style="list-style-type: none"> <li>1. This error can be caused by a disconnected terminal. First, ensure that the terminal is connected and the wiring is OK.</li> <li>2. Run circuit pack tests to check the Tone Generator circuit pack and the Tone Detector circuit pack using the <b>test board UUCSS short</b> command.</li> <li>3. Resolve any problems that are detected on the Tone Generator circuit pack or Tone Detector circuit pack.</li> <li>4. If the Tone Generator and Tone Detector circuit packs are functioning properly, and the test still fails, replace the Hybrid Line circuit pack.</li> </ol> <p> <b>NOTE:</b>                      If the Hybrid Circuit and Conference Circuit Test fails for all ports on a circuit pack, a -5 volt power problem is indicated. The AC power unit may be defective. The system may contain a TN752 power unit circuit pack OR a 631DB AC power unit, <i>but not both types of power units</i>. To investigate problems with a power unit, refer to "CARR-POW".</p>
	PASS	<p>Hybrid Circuit and Conference Circuit Test passed. The hybrid circuitry is transmitting properly.</p> <ol style="list-style-type: none"> <li>1. If complaints still exist, investigate by using other port tests, and by examining the station, wiring, and connections.</li> </ol>
0	NO BOARD	<p>The test could not relate the internal ID to the port (no board). This could be due to incorrect translations, no board inserted, an incorrect board inserted, or an insane board inserted.</p> <ol style="list-style-type: none"> <li>1. Check that the board translations are correct. Use the <b>list config</b> command, and resolve any problems.</li> <li>2. If the board was found to be correctly inserted in step 1, issue the <b>busyout board</b> command.</li> <li>3. Issue the <b>reset board</b> command.</li> <li>4. Issue the <b>release busy board</b> command.</li> <li>5. Issue the <b>test board long</b> command. This should re-establish the linkage between the internal ID and the port. If this is not the case, check that there is a valid board inserted.</li> </ol>

### Hybrid Line Local Digital Looparound Test (#58)

This test checks the control channel between the Switch Processing Element (SPE) and the port's digital circuitry. The SPE sends transparent data to the on-board microprocessor and compares the data echoed back. This test is repeated three times.

**Table 9-352. TEST #58 Hybrid Line Local Digital Looparound Test**

Error Code	Test Result	Description/ Recommendation
	ABORT	Internal system error. 1. Retry the command at 1-minute intervals a maximum of 5 times.
1000	ABORT	System resources required to run this test are not available. The port may be busy with a valid call. 1. Use the <b>display port UUCSSpp</b> command to determine the station extension number of the port. Use the <b>status station</b> command to determine the service state of the port. If the port is in use, wait until the port is idle before testing. 2. If the port status is idle, then retry the command at 1-minute intervals a maximum of 5 times.
1004	ABORT	The port was seized by a valid call during the test. The test has been aborted. 1. Use the <b>display port UUCSSpp</b> command to determine the station extension number of the port. Use the <b>status station</b> command to determine the service state of the port. If the port is in use, wait until the port is idle before testing. 2. Retry the command at 1-minute intervals a maximum of 5 times.
2000	ABORT	Response to the test was not received within the allowable time period. 1. Retry the command at 1-minute intervals a maximum of 5 times.
1,2,3	FAIL	The control channel between the processor and the port is not transmitting properly. This port is not operable. 1. Retry the test. 2. If the failure still occurs, issue the <b>busyout</b> and the <b>release busy</b> commands, and then retest. 3. If the failure is occurring on more than one port on the board, suspect the board. 4. If the failure is occurring on several boards in the same carrier, escalate the problem. 5. If the failure appears to be isolated to one port, check all wiring to the set and all set connections. 6. Replace the circuit pack as a last resort.
	PASS	Hybrid Line Local Digital Looparound Test passed. The control channel is transmitting properly. 1. If complaints still exist, investigate by using other circuit pack tests, and by examining the station, wiring, and connections.

**Table 9-352. TEST #58 Hybrid Line Local Digital Looparound Test — Continued**

Error Code	Test Result	Description/ Recommendation
0	NO BOARD	<p>The test could not relate the internal ID to the port (no board). This could be due to incorrect translations, no board is inserted, an incorrect board is inserted, or an insane board is inserted.</p> <ol style="list-style-type: none"> <li>1. Check to ensure that the board translations are correct. Use the <b>list config</b> command, and resolve any problems that are found.</li> <li>2. If the board was found to be correctly inserted in step 1, issue the <b>busyout board</b> command.</li> <li>3. Issue the <b>reset board</b> command.</li> <li>4. Issue the <b>release busy board</b> command.</li> <li>5. Issue the <b>test board long</b> command. This should re-establish the linkage between the internal ID and the port. If this is not the case, dispatch to check to ensure that there is a valid board inserted.</li> </ol>

### Hybrid Line Remote Digital Looparound Test (#59)

This test checks the digital control pair from the port circuit to the terminal. The on-board microprocessor sends a message to the terminal and checks for a proper return message. This test is repeated three times, with two out of the three attempts passing being sufficient for this test to pass. This test will run if the station is in-service or out-of-service.

**Table 9-353. TEST #59 Hybrid Line Remote Digital Looparound Test**

Error Code	Test Result	Description/ Recommendation
	ABORT	<p>Internal system error</p> <ol style="list-style-type: none"> <li>1. Retry the command at 1-minute intervals a maximum of 5 times.</li> </ol>

*Continued on next page*

**Table 9-353. TEST #59 Hybrid Line Remote Digital Looparound Test — Continued**

Error Code	Test Result	Description/ Recommendation
1	ABORT	<p>A request for a remote station audit aborted even though all internal resources were correctly allocated.</p> <ol style="list-style-type: none"> <li>1. Look in the error log for Error Type 18 (port busied out) for this port. If this Error Type is present, release the port via the <b>release port UUCSSpp</b> command or the <b>release station extension</b> command, and then run the test again.</li> <li>2. Make sure that the terminal is connected.</li> <li>3. Retry the command at 1-minute intervals for a maximum of 5 times.</li> </ol>
1000	ABORT	<p>System resources required to run this test are not available. The port may be busy with a valid call.</p> <ol style="list-style-type: none"> <li>1. Use the <b>display port UUCSSpp</b> command to determine the station extension number of the port. Use the <b>status station</b> command to determine the service state of the port. If the port is in use, wait until the port is idle before testing.</li> <li>2. If the port status is idle, then retry the command at 1-minute intervals a maximum of 5 times.</li> </ol>
2000	ABORT	<p>Response to the test request was not received within the allowable time period.</p> <ol style="list-style-type: none"> <li>1. Retry the command at 1-minute intervals a maximum of 5 times.</li> </ol>
1,2,3	FAIL	<p>No response was received within the allowable time period on one of the transmissions to the terminal. This indicates a problem with the data link to the voice terminal. This could be a sleeping set problem or it may be due to wiring or an unplugged or defective set.</p> <ol style="list-style-type: none"> <li>1. Check for errors in the error log, for example, error 1537.</li> <li>2. Remotely issue the <b>busyout</b> and <b>release busy</b> commands, and run the short test sequence on the port to check for other errors associated with the port or terminal.</li> <li>3. Check the wiring to the set if it appears that the terminal is not responding to any tests; otherwise, replace the terminal and rerun the test.</li> <li>4. If the test still fails, replace the circuit pack and reconnect the original terminal.</li> </ol>
	PASS	<p>Hybrid Line Remote Digital Looparound Test passed. The hybrid circuit pack is sending and receiving proper messages to and from the voice terminal.</p> <ol style="list-style-type: none"> <li>1. If problems still exist, investigate using other circuit pack tests and by examining the station, wiring, and connections.</li> </ol>

*Continued on next page*



**Table 9-353. TEST #59 Hybrid Line Remote Digital Looparound Test — Continued**

Error Code	Test Result	Description/ Recommendation
0	NO BOARD	<p>The test could not relate the internal ID to the port (no board). This could be due to incorrect translations, no board is inserted, an incorrect board is inserted, or an insane board is inserted.</p> <ol style="list-style-type: none"> <li>1. Check to ensure that the board translations are correct. Use the <b>list config</b> command, and resolve any problems that are found.</li> <li>2. If the board was found to be correctly inserted in step 1, issue the <b>busyout board</b> command.</li> <li>3. Issue the <b>reset board</b> command.</li> <li>4. Issue the <b>release busy board</b> command.</li> <li>5. Issue the <b>test board long</b> command. This should re-establish the linkage between the internal ID and the port. If this is not the case, dispatch to check to ensure that there is a valid board inserted.</li> </ol>

### Hybrid Line Lamp Updates Test (#60)

For this test, the software lights the lamps on the terminal based on the status record contained in the processor. The lamp updates will run only if the station is in-service.

**Table 9-354. TEST #60 Hybrid Line Lamp Updates Test**

Error Code	Test Result	Description/ Recommendation
1	ABORT	<p>A request for a remote station lamp update aborted even though all internal resources were correctly allocated.</p> <ol style="list-style-type: none"> <li>1. Look in the error log for Error Type 18 (port busied out) for this port. If this Error Type is present, release the port via the <b>release port UUCSSpp</b> command or the <b>release station extension</b> command, and then run the test again.</li> <li>2. Make sure that the terminal is connected.</li> <li>3. Retry the command at 1-minute intervals for a maximum of 5 times.</li> </ol>
2	ABORT	<p>Internal system error</p> <ol style="list-style-type: none"> <li>1. Retry the command at 1-minute intervals a maximum of 5 times.</li> </ol>

*Continued on next page*

Table 9-354. TEST #60 Hybrid Line Lamp Updates Test — Continued

Error Code	Test Result	Description/ Recommendation
3	ABORT	The station is in a ready for service or an out of service state. This may be due to wiring or an unplugged or defective set. <ol style="list-style-type: none"> <li>1. Make sure terminal is connected and the wiring is correct.</li> <li>2. Retry the command at 1-minute intervals a maximum of 5 times.</li> </ol>
1000	ABORT	System resources required to run this test are not available. The port may be busy with a valid call. <ol style="list-style-type: none"> <li>1. Use the <b>display port UUCSSpp</b> command to determine the station extension number of the port. Use the <b>status station</b> command to determine the service state of the port. If the port is in use, wait until the port is idle before testing.</li> <li>2. If the port status is idle, then retry the command at 1-minute intervals a maximum of 5 times.</li> </ol>
1392	ABORT	This port is currently a TTI port and the test will not execute on it. <ol style="list-style-type: none"> <li>1. Verify that the port is a TTI port using either the <b>display port</b> command (the display shows that the port is a TTI port) or the <b>list config</b> command (the display shows a <math>\tau</math> for the port).</li> <li>2. If either <b>list config</b> or <b>display port</b> indicate that the port is <i>not</i> a TTI port, escalate the problem. If both commands indicate that the port is a TTI port, the abort is correct, and no action is necessary.</li> </ol>
	FAIL	Internal system error <ol style="list-style-type: none"> <li>1. Retry the command at 1-minute intervals a maximum of 5 times.</li> </ol>
	PASS	Hybrid Line Lamp Updates completed successfully <ol style="list-style-type: none"> <li>1. If complaints still exist, investigate by using other circuit pack tests, and by examining the station, wiring, and connections.</li> </ol>
0	NO BOARD	The test could not relate the internal ID to the port (no board). This could be due to incorrect translations, no board is inserted, an incorrect board is inserted, or an insane board is inserted. <ol style="list-style-type: none"> <li>1. Check to ensure that the board translations are correct. Use the <b>list config</b> command, and resolve any problems that are found.</li> <li>2. If the board was found to be correctly inserted in step 1, issue the <b>busyout board</b> command.</li> <li>3. Issue the <b>reset board</b> command.</li> <li>4. Issue the <b>release busy board</b> command.</li> <li>5. Issue the <b>test board long</b> command. This should re-establish the linkage between the internal ID and the port. If this is not the case, dispatch to check to ensure that there is a valid board inserted.</li> </ol>

## Hybrid Line Audits Test (#61)

This is a series of three tests that are classified as audits. These audits will abort if attempted on an out-of-service station. The tests are as follows:

- Switchhook Audit—This is an update of the SPE records according to the circuit packs' records.
- Bad Scan Inquiry—A message is sent uplink that contains a count that is generated due to certain events relating to the data link conditions. This is an indication of data transmission problems between the Hybrid circuit pack and the voice terminal.
- EPF Inquiry—The status of the Electronic Power Feed is sent uplink. Possible conditions are: EPF-on-ok, EPF-off, EPF-no-load, and EPF-on-overcurrent.

**Table 9-355. TEST #61 Hybrid Line Audits Test**

Error Code	Test Result	Description/ Recommendation
1	ABORT	Internal system error
2	ABORT	The test was aborted due to an internal system error during the switchhook audit.  Internal system error occurred during bad scan inquiry audit. <ol style="list-style-type: none"> <li>1. Make sure that the station is not in an out of service state.</li> <li>2. Retry the command at 1-minute intervals a maximum of 5 times.</li> </ol>
3	ABORT	This port may have been busied out by system technician. <ol style="list-style-type: none"> <li>1. Look in the Error Log for Error Type 18 (port busied out) for this port. If this Error Type is present, release the port via the <b>release station &lt;extension&gt;</b> command and run the test again.</li> <li>2. Make sure that the terminal is connected.</li> <li>3. Retry the command at 1-minute intervals a maximum of 5 times.</li> </ol>
1000	ABORT	System resources required to run this test are not available. The port may be busy with a valid call. <ol style="list-style-type: none"> <li>1. Use the <b>display port UUCSSpp</b> to determine the station extension number of the port. Use the <b>status station</b> command to determine the service state of the port. If the port is in use, wait until the port is idle before testing.</li> <li>2. If the port status is idle, then retry the command at 1-minute intervals a maximum of 5 times.</li> </ol>

*Continued on next page*

Table 9-355. TEST #61 Hybrid Line Audits Test — *Continued*

Error Code	Test Result	Description/ Recommendation
1004	ABORT	<p>The port was seized by a valid call during the test. The test has been aborted.</p> <ol style="list-style-type: none"><li>1. Use the <b>display port UUCSSpp</b> command to determine the station extension number of the port. Use the <b>status station</b> command to determine the service state of the port. If the port is in use, wait until the port is idle before testing.</li><li>2. Retry the command at 1-minute intervals a maximum of 5 times.</li></ol>
1392	ABORT	<p>This port is currently a TTI port and the test will not execute on it.</p> <ol style="list-style-type: none"><li>1. Verify that the port is a TTI port using either the <b>display port</b> command (the display shows that the port is a TTI port) or the <b>list config</b> command (the display shows a <math>\tau</math> for the port).</li><li>2. If either <b>list config</b> or <b>display port</b> indicate that the port is <i>not</i> a TTI port, escalate the problem. If both commands indicate that the port is a TTI port, the abort is correct, and no action is necessary.</li></ol>
2000	ABORT	<p>Response to the test request was not received within the allowable time period.</p>

*Continued on next page*

**Table 9-355. TEST #61 Hybrid Line Audits Test — Continued**

Error Code	Test Result	Description/ Recommendation
	FAIL	Internal system error 1. Retry the command at 1-minute intervals a maximum of 5 times.
	PASS	Hybrid Line Audits Test passed. 1. Although this test will never actually return a FAIL result except for the <b>Internal system error</b> described above, it is possible that it will enter Error Types 257 or 513 into the Error Log. To determine if there are any problems that don't show up in the test result, look for these Error Types in the Error Log. 2. If these errors appear in the Error Log, or if user complaints still exist, investigate by using other circuit pack tests, and by examining the station, wiring, and connections.
0	NO BOARD	The test could not relate the internal ID to the port (no board). This could be due to incorrect translations, no board is inserted, an incorrect board is inserted, or an insane board is inserted. 1. Check to ensure that the board translations are correct. Use the <b>list config</b> command, and resolve any problems that are found. 2. If the board was found to be correctly inserted in step 1, issue the <b>busyout board</b> command. 3. Issue the <b>reset board</b> command. 4. Issue the <b>release busy board</b> command. 5. Issue the <b>test board long</b> command. This should re-establish the linkage between the internal ID and the port. If this is not the case, dispatch to check to ensure that there is a valid board inserted.

### Hybrid Line Ringer Update Test (#62)

In this update, a “ringer on” or a “ringer off” message is sent to the firmware to start and stop the ringer on the set.

**Table 9-356. TEST #62 Hybrid Line Ringer Update Test**

Error Code	Test Result	Description/ Recommendation
3	ABORT	This port may have been busied out by system technician. <ol style="list-style-type: none"> <li>1. Look in the Error Log for Error Type 18 (port busied out) for this port. If this Error Type is present, release the port via the <b>release station &lt;extension&gt;</b> command and run the test again.</li> <li>2. Make sure that the terminal is connected.</li> <li>3. Retry the command at 1-minute intervals a maximum of 5 times.</li> </ol>
1000	ABORT	System resources required to run this test are not available. The port may be busy with a valid call. <ol style="list-style-type: none"> <li>1. Use the <b>display port UUCSSpp</b> command to determine the station extension number of the port. Use the <b>status station</b> command to determine the service state of the port. If the port is in use, wait until the port is idle before testing.</li> <li>2. If the port status is idle, then retry the command at 1-minute intervals a maximum of 5 times.</li> </ol>
1392	ABORT	This port is currently a TTI port and the test will not execute on it. <ol style="list-style-type: none"> <li>1. Verify that the port is a TTI port using either the <b>display port</b> command (the display shows that the port is a TTI port) or the <b>list config</b> command (the display shows a t for the port).</li> <li>2. If either <b>list config</b> or <b>display port</b> indicate that the port is <i>not</i> a TTI port, escalate the problem. If both commands indicate that the port is a TTI port, the abort is correct, and no action is necessary.</li> </ol>
	FAIL	Internal system error <ol style="list-style-type: none"> <li>1. Retry the command at 1-minute intervals a maximum of 5 times.</li> </ol>
	PASS	Hybrid Station Ringer Update passed <ol style="list-style-type: none"> <li>1. If complaints still exist, investigate using other circuit pack tests on this circuit pack, and by examining the terminal, wiring, and connections.</li> </ol>

Table 9-356. TEST #62 Hybrid Line Ringer Update Test — Continued

Error Code	Test Result	Description/ Recommendation
0	NO BOARD	<p>The test could not relate the internal ID to the port (no board). This could be due to incorrect translations, no board is inserted, an incorrect board is inserted, or an insane board is inserted.</p> <ol style="list-style-type: none"><li>1. Check to ensure that the board translations are correct. Use the <b>list config</b> command, and resolve any problems that are found.</li><li>2. If the board was found to be correctly inserted in step 1, issue the <b>busyout board</b> command.</li><li>3. Issue the <b>reset board</b> command.</li><li>4. Issue the <b>release busy board</b> command.</li><li>5. Issue the <b>test board long</b> command. This should re-establish the linkage between the internal ID and the port. If this is not the case, dispatch to check to ensure that there is a valid board inserted.</li></ol>

## INADS (INADS Link)

---

MO Name (in Alarm Log)	Alarm Level	Initial Command to Run	Full Name of MO
INADS	none	test inads-link	INADS Link

The INADS Link maintenance object (MO) represents the software and communications link required by the switch to make a call to the Initialization and Administration System (INADS). The purpose of the INADS Link MO is to check the communications link between the system and INADS and verify that the alarm notification process works correctly. An INADS technician can test the process remotely to verify that alarms will be reported to INADS, or a system technician may want to test the connection while on-site at installation time or during subsequent service calls.

Although the INADS Link MO is never alarmed, the errors are logged. The errors are only logged as a result of the **test inads-link** command being issued.

### Error Log Entries and Test to Clear Values

---

The Hardware Error Log entries are described as part of the INADS Link Test description below.

### System Technician-Demanded Tests: Descriptions and Error Codes

---

The **test inads-link** command is different from other test commands. This command does not have a long or short option, and the test on the INADS Link does not have an associated test number. When the **test inads-link** command is issued, the user immediately sees either the "Command successfully completed" or "Command failed" message.

### INADS Link Test (No Test Number)

The INADS Link Test attempts to place a call to INADS (in the background) to verify the communications link to INADS. When the **test inads-link** command is entered, the user immediately sees either `Command successfully completed` or `Command failed`. The "Command failed" message appears when a previously run **test inads-link** command is in progress or the system has active alarms which must be reported to INADS. The "Command successfully completed" means the switch will start the attempt to call INADS in 2 minutes (the test will still run even if Alarm Origination is disabled). The 2-minute delay allows a remote INADS technician time enough to hang up the call and thus free up the INADS line so that the switch can call INADS back. As error conditions are encountered, errors are logged against INADS. Error codes 1 through 9 can be logged if the test result was "Command successfully completed" and Error Codes 10 and 11 can be logged if the test result was "Command failed." An error



is also logged against INADS if the call to INADS finally succeeds. The INADS software (release 3.2 or later) recognizes this special "test inads" type of alarm and will automatically open and then close a trouble ticket which indicates that the reason for the trouble ticket is a **test inads-link** command. The trouble ticket alarm will contain a "TESTING INADS LINK" description field.

After entering the command, it may take as long a 9 minutes for the switch to place the call and for INADS to respond. The Error Log should be examined using the category **inads** 10 minutes after successfully entering the command to determine if the call was successful. [Table 9-357](#) explains the error codes.

**Table 9-357. INADS Link Test Error Log Entries**

Error Code	Test Result	Description/ Recommendation
1	0	The call was successfully placed to INADS. No trouble found.
2	0	Informative error indicating that alarm origination was disabled at the time of the test. The test will still run even if alarm origination is disabled. <ol style="list-style-type: none"><li>1. If Alarm Origination is desired, then enable this feature via the Maintenance-Related System Parameters Form.</li><li>2. Repeat the test.</li></ol>
3	0	The INADS connection is currently in use. <ol style="list-style-type: none"><li>1. Wait 10 minutes and retry this command.</li></ol>
4	0	INADS did not answer the alarm origination call. <ol style="list-style-type: none"><li>1. Verify INADS is up and running.</li><li>2. Verify that the INADS phone number and switch product id are correct via the Maintenance-Related System Parameters Form.</li><li>3. Enable alarm origination via the Maintenance-Related System Parameters Form and test the SYSAM (System Access Maintenance) by issuing the <b>test maintenance a b</b> command. If SYSAM Tests #916 and #917 do not pass, then refer to SYSAM (System Access Maintenance) Maintenance documentation.</li><li>4. Retry the command.</li></ol>
5	0	No INADS phone number administered. <ol style="list-style-type: none"><li>1. Administer the INADS phone number via the Maintenance-Related System Parameters Form.</li><li>2. Retry the command.</li></ol>

*Continued on next page*

Table 9-357. INADS Link Test Error Log Entries — Continued

Error Code	Test Result	Description/ Recommendation
6	0	INADS did not send the acknowledgment message to the “test inads alarm” message. <ol style="list-style-type: none"><li>1. Verify that the INADS phone number and switch product id are correct via the Maintenance-Related System Parameters Form.</li><li>2. Verify INADS is up and running.</li><li>3. Retry the command.</li></ol>
7	0	INADS sent a negative acknowledgment to the “TESTING INADS LINK” message. <ol style="list-style-type: none"><li>1. Verify that the product id on the switch and in the INADS database are the same. Use the Maintenance-Related System Parameters Form to determine the product id the switch has.</li><li>2. Rerun the test.</li></ol>
8	0	Internal system error; system received an invalid return code.
9	0	Internal system error <ol style="list-style-type: none"><li>1. Try the command again at 1-minute intervals up to 5 times.</li></ol>
10	0	There is already a <b>test inads-link</b> command in progress. <ol style="list-style-type: none"><li>1. Wait 10 minutes for the present command to finish.</li><li>2. Review the results of the present command by viewing the Error Log and selecting the category “inads-link.”</li></ol>
11	0	The switch is trying to report alarms to INADS. The test cannot be run at this time. <ol style="list-style-type: none"><li>1. Wait 10 minutes and retry the command.</li></ol>

## ISDN-PLK (ISDN-PRI Signaling Link Port)

MO Name (in Alarm Log)	Alarm Level	Initial Command to Run <sup>1</sup>	Full Name of MO
ISDN-LNK <sup>2</sup>	MINOR	test port <i>UUCSSpp</i> l	ISDN-PRI Signaling Link Port
ISDN-LNK	WARNING	test port <i>UUCSSpp</i> sh	ISDN-PRI Signaling Link Port

1. pp is 24 for 24-channel interfaces and 16 for 32-channel interfaces>
2. For additional related information, see "UDS1-BD (UDS1 Interface Circuit Pack)"

### NOTE:

This MO was formerly known as "ISDN-LNK (ISDN-PRI Signaling Link Port)".

The ISDN-PRI interface uses out-of-band signaling (as opposed to robbed-bit, in-band signaling) to transmit control messages between two endpoints. User information channels carry digitized voice and digital data and are known as bearer channels (B-channels). B-channels are assigned to DS1 ISDN trunks or PRI endpoints. Call control signaling for the B-channels is combined and carried over the separate ISDN-PRI Signaling Link Port D-channel.

The ISDN-PRI Signaling Link Port (ISDN-LNK) is a port on a TN464C/D UDS1 Interface circuit pack, which has a direct interface to the packet bus which carries D-channel messages to the processor. The associated B-channels can use ports on the same circuit pack or ports on other TN464C/Ds or TN767 DS1 Interface circuit packs. (The TN722 cannot be used for this application). The B-channels are connected to the TDM Bus.

Two types of DS1 interfaces exist:

- 24 DS0 channels on a 1.544 Mbps link
- 31 DS0 channels + 1 framing channel on a 2.048 Mbps link

On 24-channel interfaces, the B-channels may use any of the first 23 ports. The signaling link is assigned to the 24th port. On 32-channel interfaces, the DS1 ISDN Trunks (B-channels) may use any of ports 1 to 15 and 17 through 31. The signaling link is assigned to the 16th port. The 32nd channel (port 0) is used for framing. In NFAS configurations, the 24th or 16th ports on some of the DS1 circuit packs may be used for B-channels. Refer to ISDN-SGR for further information.

A problem with the ISDN-LNK will have an effect on all of the associated B-channels since without it no call control information can be conveyed to the far-end switch or terminal adapter. Stable calls may remain operational, but no new calls can be made. The ISDN-LNK in turn depends on the TN464C/D UDS1 Interface circuit pack it resides on and the packet bus which provides the link to the processor. If there are problems with the ISDN-LNK, also investigate the

TN464C/D UDS1 Interface circuit pack (UDS1-BD) and the packet bus (PKT-BUS).

## Error Log Entries and Test to Clear Values

Table 9-358. ISDN-PRI Signaling Link Port Error Log Entries

Error Type	Aux Data	Associated Test	Alarm Level	On/Off Board	Test to Clear Value
0 <sup>1</sup>	0	Any	Any	Any	test port <i>UUCSSpp</i> <sup>2</sup>
18 (a)	0	busyout port <i>UUCSSpp</i> <sup>2</sup>	WARNING	OFF	release port <i>UUCSSpp</i> <sup>2</sup>
130 (b)		None	WARNING	ON	test port <i>UUCSSpp</i> <sup>2</sup>
1537 (c)	46210		WARNING	OFF	
1793 (d)					test board UUCSS I
3585 (e)	46222		MINOR	ON	
3841 (f)	46211				
3842 (g)	46223				
3843 (h)		Signaling Port LAN Loopback test (#939)			test port <i>UUCSSpp</i> <sup>2</sup> I

1. Run the Short Test Sequence first. If all tests pass, run the Long Test Sequence. Refer to the appropriate test description and follow the recommended procedures.
2. pp is 24 for 24-channel interfaces and 16 for 32-channel interfaces.

### Notes:

- a. The D-channel is demand busied out. No calls can be made over this D-channel.
- b. This Error Type indicates that the circuit pack has been removed or has been insane for more than 11 minutes. To clear the error, reinsert or replace the circuit pack.
- c. Link error. This error occurs when the port receives an invalid frame over the D-channel. This error normally indicates an off-board problem usually related to transmission errors on the DS1 facility. Execute **list measurements ds1-log** for the UDS1 TN464 circuit pack on which the D-channel resides. If the UDS1 is reporting some errors, then the DS1 facility has experienced transmission problems which could have caused the ISDN-LNK to report a Link Error.

If the UDS1 is not reporting errors, execute the long test sequence for the D-channel. Investigate any errors. If there are none, execute a long test sequence for the UDS1 circuit pack (UDS1-BD). Investigate any errors.

If no errors could be found by testing, the Link Error is probably not affecting service. However, if this Link Error continues to be logged, follow normal escalation procedures.

- d. UDS1 Interface circuit pack is out-of-service. Look for and resolve UDS1-BD errors in the Hardware Error Log.
- e. Transmit FIFO Overflow error. This error indicates that the circuit pack is having problems transmitting data to the Packet Bus, thus affecting the conveyance of signaling information over the D-channel. Specifically, this error occurs when the Packet Bus transmit buffers overflow. This condition probably indicates a hardware problem.

The actual alarming level will depend on the options chosen via the **set options** command on the G3-MT terminal. ISDN-PRI Signaling Link Port alarms are treated as Station alarms, and their default alarming option is to downgrade all alarms to Warning. The value shown in the preceding table indicates the normal, unfiltered case (option "y" on the set options form).

- f. Bad DLCI error. This error occurs when a LAPD frame is received across the DS1 facility which contains a DLCI which does not have a valid entry in the on-board translation memory. This error normally indicates an off-board problem usually related to a broken endpoint or a state mismatch between a remote endpoint and the local call processing software. Maintenance will not start any testing or generate any alarms in response to this error.
- g. Receive FIFO Overflow error. This error occurs when the circuit pack detects an overflow of its receive buffers. If it occurs frequently, it may indicate a LAPD parameter mismatch between the two end-points of a packet switched connection. LAPD should be able to recover from this problem, but it may degrade the performance of the LAN Bus. Maintenance will not start any testing or generate any alarms in response to this error.
- h. This error occurs when the *Signaling Port LAN Loopback Test (#939)* fails. Run the long test sequence and pay particular attention to the results of Test #939.

## System Technician-Demanded Tests: Descriptions and Error Codes

The command to test the ISDN-LNK MO is **test port UUCSSpp** where pp is 24 for 24-channel interfaces and 16 for 32-channel interfaces.

Order of Investigation	Short Test Sequence	Long Test Sequence	D/ND <sup>1</sup>
Signaling Port LAN Loopback Test (#939)		X	D
Signaling Link Board Check (#643)	X	X	ND

1. D = Destructive; ND = Nondestructive

### Signaling Link Board Check (#643)

This test checks the health of the TN464C/D UDS1 Interface transporting the ISDN-PRI Signaling Link Port

**Table 9-359. TEST #643 Signaling Link Board Check**

Error Code	Test Result	Description/ Recommendation
	ABORT	Internal system error 1. Retry the command at 1-minute intervals for a maximum of 5 times.
1700	ABORT	Rollabout video abort. The PRI terminal adapter associated with this D-channel port is detached from the circuit pack. This is normal when the rollabout video feature is enabled. To complete a test on this port: 1. Re-attach the disconnected PRI terminal adapter 2. Disable the rollabout video feature on this board by entering <b>change ds1 UUCSS</b> and set the "Alarm when PRI Endpoint Detached?" field to "y."
8	FAIL	The UDS1 TN464C/D circuit pack is not in-service. 1. Check the Hardware Error Log for entries logged against UDS1-BD, and consult "UDS1-BD" for repair procedures.
	PASS	The UDS1 Interface circuit pack transporting the ISDN-PRI Signaling Link Port is in-service.

### Signaling Port LAN Loopback Test (#939)

**This test is destructive.**

This test verifies the connectivity of an ISDN-PRI signaling port (D-channel) across the LAN bus, also known as the packet bus. It will execute only if the port is out-of-service. Failure of this test indicates a fault associated with the port hardware on the circuit pack.

**Table 9-360. TEST #939 Signaling Port LAN Loopback**

Error Code	Test Result	Description/ Recommendation
1015	ABORT	The port is not in the out-of-service state. Use the <b>busyout port UUCSSpp</b> command to place it in the out-of-service state and repeat this test.   <b>CAUTION:</b> <i>The busyout will prevent new call originations on all B-channels in the signaling group until the port is released.</i>
1139	ABORT	The Packet Bus in this port network is out-of-service. 1. Follow repair procedures for the Packet Bus. 2. Enter <b>test port UUCSSpp long</b> command and check results of this test (#939).
1141	ABORT	The Packet Interface circuit pack is out-of-service. 1. Follow repair procedures for PKT-INT. 2. Enter <b>test port UUCSSpp long</b> command and check results of this test (#939).
1144	ABORT	The Packet Bus in the PPN is out-of-service. 1. Follow repair procedures for the Packet Bus. 2. Enter <b>test port UUCSSpp long</b> command and check results of this test (#939).
2012	ABORT	Internal system error.
2100	ABORT	Could not allocate the necessary system resources to run this test. 1. Retry the command at 1-minute intervals a maximum of 5 times.
	FAIL	The Loopback Test has failed. 1. If the test fails repeatedly, attempt to reset the circuit pack when the other ports on the board are not in use. Reset the circuit pack by entering <b>busyout board UUCSS</b> and <b>reset board UUCSS</b> . 2. Repeat the test and, if it continues to fail, replace the circuit pack.
	PASS	Connectivity of the D-channel over the Packet Bus is operational.

## ISDN-LNK (ISDN-PRI Signaling Link Port)

MO Name (in Alarm Log)	Alarm Level	Initial Command to Run <sup>1</sup>	Full Name of MO
ISDN-LNK <sup>2</sup>	MINOR	test port <i>UUCSSpp l</i>	ISDN-PRI Signaling Link Port
ISDN-LNK	WARNING	test port <i>UUCSSpp sh</i>	ISDN-PRI Signaling Link Port

1. pp is 24 for 24-channel interfaces and 16 for 32-channel interfaces
2. For additional related information, see [“UDS1-BD \(UDS1 Interface Circuit Pack\)”](#).

### NOTE:

See the figures in the [“ISDN-SGR \(ISDN-PRI Signaling Group\)”](#) section of this chapter for an illustration of the principles described below.

The ISDN-PRI interface uses out-of-band signaling (as opposed to robbed-bit, in-band signaling) to transmit control messages between two endpoints. User information channels carry digitized voice and digital data and are known as bearer channels (B-channels). B-channels are assigned to DS1 ISDN trunks or PRI endpoints. Call control signaling for the B-channels is combined and carried over the separate ISDN-PRI Signaling Link Port D-channel.

The ISDN-PRI Signaling Link Port (ISDN-LNK) is a port on a TN464C/D UDS1 Interface circuit pack, which has a direct interface to the packet bus which carries D-channel messages to the processor. The associated B-channels can use ports on the same circuit pack or ports on other TN464C/Ds or TN767 DS1 Interface circuit packs. (The TN722 cannot be used for this application). The B-channels are connected to the TDM Bus.

Two types of DS1 interfaces exist:

- 24 DS0 channels on a 1.544 Mbps link
- 31 DS0 channels + 1 framing channel on a 2.048 Mbps link

The 32-channel mode is supported only on TN464 series circuit packs and on G3r V2 systems.

On 24-channel interfaces, the B-channels may use any of the first 23 ports. The signaling link is assigned to the 24th port. On 32-channel interfaces, the DS1 ISDN Trunks (B-channels) may use any of ports 1 to 15 and 17 through 31. The signaling link is assigned to the 16th port. The 32nd channel (port 0) is used for framing. In NFAS configurations, the 24th or 16th ports on some of the DS1 circuit packs may be used for B-channels. Refer to ISDN-SGR for further information.



A problem with the ISDN-LNK will have an effect on all of the associated B-channels since without it no call control information can be conveyed to the far-end switch or terminal adapter. Stable calls may remain operational, but no new calls can be made. The ISDN-LNK in turn depends on the TN464C/D UDS1 Interface circuit pack it resides on and the packet bus which provides the link to the processor. If there are problems with the ISDN-LNK, also investigate the TN464C/D UDS1 Interface circuit pack (UDS1-BD) and the packet bus (PKT-BUS).

## Hardware Error Log Entries and Test to Clear Values

### ISDN-PRI Signaling Link Port Error Log Entries

Error Type	Aux Data	Associated Test	Alarm Level	On/Off Board	Test to Clear Value
0 <sup>1</sup>	0	Any	Any	Any	test port <i>UUCSSpp</i> <sup>2</sup>
18 (a)	0	busyout port <i>UUCSSpp</i> <sup>2</sup>	WARNING	OFF	release port <i>UUCSSpp</i> <sup>2</sup>
130 (b)		None	WARNING	ON	test port <i>UUCSSpp</i> <sup>2</sup>
1537 (c)	46210		WARNING	OFF	
1793 (d)					test board UUCSS I
3585 (e)	46222		MINOR	ON	
3841 (f)	46211				
3842 (g)	46223				
3843 (h)		Signaling Port LAN Loopback test (#939)			test port <i>UUCSSpp</i> <sup>2</sup> I

1. Run the Short Test Sequence first. If all tests pass, run the Long Test Sequence. Refer to the appropriate test description and follow the recommended procedures.
2. pp is 24 for 24-channel interfaces and 16 for 32-channel interfaces.

#### Notes:

- a. The D-channel is demand busied out. No calls can be made over this D-channel.
- b. This Error Type indicates that the circuit pack has been removed or has been insane for more than 11 minutes. To clear the error, reinsert or replace the circuit pack.

- c. Link error. This error occurs when the port receives an invalid frame over the D-channel. This error normally indicates an off-board problem usually related to transmission errors on the DS1 facility. Execute **list measurements ds1-log** for the UDS1 TN464 circuit pack on which the D-channel resides. If the UDS1 is reporting some errors, then the DS1 facility has experienced transmission problems which could have caused the ISDN-LNK to report a Link Error.

If the UDS1 is not reporting errors, execute the long test sequence for the D-channel. Investigate any errors. If there are none, execute a long test sequence for the UDS1 circuit pack (UDS1-BD). Investigate any errors.

If no errors could be found by testing, the Link Error is probably not affecting service. However, if this Link Error continues to be logged, follow normal escalation procedures.

- d. UDS1 Interface circuit pack is out-of-service. Look for and resolve UDS1-BD errors in the Hardware Error Log.
- e. Transmit FIFO Overflow error. This error indicates that the circuit pack is having problems transmitting data to the Packet Bus, thus affecting the conveyance of signaling information over the D-channel. Specifically, this error occurs when the Packet Bus transmit buffers overflow. This condition probably indicates a hardware problem.

The actual alarming level will depend on the options chosen via the **set options** command on the G3-MT terminal. ISDN-PRI Signaling Link Port alarms are treated as Station alarms, and their default alarming option is to downgrade all alarms to Warning. The value shown in the preceding table indicates the normal, unfiltered case (option "y" on the set options form).

- f. Bad DLCI error. This error occurs when a LAPD frame is received across the DS1 facility which contains a DLCI which does not have a valid entry in the on-board translation memory. This error normally indicates an off-board problem usually related to a broken endpoint or a state mismatch between a remote endpoint and the local call processing software. Maintenance will not start any testing or generate any alarms in response to this error.
- g. Receive FIFO Overflow error. This error occurs when the circuit pack detects an overflow of its receive buffers. If it occurs frequently, it may indicate a LAPD parameter mismatch between the two end-points of a packet switched connection. LAPD should be able to recover from this problem, but it may degrade the performance of the LAN Bus. Maintenance will not start any testing or generate any alarms in response to this error.
- h. This error occurs when the *Signaling Port LAN Loopback Test (#939)* fails. Run the long test sequence and pay particular attention to the results of Test #939.

## System Technician-Demanded Tests: Descriptions and Error Codes

The command to test the ISDN-LNK MO is **test port UUCSSpp** where pp is 24 for 24-channel interfaces and 16 for 32-channel interfaces.

Order of Investigation	Short Test Sequence	Long Test Sequence	D/ND <sup>1</sup>
Signaling Port LAN Loopback Test (#939)		X	D
Signaling Link Board Check (#643)	X	X	ND

1. D = Destructive; ND = Nondestructive

### Signaling Link Board Check (#643)

This test checks the health of the TN464C/D UDS1 Interface transporting the ISDN-PRI Signaling Link Port

**Table 0-1. TEST #643 Signaling Link Board Check**

Error Code	Test Result	Description/ Recommendation
	ABORT	Internal System Error 1. Retry the command at 1-minute intervals for a maximum of 5 times. 2. If the test continues to abort, escalate the problem.
1700	ABORT	Rollabout video abort. The PRI terminal adapter associated with this D-channel port is detached from the circuit pack. This is normal when the rollabout video feature is enabled. To complete a test on this port, do one of the following: 1. Re-attach the disconnected PRI terminal adapter 2. Disable the rollabout video feature on this board by entering <b>change ds1 UUCSS</b> and set the field labeled "Alarm when PRI Endpoint Detached?" to "y."
8	FAIL	The UDS1 TN464C/D circuit pack is not in-service. 1. Check the Hardware Error Log for entries logged against UDS1-BD and consult the <a href="#">"UDS1-BD (UDS1 Interface Circuit Pack)"</a> Maintenance documentation for repair procedures.
	PASS	The UDS1 Interface circuit pack transporting the ISDN-PRI Signaling Link Port is in-service.

### Signaling Port LAN Loopback Test (#939)

**This test is destructive.**

This test verifies the connectivity of an ISDN-PRI signaling port (D-channel) across the LAN bus, also known as the packet bus. It will execute only if the port is out-of-service. Failure of this test indicates a fault associated with the port hardware on the circuit pack.

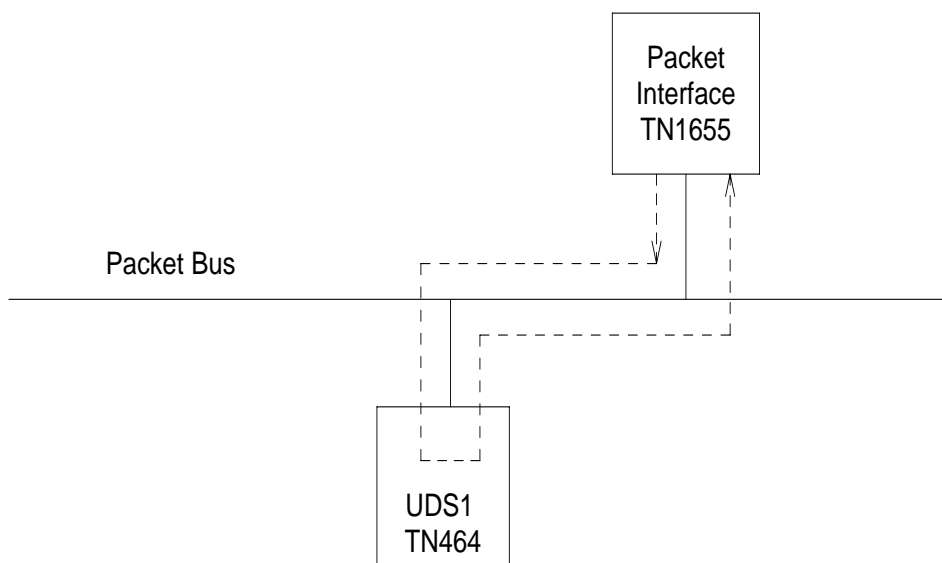

Figure 9-51. Signaling Port LAN (Packet Bus) Loopback

Table 0-2. TEST #939 Signaling Port LAN Loopback

Error Code	Test Result	Description/ Recommendation
1015	ABORT	<p>The port is not in the out-of-service state. Use the <b>busyout port</b> UUCSSpp command to place it in the out-of-service state and repeat this test.</p> <p><b>CAUTION:</b>                      The <b>busyout</b> will prevent new call originations on all B-channels in the signaling group until the port is released.</p>

Continued on next page

**Table 0-2. TEST #939 Signaling Port LAN Loopback — Continued**

Error Code	Test Result	Description/ Recommendation
1139	ABORT	The Packet Bus in this port network is out-of-service. 1. Follow repair procedures for the Packet Bus. 2. Enter <b>test port UUCSSpp long</b> command and check results of this test (#939).
1141	ABORT	The Packet Interface circuit pack is out-of-service. 1. Follow repair procedures for PKT-INT. 2. Enter <b>test port UUCSSpp long</b> command and check results of this test (#939).
1144	ABORT	The Packet Bus in the PPN is out-of-service. 1. Follow repair procedures for the Packet Bus. 2. Enter <b>test port UUCSSpp long</b> command and check results of this test (#939).
2012 2100	ABORT ABORT	Internal system error. Could not allocate the necessary system resources to run this test. 1. Retry the command at 1-minute intervals a maximum of 5 times. 2. If the test continues to abort, escalate the problem.
	FAIL	The Loopback Test has failed. 1. If the test fails repeatedly, attempt to reset the circuit pack when the other ports on the board are not in use. Reset the circuit pack by entering <b>busyout board UUCSS</b> and <b>reset board UUCSS</b> . 2. Repeat the test and, if it continues to fail, replace the circuit pack.
	PASS	Connectivity of the D-channel over the Packet Bus is operational.

## ISDN-SGR (ISDN-PRI Signaling Group)

MO Name (in Alarm Log)	Alarm Level	Initial Command to Run <sup>1</sup>	Full Name of MO
ISDN-SGR	MINOR	test sig-group <i>grp#</i>	ISDN-PRI Signaling Group
ISDN-SGR	WARNING	test sig-group <i>grp#</i>	ISDN-PRI Signaling Group

- grp#* is the signaling group number (1-166); the test sequence can be either short or long.

An ISDN-PRI Signaling Group is a collection of B-channels for which a given ISDN-PRI Signaling Channel Port (D-channel) carries signaling information. B-channels carry voice or data and can be assigned to DS1 ISDN trunks (ISDN-TRK) or PRI endpoint ports (PE-BCHL).

### ⇒ NOTE:

Throughout this discussion the term B-channels refers to ISDN-TRKs or PE-BCHLs, depending on the application under investigation.

The following circuit packs are supported in the implementation of ISDN-PRI.

Circuit Pack	Channel Types	Interface
TN464C/D	B and D channels	24 or 32 channel
TN767	B channels	24 channel
TN464B	B channels	32 channel (G3r V2 only)

The TN464C/D UDS1 Interface circuit pack, which has a direct interface to the packet bus, is required for D-channel signaling. There are two types of DS1 interfaces:

- 24 DS0 channels on a 1.544 Mbps link
- 31 DS0 channels + 1 framing channel on a 2.048 Mbps link

The following discussion describes 24-channel interface signaling groups. The 32-channel interface works the same way, except that only port number 16 is used for signaling instead of port number 24. Ports 1 through 15 and 17 through 31 are used for B-channels. The 32nd channel (port 0) is always used for framing.

ISDN-PRI D-channel signaling can be combined with a group of B-channels in three basic ways:

- Facility-associated signaling (FAS)
- Nonfacility-associated (NFAS) simplex signaling

■ NFAS duplex signaling

In a FAS signaling group, the 24th port of the TN464C/D UDS1 Interface circuit pack carries D-channel signaling for up to 23 B-channel ports on the same circuit pack.

In an NFAS signaling group, the 24th port of one TN464C/D UDS1 Interface can carry D-channel signaling for B-channels on several other DS1 circuit pack as well, including TN767s and TN464Bs. The 24th port on the other circuit packs can be used for B-channels. A D-channel in an NFAS group can signal for B-channels on a total of 20 DS1 circuit packs.

NFAS duplex signaling provides increased reliability, which is highly desirable since NFAS permits the D-channel to signal for many more B-channels. NFAS Duplex allows the administration of a backup D-channel which remains in a standby state until the active D-channel goes down. If the active D-Channel does go down, the backup D-Channel takes over and provides signaling for all the B-channels in the signaling group.

The operation of the entire ISDN-PRI signaling group depends on several other entities: the ISDN-PRI signaling channel ports, the TN464C/D UDS1 Interface circuit pack on which the D-channels reside and the system link that is carried over the packet bus to the processor. When there are problems with the ISDN-PRI signaling group, also investigate ISDN-LNK, UDS1-BD, SYS-LINK, and PKT-BUS.

## Error Log Entries and Test to Clear Values

**Table 9-361. ISDN-PRI Signaling Group Error Log Entries**

Error Type	Aux Data	Associated Test	Alarm Level	On/Off Board	Test to Clear Value
0 <sup>1</sup>	0	Any	Any		test sig-group grp#
1 (a)	Any	None			
257 (b)	Any	None			test sig-group grp#
513 (c)	Any	None			test sig-group grp#
769	Any	Primary Signaling Link Hardware Check (#636)			test sig-group grp#
1025	Any	Secondary Signaling Link Hardware Check (#639)			test sig-group grp#
1793 (d)	Any	Layer 2 Status (Test #647)	WARNING	OFF	test sig-group grp#
2049 (e)	Any	Layer 2 Status (Test #647)	WARNING	OFF	test sig-group grp#
2305 (f)	Any	Remote Layer 3 Query (Test #637)	MINOR	OFF	test sig-group grp#

Table 9-361. ISDN-PRI Signaling Group Error Log Entries — Continued

Error Type	Aux Data	Associated Test	Alarm Level	On/Off Board	Test to Clear Value
3585 (g)	Port number	None			
3840 to 3928(h)	Port number	None			

1. Run the Short Test Sequence first. If all tests pass, run the Long Test Sequence. Refer to the appropriate test description and follow the recommended procedures.

**Notes:**

- a. This switch sent a message to the far-end switch or terminal adapter, and the far-end did not respond in the allotted time. Possible causes include link failure and congestion or outage at the far-end. The Aux Data field contains Layer 3 protocol information used by internal counters.

If no other symptoms are not present, no action is required. If Layer 3 communication is down, there should be indications in the form of alarms and errors for link components. Check out other errors against ISDN-SGR, ISDN-TRK, and other hardware components on the link.

There is no test to clear these errors. The error counter is decremented by 1 every 15 minutes.

- b. This error indicates that the primary signaling channel connection has been lost for more than 90 seconds. If a secondary signaling channel does not exist or is not in-service, the associated B-channels will be placed in the ISDN Maintenance/Far-End state. The B-channels will not be usable for outgoing calls, although incoming calls will still be accepted. The switch will automatically attempt to recover the signaling link. Pay particular attention to the results of Test #636 (Primary Signaling Link Hardware Check) in the test sequence. When the link does recover, the B-channels will be negotiated back to the In-Service state and their alarms will be retired.

When this error occurs, the state of the Signaling Group is changed to out-of-service (verify using the **status sig-group** command).

- c. This error indicates that the secondary signaling channel connection has been lost for more than 90 seconds. If the primary signaling channel is not in-service, B-channels will be placed in the ISDN Maintenance/Far-End state. The B-channels will not be usable for outgoing calls, although incoming calls will still be accepted. The switch will automatically attempt to recover the signaling link. Pay particular attention to the results of Test



#639 (Secondary Signaling Link Hardware Check) in the test sequence. When the link does recover, the B-channels will be negotiated back to the In-Service state and their alarms will be retired.

When this error occurs, the state of the Signaling Group is changed to out-of-service (verify using the **status sig-group** command).

- d. This error indicates a failure of the Layer 2 Query Test for the primary signaling channel
- e. This error indicates a failure of the Layer 2 Query Test for the secondary signaling channel.
- f. This error indicates a failure of Test #637, the Remote Layer 3 Query. A specific message was sent to the far-end switch, and it did not respond within the allotted time. Investigate elements of the ISDN PRI D-channel(s) (ISDN-LNK) for both this switch and the Far-end switch. If Test #637 fails twice in a row, the B-channels will be alarmed and made unavailable for outgoing calls (although incoming calls will still be accepted). When Test #637 succeeds and the Far-end switch starts responding properly, the DS1 ISDN Trunk (B-channels) will be placed back into normal operation and their alarms will be retired.
- g. A SERV or SERV ACK ISDN D-channel message has been received by a non-US-type interface (country option other than 1 on the DS1 administration form). However, these messages are used only for duplex NFAS signaling which is supported only by country protocol 1.

Thus, there may be a mismatch in administration between the local and far-end switches. Consult with the customer's network provider to determine whether the D-channel is set up correctly on the far-end switch.

- h. These Error Types are used to report certain error messages received by the ISDN-PRI Signaling Group for one of its associated B-channels. The aux data field shows for which B-channel (port number) the message was received.

The error code generated equals 3840+x, where x is a Cause Value defined by the ISDN PRI Specification. Note that there is no Test to Clear Value for these Error Types; selected ISDN cause values are placed in the log when they are received, but no direct action or alarming is performed solely in response to receiving them. They provide added data that may prove useful when tracking down obscure networking and routing problems. The following table provides more information:

**Table 9-362. Descriptions and Recommendations for Error Types 3840-3928**

Error Code	Description	Recommendation
3842	A request has been made to use a transit network or common carrier that cannot be accessed.	<ol style="list-style-type: none"> <li>1. From the circuit pack and port number (in the Aux Data field), determine the trunk group against which the error was reported.</li> <li>2. Check all routing patterns containing this trunk group for validity of interexchange carriers requested (IXC field).</li> </ol>
3846	The far-end switch has indicated that the B-channel (trunk) is not acceptable for use in the call for which it was requested.	<p>This could indicate an administration problem (for example, the local switch and the far-end switch have different B-channels administered), or could reflect the occurrence of a normal race condition (for example, the local switch has requested use of a B-channel which the far-end switch had just reserved for use on another call).</p> <ol style="list-style-type: none"> <li>1. From the circuit pack and port number (in the Aux Data field), determine the trunk group against which the error was reported.</li> <li>2. Issue the <b>status trunk</b> command for the indicated trunk.</li> <li>3) Refer to the "DS1 ISDN Trunk Service States" and "ISDN-PRI Trunk Service States" sections of ISDN-TRK for recovery suggestions.</li> </ol>
3858	Similar to Error Type 1. The switch sent an ISDN message to the far-end switch or terminal adapter which did not respond in the allotted time.	Follow same recommendations as for Error Type 1.
3878	The far-end switch has indicated that the network is not functioning correctly and that the condition may last a relatively long period of time (for example, immediately re-attempting the call may not be successful).	<ol style="list-style-type: none"> <li>1. From the circuit pack and port number (in the Aux Data field), determine the trunk group against which the error was reported.</li> <li>2. Consult with the network provider to determine the nature and expected duration of the out of service condition.</li> <li>3. Consider modifying all routing patterns containing this trunk group, to route calls around the network which is out of service.</li> </ol>

*Continued on next page*

**Table 9-362. Descriptions and Recommendations for Error Types 3840-3928 — Continued**

Error Code	Description	Recommendation
3890	<p>A request to use a network service (e.g., SDN) has been denied. Administration somewhere on the network has indicated that the requested service has not been subscribed to or purchased for this trunk.</p>	<p>This could be a local administration problem only, or a mismatch between the local administration and that of the network provider.</p> <ol style="list-style-type: none"> <li>1. From the circuit pack and port number (in the Aux Data field), determine the trunk group against which the error was reported.</li> <li>2. Display the trunk group form: If the trunk group is Call-by-Call (Service Type is "cbc"), check all routing pattern forms containing this trunk group to see if the Service/Feature fields contain the correct network services purchased for this trunk. If the trunk group is not Call-by-Call, check that the Service Type field contains the single network service purchased for this trunk.</li> <li>3. If local administration appears correct, consult with the customer and/or the network provider to determine the services that the customer has subscribed to for this trunk group.</li> </ol>
3892	<p>Protocol detail; may offer a clue if customer is having ISDN calls denied with an unexpected intercept tone.</p>	<p>If customer is complaining of unexpected intercept tones when accessing ISDN trunks or PRI endpoints and no other cause can be found, escalate the problem and provide the next tier with this Error Log information.</p>
3894	<p>Protocol detail; may offer a clue if customer is having ISDN calls denied with an unexpected intercept tone.</p>	<p>First, eliminate any transitory state mismatch problems by issuing the <b>test port UUCSSpp</b> command for the trunk port shown in the aux data field. Test #256 (Service State Audit) is the important test in the sequence. If this passes satisfactorily, yet the customer continues to complain of unexpected intercept tones when accessing ISDN trunks or PRI endpoints and no other cause can be found, escalate the problem and provide the next tier with this Error Log information.</p>
3905	<p>Protocol detail; may offer a clue if customer is having ISDN calls denied with an unexpected intercept tone.</p>	<p>If customer is complaining of unexpected intercept tones when accessing ISDN trunks or PRI endpoints and no other cause can be found, escalate the problem and provide the next tier with this Error Log information.</p>
3906	<p>Protocol detail; may offer a clue if customer is having ISDN calls denied with an unexpected intercept tone.</p>	<p>If customer is complaining of unexpected intercept tones when accessing ISDN trunks or PRI endpoints and no other cause can be found, escalate to the problem and provide the next tier with this Error Log information.</p>

*Continued on next page*

**Table 9-362. Descriptions and Recommendations for Error Types 3840-3928 — Continued**

Error Code	Description	Recommendation
3909	A request to use a network service has been made, but the network has rejected the request because the requested service is not implemented.	Follow the recommendations listed above for Error Type 3890.
3928	A call was denied because of a basic incompatibility between the type of call and either the facilities selected by the routing pattern or the called user itself.	This error might be helpful as a clue if the customer complains of receiving unexpected intercept tone after accessing ISDN trunks or PRI endpoints. Determine the trunk group from the circuit pack and port number (in the aux data field) and then check the BCC fields of the pertinent routing patterns. Also, investigate whether or not the calling and called endpoints are compatible (for example, some ISDN switches may not allow a voice station to call a data extension).

### System Technician-Demanded Tests: Descriptions and Error Codes

Always investigate tests in the order presented in the table below when inspecting errors in the system. By clearing error codes associated with the *Primary Signaling Link Hardware Check*, for example, you may also clear errors generated from other tests in the testing sequence.

Order of Investigation	Short Test Sequence	Long Test Sequence	D/ND <sup>1</sup>
Primary Signaling Link Hardware Check (#636)	X	X	ND
Secondary Signaling Link Hardware Check (#639)	X	X	ND
Layer 2 Status Test (#647)	X	X	ND
Remote Layer 3 Query Test (#637)	X	X	ND

1. D = Destructive; ND = Nondestructive

## Primary Signaling Link Hardware Check (#636)

The ISDN-PRI Signaling Group D-Channel port depends on the health of the TN464C/D UDS1 Interface circuit pack on which it resides. This test will fail if there are problems with either the ISDN-PRI Primary D-channel port or the UDS1 circuit pack. If there are problems with the ISDN-PRI Primary Signaling Channel port (ISDN-LNK), also investigate the UDS1 circuit pack (UDS1-BD).

Error Code	Test Result	Description/ Recommendation
	ABORT	Internal system error  1. Retry the command at 1-minute intervals a maximum of 5 times.
1700	ABORT	Rollabout video abort. The PRI terminal adapter associated with the primary D-channel port is detached from the circuit pack. This is a normal abort when the rollabout video feature is enabled. To complete test on this port, either:  1. Re-attach the disconnected PRI terminal adapter, or  2. Disable the rollabout video feature on this board by entering <b>change ds1 UUCSS</b> and set field "Alarm when PRI Endpoint Detached?" to "y."
8	FAIL	There is a problem with the UDS1 TN464C/D Circuit Pack or the ISDN-PRI Signaling Channel (D-Channel). No ISDN trunk or PRI endpoint calls can be made until the problem is resolved.  1. Consult the procedures for the UDS1 TN464C/D Circuit Pack (UDS1-BD) and the ISDN-PRI Signaling Channel (ISDN-LNK).
	PASS	The basic physical connectivity of the primary D-channel is intact and functional. One might try this test repeatedly to ensure the link is up and to uncover any transitory problems.

## Remote Layer 3 Query (#637)

This test will query the far-end switch or terminal adapter to determine if the signaling connection is functioning properly at Layer 3. It will select a B-channel in the in-service or maintenance service state and send an ISDN Layer 3 SERVICE message, which requires a response from the far end (similar to performing Test #256 on an ISDN trunk. The test will not be performed if there are no B-channels in an appropriate ISDN service state (as when none are administered or they are all out of service).

### ⇒ NOTE:

The service state can be displayed by using the **status trunk <trunk group/trunk member>** or **status pri-endpoint** command.

As is the case with Test #256 for an ISDN trunk, a PASS only indicates that a message was composed and sent to the far-end switch or terminal adapter. The ISDN PRI Specification allows up to 2 minutes for a response. Check the Error Log for "[ISDN-SGR \(ISDN-PRI Signaling Group\)](#)" errors of type 2305 for evidence of a Remote Layer 3 Query failure.

Tests #639 and #636 check the health of the D-channels and DS1/UDS1 Interface Circuit Packs. As shown in [Figure 9-52](#), this test goes one step further by checking the communication path from the processor from the processor, through the TDM/Packet Bus and DS1/UDS1 Interface circuit pack, and on to the far-end switch or terminal adapter. A special ISDN message is sent to the far-end switch or terminal adapter, which must respond within a specified amount of time. This test is designed to ensure that the communication path between the switch and the far-end is up and operational, and that the two endpoints can properly exchange ISDN control messages.

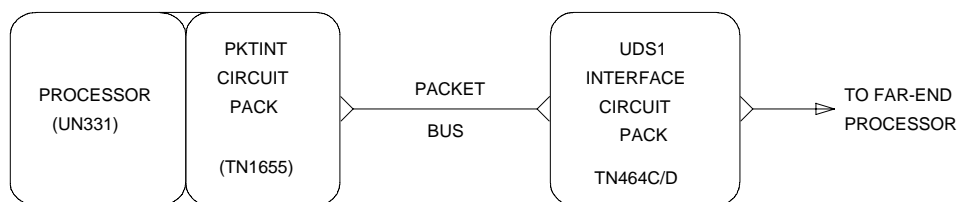

---

**Figure 9-52. Remote Layer 3 Query (Test #637)**

[Figure 9-52](#) illustrates a UDS1 Interface Circuit Pack located in the PPN. When the UDS1 board is located in an EPN, there is additional Port Network Connectivity hardware connecting the packet busses of the PPN and EPN. Examples of such hardware are the Center Stage Switch and fiber-optic cables.

**Table 9-363. TEST #637 Remote Layer 3 Query**

Error Code	Test Result	Description/ Recommendation
1006	ABORT	<p>There are no associated B-channels in an ISDN "in-service" or "maintenance" service state. This is a NORMAL ABORT.</p> <ol style="list-style-type: none"> <li>Administer or release an ISDN trunk or PRI endpoint before retrying the test. For an ISDN trunk, use the <b>status trunk</b> group#/member# command to verify the ISDN trunk state. For a PRI endpoint use <b>status pri-endpoint</b> extension. Then, retry this test when at least one B-channel is in the "in-service" or "maintenance" states.</li> </ol>
1113	ABORT	<p>The signaling channel is down. Therefore, no messages can be sent to the far-end switch or terminal adapter.</p> <ol style="list-style-type: none"> <li>Examine the results of Tests #636 and #639 and follow recommendations provided there.</li> </ol>
2100	ABORT	<p>Could not allocate the necessary system resources to run this test.</p> <ol style="list-style-type: none"> <li>Retry the command at 1-minute intervals a maximum of 5 times.</li> </ol>
2500 or none	ABORT	<p>Internal system error OR Administration Problem</p> <ol style="list-style-type: none"> <li>Determine if any B-channels are administered. If there are none, then this is a normal ABORT, since this test cannot run unless at least one B-channel is administered. If at least one B-channels is administered, there is an internal system error. Retry the command at 1-minute intervals a maximum of 5 times.</li> </ol>
	FAIL	<p>Internal system error. See description of ABORT with error code 2500.</p>
	PASS	<p>A message was composed and sent to the far-end switch or terminal adapter. The ISDN PRI specification allows up to 2 minutes for a reply. Check the Error Log for "<a href="#">ISDN-SGR (ISDN-PRI Signaling Group)</a>" for errors of type 2305 for evidence of a Remote Layer 3 Query failure. If no new errors were logged since this test was run, then this switch and the far-end switch or terminal adapter can exchange call control messages. If there is still a problem with a particular ISDN trunk or PRI endpoint, busyout the trunk and run the long test sequence, paying particular attention to the results of Test #258 (ISDN Test Call).</p>

### Secondary Signaling Link Hardware Check (#639)

The ISDN-PRI Signaling Group D-Channel port depends on the health of the TN464C/D UDS1 Interface circuit pack on which it resides. This test will fail if there are problems with either the ISDN-PRI Secondary D-channel port or the UDS1 circuit pack. This test will abort if a Secondary D-channel is not

administered for the signaling group. If there are problems with the ISDN-PRI Secondary Signaling Channel port (ISDN-LNK), also investigate the UDS1 circuit pack (UDS1-BD).

**Table 9-364. TEST #639 Secondary Signaling Link Hardware Check**

Error Code	Test Result	Description/ Recommendation
	ABORT	Internal system error 1. Retry the command at 1-minute intervals a maximum of 5 times.
1132	ABORT	The Secondary D-Channel is not administered for this Signaling Group. This is a NORMAL ABORT. Only a Primary D-Channel must be administered for a Signaling Group.
8	FAIL	There is a problem with the TN464C/D UDS1 Interface circuit pack or the ISDN-PRI Secondary Signaling Channel (D-Channel). No ISDN trunk or PRI endpoint calls can be made until the problem is resolved. 1. Consult the procedures for the UDS1 TN464C/D Circuit Pack (UDS1-BD) and the ISDN-PRI Signaling Channel (ISDN-LNK).
	PASS	The basic physical connectivity of the Signaling Group's Secondary D-channel is intact and functional. Try this test repeatedly to ensure the link is up and to uncover any transitory problems.

### Layer 2 Status Test (#647)

The Layer 2 Status Test checks the layer 2 status of the ISDN-PRI Signaling Channel (D-channel). This test will fail if there is a hardware failure or a facility problem, or if the primary and secondary ISDN-PRI D-channels are not administered correctly.

The Primary and Secondary Signaling Link Hardware tests (test 637 and 639) and the Remote Layer 3 Query test (test 637) will detect most problems caused by hardware failures or incorrect administration. However, the Layer 3 test (test 637) cannot detect end-to-end transmission problems with the Standby D-channel since Layer 3 messages are not sent on the standby channel.

For G3r, the SYS-LINK Maintenance Object reports Layer 2 ISDN-PRI D-channel problems and for G3i/s/vs, the PI-LINK Maintenance Object reports Layer 2 ISDN-PRI D-channel problems (if the D-channel is connected to the Processor Interface circuit pack). However, for G3i, the PI-LINK Maintenance Object does not monitor the Layer 2 status of the ISDN-PRI D-channel when the D-channel is connected to the Packet Control circuit pack for the ISDN-PRI over PACCON feature. The Layer 2 Query test is provided to detect D-Channel Layer 2 failures



and generate an associated Warning alarm independent of the hardware configuration used for the D-channels.

**Table 9-365. TEST #647 Layer 2 Status Query Test**

Error Code	Test Result	Description/ Recommendation
1132	ABORT	Internal system error:  The port location for the primary ISDN-PRI D-channel is not known. This condition should not be possible since an administered DS1 circuit pack must be specified when a Signaling Group is administered:  1. Retry the command at one minute intervals a maximum of five times.
1134	ABORT	Internal system error:  The associated DS1 circuit pack is not administered. This condition should not be possible since an administered DS1 circuit pack must be specified when a Signaling Group is administered.  1. Retry the command at one minute intervals a maximum of three times.
2500	ABORT	Internal system error:  1. Retry the command at one minute intervals a maximum of five times.
1	FAIL	Layer 2 of the primary signaling channel is down:  1. Examine the results of the Primary Signaling Test (#636) and follow recommendations provided there.  2. If test #636 passes, the Layer 2 Query test may still fail if the Signaling Channel at the far end has not been administered correctly or if the Signaling Channel has been busied out. Verify that the Primary Signaling Channel (D-channel) at the far end has been administered correctly. Verify that the DS1 port used for the Primary D-channel has not been busied out at the far end.
2	FAIL	Layer 2 of the secondary signaling channel is down.  1. Examine the results of Secondary Signaling Link Hardware Test (#639) and follow recommendations provided there.  2. If tests #639 passes, the Layer 2 Query test may still fail if the Signaling Channel at the far end has not been administered correctly or if the Signaling Channel has been busied out. Verify that the Secondary Signaling Channel (D-channel) at the far end has been administered correctly. Verify that the DS1 port used for the Secondary D-channel has not been busied out at the far end.

*Continued on next page*

**Table 9-365. TEST #647 Layer 2 Status Query Test — Continued**

Error Code	Test Result	Description/ Recommendation
3	FAIL	Both the primary and secondary are down. <ol style="list-style-type: none"> <li>1. Examine the results of the Primary and Secondary Signaling Link Hardware Tests (#636 and #639) and follow recommendations provided there.</li> <li>2. If tests #636 and #639 pass, the Layer 2 Query test may still fail if the Signaling Channel at the far end has not been administered correctly or if the Signaling Channel has been busied out. Verify that the Primary and Secondary Signaling Channel (D-channel) at the far end has been administered correctly. Verify that the DS1 port used for the Primary and Secondary D-channels has not been busied out at the far end.</li> </ol>
	PASS	The Primary Signaling Channel is up and, if administered the Secondary Channel is up.

## ISDN-TRK (DS1 ISDN Trunk)

MO Name (in Alarm Log)	Alarm Level	Initial Command to Run <sup>1</sup>	Full Name of MO
ISDN-TRK <sup>2</sup>	MAJOR <sup>3</sup>	test port UUCSSpp l	DS1 ISDN Trunk
ISDN-TRK	MINOR	test port UUCSSpp l	DS1 ISDN Trunk
ISDN-TRK	WARNING	test port UUCSSpp sh	DS1 ISDN Trunk

1. UU is the universal cabinet number (1 for PPN, 2 -44 for EPN s). C is the carrier designation (A, B, C, D, or E). SS is the number of the slot in which the circuit pack resides (01 to 21). pp is the two digit port number (01, 02, ...).
2. For additional repair information, see also DS1-BD for TN767 ports and UDS1-BD for TN464C/D ports.
3. A MAJOR alarm on a trunk indicates that alarms on these trunks are not downgraded by the **set options** command.

### ⇒ NOTE:

Many trunk problems are caused by incorrect settings of parameters on the trunk group administration form. Settings must be compatible with the local environment and with parameter settings on the far-end. The Application Notes section of that book shows the correct settings for administrable timers and other parameters on a country-by-country basis.

### ⇒ NOTE:

See the figures in the [“ISDN-SGR \(ISDN-PRI Signaling Group\)”](#) section of this chapter for an illustration of the principles described below. Throughout this section, the general term DS1 circuit pack refers to TN464 and TN767 series circuit packs.

A DS1 ISDN trunk is a 64 Kbps bearer channel used to transmit digitized voice or data traffic. These trunks, or B-channels, use a separate channel, the D-channel for call-control signaling. This mode of operation is known as out-of-band signaling, as opposed to in-band robbed-bit signaling, in which signaling is carried in the same channel as the voice or data traffic. One D-channel, or ISDN signaling link (ISDN-LNK), carries signaling messages for several B-channels, forming an ISDN signaling group (ISDN-SGR).

A B-channel may be a port on either a TN464 series UDS1 circuit pack or a TN767 series DS1 Interface circuit pack.

Two types of DS1 interfaces exist:

- 24 DS0 channels on a 1.544 Mbps link
- 31 DS0 channels + 1 framing channel on a 2.048 Mbps link

On 24-channel interfaces, any of the first 23 ports on the DS1 circuit packs can be a B-channel. On the TN464C/D UDS1 circuit pack, the 24th port may be used as a B-channel or as a D-channel depending on the type of ISDN-PRI signaling group (FAS or NFAS) implemented on the circuit pack. For more details, refer to ["ISDN-SGR \(ISDN-PRI Signaling Group\)"](#)P in this chapter. On the TN767 DS1 circuit pack, all 24 ports are used as B-channels since D-channel signaling is not supported on the TN767 circuit pack. The signaling for these B-channels is done over a D-channel located on a UDS1 TN464C/D board.

On 32 channel interfaces, any of ports 1-15 and 17-31 on the DS1 interface circuit pack can be a B-channel. The 16th port may be used as a B-channel or as a D-channel depending on the type of ISDN-PRI signaling group (FAS or NFAS) to which it belongs. For more details, refer to ["ISDN-SGR \(ISDN-PRI Signaling Group\)"](#) and "DS1-BD (DS1 Interface Circuit Pack)" in this chapter.

For interfaces using country protocol 1 on the DS1 circuit pack administration form (including US), the signaling protocol used for the maintenance of the B-channel is defined by the Lucent ISDN-PRI specification. For interfaces using country protocols other than 1, the signaling protocol used for the maintenance of the B-channel is defined by the CCITT ISDN-PRI Specification.

There are five possible service states for a B-channel. The service state is negotiated with the far-end switch, changes over time, and may have a far-end and near-end components. The service state is initialized to out-of-service/Far-End and an attempt is made to negotiate it to in-service.

The Lucent ISDN-PRI Specification defines the possible SERVICE STATES for a B-channel. The service state is negotiated with the far-end switch, changes over time, and may have a far-end or near-end component. The service state is initialized to the Out-Of-Service/Far-End state and an attempt is made to negotiate it to In-Service.

#### NOTE:

The service state of a particular DS1 ISDN Trunk B-channel can be displayed by issuing the **status trunk trunk group/trunk member** system technician command.

When a call is present, the specification defines the permissible call states as well. There are tests in the short and long test sequences for DS1 ISDN Trunk designed to audit these states and ensure agreement between both ends of the PRI connection.

## Alarming Based on Service States

A warning alarm is logged against a DS1 ISDN B-channel trunk when it is placed in the Maintenance/Far-End or Out-Of-Service/Far-End states, during which the trunk is unusable for outgoing calls. When a warning alarm is present, use **status trunk group#/member#** command to determine the exact state. Other alarms can be diagnosed by using the short and/or long test sequences. Note that an

ISDN B-channel trunk can be placed in a Far-End service state by either action taken by the far-end switch or by failure of the far-end switch to respond. For example, if the far-end does not respond to a Remote Layer 3 Query (Test #637 for ISDN-SGR), the associated DS1 ISDN trunk B-channels will be placed in the Maintenance/Far-End service state.

As a port on a DS1 circuit pack (DS1-BD or UDS1-BD), and as part of a signaling group dependent on a D-channel (ISDN-LNK) for signaling, operation of the ISDN-TRK is dependent on the health of these other maintenance objects. The ISDN D-channel in turn depends on the Packet Bus (PKT-BUS) for transmission through the system. Keep this hierarchy of dependencies in mind when diagnosing problems.

## DS1 ISDN Trunk Service States

The **status trunk** command displays the following possible service states for ISDN trunks. [Table 9-366](#) gives recommended procedures for each state.

- In-Service (INS)

The B-channel is in its normal operating state.

- Out-of-Service/Far-End (OOS/FE)

A B-Channel is initialized to this state when administered. The switch sends messages to the far-end to negotiate the B-channel into service. If the far-end does not respond to the messages within a certain time period, then the service state remains out-of-service and maintenance will periodically resend the messages. The trunk is unusable for incoming and outgoing calls.

- Out-of-Service/Near-End (OOS/NE)

This is the state of the trunk when the NPE Crosstalk Test fails or when the trunk is busied out by system technician. In this state, the trunk is unusable for incoming or outgoing calls. No messages are sent to the far-end until the signaling link comes back into service or the trunk is released by system technician.

- Maintenance/Far-End (MTC/FE)

This state is reached when the far-end does not respond to messages sent over the signaling link for a particular trunk after a certain amount of time. This state is different from OOS/FE since the signaling link must have initially been up and the B-Channels in-service. The switch will periodically send messages to the far-end to try to negotiate the trunk (B-channel) into service. The trunk is unusable for outgoing calls but will service incoming call requests from the far-end. Note that transitions into MTC/FE do not drop stable calls. Therefore, if the service state changes from in-service to MTC/FE, then stable calls are unaffected.

- Maintenance/Near-End (MTC/NE)

The trunk (B-channel) is in this state if the signaling channel (ISDN-LNK) is busied out by system technician. The trunk (B-channel) is also temporarily in this state if system technician has issued a **test trunk trunk group/trunk member long** command. This command will execute the ISDN-PRI test call. This test will change the state of the trunk member to MTC/NE for the duration of the test unless a call request comes in from the far-end. In that case, the test would abort. Note that transitions into MTC/NE do not drop stable calls. In this state, the B-Channel is not usable for new incoming or outgoing calls.

- Pending States

In addition to one of the above components, the service state may have a *pending* component, indicating that the switch is waiting for a reply from the far-end. These service states remain in effect until either a response is received or the allotted waiting time expires.

- Pending-in-Service

- The near-end is waiting for a response from the far-end to a B-channel maintenance message requesting that the B-channel be transitioned to in-service.

- Pending-Maintenance

- This state is supported only by systems using country protocol 1 (including US). The near-end is waiting for a response from the far-end to a maintenance message requesting that the B-channel be transitioned to the maintenance service state.

- Call Activity States

The in-service service state also has a call activity component.

- Active

- A call is connected over the B-channel (for example, *in-service/active*).

- Idle

- There is no call currently on the B-channel (for example, *in-service/idle*).

**Table 9-366. TEST #161 Looparound Test**

Service State	Alarm <sup>1</sup>	Possible Cause	Possible Solution
out-of-service/NE	Warning	Trunk is demand busied out.	Enter <b>release trunk</b> grp#/mbr#.
	Minor	NPE Crosstalk Test (#6) failed.	Replace DS1/UDS1 circuit pack.
	None	DS1 or UDS1 circuit pack lost its signal.	Is the DS1/UDS1 circuit pack or cable removed? Is the far-end switch restarting? Check circuit pack using procedures in DS1-BD or UDS1-BD.
out-of-service/FE	Warning	Unadministered far-end	Administer corresponding trunk on far-end switch.
	Warning	The far-end trunk is busied out.	Check the status of the far-end switch.
pending-in-service, pending-maint	None	Maintenance message was sent and the switch is waiting up to 2 min. for a reply from the far-end.	Wait 2 minutes and check service state after the pending state has cleared.
maint-NE	None	ISDN test call in progress ( <b>test trunk long</b> and <b>test isdn-testcall</b> commands)	Wait several minutes for test to finish and check status again.
	None	System link has been busied out by command.	Check link status. Release link with <b>release link</b> link#.
maint-FE	Warning	Signaling channel has been down for over 90 sec.	Consult ISDN-SGRP and/or ISDN-LNK. Far-end signaling channel may be busied out, or the far-end switch may currently be restarting.
	Warning	Repeated failure of far end to respond to messages.	Maintenance software will periodically try to resend messages. You can speed the process with <b>test trunk</b> grp#/mbr# and/or <b>test signaling-gr #</b> .
	Warning	The far-end trunk is being tested.	Check status of the far-end switch. Wait for testing to finish.
in-service	None	Normal operating state	

1. ISDN-TRK alarms; alarms against other objects may also be present.

## Error Log Entries and Test to Clear Values

Table 9-367. DS1 ISDN Trunk Error Log Entries

Error Type	Aux Data	Associated Test	Alarm Level	On/Off Board	Test to Clear Value
0 <sup>1</sup>	0	Any	Any	Any	test port <i>UUCSSpp</i>
1(a)	Any	None			test port <i>UUCSSpp</i>
15(b)	Any	Audit and Update Test (#36)			
18	0	busyout trunk <i>grp/mbr</i>			release trunk <i>grp/mbr</i>
129(c)		None	WARNING	OFF	test port <i>UUCSSpp</i>
130(d)		None	WARNING	ON	test port <i>UUCSSpp</i>
257(e)	Any	None			test port <i>UUCSSpp</i>
513(f)	Any	None	WARNING	OFF	test port <i>UUCSSpp</i>
769(e)	Any	None			test port <i>UUCSSpp</i>
1281	Any	Conference Circuit Test (#7)	MAJ/MIN/WRN <sup>2</sup>	ON	test port <i>UUCSSpp</i>   r 4
1537	Any	NPE Crosstalk Test (#6)	MAJ/MIN/WRN <sup>2</sup>	ON	test port <i>UUCSSpp</i>   r 3
1793(g)	Any	None			test port <i>UUCSSpp</i>
3073(h)	Any	Service State Audit (#256)			test port <i>UUCSSpp</i>
3585(i)	Any	None			none
3841(j)	Any	None	WARNING	OFF	None

1. Run the Short Test Sequence first. If all tests pass, run the Long Test Sequence. Refer to the appropriate test description and follow the recommended procedures.
2. Major or minor alarms may be downgraded to Warning alarms based on the value used in the set options command.

Notes:

- a. These Error Types indicate a disagreement between this switch and the switch at the other end of the trunk connection with regard to the ISDN call state of the DS1 ISDN Trunk. This switch will automatically try to recover by clearing the call, (that is, call will be torn down). You can use the **status trunk group#/member#** command to determine the state of the trunk.

When running the Short Test Sequence of tests, pay close attention to the results of the Call State Audit Test (#257).



- b. Software audit error and does not indicate a hardware malfunction. Run the Short Test Sequence and investigate associated errors.
- c. The far-end switch changed its ISDN service state to either *out-of-service* or *maintenance*. This may be a temporary condition due to testing of that trunk by the far-end, or a hardware problem with the trunk. Outgoing calls will not be allowed over the trunk. To investigate the status of the trunk, issue the **status trunk** group#/member# command.
- d. This Error Type indicates that the circuit pack has been removed or has been insane for more than 11 minutes. To clear the error, reinsert or replace the circuit pack.
- e. These Error Types indicate a disagreement between this switch and the switch at the other end of the trunk connection with regard to the ISDN service state of the DS1 ISDN Trunk. This switch will automatically try to recover by performing a service state audit. You can use the **status trunk** group#/member# command to determine the state of the trunk.

When running the Short Test Sequence, pay close attention to the results of the Service State Audit Test (#256).

- f. This trunk is not recognized by the far-end switch. Investigate the trunk administration for both switches and make changes as necessary.
- g. This error indicates a failure of the DS1/UDS1 Interface circuit pack. When running the Short Test Sequence, the results of the Signaling Link State Check Test (#255) are important.
- h. Service State Audit attempt failed (see Test #256). The trunks will not be usable for any outgoing calls (although incoming calls will be accepted) until the test passes and the trunk state is changed to in-service (use **status trunk** group#/member# to investigate trunk status).
- i. Error Type 3585 appears when the switch receives an ISDN RESTART message for an ISDN trunk. Calls are cleared with the RESTART message. Therefore, this Error Type may be associated with a dropped call report from a user.

The following Aux Data values for Error Type 3585 represent the trunk's ISDN call state at the time the unexpected request to restart the channel was received from the remote switch. This information can be useful if dropped calls (cutoffs) are reported by users of the ISDN-PRI trunks.

The meanings of Aux Data values are shown below; ignore any others.

Aux Data	Cause
0	A idle trunk received a restart.
10	A call in a stable, talking state was cleared unexpectedly by the far-end with an ISDN RESTART message. This state is called the "active" state.

Aux Data	Cause
4 7 8 260 263	A call that has not reached the active state, but has at least reached a ringing state, was cleared unexpectedly by the far-end with an ISDN RESTART message.
1 3 6 9 265	A call that has not yet reached a ringing state was cleared unexpectedly by the far-end with an ISDN RESTART message.
11 12 19 531 267 268	A call that was in the process of clearing anyway has been cleared by the far-end with an ISDN RESTART message. If this condition occurs frequently, it may mean that the far-end is attempting to clear trunks that it thinks are in a "hung" state. The RESTART message brings the trunk to an idle condition.

- j. An ISDN trunk selected by the near-end has been rejected 10 times by the far-end without a successful call. This may indicate a service state mismatch between the near-end and far-end for this trunk that is effecting the end user (that is, customer receives unexpected intercept tones when accessing ISDN trunks). This may indicate that the ISDN trunk is not administered on the far-end.

The Aux field contains the physical name of the ISDN trunk in decimal. Then, verify that the far-end has this trunk administered.

The Warning alarm will be retired automatically whenever an outgoing or incoming call that uses this trunk is answered by the called endpoint. If problems persist, then busy-out the ISDN trunk to take it out of the hunt group.

## System Technician-Demanded Tests: Descriptions and Error Codes

Always investigate tests in the order presented in the table below when inspecting errors in the system. By clearing error codes associated with the *NPE Crosstalk Test*, for example, you may also clear errors generated from other tests in the testing sequence.

**Table 9-368. System Technician-Demanded Tests: DS1-BD**

Order of Investigation	Short Test Sequence	Long Test Sequence	D/ND <sup>1</sup>
NPE Crosstalk Test (#6)		X	ND
Conference Circuit Test (#7)		X	ND
Audit and Update Test (#36)	X	X	ND
Signaling Link State Check Test (#255)	X	X	ND
Service State Audit Test (#256)	X	X	ND
Call State Audit Test (#257)	X	X	ND
ISDN Test Call Test (#258)		X	ND

1. D = Destructive, ND = Non-destructive

### NPE Crosstalk Test (#6)

The NPE Crosstalk Test verifies that this port's NPE channel talks on the selected time slot and never crosses over to time slots reserved for other connections. If the NPE is not working correctly, one-way and noisy connections may be observed. This test is usually only part of a port's long test sequence and takes about 20 to 30 seconds to complete.

#### NOTE:

The TN464C/D UDS1 circuit pack has one SCOTCH-NPE chip instead of several NPE chips.

**Table 9-369. TEST #6 NPE Crosstalk Test**

Error Code	Test Result	Description/ Recommendation
	ABORT	Could not allocate the necessary system resources to run this test. 1. Retry the command at 1-minute intervals for a maximum of 5 times.
1000	ABORT	System resources required to run this test are not available. The port may be in use on a valid call. 1. Use <b>status station</b> or <b>status trunk</b> commands to determine when the port is available for testing. 2. Retry the command at 1-minute intervals for a maximum of 5 times.
1001	ABORT	Could not allocate the necessary system resources to run this test. 1. Retry the command at 1-minute intervals for a maximum of 5 times.
1002	ABORT	The system could not allocate time slots for the test. The system may be under heavy traffic conditions or it may have time slots out-of-service due to TDM-Bus errors. 1. If system has no TDM-Bus errors and is not handling heavy traffic, repeat test at 1-minute intervals for a maximum of 5 times.
1003	ABORT	The system could not allocate a tone receiver for the test. The system may be oversized for the number of tone detectors present or some tone detectors may be out-of-service. 1. Resolve any TTR-LEV errors. 2. Resolve any TONE-PT errors. 3. If neither condition exists, retry the test at 1-minute intervals for a maximum of 5 times.
1004	ABORT	The port has been seized by a user for a valid call. Use <b>status station</b> or <b>status trunk</b> commands to determine when the port is available for testing. 1. Retry the command at 1-minute intervals for a maximum of 5 times.
1018	ABORT	Maintenance is disable on this trunk. 1. Enable maintenance by entering "y" in the "Maintenance Tests?" field on page 2 of the <b>change trunk-group</b> form.
1117	ABORT	A service state audit message is outstanding. 1. Wait 2 minutes and then try again.
2000	ABORT	Response to the test was not received within the allowable time period. 1. Retry the command at 1-minute intervals for a maximum of 5 times.

*Continued on next page*

**Table 9-369. TEST #6 NPE Crosstalk Test — Continued**

<b>Error Code</b>	<b>Test Result</b>	<b>Description/ Recommendation</b>
2020	ABORT	The test did not run due to an already existing error on the specific port or a more general circuit pack error. <ol style="list-style-type: none"><li>1. Examine Error Log for existing errors against this port or the circuit pack and attempt to diagnose the already existing error.</li></ol>
2100	ABORT	Could not allocate the necessary system resources to run this test. <ol style="list-style-type: none"><li>1. Retry the command at 1-minute intervals for a maximum of 5 times.</li></ol>
Any	FAIL	The NPE of the tested port was found to be transmitting in error. This will cause noisy and unreliable connections. The ISDN-TRK is moved to out-of-service/near-end state. <ol style="list-style-type: none"><li>1. Replace the circuit pack.</li></ol>
	PASS	The port is able to communicate over the TDM Bus.

### Conference Circuit Test (#7)

The Conference Circuit test verifies that the NPE channel for the port being tested can correctly perform the conferencing function. The NPE is instructed to listen to several different tones and conference the tones together. The resulting signal is then measured by a tone detector port. If the level of the tone is within a certain range, the test passes.

#### NOTE:

The TN464C/D UDS1 circuit pack has one SCOTCH-NPE chip instead of several NPE chips.

**Table 9-370. TEST #7 Conference Circuit Test**

Error Code	Test Result	Description/ Recommendation
	ABORT	Could not allocate the necessary system resources to run this test. 1. Retry the command at 1-minute intervals for a maximum of 5 times.
1000	ABORT	System resources required to run this test are not available. The port may be in use on a valid call. Use <b>status station</b> or <b>status trunk</b> commands to determine when the port is available for testing.
1004	ABORT	The port has been seized by a user for a valid call. Use status station or status trunk to determine when the port is available for testing. 1. Retry the command at 1-minute intervals for a maximum of 5 times.
1018	ABORT	Maintenance is disabled on this trunk. 1. Enable maintenance by entering "y" in the "Maintenance Tests?" field on page 2 of the <b>change trunk-group</b> form.
1020	ABORT	The test did not run due to an already existing error on the specific port or a more general circuit pack error. 1. Examine Error Log for existing errors against this port or the circuit pack and attempt to diagnose the already existing error.
2000	ABORT	Response to the test request was not received within the allowable time period.
2100	ABORT	Could not allocate the necessary system resources to run this test. 1. Retry the command at 1-minute intervals for a maximum of 5 times.
Any	FAIL	The NPE of the tested port did not conference the tones correctly. This will cause noisy and unreliable connections. 1. Replace the circuit pack.
	PASS	The port can correctly conference multiple connections. User-reported troubles on this port should be investigated using other port tests and examining station, trunk, or external wiring.

### Audit and Update Test (#36)

This test sends port level translation data from switch processor to the DS1 interface circuit pack to assure that the trunk's translation is correct. The port audit operation verifies the consistency of the current state of trunk kept in the DS1 interface circuit pack and in the switch software.

**Table 9-371. TEST #36 Audit and Update Test**

Error Code	Test Result	Description/ Recommendation
1018	ABORT	Maintenance is disabled on this trunk. 1. Enable maintenance by entering "y" in the "Maintenance Tests?" field on page 2 of the <b>change trunk-group</b> form.
	ABORT	Internal system error
2000	ABORT	Response to the test request was not received within the allowable time period.
2100	ABORT	Could not allocate the necessary system resources to run this test.
	FAIL	Test failed due to internal system error. 1. Retry the command at 1-minute intervals for a maximum of 5 times.
	PASS	Trunk translation has been updated successfully. The current trunk states kept in the DS1 interface circuit pack and switch software are consistent.

### Signaling Link State Check Test (#255)

The DS1 ISDN Trunk depends on the health of the appropriate TN464C/D UDS1 Interface circuit pack or TN767 DS1 interface circuit pack for proper operation. It also depends on the ISDN-PRI D-channel (ISDN-LNK) trunk. This test checks the status of those critical elements.

**Table 9-372. TEST #255 Signaling Link State Check Test**

Error Code	Test Result	Description/ Recommendation
None	ABORT	Internal system error
0	ABORT	
1114	ABORT	The signaling link is in a transitional state. 1. Retry the command at 1-minute intervals for a maximum of 5 times.
1018	ABORT	Maintenance is disable on this trunk. 1. Enable maintenance by entering "y" in the "Maintenance Tests?" field on page 2 of the <b>change trunk-group</b> form.

*Continued on next page*

**Table 9-372. TEST #255 Signaling Link State Check Test — Continued**

<b>Error Code</b>	<b>Test Result</b>	<b>Description/ Recommendation</b>
4	FAIL	There is a problem with the signaling channel. <ol style="list-style-type: none"><li>1. Consult the procedures for the ISDN-PRI Signaling Group (ISDN-SGRP). Further information may also be obtained by consulting the procedures for the ISDN-PRI Signaling Channel (ISDN-LNK).</li></ol>
8	FAIL	There is a problem with the DS1 interface circuit pack. <ol style="list-style-type: none"><li>1. Consult the procedures for the appropriate DS1 interface circuit pack (DS1-BD or UDS1-BD).</li></ol>
	PASS	The signaling link hardware is OK.

## Service State Audit (#256)

As noted in the general description for DS1 ISDN Trunk, these trunks may be in one of several service states. This test performs a Service State Audit with the far-end switch.

For interfaces using country protocol 1 (including the US) the Service State Audit executes in all trunk service states. A message is sent to the far-end switch to ensure that both sides agree on the service state. A PASS for this test simply means that the message has been successfully sent. Two minutes are allowed for a reply. If no reply is received within that 2 minute window, the message is sent out again. If that attempt fails, an Error Type 3073 will be logged and the switch will attempt another Service State Audit every 15 minutes. If the trunk was initially in-service, it is placed in the maintenance/far-end state. No outgoing calls will be placed over this trunk, but incoming calls will be accepted. If an incoming call is presented with the trunk in such a state, a Service State Audit is immediately attempted (the switch does not wait for the 15-minute cycle, but tries to recover immediately).

For interfaces not using country protocol 1, the Service State Audit executes only if the trunk is in the out-of-service/far-end state. A message is sent to the far-end switch to attempt to bring the trunk back into the in-service state. A PASS for this test simply means that the message has been successfully sent. Two minutes are allowed for a reply. If no reply is received within that two minute window, the message is sent out again. If again no response is received within two minutes, the trunk remains in the out-of-service/far-end state. The switch will attempt another Service State Audit after an hour has passed.



To investigate the service state of the DS1 ISDN Trunk, issue the **status trunk** group#/member# command.

**Table 9-373. TEST #256 Service State Audit Test**

Error Code	Test Result	Description/ Recommendation
1000	ABORT	Resources required to run this test were not available. The port may be on a valid call or initializing. Use <b>status station</b> or <b>status trunk</b> to determine when the trunk is available for testing. Check the results of Test #255.
1018	ABORT	Maintenance is disable on this trunk. 1. Enable maintenance by entering "y" in the "Maintenance Tests?" field on page 2 of the <b>change trunk-group</b> form.
1113	ABORT	The signaling link has failed, so the system cannot send any messages on behalf of this trunk. 1. Check the results of Test #255 and consult procedures for " <a href="#">ISDN-SGR (ISDN-PRI Signaling Group)</a> " in this chapter.
1114	ABORT	The signaling link is in a transitional state. 1. Retry the command at 1-minute intervals for a maximum of 5 times.
1116	ABORT	The trunk is not in the out-of-service/far-end state, which is required to run this test on systems using a country protocol other than 1.
1117	ABORT	A service state audit message is outstanding. 1. Wait 2 minutes and then try again.
2100	ABORT	Could not allocate the necessary system resources to run this test. 1. Retry the command at 1-minute intervals for a maximum of 5 times.
1113	FAIL	The signaling link has failed; the system cannot send any messages on behalf of this trunk. 1. Consult procedures for ISDN-SGR (ISDN-PRI Signaling Group) and ISDN-LNK (ISDN Signaling Link Port).
	FAIL	Internal system error 1. Retry the command at 1-minute intervals for a maximum of 5 times.
	PASS	Wait 4 minutes and then check the Error Log for any new errors of type 3073. If there are none, then both sides of the ISDN connection agree on the service state; the negotiation succeeded. If there is a new 3073 error, then the negotiation failed (the far-end switch twice failed to respond within 2 minutes). The switch will automatically retry every 15 minutes. If the trunk was initially in-service, it is now placed in the maintenance/far-end state. Incoming calls will be accepted, but no outgoing calls can be originated. If an incoming call is presented, another Service State Audit will be immediately performed in an attempt to put the DS1 ISDN Trunk in the proper state.

### Call State Audit Test (#257)

If a call is active on the trunk, the switches on both sides of the connection should agree on the ISDN state of the call, as defined in the ISDN Protocol Specification. This test audits internal call state data by querying the far-end switch as to the ISDN state of the call. It can be helpful when trying to clear a hung call. If the internal call state data on the near-end switch is different than that of the far-end switch, then *the call will be torn down*.

As with Test #256 (Service State Audit), a PASS simply means that an appropriate message was composed and sent to the far-end switch. The ISDN Specification allows up to 2 minutes for a reply. If a reply is not received within the 2 minute window, a protocol time-out violation will be recorded in the error log against the associated signaling channel (ISDN-LNK, Error Type 1).

**Table 9-374. TEST #257 Call State Audit Test**

Error Code	Test Result		Description/ Recommendation
1018	ABORT	Maintenance is disabled on this trunk.	1. Enable maintenance by entering "y" in the "Maintenance Tests?" field on page 2 of the <b>change trunk-group</b> form.
1019	ABORT	An audit is already in progress.	1. Wait 2 minutes and try again.
1113	ABORT	The signaling link has failed, so the system cannot send any messages on behalf of this trunk.	1. Check the results of Test #255 (Signaling Link State Check).
1114	ABORT	The signaling link is in a transitional state.	1. Retry the command at 1-minute intervals for a maximum of 5 times.
1116	ABORT	The trunk is in an out-of-service ISDN service state.	1. A call cannot be present if the trunk is in an ISDN out-of-service state, so a call state audit would be inappropriate. No action necessary. (Use the <b>status trunk group#/member#</b> command to investigate the ISDN state of the trunk).
2100	ABORT	Could not allocate the necessary system resources to run this test.	1. Retry the command at 1-minute intervals for a maximum of 5 times.
	FAIL	Internal system error	1. Retry the command at 1-minute intervals for a maximum of 5 times.

Table 9-374. TEST #257 Call State Audit Test — Continued

Error Code	Test Result	Description/ Recommendation
	PASS	This switch sent a call state auditing message to the far-end switch to verify the state of the call active on this trunk. If a call state mismatch is found, then the call will be torn down within two minutes. If no call was active, then no message was sent.

### ISDN Test Call Test (#258)

This test performs a far-end loop around to a far-end switch over an ISDN trunk. The trunk's service state must be in-service, maint-NE, or out-of-service/NE, and no call can be active on the trunk. The test call can be initiated as part of a long test sequence, or as an individual test, as described below. This test is valid only for systems using country protocol 1 (including US), or when the far end has loop-around capability.

A test call connection is established to a far-end switch over the ISDN trunk to be tested. The digital port on a TN711D Maintenance/Test circuit pack generates a test-pattern bit stream which is sent to the far-end switch and echoed back. The received pattern is then compared to the sent pattern and checked for errors that indicate a loss of integrity on the communications path.

If a test call is running when scheduled maintenance starts, the green LED is turned off. To determine if a test call is still running, use the **list isdn-testcall** and **status isdn-testcall** commands. A lit yellow LED on the Maintenance/Test circuit pack also indicates that a test call is running.

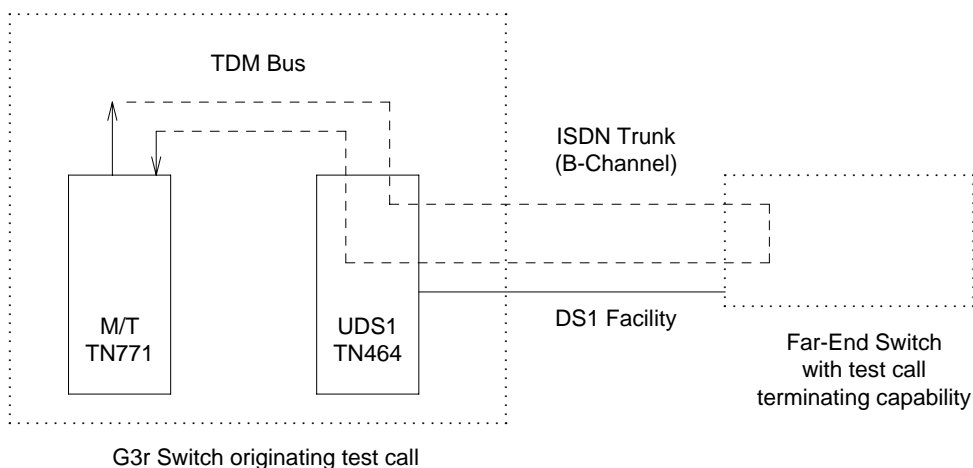

**Figure 9-53. Outgoing ISDN-PRI Test Call**

## Synchronous Test Calls

You can initiate a synchronous outgoing test call by entering one of the following commands:

- **test trunk** group#/member# long [repeat #]
- **test board** UUCSS long [repeat #]
- **test port** UUCSSpp long [repeat #]

The above test sequences include a test-call for ISDN-PRI trunks. The duration of the test call is 8.6 seconds for If unrestricted (B8ZS) B-channels and 9.4 seconds for restricted (ZCS) B-channels. The test fails if the bit error rate retrieved from the Maintenance/Test digital port is greater than 0. When this occurs, you will need to perform further diagnostics, such as the **test isdn-testcall** command described below.

## Asynchronous Test Calls

You can start, query, and stop an outgoing test call by using the following maintenance commands:

- **test isdn-testcall** group#/member# [minutes #]

This command initiates an outgoing ISDN-PRI test call for a maximum of 120 minutes. Default times are as above. Only one trunk per port network can be tested at one time.

- **status isdn-testcall** group#/member#

This command displays the progress of the outgoing test call by reporting bit and block error rates of the tested B-Channel.

- **clear isdn-testcall** group#/member#

This command terminates an outgoing test call already in progress. Measurements already collected are not cleared until the next test call begins.

A PASS of the asynchronous test indicates only that the test call was successfully established. Use the **status** and **list** commands to get the results of the test.

 **NOTE:**

Before attempting to make an ISDN-PRI test call to the public network (that is, the network is the far-end), make sure that test call service is provisioned by the network. The user must subscribe to Test Type 108 service and have the correct far-end test call number administered on the trunk group form for the call to be allowed.

**Table 9-375. TEST #258 ISDN Test Call**

Error Code	Test Result	Description/ Recommendation
4	ABORT	There is a problem with the Signaling Channel. <ol style="list-style-type: none"><li>1. Consult the procedures for the ISDN-PRI Signaling Group (ISDN-SGRP). Further information may also be obtained by consulting the procedures for the ISDN-PRI Signaling Channel (ISDN-LNK).</li></ol>
8	ABORT	There is a problem with the DS1 interface circuit pack. <ol style="list-style-type: none"><li>1. Consult the procedures for the appropriate DS1 interface circuit pack (DS1-BD or UDS1-BD).</li></ol>
1004	ABORT	B channel in use. <ol style="list-style-type: none"><li>1. Determine if a call is active on this DS1 ISDN Trunk via the <b>status trunk</b> group#/member# command.</li><li>2. When the service state indicates in-service/idle, retry the test.</li></ol>
1005	ABORT	Bad Configuration (such as no Maintenance/Test circuit pack) <ol style="list-style-type: none"><li>1. Make sure the Maintenance/Test Circuit Pack is inserted.</li><li>2. Repeat the test.</li></ol>
1018	ABORT	Test call is disabled. <ol style="list-style-type: none"><li>1. Enable Maintenance on the Trunk Group form.</li></ol>

*Continued on next page*

Table 9-375. TEST #258 ISDN Test Call — Continued

Error Code	Test Result	Description/ Recommendation
1019	ABORT	Another Test call is in progress. <ol style="list-style-type: none"><li>1. Issue the <b>list isdn-testcall</b> command to locate the test call.</li><li>2. Issue the <b>status isdn-testcall</b> command to find out the duration and start time of the test call.</li><li>3. Issue the <b>clear isdn-testcall</b> command to stop the test call from running.</li><li>4. If time and duration indicate that the test call should have stopped, and the <b>clear isdn-testcall</b> command does not work, refer to M/T-DIG (Maintenance/Test Digital Port) for recommended maintenance strategy.</li></ol>
1020	ABORT	There is a problem with the DS1 Interface Circuit Pack. <ol style="list-style-type: none"><li>1. Refer to "DS1-BD or UDS1-BD".</li></ol>
1024	ABORT	(M/T-DIG) Maintenance/Test Digital Port in use. <ol style="list-style-type: none"><li>1. Wait until yellow and green LED s are turned off on the M/T-BD (Maintenance/Test circuit pack).</li><li>2. Retry test. If problem persists, refer to M/T-DIG (Maintenance/Test Digital Port).</li></ol>
1113	ABORT	The signaling link has failed. Therefore, the system cannot send any messages on behalf of this trunk. <ol style="list-style-type: none"><li>1. Check the results of Test #255 (Signaling Link State Check Test).</li></ol>
1116	ABORT	The switch could not appropriately change the ISDN service state. <ol style="list-style-type: none"><li>1. Determine if a call is active on this DS1 ISDN Trunk (use the <b>status trunk group#/member#</b> command). If so, proceed as for Error Code 1119.</li><li>2. If not, check the Error and Alarm Logs for problems with this ISDN-TRK (DS1 ISDN Trunk) MO.</li></ol>
1117	ABORT	ISDN Service message is already outstanding. <ol style="list-style-type: none"><li>1. Wait 2 minutes. Then try again.</li></ol>
1118	ABORT	Far-end of ISDN trunk is not administered. <ol style="list-style-type: none"><li>1. Check the administration of the far-end ISDN trunk.</li><li>2. Issue the <b>status trunk group#/member#</b> command.</li><li>3. Try the test again.</li></ol>
1119	ABORT	The test call was aborted due to a normal call attempt on this trunk. <b>NOTE:</b> The test call will only be performed if the trunk is idle. <ol style="list-style-type: none"><li>1. Either wait for the normal call to terminate normally, or force it to be dropped by using the <b>busyout trunk trunk group/trunk member</b> command to busyout the DS1 ISDN Trunk. When the trunk is idle, retry the test.</li></ol>

Continued on next page

**Table 9-375. TEST #258 ISDN Test Call — Continued**

Error Code	Test Result	Description/ Recommendation
1120	ABORT	The DS1 ISDN Trunk is in the ISDN out-of-service/far-end state. 1. Try to change the service state via Test #256 (Service State Audit Test) and then try this test again. Keep in mind that the trunk may be in the out-of-service/far-end state due to problems at the far-end switch. If that is the case, no remedial action can be taken at this end.
1122	ABORT	There is no test line number for the far-end switch. 1. Check the Trunk Group Administration form.
1123	ABORT	There is no Feature Access Code administration for this Facility Test. 1. Check the Dial Plan and Feature Administration forms.
2000 2012 None	ABORT	Internal system error. 1. Retry the command at 1-minute intervals a maximum of 5 times.
2035	ABORT	The call has timed out, perhaps because of a lack of system resources. 1. Wait 1 minute and try again.
2036 2037	ABORT	Internal system error. 1. Follow recommendation for ABORT code 2012.
2038 2039	ABORT	A problem occurred while trying to read the test data. 1. Wait 1 minute and then try again. If the test aborts again in the same manner, there is a serious internal problem.
2040	ABORT	Internal system error. Follow recommendations for ABORT code 2012.
2041	ABORT	The call has timed out, perhaps because of a lack of system resources. Follow recommendations for ABORT code 2035.
2066	ABORT	Could not establish test call. 1. Retry the command at 1-minute intervals a maximum of 5 times.
2067	ABORT	The call has timed out, perhaps because of a lack of system resources. Follow recommendations for ABORT code 2035.
2074	ABORT	Bit and Block Error query failed. 1. Retry the command at 1-minute intervals a maximum of 5 times. 2. If the test continues to abort, there may be a serious internal problem with M/T-DIG (Maintenance/Test Digital Port). If this is the case, refer to the M/T-DIG (Maintenance/Test Digital Port).
2075	ABORT	Internal system error. Follow recommendations for ABORT code 2012.
2100	ABORT	Could not allocate the necessary system resources to run this test. 1. Retry the command at 1-minute intervals a maximum of 5 times.

**Table 9-375. TEST #258 ISDN Test Call — Continued**

Error Code	Test Result	Description/ Recommendation
2104	ABORT	Call dropped or could not be originated. <ol style="list-style-type: none"> <li>1. Make sure service is provisioned by the network.</li> <li>2. Check the administration of the far-end test line extension on the trunk group administration form.</li> <li>3. Check the administration of the Testcall BCC (Bearer Capability Class) on the trunk group administration form.</li> <li>4. Check the reason for termination with <b>status isdn-testcall</b>.</li> <li>5. For further instructions see Troubleshooting ISDN Testcalls in Chapter 6.</li> <li>6. Try the test again.</li> </ol>
2201 2202 2203 2204 2205	ABORT	Internal system error. Follow recommendations for ABORT code 2012.
2206	ABORT	Could not allocate the necessary system resources to run this test. Follow recommendations for ABORT code 2100.
2208	ABORT	Internal system error. Follow recommendations for ABORT code 2012.
2209 2210	ABORT	Could not allocate the necessary system resources to run this test. Follow recommendations for ABORT code 2100.
2211	ABORT	Internal system error. Follow recommendations for ABORT code 2012.
2212	ABORT	Call terminated by unexpected disconnect. <ol style="list-style-type: none"> <li>1. Wait 1 minute and then try again.</li> </ol>
2213	ABORT	The call has timed-out, perhaps because of a lack of system resources. Follow recommendations for ABORT code 2035.
2214	ABORT	Call terminated by unexpected disconnect. <ol style="list-style-type: none"> <li>1. Wait 1 minute and then try again.</li> </ol>
2215 2216 2217 2218 2219	ABORT	Internal system error. Follow recommendations for ABORT code 2012.
2220	ABORT	Call terminated prematurely. <ol style="list-style-type: none"> <li>1. Wait 1 minute and try again.</li> </ol>

*Continued on next page*



Table 9-375. TEST #258 ISDN Test Call — Continued

Error Code	Test Result	Description/ Recommendation
2221 2222 2223 2224 2225 2226	ABORT	Internal system error. Follow recommendations for ABORT code 2012.
2227	ABORT	Could not allocate the necessary system resources to run this test. Follow recommendations for ABORT code 2100.
2042	FAIL	<p>Comparison of data sent to data received indicates a loss of integrity on the communications path.</p> <ol style="list-style-type: none"> <li>1. Take the trunk out of service and check the quality of the DS1 connection, including the transmission facility and any external equipment such as DAC s, CSU s, etc. Use <b>test isdn-testcall</b> and <b>status isdn-testcall</b> commands to get the bit and block error rates.</li> </ol>
	PASS	<p>The test pattern was sent and received properly. If the synchronous test call was performed (long test sequence), this indicates that the communications path is operating properly. If the <b>test isdn-testcall</b> command was used, PASS indicates only that the test call was established. Use the <b>status isdn-testcall</b> command to get the bit and block error rates detected by the test. If the bit and block error rates are not acceptable, perform a complete analysis of the DS1 facility including the transmission facility and any external equipment such as DAC s, CSU s, etc.</p>

## JNL-PRNT (Journal Printer Link)

---

MO Name (in Alarm Log)	Alarm Level	Initial Command to Run	Full Name of MO
JNL-PRNT	MINOR	test journal wakeup-log	Journal Printer Link
JNL-PRNT	WARNING	test journal wakeup-log	Journal Printer Link

The maintenance strategies for JNL-PRNT (Journal Printer Link) and PMS-PRNT (PMS Printer Link) are the same. Refer to the "PMS-PRNT/JNL-PRNT (PMS Printer Link)" section of this chapter.

## **LGATE-AJ**

---

See BRI-SET

## **LGATE-BD**

---

See BRI-BD

## **LGATE-PT**

---

See BRI-PT

## LOG-SVN (Login Security Violation)

MO Name (in Alarm Log)	Alarm Level	Initial Command to Run <sup>1</sup>	Full Name of MO
LOG-SVN	MAJOR	enable login <login ID>	Login Security Violation

- Where <login ID> is the Lucent services login ID for which the security violation was detected. The **Alt Name** field indicates the login ID associated with the security violation and the major alarm.

The Security Violation Notification (SVN) feature provides notification when the number of failed attempts to access the system administration/maintenance interface meets or exceeds customer administered threshold parameters.

A major alarm is logged whenever a security violation is detected involving an Lucent services login ID and that login ID has been disabled as a result of detection of the security violation. The capability to disable a login ID following detection of a security violation involving that login ID is administrable on a per login ID basis.

Refer to the *DEFINITY Communications System Generic 3 V2 Implementation*, 555-230-653, Issue 1 for information on administration required for the Security Violation Notification feature, and the option to disable a login ID following detection of a security violation involving the affected login ID.

## Error Log Entries and Test to Clear Values

Table 9-376. Security Violation Notification Error Log Entries

Error Type	Aux Data	Associated Test	Alarm Level	On/Off Board	Test to Clear Value
1-15	None	None	Major	OFF	enable login <login ID>

General Information about **log-svn** error log entries:

- The number (1 - 15), that appears in the error type field, corresponds to the location of the login in the internal login data structure.
- The *Alt Name* field on the alarm report indicates the login ID associated with the security violation and major alarm.
- These errors/alarm are associated with a number of failed attempts to access the system management/maintenance interface using an Lucent services login ID that meet or exceed the customer administered threshold parameters. The associated alarm is immediately raised as a major alarm.

- d. The affected login ID will be disabled as a result of detection of the security violation, unless it is the last enabled INADS type login on the system. The provision to disable a login ID following detection of a security violation involving that login ID is administerable on a login ID basis.
- e. The **enable login** command is used to both enable a login that has been disabled, and to retire any login security violation alarms associated with the login ID.
- f. Use of the **enable login** command to enable a login and/or retire alarms must be executed using a login ID with greater service level hierarchy permissions.
- g. Access to the **enable login** command is controlled through the Administer Permissions field on the Command Permission Categories form. This field (Administer Permissions) must be set to "y" to access the enable login command.
- h. The *Port* alarm report field will set to the port where the final invalid login attempt, involving the alarmed login ID, was detected. Valid port values for G3i products include:
  - MGR1 — Dedicated manager 1 or G3 management terminal connection
  - NET-n — Network controller dial up port
  - INADS — INADS port
  - EPN — EPN maintenance EIA port
  - EIA — Other EIA portValid port value for G3r products include:
  - SYSAM \_LOC — Local administration port
  - SYSAM \_RMT — Remote administration port
  - SYS\_PORT — System Port
  - MAINT — Maintenance port
- i. The *Svc State* alarm report field will be set to OUT if the login ID is in the disabled state as a result of detection of a security violation involving the login ID. Once the login ID has been enabled, the field will be set to IN.
- j. The source or reason of the failed login attempts should be identified and the cause corrected prior to re-enabling a login ID and/or retiring any alarms associated with the login ID. The cause may be something as innocuous as the failure of Lucent services automatic login software, to something as insidious as a hacker attempting to gain access to the switch system management interface.

Prior to retiring an SVN alarm and enabling the associated login ID, the **monitor security-violations login** command can be used to access information about the invalid login attempts that caused the security violation. This information can

be useful in determining the source of the invalid attempts and analyzing why they occurred.

The **list logins** command provides status information about logins on the system. If a login has been disabled as a result of a security violation, the status will be "*svn-disabled*."

## Procedure to Retire SVN Alarm

To retire a SVN alarm:

1. Enter the command **enable login <login ID>**.

The login ID associated with that alarm is displayed in the *Alt Name* field of the alarm report and the alarm is retired.

## MAINT (EPN Maintenance Circuit Pack)

---

MO Name (in Alarm Log)	Alarm Level	Initial Command to Run	Full Name of MO
MAINT	MINOR	test maintenance sh	EPN Maintenance Circuit Pack
MAINT	MAJOR	test maintenance l	EPN Maintenance Circuit Pack

The TN775B EPN Maintenance circuit pack monitors and supports environmental maintenance for EPN multicarrier or single-carrier cabinets. The EPN Maintenance circuit pack provides switch software with a mechanism to activate or deactivate Emergency Transfer in the EPN. Control by the system of Emergency Transfer can be overridden by the Emergency Transfer Switch on the faceplate of the circuit pack. The EPN Maintenance circuit pack invokes Emergency Transfer when the EPN loses contact with the PPN or when the EPN Maintenance circuit pack loses contact with all Expansion Interface circuit packs. The EPN Maintenance circuit pack handles loss of AC power in the EPN multicarrier cabinet by supplying battery power for 15 seconds to the EPN cabinet and then an additional 10 minutes of power to just the control carrier in the EPN. When power fails in a single-carrier EPN cabinet, no such power holdover is available. In the event that an Expansion Interface circuit pack goes insane and is reset six times within 15 minutes, the EPN Maintenance circuit pack will hold the Expansion Links reset preventing the Expansion Interface circuit pack from running.

The EPN Maintenance circuit pack has alarm LED s which indicate the presence of Major, Minor, and Warning alarms. A flashing LED indicates the presence of an alarm within the cabinet. A continuously lit LED indicates the presence of an alarm elsewhere in the system.

A management terminal (G3-MT) can be directly connected to the TN775B EPN Maintenance circuit pack. This link operates at 9600 baud, but system software throttles the rate of data flow to the TN775B for display on the G3-MT to about 1200 baud. All system commands can be executed via the EPN G3-MT login. However, due to the slow speed at which the EPN login operates, it is recommended that it be used only for maintenance sessions and not for system administration.

The PPN communicates with the EPN Maintenance circuit pack via the following path; uplink messages from the EPN Maintenance circuit pack to the PPN take exactly the reverse path. Messages flow from the UN331B Processor circuit pack in the SPE to the TN1655 Packet Interface circuit pack, over the Lan Bus to the Active PPN Expansion Interface circuit pack, across the fiber link to the Active EPN Expansion Interface circuit pack, and over a serial link to the EPN Maintenance circuit pack.

The EPN Maintenance circuit pack must be physically inserted into the dedicated slot marked Maintenance in the A carrier of the EPN. The serial links from the EPN Maintenance circuit pack to the Expansion Interface circuit packs are physically connected from this dedicated slot to slots 2A01 and 2B02 (2B02 is used only if there is duplicated Port Network Connectivity). The serial link from slot 2A01 to the maintenance slot is hard-wired into the backplane of carrier A, whereas the serial link from slot 2B02 to the maintenance slot is a ribbon cable connecting the two slots. The serial link from the EPN Maintenance circuit pack to the terminal is also a ribbon cable which plugs into a connector labeled TERM on the back of carrier A.

The maintenance strategy for the EPN Maintenance circuit pack consists of checking the integrity of the communications path to/from the EPN Maintenance circuit pack, testing individual hardware components on the EPN Maintenance circuit pack, and keeping the alarm LEDs up-to-date. The individual hardware components include the serial interfaces which handle the serial links connected to the EPN Maintenance circuit pack. There are three serial interfaces, one for each possible Expansion Interface circuit pack and one for the terminal.

Since the EPN Maintenance circuit pack supports environmental maintenance in the EPN, trouble with the EPN Maintenance circuit pack can cause environmental maintenance to falsely detect problems. In a multicarrier cabinet EPN, these environmental MOs include: POWER (Battery & Battery Charger), CARR-POW (Carrier Port Power Unit), AC-POWER (AC Power), CABINET (Cabinet Sensors), EMG-XFER (Emergency Transfer), EXT-DEV (External Device Alarm), and CUST-ALM (Customer-Provided Alarming Device). In a single carrier cabinet EPN, these environmental MOs include DC-POWER (Single Carrier Cabinet Power), EMG-XFER (Emergency Transfer), EXT-DEV (External Device Alarm), and CUST-ALM (Customer-Provided Alarming Device).



## Error Log Entries and Test to Clear Values

**Table 9-377. EPN Maintenance Circuit Pack Error Log Entries**

Error Type	Aux Data	Associated Test	Alarm Level	On/Off Board	Test to Clear Value
0 <sup>1</sup>	0	Any	Any	Any	test maintenance sh r 1
1(a)	0 1	EPN Maintenance Circuit Pack Reset Test (#306)	MINOR	ON	test maintenance l
513(a)	0 1	MGR I Channel Loop Test (#228)	MINOR	ON	test maintenance sh r 3
769(b)	Any	Sanity Handshake Test (#106)			
1537(a)	0 1	Sanity Maze Test (#303)	MINOR	ON	test maintenance sh r 3
2561(a)	0 1	Sanity Handshake Test (#106)	MINOR	ON	test maintenance sh r 3
2817(a)	0(b) 1	Serial Channel Loop Test (#229)	MINOR	ON	test maintenance sh r 3
3329(c)	Any	Serial Link Test (#337)	MINOR/ WARNING <sup>2</sup>	OFF	test maintenance sh r 3
3585(d)	Any	Serial Link Test (#337)	MINOR/ WARNING <sup>2</sup>	OFF	test maintenance sh r 3

1. Run the Short Test Sequence first. If all tests pass, run the Long Test Sequence. Refer to the appropriate test description and follow the recommended procedures.
2. Major and Minor alarms may be downgraded to Warning alarms based on the value used in the **set options** command.

### Notes:

- a. A value of 0 indicates that PNC-A (and therefore, the Expansion Interface circuit pack located on PNC-A) was active when this error occurred. A value of 1 indicates that PNC-B (and therefore, the Expansion Interface circuit pack located on PNC-B) was active when this error occurred. To clear this problem, make sure the Active PNC is the same as that indicated by the Aux Value.
- b. Multiple values can appear in the Aux Data field. There will be other errors in the log if there is a real problem. Use these other errors to troubleshoot the problem.
- c. The serial link between the Expansion Interface circuit pack in the A carrier and the EPN Maintenance circuit pack is defective.

- d. The serial link between the Expansion Interface circuit pack in the B carrier and the EPN Maintenance circuit pack is defective.

## System Technician-Demanded Tests: Descriptions and Error Codes

Always investigate tests in the order presented in the table below when inspecting errors in the system. By clearing error codes associated with the *Sanity Handshake Test*, for example, you may also clear errors generated from other tests in the testing sequence.

Order of Investigation	Short Test Sequence	Long Test Sequence	D/ND <sup>1</sup>
Sanity Handshake Test (#106)	X	X	ND
EPN Maintenance Circuit Pack Reset Test (#306)		X	D
Serial Channel Local Looparound Test (#229)	X	X	ND
MGR I Channel Local Looparound Test (#228)		X	D
EPN Maintenance Circuit Pack Sanity Maze Test (#303)	X	X	ND
EPN Maintenance Circuit Pack Serial Link Test (#337)	X	X	ND

1. D = Destructive, ND = Non-destructive

### Sanity Handshake Test (#106)

This test checks the EPN Maintenance circuit pack's ability to respond to queries. A message is sent to the EPN Maintenance circuit pack which then sends a message back. If the response message is received, then the EPN Maintenance circuit pack is queried for the EPN cabinet type (valid EPN cabinet types are single carrier and multicarrier cabinets). The EPN Maintenance circuit pack reads pins on the backplane of carrier A that identify the type of cabinet and report this information. If a valid cabinet type is returned, then the test passes.

Table 9-378. TEST #106 Sanity Handshake Test

Error Code	Test Result	Description/ Recommendation
	ABORT	Internal system error.
1000	ABORT	System resources required for this test are not available.
2000	ABORT	Response to cabinet query was not received in the allowable time period.

*Continued on next page*

**Table 9-378. TEST #106 Sanity Handshake Test — Continued**

Error Code	Test Result	Description/ Recommendation
2033	ABORT	Internal system error. 1. Retry the command at 1-minute intervals a maximum of five times.
2046	ABORT	The EPN Maintenance circuit pack reported an invalid cabinet type. Not knowing the cabinet type of the EPN will prevent all EPN environment maintenance from running. 1. Retry the command. 2. If the test continues to abort with 2046, then either the EPN Maintenance circuit pack is defective, or the EPN cabinet wiring is defective. First, replace the EPN Maintenance circuit pack. 3. If the test continues to abort with 2046, then the EPN cabinet wiring is defective in the A carrier and the EPN Maintenance circuit pack cannot read the backplane pins to determine the cabinet type.
10601	ABORT	Test disabled via software patch.

*Continued on next page*

**Table 9-378. TEST #106 Sanity Handshake Test — Continued**

Error Code	Test Result	Description/ Recommendation
	FAIL	<p>EPN Maintenance circuit pack did not respond to Sanity Handshake and the test timed out.</p> <ol style="list-style-type: none"> <li>1. Verify that the carrier A power units are good. If the -5 volt unit is defective in the A carrier, then communication with the EPN Maintenance circuit pack will not be possible.</li> <li>2. If the -5 volt unit is good and this test continuously fails, background maintenance will automatically escalate to an EPN Maintenance circuit pack Reset (Test #306). Otherwise, manually invoke an EPN Maintenance circuit pack Reset by issuing the <b>test maintenance long</b> command and evaluating any generated error codes from Test #306. If Test #306 passes, this test should also PASS. Use the following steps to determine if the EPN Maintenance circuit pack, or the serial link to the EPN Maintenance circuit pack, is defective:</li> </ol> <p>Duplicated Port Network Connectivity:</p> <ol style="list-style-type: none"> <li>1. Switch Port Network Connectivity by entering <b>reset pnc interchange</b>.</li> <li>2. Run the Short Test Sequence against the EPN Maintenance circuit pack. If Test #106 still fails, replace the EPN Maintenance circuit pack and retest. Otherwise, follow the error routines for any errors that are logged by this Short Test.</li> </ol> <p>Simplex Port Network Connectivity:</p> <ol style="list-style-type: none"> <li>1. Replace the EPN Maintenance circuit pack and invoke the Short Test Sequence against it.</li> <li>2. If error persists, replace the EPN Expansion Interface circuit pack, <b>at a time when the EPN can go down with minimal inconvenience</b>.</li> <li>3. If the error still persists, the problem is with the actual serial link in A carrier backplane and not with the EPN Maintenance circuit pack.</li> </ol>
	PASS	<p>The communications path to and from the EPN Maintenance circuit pack is sane, and the EPN Maintenance circuit pack can read and report the correct EPN cabinet type. The EPN Maintenance circuit pack may still have problems related to Tests #228, #229, #303, or #306.</p>

### Management Terminal Channel Local Loop-Around Test (#228)

**This test is destructive.**

This test checks TN775B on-board circuitry associated with the serial link for the management terminal connection. This test will not cause the local terminal login

to drop, but any data displayed on the terminal while the test is running will be lost.

The EPN Maintenance circuit pack has 3 separate serial interfaces:

- One to the management terminal which is tested by Test #228
- One to the active EI circuit pack which is tested by Test #229
- One to the standby EI circuit pack which is tested by Test #229

**Table 9-379. TEST #228 Management Terminal Channel Local Loop-Around Test**

Error Code	Test Result	Description/ Recommendation
1000	ABORT	System resources required for this test are not available.
2000	ABORT	Response to the test was not received within the allowable time period.
2033	ABORT	Internal system error. 1. Retry the command at 1-minute intervals a maximum of 5 times.
2034	ABORT	Background EPN Maintenance circuit pack maintenance is running the MGR I Channel Local Looparound Test. 1. Wait 30 seconds and retry the test a maximum of 5 times.
22801	ABORT	Test disabled via software patch.
	FAIL	Test failed which means the EPN terminal is not usable. 1. Run the test three more times. Replace the EPN Maintenance circuit pack if the test continues to fail.
	PASS	The serial interface circuitry on the EPN Maintenance circuit pack which controls the EPN-connected terminal is functioning properly. If there are still troubles with the EPN G3-MT terminal, the problem may be one of the following: 1. The EPN-connected terminal is not configured properly. The connection between the terminal and the EPN Maintenance circuit pack must be set up at 9600 baud. 2. The serial link from the back of carrier A to the EPN terminal may be defective. The serial link consists of the connector on the back of carrier A labeled TERM and the ribbon cable running to the terminal. 3. The terminal may be defective. Try another terminal. 4. Since this test is not 100 percent accurate, there may still be problems with the EPN Maintenance circuit pack.

## Serial Channel Local Looparound Test (#229)

This test checks TN775B on-board circuitry associated with the serial links to the Expansion Interface circuit packs. A request is sent to the EPN Maintenance circuit pack over the Active link via the Active Expansion Interface circuit pack serial interface circuitry to test the serial interface circuitry of the standby Expansion Interface circuit pack link. If a response is received, then by definition the serial interface circuitry associated with the Active link is good.

The EPN Maintenance circuit pack has 3 separate serial interfaces:

- One to the management terminal which is tested by Test #228
- One to the active EI circuit pack which is tested by Test #229
- One to the standby EI circuit pack which is tested by Test #229

**Table 9-380. TEST #229 Serial Channel Local Looparound Test**

Error Code	Test Result	Description/ Recommendation
1000	ABORT	System resources required to run this test are not available.
2000	ABORT	Response to the test request was not received within the allowable time period.
2033	ABORT	Internal system error. 1. Retry the command at one-minute intervals a maximum of 5 times.
2034	ABORT	Background EPN Maintenance circuit pack maintenance is running the Serial Channel Local Looparound Test. 1. Wait 30 seconds, and retry the test a maximum of 5 times.
22901	ABORT	Test disabled via software patch.

*Continued on next page*

**Table 9-380. TEST #229 Serial Channel Local Looparound Test — Continued**

Error Code	Test Result	Description/ Recommendation
	FAIL	<p>The on-board circuitry associated with the Standby serial link is defective. Since the EPN Maintenance circuit pack reported this failure, the on-board circuitry associated with the Active serial link is functional.</p> <ol style="list-style-type: none"> <li>1. This test checks the circuitry on the EPN Maintenance circuit pack associated with the Standby Expansion Interface link.                             <ol style="list-style-type: none"> <li>a. In a switch without duplicated Port Network Connectivity, current service will not be affected because the circuitry failing is not being used. Nevertheless, a Minor alarm will remain in the Alarm Log against MAINT. Therefore, the EPN Maintenance circuit pack must be replaced.</li> <li>b. In a switch with duplicated Port Network Connectivity, service will not be affected as long as you DO NOT INTERCHANGE THE PNCS; otherwise, the connection to the EPN Maintenance circuit pack will be lost. Losing the EPN Maintenance circuit pack connection will mean loss of the connection to the terminal and EPN Environment maintenance. The EPN Maintenance circuit pack must be replaced to correct this problem.</li> </ol> </li> </ol>
	PASS	<p>The on-board circuitry associated with both Expansion Interface circuit pack serial links is good. If there is still a problem communicating with the EPN Maintenance circuit pack, check the following:</p> <ol style="list-style-type: none"> <li>1. The cable comprising the serial link (B carrier Expansion Interface circuit pack to EPN Maintenance circuit pack only) may be defective.</li> <li>2. The EPN Maintenance circuit pack may actually be defective.</li> </ol> <p><b>⇒ NOTE:</b>                      This test may not be 100 percent accurate.</p> <ol style="list-style-type: none"> <li>3. The Expansion Interface circuit pack on the Standby link may be defective.</li> </ol>

**EPN Maintenance Circuit Pack Sanity Maze Test (#303)**

The EPN Maintenance circuit pack processor has direct access to special registers in the EPN Maintenance circuit pack. These registers are tied to such things as the Expansion Interface circuit pack reset leads and Carrier Port Power Unit reset leads (which enable the EPN Maintenance circuit pack to recycle carriers). To prevent an insane EPN Maintenance circuit pack from inadvertently controlling these external devices, a special interface called the Sanity Maze is provided that must first be navigated by the EPN Maintenance circuit pack

processor prior to any register access. There are two parts to the test. Part 1 involves navigating the Sanity Maze to toggle an unused lead. Part 2 attempts to toggle an unused lead without first navigating the Sanity Maze. The Sanity Maze test passes if Part 1 is successful and Part 2 fails.

**Table 9-381. TEST #303 EPN Maintenance Circuit Pack Sanity Maze Test**

Error Code	Test Result	Description/ Recommendation
1000	ABORT	System resources required to run this test are not available.
2000	ABORT	Response to the test was not received within the allowable time period.
2033	ABORT	1. Retry the command at one-minute intervals a maximum of 5 times.
	FAIL	The Sanity Maze of the EPN Maintenance circuit pack is defective. 1. Replace the EPN Maintenance circuit pack.
	PASS	The Sanity Maze is working properly, and the EPN Maintenance circuit pack can access the unused register. If <b>recycle carrier</b> commands (for EPN carriers) do not work, the following problems may still exist: 1. The Carrier Port Power Unit or wiring to the Carrier Port Power Unit may be defective. Refer to CARR-POW (Carrier Port Power Unit) Maintenance documentation. 2. Since this test only tests the EPN, there is a very small probability that the EPN Maintenance circuit pack cannot access those registers that deal with EPN devices. The EPN Maintenance circuit pack may need to be replaced.

### EPN Maintenance Circuit Pack Reset Test (#306)

**This test is destructive.**

The terminal connection will be dropped and, if the Emergency Transfer switch is in the AUTO position, Emergency Transfer will be disabled for the duration of the test.

The EPN Maintenance circuit pack is reset by the Active Expansion Interface circuit pack. After the Expansion Interface circuit pack reports that the EPN Maintenance circuit pack has reset, a handshake message is sent to the EPN Maintenance circuit pack. If the EPN Maintenance circuit pack responds to the handshake, the test passes. If not, it fails. If the test passes, the EPN-connected terminal is brought back up, and Emergency Transfer is restored to its previous state.



**Table 9-382. TEST #306 EPN Maintenance Circuit Pack  
 Reset Test**

Error Code	Test Result	Description/ Recommendation
1000	ABORT	System resources required to run this test are not available. 1. Retry the command at one-minute intervals a maximum of 5 times.
1018	ABORT	Test disabled via software patch.
2029	ABORT	Internal system error. 1. Retry the command at one-minute intervals a maximum of 5 times.
2500	ABORT	Internal system error. 1. Retry the command at one-minute intervals a maximum of 5 times.
1204 1205	FAIL	El circuit pack could not reset the EPN Maintenance circuit pack. For duplicated Port Network Connectivity: 1. The standby El circuit pack may be defective and, thereby, preventing the active El circuit pack from resetting the EPN Maintenance circuit pack. Unplug the standby El circuit pack, and attempt to reset the EPN Maintenance circuit pack using the <b>test maint long</b> command. If Test #306 passes, replace the standby El circuit pack, and attempt the reset test again. If Test #306 fails, then replace the Standby EPN El circuit pack. 2. The active El circuit pack may be defective and unable to reset the EPN Maintenance circuit pack. Interchange the PNC by entering the <b>reset pnc interchange</b> command. Now reset the EPN Maintenance circuit pack again by using the <b>test maintenance long</b> command. If the test passes, the problem is with the known standby El circuit pack. Repeat Step 2 to determine if the standby El circuit pack should be replaced.

*Continued on next page*

**Table 9-382. TEST #306 EPN Maintenance Circuit Pack  
 Reset Test — Continued**

Error Code	Test Result	Description/ Recommendation
1205 (cont'd.)		<p>3. Replace the EPN Maintenance circuit pack, and run the test again. If the test passes, the problem is with the EPN Maintenance circuit pack. Interchange the PNC by entering the <b>reset pnc interchange</b> command and run the test again. The test should pass with both EI circuit packs being active.</p> <p>4. If the B carrier EI circuit pack is active, the ribbon cable connecting the Expansion Interface circuit pack and the EPN Maintenance circuit pack may be defective. Check the ribbon cable to make sure it is connected properly and is not damaged.</p> <p>For simplex Port Network Connectivity:</p> <ol style="list-style-type: none"> <li>1. Replace the EPN Maintenance circuit pack, and run the test again. If it passes, the problem is with the EPN Maintenance circuit pack.</li> <li>2. If the test fails, replace the EI circuit pack. If the tests passes, the problem is with the EI circuit pack.</li> <li>3. If the test still fails, the problem is with the serial link wired into the backplane of carrier A.</li> </ol>
2005	FAIL	<p>EPN Maintenance Circuit Pack Reset passed, but the EPN Maintenance circuit pack did not respond to subsequent handshake message. Retry this command three more times. If it continues to fail, the EPN Maintenance circuit pack, the active EI circuit pack, or the serial link is defective. To determine which is defective, follow the appropriate procedures that follow.</p> <p>Duplicated Port Network Connectivity:</p> <ol style="list-style-type: none"> <li>1. Interchange PNCs by entering <b>reset pnc interchange</b>.</li> <li>2. Run the Short Test Sequence against the EPN Maintenance circuit pack. If Test #306 still fails, replace the EPN Maintenance circuit pack and retest. Otherwise, follow the error routines for any errors that are logged by this Short Test Sequence.</li> </ol> <p>Simplex Port Network Connectivity:</p> <ol style="list-style-type: none"> <li>1. Replace the EPN Maintenance circuit pack and invoke the Short Test Sequence against it.</li> <li>2. If the error persists, replace the EI circuit pack, at a time when the EPN can go down with minimal inconvenience.</li> <li>3. If the error still persists, the problem is with the actual serial link in A carrier backplane and not with the EPN Maintenance circuit pack.</li> </ol>
	PASS	<p>The active EI circuit pack can reset the EPN Maintenance circuit pack. This implies the EPN Maintenance circuit pack, the active EI circuit pack, and Active serial link are sane. There could still be a problem with the standby EI circuit pack and standby serial link in a Duplication Option system.</p>

## EPN Maintenance Circuit Pack Serial Link Test (#337)

**This test is destructive.**

This test checks the serial link from the standby EI circuit pack to the EPN Maintenance circuit pack. If there is no standby link, or the standby link is down at the time of the test, this test will abort.



**NOTE:**

The status of the link is changed to "down" when the standby EI circuit pack begins initialization tests (for example, after being reset). The link status is then updated at the conclusion of these tests.

**Table 9-383. TEST #337 EPN Maintenance Circuit Pack Serial Link Test**

Error Code	Test Result	Description/ Recommendation
1000	ABORT	System resources required for this test are not available. 1. Retry the command at one-minute intervals a maximum of 5 times.
2029 2500	ABORT	Internal system error. 1. Retry the command at one-minute intervals a maximum of 5 times.
	FAIL	The serial link between the currently standby EI circuit pack and the EPN Maintenance circuit pack is defective. If the standby EXP-INTF is on the A carrier, then error type 3329 is logged. If the standby EXP-INTF is on the B carrier, then error type 3585 is logged. 1. <i>If error type 3585 was logged</i> , check to see if the ICCA/ICCB cables between carriers A and B are present and properly connected (ICCA to ICCA, and ICCB to ICCB). The location of these connectors is shown in the figures "Expansion Control Carrier (J58890AF)" in Chapter 2. Install or reconnect the cables if necessary and rerun the test. 2. Replace the EPN Maintenance circuit pack. 3. Rerun the test. If the test continues to fail, replace the Standby EPN Expansion Interface circuit pack. 4. Rerun the test. If the test continues to fail and the Standby link is on the B carrier, then replace the ribbon cable that carries the serial link from Expansion Interface circuit pack B to the EPN Maintenance circuit pack.
	PASS	The serial link from the Standby Expansion Links to the EPN Maintenance circuit pack is working.

## MAPD-BD (MAPD Interface Circuit Pack TN802)

---

MO Name (in Alarm Log)	Alarm Level	Initial Command to Run <sup>1</sup>	Full Name of MO
MAPD-BD	MAJOR	test board UUCSS sh	MAPD Interface Circuit Pack
MAPD-BD	MINOR	test board UUCSS I	MAPD Interface Circuit Pack
MAPD-BD	WARNING	test board UUCSS sh	MAPD Interface Circuit Pack

1. UU is the universal cabinet number (1 for PPN, 2 - 44 for EPNs). C is the carrier designation (A, B, C, D, or E). SS is the number of the slot in which the circuit pack resides (01 to 21).

The TN802 Multiple Application Platform for DEFINITY (MAPD) circuit pack allows sending voice and fax from DEFINITY ECS through the Internet to another DEFINITY also having this feature or to other PBXs that are equipped with the Internet Telephony Server (ITS-E).

Throughout this section the term TN802 means the MAPD IP trunk circuit pack.

Be sure to observe these special considerations for the TN802:

- Port alarms on this circuit pack display as "TIE-DS1" in the Alarm and Error logs.
- The **reset board** command reboots the MAPD PC CPU, but **busyout board** only busys out all of the emulated ports on the board.
- Switch resets that take the switch out of service for more than 20 seconds also cause the MAPD's PC to reboot, which takes several minutes to complete.

### Switch-demanded tests

---

Switch-demanded diagnostic tests on the TN802 do not run unless the Internet trunking application is running on Windows NT<sup>TM</sup>, located on the circuit pack.

### Feature limitations

---

The Internet trunking application relies on the single call scenario, or a direct, point-to-point call that does not terminate at multiple DEFINITY nodes through call processing. [Table 9-384](#) describes the feature limitations for DEFINITY ECS.

**Table 9-384. DEFINITY ECS IP trunk feature/performance limitations**

Feature/ Performance	Description	Recommendation
Abbreviated Dialing	Abbreviated Dial strings with embedded pauses lose digits after the pause	Most calls work. Do not create Abbreviated dial strings with embedded pauses.
Compression limitations	All IP trunk calls go through A/D conversion, which uses compression to reduce bandwidth. Each compression degrades the voice signal and creates call processing delay.	No more than 3 compression/decompression cycles for any call.  <b>⇒ NOTE:</b> The compression/decompression that most voice mail systems use must be counted as 1 cycle.
Call Classifier	IP trunk's compression/decompression cycle makes ringback, busy and voice detection	Do not administer these features: <ul style="list-style-type: none"> <li>■ Call Coverage Redirected Off-Net (CCRON)</li> <li>■ Certain wireless phone coverage</li> </ul>
Call Coverage Call Forwarding Call Transfer	Calls extended across multiple DEFINITY ECS nodes require multiple call paths. Significant voice quality degradation is likely.	Multiple call paths not recommended
Conferencing	Voice quality and delay problems if the party controlling the conference is on the IP trunk (voice paths from external callers come in on the IP trunk, are conferenced, then sent out to other external parties across an IP trunk)	Avoid conference calls where at least two other parties are on the other side of the IP trunk.  <b>⇒ NOTE:</b> The following conferences work OK: <ul style="list-style-type: none"> <li>■ Conferences of parties on the local DEFINITY ECS</li> <li>■ Conferences controlled by the local DEFINITY ECS, involving local parties and only 1 party on the other side of an IP trunk</li> </ul>

*Continued on next page*

**Table 9-384. DEFINITY ECS IP trunk feature/performance limitations — Continued**

Feature/ Performance	Description	Recommendation
DCS	Know limitations: <ul style="list-style-type: none"><li>■ Auto Callback</li></ul>	Coordinate specific administration and between the IP trunk and DEFINITY ECS for any DCS functionality. Some limitations on routing flexibility may apply.
ISDN	IP trunking has no signalling capability.	ISDN not supported. This includes: <ul style="list-style-type: none"><li>■ 10-digit number display</li><li>■ QSIG</li><li>■ Path replacement</li></ul>
Voice mail	Calls that have terminated at one location and then cover to a second site for voice mail coverage can have voice quality degradation.	Centralized voice mail through an IP network is not recommended.

## Backing up to the PCMCIA disk

[Table 9-385](#) details how to back up administration data for the IP trunk application to and restored from the local PCMCIA disk and the Ethernet port. Before backing up, be sure to shut down the application running on the circuit pack, following the procedures in the [“Shutting down NT on the TN802”](#) section.

**Table 9-385. Backing up TN802 administration data**

Step	Description	Comments
1.	Busyout circuit pack	At the DEFINITY ECS terminal type <b>busyout board UUCSS</b> (the address of the TN802 circuit pack) and press Enter.
2.	Backup administration TN802 to disk	At the Windows NT desktop, double-click on the <b>IP Trunk Backup Restore</b> icon.  The IP Trunk Backup/Restore Utility screen appears.

*Continued on next page*

**Table 9-385. Backing up TN802 administration data — Continued**

Step	Description	Comments
3.	Select utility	In the IP Trunk Backup/Restore Utility dialog screen, click on <b>Files, Backup</b> .  The IP Trunk Backup screen appears.
4.	Select backup	In the IP Trunk Backup screen, click on the <b>Backup</b> button
5.	Wait	Backup can take as much as 20 minutes to complete.
6.	Release circuit pack	At the DEFINITY ECS terminal type <b>release board UUCss</b> (the address of the TN802 circuit pack) and press Enter.

**⇒ NOTE:**

Local restore of a complete system from the PCMCIA disk should not require more than 20 minutes assuming that a replacement MAPD pack is available and pre-loaded with the IP trunk application software.

**Restoring data from the PCMCIA disk****Before you start**

1. Shut down the application running on the circuit pack. See [“Shutting down NT on the TN802”](#).
2. Remove the defective IP Trunk circuit pack from the switch (if applicable).
3. Install the replacement IP Trunk circuit pack in the switch (if applicable).
4. Insert the backup diskette into the IP Trunk circuit pack.

**Table 9-386. Restore TN802 administration data**

Step	Description	Comments
1.	Restore IP Trunk administration	At the Windows NT desktop, double-click on the IP Trunk Back UP Restore icon.  The IP Trunk Backup/Restore Utility screen appears.

*Continued on next page*

**Table 9-386. Restore TN802 administration data — Continued**

Step	Description	Comments
2.	Select utility	In the IP Trunk Backup/Restore Utility dialog screen, click <b>Files, Restore</b> .  The IP Trunk Backup screen appears
3.	Select restore	In the IP Trunk Backup screen, click on the <b>Restore</b> button.
4.	Wait	Wait until the yellow Disk-In-Use LED (Note 5 in <a href="#">Figure 9-54</a> ) light is out.

## **PSTN fallback feature**

The Public Switched Telephone Network (PSTN) fallback feature is available on the Internet trunk application software, which periodically pings the remote destinations that the software calls. When the far end returns a poor response time to the ping, DEFINITY's ARS or AAR network routing patterns bypass those ports and direct the call to another port, typically on a PSTN trunk.

When the remote destinations show acceptable response times to subsequent pings, the corresponding ports are returned to "idle," where they are available for service.

## **Cabinet configuration**

Because of overheating, the TN802 circuit pack should not be placed directly above or below another MAPD circuit pack.

## **UPS protection**

Because Windows NT is more vulnerable to damage from a power interruption than the DEFINITY ECS, uninterrupted power supply (UPS) protection is strongly recommended for systems using the TN802 circuit pack.



## Faceplate

---

[Figure 9-54](#) shows the TN802 faceplate.

---

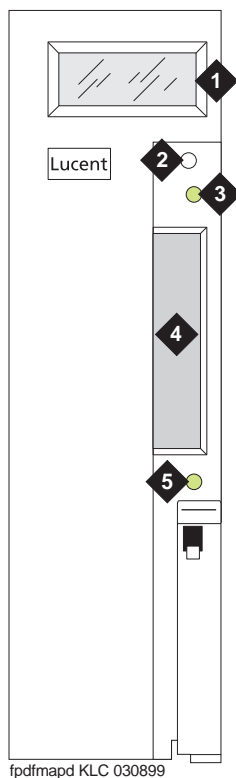

### Figure Notes:

- |   |                                  |
|---|----------------------------------|
| 1. LCD display (see <a href="#">Table 9-387</a> ) | 4. PCMCIA card slot              |
| 2. Reset button (recessed)                        | 5. Yellow PCMCIA disk-in-use LED |
| 3. Red board status LED                           |                                  |

---

**Figure 9-54. TN802 faceplate**

[Table 9-387](#) lists the TN802 LCD messages that you might see if installing or servicing an IP Trunk.

**Table 9-387. TN802 LCD messages for IP trunks**

Display	Explanation
PC BOOT	The TN802 MAPD PC is booting up.
IP TRK #	IP Trunk application is running (# character blinks)
IML DWN #	Internal error on the IP Trunk. System shuts down and sends an error message to the board.
MSHUT # where both MSHUT and # are blinking	The system is in the process of shutting down due to a front panel button press. DO NOT attempt to remove board.
MSHUT #, where # is blinking	The system has shut down gracefully.

## Support for laptop PCs

Field technicians can access the TN802 circuit pack through:

1. [“pcANYWHERE® client software”](#)
2. [“Directly-connected keyboard, monitor, and mouse”](#)

### pcANYWHERE® client software

1. Attach a male-to-male serial cable and a NULL modem connector (if not built into the cable you use) to the COM2 connector (Note 8 in [Figure 9-55](#)) Attach the other end to the serial port of your laptop.
2. Launch the pcANYWHERE® application.
3. Click on Add Remote Control Item.
4. In the Properties window, choose the communication port to which you connected the cable in Step 1.

- Click on Details and configure the settings ([Table 9-388](#)):

**Table 9-388. Remote connection settings**

Field	Value
Speed	38,400
Parity	None (default)
Flow Control	RTS/CTS
Started by	Carrier detect (DCD)
Ended by	Carrier detect (DCD)

- Click on the new item icon and the laptop connects to the host pcANYWHERE<sup>®</sup> application on the TN802 circuit pack.

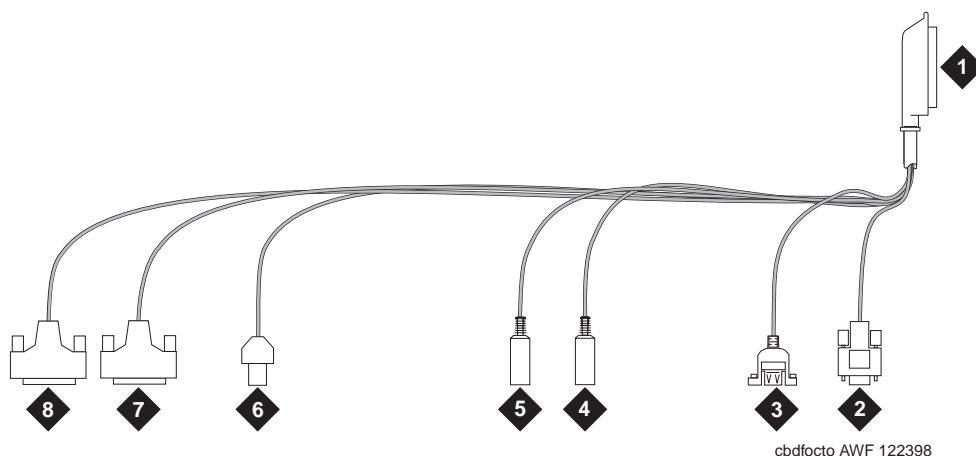

**Figure Notes:**

- |                               |                            |
|-------------------------------|----------------------------|
| 1. To TN802 cabinet backplane | 5. Mouse                   |
| 2. VGA monitor                | 6. Ethernet                |
| 3. USB (Universal Serial Bus) | 7. 25-pin modem connection |
| 4. Keyboard                   | 8. 25-pin COM2 connection  |

**Figure 9-55. TN802 external cable assembly**

## Directly-connected keyboard, monitor, and mouse



### NOTE:

You need 2 power sources for the monitor and the modem in order to complete this procedure.



### NOTE:

The TN802 circuit pack must be booted with a local mouse and keyboard connected to it for these devices to work.

1. Connect the VGA monitor to the VGA connector of the TN802 external cable.
2. Plug the monitor into an AC power receptacle, and turn it on.
3. Attach the keyboard to the keyboard connector of the TN802 external cable assembly.
4. Attach the mouse to the mouse connector of the TN802 external cable assembly.
5. Insert the circuit pack to cause it to boot.

## Troubleshooting LAN connections

This section contains information for troubleshooting

- [“External connections to the LAN”](#)
- [“Internal connections to the LAN”](#)

### External connections to the LAN

Test the external connections to the LAN by pinging the

- local host
  - external IP trunk server
  - another device connected to the network:
1. Click Start in Windows (lower lefthand corner), then select Programs, then Command Prompt.

This starts a DOS command line session.

2. At the command prompt, type **ping 127.0.0.1** (the local host default address) and press Enter.

If configured correctly, the system displays:

```
Reply from nnn.nn.nn.nn: bytes=32 time <##ms TTL=###
```

If there is no reply:

- a. Escalate the problem or replace the circuit pack. The problem is not with the external network but within the circuit pack.
3. At the command prompt, type **ping nnn.nn.nn.nn** (the external IP trunk server address) and press Enter.

If configured correctly, the system displays:

```
Reply from nnn.nn.nn.nn: bytes=32 time <##ms TTL=###
```

If there is no reply, verify the IP address and check the physical connections to and from the TN802 circuit pack.

4. At the command prompt, type **ping nnn.nn.nn.nn** (the IP address of another computer on the network) and press Enter.

If configured correctly, the system displays:

```
Reply from nnn.nn.nn.nn: bytes=32 time <##ms TTL=###
```

If there is no reply

- a. Verify the IP address
  - b. Check the physical connections to and from the TN802 circuit pack.
  - c. Check the internal cables on the TN802 circuit pack (Notes 4 and 6 in [Figure 9-57](#)).
  - d. Try pinging another device on the same subnet.
  - e. Try pinging the gateway to the rest of the network from the subnet.
  - f. Try pinging a device not on the local subnet but on the network or another subnet.
5. When finished, at the command prompt type **exit** and press Enter.

## Internal connections to the LAN

Test the internal connections to the LAN by pinging the

- local host
  - internal IP trunk server
  - another device connected to the network:
1. Click Start in Windows (lower lefthand corner), then select Programs, then Command Prompt.

This starts a DOS command line session.

2. At the command prompt, type **ping 127.0.0.1** (the local host default address) and press Enter.

If configured correctly, the system displays:

```
Reply from nnn.nn.nn.nn: bytes=32 time <##ms TTL=###
```

If there is no reply:

- a. Check that the internal cables on the TN802 circuit pack (Notes 4 and 6 in [Figure 9-57](#)) have not worked loose.
  - b. Otherwise, replace the circuit pack.
3. At the command prompt, type **ping 10.32.64.97** (the internal IP trunk server address) and press Enter.

If configured correctly, the system displays:

```
Reply from nnn.nn.nn.nn: bytes=32 time <##ms TTL=###
```

If there is no reply:

- a. Check that the internal cables on the TN802 circuit pack (Notes 4 and 6 in [Figure 9-57](#)) have not worked loose.
  - b. Otherwise, replace the circuit pack.
4. At the command prompt, type **ping 10.32.64.96** (the IP address of the internal Motorola MPC860 processor) and press Enter.

If configured correctly, the system displays:

```
Reply from nnn.nn.nn.nn: bytes=32 time <##ms TTL=###
```

If there is no reply:

- a. Check that the internal cables on the TN802 circuit pack (Notes 4 and 6 in [Figure 9-57](#)) have not worked loose.
  - b. Otherwise, replace the circuit pack.
5. Ping the gateway: at the command prompt, type **ping XX.XXX.XXX.XXX** (the IP address of the gateway) and press Enter.
6. When finished, at the command prompt type **exit** and press Enter.

## Board assembly and cables

[Figure 9-56](#) shows the circuit pack with the two additional boards connected through the side plane.

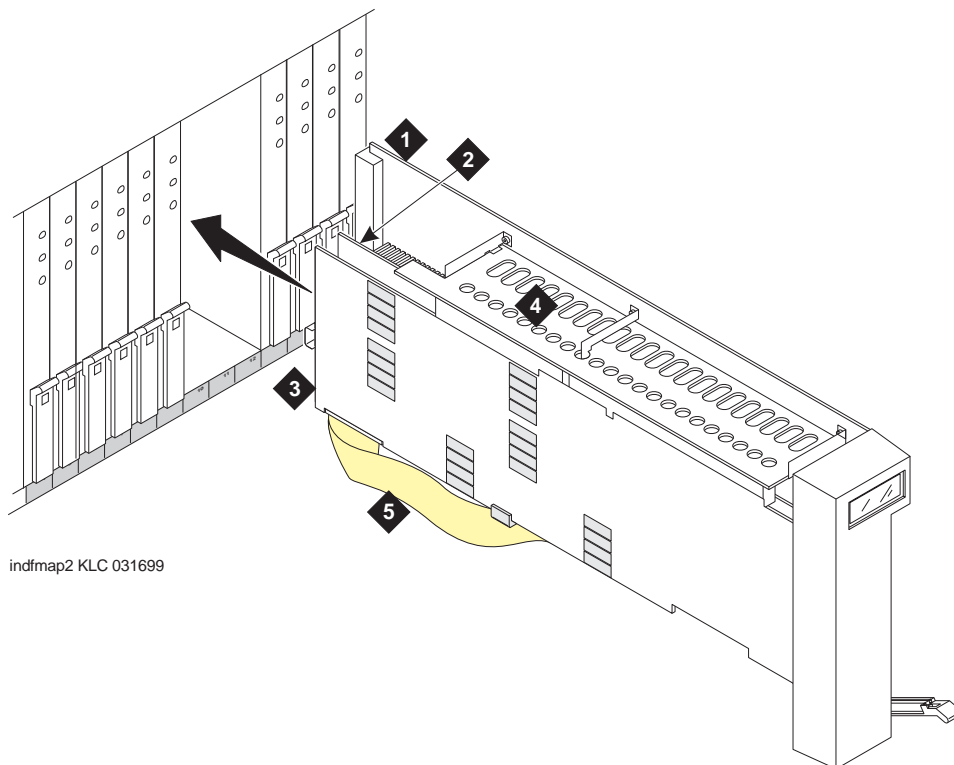

### Figure Notes:

- |  |   |
|--|---|
| 1. Main TN802 board                    | 4. Side plane   |
| 2. Texas Microsystems Inc. (TMI) board | 5. SCSA (Signal Computing System Architecture) ribbon cable |
| 3. Analogic board                      |   |

**Figure 9-56. TN802 board assembly**

[Figure 9-57](#) shows a side view of the thee boards and interconnecting cables that make up the TN802.

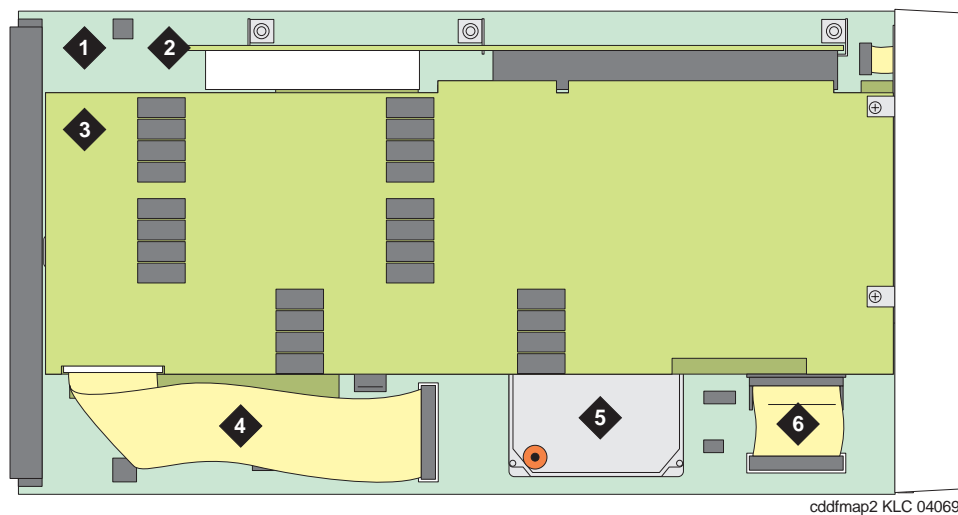

**Figure Notes:**

- |                     |   |
|---------------------|---|
| 1. Main TN802 board | 4. SCSA (Signal Computing System Architecture) ribbon cable |
| 2. Side plane       | 5. Hard drive   |
| 3. Analogic board   | 6. Processor I/O ribbon cable                               |

**Figure 9-57. TN802 board assembly and cables (side view)**



[Figure 9-58](#) shows the end view of the three boards and interconnecting cables on the TN802.

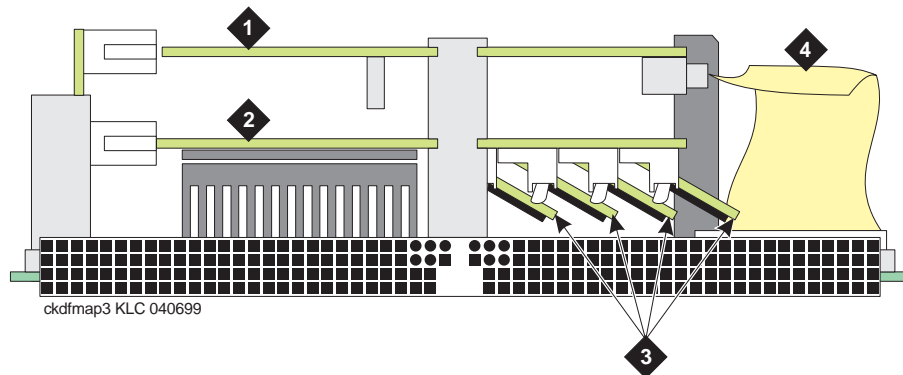

**Figure Notes:**

- |  |   |
|--|---|
| 1. Analogic board                      | 3. SIMMs (memory) <sup>1</sup>                              |
| 2. Texas Microsystems Inc. (TMI) board | 4. SCSA (Signal Computing System Architecture) ribbon cable |

- 
1. If the board is seated and you hear fast beeping, it means that one of the small boards containing the memory chips is dislodged. Secure the memory board firmly in the receptacle and reseat the circuit pack.

**Figure 9-58. TN802 board assembly and cables (end view)**

**Replacing the hard disk**

The TN802 hard drive (Note 5 in [Figure 9-57](#)) is field-replaceable.

**Table 9-389. Replacing the TN802 hard drive**

Step	Description	Comments
1.	Shut down NT	Shut down Windows NT by either method described in the <a href="#">“Shutting down NT on the TN802”</a> section.
2.	Remove the circuit pack	Unlatch the circuit pack and remove it from the carrier.

*Continued on next page*

**Table 9-389. Replacing the TN802 hard drive — *Continued***

Step	Description	Comments
3.	Remove the hard drive	Remove the 2 screws and lift the hard drive out of its mounting bracket.
4.	Replace the hard drive	Position the new hard drive in the mounting bracket and replace the 2 screws (Step 3).
5.	Replace the circuit pack	Slide the circuit pack into the slot and lock the latching lever.
6.	Wait for initialization	Wait for <ul style="list-style-type: none"> <li data-bbox="554 555 963 609">■ the circuit pack to reseal (faceplate LEDs light then go out)</li> <li data-bbox="554 627 1001 680">■ Windows NT boots (PC BOOT displays on the faceplate LCD)</li> <li data-bbox="554 698 976 752">■ IP Trunk application to run (IP TRK # displays on the faceplate LCD)</li> </ul>

## Error Log Entries and Test to Clear Values

Table 9-390. MAPD (TN802) Error Log entries

Error Type	Aux Data	Associated Test	Alarm Level	On/Off Board	Test to Clear Value
0 <sup>1</sup>	0	Any	Any	Any	test board UUCSS
1 (a)	0	Circuit pack removed or SAKI Test (#53)	MIN/ WRN <sup>2</sup>	ON	
2 (b)					
18 (c)	0	busyout board UUCSS	WRN	OFF	release board UUCSS
23 (d)	0		WRN	OFF	add ds1 UUCSS
125 (e)	none 3	None	MIN/ WRN <sup>3</sup>	ON	
257	65535	Control Channel Loop Test (#52)	MIN	ON	test board UUCSS l r 20
257 (f)	Any	None			
513 (g)	Any		MIN/ WRN <sup>3</sup>	ON	
514 (h)	46086		MIN/ WRN <sup>3</sup>	ON	
769 (i)	46085		MIN/ WRN <sup>3</sup>	ON	
770 (j)	46096		MIN/ WRN <sup>3</sup>	ON	
1025 (d)	4363	NPE Audit Test (#50)			
1281	Any	Loss of Signal Alarm Inquiry Test (#138)	MIN/ WRN <sup>3</sup>	OFF	test board UUCSS
1537 (k)	46082		MIN/ WRN <sup>3</sup>	ON	
1538 (l)	Any		MIN/ WRN <sup>3</sup>	ON	
1793	Any	Blue Alarm Inquiry Test (#139)	MAJ/ MIN/ WRN <sup>4</sup>	OFF	test board UUCSS
2049	Any	Red Alarm Inquiry Test (#140)	MIN/WR N <sup>3</sup>	OFF	test board UUCSS
2305	Any	Yellow Alarm Inquiry Test (#141)	MIN/ WRN <sup>3</sup>	OFF	test board UUCSS

Continued on next page

**Table 9-390. MAPD (TN802) Error Log entries — Continued**

Error Type	Aux Data	Associated Test	Alarm Level	On/Off Board	Test to Clear Value
2306	Any	Yellow Alarm Inquiry Test (#141)	MIN/ WRN <sup>3</sup>	OFF	test Board UUCSS
2561	Any	Major Alarm Inquiry Test (#142)	MIN/ WRN <sup>3</sup>	OFF	test board UUCSS
2817		Minor Alarm Inquiry Test (#143)	MIN/ WRN <sup>3</sup>	OFF	test board UUCSS
3073 to 3160 (m)	Any	Slip Alarm Inquiry Test (#144)	MIN/ WRN <sup>3</sup>	OFF	test board UUCSS r 6
3330 (n)	46083		MIN/ WRN <sup>3</sup>	ON	
3585 to 3601 (o)	Any	Misframe Alarm Inquiry Test (#145)	MIN/ WRN <sup>3</sup>	OFF	test board UUCSS r 6
3840 (p)	Any	None			
3841 (q)	4358				
3842 (r)	46097				
3843 (s)	46081				
3999 (t)	Any	None			

1. Run the Short Test Sequence first. If all tests pass, run the Long Test Sequence. Refer to the appropriate test description and follow the recommended procedures.
2. If ports are assigned to the circuit pack, then a minor alarm is raised. If no ports are assigned to the circuit pack, then a warning alarm is raised. The alarm is raised after the circuit pack has been missing for a period of 15 minutes. Warning alarms are also raised against any ports administered on the circuit pack.
3. Minor alarms on this MO may be downgraded to warning alarms based on values set in the **set options** command.
4. Major alarms on this MO may be downgraded to minor or warning alarms based on values set in the **set options** command.

**Notes:**

- a. Error Type 1: indicates that the circuit pack has totally stopped functioning or is not fully administered. The alarm is logged about 15 minutes after the circuit pack has been removed or 11 minutes after the SAKI Test (#53) fails.

To be fully administered, a MAPD circuit pack must meet all of these conditions:

- Have an entry in the circuit plan (**change circuit pack**)
- Be administered (**add ds1 UUCSS**)
- Be physically inserted into the correct slot

If the circuit pack has an entry in the circuit plan and either of the other two conditions are *not* met, a MINOR alarm is logged. To resolve the error, either:

1. Make sure the circuit pack is properly administered and that a functioning MAPD circuit pack is inserted in the correct slot, OR
2. Completely remove the MAPD-BD from the system:
  - a. Shut down NT (see [“Shutting down NT on the TN802”](#))
  - b. Remove any administered DS1 trunks, access endpoints, or PRI endpoints associated with the circuit pack from their respective trunk groups.
  - c. Remove the DS1 (**remove ds1 UUCSS**) and circuit pack (**change circuit pack UUCSS**) administration.

If the circuit pack is properly administered and the red LED is still on, follow the instructions for LED Alarms with Error Type 1 in Chapter 7.

- b. Error Type 2: NT is down and the system attempts to reset the board. If the reset fails, the board is probably bad.
  1. Replace the circuit pack.
- c. Error Type 18: the circuit pack has been busied out.
  1. Release the board (**release board UUCSS**).
- d. Error Type 23 and 1025: the MAPD-BD circuit pack is not completely administered. In addition to insertion, the MAPD circuit pack must have all of the following administration:
  - Have an entry in the circuit plan (**change circuit pack**)
  - Be administered as DS1 (**add ds1 UUCSS**)

The MAPD circuit pack differs from others in that inserting it into the switch backplane is not enough to make the board usable.

- e. Error Type 125, no Aux Data: A wrong circuit pack is inserted in the slot where this circuit pack is logically administered. To resolve this problem, either:
  1. Remove the wrong circuit pack and insert the logically administered circuit pack, OR
  2. Re-administer this slot (**change circuit-pack**) to match the circuit pack inserted.
- f. Error Type 257: this error is associated with the Common Port Circuit Pack Maintenance Test. Refer to XXX-BD (Common Port Circuit Pack) Maintenance documentation for details.

- g. Error Type 513: transient hardware problem.

Aux Data:

- 4352 External RAM failure
- 4353 Internal RAM failure
- 4355 Internal ROM failure

1. If the same Error Type/Aux Data value occurs more than once in a 24 hour period, the circuit pack should be replaced. See ["Shutting down NT on the TN802"](#) before removing the circuit pack.

If the MAPD board detects only one of these hardware problems, then the error is resolved when none of these faults are detected for 10 minutes.

- h. Error Type 514: LAN External RAM Error; hardware fault in the PPE external RAM, used for message buffering to and from the Packet Bus. This error should not occur regularly.

1. If this error occurs 10 times within 30 minutes, replace the circuit pack. See ["Shutting down NT on the TN802"](#) before removing the circuit pack.

- i. Error Type 769: Transmit FIFO Underflow (threshold is 3 errors within 10 minutes); the circuit pack cannot find the "end of frame" bit when transmitting a frame to Packet Bus.

1. Clear the alarm using the following command sequence:

- a. **busyout board UUCSS**
- b. **reset board UUCSS**
- c. **test board UUCSS long clear**
- d. **release board UUCSS**

2. If the error recurs within 10 minutes, replace the circuit pack. See ["Shutting down NT on the TN802"](#) before removing the circuit pack.

- j. Error Type 770: unable to Write LAN Translation RAM (threshold is 2 errors within 10 minutes); a call is aborted because there are no available translation RAM locations for the call connection attempt.

1. Clear the alarm using the following command sequence:

- a. **busyout board UUCSS**
- b. **reset board UUCSS**
- c. **test board UUCSS long clear**
- d. **release board UUCSS**

2. If the error recurs within 10 minutes, replace the circuit pack. See ["Shutting down NT on the TN802"](#) before removing the circuit pack.

- k. Error Type 1537: LAN Bus Timeout; the circuit pack transmitted too many bytes on the LAN bus for a single frame. This condition may be caused by:
- an on-board fault
  - faulty data received on one of the circuit pack's external ports. If any of the ports on this circuit pack are alarmed, refer to the repair procedures for those maintenance objects.

If the error occurs 3 times within 10 minutes, the system raises the board alarm and isolates it from the Packet Bus.

1. Clear the alarm and restore the board to the Packet Bus using the following command sequence:
    - a. **busyout board UUCSS**
    - b. **reset board UUCSS**
    - c. **test board UUCSS long clear**
    - d. **release board UUCSS**
  2. If the problem persists, and there are no PKT-BUS alarms or port alarms, then replace the circuit pack. See [“Shutting down NT on the TN802”](#) before removing the circuit pack.
- l. Error Type 1538: hyperactive circuit pack is out-of-service and may exhibit one or more of the following symptoms:
- The common circuit pack tests (for example, Test #50 and/or Test #52) abort with Error Code 2000.
  - Port tests on this circuit pack return NO-BOARD.
  - A busyout/release of the circuit pack has no affect on test results.
  - A **list configuration** command shows that the circuit pack and ports are properly installed.

The circuit pack is isolated from the system and all trunks or ports on this circuit pack are placed into the out-of-service state. The system attempts to restore the circuit pack within 20-30 minutes. When no faults are detected for 20-30 minutes, the MAPD Interface circuit pack is restored to normal operation and all trunks or ports on the MAPD Interface circuit pack return to the in-service state.

1. If the board is not restored to normal operation, or the error recurs after the board is restored to normal operation, escalate the problem.
- m. Error Type 3073 - 3160: board is reporting slip errors. Aux Data shows the last reported slip count.
- n. Error Type 3330: LAN Critical error; critical failure in the Packet Bus interface to the circuit pack. This failure may be due to an on-board or a Packet Bus fault.

1. If the Packet Bus is alarmed, refer to the PKT-BUS Maintenance documentation for recommended repair procedures.
  2. If the Packet Bus is not alarmed, clear the alarm and restore the board to the Packet Bus using the following command sequence:
    - a. **busyout board UUCSS**
    - b. **reset board UUCSS**
    - c. **test board UUCSS clear**
    - d. **release board UUCSS**
  3. If the problem persists, and there are no PKT-BUS alarms, then replace the circuit pack. See ["Shutting down NT on the TN802"](#) before removing the circuit pack.
- o. Error Type 3585 - 3601: the board received misframe errors; the Aux Data shows the last reported misframe count.
- p. Error Type 3840: the circuit pack received a bad control channel message from the switch. This error is not service-affecting, and requires no action. The Aux Data describes the following error events:
- |      |                     |
|------|---------------------|
| 4096 | Bad major heading   |
| 4097 | Bad port number     |
| 4098 | Bad data            |
| 4099 | Bad sub-qualifier   |
| 4100 | State inconsistency |
| 4101 | Bad logical link    |
- q. Error Type 3841: the circuit pack detected a transient hardware logic error (for example, program logic inconsistency). This error resolves when no faults are detected for 100 minutes. The value in Aux Data field (4358) indicates the type of hardware problem.
- r. Error Type 3842: Bad Translation RAM Location Found error; the call continues by using another translation location. This error is not service-affecting and requires no action.
- s. Error Type 3843: LAN Receive Parity error; the circuit pack detected an error in a received frame from the Packet Bus. These errors are most likely caused by a Packet Bus problem, but may be due to a circuit pack fault.
1. Determine whether the problem is isolated to this circuit pack or if the problem is caused by Packet Bus faults (see PKT-BUS).
- t. Error Type 3999: the circuit pack sent a large number of control channel messages to the switch within a short period of time.



Error Type 1538 (hyperactivity) also present?	Then the switch:
Y	Takes the circuit pack out-of-service due to hyperactivity
N	Does not take the circuit pack out-of-service, but the circuit pack has generated 50% of the messages necessary to be considered hyperactive. This may be normal during heavy traffic periods.

## Shutting down NT on the TN802

Before removing the TN802 circuit pack from the carrier, shut Windows NT™ down first by *following either procedure* described in [Table 9-391](#):

**Table 9-391. Windows NT shutdown procedures**

Step	Faceplate button	PC interface
1.	Push the recessed button on the front faceplate and hold it in.	Click on the “Start” button in the lower, lefthand corner.
2.	“M shut” flashes on the LCD display	Click on “Shut Down.”
3.	When shutdown is complete, “MSHUT #” displays (“#” is blinking).	Choose the “Shut down the computer?” radio button.
4.	Remove the circuit pack.	Click on “OK.”
5.		Wait for the message indicating that shutdown is complete.
6.		Remove the circuit pack.

## System Technician-Demanded Tests: Descriptions and Error Codes

Investigate tests in the order they are presented in [Table 9-392](#). By clearing error codes associated with the NPE Connection Audit Test, for example, you may also clear errors generated from other tests in the testing sequence.

**Table 9-392. System Technician-Demanded Tests**

Order of Investigation	Apply to TN802? <sup>1</sup>	Short Test Sequence	Long Test Sequence	Reset Board Sequence	D/ND <sup>2</sup>
NPE Connection Audit Test (#50)	Y		X		ND
Control Channel Loop Test (#52)	Y		X		ND
Loss of Signal Alarm Inquiry Test (#138)	N	X	X		ND
Blue Alarm Inquiry Test (#139)	N	X	X		ND
Red Alarm Inquiry Test (#140)	N	X	X		ND
Yellow Alarm Inquiry Test (#141)	N	X	X		ND
Major Alarm Inquiry Test (#142)	N	X	X		ND
Minor Alarm Inquiry Test (#143)	N	X	X		ND
Slip Alarm Inquiry Test (#144)	N	X	X		ND
Misframe Alarm Inquiry Test (#145)	N	X	X		ND
Translation Update Test (#146)	N	X	X		ND
SAKI Sanity Test (#53)	Y			X	D

1. N = No; this test either passes or ABORTS with Error Code 2000 (problem with NT)
2. D = Destructive; ND = Nondestructive

**NPE Connection Audit Test (#50)**

The system sends a message to the on-board microprocessor to update the network connectivity translation for the SCOTCH-NPE chip on the circuit pack.

**Table 9-393. TEST #50 NPE Connection Audit Test**

Error Code	Test Result	Description/ Recommendation
None 2100	ABORT	System resources required for this test are not available. 1. Retry the command at 1-minute intervals a maximum of 5 times.
1019	ABORT	The test aborted because a test was already running on the port. 1. Retry the command at 1-minute intervals for a maximum of 5 times.

**Table 9-393. TEST #50 NPE Connection Audit Test — Continued**

Error Code	Test Result	Description/ Recommendation
	FAIL	Internal system error 1. Retry the command at 1-minute intervals a maximum of 5 times.
	PASS	The circuit pack's SCOTCH-NPE chip has been updated with its translation.
0	NO BOARD	The test could not relate the internal ID to the port (no board). This could be due to incorrect translations, no board is inserted, an incorrect board is inserted, or an insane board is inserted.  1. Ensure that the board translations are correct. Execute the <b>add ds1 UUCSS</b> command to administer the MAPD interface if it is not already administered.  2. If the board was already administered correctly, check the error log to determine whether the board is hyperactive. If this is the case, the board is shut down. Reseating the board re-initializes the board.  3. If the board was found to be correctly inserted in Step 1, then issue the <b>busyout board</b> command.  4. Issue the <b>reset board</b> command.  5. Issue the <b>release busy board</b> command.  6. Issue the <b>test board long</b> command.  This should re-establish the linkage between the internal ID and the port.

### Control Channel Looparound Test (#52)

This test queries the circuit pack for its circuit pack code and vintage and verifies its records.

**Table 9-394. TEST #52 Control Channel Looparound Test**

Error Code	Test Result	Description/ Recommendation
None 2100	ABORT	System resources required for this test are not available. 1. Retry the command at 1-minute intervals a maximum of 5 times.

*Continued on next page*

**Table 9-394. TEST #52 Control Channel Looparound Test — Continued**

Error Code	Test Result	Description/ Recommendation
	FAIL	The circuit pack failed to return the circuit pack code or vintage. <ol style="list-style-type: none"> <li>1. Retry the command a maximum of 5 times.</li> <li>2. If the problem continues, and if the circuit pack is one of the Port circuit packs, replace the circuit pack.</li> <li>3. Otherwise, if the circuit pack is part of the SPE, use the procedure described in <i>Replacing SPE Circuit Packs</i> in Chapter 5.</li> </ol>
	PASS	Communication with this circuit pack is successful.
0	NO BOARD	The test could not relate the internal ID to the port (no board). This could be due to incorrect translations, no board is inserted, an incorrect board is inserted, or an insane board is inserted. <ol style="list-style-type: none"> <li>1. Ensure that the board translations are correct. Execute the <b>add ds1 UUCSS</b> command to administer the MAPD interface if it is not already administered.</li> <li>2. If the board was already administered correctly, check the error log to determine whether the board is hyperactive. If this is the case, the board is shut down. Reseating the board re-initializes the board.</li> <li>3. If the board was found to be correctly inserted in step 1, then issue the <b>busyout board</b> command.</li> <li>4. Issue the <b>reset board</b> command.</li> <li>5. Issue the <b>release busy board</b> command.</li> <li>6. Issue the <b>test board long</b> command.</li> </ol> This should re-establish the linkage between the internal ID and the port.

### SAKI Sanity Test (#53)

**This test is destructive.**

This test resets the circuit pack. The test is highly destructive and can only be initiated by a system technician-demanded **reset board UUCSS** command.

**Table 9-395. TEST #53 SAKI Sanity Test**

Error Code	Test Result	Description/ Recommendation
None	ABORT	System resources required for this test are not available. 1. Retry the <b>reset board</b> command at 1-minute intervals a maximum of 5 times.
1015	ABORT	Port is not out-of-service. 1. Busyout the circuit pack ( <b>busyout board UUCSS</b> ). 2. Execute the <b>reset board</b> command again.
2100	ABORT	System resources required for this test are not available. 1. Retry the <b>reset board</b> command at 1-minute intervals a maximum of 5 times.
1 2	FAIL FAIL	The circuit pack failed to reset. The circuit pack failed to restart. 1. Execute the <b>reset board</b> command again. 2. If the problem persists, replace the circuit pack.
	PASS	The circuit pack initializes correctly. 1. Run the Short Test Sequence.
0	NO BOARD	The test could not relate the internal ID to the port (no board). This could be due to incorrect translations, no board is inserted, an incorrect board is inserted, or an insane board is inserted. 1. Ensure that the board translations are correct. Execute the <b>add ds1 UUCSS</b> command to administer the MAPD interface if it is not already administered. 2. If the board was already administered correctly, check the error log to determine whether the board is hyperactive. If this is the case, the board is shut down. Reseating the board re-initializes the board. 3. If the board was found to be correctly inserted in step 1, then issue the <b>busyout board</b> command. 4. Issue the <b>reset board</b> command. 5. Issue the <b>release busy board</b> command. 6. Issue the <b>test board long</b> command. This should re-establish the linkage between the internal ID and the port.

## Loss of Signal Alarm Inquiry Test (#138)

This test is meaningless for the TN802 MAPD circuit pack. [Table 9-396](#) details the test results.

**Table 9-396. Loss of Signal Inquiry Test (#138) results**

Windows NT up on the TN802?	Then	Cause
Y	Test passes	
Y	Test aborts with ABORT 2000 Error Code.	Windows NT is not communicating with the angel firmware.
N	Test aborts with ABORT 2000 Error Code.	Windows NT down.

## Blue Alarm Inquiry Test (#139)

This test is meaningless for the TN802 MAPD circuit pack. [Table 9-397](#) details the test results.

**Table 9-397. Blue Alarm Inquiry Test (#139) results**

Windows NT up on the TN802?	Then	Cause
Y	Test passes	
Y	Test aborts with ABORT 2000 Error Code.	Windows NT is not communicating with the angel firmware.
N	Test aborts with ABORT 2000 Error Code.	Windows NT down.

## Red Alarm Inquiry Test (#140)

This test is meaningless for the TN802 MAPD circuit pack. [Table 9-398](#) details the test results.

**Table 9-398. Red Alarm Inquiry Test (#140) results**

If Windows NT is up on the TN802	When the switch confirms Red alarm:
Y	Test passes
N	Test aborts with ABORT 2000 Error Code.

### Yellow Alarm Inquiry Test (#141)

This test is meaningless for the TN802 MAPD circuit pack. [Table 9-399](#) details the test results.

**Table 9-399. Yellow Alarm Inquiry Test (#141) results**

If Windows NT is up on the TN802	When the switch confirms Yellow alarm:
Y	Test passes
N	Test aborts with ABORT 2000 Error Code.

### Major Alarm Inquiry Test (#142)

This test is meaningless for the TN802 MAPD circuit pack. [Table 9-400](#) details the test results.

**Table 9-400. Major Alarm Inquiry Test (#142) results**

If Windows NT is up on the TN802	When the switch confirms Major alarm:
Y	Test passes
N	Test aborts with ABORT 2000 Error Code.

### Minor Alarm Inquiry Test (#143)

This test is meaningless for the TN802 MAPD circuit pack. [Table 9-401](#) details the test results.

**Table 9-401. Minor Alarm Inquiry Test (#142) results**

If Windows NT is up on the TN802	When the switch confirms Minor alarm:
Y	Test passes
N	Test aborts with ABORT 2000 Error Code.

### Slip Alarm Inquiry Test (#144)

This test is meaningless for the TN802 MAPD circuit pack. [Table 9-402](#) details the test results.



**NOTE:**

The query for slips always returns a 0 count.

**Table 9-402. Slip Alarm Inquiry Test (#144) results**

If Windows NT is up on the TN802	When the switch confirms Slip alarm:
Y	Test passes
N	Test aborts with ABORT 2000 Error Code.

### Misframe Alarm Inquiry Test (#145)

This test is meaningless for the TN802 MAPD circuit pack. [Table 9-403](#) details the test results.

#### NOTE:

The query for misframes always returns a 0 count.

**Table 9-403. Misframe Alarm Inquiry Test (#145) results**

If Windows NT is up on the TN802	When the switch confirms Misframe alarm:
Y	Test passes
N	Test aborts with ABORT 2000 Error Code.

### Translation Update Test (#146)

The Translation Update Test sends the circuit-pack-level information to the MAPD Interface circuit pack. Translation includes the following data administered for a MAPD Interface circuit pack (report from **display ds1 UUCSS** command):

- DS1 Link Length between two DS1 endpoints
- Synchronization Source Control
- All Zero Suppression
- Framing Mode
- Signaling Mode
- Time Slot Number of the 697-Hz tone
- Time Slot Number of the 700-Hz tone



**Table 9-404. TEST #146 Translation Update Test**

Error Code	Test Result	Description/ Recommendation
	ABORT	Internal system error 1. Retry the command at 1-minute interval s a maximum of 5 times.
	FAIL	Internal system software error. 1. Verify the MAPD Interface circuit pack translation ( <b>display ds1 UUCSS</b> ).
	PASS	Translation data has been downloaded to the MAPD Interface circuit pack successfully.
0	NO BOARD	The test could not relate the internal ID to the port (no board). This could be due to incorrect translations, no board is inserted, an incorrect board is inserted, or an insane board is inserted. 1. Ensure that the board translations are correct. Execute the <b>add ds1 UUCSS</b> command to administer the MAPD interface if it is not already administered. 2. If the board was already administered correctly, check the error log to determine whether the board is hyperactive. If this is the case, the board is shut down. Reseating the board re-initializes the board. 3. If the board was found to be correctly inserted in step 1, then issue the <b>busyout board</b> command. 4. Issue the <b>reset board</b> command. 5. Issue the <b>release busy board</b> command. 6. Issue the <b>test board long</b> command. This should re-establish the linkage between the internal ID and the port.

## MEM-BD (32MB Memory Circuit Pack)

MO Name (in Alarm Log)	Alarm Level	Initial Command to Run <sup>1</sup>	Full Name of MO
MEM-BD	MAJOR <sup>2</sup>	test memory UUCS I	32M Memory Circuit Pack
MEM-BD	MINOR	test memory UUCS s	32M Memory Circuit Pack
MEM-BD	WARNING		32M Memory Circuit Pack

1. UU is the cabinet number (always 1, not required). With simplex SPE, carrier designation is not required. With duplicated SPEs, carrier a or b must be specified. S is the number of the circuit pack slot (1 to 4 for Memory slots). If the slot number is *not* specified, all Memory circuit packs in the specified carrier will be tested.
2. After a spontaneous SPE interchange has occurred, the Alarm Log retains for three hours a record of any MAJOR ON-BOARD alarm against an SPE component that took place before the interchange. If a spontaneous interchange has occurred (as indicated by STBY-SPE error type 103 or the **display initcauses** screen), and handshake is down, (check with **status spe**), replace the alarmed circuit pack on the standby SPE. If handshake is up, execute a **test long clear** of the alarmed circuit pack and follow recommended procedures.

The memory circuit packs contain the system software which is executed after it is loaded from tape or disk. The processor and the memory circuit packs form the most critical component for all system operation.

The processor must be able to access the memory for all system activity or the system will go into SPE-down mode. In SPE-down mode, fatal memory errors may show up as processor circuit pack errors.

Each memory circuit pack has 32 Mbytes of capacity. The SPE carrier(s) contain four dedicated slots for Memory circuit packs. Depending on its size, the system uses from two to four of these slots. Memory circuit packs must reside in contiguous slots, starting Memory slot one.

Each Memory circuit pack contains its own error detection and correction (EDC) circuit, parity checker and burst read function.

The EDC circuit operates by checking the contents of memory both as memory locations are accessed by the Processor and periodically by a built-in "scrubbing" function. The scrubbing function checks for errors through the entire Memory circuit pack every 111 seconds. It flags and corrects single-bit errors automatically and flags (but does not correct) multiple bit errors. If the EDC circuit fails, the Memory circuit pack will not be able to detect and correct single bit errors or detect and flag multiple bit errors. If a single or multiple bit error occurs, the system may not continue to operate correctly.

The Memory parity checker detects bad parity over the Processor Bus when any Bus Master writes memory. It also generates parity (for checking by the

Processor) on Memory reads. If the parity checking logic fails, it will either generate errors when it shouldn't (a serious error condition that will probable result in SPE Down) or miss errors when present (less serious).

The burst read circuit supports a special, block read mode used by the Processor to quickly load program instructions into the Processor cache. Given a single starting address over the Processor Bus, the Memory transfers four words of data back to the Processor. This reduces the time it takes for the Processor to get instructions. Problems in this circuit may be due to the Memory circuit pack or Processor and will result in SPE Down.

If the PBX system is equipped with High Reliability or Critical Reliability option (i.e. with duplicated SPEs), and if a failure of the active Memory circuit pack causes a MAJOR on-board alarm, a SPE interchange will occur if the health of the standby SPE permits the interchange.

## Error Log Entries and Test to Clear Values

Table 9-405. MEM-BD Error Log Entries

Error Type	Aux Data	Associated Test	Alarm Level	On/Off Board	Test to Clear Value
0 <sup>1</sup>	0	Any	Any	Any	test memory UUCS sh r 1
1		Memory RAM Checksum Test (#903)	MAJOR	OFF	test memory UUCS l r 1
3(a)		Memory RAM Checksum Test (#903)	MAJOR <sup>2</sup>	OFF	test memory UUCS l r 1
101(b)		none	WNG	OFF	
150(c)		none	MAJOR <sup>2</sup>	ON	test memory UUCS l c
257		Memory Parity Checker Test (#906)	MINOR	ON	test memory UUCS sh r 2
513	Any(d)	Memory Single Bit Errors (#902)	MINOR	ON	test memory UUCS l r 10
769		Memory Multiple Bit Errors (#902)	MAJOR <sup>2</sup>	ON	test memory UUCS l r 2
1025		Memory Error Detection/Correction Test (#907)	MINOR	ON	test memory UUCS sh r 1
1281		Memory Burst Read Test (#908)	MAJOR <sup>2</sup>	ON	test memory UUCS sh r 1

1. Run the Short Test Sequence first. If all tests pass, run the Long Test Sequence. Refer to the appropriate test description and follow the recommended procedures.
2. If a spontaneous interchange has occurred (as indicated by STBY-SPE error type 103 or the **display initcauses** screen), and handshake is down, (check with **status spe**), replace the alarmed circuit pack on the standby SPE. If handshake is up, execute a **test long clear** of the alarmed circuit pack and follow recommended procedures.

### Notes:

- a. This error (3) indicates that a software patch has been applied and either the software patch is bad or was installed incorrectly.
  1. Back out the software patch and run the **test memory UUCS long** command to verify that the problem has been cleared.
  2. If the PBX system is equipped with High Reliability or Critical Reliability option (i.e. with duplicated SPEs), and this error occurs, a SPE interchange will occur if the health of the standby SPE permits the interchange.

- b. This error (101) indicates that this Memory circuit pack is not required.
  - 1. Remove the extra Memory circuit pack at the earliest convenience to resolve this alarm. To replace the Memory circuit pack, use the procedure described in *Replacing SPE Circuit Packs* in [Chapter 5, "Alarms, Errors, and Troubleshooting"](#).
- c. This error (150) indicates that a SPE interchange has occurred and that the Memory circuit pack was the cause of the spontaneous interchange.
  - 1. If other MEM-BD errors are present, investigate these errors.
  - 2. If no other MEM-BD errors are present, run the **test memory UUCS long clear** command and investigate any test failure.
- d. The aux data indicates the number of single bit errors detected since the last time the test was run.

## System Technician-Demanded Tests: Descriptions and Error Codes

---

Always investigate tests in the order presented in the table below. By clearing error codes associated with the *Memory Single/Multiple Bit Error Audit*, for example, you may also clear errors generated from other tests in the testing sequence.

Order of Investigation	Short Test Sequence	Long Test Sequence	Reset Board Sequence	D/ND <sup>1</sup>
Single/Multiple Bit Error Audit (#902)		X		ND
Memory Burst Read Test (#908)	X	X		ND
Memory Error Detection/Correction Test (#907)	X	X		ND
Memory RAM Checksum Test (#903)		X		ND
Memory Parity Checker Test (#906)	X	X		ND

---

1. D = Destructive, ND = Non-destructive

### Memory Single/Multiple Bit Error Audit (#902)

This audit waits for the hardware scrubbing circuits in the Memory circuit packs to make a complete pass through Memory and reports any single or multiple bit errors that may have been found. If the **test memory a|b long** command is used, this test executes once for each equipped Memory circuit pack

**Table 9-406. TEST #902 Memory Single/Multiple Bit Error Audit**

Error Code	Test Result	Description/ Recommendation
100	ABORT	The requested test did not complete within the allowable time period. 1. Retry the command.
1022 1335 2500	ABORT	Internal system error. 1. Retry the command.
1338	ABORT	The test is not allowed to run since a planned SPE interchange is in progress. This may be caused by a planned interchange initiated automatically during 24 hour scheduled testing. 1. Wait 3 minutes and retry the command.
1339	ABORT	The test could not run on the standby Memory circuit pack in the standby SPE carrier because the standby SPE is unavailable. 1. Refer to the section on "STBY-SPE (Standby SPE Maintenance)" procedures for information on why a standby SPE may be unavailable and what repair actions should be taken. The <b>status spe</b> screen should indicate that handshake is down. This may be caused by a variety of reasons such as the SPE-SELECT switches on the DUPINT circuit packs being set to the position of the active SPE, a failure of the DUPINT circuit pack, or loss of power on the standby SPE. The <i>SPE Selected field</i> on the <b>status spe-standby</b> screen will display <i>spe a</i> or <i>spe b</i> if both SPE-SELECT switches are in the a or b positions, respectively.
2000	ABORT	Response to the test request was not received within the allowable time period. If the system is equipped with the High Reliability or Critical Reliability Configuration and if the Memory circuit pack is on the standby SPE, this abort code may indicate that the standby SPE is not responding to the handshake message. If this is the case, the standby SPE maintenance software may take up to two minutes to indicate that handshake communication with the standby SPE is down. The ABORT code will then change to 1339 (handshake communication down). 1. Retry the command at 1-minute intervals, a maximum of 3 times.
2315	ABORT	The test was not run, because this is an extra Memory circuit pack. No testing is allowed for extra Memory circuit packs.
2334	ABORT	The hardware mailbox on the standby Duplication Interface board is not ready to receive messages. 1. Retry the command at 1-minute intervals, a maximum of 5 times.

*Continued on next page*

**Table 9-406. TEST #902 Memory Single/Multiple Bit Error Audit — Continued**

Error Code	Test Result	Description/ Recommendation
	FAIL	The audit detected one or more single or multiple bit errors on the indicated Memory circuit pack(s). <ol style="list-style-type: none"><li data-bbox="282 390 526 413">1. Retry the command.</li><li data-bbox="282 431 1038 455">2. If the test continues to fail, replace the affected Memory circuit pack.</li><li data-bbox="282 473 1093 557">3. If the test continues to fail after replacing the Memory circuit pack, replace the Processor circuit pack. To replace the circuit packs, use the procedure described in <i>Replacing SPE Circuit Packs</i> in Chapter 5.</li></ol>
	PASS	The Memory does not contain any single or multiple bit errors.

### Memory RAM Checksum Test (#903)

This test computes the checksum of the system software text module. This test is only run when the Memory circuit pack in slot one is being tested. If this test fails, the RAM is corrupt. It does NOT indicate a hardware problem.

DO NOT REPLACE the Memory circuit pack when this is the only error or failing test.

For systems equipped with the Standard Reliability configuration, do a system restart (enter **reset system 4**) as soon as possible. For systems equipped with the High Reliability or Critical Reliability configuration, perform the following steps as soon as possible:

1. Busyout the standby SPE (enter **busyout spe-standby**).
2. Reboot the standby SPE (enter **reset spe-standby 4**).
3. Wait for the standby SPE to reboot (about 5 minutes).
4. Lock the standby SPE into active mode using the SPE-SELECT switches on the DUPINT circuit packs. This will cause the new active SPE to perform COLD reset and the new standby SPE will perform a reboot

**Table 9-407. TEST #903 RAM Checksum Test**

Error Code	Test Result	Description/ Recommendation
100	ABORT	The requested test did not complete within the allowable time period. 1. Retry the command.
1022 1335 2500	ABORT	Internal system error. 1. Retry the command.
1338	ABORT	The test is not allowed to run since a planned SPE interchange is in progress. This may be caused by a planned interchange initiated automatically during 24 hour scheduled testing. 1. Wait 3 minutes and retry the command.
1339	ABORT	The test could not run on the standby Memory circuit pack in the standby SPE carrier because the standby SPE is unavailable. 1. Refer to the section on "STBY-SPE (Standby SPE Maintenance)" procedures for information on why a standby SPE may be unavailable and what repair actions should be taken. The <b>status spe</b> screen should indicate that handshake is down. This may be caused by a variety of reasons such as the SPE-SELECT switches on the DUPINT circuit packs being set to the position of the active SPE, a failure of the DUPINT circuit pack, or loss of power on the standby SPE. The <i>SPE Selected field</i> on the <b>status spe-standby</b> screen will display <i>spe a</i> or <i>spe b</i> if both SPE-SELECT switches are in the a or b positions, respectively.
2000	ABORT	Response to the test request was not received within the allowable time period. If the system is equipped with the High Reliability or Critical Reliability Configuration and if the Memory circuit pack is on the standby SPE, this abort code may indicate that the standby SPE is not responding to the handshake message. If this is the case, the standby SPE maintenance software may take up to two minutes to indicate that handshake communication with the standby SPE is down. The ABORT code will then change to 1339 (handshake communication down). 1. Retry the command at 1-minute intervals, a maximum of 3 times.
2315	ABORT	The test was not run, because this is an extra Memory circuit pack. No testing is allowed for extra Memory circuit packs.
2334	ABORT	The hardware mailbox on the standby Duplication Interface board is not ready to receive messages. 1. Retry the command at 1-minute intervals, a maximum of 5 times.

*Continued on next page*



**Table 9-407. TEST #903 RAM Checksum Test — Continued**

Error Code	Test Result	Description/ Recommendation
	FAIL	<p>The system may or may not continue to operate correctly. The system may fail at some future date when some action requires access to the corrupted area of the RAM. For systems equipped with the Standard Reliability configuration:</p> <ol style="list-style-type: none"> <li>Restart the system with a <b>reset system 4</b> and observe the startup memory tests (refer to <a href="#">Chapter 4, "Initialization and Recovery"</a>, for a list of tests).</li> </ol> <p>For systems equipped with the High Reliability or Critical Reliability configuration:</p> <ol style="list-style-type: none"> <li>Busyout the standby SPE (enter <b>busyout spe-standby</b>).</li> <li>Reboot the standby SPE (enter <b>reset spe-standby 4</b>).</li> <li>Wait for the standby SPE to reboot (about 5 minutes).</li> <li>Lock the standby SPE into active mode using the SPE-SELECT switches on the DUPINT circuit packs. This will cause the new active SPE to perform COLD reset and the new standby SPE will perform a reboot.</li> </ol>
	PASS	The RAM checksum is correct.

### Memory Parity Checker Test (#906)

This test checks the operation of the Memory circuit pack parity generators and checkers. If the **test memory alj** command is used, this test executes once for each equipped Memory circuit pack

**Table 9-408. TEST #906 Memory Parity Checker Test**

Error Code	Test Result	Description/ Recommendation
100	ABORT	<p>The requested test did not complete within the allowable time period.</p> <ol style="list-style-type: none"> <li>Retry the command.</li> </ol>
1022 1335 2500	ABORT	<p>Internal system error.</p> <ol style="list-style-type: none"> <li>Retry the command.</li> </ol>
1338	ABORT	<p>The test is not allowed to run since a planned SPE interchange is in progress. This may be caused by a planned interchange initiated automatically during 24 hour scheduled testing.</p> <ol style="list-style-type: none"> <li>Wait 3 minutes and retry the command.</li> </ol>

**Table 9-408. TEST #906 Memory Parity Checker Test — Continued**

Error Code	Test Result	Description/ Recommendation
1339	ABORT	<p>The test could not run on the standby Memory circuit pack in the standby SPE carrier because the standby SPE is unavailable.</p> <ol style="list-style-type: none"> <li>1. Refer to the section on "STBY-SPE (Standby SPE Maintenance)" procedures for information on why a standby SPE may be unavailable and what repair actions should be taken. The <b>status spe</b> screen should indicate that handshake is down. This may be caused by a variety of reasons such as the SPE-SELECT switches on the DUPINT circuit packs being set to the position of the active SPE, a failure of the DUPINT circuit pack, or loss of power on the standby SPE. The <i>SPE Selected field</i> on the <b>status spe-standby</b> screen will display <i>spe a</i> or <i>spe b</i> if both SPE-SELECT switches are in the a or b positions, respectively.</li> </ol>
2000	ABORT	<p>Response to the test request was not received within the allowable time period. If the system is equipped with the High Reliability or Critical Reliability Configuration and if the Memory circuit pack is on the standby SPE, this abort code may indicate that the standby SPE is not responding to the handshake message. If this is the case, the standby SPE maintenance software may take up to two minutes to indicate that handshake communication with the standby SPE is down. The ABORT code will then change to 1339 (handshake communication down).</p> <ol style="list-style-type: none"> <li>1. Retry the command at 1-minute intervals, a maximum of 3 times.</li> </ol>
2315	ABORT	<p>The test was not run, because this is an extra Memory circuit pack. No testing is allowed for extra Memory circuit packs.</p>
2334	ABORT	<p>The hardware mailbox on the standby Duplication Interface board is not ready to receive messages.</p> <ol style="list-style-type: none"> <li>1. Retry the command at 1-minute intervals, a maximum of 5 times.</li> </ol>
	FAIL	<p>The Memory circuit pack cannot detect parity error conditions. If the test fails on all equipped Memory circuit packs, the Processor may be at fault. Run the tests described in the "PROCR (RISC Processor Circuit Pack)" section of this manual.</p> <ol style="list-style-type: none"> <li>1. Retry the command.</li> <li>2. If the test continues to fail, replace the Memory circuit pack.</li> <li>3. If the test continues to fail, replace the Processor circuit pack. To replace the circuit packs, use the procedure described in <i>Replacing SPE Circuit Packs</i> in Chapter 5.</li> </ol>
	PASS	<p>The Memory Parity Checker circuit is operating properly.</p>

## Memory Error Detection/Correction Test (#907)

This test checks the error detection/correction circuitry on the Memory circuit pack. It tests a few reserved memory locations to verify that single bit errors can be corrected and multiple bit errors can be detected. If the **test memory a|b** command is used, this test executes once for each equipped Memory circuit pack

**Table 9-409. TEST #907 Memory Error Detection/Correction Test**

Error Code	Test Result	Description/ Recommendation
100	ABORT	The test did not complete within the allowable time period. 1. Retry the command.
1022 1335 2500	ABORT	Internal system error. 1. Retry the command.
1338	ABORT	The test is not allowed to run since a planned SPE interchange is in progress. This may be caused by a planned interchange initiated automatically during 24 hour scheduled testing. 1. Wait 3 minutes and retry the command.
1339	ABORT	The test could not run on the standby Memory circuit pack in the standby SPE carrier because the standby SPE is unavailable. 1. Refer to the section on "STBY-SPE (Standby SPE Maintenance)" procedures for information on why a standby SPE may be unavailable and what repair actions should be taken. The <b>status spe</b> screen should indicate that handshake is down. This may be caused by a variety of reasons such as the SPE-SELECT switches on the DUPINT circuit packs being set to the position of the active SPE, a failure of the DUPINT circuit pack, or loss of power on the standby SPE. The <b>SPE Selected field</b> on the <b>status spe-standby</b> screen will display <i>spe a</i> or <i>spe b</i> if both SPE-SELECT switches are in the a or b positions, respectively.
2000	ABORT	Response to the test request was not received within the allowable time period. If the system is equipped with the High Reliability or Critical Reliability Configuration and if the Memory circuit pack is on the standby SPE, this abort code may indicate that the standby SPE is not responding to the handshake message. If this is the case, the standby SPE maintenance software may take up to two minutes to indicate that handshake communication with the standby SPE is down. The ABORT code will then change to 1339 (handshake communication down). 1. Retry the command at 1-minute intervals, a maximum of 3 times.
2315	ABORT	The test was not run, because this is an extra Memory circuit pack. No testing is allowed for extra Memory circuit packs.

*Continued on next page*

**Table 9-409. TEST #907 Memory Error Detection/Correction Test — Continued**

Error Code	Test Result	Description/ Recommendation
2334	ABORT	The hardware mailbox on the standby Duplication Interface board is not ready to receive messages.  1. Retry the command at 1-minute intervals, a maximum of 5 times.
	FAIL	The Memory EDC circuitry is not working correctly. The system may not continue to operate correctly if single or multiple bit errors occur in Memory at a later time. If the test fails on all equipped Memory circuit packs, the Processor may be at fault. Run the tests described in the Processor section of this manual.  1. Replace the affected Memory circuit when convenient. 2. If the test continues to fail after replacing the Memory circuit pack, replace the Processor circuit pack. To replace the circuit packs, use the procedure described in <i>Replacing SPE Circuit Packs</i> in Chapter 5.
	PASS	The Memory EDC circuitry is working normally.

### Memory Burst Read Test (#908)

This test verifies that the Memory Burst Read function works properly on both the Memory and Processor circuit packs. If the **test memory a|b** command is used, this test executes once for each equipped Memory circuit pack

**Table 9-410. TEST #908 Memory Burst Read Test**

Error Code	Test Result	Description/ Recommendation
100	ABORT	The requested test did not complete within the allowable time period.  1. Retry the command.
1022 1335 2500	ABORT	Internal system error.  1. Retry the command.
1338	ABORT	The test is not allowed to run since a planned SPE interchange is in progress. This may be caused by a planned interchange initiated automatically during 24 hour scheduled testing.  1. Wait 3 minutes and retry the command.

*Continued on next page*

Table 9-410. TEST #908 Memory Burst Read Test — Continued

Error Code	Test Result	Description/ Recommendation
1339	ABORT	<p>The test could not run on the standby Memory circuit pack in the standby SPE carrier because the standby SPE is unavailable.</p> <ol style="list-style-type: none"> <li>1. Refer to the section on "STBY-SPE (Standby SPE Maintenance)" procedures for information on why a standby SPE may be unavailable and what repair actions should be taken. The <b>status spe</b> screen should indicate that handshake is down. This may be caused by a variety of reasons such as the SPE-SELECT switches on the DUPINT circuit packs being set to the position of the active SPE, a failure of the DUPINT circuit pack, or loss of power on the standby SPE. The <i>SPE Selected field</i> on the <b>status spe-standby</b> screen will display <i>spe a</i> or <i>spe b</i> if both SPE-SELECT switches are in the a or b positions, respectively.</li> </ol>
2000	ABORT	<p>Response to the test request was not received within the allowable time period. If the system is equipped with the High Reliability or Critical Reliability Configuration and if the Memory circuit pack is on the standby SPE, this abort code may indicate that the standby SPE is not responding to the handshake message. If this is the case, the standby SPE maintenance software may take up to two minutes to indicate that handshake communication with the standby SPE is down. The ABORT code will then change to 1339 (handshake communication down).</p> <ol style="list-style-type: none"> <li>1. Retry the command at 1-minute intervals, a maximum of 3 times.</li> </ol>
2315	ABORT	<p>The test was not run, because this is an extra Memory circuit pack. No testing is allowed for extra Memory circuit packs.</p>
2334	ABORT	<p>The hardware mailbox on the standby Duplication Interface board is not ready to receive messages.</p> <ol style="list-style-type: none"> <li>1. Retry the command at 1-minute intervals, a maximum of 5 times.</li> </ol>
	FAIL	<p>The Burst Read circuit is not functioning properly.</p> <ol style="list-style-type: none"> <li>1. If the test fails on more than one Memory circuit pack, replace the Processor and retry the test.</li> <li>2. If the test fails only on one Memory circuit pack, replace the affected Memory circuit pack.</li> <li>3. If the test continues to fail only on the same Memory circuit pack, replace the Processor. To replace the circuit packs, use the procedure described in <i>Replacing SPE Circuit Packs</i> in Chapter 5.</li> </ol>
	PASS	<p>The Burst Read portion of the Memory and Processor circuit packs is operating correctly.</p>

## MET-BD (MET Line Circuit Pack)

---

MO Name (in Alarm Log)	Alarm Level	Initial Command to Run <sup>1</sup>	Full Name of MO
MET-BD	MINOR	test board UUCSS sh	MET Line Circuit Pack
MET-BD	WARNING	test board UUCSS sh	MET Line Circuit Pack

- 
1. *UU* is the universal cabinet number (1 for PPN, 2 - 44 for EPNs). *C* is the carrier designation (A, B, C, D, or E). *SS* is the number of the slot in which the circuit pack resides (01 to 21).

Refer to XXX-BD (Common Port Circuit Pack) Maintenance documentation for circuit pack level errors. See also MET-LINE (MET Line) Maintenance documentation for related line information.

## MET-LINE (MET Line)

---

MO Name (in Alarm Log)	Alarm Level	Initial Command to Run <sup>1</sup>	Full Name of MO
MET-LINE	MINOR	test port UUCSSpp l	MET Line
MET-LINE	WARNING	test port UUCSSpp sh	MET Line

1. UU is the universal cabinet number (1 for PPN, 2 - 44 for EPNs). C is the carrier designation (A, B, C, D, or E). SS is the number of the slot in which the circuit pack resides (01 to 21). pp is the two digit port number (01, 02, ...).

The TN735 MET Line circuit pack supports four of these sets as shown below. Each MET set uses three pairs of wires: an analog voice pair, a transmit pair, and a receive pair. Power is sent over the transmit and receive pairs. The MET Line circuit pack supports all 10-, 20-, and 30-button sets.

This section describes MET-LINE (MET Line) maintenance. MET-LINE maintenance is closely related to, and interacts with, MET-BD (MET Line circuit pack) maintenance. This interaction should be kept in mind when troubleshooting MET Line problems.

This section occasionally refers to a station's *service states*. The service states are defined as follows:

Out-of-Service	The port, and thus the station, have been removed from service. A busyout of a port will cause it to be out-of-service.
Ready-for-Service	The port on the circuit pack has been put into service, but the voice terminal has not yet established signaling communications with the port.
In-Service	The voice terminal has established signaling communications with the port, and the system is ready to process calls to and from that station. A terminal in the ready-for-service state will progress to the in-service state if it is functioning normally, but it can also be forced into the in-service state if it goes off-hook.

Use the **status station** command to determine terminal service state. Status is reported as either out-of-service, in-service, or "disconnect," which means the station is in the ready-for-service state.

## Error Log Entries and Test to Clear Values

Table 9-411. MET Line Error Log Entries

Error Type	Aux Data	Associated Test	Alarm Level	On/Off Board	Test to Clear Value
0 <sup>1</sup>	0	Any	Any	Any	test port UUCSSpp sh r 1
1 (a)	40987	None			
18 (b)	0	busyout port UUCSSpp	WARNING	OFF	release port UUCSSpp
130 (c)		None	WARNING	ON	test port UUCSSpp sh
257 (d)	40988	None	MIN/WRN <sup>2</sup>	OFF	
513 (e)	40965	Hybrid Line Station Audits Test (#61)	WARNING	OFF	test port UUCSSpp sh r 4
769		Port Diagnostic Test (#35)	MIN/WRN <sup>2</sup>	ON	test port UUCSSpp l r 3
1025		Hybrid & Conf. Circuits Test (#57)	MIN/WRN <sup>2</sup>	ON	test port UUCSSpp l r 3
1537 (f)	40968	None	MIN/WRN <sup>2</sup>	OFF	
1793		TDM NPE Crosstalk Test (#6)	MIN/WRN <sup>2</sup>	ON	test port UUCSSpp l r 3
2049 (g)	32770				
2049 (h)	40967				
3840 (i)	40989				

1. Run the Short Test Sequence first. If all tests pass, run the Long Test Sequence. Refer to the appropriate test description and follow the recommended procedures.
2. Major or Minor alarms MO may be downgraded to Warning alarms based on the values used in the **set options** command.

### Notes:

- a. The data link between the port and the terminal is not operational, i.e., the port circuitry has detected an off-board problem. Verify that the MET set is connected and that the Electronic Power Feed (EPF) test passes. If data transmission problems are experienced, check for defective wiring or a defective voice terminal, or move terminal electrically closer to the switch (i.e., reduce the length of the wiring between the terminal and the switch). If the problem persists, replace the circuit pack. Once the problem is resolved, the system retires the alarm after a predetermined time delay.



- b. Error type 18 is logged when maintenance personnel busyout the port. maintenance personnel. The port is released from busyout via the **release port UUCSSpp** command.
- c. The circuit pack has been removed or has been insane for more than 11 minutes. To clear the error, reinsert or replace the circuit pack.
- d. The EPF has been turned off due to an overcurrent condition at the voice terminal. Check for defective wiring or a damaged jack, and verify that the voice terminal is an MET set. Once the problem is resolved, the system retires the alarm after a predetermined time delay.
- e. The EPF inquiry audit has returned “epf-no-load” messages. This usually indicates that the voice terminal has been disconnected or that there is a defect in the wiring to the terminal. Check out both possibilities.  
  
When the EPF inquiry audit subsequently receives an “epf-on-ok” or an “epf-off-ok” message, the system will take action to retire the alarm.
- f. The port has reported a problem with the data link to the voice terminal. Ignore this error if there are no complaints about the voice terminal. Otherwise, make sure the voice terminal is connected, check for defective wiring, check for a defective voice terminal, and decrease the length of the wiring between the voice terminal and the switch. If the problem persists, replace the circuit pack.
- g. The voice terminal went off-hook while it was in the ready-for-service state. Use the **status system** command to determine the state of the voice terminal. The off-hook should have moved the station to in-service. No repair action is necessary.
- h. This code is generated when the link between the circuit pack and the voice terminal is successfully reset. No repair action is necessary.
- i. The hardware sent an uplink message indicating that the Electric Power Feed (EPF) is not loaded, that is, it is not currently supplying power to a voice terminal. No repair action is necessary.

## **System Technician-Demanded Tests: Descriptions and Error Codes**

---

Always investigate tests in the order presented in the table below when inspecting errors in the system. By clearing error codes associated with the *Port Diagnostic Test*, for example, you may also clear errors generated from other tests in the testing sequence.

**Table 9-412. System Technician-Demanded Tests: MET-LINE**

Order of Investigation	Short Test Sequence	Long Test Sequence	D/ND <sup>1</sup>
NPE Crosstalk Test (#6)		X	ND
Port Diagnostic Test (#35)		X	ND
MFAT Electronic Power Feed Test (#56)		X	ND
Hybrid Circuit and Conference Circuit Test (#57)		X	ND
Station Lamp Update Test (#60)	X	X	ND
Station Audits Test (#61)	X	X	ND
Ringer Update Test (#62)	X	X	ND

1. D = Destructive, ND = Non-destructive

### NPE Crosstalk Test (#6)

The NPE Crosstalk Test verifies that this port's NPE channel talks on the selected time slot and never crosses over to time slots reserved for other connections. If the NPE is not working correctly, one-way and noisy connections may be observed. This test is part of a port's Long Test Sequence and takes about 20 to 30 seconds to complete.

**Table 9-413. TEST #6 NPE Crosstalk Test**

Error Code	Test Result	Description/ Recommendation
	ABORT	Could not allocate the necessary system resources to run this test. 1. Retry the command at 1-minute intervals a maximum of 5 times.
1000	ABORT	System resources required to run this test are not available. The port may be busy with a valid call. 1. Use the <b>display port UUCSSpp</b> command to determine the station extension of the port. Use <b>status station</b> to determine the service state of the port. If the port is in use, wait until the port is idle before testing. 2. If the port status is idle, then retry the command at 1-minute intervals a maximum of 5 times.

*Continued on next page*

**Table 9-413. TEST #6 NPE Crosstalk Test — Continued**

Error Code	Test Result	Description/ Recommendation
1001	ABORT	System resources required to run this test are not available. This could be due to a failure to seize the port. 1. Retry the command at 1-minute intervals a maximum of 5 times.
1002	ABORT	The system could not allocate time slots for the test. The system may be under heavy traffic conditions or it may have time slots out-of-service due to TDM-BUS errors. 1. If system has no TDM-BUS errors and is not handling heavy traffic, repeat test at 1-minute intervals a maximum of 5 times.
1003	ABORT	The system could not allocate a tone receiver for the test. The system may be oversized for the number of Tone Detectors present or some Tone Detectors may be out-of-service. 1. Resolve any TTR-LEV errors. 2. Resolve any TONE-PT errors. 3. If neither condition exists, retry the test at 1-minute intervals a maximum of 5 times.
1004	ABORT	The port was seized by a valid call during the test. The test has been aborted. 1. Use the <b>display port UUCSSpp</b> command to determine the station extension of the port. Use the <b>status station</b> command to determine the service state of the port. If the port is in use, wait until the port is idle before testing. 2. Retry the command at 1-minute intervals a maximum of 5 times.
1018	ABORT	Test disabled via administration. This only applies to analog stations. The default for this field is 'y,' so you may want to determine why it has been turned off on this station. 1. To enable the test for the particular analog station being tested, enter the <b>change station extension</b> command and change the 'Test' field on the 'Station' form from 'n' to 'y.'
2000	ABORT	Response to the test request was not received within the allowable time period. 1. Retry the command at 1-minute intervals a maximum of 5 times.
2020	ABORT	The test did not run due to an already existing error on the specific port or a more general circuit pack error. 1. Examine Error Log for existing errors against this port or the circuit pack and attempt to diagnose the already existing error.
2100	ABORT	System resources required to run this test are not available. This could be due to a failure to seize the port. 1. Retry the command at 1-minute intervals a maximum of 5 times.

**Table 9-413. TEST #6 NPE Crosstalk Test — Continued**

Error Code	Test Result	Description/ Recommendation
Any	FAIL	<p>This test can fail due to on-board or off-board problems. Off-board problems of concern include EXP-PN and EXP-INTF faults, TDM-BUS faults, and faults associated with the tone detectors/tone generators. Clear all off-board problems before replacing the board. Keep in mind that a TDM-BUS problem is usually the result of a faulty board connected to the backplane or bent pins on the backplane.</p> <ol style="list-style-type: none"> <li>1. Resolve any EXP-PN and/or EXP-INTF errors.</li> <li>2. Resolve any TDM-BUS errors.</li> <li>3. Resolve any TONE-BD and/or TONE-PT errors.</li> <li>4. Test the board when the faults from steps 1, 2, and 3 are cleared. Replace the board only if the test fails.</li> </ol>
	PASS	<p>The port uses its allocated time slots correctly. Investigate user-reported troubles on this port using other port tests and by examining station, trunk, or external wiring.</p>
0	NO BOARD	<p>The test could not relate the internal ID to the port (no board). This could be due to incorrect translations, no board is inserted, an incorrect board is inserted, or an insane board is inserted.</p> <ol style="list-style-type: none"> <li>1. Check to ensure that the board translations are correct. Use the <b>list config</b> command, and resolve any problems that are found.</li> <li>2. If the board was found to be correctly inserted in step 1, issue the <b>busyout board</b> command.</li> <li>3. Issue the <b>reset board</b> command.</li> <li>4. Issue the <b>release busy board</b> command.</li> <li>5. Issue the <b>test board long</b> command. This should re-establish the linkage between the internal ID and the port. If this is not the case, check to ensure that there is a valid board inserted.</li> </ol>

### Port Diagnostic Test (#35)

This test checks a port's battery feed circuitry. The battery feed circuitry is tested for proper battery voltage by testing the switchhook state. In response to the test message, the on-board firmware terminates the line and checks for switch-hook presence. The termination is then removed, and a check is made for no switch-hook presence. The MET set must be on-hook for the test to execute.

**Table 9-414. TEST #35 Port Diagnostic Test**

Error Code	Test Result	Description/ Recommendation
	ABORT	Internal system error. 1. Retry the command at 1-minute intervals a maximum of 5 times.
1000	ABORT	System resources required to run this test are not available. The port may be busy with a valid call. 1. Use the <b>display port UUCSSpp</b> command to determine the station extension of the port. Use the <b>status station</b> command to determine the service state of the port. If the port is in use, wait until the port is idle before testing. 2. If the port status is idle, then retry the command at 1-minute intervals a maximum of 5 times.
1004	ABORT	The port was seized by a valid call during the test. The test has been aborted. 1. Use the <b>display port UUCSSpp</b> command to determine the station extension of the port. Use the <b>status station</b> command to determine the service state of the port. If the port is in use, wait until the port is idle before testing.  <b>⇒ NOTE:</b> The battery feed circuitry is tested for proper battery voltage by testing the switchhook state. In response to the test message, the on-board firmware terminates the line and checks for switch-hook presence. The termination is then removed, and a check is made for no switch-hook presence. The MET set must be on-hook for the test to execute. 2. If the port status is idle, then retry the command at 1-minute intervals a maximum of 5 times.
1018	ABORT	Test disabled via software patch.
2000	ABORT	This port may have been busied out. 1. Look in the Error Log for Error Type 18 (port busied out) for this port. If this error type is present, then release the port via the <b>release station &lt;extension&gt;</b> command and run the test again. 2. Make sure that the terminal is connected. 3. Retry the command at 1-minute intervals a maximum of 5 times.
2100	ABORT	Could not allocate the necessary system resources to run this test. This could be due to a failure to seize the port. 1. Retry the command at 1-minute intervals a maximum of 5 times.

*Continued on next page*

**Table 9-414. TEST #35 Port Diagnostic Test — Continued**

Error Code	Test Result	Description/ Recommendation
	FAIL	Battery Feed Test failed. This port is out-of-service. <ol style="list-style-type: none"> <li>1. Other ports on this circuit pack are not affected. Place user on a different port, if available, until a replacement circuit pack can be obtained.</li> <li>2. Replace circuit pack when available.</li> </ol>
	PASS	Battery Feed Test passed. Current flow is properly detected for this port. <ol style="list-style-type: none"> <li>1. If users are reporting problems, examine connections to the port.</li> </ol>
0	NO BOARD	The test could not relate the internal ID to the port (no board). This could be due to incorrect translations, no board is inserted, an incorrect board is inserted, or an insane board is inserted. <ol style="list-style-type: none"> <li>1. Check to ensure that the board translations are correct. Use the <b>list config</b> command, and resolve any problems that are found.</li> <li>2. If the board was found to be correctly inserted in step 1, issue the <b>busyout board</b> command.</li> <li>3. Issue the <b>reset board</b> command.</li> <li>4. Issue the <b>release busy board</b> command.</li> <li>5. Issue the <b>test board long</b> command. This should re-establish the linkage between the internal ID and the port. If this is not the case, check to ensure that there is a valid board inserted.</li> </ol>

**MFAT Electronic Power Feed (#56)**

The software requests that the EPF be turned on for a given port. The hardware then attempts to turn on that port's station power unit. If no current is drawn, the station is probably not connected. If an overcurrent condition is sensed (too much current is drawn), a short may exist in the loop, or the voice terminal may be defective. The test results in a message indicating that either the EPF was turned on successfully with no problems, or an overcurrent condition exists. This test is repeated after a 5 second delay. If either test is not successful, the test aborts. Although this test will never actually return a fail result (except for the internal system error), an error type 257 entry will be made in the error log when the test has completed if the overcurrent case is detected by the hardware.

**Table 9-415. TEST #56 MFAT Electronic Power Feed Test**

Error Code	Test Result	Description/ Recommendation
	ABORT	The test was aborted due to an internal system error on a software request to the board. <ol style="list-style-type: none"> <li>1. Retry the command at 1-minute intervals a maximum of 5 times.</li> </ol>
1000	ABORT	System resources required to run this test are not available. The port may be busy with a valid call. <ol style="list-style-type: none"> <li>1. Use the <b>display port UUCSSpp</b> command to determine the station extension of the port. Use the <b>status station</b> command to determine the service state of the port. If the port is in use, wait until the port is idle before testing.</li> <li>2. If the port status is idle, then retry the command at 1-minute intervals a maximum of 5 times.</li> </ol>
	FAIL	The test failed with an internal error while it was attempting to turn on the EPF. <ol style="list-style-type: none"> <li>1. Retry the command at 1-minute intervals a maximum of 5 times.</li> </ol>
	PASS	Electronic Power Feed Test passed. The message to turn on the power to the station was successfully sent to the port. <ol style="list-style-type: none"> <li>1. Although this test will never actually return a FAIL result except for the <b>Internal system error</b> described above, it will log an error if the overcurrent case is detected by the hardware. Check the Error Log for any entries with Error Type 257 when the test has completed.</li> <li>2. If Error Type 257 does not appear in the Error Log within 10 seconds after completion of this test, it is safe to assume that the test sensed no problems with the power to the station. You can verify that the station is powered up correctly by executing a self-test on the station, and checking that all the feature buttons are operating.</li> <li>3. The appearance of Error Type 257 in the Error Log indicates a station power problem. Check for a wiring short, a damaged jack, a defective voice terminal, or an incorrect type of terminal.</li> </ol>

Table 9-415. TEST #56 MFAT Electronic Power Feed Test — *Continued*

Error Code	Test Result	Description/ Recommendation
0	NO BOARD	<p>The test could not relate the internal ID to the port (no board). This could be due to incorrect translations, no board is inserted, an incorrect board is inserted, or an insane board is inserted.</p> <ol style="list-style-type: none"><li>1. Check to ensure that the board translations are correct. Use the <b>list config</b> command, and resolve any problems that are found.</li><li>2. If the board was found to be correctly inserted in step 1, issue the <b>busyout board</b> command.</li><li>3. Issue the <b>reset board</b> command.</li><li>4. Issue the <b>release busy board</b> command.</li><li>5. Issue the <b>test board long</b> command. This should re-establish the linkage between the internal ID and the port. If this is not the case, check to ensure that there is a valid board inserted.</li></ol>

### MET Circuit and Conference Circuit Test (#57)

This test checks two different port circuit functions. The Hybrid Circuit test performs an analog reflective looparound measurement on the port's hybrid circuitry. The Conference Circuit test performs a conference test on the port's NPE.

For Hybrid Circuit Test results to be valid, a voice terminal must be connected to the port being tested. The test instructs the on-board microprocessor to put the port in analog reflective looparound mode. The Tone-Clock circuit pack supplies a 1004-Hz tone to the port's listen time slot and a General Purpose Tone Detector (GPTD) measures the level of the reflected signal appearing on port's talk time slot.

The Conference Test is performed only if the Hybrid Circuit Test passes. The Conference Circuit Test verifies that the Network Processing Element (NPE) is able to correctly conference several test tones together. The test is executed in two parts. The first half of the test verifies operation of the NPE's first three conference channels, and the second half verifies the NPE's remaining four conference channels. The test puts the NPE in loop-around mode and instructs it to talk on a specified time slot while listening to a 1004-Hz tone using the Conference Channels. A GPTD then measures the signal and noise levels of the conferenced output and reports whether or not these fall within a specified acceptable range.



**Table 9-416. TEST #57 Hybrid Circuit and Conference Circuit Test**

Error Code	Test Result	Description/ Recommendation
	ABORT	Could not allocate the necessary system resources to run this test. 1. Retry the command at 1-minute intervals a maximum of 5 times.
1000	ABORT	System resources required to run this test are not available. The port may be busy with a valid call.  1. Use the <b>display port UUCSSpp</b> command to determine the station extension of the port. Use the <b>status station</b> command to determine the service state of the port. If the port is in use, wait until the port is idle before retesting.  2. If the port status is idle, then retry the command at 1-minute intervals a maximum of 5 times.
1001	ABORT	System resources required to run this test were not available. This could be due to a failure to seize the port.  1. Retry the command at 1-minute intervals a maximum of 5 times.
1002	ABORT	The system could not allocate time slots for the test. The system may be under heavy traffic conditions or it may have time slots out-of-service due to TDM-BUS errors.  1. If system has no TDM-BUS errors and is not handling heavy traffic, repeat test at 1-minute intervals a maximum of 5 times.
1003	ABORT	The system could not allocate a tone receiver for the test. The system may be oversized for the number of Tone Detectors present or some Tone Detectors may be out-of-service.  1. Resolve any TTR-LEV errors. 2. Resolve any TONE-PT errors. 3. If neither condition exists, retry the test at 1-minute intervals a maximum of 5 times.
1004	ABORT	The port was seized by a valid call during the test. The test has been aborted.  1. Use the <b>display port UUCSSpp</b> command to determine the station extension of the port. Use the <b>status station</b> command to determine the service state of the port. If the port is in use, wait until the port is idle before testing.  2. Retry the command at 1-minute intervals a maximum of 5 times.
2000	ABORT	Response to the test request was not received within the allowable time period.  1. Retry the command at 1-minute intervals a maximum of 5 times.
2012	ABORT	Internal system error.
2103	ABORT	The system could not make the conference connection for the test.  1. Retry the command at 1-minute intervals a maximum of 5 times.

*Continued on next page*

**Table 9-416. TEST #57 Hybrid Circuit and Conference Circuit Test — Continued**

Error Code	Test Result	Description/ Recommendation
7	FAIL	<p>The conference circuit test failed. The conference circuit test is performed only if the hybrid test passes. The conference circuit test verifies that the network processing element (NPE) is able to correctly conference several test tones together. The test is executed in two parts. The first half of the test verifies the operation of the NPE's first three conference channels, while the second half verifies the NPE's remaining four conference channels. The test puts the NPE in loop around mode and instructs it to talk on a specified time slot while listening to a 1004 Hz tone, using the conference channels. A GPTD then measures the signal and noise levels of the conferenced output and reports whether or not these are within an acceptable range. The failure may be due to off-board circumstances, the most common of which is an off-hook occurring during the test. It is possible that the port may still be functional from a user's point of view. Also, check the error logs against the GPTD-BD, the TONE-BD, and the TONE-PT.</p> <ol style="list-style-type: none"> <li>1. This error can be caused by a disconnected terminal. First, ensure that the terminal is connected and the wiring is OK.</li> <li>2. Then, issue the <b>display port</b> and the <b>station status</b> commands to determine if the station is idle. If it is idle, issue the <b>test port</b> command for this port.</li> <li>3. If test continues to fail, issue the <b>busyout port</b> and the <b>release port</b> commands, and then retest the port.</li> </ol>
57	FAIL	<p>Hybrid Circuit Test failed. This can result in noisy or bad connections.</p> <ol style="list-style-type: none"> <li>1. Run circuit pack tests to check the Tone Generator circuit pack and the Tone Detector circuit pack, using <b>test board UUCSS short</b> command.</li> <li>2. Resolve any problems that are detected on the Tone Generator circuit pack or Tone Detector circuit pack.</li> <li>3. If the Tone Generator and Tone Detector circuit packs are functioning properly, and the test still fails, replace the MET Line circuit pack.</li> </ol> <p><b>⇒ NOTE:</b>                      If the Hybrid Circuit and Conference Circuit Test fails for all ports on a circuit pack, a -5 volt power problem is indicated. To investigate problems with a power unit, refer to "CARR-POW".</p>

*Continued on next page*

**Table 9-416. TEST #57 Hybrid Circuit and Conference Circuit Test — Continued**

Error Code	Test Result	Description/ Recommendation
	PASS	Hybrid Circuit and Conference Circuit Test passed. The hybrid circuitry is transmitting properly. <ol style="list-style-type: none"> <li>1. If complaints persist, investigate by using other port tests, and by examining the station, wiring, and connections.</li> </ol>
0	NO BOARD	The test could not relate the internal ID to the port (no board). This could be due to incorrect translations, no board is inserted, an incorrect board is inserted, or an insane board is inserted. <ol style="list-style-type: none"> <li>1. Check to ensure that the board translations are correct. Use the <b>list config</b> command, and resolve any problems that are found.</li> <li>2. If the board was found to be correctly inserted in step 1, issue the <b>busyout board</b> command.</li> <li>3. Issue the <b>reset board</b> command.</li> <li>4. Issue the <b>release busy board</b> command.</li> <li>5. Issue the <b>test board long</b> command. This should re-establish the linkage between the internal ID and the port. If this is not the case, check to ensure that there is a valid board inserted.</li> </ol>

### MET Line Station Lamp Updates Test (#60)

For this test, the software lights the lamps on the terminal based on the status record contained in the processor. The lamp updates run only if the station is in-service.

**Table 9-417. TEST #60 MET Line Station Lamp Updates Test**

Error Code	Test Result	Description/ Recommendation
1	ABORT	This port may have been busied out. <ol style="list-style-type: none"> <li>1. Look in the Error Log for Error Type 18 (port busied out) for this port. If this error type is present, then release the port via the <b>release station &lt;extension&gt;</b> command and run the test again.</li> <li>2. Make sure that the terminal is connected.</li> <li>3. Retry the command at 1-minute intervals a maximum of 5 times.</li> </ol>

*Continued on next page*

**Table 9-417. TEST #60 MET Line Station Lamp Updates Test — Continued**

Error Code	Test Result	Description/ Recommendation
2	ABORT	Internal system error 1. Retry the command at 1-minute intervals a maximum of 5 times.
3	ABORT	Station is in ready-for-service or out-of-service state. This may be due to wiring or an unplugged or defective set. 1. Make sure terminal is connected and the wiring is correct. 2. Retry the command at 1-minute intervals a maximum of 5 times.
1000	ABORT	System resources required to run this test are not available. The port may be busy with a valid call. 1. Use the <b>display port UUCSSpp</b> command to determine the station extension of the port. Use the <b>status station</b> command to determine the service state of the port. If the port is in use, wait until the port is idle before testing. 2. If the port status is idle, then retry the command at 1-minute intervals a maximum of 5 times.
	FAIL	Internal system error. 1. Retry the command at 1-minute intervals a maximum of 5 times.
	PASS	MET Line Station Lamp Updates completed successfully. 1. If complaints persist, investigate by using other circuit pack tests, and by examining the station, wiring, and connections.
0	NO BOARD	The test could not relate the internal ID to the port (no board). This could be due to incorrect translations, no board is inserted, an incorrect board is inserted, or an insane board is inserted. 1. Check to ensure that the board translations are correct. Use the <b>list config</b> command, and resolve any problems that are found. 2. If the board was found to be correctly inserted in step 1, issue the <b>busyout board</b> command. 3. Issue the <b>reset board</b> command. 4. Issue the <b>release busy board</b> command. 5. Issue the <b>test board long</b> command. This should re-establish the linkage between the internal ID and the port. If this is not the case, check to ensure that there is a valid board inserted.

## MET Line Station Audits Test (#61)

This is a series of three tests that are classified as audits. These audits will abort if attempted on an out-of-service station. Although this test will never actually return a fail result (except for the internal system error), it is possible that it will enter error types 257 (over current) or 513 (open circuit) into the error log. To determine if there are any problems that do not show up in the test result, look for these error types in the error log. If these errors appear in the error log or if user complaints still exist, investigate by using other circuit pack tests and by examining the station, the wiring, and the connections. The tests are as follows:

- |                  |   |
|------------------|---|
| Switchhook Audit | This is an update of the SPE records according to the circuit packs' records.   |
| Bad Scan Inquiry | A message is sent uplink that contains a count that is generated due to certain events relating to the link conditions. This is an indication of data transmission problems between the MET Line circuit pack and the voice terminal. |
| EPF Inquiry      | The status of the Electronic Power Feed is sent uplink. Possible conditions are: EPF-on-ok, EPF-off, EPF-no-load, and EPF-on-overcurrent.   |

**Table 9-418. TEST #61 MET Line Station Audits Test**

Error Code	Test Result	Description/ Recommendation
1	ABORT	Internal system error
2	ABORT	The test was aborted due to an internal system error during the switchhook audit.
3	ABORT	The test was aborted due to an internal system error during the bad scan inquiry.
		The test was aborted due to an internal system error during the EPF audit inquiry.
		<ol style="list-style-type: none"> <li>1. Make sure that the station is not in an out-of-service state.</li> <li>2. Retry the command at 1-minute intervals for a maximum of 5 times.</li> </ol>

*Continued on next page*

**Table 9-418. TEST #61 MET Line Station Audits Test — Continued**

Error Code	Test Result	Description/ Recommendation
1000	ABORT	System resources required to run this test are not available. The port may be busy with a valid call. <ol style="list-style-type: none"> <li>1. Use the <b>display port UUCSSpp</b> command to determine the station extension of the port. Use the <b>status station</b> command to determine the service state of the port. If the port is in use, wait until the port is idle before testing.</li> <li>2. If the port status is idle, then retry the command at 1-minute intervals a maximum of 5 times.</li> </ol>
1004	ABORT	The port was seized by a valid call during the test. The test has been aborted. <ol style="list-style-type: none"> <li>1. Use the <b>display port UUCSSpp</b> command to determine the station extension of the port. Use the <b>status station</b> command to determine the service state of the port. If the port is in use, wait until the port is idle before testing.</li> <li>2. Retry the command at 1-minute intervals a maximum of 5 times.</li> </ol>
2000	ABORT	Response to the test request was not received within the allowable time period. <ol style="list-style-type: none"> <li>1. Retry the command at 1-minute intervals a maximum of 5 times.</li> </ol>
	FAIL	The test failed due to an internal system error. <ol style="list-style-type: none"> <li>1. Retry the command at 1-minute intervals a maximum of 5 times.</li> </ol>

*Continued on next page*

**Table 9-418. TEST #61 MET Line Station Audits Test — Continued**

Error Code	Test Result	Description/ Recommendation
	PASS	Hybrid Line Station Audits passed. <ol style="list-style-type: none"> <li>1. Although this test will never actually return a FAIL result except for the <b>Internal system error</b> described above, it is possible that it will enter Error Types 257 or 513 into the Error Log. To determine if there are any problems that don't show up in the test result, look for these error types in the Error Log.</li> <li>2. If these errors appear in the Error Log, or if user complaints persist, investigate by using other circuit pack tests, and by examining the station, wiring, and connections.</li> </ol>
0	NO BOARD	The test could not relate the internal ID to the port (no board). This could be due to incorrect translations, no board is inserted, an incorrect board is inserted, or an insane board is inserted. <ol style="list-style-type: none"> <li>1. Check to ensure that the board translations are correct. Use the <b>list config</b> command, and resolve any problems that are found.</li> <li>2. If the board was found to be correctly inserted in step 1, issue the <b>busyout board</b> command.</li> <li>3. Issue the <b>reset board</b> command.</li> <li>4. Issue the <b>release busy board</b> command.</li> <li>5. Issue the <b>test board long</b> command. This should re-establish the linkage between the internal ID and the port. If this is not the case, check to ensure that there is a valid board inserted.</li> </ol>

**MET Line Ringer Update Test (#62)**

In this update, a “ringer on” or a “ringer off” message is sent to the firmware to start and stop the ringer on the set.

**Table 9-419. TEST #62 MET Line Ringer Update Test**

Error Code	Test Result	Description/ Recommendation
3	ABORT	This port may have been busied out. <ol style="list-style-type: none"> <li>1. Look in the Error Log for Error Type 18 (port busied out) for this port. If present, release the port via <b>release station &lt;extension&gt;</b> and run the test again.</li> <li>2. Make sure that the terminal is connected.</li> <li>3. Retry the command at 1-minute intervals a maximum of 5 times.</li> </ol>
1000	ABORT	System resources required to run this test are not available. The port may be busy with a valid call. <ol style="list-style-type: none"> <li>1. Use <b>display port UUCSSpp</b> to determine the station extension of the port. Use <b>status station</b> to determine the service state of the port. If the port is in use, wait until the port is idle before testing.</li> <li>2. If the port status is idle, retry the command at 1-minute intervals a maximum of 5 times.</li> </ol>
	FAIL	Internal system error <ol style="list-style-type: none"> <li>1. Retry the command at 1-minute intervals a maximum of 5 times.</li> </ol>
	PASS	Hybrid Station Ringer Update passed. <ol style="list-style-type: none"> <li>1. If complaints persist, investigate using other circuit pack tests, and by examining the terminal, wiring, and connections.</li> </ol>
0	NO BOARD	The test could not relate the internal ID to the port. This could be due to incorrect translations, no board is inserted, an incorrect board is inserted, or an insane board is inserted. <ol style="list-style-type: none"> <li>1. Check to ensure that the board translations are correct. Use the <b>list config</b> command, and resolve any problems that are found.</li> <li>2. Issue the <b>busyout board</b> command.</li> <li>3. Issue the <b>reset board</b> command.</li> <li>4. Issue the <b>release busy board</b> command.</li> <li>5. Issue the <b>test board long</b> command. This should re-establish the linkage between the internal ID and the port. If this is not the case, check to ensure that there is a valid board inserted.</li> </ol>



## MIS (Management Information System)

---

MO Name (in Alarm Log)	Alarm Level	Initial Command to Run	Full Name of MO
MIS	WRN	release mis	Management Information System

The Management Information System (MIS)/Call Management System (CMS) maintenance object is used only to monitor MIS busyouts during administration of MIS translations. There are no hardware failures associated with this MO.

The MIS/CMS is an adjunct processor that collects Automatic Call Distribution (ACD) data sent from the switch. In order to change MIS translations, a switch administrator must first enter a **busyout mis** command at the G3-MT. When the MIS is busied out, the switch will stop sending ACD data to the MIS, and a Warning alarm will be raised.

When the switch administrator is finished, a **release mis** command should be entered at the terminal. This will clear the Warning alarm and allow the switch to send ACD data to the MIS.

### Error Log Entries and Test to Clear Values

---

Table 9-420. Management Information System Error Log Entries

Error Type	Aux Data	Associated Test	Alarm Level	On/Off Board	Test to Clear Value
0 <sup>1</sup>	0	Any	Any	Any	release mis
18 <sup>2</sup>	0	busyout mis	WARNING	ON	release mis

1. Run the Short Test Sequence first. If all tests pass, run the Long Test Sequence. Refer to the appropriate test description and follow the recommended procedures.
  2. When the **busyout MIS** command is issued, no data is sent to the MIS/CMS regardless of the link state. To allow data to be sent to MIS/CMS, a **release mis** command must be issued from the terminal.
-

## MMI-BD

---

MO Name (in Alarm Log)	Alarm Level	Initial Command to Run <sup>1</sup>	Full Name of MO
MMI-BD	MAJOR	test board UUCSS l r#	Multimedia Interface Circuit Pack
MMI-BD	MINOR	test board UUCSS l r#	Multimedia Interface Circuit Pack
MMI-BD <sup>2</sup>	WARNING	test board UUCSS s r#	Multimedia Interface Circuit Pack

1. Where UU is the universal cabinet number (1 for PPN and 2-44 for EPN); C is the carrier designation (for example, A, B, C, D, or E); SS is the address of the slot in the carrier where the circuit pack is located (for example, 01, 02, ...); and pp is the two digit port number (01, 02, 03, ...).
2. Refer to XXX-BD (Common Port Board).

Two circuit packs can be used for multimedia connections:

- [“TN787D \(or later\)”](#)
- [“TN2207/Expansion Services Module”](#)

### TN787D (or later)

The Multimedia Interface Circuit Pack (TN787D or later and also called the MMCH circuit pack) provides a number of H.221 protocol terminations for bit streams received from the TDM bus. The Multimedia Interface demultiplexes the H.221 bit stream (audio, video, data, control, and indication signals) and transmits the bit streams onto the TDM bus so that the appropriate circuit packs can process them.

The Multimedia Interface circuit pack is commonly referred to as the MMI pack for H.221 protocol termination. There are 32 ports (also called resources) on the circuit pack. See [“MMI-PT”](#) for maintenance of these resources.

The MMI circuit pack contains 4 digital signal processors that manage the 32 resources.

#### NOTE:

Refer to [“Multimedia Call Handling \(MMCH\)”](#) in [Chapter 5, “Alarms, Errors, and Troubleshooting”](#) for MMCH troubleshooting information.

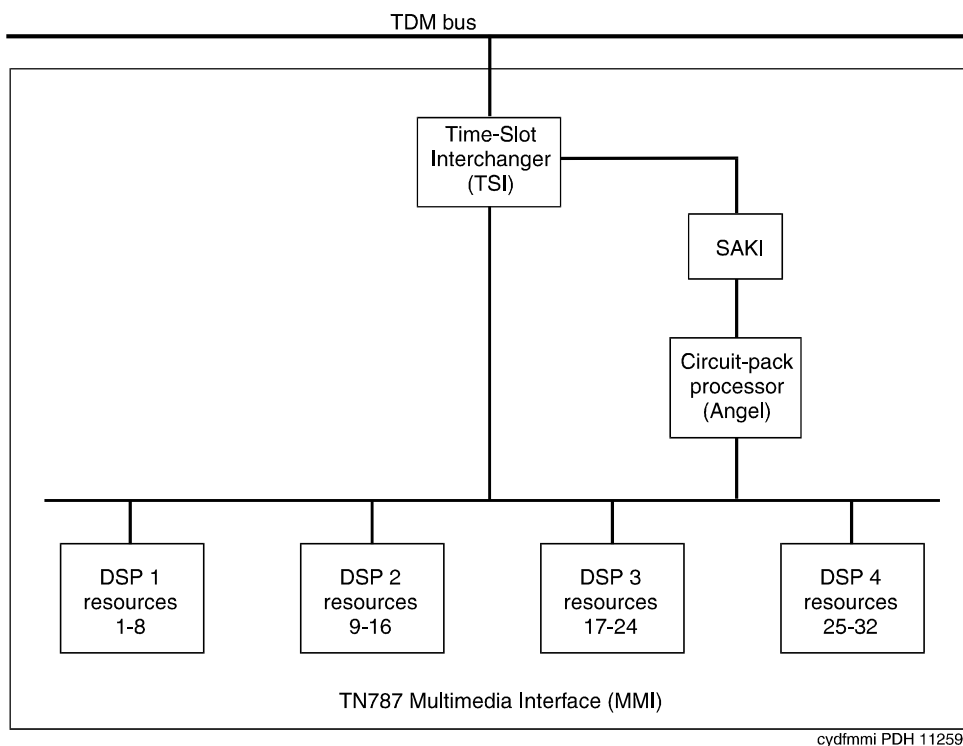
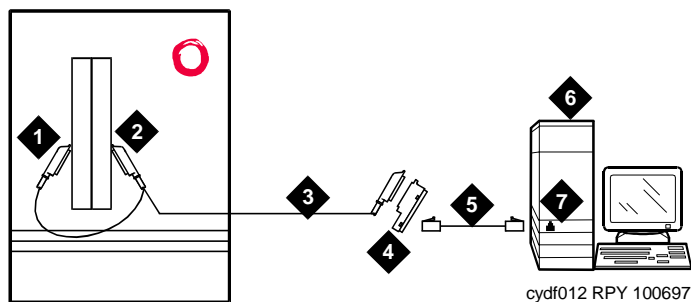

**Figure 9-59. TN787 Multimedia Interface (MMI) Circuit Pack**

### TN2207/Expansion Services Module

The TN2207 circuit pack permits connecting an Expansion Services Module (ESM). See [Figure 9-60](#) for connectivity.

- Provides T.120 data sharing capability on a MMCH multipoint H.320 video conference
- Each conference participant must have endpoints administered and a personal computer with the H.320 video application installed.
- The DEFINITY ECS must have the expansion service module installed.



**Figure 9-60. Typical ESM connections**

**Figure notes**

1. Port B Y-cable connector to a TN787 Multimedia Interface (MMI) circuit pack
2. Port A Y-cable connector to a TN2207 PRI circuit pack
3. 25-pair Y-cable
4. 356A adapter
5. D8W cord connected to 356A adapter port 1
6. Expansion Service Module (ESM)
7. Port B on compatible primary rate interface (PRI) card

**CAUTION:**

*The TN2207 circuit pack is the only pack allowing connection of an ESM to the DEFINITY ECS switch.*

## Error Log Entries and Test to Clear Values

Table 9-421. MMI-BD Error Log Entries

Error Type	Aux Data	Associated Test	Alarm Level	On/Off Board	Test to Clear Value
0 <sup>1</sup>	0	Any	Any	Any	test board UUCSS sh r 1
1 (a)	Any	None	MIN	ON	
18 (b)	0	Busyout board UUCSS	WNG	OFF	release board UUCSS
217 (c)	0	None	WNG	ON	
257 (d)	65535	Control Channel Loop Test (#52)	MIN	ON	test board UUCSS r 3
513 (e)	4352 to 4357	Uplink error from pack			
769 (f)	Any	MMI Synchronization Status Test #1123			
1281 (g)	Any	Circuit Pack Restart Test (#594)	MAJ	ON	
1538 (h)	Any	Software detected error	MIN	ON	
1793 (i)	ANY	TSI XTalk (#6)	MIN	ON	test board UUCSS l r 3
2049 (j)	Any	TSI Loop (#1108)	MAJ	ON	test board UUCSS l r 3

1. Run the short test sequence first. If all tests pass, run the long test sequence. Refer to the appropriate test description and follow the recommended procedures.

### Notes:

- a. The circuit pack stopped functioning or it was physically removed from the system. The alarm logs approximately 11 minutes after the circuit pack has been removed and/or the SAKI Sanity Test (#53) fails.

If the circuit pack is in the system and the red LED is on, follow the instructions for a red alarm in [“Circuit Pack LEDs”](#) in [Chapter 7, “LED Interpretation”](#). Also, see “Handling Common Port Circuit Packs.”

- b. This circuit pack has been busied out using the **busyout board UUCSS** command.
- c. There are more than four MMI circuit packs in the system. Remove the circuit pack that generated the error in the error log by locating the slot indicated by the error.

- d. Indicates transient communication problems between the switch and this circuit pack. Execute the **test board UUCSS** command and refer to the repair procedures for the Control Channel Looparound Test (#52) in the XXX-BD section.
- e. The circuit pack detected an Angel on-board hardware failure. The reported aux data values correspond to the following detected errors:

- 4352 - External RAM error
- 4253 - Internal RAM error
- 4355 - ROM Checksum error
- 4357 - Instruction set error

Reset the circuit pack by using the **busyout board UUCSS**, **reset board UUCSS**, and **release board UUCSS** commands. When reset, the circuit pack executes a set of tests to detect the presence of any of the above faults. The detection of one these errors during initialization causes the circuit pack to lock up and appear insane to the system. See the repair procedures in note b for Error Type 1.

- f. This MMI circuit pack reported a loss of MMI synchronization. Refer to test #1123 for repair procedures.
- g. A failure of the time slot interchanger has been detected. Reset the circuit pack using the **busyout board UUCSS**, **reset board UUCSS**, and **release board UUCSS** commands. If the reset passes, then the on-board circuitry is healthy. Retire the alarm using the **test board UUCSS long clear** command followed by **release board UUCSS**.
- h. The circuit pack is hyperactive; that is, it is flooding the switch with messages sent over the control channel. The circuit pack is taken out of service when a threshold number of these errors is reported to the switch. Clear the alarm using the following commands: **busyout board UUCSS**, **reset board UUCSS**, **test board UUCSS long clear**, **release board UUCSS**. If the error recurs within 10 minutes, replace the circuit pack.
- i. The TSI Cross Talk Test (#6) failed. See the description of this test and follow the repair procedures.
- j. The TSI Looparound Test (#1108) failed. See the description of this test and follow the repair procedures.

### **System Technician-Demanded Tests: Descriptions and Error Code**

---

Always investigate tests in the order presented in [Table 9-422](#) below when inspecting errors in the system. By clearing error codes associated with the TSI Crosstalk Test (#6), for example, you may also clear errors generated from other tests in the testing sequence.

**Table 9-422. System Technician-Demanded Tests: MMI-BD**

Order of Investigation	Short Test Sequence	Long Test Sequence	Reset Board Sequence	D/ND <sup>1</sup>
TSI Crosstalk (#6)		X		ND
TSI Looparound Test (#1108)		X		ND
MMI SYNC Status Test (#1123)	X			ND
MMI SYNC Status Test (#1122)		X		ND
Control Channel Looparound Test (#52) <sup>2</sup>	X	X		ND
SAKI Sanity Test (#53) <sup>2</sup>			X	D

1. D = Destructive, ND = Non-destructive
2. Refer to the repair procedure described in XXX-BD (Common Port Circuit Pack) for a description of this test.

### TSI Crosstalk Test (#6)

This test is non-destructive.

The Time Slot Interchanger (TSI) chip controls connectivity to the TDM bus. The TSI Cross Talk Test verifies that this TSI talks on the selected TDM bus time slot and never crosses over to time slots reserved for other connections. If the TSI is not working correctly, one-way and noisy connections may occur. If the test passes, then the TSI is able to communicate over the TDM bus. This test is part of the circuit pack's demand and scheduled long test sequence, and takes approximately 20 to 30 seconds to complete.

**Table 9-423. TEST #6 TSI Crosstalk Test**

Error Code	Test Result	Description/Recommendation
	ABORT	Internal system error. This is an abnormal abort. 1. Retry the command at 1-minute intervals a maximum of 5 times.
1002	ABORT	The system could not allocate time slots for the test, the traffic load on the system is very high, or the time slots are out-of-service due to TDM-BUS errors. 1. If the system has no TDM-BUS errors and is not handling heavy traffic, repeat the test at 1-minute intervals a maximum of 5 times.

*Continued on next page*

**Table 9-423. TEST #6 TSI Crosstalk Test — Continued**

Error Code	Test Result	Description/Recommendation
1003	ABORT	The system could not allocate a tone detector for the test. The system is oversized for the number of tone detectors present, or some tone detectors are out-of-service. <ol style="list-style-type: none"> <li>1. Resolve any TTR-LEV errors.</li> <li>2. Resolve any TONE-PT errors.</li> <li>3. If neither condition exists, retry the test at 1-minute intervals a maximum of 5 times.</li> </ol>
2000	ABORT	Response to the test was not received from the MMI-BD circuit pack within the allowable time period. <ol style="list-style-type: none"> <li>1. If this result occurs repeatedly, attempt to reset the circuit pack if the other ports are not in use. Reset the circuit pack by issuing the <b>busyout board PCSS</b>, <b>reset board UUCSS</b>, followed by the <b>release board UUCSS</b> commands.</li> <li>2. If this result occurs again, replace the circuit pack.</li> </ol>
2012	ABORT	Internal system error. This is an abnormal abort.
2100	ABORT	Could not allocate the necessary resources to run this test. This is an abnormal abort. <ol style="list-style-type: none"> <li>1. Retry the command at 1-minute intervals a maximum of 5 times.</li> </ol>
	FAIL	The TSI was found to be transmitting in error. This causes noisy and unreliable connections. <ol style="list-style-type: none"> <li>1. Replace the circuit pack.</li> </ol>
	PASS	The TSI is correctly using its allocated time slots.

### TSI Looparound Test (#1108)

This test is non-destructive.

During this test, the MMI's Time Slot Interchanger (TSI) listens to a TDM timeslot. A digital count tone loops back in the TSI and onto another TDM timeslot without passing through any resource hardware. A tone detector port verifies the looped data. If the digital count is correct, then the test passes. The test is done for both TDM buses. Failures indicate that the TSI is unreliable.



**Table 9-424. TEST #1108 TSI Looparound Test**

Error Code	Test Result	Description/Recommendation
	ABORT	Internal system error. This is an abnormal abort. 1. Retry the command at 1-minute intervals a maximum of 5 times.
1002	ABORT	The system could not allocate time slots for the test. Either the traffic load on the system is very high or time slots is out-of-service due to TDM-BUS errors. 1. If the system has no TDM-BUS errors and is not handling heavy traffic, repeat the test at 1-minute intervals a maximum of 5 times.
1003	ABORT	The system could not allocate a tone detector for the test. The system may be oversized for the number of Tone Detectors present, or some Tone Detectors may be out-of-service. 1. Resolve any TTR-LEV errors. 2. Resolve any TONE-PT errors. 3. If neither condition exists, retry the test at 1-minute intervals a maximum of 5 times.
2000	ABORT	Response to the test was not received from the Tone Detector circuit pack within the allowable time period. 1. If this result occurs repeatedly, attempt to reset the circuit pack (if the other ports are not in use). Reset the circuit pack by issuing the <b>busyout board UUCSSpp</b> and the <b>reset board UUCSSpp</b> commands followed by the <b>release board UUCSSpp</b> command. 2. If this result occurs again, replace the circuit pack.
2012	ABORT	Internal system error. This is an abnormal abort.
2100	ABORT	Could not allocate the necessary resources to run this test. This is an abnormal abort. 1. Retry the command at 1-minute intervals a maximum of 5 times.
	FAIL	The TSI was found to be transmitting in error, causing noisy and unreliable connections. 1. Replace the circuit pack.
	PASS	The TSI is correctly using its allocated time slots.

### MMI Synchronization Status Test (#1122 and 1123)

This test is non-destructive.

To support applications involving multiple MMI circuit packs, the appropriate MMI circuit packs must be synchronized with one another. One such circuit pack

is designated as the master sync source, which provides the synchronization signal onto the TDM bus. The other MMI circuit packs in the system listen to this signal.

This test monitors this synchronization state. The test fails if the MMI circuit pack is not in sync. The test passes with auxiliary code 1100 if the MMI circuit pack is in sync and is providing the synchronization signal for the system. The test also passes with an auxiliary code of 1101 if the MMI circuit pack is in sync and listening to the sync signal. MMI circuit packs do not lose the synchronization signal unless an MMI circuit pack is either pulled out of the system or reset by using a technician command.

Test #1122 runs when the **long** option of the **test board** command is entered, initiating the recovery of synchronization. Test #1123 runs when the **short** option of the **test board** command is entered, giving the status of the synchronization. You need not necessarily run the **long** option since synchronization signal recovery should be taking place within software running in the background. Use the **long** option only if synchronization is not established within 5 minutes of investigating the problem.

**Table 9-425. TEST #1122/1123 MMI Synchronization Status Test**

Error Code	Test Result	Description/Recommendation
	ABORT	Internal system error. This is an abnormal abort. 1. Retry the command at 1-minute intervals a maximum of 5 times.
2000	ABORT	A response to the test was not received from the MMI circuit pack within the allowable time period. 1. If this result occurs repeatedly and the MMI circuit pack is idle, reset the circuit pack using <b>busyout board UUCSS</b> , then <b>reset board UUCSS</b> , followed by <b>release board UUCSS</b> . 2. Rerun the test; if the same result occurs again, replace the MMI circuit pack.
2012	ABORT	Internal system error
2100	ABORT	Could not allocate the necessary resources to run this test. This is an abnormal abort. 1. Retry the command at 1-minute intervals a maximum of 5 times.
	FAIL	The MMI circuit pack is out of MMI synchronization. Run the <b>long</b> option of the <b>test board</b> command. 1. Wait up to 5 minutes, and then reset the circuit pack with these commands: <b>busyout board UUCSS</b> , then <b>reset board UUCSS</b> , followed by <b>release board UUCSS</b> . 2. Rerun the test; if the same result occurs again, replace the circuit pack.

**Table 9-425. TEST #1122/1123 MMI Synchronization Status Test — Continued**

Error Code	Test Result	Description/Recommendation
1100	PASS	The MMI circuit pack is providing the synchronization correctly. This MMI circuit pack is designated as the Master Sync source.
1101	PASS	The MMI circuit pack is listening to the synchronization signal correctly.

### **Control Channel Looparound Test (#52)**

Refer to the repair procedure described in the XXX-BD (Common Port Circuit Pack) maintenance documentation as Control Channel Looparound Test (#52).

### **SAKI Sanity Test (#53)**

Refer to the repair procedure described in the XXX-BD (Common Port Circuit Pack) maintenance documentation as SAKI Sanity Test (#53).

## MMI-LEV (Multimedia Interface Resource Level)

---

MO Name (in Alarm Log)	Alarm Level	Initial Command to Run	Full Name of MO
MMI-LEV	MAJOR	See <a href="#">"Resolving MMI-LEV Errors/Alarms"</a> (below)	MMI-LEV

The Multimedia Interface Resource Level MO monitors MMI efficiency by tracking the number of MMI ports that are in-service, and then comparing that number with the value entered in the `MMIS` field on the System-Parameters Maintenance form. This `MMIS` field is located under the Minimum Maintenance Threshold section. The `MMIS` field contains the minimum number of MMI ports needed for the Multimedia Call Handling (MMCH) feature to run efficiently and is an administrable field. This field must contain a minimum threshold number for MMI port capacity of between 0-128. The MMCH feature must be enabled on the System-Parameters Customer-Options form before the `MMIS` field can be changed to a number greater than zero. The algorithm for determining that a low level of MMI resources exists uses the value entered in the `MMIS` field, and the number of MMI ports that are in-service in the system.

Each MMI circuit pack contains a maximum of 32 ports. If the number of in-service MMI ports falls below the minimum port capacity (value entered on the System Parameters Maintenance form under the Minimum Maintenance Threshold section and in the `MMI` field), a MMI-LEV error is logged. If this outage continues for 15 minutes, a MAJOR alarm is raised.

### Resolving MMI-LEV Errors/Alarms

---

MMI ports are a key part of the MMCH feature, and any loss in the number of ports available for use degrades the MMCH customer-defined service level.

If a MMI circuit pack or port is busied out using the **busyout board** or **busyout port** commands, these out-of-service ports are not included in the MMI level calculation, thus allowing a technician to busy out a MMI circuit pack for maintenance reasons without causing a MAJOR alarm to be raised. However, if all of the ports on the MMI circuit pack are not made busy and the circuit pack is removed, an alarm is raised.

#### NOTE:

When diagnosing a MMI-LEV problem, begin by resolving any alarms raised against MMI-BD or MMI-PT maintenance objects. Clearing MMI-BD or MMI-PT alarms may clear the MMI-LEV alarm.

The MMI circuit pack is maintained by the software like the Tone Detector circuit pack, which can be removed and reinserted in any port board slot without

administration. Similarly, if a MMI circuit pack is removed from service logically by failing the Archangel sanity scan test or is removed from service physically by removing the circuit pack from the carrier, no error/alarm is raised against either the MMI-BD or the MMI-PT maintenance objects. Therefore, if a MMI-LEV error/alarm exists, yet no alarms have been raised against MMI-BD or MMI-PT maintenance objects, a MMI circuit pack may have been removed from service causing the MMI-LEV error/alarm. To resolve a MMI-LEV MAJOR alarm, restore the number of MMI ports available for service to be equal to or greater than the calculated port capacity.

To determine how many MMI circuit packs are needed for the MMCH feature:

1. Using the **display system-parameters maintenance** command, locate the number listed in the Minimum Maintenance Thresholds (MMIS) field and record this number.
2. Use the **list configuration** command to verify the number of MMI ports.
3. Compare this number with the value listed in the MMIS field on the System-Parameters Maintenance form (number listed in step 1 a minimum thresholds number for MMI ports of between 0-128). Each MMI circuit pack contains a maximum of 32 ports. If this number in the MMIS field is less than or equal to 32, one MMI circuit pack is needed. If this number is 64, then two MMI circuit pack are needed.
4. Use the **list configuration** command to verify that the number of MMI circuit packs listed agrees with the required minimum port capacity (from step 1). If the number of MMI circuit packs listed in the step 2 differs from the calculated number, restore the number of MMI circuit packs to the correct value, in order to resolve the MMI-LEV alarm.

## Error Log Entries and Test to Clear Values

Table 9-426. MMI-LEV Error Log Entries

Error Type	Aux Data	Associated Test	Alarm Level	On/ Off Board	Test to Clear Value
1 <sup>1</sup>	Any	None	MAJOR	OFF	

1. The number of MMI resources in the system that are in service has fallen below the calculated minimum value. If the number of in-service MMI ports falls below the MMCH port capacity (value entered in the Minimum Maintenance Thresholds for MMIs field) on the System-Parameters Maintenance form, a MMI-LEV error is logged. If this outage continues for 15 minutes, a MAJOR alarm is raised.

To resolve this alarm, correct the out-of-service problem by following these procedures:

1. See "MMI-PT" and "MMI-BD" and resolve any associated alarms.

9 Maintenance Object Repair Procedures  
*MMI-LEV (Multimedia Interface Resource Level)*

9-1070

2. If a MMI-LEV error/alarm exist and none has been raised against MMI-BD or MMI-PT maintenance objects, an MMI circuit pack may have been removed from service causing the MMI-LEV error/alarm. To resolve a MMI-LEV MAJOR alarm, restore the number of MMI ports available for service to be equal to or more than the calculated port capacity. See the ["Resolving MMI-LEV Errors/Alarms"](#) section above for details.
3. If the error continues to alarm, escalate the problem.

**System Technician-Demanded Tests:  
Descriptions and Error Code**

---

There are no System Technician-Demanded tests for MMI-LEV.

## MMI-PT

---

MO Name (in Alarm Log)	Alarm Level	Initial Command to Run <sup>1</sup>	Full Name of MO
MMI-PT	MAJOR	test port UUCSSpp l r#	Multimedia Interface Port
MMI-PT	MINOR	test port UUCSSpp l r#	Multimedia Interface Port
MMI-PT	WARNING	test port UUCSSpp l r#	Multimedia Interface Port

1. Where UU is the universal cabinet number (1 for PPN and 2-44 for EPN); C is the carrier designation (for example, A, B, C, D, or E); SS is the address of the slot in the carrier where the circuit pack is located (for example, 01, 02, ...); and pp is the two digit port number (01, 02, 03, ...).

**NOTE:**

Refer to [Chapter 5, "Alarms, Errors, and Troubleshooting"](#) for MMCH troubleshooting information.

The Multimedia Interface Circuit Pack provides a number of H.221 protocol terminations for bit streams received from the TDM bus. The Multimedia Interface demultiplexes the H.221 bit stream (audio, video, data, control, and indication signals) and transmits the bit streams onto the TDM bus to be processed by the appropriate circuit packs.

Each Multimedia Interface Circuit Pack contains 32 separately maintained "ports," more commonly referred to as "resources." MMI-PT represents one of these 32 resources. At system boot or when the circuit pack is inserted, 32 resources are inserted into the system.

The MMI circuit pack contains 4 Digital Signal Processors (DSPs) which manage the 32 resources. These resources are directly mapped to DSPs:

Resource	Direct Map
1-8	DSP1
9-16	DSP2
17-24	DSP3
25-32	DSP4

All 8 resources that the circuit pack controls may be placed out of service by the failure of one of these DSPs.

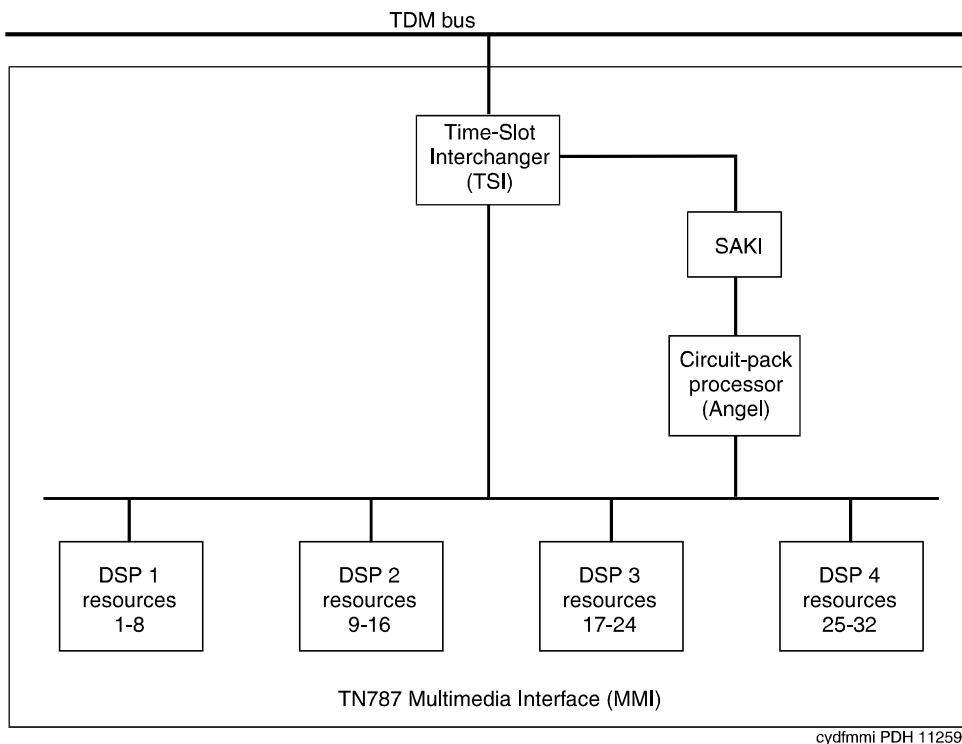

**Figure 9-61. TN787 MULTIMEDIA INTERFACE (MMI) CIRCUIT PACK**



## Error Log Entries and Test to Clear Values

Table 9-427. MMI-PT Error Log Entries

Error Type	Aux Data	Associated Test	Alarm Level	On/ Off Board	Test to Clear Value
0 <sup>1</sup>	0	Any	Any	Any	test port UUCSSpp sh r 1
1 (a)	Any	Uplink error from pack			
18 (b)	0	Busyout port PCSSpp	WNG	OFF	release port UUCSSpp
130 (c)	Any	Software generated	WNG	ON	
257 (d)	Any	None	MAJ/ MIN	ON	
513 (e)	Any	Resource Loopback Test (#1111)	MIN	ON	test port UUCSSpp sh r 3
1025 (f)	Any	Uplink error from pack			
3841 - 3844 (g)	Any	Uplink error from pack			

1. Run the short test sequence first. If all tests pass, run the Long Test Sequence. Refer to the appropriate test description and follow the recommended procedures.

### Notes:

- a. The customer endpoint connected on a conference sent too many messages to the VSP-MCU in a specified amount of time. Check the "status conference" forms to correlate which customer had the problem. This is a customer endpoint problem and not a VSP-MCU problem.
- b. This port has been busied out by the **busyout port UUCSSpp** command.
- c. Indicates that the circuit pack has been removed or has been insane for more than 11 minutes. To clear the error, replace or reseat the circuit pack.
- d. This error occurs if the MMI circuit pack detects a DSP Error. Maintenance software will reset the DSP when this error is received. This error is logged for all 8 resources connected to this particular DSP. If this DSP continues to fail sanity, a Minor alarm is raised. Replace the circuit pack.
- e. This error occurs when the Resource Looparound Test (#1111) fails. Run the Long Test Sequence and note the results of Test #1111.
- f. This error occurs if either the MMI or Voice Conditioner (VC) circuit packs reports a loss of framing on the service channel between these two circuit packs. When a customer endpoint establishes a call to the VSP-MCU, a channel is established between the MMI resource and the VC port. If this channel is detected to go down by either circuit pack, an uplink message is sent. This error is then forwarded to maintenance for both circuit packs. Run the Long Test Sequence for this MMI resource, and if any of the tests

fail, follow the repair procedures for that test. If all tests pass, the cause of the problem might be with the VC pack. See the "VC-DSPPT" repair procedures.

- g. These errors are not related to VSP-MCU. They could be caused by network problems or from the customer endpoints. They are presented here for logging purposes only.

Code	Description
3841	CRC4 Error (Frame checksum error)
3842	Correctable BAS (Control msg single or double bit error, but correctable)
3843	Uncorrectable BAS (Control msg bit error -three or more bit, uncorrectable)
3844	Protocol Error (H.221 Protocol error from endpoint detected)

**System Technician-Demanded Tests:  
 Descriptions and Error Codes**

---

Order of Investigation	Short Test Sequence	Long Test Sequence	D/ND <sup>1</sup>
Resource Looparound Test (#1111)	X	X	D

---

1. D = Destructive; ND = Nondestructive

**Resource Looparound Test (#1111)**

**This test is destructive.**

This test checks the connectivity of the resource within MMI circuit pack and out to the TDM bus. The object is to test the circuitry that an H.221 bit stream comes in contact with when that stream is demultiplexed, pre-processed, written to the TDM bus and then reread (looped in the TSI), post-processed, multiplexed, and then written back to the TDM bus for verification. The video, audio, and data components of the bit stream are tested separately. If any one of these tests fails, then the resource is taken out of service.

**Table 9-428. TEST #1111 Resource Looparound Test**

Error Code	Test Result	Description/Recommendation
1000	ABORT	System resources required to run this test are not available. The port may be busy with a valid call. <ol style="list-style-type: none"> <li>1. Retry the command at 1-minute intervals a maximum of five times.</li> <li>2. Use the <b>status conference</b> command to determine if there is an active conference. If a call is active, the test cannot be run until the conference call terminates.</li> </ol>
1002	ABORT	The system could not allocate time slots for the test. The traffic load on the system may be very high or time slots may be out-of-service due to TDM-Bus errors. <ol style="list-style-type: none"> <li>1. If the system has no TDM-BUS errors and is not handling heavy traffic, repeat the test at 1-minute intervals a maximum of five times.</li> </ol>
1003	ABORT	The system could not allocate a tone detector for the test. The system is oversized for the number of tone detectors present or some tone detectors are out-of-service. <ol style="list-style-type: none"> <li>1. Resolve any TTR-LEV errors.</li> <li>2. Resolve any TONE-PT errors.</li> <li>3. If neither condition exists, retry the test at 1-minute intervals a maximum of five times.</li> </ol>
1004	ABORT	The resource has been seized by a user for a valid call. Use the <b>status conference</b> command to verify that there is a conference call active. <ol style="list-style-type: none"> <li>1. If there are no conference calls, retry the command at 1-minute intervals a maximum of five times.</li> </ol>
2000	ABORT	Response to the test was not received from the Tone Detector circuit pack within the allowable time period. <ol style="list-style-type: none"> <li>1. If this result occurs repeatedly, reset the circuit pack, if the other ports are not in use. Reset the circuit pack by issuing the <b>busyout board UUCSSpp</b> and the <b>reset board UUCSSpp</b> commands, followed by the <b>release board UUCSS</b> command.</li> <li>2. If this result occurs again, replace the circuit pack.</li> </ol>
2012	ABORT	Internal system error
2100	ABORT	Could not allocate the necessary resources to run this test. Abnormal abort. <ol style="list-style-type: none"> <li>1. Retry the command at 1-minute intervals a maximum of 5 times.</li> </ol>

*Continued on next page*

**Table 9-428. TEST #1111 Resource Looparound Test — Continued**

Error Code	Test Result	Description/Recommendation
0, 1, 2	FAIL	This resource cannot guarantee data integrity and is out-of-service. The following error codes indicate failure of a particular media loop:  0 = video 1 = audio 2 = low-speed data  1. Replace the circuit pack
	PASS	The resource is functioning normally.

## MMI-SYNC

---

MO Name (in Alarm Log)	Alarm Level	Initial Command to Run <sup>1</sup>	Full Name of MO
MMI-SYNC	MINOR	test board UUCSS l r#	Multimedia Interface Circuit Pack

1. Where UU is the universal cabinet number (1 for PPN and 2-44 for EPN); C is the carrier designation (for example, A, B, C, D, or E); SS is the address of the slot in the carrier where the circuit pack is located (for example, 01, 02, ...); and pp is the two digit port number (01, 02, 03, ...).

**NOTE:**

Refer to [Chapter 5, "Alarms, Errors, and Troubleshooting"](#) for MMCH troubleshooting information.

Each Port Network (PN) must have a TN787D or later MMI circuit pack assigned as the Multimedia Interface (MMI) master synchronization source for that PN. If one or more MMI circuit pack is administered in a PN, one MMI circuit pack is designated as the master synchronization source for all MMI circuit packs within that PN.

The MMI circuit pack generates a synchronization signal and puts that signal on the TDM bus. Other MMI packs or any other circuit pack within a PN can listen to this signal and "synchronize up" to it. The first MMI circuit pack inserted in a PN is normally designated as the master. As subsequent MMI packs are inserted, they are instructed to listen and synchronize to the time-slot of the master MMI. In the unlikely case of an MMI losing this reference, an uplink message is sent from the MMI circuit pack that lost the signal to maintenance, which also clears the "event" counter on this MMI with a downlink message. This forces the MMI circuit pack to return the current state of the synchronization signal. If the signal is still lost, then the recovery algorithm is entered. Note that during this time, the MMI circuit pack synchronizes to its internal clock, and there should be no service disruption. A loss of synchronization is usually the result of a circuit pack failure. The maintenance strategy is to switch the master source away from the bad pack to another healthy MMI circuit pack within the PN.

A synchronization switch takes place if half or more of the MMI circuit packs in a PN report a loss of synchronization. For example, a PN with two MMIs reporting a loss of sync source switches immediately, three and four MMIs switch if two report the loss, and so forth. A healthy MMI circuit pack becomes the master synchronization source providing the signal on a new timeslot. The other MMI circuit packs within the PN are instructed to listen to this new signal, and the old master stops providing the signal and now listens to the new master MMI. If an MMI is physically removed from the system, then the remaining MMIs report the loss of synchronization. The first MMI with no alarms present becomes the new master of that PN. Once a synchronization switch has occurred, another switch is not allowed for 15 minutes to avoid hyperactive switching. If all the MMIs have alarms, then no switch is made.

If the MMI circuit pack that provides synchronization is craft busied out, it will not affect the PN synchronization. The signal is still provided by the busied-out pack. There is no affect on synchronization if the technician issues a release of the busied-out MMI. Synchronization is not affected by a warm start of the system (reset system 1). For all other restarts (reboot through cold 2), MMI synchronization recovers during board insertion.

## Error Log Entries and Test to Clear Values

Table 9-429. MMI-SYNC Error Log Entries

Error Type	Aux Data	Associated Test	Alarm Level	On/Off Board	Test to Clear Value
1	Any	None			See note <sup>1</sup>
257	Any	None	MINOR	OFF	See note <sup>2</sup>

1. An MMI synchronization switch was successful. Refer to MMI-BD errors for the reason for the switch.
2. The requested MMI synchronization switch failed. Resolve all MMI-BD alarms.

## System Technician-Demanded Tests: Descriptions and Error Codes

There are no system technician-demanded tests for MMI-SYNC.

## MODEM-BD (Modem Pool Circuit Pack)

MO Name (in Alarm Log)	Alarm Level	Initial Command to Run <sup>1</sup>	Full Name of MO
MODEM-BD	MIN	test board UUCSS sh	Modem Pool Circuit Pack
MODEM-BD	WRN	test board UUCSS sh	Modem Pool Circuit Pack

1. *UU* is the universal cabinet number (1 for PPN, 2 - 44 for EPNs). *C* is the carrier designation (A, B, C, D, or E). *SS* is the number of the slot in which the circuit pack resides (01 to 21).

Refer to XXX-BD (Common Port Circuit Pack) for circuit pack level errors. See also MODEM-PT (Modem Pool Port) for related port information.

## MODEM-PT (Modem Pool Port)

---

MO Name (in Alarm Log)	Alarm Level	Initial Command to Run <sup>1</sup>	Full Name of MO
MODEM-PT	MINOR	test port UUCSSpp s	Modem Pool Port

1. *UU* is the universal cabinet number (1 for PPN, 2 - 44 for EPNs). *C* is the carrier designation (A, B, C, D, or E). *SS* is the number of the slot in which the circuit pack resides (01 to 21). *pp* is the two digit port number (01, 02, ...).

The Modem Pool Port provides an interface for digital and analog data communication devices or ports connected to the PBX. It may be thought of as a PBX data communications “conversion resource” because it converts analog modem signals typically used in the telephone network into digital signals that are compatible with the internal PBX network and vice versa.

There may be a number of these conversion resources available in the PBX, each assigned to an available Modem Pool Group. Only one conversion resource is used per data connection. The PBX software usually adds the conversion resource into a data connection if it determines that it is necessary for the call. Typical connections that include Modem Pool conversion resources include data calls from Analog Line or Central Office Trunk ports to any digital port or Digital Line or Trunk ports to any analog port. An example of a Data Module to Central Office Trunk connection using a Modem Pool conversion resource is shown in [Figure 9-62](#). In the case where a local data call originates from an analog port normally used for voice service only and terminates on a digital port, a Data Origination access code must be dialed before the extension number for the Modem Pool conversion resource to be included in the connection.

Each Modem Pool conversion resource contains two ports. One of these, an analog port, is connected (via the PBX network) to the analog line or trunk port that is the source of the modem signal. The second port is referred to as the digital port and is connected (again through the PBX network) to the digital line or trunk port associated with the Data Module in the connection. The analog modem signals enter the analog port of the conversion resource in standard Pulse Code Modulation (PCM) format, but are converted into Data Communications Protocol (DCP) format before going to the digital line or trunk in the connection.

## Integrated Modem Pools

---

There are two primary types of Modem Pool conversion resources available: an Integrated Pooled Modem and a Combined Modem Pool. The integrated TN758 Pooled Modem circuit pack contains two independent 300 or 1200 baud conversion resources. Each conversion resource contains two interfaces to the PBX digital network: an analog port and a digital port. The analog port is

connected through the PBX network to the analog line or trunk port containing the analog modem signals. The digital port connects through the PBX network to the digital line or trunk port in the call. The figure below shows a typical end-to-end connection using a conversion resource on the integrated Pooled Modem circuit pack.

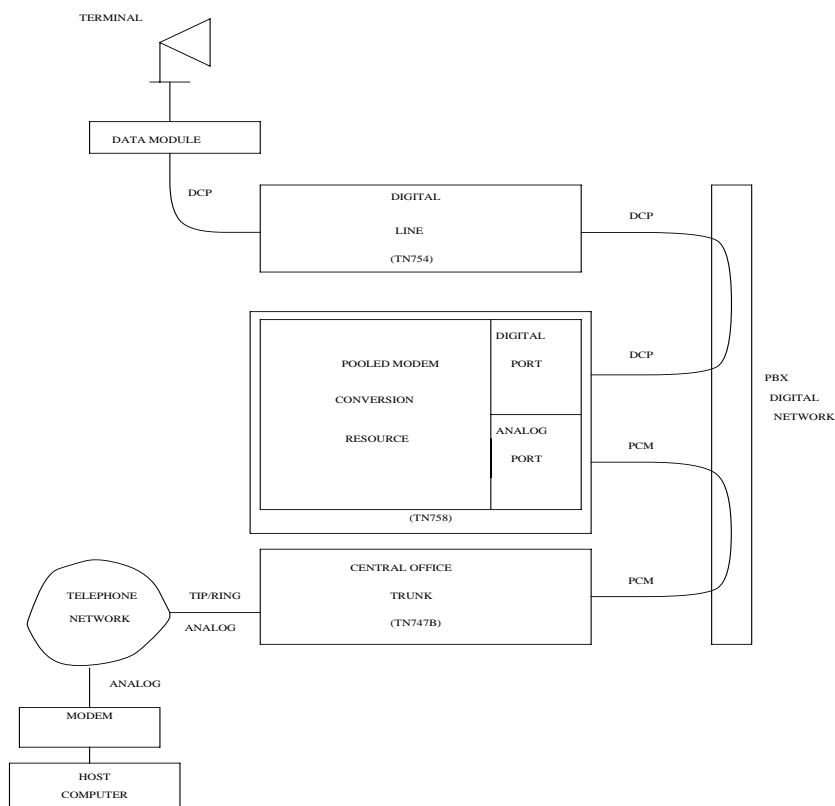

Figure 9-62. Typical Modem Pool Switched Connection with Integrated Pooled Modem



## **Combined Modem Pools**

---

The Combined Modem Pool conversion resource is the second type available. The function served by the Combined Modem Pool is similar to that of the integrated Pooled Modem circuit pack, but the physical implementation is much different. It has the advantage of supporting any speed the external modem can support. The integrated Pooled Modem circuit pack can only support 300 or 1200 baud transmission rates. The Combined Modem Pool conversion resource consists of a port on an Analog Line circuit pack, an external modem, a Data Module, and a port on a TN754 Digital Line circuit pack. The tip and ring interface of the Analog Line is connected to the modem, the RS-232C interface of the modem connects to the Data Module, and the DCP interface on the Data Module is connected to the Digital Line port.

The analog modem signals pass through the Analog Line port to the modem. The modem converts these to RS-232C signals which are passed on to the Data Module. The Data Module further converts the signals to the DCP protocol for the Digital Line port which passes the signals on to the PBX network.

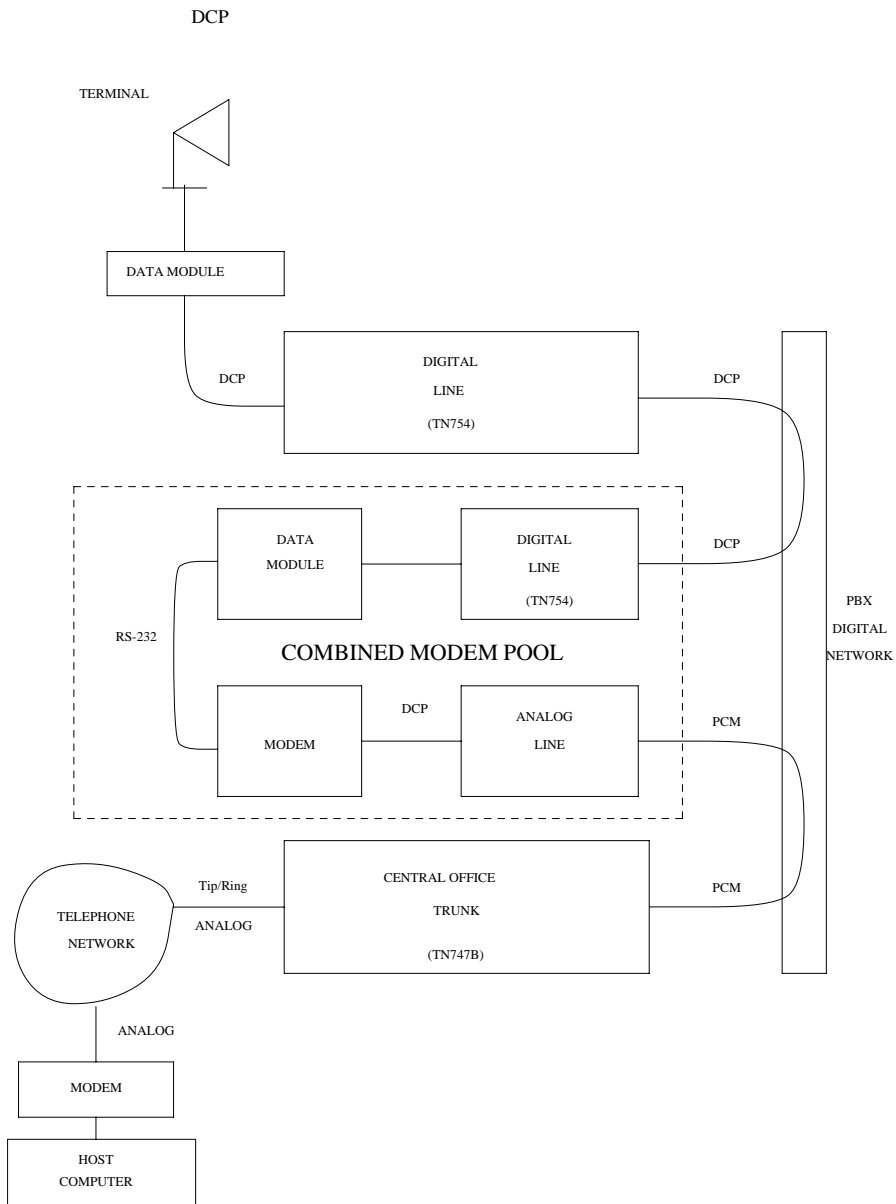

**Figure 9-63. Typical Modem Pool Switched Connection with Combined Modem Pool**

## Troubleshooting Modem-Pool Symptoms

Certain customer-reported troubles may provide important information for troubleshooting Modem Pool problems. For example, if the customer tries to make a data call requiring a Modem Pool conversion resource, and the Modem Pool and Data Module speeds or other options do not match, they may receive a "CHECK OPTIONS" error message on the terminal. In this case, check the Modem Pool administration and Data Module option settings. If the Modem Pool is a Combined type, check also the option settings on the external Modem and Data Module, and cabling and connections between the Digital Line port, Data Module, Analog Line port, and Modem.

## Testing Modem-Pools

There are three types of commands that can be used to test Modem Pool circuits: **test port**, **test modem-pool #**, and **test board**. The **test port** command is generally the first test to run after the Error Log is evaluated and an entry is found for a Modem Pool port. The **test modem-pool #** command runs the same tests as the **test port short** command performed on a Modem Pool port. However, the **test modem-pool #** command can automatically test all ports in the Modem Pool group number specified in #. The **test board** command performs the same tests as **test port** and **test modem-pool #** plus additional tests for circuits common to the entire circuit pack. Refer to the "XXX-BD (Common Port Circuit Pack)" section for information on additional tests performed with **test board** (#50, #52, and #53).

If the Modem Pool port or group being tested with **test modem-pool #** contains Combined Modem Pools, the ports on the associated Analog Line circuit pack and the TN754 Digital Line circuit pack are tested as a group. Note, however, that Combined Modem Pools are not tested with the tests described in this section and the repair information related to Tests # 96, 97, 98, and 99 is not applicable. The Analog port of the Combined Modem port is tested with Analog port tests, and the Digital port of the Combined Modem port is tested with TDMODULE/PDMODULE tests. Therefore, use the repair procedures outlined in the ANL-LINE, ANL-16-L, ANL-NE-L, and TDMODULE/PDMODULE Maintenance documentation when interpreting the results of the execution of the **test modem-pool #** command on Combined Modem Pools.

## Error Log Entries and Test to Clear Values

**Table 9-430. Modem Pool Port Error Log Entries**

Error Type	Aux Data	Associated Test	Alarm Level	On/Off Board	Test to Clear Value
0 <sup>1</sup>	0	Any	Any	Any	test port UUCSSpp sh r 1
18	0	busyout UUCSS	WARNING	OFF	release port UUCSS
130 <sup>2</sup>		None	WARNING	ON	test port UUCSSpp sh
257		Conversion Resource Loop (#98)	MINOR	ON	test port UUCSS s r 3
513		Modem Conference (#97)	MINOR	ON	test port UUCSS l r 3
769		Modem NPE Crosstalk (#96)	MINOR	ON	test port UUCSS l r 3

1. Run the Short Test Sequence first. If all tests pass, run the Long Test Sequence. Refer to the appropriate test description and follow the recommended procedures.
2. This error type indicates that the circuit pack has been removed or has been insane for more than 21 minutes. To clear the error, reinsert or replace the circuit pack.

## System Technician-Demanded Tests: Descriptions and Error Codes

---

Always investigate tests in the order presented in the table below when inspecting errors in the system. By clearing error codes associated with the *Modem Pool Conference Test*, for example, you may also clear errors generated from other tests in the testing sequence.

Order of Investigation	Short Test Sequence	Long Test Sequence	D/ND <sup>1</sup>
Modem Pool NPE Crosstalk Test (#96)		X	D
Modem Pool Conference Test (#97)		X	D
Modem Pool Conversion Resource Looparound Test (#98)	X	X	ND
Modem Pool Audits Test (#99)	X	X	ND

---

1. D = Destructive, ND = Non-destructive



### NOTE:

The tests in this section do not apply to Combined Modem Pool conversion resources. The standard Digital Line and/or Analog Line port tests are run on the ports associated with the Combined Modem Pool. Consult the test descriptions for those maintenance objects when repairing Combined Modem Pool arrangements.

## Modem Pool NPE Crosstalk Test (#96)

**This test is destructive.**

The Modem Pool Crosstalk Test verifies that the NPE is connected only to the desired time slot and is not crosstalking on other time slots. This test operates exactly like Test #6 for other types of port circuits but is performed twice in order to test both NPEs in the Modem Pool Port

**Table 9-431. TEST #96 Modem Pool NPE Crosstalk Test**

Error Code	Test Result	Description/ Recommendation
	ABORT	System resources required for this test are not available. 1. Retry the command at 1-minute intervals a maximum of 5 times.
1000	ABORT	System resources required for this test are not available. The port may be in use on a valid call. Determine if the port is available for testing. 1. Retry the command at 1-minute intervals a maximum of 5 times.
1001	ABORT	System resources required to run this test are not available. 1. Retry the command at 1-minute intervals a maximum of 5 times.
1002	ABORT	The system could not allocate time slots for the test. The system may be under heavy traffic conditions or it may have time slots out-of-service due to TDM-BUS errors. 1. If the system has no TDM-BUS errors and is not handling heavy traffic, repeat the test at 1-minute intervals a maximum of 5 times.
1003	ABORT	The system could not allocate a tone receiver for the test. The system may be oversized for the number of Tone Detectors present or some Tone Detectors may be out-of-service. 1. Resolve any TTR-LEV errors. 2. Resolve any TONE-PT errors. 3. If neither condition exists, retry the test at 1-minute intervals a maximum of 5 times.
1004	ABORT	The port has been seized by a user for a valid call. Determine whether the port is available for testing. 1. Retry the command at 1-minute intervals a maximum of 5 times.
1020	ABORT	The test did not run due to a previously existing error on the specific port or because of a more general circuit pack error. 1. Examine the Error Log for existing errors against this port or the circuit pack, and attempt to diagnose the previously existing errors.
2000	ABORT	A response to the test was not received within the allowable time period. 1. Retry the command at 1-minute intervals a maximum of 5 times.

*Continued on next page*

**Table 9-431. TEST #96 Modem Pool NPE Crosstalk Test — Continued**

Error Code	Test Result	Description/ Recommendation
2100	ABORT	System resources required for this test are not available. 1. Retry the command at 1-minute intervals a maximum of 5 times.
6000	ABORT	System resources needed to complete the test could not be allocated for the digital section of the Modem Pool conversion resource. Ordinarily, this means the conversion resource or other hardware used during the test was in use. 1. Wait 1 minute and attempt the test again. 2. If the same error occurs, use the <b>status port</b> command to determine whether the Modem Pool conversion resource is in use. 3. If the conversion resource is in use, and it is absolutely necessary to test it, the call must be dropped by issuing a <b>busyout port UUCSS</b> command against the conversion resource. Run the test again. 4. If the same error occurs while the conversion resource is idle, busyout both Modem Pool conversion resources on the TN758 Pooled Modem circuit pack containing the conversion resource under test. 5. If the test continues to fail or abort, replace the Pooled Modem circuit pack and retest.
6001	ABORT	System resources needed to complete the test could not be allocated for the analog section of the Modem Pool conversion resource. Follow the test procedures for the previous error code.
NONE	FAIL	The test failed. This error is internal to the Pooled Modem circuit pack and does not involve external equipment or interfaces. 1. Busy-out both of the TN758 Pooled Modem conversion resources on the circuit pack containing the failing conversion resource. 2. If the test continues to fail, replace the Pooled Modem circuit pack and retest.
ANY	FAIL	The NPE of the tested port was found to be transmitting in error. This condition will cause noisy and unreliable connections. 1. If the remaining ports are currently not in use (the yellow LED is off), reset the circuit pack and repeat the test. 2. If the test fails again, replace the circuit pack.
	PASS	The port is correctly using its allocated time slots. Investigate user-reported troubles on this port using other port tests and by examining station, trunk, or external wiring.

**Modem Pool Conference Test (#97)**

**This test is destructive.**

The Modem Pool Conference Test checks most of the switching and gain control functions provided by the NPE circuit in the analog section of the conversion resource. This test conferences a 1004-Hz tone through the NPE, looping it back so that it can be verified with a Tone Detector circuit

**Table 9-432. TEST #97 Modem Pool Conference Test**

Error Code	Test Result	Description/ Recommendation
1000	ABORT ABORT	System resources required for this test are not available. System resources required to run this test are not available. The port may be in use on a valid call. Determine whether the port is available for testing.
1002	ABORT	The system could not allocate time slots for the test. The system may be under heavy traffic conditions or it may have time slots out-of-service due to TDM-BUS errors.  1. If the system has no TDM-BUS errors and is not handling heavy traffic, repeat test at 1-minute intervals a maximum of 5 times.
1003	ABORT	The system could not allocate a tone receiver for the test. The system may be oversized for the number of Tone Detectors present or some Tone Detectors may be out-of-service.  1. Resolve any TTR-LEV errors. 2. Resolve any TONE-PT errors. 3. If neither condition exists, retry the test at 1-minute intervals a maximum of 5 times.
1004	ABORT	The port has been seized by a user for a valid call. Determine whether the port is available for testing.  1. Retry the command at 1-minute intervals a maximum of 5 times.
1020	ABORT	The test did not run due to a previously existing error on the specific port or because of a more general circuit pack error.  1. Examine the Error Log for existing errors against this port or the circuit pack, and attempt to diagnose previously existing errors.
2000	ABORT	The response to the test was not received in the allowable time period.
2012	ABORT	Internal system error.
2100	ABORT	System resources required for this test are not available.
2103	ABORT	The system could not make the conference connection for the test.  1. Retry the command at 1-minute intervals a maximum of 5 times.

*Continued on next page*

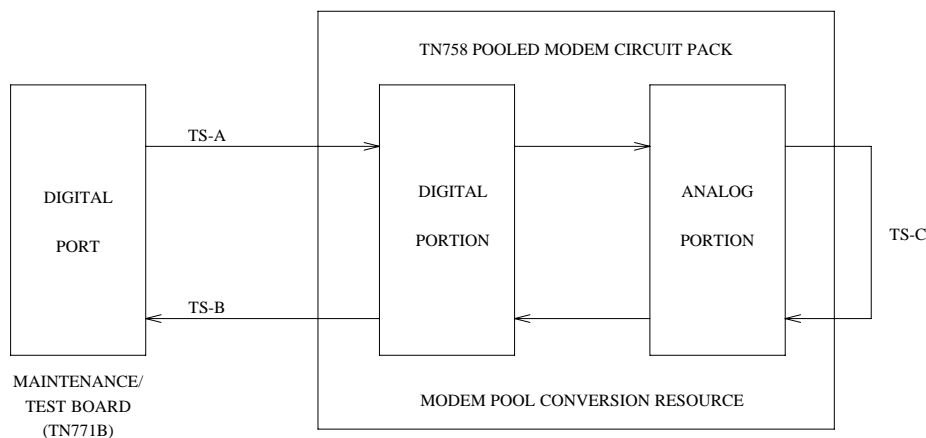

Table 9-432. TEST #97 Modem Pool Conference Test — Continued

Error Code	Test Result	Description/ Recommendation
4000	ABORT	<p>System resources needed to complete the test could not be allocated. Ordinarily, this means the conversion resource or other hardware used during the test was in use.</p> <ol style="list-style-type: none"> <li>1. Wait 1 minute and attempt the test again.</li> <li>2. If the same error occurs, use the <b>status port</b> command to determine whether the Modem Pool conversion resource is in use.</li> <li>3. If the conversion resource is in use, and it is absolutely necessary to test it, the call must be dropped by issuing a <b>busyout port UUCSS</b> command against the conversion resource. Run the test again.</li> <li>4. If the same error occurs while the conversion resource is idle, busyout both Modem Pool conversion resources on the TN758 Pooled Modem circuit pack containing the conversion resource under test. Run the test again.</li> <li>5. If the test continues to abort, replace the Pooled Modem circuit pack and retest.</li> </ol>
6551 5	ABORT	<p>System resources required for this test are not available.</p> <ol style="list-style-type: none"> <li>1. Retry the command at 1-minute intervals a maximum of 5 times.</li> <li>2. Issue the <b>test port long</b> command on the port on which the test aborted. If any test aborted or failed, follow recommended maintenance strategy for the appropriate port type (for example, ANL-LINE, DIG-LINE).</li> </ol>
None	FAIL	<p>The test failed. This error is internal to the Pooled Modem circuit pack and does not involve external equipment or interfaces.</p> <ol style="list-style-type: none"> <li>1. Busy-out both of the TN758 Pooled Modem conversion resources on the circuit pack containing the failing conversion resource.</li> <li>2. If the test continues to fail, replace the Pooled Modem circuit pack and retest.</li> </ol>
Any	FAIL	<p>The Network Processing Element (NPE) of the tested port did not conference the tones correctly. This will cause noisy and unreliable connections.</p> <ol style="list-style-type: none"> <li>1. If the remaining ports are currently not in use (the yellow LED is off), reset the circuit pack and repeat the test.</li> <li>2. If the test fails again, replace the circuit pack.</li> </ol>
	PASS	<p>The port can correctly conference multiple connections. User-reported troubles on this port should be investigated using other port tests and by examining station, trunk, or external wiring.</p>

## Modem Pool Conversion Resource Loop-Around Test (#98)

The Modem Pool Conversion Resource Looparound Test is set up as follows:



**Figure 9-64. Modem Pool Conversion Resource Loop-Around**

Test data patterns are transmitted from a Maintenance/Test Board digital port over network time slot A through the digital port on the conversion resource, looped around through the analog port via time slot C back to the Maintenance/Test Board digital port circuit via time slot B where the patterns are checked for accuracy. Finally, the test forces a disconnect by breaking the connection between the Maintenance/Test Board digital port and the Modem Pool Port (time slot A) and verifying that the Maintenance/Test Board digital port and Modem Pool Port go on-hook within the proper time. This test attempts to allocate a Maintenance/Test Board digital port, Modem Pool Port, and other internal resources. If any of these allocation attempts fail, the test cannot be completed and a specific abort error is reported.

**Table 9-433. TEST #98 Modem Pool Conversion Resource  
 Looparound Test**

Error Code	Test Result	Description/ Recommendation
1000	ABORT	<p>System resources needed to complete the test could not be allocated for the digital section of the Modem Pool conversion resource. Ordinarily, this means the conversion resource or other hardware used during the test was in use.</p> <ol style="list-style-type: none"> <li>1. Wait 1 minute and attempt the test again.</li> <li>2. If the conversion resource is in use, and it is absolutely necessary to test it, the call will have to be dropped by issuing a <b>busyout port UUCSSpp</b> command against the conversion resource. Run the test again. If the test passes, release the port.</li> <li>3. If the same error occurs while the conversion resource is idle, busy out both Modem Pool conversion resources on the TN758 Pooled Modem circuit pack containing the conversion resource under test. Rerun the test.</li> <li>4. If the test continues to abort, replace the Pooled Modem circuit pack and retest.</li> </ol>
1180	ABORT	<p>A Maintenance/Test Board digital port could not be allocated for this test. This error is more closely related to the digital port on the specific Maintenance/Test Board circuit pack used for this test than the TN758 Pooled Modem circuit pack itself. Therefore, any hardware testing or replacement activities will focus on the Maintenance/Test Board circuit pack. Verify that the digital ports of the Maintenance/Test Board are present if this error occurs.</p> <ol style="list-style-type: none"> <li>1. Use the <b>list config</b> command to verify that both of the Maintenance/Test Board digital ports are present. The display should show entries for both port 02 and port 03.</li> <li>2. If the digital ports (02 and 03) are not present, refer to the M/T-BD Maintenance documentation.</li> <li>3. If the digital ports are present, retry the command at 1 minute intervals a maximum of 5 times.</li> </ol>
1181	ABORT	<p>No time-slots available to connect digital ports for the test.</p> <ol style="list-style-type: none"> <li>1. Retry the command at 1 minute intervals a maximum of 5 times.</li> </ol>
1182	ABORT	<p>Internal system error. Failed to connect the digital ports with time-slots.</p> <ol style="list-style-type: none"> <li>1. Retry the command at 1 minute intervals a maximum of 5 times.</li> </ol>

*Continued on next page*

**Table 9-433. TEST #98 Modem Pool Conversion Resource  
 Looparound Test — Continued**

Error Code	Test Result	Description/ Recommendation
1340	ABORT	No Maintenance/Test digital port is currently available to perform this test. <ol style="list-style-type: none"> <li>1. Use <b>list config</b> to determine whether any Maintenance/Test digital ports (ports 02 and 03 on the Maintenance/Test circuit pack) are present in the system. Because at least one Maintenance/Test circuit pack must always be present in the PPN of any G3r system, there should be at least two such ports present. If the ports are present, proceed to step 2. Otherwise, determine why no ports appear in the <b>list config</b> display.</li> <li>2. If the ports are present and no errors are logged against them, retry the command at 1 minute intervals a maximum of 5 times.</li> <li>3. If the test continues to abort, replace the Maintenance/Test circuit pack.</li> </ol>
2004	ABORT	Off-Hook was not received from the Pooled Modem. <ol style="list-style-type: none"> <li>1. Busy-out the digital port being tested on the Pooled Modem circuit pack. Retry the command at 1 minute intervals a maximum of 5 times.</li> <li>2. If the test still aborts, replace the circuit pack.</li> </ol>
2005	ABORT	The Maintenance/Test Board digital port and the Pooled Modem Board digital port failed to handshake. <ol style="list-style-type: none"> <li>1. Retry the command at 1 minute intervals a maximum of 5 times.</li> <li>2. If the test still aborts, replace the Pooled Modem circuit pack.</li> </ol>
2312	ABORT	The Looparound Test did not complete, failed to receive loop-back data. <ol style="list-style-type: none"> <li>1. Retry the test, if still aborts, replace the Pooled Modem Board.</li> </ol>
2313	ABORT	The Maintenance/Test Board digital port allocated for this test did not respond to downlinked message. <ol style="list-style-type: none"> <li>1. Retry the command at 1 minute intervals a maximum of 5 times.</li> <li>2. If the test continues to abort, replace the MTB.</li> </ol>
2314	ABORT	The Modem Pool digital port did not respond to downlinked message. This error is internal to the Modem Pool circuit pack and does not involve external equipment or interfaces. <ol style="list-style-type: none"> <li>1. Busy-out the TN758 Pooled Modem conversion resources on the circuit pack.</li> <li>2. If the test continues to abort, replace the Pooled Modem circuit pack and retest.</li> </ol>
2500	ABORT	Internal system error. <ol style="list-style-type: none"> <li>1. Retry the command at 1 minute intervals a maximum of 5 times.</li> </ol>

*Continued on next page*

**Table 9-433. TEST #98 Modem Pool Conversion Resource  
 Looparound Test — Continued**

Error Code	Test Result	Description/ Recommendation
2323	ABORT	The Maintenance Test circuit pack digital port allocated for this test did not disconnect properly. This error is more closely related to the Maintenance Test circuit pack digital port used for this test than the TN758 Pooled Modem circuit pack itself. Therefore, any hardware testing or replacement activities will focus on the Maintenance Test circuit pack. <ol style="list-style-type: none"> <li>1. Wait 1 minute and attempt the test again a maximum of 5 times.</li> </ol>
2324	ABORT	The digital portion of the tested Modem Pool port did not disconnect properly. <ol style="list-style-type: none"> <li>1. Wait 1 minute and attempt the test again.</li> <li>2. If the test continues to abort, replace the Pooled Modem circuit pack and retest.</li> </ol>
2325	FAIL	The Modem Pool port did not respond with an on-hook message when the connection to the TN711 Maintenance/Test digital port was broken, indicating a likely problem with the TN758 Pooled Modem circuit pack. <ol style="list-style-type: none"> <li>1. Busy-out both of the TN758 Pooled Modem conversion resources on the circuit pack containing the failing conversion resource.</li> <li>2. If the test continues to fail, replace the Pooled Modem circuit pack and retest.</li> </ol>
	FAIL	The Looparound Test failed, the loop-back data did not match the original data. <ol style="list-style-type: none"> <li>1. Repeat Test #98.</li> <li>2. If the test fails again, replace the Pooled Modem circuit pack.</li> </ol>
	PASS	The port can correctly transmit/receive data.

**Modem Pool Audit Test (#99)**

This audit updates the Modem Pool conversion resource status contained in the TN758 Pooled Modem circuit pack's microprocessor. It does not actually test the Pooled Modem circuit pack; therefore, there are no FAIL codes. The audit can only be performed on idle conversion resources. If the conversion resource is in use, the audit will abort

**Table 9-434. TEST #99 Modem Pool Audit Test**

Error Code	Test Result	Description/ Recommendation
None	ABORT	<p>The system was not able to allocate all the necessary resources to execute this test. An ABORT simply indicates that the conversion resource was in use when the audit was performed. No repair action is necessary unless the conversion resource was known to be idle during the test (yellow in-use LED was off) or was busied out before the test was run. In that case, a TN758 failure condition may exist and the following procedure should be used:</p> <ol style="list-style-type: none"> <li>1. Busyout both of the TN758 Pooled Modem conversion resources on the circuit pack containing the failing conversion resource.</li> <li>2. If the test continues to abort, replace the Pooled Modem circuit pack and retest.</li> </ol>

## M/T-ANL (Maintenance/Test Analog Port)

MO Name (in Alarm Log)	Alarm Level	Initial Command to Run <sup>1</sup>	Full Name of MO
M/T-ANL	Minor	test port UUCSSpp l	Maintenance/Test Analog Port
M/T-ANL	Warning	release port UUCSSpp	Maintenance/Test Analog Port

1. *UU* is the universal cabinet number (1 for PPN, 2 - 44 for EPNs). *C* is the carrier designation (A, B, C, D, or E). *SS* is the number of the slot in which the circuit pack resides (01 to 21). *pp* is the two digit port number (01, 02, ...).

The Maintenance/Test Analog Port is port number 1 on the TN771 Maintenance/Test circuit pack. This port is used by the Automatic Transmission Measurement System (ATMS) as an Originating Test Line (OTL) or Terminating Test Line (TTL) for test calls over analog trunks. For more details, see "Automatic Trunk Transmission System" in [Chapter 6, "Additional Maintenance Procedures"](#). [Figure 9-65](#) shows a typical ATMS configuration.

M/T-ANL maintenance ensures that the analog trunk's testing function is operating correctly. An alarm against M/T-ANL can reduce service, but it will not block it. To accurately measure performance and health of analog trunks, the TN771 should be replaced when a new circuit pack is available.

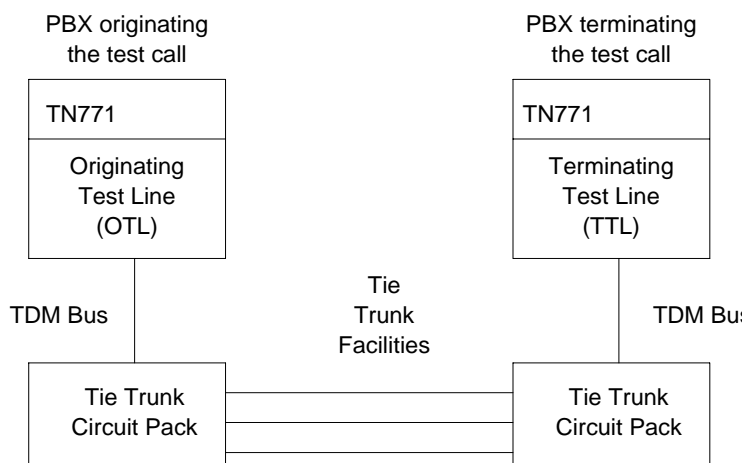

**Figure 9-65. ATMS Tie Trunk Test Call**

## Error Log Entries and Test to Clear Values

Table 9-435. M/T-ANL Error Log Entries

Error Type	Aux Data	Associated Test	Alarm Level	On/Off Board	Test to Clear Value
0 <sup>1</sup> (a)	0	Any	Any	Any	test port UUCSSpp
1 (b)	41018	none	MINOR	ON	test port UUCSSpp l r 3
18	0	busyout port UUCSSpp	WARNING	OFF	release port UUCSSpp
257	Any	NPE Crosstalk test (#9)	MINOR	ON	test port UUCSSpp l r 3
513	Any	Analog Port Sanity Test (#963)	MINOR	ON	test port UUCSS01 r 2
769	Any	Analog Port Digital Looparound Test (#13)	MINOR	ON	test port UUCSSpp r 3
3840(c)	Any	Hook State Inquiry test (#566)			

1. Run the Short Test Sequence first. If all tests pass, run the Long Test Sequence. Refer to the appropriate test description and follow the recommended procedures.

### Notes:

- a. This error code appears in the Error Log only if the MTB circuit pack has been removed since the Error Log was last cleared. Verify that the circuit pack has been reinserted.
- b. This error indicates a hardware failure on the Analog Port circuitry. Replace the Maintenance/Test circuit pack if the alarm is not resolved by the command above.
- c. This error indicates that call processing records did not agree with on-board records for the hook state (on-/off-hook) of the Maintenance/Test Analog Port. This error is not service-affecting and no action is required.



## System Technician-Demanded Tests: Descriptions and Error Codes

Always investigate tests in the order presented in the following table when inspecting errors in the system. By clearing error codes associated with the *Analog Port Sanity Test*, for example, you may also clear errors generated from other tests in the testing sequence.

Order of Investigation	Short Test Sequence	Long Test Sequence	D/ND <sup>1</sup>
Analog Port Sanity Test (#963)	X	X	ND
Digital Looparound Test (#13)	X	X	ND
NPE Crosstalk Test (#9)		X	ND
Hook State Inquiry (#566)	X	X	ND
Clear Error Counters (#270)		X	ND

1. D = Destructive, ND = Non-destructive

### NPE Crosstalk Test (#9)

The NPE Crosstalk Test verifies that this port's NPE channel talks on the selected time slot and never crosses over to time slots reserved for other connections.

One or more Network Processing Elements (NPE) reside on each circuit pack with a TDM Bus interface. The NPE controls port connectivity, gain, and provides conferencing functions on a per port basis. If the NPE is not working correctly, one way and/or noisy connections may be observed. This test is part of a port's long test sequence and takes approximately 10 to 20 seconds to complete

**Table 9-436. TEST #9 NPE Cross Talk Test**

Error Code	Test Result	Description/ Recommendation
1000	ABORT	System resources required to run this test are not available. The port may be in use on a valid ATMS trunk test call. 1. Retry the command at 1-minute intervals a maximum of 3 times.
1001	ABORT	System resources required to run this test are not available. 1. Retry the command at 1-minute intervals a maximum of 3 times.

*Continued on next page*

**Table 9-436. TEST #9 NPE Cross Talk Test — Continued**

Error Code	Test Result	Description/ Recommendation
1002	ABORT	<p>The system could not allocate time slots for the test. The system may be under heavy traffic conditions or it may have time slots out of service due to TDM-BUS errors. A system is considered under heavy traffic when the Call Processing Occupancy is greater than 50% or when the System Management and the Call Processing Occupancies together exceed 65%. To view the system occupancy measurements enter the command <b>status system health</b> on the system technician terminal.</p> <ol style="list-style-type: none"> <li>1. If system has no TDM-BUS errors and is not handling heavy traffic, repeat test at 1-minute intervals a maximum of 3 times.</li> </ol>
1003	ABORT	<p>The system could not allocate a tone receiver for the test. The system may be oversized for the number of tone detectors present or some tone detectors may be out-of-service.</p> <ol style="list-style-type: none"> <li>1. Resolve any TTR-LEV errors.</li> <li>2. Resolve any TONE-PT errors.</li> <li>3. If neither condition exists, retry the test at 1-minute intervals a maximum of 3 times.</li> </ol>
1004	ABORT	<p>The port has been seized by a valid ATMS test call.</p> <ol style="list-style-type: none"> <li>1. Retry the command at 1-minute intervals a maximum of 3 times.</li> <li>2. If the test continues to abort and the port is not in use on a valid ATMS Test Call, escalate the problem. To determine whether the port is in use by an ATMS Test Call enter <b>status station ext</b> where <b>ext</b> is the assigned ATMS station number.</li> </ol>
2000	ABORT	<p>Response to the test request was not received within the allowable time period.</p> <ol style="list-style-type: none"> <li>1. Retry the command at 1-minute intervals a maximum of 3 times.</li> </ol>
2100	ABORT	<p>System resources required to run this test are not available.</p> <ol style="list-style-type: none"> <li>1. Retry the command at 1-minute intervals a maximum of 3 times.</li> </ol>
Any	FAIL	<p>The NPE of the tested port was found to be transmitting in error. This will cause noisy and unreliable connections.</p> <ol style="list-style-type: none"> <li>1. If the remaining ports are currently not in use (yellow LED is off), try to reset the circuit pack via the <b>busyout board UUCSS, reset board UUCSS, release board UUCSS</b> command sequence. Then repeat the test.</li> <li>2. If the test fails again, replace circuit pack.</li> </ol>
	PASS	<p>The port is correctly using its allocated time slots. User-reported troubles on this port should be investigated by examining station, trunk, or external wiring.</p>

### Analog Port Digital Looparound Test (#13)

This test is a modification of the Voice and Control Channel Local Loop Test used by Digital Station (DIG-LINE) maintenance. This test does not perform the control channel and secondary information channel loop around tests as described for DIG-LINE, as these data paths do not exist for the Maintenance/Test Analog Port. The primary information channel is tested by first looping back the data channel onto the TDM Bus, and then sending a digital count from the Tone-Clock circuit pack and receiving the same digital count with a general purpose tone detector. A conference test is done next for the primary information channel. This test is the same as Conference Test (#6).

Only one value (Pass, Fail, or Abort) is generated as a result of the two tests. If either fails or aborts, the sequence is stopped

**Table 9-437. TEST #13 Analog Port Digital Looparound Test**

Error Code	Test Result	Description/ Recommendation
	ABORT	Internal system error 1. Retry the command at 1-minute intervals a maximum of 3 times.
1000	ABORT	The port is in use on a valid ATMS Test Call. 1. Retry the command at 1-minute intervals a maximum of 3 times. 2. If the test continues to abort and the port is not in use on a valid ATMS Test Call, escalate the problem. To determine whether the port is in use by an ATMS Test Call enter <b>status station ext</b> where <b>ext</b> is the assigned ATMS station number.
1001	ABORT	System resources required to run this test are not available. 1. Retry the command at 1-minute intervals a maximum of 3 times.
1002	ABORT	The system could not allocate time slots for the test. The system may be under heavy traffic conditions, or it may have time slots out-of-service due to TDM-BUS errors. A system is considered under heavy traffic when the Call Processing Occupancy is greater than 50% or when the System Management and the Call Processing Occupancies together exceed 65%. To view the system occupancy measurements enter the command <b>status system health</b> on the system technician terminal. 1. If the system has no TDM-BUS errors and is not handling heavy traffic, repeat the test at 1-minute intervals a maximum of 3 times.

*Continued on next page*

**Table 9-437. TEST #13 Analog Port Digital Looparound Test — Continued**

Error Code	Test Result	Description/ Recommendation
1003	ABORT	<p>The system could not allocate a tone receiver for the test. The system may be oversized for the number of tone detectors present, or some tone detectors may be out-of-service.</p> <ol style="list-style-type: none"> <li>1. Resolve any TTR-LEV errors. i</li> <li>2. Resolve any TONE-PT errors.</li> <li>3. If neither condition exists, retry the command at 1-minute intervals a maximum of 3 times.</li> </ol>
1004	ABORT	<p>The port was seized by a valid ATMS Test Call.</p> <ol style="list-style-type: none"> <li>1. Retry the command at 1 minute intervals a maximum of 3 times.</li> <li>2. If the test continues to abort and the port is not in use on a valid ATMS Test Call, escalate the problem. To determine whether the port is in use by an ATMS Test Call enter <b>status station ext</b> where <b>ext</b> is the assigned ATMS station number.</li> </ol>
2000	ABORT	<p>Response to the test request was not received within the allowable time period.</p> <ol style="list-style-type: none"> <li>1. Retry the command at 1 minute intervals a maximum of 3 times.</li> </ol>
7	FAIL	<p>Conference test failed on the primary information channel.</p> <ol style="list-style-type: none"> <li>1. Run the circuit pack tests to check the Tone/Clock (TONE-BD) circuit pack and the Tone Detector circuit pack via the <b>test board UUCSS</b> command.</li> <li>2. Resolve any problems that are detected on the Tone/Clock (TONE-BD) circuit pack or Tone Detector circuit pack. See the section on Tone Generator circuit pack.</li> <li>3. If the Tone/Clock and Tone Detector circuit packs are functioning properly, and the test still fails, replace the Maintenance/Test circuit pack.</li> </ol>
14	FAIL	<p>The primary information channel is not transmitting properly. User may not notice any interruption in service or may not be able to use this port.</p> <ol style="list-style-type: none"> <li>1. Run the circuit pack tests to check the Tone Generator circuit pack and the Tone Detector circuit pack using <b>test board UUCSS</b>.</li> <li>2. Resolve any problems that are detected on the Tone Generator circuit pack or Tone Detector circuit pack. See the section on Tone Generator circuit pack.</li> <li>3. If the Tone Generator and Tone Detector circuit packs are functioning properly, and the test still fails, replace the Maintenance/Test Circuit Pack.</li> </ol>
	PASS	<p>The Maintenance/Test Analog Port analog trunk testing capability is operating correctly.</p>

## Clear Error Counters (#270)

The ports on the Maintenance/Test circuit pack continually run self-tests, whenever the port is idle. The Angel uses a counter so that the Background Maintenance Failure message is only sent uplink once (this keeps a failed port/circuit pack from flooding the SPE with a string of messages). Many circuit packs have counters in the Angel firmware. These counters are used so that Control Channel Message Set (CCMS) messages are not continuously sent uplink. Using this method, the message will be sent once, when the counter reaches some preset threshold, and then not sent again until the counter is cleared. This test is used to clear the counter, so that if the port continues to fail during or after SPE-demanded testing, the Angel will send a message to indicate that fact.

This test is only used to send a message to the Angel on the Maintenance/Test Circuit Pack. Therefore, this test should never abort or fail.

**Table 9-438. TEST #270 Clear Error Counters**

Error Code	Test Result	Description/ Recommendation
	PASS	The message to clear the Maintenance/Test circuit pack's counter for Background Maintenance Failures has been sent.

**Hook State Inquiry (#566)**

This test ensures that the Maintenance/Test Analog Port maintenance software and call processing agree on the on-/off-hook status of the Maintenance/Test Analog Port.

**Table 9-439. TEST #566 Hook State Inquiry**

Error Code	Test Result	Description/ Recommendation
1	ABORT	Switch hook audit timed out. No response was received from the circuit pack for information about the switch hook state.  1. Retry the command at 1-minute intervals a maximum of 3 times. 2. If the test continues to abort, replace the circuit pack and repeat the test.
2100	ABORT	System resources required to run this test are not available.  1. Retry the command at 1-minute intervals a maximum of 3 times.
Any	FAIL	Internal system error  1. Retry the command at 1-minute intervals a maximum of 3 times. 2. If the test continues to fail reset the circuit pack via the <b>busyout board UUCSS, reset board UUCSS, release board UUCSS</b> command sequence. 3. Retry the command at 1-minute intervals a maximum of 3 times.
	PASS	Call processing and Maintenance/Test Analog Port maintenance software agree on the Maintenance/Test Analog Port hook state.

## Analog Port Sanity Test (#963)

This test verifies that the port circuitry involved in the analog trunk testing on the Maintenance/Test Analog Port is functioning properly.

This test will abort if an ATMS Test Call is in progress on the Maintenance/Test Analog Port when the test is requested.

**Table 9-440. TEST #963 Analog Port Sanity Test**

Error Code	Test Result	Description/ Recommendation
2000	ABORT	Response to the test request was not received within the allowable time period.
2100	ABORT	System resources required to run this test are not available.
2500	ABORT	An internal operation failed; the test could not be completed. 1. Retry the command at 1-minute intervals a maximum of 3 times.
50	FAIL	The switch was unable to communicate with the port circuitry used for analog trunk testing. 1. Reset the circuit pack via the <b>busyout board UUCSS, reset board UUCSS, release board UUCSS</b> command sequence. 2. Test the port again via the <b>test port UUCSS01 I</b> command. 3. If the test fails again, replace the circuit pack.
	PASS	The Maintenance/Test Analog Port analog trunk testing capability is operating correctly.

## M/T-BD (Maintenance/Test Circuit Pack)

MO Name As It Appears in Alarm Log	Alarm Level	Initial System Technician Command to Run <sup>1</sup>	Full Name of MO
M/T-BD	MIN	test board UUCSS I	Maintenance/Test Circuit Pack
M/T-BD	WRN	release board UUCSS	Maintenance/Test Circuit Pack

1. UU is the universal cabinet number (1 for PPN, 2 - 44 for EPNs). C is the carrier designation (A, B, C, D, or E). SS is the number of the slot in which the circuit pack resides (01 to 21).

The Maintenance/Test Circuit Pack supports Packet Bus fault detection and bus reconfiguration for the port network in which it is installed. The circuit pack also provides Analog Trunk testing, and data loopback testing of DCP Mode 2 endpoints and Digital (ISDN) Trunk Facilities via the TDM bus.

Port 1 of the Maintenance/Test board is the Analog Test port which provides the Analog Trunk testing function for Automatic Transmission Measurement System (ATMS). ATMS is a feature in which calls are made from a device called an Originating Test Line (OTL) over a specific trunk to a device called a Terminating Test Line (TTL). The OTL and TTL can then send tones over the trunk under test and determine the quality of the connection. Ports 2 and 3 are the Digital ports which provide the Digital (ISDN) Trunk testing functions. Port 4 is the Packet port which provides the Packet Bus maintenance function.

Refer to XXX-BD (Common Port Circuit Pack) Maintenance documentation for circuit pack level errors. See also M/T-ANA (Maintenance/Test Analog Test Port), M/T-DIG (Maintenance/Test Digital Port) and M/T-PKT (Maintenance/Test Packet Bus Port) Maintenance documentation for related analog test port digital port and Packet Bus port information, respectively.

All ports except the Analog port (port 1) of the Maintenance/Test Board are automatically administered when the circuit pack is inserted into the system and they are removed when the circuit pack is unplugged from the system. The Analog port however, is administered via the station screen with the type "105TL" for an OTL or a TTL. This port remains administered even after the circuit pack is physically removed from the system. Care should be taken to remove the OTL or the TTL before unplugging the circuit pack.



## Hardware Error Log Entries and Test to Clear Values

### Maintenance/Test Board Error Log Entries

Error Type	Aux Data	Associated Test	Alarm Level <sup>1</sup>	On/Off Board	Test to Clear Value
0 <sup>2</sup>	0	Any	Any	Any	test port UUCSSpp sh r 1
1(a)	0	SAKI Sanity Test (#53)	MINOR	ON	See footnote a
18(b)	0	Busyout Board	WARNING	OFF	release board UUCSS
36(c)	0				
217(e)		WARNING	ON		
257(d)	0	CC Loop Test (#52)	MINOR	ON	test board UUCSS r3
267(e)		WARNING	ON		
513(f)	4352 to 4357				
769(g)	4358				
1025(h)	4363	NPE Audit Test (#50)			test board UUCSS I
1538(i)	0		MINOR	ON	
3840(j)	4096 to 4101				
3999 (k)	Any	None			

1. Major or Minor alarms on this MO may have been downgraded to Warning alarms based on the values used in the **set options** command.
2. Run the Short Test Sequence first. If all tests pass, run the Long Test Sequence. Refer to the appropriate test description and follow the recommended procedures.

#### Notes:

- a. This error indicates that the circuit pack has stopped functioning. Reset the circuit pack via **busyout board UUCSS**, **reset board UUCSS**, and **release board UUCSS** commands. If the SAKI Sanity Test (#53) passes, then the on-board circuitry is healthy. If the SAKI Sanity Test (#53) fails, replace the circuit pack.
- b. The circuit pack has been busied out via the **busyout board UUCSS** command. Execute **release board UUCSS** command.

- c. A port processor on the circuit pack failed to initialize. Reset the circuit pack via **busyout board UUCSS**, **reset board UUCSS**, and **release board UUCSS**. If the problem does not go away, replace the circuit pack.
- d. A Control Channel Protocol Error has occurred. This may be due to an on-board hardware failure detected by the circuit pack. Reset the circuit pack by executing **busyout board UUCSS** and **reset board UUCSS** commands. If there is a problem, it will be detected during initialization and will cause the circuit pack to lock up and appear insane to the system.
- e. An extra TN771D circuit pack has been inserted into the port network.
- f. An on-board hardware failure has been detected by the circuit pack. Reset the circuit pack via the **busyout board UUCSS**, **reset board UUCSS**, and **release board UUCSS** commands. If SAKI Sanity Test (#53) passes, the circuitry is healthy. If SAKI Sanity Test (#53) fails, replace the circuit pack.
- g. This error is reported by the circuit pack when it detects a program logic error. While no action is required, this error may lead to errors of other types being reported against this circuit pack.
- h. This error is reported by the circuit pack when it cannot update NPE memory and read it back. This error type can be ignored, but may lead to errors of other types being reported against this circuit pack.
- i. Excessive number of messages have been received from the Maintenance/Test circuit pack. This may be due to a hardware problem on the circuit pack. The switch will take the board out of service and periodically put it back into service to see if the problem has disappeared. If the problem persists, replace the circuit pack.
- j. This error is not service affecting. No action is required. This error is reported by the circuit pack when it receives a bad control channel message from the switch.
- k. Error type 3999 indicates that the circuit pack sent a large number of control channel messages to the switch within a short period of time. If error type 1538 is also present, then the circuit pack was taken out-of-service due to hyperactivity. If error type 1538 is not present, then the circuit pack has not been taken out-of-service, but it has generated 50% of the messages necessary to be considered hyperactive. This may be completely normal during heavy traffic periods. However, if this error type is logged when the circuit pack is being lightly used, it may indicate a problem with the circuit pack or the equipment attached to it.

## System Technician-Demanded Tests: Descriptions and Error Codes

Always investigate tests in the order presented in the table below when inspecting errors in the system. By clearing error codes associated with the

*Control Channel Loop Around Test* for example, you may also clear errors generated from other tests in the testing sequence.

<b>Order of Investigation</b>	<b>Short Test Sequence</b>	<b>Long Test Sequence</b>	<b>D/ND<sup>1</sup></b>
Control Channel Loop-Around Test (#52)	X	X	ND
NPE Audit Test (#50)		X	ND

---

1. D = Destructive, ND = Non-destructive

Repair procedures for the above tests are described in "XXX-BD (Common Port Circuit Pack)" Maintenance documentation section.

## M/T-DIG (Maintenance/Test Digital Port)

---

MO Name As It Appears in Alarm Log	Alarm Level	Initial System Technician Command to Run <sup>1</sup>	Full Name of MO
M/T-DIG	Minor	test port UUCSSpp l	Maintenance/Test Digital Port
M/T-DIG	Warning	release port UUCSSpp	Maintenance/Test Digital Port

- 
1. UU is the universal cabinet number (1 for PPN, 2 - 44 for EPNs). C is the carrier designation (A, B, C, D, or E). SS is the number of the slot in which the circuit pack resides (01 to 21). pp is the two digit port number (01, 02, ...).

The Maintenance/Test Digital Port is a port on the TN771D circuit pack. Ports 2 and 3 are Digital Ports. The Maintenance/Test Digital Port provides the ability to perform digital (i.e., ISDN-PRI) trunk testing via the TDM Bus. For an ISDN-PRI test call, connections are set up in the system as shown in [Figure 9-66](#).

When the Maintenance/Test Digital Port is participating in an ISDN-PRI test call, the port sends a stream of pseudo-random data along the connected B-channel. The far end loops back this data, and the Maintenance/Test Digital Port compares the data to that which was sent. Errors are recorded on a bit and block basis. Refer to ISDN-TRK (DS1 ISDN Trunk) Maintenance documentation for more information on ISDN-PRI test calls.

The Maintenance/Test Digital Port maintenance ensures that the digital trunk testing function is operating correctly. The Maintenance/Test Digital Port is alarmed if maintenance determines that the digital port is operating incorrectly.

### NOTE:

An alarm on the Maintenance/Test Digital Port reduces service, but does not block it since the ISDN-TRK has other means to determine the health of the ISDN-PRI trunk facility. However, to accurately measure the error performance and to ensure accuracy of the health of the ISDN-PRI trunk, the Maintenance/Test circuit pack should be replaced when a new circuit pack is available.

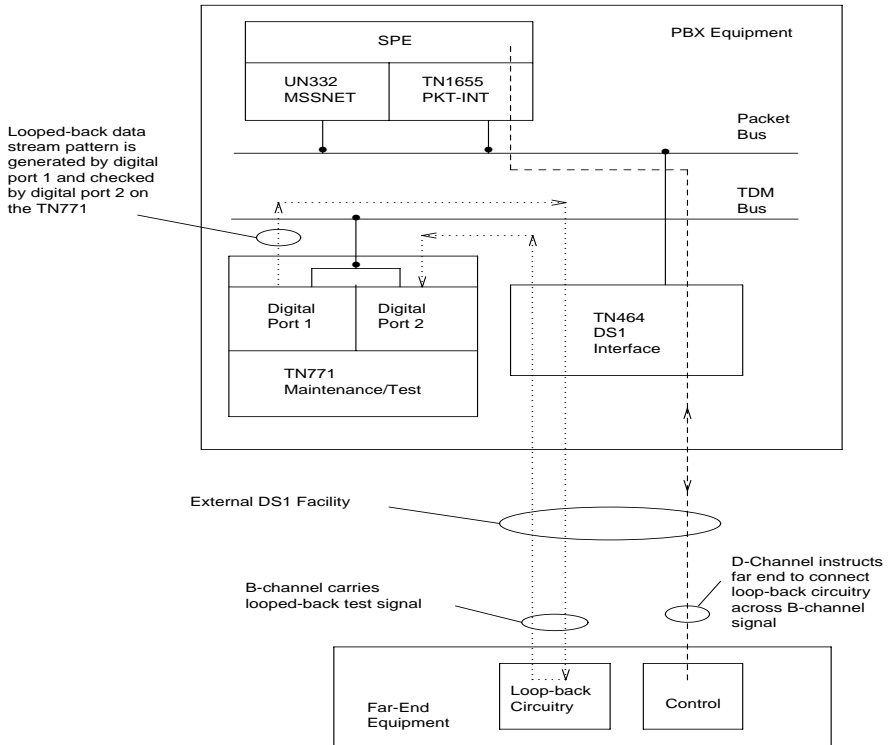

Figure 9-66. ISDN-PRI Outgoing Test Call

## Hardware Error Log Entries and Test to Clear Values

---

### M/T-DIG Error Log Entries

Error Type	Aux Data	Associated Test	Alarm Level	On/Off Board	Test to Clear Value
0 <sup>1</sup>	0	Any	Any	Any	test port UUCSSpp
1 (a)	41018	none	MINOR	ON	test port UUCSSpp l r 3
18 (b)	0	busy-out port UUCSSpp	WARNING	OFF	release port UUCSSpp
257 (c)	Any	NPE Crosstalk Test (#9)	MINOR	ON	test port UUCSSpp l r 3
513 (d)	Any	Digital Port Sanity Test (#565)	MINOR	ON	test port UUCSS02 r 2
769 (e)	Any	Digital Port Loop Around Test (#13)	MINOR	ON	test port UUCSSpp r 3
3840 (f)	Any	Hook State Inquiry test (#566)			

1. Run the Short Test Sequence first. If all tests pass, run the Long Test Sequence. Refer to the appropriate test description and follow the recommended procedures.

#### Notes:

- a. This error indicates a hardware failure on the Digital Port circuitry. Replace the Maintenance/Test circuit pack if the alarm is not resolved by the command above.
- b. The port has been busied out via the **busy-out port UUCSSpp** command.
- c. This error indicates that Maintenance/Test Digital Port is talking on more than just its assigned time slot. Replace the Maintenance/Test circuit pack.
- d. This error indicates that the Maintenance/Test Digital Port has failed its self-test. Since the Digital Port Sanity Test runs only on port 2, but tests both ports 2 and 3, both ports will be alarmed when the test fails. Note that the command above indicates to test port 2, even if the error is logged against port 3.
- e. This error indicates that the Maintenance/Test Digital Port has been unable to successfully loop data from a tone generator to a tone detector.
- f. This error indicated that call processing records did not agree with on-board records for the hook state (on-/off-hook) of the Maintenance/Test Digital Port. This error is not service-affecting and no action is required.

## System Technician-Demanded Tests: Descriptions and Error Codes

---

Always investigate tests in the order presented in the following table when inspecting errors in the system. By clearing error codes associated with the *Digital Port Sanity Test*, for example, you may also clear errors generated from other tests in the testing sequence.

Order of Investigation	Short Test Sequence	Long Test Sequence	D/ND <sup>1</sup>
Digital Port Sanity Test (#565)	X	X	ND
Digital Port Loop Around Test (#13)	X	X	ND
NPE Crosstalk Test (#9)		X	ND
Hook State Inquiry (#566)	X	X	ND
Clear Error Counters (#270)		X	ND

---

1. D = Destructive, ND = Non-destructive

### NPE Crosstalk Test (#9)

This test is a modified version of the Digital Line NPE Crosstalk Test used by DIG-LINE maintenance.

One or more Network Processing Elements (NPE) reside on each circuit pack with a TDM Bus interface. The NPE controls port connectivity, gain, and provides conferencing functions on a per port basis. The NPE Crosstalk Test verifies that this port's NPE channel talks on the selected time slot and never crosses over to time slots reserved for other connections. If the NPE is not working correctly, one way and/or noisy connections may be observed. This test is part of a port's long test sequence and takes approximately 10 to 20 seconds to complete. This test is a modified version of the Digital Line NPE Crosstalk Test used by DIG-LINE maintenance

**Table 9-441. TEST #9 NPE Cross Talk Test**

Error Code	Test Result	Description/ Recommendation
1000	ABORT	<p>System resources required to run this test are not available. The port may be in use on a valid ISDN-PRI test call. Use the <b>list isdn-testcall</b> command to determine if the port is in use (if the port is listed in the M/T Port column). If it is in use, either wait for the test call to complete (as indicated in the Start Time and Duration fields in the above display), or abort the test call with the <b>clear isdn-testcall grp/mem</b> command, where <b>grp/mem</b> is determined from the B-channel field of the above display.</p> <ol style="list-style-type: none"> <li>1. Retry the command at 1-minute intervals a maximum of 5 times.</li> <li>2. If the test continues to abort and the port is not in use, escalate the problem.</li> </ol>
1001	ABORT	<p>System resources required to run this test are not available.</p> <ol style="list-style-type: none"> <li>1. Retry the command at 1-minute intervals a maximum of 5 times.</li> <li>2. If the test continues to abort, escalate the problem.</li> </ol>
1002	ABORT	<p>The system could not allocate time slots for the test. The system may be under heavy traffic conditions or it may have time slots out of service due to TDM-BUS errors.</p> <ol style="list-style-type: none"> <li>1. If system has no TDM-BUS errors and is not handling heavy traffic, repeat test at 1-minute intervals a maximum of 5 times.</li> <li>2. If the test continues to abort, escalate the problem.</li> </ol>
1003	ABORT	<p>The system could not allocate a tone receiver for the test. The system may be oversized for the number of tone detectors present or some tone detectors may be out-of-service.</p> <ol style="list-style-type: none"> <li>1. Resolve any TTR-LEV errors.</li> <li>2. Resolve any TONE-PT errors.</li> <li>3. If neither condition exists, retry the test at 1-minute intervals a maximum of 5 times.</li> <li>4. If the test continues to abort, escalate the problem.</li> </ol>
1004	ABORT	<p>The port has been seized by a valid ISDN-PRI test call. Use the <b>list isdn-testcall</b> command to determine which call is using the port (from the M/T Port column). Either wait for the test call to complete (as indicated in the Start Time and Duration fields of the above display), or abort the test call with the <b>clear isdn-testcall grp/mem</b> command, where <b>grp/mem</b> is determined from the B-channel field of the above display.</p> <ol style="list-style-type: none"> <li>1. Retry the command at 1-minute intervals a maximum of 5 times.</li> <li>2. If the test continues to abort and the port is not in use, escalate the problem.</li> </ol>

*Continued on next page*



**Table 9-441. TEST #9 NPE Cross Talk Test — Continued**

Error Code	Test Result	Description/ Recommendation
2000	ABORT	Response to the test request was not received within the allowable time period.
2100	ABORT	System resources required to run this test are not available. <ol style="list-style-type: none"> <li>1. Retry the command at 1-minute intervals a maximum of 5 times.</li> <li>2. If the test continues to abort, escalate the problem.</li> </ol>
Any	FAIL	The NPE of the tested port was found to be transmitting in error. This will cause noisy and unreliable connections. <ol style="list-style-type: none"> <li>1. If the remaining ports are currently not in use (yellow LED is off), try to reset the circuit pack. Then repeat the test.</li> <li>2. If the test fails again, replace circuit pack.</li> </ol>
	PASS	The port is correctly using its allocated time slots. User-reported troubles on this port should be investigated using other port tests and by examining station, trunk, or external wiring.

### Digital Port Loop Around Test (#13)

This test is a modification of the Voice and Control Channel Local Loop Test used by Digital Station (DIG-LINE) maintenance. This test does not perform the control channel and secondary information channel loop around tests as described for DIG-LINE, as these data paths do not exist for the Maintenance/Test Digital Port. The primary information channel is tested by first looping back the data channel onto the TDM Bus, and then sending a digital count from the Tone-Clock circuit pack and receiving the same digital count with a general purpose tone detector. A conference test is done next for the primary information channel. This test is the same as Conference Test (#6).

Only one value (Pass, Fail, or Abort) is generated as a result of the two tests. If either fails or aborts, the sequence is stopped.

**Table 9-442. TEST #13 Digital Port Loop Around Test**

Error Code	Test Result	Description/ Recommendation
	ABORT	Internal System Error <ol style="list-style-type: none"> <li>1. Retry the command at 1-minute intervals a maximum of 5 times.</li> <li>2. If the test continues to abort, escalate the problem.</li> </ol>
1000	ABORT	The port is use on a valid ISDN-PRI Test Call. Use the <b>list isdn-testcall</b> command to determine which call is using the port (from the M/T Port column). Either wait for the test call to complete (as indicated in the Start Time and Duration fields in the above display), or abort the test call with the <b>clear isdn-testcall grp/mem</b> command, where grp/mem is determined from the B-channel field of the above display. <ol style="list-style-type: none"> <li>1. Retry the command at 1-minute intervals a maximum of 5 times.</li> <li>2. If the test continues to abort and the port is not in use, escalate the problem.</li> </ol>
1001	ABORT	System resources required to run this test are not available. <ol style="list-style-type: none"> <li>1. Retry the command at 1-minute intervals a maximum of 5 times.</li> <li>2. If the test continues to abort, escalate the problem.</li> </ol>
1002	ABORT	The system could not allocate time slots for the test. The system may be under heavy traffic conditions, or it may have time slots out-of-service due to TDM-BUS errors. <ol style="list-style-type: none"> <li>1. If the system has no TDM-BUS errors and is not handling heavy traffic, repeat the test at 1-minute intervals a maximum of 5 times.</li> <li>2. If the test continues to abort, escalate the problem.</li> </ol>
1003	ABORT	The system could not allocate a tone receiver for the test. The system may be oversized for the number of tone detectors present, or some tone detectors may be out-of-service. <ol style="list-style-type: none"> <li>1. Resolve any TTR-LEV errors.</li> <li>2. Resolve any TONE-PT errors.</li> <li>3. If neither condition exists, retry the command at 1-minute intervals a maximum of 5 times.</li> <li>4. If the test continues to abort, escalate the problem.</li> </ol>

*Continued on next page*

**Table 9-442. TEST #13 Digital Port Loop Around Test — Continued**

Error Code	Test Result	Description/ Recommendation
1004	ABORT	The port was seized by a valid ISDN-PRI Test Call. Use the <b>list isdn-testcall</b> command to determine which call is using the port (from the M/T Port column). Either wait for the test call to complete (as indicated in the Start Time and Duration fields of the above display), or abort the test call with the <b>clear isdn-testcall grp/mem</b> command, where grp/mem is determined from the B-channel field of the above display. <ol style="list-style-type: none"> <li>1. Retry the command at 1-minute intervals a maximum of 5 times.</li> <li>2. If the test continues to abort and the port is not in use, escalate the problem.</li> </ol>
2000	ABORT	Response to the test request was not received within the allowable time period.
2100	ABORT	System resources required to run this test are not available. <ol style="list-style-type: none"> <li>1. Retry the test at 1-minute intervals a maximum of 5 times.</li> <li>2. If the test continues to abort, escalate the problem.</li> </ol>
7	FAIL	Conference test failed on the primary information channel. In most cases, the user may not notice a disruption in service. <ol style="list-style-type: none"> <li>1. Run the circuit pack tests to check the Tone Generator circuit pack and the Tone Detector circuit pack via the <b>test board UUCSS</b> command.</li> <li>2. Resolve any problems that are detected on the Tone Generator circuit pack or Tone Detector circuit pack.</li> <li>3. If the Tone Generator and Tone Detector circuit packs are functioning properly, and the test still fails, replace the Maintenance/Test circuit pack.</li> </ol>
14	FAIL	The primary information channel is not transmitting properly. User impact may range from nothing to not being able to use this port. <ol style="list-style-type: none"> <li>1. Run the circuit pack tests to check the Tone Generator circuit pack and the Tone Detector circuit pack using <b>test board UUCSS</b>.</li> <li>2. Resolve any problems that are detected on the Tone Generator circuit pack or Tone Detector circuit pack.</li> <li>3. If the Tone Generator and Tone Detector circuit packs are functioning properly, and the test still fails, replace the Maintenance/Test Circuit Pack.</li> </ol>
	PASS	The Maintenance/Test Digital Port digital trunk testing capability is operating correctly.

## Clear Error Counters (#270)

This test is not an actual test in the strict sense of the word. Many circuit packs have counters in the Angel firmware. These counters are used so that Control Channel Message Set (CCMS) messages are not continuously sent uplink. Using this method, the message will be sent once, when the counter reaches some preset threshold, and then not sent again until the counter is cleared.

The ports on the Maintenance/Test circuit pack continually run self-tests, whenever the port is idle. The Angel uses a counter so that the Background Maintenance Failure message is only sent uplink once (this keeps a failed port/circuit pack from flooding the SPE with a string of messages). This test is used to clear the counter, so that if the port continues to fail during or after SPE-demanded testing, the Angel will send a message to indicate that fact.

This test is only used to send a message to the Angel on the Maintenance/Test Circuit Pack. Therefore, this test should never abort or fail.

**Table 9-443. TEST #270 Clear Error Counters**

Error Code	Test Result	Description/ Recommendation
Any	ABORT	This test should never abort.
Any	FAIL	This test should never fail. 1. Retry the command at 1-minute intervals a maximum of 5 times. 2. If the test continues to fail, escalate the problem.
	PASS	The message to clear the Maintenance/Test circuit pack's counter for Background Maintenance Failures has been sent.

## Digital Port Sanity Test (#565)

This test verifies that the port circuitry involved in the digital trunk testing on the Maintenance/Test Digital Port is functioning properly. This circuitry is common to both Maintenance/Test Digital Ports on the Maintenance/Test circuit pack. Therefore, this test is only run for port 2. The test will abort when run on port 3, as described in [Table 9-444](#).

This test operates by connecting the two Maintenance/Test Digital Ports on the TDM Bus so that they talk and listen to each other. Then four self-tests are attempted: (a) sending data from port 2 to port 3 in asynchronous mode; (b) sending data from port 3 to port 2 in asynchronous mode; (c) sending data from port 2 to port 3 in synchronous mode; and (d) sending data from port 3 to port 2 in synchronous mode. The test passes if all four of these self-tests are successful. The test will stop as soon as any one of these self-tests fails.

This test will abort if an ISDN Test Call is in progress on either Maintenance/Test Digital Port when the test is requested, or if an ISDN Test Call is initiated while the Digital Port Sanity Test is in progress

**Table 9-444. TEST #565 Digital Port Sanity Test**

Error Code	Test Result	Description/ Recommendation
1000	ABORT	<p>One of the Maintenance/Test Digital Ports is busy with background maintenance.</p> <ol style="list-style-type: none"> <li>1. Either wait for the port to become idle, or busy-out both Maintenance/Test Digital Ports on the Maintenance/Test circuit pack via the <b>busy-out port UUCSS02</b> and <b>busy-out port UUCSS03</b> commands, respectively.</li> <li>2. Release the ports (if they were busied out) via the <b>release port UUCSS02</b> and <b>release port UUCSS03</b> commands, respectively.</li> <li>3. Retry the command at 1-minute intervals a maximum of 5 times.</li> <li>4. If the test continues to abort, escalate the problem.</li> </ol>
1002	ABORT	<p>The system could not allocate time slots for the test. The system may be under heavy traffic conditions, or it may have time slots out-of-service due to TDM-BUS errors.</p> <ol style="list-style-type: none"> <li>1. If the system has no TDM-BUS errors, and if not handling heavy traffic, repeat the test at 1-minute intervals a maximum of 5 times.</li> <li>2. If the test continues to abort, escalate the problem.</li> </ol>
1004	ABORT	<p>The port was seized by a valid ISDN-PRI Test Call. Use the <b>list isdn-testcall</b> command to determine which call is using the port (from the M/T Port column). Either wait for the test call to complete (as indicated in the Start Time and Duration fields of the above display), or abort the test call with the <b>clear isdn-testcall grp/mem</b> command, where <b>grp/mem</b> is determined from the B-channel field of the above display.</p>
1019	ABORT	<p>An ISDN Test Call is in progress using this Maintenance/Test circuit pack. The Maintenance/Test circuit pack cannot perform a self-test on one of its Digital Ports while an ISDN Test Call is using either of the Digital Ports. Use the <b>list isdn-testcall</b> command to determine which call is using the port (from the M/T Port column). Either wait for the test call to complete (as indicated in the Start Time and Duration fields of the above display), or abort the test call with the <b>clear isdn-testcall grp/mem</b> command, where <b>grp/mem</b> is determined from the B-channel field of the above display.</p> <ol style="list-style-type: none"> <li>1. Retry the command at 1-minute intervals a maximum of 5 times.</li> <li>2. If the test continues to abort and the port is not in use, escalate the problem.</li> </ol>

*Continued on next page*

**Table 9-444. TEST #565 Digital Port Sanity Test — Continued**

Error Code	Test Result	Description/ Recommendation
1138	ABORT	This test does not run on port 3 of the Maintenance/Test circuit pack. This test will only run on port 2. Look at the results of the Digital Port Sanity Test for port 2.  1. Run the command again for port 2 via the <b>test port UUCSS02</b> or <b>test port UUCSS02 I</b> command.
2000	ABORT	Response to the test request was not received within the allowable time period.
2100	ABORT	System resources required to run this test are not available.
2500	ABORT	An internal operation failed; the test could not be completed.  1. Retry the command at 1-minute intervals a maximum of 5 times. 2. If the test continues to fail, escalate the problem.
50	FAIL	The switch was unable to communicate with the port circuitry used for digital trunk testing.
100	FAIL	Data was not sent from port 2 to port 3 successfully in asynchronous mode.
101	FAIL	Data was not sent from port 3 to port 2 successfully in asynchronous mode.
102	FAIL	Data was not sent from port 2 to port 3 successfully in synchronous mode.
103	FAIL	Data was not sent from port 3 to port 2 successfully in synchronous mode.  1. Reset the circuit pack via the <b>busy-out board UUCSS, reset board UUCSS, release board UUCSS</b> command sequence. 2. Test the port again via the <b>test port UUCSS02 I</b> command. 3. If the test fails again, replace the circuit pack.
	PASS	The Maintenance/Test Digital Port digital trunk testing capability is operating correctly.

### Hook State Inquiry (#566)

This test ensures that the Maintenance/Test Digital Port maintenance software and call processing agree on the on-/off-hook status of the Maintenance/Test Digital Port.

**Table 9-445. TEST #566 Hook State Inquiry**

Error Code	Test Result	Description/ Recommendation
1	ABORT	Switch hook audit timed out. No response was received from the circuit pack for information about the switch hook state. <ol style="list-style-type: none"> <li>1. Retry the command at 1-minute intervals a maximum of 5 times.</li> <li>2. If the test continues to abort, replace the circuit pack and repeat the test.</li> <li>3. If the test continues to abort, escalate the problem.</li> </ol>
2100	ABORT	System resources required to run this test are not available. <ol style="list-style-type: none"> <li>1. Retry the command at 1-minute intervals a maximum of 5 times.</li> <li>2. If the test continues to abort, escalate the problem.</li> </ol>
Any	FAIL	Internal System Error This test should never return a failure. <ol style="list-style-type: none"> <li>1. Retry the command at 1-minute intervals a maximum of 5 times.</li> <li>2. If the test continues to fail reset the circuit pack via the <b>busy-out board UUCSS, reset board UUCSS, release board UUCSS</b> command sequence.</li> <li>3. Retry the command at 1-minute intervals a maximum of 5 times.</li> <li>4. If the test continues to fail, escalate the problem.</li> </ol>
	PASS	Call processing and Maintenance/Test Digital Port maintenance software agree on the Maintenance/Test Digital Port hook state.

## M/T-PKT (Maintenance/Test Packet Bus Port)

---

MO Name As It Appears in Alarm Log	Alarm Level	Initial System Technician Command to Run <sup>1</sup>	Full Name of MO
M/T-PKT	Minor	test port UUCSSpp l	Maintenance/Test Packet Bus Port
M/T-PKT	Warning	release port UUCSSpp	Maintenance/Test Packet Bus Port

1. UU is the universal cabinet number (1 for PPN, 2 - 44 for EPNs). C is the carrier designation (A, B, C, D, or E). SS is the number of the slot in which the circuit pack resides (01 to 21). pp is the two digit port number (01, 02, ...).

The Maintenance/Test Packet Bus Port (M/T-PKT) is port number 4 on the TN771 Maintenance/Test circuit pack. The Packet Bus port provides the following Packet Bus maintenance functions:

- Packet Bus fault detection  
The ability to detect faults (e.g., shorts, open leads) on the Packet Bus autonomously (i.e. without SPE involvement).
- Packet Bus reconfiguration  
The ability to swap faulty leads with spare leads autonomously so that the Packet Bus remains operational. This is accomplished by sending messages to all Packet circuit packs [e.g., ISDN-BRI (TN556)] telling them which spare leads to use on the Packet Bus.

M/T-PKT maintenance ensures that these maintenance functions are operating correctly. The Maintenance/Test Packet Bus Port is alarmed if maintenance determines that the port's maintenance functions are operating incorrectly.

When M/T-PKT maintenance determines that the Packet Bus Port is defective, the Packet Bus fault detection and Packet Bus reconfiguration functions provided by the port will be turned off.

M/T-PKT maintenance interacts with Packet Bus maintenance. Therefore, there may be alarms on the Packet Bus when there is a fault on the M/T-PKT. Refer to PKT-BUS (Packet Bus) Maintenance documentation for further information.



## Hardware Error Log Entries and Test to Clear Values

---

### M/T-PKT Error Log Entries

Error Type	Aux Data	Associated Test	Alarm Level	On/Off Board	Test to Clear Value
0 <sup>1</sup>	0	Any	Any	Any	test port UUCSSpp
1 (a)	41018	none	MINOR	ON	test port UUCSSpp l r 3
18 (b)	0	busyout port UUCSSpp	WARNING	OFF	release port UUCSSpp
257 (c)	Any	none	MINOR	ON	
513 (d)	Any	Packet Bus Port Health Inquiry Test (#567)	MINOR	ON	test port UUCSSpp r 3

1. Run the Short Test Sequence first. If all tests pass, run the Long Test Sequence. Refer to the appropriate test description and follow the recommended procedures.

#### Notes:

- a. This error indicates a hardware failure with the port circuitry which provides the Packet Bus maintenance functions. Replace the Maintenance/Test circuit pack if the alarm is not resolved by the test command above.
- b. The port has been busied out via the **busyout port UUCSSpp** command.
- c. This error indicates that the Maintenance/Test Packet Bus Port has reconfigured the Packet Bus by swapping a bad lead to a spare. Note that this error is sent up whenever the Maintenance/Test Packet Bus Port is initialized (since the Packet Bus Port reconfigures the Packet Bus to whatever state it determines the Packet Bus is in). This will occur if the circuit pack is inserted, if the system is restarted, or if the port is released from a busyout state. Therefore, it is normal for this error to be present in the error log.

If the M/T-PKT reconfigures the Packet Bus 6 times within 15 minutes, a Minor alarm is raised indicating that either Packet Bus maintenance functions are not operating correctly, or many changes are taking place on the Packet Bus (circuit pack insertions or removals). If the system has been in a stable state for more than 15 minutes, try the following procedure:

1. Reset the Maintenance/Test circuit pack from the G3-MT as follows:
  - Enter the **busyout board UUCSS** command.
  - Enter the **reset board UUCSS** command.
  - Enter the **release board UUCSS** command.
2. Wait 15 minutes.
3. If the error recurs, replace the Maintenance/Test circuit pack.

When this alarm is active, the yellow LED will be in one of three states:

- An unlit yellow LED indicates no activity on the Maintenance/Test circuit pack. You can replace the Maintenance/Test circuit pack.
  - If there is an indication of an uncorrectable fault on the Packet Bus, the yellow LED will be blinking at a rate of 1 Hz. It is OK to replace the Maintenance/Test circuit pack. Ignore the Packet Bus error indication, since the Maintenance/Test circuit pack has been determined to be defective.
  - If there is other activity on the Maintenance/Test circuit pack (i.e. ISDN Test Call), or if there is an indication of a correctable fault on the Packet Bus, the yellow LED will be on steady. If there is an ISDN Test Call in progress, it must be halted via the **clear isdn-testcall grp/member** command prior to replacing the circuit pack. Ignore the Packet Bus error indication, since the Maintenance/Test circuit pack has been determined to be defective.
- d. This error indicates a failure of the Packet Bus Port Health Inquiry Test. Either the Packet Bus Port has reported a self-test failure, or the SPE is able to communicate with the Maintenance/Test Circuit Pack but not with the Maintenance/Test Circuit Pack Packet Bus Port. Refer to the description of the Packet Bus Port Health Inquiry Test, and follow the instructions indicated for the failure code that matches the Aux Data field.

## System Technician-Demanded Tests: Descriptions and Error Codes

Always investigate tests in the order presented in the following table when inspecting errors in the system.

Order of Investigation	Short Test Sequence	Long Test Sequence	D/ND <sup>1</sup>
Packet Bus Port Health Inquiry Test (#567)	X	X	ND
Clear Error Counters (#270)		X	ND

1. D = Destructive, ND = Non-destructive

## Clear Error Counters (#270)

This test is not an actual test in the strict sense of the word. Many circuit packs have counters in the Angel firmware. The circuit pack's Angel continuously runs port self-tests on idle ports and keeps track of any errors it detects by incrementing a firmware counter. When the counter value reaches some preset threshold, the Angel sends a single CCMS (Control Channel Message Set) error message uplink to the SPE. No more error messages of that type are sent uplink until the SPE sends a downlink message to clear the counter. This strategy keeps a failed port/circuit pack from flooding the SPE with a continuous string of identical error messages). This test is used to clear the counter, so that if the port continues to fail during or after SPE-demanded testing, the Angel will send a message to indicate that fact.

This test is only used to send a downlink message to the Angel on the Maintenance/Test circuit pack. Since the Angel normally provides no uplink response to this message, this test should never abort or fail.

**Table 9-446. TEST #270 Clear Error Counters**

Error Code	Test Result	Description/ Recommendation
Any	ABORT	This test should never abort.
Any	FAIL	This test should never fail. <ol style="list-style-type: none"> <li>1. Retry the command at 1-minute intervals a maximum of 5 times.</li> <li>2. If the test continues to fail, escalate the problem.</li> </ol>
	PASS	The message to clear the Maintenance/Test circuit pack's counter for Background Maintenance Failures has been sent.

## Packet Bus Port Health Inquiry Test (#567)

This test verifies that the Packet Bus fault detection maintenance function of the M/T-PKT is functioning properly. This is done by having the M/T-PKT perform a self-test. If this self-test passes, then the Packet Bus Port Health Inquiry Test passes. If the self-test fails, or the SPE cannot communicate with the M/T-PKT, then the test fails

**Table 9-447. TEST #567 Consistency Test**

Error Code	Test Result	Description/ Recommendation
2000	ABORT	Response to the test request was not received within the allowable time period.
2100	ABORT	System resources necessary to run this test are not available.
2500	ABORT	An internal operation failed, and the test could not be completed. <ol style="list-style-type: none"> <li>1. Retry the command at 1-minute intervals a maximum of 5 times.</li> <li>2. If the test continues to abort, escalate the problem.</li> </ol>
2059	FAIL	The M/T-PKT has reported a failure of the on-board self-test.
2060	FAIL	The M/T-PKT has reported an invalid state for the Packet Bus.
2061	FAIL	The SPE cannot communicate with the M/T-PKT, but is able to communicate with the Maintenance/Test Circuit Pack. <ol style="list-style-type: none"> <li>1. Retry the command.</li> <li>2. If the test continues to fail, replace the Maintenance/Test circuit pack and retry the command.</li> <li>3. If the test continues to fail, refer to PKT-BUS Maintenance documentation to determine if the M/T-PKT failure is being caused by a Packet Bus fault.</li> </ol>
	PASS	The M/T-PKT Packet Bus fault detection capability is operating correctly.

## OPS-LINE (DS1 Off Premises Station Line)

MO Name (in Alarm Log)	Alarm Level	Initial Command to Run	Full Name of MO
OPS-LINE	MINOR	test station <i>extension</i> l	DS1 OPS Line
OPS-LINE	WARNING	test station <i>extension</i>	DS1 OPS Line

An analog Off-Premises Station (OPS) can be connected to the system through a DS1 link. A TN767 DS1 Interface circuit pack or a TN464 UDS1 Interface circuit pack can support up to 24 DS1 OPSs. Since the DS1 OPS is an analog telephone set, a channel multiplexer is necessary as the remote DS1 endpoint that converts the digital signal of a DS1 port to the OPS Line and vice versa.

The DS1 OPS Line Maintenance provides a strategy to maintain an OPS Line via a trunk port of the TN767 DS1 Interface circuit pack or the TN464 UDS1 Interface circuit pack. (Throughout this section, the term DS1 Interface can apply to either of these circuit packs.) The strategy covers initialization tests, periodic tests, scheduled tests, system technician-demanded tests, and alarm resolution and escalation. Two service states are specified in a DS1 OPS Line maintenance. They are: *out-of-service*, in which the line is in a deactivated state and cannot be used for either incoming or outgoing calls; or *in-service*, in which the line is in an activated state and can be used for both incoming and outgoing calls. If the DS1 Interface circuit pack is out-of-service, then all lines on the DS1 Interface circuit pack are put into the out-of-service state, and a Warning alarm is raised.

For maintenance of the remote DS1 endpoint (for example, a Channel Division Multiplexer or D4 Channel Bank), refer to the maintenance documentation from its vendor for details.

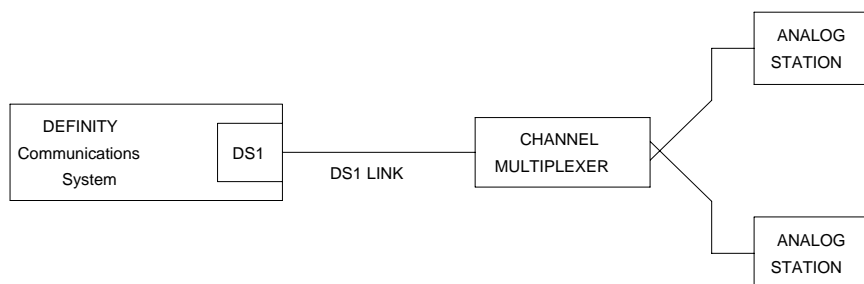

Figure 9-67. DS1 OPS Line Interactions

## Error Log Entries and Test to Clear Values

**Table 9-448. DS1 OPS Maintenance Error Log Entries**

Error Type	Aux Data	Associated Test	Alarm Level	On/Off Board	Test to Clear Value
0 <sup>1</sup>	0	Any	Any	Any	test station <ext>
15(a)	Any	Audit and Update Test (#36)			
18(b)	0	busyout station <ext>	WARNING	OFF	release station <ext>
130(c)		None	WARNING	ON	test station <ext>
1281		Conference Circuit Test (#7)	MINOR	ON	test station <ext>   r 4
1537		NPE Crosstalk Test (#6)	MINOR	ON	test station <ext>   r 3
1793(d)					test board UUCSS I

1. Run the Short Test Sequence first. If all tests pass, run the Long Test Sequence. Refer to the appropriate test description and follow the recommended procedures.

### Notes:

- a. This is a software audit error that does not indicate any hardware malfunction. Run the Short Test Sequence and investigate associated errors (if any).
- b. The DS1 OPS Line has been busied out by a **busyout station <ext>** command. No calls can be made on this line.
- c. This error type indicates that the circuit pack has been removed or has been insane for more than 11 minutes. To clear the error, reinsert or replace the circuit pack.
- d. Error Type 1793 indicates a problem with the DS1 Interface circuit pack. Since there is no error against the OPS-LINE port, no alarm is raised against the OPS-LINE port. However, there should be errors logged against the DS1 Interface circuit pack. Look for DS1-BD/UDS1-BD errors in the Hardware Error Log and follow the appropriate procedures provided in the DS1-BD/UDS1-BD (DS1/UDS1 Interface Circuit Pack) Maintenance documentation.

## **System Technician-Demanded Tests: Descriptions and Error Codes**

---

Always investigate tests in the order presented in the table below when inspecting errors in the system. By clearing error codes associated with the *NPE Crosstalk Test*, for example, you may also clear errors generated from other tests in the testing sequence.

<b>Order of Investigation</b>	<b>Short Test Sequence</b>	<b>Long Test Sequence</b>	<b>D/ND<sup>1</sup></b>
NPE Crosstalk Test (#6)		X	ND
Conference Circuit Test (#7)		X	ND
DS1 OPS Switchhook Inquiry Test (#312)	X	X	ND
Audit and Update Test (#36)	X	X	ND

---

1. D = Destructive; ND = Nondestructive

## NPE Crosstalk Test (#6)

One or more Network Processing Elements (NPEs) reside on each circuit pack with a TDM Bus interface. (The TN464 UDS1 circuit pack has one SCOTCH-NPE chip instead of several NPE chips.) The NPE controls port connectivity and gain, and provides conferencing functions on a per-port basis. The NPE Crosstalk Test verifies that this port's NPE channel talks on the selected time slot and never crosses over to time slots reserved for other connections. If the NPE is not working correctly, one-way and noisy connections may be observed. This test is usually only part of a port's Long Test Sequence and takes about 20 to 30 seconds to complete

**Table 9-449. TEST #6 NPE Crosstalk Test**

Error Code	Test Result	Description/ Recommendation
	ABORT	Could not allocate system resources to run this test or an internal system error (software) occurred.  1. Retry the command at 1-minute intervals a maximum of 5 times.
1000	ABORT	System resources required to run this test are not available. The port may be in use on a valid call. Use <b>status station</b> or <b>status trunk</b> command to determine when the port is available for testing.  1. Retry the command at 1-minute intervals a maximum of 5 times.
1001	ABORT	Could not allocate the necessary system resources to run this test.  1. Retry the command at 1-minute intervals a maximum of 5 times.
1002	ABORT	The system could not allocate time slots for the test. The system may be under heavy traffic conditions or it may have time slots out-of-service due to TDM-BUS errors. The <b>status health</b> command can be used to determine if the system is experiencing heavy traffic.  1. If system has no TDM-BUS errors and is not handling heavy traffic, repeat test at 1-minute intervals a maximum of 5 times.
1003	ABORT	The system could not allocate a tone receiver for the test. The system may be oversized for the number of Tone Detectors present or some Tone Detectors may be out-of-service. The <b>list measurements tone-receiver</b> command will display information on the system's tone receivers.  1. Resolve any TTR-LEV errors. 2. Resolve any TONE-PT errors. 3. If neither condition exists, retry the test at 1-minute intervals a maximum of 5 times.

*Continued on next page*



**Table 9-449. TEST #6 NPE Crosstalk Test — Continued**

Error Code	Test Result	Description/ Recommendation
1004	ABORT	The test was aborted because the port was seized by a user for a valid call. Use <b>status station</b> command to determine the service state of the port. If the service state indicates that the port is in use, then the port is unavailable for certain tests. You must wait until the port is idle before retesting. <ol style="list-style-type: none"> <li>1. Retry the command at 1-minute intervals a maximum of 5 times.</li> </ol>
1020	ABORT	The test did not run due to an already existing error on the specific port or due to a more general error on the circuit pack. <ol style="list-style-type: none"> <li>1. Examine the error log for existing errors against this port or the circuit pack and attempt to diagnose the already existing error. (Error code 1793 indicates a problem with the DS1 interface board, and any problems on the associated DS1-BD or UDS1-BD should be resolved first.)</li> </ol>
2000	ABORT	Response to the test request was not received within the allowable time period. <ol style="list-style-type: none"> <li>1. Retry the command at 1-minute intervals a maximum of 5 times.</li> <li>2. If the test aborts with error code 2000 again, run short test sequence on the associated DS1-BD or UDS1-BD. If tests 138 through 145 on the associated DS1-BD or UDS1-BD are also aborting with error code 2000, hyperactivity on the board or facility is indicated. In this case, the hyperactivity problem should be dealt with first.</li> </ol>
2100	ABORT	System resources required for this test are not available. <ol style="list-style-type: none"> <li>1. Retry the command at 1-minute intervals a maximum of 5 times.</li> </ol>
Any	FAIL	The test failed. This can be due to on-board or off-board problems. Off-board problems of concern include EXP-PN and EXP-INTF faults, TDM-BUS faults, and faults associated with the tone detectors/tone generators. Clear all off-board problems before replacing the board. Keep in mind that a TDM-BUS problem is usually the result of a faulty board connected to the backplane or bent pins on the backplane. <ol style="list-style-type: none"> <li>1. Resolve any TONE-BD and/or TONE-PT errors.</li> <li>2. Retest when the faults from step 1 are cleared.</li> </ol>

*Continued on next page*

Table 9-449. TEST #6 NPE Crosstalk Test — *Continued*

Error Code	Test Result	Description/ Recommendation
	PASS	The port is correctly using its allocated time slots. User-reported troubles on this port should be investigated using other port tests and by examining station, trunk, or external wiring.
0	NO BOARD	<p>The test could not relate the internal ID to the port (no board). This could be due to incorrect translations, no board is inserted, an incorrect board is inserted, or an insane board is inserted.</p> <ol style="list-style-type: none"> <li>1. Check to ensure that the board translations are correct. Use the <b>list config</b> command, and resolve any problems that are found.</li> <li>2. If the board was found to be correctly inserted in step 1, issue the <b>busyout board</b> command.</li> <li>3. Issue the <b>reset board</b> command.</li> <li>4. Issue the <b>release busy board</b> command.</li> <li>5. Issue the <b>test board long</b> command. This should re-establish the linkage between the internal ID and the port. If this is not the case, dispatch to check to ensure that there is a valid board inserted.</li> </ol>

## Conference Circuit Test (#7)

One or more Network Processing Elements (NPEs) reside on each circuit pack with a TDM Bus interface. (The TN464 UDS1 circuit pack has one SCOTCH-NPE chip instead of several NPE chips). The NPE controls port connectivity and gain, and provides conferencing functions on a per-port basis. The Conference Circuit Test verifies that the NPE channel for the port being tested can correctly perform the conferencing function. The NPE is instructed to listen to several different tones and conference the tones together. The resulting signal is then measured by a Tone Detector port. If the level of the tone is within a certain range, the test passes

**Table 9-450. TEST #7 Conference Circuit Test**

Error Code	Test Result	Description/ Recommendation
	ABORT	System resources required for this test are not available. <ol style="list-style-type: none"><li>1. Retry the command at 1-minute intervals a maximum of 5 times.</li></ol>
1000	ABORT	System resources required to run this test are not available. The port may be in use on a valid call. Use the <b>status station</b> or <b>status trunk</b> command to determine when the port is available for testing.
1002	ABORT	The test was aborted because the system could not allocate time slots for the test. The system might be under heavy traffic conditions, or it might have time slots out of service due to TDM-BUS errors. (The <b>status health</b> command may be used to determine whether the system is experiencing heavy traffic.) <ol style="list-style-type: none"><li>1. If the system has no TDM-BUS errors, is not handling heavy traffic, and the port status is idle, retry the command at 1-minute intervals for a maximum of 5 times.</li></ol>
1003	ABORT	The system could not allocate a tone receiver for the test. The system may be oversized for the number of tone detectors present or some of the tone detectors may be out of service. Issue the <b>list measurements tone-receiver</b> command to display basic information about the system's tone receivers. <ol style="list-style-type: none"><li>1. Resolve any TTR-LEV errors.</li><li>2. Resolve any TONE-PT errors.</li><li>3. If neither condition exists, retry the test at 1-minute intervals for a maximum of 5 times.</li></ol>
1004	ABORT	The port has been seized by a user for a valid call. Use <b>status station</b> or <b>status trunk</b> command to determine when the port is available for testing. <ol style="list-style-type: none"><li>1. Retry the command at 1-minute intervals a maximum of 5 times.</li></ol>

*Continued on next page*

**Table 9-450. TEST #7 Conference Circuit Test — Continued**

Error Code	Test Result	Description/ Recommendation
1018	ABORT	The test was disabled via translation. <ol style="list-style-type: none"> <li>1. You may want to determine why the test has been disabled before you enable it.</li> <li>2. To enable the test for the particular analog station being tested, enter the 'change station extension' command, and then change the 'Test' field on the 'Station' form from 'n' to 'y.'</li> </ol>
1020	ABORT	The test did not run due to an already existing error on the specific port or due to a more general error on the circuit pack. <ol style="list-style-type: none"> <li>1. Examine the error log for existing errors against this port or the circuit pack and attempt to diagnose the already existing error. (Error code 1793 indicates a problem with the DS1 interface board, and any problems on the associated DS1-BD or UDS1-BD should be resolved first.)</li> </ol>
2000	ABORT	The test was aborted because response to the test was not received within the allowable time period. <ol style="list-style-type: none"> <li>1. Retry the command at 1-minute intervals for a maximum of 5 times.</li> <li>2. If the test aborts with error code 2000 again, run short test sequence on the associated DS1-BD or UDS1-BD. If tests 138 through 145 on the associated DS1-BD or UDS1-BD are also aborting with error code 2000, hyperactivity on the board or facility is indicated. In this case, the hyperactivity problem should be dealt with first.</li> </ol>
2100	ABORT	System resources required for this test are not available. <ol style="list-style-type: none"> <li>1. Retry the command at 1-minute intervals a maximum of 5 times.</li> </ol>

*Continued on next page*

**Table 9-450. TEST #7 Conference Circuit Test — Continued**

Error Code	Test Result	Description/ Recommendation
	FAIL	<p>The NPE of the tested port did not conference the tones correctly. This can cause noisy and unreliable connections.</p> <ol style="list-style-type: none"> <li>1. Enter the <b>list configuration board UUCSS</b> command. If the circuit pack is a TN767B vintage 8 or 9, replace the circuit pack with a TN767C V3 or later. The error log may have error type 1281 entries.</li> <li>2. Test all administered trunks on the board. If one fails, this could be an off-board problem (such as an incoming seizure or an off-hook port seizure during the test). Retest the board.</li> <li>3. If all of the ports fail, check the CARR-POW (see note below).</li> <li>4. If several ports fail, check the error log for TONE-BD or TONE-PT errors. If there are such errors, take the appropriate action. When the TONE errors have cleared, rerun the test.</li> <li>5. If the retry passes and troubles have been reported, coordinate isolation with the far-end PBX. Make sure that the near-end and far-end switches and any NTCE equipment (the CSUs) have the correct administration.</li> <li>6. Replace the circuit pack.</li> </ol> <p><b>⇒ NOTE:</b></p> <p>If the conference circuit test fails for all ports on a circuit pack, a -5 volt power problem is indicated. If a TN736 or TN752 power unit circuit pack is present, either the 631DB AC power unit or the 676B DC power unit may be defective. (The 631DB power unit is used in a medium cabinet powered by an AC source. The 645B power unit is used in a medium cabinet powered by a DC power source.) The system may contain a TN736 or TN752 power unit or a 631DB AC power unit, but not both types of power units. To investigate problems with a 631DB AC power unit, refer to the CARR-POW (carrier port power unit for AC-powered systems) Maintenance documentation. To investigate problems with a 645B DC power unit, refer to the CARR-POW (carrier port power unit for DC-powered systems) Maintenance documentation. If a red LED on TN736 or TN752 power unit circuit pack is on, replace the pack.</p>

*Continued on next page*

Table 9-450. TEST #7 Conference Circuit Test — *Continued*

Error Code	Test Result	Description/ Recommendation
	PASS	The port can correctly conference multiple connections. User-reported troubles on this port should be investigated using other port tests and by examining station, trunk, or external wiring.
0	NO BOARD	<p>The test could not relate the internal ID to the port (no board). This could be due to incorrect translations, no board is inserted, an incorrect board is inserted, or an insane board is inserted.</p> <ol style="list-style-type: none"> <li>1. Check to ensure that the board translations are correct. Use the <b>list config</b> command, and resolve any problems that are found.</li> <li>2. If the board was found to be correctly inserted in step 1, issue the <b>busyout board</b> command.</li> <li>3. Issue the <b>reset board</b> command.</li> <li>4. Issue the <b>release busy board</b> command.</li> <li>5. Issue the <b>test board long</b> command. This should re-establish the linkage between the internal ID and the port. If this is not the case, dispatch to check to ensure that there is a valid board inserted.</li> </ol>

## Audit and Update Test (#36)

This test sends port level translation data from switch processor to the DS1 Interface circuit pack to assure that the trunk's translation is correct. Translation updates include the following data: line type, dial type, timing parameters, and signaling bits enabled. The port audit operation verifies the consistency of the current state of the trunk as kept in the DS1 Interface circuit pack and in the switch software

**Table 9-451. TEST #36 Audit and Update Test**

Error Code	Test Result	Description/ Recommendation
	ABORT	Internal system error <ol style="list-style-type: none"><li>1. Retry the command at 1-minute intervals a maximum of 5 times.</li></ol>
1000	ABORT	The test was aborted because system resources required to run this test were not available. The port may be busy with a valid call. <ol style="list-style-type: none"><li>1. Use the <b>display port UUCSSpp</b> command to determine the station extension of the port. Use the <b>status station</b> command to determine the service state of the port. If the service state indicates that the port is in use, then the port is unavailable for certain tests. You must wait until the port is idle before retesting.</li><li>2. If the port is idle, retry the command at 1-minute intervals a maximum of 5 times.</li></ol>
1006	ABORT	The test was aborted because the station is out of service. This condition may be accompanied by an error type 18 entry in the error log. You may want to determine why the station was taken out of service. (When stations are taken out of service by maintenance software, the problems that preceded that point must be cleared.) <ol style="list-style-type: none"><li>1. Use the <b>status station</b> command to check the service state of the port. If the port is indeed out of service, enter the <b>release station</b> command to bring the station back into service.</li><li>2. Retry the command at 1-minute intervals a maximum of 5 times.</li></ol>
2000	ABORT	Response to the test request was not received within the allowable time period.
2100	ABORT	Could not allocate the necessary system resources to run this test. <ol style="list-style-type: none"><li>1. Retry the command at 1-minute intervals a maximum of 5 times.</li></ol>
7 or 8	FAIL	Test failed due to internal system error. Do not replace port board. <ul style="list-style-type: none"><li>■ Error code 7: the failure occurred during station translation download (to DS1 Interface circuit pack).</li><li>■ Error code 8: the failure occurred during station ringer update.</li></ul> <ol style="list-style-type: none"><li>1. Retry the command at 1-minute intervals a maximum of 5 times.</li></ol>

*Continued on next page*

Table 9-451. TEST #36 Audit and Update Test — *Continued*

Error Code	Test Result	Description/ Recommendation
	PASS	<p>Trunk translation has been updated successfully. The current trunk states kept in the DS1 Interface circuit pack and switch software are consistent. If the trunk is busied out, the test will not run but will return PASS. To verify that the station is in-service:</p> <ol style="list-style-type: none"> <li>1. Enter the <b>status station</b> command to verify that the station is in-service. If the station is in-service, no further action is necessary. If the station is out-of-service, continue to step 2.</li> <li>2. Enter the <b>release station</b> command to put the station back into in-service.</li> <li>3. Retry the test command.</li> </ol>
0	NO BOARD	<p>The test could not relate the internal ID to the port (no board). This could be due to incorrect translations, no board is inserted, an incorrect board is inserted, or an insane board is inserted.</p> <ol style="list-style-type: none"> <li>1. Check to ensure that the board translations are correct. Use the <b>list config</b> command, and resolve any problems that are found.</li> <li>2. If the board was found to be correctly inserted in step 1, issue the <b>busyout board</b> command.</li> <li>3. Issue the <b>reset board</b> command.</li> <li>4. Issue the <b>release busy board</b> command.</li> <li>5. Issue the <b>test board long</b> command. This should re-establish the linkage between the internal ID and the port. If this is not the case, dispatch to check to ensure that there is a valid board inserted.</li> </ol>



**DS1 OPS Switchhook Inquiry Test (#312)**

This test initiates the Switchhook Audit Test. The test queries the switchhook state of the Off-Premises-Station in switch software. If the state in switch software disagrees with the state on the DS1 Interface circuit pack, then the state in the switch software is updated to match the state on the DS1 Interface circuit pack

**Table 9-452. TEST #312 DS1 OPS Switchhook Inquiry Test**

<b>Error Code</b>	<b>Test Result</b>	<b>Description/ Recommendation</b>
	ABORT	Internal system error <ol style="list-style-type: none"><li>1. Retry the command at 1-minute intervals a maximum of 5 times.</li></ol>
1004	ABORT	The port has been seized by a user for a valid call. Use the <b>status station</b> command to determine when the port is available for testing. <ol style="list-style-type: none"><li>1. Retry the command at 1-minute intervals a maximum of 5 times.</li></ol>
1005	ABORT	Test failed due to incompatible configuration administered in station administration. <ol style="list-style-type: none"><li>1. Using the <b>display station</b> command, verify that the station is not the 24th port of the DS1 Interface circuit pack while common channel signaling is specified. Use the <b>display ds1</b> command to check the signaling type of the DS1 circuit pack.</li></ol>
1006	ABORT	The test was aborted because the station is out of service. This condition may be accompanied by an error type 18 entry in the error log. You may want to determine why the station was taken out of service. (When stations are taken out of service by maintenance software, the problems that led up to that must be cleared.) <ol style="list-style-type: none"><li>1. Use the <b>status station</b> command to check the state of the port. If the port is indeed out of service, enter the <b>release station</b> command to bring the station back into service.</li><li>2. Retry the command at 1-minute intervals a maximum of 5 times.</li></ol>
1020	ABORT	The DS1 Interface circuit pack is out-of-service. <ol style="list-style-type: none"><li>1. Look for DS1-BD/UDS1-BD errors in Hardware Error Log. If present, refer to the appropriate DS1-BD/UDS1-BD (DS1/UDS1 Interface Circuit Pack) Maintenance documentation.</li><li>2. Retry the command.</li></ol>

*Continued on next page*

**Table 9-452. TEST #312 DS1 OPS Switchhook Inquiry Test — Continued**

Error Code	Test Result	Description/ Recommendation
2000	ABORT	The test was aborted because response to the test was not received within the allowable time period. <ol style="list-style-type: none"> <li>1. Retry the command at 1-minute intervals for a maximum of 5 times.</li> <li>2. If the test aborts with error code 2000 again, run short test sequence on the associated DS1-BD or UDS1-BD. If tests 138 through 145 on the associated DS1-BD or UDS1-BD are also aborting with error code 2000, hyperactivity on the board or facility is indicated. In this case, the hyperactivity problem should be dealt with first.</li> </ol>
2012	ABORT	The test was aborted due to a system error.
2100	ABORT	Could not allocate the necessary system resources to run this test. <ol style="list-style-type: none"> <li>1. Retry the command at 1-minute intervals for a maximum of 5 times.</li> </ol>
1	FAIL	Internal system error. <ol style="list-style-type: none"> <li>1. Look for DS1-BD/UDS1-BD errors in the Hardware Error Log. If present, refer to the appropriate DS1-BD/UDS1-BD (DS1/UDS1 Interface Circuit Pack) Maintenance documentation.</li> <li>2. If a channel multiplexer is used as the remote DS1 endpoint to which the station connects, refer to the multiplexer vendor's maintenance document for diagnosis.</li> <li>3. Retry the command at 1-minute intervals a maximum of 5 times.</li> </ol>
	PASS	The station hook states in both switch software and DS1 Interface circuit pack are consistent.
0 2012	NO BOARD	The test could not relate the internal ID to the port (no board). This could be due to incorrect translations, no board is inserted, an incorrect board is inserted, or an insane board is inserted. <ol style="list-style-type: none"> <li>1. Check to ensure that the board translations are correct. Use the <b>list config</b> command, and resolve any problems that are found.</li> <li>2. If the board was found to be correctly inserted in step 1, issue the <b>busyout board</b> command.</li> <li>3. Issue the <b>reset board</b> command.</li> <li>4. Issue the <b>release busy board</b> command.</li> <li>5. Issue the <b>test board long</b> command. This should re-establish the linkage between the internal ID and the port. If this is not the case, dispatch to check to ensure that there is a valid board inserted.</li> </ol>

## PDATA-BD (Packet Data Line Circuit Pack)

---

MO Name (in Alarm Log)	Alarm Level	Initial Command to Run <sup>1</sup>	Full Name of MO
PDATA-BD	MINOR	test board UUCSS	PDATA Board Maintenance

- 
1. UU is the universal cabinet number (1 for PPN, 2 - 44 for EPNs). C is the carrier designation (A, B, C, D, or E). SS is the number of the slot in which the circuit pack resides (01 to 21).

The TN553 Packet Data Line (PDATA-BD) circuit pack supports the connection of twelve (12) asynchronous EIA RS-232C endpoints to the packet bus. Functions of this circuit pack are described in the PDATA-PT section.

## Error Log Entries and Test to Clear Values

Table 9-453. PDATA Board Error Log Entries

Error Type	Aux Data	Associated Test	Alarm Level <sup>1</sup>	On/Off Board	Test to Clear Value
0 <sup>2</sup>		Any	Any	Any	test port UUCSSpp sh r 1
1(a)		None	MINOR	ON	
18(b)		Busyout Board	WARNING	OFF	release board UUCSS
257(c)		CC Loop Test (#52)	MINOR	ON	test board UUCSS r3
513(d)					
769(e)					
1025(f)	4363	NPE Audit Test (#50)			
1293(g)	46088 to 46089		MINOR	ON	
1538(h)	46082		MINOR	ON	
1793(i)	46080		MINOR	ON	
2306(j)	46081				
3330(k)	46083		MINOR	ON	
3840(l)	4096 to 4101				
3843(m)	46097				
3999(n)	Any	None			

1. Major or Minor alarms may have been downgraded to Warning alarms based on the values used in the **set options** command.
2. Run the Short Test Sequence first. If all tests pass, run the Long Test Sequence. Refer to the appropriate test description and follow the recommended procedures.

### Notes:

- a. Error type 1 indicates the circuit pack has stopped functioning or has been physically removed from the system. This error type does not apply to ANN-BD, DETR-BD, S-SYN-BD, M/T-BD, or CLSFY-BD. The alarm is logged approximately 11 minutes after removal of the circuit pack or failure of the SAKI Sanity Test (#53).

Check for the physical presence of the circuit pack in the slot indicated by the alarm. If the circuit pack is not present, insert one of the proper type. If the circuit pack is present and its red LED is lit, see *LED Alarm Without Alarm Log Entry* in [Chapter 7, "LED Interpretation"](#).

- b. The circuit pack has been busied out via the **busyout board UUCSS** command.
- c. This error indicates communication problems between the switch and this circuit pack. Execute the **test board UUCSS** command and refer to the repair procedures for Control Channel Loop-Around Test (#52).
- d. An on-board hardware failure has been detected by the circuit pack. Reset the circuit pack by executing **busyout board UUCSS** and **reset board UUCSS** commands. If there is a problem, it will be detected during initialization and will cause the circuit pack to lock up and appear insane to the system. See the repair procedure in footnote (a).
- e. This error is reported by the circuit pack when it detects a program logic error. While no action is required, this error may lead to errors of other types being reported against this circuit pack.
- f. This error is reported by the circuit pack when it cannot update NPE memory and read it back. This error type can be ignored, but may lead to errors of other types being reported against this circuit pack.
- g. A critical hardware failure (one or both of the data processors are insane) has been detected on the circuit pack. Reset the circuit pack via the **busyout board UUCSS** and **reset board UUCSS** commands. If the circuit pack Restart Test (#594) passes, then the on-board circuitry is healthy. Retire the alarm via the **test board UUCSS long clear** command. If the circuit pack Restart Test (#594) fails, replace the circuit pack.

This error is also caused when the buffers on the board receive data faster than they can transmit to the endpoints (Receive FIFO Overflow). Use the above steps to repair the problem.

- h. Circuit pack is hyperactive; i.e., it is flooding the switch with messages sent over the control channel. The circuit pack is taken out-of-service when a threshold number of these errors is reported to the switch. Clear the alarm via the following commands: **busyout board UUCSS**, **reset board UUCSS**, **test board UUCSS long clear**, **release board UUCSS**. If the error recurs within 10 minutes, then replace the circuit pack.
- i. This error indicates that parity errors are detected when transmitting data to the Packet Bus. Reset the circuit pack via **busyout board UUCSS** and **reset board UUCSS** commands. Also clear the alarm via **test board UUCSS long clear**. If the error returns within 10 minutes, then replace the circuit pack.
- j. This error occurs when the circuit pack detects an error in a received frame from the packet bus. These errors are most likely caused by a packet bus problem, but may be due to a circuit pack fault.

Perform a LANHO Receive Parity Error Counter Test (#595) via **test board UUCSS I** to determine if the condition has cleared. Also refer to PKT-BUS Maintenance documentation to determine if the problem is isolated to this circuit pack or if the problem is caused by Packet Bus faults.

- k. A critical failure has been detected in the Packet Bus interface of the circuit pack. This failure may be due to an on-board fault or a Packet Bus fault. If the Packet Bus is alarmed, refer to the PKT-BUS Maintenance documentation for recommended repair procedures.

If the Packet Bus is not alarmed, reset the circuit pack via **busyout board UUCSS** and **reset board UUCSS** commands. If the circuit pack Restart Test (#594) passes, then the on board circuitry is healthy. Retire the alarm via the **test board UUCSS long clear** command. If the circuit pack Restart Test (#594) fails, replace the circuit pack.

- l. This error is not service affecting. No action is required. This error is reported by the circuit pack when it receives a bad control channel message from the switch.
- m. This error is not service-affecting. No action is required. A bad translation RAM has been detected, but call continues by using another translation RAM location.
- n. Error type 3999 indicates that the circuit pack sent a large number of control channel messages to the switch within a short period of time. If error type 1538 is also present, then the circuit pack was taken out-of-service due to hyperactivity. If error type 1538 is not present, then the circuit pack has not been taken out-of-service, but it has generated 50% of the messages necessary to be considered hyperactive. This may be completely normal during heavy traffic periods. However, if this error type is logged when the circuit pack is being lightly used, it may indicate a problem with the circuit pack or the equipment attached to it. System Technician-Demanded Tests: Descriptions and Error Codes

Always investigate tests in the order presented in the table below. By clearing error codes associated with the *Control Channel Looparound Test* for example, you may also clear errors generated from other tests in the testing sequence.

Order of Investigation	Short Test Sequence	Long Test Sequence	D/ND <sup>1</sup>
Control Channel Loop-Around Test (#52) (a)	X	X	ND
SAKI Sanity Test (#53) (a)		X	ND
LANHO Receive Parity Error Counter Test (#595)		X	D

1. D = Destructive; ND = Nondestructive

Note:

- a. For Control Channel Loop-Around Test (#52), and SAKI Sanity Test (#53) refer to the respective repair procedures described in "XXX-BD (Common Port Circuit Pack)."

## LANHO Receive Parity Error Counter Test (#595)

This test reads and clears the LANHO Receive Parity Error Counter on the circuit pack. This counter is incremented by the circuit pack firmware each time it detects a parity error in the data received from the Packet Bus.

These errors may be indicative of a circuit pack problem, Packet Bus problem, or a problem with another circuit pack on the bus. This test is useful for verifying the repair of the problem.

**Table 9-454. Test #595 LANHO Receive Parity Error Counter Test**

Error Code	Test Result	Description/ Recommendation
2000	ABORT	Response to the test was not received from the circuit pack within the allowable time period. <ol style="list-style-type: none"> <li>1. If the test aborts repeatedly a maximum of 5 times, reset the circuit pack via the <b>busyout board UUCSS</b> and <b>reset board UUCSS</b> commands.</li> <li>2. If the test aborts again, replace the circuit pack.</li> </ol>
2100	ABORT	Could not allocate the necessary system resources to run this test.
2012	ABORT	Internal system error. <ol style="list-style-type: none"> <li>1. Retry the command at 1-minute intervals a maximum of 5 times.</li> </ol>
1-10	FAIL	The circuit pack is still detecting errors of this type. The error code indicates the value of the on-board error counter. <ol style="list-style-type: none"> <li>1. Retry the command at 1-minute intervals a maximum of 5 times.</li> <li>2. If the test continues to fail, verify the validity of the Packet Bus. Run the Packet Bus maintenance test with the <b>test pkt port-network port-network-number long</b> command. If any Packet Bus tests fail, refer to the Packet Bus Maintenance documentation for recommended repair procedures.</li> <li>3. If the Packet Bus test passes, check the validity of the circuit pack. Execute a test that involves data transmission onto the Packet Bus. For example, the PDATA Port Local Loop-Around Test (#602). This test can be run by executing <b>test port UUCSSpp</b> command.</li> <li>4. Other circuit packs on the Packet Bus may be the cause of the parity error. Use the <b>display alarms</b> command to check the Error Log for other circuit packs that are alarmed. If any alarms are present for other circuit packs, retire those alarms also. Then, rerun the LANHO Receive Parity Error Counter Test (#595) via <b>test board UUCSS long</b> on this circuit pack.</li> </ol>
	PASS	No errors detected by the circuit pack.

## **PDATA-PT (Packet Data Line Port)**

<b>MO Name (in Alarm Log)</b>	<b>Alarm Level</b>	<b>Initial Command to Run<sup>1</sup></b>	<b>Full Name of MO</b>
PDATA-PT	MINOR	test port UUCSSpp	PDATA Port Maintenance
PDATA-PT	WARNING	release port UUCSSpp	PDATA Port Maintenance

1. UU is the universal cabinet number (1 for PPN, 2 - 44 for EPNs). C is the carrier designation (A, B, C, D, or E). SS is the number of the slot in which the circuit pack resides (01 to 21). pp is the two digit port number (01, 02, ...).

### **System Ports and the PDATA Circuit Pack**

The Packet Data Line Circuit (PDATA TN553) port board supports the connection of asynchronous EIA RS-232C endpoints to the packet bus. Each PDATA circuit pack has twelve (12) ports. PDATA ports are used solely to support the System Ports feature. System ports provide a means for the SPE to communicate with data applications via the TDM bus, something the SPE cannot otherwise do, since it has no direct circuit-switched access to the TDM bus. Each system port consists of a PDATA circuit pack port and a Data Line (TN726B) circuit pack port which are cross-connected at the wall field. The PDATA side of the pair provides an interface to the Packet Bus for Mode 3 packet data coming from the SPE via the Packet Interface circuit pack. The PDATA converts the Mode 3 packet data into EIA data which the Data Line circuit pack then converts to Mode 2 data and places on the TDM bus. The data stream can then be directed to any external application having an EIA interface by routing it through another Data Line port (See the figure below.) System ports allow the following applications to communicate with the SPE:

- Save/Restore of Announcement Circuit Pack Recorded Announcements
- Call Detail Recording (CDR)
- Journal Printer for the Property Management System (PMS)
- Wakeup Log Printer for the Property Management System (PMS)
- System Printer
- Data Terminals
- Remote G3-MT terminals

Although the paired PDATA and Data Line circuit packs used for system ports may be located independently and in any port network, they are usually placed in adjacent slots in the PPN.



## Data Applications and System Port Connectivity

As part of each data application, the SPE connects itself to the application device through a system port. The application device may be an external terminal, printer, or data-module, or it may be circuitry internal to the switch, as is the case for the Announcement Circuit pack data-module used to save and restore recorded announcements. The figure below is an example of a system port connection using a second Data Line circuit pack (DAT-LN-BD) port to provide dial-in access for a remote terminal.

A feature may not have a permanent connection to a system port. For example, the announcement feature uses the system port when it is saving or restoring announcement data to or from the Mass Storage System. The rest of the time it does not use a system port. This makes troubleshooting these links more difficult, since the symptoms may appear on one side of the link while the problem is on the other. If the link is no longer up, there is no way to determine which system port experienced the problem.

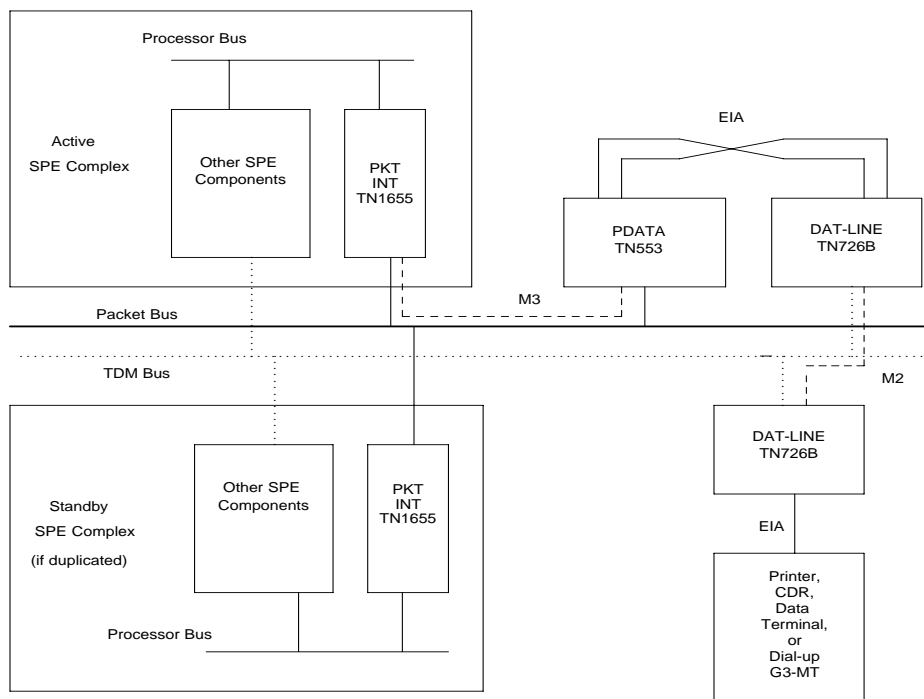

Figure 9-68. Typical System Port Connection

## Testing the System Port Pool

This section describes a method for isolating a bad system port when its location is not known. A pool of system ports is used to service the set of application features listed above. The system supports a maximum of 10 system ports. Since each Data Line Circuit pack provides 8 ports and each PDATA provides 12 ports, 2 Data Line Circuit packs and one PDATA Circuit pack are required if all 10 system ports are to be administered. If a link failed due to a faulty system port and that port is not currently connected to the feature, you will need to test the entire pool to isolate the bad system port. Follow these steps to isolate a bad port or exonerate the pool of system ports.

1. Enter **list data-module** and record the extension for each system port.  
Note: **list data-module name** option can be used to match on the name of the system ports if they are all named similarly.
2. For each system-port enter **display data-module ext** to find the Data Line (DAT-LINE) and PDATA ports administered. Each system port has a single extension that applies to both the Data Line and PDATA port. For historical reasons the PDATA is considered the **associated port**.
3. Check each port for alarms and errors using **display alarms** and **display errors**.
4. Check for SYS-LINK error or alarms for SAP-type links using **Display alarms** and **errors**.
5. Follow the repair procedures for any ports with errors.

## Identifying Components of an Application Link

Use this procedure to locate the maintenance objects that make up a given application link. You can then follow the repair procedures for each MO. In the steps given below all the MOs in a link are located before any ports are tested.

Problems with the application adjunct links are reported in two ways:

- The data application experiences problems.
- Errors or alarms are logged against a port or extension.

## Locating MOs When the Data Application Link Fails

This sequence of steps should be used if the application is experiencing problems and the health of the ports is unknown.

1. Using column three of the commands table below, find the command to display the status of the application link. Enter the command to confirm the health of the link. If the command requires a data-module extension, enter **list data-module** to determine the extension.
2. If column two of the table below shows there is a link MO for the application, enter **display alarms** and **display errors**. If there are alarms or errors against the MO, follow the repair procedures for that MO.
3. Using column 4 of the table below, find the command to display the extension of the application link. Enter the command and record the extension.
4. Enter **status data-module** ext for the extension found in the previous step. Record any connected ports.
5. If there are connected ports enter **display port** UUCSSpp and record the extension for each port. The equipment type displayed should be SYSTEM PORT DATA MODULE. Run **status data-module** ext for the connected port. Record the associated PDATA port.
6. If there are no connected ports, follow the steps in *Testing the System Port Pool* above to isolate or exonerate the system ports.
7. For each port, application extension, and connected Data Line and PDATA ports, check the alarm and error logs for entries against these ports. Follow the repair procedures for each port with problems.
8. Enter **list sys-link** and look for a SAP-type link with a port location that matches the PDATA port. Check the alarm and error logs for entries against the SYS-LINK. Follow repair procedures for SYS-LINK problems.

## Locating MOs When Only a Problem Port Is Known

A system port problem may originate in any of the following three components. You may not know at first which is causing the problem.

- The application port
- The PDATA port
- The Data Line port

1. Enter **display port** UUCSSpp to find out what kind of port this is. Record the extension and the identification field. The identification field likely indicates a system-port or another type of data-module.
2. *If the port is a system port*, enter **status data-module** ext. Record the Data Line or PDATA port. If there is a connected port do the following:
  - a. Record the location of the connected port.
  - b. Run **display port** UUCSSpp for the connected port and record the identification and extension for the port.
  - c. *If the port is an announcement port*, skip this step. Otherwise, determine whether the port's extension is administered as an application extension. Do this by executing each command in column 4 of the table below, checking the extension administered for that application against the port's extension.

For each port and application located, check the alarm and error logs for entries against these MOs. Follow repair procedures for MOs with log entries. In situations where no connected ports were listed, test each application link to ensure that more than one problem wasn't involved.

3. If the port is not a system port, enter **status data-module ext** and record the connected ports, if any are present.
4. Locate the application affected by entering each command in column 4 of the table below and checking the administered extension. The extension might be used as a remote G3-MT or data terminal.
5. If the status data-module display indicates no connected ports, follow the steps in *Testing the System Port Pool* above to verify that the system ports are working. If connected ports were displayed, enter **display port UUCSSpp** using the connected port displayed. Record the associated PDATA port.
6. For each port and application located, check the alarm and error logs for entries against these MOs. Follow the repair procedures for MOs with log entries. In situations where no connected ports were listed, test each application link to ensure that more than one problem wasn't involved.
7. Enter **list sys-link** and look for a SAP type link with a port location that matches the PDATA port. Check the alarm and error logs for entries against the SYS-LINK. Follow repair procedures for SYS-LINK problems.

**Table 9-455. Data Application Commands**

Application Name	Application MO Name	Command to Display Link Status	Command to Locate the Extension
Announcement Circuit Pack	Not Applicable	Not Applicable	display announcements
CDR	CDR-LNK	status cdr-link	display sys-param cdr
Wakeup Log Printer for the PMS Journal Printer for the PMS	JRNL-LNK	status journal-link wakeup-log	display system-parameters hospitality
System Printer	SYS-PRNT	status sp-link	display system-parameters features
Data Terminals	Not Applicable	status data-module ext	list data-module
Remote G3-MT terminals	Not Applicable	status data-module ext	list data-module

### System Port Wiring Scheme

If you find that you are having trouble with a PDATA port and you do not know which extensions are being affected or which Data Line port is attached, enter **display port** UUCSSpp with the PDATA port number to display the extension of the System Port. With this extension you can run **display data-module** ext, which will in turn identify the Data Line port. The PDATA and Data Line ports are wired together in a manner similar to a null-modem. The figure below illustrates the wiring scheme for the EIA ports. The subsequent table gives the full wiring sequence for eight Data Line ports attached to eight PDATA ports.

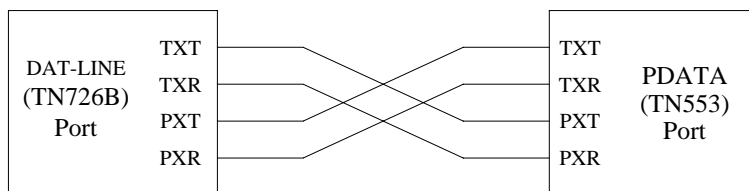

**Figure 9-69. System Port Wiring Scheme**

**Table 9-456. Wiring Table for the System Ports Feature  
 (eight ports)**

Port	Data Line Port		PDATA Port	
	Amphenol Connector Pin #	Carrier Lead Appearance	Carrier Lead Appearance	Amphenol Connector Pin #
1	27	TXT1	PXT1	27
	2	TXR1	PXR1	2
	28	PXT1	TXT1	26
	3	PXR1	TXR1	1
2	30	TXT2	PXT2	29
	5	TXR2	PXR2	4
	31	PXT2	TXT2	28
	6	PXR2	TXR2	3
3	33	TXT3	PXT3	31
	8	TXR3	PXR3	6
	34	PXT3	TXT3	30
	9	PXR3	TXR3	5
4	36	TXT4	PXT4	33
	11	TXR4	PXR4	8
	37	PXT4	TXT4	32
	12	PXR4	TXR4	7
5	39	TXT5	PXT5	35
	14	TXR5	PXR5	10
	40	PXT5	TXT5	34
	15	PXR5	TXR5	9
6	42	TXT6	PXT6	37
	17	TXR6	PXR6	12
	43	PXT6	TXT6	36
	18	PXR6	TXR6	11
7	45	TXT7	PXT7	39
	20	TXR7	PXR7	14
	46	PXT7	TXT7	38
	21	PXR7	TXR7	13

*Continued on next page*

**Table 9-456. Wiring Table for the System Ports Feature  
 (eight ports) — Continued**

Port	Data Line Port		PDATA Port	
	Amphenol Connector Pin #	Carrier Lead Appearance	Carrier Lead Appearance	Amphenol Connector Pin #
8	48	TXT8	PXT8	41
	23	TXR8	PXR8	16
	49	PXT8	TXT8	40
	24	PXR8	TXR8	15

## Error Log Entries and Test to Clear Values

Table 9-457. PDATA Port Error Log Entries

Error Type	Aux Data	Associated Test	Alarm Level <sup>1</sup>	On/Off Board	Test to Clear Value
0 <sup>2</sup>		Any	Any	Any	test port UUCSSpp sh r 1
1(a)		LAPD Connectivity Test (#558)	MINOR	ON	test port UUCSSpp r 3
18		Busy Port	WARNING	OFF	release port UUCSSpp
130(b)		None	WARNING	ON	test port UUCSSpp sh
257(c)					
513(c)					
779(c)					
1025(d)		Translation RAM Update	MINOR	ON	see footnote (c)
1281(e)					
1793(f)		Port Local Loop-Around Test (#602)	MINOR	ON	test port UUCSSpp
2049(g)		System Port Connectivity Test (#603)	MINOR	OFF	test port UUCSSpp
3842* 3843* 3844*	37914				test port UUCSSpp sh l

1. Major or Minor alarms on this MO may have been downgraded to Warning alarms based on the values used in the **set options** command.
2. Run the Short Test Sequence first. If all tests pass, run the Long Test Sequence. Refer to the appropriate test description and follow the recommended procedures.

### Notes:

- a. This error occurs if the LAPD Connectivity test fails. If this test fails repeatedly, a MINOR alarm is raised. This alarm indicates the failure to establish a LAPD link with the port and to send and receive test data over that port. See the repair procedure for LAPD Connectivity Test (#558).
- b. This error type indicates that the circuit pack has been removed or has been insane for more than 11 minutes. To clear the error, reinsert or replace the circuit pack.



- c. These three counters are incremented for errors which may or may not be caused by the PDATA port itself. For example, the Invalid LAPD Frame counter (error type 513) could exceed threshold due to a large number of "bad CRC" errors. The errors could be caused by packets arriving from the "other end" which have a bad CRC, in which case the PDATA port is behaving properly and should not be alarmed. On the other hand, the error could be caused by faulty CRC-checking hardware on the PDATA board, in which case the PDATA board should be alarmed.

Since these error counters do not necessarily indicate problems with the PDATA port itself, no alarms are raised when the counters exceed threshold. Instead, testing escalates to the LAPD Connectivity Test. If the LAPD Connectivity test fails repeatedly, then the PDATA port is the source of the problem and will be alarmed. More exhaustive tests can be run with the **reset board UUCSS** command.

- d. This error occurs if the switch has trouble in writing the translation data into memory. A MINOR alarm is raised if this error occurs. This alarm indicates the failure of either the Angel hardware or the RAM on the board. If the Angel is the cause of the failure, similar alarms should be raised against all other ports on the board. If the RAM is the cause of the failure, then only the port is affected-other ports may function normally.

No associated test can retire this alarm. The repair procedure for this alarm is as follows. First, reset the circuit pack (i.e. use *busyout board UUCSS* and *reset board UUCSS* commands). If the circuit pack comes back into service after the reset (the red LED on the circuit pack is off), then execute the *test port UUCSSpp long clear* command to clear the alarm. If the PDATA circuit pack fails to reset properly (i.e. the red LED on the circuit pack is on.), replace the circuit pack.

Notice that the corresponding Translation RAM test always passes because it issues a translation write command but does not wait around for the failure up-link message from the board.

- e. This error occurs when the receive FIFO RAM buffers on a circuit pack overflow, i.e., the circuit pack receives data from the bus faster than it can distribute the data to its endpoints. If this error occurs frequently, however, it may indicate a LAPD parameter mismatch. LAPD should be able to recover from this problem, but it may degrade the performance of the Packet Bus. No alarm is raised for this error.
- f. This error occurs if the PDATA Port Local Loop-Around test fails. If this test fails, a MINOR alarm is raised. This alarm indicates the failure of the UART device on the port. The circuit pack should be replaced if this alarm cannot be cleared. See the repair procedure for PDATA Port Local Loop-Around Test (#602) for more details.
- g. This error occurs if the System Port Connectivity Test (#603) fails or if the System Port connection fails in the call set-up procedure. This error is only applicable to ports used as a System Port. If this test fails repeatedly, a MINOR alarm is raised.

## System Technician-Demanded Tests: Descriptions and Error Codes

Always investigate tests in the order presented in the table below when inspecting errors in the system. By clearing error codes associated with the *PDATA Port Local Loop-Around Test* for example, you may also clear errors generated from other tests in the testing sequence.

Order of Investigation	Short Test Sequence	Long Test Sequence	D/ND <sup>1</sup>
PDATA Port Local Loop-Around Test (#602)	X	X	ND
LAPD Connectivity Test (#558)	X	X	D
System Port Connectivity Test (#603)	X	X	D

1. D = Destructive; ND = Nondestructive

### LAPD Connectivity Test (#558)

**This test is destructive.**

This is a connectivity test which checks if a specific PDATA port is capable of establishing a Level 2 LAPD link. The SPE will assign a LAPD bearer link between the SPE Packet Bus interface (i.e. the Packet Interface, also called PKTINT, TN1655) and the PDATA port. The SPE will send a test packet from the PKTINT to the PDATA port and it will expect to receive a reply from the PDATA port. Failure of this test may indicate an on-board fault associated with the port hardware on the PDATA circuit pack.

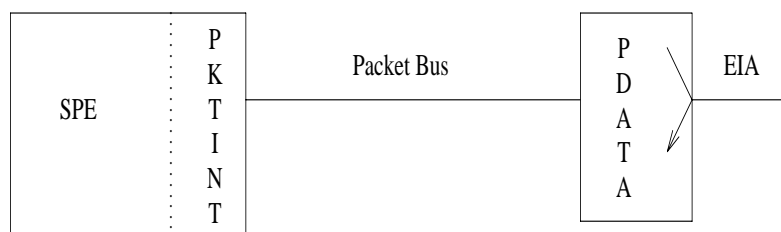

**Figure 9-70. Configuration for LAPD Connectivity Test**

**Table 9-458. TEST #558 LAPD Connectivity Test**

Error Code	Test Result	Description/ Recommendation
1000	ABORT	The port is in use for a call. Use <b>status data-module extension</b> command to determine when the port is available for testing. <ol style="list-style-type: none"> <li>1. Retry the command when the port is idle. The port may be forced to the idle state by executing <b>busyout port UUCSSpp</b>. This command is destructive causing all calls and links associated with the port to be torn down.</li> </ol>
1137	ABORT	The test link could not be created. <ol style="list-style-type: none"> <li>1. If the PDATA port is in an EPN, this is probably caused by Center Stage maintenance interactions. The Center Stage includes the Switch Node Interface (SNI), Expansion Interface (EI) and DS1C boards. Clear any problems in these boards before continuing.</li> <li>2. Retry at one minute intervals for a maximum of 3 times.</li> </ol>
1139	ABORT	The Packet Bus in this port network is out-of-service. <ol style="list-style-type: none"> <li>1. Retire the alarm associated with the Packet Bus. Please refer to the maintenance section on the packet bus for details.</li> <li>2. Retry the command when the alarm associated with the Packet Bus is retired.</li> </ol>
1141	ABORT	The Packet Interface, PKTINT, Circuit Pack (TN1655) is out-of-service. <ol style="list-style-type: none"> <li>1. Refer to the repair procedures for the PKTINT circuit pack to put the circuit pack back into service.</li> <li>2. Retry the command when the alarm associated with the Packet Interface is retired.</li> </ol>
1144	ABORT	The Packet Bus in the Port Processor Network (Network 1) is alarmed. <ol style="list-style-type: none"> <li>1. Retire the alarm associated with the Packet Bus in the Port Processor Network. Please refer to the maintenance section on the packet bus for details.</li> <li>2. Retry the command when the alarm associated with the Packet Bus is retired.</li> </ol>
2012	ABORT	Internal system error. <ol style="list-style-type: none"> <li>1. Retry the command at 1-minute intervals for a maximum of 3 times.</li> </ol>

*Continued on next page*

**Table 9-458. TEST #558 LAPD Connectivity Test — Continued**

Error Code	Test Result	Description/ Recommendation
1	FAIL	Response to the test was not received for the PDATA circuit pack within the allowable time period. <ol style="list-style-type: none"> <li>1. Retry the command at 1-minute intervals a maximum of 3 times.</li> <li>2. <b>Reset board UUCSS</b> if the other ports on the board are not in use (Yellow LED is off or run <b>status data-module extension</b>).</li> <li>3. Retry the command at 1-minute intervals a maximum of 3 times.</li> <li>4. Replace the circuit pack.</li> </ol>
2	FAIL	The received test packet from the PDATA port is different than the test packet transmitted to it. <ol style="list-style-type: none"> <li>1. If the test fails 3 times, <b>reset board UUCSS</b> if the other ports on the board are not in use (yellow LED is off or run <b>status data-module extension</b>).</li> <li>2. If the test continues to fail, replace the circuit pack.</li> </ol>
	PASS	The PDATA port is able to terminate a LAPD link.

### PDATA Port Local Loop-Around Test (#602)

**This test is destructive.**

This test verifies the per port circuitry on the PDATA circuit pack. This test is executed by the PDATA circuit pack on command by the switch. The loop-back is done internal to the circuit pack at point "A" in the figure. Failure of this test indicates an on-board fault associated with the port hardware on the circuit pack.

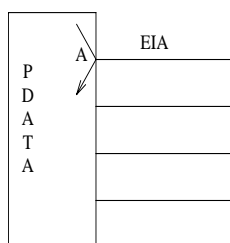

**Figure 9-71. Configuration for Port Local Loop-Around Test**

**Table 9-459. TEST #602 PDATA Port Local Loop-Around Test**

Error Code	Test Result	Description/ Recommendation
1000	ABORT	The port is in use for a call. Use <b>status data-module extension</b> command to determine when the port is available for testing. <ol style="list-style-type: none"> <li>1. Retry the command when the port is idle. The port can be made idle by executing the <b>busyout port UUCSSpp</b> command. This command is destructive causing all calls and links associated with the port to be torn down.</li> </ol>
1006	ABORT	Port is out-of-service. <ol style="list-style-type: none"> <li>1. Run <b>status data-module extension</b> to check if the port is busied out. Run <b>release port UUCSS</b> to free it, re-run the test.</li> <li>2. Refer to the PKT-BUS maintenance section and fix any problems that are related to the packet bus.</li> </ol>
2000	ABORT	Response to the test was not received for the PDATA circuit pack within the allowable time period. <ol style="list-style-type: none"> <li>1. Retry the command at 1-minute intervals a maximum of 3 times.</li> <li>2. <b>reset board UUCSS</b> if the other ports on the board are not in use (Yellow LED is off or run the <b>status data-module extension</b> command).</li> <li>3. Retry the command at 1-minute intervals a maximum of 3 times.</li> <li>4. Replace the circuit pack.</li> </ol>
2012	ABORT	Internal system error. <ol style="list-style-type: none"> <li>1. Retry the command at 1-minute intervals a maximum of 3 times.</li> </ol>
	FAIL	The PDATA circuit pack has detected a failure in the execution of the test. <ol style="list-style-type: none"> <li>1. If the test fails 3 times, <b>reset board UUCSS</b> if the other ports on the board are not in use (Yellow LED is off or run the <b>status data-module extension</b> command).</li> <li>2. If the test fails again, replace the circuit pack.</li> </ol>
	PASS	The PDATA on-board loop-around test for the port has passed verifying the integrity of the per port circuitry.

## System Port Connectivity Test (#603)

**This test is destructive.**

This test verifies the capability to communicate between the PDATA and the Data Line (TN 726B) ports of a System Port member. A System Port requires the PDATA port and the Data Line port to be wired together. Failure of this test may indicate faults with the wiring on PDATA port. Thus an off-board alarm is raised.

Since this test is applicable only to ports that are configured as a System Port, the switch aborts the test if the port is not configured as a System Port.

The switch aborts this test if calls associated with the port are in progress. If the ports are in use but tests must be run, the port can be busied out using the **busyout port UUCSSpp** command. Release the port when the tests are done. If a problem is fixed, the associated alarms will not be resolved until the port is released.

**Table 9-460. TEST #603 System Port Connectivity Test**

Error Code	Test Result	Description/ Recommendation
11	ABORT	The Data Line port could not be setup for this test.
2100	ABORT	Could not allocate Data Line resources <ol style="list-style-type: none"> <li>1. Determine the Data Line port associated with the PDATA port.</li> <li>2. Run <b>test port UUCSSpp</b>. If any of the Data Line port tests fail, resolve these problems first.</li> <li>3. If the problem persists, check the port admin and wiring</li> <li>4. Verify that the Data Line port is not busied out (<b>status data-module extension</b>) or not installed.</li> </ol>
1000	ABORT	The PDATA or Data Line port is in use for a call or maintenance tests are already running on these ports. <ol style="list-style-type: none"> <li>1. Retry the command when the port is idle. The port may be forced to the idle state by executing the <b>busyout port UUCSSpp</b> command. This command is destructive causing all calls and links associated with the port to be torn down.</li> </ol>
1005	ABORT	The configuration for this test is incorrect. <ol style="list-style-type: none"> <li>1. This is the expected test result for PDATA ports which have not been administered as a System Port.</li> <li>2. If the PDATA port is supposed to be configured as System Port, make the necessary modifications on the port administration form <b>change data-module extension</b>.</li> </ol>

*Continued on next page*

**Table 9-460. TEST #603 System Port Connectivity Test — Continued**

Error Code	Test Result	Description/ Recommendation
1115	ABORT	The PDATA port resources could not be allocated. <ol style="list-style-type: none"> <li>1. Run the <b>busyout port UUCSSpp</b></li> <li>2. Run the test again</li> <li>3. Retry the command at 1-minute intervals for a maximum of 3 times.</li> <li>4. Release the port when done.</li> </ol>
2012	ABORT	System Call Failed
2031	ABORT	Uplink messages software failed.
2500	ABORT	Internal system error. <ol style="list-style-type: none"> <li>1. Retry the command at 1-minute intervals for a maximum of 3 times.</li> </ol>
7	FAIL	Wiring does not match administration.
8	FAIL	Invalid test message sequence.
10	FAIL	Data Line port did not reset correctly.
11	FAIL	PDATA port Data Terminal Ready (DTR) did not reset correctly.
12	FAIL	PDATA port did not reset correctly.
2000	FAIL	Test timed out, most probably the administered ports are not connected correctly. For the above failure codes, use the following steps to correct the problem. <ol style="list-style-type: none"> <li>1. Enter the commands <b>list data-module</b> and <b>status data-module extension</b> on the G3-MT to find the corresponding Data Line port number and PDATA port number. Check the wiring between the PDATA port and the Data Line port. Look for loose connections, mis-wiring or broken wires.</li> <li>2. Retry test a maximum of 2 times, no need to wait between tests.</li> <li>3. If the test still fails, and the other ports on the circuit pack are not in use, enter <b>reset board UUCSS</b>. (Use <b>status data-module</b> extension or LED indicators to determine if other ports are idle).</li> <li>4. Retry test a maximum of 2 times.</li> <li>5. Replace the PDATA board.</li> <li>6. Retry test a maximum of 2 times.</li> <li>7. Replace the Data Line circuit pack.</li> <li>8. Retry test a maximum of 2 times.</li> </ol>
	PASS	The PDATA port and the Data Line port of the System Port feature are wired together as administered.

## **PDMODULE (Processor Data Module) TDMODULE (Trunk Data Module)**

<b>MO Name (in Alarm Log)</b>	<b>Alarm Level</b>	<b>Initial Command to Run<sup>1</sup></b>	<b>Full Name of MO</b>
PDMODULE <sup>2</sup>	MINOR	test port <i>UUCSSpp l</i>	Processor Data Module
PDMODULE	WARNING	test port <i>UUCSSpp s</i>	Processor Data Module
TDMODULE <sup>2</sup>	MINOR	test port <i>UUCSSpp l</i>	Trunk Data Module
TDMODULE	WARNING	test port <i>UUCSSpp s</i>	Trunk Data Module

1. UU is the universal cabinet number (1 for PPN, 2 - 44 for EPNs). C is the carrier designation (A, B, C, D, or E). SS is the number of the slot in which the circuit pack resides (01 to 21). pp is the two digit port number (01, 02, ...).
2. Digital Terminal Data Modules (DTDM), and Data Adaptors (DA) in linked mode are considered part of the Digital Line maintenance object. See the the DIG-LINE section for maintenance of these devices. DAs in stand-alone mode are included in PDMODULE.

Some of the alarms that are logged due to PDMODULE and TDMODULE test failures may be related to circuit pack problems reported during DIG-BD testing. Refer to "XXX-BD (Common Port Circuit Pack)" for information on testing digital line circuit packs.

The PDMODULE and TDMODULE maintenance objects monitor and test Digital Line circuit pack ports that are connected to Data Communications Equipment (DCE) or Data Terminal Equipment (DTE). DCE include processor data modules (MPDM) and Data Adaptors (DA). DTE include trunk data modules (DTE). These stand-alone data modules provide interfaces between DCP ports on the Digital Line circuit packs and data equipment such as terminals, host computers , and data modems. (See the following list and figure.) Data modules are used for dial-up and permanent circuit-switched data calls.

Digital Line circuit packs also connect to digital terminal data modules (DTDMs), which work in conjunction with a voice terminal. Those configurations are covered by the DIG-LINE maintenance object. Circuit pack-level maintenance is covered by DIG-BD whose strategy is described in the "XXX-BD (Common Port Circuit Pack)."

Digital line circuit packs include the TN754, TN754B, TN413, TN2136. See DIG-LINE for more information on the characteristics of these circuit packs.



## Stand-Alone DCP Data Modules

There are two types of stand-alone DCP data modules:

**Table 9-461. Stand-Alone DCP Data Modules**

Type	Name <sup>1</sup>	Interfaces to:
MPDM	Modular Processor Data Module	DTE (data terminals, host computers, printers, etc)
MTDM	Modular Trunk Data Module	DCE (modems, data modules, etc)

1. Early versions of these data modules were referred to as PDMs and TDMs, respectively. Later models are designed to provide a variety of interfaces by using interchangeable modules and are thus called modular data modules. Both types are supported by the tests described in this section

## Data Adapters

TN2136 circuit packs use IDCP signaling and a DAA2 Data Adaptor (DA) to interface to DTE. DAs can operate in either of two modes which are covered by different maintenance objects:

**Table 9-462. Data Adaptor Modes**

DA Mode	Administered as:	Endpoint	Maintenance Object
Stand-Alone	PDM	data endpoint only	PDMODULE
Linked	DTDM	IDT1/2 <sup>1</sup> and optional data terminal	DIG-LINE

1. IDT1/2: Italtel Digital Telephone, Model 1 or 2 (also known as Digital Telephones TD7210 and TD7206).

## Configurations and Maintenance

In the following discussion, the general term data module refers to MPDMs, MTDMs, and DAs. The PBX loop or digital link between a data module and the Digital Line port supports two logical information channels and one signaling channel. Data modules generally use the primary information channel for data communications and the signaling channel for dialing and call supervision. With 4-wire DCP, the secondary information channel can be used to support a second data module on a shared port.

9 Maintenance Object Repair Procedures

*PDMODULE (Processor Data Module) TDMODULE (Trunk Data Module)*

9-1162

Besides being used for data calls between terminals, computers, and data communications equipment, data modules also serve as interfaces to equipment associated with system features such as System Administration, Station Message Detailed Recording, Message Center Service, Automatic Call Distribution, Distributed Communications System, and Audio Information Exchange. Maintenance for data modules associated with these latter services are covered by other maintenance objects such as PMS-PRNT, JNL-PRNT, and PMS-LINK.

Maintenance of data modules is closely related to and interacts with Digital Line circuit pack maintenance, and test results for data modules can be affected by the health of the Digital Line circuit pack. Keep this interaction in mind when investigating customer-reported problems with data modules.

Data modules provide a variety of option switches to allow the customer to select data rates, parity, keyboard dialing, local, and remote loop back, etc. (The DAA2 Data Adaptor has an AT (Hayes) type interface that allows selection of the above parameters as well as mode — linked or stand-alone.) An incorrect selection will not necessarily cause errors, alarms or test failures, but it can result in service disruption. Refer to the installation manual provided with the data module for more information about those options.

This discussion occasionally refers to a station's service state, which is defined as follows:

Out-of-Service	The port, and thus the data module, have been removed from service. Causes for this include busyout of the port, removal of the Digital Line circuit pack and failure of the NPE Crosstalk Test (#9).
Disconnected	The port is administered but the associated digital link does not respond. An administered port is put in a disconnected state after a system reboot or circuit pack insertion. This state persists until a link-reset-pass message is received from firmware on the circuit pack.
In-Service	When switch software receives a link-reset-pass message from the port, the port is placed in service. If the link-reset-pass message is missed, and an off-hook message is received while the port is in the disconnected state, maintenance software will run an ID request test and put the port into service upon receiving a correct response.

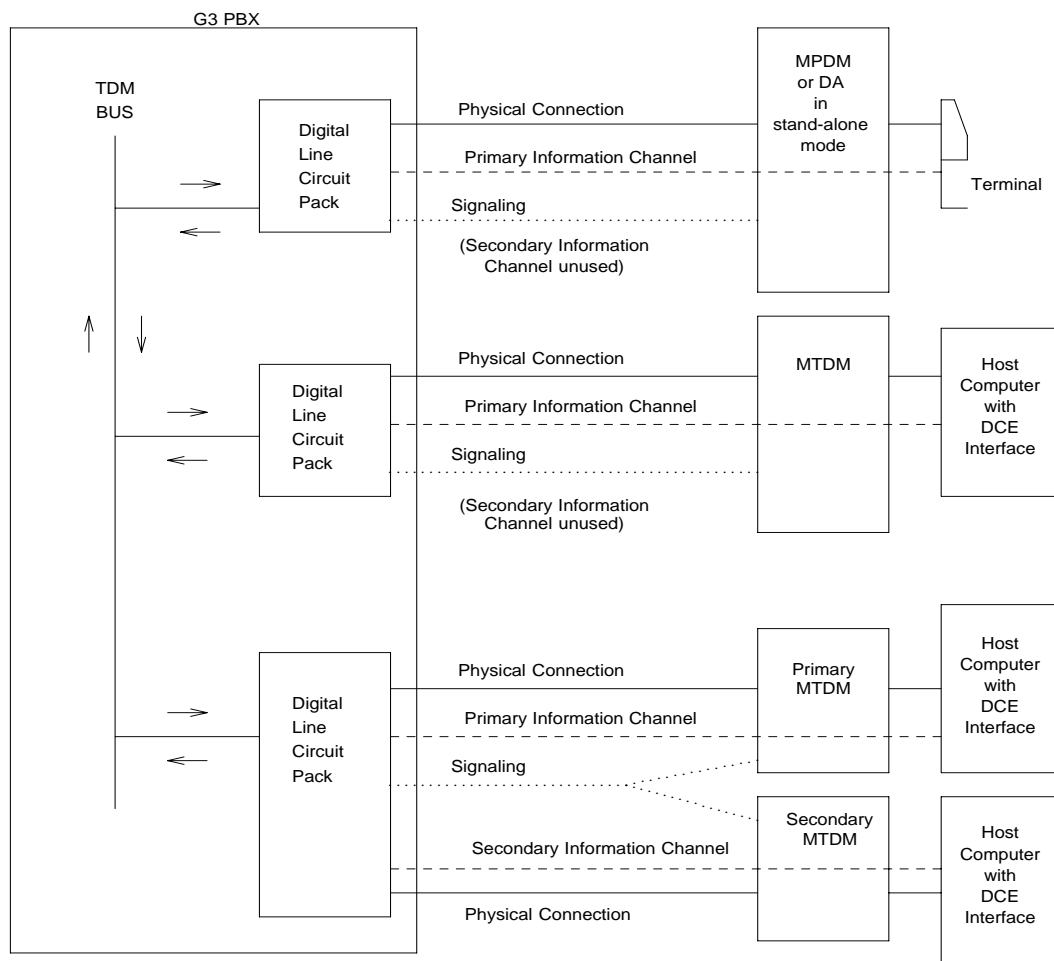

Figure 9-72. Typical Data Module Configurations

## Error Log Entries and Test to Clear Values

**Table 9-463. PDMODULE, TDMODULE Error Log Entries**

Error Type	Aux Data	Associated Test	Alarm Level	On/Off Board	Test to Clear Value
0(a)	0	None			
1(b,n)	40987	None	WARNING	OFF	
1(c,n)	1 to 20	None	WARNING	OFF	
15(d)	Any	None			
18(e)	0	busyout port <i>UUCSSpp</i>	WARNING	OFF	release port <i>UUCSSpp</i>
257(f)	40971	None			
513	0	Data Module Audits (#17)	WARNING	OFF	test port <i>UUCSSpp</i> sh r 6
769(g,n)	40988	None	WARNING	OFF	
1281	Any	Data Module Audits (#17)	WARNING	OFF	test port <i>UUCSSpp</i> sh r 4
1537(h,n)	40968	None	WARNING	OFF	
1793		Information Channel and Control Channel Looparound (#13)	MINOR	ON	test port <i>UUCSSpp</i> l r 3
2049		NPE Crosstalk (#9)	MINOR	ON	test port <i>UUCSSpp</i> l r 3
2304(i)		None			
2305(j)	32770	None			
2305(k)	40967	None			
2561(l)	Any	Data Module Internal Looparound (#175)	WARNING	OFF	test port <i>UUCSSpp</i> l r 5
2817 (m)		Link GPP Loop (183) Against Links	MAJOR	ON	
3841 n)		NONE			
3841(o)		None			

**Notes:**

- a. Error type 0 appears in the Error Log only if a Digital Line circuit pack that has ports administered has been removed since the Error Log was last cleared. Make sure that the circuit pack has been re-inserted.

9 Maintenance Object Repair Procedures

PDMODULE (Processor Data Module) TDMODULE (Trunk Data Module)

9-1165

- b. Error type 1 with aux data 40987 indicates an off-board problem detected by the port circuit, and may result in a noisy port or link. See note *n* for recommendations.
- c. Error type 1 with aux data of 1 to 20 is logged when at least 15 off-board problems have been detected with the link to the data module. Each error detected increments an on-board counter. The aux data gives the value of this counter divided by 15. The user could experience a noisy port or link. See note “n” for recommendations.
- d. Error type 15 is an internal that occurs when an audit request fails.
- e. Error type 18 is logged when the port in question is demand busied out. Make sure that the port is released from busy out.
- f. Error type 257 indicates problems with transmitting to the data module. This is usually an on-board problem and can be ignored if no user complaints are received. Otherwise, check for faulty wiring.
- g. Error type 769 indicates that EPF has been turned off due to the overcurrent condition at the data module. See the recommendations in note *n*. This may also be caused by the the PTC being in the “tripped” position due to a short on the power line. You can correct this by removing the short, unplugging the data module from the wall for about 30 seconds, and plugging it back in.
- h. Error type 1537 indicates that an in-line maintenance error has generated an off-board warning due to some problem with the link to the data module. This can be ignored if no user complaints are received. Otherwise, see note *n* for recommendations.
- i. Error type 2304 indicates an internal error. No action is necessary.
- j. Error type 2305 with aux data 32770 indicates that the data equipment went off-hook while the associated link was being initialized (in a disconnected state). Use the **status data-module** command to determine the state of the data module. The off-hook should have changed the service state to in-service. No action is necessary.
- k. Error type 2305 with aux data 40967 indicates that the link between the circuit pack and the data module has been reset successfully. The link is normally reset when the circuit pack associated with an administered port is first plugged in (assuming that the data module is already in place and connected to the associated port), when a port is first administered (assuming the associated circuit pack is plugged in and that the data module is connected to the associated port), or when a data module is first connected to an administered port. No system technician action is necessary.
- l. Error type 3841 indicates that the downlink buffer on the circuit pack has overflowed. No action is necessary.
- m. A DCP endpoint may have been disconnected.

9 Maintenance Object Repair Procedures

PDMODULE (Processor Data Module) TDMODULE (Trunk Data Module)

9-1166

- n. Make sure the data module is connected and operating properly. Check for faulty wiring. If necessary, reduce the length of the cable between the data module and the switch to 5000 ft for 24-gauge wire or 4000 ft for 24-gauge wire. Refer to *DEFINITY Communications System Generic 1 and 3 - Installation and Test*, 555-230-104.

If the problem still exists, replace the circuit pack. Once the problem has been resolved, the alarm will be retired in 60 minutes (90 min for error 1537). (These error counters use the leaky bucket mechanism.)

The DA module is not phantom-powered from the port. Thus when it is in linked mode, its range is limited by the Italtel digital phone's limit: 0.7 Km (2300) ft on 26-gauge wire or 1.8 Km (5900) ft on 22-gauge (0.6 mm) wire. If in stand-alone mode, it is limited by the maximum length of loop allowed from the Digital Line Interface (DLI) component: up to 3.5 Km (2 miles) on 22-gauge (0.6 mm) wire.

## System Technician-Demanded Tests: Descriptions and Error Codes

---

Always investigate tests in the order presented in the table below. By clearing error codes associated with the *Data Module Internal Looparound Test*, for example, you may also clear errors generated from other tests in the testing sequence.

Order of Investigation	Short Test Sequence	Long Test Sequence	D/ND <sup>1</sup>
Data Module Internal Looparound Test (#175)		X	ND
Digital Port Board Network Processing Element Crosstalk Test (#9)		X	ND
Port Circuit Information Channel and Control Channel Looparound Test (#13)		X	ND
Data Module Audits Test (#17)	X	X	ND

---

1. D = Destructive; ND = Nondestructive

### NPE Crosstalk Test (#9)

The NPE Crosstalk Test verifies that this port's NPE channel talks on the selected time slot and never crosses over to time slots reserved for other connections. If the NPE is not working correctly, one-way and noisy connections may be observed. If a secondary data module is assigned, it is tested after the primary data module. If either test fails, both data modules are taken out of service. This test usually run only during the long test sequence and takes about 20 to 30 seconds to complete.

**Table 9-464. TEST #9 NPE Crosstalk Test**

Error Code	Test Result	Description/ Recommendation
1000	ABORT	System resources required to run this test are not available. The port may be busy with a valid call. <ol style="list-style-type: none"> <li>1. Use the <b>display port UUCSSpp</b> command to determine the extension of the data module port. Use the <b>status data-module</b> command to determine the service state of the port. If the port is in use, wait until the port is idle before testing.</li> <li>2. If the port status is idle, then retry the command at 1-minute intervals a maximum of 5 times.</li> </ol>
1001	ABORT	System resources to run this test are not available. <ol style="list-style-type: none"> <li>1. Retry the command at 1-minute intervals a maximum of 5 times.</li> </ol>
1002	ABORT	The system could not allocate time slots for the test. The system may be under heavy traffic conditions or it may have time slots out-of-service due to TDM-BUS errors. <ol style="list-style-type: none"> <li>1. If system has no TDM-BUS errors and is not handling heavy traffic, repeat test at 1-minute intervals a maximum of 5 times.</li> </ol>
1003	ABORT	The system could not allocate a tone receiver for the test. The system may be oversized for the number of tone detectors present or some tone detectors may be out-of-service. <ol style="list-style-type: none"> <li>1. Resolve any TTR-LEV errors.</li> <li>2. Resolve any TONE-PT errors.</li> <li>3. If neither condition exists, retry the test at 1-minute intervals a maximum of 5 times.</li> </ol>
1004	ABORT	The port may be busy with a valid call. <ol style="list-style-type: none"> <li>1. Use the <b>display port UUCSSpp</b> command to determine the extension of the data module port. Use the <b>status data-module</b> command to determine the service state of the port. If the port is in use, wait until the port is idle before testing.</li> <li>2. Retry the command at 1-minute intervals a maximum of 5 times.</li> </ol>
1020	ABORT	Test disabled via background testing. Use <b>status data-module</b> command to determine when the data module is available for testing.
2000	ABORT	Response to the test request was not received within the allowable time period. <ol style="list-style-type: none"> <li>1. Retry the command at 1-minute intervals a maximum of 5 times.</li> </ol>
2020	ABORT	The test did not run due to a previously existing error on the specific port or a more general circuit pack error. <ol style="list-style-type: none"> <li>1. Examine Error Log for existing errors against this port or the circuit pack and attempt to diagnose the previously existing error.</li> </ol>

**Table 9-464. TEST #9 NPE Crosstalk Test — Continued**

Error Code	Test Result	Description/ Recommendation
2100	ABORT	Could not allocate the necessary system resources to run this test. 1. Retry the command at 1-minute intervals a maximum of 5 times.
2500	ABORT	Internal system error 1. Retry the command at 1-minute intervals a maximum of 5 times.
1, 2	FAIL	The NPE of the tested port was found to be transmitting in Error Log. This will cause noisy and unreliable connections. Failure code 1 indicates that the Crosstalk Test failed on the primary channel. Failure code 2 indicates that the Crosstalk Test failed on the secondary channel. 1. Replace the circuit pack.
	PASS	The port is correctly using its allocated time slots. 1. To be sure that this is not an intermittent problem, repeat this test up to a maximum of 10 times and verify that it continues to pass. 2. If complaints still exist, examine the data module, connections, and wiring.

## Information and Control Channel Local Loop Test (#13)

This is a set of four tests that check the operation of the information and control channels used between the SPE and the Digital Line port circuit. This is an Internal Looparound test only and does not check building wiring. See Test #175 for external loop around tests to the data module.

The SPE first sends a message to the on-board microprocessor to loop around both the information and control channels for the port. Then, the primary information channel loop back test is run. The test is performed by sending a digital count from the Tone/Clock circuit pack on the primary channel time slot and receiving the same digital count with a General Purpose Tone Detector. The digital count looks like transparent data to the on-board microprocessor.

With the port still in loop-around mode, the S channel Looparound Test is performed next. This test consists of sending four different transparent patterns to the on-board microprocessor, receiving them back, and comparing them.

The third test is a Looparound Test for the secondary information channel. It is performed only if a secondary data module is assigned to the port.

The fourth test is a Conference Test of the primary channel. This test is the same as the Analog Line Conference Test #6.



Only one result is reported for the three tests run. If any test fails or aborts, the sequence is stopped.

**Table 9-465. TEST #13 Information and Control Channel  
 Local Loop Test**

Error Code	Test Result	Description/ Recommendation
	ABORT	Internal system error 1. Retry the command at 1-minute intervals a maximum of 5 times.
1000	ABORT	System resources required to run this test are not available. The port may be busy with a valid call. 1. Use the <b>display port UUCSSpp</b> command to determine the data module extension. Then use <b>status data module</b> command with the extension number to determine the service state of the data module. If the service state indicates that the data module is in use, then the port is unavailable for certain tests. You must wait until the port is idle before retesting. 2. If the port status is idle, then retry the command at 1-minute intervals a maximum of 5 times.
1001	ABORT	System resources required to run this test are not available. 1. Retry the command at 1-minute intervals a maximum of 5 times.
1002	ABORT	The system could not allocate time slots for the test. The system may be under heavy traffic conditions or it may have time slots out-of-service due to TDM-BUS errors. 1. If the system has no TDM-BUS errors and is not handling heavy traffic, repeat the test at 1-minute intervals a maximum of 5 times.
1003	ABORT	The system could not allocate a tone receiver for the test. The system may be oversized for the number of tone detectors present or some tone detectors may be out-of-service. 1. Resolve any TTR-LEV errors. 2. Resolve any TONE-PT errors. 3. If neither condition exists, retry the command at 1-minute intervals for a maximum of 5 retries.
1004	ABORT	The port was seized by a valid call during the test. The test has been aborted. 1. Use the <b>display port UUCSSpp</b> command to determine the data module extension. Then use <b>status data module</b> command with the extension number to determine the service state of the data module. If the data module is in use, wait until the port is idle before retesting.
2000	ABORT	Response to the test request was not received within the allowable time period. 1. Retry the command at 1-minute intervals a maximum of 5 times.

**Table 9-465. TEST #13 Information and Control Channel  
 Local Loop Test — Continued**

Error Code	Test Result	Description/ Recommendation
2100	ABORT	System resources required for this test are not available. 1. Retry the command at 1-minute intervals a maximum of 5 times.
2500	ABORT	Internal system error 1. Retry the command at 1-minute intervals a maximum of 5 times.
7	FAIL	Conference test failed on the primary information channel. In some cases, user may not notice disruption in service. In extreme cases, conferencing feature may not work at all.
14	FAIL	The primary information channel is not transmitting properly. User impact may range from noticing nothing to not being able to use this port.
15	FAIL	The control channel between the processor and Digital Line circuit pack is not transmitting properly. This can cause a wide range of effects. The user may notice nothing or the port may be totally unusable. This could also disrupt other users. 1. Run circuit pack tests to check the Tone Generator and the Tone Detector circuit packs using the <b>test board UUCSS short</b> command. 2. Resolve any problems that are detected on the Tone Generator circuit pack or Tone Detector circuit pack. 3. If the Tone Generator and Tone Detector circuit packs are functioning properly, and the test still fails, replace the Digital Line circuit pack.
16	FAIL	The secondary information is not transmitting properly. This can cause a wide range of effects. The user may notice nothing or the port may be totally unusable. 1. To be sure that this is not an intermittent problem, repeat this test up to a maximum of 10 times to make sure it continues to pass. 2. If complaints still exist (poor data transmission), examine the data module, connections, and wiring.
	PASS	Information and Control Channel Local Loop Test passed. All channels are transmitting properly

### Data Module Audits Test (#17)

This is a series of six tests that are classified as hardware audits. The processor sends messages to the on-board microprocessor to perform the following tests:

- Switchhook Inquiry — This is an update of the processor's software records based on the on-hook/off-hook status of the data module.

9 Maintenance Object Repair Procedures

PDMODULE (Processor Data Module) TDMODULE (Trunk Data Module)

9-1171

- Bad Scan Inquiry — A message is sent uplink that contains a count generated by certain events relating to the digital loop's (link) conditions. This could be an indication of communication problems between the processor and digital port board.
- EPF inquiry — The status of the Electronic Power Feed is sent uplink. EPF is not used for data modules.
- ID Request — A request is made to the data module for its status. The data module sends its configuration information and health information back. This information is checked and a pass/fail result is provided.
- Ringer Update — This updates the data module's ringer state according to processor records.
- Translation Update — This is a message normally used with digital stations to refresh the default value that causes the station to send touch tones only in the primary information channel. This test is not used with data modules.

**Table 9-466. TEST #17 Data Module Audits Test**

Error Code	Test Result	Description/ Recommendation
1	ABORT	Switchhook audit timed out. <ol style="list-style-type: none"> <li>1. Verify the data module is connected to the PBX and repeat the test.</li> <li>2. If the test aborts, replace the data module and repeat the test.</li> <li>3. If the test continues to abort, replace the circuit pack and repeat the test.</li> </ol>
2	ABORT	ID request fails, health bit is defective, or no response from on-board microprocessor. <ol style="list-style-type: none"> <li>1. Verify that the correct data module type (PDM versus TDM) is administered.</li> <li>2. If the test aborts, replace the data module and repeat the test.</li> <li>3. If the test aborts, replace the circuit pack and repeat the test.</li> </ol>
3	ABORT	No response from EPF audit.
4	ABORT	Internal system error <ol style="list-style-type: none"> <li>1. Resolve any outstanding circuit pack maintenance problems.</li> <li>2. Retry the command at 1-minute intervals a maximum of 5 times.</li> </ol>

*Continued on next page*

**Table 9-466. TEST #17 Data Module Audits Test — Continued**

Error Code	Test Result	Description/ Recommendation
5	ABORT	Ringer update aborted (data module not in the in-service state) <ol style="list-style-type: none"> <li>1. Verify that the data module is powered (power LED on).</li> <li>2. Make sure data module is connected to the building wiring, check for faulty wiring, check for faulty data module.</li> <li>3. Retry the command at 1-minute intervals a maximum of 5 times.</li> <li>4. Replace the Data Module and repeat the test.</li> <li>5. If the test continues to abort, replace the Digital Line circuit pack and repeat the test.</li> </ol>
6	ABORT	Data module translation update aborted. <ol style="list-style-type: none"> <li>1. Verify the data module is connected to the PBX.</li> <li>2. Retry the command at 1-minute intervals a maximum of 5 times.</li> </ol>
1000	ABORT	System resources required to run this test are not available. <ol style="list-style-type: none"> <li>1. Retry the command at 1-minute intervals a maximum of 5 times.</li> </ol>
1392	ABORT	This port is currently a TTI port and the test will not execute on it. <ol style="list-style-type: none"> <li>1. Verify that the port is a TTI port using either the <b>display port</b> command (the display shows that the port is a TTI port) or the <b>list config</b> command (the display shows a <math>\tau</math> for the port).</li> <li>2. If either <b>list config</b> or <b>display port</b> indicate that the port is <i>not</i> a TTI port, escalate the problem. If both commands indicate that the port is a TTI port, the abort is correct, and no action is necessary.</li> </ol>
2000	ABORT FAIL	Response to the test was not received within the allowable time period. Internal system error <ol style="list-style-type: none"> <li>1. Retry the command at 1-minute intervals a maximum of 5 times.</li> </ol>
	PASS	Data Module Audits passed. This digital port circuit pack is functioning properly. <ol style="list-style-type: none"> <li>1. If complaints still exist, investigate by using other port tests, and by examining the data module options, wiring, and connections.</li> </ol>

### Data Module Internal Looparound Test (#175)

This test verifies that a data message can be sent from the PBX, through the building wiring, through an internal loop-around path in the data module, and back to the PBX. This path is illustrated below.

For this test to run, the "Remote Loop-Around Test" field on the Data Module administration form must be set to "y," indicating that the data module endpoint supports the test.

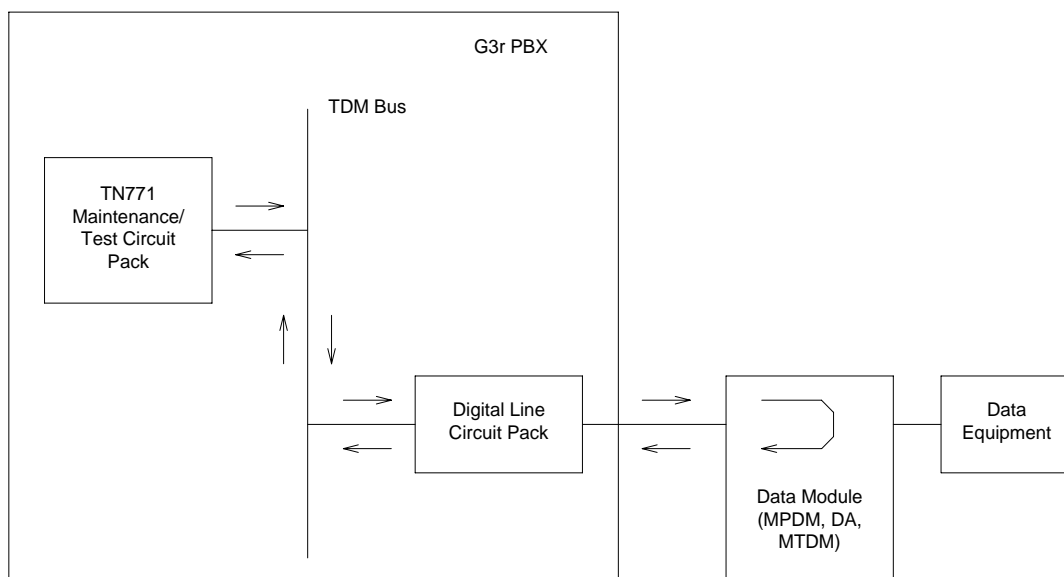

**Figure 9-73. Internal Looparound Test**

A signaling message is sent through the digital port circuit pack to the data module, requesting it to enter loop-around mode. A test pattern is then sent from the TN771 Maintenance/Test circuit pack, over the path illustrated above, and back to the TN771 where it is checked for consistency.

The test aborts if any of the following local PBX resources are not available: a digital port on the TN771 (there are two such digital ports, but only one may be used at a time), two TDM time slots and an idle digital port connected to the data module.

**Table 9-467. TEST #175 Data Module Internal LoopAround Test**

Error Code	Test Result	Description/ Recommendation
1000	ABORT	System resources required to run this test are not available. The port may be in use on a valid call. Use <b>status data-module</b> to determine when the port is available for testing. <ol style="list-style-type: none"> <li>1. Retry the command at 1-minute intervals a maximum of 5 times.</li> </ol>
1005	ABORT	Loop around testing is not enabled on the data module administration form. <ol style="list-style-type: none"> <li>1. Set "Loop-Around Test" field to "y" on the data module administration form.</li> </ol>
1042	ABORT	The port under test is a TTI port and thus has only default translations and no assigned extension. The test requires an extension assigned to the port being tested. <ol style="list-style-type: none"> <li>1. If there is a need to execute the test on this particular port, then you must fully administer the port so that it has an assigned extension.</li> </ol>
1180	ABORT	A Maintenance/Test Circuit pack digital port is not available to carry out the test. <ol style="list-style-type: none"> <li>1. Check to see if the Maintenance/Test digital ports are present (use the <b>list config board</b> command and look for ports 02 and 03).</li> <li>2. If the digital ports (02 and 03) on the M/T-BD are not present, refer to the "M/T-DIG (Maintenance/Test Digital Port)" section.</li> <li>3. If the digital ports are present, try the command again at 1-minute intervals up to 5 times.</li> </ol>
1181	ABORT	No time-slots available to connect digital ports for the test. <ol style="list-style-type: none"> <li>1. Try the command again at 1-minute intervals up to 5 times.</li> </ol>
1182	ABORT	Internal system error. Failed to connect the digital ports with time-slots. <ol style="list-style-type: none"> <li>1. Retry the command at 1-minute intervals a maximum of 5 times.</li> </ol>
1340	ABORT	No Maintenance/Test digital port is currently available to perform this test. <ol style="list-style-type: none"> <li>1. Use <b>list config</b> to determine whether any Maintenance/Test digital ports (ports 02 and 03 on the Maintenance/Test circuit pack) are present in the system. Because at least one Maintenance/Test circuit pack must always be present in the PPN of any G3r system, there should be at least two such ports present. If the ports are present, proceed to step 2. Otherwise, determine why no ports appear in the <b>list config</b> display. Refer to "M/T-DIG (Maintenance/Test Digital Port)" and M/T-BD maintenance documentation.</li> <li>2. Look for M/T-DIG errors in the Error Log. If present, refer to M/T-DIG maintenance documentation.</li> <li>3. If the ports are present and no errors are logged against them, retry the command at 1-minute intervals a maximum of 5 times.</li> <li>4. If the test continues to abort, replace the Maintenance/Test circuit pack.</li> </ol>

**Table 9-467. TEST #175 Data Module Internal LoopAround Test — Continued**

Error Code	Test Result	Description/ Recommendation
1392	ABORT	<p>This port is currently a TTI port and the test will not execute on it.</p> <ol style="list-style-type: none"> <li>1. Verify that the port is a TTI port using either the <b>display port</b> command (the display shows that the port is a TTI port) or the <b>list config</b> command (the display shows a "t" for the port).</li> <li>2. If either <b>list config</b> or <b>display port</b> indicate that the port is <b>not</b> a TTI port, escalate the problem. If both commands indicate that the port is a TTI port, the abort is correct for the test, and no action is necessary.</li> </ol>
2005	ABORT	<p>The handshake between the Maintenance/Test digital port and the Data Module failed.</p> <ol style="list-style-type: none"> <li>1. Look for M/T-DIG errors in the Error Log. If present, refer to "M/T-DIG (Maintenance/Test Digital Port)" section.</li> <li>2. If test still aborts on retry, check physical connection of data module under test. Make sure the switches are on NORM, OFF (between REM_LP and LOC_LP), 9600, and ASYN.</li> <li>3. If the test still aborts, replace the Data Module.</li> </ol>
2312	ABORT	<p>The Looparound Test did not complete, failed to receive loop-back data.</p> <ol style="list-style-type: none"> <li>1. Check for M/T-DIG error in the Error Log. If present, refer to M/T-DIG section.</li> <li>2. Retry the test, if still aborts, replace the Data Module.</li> <li>3. If the test aborts again, replace the Digital Line Circuit Pack.</li> </ol>
2313	ABORT	<p>The Maintenance/Test digital port allocated for this test did not respond to downlinked message.</p> <ol style="list-style-type: none"> <li>1. Look for M/T-DIG errors in the Error Log. If present, refer to "M/T-DIG (Maintenance/Test Digital Port)" section.</li> <li>2. Retry the command at 1-minute intervals a maximum of 5 times.</li> <li>3. If the test continues to abort, replace the MTB.</li> </ol>
2314	ABORT	<p>Data Module did not respond to downlinked message.</p> <ol style="list-style-type: none"> <li>1. Check the wiring of the Data Module under test.</li> <li>2. Verify that the Data Module is powered (power LED on).</li> <li>3. Make sure the switches are on NORM, OFF (between REM_LP and LOC_LP), 9600, and ASYN.</li> <li>4. If the test still aborts, replace the Date Module.</li> <li>5. If the same abort code appears, replace the Digital Line Circuit Pack which is connect to the Data Module.</li> </ol>

*Continued on next page*

**Table 9-467. TEST #175 Data Module Internal LoopAround Test — Continued**

Error Code	Test Result	Description/ Recommendation
2500	ABORT	Internal system error 1. Retry the command at 1-minute intervals a maximum of 5 times.
	FAIL	Data received from remote loop back does not match data sent. 1. Check for faulty wiring. 2. Replace the data module and repeat the test. 3. If the test fails, replace the Digital Line circuit pack associated with the data module and repeat the test.
	PASS	Data Module Looparound Test passed.



## PE-BCHL (PRI Endpoint Port)

MO Name (in Alarm Log)	Alarm Level	Initial Command to Run <sup>1</sup>	Full Name of MO
PE-BCHL <sup>1</sup>	MINOR	test port UUCSSpp l	PRI Endpoint Port
PE-BCHL	WARNING	test port UUCSSpp sh	PRI Endpoint Port

1. For additional repair information, see also UDS1-BD and *Troubleshooting Wideband Problems* in [Chapter 5, "Alarms, Errors, and Troubleshooting"](#).

A PRI Endpoint provides ISDN-PRI (Primary Rate Interface) connections application equipment or terminal adapters that terminate ISDN-PRI. The equipment or terminal adapters are connected to the switch via the TN464C/D UDS1 interface circuit pack. This maintenance object monitors the PRI endpoint port hardware on the UDS1 circuit pack by logging hardware errors, running tests for port initialization, and running periodic and scheduled maintenance and demand tests.

## Wideband Switching

Wideband switching supports end-to-end connectivity between customer endpoints at data rates from 128 to 1536 kbps over T1 facilities and to 1984 kbps over E1 facilities. DEFINITY switching capabilities are extended to support wideband calls comprised of multiple DS0s that are switched end-to-end as a single entity.

Wideband switching is designed for ISDN application equipment such as ISDN video codecs, but can also interface to non-ISDN application equipment by using PRI terminal adapters. In the same sense that a DEFINITY data module acts as a DCP or BRI terminal adapter between endpoint data such as V.35 and dialing interfaces such as RS-366 and a DCP interface, a PRI terminal adapter acts as a wideband terminal adapter between endpoint data and dialing interfaces and DEFINITY's line-side ISDN PRI interface. Wideband switching introduces PRI endpoints on DEFINITY line-side interfaces.

A PRI endpoint has a unique extension number and consists of one or more contiguous B-channels on a line-side T1 or E1 ISDN PRI facility. Endpoints initiate and receive calls via ISDN SETUP messages indicating the data rate and specific B-Channels to be used, and communicate all other call status information via standard ISDN messages. Any DEFINITY ISDN signaling set such as Lucent, CCITT, or ECMA may be used for a line-side ISDN PRI facility.

Multiple PRI endpoints on one line-side facility are separate and distinct within the facility. Non-overlapping contiguous sets of B-Channels are associated with each PRI endpoint, and the endpoint equipment is expected to initiate calls within these boundaries. The endpoint application equipment must:

- Use standard ISDN-PRI signaling
- Adhere to the administered PRI endpoint boundaries when initiating calls
- Handle incoming calls appropriately, based on the originating PRI endpoint

## Signaling and B-Channel States

PRI ports use a separate channel called the D-channel for call control and signaling messages. This is called out-of-band signaling. The D-channel associated with the set of B-channels is an ISDN-PRI signaling link port (ISDN-LNK). The signaling protocol used on the ISDN-PRI signaling link port D-channel is defined by one of the four selectable ISDN-PRI Specifications: Lucent, CCITT, ECMA, and ANSI.

The ISDN-PRI Specification defines the possible service states for a B-channel. The service state is negotiated with the far-end terminal adapter, changes over time, and can have a far-end and near-end components. The service state is initialized to Out-Of-Service/Far-End, and an attempt is made to negotiate it to In-Service. The service state of a particular PRI endpoint port B-channel can be displayed with the **status pri-endpoint** extension command.

If a call is present, the Specification defines the permissible call states as well. There are tests in the short and long test sequences for the PRI endpoint port designed to audit these states and ensure agreement between both ends of the PRI wideband connection.

## Alarming Based on Service States

A PRI endpoint port B-channel logs a warning alarm when it is placed in a Maintenance/Far-End or Out-Of-Service/Far-End state. While in such a state, the port is unusable for calls to the terminal adapter. However, the user can still use the other remaining ports in the PRI endpoint to make calls to and from the terminal adapter. When a warning alarm is raised, use the **status pri-endpoint** extension command to determine the exact state of the port. Other alarms can be diagnosed by using the short and long test sequences. Note that a PRI endpoint port B-channel can be placed in a far-end service state by direct action by the far-end terminal adapter or by inaction of the far-end terminal adapter. For example, if it does not respond to a Remote Layer 3 Query (see Test #260 for ISDN-LNK) the associated PRI endpoint port B-channels will be placed in the Maintenance/Far-End service state.

A PRI endpoint port is a port on a UDS1 interface circuit pack and thus depends on the health of the circuit pack for proper operation (see the following figure). A problem on the associated ISDN-PRI Signaling Link Port D-channel (ISDN-LNK) can also affect the PRI endpoint. The ISDN-PRI Signaling Link Port in turn depends on the SYS-LINK (System Link) to the Packet Interface. Keep this hierarchy of dependencies in mind when diagnosing problems.

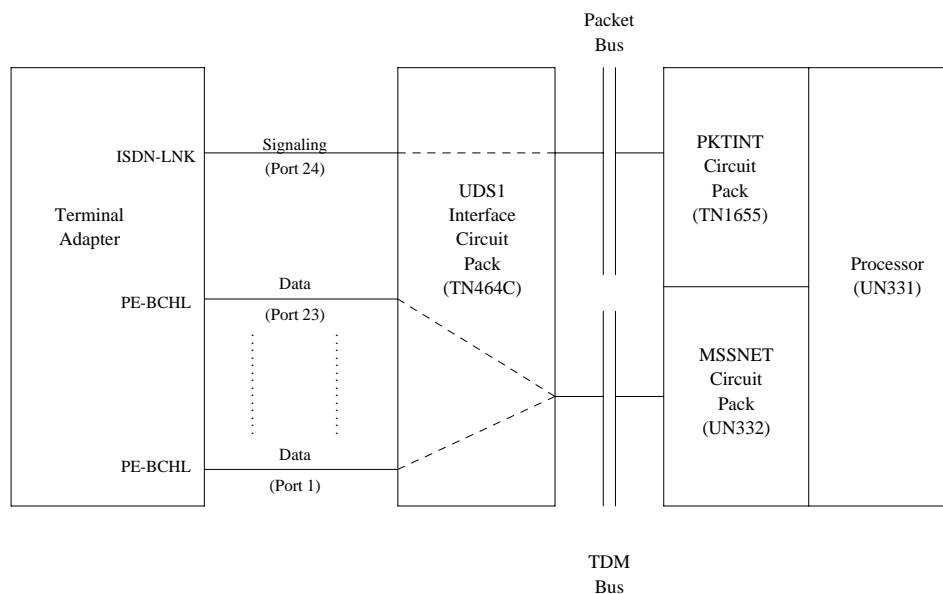

**Figure 9-74. PRI Endpoint Port Interactions**

## PRI Endpoint Port Service States

The **status pri-endpoint** extension command displays the following possible service states for PRI endpoint ports. The table that follows gives recommended procedures for each state. The figure following that shows typical progressions from one service state to another. Refer also to *Troubleshooting Wideband Problems* in [Chapter 5, "Alarms, Errors, and Troubleshooting"](#) for a layered approach to addressing PRI endpoint problems.

- In-Service (INS)

The B-channel is in its normal operating state.

- Out-of-Service/Far-End (OOS/FE)

A B-Channel is initialized to this state when first administered. The switch then sends messages to the far-end terminal adapter to negotiate the B-channel into service. If the far-end terminal adapter does not respond to the messages within a certain time period, the port remains out of service, and maintenance will periodically resend the messages. The port is unusable for incoming and outgoing calls, although other ports in the PRI endpoint can still be used.

- Out-of-Service/Near-End (OOS/NE)

This is the state of the port when a hardware failure exists on the signaling link, the NPE Crosstalk Test fails, or when the port is busied out by command. In this state, the port is unusable for calls coming in to the switch or going out to the terminal adapter, although other ports in the PRI endpoint can still be used for incoming and outgoing calls. No messages are sent to the far-end terminal adapter until the signaling link comes back into service or the port is released by command.

- Maintenance/Far-End (MTC/FE)

This state is reached when the far-end terminal adapter does not respond to messages sent over the signaling link for a particular port within a certain amount of time. This state is different from OOS/FE since the signaling link must have initially been up and the B-Channels in service. The switch will periodically send messages to the far-end terminal adapter to try to negotiate the port (B-channel) into service. The port is unusable for outgoing calls to the terminal adapter but will service incoming call requests from the far-end. Other ports of the PRI endpoint can still place outgoing calls to the terminal adapter. Transitions into MTC/FE do not drop stable calls. If the service state changes from in-service to MTC/FE, stable calls are unaffected.

- Maintenance/Near-End (MTC/NE)

The signaling link (SYS-LINK) is busied out by the **busyout**, **test port I** or **test pri-endpoint I** commands. Transitions into MTC/NE do not drop stable calls. The **busyout link lnk-no** command does not drop stable wideband calls. In this state, the B-Channel is not usable for new incoming calls to the switch or new outgoing calls to the terminal adapter.

- Pending States (PEND)

If the near-end is expecting a timed response from the far-end for a request to change the service state of a port, a *pending* state is in effect. For example, if the port is out-of-service/far-end and an in-service message was sent to the far-end, then the service state of the port is OOS/FE-PEND/INS meaning out-of-service/far-end, pending/in-service. The service state will reflect this pending state until the far-end responds or the timer expires.

**Table 9-468. PRI Endpoint Port Service States**

Service State <sup>1</sup>	Alarm	Possible Cause	Possible Solution
OOS/NE	Warning	Port has been busied out by command.	Enter <b>release pri-endpoint</b> extension.
	Minor	NPE Crosstalk Test (#6) failed.	Replace UDS1 circuit pack.
		UDS1 circuit pack lost its signal.	Is the UDS1 circuit pack removed? Is the UDS1 cable disconnected? Is the far-end terminal restarting or experiencing problems? Check circuit pack using procedures UDS1-BD.
OOS/FE	Warning	Far-end problems or incompatibility	Check administration and status of the corresponding port on the terminal adapter.
	Warning	The far-end port is busied out.	Check the status of the far-end terminal adapter.
OOS/FE PINS		Service message was sent and the switch is waiting up to 2 min. for a reply from the far-end terminal adapter.	Wait 2 min. and check service state after the PINS state has cleared.
MTC/NE		System link demand busied out	Check link status. Release with <b>release link link#</b> .
MTC/FE	Warning	Signaling channel has been down for over 90 sec.	Consult ISDN-SGRP, ISDN-LNK and/or SYS-LINK. Far-end terminal adapter may currently be restarting.
	Warning	Repeated failure of far end to respond to messages.	Maintenance software will periodically try to resend messages. You can speed the process with <b>test port UUCSSpp</b> (Test #256).
	Warning	The far-end port is being tested.	Check status of the far-end terminal adapter.
MTC/FE PINS		Service message was sent and the switch is waiting up to 2 min. for a reply from the far-end terminal adapter.	Wait 2 min. and check service state after the PINS state has cleared.

**Table 9-468. PRI Endpoint Port Service States — Continued**

Service State <sup>1</sup>	Alarm	Possible Cause	Possible Solution
INS		Normal operating state. ISDN wideband calls being completed.	

- 
1. OOS Out of Service  
 MTC Maintenance  
 FE Far-end  
 NE Near-end  
 PINS Pending in-service
-

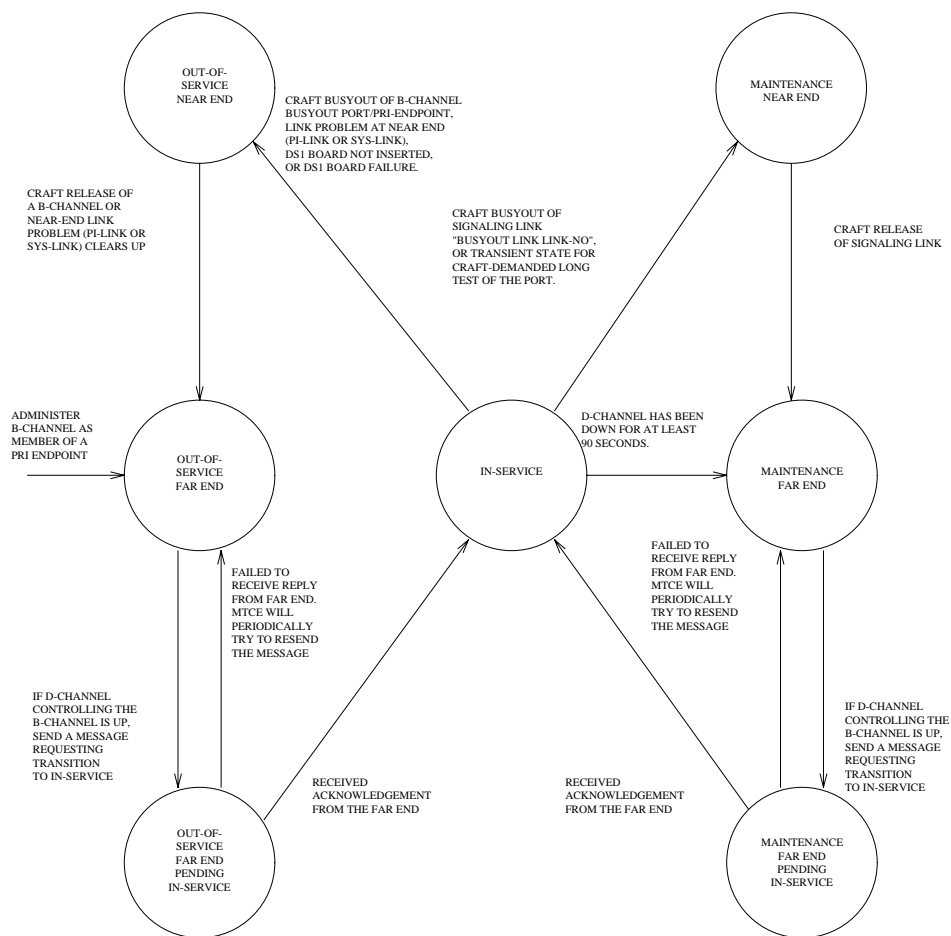

Figure 9-75. Common Progressions in PRI Endpoint Service States

## Error Log Entries and Test to Clear Values

Table 9-469. PRI endpoint port Error Log Entries

Error Type	Aux Data	Associated Test	Alarm Level	On/Off Board	Test to Clear Value
0 <sup>1</sup>	0	Any	Any	Any	test port <i>UUCSSpp</i> sh r 1
1(a)	Any	None			test port <i>UUCSSpp</i> sh r 1
15(b)	Any	Audit and Update Test (#36)			
18(c)	0	busyout pri-endpoint <i>extension</i> busyout port <i>UUCSSpp</i>			release pri-endpoint <i>extension</i> release port <i>UUCSSpp</i>
129(d)		None	WARNING	OFF	test port <i>UUCSSpp</i> sh r 1
130(e)		None	WARNING	ON	test port <i>UUCSSpp</i> sh
257(f)	Any	None			test port <i>UUCSSpp</i> sh r 1
513(g)	Any	None	WARNING	OFF	test port <i>UUCSSpp</i> sh r 1
769(f)	Any	None			test port <i>UUCSSpp</i> sh r 1
1281(h)	Any	Conference Circuit Test (#7)	MINOR	ON	test port <i>UUCSSpp</i> l r 4
1537(i)	Any	NPE Crosstalk Test (#6)	MINOR	ON	test port <i>UUCSSpp</i> l r 3
1793(j)	Any	None			test port <i>UUCSSpp</i> sh r 1
3073(k)	Any	Service State Audit (#256)			test port <i>UUCSSpp</i> sh r 2
3585(l)	Any	None			None

1. Run the Short Test Sequence first. If all tests pass, run the Long Test Sequence. Refer to the appropriate test description and follow the recommended procedures.

### Notes:

- a. These error types indicate a disagreement between this switch and the terminal adapter at the other end of the connection with regard to the ISDN *call* state of the PRI endpoint port. This switch will automatically try to recover by clearing the call (the call will be torn down). Use the **status pri-endpoint extension** command to determine the state of the port.

When running the Short Test Sequence of tests, pay close attention to the results of the Call State Audit Test (#257).

- b. This is a software audit error that does not indicate any hardware malfunction. Run the Short Test Sequence and investigate associated errors.



- c. The PRI endpoint port has been busied out by **busyout pri-endpoint** extension or **busyout port UUCSSpp**. No wideband calls can be made to this port, although wideband calls can still be made to other ports within this PRI endpoint if they are in service.
- d. The far-end terminal adapter changed its ISDN *service* state to either out-of-service or maintenance. This may be a temporary condition due to testing of this port by the far-end terminal adapter *or* a hardware problem with the port. Outgoing calls to the terminal adapter will not be allowed over the port, although calls can still be made to other ports that are in service within the same PRI endpoint. To investigate the status of the port, enter **status pri-endpoint** extension.
- e. This error type indicates that the circuit pack has been removed or has been insane for more than 11 minutes. To clear the error, reinsert or replace the circuit pack.
- f. These error types indicate a disagreement between this switch and the terminal adapter at the other end of the connection with regard to the ISDN service state of the PRI endpoint port. The switch will automatically try to recover by performing a service state audit. Use **status pri-endpoint** extension to determine the state of the port.

When running the Short Test Sequence, pay close attention to the results of the Service State Audit Test (#256).

- g. This port is not recognized by the far-end terminal adapter. Investigate the PRI endpoint administration for both the switch and the terminal adapter, and make sure they agree.
- h. The Conference Circuit Test (#7) failed on this port. See Test #7 for repair procedures.
- i. The NPE Crosstalk Test (#6) failed on this port. See Test #6 for repair procedures.
- j. This error indicates a failure of the UDS1 Interface circuit pack. The results of the Signaling Link State Check Test (#255 in the short sequence) are important.
- k. Two Service State Audit attempts have failed (see Test #256). The port will not be usable for any outgoing calls to the terminal adapter until the test passes and the port state is changed to in-service. Incoming calls from the terminal adapter *will* be accepted over this port, and other ports in the PRI endpoint can still be used for both incoming and outgoing calls to and from the terminal adapter.
- l. Error Type 3585 appears when the switch receives an ISDN RESTART message for an ISDN port that is not idle. Since calls are not typically cleared with the RESTART message, this error type may be associated with a dropped call report from a user.

The following Aux Data values for Error Type 3585 represent the port's ISDN call state at the time the unexpected RESTART request was received from the terminal adapter. This information can be useful if dropped calls are being reported by users of the PRI endpoint. Aux values that do not appear below can be ignored.

**PE-BCHL Error 3585 Aux Data**

<b>Aux Data</b>	<b>Meaning</b>
10	A call in a stable, talking state (the <i>active</i> state) was cleared unexpectedly by the far-end terminal adapter with an ISDN RESTART message.
4 7 8 260 263	A call that has not reached the active state, but has at least reached a ringing state, was cleared unexpectedly by the far-end terminal adapter with an ISDN RESTART message.
1 3 6 265	A call that has not yet reached a ringing state was cleared unexpectedly by the far-end terminal adapter with an ISDN RESTART message.
11 12 19 531 267 268	A call that was already in the process of clearing has been cleared by the far-end terminal adapter with an ISDN RESTART message. If this condition occurs frequently, it may mean that the far-end terminal adapter is attempting to clear ports that it thinks are in a "hung" state. The RESTART message puts the port in an idle condition.

**System Technician-Demanded Tests: Descriptions and Error Codes**

Always investigate tests in the order presented in the table below when inspecting errors in the system. By clearing error codes associated with the *NPE Crosstalk Test*, for example, you may also clear errors generated from other tests in the testing sequence.

Order of Investigation	Short Test Sequence	Long Test Sequence	D/ND <sup>1</sup>
NPE Crosstalk Test (#6)		X	ND
Conference Circuit Test (#7)		X	ND
Audit and Update Test (#36)	X	X	ND
Signaling Link State Check Test (#255)	X	X	ND
Service State Audit Test (#256)	X	X	ND
Call State Audit Test (#257)	X	X	ND

1. D = Destructive; ND = Nondestructive

### NPE Crosstalk Test (#6)

The NPE Crosstalk Test verifies that this port's NPE channel talks on the selected time slot and never crosses over to time slots reserved for other connections. If the NPE is not working correctly, one-way and noisy connections may be observed. This test is usually part of a port's long test sequence and takes about 20 to 30 seconds to complete.

**Table 9-470. TEST #6 NPE Crosstalk Test**

Error Code	Test Result	Description/ Recommendation
	ABORT	Could not allocate the necessary system resources to run this test. 1. Retry the command at 1-minute intervals for a maximum of 5 times.
1000	ABORT	System resources required to run this test are not available. The port may be in use on a valid call. Use <b>status pri-endpoint</b> extension commands to determine when the port is available for testing. 1. Retry the command at 1-minute intervals for a maximum of 5 times.
1001	ABORT	Could not allocate the necessary system resources to run this test. 1. Retry the command at 1-minute intervals for a maximum of 5 times.
1002	ABORT	The system could not allocate time slots for the test. The system may be under heavy traffic conditions or it may have time slots out-of-service due to TDM-Bus errors. Use the <b>status health</b> command to determine if the system is experiencing heavy traffic. Investigate and resolve any errors against TDM-BUS. 1. If system has no TDM-Bus errors and is not handling heavy traffic, repeat test at 1-minute intervals for a maximum of 5 times.

*Continued on next page*

Table 9-470. TEST #6 NPE Crosstalk Test — Continued

Error Code	Test Result	Description/ Recommendation
1003	ABORT	<p>The system could not allocate a tone receiver for the test. The system may be oversized for the number of tone detectors present or some tone detectors may be out-of-service. The <b>list measurements tone-receiver</b> command will display information on the system's tone receiver.</p> <ol style="list-style-type: none"><li>1. Resolve any errors against TTR-LEV.</li><li>2. Resolve any errors against TONE-PT.</li><li>3. If neither of the above exists, retry the test at 1-minute intervals for a maximum of 5 times.</li></ol>
1004	ABORT	<p>The port has been seized by a user for a valid call. Use <b>status pri-endpoint</b> extension to determine when the port is available for testing.</p> <ol style="list-style-type: none"><li>1. Retry the command at 1-minute intervals for a maximum of 5 times.</li></ol>
1117	ABORT	<p>A service state audit message is outstanding.</p> <ol style="list-style-type: none"><li>1. Wait 2 minutes and then try again.</li></ol>
2000	ABORT	<p>Response to the test request was not received within the allowable time period.</p> <ol style="list-style-type: none"><li>1. Retry the command at 1-minute intervals for a maximum of 5 times.</li></ol>
2020	ABORT	<p>The test did not run due to an existing error on the specific port or a more general circuit pack error.</p> <ol style="list-style-type: none"><li>1. Examine the Error Log for existing errors against this port or the circuit pack and follow recommended procedures.</li></ol>
2100	ABORT	<p>Could not allocate the necessary system resources to run this test.</p> <ol style="list-style-type: none"><li>1. Retry the command at 1-minute intervals for a maximum of 5 times.</li></ol>
Any	FAIL	<p>The NPE of the tested port was found to be transmitting in error. This will cause noisy and unreliable connections. The PE-BCHL is moved to out-of-service/near-end state.</p> <ol style="list-style-type: none"><li>1. Replace the circuit pack.</li></ol>
	PASS	<p>The port is able to communicate over the TDM Bus.</p>

### Conference Circuit Test (#7)

The Conference Circuit test verifies that the NPE channel for the port being tested can correctly perform the conferencing function. The NPE is instructed to listen to several different tones and conference the tones together. The resulting signal is measured by a tone detector port. If the level of the tone is within a certain range, the test passes.

Table 9-471. TEST #7 Conference Circuit Test

Error Code	Test Result	Description/ Recommendation
	ABORT	Could not allocate the necessary system resources to run this test. 1. Retry the command at 1-minute intervals for a maximum of 5 times.
1000	ABORT	System resources required to run this test are not available. The port may be in use on a valid call. Use <b>status pri-endpoint</b> extension commands to determine when the port is available for testing.
1004	ABORT	The port has been seized by a user for a valid call. Use <b>status pri-endpoint</b> extension to determine when the port is available for testing. 1. Retry the command at 1-minute intervals for a maximum of 5 times.
1020	ABORT	The test did not run due to an already existing error on the specific port or a more general circuit pack error. 1. Examine Error Log for existing errors against this port or the circuit pack and attempt to diagnose the already existing error.
2000	ABORT	Response to the test request was not received within the allowable time period.
2100	ABORT	Could not allocate the necessary system resources to run this test. 1. Retry the command at 1-minute intervals for a maximum of 5 times.
Any	FAIL	The NPE of the tested port did not conference the tones correctly. This will cause noisy and unreliable connections. 1. Replace the circuit pack. Even though wideband calls do not use the conferencing feature on the NPE, this failure indicates problems with the circuit pack hardware.
	PASS	The port can correctly conference multiple connections. User-reported troubles on this port should be investigated using other port tests and examining terminal adapter or external wiring.

### Audit and Update Test (#36)

This test sends port level translation data from switch processor to the UDS1 interface circuit pack to assure that the port's translation is correct. The port audit operation verifies the consistency of the current state of port kept in the UDS1 interface circuit pack and in the switch software.

**Table 9-472. TEST #36 Audit and Update Test**

Error Code	Test Result	Description/ Recommendation
2000	ABORT	Internal system error
2100	ABORT	Response to the test was not received within the allowable time period.
	ABORT	Could not allocate the necessary system resources to run this test.
	FAIL	Test failed due to internal system error. 1. Retry the command at 1-minute intervals for a maximum of 5 times.
	PASS	Port translation has been updated successfully. The current port states kept in the UDS1 interface circuit pack and switch software are consistent. If the port is busied out, the test will not run, but will return PASS. To verify that the port is in-service: <ol style="list-style-type: none"> <li>1. Enter <b>status pri-endpoint</b> extension to verify that the port is in-service. If the port is in-service, no further action is necessary. If the port is out-of-service, continue to Step 2.</li> <li>2. Enter <b>release pri-endpoint</b> extension or <b>release port UUCSSpp</b> command to put port back into in-service.</li> <li>3. Retry the test command.</li> </ol>

### Signaling Link State Check Test (#255)

As noted in the preceding general description, operation of the PRI endpoint port depends on the health of the UDS1 interface circuit pack and System Link for proper operation. This test checks the status of those critical elements.

**Table 9-473. TEST #255 Signaling Link State Check Test**

Error Code	Test Result	Description/ Recommendation
	ABORT	Internal system error 1. Retry the command at 1-minute intervals for a maximum of 5 times.

*Continued on next page*

Table 9-473. TEST #255 Signaling Link State Check Test — *Continued*

Error Code	Test Result	Description/ Recommendation
1700	ABORT	Rollabout video abort. The PRI terminal adapter associated with this PRI endpoint extension is detached from the circuit pack. This is a normal abort when the rollabout video feature is enabled.  1. Either reconnect the disconnected PRI terminal adapter or disable the rollabout video feature on this circuit pack. To do the latter, enter <b>change ds1 UUCSS</b> and set the field labeled "Alarm when PRI Endpoint Detached?" to "y."
4	FAIL	There is a problem with the Signaling Channel and/or with the System Link.  1. Consult procedures for the ISDN-GRP and SYS-LINK. See also ISDN-LNK for useful information.
8	FAIL	There is a problem with the UDS1 interface circuit pack.  1. Consult procedures for UDS1-BD.
	PASS	The signaling link hardware is OK.

## Service State Audit (#256)

As noted in the general description for PRI endpoint port, these ports may be in one of several service states as defined by the ISDN-PRI Specification. This test performs a service state audit with the far-end terminal adapter to ensure both sides agree on the service state.

A PASS for this test simply means that an audit message was successfully composed and sent out to the far-end terminal adapter. The ISDN Specification allows up to 2 minutes for a reply. If no reply is received within that 2 minute window, this switch will automatically try once again. If that attempt fails, an error will be logged (Error Type 3073) and the switch will then attempt recovery by automatically retrying approximately every 15 minutes. If the port was initially in the INS (in-service) state, it will now be placed in the MTC/FE (maintenance state, far-end problem) state. Until a Service State Audit attempt is successful, no outgoing calls will be placed over this port, but incoming calls will be accepted. The service state of this port does not affect the service state of other ports in the PRI endpoint. If an incoming call that uses this port is presented while in such a state, a Service State Audit attempt will immediately be attempted (that is, the switch will not wait for the 15-minute cycle, but will instead try to recover immediately). To investigate the status of this PRI endpoint port, issue the **status pri-endpoint** extension command.

Table 9-474. TEST #256 Service State Audit Test

Error Code	Test Result	Description/ Recommendation
1113	ABORT	The signaling link has failed, so the system cannot send any messages on behalf of this port. <ol style="list-style-type: none"><li>1. Check the results of Test #255 (Signaling Link State Check).</li></ol>
1117	ABORT	A service state audit message is outstanding. <ol style="list-style-type: none"><li>1. Wait 2 minutes and then try again.</li></ol>
1700	ABORT	Rollabout video abort. The PRI terminal adapter associated with this PRI endpoint extension is detached from the circuit pack. This is a normal abort when the rollabout video feature is enabled. <ol style="list-style-type: none"><li>1. Either reconnect the disconnected PRI terminal adapter or disable the rollabout video feature on this circuit pack. To do the latter, enter <b>change ds1 UUCSS</b> and set the field labeled "Alarm when PRI Endpoint Detached?" to "y."</li></ol>
2100	ABORT	Could not allocate the necessary system resources to run this test. <ol style="list-style-type: none"><li>1. Retry the command at 1-minute intervals for a maximum of 5 times.</li></ol>
	FAIL	Internal system error <ol style="list-style-type: none"><li>1. Retry the command at 1-minute intervals for a maximum of 5 times.</li></ol>
	PASS	Wait 4 minutes and then check the Error Log for any new errors of type 3073. If there are none, then both sides of the ISDN connection agree on the service state; the negotiation succeeded. If there is a new 3073 error, then the negotiation failed (the far-end terminal adapter twice failed to respond within the mandatory 2-minute window). This switch will automatically retry approximately every 15 minutes. If the port was initially in the INS (in-service) state, it will now be placed in the MTC/FE (maintenance, far-end problem) state (refer to the "Service States" section which precedes the PE-BCHL "Hardware Error Log Entries and Test to Clear Values" table); incoming calls will be accepted, but no outgoing calls will be originated this port. If an incoming call is presented, another Service State Audit will be immediately performed in an attempt to bring the PRI endpoint port the proper state.

### Call State Audit Test (#257)

If a call is active on the port, the switches on both sides of the connection should agree on the ISDN state of the call as defined in the ISDN Protocol Specification. This test audits internal call state data by querying the far-end terminal adapter as to the ISDN state of the call. It can be helpful when trying to clear a hung call. If the internal call state data on the near-end switch is different than that of the far-end terminal adapter, **the call will be torn down.**



As with Test #256 (Service State Audit), a PASS simply means that an appropriate message was composed and sent to the far-end terminal adapter. The ISDN Specification allows up to 2 minutes for a reply. If a reply is not received within the 2 minute window, a protocol time-out violation will be recorded in the error log against the associated signaling channel (ISDN-PRI Signaling Link Port, which is listed in the Error Log as ISDN-LNK; the Error Type is 1).

**Table 9-475. TEST #257 Call State Audit Test**

Error Code	Test Result	Description/ Recommendation
1019	ABORT	An audit is already in progress. 1. Wait 2 minutes and try again.
1113	ABORT	The signaling link has failed, so the system cannot send any messages on behalf of this port. 1. Check the results of Test #255 (Signaling Link State Check).
1116	ABORT	The port is in an out-of-service ISDN service state. 1. A call cannot be present if the port is in an ISDN out-of-service state, so a call state audit would be inappropriate. No action necessary. (Use the <b>status pri-endpoint</b> extension command to investigate the ISDN state of the port).
1700	ABORT	Rollabout video abort. The PRI terminal adapter associated with this PRI endpoint extension is detached from the circuit pack. This is a normal abort when the rollabout video feature is enabled. 1. Reconnect the disconnected PRI terminal adapter or disable the rollabout video feature on this circuit pack. To do the latter, enter <b>change ds1 UUCSS</b> and set the field labeled "Alarm when PRI Endpoint Detached?" to "y."
2100	ABORT	Could not allocate the necessary system resources to run this test. 1. Retry the command at 1-minute intervals for a maximum of 5 times.
	FAIL	Internal system error 1. Retry the command at 1-minute intervals for a maximum of 5 times.
	PASS	This switch sent a call state auditing message to the far-end terminal adapter to verify the state of the call active on this port. If a call state mismatch is found, then the call will be torn down within two minutes. If no call was active, then no message was sent.

## PGATE-BD (Packet Gateway Circuit Pack)

---

MO Name (in Alarm Log)	Alarm Level	Initial Command to Run <sup>1</sup>	Full Name of MO
PGATE-BD	MINOR	test board UUCSS long	Packet Gateway Circuit Pack
PGATE-BD	WARNING	test board UUCSS short	Packet Gateway Circuit Pack

1. UU is the universal cabinet number (1 for PPN, 2 - 44 for EPNs). C is the carrier designation (A, B, C, D, or E). SS is the number of the slot in which the circuit pack resides (01 to 21).

### Packet Gateway Circuit Pack

---

The TN577 Packet Gateway is a packet port circuit pack that provides connectivity between synchronous communication links and Packet Bus endpoints.

A LAPD signaling link is established between the Packet Gateway and the SPE for passing call control and other management information. Since one link serves all the ports on the circuit pack, maintenance of the signaling link is part of the Packet Gateway circuit pack maintenance.

Three external cabling arrangements allow port configurations supporting four RS423 connectors. External ports on Packet Gateways running the X.25 application provide switch connectivity to BX.25 adjuncts : AUDIX, CMS, ISDN Gateway, other PBXs in a DCS network, and 3B2 Message Server Adjuncts.

### Packet Gateway Congestion Controls

---

Congestion controls are activated on Packet Gateway when the number of buffers reach a specified threshold (high buffer mark). The switch releases its congestion controls when the Packet Gateway reports that it has recovered from congestion, i.e., its utilized buffer level has returned to normal levels.

A MINOR on-board alarm is raised if congestion persists on the affected Packet Gateway for a 15 minute interval or is raised immediately if the congestion controls fail to prevent all buffers from being exhausted. When congestion abates, the MINOR alarm is not retired until the Packet Gateway is free of congestion for 30 minutes.

## Error Log Entries and Test to Clear Values

Table 9-476. PGATE-BD Error Log Entries

Error Type	Aux Data	Associated Test	Alarm Level	On/Off Board	Test to Clear Value
1 (a)	0		MINOR	ON	
18 (b)			WARNING	OFF	release board UUCSS
23 (c)	0		WARNING	OFF	add pgate UUCSS
257	65535	Control Channel Loop Test (#52)	MINOR	ON	test board UUCSS l r 20
257 (d)					
513 (e)	4352 to 4357		MINOR	ON	
769 (f)	4358				
1025(g)	4363	NPE Audit Test (#50)			
1291 to 1296 (h)			MINOR	ON	reset board UUCSS
1537(i)	ANY		MINOR	ON	
1793 1794 1795 (j)			MINOR	ON	
2049 (k)		Packet Interface Test (#598)	MINOR	ON	test board UUCSS l r 3
2305 2306 (l)					
2817 2819 (m)		Congestion Query Test (#600)	MINOR	ON	test board UUCSS s r 3
3073 (n)		Link Status Test (#601)	MINOR	ON	test board UUCSS s
3329 (o)			MINOR	ON	reset board UUCSS
3568 (p)					
3840 (q)	4096 to 4100				
3841 3843 (r)					
3842 (s)					
3999 (t)	Any	None			

Notes:

- a. This error indicates that the circuit pack has stopped functioning or was physically removed from the system. Check to see whether the circuit pack is present in the slot indicated by the error. If the circuit pack is there, then reset it with **reset board UUCSS**. If the error persists, then replace the circuit pack.
- b. Packet Gateway circuit pack has been busied out by command.
- c. Packet Gateway circuit pack has not been administered for the slot in which it is inserted.
- d. This error indicates transient communication problems between the switch and this circuit pack. This error is not service affecting and can be ignored unless repeated failure of the Control Channel Loop-Around Test indicates a hardware failure of the circuit pack.
- e. A hardware failure on the circuit pack has been detected and reported by the circuit pack. These errors are detected by initialization or background tests which run on the circuit pack. The detection of one of these errors causes the circuit pack to "lock up" and appear insane to the system. See error type 1.

The reported aux data values correspond to the following detected errors:

4352:	External RAM error
4353:	Internal RAM error
4355:	ROM Checksum error
4357:	Instruction set error

- f. This error is reported by the circuit pack when it detects a program logic error. This error can be ignored, but may lead to errors of other types being reported against this circuit pack.
- g. This error is reported by the circuit pack when it cannot update NPE memory and read it back. This error type can be ignored, but may lead to errors of other types being reported against this circuit pack.
- h. A critical hardware or firmware failure has been detected on the circuit pack. The switch resets the circuit pack upon the report of one of these errors. If three of these errors are received in 15 minutes, a MINOR alarm is raised on the circuit pack. Try clearing the alarm by executing the **reset board UUCSS** command. The circuit pack should be replaced if this alarm cannot be resolved.

The reported error types correspond to the following detected errors:

1291:	Contents of translation and application program memory corrupted
1292:	Internal hardware component failure
1293:	On-board auxiliary processor insane
1294:	Internal memory access error
1296:	Call aborted due to bad translation RAM locations

- i. The circuit pack is hyperactive (flooding the switch with messages sent over the control channel) and is taken out of service when a threshold number of these errors are reported to the switch. Reset the circuit pack via the **reset board UUCSS** command to clear the alarm. If the error happens again within 15 minutes, then replace the circuit pack.
- j. These errors are detected and reported by the circuit pack when transmitting frames to the packet bus. The switch raises a MINOR alarm on the circuit pack when these errors are received by the switch at a defined rate.

These errors are reported when the following errors are detected:

1793:	Parity errors are detected when transmitting frames to the packet bus
1794:	Overflow of packet bus transmit buffers has occurred
1795:	Circuit pack cannot find end of frame when transmitting to packet bus

Reset the circuit pack via the **reset board UUCSS** command to clear the alarm. If the error happens again within 15 minutes, then replace the circuit pack.

- k. This error is reported when the "Packet Interface Test" has failed. A threshold number of these failures cause a MINOR alarm to be raised on the circuit pack. If the alarm cannot be cleared, try resetting the circuit pack to clear the problem. If the circuit pack reset is successful, execute the "Packet Interface Test" several times again. Replace the circuit pack if the "Packet Interface Test" continues to fail.
- l. This error occurs when the circuit pack detects an error in a received frame from the packet bus. These errors are most likely caused by a packet bus problem, but may be due to a circuit pack fault.

These error types are reported when the following errors are detected:

- 2305: Invalid LAPD frame received
- 2306: Parity error detected on received frame

An Invalid LAPD frame error occurs if the frame contains bad CRC, is greater than the maximum length, or violates the link level protocol.

When invalid LAPD frame errors are reported, the "Invalid LAPD Frame Error Counter Test" should be executed to determine if the condition has cleared. When bus parity errors are reported, the "LANBIC Receive Parity Error Counter Test" should be performed to determine if the condition has cleared. Execution of the Packet Interface Test should be performed if this problem persists to verify the integrity of the circuit pack. If the Packet Interface Test passes, then the repair procedure for the packet bus should be consulted.

- m. These errors occur when the Packet Gateway reports that it is congested or the "Congestion Query Test" fails. A Packet Gateway enters a congested state when the number of utilized buffers on the board exceeds a specified threshold.

The error types associated with congestion are defined as follows:

- 2817: Utilized buffers have exceeded high buffer mark
- 2819: All buffers exhausted

See description of "Congestion Query Test" for correct repair procedure to follow.

- n. This error is reported when the call control signaling link fails or when the Link Status Test fails for an X.25 Packet Gateway circuit pack. The call control signaling link is considered failed when it is disconnected at the link level and cannot be reconnected quickly. If the link cannot be reconnected quickly, a MINOR off-board alarm is raised against the circuit pack. This failure may be due to circuit pack problems, packet bus problems, or packet interface circuit pack problems.
- o. A critical failure has been detected in the Packet Bus interface of the circuit pack. The switch resets the circuit pack upon the report of one of these errors. If two of these errors are received in 15 minutes, a MINOR alarm is raised on the circuit pack. Try clearing the alarm by executing the **reset board UUCSS** command. The circuit pack should be replaced if this alarm cannot be resolved.
- p. The circuit pack is hyperactive (flooding the switch with messages sent over the control channel) and is taken out of service when a threshold number of these errors are reported to the switch. It may exhibit one or more of the following symptoms:
  1. Tests run on the ports of this circuit pack return NO-BOARD.

2. **List configuration** shows that the circuit pack and ports are properly installed.
3. A busyout/release of the circuit pack brings the board back into service.
4. Error type 3999 indicates that the circuit pack sent a large number of control channel messages to the switch within a short period of time. If error type 3586 is also present, then the circuit pack was taken out-of-service due to hyperactivity. If error type 3586 is not present, then the circuit pack has not been taken out-of-service, but it has generated 50% of the messages necessary to be considered hyperactive. This may be completely normal during heavy traffic periods. However, if this error type is logged when the circuit pack is being lightly used, it may indicate a problem with the circuit pack or the equipment attached to it.

This condition should clear itself within 30 minutes. It is recommended that the error be allowed to clear itself. If this error reoccurs within 15 minutes of being cleared, replace the circuit pack. If the same error occurs on a different circuit pack, follow normal escalation procedures.

The circuit pack can be manually brought back into service in the following ways.

- Busyout and release the circuit pack.
  - Busyout, reset and release the circuit pack.
- q. These errors are not service-affecting and can be ignored.

These errors are reported by the circuit pack when it receives a bad control channel message from the switch. The auxiliary data identifies the following error events:

4096:	Bad major heading
4097:	Bad port number
4098:	Bad data
4099:	Bad sub-qualifier
4100:	State inconsistency

- r. By themselves, these errors are not service-affecting and can be ignored. They may cause other errors which are service-affecting to be reported.

The error type indicates the following:

3841:	Internal firmware error
3843:	Bad translation RAM detected, but call continues by using another translation location

When it begins to affect service, error type 3843 escalates to error type 1296.

- s. This error is reported when the receive buffers for the packet interface overflow. Frequent occurrence of this error may be indicative of a congested circuit pack. See description of "Receive FIFO Overflow Error Counter Test."

## System Technician-Demanded Tests: Descriptions and Error Codes

---

When inspecting errors in the system and deciding which ones to address, always investigate errors in the order they are presented in the table below.

Order of Investigation	Short Test Sequence	Long Test Sequence	D/ND <sup>1</sup>
Control Channel Loop-Around Test #52	X	X	ND
Invalid LAPD Frame Error Counter Test #597		X	ND
LANBIC Receive Parity Error Counter Test #595		X	ND
Receive FIFO Overflow Error Counter Test #596		X	ND
Packet Interface Test #598	X	X	ND
Congestion Query Test #600	X	X	ND
Link Status Test #601	X	X	ND

---

1. D = Destructive; ND = Nondestructive

### Circuit Pack Restart Test (#252)

This destructive test is used to reset the circuit pack. This test is not part of either short or long demand test sequence and is executed only on detection of PPCPU errors. The circuit pack is reset via the SAKI Sanity Test (#53).

### Control Channel Loop-Around Test (#52)

This test queries the circuit pack for its circuit pack code and vintage and verifies its records.

This test is non-destructive.



**Table 9-477. TEST #52 Control Channel Loop-Around Test**

Error Code	Test Result	Description/ Recommendation
None 2100	ABORT	Could not allocate the necessary system resources to run this test. 1. Retry the command at 1-minute intervals for a maximum of 5 times.
	FAIL	The circuit pack failed to return the circuit pack code or vintage. 1. Retry the command a few times for a maximum of 5 times. 2. If the problem continues to fail, and if the circuit pack is one of the Port circuit packs, reseal the circuit pack. Otherwise, if the circuit pack is one of the Processor Complex circuit packs, see <i>Replacing SPE Circuit Packs</i> in <a href="#">Chapter 5, "Alarms, Errors, and Troubleshooting"</a> for how to pull out and reinsert the circuit pack. 3. Retry the command a few times for a maximum of 5 times. 4. If the problem continues to fail, and if the circuit pack is one of the Port Circuit Packs, replace the circuit pack. Otherwise, if the circuit pack is one of the Processor Complex Circuit Packs, see <i>Replacing SPE Circuit Packs</i> in <a href="#">Chapter 5, "Alarms, Errors, and Troubleshooting"</a> for how to replace the circuit pack. 5. Retry the command a few times for a maximum of 5 times.
	PASS	Communication with this circuit pack is successful.

## Circuit Pack Restart Test (#252)

**This test is destructive.**

This test is used to reset the circuit pack. This test is not part of either short or long demand test sequence and is executed only on detection of PPCPU errors. The circuit pack is reset via the SAKI Sanity Test (#53).

The SAKI Sanity Test resets the circuit pack. This test fails if the circuit pack does not return to a sane state after being reset.

**Table 9-478. Test #252 Circuit Pack Restart Test**

Error Code	Test Result	Description/ Recommendation
None	ABORT	Could not allocate the necessary system resources to run this test. 1. Retry the command at 1-minute intervals for a maximum of 5 times.
1015	ABORT	Port is not out-of-service. 1. Busyout the circuit pack. 2. Execute command again.
2100	ABORT	Could not allocate the necessary system resources to run this test. 1. Retry the command at 1-minute intervals for a maximum of 5 times.
1	FAIL	The circuit pack failed to reset. 1. Execute command again. 2. If the problem persists, then pull out and reinsert the circuit pack. 3. If the problem persists, replace the circuit pack.
2	FAIL	The circuit pack failed to restart. 1. Execute command again. 2. If the problem persists, then pull out and reinsert the circuit pack. 3. If the problem persists, replace the circuit pack.
	PASS	The circuit pack initializes correctly. 1. Run the short test sequence.

## LANBIC Receive Parity Error Counter Test (#595)

The test reads and clears the LANBIC Receive Parity Error Counter on the Packet Gateway circuit pack. This counter is incremented by the circuit pack when it detects a parity error with a received frame from the packet bus.

These errors may be indicative of a circuit pack problem, packet bus problem, or a problem with another circuit pack on the bus. This test is useful for verifying the repair of the problem.

This test is non-destructive.

**Table 9-479. TEST #595 LANBIC Receive Parity Error Counter Test**

Error Code	Test Result	Description/ Recommendation
2000	ABORT	Response to the test was not received from the circuit pack within the allowable time period. <ol style="list-style-type: none"> <li>1. If the test fails repeatedly, attempt to reset the circuit pack.</li> <li>2. If the test fails again, replace the circuit pack.</li> </ol>
2100	ABORT	Could not allocate the necessary system resources to run this test. <ol style="list-style-type: none"> <li>1. Retry the command at 1-minute intervals for a maximum of 5 times.</li> </ol>
2500	ABORT	Internal system error. <ol style="list-style-type: none"> <li>1. Retry the command at 1-minute intervals a maximum of 5 times.</li> </ol>
1-10	FAIL	The circuit pack is still detecting errors of this type. The error code indicates the value of the on-board error counter. <ol style="list-style-type: none"> <li>1. Retry the command at 1-minute intervals a maximum of 5 times.</li> <li>2. If the test continues to fail, execute the "Packet Interface Test".</li> <li>3. If "Packet Interface Test" passes, see repair procedures for Packet Bus.</li> </ol>
	PASS	No errors detected by circuit pack.

**Receive FIFO Overflow Error Counter Test (#596)**

The test reads and clears the Receive FIFO Overflow Error Counter on the Packet Gateway circuit pack. This counter is incremented by the circuit pack when it detects its packet bus receive buffers overflow.

These errors can occur occasionally due to the statistical sizing of the buffers. Persistent occurrence of these errors may be indicative of a congested circuit pack. Distribution of a portion of the traffic load on the circuit pack to other circuit packs in the system may be necessary.

This test is non-destructive.

**Table 9-480. TEST #596 Receive FIFO Overflow Error Counter Test**

Error Code	Test Result	Description/ Recommendation
2000	ABORT	Response to the test was not received from the circuit pack within the allowable time period. <ol style="list-style-type: none"> <li>1. If the test fails repeatedly, attempt to reset the circuit pack.</li> <li>2. If the test fails again, replace the circuit pack.</li> </ol>
2100	ABORT	Could not allocate the necessary system resources to run this test. <ol style="list-style-type: none"> <li>1. Retry the command at 1-minute intervals a maximum of 5 times.</li> </ol>
2500	ABORT	Internal system error. <ol style="list-style-type: none"> <li>1. Retry the command at 1-minute intervals a maximum of 5 times.</li> </ol>
1-10	FAIL	The circuit pack is still detecting errors of this type. The error code indicates the value of the on-board error counter. <ol style="list-style-type: none"> <li>1. Retry the command at 1-minute intervals a maximum of 5 times.</li> <li>2. If the test continues to fail, perform the "Packet Interface Test."</li> <li>3. If "Packet Interface Test" passes, see repair procedures for Packet Bus.</li> </ol>
	PASS	No errors detected by circuit pack.

### Invalid LAPD Frame Error Counter Test (#597)

The test reads and clears the Invalid LAPD Frame Error Counter on the Packet Gateway circuit pack. This counter is incremented by the circuit pack when it receives an invalid LAPD frame on its packet interface. An invalid frame is detected when a CRC error is detected on a received frame, an unrecognizable frame is received, or a recognizable frame is received in an unexpected state.

These errors may be indicative of a circuit pack problem, packet bus problem, or a problem with another circuit pack on the bus. This test is useful for verifying the repair of the problem.

This test is non-destructive.

**Table 9-481. TEST #597 Invalid LAPD Frame Error Counter Test**

Error Code	Test Result	Description/ Recommendation
2000	ABORT	Response to the test was not received from the circuit pack within the allowable time period. <ol style="list-style-type: none"> <li>1. If the test fails repeatedly, attempt to reset the circuit pack.</li> <li>2. If the test fails again, replace the circuit pack.</li> </ol>
2100	ABORT	Could not allocate the necessary system resources to run this test. <ol style="list-style-type: none"> <li>1. Retry the command at 1-minute intervals for a maximum of 5 times.</li> </ol>
2500	ABORT	Internal system error. <ol style="list-style-type: none"> <li>1. Retry the command at 1-minute intervals a maximum of 5 times.</li> </ol>
1-10	FAIL	The circuit pack is still detecting errors of this type. The error code indicates the value of the on-board error counter. <ol style="list-style-type: none"> <li>1. Retry the command at 1-minute intervals a maximum of 5 times.</li> <li>2. If the test continues to fail, execute the "Packet Interface Test".</li> <li>3. If "Packet Interface Test" passes, see repair procedures for Packet Bus.</li> </ol>
	PASS	No errors detected by circuit pack.

**Packet Interface Test (#598)**

The test checks the packet bus interface circuitry on the Packet Gateway circuit pack. Failure of this test is indicative of a faulty circuit pack.

This test is non-destructive.

**Table 9-482. TEST #598 Packet Interface Test**

Error Code	Test Result	Description/ Recommendation
2000	ABORT	Response to the test was not received from the circuit pack within the allowable time period. <ol style="list-style-type: none"> <li>1. If the test fails repeatedly, attempt to reset the circuit pack.</li> <li>2. If the test fails again, replace the circuit pack.</li> </ol>

*Continued on next page*

**Table 9-482. TEST #598 Packet Interface Test — Continued**

Error Code	Test Result	Description/ Recommendation
2012	ABORT	Internal system error. 1. Retry the command at 1-minute intervals a maximum of 5 times.
2100	ABORT	Could not allocate the necessary system resources to run this test. 1. Retry the command at 1-minute intervals for a maximum of 5 times.
	FAIL	Circuit pack has detected a failure of the Packet Interface Test. 1. Retry the command 5 times. 2. If the test continues to fail, reset the circuit pack. 3. If the test continues to fail, replace the circuit pack.
	PASS	The Packet Interface Test passes.

**Congestion Query Test (#600)**

This test determines the state of congestion on the Packet Gateway circuit pack based on the number of utilized buffers on the board. The test passes if the Packet Gateway is operating normally, used buffers are at a normal level. This test fails if the Packet Gateway is in a congested state, i.e., utilized buffers are approaching exhaust or are exhausted.

The switch automatically throttles new calls to a congested Packet Gateway. New outgoing calls are redirected to another Packet Gateway if available. New incoming calls are denied. Normal call handling is resumed when the Packet Gateway reports that it has recovered from congestion.

This test is non-destructive.

**Table 9-483. TEST #600 Congestion Query Test**

Error Code	Test Result	Description/ Recommendation
2000	ABORT	Response to the test was not received from the circuit pack within the allowable time period. 1. If the test fails repeatedly, attempt to reset the circuit pack. 2. If the test fails again, replace the circuit pack.

*Continued on next page*

**Table 9-483. TEST #600 Congestion Query Test — Continued**

Error Code	Test Result	Description/ Recommendation
2012	ABORT	Internal system error. 1. Retry the command at 1-minute intervals a maximum of 5 times.
2100	ABORT	Could not allocate the necessary system resources to run this test. 1. Retry the command at 1-minute intervals for a maximum of 5 times.
1	FAIL	The Packet Gateway is congested. Its buffer level is approaching exhaust. 1. Retry command 5 times at 1-minute intervals. 2. If command continues to fail, it may be necessary to shed load from the affected Packet Gateway if congestion persists. Examine the Packet Gateway port measurements to determine which ports are heavily utilized and the processor occupancy of the circuit pack. 3. A low processor occupancy when Packet Gateway congested indicates a failure of the circuit pack. Try resetting the circuit pack. If congestion reoccurs, replace the circuit pack. 4. A high processor occupancy validates that the Packet Gateway is actually congested due to traffic load. In the short term, congestion may be relieved by selectively busying out ports on the Packet Gateway or by busying out BRI endpoints assigned to the affected Packet Gateway. In the long term, replacement of ports on the affected Packet Gateway by new ports on existing other or new Packet Gateways or redistribution of D-Channels to existing other or new Packet Gateways has to be considered.
2	FAIL	The Packet Gateway is congested. No buffers are available at the current time. 1. Retry command 5 times at 1-minute intervals. 2. If command continues to fail, it may be necessary to shed load from the affected Packet Gateway if congestion persists. Examine the Packet Gateway port measurements to determine which ports are heavily utilized and the processor occupancy of the circuit pack. 3. A low processor occupancy when Packet Gateway congested indicates a failure of the circuit pack. Try resetting the circuit pack. If congestion reoccurs, replace the circuit pack. 4. A high processor occupancy validates that the Packet Gateway is actually congested due to traffic load. In the short term, congestion may be relieved by selectively busying out ports on the Packet Gateway or by busying out BRI endpoints assigned to the affected Packet Gateway. In the long term, replacement of ports on the affected Packet Gateway by new ports on existing other or new Packet Gateways or redistribution of D-Channels to existing other or new Packet Gateways has to be considered.
3	FAIL	The Packet Gateway circuit pack is operating normally and is not congested.

*Continued on next page*

**Table 9-483. TEST #600 Congestion Query Test — Continued**

Error Code	Test Result	Description/ Recommendation
	PASS	Hardware setting and attached cable type match Packet Gateway circuit pack administration.

**Link Status Test (#601)**

This test determines the state of the call control signaling link for X.25 Packet Gateways.

This test determines if the signaling link is connected or disconnected. If the link is connected, this test causes a test frame (called an XID frame) to be sent to the Packet Gateway circuit pack over the signaling link. The test passes if the signaling is connected and a test frame response is received by the switch. The test fails if the signaling link is disconnected or no response is received from the circuit pack.

This test is non-destructive.

**Table 9-484. TEST #601 Link Status Test**

Error Code	Test Result	Description/ Recommendation
2012	ABORT	Internal system error. 1. Retry the command at 1-minute intervals a maximum of 5 times.
2100	ABORT	The necessary system resources to execute the test could not be allocated. 1. Retry the command at 1-minute intervals a maximum of 5 times.
2	FAIL	The X.25 call control signaling link is disconnected. 1. Reexecute the test 5 times at 1-minute intervals. 2. If the test continues to fail, execute the "Packet Interface Test" to determine if the problem is due to the circuit pack. If the test fails, see repair procedures for Packet Interface Test. 3. If the Packet Interface Test passes, then see repair procedures for Packet Control circuit pack and Packet Bus.

*Continued on next page*



**Table 9-484. TEST #601 Link Status Test — Continued**

Error Code	Test Result	Description/ Recommendation
3	FAIL	No response was received to transmitted test frame for Call control link. <ol style="list-style-type: none"> <li>1. Repeat the test 5 times.</li> <li>2. If the test continues to fail for this reason, try resetting the circuit pack.</li> <li>3. If test continues to fail for this reason, try replacing the circuit pack.</li> </ol>
	PASS	The X.25 call control signaling link is connected and a correct response was received by the switch to a test packet.

## PGATE-PT (Packet Gateway Port)

---

MO Name (in Alarm Log)	Alarm Level	Initial Command to Run <sup>1</sup>	Full Name of MO
PGATE-PT	MAJOR	test port UUCSSpp long	X.25 Port Maintenance
PGATE-PT	MINOR	test port UUCSSpp long	X.25 Port Maintenance
PGATE-PT	WARNING	test port UUCSSpp	X.25 Port Maintenance

1. *UU* is the universal cabinet number (1 for PPN, 2 - 44 for EPNs). *C* is the carrier designation (A, B, C, D, or E). *SS* is the number of the slot in which the circuit pack resides (01 to 21). *pp* is the two digit port number (01, 02, ...).

The TN577 Packet Gateway circuit pack provides connectivity from the switch to adjuncts or to other switches in a Distributed Communications System (DCS).

Ports on the TN577 perform statistical multiplexing of data connections based on the X.25 data communication protocol standard. An X.25 Access Link must be established between the Packet Gateway port and the adjunct or DCS switch prior to the connection of any data sessions on the port. Such data connections consist of X.25 packet-data streams which entering the Packet Gateway port and are transported by Packet Gateway circuitry to the packet bus and then to other endpoints on the bus. An X.25 Access Link is illustrated in the description of the Link Status Test (#614).

### Packet Gateway Applications

---

The following applications and adjuncts use packet gateway ports:

- AUDIX
- Call Management System (CMS)
- Distributed Calling System (DCS)
- ISDN Gateway Adjunct
- Message Server

### Packet Gateway Configurations

---

X.25 links connect to the SPE via the packet bus and the TN1655 Packet Interface circuit pack. In addition to the configurations shown, a long distance modem can connect directly to one of the external ports on the Packet Gateway circuit pack to connect to data networks including private lines, Dataphone II networks, and Digital Data Service (DDS) networks. Disregard the references to notes in the following figures.

Adjuncts can directly connect to one of the external ports on the Packet Gateway circuit pack using a null modem or limited-distance modem. This is the preferred method for connecting adjuncts located near the switch. Similar configurations are used to connect to CMS, Message Server, and ISDN Gateway.

The RS-423 interface on the Packet Gateway circuit pack can be switched via administered connection to any DCP Mode 2 digital endpoint on the switching network. Similar configurations are used to connect to CMS, Message Server, and ISDN Gateway. In this configuration, the BX.25 link is switched over the TDM bus to a DS1 port and over a DS1 facility to another G3r switch. The Packet Gateway can use only DMI Mode 1 on the TDM bus.

DCS systems that use ISDN-PRI signaling use a TN464 Universal DS1 circuit pack and do not require a Packet Gateway.

## Link-Associated Maintenance Objects

Each link is made up of a chain of several different maintenance objects. The **list sys-link** and **status sys-link** commands can be used to identify the specific components that make up a specific link. All X.25 links use the following MOs:

- PKT-INT
- The PPN PKT-BUS
- The PKT-BUS of the port network housing the packet gateway
- PGATE-BD
- PGATE-PT

Certain configurations may also use some of the following:

- TDM-BUS
- DS1-BD
- UDS1-BD
- TIE-DS1
- ISDN-LNK
- ISDN-TRK

When investigating link problems, first resolve any problems existing at higher levels such as PKT-INT and PKT-BUS, and then proceed to problems at lower levels such as ISDN-TRK.

## Identifying Maintenance Objects That Make Up a Link

---

When the location of the port and the channel number of an X.25 link is known, the **status sys-link** command can be used to identify all of the components in the path traveled by the link. Refer to the SYS-LINK section in this chapter for more guidance in troubleshooting links.

Service problems may be reported in several different ways. Generally a problem will be associated with a local adjunct, an alarmed link that involves hop channels, or an alarmed port or trunk. The following procedures show how to locate components of a link starting with:

- The adjunct or DCS link name
- An associated hop channel number
- A port or trunk

Once the MOs making up the link are known, inspect the alarm and error logs or run tests for each maintenance object located on a suspect link. These procedures do not include isolating problems located on adjuncts or other switches. The steps sometimes require logins on different switches or adjuncts. In this discussion, the term machine refers to a switch or an adjunct.

The packet interface (PKT-INT), packet bus (PKT-BUS), and TDM-BUS are not covered by these procedures because they are part of the fabric for the connections. These components should be tested first if they are alarmed or reporting errors.

## Tracing a Link to a Given Adjunct or DCS Link

---

### 1. **display adjunct-names**

Locate and record the adjunct name that was reported and the application type. If the problem is with DCS this step can be ignored. DCS will probably be called DCS.

### 2. **display communications-interface processor-channels**

- Find the row with the application name found in the previous step. The application name if it is listed will be in the identification field.
- Record the processor-channel number, application, interface link and channel, adjunct name and machine ID. For the message server adjunct there may be more than one processor link.

### 3. **display communications-interface links**

- Find the line that has the link found in the previous step.

- Record the link, extension, destination number or TAC and the identification field. The TAC may be combined with a remote extension. Run **display dialplan** if there are questions as to valid TAC numbers.

If the destination number is a local extension, then it is probably a local data-module. This can be verified by running **display data-module ext**.

#### 4. **display communications-interface hop-channels**

Check if the link and processor channel found in the previous steps is listed in this form. If it isn't, then the major pieces of the link on this switch have been located. If the link is connected to another link, copy down all the information for that hop-channel. With the link and channel that are connected repeat steps 2 - 4. This should be repeated until there are no more links that are connected to any of the links uncovered to this point. For each link that goes to another machine follow the next instructions in the next section to obtain the MOs on the other machines. If the machine is not a Generic 3, consult the repair procedures for that machine.

5. For each extension located run **display data-module ext** to find the port and the board. The port and board should then be tested to find out if this MO is having problems. The repair section for each MO should be consulted to understand and fix the problem.
6. For each TAC located, run **display trunk-group tac tac#** to find the trunk group. The alarm and error logs should be checked for entries against this trunk group. Alternatively, the trunk group can be tested using **test trunk-group** trunk number. Refer to the repair section for that trunk type if problems are found.

### Tracing a Link When a Hop-Channel Is Involved

This problem may be reported in several different ways. Typically a given application on switch "A" in a DCS configuration is down. Using the steps in the section following this one, you find that the application connects to switch "B" over channel "x." This section shows how to continue the tracing procedure on switch B. The extension on switch B that terminates the physical link may or may not be known. If the number of the channel to B is not known, begin at the second step.

#### 1. **display communications-interface hop-channels**

Find the link that uses the known channel. Record the link/channel pairs

#### 2. **display communications-interface links**

Look at the links found in the previous step. One of the links should point back to the other switch or adjunct. Record the X.25 extension, destination number and identification field for each link.

If a destination number is specified, verify that it is a valid extension on the other machine. If the other machine is a DEFINITY Generic 3, follow the procedure in the section that follows this one. If not, refer to the maintenance documentation for the other machine.

If the link or channel is not known, scan the identification field for the known machine name that has link connectivity to this machine. For each line of data that matches, record the entire line. For links with remote destination numbers, remove the TAC and verify that the number is valid on the other machine. For Generic 3 machines this can be done using the procedure in the section following this one. If there are no matches, you must go back to the other machine and find out the channel number or the application that uses the channel before continuing.

### 3. **display station** extension

Record the port associated with the extension.

4. If the destination number field is not "external," then the number is a valid extension on another machine. The destination number can also be combined with a TAC. Run **list trunk-group** to find if a TAC is prepended to the destination number. Record the trunk-group if a TAC has been prepended.
5. Check the alarm and error logs for each extension, trunk-group or link. If alarms or errors are present follow the repair procedures for that MO.
6. If the link continues to another machine, Use the channel number, application, and identification field to continue the trace there. Repeat this procedure for Generic 3 machines.

## Tracing a Link Given a Port or Trunk

### 1. **display port UUCSSpp**

- a. Find out if the port connects to a data module or a trunk.
- b. Record its extension or trunk group.
- c. If it is a trunk group, run **display trunk** group#/member#. Record the trunk access code (TAC) and go to the next step.

### 2. **display communications-interface links**

- a. Find the link that has the extension, destination number or TAC located in the previous step. The TAC may be combined with a remote extension.
- b. Record the link, X.25 port, destination # or TAC and identification field.

If the administration was done according to the documentation guidelines, the identification field may contain what application is running. This will give you some idea as to what other problems might be related and the priority for fixing this problem.

If the destination number is a local extension, then it is probably a local data-module. If the number is remote or the word "external", look at the comment field for an indication of the data-module's extension or administered connection. More information on the local extension can be obtained by running **display data-module extension**.

### 3. **display communications-interface processor-channels**

- a. Find the row with the link number found in the previous step.
- b. Record the processor-channel number, application, interface link and channel, adjunct name and machine ID. For the Message Server Adjunct there can be more than one link.

### 4. **display communications-interface hop-channels**

- a. Check if the link and processor channel found in the previous steps is listed in this form. If it isn't, then the major pieces of the link on this switch have been located. If the link is connected to another link, copy down all the information for that hop-channel. With the link and channel that are connected, repeat steps 2 - 4. This should be repeated until there are no more links that are connected to any of the links of concern.
- b. For each extension located run **display data-module ext** to find the port and the board. The port and board should then be tested to find out if this MO is having problems. The repair section for each MO should be consulted to understand and fix the problem.
- c. For each TAC located, run **display trunk-group tac tac#** to find out the trunk group. The trunk group should then be tested using **test trunk-group E4trunk number**. The repair section should be consulted to understand and fix problems found for an MO.

## X.25 Protocol Errors

All of the X.25 port errors are generated as part of error procedures specified by the X.25 protocol. The reader is referred to the X.25 specification for more detailed explanation of these errors and their implications. These errors are logged as a result of errors detected by the far end and received by the port in X.25 packets, and as a result of errors detected by the near end and sent by the port in X.25 packets to the far end.

All of these errors are conveyed in three types of X.25 packets:

- Restart Request (Indication) Packets
- Reset Request (Indication) Packets

Restart packets cause reinitialization of the X.25 packet layer (Level 3) causing all links to be reset which are associated with the X.25 link. These packets are sent when the packet layer is first initialized or when certain errors are detected.

Reset packets are sent to reinitialize a virtual circuit in the data transfer state when specified errors are detected on the virtual circuit.

Errors are conveyed in the Cause and Diagnostic fields of these packets. The Cause Field indicates the reason for the error and the Diagnostic Field provides a further explanation of the error. Cause and diagnostic codes can be generated by either a network (DCE) or a network user (DTE). Code values are segmented such that those generated by a DTE or a DCE can be distinguished. Cause codes are further segmented to distinguish between causes delivered to a DTE which were generated by a private or public network. Essentially, a private network utilizes the PDN cause code values by offsetting the PDN value by 128. DEFINITY G3 assumes the role of a private network when generating the causes whether its side of the interface is administered as a DTE or a DCE.

A port administration option allows logging of X.25 errors to be selectively turned on or off for individual ports. A customer may choose to turn on error logging only for important network interfaces and hosts in order to capture a complete error history about these ports. For less critical interfaces, a customer may choose to turn off error logging to prevent cluttering the system error log. In this case, error logging can be turned on as needed to diagnose trouble reports with the interface. Error logging is not turned on as the administrative default for this option on X.25 Packet Gateway ports.

## Error Log Entries and Test to Clear Value

**Table 9-485. PGATE Port Error Log Entries**

Error Type	Aux Data	Associated Test	Alarm Level	On/Off Board	Test to Clear Value
0 <sup>1</sup>	0	Any	Any	Any	test port UUCSSpp s
1 (a)	0	Packet Gateway Port Local Loop-Around (#610)	MINOR	ON	test port UUCSSpp l r 3
18	0	busy port UUCSSpp	WARNING	ON	release port UUCSSpp
257 (b)	0				
513 (c)	1, 2	Level 1 State Query Test (#613)	MINOR	OFF	test port UUCSSpp r 2
769 (d)	0		WARNING	OFF	(d)
1024 to 1289 (e)	0, 3, 35768, 35769				
1537 (l)	Any	Session Status Query Test (976)	WARNING	OFF	

*Continued on next page*



Table 9-485. PGATE Port Error Log Entries

Error Type	Aux Data	Associated Test	Alarm Level	On/Off Board	Test to Clear Value
1538 (l)	0	Session Status Query Test (976)	MINOR	OFF	
2049 to 2303 (f)	1-64				
2305 to 2364 (g)	1, 129				
2305 to 2364 (h)	57, 185				
2305 to 2364 (i)	35768				
2560 to 2815 (j)	1-4156, 39865-39924				
2817 (k)		Link Status Test (#614)	MINOR	OFF	test port UUCSSpp r 2
3585	0-1	Packet Gateway Switched Port Loop-Around Test (#599)	MAJOR	ON	test port UUCSSpp l r 3

1. Run the Short Test Sequence first. If all tests pass, run the Long Test Sequence. Refer to the appropriate test description and follow the recommended procedures.

**Notes:**

- a. This error occurs when the Packet Gateway Port Local Loop-Around Test (#610) fails. Execute the **test port UUCSSpp long** command and see the repair procedures for test #610.
- b. This error occurs when a Packet Gateway port detects an overrun or an underrun condition that may be indicative of a hardware problem on the port. The Packet Gateway Port Local Loop-Around Test (#610) should be executed via the **test port UUCSSpp long** command to determine if a hardware problem exists. See the repair procedures for test #610.
- c. This error occurs when the Level 1 State Query Test (#613) fails or when the Packet Gateway port detects that the Clear To Send (aux data 1) or Data Carrier Detect (aux data 2) lead is "low" in the RS423 cable

connected to the port. This problem can be caused by cabling, data set, or transmission facility faults. For an RS423 connection, execute the **test port UUCSSpp long** command and see the repair procedures for Packet Gateway Port Remote Loop-Around Test #611.

If the port speed is administered as a switched port then the CTS will always be high but the DCD will be low only if there are transmission problems with the far-end. If this occurs, execute the **test port UUCSSpp long** command and see the repair procedures for Packet Gateway Switched Port Loop-Around Test #599.

- d. This error occurs when the port receives an invalid frame. A frame is invalid if it is greater than the maximum length, contains CRC errors, or violates the link level protocol. If this error occurs repeatedly, an off-board WARNING alarm is raised against the port. The Packet Gateway Port Remote Loop-Around Test (#611) can be used to isolate the problem. Before executing the **test port UUCSSpp long** command, refer to the repair procedures for test #611 for special instructions regarding the execution of this test. Once the repair has been verified as described in the repair procedures for test #611, the alarm can be cleared by executing the **test port UUCSSpp long clear** command.
- e. These errors occur when an X.25 Restart packet is received or sent by the switch due to a Local Procedure error or Network Congestion. Restarts are sent to initialize the packet layer interface and cause all calls on the interface to be cleared. A Local Procedure error usually indicates that one side of the interface has detected a protocol procedural error. Network Congestion normally indicates that the attached network is severely overloaded and has taken a control measure which entails restarting the X.25 interface. The value of the X.25 diagnostic code (0 to 255) contained in each packet is used to offset the base (1024) to produce unique error types. The auxiliary data value indicates the cause of the error and whether the error was sent or received. The auxiliary data value is encoded as follows:

0	Local Procedure Error received.
3	Network Congestion received.
35768	Local Procedure Error sent.
35771	Network Congestion sent.

- f. These errors are reported for processor/hop channels and is consistent with the 1984 CCITT X.25 Recommendation. This error is reported when an X.25 reset packet is received due to an DTE Originated Error (i.e., cause value). The value of the diagnostic code (1 to 255) contained in each packet is used to offset the base (2048) to produce unique error types. Note the diagnostic code of "0" (No Additional Information) is not logged as this is considered a normal resetting circumstance. Only

nonzero diagnostics are logged in this case - indicating resetting due to a detected error. The auxiliary data field of the log entry contains the affected logical channel number.

- g. These errors are reported only for PVCs and indicate loss of end-to-end communication on the PVC. This error indicates that the PVC is "Out Of Order" due to a network or remote DTE problem (e.g., the remote DTE is unattached). These errors are consistent with the 1984 CCITT X.25 Recommendation. The logical channel number (1 to 64) associated with the PVC is used to offset the the base (2304) to produce unique error types. The auxiliary data field for errors of this type contain "1" when a Public Network code has been received. The auxiliary data field contains "129" if a Private Network cause code has been received.
- h. These errors are reported only for PVCs and indicate loss of end-to-end communication on the PVC. This error indicates that the PVC is "Network Out Of Order" due to a network problem. These errors have error types 2305 through 2364 and are consistent with the 1984 CCITT X.25 Recommendation. The logical channel number (1 to 64) associated with the PVC is used to offset the the base (2304) to produce unique error types. The auxiliary data field for errors of this type contain "57" when a Public Network code or "185" when a Private Network code has been received.
- i. These errors are only reported for PVCs and indicate the loss of end-to-end communication on the PVC. This error indicates that no response is received from the endpoint when the switch attempts to reset a PVC. This error is reported to the switch by the Packet Gateway port every 6 minutes if no response continues to be received. Errors of this type normally indicate an administrative mismatch for the PVC between the switch and the attached endpoint/network. These errors have error types 2305 through 2364. These errors are consistent with the 1984 CCITT X.25 Recommendation. The logical channel number (1 to 64) associated with the PVC is used to offset the base (2304) to produce unique error types. The auxiliary data field of the log entry contains "35768" for errors of this type.
- j. This error is reported when an X.25 Reset packet is received or sent due to a Local Procedure Error (i.e., cause value 5 for Public Network or 133 for Private Network Causes). A Local Procedure error usually indicates that one side of the interface has detected a protocol procedural error. The value of the diagnostic code (0 to 255) contained in each packet is used to offset the base (2560) to produce unique error types. The auxiliary data field indicates whether the error was sent or received by the switch,

which logical channel number was affected by the error, and whether a Private or Public Network cause value was used. The auxiliary data value is encoded as follows:

- 1-64 The corresponding Public Network cause value is received over the indicated logical channel number.
- 4097-4156 The corresponding Private Network cause value is received over the indicated logical channel number. The logical channel number (1-64) is offset by the value 4096.
- 39865-39924 The corresponding Private Network cause value is sent over the indicated logical channel number. The logical channel number (1-64) is offset by the value 39864. The switch does not generate any Public Network causes.

- k. This error occurs when the Link Status Test (#614) fails. An X.25 Access Link is considered failed if it is disconnected at the link level and cannot be quickly reconnected. This failure is usually related to faults in the external port cabling, data set, transmission facility, or due to a far-end equipment failure. If the link fails, a MINOR off-board alarm is raised against the port. Execute the **test port UUCSSpp long** command and see the repair procedures for test #611.
- l. These errors occur when at least one session associated with this port is down. Error 1537 is posted when at least one but not all sessions are down. Error 1538 is posted when all the sessions on the link associated with this port are down, but the link itself is not down. The commands **status pgate-port** or **status link** can be used to isolate the session(s) that are down. Once the session information is available, appropriate actions related to the session involved may be followed.

### System Technician-Demanded Tests: Descriptions and Error Codes

Always investigate tests in the order presented in the table below when inspecting errors in the system. By clearing error codes associated with the *PDATA Port Local Loop-Around Test* for example, you may also clear errors generated from other tests in the testing sequence.

Table 9-486. System Technician-Demanded Tests: PGATE-PT

Order of Investigation	Short Test Sequence	Long Test Sequence	D/ND <sup>1</sup>
Packet Gateway Port Local Loop-Around Test (#610)		X	D

*Continued on next page*

**Table 9-486. System Technician-Demanded Tests: PGATE-PT — Continued**

Order of Investigation	Short Test Sequence	Long Test Sequence	D/ND <sup>1</sup>
Packet Gateway Switched Port Loop-Around Test (#599)		X	D
Level 1 State Query Test (#613)	X	X	ND
Link Status Test (#614)	X	X	ND
Packet Gateway Port Remote Loop-Around Test (#611) (Local Loopback, Digital and Remote Loopbacks)		X	D
Session Status Query Test (#976)	X	X	ND
Session Restart Test (#977)		X	D

1. D = Destructive, ND = Non-destructive

### Packet Gateway Switched Port Loop-Around Test (#599)

**This test is destructive.**

This test verifies that the Packet Gateway port can send and receive data on the TDM bus.

Failure of this test indicates a possible failure of the Packet Gateway circuit pack, the TDM Bus, or the digital port on the Maintenance/Test circuit pack.

This test aborts when calls are in progress on the port, or if the signaling link the port is connected to the port. This test also aborts when executed on a port whose administered speed is other than "switched.

**Table 9-487. TEST #599 Packet Gateway Switched Port Loop-Around Test**

Error Code	Test Result	Description/ Recommendation
1000	ABORT	The port is in use for a call or the X.25 Access Link is connected. Execute <b>status packet-gateway-port</b> UUCSSpp to determine when the port is available for testing. <ol style="list-style-type: none"> <li>1. Retry the command when the port is idle. The port may be forced to the idle state by executing a <b>busyout port UUCSS</b> command. The <b>busyout port</b> command is destructive causing all calls and links associated with the port to be torn down.</li> </ol>
1005	ABORT	The configuration for this test is incorrect. <ol style="list-style-type: none"> <li>1. Verify that the port under test is configured as a switched port. This error code will result when the port under test is configured as an RS423.</li> <li>2. If this is supposed to be a switched port and it is not administered that way change the configuration using <b>change data-module ext</b>. The "baud" field should display "switched".</li> </ol>
1340	ABORT	The Maintenance Test Board digital port was not available.
1341	ABORT	Allocation of timeslots failed.
1342	ABORT	Connection of ports to timeslots failed.
2000	ABORT	Uplink message not received before time limit.
2012	ABORT	Internal system error. <ol style="list-style-type: none"> <li>1. Retry the command at 1-minute intervals a maximum of 3 times.</li> </ol>
0	FAIL	Received data test pattern does not match transmitted data test pattern. <ol style="list-style-type: none"> <li>1. Retry command at 1-minute intervals a maximum of 3 times.</li> <li>2. If it still fails, eliminate that the problem is with PKT-BUS and M/T-DIG by following the repair procedures for those MOs.</li> <li>3. If they pass, replace the board. Deciding when to replace the board must be balanced against traffic on the other ports.</li> </ol>
	PASS	The circuitry of the port tested, and its connectivity across the packet bus, is functioning properly.

**Packet Gateway Port Local Loop-Around Test (#610)**

**This test is destructive.**

This test verifies the functionality of a port circuit on the Packet Gateway circuit pack. When the switch sends the test request, the Packet Gateway circuit pack

automatically loops back the signal at the port as shown in the the figure below. Failure of this test indicates the existence of a fault in the port hardware on the circuit pack.

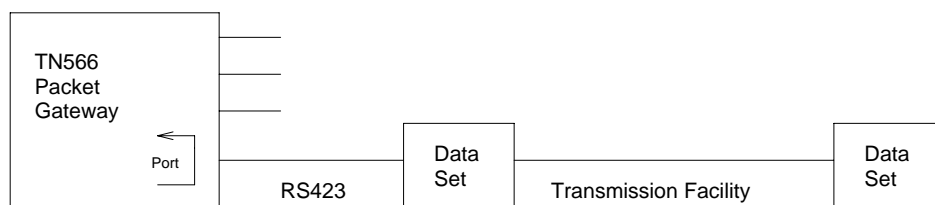

**Figure 9-76. Packet Gateway Port Local Loop-Around Test**

This test aborts if calls are using the port or if the X.25 Access Link associated with the port is connected. To avoid this, first enter **busyout data-module** extension or **busyout port** UUCSSpp or **busyout link** link#, which will cause all calls and links using the port to be torn down.

**Table 9-488. TEST #610 Packet Gateway Port Local Loop-Around Test**

Error Code	Test Result	Description/ Recommendation
1000	ABORT	The X.25 Access Link is connected or the port is in use for a call. Execute <b>status packet-gateway-port UUCSSpp</b> to determine when the port is available for testing.  1. Retry the command when the port is idle. The port may be forced to the idle state by executing a <b>busyout port UUCSSpp</b> command. This command is destructive causing all calls and links associated with the port to be torn down.
2000	ABORT	Response to the test was not received from the Packet Gateway circuit pack within the allowable time period.  1. If this result occurs repeatedly, attempt to reset the circuit pack if the other ports on the board are not in use (Yellow LED is off). Reset the circuit pack by issuing the <b>busyout board UUCSS</b> and the <b>reset board UUCSS</b> commands.  2. If this result occurs again, replace the circuit pack.
2012	ABORT	Internal system error.  1. Retry the command at 1-minute intervals a maximum of 3 times.

Table 9-488. TEST #610 Packet Gateway Port Local Loop-Around Test — Continued

Error Code	Test Result	Description/ Recommendation
	FAIL	<p>The Packet Gateway circuit pack has detected a failure in the execution of the test.</p> <ol style="list-style-type: none"><li>1. If the test fails repeatedly, attempt to reset the circuit pack if the other ports on the board are not in use (Yellow LED is off). Reset the circuit pack by issuing the <b>busyout board UUCSS</b> and the <b>reset board UUCSS</b> commands.</li><li>2. If the test fails again, replace the circuit pack.</li></ol>
	PASS	<p>The circuitry of the port tested is functioning properly.</p>

## Packet Gateway Port Remote Loop-around Test (#611)

**This test is destructive.**

This test checks the integrity of cabling and devices external to the Packet Gateway port hardware. Packet Gateway firmware executes this test on demand by sending a test frame which is looped back to the Packet Gateway by a loop-around that has been externally activated or installed at one of several points in the external connectivity (see loopbacks A, B and C in the figure below). The test passes when the sent and received test frames are identical. The test fails if the sent and received test frames do not match, or if no test frame is received prior to a time out.

If you suspect a problem in cabling or external devices, then repeat this test at points that are progressively further from the PGATE port until either a failure point is identified or the integrity of the entire path is verified. Certain site configurations may require teamwork with those who maintain the off-site transmission facilities.



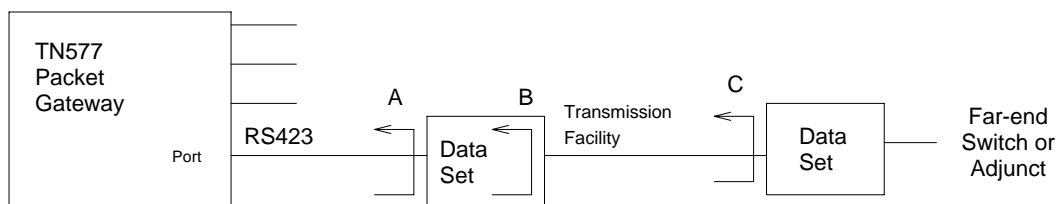

**Figure 9-77. Packet Gateway Port Remote Loop-Around Test**

Manual activation of the loopback is required for this test. If available, the Local Loopback (B in the above figure), Digital Loopback (C), and Remote Loopback (D) capabilities of external data sets may be used in conjunction with this test for fault isolation. Execution of this test with the data set in the Local Loopback mode verifies the integrity of the external port cabling. Execution of this test with the data set in the Digital Loopback mode verifies the integrity of the data set. Execution of this test with the far-end data set in the Remote Loopback mode verifies the integrity of the transmission facility.

For this test to run, the port or link must be busied out and the "Remote Loopback" field on the data-module form must be set to "y." This field should only be set to "y" when the external loopback switch has been activated for the test, and should be changed back to "n" when testing is completed and the external loopback has been deactivated.

To test to an MPDM attached to a Packet Gateway port:

1. Enter **busyout data-module** extension or **busyout port UUCSSpp** or **busyout link** link#.
2. Set the switch on the MPDM to local loopback.
3. Enter **change data-module** extension and set the "Remote Loop-Around Test" field to "y."
4. Enter **test data-module** extension **long** or **test port UUCSSpp long** or **test link** link# **long**.
5. When finished testing, enter **change data-module** extension and set the "Remote Loop-Around Test" field to "n."
6. Enter **release data-module** extension or **release port UUCSSpp** or **release link** link#.

To test through an administered connection to an MPDM attached to an adjunct (see "Packet Gateway Configurations" at the beginning of the PGATE-PT section):

1. Enter **busyout data-module** extension or **busyout port UUCSSpp** or **busyout link** link#.
2. Enter **change data-module** extension and set the "Remote Loop-Around Test" field to "y."
3. Set the switch on the MPDM to local loopback.
4. Enter **disable administered-connection** adm-conn#.
5. Attach a loopback plug to the MPDM and set the switch on the MPDM to remote loopback.
6. Enter **enable administered-connection** adm-conn#.
7. When the administered connection becomes established at the MPDM, set remote loopback to normal.
8. Enter **test data-module** extension **long** or **test port UUCSSpp long** or **test link** link# **long**.
9. When finished testing, enter **change data-module** extension and set the "Remote Loop-Around Test" field to "n."
10. Enter **release data-module** extension or **release port UUCSSpp** or **release link** link#.

If a loopback plug is not available, one can be made using a break-out box or hand-made connector. To loop back an RS232 cable, tie the following pins together:

#### RS232 Cable Loopback

Pins to Join	Pin Names
2-3	Transmit-data, Receive-data
4-5	Request-to-send, Clear-to-send
8-20	Carrier-detect, data-terminal-ready
15-17-24	Transmit-clock, Receive-clock, Transmit-clock

To loop back an RS449 cable (often used to connect AUDIX to an IDI), connect the following pins.

#### RS449 Cable Loopback

Pins to Join	Pin Names
4-6	SD-A', RD-A
5-8-17	ST-A, RS-A', TT-A'
7-9	RS-A", CS-A
12-13	TR-A', RR-A
22-24	SD-B', RD-C

**RS449 Cable Loopback**

Pins to Join	Pin Names
23-26-35	ST-C, RT-C, TT-B'
25-27	RS-B', CS-C
30-37	TR-B', SC

**Table 9-489. TEST #611 Packet Gateway Port Remote Loop-Around Test**

Error Code	Test Result	Description/ Recommendation
1000	ABORT	<p>The port is in use for an X.25 Access Link call or a call is connected. Execute <b>status packet-gateway-port UUCSSpp</b> to determine when the port is available for testing.</p> <ol style="list-style-type: none"> <li>1. Retry the command when the port is idle. The port may be forced to the idle state by executing a <b>busyout port UUCSSpp</b> command. This command is destructive causing all calls and links associated with the port to be torn down.</li> <li>2. If the test fails again, replace the circuit pack.</li> </ol>
1005	ABORT	<p>The configuration for this test is incorrect.</p> <ol style="list-style-type: none"> <li>1. Verify that the external loopback has been installed or activated.</li> <li>2. Enter <b>change data-module</b> extension and verify that the "Remote Looparound Test" field displays "y".</li> <li>3. Repeat the test.</li> <li>4. When testing is complete, deactivate the external loopback and change the "Remote Loop-Around Test" field back to "n."</li> <li>5. If the test aborts with this code while the port administration is correctly configured, escalate the problem.</li> </ol>
2000	ABORT	<p>Response to the test was not received from the Packet Gateway circuit pack within the allowable time period.</p> <ol style="list-style-type: none"> <li>1. If this result occurs repeatedly, attempt to reset the circuit pack if the other ports on the board are not in use (Yellow LED is off). Reset the circuit pack by issuing the <b>busyout board UUCSS</b> and the <b>reset board UUCSS</b> commands.</li> <li>2. Consult the repair procedures for the Packet Gateway Local Loop-Around test (#610).</li> </ol>
2012	ABORT	<p>Internal system error.</p> <ol style="list-style-type: none"> <li>1. Retry the command at 1-minute intervals a maximum of 3 times.</li> </ol>
2100	ABORT	<p>The necessary system resources to execute the test could not be allocated.</p> <ol style="list-style-type: none"> <li>1. Retry the command at 1-minute intervals a maximum of 5 times.</li> </ol>

**Table 9-489. TEST #611 Packet Gateway Port Remote Loop-Around Test — Continued**

Error Code	Test Result	Description/ Recommendation
	FAIL	<p>The Packet Gateway circuit pack has detected a failure in the execution of the test.</p> <ol style="list-style-type: none"> <li>1. Verify that the Packet Gateway Local Loop-Around test (#610) passes. Follow repair procedures for that test first if it fails.</li> <li>2. Run test #611 for each external loopback position. If any test fails, then take the action specified for that point:                             <ol style="list-style-type: none"> <li>a. Local Loopback (Loopback “B”): Replace the external port cabling.</li> <li>b. Digital Loopback (Loopback “C”): Replace the data set.</li> <li>c. Remote Loopback (Loopback “D”): Investigate potential transmission line problems. If necessary, escalate the problem to the party responsible for maintaining the off-premise transmission network.</li> </ol> </li> </ol>
	PASS	<p>Passing of this test for the following loopbacks indicates the integrity of the following pieces of equipment:</p> <ol style="list-style-type: none"> <li>1. Local Loopback (Loopback “B”). Packet Gateway port hardware plus cabling.</li> <li>2. Digital Loopback (Loopback “C”). Packet Gateway port hardware plus cabling plus data set.</li> <li>3. Remote Loopback (Loopback “D”). Packet Gateway port hardware plus cabling plus data set plus transmission line.</li> <li>4. If all the above tests pass, place the port in-service (release port UUCSSpp). Execute the <b>status packet-gateway-port UUCSSpp</b> command and verify that the transmission-related error counters are not increasing. Execute the “Link Status Test (#614)” via the <b>test port UUCSSpp</b> command. Check out equipment at far-end if this test fails.</li> </ol>

### Level 1 State Inquiry Test (#613)

This test is non-destructive.

This test determines the state of the transmission facility at the physical layer (Level 1). This test is executed by the Packet Gateway circuit pack for a port on a command from the switch. The test passes when the current status of the Data Carrier Detect (DCD) and Clear To Send (CTS) If either of these leads are low, the test fails.

If the port speed is administered as a switched port then the CTS will always be high but the DCD will be low only if there are transmission problems with the

far-end and the link had been up. If this occurs, execute the **test port UUCSSpp long** command and consult the repair procedures beginning at Packet Gateway Switched Port Loop-Around Test #599.

**Table 9-490. TEST #613 Level 1 State Inquiry Test**

Error Code	Test Result	Description/ Recommendation
2000	ABORT	Response to the test was not received from the Packet Gateway circuit pack X.25 port within the allowable time period. <ol style="list-style-type: none"> <li>1. If this result occurs repeatedly, attempt to reset the circuit pack if the other ports on the board are not in use (Yellow LED is off). Reset the circuit pack by performing the <b>busyout board UUCSS</b> and the <b>reset board UUCSS</b> commands.</li> <li>2. If this result occurs again, replace the circuit pack.</li> </ol>
2012	ABORT	Internal system error. <ol style="list-style-type: none"> <li>1. Retry the command at 1-minute intervals a maximum of 3 times.</li> </ol>
2100	ABORT	The necessary system resources to execute the test could not be allocated. <ol style="list-style-type: none"> <li>1. Retry the command at 1-minute intervals a maximum of 5 times.</li> </ol>
1	FAIL	The Clear To Send lead is "low" indicating a problem with the data set or the cable attached to the port. <ol style="list-style-type: none"> <li>1. Repeat the test.</li> <li>2. If the test still fails, verify that the data set and the Packet Gateway port are properly attached to the cable and the data set is powered on.</li> <li>3. Place the data set in the "Local Loopback" mode. Consult the repair procedures for the Packet Gateway Port Remote Loop-Around test (#611).</li> </ol>
2	FAIL	The Data Carrier Detect lead is "low" indicating a problem on the transmission side of the data set. <ol style="list-style-type: none"> <li>1. Repeat the test.</li> <li>2. If the test still fails, verify the integrity of the wiring on the transmission side of the data set. Make sure that the data set is properly attached to the transmission line.</li> <li>3. If the local transmission wiring is intact, notify the authority responsible for resolving off-premise transmission facility problems. The Packet Gateway Port Remote Loop-Around Test (#611) may be useful in diagnosing this problem.</li> </ol>
	PASS	The Level 1 interface is healthy, both the DCD and CTS leads in the RS423 cable or TDM bus are "high."

## Link Status Test (#614)

This test is non-destructive.

This test determines if the X.25 Access Link is connected or disconnected. The switch determines the state of the X.25 Access Link by sending a query to the Packet Gateway circuit pack. This test passes if the X.25 Access Link is connected and fails if it is disconnected.

---

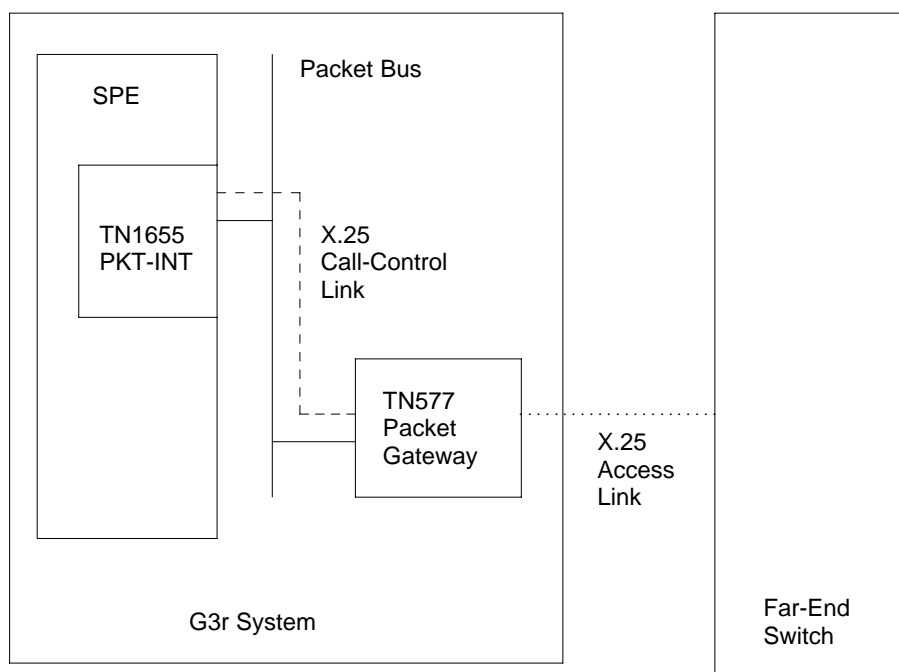

---

**Figure 9-78. Packet Gateway Links**

**Table 9-491. TEST #614 Link Status Test**

Error Code	Test Result	Description/ Recommendation
1006	ABORT	<p>The port is out of service, either due to a hardware failure or the <b>busyout port UUCSSpp</b> command.</p> <ol style="list-style-type: none"> <li>1. Check if the port has been busied out. If the error log (<b>display errors</b> command) contains error type 18 and the alarm log (<b>display alarms</b> command) contains an active WARNING alarm for this port, the port has been busied-out. This is a NORMAL abort.</li> <li>2. If the port has not been busied-out and aborts with this result, execute the Packet Gateway Port Local Loop-Around Test (#610) and the Level 1 State Query Test (#613) via the <b>test port UUCSSpp long</b> command. Consult the repair procedures for these tests.</li> </ol>
1151	ABORT	<p>The X.25 Call Control Link has failed. It is not possible at the moment to send a message to the Packet Gateway circuit pack to activate this test.</p> <ol style="list-style-type: none"> <li>1. Execute the <b>test board UUCSS</b> command and see the repair procedures for the X.25 Call Control Link Test (#601).</li> <li>2. Repeat this test once the X.25 Call Control Link has been re-established, i.e., test #601 passes.</li> </ol>
2000	ABORT	<p>Response to the test was not received from the Packet Gateway circuit pack within the allowable time period.</p> <ol style="list-style-type: none"> <li>1. If this same result occurs repeatedly, begin by executing the tests as detailed in the earlier section. Consult the individual repair procedures for a specific test if problems are found.</li> <li>2. If this result continues to occur, attempt to reset the circuit pack if the other ports on the board are not in use (Yellow LED is off). Reset the circuit pack by executing the <b>busyout board UUCSS</b> and <b>reset board UUCSS</b> commands.</li> <li>3. If this result occurs again, replace the circuit pack.</li> </ol>
2012	ABORT	<p>Internal system error.</p> <ol style="list-style-type: none"> <li>1. Retry the command at 1-minute intervals a maximum of 3 times.</li> </ol>
2100	ABORT	<p>The necessary system resources to execute the test could not be allocated.</p> <ol style="list-style-type: none"> <li>1. Retry the command at 1-minute intervals a maximum of 5 times.</li> </ol>
	FAIL	<p>Received data test pattern does not match transmitted data test pattern. Same recommendation as for error code 2 above.</p>

*Continued on next page*

**Table 9-491. TEST #614 Link Status Test — Continued**

Error Code	Test Result	Description/ Recommendation
2	FAIL	The X.25 Access Link is disconnected. <ol style="list-style-type: none"> <li>1. Execute the Packet Gateway Port Local Loop-Around Test (#610) and the Level 1 State Query Test (#613) via the <b>test port UUCSSpp long</b> command. Consult the repair procedures for these tests.</li> <li>2. If all tests pass, check far-end switch equipment. Execute the Packet Gateway Port Remote Loop-Around Test (#611) via the <b>test port UUCSSpp long</b> command. Consult the repair procedures for this test.</li> <li>3. If test #611 passes, see the repair procedures for the Packet Control circuit pack and the Packet Bus.</li> </ol>
	PASS	The X.25 Access Link is connected.

### Session Status Query Test (#976)

This test is non-destructive.

This test determines the state of the sessions on the X.25 Access Link associated with the Packet Gateway port.

This test determines if all the sessions associated with the channels using the X.25 Access Link is up or down. This test passes if the all the sessions are up and fails otherwise.

**Table 9-492. TEST #976 Session Status Query Test**

Error Code	Test Result	Description/ Recommendation
1124	ABORT	The X.25 access link associated with this Packet Gateway Port is not enabled. <ol style="list-style-type: none"> <li>1. Check if the X.25 access link is enabled for this Packet Gateway Port. If the "enable" field on "display communication-interface link" form is "n" for the link entry which contains the data module extension associated with the Packet Gateway Port, then the X.25 access link is not enabled. Set the field to "y" using <b>change communication-interface link</b> command and repeat the test. This is a NORMAL abort.</li> </ol>
2000	ABORT	Response to the test was not received within the allowable time period. <ol style="list-style-type: none"> <li>1. Retry the command at 1-minute intervals a maximum of 5 times.</li> </ol>

*Continued on next page*



**Table 9-492. TEST #976 Session Status Query Test — Continued**

Error Code	Test Result	Description/ Recommendation
2500	ABORT	Internal system error. 1. Retry the command at 1-minute intervals a maximum of 3 times.
1	FAIL	At least one (but not all) sessions on the X.25 access link associated with the Packet Gateway Port are down. Same recommendation as for error type 1537.
2	FAIL	All sessions on the X.25 access link associated with the Packet Gateway Port are down. Same recommendation as for error type 1538.
	PASS	All sessions on the X.25 access link associated with the Packet Gateway Port are up.

### Session Restart Test (#977)

**This test is destructive.**

This test destroys and attempts to restart all the sessions on the X.25 Access Link associated with the Packet Gateway port.

The test attempts to restart all the sessions as long as there is at least one session down on the link. This test aborts if the all the sessions are up.

**Table 9-493. TEST #977 Session Status Query Test**

Error Code	Test Result	Description/ Recommendation
	ABORT	All sessions are up. This is a NORMAL abort.
1124	ABORT	The X.25 access link associated with this Packet Gateway Port is not enabled. 1. Check if the X.25 access link is enabled for this Packet Gateway Port. If the "enable" field on "display communication-interface link" form is "n" for the link entry which contains the data module extension associated with the Packet Gateway Port, then the X.25 access link is not enabled. Set the field to "y" using <b>change communication-interface link</b> command and repeat the test. This is a NORMAL abort.
2000	ABORT	Response to the test was not received within the allowable time period. 1. Retry the command at 1-minute intervals a maximum of 5 times.

*Continued on next page*

**Table 9-493. TEST #977 Session Status Query Test — Continued**

<b>Error Code</b>	<b>Test Result</b>	<b>Description/ Recommendation</b>
2500	ABORT	Internal system error. 1. Retry the command at 1-minute intervals a maximum of 3 times.
	FAIL	The X.25 Access Link associated with the Packet Gateway Port is down. Same recommendation as for test type 611.
	PASS	All sessions on the X.25 access link associated with the Packet Gateway Port are restarted.

## PKT-BUS (Packet Bus)

---

MO Name (in Alarm Log)	Alarm Level	Initial Command to Run <sup>1</sup>	Full Name of MO
PKT-BUS	MAJOR	test pkt P I r 2 <sup>1</sup>	Packet Bus
PKT-BUS	MINOR	test pkt P I	Packet Bus
PKT-BUS	WARNING	test pkt P I	Packet Bus

1. where P is the port-network number indicated in the PORT field from the Alarm or Error Log.

The packet bus consists of a single bus, and one such bus appears in each port-network. The packet bus in each port-network is physically independent from those in other port-networks, so each port-network has a separate PKT-BUS maintenance object. This bus supports the following types of connections:

- Logical control links between the SPE and all Expansion Port-Networks (EPN)
- ISDN-BRI D-channel transport (signaling)
- ASAI D-channel transport (signaling)
- ISDN-PRI D-channel (signaling)
- X.25 system adjunct signaling and traffic
- System Access Ports

The TN1655 Packet Interface circuit pack provides the SPE interface to the packet bus. Packet Bus testing depends on the TN771D Maintenance/Test circuit pack, the TN1655 Packet Interface circuit pack, TN570 Expansion Interface circuit pack, and the Packet port circuit packs (TN556 ISDN-BRI Line, TN553 Packet Data Line, TN464 Universal DS1, and TN577 Packet Gateway). Packet Bus tests may abort if some of these are not present in the system. The tests may yield inconsistent results if any of this hardware is defective. The individual test descriptions provide more information.

The interactions between the packet bus and the circuit packs that use the bus are complex. Circuit pack failures can alarm the packet bus, while Packet Bus faults can alarm or interrupt service to one or more circuit packs and their ports and endpoints. The [“Packet Bus Fault Isolation and Repair”](#) section in [Chapter 5, “Alarms, Errors, and Troubleshooting”](#) describes Packet Bus maintenance and interactions circuit packs. That section should be referenced for all troubleshooting and repairs. The flowchart is the normal starting point for experienced technicians. Technicians unfamiliar with the packet bus and its implementation in R7r should study the introductory material (for example, [“What is the Packet Bus?”](#)) before using the flowchart to diagnose and repair packet bus faults.

This section on the PKT-BUS maintenance object is limited to a description of the Error and Alarm Log entries and the test sequence for the packet bus. The following list summarizes some of the important points to consider when working with the packet bus.

- The Maintenance/Test circuit pack (TN771D) is a critical tool for isolating packet bus faults. This circuit pack is present in each port network of a Critical Reliability system (duplicated SPE and PNC). In a Standard Reliability system, the circuit pack may be included as a customer option. If a TN771D is not present, *one must be taken to the customer site* to allow for proper fault isolation. The [“Packet Bus Fault Isolation and Repair”](#) section in [Chapter 5, “Alarms, Errors, and Troubleshooting”](#) describes the packet bus testing facilities of the TN771D and when one must be taken to the customer site.
- Certain catastrophic packet bus failures have an effect on maintenance software activities relating to Packet circuit packs, ports, and endpoints:
  - Packet circuit pack (BRI-BD, PGATE-BD, PDATA-BD, UDS1-BD) in-line errors indicating possible Packet Bus failures are logged in the error log, but are not acted upon.
  - Port-level (BRI-PORT, ABRI-PORT, PGATE-PT, PDATA-PT) in-line errors on Packet circuit packs which indicate possible Packet Bus failures *are not logged or acted upon*.
  - Circuit pack and port in-line errors that are not relevant to the Packet Bus, or that indicate a circuit pack failure, are acted upon in the normal fashion.
  - Periodic and scheduled background maintenance are not affected.
  - Foreground maintenance (for example, a **test board** command executed at a terminal) is not affected.

The actions in the previous list serve to reduce the system load, which could become excessive if many maintenance objects are affected by a packet bus failure. However, such an excessive load should in no way impede the isolation and the correction of the faults.

When the above actions are implemented, Error Type 3329 is logged against PKT-BUS, and a Warning alarm is raised. Other Packet Bus errors may raise more severe alarms, thereby overriding the Warning alarm.

- Since all packet traffic requires communication with the Packet Interface, circuit pack in the SPE, a packet bus failure in the Processor Port-Network (PPN) causes packet traffic in the Expansion Port-Networks (EPNs) to fail. Due to this requirement, a PPN packet bus failure must be investigated first whenever packet bus failures occur in multiple port-networks.

## Hardware Error Log Entries and Test to Clear Value

**Table 9-494. PKT-BUS Error Log Entries**

Error Type	Aux Data	Associated Test	Alarm Level	On/Off Board <sup>1</sup>	Test to Clear Value
0 <sup>2</sup>	0	Any	Any	Any	test pkt port-network
1 (a)	1-2	Packet Circuit Pack Audit Test (#570)	MAJOR	ON	test pkt port-network P I r 2
513 (b)	1-24	Maintenance/Test Circuit Pack Query Test (#572)	MAJOR	ON	test pkt port-network P I r 2
1793 (c)	Any	None			
2049 (d)	1-3	Maintenance/Test Circuit Pack Query Test (#572)	MINOR	ON	test pkt port-network P I r 2
2305 (e)	1-24	Maintenance/Test Circuit Pack Query Test (#572)			test pkt port-network P I
3329 (f)	1-7	none	WARNING	ON	test pkt port-network P I
3585 (g)	Any	none	MINOR	ON	test pkt port-network P I
3841 (h)	Any	none	MINOR	OFF	

1. ON-BOARD indicates a problem with the packet bus itself.
2. Run the Short Test Sequence first. If all tests pass, run the Long Test Sequence. Refer to the appropriate test description and follow the recommended procedures.

**Notes:**

- a. Within the last minute, packet circuit packs have reported errors that indicate a possible packet bus failure. The Aux Data value is 1 or 2, indicating that only one or more than one Packet circuit pack (respectively) have reported a possible packet bus failure.
- b. The Maintenance/Test packet bus port (M/T-PKT) for this port-network has determined that there are more packet bus faults than the port can correct. The Aux Data value indicates the number of faulty leads.
- c. Packet circuit packs have detected possible packet bus failures via in-line error or via background test failure. Examine the Error and Alarm logs for more specific PKT-BUS errors.

- d. The Maintenance/Test packet bus port (M/T-PKT) has detected a Packet Bus fault and taken corrective action by swapping to spare leads. This error appears only in Critical Reliability systems (duplicated SPEs and PNC). The Aux Data value indicates the number of faulty leads. If this is the only active error against the packet bus, *the packet bus is still in service*. Due to the disruptive nature of the packet bus Fault Isolation and Correction procedures, repairs should be deferred until a time when the least interruption in service will result. This should be determined by consultation with the customer. However, do not delay repairs for too long, since the switch will not be able to recover from another packet bus failure until the existing one is resolved. *Packet Bus Fault Isolation and Correction* in [Chapter 5, "Alarms, Errors, and Troubleshooting"](#) contains a sub-section, *A Special Precaution Concerning the TN771D* that describes how to ensure that the TN771D is providing correct information. A new TN771D may need to be taken to the customer site.
- e. The Maintenance/Test packet bus port (M/T-PKT) has detected open leads on the packet bus. The Aux Data value indicates the number of open leads.
- f. Packet circuit pack, port, and endpoint maintenance has been disabled due to a packet bus failure. The Aux Data value indicates the cause:

Aux Data	Cause
1	In-line errors from packet circuit packs
2	Uncorrectable packet bus fault reported by the Maintenance/Test packet bus port (M/T-PKT)
3	Both of the above
100x	Packet-related circuit pack, port, and endpoint maintenance in the EPN has been disabled due to a packet bus failure in the PPN. The last digit has the same meaning as the single digits listed above.

Keep in mind that although only packet circuit packs can detect and report packet bus problems, such problems can be caused by any circuit pack.

- g. Packet circuit pack, port, and endpoint maintenance has been disabled due to more than one circuit pack reporting in-line errors. If this occurs more than three times in 15 minutes a Minor alarm is raised against the packet bus. This happens when maintenance is disabled due to errors and is then re-enabled because no more errors are reported.

This error may still be present in the error log even though the Packet Circuit Pack Audit Test (#573) indicates that only one circuit pack is reporting a problem. This happens when more than one circuit pack has reported errors in any one-minute interval since the packet bus fault occurred.

- h. The Maintenance/Test packet bus port (M/T-PKT) for this port-network is not in service. This alarm does not appear for EPNs in Standard or High Reliability systems since a TN771 is not required there. The error indicates one or more of the following:
- The packet bus port has been busied out (indicated by Error Type 18), and a Warning alarm is active against M/T-PKT in the same port-network. Release the port by entering **release port UUCSS04**.
  - The packet bus port has failed. Look for alarms against M/T-PKT, and attempt to resolve these alarms.
  - The Maintenance/Test circuit pack was not recognized by the system at the last system restart. Replace the Maintenance/Test circuit pack.
  - There is no Maintenance/Test circuit pack in this port-network. One must be installed.

The TN711 must be installed before other packet bus alarms can be resolved. (Alarms against a given maintenance object are not resolved until all alarm-generating conditions have been cleared).

## System Technician-Demanded Tests: Descriptions and Error Codes

---

Always investigate tests in the order presented in the following tables. By clearing error codes associated with the *Packet Circuit Pack Audit Test*, for example, you may also clear errors generated from other tests in the testing sequence.

Order of Investigation	Short Test Sequence	Long Test Sequence	D/ND <sup>1</sup>
Packet Circuit Pack Audit Test (#573)	X	X	ND
Maintenance/Test Circuit Pack Query Test (#572)	X	X	ND

---

1. D = Destructive; ND = Nondestructive

### Maintenance/Test Circuit Pack Query Test (#572)

This test queries the Maintenance/Test packet bus port about the state of health of the packet bus. If the Maintenance/Test circuit pack indicates that the packet bus has faults, the test fails. The corresponding failure code describes the severity, type, and number of faults. The test passes if the packet bus is fault-free.

#### NOTE:

A Maintenance/Test circuit pack is usually not present in any EPN of a system without duplicated PNC (Critical Reliability). Customers may

optionally install a Maintenance/Test circuit pack in order to make use of its analog trunk and digital line test capabilities, and to enhance the system's analog trunk and digital line test capabilities, system's ability to quickly recognize a packet bus failure.

**Table 9-495. Test #572 Maintenance/Test Circuit Pack Query Test**

Error Code	Test Result	Description/ Recommendation
1006	ABORT	The packet bus port of the Maintenance/Test circuit pack is out of service. <ol style="list-style-type: none"> <li>1. Determine if the port is busied out. If so, release it with the <b>release port UUCSS04</b> command. Then retry the test command.</li> <li>2. If there are alarms active against the packet bus port (MT-PKT), refer to M/T-PKT Maintenance documentation to resolve them. Then retry the test command.</li> </ol>
1142	ABORT	No Maintenance/Test circuit pack packet bus port is in service in this port-network. <ol style="list-style-type: none"> <li>1. If this port-network is required by configuration guidelines to have a Maintenance/Test circuit pack (i.e., it is either a PPN or else an EPN in a system having both SPE and PNC duplication) either                             <ol style="list-style-type: none"> <li>a. the Maintenance/Test circuit pack for this port-network has failed, and should be replaced,</li> <li>b. the Maintenance/Test circuit pack has been busied out, and should be released, or</li> <li>c. there is no Maintenance/Test circuit pack in this port-network, and one must be installed.</li> </ol> </li> <li>2. In an EPN of a system without both SPE and PNC duplication, the Maintenance/Test packet bus Port is not required and may not be present. If it is present, and is busied out, or has failed, release or replace the circuit pack. If there is no Maintenance/Test circuit pack, ignore the results of this test for this port-network.</li> </ol>
2000	ABORT	The test timed-out while waiting for an uplink CCMS response from the Maintenance/Test packet bus port. <ol style="list-style-type: none"> <li>1. Re-enter the command at 1-minute intervals a maximum of 5 times.</li> <li>2. If the test continues to abort, check for problems with the Maintenance/Test packet bus port (look for M/T-PKT in the Error and Alarm Logs).</li> </ol>
2059	ABORT	The Maintenance/Test packet bus port has reported a hardware failure. <ol style="list-style-type: none"> <li>1. Refer to M/T-PKT Maintenance documentation to correct the problem.</li> <li>2. Re-enter the test command.</li> </ol>

*Continued on next page*



**Table 9-495. Test #572 Maintenance/Test Circuit Pack Query Test — Continued**

Error Code	Test Result	Description/ Recommendation
2077	ABORT	<p>The Maintenance/Test Circuit Pack Query located more than one Maintenance/Test packet bus port in the port-network.</p> <p><b>⇒ NOTE:</b>                      The software should not allow this to occur. This is an internal system error. Escalate the problem, but also attempt the following work-around steps.</p> <ol style="list-style-type: none"> <li>1. Remove all Maintenance/Test circuit packs from the port-network.</li> <li>2. Insert one Maintenance/Test circuit pack (there should not be more than one in a port-network).</li> <li>3. Re-enter the test command.</li> </ol>
2100	ABORT	<p>Maintenance could not allocate all of the necessary system resources to perform this test.</p>
2500	ABORT	<p>An internal operation failed; the test could not be completed.</p> <ol style="list-style-type: none"> <li>1. Re-enter the command at 1-minute intervals a maximum of 5 times.</li> </ol>

*Continued on next page*

**Table 9-495. Test #572 Maintenance/Test Circuit Pack  
 Query Test — Continued**

Error Code	Test Result	Description/ Recommendation
1xxx	FAIL	The Maintenance/Test packet bus port has detected faults on the Packet Bus. The error codes are interpreted as follows:
2xxx		The Maintenance/Test packet bus port has reconfigured the packet bus around the faulty leads. This action only occurs in Critical Reliability systems (duplicated SPE and PNC).
x0xx		The Maintenance/Test packet bus port is unable to correct all of the Packet Bus faults it has detected.
x1xx		None of the packet bus faults are open faults.
xxyy		At least some of the packet bus faults are open faults. Look for error type 2305 in the Error Log. The Aux Data value indicates the number of open leads.
		The last two digits of the error code indicate the total number of faulty packet bus leads detected.
		Examples: Error Code 2003 FAIL: The Maintenance/Test packet bus port has detected 3 faulty leads. None of them are opens. At least one was unable to be corrected. Error Code 1103 FAIL: The Maintenance/Test Packet Port has detected 3 faulty leads. At least one is an open. The Maintenance/Test circuit pack was able to correct all of them by reconfiguring.
		1. Refer to the <a href="#">“Packet Bus Fault Isolation and Repair”</a> section in <a href="#">Chapter 5, “Alarms, Errors, and Troubleshooting”</a>
	PASS	No faults have been detected on the packet bus by the Maintenance/Test circuit pack. This is an indication that the packet bus is operating correctly.

### Packet Circuit Pack Audit Test (#573)

This test determines whether Packet circuit packs have reported Packet Bus-related in-line errors within the last minute. If so, the failure code indicates whether one or more than one circuit pack has reported such failures.

If the test has failed within the last 5 minutes, there is a 15 second delay before the result is returned. This prevents a repeated sequence of this test from always reporting the same result. If the test passes and a FAIL has not occurred within the last five minutes, a PASS is returned immediately.

**Table 9-496. Test #573 Packet Circuit Pack Audit Test**

Error Code	Test Result	Description/ Recommendation
2500	ABORT	An internal operation failed; the test could not be repeated. 1. Re-enter the command at one-minute intervals a maximum of five times.
1	FAIL	One Packet circuit pack has reported packet bus-related in-line errors within the last minute.
2	FAIL	More than one Packet circuit pack has reported packet bus-related in-line errors within the last minute.
	PASS	No Packet circuit packs have reported packet bus-related in-line errors within the last minute. This indicates that the packet bus is healthy, or that a packet bus fault is transient or is being caused by a faulty Packet circuit pack. If this test passes, but there are other signs of a packet bus failure (for example, logged errors or alarms, or other test failures), refer to the <a href="#">“Packet Bus Fault Isolation and Repair”</a> section in <a href="#">Chapter 5, “Alarms, Errors, and Troubleshooting”</a> .

## PKT-INT (Packet Interface Circuit Pack)

MO Name (in Alarm Log)	Alarm Level	Initial Command to Run <sup>1</sup>	Full Name of MO
PKT-INT	MAJOR <sup>2</sup>	reset packet-interface CS	Packet Interface Circuit Pack
PKT-INT	MINOR	test packet-interface CS I	Packet Interface Circuit Pack
PKT-INT	WARNING	test packet-interface CS I	Packet Interface Circuit Pack

1. C is the carrier location (a or b), S is the position number of the Packet Interface circuit pack (1, 2, or 3). The carrier location is required only for duplicated SPEs.
2. If a spontaneous interchange has occurred (as indicated by STBY-SPE error type 103 or the **display initcauses** screen), and handshake is down, (check with **status spe**), replace the alarmed circuit pack on the standby SPE. If handshake is up, execute a **test long clear** of the alarmed circuit pack and follow recommended procedures.

The Packet Interface (PKT-INT) circuit pack (TN1655) serves as an interface between the Switch Processing Element (SPE) and the Packet bus in the Processor Port Network (see the figure in the following pages).

The PKT-INT supports links used for call setup of all ports located in Expansion Port Networks (EPNs). Therefore, if the PBX system is equipped with the Standard Reliability configuration (without duplicated SPEs), a failure of the Packet Interface circuit pack will prevent call origination and tear-down from telephones and trunks connected to EPNs. In addition to affecting telephone service, a failure of the Packet Interface circuit pack will affect service provided by the following circuit packs that connect to the Packet bus:

- TN464C Universal DS1 circuit pack — ISDN PRI service
- TN553 Packet Data Line circuit pack — System Port feature used for connectivity to features such as Call Detail Recording and dial-up administration.
- TN556 ISDN-BRI Line circuit pack — ISDN BRI service
- TN577 Packet Gateway circuit pack — BX.25 links used for services requiring BX.25 links such as AUDIX and Distributed Communications Systems

If the PBX system is equipped with the High Reliability or Critical Reliability option (i.e. with duplicated SPEs), and if a failure of the Packet Interface circuit pack on the active SPE causes a MAJOR alarm, a SPE interchange will occur if the state of health of the standby SPE is high enough to permit an interchange. A MAJOR alarm caused by a failure of a Packet Interface circuit pack on the standby SPE will drop the state of health of the standby SPE which prevents any attempt to interchange SPEs.

The links that pass through the Packet Interface circuit pack are identified as application links and system links as follows:

1. Application links

a. EIA endpoints requiring connectivity to the SPE.

These links pass over the Packet bus, through the System Ports, and over the TDM bus to provide connectivity from the SPE to endpoints on the TDM bus (see figure below).

The following system features use application links of this type.

- Call Detail Recording (CDR)
- Dial-up administration
- Property Management System (PMS)
- Journal printer
- Wake-up log printer
- Announcement circuit pack upload/download of recorded messages

b. BX.25 links supported by the Packet Gateway.

The following system features use application links of this type.

- Distributed Communication System (DCS)
- Audio Information Exchange (AUDIX)
- Messaging Service Adjunct (MSA)
- Call Management System (CMS)
- Outgoing Call Management (OCM)
- Adjunct Switch Application Interface (ASAI)

2. System links

- Expansion Archangel links (signaling links for call setup of endpoints in an EPN)
- Center Stage Control Network (CSCN) links
- ISDN PRI D channel signaling links
- Packet Gateway call control links (signaling links to the Packet Gateway circuit pack)
- ISDN BRI D channel broadcast and point-to-point signaling links
- Adjunct Switch Application Interface (ASAI) links

The PBX has been designed for a maximum of three Packet Interface circuit packs but only one Packet Interface circuit pack is required for the current PBX hardware configuration. The Packet Interface circuit pack will normally be inserted in the first Packet Interface slot provided in the control carrier although it

will operate in any one of the three slots provided. If more than one Packet Interface circuit pack is inserted, an alarm will be generated. For a system equipped with duplicated SPEs, the slot used for the Packet Interface circuit pack on the standby SPE must be the same slot position as that used on the active SPE or an alarm will be generated against the Packet Interface circuit pack in the standby SPE.

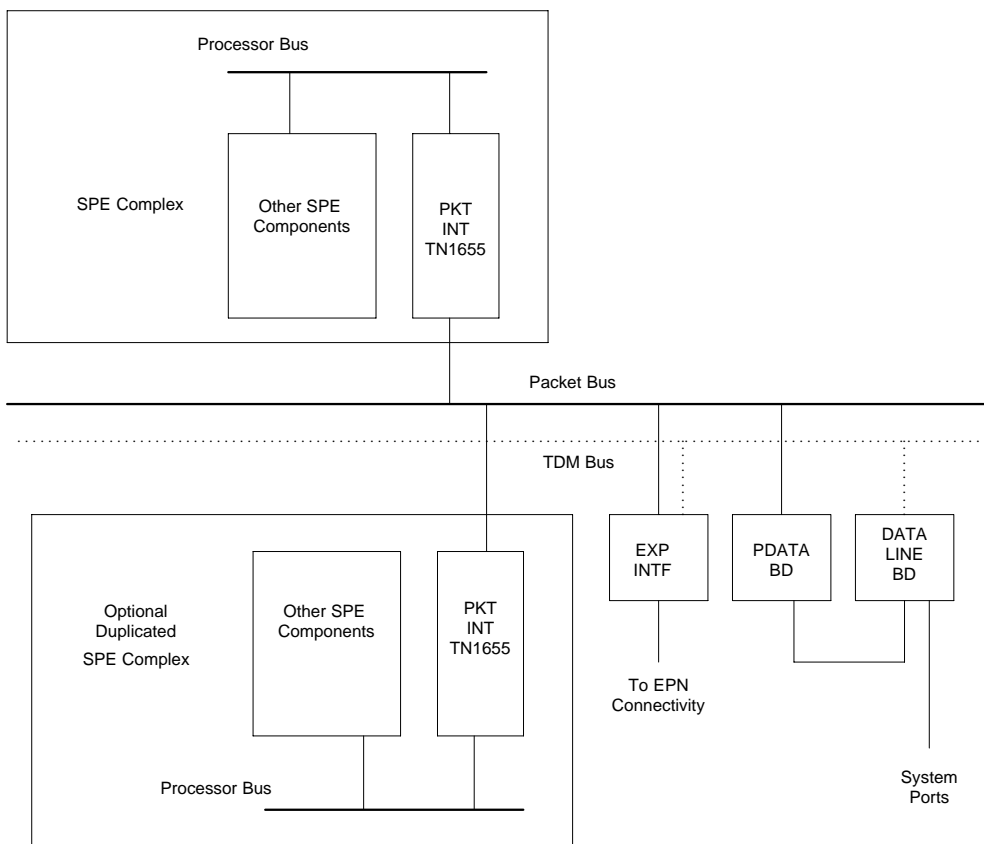

**Figure 9-79. Packet Interface Connectivity**

## Packet Interface Service Operations

The following sections provides more background information about Packet Interface service operations.

## Administration

There are no **add** or **remove** commands associated with the Packet Interface circuit packs. Instead, Packet Interface fields (*Packet Intf1*, *Packet Intf2*, *Packet Intf3*) that appear under the SPE Optional Boards category on the second page of the System Parameters Maintenance Form are provided to indicate whether the Packet Interface circuit pack is administered.

If a Packet Interface circuit pack is physically present, the corresponding Packet Interface field is set to “y” when the system boots, and no change to that field is allowed. (If the system is equipped with duplicated SPEs, a Packet Interface field is set to “y” when either SPE carrier contains a Packet Interface circuit pack in the corresponding position.) If a Packet Interface circuit pack is not present, then the value for the Packet Interface field is read from translation data stored on disk or tape. If the field is set to “n,” a Packet Interface circuit pack may be administered by changing the corresponding Packet Interface field to “y.”

## Packet Interface Circuit Pack Replacement

When replacing a Packet Interface circuit pack, follow the procedure used for replacing any circuit pack in the SPE carrier. The SPE carrier must be powered down before a Packet Interface circuit pack is removed or added and then the SPE carrier must be powered back up after the circuit pack is inserted.

Packet Interface circuit packs should not be plugged in or removed from a running system since configuration tables in software need to be updated at system restart time. This is also true for Packet Interface circuit packs in the standby SPE carrier when the system is equipped with duplicated SPEs. Refer to *Replacing SPE Circuit Packs* in [Chapter 5, “Alarms, Errors, and Troubleshooting”](#) for more information on the procedures for replacing circuit packs in a standby SPE carrier.

## Demand Reset of a Packet Interface Board

A demand reset of a Packet Interface circuit pack on an active SPE via the entry of a **reset packet-interface** command will be denied by system software if the Packet Interface is in service (has not been placed in an out-of-service state by background maintenance software). Otherwise, a reset of an in-service Packet Interface circuit pack would cause severe service disruption including the loss of all existing calls and dropped links to adjuncts such as AUDIX. The software that controls Packet Interface maintenance puts a Packet Interface circuit pack in the out-of-service state if that circuit pack has been reset three times within the last 15 minutes. as part of the automatic recovery action that is initiated when a hardware fatal fault condition is detected.

A demand reset of a Packet Interface circuit pack on the standby SPE is not disruptive and is allowed regardless of the service state of the associated maintenance software. When a standby Packet Interface circuit pack is reset, memory shadowing is turned off and then back on. A memory refresh is then performed to update the state of the standby Packet Interface circuit pack and to

refresh the standby's memory. It takes several minutes after a Packet Interface circuit pack on the standby SPE is reset before memory refresh of the standby SPE is complete. During that time, demand tests of the standby Packet Interface circuit will abort.

## Service States

Packet Interface maintenance software maintains a state variable that keeps track of the in-service/out-of-service state of each Packet Interface circuit pack. In a system equipped with a single SPE, if maintenance software detects that a Packet Interface circuit pack has a "fatal fault", it will automatically attempt to reset that circuit pack as quickly as possible. An extensive set of diagnostic tests are run when the circuit pack is reset.

If the circuit pack diagnostic tests do not pass in a system without duplicated SPEs, the failing Packet Interface circuit pack is placed in an out-of-service state. All links handled by that circuit pack will go out of service. This is a disruptive action since established calls associated with telephones connected to Expansion Port Networks are dropped as a result of the EPNs being taken out of service.

If the system is equipped with duplicated SPEs and if the standby SPE has an acceptable state-of-health, an SPE interchange will occur instead of a reset of the Packet Interface circuit pack. This is less disruptive than a reset since stable calls are not disconnected.

A Packet Interface circuit pack will also be put in the "out-of-service" state if the circuit pack has reported a fatal fault at system initialization time or if the circuit pack has been reset by background maintenance three times within the last 15 minutes, whether or not the Reset test passes. The state of a Packet Interface circuit pack can be determined by using the **status packet-interface** command.

## Duplication Impact

The Packet Interface circuit pack is a single point of failure in a system that is not equipped with duplicated SPEs. If this is not acceptable, customers have the option of upgrading to a configuration with a duplicated SPE processor complex as part of the High Reliability or Critical Reliability Configuration. The previous figure shows the configuration with duplicated processors. The following concepts apply only when the processors are duplicated.

- Configuration Mismatch

The number and position of Packet Interface circuit packs on the standby SPE must match exactly the number and position of Packet Interface circuit packs on the active SPE. If this is not the case, a MAJOR alarm is raised against a missing Packet Interface circuit pack on the standby SPE and a WARNING alarm is raised against extra Packet Interface circuit packs on the standby SPE.



The system is provided with 3 slots for a maximum of 3 Packet Interface circuit packs. Only one Packet Interface circuit pack is required. This circuit pack is typically plugged into the first slot but it may be plugged into any of three slots. A WARNING alarm will be raised if more than one Packet Interface circuit pack is present in an SPE carrier.

The version of firmware on a standby Packet Interface circuit pack must also match the version of firmware on the corresponding active Packet Interface circuit pack. If this is not the case, the standby Packet Interface circuit pack enters a fatal fault state and the standby Packet Interface circuit pack maintenance software sets its corresponding in-service/out-of-service state to out-of-service.

The configuration checks are only made if the active SPE can communicate with the standby SPE. If the standby SPE is locked off-line by setting the SPE-SELECT switches on the DUPINT circuit packs to the position of the active SPE, the mismatch test is not run and therefore, the mismatch is not detected.

- Packet Bus Connection

In a system equipped with duplicated SPEs, the Packet Interface circuit packs in the Standby SPE can not access the Packet Bus to write data except during the time of a planned SPE interchange and when the Peer Link Test (#888) is run. Consequently, the Maintenance Looparound Test (#886) that requires access to the Packet Bus is not run on Packet Interface circuit packs on the Standby SPE.

- SPE Interchange

Severe Packet Interface circuit pack faults which cause system and application links to go down will be detected within 1 second. A fatal fault error message will be generated and the Packet Interface maintenance software will attempt to run the Packet Interface Reset test. In systems equipped with the High Reliability or Critical Reliability Configuration this will result in a request for an SPE interchange instead of a reset of the Packet Interface circuit pack since stable calls are preserved across an SPE interchange.

- Clearing Alarms on Standby Packet Interface Circuit Packs

Alarms for Packet Interface circuit packs on the standby SPE are not cleared automatically when handshake communication with the standby SPE goes down. Handshake communication will go down when the standby SPE is powered down (as part of the repair procedures) or when the SPE-SELECT switches on the DUPINT circuit packs are set to the position of the active SPE. Packet Interface alarms remain after an SPE interchange. This means that memory shadowing will not turn on after an SPE interchange if a Packet Interface circuit pack on the standby SPE had a Major alarm before the interchange. If the Packet Interface circuit pack is replaced, the alarm will still be present. A demand reset of the standby PKT-INT is required to clear the alarm.

## Maintenance Object Interactions

### ■ Packet Bus Maintenance

The Packet Interface circuit pack physically interacts with the PKT-BUS (Packet Bus). For certain types of Packet Interface circuit pack errors, it may be difficult to isolate the fault to one of these two components. In these cases, Packet Interface maintenance will forward the error report to the Packet Bus maintenance, thus causing Packet Bus maintenance to record a Packet Bus fault in the hardware error log and to run appropriate Packet Bus tests.

### ■ Packet Circuit Pack Maintenance

The operation of the Packet Interface circuit pack affects the operation and maintenance of other circuit packs connected to the Packet bus. This includes:

1. Expansion Interface circuit pack maintenance (EXP-INTF)
2. Packet Data Line as part of the System Port (PDATA-BD)  
A System Port is used for connectivity to endpoints connected to the TDM bus such as CDR and dial-up G3-MTs.
3. BRI applications (BRI-PT)
4. Packet Gateway applications (PGATE) for X.25 interfaces
5. Universal DS1 applications (UDS1) for ISDN/PRI applications

Some errors of Packet Circuit Packs may require examination of the Packet Interface operating status. To obtain this information, examine the Error and Alarm Logs for PKT-INT entries. Also issue the **status packet-interface** command to determine the service state of the Packet Interface circuit packs (e.g., in-service/out-of-service) and information about the total number of Packet Interface links assigned to a Packet Interface circuit pack. For a Packet Interface circuit pack in the standby SPE in a system equipped with duplicated SPEs, a Packet Interface is shown to be a “standby” mode if it is not out of service due to a failure condition. The number of links for a standby Packet Interface is always zero.

In general, if all links for a Packet Interface circuit pack on an Active SPE are shown in the “Failed Links” category, there may be a fault on the Packet Interface circuit pack or on the Packet Bus that caused all links to go down. If only a small percentage of the links are shown as “Failed Links,” then the Packet Interface circuit pack is probably not the source of the problem. Examples of the source of individual link failures include the failure of a BRI telephone set, a disconnect of the cord to a BRI set, and a failure or removal of an Expansion Interface circuit pack in an Expansion Port Network. The disconnect of a BRI set causes three link failures and the removal of a EI board in an EPN causes one link failure. Refer to [Chapter 8, “Maintenance Commands”](#), for more information on the **status packet-interface** command.

For the case where not all links are in the “Failed Links” category, examine the alarm log and error log for failures of the following circuit pack types and follow the repair procedures for those circuit packs before considering replacing the associated Packet Interface circuit pack:

- Expansion Interface circuit pack (EXP-INTF)
- Switch Node Interface circuit pack (SNI-BD)
- Switch Node Clock circuit pack (SNC-BD)
- Packet Data Line circuit packs and ports (PDATA-BD, PDATA-PT)
- ISDN-BRI Line circuit packs, ports, and stations (BRI-BD, BRI-PORT, BRI-SET)
- Packet Gateway circuit packs and ports (PGATE-BD, PGATE-PT)
- Universal DS1 circuit packs and ports (UDS1-BD, TIE-DS1)

## Error Log Entries and Test to Clear Values

**Table 9-497. Packet Interface Error Log Entries**

Error Type	Aux Data	Associated Test	Alarm Level	On/Off Board	Test to Clear Value
0 <sup>1</sup>	0	Any	Any	ON	test packet-interface CS l r 2
1 (a)	Any	None	MAJOR <sup>2</sup>	ON	reset packet-interface CS <sup>3</sup>
10 (b)	0	None			
23 (c)	0	None	MAJOR <sup>2</sup>	OFF	
23 (d)	0	None	MINOR	OFF	
50 (e)	0	None			
100 (f)	0	None			
150 (g)	0	None	MAJOR	ON	test packet-interface CN l c
200 (h)	0	None	MAJOR <sup>2</sup>	OFF	
217 (j)	0	None	WARNING	OFF	
257 (i)	Any	None	MAJOR <sup>2</sup>	ON	reset packet-interface CS <sup>3</sup>
267 (j)	0	None	WARNING	OFF	
513 (k)	Any	None	MAJOR <sup>2</sup>	ON	reset packet-interface CS <sup>3</sup>
769 (l)	Any	Maintenance Looparound Test (#886)	MAJOR <sup>2</sup>	ON	test packet-interface CS s r 2

*Continued on next page*

**Table 9-497. Packet Interface Error Log Entries — Continued**

Error Type	Aux Data	Associated Test	Alarm Level	On/Off Board	Test to Clear Value
1025, (m)	Any	Private Looparound Test (#885)	MAJOR <sup>2</sup>	ON	reset packet-interface CS <sup>3</sup>
1026	Any	None	MAJOR <sup>2</sup>	ON	reset packet-interface CS <sup>3</sup>
1281 (n)	Any	None	MAJOR <sup>2</sup>	ON	reset packet-interface CS <sup>3</sup>
1537 (o)	Any	Memory Checksum Test (884)	MINOR	ON	test packet-interface CS l r 2
1793 (p)	Any	Memory Checksum Test (#884)	MINOR	ON	test packet-interface CS l r 2
2049 (q)	Any	None	WARNING	ON	test packet-interface CS r 25
2305 (r)	Any	None			test packet-interface CS r 2
2561 (s)	Any	Active-Standby Peer Link Test (#888)	MINOR	OFF	test packet-interface CS s r 2
2817 (t)	Any	Read and Clear Test (#887)	MINOR/ MAJOR <sup>2</sup>	ON	test packet-interface CS s
3074, 3073, 3072 (u)	Any	Maintenance Looparound Test (#886)	WARNING	OFF	test packet-interface CS s r 2
3329 (v)	Any	None	WARNING	OFF	reset packet-interface CS <sup>3</sup>
3585 (w)	Any	None	WARNING	OFF	reset packet-interface CS <sup>3</sup>
3841 (x)	Any	None	MAJOR <sup>2</sup>	OFF	reset packet-interface CS <sup>3</sup>

1. Indicates that an alarm was raised but an associated error was not entered into the hardware error log due to a momentary overload condition caused by a burst of hardware or software error reports. Run the long test sequence. Refer to the appropriate test descriptions for any failures and follow the recommended procedures.
2. If a spontaneous interchange has occurred (as indicated by STBY-SPE error type 103 or the **display initcauses** screen), and handshake is down, (check with **status spe**), replace the alarmed circuit pack on the standby SPE. If handshake is up, execute a **test long clear** of the alarmed circuit pack and follow recommended procedures.
3. A Packet Interface circuit pack on an active SPE can only be reset if it has been taken out of service by background maintenance software. A Packet Interface circuit pack on a standby SPE can be reset independent of its service state.

Notes:

- a. Error 1 occurs when background maintenance software has reset the Packet Interface circuit pack as a fault recovery action. It is used to keep track of the number of times that the Packet Interface circuit pack is reset, independent of whether or not the Reset test passed. Once three of these errors have occurred in the last 15 minutes, maintenance will place the Packet Interface circuit pack into an out-of-service state, and a MAJOR on-board alarm will be raised on the Packet Interface circuit pack.
  1. Check to see if error codes 257, 513, 769, 1025, 1281, or 3841 are present in the hardware error log. If one or more of those error codes are present, refer to the information associated with those errors for the appropriate repair procedures.
  2. If no other Packet Interface errors appear in the error log, and if the Packet Interface circuit pack is not in a held reset state as indicated by the absence of a MAJOR alarm with a Service State of OUT, no action should be taken. If a Packet Interface MAJOR alarm is present and no other Packet Interface error codes are in the hardware error log, execute a demand reset by entering **reset packet-interface CS** and refer to the repair procedures for Test # 889.
- b. Error 10 indicates that the Packet Interface maintenance software caused an escalating system WARM restart as part of a recovery action for certain Packet Interface circuit pack failures. A SYSTEM error type 10 should also be present, indicating that a software initiated WARM restart occurred.
  1. Check to see if error types 513, 1025, or 3074 are present in the hardware error log. If they are present, refer to the repair procedures for those errors for further action.
- c. Error 23 along with an associated MAJOR alarm indicates that (a) Packet Interface circuit pack translation data was loaded from the tape or disk at boot time but the Packet Interface circuit pack was not detected to be physically present or (b) a Packet Interface circuit pack is on the active SPE but a corresponding Packet Interface circuit pack on the standby SPE is missing.
  1. If the Packet Interface circuit pack is physically present, replace the circuit pack. The SPE must be rebooted to resolve the alarm.
  2. Otherwise, insert the missing Packet Interface circuit pack into the system or use the **change system-parameters maintenance** command to change the entries for Packet Interface circuit packs to match the circuit packs actually present. If a Packet Interface circuit is added to the system, the SPE must be rebooted to resolve the alarm.
- d. Error 23 along with an associated MINOR alarm occurs when a user logically administers a Packet Interface circuit pack using the **change system-parameters maintenance** command when the Packet Interface circuit pack is not physically present.

1. Use the **display system-parameters maintenance** command to determine the number of Packet Interface circuit packs logically or physically present.
  2. Insert the missing Packet Interface circuit pack into the system or use the **change system-parameters maintenance** command to change the entries for Packet Interface circuit packs to match those actually present.
- e. Error 50 indicates that the SPE is sending more downlink messages than the Packet Interface can keep up with. This is an in-line error not produced by any test. When this error is reported, application software is slowed down to allow the Packet Interface to process existing downlink messages. If there is a hardware problem, the Packet Interface test will normally cause other errors to be logged. In the rare case where there are no other PKT-INT errors logged but error 50 occurs more than 10 times in the last hour, follow normal escalation procedures.
- f. Error 100 indicates that the SPE requested a reset of Packet Interface circuit packs on the active SPE as part of a Packet Interface circuit pack recovery action. In a High Reliability or Critical Reliability system, an SPE interchange will occur instead of a Packet Interface circuit pack reset, if the health of the standby SPE allows an interchange.
1. If no other PKT-INT errors except error code 1 are present, this means that the Packet Interface circuit pack was in a fatal fault state at the time of system initialization or SPE interchange and it was reset successfully. No other actions are required.
  2. If PKT-INT error codes other than error code 1 are present, refer to the repair procedures for those errors to correct the failure.
- g. Error 150 indicates that a SPE interchange occurred and that the Packet Interface circuit pack was the cause of the spontaneous interchange.
1. If other PKT-INT errors are present, investigate those errors.
  2. If no other PKT-INT errors are present, run the **test packet-interface long clear** command and investigate any failures.
- h. Error 200 indicates that memory shadowing was turned off in preparation for resetting a Packet Interface circuit pack on the active SPE in a system with the High Reliability or Critical Reliability Configuration. No action should be taken based on this error code. Normally, when the state of health of the standby SPE allows an SPE interchange, an SPE interchange will be requested instead of a Packet Interface reset. However, if the state of health of the standby SPE does not permit an SPE interchange, the Packet Interface circuit pack on the active SPE will be reset. As part of that reset action, memory shadowing is turned off so that the Packet Interface circuit pack on the standby SPE will be refreshed after the active Packet Interface circuit pack is reset.

- i. Error 257 indicates that the circuit pack detected a fatal failure. This error is a very serious and when it occurs, maintenance software immediately escalates testing to the destructive reset test (#889).
  1. If the Packet Interface circuit has a MAJOR alarm:
    - a. Reset the Packet Interface circuit pack using the **reset packet-interface CS** command.
    - b. Refer to the repair procedures for the Packet Interface Reset Test (#889).
  2. If the Packet Interface circuit pack is not alarmed, no action is required.
- j. Errors 267 and 217 indicate that the number of Packet Interface circuit packs detected as being physically present exceeds number of Packet Interface circuit packs supported by the software configuration or, if the SPEs are duplicated, that a Packet Interface circuit pack is detected as being physically present on the standby SPE but the corresponding Packet Interface circuit pack on the active SPE is not present.
  1. If more than one Packet Interface circuit pack is inserted in the active or standby SPE carrier, remove the extra circuit pack(s).
  2. If the SPE is duplicated, visually check that the number and location of Packet Interface circuit packs in the standby SPE carrier match the number and location of Packet Interface circuit packs in the active SPE carrier. If there is a mismatch, insert Packet Interface circuit packs in the standby SPE to match the Packet Interface circuit packs in the active SPE.
- k. Error 513 is called Message Handshake failure. It indicates that a failure with the message protocol between the SPE software and the Packet Interface circuit pack was detected.
  1. If the Packet Interface circuit has a MAJOR alarm:
    - a. Reset the Packet Interface circuit pack using the **reset packet-interface CS** command.
    - b. Refer to the repair procedures for the *Packet Interface Reset Test* (#889).
  2. If the Packet Interface circuit pack is not alarmed, no action is required.
- l. Error 769 indicates that there was a failure in the *Packet Looparound test*. A maintenance looparound link cannot be established or the Packet Interface circuit pack cannot send and receive data correctly as part of the looparound test (Test #886). If the number of errors exceeds a defined threshold, a Major alarm will be raised.

In a system equipped with duplicated SPEs, a failure of the Maintenance Looparound test may have caused an SPE interchange which would result in an alarm associated with error code 769 being reported against a Packet Interface circuit pack that is currently on the standby SPE. If so, it

may be necessary to force the standby SPE to go active by using the SPE-SELECT switches on the DUPINT circuit packs to run the Maintenance Looparound test to make sure the problem is cleared.

For more information, refer to the repair procedures of Test #886.

- m. Error 1025 indicates a failure of the private Level 3 looparound test (Test #885).
  - 1. If the Packet Interface circuit has a MAJOR alarm:
    - a. Reset the Packet Interface circuit pack using the **reset packet-interface CS** command.
    - b. Refer to the repair procedures for the *Packet Interface Reset Test (#889)*.
  - 2. If the Packet Interface circuit pack is not alarmed, no action is required.
- n. Error 1281 indicates that the Packet Interface circuit pack has Translation RAM failures. PKT-INT Translation RAM is used to convert the addresses of a packet to the destination endpoint address.
  - 1. If the Packet Interface circuit has a MAJOR alarm:
    - a. Reset the Packet Interface circuit pack using the **reset packet-interface CS** command.
    - b. Refer to the repair procedures for the *Packet Interface Reset Test (#889)*.
  - 2. If the Packet Interface circuit pack is not alarmed, no action is required.
- o. Error 1537 indicates a Boot PROM memory failure. The Packet Interface circuit pack may still be operational if no other errors are reported. However the circuit pack may report a fatal fault during board initialization. This may occur during a system recovery level more severe than a WARM restart. For more information, refer to Test #884.
- p. Error 1793 indicates a FLASH Memory test failure. The Packet Interface circuit pack may still be operational if no other errors are reported. However the circuit pack may report a fatal fault during board initialization. This may occur during a system recovery level more severe than a WARM restart. For more information, refer to the repair procedures of Test #884.
- q. Error 2049 indicates a LAPD Received Buffer Overflow error. The Packet Interface circuit pack Packet bus receive buffer overflowed. For more information, refer to the repair procedures of Test #887.
- r. Error 2305 indicates a Packet Bus Interface Detected Parity failure. The Packet Interface circuit pack received packets with parity error from the Packet bus.
  - 1. Check for errors logged against the Packet bus and Maintenance/Test circuit pack. Refer to the appropriate repair procedures to clear those errors first.



2. Check all other circuit packs connected to the Packet bus in the same cabinet. Packet Bus failures are likely to be caused by a faulty circuit pack connected to the backplane or bent pins on the back plane.
  3. If steps 1 and 2 above do not clear the problem, execute the **test packet-interface** command and follow repair procedures described for Test #887.
- s. Error 2561 indicates a Active-Standby Peer Link test failure indicating a possible failure of the Packet Interface circuit pack on the active SPE or a failure of the corresponding Packet Interface circuit pack on the standby SPE. If the number of errors exceeds a defined threshold, a Minor alarm will be raised. For more information, refer to the repair procedures of Test #888.
- t. Error 2817 indicates a Standby Packet Interface circuit pack Translation RAM failure. A MINOR alarm is raised when there are 1 to 5 bad locations and a MAJOR alarm is raised when there are 5 or more bad locations. Execute the **test packet-interface** command and follow repair procedures described for Test #887.
- u. Errors 3074, 3073, and 3072 indicate PKT-INT Transmit Buffer Overflow, which means that the number of transmit buffers required by software exceeded the number available. A 3074 error is generated when the PKINT sends an in-line hardware error to maintenance software indicating transmit buffer overflow. As part of the background recovery action for this error, maintenance software will automatically run the Maintenance Looparound test (#886). If that test fails, maintenance software generates error codes 3073 and 3072, and it requests a system WARM restart. If, after the WARM restart, transmit buffer overflow errors continue to be reported, maintenance software generates error code 100 and it resets the PKT-INT. These errors may be the result of system overload due to a problem with communication between the PKT-INT and the EPNs.
1. Check for errors logged against the Expansion Interface circuit pack, the Switch Node Interface circuit pack, Packet Gateway circuit pack, the Packet Data Line circuit packs associated with the System Ports, BRI Line circuit packs and BRI endpoints, and the Universal DS1 circuit packs supporting PRI service. Errors against those components should be cleared first.
  2. Enter the **test packet-interface short** command against the Packet Interface circuit pack associated with the error. If the Maintenance Looparound test (#886) test passes, the alarm will clear. If the test fails, repeat the test 5 times. If it continues to fail, follow normal escalation procedures.
- v. Error 3329 indicates that the TDM clock has failed. The Tone Board should have been alarmed (TONE-BD, TDM-CLK). Refer to TDM-CLK and/or TONE-BD for further action. The Packet Interface circuit is taken out of service when this failure occurs. Execute the **reset packet-interface** command to bring the Packet Interface circuit back into service.

- w. Error 3585 indicates that a Packet bus failure has been detected and that the Packet bus is alarmed. Refer to the Packet Bus maintenance documentation for further action.
- x. Error 3841 indicates that the Packet Interface circuit pack has reported a fatal fault failure condition that may be caused by a Packet Bus failure on the Processor Port Network.
  1. If error 3585 has also been reported, refer to the maintenance documentation for PKT (Packet Bus) maintenance. After the Packet Bus failure has been corrected, execute the **reset packet-interface** command to bring the Packet Interface circuit back into service.
  2. If error 3585 has not been reported, enter the **reset packet-interface** command and follow the repair steps associated with test #889.

## System Technician-Demanded Tests: Descriptions and Error Codes

Always investigate tests in the order presented in the table below. By clearing error codes associated with the *Packet Interface Private Looparound* test for example, you may also clear errors generated from other tests in the testing sequence.

Order of Investigation	Short Test Sequence	Long Test Sequence	Reset Board Sequence	D/ND <sup>1</sup>
Packet Interface Reset Test (#889)			X	D
Packet Interface Private Looparound Tests (#885)		X		ND
Packet Interface Maintenance Looparound Test (#886) (a)	X	X		ND
Packet Interface Memory Checksum Test (#884)		X		ND
Packet Interface Error Counter Read and Clear Test (#887)	X	X		ND
Packet Interface Active-Standby Peer Link Test (#888) (b)	X	X		ND

1. D = Destructive; ND = Nondestructive

### Notes:

- a. This test is run only on a Packet Interface circuit pack on an active SPE.
- b. This test is run only on a Packet Interface circuit pack on a standby SPE.

## Memory Checksum Test (#884)

This test involves sending a message to the Packet Interface circuit pack to run private non-destructive memory checksum tests on the firmware text residing in Boot PROM and FLASH memory. If the test fails during background testing, the circuit pack will remain operational until a reset is executed on the circuit pack. Then the initialization firmware will fail and will put the circuit pack in an out-of-service state.

**Table 9-498. TEST #884 Memory Checksum Test**

Error Code	Test Result	Description/ Recommendation
1006 1137	ABORT	Packet Interface circuit pack is in the out-of-service state so normal maintenance tests will not run on that circuit pack.  1. Request a Packet Interface circuit pack reset using the <b>reset packet-interface CS</b> command. Refer to the Packet Interface Reset Test (#889) repair procedures for further action.
1334	ABORT	The Packet Interface circuit pack command queue is full. This should be a temporary condition caused by a high rate of commands being sent to a Packet Interface circuit pack. Continued operation with a full command queue will cause a system WARM restart that may escalate to more severe restart levels.  1. Retry the command at 10-second intervals, a maximum of 5 times.
1338	ABORT	The test is not allowed to run since a planned SPE interchange is in progress. A planned interchange may be caused by 24 hour scheduled testing. During this time the terminal will be held out of service but it should recover automatically after three minutes.  1. Wait three minutes and retry the command.
1339	ABORT	The test could not run on the standby Packet Interface circuit pack because the standby SPE is unavailable.  1. Refer to the STBY-SPE maintenance documentation for information on why a standby SPE may be unavailable and what repair actions should be taken. The <b>status spe</b> screen should indicate that handshake is down. This may be caused by a variety of reasons such as the setting the SPE-SELECT switches on the DUPINT circuit packs to the position of the active SPE, a failure of the DUPINT circuit pack, or loss of power on the standby SPE. The <i>SPE Selected</i> field on the <b>status spe</b> screen will display <i>spe a</i> or <i>spe b</i> if the SPE-SELECT switches are in the a or b position, respectively.

*Continued on next page*

**Table 9-498. TEST #884 Memory Checksum Test — Continued**

Error Code	Test Result	Description/ Recommendation
1347	ABORT	<p>The test could not run because refresh of the standby SPE's memory is not complete.</p> <ol style="list-style-type: none"> <li>1. Enter <b>status spe</b> and verify that refresh is not complete. Wait until the status screen indicates that refresh is complete and try the command again. The status screen should indicate that shadowing is on. If some event such as a major alarm on a Packet Interface circuit pack on the standby SPE causes shadowing to turn off, refresh cannot complete and abort code 1350 will be returned when <b>test packet-interface</b> is entered.</li> </ol>
1350	ABORT	<p>The test could not run because memory shadowing has not started.</p> <ol style="list-style-type: none"> <li>1. Enter <b>status spe</b> and verify that shadowing has not started. The SPE is locked when the SPE-SELECT switches on the DUPINT circuit pack are set to the position of the active SPE. Return the switches to the neutral position. If the SPE is not locked, verify that there are no alarms active for the standby SPE. If there are, enter "display alarms" and verify that there are no major alarms against the standby Packet Interface circuit packs. If there are, clear those alarms first.</li> </ol>
2000	ABORT	<p>Response to the test request was not received within the allowable time period. If the system is equipped with the High Reliability or Critical Reliability Configuration and if the Packet Interface circuit pack is on the standby SPE, this abort code may indicate that the standby SPE is not responding to the handshake message. If this is the case, the standby SPE maintenance software may take up to two minutes to indicate that handshake communication with the standby SPE is down. The ABORT code will then change to 1339 (standby SPE unavailable).</p> <ol style="list-style-type: none"> <li>1. Retry the command at 1-minute intervals, a maximum of 3 times.</li> </ol>
2500	ABORT	<p>Internal system error</p> <ol style="list-style-type: none"> <li>1. Retry the command.</li> </ol>
	NO BOARD	<p>The Packet Interface circuit pack is administered but it is not detected as being physically present.</p> <ol style="list-style-type: none"> <li>1. If the Packet Interface circuit pack is present, replace it.</li> <li>2. If the Packet Interface circuit pack is not physically present, use the <b>display system-parameters maintenance</b> command to check if the Packet Interface circuit pack is administered as being present. If it is administered, use the <b>change system-parameters maintenance</b> command to change the Packet Interface circuit packs administered to be those actually present.</li> </ol>

*Continued on next page*

Table 9-498. TEST #884 Memory Checksum Test — *Continued*

Error Code	Test Result	Description/ Recommendation
1537	FAIL	<p>The Boot PROM memory checksum test failed. The circuit pack may still be operational.</p> <ol style="list-style-type: none"> <li>1. Retry the command.</li> <li>2. If the same error code occurs                             <ol style="list-style-type: none"> <li>a. If the system is not equipped with the High Reliability or Critical Reliability Configuration replace the circuit pack at a time that would cause the least disruption of service. The circuit pack is still functional but should be replaced since it may not operate after a system reboot and it will enter a fatal fault state if it is reset for other reasons.</li> <li>b. If the system is equipped with the High Reliability or Critical Reliability Configuration and if the Packet Interface circuit pack is on the standby SPE, replace that circuit pack.</li> <li>c. If the system is equipped with the High Reliability or Critical Reliability Configuration and if the Packet Interface circuit pack is on the active SPE, perform a planned SPE interchange by entering the command <b>reset system interchange</b>. Use the <b>status spe</b> command to determine when refresh is complete (between 2 to 10 minutes, depending on system size) and retry the test command. If the test of the circuit pack on the standby SPE continues to fail, replace that circuit pack.</li> </ol> </li> </ol>
1793	FAIL	<p>The Flash memory checksum test failed. The circuit pack may still be operational but it will fail if a reset is executed.</p> <ol style="list-style-type: none"> <li>1. Retry the command.</li> <li>2. If the same error code occurs                             <ol style="list-style-type: none"> <li>a. If the system is not equipped with the High Reliability or Critical Reliability Configuration replace the circuit pack at a time that would cause the least disruption of service. The circuit pack is still functional but should be replaced since it may not operate after a system reboot and it will enter a fatal fault state if it is reset for other reasons.</li> <li>b. If the system is equipped with the High Reliability or Critical Reliability Configuration and if the Packet Interface circuit pack is on the standby SPE, replace that circuit pack.</li> <li>c. If the system is equipped with the High Reliability or Critical Reliability Configuration and if the Packet Interface circuit pack is on the active SPE, perform a planned SPE interchange by entering the command <b>reset system interchange</b>. Use the <b>status spe</b> command to determine when refresh is complete (between 2 to 10 minutes, depending on system size) and retry the test command. If the test of the circuit pack on the standby SPE continues to fail, replace that circuit pack.</li> </ol> </li> </ol>

*Continued on next page*

**Table 9-498. TEST #884 Memory Checksum Test — Continued**

Error Code	Test Result	Description/ Recommendation
	PASS	The circuit pack's firmware is in a proper state. If problems are still reported on the circuit pack, check for errors on the Private Looparound test (#885) and Maintenance Looparound Test (#886).

### Private Looparound Tests (#885)

This test requests the Packet Interface circuit pack to execute its three private looparound tests: Level 2 looparound, Broadcast path looparound, and Level 3 looparound. These tests verify the health of the circuit pack's Packet Bus interface, as well as the translation RAM, inward and outward bound data paths, parity indications and CRC calculations, and the Level 3 processing firmware.

- Level 2 (LAPD) Link Looparound

LAPD is a link level protocol that is used for all system links. This test verifies the health of the processing of these links.

- Broadcast Link Looparound

Each ISDN BRI port has two associated broadcast signaling links, one for call control and one for maintenance and management. Since these links have separate routing circuitry from the Level 2 Looparound, this test forces a CRC error to verify the CRC hardware associated with the broadcast data path.

- Level 3 Link Looparound

Level 3 Links support the X.25 Data Phase protocol used with the Packet Gateway to support X.25 links such as those used for AUDIX. This test verifies the health of the Level 3 firmware. Since soft errors are possible, the Packet Interface circuit pack retries the test before reporting an error.

These tests are also run as part of the reset tests. If the Level 2 or Level 3 looparound test fail as background tests, a "fatal error" message will be sent to the Packet Interface maintenance software and the Packet Interface circuit pack will be put in the "out-of-service" state. Therefore, it is expected that the repair procedures associated with Abort Code 1137 (out-of-service) would normally be followed when failures with the Level 2 and Level 3 tests occur.

**Table 9-499. TEST #885 Private Looparound Tests**

Error Code	Test Result	Description/ Recommendation
1006 1137	ABORT	Packet Interface circuit pack is in the out-of-service state so normal maintenance tests will not run on that circuit pack.  1. Request a Packet Interface circuit pack reset using the <b>reset packet-interface CS</b> command. Refer to the Packet Interface Reset Test (#889) repair procedures for further action.
1334	ABORT	The Packet Interface circuit pack command queue is full. This should be a temporary condition caused by a high rate of commands being sent to a Packet Interface circuit pack. Continued operation with a full command queue will cause a system WARM restart that may escalate to more severe restart levels.  1. Retry the command at 10-second intervals, a maximum of 5 times.
1338	ABORT	The test is not allowed to run since a planned SPE interchange is in progress. A planned interchange may be caused by 24 hour scheduled testing. During this time the terminal will be held out of service but it should recover automatically after 3 minutes.  1. Wait 3 minutes and retry the command.
1339	ABORT	The test could not run on the standby Packet Interface circuit pack because the standby SPE is unavailable.  1. Refer to the STBY-SPE maintenance documentation for information on why a standby SPE may be unavailable and what repair actions should be taken. The <b>status spe</b> screen should indicate that handshake is down. This may be caused by a variety of reasons such as the setting the SPE-SELECT switches on the DUPINT circuit packs to the position of the active SPE, a failure of the DUPINT circuit pack, or loss of power on the standby SPE. The <i>SPE Selected field</i> on the <b>status spe</b> screen will display <i>spe a</i> or <i>spe b</i> if the SPE-SELECT switches are in the a or b position, respectively.
1347	ABORT	The test could not run because refresh of the standby SPE's memory is not complete.  1. Enter <b>status spe</b> and verify that refresh is not complete. Wait until the status screen indicates that refresh is complete and try the command again. The status screen should indicate that shadowing is on. If some event such as a major alarm on a Packet Interface circuit pack on the standby SPE causes shadowing to turn off, refresh cannot complete and abort code 1350 will be returned when the test packet-interface command is entered.

*Continued on next page*

Table 9-499. TEST #885 Private Looparound Tests — Continued

Error Code	Test Result	Description/ Recommendation
1350	ABORT	<p>The test could not run because memory shadowing has not started.</p> <ol style="list-style-type: none"> <li>1. Enter <b>status spe</b> and verify that shadowing has not started. The SPE is locked when both SPE-SELECT switches on the two DUPINT circuit packs are set to the position of the active SPE. Return the switches to the neutral position. If the SPE is not locked, verify that there are no alarms active for the standby SPE. If there are, enter "display alarms" and verify that there are no major alarms against the standby Packet Interface circuit packs. If there are, clear those alarms first.</li> </ol>
2000	ABORT	<p>Response to the test request was not received within the allowable time period. If the system is equipped with the High Reliability or Critical Reliability Configuration and if the Packet Interface circuit pack is on the standby SPE, this abort code may indicate that the standby SPE is not responding to the handshake message. If this is the case, the standby SPE maintenance software may take up to two minutes to indicate that handshake communication with the standby SPE is down. The ABORT code will then change to 1339 (standby SPE unavailable).</p> <ol style="list-style-type: none"> <li>1. Retry the command at 1-minute intervals, a maximum of 3 times.</li> </ol>
2500	ABORT	<p>Internal system error</p> <ol style="list-style-type: none"> <li>1. Retry the command.</li> </ol>
	NO BOARD	<p>The Packet Interface circuit pack is administered but it is not detected as being physically present.</p> <ol style="list-style-type: none"> <li>1. If the Packet Interface circuit pack is present, replace it.</li> <li>2. If the Packet Interface circuit pack is not physically present, use the <b>display system-parameters maintenance</b> command to check if the Packet Interface circuit pack is administered as being present. If it is administered, use the <b>change system-parameters maintenance</b> command to change the Packet Interface circuit packs administered to be those actually present.</li> </ol>
1	FAIL	<p>The Private Link Broadcast looparound test failed. The circuit pack will enter a fatal fault state when this occurs and the Packet Interface Maintenance software should put the circuit in a out-of-service state. Therefore by the time further action is taken, it is expected that the test will abort with ABORT code 1137 and a demand reset should be used to test the circuit pack.</p> <ol style="list-style-type: none"> <li>1. Reset the circuit pack using the <b>reset packet-interface CS</b> command. Refer to the repair procedures for the Packet Interface Reset Test (#889) for further action.</li> <li>2. If the test continues to fail, replace the Packet Interface circuit pack.</li> </ol>

Continued on next page



Table 9-499. TEST #885 Private Looparound Tests — Continued

Error Code	Test Result	Description/ Recommendation
2	FAIL	<p>The Private Level 2 looparound test failed. The circuit pack will enter a fatal fault state when this occurs and the Packet Interface Maintenance software should put the circuit in a out-of-service state. Therefore by the time further action is taken, it is expected that the test will abort with ABORT code 1137 and a demand reset should be used to test the circuit pack.</p> <ol style="list-style-type: none"> <li>1. Reset the circuit pack using the <b>reset packet-interace CS</b> command. Refer to the repair procedures for the Packet Interface Reset Test (#889) for further action.</li> <li>2. If the test continues to fail, replace the Packet Interface circuit pack.</li> </ol>
3	FAIL	<p>The Private Link Level 3 looparound test failed. The circuit pack may still be operational.</p> <ol style="list-style-type: none"> <li>1. Retry the command.</li> <li>2. If the test continues to fail with the same error code:                         <ol style="list-style-type: none"> <li>a. If the system is not equipped with the High Reliability or Critical Reliability Configuration replace the Packet Interface circuit pack.</li> <li>b. If the system is equipped with the High Reliability or Critical Reliability Configuration and if the Packet Interface circuit pack is on the standby SPE, replace the circuit pack on the standby SPE.</li> <li>c. If the system is equipped with the High Reliability or Critical Reliability Configuration and if the Packet Interface circuit pack is on the active SPE,</li> </ol> </li> <li>3. Perform a planned SPE interchange by entering the command <b>reset system interchange</b>. Use the <b>status spe</b> command to determine when refresh is complete (between 2 to 10 minutes, depending on system size) and retry the test command.</li> <li>4. If the test of the circuit pack on the standby SPE continues to fail, replace that circuit pack.</li> </ol>
	PASS	<p>All the private looparound tests passed. The circuit pack is functioning properly. If the system is still unable to place calls on cabinets other than the SPE cabinet, then:</p> <ol style="list-style-type: none"> <li>1. Display the error log using the command <b>display errors</b> and check for errors on the Packet Bus and Maintenance/Test circuit pack. Clear those errors first.</li> <li>2. Check all other circuit packs connected to the Packet Bus in the same cabinet. Packet Bus failures are likely to be caused by a faulty circuit pack connected to the backplane or bent pins on the back plane. Refer to the PKT-BUS maintenance documentation for repair procedures.</li> </ol>

## Maintenance Looparound Test (#886)

This test checks whether the Packet Interface circuit pack can send and receive data correctly. It establishes a LAPD link from a Packet Interface circuit pack back to the same Packet Interface circuit pack and transmits and receives test data over that testing link. While timing signals from the Packet Bus are used for the data transfer, the data itself is looped around on the circuit pack at the interface to the Packet Bus and does not get sent over the Packet Bus.

### ⇒ NOTE:

This test is not run if the Packet Interface circuit pack is on a standby SPE in a system equipped with duplicated SPEs. However, a failure of the Maintenance Looparound test may have caused an SPE interchange which would result in an alarm associated with the looparound failure error code 769 being reported against a Packet Interface circuit pack that is currently on the standby SPE. If that is the case, and if all other Packet Interface tests associated with the **test packet-interface CS long** pass, force the standby SPE to go active by using the SPE-SELECT switches. Then enter the **test packet-interface CS** command to run the Maintenance Looparound test to make sure the problem has been cleared.

Table 9-500. TEST #886 Maintenance Looparound Test

Error Code	Test Result	Description/ Recommendation
1006 1137	ABORT	<p>Packet Interface circuit pack is in the out-of-service state so normal maintenance tests will not run on that circuit pack.</p> <ol style="list-style-type: none"> <li>1. Request a Packet Interface circuit pack reset using the <b>reset packet-interface CS</b> command. Refer to the Packet Interface Reset Test (#889) maintenance documentation for further action.</li> </ol>
1139	ABORT	<p>The Packet Bus is alarmed</p> <ol style="list-style-type: none"> <li>1. Try to retire the alarm associated with the Packet Bus. Refer to the Alarm Log via the <b>display alarms</b> command. Refer to the maintenance documentation for Packet Bus Maintenance for further action.</li> <li>2. Retry the command when the alarm associated with the Packet Bus is retired.</li> </ol>
1335	ABORT	<p>Internal system error. The Packet Interface circuit pack is on the standby SPE and this test is not allowed to execute on a Packet Interface circuit pack on the standby SPE.</p> <ol style="list-style-type: none"> <li>1. If you wish to run this test on the standby Packet Interface, you must first make it active with <b>reset system interchange</b>. Be sure you understand the implications explained in <i>Planned SPE Interchange</i> in <a href="#">Chapter 5, "Alarms, Errors, and Troubleshooting"</a>.</li> </ol>

Continued on next page

**Table 9-500. TEST #886 Maintenance Looparound Test — Continued**

Error Code	Test Result	Description/ Recommendation
1338	ABORT	The test is not allowed to run since a planned SPE interchange is in progress. A planned interchange may be caused by 24 hour scheduled testing. During this time the terminal will be held out of service but it should recover automatically after 3 minutes. <ol style="list-style-type: none"> <li>1. Wait 3 minutes and retry the command.</li> </ol>
1373	ABORT	Could not establish the link loop around link to run this test. <ol style="list-style-type: none"> <li>1. Retry the command at 1-minute intervals, a maximum of 3 times.</li> </ol>
2060	ABORT	Packet link bus went down during maintenance looparound test. <ol style="list-style-type: none"> <li>1. Retry the command at 1-minute intervals, a maximum of 5 times.</li> <li>2. If there are errors associated with the Packet Bus, refer to the maintenance information associated with the Packet Bus.</li> </ol>
2100	ABORT	Could not allocate the necessary system resources to run this test. <ol style="list-style-type: none"> <li>1. Retry the command at 1-minute intervals, a maximum of 5 times.</li> </ol>
2500	ABORT	Internal system error <ol style="list-style-type: none"> <li>1. Retry the command at 1-minute intervals, a maximum of 5 times.</li> </ol>
	NO BOARD	The Packet Interface circuit pack is administered but it is not detected as being physically present. <ol style="list-style-type: none"> <li>1. If the Packet Interface circuit pack is present, replace it.</li> <li>2. If the Packet Interface circuit pack is not physically present, use the <b>display system-parameters maintenance</b> command to check if the Packet Interface circuit pack is administered as being present. If it is administered, use the <b>change system-parameters maintenance</b> command to change the Packet Interface circuit packs administered to be those actually present.</li> </ol>

*Continued on next page*

**Table 9-500. TEST #886 Maintenance Looparound Test — Continued**

Error Code	Test Result	Description/ Recommendation
1-3	FAIL	<p>The test failed. Maintenance was unable to establish a looparound link from the Packet Interface circuit pack back to itself or was unable to receive data that was sent out over one side of the looparound link.</p> <ol style="list-style-type: none"> <li>1. Issue the <b>test packet-interface CS</b> command to retry the test. If the same error code is observed, background maintenance software will automatically attempt to reset the circuit pack and clear the problem.</li> <li>2. Retry the command and if the test fails, replace the circuit pack.</li> <li>3. If the test continues to fail after replacing the circuit pack, run the <b>test packet P long</b> command. If any of the tests fail, the fault may be on the Packet Bus. Refer to the PKT-BUS (Packet Bus) Maintenance documentation for recommended repair procedures.</li> <li>4. If the test continues to fail after the circuit pack is replaced and with no other alarms associated with the Packet Bus or circuit packs connected to the Packet Bus, follow normal escalation procedures.</li> </ol>
	PASS	<p>This test passed. The circuit pack and its interface with the SPE are functioning properly. If the system is unable to place calls on cabinets other than the SPE cabinet, then:</p> <ol style="list-style-type: none"> <li>1. Check for errors on the Packet Bus and Maintenance/Test circuit pack. Solve those errors first.</li> <li>2. Check all other circuit packs connected to the Packet Bus in the same cabinet. Packet Bus failures are likely to be caused by a faulty circuit pack connected to the backplane or bent pins on the back plane.</li> <li>3. Check the Packet Interface circuit pack connections to the Packet Bus.</li> </ol>

### Read and Clear Board Counters (#887)

This test involves sending commands to read on-circuit pack error counters on the Packet Interface circuit pack. It also verifies the message interface between the SPE and the Packet Interface circuit pack.

This test checks different circuit pack counters depending on whether the circuit pack is on the active or standby SPE.

If the Packet Interface circuit pack is on the active SPE, this test reads and clears the Parity Error counter and FIFO Overflow counter. Those counters are not used when a Packet Interface circuit pack is in standby mode.

If the Packet Interface circuit pack is on the standby SPE, this test reads but does not clear a Translation RAM counter. The Translation RAM counter is not cleared

since the number of bad translations RAM locations indicates bad locations that cannot be used. For a Packet Interface Circuit Pack on the active SPE, information about the number of bad Translation location is sent to maintenance software as an in-line error from the circuit pack so it is not necessary to read a counter location.

**Table 9-501. TEST #887 Read and Clear Board Counters**

Error Code	Test Result	Description/ Recommendation
1006 1137	ABORT	Packet Interface circuit pack is in the out-of-service state so normal maintenance tests will not run on that circuit pack.  1. Request a Packet Interface circuit pack reset using the <b>reset packet-interface CS</b> command. Refer to the Packet Interface Reset Test (#889) maintenance documentation for repair procedures.
1338	ABORT	The test is not allowed to run since a planned SPE interchange is in progress. A planned interchange may be caused by 24 hour scheduled testing. During this time the terminal will be held out of service but it should recover automatically after 3 minutes.  1. Wait 3 minutes and retry the command.
1339	ABORT	The test could not run on the standby Packet Interface circuit pack because the standby SPE is unavailable.  1. Refer to the STBY-SPE maintenance documentation for information on why a standby SPE may be unavailable and what repair actions should be taken. The <b>status spe</b> screen should indicate that handshake is down. This may be caused by a variety of reasons such as the setting the SPE-SELECT switches on the DUPINT circuit packs to the position of the active SPE, a failure of the DUPINT circuit pack, or loss of power on the standby SPE, The <i>SPE Selected field</i> on the <b>status spe</b> screen will display <i>spe a</i> or <i>spe b</i> if the SPE-SELECT switches are in the a or b position, respectively.
1347	ABORT	The test could not run because refresh of the standby SPE's memory is not complete.  1. Enter <b>status spe</b> and verify that refresh is not complete. Wait until the status screen indicates that refresh is complete and try the command again. The status screen should indicate that shadowing is on. If some event such as a major alarm on a Packet Interface circuit pack on the standby SPE causes shadowing to turn off, refresh cannot complete and abort code 1350 will be returned when the test packet-interface command is entered.

*Continued on next page*

**Table 9-501. TEST #887 Read and Clear Board Counters — Continued**

Error Code	Test Result	Description/ Recommendation
1350	ABORT	<p>The test could not run because memory shadowing has not started.</p> <ol style="list-style-type: none"> <li>1. Enter <b>status spe</b> and verify that shadowing has not started. The SPE is locked when the SPE-SELECT switches on the DUPINT circuit pack are set to the position of the active SPE. Return the switches to the neutral position. If the SPE is not locked, verify that there are no alarms active for the standby SPE. If there are, enter <b>display alarms</b> and verify that there are no major alarms against the standby Packet Interface circuit packs. If there are, clear those alarms first.</li> </ol>
2000	ABORT	<p>Response to the test request was not received within the allowable time period. If the system is equipped with the High Reliability or Critical Reliability Configuration and if the Packet Interface circuit pack is on the standby SPE, this abort code may indicate that the standby SPE is not responding to the handshake message. If this is the case, the standby SPE maintenance software may take up to two minutes to indicate that handshake communication with the standby SPE is down. The ABORT code will then change to 1339 (standby SPE unavailable).</p> <ol style="list-style-type: none"> <li>1. Retry the command at 1-minute intervals, a maximum of 3 times.</li> </ol>
2500	ABORT	<p>Internal system error</p> <ol style="list-style-type: none"> <li>1. Retry the command.</li> </ol>
NO BOARD	NO BOARD	<p>The Packet Interface circuit pack is administered but it is not detected as being physically present.</p> <ol style="list-style-type: none"> <li>1. If the Packet Interface circuit pack is present, replace it.</li> <li>2. If the Packet Interface circuit pack is not physically present, use the <b>display system-parameters maintenance</b> command to check if the Packet Interface circuit pack is administered as being present. If it is administered, use the <b>change system-parameters maintenance</b> command to change the Packet Interface circuit packs administered to be those actually present.</li> </ol>

*Continued on next page*

Table 9-501. TEST #887 Read and Clear Board Counters — *Continued*

Error Code	Test Result	Description/ Recommendation
256 512 768	FAIL	<p>The Packet Interface circuit pack on the active SPE has an error counter set. The following error codes are possible: 256: Parity error 512: FIFO overflow 768: Parity error and FIFO overflow error</p> <ol style="list-style-type: none"> <li>1. If error code 256 or 768 is reported the Packet Interface circuit pack received a parity error off the Packet Bus.                             <ol style="list-style-type: none"> <li>a. First check for alarms logged against the Packet Bus. Refer to the PKT-BUS maintenance documentation to clear those errors first.</li> <li>b. Then check for alarms and errors logged against other circuit packs connected to the Packet bus in the Processor Port Network cabinet. A list of packet circuit packs is presented in the first section of this repair procedure. Refer to the repair procedures for those circuit packs, in this manual, to clear those errors first.</li> <li>c. If the system is not equipped with the High Reliability or Critical Reliability Configuration, replace the circuit pack at a time that would cause the least disruption of service. The circuit pack is still functional but should be replaced.</li> <li>d. If the system is equipped with the High Reliability or Critical Reliability Configuration and if the Packet Interface circuit pack is on the standby SPE, replace that circuit pack.</li> <li>e. If the system is equipped with the High Reliability or Critical Reliability Configuration and if the Packet Interface circuit pack is on the active SPE, perform a planned SPE interchange by entering the command <b>reset system interchange</b>. Replace the circuit pack on the standby SPE.</li> </ol> </li> </ol>
256 512 768	FAIL (cont'd.)	<ol style="list-style-type: none"> <li>2. If error code 512 or 768 is reported for a Packet Interface on an <b>active SPE</b>, the receive FIFO in the PKT-INT has overflowed. This may be an indication that additional Packet Interface circuit packs are required. For the current hardware configuration, only one Packet Interface circuit pack is allowed so the problem should be escalated if the repair steps presented below do not correct the problem. Retry the command after a one minute delay and if the test continues to fail:                             <ol style="list-style-type: none"> <li>a. If the system is equipped with the High Reliability or Critical Reliability Configuration and if the Packet Interface circuit pack is on the active SPE, perform a planned SPE interchange by entering the command <b>reset system interchange</b>. Replace the circuit pack</li> <li>b. ) Otherwise, (the system is not equipped with the High Reliability or Critical Reliability Configuration) replace the circuit pack at a time that would cause the least service disruption.</li> </ol> </li> <li>3. If error code 512 or 768 is reported for a Packet Interface on a standby SPE, replace the Packet Interface circuit pack.</li> </ol>

*Continued on next page*

Table 9-501. TEST #887 Read and Clear Board Counters — *Continued*

Error Code	Test Result	Description/ Recommendation
1024-1096	FAIL	<p>The Packet Interface circuit pack on the standby SPE has bad Translation RAM locations. A MINOR alarm is generated when the number of bad locations is from 1 and 4. A MAJOR alarm is generated if the number of bad locations is 5 or more. The MAJOR alarm prevents a planned SPE interchange. (A planned interchange may be administered to occur automatically every 24 hours or it may be requested by using the <b>reset system interchange</b> command.)</p> <ol style="list-style-type: none"><li>1. If a MAJOR alarm is associated with this error, replace the alarmed Packet Interface circuit pack.</li><li>2. If a MINOR alarm is associated with this error, replace the alarmed Packet Interface circuit pack at a time that would cause the least disruption to service.</li></ol>
	PASS	<p>The SPE is able to communicate with the Packet Interface circuit pack. If problems are still reported on the circuit pack, check for failures using the Private Looparound test (#885) and Maintenance Looparound test (#886).</p>

### Active-Standby Peer Link Test (#888)

The Active-Standby Peer Link Test is only run in a system equipped with the High Reliability or Critical Reliability Configuration. It verifies that the Peer Link can be set up between the active and standby SPEs. The Peer Link is a link set up across the Packet Bus between the Packet Interface circuit pack on the active and standby SPEs. It is used for forwarding data and control messages between the active and standby SPE in preparation for a planned SPE interchange. This test not only checks the operation of setting up a Peer Link but it also verifies that the active and standby Packet Interface circuit packs can communicate over the Packet Bus.

This test is run against the standby Packet Interface circuit pack although it checks functionality on both the active and standby Packet Interface Circuit Packs.



**Table 9-502. TEST #888 Active-Standby Peer Link Test**

Error Code	Test Result	Description/ Recommendation
1006 1137	ABORT	Packet Interface circuit pack is in the out-of-service state so normal maintenance tests will not run on that circuit pack. <ol style="list-style-type: none"> <li>1. Request a Packet Interface circuit pack reset using the <b>reset packet-interface CS</b> command. Refer to the Packet Interface Reset Test (#889) repair procedures for further action.</li> </ol>
1139	ABORT	The Packet Bus is alarmed. <ol style="list-style-type: none"> <li>1. Try to retire the alarm associated with the Packet Bus. Refer to the Alarm Log via the <b>display alarms</b> command. Refer to the PKT-BUS Packet Bus maintenance documentation for further action.</li> <li>2. Retry the command when the alarm associated with the Packet Bus is retired.</li> </ol>
1336	ABORT	Internal system error. <ol style="list-style-type: none"> <li>1. If you wish to run this test on the standby Packet Interface, you must first make it active with <b>reset system interchange</b>. Be sure you understand the implications explained in <i>Planned SPE Interchange</i> in <a href="#">Chapter 5, "Alarms, Errors, and Troubleshooting"</a>.</li> </ol>
1337	ABORT	The test is not allowed to run since a PNC (Port Network Connectivity) interchange is in progress. A PNC interchange may be initiated on demand with the use of the <b>reset pnc interchange</b> command or as a result of a recovery action. <ol style="list-style-type: none"> <li>1. Wait 3 minutes and retry the command.</li> </ol>
1338	ABORT	The test is not allowed to run since a planned SPE interchange is in progress. A planned interchange may be caused by 24 hour scheduled testing. During this time the terminal will be held out of service but it should recover automatically after 3 minutes. <ol style="list-style-type: none"> <li>1. Wait 3 minutes and retry the command.</li> </ol>
1339	ABORT	The test could not run on the standby Packet Interface circuit pack because the standby SPE is unavailable. <ol style="list-style-type: none"> <li>1. Refer to the STBY-SPE maintenance documentation for information on why a standby SPE may be unavailable and what repair actions should be taken. The <b>status spe</b> screen should indicate that handshake is down. This may be caused by a variety of reasons such as the setting the SPE-SELECT switches on the DUPINT circuit packs to the position of the active SPE, a failure of the DUPINT circuit pack, or loss of power on the standby SPE. The <i>SPE Selected field</i> on the <b>status spe</b> screen will display <i>spe a</i> or <i>spe b</i> if the SPE-SELECT switches are in the a or b position, respectively.</li> </ol>

*Continued on next page*

Table 9-502. TEST #888 Active-Standby Peer Link Test — Continued

Error Code	Test Result	Description/ Recommendation
1347	ABORT	<p>The test could not run because refresh of the standby SPE's memory is not complete.</p> <ol style="list-style-type: none"><li>1. Enter <b>status spe</b> and verify that refresh is not complete. Wait until the status screen indicates that refresh is complete and try the command again. The status screen should indicate that shadowing is on. If some event such as a major alarm on a Packet Interface circuit pack on the standby SPE causes shadowing to turn off, refresh cannot complete and abort code 1350 will be returned when the test packet-interface command is entered.</li></ol>
1350	ABORT	<p>The test could not run because memory shadowing has not started.</p> <ol style="list-style-type: none"><li>1. Enter <b>status spe</b> and verify that shadowing has not started. The SPE is locked when the SPE-SELECT switches on the DUPINT circuit pack are set to the position of the active SPE. If the SPE is locked, return the switches to the neutral position. If the SPE is not locked, verify that there are no alarms active for the standby SPE. If there are, enter <b>display alarms</b> and verify that there are no major alarms against the standby Packet Interface circuit packs. If there are, clear those alarms first.</li></ol>
2000	ABORT	<p>Response to the test request was not received within the allowable time period. If the system is equipped with the High Reliability or Critical Reliability Configuration and if the Packet Interface circuit pack is on the standby SPE, this abort code may indicate that the standby SPE is not responding to the handshake message. If this is the case, the standby SPE maintenance software may take up to two minutes to indicate that handshake communication with the standby SPE is down. The ABORT code will then change to 1339 (standby SPE unavailable).</p> <ol style="list-style-type: none"><li>1. Retry the command at 1-minute intervals, a maximum of 3 times.</li></ol>
2500	ABORT	<p>Internal system error</p> <ol style="list-style-type: none"><li>1. Retry the command.</li></ol>
	NO BOARD	<p>The Packet Interface circuit pack is administered but it is not detected as being physically present.</p> <ol style="list-style-type: none"><li>1. If the Packet Interface circuit pack is present, replace it.</li><li>2. If the Packet Interface circuit pack is not physically present, use the <b>display system-parameters maintenance</b> command to check if the Packet Interface circuit pack is administered as being present. If it is administered, use the <b>change system-parameters maintenance</b> command to change the Packet Interface circuit packs administered to be those actually present.</li></ol>

Continued on next page

**Table 9-502. TEST #888 Active-Standby Peer Link Test — Continued**

Error Code	Test Result	Description/ Recommendation
1	FAIL	<p>Peer link setup between the active and standby Packet Interface circuit packs failed.</p> <ol style="list-style-type: none"> <li>1. Use the <b>display alarms</b> command to display the active alarms. If there are any errors associated with the Packet Bus, refer to the PKT-BUS maintenance documentation to clear the Packet Bus problems first.</li> <li>2. Retry the test command after a one minute delay.</li> <li>3. If the test continues to fail, replace the Packet Interface circuit pack on the standby SPE.</li> </ol>
1 (cont'd.)	FAIL	<ol style="list-style-type: none"> <li>4. If the test continues to fail:                     <ol style="list-style-type: none"> <li>a. Use the <b>display alarms</b> command to display the active alarms. Verify that there are no alarms on the standby SPE components other than the PKT-INT alarms for the Peer Link failure. If there are other alarms for SPE components, clear those alarms first. Enter the <b>status spe</b> command and verify that refresh is complete. If it is not, refer to the repair procedures for STBY-SPE for further action.</li> <li>b. Initiate an SPE interchange by moving the SPE SELECT switches on the DUPINT circuit packs to the position corresponding to the carrier location of the standby SPE. This will cause an SPE interchange using a WARM restart, assuming refresh is complete. Established calls will not be disconnected.</li> <li>c. Replace the Packet Interface circuit pack on the standby SPE and restore the SPE SELECT switches to their neutral position. (Refer to Replacing SPE Circuit Packs in <a href="#">Chapter 5, "Alarms, Errors, and Troubleshooting"</a> for procedures for replacing circuit packs in a standby SPE carrier.)</li> <li>d. Enter the <b>status SPE</b> command at on minute intervals up to 10 minutes to check for completion of memory refresh.</li> </ol> </li> </ol>

*Continued on next page*

**Table 9-502. TEST #888 Active-Standby Peer Link Test — Continued**

Error Code	Test Result	Description/ Recommendation
2	FAIL	<p>No response from the active Packet Interface circuit pack to a request to the Packet Interface on the active SPE for peer link setup between the active and standby Packet Interface circuit pack.</p> <ol style="list-style-type: none"> <li>1. Retry the test command after a one minute delay.</li> <li>2. If the test continues to fail:                             <ol style="list-style-type: none"> <li>a. Use the <b>display alarms</b> command to display the active alarms. Verify that there are no alarms on the standby SPE components other than the alarm for the Peer Link failure. If there are, clear those alarms first.</li> <li>b. Initiate an SPE interchange by moving the SPE SELECT switches on the DUPINT circuit packs to the position corresponding to the carrier location of the standby SPE. This will cause an SPE interchange using a WARM restart. Established calls will not be disconnected.</li> <li>c. Replace the Packet Interface circuit pack on the standby SPE and restore the SPE SELECT switches to their neutral position. (Refer to Replacing SPE Circuit Packs in <a href="#">Chapter 5, "Alarms, Errors, and Troubleshooting"</a> for procedures for replacing circuit packs in a standby SPE carrier.)</li> <li>d. Enter the <b>status SPE</b> command at on minute intervals up to 10 minutes to wait for memory refresh to complete.</li> </ol> </li> </ol>
	PASS	<p>The SPE is able to communicate with the Packet Interface circuit pack. If problems are still reported on the circuit pack, check for errors on the Private Looparound Tests (#885) and Maintenance Looparound Tests (#886).</p>

### Reset Test (#889)

The reset action initializes the Packet Interface circuit pack and causes the firmware on the Packet Interface circuit pack to run a comprehensive set of diagnostic tests.

The demand reset action will abort if the specified Packet Interface circuit pack is on an active SPE (versus a standby SPE) and if that Packet Interface circuit pack is in the in-service state.

A Packet Interface circuit pack is put in the out-of-service state automatically if it has been reset 3 times by background maintenance within the last 15 minutes, independent of the results of the reset action.

If the system is equipped with the High Reliability or Critical Reliability Configuration and if the Packet Interface circuit pack is on the standby SPE, the

demand reset action will run if handshake is up, independent of the service state of the circuit pack. Shadowing is turned off automatically when a standby PKT-INT is reset. Memory refresh can then take up to 10 minutes to complete.

**Table 9-503. TEST #889 Reset Test**

Error Code	Test Result	Description/ Recommendation
1334	ABORT	<p>The Packet Interface circuit pack command queue is full. This should be a temporary condition caused by a high rate of commands being sent to a Packet Interface circuit pack. Continued operation with a full command queue will cause a system WARM restart that may escalate to more severe restart levels.</p> <ol style="list-style-type: none"> <li>1. Retry the command at 10 second intervals, a maximum of 5 times.</li> </ol>
1338	ABORT	<p>The test is not allowed to run since a planned SPE interchange is in progress. A planned interchange may be caused by 24 hour scheduled testing. During this time the terminal will be held out of service but it should recover automatically after 3 minutes.</p> <ol style="list-style-type: none"> <li>1. Wait 3 minutes and retry the command.</li> </ol>
1339	ABORT	<p>The test could not run on the standby Packet Interface circuit pack because the standby SPE is unavailable.</p> <ol style="list-style-type: none"> <li>1. Refer to "STBY-SPE" for information on why a standby SPE may be unavailable and what repair actions should be taken. The <b>status spe</b> screen should indicate that handshake is down. This may be caused by setting the SPE-SELECT switches on the DUPINT circuit packs to the position of the active SPE, a failure of the DUPINT circuit pack, or loss of power on the standby SPE. The <i>SPE Selected field</i> on the <b>status spe</b> screen will display <i>spe a</i> or <i>spe b</i> if the SPE-SELECT switches are in the a or b position, respectively.</li> </ol>
1347	ABORT	<p>The Packet Interface circuit pack on the standby SPE is in an uninstalled state even though it is physically present. This can be caused by replacing that circuit pack without following the "lock-and-power-down" procedure for replacing SPE circuit packs.</p> <ol style="list-style-type: none"> <li>1. Use the <b>status packet-interface</b> command to determine the service state of the Packet Interface circuit pack. If the state is not "uninstalled", follow normal escalation procedures.</li> <li>2. Remove and restore power to the standby SPE carrier.</li> <li>3. Enter <b>status spe</b> and wait until that screen indicates that memory refresh is complete.</li> <li>4. If refresh does not complete, check the alarm log for alarms against a shadowing-relevant component and follow recommendations for that component.</li> <li>5. If there is an alarm against PKT-INT, replace the Packet Interface circuit pack and retry the command.</li> </ol>

**Table 9-503. TEST #889 Reset Test — Continued**

Error Code	Test Result	Description/ Recommendation
1362	ABORT	<p>The Reset test is not allowed to run because the Packet Interface circuit pack is in service. Resetting a Packet Interface circuit pack that is in-service on an active SPE is not allowed since this is a destructive test (existing phone calls involving telephones connected to Expansion Port Networks would be disconnected).</p> <ol style="list-style-type: none"> <li>1. Use the <b>status packet-interface</b> command to determine the service state of the Packet Interface circuit pack. If the state is "out-of-service", try the Reset command again.</li> </ol>
2000	ABORT	<p>Response to the test request was not received within the allowable time period. If the system is equipped with the High Reliability or Critical Reliability Configuration and if the Packet Interface circuit pack is on the standby SPE, this abort code may indicate that the standby SPE is not responding to the handshake message. If this is the case, the standby SPE maintenance software may take up to two minutes to indicate that handshake communication with the standby SPE is down. The ABORT code will then change to 1339 (standby SPE unavailable).</p> <ol style="list-style-type: none"> <li>1. Retry the command at 1-minute intervals, a maximum of 3 times.</li> </ol>
2500	ABORT	<p>Internal system error</p> <ol style="list-style-type: none"> <li>1. Retry the command.</li> </ol>

*Continued on next page*

Table 9-503. TEST #889 Reset Test — Continued

Error Code	Test Result	Description/ Recommendation
	NO BOARD	<p>The Packet Interface circuit pack is administered but is not detected as being physically present.</p> <ol style="list-style-type: none"> <li>1. If the Packet Interface circuit pack is present, replace it.</li> <li>2. If the Packet Interface circuit pack is not physically present, use the <b>display system-parameters maintenance</b> command to check if the Packet Interface circuit pack is administered as being present. If it is administered, use the <b>change system-parameters maintenance</b> command to change the Packet Interface circuit packs administered to be those actually present.</li> </ol> <p><b>⇒ NOTE:</b>                      If the system is equipped with the High Reliability or Critical Reliability Configuration, the Packet Interface entry on the system-parameters maintenance screen will show "y" if translation data is present for a Packet Interface circuit pack on either the active or standby SPE or if a Packet Interface circuit pack is present on either the active or standby SPE. The corresponding entry on the screen can only be changed from "y" to "n" if a Packet Interface circuit pack is not physically present in the active SPE. However, if the system is restarted with a restart level equal or greater than a WARM restart, the Packet Interface circuit pack maintenance software will automatically detect any Packet Interface circuit pack physically present on the active or standby SPE and the corresponding field on the system-parameters maintenance screen will show a "y."</p>
5001	FAIL	<p>The TDM clock on the Processor Port Network has failed.</p> <ol style="list-style-type: none"> <li>1. Refer to the "TDM-CLK" to clear this failure.</li> </ol>
5002	FAIL	<p>The Packet Bus on the Processor Port Network has failed.</p> <ol style="list-style-type: none"> <li>1. Refer to "PKT-BUS" to clear this failure.</li> </ol>

*Continued on next page*

Table 9-503. TEST #889 Reset Test — Continued

Error Code	Test Result	Description/ Recommendation
Any Other Than Those Listed Above	FAIL	<p>The Packet Interface circuit pack diagnostic tests failed. If the system is equipped with the High Reliability or Critical Reliability Configuration, the reset will run only on demand if the Packet Interface circuit pack is on the standby SPE or if Packet Interface circuit pack is in an out-of-service state on the active SPE (which means an SPE interchange was not allowed because the standby SPE is not healthy). If the latter case is true, also refer to the repair procedures for STBY-SPE for clearing the problem on the standby SPE.</p> <ol style="list-style-type: none"> <li>1. Retry the command <b>reset packet-interface</b></li> <li>2. If the reset fails, replace the circuit pack. (Refer to Replacing SPE Circuit Packs in <a href="#">Chapter 5, "Alarms, Errors, and Troubleshooting"</a> for procedures for replacing circuit packs in a standby SPE carrier.)</li> <li>3. If the Packet Interface circuit pack is on the standby SPE, enter the <b>status SPE</b> command at one minute intervals up to 10 minutes after the circuit pack is replaced to check for completion of memory refresh.</li> </ol>
	PASS	<p>The Packet Interface circuit pack diagnostic software passed. The Packet Interface circuit pack is put back into service automatically. If the Packet Interface on the standby SPE continues to report an in-line fatal fault code (error 257) and as a result goes into the out-of-service state even though the demand reset test passes, the firmware version of the Packet Interface circuit pack on the standby SPE may not be the same as the firmware version of the Packet Interface circuit pack on the active SPE. Use the <b>list configuration control</b> command to determine if the vintage of the Packet Interface circuit packs on the active and standby SPEs is the same.</p>



## PMS-LINK (Property Management System Link)

MO Name (in Alarm Log)	Alarm Level	Initial Command to Run	Full Name of MO
PMS-LINK	MINOR	test pms l	PMS Link
PMS-LINK	WARNING	test pms	PMS Link

Property Management System (PMS) is a stand-alone computer system that environments such as hotels or hospitals use for services such as reservations, registration, messaging, housekeeping, night audit, billing, and inventory. The PMS Link provides a communications channel between the switch and the customer-owned PMS so that the PMS can interrogate the system for information related to the following features:

- Message Waiting Notification
- Controlled Restriction
- Housekeeping Status
- Check-in/Check-out
- Room Change/Room Swap

Refer to *DEFINITY Communications System Generic 3 Feature Description*, 555-230-204, for details of the PMS feature. The PMS device connects to the system via a data module (PDM, MPDM, DTDM) connected to a port on a TN754 Digital Line circuit pack which is administered as a data extension. A PMS device can also be connected through an ADU to a port on TN726B. The PMS link to the processor is via a system port. A system port is comprised of a port on the TN726B Data Line circuit pack and a port on the TN553 Packet Data circuit pack connected to each other in a null-modem fashion. Refer to the PDATA-PT section for information on the system port connectivity.

PMS Link maintenance provides a strategy for maintaining the link between the switch and a PMS device. The strategy includes a set of tests for periodic diagnosis, detection of errors during normal operation, actions for troubleshooting, and raising alarms for serious problems. PMS Link Maintenance uses a “try-and-wait” mechanism for maintaining the PMS Link. If a PMS Link is torn down due to an error, PMS Link Maintenance attempts to bring up the link immediately. If the Link Setup fails, PMS Link Maintenance will wait for five minutes before the next retry. If the number of retries reaches a threshold (12), a Minor alarm is raised for service attention.

PMS Link Maintenance does not cover the maintenance of the elements composing the PMS physical link (the external PMS device, Data Module (PDM/MPDM/DTDM), Digital Line Port of a TN754 Digital Line circuit pack, ADU, or Data Line Port of TN726B Data Line circuit pack). If PMS Link Maintenance

cannot restore the PMS Link, then the maintenance tests of these individual components of the PMS Link must be executed to diagnose faults. If the **test pms-link** command fails, no alarm will be generated.

The **list pms-down** command lists all events that have meaning to the PMS that have occurred while the link between the switch and the PMS was down. For example, any room status codes entered by hotel housekeeping staff during a time of PMS outage would be shown in this report.

## Procedures for Restoring the PMS Link

1. Determine the status of the PMS Link.

Enter **status pms** command and make sure that the PMS Link is not busied out for maintenance. If the link is "down," then continue with the next step.

2. Where does the PMS Link connect?

Enter **display system hospitality** and find out the destinations of the PMS Link.

3. Determine the status of the data extension.

Enter **status data** extension command and verify whether the data extension is in in-service/idle state. If the data extension is NOT available, then look for the extension number in Alt Name field of Hardware Error Log. Refer to the "XXX-BD (Common Port Circuit Pack)" section for resolutions.

4. Is the external PMS device available?

Make sure that the PMS device is ON-LINE and ready for service. Check the physical connectivity between Data Module and the PMS device.

5. If the problem is not found in the above steps, check the system port for any problems. Refer to the PDATA-PT section for description about system port and its connectivity.

When restoring the PMS link it is necessary to execute maintenance test on different objects that comprise the PMS link. It is recommended that you busy out the PMS link before trying to restore the link. When the PMS Link is busied out, all PMS Link maintenance actions are deactivated, and interference with tests of other MOs is prevented.

## Hardware Error Log Entries and Test to Clear Values

Table 9-504. PMS Link Maintenance Error Log Entries

Error Type	Aux Data	Associated Test	Alarm Level	On/Off Board	Test to Clear Value
0 <sup>1</sup>	0	Any	Any	Any	test pms sh r 1
18 (a)	0	busyout pms-link	WARNING	OFF	release pms-link
257 (b)	Any	Link Retry Test (#215)	MINOR/ <sup>2</sup> WARNING	OFF	test pms-link l
513 (c)	Any	None			test pms-link
769 (d)	Any	None			
1025 (e)	40-49	None			
1281 (f)	10-19	None			
1537 (g)	N0-N9	None			
1793 (h)	Any	None			test pms-link
2049 (i)	Any	None			
2305 (j)	50-59	None			release pms-link or test pms-link
2561 (k)	Any	None			test pms-link
2817 (l)	100-109 200-209 300-309	None			
3073 (m)	70-79	None			
3841 (n)	20-29	None			

1. Run the Short Test Sequence first. If all tests pass, run the Long Test Sequence. Refer to the appropriate test description and follow the recommended procedures.
2. Minor alarms on this MO may be downgraded to Warning alarms based on the value used in the **set options** command.

### Notes:

- a. The PMS Link has been busied out with the **busyout pms-link** command. The link is torn down. Enter the **release pms-link** command to restore the link.
- b. The Link Retry Test (#215) fails. An error was detected when setting up the link. Refer to the *Procedures for Restoring the PMS Link* above.
- c. The PMS physical link is down for one of the following reasons:
  - Cable to the PMS device is disconnected.

- The PMS device is powered off.
- The data extension to which the PMS device connects has been busied out.

Check the connectivity of wire and cable among wall jacket, data module, and the PMS device. Enter **status data <extension>** and verify that the data extension of the PMS device is in in-service/idle state. If the data extension is not available, then refer to *Procedures for Restoring the PMS Link* above.

- d. There has been no communication between the switch and the PMS for a period of time specified in “system hospitality” administration. The PMS Link is torn down. To clear this error, refer to *Procedures for Restoring the PMS Link* above.
- e. The link was taken down because the switch could not receive an incoming message from the PMS. The message from the PMS repeatedly had corrupted data or the switch received requests for acknowledgment but never received a message to be processed. If this error type occurs frequently (more than once a month), advise the customer to call the vendor of the PMS to check out the PMS device. Once the PMS Link is successfully established, this error disappears from the Hardware Error Log.
- f. The link was taken down because the switch could not send an outgoing message. The message, which was sent but not acknowledged, was flushed. If this error type occurs frequently (more than once a month), advise the customer to call the vendor of the PMS to check out the PMS device. Once the PMS Link is successfully established, this error disappears from the Hardware Error Log.
- g. The PMS has been busied out for maintenance at the request of the PMS. The PMS Link is torn down. The reason code (N), if present, is that supplied by the PMS in the request message. If this error type recurs frequently (that is, more than once a month), advise the customer to call the vendor of the PMS to check out the PMS device. Once the PMS Link is successfully established, this error disappears from the Hardware Error Log. No alarm is raised against this error.
- h. Due to either heavy call traffic, or the PMS protocol message rate being faster than the PMS/PBX protocol specifications allow, the PMS Link is torn down. PMS Link maintenance software will wait for five minutes before attempting to set up the link again. If this error type occurs frequently (more than once a month), advise the customer to call the vendor of the PMS to check out the PMS device. Once the PMS Link is successfully established, this error disappears from the Hardware Error Log. The PMS should be checked for adherence to message rate defined in the PMS/PBX protocol specifications. No alarm is raised against this error.
- i. The attempt to swap the database between PBX and PMS failed three times consecutively due to excessive PMS/PBX protocol violations, buffer overflows, or PMS Link outages. The PMS Link is NOT torn down. If this error type occurs frequently (more than once a month), advise the

customer to call the vendor of the PMS to check out the PMS device. Once the PMS Link is successfully established, this error disappears from the Hardware Error Log. No alarm is raised against this error.

- j. The PMS Link has been busied out with the **busyout pms-link** command or has been brought down with the **test pms-link long** command. The PMS Link is torn down, and PMS Link maintenance will stop attempting to reestablish the link in the case where the **busyout pms-link** command has been used. When the **test pms-link long** command has been used, PMS Link maintenance will continue to try to reset the link. To restore the PMS Link after use of the **busyout pms-link** command, issue the **release pms-link** command. To restore the PMS Link after use of the **test pms-link long** command, issue the **test pms-link** command.
- k. The PMS Link is physically established, but the protocol has not been started by the PMS before the protocol timer expires. The PMS Link is NOT torn down. If this error type occurs frequently (more than once a month), advise the customer to call the vendor of the PMS to check out the PMS device. Once the PMS Link is successfully established, this error disappears from the Hardware Error Log. The PMS should be checked to make sure that it will attempt to start the protocol according to the PMS/PBX protocol specifications. No alarm is raised against this error.
- l. For Error Type 2817 look for the following AUX data:

10x     The PMS violated the application protocol. The first message after a request to initiate a database exchange was not the start of a database exchange. The message is processed. If this error type with this aux data value occurs frequently (more than once a month), advise the customer to call the vendor of the PMS to check out the PMS device. Once the PMS Link is successfully established, this error disappears from the Hardware Error Log.

20x     The PMS violated the application protocol. The start of a database exchange was received in a state in which it was not expected. The message is ignored. If this error type with this Aux data value occurs frequently (more than once a month), advise the customer to call the vendor of the PMS to check out the PMS device. Once the PMS Link is successfully established, this error disappears from the Hardware Error Log.

30x     The PMS violated the application protocol. The end of a database exchange was received when no exchange was in progress. The message is ignored. If this error type with this Aux Data value occurs frequently (more than once a month), advise the customer to call the vendor of the PMS to check out the PMS device. Once the PMS Link is successfully established, this error disappears from the Hardware Error Log. No alarm is raised against this error.

The PMS should be assessed for adherence to the PMS/PBX protocol specifications.

- m. The link was taken down by the switch because the threshold for application protocol violations has been exceeded by the PMS. The protocol never started and messages were received and/or messages were received in a state in which they were not expected. (Refer to Error Type 2817 for recommended strategy.)
- n. Link was taken down by the switch because the threshold for link protocol violations has been exceeded by the PMS. PMS is sending "garbage" to the switch.

## System Technician-Demanded Tests: Descriptions and Error Codes

---

Always investigate tests in the order presented in the table below. By clearing error codes associated with the *Link Retry Test*, for example, you may also clear errors generated from other tests in the testing sequence.

Order of Investigation	Short Test Sequence	Long Test Sequence	D/ND <sup>1</sup>
Link Tear Down Test (#213)		X	D
Link Retry Test (#215)	X	X	ND

---

1. D = Destructive; ND = Nondestructive

### Link Tear Down Test (#213)

**This test is destructive.**

This test disconnects the existing link between the system and the external PMS device. If the link has been disconnected already, then this test just returns "PASS." All resources allocated for a PMS Link are released after this test.

**Table 9-505. TEST #213 Link Tear Down Test**

Error Code	Test Result	Description/ Recommendation
40 50	ABORT	Internal system error. 1. Retry the command at one-minute intervals a maximum of 5 times.
1010	ABORT	The PMS Link has been busied out and placed in the out-of-service state. 1. Enter <b>release pms-link</b> command to release the PMS Link from busyout state. 2. Retry <b>test pms long</b> command to execute the test.
2012	ABORT	Internal system error. 1. Retry the command at one-minute intervals a maximum of 5 times.
	FAIL	Internal system error. 1. Retry the command at one-minute intervals a maximum of 5 times.
	PASS	The PMS Link is torn down.

### Link Retry Test (#215)

This test sends a message to the PMS software process to make a data call to the extension where the PMS device connects. If the PMS Link is already up, then this test passes without making any data call.

**Table 9-506. TEST #215 Link Retry Test**

Error Code	Test Result	Description/ Recommendation
10 20	ABORT	Internal system error. 1. Retry the command at one-minute intervals a maximum of 5 times.
30	ABORT	Internal system error. 1. Refer back to the "Procedures for Restoring the PMS Link" section for resolution.
1010	ABORT	The PMS Link has been busied out and placed in the out-of-service state. 1. Enter <b>release pms-link</b> command to release the PMS Link from busyout state. 2. Retry <b>test pms</b> command to execute the test.

*Continued on next page*

**Table 9-506. TEST #215 Link Retry Test**

<b>Error Code</b>	<b>Test Result</b>	<b>Description/ Recommendation</b>
2012	ABORT	Internal system error. 1. Retry the command at one-minute intervals a maximum of 5 times.
	FAIL	The PMS Link CANNOT be established. 1. Refer back to the "Procedures for Restoring the PMS Link" section for restoring the PMS Link.
	PASS	The PMS Link is up.



## **PMS-PRNT/JNL-PRNT (PMS Printer Link)**

<b>MO Name (in Alarm Log)</b>	<b>Alarm Level</b>	<b>Initial Command to Run</b>	<b>Full Name of MO</b>
PMS-PRNT/JNL-PRNT	MINOR	test journal [pms-log   wakeup-log]	PMS Printer/ Journal Printer
PMS-PRNT/JNL-PRNT	WARNING	test journal [pms-log   wakeup-log]	PMS Printer/ Journal Printer

A journal printer is a printer to which Emergency Access to Attendant, Wakeup and Property Management System (PMS) events are printed as they occur. The PMS-log printer is used as a backup of the PMS output device to print an audit trail of all PMS transactions and Housekeeping Status Change events when the PMS Printer Link is not available. There may be one or two journal printers. If there is one, all events are printed there. If there are 2, then emergency access, wakeup events, and scheduled reports are printed on one printer (JNL-PRNT), and PMS events are printed at the other (PMS-PRNT).

The scheduled report printer is where summaries of daily wakeup activity and emergency access activity are printed. If the customer requests a summary report, the report will be printed exactly once per day.

The distinction between Journal and Scheduled report printers is logical rather than physical. Whether or not there are two printers, the scheduled reports are always sent to the printer that journals the wakeup and emergency access events. A scheduled report will temporarily suspend the journal activity. Upon completion of the scheduled report, journaling will be resumed after the printing of all the withheld events.

The journal printer device connects to the system via a data module (PDM, MPDM, DTDM) connected to a port on a TN754 Digital Line circuit pack that is administered as a data extension. A journal printer device can also be connected through an ADU to a port on TN726B Data Line circuit pack. The journal printer link to the processor is via a system port. comprised of a port on the TN726B Data Line circuit pack and a port on the TN553 Packet Data circuit pack connected to each other in a null-modem fashion. Refer to the PDATA-PT Maintenance Service Description for information on the system port connectivity.

PMS/JOURNAL Printer Link Maintenance provides a strategy for maintaining the link between the system and a PMS device (an external Journal Printer device). The strategy includes a set of tests for periodic diagnosis, detection of errors during normal operation, actions for troubleshooting, and raising alarms for serious problems. PMS Printer Link Maintenance uses a try-and-wait mechanism. If a PMS Printer Link is torn down due to an error, PMS Printer Link Maintenance will try to bring the link up immediately. If the link setup fails, PMS Link

Maintenance will wait for five minutes before the next trial. If the number of retries reaches a threshold (15), a Minor alarm is raised for service attention.

PMS Printer Link Maintenance does not cover the maintenance of the elements composing the journal printer physical link (for instance, the external printer device, Data Module (PDM/MPDM/DTDM), Digital Line Port or ADU and Data Line Port). If PMS Printer Link maintenance cannot restore the PMS Printer Link, then the maintenance tests of individual components of the PMS Link must be executed to diagnose faults.

The **list pms-down** command lists all events that have meaning to the PMS that have occurred while the link between the switch and the PMS was down. For example, any room status codes entered by hotel housekeeping staff during a time of PMS outage would be reflected in this report.

## Procedures for Restoring the PMS Printer Link

1. Determine the status of the PMS Printer Link.

Enter **status journal-printer wakeup-log|pms-log** and make sure that the journal printer link is not busied out for maintenance. If the link is down, then continue to the next step.

2. Where does the journal printer link connect?

Enter **display system hospitality** and find out the destinations of the PMS Printer Link.

3. Determine the status of the data extension.

Enter **status data extension** command and verify that the data extension is in the in-service/idle state. If the data extension is *not* available, look for the extension number in the Alt Name field of the Hardware Error Log. Refer to "XXX-BD (Common Port Circuit Pack)" for resolutions.

4. Is the external printer device available?

Make sure that the printer device is ON-LINE and ready for service. Check the physical connectivity between Data Module and the printer device.

5. If the problem is not found in the above steps, check the system port for any problems. Refer to "PDATA-PT" for a description of system ports.

It should be noted that when restoring the PMS printer link, it is necessary to execute tests on different maintenance objects that comprise the link; it is recommended that you busy out the PMS printer link before trying to restore the link. If the PMS printer Link is busied out, then all PMS printer Link maintenance actions are deactivated, and interference with tests of other MOs is prevented.

## Error Log Entries and Test to Clear Values

Table 9-507. PMS-PRNT/JNL-PRNT Link Maintenance Error Log Entries

Error Type	Aux Data	Associated Test	Alarm Level	On/Off Board	Test to Clear Value
0 <sup>1</sup>	0	Any	Any	Any	test journal wakeup-log pms-log sh
18 (a)	0	busyout journal wakeup-log/pms-log	WARNING	OFF	release journal wakeup-log pms-log
257 (b)	Any	Link Retry Test(#215)	MINOR <sup>2</sup> WARNING	OFF	test journal wakeup-log pms-log l
513 (c)	Any				test journal wakeup-log pms-log
769 (d)					

1. Run the Short Test Sequence first. If all tests pass, run the Long Test Sequence. Refer to the appropriate test description and follow the recommended procedures. Both PMS Printer and Journal Printer are administered to the same extension, and the printer is not connected. Refer to the *Procedures for Restoring the PMS Printer Link* above for resolution.
2. Minor alarms may be downgraded to Warning alarms based on the value used in the **set options** command.

### Notes:

- a. Craft busied out the Journal Printer Link. The link is torn down. Enter **release** command to restore the link.
- b. Link Retry Test (#215) fails. Physical link cannot be set up, usually because of hardware problems such as power off or cable disconnect. Refer to "Procedures for Restoring the PMS Printer Link" above.
- c. Physical link cannot be set up, usually because of hardware problems such as power off or cable disconnect. The PMS Printer Link physical link is down due to the following causes: cable to the printer device is disconnected, the printer device is powered off, or the data extension where the printer device connects to has been busied out. Check the connectivity of wire and cable among wall jacket, data module, and the printer device. Enter **status data <extension>** and verify that the data extension of the printer device is in the in-service/idle state. If the data extension is not available, then refer to the "Procedures for Restoring the PMS Printer Link" above.
- d. Link idle timer; link comes down. This indicates that the printer device is in an off-line state, for example, paper jam or paper out. Check the printer device and act promptly to put it back to on-line state. Enter **test journal wakeup-log|pms-log** command to set up the printer link.

## System Technician-Demanded Tests: Descriptions and Error Codes

Always investigate tests in the order presented in the table below. By clearing error codes associated with the *Link Retry Test*, for example, you may also clear errors generated from other tests in the testing sequence.

Order of Investigation	Short Test Sequence	Long Test Sequence	D/ND <sup>1</sup>
Link Tear Down Test (#213)		X	D
Link Retry Test (#215)	X	X	ND

1. D = Destructive; ND = Nondestructive

### Link Tear Down Test (#213)

**This test is destructive.**

This test disconnects the existing link between the system and the external printer device. If the link has been disconnected already, this test just returns PASS. All resources allocated for a PMS Printer Link are released after this test.

**Table 9-508. TEST #213 Link Tear Down Test**

Error Code	Test Result	Description/ Recommendation
40	ABORT	Internal system error.
50	ABORT	Internal system error. 1. Retry the command at one-minute intervals a maximum of 5 times.
1010	ABORT	The link has been busied out to out-of-service. 1. Enter <b>release journal wakeup-log pms-log</b> command to release the link from busyout state. 2. Retry <b>test journal wakeup-log pms-log l</b> command to execute the test.
2012	ABORT	Internal system error. 1. Retry the command at one-minute intervals a maximum of 5 times.
	FAIL	Internal System error. 1. Retry the command at one-minute intervals a maximum of 5 times.
	PASS	The link is torn down.

## Link Retry Test (#215)

This test sends a message to the journal printer management software process to make a data call to the extension where the printer device connects to. If the journal printer link is already up, this test passes without making any data call.

**Table 9-509. TEST #215 Link Retry Test**

Error Code	Test Result	Description/ Recommendation
10	ABORT	Internal system error.
20	ABORT	Internal system error. 1. Retry the command at one-minute intervals a maximum of 5 times.
30	ABORT	Internal system error. 1. Refer to the "Procedures for Restoring the PMS Printer Link" section for instructions.
1010	ABORT	The PMS Printer Link has been busied out to out-of-service. 1. Enter <b>release journal wakeup-log pms-log</b> command to release the link from busyout state. 2. Retry <b>test journal wakeup-log pms-log I</b> command to execute the test.
2012	ABORT	Internal system error. 1. Retry the command at one-minute intervals a maximum of 5 times.
	FAIL	The link CANNOT be established. 1. Refer to the "Procedures for Restoring the PMS Printer Link" section for instructions.
	PASS	The link is up.

## **PNC-DUP (PNC Duplication)**

<b>MO Name (in Alarm Log)</b>	<b>Alarm Level</b>	<b>Initial Command to Run</b>	<b>Full Name of MO</b>
PNC-DUP	NA	status pnc	PNC duplication

In systems with the Critical Reliability option, the following components, which together comprise the Port Network Connectivity (PNC), are duplicated:

- Expansion Interface (EI) TN570 circuit packs in the port networks (PNs)
- Switch Node Interface (SNI) TN573 circuit packs in switch nodes
- DS1 Converter (DS1C) TN574 circuit packs for remote EPN connections
- Fiber-optic cables (metallic in certain cases) connecting the above circuit packs
- DS1 facilities between the DS1Cs
- Switch Node Clock (SNC) TN572 circuit packs

Although not part of the PNC, Tone-Clock circuit packs are also duplicated in each PN. The PNC is available in two different configurations: direct connect, in which each port network is connected directly by fiber optic links to each other PN; and Center Stage Switch (CSS) which utilizes one or two switch nodes to interconnect the PNs. All systems have one Processor Port Network (PPN). Direct connect systems can have up to two Expansion Port Networks (EPNs). CSS systems with one switch node can have up to 15 EPNS. CSS systems with two switch node can have up to 21 EPNS. See the following figures.

PNC duplication architecture utilizes an active/standby duplication scheme, in which one complete set of PNC components supports call processing, while the duplicate PNC is held in reserve. All calls on the active PNC are simultaneously set up, or shadowed, on the standby PNC in order for it to be capable of instantly assuming active status when necessary, allowing for interchanges without service disruption (in the case of single faults).

The PNC-DUP maintenance object tracks the health of the active and standby PNCs, controls planned and spontaneous interchanges, and manages related functions such as double call refresh and unrefresh, antithrashing, and so on. The main responsibility of PNC-DUP is to recover the system to full service in the event of a fault. In the event of multiple faults PNC-DUP will do its best to maximize service continuity.

PNC duplication does not introduce any additional types of hardware or hardware faults, and there are no tests associated with the PNC-DUP MO. Instead, it's error log entries are used to log useful information about the occurrence and causes of interchanges in order to facilitate diagnosis of problems which can then be addressed by using the documentation for the individual maintenance object involved.

## PNC-DUP Related Commands

The following commands and their output screens are fully described in [Chapter 8, "Maintenance Commands"](#).

<code>status pnc</code>	This command displays information about the operational status of both PNCs including state of health, alarms, busyouts and locks, and so on.
<code>reset pnc interchange</code>	This command is used to initiate a demand PNC interchange. If the standby is healthy (state of health indexes all zero), there is no effect on service. Otherwise, calls may be dropped.
<code>set pnc</code>	This command is used to lock or unlock the active PNC, preventing interchanges. It does not interfere with double call setup.
<code>busyout pnc</code>	This removes the standby PNC from service. See also the following section on busyout of PNC components.

## Busyouts and PNC-DUP

**Busyout pnc** puts the standby PNC in the busyout state. In this condition:

1. Double call set up is turned off.
2. The standby PNC is unrefreshed; existing duplicate call connections are removed.
3. PNC interchanges are prevented.

Upon release, interchanges are re-enabled and a global refresh of double call setup on the standby is performed.

When PNC duplication is in effect:

- An active PNC component cannot be busied-out.
- A standby PNC component can only be busied-out when the standby PNC is first busied-out.
- The standby PNC cannot be released unless all standby PNC components are released.

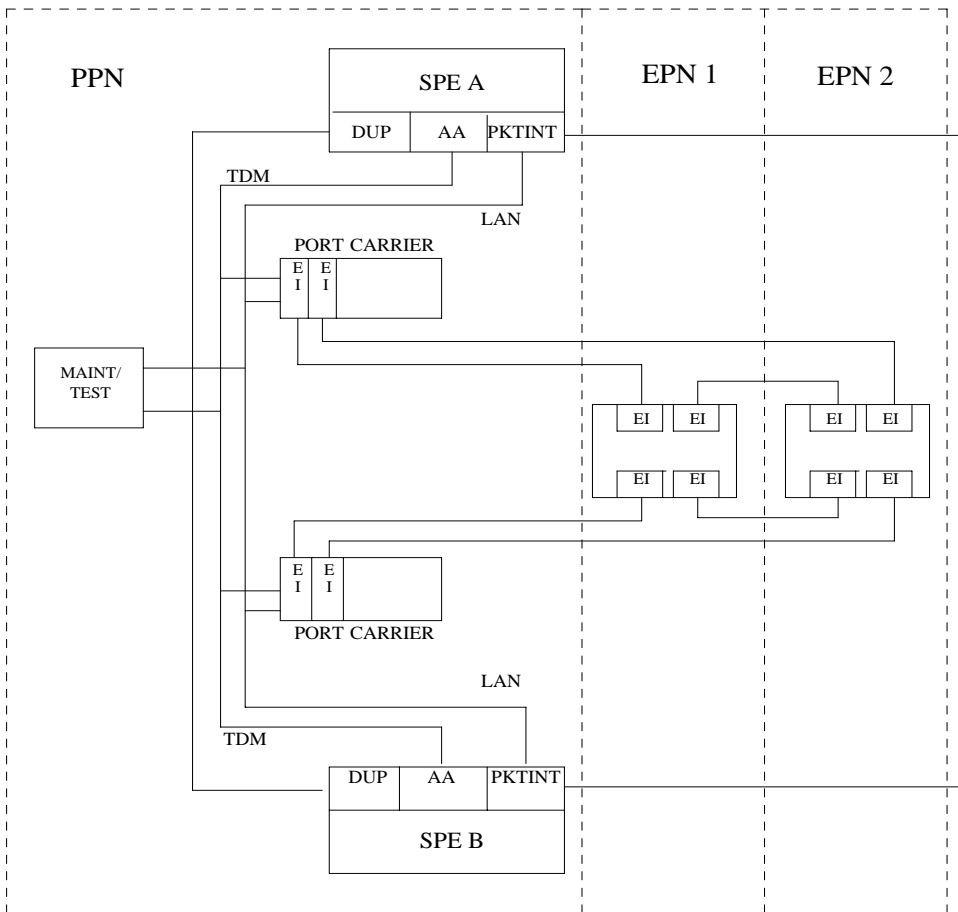

Figure 9-80. Duplicated Direct Connect PNC Connectivity



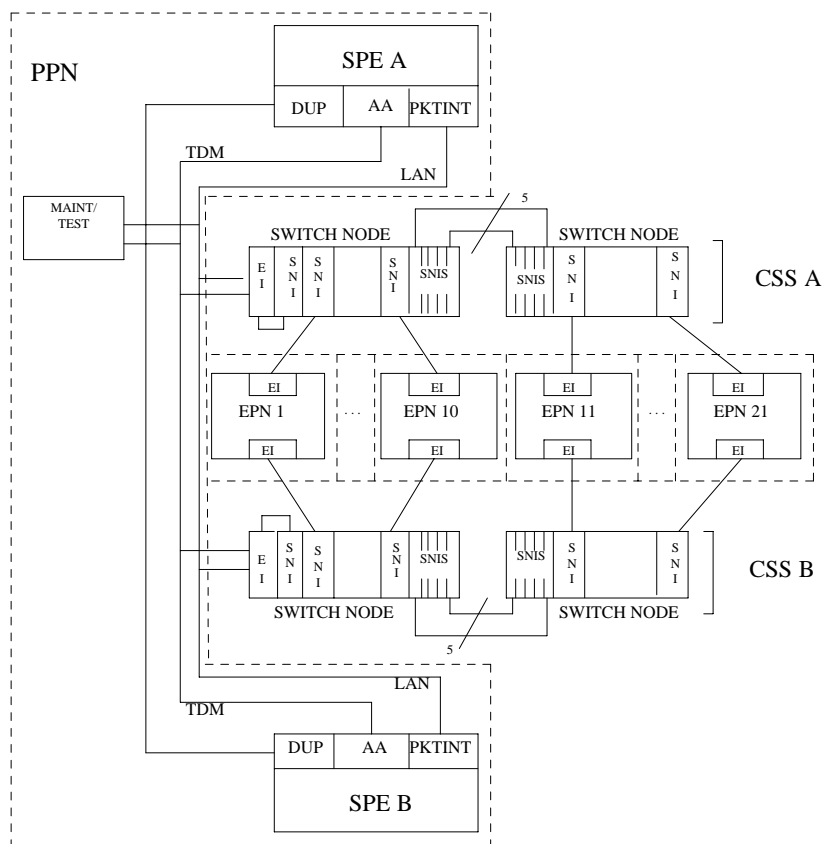

Figure 9-81. Duplicated PNC with Center Stage Switch

## Enabling and Removing PNC Duplication

To enable PNC duplication perform the following sequence of steps:

1. Enable PNC-DUP on the **change system-parameters customer-options** form.
2. Fully administer duplicate fiber link connectivity. Verify by **list fibers**.
3. Trun on PNC-DUP via the **change system-parameters duplication** form. This is note allowed if any component of either PNC (A or B) is busied out.

4. The system must insert all connectivity-related components for both standby and active PNC. For CSS configurations this takes up to 5 minutes depending upon CSS circuit pack insertion. For Direct Connect configurations this is declared complete at 5 minutes after the first appearance of the terminal login prompt.
5. The PNC-DUP initialization anti-thrashing timer must expire (this occurs 5 minutes after completion of board insertion, PNC interchange, or system reset of level 2 or higher).

To disable PNC duplication perform the following sequence of steps:

1. Verify that the A-PNC is active. A forced interchange may be required. See **reset pnc** in [Chapter 8, "Maintenance Commands"](#).
2. Busyout the standby PNC (B-PNC).
3. Turn off the system parameter for PNC-DUP via **change system-parameters duplication**.

After PNC duplication has been removed, configuration audits will generate the alarm shown below and possibly others. To clear this alarm, the B-PNC fibers, circuit packs in switch node carriers ( EIs, SNIs, SNCs, and DS1Cs), and switch node carriers must be removed as outlined in the following steps.

```
01D  SN_CONF  5000  255
```

In this case, 01D is the B-PNC switch node from which duplication was removed.

4. Remove the B-PNC fibers by removing the Endpoint Board Locations on the **change fiber** form for all fibers. For fibers using DS1Cs, remove the B-PNC DS1C Board Locations on page 3 of the **change fiber** form.
5. Remove the B-PNC circuit packs starting with the switch node carrier most distant from the SPE complex. Use **change circuit pack UUC**, page to the B-PNC carrier and remove all of the circuit packs there. Remove all circuit packs in the other B-PNC switch node carriers.

If the Expansion Interface circuit pack associated with the PPN is located in the switch node carrier closest to the SPE, it cannot be removed from translation until it has been busied-out and disconnected from the carrier slot.

When SNI, SNC, or DS1C circuit packs are removed from a B-PNC carrier, any alarms against them should be resolved.

6. Remove the B-PNC switch node carriers. Use **change cabinet UUC** and enter **not-used** for B-PNC carriers.

Any alarm against the carrier such as 01D SN-CONF should be resolved. The B-PNC carriers and associated circuit packs should not be alarmed.

7. Disable PNC duplication on the **change system-parameters customer-options** form by changing "PNC Duplication" to "no."

If an alarm exists against any Expansion Interface circuit pack connected to a B-PNC carrier, attempt to use **test board UUCSS long clear** to clear the alarm.

Alterations to PNC which involve only the *addition* of fiber connectivity can be done with PNC-DUP operational. Alterations requiring the *removal* of fiber connectivity must be done with PNC-DUP removed. PNC-DUP must be removed and translations should be saved before any hardware changes are made.

## Steady State LEDs

---

The LEDs of PNC components in a stable duplicated system should appear as follows:

- The *active* EIs in the EPNs are functioning as archangels. Their LEDs flash in a pattern of 2 seconds on 200 milliseconds off.
- The EPN standby EIs yellow LEDs are off.
- The PPN active EI yellow LED is on solid.
- The PPN standby EI yellow LED is off.
- The SNIs on the active switch node(s) have yellow LEDs on solid.
- The SNIs on the standby switch node(s) have yellow LEDs off.
- Active DS1Cs yellow LEDs are on solid.
- Standby DS1Cs yellow LEDs are off.
- DS1C facility green LEDs are on if the corresponding facility is equipped.

## PNC State of Health

---

PNC-DUP software monitors the health of the two PNCs as determined by their state of health (SOH) vectors, and initiates an interchange when the health of the active falls below that of the standby (unless prevented from doing so by a PNC lock, busyout, or antithrashing mechanism). Potentially service-disrupting faults which occur in PNC components are reported to PNC-DUP and incorporated in the state of health for the affected PNC. The SOHs of both PNCs are displayed on the **status pnc** screen.

status pnc

page 1 of 1

## PORT NETWORK CONNECTIVITY

Duplicated? yes  
Software Locked? no  
Standby Busied? no  
Direct Connect? no  
Standby Refreshed? yes  
Interchange Disabled? no

## A-PNC

Mode: active  
State of Health: functional  
Inter PN Index: 00.00.00.00.00  
Inter SN Index: 00.00  
Major Alarms: 0  
Minor Alarms: 0  
Warning Alarms: 0  
SN Locations: 01E

## B-PNC

Mode: standby  
State of Health: functional  
Inter PN Index: 00.00.00.00.00  
Inter SN Index: 00.00  
Major Alarms: 0  
Minor Alarms: 0  
Warning Alarms: 0  
SN Locations: 01D

**Screen 9-1. Status PNC Screen with Standby PNC Fully In-Service****PNC State of Health Indexes**

The Inter-PN and Inter-SN Indexes form the state of health vector, which is used to track and compare the states of health of both PNCs. The fields making up the indexes are two digit numbers separated by periods (.), with each field representing a different class of faults. The fault class fields are arranged in order of decreasing importance from left to right. In other words, each field in the index supersedes the following fields in determining which PNC is healthiest. A fault class drives an interchange only when all of the higher priority fault classes are equal. A zero entry indicates no faults in that class. Increasing numbers indicate increasingly higher numbers of faults present in that class.

The Inter-PN Index contains five fields (XX.XX.XX.XX.XX), and the Inter-SN Index has two (XX.XX). The Inter-PN Index reports faults in connectivity between port networks and supersedes the Inter-SN Index, which reports faults in connectivity between switch nodes. (The Inter-SN Index is only meaningful for systems with a center stage switch having 2 switch nodes, each of which is duplicated).

The meaning of each fault class field is given in the following table. A zero entry indicates that there are no such faults reported. Higher numbers indicate increasing number of faults. All zeros indicates perfect state of health. Unless the PNCs are locked, the active PNC's state of health should always be equal to or better than the standby's. (Otherwise, the system would perform a spontaneous interchange.)

After a PNC-related alarm is cleared, the system performs a partial refresh of the standby PNC. The corresponding fault class field is not updated to reflect the improved state of health until the refresh is done. The state of health indexes will not agree with the current alarm status during this period.

Inter SN Index: FC\_SNIL s11.s10 FC\_SNIHW

**Table 9-510. PNC State of Health Fault Classes**

Fault Class	Priority	Description	MOs
FC_EAL	1	Number of PNs with EALs down	EXP-PN
FC_INL	2	Number of PNs with LINL, RINL, or EI-SNI neighbor link faults	EXP-PN SN-CONF
FC_HW	3	Number of PNs affected by hardware faults in a link having an EI as an endpoint (Endpoints can be determined with <b>list fiber-link</b> .)	EXP-INTF SN-CONF FIBER-LK SNI-BD DS1C-BD
FC_PER	4	Number of PNs affected by SNI peer link faults for SNIs connected to EIs	SNI-PEER
FC_DS1	5	Number of PNs affected by DS1C facility faults	DS1FAC
FC_SNIL	6	Number of inter-switch-node fibers affected by peer or neighbor link faults	SNI-PEER
FC_SNIHW	7	Number of inter-switch-node fibers affected by hardware faults	SN-CONF SNI-BD FIBER-LK

In multinode CSS configurations FC\_DS1 is considered less critical than FC\_SNIL since DS1C constraints affect only one EPN and indicate restricted bandwidth. However FC\_SNIL can indicate problems for all EPNs on the far end switch node (the one downlink from the PPN). If the DS1C problem is critical (for example, loss of all bandwidth to the affected EPN) a constraint with a higher order fault class will be reported to PNC DUP.

## Resolving Poor State of Health

When the SOHs for both PNCs are not all zeros (perfect health), use the following steps to identify and repair the problem.

1. Look for PNC component alarms (major or minor) for the PNC side whose SOH is not all zero. The standby PNC should be repaired first.
2. Busy-out the standby PNC.

3. Follow the appropriate diagnostic and repair procedures for the alarmed PNC components just as with a simplex PNC. Both the alarm and error logs should be examined to isolate the fault.
4. Verify that the related PNC SOH is restored to all zeros.
5. Release the standby PNC for busy-out.

## Refresh and Unrefresh of the Standby PNC

In a fully functional PNC with healthy standby and active sides, the standby PNC has a complete set of call connections corresponding to those in the active PNC. If, however, the state of health of the standby PNC degrades, a selective unrefresh of those connections which utilize the faulted component(s) is performed. If the health of the standby PNC improves, a selective refresh of connections on the affected route is performed. so that call setup is consistent between the active PNC and the healthy parts of the standby PNC.

The `Standby Refreshed?` field on the **status pnc** screen does *not* refer to the selective type of refresh. It refers only to a global refresh which is performed when:

- The system is initialized and PNC duplication is enabled.
- There has been a spontaneous PNC interchange.
- The standby PNC has been released from busy-out.
- A system reset of level 2 or higher has taken place.

The refreshed field may display `yes` when in fact the standby is partially unrefreshed. An interchange into an incompletely refreshed standby will result in dropped calls. This can happen when a more severe fault occurs on the active PNC, or when **set pnc interchange** is used with the override option.

## PNC Interchanges

PNC spontaneous interchanges occur when PNC duplication software determines that the SOH of the standby PNC is better than that of the active PNC. PNC-DUP executes a spontaneous interchange only when a message from a PNC component maintenance object sends a message indicating that either a fault has occurred on the active PNC, or a fault has been resolved on the standby PNC such that the state of health of the active PNC is now lower than that of the standby.

This message will usually indicate the type and location of the failed connectivity component. A corresponding major or minor alarm is logged by the reporting MO, stimulating an alarm report.

In the less common situation when the resolution of a fault on the standby renders it more healthy than a simultaneously faulted active PNC, the message will indicate the type and location of the *improved* component.

Once the interchange completes, the failed component will be on the standby PNC. A demand interchange can be requested in the presence or absence of standby PNC faults. The following sequence of actions can be observed during a fault-free interchange:

1. The Expansion Interfaces currently acting as archangels in the EPNs are deactivated as indicated by the yellow LEDs going from flashing to on solid.
2. The PPN EIs are interchanged as indicated by the new standby EI yellow LED off and the new active EI yellow LED on solid.
3. One by one the EPN EIs are interchanged as indicated by new standby EI yellow LED turning off and the new active EI yellow LED flashing (2 seconds on, 200 milliseconds off). At this point the interchange is functionally complete.
4. The SNIs yellow LEDs are updated. so that the SNIs on the active SN have yellow LEDs on, while the standby SN's SNIs yellow LEDs turn off.

Certain conditions may interfere with the normal execution of the interchange:

1. In a faulted spontaneous interchange it is possible the EPN/EPNs directly affected by the fault will be the last to interchange.
2. A user directly affected by the single fault instigating a PNC interchange can experience a momentary outage of voice path connectivity during the switch.
3. If faults exist on both the standby and active PNC, it is possible to have some EPNs go out of service while others are returned to service.
4. The new standby SNIs yellow LED may not be off due to a fault in the line of communication path to the standby SNIs. In a multi-fault interchange, LEDs on the new active SNIs may not be on for the same reason.

In any multifault situation, rely on **status pnc** to determine which is the active PNC.

PNC duplication informs Timing Synchronization maintenance when a PNC interchange has been completed and indicates which PNC is active. This will cause Synchronization to audit and insure that the primary source for synchronization of Tone-Clocks in each PN is supplied by a path associated with the active PNC.

## Antithrashing and PNC Interchanges

Following a spontaneous PNC interchange, subsequent PNC interchanges are prevented for 5 minutes. This condition is indicated by a "yes" in the Interchange Disabled? field of the status pnc screen. After 5 minutes, the antithrashing, timer expires, interchange decisions are re-enabled, and the field displays "no." *Should a catastrophic failure occur on the active PNC during the period when "Interchange Disabled?" is set to "yes" there will be no spontaneous PNC interchange.* Demand PNC interchanges also invoke anti-thrashing, but only for a period of 30 seconds. During antithrashing mode, demand interchanges are also prevented unless the override option is specified. Use of this option will cause a service disruption.

## Repairs on the Standby PNC Components

### CAUTION:

*If there is a TDM-CLK alarm, system timing may be routed through part of the standby PNC, and circuit switched data may be affected by the following repair procedures. This can happen, for example, when a slave tone/clock circuit pack experiences a loss of signal and switches to receive timing from the standby EI. In this case TDM-CLK 2305 error will be logged, and the clock problem should be addressed first, if possible.*

To repair PNC components in a duplicated PNC proceed as follows:

1. Most repairs will involve fixing a single fault on the standby PNC. Use **set pnc lock** or **busy-out pnc** to prevent an interchange into the PNC being repaired.
2. If a faulty component exists on the currently active PNC, the standby PNC is more severely faulted. Normally the standby PNC will be fully repaired first since it is the most severely impaired. To repair the active PNC, request an interchange via the **reset pnc interchange override-and-lock** command. The *override-and-lock* option ensures that no subsequent interchange will occur during the repair of the standby PNC. The demand interchange may not be necessary if the following conditions drive a spontaneous interchange:
  - The anti-thrashing period from the last interchange has expired.
  - The global refresh from releasing the standby PNC has completed.

The standby PNC SOH is better than the active.

3. At this point, the faulty component will be on the standby PNC, and the PNCs are locked in their current active/standby state. Busy-out the PNC. Then fault isolation and component testing procedures for the individual PNC components can be used just as for a simplex PNC. Replacement of components will not disrupt operation of the active PNC.



4. Once the failed component is replaced, test the standby PNC component from the terminal to ensure the replacement is functioning properly.
5. When confident that the problem has been resolved, as indicated by a state of health with all zeros, (**status pnc**), unlock and release the pnc. Note that no further PNC interchange is required since you can test the standby PNC as thoroughly as the active.

### Interactions: SPE Resets and PNC Interchanges

- After a system reset 4 (reboot), the A PNC is always the active.
- A system reset of level 1 (warm), 2 (cold2) or 3 (cold1) does not change which PNC is active. If a PNC interchange was in progress when the reset took place, the PNC interchange still goes to completion.
- If a system reset level 1 (warm) takes place during a PNC interchange, the reset is escalated to level 2 (cold2).

### Fault Isolation Using Duplicated PNC

PNC duplication, can, in some cases aid in the isolation of faults. PNC interchanges can be used to help indict the faulty hardware. Following are two examples demonstrating this technique.

- There is a fault which can occur in either the PPN EI or the PKT-INT which cannot be readily attributed to one board or the other. If the packet bus transceivers on either the PKT-INT or EI fail, it will be apparent that the two boards cannot communicate, but it will not be clear which board is at fault. In this case, a planned interchange of the PNC can be used to indict one of the two boards. If the interchange cures the problem, the EI was at fault. If the interchange does not cure the problem, the PKT-INT is suspect, provided there are no PKT-BUS faults.
- A similar relationship exists for the EPN Archangel (active EI) and certain TDM bus problems. If the EAA is unable to communicate with a port board over the TDM bus, either the EAA has a fault, the port board has a fault, or there is a problem with the TDM bus itself. If TDM bus maintenance tests find no problems with the bus, then it is either the port board or the EAA. It may be simpler to replace the port board than to request a PNC interchange. However, if it is not clear which port board may be at fault, or maintenance is being performed remotely, verify that the EAA is not at fault by executing a PNC interchange. If the interchange solves the problem, then the EAA is faulty. If the problem persists after the interchange, but TDM bus maintenance finds no problem, then the port board is faulty.

## Error Log Entries

Whenever a PNC interchange takes place, an error is logged against PNC-DUP with a code that conveys information about the cause of the interchange and which PNC became active. There are no alarms associated with PNC-DUP errors, but there should be an alarm against the PNC component that drove the interchange. There are no PNC-DUP test sequences, but **status pnc** will provide information regarding the status of the PNCs. The information given in the following tables will help to identify areas of the Alarm Log to be investigated to find the source the problem. .

Error Code	Aux Data
00000 (a)	None
10000 to 10021 (b)	1
10100 to 10121 (c)	<a href="#">1</a>
10200 to 10221 (d)	<a href="#">1</a>
10300 to 10321 (e)	<a href="#">1</a>
10400 to 10421 (f)	<a href="#">1</a>
10601 to 10627 (g)	<a href="#">1</a>
10701 to 10727 (h)	<a href="#">1</a>
11000 to 11021 (i)	<a href="#">1</a>
11100 to 11121 (j)	<a href="#">1</a>
11200 to 11221 (k)	<a href="#">1</a>
11300 to 11321 (l)	<a href="#">1</a>
11400 to 11421 (m)	<a href="#">1</a>
11601 to 11627 (n)	<a href="#">1</a>
11701 to 11727 (o)	<a href="#">1</a>
20000 to 20021 (p)	<a href="#">1</a>
20100 to 20121 (q)	<a href="#">1</a>

Error Code	Aux Data
20200 to 20221 (r)	<a href="#">1</a>
20300 to 20321 (s)	<a href="#">1</a>
20400 to 20421 (t)	<a href="#">1</a>
20601 to 20627 (u)	<a href="#">1</a>
20701 to 20727 (v)	<a href="#">1</a>
21000 to 21021 (w)	<a href="#">1</a>
21100 to 21121 (x)	<a href="#">1</a>
21200 to 21221 (y)	<a href="#">1</a>
21300 to 21321 (z)	<a href="#">1</a>
21400 to 21421 (aa)	<a href="#">1</a>
21601 to 21627 (ab)	<a href="#">1</a>
21701 to 21727 (ac)	<a href="#">1</a>
51000 (ad)	<a href="#">1</a>
52000 (ae)	<a href="#">1</a>
53000 (af)	<a href="#">1</a>
60801 (ag)	<a href="#">1</a>
60800 (ah)	<a href="#">1</a>

- The Aux Data indicates which PNC became active after the PNC interchange: "0" denotes PNC-A; "1" denotes PNC-B.

Error Type	Aux Data	Associated Test	Alarm Level	On/Off Board	Test to Clear Value
18	None	busy PNC-DUP	WARNING	ON	release pnc-dup

### Notes:

- An error took place in generating the error code.

- b. A spontaneous PNC interchange took place in response to the retiring of an alarm on the A-PNC associated with fault class FC\_EAL. Use **status pnc** to look at the state of health indexes for the PNCs, and investigate any associated alarms. Adding 1 to the last two digits of the error code gives the PN number of the port network that reported the retired alarm. (10003 points to port network 4) **List config port-network** gives the cabinet number associated with a port network.
- c. A spontaneous PNC interchange took place in response to the retiring of an alarm on the A-PNC associated with fault class FC\_INL. Use **status pnc** to look at the state of health indexes for the PNCs, and investigate any associated alarms. Adding 1 to the last two digits of the error code gives the PN number of the port network that reported the retired alarm. (10003 points to port network 4) **List config port-network** gives the cabinet number associated with a port network.
- d. A spontaneous PNC interchange took place in response to the retiring of an alarm on the A-PNC associated with fault class FC\_HW. Use **status pnc** to look at the state of health indexes for the PNCs, and investigate any associated alarms. Adding 1 to the last two digits of the error code gives the PN number of the port network that reported the retired alarm. (10203 points to port network 4.) **List config port-network** gives the cabinet number associated with a port network.
- e. A spontaneous PNC interchange took place in response to the retiring of an alarm on the A-PNC associated with fault class FC\_PER. Use **status pnc** to look at the state of health indexes for the PNCs, and investigate any associated alarms. Adding 1 to the last two digits of the error code gives the PN number of the port network that reported the retired alarm. (10303 points to port network 4.) **List config port-network** gives the cabinet number associated with a port network.
- f. A spontaneous PNC interchange took place in response to the retiring of an alarm on the A-PNC associated with fault class FC\_DS1. Use **status pnc** to look at the state of health indexes for the PNCs, and investigate any associated alarms. Adding 1 to the last two digits of the error code gives the PN number of the port network that reported the retired alarm. (10403 points to port network 4.) **List config port-network** gives the cabinet number associated with a port network.
- g. A spontaneous PNC interchange took place in response to the retiring of an alarm on the A-PNC associated with fault class FC\_SNIL. Use **status pnc** to look at the state of health indexes for the PNCs, and investigate any associated alarms. The last two digits of the error code indicate the fiber-link number (01-27) of the fiber that reported the retired alarm. **List fiber-link** gives the location of the fiber.
- h. A spontaneous PNC interchange took place in response to the retiring of an alarm on the A-PNC associated with fault class FC\_SNIHW. Use **status pnc** to look at the state of health indexes for the PNCs, and investigate any associated alarms. The last two digits of the error code indicate the fiber-link number (01-27) of the fiber that reported the retired alarm. **List fiber-link** gives the location of the fiber.

- i. A spontaneous PNC interchange took place in response to the occurrence of a major or minor alarm on the A-PNC associated with fault class FC\_EAL. This indicates that one or more Expansion Archangel Links are down. Investigate any EXP-PN alarms. Adding 1 to the last two digits of the error code gives the PN number of the port network that reported the alarm. (11003 points to port network 4.) **List config port-network** gives the cabinet number associated with a port network.
- j. A spontaneous PNC interchange took place in response to the occurrence of a major or minor alarm on the A-PNC associated with fault class FC\_INL. This indicates that one or more neighbor or indirect neighbor links with an EI as an endpoint have experienced faults. Investigate any alarms against EXP-PN and SN-CONF. Adding 1 to the last two digits of the error code gives the PN number of the port network that reported the alarm. (11103 points to port network 4.) **List config port-network** gives the cabinet number associated with a port network.
- k. A spontaneous PNC interchange took place in response to the occurrence of a major or minor alarm on the A-PNC associated with fault class FC\_HW. This indicates that one or more neighbor or indirect neighbor links with an EI as an endpoint have experienced faults. Investigate any alarms against EXP-PN and SN-CONF. Adding 1 to the last two digits of the error code gives the PN number of the port network that reported the alarm. (11203 points to port network 4.) **List config port-network** gives the cabinet number associated with a port network.
- l. A spontaneous PNC interchange took place in response to the occurrence of a major or minor alarm on the A-PNC associated with fault class FC\_PER. This indicates one or more faults on peer links that connect SNIs to EIs. Investigate any alarms against SNI-PEER. Adding 1 to the last two digits of the error code gives the PN number of the port network that reported the alarm. (11303 points to port network 4.) **List config port-network** gives the cabinet number associated with a port network.
- m. A spontaneous PNC interchange took place in response to the occurrence of a major or minor alarm on the A-PNC associated with fault class FC\_DS1. This indicates faults on one or more DS1C facilities. Investigate any alarms against DS1-FAC. Adding 1 to the last two digits of the error code gives the PN number of the port network that reported the alarm. (11403 points to port network 4.) **List config port-network** gives the cabinet number associated with a port network.
- n. A spontaneous PNC interchange took place in response to the occurrence of a major or minor alarm on the A-PNC associated with fault class FC\_SNIL. This indicates one or more faults on peer or neighbor links between SNIs on different switch nodes. Investigate any alarms against SNI-PEER. The last two digits of the error code indicate the fiber-link number (01-27) of the fiber that reported the retired alarm. **List fiber-link** gives the location of the fiber.
- o. A spontaneous PNC interchange took place in response to the occurrence of a major or minor alarm on the A-PNC associated with fault class FC\_SNIHW. This indicates one or more faults on hardware connecting SNIs on

different switch nodes. Investigate any alarms against SN-CONF, SNI-BD, FIBER-LK. The last two digits of the error code indicate the fiber-link number (01-27) of the fiber that reported the retired alarm. **List fiber-link** gives the location of the fiber.

- p. A spontaneous PNC interchange took place in response to the retiring of an alarm on the B-PNC associated with fault class FC\_EAL. Use **status pnc** to look at the state of health indexes for the PNCs, and investigate any associated alarms. Adding 1 to the last two digits of the error code gives the PN number of the port network that reported the retired alarm. (20003 points to port network 4.) **List config port-network** gives the cabinet number associated with a port network.
- q. A spontaneous PNC interchange took place in response to the retiring of an alarm on the B-PNC associated with fault class FC\_INL. Use **status pnc** to look at the state of health indexes for the PNCs, and investigate any associated alarms. Adding 1 to the last two digits of the error code gives the PN number of the port network that reported the retired alarm. (20103 points to port network 4.) **List config port-network** gives the cabinet number associated with a port network.
- r. A spontaneous PNC interchange took place in response to the retiring of an alarm on the B-PNC associated with fault class FC\_HW. Use **status pnc** to look at the state of health indexes for the PNCs, and investigate any associated alarms. Adding 1 to the last two digits of the error code gives the PN number of the port network that reported the retired alarm. (20203 points to port network 4.) **List config port-network** gives the cabinet number associated with a port network.
- s. A spontaneous PNC interchange took place in response to the retiring of an alarm on the B-PNC associated with fault class FC\_PER. Use **status pnc** to look at the state of health indexes for the PNCs, and investigate any associated alarms. Adding 1 to the last two digits of the error code gives the PN number of the port network that reported the retired alarm. (20303 points to port network 4.) **List config port-network** gives the cabinet number associated with a port network.
- t. A spontaneous PNC interchange took place in response to the retiring of an alarm on the B-PNC associated with fault class FC\_DS1. Use **status pnc** to look at the state of health indexes for the PNCs, and investigate any associated alarms. Adding 1 to the last two digits of the error code gives the PN number of the port network that reported the retired alarm. (20403 points to port network 4.) **List config port-network** gives the cabinet number associated with a port network.
- u. A spontaneous PNC interchange took place in response to the retiring of an alarm on the B-PNC associated with fault class FC\_SNIL. Use **status pnc** to look at the state of health indexes for the PNCs, and investigate any associated alarms. The last two digits of the error code indicate the fiber-link number (01-27) of the fiber that reported the retired alarm. **List fiber-link** gives the location of the fiber.

- v. A spontaneous PNC interchange took place in response to the retiring of an alarm on the B-PNC associated with fault class FC\_SNIHW. Use **status pnc** to look at the state of health indexes for the PNCs, and investigate any associated alarms. The last two digits of the error code indicate the fiber-link number (01-27) of the fiber that reported the retired alarm. **List fiber-link** gives the location of the fiber.
- w. A spontaneous PNC interchange took place in response to the occurrence of a major or minor alarm on the B-PNC associated with fault class FC\_EAL. This indicates that one or more Expansion Archangel Links are down. Investigate any EXP-PN alarms. Adding 1 to the last two digits of the error code gives the PN number of the port network that reported the alarm. (21003 points to port network 4.) **List config port-network** gives the cabinet number associated with a port network.
- x. A spontaneous PNC interchange took place in response to the occurrence of a major or minor alarm on the B-PNC associated with fault class FC\_INL. This indicates that one or more neighbor or indirect neighbor links with an EI as an endpoint have experienced faults. Investigate any alarms against EXP-PN and SN-CONF. Adding 1 to the last two digits of the error code gives the PN number of the port network that reported the alarm. (21103 points to port network 4.) **List config port-network** gives the cabinet number associated with a port network.
- y. A spontaneous PNC interchange took place in response to the occurrence of a major or minor alarm on the B-PNC associated with fault class FC\_HW. This indicates that one or more neighbor or indirect neighbor links with an EI as an endpoint have experienced faults. Investigate any alarms against EXP-PN and SN-CONF. Adding 1 to the last two digits of the error code gives the PN number of the port network that reported the alarm. (21203 points to port network 4.) **List config port-network** gives the cabinet number associated with a port network.
- z. A spontaneous PNC interchange took place in response to the occurrence of a major or minor alarm on the B-PNC associated with fault class FC\_PER. This indicates faults on peer links that connect SNIs to EIs. Investigate any alarms against SNI-PEER. Adding 1 to the last two digits of the error code gives the PN number of the port network that reported the alarm. (21303 points to port network 4.) **List config port-network** gives the cabinet number associated with a port network.
- aa. A spontaneous PNC interchange took place in response to the occurrence of a major or minor alarm on the B-PNC associated with fault class FC\_DS1. This indicates faults on one or more DS1C facilities. Investigate any alarms against DS1-FAC. Adding 1 to the last two digits of the error code gives the PN number of the port network that reported the alarm. (21403 points to port network 4.) **List config port-network** gives the cabinet number associated with a port network.
- ab. A spontaneous PNC interchange took place in response to the occurrence of a major or minor alarm on the B-PNC associated with fault class FC\_SNIL. This indicates faults on peer or neighbor links between SNIs on

- different switch nodes. Investigate any alarms against SNI-PEER. The last two digits of the error code indicate the fiber-link number (01-27) of the fiber that reported the alarm. **List fiber-link** gives the location of the fiber.
- ac. A spontaneous PNC interchange took place in response to the occurrence of a major or minor alarm on the B-PNC associated with fault class FC\_SNIHW. This indicates faults on hardware connecting SNIs on different switch nodes. Investigate any alarms against SN-CONF, SNI-BD, FIBER-LK. The last two digits of the error code indicate the fiber-link number (01-27) of the fiber that reported the alarm. **List fiber-link** gives the location of the fiber.
  - ad. A spontaneous PNC interchange took place upon the expiration of the anti-thrashing timer.
  - ae. A spontaneous PNC interchange took place upon the unlocking of the PNCs with the **set pnc unlock** command.
  - af. A spontaneous PNC interchange took place upon the completion of a global refresh of the standby.
  - ag. A demand interchange was executed with the **reset pnc interchange** command.
  - ah. A demand interchange was executed with the **reset pnc interchange** command using the **override-and-lock** option.



## POWER

---

### Battery and Charger for AC-Powered Systems

---

MO Name (in Alarm Log)	Alarm Level	Initial Command to Run <sup>1</sup>	Full Name of MO
POWER	MINOR	test environment UU	Battery and Battery Charger

1. UU is the cabinet number indicated in the PORT field from the Alarm or Error Log.

DEFINITY Systems support two different cabinet types: multicarrier and single carrier. Single carrier cabinets are used only for EPNs. Both cabinet types may be powered by either AC or DC external power source. Environmental maintenance differs according to cabinet type and external power supply.

AC-powered Multi-Carrier Cabinets can be equipped with rechargeable batteries that provide backup power during short power outages. Battery backup is optional on cabinets powered by an Uninterruptible Power Supply (UPS), and is required on those that are not. DC-powered cabinets and single-carrier cabinets do not have battery backup, and this MO is not valid for those cabinets.

The battery backup for the J58890CH unit consists of one battery assembly and charger. The battery backup for the J58890CE unit consists of three 48V batteries and a battery charger. Each cabinet so equipped has its own independent battery backup unit. When power to the cabinet is interrupted, a warning alarm is logged against AC-POWER and the system draws power from the backup batteries. This is known as Nominal Power Holdover (NPH). If power is restored before the NPH time expires, the alarm is resolved. If power does not return, error logs are saved to the Mass Storage System. The nominal power holdover provided is as follows:

**PPN Cabinet:**

All carriers	10 seconds
Simplex control carrier	10 minutes
Duplicated control carriers	5 minutes

**EPN cabinet:**

All carriers	15 seconds
Expansion control carrier	10 minutes

When AC power is restored after an outage, the battery charger fully recharges the batteries within 30 hours.

In a multi-carrier cabinet system, the Battery & Battery Charger maintenance object represents the battery charger and the battery which are located in the



lower left corner of the cabinet. Should anything go wrong with the battery or charger, they must be replaced using the procedure described in the “Replacing the Battery and Battery Charger” section below. The system will detect one of the following three problems with the batteries or charger:

- Reserve Fault: the charger has detected a problem within itself or the batteries and has notified the system.
- High Charge Rate: the batteries have been charging at a high charge rate for an excessively long period of time. This indicates that there is a short in the batteries or the charger.
- Prepare to Disconnect (Low Battery): the batteries are in danger of being drained to a point where the batteries would be damaged. This warning often occurs after multiple power failures.

The batteries take 30 hours to fully charge after being drained. A fully charged battery pack should bridge two power failures without causing a low battery warning to occur.

## Replacing the Battery and Battery Charger (J58890CE)

1. Move the power switch on the battery charger to OFF.



### **WARNING:**

*Always turn off the battery charger before replacing the batteries.  
Failure to do so will result in damage to the 397C battery charger.*

2. Disconnect the cord from the outlet on the front of the battery charger.
3. Remove the screw at the top left of the cover and open the cover to access the charger.
4. Check the battery voltages at the test points. Check all 3 batteries wired in series (the voltage should be 144 volts, 3 X 48 volts = 144 volts) .



### **NOTE:**

An ordinary voltmeter can be used to check battery voltages at the test points, but it may not produce valid results. If the battery voltage readings are below 48 volts (the voltages at test points should read 144 volts, 3 x 48 volts = 144 volts), the battery is probably defective. However, a normal voltage reading does not necessarily mean the battery is good; under load, a defective battery with a normal reading on the voltmeter may discharge rapidly.

5. Check the battery dates and the preventive maintenance log. Replace the batteries if they are more than 2.5 years-old.

**⇒ NOTE:**

If any defective batteries are found, replace all of them. Batteries are ordered in sets of three and should be replaced as such.

6. If no defective batteries are found, replace the entire charger.
7. Close the cover and secure it with the screw.
8. Reconnect the cord and move the power switch to ON.

### Replacing the Battery Assembly (J58890CH)

The batteries are replaced as an entire assembly.

1. Check the battery voltages at the test points (on the Battery Interface Unit (BIU)).
2. Remove the BIU from the power distribution unit.
3. Disconnect the battery plug from the power distribution unit (J20).
4. Remove the battery assembly from the rear of the cabinet.
5. Install the new battery assembly in the reverse order.
6. Plug the BIU back into the power distribution unit.

### Error Log Entries and Test to Clear Values

**Table 9-511. Battery & Battery Charger Error Log Entries**

Error Type	Aux Data	Associated Test	Alarm Level	On/Off Board	Test to Clear Value
0 <sup>1</sup>	0	Any	Any	Any	test environment UU sh r 1
1	Any	Battery & Battery Charger Query Test (#5) (error code 8)	MINOR	ON	test environment UU s r 1
257	Any	Battery & Battery Charger Query Test (#5) (error code 4)	MINOR	ON	test environment UU s r 1
769	Any	Battery & Battery Charger Query Test (#5) (error code 2)	MINOR	ON	test environment UU s r 1

**Table 9-511. Battery & Battery Charger Error Log Entries — Continued**

Error Type	Aux Data	Associated Test	Alarm Level	On/Off Board	Test to Clear Value
3840(a)	1005 or 1028	Associated Battery & Battery Charger Query Test (#5)			test environment <i>UU s r 1</i>

1. Run the Short Test Sequence first. If all tests pass, run the Long Test Sequence. Refer to the appropriate test description and follow the recommended procedures.

Note:

- a. Check to see if the battery charger is connected. If the cabinet is powered by a UPS, there is no battery backup, and this error can be ignored.

**System Technician-Demanded Tests: Descriptions and Error Codes**

Always investigate tests in the order presented in the table below when inspecting errors in the system. By clearing error codes associated with the *Battery & Battery Charger Query Test*, for example, you may also clear errors generated from other tests in the testing sequence.

**Table 9-512. System Technician-Demanded Tests: POWER**

Order of Investigation	Short Test Sequence	Long Test Sequence	D/ND <sup>1</sup>
Battery & Battery Charger Query Test (#5)	X	X	ND
AC Power Query Test (#78) (a)	X	X	ND
Power Unit Query Test (carrier E) (#127) (b)	X	X	ND
Power Unit Query Test (carrier D) (#127) (b)	X	X	ND
Power Unit Query Test (carrier A) (#127) (b)	X	X	ND
Power Unit Query Test (carrier B) (#127) (b)	X	X	ND
Power Unit Query Test (carrier C) (#127) (b)	X	X	ND
Emergency Transfer Query Test (#124) (c)	X	X	ND
Cabinet Sensors Query Test (#122) (d)	X	X	ND
External Alarm Lead Query Test (#120) (e)	X	X	ND

*Continued on next page*

**Table 9-512. System Technician-Demanded Tests: POWER — Continued**

Order of Investigation	Short Test Sequence	Long Test Sequence	D/ND <sup>1</sup>
Analog Ring Generator Initialization Test (#117) (f)	X	X	ND
Analog Ring Generator Query Test (#118) (f)	X	X	ND

1. D = Destructive, ND = Non-destructive

Notes:

- a. Refer to AC-POWER (AC Power) for a description of this test.
- b. Refer to CARR-POW for a description of this test.
- c. Refer to EMG-XFER (Emergency Transfer) for a description of this test.
- d. Refer to CABINET (Cabinet Sensors) for a description of this test.
- e. Refer to EXT-DEV (External Alarm) for a description of this test.
- f. Refer to RING-GEN (Analog Ring Generator) for a description of this test.

**Battery & Battery Charger Query Test (#5)**

This test queries the SYSAM in the PPN or the EPN Maintenance circuit pack in an EPN for the status of the battery pack and battery charger, and reports the result. During this test, the status LED on the battery charger is lit and extinguished if the status of the battery charger is reported as normal. This event is a result of checking that the battery charger is connected.

**Table 9-513. TEST #5 Battery & Battery Charger Query Test**

Error Code	Test Result	Description/ Recommendation
1000	ABORT	System resources required to run this test are not available. 1. Retry the command at 1-minute intervals a maximum of 5 times.

*Continued on next page*

Table 9-513. TEST #5 Battery & Battery Charger Query Test — *Continued*

Error Code	Test Result	Description/ Recommendation
1005	ABORT	<p>The battery charger is not connected. If the system has a UPS, ignore this error since the batteries and charger are not required.</p> <ol style="list-style-type: none"> <li>The batteries will probably need charging and may be drained if there were power outages. Reconnect the battery charger to allow the batteries to recharge. If test #5 is run before the batteries are completely charged, the test will fail.</li> <li>Wait 24 hours and rerun the test.</li> </ol>
2000	ABORT	<p>Response to the test request was not received within the allowable time period.</p> <ol style="list-style-type: none"> <li>Retry the command at 1-minute intervals a maximum of 5 time.</li> <li>If the test continues to ABORT with error code 2000, check for system powering problems with the A carrier (PPN or EPN). Look for and resolve all AC-POWER and CARR-POW alarms in a multicarrier cabinet system. Then, repeat the test.</li> <li>If the test continues to ABORT with a 2000 error code, check for and resolve all SYSAM errors in a PPN or MAINT (EPN Maintenance circuit pack) errors in an EPN. Then, repeat the test.</li> </ol>
2029 2319 2320 2500	ABORT	<p>Internal system error</p> <ol style="list-style-type: none"> <li>Retry the command at 1-minute intervals a maximum of 5 times.</li> </ol>
2	FAIL	<p>The system is in nominal power holdover, and the battery is currently so low that the system will disconnect power very shortly.</p> <ol style="list-style-type: none"> <li>If power returns, then the port carriers in the PPN should power-up again. All the circuit packs should be reinserted, and the system should continue to operate normally. There will probably be a minor alarm against Battery &amp; Battery Charger due to the fact that the batteries are recharging.</li> <li>If power does not return, the system will shut down to prevent damage to the batteries. Restore power, and the system will reboot. <i>No manual intervention is required.</i> 3) Rerun the test. If the test still fails, then the SYSAM in a PPN or the EPN MAINT (Maintenance) circuit pack in an EPN could be reporting this condition incorrectly. Resolve all alarms on these MOs and rerun the test. There are failures that can occur on the SYSAM and EPN Maintenance circuit pack that <i>will not</i> be detected by their respective maintenance, but which will cause many, if not all, environment tests to fail. If many environment tests are failing, the suspect circuit pack, depending on the system configuration, should be replaced and the test rerun.</li> </ol>



*Continued on next page*

**Table 9-513. TEST #5 Battery & Battery Charger Query Test — Continued**

Error Code	Test Result	Description/ Recommendation
4	FAIL	The battery is currently being charged. 1. After 30 hours, the battery should be fully charged, and this error should clear.
		2. If after 30 hours the battery is still in the high charge rate, an alarm will be raised. Display the Error Log with the <b>display errors</b> command and select the category “environ” to display only environment-related errors. Look for POWER errors of type 257. The <i>first occurrence</i> of this error indicates the time when the battery started charging. Use this time as the starting point to determine if the battery has been charging for 30 hours. If the battery has been charging for 30 hours, then replace the battery and battery charger.   <b>CAUTION:</b> <i>Read the section, “Replacing the Battery and Battery Charger” before proceeding. 3) Rerun the test. If the test still fails, then SYSAM in a PPN or the EPN MAINT (Maintenance) circuit pack in an EPN could be reporting this condition incorrectly. There are failures that can occur on the SYSAM and EPN Maintenance circuit pack that will not be detected by their respective maintenance, but which will cause many, if not all, environment tests to fail. If many environment tests are failing, the suspect circuit pack, depending on the system configuration, should be replaced and the test rerun. Resolve all alarms on these MOs, and rerun the test.</i>
6	FAIL	This indicates that error codes 2 and 4 have occurred. Refer to these descriptions. Also, refer to the description for error code 14 for this test.

*Continued on next page*

**Table 9-513. TEST #5 Battery & Battery Charger Query Test — Continued**

Error Code	Test Result	Description/ Recommendation
8	FAIL	<p> <b>NOTE:</b>                      For a Global AC MCC (J58890CH) use the procedures outlined in step 3.</p> <p>There is a reserve power fault. A problem exists with the battery charger or, less likely, the batteries.</p> <ol style="list-style-type: none"> <li>1. Replace the battery charger and the battery. The fault should disappear.</li> </ol> <p> <b>WARNING:</b>  <i>Always turn off the battery charger before replacing the batteries.</i></p> <ol style="list-style-type: none"> <li>2. Rerun the test. If the test still fails, then SYSAM in a PPN or the EPN MAINT (Maintenance) circuit pack in an EPN could be reporting this condition incorrectly. Resolve all alarms on these MOs and rerun the test. There are failures that can occur on the SYSAM and EPN Maintenance circuit pack that <i>will not</i> be detected by their respective maintenance, but which will cause many, if not all, environment tests to fail. If many environment tests are failing, the suspect circuit pack, depending on the system configuration, should be replaced and the test rerun.</li> </ol> <p><i>More information continues.</i></p>
8 (cont'd.)	FAIL (cont'd.)	<ol style="list-style-type: none"> <li>3. Procedures for a Global MCC (J58890CH):                         <ol style="list-style-type: none"> <li>a. Look to see if any “red” LEDs are “on” on any of the rectifier modules or the BIU (Battery Interface Unit) located in the Power Distribution Unit (J58890CH).</li> <li>b. If the BTW (Battery Temp Warning) LED on the BIU is “on” check the batteries for a over temp condition<sup>(a)</sup> if temp is normal<sup>(a)</sup> replace the BIU, If the test still fails replace the battery in a small battery system. For a large battery system escalate the problem.</li> <li>c. If the BNA (Battery Not Available) LED is “on” check the battery connections including connector J20.</li> </ol> </li> </ol>

*Continued on next page*

**Table 9-513. TEST #5 Battery & Battery Charger Query Test — Continued**

Error Code	Test Result	Description/ Recommendation												
		<p>d. If you have an alarm and all LEDs are ok (PWR OK and BOK) on the rectifier modules, and the BIU (Battery Interface Unit), make sure the BIU and the RM0850 rectifiers are seated properly (plugged in). If the BOK LED on the BIU is ok use the following information to check the number of rectifiers serving this cabinet:</p> <table data-bbox="316 476 816 709"> <thead> <tr> <th data-bbox="316 476 551 534">Number of carriers per cabinet</th> <th data-bbox="551 476 816 534">Number of rectifiers per cabinet</th> </tr> </thead> <tbody> <tr> <td data-bbox="316 566 551 587">1</td> <td data-bbox="551 566 816 587">2</td> </tr> <tr> <td data-bbox="316 593 551 614">2</td> <td data-bbox="551 593 816 614">3</td> </tr> <tr> <td data-bbox="316 620 551 641">3</td> <td data-bbox="551 620 816 641">3</td> </tr> <tr> <td data-bbox="316 646 551 668">4</td> <td data-bbox="551 646 816 668">4</td> </tr> <tr> <td data-bbox="316 673 551 695">5</td> <td data-bbox="551 673 816 695">4</td> </tr> </tbody> </table> <p>If the number of rectifiers is correct replace the maintenance circuit pack in the EPN or PPN.</p>	Number of carriers per cabinet	Number of rectifiers per cabinet	1	2	2	3	3	3	4	4	5	4
Number of carriers per cabinet	Number of rectifiers per cabinet													
1	2													
2	3													
3	3													
4	4													
5	4													
10	FAIL	Error codes 2 and 8 have occurred. Refer to these descriptions. Also, refer to the description for error code 14 for this test.												
12	FAIL	Error codes 4 and 8 have occurred. Refer to these descriptions. Also, refer to the description for error code 14 for this test.												
14	FAIL	<p>Error codes 2, 4, and 8 have occurred. Refer to these descriptions.</p> <p><b>⇒ NOTE:</b>                      This could also indicate that the detection logic on the SYSAM or EPN MAINT (Maintenance) circuit pack is defective. Such an error will not be detected by the respective maintenance. If many environment tests are failing, replace the suspect circuit pack (depending on system configuration).</p>												
	PASS	The SYSAM in a PPN or the EPN Maintenance circuit pack in an EPN has reported that the status of Battery & Battery Charger is good.												

- a The equipment must be installed in a well-ventilated area. Maximum equipment performance is obtained at an ambient room temperature between 40 and 120 degrees Fahrenheit (4 and 49 degrees Celsius) for short term operation (not more than 72 consecutive hours or 15 days in a year) and up to 110 degrees Fahrenheit (43 degrees Celsius) for continuous operation.



## Battery and Charger for DC-Powered Systems

MO Name (in Alarm Log)	Alarm Level	Initial Command to Run <sup>1</sup>	Full Name of MO
POWER	MINOR	test environment <i>UU</i>	Battery & Battery Charger

1. *UU* is the cabinet number indicated in the PORT field from the Alarm or Error Log.



**NOTE:**

This MO applies to the J58890CE and the J58890CH-1 with large battery holdover.

This MO represents the battery backup unit found in AC-powered multi-carrier cabinets. Because the system does not recognize the type of external power, this MO exists in DC-Powered multi-carrier cabinets but serves no functional purpose. In such cabinets, all POWER tests should always either pass or abort, and no POWER alarms should be raised.

DEFINITY Systems support two different cabinet types: multi-carrier and single-carrier. Single-carrier cabinets are used only for EPNs. Both cabinet types may be powered by either AC or DC external power source. Environmental maintenance differs according to cabinet type and external power supply.

## Error Log Entries and Test to Clear Values

Table 9-514. Battery & Battery Charger Error Log Entries

Error Type	Aux Data	Associated Test	Alarm Level	On/Off Board	Test to Clear Value
0 <sup>1</sup>	0	Any	Any	Any	test environment UU sh r 1
1	Any	Battery & Battery Charger Query Test (#5) (error code 8)	MINOR	ON	test environment UU s r 1
257	Any	Battery & Battery Charge Query Test (#5) (error code 4)	MINOR	ON	test environment UU s r 1
769	Any	Battery & Battery Charger Query Test (#5) (error code 2)	MINOR	ON	test environment UU s r 1
3840(a)	1005 or 1028	Associated Battery & Battery Charger Query Test (#5)			test environment UU s r 1

1. Run the Short Test Sequence first. If all tests pass, run the Long Test Sequence. Refer to the appropriate test description and follow the recommended procedures.

**Note:**

- a. This error occurs is valid only for AC-powered multi-carrier cabinets with battery backup. For DC-powered cabinets, you cannot clear the error and it should be ignored.

### Battery Holdover (Large Batteries)

The large batteries are mounted inside a separate battery cabinet and can supply holdover times of 2 to 8 hours depending on the size of the battery. The batteries are circuit breaker protected and are charged by the J58890CH-1. The batteries also contain a thermal sensor that change the charging voltage depending on the battery temperature.

**System Technician-Demanded Tests: Descriptions  
and Error Codes**

Always investigate tests in the order presented in the table below when inspecting errors in the system. By clearing error codes associated with the *Battery & Battery Charger Query Test*, for example, you may also clear errors generated from other tests in the testing sequence.

Order of Investigation	Short Test Sequence	Long Test Sequence	D/ND*
Battery & Battery Charger Query Test (#5)	X	X	ND
AC Power Query Test (#78) (a)	X	X	ND
Power Unit Query Test (carrier E) (#127) (b)	X	X	ND
Power Unit Query Test (carrier D) (#127) (b)	X	X	ND
Power Unit Query Test (carrier A) (#127) (b)	X	X	ND
Power Unit Query Test (carrier B) (#127) (b)	X	X	ND
Power Unit Query Test (carrier C) (#127) (b)	X	X	ND
Emergency Transfer Query Test (#124) (c)	X	X	ND
Cabinet Sensors Query Test (#122) (d)	X	X	ND
External Alarm Lead Query Test (#120) (e)	X	X	ND
Analog Ring Generator Initialization Test (#117) (f)	X	X	ND
Analog Ring Generator Query Test (#118) (f)	X	X	ND

**Notes:**

- a. Refer to AC-POWER for a description of this test.
- b. Refer to CARR-POW for AC- and DC-Powered Systems section for a description of this test.
- c. Refer to EMG-XFER for a description of this test.
- d. Refer to CABINET for a description of this test.
- e. Refer to EXT-DEV for a description of this test.
- f. Refer to RING-GEN for a description of this test.

**Battery & Battery Charger Query Test (#5)**

This test queries the SYSAM in the PPN or the EPN Maintenance circuit pack in an EPN for the status of the battery pack and battery charger, and reports the result. In a DC-Powered system, this test should never fail. During this test, the status LED on the battery charger is lit and extinguished if the status of the battery charger is reported as normal. This event is a result of checking that the battery charger is connected.

**Table 9-515. TEST #5 Battery & Battery Charger Query Test**

Error Code	Test Result	Description/ Recommendation
1000	ABORT	System resources required to run this test are not available.
1005	ABORT	Battery charger is not connected. DC-powered cabinets do not have battery backup; ignore this error.
2000	ABORT	Response to the test request was not received within the allowable time period.
2028	ABORT	Internal system error prevented the extinguishing of the Battery Charger status LED.  1. Since this test is not relevant for DC-powered systems, an occurrence of this error indicates possible existence of internal system problems.
2029 2319 2320 2500	ABORT	Internal system error  1. Try the command again at 1-minute intervals up to 5 times.
any	FAIL	The SYSAM in a PPN or the EPN Maintenance circuit pack in an EPN is incorrectly reporting a problem with power. If this test fails for a DC-powered cabinet, the circuit pack has a problem. Replace the suspect circuit pack and run the test again.
	PASS	All that can be inferred is that the SYSAM in a PPN or the EPN Maintenance circuit pack in an EPN in an EPN multicarrier cabinet system is working properly for this test.

## PPP-PT (Control LAN Packet/Port)

MO Name (in Alarm Log)	Alarm Level	Initial Command to Run <sup>1</sup>	Full Name of MO
PPP-PT	MAJOR	test port UUCSSpp long	PPP Port Maintenance
PPP-PT	MINOR	test port UUCSSpp long	PPP Port Maintenance
PPP-PT	WARNING	test port UUCSSpp	PPP Port Maintenance

1. *UU* is the universal cabinet number (1 for PPN, 2 - 44 for EPNs). *C* is the carrier designation (A, B, C, D, or E). *SS* is the number of the slot in which the circuit pack resides (01 to 21). *pp* is the two digit port number (01, 02, ...).

The TN799 Control LAN (CLAN) packet port circuit pack provides TCP/IP connection to adjuncts applications such as CMS, Intuity, and DCS Networking. The CLAN circuit pack has 1-10baseT Ethernet connection and up to 16 DS0 physical interfaces for PPP connections. Two integrated modems provide remote PPP connectivity over analog facilities. Multiple CLAN circuit packs (maximum 2 per system) in a system gives additional TCP/IP capacity.

A remote socket control link (RSCL) links the CLAN and the SPE to pass call control and other management information. Since one link serves all the ports on the circuit pack, maintenance of the RSCL is part of the CLAN circuit pack maintenance.

### NOTE:

The CLAN TN799 circuit pack combines the functions of the PGATE and PI circuit packs into one circuit pack. The PGATE or PI can be used with the CLAN to create an X.25 to TCP/IP bridge for adjunct and DCS connectivity.

## Control LAN Congestion Controls

The switch activates congestion controls on CLAN when it detects buffers exceeding the threshold. The switch releases the congestion controls when the CLAN reports that its buffer level has returned to normal levels.

If congestion:	Then the switch:
Persists for a 14-minute interval	Raises MINOR alarm
Exhausts buffers	Raises MINOR alarm
Ceases for 12 minutes	Retires MINOR alarm

## Error Log Entries and Test to Clear Value

Table 9-516. CLAN Port Error Log Entries

Error Type	Aux Data	Associated Test	Alarm Level	On/Off Board	Test to Clear Value
0 <sup>1</sup>	0	Any	Any	Any	test port UUCSSpp s
1 (a)	0	SCOTCH Sync Looparound Test (#1275)	MINOR	ON	test port UUCSSpp l r 3
257 (b)	0	Under-run/Over-run Error	WARNING	OFF	
513 (c)	0	PPP Link Failure	MINOR	OFF	
769 (d)	0	Invalid Frame Error	WARNING	OFF	
1281 (e)	0	Far-end disconnect			
1537, 1538 (f)	See note	Session Status Test (#1286)	MINOR	OFF	
1793-1920 (g)	See note	Socket Failure			
2305-2560 (h)	See note	Session Down error Session #s 1-256			
2561-2816 (h)	See note	Session Down error Session #s 257-512			
3329 (i)	35768	TCP/IP Ping Test (#1281)	WARNING	OFF	
3585 (j)	0-1	TDM Looparound Test (#1285)	MAJOR	ON	test port UUCSSpp l r 3

1. Run the Short Test Sequence first. If all tests pass, run the Long Test Sequence. Refer to the appropriate test description and follow the recommended procedures.

### Notes:

- a. **Error Type 001:** SCOTCH Synchronous Looparound Test (#1275) failed.
  1. Test the port (**test port UUCSSpp long**).
  2. Refer to SCOTCH Synchronous Looparound Test (#1275) repair procedures.
- b. **Error Type 257:** CLAN port detected overrun or underrun condition that may indicate a hardware problem.
  1. Test for hardware problem (**test port UUCSSpp long**).

2. Refer to SCOTCH Synchronous Looparound Test (#1275) repair procedures to verify repair.
  3. Clear the alarm (**test port UUCSSpp long clear**).
- c. **Error Type 513:** PPP link lost end-to-end connectivity.
1. Test for hardware problem (**test port UUCSSpp long**).
  2. Run TDM Looparound Test (#1285) and refer to repair procedures if there is a hardware problem.
- If there is no hardware problem, the switch tries to re-establish PPP link.
- d. **Error Type 769:** Port received an invalid frame, which
- is greater than the maximum length
  - contains CRC errors
  - violates the link level protocol.
1. Test the port (**test port UUCSSpp long**).
  2. Refer to TDM Port Looparound Test (#1285) to verify repair.
  3. Clear the alarm (**test port UUCSSpp long clear**).
- e. **Error Type 1281:** System software received an indication that the far-end has requested a disconnect of a session on this link. This is a log-only error.
- f. **Error Type 1537, 1538:** Some or all port sessions (sockets) are down.

If the switch indicates that:	Then it:
Some of the sessions are down	Raises off-board WARNING
All of the sessions are down	Raises off-board MINOR alarm

- g. **Error Type 1793-1920:** system software received an indication that a socket was closed due to an error. Error Type indicates the application f the application associated with this socket.

Error Type	Application
1794	DCS
1795	AUDIX
1796	CMS
1797	ISDN Gateway

Aux Data indicates the internal application number.

- h. **Error Type 2305-2816:** System software detected a session is down. Aux Data indicates the session number.

- i. **Error Type 3329:** TCP/IP Ping Test failed.

If the switch:	Then it:
Exceeds threshold failure rate	Raises off-board WARNING alarm on circuit pack

- j. **Error Type 3585:** TDM Port Looparound Test (#1285) failed.

1. Test the port (**test port UUCsspp long**).
2. Refer to "[TDM Looparound Test \(#1285\)](#)" repair procedure.

## System Technician-Demanded Tests: Descriptions and Error Codes

Investigate errors in the order they appear in the table below.

**Table 9-517. System Technician-Demanded Tests: CLAN-PT**

Order of Investigation	Short Test Sequence	Long Test Sequence	D/ND <sup>1</sup>
TDM Looparound Test (#1285)		X	D
SCOTCH Synchronous Looparound Test (#1275)		X	D
TCP/IP Ping Test (#1281)	X	X	ND
Session Status Test (#1286)	X	X	ND
PPP Link Status Test (#1279)	X	X	ND

*Continued on next page*

<sup>1</sup> D = Destructive, ND = Non-destructive

### TDM Looparound Test (#1285)

**This test is destructive.**

This test verifies whether the CLAN PPP port can send and receive data on the TDM bus. This test has a tone generator send tones on a timeslot, and it has a



tone receiver receive tones on another timeslot. The tones are looped through the ppp port.

If the received tones:	Then:
Match the tones sent	The test passes
Do not match the tones sent	The test fails

Test failure indicates failure of the

- CLAN (TN799) circuit pack
- TDM Bus
- Tone generator / tone receiver circuit pack

**Table 9-518. TEST #1285 TDM Looparound Test**

Error Code	Test Result	Description/ Recommendation
1000	ABORT	The port is in use. 1. Determine port status ( <b>status clan-port UUCSSpp</b> ). 2. If port is idle, retry the TDM Looparound Test (#1285). 3. If port is not idle, busyout the port ( <b>busyout port UUCSS</b> ).
1002	ABORT	No TDM bus timeslots available for the test. 1. Retry the command at 1-minute intervals, up to 5 times.
1003	ABORT	No more tone receivers idle for use in this test. 1. Retry the command at 1-minute intervals, up to 5 times.
2000	ABORT	Did not receive circuit pack test response within the allowable time period. 1. If this problem persists, reset the circuit pack ( <b>busyout board UUCSS</b> and <b>reset board UUCSS</b> ). 2. If the problem persists, replace the circuit pack.
2012	ABORT	Internal system error. 1. Retry the command at 1-minute intervals, up to 3 times.

*Continued on next page*

**Table 9-518. TEST #1285 TDM Looparound Test — Continued**

Error Code	Test Result	Description/ Recommendation
2100	ABORT	Could not allocate the necessary system resources to run test. 1. Retry the command at 1-minute intervals, up to 5 times.
	FAIL	Received tones do not match transmitted tones. 1. Retry command at 1-minute intervals, up to 3 times. 2. If the problem persists, refer to TDM-BUS, Tone Generator, and Tone Receiver repair procedures. 3. If the problem persists, replace the circuit pack.
	PASS	Port connections across the TDM bus function properly.

### SCOTCH Synchronous Looparound Test (#1275)

**This test is destructive.**

This test verifies the circuit in the datapath of a ppp call. This test fails if the data transmitted on the port does not match the data received in the looparound mode. Failure of this test indicates a port hardware fault on the circuit pack.

**Table 9-519. TEST #1275 SCOTCH Synchronous Looparound Test**

Error Code	Test Result	Description/ Recommendation
1000	ABORT	The port is in use or PPP link is connected. 1. Determine when the port is available for testing ( <b>status clan-port UUCSSpp</b> ). 2. If necessary, busyout the circuit pack ( <b>busyout port UUCSSpp</b> ). 3. Retry the test (#1275) when the port is idle.
1002	ABORT	No TDM bus timeslots available for the test. 1. Retry the command at 1-minute intervals, up to 5 times.
1963	ABORT	Firmware indicates that the port is in use or ppp link is connected. 1. Determine when the port is available for testing ( <b>status clan-port UUCSSpp</b> ). 2. If necessary, busyout the circuit pack ( <b>busyout port UUCSSpp</b> ). 3. Retry the test (#1275) when the port is idle.

*Continued on next page*

**Table 9-519. TEST #1275 SCOTCH Synchronous Looparound Test — Continued**

Error Code	Test Result	Description/ Recommendation
2000	ABORT	Did not receive circuit pack test response within the allowable time period. 1. If this problem persists, reset the circuit pack ( <b>busyout board UUCSS</b> and <b>reset board UUCSS</b> ). 2. If the problem persists, replace the circuit pack.
2012	ABORT	Internal system error. 1. Retry the command at 1-minute intervals, up to 3 times.
2100	ABORT	Could not allocate the necessary system resources to run test. 1. Retry the command at 1-minute intervals, up to 5 times.
	FAIL	CLAN circuit pack detected test failure. 1. If the problem persists, reset the circuit pack ( <b>busyout board UUCSS</b> and <b>reset board UUCSS</b> ). 2. If the problem persists, replace the circuit pack.
	PASS	Port circuitry functioning properly.

**TCP/IP Ping Test (#1281)**

This non-destructive test fails if the endpoint fails to respond. Use this test to check the circuitry in the data path for a peer-to-peer IP layer connection.

**Table 9-520. TEST #1281 TCP/IP Ping Test**

Error Code	Test Result	Description/ Recommendation
1, 2	ABORT	Internal error 1. Retry the command at 1-minute intervals a maximum of 3 times
7	ABORT	Destination unreachable. 1. Verify that at least one destination reachable through this port is up. Once verified, test the port again ( <b>test port UUCSS</b> ) verify that the TCP/IP Ping Test (#1281) passes.

*Continued on next page*

Table 9-520. TEST #1281 TCP/IP Ping Test — Continued

Error Code	Test Result	Description/ Recommendation
1005	ABORT	Test configuration is incorrect. <ol style="list-style-type: none"><li>1. Verify PPP link is in-service (<b>status clan-port UUCSSpp</b> or <b>status link n</b>).</li><li>2. Verify routing table has reachable destinations.</li><li>3. Repeat the test.</li></ol>
1124	ABORT	ppp link is not enabled. <ol style="list-style-type: none"><li>1. Verify that the ppp link is enabled (<b>status port UUCSSpp</b>, <b>status link n</b>, or <b>display data-module</b>).</li><li>2. If the link is not enabled, enable the link (<b>change data-module</b>).</li><li>3. Repeat the test.</li></ol>
1125	ABORT	PPP link not in service. <ol style="list-style-type: none"><li>1. Verify whether ppp link is in service (<b>status port UUCSSpp</b> or <b>status link n</b>).</li><li>2. If the ppp link is not in service, release the link (<b>release link n</b> or <b>release port UUCSSpp</b>).</li><li>3. Repeat the test.</li></ol>
2000	ABORT	Response to the test was not received from the CLAN circuit pack within the allowable time period. <ol style="list-style-type: none"><li>1. If this result occurs repeatedly, attempt to reset the circuit pack if the other ports on the board are not in use (Yellow LED is off). Reset the circuit pack (<b>busyout board UUCSS</b> and <b>reset board UUCSS</b>).</li><li>2. If this result occurs again, replace the circuit pack.</li></ol>
2012	ABORT	Internal system error. <ol style="list-style-type: none"><li>1. Retry the command at 1-minute intervals, up to 3 times.</li></ol>
2100	ABORT	Could not allocate the necessary system resources to run test. <ol style="list-style-type: none"><li>1. Retry the command at 1-minute intervals, up to 5 times.</li></ol>
2500	ABORT	Internal system error. <ol style="list-style-type: none"><li>1. Retry the command at 1-minute intervals, up to 3 times.</li></ol>
1003	FAIL	Ping to the destination failed due to on-board problem. <ol style="list-style-type: none"><li>1. Test the port (<b>test port UUCSSpp</b>) and verify Session Status Test (#1286) result.</li><li>2. If this test indicates that all sessions on the port are down, escalate the problem.</li></ol>

*Continued on next page*

**Table 9-520. TEST #1281 TCP/IP Ping Test — Continued**

Error Code	Test Result	Description/ Recommendation
1007	FAIL	Ping to the destination failed due to the destination down. <ol style="list-style-type: none"> <li>1. Verify that at least one destination reachable through this port is up.</li> <li>2. Once verified, test the port (<b>test port UUCSSpp</b>) and verify TCP/IP Ping Test (#1281) passes.</li> </ol>
	PASS	TCP/IP Ping Test (#1281) is successful.

**Session Status Test (#1286)**

This non-destructive test determines the status of all PPP port sessions. This test queries the system software on port session status.

If the system software indicates that:	Then the switch:
All port sessions are up (ALL UP)	Raises no alarm, or retires alarm
Some port sessions are up (SOME UP)	Raises MINOR alarm
All port sessions are down (ALL DOWN)	Raises MINOR alarm

**Table 9-521. TEST #1286 Session Status Test**

Error Code	Test Result	Description/ Recommendation
1124	ABORT	ppp link is not enabled. <ol style="list-style-type: none"> <li>1. Verify that the ppp link is enabled (<b>status port UUCSSpp, status link n, or display data-module</b>).</li> <li>2. If the link is not enabled, enable the link (<b>change data-module</b>).</li> <li>3. Repeat the test.</li> </ol>
1125	ABORT	PPP link not in service. <ol style="list-style-type: none"> <li>1. Verify whether PPP link is in service (<b>status port UUCSSpp or status link n</b>).</li> <li>2. If the PPP link is not in service, release the link (<b>release link n or release port UUCSSpp</b>).</li> <li>3. Repeat the test.</li> </ol>

**Table 9-521. TEST #1286 Session Status Test — Continued**

Error Code	Test Result	Description/ Recommendation
2000	ABORT	Did not receive circuit pack test response within the allowable time period. <ol style="list-style-type: none"> <li>1. If the problem persists, reset the circuit pack (<b>busyout port UUCSSpp</b> and <b>reset board UUCSS</b>).</li> <li>2. If the problem persists, replace the circuit pack.</li> </ol>
2100	ABORT	Could not locate the necessary system resources to run this test. <ol style="list-style-type: none"> <li>1. Retry the command at 1-minute intervals, up to 5 times.</li> </ol>
2500	ABORT	Internal system error. <ol style="list-style-type: none"> <li>1. Retry the command at 1-minute intervals, up to 3 times.</li> </ol>
1	FAIL	System software indicates at least one PPP link session is down (SOME UP). <ol style="list-style-type: none"> <li>1. Isolate downed sessions (<b>status port UUCSSpp</b> or <b>status link n</b>).</li> </ol> Follow actions based on session information.
2	FAIL	System software indicates all PPP sessions are down (ALL DOWN). <ol style="list-style-type: none"> <li>1. Test the port (<b>test port UUCSSpp</b>) to verify the SCOTCH Synchronous Looparound Test (#1275) result.</li> <li>2. If test passes, wait for system software to indicate ALL UP.</li> </ol>
	PASS	All sessions up.

### PPP Link Status Inquiry Test (#1279)

This non-destructive test determines the state of the PPP link.

If the PPP link is:	Then:
Connected	The test passes
Disconnected	The test fails

**Table 9-522. TEST #1279 PPP Link Status Inquiry Test**

Error Code	Test Result	Description/ Recommendation
1124	ABORT	ppp link is not enabled. 1. Verify that the ppp link is enabled ( <b>status port UUCSSpp, status link n, or display data-module</b> ). 2. If the link is not enabled, enable the link ( <b>change data-module</b> ). 3. Repeat the test.
1125	ABORT	PPP Link is not in service. 1. Verify whether PPP link is in-service ( <b>status port UUCSSpp or status link n</b> ). 2. If the PPP link is not in service, release the link ( <b>release link n or release port UUCSSpp</b> ). 3. Repeat the test.
2100	ABORT	Could not locate the necessary system resources to run this test. 1. Retry the command at 1-minute intervals, up to 5 times.
2500	ABORT	Internal system error. 1. Retry the command at 1-minute intervals, up to 3 times.
	FAIL	PPP link is down. 1. Test the port ( <b>test port UUCSSpp long</b> ) to verify the SCOTCH Synchronous Local Loop Around Test (#1275) result. 2. If the test passes, wait for sessions to come up.
	PASS	PPP link is up.

## **PRI-CDR/SEC-CDR (Call Detail Recording Link)**

<b>MO Name (in Alarm Log)</b>	<b>Alarm Level</b>	<b>Initial Command to Run</b>	<b>Full Name of MO</b>
PRI-CDR/SEC-CDR	MINOR	test cdr primary/secondary l	CDR Link
PRI-CDR/SEC-CDR	WARNING	test cdr primary/secondary	CDR Link

The CDR feature records detailed call information on all incoming and outgoing calls on specified trunk groups and sends this information to a CDR output device. The two physical links can be administered for connecting external CDR output devices to the system. They are identified as the primary CDR (PRI-CDR) link and the secondary CDR (SEC-CDR) link. The CDR device connects to the system via a data module (PDM, MPDM, DTDM) connected to a port on a TN754 Digital Line circuit pack that is administered as a data extension. A CDR device can also be connected through an ADU to a port on TN726B. The CDR link to the processor is via a system port. A system port is comprised of a port on the TN726B Data Line circuit pack and a port on the TN553 Packet Data circuit pack connected to each other in a null-modem fashion. Refer to the PDATA-PT section for information on the system port connectivity. External CDR output devices include:

- 94A Local Storage Unit (LSU)
- TELESEER CDR Unit
- Call Accounting System (CAS)
- Call Detail Recording Unit (CDRU)
- Printer
- Host computer
- Personal computer (PC)
- Customer-provided equipment

CDR Link Maintenance provides a strategy for maintaining the link between the system and an external CDR output device. The strategy includes a set of tests for periodic diagnosis, detection of errors during normal operation, actions for troubleshooting, and raising alarms for serious problems. CDR Link Maintenance uses a try-and-wait mechanism for maintaining the CDR link. If the CDR link is torn down due to an error, CDR Link Maintenance tries to bring the CDR link up. If the Link Setup fails, CDR Link Maintenance will wait for 30 seconds before the next retry. If the number of retries reaches a threshold (two), a Minor alarm is raised for service attention.



CDR Link Maintenance does not cover the maintenance of the elements composing the CDR physical link:

- External CDR output device
- Data Module (PDM/MPDM/DTDM) and Digital Line Port of TN754 Digital Line circuit pack
- ADU and Data Line Port of TN726B Data Line circuit pack

If CDR Link Maintenance cannot restore the CDR link, the maintenance tests of these individual components of the CDR link must be executed to diagnose faults.

## Procedures for Restoring the CDR Link

1. Determine the status of CDR links.  
Enter **status cdr** command and make sure that the CDR links are not busied out for maintenance. If the link is down, then continue to the next step.
2. Where does the CDR link connect to?  
Enter **display system feature** and find out the destinations of CDR links. Continue to the next step.
3. Enter the **status data extension** command and verify whether the data extension is in the in-service/idle state. If the data extension is *not* available, then look for the extension number in the Alt Name field of the Hardware Error Log and refer to "XXX-BD (Common Port Circuit Pack)" for resolutions.
4. Is the external CDR output device available?  
Make sure that the CDR output device is on-line and ready for service. Check the physical connectivity between Data Module and the CDR output device.
5. If the problem is not found in the above steps, check the system port for any problems. Refer to the PDATA-PT section for description about system port and its connectivity.

When restoring the CDR link it is necessary to execute maintenance test on different objects that comprise the CDR link. It is recommended that you busy out the CDR link before trying to restore the link. When the CDR Link is busied out, then all CDR Link maintenance actions are deactivated, and interference to tests of other MOs is prevented.

## Error Log Entries and Test to Clear Values

Table 9-523. CDR Link Maintenance Error Log Entries

Error Type	Aux Data	Associated Test	Alarm Level	On/Off Board	Test to Clear Value
0 <sup>1</sup>	0	Any	Any	Any	test cdr primary secondary sh
18(a)	0	busyout cdr primary secondary	WARNING	OFF	release cdr primary secondary
257(b)	Any	Link Retry Test (#215)	MINOR/ <sup>2</sup> WARNING	OFF	test cdr primary secondary l
513(c)					test cdr primary secondary
1025(d)					
1281(e)	Any				

1. Run the Short Test Sequence first. If all tests pass, run the Long Test Sequence. Refer to the appropriate test description and follow the recommended procedures.
2. Minor alarms may be downgraded to Warning alarms based on the value used in the **set options** command.

### Notes:

- a. The CDR link is busied out. The CDR link is torn down.
- b. Link Retry Test (#215) fails. An error was detected when setting up the link. Refer to the preceding section "Procedures for Restoring the CDR Link" for resolution.
- c. The CDR physical link is down for one of the following reasons:
  - Cable to the CDR output device is disconnected.
  - CDR output device is powered off.
  - The data extension where the CDR output device connects to has been busied out or there is a scheduled daily interchange.

Check the connectivity of wire and cable among wall jacket, data module, and the CDR output device. Enter **status data extension** and verify that the data extension of the CDR output device is in the in-service/idle state. If the data extension is not available, then refer to The preceding section "Procedures for Restoring the CDR Link" for resolution. Issue the **display system-parameters-maintenance** command to see the start time of daily maintenance. If the error occurs and is resolved during of daily maintenance, it can be ignored.

- d. This error indicates that the CDR output device is in an off-line state, (for example, due to paper jam or paper out for a printer device). The CDR link is torn down. Check the CDR output device and act promptly to put it back to on-line state. Enter **test cdr primary|secondary** command to set up the CDR link.
- e. Software detects an overflow of CDR records generated in the switch due to the heavy trunk traffic and low speed CDR output device. If both primary and secondary links are ON, the secondary link is torn down temporarily for two minutes to speed up the output process to the primary link. No action is necessary for this error type.

## System Technician-Demanded Tests: Descriptions and Error Codes

Always investigate tests in the order presented in the table below when inspecting errors in the system. By clearing error codes associated with the *Link Retry Test*, for example, you may also clear errors generated from other tests in the testing sequence.

Order of Investigation	Short Test Sequence	Long Test Sequence	D/ND <sup>1</sup>
Link Tear Down Test (#213)		X	D
Link Retry Test (#215)	X	X	ND

1. D = Destructive; ND = Nondestructive

### Link Tear Down Test (#213)

**This test is destructive.**

This test disconnects the existing link between the system and the external CDR output device. If the link has been disconnected already, this test just returns PASS. All resources allocated for a CDR link are released after this test.

**Table 9-524. TEST #213 Link Tear Down Test**

Error Code	Test Result	Description/ Recommendation
40	ABORT	Internal system error.
50	ABORT	Internal system error. 1. Retry the command at one-minute intervals for a maximum of 5 times.

**Table 9-524. TEST #213 Link Tear Down Test**

Error Code	Test Result	Description/ Recommendation
1010	ABORT	The CDR link has been busied out to out-of-service. 1. Enter the <b>release cdr primary secondary</b> command to release the CDR link from busyout state. 2. Retry the <b>test cdr primary secondary long</b> command to execute the test.
2012	ABORT	Internal system error. 1. Retry the command at one-minute intervals a maximum of 5 times.
	FAIL	Internal system error. 1. Retry the command at one-minute intervals for a maximum of 5 times.
	PASS	The CDR link is torn down.

### Link Retry Test (#215)

This test sends a message to the CDR software process to make a data call to the extension where the CDR output device connects to. If the CDR link is already up, then this test will be passed without making any data call.

**Table 9-525. TEST #215 Link Retry Test**

Error Code	Test Result	Description/ Recommendation
10	ABORT	Internal system error.
20	ABORT	Internal system error. 1. Retry the command at 1-minute intervals for a maximum of 5 times.
30	ABORT	Internal system error. 1. Refer to “Procedures for Restoring the CDR Link” for instructions.
1010	ABORT	The CDR link has been busied out to out-of-service. 1. Enter <b>release cdr primary secondary</b> command to release the CDR link from busyout state. 2. Retry <b>test cdr primary secondary long</b> command to execute the test.

*Continued on next page*

**Table 9-525. TEST #215 Link Retry Test**

<b>Error Code</b>	<b>Test Result</b>	<b>Description/ Recommendation</b>
2012	ABORT	Internal system error. 1. Retry the command at 1-minute intervals a maximum of 5 times.
	FAIL	The CDR link CANNOT be established. 1. Refer to the "Procedures for Restoring the CDR Link" for instructions.
	PASS	The CDR link is up.

## PROC-SAN (Process Sanity Audits)

MO Name (in Alarm Log)	Alarm Level	Initial Command to Run	Full Name of MO
PROC-SAN	none	none	Process Sanity Audits

The Process Sanity Audits maintenance object is responsible for monitoring the sanity of software processes in the system. If the Process Sanity Audits MO detects that a process has gone insane (does not respond to a sanity message within an allotted time period), the process will be restarted. If the Process Sanity Audits MO detects that multiple processes (or a single key process) do not respond to sanity messages within an allotted time period, a system recovery action will be initiated.

The Process Sanity Audits MO has no alarms and no tests. Certain errors are logged to the Hardware Error Log for information purposes only.

### Error Log Entries and Test to Clear Values

**Table 9-526. Process Sanity Audits Error Log Entries**

Error Type	Aux Data	Associated Test	Alarm Level	On/Off Board	Test to Clear Value
0	0	Any	Any	Any	none
10 (a)	0	none	none	none	none
204 (a)	any	none	none	none	none

**Note:**

- a. These errors indicate that a system recovery action has been taken because one or more software processes failed to respond to a sanity audit in a timely fashion. As a result of the recovery action, the system may have temporarily suspended service for a period of time surrounding the error.

## PROCR (RISC Processor Circuit Pack)

MO Name (in Alarm Log)	Alarm Level	Initial Command to Run <sup>1</sup>	Full Name of MO
PROCR	MAJOR <sup>2</sup>	test processor UUC l	RISC Processor Circuit Pack
PROCR	MINOR	test processor UUC s	RISC Processor Circuit Pack

1. UU is the cabinet number (always 1, not required). With simplex SPE, carrier designation is not required. With duplicated SPEs, carrier a or b must be specified.
2. After a spontaneous SPE interchange has occurred, the Alarm Log retains for three hours a record of any MAJOR ON-BOARD alarm against an SPE component that took place before the interchange. If a spontaneous interchange has occurred (as indicated by STBY-SPE error type 103 or the **display initcauses** screen), and handshake is down, (check with **status spe**), replace the alarmed circuit pack on the standby SPE. If handshake is up, execute a **test long clear** of the alarmed circuit pack and follow recommended procedures.

The UN331B Processor circuit pack executes the system software, including all call processing, maintenance and administration functions. The Processor circuit pack is the most critical component for correct system operation.

Full system operation depends on nearly every circuit pack in the SPE. However, the ability to load and run the maintenance software by the Processor circuit pack depends only on correct Memory, Processor Bus, Tape-Disk-MSSNET and SYSAM operation.

There are many Processor circuit pack problems (or other SPE problems) that will result in the SPE being unable to load or run software. This condition is indicated by the message "SPE Down" displayed on the terminal. In these cases, refer to the SPE DOWN section of this manual for repair procedures.

The Processor circuit pack contains an instruction cache and a data cache. These caches provide local, high speed memory that is closely coupled with the processing function on the Processor circuit pack. The local nature of the caches speeds up system operation by eliminating many external Memory accesses when reading instructions or data. As the Processor runs, it tries to use information already in the cache so that time will not be wasted going out to memory. If it does not find the information in the cache, it reads it from memory and stores it in the cache for possible future use. Over time, most instruction or data accesses are likely to be satisfied by current information in the cache. Problems in the cache circuits may stop the Processor from running or may only result in reduced system performance.

The Processor circuit pack contains a Burst Read function that transfers multiple words of instructions from memory with each request. This is done to speed up the transfer of information from the Memory to the Processor, and is especially helpful for "filling up" the cache in parallel with internal processing on Processor circuit pack. Most of the circuitry needed to support this function is found on the

Memory circuit packs, but part of this function is on the Processor as well. Refer to Memory documentation for test information.

The Processor circuit pack contains a Write Buffer function that helps prevent internal processing operations from being held up by Processor Bus activity. If the Processor needs to write to Memory, it writes to the Write Buffer. If the Processor Bus is in use at this time, the information is transferred to Memory at an appropriate time. Up to 12 processor writes can be pending, waiting for transfer to memory.

The Processor Bus contains parity checking functions. If one address or data bit is corrupted during an access cycle, the error detection logic detects and reports this to Processor circuit pack.

The Processor circuit pack contains interrupt and exception signals that tell the Processor when normal or erroneous events occur in SPE components. An example of a normal event is an interrupt that occurs when data provided by an SPE component such as the SYSAM is available for the Processor. An example of an error-indicating exception is detection of a parity error on the Bus when Processor reads Memory. These types of errors result in system recovery actions which are described in [Chapter 4, "Initialization and Recovery"](#).

The Processor circuit pack contains an erasable, programmable read-only memory (BOOTPROM) that contains the system initialization and low-level diagnostic programs. Problems in this hardware may result in difficulties with system start-up, restart, or SPE maintenance testing in general.

If the PBX system is equipped with High Reliability or Critical Reliability option (i.e. with duplicated SPEs), and if a failure of the active Processor circuit pack causes a MAJOR on-board alarm, a SPE interchange will occur if the health of the standby SPE permits the interchange. Refer to Replacing SPE Circuit Packs in Chapter 5 for more information about duplicated SPEs.



## Error Log Entries and Test to Clear Values

Table 9-527. PROCR Error Log Entries

Error Type	Aux Data	Associated Test	Alarm Level	On/Off Board	Test to Clear Value
0 <sup>1</sup>	0	Any	Any	Any	test processor UUC s r 1
1		BOOTPROM Checksum Test (#897)	MAJOR <sup>2</sup>	ON	test processor UUC s r 1
150(a)	Any	None	MAJOR†	ON	test processor UUC l c
257		Parity Checker Test (#899)	MINOR	ON	test processor UUC s r 2
513		Write Buffer Test (#900)	MAJOR†	ON	test processor UUC s r 1
1025		Cache Audit (#896)	MINOR	ON	test processor UUC s r 2
1026(b)		Cache Audit (#896)	MAJOR	ON	test processor UUC s r 2
1281		Cache Test (#895)	MAJOR†	ON	test processor UUC l r 1

1. Run the Short Test Sequence first. If all tests pass, run the Long Test Sequence. Refer to the appropriate test description and follow the recommended procedures.
2. If a spontaneous interchange has occurred (as indicated by STBY-SPE error type 103 or the **display init causes** screen), and handshake is down, (check with **status spe**), replace the alarmed circuit pack on the standby SPE. If handshake is up, execute a **test long clear** of the alarmed circuit pack and follow recommended procedures.

### Notes:

- a. This error (150) indicates that a SPE interchange has occurred and that the Processor circuit pack was the cause of the spontaneous interchange.
  1. If other PROCR errors are present, investigate these errors.
  2. If no other PROCR errors are present, run the **test processor a|b long clear** command and investigate any test failures.
- b. A parity error was detected in the processor's data cache or instruction cache. In a system with duplicated SPEs, this error can be generated only while the processor is running on the active SPE since the software running on the standby processor does not use the Processor data and instruction caches. Therefore, if PROC error 1026 is present for a processor on the standby SPE, that error must have been generated some time in the past when the processor was running as the active SPE.

Execute the **test processor long** command for a processor either on the active or standby SPE, and if any tests fail, follow the repair procedures for those failures. It is unlikely that a parity error will occur at the time the

Processor Cache Audit test (#896) is run on demand. However, the processor Cache test (#895) may uncover a failure that can cause cache parity errors.

If no tests fail but a MAJOR alarm is present as a result of the 1026 error, replace the Processor circuit pack since multiple cache parity errors have occurred in the past and will probably occur again which can cause call processing failures.

## System Technician-Demanded Tests: Descriptions and Error Codes

---

Always investigate tests in the order presented in the table below. By clearing error codes associated with the *Processor Cache Test*, for example, you may also clear errors generated from other tests in the testing sequence.

Order of Investigation	Short Test Sequence	Long Test Sequence	Reset Board Sequence	D/ND <sup>1</sup>
Processor Cache Test (#895)		X		D
Processor Cache Audit (#896)	X	X		ND
Processor BOOTPROM Checksum Test (#897)	X	X		ND
Processor Parity Checker Test (#899)	X	X		ND
Processor Write Buffer Test (#900)	X	X		ND

---

1. D = Destructive; ND = Nondestructive

### Processor Cache Test (#895)

**This test is destructive.**

This test overwrites the contents in the Instruction and Data Caches, requiring them to be refilled during normal execution.

This test verifies that the Processor Instruction and Data Caches are functional. Some errors in the caches will cause the Processor to stop functioning, while others simply reduce performance by forcing instructions or data to be read from memory more often than would normally be necessary. In any case, cache problems are serious and the Processor circuit pack must be replaced as soon as possible if they are detected.

**Table 9-528. TEST #895 Processor Cache Test**

Error Code	Test Result	Description/ Recommendation
100	ABORT	The requested test did not complete within the allowable time period. 1. Retry the command.
1022 1335 2500	ABORT	Internal system error 1. Retry the command.
1338	ABORT	The test is not allowed to run since a planned SPE interchange is in progress. This may be caused by a planned interchange initiated automatically during 24 hour scheduled testing. 1. Wait 3 minutes and retry the command.
1339	ABORT	The test could not run on the standby Processor circuit pack in the standby SPE carrier because the standby SPE is unavailable. 1. Refer to "STBY-SPE" for information on why a standby SPE may be unavailable and what repair actions should be taken. The screen for the <b>status spe</b> command should indicate that handshake is down. This may be caused by a variety of reasons such as the SPE-SELECT switches on the DUPINT circuit packs being set to the position of the active SPE, a failure of the DUPINT circuit pack, or loss of power on the standby SPE. The <i>SPE Selected</i> field on the <b>status spe</b> screen will display <i>spe a</i> or <i>spe b</i> if both SPE-SELECT switches are in the a or b positions, respectively.
2000	ABORT	Response to the test request was not received within the allowable time period. If the system is equipped with the high reliability or critical reliability configuration and if the Processor circuit pack is on the standby SPE, this abort code may indicate that the standby SPE is not responding to the handshake message. If this is the case, the standby SPE maintenance software may take up to two minutes to indicate that handshake communication with the standby SPE is down. The ABORT code will then change to 1339 (standby SPE unavailable). 1. Retry the command at 1-minute intervals, a maximum of 3 times.
2334	ABORT	The hardware mail on the standby Duplication Interface board is not ready to receive messages. 1. Retry the command at 1-minute intervals, a maximum of 5 times.
	FAIL	The Processor cache is not functioning correctly. 1. Replace the Processor circuit pack immediately. To replace the Processor circuit pack, refer to <i>Replacing SPE Circuit Packs</i> in Chapter 5.
	PASS	The cache portion of the Processor circuit pack is operating correctly.

## Processor Cache Parity Audit (#896)

This audit checks the state of the Cache Parity bit maintained by the R3000 CPU. If this bit is set, there may be problems with either the CPU, the Instruction, or Data Cache. An indication of bad cache parity won't itself mean that the system won't operate, but minor to severe performance degradation may be present. For example, a single bad bit in either cache could cause this bit to be set. If the faulty word is seldom accessed, the impact will be small. If the bit is accessed frequently, there could be serious problems with much, or all, of the cache (stuck data bit) with the only direct indication again being the cache parity error or cache test error.

**Table 9-529. TEST #896 Processor Cache Parity Audit**

Error Code	Test Result	Description/ Recommendation
100	ABORT	The requested test did not complete within the allowable time period. 1. Retry the command.
1022	ABORT	Internal system error 1. Retry the command.
1335	ABORT	This test is only run on the active SPE since the standby processor does not use the cache memory. Cache failures may cause cache parity errors on the active SPE which can be logged against a standby SPE if an SPE interchange has taken place.  If a PROC 1026 error code is present in the hardware error log for a processor on the standby SPE:  a. Enter the test memory long command to run the Processor Cache test (#895) to verify that the cache has not failed.  b. Request an SPE interchange by entering <b>reset system interchange</b> and run the short processor test sequence <b>test processor</b> while the processor is on the active SPE.  c. If all test pass but a MAJOR alarm is present as a result of a 1026 error in the hardware error log, replace the processor circuit pack since multiple cache parity errors have occurred in the past and will probably occur again which can cause call processing failures.
2500	ABORT	Internal system error 1. Retry the command.
1338	ABORT	The test is not allowed to run since a planned SPE interchange is in progress. This may be caused by a planned interchange initiated automatically during 24 hour scheduled testing.  1. Wait 3 minutes and retry the command.

*Continued on next page*

Table 9-529. TEST #896 Processor Cache Parity Audit — *Continued*

Error Code	Test Result	Description/ Recommendation
1339	ABORT	<p>The test could not run on the standby Processor circuit pack in the standby SPE carrier because the standby SPE is unavailable.</p> <ol style="list-style-type: none"> <li>1. Refer to the STBY-SPE maintenance documentation for information on why a standby SPE may be unavailable and what repair actions should be taken. The screen for the <b>status spe</b> command should indicate that handshake is down. This may be caused by a variety of reasons such as the SPE-SELECT switches on the DUPINT circuit packs being set to the position of the active SPE, a failure of the DUPINT circuit pack, or loss of power on the standby SPE. The <i>SPE Selected</i> field on the <b>status spe</b> screen will display <i>spe a</i> or <i>spe b</i> if both SPE-SELECT switches are in the a or b positions, respectively.</li> </ol>
2000	ABORT	<p>Response to the test request was not received within the allowable time period. If the system is equipped with the High Reliability or Critical Reliability Configuration and if the Processor circuit pack is on the standby SPE, this abort code may indicate that the standby SPE is not responding to the handshake message. If this is the case, the standby SPE maintenance software may take up to two minutes to indicate that handshake communication with the standby SPE is down. The ABORT code will then change to 1339 (standby SPE unavailable).</p> <ol style="list-style-type: none"> <li>1. Retry the command at 1-minute intervals, a maximum of 3 times.</li> </ol>
2334	ABORT	<p>The hardware mail on the standby Duplication Interface board is not ready to receive messages.</p> <ol style="list-style-type: none"> <li>1. Retry the command at 1-minute intervals, a maximum of 5 times.</li> </ol>
	FAIL	<p>The Cache Parity Error bit is set, there may be problems with either the CPU or the Instruction or Data Cache.</p> <ol style="list-style-type: none"> <li>1. Retry the command.</li> <li>2. If the test continues to fail, run <b>test processor a b long</b>.</li> <li>3. If the Processor Cache test (#895) or the Processor Cache Parity Audit (#896) fails, replace the Processor circuit pack. To replace the Processor circuit pack, refer to <i>Replacing SPE Circuit Packs</i> in Chapter 5.</li> </ol>
	PASS	<p>The Processor has not detected any parity errors in the Instruction and Data Caches since the last time this audit was run.</p>

### Processor BOOTPROM Checksum Test (#897)

This test computes the checksum of the Processor's bootstrap BOOTPROM and compares it to a predetermined value stored within the BOOTPROM. A failure of this test indicates the BOOTPROM is corrupt.

**Table 9-530. TEST #897 Processor BOOTPROM Checksum Test**

Error Code	Test Result		Description/ Recommendation
100	ABORT	The requested test did not complete within the allowable time period. 1. Retry the command.	
1022 1335 2500	ABORT	Internal system error 1. Retry the command.	
1338	ABORT	The test is not allowed to run since a planned SPE interchange is in progress. This may be caused by a planned interchange initiated automatically during 24 hour scheduled testing. 1. Wait 3 minutes and retry the command.	
1339	ABORT	The test could not run on the standby Processor circuit pack in the standby SPE carrier because the standby SPE is unavailable. 1. Refer to the STBY-SPE maintenance documentation for information on why a standby SPE may be unavailable and what repair actions should be taken. The screen for the <b>status spe</b> command should indicate that handshake is down. This may be caused by a variety of reasons such as the SPE-SELECT switches on the DUPINT circuit packs being set to the position of the active SPE, a failure of the DUPINT circuit pack, or loss of power on the standby SPE. The <i>SPE Selected</i> field on the <b>status spe</b> screen will display <i>spe a</i> or <i>spe b</i> if both SPE-SELECT switches are in the a or b positions, respectively.	
2000	ABORT	Response to the test request was not received within the allowable time period. If the system is equipped with the High Reliability or Critical Reliability Configuration and if the Processor circuit pack is on the standby SPE, this abort code may indicate that the standby SPE is not responding to the handshake message. If this is the case, the standby SPE maintenance software may take up to two minutes to indicate that handshake communication with the standby SPE is down. The ABORT code will then change to 1339 (standby SPE unavailable). 1. Retry the command at 1-minute intervals, a maximum of 3 times.	
2334	ABORT	The hardware mail on the standby Duplication Interface board is not ready to receive messages. 1. Retry the command at 1-minute intervals, a maximum of 5 times.	
FAIL		The computed checksum did not match the BOOTPROM checksum. The system may not continue to operate correctly. The system may fail at some future date when the corrupted area the bootstrap BOOTPROM is accessed. 1. Replace the Processor circuit pack. To replace the Processor circuit pack, refer to <i>Replacing SPE Circuit Packs</i> in <a href="#">Chapter 5, "Alarms, Errors, and Troubleshooting"</a> .	

**Table 9-530. TEST #897 Processor BOOTPROM Checksum Test — Continued**

Error Code	Test Result	Description/ Recommendation
	PASS	The computed checksum matched the BOOTPROM checksum. This part of the Processor will continue to operate normally.

### Processor Parity Checker Test (#899)

This test verifies that the Processor can detect parity errors on the bus. If this part of the Processor circuit pack is faulty, the system may continue to operate properly, but may not correctly respond if a bus problem arises later. The Processor reads a special memory location on the SYSAM circuit pack to perform this test. Problems with the SYSAM may also cause this test to fail.

**Table 9-531. TEST #899 Processor Parity Checker Test**

Error Code	Test Result	Description/ Recommendation
100	ABORT	The requested test did not complete within the allowable time period. 1. Retry the command.
1022 1335 2500	ABORT	Internal system error 1. Retry the command.
1338	ABORT	The test is not allowed to run since a planned SPE interchange is in progress. This may be caused by a planned interchange initiated automatically during 24 hour scheduled testing. 1. Wait 3 minutes and retry the command.
1339	ABORT	The test could not run on the standby Processor circuit pack in the standby SPE carrier because the standby SPE is unavailable. 1. Refer to the STBY-SPE maintenance documentation for information on why a standby SPE may be unavailable and what repair actions should be taken. The screen for the <b>status spe</b> command should indicate that handshake is down. This may be caused by a variety of reasons such as the SPE-SELECT switches on the DUPINT circuit packs being set to the position of the active SPE, a failure of the DUPINT circuit pack, or loss of power on the standby SPE. The <i>SPE Selected</i> field on the <b>status spe</b> screen will display <i>spe a</i> or <i>spe b</i> if both SPE-SELECT switches are in the a or b positions, respectively.

*Continued on next page*

**Table 9-531. TEST #899 Processor Parity Checker Test — Continued**

Error Code	Test Result	Description/ Recommendation
2000	ABORT	Response to the test request was not received within the allowable time period. If the system is equipped with the High Reliability or Critical Reliability Configuration and if the Processor circuit pack is on the standby SPE, this abort code may indicate that the standby SPE is not responding to the handshake message. If this is the case, the standby SPE maintenance software may take up to two minutes to indicate that handshake communication with the standby SPE is down. The ABORT code will then change to 1339 (standby SPE unavailable).  1. Retry the command at 1-minute intervals, a maximum of 3 times.
2334	ABORT	The hardware mail on the standby Duplication Interface board is not ready to receive messages.  1. Retry the command at 1-minute intervals, a maximum of 5 times.
	FAIL	The Processor cannot detect bus parity error conditions.  1. Retry the command.  2. If the test continues to fail, replace the Processor circuit pack.  3. If the test continues to fail after replacing the Process circuit pack, replace the SYSAM circuit pack. To replace the Processor circuit pack, refer to <i>Replacing SPE Circuit Packs</i> in Chapter 5.
	PASS	The Processor Parity Checker is functional.

**Processor Write Buffer Test (#900)**

This test verifies that the Write Buffer operates properly on the Processor circuit pack. Failure of this test is serious. The Processor circuit pack must be replaced as soon as possible.

**Table 9-532. TEST #900 Processor Write Buffer Test**

Error Code	Test Result	Description/ Recommendation
100	ABORT	The requested test did not complete within the allowable time period.  1. Retry the command.

*Continued on next page*



Table 9-532. TEST #900 Processor Write Buffer Test — *Continued*

Error Code	Test Result	Description/ Recommendation
1022 1335 2500	ABORT	Internal system error 1. Retry the command.
1338	ABORT	The test is not allowed to run since a planned SPE interchange is in progress. This may be caused by a planned interchange initiated automatically during 24 hour scheduled testing. 1. Wait 3 minutes and retry the command.
1339	ABORT	The test could not run on the standby Processor circuit pack in the standby SPE carrier because the standby SPE is unavailable. 1. Refer to the STBY-SPE maintenance documentation for information on why a standby SPE may be unavailable and what repair actions should be taken. The screen for the <b>status spe</b> command should indicate that handshake is down. This may be caused by a variety of reasons such as the SPE-SELECT switches on the DUPINT circuit packs being set to the position of the active SPE, a failure of the DUPINT circuit pack, or loss of power on the standby SPE. The <i>SPE Selected</i> field on the <b>status spe</b> screen will display <i>spe a</i> or <i>spe b</i> if both SPE-SELECT switches are in the a or b positions, respectively.
2000	ABORT	Response to the test request was not received within the allowable time period. If the system is equipped with the High Reliability or Critical Reliability Configuration and if the Processor circuit pack is on the standby SPE, this abort code may indicate that the standby SPE is not responding to the handshake message. If this is the case, the standby SPE maintenance software may take up to two minutes to indicate that handshake communication with the standby SPE is down. The ABORT code will then change to 1339 (standby SPE unavailable). 1. Retry the command at 1-minute intervals, a maximum of 3 times.
2334	ABORT	The hardware mail on the standby Duplication Interface board is not ready to receive messages. 1. Retry the command at 1-minute intervals, a maximum of 5 times.
	FAIL	The Processor Write Buffer is not operating correctly. 1. Replace the Processor circuit pack immediately. To replace the Processor circuit pack, refer to <i>Replacing SPE Circuit Packs</i> in Chapter 5.
	PASS	The Write Buffer portion of the Processor circuit pack is operating correctly.

## RING-GEN

---

### Analog Ring Generator

---

MO Name (in Alarm Log)	Alarm Level	Initial Command to Run <sup>1</sup>	Full Name of MO
RING-GEN	MAJOR	test environment P	Analog Ring Generator

1. P is the port network number indicated in the PORT field from the Alarm or Error Log.

Analog phones must be provided with a voltage that allows them to ring. The Analog Ring Generator maintenance object represents the device that provides the ringing voltage for all analog phones associated with a given cabinet. In a multi-carrier cabinet, the ring generator resides in the power distribution unit. It is protected by a fuse located next to the main circuit breaker on the front of the unit. In single-carrier cabinets, the ring generator is part of the WP-91153 power supply. Failure of the ring generator results in loss of ringing on analog phones. Ringing on digital and hybrid phones is not affected.

The ringing voltage is monitored by the Tone-Clock circuit pack. In a port network with duplicated Tone-Clocks, it is the active Tone-Clock that performs this function. In an EPN made up of single-carrier cabinets, the Tone-Clock monitors only the ringing voltage in the carrier that contains the tone clock.

The TN2036 Voltage Range circuit pack provides easy access for testing the various voltages on the backplane pins. For more information, refer to Chapter 5.

## Error Log Entries and Test to Clear Values

**Table 9-533. Analog Ring Generator Error Log Entries**

Error Type	Aux Data	Associated Test	Alarm Level	On/Off Board	Test to Clear Value
0 <sup>1</sup>	0	Any	Any	Any	test environment UU
1		Analog Ring Generator Query (#118)	MAJOR	ON	test environment UU r 3

1. Run the Short Test Sequence first. If all tests pass, run the Long Test Sequence. Refer to the appropriate test description and follow the recommended procedures.

## System Technician-Demanded Tests: Descriptions and Error Codes

Always investigate tests in the order presented in the table below when inspecting errors in the system. By clearing error codes associated with the *Analog Ring Generator Initialization Test*, for example, you may also clear errors generated from other tests in the testing sequence.

**Table 9-534. Multicarrier Cabinet**

Order of Investigation	Short Test Sequence	Long Test Sequence	D/ND <sup>1</sup>
Analog Ring Generator Initialization Test (#117)	X	X	ND
Analog Ring Generator Query Test (#118)	X	X	ND
Battery & Battery Charger Query Test (#5) (a)	X	X	ND
AC Power Query Test (#78) (b)	X	X	ND
OLS Query Test (Carrier E) (#127) (c)	X	X	ND
OLS Query Test (Carrier D) (#127) (c)	X	X	ND
OLS Query Test (Carrier A) (#127) (c)	X	X	ND
OLS Query Test (Carrier B) (#127) (c)	X	X	ND
OLS Query Test (Carrier C) (#127) (c)	X	X	ND
Emergency Transfer Query Test (#124) (d)	X	X	ND
Cabinet Sensors Query Test (#122) (e)	X	X	ND
External Alarm Lead Query Test (#120) (f)	X	X	ND

1. D = Destructive, ND = Non-destructive

Notes:

- a. Refer to POWER for a description of this test.
- b. Refer to AC-POWER for a description of this test.
- c. Refer to CARR-POW for a description of this test.
- d. Refer to EMG-XFER for a description of this test.
- e. Refer to CABINET for a description of this test.
- f. Refer to EXT-DEV for a description of this test.

**Table 9-535. Single-Carrier Cabinet**

Order of Investigation	Short Test Sequence	Long Test Sequence	D/ND <sup>1</sup>
Analog Ring Generator Initialization Test (#117)	X	X	ND
Analog Ring Generator Query Test (#118)	X	X	ND
Single-Carrier Cabinet Power Query Test (#79) (a)	X	X	ND
Emergency Transfer Query Test (#124) (b)	X	X	ND
External Alarm Lead Query Test (#120) (c)	X	X	ND

1. D = Destructive, ND = Non-destructive

Notes:

- a. Refer to DC-POWER for a description of this test.
- b. Refer to EMG-XFER for a description of this test.
- c. Refer to EXT-DEV for a description of this test.

**Analog Ring Generator Initialization Test (#117)**

The TN768, or TN780 will report an error to the system software if the ringing voltage falls to low (only if system software has made a request to the TN768, or TN780 to monitor the voltage). The Analog Ring Generator Initialization Test sends a request to the TN768, or TN780. If there are redundant tone/clock circuit packs in the port network, then the request is sent only to the active tone/clock.

**Table 9-536. TEST #117 Analog Ring Generator Initialization Test**

Error Code	Test Result	Description/ Recommendation
1 1000 1001 1003 1115 2012 2100	ABORT	The system software is unable to determine the active tone/clock circuit pack, unable to allocated the resources necessary to run the test, or unable to send a down link message. <ol style="list-style-type: none"> <li>1. Wait for the green LED on the active tone/clock to go out; use the <b>status port-network</b> command to determine the active Tone/Clock circuit pack.</li> <li>2. Rerun the test. If the test aborts again, refer to TDM-CLK.</li> </ol>
2000	ABORT	Response to the request was not received within the allowable time period. <ol style="list-style-type: none"> <li>1. Look for TDM-CLK errors and alarms. Resolve all other Tone/Clock problems first.</li> <li>2. Rerun the test.</li> </ol>
	PASS	The active Tone/Clock has successfully been enabled to monitor the ringing voltage level.

### Analog Ring Generator Query Test (#118)

The Analog Ring Generator Query Test requests the active Tone/Clock circuit pack to check the ringing voltage. The tone/clock circuit pack replies with PASS if the ringing voltage is adequate to ring the analog phones. If not, the active tone/clock circuit pack replies with a FAIL.

**Table 9-537. TEST #118 Analog Ring Generator Query Test**

Error Code	Test Result	Description/ Recommendation
1 1000 1001 1003 1115 2012 2100	ABORT	Could not seize the resources to run the test. Other maintenance is running on the active tone/clock circuit pack. <ol style="list-style-type: none"> <li>1. Wait for the green LED on the active tone/clock circuit pack to go out; use the <b>status port-network</b> command to determine the active Tone/Clock circuit pack.</li> <li>2. Rerun the test. If the test aborts again, refer to TDM-CLK.</li> </ol>
2000	ABORT	Response to the request was not received within the allowable time period. <ol style="list-style-type: none"> <li>1. Look for TDM-CLK errors and alarms. Resolve all other tone/clock problems first.</li> <li>2. Rerun the test.</li> </ol>

*Continued on next page*

**Table 9-537. TEST #118 Analog Ring Generator Query Test — Continued**

Error Code	Test Result	Description/ Recommendation
	FAIL	<p>The ringing voltage is below acceptable levels. <b>Procedure for a multicarrier cabinet system:</b></p> <ol style="list-style-type: none"> <li>1. If this is a duplicated SPE system, then determine the active Tone/Clock circuit pack by issuing a <b>status port-network</b> command. Make the Standby Tone/Clock circuit pack active via the <b>set tone-clock PC</b> command and rerun the test.                             <ol style="list-style-type: none"> <li>a. If the test passes, then the trouble is with the now Standby Tone/Clock circuit pack. Refer to "TONE-BD" for details on replacing the Standby Tone/Clock circuit pack. After the circuit pack is replaced, make this Tone/Clock active again by issuing the <b>set tone-clock PC</b> command and rerun the test.</li> <li>b. If the test fails, then proceed with Step 2.</li> </ol> </li> <li>2. Resolve CARR-POW alarms first, and then rerun the test.</li> <li>3. Check fuse on the power distribution unit. Replace if it is open, and rerun the test. If the test still fails, then an analog line circuit pack could be defective and causing the ring generator and/or fuse to fail.</li> <li>4. Unseat all analog circuit packs in the affected cabinet, and rerun the test.</li> <li>5. If the test passes, then the ring generator is healthy, and one of the analog circuit packs is defective. Replace the analog circuit packs one at a time, and rerun the test to determine which circuit pack is causing the problem. When the defective analog circuit pack is found, replace it and rerun the test. If the test still fails, proceed with Step 6.</li> </ol>
	FAIL (cont'd.)	<ol style="list-style-type: none"> <li>6. Since the test still fails, the ring generator is defective.                             <ol style="list-style-type: none"> <li>a. If the reset button on the ring generator is out, press it in.</li> <li>b. Originate calls to several analog stations on different port circuit packs in different carriers in the affected port network.</li> <li>c. If called stations ring, the fault is cleared. Proceed to Step d. If no stations ring, replace the ring generator.</li> <li>d. Rerun the test. If the test still fails, proceed to Step 7.</li> </ol> </li> <li>7. The active tone/clock may be faulty and incorrectly reporting the level of the ringing voltage. Replace the active tone/clock and rerun the test. Refer to "TONE-BD" for details on replacing the tone/clock. Rerun the test.</li> </ol>

*Continued on next page*

Table 9-537. TEST #118 Analog Ring Generator Query Test — *Continued*

Error Code	Test Result	Description/ Recommendation
	FAIL (cont'd. )	<p><b>Procedure for a single-carrier cabinet system:</b></p> <p>This failure indicates that there is no ringing voltage in the carrier where the active tone/clock circuit pack resides. Other carriers may or may not have ringing voltage.</p> <ol style="list-style-type: none"> <li>1. If this is a duplicated system, determine the active Tone-Clock circuit pack by issuing a <b>status system</b> command. Make the Standby Tone-Clock circuit pack active via the <b>set tone-clock PC</b> command and rerun the test.                         <ol style="list-style-type: none"> <li>a. If the test passes, then the trouble is with the “new” stand by Tone-Clock circuit pack. Refer to “TONE-BD” for details on replacing the standby Tone-Clock circuit pack. After the circuit pack is replaced, make this Tone-Clock active again by issuing the <b>set tone-clock PC</b> command and rerun the test.</li> <li>b. If the test fails, then proceed with Step 2.</li> </ol> </li> <li>2. Unseat all analog circuit packs in the cabinet that contains the Active Tone/Clock circuit pack and rerun the test.</li> <li>3. If the test passes, then the ring generator is healthy and one of the analog circuit packs is defective. Replace the analog circuit packs one at a time, and rerun the test to determine which circuit pack is causing the problem. Replace the defective analog circuit pack. Rerun the test. If the test still fails, go to Step 4.</li> <li>4. Replace the WP-91153 power unit for the affected carrier, and rerun the test. If the test still fails, go to Step 5.</li> <li>5. The active tone/clock may be faulty and incorrectly reporting the level of the ringing voltage. Replace the active tone/clock and rerun the test. Refer to “TONE-BD” for details on replacing the active tone/clock circuit pack. Rerun the test.</li> </ol>
	PASS	The analog ringing voltage level is acceptable. For a single-carrier cabinet stack, ringing voltage is acceptable in the cabinet containing the active tone/clock circuit pack.

## S-SYN-BD (Speech Synthesis Circuit Pack)

---

MO Name (in Alarm Log)	Alarm Level	Initial Command to Run <sup>1</sup>	Full Name of MO
S-SYN-BD	MIN	test board UUCSS sh	Speech Synthesis Circuit Pack
S-SYN-BD	WRN	test board UUCSS sh	Speech Synthesis Circuit Pack

- 
1. UU is the universal cabinet number (1 for PPN, 2 - 44 for EPNs). C is the carrier designation (A, B, C, D, or E). SS is the number of the slot in which the circuit pack resides (01 to 21).

Refer to "XXX-BD (Common Port Circuit Pack)" for circuit pack level errors. See also S-SYN-PT (Speech Synthesis Port) for related port information.



## S-SYN-PT (Speech Synthesis Port)

MO Name (in Alarm Log)	Alarm Level	Initial Command to Run <sup>1</sup>	Full Name of MO
S-SYN-PT	MAJOR	test port UUCSSpp sh	Speech Synthesis Port
S-SYN-PT	MINOR	test port UUCSSpp l	Speech Synthesis Port
S-SYN-PT	WARNING	test port UUCSSpp sh	Speech Synthesis Port

1. UU is the universal cabinet number (1 for PPN, 2 - 44 for EPNs). C is the carrier designation (A, B, C, D, or E). SS is the number of the slot in which the circuit pack resides (01 to 21). pp is the two digit port number (01, 02, ...).

The TN725B Speech Synthesis circuit pack provides four independent Speech Synthesis Ports which may be connected to any of the voice time slots on the Time Division Multiplex (TDM) Bus. Each Speech Synthesis Port consists of a speech synthesizer device (SSD) and is managed by a custom-coded programmable speech synthesizer (PSS) controller. The PSS controller is, in turn, controlled by the on-board microprocessor via a command interface specifically designed for this application. The PSS controller's main function is the orderly transfer of encoded speech from the speech vocabulary read-only memory (ROM) to the SSDs. The SSDs decode it and produce 64 kb/s 5-255 PCM (Pulse Code Modulation) speech. The encoded speech is stored in up to 512K bytes of on-board ROM. In addition, each Speech Synthesis Port has an associated dual-tone multifrequency receiver (DTMR) to receive touch-tone digits from a station set connected to the port via a voice time slot. The station set may be connected to the Speech Synthesis Port through either a line or trunk circuit.

When there is an incoming call to a port, the "listen" network time slot is connected to the DTMF receiver input and the "talk" network time slot is connected to the SSD output. This enables the Speech Synthesis Port to support speech synthesis features or touch-tone input with voice response features. Some of the features that use the Speech Synthesis Port's capabilities include Leave Word Calling, Automatic Circuit Assurance, Automatic Wakeup (hotel-motel), and Do Not Disturb (hotel-motel).

The Speech Synthesis circuit pack should not be confused with the Announcement circuit pack. Different voice features are supported by each circuit pack.

## Error Log Entries and Test to Clear Values

**Table 9-538. Speech Synthesis Port Error Log Entries**

Error Type	Aux Data	Associated Test	Alarm Level	On/Off Board	Test to Clear Value
0 <sup>1</sup>	0	Any	Any	Any	test port UUCSSpp sh r 1
1(a)	17672	None			
18	0	busy-out port UUCSSpp	WARNING	OFF	release port UUCSSpp
130(b)		None	WARNING	ON	test port UUCSSpp sh
257		Speech Synthesis PSS Handshake Test (#168)	MAJOR	ON	test port UUCSSpp sh r 2
513	17922	Speech Synthesis Memory Test (#166)	MINOR	ON	test port UUCSSpp sh r 2
769	17664	Speech Synthesis DTMF Receiver Inquiry Test (#164)	MINOR	ON	test port UUCSSpp sh r 2
1025	17670	Speech Synthesis SSD Inquiry Test (#167)	MINOR	ON	test port UUCSSpp sh r 2
1281		Speech Synthesis DSP Tone Test (#165)	MINOR	ON	test port UUCSSpp sh r 2
1537		Speech Synthesis Memory Test (#166)	MINOR	ON	test port UUCSSpp sh r 2
1793		Speech Synthesis DTMF Receiver Test (#163)	MINOR	ON	test port UUCSSpp l r 2
2049(c)		Conference Circuit Test (#7)	MINOR	ON	test port UUCSSpp l r 2
2305		NPE Crosstalk Test (#6)	MINOR	ON	test port UUCSSpp l r 2
3840(d)	Any	None			

1. Run the Short Test Sequence first. If all tests pass, run the Long Test Sequence. Refer to the appropriate test description and follow the recommended procedures.

### Notes:

- a. An in-line failure of the on-board microprocessor/PSS handshake has occurred. Refer to Test #168 for repair procedures.
- b. This error type indicates that the circuit pack been removed or has been insane for more than 11-minutes. To clear the error, reinsert or replace the circuit pack.

- c. A transient error that does not cause an alarm can occasionally occur during a SPE, TDM BUS, or Tone Clock interchange. Test the port and follow the instructions for conference Test (#7).
- d. This error is not service-affecting and no action is required.

## System Technician-Demanded Tests: Descriptions and Error Codes

---

Always investigate tests in the order presented in the table below when inspecting errors in the system. By clearing error codes associated with the *NPE Crosstalk Test*, for example, you may also clear errors generated from other tests in the testing sequence.

Order of Investigation	Short Test Sequence	Long Test Sequence	D/ND <sup>1</sup>
Speech Synthesis PSS Handshake Test (#168)	X	X	ND
NPE Crosstalk Test (#6)		X	ND
Conference Circuit Test (#7)		X	ND
Speech Synthesis DTMF Receiver Test (#163)		X	ND
Speech Synthesis Memory Test (#166)	X	X	ND
Speech Synthesis DSP Tone Test (#165)	X	X	ND
Speech Synthesis SSD Inquiry Test (#167)	X	X	ND
Speech Synthesis DTMF Receiver Inquiry Test (#164)	X	X	ND
Speech Synthesis Parameter Update Test (#169)	X	X	ND

---

1. D = Destructive, ND = Non-destructive

### NPE Crosstalk Test (#6)

The NPE Crosstalk Test verifies that this port's NPE channel talks on the selected time slot and never crosses over to time slots reserved for other connections. If the NPE is not working correctly, one-way and noisy connections may occur. This test is usually only part of a port's Long Test Sequence and takes about 20 to 30 seconds to complete.

**Table 9-539. TEST #6 NPE Crosstalk Test**

Error Code	Test Result	Description/ Recommendation
	ABORT	Could not allocate the necessary system resources to run this test. 1. Retry the command at 1-minute intervals a maximum of 5 times.
1000	ABORT	System resources required to run this test are not available. The port may be busy with a valid call and therefore unavailable for certain tests. You must wait until the port is idle (yellow LED is off) before retesting. 1. If the port is idle, retry the command at 1-minute intervals a maximum of 5 times.
1001	ABORT	Could not allocate the necessary system resources to run this test. 1. Retry the command at 1-minute intervals a maximum of 5 times.
1002	ABORT	The system could not allocate time slots for the test. The system may be under heavy traffic conditions or it may have time slots out-of-service due to TDM-BUS errors. 1. If system has no TDM-BUS errors and is not handling heavy traffic, repeat test at 1-minute intervals a maximum of 5 times.
1003	ABORT	The system could not allocate a tone receiver for the test. The system may be oversized for the number of Tone Detectors present or some Tone Detectors may be out-of-service. 1. Resolve any TTR-LEV errors. 2. Resolve any TONE-PT errors. 3. If neither condition exists, retry the test at 1-minute intervals a maximum of 5 times.
1004	ABORT	The port was seized by a valid call during the test and the test has been aborted. You must wait until the port is idle (yellow LED is off) before retesting. 1. Retry the command at 1-minute intervals a maximum of 5 times.
1020	ABORT	The test did not run due to an already existing error on the specific port or a more general circuit pack error. 1. Examine Error Log for existing errors against this port or the circuit pack and attempt to diagnose the already existing error.
2000	ABORT	Response to the test request was not received within the allowable time period.
2100	ABORT	Could not allocate the necessary system resources to run this test. 1. Retry the command at 1-minute intervals a maximum of 5 times.

*Continued on next page*

**Table 9-539. TEST #6 NPE Crosstalk Test — Continued**

Error Code	Test Result	Description/ Recommendation
Any	FAIL	The NPE of the tested port was found to be transmitting in error. This will cause noisy and unreliable connections. 1. Replace the circuit pack.
	PASS	The port is correctly using its allocated time slots. User-reported troubles on this port should be investigated using other port tests and by examining the Error Log.

### Conference Circuit Test (#7)

One or more Network Processing Elements (NPEs) reside on each circuit pack with a TDM Bus interface. The NPE controls port connectivity and gain, and provides conferencing functions on a per-port basis. The Conference Circuit Test verifies that the NPE channel for the port being tested can correctly perform the conferencing function. The NPE is instructed to listen to several different tones and conference the tones together. The resulting signal is then measured by a Tone Detector port. If the level of the tone is within a certain range, the test passes.

**Table 9-540. TEST #7 Conference Circuit Test**

Error Code	Test Result	Description/ Recommendation
	ABORT	Could not allocate the necessary system resources to run this test. 1. Retry the command at 1-minute intervals a maximum of 5 times.
1000	ABORT	System resources required to run this test are not available. The port may be busy with a valid call and therefore unavailable for certain tests. You must wait until the port is idle (yellow LED is off) before retesting. 1. If the port is idle, retry the command at 1-minute intervals a maximum of 5 times.
1004	ABORT	The port was seized by a valid call during the test and the test has been aborted. You must wait until the port is idle (yellow LED is off) before retesting. 1. Retry the command at 1-minute intervals a maximum of 5 times.

*Continued on next page*

**Table 9-540. TEST #7 Conference Circuit Test — Continued**

Error Code	Test Result	Description/ Recommendation
1020	ABORT	The test did not run due to an already existing error on the specific port or a more general circuit pack error. <ol style="list-style-type: none"><li>1. Examine Error Log for existing errors against this port or the circuit pack and attempt to diagnose the already existing error.</li></ol>
2000	ABORT	Response to the test request was not received within the allowable time period.
2100	ABORT	Could not allocate the necessary system resources to run this test. <ol style="list-style-type: none"><li>1. Retry the command at 1-minute intervals a maximum of 5 times.</li></ol>
Any	FAIL	The NPE of the tested port did not conference the tones correctly. This causes noisy and unreliable connections. <ol style="list-style-type: none"><li>1. Retry the test.</li><li>2. If the Test continues to fail then replace the circuit pack.</li></ol>
	PASS	The port can correctly conference multiple connections. User-reported troubles on this port should be investigated using other port tests and by examining the Error Log.

### Speech Synthesis DTMF Receiver Test (#163)

A series of dual-tone multifrequency (DTMF) tones are conferenced from the TDM Bus into the port's DTMF receiver and checked to see if the correct tones have been detected during the correct intervals. If all the DTMF tones were detected correctly, the test passes. If any of the tones were not detected correctly, the test fails.

**Table 9-541. TEST #163 Speech Synthesis DTMF Receiver**

Error Code	Test Result	Description/ Recommendation
	ABORT	Could not allocate the necessary system resources to run this test. <ol style="list-style-type: none"><li>1. Retry the command at 1-minute intervals a maximum of 5 times.</li></ol>
1000	ABORT	System resources required to run this test are not available. The port may be busy with a valid call and therefore unavailable for certain tests. You must wait until the port is idle (yellow LED is off) before retesting. <ol style="list-style-type: none"><li>1. If the port is idle, retry the command at 1-minute intervals a maximum of 5 times.</li></ol>

*Continued on next page*

**Table 9-541. TEST #163 Speech Synthesis DTMF Receiver — Continued**

Error Code	Test Result	Description/ Recommendation
2000	ABORT	Response to the test request was not received within the allowable time period.
2100	ABORT	Could not allocate the necessary system resources to run this test. 1. Retry the command at 1-minute intervals a maximum of 5 times.
Any	FAIL	DTMF tones were not detected. This type of failure may cause features using touch-tone input to the Speech Synthesis Port to malfunction. 1. Verify that the Tone-Clock circuit pack is functioning correctly by checking the Error Log and using the <b>test tone-clock long</b> command. 2. If the test fails again, replace the Speech Synthesis circuit pack.
	PASS	The port has detected all DTMF tones correctly. User-reported troubles should be investigated using other tests and by verifying other ports on this circuit pack are working correctly.

**Speech Synthesis DTMF Receiver Inquiry Test (#164)**

This test determines the sanity of the port's dual-tone multifrequency (DTMF) receiver. The on-board microprocessor tests the port's DTMF receiver and determines if it is in a sane (test passes) or insane (test fails) condition.

**Table 9-542. TEST #164 Speech Synthesis DTMF Receiver Inquiry Test**

Error Code	Test Result	Description/ Recommendation
	ABORT	Could not allocate the necessary system resources to run this test. 1. Retry the command at 1-minute intervals a maximum of 5 times.
1000	ABORT	System resources required to run this test are not available. The port may be busy with a valid call and therefore unavailable for certain tests. You must wait until the port is idle (yellow LED is off) before retesting. 1. If the port is idle, retry the command at 1-minute intervals a maximum of 5 times.
2000	ABORT	Response to the test request was not received within the allowable time period.
2100	ABORT	Could not allocate the necessary system resources to run this test. 1. Retry the command at 1-minute intervals a maximum of 5 times.

**Table 9-542. TEST #164 Speech Synthesis DTMF Receiver Inquiry Test — Continued**

Error Code	Test Result	Description/ Recommendation
Any	FAIL	The DTMF receiver for this port is insane. 1. If the test fails again, replace the circuit pack.
	PASS	The DTMF receiver for this port is sane. User-reported troubles should be investigated using other tests and by verifying other ports on this circuit pack are working correctly.

### Speech Synthesis DSP Tone Test (#165)

The digital signal processor (DSP) associated with each port can generate a 440-Hz tone whose presence can be detected by TN748 General Purpose Tone Detector circuit packs. A 440-Hz tone is generated for 500 ms on a specified time slot which is being listened to by the detector circuit. If the detector determines the tone is present on the time slot, the test passes; otherwise, it fails.

**Table 9-543. TEST #165 Speech Synthesis DSP Tone Test**

Error Code	Test Result	Description/ Recommendation
	ABORT	Could not allocate the necessary system resources to run this test. 1. Retry the command at 1-minute intervals a maximum of 5 times.
1000	ABORT	System resources required to run this test are not available. The port may be busy with a valid call and therefore unavailable for certain tests. You must wait until the port is idle (yellow LED is off) before retesting. 1. If the port is idle retry the command at 1-minute intervals a maximum of 5 times.
1001 1002 1003	ABORT	System resources required to run this test are not available. 1. Retry the command at 1-minute intervals a maximum of 5 times.
1021	ABORT	The 440-Hz tone was not detected by the Tone Detector circuit and inter-digit time-out has occurred on the Tone Detector circuit. 1. Retry the command at 1-minute intervals a maximum of 5 times. 2. If the test continues to abort, verify all Tone Detector circuit packs in the system are functioning correctly by checking the Error Log and using the <b>test board UUCSS long</b> command. Replace any faulty Tone Detector circuit packs and repeat the test. 3. If the test continues to abort, replace the Speech Synthesis circuit pack.
2000	ABORT	Response to the test request was not received within the allowable time period.

*Continued on next page*



**Table 9-543. TEST #165 Speech Synthesis DSP Tone Test — Continued**

Error Code	Test Result	Description/ Recommendation
2100	ABORT	Could not allocate the necessary system resources to run this test. 1. Retry the command at 1-minute intervals a maximum of 5 times.
Any	FAIL	The 440-Hz tone was not detected by the Tone Detector circuits. 1. If the test fails again, verify all Tone Detector circuit packs in the system are functioning correctly by checking the Error Log and using the <b>test board UUCSS long</b> command. Replace any faulty Tone Detector circuit packs and repeat the test. 2. If the test fails again, replace the Speech Synthesis circuit pack.
	PASS	The 440-Hz tone has been detected correctly. User-reported troubles should be investigated using other tests and by verifying other ports on this circuit pack are working correctly.

### Speech Synthesis Memory Test (#166)

The encoded speech for the Speech Synthesis circuit pack is stored in on-board read-only memory (ROM). A checksum is computed for each 32K speech memory block and compared against a known checksum value. If all computed checksum values are successfully compared against the stored checksum values, the test passes. If, while testing the speech complex memory, the on-board microprocessor finds a memory error, the test is terminated and a failure is reported. This type of failure may affect other ports on the Speech Synthesis circuit pack, resulting in errors or alarms on each port.

**Table 9-544. TEST #166 Speech Synthesis Memory Test**

Error Code	Test Result	Description/ Recommendation
	ABORT	Could not allocate the necessary system resources to run this test. 1. Retry the command at 1-minute intervals a maximum of 5 times.
1000	ABORT	System resources required to run this test are not available. The port may be busy with a valid call and therefore unavailable for certain tests. You must wait until the port is idle (yellow LED is off) before retesting. 1. If the port is idle, retry the command at 1-minute intervals a maximum of 5 times.

*Continued on next page*

**Table 9-544. TEST #166 Speech Synthesis Memory Test — Continued**

Error Code	Test Result	Description/ Recommendation
1019	ABORT	Test is already running on a different port, possibly due to background maintenance activity. Only one of these tests may be active on a circuit pack at a time.  1. Retry the command at 1-minute intervals a maximum of 5 times.
2000	ABORT	Response to the test request was not received within the allowable time period.
2100	ABORT	Could not allocate the necessary system resources to run this test.  1. Retry the command at 1-minute intervals a maximum of 5 times.
Any	FAIL	The computed checksum from the speech vocabulary ROM did not compare correctly with the stored checksum. This type of failure may cause features using the Speech Synthesis Port's speech services to malfunction and result in degradation of synthesized speech quality ranging from insignificant to major.  1. Replace the circuit pack.
	PASS	The computed checksum values were successfully compared against the stored checksum values. User-reported troubles should be investigated using other tests and by verifying other ports on this circuit pack are working correctly.

### Speech Synthesis SSD Inquiry Test (#167)

This test determines the sanity of the specified port's speech synthesis device (SSD). The on-board microprocessor tests the port's SSD and determines if it is in a sane (test passes) or insane (test fails) condition. Other ports on the Speech Synthesis circuit pack will continue to function correctly during this type of failure.

**Table 9-545. TEST #167 Speech Synthesis SSD Inquiry Test**

Error Code	Test Result	Description/ Recommendation
	ABORT	Could not allocate the necessary system resources to run this test.  1. Retry the command at 1-minute intervals a maximum of 5 times.
1000	ABORT	System resources required to run this test are not available. The port may be busy with a valid call and therefore unavailable for certain tests. You must wait until the port is idle (yellow LED is off) before retesting.  1. If the port is idle, retry the command at 1-minute intervals a maximum of 5 times.
2000	ABORT	Response to the test request was not received within the allowable time period.

**Table 9-545. TEST #167 Speech Synthesis SSD Inquiry Test — Continued**

Error Code	Test Result	Description/ Recommendation
2100	ABORT	Could not allocate the necessary system resources to run this test. 1. Retry the command at 1-minute intervals a maximum of 5 times.
Any	FAIL	The SSD is insane. 1. Replace the circuit pack.
	PASS	The SSD is sane. User-reported troubles should be investigated using other tests and by verifying other ports on this circuit pack are working correctly.

### Speech Synthesis PSS Handshake Test (#168)

This test verifies control functionality between the on-board microprocessor and programmable speech synthesizer (PSS) controller. A failure occurs if either of the following events occur:

- The on-board microprocessor times out while waiting for the PSS controller to respond.
- An invalid command is received by the on-board microprocessor from the PSS controller.

This type of failure will affect all four ports on the Speech Synthesis circuit pack, resulting in errors or alarms on each port.

**Table 9-546. TEST #168 Speech Synthesis PSS Handshake Test**

Error Code	Test Result	Description/ Recommendation
	ABORT	Could not allocate the necessary system resources to run this test. 1. Retry the command at 1-minute intervals a maximum of 5 times.
1000	ABORT	System resources required to run this test are not available. The port may be busy with a valid call and therefore unavailable for certain tests. You must wait until the port is idle (yellow LED is off) before retesting. 1. If the port is idle, retry the command at 1-minute intervals a maximum of 5 times.
2000	ABORT	Response to the test request was not received within the allowable time period.
2100	ABORT	Could not allocate the necessary system resources to run this test. 1. Retry the command at 1-minute intervals a maximum of 5 times.

*Continued on next page*

**Table 9-546. TEST #168 Speech Synthesis PSS Handshake Test — Continued**

Error Code	Test Result	Description/ Recommendation
Any	FAIL	The on-board microprocessor has timed out while waiting for the PSS controller to respond or an invalid command has been received by the on-board microprocessor from the PSS controller. This type of failure may cause features using the Speech Synthesis Port's speech services to malfunction.  1. Replace the circuit pack.
	PASS	The on-board microprocessor/PSS handshake is working correctly. User-reported troubles should be investigated using other tests and by verifying other ports on this circuit pack are working correctly.

### Speech Synthesis Parameter Update Test (#169)

This test updates the dual-tone multifrequency (DTMF) interdigit time-out parameter used by the Speech Synthesis circuit pack so that it is consistent with that specified by the switch processing element (SPE).

**Table 9-547. TEST #169 Speech Synthesis Parameter Update Test**

Error Code	Test Result	Description/ Recommendation
	ABORT	Could not allocate the necessary system resources to run this test.  1. Retry the command at 1-minute intervals a maximum of 5 times.
1000	ABORT	System resources required to run this test are not available. The port may be busy with a valid call and therefore unavailable for certain tests. You must wait until the port is idle (yellow LED is off) before retesting.  1. If the port is idle, retry the command at 1-minute intervals a maximum of 5 times.
2100	ABORT	Could not allocate the necessary system resources to run this test.  1. Retry the command at 1-minute intervals a maximum of 5 times.
Any	FAIL	An internal system error has occurred.
	PASS	The DTMF interdigit time-out parameter has been updated.  1. User-reported troubles should be investigated using other tests and by verifying that other ports on this circuit pack are working correctly.

The SEC-CDR (SEC-CDR Link) maintenance strategy is covered in the PRI-CDR/SEC-CDR (PRI-CDR Link) Maintenance documentation.

## SN-CONF (Switch Node Configuration)

---

MO Name (in Alarm Log)	Alarm Level	Initial Command to Run <sup>1</sup>	Full Name of MO
SN-CONF	MAJOR	test board UUCSS s	Switch Node Configuration
SN-CONF	MINOR	test board UUCSS <sup>2</sup>	Switch Node Configuration

1. UU is the universal cabinet number (1 for PPN, 2 — 44 for EPNs). C is the carrier designation (A, B, C, D, or E). SS is the number of the slot in which the circuit pack resides (01 to 21). pp is the two digit port number (01, 02, ...).
2. If the error and alarm logs display the switch node carrier location UUC, (cabinet and carrier only), run the *long* test sequence on the active SNC in the carrier, (slot 10 or 12). If the error and alarm logs display a circuit pack location, UUCSS, run the *short* test sequence on the alarmed SNI.

A switch node carrier contains:

- Up to 16 Switch Node Interface (SNI) TN573 circuit packs in slots 2 through 9 and slots 13 through 20
- One or two Switch Node Clock (SNC) TN572 circuit packs in slots 10 and 12
- An Expansion Interface (EI) TN570 circuit pack, a DS1 Converter (DS1C) TN574 circuit pack, or no circuit pack in slot 1
- An optional DS1 CONV circuit pack in slot 21

SN-CONF errors and alarms are generated for two types of failures:

1. Failure of a board in the switch node carrier to insert (be detected by software).
2. A problem found by running the Configuration Audit (test #759). Test 759 is executed for either an SNI or SNC circuit pack during scheduled maintenance or as part of the **test board UUCSS s** command.

For SNI circuit packs, test 759 queries the SNI for SNCs in the same switch node carrier, SNI peers, DS1 CONVs, and EI or SNI neighbors that the SNI can communicate with and compares this data to the administered data.

For SNC circuit packs, test 759 queries the SNC for SNCs and SNIs in the same switch node carrier that the SNC can communicate with and compares this data to the administered data.

Switch node carriers are part of port network connectivity (PNC). For background information about PNC, refer to the Maintenance Architecture and Hardware Configurations chapters and related maintenance objects.

## Error Log Entries and Test to Clear Values

### SN-CONF Error Log Entries

Error Type	Aux Data	Associated Test	Alarm Level	On/Off Board	Test to Clear Value
0 <sup>1</sup>	0	Any	Any	Any	test board UUCSS sh r 1
5000(a)	Any	processor route audit (#760)	MINOR	OFF	test board UUCSS I rep 1
6000(b)	1	configuration audit (#759)	MAJOR	OFF	test board UUCSS rep 1
6000(b)	2	configuration audit (#759)	MAJOR	OFF	test board UUCSS rep 1
6001(c)	Any	configuration audit (#759)	MAJOR	OFF	test board UUCSS rep 1
6002(d)	1	configuration audit (#759)	MAJOR	OFF	test board UUCSS rep 1
6002(d)	2	configuration audit (#759)	MAJOR	OFF	test board UUCSS rep 1
6003(e)	Any	configuration audit (#759)	MAJOR	OFF	test board UUCSS rep 1
6004(f)	Any	configuration audit (#759)	MAJOR	OFF	test board UUCSS rep 1
6005(g)	Any	configuration audit (#759)	MAJOR	OFF	test board UUCSS rep 1
6005(g)	1	configuration audit (#759)	MAJOR	OFF	test board UUCSS rep 1
6005(g)	2	configuration audit (#759)	MAJOR	OFF	test board UUCSS rep 1
6006(h)	Any	configuration audit (#759)	MINOR	OFF	test board UUCSS rep 1
6007(i)	Any	configuration audit (#759)	MINOR	OFF	test board UUCSS rep 1

1. Run the Short Test Sequence first. If all tests pass, run the Long Test Sequence. Refer to the appropriate test description and follow the recommended procedures.

#### Notes:

- a. At least one administered circuit pack in this switch node carrier was not inserted, or one or more administered circuit packs in this switch node carrier did not respond to Test 760 with an up-link board insertion message.

To resolve this error, run test 760 via **test board UUCSS I** for an SNC in the same switch node carrier that has this error.

- b. No neighbor link is administered but the SNI has one. If the aux data is 1, the type of neighbor connected is an EI. If the aux data is 2, the type of neighbor connected is an SNI.

To resolve error type 6000 with aux data 1, refer to FAIL code 133 for test 759. To resolve error type 6000 with aux data 2, refer to FAIL code 134 for test 759.

- c. No neighbor link exists between the SNI and its neighbor, but a neighbor link, i.e. fiber link, is administered.

To resolve this error, refer to FAIL code 135 for test 759.

- d. The physical neighbor type does not match administration. If the aux data is 1, the type of neighbor administered is an SNI and the type of neighbor connected is an EI. If the aux data is 2, the type of neighbor administered is an EI and the type of neighbor connected is an SNI.

To resolve error type 6002 with aux data 1, refer to FAIL code 136 for test 759. To resolve error type 6002 with aux data 2, refer to FAIL code 137 for test 759.

- e. The neighbor location does not match administration.

To resolve this error, refer to FAIL code 138 for test 759.

- f. A peer link does not exist to another equipped SNI. The aux data equals the slot number of the SNI to which this SNI or SNC does not have a peer link. To resolve this error, refer to the FAIL code for test 759 corresponding to the aux data on the following table:

Aux Data (slot no.)	Test 759 FAIL Code
2	102
3	103
4	104
5	105
6	106
7	107
8	108
9	109
13	113
14	114
15	115
16	116
17	117
18	118
19	119
20	120

- g. A link does not exist to one of the SNCs. If the aux data is not 1 or 2, the link from this SNI to the active SNC does not exist. If the aux data is 1, the link from this SNC to the active SNC does not exist. If the aux data is 2, the link from this SNC to the standby SNC does not exist.

To resolve this error, refer to FAIL code 112 for test 759.

- h. The SNI is administered to be connected to a DS1C but is not.

To resolve this error, refer to FAIL code 139 for test 759.

- i. The SNI is connected to a DS1C, but no DS1C is administered.

To resolve this error, refer to FAIL code 140 for test 759.

## System Technician-Demanded Tests: Descriptions and Error Codes

---

Always investigate tests in the order presented in the table below when inspecting errors in the system. By clearing error codes associated with the *Configuration Audit* for example, you may also clear errors generated from other tests in the testing sequence.

Order of Investigation	Short Test Sequence	Long Test Sequence	Reset Board Sequence	D/ND <sup>1</sup>
Configuration Audit (#759)	X	X		ND
Processor Route Audit (#760)		X		ND

- 
1. D = Destructive, ND = Non-destructive

### Configuration Audit (#759)

This test is non-destructive.

#### ⇒ NOTE:

For descriptions of result codes for this test refer to:

- SNC-BD when the circuit pack tested is a Switch Node Clock (circuit pack slots 10 or 12).
- SNI-BD when the circuit pack tested is a Switch Node Interface (circuit pack slots 2-9 or 13-20).

This test is run via the **test board short** or **test board long** command for SNI circuit packs or SNC circuit packs.

For SNI circuit packs, this test queries the SNI for SNCs in the same switch node carrier, SNI peers, DS1Cs, and EI or SNI neighbors that the SNI can communicate with and compares this data to the administered data.

For SNC circuit packs, this test queries the SNC for SNCs and SNIs in the same switch node carrier that the SNC can communicate with and compares this data to the administered data.

Failures of this test cause entries in the error and alarm logs against Switch Node Configuration (SN-CONF) with the board location of the SNI or SNC.



## Incorrectly Connected Administered Fibers

Some physically connected fibers that do not match fiber administration can cause port network problems that are not detected and alarmed by PNC test. The symptoms will usually be phone calls not working correctly, and port network component alarms because of translation mismatches.

This test is unable to detect the case where an SNI is connected to the same type of board (EI or SNI) as administered but located in a different cabinet but the same carrier and same slot as the administered fiber endpoint. The administered fiber endpoint can be viewed with the **list fiber-link** command. This test can only detect if the fiber endpoint connected to the SNI is in a different carrier, slot location than the administered fiber endpoint.

## Incorrectly Connected Administered SNI-EI Fibers

If the SNI is connected to the same type of fiber endpoint as the administered fiber endpoint, but the location is the same as administered except for the cabinet, all phone calls will not work correctly; some phone calls will not go through and some phone calls will ring the wrong phone.

The **test led** command can be used in this case to check connectivity.

1. Run the **test led port-network** command on each administered port network and verify that the LEDs on the correct port network are lit.
2. If they are not lit, check that the fiber connections to the port network are consistent with the administered fibers (**list fiber-link**) that does not light the LEDs as expected.
3. Run **test led switch-node** on each administered switch node carrier and verify that the LEDs on the correct carrier are lit.
4. If they are not, check the connectivity to the switch node carrier that does not light the LEDs as expected.

## Incorrectly Connected SNI-SNI Fibers between 3 Switch Nodes

If the system has more than 2 switch nodes, SNI-SNI fibers administered between 2 switch nodes could be incorrectly connected to a third switch node. This is a problem that could occur during installation or when inter-switch node fibers are changed. For multiple fibers to a distant switch node (not the PPN switch node), an incorrect connection would not appear as a problem unless this fiber is used for a system-link to a port network connected to the distant switch node. The **status system-link** command can be used to determine the boards in the path from the PPN to a specific port network. A specific SNI-SNI fiber connection must be in the system-link path to be checked with the port network LED test.

## Forcing SNI-SNI Fiber Connection

To force an SNI-SNI fiber connection to be used as a system-link remove all SNI-SNI connections except the fiber-link being tested at the distant switch node by removing SNI boards in the distant switch node.

1. Use the **status system-link** command to verify that the fiber selected for test is in the path to the EPN connected to the distant switch node that will be used for the LED test.
2. Run the **test led** sequence to a port network as described above to verify this fiber connection.
3. Repeat the above procedure for each of the SNI-SNI fibers terminating on the distant switch node.

## Testing Multiple Fiber Connections

To test multiple fiber connections to a distant switch node:

1. Use the **list fiber-link** command to determine the number of SNI-SNI fibers that are administered and terminate on the distant switch node.
2. Run the **test led port-network** command on a port network connected to the distant switch node and verify the LEDs on the correct port network are lit.
3. Use the **status system-link** command and select the active EI in the port network connected to the distant port network under test. This display will show the path from the PPN and the SNI-SNI fiber being used.
4. If the port network LEDs are not lit, verify that the fiber connections to the port network are consistent with the administration assignments by using the **list fiber-link** command.
5. If the port network LEDs are lit and there are multiple fibers to the distant switch node, remove the SNC that is listed by the **list fiber-link** command for this path.
6. Use the **status system-link** command to determine the new path from the PPN to the distant switch.
7. Run the **test led port-network** command on a port network connected to the distant switch node and verify that the LEDs on the correct port network are lit.
8. Repeat steps 5 — 7 until all SNI-SNI fiber connections to the distant switch have been tested.

## Processor Route Audit Test (#760)

This test is non-destructive.

This test sends processor routes to all SNIs and SNCs in the same carrier as the SNC that the **test board UCSS** command was run for. The processor route is

used for the boards to send uplink messages to the SPE and gives a sequence of boards for the message to get routed through so that the message ends up at the SPE. If the SNI and SNC boards do not have processor routes, they will not be able to send any in-line errors to the SPE.

When each individual board receives the processor routes, it sends a board insertion message uplink and software inserts that board if it has not already been inserted. Each board is sent either one or two processor routes depending on the configuration.

The **test led** or **list config carrier** command can be used to see whether boards are inserted.

The processor route test is run as part of the long test sequence for SNC boards.

**Table 9-548. TEST #760 Processor Route Audit Test**

Error Code	Test Result	Description/ Recommendation
2100	ABORT	Could not allocate the necessary system resources to run this test. 1. Retry the command at 1-minute intervals a maximum of 3 times.
2300	ABORT	The downlink message necessary to run this test could not be sent. 1. Retry the command at 1-minute intervals a maximum of 3 times.
2301	ABORT	The software timer could not be set before sending the downlink message necessary to run this test. 1. Retry the command at 1-minute intervals a maximum of 3 times.
2306	ABORT	None of the circuit packs in this switch node carrier are responding to the processor route messages sent by software. 1. Run the <b>test led switch-node</b> for the switch node that this switch node carrier resides in to verify whether the LEDs on any of the boards light. 2. If none of the LEDs light for the boards in this carrier, fix any problems associated with the connectivity of this carrier to the SPE. Use <b>list fiber-link</b> to determine the fiber connections to this carrier. Check the LEDs on all SNIs and EIs and fix any fiber problems. Enter <b>display errors</b> and follow the associated repair procedures for any EXP-INTF error entries associated with the PPN. Also, follow the associated repair procedures for any SYNC, SNI-BD, SNC-BD, FIBER-LK, or SNI-PEER error entries.
2500	ABORT	Internal System Error 1. Retry the command at 1-minute intervals a maximum of 3 times.

*Continued on next page*

Table 9-548. TEST #760 Processor Route Audit Test — *Continued*

Error Code	Test Result	Description/ Recommendation
	FAIL	<p>If this test fails, not all of the administered circuit packs in this switch node carrier responded with an up-link board insertion message. Check to see that administered SNI and SNC boards match the physically installed SNI and SNC boards by entering <b>list config carrier UUC</b>. The command output will show "NO BOARD" for every board that is administered, but not inserted.</p> <ul style="list-style-type: none"> <li>■ If all administered boards are inserted, run this test again.</li> <li>■ If administration does not match the physical configuration, and is <i>correct</i>, insert the missing circuit packs in this switch node carrier.</li> <li>■ If administration does not match the physical configuration, and is <i>incorrect</i>, change the administration and run this test again.</li> <li>■ If <i>none</i> of the administered boards in this switch node carrier were inserted, fix any other SN-CONF errors by following the associated repair procedures for SN- CONF. Use <b>display errors</b> with category <b>pnc</b> to view SN-CONF errors. Next check if any INLs, LNLs, or RNLs are down with <b>list sys-link</b>. If any INLs, LNLs, or RNLs are down, refer to the SYS-LINK section for fixing link problems.</li> </ul>
	PASS	<p>If this test passes, all of the administered circuit packs in this switch node carrier were inserted.</p>

## SNC-BD (Switch Node Clock Circuit Pack)

---

MO Name (in Alarm Log)	Alarm Level	Initial Command to Run <sup>1</sup>	Full Name of MO
SNC-BD	MAJOR	test board UUCSS s	SNC Circuit Pack
SNC-BD	MINOR	test board UUCSS s	SNC Circuit Pack

1. UU is the universal cabinet number (1 for PPN, 2 - 44 for EPNs). C is the carrier designation (A, B, C, D, or E). SS is the number of the slot in which the circuit pack resides (10 or 12).

The Switch Node Clock (SNC) TN572 circuit pack is part of the Center Stage Switch (CSS) configuration. It resides in a switch node carrier that alone or with other switch nodes make up a CSS. In a high reliability system (duplicated SPE, simplex PNC), each SNC is duplicated such that there are two SNCs on each switch node carrier. In a critical reliability system (duplicated SPE and PNC), each switch node is fully duplicated, and there is one SNC on each switch node carrier. SNCs are placed in slots 10 and 12 of the switch node carrier.

The active SNC communicates with each circuit pack in the switch node carrier over the serial channel bus on the backplane. In addition, the active SNC provides timing to the circuit packs in the switch node carrier via the clock busses. The active SNC uses Timing Priority Number (TPN) links with each Switch Node Interface (SNI) and the other SNC to receive and distribute TPNs. TPNs are used for setting up the correct timing distribution for the switch node carrier. The active SNC receives timing for the switch node carrier from each SNI circuit pack in the carrier and chooses the SNI with the best timing reference for the switch node carrier timing signal the SNC puts out on the clock busses. The timing reference for each SNI is derived from the fiber signal to each SNI. The active SNC chooses the SNI to receive timing from by choosing the SNI with the lowest numbered TPN which means that the SNI is closest to the system timing source. The active SNC also verifies that the SNI reference signal is good before using that SNI as the timing reference for the switch node carrier. The active SNC then supplies this timing over the clock busses on the backplane to all the SNI and SNC circuit packs in the carrier. For more information on timing synchronization including how the SNC fits into the overall synchronization configuration, see the SYNC section.

The SNC circuit packs are associated with three maintenance objects:

- The SNC-BD MO covers general SNC board errors and errors with the serial communication channel between the active and standby SNCs.
- The SNC-LINK MO covers errors between the active SNC and SNIs over the serial channel (aux data is 1). Also, the SNC-LINK MO covers TPN Link errors between the active SNC and SNIs (aux data is 2).
- The SNC-REF MO covers errors the active SNC detects with SNI reference signals.

SNC circuit packs are part of port network connectivity (PNC). For background information about PNC, refer to the Maintenance Architecture and Hardware Configurations chapters.

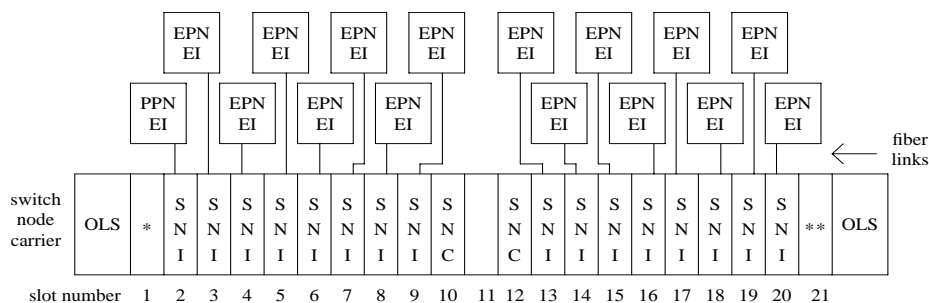

\* = An EI or a DS1C circuit pack may reside in this slot  
 \*\* = A DS1C circuit pack may reside in this slot

Switch Node Clock (SNC) TN572  
 Switch Node Interface (SNI) TN573  
 Expansion Interface (EI) TN570  
 DS1 Converter (DS1C) TN574  
 Online Switcher (OLS) power supply

**Figure 9-82. A Center Stage Switch Configuration**

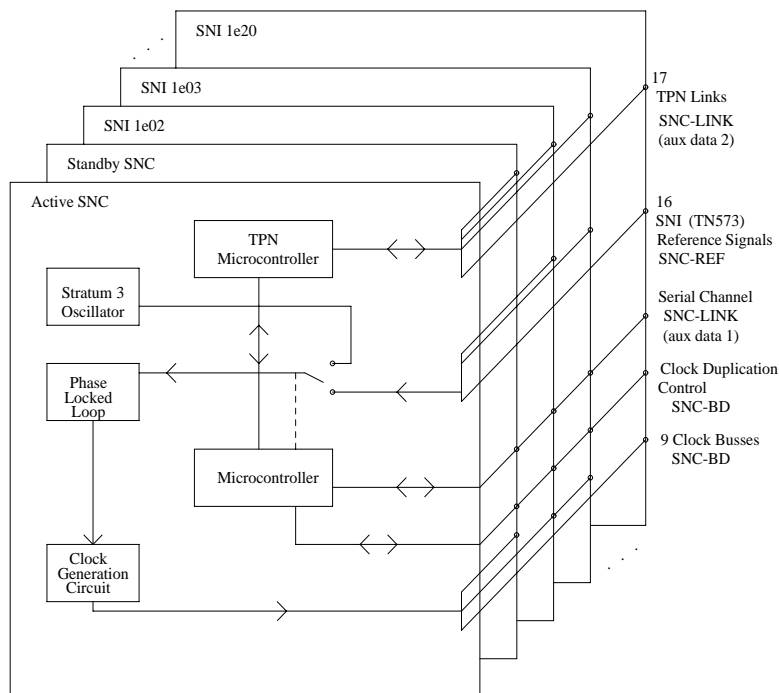

**Figure 9-83. SNC Functions**

## SNC LEDs

SNC circuit packs have the standard red, green and yellow LEDs. The red and green LEDs operate as usual: red means an alarm condition and green indicates maintenance testing in progress. If the yellow LED is lit this indicates that the SNC is the active circuit pack, supplying timing to the carrier. In a high reliability system (duplicated SPE, simplex PNC), the standby SNC on a carrier will be unlit. In a critical reliability system (duplicated PNC), an SNC on a standby switch node carrier will be lit since it is providing timing for the standby carrier.

## Clear Firmware-Counters Command

SNC firmware generates error reports independently of technician-demanded tests. Therefore, the **test board** UUCSS clear command will not affect the error status reported by firmware. The **clear firmware-counters** command will clear all firmware-generated errors unconditionally.

The **clear firmware-counters** UUCSS command sends a downlink message to the SNC circuit pack, causing it to clear out its firmware error counters and failure

database. Once the firmware failure database is cleared, the failure audit test (#777) will pass. If problems still exist, the firmware will increment its error counters and the failure audit test will begin failing again.

This command should not be used as a replacement for the repair procedures associated with the hardware error log entries. This command may be useful if a problem has been fixed and off-board alarms associated with the problem are still active.

## Replacing SNC Circuit Packs

---

### **WARNING:**

*Do not power down a Switch Node carrier to replace a circuit pack.  
Replacing an SNC on a system with unduplicated SNCs disrupts service.*

## Standard Reliability System (Simplex SPE, PNC and SNCs)

**This procedure is destructive. Any links through the switch node carrier will go down.**

1. Pull out the SNC circuit pack to be replaced.
2. Insert a new SNC circuit pack.
3. Wait for the SNC to reset. (The red and green LEDs light and then go out. The yellow LED should be on solid.)
4. **Test alarm long clear** category **exp-intf**. **Do not busyout the Expansion Interface circuit packs.**
5. Wait 5 minutes for SNI-BD, SNI-PEER, FIBER-LK, and DS1 CONV-BD alarms to clear, or enter **clear firmware-counters**.

## High Reliability System (Duplicated SPE and SNCs, Simplex PNC)

**This procedure is non-destructive.**

1. If the SNC circuit pack to be replaced is the active SNC in the switch node carrier (yellow LED is on solid), first set the standby SNC to active via the **set switch-node-clock** command.
2. When the SNC circuit pack is in standby mode (yellow LED is off), pull out the SNC circuit pack to be replaced.
3. Insert a new SNC circuit pack.
4. Wait for the SNC to reset. (The red and green LEDs light and then go out.) The yellow LED should be off since the SNC circuit pack is in standby mode.



## Critical Reliability System (Duplicated SPE and PNC)

### **WARNING:**

*On a system with duplicated PNC, synchronization may be provided over a combination of active and standby components. This condition is indicated by an OFF-BOARD WARNING alarm against TDM-CLK with error type 2305. Repairs to standby PNC in this state may disrupt service. Otherwise, if the active PNC is functional, replacement of a standby component will not disrupt service.*

#### STEPS:

Enter **status pnc**                      Verify that the component to be replaced is on the standby PNC.

Enter **busyout pnc**

Enter **busyout board**                      UUCSS represents the cabinet-carrier-slot address of the circuit pack  
**UUCSS**                                      to be replaced.

Replace the circuit pack

Enter **release board**  
**UUCSS**

### **CAUTION:**

*Do not busyout any Expansion Interface circuit pack after this point.*

Enter **test alarms long**  
**clear** for category  
**exp-intf**

Wait 5 minutes for SNI-BD,                      Use the letter designation of the pnc which holds the replaced  
SNI-PEER, FIBER-LK, and                      component (the standby pnc).  
DS1C alarms to clear, or  
enter **clear firmware**  
**counters <a-pnc or**  
**b-pnc>**

Enter **status pnc**                      If either PNC state-of-health is not "functional", consult the ["PNC-DUP \(PNC Duplication\)"](#) section.

Enter **release pnc**

## Error Log Entries and Test to Clear Values

**Table 9-549. SNC Board Error Log Entries**

Error Type	Aux Data	Associated Test	Alarm Level	On/Off Board	Test to Clear Value
0 <sup>1</sup>	0	Any	Any	Any	test board UUCSS r 1
1(a)	Any	Failure Audit (#777)	MAJOR	ON	test board UUCSS r 1
18(b)	0	busyout board UCSS	WARNING	OFF	release board UCSS
257(c)	Any	Failure Audit (#777)	MAJOR	OFF	test board UUCSS r 1
513(d)	Any	Failure Audit (#777)	MINOR	OFF	test board UUCSS r 1
769(e)	Any	Failure Audit (#777)	MINOR	OFF	test board UUCSS r 1
1025(f)	Any	Failure Audit (#777)	MAJOR	ON	test board UUCSS r 1
1281(g)	Any	Failure Audit (#777)	MINOR	OFF	test board UUCSS r 1
1537(h)	Any	Failure Audit (#777)	MINOR	ON	test board UUCSS r 1
1793(i)	Any	Failure Audit (#777)	MAJOR	ON	test board UUCSS r 1
2049(j)	Any	Failure Audit (#777)	MAJOR	ON	test board UUCSS r 1

1. Run the Short Test Sequence first. If all tests pass, run the Long Test Sequence. Refer to the appropriate test description and follow the recommended procedures.

### Notes:

- a. Error type 1 indicates SNC on-board microcontroller error. (This occurs whenever the microcontroller sanity test fails, the ROM has problems, the processor internal or external RAM is faulty, or the firmware instruction test fails. In addition, this error indicates problems with the interrupt capabilities, the dual port RAM and the RTM (Real Time Monitor) interface on the faceplate of the SNC.)

Replace the SNC circuit pack.

- b. This error indicates that the SNC circuit pack has been busied out via the **busyout board UCSS** command. To resolve this error, release the SNC circuit pack via the **release board UCSS** command.

- c. These errors occur whenever firmware detects failure of the phase-locked loop, inability to lock, or failure of the clock drivers and the problem is off-board.

1. Enter **display errors** and if SNC-BD error type 1793 exists in the hardware error log, follow the associated repair procedures for SNC-BD error 1793.

2. Enter **display errors** and if no SNI-BD 1025 errors exist in the error log, replace the active SNC.
  3. Enter **display errors** and if any SNI-BD 1025 errors exist in the error log, follow the associated repair procedure in the SNI-BD section for these errors.
- d. This error occurs whenever the active SNC determines that there is a problem communicating with the standby SNC via the connecting serial channel.

**If the switch node carrier is administered with duplicate SNCs:**

1. If the standby SNC (the one with its yellow LED off) has this error, escalate the problem. (**Status switch-node** will also display the active and standby SNCs.)
2. If the system originally had duplicate SNCs and the standby SNC was removed and never replaced and the active SNC has not been reset after the standby SNC was removed, this error will occur.

**If you do not intend to replace the SNC:**

- a. Remove the standby SNC from circuit pack administration via **change circuit-pack**.
- b. If the problem persists, replace the active SNC circuit pack.

**Otherwise:**

- a. Insert an SNC circuit pack.
3. Check the error log via **display errors**. If SNIs in the switch node carrier also have problems communicating with the active SNC, i.e. error code 257 is logged against SNI-BD, then replace the active SNC.
4. Replace the standby SNC circuit pack.
5. Retry the **test board** command. Check the error log via **display errors**. If this error is still in the error log, replace the active SNC.

**If the switch node carrier is administered with only one SNC:**

1. If step 2 above does not apply, replace the SNC.
- e. This error occurs whenever the standby SNC determines that there is a problem communicating with the active SNC via the connecting serial channel.
1. If the active SNC (the one with its yellow LED on) has this error, escalate the problem. (**Status switch-node** will also display the active and standby SNCs.)
  2. Check the error log via **display errors**. If more than one SNI in the switch node carrier has problems communicating with the active SNC, i.e. error code 257 is logged against SNI-BD, then replace the active SNC.

3. If a single SNI has SNI-BD error 257, replace the SNI circuit pack.
  4. Replace the standby SNC circuit pack.
  5. Retry the **test board** command. Check the error log via **display errors**. If this error is still in the error log, replace the active SNC.
- f. This error occurs when the firmware detects problems with the various hardware circuit monitors (e.g. loss of reference monitor) that verify correct operation of the reference links.

Replace the SNC circuit pack.

- g. This error occurs when the firmware detects problems with the interface used to track the status of both SNCs when there are duplicated SNCs in a switch node carrier. When this error occurs, software may have incorrect information from SNC firmware for which SNC is active. Therefore, the yellow LEDs on the SNCs must be checked in the following repair procedure and the **status switch-node** command should not be used when this error type occurs.

If the switch node carrier has duplicate SNCs:

1. Replace the SNC that does not have its yellow LED lit.
2. Retry the **test board** command. Check the error log via **display errors**. If this error is still in the error log, replace the SNC that has its yellow LED lit.

If the switch node carrier has only one SNC, replace the SNC.

- h. This error occurs whenever a loss of signal from the SNC on-board Stratum 3 oscillator is detected by the firmware.

Replace the SNC circuit pack.

- i. These errors occur whenever firmware detects failure of the phase-locked loop, inability to lock, or failure of the clock drivers and the problem is on-board.

Replace the SNC circuit pack.

If the error persists, follow normal escalation procedures.

- j. This error occurs when the firmware detects problems with the microcontroller used for Timing Priority Number processing.

Replace the SNC circuit pack.

## System Technician-Demanded Tests: Descriptions and Error Codes

---

Always investigate tests in the order presented in the table below when inspecting errors in the system. By clearing error codes associated with the *configuration audit* for example, you may also clear errors generated from other tests in the testing sequence.

Order of Investigation	Short Test Sequence	Long Test Sequence	Reset Board Sequence	D/ND <sup>1</sup>
Configuration Audit (#759)	X	X		ND
Failure Audit(#777)	X	X		ND
Processor Route Audit(#760)		X		ND
SNC On-Board Test(#778)	X	X		ND
TPN Test(#779)	X	X		ND
Switch Node Clock Reset Test(#780)			X	D

1. D = Destructive, ND = Non-destructive

### ⇒ NOTE:

Test #983 is not an actual demand maintenance test. This test number is used to report results of executing of the **clear firmware-counters** command. Refer to error codes for Test #777.

### Configuration Audit (#759)

This test is non-destructive.

This test is run via the **test board short** or **test board long** command for SNC circuit packs.

For SNC circuit packs, this test queries the SNC for SNCs and SNIs in the same switch node carrier that the SNC can communicate with and compares this data to the administered data.

Failures of this test cause entries in the error and alarm logs against Switch Node Configuration (SN-CONF) with the board location of the SNC.

**Table 9-550. TEST #759 Configuration Audit**

Error Code	Test Result	Description/ Recommendation
2100	ABORT	Could not allocate the necessary system resources to run this test. 1. Retry the command at 1-minute intervals a maximum of 3 times.
2300	ABORT	The downlink message necessary to run this test could not be sent. 1. Retry the command at 1-minute intervals a maximum of 3 times.
2301	ABORT	The software timer could not be set before sending the downlink message necessary to run this test. 1. Retry the command at 1-minute intervals a maximum of 3 times.
2306	ABORT	The SNC circuit pack is not responding to test requests sent by software. 1. Run the <b>test led switch-node</b> for the switch node that this board resides in to verify whether the LEDs on the board light. 2. If the LEDs on the other boards in the carrier light, but the LEDs on this board do not light, run test 760 via <b>test board UUCSS I</b> for the active SNC in this carrier. Wait 5 minutes and then try step 1 one more time. If the LEDs on this board still do not light, replace this board. Replacing an SNC may be service interrupting. Refer to the SNC-BD section for the procedure for replacing an SNC. 3. If none of the LEDs light for the boards in the same carrier as this board, fix any problems associated with the connectivity of this carrier to the SPE. Check <b>list fibers</b> to determine the fiber connections to this carrier. Check the LEDs on all SNIs and EIs and fix any fiber problems. Enter <b>display errors</b> and follow the associated repair procedures for any EXP-INTF error entries associated with the PPN. Also, follow the associated repair procedures for any SYNC, SNI-BD, SNC-BD, FIBER-LK, or SNI-PEER error entries.
2500	ABORT	Internal System Error 1. Retry the command at 1-minute intervals a maximum of 3 times.

*Continued on next page*

Table 9-550. TEST #759 Configuration Audit — *Continued*

Error Code	Test Result	Description/ Recommendation
102	FAIL	<p>The SNC circuit pack cannot communicate with the SNI in slot 2.</p> <ol style="list-style-type: none"> <li>1. If a standby SNC (one with its yellow LED off) was tested and resulted in this error code, follow normal escalation procedures. (<b>status switch-node</b> will also display the active and standby SNCs.)</li> <li>2. Use <b>list configuration carrier</b> to determine whether an SNI is physically present in slot 2. If the <code>Vintage</code> field indicates that a circuit pack is present, proceed to step 3. If the <code>Vintage</code> field reports <code>no board</code>, do one of the following:                         <ul style="list-style-type: none"> <li>■ If an SNI is not supposed to be installed in slot 2:                                 <ol style="list-style-type: none"> <li>a. This failure will not affect service. The missing SNI can be removed from administration with <b>change circuit-pack</b>.</li> <li>b. If the error persists, reset the active SNC circuit pack with <b>reset board UUCSS</b>. If the error still persists, replace the active SNC circuit pack.</li> </ol> </li> <li>■ If an SNI is supposed to be installed in slot 2, insert one.</li> </ul> </li> <li>3. <b>Display errors</b> for category <b>pnc</b>. If the SNC has SNC-BD error 513, or SNC-LINK errors with aux data 1 pointing to other SNIs besides the one in slot 2, replace the active SNC circuit pack.</li> <li>4. If SNIs in the same carrier have SNI-BD error 257 logged, (indicating they are having trouble communicating with the SNC), replace the active SNC circuit pack.</li> <li>5. If the SNC being tested has SNC-LINK error type 1, replace the SNI in slot 2. Replacing an SNI may interrupt service. Refer to the SNI-BD section for the procedure for replacing an SNI.</li> <li>6. If the SNC being tested still has SNC-LINK error type 1, replace the SNC circuit pack.</li> </ol>

*Continued on next page*

**Table 9-550. TEST #759 Configuration Audit — Continued**

Error Code	Test Result	Description/ Recommendation
103	FAIL	<p>The SNC circuit pack cannot communicate with the SNI in slot 3.</p> <ol style="list-style-type: none"> <li>1. If a standby SNC (one with its yellow LED off) was tested and resulted in this error code, follow normal escalation procedures. (<b>status switch-node</b> will also display the active and standby SNCs.)</li> <li>2. Use <b>list configuration carrier</b> to determine whether an SNI is physically present in slot 3. If the <code>Vintage</code> field indicates that a circuit pack is present, proceed to step 3. If the <code>Vintage</code> field reports <code>no board</code>, do one of the following:                         <ul style="list-style-type: none"> <li>■ If an SNI is not supposed to be installed in slot 3:                                 <ol style="list-style-type: none"> <li>a. This failure will not affect service. The missing SNI can be removed from administration with <b>change circuit-pack</b>.</li> <li>b. If the error persists, reset the active SNC circuit pack with <b>reset board UUCSS</b>. If the error still persists, replace the active SNC circuit pack.</li> </ol> </li> <li>■ If an SNI is supposed to be installed in slot 3, insert one.</li> </ul> </li> <li>3. <b>Display errors</b> for category <b>pnc</b>. If the SNC has SNC-BD error 513, or SNC-LINK errors with aux data 1 pointing to other SNIs besides the one in slot 3, replace the active SNC circuit pack.</li> <li>4. If SNIs in the same carrier have SNI-BD error 257 logged, (indicating they are having trouble communicating with the SNC), replace the active SNC circuit pack.</li> <li>5. If the SNC being tested has SNC-LINK error type 257, replace the SNI in slot 3. Replacing an SNI may interrupt service. Refer to the SNI-BD section for the procedure for replacing an SNI.</li> <li>6. If the SNC being tested still has SNC-LINK error type 257, replace the SNC circuit pack.</li> </ol>

*Continued on next page*



**Table 9-550. TEST #759 Configuration Audit — Continued**

Error Code	Test Result	Description/ Recommendation
104	FAIL	<p>The SNC circuit pack cannot communicate with the SNI in slot 4.</p> <ol style="list-style-type: none"> <li>1. If a standby SNC (one with its yellow LED off) was tested and resulted in this error code, follow normal escalation procedures. (<b>status switch-node</b> will also display the active and standby SNCs.)</li> <li>2. Use <b>list configuration carrier</b> to determine whether an SNI is physically present in slot 4. If the <code>Vintage</code> field indicates that a circuit pack is present, proceed to step 3. If the <code>Vintage</code> field reports <code>no board</code>, do one of the following:                         <ul style="list-style-type: none"> <li>■ If an SNI is not supposed to be installed in slot 4:                                 <ol style="list-style-type: none"> <li>a. This failure will not affect service. The missing SNI can be removed from administration with <b>change circuit-pack</b>.</li> <li>b. If the error persists, reset the active SNC circuit pack with <b>reset board UUCSS</b>. If the error still persists, replace the active SNC circuit pack.</li> </ol> </li> <li>■ If an SNI is supposed to be installed in slot 4, insert one.</li> </ul> </li> <li>3. <b>Display errors</b> for category <b>pnc</b>. If the SNC has SNC-BD error 513, or SNC-LINK errors with aux data 1 pointing to other SNIs besides the one in slot 4, replace the active SNC circuit pack.</li> <li>4. If SNIs in the same carrier have SNI-BD error 257 logged, (indicating they are having trouble communicating with the SNC), replace the active SNC circuit pack.</li> <li>5. If the SNC being tested has SNC-LINK error type 513, replace the SNI in slot 4. Replacing an SNI may interrupt service. Refer to the SNI-BD section for the procedure for replacing an SNI.</li> <li>6. If the SNC being tested still has SNC-LINK error type 513, replace the SNC circuit pack.</li> </ol>

*Continued on next page*

**Table 9-550. TEST #759 Configuration Audit — Continued**

Error Code	Test Result	Description/ Recommendation
105	FAIL	<p>The SNC circuit pack cannot communicate with the SNI in slot 5.</p> <ol style="list-style-type: none"> <li>1. If a standby SNC (one with its yellow LED off) was tested and resulted in this error code, follow normal escalation procedures. (<b>status switch-node</b> will also display the active and standby SNCs.)</li> <li>2. Use <b>list configuration carrier</b> to determine whether an SNI is physically present in slot 5. If the <code>Vintage</code> field indicates that a circuit pack is present, proceed to step 3. If the <code>Vintage</code> field reports <code>no board</code>, do one of the following:                         <ul style="list-style-type: none"> <li>■ If an SNI is not supposed to be installed in slot 5:                                 <ol style="list-style-type: none"> <li>a. This failure will not affect service. The missing SNI can be removed from administration with <b>change circuit-pack</b>.</li> <li>b. If the error persists, reset the active SNC circuit pack with <b>reset board UUCSS</b>. If the error still persists, replace the active SNC circuit pack.</li> </ol> </li> <li>■ If an SNI is supposed to be installed in slot 5, insert one.</li> </ul> </li> <li>3. <b>Display errors</b> for category <b>pnc</b>. If the SNC has SNC-BD error 513, or SNC-LINK errors with aux data 1 pointing to other SNIs besides the one in slot 5, replace the active SNC circuit pack.</li> <li>4. If SNIs in the same carrier have SNI-BD error 257 logged, (indicating they are having trouble communicating with the SNC), replace the active SNC circuit pack.</li> <li>5. If the SNC being tested has SNC-LINK error type 769, replace the SNI in slot 5. Replacing an SNI may interrupt service. Refer to the SNI-BD section for the procedure for replacing an SNI.</li> <li>6. If the SNC being tested still has SNC-LINK error type 769, replace the SNC circuit pack.</li> </ol>

*Continued on next page*

**Table 9-550. TEST #759 Configuration Audit — Continued**

Error Code	Test Result	Description/ Recommendation
106	FAIL	<p>The SNC circuit pack cannot communicate with the SNI in slot 6.</p> <ol style="list-style-type: none"> <li>1. If a standby SNC (one with its yellow LED off) was tested and resulted in this error code, follow normal escalation procedures. (<b>status switch-node</b> will also display the active and standby SNCs.)</li> <li>2. Use <b>list configuration carrier</b> to determine whether an SNI is physically present in slot 6. If the <code>Vintage</code> field indicates that a circuit pack is present, proceed to step 3. If the <code>Vintage</code> field reports <code>no board</code>, do one of the following:                         <ul style="list-style-type: none"> <li>■ If an SNI is not supposed to be installed in slot 6:                                 <ol style="list-style-type: none"> <li>a. This failure will not affect service. The missing SNI can be removed from administration with <b>change circuit-pack</b>.</li> <li>b. If the error persists, reset the active SNC circuit pack with <b>reset board UUCSS</b>. If the error still persists, replace the active SNC circuit pack.</li> </ol> </li> <li>■ If an SNI is supposed to be installed in slot 6, insert one.</li> </ul> </li> <li>3. <b>Display errors</b> for category <b>pnc</b>. If the SNC has SNC-BD error 513, or SNC-LINK errors with aux data 1 pointing to other SNIs besides the one in slot 6, replace the active SNC circuit pack.</li> <li>4. If SNIs in the same carrier have SNI-BD error 257 logged, (indicating they are having trouble communicating with the SNC), replace the active SNC circuit pack.</li> <li>5. If the SNC being tested has SNC-LINK error type 1025, replace the SNI in slot 6. Replacing an SNI may interrupt service. Refer to the SNI-BD section for the procedure for replacing an SNI.</li> <li>6. If the SNC being tested still has SNC-LINK error type 1025, replace the SNC circuit pack.</li> </ol>

*Continued on next page*

**Table 9-550. TEST #759 Configuration Audit — Continued**

Error Code	Test Result	Description/ Recommendation
107	FAIL	<p>The SNC circuit pack cannot communicate with the SNI in slot 7.</p> <ol style="list-style-type: none"> <li>1. If a standby SNC (one with its yellow LED off) was tested and resulted in this error code, follow normal escalation procedures. (<b>status switch-node</b> will also display the active and standby SNCs.)</li> <li>2. Use <b>list configuration carrier</b> to determine whether an SNI is physically present in slot 7. If the <code>Vintage</code> field indicates that a circuit pack is present, proceed to step 3. If the <code>Vintage</code> field reports <code>no board</code>, do one of the following:                         <ul style="list-style-type: none"> <li>■ If an SNI is not supposed to be installed in slot 7:                                 <ol style="list-style-type: none"> <li>a. This failure will not affect service. The missing SNI can be removed from administration with <b>change circuit-pack</b>.</li> <li>b. If the error persists, reset the active SNC circuit pack with <b>reset board UUCSS</b>. If the error still persists, replace the active SNC circuit pack.</li> </ol> </li> <li>■ If an SNI is supposed to be installed in slot 7, insert one.</li> </ul> </li> <li>3. <b>Display errors</b> for category <b>pnc</b>. If the SNC has SNC-BD error 513, or SNC-LINK errors with aux data 1 pointing to other SNIs besides the one in slot 7, replace the active SNC circuit pack.</li> <li>4. If SNIs in the same carrier have SNI-BD error 257 logged, (indicating they are having trouble communicating with the SNC), replace the active SNC circuit pack.</li> <li>5. If the SNC being tested has SNC-LINK error type 1281, replace the SNI in slot 7. Replacing an SNI may interrupt service. Refer to the SNI-BD section for the procedure for replacing an SNI.</li> <li>6. If the SNC being tested still has SNC-LINK error type 1281, replace the SNC circuit pack.</li> </ol>

*Continued on next page*

**Table 9-550. TEST #759 Configuration Audit — Continued**

Error Code	Test Result	Description/ Recommendation
108	FAIL	<p>The SNC circuit pack cannot communicate with the SNI in slot 8.</p> <ol style="list-style-type: none"> <li>1. If a standby SNC (one with its yellow LED off) was tested and resulted in this error code, follow normal escalation procedures. (<b>status switch-node</b> will also display the active and standby SNCs.)</li> <li>2. Use <b>list configuration carrier</b> to determine whether an SNI is physically present in slot 8. If the <code>Vintage</code> field indicates that a circuit pack is present, proceed to step 3. If the <code>Vintage</code> field reports <code>no board</code>, do one of the following:                         <ul style="list-style-type: none"> <li>■ If an SNI is not supposed to be installed in slot 8:                                 <ol style="list-style-type: none"> <li>a. This failure will not affect service. The missing SNI can be removed from administration with <b>change circuit-pack</b>.</li> <li>b. If the error persists, reset the active SNC circuit pack with <b>reset board UUCSS</b>. If the error still persists, replace the active SNC circuit pack.</li> </ol> </li> <li>■ If an SNI is supposed to be installed in slot 8, insert one.</li> </ul> </li> <li>3. <b>Display errors</b> for category <b>pnc</b>. If the SNC has SNC-BD error 513, or SNC-LINK errors with aux data 1 pointing to other SNIs besides the one in slot 8, replace the active SNC circuit pack.</li> <li>4. If SNIs in the same carrier have SNI-BD error 257 logged, (indicating they are having trouble communicating with the SNC), replace the active SNC circuit pack.</li> <li>5. If the SNC being tested has SNC-LINK error type 1537, replace the SNI in slot 8. Replacing an SNI may interrupt service. Refer to the SNI-BD section for the procedure for replacing an SNI.</li> <li>6. If the SNC being tested still has SNC-LINK error type 1537, replace the SNC circuit pack.</li> </ol>

*Continued on next page*

**Table 9-550. TEST #759 Configuration Audit — Continued**

Error Code	Test Result	Description/ Recommendation
109	FAIL	<p>The SNC circuit pack cannot communicate with the SNI in slot 9.</p> <ol style="list-style-type: none"> <li>1. If a standby SNC (one with its yellow LED off) was tested and resulted in this error code, follow normal escalation procedures. (<b>status switch-node</b> will also display the active and standby SNCs.)</li> <li>2. Use <b>list configuration carrier</b> to determine whether an SNI is physically present in slot 9. If the <code>Vintage</code> field indicates that a circuit pack is present, proceed to step 3. If the <code>Vintage</code> field reports <code>no board</code>, do one of the following:                         <ul style="list-style-type: none"> <li>■ If an SNI is not supposed to be installed in slot 9:                                 <ol style="list-style-type: none"> <li>a. This failure will not affect service. The missing SNI can be removed from administration with <b>change circuit-pack</b>.</li> <li>b. If the error persists, reset the active SNC circuit pack with <b>reset board UUCSS</b>. If the error still persists, replace the active SNC circuit pack.</li> </ol> </li> <li>■ If an SNI is supposed to be installed in slot 9, insert one.</li> </ul> </li> <li>3. <b>Display errors</b> for category <b>pnc</b>. If the SNC has SNC-BD error 513, or SNC-LINK errors with aux data 1 pointing to other SNIs besides the one in slot 9, replace the active SNC circuit pack.</li> <li>4. If SNIs in the same carrier have SNI-BD error 257 logged, (indicating they are having trouble communicating with the SNC), replace the active SNC circuit pack.</li> <li>5. If the SNC being tested has SNC-LINK error type 1793, replace the SNI in slot 9. Replacing an SNI may interrupt service. Refer to the SNI-BD section for the procedure for replacing an SNI.</li> <li>6. If the SNC being tested still has SNC-LINK error type 1793, replace the SNC circuit pack.</li> </ol>

*Continued on next page*

**Table 9-550. TEST #759 Configuration Audit — Continued**

Error Code	Test Result	Description/ Recommendation
112	FAIL	<p>The SNC circuit pack cannot communicate with the other SNC.</p> <p><b>If this test was run on the active SNC and if the switch node carrier is administered with duplicate SNCs:</b></p> <ol style="list-style-type: none"> <li>1. If the system originally had duplicate SNCs and the standby SNC was removed and never replaced, this error will occur. <i>If you do not intend to replace the SNC:</i> <ol style="list-style-type: none"> <li>a. Remove the standby SNC from circuit pack administration via <b>change circuit-pack</b>.</li> <li>b. If the problem persists, reset the active SNC circuit pack via <b>reset board UUCSS</b>. If the problem persists after the reset, replace the active SNC circuit pack.</li> </ol> </li> <li>2. Check the error log via <b>display errors</b>. If SNIs in the switch node carrier also have problems communicating with the active SNC, i.e. error code 257 is logged against SNI-BD, then replace the active SNC.</li> <li>3. Replace the standby SNC circuit pack.</li> <li>4. Retry the <b>test board</b> command. If this test continues to fail, replace the active SNC.</li> </ol> <p><b>If this test was run on the active SNC and if the switch node carrier is administered with only one SNC:</b></p> <ol style="list-style-type: none"> <li>1. Replace the SNC.</li> </ol>
112	FAIL (cont'd.)	<p><b>If this test was run on the standby SNC:</b></p> <ol style="list-style-type: none"> <li>1. Check the error log via <b>display errors</b>. If more than one SNI in the switch node carrier has problems communicating with the active SNC, i.e. error code 257 is logged against SNI-BD, then replace the active SNC.</li> <li>2. Replace the standby SNC circuit pack.</li> <li>3. Retry the <b>test board</b> command. Check the error log via <b>display errors</b>. If this error is still in the error log, replace the active SNC.</li> </ol>

*Continued on next page*

Table 9-550. TEST #759 Configuration Audit — *Continued*

Error Code	Test Result	Description/ Recommendation
113	FAIL	<p>The SNC circuit pack cannot communicate with the SNI in slot 13.</p> <ol style="list-style-type: none"> <li>1. If a standby SNC (one with its yellow LED off) was tested and resulted in this error code, follow normal escalation procedures. (<b>status switch-node</b> will also display the active and standby SNCs.)</li> <li>2. Use <b>list configuration carrier</b> to determine whether an SNI is physically present in slot 13. If the <code>Vintage</code> field indicates that a circuit pack is present, proceed to step 3. If the <code>Vintage</code> field reports <code>no board</code>, do one of the following:                     <p>If an SNI is not supposed to be installed in slot 13:</p> <ol style="list-style-type: none"> <li>a. This failure will not affect service. The missing SNI can be removed from administration with <b>change circuit-pack</b>.</li> <li>b. If the error persists, reset the active SNC circuit pack with <b>reset board UUCSS</b>. If the error still persists, replace the active SNC circuit pack.</li> </ol> <p>If an SNI is supposed to be installed in slot 13, insert one.</p> </li> <li>3. <b>Display errors</b> for category <b>pnc</b>. If the SNC has SNC-BD error 513, or SNC-LINK errors with aux data 1 pointing to other SNIs besides the one in slot 13, replace the active SNC circuit pack.</li> <li>4. If SNIs in the same carrier have SNI-BD error 257 logged, (indicating they are having trouble communicating with the SNC), replace the active SNC circuit pack.</li> <li>5. If the SNC being tested has SNC-LINK error type 2049, replace the SNI in slot 13. Replacing an SNI may interrupt service. Refer to the SNI-BD section for the procedure for replacing an SNI.</li> <li>6. If the SNC being tested still has SNC-LINK error type 2049, replace the SNC circuit pack.</li> </ol>

*Continued on next page*



Table 9-550. TEST #759 Configuration Audit — *Continued*

Error Code	Test Result	Description/ Recommendation
114	FAIL	<p>The SNC circuit pack cannot communicate with the SNI in slot 14.</p> <ol style="list-style-type: none"> <li>1. If a standby SNC (one with its yellow LED off) was tested and resulted in this error code, follow normal escalation procedures. (<b>status switch-node</b> will also display the active and standby SNCs.)</li> <li>2. Use <b>list configuration carrier</b> to determine whether an SNI is physically present in slot 14. If the <code>Vintage</code> field indicates that a circuit pack is present, proceed to step 3. If the <code>Vintage</code> field reports <code>no board</code>, do one of the following:                     <p>If an SNI is not supposed to be installed in slot 14:</p> <ol style="list-style-type: none"> <li>a. This failure will not affect service. The missing SNI can be removed from administration with <b>change circuit-pack</b>.</li> <li>b. If the error persists, reset the active SNC circuit pack with <b>reset board UUCSS</b>. If the error still persists, replace the active SNC circuit pack.</li> </ol> <p>If an SNI is supposed to be installed in slot 14, insert one.</p> </li> <li>3. <b>Display errors</b> for category <b>pnc</b>. If the SNC has SNC-BD error 513, or SNC-LINK errors with aux data 1 pointing to other SNIs besides the one in slot 14, replace the active SNC circuit pack.</li> <li>4. If SNIs in the same carrier have SNI-BD error 257 logged, (indicating they are having trouble communicating with the SNC), replace the active SNC circuit pack.</li> <li>5. If the SNC being tested has SNC-LINK error type 2305, replace the SNI in slot 14. Replacing an SNI may interrupt service. Refer to the SNI-BD section for the procedure for replacing an SNI.</li> <li>6. If the SNC being tested still has SNC-LINK error type 2305, replace the SNC circuit pack.</li> </ol>

*Continued on next page*

Table 9-550. TEST #759 Configuration Audit — *Continued*

Error Code	Test Result	Description/ Recommendation
115	FAIL	<p>The SNC circuit pack cannot communicate with the SNI in slot 15.</p> <ol style="list-style-type: none"> <li>1. If a standby SNC (one with its yellow LED off) was tested and resulted in this error code, follow normal escalation procedures. (<b>status switch-node</b> will also display the active and standby SNCs.)</li> <li>2. Use <b>list configuration carrier</b> to determine whether an SNI is physically present in slot 15. If the <code>Vintage</code> field indicates that a circuit pack is present, proceed to step 3. If the <code>Vintage</code> field reports <code>no board</code>, do one of the following:                     <p>If an SNI is not supposed to be installed in slot 15:</p> <ol style="list-style-type: none"> <li>a. This failure will not affect service. The missing SNI can be removed from administration with <b>change circuit-pack</b>.</li> <li>b. If the error persists, reset the active SNC circuit pack with <b>reset board UUCSS</b>. If the error still persists, replace the active SNC circuit pack.</li> </ol> <p>If an SNI is supposed to be installed in slot 15, insert one.</p> </li> <li>3. <b>Display errors</b> for category <b>pnc</b>. If the SNC has SNC-BD error 513, or SNC-LINK errors with aux data 1 pointing to other SNIs besides the one in slot 15, replace the active SNC circuit pack.</li> <li>4. If SNIs in the same carrier have SNI-BD error 257 logged, (indicating they are having trouble communicating with the SNC), replace the active SNC circuit pack.</li> <li>5. If the SNC being tested has SNC-LINK error type 2561, replace the SNI in slot 15. Replacing an SNI may interrupt service. Refer to the SNI-BD section for the procedure for replacing an SNI.</li> <li>6. If the SNC being tested still has SNC-LINK error type 2561, replace the SNC circuit pack.</li> </ol>

*Continued on next page*

Table 9-550. TEST #759 Configuration Audit — *Continued*

Error Code	Test Result	Description/ Recommendation
116	FAIL	<p>The SNC circuit pack cannot communicate with the SNI in slot 16.</p> <ol style="list-style-type: none"> <li>1. If a standby SNC (one with its yellow LED off) was tested and resulted in this error code, follow normal escalation procedures. (<b>status switch-node</b> will also display the active and standby SNCs.)</li> <li>2. Use <b>list configuration carrier</b> to determine whether an SNI is physically present in slot 16. If the <code>Vintage</code> field indicates that a circuit pack is present, proceed to step 3. If the <code>Vintage</code> field reports <code>no board</code>, do one of the following:                     <p>If an SNI is not supposed to be installed in slot 16:</p> <ol style="list-style-type: none"> <li>a. This failure will not affect service. The missing SNI can be removed from administration with <b>change circuit-pack</b>.</li> <li>b. If the error persists, reset the active SNC circuit pack with <b>reset board UUCSS</b>. If the error still persists, replace the active SNC circuit pack.</li> </ol> <p>If an SNI is supposed to be installed in slot 16, insert one.</p> </li> <li>3. <b>Display errors</b> for category <b>pnc</b>. If the SNC has SNC-BD error 513, or SNC-LINK errors with aux data 1 pointing to other SNIs besides the one in slot 16, replace the active SNC circuit pack.</li> <li>4. If SNIs in the same carrier have SNI-BD error 257 logged, (indicating they are having trouble communicating with the SNC), replace the active SNC circuit pack.</li> <li>5. If the SNC being tested has SNC-LINK error type 2817, replace the SNI in slot 16. Replacing an SNI may interrupt service. Refer to the SNI-BD section for the procedure for replacing an SNI.</li> <li>6. If the SNC being tested still has SNC-LINK error type 2817, replace the SNC circuit pack.</li> </ol>

*Continued on next page*

**Table 9-550. TEST #759 Configuration Audit — Continued**

Error Code	Test Result	Description/ Recommendation
117	FAIL	<p>The SNC circuit pack cannot communicate with the SNI in slot 17.</p> <ol style="list-style-type: none"> <li>1. If a standby SNC (one with its yellow LED off) was tested and resulted in this error code, follow normal escalation procedures. (<b>status switch-node</b> will also display the active and standby SNCs.)</li> <li>2. Use <b>list configuration carrier</b> to determine whether an SNI is physically present in slot 17. If the <code>Vintage</code> field indicates that a circuit pack is present, proceed to step 3. If the <code>Vintage</code> field reports <code>no board</code>, do one of the following:                     <p>If an SNI is not supposed to be installed in slot 17:</p> <ol style="list-style-type: none"> <li>a. This failure will not affect service. The missing SNI can be removed from administration with <b>change circuit-pack</b>.</li> <li>b. If the error persists, reset the active SNC circuit pack with <b>reset board UUCSS</b>. If the error still persists, replace the active SNC circuit pack.</li> </ol> <p>If an SNI is supposed to be installed in slot 17, insert one.</p> </li> <li>3. <b>Display errors</b> for category <b>pnc</b>. If the SNC has SNC-BD error 513, or SNC-LINK errors with aux data 1 pointing to other SNIs besides the one in slot 17, replace the active SNC circuit pack.</li> <li>4. If SNIs in the same carrier have SNI-BD error 257 logged, (indicating they are having trouble communicating with the SNC), replace the active SNC circuit pack.</li> <li>5. If the SNC being tested has SNC-LINK error type 3073, replace the SNI in slot 17. Replacing an SNI may interrupt service. Refer to the SNI-BD section for the procedure for replacing an SNI.</li> <li>6. If the SNC being tested still has SNC-LINK error type 3073, replace the SNC circuit pack.</li> </ol>

*Continued on next page*

Table 9-550. TEST #759 Configuration Audit — *Continued*

Error Code	Test Result	Description/ Recommendation
118	FAIL	<p>The SNC circuit pack cannot communicate with the SNI in slot 18.</p> <ol style="list-style-type: none"> <li>1. If a standby SNC (one with its yellow LED off) was tested and resulted in this error code, follow normal escalation procedures. (<b>status switch-node</b> will also display the active and standby SNCs.)</li> <li>2. Use <b>list configuration carrier</b> to determine whether an SNI is physically present in slot 18. If the <code>Vintage</code> field indicates that a circuit pack is present, proceed to step 3. If the <code>Vintage</code> field reports <code>no board</code>, do one of the following:                     <p>If an SNI is not supposed to be installed in slot 18:</p> <ol style="list-style-type: none"> <li>a. This failure will not affect service. The missing SNI can be removed from administration with <b>change circuit-pack</b>.</li> <li>b. If the error persists, reset the active SNC circuit pack with <b>reset board UUCSS</b>. If the error still persists, replace the active SNC circuit pack.</li> </ol> <p>If an SNI is supposed to be installed in slot 18, insert one.</p> </li> <li>3. <b>Display errors</b> for category <b>pnc</b>. If the SNC has SNC-BD error 513, or SNC-LINK errors with aux data 1 pointing to other SNIs besides the one in slot 18, replace the active SNC circuit pack.</li> <li>4. If SNIs in the same carrier have SNI-BD error 257 logged, (indicating they are having trouble communicating with the SNC), replace the active SNC circuit pack.</li> <li>5. If the SNC being tested has SNC-LINK error type 3329, replace the SNI in slot 18. Replacing an SNI may interrupt service. Refer to the SNI-BD section for the procedure for replacing an SNI.</li> <li>6. If the SNC being tested still has SNC-LINK error type 3329, replace the SNC circuit pack.</li> </ol>

*Continued on next page*

Table 9-550. TEST #759 Configuration Audit — *Continued*

Error Code	Test Result	Description/ Recommendation
119	FAIL	<p>The SNC circuit pack cannot communicate with the SNI in slot 19.</p> <ol style="list-style-type: none"> <li>1. If a standby SNC (one with its yellow LED off) was tested and resulted in this error code, follow normal escalation procedures. (<b>status switch-node</b> will also display the active and standby SNCs.)</li> <li>2. Use <b>list configuration carrier</b> to determine whether an SNI is physically present in slot 19. If the <code>Vintage</code> field indicates that a circuit pack is present, proceed to step 3. If the <code>Vintage</code> field reports <code>no board</code>, do one of the following:                     <p>If an SNI is not supposed to be installed in slot 19:</p> <ol style="list-style-type: none"> <li>a. This failure will not affect service. The missing SNI can be removed from administration with <b>change circuit-pack</b>.</li> <li>b. If the error persists, reset the active SNC circuit pack with <b>reset board UUCSS</b>. If the error still persists, replace the active SNC circuit pack.</li> </ol> <p>If an SNI is supposed to be installed in slot 19, insert one.</p> </li> <li>3. <b>Display errors</b> for category <b>pnc</b>. If the SNC has SNC-BD error 513, or SNC-LINK errors with aux data 1 pointing to other SNIs besides the one in slot 19, replace the active SNC circuit pack.</li> <li>4. If SNIs in the same carrier have SNI-BD error 257 logged, (indicating they are having trouble communicating with the SNC), replace the active SNC circuit pack.</li> <li>5. If the SNC being tested has SNC-LINK error type 3585, replace the SNI in slot 19. Replacing an SNI may interrupt service. Refer to the SNI-BD section for the procedure for replacing an SNI.</li> <li>6. If the SNC being tested still has SNC-LINK error type 3585, replace the SNC circuit pack.</li> </ol>

*Continued on next page*

Table 9-550. TEST #759 Configuration Audit — Continued

Error Code	Test Result	Description/ Recommendation
120	FAIL	<p>The SNC circuit pack cannot communicate with the SNI in slot 20.</p> <ol style="list-style-type: none"> <li>1. If a standby SNC (one with its yellow LED off) was tested and resulted in this error code, follow normal escalation procedures. (<b>status switch-node</b> will also display the active and standby SNCs.)</li> <li>2. Use <b>list configuration carrier</b> to determine whether an SNI is physically present in slot 20. If the <code>Vintage</code> field indicates that a circuit pack is present, proceed to step 3. If the <code>Vintage</code> field reports <code>no board</code>, do one of the following:                     <p>If an SNI is not supposed to be installed in slot 20</p> <ol style="list-style-type: none"> <li>a. This failure will not affect service. The missing SNI can be removed from administration with <b>change circuit-pack</b>.</li> <li>b. If the error persists, reset the active SNC circuit pack with <b>reset board UUCSS</b>. If the error still persists, replace the active SNC circuit pack.</li> </ol> <p>If an SNI is supposed to be installed in slot 20, insert one.</p> </li> <li>3. <b>Display errors</b> for category <b>pnc</b>. If the SNC has SNC-BD error 513, or SNC-LINK errors with aux data 1 pointing to other SNIs besides the one in slot 20, replace the active SNC circuit pack.</li> <li>4. If SNIs in the same carrier have SNI-BD error 257 logged, (indicating they are having trouble communicating with the SNC), replace the active SNC circuit pack.</li> <li>5. If the SNC being tested has SNC-LINK error type 3841, replace the SNI in slot 20. Replacing an SNI may interrupt service. Refer to the SNI-BD section for the procedure for replacing an SNI.</li> <li>6. If the SNC being tested still has SNC-LINK error type 3841, replace the SNC circuit pack.</li> </ol>
	PASS	<p>The administered data and the circuit packs the SNC can communicate with match.</p>
0	NO BOARD	<p>No board was detected by the test.</p> <ol style="list-style-type: none"> <li>1. Check that SNC board is properly translated and inserted.</li> <li>2. Run the test again. If it fails, reset the board. An SNC should be reset instead of reseating the circuit pack. The <b>reset board</b> command should almost never be used on an SNC. It may be necessary to use the <b>reset board</b> command if the SNC circuit pack gets into a mode where it cannot communicate with software. If an SNC with active errors and alarms is reset, the errors and alarms may take a while to come back, therefore the <b>reset board</b> command can mask real problems.</li> <li>3. Run the test again. If it fails, the ID chip on board may be bad. Replace the board and retest.</li> </ol>

## Processor Route Audit Test (#760)

This test is non-destructive.

This test sends processor routes to all SNIs and SNCs in the same carrier as the SNC that the **test board UCSS** command was run for. The processor route is used for the boards to send uplink messages to the SPE and gives a sequence of boards for the message to get routed through so that the message ends up at the SPE. If the SNI and SNC boards do not have processor routes, they will not be able to send any in-line errors to the SPE.

When each individual board receives the processor routes, it sends a board insertion message uplink and software inserts that board if it has not already been inserted. Each board is sent either one or two processor routes depending on the configuration.

Use **test led** or **list config carrier** to see whether boards are inserted.

**Table 9-551. TEST #760 Processor Route Audit Test**

Error Code	Test Result	Description/ Recommendation
2100	ABORT	Could not allocate the necessary system resources to run this test. 1. Retry the command at 1-minute intervals a maximum of 3 times.
2300	ABORT	The downlink message necessary to run this test could not be sent. 1. Retry the command at 1-minute intervals a maximum of 3 times.
2301	ABORT	The software timer could not be set before sending the downlink message necessary to run this test. 1. Retry the command at 1-minute intervals a maximum of 3 times.
2306	ABORT	None of the circuit packs in this switch node carrier are responding to the processor route messages sent by software. 1. Run the <b>test led switch-node</b> for the switch node that this switch node carrier resides in to verify whether the LEDs on any of the boards light. 2. If none of the LEDs light for the boards in this carrier, fix any problems associated with the connectivity of this carrier to the SPE. Use the <b>list fiber link</b> command to obtain a list of the fiber connections to this carrier. Check the LEDs on all SNIs and EIs and fix any fiber problems. Enter <b>display errors</b> and follow the associated repair procedures for any EXP-INTF error entries associated with the PPN. Also, follow the associated repair procedures for any SYNC, SNI-BD, SNC-BD, FIBER-LK, or SNI-PEER error entries.
2500	ABORT	Internal System Error 1. Retry the command at 1-minute intervals a maximum of 3 times.

*Continued on next page*



Table 9-551. TEST #760 Processor Route Audit Test — Continued

Error Code	Test Result	Description/ Recommendation
	FAIL	<p>If this test fails, not all of the administered circuit packs in this switch node carrier responded with an up-link board insertion message. Check to see that administered SNI and SNC boards match the physically installed SNI and SNC boards by entering <b>list config carrier</b> UUC. The command output will show "NO BOARD" for every board that is administered, but not inserted.</p> <ul style="list-style-type: none"> <li>■ If all administered boards are inserted, run this test again.</li> <li>■ If administration does not match the physical configuration, and is correct, insert the missing circuit packs in this switch node carrier.</li> <li>■ If <i>none</i> of the administered boards in this switch node carrier were inserted, fix any other SN-CONF errors by following the associated repair procedures for SN-CONF. Use <b>display errors</b> with category <b>pnc</b> to view SN-CONF errors. Next check if any INLs, LNLs, or RNLs are down, refer to the SYS-LINK section for fixing link problems.</li> </ul>
	PASS	<p>If this test passes, all of the administered circuit packs in this switch node carrier were inserted.</p>
0	NO BOARD	<p>No board was detected by the test.</p> <ol style="list-style-type: none"> <li>1. Check that SNC board is properly translated and inserted.</li> <li>2. Run the test again. If it fails, reset the board. An SNC should be reset instead of reseating the circuit pack. The <b>reset board</b> command should almost never be used on an SNC. It may be necessary to use the <b>reset board</b> command if the SNC circuit pack gets into a mode where it cannot communicate with software. If an SNC with active errors and alarms is reset, the errors and alarms may take a while to come back, therefore the <b>reset board</b> command can mask real problems.</li> <li>3. Run the test again. If it fails, the ID chip on board may be bad. Replace the board and retest.</li> </ol>

### Failure Audit (#777)

This test is non-destructive.

This test queries the SNC for any existing failures and any unacknowledged cleared failure messages. Each failure generates an error and alarm entry against SNC-BD, SNC-LINK, or SNC-REF. An unacknowledged cleared failure message is a message the SNC circuit pack sent to software indicating a previous failure is now gone and the SNC circuit pack did not receive a message from software indicating that the failure message was received by software.

If no failures are detected by the SNC circuit pack, this test will pass.

If this test reports failures, the results screen for the **test board** command will show **FAIL** with no FAIL code. The error log must then be displayed via **display errors** with category PNC to view all SNC related errors: SNC-BD, SNC-LINK, and SNC-REF.

**Table 9-552. TEST #777 Failure Audit**

Error Code	Test Result	Description/ Recommendation
	ABORT	Internal System Error 1. Retry the command at 1-minute intervals a maximum of 3 times.
2100	ABORT	Could not allocate the necessary system resources to run this test. 1. Retry the command at 1-minute intervals a maximum of 3 times.
2300	ABORT	The downlink message necessary to run this test could not be sent. 1. Retry the command at 1-minute intervals a maximum of 3 times.
2301	ABORT	The software timer could not be set before sending the downlink message necessary to run this test. 1. Retry the command at 1-minute intervals a maximum of 3 times.
2306	ABORT	The SNC circuit pack is not responding to test requests sent by software. 1. Run the <b>test led switch-node</b> for the switch node that this board resides in to verify whether the LEDs on the board light. 2. If the LEDs on the other boards in the carrier light, but the LEDs on this board do not light, run test 760 via <b>test board UUCSS I</b> for the active SNC in this carrier. Wait 5 minutes and then try step 1 one more time. If the LEDs on this board still do not light, replace this board. Replacing an SNC may be service interrupting. Refer to the SNC-BD section for the procedure for replacing an SNC. 3. If none of the LEDs light for the boards in the same carrier as this board, fix any problems associated with the connectivity of this carrier to the SPE. Use the <b>list fiber link</b> command to obtain a list of the fiber connections to this carrier. Check the LEDs on all SNIs and EIs and fix any fiber problems. Enter <b>display errors</b> and follow the associated repair procedures for any EXP-INTF error entries associated with the PPN. Also, follow the associated repair procedures for any SYNC, SNI-BD, SNC-BD, FIBER-LK, or SNI-PEER error entries.

*Continued on next page*

**Table 9-552. TEST #777 Failure Audit — Continued**

Error Code	Test Result	Description/ Recommendation
	FAIL	The SNC circuit pack reported failures or retransmitted a cleared failure message. <ol style="list-style-type: none"> <li>1. Check the error and alarm logs for SNC-BD, SNC-LINK, or SNC-REF entries. Use the <b>display errors</b> and <b>display alarms</b> commands with category PNC. Fix any problems found by referring to the SNC Board, SNC Link, or SNC Reference Error Log Entries tables in this section and follow the associated repair procedures.</li> <li>2. If no SNC-BD, SNC-LINK, or SNC-REF errors exist in the error and alarm logs, retry the command.</li> </ol>
	PASS	No problems are detected on the board.
0	NO BOARD	No board was detected by the test. <ol style="list-style-type: none"> <li>1. Check that SNC board is properly translated and inserted.</li> <li>2. Run the test again. If it fails, reset the board. An SNC should be reset instead of reseating the circuit pack. The <b>reset board</b> command should almost never be used on an SNC. It may be necessary to use the <b>reset board</b> command if the SNC circuit pack gets into a mode where it cannot communicate with software. If an SNC with active errors and alarms is reset, the errors and alarms may take a while to come back, therefore the <b>reset board</b> command can mask real problems.</li> <li>3. Run the test again. If it fails, the ID chip on board may be bad. Replace the board and retest.</li> </ol>

### SNC On-Board Test (#778)

This test is non-destructive.

This test queries the SNC circuit pack for status of the background tests run on-board. These background tests include an SNC on-board microcontroller test, clock test, an SNC on-board Stratum 3 oscillator test, and TPN microcontroller test.

**Table 9-553. TEST #778 SNC On-Board Test**

Error Code	Test Result	Description/ Recommendation
2100	ABORT	Could not allocate the necessary system resources to run this test. 1. Retry the command at 1-minute intervals a maximum of 3 times.
2300	ABORT	The downlink message necessary to run this test could not be sent. 1. Retry the command at 1-minute intervals a maximum of 3 times.
2301	ABORT	The software timer could not be set before sending the downlink message necessary to run this test. 1. Retry the command at 1-minute intervals a maximum of 3 times.
2303	ABORT	The SNC circuit pack responded that the software test requested is not valid. 1. Retry the command at 1-minute intervals a maximum of 3 times.
2304	ABORT	SNC firmware is not able to run the test. 1. Retry the command at 1-minute intervals a maximum of 3 times.
2306	ABORT	The SNC circuit pack is not responding to test requests sent by software. 1. Run the <b>test led switch-node</b> for the switch node that this board resides in to verify whether the LEDs on the board light. 2. If the LEDs on the other boards in the carrier light, but the LEDs on this board do not light, run test 760 via <b>test board UUCSS I</b> for the active SNC in this carrier. Wait 5 minutes and then try step 1 one more time. If the LEDs on this board still do not light, replace this board. Replacing an SNC may be service interrupting. Refer to the SNC-BD section for the procedure for replacing an SNC. 3. If none of the LEDs light for the boards in the same carrier as this board, fix any problems associated with the connectivity of this carrier to the SPE. Use the <b>list fiber link</b> command to obtain a list of the fiber connections to this carrier. Check the LEDs on all SNIs and EIs and fix any fiber problems. Enter <b>display errors</b> and follow the associated repair procedures for any EXP-INTF error entries associated with the PPN. Also, follow the associated repair procedures for any SYNC, SNI-BD, SNC-BD, FIBER-LK, or SNI-PEER error entries.
101	FAIL	The SNC circuit pack has on-board microcontroller failure.
128	FAIL	The SNC circuit pack has a problem with its clock; firmware has detected a phase-locked loop failure, an inability to lock, or a failure of the clock drivers.
129	FAIL	The SNC circuit pack has a problem with the SNC on-board Stratum 3 oscillator.
130	FAIL	The SNC circuit pack has a problem with the TPN microcontroller. 1. Replace the SNC circuit pack.
	PASS	No problems exist with the on-board functions verified by this test.

**Table 9-553. TEST #778 SNC On-Board Test — Continued**

Error Code	Test Result	Description/ Recommendation
0	NO BOARD	No board was detected by the test. <ol style="list-style-type: none"> <li>1. Check that SNC board is properly translated and inserted.</li> <li>2. Run the test again. If it fails, reset the board. An SNC should be reset instead of reseating the circuit pack. The <b>reset board</b> command should almost never be used on an SNC. It may be necessary to use the <b>reset board</b> command if the SNC circuit pack gets into a mode where it cannot communicate with software. If an SNC with active errors and alarms is reset, the errors and alarms may take a while to come back, therefore the <b>reset board</b> command can mask real problems.</li> <li>3. Run the test again. If it fails, the ID chip on board may be bad. Replace the board and retest.</li> </ol>

**TPN Test (#779)**

This test is non-destructive.

This test queries the SNC circuit pack for status of the ROM and internal RAM background tests for the TPN microcontroller.

**Table 9-554. TEST #779 TPN Test**

Error Code	Test Result	Description/ Recommendation
2100	ABORT	Could not allocate the necessary system resources to run this test. <ol style="list-style-type: none"> <li>1. Retry the command at 1-minute intervals a maximum of 3 times.</li> </ol>
2300	ABORT	The downlink message necessary to run this test could not be sent. <ol style="list-style-type: none"> <li>1. Retry the command at 1-minute intervals a maximum of 3 times.</li> </ol>
2301	ABORT	The software timer could not be set before sending the downlink message necessary to run this test. <ol style="list-style-type: none"> <li>1. Retry the command at 1-minute intervals a maximum of 3 times.</li> </ol>
2302	ABORT	Software received unexpected message data from the SNC circuit pack. <ol style="list-style-type: none"> <li>1. Retry the command at 1-minute intervals a maximum of 3 times.</li> </ol>

*Continued on next page*

**Table 9-554. TEST #779 TPN Test — Continued**

Error Code	Test Result	Description/ Recommendation
2303	ABORT	The SNC circuit pack responded that the software test requested is not valid. 1. Retry the command at 1-minute intervals a maximum of 3 times.
2304	ABORT	SNC circuit pack responded that it is not able to run the test requested by software. 1. Retry the command at 1-minute intervals a maximum of 3 times.
2306	ABORT	The SNC circuit pack is not responding to test requests sent by software. 1. Run the <b>test led switch-node</b> for the switch node that this board resides in to verify whether the LEDs on the board light. 2. If the LEDs on the other boards in the carrier light, but the LEDs on this board do not light, run test 760 via <b>test board UUCSS I</b> for the active SNC in this carrier. Wait 5 minutes and then try step 1 one more time. If the LEDs on this board still do not light, replace this board. Replacing an SNC may be service interrupting. Refer to the SNC-BD section for the procedure for replacing an SNC. 3. If none of the LEDs light for the boards in the same carrier as this board, fix any problems associated with the connectivity of this carrier to the SPE. Use the <b>list fiber link</b> command to obtain a list of the fiber connections to this carrier. Check the LEDs on all SNIs and EIs and fix any fiber problems. Enter <b>display errors</b> and follow the associated repair procedures for any EXP-INTF error entries associated with the PPN. Also, follow the associated repair procedures for any SYNC, SNI-BD, SNC-BD, FIBER-LK, or SNI-PEER error entries.
	FAIL	The test failed. Replace the SNC circuit pack.
	PASS	No problems exist with the TPN microcontroller.
0	NO BOARD	No board was detected by the test. 1. Check that SNC board is properly translated and inserted. 2. Run the test again. If it fails, reset the board. An SNC should be reset instead of reseating the circuit pack. The <b>reset board</b> command should almost never be used on an SNC. It may be necessary to use the <b>reset board</b> command if the SNC circuit pack gets into a mode where it cannot communicate with software. If an SNC with active errors and alarms is reset, the errors and alarms may take a while to come back, therefore the <b>reset board</b> command can mask real problems. 3. Run the test again. If it fails, the ID chip on board may be bad. Replace the board and retest.

## Switch Node Clock Reset Test (#780)

**This test is destructive.**

This test resets the SNC circuit pack via the **reset board UUCSS** command when an SNC circuit pack location is entered. If the system has PNC duplication, the active SNC on the active PNC cannot be reset.

If the SNC is active and the **reset board** command is executed, an SNI in the same carrier as the SNC will be told by software to reset the SNC via the TPN link. If no inserted SNIs in the same carrier as the SNC can successfully reset the SNC, software will send a reset message directly to the SNC. Software first tries to reset the SNC via an SNI in case the SNC is insane because the latter method (sending the reset message directly to the SNC) will not work if the SNC is insane.

If an active SNC is reset and a standby SNC exists in the same switch node carrier, the standby SNC will become active. The **reset board** command should not be used to make a standby SNC active. Instead, the **set switch-node-clock UUCSS** command should be used.

If the SNC is standby and the **reset board** command is executed, the active SNC is told by software to reset the standby SNC via the TPN link.

An SNC should be reset instead of reseating the circuit pack. The **reset board** command should almost never be used on an SNC. It may be necessary to use the **reset board** command if the SNC circuit pack gets into a mode where it cannot communicate with software.

**Table 9-555. TEST #780 Switch Node Clock Reset Test**

Error Code	Test Result	Description/ Recommendation
2100	ABORT	Could not allocate the necessary system resources to run this test. 1. Retry the command at 1-minute intervals a maximum of 3 times.
2300	ABORT	The downlink message necessary to run this test could not be sent. 1. Retry the command at 1-minute intervals a maximum of 3 times.
2301	ABORT	The software timer could not be set before sending the downlink message necessary to run this test. 1. Retry the command at 1-minute intervals a maximum of 3 times.
2302	ABORT	Software received unexpected message data from the SNC circuit pack. 1. Retry the command at 1-minute intervals a maximum of 3 times.

*Continued on next page*

**Table 9-555. TEST #780 Switch Node Clock Reset Test — Continued**

Error Code	Test Result	Description/ Recommendation
2303	ABORT	The SNC circuit pack responded that the software test requested is not valid. 1. Retry the command at 1-minute intervals a maximum of 3 times.
2304	ABORT	SNC circuit pack responded that it is not able to run the test requested by software. 1. Retry the command at 1-minute intervals a maximum of 3 times.
2306	ABORT	The SNC circuit pack is not responding to test requests sent by software. 1. Run the <b>test led switch-node</b> for the switch node that the SNC resides in to verify whether the LEDs on the board light. 2. If the LEDs on the other boards in the carrier light, but the LEDs on this board do not light, run test 760 via <b>test board UUCSS I</b> for the active SNC in this carrier. Wait 5 minutes and then try step 1 one more time. If the LEDs on this board still do not light, replace this board. Replacing an SNC may be service interrupting. Refer to the SNC-BD section for the procedure for replacing an SNC. 3. If none of the LEDs light for the boards in the same carrier as this board, fix any problems associated with the connectivity of this carrier to the SPE. Use the <b>list fiber link</b> command to obtain a list of the fiber connections to this carrier. Check the LEDs on all SNIs and EIs and fix any fiber problems. Enter <b>display errors</b> and follow the associated repair procedures for any EXP-INTF error entries associated with the PPN. Also, follow the associated repair procedures for any SYNC, SNI-BD, SNC-BD, FIBER-LK, or SNI-PEER error entries.
2500	ABORT	Internal System Error 1. Retry the command at 1-minute intervals a maximum of 3 times.

*Continued on next page*



Table 9-555. TEST #780 Switch Node Clock Reset Test — *Continued*

Error Code	Test Result	Description/ Recommendation
	PASS	The reset message was sent out successfully to the active SNC or to an SNI. A PASS does not necessarily mean the SNC circuit pack was successfully reset. The reset can be verified by checking that the red and green LEDs turn on and then turn off. If an SNC circuit pack fails one of the firmware tests run during its reset sequence, the red LED will stay on and the circuit pack should be replaced.
0	NO BOARD	No board was detected by the test. <ol style="list-style-type: none"><li>1. Check that SNC board is properly translated and inserted.</li><li>2. Run the test again. If it fails, reset the board. An SNC should be reset instead of reseating the circuit pack. The <b>reset board</b> command should almost never be used on an SNC. It may be necessary to use the <b>reset board</b> command if the SNC circuit pack gets into a mode where it cannot communicate with software. If an SNC with active errors and alarms is reset, the errors and alarms may take a while to come back, therefore the <b>reset board</b> command can mask real problems.</li><li>3. Run the test again. If it fails, the ID chip on board may be bad. Replace the board and retest.</li></ol>

### Clear Firmware Counters (#983)

This test number is used to report unsuccessful results of the **clear firmware-counters** command. This is not an actual demand maintenance test. If the command aborts, refer to the error codes listed for Test #777.

## **SNC-LINK (Switch Node Clock Link)**

<b>MO Name (in Alarm Log)</b>	<b>Alarm Level</b>	<b>Initial Command to Run<sup>1</sup></b>	<b>Full Name of MO</b>
SNC-LINK	MINOR	test board UUCSS s	SNC Link

1. UU is the universal cabinet number (1 for PPN, 2 - 44 for EPNs). C is the carrier designation (A, B, C, D, or E). SS is the number of the slot in which the circuit pack resides (10 or 12).

The SNC-LINK maintenance object reports errors in communications between the active Switch Node Clock and Switch Node Interfaces over the serial channel (aux data 1) and the TPN link (aux data 2). SNC-LINK errors are described on the following pages. For a complete description of SNCs and SNIs, including circuit pack replacement instructions, see maintenance objects SNI-BD and SNC-BD.

## Error Log Entries and Test to Clear Values

**Table 9-556. SNC-LINK Hardware Error Log Entries**

Error Type	Aux Data	SNI Slot <sup>1</sup>	Associated Test	Alarm Level	On/Off Board	Test to Clear Value
0 <sup>2</sup>	0		Any	Any	Any	test board UUCSS r 1
1	1 (a)	2	Failure Audit (#777)	MINOR	OFF	test board UUCSS r 1
1	2 (b)	2	Failure Audit (#777)	MINOR	OFF	test board UUCSS r 1
257	1 (a)	3	Failure Audit (#777)	MINOR	OFF	test board UUCSS r 1
257	2 (b)	3	Failure Audit (#777)	MINOR	OFF	test board UUCSS r 1
513	1 (a)	4	Failure Audit (#777)	MINOR	OFF	test board UUCSS r 1
513	2 (b)	4	Failure Audit (#777)	MINOR	OFF	test board UUCSS r 1
769	1 (a)	5	Failure Audit (#777)	MINOR	OFF	test board UUCSS r 1
769	2 (b)	5	Failure Audit (#777)	MINOR	OFF	test board UUCSS r 1
1025	1 (a)	6	Failure Audit (#777)	MINOR	OFF	test board UUCSS r 1
1025	2 (b)	6	Failure Audit (#777)	MINOR	OFF	test board UUCSS r 1
1281	1 (a)	7	Failure Audit (#777)	MINOR	OFF	test board UUCSS r 1
1281	2 (b)	7	Failure Audit (#777)	MINOR	OFF	test board UUCSS r 1
1537	1 (a)	8	Failure Audit (#777)	MINOR	OFF	test board UUCSS r 1
1537	2 (b)	8	Failure Audit (#777)	MINOR	OFF	test board UUCSS r 1
1793	1 (a)	9	Failure Audit (#777)	MINOR	OFF	test board UUCSS r 1
1793	2 (b)	9	Failure Audit (#777)	MINOR	OFF	test board UUCSS r 1
2049	1 (a)	13	Failure Audit (#777)	MINOR	OFF	test board UUCSS r 1
2049	2 (b)	13	Failure Audit (#777)	MINOR	OFF	test board UUCSS r 1
2305	1 (a)	14	Failure Audit (#777)	MINOR	OFF	test board UUCSS r 1
2305	2 (b)	14	Failure Audit (#777)	MINOR	OFF	test board UUCSS r 1
2561	1 (a)	15	Failure Audit (#777)	MINOR	OFF	test board UUCSS r 1
2561	2 (b)	15	Failure Audit (#777)	MINOR	OFF	test board UUCSS r 1
2817	1 (a)	16	Failure Audit (#777)	MINOR	OFF	test board UUCSS r 1
2817	2 (b)	16	Failure Audit (#777)	MINOR	OFF	test board UUCSS r 1
3073	1 (a)	17	Failure Audit (#777)	MINOR	OFF	test board UUCSS r 1
3073	2 (b)	17	Failure Audit (#777)	MINOR	OFF	test board UUCSS r 1
3329	1 (a)	18	Failure Audit (#777)	MINOR	OFF	test board UUCSS r 1

*Continued on next page*

**Table 9-556. SNC-LINK Hardware Error Log Entries — Continued**

Error Type	Aux Data	SNI Slot <sup>1</sup>	Associated Test	Alarm Level	On/Off Board	Test to Clear Value
3329	2 (b)	18	Failure Audit (#777)	MINOR	OFF	test board UUCSS r 1
3585	1 (a)	19	Failure Audit (#777)	MINOR	OFF	test board UUCSS r 1
3585	2 (b)	19	Failure Audit (#777)	MINOR	OFF	test board UUCSS r 1
3841	1 (a)	20	Failure Audit (#777)	MINOR	OFF	test board UUCSS r 1
3841	2 (b)	20	Failure Audit (#777)	MINOR	OFF	test board UUCSS r 1

1. The location of the SNI with which the SNC cannot communicate.
2. Run the Short Test Sequence first. If all tests pass, run the Long Test Sequence. Refer to the appropriate test description and follow the recommended procedures.

**Notes:**

- a. This error occurs whenever the active SNC determines that there is a problem communicating with an SNI circuit pack in the same carrier via the connecting multiprocessor serial channel used for transmitting CSCN messages. The slot location of the SNI with which the SNC cannot communicate is given in [Table 9-556](#).
  1. Check the error log via **display errors**.
  2. If any SNI-PEER errors exist in the hardware error log, follow the associated repair procedures for SNI-PEER errors.
  3. If the SNC has SNC-LINK errors with aux data of 1 against other SNIs and/or has SNC-BD error 513, replace the SNC circuit pack.
  4. If SNIs in the same carrier have SNI-BD error 257 logged indicating they are having trouble communicating with the SNC, replace the SNC circuit pack.
  5. Use **list configuration carrier** to determine whether an SNI is physically present in the slot pointed to by the SNC-LINK error. If the `Vintage` field indicates that a circuit pack is present, proceed to step 6. If the `Vintage` field reports `no board`, do one of the following:
    - If an SNI is not supposed to be installed in this slot:
    - Remove the SNI from circuit pack administration with **change circuit-pack**.
    - If the error remains, readminister the SNI circuit pack and then remove it from administration again.

- If the error still remains, replace the active SNC circuit pack.
  - If an SNI should be installed in this slot, but is missing, insert an SNI circuit pack.
6. Replace the SNI that the SNC is complaining about.
  7. Retry the command. If this error is still in the error log, continue with the following steps.
  8. Replace the SNC circuit pack.
  9. If a standby SNC (the one with its yellow LED off) has this error, escalate the problem. (**Status switch-node** will also display the active and standby SNCs.)
- b. This error occurs whenever the active SNC determines that there is a problem communicating with an SNI circuit pack in the same carrier via the TPN communication channel. The slot location of the SNI with which the SNC cannot communicate is given in [Table 9-556](#).
1. Check the error log via **display errors**. If more than one SNI in the same carrier have SNI-BD errors with error type 769, replace the SNC.
  2. Check the error log via **display errors**. If the SNC has more than one SNC-LINK error with aux data of 2, replace the SNC.
  3. Verify that the SNI the SNC is complaining about exists in the slot indicated by the error code. If the SNI does not exist:

**If you do not intend to replace the SNI:**

- a. Remove the SNI from circuit pack administration via **change circuit-pack**.
- b. If the error remains, readminister the SNI circuit pack and then remove it from administration again.
- c. If the problem persists, replace the active SNC circuit pack.

**Otherwise:**

- a. Insert an SNI circuit pack.

If this step does not apply, continue with the following steps.

4. Replace the SNI circuit pack that the SNC is complaining about.
5. Retry the command. If this error is still in the error log, continue with the following steps.
6. Replace the SNC circuit pack.
7. If a standby SNC (the one with its yellow LED off) has this error, escalate the problem. (**Status switch-node** will also display the active and standby SNCs.)
8. Retry the command. If this error is still in the error log, escalate the problem.

## System Technician-Demanded Tests: Descriptions and Error Codes

---

Always investigate tests in the order presented in the table below when inspecting errors in the system. By clearing error codes associated with the *configuration audit* for example, you may also clear errors generated from other tests in the testing sequence.

Order of Investigation	Short Test Sequence	Long Test Sequence	Reset Board Sequence	D/ND <sup>1</sup>
Configuration Audit (#759)	X	X		ND
Failure Audit(#777)	X	X		ND
Processor Route Audit(#760)		X		ND
SNC On-Board Test(#778)	X	X		ND
TPN test(#779)	X	X		ND
Switch Node Clock Reset Test(#780)			X	D

---

1. D = Destructive, ND = Non-destructive

Refer to maintenance object SNC-BD for descriptions of tests and results.

## SNC-REF (Switch Node Clock Reference)

---

MO Name (in Alarm Log)	Alarm Level	Initial Command to Run <sup>1</sup>	Full Name of MO
SNC-REF	MAJOR	test board UUCSS s	SNC Reference

1. UU is the universal cabinet number (1 for PPN, 2 -44 for EPNs). C is the carrier designation (A, B, C, D, or E). SS is the number of the slot in which the circuit pack resides (10 or 12).

The SNC-REF maintenance object reports errors in SNI reference signals detected by the active Switch Node Clock. Descriptions of SNC-REF errors are described on the following pages. For a complete description of SNCs and SNIs, including circuit pack replacement instructions, see maintenance objects SNI-BD and SNC-BD.

## Error Log Entries and Test to Clear Value

**Table 9-557. SNC Reference Error Log Entries**

Error Type	Aux Data	SNI Slot <sup>1</sup>	Associated Test	Alarm Level	On/Off Board	Test to Clear Value
0 <sup>2</sup>	0		Any	Any	Any	test board UUCSS r 1
1(a)	Any	2	Failure Audit (#777)	MAJOR	OFF	test board UUCSS r 1
257(a)	Any	3	Failure Audit (#777)	MAJOR	OFF	test board UUCSS r 1
513(a)	Any	4	Failure Audit (#777)	MAJOR	OFF	test board UUCSS r 1
769(a)	Any	5	Failure Audit (#777)	MAJOR	OFF	test board UUCSS r 1
1025(a)	Any	6	Failure Audit (#777)	MAJOR	OFF	test board UUCSS r 1
1281(a)	Any	7	Failure Audit (#777)	MAJOR	OFF	test board UUCSS r 1
1537(a)	Any	8	Failure Audit (#777)	MAJOR	OFF	test board UUCSS r 1
1793(a)	Any	9	Failure Audit (#777)	MAJOR	OFF	test board UUCSS r 1
2049(a)	Any	13	Failure Audit (#777)	MAJOR	OFF	test board UUCSS r 1
2305(a)	Any	14	Failure Audit (#777)	MAJOR	OFF	test board UUCSS r 1
2561(a)	Any	15	Failure Audit (#777)	MAJOR	OFF	test board UUCSS r 1
2817(a)	Any	16	Failure Audit (#777)	MAJOR	OFF	test board UUCSS r 1
3073(a)	Any	17	Failure Audit (#777)	MAJOR	OFF	test board UUCSS r 1
3329(a)	Any	18	Failure Audit (#777)	MAJOR	OFF	test board UUCSS r 1
3585(a)	Any	19	Failure Audit (#777)	MAJOR	OFF	test board UUCSS r 1
3841(a)	Any	20	Failure Audit (#777)	MAJOR	OFF	test board UUCSS r 1

- The slot location of the SNI with which the SNC cannot communicate.
- Run the Short Test Sequence first. If all tests pass, run the Long Test Sequence. Refer to the appropriate test description and follow the recommended procedures.

### Notes:

- This error occurs whenever the active or standby SNC detects problems in its timing reference with an SNI circuit pack in the same carrier. The slot location of the SNI with which the SNC cannot communicate is given in the error table above.

### If duplicated SNCs exist in the carrier:

- If the SNCs are duplicated in the carrier, check the error log via **display errors**. If both SNCs have this error, replace the SNI that the SNCs are complaining about.



2. If the error occurred only on the standby SNC and the active SNC in the carrier does not have this error, reset the standby SNC via the **reset board** command. (The active and standby SNCs are displayed via **status switch-node**.) If this error comes back after the standby has been reset, replace the standby SNC.
3. Retry the command. If this error is still in the error log, continue with the following steps.
4. If the active SNC has this error, use the **set switch-node-clock** command to set the standby SNC to active. If the new active SNC had this error, replace the SNI that the SNC is complaining about. Otherwise, replace the SNC that originally had this error.

**If only one SNC exists in the carrier:**

1. Replace the SNI that the SNC is complaining about.
2. Retry the command. If this error is still in the error log, continue with the following step.
3. Replace the SNC.

**System Technician-Demanded Tests: Descriptions and Error Codes**

---

Always investigate tests in the order presented in the table below when inspecting errors in the system. By clearing error codes associated with the *configuration audit* for example, you may also clear errors generated from other tests in the testing sequence.

Order of Investigation	Short Test Sequence	Long Test Sequence	Reset Board Sequence	D/ND <sup>1</sup>
Configuration Audit (#759)	X	X		ND
Failure Audit(#777)	X	X		ND
Processor Route Audit(#760)		X		ND
SNC On-Board Test(#778)	X	X		ND
TPN test(#779)	X	X		ND
Switch Node Clock Reset Test (#780)			X	D

---

1. D = Destructive, ND = Non-destructive

Refer to maintenance object SNC-BD for descriptions of tests and results.

## SNI-BD (SNI Circuit Pack)

MO Name As It Appears in Alarm Log	Alarm Level	Initial System Technician Command to Run <sup>1</sup>	Full Name of MO
SNI-BD	MAJOR	test board UUCSS s	SNI Circuit Pack
SNI-BD	MINOR	test board UUCSS s	SNI Circuit Pack
SNI-BD	WARNING	test board UUCSS s	SNI Circuit Pack

1. UU is the universal cabinet number (1 for PPN, 2 -44 for EPNs). C is the carrier designation (A, B, C, D, or E). SS is the number of the slot in which the circuit pack resides (01 to 21).

The TN573 Switch Node Interface (SNI)circuit pack is part of the Center Stage Switch (CSS)configuration. It resides in a switch note carrier that alone or with other switch nodes make up a CSS. SNIs connect to other SNIs or Expansion Interface (EI) circuit packs via fiber links. SNI to EI fiber links are used to connect port networks to a switch node carrier and SNI to SNI fiber links are used as inter-switch node fibers. In critical reliability systems, the fiber link connections are duplicated as part of Port Network Connectivity (PNC) duplication. In standard reliability and high reliability systems, the PNC is not duplicated.

There may be up to 16 SNIs in a switch node carrier. They are located in slots 2 through 9 and slots 13 through 20. Slot 11 in a switch node carrier is not used. One or two TN572 boards (SNCs) must reside in switch node carrier positions 10 and 12. The SNIs connect to other SNIs in the same carrier via the backplane; these connections within the same carrier are referred to as peer-links. Each SNI also connects via an optical fiber or metallic connection to another SNI in another carrier or to an EI in the Processor Port Network (PPN) or in an Expansion Port Network (EPN). These connections are referred to as fiber-links.

The Switch Node Clock (SNC) provides timing for the SNIs in the entire carrier. When two SNCs reside in the same switch node carrier, one is in active mode and one is in standby mode. The yellow LED on the active SNC will be on solid. The yellow LED on the standby SNC will be off. See the SYNC section for an explanation of how SNIs are involved in timing synchronization.

[Figure 9-84](#) shows an unduplicated CSS with one switch node. A single switch node can accommodate up to 16 port networks, including the PPN. A system with two switch nodes can accommodate up to 22 port networks. [Figure 9-85](#) shows a two-switch node CSS with duplicated PNC (four switch node carriers). In this configuration, each PNC (A and B) contains two switch nodes. The cabinet numbers for the switch node carriers are typical cabinet numbers. The EPNs and PPN on the top half of the figure (PNC A) are the same as the EPNs and PPN on the bottom half of the figure (PNC B).

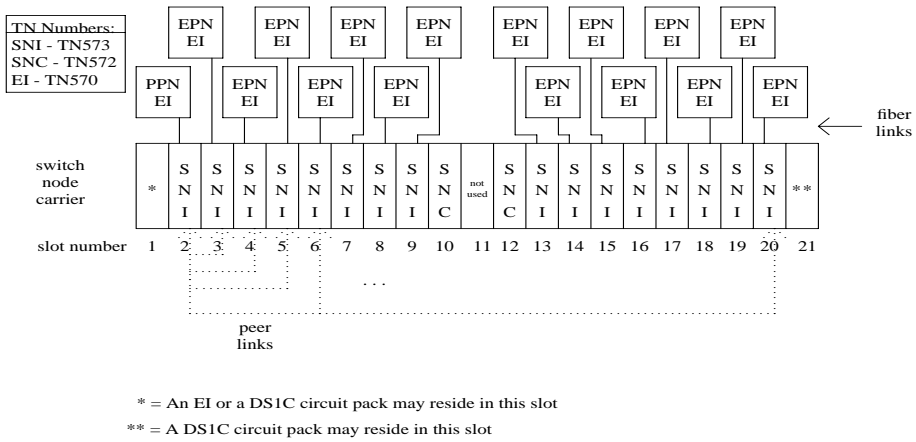

**Figure 9-84. CSS Configuration with Simplex PNC and 1 Switch Node Carrier**

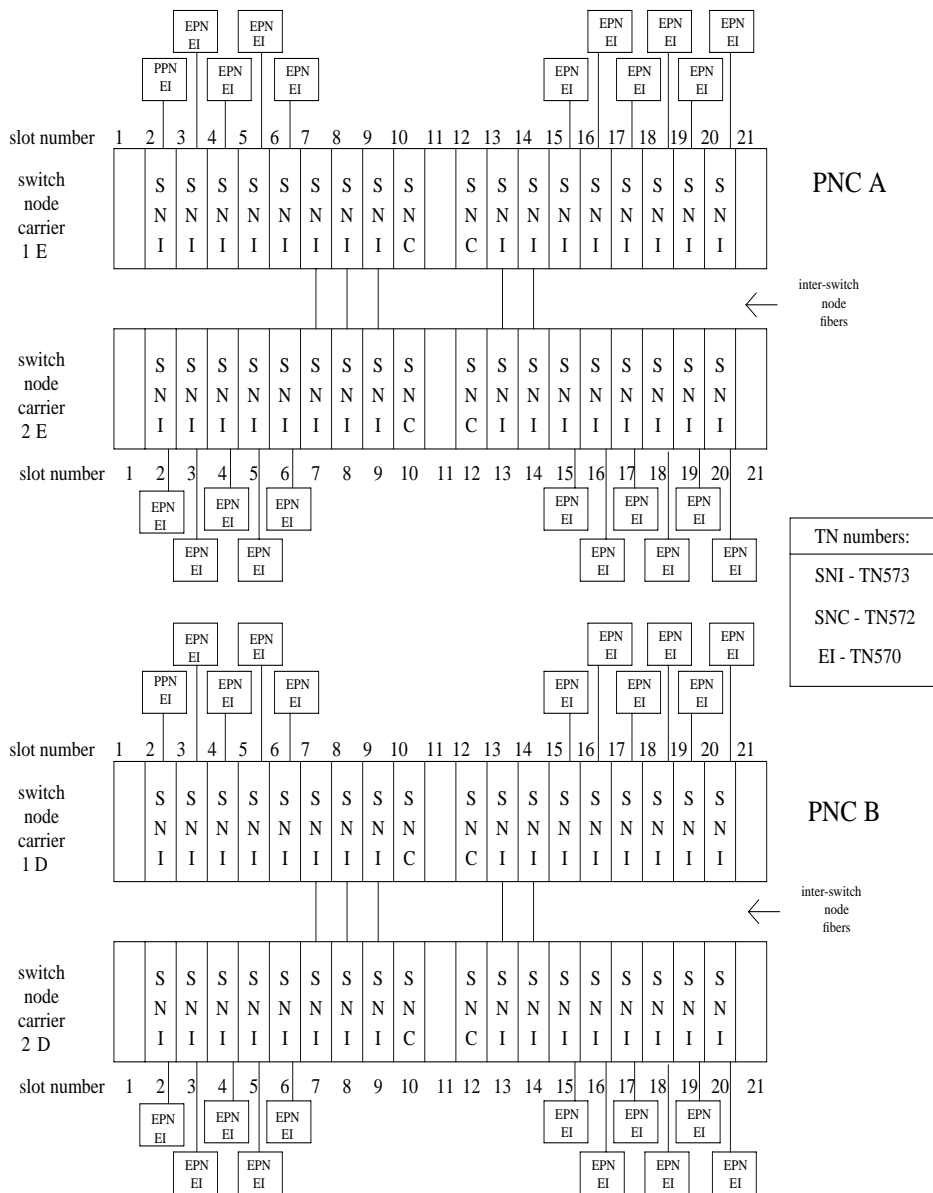

**Figure 9-85. CSS Configuration with Duplicated PNC and 4 Switch Node Carriers**

## Remote EPNs

---

A DS1 converter complex can be used to provide connectivity to a remotely located port network. The DS1 converter complex consists of two TN574 DS1 converter (DS1C) circuit packs connected by 1 to 4 DS1 facilities. The DS1C complex is administered as a fiber link.

---

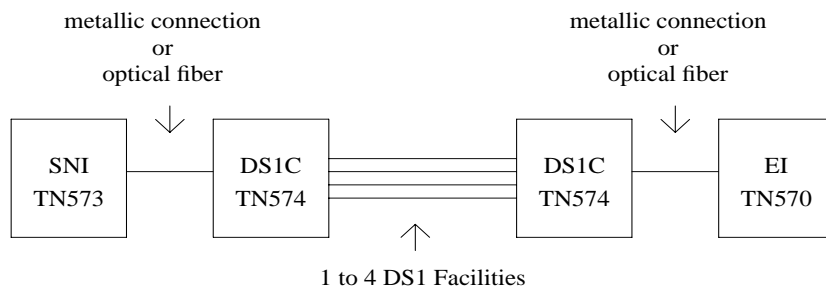

---

**Figure 9-86. Fiber Link over a DS1 Converter Complex**

## SNI LEDs

---

The SNI circuit pack has red, green and yellow LEDs. The red and green LEDs have the usual meaning, with red signifying an on-board alarm, and green signifying maintenance testing in progress. The red and green LEDs will come on and then turn off when the circuit pack is reset.

### ➤ NOTE:

If the red LED is on without any alarms active against the circuit pack, replace the SNI circuit pack. This indicates that SNI firmware has detected a fault and is unable to notify software.

The yellow LED indicates status information as follows:

**SNI Yellow LED states**

Condition	LED on	LED off
Fiber out of Frame	0.1 second	0.1 second
In frame, No Neighbor <sup>1</sup>	0.5 second	0.5 second
SNI active	solid on	never off
SNI standby	never on	solid off

- 
1. The fiber is in frame but a communication problem exists to the neighbor.

## SNI Administration and SNI Board Insertion

The circuit packs in the switch node carrier will not function properly unless administration is performed first. For example, without fiber link administration, phone calls cannot be made through the CSS, CSS circuit packs will not be inserted, and maintenance software cannot test the CSS circuit packs.

For simplex PNC configurations, administration must be done in the following order before SNIs will be inserted:

1. Cabinet Administration: The switch node carriers must be administered into the proper cabinets. When this form is submitted by pressing ENTER, these carriers will be assigned switch node numbers. The **list cabinet** command can then be used to determine the numbers for the carriers of interest.
2. Circuit Pack Administration: All of the boards in the switch node carriers must be administered.
3. Fiber-link Administration: The fibers between the TN570s and the TN573 (or TN573 to TN573) must be administered via the **add fiber-link** command. A DS1C converter complex is added to a fiber link via the **add fiber-link** command also.

For duplicated PNC configurations, administration must be done in the following order before SNIs will be inserted:

1. Activate PNC duplication administration via the **change system-parameters customer-options** command.
2. Cabinet Administration: The switch node carriers and duplicate switch node carriers must be administered into the proper cabinets. When this form is submitted by depressing the "enter" key, these carriers will be assigned switch node numbers. The **list cabinet** command can then be used to determine the numbers for the carriers of interest.

3. Circuit Pack Administration: All of the boards in the switch node carriers must be administered.
4. Fiber-link Administration: The fibers between the TN570s and the TN573 (or TN573 to TN573) must be administered via the **add fiber-link** command. If the system is being changed from a simplex PNC configuration to a duplicate PNC configuration, the **change fiber-link command** can be used to administer the b-pnc fiber link endpoints on the existing fiber links. A DS1C converter complex is added to a fiber link via the **add fiber-link** command also.
5. PNC duplication is enabled via the **change system-parameters duplication** command.

## Clear Firmware-Counters Command

SNI firmware generates error reports autonomously. This takes place independently of technician-demanded tests. Therefore, the **test board UUCSS** clear command will not affect the error status reported by firmware. The clear firmware-counters command will clear all firmware-generated errors unconditionally.

The **clear firmware-counters UUCSS** command sends a downlink message to the SNI circuit packs, causing them to clear out their firmware error counters and failure databases. Once the firmware failure database is cleared, the failure audit test (#777) will pass. If problems still exist, the firmware will increment its error counters and the failure audit test will begin failing again.

This command should not be used as a replacement for the repair procedures associated with the hardware error log entries. This command may be useful if a problem has been fixed and off-board alarms associated with the problem are still active.

## Replacing an SNI Circuit Pack—Simplex PNC

---



### WARNING:

*Do not power down a Switch Node carrier to replace a circuit pack.*



### WARNING:

*Replacing a Switch Node Interface, Switch Node Clock, Expansion Interface or DS1 Converter circuit pack on a simplex system disrupts service. The service effect can range from outage of a single EPN to outage of the entire system.*

1. Enter **busyout board UUCSS** UUCSS represents the cabinet-carrier-slot address of the circuit pack to be replaced.
2. Replace the circuit pack
3. Wait for the circuit pack to reset Red and green LEDs will light and then go out.
4. Enter **release board UUCSS**
5. Enter **test alarms long clear** for category **exp-intf**.
6. Wait 5 minutes for SNI-BD, FIBER-LK AND DS1C-BD alarms to clear, or enter **clear firmware counters a-pnc**.



### CAUTION:

*Do not busyout any Expansion Interface circuit pack after this point.*



## Replacing an SNI Circuit Pack— Duplicated PNC

### WARNING:

*On a system with duplicated PNC, synchronization may be provided over a combination of active and standby components. This condition is indicated by an OFF-BOARD WARNING alarm against TDM-CLK with error type 2305. Repairs to standby PNC in this state may disrupt service. Otherwise, if the active PNC is functional, replacement of a standby component will not disrupt service.*

1. Enter **status pnc** Verify that the component to be replaced is on the standby PNC.
2. Enter **busyout pnc**
3. Enter **busyout board UUCSS** UUCSS represents the cabinet-carrier-slot address of the circuit pack to be replaced.
4. Replace the circuit pack
5. Enter **release board UUCSS**  
 **CAUTION:**  
*Do not busyout any Expansion Interface circuit pack after this point.*
6. Enter **test alarms long clear** for category **exp-intf**.
7. Wait 5 minutes for SNI-BD, SNI-PEER, FIBER-LK, and DS1C alarms to clear, or enter **clear firmware counterssp 0 <a-pnc or b-pnc>**. Use the letter designation of the pnc which holds the replaced component (the standby pnc).
8. Enter **status pnc**. If either PNC state-of-health is not "functional", consult the ["PNC-DUP \(PNC Duplication\)"](#) section.
9. Enter **release pnc**.

## Switch Node Interface Manual Loop Back Procedure

**This procedure is destructive.**

This procedure is to be used when an SNI circuit pack cannot be tested by software. This can occur when communication between the switch node carrier and the SPE is down. Before using this procedure, the configuration audit test (#759) should be run on SNI circuit packs where possible via **test board UUCSS s**. Also, the processor route audit test (#760) should be run via the **test board UUCSS long** command for the active SNC in the switch node carrier. If the active SNC is not inserted, test 760 can be run via **test hardware-group pnc P**, where P is **a-pnc** or **b-pnc**.

Before using this procedure, first determine whether more than one SNI is unable to communicate with software. Verify SNI and SNC circuit pack insertion via the **list configuration carrier UUC** command, where UUC is the cabinet and carrier location of a switch node carrier. Check for SNI and SNC insertion for every administered switch node carrier.

If all of the SNIs and SNCs are not inserted ("NO BOARD" is displayed for each board) in the entire PNC (either the a-pnc or the b-pnc), then the link between the PPN EI (on the PNC where SNI and SNC circuit packs did not insert) and the connected SNI is not functioning properly. If this case applies, perform the following steps:

1. Run the **test board UUCSS** command on the PPN EI and fix any problems found.
2. Perform the manual loopback procedure for the PPN EI.
3. Perform the manual loopback procedure for the SNI connected to the PPN EI.
4. Replace the active SNC.

If the system has a two level switch node carrier configuration, i.e. SNI-SNI fiber links exist, and the SNIs and SNCs in the second switch node carrier only (the switch node carrier that has no SNI connected to the PPN EI) are not inserted and at least two SNI-SNI fiber links exist, perform the following steps:

1. Run the **test board UUCSS long** command on the SNIs in the first switch node carrier that are connected to SNIs in the second switch node carrier and fix any problems found.
2. Replace the active SNC.
3. Perform the manual loopback procedure for the SNIs in the second switch node carrier that are connected to SNIs in the first switch node carrier.

If software is unable to communicate with an EPN EI but can communicate with the connected SNI:

1. Run the **test board UUCSS long** command on the connected SNI and fix any problems found.
2. Perform the manual loopback procedure for the EPN EI.

When the connection to the SNI circuit pack is via fiber, a short length of optical fiber is required for this procedure. If a metallic cable is used in the connection, the metallic connector must be removed from the back of the carrier, and a lightwave transceiver connected in its place. The short length of optical fiber can then be used.

If this procedure is run on both endpoints on a fiber link (Expansion Interface circuit packs or Switch Node Interface circuit packs), and both check out fine, then the failure is most likely in the connection (fiber or metallic) itself if neither endpoint circuit pack is busied out, but the link remains inactive.

1. Busyout the circuit pack (Expansion Interface or SNI) using the **busyout board UUCSS** command.
2. Disconnect the transmit and receive fiber pair from the lightwave transceiver on the back of the circuit pack (Expansion Interface or Switch Node Interface) slot.



**NOTE:**

Note which is the transmit fiber and which is the receive fiber for proper re-connection at the end of this procedure. The fiber connected to the transmit side of the lightwave transceiver on one circuit pack should be connected to the receive side of the lightwave transceiver on the circuit pack on the opposite end of the fiber.

3. Using a spare fiber jumper cable, interconnect the transmit and receive jacks of the lightwave transceiver as shown in [Figure 9-87](#).



**NOTE:**

Make sure that the total length of the fiber jumper cable does not exceed the maximum length recommended for the fiber link connections between cabinets. This is necessary so that the testing of the Expansion Interface or SNI circuit pack is done within connectivity guidelines so that test results are not influenced due to the cable length not meeting requirements.

4. Go to the front of the cabinet and inspect the yellow LED.
  - If the yellow LED flashes on at a rate of once per second, the (Expansion Interface or Switch Node Interface) circuit pack or transceiver should be replaced.
  - If the yellow LED flashes on at a rate of five times per second, the circuit pack (Expansion Interface or Switch Node Interface) or the lightwave transceiver may need replacement. This condition may also be due to a faulty system clock on the network containing the Expansion Interface circuit pack or in the switch node carrier containing the SNI.
  - If the yellow LED was blinking before starting this procedure and the yellow LED is not blinking now, this circuit pack (Expansion Interface or Switch Node Interface) and the lightwave transceiver are functioning properly.
5. Replace faulty component(s) and reconnect the original fiber. Be sure to reconnect the fibers properly as noted in Step 2.
6. Release Expansion Interface circuit pack or Switch Node Interface circuit pack with the **release board UUCSS** command.

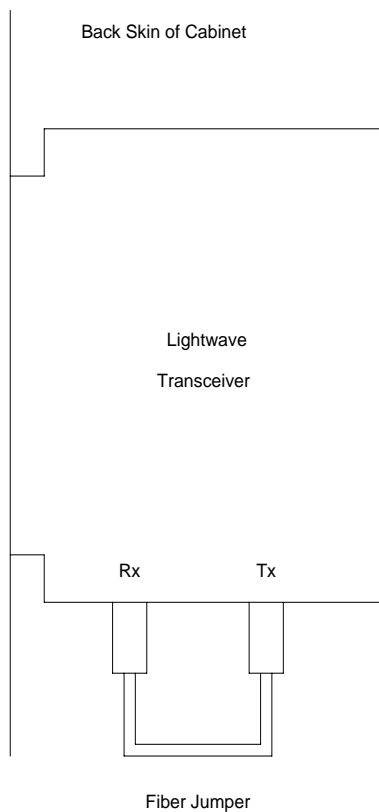

---

**Figure 9-87. Interconnection of Lightwave Transceiver Transmit/Receive Jacks**

## Error Log Entries and Test to Clear Values

**Table 9-558. SNI Board Error Log Entries**

Error Type	Aux Data	Associated Test	Alarm Level	On/Off Board	Test to Clear Value
0 <sup>1</sup>	0	Any	Any	Any	test board UUCSS r 1
1(b)	any	failure audit (#777) (a)	MAJ/MIN/WAR	ON	test board UUCSS r 1
18(c)	0	busyout board UUCSS	WARNING	OFF	release board UUCSS
125(d)		None	MINOR	ON	
257(e)	any	failure audit (#777) (a)	MAJ/MIN/WAR	OFF	test board UUCSS r 1
513(f)	any	failure audit (#777) (a)	MAJ/MIN/WAR	OFF	test board UUCSS r 1
769(g)	any	failure audit (#777) (a)	MAJ/MIN/WAR	OFF	test board UUCSS r 1
1025(h)	any	failure audit (#777) (a)	MAJ/MIN/WAR	ON/OFF	test board UUCSS r 1
1281(i)	any	failure audit (#777) (a)	MAJ/MIN/WAR	ON	test board UUCSS r 1
1537(j)	any	failure audit (#777) (a)	MAJ/MIN/WAR	OFF	test board UUCSS r 1
2561(k)	any	failure audit (#777) (a)	MAJ/MIN/WAR	ON	test board UUCSS r 1
2817(l)	any	failure audit (#777) (a)	MAJ/MIN/WAR	ON	test board UUCSS r 1

1. Run the Short Test Sequence first. If all tests pass, run the Long Test Sequence. Refer to the appropriate test description and follow the recommended procedures.

### Notes:

- a. The first time you see an SNI-BD error in the error log, run the **test board UUCSS** command. If the failure audit test (#777) fails, enter **display errors** for this SNI circuit pack and continue with the associated repair procedures for SNI-BD errors.
- b. This error indicates a problem that the SNI may have trouble communicating with all of the other SNI and SNC circuit packs in the switch node carrier.
  1. Replace the SNI circuit pack.
- c. This error indicates that the SNI circuit pack has been busied out via the **busyout board UUCSS** command. To resolve this error, release the SNI circuit pack via the **release board UUCSS** command.
- d. The SNI circuit pack is incompatible with the TN1654 DS1 Converter board. A TN573B or later suffix SNI board must be used when connecting to a TN1654 DS1 Converter board. Replace with a newer suffix.
- e. This error indicates that the SNI cannot communicate with the active SNC.

1. Check the error log via **display errors** for other SNI circuit packs with the 257 SNI-BD error. If other SNI circuit packs in the same switch node carrier have error 257, then replace the active SNC.
  2. Replace this SNI.
  3. Replace the active SNC in the same switch node carrier.
  4. Enter **display errors** and if this error is still in the error log, follow normal escalation procedures.
- f. This error indicates that the SNI cannot communicate with the DS1C.
1. Perform the Fiber Fault Isolation Procedure described in Chapter 5.
- g. This error indicates a failure communicating synchronization control data with the active SNC.

Look at all of the SNI-BD errors in the log via **display errors** and **display alarms** to determine whether to follow procedure 1 or procedure 2. See the table below which lists pairs of SNIs that are considered to be adjacent. Use Procedure 2 if either of the following two conditions is present:

- At least one pair of adjacent SNIs in this carrier has Error 769 with an off-board alarm logged against both SNIs in the pair.
- The active SNC in this carrier has error 257.

If neither of the above is true, follow Procedure 1.

#### Adjacent SNI Slot Numbers

2 & 3  
4 & 5  
6 & 7  
8 & 9  
13 & 14  
15 & 16  
17 & 18  
19 & 20

#### Procedure 1 (suspect TPN link or clock generation out of lock problem):

1. Enter **display alarms** and **display errors** and follow the procedures for any on-board SNI-BD error and alarm entries.
2. If more than one SNI circuit pack in the same switch node carrier has SNI-BD error 769 with an off board alarm, replace the active SNC in the same carrier.
3. Replace this SNI.

4. Replace the active SNC in the same carrier.

**Procedure 2 (suspect clock generation out of lock problem):**

1. If only one SNC exists in this switch node carrier, replace the SNC. If two SNCs exist in this switch node carrier, perform the following steps:
    - a. Set the standby SNC to active by running the **set switch-node-clock UUCSS** command with the standby SNC's location.
    - b. If the problem goes away, replace the SNC that was previously active. Then set the SNC that was just replaced to active via the **set switch-node-clock UUCSS** command. If the problem returns, assume that the SNC that was just replaced was not at fault and go to step 2 below.
    - c. If the problem persists, switch back to the previously active SNC via the **set switch-node-clock** command and go to step 2 below.
  2. Replace the leftmost SNI from the pair of adjacent SNIs.
  3. Replace the rightmost SNI from the pair of adjacent SNIs.
  4. If none of the above steps cleared this error, this could be a switch node carrier backplane problem.
- h. This error indicates a failure communicating synchronization control data over the fiber-link.

If the error is logged as an on-board error:

1. Replace the SNI circuit pack.

If the error is logged as an off-board error:

1. Enter **display errors** and follow the associated repair procedures for FIBER-LK errors.
  2. Replace the SNI with this error.
  3. Replace the other endpoint of the fiber-link if no DS1C complex is administered on the fiber-link (use **list fiber-link** to determine whether a DS1C complex is administered). If a DS1C complex is administered on the fiber-link, replace the circuit packs in this order:
    - i. Replace the DS1C circuit pack connected to this SNI.
    - ii. Replace the other DS1C circuit pack.
    - iii. Replace the other endpoint of the fiber-link.
- i. This error indicates a processor complex failure.
1. Replace the SNI circuit pack.

- j. This error indicates that excessive slips have occurred.  
 Follow the steps for diagnosing synchronization problems when slips have occurred in the SYNC section.
- k. This error indicates that the SNI cannot communicate with its neighbor.  
 The SNI is at fault.
  - 1. Replace the SNI circuit pack.
- l. This error indicates that the SNI cannot communicate with one of its peers.  
 The SNI is at fault.
  - 1. Replace the SNI circuit pack.

## System Technician-Demanded Tests: Descriptions and Error Codes

Always investigate tests in the order presented in the table below when inspecting errors in the system. By clearing error codes associated with the *Configuration Audit* for example, you may also clear errors generated from other tests in the testing sequence.

Order of Investigation	Short Test Sequence	Long Test Sequence	Reset Board Sequence	D/ND <sup>1</sup>
Configuration Audit (#759)	X	X		ND
Failure Audit(#777)	X	X		ND
Fiber Out of Frame Query(#989)	X	X		ND
Packet Neighbor Test(#767)	X	X		ND
Circuit Path Test(#755)	X	X		ND
Destructive Facility Test(#757)		X		D
Off-board Destructive Facility Test(#756)		X		D
Switch Node Interface Reset Test(#761)			X	D

1. D = Destructive, ND = Non-destructive



**NOTE:**

Test #982 is not an actual demand maintenance test. This test number is used to report results of executing of the **clear firmware-counters** command. Refer to error codes for Test #777.

### SNI Circuit Path Test (#755)

This test is non-destructive. This test performs a non-destructive test of the circuit path.



**Table 9-559. TEST #755 SNI Circuit Path Test**

Error Code	Test Result	Description/ Recommendation
2100	ABORT	Could not allocate the necessary system resources to run this test. 1. Retry the command at 1-minute intervals a maximum of 3 times.
2300	ABORT	The downlink message necessary to run this test could not be sent. 1. Retry the command at 1-minute intervals a maximum of 3 times.
2301	ABORT	The software timer could not be set before sending the downlink message necessary to run this test. 1. Retry the command at 1-minute intervals a maximum of 3 times.
2302	ABORT	Software received incorrect message data from the SNI circuit pack. 1. Retry the command at 1-minute intervals a maximum of 3 times.
2303	ABORT	The SNI circuit pack responded that software test requested is not valid. 1. Retry the command at 1-minute intervals a maximum of 3 times.
2304	ABORT	SNI circuit pack responded that it is not able to run the test requested by software. 1. Retry the command at 1-minute intervals a maximum of 3 times.
2306	ABORT	The SNI circuit pack is not responding to test requests sent by software. 1. Run the <b>test led switch-node</b> for the switch node that the SNI resides in to verify whether the LEDs on the board light. 2. If the LEDs on the other boards in the carrier light, but the LEDs on this board do not light, run test 760 via <b>test board UUCSS I</b> for the active SNC in this carrier. Wait 5 minutes and then try step 1 one more time. If the LEDs on this board still do not light, replace this board. Replacing an SNI may be service interrupting. Refer to the SNI-BD section for the procedure for replacing an SNI. 3. If none of the LEDs light for the boards in the same carrier as this board, fix any problems associated with the connectivity of this carrier to the SPE. Check <b>list fiber-link</b> to determine the fiber connections to this carrier. Check the LEDs on all SNIs and EIs and fix any fiber problems. Enter <b>display errors</b> and follow the associated repair procedures for any EXP-INTF error entries associated with the PPN. Also, follow the associated repair procedures for any SYNC, SNI-BD, SNC-BD, FIBER-LK, or SNI-PEER error entries. 4. Follow the procedure described above, SNI Manual Loopback to determine whether the circuit pack or the fiber connection is faulty.

*Continued on next page*

**Table 9-559. TEST #755 SNI Circuit Path Test — Continued**

Error Code	Test Result	Description/ Recommendation
102	FAIL	<p>The SNI circuit pack cannot communicate with the SNI in slot 2 over the circuit path.</p> <ol style="list-style-type: none"> <li>Fix any on-board SNI-BD errors against this SNI and the SNI in slot 2. Use <b>display errors</b> to find any SNI-BD errors and check <b>display alarms</b> to see whether the errors have on-board alarms. Then follow the associated repair procedures for SNI-BD.</li> <li>Check the error log via <b>display errors</b> for other SNI circuit packs with SNI-PEER error type 1. If other SNI circuit packs have SNI-PEER error type 1, then replace the SNI in slot 2. Replacing an SNI may be service interrupting. Refer to the SNI-BD section for the procedure for replacing an SNI.</li> </ol> <p><b>⇒ NOTE:</b>                      If other SNI circuit packs do not have SNI-PEER error type 1 errors, the problem could be at either of the peer SNI boards. It is arbitrary as to which SNI is replaced first. Proceed as follows:</p> <ol style="list-style-type: none"> <li>Replace this SNI.</li> <li>Replace the SNI in slot 2.</li> </ol>
103	FAIL	<p>The SNI circuit pack cannot communicate with the SNI in slot 3 over the circuit path.</p> <ol style="list-style-type: none"> <li>Fix any on-board SNI-BD errors against this SNI and the SNI in slot 3. Use <b>display errors</b> to find any SNI-BD errors and check <b>display alarms</b> to see whether the errors have on-board alarms. Then follow the associated repair procedures for SNI-BD.</li> <li>Check the error log via <b>display errors</b> for other SNI circuit packs with SNI-PEER error type 257. If other SNI circuit packs have SNI-PEER error type 257, then replace the SNI in slot 3. Replacing an SNI may be service interrupting. Refer to the SNI-BD section for the procedure for replacing an SNI.</li> </ol> <p><b>⇒ NOTE:</b>                      If other SNI circuit packs do not have SNI-PEER error type 257 errors, the problem could be at either of the peer SNI boards. It is arbitrary as to which SNI is replaced first. Proceed as follows:</p> <ol style="list-style-type: none"> <li>Replace this SNI.</li> <li>Replace the SNI in slot 3.</li> </ol>

*Continued on next page*

**Table 9-559. TEST #755 SNI Circuit Path Test — Continued**

Error Code	Test Result	Description/ Recommendation
104	FAIL	<p>The SNI circuit pack cannot communicate with the SNI in slot 4 over the circuit path.</p> <ol style="list-style-type: none"> <li>Fix any on-board SNI-BD errors against this SNI and the SNI in slot 4. Use <b>display errors</b> to find any SNI-BD errors and check <b>display alarms</b> to see whether the errors have on-board alarms. Then follow the associated repair procedures for SNI-BD.</li> <li>Check the error log via <b>display errors</b> for other SNI circuit packs with SNI-PEER error type 513. If other SNI circuit packs have SNI-PEER error type 513, then replace the SNI in slot 4. Replacing an SNI may be service interrupting. Refer to the SNI-BD section for the procedure for replacing an SNI.</li> </ol> <p><b>⇒ NOTE:</b>                      If other SNI circuit packs do not have SNI-PEER error type 513 errors, the problem could be at either of the peer SNI boards. It is arbitrary as to which SNI is replaced first. Proceed as follows:</p> <ol style="list-style-type: none"> <li>Replace this SNI.</li> <li>Replace the SNI in slot 4.</li> </ol>
105	FAIL	<p>The SNI circuit pack cannot communicate with the SNI in slot 5 over the circuit path.</p> <ol style="list-style-type: none"> <li>Fix any on-board SNI-BD errors against this SNI and the SNI in slot 5. Use <b>display errors</b> to find any SNI-BD errors and check <b>display alarms</b> to see whether the errors have on-board alarms. Then follow the associated repair procedures for SNI-BD.</li> <li>Check the error log via <b>display errors</b> for other SNI circuit packs with SNI-PEER error type 769. If other SNI circuit packs have SNI-PEER error type 769, then replace the SNI in slot 5. Replacing an SNI may be service interrupting. Refer to the SNI-BD section for the procedure for replacing an SNI.</li> </ol> <p><b>⇒ NOTE:</b>                      If other SNI circuit packs do not have SNI-PEER error type 769 errors, the problem could be at either of the peer SNI boards. It is arbitrary as to which SNI is replaced first. Proceed as follows:</p> <ol style="list-style-type: none"> <li>Replace this SNI.</li> <li>Replace the SNI in slot 5.</li> </ol>

*Continued on next page*

**Table 9-559. TEST #755 SNI Circuit Path Test — Continued**

Error Code	Test Result	Description/ Recommendation
106	FAIL	<p>The SNI circuit pack cannot communicate with the SNI in slot 6 over the circuit path.</p> <ol style="list-style-type: none"> <li>Fix any on-board SNI-BD errors against this SNI and the SNI in slot 6. Use <b>display errors</b> to find any SNI-BD errors and check <b>display alarms</b> to see whether the errors have on-board alarms. Then follow the associated repair procedures for SNI-BD.</li> <li>Check the error log via <b>display errors</b> for other SNI circuit packs with SNI-PEER error type 1025. If other SNI circuit packs have SNI-PEER error type 1025, then replace the SNI in slot 6. Replacing an SNI may be service interrupting. Refer to the SNI-BD section for the procedure for replacing an SNI.</li> </ol> <p><b>⇒ NOTE:</b>                      If other SNI circuit packs do not have SNI-PEER error type 1025 errors, the problem could be at either of the peer SNI boards. It is arbitrary as to which SNI is replaced first. Proceed as follows:</p> <ol style="list-style-type: none"> <li>Replace this SNI.</li> <li>Replace the SNI in slot 6.</li> </ol>
107	FAIL	<p>The SNI circuit pack cannot communicate with the SNI in slot 7 over the circuit path.</p> <ol style="list-style-type: none"> <li>Fix any on-board SNI-BD errors against this SNI and the SNI in slot 7. Use <b>display errors</b> to find any SNI-BD errors and check <b>display alarms</b> to see whether the errors have on-board alarms. Then follow the associated repair procedures for SNI-BD.</li> <li>Check the error log via <b>display errors</b> for other SNI circuit packs with SNI-PEER error type 1281. If other SNI circuit packs have SNI-PEER error type 1281, then replace the SNI in slot 7. Replacing an SNI may be service interrupting. Refer to the SNI-BD section for the procedure for replacing an SNI.</li> </ol> <p><b>⇒ NOTE:</b>                      If other SNI circuit packs do not have SNI-PEER error type 1281 errors, the problem could be at either of the peer SNI boards. It is arbitrary as to which SNI is replaced first. Proceed as follows:</p> <ol style="list-style-type: none"> <li>Replace this SNI.</li> <li>Replace the SNI in slot 7.</li> </ol>

*Continued on next page*

**Table 9-559. TEST #755 SNI Circuit Path Test — Continued**

Error Code	Test Result	Description/ Recommendation
108	FAIL	<p>The SNI circuit pack cannot communicate with the SNI in slot 8 over the circuit path.</p> <ol style="list-style-type: none"> <li>Fix any on-board SNI-BD errors against this SNI and the SNI in slot 8. Use <b>display errors</b> to find any SNI-BD errors and check <b>display alarms</b> to see whether the errors have on-board alarms. Then follow the associated repair procedures for SNI-BD.</li> <li>Check the error log via <b>display errors</b> for other SNI circuit packs with SNI-PEER error type 1537. If other SNI circuit packs have SNI-PEER error type 1537, then replace the SNI in slot 8. Replacing an SNI may be service interrupting. Refer to the SNI-BD section for the procedure for replacing an SNI.</li> </ol> <p><b>⇒ NOTE:</b>                      If other SNI circuit packs do not have SNI-PEER error type 1537 errors, the problem could be at either of the peer SNI boards. It is arbitrary as to which SNI is replaced first. Proceed as follows:</p> <ol style="list-style-type: none"> <li>Replace this SNI.</li> <li>Replace the SNI in slot 8.</li> </ol>
109	FAIL	<p>The SNI circuit pack cannot communicate with the SNI in slot 9 over the circuit path.</p> <ol style="list-style-type: none"> <li>Fix any on-board SNI-BD errors against this SNI and the SNI in slot 9. Use <b>display errors</b> to find any SNI-BD errors and check <b>display alarms</b> to see whether the errors have on-board alarms. Then follow the associated repair procedures for SNI-BD.</li> <li>Check the error log via <b>display errors</b> for other SNI circuit packs with SNI-PEER error type 1793. If other SNI circuit packs have SNI-PEER error type 1793, then replace the SNI in slot 9. Replacing an SNI may be service interrupting. Refer to the SNI-BD section for the procedure for replacing an SNI.</li> </ol> <p><b>⇒ NOTE:</b>                      If other SNI circuit packs do not have SNI-PEER error type 1793 errors, the problem could be at either of the peer SNI boards. It is arbitrary as to which SNI is replaced first. Proceed as follows:</p> <ol style="list-style-type: none"> <li>Replace this SNI.</li> <li>Replace the SNI in slot 9.</li> </ol>

*Continued on next page*

**Table 9-559. TEST #755 SNI Circuit Path Test — Continued**

Error Code	Test Result	Description/ Recommendation
113	FAIL	<p>The SNI circuit pack cannot communicate with the SNI in slot 13 over the circuit path.</p> <ol style="list-style-type: none"> <li>Fix any on-board SNI-BD errors against this SNI and the SNI in slot 13. Use <b>display errors</b> to find any SNI-BD errors and check <b>display alarms</b> to see whether the errors have on-board alarms. Then follow the associated repair procedures for SNI-BD.</li> <li>Check the error log via <b>display errors</b> for other SNI circuit packs with SNI-PEER error type 2049. If other SNI circuit packs have SNI-PEER error type 2049, then replace the SNI in slot 13. Replacing an SNI may be service interrupting. Refer to the SNI-BD section for the procedure for replacing an SNI.</li> </ol> <p><b>⇒ NOTE:</b>                      If other SNI circuit packs do not have SNI-PEER error type 2049 errors, the problem could be at either of the peer SNI boards. It is arbitrary as to which SNI is replaced first. Proceed as follows:</p> <ol style="list-style-type: none"> <li>Replace this SNI.</li> <li>Replace the SNI in slot 13.</li> </ol>
114	FAIL	<p>The SNI circuit pack cannot communicate with the SNI in slot 14 over the circuit path.</p> <ol style="list-style-type: none"> <li>Fix any on-board SNI-BD errors against this SNI and the SNI in slot 14. Use <b>display errors</b> to find any SNI-BD errors and check <b>display alarms</b> to see whether the errors have on-board alarms. Then follow the associated repair procedures for SNI-BD.</li> <li>Check the error log via <b>display errors</b> for other SNI circuit packs with SNI-PEER error type 2305. If other SNI circuit packs have SNI-PEER error type 2305, then replace the SNI in slot 14. Replacing an SNI may be service interrupting. Refer to the SNI-BD section for the procedure for replacing an SNI.</li> </ol> <p><b>⇒ NOTE:</b>                      If other SNI circuit packs do not have SNI-PEER error type 2305 errors, the problem could be at either of the peer SNI boards. It is arbitrary as to which SNI is replaced first. Proceed as follows:</p> <ol style="list-style-type: none"> <li>Replace this SNI.</li> <li>Replace the SNI in slot 14.</li> </ol>

*Continued on next page*

**Table 9-559. TEST #755 SNI Circuit Path Test — Continued**

Error Code	Test Result	Description/ Recommendation
115	FAIL	<p>The SNI circuit pack cannot communicate with the SNI in slot 15 over the circuit path.</p> <ol style="list-style-type: none"> <li>Fix any on-board SNI-BD errors against this SNI and the SNI in slot 15. Use <b>display errors</b> to find any SNI-BD errors and check <b>display alarms</b> to see whether the errors have on-board alarms. Then follow the associated repair procedures for SNI-BD.</li> <li>Check the error log via <b>display errors</b> for other SNI circuit packs with SNI-PEER error type 2561. If other SNI circuit packs have SNI-PEER error type 2561, then replace the SNI in slot 15. Replacing an SNI may be service interrupting. Refer to the SNI-BD section for the procedure for replacing an SNI.</li> </ol> <p><b>⇒ NOTE:</b>                      If other SNI circuit packs do not have SNI-PEER error type 2561 errors, the problem could be at either of the peer SNI boards. It is arbitrary as to which SNI is replaced first. Proceed as follows:</p> <ol style="list-style-type: none"> <li>Replace this SNI.</li> <li>Replace the SNI in slot 15.</li> </ol>
116	FAIL	<p>The SNI circuit pack cannot communicate with the SNI in slot 16 over the circuit path.</p> <ol style="list-style-type: none"> <li>Fix any on-board SNI-BD errors against this SNI and the SNI in slot 16. Use <b>display errors</b> to find any SNI-BD errors and check <b>display alarms</b> to see whether the errors have on-board alarms. Then follow the associated repair procedures for SNI-BD.</li> <li>Check the error log via <b>display errors</b> for other SNI circuit packs with SNI-PEER error type 2817. If other SNI circuit packs have SNI-PEER error type 2817, then replace the SNI in slot 16. Replacing an SNI may be service interrupting. Refer to the SNI-BD section for the procedure for replacing an SNI.</li> </ol> <p><b>⇒ NOTE:</b>                      If other SNI circuit packs do not have SNI-PEER error type 2817 errors, the problem could be at either of the peer SNI boards. It is arbitrary as to which SNI is replaced first. Proceed as follows:</p> <ol style="list-style-type: none"> <li>Replace this SNI.</li> <li>Replace the SNI in slot 16.</li> </ol>

*Continued on next page*

Table 9-559. TEST #755 SNI Circuit Path Test — *Continued*

Error Code	Test Result	Description/ Recommendation
117	FAIL	<p>The SNI circuit pack cannot communicate with the SNI in slot 17 over the circuit path.</p> <ol style="list-style-type: none"> <li>Fix any on-board SNI-BD errors against this SNI and the SNI in slot 17. Use <b>display errors</b> to find any SNI-BD errors and check <b>display alarms</b> to see whether the errors have on-board alarms. Then follow the associated repair procedures for SNI-BD.</li> <li>Check the error log via <b>display errors</b> for other SNI circuit packs with SNI-PEER error type 3073. If other SNI circuit packs have SNI-PEER error type 3073, then replace the SNI in slot 17. Replacing an SNI may be service interrupting. Refer to the SNI-BD section for the procedure for replacing an SNI.</li> </ol> <p><b>⇒ NOTE:</b>                      If other SNI circuit packs do not have SNI-PEER error type 3073 errors, the problem could be at either of the peer SNI boards. It is arbitrary as to which SNI is replaced first. Proceed as follows:</p> <ol style="list-style-type: none"> <li>Replace this SNI.</li> <li>Replace the SNI in slot 17.</li> </ol>
118	FAIL	<p>The SNI circuit pack cannot communicate with the SNI in slot 18 over the circuit path.</p> <ol style="list-style-type: none"> <li>Fix any on-board SNI-BD errors against this SNI and the SNI in slot 18. Use <b>display errors</b> to find any SNI-BD errors and check <b>display alarms</b> to see whether the errors have on-board alarms. Then follow the associated repair procedures for SNI-BD.</li> <li>Check the error log via <b>display errors</b> for other SNI circuit packs with SNI-PEER error type 3329. If other SNI circuit packs have SNI-PEER error type 3329, then replace the SNI in slot 18. Replacing an SNI may be service interrupting. Refer to the SNI-BD section for the procedure for replacing an SNI.</li> </ol> <p><b>⇒ NOTE:</b>                      If other SNI circuit packs do not have SNI-PEER error type 3329 errors, the problem could be at either of the peer SNI boards. It is arbitrary as to which SNI is replaced first. Proceed as follows:</p> <ol style="list-style-type: none"> <li>Replace this SNI.</li> <li>Replace the SNI in slot 18.</li> </ol>

*Continued on next page*



**Table 9-559. TEST #755 SNI Circuit Path Test — Continued**

Error Code	Test Result	Description/ Recommendation
119	FAIL	<p>The SNI circuit pack cannot communicate with the SNI in slot 19 over the circuit path.</p> <ol style="list-style-type: none"> <li>Fix any on-board SNI-BD errors against this SNI and the SNI in slot 19. Use <b>display errors</b> to find any SNI-BD errors and check <b>display alarms</b> to see whether the errors have on-board alarms. Then follow the associated repair procedures for SNI-BD.</li> <li>Check the error log via <b>display errors</b> for other SNI circuit packs with SNI-PEER error type 3585. If other SNI circuit packs have SNI-PEER error type 3585, then replace the SNI in slot 19. Replacing an SNI may be service interrupting. Refer to the SNI-BD section for the procedure for replacing an SNI.</li> </ol> <p><b>⇒ NOTE:</b>                      If other SNI circuit packs do not have SNI-PEER error type 3385 errors, the problem could be at either of the peer SNI boards. It is arbitrary as to which SNI is replaced first. Proceed as follows:</p> <ol style="list-style-type: none"> <li>Replace this SNI.</li> <li>Replace the SNI in slot 19.</li> </ol>
120	FAIL	<p>The SNI circuit pack cannot communicate with the SNI in slot 20 over the circuit path.</p> <ol style="list-style-type: none"> <li>Fix any on-board SNI-BD errors against this SNI and the SNI in slot 20. Use <b>display errors</b> to find any SNI-BD errors and check <b>display alarms</b> to see whether the errors have on-board alarms. Then follow the associated repair procedures for SNI-BD.</li> <li>Check the error log via <b>display errors</b> for other SNI circuit packs with SNI-PEER error type 3841. If other SNI circuit packs have SNI-PEER error type 3841, then replace the SNI in slot 20. Replacing an SNI may be service interrupting. Refer to the SNI-BD section for the procedure for replacing an SNI.</li> </ol> <p><b>⇒ NOTE:</b>                      If other SNI circuit packs do not have SNI-PEER error type 3841 errors, the problem could be at either of the peer SNI boards. It is arbitrary as to which SNI is replaced first. Proceed as follows:</p> <ol style="list-style-type: none"> <li>Replace this SNI.</li> <li>Replace the SNI in slot 20.</li> </ol>

*Continued on next page*

**Table 9-559. TEST #755 SNI Circuit Path Test — Continued**

Error Code	Test Result	Description/ Recommendation
122	FAIL	<p>The SNI circuit pack cannot communicate with its neighbor via the circuit path.</p> <ol style="list-style-type: none"> <li>1. Fix any on-board errors (SNI-BD, EXP-INTF, and/or DS1C-BD) against the components of this fiber link by using <b>display errors</b> and <b>display alarms</b> and following the associated repair procedures. (Use the <b>list fiber-link</b> command to find the fiber link associated with this SNI. The <b>display fiber-link</b> command can then be used to find the endpoints of the fiber link and the DS1C circuit pack locations if this fiber link has a DS1 Converter Complex administered.)</li> <li>2. Enter <b>display errors</b> and follow the associated repair procedures for any FIBER-LK entries for the fiber this SNI is administered on. Check <b>list fiber-link</b> to determine the administered fiber.</li> <li>3. If this fiber link has a DS1 converter complex administered, enter <b>display errors</b> and <b>display alarms</b> and follow the associated repair procedures for any off-board DS1C-BD or DS1-FAC entries for either of the DS1C boards administered or for the DS1 facilities associated with either of the DS1C boards administered.</li> <li>4. Replace this SNI.</li> </ol>
	PASS	The SNI passed the sni circuit path test.
0	NO BOARD	<p>No board was detected by the test.</p> <ol style="list-style-type: none"> <li>1. Check that board is properly translated and inserted.</li> <li>2. Run the test again. If it fails, reset the board. An SNI should be reset instead of reseating the circuit pack. The <b>reset board</b> command should almost never be used on an SNI. It may be necessary to use the <b>reset board</b> command if the SNI circuit pack gets into a mode where it cannot communicate with software. If an SNI with active errors and alarms is reset, the errors and alarms may take a while to come back, therefore the <b>reset board</b> command can mask real problems.</li> <li>3. Run the test again. If it fails, the ID chip on board may be bad. Replace the board and retest.</li> </ol>

**SNI Off-board Destructive Facility Test (#756)**

**This test is destructive.**

The SNI runs a destructive looparound of the off-board and on-board looparounds. This test returns the result of the off-board looparound, while test 757 returns the result of the on-board looparound.

**Table 9-560. TEST #756 SNI Off-Board Destructive Facility Test**

Error Code	Test Result	Description/ Recommendation
1015	ABORT	The system will not allow this test to be run because the SNI circuit pack has not been busied out. Busy out the SNI circuit pack with <b>busyout board</b> . Repeat the <b>test board UUCSS long</b> command.
1415	ABORT	The lightwave transceiver is not present. <ol style="list-style-type: none"> <li>1. If a lightwave transceiver is not supposed to be present, do nothing. For example, an SNI connected to a DS1C circuit pack or an SNI with a metallic connection does not have a lightwave transceiver. This test can only be run when a lightwave transceiver exists.</li> <li>2. Otherwise, check the lightwave transceiver connections.</li> <li>3. If OK, replace the lightwave transceiver. If a fiber out of frame condition exists and lightwave transceivers are used, check that the lightwave transceivers are of the same type, that is, both are 9823a or both are 9823b. If they are not the same type, replace one of the lightwave transceivers:                             <ul style="list-style-type: none"> <li>■ 9823a is used for distances up to 4900 feet.</li> <li>■ 9823b is used for distances up to 25,000 feet.</li> </ul> </li> <li>4. If the test continues to abort, replace the SNI circuit pack.</li> </ol>
2100	ABORT	Could not allocate the necessary system resources to run this test. <ol style="list-style-type: none"> <li>1. Retry the command at 1-minute intervals a maximum of 3 times.</li> </ol>
2300	ABORT	The downlink message necessary to run this test could not be sent. <ol style="list-style-type: none"> <li>1. Retry the command at 1-minute intervals a maximum of 3 times.</li> </ol>
2301	ABORT	The software timer could not be set before sending the downlink message necessary to run this test. <ol style="list-style-type: none"> <li>1. Retry the command at 1-minute intervals a maximum of 3 times.</li> </ol>
2304	ABORT	SNI circuit pack responded that it is not able to run the test requested by software. <ol style="list-style-type: none"> <li>1. Retry the command at 1-minute intervals a maximum of 3 times.</li> </ol>

*Continued on next page*

**Table 9-560. TEST #756 SNI Off-Board Destructive Facility Test — Continued**

Error Code	Test Result	Description/ Recommendation
2306	ABORT	<p>The SNI circuit pack is not responding to test requests sent by software.</p> <ol style="list-style-type: none"> <li>1. Run the <b>test led switch-node</b> for the switch node that the SNI resides in to verify whether the LEDs on the board light.</li> <li>2. If the LEDs on the other boards in the carrier light, but the LEDs on this board do not light, run test 760 via <b>test board UUCSS I</b> for the active SNC in this carrier. Wait 5 minutes and then try step 1 one more time. If the LEDs on this board still do not light, replace this board. Replacing an SNI may be service interrupting. Refer to the SNI-BD section for the procedure for replacing an SNI.</li> <li>3. If none of the LEDs light for the boards in the same carrier as this board, fix any problems associated with the connectivity of this carrier to the SPE. Check <b>list fiber-link</b> to determine the fiber connections to this carrier. Check the LEDs on all SNIs and EIs and fix any fiber problems. Enter <b>display errors</b> and follow the associated repair procedures for any EXP-INTF error entries associated with the PPN. Also, follow the associated repair procedures for any SYNC, SNI-BD, SNC-BD, FIBER-LK, or SNI-PEER error entries.</li> <li>4. Follow the procedure described above, SNI Manual Loopback to determine whether the circuit pack or the fiber connection is faulty.</li> </ol>
127	FAIL	<p>The data is not correctly looped around.</p> <ol style="list-style-type: none"> <li>1. Check the lightwave transceiver or metallic physical connections.</li> <li>2. If connections OK, replace the lightwave transceiver or the metallic interconnect.</li> <li>3. If the test still fails, replace the SNI circuit pack.</li> </ol>
	PASS	<p>No problems associated with this test are detected on the SNI.</p>
0	NO BOARD	<p>No board was detected by the test.</p> <ol style="list-style-type: none"> <li>1. Check that board is properly translated and inserted.</li> <li>2. Run the test again. If it fails, reset the board. An SNI should be reset instead of reseating the circuit pack. The <b>reset board</b> command should almost never be used on an SNI. It may be necessary to use the <b>reset board</b> command if the SNI circuit pack gets into a mode where it cannot communicate with software. If an SNI with active errors and alarms is reset, the errors and alarms may take a while to come back, therefore the <b>reset board</b> command can mask real problems.</li> <li>3. Run the test again. If it fails, the ID chip on board may be bad. Replace the board and retest.</li> </ol>

**SNI Destructive Facility Test (#757)**

**This test is destructive.**

The SNI runs a destructive looparound of the off-board and on-board looparounds. This test returns the result of the on-board looparound, while test 756 returns the result of the off-board looparound.

**Table 9-561. TEST #757 SNI Destructive Facility Test**

<b>Error Code</b>	<b>Test Result</b>	<b>Description/ Recommendation</b>
1015	ABORT	The system will not allow this test to be run because the SNI circuit pack has not been busied out. Busy out the SNI circuit pack with <b>busyout board</b> . Repeat the <b>test board UUCSS long</b> command.
2100	ABORT	Could not allocate the necessary system resources to run this test. 1. Retry the command at 1-minute intervals a maximum of 3 times.
2300	ABORT	The downlink message necessary to run this test could not be sent. 1. Retry the command at 1-minute intervals a maximum of 3 times.
2301	ABORT	The software timer could not be set before sending the downlink message necessary to run this test. 1. Retry the command at 1-minute intervals a maximum of 3 times.
2304	ABORT	SNI circuit pack responded that it is not able to run the test requested by software. 1. Retry the command at 1-minute intervals a maximum of 3 times.

*Continued on next page*

**Table 9-561. TEST #757 SNI Destructive Facility Test — Continued**

Error Code	Test Result	Description/ Recommendation
2306	ABORT	<p>The SNI circuit pack is not responding to software test requests.</p> <ol style="list-style-type: none"> <li>1. Run the <b>test led switch-node</b> for the switch node that the SNI resides in to verify whether the LEDs on the board light.</li> <li>2. If the LEDs on the other boards in the carrier light, but the LEDs on this board do not light, run test 760 via <b>test board UUCSS I</b> for the active SNC in this carrier. Wait 5 minutes and then try step 1 one more time. If the LEDs on this board still do not light, replace this board. Replacing an SNI may be service interrupting. Refer to the SNI-BD section for the procedure for replacing an SNI.</li> <li>3. If none of the LEDs light for the boards in the same carrier as this board, fix any problems associated with the connectivity of this carrier to the SPE. Check <b>list fiber-link</b> to determine the fiber connections to this carrier. Check the LEDs on all SNIs and EIs and fix any fiber problems. Enter <b>display errors</b> and follow the associated repair procedures for any EXP-INTF error entries associated with the PPN. Also, follow the associated repair procedures for any SYNC, SNI-BD, SNC-BD, FIBER-LK, or SNI-PEER error entries.</li> <li>4. Follow the procedure described above, SNI Manual Loopback to determine whether the circuit pack or the fiber connection is faulty.</li> </ol>
127	FAIL	<p>The data is not correctly looped around.</p> <ol style="list-style-type: none"> <li>1. Replace the SNI circuit pack.</li> </ol>
	PASS	<p>No problems associated with this test are detected on the SNI.</p>
0	NO BOARD	<p>No board was detected by the test.</p> <ol style="list-style-type: none"> <li>1. Check that board is properly translated and inserted.</li> <li>2. Run the test again. If it fails, reset the board. An SNI should be reset instead of reseating the circuit pack. The <b>reset board</b> command should almost never be used on an SNI. It may be necessary to use the <b>reset board</b> command if the SNI circuit pack gets into a mode where it cannot communicate with software. If an SNI with active errors and alarms is reset, the errors and alarms may take a while to come back, therefore the <b>reset board</b> command can mask real problems.</li> <li>3. Run the test again. If it fails, the ID chip on board may be bad. Replace the board and retest.</li> </ol>

**Configuration Audit (#759)**

This test is non-destructive.

### ⇒ NOTE:

For descriptions of result codes for this test refer to:

- SNC-BD when the circuit pack tested is a Switch Node Clock (circuit pack slots 10 or 12).
- SNI-BD when the circuit pack tested is a Switch Node Interface (circuit pack slots 2-9 or 13-20).

This test is run via the **test board short** or **test board long** command for SNI circuit packs or SNC circuit packs.

For SNI circuit packs, this test queries the SNI for SNCs in the same switch node carrier, SNI peers, DS1Cs, and EI or SNI neighbors that the SNI can communicate with and compares this data to the administered data.

For SNC circuit packs, this test queries the SNC for SNCs and SNIs in the same switch node carrier that the SNC can communicate with and compares this data to the administered data.

Failures of this test cause entries in the error and alarm logs against Switch Node Configuration (SN-CONF) with the board location of the SNI or SNC.

## Incorrectly Connected Administered Fibers

Some physically connected fibers that do not match fiber administration can cause port network problems that are not detected and alarmed by PNC tests. The symptoms will usually be many phone calls not working correctly, and port network component alarms because of translation mismatches.

This test is unable to detect the case where an SNI is connected to the same type of board (EI or SNI) as administered but located in a different cabinet but the same carrier and same slot as the administered fiber endpoint. The administered fiber endpoint can be viewed with the **list fiber-link** command. This test can only detect if the fiber endpoint connected to the SNI is in a different carrier, slot location than the administered fiber endpoint.

## Incorrectly Connected Administered SNI-EI Fibers

If the SNI is connected to the same type of fiber endpoint as the administered fiber endpoint, but the location is the same as administered except for the cabinet, many phone calls will not work correctly; some phone calls will not go through and some phone calls will ring the wrong phone.

The **test led** command can be used in this case to check connectivity.

1. Run the **test led port-network** command on each administered port network and verify that the LEDs on the correct port network are lit.
2. If they are not lit, check that the fiber connections to the port network are consistent with the administered fibers (**list fiber-link**) that does not light the LEDs as expected.

3. Run **test led switch-node** on each administered switch node carrier and verify that the LEDs on the correct carrier are lit.
4. If they are not, check the connectivity to the switch node carrier that does not light the LEDs as expected.

### **Incorrectly Connected Administered SNI-SNI Fibers between 3 Switch Nodes**

If the system has more than 2 switch nodes, SNI-SNI fibers administered between 2 switch nodes could be incorrectly connected to a third switch node. This is a problem that could occur during installation or when inter-switch node fibers are changed. For multiple fibers to a distant switch node (not the PPN switch node), an incorrect connection would not appear as a problem unless this fiber is used for a system-link to a port network connected to the distant switch node. The **status system-link** command can be used to determine the boards and fiber-links in the path from the PPN to a specific port network. A specific SNI-SNI fiber connection must be in the system-link path to be checked with the port network LED test.

One method to force an SNI-SNI fiber connection to be used as a system-link is to physically remove all SNI-SNI connections except the fiber-link being tested at the distant switch node by physical removing SNI boards in the distant SWItch node.

1. Use the **status system-link** command to verify that this fiber selected for test is in the path to the EPN connected to the distant switch node that will be used for the LED test.
2. Run the **test led** sequence to a port network as described above to verify this fiber connection.
3. Repeat this procedure for each of the other SNI-SNI fibers terminating on this distant switch node.

Another method for testing multiple fiber connections to a distant switch node is described below.

1. Use the **list fiber-link** command to determine the number of SNI-SNI fibers that are administered and terminating on this switch node.
2. Run the **test led port-network** command on a port network connected to this distant switch node and verify that the LEDs on the correct port network are lit.
3. Use the **status system-link** command and select the active EI in the port network connected to the distant switch node being tested. This display will show the path from the PPN and the SNI-SNI fiber being used in this path.
4. If they are not lit, check that the fiber connections to the port network are consistent with the administered fibers (**list fiber-link**) that does not light the LEDs as expected.



5. If the port network LEDs are lit and we have multiple SNI-SNI fibers to this distant switch node, physically remove the SNI that is listed in this path.
6. Use the **status system-link** command to determine the new path from the PPN to the this distant switch.
7. Run the **test led port-network** command on a port network connected to the distant switch node and verify that the LEDs on the correct port network are lit.
8. Continue with steps 5 — 7 above until the last SNI-SNI fiber to this distant switch node has been tested.

**Table 9-562. TEST #759 Configuration Audit**

Error Code	Test Result	Description/ Recommendation
2100	ABORT	Could not allocate the necessary system resources to run this test. 1. Retry the command at 1-minute intervals a maximum of 3 times.
2300	ABORT	The downlink message necessary to run this test could not be sent. 1. Retry the command at 1-minute intervals a maximum of 3 times.
2301	ABORT	The software timer could not be set before sending the downlink message necessary to run this test. 1. Retry the command at 1-minute intervals a maximum of 3 times.
2306	ABORT	The SNI circuit pack is not responding to test requests sent by software. 1. Run the <b>test led switch-node</b> for the switch node that this board resides in to verify whether the LEDs on the board light. 2. If the LEDs on the other boards in the carrier light, but the LEDs on this board do not light, run test 760 via <b>test board UUCSS</b> for the active SNC in this carrier. Wait 5 minutes and then try step 1 one more time. If the LEDs on this board still do not light, replace this board. Replacing an SNI may be service interrupting. Refer to the SNI-BD section for the procedure for replacing an SNI. 3. If none of the LEDs light for the boards in the same carrier as this board, fix any problems associated with the connectivity of this carrier to the SPE. Check <b>list fiber-link</b> to determine the fiber connections to this carrier. Check the LEDs on all SNIs and EIs and fix any fiber problems. Enter <b>display errors</b> and follow the associated repair procedures for any EXP-INTF error entries associated with the PPN. Also, follow the associated repair procedures for any SYNC, SNI-BD, SNC-BD, FIBER-LK, or SNI-PEER error entries. 4. Follow the procedure described above, SNI Manual Loopback to determine whether the circuit pack or the fiber connection is faulty.
2500	ABORT	Internal System Error 1. Retry the command at 1-minute intervals a maximum of 3 times.

Table 9-562. TEST #759 Configuration Audit — *Continued*

Error Code	Test Result	Description/ Recommendation
102	FAIL	<p>The SNI circuit pack cannot communicate with the equipped SNI in slot 2.</p> <ol style="list-style-type: none"><li>1. Perform the Fiber Fault Isolation Procedure described in Chapter 5. This will resolve multiple SNI-PEER errors.</li><li>2. If the SNI being tested has SNI-PEER error type 1, replace the SNI being tested. Replacing an SNI may be service interrupting. Refer to the SNI-BD section for the procedure for replacing an SNI. To view SNI-PEER errors, use the <b>display errors</b> command with category PNC-PEER. Retry the command.</li><li>3. If the SNI being tested has SNI-PEER error type 1, replace the SNI in slot 2. Replacing an SNI may be service interrupting. Refer to the SNI-BD section for the procedure for replacing an SNI. Retry the command.</li></ol>
103	FAIL	<p>The SNI circuit pack cannot communicate with the equipped SNI in slot 3.</p> <ol style="list-style-type: none"><li>1. Perform the Fiber Fault Isolation Procedure described in Chapter 5. This will resolve multiple SNI-PEER errors.</li><li>2. If the SNI being tested has SNI-PEER error type 257, replace the SNI being tested. Replacing an SNI may be service interrupting. Refer to the SNI-BD section for the procedure for replacing an SNI. To view SNI-PEER errors, use the <b>display errors</b> command with category PNC-PEER. Retry the command.</li><li>3. If the SNI being tested has SNI-PEER error type 257, replace the SNI in slot 3. Replacing an SNI may be service interrupting. Refer to the SNI-BD section for the procedure for replacing an SNI. Retry the command.</li></ol>
104	FAIL	<p>The SNI circuit pack cannot communicate with the equipped SNI in slot 4.</p> <ol style="list-style-type: none"><li>1. Perform the Fiber Fault Isolation Procedure described in Chapter 5. This will resolve multiple SNI-PEER errors.</li><li>2. If the SNI being tested has SNI-PEER error type 513, replace the SNI being tested. Replacing an SNI may be service interrupting. Refer to the SNI-BD section for the procedure for replacing an SNI. To view SNI-PEER errors, use the <b>display errors</b> command with category PNC-PEER. Retry the command.</li><li>3. If the SNI being tested has SNI-PEER error type 513, replace the SNI in slot 4. Replacing an SNI may be service interrupting. Refer to the SNI-BD section for the procedure for replacing an SNI. Retry the command.</li></ol>

*Continued on next page*

**Table 9-562. TEST #759 Configuration Audit — Continued**

Error Code	Test Result	Description/ Recommendation
105	FAIL	<p>The SNI circuit pack cannot communicate with the equipped SNI in slot 5.</p> <ol style="list-style-type: none"> <li>1. Perform the Fiber Fault Isolation Procedure described in Chapter 5. This will resolve multiple SNI-PEER errors.</li> <li>2. If the SNI being tested has SNI-PEER error type 769, replace the SNI being tested. Replacing an SNI may be service interrupting. Refer to the SNI-BD section for the procedure for replacing an SNI. To view SNI-PEER errors, use the <b>display errors</b> command with category PNC-PEER. Retry the command.</li> <li>3. If the SNI being tested has SNI-PEER error type 769, replace the SNI in slot 5. Replacing an SNI may be service interrupting. Refer to the SNI-BD section for the procedure for replacing an SNI. Retry the command.</li> </ol>
106	FAIL	<p>The SNI circuit pack cannot communicate with the equipped SNI in slot 6.</p> <ol style="list-style-type: none"> <li>1. Perform the Fiber Fault Isolation Procedure described in Chapter 5. This will resolve multiple SNI-PEER errors.</li> <li>2. If the SNI being tested has SNI-PEER error type 1025, replace the SNI being tested. Replacing an SNI may be service interrupting. Refer to the SNI-BD section for the procedure for replacing an SNI. To view SNI-PEER errors, use the <b>display errors</b> command with category PNC-PEER. Retry the command.</li> <li>3. If the SNI being tested has SNI-PEER error type 1025, replace the SNI in slot 6. Replacing an SNI may be service interrupting. Refer to the SNI-BD section for the procedure for replacing an SNI. Retry the command.</li> </ol>
107	FAIL	<p>The SNI circuit pack cannot communicate with the equipped SNI in slot 7.</p> <ol style="list-style-type: none"> <li>1. Perform the Fiber Fault Isolation Procedure described in Chapter 5. This will resolve multiple SNI-PEER errors.</li> <li>2. If the SNI being tested has SNI-PEER error type 1281, replace the SNI being tested. Replacing an SNI may be service interrupting. Refer to the SNI-BD section for the procedure for replacing an SNI. To view SNI-PEER errors, use the <b>display errors</b> command with category PNC-PEER. Retry the command.</li> <li>3. If the SNI being tested has SNI-PEER error type 1281, replace the SNI in slot 7. Replacing an SNI may be service interrupting. Refer to the SNI-BD section for the procedure for replacing an SNI. Retry the command.</li> </ol>

*Continued on next page*

**Table 9-562. TEST #759 Configuration Audit — Continued**

Error Code	Test Result	Description/ Recommendation
108	FAIL	<p>The SNI circuit pack cannot communicate with the equipped SNI in slot 8.</p> <ol style="list-style-type: none"> <li>1. Perform the Fiber Fault Isolation Procedure described in Chapter 5. This will resolve multiple SNI-PEER errors.</li> <li>2. If the SNI being tested has SNI-PEER error type 1537, replace the SNI being tested. Replacing an SNI may be service interrupting. Refer to the SNI-BD section for the procedure for replacing an SNI. To view SNI-PEER errors, use the <b>display errors</b> command with category PNC-PEER. Retry the command.</li> <li>3. If the SNI being tested has SNI-PEER error type 1537, replace the SNI in slot 8. Replacing an SNI may be service interrupting. Refer to the SNI-BD section for the procedure for replacing an SNI. Retry the command.</li> </ol>
109	FAIL	<p>The SNI circuit pack cannot communicate with the equipped SNI in slot 9.</p> <ol style="list-style-type: none"> <li>1. Perform the Fiber Fault Isolation Procedure described in Chapter 5. This will resolve multiple SNI-PEER errors.</li> <li>2. If the SNI being tested has SNI-PEER error type 1793, replace the SNI being tested. Replacing an SNI may be service interrupting. Refer to the SNI-BD section for the procedure for replacing an SNI. To view SNI-PEER errors, use the <b>display errors</b> command with category PNC-PEER. Retry the command.</li> <li>3. If the SNI being tested has SNI-PEER error type 1793, replace the SNI in slot 9. Replacing an SNI may be service interrupting. Refer to the SNI-BD section for the procedure for replacing an SNI. Retry the command.</li> </ol>
112	FAIL	<p>The SNI circuit pack cannot communicate with the active SNC.</p> <ol style="list-style-type: none"> <li>1. Check the error log for other SNI circuit packs in the same carrier with a 257 SNI-BD error. Use <b>display errors</b> with category PNC to view SNI-BD errors. If other SNI circuit packs in the same switch node carrier have error 257, then replace the active SNC in this switch node carrier. Replacing an SNC may be service interrupting. Refer to the SNC-BD section for the procedure for replacing an SNC. If other SNI circuit packs in the same carrier do not have SNI-BD error type 257 logged, proceed to step 2.</li> <li>2. Replace this SNI. Replacing an SNI may be service interrupting. Refer to the SNI-BD section for the procedure for replacing an SNI.</li> <li>3. Replace the active SNC in the same switch node carrier. Replacing an SNC may be service interrupting. Refer to the SNC-BD section for the procedure for replacing an SNC.</li> </ol>

*Continued on next page*

**Table 9-562. TEST #759 Configuration Audit — Continued**

Error Code	Test Result	Description/ Recommendation
113	FAIL	<p>The SNI circuit pack cannot communicate with the equipped SNI in slot 13.</p> <ol style="list-style-type: none"> <li>1. Perform the Fiber Fault Isolation Procedure described in Chapter 5. This will resolve multiple SNI-PEER errors.</li> <li>2. If the SNI being tested has SNI-PEER error type 2049, replace the SNI being tested. Replacing an SNI may be service interrupting. Refer to the SNI-BD section for the procedure for replacing an SNI. To view SNI-PEER errors, use the <b>display errors</b> command with category PNC-PEER. Retry the command.</li> <li>3. If the SNI being tested has SNI-PEER error type 2049, replace the SNI in slot 13. Replacing an SNI may be service interrupting. Refer to the SNI-BD section for the procedure for replacing an SNI. Retry the command.</li> </ol>
114	FAIL	<p>The SNI circuit pack cannot communicate with the equipped SNI in slot 14.</p> <ol style="list-style-type: none"> <li>1. Perform the Fiber Fault Isolation Procedure described in Chapter 5. This will resolve multiple SNI-PEER errors.</li> <li>2. If the SNI being tested has SNI-PEER error type 2305, replace the SNI being tested. Replacing an SNI may be service interrupting. Refer to the SNI-BD section for the procedure for replacing an SNI. To view SNI-PEER errors, use the <b>display errors</b> command with category PNC-PEER. Retry the command.</li> <li>3. If the SNI being tested has SNI-PEER error type 2305, replace the SNI in slot 14. Replacing an SNI may be service interrupting. Refer to the SNI-BD section for the procedure for replacing an SNI. Retry the command.</li> </ol>
115	FAIL	<p>The SNI circuit pack cannot communicate with the equipped SNI in slot 15.</p> <ol style="list-style-type: none"> <li>1. Perform the Fiber Fault Isolation Procedure described in Chapter 5. This will resolve multiple SNI-PEER errors.</li> <li>2. If the SNI being tested has SNI-PEER error type 2561, replace the SNI being tested. Replacing an SNI may be service interrupting. Refer to the SNI-BD section for the procedure for replacing an SNI. To view SNI-PEER errors, use the <b>display errors</b> command with category PNC-PEER. Retry the command.</li> <li>3. If the SNI being tested has SNI-PEER error type 2561, replace the SNI in slot 15. Replacing an SNI may be service interrupting. Refer to the SNI-BD section for the procedure for replacing an SNI. Retry the command.</li> </ol>

*Continued on next page*

**Table 9-562. TEST #759 Configuration Audit — Continued**

Error Code	Test Result	Description/ Recommendation
116	FAIL	<p>The SNI circuit pack cannot communicate with the equipped SNI in slot 16.</p> <ol style="list-style-type: none"> <li>1. Perform the Fiber Fault Isolation Procedure described in Chapter 5. This will resolve multiple SNI-PEER errors.</li> <li>2. If the SNI being tested has SNI-PEER error type 2817, replace the SNI being tested. Replacing an SNI may be service interrupting. Refer to the SNI-BD section for the procedure for replacing an SNI. To view SNI-PEER errors, use the <b>display errors</b> command with category PNC-PEER. Retry the command.</li> <li>3. If the SNI being tested has SNI-PEER error type 2817, replace the SNI in slot 16. Replacing an SNI may be service interrupting. Refer to the SNI-BD section for the procedure for replacing an SNI. Retry the command.</li> </ol>
117	FAIL	<p>The SNI circuit pack cannot communicate with the equipped SNI in slot 17.</p> <ol style="list-style-type: none"> <li>1. Perform the Fiber Fault Isolation Procedure described in Chapter 5. This will resolve multiple SNI-PEER errors.</li> <li>2. If the SNI being tested has SNI-PEER error type 3073, replace the SNI being tested. Replacing an SNI may be service interrupting. Refer to the SNI-BD section for the procedure for replacing an SNI. To view SNI-PEER errors, use the <b>display errors</b> command with category PNC-PEER. Retry the command.</li> <li>3. If the SNI being tested has SNI-PEER error type 3073, replace the SNI in slot 17. Replacing an SNI may be service interrupting. Refer to the SNI-BD section for the procedure for replacing an SNI. Retry the command.</li> </ol>
118	FAIL	<p>The SNI circuit pack cannot communicate with the equipped SNI in slot 18.</p> <ol style="list-style-type: none"> <li>1. Perform the Fiber Fault Isolation Procedure described in Chapter 5. This will resolve multiple SNI-PEER errors.</li> <li>2. If the SNI being tested has SNI-PEER error type 3329, replace the SNI being tested. Replacing an SNI may be service interrupting. Refer to the SNI-BD section for the procedure for replacing an SNI. To view SNI-PEER errors, use the <b>display errors</b> command with category PNC-PEER. Retry the command.</li> <li>3. If the SNI being tested has SNI-PEER error type 3329, replace the SNI in slot 18. Replacing an SNI may be service interrupting. Refer to the SNI-BD section for the procedure for replacing an SNI. Retry the command.</li> </ol>

*Continued on next page*

**Table 9-562. TEST #759 Configuration Audit — Continued**

Error Code	Test Result	Description/ Recommendation
119	FAIL	<p>The SNI circuit pack cannot communicate with the equipped SNI in slot 19.</p> <ol style="list-style-type: none"> <li>1. Perform the Fiber Fault Isolation Procedure described in Chapter 5. This will resolve multiple SNI-PEER errors.</li> <li>2. If the SNI being tested has SNI-PEER error type 3585, replace the SNI being tested. Replacing an SNI may be service interrupting. Refer to the SNI-BD section for the procedure for replacing an SNI. To view SNI-PEER errors, use the <b>display errors</b> command with category PNC-PEER. Retry the command.</li> <li>3. If the SNI being tested has SNI-PEER error type 3585, replace the SNI in slot 19. Replacing an SNI may be service interrupting. Refer to the SNI-BD section for the procedure for replacing an SNI. Retry the command.</li> </ol>
120	FAIL	<p>The SNI circuit pack cannot communicate with the equipped SNI in slot 20.</p> <ol style="list-style-type: none"> <li>1. Perform the Fiber Fault Isolation Procedure described in Chapter 5. This will resolve multiple SNI-PEER errors.</li> <li>2. If the SNI being tested has SNI-PEER error type 3841, replace the SNI being tested. Replacing an SNI may be service interrupting. Refer to the SNI-BD section for the procedure for replacing an SNI. To view SNI-PEER errors, use the <b>display errors</b> command with category PNC-PEER. Retry the command.</li> <li>3. If the SNI being tested has SNI-PEER error type 3841, replace the SNI in slot 20. Replacing an SNI may be service interrupting. Refer to the SNI-BD section for the procedure for replacing an SNI. Retry the command.</li> </ol>
133	FAIL	<p>No neighbor link is administered, but the SNI has an EI neighbor.</p> <ol style="list-style-type: none"> <li>1. Administer the SNI on a fiber link to the EI neighbor it is connected to via the <b>add fiber-link next</b> command. Or remove both fiber endpoints (i.e., this SNI and its EI neighbor) and remove the fiber endpoints from circuit pack administration via <b>change circuit-pack</b>.</li> </ol>
134	FAIL	<p>No neighbor link is administered, but the SNI has an SNI neighbor.</p> <ol style="list-style-type: none"> <li>1. Administer the SNI on a fiber link to the SNI neighbor it is connected to via the <b>add fiber-link next</b> command. Or remove both fiber endpoints (i.e., this SNI and its SNI neighbor) and remove the fiber endpoints from circuit pack administration via <b>change circuit-pack</b>.</li> </ol>
135	FAIL	<p>The SNI circuit pack cannot communicate with its neighbor. The SNI has an administered neighbor, but cannot communicate with its neighbor.</p> <ol style="list-style-type: none"> <li>1. Check if the administered neighbor is inserted. If not, insert the neighbor circuit pack.</li> <li>2. Perform the Fiber Fault Isolation Procedure described in Chapter 5.</li> </ol>

*Continued on next page*

**Table 9-562. TEST #759 Configuration Audit — Continued**

Error Code	Test Result	Description/ Recommendation
136	FAIL	The SNI's administered neighbor does not match the physical neighbor connected. The type of neighbor administered is an SNI and the type of neighbor physically connected is an EI. Enter <b>list fiber-link</b> and verify that the fiber optic cable and metallic cable connections are installed as administered.
137	FAIL	The SNI's administered neighbor does not match the physical neighbor connected. The type of neighbor administered is an EI and the type of neighbor physically connected is an SNI. Enter <b>list fiber-link</b> and verify that the fiber optic cable and metallic cable connections are installed as administered.
138	FAIL	The physical neighbor location does not match administered neighbor location. The carrier and slot of the administered neighbor do not match the carrier and slot of the physical neighbor. Enter <b>list fiber-link</b> and verify that the fiber optic cable and metallic cable connections are installed as administered. If the problem does not seem to be caused by a physical connection problem or an administration problem, replace the neighbor circuit pack. It is possible for the neighbor circuit pack to have a hardware problem that causes it to report a wrong angel address (physical carrier/slot address) to software.
139	FAIL	<p>The SNI is administered to be connected to a DS1C but is not physically connected to a DS1C. <i>If a DS1C is not supposed to be connected to this SNI</i>, change administration to remove the DS1 converter complex from the fiber link associated with this SNI by:</p> <ol style="list-style-type: none"> <li>1. Determine which fiber that this SNI is an endpoint of by checking <b>list fiber-link</b>.</li> <li>2. Remove this fiber with the <b>remove fiber-link</b> command.</li> <li>3. Add the fiber back via <b>add fiber-link</b>, and do not administer the DS1 converter complex at this time.</li> </ol>

*Continued on next page*



**Table 9-562. TEST #759 Configuration Audit — Continued**

Error Code	Test Result	Description/ Recommendation
140	FAIL	<p>The SNI is physically connected to a DS1C but is not administered to be connected to a DS1C.</p> <p><b>Either</b> add the DS1 converter complex to the fiber that this SNI is associated with by:</p> <ol style="list-style-type: none"> <li>1. Determine which fiber that this SNI is an endpoint of by checking <b>list fiber-link</b>.</li> <li>2. Remove this fiber with the <b>remove fiber-link</b> command.</li> <li>3. Add the fiber back via <b>add fiber-link</b>, and at this time also administer the DS1 converter complex.</li> </ol> <p><b>Or:</b></p> <ol style="list-style-type: none"> <li>1. Remove the DS1C connection and connect the SNI directly to its administered fiber endpoint.</li> <li>2. Verify that the fiber optic cable and metallic cable connections are installed as administered by entering <b>list fiber-link</b>.</li> </ol>
	PASS	<p>The administered data and the circuit packs the SNI can communicate with match.</p>
0	NO BOARD	<p>No board was detected by the test.</p> <ol style="list-style-type: none"> <li>1. Check that board is properly translated and inserted.</li> <li>2. Run the test again. If it fails, reset the board. An SNI should be reset instead of reseating the circuit pack. The <b>reset board</b> command should almost never be used on an SNI. It may be necessary to use the <b>reset board</b> command if the SNI circuit pack gets into a mode where it cannot communicate with software. If an SNI with active errors and alarms is reset, the errors and alarms may take a while to come back, therefore the <b>reset board</b> command can mask real problems.</li> <li>3. Run the test again. If it fails, the ID chip on board may be bad. Replace the board and retest.</li> </ol>

**Switch Node Interface Reset Test (#761)**

**This test is destructive.**

This test resets the SNI circuit pack via the **reset board UUCSS** command when an SNI circuit pack location is entered. The SNI is reset via the active SNC circuit pack in the carrier. If the SNI is connected to the PPN EI, the SNI is reset via its PPN EI neighbor. If an SNI with an EPN EI or another SNI as its neighbor cannot be reset via the active SNC, i.e., if no software communication exists between the

active SNC and the SPE, an attempt will be made to reset the SNI via its neighbor.

An SNI should be reset instead of reseating the circuit pack. The **reset board** command should almost never be used on an SNI. It may be necessary to use the **reset board** command if the SNI circuit pack gets into a mode where it cannot communicate with software.

If an SNI with active errors and alarms is reset, the errors and alarms may take a while to come back, therefore the **reset board** command can mask real problems.

**Table 9-563. TEST #761 Switch Node Interface Reset Test**

Error Code	Test Result	Description/ Recommendation
2100	ABORT	Could not allocate the necessary system resources to run this test. 1. Retry the command at 1-minute intervals a maximum of 3 times.
2300	ABORT	The downlink message necessary to run this test could not be sent. 1. Retry the command at 1-minute intervals a maximum of 3 times.
2301	ABORT	The software timer could not be set before sending the downlink message necessary to run this test. 1. Retry the command at 1-minute intervals a maximum of 3 times.
2302	ABORT	Software received incorrect message data from the SNI circuit pack. 1. Retry the command at 1-minute intervals a maximum of 3 times.
2303	ABORT	The SNI circuit pack responded that the software test requested is invalid. 1. Retry the command at 1-minute intervals a maximum of 3 times.
2304	ABORT	SNI circuit pack responded that it is not able to run the test requested by software. 1. Retry the command at 1-minute intervals a maximum of 3 times.

*Continued on next page*

**Table 9-563. TEST #761 Switch Node Interface Reset Test — Continued**

Error Code	Test Result	Description/ Recommendation
2306	ABORT	<p>The SNI circuit pack is not responding to test requests sent by software.</p> <ol style="list-style-type: none"> <li>1. Run the <b>test led switch-node</b> for the switch node that the SNI resides in to verify whether the LEDs on the board light.</li> <li>2. If the LEDs on the other boards in the carrier light, but the LEDs on this board do not light, run test 760 via <b>test board UUCSS I</b> for the active SNC in this carrier. Wait 5 minutes and then try step 1 one more time. If the LEDs on this board still do not light, replace this board. Replacing an SNI may be service interrupting. Refer to the SNI-BD section for the procedure for replacing an SNI.</li> <li>3. If none of the LEDs light for the boards in the same carrier as this board, fix any problems associated with the connectivity of this carrier to the SPE. Check <b>list fiber-link</b> to determine the fiber connections to this carrier. Check the LEDs on all SNIs and EIs and fix any fiber problems. Enter <b>display errors</b> and follow the associated repair procedures for any EXP-INTF error entries associated with the PPN. Also, follow the associated repair procedures for any SYNC, SNI-BD, SNC-BD, FIBER-LK, or SNI-PEER error entries.</li> <li>4. Follow the procedure described above, SNI Manual Loopback to determine whether the circuit pack or the fiber connection is faulty.</li> </ol>
2316	ABORT	<p>The reset of the SNI circuit pack was attempted via the connected DS1C circuit pack. This ABORT code indicates that the fiber is not administered, but in this particular case it also indicates a software problem.</p> <ol style="list-style-type: none"> <li>1. Retry the command at 1-minute intervals a maximum of 1 time.</li> </ol>
2500	ABORT	<p>Internal System Error</p> <ol style="list-style-type: none"> <li>1. Retry the command at 1-minute intervals a maximum of 3 times.</li> </ol>
	PASS	<p>The reset message was sent out successfully to the active SNC or to the SNI's neighbor. A PASS does not necessarily mean the SNI circuit pack was successfully reset. The reset can be verified by checking that the red and green LEDs turn on and then turn off. If an SNI circuit pack fails one of the firmware tests run during its reset sequence, the red LED will stay on and the circuit pack should be replaced.</p>

*Continued on next page*

**Table 9-563. TEST #761 Switch Node Interface Reset Test — Continued**

Error Code	Test Result	Description/ Recommendation
0	NO BOARD	No board was detected by the test. <ol style="list-style-type: none"> <li>1. Check that board is properly translated and inserted.</li> <li>2. Run the test again. If it fails, reset the board. An SNI should be reset instead of reseating the circuit pack. The <b>reset board</b> command should almost never be used on an SNI. It may be necessary to use the <b>reset board</b> command if the SNI circuit pack gets into a mode where it cannot communicate with software. If an SNI with active errors and alarms is reset, the errors and alarms may take a while to come back, therefore the <b>reset board</b> command can mask real problems.</li> <li>3. Run the test again. If it fails, the ID chip on board may be bad. Replace the board and retest.</li> </ol>

### Packet Neighbor Link Test (#767)

This test is non-destructive.

This test checks the packet path of the neighbor circuit pack and the peer circuit packs. A packet is sent from the SNI being tested to the peer SNIs and to the neighbor EI or SNI. If the other EI or SNI sends the same data back in the packet, this test passes. Otherwise, this test fails.

**Table 9-564. TEST #767 Packet Neighbor Link Test**

Error Code	Test Result	Description/ Recommendation
2100	ABORT	Could not allocate the necessary system resources to run this test. <ol style="list-style-type: none"> <li>1. Retry the command at 1-minute intervals a maximum of 3 times.</li> </ol>
2300	ABORT	The downlink message necessary to run this test could not be sent. <ol style="list-style-type: none"> <li>1. Retry the command at 1-minute intervals a maximum of 3 times.</li> </ol>
2301	ABORT	The software timer could not be set before sending the downlink message necessary to run this test. <ol style="list-style-type: none"> <li>1. Retry the command at 1-minute intervals a maximum of 3 times.</li> </ol>
2302	ABORT	Software received incorrect message data from the SNI circuit pack. <ol style="list-style-type: none"> <li>1. Retry the command at 1-minute intervals a maximum of 3 times.</li> </ol>

*Continued on next page*

**Table 9-564. TEST #767 Packet Neighbor Link Test — Continued**

Error Code	Test Result	Description/ Recommendation
2303	ABORT	<p>The SNI circuit pack responded that the software test requested is invalid.</p> <ol style="list-style-type: none"><li data-bbox="284 354 990 390">1. Retry the command at 1-minute intervals a maximum of 3 times.</li></ol>
2304	ABORT	<p>SNI firmware is not able to run the test. For this particular test, the SNI circuit pack must be able to communicate with its neighbor.</p> <ol style="list-style-type: none"><li data-bbox="284 476 1101 682">1. Verify that the SNI can communicate with its neighbor by checking the yellow LED of the SNI to make sure the SNI is in frame or by running the <b>test board</b> command for the SNI and checking test 989 for fiber out-of-frame. If the results of Test 989 indicate that the fiber is out-of-frame, follow the recommendation associated with the test failure. If a DS1 converter complex exists on the fiber link, enter <b>display errors</b> and follow the associated repair procedures for any DS1C-BD and DS1-FAC entries.</li><li data-bbox="284 691 990 727">2. Retry the command at 1-minute intervals a maximum of 3 times.</li></ol>
2306	ABORT	<p>The SNI circuit pack is not responding to test requests sent by software.</p> <ol style="list-style-type: none"><li data-bbox="284 781 1050 835">1. Run the <b>test led switch-node</b> for the switch node carrier that the SNI resides in to verify whether the LEDs on the board light.</li><li data-bbox="284 852 1101 1032">2. If the LEDs on the other boards in the carrier light, but the LEDs on this board do not light, run test 760 via <b>test board UUCSS I</b> for the active SNC in this carrier. Wait 5 minutes and then try step 1 one more time. If the LEDs on this board still do not light, replace this board. Replacing an SNI may be service interrupting. Refer to the SNI-BD section for the procedure for replacing an SNI.</li><li data-bbox="284 1050 1101 1283">3. If none of the LEDs light for the boards in the same carrier as this board, fix any problems associated with the connectivity of this carrier to the SPE. Check <b>list fiber-link</b> to determine the fiber connections to this carrier. Check the LEDs on all SNIs and EIs and fix any fiber problems. Enter <b>display errors</b> and follow the associated repair procedures for any EXP-INTF error entries associated with the PPN. Also, follow the associated repair procedures for any SYNC, SNI-BD, SNC-BD, FIBER-LK, or SNI-PEER error entries.</li><li data-bbox="284 1300 1025 1354">4. Follow the procedure described above, SNI Manual Loopback to determine whether the circuit pack or the fiber connection is faulty.</li></ol>

*Continued on next page*

**Table 9-564. TEST #767 Packet Neighbor Link Test — Continued**

Error Code	Test Result	Description/ Recommendation
102	FAIL	<p>The SNI circuit pack cannot communicate with the SNI in slot 2 over the packet path.</p> <ol style="list-style-type: none"> <li>1. Fix any on-board SNI-BD errors against this SNI and the SNI in slot 2. Use the <b>display errors</b> command to find any SNI-BD errors and use the display alarms command to determine whether the errors have on-board alarms. Then, follow the associated repair procedures for the SNI-BD as described in the Maintenance manual.</li> <li>2. Using the <b>display errors</b> command, check the error log for other SNI circuit packs with SNI-PEER error type 1. If other SNI circuit packs have SNI-PEER error type 1 errors, replace the SNI in slot 2. Replacing an SNI may be service interrupting. Refer to the SNI-BD Maintenance documentation for the procedure for replacing an SNI.</li> </ol> <p><b>⇒ NOTE:</b>                      If other SNI circuit packs do not have SNI-PEER error type 1 errors, the problem could be at either of the peer SNI boards. It is arbitrary as to which SNI is replaced first.</p> <ol style="list-style-type: none"> <li>3. Replace the SNI being tested.</li> <li>4. Replace the SNI in slot 2.</li> </ol>
103	FAIL	<p>The SNI circuit pack cannot communicate with the SNI in slot 3 over the packet path.</p> <ol style="list-style-type: none"> <li>1. Fix any on-board SNI-BD errors against this SNI and the SNI in slot 3. Use the <b>display errors</b> command to find any SNI-BD errors and use the display alarms command to determine whether the errors have on-board alarms. Then, follow the associated repair procedures for the SNI-BD as described in the Maintenance manual.</li> <li>2. Using the <b>display errors</b> command, check the error log for other SNI circuit packs with SNI-PEER error type 257. If other SNI circuit packs have SNI-PEER error type 257 errors, replace the SNI in slot 3. Replacing an SNI may be service interrupting. Refer to the SNI-BD Maintenance documentation for the procedure for replacing an SNI.</li> </ol> <p><b>⇒ NOTE:</b>                      If other SNI circuit packs do not have SNI-PEER error type 257 errors, the problem could be at either of the peer SNI boards. It is arbitrary as to which SNI is replaced first.</p> <ol style="list-style-type: none"> <li>3. Replace the SNI being tested.</li> <li>4. Replace the SNI in slot 3.</li> </ol>

*Continued on next page*

**Table 9-564. TEST #767 Packet Neighbor Link Test — Continued**

Error Code	Test Result	Description/ Recommendation
104	FAIL	<p>The SNI circuit pack cannot communicate with the SNI in slot 4 over the packet path.</p> <ol style="list-style-type: none"> <li>Fix any on-board SNI-BD errors against this SNI and the SNI in slot 4. Use the <b>display errors</b> command to find any SNI-BD errors and use the display alarms command to determine whether the errors have on-board alarms. Then, follow the associated repair procedures for the SNI-BD as described in the Maintenance manual.</li> <li>Using the <b>display errors</b> command, check the error log for other SNI circuit packs with SNI-PEER error type 513. If other SNI circuit packs have SNI-PEER error type 513 errors, replace the SNI in slot 4. Replacing an SNI may be service interrupting. Refer to the SNI-BD Maintenance documentation for the procedure for replacing an SNI.</li> </ol> <p><b>⇒ NOTE:</b>                      If other SNI circuit packs do not have SNI-PEER error type 513 errors, the problem could be at either of the peer SNI boards. It is arbitrary as to which SNI is replaced first.</p> <ol style="list-style-type: none"> <li>Replace the SNI being tested.</li> <li>Replace the SNI in slot 4.</li> </ol>
105	FAIL	<p>The SNI circuit pack cannot communicate with the SNI in slot 5 over the packet path.</p> <ol style="list-style-type: none"> <li>Fix any on-board SNI-BD errors against this SNI and the SNI in slot 5. Use the <b>display errors</b> command to find any SNI-BD errors and use the display alarms command to determine whether the errors have on-board alarms. Then, follow the associated repair procedures for the SNI-BD as described in the Maintenance manual.</li> <li>Using the <b>display errors</b> command, check the error log for other SNI circuit packs with SNI-PEER error type 769 . If other SNI circuit packs have SNI-PEER error type 769 errors, replace the SNI in slot 5. Replacing an SNI may be service interrupting. Refer to the SNI-BD Maintenance documentation for the procedure for replacing an SNI.</li> </ol> <p><b>⇒ NOTE:</b>                      If other SNI circuit packs do not have SNI-PEER error type 769 errors, the problem could be at either of the peer SNI boards. It is arbitrary as to which SNI is replaced first.</p> <ol style="list-style-type: none"> <li>Replace the SNI being tested.</li> <li>Replace the SNI in slot 5.</li> </ol>

*Continued on next page*

**Table 9-564. TEST #767 Packet Neighbor Link Test — Continued**

Error Code	Test Result	Description/ Recommendation
106	FAIL	<p>The SNI circuit pack cannot communicate with the SNI in slot 6 over the packet path.</p> <ol style="list-style-type: none"> <li>Fix any on-board SNI-BD errors against this SNI and the SNI in slot 6. Use the <b>display errors</b> command to find any SNI-BD errors and use the display alarms command to determine whether the errors have on-board alarms. Then, follow the associated repair procedures for the SNI-BD as described in the Maintenance manual.</li> <li>Using the <b>display errors</b> command, check the error log for other SNI circuit packs with SNI-PEER error type 1025. If other SNI circuit packs have SNI-PEER error type 1025 errors, replace the SNI in slot 6. Replacing an SNI may be service interrupting. Refer to the SNI-BD Maintenance documentation for the procedure for replacing an SNI.</li> </ol> <p><b>⇒ NOTE:</b>                      If other SNI circuit packs do not have SNI-PEER error type 1025 errors, the problem could be at either of the peer SNI boards. It is arbitrary as to which SNI is replaced first.</p> <ol style="list-style-type: none"> <li>Replace the SNI being tested.</li> <li>Replace the SNI in slot 6.</li> </ol>
107	FAIL	<p>The SNI circuit pack cannot communicate with the SNI in slot 7 over the packet path.</p> <ol style="list-style-type: none"> <li>Fix any on-board SNI-BD errors against this SNI and the SNI in slot 7. Use the <b>display errors</b> command to find any SNI-BD errors and use the display alarms command to determine whether the errors have on-board alarms. Then, follow the associated repair procedures for the SNI-BD as described in the Maintenance manual.</li> <li>Using the <b>display errors</b> command, check the error log for other SNI circuit packs with SNI-PEER error type 1281. If other SNI circuit packs have SNI-PEER error type 1281 errors, replace the SNI in slot 7. Replacing an SNI may be service interrupting. Refer to the SNI-BD Maintenance documentation for the procedure for replacing an SNI.</li> </ol> <p><b>⇒ NOTE:</b>                      If other SNI circuit packs do not have SNI-PEER error type 1281 errors, the problem could be at either of the peer SNI boards. It is arbitrary as to which SNI is replaced first.</p> <ol style="list-style-type: none"> <li>Replace the SNI being tested.</li> <li>Replace the SNI in slot 7.</li> </ol>

*Continued on next page*



**Table 9-564. TEST #767 Packet Neighbor Link Test — Continued**

Error Code	Test Result	Description/ Recommendation
108	FAIL	<p>The SNI circuit pack cannot communicate with the SNI in slot 8 over the packet path.</p> <ol style="list-style-type: none"> <li>1. Fix any on-board SNI-BD errors against this SNI and the SNI in slot 8. Use the <b>display errors</b> command to find any SNI-BD errors and use the display alarms command to determine whether the errors have on-board alarms. Then, follow the associated repair procedures for the SNI-BD as described in the Maintenance manual.</li> <li>2. Using the <b>display errors</b> command, check the error log for other SNI circuit packs with SNI-PEER error type 1537. If other SNI circuit packs have SNI-PEER error type 1537 errors, replace the SNI in slot 8. Replacing an SNI may be service interrupting. Refer to the SNI-BD Maintenance documentation for the procedure for replacing an SNI.</li> </ol> <p><b>⇒ NOTE:</b>                      If other SNI circuit packs do not have SNI-PEER error type 1537 errors, the problem could be at either of the peer SNI boards. It is arbitrary as to which SNI is replaced first.</p> <ol style="list-style-type: none"> <li>3. Replace the SNI being tested.</li> <li>4. Replace the SNI in slot 8.</li> </ol>
109	FAIL	<p>The SNI circuit pack cannot communicate with the SNI in slot 9 over the packet path.</p> <ol style="list-style-type: none"> <li>1. Fix any on-board SNI-BD errors against this SNI and the SNI in slot 9. Use the <b>display errors</b> command to find any SNI-BD errors and use the display alarms command to determine whether the errors have on-board alarms. Then, follow the associated repair procedures for the SNI-BD as described in the Maintenance manual.</li> <li>2. Using the <b>display errors</b> command, check the error log for other SNI circuit packs with SNI-PEER error type 1793. If other SNI circuit packs have SNI-PEER error type 1793 errors, replace the SNI in slot 9. Replacing an SNI may be service interrupting. Refer to the SNI-BD Maintenance documentation for the procedure for replacing an SNI.</li> </ol> <p><b>⇒ NOTE:</b>                      If other SNI circuit packs do not have SNI-PEER error type 1793 errors, the problem could be at either of the peer SNI boards. It is arbitrary as to which SNI is replaced first.</p> <ol style="list-style-type: none"> <li>3. Replace the SNI being tested.</li> <li>4. Replace the SNI in slot 9.</li> </ol>

*Continued on next page*

**Table 9-564. TEST #767 Packet Neighbor Link Test — Continued**

Error Code	Test Result	Description/ Recommendation
113	FAIL	<p>The SNI circuit pack cannot communicate with the SNI in slot 13 over the packet path.</p> <ol style="list-style-type: none"> <li>1. Fix any on-board SNI-BD errors against this SNI and the SNI in slot 13. Use the <b>display errors</b> command to find any SNI-BD errors and use the display alarms command to determine whether the errors have on-board alarms. Then, follow the associated repair procedures for the SNI-BD as described in the Maintenance manual.</li> <li>2. Using the <b>display errors</b> command, check the error log for other SNI circuit packs with SNI-PEER error type 2049. If other SNI circuit packs have SNI-PEER error type 2049 errors, replace the SNI in slot 13. Replacing an SNI may be service interrupting. Refer to the SNI-BD Maintenance documentation for the procedure for replacing an SNI.</li> </ol> <p><b>⇒ NOTE:</b>                      If other SNI circuit packs do not have SNI-PEER error type 2049 errors, the problem could be at either of the peer SNI boards. It is arbitrary as to which SNI is replaced first.</p> <ol style="list-style-type: none"> <li>3. Replace the SNI being tested.</li> <li>4. Replace the SNI in slot 13.</li> </ol>
114	FAIL	<p>The SNI circuit pack cannot communicate with the SNI in slot 14 over the packet path.</p> <ol style="list-style-type: none"> <li>1. Fix any on-board SNI-BD errors against this SNI and the SNI in slot 14. Use the <b>display errors</b> command to find any SNI-BD errors and use the display alarms command to determine whether the errors have on-board alarms. Then, follow the associated repair procedures for the SNI-BD as described in the Maintenance manual.</li> <li>2. Using the <b>display errors</b> command, check the error log for other SNI circuit packs with SNI-PEER error type 2305. If other SNI circuit packs have SNI-PEER error type 2305 errors, replace the SNI in slot 14. Replacing an SNI may be service interrupting. Refer to the SNI-BD Maintenance documentation for the procedure for replacing an SNI.</li> </ol> <p><b>⇒ NOTE:</b>                      If other SNI circuit packs do not have SNI-PEER error type 2305 errors, the problem could be at either of the peer SNI boards. It is arbitrary as to which SNI is replaced first.</p> <ol style="list-style-type: none"> <li>3. Replace the SNI being tested.</li> <li>4. Replace the SNI in slot 14.</li> </ol>

*Continued on next page*

**Table 9-564. TEST #767 Packet Neighbor Link Test — Continued**

Error Code	Test Result	Description/ Recommendation
115	FAIL	<p>The SNI circuit pack cannot communicate with the SNI in slot 15 over the packet path.</p> <ol style="list-style-type: none"> <li>1. Fix any on-board SNI-BD errors against this SNI and the SNI in slot 15. Use the <b>display errors</b> command to find any SNI-BD errors and use the display alarms command to determine whether the errors have on-board alarms. Then, follow the associated repair procedures for the SNI-BD as described in the Maintenance manual.</li> <li>2. Using the <b>display errors</b> command, check the error log for other SNI circuit packs with SNI-PEER error type 2561. If other SNI circuit packs have SNI-PEER error type 2561 errors, replace the SNI in slot 15. Replacing an SNI may be service interrupting. Refer to the SNI-BD Maintenance documentation for the procedure for replacing an SNI.</li> </ol> <p><b>⇒ NOTE:</b>                      If other SNI circuit packs do not have SNI-PEER error type 2561 errors, the problem could be at either of the peer SNI boards. It is arbitrary as to which SNI is replaced first.</p> <ol style="list-style-type: none"> <li>3. Replace the SNI being tested.</li> <li>4. Replace the SNI in slot 15.</li> </ol>
116	FAIL	<p>The SNI circuit pack cannot communicate with the SNI in slot 16 over the packet path.</p> <ol style="list-style-type: none"> <li>1. Fix any on-board SNI-BD errors against this SNI and the SNI in slot 16. Use the <b>display errors</b> command to find any SNI-BD errors and use the display alarms command to determine whether the errors have on-board alarms. Then, follow the associated repair procedures for the SNI-BD as described in the Maintenance manual.</li> <li>2. Using the <b>display errors</b> command, check the error log for other SNI circuit packs with SNI-PEER error type 2817. If other SNI circuit packs have SNI-PEER error type 2817 errors, replace the SNI in slot 16. Replacing an SNI may be service interrupting. Refer to the SNI-BD Maintenance documentation for the procedure for replacing an SNI.</li> </ol> <p><b>⇒ NOTE:</b>                      If other SNI circuit packs do not have SNI-PEER error type 2817 errors, the problem could be at either of the peer SNI boards. It is arbitrary as to which SNI is replaced first.</p> <ol style="list-style-type: none"> <li>3. Replace the SNI being tested.</li> <li>4. Replace the SNI in slot 16.</li> </ol>

*Continued on next page*

**Table 9-564. TEST #767 Packet Neighbor Link Test — Continued**

Error Code	Test Result	Description/ Recommendation
117	FAIL	<p>The SNI circuit pack cannot communicate with the SNI in slot 17 over the packet path.</p> <ol style="list-style-type: none"> <li>1. Fix any on-board SNI-BD errors against this SNI and the SNI in slot 17. Use the <b>display errors</b> command to find any SNI-BD errors and use the display alarms command to determine whether the errors have on-board alarms. Then, follow the associated repair procedures for the SNI-BD as described in the Maintenance manual.</li> <li>2. Using the <b>display errors</b> command, check the error log for other SNI circuit packs with SNI-PEER error type 3073. If other SNI circuit packs have SNI-PEER error type 3073 errors, replace the SNI in slot 17. Replacing an SNI may be service interrupting. Refer to the SNI-BD Maintenance documentation for the procedure for replacing an SNI.</li> </ol> <p><b>⇒ NOTE:</b>                      If other SNI circuit packs do not have SNI-PEER error type 3073 errors, the problem could be at either of the peer SNI boards. It is arbitrary as to which SNI is replaced first.</p> <ol style="list-style-type: none"> <li>3. Replace the SNI being tested.</li> <li>4. Replace the SNI in slot 17.</li> </ol>
118	FAIL	<p>The SNI circuit pack cannot communicate with the SNI in slot 18 over the packet path.</p> <ol style="list-style-type: none"> <li>1. Fix any on-board SNI-BD errors against this SNI and the SNI in slot 18. Use the <b>display errors</b> command to find any SNI-BD errors and use the display alarms command to determine whether the errors have on-board alarms. Then, follow the associated repair procedures for the SNI-BD as described in the Maintenance manual.</li> <li>2. Using the <b>display errors</b> command, check the error log for other SNI circuit packs with SNI-PEER error type 3329. If other SNI circuit packs have SNI-PEER error type 3329 errors, replace the SNI in slot 18. Replacing an SNI may be service interrupting. Refer to the SNI-BD Maintenance documentation for the procedure for replacing an SNI.</li> </ol> <p><b>⇒ NOTE:</b>                      If other SNI circuit packs do not have SNI-PEER error type 3329 errors, the problem could be at either of the peer SNI boards. It is arbitrary as to which SNI is replaced first.</p> <ol style="list-style-type: none"> <li>3. Replace the SNI being tested.</li> <li>4. Replace the SNI in slot 18.</li> </ol>

*Continued on next page*

**Table 9-564. TEST #767 Packet Neighbor Link Test — Continued**

Error Code	Test Result	Description/ Recommendation
119	FAIL	<p>The SNI circuit pack cannot communicate with the SNI in slot 19 over the packet path.</p> <ol style="list-style-type: none"> <li>1. Fix any on-board SNI-BD errors against this SNI and the SNI in slot 19. Use the <b>display errors</b> command to find any SNI-BD errors and use the display alarms command to determine whether the errors have on-board alarms. Then follow the associated repair procedures for the SNI-BD as described in the Maintenance manual.</li> <li>2. Using the <b>display errors</b> command, check the error log for other SNI circuit packs with SNI-PEER error type 3585. If other SNI circuit packs have SNI-PEER error type 3585 errors, replace the SNI in slot 19. Replacing an SNI may be service interrupting. Refer to the SNI-BD Maintenance documentation for the procedure for replacing an SNI.</li> </ol> <p><b>⇒ NOTE:</b>                      If other SNI circuit packs do not have SNI-PEER error type 3585 errors, the problem could be at either of the peer SNI boards. It is arbitrary as to which SNI is replaced first.</p> <ol style="list-style-type: none"> <li>3. Replace the SNI being tested.</li> <li>4. Replace the SNI in slot 19.</li> </ol>
120	FAIL	<p>The SNI circuit pack cannot communicate with the SNI in slot 20 over the packet path.</p> <ol style="list-style-type: none"> <li>1. Fix any on-board SNI-BD errors against this SNI and the SNI in slot 20. Use the <b>display errors</b> command to find any SNI-BD errors and use the display alarms command to determine whether the errors have on-board alarms. Then, follow the associated repair procedures for the SNI-BD as described in the Maintenance manual.</li> <li>2. Using the <b>display errors</b> command, check the error log for other SNI circuit packs with SNI-PEER error type 3841. If other SNI circuit packs have SNI-PEER error type 3841 errors, replace the SNI in slot 20. Replacing an SNI may be service interrupting. Refer to the SNI-BD Maintenance documentation for the procedure for replacing an SNI.</li> </ol> <p><b>⇒ NOTE:</b>                      If other SNI circuit packs do not have SNI-PEER error type 3841 errors, the problem could be at either of the peer SNI boards. It is arbitrary as to which SNI is replaced first.</p> <ol style="list-style-type: none"> <li>3. Replace the SNI being tested.</li> <li>4. Replace the SNI in slot 20.</li> </ol>

*Continued on next page*

**Table 9-564. TEST #767 Packet Neighbor Link Test — Continued**

Error Code	Test Result	Description/ Recommendation
123	FAIL	<p>The SNI circuit pack cannot communicate with its neighbor via the packet path.</p> <ol style="list-style-type: none"> <li>1. Fix any on-board errors (SNI-BD, EXP-INTF, and/or DS1C-BD) against the components of this fiber link by using <b>display errors</b> and <b>display alarms</b> and following the associated repair procedures. (Use the <b>list fiber-link</b> command to find the fiber link associated with this SNI. The <b>display fiber-link</b> command can then be used to find the endpoints of the fiber link and the DS1C circuit pack locations if this fiber link has a DS1 Converter Complex administered.)</li> <li>2. Enter <b>display errors</b> and <b>display alarms</b> and follow the associated repair procedures for any SNC-BD error entries with corresponding on-board alarm entries.</li> <li>3. Enter <b>display errors</b> and follow the associated repair procedures for any SYNC entries.</li> <li>4. If this FIBER-LK has circuit, packet, and control path errors, check the lightwave transceiver connections or metallic connections. Use the LED states to verify whether the connections are correct. Also, a test fiber-link s command can be run to determine whether a fiber out of frame condition exists on the fiber link; the SNI Fiber Out-of-Frame Query (#989) reports whether a fiber out of frame condition exists for an SNI endpoint and the Expansion Interface Fiber Out-of-Frame Query test (#238) reports whether a fiber out of frame condition exists for an Expansion Interface endpoint.</li> <li>5. Replace the lightwave transceivers if present.</li> <li>6. Replace one of the endpoint boards.</li> <li>7. Replace the other endpoint board.</li> <li>8. Replace the DS1 CONV circuit packs if a DS1 CONV converter complex is administered on this fiber.</li> </ol>
	PASS	<p>The SNI can communicate with the peer SNIs and the neighbor over the packet path.</p>

*Continued on next page*

**Table 9-564. TEST #767 Packet Neighbor Link Test — Continued**

Error Code	Test Result	Description/ Recommendation
0	NO BOARD	No board was detected by the test. <ol style="list-style-type: none"> <li>1. Check that board is properly translated and inserted.</li> <li>2. Run the test again. If it fails, reset the board. An SNI should be reset instead of reseating the circuit pack. The <b>reset board</b> command should almost never be used on an SNI. It may be necessary to use the <b>reset board</b> command if the SNI circuit pack gets into a mode where it cannot communicate with software. If an SNI with active errors and alarms is reset, the errors and alarms may take a while to come back, therefore the <b>reset board</b> command can mask real problems.</li> <li>3. Run the test again. If it fails, the ID chip on board may be bad. Replace the board and retest.</li> </ol>

**Failure Audit (#777)**

This test is non-destructive.

This test queries the SNI for any existing failures and any unacknowledged cleared failure messages. Each failure generates an error and alarm entry against SNI-BD, SNI-PEER, or FIBER-LK. An unacknowledged cleared failure message is a message the SNI circuit pack sent to software indicating a previous failure is now gone and the SNI circuit pack did not receive a message from software indicating that the failure message was received by software.

If no failures are detected by the SNI circuit pack, this test will pass.

If this test reports failures, the results screen for the **test board** command will show **FAIL** with no FAIL code. The error log must then be displayed via **display errors** with category PNC to view all SNI-BD and FIBER-LK errors and category PNC-PEER to view all SNI-PEER errors.

**Table 9-565. TEST #777 Failure Audit**

Error Code	Test Result	Description/ Recommendation
	ABORT	Internal System Error <ol style="list-style-type: none"> <li>1. Retry the command at 1-minute intervals a maximum of 3 times.</li> </ol>

*Continued on next page*

**Table 9-565. TEST #777 Failure Audit — Continued**

Error Code	Test Result	Description/ Recommendation
2100	ABORT	Could not allocate the necessary system resources to run this test. 1. Retry the command at 1-minute intervals a maximum of 3 times.
2300	ABORT	The downlink message necessary to run this test could not be sent. 1. Retry the command at 1-minute intervals a maximum of 3 times.
2301	ABORT	The software timer could not be set before sending the downlink message necessary to run this test. 1. Retry the command at 1-minute intervals a maximum of 3 times.
2306	ABORT	The SNI circuit pack is not responding to test requests sent by software. 1. Run the <b>test led switch-node</b> for the switch node that the SNI resides in to verify whether the LEDs on the board light. 2. If the LEDs on the other boards in the carrier light, but the LEDs on this board do not light, run test 760 via <b>test board UUCSS I</b> for the active SNC in this carrier. Wait 5 minutes and then try step 1 one more time. If the LEDs on this board still do not light, replace this board. Replacing an SNI may be service interrupting. Refer to the SNI-BD section for the procedure for replacing an SNI. 3. If none of the LEDs light for the boards in the same carrier as this board, fix any problems associated with the connectivity of this carrier to the SPE. Check <b>list fiber-link</b> to determine the fiber connections to this carrier. Check the LEDs on all SNIs and EIs and fix any fiber problems. Enter <b>display errors</b> and follow the associated repair procedures for any EXP-INTF error entries associated with the PPN. Also, follow the associated repair procedures for any SYNC, SNI-BD, SNC-BD, FIBER-LK, or SNI-PEER error entries. 4. Follow the procedure described above, SNI Manual Loopback to determine whether the circuit pack or the fiber connection is faulty.

*Continued on next page*



Table 9-565. TEST #777 Failure Audit — Continued

Error Code	Test Result	Description/ Recommendation
	FAIL	<p>The SNI circuit pack reported failures or retransmitted a cleared failure message.</p> <ol style="list-style-type: none"><li>1. If this is the first time this test was run, run the test again. If there were any previous failure messages that software did not acknowledge, this test will FAIL even if the failure messages indicate a FAIL to PASS transition, i.e., a problem has gone away. If this test is run twice and FAILs both times, then at least one problem still exists.</li><li>2. Fix any SNI-BD, SNI-PEER, and FIBER-LK errors by following the associated repair procedures. Use the <b>display errors</b> and <b>display alarms</b> commands with category PNC for SNI-BD and FIBER-LK and category PNC-PEER for SNI-PEER. Fix any problems found by referring to the SNI Board or SNI Peer Error Log Entries tables in this section or Fiber Link Error Log Entries tables in the "<a href="#">FIBER-LK (Fiber Link)</a>" section.</li><li>3. If no SNI-BD, SNI-PEER, or FIBER-LK entries exist in the error and alarm logs, retry the command.</li></ol>
	PASS	No problems are detected on the board.
0	NO BOARD	<p>No board was detected by the test.</p> <ol style="list-style-type: none"><li>1. Check that board is properly translated and inserted.</li><li>2. Run the test again. If it fails, reset the board. An SNI should be reset instead of reseating the circuit pack. The <b>reset board</b> command should almost never be used on an SNI. It may be necessary to use the <b>reset board</b> command if the SNI circuit pack gets into a mode where it cannot communicate with software. If an SNI with active errors and alarms is reset, the errors and alarms may take a while to come back, therefore the <b>reset board</b> command can mask real problems.</li><li>3. Run the test again. If it fails, the ID chip on board may be bad. Replace the board and retest.</li></ol>

### Clear Firmware Counters (#982)

This test number is used to report unsuccessful results of the **clear firmware-counters** command. This is not an actual demand maintenance test. If the command aborts, refer to the error codes listed for Test #777.

### SNI Fiber Out of Frame Query (#989)

This test is non-destructive.

The SNI circuit pack reports whether a fiber out of frame condition exists, whether a loss of signal condition exists, and whether the lightwave transceiver is present.

**Table 9-566. TEST #989 SNI Fiber Out of Frame Query**

Error Code	Test Result	Description/ Recommendation
2100	ABORT	Could not allocate the necessary system resources to run this test. 1. Retry the command at 1-minute intervals a maximum of 3 times.
1415	ABORT	The lightwave transceiver is not present. 1. If a lightwave transceiver is not supposed to be present, do nothing. For example, an SNI connected to a DS1C circuit pack or an SNI with a metallic connection does not have a lightwave transceiver. 2. Otherwise, check the lightwave transceiver connections. 3. If OK, replace the lightwave transceiver. If a fiber out of frame condition exists and lightwave transceivers are used, check that the lightwave transceivers are of the same type, that is, both are 9823a or both are 9823b. If they are not the same type, replace one of the lightwave transceivers: <ul style="list-style-type: none"> <li>■ 9823a is used for distances up to 4900 feet.</li> <li>■ 9823b is used for distances up to 25,000 feet.</li> </ul> 4. If the test continues to abort, replace the SNI circuit pack.
2300	ABORT	The downlink message necessary to run this test could not be sent. 1. Retry the command at 1-minute intervals a maximum of 3 times.
2301	ABORT	The software timer could not be set before sending the downlink message necessary to run this test. 1. Retry the command at 1-minute intervals a maximum of 3 times.
2304	ABORT	SNI circuit pack responded that it is not able to run the test requested by software. 1. Retry the command at 1-minute intervals a maximum of 3 times.

*Continued on next page*

**Table 9-566. TEST #989 SNI Fiber Out of Frame Query — Continued**

Error Code	Test Result	Description/ Recommendation
2306	ABORT	<p>The SNI circuit pack is not responding to test requests sent by software.</p> <ol style="list-style-type: none"> <li>1. Run the <b>test led switch-node</b> for the switch node that the SNI resides in to verify whether the LEDs on the board light.</li> <li>2. If the LEDs on the other boards in the carrier light, but the LEDs on this board do not light, run test 760 via <b>test board UUCSS I</b> for the active SNC in this carrier. Wait 5 minutes and then try step 1 one more time. If the LEDs on this board still do not light, replace this board. Replacing an SNI may be service interrupting. Refer to the SNI-BD section for the procedure for replacing an SNI.</li> <li>3. If none of the LEDs light for the boards in the same carrier as this board, fix any problems associated with the connectivity of this carrier to the SPE. Check <b>list fiber-link</b> to determine the fiber connections to this carrier. Check the LEDs on all SNIs and EIs and fix any fiber problems. Enter <b>display errors</b> and follow the associated repair procedures for any EXP-INTF error entries associated with the PPN. Also, follow the associated repair procedures for any SYNC, SNI-BD, SNC-BD, FIBER-LK, or SNI-PEER error entries.</li> <li>4. Follow the procedure described above, SNI Manual Loopback to determine whether the circuit pack or the fiber connection is faulty.</li> </ol>
2500	ABORT	<p>Internal System Error</p> <ol style="list-style-type: none"> <li>1. Retry the command at 1-minute intervals a maximum of 3 times.</li> </ol>
141	FAIL	<p>The SNI circuit pack has a fiber out of frame condition, but no loss of signal condition. Also, a lightwave transceiver is connected to the SNI circuit pack.</p> <ol style="list-style-type: none"> <li>1. Check that the connected circuit pack is physically installed. The connected circuit pack is the other endpoint of the fiber-link if no DS1C complex is administered (check via <b>list fiber-link</b>). Otherwise, if a DS1C complex is administered, the connected circuit pack is the DS1C circuit pack connected to the SNI circuit pack.</li> <li>2. Perform the Fiber Fault Isolation Procedure described in Chapter 5.</li> <li>3. Replace this SNI circuit pack.</li> <li>4. Replace the connected circuit pack.</li> </ol>

*Continued on next page*

**Table 9-566. TEST #989 SNI Fiber Out of Frame Query — Continued**

Error Code	Test Result	Description/ Recommendation
142	FAIL	<p>The SNI circuit pack has a fiber out-of-frame condition, but no loss of signal condition. Also, no lightwave transceiver is connected to the SNI circuit pack.</p> <ol style="list-style-type: none"> <li>1. Check that the connected circuit pack is physically installed. The connected circuit pack is the other endpoint of the fiber-link if no DS1C complex is administered (check via <b>list fiber-link</b>). Otherwise, if a DS1C complex is administered, the connected circuit pack is the DS1C circuit pack connected to the SNI circuit pack.</li> <li>2. If a lightwave transceiver is not supposed to be present, go to step 2. For example, an SNI connected to a DS1C circuit pack or an SNI with a metallic connection does not have a lightwave transceiver. Otherwise, check the lightwave transceiver connections. If OK, replace the lightwave transceiver. If a fiber out-of-frame condition exists and lightwave transceivers are used, check that the lightwave transceivers are of the same type, that is, both are 9823a or both are 9823b. If they are not the same type, replace one of the lightwave transceivers:                         <ul style="list-style-type: none"> <li>■ 9823a is used for distances up to 4900 feet.</li> <li>■ 9823b is used for distances up to 25,000 feet.</li> </ul> </li> <li>3. Perform the Fiber Fault Isolation Procedure described in Chapter 5.</li> <li>4. Replace this SNI circuit pack.</li> <li>5. Replace the connected circuit pack.</li> </ol>
143	FAIL	<p>The SNI circuit pack has a loss of signal condition, but no fiber out of frame condition. Also, a lightwave transceiver is connected to the SNI circuit pack.</p> <ol style="list-style-type: none"> <li>1. Check that the connected circuit pack is physically installed. The connected circuit pack is the other endpoint of the fiber-link if no DS1C complex is administered (check via <b>list fiber-link</b>). Otherwise, if a DS1C complex is administered, the connected circuit pack is the DS1C circuit pack connected to the SNI circuit pack.</li> <li>2. Perform the Fiber Fault Isolation Procedure described in Chapter 5.</li> <li>3. Replace this SNI circuit pack.</li> <li>4. Replace the connected circuit pack.</li> </ol>

*Continued on next page*

**Table 9-566. TEST #989 SNI Fiber Out of Frame Query — Continued**

Error Code	Test Result	Description/ Recommendation
144	FAIL	<p>The SNI circuit pack has a loss of signal condition, but no fiber out of frame condition. Also, no lightwave transceiver is connected to the SNI circuit pack.</p> <ol style="list-style-type: none"> <li>1. Check that the connected circuit pack is physically installed. The connected circuit pack is the other endpoint of the fiber-link if no DS1C complex is administered (check via <b>list fiber-link</b>). Otherwise, if a DS1C complex is administered, the connected circuit pack is the DS1C circuit pack connected to the SNI circuit pack.</li> <li>2. If a lightwave transceiver is not supposed to be present, go to step 2. For example, an SNI connected to a DS1C circuit pack or an SNI with a metallic connection does not have a lightwave transceiver. Otherwise, check the lightwave transceiver connections. If OK, replace the lightwave transceiver. If a fiber out-of-frame condition exists and lightwave transceivers are used, check that the lightwave transceivers are of the same type, that is, both are 9823a or both are 9823b. If they are not the same type, replace one of the lightwave transceivers:                         <ul style="list-style-type: none"> <li>■ 9823a is used for distances up to 4900 feet.</li> <li>■ 9823b is used for distances up to 25,000 feet.</li> </ul> </li> <li>3. Perform the Fiber Fault Isolation Procedure described in Chapter 5.</li> <li>4. Replace this SNI circuit pack.</li> <li>5. Replace the connected circuit pack.</li> </ol>
145	FAIL	<p>The SNI circuit pack has a fiber out of frame condition and a loss of signal condition. Also, a lightwave transceiver is connected to the SNI circuit pack.</p> <ol style="list-style-type: none"> <li>1. Check that the connected circuit pack is physically installed. The connected circuit pack is the other endpoint of the fiber-link if no DS1C complex is administered (check via <b>list fiber-link</b>). Otherwise, if a DS1C complex is administered, the connected circuit pack is the DS1C circuit pack connected to the SNI circuit pack.</li> <li>2. Perform the Fiber Fault Isolation Procedure described in Chapter 5.</li> <li>3. Replace this SNI circuit pack.</li> <li>4. Replace the connected circuit pack.</li> </ol>

*Continued on next page*

Table 9-566. TEST #989 SNI Fiber Out of Frame Query — Continued

Error Code	Test Result	Description/ Recommendation
146	FAIL	<p>The SNI circuit pack has a fiber out of frame condition, and a loss of signal condition. Also, no lightwave transceiver is connected to the SNI circuit pack.</p> <ol style="list-style-type: none"> <li>1. Check that the connected circuit pack is physically installed. The connected circuit pack is the other endpoint of the fiber-link if no DS1C complex is administered (check via <b>list fiber-link</b>). Otherwise, if a DS1C complex is administered, the connected circuit pack is the DS1C circuit pack connected to the SNI circuit pack.</li> <li>2. If a lightwave transceiver is not supposed to be present, go to step 2. For example, an SNI connected to a DS1C circuit pack or an SNI with a metallic connection does not have a lightwave transceiver. Otherwise, check the lightwave transceiver connections. If OK, replace the lightwave transceiver. If a fiber out-of-frame condition exists and lightwave transceivers are used, check that the lightwave transceivers are of the same type, that is, both are 9823a or both are 9823b. If they are not the same type, replace one of the lightwave transceivers:                         <ul style="list-style-type: none"> <li>■ 9823a is used for distances up to 4900 feet.</li> <li>■ 9823b is used for distances up to 25,000 feet.</li> </ul> </li> <li>3. Perform the Fiber Fault Isolation Procedure described in Chapter 5.</li> <li>4. Replace this SNI circuit pack.</li> <li>5. Replace the connected circuit pack.</li> </ol>
	PASS	<p>No problems associated with this test are detected on the SNI.</p>
0	NO BOARD	<p>No board was detected by the test.</p> <ol style="list-style-type: none"> <li>1. Check that board is properly translated and inserted.</li> <li>2. Run the test again. If it fails, reset the board. An SNI should be reset instead of reseating the circuit pack. The <b>reset board</b> command should almost never be used on an SNI. It may be necessary to use the <b>reset board</b> command if the SNI circuit pack gets into a mode where it cannot communicate with software. If an SNI with active errors and alarms is reset, the errors and alarms may take a while to come back, therefore the <b>reset board</b> command can mask real problems.</li> <li>3. Run the test again. If it fails, the ID chip on board may be bad. Replace the board and retest.</li> </ol>

## **SNI-PEER (SNI Peer Link)**

---

<b>MO Name (in Alarm Log)</b>	<b>Alarm Level</b>	<b>Initial Command to Run<sup>1</sup></b>	<b>Full Name of MO</b>
SNI-PEER	MAJOR	test board UUCSS s	SNI Peer Link
SNI-PEER	MINOR	test board UUCSS s	SNI Peer Link
SNI-PEER	WARNING	test board UUCSS s	SNI Peer Link

- 
1. UU is the universal cabinet number (1 for PPN, 2 -44 for EPNs). C is the carrier designation (A, B, C, D, or E). SS is the number of the slot in which the circuit pack resides (01 to 21).

SNI Peers are Switch Node Interfaces residing on the same Switch Node Carrier. SNI-PEER maintenance involves testing of the links between SNI Peers. SNI-PEER errors are described on the following pages. For a full description of SNIs, including circuit pack replacement, see SNI-BD.

## Error Log Entries and Test to Clear Values

Table 9-567. SNI-PEER Hardware Error Log Entries

Error Type	Aux Data	SNI Slot <sup>1</sup>	Associated Test	Alarm Level	On/Off Board	Test to Clear Value
0 <sup>2</sup>	0		Any	Any	Any	test board UUCSS r 1
1	any	2	Failure Audit (#777)	MAJ/MIN/ WAR	OFF	test board UUCSS r 1
257	any	3	Failure Audit (#777)	MAJ/MIN/ WAR	OFF	test board UUCSS r 1
513	any	4	Failure Audit (#777)	MAJ/MIN/ WAR	OFF	test board UUCSS r 1
769	any	5	Failure Audit (#777)	MAJ/MIN/ WAR	OFF	test board UUCSS r 1
1025	any	6	Failure Audit (#777)	MAJ/MIN/ WAR	OFF	test board UUCSS r 1
1281	any	7	Failure Audit (#777)	MAJ/MIN/ WAR	OFF	test board UUCSS r 1
1537	any	8	Failure Audit (#777)	MAJ/MIN/ WAR	OFF	test board UUCSS r 1
1793	any	9	Failure Audit (#777)	MAJ/MIN/ WAR	OFF	test board UUCSS r 1
2049	any	13	Failure Audit (#777)	MAJ/MIN/ WAR	OFF	test board UUCSS r 1
2305	any	14	Failure Audit (#777)	MAJ/MIN/ WAR	OFF	test board UUCSS r 1
2561	any	15	Failure Audit (#777)	MAJ/MIN/ WAR	OFF	test board UUCSS r 1
2817	any	16	Failure Audit (#777)	MAJ/MIN/ WAR	OFF	test board UUCSS r 1
3073	any	17	Failure Audit (#777)	MAJ/MIN/ WAR	OFF	test board UUCSS r 1
3329	any	18	Failure Audit (#777)	MAJ/MIN/WAR	OFF	test board UUCSS r 1
3585	any	19	Failure Audit (#777)	MAJ/MIN/WAR	OFF	test board UUCSS r 1
3841	any	20	Failure Audit (#777)	MAJ/MIN/WAR	OFF	test board UUCSS r 1

1. Run the Short Test Sequence first. If all tests pass, run the Long Test Sequence. Refer to the appropriate test description and follow the recommended procedures.
2. The slot location of the SNI at the other end of the peer link indicted by the SNI reporting the error.

Notes:

For **all** errors in [Table 9-567](#), the SNI circuit pack reporting the error is indicating that it has a problem with the control path, circuit path, or packet path to the SNI peer in the slot indicated on the error table.

First, the Failure Audit test (#777) should be run to confirm whether the error still exists.



If the SNI is reporting an SNI-PEER error against a slot that does not contain an SNI, either change circuit pack administration via **change circuit-pack** to unadminister the SNI, or insert an SNI into the indicated slot. **List configuration carrier** can be used to determine whether an SNI circuit pack is inserted. Otherwise, **display errors** and look at *all* of the SNI-PEER errors in the log. If either of the following two conditions are present, follow Procedure 2 below.

- Do many SNIs have SNI-PEER errors pointing to the same 2 adjacent SNIs?
- Do 2 adjacent SNIs have SNI-PEER errors pointing to many other SNIs?

If neither condition is present, follow Procedure 1 below. When using either procedure, refer to SNI-BD or SNC-BD for circuit pack replacement instructions.

Slot Numbers of Adjacent SNIs	Point to This SNI Pair
2, 3	1, 257
4, 5	513, 769
6, 7	1025, 1281
8, 9	1537, 1793
13, 14	2049, 2305
15, 16	2561, 2817
17, 18	3073, 3329
19, 20	3585, 3841

**Procedure 1:** Proceed through the following steps *until* the problem is resolved:

1. Perform the Fiber Fault Isolation Procedure described in Chapter 5.
2. Replace the SNI pointed to by the SNI-PEER error type (see the SNI Slot column in the preceding table, *SNI-PEER Error Log Entries*).
3. Replace the SNI reporting the SNI-PEER error.
4. Replace the active SNC.

**Procedure 2:** If either of the two patterns described before are present, then the clock signal between active SNC and 2 Adjacent SNIs is suspect. Proceed through the following steps *until* the problem is resolved:

1. If only one SNC exists in this switch node carrier, replace the SNC. If two SNCs exist in this switch node carrier, perform the following steps:
  - a. Set the standby SNC to active by executing **set switch-node-clock UUCSS** with the standby SNC's location.
  - b. If the problem persists, switch back to the previously active SNC via the **set switch-node-clock** command and go to step 2 below.

- c. If the problem went away, replace the SNC that was previously active. Then set the newly replaced SNC to active. If the problem returns, assume that the SNC that was just replaced was not at fault and go to step 2 below.
2. Replace the leftmost SNI from the pair of adjacent SNIs.
3. Replace the rightmost SNI from the pair of adjacent SNIs.
4. This could indicate a problem with the switch-node-carrier backplane.

## System Technician-Demanded Tests: Descriptions and Error Codes

---

Always investigate tests in the order presented in the table below when inspecting errors in the system. By clearing error codes associated with the *Configuration Audit* for example, you may also clear errors generated from other tests in the testing sequence.

Order of Investigation	Short Test Sequence	Long Test Sequence	Reset Board Sequence	D/ND <sup>1</sup>
Configuration Audit (#759)	X	X		ND
Failure Audit (#777)	X	X		ND
Fiber Out of Frame Query (#989)	X	X		ND
Packet Neighbor Test (#767)	X	X		ND
Circuit Path Test (#755)	X	X		ND
Destructive Facility Test (#757)		X		D
Off-board Destructive Facility Test (#756)		X		D
Switch Node Interface Reset Test (#761)			X	D

---

1. D = Destructive, ND = Non-destructive

For descriptions of these tests, refer to the SNI-BD section of this chapter.

## **SPE-SELE (SPE Select Switch)**

---

<b>MO Name (in Alarm Log)</b>	<b>Alarm Level</b>	<b>Initial Command to Run</b>	<b>Full Name of MO</b>
SPE-SELE	MAJOR	none	SPE Select Switch
SPE-SELE	WARNING	none	SPE Select Switch

The SPE Select Switch MO monitors the position of the SPE Select switches located on the front of each UN330B Duplication Interface board. Each switch may be in one of three possible positions: Auto, A selected, B selected. Both switches, one on the active Duplication Interface board and one on the standby, should be set to the same designation. The switches control selection of the active SPE and cause alarms as follows:

- If both switches are in the AUTO position, the SPE that is the healthiest, as determined by the state-of-health bits on the boards, is selected as active. No alarm is raised.
- If one SPE Select switch is in the AUTO position and one selecting either A or B carrier as active, or one switch selects A and the other selects B, the boards default to handling the selection of which carrier is active as if both switches were in the AUTO position. A WARNING alarm appears after one hour. The alarm is resolved 5 minutes after the switches are returned to identical positions.
- If both switches select either A carrier or B carrier active, then the Duplication Interface boards will force that carrier active (irrespective of state-of-health) and the red Override LED is lit. A MAJOR alarm is raised by SPE-SELE if the switches remain in these positions for more than 6 hours. The alarm is resolved within 5 minutes of the switches being returned to AUTO.

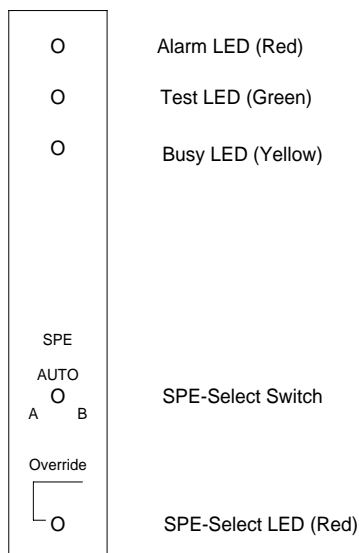

**Figure 9-88. Duplication Interface Circuit Pack**

**Error Log Entries and Test to Clear Values**

**Table 9-568. SPE Select Switch Error Log Entries**

Error Type	Aux Data	Associated Test	Alarm Level	On/Off Board	Test to Clear Value
0 <sup>1</sup>	0	Any	Any	Any	
1(a)	0	none	WARNING	OFF	
257(b)	0	none	MAJOR	OFF	

1. Check the position of the SPE-Select switches.

**Notes:**

- a. Error 1 appears when one SPE Select Switch is in the AUTO position and the other is in the select A or select B position. Placing both switches in the AUTO position will retire the alarm immediately.
- b. Error 257 appears when both SPE Select Switches are in the select A or select B position for more that 6 hours. Placing both switches in the AUTO position will retire the alarm immediately.

## **STBY-SPE (Standby SPE Maintenance)**

<b>MO Name (in Alarm Log)</b>	<b>Alarm Level</b>	<b>Initial Command to Run</b>	<b>Full Name of MO</b>
STBY-SPE	MAJOR	test spe-standby l	Standby SPE Maintenance
STBY-SPE	MINOR	test spe-standby l	Standby SPE Maintenance
STBY-SPE	WARNING	test spe-standby l	Standby SPE Maintenance

The general principles of SPE duplication, including the following topics, are discussed in Chapter 1:

- Standby Maintenance Architecture
- Standby State-of-Health and Availability
- Handshake Communication
- Memory Shadowing and Refresh
- Maintenance Software
- Standby Initialization

Troubleshooting a duplicated SPE, and replacing SPE components, are discussed in Chapter 5. The SPE-Down or SPE-Locked interface is discussed in Chapter 4.

Maintenance of the standby SPE is organized around the STBY-SPE maintenance object. It relies on documentation of the other SPE maintenance objects:

PROCR	SYSAM	MEM-BD
SW-CTL	H-ADAPTR	TAPE
DISK	DUPINT	DUP-CHL

Once a general SPE problem has been isolated to the level of one of these individual packs, the service documentation for that MO should be consulted. It is the responsibility of standby SPE maintenance described here to keep the standby SPE fully available for an interchange.

## Standby Availability

---

Various factors affect the availability of the standby SPE:

- The condition of the individual hardware components of the standby SPE
- Standby memory content
- Standby State-of-Health (SOH)
- Standby SPE-Down
- System Time-of-Day

The health of both the active and standby is tracked as a State-of-Health (SOH) value. State-of-Health is discussed fully in Chapter 1.

The SOH of the standby SPE can be determined with the "status spe" command. A complete description of this command and its output appears in Chapter 8. For the standby to be fully available, the fields (for the SPE with mode *standby*, where applicable) should read as follows:

Duplicated?	yes
SPE Selected?	auto (otherwise, the SPE-Select switches will prevent any interchange)
Standby Busied	no
Standby Refreshed?	yes
Standby Shadowing	on
Standby Handshake?	up
Recent Spontaneous Interchange?	no
State-of-Health	functional

Any divergence from these conditions, except during system recovery or technician-initiated maintenance, requires immediate investigation.

## Locking the Active SPE

---

Duplication Interface hardware supports the ability to lock the active SPE into active mode. On each Duplication Interface circuit pack is an SPE-SELECT switch which can be set in three positions: A, B, Auto. These are normally set with both switches on AUTO, allowing system software to govern which SPE is active. When the SPE-SELECT switches on both SPE's Duplication Interface circuit packs are set to the position A, then the SPE in carrier A is locked active and the B-carrier SPE is locked standby. Setting both to B locks the B carrier active. Any other combination of settings results in AUTO mode. *In locked mode, the system operates as if it is simplex:*

- The standby SPE is inaccessible to the active SPE and active G3-MT login.
- No SPE-interchange is possible.
- Handshake is down and memory shadowing is off.

 **WARNING:**

*Transition the system into the lock mode with extreme care. Always move the switches into the position designating the **active** SPE carrier. Switching to a faulted standby can cause a total service outage.*

The locked state is intended for temporary use to prevent interchanges during maintenance sessions. Alarms are raised if the switches are left out of the AUTO position for an extended length of time (SPE-SEL).

To lock the SPEs, first determine which is active:

- The active Duplication Interface's yellow LED will be lit.
- **status spe** reports active/standby status of each SPE.

*Making sure you are grounded, move the switches one at a time to the letter designating the active carrier. Wait a few seconds, then verify that the lock took effect:*

- The red LED labeled OVERRIDE on both Duplication Interface circuit packs should be lit.
- **status spe** displays `spe-a locked` in the `SPE SELECTED` field if the A SPE is locked active. This verifies that internal software is aware of the lock state. The screen will also indicate that handshake is down, memory shadowing is off and the standby is not refreshed. The standby SPE is technically not in service while locked, and its SOH can vary.

To unlock the active SPE, move both SPE-SELECT switches back to AUTO. System software will automatically try to bring the standby SPE into full service, by establishing handshake, refreshing memory, and raising the standby's SOH if appropriate.

 **CAUTION:**

*When exiting the locked state, a spontaneous SPE interchange is possible if active SPE SOH is not functional. Always check first with **status spe** (unless the interchange is desired).*

After exiting the locked state, make sure the standby returns fully to service (SOH functional). When the system is in the locked state, all alarms against the standby SPE (STBY-SPE), (except the WARNING alarm raised in the busyout state), are automatically cleared by the system.

## Replacing SPE Circuit Packs

---

To replace any SPE circuit pack on a duplicated system, always use the "lock-and-power-down" procedure described fully in Chapter 5. This procedure allows replacements without service disruption, and guarantees that the system is returned to full normal operation.

## Memory Shadowing

---

Memory shadowing is used to keep the standby SPE's memory content up-to-date relative to the active SPE's memory. A standby SPE that has just rebooted, exited lock mode or just been released from busyout must undergo this full re-initialization. System software tracks the operation and raises a major alarm when refresh failure occurs. If shadowing stays on, system software automatically tries to refresh again 5 minutes later.

Generally, memory shadowing should always remain on unless:

- The standby SPE is undergoing any restart.
- The active SPE is undergoing a restart level of 2 or greater.
- The active SPE is locked.
- The standby SPE is busied out.

In any other situation, it is an error condition for shadowing to be off. The first two situations are transitory and shadowing should automatically be restored within 10 minutes. If shadowing has been on for several minutes, it is an error condition for the standby not to be refreshed. A standby SPE with no critical component alarms that is either not refreshed or does not have shadowing on should have SOH level *not refreshed*.

## Busyout of the Standby SPE

---

The standby SPE can be placed in the state of maintenance busyout with the command **busyout spe-standby**. This creates the following conditions:

- The SOH of the standby SPE is kept artificially at level *partially-functional* regardless of the actual state of its components.
- Memory shadowing is turned off. Standby memory content is not in agreement with that of the active SPE
- A Warning alarm is raised against STBY-SPE with error type 18. This Warning alarm supersedes all other alarms against STBY-SPE.
- The **status spe** field `Standby Busied?` will display `yes`.



**release spe-standby** causes the following:

- The standby SPE's SOH returns to the appropriate level based on its component alarms.
- After verifications, software turns on shadowing and refreshes the standby's memory.

Busyout is used to discourage the likelihood of interchange and prevent side effects of memory shadowing. For example:

- When it is necessary to run the long demand test sequence for the duplication-interface hardware or to reset the standby SPE's Packet-interface circuit packs
- To allow destructive testing of components relevant to shadowing (packet-interface, memory, or duplication interface packs).

When the standby SPE is busied out, handshake communication is maintained if possible. The standby SPE can be busied-out at any time the G3-MT interface is available, including when the system is initializing or when the active SPE is locked. Busyout applies to only one instance of the SPEs. If SPE B is busied out and an SPE interchange occurs A-carrier SPE is not busied out.

When releasing a standby SPE from the busyout state, make sure that the standby SPE is brought fully back to service. Wait until the standby is refreshed and its SOH returns to level *functional* to make sure repair actions did not disable the standby SPE.

## Initialization: Bringing the Standby SPE Up

When the standby SPE has been out of service or is first coming up, SPE software executes the following steps:

1. Establishes handshake communication
2. Raises the standby SPE's SOH to *not refreshed* if it has no critical component alarms, or *partially functional* if it does have critical component alarms
3. Tests for component mismatch (test number 920)
4. Turns on memory shadowing
5. Refreshes standby memory
6. If there are no critical-component major alarms, raises the standby SPE's SOH to *functional*

This normally takes about 5 minutes. Should a step of this initialization sequence fail, the step is retried until it succeeds. The failed condition is alarmed so that it can be diagnosed and corrected.

## Other Mechanisms: Status Command and SPE-Down Interface

---

There are certain maintenance tools available for dealing with the standby SPE which can be used regardless of the state of handshake communication or memory shadowing.

Always start with and continue to use **status spe** to determine completely the status of the standby SPE.

When handshake communication is down, there is no access from the usual G3-MT connection to test the standby. In this case, locking the active SPE with the switches has no harmful effect on switch service and allows terminal access into the standby SPE via the SPE-Down or SPE-Locked Interface. With this interface, you can run low level tests on individual components and request reboots of the standby SPE. Whenever the SPEs are locked and the SPE-Locked Interface is in use. Instructions on how to bring up and use this interface are described in Chapter 4. When using this tool, do not unlock the SPE until all tests of standby SPE components have passed.

## Recent Interchange Mode

---

The event of a spontaneous SPE interchange is intended to be a rare event and reflects a serious hardware failure on the formerly active SPE. Generally, when such an interchange has occurred, that SPE (now standby) requires diagnosis and repair action. There should be information in the error and alarm logs to indicate the specific problem. System software will attempt to establish handshake communication with the SPE, refresh its memory, bring it into service as a standby SPE, and diagnose its problems.

Regardless of any success in bringing that standby SPE into service, software will not improve the SOH of that SPE until either:

- Technician-demanded testing addresses the problem
- One hour has passed since the interchange

This mode, called Recent Interchange Mode, is reported on the **status spe** screen and serves to prevent further interchanges from occurring too quickly. Additionally, a minor alarm with error 103 is logged against STBY-SPE and the SOH of that SPE is allowed to get no better than *partially functional*. *Troubleshooting a Duplicated SPE* in Chapter 5 describes an approach to diagnosing problems under this condition.

There are two ways in which the standby SPE can exit recent interchange mode.

- a. You can run **test spe-standby long clear** and wait until all the tests of STBY-SPE have completed. (this runs tests of *all* components of the standby SPE in addition to those for STBY-SPE). The first test of the sequence (#855) fails, because the standby SOH is at level *partially functional*. The execution of this sequence clears the minor alarm against STBY-SPE and allows normal treatment of the standby SPE. If the standby is refreshed and has no major alarms against critical components, its SOH will be allowed to improve to *functional*.
- b. Alternately, when one hour has passed since the last spontaneous interchange, system software automatically transitions the standby SPE out of recent interchange mode. The minor alarm clears and the standby SPE's SOH level is allowed to go to its appropriate value (typically *functional* if there are no major component alarms and it is refreshed).

## Resolving Error Conditions on the Standby SPE

Divergence of the standby SPE from the state of full availability involves one of the following events:

- Handshake communication is down
- Memory shadowing is off
- The standby SPE is not refreshed
- The standby SOH is not *functional*

A hierarchical approach is recommended in the above order. Follow the steps presented in the following diagram.

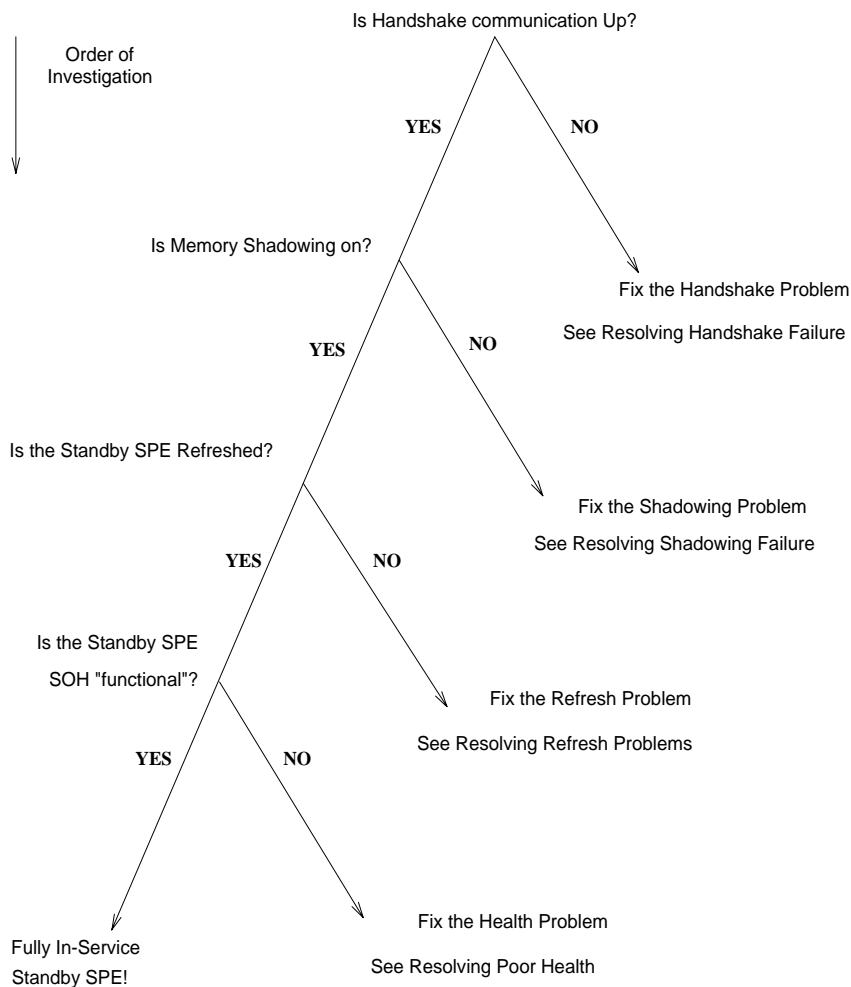

**Figure 9-89. Resolving Standby-SPE Errors**

## Resolving Handshake Failure

When handshake fails, a major alarm with error 1 is repeatedly logged against STBY-SPE reflecting the fact that over a 2-minute period, no successful communication has occurred with the standby SPE. When the system is in lock mode, handshake is taken down with no alarm or error logged. When the standby SPE is busied out, handshake communication is kept up. If handshake should fail during busyout, the major alarm will not appear, but error 1 and the usual busyout warning alarm with error 18 will be logged. You can always determine if handshake is up with **status spe**.

To restore handshake, proceed through the following steps.

1. Make sure that the SPE is not locked, and that it has power. Resolve any CARR-POW alarms on the standby SPE carrier. (If the standby SOH is partially functional or better, you can assume that the standby SPE has power.)
2. Busyout the standby SPE and run **test dup long**. Some DUP-CHL tests may abort due to the absence of handshake. If any tests *fail*, follow procedures in DUPINT and then DUP-CHL to resolve the problem. If you replace any DUPINT hardware, wait to see if the standby SPE can be fully restored to service.
3. If the above tests did not fail, lock the SPEs with the SPE-select switches and use the SPE-down interface to test the standby components as described in Chapter 4. If all tests pass, proceed to the next step. Replace any component that fails testing. (Use the lock-and-power-down technique.) Bring the SPE back up as described in Chapter 4.
4. With the standby still busied out, issue the command **r** to reboot the standby SPE and immediately unplug the STANDBY terminal connector. The standby should still be busied out. Wait for the yellow LED on the standby Processor to begin flashing, unlock the SPEs, and monitor the standby with **status spe**.
5. If handshake is established, release the standby SPE from busyout and monitor its recovery with **status spe**. If the onset of memory shadowing or refresh causes handshake to fail, then suspicion is cast on these standby circuit packs:
  - DUPINT
  - PKT-INT
  - MEMORY
  - MSSNET

Replace each of these in the standby in the above order, using lock-and-power-down. For each one, bring up the standby SPE and wait to see if handshake and memory refresh succeed.

## Resolving Shadowing Failure

This section addresses the situation in which handshake communication is up, but memory shadowing is not on after reasonable initialization time, or is repeatedly turning on and off. If the onset of memory shadowing is causing handshake failure, see the preceding section.

The following conditions prevent memory shadowing:

- Busyout of the standby SPE
- Locking of the SPEs by means of the SPE-select switches

- Alarms against components relevant to shadowing
- A mismatch between the hardware configurations of the active and standby SPEs
- Incomplete initialization of the standby after a restart

When memory shadowing is not on, system software checks every 30 seconds to see if the above conditions are gone, allowing it to restore shadowing. Examine the Hardware Error Log for any of the following indications.

### STBY-SPE Error 257

This usually represents inhibiting of memory shadowing by the standby SPE. This can occur if the standby SPE is undergoing any level of restart or if the standby PKT-INT circuit pack is being reset. Typically this condition clears quickly. In the case that the standby SPE has restarted, there should be an STBY-SPE error 514 logged. If the 257 error persists with handshake staying up, look for problems with the standby PKT-INT board (red LED). It may be necessary to reset the standby PKT-INT board (**reset packet-interface**) to clear the inhibiting of shadowing. See "PKT-INT".

### STBY-SPE Error 260

This indicates that the mechanism in the active SPE's Duplication Interface circuit pack to turn on shadowing has somehow failed. When this occurs, busyout the standby SPE and run **test dup long**. Follow instructions for DUPINT.

### STBY-SPE Error 1537

This error indicates a component mismatch between the active and standby SPEs. Use **list config control** to determine what components are in the PPN carriers A and B. Correct any mismatches. Use the lock-and-power-down method described in Chapter 5 to replace circuit packs.

## DUPINT or DUP-CHL Alarms

As long as any alarms against either of these MOs persist, memory shadowing will not be turned on.

## Standby PKT-INT Major Alarms

These prevent memory shadowing. See “PKT-INT”. It may be necessary to reset the board (**reset packet-interface**).

## Standby MEM-BD Major Alarms

These prevent memory shadowing. See “MEM-BD”.

When you observe any of the above problems, first busyout the standby SPE, then fix the given problem (usually with a lock-and-power-down replacement), then release the standby SPE.

If any of the above problems persist, or if none of them appears but shadowing remains off in the presence of good handshake, escalate the problem.

## Resolving Refresh Problems

---

It can happen that handshake communication and memory shadowing can both be maintained to a standby SPE, but for some reason that SPE cannot be completely refreshed. In this case, one must distinguish between delays in refresh completion and outright failure. This section addresses the situation in which shadowing remains on, handshake remains up, but refresh will not complete.

### Delays in Refresh

Under extremely heavy occupancy loads, standby refresh can be delayed but it is still expected to complete within 10 minutes of the time when memory shadowing was turned on. You should not see delays greater than this without some STBY-SPE alarm.

### Failure of Refresh

The refresh operation occurs in two steps:

- Refresh of Packet Interface dual port RAM (very quick execution)
- Refresh of all memory on all memory boards

A failure can occur in either of these steps. When refresh fails, STBY-SPE error code 1281 is logged. The auxiliary data indicates which aspect of refresh failed. Aux code 1383 indicates that the memory board part has failed. This typically indicates a problem with *active* SPE memory circuit packs. Execute the long test sequence against both active SPE memory circuit packs and see “MEM-BD”. If

no problems are revealed in the memory long test sequence, but memory refresh persists in failing with error 1281 error aux 1383, escalate the problem.

Error code 1281 with auxiliary data 1381 indicates that refresh of the packet-interface dual port RAM has failed. If this persists, one should look for problems with either active SPE or standby SPE packet-interface boards. Follow the procedures outlined in PKT-INT to fully test the active SPE's Packet-interface. Note that, since the standby SPE is not refreshed, one cannot execute the long demand test sequence on the standby Packet Interface. One can however trigger a reset of that circuit pack. If the active PKT-INT passes all tests of the long sequence and if the standby PKT-INT successfully resets, the problem should clear. If error 1281 aux 1381 persists, escalate the problem.

Error code 1281 with auxiliary data 1380 indicates that memory shadowing was turned off during refresh and the refresh has therefore terminated in failure. This situation should be treated as a shadowing failure and approached as described in the section *Resolving Shadowing Failure*. If memory shadowing is restored, but refresh again fails with code 1380, escalate attention to the problem.

One particular way memory or PKT-INT refresh can be led to fail is by inserting one of these circuit packs into its slot without powering down the carrier. If this happens, it may be necessary to cycle power on the given carrier and let the LMM run all tests of components on the carrier to clear the problem. If such an SPE is in standby mode, **reset spe-standby 4** would also cause the appropriate initialization to occur. Always follow the lock-and-power-down approach to replace circuit packs on the standby SPE.

## Resolving Poor Health

It can happen that a standby SPE is properly maintaining handshake communication, shadowing is on and the standby is fully refreshed, but for some reason the SOH of that standby SPE remains at a level other than *functional*.

For example, in a heavily loaded system, the standby SOH may temporarily stay at *not refreshed*, but eventually it should clear. Once refresh completes, system software begins an effort to improve the standby SOH from *not refreshed* to *functional*. This effort can be delayed, but within a few minutes one should see the change. If one sees an indefinite persistence of this health level, in an otherwise perfect standby SPE, escalate the problem. This should be an extremely rare event.

If the standby SOH Stays at *partially functional*, either the standby SPE is in *recent interchange mode* or there is a major alarm against some critical standby component (see the table above). For the first case, verify the situation with **status spe** and then clear the recent interchange mode by executing **test spe-standby long**. Wait until at least the first four tests of the sequence complete, then cancel out of the command. The standby SOH should eventually be raised to *functional*. In the second case, check the alarm log to see if there is any major alarm against any component of the standby SPE. If you find one, fix



that problem, (usually by replacing the circuit pack). Then the SOH problem should eventually clear. If you lock-and-power-down the standby SPE to replace the given pack, you'll need to test it while in locked mode until all tests pass and then unlock and wait for system software to re-initialize the standby SPE. Only then should you expect standby SOH to be improved to level *functional*.

If neither the recent interchange mode nor a standby component alarm exist, but standby SOH persists at level *partially functional*, escalate the problem.

## Error Log Entries and Test to Clear Values

**Table 9-569. STBY-SPE Error Log Entries**

Error Type	Aux Data	Associated Test	Alarm Level	On/Off Board	Test to Clear Value
0 <sup>1</sup>	0	Any	Any	Any	test spe-standby I
1(a)		Standby SPE Handshake Test (#919)	MAJOR	OFF	
18(b)		busyout spe-standby	WARNING	OFF	rel spe-standby
103(c)		None	MINOR	OFF	test spe-standby I
257(d)		standby SPE status query (#855)	MAJOR	OFF	
260(e)		standby SPE status query (#855)	MAJOR	OFF	
514(f)		None	MAJOR	OFF	
770(g)		standby SPE TOD Comparison Test (#858)	MINOR	OFF	test spe-standby I
1025(h)		standby SPE status query (#855)	MAJOR	OFF	test spe-standby I
1281(i)	any	standby SPE status query (#855)	MAJOR	OFF	
1537(j)	any	standby SPE configuration Matchup test (#920)	MAJOR	OFF	test spe-standby I

1. Run the Short Test Sequence first. If all tests pass, run the Long Test Sequence. Refer to the appropriate test description and follow the recommended procedures.

### Notes:

- a. Indicates that a single handshake attempt has failed. Use "status spe" to see if handshake is down. If "status spe" indicates that handshake is up, ignore this error. If handshake is down, see *Resolving Handshake Failure*.

- b. Presence of this error indicates that the standby SPE has is busied out. When busied out, standby SPE's health is kept at the level *partially functional* and memory shadowing is kept off.
- c. Error 103 indicates that a spontaneous interchange has taken place. This lowers the now standby SPE's state-of-health to *partially functional*, raises a MINOR alarm against the standby SPE, and invokes recent interchange mode (anti-thrashing). After one hour, or entering **Test spe-standby long** or **busyout spe-standby**, the alarm clears, recent interchange mode is lifted, and the standby's state of health assumes the appropriate value (usually *functional*).

After a spontaneous SPE interchange has occurred, the Alarm Log retains a record of any MAJOR ON-BOARD alarm against an SPE component that took place before the interchange. This record is retained for three hours and may indicate the cause of the interchange when testing is not possible or conclusive. If handshake has not been restored (check with **status spe**), replace the alarmed circuit pack on the standby SPE. If handshake is up, and such an alarm is logged against SW-CTL, replace the standby MSSNET circuit pack. If handshake is up, and such an alarm is logged against one of the other SPE components, execute a **test long clear** of the alarmed standby component and follow repair instructions for that maintenance object.

- d. This error represents inhibiting of memory shadowing by the standby SPE. If this error occurs accompanied by error 514, then the standby SPE has reset, so wait 5 minutes for this condition to clear. If the 257 error persists, or did not occur with a 514, then how you proceed depends on whether handshake is up. If handshake is not up, deal with the handshake failure problem (see the section *Resolving Handshake Failure*). If handshake is up, look for errors or red LEDs indicting the standby packet-interface circuit pack or either of the duplication-interface circuit packs. If such problems exist consult the appropriate MO documentation. When no PKTINT errors or alarms are present, the PKTINT may still be the cause of the problem. Try **reset packet-interface [a|b]** to reset the standby PKTINT and wait two minutes, after which shadowing should be turned on. If 257 continues to persist, with handshake up, and no associated packet-interface or duplication-interface problems, escalate the problem.
- e. This error indicates that shadowing could not be turned on due to a problem with the duplication-interface hardware. **Busyout spe-standby**, run **test duplication-interface long**, and consult the DUPINT section. Once all tests of duplication-interface have passed, and all alarms against it have cleared, **release spe-standby** and wait 10 minutes for normal initialization to complete. If error 260 recurs, escalate the problem.
- f. This error indicates that the standby SPE has been reset. Wait 5 minutes and then use "status spe" to see if the standby SPE is refreshed. If so, ignore the 514 error. If not, or if 514 recurs frequently, then lock the standby SPE and proceed to trouble-shoot it with the SPE-Down Interface.

If all SPE-Down Interface tests pass, and error 514 recurs, then there is probably a software problem in the standby SPE: follow normal escalation procedures.

- g. Indicates that the two Time-of-Day (TOD) clocks of the active and standby SPEs were detected to be more than 30 seconds apart. Run the short test sequence on each of the two SPEs' SYSAM circuit packs (see service documentation for TN1648). If any of these tests fail, fix the problem with that SYSAM pack (as described in TN1648 service documentation). If no SYSAM tests fail, and if the 770 persists, then replace the standby SYSAM pack (via the lock-and-power-down approach) and wait for the repaired standby SPE to initialize again (after unlocking). If, after all this, the 770 persists, then, once the standby SPE is fully refreshed and of *functional* health, perform a planned SPE interchange ("reset system interchange") and replace the now-standby (other) SYSAM pack (again: use lock-and-power-down). Now let the standby re-initialize. If, the 770 error persists, escalate the problem.
- h. This indicates that the standby SPE is down (has a power or sanity problem) and is associated with a *non-functional* SOH level (as revealed by "status spe"). Check for any power alarms (CARR-POW) and deal with them. If none, trouble-shoot the standby SPE by locking and using the SMT. Do not unlock the standby SPE until all SMT tests of it have passed.
- i. Represents an instance of refresh failure. Look at the auxiliary data associated with the error. There are the following possibilities:
  - Aux data 1380

This indicates that memory shadowing was turned off during refresh. Proceed as you would to solve a shadowing problem (see the section *Resolving Shadowing Failure*). If shadowing returns, wait 10 minutes for the system to automatically retry refresh. Also, problems with the standby PKT-INT might lead standby software to turn off shadowing during refresh. So look for a red LED on the standby PKT-INT. If you find this, follow PKT-INT service documentation to repair. Then wait for the automatic retry of refresh.
  - Aux data 1381

This indicates a failure of PKT-INT refresh. Consult PKT-INT service documentation to test and repair both active and standby PKT-INTs while the standby is not refreshed. Then wait for the automatic retry of refresh.
  - Aux data 1383

This indicates that refresh of one of the memory packs has failed. Typically this indicates a problem with one of the active SPE MEM-BDs. Consult MEM-BD service documentation of execute the long test sequence on these packs. Fix any problems you encounter. Then wait for the automatic retry of refresh.

- any other value  
 System software problem; escalate the problem.

If all memory and packet-interface packs pass all test and refresh failure persists, escalate the problem.

- j. This error indicates a possible mismatch in hardware configuration between active and standby SPEs for other than disk and tape components. Auxiliary data indicates the general area of the mismatch:

- Aux data 1374  
 Indicates a mismatch of PKT-INT circuit packs
- Aux data 1375  
 Indicates a mismatch of MEM-BD circuit packs
- Aux data 1376  
 Indicates a mismatch of Processor, SYSAM, DUPINT or MSSNET circuit packs

If handshake is up, use the "list config control" command to compare components of the two SPEs; then verify and correct the discrepancy. If no discrepancies are revealed, escalate the problem. If handshake is down, fix that problem (see *Resolving Handshake Failure*).

## System Technician-Demanded Tests: Descriptions and Error Codes

---

Always investigate tests in the order presented in the table below.

Order of Investigation	Short Test Sequence	Long Test Sequence	D/ND <sup>1</sup>
Standby SPE Status Query Test (#855)	X	X	ND
Standby SPE Handshake Test (#919)	X	X	ND
Standby SPE Time-of-Day Comparison Test (#858)	X	X	ND
Standby SPE Configuration Matchup Test (#920)		X	ND

---

1. D = Destructive, ND = Non-destructive

The **reset spe-standby [1|2|3|4]** command executes a restart of the specified level on the standby SPE. It can be used to attempt to clear certain apparent software problems. Handshake must be up. Any standby restart causes memory shadowing to be turned off, requiring several minutes for refresh to complete.

**Standby SPE Status Query Test (#855)**

This test *does not require handshake communication*. It reads the active SPE's duplication interface circuit pack hardware register to determine standby SOH, status of the lock switches, and whether shadowing is currently turned on. It updates all internal status data kept about the standby SPE (which can be read via the "status spe" command). This test is considered to pass if standby SOH is *functional*, memory shadowing is turned on and the standby memory is fully refreshed. It returns different failure codes depending of which of these conditions is not met. Abort codes reflect that the status data could not be read.

**Table 9-570. TEST #855 Standby SPE Status Query Test**

Error Code	Test Result	Description/ Recommendation
1330	ABORT	Test cannot run due to duplication-interface hardware failure. <ol style="list-style-type: none"><li>1. <b>busyout spe-standby</b></li><li>2. <b>test duplication-interface long</b></li><li>3. Proceed according to the DUPINT and DUP-CHL service documentation in this chapter.</li><li>4. If all DUPINT tests pass, rerun command.</li></ol>
1338	ABORT	Test cannot run because a planned SPE interchange is in progress <ol style="list-style-type: none"><li>1. Wait for the planned SPE interchange to complete (this might have been stimulated by a craft request or by scheduled maintenance).</li></ol>
1321	FAIL	Test failed because the SPEs are in locked mode. <ol style="list-style-type: none"><li>1. Check that the SPE-SELECT switches on the two DUPINT packs agree with this. This failure will clear once the SPEs are unlocked.</li></ol>

*Continued on next page*

**Table 9-570. TEST #855 Standby SPE Status Query Test — Continued**

Error Code	Test Result	Description/ Recommendation
1322	FAIL	<p>Test failed because memory shadowing is off (but not inhibited). When not inhibited by the standby SPE, memory shadowing can be off for the following reasons:</p> <ol style="list-style-type: none"> <li>1. Shadowing has not been turned on yet (temporary condition). To allow for this, the test again (or <b>status spe</b>) after 5 minutes to see if shadowing is then on.</li> <li>2. There is a failure in the duplication-interface hardware: to allow for this, look for errors or alarms against the duplication-interface hardware (DUPINT and DUP-CHL): address these according to duplication-interface documentation. Then re-run the test.</li> <li>3. Handshake has not been established between the two SPEs: use "status spe" to see if handshake is up. If it is not, address that problem according to the section <i>Resolving Handshake Failure</i>.</li> <li>4. There is a hardware configuration mismatch between components of the two SPEs. Look for error 1537 in the hardware error log and use "list config control" to identify the hardware discrepancy between SPEs. Fix this.</li> <li>5. There is a major alarm against the memory (MEM-BD), packet-interface (PKT-INT) or switch-control (SW-CTL) circuit packs of the standby SPE. Look for alarms against these and correct the problem.</li> </ol>
1324	FAIL	<p>Test failed because standby SPE has <i>partially functional</i> SOH;</p> <ol style="list-style-type: none"> <li>1. Use "display alarms" to see alarms against standby SPE components.</li> <li>2. If a MINOR alarm is active against the current carrier of STBY-SPE, associated with an error 103, then clear this condition with "test spe-standby long". If a WARNING alarm exists against STBY-SPE, use "status spe" to see if the standby is busied out. If so, "release spe-standby" will clear the health problem.</li> <li>3. Use "status spe" to see if handshake is up. If it is not, deal with that problem according to the section <i>Resolving Handshake Failure</i>.</li> <li>4. Otherwise look for a MAJOR, ON-BOARD alarm against the processor (PROCR), memory (MEM-BD), switch-control (SW-CTL), packet-interface (PKT-INT), or SYSAM circuit packs of the standby SPE. Using the lock-and-power-down approach, replace the offending circuit pack on the standby SPE. Consult the documentation for that component to clear its alarms. Once the alarm against the offending component clears, the SOH of the standby SPE will automatically improve from the <i>partially functional</i> level. If error 1324 persists and either none of the above cases is true or you have fixed all of these particular problems, escalate the problem.</li> </ol>

*Continued on next page*

**Table 9-570. TEST #855 Standby SPE Status Query Test — Continued**

Error Code	Test Result	Description/ Recommendation
1325	FAIL	Test failed because memory shadowing is off due to its being inhibited from the standby SPE <ol style="list-style-type: none"> <li>1. This can be a temporary condition, wait 5 minutes and run the test again.</li> <li>2. If handshake is not established (use <b>status spe</b> to see this), deal with that problem according to the preceding section "Resolving Handshake Failure"</li> <li>3. Rerun the test; if the same 1325 failure recurs, look for problems with the duplication-interface circuit packs (both SPEs) or with the standby SPE's packet-interface pack (look for red LEDs on these). Fix these problems according to the service documentation for these packs.</li> </ol>
1326	FAIL	Test failed because standby memory is not refreshed. <ol style="list-style-type: none"> <li>1. Retry the test (or "status spe") after 10 minutes, to see if standby is then refreshed.</li> </ol>
1329	FAIL	Test failed because standby SPE has <i>non-functional</i> SOH; this means that the standby SPE is down. <ol style="list-style-type: none"> <li>1. Look for power alarms (CARR-POW) against the standby SPE carrier; address these.</li> <li>2. Otherwise, lock the standby SPE and trouble-shoot it with the SMT (as you'd diagnose any down SPE. If you cannot revive the standby SPE or if, upon getting it out of the SPE-down state, error 1339 persists for this test, follow normal escalation procedures.</li> </ol>
	PASS	Standby SPE is fully in service (SOH functional, memory content refreshed).

### Standby SPE Time-of-Day Comparison Test (#858)

This test, available only when handshake communication is up, compares the SYSAM board's Time-of-Day clock values in the two SPEs. The test passes if the two clocks differ by less than 20 seconds. Failure of this test means that the two clocks have drifted apart but that each clock appears to be moving forward. Having the two TOD clocks more than 20 seconds apart can make spontaneous SPE interchanges disruptive to the point of dropping calls. Repeated failure of this test indicates that one or both of the two SYSAM packs will have to be replaced.

**Table 9-571. TEST #858 Standby SPE Time-of-Day Comparison Test**

Error Code	Test Result	Description/ Recommendation
1000 2029	ABORT	Either of these codes indicates that the test cannot run because internal resources cannot be allocated to read active clock.  1. Consult SYSAM service documentation for time-of-day clock tests.
1338	ABORT	Test cannot run because a planned SPE interchange is pending.  1. Wait for the planned interchange to complete, then for handshake to come up, then re-run test on newly standby SPE.
1339	ABORT	Test cannot run because handshake communication is not up.  1. Wait 5 minutes and try test again. If handshake is still not up (you get a 1339), solve the handshake problem as described in <i>Resolving Handshake Failure</i>
1346	ABORT	Test could not read standby SPE's TOD clock.  1. Test standby SPE's SYSAM and consult that section in this chapter.
1377	ABORT	A-carrier SPE's clock is not moving forward.  1. Test A-carrier SYSAM's time-of-day clock according to SYSAM service documentation.
1378	ABORT	B-carrier SPE's clock is not moving forward.  1. Test B-carrier SYSAM's time-of-day clock according to SYSAM service documentation.
2000	ABORT	Effort to read the clock timed out.  1. Test each of the two SPE's SYSAMs (test maint {1a 1b}) as described in SYSAM service documentation. Once these all pass, repeat this test.
	FAIL	Standby TOD clock differs from active's by more than 20 seconds.  1. Wait 1-minute; repeat the test. If test passes, there is no problem.  2. If test fails, use the lock-power-down approach to replace the TN1648 SYSAM circuit pack on the standby SPE. After the repaired standby SPE is fully initialized (handshake has been re-established), repeat the test.  3. If the test fails again, run it again it 1-minute later. If it fails again, perform a planned SPE interchange and wait for it to complete, Replace the standby SYSAM pack with another new replacement pack. Note that this repair procedure requires two extra SYSAM circuit packs.
	PASS	The two SPE's TOD clocks are within tolerable limits of one another.



## Standby SPE Handshake Test (#919)

This test causes software to send a handshake request message to the standby SPE (this is the same handshake request message sent every 30 seconds automatically by the software). For this test to pass, standby software must respond to this message in less than 3 seconds. Persistent failure of this test indicates that handshake communication is down (as can be discerned from the "status spe" command). This should be dealt with as described in the preceding section "Resolving Handshake Failure."

**Table 9-572. Test #919 Standby SPE Handshake Test**

Error Code	Test Result	Description/ Recommendation
1321	ABORT	Test cannot run due to SPEs being locked.  1. Inter-SPE communication is not possible while in locked mode. Verify that SPEs are locked with lock switches. Handshake communication may resume once the SPEs are unlocked.
1330	ABORT	Test cannot run due to problem in DUPINT hardware.  1. Test the duplication-interface hardware according to the service documentation for DUPINT and DUP-CHL.
1338	ABORT	Test cannot run due to planned SPE interchange pending.  1. Wait for the planned SPE interchange to complete, then retry the test.
	FAIL	Standby SPE did not respond to handshake request within 3 seconds.  1. Wait 2 minutes and try the test again.  2. If test fails again, use "status spe" to see if handshake communication is up. If it is not and there is a STBY-SPE MAJOR alarm, then deal with the problem according to the preceding section Resolving Handshake Failure."
	PASS	Handshake request was responded to within 3 seconds; handshake communication is up.

## Standby SPE Configuration Matchup Test (#920)

This test requires that handshake be up. It checks to see if the hardware configuration of the standby SPE is in agreement with that of the active SPE, *ignoring tape and disk components*. Active SPE software sends a message to the standby requesting a list of the latter's components. This list is compared to the list of known components on the active SPE.

This match is necessary for memory shadowing to operate correctly, and for the standby SPE to be able to take on active SPE status correctly. Failure indicates that, for some SPE component other than disk or tape, the two SPE

configurations disagree. This is a serious problem. Memory shadowing is automatically turned off as long as a configuration mismatch exists. As long as this condition holds, any spontaneous SPE interchange which might occur results in all calls being dropped and a COLD-1 restart on the newly active SPE.

**Table 9-573. TEST #920 Standby SPE Configuration Matchup Test**

Error Code	Test Result	Description/ Recommendation
1338	ABORT	Test cannot run because a planned SPE interchange is pending. <ol style="list-style-type: none"> <li>1. Wait for the planned interchange to complete, then for handshake to come up, then re-run test on newly standby SPE.</li> </ol>
1339	ABORT	Test cannot run because handshake communication is not up. <ol style="list-style-type: none"> <li>1. Wait 5 minutes and try test again. If handshake is still not up (you get a 1339), solve the handshake problem as described in "Resolving Handshake Failure".</li> </ol>
2000	ABORT	Communication with Standby SPE timed out. <ol style="list-style-type: none"> <li>1. Retry the test once after 2 minutes.</li> </ol>
1374	FAIL	Test failed due to mismatch in packet-interface circuit packs. <ol style="list-style-type: none"> <li>1. Use <b>list config control</b> to verify discrepancy.</li> <li>2. Fix the indicated discrepancy in packet-interface packs.</li> <li>3. Re-run test. This mismatch test is not sensitive to firmware differences between the two packet-interface circuit packs. See the PKT-INT section for dealing with firmware variations.</li> </ol>
1375	FAIL	Test failed due to mismatch in memory circuit packs. <ol style="list-style-type: none"> <li>1. Use "list config control" to verify discrepancy.</li> <li>2. Fix the indicated discrepancy in memory packs.</li> <li>3. Re-run test.</li> </ol>
1376	FAIL	Test failed due to mismatch in either PROCR, SYSAM, DUPINT, or MSSNET circuit packs. <ol style="list-style-type: none"> <li>1. Use <b>list config control</b> to verify this highly unlikely discrepancy.</li> <li>2. Fix the indicated discrepancy.</li> <li>3. Re-run test.</li> </ol>
	PASS	Active and standby SPEs' hardware configurations agree in all critical components.

## STO-DATA (Stored Data)

MO Name (in Alarm Log)	Alarm Level	Initial Command to Run	Full Name of MO
STO-DATA	MINOR	test stored-data [long]*	Stored Data
STO-DATA	WARNING	test stored-data	Stored Data



### NOTE:

STO-DATA problems can be caused by faulty MSS hardware or hardware used to provide communication between active and standby SPEs. If hardware errors are present for H-ADAPTER, TAPE, DISK, or DUPINT, investigate those first and then run **test stored-data** to address file inconsistencies.

The Mass Storage System (MSS) consists of the following components which are part of the system's SPE:

- TN1656 Disk circuit pack
- TN1656 Tape circuit pack
- Host Adapter circuit located on the UN332 MSS/Network Control circuit pack

Each disk and tape drive stores 2 copies of each of the following:

- The software that the system runs (the "boot image")
- Translation data
- Software update data (also known as program updates or patches)
- Announcement files from the TN750 Announcement circuit pack
- File directory
- Error log
- In special circumstances, a core dump of all system memory (single copy)

The disk is the primary storage device. Files on disk are generally used to reboot the system or to restore files that are lost or corrupted during a malfunction. The tape is used to backup the disk and as a portable medium for data, such as is used for introduction of a new software load.

In High and Critical Reliability systems (duplicated SPE) the tape and disk drives are duplicated as part of the PPN control carrier, resulting in a total of 4 devices, each storing 2 copies of the aforementioned files. Ideally, the files on all of the devices are identical, but malfunctions or even normal operations can lead to inconsistencies.

## Data Inconsistencies and STO\_DATA Tests

The STO-DATA maintenance object is not a hardware component, but a strategy used to test for consistency between corresponding files on the different storage devices. When inconsistencies are found, STO-DATA errors and alarms are generated. The translation, announcement, and software update files are checked by comparing timestamps created when the files were saved from system memory. The boot image files are checked by comparing vintage numbers. The other files are not checked.

On systems with simplex SPE, a STO-DATA test compares the files on tape to those on the disk. On systems with duplicated SPEs, the following comparisons of corresponding files are made:

1. Disk to tape (active SPE)
2. Disk to tape (standby SPE)
3. Disk (active SPE) to disk (standby SPE)
4. Tape (active SPE) to tape (standby SPE)

The data consistency tests are run as part of the short and long demand test sequences and automatically during daily scheduled maintenance. Test results point to which files, if any, are out of date.

In addition to the data consistency tests, checksum tests are run during the long demand test sequence to verify that the checksums of both copies of the boot image on each storage device are the same. This capability is useful when the system has booted using a boot image other than the first copy on disk. (An alarm and unique error code identify this situation). In addition to test results, you can use the **list configuration software** command to retrieve detailed information about the files on each storage device.

## Backing Up Data: MSS Commands

---

Several commands are available for copying files from system memory to the MSS, and for copying files from one MSS device to another. They are summarized in the following table. Refer to Chapter 8, for complete descriptions and additional options for these commands.

**Table 9-574. Mass Storage System Commands**

Command	Execution Time *	Action/Remarks
save translation [disk] <sup>1</sup>	2 minutes	Copy translation from system memory to disk File is timestamped at time of command.
save announcement	40 minutes	Copy announcement file from TN750 to disk File is timestamped at time of command. Use after recording announcements.
restore announcement	40 minutes	Copy announcement file from disk back to TN750 Use after a TN750 or announcement administration error.
backup disk [incremental]	20-50 minutes	Copy from disk to tape all files on disk that are newer Done to both SPEs if duplicated
backup disk full	50 minutes	Copy all disk files to tape Done to both SPEs if duplicated Use after replacing tape cartridge.
restore disk [full]	50 minutes	Copy all tape files to disk Use after disk is replaced. Done to both SPEs if duplicated.
copy announcement tape	2 minutes	Copy announcement file from disk to tape Keeps timestamps consistent.
copy update-file tape	2 minutes	Copy update file from disk to tape Keeps timestamps consistent.

- 
1. Execution times vary; those shown are expected maximums. Entries in brackets ([ ]) are defaults and need not be entered. Pipes (|) indicate a choice between options.
- 

The following commands are not used in normal backup or maintenance procedures. They are sometimes useful in special situations such as software updates or resolving specific file inconsistencies between devices.

**Table 9-575. Special Purpose MSS Commands**

Command	Execution Time <sup>1</sup>	Action/Remarks
save translation tape	10 minutes	Copy translation from memory to tape Use only for special situations. Causes STO-DATA tests to fail since tape timestamp is newer than disk.
copy announcement spe-a spe-b disk	2 minutes	Copy announcement data from tape to disk Useful for restoring announcement file on disk
copy update-file spe-a spe-b disk	2 minutes	Copy update (patch) data from tape to disk Useful for restoring update data on disk
copy bootimage [spe-a spe-b both] tape	2 minutes	Copy boot image from disk to tape Useful for restoring boot image on tape
copy bootimage [spe-a spe-b both] disk	2 minutes	Copy boot image from tape to disk Useful for restoring boot image on disk

1. Execution times vary; those shown are expected maximums. Entries in brackets ([ ]) are defaults and need not be entered. Pipes (|) indicate a choice between options.

## Automatic Backups

During normal operations, files in system memory, on disk, and on tape can become inconsistent (for example, when translations are changed, when announcements are saved). During daily scheduled maintenance, several actions are take to keep data files consistent:

1. At the start of scheduled maintenance, translations and error logs are saved. This step must be enabled by the "Save Translation" field on the **change system-parameters maintenance** form.
2. Disk files are backed up to tape.
3. STO-DATA tests are run along with other daily maintenance tests.

At the end of this sequence, disk and tape files should all be identical, and translations and error logs files should be current with system memory. Announcement files are not saved automatically, and should be manually saved after recording or altering announcements. The automatic backup will however transfer these from disk to tape.

## File Inconsistencies: Causes

A number of things can cause files to become inconsistent between devices.

**Test stored data** and **list configuration software** can be used to identify which files are affected. Described below are some of the causes of inconsistencies.

## Save commands

Whenever a **save translation** or **announcements** is executed, the files on disk are newer than the files on tape until a **backup disk** is performed either by command or by daily scheduled maintenance. If **test stored-data** is run before a backup, Tests #833 and #834 will fail with error code 1 or 8, generating a warning alarm against STO-DATA. Once a disk backup is performed, running the stored data tests will clear the alarm. A copy command can be used instead of backup to save time; take extra care to enter the right options so good files are not lost.

When **save translation tape** or **save announcements tape** is executed, timestamps on the tape files will be newer than those on the disk files. (This is the opposite of normal operational sequences.) These commands should not be used as part of standard administration or repair procedures. When the files are in this state, automatic or demand incremental backups from disk will be prevented from overwriting the tape files, and subsequent STO-DATA tests will fail, generating warning alarms.

Save to tape commands may be useful when the disk has failed and the tape is being used temporarily for primary storage. Once the disk is replaced, **restore disk** can be used to recoordinate the files.

## Dirty Files

Two copies of each file are stored on each MSS device. This protects against data loss in case a failure occurs while data is being written. If such a failure occurs, or if a tape cartridge is pulled out of the drive while data is being written to it, the incomplete file is marked as a "dirty" file. The system will then use the other copy for reading data and will generate a minor alarm against TAPE or DISK. AS long as one of the copies is clean, STO-DATA tests will test the clean copy and not report any errors.

## Tape Replacement

Tape cartridges are periodically replaced (for example, after a TAPE warning alarm with error type 2305, indicating that 90% of its useful life has been exceeded). Until a full disk backup is performed, the new tape will be inconsistent with the disk.

## Inconsistent Files: Solutions

---

The best way to clear STO-DATA alarms is to perform a **save translation** or **announcements** (if those files are affected), followed by a **backup disk**. Daily scheduled maintenance also performs this sequence. There are unusual situations in which other actions are required. If problems exist on the TN750 Announcement circuit pack, avoid saving announcements until resolving those problems. Otherwise, good copies of the files could be overwritten by bad ones.

The default for the backup command is “incremental,” meaning that files on tape with newer timestamps than those on disk are not overwritten. This can occur when a save is made to tape. Save followed by backup will still work, but time can be saved by **restore disk**.

## Inconsistency across SPEs

When the SPE is duplicated, disruptions to inter-SPE communication, or MSS writes on one SPE but not on the other, can cause files to be inconsistent between devices on the different SPEs. You can detect this situation by running **list configuration software long** and inspecting the timestamps and software version numbers. Correct procedure depends on which device has the correct boot image.

### Disk on Active SPE Has Correct Boot Image:

1. **save translation active** (2 min)
2. **backup disk active** (40 min)
3. Put the tape cartridge from the active SPE into the tape drive on the standby SPE. Put the tape cartridge from the standby SPE into the tape drive on the active SPE.
4. **backup disk active** (40 min)
5. **restore disk standby** (40 min)
6. **test stored data**

### Tape on Active SPE Has Correct Boot Image:

1. **save translation tape active** (2 min)
2. **restore disk active** (40 min)
3. Put the tape cartridge from the active SPE into the tape drive on the standby SPE. Put the tape cartridge from the standby SPE into the tape drive on the active SPE.
4. **backup disk active** (40 min)
5. **restore disk standby** (40 min)
6. **test stored data**



## Error Log Entries and Test to Clear Values

**Table 9-576. STORED-DATA Error Log Entries**

Error Type	Aux Data	Associated Test	Alarm Level	On/Off Board	Test to Clear Value
1 (a)	1 to 6	Carrier A Tape-Disk Consistency Test (#833)	WARNING	OFF	test stored-data
257 (b)	1	Carrier A Tape-Disk Consistency Test (#833)	WARNING	OFF	test stored-data
513 (a)	1 to 6	Carrier B Tape-Disk Consistency Test (#834)	WARNING	OFF	test stored-data
542 (c)	0	Scheduled translation save	-	-	
543 (d)	0	Scheduled disk backup	-	-	
769 (b)	1	Carrier B Tape-Disk Consistency Test (#834)	WARNING	OFF	test stored-data
1025 (e)	1 to 6	Tape-Tape Consistency Test (#835)	MINOR	OFF	test stored-data
1281 (f)	1	Tape-Tape Consistency Test (#835)	MINOR	OFF	test stored-data
1537 (e)	1 to 6	Disk-Disk Consistency Test (#836)	MINOR	OFF	test stored-data
1793 (f)	1	Disk-Disk Consistency Test (#836)	MINOR	OFF	test stored-data
2049 (g)	1 to 3	Carrier A Boot Image Test (#837) (Runs at system boot time only)	MINOR	OFF	test stored-data long
2305 (g)	1 to 3	Carrier B Boot Image Test (#837) (Runs at system boot time only)	MINOR	OFF	test stored-data long
2561 (h)	300043 001430 201	Carrier A Tape Checksum Test (#829)	MINOR	OFF	test stored-data long
2817 (h)	300043 001430 201	Carrier A Disk Checksum Test (#830)	MINOR	OFF	test stored-data long
3073 (h)	30004 30014 30201	Carrier B Tape Checksum Test (#831)	MINOR	OFF	test stored-data long

*Continued on next page*

**Table 9-576. STORED-DATA Error Log Entries — Continued**

Error Type	Aux Data	Associated Test	Alarm Level	On/Off Board	Test to Clear Value
3329 (h)	30004 30014 30201	Carrier B Disk Checksum Test (#832)	MINOR	OFF	test stored-data long
3585 (i)	Any		WARNING	OFF	test stored-data
3586 (j)	Any		WARNING	OFF	test stored-data
3587 (k)	Any		WARNING	OFF	test stored-data
3841 (i)	Any		WARNING	OFF	test stored-data
3842 (j)	Any		WARNING	OFF	test stored-data
3843 (k)	Any		WARNING	OFF	test stored-data

Notes:

- a. Error types 1 and 513 indicate that one or more of the following conditions has occurred on Carrier A or Carrier B respectively: the timestamps of the translation files on the two storage devices are inconsistent, the timestamps of the announcement files on the two storage devices are inconsistent, or the timestamps of the program update files on the two storage devices are inconsistent.

The auxiliary data for the error type can be used to determine which files are inconsistent. That information is presented in the table below. More than one data inconsistency may exist, but only the fault with the highest auxiliary data number will appear in the error log. Enter the **test stored-data** command to obtain more information about the failure and follow the associated repair procedures.

**Table 9-577. Auxiliary Data for Error Types 1 and 513**

Aux Data	Data File Inconsistency
1	Disk translation data is newer than the tape translation data
2	Tape translation data is newer than the disk translation data
3	Disk announcement data is newer than the tape announcement data
4	Tape announcement data is newer than the disk announcement data
5	Disk program update data is newer than the tape program update data
6	Tape program update data is newer than the disk program update data

- b. Error types 257 and 769 indicate that the vintages of the boot images on the two storage devices on Carrier A or Carrier B respectively, are inconsistent.
  1. Use the **list configuration software-vintage** command to get the vintage numbers and install the correct vintage.
  2. Run the data storage tests by entering **test stored-data** to retire the alarm.
  3. If the STORED-DATA tests fail, refer to the repair procedures for those tests for further information.
- c. Error type 542 indicates that the scheduled daily save-translation operation failed. If a STORED-DATA alarm is active, it is due to a data inconsistency.
  1. Refer to the alarm log and clear any failures associated with the HOST ADAPTER, TAPE, or DUPINT circuit and clear those problems first.
  2. Then save translation manually by entering **save translation** and backup the disk manually by entering **backup disk**. Note: this operation may take up to an hour.
  3. Run the data storage tests by entering **test stored-data** to retire the alarm.
  4. If the STORED-DATA tests fail, refer to the repair procedures for those tests for further information.
- d. Error type 543 indicates that the scheduled daily disk backup operation failed. If a STORED-DATA alarm is active, it is due to a data inconsistency.
  1. Refer to the alarm log and clear any failures associated with the HOST ADAPTER, DISK, or DUPINT circuit and clear those problems first.
  2. Then backup translation manually by entering **backup disk**. Note: this operation may take up to an hour.
  3. Run the data storage tests by entering **test stored-data** to retire the alarm.
  4. If the STORED-DATA tests fail, refer to the repair procedures for those tests for further information.
- e. Error types 1025 and 1537 indicate that one or more of the following conditions has occurred between the tapes or between the disks respectively, in each carrier: the timestamps of the translation files on the two storage devices are inconsistent, the timestamps of the announcement files on the two storage devices are inconsistent, or the timestamps of the program update files on the two storage devices are inconsistent.

This auxiliary data for the error type can be used to determine which files are inconsistent. That information is presented in the table below. More than one data inconsistency may exist, but only the fault with the highest auxiliary data number will appear in the error log. Enter the **test stored-data** command to obtain more information about the failure and follow the associated repair procedures.

#### Auxiliary Data for Error Types 1025 and 1537

Aux Data	Data File Inconsistency
1	Translation data on the carrier A device is newer than the translation data on the carrier B device
2	Translation data on the carrier B device is newer than the translation data on the carrier A device
3	Announcement data on the carrier A device is newer than the announcement data on the carrier B device
4	Announcement data on the carrier B device is newer than the announcement data on the carrier A device
5	Program update data on the carrier A device is newer than the program update data on the carrier B device
6	Program update data on the carrier B device is newer than the program update data on the carrier A device

- f. Error types 1281 and 1793 indicate that the vintages of the boot images on two the storage devices on Carrier A or Carrier B respectively, are inconsistent. Use the **list configuration software-vintage** command to get the vintage numbers and install the correct vintage.
- g. Error types 2049 and 2305 indicate that a copy of the boot image other than the primary copy on the primary device on Carrier A or Carrier B, respectively, was used to boot the system. The check of which copy of the boot image was used is made only at boot time. Use the following procedures based on the Auxiliary Data to clear the problem on Carrier A or Carrier B.

**Table 9-578. Auxiliary Data for Error Types 2049 and 2305**

Aux Data	Description / Recommendation
1	<p>The secondary boot image on the disk was used to boot the system.</p> <ol style="list-style-type: none"> <li>1. Run <b>test stored-data long</b> to verify that the primary copy of the boot image is invalid.</li> <li>2. Restore the bad copy from the tape by issuing a <b>restore disk</b> command.</li> <li>3. Run <b>test stored-data long</b> to retire the alarm.</li> </ol>
2	<p>The primary boot image on the tape was used to boot the system.</p> <ol style="list-style-type: none"> <li>1. Run <b>test disk long</b> for the disk on the SPE carrier which reports the failure. If any tests fail, refer to DISK repair procedures for further action.</li> <li>2. ) Run <b>test stored-data long</b> to verify that the primary and secondary copies of the boot image on the disk are invalid.</li> <li>3. Restore the copies on the primary device from the copies on the secondary device by issuing a <b>restore disk</b> command.</li> <li>4. Run <b>test stored-data long</b> to retire the alarm.</li> </ol>
3	<p>The secondary boot image on the tape was used to boot the system.</p> <ol style="list-style-type: none"> <li>1. Run <b>test stored-data long</b> to verify that the primary and secondary copies of the boot image on the disk and the primary copy of the boot image on the tape are all invalid.</li> <li>2. Insert a backup tape of the correct vintage.</li> <li>3. Run <b>save translation tape</b> to get the latest translation on the backup tape.</li> <li>4. Run <b>copy announcement tape</b> to get the latest announcements on the backup tape.</li> <li>5. Run <b>restore disk</b> to copy the good boot images, translations, announcements and software update files to the disk.</li> <li>6. Run <b>test stored-data long</b> to retire the alarm.</li> </ol>

- h. Error types 2561, 2817, 3073, and 3329 indicate that the checksum test for the two copies of the boot image on the Carrier A tape, Carrier A disk, Carrier B tape, or Carrier B disk, respectively, are inconsistent. (Auxiliary data 30004 indicates that the device could not be read, auxiliary data 30014 indicates that the file type is invalid, and auxiliary data 30201 indicates the checksum is bad).
- i. Error types 3585 and 3841 indicate that a save translation to disk failed on carrier A or B, respectively.
  1. Refer to the alarm log and clear any H-ADAPTR, DISK, TAPE, or DUPINT alarms first.
  2. Enter **save translation**. This operation may take up to an hour.

3. Run **test stored-data** to retire the alarm.
  4. If the Stored Data tests fail, refer to the repair procedures for those tests.
- j. Error types 3586 and 3842 indicate that an attempt to restore the disk from tape failed on carrier A or B, respectively.
1. Refer to the alarm log and clear any H-ADAPTR, DISK, TAPE, or DUPINT alarms first.
  2. Enter **restore disk**. This operation may take up to an hour.
  3. Run **test stored-data** to retire the alarm.
  4. If the Stored Data tests fail, refer to the repair procedures for those tests.
- k. Error types 3587 and 3843 indicate that an attempt to backup the disk to the tape failed on carrier A or B, respectively.
1. Refer to the alarm log and clear any H-ADAPTR, DISK, TAPE, or DUPINT alarms first.
  2. Enter **backup disk**. This operation may take up to an hour.
  3. Run **test stored-data** to retire the alarm.
  4. If the Stored Data tests fail, refer to the repair procedures for those tests.

## System Technician-Demanded Tests

The sequence of tests performed depends on whether the SPE is duplicated.

Always investigate tests in the order presented in the table below when inspecting errors in the system. By clearing error codes associated with the *A Carrier Tape Checksum Test*, for example, you may also clear errors generated from other tests in the testing sequence.

SPE:	Short Sequence				Long Sequence			
	Simplex		Duplex		Simplex		Duplex	
	D	T	D	T	D	T	D	T
MSS (D:disk/tape, T:tape only)								
A Carrier Tape Checksum Test (#829)					X	X	X	X
B Carrier Tape Checksum Test (#830)							X	X
A Carrier Disk Checksum Test (#831)					X		X	
B Carrier Disk Checksum Test (#832)							X	
A Carrier Tape to Disk Consistency Test (#833)	X		X		X		X	

SPE: MSS (D:disk/tape, T:tape only)	Short Sequence				Long Sequence			
	Simplex		Duplex		Simplex		Duplex	
	D	T	D	T	D	T	D	T
B Carrier Tape to Disk Consistency Test (#834)			X		X		X	
A to B Carrier Tape Consistency Test (#835)			X	X			X	X
A to B Carrier Disk Consistency Test (#836)			X				X	

The A/B Carrier Boot Image Test (#837) runs only at system boot time.

### A Carrier and B Carrier Tape Checksum Tests (#829/#830)

A checksum is done on the primary copy of the boot image on the tape and also on the secondary copy of the boot image on the tape. A comparison is made to verify that these two checksums are the same. This test is run as part of the **test stored-data long** demand test.

Table 9-579. TESTS #829 and #830 Tape Checksum Tests

Error Code	Test Result	Description/ Recommendation
1303	ABORT	Could not run the test—internal MSS error 1. Retry the command
1304	ABORT	Could not allocate the Mass Storage System to run this test 1. Retry the command at 1-minute intervals for a maximum of 5 retries. 2. If the test continues to abort, verify that the daily translation-save operation is not in progress (Use the <b>display system-parameters maintenance</b> command to display the start time for scheduled maintenance and the "y/n" option for saving translation daily).
1338	ABORT	Could not run the test on the Standby SPE—Interchange pending. 1. Refer to the documentation for STBY-SPE maintenance. 2. After interchange occurs, run test on new active SPE.
1339	ABORT	Could not run the test on the Standby SPE—Handshake down. 1. Refer to the documentation for STBY-SPE maintenance. 2. When the standby SPE is restored to service (use <b>status spe</b> to determine state of standby SPE) retry the command.

Continued on next page

Table 9-579. TESTS #829 and #830 Tape Checksum Tests — *Continued*

Error Code	Test Result	Description/ Recommendation
1347	ABORT	Could not run the test on the Standby SPE—Refresh not complete. 1. When the standby SPE is restored to service (use <b>status spe</b> to determine state of standby SPE) retry the command.
1350	ABORT	Could not run the test on the Standby SPE—Shadowing not enabled. 1. When the standby is restored to service (use <b>status spe</b> to determine state of standby) retry the command.
2000	ABORT	Response to the test request was not received within the allowable time period. 1. Retry the command at 1-minute intervals for a maximum of 5 retries.
2500	ABORT	Could not run the test on the Standby SPE—Internal software error. 1. Retry the command at 1-minute intervals a maximum of 5 retries.
30004	FAIL	The tape could not be read. 1. Verify a tape cartridge is in the tape drive. 2. Retry the command at 1-minute intervals for a maximum of 5 retries.
30014	FAIL	An invalid file system was found. 1. Verify the correct tape cartridge is in the tape drive. 2. Otherwise, insert the correct tape cartridge and re-run <b>test stored-data long</b> .
30201	FAIL	The checksums of the boot images for the tape are inconsistent. 1. If a tape-only system, replace the tape. Follow the procedures presented in the Section <b>XXX</b> of this manual. 2. If a disk/tape system, run <b>backup disk full</b> on the carrier containing the bad tape (this could take up to an hour to complete). 3. Run <b>test stored-data long</b> to resolve the alarms.
	PASS	The checksums are consistent between the two boot images on the tape. 1. If other mss errors are present, refer to the maintenance information for the HOST ADAPTER, TAPE, and DISK maintenance objects to clear those errors.



## A and B Carrier Disk Checksum Tests (#831/#832)

A checksum is done on the primary copy of the boot image on the disk and also on the secondary copy of the boot image on the disk. A comparison is made to verify that these two checksums are the same. This test is run as part of the **test stored-data long** demand test.

Table 9-580. TESTS #831 and #832 Disk Checksum Tests

Error Code	Test Result	Description/ Recommendation
1303	ABORT	Could not run the test—internal MSS error.
1304	ABORT	Could not allocate the Mass Storage System to run this test 1. Retry the command at 1-minute intervals for a maximum of 5 retries. 2. If the test continues to abort, verify that the daily translation-save operation is not in progress (issue the <b>display system-parameters maintenance</b> command to display the time for scheduled maintenance and the "y/n" option for saving translation daily).
1338	ABORT	Could not run the test on the Standby SPE—Interchange pending. 1. Refer to the documentation for STBY-SPE maintenance. 2. After interchange occurs, run test on new active SPE.
1339	ABORT	Could not run the test on the Standby SPE—Handshake down. 1. Refer to the documentation for STBY-SPE maintenance. 2. When the standby is restored to service (use <b>status spe</b> to determine state of standby) retry the command.
1347	ABORT	Could not run the test on the Standby SPE—Refresh not complete. 1. When the standby is restored to service (use <b>status spe</b> to determine state of standby) retry the command.
1350	ABORT	Could not run the test on the Standby SPE—Shadowing not enabled. 1. When the standby is restored to service (use <b>status spe</b> to determine state of standby) retry the command.
2000	ABORT	Response to the test request was not received within the allowable time period. 1. Retry the command at 1-minute intervals for a maximum of 5 retries.
2500	ABORT	Could not run the test on the Standby SPE—Internal software error. 1. Retry the command at 1-minute intervals for a maximum of 5 retries.

*Continued on next page*

Table 9-580. TESTS #831 and #832 Disk Checksum Tests — *Continued*

Error Code	Test Result	Description/ Recommendation
30201	FAIL	The checksums of the boot images for the disk were inconsistent. <ol style="list-style-type: none"><li>1. Run <b>restore disk full</b> on the carrier containing the bad disk (this could take up to an hour to complete).</li><li>2. Run <b>test stored-data long</b> to resolve the alarms.</li></ol>
	PASS	The checksums are consistent between the two boot images on the disk. <ol style="list-style-type: none"><li>1. If other mss errors are present, refer to the maintenance information for the HOST ADAPTER, TAPE, and DISK maintenance objects to clear those errors.</li></ol>

### Test #833 (A Carrier) and #834 (B Carrier) Tape to Disk Consistency Tests

There are two copies of the boot image, translation data, announcement data, and program update date on each storage device. In each of the checks performed by these tests, the system chooses one copy of each that it deems "best." These tests then perform four checks. First, the vintage of one of the boot images on tape is compared to the vintage of one of the boot images on disk. The test verifies that the two chosen copies are consistent. Second, the time stamp of one of the copies of the translation file on the tape is compared to the time stamp of one of the translation files on the disk. If the files are inconsistent, the test reports which one is newer. Next, the time stamp of one of the copies of the announcements file on the tape is compared to the time stamp of one of the announcements files on the disk. Finally, the time stamp of one of the copies of the program update file on the tape is compared to the time stamp of one of the program update files on the disk. If the files are inconsistent, the test again reports which one is newer.

This test is run as part of the **test stored-data** demand test and during daily scheduled maintenance. The following table is used in diagnosing fail results.

**Table 9-581. TESTS #833 and #834 Failure Numbers**

Failure Number	File Inconsistency
1	The translation file on the disk is newer than the translation file on the tape.
2	The translation file on the tape is newer than the translation file on the disk.
4	The vintages of the boot images on the tape and disk are inconsistent.
8	The announcement file on the disk is newer than the announcement file on the tape.
16	The announcement file on the tape is newer than the announcement file on the disk.
32	The program update file on the disk is newer than the program update file on the tape.
64	The program update file on the tape is newer than the program update file on the disk.

**Table 9-582. TESTS #833 (A Carrier) and #834 (B Carrier)  
 Tape to Disk Consistency Tests**

Error Code	Test Result	Description/ Recommendation
1304	ABORT	Could not allocate the Mass Storage System to run this test 1. Retry the command at 1-minute intervals for a maximum of 5 retries. 2. If the test continues to abort, verify that the daily translation-save operation is not in progress (issue the <b>display system-parameters maintenance</b> command to display the time for scheduled maintenance and the "y/n" option for saving translation daily).
1333	ABORT	Could not run the test—internal MSS error.
1338	ABORT	Could not run the test on the Standby SPE—Interchange pending. 1. Refer to the documentation for STBY-SPE maintenance. 2. After interchange occurs, run test on new active SPE.
1339	ABORT	Could not run the test on the Standby SPE—Handshake down. 1. Refer to the documentation for STBY-SPE maintenance. 2. When the standby is restored to service (use <b>status spe</b> to determine state of standby) retry the command.
1347	ABORT	Could not run the test on the Standby SPE—Refresh not complete. 1. When the standby is restored to service (use <b>status spe</b> to determine state of standby) retry the command.

*Continued on next page*

**Table 9-582. TESTS #833 (A Carrier) and #834 (B Carrier)  
 Tape to Disk Consistency Tests — Continued**

Error Code	Test Result	Description/ Recommendation
1350	ABORT	Could not run the test on the Standby SPE—Shadowing not enabled. 1. When the standby is restored to service (use <b>status spe</b> to determine state of standby) retry the command.
2000	ABORT	Response to the test was not received within the allowable time period. 1. Retry the command at 1-minute intervals for a maximum of 5 retries.
2500	ABORT	Could not run the test on the Standby SPE—Internal software error. 1. Retry the command at 1-minute intervals for a maximum of 5 retries.
Any	FAIL	One or more of the 4 files checked was inconsistent with the file on the other device. 1. Enter <b>list configuration software</b> to determine the inconsistent file. If a file on tape is the older file, use <b>backup disk</b> to copy the disk file to the tape. If a file on disk is older file, use <b>restore disk</b> to copy the tape file to the disk. 2. If for some reason the <b>list configuration software</b> command does not provide the necessary data: a. Convert the error code to a set of failure numbers. The error code returned by the test is the sum of one or more failure numbers listed in the table at the beginning of this test description, <i>Tests 833 and 834 Failure Numbers</i> . Using that table, subtract the largest failure number possible (so as to leave a positive remainder) from the error code and note the associated inconsistency from the table. Continue subtracting failure numbers from the remainder until the remainder is 0. The numbers subtracted represent the inconsistencies found. b. Use the results of the four consistency tests (#833, #834, #835 and #836) to determine the device with the incorrect files. If the files on the tape are newer than the files on the disk, restore the disk from the tape ( <b>restore disk</b> ). If the files on the disk are newer than the files on the tape, backup the tape from its disk ( <b>backup disk</b> ).
	PASS	The files are consistent between the disk and the tape. 1. If other MSS errors are present, refer to the H-ADAPTR, TAPE, and DISK sections.

**Tape to Tape and Disk to Disk Consistency Tests  
 (#835/#836)**

There are two copies of the boot image, translation data, announcement data and program update data on each storage device. In each of the checks performed by these tests, the system chooses one copy of each that it deems "best." These tests then perform four checks. First, the vintage of one boot image

on the Carrier A device is compared to the vintage of one boot image on the Carrier B device. The test verifies that the two chosen copies are consistent. Second, the time stamp of one copy of the translation file on the Carrier A device is compared to the time stamp of one copy of the translation file on the Carrier B device. If the files are inconsistent, the test reports which one is newer. Next, the time stamp of one copy of the announcement file on the Carrier A device is compared to the time stamp of one copy of the announcement file on the Carrier B device. Finally, the time stamp of one copy of the program update file on the Carrier A device is compared to the time stamp of one copy of the program update files on the Carrier B device. If the files are inconsistent, the test again reports which one is newer.

This test is run as part of the **test stored-data** demand test and during daily scheduled maintenance. The following table is used in diagnosing fail results.

**Table 9-583. TEST #835 and #836 Failure Numbers**

Failure Number	File Inconsistency
1	The translation file on the Carrier A device is newer than the translation file on the Carrier B device.
2	The translation file on the Carrier B device is newer than the translation file on the Carrier A device.
4	The vintages of the boot images on the two devices are inconsistent.
8	The announcement file on the Carrier A device is newer than the announcement file on the Carrier B device.
16	The announcement file on the Carrier B device is newer than the announcement file on the Carrier A device.
32	The program update file on the Carrier A device is newer than the program update file on the Carrier B device.
64	The program update file on the Carrier B device is newer than the program update file on the Carrier A device.

**Table 9-584. TESTS #835 and #836 Tape to Tape and Disk to Disk Consistency Tests**

Error Code	Test Result	Description/ Recommendation
1304	ABORT	Could not allocate the Mass Storage System to run this test 1. Retry the command at 1-minute intervals for a maximum of 5 retries. 2. If the test continues to abort, verify that the daily translation-save operation is not in progress (issue the <b>display system-parameters maintenance</b> command to display the time for scheduled maintenance and the "y/n" option for saving translation daily).
1333 1338	ABORT ABORT	Could not run the test—internal MSS error. Could not run the test on the Standby SPE—Interchange pending. 1. Refer to the documentation for STBY-SPE maintenance. 2. After interchange occurs, run test on new active SPE.
1339	ABORT	Could not run the test on the Standby SPE—Handshake down. 1. Refer to the documentation for STBY-SPE maintenance. 2. When the standby is restored to service (use <b>status spe</b> to determine state of standby) retry the command.
1347	ABORT	Could not run the test on the Standby SPE—Refresh not complete. 1. When the standby is restored to service (use <b>status spe</b> to determine state of standby) retry the command.
1350	ABORT	Could not run the test on the Standby SPE—Shadowing not enabled. 1. Retry the command at 1-minute intervals for a maximum of 5 retries.
2000	ABORT	Response to the test request was not received within the allowable time period. 1. Retry the command at 1-minute intervals for a maximum of 5 retries.
2500	ABORT	Could not run the test on the Standby SPE—Internal software error. 1. Retry the command at 1-minute intervals for a maximum of 5 retries.

*Continued on next page*

**Table 9-584. TESTS #835 and #836 Tape to Tape and Disk to Disk Consistency Tests — Continued**

Error Code	Test Result	Description/ Recommendation
Any	FAIL	<p>One or more of the 4 files checked was inconsistent with the file on the other device.</p> <ol style="list-style-type: none"> <li>1. Enter <b>list configuration software</b> to determine the inconsistent file. If a file on tape is the older file, use <b>backup disk</b> to copy the disk file to the tape. If a file on disk is older file, use <b>restore disk</b> to copy the tape file to the disk.</li> <li>2. If for some reason the <b>list configuration software</b> command does not provide the necessary data:                         <ol style="list-style-type: none"> <li>a. Convert the error code to a set of failure numbers. The error code returned by the test is the sum of one or more failure numbers listed in the table at the beginning of this test description, <i>Tests 835 and 836 Failure Numbers</i>. Using that table, subtract the largest failure number possible (so as to leave a positive remainder) from the error code and note the associated inconsistency from the table. Continue subtracting failure numbers from the remainder until the remainder is 0. The numbers subtracted represent the inconsistencies found.</li> <li>b. Use the results of the four consistency tests (#833, #834, #835 and #836) to determine the device with the incorrect files. If the files on the tape are newer than the files on the disk, restore the disk from the tape (<b>restore disk</b>). If the files on the disk are newer than the files on the tape, backup the tape from its disk (<b>backup disk</b>).</li> </ol> </li> </ol>
	PASS	<p>The files are consistent between the compared devices.</p> <ol style="list-style-type: none"> <li>1. If other MSS errors are present, refer to the H-ADAPTR, TAPE, and DISK sections.</li> </ol>

## STRAT-3 (Stratum 3 Clock)

MO Name (in Alarm Log)	Alarm Level	Initial Command to Run	Full Name of MO
STRAT-3	MAJOR	test synchronization	Stratum 3 Clock
STRAT-3	MINOR	test synchronization	Stratum 3 Clock

The *Digital Synchronization Network Plan (PUB 60110)* specifies a hierarchy of synchronization nodes consisting of strata 1 to 4, where the sole Stratum 1 clock in the network is the most accurate. The Release 5r system supports both Stratum 3 and Stratum 4 operations. Refer to "SYNC (Synchronization)" for details on Stratum 4 operation.

A Stratum 3 clock derives its timing from two DS1 references connected to a Stratum 3 or better source. The Stratum 3 clock provides a holdover of at least 24 hours should both DS1 references fail. (After 24 hours, the Stratum 3 clock still provides service but its accuracy may be degraded). The *Digital Synchronization Network Plan (PUB 60110)* requires that the Stratum 3 clock have duplicated components.

The Stratum 3 clock can be configured with only one DS1 input if one of the Clock Input cards is removed. Also, the Stratum 3 clock can free run (use its internal clock without using DS1 inputs, if both Clock Input cards are removed).

The recognition of the Stratum 3 clock itself as well as its alarm signals, is supported only by the TN780 Tone-Clock circuit pack. The TN780 Tone-Clock circuit pack is also backwards-compatible with the TN768 Tone-Clock circuit pack. The Stratum 3 clock may be connected to the PPN if the TN780 Tone-Clock circuit pack(s) is present in that port network. The Stratum 3 clock should never be connected to an EPN.

The only operation that software can perform is a query of the alarm leads. The only recovery action that can be performed on a catastrophic failure of the Stratum 3 clock is using the local oscillator on the active TN780 Tone-Clock circuit pack. Neither software nor the TN780 Tone-Clock circuit pack can request additional information about the health of the Stratum 3 clock other than the information provided by the alarm leads. Furthermore, neither the software nor the TN780 Tone-Clock circuit pack can request that the external clock switch references, change configuration, disable/enable, initialize, and so forth.

In the system, the Stratum 3 clock has been implemented as an external which follows the specification in PUB 60110 for Stratum 3. The only external Stratum 3 clock that is supported is the Telecom Solutions Digital Clock Distributor™ for Customer Premise Timing (DCD-CPT) Stratum 3 clock. [Figure 9-90](#) shows how the Stratum 3 hardware configuration provides clock and alarm signals to the TN780 Tone-Clock circuit pack(s). The reference DS1 facilities connect directly to the Stratum 3 clock for timing purposes, but the DS1 data may be routed into the



switch by using a Y connector (H-600-274 G1 for the 50 pin DS1 end or H-600-274 G2 for the 15 pin DS1 end).

For more information on the installation of the Stratum 3 clock, see the *DEFINITY Enterprise Communications Server Release 5.4 Installation and Test for Multi-Carrier Cabinets*.

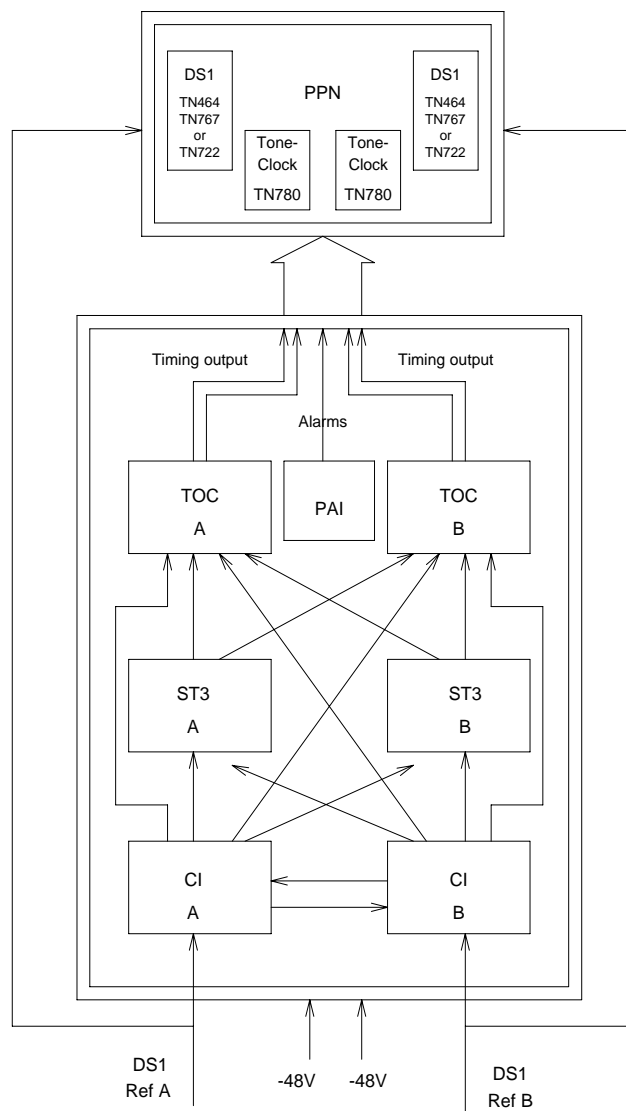

Figure 9-90. Stratum 3 Clock Hardware Configuration

## Stratum 3 Clock LED Strategy

---



**NOTE:**

When looking in the Stratum 3 cabinet, “A” card is on the left and “B” card is on the right.



**NOTE:**

The normal LED scheme is not followed for this device. Green LEDs do not indicate maintenance activity. There are no yellow LEDs, and there are more than three LEDs per circuit pack.



**NOTE:**

Removal of a card in the Stratum 3 clock may cause alarm(s) to be resolved and the query test to pass. However, the removed cards should still be replaced to restore the Stratum 3 clock to full service.

The Stratum 3 clock has the following components:

- 2 Clock Input cards (CI)  
Provides the logic to select the better DS1 reference or Clock Input card. The red FAIL LED on this card indicates a failure with the card or the DS1 reference connected to it.
- 2 Stratum 3 Cards (ST3)  
Provides 24-hour holdover. The red FAIL LED on this card indicates a failure with the card. Replace the card.
- 2 Timing Output Cards (TOC)  
Provides cable length compensation, multiple output ports, selection of the ST3, and CI outputs. This type of card has two red failure LEDs: one indicates a failure of the card; the other indicates a failure in one or more output ports. In either case, replace the card.
- 1 PBX (Private Branch Exchange) Alarm Interface (PAI)  
Filters power supplied to the clock, provides fuse protection, and provides alarm indications based on inputs supplied by other cards. The six LEDs on this card provide indications for the six alarm or status conditions as follows:
  - Loss of DS1 reference A
  - Loss of DS1 reference B
  - Loss of one clock unit
  - Loss of both clock units
  - Loss of one power supply
  - Loss of both power supplies

The output of the CI and PAI cards go directly to the TN780 Tone-Clock circuit pack via two 25-pair amphenol-terminated cables. All of the cards have red and/or green LEDs for providing status or alarm indications. The abbreviations used in the table are defined above except for SRC (source) and PLL (Phase Locked Loop).

**Table 9-585. Stratum 3 Clock LED Indications**

Card	Name	Color	Indication
PAI	REF A	Red	Loss of input reference A or CI A failed
	REF B	Red	Loss of input reference B or CI A failed
	ST A	Red	Failed Stratum 3 clock A
	ST B	Red	Failed Stratum 3 clock B
	PWR A	Green	-48VDC A present
	PWR B	Green	-48VDC B present
CI	FAIL	Red	Card failure
	DS1	Green	DS1 source present
	CC	Green	Composite clock source <sup>1</sup> present
	SRC ACTIVE	Green	Card is currently on-line
ST3	FAIL	Red	Card failure
	LOCK	Red	PLL lost sync with reference or holdover mode
	REF A	Red	Timing Reference from CI A
	REF B	Red	Timing Reference from CI B
TOC	FAIL	Red	Card failure
	PORT ALM	Red	Output port alarm (one or more)
	ST	Green	Reference present from ST clock
	INPUT	Green	Reference present from CI
	500'	Green	500 feet phase advance
	1000'	Green	1000 feet phase advance

1. Composite Clock (CC) source refers to the protocol used to electrically transfer timing from the Stratum 3 clock to the switch. The Composite Clock source is not relevant to the system.

## Error Log Entries and Test to Clear Values

**Table 9-586. Stratum 3 Clock Error Log Entries**

Error Type	Aux Data	Associated Test	Alarm Level	On/Off Board	Test to Clear Value
0 <sup>1</sup>	0	Any	Any	Any	test synchronization r 4
1(a)	Any	Stratum 3 Clock Alarm Query (#649)	MINOR	OFF	test synchronization r 4
18(b)	0	disable sync	WARNING	OFF	enable sync
257(c)	Any	Stratum 3 Clock Alarm Query (#649)	MINOR	OFF	test synchronization r 4
513(d)	Any	Stratum 3 Clock Alarm Query (#649)	MINOR	ON	test synchronization r 4
769(e)	Any	Stratum 3 Clock Alarm Query (#649)	MINOR	ON	test synchronization r 4
1025(f)	Any	Stratum 3 Clock Alarm Query (#649)	MINOR/ MAJOR(h)	ON	test synchronization r 4
1281(g)	Any	Stratum 3 Clock Alarm Query (#649)	MINOR/ MAJOR(h)	ON	test synchronization r 4
1537(i)		none	MINOR/ MAJOR(h)	ON	
1793(j)		none	MINOR/ MAJOR(h)	ON	

1. Run the Short Test Sequence first. If all tests pass, run the Long Test Sequence. Refer to the appropriate test description and follow the recommended procedures.

### Notes:

- a. This error type corresponds to FAIL code 1 of the Stratum 3 Clock Alarm Query (test #649): either reference A failed or the CI card A failed.
- b. This error indicates that Synchronization Maintenance has been disabled via the **disable synchronization-switch** command. Execute the **enable synchronization-switch** command to enable Synchronization Maintenance reference switching and to resolve this alarm.
- c. This error type corresponds to FAIL code 2 of the Stratum 3 Clock Alarm Query (test #649): one power supply failed.
- d. This error type corresponds to FAIL code 4 of the Stratum 3 Clock Alarm Query (test #649): one clock unit failed.
- e. This error type corresponds to FAIL code 8 of the Stratum 3 Clock Alarm Query (test #649): either reference B failed or the CI card B failed.

- f. This error type corresponds to FAIL code 16 of the Stratum 3 Clock Alarm Query (test #649): all power supplies failed.
- g. This error type corresponds to FAIL code 32 of the Stratum 3 Clock Alarm Query (test #649): all clock unit(s) failed.
- h. An OFF-BOARD alarm on the Stratum 3 clock, indicates a DS1 facility problem; an ON-BOARD alarm indicates a fault in either the Stratum 3 clock or the connection between the Stratum 3 clock and the switch. If the Stratum 3 clock cannot be referenced and the local oscillator on the TN780 Tone-Clock circuit pack must serve as the reference, a Major alarm is raised. Otherwise, a Minor alarm is raised.
- i. This error can be caused by one of the following conditions:
  - One or both TOCs (Timing Output Cards) has failed.
  - The connection between the Stratum 3 clock and the TN780 Tone-Clock circuit pack is faulty.
  - The TN780 Tone-Clock circuit pack is defective.

A Minor alarm results if the Stratum 3 clock can still provide timing to the switch; otherwise, a Major alarm will be raised because the Stratum 3 clock is not providing timing and the switch is referencing the local oscillator on the TN780 Tone-Clock circuit pack. If only the Active TN780 Tone-Clock circuit pack is faulty, the Standby TN780 Tone-Clock circuit pack becomes active and remains synchronized to the Stratum 3 clock. When the system switches to the Standby Tone-Clock circuit pack, the alarm is resolved, and a TDM-CLK alarm is raised to indicate a possible problem on the TN780 Tone-Clock.

If the alarm is minor:

Look for a red LED on either or both TOC cards. If there is a red LED, then replace the card. If there is no red LED, then, using the *Stratum 3 Wiring Guide*, check that the wiring installation is correct. After replacing the card or correctly rewiring the installation, clear the alarm by first issuing the **disable synchronization-switch** command followed by the **enable synchronization-switch** command. The latter procedure will cause synchronization software to switch back to using the Stratum 3 clock again. Wait 2 minutes and then execute the **status synchronization** command. If Maintenance Name on the status screen shows "STRAT-3," then the problem is resolved.



**CAUTION:**

The **disable synchronization-switch** command followed by the **enable synchronization-switch** command may cause slip alarms. The circuit packs that can experience slips and the associated error log entry for slips are as follows.

**Table 9-587. Timing Slip Error Types**

Circuit Pack Name	Error Log Name	Error Log Entry for Slips
DS1 Interface	DS1-BD	3073 to 3160
Expansion Interface	EXP-INTF	2305
Switch Node Interface	SNI-BD	1537
Tone-Clock	TDM-CLK	1025
UDS1 Interface	UDS1-BD	3073 to 3160

If the alarm is major:

Check connections between the Stratum 3 clock and the switch. If there are no loose connections, then, using the *Stratum 3 Wiring Guide*, check that the wiring installation is correct. After reconnecting the loose connection or correctly rewiring it, clear the alarm by first issuing the **disable synchronization-switch** command followed by the **enable synchronization-switch** command. Wait 1-minute, and then execute the **status synchronization** command. If Maintenance Name on the status screen shows "STRAT-3," then the problem is resolved.

If the Standby Tone-Clock circuit pack became active:

Check the connection between the Stratum 3 clock and the TN780 Tone-Clock circuit pack from which the system has just switched. If there are no loose connections, then, replace the TN780 Tone-Clock circuit pack. Refer to the "How to Replace the Tone-Clock circuit pack" section in the TDM-CLK (TDM Bus Clock) Maintenance documentation. Before switching back to the new TN780 Tone-Clock circuit pack, use the **test tone-clock UC long** command to check that the Tone-Clock is receiving a signal from the Stratum 3 clock. If all tests pass, switch to the new Tone-Clock circuit pack via the **set tone-clock UC override** command. If Test #651 fails, then the original TN780 Tone-Clock should be reinserted, and the cable between the Stratum 3 clock and the TN780 Tone-Clock circuit pack should be replaced. If Test #651 continues to fail, then escalate the problem.

For all of the above cases if slip alarms exist after following the repair procedures, clear the slip alarms by running the **test board** command with the **clear** option. See the table on the previous page for a list of circuit packs and associated slip error log entries.

This error indicates that the Tone-Clock circuit pack in the master port network is not a TN780. If duplicate Tone-Clock circuit packs exist in the master port network, this error may mean that one or both Tone-Clock circuit packs are not TN780s. Verify that the Tone-Clock(s) in the master port network are TN780s.

## System Technician-Demanded Tests: Descriptions and Error Codes

---

Always investigate tests in the order presented in the following table when inspecting errors in the system. By clearing error codes associated with the *Stratum 3 Clock Alarm Query Test*, for example, you may also clear errors generated from other tests in the testing sequence.

The **test synchronization** commands also runs the Test Synchronization test (test #417). Test 417 is described in the SYNC section.

Order of Investigation	Short Test Sequence	Long Test Sequence	D/ND <sup>1</sup>
Stratum 3 Clock Alarm Query (#649)	X	X	ND

1. D = Destructive, ND = Non-destructive

### Stratum 3 Clock Alarm Query (#649)

This test queries the Stratum 3 clock for its alarm status and reports the results of the query. The Stratum 3 clock provides the system with the following six alarm indications via the TN780 Tone-Clock circuit pack:

- Reference A failed or CI card A failed.
- Reference B failed or CI card B failed.
- One power supply failed.
- All power supplies failed.
- One clock unit failed.
- All clock unit(s) failed.

#### CAUTION:

*The removal of a card in the Stratum 3 clock may cause alarm(s) to be resolved and the query test to pass. However, the removed cards should still be replaced to restore the Stratum 3 clock to full service.*

**Table 9-588. TEST #161 Looparound Test**

Error Code	Test Result	Description/ Recommendation
1001	ABORT	The system could not allocate the necessary resources to run this test. 1. Retry the command at 1-minute intervals up to a maximum of 3 times.
1005	ABORT	This test aborts when it is run on a Stratum 4 system. Do not change synchronization to Stratum 3 without consulting the synchronization plan administrator for this switch.
2500	ABORT	Internal System Error 1. Retry the command at 1-minute intervals a maximum of 3 times.
1	FAIL	Either Reference A failed or CI card A failed. This condition usually indicates a failure of the DS1 reference; however, there may also be a failure of the CI card to which the reference is connected. The system technician dispatched to investigate this problem should take a spare CI card in case the CI card caused the failure. If you are NOT ON-SITE, use the following procedure: 1. Look for DS1-BD (DS1 Interface Circuit Pack) errors using the <b>display error</b> command. Refer to the DS1-BD Maintenance documentation for recommended strategy to resolve any DS1-BD errors found. 2. If there are no DS1-BD errors OR after resolving all DS1-BD errors, issue the <b>test synchronization r 4</b> command to determine if the alarm is still present. If all repetitions of the tests pass, then the alarm no longer exists. Otherwise, the system technician should be dispatched with a spare CI card to use the following instructions on-site. ( <i>continued</i> )

*Continued on next page*



**Table 9-588. TEST #161 Looparound Test — Continued**

Error Code	Test Result	Description/ Recommendation
1	FAIL	<p>(continued)</p> <p>If you are ON-SITE, use the following procedure:</p> <ol style="list-style-type: none"> <li>1. Look for a red LED on CI card A (i.e., the left CI card). If there is a red LED, then replace the CI card, if a spare is available. If no spare CI is available on-site, proceed to Step 3. If after replacing the CI card, the red LED on the new CI card lights also, then proceed to Step 3.</li> <li>2. If a spare CI card is available, replace the suspect CI card. Otherwise, issue the <b>test synchronization r 4</b> command to clear the alarm. If any test repetitions fail, then follow the procedure for those failures.</li> <li>3. Look for DS1-BD (DS1 Interface Circuit Pack) errors using the <b>display error</b> command. Refer to the DS1-BD Maintenance documentation for recommended strategy to resolve any DS1-BD errors found. If there are no DS1-BD errors, then proceed to Step 5.</li> <li>4. After all DS1-BD errors have been resolved, then determine if the alarm still exists by issuing the <b>test synchronization r 4</b> command to clear the alarm. If any test repetitions fail, then follow the procedure for those failures.</li> <li>5. Check the DS1 reference A connections to the Stratum 3 clock.</li> <li>6. Determine if the alarm still exists by issuing the <b>test synchronization r 4</b> command to clear the alarm. If any test repetitions fail, then follow the procedure for those failures.</li> </ol>
2	FAIL	<p>One power supply failed. This error only occurs when the Stratum 3 clock has two power supplies, and one of them has failed. However, the clock can function with one power supply.</p> <ol style="list-style-type: none"> <li>1. Locate the failed power supply by looking for a power supply with a red LED and replace it. The power supply is located under the Stratum 3 clock carrier.</li> <li>2. Determine if the alarm still exists by issuing the <b>test synchronization r 4</b> command to clear the alarm. If any test repetitions fail, then follow the procedures for those test failures.</li> </ol>
4	FAIL	<p>One clock unit failed.</p> <ol style="list-style-type: none"> <li>1. Look at the Stratum 3 cabinet for a red LED on a circuit card marked "ST3." Replace the card.</li> <li>2. Determine if the alarm still exists by issuing the <b>test synchronization r 4</b> to clear the alarm. If any test repetitions fail, then follow the procedures for those failures.</li> </ol>

*Continued on next page*

**Table 9-588. TEST #161 Looparound Test — Continued**

Error Code	Test Result	Description/ Recommendation
8	FAIL	<p>Reference B failed or CI card B failed. This condition usually indicates a failure of the DS1 reference; however, there may also be a failure of the CI card to which the reference is connected. The system technician dispatched to investigate this problem should take a spare CI card in case the CI card caused the failure. If you are NOT ON-SITE, use the following procedure:</p> <ol style="list-style-type: none"> <li>1. If there were no DS1-BD errors, OR if all DS1-BD errors have been resolved, enter <b>test synchronization r 4</b> to determine if the alarm is still present. If all repetitions of the tests pass, the alarm no longer exists. Otherwise, the system technician should be dispatched with a spare CI card to perform the following instructions on-site.</li> </ol>
8	FAIL (cont'd.)	<p>If you are ON-SITE, use the following procedure:</p> <ol style="list-style-type: none"> <li>1. Look for a red LED on a CI card B (the CI card on the right). If there is a red LED, then replace the CI card, if a spare is available. If no spare CI is available on-site, proceed to Step 3. If, after replacing the CI card, the red LED on the new CI card lights, proceed to Step 3.</li> <li>2. Otherwise, enter <b>test synchronization r 4</b> to clear the alarm. If any test repetitions fail, follow the procedure for those failures.</li> <li>3. Enter <b>display errors</b> and look for DS1-BD errors. If there are any, refer to "DS1-BD". If there are no DS1-BD errors, proceed to Step 5.</li> <li>4. After all DS1-BD errors have been resolved, determine if the alarm still exists with <b>test synchronization r 4</b>. If any test repetitions fail, follow procedures for those failures.</li> <li>5. Check the DS1 reference A connections to the Stratum 3 clock.</li> <li>6. Determine if the alarm still exists with <b>test synchronization r 4</b> to clear the alarm. If any test repetitions fail, then follow procedures for those failures.</li> </ol>
16	FAIL	<p>All power supplies failed.</p> <ol style="list-style-type: none"> <li>1. Replace the failed power supplies.</li> <li>2. If battery backup for the Stratum 3 clock is not supplied or if the battery backup holdover time has been exceeded, then the system will be referencing the local oscillator on the Active TN780 Tone-Clock circuit pack until software detects that one or both power supplies has(have) been restored (approximately 40 minutes). To speed up this restoration, issue the <b>test synchronization r 4</b> command. All tests should pass. If any repetitions should fail, then follow the procedures for those failures. The battery backup is located under the Stratum 3 clock carrier.</li> </ol>

*Continued on next page*

**Table 9-588. TEST #161 Looparound Test — Continued**

Error Code	Test Result	Description/ Recommendation
32	FAIL	All clock unit(s) failed. 1. Look at the Stratum 3 cabinet for red LEDs on circuit cards marked "ST3." Replace the card(s). 2. Determine if the alarm still exists by issuing the <b>test synchronization r 4</b> command to clear the alarm. If any test repetitions fail, then follow the procedure for those failures.
2101	FAIL	The TN780 Tone-Clock circuit pack detects loss of signal. Refer to note h of the STRAT-3 Hardware Error Log Entries table in the STRAT-3 (Stratum 3 Clock) Maintenance documentation for replacement procedures.
	PASS	The Stratum 3 clock has reported that it has no alarm conditions. If synchronization problems have been reported, look for SYNC errors and refer to SYNC (Synchronization) Maintenance documentation for recommended strategy for those errors.

## SVC-SLOT (Service Slot)

MO Name (in Alarm Log)	Alarm Level	Initial Command to Run	Full Name of MO
SVC-SLOT	MINOR	none	Service Slot

The Service Slot maintenance object detects the insertion of an invalid circuit pack a dedicated SERVICE slot. The SERVICE slot is the leftmost slot in the J58890BB Port Carrier, and is identified as slot location "00" in all commands, field entries, and displays on the management terminal.

Since this slot does not provide tip and ring connectivity to the wall field, only the following circuit packs are allowed:

- TN744 Call Classifier
- TN750 Integrated Announcement
- TN771 Maintenance/Test
- TN725 Speech Synthesizer
- TN433 Speech Synthesizer
- TN457 Speech Synthesizer
- TN748 Tone Detector
- TN420 Tone Detector
- TN755 Neon Power Unit

A MINOR alarm is generated against the Service Slot maintenance object when a circuit pack with a type other than that listed above is inserted in a SERVICE slot.

The Service Slot maintenance object name is used instead of the maintenance object name for the illegal circuit pack to prevent any attempt to assign a port to an illegal circuit pack physically inserted in the SERVICE slot.

## Error Log Entries and Test to Clear Values

**Table 9-589. Service Slot Error Log Entries**

Error Type	Aux Data	Associated Test	Alarm Level	On/Off Board	Test to Clear Value
600(a)		None	MINOR	ON	

Note:

- a. Error type 600 indicates that a non-permitted circuit pack was inserted in slot 00, the SERVICE slot, of a J58890BB port carrier. See the preceding list of valid circuit packs for this slot.

The code of the invalid circuit pack can be displayed by using the **list configuration board UUCSS** command where UU is the cabinet number, C is the carrier letter, and SS is the slot number (always 00) of the alarmed circuit pack.

To retire the alarm, remove the invalid circuit pack.

## SW-CTL (Switch Control)

MO Name (in Alarm Log)	Alarm Level	Initial Command to Run <sup>1</sup>	Full Name of MO
SW-CTL	MAJOR <sup>2</sup>	test switch-control [a b] short	Switch Control
SW-CTL	WARNING	test switch-control [a b] short	Switch Control

1. In a system with simplex SPE, the carrier location, a need not be specified. In a system with duplicated SPEs, carrier a or b must be specified.
2. After a spontaneous SPE interchange has occurred, the Alarm Log retains for three hours a record of any MAJOR ON-BOARD alarm against an SPE component that took place before the interchange. If a spontaneous interchange has occurred (as indicated by STBY-SPE error type 103 or the **display initcauses** screen), and such an alarm is logged against SW-CTL, then replace the standby MSSNET circuit pack using the "lock-and-power-down" procedure described in Chapter 5.

The Switch Control resides on the MSSNET (Mass Storage System and Network Control) circuit pack (UN332). The Mass Storage System Host Adapter (HA) also resides on the MSSNET circuit pack. Systems equipped with the Standard Reliability configuration have a single MSSNET circuit pack and systems equipped with the High Reliability or Critical Reliability configuration have two MSSNET circuit packs, one in each Switch Processing Element (SPE) complex. The MSSNET cannot be replaced in a system with one SPE complex without bringing the system down. The MSSNET in the standby SPE of a system equipped with the High Reliability or Critical Reliability option can be replaced without affecting normal system operation.

The Switch Control sends control information between the SPE and port circuit packs on the Processor Port Network (PPN) as shown in [Figure 9-91](#). This control information is sent via the PPN cabinet's TDM (Time Division Multiplexed) bus. The portion of the TDM bus used to transmit control messages is called the control channel. The control channel can be on either TDM bus A or TDM bus B, but only one of the two buses is used for the control channel at any give time.

The Switch Control is involved in sending control channel messages for the setup and takedown of all calls involving endpoints connected to the PPN, but is not involved in the voice or data transmission that takes place during established calls. The Switch Control is also involved in setting up system links used for control of calls involving endpoints connected to Expansion Port Networks (EPNs). Once those links are set up at system boot time, a failure of the Switch Control will not affect existing calls or new calls involving those EPN endpoints.

One of the functions of the Switch Control is to detect when port circuit packs are plugged into or removed from the PPN cabinet. The Switch Control also monitors the health of the control channel on the PPN cabinet TDM bus and informs the SPE when errors occur.

The Switch Control also contains hardware to monitor critical system timing signals and informs the SPE when these signals fail. For example, if the timing signals from a Tone/Clock circuit pack fail, the Switch Control will inform the SPE and the SPE can then switch to a standby Tone/Clock circuit pack, (if Tone-Clocks are duplicated).

On High and Critical Reliability systems (duplicated SPE), a MAJOR alarm failure of the Switch Control circuit on the active SPE results in an SPE interchange, if the health of the standby SPE permits. (Refer to Chapter 1 for more information about duplicated SPEs.) The following sections assume that if the SPEs are duplicated, and if a Switch Control circuit has a MAJOR alarm, the MSSNET circuit pack associated with that Switch Control circuit is located in the standby SPE.

As mentioned above, the MSSNET circuit pack contains both the Switch Control circuit and the MSS Host Adapter circuit. A failure of either circuit will light the red LED on the MSSNET circuit pack.

The **test mssnet** command tests both the Switch Control circuit and the MSS Host Adapter circuit on the MSSNET circuit pack. Whenever the MSSNET circuit pack is replaced, **test mssnet** should be used to verify that both circuits are operating correctly.

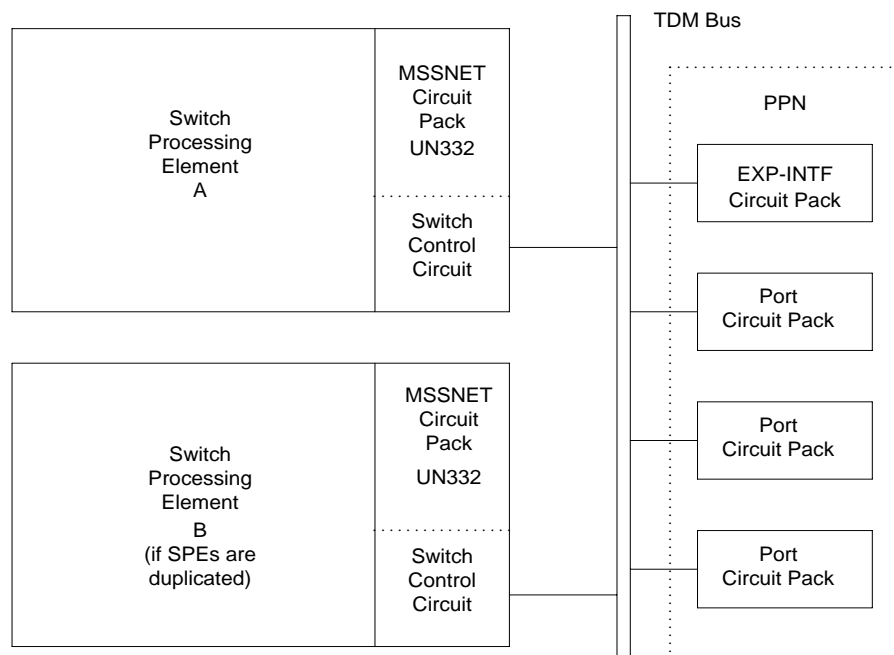

Figure 9-91. Switch Control Connectivity

## Error Log Entries and Test to Clear Values

**Table 9-590. Switch Control Error Log Entries**

Error Type	Aux Data	Associated Test	Alarm Level	On/Off Board	Test to Clear Value
0 <sup>1</sup>	0	Any	Any	Any	test switch-control [a b] r 3
1(a)		Control Transmission Test (#94)Channel	MAJOR <sup>2</sup>	ON	test switch-control [a b] r 3
2(b)		Control Channel Transmission Test (#94)	MAJOR <sup>2</sup>	ON	test switch-control [a b] r 3
150(c)	Any	None	MAJOR <sup>2</sup>	ON	test switch-control [a b] l c
257(d)	Any	None			
769(e)		None			
1025(f)		Control Channel Interface Test (#92)	MAJOR <sup>2</sup>	ON	test switch-control [a b] r 2
1281(g)		None			
1537(h)		Switch Control Reset Test (#93)	MAJOR <sup>2</sup>	ON	test switch-control [a b] l r 2
1793(i)		None			
2561(j)		None	WARNING	OFF	

- Indicates that an alarm was raised but the associated error could not be entered into the hardware error log due to a momentary overload condition. Run the short test sequence and refer to the appropriate test description for tests that fail.
- After a spontaneous SPE interchange has occurred, the Alarm Log retains for three hours a record of any MAJOR ON-BOARD alarm against an SPE component that took place before the interchange. If a spontaneous interchange has occurred (as indicated by STBY-SPE error type 103 or the **display initcauses** screen), and such an alarm is logged against SW-CTL, then replace the standby MSSNET circuit pack using the "lock-and-power-down" procedure described in Chapter 5.

### Notes:

- A 1 error indicates that there has been 8 or more Processor Port Network circuit pack removals in less than 15 minutes. This action may be forced manually by removing power to a port carrier or pulling out at least 8 port circuit packs within 15 minutes. The generation of this error may indicate that there is a problem with the Switch Control circuit on the MSSNET circuit pack or that there is a problem with the TDM bus. Three successful completions of the Control Channel test (#94) will resolve the MAJOR alarm caused by this error.
- A 2 error indicates that the Switch Control Channel Transmission test (#94) failed. This error may not cause a Switch Control alarm if Error Type 769 is also present since this error may actually be caused by the loss of clock



signals and not by a Switch Control failure. If the system is not equipped with the High Reliability or Critical Reliability option, or if the Switch control circuit is on the active processor, use the **test switch-control** command to test the Switch Control.

In a system is equipped with duplicated SPEs and the hardware error is reported against the Switch Control on the standby processor, use the following procedures. The Control Channel Transmission test which detected this error cannot run on the Switch Control circuit on the standby SPE since the Switch Control circuit on the standby SPE is not allowed access to the TDM bus. Therefore if the system is equipped with duplicated SPEs and if this error is associated with the Switch Control circuit on the standby SPE, the error was detected while the Switch Control circuit was running on an active SPE.

To allow the Control Channel test to run on this circuit, it will be necessary to initiate an SPE interchange, using the procedures described below. This action should only be taken during a time that would cause the least service disruption since exiting calls may disconnect if a failure detected on the newly active Switch Control circuit causes a spontaneous switch back to the other SPE. If this possible action is *not* acceptable, first verify that no TDM bus problems are detected when the **test TDM 1** command is entered and then replace the MSSNET circuit pack on the standby SPE. If TDM problems are detected, refer to the TDM-BUS maintenance documentation to clear those problems.

1. Initiate a test of the Switch Control circuit on the standby SPE using the **test switch-control C long** command (where C represents the carrier location of the standby SPE) to make sure no other failure conditions can be detected. If failures are detected, use the diagnostic information associated with those tests to clear the failure before proceeding.
  2. Initiate an SPE interchange using the **reset system interchange** command. This should be done at a time that would cause the least service disruption since a fault may still exist on the MSSNET circuit pack. If the system reset command fails, refer to *Failure of Planned Interchange* in Chapter 5 for further actions.
  3. Enter the **test switch-control** command for the Switch Control now on the active SPE and verify that the Control Channel Transmission test (#94) passes. If a failure occurs, an automatic SPE interchange may occur. If an interchange back to the original SPE occurs, replace the MSSNET board on the standby SPE and go back to step 1 above. If other failures are detected, use the repair procedures associated with those tests to clear the failure.
- c. A 150 error indicates that a SPE interchange occurred and that the Switch Control circuit on the MSSNET circuit pack was the cause of the spontaneous interchange.
1. If other SW-CTL errors are present, investigate those errors

2. If no other SW-CTL errors are present, run the **test switch-control a|b long clear** command and investigate those failures.
- d. A 257 error is logged when the Switch Control circuit reports that tests of its internal memory (RAM or ROM) have failed. The receipt of this error causes Switch Control maintenance to run specific Switch Control tests. If there is a problem, the Switch Control tests will normally cause other errors to be logged. In the rare case where no other errors are logged but 257 errors are occurring at a high rate (more than 10 in the last hour) the MSSNET circuit pack should be replaced during a time that would cause the least service disruption. If the system is equipped with the High Reliability or Critical Reliability Configuration this can be done immediately since a MSSNET circuit pack on the standby SPE can be replaced without affecting service.
- e. A 769 error occurs when the Switch Control reports a loss of timing signals to the SPE. When this error is present, the Switch Control will not normally be alarmed since any Switch Control test failures are really the result of faulty signals from the Tone/Clock circuit pack. See "TDM-CLK" for the procedures needed to diagnose Tone/Clock circuit pack troubles.
- f. A 1025 error indicates that there has been a failure of the Control Channel Interface Test (#92). Refer to the diagnostics for that test to clear the problem.
- g. A 1281 error is called a Switch Control handshake error. It is an in-line error not produced by any test. The Aux Data for this error is not meaningful. This error can be ignored.

The receipt of this errors causes Switch Control maintenance to run specific Switch Control tests. If there is a problem, the Switch Control tests would cause other errors to be logged. 1281 errors do not cause alarms so there is no specific action that can be taken when these errors are observed.

- h. A 1537 error indicates that the Switch Control Reset test (#92) failed. A MAJOR alarm is raised if this test fails. Refer to the repair procedures for the Switch Control Reset test (#93).
- i. A 1793 error is an in-line error that indicates a possible problem with the interface between the Switch Control and the SPE. The Aux Data for this error is not meaningful. The receipt of this error causes Switch Control maintenance to run specific Switch Control tests. If there is a problem, the Switch Control tests will normally cause other errors to be logged. In the rare case where no other errors are logged but 1793 errors are occurring at a high rate (more than 10 in the last hour) the MSSNET circuit pack should be replaced during a time that would cause the least service disruption. If the system is equipped with the High Reliability or Critical Reliability Configuration this can be done immediately since a MSSNET circuit pack on the standby SPE can be replaced without affecting service.
- j. A 2561 error indicates that a software message buffer for downlink port board messages has overflowed and those messages were thrown away. The Aux Data for this error is not meaningful. The SPE is sending more

downlink port board messages to the Switch Control than the Switch Control is able to process. A WARNING alarm for this condition will automatically be resolved if no errors of this type are detected within a 15 minute period. If no other errors are logged but 2561 errors are occurring at a high rate (more than 10 in the last hour), follow normal escalation procedures.

## System Technician-Demanded Tests: Descriptions and Error Codes

---

Always investigate tests in the order presented in the table below when inspecting errors in the system. By clearing error codes associated with the *Switch Control Reset Test* for example, you may also clear errors generated from other tests in the testing sequence.

Order of Investigation	Short Test Sequence	Long Test Sequence	Reset Board Sequence	D/ND <sup>1</sup>
Switch Control Reset Test (#93)		X		D
Control Channel Interface Test (#92)	X	X		ND
Control Channel Transmission Test (#94) <sup>2</sup>	X	X		ND

1. D = Destructive, ND = Non-destructive
2. When the SPE is duplicated, this test runs only on the Switch Control circuit on the active SPE. An interchange must be performed to test the other one.

### Switch Control Channel Interface Test (#92)

Loop-back messages are sent to the Switch Control via the interface used for control channel messages. The messages are returned to the SPE for verification via the same interface. The TDM bus is not involved in this test since the messages are looped back on the MSSNET circuit pack.

**Table 9-591. TEST #92 Control Channel Interface Test**

Error Code	Test Result	Description/ Recommendation
1338	ABORT	The test is not allowed to run since a planned SPE interchange is in progress. This may be caused by a planned interchange initiated automatically during 24 hour scheduled testing.  1. Wait 3 minutes and retry the command.
1339	ABORT	The test could not run on the standby Switch Control on the MSSNET circuit pack in the standby SPE carrier because the standby SPE is unavailable.  1. Refer to the STBY-SPE maintenance documentation for information on why a standby SPE may be unavailable and what repair actions should be taken. The screen for the <b>status spe</b> command should indicate that handshake is down. This may be caused by a variety of reasons such as the SPE-SELECT switches on the DUPINT circuit packs being set to the position of the active SPE, a failure of the DUPINT circuit pack, or loss of power on the standby SPE. The <i>SPE Selected</i> field on the <b>status spe</b> screen will display <i>spe a</i> or <i>spe b</i> if both SPE-SELECT switches are in the a or b positions, respectively.
2000	ABORT	Response to the test request was not received within the allowable time period. If the system is equipped with the High Reliability or Critical Reliability Configuration and if the MSSNET circuit pack is on the standby SPE, this abort code may indicate that the standby SPE is not responding to the handshake message. If this is the case, the standby SPE maintenance software may take up to two minutes to indicate that handshake communication with the standby SPE is down. The ABORT code will then change to 1339 (standby SPE unavailable).  1. Retry the command at 1-minute intervals, a maximum of 3 times.
2012 2500	ABORT	Internal System Error  1. Retry the command.
2100 none	ABORT	Could not allocate the necessary system resources to run this test.  1. Retry the command at 1-minute intervals a maximum of 3 retries.
2334	ABORT	The hardware mailbox in the standby Duplication Interface circuit pack is not ready to receive messages.  1. Retry the command at 1-minute intervals for a maximum of 5 times.

*Continued on next page*

**Table 9-591. TEST #92 Control Channel Interface Test — Continued**

Error Code	Test Result	Description/ Recommendation
Any	FAIL	<p>Messages could not be looped back through the control channel interface. If the system is equipped with the Standard Reliability configuration, you will probably not be able to make or receive calls involving telephones connected to the Processor Port Network.</p> <ol style="list-style-type: none"> <li>1. This failure could be due to either a MSSNET circuit pack hardware failure or the loss of system timing signals. If the Switch Control is alarmed, then a MSSNET circuit pack failure should be suspected. If the Switch Control is not alarmed, then investigate the possibility of the loss of system timing signals before attempting to replace the MSSNET circuit pack. See "TDM-CLK". A TDM Bus Clock problem may cause many port circuit pack red LEDs to light. If only the MSSNET circuit pack LED is lit, suspect the MSSNET circuit pack. If many port circuit pack red LEDs are lit, suspect a TDM Bus Clock problem. Test #92 and Test #94 run as part of the test sequence for the <b>test switch-control C</b> command (where C represents the carrier location of the circuit under test). Both tests will fail if the system timing signals are lost. If test #94 passes, then do not suspect the loss of timing signals.</li> </ol>
Any (cont'd.)	FAIL	<ol style="list-style-type: none"> <li>2. Run the short test sequence several times to make sure that this failure is occurring consistently. Then run the long test sequence to reset the Switch Control. Sometimes running the long test sequence may clear the problem. If the test is still failing, proceed to step 3 or 4.</li> <li>3. If the system is still able to process calls, replace the MSSNET circuit pack during a time that would cause the least service disruption. If the system is equipped with the High Reliability or Critical Reliability Configuration this can be done immediately since a MSSNET circuit pack on the standby SPE can be replaced without affecting service. The procedure for replacing the MSSNET circuit pack is described in "<a href="#">Replacing SPE Circuit Packs</a>" in Chapter 5.</li> <li>4. If calls cannot be made, then replace the MSSNET circuit pack immediately. The procedure for replacing the MSSNET circuit pack is described in "Replacing SPE Circuit Packs" in Chapter 5.</li> </ol>
	PASS	<p>The control channel interface between the SPE and the Switch Control is working correctly</p>

### Switch Control Reset Test (#93)

**This test is destructive if the Switch Control is on the active SPE.**

This test resets the Switch Control and determines if it can successfully go through its initialization sequence. The test is destructive if the Switch Control circuit is on an active SPE since there is the possibility of losing some control

messages to or from port circuit packs. This test will not affect established calls but call setup may be affected for several seconds.

**Table 9-592. TEST #93 Switch Control Reset Test**

Error Code	Test Result	Description/ Recommendation
1338	ABORT	The test is not allowed to run since a planned SPE interchange is in progress. This may be caused by a planned interchange initiated automatically during 24 hour scheduled testing. <ol style="list-style-type: none"> <li data-bbox="278 503 725 534">1. Wait 3 minutes and retry the command.</li> </ol>
1339	ABORT	The test could not run on the standby Switch Control on the MSSNET circuit pack in the standby SPE carrier because the standby SPE is unavailable. <ol style="list-style-type: none"> <li data-bbox="278 623 1102 892">1. Refer to the STBY-SPE maintenance documentation for information on why a standby SPE may be unavailable and what repair actions should be taken. The screen for the <b>status spe</b> command should indicate that handshake is down. This may be caused by a variety of reasons such as the SPE-SELECT switches on the DUPINT circuit packs being set to the position of the active SPE, a failure of the DUPINT circuit pack, or loss of power on the standby SPE. The <i>SPE Selected</i> field on the <b>status spe</b> screen will display <i>spe a</i> or <i>spe b</i> if the SPE-SELECT switches are in the a or b positions, respectively.</li> </ol>
2000	ABORT	Response to the test request was not received within the allowable time period. If the system is equipped with the High Reliability or Critical Reliability Configuration and if the MSSNET circuit pack is on the standby SPE, this abort code may indicate that the standby SPE is not responding to the handshake message. If this is the case, the standby SPE maintenance software may take up to two minutes to indicate that handshake communication with the standby SPE is down. The ABORT code will then change to 1339 (standby SPE unavailable). <ol style="list-style-type: none"> <li data-bbox="278 1152 992 1188">1. Retry the command at 1-minute intervals, a maximum of 3 times.</li> </ol>
2012	ABORT	Request for results timed out.
2500	ABORT	Internal System Error <ol style="list-style-type: none"> <li data-bbox="278 1286 633 1322">1. Retry the command two times.</li> </ol>
2013 2100 none	ABORT	Could not allocate the necessary system resources to run this test. <ol style="list-style-type: none"> <li data-bbox="278 1376 992 1421">1. Retry the command at 1-minute intervals a maximum of 3 retries.</li> </ol>
2334	ABORT	The hardware mailbox in the standby Duplication Interface circuit pack is not ready to receive messages. <ol style="list-style-type: none"> <li data-bbox="278 1510 1018 1533">1. Retry the command at 1-minute intervals for a maximum of 5 times.</li> </ol>

*Continued on next page*

**Table 9-592. TEST #93 Switch Control Reset Test — Continued**

Error Code	Test Result	Description/ Recommendation
	FAIL	<p>The Switch Control could not be successfully reset. If the system is equipped with the Standard Reliability configuration, you will probably not be able to make or receive calls involving telephones connected to the Processor Port Network.</p> <ol style="list-style-type: none"> <li>1. This failure could be due to either a MSSNET circuit pack hardware failure or the loss of system timing signals. If the Switch Control is alarmed, then a MSSNET circuit pack failure should be suspected. If the Switch Control is not alarmed, then investigate the possibility of the loss of system timing signals. See "TDM-CLK". A TDM Bus Clock problem may cause many port circuit pack red LEDs to light. If only the MSSNET circuit pack LED is lit, suspect the MSSNET circuit pack. If many port circuit pack red LEDs are lit, suspect a TDM Bus Clock problem. Test #92 and Test #94 run as part of the test sequence for the <b>test switch-control C</b> command (where C represents the carrier location of the circuit under test). Both tests will fail if the system timing signals are lost. If test #94 passes, then do not suspect the loss of timing signals. If the MSSNET circuit pack is determined to be at fault, proceed to step 2.</li> <li>2. If the system is still able to process calls, replace the MSSNET circuit pack during a time that would cause the least service disruption. If the system is equipped with the High Reliability or Critical Reliability Configuration this can be done immediately since a MSSNET circuit pack on the standby SPE can be replaced without affecting service. The procedure for replacing the MSSNET circuit pack is described in "Replacing SPE Circuit Packs" in Chapter 5.</li> <li>3. If calls cannot be made, then replace the MSSNET circuit pack immediately. The procedure for replacing the MSSNET circuit pack is described in "Replacing SPE Circuit Packs" in Chapter 5.</li> </ol>
	PASS	<p>The Switch Control has initialized correctly. Look at results of the other tests to see if it is operating correctly.</p>

### Switch Control-Channel Transmission Test (#94)

Control channel messages are sent from the SPE to selected port circuit packs and the response from the port circuit packs is checked. This tests the ability of the Switch Control to send and receive messages on the control channel of the TDM bus.

For the case when the system is equipped with the High Reliability or Critical Reliability configuration, this test cannot run on the Switch Control in a standby SPE. However, this test may have run and failed while the Switch Control was on the active SPE which will alarm the Switch Control and cause an SPE

interchange. In that case, Error Types 2 and 150 will be entered in the error log for the Switch Control on the standby SPE, indicating that a failure of the Switch Control Transmission Test caused a spontaneous SPE interchange. Refer to the Error Log information presented earlier in this repair document for the procedures to clear problems associated with a SW-CTL error log entry of 2.

**Table 9-593. TEST #94 Control Channel Transmission Test**

Error Code	Test Result	Description/ Recommendation
0	ABORT	The port circuit packs necessary for this test are not available. For this test to pass, it must receive a successful response to a circuit pack query message from at least one of the following circuit pack types in the PPN cabinet: Tone/Clock circuit pack (TN768 or TN780) Tone Detector circuit pack (TN599) <ol style="list-style-type: none"> <li>1. Retry the command at 1-minute intervals a maximum of 5 retries.</li> <li>2. If the test keeps aborting with this abort code, replace the MSSNET circuit pack.</li> <li>3. If the test keeps aborting with this abort code, verify that the PPN has at least one of the circuit packs listed above.</li> </ol>
1335	ABORT	Internal System Error. The MSSNET circuit pack is on the standby SPE and this test is not allowed to execute on a MSSNET circuit pack on the standby SPE. <ol style="list-style-type: none"> <li>1. If this abort code is received for a Switch Control on a standby SPE in a system equipped with the High Reliability or Critical Reliability configuration, there must be a software error. Test #94 is not allowed to run on a standby Switch Control.</li> <li>2. Retry the command at 1-minute intervals, a maximum of 5 times.</li> </ol>
1338	ABORT	The test is not allowed to run since a planned SPE interchange is in progress. This may be caused by a planned interchange initiated automatically during 24 hour scheduled testing. <ol style="list-style-type: none"> <li>1. Wait 3 minutes and retry the command.</li> </ol>
2012 2500	ABORT	Internal System Error <ol style="list-style-type: none"> <li>1. Retry the command.</li> </ol>
2013 2100 none	ABORT	Could not allocate the necessary system resources to run this test. <ol style="list-style-type: none"> <li>1. Retry the command at 1-minute intervals a maximum of 3 retries.</li> </ol>

*Continued on next page*



Table 9-593. TEST #94 Control Channel Transmission Test — *Continued*

Error Code	Test Result	Description/ Recommendation
0	FAIL	<p>The Switch Control cannot communicate on the TDM bus control channel. If the system is equipped with the Standard Reliability configuration, you will probably not be able to make or receive calls involving telephones connected to the Processor Port Network.</p> <ol style="list-style-type: none"> <li>1. Run the short test sequence several times to make sure that this failure is occurring consistently. Then run the long test sequence to reset the Switch Control. Sometimes, running the long test sequence may clear the problem. Remember that the long test sequence is <i>destructive</i>. Placing and receiving of calls will be affected for several seconds.</li> <li>2. If there are no TDM Bus alarms against the standby TDM bus, switch the control channel from its current bus to the standby bus using the <b>set tdm</b> command. Refer to the TDM-BUS maintenance documentation for information on how to use this command. If this test passes on the new bus, then investigate the possibility of TDM Bus failures. If the test fails even after the control channel is switched to the standby TDM bus, then proceed to Step 3 or 4.</li> <li>3. If the system is still able to process calls, replace the MSSNET circuit pack during a time that would cause the least service disruption. If the system is equipped with the High Reliability or Critical Reliability Configuration this can be done immediately since a MSSNET circuit pack on the standby SPE can be replaced without affecting service. The procedure for replacing the MSSNET circuit pack is described in "Replacing SPE Circuit Packs" in Chapter 5.</li> <li>4. If calls cannot be made, then replace the MSSNET circuit pack immediately. The procedure for replacing the MSSNET circuit pack is described in "Replacing SPE Circuit Packs" in Chapter 5.</li> </ol>
	PASS	<p>The Switch Control can communicate with selected port circuit packs over the TDM bus.</p>

## SYNC (Synchronization)

---

MO Name (in Alarm Log)	Alarm Level	Initial Command to Run	Full Name of MO
SYNC	MINOR	display errors	Synchronization
SYNC	WARNING	test synchronization	Synchronization

This section discusses synchronization problems local to the switch. For further information about synchronization including network synchronization, see the *AT&T Network and Data Connectivity*.

Synchronization Maintenance is composed of both hardware and software components and its purpose is to provide a common reference frequency for reliable digital communication between the G3r system and other PBXs, Central Offices(COs) or Customer-Premises Equipment (CPE). Synchronization is implemented using several system components including:

- TN768 or TN780 Tone-Clock
- TN722, TN767 and TN 464 DS1 Interfaces (all suffixes)
- TN572 Switch Node Clock
- TN573 Switch Node Interface
- TN570 Expansion Interface

Synchronization is achieved between the Processor Port Network (PPN) and the Expansion Port Networks (EPNs) via the port network connectivity (PNC) between the networks. Depending on the network synchronization plan and the status of synchronization sources, the system timing reference may be a Tone-Clock circuit pack, DS1 interface or UDS1 circuit packs, or an external Stratum 3 clock. Stratum 4 synchronization extracts timing information directly from a DS1 reference, UDS1 reference, or a Tone-Clock. Stratum 3 synchronization requires the use of a Stratum 3 clock that provides a timing signal derived from DS1 references to the Tone-Clock circuit pack. The external Stratum 3 clock is a more stable timing source than the Stratum 4 clock and provides 24-hour holdover in case of reference failures and redundant components.

If both a primary and a secondary reference are administered for Stratum 4 synchronization, both references must reside in the same port network.

## Stratum 4 Synchronization

---

The system can be configured with primary and secondary synchronization references (DS1 or UDS1 interface circuit packs) when using Stratum 4 synchronization. If this is the master synchronization source for the network, then its local oscillator is used and no DS1s are used as references. If this system is a slave in the network, a primary reference must be used as the synchronization reference and the secondary reference is optional:

- If the primary synchronization reference is not providing a valid timing signal, the system automatically switches to the secondary synchronization reference.
- If the primary synchronization reference is invalid and secondary reference does not provide a valid timing signal or is not administered as a synchronization reference, a Tone-Clock circuit pack provides the system timing source.
- If the system is using the local oscillator as the timing source (both the primary and secondary references are providing invalid timing signals), should either the primary or secondary reference becomes valid again, the system switches back to the primary or secondary source.
- When both the primary and secondary source become valid, the system switches to the primary source, since the primary source is always preferred over the secondary source when both sources are equally healthy.

If the primary synchronization reference is providing a valid timing signal, then the flow of system synchronization would travel from the DS1 interface circuit pack in the PPN across the active PPN to EPN fiber links to the two EPNs. The PPN DS1 interface circuit pack provides a timing signal for the PPN Tone-Clock circuit pack and the PPN Tone-Clock circuit pack provides timing for all circuit packs in the PPN. Each PPN Expansion Interface circuit pack uses the timing generated by the Tone-Clock circuit pack to clock data from the fiber links to the Expansion Interface circuit packs in the two EPNs. The active EPN Expansion Interface circuit pack uses the received data stream to generate a timing signal. The Tone-Clock circuit packs in the EPNs use this signal to generate timing for all the circuit packs in their respective EPNs. The PPN, in the above mentioned scenario, is designated the *master* port network and the EPNs are called *slave* port networks. The *master* port network is defined as the port network that contains the system synchronization source. If the primary synchronization reference does not provide a valid timing signal, Synchronization Maintenance will switch to the secondary reference. *Both the primary and secondary references must reside in the same port network, which may be any port network. The PPN is the recommended location.*

If TDM-CLK error 2305 is in the error log, then a slave Tone-Clock loss of signal condition exists on the slave Tone-Clock circuit pack that has this error. If only one loss of signal occurred, the slave Tone-Clock circuit pack is receiving the timing signal from the standby EI circuit pack (in this example, the timing is

coming from the PPN to the EPN over the standby fiber link). If another loss of signal occurred after the Tone-clock circuit pack switched to receive timing from the standby EI, the Tone-clock circuit pack will run on its local oscillator. The yellow LED on the Tone-clock circuit pack flashes at the 2.7 seconds on and .3 seconds off rate (mostly on) if timing is received from an external source (an EI in this example). Otherwise, if the Tone-clock circuit pack is running on its local oscillator, the yellow LED flashes at the .3 seconds on and 2.7 seconds off rate (mostly off).

The TN722 DS1 Interface circuit pack does not provide a synchronization reference as reliable as the TN767 or TN464C circuit packs. Therefore, it is recommended that the TN767 or TN464C circuit packs are used as primary or secondary sources instead of the TN722 type DS1 circuit packs.

### Stratum 3 Synchronization

[Figure 9-92](#) illustrates one possible configuration of Stratum 3 synchronization.

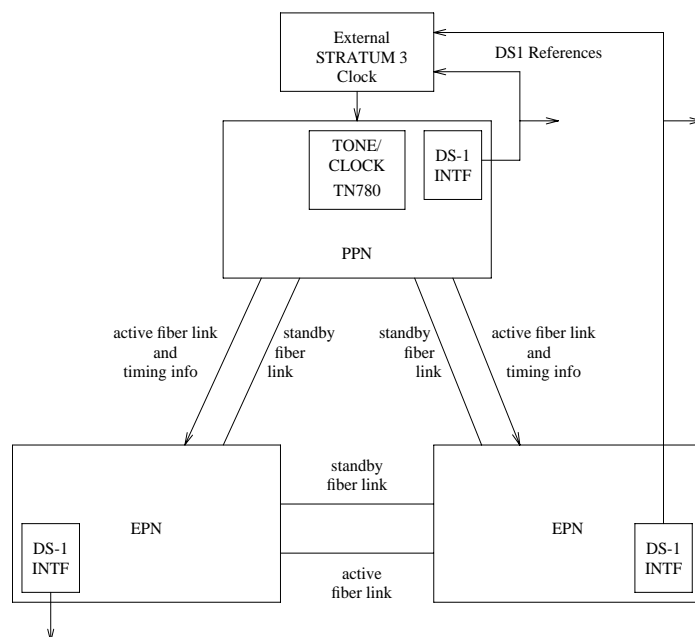

**Figure 9-92. Typical Duplicated Direct-Connect Stratum 3 Synchronization Configuration**

For Stratum 3 synchronization, an external clock provides a timing signal to a TN780 Tone-Clock circuit pack, and the TN780 provides timing to all circuit

packs in the PPN in which the TN780 resides (the external stratum 3 clock is only allowed in the PPN). Each PPN Expansion Interface circuit pack uses the timing generated by the TN780 to clock data from the active PPN to EPN fiber links. The active EPN Expansion Interface circuit packs use the received data stream to generate a timing signal which is used by the Tone-Clock circuit packs in the EPNs to provide timing for all circuit packs in their respective EPNs. (The EPN Tone-Clock circuit packs can be either TN780s or TN768s; only the Tone-Clock circuit pack(s) connected to the external Stratum 3 clock must be TN780s.) The PPN, in the above mentioned scenario, is designated the *master* port network and the EPNs are called *slave* port networks. The *master* port network is defined as the port network that contains the system synchronization source, the Stratum 3 clock in this case. The Stratum 4 equipment (usually a PBX) should never provide timing to a Stratum 3 PBX.

If TDM-CLK error 2305 is in the error log, then a slave Tone-Clock loss of signal condition exists on the slave Tone-Clock circuit pack that has this error. If only one loss of signal occurred, the slave Tone-Clock circuit pack is receiving the timing signal from the standby EI circuit pack (in this example, the timing is coming from the PPN to the EPN over the standby fiber link). If another loss of signal occurred after the Tone-clock circuit pack switched to receive timing from the standby EI, the Tone-clock circuit pack will run on its local oscillator. The yellow LED on the Tone-clock circuit pack flashes at the 2.7 seconds on and .3 seconds off rate (mostly on) if timing is received from an external source (an EI in this example). Otherwise, if the Tone-clock circuit pack is running on its local oscillator, the yellow LED flashes at the .3 seconds on and 2.7 seconds off rate (mostly off).

## Synchronization in a Center Stage Switch Configuration

---

In the following typical duplicated Center Stage Switch (CSS) configuration, the timing signal from the *master* port network, the PPN in this diagram, is sent to all circuit packs in its network. The timing signal is sent from the Expansion Interface (EI) circuit packs in the PPN to the Switch Node Interface (SNI) circuit packs in the switch node carriers. The EIs in the *master* port network also sends out a timing priority number (TPN) of 1. Every *slave* port network EI sends out a TPN of 30. The active Switch Node Clock (SNC) circuit pack in each switch node carrier decides which SNI is providing the timing signal that the switch node carrier should synchronize to by looking at each SNI's incoming TPN. The SNC chooses the SNI with the lowest numbered TPN to synchronize to. The SNC then sends the timing signal to all SNIs and the standby SNC, if a standby SNC is present, in the switch node carrier. The SNC also sends out a TPN equal to 1 plus the lowest incoming TPN. Each SNI in the switch node sends the timing signal received from the SNC and the TPN from the SNC out on its associated fiber.

If TDM-CLK error 2305 is in the error log, then a slave Tone-Clock loss of signal condition exists on the slave Tone-Clock circuit pack that has this error. In this case, the slave Tone-Clock circuit pack is receiving the timing signal from the standby EI circuit pack in the port network that has the TDM-CLK 2305 error or

from its local oscillator. The yellow LED on the Tone-clock circuit pack flashes at the 2.7 seconds on and .3 seconds off rate (mostly on) if timing is received from an external source (for example, an EI circuit pack). Otherwise, if the Tone-clock circuit pack is running on its local oscillator, the yellow LED flashes at the .3 seconds on and 2.7 seconds off rate (mostly off).

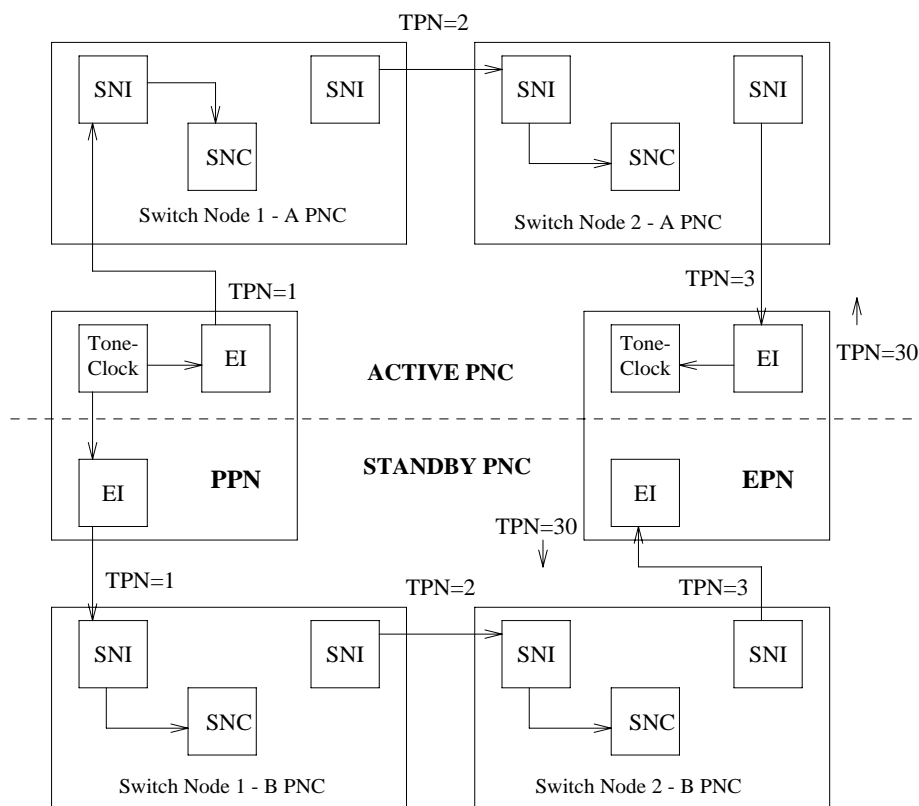

Timing information is sent through both the active and standby PNCs, but the EPNs normally derive timing from the EIs on the active PNC.

**Figure 9-93. Typical Center Stage Switch Synchronization Configuration -Two Switch Nodes, Duplicated PNC**

### Synchronization Troubleshooting

For both Stratum 3 and 4 operation, major and minor alarms indicate that there is a problem with the system synchronization references. These alarms will be resolved when the alarmed synchronization reference is restored.

The **change synchronization** command is used to administer whether Stratum 3 or Stratum 4 synchronization is being used. The **change synchronization** command allows primary and secondary references to be administered for the Stratum 4 option.

The **status synchronization** command shows the current synchronization reference. The **display synchronization** command shows the synchronization references (e.g. primary, secondary, stratum 3) that are administered.

The **list timing-source** command displays all DS1 and UDS1 locations that are allowed to be administered as primary or secondary references with the **change synchronization** command.

Other commands associated with Synchronization Maintenance are **disable synchronization-switch** and **enable synchronization-switch**. These commands are used to disable the ability of Synchronization Maintenance to switch between synchronization references and to enable this switching ability, respectively. The **set synchronization** command is executed only after synchronization has been disabled and is used to manually switch to a specific synchronization reference. This command is useful to diagnose synchronization problems by forcing a specific reference (DS1, UDS1, or Tone-Clock) to be the system synchronization reference to determine if a specific reference is providing a valid timing signal. To switch synchronization to the Stratum 3 clock, use the **enable synchronization-switch** command after verifying that the Stratum 3 clock is wired correctly.

## Approach to Troubleshooting

Slip errors are the primary symptom associated with being unsynchronized.

A correct Synchronization plan for the network keeps the systems within the network transmitting data at approximately the same rate to avoid situations where:

- One system transmits data at a rate faster than another system can receive the data (in which case data is lost).
- One system transmits data at a rate slower than another system expects to receive data (in which case data is repeated).

Either of these situations, data being lost or repeated, is a slip.

When troubleshooting synchronization problems when slips are the primary error log entry indications of a synchronization problem, requires that the problem be isolated to:

- A problem outside of the switch, i.e., the switch is not properly synchronized to the rest of the network.
- A problem internal to the switch.

DS1 and UDS1 circuit packs can be administered with slip detection enabled via the **Slip Detection?** field set to a **y** (see the **add ds1**, **change ds1**, and **display ds1** commands). All DS1 and UDS1 circuit packs administered as slip enabled will be counted in the following algorithm:

When over half of the DS1 and UDS1 circuit packs administered as slip enabled are experiencing slips, and the primary or secondary synchronization reference is the current synchronization reference, synchronization will try the other administered synchronization reference.

In situations where one or many circuit packs in the system are experiencing slips, the problem could be with the synchronization reference, with individual circuit packs, or with phase modulation of the transmitted digital bit streams due to environmental variations of the transmission facilities (such as temperature variations that affect the electrical length of a transmission line). The circuit packs that can experience slips and the associated error log entry for slips are as follows.

**Table 9-594. Error Log Entries for Slip Errors**

---

<b>Circuit Pack</b>	<b>Error Log Name</b>	<b>Error Log Entry for Slips</b>
DS1 Interface	DS1-BD	3073 to 3160
Expansion Interface	EXP-INTF	2305
Switch Node Interface	SNI-BD	1537
Tone-Clock	TDM-CLK	1025
UDS1 Interface	UDS1-BD	3073 to 3160

---

When slips occur on the circuit packs mentioned above, first consult the individual circuit pack section in the manual for each circuit pack that has slips. If slips occur in low numbers, they may be due to environmental conditions as described above. If no service degradation is occurring, no action is necessary. Whenever the system switches synchronization sources, slips can be expected from DS1-BD, UDS1-BD, and EXP-INTF circuit packs. If service degradation occurs, after following the repair steps in the individual section, use the following trouble shooting techniques.



The following table lists circuit packs that can report slips and related circuit packs whose hardware problems that cause those slips.

**Table 9-595. Slips and Related Circuit Packs**

<b>Circuit Pack Reporting Slips</b>	<b>Associated Circuit Packs That Can Cause Slips</b>
DS1 Interface	Active Tone-Clock in same port network
Expansion Interface	Active Tone-Clock in same port network or circuit pack at opposite end of fiber or metallic connection
Switch Node Interface	Circuit pack at opposite end of fiber or metallic connection, or active Switch Node Clock circuit pack in same switch node carrier
Tone-Clock	Current DS1 reference
UDS1 Interface	Active Tone-Clock in same port network

**Troubleshooting Synchronization Problems**

The following flow chart presents a logical approach to troubleshooting synchronization problems in conjunction with the background information presented above. Explanatory notes follow the charts.

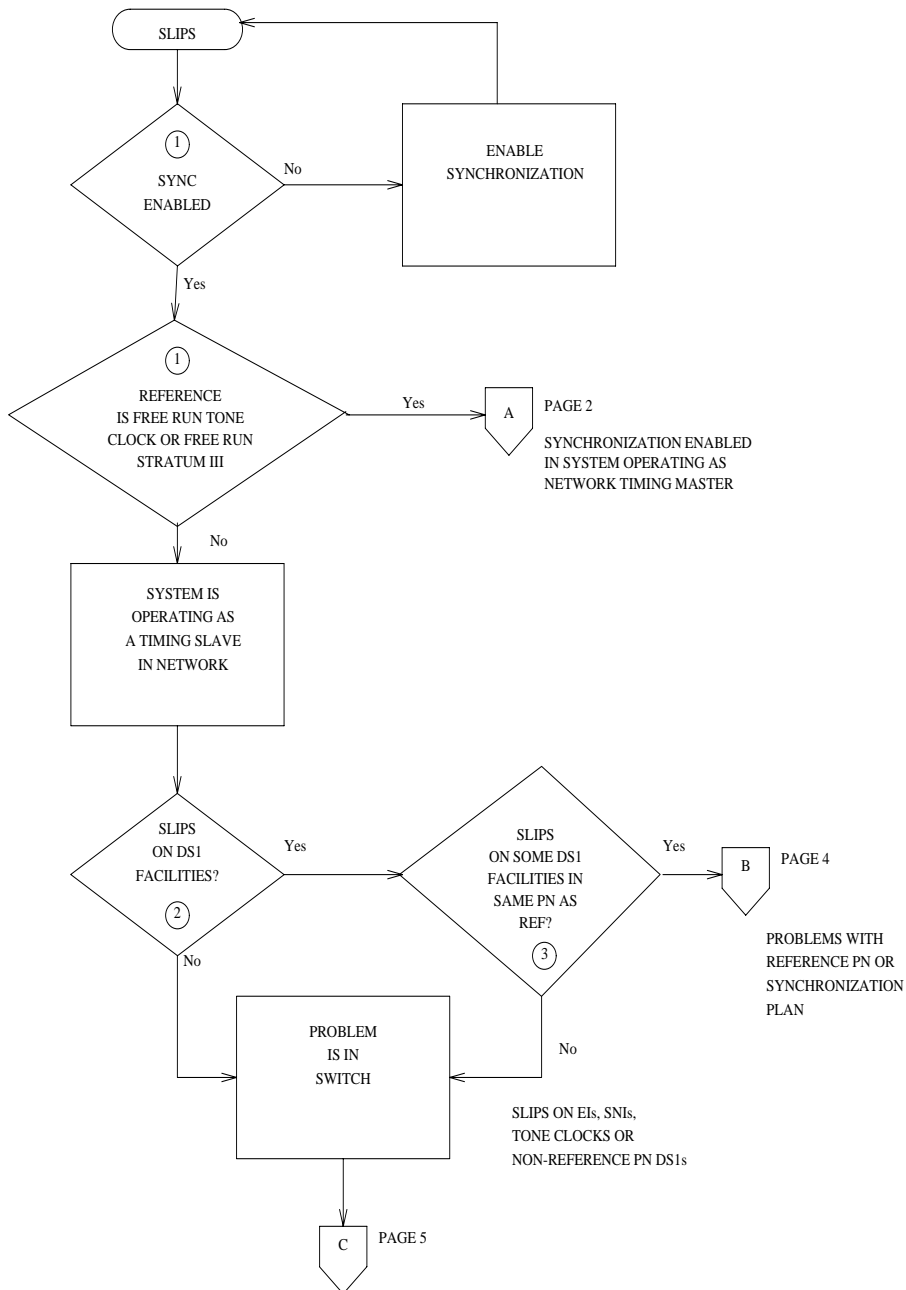

Figure 9-94. Synchronization Troubleshooting, Page 1 of 6

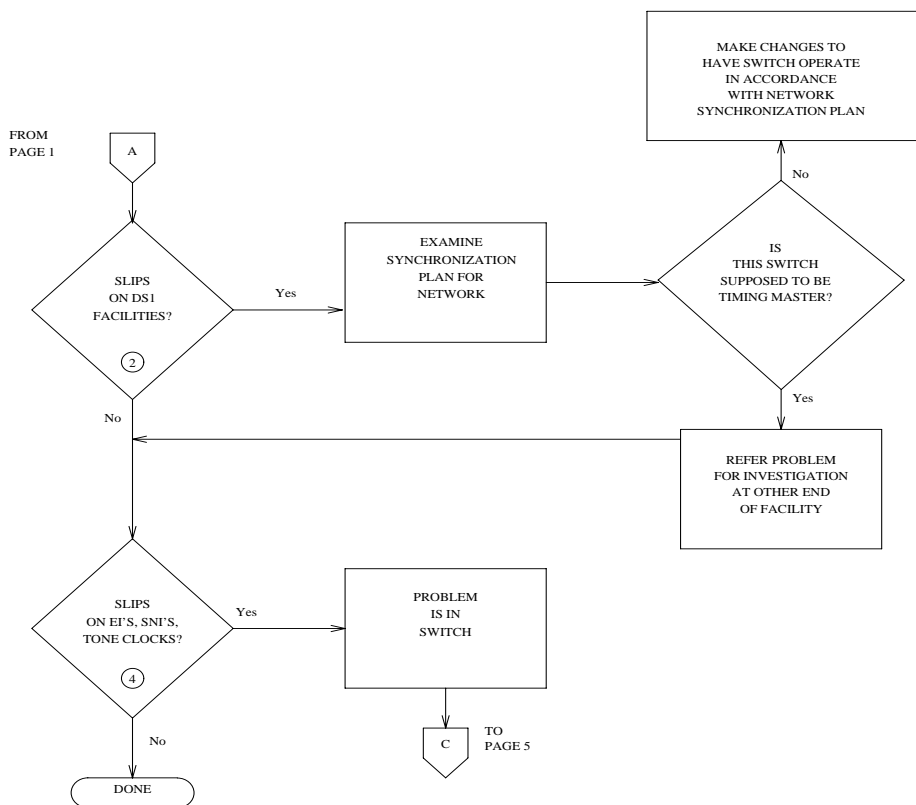

Figure 9-95. Synchronization Troubleshooting, Page 2 of 6

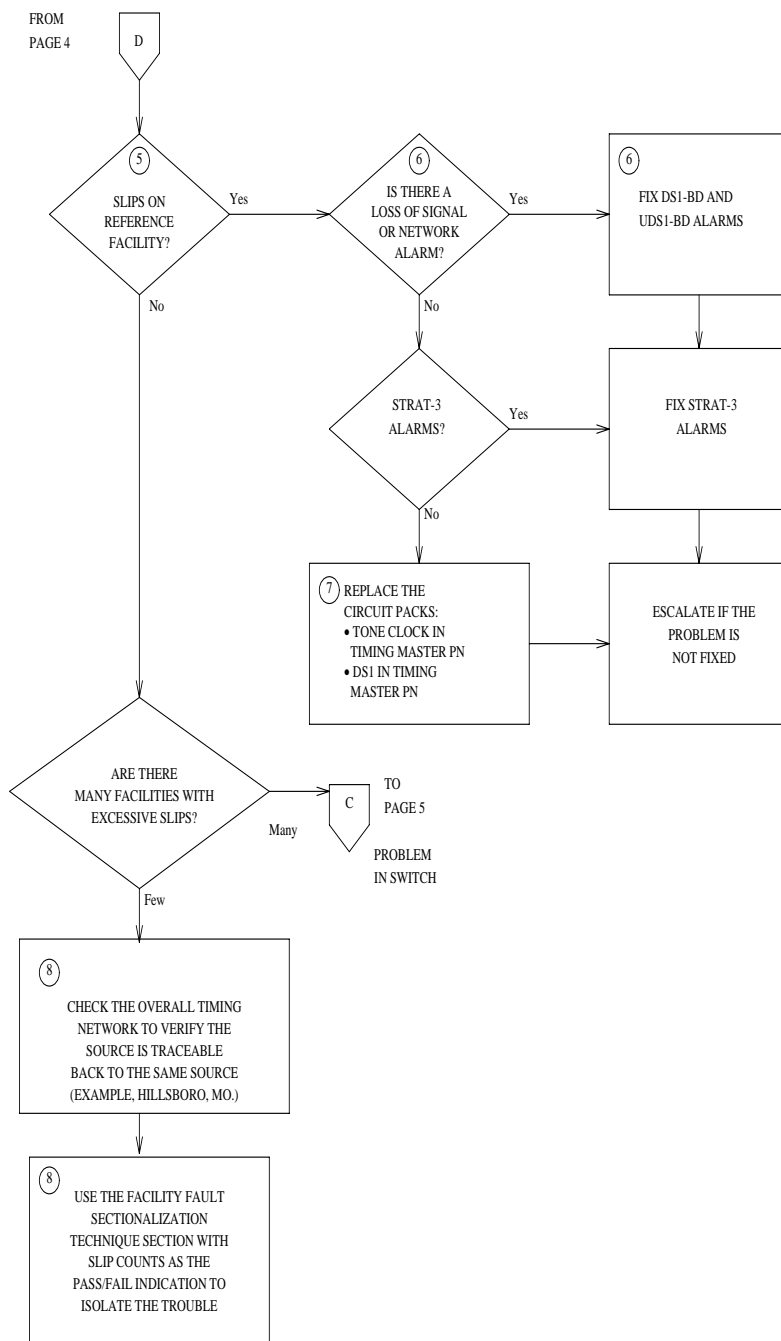

Figure 9-96. Synchronization Troubleshooting, Page 3 of 6

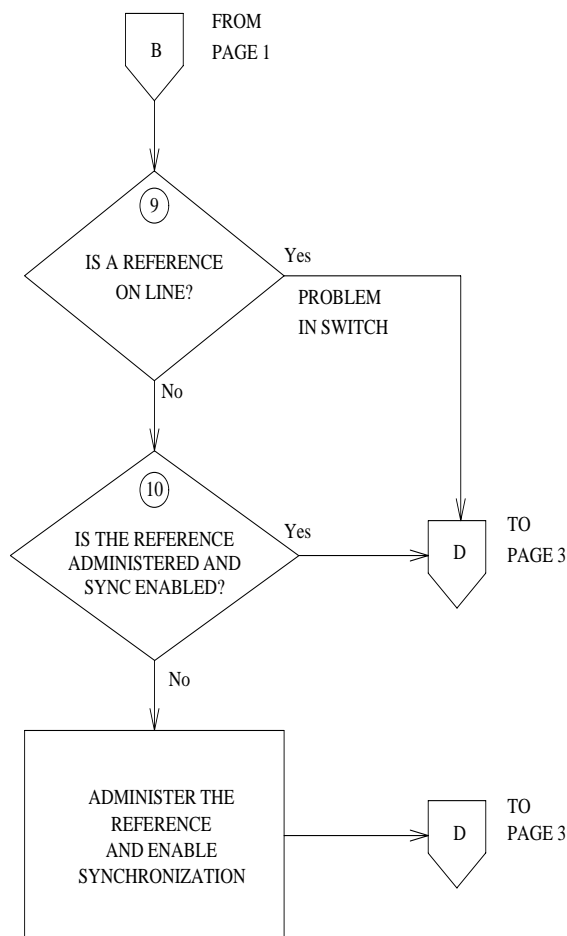

Figure 9-97. Synchronization Troubleshooting, Page 4 of 6

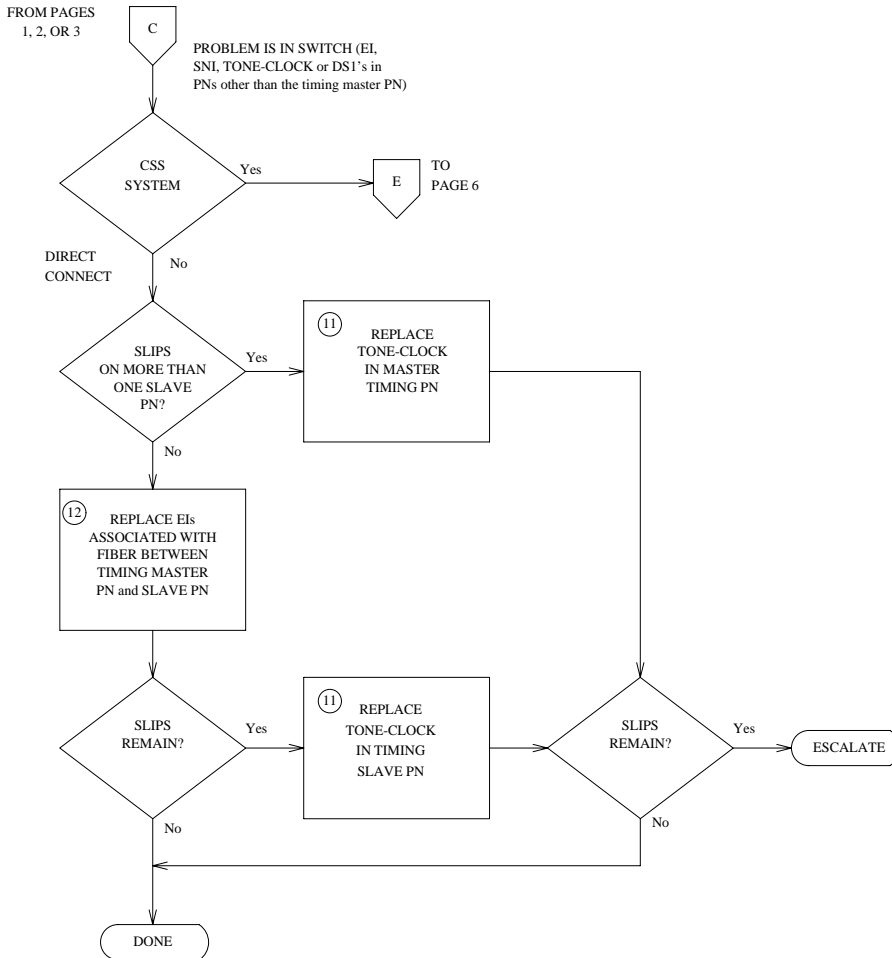
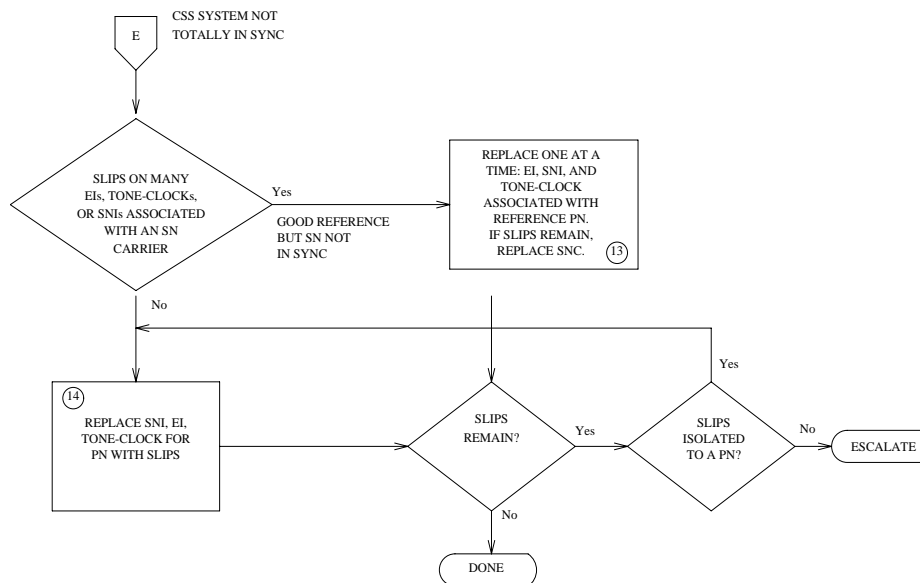

Figure 9-98. Synchronization Troubleshooting, Page 5 of 6



**Figure 9-99. Synchronization Troubleshooting, Page 6 of 6**

Notes for Sheet 1 through Sheet 6 flowcharts (when checking for slip errors, use the table above, *Error Log Entries for Slip Errors*):

1. Use the **status synchronization** command to determine whether synchronization is enabled and to determine the on-line reference. If the on-line reference is a tone-clock board, the switch is operating in free run mode. If the Stratum 3 is displayed, and no DS1s are connected to the Stratum 3 clock or no DS1 connection existed to the Stratum 3 clock for over 24 hours, then the Stratum 3 clock is in free run mode.
2. Check for slip errors against DS1-BD and UDS1-BD.
3. If Stratum 3 is administered (**display synchronization**) and on-line (**status synchronization**), check for DS1-BD or UDS1-BD slip errors for the DS1(s) or UDS1(s) used as input to the Stratum 3 clock. Check the LED indications on the Stratum 3 clock to determine which DS1 is providing input to the Stratum 3 and examine the cross connect information for that DS1.
4. Check for slips errors against EXP-INTF, SNI-BD, and TDM-CLK.

5. Check **status synchronization** for the current DS1 reference. If a DS1 or UDS1 is on-line, check for slips on that DS1 or UDS1. If Stratum 3 synchronization is administered and the Stratum 3 clock is used as the reference (i.e. the tone-clock local oscillator is not on-line), follow the procedure in step 3 to determine the DS1 reference used as input to the Stratum 3 clock and check for slips on that reference.
6. Check for LOS, Blue, Yellow, and Red Alarms on the on-line reference facility and fix those problems first. See the DS1-BD and/or UDS1-BD for the error log entries associated with the above mentioned alarms. Replace the circuit packs one at a time and wait at least one hour to determine if the problem has gone away. This procedure is disruptive and should be done after hours if possible. An alternative to replacing the tone-clock circuit pack in systems where the tone-clocks are duplicated, is to run the **set tone-clock** command to switch tone-clocks. If the problem goes away, the previously active tone-clock should be replaced.
7. If a few facilities are experiencing slips or are unusable references, the clock source for facilities with slips or that are unusable is not traceable to the same ultimate source as the clock source for the on-line reference facility.

Examine the overall timing network for the interconnected DS-1 to determine if the clock can be traced back to a single source and if the reference designations for each location in the distribution of timing is supplied in accordance with the *synchronization plan* for the customer. Examine the capability of the external transmission equipment to pass or provide timing.

Verify the integrity of the on-site hardware by using the *Facility Fault Sectionalization* section, which loops the transmit signal to the receive signal and verifies that the excessive slips or the unusable reference are no longer observed.

This is a time consuming process that disrupts service. You should perform it after hours if the service being provided by the system is acceptable as determined by checking with the customer.

8. Use **status synchronization** to determine the on-line reference. If a DS1 or Stratum 3 reference is not on-line and the local oscillator of a tone-clock board is on-line, then the answer to this question is "no".
9. Use **display synchronization** to find out what references, if any, are administered. Use **status synchronization** to find out whether synchronization is enabled.
10. If tone-clocks are duplicated, the **set tone-clock** command can be used to switch tone-clocks. If slips go away, then replace the tone-clock that was just switched away from.



11. Use **status pnc** to determine which PNC is active. Then use **list fiber-links** to determine the EIs on the active PNC and the EIs associated with the slave PN. If the switch does not have PNC duplication, the EIs are all on the active PNC, A-PNC. A PNC interchange can be done via **reset pnc interchange** before replacing EIs if the system has PNC duplication. If the slips go away after the PNC interchange, replace the EIs that were previously active.
12. Replace the circuit packs one at a time and wait at least one hour to determine if the problem has gone away. This procedure is disruptive and should be done after hours if possible.

An alternative to replacing the EI and SNI in systems where the PNC is duplicated, is to perform a PNC interchange via **reset pnc interchange**. If the problem goes away, either the EI or the SNI on the previously active PNC should be replaced. Replace one at a time and make that PNC active again to determine whether the problem is fixed.

An alternative to replacing the tone-clock circuit pack in systems where the tone-clocks are duplicated, is to run the **set tone-clock** command to switch tone-clocks. If the problem goes away, the previously active tone-clock should be replaced.

Also, before replacing an SNC circuit pack, the **set switch-node-clock** command can be used if SNCs are duplicated in the carrier. If the problem goes away, the previously active SNC should be replaced.

13. Replace the circuit packs one at a time and wait at least one hour to determine if the problem has gone away. This procedure is disruptive and should be done after hours if possible.

An alternative to replacing the EI and SNI in systems where the PNC is duplicated, is to perform a PNC interchange via **reset pnc interchange**. If the problem goes away, either the EI or the SNI on the previously active PNC should be replaced. Replace one at a time and make that PNC active again to determine whether the problem is fixed.

An alternative to replacing the tone-clock circuit pack in systems where the tone-clocks are duplicated, is to run the **set tone-clock** command to switch tone-clocks. If the problem goes away, the previously active tone-clock should be replaced.

Also, before replacing an SNC circuit pack, the **set switch-node-clock** command can be used if SNCs are duplicated in the carrier. If the problem goes away, the previously active SNC should be replaced.

## Facility Fault Sectionalization

DS-1 facility fault sectionalization involves looping around the DS-1 signal at on-site access points to localize the source of the problem to equipment and wiring on either the near side or far side of the loop-around point.

### WARNING:

*The facility fault sectionalization technique disrupts service. When you perform the looparound on a facility, make sure it is not the on-line synchronization reference or a system outage will occur.*

When you use this technique to investigate problems on facilities with multiplex or DACS equipment, the technique becomes cumbersome because all of the 64 Kbps (B-channels) or subrate channels corresponding to the DS-1 facility need to be looped around.

[Figure 9-100](#) shows a sequence of units (1 though n) that may be connected as the on-site equipment. A typical example is the case where the only on-site equipment is channel-terminating equipment designated Unit #1. A more complex, less typical example might have a DACS as Unit #1, a protection switch as Unit #2, and a DS-1-level microwave radio system as Unit #3.

The flowchart in [Figure 9-101](#) gives an overview of the facility fault sectionalization technique. It is important that you know the configuration and wiring of the equipment for the problem facility in order to support this technique.

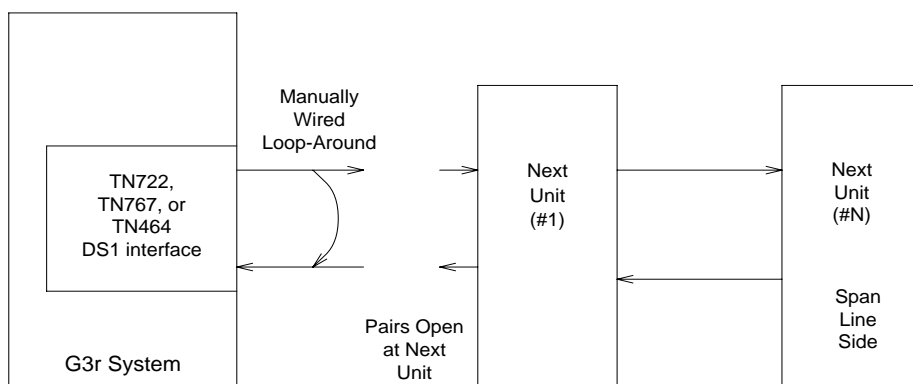

**Figure 9-100. Manual Looparound for Facility Fault Sectionalization**

Since the technique is time consuming, fix any DS1-BD, UDS1-BD, STRAT-3, or SYNC errors first that are not slip errors.

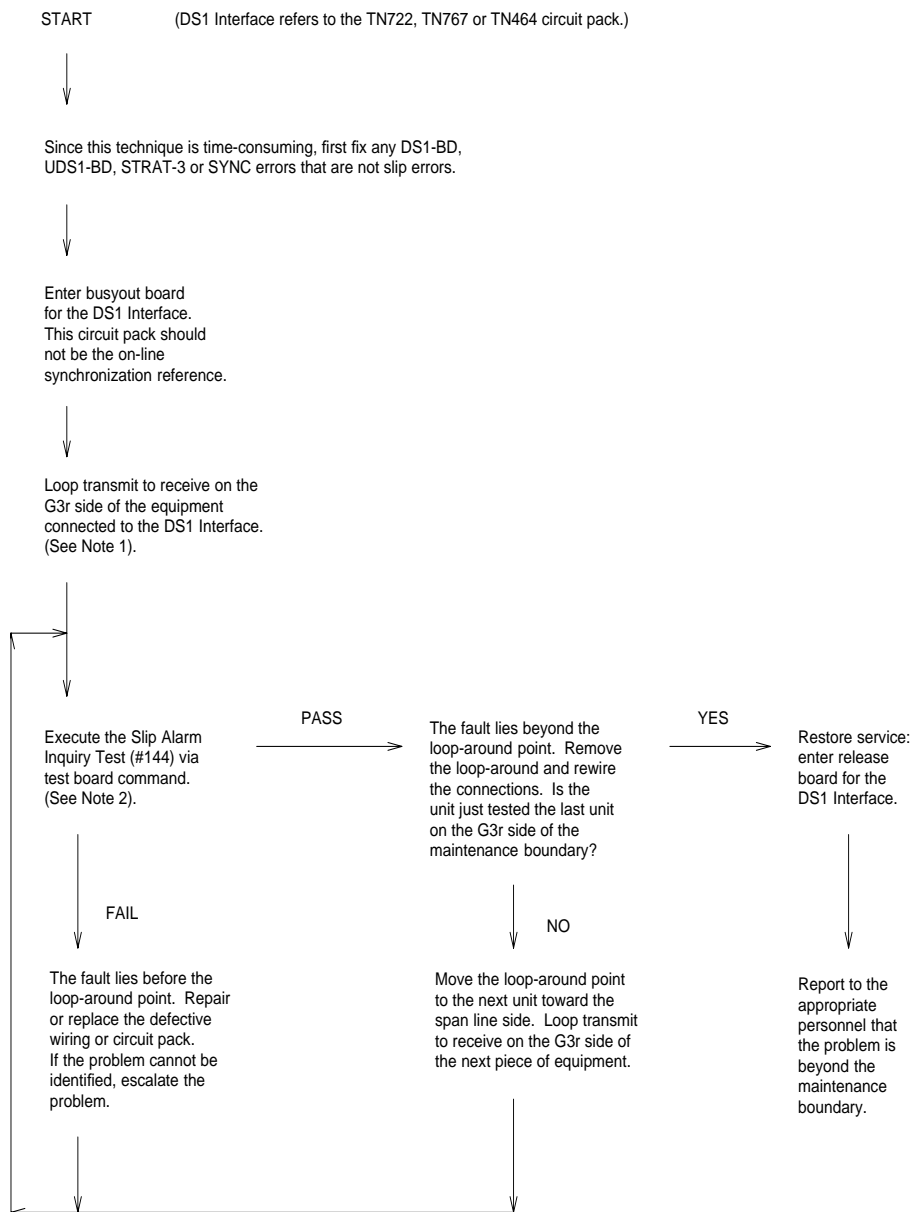

**Figure 9-101. Facility Fault Sectionalization**

**Notes to Facility Fault Sectionalization Flowchart**

1. Loop transmit to receive on the system side.

Remove the transmit signal from the TN722, TN767, or TN464 circuit pack inputs and outputs and loop it around to the receive signal going toward the TN722, TN767, or TN464 circuit pack at the first unit wired to the TN722, TN767, or TN464 circuit pack. (See [Figure 9-100](#)).

The looparound signal may take different forms depending on the installation.

- In some cases, the unit connected to the system may provide a switch or a terminal interface to control the desired looparound. Make sure that the signal is looped toward the system and that the timing signal is looped.
- In most cases, it may be necessary to temporarily rewire connections at the cross-connect fields to loop the signal back toward the switch.

The point at which the signal is looped should be one at which physical access is easy and where the signal level is within the line compensation (i.e. equalization) range of the hardware connected. A few cases exist where access to the looparound cannot be easily provided at locations where the signal level is within the line compensation range of the hardware. The line compensation can be changed via the **change ds1 UUCSS** command.

2. Execute the **test board UUCSS** command for the TN722, TN767 or TN464. Look at results of Test #144, the Slip Alarm Inquiry Test. When this test fails, the error code gives the number of slips detected since the last Slip Inquiry Test was run. If the test fails, run it at least one more time to ensure that slips have occurred since the looparound was installed.

## Timing Loops

A timing loop exists whenever a system receives timing from another system whose timing reference is directly or indirectly derived from itself. The system synchronization planner *must avoid creating a timing loop* when administering the synchronization references in a system. Timing loops can lead to loss of digital data between systems that are exchanging data with any system within the loop. An invalid timing signal will also be generated by any system within the loop, thus propagating the invalid timing signal to any system(s) using a system within the loop as a synchronization reference.

A correctly designed network has no loops and each piece of equipment in the network is supplied by a clock of equal or lower stratum (i.e.,: the inputs to a Stratum 3 clock should NEVER be from a Stratum 4 device). *Synchronization administration changes should never be done without consulting the overall synchronization plan for the network. If you suspect that synchronization administration changes are needed, follow normal escalation procedures.*

## Synchronization Switches Away from the Current Timing Reference

Synchronization will switch away from a DS1 reference (primary or secondary) if the current DS1 reference is not providing a valid timing signal. The other DS1 reference will be used if one is administered and providing a valid timing signal. Otherwise, the local oscillator of the Tone-Clock circuit pack in the same port network as the DS1 reference will be used. The following conditions will cause a synchronization switch:

- The current DS1 reference is not inserted (i.e. **list configuration board UUCSS** shows "no board").
- The current DS1 reference has a loss of signal error (DS1-BD and UDS1-BD error type 1281), a blue alarm error (DS1-BD and UDS1-BD error type 1793), a red alarm error (DS1-BD and UDS1-BD error type 2049), or a hyperactive angel error (DS1-BD and UDS1-BD error type 1538). A corresponding alarm log entry is not required.
- DS1 and UDS1 circuit packs can be administered with slips detection enabled via the **Slip Detection?** field set to a **y** (see the **add ds1**, **change ds1**, and **display ds1** commands). When over half of the DS1 and UDS1 circuit packs administered as slip enabled are experiencing slips, and the primary or secondary synchronization reference is the current synchronization reference, synchronization will try the other administered synchronization reference if the other administered reference does not have the above two conditions. The **list measurements ds1-log** command can be used to get an historical perspective of DS1 facility operation.

The following conditions will cause a switch to the other DS1 reference if one exists and the other DS1 reference is more healthy:

- The current DS1 reference has a misframe error (DS1-BD error type 3329 to 3345 or UDS1-BD error type 3585-3601). A corresponding alarm log entry is not required.
- The current DS1 reference has a slip alarm (DS1-BD and UDS1-BD error type 3073 to 3160). A corresponding alarm log entry is required.

If the above conditions are repaired and no longer apply, synchronization will switch back to the primary reference.

## Tone-Clock Circuit Pack LEDs

The yellow and green LEDs of the TN768 and TN780 Tone-Clock circuit packs flash in a specific pattern to indicate the status of the circuit pack. For example, these flashing LED patterns are used to indicate if a Tone-Clock circuit pack is deriving timing from an external source or whether the Tone-Clock circuit pack is providing the timing signal for the port network.

The yellow and green LED patterns for the TN768 and TN780 Tone-Clock circuit pack are as follows:

**Table 9-596. Tone-Clock Yellow/Green LED Flashing Codes**

Circuit Pack Condition	Tone-Clock State	Explanation
<sup>1</sup> flashing yellow 2.7 seconds on .3 seconds off	active	This light pattern indicates that an external timing source is being used as a synchronization reference.
flashing yellow .3 seconds on 2.7 seconds off	active	This light pattern indicates that the circuit pack is being used as a synchronization reference.
steady yellow on	active	This light pattern indicates that the light has been reset but has not been told which synchronization reference source to use.
steady yellow off	standby	This light pattern indicates that the circuit pack is in standby mode (neither generating tones nor supplying clocks).
"jingle bells" green and yellow .1 seconds on, .2 seconds off, .1 seconds on, .4 seconds off, .4 seconds on, .4 seconds off,	standby	The system is running maintenance tests on the standby circuit pack. (the standby Tone-Clock circuit pack is providing tones.)
other green and yellow	active	The system is running maintenance tests on the active circuit pack

1. The external synchronization reference being used is a primary reference, a secondary reference, or the external stratum 3 clock when the Tone-Clock is in the master port network. The external synchronization reference used in a slave port network is the Expansion Interface circuit pack.

## Error Log Entries and Test to Clear Values

**Table 9-597. Synchronization Maintenance Error Log Entries**

Error Type	Aux Data	Associated Test	Alarm Level	On/Off Board	Test to Clear Value
0 <sup>1</sup>	0	Any	Any	Any	test synchronization
1(a)*		None	WARNING/MINOR(h)	OFF	None
18(b)	0	disable sync	WARNING	OFF	enable sync
257(c)*		None	WARNING/MINOR(h)	OFF	None
513(d)*		None	WARNING/MAJOR(h)	OFF	None
769(e)		None	MAJOR	OFF	None
1793(f) <sup>2</sup>	0-50	None	MAJOR	OFF	None
2049(g) <sup>2</sup>	0	None	WARNING	OFF	None

1. Run the Short Test Sequence first. If all tests pass, run the Long Test Sequence. Refer to the appropriate test description and follow the recommended procedures.
2. It may take up to 1 hour for these alarms to clear via the "leaky bucket" strategy.

### Notes:

- a. This error indicates a problem with the primary DS1 reference. It will be cleared when the primary reference is restored. The following steps should give an indication of the source of the problem:
  1. Check if the primary DS1 interface circuit pack is inserted in the carrier via the **list configuration board UUCSS** command.
  2. Verify that the administered primary reference matches the DS1 reference from the network synchronization plan.
  3. Test the primary DS1 interface circuit pack via the **test board UUCSS long** command. Check the Error Log for DS1-BD or UDS1-BD errors and refer to the DS1-BD or UDS1-BD (DS1 Interface Circuit Pack or UDS1 Interface Circuit Pack) Maintenance documentation to resolve any errors associated with the primary DS1 (DS1 or UDS1) interface circuit pack. If the only errors against DS1-BD or UDS1-BD are slip errors, then follow the procedures described in the troubleshooting section above. If no errors are listed in the Error Log for the primary DS1 interface circuit pack, continue with the following steps.
  4. Test the active Tone-Clock circuit pack in the master port network via the **test tone-clock UUC long** command. Check the Error Log for TDM-CLK errors and verify that TDM Bus Clock Test #148 (TDM Bus Clock Circuit Status Inquiry test) passes successfully. If Test

#148 fails with an Error Code 2 through 32, refer to the TDM-CLK (TDM Bus Clock) Maintenance documentation to resolve the problem. If not, continue with the following steps.

5. Execute the **disable synchronization-switch** and then the **enable synchronization-switch** commands. These two commands (when executed together) will switch the system synchronization reference to the primary DS1 interface circuit pack. Check the Error Log and execute the **status synchronization** command to verify that the primary DS1 interface circuit pack is still the system synchronization reference. If the primary DS1 interface circuit pack is not the system synchronization reference, and the master port network does not have duplicate Tone-Clock circuit packs, escalate the problem. If not, continue with the following step.
6. *Duplicated Tone-Clock circuit packs in the master port network:*  
Switch Tone-Clock circuit packs on the master port network via the **set tone-clock UUC** command, and repeat the disable/enable commands described in the previous step.

Switch Tone-Clock circuit packs on the master port network via the **set tone-clock UUC** command, and repeat the disable/enable commands described in the previous step.

- b. This error indicates that Synchronization Maintenance has been disabled via the **disable synchronization-switch** command. Execute the **enable synchronization-switch** command to enable Synchronization Maintenance reference switching and to resolve this alarm.
- c. This error indicates a problem with the secondary DS1 reference. It will be cleared when the secondary reference is restored. Refer to note (a) to resolve this error substituting **secondary** for **primary** in the preceding resolution steps.
- d. This error indicates that the Tone-Clock circuit pack is providing the timing source for the system. The primary and secondary (if administered) are not providing a valid timing signal. Investigate errors 1 and 257 to resolve this error.
- e. This error indicates that the external Stratum 3 Clock fails to provide the system timing reference. Refer to Stratum 3 Clock Maintenance document to resolve the defective synchronization reference.
- f. This error indicates excessive switching of system synchronization references has occurred. When this error occurs, synchronization is disabled and the Tone-Clock circuit pack (in the master port network) becomes the synchronization reference for the system. Execute the following steps to resolve this error:
  1. Check for timing loops and resolve any loops that exist.
  2. Test the active Tone-Clock circuit pack in the master port network via the **test tone-clock UUC long** command. Check the Error Log for TDM-CLK errors and verify that TDM Bus Clock Test #148 (TDM



Bus Clock Circuit Status Inquiry test) passes successfully. If Test #148 fails with an Error Code 2 through 32, refer to “TDM-CLK” to resolve the problem. If not, continue with the following steps.

3. *Duplicated Tone-Clock circuit packs in the master port network:*  
Switch Tone-Clock circuit packs on the master port network via the **set tone-clock UUC** command.

Switch Tone-Clock circuit packs on the master port network via the **set tone-clock UUC** command.

*For simplex Tone-Clock circuit packs in the master port network:* If this is not a Stratum 3 system, replace the primary and secondary (if administered) DS1 Interface circuit packs.

4. Investigate any other SYNC or STRAT-3 errors.
- g. This error indicates that the Expansion Interface circuit packs are experiencing timing slips. This error will increase the bit error rates for data transmission between port networks. The Expansion Interface circuit packs with timing slips have EXP-INTF error 2305.

1. Check the LEDs on the active Tone-Clock circuit packs in the system and verify that the system is properly synchronized.
2. Verify that all the TDM/LAN Bus cables on the backplane are marked WP-91716. Also for a Multi-Carrier Cabinet (MCC), check that the bus terminator type is a ZAHF4 TDM/LAN.

For a Single Carrier Cabinet verify that the bus terminator type is a AHF110 TDM/LAN.

3. Check for timing loops, and resolve any loops that exist.
4. Check the Error Log for any active as well as resolved Expansion Interface circuit pack errors and refer to EXP-INTF (Expansion Interface Circuit Pack) Maintenance documentation to resolve any errors found.

5. *Duplicated Tone-Clock circuit packs in the slave port networks:*

- Switch Tone-Clock circuit packs in the slave port networks where EXP-INTF error 2305 also occurs via the **set tone-clock UUC** system technician command. The error count for this particular error should start decrementing once the problem is solved—if the count does not decrease in 15 minutes the problem still persists.
- If the problem still persists, switch the Tone-Clock in the slave port network back to the previous configuration. Then, perform a PNC interchange via the **reset pnc interchange** command.
- If the problem still persists, switch the PNC back to the previous configuration via the **reset pnc interchange** command. Then, switch the Tone-Clock circuit packs in the master port network via **set tone-clock UUC**.

- If the problem still persists, switch the Tone-Clock circuit packs in the master port network back to the previous configuration via **set tone-clock UUC**.
- Replace the active Expansion Interface circuit pack in the master port network.
- In a CSS configuration, replace the Switch Node Interface circuit pack connected to the active Expansion Interface circuit pack in the master port network. The **list fiber-link** command can be used to determine the Switch Node Interface circuit pack that is connected to the active Expansion Interface circuit pack in the master port network.
- If the system synchronization reference is a Tone-Clock circuit pack or the Stratum 3 Clock, follow normal escalation procedures. If the system synchronization reference is a DS1 interface circuit pack, administer a different DS1 interface circuit pack as the primary synchronization reference. If the problem still is not resolved and any slip errors remain, follow the procedures described in the troubleshooting section above.

6. *Simplex Tone-Clock circuit packs in the slave port networks:*

- Switch the Tone-Clock circuit packs in the master port network via **set tone-clock UUC**.
- If the problem still persists, switch the Tone-Clock circuit packs in the master port network back to the previous configuration via **set tone-clock UUC**. Test the Tone-Clock circuit packs in the master and slave port networks via the **test tone-clock UUC long** command. Check the Error Log for TDM-CLK errors and verify that TDM Bus Clock Test #148 (TDM Bus Clock Circuit Status Inquiry test) passes successfully. If Test #148 fails with an Error Code 2 through 32, refer to "TDM-CLK" to resolve the problem. If not, continue with the following steps.
- If the master and slave Tone-Clock circuit packs *do not* fail TDM Bus Clock Test #150 (TDM Bus Clock PPM Inquiry test), replace the Expansion Interface circuit packs that have EXP-INTF error 2305.
- If the system synchronization reference is a Tone-Clock circuit pack and the master Tone-Clock circuit pack fails TDM Bus Clock Test #150, follow the steps listed in "TDM-CLK" to replace the master Tone-Clock circuit pack.
- If the system synchronization reference is a DS1 interface circuit pack and the master Tone-Clock circuit pack fails TDM Bus Clock Test #150, the primary or secondary (if administered) synchronization references are not providing valid timing signals for the system. Check the system

synchronization references administered, and follow the steps outlined in note (a) if the primary synchronization reference is providing timing for the system or note (c) if the secondary synchronization reference is providing timing for the system.

- If the slave Tone-Clock circuit pack fails TDM Bus Clock Test #150 but the master Tone-Clock *does not* fail this test, the master Tone-Clock circuit pack must be replaced. Follow the Tone-Clock replacement steps listed in “TDM-CLK”.
- Replace the active Expansion Interface circuit pack in the master port network.
- In a CSS configuration, replace the Switch Node Interface circuit pack connected to the active Expansion Interface circuit pack in the master port network. The **list fiber-link** command can be used to determine the Switch Node Interface circuit pack that is connected to the active Expansion Interface circuit pack in the master port network.
- If the problem still is not resolved and any slip errors remain, follow the procedures described in the troubleshooting section above.

This error is cleared by a leaky bucket strategy and takes one hour to clear (leak away) the error counter once it is alarmed. Therefore, it may take up to one hour to clear the alarm after the problem is cleared.

- h. Noise on the DS1 line can cause transient alarms on synchronization. Therefore, when a sync problem occurs on error types 1, 257, or 513, a WARNING alarm is first raised for 15 to 20 minutes before the alarm is upgraded to a MINOR or MAJOR alarm.

## System Technician-Demanded Tests: Descriptions and Error Codes

Always investigate tests in the order presented in the table below when inspecting errors in the system.

If Stratum 3 is administered via **change synchronization**, the Stratum 3 Clock Alarm Query test (test #649) will also execute when the **test synchronization** command is run. Test 649 is described in the STRAT-3 section.

Order of Investigation	Short Test Sequence	Long Test Sequence	D/ND <sup>1</sup>
Test Synchronization Test (#417)	X	X	ND

1. D = Destructive, ND = Non-destructive

### Test Synchronization Test (#417)

This test updates all the Synchronization Maintenance component circuit packs with the correct information regarding their role in providing synchronization for the system. All the Tone-Clock, Expansion Interface, DS1 Interface and UDS1 Interface circuit packs in the system are updated via this test. This test will either pass or abort.

**Table 9-598. TEST #417 Test Synchronization Test**

Error Code	Test Result	Description/ Recommendation
1000	ABORT	System resources required to run this test are not available. 1. Retry the command at 1-minute intervals a maximum of 3 times.
1115	ABORT	Could not allocate the necessary system resources to run this test. 1. Retry the command at 1-minute intervals a maximum of 3 times.
2500	ABORT	Internal System Error 1. Retry the command at 1-minute intervals a maximum of 3 times.
	PASS	The Synchronization Maintenance component circuit pack parameters have been successfully updated. The system should be synchronized after successful execution of this test. If synchronization problems still exist, refer to the Error Log to obtain information regarding the source of the problem.

## **SYS-LINK (System Links)**

---

MO Name (in Alarm Log)	Alarm Level	Initial Command to Run	Full Name of MO
SYS-LINK	MINOR	test sys-link UUCSSpp	SYSTEM LINKS
SYS-LINK	WARNING	test sys-link UUCSSpp	SYSTEM LINKS

System Links are packet links that originate at the Packet Interface board and traverse various hardware components to specific endpoints. The hardware components involved on the forward and reverse routes can be different, depending upon the configuration and switch administration. Various types of links are defined by their endpoints:

EAL	Expansion Archangel Link terminating at an Expansion Interface board. This link carries CCMS messages.
INL	Indirect Neighbor Link terminating at a Switch Node Interface board
PACL	PNC ATM Control Link terminating at a PNC ATM EI board. This link carries ATM signaling commands from CaPro to the remote TN2238 (ATM-EI) boards.
PGC	Packet Gateway Call-Control Link terminating at a Packet Gateway board
PRI	ISDN PRI D-Channel Link terminating at a Universal DS1 board
SAP	System (Access) Port Link terminating at a Packet Data port
X.25	BX.25 Link terminating at a Packet Gateway port

### **Recording System Link Events**

---

The system links maintenance object records all errors encountered on the links. Most of these events are not extraordinary unless they occur with an alarming frequency. The events are logged as they occur, leaving a "trail" to help analyze abnormal behavior exhibited by the endpoints attached to the links or the links themselves.

When a link goes down, an alarm is raised immediately. For EAL, INL, and PACL link types a MINOR alarm is raised; for all other link types a WARNING alarm is raised. Other alarming conditions that do not cause the link to go down get a WARNING alarm, regardless of the link type.

### **Identifying a System Link**

---

In order to trace problems associated with a system link, it is necessary to find its location. The following methods can be used to find the location of the system link:

## Display Errors/Alarms

The output of the **display errors** or **display alarm** commands shows the location of the system link for entries with a Maintenance Name of SYS-LINK. You can restrict the scope of the output of these commands by specifying **sys-link** in the **Category** field on the input form. The link type and channel number, if any, are listed under the **Alt Name** field of the report.

## List sys-link

The **list sys-link** command lists all system links (location, link type, and channel number) present in the system.

### ⇒ NOTE:

In case of the X.25 link type, a single endpoint carries multiple links. A combination of the endpoint and channel number is used to uniquely identify the link. All other links can be uniquely identified by their endpoints.

## Common Procedure for Repairing Link Problems

The state of a system link is dependent on the state of the various hardware components that it travels over. To resolve any problems associated with a system link, use the following procedure.

The switch maintains a list of hardware components over which the link travels, called the hardware path. There are two hardware paths: the current hardware path and the faulted hardware path for each of the system links. The current hardware path is present only for those links that are currently up. When a link is down, the current hardware path is empty. The faulted hardware path is always present once the link has gone down and is *not cleared when the link subsequently recovers*. The faulted path preserves the path that the link traversed when it last went down. The time at which the faulted path was last recorded is preserved and is accessible through the **status sys-link location** and **list sys-link** commands. Therefore, the focus of attention for problems which do not involve a link that is down is the current hardware path. If the link is down, faulted hardware path is the focus of attention.

The **status sys-link location** command shows the state of both the hardware paths (current and faulted) along with the state of each of the components in the hardware path. When analyzing any system link problem

1. Look for alarms on the components listed under desired hardware path.
2. If any alarms are present, then follow the maintenance procedures for the alarmed components to clear those alarms first.

### ⇒ NOTE:

For systems using ATM EI PNC (TN2238 circuit pack) and where link alarms are present, refer to "[ATM-BCH \(ATM B-Channel Trunk\)](#)" and the "[ATM Tips](#)" section in [Chapter 5](#).

3. When all the components are alarm free, wait for 3 minutes to allow the links to recover.
4. Test the system link (**test sys-link PCSSpp long clear**) and notice any tests that fail.
5. If there are any failures, fix the problems indicated by the tests and repeat the procedure.

## Error Log Entries and Test to Clear Values

Table 9-599. Maintenance Error Log Entries

Error Type	Aux Data	Associated Test	Alarm Level	On/Off Board	Test to Clear Value
13 (a)		System Link Status (985)	MINOR/ WARNING	OFF	
257 (b)			WARNING	OFF	test sys-link UUCSSpp l cl
513 (c)			WARNING	OFF	test sys-link UUCSSpp l cl
772 (d)			WARNING	OFF	test sys-link UUCSSpp l cl
1025 (e)			WARNING	OFF	test sys-link UUCSSpp l cl
1281 (f)			WARNING	OFF	test sys-link UUCSSpp l cl
1537 (g)			WARNING	OFF	test sys-link UUCSSpp l cl
1793 (h)			WARNING	OFF	test sys-link UUCSSpp l cl

Notes:

- a. This error indicates that the link went down. The link may have gone down or never come up. Enter command **status sys-link location** and check the value of the `Faulted Path` field. If the value is `default`, then the link never came up. If the value is `present`, then the link came up and then went down.
  1. Follow the information in the [“Common Procedure for Repairing Link Problems”](#) section above.
  2. Wait for 3-5 min. before checking the link state.
  3. Repeat the procedure until there are no problems with the components.
- b. This error indicates that the link has experienced uplink flow control. Manifest effect of this error is that the end-point may be hyperactive. The system link is alarmed if 4 or more errors of this type are detected within 10 min.

1. Follow the information in the [“Common Procedure for Repairing Link Problems”](#) section above.
  2. Clear errors and wait for 10 min.
- c. This error indicates that the link has experienced downlink flow control, meaning that some information packets from the packet interface board have been lost. The link is reset on first occurrence, hence, Error 1025 is also logged. The system link is alarmed if 2 or more errors of this type are detected within 10 min.
1. Follow the information in the [“Common Procedure for Repairing Link Problems”](#) section above.
  2. Clear errors and wait for 10 min.
- d. This error indicates that the link experienced a temporary disconnect due to excessive resets or state transitions, meaning that the link is taken down and then brought up again. The system link is alarmed if 2 or more errors of this type are detected within 10 min.
1. Follow the information in the [“Common Procedure for Repairing Link Problems”](#) section above.
  2. Clear errors and wait for 10 min.
- e. This error indicates that the link has been reset, meaning that information packets queued at the time of reset are lost. The system link is alarmed if 20 or more errors of this type are detected within 10 min.
1. Follow the information in the [“Common Procedure for Repairing Link Problems”](#) section above.
  2. Clear errors and wait for 10 min.
- f. This error indicates that the link has experienced slow transmit rate because the remote endpoint is busy. The effect of this error is that the endpoint location may experience slower throughput rate and/or noisy transmission. The system link is alarmed if 4 or more errors of this type are detected within 10 min.
1. Ensure that the remote endpoint is functioning properly.
  2. If the problem persists, follow the information in the [“Common Procedure for Repairing Link Problems”](#) section above.
  3. Clear errors and wait for 10 min.
- g. This error indicates that the link has experienced slow transmit rate due to excessive retransmission. Possible causes for this error may be that the switch is overrunning the endpoint or that the endpoint is sick. The effect of this error is that the endpoint location may experience slower throughput rate. The system link is alarmed if 4 or more errors of this type are detected within 10 min.
1. Follow the information in the [“Common Procedure for Repairing Link Problems”](#) section above.



2. Clear errors and wait for 10 min.
- h. This error indicates that the link has experienced slow transmit rate due to unknown causes, meaning that the endpoint location may experience slower throughput rate and the Packet Interface may experience backup or congestion. The system link is alarmed if 4 or more errors of this type are detected within 10 min.
1. Follow the information in the [“Common Procedure for Repairing Link Problems”](#) section above.
  2. Clear errors and wait for 10 min.

## System Technician-Demanded Tests: Descriptions and Error Codes

---

Testing for system links is different from the standard test procedures for Maintenance Objects. In addition to testing the system link maintenance object, the user is allowed to test all the components in the path of the system link. There are two paths preserved for the link. The current path, if present, represents the path traversed by the link currently. This path is not present when the link is down. The other path, the faulted path, is present if the link has ever gone down or never come up. If the link came up and went down, then the faulted path is marked `present`. If the link never came up, the faulted path is marked `Default`. In either case, it represents the path on which the link was attempted or established unsuccessfully.

Test command for the system links, **test sys-link UUCSSpp** can be specified with `current` or `faulted` as an optional argument if the user wishes to test all the components in the specified path. The tests executed will be the same if the user were to test each component manually. In the event that the user does not specify any path, then only the tests specified for the system links are executed.

Order of Investigation	Short Test Sequence	Long Test Sequence	D/ND <sup>1</sup>
System Link Status (#985)	X	X	N

---

1. D = Destructive, ND = Non-destructive

### System Link Status (#985)

This test is non-destructive. This test queries the switch for the status of the system link and verifies that all switch components have the same view of the link state.

**Table 9-600. TEST #985 System Link Status**

Error Code	Test Result	Description/ Recommendation
1007	ABORT	Could not locate the system link associated with this location 1. Retry the command at 1-minute intervals for a maximum of 5 times.
2500	ABORT	Internal system error 1. Retry the command at 1-minute intervals for a maximum of 5 times.
6	FAIL	The system link is down. 1. Follow the procedure for Error Type 13.
	PASS	The system link is up.

## SYS-PRNT (System Printer)

MO Name As It Appears in Alarm Log	Alarm Level	Initial System Technician Command to Run	Full Name of MO
SYS-PRNT	MINOR	test sp-link l	System Printer
SYS-PRNT	WARNING	release sp-link	System Printer

The Report Scheduler feature provides the capability to schedule printing of output from selected administration commands on an asynchronous System Printer (SYS-PRNT) or a Personal Computer (PC). The System Printer device connects to the system via a data module (PDM, MPDM, DTDM) connected to a port on a TN754 Digital Line circuit pack which is administered as a data extension. A System Printer device can also be connected through an ADU to a port on TN726B Data Line circuit pack. The System Printer link to the processor is via a system port. A system port is comprised of a port on the TN726B Data Line circuit pack and a port on the TN553 Packet Data circuit pack connected to each other in a null-modem fashion. Refer to the PDATA-PT section for information on the system port connectivity.

System Printer Link Maintenance provides a strategy for maintaining the link between the system and an external SYS-PRNT output device. The strategy includes a set of tests for detection of errors during normal operation, troubleshooting actions, and alarms for serious problems. System Printer Link Maintenance uses a try-and-wait mechanism for maintaining the SYS-PRNT link. A minor alarm is raised when the link set-up fails. A warning alarm is raised when the SPE has been busied out. A maximum of two link retry attempts is made. After the second attempt, set-up attempts are only made by the application software. (The 15-minute timer fires and jobs are printed unless an immediate job was entered.) After two unsuccessful attempts to establish the link, a MINOR alarm is raised. If the System Printer Link is torn down due to an error, System Printer Link Maintenance will raise a MINOR alarm but will not attempt to bring up the System Printer Link.

System Printer Link Maintenance does not cover the elements comprising the SYS-PRNT physical link: the external SYS-PRNT output device, the Data Module (PDM/MPDM/DTDM) and TN754 Digital Line, or the ADU and TN726B Data Line. If System Printer Link Maintenance cannot restore the System Printer Link, the maintenance tests of these individual components of the System Printer Link must be executed to diagnose faults.

## Procedures for Restoring the System Printer Link

1. Determine the status of the System Printer Link via the **status sp-link** command. Verify that the System Printer Link is not busied out for maintenance. This is indicated by a `no` in the `Maintenance Busy?` field. If the System Printer Link has been busied out, issue the **release sp-link** command. If the link is `down`, proceed to Step 2.
2. Issue the **display system feature** command to determine the location of the System Printer Link.

Enter the **status data-module <extension>** command and verify that the data extension is in-service/idle. If the data extension is *not* available, refer to the `Port` field. Look for errors and/or alarms on the circuit pack with which this extension is associated. Follow repair instructions for the appropriate MO. Continue with Step 3.

3. Verify the availability of the external SYS-PRNT output device. Make sure that the output device is *on-line* and ready-for-service. Check the physical connectivity between the Data Module and the SYS-PRNT output device.
4. Verify that there is at least one system port available. The System Printer Link can not be established unless there is a system port available. Refer to "PDATA-PT" for more information on system ports.
5. If the problem is not found in the above steps, check the system port for any problems. Refer to "PDATA-PT" for description about system port and its connectivity.

It should be noted that when restoring the System Printer link it is necessary to execute tests on different maintenance objects that comprise the System Printer link. It is recommended that you busy out the System Printer link before trying to restore the link. When the System Printer Link is busied out, all System Printer Link maintenance actions are deactivated, and interference with tests of other MOs is prevented.

## Error Log Entries and Test to Clear Values

**Table 9-601. SYS-PRNT Maintenance Error Log Entries**

Error Type	Aux Data	Associated Test	Alarm Level	On/Off Board	Test to Clear Value
0	0	Any	Any	Any	test sp-link
18 (a)	0	busyout sp-link	WARNING	OFF	release sp-link
257(b)	1, 3 4, 5, 6	Link Retry Test (#215)	MINOR/ <sup>1</sup> WARNING	OFF	test sp-link I
513 (c)	0	None	MINOR	OFF	test sp-link

1. Minor alarms may be downgraded to Warning alarms based on the value used in the **set options** command.

### Notes:

- a. The System Printer Link has been busied out.
- b. A failure was encountered while attempting to set up the System Printer Link. This attempt could have been initiated by either Report Scheduler software or by link maintenance during automatic link retry or as a result of a Link Retry Test (#215) request. The Aux Data field indicates the following:

- 1 No system port available. Refer to PDATA-PT for explanation.
- 3, 4 Time-out during setup attempt. Most likely due to problem with physical link or printer status.
- 5 Internal system error. Most likely temporary/sporadic failure.
- 2, 6 The data module the printer is trying to use is busy with another call. Use the **Status data module** command to determine when the port is available for testing.

Refer to the preceding section "Procedures for Restoring the System Printer Link for recommended maintenance strategy.

- c. The SYS-PRNT was interrupted for one of the following reasons:
  - The cable to the SYS-PRNT output device is disconnected
  - The SYS-PRNT output device is powered off
  - The data extension to which the SYS-PRNT output device connects has been busied out
  - Internal software error

Check the connectivity of the wires and cables among the wall jacket, data module, and SYS-PRNT output device. Follow the instructions provided in *Procedures for Restoring the System Printer Link* above.

## System-Technician-Demanded Tests: Descriptions And Error Codes

---

When inspecting errors in the system and deciding which ones to address, always investigate errors in the order they are presented in the table below. By clearing error codes associated with the *Link Retry Test*, for example, you may also clear errors generated from other tests in the testing sequence.

Order of Investigation	Short Test Sequence	Long Test Sequence	D/ND <sup>1</sup>
Link Tear Down Test (#213)		X	D
Link Retry Test (#215)	X	X	ND

---

1. D = Destructive, ND = Non-destructive

### Link Tear Down Test (#213)

**This test is destructive.**

The Link Tear Down Test disconnects the existing link between DEFINITY Generic 3 and the external SYS-PRNT output device. If the link has been disconnected already, this test just returns PASS. All resources allocated for a System Printer Link are released after this test.

**Table 9-602. TEST #213 Link Tear Down Test**

Error Code	Test Result	Description/ Recommendation
40, 50	ABORT	Internal System Error. 1. Retry the command at 1 -minute intervals a maximum of two times.
1010	ABORT	The System Printer Link has been busied out. 1. Enter the <b>release sp-link</b> command to release the System Printer Link from the busyout state. 2. Reissue the <b>test sp-link long</b> command to execute the test.
2012	ABORT	Internal System Error. 1. Retry the command at 1-minute intervals a maximum of five times.
	FAIL	Internal System Error. 1. Retry the command at 1-minute intervals a maximum of two times.
	PASS	The System Printer Link is torn down or a Short Test Sequence was executed and the link was not torn down.

### Link Retry Test (#215)

This test sends a message to the System Printer management software process instructing it to make a data call to the extension connected to the printer. If the System Printer link is already up, this test passes without making any data call.

**Table 9-603. TEST #215 Link Retry Test**

Error Code	Test Result	Description/ Recommendation
10, 20	ABORT	Internal System Error. 1. Retry the command at 1-minute intervals a maximum of two times.
30	ABORT	Internal System Error. 1. Refer to the "Procedures for Restoring the System Printer Link" section for recommended maintenance strategy.
1010	ABORT	The System Printer Link has been busied out. 1. Enter the <b>release sp-link</b> command to release the System Printer Link from the busyout state. 2. Reissue the <b>test sp-link long</b> command to execute the test.
2012	ABORT	Internal System Error. 1. Retry the command at 1-minute intervals a maximum of five times.

*Continued on next page*

**Table 9-603. TEST #215 Link Retry Test — Continued**

Error Code	Test Result	Description/ Recommendation
	FAIL	The System Printer Link CANNOT be established. 1. Refer to the "Procedures for Restoring the System Printer Link" section for recommended maintenance strategy.
	PASS	The System Printer Link is up.

## SYSAM (Circuit Pack)

MO Name (in Alarm Log)	Alarm Level	Initial Command to Run <sup>1</sup>	Full Name of MO
SYSAM	MAJOR <sup>2</sup>	test maintenance UUC I	System Access and Maintenance circuit pack
SYSAM	MINOR	test maintenance UUC s	System Access and Maintenance circuit pack
SYSAM	WARNING	test maintenance UUC s	System Access and Maintenance circuit pack

1. UU is the cabinet number (always 1, not required). C is the carrier designation (a or b). With simplex SPE the carrier location is not required. With duplicated SPEs, carrier a or b must be specified.
2. After a spontaneous SPE interchange has occurred, the Alarm Log retains for three hours a record of any MAJOR ON-BOARD alarm against an SPE component that took place before the interchange. If a spontaneous interchange has occurred (as indicated by STBY-SPE error type 103 or the **display initcauses** screen), and handshake is down, (check with **status spe**), replace the alarmed circuit pack on the standby SPE. If handshake is up, execute a **test long clear** of the alarmed circuit pack and follow recommended procedures.

The System Access and Maintenance (SYSAM) circuit pack, TN1648:

- Is a required component of the SPE Complex
- Monitors the sanity of the RISC Processor circuit pack and environmental conditions
- Provides the serial interface for the G3-MT terminal and the communication interface to INADS or other service locations for alarm reporting and remote maintenance capability
- Provides the Time-Of-Day Clock for the system.



In addition to the usual red, green, and yellow LEDs, the SYSAM circuit pack has alarm, acknowledgment and emergency transfer LEDs whose meanings are explained in the [“SYSAM and Maintenance Circuit Pack LEDs”](#) in [Chapter 7](#).



**NOTE:**

Pay attention to the extra LEDs on the *active* SYSAM only. Indications given by these extra LEDs on a *standby* SYSAM (duplicated SPE) are not meaningful.

**Error Log Entries and Test to Clear Values**

**Table 9-604. SYSAM Error Log Entries**

Error Type	Aux Data	Associated Test	Alarm Level	On/Off Board	Test to Clear Value
0 <sup>1</sup>	0	Any	Any	Any	test processor UUC s r 1
1		SYSAM Reset Test	MAJOR <sup>2</sup>	ON	test maintenance UUC l r 1
150 (a)	Any	None	MAJOR <sup>2</sup>	ON	test maintenance UUC l c
257		Analog Looparound Test (#917)	MINOR	ON	test maintenance UUC l r 3
513 (b)		G3-MT Looparound Test (#915)	MINOR	ON	test maintenance UUC s r 3
769(c)	Any	Sanity Handshake Test	WARNING	OFF	test maintenance UUC s r 3
1025		Out-Pulse Relay Test (#916)	MINOR	OFF	test maintenance UUC l r 5
1281		Time of Day Clock Test	MAJOR <sup>2</sup>	ON	test maintenance UUC s r 3
1537		Sanity Handshake Test	MINOR	ON	test maintenance UUC s r 3
1793(d)	None		WARNING	ON	
2049		SYSAM Dual Port Ram Test	MAJOR <sup>2</sup>	ON	test maintenance UUC l r 1
2561 (e)		G3-MT Looparound Test(#915)	MINOR	ON	test maintenance UUC s r 3
2817 (f)	Any	External Modem Present Test (#912)	MINOR	OFF	test maintenance UUC s r 3

1. Run the Short Test Sequence first. If all tests pass, run the Long Test Sequence. Refer to the appropriate test description and follow the recommended procedures.
2. After a spontaneous SPE interchange has occurred, the Alarm Log retains for three hours a record of any MAJOR ON-BOARD alarm against an SPE component that took place before the interchange. If a spontaneous interchange has occurred (as indicated by STBY-SPE error type 103 or the **display initcauses** screen), and handshake is down, (check with **status spe**), replace the alarmed circuit pack on the standby SPE. If handshake is up, execute a **test long clear** of the alarmed circuit pack and follow recommended procedures.

Notes:

- a. Error 150 indicates that a SPE interchange has occurred and that the SYSAM circuit pack was the cause of the spontaneous interchange.
  1. If other SYSAM errors are present, investigate these errors.
  2. If no other SYSAM errors are present, run the **test maintenance a|b long clear** command and investigate any test failures.
- b. Error 513 indicates that the circuitry associated with active port on the SYSAM circuit pack is not functioning properly. This circuitry can only be tested when the SYSAM is in the active SPE.
- c. Error 769 indicates that one of the following in-line errors has occurred:
  1. The "No Case" error indicates that the SYSAM firmware received a message that does not match any known message format.
  2. The "Background Fault" error indicates that one of the following SYSAM firmware background test failed: CPU Test, EPROM Checksum Test, RAM Test, or NVRAM Checksum Test.
  3. The "Logical Inconsistency" error indicates that the SYSAM firmware has determined that the SYSAM circuit pack is in a logically inconsistent state.

These errors indicate that the SYSAM's sanity may be questionable. SYSAM software will run the Sanity Handshake Test in response to these errors. If these errors are reported repeatedly, SYSAM software will reset the SYSAM circuit pack via the SYSAM Reset Test.

- d. Error 1793 indicates that the Sanity Timer Test initialization test failed on the last time the system rebooted. (Refer to "Routine Maintenance Procedures"). Replace the SYSAM circuit pack and verify that the Sanity Timer Test passes after replacing the circuit pack. To replace the SYSAM circuit pack, refer to ["Replacing SPE Circuit Packs"](#) in Chapter 5.
- e. Error 2561 indicates that the standby G3-MT port on the standby SYSAM circuit pack is not functioning properly. Standby port circuitry on the active SYSAM is not tested.
- f. Error 2817 with aux 2060 indicates that external modem is administered on a switch with an active TN1648 suffix A. The external modem capability requires a TN1648 suffix B or later. Set the `Modem Connection:` field on the System-parameters Maintenance screen to **internal**.

## System Technician-Demanded Tests: Descriptions and Error Codes

Always investigate tests in the order presented in the table below when inspecting errors in the system. By clearing error codes associated with the *SYSAM Reset Test*, for example, you may also clear errors generated from other tests in the testing sequence.

Order of Investigation	Short Test Sequence	Long Test Sequence	Reset Board Sequence	D/ND <sup>1</sup>
SYSAM Reset Test (#909)(a)		X	X	D
SYSAM Dual Port Ram Test (#910)(a)		X	X	D
Sanity Handshake Test (#911)	X	X		ND
Time of Day Clock Test (#913)	X	X		ND
G3-MT Looparound Test (#915)	X	X		ND
Outpulse Relay Test (#916) (b)	X	X		ND
Analog Looparound Test (#917) (b)	X	X		ND
External Modem Present Test (#912) (b)(c)	X	X		ND

1. D = Destructive, ND = Non-destructive

### Notes:

- a. If you are invoking the long test sequence from the PPN G3-MT, the SYSAM Reset Test and SYSAM DPR Test will cause the PPN G3-MT to logoff and tear down any SYSAM Remote Access connection. After the test sequence runs, the Error Log should be examined for SYSAM errors of type 1 and 2049 to determine if either SYSAM Reset Test or SYSAM DPR Test have failed. If you are invoking the long demand test sequence from an EPN G3-MT, all tests listed above will run and the results will display on the EPN G3-MT. The PPN G3-MT will still be logged off and any SYSAM Remote Access connection will be torn down.
- b. These tests can be run only on the active SYSAM circuit pack. If you are invoking the long test sequence on the standby SYSAM circuit pack, these tests (Outpulse Relay Test, Analog Looparound Test, and External Modem Present Test) do not run.
- c. This test aborts if an external modem is not administered.

### SYSAM Reset Test (#909)

**This test is destructive.**

This test resets the SYSAM circuit pack. The destructive nature of this test causes the PPN G3-MT to logoff and any SYSAM Remote Access connection (for example, INADS connection) to be torn down.

The reset test causes terminals connected to the SYSAM either directly or through the remote access port to logoff prior to the test results being displayed. To determine a test result from one of these locations, log back in and examine the Error Log for SYSAM error type 1 with no Aux Data. This error entry indicates that the SYSAM Reset Test failed and that the SYSAM circuit pack should be replaced.

If the test is being run from somewhere other than the SYSAM ports, (for example, a G3-MT connected to an EPN Maintenance circuit pack), test results are displayed on the screen without a logoff taking place.

**Table 9-605. Test #909 SYSAM Reset Test**

Error Code	Test Result	Description/ Recommendation
100	ABORT	The requested test did not complete within the allowable time period. 1. Retry the command.
1000	ABORT	System resources required to run this test are not available. 1. Retry the command at 1-minute intervals, a maximum of 5 times.
1318 1335 2029 2033 2500	ABORT	Internal System Error 1. Retry the command.
1338	ABORT	The test is not allowed to run since a planned SPE interchange is in progress. This may be caused by a planned interchange initiated automatically during 24 hour scheduled testing. 1. Wait 3 minutes and retry the command.
1339	ABORT	The test could not run on the standby SYSAM circuit pack in the standby SPE carrier because the standby SPE is unavailable. 1. Refer to the STBY-SPE maintenance documentation for information on why a standby SPE may be unavailable and what repair actions should be taken. The screen for the <b>status spe</b> command should indicate that handshake is down. This may be caused by a variety of reasons such as the SPE-SELECT switches on the DUPINT circuit packs set as the active SPE, a failure of the DUPINT circuit pack, or loss of power on the standby SPE. The <b>SPE Selected</b> field on the <b>status spe</b> screen displays <b>spe a</b> or <b>spe b</b> if both SPE-SELECT switches are in the a or b positions, respectively.

**Table 9-605. Test #909 SYSAM Reset Test — Continued**

Error Code	Test Result	Description/ Recommendation
2000	ABORT	Response to the test request was not received within the allowable time period. If the system is a High or Critical Reliability configuration and if the SYSAM circuit pack is on the standby SPE, this abort code may indicate that the standby SPE is not responding to the handshake message. If this is the case, the standby SPE maintenance software may take up to two minutes to indicate that handshake communication with the standby SPE is down. The ABORT code then changes to 1339 (standby SPE unavailable). <ol style="list-style-type: none"> <li>1. Retry the command at 1-minute intervals, a maximum of 3 times.</li> </ol>
2334	ABORT	The hardware mailbox on the standby Duplication Interface board is not ready to receive messages. <ol style="list-style-type: none"> <li>1. Retry the command at 1-minute intervals, a maximum of 5 times.</li> </ol>
	FAIL	The circuit pack was reset, but responded with a NOT PASS status indicating it did not pass initialization correctly. The SYSAM is not functioning correctly. The system should continue to operate but will not have the ability to perform alarm origination, if needed. Environmental monitoring, the PPN G3-MT, and the System Sanity Timer are lost. <ol style="list-style-type: none"> <li>1. Retry the command.</li> <li>2. If test continues to fail, replace the SYSAM circuit pack. To replace the SYSAM circuit pack, refer to <a href="#">“Replacing SPE Circuit Packs”</a> in Chapter 5.</li> </ol>
	PASS	The circuit pack was reset, it did pass initialization correctly. The other SYSAM tests should be examined to verify that the SYSAM is functioning normally. <ol style="list-style-type: none"> <li>1. Execute <b>test maintenance a b short</b> and verify that the SYSAM is operating correctly.</li> </ol>

## SYSAM Dual Port RAM Test (#910)

**This test is destructive.**

This test terminates any PPN G3-MT or SYSAM Remote Access session. This is a coordinated test of the Processor circuit pack's and SYSAM circuit pack's on-board microprocessor ability to access the SYSAM's Dual Port RAM (DPR). Control messages and data are passed through the DPR. The test forces both the Processor and the on-board microprocessor to read and write the DPR simultaneously in alternate locations.

The DPR test causes the PPN G3-MT and SYSAM Remote Access sessions to logoff prior to the test result being displayed. To determine the test result, log back in and examine the Error Log for an error against SYSAM, Error Code 2049,

no Aux Data. This error entry indicates that the SYSAM DPR Test failed and that the SYSAM circuit pack should be replaced.

If the test is being run from somewhere other than the PPN G3-MT or SYSAM Remote Access connection (for example, EPN G3-MT), the test results will be displayed on the screen.

**Table 9-606. Test #910 SYSAM Dual Port RAM Test**

Error Code	Test Result	Description/ Recommendation
100	ABORT	The requested test did not complete within the allowable time period. 1. Retry the command.
1000	ABORT	System resources required to run this test are not available. 1. Retry the command at 1-minute intervals, a maximum of 5 times.
1318 1335 2029 2033 2500	ABORT	Internal system error 1. Retry the command.
1338	ABORT	The test is not allowed to run since a planned SPE interchange is in progress. This may be caused by a planned interchange initiated automatically during 24 hour scheduled testing. 1. Wait 3 minutes and retry the command.
1339	ABORT	The test could not run on the standby SYSAM circuit pack in the standby SPE carrier because the standby SPE is unavailable. 1. Refer to the STBY-SPE maintenance documentation for information on why a standby SPE may be unavailable and what repair actions should be taken. The screen for the <b>status spe</b> command should indicate that handshake is down. This may be caused by a variety of reasons such as the SPE-SELECT switches on the DUPINT circuit packs being set to the position of the active SPE, a failure of the DUPINT circuit pack, or loss of power on the standby SPE. The <i>SPE selected</i> field on the <b>status spe</b> screen displays <i>spe a</i> or <i>spe b</i> if both SPE-SELECT switches are in the a or b positions, respectively.
2000	ABORT	Response to the test request was not received within the allowable time period. If the system is a High or Critical Reliability configuration and if the SYSAM circuit pack is on the standby SPE, this abort code may indicate that the standby SPE is not responding to the handshake message. If this is the case, the standby SPE maintenance software may take up to two minutes to indicate that handshake communication with the standby SPE is down. The ABORT code then changes to 1339 (standby SPE unavailable). 1. Retry the command at 1-minute intervals, a maximum of 3 times.

**Table 9-606. Test #910 SYSAM Dual Port RAM Test — Continued**

Error Code	Test Result	Description/ Recommendation
2334	ABORT	The hardware mailbox on the standby Duplication Interface board is not ready to receive messages. 1. Retry the command at 1-minute intervals, a maximum of 5 times.
	FAIL	The DPR is not functioning correctly. Communication between the Processor and SYSAM is lost. The system is not able to report environmental alarms, use the PPN G3-MT, or use the SYSAM Remote Access connection if the need should arise. 1. Retry the command. 2. If the test continues to fail, replace the SYSAM circuit pack. 3. Retry the command. 4. If the test continues to fail, replace the Processor circuit pack. 5. Retry the command. 6. Replace the SPE circuit packs. See <a href="#">"Replacing SPE Circuit Packs"</a> in Chapter 5.
	PASS	Dual Port RAM is functioning. Communication does exist between the Processor and SYSAM circuit packs.

### Sanity Handshake Test (#911)

This test checks the SYSAM circuit pack's ability to respond to queries. A message is sent to the SYSAM circuit pack, which then returns a message. The SYSAM must reply for this test to pass. If this test fails, the SYSAM circuit pack should be considered insane, the circuit pack should be reset with the **reset maintenance a | b** command.

**Table 9-607. Test #911 Sanity Handshake Test**

Error Code	Test Result	Description/ Recommendation
100	ABORT	The requested test did not complete within the allowable time period. 1. Retry the command.
1000	ABORT	System resources required to run this test are not available. 1. Retry the command at 1-minute intervals, a maximum of 5 times.

*Continued on next page*

Table 9-607. Test #911 Sanity Handshake Test — Continued

Error Code	Test Result	Description/ Recommendation
1318 1335 2029 2033 2500	ABORT	Internal system error  1. Retry the command.
1338	ABORT	The test is not allowed to run since a planned SPE interchange is in progress. This may be caused by a planned interchange initiated automatically during 24 hour scheduled testing.  1. Wait 3 minutes and retry the command.
1339	ABORT	The test could not run on the standby SYSAM circuit pack in the standby SPE carrier because the standby SPE is unavailable.  1. Refer to the STBY-SPE maintenance documentation for information on why a standby SPE may be unavailable and what repair actions should be taken. The screen for the <b>status spe</b> command should indicate that handshake is down. This may be caused by a variety of reasons such as the SPE-SELECT switches on the DUPINT circuit packs being set to the position of the active SPE, a failure of the DUPINT circuit pack, or loss of power on the standby SPE. The <code>SPE selected</code> field on the <b>status spe</b> screen displays <code>spe a</code> or <code>spe b</code> if both SPE-SELECT switches are in the <code>a</code> or <code>b</code> positions, respectively.
2000	ABORT	Response to the test request was not received within the allowable time period. If the system is equipped with the High Reliability or Critical Reliability Configuration and if the SYSAM circuit pack is on the standby SPE, this abort code may indicate that the standby SPE is not responding to the handshake message. If this is the case, the standby SPE maintenance software may take up to two minutes to indicate that handshake communication with the standby SPE is down. The ABORT code then changes to 1339 (standby SPE unavailable).  1. Retry the command at 1-minute intervals, a maximum of 3 times.
2318	ABORT	The standby SYSAM was not responding within the allowable time period.  1. Retry the command at 1-minute intervals, a maximum of 3 times.
2334	ABORT	The hardware mailbox on the standby Duplication Interface board is not ready to receive messages.  1. Retry the command at 1-minute intervals, a maximum of 5 times.

*Continued on next page*



**Table 9-607. Test #911 Sanity Handshake Test — Continued**

Error Code	Test Result	Description/ Recommendation
	FAIL	The SYSAM did not respond to the sanity handshake query. <ol style="list-style-type: none"> <li>1. Run the <b>test maintenance 1a b long</b> command. The terminal login drops, and you must login again.</li> <li>2. If test continues to fail, replace the SYSAM circuit pack at the earliest convenience.</li> <li>3. Retry the command.</li> <li>4. Replace the SYSAM circuit pack. To replace the SYSAM circuit pack, refer to <a href="#">"Replacing SPE Circuit Packs"</a> in Chapter 5.</li> </ol>
	PASS	The SYSAM did respond to the sanity handshake query. <ol style="list-style-type: none"> <li>1. Examine other SYSAM tests for errors.</li> </ol>

### SYSAM Refresh Test (#912)

This test checks the current state of the Alarm Panel LEDs on the SYSAM circuit pack and attempts to resynchronize them to reflect the current alarm levels in the system. Any discrepancies are resolved by changing the Alarm Panel LEDs to what maintenance believes the alarm levels should be. The SYSAM Refresh Test runs only in G3r V1 software loads preceding Release 6.0. Newer software has replaced the SYSAM Refresh Test with the External Modem Present Test (*both* use the Test #912 number).

**Table 9-608. Test #912 SYSAM Refresh Test**

Error Code	Test Result	Description/ Recommendation
100	ABORT	The requested test did not complete within the allowable time period. <ol style="list-style-type: none"> <li>1. Retry the command.</li> </ol>
1000	ABORT	System resources required to run this test are not available. <ol style="list-style-type: none"> <li>1. Retry the command at 1-minute intervals, a maximum of 5 times.</li> </ol>
1318 1335 2029 2033 2500	ABORT	Internal system error <ol style="list-style-type: none"> <li>1. Retry the command.</li> </ol>

**Table 9-608. Test #912 SYSAM Refresh Test — Continued**

Error Code	Test Result	Description/ Recommendation
1338	ABORT	The test is not allowed to run since a planned SPE interchange is in progress. This may be caused by a planned interchange initiated automatically during 24 hour scheduled testing.  1. Wait 3 minutes and retry the command.
1339	ABORT	The test could not run on the standby SYSAM circuit pack in the standby SPE carrier because the standby SPE is unavailable.  1. Refer to the STBY-SPE maintenance documentation for information on why a standby SPE may be unavailable and what repair actions should be taken. The screen for the <b>status spe</b> command should indicate that handshake is down. This may be caused by a variety of reasons such as the SPE-SELECT switches on the DUPINT circuit packs being set to the position of the active SPE, a failure of the DUPINT circuit pack, or loss of power on the standby SPE. The <code>SPE selected</code> field on the <b>status spe</b> screen displays <code>spe a</code> or <code>spe b</code> if both SPE-SELECT switches are in the a or b positions, respectively.
2000	ABORT	Response to the test request was not received within the allowable time period. If the system is a High or Critical Reliability configuration and if the SYSAM circuit pack is on the standby SPE, this abort code may indicate that the standby SPE is not responding to the handshake message. If this is the case, the standby SPE maintenance software may take up to two minutes to indicate that handshake communication with the standby SPE is down. The ABORT code then changes to 1339 (standby SPE unavailable).  1. Retry the command at 1-minute intervals, a maximum of 3 times.
2005	FAIL	Could not handshake with the SYSAM circuit pack. The SYSAM circuit pack did not respond to a query message sent to it. Run the <b>test maintenance a b short</b> , and refer to the repair procedures outlined for the Sanity Handshake Test.
2318	ABORT	The standby SYSAM was not responding within the allowable time period.  1. Retry the command at 1-minute intervals, a maximum of 3 times.
2334	ABORT	The hardware mailbox on the standby Duplication Interface board is not ready to receive messages.  1. Retry the command at 1-minute intervals, a maximum of 5 times.

*Continued on next page*

**Table 9-608. Test #912 SYSAM Refresh Test — Continued**

Error Code	Test Result	Description/ Recommendation
	FAIL	Internal System Error 1. Retry the command
	PASS	The SYSAM circuit pack has been sent the correct state for the system LEDs. If the LEDs do not reflect the system alarms shown in the alarm log, the SYSAM circuit pack may have problems.  1. Verify the LEDs on the SYSAM circuit pack can be changed by issuing the <b>test led port-network 1</b> command. All the SYSAM circuit pack LEDs should go on and then off, and then be refreshed.  2. After the <b>test led port-network 1</b> command finishes, if the SYSAM circuit pack LEDs do not reflect the alarm log, follow normal escalation procedures.

**Time-Of-Day Clock Test (#913)**

The short term accuracy of the time-of-day clock is tested. The test reads the clock once, waits 10 seconds, and then reads the clock again. The second reading of the clock must be within certain limits (10 seconds) relative to the first reading for the test to pass. The **display time** command can be used to display the current setting of the time-of-day clock.

If the time-of-day clock is not functioning correctly, the software time-of-day clock is used (this clock is not as accurate as the hardware clock).

**Table 9-609. Test #913 Time-Of-Day Clock Test**

Error Code	Test Result	Description/ Recommendation
100	ABORT	The requested test did not complete within the allowable time period. 1. Retry the command.
1000	ABORT	System resources required to run this test are not available. 1. Retry the command at 1-minute intervals, a maximum of 5 times.

*Continued on next page*

**Table 9-609. Test #913 Time-Of-Day Clock Test — Continued**

Error Code	Test Result	Description/ Recommendation
1318 1335 2029 2033 2500	ABORT	Internal system error  1. Retry the command.
1338	ABORT	The test is not allowed to run since a planned SPE interchange is in progress. This may be caused by a planned interchange initiated automatically during 24 hour scheduled testing.  1. Wait 3 minutes and retry the command.
1339	ABORT	The test could not run on the standby SYSAM circuit pack in the standby SPE carrier because the standby SPE is unavailable.  1. Refer to the STBY-SPE maintenance documentation for information on why a standby SPE may be unavailable and what repair actions should be taken. The screen for the <b>status spe</b> command should indicate that handshake is down. This may be caused by a variety of reasons such as the SPE-SELECT switches on the DUPINT circuit packs being set to the position of the active SPE, a failure of the DUPINT circuit pack, or loss of power on the standby SPE. The <code>SPE selected</code> field on the <b>status spe</b> screen displays <code>spe a</code> or <code>spe b</code> if both SPE-SELECT switches are in the a or b positions, respectively.
2000	ABORT	Response to the test request was not received within the allowable time period. If the system is a High or Critical Reliability configuration and if the SYSAM circuit pack is on the standby SPE, this abort code may indicate that the standby SPE is not responding to the handshake message. If this is the case, the standby SPE maintenance software may take up to two minutes to indicate that handshake communication with the standby SPE is down. The ABORT code then changes to 1339 (standby SPE unavailable).  1. Retry the command at 1-minute intervals, a maximum of 3 times.
2318	ABORT	The standby SYSAM was not responding within the allowable time period.  1. Retry the command at 1-minute intervals, a maximum of 3 times.
2334	ABORT	The hardware mailbox on the standby Duplication Interface board is not ready to receive messages.  1. Retry the command at 1-minute intervals, a maximum of 5 times.

*Continued on next page*

**Table 9-609. Test #913 Time-Of-Day Clock Test — Continued**

Error Code	Test Result	Description/ Recommendation
any	FAIL	<p>The short term accuracy of the time-of-day clock is not within limits (10 seconds <math>\geq</math> difference <math>\leq</math> 20 seconds).</p> <p><b>⇒ NOTE:</b>                      Error Code <i>any</i> indicates the difference between the two reads. A zero (0) indicates that the time-of-day clock is not running.</p> <ol style="list-style-type: none"> <li>1. Run the short test sequence several times to make sure the error is occurring consistently.</li> <li>2. If test continues to fail consistently, replace the SYSAM circuit pack at the earliest convenience.</li> <li>3. After replacing the SYSAM, you must set the time-of-day clock via the <b>set time</b> command. To replace the SYSAM circuit pack, refer to <a href="#">“Replacing SPE Circuit Packs”</a> in Chapter 5.</li> </ol>
	PASS	<p>The short term accuracy of the time-of-day clock on the SYSAM circuit pack is within limits.</p>

### SYSAM G3-MT Looparound Test (#915)

This test places the G3-MT port on the SYSAM circuit pack into loop-around mode and verifies the data integrity of the channel. The test is non-destructive but may cause a momentary loss of keyboard input from the G3-MT while the test is running (about 1 second).

On High and Critical Reliability systems, there are two G3-MT ports on each of the two SYSAM circuit packs: one is labeled ACTIVE and the other STANDBY. On the current active SYSAM circuit pack, only the ACTIVE port is tested. On the current standby SYSAM circuit pack, only the STANDBY port is tested.

**Table 9-610. TEST #915 SYSAM G3-MT Looparound Test**

Error Code	Test Result	Description/ Recommendation
100	ABORT	The requested test did not complete within the allowable time period. 1. Retry the command.
1000	ABORT	System resources required to run this test are not available. 1. Retry the command at 1-minute intervals, a maximum of 5 times.
1318 1335 2029 2033 2500	ABORT	Internal system error 1. Retry the command.
1338	ABORT	The test is not allowed to run with a planned SPE interchange in progress. This may be caused by a planned interchange initiated automatically during 24 hour scheduled testing. 1. Wait 3 minutes and retry the command.
1339	ABORT	The test could not run on the standby SYSAM circuit pack in the standby SPE carrier because the standby SPE is unavailable. 1. Refer to the STBY-SPE maintenance documentation for information on why a standby SPE may be unavailable, and related repair actions. The screen for the <b>status spe</b> command should indicate that handshake is down. This may be caused by a variety of reasons such as the SPE-SELECT switches on the DUPINT circuit packs being set to the position of the active SPE, a failure of the DUPINT circuit pack, or loss of power on the standby SPE. The <b>SPE selected</b> field on the <b>status spe</b> screen displays <b>spe a</b> or <b>spe b</b> if both SPE-SELECT switches are in the a or b positions, respectively.
2000	ABORT	Response to the test request was not received within the allowable time period. If the system is equipped with the High Reliability or Critical Reliability Configuration and if the SYSAM circuit pack is on the standby SPE, this abort code may indicate that the standby SPE is not responding to the handshake message. If this is the case, the standby SPE maintenance software may take up to two minutes to indicate that handshake communication with the standby SPE is down. The ABORT code then changes to 1339 (standby SPE unavailable). 1. Retry the command at 1-minute intervals, a maximum of 3 times.
2334	ABORT	The hardware mailbox on the standby Duplication Interface board is not ready to receive messages. 1. Retry the command at 1-minute intervals, a maximum of 5 times.

*Continued on next page*

**Table 9-610. TEST #915 SYSAM G3-MT Looparound Test — Continued**

Error Code	Test Result	Description/ Recommendation
2318	FAIL	<p>The STANDBY port on the SYSAM circuit pack on the standby SPE did not respond to the test in time. If this test fails at least 3 times in a row, the STANDBY port is probably unusable for diagnostics through the SPE-Down or SPE-Standby Interfaces. Other than this unavailability, this failure should cause no service effects.</p> <ol style="list-style-type: none"> <li>1. Try the test again at 1-minute intervals up to a maximum of 3 times.</li> <li>2. If the test fails all 3 attempts, replace the standby SYSAM circuit pack at the earliest convenience. To replace the SYSAM circuit pack, refer to <a href="#">“Replacing SPE Circuit Packs”</a> in Chapter 5.</li> </ol>
	FAIL	<p>The SYSAM G3-MT channel failed the loop around test. The G3-MT will probably be unusable for administration or maintenance. The EPN G3-MT, if available, or remote access can still be used.</p> <ol style="list-style-type: none"> <li>1. Retry the command.</li> <li>2. If test continues to fail, replace the SYSAM circuit pack at the earliest convenience. To replace the SYSAM circuit pack, refer to <a href="#">“Replacing SPE Circuit Packs”</a> in Chapter 5.</li> </ol>
	PASS	<p>The G3-MT channel passed the loop around test.</p> <ol style="list-style-type: none"> <li>1. If the PPN G3-MT is not usable, check the G3-MT and associated cabling.</li> </ol>

### **SYSAM Outpulse Relay Test (#916)**

This test validates the operation of the SYSAM Remote Access CO trunk used for Alarm Origination and remote access. The SYSAM goes off-hook and then on-hook on this trunk. If loop current is detected then the test passes. If the external modem is administered, the SYSAM sends an AT command sequence that causes the external modem to go off-hook and wait for dial-tone. If the modem detects dial-tone, the test passes.

This test is not allowed if the remote access line is in use or if the SYSAM is on the Standby SPE in SPE Duplication Option systems. Also, this test must be administered for testing through the **change system-parameters maintenance** form.

**⇒ NOTE:**

When using an active TN1648 (prior to suffix B), and even though the modem is administered as “external,” this only tests the internal modem.

**Table 9-611. TEST #916 SYSAM Outpulse Relay Test**

Error Code	Test Result	Description/ Recommendation
100	ABORT	The requested test did not complete within the allowable time period. 1. Retry the command.
1000	ABORT	System resources required to run this test are not available. 1. Retry the command at 1-minute intervals, a maximum of 5 times.
1018	ABORT	The test has been disabled via administration. 1. To enable test, set the <code>Test Remote Access Port</code> field to <b>y</b> on the system-parameters maintenance screen. 2. Retry the command.
1318 1335 2029 2033 2500	ABORT	Internal system error 1. Retry the command.
1338	ABORT	The test is not allowed to run since a planned SPE interchange is in progress. This may be caused by a planned interchange initiated automatically during 24 hour scheduled testing. 1. Wait 3 minutes and retry the command.
1339	ABORT	The test could not run on the standby SYSAM circuit pack in the standby SPE carrier because the standby SPE is unavailable. 1. Refer to the STBY-SPE maintenance documentation for information on why a standby SPE may be unavailable and what repair actions should be taken. The screen for the <b>status spe</b> command should indicate that handshake is down. This may be caused by a variety of reasons such as the SPE-SELECT switches on the DUPINT circuit packs being set to the position of the active SPE, a failure of the DUPINT circuit pack, or loss of power on the standby SPE. The <code>SPE selected</code> field on the <b>status spe</b> screen displays <code>spe a</code> or <code>spe b</code> if both SPE-SELECT switches are in the a or b positions, respectively.
1364	ABORT	The component on which the test was to be run is on the Standby SPE. This test may only be run on this component when it resides on the Active SPE. 1. To verify the remote access line is working (connected), run this on the Active SYSAM.
1379	ABORT	System could not determine if testing of remote access port is administered. 1. Check system-parameters maintenance screen for a <b>y</b> in the <code>Test Remote Access Port</code> field. 2. Retry the command.

*Continued on next page*



**Table 9-611. TEST #916 SYSAM Outpulse Relay Test — Continued**

Error Code	Test Result	Description/ Recommendation
2000	ABORT	<p>Response to the test request was not received within the allowable time period. If the system is s High or Critical Reliability configuration and if the SYSAM circuit pack is on the standby SPE, this abort code may indicate that the standby SPE is not responding to the handshake message. If this is the case, the standby SPE maintenance software may take up to two minutes to indicate that handshake communication with the standby SPE is down. The ABORT code then changes to 1339 (standby SPE unavailable).</p> <ol style="list-style-type: none"> <li>1. Retry the command at 1-minute intervals, a maximum of 3 times.</li> </ol>
2034	ABORT	<p>The remote access port is busy. A remote user is probably dialed into the switch.</p> <ol style="list-style-type: none"> <li>1. If a remote user is dialed in, remote access line is working. No need to run test. Use the <b>status logins</b> command to verify that the SYSAM-RMT port is in use.</li> </ol>
	FAIL	<p>SYSAM reported test failure. No loop current detected.</p> <ol style="list-style-type: none"> <li>1. Retry the command.</li> <li>2. For an external modem, if the test continues to fail:                         <ol style="list-style-type: none"> <li>a. If the External Modem Present Test (#912) failed, use the external modem recommendations listed in Test #912.</li> <li>b. If the External Modem Present Test (#912) passes, the SYSAM most likely received a NO DIALTONE response to the ATD command sent from the SYSAM. This problem is between the modem and the INADS trunk.</li> </ol> </li> <li>3. If test continues to fail, examine SYSAM remote access line for connectivity, manually check line for loop current.</li> <li>4. If SYSAM remote access line checks out fine, but test still fails, check backplane connector cabling. Also, check the cabling from the wall field to the backplane.</li> <li>5. If backplane cabling checks out fine, replace SYSAM circuit pack at earliest convenience. To replace the SYSAM circuit pack, refer to "Replacing SPE Circuit Packs" in Chapter 5.</li> </ol>
	PASS	<p>SYSAM detected loop current on remote access port.</p> <ol style="list-style-type: none"> <li>1. If system cannot call remote maintenance facility or remote maintenance facility cannot contact system, check with local Central Office for problems with SYSAM remote access line.</li> </ol>

## SYSAM Analog Looparound Test (#917)

This test checks the on-board modem circuitry of the SYSAM circuit pack associated with the SYSAM remote access port. Test data is looped through the on-board modem and verified for integrity. If the external modem is administered, the test loops data in the MTP DUART ahead of the connection to the external modem. This test also causes the MTP DUART to verify that Clear-To-Send (CTS) is being supplied by the modem.

This test is not allowed if the remote access port is in use or if the SYSAM is on the Standby SPE in SPE Duplication Option systems. Also, this test must be administered for testing through the **change system-parameters maintenance** screen.

**⇒ NOTE:**

This test does not send any data onto the SYSAM remote access line, but the test does require the line to be present to pass reliably.

**⇒ NOTE:**

When using an active TN1648 (prior to suffix B), and even though the modem is administered as “external,” this only tests the internal modem.

**Table 9-612. TEST #917 SYSAM Analog Looparound Test**

Error Code	Test Result	Description/ Recommendation
100	ABORT	The requested test did not complete within the allowable time period. 1. Retry the command.
1000	ABORT	System resources required to run this test are not available. 1. Retry the command at 1-minute intervals, a maximum of 5 times.
1018	ABORT	The test has been disabled by administration. 1. To enable test, set the <code>Test Remote Access Port</code> field to <b>y</b> on the system-parameters maintenance screen. 2. Retry the command.
1318 1335 2029 2033 2500	ABORT	Internal System Error 1. Retry the command.
1338	ABORT	The test is not allowed to run since a planned SPE interchange is in progress. This may be caused by a planned interchange initiated automatically during 24 hour scheduled testing. 1. Wait 3 minutes and retry the command.

**Table 9-612. TEST #917 SYSAM Analog Looparound Test — Continued**

Error Code	Test Result	Description/ Recommendation
1339	ABORT	<p>The test could not run on the standby SYSAM circuit pack in the standby SPE carrier because the standby SPE is unavailable.</p> <ol style="list-style-type: none"> <li>1. Refer to the STBY-SPE maintenance documentation for information on why a standby SPE may be unavailable and what repair actions should be taken. The screen for the <b>status spe</b> command should indicate that handshake is down. This may be caused by a variety of reasons such as the SPE-SELECT switches on the DUPINT circuit packs being set to the position of the active SPE, a failure of the DUPINT circuit pack, or loss of power on the standby SPE. The <code>SPE selected</code> field on the <b>status spe</b> screen displays <code>spe a</code> or <code>spe b</code> if both SPE-SELECT switches are in the a or b positions, respectively.</li> </ol>
1364	ABORT	<p>The component on which the test was to be run is on the Standby SPE. This test may only be run on this component when it resides on the Active SPE.</p> <ol style="list-style-type: none"> <li>1. To verify the remote access line is working (connected), run this on the Active SYSAM.</li> </ol>
1379	ABORT	<p>System could not determine if testing of remote access port is administered.</p> <ol style="list-style-type: none"> <li>1. Check system-parameters maintenance screen for a <b>y</b> in the <code>Test Remote Access Port</code> field.</li> <li>2. Retry the command.</li> </ol>
2000	ABORT	<p>Response to the test request was not received within the allowable time period. If the system is a High or Critical Reliability configuration and if the SYSAM circuit pack is on the standby SPE, this abort code may indicate that the standby SPE is not responding to the handshake message. If this is the case, the standby SPE maintenance software may take up to two minutes to indicate that handshake communication with the standby SPE is down. The ABORT code then changes to 1339 (standby SPE unavailable).</p> <ol style="list-style-type: none"> <li>1. Retry the command at 1-minute intervals, a maximum of 3 times.</li> </ol>
2034	ABORT	<p>The remote access port is busy. A remote user is probably dialed into the switch.</p> <ol style="list-style-type: none"> <li>1. Wait until the remote user session is terminated, retry the command.</li> </ol>
2317	ABORT	<p>Test #916 SYSAM Outpulse Relay Test failed.</p> <ol style="list-style-type: none"> <li>1. Follow instructions for FAIL result for SYSAM Outpulse Relay Test (#916).</li> </ol>

*Continued on next page*

**Table 9-612. TEST #917 SYSAM Analog Looparound Test — Continued**

Error Code	Test Result	Description/ Recommendation
	FAIL	<p>SYSAM reported test failure. The system is not able to reliably contact any remote maintenance facility with alarm data or dialed into through the SYSAM remote access port. The system continues to provide reliable service.</p> <ol style="list-style-type: none"> <li>1. For an internal modem:                             <ol style="list-style-type: none"> <li>a. If SYSAM Outpulse Relay test (#916) is also failing, check for presence of SYSAM remote access line and resolve SYSAM remote access line problems.</li> <li>b. If test #916 passes, the fault is on the SYSAM circuit pack, replace at the earliest convenience. To replace the SYSAM circuit pack, refer to "Replacing SPE Circuit Packs" in Chapter 5.</li> </ol> </li> <li>2. For an external modem:                             <ol style="list-style-type: none"> <li>a. Check the power to the modem.</li> <li>b. Check the RS-232 connection from the external modem connector to the modem. Transmit, Receive, RTS, and CTS signals must be communicating between the MTP DUART hardware and the modem hardware.</li> <li>c. The SYSAM DUART or related circuitry on the processor circuit pack may have failed. The circuit pack should be changed at your convenience.</li> </ol> </li> </ol>
	PASS	<p>SYSAM detected correct data through loop around connection.</p> <ol style="list-style-type: none"> <li>1. If system cannot call remote maintenance facility or remote maintenance facility cannot contact system, check with local Central Office for problems with SYSAM remote access line.</li> </ol>

### **SYSAM External Modem Present Test (#912)**

This test is a nondestructive test on the remote access line, and will run only if the channel is idle. The test validates the presence of an external modem with a firmware invoked AT command. The test passes if the modem responds with "OK" to the AT command. This test also validates external modem administration. This test will fail if an external modem is administered on a switch with an active TN1648 suffix A.

This test is not allowed if the remote access line is in use or if the SYSAM is on the Standby SPE in SPE Duplication Option systems. Also, this test must be administered for testing through the **change system-parameters maintenance** screen.

**Table 9-613. TEST #912 SYSAM External Modem Present Test**

Error Code	Test Result	Description/ Recommendation
100	ABORT	The requested test did not complete within the allowable time period. 1. Retry the command.
1000	ABORT	System resources required to run this test are not available. 1. Retry the command at 1-minute intervals, a maximum of 5 times.
1018	ABORT	The test has been disabled by administration. 1. To enable test, set the <code>Test Remote Access Port</code> field to <b>y</b> on the system-parameters maintenance screen. 2. Retry the command.
1049	ABORT	External modem is not administered. When using an active TN1648 (prior to suffix B), this abort code is normal, because only this test only applies to external modems.
1318 1335 2029 2033 2500	ABORT	Internal system error 1. Retry the command.
1338	ABORT	The test is not allowed to run since a planned SPE interchange is in progress. This may be caused by a planned interchange initiated automatically during 24 hour scheduled testing. 1. Wait 3 minutes and retry the command.
1339	ABORT	The test could not run on the standby SYSAM circuit pack in the standby SPE carrier because the standby SPE is unavailable. 1. Refer to the <a href="#">“STBY-SPE (Standby SPE Maintenance)”</a> documentation for information on why a standby SPE may be unavailable and what repair actions should be taken. The screen for the <b>status spe</b> command should indicate that handshake is down. This may be caused by a variety of reasons such as the SPE-SELECT switches on the DUPINT circuit packs being set to the position of the active SPE, a failure of the DUPINT circuit pack, or loss of power on the standby SPE. The <code>SPE selected</code> field on the <b>status spe</b> screen displays <code>spe a</code> or <code>spe b</code> if both SPE-SELECT switches are in the a or b positions, respectively.
1364	ABORT	The component on which the test was to be run is on the Standby SPE. This test may only be run on this component when it resides on the Active SPE. 1. To verify the remote access line is working (connected), run this on the Active SYSAM.

*Continued on next page*

**Table 9-613. TEST #912 SYSAM External Modem Present Test — Continued**

Error Code	Test Result	Description/ Recommendation
1379	ABORT	System could not determine if testing of remote access port is administered. <ol style="list-style-type: none"> <li>1. Check system-parameters maintenance screen for a <b>y</b> in the <code>Test Remote Access Port</code> field.</li> <li>2. Retry the command.</li> </ol>
2000	ABORT	Response to the test request was not received within the allowable time period. If the system is a High or Critical Reliability configuration and if the SYSAM circuit pack is on the standby SPE, this abort code may indicate that the standby SPE is not responding to the handshake message. If this is the case, the standby SPE maintenance software may take up to two minutes to indicate that handshake communication with the standby SPE is down. The ABORT code will then change to 1339 (standby SPE unavailable). <ol style="list-style-type: none"> <li>1. Retry the command at 1-minute intervals, a maximum of 3 times.</li> </ol>
2034	ABORT	The remote access port is busy. A remote user has probably dialed into the switch. <ol style="list-style-type: none"> <li>1. If a remote user is dialed in, remote access line is working. No need to run test. Use the <b>status logins</b> command to verify that the SYSAM-RMT port is in use.</li> </ol>
2080	FAIL	An external modem is administered on a switch with an active TN1648 (prior to suffix B.) <ol style="list-style-type: none"> <li>1. Set the <code>Modem Connection:</code> field on the system-parameters maintenance screen to <b>internal</b>. (The external modem capability requires a TN1648 suffix B or later.)</li> <li>2. Retry the command.</li> </ol>

*Continued on next page*

**Table 9-613. TEST #912 SYSAM External Modem Present Test — Continued**

Error Code	Test Result	Description/ Recommendation
	FAIL	<p>SYSAM reported test failure. The SYSAM did not receive an "OK" response after sending the "AT" command to the modem.</p> <ol style="list-style-type: none"> <li>1. If the Analog Looparound Test (#917) failed, follow the external modem recommendations for that failure.</li> <li>2. If the Analog Looparound Test (#917) passes:                             <ol style="list-style-type: none"> <li>a. Check the RS-232 connection from the external modem connector to the modem. RTS and CTS signal are being communicated between the SYSAM DUART hardware and the modem hardware. Transmit and receive signals may not be communicated correctly.</li> <li>b. Check the modem administration using the change system-parameters maintenance command, especially changes from default parameters.</li> <li>c. Check the modem settings, especially changes from factory defaults.</li> </ol> </li> </ol> <p><b>⇒ NOTE:</b>                      The fault may be on the SYSAM circuit pack. The circuit pack may need to be replaced.</p>
	PASS	<p>Modem administration matches SYSAM capability and SYSAM detected loop current on remote access port.</p> <ol style="list-style-type: none"> <li>1. If system cannot call remote maintenance facility or remote maintenance facility cannot contact system, check with local Central Office for problems with SYSAM remote access line.</li> </ol>

## SYSTEM (System)

---

MO Name ( in Alarm Log)	Alarm Level	Initial Command to Run <sup>1</sup>	Full Name of MO
SYSTEM	None	None	System

1. SYSTEM has no associated alarms and thus appears only in the Error Log. There are no tests that run on SYSTEM.

The SYSTEM maintenance object is used to log information about system resets, including interchanges. When software encounters a problem with hardware, or with its own processes, and requests a restart to clear the problem, an error is logged under SYSTEM. For example, if there is a loss of clock in the Processor Port Network (PPN) in a system with duplicated SPEs, the system switches to the other clock and then executes a level 2 system reset to recover from hardware problems caused by the loss of clock. Errors logged under SYSTEM can help to determine the cause of a reset. The **display initcauses** screen should also contain information about the reset. See [“Troubleshooting a Duplicated SPE”](#) in [Chapter 5](#) for more information about interchanges.



## Error Log Entries and Test to Clear Values

**Table 9-614. System Error Log Entries**

Error Type	Aux Data	Associated Test	Alarm Level	On/Off Board	Test to Clear Value
8 (a)	0	None			
9 (b)	Any	None			
10 (c)	Any	None			
601 (d)	Any	None			
602 (e)	Any	None			
605 (f)	(p)	None			
606 (g)	Any	None			
607 (h)	Any	None			
6001 (i)	Any	None			
6002 (j)	(o)	None			
6003 (k)	(o)	None			
6101 (l)	Any	None			
6102 (m)	(o)	None			
6103 (n)	(o)	None			

**Notes:**

- a. Software requested a System Restart Level 3.
- b. Software requested a System Restart Level 2.
- c. Software requested a System Restart Level 1.
- d. An error occurred during initialization.
- e. Translation data was corrupted, so the system requested a Restart Level 3 to reload translation data from the Mass Storage System (MSS).
- f. A **reset system interchange** or a scheduled SPE interchange failed. The AUX Data indicates the cause of the failure. Consult the table in note p. Use **status spe** to determine the current SPE status and follow the Standby SPE Maintenance procedures to resolve the problems that are preventing the SPE interchange.

- g. A **reset system interchange health-override** command has failed. The standby SPE state-of-health (SOH) would not allow a spontaneous SPE interchange. Use **status spe** to determine the current SPE status and follow the Standby SPE Maintenance procedures to resolve the problems that are preventing the SPE interchange.
- h. A requested SPE interchange has failed because the SPEs are locked by means of the SPE-Select switches on the duplication interface circuit packs, with the SYSAM lock switches.
- i. Error 6001 indicates that an operating system error occurred on the active SPE. The aux data gives the source of the error:

Aux-Data Value	Operating System Error Type
5	Software Abort
6	SPE Bus Error

- j. Error 6002 indicates that an application error occurred on the active SPE. See note (o) to diagnose the error using the aux data.
- k. Error 6003 indicates that an application alarm occurred on the active SPE. See note (o) to diagnose the error using the aux data.
- l. Error 6100 indicates that an operating system error occurred on the standby SPE. See error 6001 (i) to interpret the aux data.
- m. Error 6102 indicates that an application error occurred on the standby SPE. See note (o) to diagnose the error using the aux data.
- n. Error 6103 indicates that an application alarm occurred on the standby SPE. See note (o) to diagnose the error using the aux data.

- o. For error types 6002, 6003, 6102, and 6103, the aux-data value points to the MO that the error or alarm is logged against. The following table lists possible aux-data values and their associated MOs. Locate the Error Log entry for the indicated MO and follow the instructions for that error.

AUX Data	Implicated Maintenance Object
4137	PKT-INT
16384	PROCR
16385	MEM-BD
16386	SYSAM
16389	DUPINT
16391	SW-CTL
16392	HOST-ADAPTER
16397	TAPE
16398	DISK

- p. The following table and notes give causes and recommendations for each AUX data value for error 605.

**Table 9-615. SYSTEM Error 605 AUX Data, Failure of Planned Interchange**

Aux Data	See Note	Explanation
1352	1	Standby SOH "non-functional"
1353	1	Standby SOH not "functional"
1355	1	Handshake Communication with Standby SPE is down
1356	1	Memory Shadowing not enabled
1357	1	Standby memory not refreshed
1358	2	Mass Storage System was in use
1359	3	PKT-INT link migration failed
1360	1	Interchange failed *
1361	4	SW-CTL failure
1369	7	Could not suspend G3-MT connectivity *
1370	4	Could not freeze active SW-CTL *
1371	5	Internal Error associated with processor interrupts *
1372	6	Minor alarm on standby SYSAM or PKT-INT
1395		SPE Duplication not administered

**Table 9-615. SYSTEM Error 605 AUX Data, Failure of Planned Interchange**

1396	3	PKT-INT Link Migration failure in Begin Step *
1397	3	PKT-INT Link Migration denied, (peer test in progress)
1398	3	PKT-INT Link Migration failure in Completion Step *
1399	3	PKT-INT Link Migration failure in Finish Step *
1400	4	Could Not Idle SW-CTL dual port RAM *
1401	4	Could Not Refresh SW-CTL dual port RAM *
1402	5	Internal Error (could not get duplication status)
1403	5	Unable to inhibit Standby Maintenance Monitor
1404	5	Failure to determine Standby SPE alarm status
1406	3	Active SPE's PKT-INT in held-reset state
1418	8	Active Duplication Interface circuit pack is in a bad state and needs to be reset.
2500	5	Internal Software failure (* sometimes)

**Notes for SYSTEM Error 605 AUX Data:**

1. Follow repair instructions in "STBY-SPE" for the particular standby SPE problem. After fixing that problem, try the interchange again.
2. Mass Storage System is in use. Check Disk and Tape LEDs for activity. Wait until all MSS activity completes, then retry the interchange again. If the problem persists, check for alarms and errors against MSS components and follow the repair procedures for the "MSS" maintenance object.
3. Test the PKT-INT on both carriers with the long test sequence. Follow procedures for "PKT-INT". Once *all* tests of both PKT-INTs pass, try the interchange again.
4. Consult SW-CTL service documentation. Test SW-CTL on both carriers with the long test sequence. Follow repair instructions for any failures. Once *all* tests of both SW-CTLs pass, try the interchange again.
5. Make sure the standby SPE is refreshed, then try the interchange again.
6. Examine alarm log to determine which of the PKT-INT or SYSAM circuit packs has a minor alarm against it. Consult the section in this chapter for that circuit pack.
7. Check for errors or alarms against active SPE's SYSAM. If you find any, consult SYSAM service documentation. If you find none, and if all tests of the SYSAM long sequence pass, try the interchange again.
8. Run **test duplication-interface long** and follow instructions for any test that does not pass.

## TAPE

---

MO Name (in Alarm Log)	Alarm Level	Initial Command to Run <sup>1</sup>	Full Name of MO
TAPE	WARNING	test tape a b long	MSS Tape circuit pack
TAPE	MINOR	test tape a b long	MSS Tape circuit pack
TAPE	MAJOR <sup>2</sup>	test tape a b long	MSS Tape circuit pack

1. In a system with a simplex SPE, the carrier need not be specified. In a system with duplicated SPEs, carrier a or b must be specified.
2. This alarm occurs when the system undergoes a reset of level 3, 4, or 5, and the switch cannot load translation from tape; it also occurs when a program update cannot be applied. See the Error Log Table, error type 3585.

## Description

---

The TN1656 Tape circuit pack is part of the Mass Storage System (MSS). The MSS provides non-volatile storage for system software, translation data, announcement data and program update data. As shown in [Figure 9-102](#), the MSS consists of a Host Adapter circuit on the UN332 MSS-Network Control circuit pack (MSSNET), a Small Computer System Interface (SCSI) bus, a TN1656 Tape circuit pack and the TN1657 Disk Drive circuit pack. The Disk Drive acts as the primary storage device. The Tape Drive serves as a backup device and as a removable medium for system data.

The system is usually booted from the bootimage stored on disk. The **save translation** and **save announcements** commands save to disk the memory-resident translation data and TN750-resident announcement data, respectively. The **backup disk** command copies data from the disk to the tape for backup storage. The **restore disk** command copies data from the tape back to disk. All MSS components reside in the SPE, or PPN control carrier (carrier A for a simplex SPE, carriers A and B for a duplicated SPE).

The Tape circuit pack contains SCSI bus terminators, a -48V to +12V power converter, an industry standard SCSI based Tape Drive, and interface circuitry to the private bus to control the LEDs, detect the presence of the circuit pack, and identify the vintage of the hardware.

A -48V to +12V converter circuit on the Tape circuit pack provides power for both the Tape Drive and the Disk Drive. The presence of +12V on these circuit packs is monitored separately by maintenance software so that a failure of the +12V converter on the Tape circuit pack can be identified or ruled out as the source of the problem when the Disk Drive loses +12V power.

The Host Adapter Circuit, Tape circuit pack, and Disk circuit pack are treated as separate, but related, maintenance objects (H-ADAPTER, TAPE, and DISK). Since the Disk circuit pack is controlled by SCSI commands which are generated by the Host Adapter, problems with the Host Adapter can prevent communications with the Disk. Whenever the Host Adapter is taken out of service by the **busy-out host-adapter** command, or due to failure of a critical Host Adapter test, the Tape and Disk maintenance objects are also placed in a maintenance busyout state.

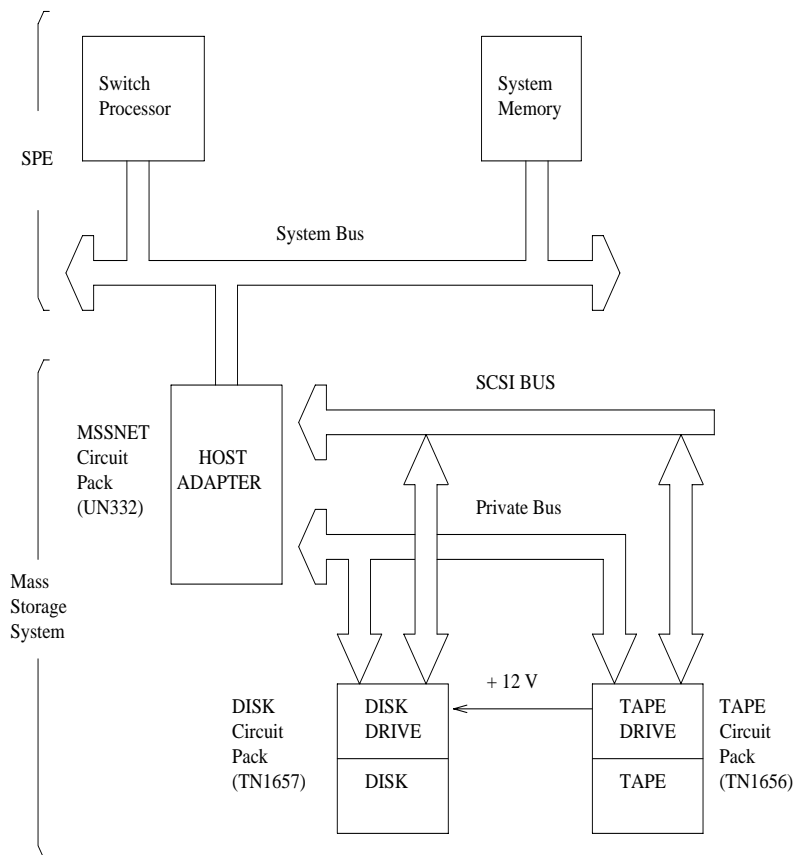

Figure 9-102. Mass Storage System Interactions

### General Repair Procedures for TAPE

The following guidelines should be followed when troubleshooting and resolving tape problems.

1. Cleaning the tape drive head is very important. Dirty tape drive heads may cause problems that appear to be hardware related.

A tape drive head with abrasive particles can permanently damage a new tape. A worn tape may leave abrasive particles in the tape drive head. Follow the tape head cleaning instructions that appear at the end of the test descriptions for TAPE.

2. *Avoid saving translations or announcements* on the backup tape cartridge if all other Tape Drive and Host Adapter problems have not been resolved.

If there is something wrong with the Mass Storage System, an attempt to save translations or announcements could destroy a good copy of the files on the tape cartridge.

3. In a system configured with duplicated SPEs, the tests run on the standby Tape circuit pack are identical to those run on the active Tape circuit pack. Communications between the active and standby SPEs is provided by the DUPINT circuit pack for both the control channel and memory shadowing. Therefore, problems with the DUPINT circuit pack may affect maintenance tests of the standby Tape circuit pack.
4. Check the error log for power related problems and refer to the maintenance documentation on power.
5. The *data on the tape cartridge will likely be destroyed* if:
  - The tape cartridge is removed when the amber LED on the Tape circuit pack is on.
  - The Tape circuit pack is removed while the amber LED on the Tape Circuit is on.
  - Power is removed from the Tape Drive while the amber LED on the Tape circuit pack is on.
6. The *data on the disk will likely be destroyed* if the Tape circuit pack is removed while the amber LED on the Disk Drive is on.
7. Dirty Tape Drive heads may cause problems that appear to be hardware related. To clean the tape heads in the Tape Drive, follow the tape head cleaning procedure at the end of this section.
8. Since maintenance software cannot always distinguish between errors caused by the tape cartridge and those caused by the Tape Drive or Host Adapter, check for tape cartridge errors first.
  - Make sure there is a tape cartridge in the Tape Drive.
  - Make sure that the write protect lock is not active. To deactivate write protect, slide the *RECORD* switch on the tape cartridge in the direction of the arrow on the switch.

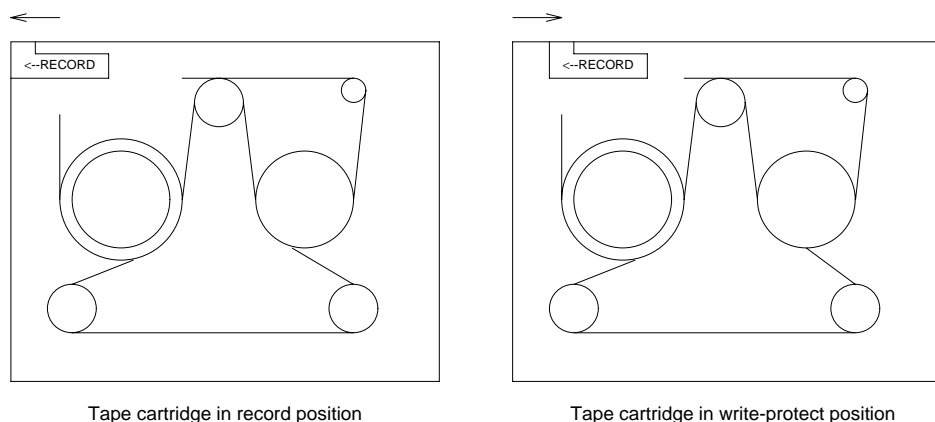

**Figure 9-103. Mass Storage System Interactions**

## Replacing a TAPE Cartridge

If the tape cartridge needs to be replaced, follow the procedure given below:

1. Resolve all other Tape circuit pack alarms/problems.
2. Install a new tape cartridge which has the same release number or, if that is not practical, install a tape cartridge with the same file layout as the original tape cartridge. Generally the file layouts are the same for tapes formatted for same product (G3r V1 or G3r V2). However, for G3r V1, a new file was added to the tape starting with the 6.1 release to support the **restore disk install** command. Therefore depending on the release number of the existing tape, a tape earlier than 6.1 or later than 6.0 should be used for G3r V1.

When a tape cartridge is first inserted, there should be a spinning noise indicating that the Tape Drive is performing a retension pass (moving the tape forward and then back to the tape mark several times). This may take several minutes.

3. Verify that the tape cartridge has an acceptable release number by checking the Software Version via the **list configuration software-vintage** command.
4. If a new tape cartridge is not available, but all other tape alarms/problems have been resolved, then replace the damaged tape cartridge with the backup tape cartridge. Wait for the retension pass to complete.
5. Verify that the tape cartridge has the latest translations by issuing the **list configuration software-vintage** command. If the tape cartridge does not have the latest translation or announcement files, then perform a **backup disk**.



## Replacing the TAPE Circuit Pack

---

### For a Simplex SPE:

- a. Enter **busyout host-adapter**. The Host Adapter should be "busied out" to prevent other applications from trying to access the tape or the disk. The Tape circuit pack supplies +12V to the Disk circuit pack so when it is removed, the Disk circuit pack will also go out of service.
- b. Replace the Tape circuit pack and insert the tape cartridge into the new Tape circuit pack.
- c. Issue the **reset host-adapter** command. This may take up to 3 minutes to complete since it waits for the tape to retension.
- d. Issue the **release host-adapter** command.
- e. Issue the **status spe** command and check that the status screen indicates that the tape and disk are now in service.

### For a Duplicated SPE:

- a. See "[Replacing SPE Circuit Packs](#)" in Chapter 5.
- b. After the standby SPE is powered up and fully refreshed, test the standby tape using the **test tape long** command.

## Error Log Entries and Test to Clear Values

---

Table 9-616. TAPE Error Log Entries

Error Type	Aux Data <sup>1</sup>	Associated Test	Alarm Level	On/Off Board	Test to Clear Value
1 (a)	any	Tape Reset (#894)	MINOR	OFF	reset tape a b <sup>2</sup>
18 (b)	0	Busyout Tape (#817)	WARNING	OFF	release tape a b <sup>2</sup>
250 (c)	0	Reset Tape (#894)	WARNING	OFF	reset tape a b <sup>2</sup>
257 (d)	any	Tape Looparound (#814)	WARNING	OFF	test tape a b <sup>2</sup> sh rep 2
513 (e)	any	Tape Diagnostics (#813)	MINOR	ON	test tape a b <sup>2</sup> sh rep 2
526 (f)	0	Busyout Host-adapter	WARNING	OFF	release host-adptr a b <sup>2</sup>
529 (g)	0		WARNING	OFF	reset tape a b <sup>2</sup>
769 (h)	any	Tape Looparound (#814)	MINOR	ON	test tape a b <sup>2</sup> sh rep 2

*Continued on next page*

**Table 9-616. TAPE Error Log Entries — Continued**

Error Type	Aux Data <sup>1</sup>	Associated Test	Alarm Level	On/Off Board	Test to Clear Value
1025 (i)	any	Tape Write-Read (#810)	MINOR	OFF	test tape a b <sup>2</sup> long rep 2
1281 (j)	any	Tape Diagnostics (#813)	MINOR	ON	test tape a b <sup>2</sup> sh rep 2
1537 (k)	any	Tape Write-Read (#810)	WARNING	OFF	test tape a b <sup>2</sup> long rep 2
1793 (l)	any	Tape Looparound (#814)	MINOR	OFF	test tape a b <sup>2</sup> sh rep 2
2049 (m)	any	Tape Looparound (#814)	MINOR	OFF	test tape a b <sup>2</sup> sh rep 2
2305 (n)	<sup>2</sup>	Tape Frmwr Counters (#812)	WARNING	OFF	reset tape a b <sup>2</sup>
2306 (o)	5504	Tape Frmwr Counters (#812)	WARNING	OFF	test tape a b <sup>2</sup> sh rep 2
2561 (p)	any	Tape Write-Read (#810)	MINOR	OFF	test tape a b <sup>2</sup> long rep 2
2817 (q)	any	Tape Status (#815)	WARNING	ON	test tape a b <sup>2</sup> sh rep 2
3073 (r)	any	In-line	MINOR	ON	test tape a b <sup>2</sup> long rep 2
3329 (s)	any	Tape Audit (#811)	MINOR	OFF	test tape a b <sup>2</sup> long rep 2
3585 (t)	408		MAJOR/ MINOR	OFF	
3585 (u)	409		MAJOR/ MINOR	OFF	
3841 (v)	<sup>3</sup>	Miscellaneous	MINOR	OFF	test tape a b* long rep 1

1. The number of times the tape has been accessed. This number is at least 90% of the manufacturer's recommended limit.
2. In a system with a simplex SPE, the carrier does not have to be specified. In a system with duplicated SPE, the carrier (a or b) must be specified.
3. If error type 1 with aux data of 123 is present, this field will have the out of service cause data. See the *MSS Error Actions* table at the end of the section on TAPE.

The "service state" field in the Alarm Log refers to the accessibility of the device. IN (in service) means that users can access the device and all maintenance tests will run. MTC (maintenance busy) means that the device is "busied out" and users cannot access it although all demand maintenance tests will run. OUT (out

of service) means that users cannot access the device but background and demand testing can run.

Notes:

- a. Error type 1 means that the device is out of service as a result of maintenance tests detecting a critical failure of the tape drive.
- b. Error type 18 means that the Tape was busied out on demand from the System Access Terminal.
- c. Error type 250 means that the Reset Test (#809 or #894) failed.
- d. Error type 257 means that the device could not be accessed.
- e. Error type 513 means that on-board tape drive diagnostics tests requested by the Tape Diagnostic Test (#813) failed.
- f. Error type 526 means that the Host Adapter was busied out. This also causes the Tape to be busied out.
- g. Error type 529 means that there was a failure to put the tape in service or to take it out of service.
- h. Error type 769 means that the tape Loop-around Test (#814) failed.
- i. Error type 1025 means that a tape medium error was detected when the tape was read or written. The tape cartridge should be replaced if this error continues to be reported.
- j. Error type 1281 indicates that a hardware failure condition was detected by the Firmware Error Counters Read and Clear Test (#812). See the *MSS Error Actions* table at the end of the section on TAPE.
- k. Error type 1537 indicates that the tape cartridge is write protected. Check the RECORD switch on the tape cartridge. It should be pushed forward in the direction shown by the arrow on the switch.
- l. Error type 1793 is an in-line error from the tape control software that indicates there was a problem with the SCSI Bus Access Failure or Memory Access Failure between the Host Adapter circuit pack and the Tape circuit pack. See the *MSS Error Actions* table at the end of the section on TAPE.
- m. Error type 2049 indicates that a bad command was sent to the tape drive. This may be caused by a software error or a hardware failure. Execute the **test tape long** command and fix any failures associated with those tests.
- n. Error type 2305 means that the tape has exceeded 90% of the manufacturer's recommended limit of accesses. The tape should be replaced as soon as practical. This alarm can be retired by issuing the **reset tape** command but it will reappear each time the Tape Firmware Counter Test (#812) is run.
- o. Error type 2306 means that a block has been reassigned on the tape or an attempt to reassign a block has failed. The tape should be replaced as soon as practical.

- p. Error type 2561 indicates that the Data Write-Read Test (#810) failed.
- q. Error 2817 indicates that the Tape Status Test (#815) detected a fault. See the *MSS Error Actions* table at the end of the section on TAPE.
- r. Error type 3073 indicates in-line errors reported by the tape control software. See the *MSS Error Actions* table at the end of the section on TAPE.
- s. Error type 3329 indicates that the Tape Audit Test (#811) detected a corrupted directory file. Execute the **test tape long** command and fix any failures associated with those tests. The Auxiliary Code for this Error Log entry and the failure code for the Tape Audit test indicate the directory file that is corrupted. If Test 811 does not fail, follow normal escalation procedures.
- t. Error type 3585 with auxiliary data 408 indicates that there was an error in reading translation data from the tape and/or disk.

This error only occurs on a system reset 3,4, or 5 (Cold 1, system reboot, or extended system reboot). If a disk is present, the system first tries to read translation from the first and second copies of translation on the disk and, if that fails, it tries to read translation from the first and second copies of translation on the tape.

If an error was detected with reading translation from the disk and then the tape, a 408 error will be logged. This error will invoke *Emergency Transfer* on a system with simplex SPE. It will cause an SPE interchange if the system is equipped with duplicated SPEs. To clear this alarm, correct all other tape errors.

If the SPE is not duplicated, it may be necessary to use a backup tape to first restore translation data to the disk. A new backup tape should be obtained as soon as possible.

If the system is equipped with duplicated SPEs and if the alarm is associated with the tape on the standby SPE the active SPE should be running with the most current translation. Therefore after correcting any hardware failures associated with the tape and disk on the standby SPE, a **save translation** command should be used to save translations to the disk and tape on the standby SPE.

- u. Error type 3585 with auxiliary data 409 means that there was an error in reading the program update file from both the disk and tape or there was an error in applying the program update file once it was successfully read from the disk or tape.

This error only occurs during a system reset 4 or 5 (system reboot or extended system reboot). If a disk is present, the system will try to read the program update file from the disk first and, if that fails, it will try to read the program update file from the tape. After it succeeds in reading a copy of the program update file, it will check to see if the program update information is appropriate for the software version in memory before it applies it to the software boot image.

If an error is detected with any part of the process of reading the program update file from the disk or tape and applying the program update to memory, a hardware error 409 will be generated. This error will invoke a MAJOR alarm and *Emergency Transfer* on a system with simplex SPE. It will initiate an SPE interchange followed by a MINOR alarm on a system with duplicated SPEs. When this error occurs, the copies of the program update files on the disk and tape are invalidated so that those files no longer appear when a **list configuration software** command is entered from the System Access terminal.

To clear this alarm, first correct any other tape and disk alarms. Then restore the two copies of the program update files on the disk and tapes and apply those upgrades using "[Software updates](#)" in Chapter 6.

- v. Error type 3841 is used to record miscellaneous data when an out-of-service condition occurs. See the *MSS Error Actions* table at the end of the section on TAPE.

## System Technician-Demanded Tests: Descriptions and Error Codes

---

Always investigate tests in the order presented in the table below when inspecting errors in the system. By clearing error codes associated with the *Reset Test*, for example, you may also clear errors generated from other tests in the testing sequence.

Order of Investigation	Short Test Sequence	Long Test Sequence	Reset Board Sequence	D/ND <sup>1</sup>
Tape Reset Test (#809)	X	X		ND
Tape Diagnostic Test (#813)	X	X		ND
Tape Looparound Test (#814)	X	X		ND
Tape Status Test (#815)	X	X		ND
Tape Firmware Error				
Counters Read and Clear Test (#812)	X	X		ND
Tape Write-Read Test (#810)		X		ND
Tape Audit Test (#811)		X		ND
Tape Reset (#894)			X	ND

---

1. D = Destructive; ND = Nondestructive

### Tape Reset Test (#809 and #894)

The Tape Reset Test consists of the following steps controlled by firmware on the Host Adapter Circuit (located on the MSSNET CIRCUIT PACK):

- Tape Drive reset
 

An SCSI "BUS DEVICE RESET" message is transmitted to the Tape Drive to reset it.
- Presence test
 

An SCSI "INQUIRY" command is sent to the Tape Drive to attempt to query with it. If the Tape Drive is present, it will return information about the device type, whether or not its medium is removable, compatibility with established standards, vendor and product IDs, and other miscellaneous information.
- Capacity test
 

An SCSI "READ CAPACITY" command is sent to the Tape Drive. It returns with the logical block address and the block length of the last logic block on the medium.

An SCSI "READ DATA BUFFERS" command is sent to the Tape Drive. This returns the size of the controller memory data buffers.

An SCSI "READ DEFECT DATA" command is sent to the Tape Drive. This returns the addresses of bad blocks on the tape that must be mapped around.
- Device Diagnostic Tests
 

An SCSI "SEND DIAGNOSTICS" command is sent to the Tape Drive to initiate a set of device-dependent self-tests that are run as a unit. Failures can be for multiple reasons and the return code which indicates the cause of failure is vendor unique. A failure condition will be reported as single failure type since the only repair action is to replace the Tape circuit pack.

**Table 9-617. TEST #809/#894 Tape Reset Test**

Error Code	Test Result	Description/ Recommendation
526	ABORT	The Host Adapter has been busied out. 1. Issue the <b>release host-adapter</b> command.
1316	ABORT	Could not get access to the Mass Storage System. Other application software may be using it or background maintenance tests may be running. 1. Retry the command at 1-minute intervals for a maximum of 5 retries. 2. If the test continues to abort, verify that the daily translation-save operation is not in progress (issue the <b>display system-parameters maintenance</b> command to display the time for scheduled maintenance and the "y/n" option for saving translation daily).

*Continued on next page*

**Table 9-617. TEST #809/#894 Tape Reset Test — Continued**

Error Code	Test Result	Description/ Recommendation
1335	ABORT	Could not run the test on the Standby SPE—Duplication not administered. 1. Refer to the documentation for STBY-SPE maintenance. 2. Administer standby present.
1338	ABORT	Could not run the test on the Standby SPE—Interchange pending. 1. Refer to the documentation for STBY-SPE maintenance. 2. After interchange occurs, run test on new active SPE.
1339	ABORT	Could not run the test on the Standby SPE—Handshake down. 1. Refer to the documentation for STBY-SPE maintenance. 2. When the standby is restored to service (use <b>status spe</b> to determine state of standby) retry the command.
1347	ABORT	Could not run the test on the Standby SPE—Refresh not complete. 1. When the standby is restored to service (use <b>status spe</b> to determine state of standby) retry the command.
1350	ABORT	Could not run test on Standby SPE—Shadowing not enabled. 1. When the standby is restored to service (use <b>status spe</b> to determine state of standby) retry the command.
2000	ABORT	Response to the test request was not received within the allowable time period. 1. Retry the command at 1-minute intervals for a maximum of 5 retries.
2500	ABORT	Could not run the test on the Standby SPE—Internal software error. 1. Retry the command at 1-minute intervals for a maximum of 5 retries.
5102	ABORT	Could not allocate the Mass Storage System to run this test 1. Retry the command at 1-minute intervals for a maximum of 5 retries. 2. If the test continues to abort, verify that the daily translation-save operation is not in progress (issue the <b>display system-parameters maintenance</b> command to display the time for scheduled maintenance and the "y/n" option for saving translation daily).
	NO BOARD	The tape has been placed in the "uninstalled" state. 1. Verify that a tape cartridge is installed and not write-protected and that the tape drive is fully inserted and powered up. 2. Attempt a demand reset of the tape.

*Continued on next page*

Table 9-617. TEST #809/#894 Tape Reset Test — Continued

Error Code	Test Result	Description/ Recommendation
201	FAIL	The Tape Drive is not responding or it may not be present. <ol style="list-style-type: none"><li>1. Verify that the Tape circuit pack is present and powered.</li><li>2. Replace the Tape circuit pack.</li><li>3. If the reset continues to fail with this error code, replace the Host Adapter circuit pack.</li></ol>
5124	FAIL	It has been detected that no tape cartridge is installed. <ol style="list-style-type: none"><li>1. Verify that a tape cartridge is installed and not write-protected.</li><li>2. If the reset continues to fail with this error code, continue with the steps below for the general reset failure case.</li></ol>
1	FAIL	The Tape could not be reset successfully. <ol style="list-style-type: none"><li>1. Verify that a tape cartridge is installed and not write-protected.</li><li>2. If the test continues to fail, replace the Tape cartridge. Wait for the retention pass to complete. If the test succeeds, issue the <b>backup disk</b> command.</li><li>3. If the test continues to fail, replace the Tape circuit pack.</li><li>4. If the test continues to fail, replace the MSSNET circuit pack.</li></ol>
	PASS	The Tape was reset correctly. Check other test results to see if it is operating correctly.

1. See the MSS Error Actions table at the end of the section on TAPE.

## Tape Write-Read Test (#810)

The Tape Write-Read Test verifies that data can be written to a specific file on the tape and read back successfully. It does not test the integrity of other files on the tape. This test consists of the following steps:

1. Maintenance software in the SPE issues a request to the Host Adapter for a transfer of data between SPE memory and a specified block on the tape.

The Host Adapter firmware issues an SCSI **WRITE** command to the Tape Drive which results in a transfer of data between the SPE memory and the tape.



2. Maintenance software in the SPE issues a request to the Host Adapter to run a checksum on the data previously written to the tape.

The Host Adapter reads the data off the tape and computes a checksum which is returned to the SPE maintenance software.

3. Maintenance software compares the value of the checksum from the Host Adapter with the checksum it previously calculated on the data it stored on the tape.

Multiple failure conditions can occur during this test since it uses both the software and hardware functions used during normal operations.

**Table 9-618. TEST #810 Tape Write-Read Test**

Error Code	Test Result	Description/ Recommendation
1301 1302	ABORT	Could not run the test—internal MSS error 1. Retry the command
1304	ABORT	Could not allocate the Mass Storage System to run this test. Other application software may be using it or background maintenance tests may be running. 1. Retry the command at 1-minute intervals for a maximum of 5 retries. 2. If the test continues to abort, verify that the daily translation-save operation is not in progress (Use the <b>display system-parameters maintenance</b> command to display the start time for scheduled maintenance and the "y/n" option for saving translation daily).
1316	ABORT	Could not get access to the Mass Storage System. Other application software may be using it or background maintenance tests may be running. 1. Retry the command at 1-minute intervals for a maximum of 5 retries. 2. If the test continues to abort, verify that the daily translation-save operation is not in progress (issue the <b>display system-parameters maintenance</b> command to display the time for scheduled maintenance and the "y/n" option for saving translation daily).
1335	ABORT	Could not run the test on the Standby SPE—Duplication not administered. 1. Refer to the documentation for STBY-SPE maintenance. 2. Administer standby present.
1338	ABORT	Could not run the test on the Standby SPE—Interchange pending. 1. Refer to the documentation for STBY-SPE maintenance. 2. After interchange occurs, run test on new active SPE.

*Continued on next page*

Table 9-618. TEST #810 Tape Write-Read Test — *Continued*

Error Code	Test Result	Description/ Recommendation
1339	ABORT	Could not run the test on the Standby SPE—Handshake down. <ol style="list-style-type: none"> <li>1. Refer to the documentation for STBY-SPE maintenance.</li> <li>2. When the standby is restored to service (use <b>status spe</b> to determine state of standby) retry the command.</li> </ol>
1347	ABORT	Could not run the test on the Standby SPE—Refresh not complete. <ol style="list-style-type: none"> <li>1. When the standby is restored to service (use <b>status spe</b>), retry the command.</li> </ol>
1350	ABORT	Could not run the test on the Standby SPE—Shadowing not enabled. <ol style="list-style-type: none"> <li>1. When standby is restored to service (use <b>status spe</b>), retry command.</li> </ol>
2000	ABORT	Response to the test request was not received within the allowable time period. <ol style="list-style-type: none"> <li>1. Retry the command at 1-minute intervals for a maximum of 5 retries.</li> </ol>
2500	ABORT	Could not run the test on the Standby SPE—Internal software error. <ol style="list-style-type: none"> <li>1. Retry the command at 1-minute intervals for a maximum of 5 retries.</li> </ol>
5102	ABORT	Could not allocate the Mass Storage System to run this test <ol style="list-style-type: none"> <li>1. Retry the command at 1-minute intervals for a maximum of 5 retries.</li> <li>2. If the test continues to abort, verify that the daily translation-save operation is not in progress (issue the <b>display system-parameters maintenance</b> command to display the time for scheduled maintenance and the "y/n" option for saving translation daily).</li> </ol>
	NO BOARD	The tape has been placed in the "uninstalled" state. <ol style="list-style-type: none"> <li>1. Verify that a tape cartridge is installed and not write-protected and that the tape drive is fully inserted and powered up.</li> <li>2. Attempt a demand reset of the tape.</li> </ol>
1	FAIL	The tape could not be accessed, the checksum on the data written did not match the checksum in memory or the data read did not match the data written. <ol style="list-style-type: none"> <li>1. Verify that a tape cartridge is installed and not write-protected.</li> <li>2. If a non-write-protected tape was inserted, remove it and clean the Tape Heads.</li> <li>3. If the test continues to fail, replace the Tape Cartridge. Wait for the retension pass to complete. If the test succeeds, issue the <b>backup disk</b> command.</li> <li>4. If the test continues to fail, replace the Tape circuit pack.</li> <li>5. If the test continues to fail, replace the MSSNET circuit pack.</li> </ol>

*Continued on next page*

**Table 9-618. TEST #810 Tape Write-Read Test — Continued**

Error Code	Test Result	Description/ Recommendation
	PASS	The Tape write-read test succeeded. Check other test results to see if it is operating correctly.

1. See the MSS Error Actions table at the end of the section on TAPE.

### Tape Audit Test (#811)

The Tape Audit Test verifies the following Tape Medium conditions.

- The directory can be read.
- There are no "dirty" files. A file is said to be "dirty" if the data in the file is not complete or if the directory entry for that file was not updated after the data was written to the device.
- The tape has not exceeded the number of passes recommended by the manufacturer. If the tape has exceeded 90% of the manufacturer's recommended limit of accesses, the tape should be replaced. An alarm indicating this will appear nightly after scheduled maintenance is executed. This alarm can be retired by issuing the **reset tape** command.

**Table 9-619. TEST #811 Tape Audit Test**

Error Code	Test Result	Description/ Recommendation
1316	ABORT	Could not get access to the Mass Storage System. Other application software may be using it or background maintenance tests may be running. <ol style="list-style-type: none"> <li>1. Retry the command at 1-minute intervals for a maximum of 5 retries.</li> <li>2. If the test continues to abort, verify that the daily translation-save operation is not in progress (issue the <b>display system-parameters maintenance</b> command to display the time for scheduled maintenance and the "y/n" option for saving translation daily).</li> </ol>
1335	ABORT	Could not run the test on the Standby SPE—Duplication not administered. <ol style="list-style-type: none"> <li>1. Refer to the documentation for STBY-SPE maintenance.</li> <li>2. Administer standby present.</li> </ol>

*Continued on next page*

**Table 9-619. TEST #811 Tape Audit Test — Continued**

Error Code	Test Result	Description/ Recommendation
1338	ABORT	Could not run the test on the Standby SPE—Interchange pending. <ol style="list-style-type: none"> <li>1. Refer to the documentation for STBY-SPE maintenance.</li> <li>2. After interchange occurs, run test on new active SPE.</li> </ol>
1339	ABORT	Could not run the test on the Standby SPE—Handshake down. <ol style="list-style-type: none"> <li>1. Refer to the documentation for STBY-SPE maintenance.</li> <li>2. When the standby is restored to service (use <b>status spe</b> to determine state of standby) retry the command.</li> </ol>
1347	ABORT	Could not run the test on the Standby SPE—Refresh not complete. <ol style="list-style-type: none"> <li>1. When the standby is restored to service (use <b>status spe</b> to determine state of standby) retry the command.</li> </ol>
1350	ABORT	Could not run the test on the Standby SPE—Shadowing not enabled. <ol style="list-style-type: none"> <li>1. When the standby is restored to service (use <b>status spe</b> to determine state of standby) retry the command.</li> </ol>
2000	ABORT	Response to the test request was not received within the allowable time period. <ol style="list-style-type: none"> <li>1. Retry the command at 1-minute intervals for a maximum of 5 retries.</li> </ol>
2500	ABORT	Could not run the test on the Standby SPE—Internal software error. <ol style="list-style-type: none"> <li>1. Retry the command at 1-minute intervals for a maximum of 5 retries.</li> </ol>
5102	ABORT	Could not allocate the Mass Storage System to run this test <ol style="list-style-type: none"> <li>1. Retry the command at 1-minute intervals for a maximum of 5 retries.</li> <li>2. If the test continues to abort, verify that the daily translation-save operation is not in progress (issue the <b>display system-parameters maintenance</b> command to display the time for scheduled maintenance and the "y/n" option for saving translation daily).</li> </ol>
	NO BOARD	The tape has been placed in the "uninstalled" state. <ol style="list-style-type: none"> <li>1. Verify that a tape cartridge is installed and not write-protected and that the tape drive is fully inserted and powered up.</li> <li>2. Attempt a demand reset of the tape.</li> </ol>

*Continued on next page*

Table 9-619. TEST #811 Tape Audit Test — *Continued*

Error Code	Test Result	Description/ Recommendation
1	FAIL	The audit of the tape directory failed. <ol style="list-style-type: none"><li>1. Verify that a tape cartridge is installed.</li><li>2. Perform a <b>backup disk</b>. This may take up to an hour to complete.</li><li>3. If the test continues to fail, replace the Tape Cartridge. Wait for the retension pass to complete and rerun the test. If the test succeeds, issue the <b>backup disk</b> command.</li><li>4. If the test continues to fail, replace the Tape circuit pack.</li><li>5. If the test continues to fail, determine if other Tape, Disk, or Host Adapter tests fail, and if they do, follow the repair procedures for those failures.</li></ol>
	PASS	The tape directory audit succeeded. Check other results to see if it is operating correctly.

1. See the MSS Error Actions table at the end of the section on TAPE.

## Tape Firmware Error Counters Read and Clear Test (#812)

The Host Adapter firmware is constantly running background tests on each of its devices. When an error is detected by one of these background tests, the appropriate counter in the host adapter dual port RAM is incremented. The Tape Firmware Error Counters Read and Clear Test requests that the firmware return these errors to the software and clear the area in dual port RAM. If any counter is non-zero, the software then increments the appropriate software counter. The 16 errors reported by the firmware are:

- Unexpected interrupt from the SCSI Bus Interface Controller Chip (SBICC)
- SBICC timed out during SCSI command
- Error interrupt from the Direct Memory Access Controller (DMAC)
- DMAC timeout without issuing interrupt
- Tape self-test failed

- Tape external looparound test failed
- Command failed with bad sense key
- Tape could not be accessed
- Flaw detected in tape medium
- Unrecoverable hardware error on tape
- Invalid parameter in SCSI command
- Media removed or device reset
- Tape is write protected
- Tape reached end of medium
- Block reassigned on tape
- Block reassignment on tape failed

Also this test checks for two other conditions: the presence of grown defects on the tape medium, and whether the tape has been accessed in excess of 90% of the manufacturer's suggested maximum.

**Table 9-620. TEST #812 Tape Firmware Error Counters Read and Clear Test**

Error Code	Test Result	Description/ Recommendation
1305	ABORT	Could not read firmware error counters. 1. Retry the command at 1-minute intervals a maximum of 5 times.
1306	ABORT	Could not read configuration area for defect information. 1. Retry the command at 1-minute intervals a maximum of 5 times.
1316	ABORT	Could not get access to the Mass Storage System. Other application software may be using it or background maintenance tests may be running. 1. Retry the command at 1-minute intervals a maximum of 5 times. 2. If the test continues to abort, verify that the daily translation-save operation is not in progress (issue the <b>display system-parameters maintenance</b> command to display the time for scheduled maintenance and the "y/n" option for saving translation daily).
1335	ABORT	Could not run the test on the Standby SPE—Duplication not administered. 1. Refer to the documentation for STBY-SPE maintenance. 2. Administer standby present.

*Continued on next page*

**Table 9-620. TEST #812 Tape Firmware Error Counters Read and Clear Test — Continued**

Error Code	Test Result	Description/ Recommendation
1338	ABORT	Could not run the test on the Standby SPE—Interchange pending. <ol style="list-style-type: none"> <li>1. Refer to the documentation for STBY-SPE maintenance.</li> <li>2. After interchange occurs, run test on new active SPE.</li> </ol>
1339	ABORT	Could not run the test on the Standby SPE—Handshake down. <ol style="list-style-type: none"> <li>1. Refer to the documentation for STBY-SPE maintenance.</li> <li>2. When standby is restored to service (use <b>status spe</b> to determine state of standby) retry command.</li> </ol>
1347	ABORT	Could not run the test on the Standby SPE—Refresh not complete. <ol style="list-style-type: none"> <li>1. When standby is restored to service (use <b>status spe</b> to determine state of standby) retry command.</li> </ol>
1350	ABORT	Could not run the test on the Standby SPE—Shadowing not enabled. <ol style="list-style-type: none"> <li>1. When standby is restored to service (use <b>status spe</b> to determine state of standby) retry command.</li> </ol>
2000	ABORT	Response to the test request was not received within the allowable time period. <ol style="list-style-type: none"> <li>1. Retry the command at 1-minute intervals a maximum of 5 times.</li> </ol>
2500	ABORT	Could not run the test on the Standby SPE—Internal software error. <ol style="list-style-type: none"> <li>1. Retry the command at 1-minute intervals a maximum of 5 times.</li> </ol>
5102	ABORT	Could not allocate the Mass Storage System to run this test <ol style="list-style-type: none"> <li>1. Retry the command at 1-minute intervals a maximum of 5 times.</li> <li>2. If the test continues to abort, verify that the daily translation-save operation is not in progress (issue the <b>display system-parameters maintenance</b> command to display the time for scheduled maintenance and the "y/n" option for saving translation daily).</li> </ol>
	NO BOARD	The tape has been placed in the "uninstalled" state. <ol style="list-style-type: none"> <li>1. Verify that a tape cartridge is installed and not write-protected and that the tape drive is fully inserted and powered up.</li> <li>2. Attempt a demand reset of the tape.</li> </ol>

*Continued on next page*

**Table 9-620. TEST #812 Tape Firmware Error Counters Read and Clear Test — Continued**

Error Code	Test Result	Description/ Recommendation
7	FAIL	<p>Background tests run by the Host Adapter detected that the tape could not be accessed at some time previous to executing the read-and-clear test. This error may have been caused by removing and reinserting the tape cartridge. The read-and-clear test or reset test must be run at least once before this error is cleared.</p> <ol style="list-style-type: none"> <li>1. Try <b>test tape</b> again to see if the error has cleared.</li> <li>2. Verify that the Tape Cartridge is present.</li> <li>3. If the test continues to fail, replace the Tape circuit pack.</li> </ol>
11	FAIL	<p>Background tests run by the Host Adapter detected that the Tape drive was reset at some time previous to executing the read-and-clear test. This error may have been caused by removing and reinserting the tape cartridge. The read-and-clear test or reset test must be run at least once before this error is cleared.</p> <ol style="list-style-type: none"> <li>1. Try <b>test tape</b> again to see if the error has cleared.</li> <li>2. If the test continues to fail, replace the Tape circuit pack.</li> </ol>
5504	FAIL	<p>A tape block has been reassigned to a different location on the tape as a result of a medium error. This is referred to as a "grown defect." Tape performance will be affected since the tape drive must search ahead to read or write this block and then return to where it left off. Continued testing will not correct the problem. The tape should be replaced as soon as practicable.</p> <ol style="list-style-type: none"> <li>1. Run the STO-DATA tests to verify that the boot images, translations, announcements, etc., are valid.</li> <li>2. If errors are detected, run <b>backup disk full</b> to restore good copies to the tape.</li> <li>3. If the STO-DATA tests continue to fail, replace the tape.</li> </ol>
5512	FAIL	<p>Ninety per cent of the manufacturer's recommended limit for tape accesses has been exceeded. Continued testing will not correct the problem and the tape will need to be replaced as soon as practicable.</p>

*Continued on next page*



**Table 9-620. TEST #812 Tape Firmware Error Counters Read and Clear Test — Continued**

Error Code	Test Result	Description/ Recommendation
1	FAIL	At least one of the firmware error counters was non-zero. <ol style="list-style-type: none"> <li>1. Run the <b>test tape</b> command again to verify that this failure was not from a failure condition which has been cleared as a result of this test clearing the firmware counters.</li> <li>2. Verify that a tape cartridge is installed and not write-protected.</li> <li>3. If a non-write-protected tape was inserted, retry the command at 1-minute intervals a maximum of 5 times.</li> <li>4. If the test continues to fail, remove the tape cartridge and clean the Tape Heads.</li> <li>5. If the test continues to fail, replace the Tape Cartridge. Wait for the retension pass to complete. If the test succeeds, issue the <b>backup disk full</b> command.</li> <li>6. If the test continues to fail, replace the Tape circuit pack.</li> <li>7. If the test continues to fail, replace the MSSNET circuit pack.</li> </ol>
	PASS	The firmware error counters were zero. Check other test results to see if it is operating correctly.

1. See the MSS Error Actions table at the end of the section on TAPE.

### Tape Diagnostic Test (#813)

The Tape Diagnostic test causes the Host Adapter to send an SCSI **SEND DIAGNOSTICS** command to the TAPE circuit pack. This initiates a set of device-dependent self-tests that are run as a unit. Failures can be for multiple reasons. The return code which indicates the cause of failure is vendor unique. A failure condition will be reported as single failure type since the only repair action is to replace the Tape circuit pack.

**Table 9-621. TEST #813 Tape Diagnostic Test**

Error Code	Test Result	Description/ Recommendation
1316	ABORT	Could not get access to the Mass Storage System Other application software may be using it or background maintenance tests may be running. <ol style="list-style-type: none"> <li>1. Retry the command at 1-minute intervals a maximum of 5 times.</li> <li>2. If the test continues to abort, verify that the daily translation-save operation is not in progress (issue the <b>display system-parameters maintenance</b> command to display the time for scheduled maintenance and the "y/n" option for saving translation daily).</li> </ol>
1335	ABORT	Could not run the test on the Standby SPE—Duplication not administered. <ol style="list-style-type: none"> <li>1. Refer to the documentation for STBY-SPE maintenance.</li> <li>2. Administer standby present.</li> </ol>
1338	ABORT	Could not run the test on the Standby SPE—Interchange pending. <ol style="list-style-type: none"> <li>1. Refer to the documentation for STBY-SPE maintenance.</li> <li>2. After interchange occurs, run test on new active SPE.</li> </ol>
1339	ABORT	Could not run the test on the Standby SPE—Handshake down. <ol style="list-style-type: none"> <li>1. Refer to the documentation for STBY-SPE maintenance.</li> <li>2. When the standby is restored to service (use <b>status spe</b> to determine state of standby) retry the command.</li> </ol>
1347	ABORT	Could not run the test on the Standby SPE—Refresh not complete. <ol style="list-style-type: none"> <li>1. When the standby is restored to service (use <b>status spe</b> to determine state of standby) retry the command.</li> </ol>
1350	ABORT	Could not run the test on the Standby SPE—Shadowing not enabled. <ol style="list-style-type: none"> <li>1. When the standby is restored to service (use <b>status spe</b> to determine state of standby) retry the command.</li> </ol>
2000	ABORT	Response to the test request was not received within the allowable time period. <ol style="list-style-type: none"> <li>1. Retry the command at 1-minute intervals a maximum of 5 times.</li> </ol>
2500	ABORT	Could not run the test on the Standby SPE—Internal software error. <ol style="list-style-type: none"> <li>1. Retry the command at 1-minute intervals a maximum of 5 times.</li> </ol>
5102	ABORT	Could not allocate the Mass Storage System to run this test <ol style="list-style-type: none"> <li>1. Retry the command at 1-minute intervals a maximum of 5 times.</li> <li>2. If the test continues to abort, verify that the daily translation-save operation is not in progress (issue the <b>display system-parameters maintenance</b> command to display the time for scheduled maintenance and the "y/n" option for saving translation daily).</li> </ol>

Table 9-621. TEST #813 Tape Diagnostic Test — Continued

Error Code	Test Result	Description/ Recommendation
	NO BOARD	The tape has been placed in the "uninstalled" state. <ol style="list-style-type: none"><li>1. Verify that a tape cartridge is installed and not write-protected and that the tape drive is fully inserted and powered up.</li><li>2. Attempt a demand reset of the tape.</li></ol>
1	FAIL	A Tape diagnostic test failed. <ol style="list-style-type: none"><li>1. Verify that a tape cartridge is installed and not write-protected.</li><li>2. If a tape was inserted, remove it and clean the Tape Heads.</li><li>3. If the test continues to fail, replace the Tape Cartridge. Wait for the retension pass to complete. If the test succeeds, issue the <b>backup disk</b> command.</li><li>4. If the test continues to fail, replace the Tape circuit pack.</li><li>5. If the test continues to fail, replace the MSSNET circuit pack.</li></ol>
	PASS	The Tape passed all diagnostic tests. Check other test results to see if it is operating correctly.

1. See the MSS Error Actions table at the end of the section on TAPE.

## Tape Loop-around Tests (#814)

This test extends the Host Adapter Loop-Around test to send data from the Host Adapter to buffers on the Tape circuit pack and back to the Host Adapter. It may detect errors related to the Host Adapter, SCSI bus, and the Tape circuit pack. It is intended to functionally test the Tape Drive circuit pack to the extent possible without actually writing data to the tape.

This test consists of two sets of tests:

- Tape Internal Loop-around

Data is generated in the RAM of the Host Adapter and transferred to its SCSI Data Memory. An SCSI **WRITE DATA BUFFERS** command is sent to the Tape circuit pack which causes the Tape Drive circuit pack to copy the data to its buffers. An SCSI **READ DATA BUFFERS** command is then sent by the Host Adapter to the Tape Drive circuit pack which causes the Tape circuit pack to transfer the data from its buffers back to the Host Adapter's SCSI Data Memory. The Host Adapter then copies the data back to its private RAM where it compares it with the original test data.

■ Tape External Loop-around

This test is similar to the Internal Loop-around test except that the data originates in the Host Adapter's Dual Port RAM and it is transferred to and from the SCSI Data Memory using SPE system bus accesses. Only a small amount of data is sent to the Tape Drive circuit pack in order to keep system bus access to a minimum.

**Table 9-622. TEST #814 Tape Loop-around Test**

Error Code	Test Result	Description/ Recommendation
1316	ABORT	Could not get access to the Mass Storage System. Other application software may be using it or background maintenance tests may be running. <ol style="list-style-type: none"> <li>1. Retry the command at 1-minute intervals a maximum of 5 times.</li> <li>2. If the test continues to abort, verify that the daily translation-save operation is not in progress (issue the <b>display system-parameters maintenance</b> command to display the time for scheduled maintenance and the "y/n" option for saving translation daily).</li> </ol>
1335	ABORT	Could not run the test on the Standby SPE—Duplication not administered. <ol style="list-style-type: none"> <li>1. Refer to the documentation for STBY-SPE maintenance.</li> <li>2. Administer standby present.</li> </ol>
1338	ABORT	Could not run the test on the Standby SPE—Interchange pending. <ol style="list-style-type: none"> <li>1. Refer to the documentation for STBY-SPE maintenance.</li> <li>2. After interchange occurs, run test on new active SPE.</li> </ol>
1339	ABORT	Could not run the test on the Standby SPE—Handshake down. <ol style="list-style-type: none"> <li>1. Refer to the documentation for STBY-SPE maintenance.</li> <li>2. When the standby is restored to service (use <b>status spe</b> to determine state of standby) retry the command.</li> </ol>
1347	ABORT	Could not run the test on the Standby SPE—Refresh not complete. <ol style="list-style-type: none"> <li>1. When the standby is restored to service (use <b>status spe</b> to determine state of standby) retry the command.</li> </ol>
1350	ABORT	Could not run the test on the Standby SPE—Shadowing not enabled. <ol style="list-style-type: none"> <li>1. When the standby is restored to service (use <b>status spe</b> to determine state of standby) retry the command.</li> </ol>
2000	ABORT	Response to the test request was not received within the allowable time period. <ol style="list-style-type: none"> <li>1. Retry the command at 1-minute intervals a maximum of 5 times.</li> </ol>
2500	ABORT	Could not run the test on the Standby SPE—Internal software error. <ol style="list-style-type: none"> <li>1. Retry the command at 1-minute intervals a maximum of 5 times.</li> </ol>

**Table 9-622. TEST #814 Tape Loop-around Test — Continued**

Error Code	Test Result	Description/ Recommendation
5102	ABORT	Could not allocate the Mass Storage System to run this test <ol style="list-style-type: none"> <li>1. Retry the command at 1-minute intervals a maximum of 5 times.</li> <li>2. If the test continues to abort, verify that the daily translation-save operation is not in progress (issue the <b>display system-parameters maintenance</b> command to display the time for scheduled maintenance and the "y/n" option for saving translation daily).</li> </ol>
	NO BOARD	The tape has been placed in the "uninstalled" state. <ol style="list-style-type: none"> <li>1. Verify that a tape cartridge is installed and not write-protected and that the tape drive is fully inserted and powered up.</li> <li>2. Attempt a demand reset of the tape.</li> </ol>
1	FAIL	The Tape loop-around test failed. <ol style="list-style-type: none"> <li>1. Verify that a tape cartridge is installed and not write-protected.</li> <li>2. If a tape was inserted, remove it and clean the Tape Heads.</li> <li>3. If the test continues to fail, replace the Tape Cartridge. Wait for the retension pass to complete. If the test succeeds, issue the <b>backup disk</b> command.</li> <li>4. If the test continues to fail, replace the Tape circuit pack.</li> <li>5. If the test continues to fail, replace the MSSNET circuit pack.</li> </ol>
	PASS	The Tape loop-around test passed. Look at the results of other tests to see if it is operating correctly.

1. See the MSS Error Actions table at the end of the section on TAPE.

### Tape Status Test (#815)

The Tape Status Test verifies the following:

- The Host Adapter knows about the existence of the Tape Drive circuit pack.
- The LEDs on the faceplate can be turned on and off correctly.

Note that this only verifies that the control and status logic for the LEDs is operating correctly. The operation of the LEDs may also be tested visually by using the **test led** command.

- +12V from on-board DC-to-DC converters are present.

**Table 9-623. TEST #815 Tape Status Test**

Error Code	Test Result	Description/ Recommendation
1306 1307 1308	ABORT	Internal software error between maintenance software and MSS driver. 1. Retry the command at 1-minute intervals a maximum of 5 times.
1316	ABORT	Could not get access to the Mass Storage System. Other application software may be using it or background maintenance tests may be running. 1. Retry the command at 1-minute intervals a maximum of 5 times. 2. If the test continues to abort, verify that the daily translation-save operation is not in progress (issue the <b>display system-parameters maintenance</b> command to display the time for scheduled maintenance and the "y/n" option for saving translation daily).
1335	ABORT	Could not run the test on the Standby SPE—Duplication not administered. 1. Refer to the documentation for STBY-SPE maintenance. 2. Administer standby present.
1338	ABORT	Could not run the test on the Standby SPE—Interchange pending. 1. Refer to the documentation for STBY-SPE maintenance. 2. After interchange occurs, run test on new active SPE.
1339	ABORT	Could not run the test on the Standby SPE—Handshake down. 1. Refer to the documentation for STBY-SPE maintenance. 2. When the standby is restored to service (use <b>status spe</b> to determine state of standby) retry the command.
1347	ABORT	Could not run the test on the Standby SPE—Refresh not complete. 1. When the standby is restored to service (use <b>status spe</b> to determine state of standby) retry the command.
1350	ABORT	Could not run the test on the Standby SPE—Shadowing not enabled. 1. When the standby is restored to service (use <b>status spe</b> to determine state of standby) retry the command.
2000	ABORT	Response to the test request was not received within the allowable time period. 1. Retry the command at 1-minute intervals a maximum of 5 times.
2500	ABORT	Could not run the test on the Standby SPE—Internal software error. 1. Retry the command at 1-minute intervals a maximum of 5 times.

*Continued on next page*

**Table 9-623. TEST #815 Tape Status Test — Continued**

Error Code	Test Result	Description/ Recommendation
5102	ABORT	Could not allocate the Mass Storage System to run this test <ol style="list-style-type: none"> <li>1. Retry the command at 1-minute intervals a maximum of 5 times.</li> <li>2. If the test continues to abort, verify that the daily translation-save operation is not in progress (issue the <b>display system-parameters maintenance</b> command to display the time for scheduled maintenance and the "y/n" option for saving translation daily).</li> </ol>
	NO BOARD	The tape has been placed in the "uninstalled" state. <ol style="list-style-type: none"> <li>1. Verify that a tape cartridge is installed and not write-protected and that the tape drive is fully inserted and powered up.</li> <li>2. Attempt a demand reset of the tape.</li> </ol>
1	FAIL	The tape configuration information shows the tape circuit pack is missing or the tape LED test failed. <ol style="list-style-type: none"> <li>1. Verify that a tape cartridge is installed and not write-protected.</li> <li>2. If a tape was inserted, remove it and clean the tape heads.</li> <li>3. If the test continues to fail, replace the Tape Cartridge. Wait for the retention pass to complete. If the test succeeds, issue the <b>backup disk</b> command.</li> <li>4. If the test continues to fail, replace the Tape circuit pack.</li> <li>5. If the test continues to fail, replace the MSSNET circuit pack.</li> </ol>
	PASS	The Tape status test passed successfully. Check other test results to see if it is operating correctly.

1. See the MSS Error Actions table at the end of the section on TAPE.

### Tape Reset Test (#894)

The Tape Reset Test is run on as part of the **reset tape** command. The test results for Test 894 are the same as those for Test 809, which is run as part of the **test tape** sequence. All tape alarms are cleared when Test 894 passes, while only some tape alarms may clear when Test 809 passes. Refer to results for Test 809 for repair procedures.

## Tape Drive Head Cleaning Procedure

The following procedures should be used to clean the PBX Tape Drive(s). **A Tape Drive should be cleaned once every three months** to reduce the risk of losing information and to prevent unexpected service calls. An entry should be made in the Lucent Preventive Maintenance Log when this is done (see Chapter 6).

A DC2000 Series Data Cartridge Tape Drive Cleaning Kit from 3M is used to clean the tape head and the tape capstan. This kit consists of a Cleaning Positioning Cartridge and 20 cleaning wands (Comcode 406622464 or 3M Reorder number DC051111-12947). A refill kit of 20 cleaning wands is also available (Comcode 406622472 or 3M Reorder Number DC051111-12948).

### NOTE:

The cleaning wands are flammable. Dispose of properly.

1. Busy out the Tape circuit pack using the **busyout tape c** command where *c* is the carrier number (a or b). This prevents background maintenance tests and other application software from trying to access the tape.
2. Eject the Tape Cartridge from the Tape circuit pack (TN1656). Insert the Cleaning Position Cartridge into the Tape Drive with the **label side to the left** (see Picture 1).
3. Prepare the cleaning wand for use as follows: Hold the bristle end down, crush the wand at the "x" area and squeeze to release fluid and saturate the bristles.
4. Insert the wand into **R/W Head Slot** (top of cartridge, see Picture 2) with gentle twisting motion. Stop when solid resistance is felt. Rotate the wand 6 turns while raising and lowering end of wand.
5. Remove the used wand and discard.
6. Prepare a second wand as described in step 3 above.
7. Eject the Cleaning Position Cartridge out of the Tape circuit pack and reinsert it. This will condition the tape drive to move the capstan when the cleaning wand is inserted in the next step.
8. Insert the wand into the **Capstan Slot** (middle of cartridge, see Picture 2) within 10 seconds after the Cleaning Position Cartridge was reinserted.
9. Apply a gentle forward pressure to the wand for about 15 seconds. You should be able to feel the capstan moving.
10. Remove the used wand and discard.
11. Eject the Cleaning Positioning Cartridge and insert the PBX Tape Cartridge back into the Tape Drive.

### NOTE:

After the Tape Cartridge is inserted back into the Tape Drive, it will run through a retension pass which will take up to two minutes to



complete. During that time, the **reset tape** command entered in the next step causes a "please wait" message to flash on the terminal screen while the tape is retensioning, but the command will complete after the retension pass completes.

12. Reset the Tape circuit pack using the **reset tape c** command where *c* is the carrier number (a or b). This will clear out a tape error that indicates the tape cartridge had been removed and reinserted.
13. Release the Tape from its maintenance busy-out state using the **release tape c** command where *c* is the carrier number (a or b).

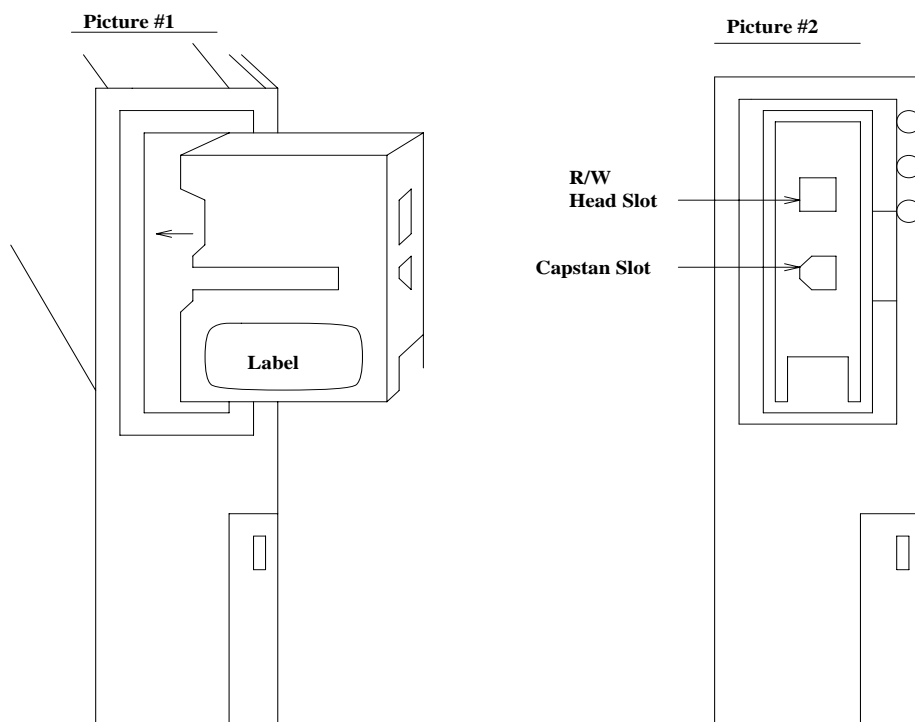

Figure 9-104. Mass Storage System Interactions

**Table 9-624. MSS Error Actions**

Code	Description
0	Unexpected interrupt from SBICC.
1	SBICC timed out during SCSI command.
2	DMAC generated error interrupt.
3	DMAC timed out without interrupt.
4	Tape self-test failed.
5	Tape external looparound test failed.
6	Command failed with bad SENSE key.
7	Tape could not be accessed.
8	Flaw detected in tape medium.
9	Unrecoverable hardware failure on tape.
10	Invalid parameter in SCSI command.
11	Media removed or tape reset.
12	Tape is write protected.
13	Tape reached end of medium.
14	Block reassigned on tape.
15	Block reassignment failed on tape.
16	Inconsistent capacity data
17	Device busy
18	Device reservation conflict
19	Request sense failed
101	Unrecognized <i>opcode</i> .
102	Unrecognized <i>modifier</i> .
103	<i>xlist_length</i> too long.
104	Invalid transfer address.
105	Intra-device copy ranges overlap.
121	Device invalid for <i>opcode</i> requested.
122	Device non-existent.
123	Device is out of service.
124	<i>to_byte</i> or <i>from_byte</i> is out of range.
125	<i>to_byte</i> + <i>numbytes</i> is invalid or <i>from_byte</i> + <i>numbytes</i> is invalid.

*Continued on next page*

**Table 9-624. MSS Error Actions — Continued**

Code	Description
126	Type of device is invalid for <i>opcode</i> requested.
201	An unexpected interrupt code was returned from the SBICC. This represents a protocol error that could be the result of the HA or the target device. The device may not be present.
251	SBICC timed out. This could be the fault of the HA or target device. The HA will attempt to reset the SBICC.
301	DMAC error. This could be the fault of the HA or the SCSI target device.
351	DMAC timed out. This could be the fault of the HA or the SCSI target device. The HA will attempt to reset the SBICC.
401	Could not save announcements or program update file.
408	Could not read translation from the Disk and Tape as part of system initialization.
409	Could not apply program update file.
422	Could not save translations.
501	A non-critical diagnostic test failed on the Host Adapter. This includes the USART chip test and the LED tests.
511	A diagnostic test requiring bus mastership failed. This happens only as the result of an MSS_DIAG command. This could be the fault of the HA or the system. Therefore the board does not put itself in held reset state. Rather, the error is reported and counters are incremented.
521	The HA looparound test requiring bus mastership failed. This happens only as the result of an MSS_LOOPAROUND command. This could be the fault of the HA or the system. Therefore the board does not put itself in held reset state. Rather, the error is reported and counters are incremented.
531	Target device <b>SEND DIAGNOSTICS</b> self-test indicated a hardware error. This indicates that there are problems with the controller or the device, and it should be taken out of service. This error will not occur if other errors (e.g. SBICC) prevent the <b>SEND DIAGNOSTICS</b> command from running.
551	The target device internal looparound failed due to data corruption. Other errors (SBICC, SCSI check condition) would cause a different error code to be reported. This failure demonstrates that the target may potentially corrupt data and it should be taken out of service.
552	The target device external looparound failed due to data corruption. Other errors (SBICC, SCSI check condition) cause a different error code to be reported. This failure demonstrates that the target may potentially corrupt data. However, the HA does not take the device out of service as a result of this error. This test is only run following the target device internal looparound which detects actual problems with the target device. This failure implicates the HA bus interface or a system problem.
561	When the MSS_RESET command was issued for a device, it was found not to be present.
562	When the MSS_RESET command was issued for a device, the NQUIRY command failed.

*Continued on next page*

**Table 9-624. MSS Error Actions — Continued**

Code	Description
563	When the MSS_RESET command was issued for a device, the TEST UNIT READY command failed
564	When the MSS_RESET command was issued for a device, the READ CAPACITY command failed
565	The device reset failed.
566	Device type not supported.
567	Capacity data is inconsistent.
568	Block size doesn't divide into 8K.
601	<b>REQUEST SENSE</b> failed.
700	Indicates that there is no specific sense key information for a SCSI target on which a <b>REQUEST SENSE</b> was issued. This should never happen because firmware only asks for sense information if errors occurred.
701	SCSI sense information reported a recovered error on a SCSI target where it didn't make sense. Normally recovered errors are filtered by the HA firmware for reads and writes. However, for other commands, this is reported to software.
702	SCSI sense information indicates that the target device cannot be accessed. This will occur if the tape cartridge is not present.
703	SCSI sense information indicates that a SCSI command terminated with a nonrecovered error condition probably caused by a flaw in the medium or an error in the recorded data.
704	SCSI sense information indicates a nonrecoverable hardware failure occurred. The tape may be broken.
705	SCSI sense information indicates that there was an illegal parameter in the command descriptor block or in additional parameters supplied. This could be caused by a HA firmware failure or a problem with the target device.
706	SCSI sense information indicates that the target device's removable medium may have been changed or the target controller has been reset.
707	SCSI sense information indicates that reads or writes were attempted for a medium that was protected from this operation.
708	SCSI sense information indicates that a write-once read-multiple device or a sequential-access device encountered a blank block while reading or a write-once read-multiple device encountered a nonblank block while writing. This should never happen; the HA only supports direct access devices.
709	SCSI sense information indicates a vendor-unique sense key.
710	SCSI sense information indicates a <b>COPY</b> , <b>COMPARE</b> , or <b>COPY AND VERIFY</b> command was aborted due to an error condition on the source device, the destination device, or both. This shouldn't happen since these commands aren't issued by the HA.
711	SCSI sense information indicates that the target controller aborted the command.

*Continued on next page*

**Table 9-624. MSS Error Actions — Continued**

Code	Description
712	SCSI sense information indicates that a <b>SEARCH DATA</b> command has satisfied an equal comparison. This should not happen since this command is not issued by the HA.
713	This indicates that a buffered peripheral device has reached the end-of-medium and data remains in the buffer that has not been written to the medium.
714	This indicates that the source data did not match the data read from the medium. This should not happen since the HA does not issue any commands involving comparisons.
715	SCSI sense information returned a reserved sense key. This should not happen.
758	Device returned busy.
764	Device returned reservation conflict status.
801	HA firmware was attempting to process a command requiring system bus access and the NOGOINT interrupt occurred. This probably indicates that system software failed to enable bus access before issuing an MSS command requiring it. It also could indicate a system problem or a HA problem.
802	HA firmware was accessing the system bus and it timed out. This could be a result of MSS command argument errors, system problems, or a HA problem.
803	HA firmware was accessing the system bus and received a data-parity interrupt. This could indicate a system or HA problem.
804	HA firmware was accessing the system bus and received a error detection and correction interrupt. This could indicate a system or HA problem.
805	System bus error test failed.
1001	Firmware error
1002	Cheetah/Pecos error
1003	Both the 68020 and the DMAC tried to access the same location in the SDM concurrently.
1004	HA firmware couldn't put a response in the response queue because it was full. This could be the fault of the HA, or system software. However, there is no way to recover, therefore the HA places itself in held reset.
2001	A critical diagnostic test on the Host Adapter failed making it dangerous to continue service.
2002	The Host Adapter internal looparound test failed because of data corruption.
3001	An exception occurred indicating a serious hardware or firmware problem. Additional information will be placed in HA DPRAM about which exception occurred and the address at which it occurred.
3002	An interrupt occurred when it should not have. This includes interrupts that are a normal part of command processing but that occurred unexpectedly.
4001	The checksum of the firmware image in memory prior to FLASH PROM programming failed.

*Continued on next page*

**Table 9-624. MSS Error Actions — Continued**

Code	Description
4002	Flash PROM programming failed.
5000	The tape cartridge has been changed or the tape drive has been reset by firmware.
5001	Alternate copy of file used—primary could not be accessed.
5113	Device out of service
5124	No tape cartridge in tape drive.
5126	Handshake not up
5127	Memory refresh not complete
5200	Kernel call received a notification.
5201	Spurious interrupt from MSSNET.
5202	Message received on an unexpected class.
5203	File system on the device is corrupt.
5204	Driver failed to get parity error interrupt.
5205	Driver failed to get EDC error interrupt.
5206	Driver failed to get timeout interrupt.
5207	Alternate file could not be accessed.
5208	Bad path index on software call.
5209	Driver failed to get bus error interrupt.
5210	MSS client died.
5212	File 0 (directory) corrupt.
5213	File 1 (alternate directory) corrupt.
5214	File 2 (small boot image) corrupt.
5215	File 3 (alternate small boot image) corrupt.
5216	File 4 (program update file) corrupt.
5217	File 5 (alternate program update file) corrupt.
5218	File 6 (translation file) corrupt.
5219	File 7 (alternate translation file) corrupt.
5220	File 8 (error log) corrupt.
5221	File 9 (alternate error log) corrupt.
5222	File 10 (downloadable firmware) corrupt.
5223	File 11 (alternate downloadable firmware) corrupt.

*Continued on next page*

**Table 9-624. MSS Error Actions — Continued**

Code	Description
5224	File 12 (announcement file) corrupt.
5225	File 13 (alternate announcement file) corrupt.
5226	File 14 (maintenance scratch file) corrupt.
5227	File 15 (small config core dump) corrupt.
5228	File 16 (large boot image) corrupt.
5229	File 17 (alternate boot image) corrupt.
5230	File 18 (large core dump on disk) corrupt.
5231	File 19 (large core dump on tape) corrupt.
5300	Command timed out.
5301	Driver ran out of resources.
5302	Device or host adapter is not ready.
5303	State information is invalid.
5304	Firmware returned unexpected tag.
5305	MSSNET board is not inserted.
5400	Initialization error.
5401	Kernel call failed.
5402	Timer call failed.
5403	DUPINT call failed.
5404	DRIP call failed.
5405	Critical path destroyed.
5406	Internal error.
5504	Block reassigned on tape as a result of a medium error
5505	While running status test, configuration test failed.
5506	While running status test, LED test failed.
5507	Status test found host adapter in "held reset" state.
5508	Unable to obtain path to PAM.
5509	Translations were not locked.
5510	+5V not present
5511	+12V not present
5512	Exceeded 90% of manufacturer's recommended tape access limit.

*Continued on next page*

**Table 9-624. MSS Error Actions — Continued**

Code	Description
5513	Disk capacity not sufficient for memory size.
5514	Disk not configured for larger memory size.
30003	Cannot write to tape, cartridge or device error.
30004	Cannot read from tape, cartridge or device error.
30017	Checksum error in block.
30203	Write-read mismatch error.



## TBRI-BD (TN2185 ISDN Trunk-Side BRI)

---

MO Name (in Alarm Log)	Alarm Level	Initial Command to Run <sup>1</sup>	Full Name of MO
TBRI-BD	MINOR	test board UUCSS I r#	TBRI-BD

1. Where UU is the universal cabinet number (1 for PPN, 2 -44 for EPN), C is the carrier designation (A, B, C, D, or E), SS is the carrier slot address where the circuit pack is located (1, 2, and so forth), and pp is the two-digit port number (1, 2, 3, and so forth).

The TN2185 circuit pack contains eight, 4-wire ports that interface to the network at the ISDN S/T reference point over two 64 Kb/s channels (B1 and B2) and over a 16Kb/s signaling (D) channel. The B1 and B2 channels can be simultaneously circuit switched or individually packet switched. Only one channel per trunk can be packet switched due to Packet Processing Element (PPE) limitations. The D channel is either circuit switched or packet switched. Packet switching uses the PPE to combine all D channels into a single physical channel, which is then routed via the concentration highway to the Network Control Element (NCE) and then to the TDM bus. The circuit-switched connections have a Mu-law or A-law option for voice and operate as 64Kb/s clear data channels. The packet-switched channels support the LAPD protocol and conform with the CCITT Q.920 Recommendations for D-channel signaling.

### LEDs

The three LEDs on the circuit pack's faceplate indicate board status. When illuminated, the red LED indicates a board failure or a major or minor on-board alarm, the green LED indicates that testing is in progress, and the amber LED indicates that the board is in use.

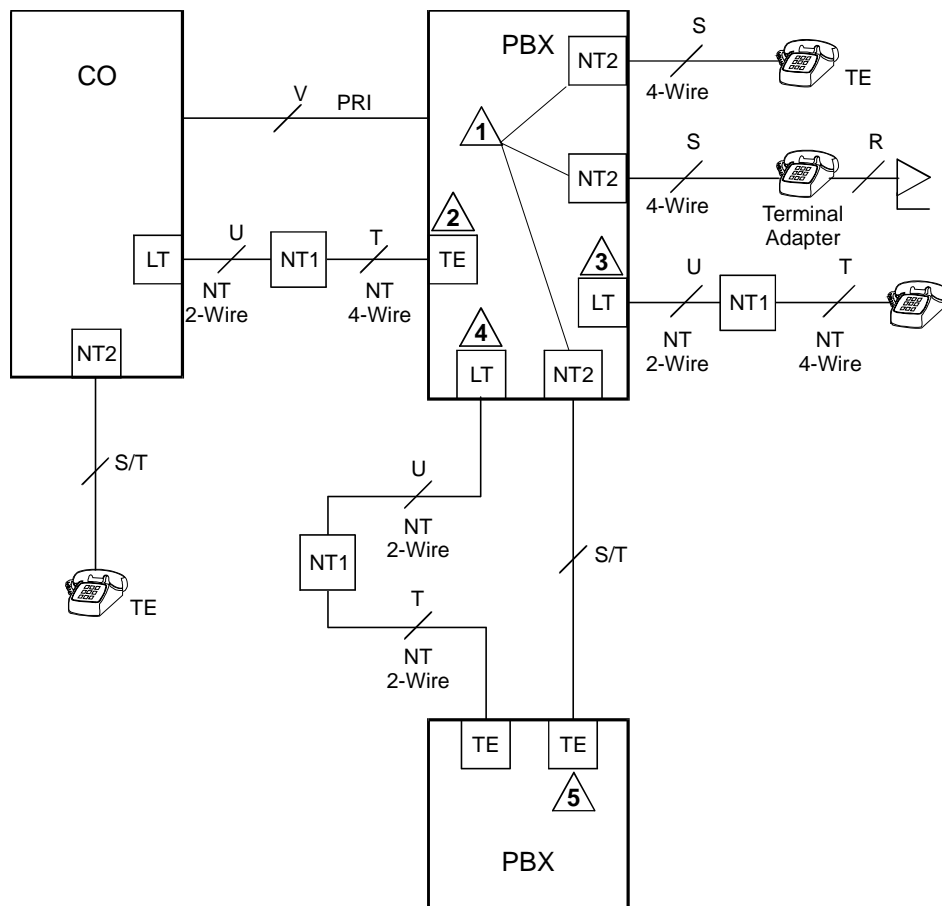

ISDN Interface Reference Points

cydfisdn RPY 072397

Figure 9-105. Integrated Trunk-Side BRI, ISDN Interface Reference Points

ISDN Interface Reference Point definitions:

- LT Logical Terminal
- V Primary Rate user/network (asymmetrical) trunk interface. The ECS is capable of acting as the user or as the network side of this 1.544 - or 2.048-Mbps interface.
- R Interface between Terminal Equipment and Network Termination
- S Basic Rate network-side 4-wire line interface
- S/T 4-wire Basic Rate connection to a Network Termination<sup>1</sup>.
- T 4-wire Basic Rate interface to a Network Termination.<sup>2</sup>

- TE Terminal Equipment
- U Basic Rate network-side 2-wire line interface.
- 1 TN556B ISDN-BRI 4-Wire S/T-NT Line (A-law)
- 2 TN 2185 ISDN-BRI 4-Wire S Interface (Trunk Side)
- 3 TN2198 ISDN-BRI 2-Wire U Interface
- 4 TN2198 ISDN-BRI 2-Wire U Interface
- 5 TN 2185 ISDN-BRI 4-Wire S Interface (Trunk Side)

1. Network Termination 2 (NT2), that terminates Layer 1 and higher layers. PBXs, LANs, and terminal controllers typically provide NT2 functionality including protocol handling and multiplexing for Layers 2 and 3.
2. Network Termination 1 (NT1), that terminates Layer 1 and monitors maintenance, performance, timing, power transfer, multiplexing, and multi-drop termination with contention resolution.

## Hardware Error Log Entries and Test to Clear Values

**Table 9-625. TBRI-BD Error Log Entries**

<b>Error Type</b>	<b>Aux Data</b>	<b>Associated Test</b>	<b>Alarm Level</b>	<b>On/Off Board</b>	<b>Test to Clear Value</b>
0 <sup>1</sup>	0	Any	Any	Any	test board UUCSS sh r 1
1 (a)	Any	None	MINOR	ON	
257 (b)	65535	Control Channel Loop Test (#52)	MINOR	ON	test board UUCSS r 20
513 (c)	4352 to 4357		None	ON	
769 (d)	4358				
1025 (e)		NPE/NCE Audit Test (#50)	None	ON	
1291 (f)	4359	Clear Error Counters (#270)	MINOR	ON	
1294 (g)	46088 to 46096	SAKI Sanity Test (#53)	MINOR	ON	See (h)
1537 (h)	46082		MINOR	ON	
1793 (i)	46080		MINOR	ON	
1794 (i)	46094		MINOR	ON	

*Continued on next page*

Table 9-625. TBRI-BD Error Log Entries — Continued

Error Type	Aux Data	Associated Test	Alarm Level	On/Off Board	Test to Clear Value
1795 (i)	46085		MINOR	ON	
2305 (j)	46104		None	ON	
2306 (i)	46081		None	ON	
3330 (j)	46083		MINOR	OFF	
3586 (k)			MINOR	OFF	
3840(l)	4096 to 4101				
3842 (m)	46095				
3843 (n)	46097				

1. Run the Short Test Sequence first. If all tests pass, run the Long Test Sequence. Refer to the appropriate test description and follow the recommended procedures.

Notes:

- a. The circuit pack stopped functioning or is physically removed from the system.

 **NOTE:**

This alarm logs approximately 11 minutes after removing the circuit pack and/or the SAKI Sanity Test (#53) fails.

If the circuit pack is not in the system, insert a circuit pack in the same slot as the error indicates. See note (g).

- b. Transient communication problems between the switch and this circuit pack. Execute the **test board UUCSS** command and refer to the repair procedures for the Control Channel Loop Around Test (#52).
- c. On-board hardware failure. Aux data values correspond to the following detected errors:

- |      |                       |
|------|-----------------------|
| 4352 | External RAM error    |
| 4353 | Internal RAM error    |
| 4355 | ROM Checksum error    |
| 4357 | Instruction set error |

Reset the circuit pack with the **busyout board UUCSS** and **reset board UUCSS** commands. When reset, the circuit pack executes a set of tests to detect the presence of any of the faults listed above. Detection of one of these errors during initialization causes the circuit pack to lock-up and appear insane to the system. See the repair procedure in Note (a).

- d. The circuit pack detects a program logic error. While no action is required, this error can lead to other errors against this circuit pack.
- e. The circuit pack cannot update and read back NPE/NCE memory. This error can be ignored, but may lead to other errors against this circuit pack.
- f. The TN2185 board notifies maintenance software that it has detected a parity error while accessing its dynamic RAM (that stores the board's translation information and downloadable application firmware). Maintenance software resets the circuit pack.
- g. Unable to write LAN Translation RAM Error (internal memory access error). Translation RAM locations for the call connection attempt are not available, and one or more RAM locations are bad due to a translation RAM read-back error. Reset the circuit pack with the **busyout board UUCSS** and **reset board UUCSS** commands. If the Circuit Pack Restart Test (#594) passes, then the on-board circuitry is healthy. Retire the alarm with the **test board UUCSS long clear** command. If the Circuit Pack Restart Test (#594) fails, replace the circuit pack.
- h. Frame overrun at Packet Bus interface. Due to an on-board fault or by faulty data received on one of the circuit pack's external ports. If any of the ports on this circuit pack is alarmed, refer to the repair procedures for those maintenance objects. If this error persists, maintenance software removes the board from service; replace the circuit pack.
- i. The circuit pack is has problems transmitting/receiving data to/from the Packet Bus.
  - 1793 Parity errors are detected when transmitting data to the Packet Bus.

- 1794 Packet Bus transmit buffers overflow.
- 1795 Circuit pack cannot find end of frame when transmitting to Packet Bus. Clear the alarm with: **busyout board UUCSS**, **reset board UUCSS**, **test board UUCSS long clear**, **release board UUCSS**. If the error recurs within 10 minutes, replace the circuit pack.
- 2306 Error in a received frame from the Packet Bus, most likely caused by a packet bus problem, but may be due to a circuit pack fault. An invalid Link Access Procedure Data (LAPD) frame error occurs if the frame contains a bad Cyclical Redundancy Check (CRC). If bus parity errors occur, run the LAN Receive Parity Error Counter Test (#595) to determine if the condition has cleared. Refer to the maintenance documentation to determine if the problem is isolated to this circuit pack or is caused by Packet Bus faults.

- j. Error Type (2305, 3330): A critical failure in the Circuit Pack's Packet Bus interface. Possible causes include either a Packet Bus fault or an on-board fault, for example, the board received a bad CRC or invalid DLCI. If the Packet Bus is alarmed, refer to the "*Maintenance Manual*" section for Packet Bus fault location and recommended repair procedures. The number of ISDN circuit packs displaying this error increases the probability of errors due to Packet Bus problems.

If there are no Packet Bus alarms, reset the circuit pack with the **busyout board UUCSS** and **reset board UUCSS** commands. If the Circuit Pack Restart Test (#594) passes, then the on-board circuitry is healthy. Retire the alarm with the **test board UUCSS long clear** command. If the Circuit Pack Restart Test (#594) fails, replace the circuit pack.

- k. The SPE software detects an excessive number of up-link messages from the TN2185 board within a certain time period. To prevent the faulty board from flooding the switch with data, the switch software takes the board out of service and alarms it. The switch software also tells the Archangel to ignore up-link messages from the board.

When the board is alarmed due to this error, the switch software periodically puts the board back in service and tells the Archangel to process up-link messages from the board. If the problem still exists, the software takes the circuit pack out of service again. If the circuit pack does not exhibit the problem for a certain time period, then maintenance software resolves the alarm and the circuit pack is left in service.

- l. The circuit pack received an inconsistent down-link message (a bad header, port number, data, subqualifier, or logical link) over the Control Channel.
- m. The board is receiving data from the bus faster than it can distribute the data to its endpoints, causing the FIFO RAM buffer to overflow. This error can occur occasionally due to the statistical sizing of the buffers. If it

occurs frequently, it may indicate a LAPD parameter mismatch. LAPD should recover from this problem, but it may degrade the performance of the LAN bus.

When this error is reported, maintenance reads and clears the board counter and logs the problem in the maintenance error log.

- n. Bad translation RAM detected, but the call continues by using another translation location. The circuit pack reports this error when it cannot update NPE/NCE memory and read it back. This error is not service-affecting and can be ignored, but can lead to other types of errors against this circuit pack.

## System Technician-Demanded Tests: Descriptions and Error Codes

---

When inspecting errors in the system, always investigate tests in the order listed below. By clearing error codes associated with the *Control Channel Loop Around Test*, for example, you may also clear errors generated from other tests in the testing sequence.

Order of Investigation	Short Test Sequence	Long Test Sequence	D/ND <sup>1</sup>
Control Channel Loop-Around Test (#52)	X	X	ND
NPE/NCE Audit Test (#50)		X	ND
LAN Receive Parity Error Counter Test (#595)		X	ND

---

1. D = Destructive; ND = Nondestructive

### Control Channel Loop Around Test (#52)

Refer to the repair procedure described in the "XXX-BD (Common Port Circuit Pack)" section.

### NPE /NCE Audit Test (#50)

Refer to the repair procedure described in the "XXX-BD (Common Port Circuit Pack)" section.

### SAKI Sanity Test (#53)

**This is a destructive test.**

Refer to the repair procedure described in the "XXX-BD (Common Port Circuit Pack)" section. This test is only run as a part of a reset board procedure.

## LAN Receive Parity Error Counter Test (#595)

This test is nondestructive. The test reads and clears the circuit pack's LAN Receive Parity Error Counter. This counter increments when it detects a parity error from the Packet Bus. These errors may indicate problems with a circuit pack, Packet Bus, or with another circuit pack on the bus. Use this test to verify the repair.

**Table 9-626. TEST #595 LAN Receive Parity Error Counter Test**

Error Code	Test Result	Description/ Recommendation
2000	ABORT	Response to the test was not received from the circuit pack within the allowable time period. <ol style="list-style-type: none"> <li>1. If the test aborts repeatedly a maximum of 5 times, reset the circuit pack via the <b>busyout board UUCSS</b> and <b>reset board UUCSS</b> commands.</li> <li>2. If the test aborts again, replace the circuit pack.</li> </ol>
2100 2012	ABORT ABORT	Could not allocate the necessary system resources to run this test. Internal system error. <ol style="list-style-type: none"> <li>1. Retry the command at 1-minute intervals a maximum of 5 times.</li> </ol>
1-10	FAIL	The circuit pack is still detecting errors of this type. The error code indicates the value of the on-board error counter. <ol style="list-style-type: none"> <li>1. Retry the command at 1-minute intervals a maximum of 5 times.</li> <li>2. If the test continues to fail, verify the validity of the Packet Bus. Run the Packet Bus maintenance test with the <b>test pkt P long</b> command. If any Packet Bus tests fail, refer to the "PKT-BUS (Packet Bus)" section for recommended repair procedures.</li> <li>3. If the Packet Bus test passes, check the validity of the circuit pack. Execute a test that involves data transmission onto the Packet Bus. For example, the <b>test port UUCSSpp</b> command may use the connectivity tests of the BRI-PORT maintenance object. If the test fails, refer to the repair procedures; otherwise, proceed to the next step.</li> <li>4. Other circuit packs on the Packet Bus may be causing of the parity error. Use the <b>display errors</b> command to check the Error Log for alarmed other circuit packs. Resolve any alarms for other circuit packs as well. Rerun the LAN Receive Parity Error Counter Test (#595).</li> </ol>
	PASS	No errors detected.



## TBRI-PT (TN2185 ISDN Trunk-Side BRI Port)

MO Name (in Alarm Log)	Alarm Level	Initial Command to Run <sup>1</sup>	Full Name of MO
TBRI-PT	MAJOR	test port UUCSS I r#	TBRI-PT
TBRI-PT	MINOR	test port UUCSS I r#	TBRI-PT
TBRI-PT	WARNING	test port UUCSS s r#	TBRI-PT

- Where UU is the universal cabinet number (1 for PPN, 2 -44 for EPN), C is the carrier designation (A, B, C, D, or E), SS is the carrier slot address where the circuit pack is located (1, 2, and so forth), and pp is the two-digit port number (1, 2, 3, and so forth).

This document describes the port maintenance features of the DEFINITY<sup>®</sup> ISDN Trunk-side BRI board (TN2185). The circuit pack provides 8 S/T ISDN 2B+D ports that interface to either the central office or another PBX.

The TN2185 circuit pack contains eight, 4-wire ports that interface to the network at the ISDN S/T reference point over two 64 Kb/s channels (B1 and B2) and over a 16Kb/s signaling (D) channel. The B1 and B2 channels can be simultaneously circuit switched, or individually packet switched. Only one channel per trunk can be packet switched due to Packet Processing Element (PPE) limitations. The D channel is either circuit switched or packet switched. Packet switching uses the PPE to combine all D channels into a single physical channel, which is then routed via the concentration highway to the Network Control Element (NCE) and then to the TDM bus. The circuit-switched connections have a Mu-law or A-law option for voice and operate as 64Kb/s clear data channels. The packet-switched channels support the LAPD protocol and conform with the CCITT Q.920 Recommendations for D-channel signaling.

### LEDs

The three LEDs on the circuit pack's faceplate indicate board status. When illuminated, the red LED indicates a board failure or a major or minor on-board alarm, the green LED indicates that testing is in progress, and the amber LED indicates that the board is in use.

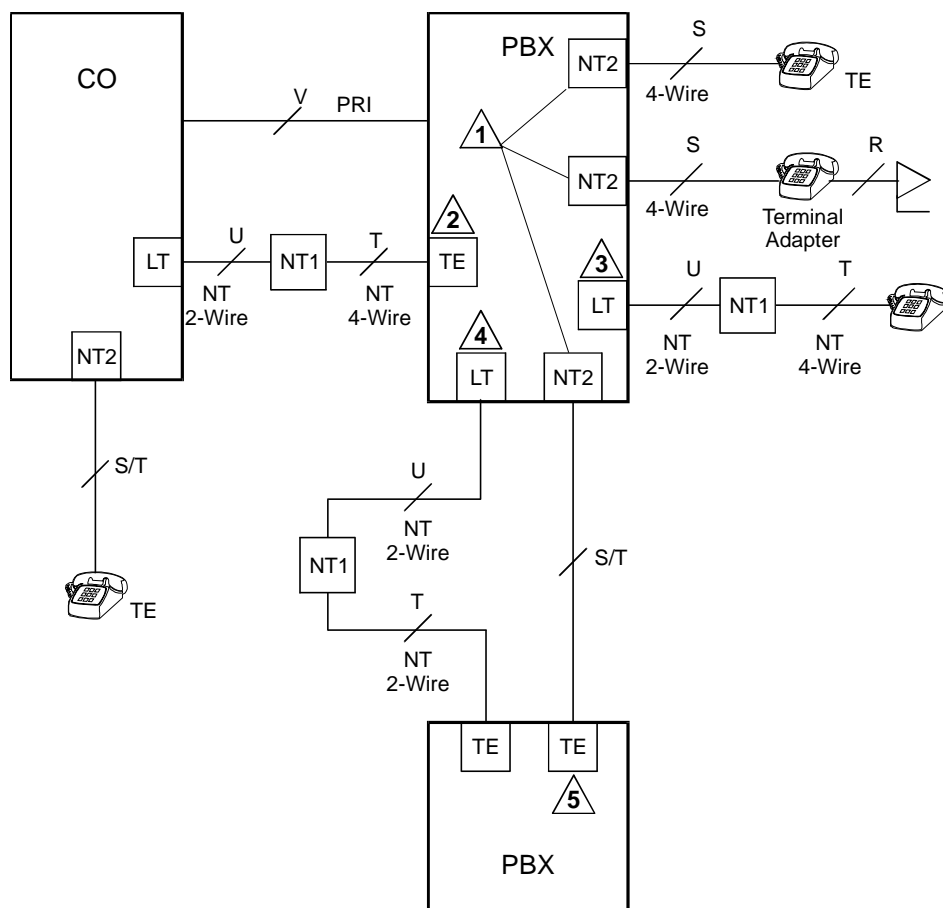

ISDN Interface Reference Points

cydfisdn RPY 072397

Figure 9-106. Integrated Trunk-Side BRI, ISDN Interface Reference points

ISDN Interface Reference Point definitions:

- LT Logical Terminal
- V Primary Rate user/network (asymmetrical) trunk interface. The ECS is capable of acting as the user or as the network side of this 1.544 - or 2.048-Mbps interface.
- R Interface between Terminal Equipment and Network Termination
- S Basic Rate network-side 4-wire line interface
- S/T 4-wire Basic Rate connection to a Network Termination<sup>1</sup>.
- T 4-wire Basic Rate interface to a Network Termination.<sup>2</sup>

- TE Terminal Equipment
- U Basic Rate network-side 2-wire line interface.
- 1 TN556B ISDN-BRI 4-Wire S/T-NT Line (A-law)
- 2 TN 2185 ISDN-BRI 4-Wire S Interface (Trunk Side)
- 3 TN2198 ISDN-BRI 2-Wire U Interface
- 4 TN2198 ISDN-BRI 2-Wire U Interface
- 5 TN 2185 ISDN-BRI 4-Wire S Interface (Trunk Side)

1. Network Termination 2 (NT2), that terminates Layer 1 and higher layers. PBXs, LANs, and terminal controllers typically provide NT2 functionality including protocol handling and multiplexing for Layers 2 and 3.
2. Network Termination 1 (NT1), that terminates Layer 1 and monitors maintenance, performance, timing, power transfer, multiplexing, and multi-drop termination with contention resolution.

## Hardware Error Log Entries and Test to Clear Values

Table 9-627. TBRI-PT Error Log Entries

Error Type	Aux Data	Associated Test	Alarm Level	On/Off Board	Test to Clear Value
0 <sup>1</sup>	0	Any	Any	Any	test Port UCSSPP sh r 1
1 (a)		Level 1 Status Test (#1242)	MINOR	OFF	
129 <sup>2</sup>					
257(b)					
513 (c)	46222	XMIT FIFO Overflow	MINOR	ON	
514 (d)		XMIT FIFO Overflow (TDM)	MINOR	ON	
769 (e)		Traffic Hyperactivity	MINOR	OFF	
1025 (f)					
1281 (g)		NPE Crosstalk Test (#617)	MINOR	ON	
1537 (h)	46210	CRC error (D-Channel)	MINOR	OFF	
1538 (i)		CRC error (TDM D-Channel)	MINOR	OFF	

**Table 9-627. TBRI-PT Error Log Entries — Continued**

Error Type	Aux Data	Associated Test	Alarm Level	On/Off Board	Test to Clear Value
1793 (j)		BRI Port Local TDM Looparound Test (#619)	MINOR	ON	
2049 (k)			MINOR	OFF	
2305 (l)		Layer 3 Query (#1243)	MINOR	OFF	
3073 (m)		Slip Query Test (#1244)	MINOR	OFF	
3585 (n)		Receive FIFO Overflow (TDM D-Channel)	Log Only	ON	
3586 (o)					
3587 (p)					
3588 (q)	46223				
3589 (r)					
3590 (s)	46211				
3591 (t)					
3592 (u)					
3841 to 3942 (v)					

1. Run the Short Test Sequence first. If all tests pass, run the Long Test Sequence. Refer to the appropriate test description and follow the recommended procedures.
2. The far-end switch changed the ISDN service state. This may be a temporary condition.

**Notes:**

- a. Loss of continuity of Layer 1 to the far-end. It is assumed that Layer 1 remains active, even when both B-Channels are idle.

This test determines whether Layer 1 is active or not. If Layer 1 is not active, the test attempts to activate it. If Layer 1 cannot be activated, the port is taken out of service, and the test fails.

- b. The D-Channel failed at Layer 2. Expiration of this timer indicates that attempts to bring the failed link back into service have not succeeded and some recovery actions should be taken on the associated B-Channels. Upon expiration, associated in-service B-channels are put in the out-of-service/far end state.

- c. Error Type (513): On-board hardware failure. The FIFO RAM buffers have overflowed, indicating a hardware problem.
- d. Error Type (514): Transmit FIFO Overflow - This error indicates that the circuit pack is having problems transmitting data to the TDM D-Channel. This error only occurs only a system that switches the packet implementation of the D-channel over the TDM Bus. This error indicates an on board problem related to the packet implementation of the D-Channel (R6.2 and higher).
- e. Error Type (769): The port is generating too many uplinks. The link is being suspended.
- f. Error Type (1025): An expired timer has created an unexpected event. The timer could be any of the following:

Timer	Event
T3031	ISDN T3031 timeout
T3032	ISDN T3032 timeout
T305	ISDN T305 timeout
T3081	ISDN T3081 timeout
T3082	ISDN T3082 timeout
TL3	Status Inquiry
T304	Setup ACK
T310	Call Proceeding Receive
T313	Connect SEND

- g. Error Type (1281): This error occurs when the NPE Crosstalk Test (#617) has failed. The test will be repeated every 15 minutes until it passes. Follow normal trouble shooting procedures for NPE Crosstalk Test (#617). If this does not fix the problem, follow normal escalation procedures.
- h. Error Type (1537): The board received a bad Cyclical Redundancy Check (CRC) over the D-Channel. This error is reported on a per-port basis. When the CRC errors exceed 5 within 15 minutes, the port is taken out of service for 5 seconds. If 5 more CRC errors are received within 15 minutes of the first set of 5 errors, the port is taken out of service for 1 minute. If 5 more CRC errors are received within 15 minutes of the previous 5, the port is taken out of service for 15 minutes.

This error is most likely due to a problem with backplane wiring, a noise source, or no termination (an open circuit). It usually does not indicate a problem with the circuit pack.

1. Check the backplane wiring.
2. If the problem persists escalate the problem.

- i. Error Type (1538): This error occurs when a frame with a bad CRC is received by the BRI trunk board. This error only occurs on a system that switches the packet implementation of the D-channel over the TDM bus. This error indicates an off board problem related to the packet implementation of the TDM D-Channel (R6.2 and later).
- j. Error Type (1793): The BRI Port Local TDM Loop Around Test (#619) failed. Run the Long Test Sequence paying particular attention to the results of the BRI TDM Port Loop Test (#619).
- k. Error Type (2049): The Layer 2 Link Query failed. The test is repeated every 15 minutes until it passes.
- l. Error Type (2305): The Remote Layer 3 Query failed. The test is repeated every 15 minutes until it passes.
- m. Error Type (3073): A frame of information had to be repeated or deleted. Slips usually occur when the received bit rate is not synchronized with the TDM Bus clock.
- n. Error Type (3585): The circuit pack detected an overflow of its receive buffers. This error occurs only a system that switches the packet implementation of the D-Channel over the TDM bus. This error indicates an on board problem related to the packet implementation of the TDM D-Channel (R6.2 and higher).
- o. Error Type (3586): Each port can support up to three Terminal Endpoint Identifiers (TEIs). Each channel on the port can request a TEI assignment from the switch if it supports ISDN-BRI TEI assignment procedures. If switch services gets a request for a fourth TEI on a port, it reports this event to maintenance software and initiates TEI check procedures on the port. Check to see if the correct number of channels are administered for this port.  

The user side supports automatic TEI assignment by the network. Both fixed and automatic TEI assignment are supported on the network side.
- p. Error Type (3587)Service Profiler IDentifier (SPID) value is invalid or is a duplicate of another SPID that is already initialized at Layer 3 on the port. SPIDs are not used on the TN2185 circuit pack. However there will be related events.
- q. Error Type (3588): The board receives D-Channel data from the bus faster than it can process the data. The FIFO RAM buffers overflowed. This error occurs occasionally due to the statistical sizing of the buffers; however, frequent occurrences may indicate a LAPD parameter mismatch between the two endpoints of a packet-switched connection. Run the Long Test Sequence paying particular attention to the results of the Receive FIFO Overflow Test (#625).
- r. Error Type (3589): The BRI Port Local LAN Loop Around Test (#618) failed. Run the Long Test Sequence and pay particular attention to the results of Test #618.

- s. Error Type (3590): An activated BRI port receives a frame containing a DLCI over a D-Channel for which it does not have a translation. This error normally indicates an off-board problem related to a state mismatch between the far-end and the switch. This error is logged only.
- t. Error Type (3591): The port is generating too many uplinks and is taken out of service.
- u. Error Types (3841-3942): [Table 9-628](#) contains the received ISDN cause values for Errors 3841-3942 that are recorded in the hardware error logs. Unless otherwise stated, the cause values are D-Channel events. The aux data field shows which port caused the error.

**Table 9-628. Cause Values for Error 3841-3942**

Value	Type of Problem	Meaning
2	admin	No route to specific transit network
3	admin	No route to destination (or Germany bcap not imp)
6	admin	Channel unacceptable
18	switch problems	No user responding
38	switch problems	Network failure
50	subscription	Requested facility not subscribed
52	admin	Outgoing calls barred
54	admin	Incoming calls barred
62	subscription	Service not authorized
63	admin/sub	Service/option not available
65	admin/sub	Bearer capability not implemented
66	admin/sub	Channel type not implemented
69	admin/sub	Requested facility not implemented
70	admin/sub	Only restricted digital BC available
79	admin	Service/option not implemented
88	admin	Incompatible destination
102	switch problems	Recovery on timer expired

## System Technician-Demanded Tests: Descriptions and Error Codes

When inspecting errors in the system, always investigate tests in the order listed below. By clearing error codes associated with the *Control Channel Loop Around Test*, for example, you may also clear errors generated from other tests in the testing sequence.

Order of Investigation	Short Test Sequence	Long Test Sequence	D/ND <sup>1</sup>
BRI Local LAN Port Loop Around Test (#618)		X	D
BRI TDM Port Loop Around Test (#619)		X	D
L1 State Query Test (#1242)	X	X	D
CRC Error Counter Test (#623)		X	ND
Receive FIFO Overflow Test (#625)		X	ND
Layer 3 Query Test (#1243)		X	ND
Slip Query Test (#1244)	X	X	ND
Clear Error Counters Test (#270)	X	X	ND
NPE Crosstalk Test (#617)		X	D

1. D = Destructive; ND = Nondestructive

### Clear Error Counters Test (#270)

This test is nondestructive.

This test clears the various error counters associated with each TBRI-PT. This test passes if maintenance software is able to successfully send the downlink messages; the test aborts otherwise.

Table 9-629. TEST #270 Clear Error Counters

Error Code	Test Result	Description/ Recommendation
Any	ABORT	Maintenance could not send the downlink message.
	PASS	The message to clear the error counters of the TBRI-PT maintenance object has been sent.



## NPE Crosstalk Test (#617)

**This test is conditionally destructive.**

One or more NPEs reside on each circuit pack with a TDM Bus interface. The NPE controls port connectivity and gain and provides conferencing functions on a per-port basis. The NPE Crosstalk Test verifies that this port's NPE channel talks on the selected time slot and never crosses over to time slots reserved for other connections. If the NPE is not working correctly, one-way and noisy connections may be observed. This test is part of a port's Long Test Sequence and takes approximately 20 to 30 seconds to complete. Crosstalk testing is performed on both B-channels (B1 and B2) associated with a BRI port. If this test fails on either channel, any channel connected to the port is taken out-of-service. This test aborts if the port and its associated channels are not in the idle state.

**Table 9-630. TEST #617 NPE Crosstalk Test**

Error Code	Test Result	Description/ Recommendation
1000	ABORT	System resources required to run this test are not available. The port may be busy with a valid call. <ol style="list-style-type: none"> <li>1. Use the <b>display port UUCSSpp</b> command to determine the station extension or trunk group/member number of the port. Use the <b>status bri-port UUCSSpp</b> command to determine the service state of the port. If the service state indicates that the port is in use, then the port is unavailable for certain tests. Wait until the port is idle before retesting.</li> <li>2. If the port status is idle, then retry the command at 1-minute intervals a maximum of 5 times.</li> </ol>
1004	ABORT	The port has been seized by a user for a valid call. Use the <b>status bri-port</b> command to determine when the port is available for testing. <ol style="list-style-type: none"> <li>1. Retry the command at 1-minute intervals a maximum of 5 times.</li> <li>2. If the test continues to abort and the port is not in use, escalate the problem.</li> </ol>
1005	ABORT	This test is not valid for this type of translation. Ports administered as "ASAI" or "ADJK" can not run this test, because the B channels associated with the port are not used by ASAI or Lucent Adjunct Links. This is a normal condition.
2012	ABORT	Internal system error
2100	ABORT	Could not allocate the necessary resources to run this test. <ol style="list-style-type: none"> <li>1. Retry the command at 1-minute intervals a maximum of 5 times.</li> </ol>

*Continued on next page*

**Table 9-630. TEST #617 NPE Crosstalk Test — Continued**

Error Code	Test Result	Description/ Recommendation
1, 2	FAIL	The NPE of the tested port was found to be transmitting in error, causing noisy and unreliable connections. Error code 1 indicates that the NPE Crosstalk Test failed on Channel B1. Error code 2 indicates that the NPE Crosstalk Test failed on Channel B2.  1. Replace circuit pack.
	PASS	The port is correctly using its allocated time slots.  1. To be sure that this is not an intermittent problem, repeat this test a maximum of 10 times to ensure it continues to pass.  2. If complaints still exist, examine the connections and wiring.

## **BRI Port Local LAN Looparound Test (#618)**

**This test is destructive.**

This test checks the connectivity of the BRI port across the LAN bus. Because this test is destructive, run this test only if the port is out-of-service.

Failures of this test indicate either on-board faults associated with the TBRI-PT hardware on the circuit pack or problems with the LAN Bus, which is used to form connectivity between the switch and the TBRI-PT.

If the port is in a state other than out-of-service, the BRI Port Local LAN Looparound Test will abort. If the port is out-of-service, then the port is put into a local looparound mode and the following test is executed.

A looparound test is performed across the Packet Bus for the D-Channel. The switch sends data over a packet connection, which is looped back by the BRI port (D-Channel) and received back by the switch. The test passes if the packet connection can be established and the transmitted data is received unaltered. The test aborts if the Packet Bus is alarmed in the Processor Port Network (or the port network in which that circuit pack resides) or if the Packet Interface board is out-of-service. The test fails due to either on-board faults associated with the BRI port hardware on the circuit pack or problems with the LAN bus.

**Table 9-631. TEST #618 BRI Port Local LAN Looparound**

Error Code	Test Result	Description/ Recommendation
1015	ABORT	<p>The port is not out-of-service.</p> <ol style="list-style-type: none"> <li>1. Use the <b>status bri-port UUCSSpp</b> command to determine the status of the port.</li> <li>2. If it is in use, wait until it is idle, and then use the <b>busyout port UUCSSpp</b> command to place it in the out-of-service state and repeat this test.</li> </ol> <p> <b>CAUTION:</b>  <i>Since the busyout command is destructive, execution of this command prior to the port being idle causes all calls associated with the BRI port to be torn down.</i></p>
1139	ABORT	<p>The Packet Bus in the port network is out-of-service.</p> <ol style="list-style-type: none"> <li>1. Follow the repair procedures for the Packet Bus.</li> <li>2. Run the <b>test port long UUCSSpp</b> command and verify the repair by viewing the results of the BRI Port Local LAN Looparound Test (#618).</li> </ol>
1141	ABORT	<p>The PKT-CTRL is out-of-service.</p> <ol style="list-style-type: none"> <li>1. Follow the repair procedures for the PKT-CTRL.</li> <li>2. Run the <b>test port long UUCSSpp</b> command and verify the repair by viewing the results of the BRI Port Local LAN Looparound Test (#618).</li> </ol>
1144	ABORT	<p>The PPN Packet Bus is out-of-service.</p> <ol style="list-style-type: none"> <li>1. Follow the repair procedures for the Packet Bus.</li> <li>2. Run the <b>test port long UUCSSpp</b> command and verify the repair by viewing the results of the BRI Port Local LAN Looparound Test (#618).</li> </ol>
2012 2100	ABORT	<p>Internal system error                      Could not allocate the necessary system resources to run this test.</p> <ol style="list-style-type: none"> <li>1. Retry the command at 1-minute intervals a maximum of 5 times.</li> </ol>
	FAIL	<p>The Looparound Test has failed.</p> <ol style="list-style-type: none"> <li>1. If the test fails repeatedly, attempt to reset the circuit pack with the <b>busyout board UUCSS</b> and the <b>reset board UUCSS</b> commands if the other ports on the board are not in use.</li> <li>2. If the test fails again, execute <b>test pkt P</b>. If this fails, follow failure procedures in the PKT-BUS section.</li> <li>3. If the tests in Step 2 pass, the problem is local to the BRI board. Replace the trunk circuit pack.</li> </ol>
	PASS	<p>The BRI Port Local LAN Looparound Test passed.</p>

## BRI Port Local TDM Looparound Test (#619)

**This test is conditionally destructive.**

This test verifies the connectivity of a BRI port across the TDM Bus. It aborts if calls associated with the port are in progress. Failure of this test indicates an on-board fault associated with the port hardware on the circuit pack.

This Looparound Test runs the following individual tests on the two B-channels (B1 and B2) associated with the port:

- A Looparound Test across the TDM Bus for B1.
- A Conference Circuit Test for B1.
- A Looparound Test across the TDM Bus for B2.
- A Conference Circuit Test for B2.

The tests are run in the above order. If one fails, the remaining tests in the sequence are not executed, and maintenance software returns an error code.

**Table 9-632. TEST #619 BRI Port Local TDM Loop Around**

Error Code	Test Result	Description/ Recommendation
1000	ABORT	The system resources required to run this test are not available. The port may be busy with a valid call. <ol style="list-style-type: none"> <li>1. Use the <b>display port UUCSSpp</b> command to determine the trunk group/member number of the port. Use the <b>status bri-port UUCSSpp</b> command to determine the service state of the port. If the service state indicates that the port is in use, then the port is unavailable for certain tests. Wait until the port is idle before retesting.</li> <li>2. If the port is idle, then retry the command at 1-minute intervals a maximum of 5 times.</li> </ol>
1002	ABORT	The system could not allocate time slots for the test. The system may be under heavy traffic conditions or it may have time slots out-of-service due to TDM-BUS errors. <ol style="list-style-type: none"> <li>1. If the system has no TDM-BUS errors and is not handling heavy traffic, repeat test at 1-minute intervals a maximum of 5 times.</li> </ol>
1003	ABORT	The system could not allocate a tone receiver for the test. The system may be oversized for the number of Tone Detectors present or some Tone Detectors may be out-of-service. <ol style="list-style-type: none"> <li>1. Resolve any TTR-LEV errors.</li> <li>2. Resolve any TONE-PT errors.</li> <li>3. If neither condition exists, retry the test at 1-minute intervals a maximum of 5 times.</li> </ol>

**Table 9-632. TEST #619 BRI Port Local TDM Loop Around — Continued**

Error Code	Test Result	Description/ Recommendation
1004	ABORT	The port has been seized by a user for a valid call. Use the <b>status trunk</b> command for the trunks associated with this port and determine when the port is available for testing. <ol style="list-style-type: none"> <li>1. Retry the command at 1-minute intervals a maximum of 5 times.</li> <li>2. If the test continues to abort and the port is not in use, escalate the problem.</li> </ol>
1005	ABORT	This test is not valid for this type of translation. Ports administered as <b>ASAI</b> or <b>ADJK</b> cannot run this test because the B channels associated with the port are not used by ASAI or Lucent Adjunct Links. This is a normal condition.
2000	ABORT	Response to the test was not received from the BRI-LINE circuit pack within the allowable time period. <ol style="list-style-type: none"> <li>1. If this result occurs repeatedly, attempt to reset the circuit pack with the <b>busyout board UUCSS</b> and the <b>reset board UUCSS</b> commands if the other ports on the board are not in use.</li> <li>2. If this result occurs again, replace the circuit pack.</li> </ol>
2012	ABORT	Internal system error
2100	ABORT	Could not allocate the necessary resources to run this test. <ol style="list-style-type: none"> <li>1. Retry the command at 1-minute intervals a maximum of 5 times.</li> </ol>
2103	ABORT	The system could not make the conference connection for the test. <ol style="list-style-type: none"> <li>1. Retry the command at 1-minute intervals a maximum of 5 times.</li> </ol>
1, 2	FAIL	The TDM Looparound failed on one of the channels. <ul style="list-style-type: none"> <li>■ Error Code 1 — TDM Loop Around Test failed on B1.</li> <li>■ Error Code 2 — TDM Loop Around Test failed on B2.</li> </ul>
7, 8	FAIL	The Conference Circuit Tests failed on a B-channel. <ul style="list-style-type: none"> <li>■ Error Code 7 — test failed on B1</li> <li>■ Error Code 8 — test failed on B2.</li> </ul> <ol style="list-style-type: none"> <li>1. If the test fails repeatedly, attempt to reset the circuit pack with the <b>busyout board UUCSS</b> and the <b>reset board UUCSS</b> commands if the other ports on the board are not in use.</li> <li>2. If the test fails again, replace the circuit pack.</li> </ol>
	PASS	The BRI Port Local TDM Loop Around Test passed.

## CRC Error Counter Test (#623)

This test is nondestructive.

This test reads the BRI port's CRC error counters that are maintained on the BRI circuit pack. The Cyclic Redundancy Check (CRC) is a means of error detection used to determine the integrity of data frame contents. The CRC error counter is incremented by the circuit pack when it detects a CRC error. The test passes if the value of the counter is 0 (that is, the error is cleared). If the counter is non-zero, the test fails, and the value of the counter is displayed in the `Error Code` field.

**Table 9-633. TEST #623 CRC Error Counter Test**

Error Code	Test Result	Description/ Recommendation
ANY	FAIL	This error occurs when a frame with a bad CRC is received over the D-Channel by the BRI board. This error is reported on a per-port basis when the counter goes over the threshold. This error is most likely due to a problem with the wiring or interference on the wiring caused by a noise source or no termination. It usually does not indicate a problem with the circuit pack.
	PASS	The CRC error counter was read correctly and has a value of 0.

## Receive FIFO Overflow Error Counter Test (#625)

This test is nondestructive.

This test reads and clears the BRI port's Receive FIFO Overflow error counter maintained on the TBRI-BD circuit pack. This counter is incremented by the circuit pack when it detects an overflow of its receive buffers. The test passes if the value of the counter is 0 (that is, the error is cleared). If the counter is non-zero, the test fails, and the value of the counter is displayed in the `Error Code` field.

This error can occur if signaling frames are being received from the Packet Bus at a rate sufficient to overflow the receive buffers on the circuit pack for a port OR if a hardware fault is causing the receive buffers not to be emptied properly by the circuit pack. This test is useful for verifying the repair of the problem.

**Table 9-634. TEST #625 Receive FIFO Overflow Error Counter Test**

Error Code	Test Result	Description/ Recommendation
2000	ABORT	Response to the test was not received from the circuit pack within the allowable time period. <ol style="list-style-type: none"> <li>1. If the test aborts repeatedly a maximum of 5 times, reset the circuit pack with the <b>busyout board UUCSS</b> and <b>reset board UUCSS</b> commands.</li> <li>2. If the test aborts again, replace the circuit pack.</li> </ol>
2012 2100	ABORT ABORT	Internal system error Could not allocate the necessary system resources to run this test. <ol style="list-style-type: none"> <li>1. Retry the command at 1-minute intervals a maximum of 5 times.</li> </ol>
value	FAIL	The TBRI-BD circuit pack is still detecting errors of this type. The Error Code field contains the value of this counter. <ol style="list-style-type: none"> <li>1. Retry the command at 1-minute intervals a maximum of 5 times.</li> <li>2. If the test continues to fail, run the Long Test Sequence and pay particular attention to the Looparound Tests (#618 and #619). See the repair procedures for the executed test if it fails. Otherwise, go to the next step.</li> <li>3. Replace the circuit pack.</li> </ol>
	PASS	The Receive FIFO Overflow error counter was read correctly and has a value of 0.

### Level 1 Status Inquiry Test (#1242)

This test is nondestructive.

This test determines the state of the transmission facility of a BRI port at the Level 1 (L1) physical layer: Activated, Pending Activation, or Deactivated.

The Activated state is the correct state for an ISDN-BRI port. In this state the L1 interface can send and receive synchronized signals. This test passes if the state of L1 is Activated. This test also passes if software has taken this port out of service. See the description of the L1 "Deactivated State" below for more details.

The Pending Activation state indicates a problem with the channels, the wiring, or the TBRI-BD circuit pack. When in this state, the Level 1 interface is either not receiving any L1 framing from the channel, or it is communicating with the channel but cannot transition to the Activated state.

The Deactivated state indicates a problem with the TBRI-BD circuit pack. When in this state, the Level 1 interface is not active, and an idle signal is transmitted to the channels or that Layer 1 was deactivated by the switch. When an TBRI-PT port is placed in the out-of-service state, Level 1 is also put into the Deactivated state. This could be due either to the system detecting a fault with the port or to a **busyout port UUCSSpp** request.

**Table 9-635. TEST #1242 Level 1 Status Inquiry**

Error Code	Test Result	Description/ Recommendation
1187	ABORT	<p>The board or port may be busied out.</p> <ol style="list-style-type: none"> <li>1. Look in the Error Log for Error Type 18 (port busied out) for this port and TBRI-BD (board busied out). If this error type is present for TBRI-PT only, then release the port with the <b>release port pp</b> command and run the test again. If the error is present for both TBRI-BD and TBRI-PT, then release the board with the <b>release board UUCSS</b> command and run the test again.</li> </ol> <p><b>⇒ NOTE:</b>                      When you release a port, you release all ports associated with it. If certain ports still need to be busied out, use the <b>release port UUCSSpp</b> command to busy them out.</p> <ol style="list-style-type: none"> <li>2. Make sure the terminal is connected.</li> <li>3. Retry the command at 1-minute intervals a maximum of 5 times.</li> </ol>
2000	ABORT	<p>Response to the test was not received from the circuit pack within the allowable time period.</p> <ol style="list-style-type: none"> <li>1. If the test aborts repeatedly a maximum of 5 times, reset the circuit pack with the <b>busyout board UUCSS</b> and <b>reset board UUCSS</b> commands.</li> <li>2. If the test aborts again, replace the circuit pack.</li> </ol>
2012	ABORT	<p>Internal system error</p>
2100	ABORT	<p>Could not allocate the necessary system resources to run this test.</p> <ol style="list-style-type: none"> <li>1. Retry the command at 1-minute intervals a maximum of 5 times.</li> </ol>

*Continued on next page*



Table 9-635. TEST #1242 Level 1 Status Inquiry — Continued

Error Code	Test Result	Description/ Recommendation
1	FAIL	<p>Received a status of Level 1 Pending Activation. U interface down indicating a problem with a connection between the switch and the NT1, a 2- to 4-wire converter that is used to connect 4-wire terminals to a 2-wire TN2198 or TN2185 circuit pack.</p> <ol style="list-style-type: none"> <li>1. Verify that the connections between the switch and the NT1 are good. Verify that the NT1 has power.</li> <li>2. Execute the <b>test port UUCSSpp</b> command and review the results of the Level 1 Status Inquiry Test to verify the repair. If this test still fails, proceed to Step 3.</li> <li>3. Follow the manufacturers repair procedures for the NT1. Then execute the <b>test port UUCSSpp</b> command and review the results of the Level 1 Status Inquiry Test to verify repair.</li> </ol>
2	FAIL	<p>Received a status of Level 1 Pending Activation. U interface up, S/T interface down, which indicates a problem with the NT1 or the wiring between the NT1 and the BRI endpoint (S/T interface).</p> <ol style="list-style-type: none"> <li>1. Execute the <b>test port UUCSSpp</b> command and review the results of the Level 1 Status Inquiry test to verify the repair. If this test still fails, proceed to Step 2.</li> <li>2. Follow the manufacturer-recommended repair procedures for the NT1. Then execute the <b>test port UUCSSpp</b> command and review the results of the Level 1 Status Inquiry test to verify repair.</li> </ol>
3	FAIL	<p>Received a status of Level 1 Deactivated; the port is out-of-service.</p> <ol style="list-style-type: none"> <li>1. Issue the <b>status bri-port UUCSSpp</b> command to verify that the service state of the port is out-of-service. If the service state of the port is not out-of-service, escalate the problem to the next tier. Otherwise, proceed to Step 2.</li> <li>2. If the port has been placed out-of-service with the <b>busyout port UUCSSpp</b> command, try releasing the port by executing the <b>release port UUCSSpp</b> command. Then issue the <b>test port long UUCSSpp</b> command and review the results of Level 1 Status Inquiry test. If this test still fails, proceed to Step 3.</li> <li>3. After executing the <b>test port long UUCSSpp</b> command, review the results of all the tests. Follow the repair procedures for any tests that fail. Verify repair of the problem by executing the <b>test port UUCSSpp</b> command and by determining that the Level 1 Status test passes. If the test continues to fail for this reason, escalate the problem to the next tier.</li> </ol>

Continued on next page

**Table 9-635. TEST #1242 Level 1 Status Inquiry — Continued**

Error Code	Test Result	Description/ Recommendation
4	FAIL	Received a status of Level 1 Pending Activation, the NT1 has a loss of power indicating a problem with the NT1. <ol style="list-style-type: none"> <li>1. Follow the manufacturer-recommended repair procedures for the NT1.</li> <li>2. Execute the <b>test port UUCSSpp</b> command and review the results of the Level 1 Status Inquiry test to verify the repair.</li> </ol>
	PASS	This test indicates that Level 1 is activated or that software has taken the port out of service.

### Layer 3 Query Test (#1243)

This test is nondestructive.

This test is used to check the application layer communications across the in-service ISDN D-Channel. The test passes if a status enquiry message is successfully sent, fails if the signaling link is down, and aborts if a query is already running or there is an internal error.

**Table I-3. TEST #1243 Layer 3 Query**

Error Code	Test Result	Description/ Recommendation
1019	ABORT	Test is already running.
1113	ABORT	The signaling link is down. <ol style="list-style-type: none"> <li>1. Use the <b>test port UUCSSpp long</b> command to clear any errors which prevent establishment of the signaling link.</li> <li>2. Examine the results of Test #626, which is executed with the command. If this test aborts or fails, follow the repair procedure for the Signaling Link Status Test.</li> <li>3. Escalate problem if BRI Layer 3 Query Test continues to abort.</li> </ol>
1139	ABORT	The Packet Bus in the port network is out-of-service. <ol style="list-style-type: none"> <li>1. Follow the repair procedures for the Packet Bus.</li> <li>2. After completing Step 1, execute the <b>test port long UUCSSpp</b> command and review the results of the BRI Port Local LAN Looparound Test to verify the repair.</li> </ol>

*Continued on next page*

Table I-3. TEST #1243 Layer 3 Query — Continued

Error Code	Test Result	Description/ Recommendation
1141	ABORT	The PKT-CTRL is out-of-service. <ol style="list-style-type: none"> <li>1. Consult the repair procedure for PKT-CTRL.</li> <li>2. If Step 1 does not resolve the problem, escalate to the next tier.</li> </ol>
1144	ABORT	The PPN Packet Bus is out-of-service. <ol style="list-style-type: none"> <li>1. Follow the repair procedures for the Packet Bus in the PPN.</li> <li>2. After completing Step 1, execute the <b>test port long UUCSSpp</b> command and review the results of the BRI Port Local LAN Looparound Test to verify the repair.</li> </ol>
1187	ABORT	The circuit pack or port may have been busied out by a technician. <ol style="list-style-type: none"> <li>1. Look in the Error Log for Error Type 18 (busied out) for TBRI-BD or TBRI-PT.                             <ol style="list-style-type: none"> <li>a. If this error type is present for TBRI-PT, then release the port with the <b>release port UUCSSpp</b> command and run the test again.</li> <li>b. If the error is present for both TBRI-BD and TBRI-PT, then release the circuit pack with the <b>release board PUUCSS</b> command and run the test again.</li> </ol> </li> </ol> <p><b>⇒ NOTE:</b>                      When you release the circuit pack, you release all ports associated with it. If certain ports still need to be busied out, use the <b>release port UUCSSpp</b> command to busy them out.</p> <ol style="list-style-type: none"> <li>2. Make sure the terminal is connected.</li> <li>3. Retry the command at 1-minute intervals a maximum of 5 times.</li> </ol>
2012	ABORT	Internal system error
2100	ABORT	Could not allocate the necessary system resources to run this test. <ol style="list-style-type: none"> <li>1. Retry the command at 1-minute intervals a maximum of 5 times.</li> </ol>
	PASS	The switch has successfully sent a Status Enquiry message.

### Slip Query Test (#1244)

This test is nondestructive.

Slips occur when the transmitter and receiver are not running at precisely the same clock rate. The Slip Alarm Inquiry Test polls the total number of slips that have occurred on a link.

When the TN2185 circuit pack detects a slip condition, maintenance software initiates the Slip Alarm Inquiry Test to query the slip counters on the TN2185 circuit pack and total the slip counts in the maintenance software.

If the slip count is over the threshold, a Minor alarm is raised against the TN2185 circuit pack, leaving all ports of the TN2185 circuit pack in the in-service state. If the TN2185 circuit pack is used to supply the system synchronization source, the MINOR alarm will initiate a synchronization source switch. See TDM-BUS and SYNC for additional information.

**Table I-4. TEST #1244 Slip Alarm Inquiry Test**

Error Code	Test Result	Description/ Recommendation
2000	ABORT	Internal System Error
2100	ABORT	Response to the test request was not received within the allowable time period. If Error Type 1538 is present in the Error Log, follow the maintenance strategy recommended for this error type.
1 to 88	FAIL	<p>Could not allocate the necessary system resources to run this test.</p> <ol style="list-style-type: none"> <li>1. Retry the command at 1-minute intervals for a maximum of 5 times.</li> </ol> <p>The circuit pack and the remote endpoint are not synchronized to the same clock rate, which has generated the Slip alarm. The error code equals the number of slips detected by the TN2185 circuit pack since the last Slip Alarm Inquiry Test.</p> <ol style="list-style-type: none"> <li>1. Retry the command at 1-minute intervals a maximum of 5 times.</li> <li>2. If the circuit pack is a TN2185, enter the <b>list measurement ds1-log UUCSS</b> command to read the error seconds measurement.</li> <li>3. Verify that both endpoints of the DS1 link are administered using the same signaling mode, framing mode, and line coding.</li> <li>4. Check the physical connections of DS1 Interface circuit packs and cable.</li> <li>5. Replace the local DS1 Interface circuit pack and repeat the test.</li> <li>6. Contact T1 Network Service to diagnose the remote DS1 endpoint.</li> </ol>
	PASS	No Slip alarm is detected on the DS1 Interface circuit pack.
0	NO BOARD	<p>The DS1 Interface circuit pack is not administered.</p> <ol style="list-style-type: none"> <li>1. Administer the DS1 Interface circuit pack by issuing the <b>add ds1 UUCSS</b> command.</li> <li>2. Run the test again.</li> <li>3. If the test continues to return NO BOARD, escalate the problem.</li> </ol>

## TBRI-TRK (TN2185 ISDN Trunk-Side BRI)

MO Name (in Alarm Log)	Alarm Level	Initial Command to Run <sup>1</sup>	Full Name of MO
TBRI-TRK <sup>2</sup>	MAJOR <sup>3</sup>	test trunk UUCSSpp l	MO_TBRI_TRK
TBRI-TRK	MINOR	test trunk UUCSSpp l	MO_TBRI_TRK
TBRI-TRK	WARNING	test trunk UUCSSpp sh	MO_TBRI_TRK

1. Where UU is the universal cabinet number (1 for PPN, 2 -44 for EPN), C is the carrier designation (A, B, C, D, or E), SS is the carrier slot address where the circuit pack is located (1, 2, and so forth), and pp is the two-digit port number (1, 2, 3, and so forth).
2. For additional repair information, also see TBRI-BD and TBRI-PT Maintenance documentation.
3. A MAJOR alarm on a trunk indicates that alarms on these trunks are not downgraded by the **set options** command and that at least 75 percent of the trunks in this trunk group are alarmed.

The TN2185 circuit pack contains eight, 4-wire ports that interface to the network at the ISDN S/T reference point over two 64 Kb/s channels (B1 and B2) and over a 16Kb/s signaling (D) channel. The B1 and B2 channels can be simultaneously circuit switched, or individually packet switched. Only one channel per trunk can be packet switched due to Packet Processing Element (PPE) limitations. The D channel is either circuit switched or packet switched. Packet switching uses the PPE to combine all D channels into a single physical channel, which is then routed via the concentration highway to the Network Control Element (NCE) and then to the TDM bus. The circuit-switched connections have a Mu-law or A-law option for voice and operate as 64Kb/s clear data channels. The packet-switched channels support the LAPD protocol and conform with the CCITT Q.920 Recommendations for D-channel signaling.

### LEDs

The three LEDs on the circuit pack's faceplate indicate board status. When illuminated, the red LED indicates a board failure or a major or minor on-board alarm, the green LED indicates that testing is in progress, and the amber LED indicates that the board is in use.

## System Technician-Demanded Tests: Descriptions and Error Codes

Always investigate tests in the order presented in the table below when inspecting errors in the system. By clearing error codes associated with the *Services State Test*, for example, you may also clear errors generated from other tests in the testing sequence.

Order of Investigation	Short Test Sequence	Long Test Sequence	D/ND <sup>1</sup>
Signaling Link State Check Test (#1251)	X	X	ND
Service State Audit Test (#256)	X	X	ND
Call State Audit Test (#257)	X	X	ND
ISDN Test Call Test (#258)		X	ND

1. Destructive; ND = Nondestructive

### Signaling Link State (#1251)

This test is non-destructive.

This test checks the current state of the signaling link. The test looks at the board-level translations, checks that the board is physically inserted, gets the state of the D-Channel and service state of the port.

The test passes if the signaling link (D-Channel) is connected and operating normally. The test fails if the board is not installed, the signaling link is disconnected, or if the port is out of service. The test aborts otherwise.

**Table 9-636. TEST #1251 Signaling Link State Test**

Error Code	Test Result	Description/ Recommendation
	ABORT	Internal system error
1018	ABORT	The test is disabled. 1. Enable the test by entering <b>enable test #1251</b> .
1114	ABORT	The signaling link is in a transitional state. 1. Retry the command at 1-minute intervals a maximum of 5 times. 2. If the test continues to abort, escalate the problem.

*Continued on next page*

**Table 9-636. TEST #1251 Signaling Link State Test — Continued**

Error Code	Test Result	Description/ Recommendation
8	FAIL	The signaling link is down. 1. Consult the procedures for the TBRI-PT maintenance object.
9	FAIL	The port is out of service. 1. Return the port to an in-service state.
	PASS	The signaling link is connected and operating normally.

### Service State Audit (#256)

This test is nondestructive.

This test performs a service state audit on an ISDN B-Channel. The test passes if Call Processing informs Maintenance that the Restart message was transmitted successfully, or if the B-Channel was busy and could not send the message.

The test fails if the board is not inserted or translated properly, or if a reply is not received within a certain amount of time.

The test aborts if the signaling link is disconnected, if a message is already outstanding, or if the necessary resources could not be allocated.

To investigate the service state of the TN2185 ISDN Trunk-Side BRI Channel, issue the **status trunk trunk-group/trunk-member** command.

**Table 9-637. TEST #256 Service State Audit Test**

Error Code	Test Result	Description/ Recommendation
1000	ABORT	System resources required to run this test are not available. The port may be on a valid call. Use <b>status trunk</b> to determine when trunk is available for testing. 1. Check the results of Test #1251 (Signaling Link State Check).
1018	ABORT	The test is disabled. 1. Enable maintenance by entering <b>y</b> in the Maintenance Tests? field on page 2 of the <b>change trunk-group</b> form.

*Continued on next page*

Table 9-637. TEST #256 Service State Audit Test — Continued

Error Code	Test Result	Description/ Recommendation
1113	ABORT	The signaling link has failed, so the system cannot send any messages on behalf of this trunk. 1. Check the results of Test #1251 (Signaling Link State Test).
1114	ABORT	The signaling link is in a transitional state. 1. Retry the command at 1-minute intervals a maximum of 5 times.
1116	ABORT	The trunk is not in a service state which is appropriate for running the test. This test is only performed in the OOS/FE state.
1117	ABORT	A service state audit message is outstanding. 1. Wait two minutes and then try again.
2100	ABORT	Could not allocate the necessary system resources to run this test. 1. Retry the command at 1-minute intervals a maximum of 5 times.
	FAIL	Internal system error 1. Retry the command at 1-minute intervals a maximum of 5 times.
	PASS	Wait 4 minutes and then check the Error Log for any new errors of type 3073. If there are none, then both sides of the ISDN connection agree on the service state; the negotiation succeeded. If there is a new 3073 error, then the negotiation failed (the far-end switch twice failed to respond within 2 minutes). The switch automatically retries every 15 minutes. If the trunk was initially in-service, it is now placed in the maintenance/far-end state. Incoming calls are accepted, but no outgoing calls can be originated. If an incoming call is presented, another Service State Audit is immediately performed in an attempt to put the TN2185 ISDN Trunk-Side BRI Channel in the proper state.

### Call State Audit Test (#257)

This test is nondestructive.

This test performs a call state audit on an ISDN B-Channel, and upon successful completion, guarantees that both sides of the interface are in a consistent call state for connections using the B-Channel. The test can be helpful when trying to clear a hung call. If the internal call state data to the near-end switch is different from that of the far-end switch, the call will be torn down.

The test passes if the audit is successful.



The test fails if the board is not inserted, if there is an internal system error, or if a reply was not received within the prescribed amount of time.

The test aborts if the signaling link is disconnected, the request is already active, or if the B-Channel is in an Out-Of-Service state.

**Table 9-638. TEST #257 Call State Audit Test**

Error Code	Test Result	Description/ Recommendation
1018	ABORT	The test is disabled. 1. Enable the test by entering <b>y</b> in the <code>Maintenance Tests?</code> field on page 2 of the <b>change trunk-group</b> form.
1019	ABORT	An audit is already in progress. 1. Wait two minutes and try again.
1113	ABORT	The signaling link has failed, so the system cannot send any messages on behalf of this trunk. 1. Check the results of Test #1251 (Signaling Link State Check).
1114	ABORT	The signaling link is in a transitional state. 1. Retry the command at 1-minute intervals a maximum of 5 times.
1116	ABORT	The trunk is in an out-of-service ISDN service state. 1. A call cannot be present if the trunk is in an ISDN out-of-service state, so a call state audit would be inappropriate. No action necessary. (Use the <b>status trunk</b> command.)
2100	ABORT	Could not allocate the necessary system resources to run this test. 1. Retry the command at 1-minute intervals a maximum of 5 times.
	FAIL	Internal system error 1. Retry the command at 1-minute intervals a maximum of 5 times.
	PASS	The audit passed successfully.

### ISDN Test Call Test (#258)

This test performs a far-end loop around to a far-end switch over an ISDN trunk. The trunk's service state must be in-service, maint-NE, or out-of-service/NE, and no call can be active on the trunk.

A test call connection is established to a far-end switch over the ISDN trunk to be tested. The digital port on a TN711D Maintenance/Test circuit pack generates a test-pattern bit stream that is sent to the far-end switch and echoed back. The received pattern is then compared to the sent pattern and checked for errors that indicate a loss of integrity on the communications path.

If a test call is running when scheduled maintenance starts, the green LED is turned off. To determine if a test call is still running, use the **list isdn-testcall** and **status isdn-testcall** commands. A lit yellow LED on the Maintenance/Test circuit pack also indicates that a test call is running.

There are two methods available to place an outgoing ISDN Trunk-side BRI trunk test call:

1. The test call connection is established over the TDM Bus of the transmit and receive sides of the ISDN Trunk-side BRI trunk to a data channel. This method is selected when no Maintenance/Test circuit pack resides in the system.
2. The test call connection is established over the TDM Bus of the transmit and receive sides of the ISDN Trunk-side BRI trunk to a digital trunk testing port on the Maintenance/Test circuit pack. The Maintenance/Test Digital Port generates a pseudo bit stream.

A test is run periodically to check if the call is hung. If so, it gracefully tears down the call to release the resources.

## Synchronous Commands

You can demand a synchronous outgoing test call by using the following maintenance commands:

- **test trunk trunk-group-no/member-no long [repeat number]**
- **test board UUCsspp long [repeat number]**
- **test port port-location long [repeat number]**

Whenever a circuit translates to an ISDN Trunk-side BRI trunk during a Long Test Sequence, an outgoing test call is invoked, and the duration of the test call is 8.6 seconds. Once the test call completes, the bit error rate is retrieved from the Maintenance/Test Digital Port. A bit error rate greater than zero is reported as a failure to the Manager I terminal (MGRI). A failure indicates the need to run further diagnostics.

If no Maintenance/Test circuit pack exists, the outgoing ISDN Trunk-side BRI trunk test call is established over a high-speed data channel on the Network Control (NETCON) circuit pack (DATA-BD).

## Asynchronous Commands

### NOTE:

Only one trunk can be tested in a given port network, until the test call is canceled or completes.

Table 9-639. TEST #258 ISDN TEST Call

Error Code	Test Result	Description/ Recommendation
4	ABORT	There is a problem with the Processor Interface Link. <ol style="list-style-type: none"><li>1. Refer to the PI-LINK (Processor Interface Link) Maintenance documentation.</li></ol>
1004	ABORT	B channel in use. <ol style="list-style-type: none"><li>1. Determine if a call is active on this ISDN Trunk-side BRI trunk via the <b>status trunk</b> command.</li><li>2. When the service state indicates in-service/idle, retry the test.</li></ol>
1005	ABORT	Bad Configuration (that is, no Maintenance/Test circuit pack) Issue the <b>test trunk &lt;trunk Group/trunk member&gt;</b> command and make sure there is a DATA-CHL (NETCON channel) administered.
1018	ABORT	Test call is disabled. <ol style="list-style-type: none"><li>1. Enable Maintenance on the Trunk Group form.</li></ol>
1024	ABORT	(M/T-DIG) Maintenance/Test Digital Port in use. <ol style="list-style-type: none"><li>1. Wait until yellow and green LEDs are turned off on the M/T-BD (Maintenance/Test circuit pack).</li><li>2. Retry the test. If problem persists, refer to M/T-DIG (Maintenance/Test Digital Port) documentation.</li></ol>
1113	ABORT	The signaling link has failed; the system cannot send any messages on behalf of this trunk. <ol style="list-style-type: none"><li>1. Check the results of Test #1251 (Signaling Link State Check Test).</li></ol>
1114	ABORT	The signaling link is in a transitional state. <ol style="list-style-type: none"><li>1. Retry the command at 1-minute intervals a maximum of 5 times.</li></ol>
1116	ABORT	The switch could not appropriately change the ISDN service state. <ol style="list-style-type: none"><li>1. Determine if a call is active on this ISDN Trunk-side BRI trunk (use the <b>status trunk</b> command).</li><li>2. If not, check the Error and Alarm Logs for problems with this TBRI-TRK MO.</li></ol>
1117	ABORT	ISDN B-channel maintenance message is already outstanding. <ol style="list-style-type: none"><li>1. Wait two minutes, then try again.</li></ol>
1118	ABORT	Far-end of ISDN trunk is not administered. <ol style="list-style-type: none"><li>1. Check the administration of the far-end ISDN trunk.</li><li>2. Issue the <b>status trunk</b> command and try the test again.</li></ol>

*Continued on next page*

**Table 9-639. TEST #258 ISDN TEST Call — Continued**

Error Code	Test Result	Description/ Recommendation
1119	ABORT	The test call was aborted due to a normal call attempt on this trunk. The test call is performed only if the trunk is idle.  1. Either wait for the normal call to terminate normally, or force it to be dropped by using the <b>busyout trunk</b> command.
1120	ABORT	The ISDN Trunk-side BRI trunk is in the ISDN out-of-service/far-end state.  1. Try to change the service state via Test #256 (Service State Audit Test). Then retry this test. <b>However, the trunk may be in the out-of-service/far-end state due to problems at the far-end switch. If that is the case, no remedial action can be taken at this end.</b>
1122	ABORT	There is no test line number for the far-end switch.  1. Check the Trunk Group Administration form.
1123	ABORT	There is no Feature Access Code administration for this Facility Test.  1. Check the Dial Plan and Feature Administration forms.
2012 None 2000	ABORT	Internal system error  1. Retry the command at 1-minute intervals a maximum of 5 times.
2035	ABORT	The call has timed out, perhaps because of a lack of system resources.  1. Wait 1 minute and try again.
2036 2037	ABORT	Internal system error  1. Follow the recommendation for ABORT code 2012.
2038 2039	ABORT	A problem occurred while trying to read the test data.  1. Wait one minute and then try again.  2. If the test aborts again in the same manner, there is a serious internal problem. If so, escalate the problem.
2040	ABORT	Internal system error  1. Follow the recommendations for ABORT code 2012.
2041	ABORT	The call has timed out, perhaps because of a lack of system resources.  1. Follow the recommendations for ABORT code 2035.
2066	ABORT	Could not establish test call.  1. Retry the command at 1-minute intervals a maximum of 5 times.
2067	ABORT	The call has timed out, perhaps because of a lack of system resources.  1. Follow the recommendations for ABORT code 2035.

*Continued on next page*

**Table 9-639. TEST #258 ISDN TEST Call — Continued**

Error Code	Test Result	Description/ Recommendation
2074	ABORT	Bit and Block Error query failed. <ol style="list-style-type: none"> <li>1. Retry the command at 1-minute intervals a maximum of 5 times.</li> <li>2. If the test continues to abort, there may be a serious internal problem with M/T-DIG (Maintenance/Test Digital Port). If this is the case, refer to the M/T-DIG (Maintenance/Test Digital Port) Maintenance documentation.</li> </ol>
2075	ABORT	Internal system error <ol style="list-style-type: none"> <li>1. Follow the recommendations for ABORT code 2012.</li> </ol>
2100	ABORT	Could not allocate the necessary system resources to run this test. <ol style="list-style-type: none"> <li>1. Retry the command at 1-minute intervals a maximum of 5 times.</li> </ol>
2104	ABORT	Call dropped or could not be originated. <ol style="list-style-type: none"> <li>1. Make sure service is provisioned by the network.</li> <li>2. Check the administration of the far-end test line extension on the trunk group administration form.</li> <li>3. Check the administration of the test call BCC (Bearer Capability Class) on the trunk group administration form.</li> <li>4. Try the test again.</li> </ol>
2201 2202 2203 2204 2205	ABORT	Internal system error <ol style="list-style-type: none"> <li>1. Follow the recommendations for ABORT code 2012.</li> </ol>
2206	ABORT	Could not allocate the necessary system resources to run this test. <ol style="list-style-type: none"> <li>1. Follow the recommendations for ABORT code 2100.</li> </ol>
2208	ABORT	Internal system error <ol style="list-style-type: none"> <li>1. Follow the recommendations for ABORT code 2012.</li> </ol>
2209 2210	ABORT	Could not allocate the necessary system resources to run this test. <ol style="list-style-type: none"> <li>1. Follow the recommendations for ABORT code 2100.</li> </ol>
2211	ABORT	Internal system error <ol style="list-style-type: none"> <li>1. Follow the recommendations for ABORT code 2012.</li> </ol>
2212	ABORT	Call terminated by unexpected disconnect. <ol style="list-style-type: none"> <li>1. Wait one minute and then try again.</li> </ol>
2213	ABORT	The call has timed-out, perhaps because of a lack of system resources. <ol style="list-style-type: none"> <li>1. Follow the recommendations for ABORT code 2035.</li> </ol>

*Continued on next page*

**Table 9-639. TEST #258 ISDN TEST Call — Continued**

Error Code	Test Result	Description/ Recommendation
2214	ABORT	Call terminated by unexpected disconnect. 1. Wait one minute and then try again.
2215 2216 2217 2218 2219	ABORT	Internal system error 1. Follow recommendations for ABORT code 2012.
2220	ABORT	Call terminated prematurely. 1. Wait one minute and try again.
2221 2222 2223 2224 2225 2226	ABORT	Internal system error 1. Follow recommendations for ABORT code 2012.
2227	ABORT	Could not allocate the necessary system resources to run this test. 1. Follow the recommendations for ABORT code 2100.
2042	FAIL	<b>This is the main purpose of the test.</b> The comparison of the data sent with the data received indicates a loss of integrity on the communications path.  1. The trunk should be taken out-of-service and the quality of the ISDN Trunk-side BRI line should be investigated. The investigation should include an in-depth analysis of the facility including the transmission facility and any external equipment such as DACs, CSUs, etc.
	PASS	The call worked. A test pattern was sent and received properly; the communications path is OK if the synchronous test call command was issued. An in-depth analysis of the ISDN Trunk-side BRI trunk facility including the transmission facility and any external equipment such as DACs, CSUs, and others should take place if the bit and block error rates are not acceptable.

## TDM-BUS (TDM Bus)

---

MO Name (in Alarm Log)	Alarm Level	Initial Command to Run <sup>1</sup>	Full Name of MO
TDM-BUS	MAJOR	test tdm P	TDM Bus
TDM-BUS	MINOR	test tdm P	TDM Bus
TDM-BUS	WARNING	test tdm P	TDM Bus

1. P is the Port Network number. Use **list cabinet** to find the port network(s) contained in a given cabinet.

Each port network has a pair of TDM busses, designated TDM Bus A and TDM Bus B, each with 256 time slots. This division allows for duplication of control channels and dedicated tone time slots. The first five time slots on each bus are reserved for the control channel, which is active on only one bus at a time in each Port Network. The next 17 time slots are reserved for system tones such as dial tone, busy tone and so on. As with the control channel, these time slots are active on only one bus, A or B, at a time. The rest of the time slots on each bus are for general system use such as carrying call-associated voice data. The 17 dedicated tone time slots that are inactive can also be used for call processing when all other available time slots are in use.

When the system initializes, the control channel is on TDM Bus A and the dedicated tones on TDM Bus B in each Port Network. If a failure occurs on one of the two busses, the system will switch any control, tone and traffic channels to the other bus. Service will still be provided, though at a reduced capacity.

The **set tdm PC** command has the effect of putting both the control channel and tone time slots on a specified bus, A or B. P specifies the port network number, and C specifies the TDM bus, A or B. Throughout this discussion, PC refers to a specific TDM Bus. References to *port circuit packs* include all circuit packs that terminate on the TDM bus, including the Expansion Interface TN570, and the following service circuit port boards: Call Classifier (TN744), Integrated Announcement (TN750), Maintenance/Test (TN771), Speech Synthesizer (TN725B), Tone Detector (TN748 or TN420). Other terms used are:

- Control Channel Bus: the TDM Bus carrying the active control channel.
- Non-Control Channel Bus: the tdm bus with the inactive control channel.
- Tone Bus: the TDM bus carrying the active tone time slots
- Non-Tone Bus: the TDM Bus with the inactive tone time slots

## TDM Bus Fault Detection and Isolation

---

TDM Bus are usually caused by one of the following:

- A defective circuit pack connected to the backplane
- Bent pins on the backplane
- Defective bus cables or terminators

It is possible that a circuit pack can cause a TDM Bus fault and still exhibit trouble-free operation. For example, insertions of any circuit pack into a slot with TDM Bus terminations may bend the backplane pins and short two leads together. Since the TDM Bus is a shared resource, identification of the cause of a TDM Bus fault can be difficult. If a TDM Bus problem is suspected, run the **test tdm P** command. If any of the resulting tests fail, you must perform a manual TDM Bus isolation procedure to identify the cause of the problem.

### **WARNING:**

*Since the TDM Bus fault isolation procedure involves removing circuit packs and possibly disconnecting entire carriers, the procedure is extremely destructive to the port network that contains the TDM Bus being tested. If possible, arrange to perform this procedure at a time when traffic is minimal.*

As circuit packs are removed or entire carriers are disconnected, any active calls terminating on those circuit packs or carriers will be dropped. If you have any hints about a particular circuit pack that may be causing the TDM Bus problem investigate those before performing this procedure (for example, look at any circuit packs that were inserted into the PN just before the TDM bus problem appeared).

When straightening or replacing backplane pins in a carrier that contains a CFY1B Current Limiter, power to the *cabinet* must be removed. When straightening or replacing backplane pins in a carrier that does NOT contain a CFY1B Current Limiter, power to that *carrier* must be shut off. Failure to follow this procedure may result in damage to circuit packs and power supplies, and can be hazardous to the technician.

### **NOTE:**

Maintenance software requires TN748 or TN420 Tone Detector circuit pack to test the TDM Bus. Before starting these procedures, make sure that one of these is installed in the port network being investigated.

## Procedure 1

---

This procedure is an attempt to isolate the TDM Bus fault to circuit packs that are essential to the system operation. For each of the following circuit packs in the port network where the TDM Bus fault appears, perform Procedure 1.



Circuit Pack	Error Log Names
Tone-Clock	TONE-BD, TONE-PT, and TDM-CLK
MSS/Network Control*	SW-CTL and H-ADAPTER
Tone Detector	DETR-BD, GPTD-PT, and DTMR-PT
Expansion Interface	EXP-INTF
Packet Interface*	PKT-INT

1. Display the Alarm Log for the circuit pack via the **display alarms** command.
2. If there are alarms for the circuit pack, refer to that section and try to resolve the alarms.
3. Whether or not all the alarms can be cleared, test the TDM Bus again via the **test tdm P** command.
4. If some TDM Bus tests fail, implement Procedure 1 for the next circuit pack.
5. If all the TDM Bus tests pass, the problem has been fixed.
6. If all circuit packs in the list have been investigated, go to Procedure 2.

## Procedure 2

Procedure 2 removes and reinserts port circuit packs (those in the purple slots) one or more at a time. Use this procedure for each port circuit pack in the port network until the problem is resolved or until all circuit packs in the port network have been tried. To execute diagnostic procedures on the Expansion Interface and Tone/Clock circuit packs, refer to Procedure 3. Although these circuit packs reside in purple slots, procedure 2 does not apply. This procedure *does* apply to the Tone Detector circuit pack.

If the TDM Bus problem is present when the circuit pack is inserted, but is resolved when the circuit pack is removed, either the circuit pack or the backplane pins in that slot are causing the problem. If the backplane pins are intact, replace the circuit pack. If some of the tests fail regardless of whether the circuit pack is inserted or removed, and the backplane pins are intact, the circuit pack is not the cause of the problem. In a multiple failure situation, the circuit pack could be one cause of the TDM Bus problem. However, other simultaneous failures might also be responsible for TDM Bus faults. In Procedure 2, an option of working either with one circuit pack at a time or with multiple circuit packs simultaneously is available. In view of this capability, determine the level of service interruption that will be acceptable during the procedure. If causing a disruption to all users in the port network is deemed permissible, large groups of circuit packs should be worked with in order to get the job done quickly. However, *if large service disruptions are to be avoided*, work with one circuit

pack at a time. This option is slower, but it disrupts only the users of a single circuit pack.

1. Remove one or several circuit packs as appropriate. Any circuit packs that reside on the TDM Bus that have been recently inserted should be checked first.

If you decide to remove multiple circuit packs, consider working with an entire carrier at a time to more quickly and reliably determine which circuit packs are *not* the source of trouble.

2. Run *test tdm P* to determine if the TDM Bus fault is still present.
3. If any of the TDM Bus tests fail:
  - Determine if the backplane pins in the removed circuit pack's slot appear to be bent.
  - If the backplane pins are not bent, reinsert the circuit pack(s), and perform Procedure 2 for the next set of circuit packs.
  - If the backplane pins are bent, remove power to this carrier in the manner described previously.
  - Straighten or replace the pins and reinsert the circuit pack.
  - Restore power and repeat Procedure 2, beginning with Step 2, for the same circuit pack(s).
4. If none of the TDM Bus tests fail:
  - Reinsert the circuit pack(s) *one at a time*, and repeat the following substeps until all of the circuit packs have been reinserted.
  - Run **test tdm P** to determine if the TDM Bus fault has returned.
  - If any of the TDM Bus tests fail, the reinserted circuit pack is defective. Replace this circuit pack and repeat this procedure for the next circuit pack.
  - If none of the TDM Bus tests fail when all of the circuit packs have been reinserted, the problem has been fixed and the procedure is completed.

Continue with Procedure 3 if all the port circuit packs have been checked, but the TDM Bus fault is still not resolved.

### **Procedure 3**

---

This procedure removes and reinserts SPE and EPN control circuit packs, as listed in the table at the beginning of this section. In the PPN processor carrier (SPE), the TDM Bus terminates on slots 11-15. When running diagnostics in the PPN, the following circuit packs should be tested:

- TN1655 Packet Interface (three slots available per carrier)
- TN768/TN780 Tone/Clock

- UN332 MSSNET
- TN570 Expansion Interface

Although the Packet Interface circuit pack does not communicate over the TDM bus, the bus does terminate at those slots. TDM Bus failures could be caused by bent backplane pins.

When running TDM Bus diagnostics in an EPN, the following circuit packs should be tested with this procedure:

- TN570 Expansion Interface
- TN768/TN780 Tone/Clock

When using this procedure on an EPN, the Tone/Clock circuit pack should be the next-to-last one checked. The Expansion Interface circuit pack (TN570) should be the last one checked, since removing this circuit pack disconnects its EPN. In a system with duplicated PNC, disruption of traffic can be minimized by following the procedure for the standby TN570 Expansion Interface circuit pack, then entering a **reset pnc interchange**. The formerly active Expansion Interface will now be standby and can be checked without affecting service to the EPN.

At steps in the procedure that require the removal and/or replacement of circuit packs, refer to the Maintenance Object documentation for the given circuit pack for instructions. SPE and/or PNC interchanges may be required to complete these steps with the least amount of service disruption.

### Procedure for PPN with Simplex SPE or EPN with Simplex PNC

1. Remove the suspect circuit pack.
2. As in Procedure 2, determine if the backplane pins in the removed circuit pack's slot are bent.
3. If the backplane pins are bent, do the following:
  - a. Power down the control carrier as described in the previous warning statement.
  - b. Straighten or replace the pins.
  - c. Insert the same circuit pack.
  - d. Turn the power back on to reboot the system or to restart the EPN.
  - e. Run **test tdm P** to determine if the TDM Bus fault still exists.
  - f. If none of the TDM Bus test fail, the procedure is complete.
  - g. If some of the TDM Bus tests fail, replace the suspect circuit pack and go to step 6.
4. If the backplane pins are not bent, replace the circuit pack.
5. Turn the power back on to reboot the system.

6. Run **test tdm P** to determine if the TDM Bus fault is still present. If none of the TDM Bus tests fail, the procedure is completed.
7. If the TDM Bus fault is still present, the suspect circuit pack was not the cause of the TDM Bus failure. Do the following:
  - a. Remove the replacement circuit pack that was just inserted and replace it with the previously suspected circuit pack.
  - b. Repeat Procedure 3 for the next circuit pack on the list for this procedure.

If Procedure 3 fails to identify the cause of the problem, go to Procedure 4.

### Procedure for PPN with Duplicated SPE or EPN with Duplicated PNC

In this type of configuration, the test procedure is made up of several independent parts. In a duplicated system it is desirable to investigate whether or not circuit packs are causing problems on the TDM Bus when they are in active mode or when they are in standby mode or both. The procedure utilizes SPE interchange in the PPN, or a PNC interchange in the EPN. If the TDM Bus fault disappears after the interchange takes place, the newly standby MSSNET (PPN), or Expansion Interface (EPN), is suspect and should be replaced. If the problem still exists, the Tone/Clocks are then interchanged. If the TDM Bus failure then disappears, the newly standby Tone/Clock is suspect and should be replaced. If the TDM Bus problem still exists, then the procedure begins diagnostics on individual circuit packs and backplane pins.

#### Part 1 (PPN Procedure)

1. If performing this procedure for a PPN carrier, execute **status port-network** to determine which SPE is currently active. Run **reset system interchange** to make the currently active SPE standby.
2. Run **test tdm P** to determine if the TDM Bus fault is still present.
3. If the TDM Bus fault is gone, replace the formerly active MSSNET circuit pack.
4. Run **reset system interchange** again to get the new MSSNET circuit pack on the active SPE.
5. Run **test tdm P** to determine if the TDM Bus fault is still present.
6. If the TDM Bus fault is still present, replace the new MSSNET circuit pack with the original suspect circuit pack, and continue on to Part 3.
7. If the TDM Bus fault has disappeared, the procedure is complete.

#### Part 2 (EPN Procedure)

1. If doing this procedure for an EPN carrier, execute the **status pnc** command to determine which PNC is currently active. Run **reset pnc interchange** to make the currently active PNC standby.

2. Run **test tdm P** to determine if the TDM Bus fault is still present.
3. If the TDM Bus fault is gone, replace the formerly active Expansion Interface circuit pack.
4. Run **reset pnc interchange** again to make get the new Expansion Interface circuit pack on the active SPE.
5. Run **test tdm P** to determine if the TDM Bus fault is still present.
6. If the TDM Bus fault is still present, replace the new Expansion Interface circuit pack with the original suspect circuit pack, and continue on to Part 3.
7. If the TDM Bus fault has disappeared, the procedure is complete.

### Part 3

1. Run **set tone-clock** to make the currently active Tone/Clock standby.
2. Run **test tdm P** to determine if the TDM Bus fault is still present.
3. If the TDM Bus fault is gone, replace the formerly active Tone/Clock circuit pack.
4. Run **set tone-clock** again to make the new Tone/Clock circuit pack active.
5. Run **test tdm P** to determine if the TDM Bus fault is still present.
6. If the TDM Bus fault is still present, replace the new Tone/Clock circuit pack with the original suspect circuit pack, and continue on to Part 4.

### Part 4

Part 4 should be used for each individual circuit pack as listed in the previous table. Run this procedure on all circuit packs on the standby SPE or standby PNC. If the TDM Bus failure still exists once the standby circuit packs have all been tested, execute either **reset system interchange** (PPN) or **reset pnc interchange** (EPN), followed by **set tone-clock** to get the currently active circuit packs into standby mode so that this procedure can be run on each of them.

1. Remove the inactive suspect circuit pack.
2. As in Procedure 2, determine if the backplane pins in the removed circuit pack's slot are bent.
3. If the pins are bent, do the following:
  - a. Remove power as described in the previous warning statement.
  - b. Straighten or replace the pins.
  - c. Restore power.
  - d. Run **test tdm P** to determine if the TDM Bus fault is still present.
  - e. If the TDM Bus failure is still present, the problem is with another circuit pack. Reinsert the original suspect circuit pack and continue with Part 4 for the next circuit pack.

- f. If the TDM Bus failure has disappeared, reinsert the circuit pack and run the **test tdm P** command to see if the TDM Bus failure is still present.  
  
If any of the TDM Bus tests fail, replace the suspect circuit pack. The procedure is complete.  
  
If none of the TDM Bus test fail, the procedure is complete.
4. If the backplane pins are not bent, run the **test tdm P** command to determine if the TDM Bus fault is still present.  
  
command to determine if the TDM Bus fault is still present.
  - a. If any of the TDM Bus tests fail, the problem is with another circuit pack. Reinsert the original suspect circuit pack and continue with Part 4 for the next circuit pack.
  - b. If none of the TDM Bus tests fail, replace the suspect circuit pack. The procedure is complete.
5. If all standby circuit packs have been tested, and the TDM Bus failure still exists, execute the **reset system interchange** (PPN) or the **reset pnc interchange** commands (EPN), and the **set tone-clock** command to get the currently active circuit packs into standby mode. Continue with Part 4 of this procedure for each of the newly active circuit packs.

#### Procedure 4

Procedure 4 attempts to isolate the TDM Bus failure to a particular set of carriers. Only the circuit packs in selected carriers are checked. Procedure 4 is used if the preceding procedures fail, because it can help locate multiple circuit pack failures and failures of the carrier hardware itself.

In this procedure, the TDM/LAN Cable Assemblies and TDM/LAN Bus terminators are replaced. If this action does not resolve the TDM Bus fault, the carriers are reconfigured so that certain carriers are disconnected from the TDM Bus. This is done by moving the TDM/LAN Bus terminators (ZAHF4) on the carrier backplane. To terminate a TDM Bus at the end of a particular carrier, the TDM Bus cable that connects the carrier to the next carrier should be unplugged and replaced with the TDM/LAN Bus terminator (see [Figure 9-107](#)). When the length of the TDM Bus is modified the circuit packs that are essential to the system operation and TDM Bus maintenance (for example, MSSNET and Tone/Clock), must still be connected to the new *shortened* TDM Bus.

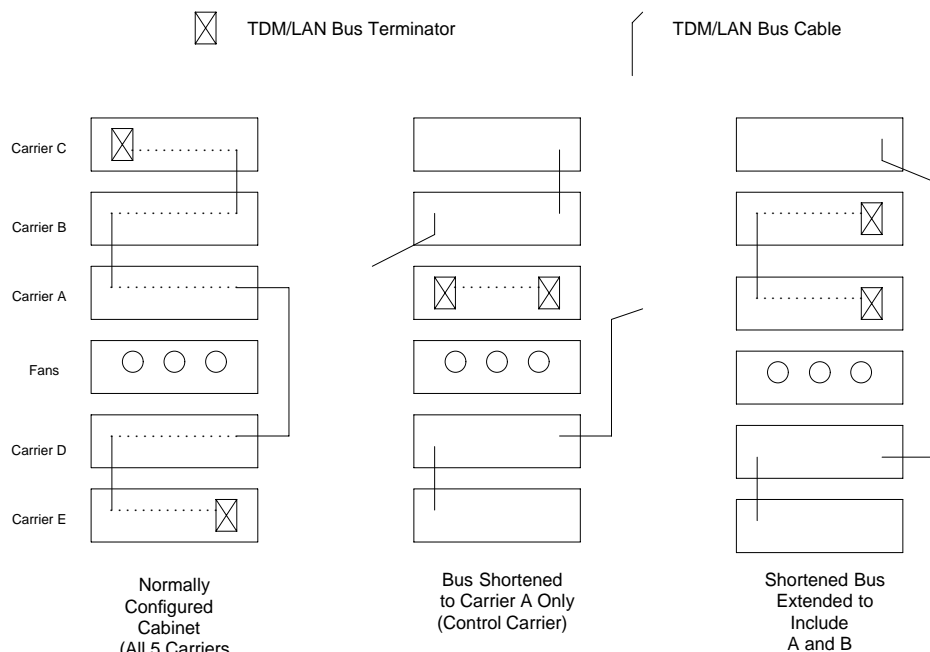

**Figure 9-107. Carrier Rewiring Example—Rear View of Five-Carrier Cabinet**

After cabling changes are made and verified, power must be restored to the port network. Circuit packs in carriers that are not part of the shortened bus are not inserted. As a result, these circuit packs are alarmed. Ignore these alarms for now. All alarms should be resolved when the cabinet is restored to its original configuration.

Procedure 4 is organized into two parts. Part 1 attempts to clear the TDM Bus fault by replacing all the bus cabling and terminators within a port-network. Part 2 attempts to isolate the fault to a particular carrier by extending the TDM Bus from the control carrier to additional carriers one at a time.

**⚠ WARNING:**  
*Power must be removed from the entire port network before any cables or terminators are removed. Failure to follow this procedure can cause damage to circuit packs and power supplies, and can be hazardous to the technician.*

**Part 1**

1. If spare TDM/LAN Cable assemblies and TDM/LAN Bus Terminators are not available, go to Part 2 of this procedure.

2. Power down the port network.
3. Replace all of the TDM/LAN Cable Assemblies and both TDM/LAN Bus Terminators.
4. Restore power to the port network.
5. Run the **test tdm P** command to determine if the TDM Bus fault is still present.  
  
command to determine if the TDM Bus fault is still present.
6. If the TDM Bus fault is resolved, the procedure is completed. Otherwise, go to Part 2.

### Processor Port Network:

1. Terminate the TDM Bus so that it extends only across the Active SPE control carrier.
2. Determine if the TDM Bus fault is still present by running the **test tdm P** command. While the TDM bus is extended only across SPE control carriers the non-control channel test (#297) will not run on the non-control channel because of the absence of a Tone Detector on the shortened bus. After the TDM Bus tests are run once, run the **set tdm PC** command to move the control channel to the non-active bus (the **status port-network P** command will show which bus is currently active). After the bus switch has occurred, run the  
  
command will show which bus is currently active). After the bus switch has occurred, run the **test tdm P** command again to determine if the newly active bus is faulted.
3. If none of the TDM Bus tests fail, extend the TDM Bus to another carrier. If that carrier is an SPE control carrier, repeat this procedure beginning at step 2. If the carrier is not an SPE control carrier, the **test tdm P** command only needs to be executed once since there is now a Tone Detector present on the bus and both the control and non-control channels will be tested in one test sequence.
4. If some of the TDM Bus tests fail, and since Procedures 2 and 3 have not resolved the problem, the added carrier(s) are defective and must be replaced.

### Expansion Port Networks:

1. Terminate the TDM Bus so that it extends only across the carrier that contains the Active Expansion Interface.



2. Determine if the TDM Bus fault is still present by running the **test tdm P** command.

If the *shortened* TDM Bus does not extend to a carrier that contains the Tone Detector circuit pack, the non-control channel test (#297) will not be able to run and the bus that the non-control channel was on will not be tested. If this is the case, run the **set TDM PC** command to move the control channel to the non-active Bus. The **status port-network P** command will show which Bus is currently active. After the Bus switch has occurred, run the **test tdm P** command again to determine if the newly active Bus is faulted.

Another option in an EPN is to move a Tone Detector circuit pack to an empty slot (if one is available) in the carrier where the TDM bus is terminated. This would allow both the control channel and non-control channel tests to run and would not require that the **set tdm P** command be run.

3. If none of the TDM Bus tests fail, extend the TDM Bus to another carrier, and repeat the procedure in the previous step. When a carrier that causes the fault to recur is added, perform Procedure 2 for only the circuit packs in that carrier.
4. If any of the TDM Bus test fail, and Procedures 2 and 3 have not resolved the problem, the added carrier(s) are defective and must be replaced.

## Restarting Non-functioning Port Circuit Packs

A defective TDM Bus Control Channel or system timing reference on one of the networks can result in port circuit packs (those not on a control carrier) on this port network entering the reset state. When this situation occurs, the circuit pack will stop functioning and its red LED will light. The system will not detect the presence of a circuit pack when the circuit pack is in the reset state. Hence, executing the **list config board** command will indicate that the circuit pack is not present.

If a circuit pack enters the reset state it will remain out of service until it receives a restart message form the control channel on the same TDM Bus, A or B, that was active when it reset, or until it is powered up again.

To force the system to send a restart message to all circuit packs on a network, try one of the following methods, depending on the circumstances. A circuit pack that is functioning normally (is not in the reset state) will ignore the restart message.

### Procedure 1 (Non-destructive)

Execute the Idle Time Slot Test (#294) by issuing the command **test tdm P** when the control channel is on the same TDM Bus as it was when the circuit pack entered the reset state.

### Procedure 2 (Non-Destructive)

If you are at the site, reseal the circuit pack. This action will cause the circuit pack that was in the reset state to begin functioning on the *current* Control Channel bus.

### Procedure 3 (Destructive)

Reset the port network that contains the circuit pack that is in the reset state. When a network is reset, two restart messages, one on the control channel of each TDM Bus, are sent to each circuit pack on the network. *To reset an EPN only*, execute the **reset port-network P level 2** command. *Resetting the EPN will disrupt all calls going to and originating from the EPN.*

### Procedure 4 (Destructive)

Execute the **recycle carrier PC** command. *This command will remove and return power to the designated port carrier. Thus, any other circuit packs on this carrier will also be temporarily taken out-of-service.*

## Error Log Entries and Test to Clear Values

**Table 9-640. TDM Bus Error Log Entries**

Error Type	Aux Data	Associated Test	Alarm Level	On/Off Board	Test to Clear Value
0	0	Any	Any	Any	test tdm P
1	0	Control Channel Test (#296)	MINOR	ON	test tdm P r 3
18(a)	0	busyout tdm PC	WARNING	ON	release tdm PC
35(b)	0-1	TDM Bus Corruption	MINOR	ON	set tdm PC
257(c)	0	None	MAJOR	ON	
513(d)	Any	Idle Time Slot Test (#294)	MINOR	ON	test tdm P r 3
769(e)	Any	Idle Time Slot Test (#294)	WARNING	ON	test tdm P r 3
769(f)	Any	Idle Time Slot Test (#294)			(see Notes)
1025(g)	Any	None			
3872(h)	Any	None			
3873(h)	Any	None			
3874(h)	Any	None			
3877(h)	Any	None			

Notes:

- a. The TDM Bus has been busied out by the technician. The error will retire when the technician releases the TDM Bus.
- b. This error indicates the TDM Bus is corrupted. If the corruption was on the Control Channel bus, TDM Bus maintenance will automatically switch the control channel and/or tones to the other bus. The same strategy applies if the corruption was on the bus carrying the tones.

An aux data value of 0 indicates the last reported TDM Bus corruption was on the Control channel bus.

An aux data value of 1 indicates the last reported TDM Bus corruption was on the Non-Control channel bus.

If this error is logged on both TDM Buses (A and B) on the PPN within two or three minutes, the red LED of several circuit packs may or may not be lit and there could be Switch Control (SW-CTL) errors. Under these circumstances do the following:

- Display the Hardware Error Log via the **display errors** command and look for SW-CTL (Switch Control) errors.
  - If there are any errors logged against the Switch Control, try to resolve them.
  - Test the TDM Bus via the **test tdm P** command.
  - If all the TDM Bus tests pass, the problem has been fixed.
- c. This error indicates the TDM Bus was switched to the other bus due to TDM Bus corruption. The aux data value is not meaningful and no action is required. Look for other TDM-BUS errors to determine the cause of this error.
  - d. This error indicates that some time slots are corrupted in the specified TDM Bus. The Minor alarm is raised when there are more than 50 bad time slots in the bus. The aux data indicates the number of bad time slots found by the test.
  - e. This error indicates that some time slots are corrupted in the specified TDM Bus. The Warning alarm is raised when there are more than 10 bad time slots but less than or up to 50 bad ones in the bus. The aux data value indicates the number of bad time slots found by the test.
  - f. This error indicates the idle time slot test found less than 10 bad time slots in the TDM Bus. The aux data value indicates the number of bad time slots found by the test. There is no alarm associated with this error.
  - g. This error indicates that the daily TDM Bus switch was not successful. The Switch Control (PPN) or Active Expansion Interface (EPN) cannot talk on the bus that software was trying to switch into. There is no alarm associated with this error.

- h. These errors indicate communication problems which may be causing message loss. TDM Bus maintenance may switch the Control Channel bus and/or Tone bus to the other bus. Test the TDM Bus via the **test tdm P** command and follow the procedures according to the error codes reported from the test. The aux data value shows the Angel id number for which a downlink message was lost.

**Technician-Demanded Tests:**  
**Descriptions and Error Codes**

---

Always investigate tests in the order presented in the table below. By clearing error codes associated with the *Control Channel Test*, for example, you may also clear errors generated from other tests in the testing sequence.

Order of Investigation	Short Test Sequence	Long Test Sequence	D/ND <sup>1</sup>
Control Channel Test on the Control Channel Bus (#296)	X	X	ND
Digit Detection Test on the Non-Control Channel Bus (#297)	X	X	ND
Idle Time Slot Test (#294)	X	X	ND

---

1. D = Destructive; ND = Nondestructive

**Idle Time Slot Test on TDM Bus A or B (#294)**

The Idle Time Slot Test detects noisy time slots on the bus and takes them out-of-service. The Tone Detector circuit pack is told to listen to idle time slots and if it detects any noise on a time slot, it returns a failure. At the end of the test, any out-of-service time slots are retested to see if they are still noisy and restored to service if they are idle. After all the time slots have been tested, maintenance counts the number of bad time slots and reports the number to the technician in the error code field. No more than 220 time slots will be taken out-of-service on one bus and no more than 300 will be taken out-of-service on both buses at one time.

**Table 9-641. TEST #294 Idle Time Slot Test on TDM Bus A or TDM Bus B**

Error Code	Test Result	Description/ Recommendation
None	ABORT	Could not allocate the necessary system resources to run this test. For example, maintenance could be running on the Tone Detector circuit pack and it is using the CPTRs.
1115	ABORT	Could not allocate the necessary system resources to run this test. <ol style="list-style-type: none"> <li>1. Retry the command at 1-minute intervals for a maximum of 3 times.</li> </ol>
Any	FAIL	The error code indicates the number of bad time slots that were detected. The cause of this failure is most likely due to a bad port circuit pack and not the TDM Bus itself. <ol style="list-style-type: none"> <li>1. Execute the command again.</li> <li>2. If the error persists, check the Error and Alarm Logs for alarms, on the port network where the faulted TDM Bus resides, on port circuit packs from the NPE Crosstalk Test. Also check for EXP-INTF alarms associated with error type 1537.</li> <li>3. Refer to the appropriate circuit pack's documentation to clear the circuit pack's problem.</li> <li>4. Test the TDM Bus again. If the error continues, refer to the "TDM Bus Fault Detection and Isolation Procedure" described earlier.</li> </ol>
	PASS	The success of this test indicates all the idle time slots that are supposed to be idle are indeed idle. There is no noise on any of the idle time slots.

### Control Channel Test (#296)

This tests the integrity of the Control Channel bus by ensuring that communication through the TDM Bus is operational. The test attempts to query a circuit pack whose presence is required in each port network for proper operation (Tone/Clock or Tone Detector). If a reply from the queried circuit pack is received, the TDM Bus is considered operational and the test passes. If no reply is received, the Bus is not operational and the test fails.

**Table 9-642. TEST #296 Control Channel Test**

Error Code	Test Result	Description/ Recommendation
Any other than 1005	ABORT	Internal system error. 1. Retry the command at one-minute intervals for a maximum of three times.
1005	ABORT	Since this test is valid only on the control channel bus, it aborts execution when run on the non-control channel bus. This is a valid response. Use the <b>status port-network</b> command to verify which bus is the control channel bus.
None	FAIL	Communication through the Control Channel is not working. The problem is not necessarily the TDM Bus itself. 1. Display the hardware error and alarm log for the Tone-Clock circuit pack and for the Tone Detector circuit pack in the port network where the faulted TDM Bus resides. Refer to Maintenance documentation for TONE-BD (Tone-Clock Circuit Pack), TONE-PT (Tone Generator), GPTD-PT (General Purpose Tone Detector Port), and DTMR-PT (Dual Tone Multi-Frequency Port). 2. Resolve the errors and alarms for the Tone-Clock and Tone Detector circuit packs. 3. If the faulted TDM Bus is in the PPN, display the hardware error and alarm log and look for SW-CTL errors and alarms. 4. If the faulted TDM Bus is on the EPN, display the hardware error and alarm log and look for errors and alarms for the active Expansion Interface circuit pack. Refer to EXP-INTF (Expansion Interface Circuit Pack) Maintenance documentation and resolve its errors. 5. Execute the <b>test tdm P</b> command again. 6. If the test still fails, refer to the "TDM Bus Fault Detection and Isolation Procedure" described earlier.
	PASS	Communication through the control channel bus is operational.

## Digit Detection Test (#297)

This test is executed on the Non-Control Channel bus. The Tone-Clock circuit pack is told to put a tone on the Non-Control Channel bus and the Tone Detector circuit pack is told to listen to it. The test passes if the tone is successfully transmitted on the Non-Control Channel bus.

**Table 9-643. TEST #297 Digit Detection Test**

Error Code	Test Result	Description/ Recommendation
None 1001 2100	ABORT	Could not allocate the necessary system resources to run this test.
1005	ABORT	Since this test is valid only on the non-control channel bus, it aborts execution when run on the control channel bus. This is a valid response. Use the <b>status port-network</b> command to verify which bus is the control channel bus.
2000	ABORT	Response to the test request was not received within the allowable time period. 1. Retry the command at one-minute intervals a maximum of three times.
None	FAIL	This failure indicates that communication on the Non-Control Channel is not reliable. 1. Execute the command again. 2. If the problem persists, test the active Tone-Clock circuit pack and Tone Detector circuit pack in the port network where the faulted TDM Bus resides, to make sure they are healthy. Refer to TONE-BD (Tone-Clock Circuit Pack), TONE-PT (Tone Generator), GPTD-PT (General Purpose Tone Detector Port), and DTMR-PT (Dual Tone Multi-Frequency Port). 3. Execute the command again. 4. If the problems persists, refer to the "TDM Bus Fault Detection and Isolation Procedure" described earlier.
	PASS	The non-control channel bus is operational.

## TDM-CLK (TDM Bus Clock)

MO Name (in Alarm Log)	Alarm Level	Initial Command to Run <sup>1</sup>	Full Name of MO
TDM-CLK	MAJOR	test tone-clock UUC short	TDM Bus Clock
TDM-CLK	MINOR	test tone-clock UUC short	TDM Bus Clock
TDM-CLK	WARNING	release tone-clock UUC	TDM Bus Clock

1. UU is the universal cabinet number (1 for PPN, 2 -44 for EPNs). C is the carrier designation (A, B, C, D, or E).

### ⇒ NOTE:

Replacing the tone/clock circuit pack requires a special procedure described in the documentation for TONE-BD. That section also describes the LED displays for this board.

The Time Division Multiplex (TDM) Bus Clock resides on the Tone-Clock circuit pack, providing clocking signals both for the TDM Bus and the LAN Bus. The Tone-Clock circuit pack is a critical component in the system and is necessary to ensure the operation of all port circuit packs in the system. The TDM buses of the PPN and any EPNs are synchronized together. The system timing reference can be derived internally from the Tone-Clock circuit pack in any PN, or from an external (off-board) timing reference. Currently, the TDM Bus Clock supports synchronizing the TDM Bus with interface rates from Digital Signal 1 (DS1) facilities as primary or primary and secondary references, and from Stratum 3 Clock (STRAT-3) facilities. Only the TN780 tone-clock supports a Stratum 3 clock.

Moreover, the Tone-Clock circuit pack aids in monitoring and selecting synchronization references. The Tone-Clock circuit pack, after detecting that the external source of timing is not valid, will automatically begin its escalation procedure, according to the facilities administered. In the following table, successive losses of signal cause escalation from left to right.

### ⇒ NOTE:

Switching back to a DS1 source is handled by synchronization maintenance, once any problems with it have been corrected and tested. However, once synchronization has been switched to the internal timing source of the master Tone-Clock circuit pack, *switching back to a Stratum 3 Clock must be initiated by a technician* after the external reference has been repaired.



Tone-Clock Role	Synchronization Facilities	Initial External Synchronization Source	Backup External Synchronization Source	Internal Source
<b>MASTER</b>	Stratum 3 Clock	Source "A"	Source "B"	Local oscillator
	DS1 Primary and Secondary	DS1 Primary	DS1 Secondary	
	DS1 Primary Only	DS1 Primary	None	
	No External Source	None	None	
<b>SLAVE</b>	PNC Duplication	Active EI	Standby EI	
	No PNC Duplication	Active EI	None	

See "Synchronization" for more details of the escalation plan. *There exists a strong interdependency among the DS1 Interface circuit pack Maintenance, Synchronization Maintenance, and TDM Bus Clock Maintenance MOs.*

See the section on "TONE-BD" for a discussion of the relationship of Tone-Clock circuit packs with the various Reliability Options.

## Error Log Entries and Test to Clear Values

**Table 9-644. TDM Bus Clock Error Log Entries**

Error Type	Aux Data	Associated Test	Alarm Level	On/Off Board <sup>1</sup>	Test to Clear Value
0 <sup>2</sup>	0	Any	Any	Any	test tone-clock UUC sh r 1
1(a)	0	None	MINOR	OFF	
18(b)	0	busyout tone-clock UUC	WARNING	OFF	release tone-clock UUC
130(c)		None			
257(d)		None	WARNING	OFF	
513(e)	Any	Clock Circuit Status Inquiry (#148)	MINOR <sup>3</sup>	OFF	test tone-clock UUC
769(f)	Any	Clock Circuit Status Inquiry (#148)	MAJOR <sup>‡</sup>	ON	test tone-clock UUC sh r 10
1025(g)	Any	Clock Slip Inquiry(#149)			test tone-clock UUC sh
1281(h) 1282(h)	Any	None	MINOR	OFF	
1537	Any	Clock PPM Inquiry(#150)			test tone-clock UUC sh
2049(i)	Any	Standby Reference Health Check Test(#651)	MAJOR <sup>3</sup>	ON	test tone-clock UUC
2305(j)	0	None	WARNING	OFF	

- As a general rule, any *on board* errors against the TDM Bus Clock should be resolved before pursuing any other errors against SPE or PNC components. *Off board* clock errors may be caused by other board errors, and should usually be addressed once any on board errors have been resolved.
- Run the Short Test Sequence first. If all tests pass, run the Long Test Sequence. Refer to the appropriate test description and follow the recommended procedures.
- Major or Minor alarms on this MO may have been downgraded to Warning alarms based on the values used in the **set options** command.

### Notes:

- The Tone-Clock circuit pack may have a clock at the edge of its specified frequency. This can cause Expansion Interface circuit packs and SNI circuit packs to go out-of-frame or report no-neighbor conditions. This can in turn cause EPNs, Expansion Archangel Links (EALs), Remote Neighbor Links (RNLs), and/or Local Neighbor Links (LNLs) to go down. When this error is alarmed, Clock Health Inquiry Test (#46) will fail with an error code of 1.
  - Replace the Tone-Clock circuit pack identified in the error log. See *How to Replace the Tone-Clock Circuit Pack* in the TONE-BD section.

- b. The indicated Tone-Clock circuit pack has been made unavailable via the **busyout tone-clock UUC** command. It only applies to systems which have the High or Critical Reliability Option administered, because only a standby Tone-Clock circuit pack may be made busy by that command. To resolve this error, execute the **release tone-clock UUC** command for the alarmed circuit pack.
- c. This error type indicates that the circuit pack has been removed or has been insane for more than 11-minutes. To clear the error, reinsert or replace the circuit pack.
- d. The Tone-Clock circuit pack in the PPN is not a TN780 while a Stratum 3 synchronization is administered. Replace the Tone-Clock in the PPN with a TN780, or change synchronization administration to Stratum 4 if a Stratum 3 clock is not being used.
- e. The tone-clock has reported an out-of-lock condition. A aux value of 1 indicates this error is an out-of-lock with the primary reference. A aux value of 2 indicates this error is an out-of-lock with the secondary reference. It could not lock onto the frequency of that synchronization reference. This will lead to a change in the synchronization reference if the condition continues.
- f. The Tone-Clock circuit pack may be defective, however it may be a software failure that can be corrected by testing.
  1. Check to see if the board is duplicated (**list cabinet** and **status port-network**) on the affected port network.
  2. If the board is not duplicated, use test tone UUCSS long to resolve the errors. The long test resets the board and is required to reload on-board RAM associated with the TN2182's DSPs. The effect is that tone detectors are taken out of service momentarily and tones are removed from the TDM bus for about 10 seconds, meaning that no dial tone or touch tones are available during this interval. This will probably not affect calls in progress, but could cause a call origination to abort or a user not to get dial tone when going off hook.
  3. If all tests pass and the alarm does not resolve, retest with **test tone UUCSS long clear**.
  4. If the test passes, terminate the repair process. If the test fails, replace the circuit pack at the customer's convenience.
  5. If this error was logged against the standby Tone-Clock, and if the Aux Data value was 18369, SYNC (Synchronization) maintenance acts on this error. No corrective action is required. For any other Aux Data, go to the next step.
  6. If the board is duplicated, switch to the standby side (**set tone**).
  7. Test the alarmed board (test tone UUCSS long). This resets the board and is required to reload on-board RAM associated with the TN2182's DSPs.

8. If all tests pass and the alarm does not resolve, retest (**test tone UUCSS long clear**).
  9. If the test passes, terminate the repair process. If the test fails, replace the circuit pack at the customer's convenience.
- g. Tone-Clock circuit pack on-board maintenance has detected one or more *clock slips*, timing differences between its internal reference source and the synchronization signal provided by the master Tone-Clock. Although no clock slip errors are expected during normal operation, both manual and automatic interchanges of Tone-Clock circuit packs, synchronization references, and PNCs, may result in clock slip counts.

If error 1281 also is logged for the same Tone-Clock circuit pack, it is related to this problem, and should be corrected first. Otherwise, continue with the procedure below.

1. Use **test tone-clock UUC**, and examine the results of test #149 to see if slip errors are still occurring. If no new slip errors are reported, and if these errors are not causing a TDM-CLK alarm, they may be ignored. Use **test tone-clock UUC long clear** to clear the errors.
2. Otherwise, enter the **display errors** command, and follow corrective procedures for any other TDM-CLK, TONE-BD, SYNC, DS1C-BD, EXP-INTF, SNC-BD, and SNI-BD errors logged, except for those in [Table 9-645](#).

**Table 9-645. Error Log Entries for Slip Errors**

Circuit Pack Name	Error Log Name	Error Log Entry for Slips
DS1 Interface	DS1-BD	3073 to 3160
Expansion Interface	EXP-INTF	2305
Switch Node Interface	SNI-BD	1537
Tone-Clock	TDM-CLK	1025
UDS1 Interface	UDS1-BD	3073 to 3160
DS1C Circuit Pack	DS1C-BD	3329

3. If 1025 errors persist, refer to SYNC Maintenance in this manual and follow the procedures in the "Approach to Troubleshooting" section.
- h. Error Type 1281—This error is an indication that the Tone-Clock circuit pack has detected a loss of timing signal from the system synchronization reference. The Tone-Clock circuit pack has switched synchronization references.
1. Resolve any errors logged against the SYNC or STRAT-13 maintenance objects.

2. Refer to SYNC maintenance, in the “Approach to Troubleshooting” section, if the error is not resolved by step 1

Error Type 1282—Indicates that the TN2182 tone-clock was synchronized to a DS1 facility and that the reference frequency provided by the DS1 drifted beyond a range that could be tracked by the TN2182. Therefore the TN2182 is no longer synchronized to that DS1 reference. If a second DS1 is available, the tone-clock may be synchronized to that reference. If no secondary DS1 reference is available, the tone-clock will run off of its internal clock. This may result in slips being reported by the tone-clock and all DS1 facilities.

- i. The tone-clock circuit pack in the master port network was unable to detect the incoming synchronization signal, but the other tone-clock was able to detect the references. If the aux data is 0, the problem is with the signal on the primary. If the aux data is 1, the problem is with the signal on the secondary. The system should switch clocks in this situation.
  1. If this error is against a PPN clock board and the system is using a Stratum 3 clock, check the cabling that brings the stratum 3 signal to this clock board.
  2. Replace the current standby Tone-Clock circuit pack. See *How to Replace the Tone-Clock Circuit Pack* in the TONE-BD section.
- j. The indicated active Tone-Clock circuit pack, which is on a port network that does not contain the system synchronization reference (a **slave** Tone-Clock), has detected a loss of timing signal from its EXP-INTF synchronization source.
  1. Enter **display errors** and **display alarms**, and follow the associated repair procedures for EXP-INTF, TDM-CLK, and TONE-BD error log entries that have on-board alarms.
  2. If the 2305 errors persist, follow the repair procedures for EXP-INTF error log entries 257, 769, or 770, or any errors logged against SNI-BD, SNC-BD, or FIBER-LK.
  3. If the 2305 errors persist:
    - a. *For Port Networks with more than one Tone-Clock circuit pack*, execute the command test synchronization r 10, and check to see if new 2305 errors against TDM-CLK were reported. If not, execute reset PNC interchange and then test synchronization r 10 again, and recheck for new 2305 errors against TDM-CLK
    - b. *For Port Networks with a single Tone-Clock circuit pack*, execute the command test synchronization r 10, and check to see if new 2305 errors were reported.

If no new instances of the 2305 errors were logged for either test, then enter **test tone-clock UUC long clear** to clear the TDM-CLK errors and the procedure is complete.

4. For Port Networks with more than one Tone-Clock circuit pack, interchange Tone-Clocks with the **set tone-clock UUC**, then run **test synchronization r 10**, and check to see if new 2305 errors are reported against the new active Tone-Clock circuit pack. If not, replace the standby Tone-Clock circuit pack. See *How to Replace the Tone-Clock Circuit Pack* in the TONE-BD section. If this clears the error, the problem has been resolved.
5. Replace the EI circuit pack for the active PNC. In the direct-connect case, use the **list fibers** command to identify which active EI connects with the PPN.
6. If the problem is still not cleared, and the Tone-Clock circuit pack reported in the error log has not been replaced up to now, replace it. See *How to Replace the Tone-Clock Circuit Pack* in the TONE-BD section.

### System Technician-Demanded Tests: Descriptions and Error Codes

---

Always investigate tests in the order presented in the table below when inspecting errors in the system. By clearing error codes associated with the *SAKI Reset Test* for example, you may also clear errors generated from other tests in the testing sequence.

Order of Investigation	Short Test Sequence	Long Test Sequence	Reset Board Sequence	D/ND <sup>1</sup>
SAKI Reset Test (#53) (a)		X		D
Clock Health Test (#46) (b)	X	X		ND
Control Channel Looparound Test (#52) (a)	X	X		ND
Tone Generator Crosstalk Test (#90) (c)		X		ND
Tone Generator Transmission Test (#40) (c)	X	X		ND
Tone Generator Audit/Update Test (#41) (c)	X	X		ND
TDM Bus Clock Circuit Status Inquiry Test (#148)	X	X		ND
TDM Bus Clock Slip Inquiry Test (#149)(e)	X	X		ND
TDM Bus Clock PPM Inquiry Test (#150)	X	X		ND

Order of Investigation	Short Test Sequence	Long Test Sequence	Reset Board Sequence	D/ND <sup>1</sup>
TDM Bus Clock Parameter Update Test (#151)	X	X		ND
Board Type Check Test (#574)	X	X		ND
Standby Reference Health Check Test (#651) (d)		X		ND

1. D = Destructive; ND = Nondestructive

Notes:

- a. Refer to XXX-BD (Common Port Circuit Pack) Maintenance documentation for descriptions of these tests.
- b. Refer to TONE-BD (Tone-Clock Circuit Pack) documentation for a description of this test.
- c. Refer to TONE-PT (Tone Generator) documentation for descriptions of these tests.
- d. This test only runs on the Standby Tone-Clock circuit pack in a Port Network with more than one Tone-Clock circuit pack (High or Critical Reliability Option). The circuit pack must be a TN780 code with firmware revision 2 or above, or be a TN2182.
- e. Test #149 is not run on the TN2182.

**TDM Bus Clock Circuit Status Inquiry Test (#148)**

The TDM Bus Clock circuitry is checked for sanity. Any problems that are found are reported via error codes

**Table 9-646. TEST #148 TDM Bus Clock Circuit Status Inquiry Test**

Error Code	Test Result	Description/ Recommendation
None 1001	ABORT	The system could not allocate the necessary resources for the test. 1. Wait 1-minute, and retry the test.
2000	ABORT	Response to the test was not received within the allowable time period.
2100	ABORT	System resources required to run this test are not available. 1. Retry the command at 1-minute intervals a maximum of 5 times.

*Continued on next page*

**Table 9-646. TEST #148 TDM Bus Clock Circuit Status Inquiry Test — Continued**

Error Code	Test Result	Description/ Recommendation
1	FAIL	<p>This error means the Tone-Clock circuit pack framing verification firmware reports an error in the clock synchronization signal coming into this Port Network.</p> <ol style="list-style-type: none"> <li>1. If the Tone-Clock circuit pack reporting the problem is a master clock, then the system synchronization reference is providing a bad timing source. Refer to SYNC (Synchronization) or STRAT-3 (Stratum 3 Clock) Maintenance documentation to change the system synchronization reference.</li> <li>2. If the Tone-Clock circuit pack is a slave clock, then the EI to which it is listening is providing a bad timing source. Follow the diagnostic procedures specified for TDM-CLK Error Code 2305.</li> <li>3. If no problem can be found with the incoming synchronization signal, replace the Tone-Clock circuit pack. See <i>How to Replace the Tone-Clock Circuit Pack</i> in the TONE-BD section.</li> </ol>
2	FAIL	<p>This error indicates that Tone-Clock circuit pack has inaccurately detected loss of signal on the incoming synchronization timing source.</p>
4 or 8	FAIL	<p>The local oscillator on the Tone-Clock circuit pack has failed.</p>
16 or 32	FAIL	<p>The circuitry on the Tone-Clock circuit pack used to detect synchronization timing errors has failed.</p> <ol style="list-style-type: none"> <li>1. Errors 2, 4, 8, 16, and 32 indicate that there is poor synchronization between port networks and external facilities. It may be noticeable to the customer in the form of errors in data communications. The Tone-Clock circuit pack is defective. See <i>How to Replace the Tone-Clock Circuit Pack</i> in the TONE-BD section.</li> </ol>
64	FAIL	<p>This message is only sent when an uplink message has reported the loss of valid synchronization timing information coming into this Port Network. It has been reported in TDM-CLK Error Log entries; one or more of 1025, 1281, 1537, 2049 and 2305.</p> <ol style="list-style-type: none"> <li>1. Resolve the errors indicated. No separate corrective action is required.</li> </ol>

*Continued on next page*



**Table 9-646. TEST #148 TDM Bus Clock Circuit Status Inquiry Test — Continued**

Error Code	Test Result	Description/ Recommendation
65	FAIL	<p>The tone-clock is currently not able to lock on to the current synchronization reference. If this tone-clock is in the master port network:</p> <ol style="list-style-type: none"> <li>1. Examine the error log for any DS1-BD, SYNC or other TDM-CLK errors and resolve as applicable.</li> <li>2. Run this test again via the test tone-clock UUC command.</li> <li>3. Examine the DS1 measurements to determine if the facility is healthy.</li> <li>4. Administer a new synchronization reference.</li> <li>5. Replace the DS1 board currently supplying the reference.</li> </ol> <p>If this tone-clock is in the slave port network:</p> <ol style="list-style-type: none"> <li>1. Examine the error log for any SYNC, EXP-INTF or other TDM-CLK errors.</li> <li>2. Run this test again via the test tone-clock UUC command.</li> </ol>
66	FAIL	<p>There is an on-board failure of TDM clock hardware.</p> <ol style="list-style-type: none"> <li>1. Use <b>test tone UUCSS long</b> to resolve the problem. The long test resets the board and is required to reload on-board RAM associated with the TN2182's DSPs. The effect is that tone detectors are taken out of service momentarily and tones are removed from the TDM bus for about 10 seconds. This means that no dial tone or touch tones are available during this interval. It probably will not affect calls in progress, but could cause a call origination to abort or a user will not get dial tone when going off hook.</li> <li>2. If the test passes and the alarm does not resolve, retest (<b>test tone UUCSS long clear</b>).</li> <li>3. If the test passes, terminate the repair process. If it fails, replace the circuit pack at the customer's convenience.</li> </ol>
	PASS	<p>TDM Bus Clock Circuit Status is sane. There are no clock-detection circuit problems on the Tone-Clock circuit pack.</p>

### TDM Bus Clock Slip Inquiry Test (#149)

This test evaluates the quality of the synchronization source for the Tone-Clock circuit pack.



**NOTE:**

This test does not apply to the TN2182

**Table 9-647. TEST #149 TDM Bus Clock Slip Inquiry Test**

Error Code	Test Result	Description/ Recommendation
	ABORT	The system could not allocate the necessary resources for the test.
1001	ABORT	The system could not allocate the necessary resources for the test. 1. Wait 1-minute, and retry the test.
2000	ABORT	Response to the test request was not received within the allowable time period.
2100	ABORT	System resources required to run this test are not available. 1. Retry the command at 1-minute intervals a maximum of 5 times.
Any	FAIL	<p>The error code represents the number of timing slips detected on the incoming synchronization source since the last slip inquiry was sent to the Tone-Clock circuit pack. The incoming synchronization signal can be from one of four sources:</p> <ol style="list-style-type: none"> <li>1. A Stratum 3 Clock, if that option is administered and the circuit pack tested was the active Tone-Clock in the PPN.</li> <li>2. A DS1 Interface circuit pack, if DS1 Synchronization is administered, and associated with the circuit pack tested.</li> <li>3. The local oscillator on the master Tone-Clock circuit pack, if it is providing the system clocking signals.</li> <li>4. An EXP-INTF circuit pack, if the port network on which the test was executed does not contain the current system synchronization reference.</li> </ol> <p>The error code is a variable amount ranging from 1 to 255.</p> <ol style="list-style-type: none"> <li>1. Small numbers of slips should not result in service degradation. If the error code is small (1 or 2), rerun the test. If the error only occurs infrequently, it may be ignored.</li> <li>2. Otherwise, refer to the "Approach to Troubleshooting" section in the Synchronization (SYNC) Maintenance section of this manual.</li> </ol>
	PASS	The Tone-Clock circuit pack does not detect any timing slips. This indicates that the incoming synchronization timing source is valid or that the system synchronization reference is a Tone-Clock circuit pack. The <b>status synchronization</b> command should be used to verify that the desired synchronization reference is providing timing for the system.

**TDM Bus Clock PPM Inquiry Test (#150)**

This test evaluates the quality of the synchronization source for the Tone-Clock circuit pack.

**Table 9-648. TEST #150 TDM Bus Clock PPM Inquiry Test**

Error Code	Test Result	Description/ Recommendation
1001	ABORT	The system could not allocate the necessary resources for the test.
	ABORT	The system could not allocate the necessary resources for the test. 1. Wait 1-minute, and retry the test.
255	ABORT	The test was not executed because the Tone-Clock circuit pack was using its local oscillator rather than synchronizing to an external source. 1. Verify that this Tone-Clock circuit pack is expected to be the synchronization source. If not, correct the synchronization information and re-execute the test.
2000	ABORT	Response to the test request was not received within the allowable time period.
2100	ABORT	System resources required to run this test are not available. 1. Retry the command at 1-minute intervals a maximum of 5 times.
Any	FAIL	The error code represents the rate (in Parts Per Million, or PPM) at which clock slip errors have been detected on the incoming synchronization source since the last PPM inquiry was sent to the Tone-Clock circuit pack. A failure of this test indicates that we are outside of Stratum 4 or Stratum 3 timing specifications on the incoming timing source. The error code is a variable amount ranging from 1 to 254. 1. If error 1537 is entered in the hardware error log against TDM-CLK, then the board has switched timing sources. Follow the procedures associated with hardware log error code 1537. 2. Otherwise, refer to "Approach to Troubleshooting" in the Synchronization (SYNC) Maintenance section of this manual.
	PASS	The Tone-Clock circuit pack does not detect timing any PPM errors. This indicates that the external synchronization timing source is valid or that the system synchronization reference is a Tone-Clock circuit pack. Use the <b>status synchronization</b> command to verify that the desired synchronization reference is providing timing for the system.

## TDM Bus Clock Parameter Update Test (#151)

This test updates the following internal parameters on the Tone-Clock circuit pack:

- Disable in-line duplication status messages.
- Disable in-line substrate frame maintenance messages (TN768, TN780 only).
- Set the PPM threshold at 60 PPM for TN768 and TN780. Set the PPM threshold at 85 PPM for TN2182.
- Enable PPM threshold switching
- Set the number of slips to trigger *loss of signal* - currently 30 per 5 millisecond period
- Enable the on-board synchronization switching algorithm (see above)
- Enable holdover operation (TN2182 only).

This is not a test and will always pass without identifying or reporting any Tone-Clock circuit pack errors

**Table 9-649. TEST #151 TDM Bus Clock Parameter Update Test**

Error Code	Test Result	Description/ Recommendation
ABORT	FAIL	Internal system error
		Internal system error
		1. Retry the command at 1-minute intervals a maximum of 5 times.
PASS		The Tone-Clock circuit pack parameters have been successfully updated.

## Board Type Check Test (#574)

This test verifies that a Tone-Clock circuit pack administered with a Stratum 3 Clock source has code TN780

**Table 9-650. TEST #574 Board Type Check Test**

Error Code	Test Result	Description/ Recommendation
2012	ABORT	Internal system error 1. Retry the command at 1-minute intervals a maximum of 5 times.
ANY	FAIL	Stratum 3 Clock Synchronization is administered for the carrier in which this Tone-Clock circuit pack resides, but the Tone-Clock does not have code TN780. 1. If the Stratum 3 Clock option is incorrectly administered, remove it. 2. Otherwise, replace the circuit pack. See <i>How to Replace the Tone-Clock Circuit Pack</i> in the TONE-BD section.
	PASS	The proper (TN780) Tone-Clock circuit pack code is present for Stratum 3 Clock synchronization.

## Standby Reference Health Check Test (#651)

This test evaluates the quality of the external synchronization timing source for a standby Tone-Clock circuit pack. All administered synchronization timing sources must be valid for this test to pass. If the tone-clock circuit pack and the synchronization timing sources are in different port networks, the EI circuit packs transport the timing sources to the tone-clock.

**Table 9-651. TEST #651 Standby Reference Health Check Test**

Error Code	Test Result	Description/ Recommendation
	ABORT	This test may already be running due to a tone-clock installation, scheduled maintenance, alarm activity, or a technician-demand test from another terminal. This abort can also occur due to an internal system error. 1. Try the command again at 1-minute intervals up to five times.
1184	ABORT	This test requires an external synchronization source to be administered (DS1 primary, DS1 primary and secondary, or Stratum 3 Clock). 1. Administer the external synchronization source and retry the test.

*Continued on next page*

**Table 9-651. TEST #651 Standby Reference Health Check Test — Continued**

Error Code	Test Result	Description/ Recommendation
2500	ABORT	Internal system error 1. Try the command again at 1-minute intervals up to 5 times.
0	FAIL	The external synchronization timing source for side A of the Stratum 3 clock, or for the primary DS1 reference is either absent or invalid. The external synchronization timing source for side B of the Stratum 3 clock, or for the secondary DS1 reference is not yet tested.
1	FAIL	The external synchronization timing source for side B of the Stratum 3 clock, or for the secondary DS1 reference is either absent or invalid. 1. Correct the synchronization source problem. Refer to the Synchronization (SYNC) maintenance section of this manual. 2. If the error still exists, replace the Tone-Clock circuit pack reported in the error log. See <i>How to Replace the Tone-Clock Circuit Pack</i> in the TONE-BD section.
	PASS	The external synchronization timing source is valid.

## TDMODULE (Trunk Data Module)

---

MO Name (in Alarm Log)	Alarm Level	Initial Command to Run <sup>1</sup>	Full Name of MO
TDMODULE	MIN	test port UUCSSpp	Trunk Data Module
TDMODULE	WRN	test port UUCSSpp	Trunk Data Module

- 
1. UU is the universal cabinet number (1 for PPN, 2 -44 for EPNs). C is the carrier designation (A, B, C, D, or E). SS is the number of the slot in which the circuit pack resides (01 to 21). pp is the two digit port number (01, 02, and so forth).

The TDMODULE (Trunk Data Module) is covered in the PDMODULE (Data Module).

## TIE-BD (Tie Trunk Circuit Pack)

---

MO Name (in Alarm Log)	Alarm Level	Initial Command To Run <sup>1</sup>	Full Name of MO
TIE-BD	MIN	test board UUCSS sh	Tie Trunk Circuit Pack
TIE-BD	WRN	test board UUCSS sh	Tie Trunk Circuit Pack

- 
1. UU is the universal cabinet number (1 for PPN, 2 - 44 for EPNs). C is the carrier designation (A, B, C, D, or E). SS is the number of the slot in which the circuit pack resides (01 to 21). pp is the two digit port number (01, 02, ...).

Refer to XXX-BD (Common Port Circuit Pack) Maintenance documentation for circuit pack level errors. See also TIE-TRK (Tie Trunk) Maintenance documentation for related trunk information.



## TIE-DS1 (DS1 Tie Trunk)

MO Name (in Alarm Log)	Alarm Level	Initial Command to Run	Full Name of MO
TIE-DS1 <sup>1</sup>	MAJOR <sup>2</sup>	test trunk <i>grp/mbr</i> <sup>3</sup>	DS1 Tie Trunk
TIE-DS1	MINOR	test trunk <i>grp/mbr</i> <sup>3</sup>	DS1 Tie Trunk
TIE-DS1	WARNING	test trunk <i>grp/mbr</i>	DS1 Tie Trunk

1. For additional repair information, see DS1-BD documentation if the tie trunk is on a TN722 or TN767 DS1 circuit pack. See UDS1-BD documentation if the tie trunk is on a TN464C/D UDS1 circuit pack.
2. A MAJOR alarm on a trunk indicates that alarms on these trunks are not downgraded by the **set options** command and that at least 75% of the trunks in this trunk group are alarmed. For more information on the **set options** command, see [Chapter 8, "Maintenance Commands"](#)
3. For TN767B vintage 8 or 9 circuit packs, a failure of Test #136 causes a subsequent failure of Test #7. Test #136 is part of the short sequence and generates off-board alarms Test #7 is part of the long sequence and generates on-board alarms. Before entering **busyout**, **release**, **reset** or **test board long** commands, check the vintage number of the circuit pack with **list configuration board** UUCSS. If it is TN767B vintage 8 or 9, do not use the above commands until first making sure that Test #136 passes via **test board short**. Otherwise, extraneous on-board alarms may be generated.

### ⇒ NOTE:

Many trunk problems are caused by incorrect settings of parameters on the trunk group administration form. Settings must be compatible with the local environment and with parameter settings on the far-end. Refer to *DEFINITY Enterprise Communications Server Release 5.4 Administration and Feature Description*, for information on how to administer trunks. The Application Notes section of that book shows the correct settings for administrable timers and other parameters on a country-by-country basis.

The DS1 tie trunk provides both voice and data communications between two PBX switches. There are two types of DS1 interfaces:

- 24 DS0 channels on a 1.544 Mbps link
  - 31 DS0 channels + 1 framing channel on a 2.048 Mbps link
- 32-channel mode is supported only on TN464 circuit packs and on G3r V2 systems.

DS1 Tie Trunks are used widely in the Distributed Communications System (DCS) and Central Attendant Service (CAS) system features.

A DS1 tie trunk can also be used as an access endpoint which is a non-signaling channel with bandwidth for voice-grade data, 56 Kbps data or 64 Kbps data.

DS1 tie trunk maintenance provides a strategy to maintain a DS1 tie trunk via a port on either the TN722 or TN767 DS1 Interface circuit pack or the TN464C/D UDS1 Interface circuit pack. Throughout this TIE-DS1 section, the term DS1 Interface applies to DS1 and UDS1 circuit packs.

The DS1 tie trunk maintenance strategy covers logging DS1 tie trunk hardware errors, running tests for trunk initialization, periodic and scheduled maintenance, system technician-demanded tests, and alarm escalation and resolution. Three different trunk service states are specified in DS1 tie trunk maintenance:

Out-of-service	The trunk is deactivated and cannot be used for incoming or outgoing calls.
In-service	The trunk is activated and can be used for both incoming and outgoing calls.
Disconnect (ready-for-service)	The trunk is in an activated state but can only be used for an incoming call.

If the DS1 Interface circuit pack is out of service, then all trunks on the DS1 Interface circuit pack are also placed into the out-of-service state and a Warning alarm is raised.

## Hardware Error Log Entries and Test to Clear Values

Table 9-652. DS1 Tie Trunk Maintenance Error Log Entries

Error Type	Aux Data	Associated Test	Alarm Level	On/Off Board	Test to Clear Value
0 <sup>1</sup>	0	Any	Any	Any	test trunk <i>grp/mbr</i>
1(a)	57476 57477 57485 57487				
15(b)	Any	Port Audit and Update Test (#36)			
18(c)	0	busyout trunk <i>grp/mbr</i>	WARNING	OFF	release trunk <i>grp/mbr</i> <sup>2</sup>
130(a)		None	WARNING	ON	test trunk <i>grp/mbr</i>
257(e)	57473 57474				
513(f)	57392	DS1 Tie Trunk Seizure Test (#136)	MIN/MAJ <sup>3</sup>		
769(g)	57393	DS1 Tie Trunk Seizure Test (#136)	MIN/MAJ <sup>3</sup>		
1025		DS1 Tie Trunk Seizure (Test #136)	MIN/WRN <sup>4</sup>	OFF	test trunk <i>grp/mbr</i> r 2
1281		Conference Circuit (Test #7)	MIN/WRN <sup>4</sup>	ON	test trunk <i>grp/mbr</i> l r 4 <sup>2</sup>
1537		NPE Crosstalk Test (#6)	MIN/WRN <sup>4</sup>	ON	test trunk <i>grp/mbr</i> l r 3 <sup>2</sup>
1793(h)					test board UUCSS long <sup>2</sup>
2305(i)	50944	DS1 Tie Trunk Seizure Test (#136)	MIN/MAJ <sup>3</sup>	OFF	
2562(j)	16665				
2817(k)	52992				
3840(l)	Any	Port Audit and Update (Test #36)			

1. Run the Short Test Sequence first. If all tests pass, run the Long Test Sequence. Refer to the appropriate test description and follow the recommended procedures.
2. For TN767B vintage 8 or 9 circuit packs, a failure of Test #136 causes a subsequent failure of Test #7. Test #136 is part of the short sequence and generates off-board alarms. Test #7 is part of the long sequence and generates on-board alarms. Before entering **busyout**, **release**, **reset** or **test board long** commands, check the vintage number of the circuit pack with **list configuration board UUCSS**. If it is TN767B vintage 8 or 9, do not use the above commands until first making sure that Test #136 passes via **test board short**. Otherwise, extraneous on-board alarms may be generated.

9 Maintenance Object Repair Procedures  
TIE-DS1 (DS1 Tie Trunk)

9-1740

3. This alarm will only be raised when the System-Parameter Country form has the Base Tone Generator field set to 4 (Italy). This alarm will be a MINOR alarm unless 75% or more trunks in this trunk group are out of service, then the alarm will be upgraded to a MAJOR alarm.
  4. Major or Minor alarms on this MO may be downgraded to Warning alarms based on the values used in the **set options** command.
- 

Notes:

- a. Error Type 1—The DS1 Interface circuit pack detects a hardware error on the DS1 tie trunk. This error can be caused by incompatible translations. Make sure the parameters administered on the DS1 circuit pack form match those administered on the far-end switch. See *DEFINITY Communications System Generic 3 V2 Implementation*, 555-230-653, and *DEFINITY Communications System Generic 2.2 and Generic 3 V2 DS1/CEPT/ISDN-PRI Reference*, 555-025-107, for details.

The Aux Data field indicates the following hardware error types:

57476	On-hook before wink
57477	On-hook before ready to receive digits
57485	Wink too short for valid signal
57487	The timer expired while waiting for an off-hook signal from the far end as a response at end of digits dialing. Check the far-end switch for related problems.

If all administration errors between the switch and the far-end match, and these errors continue to recur, follow normal escalation procedures.

- b. Error Type 15—This is a software audit error that does not indicate any hardware malfunction. Run Short Test Sequence and investigate associated errors (if any).
- c. Error Type 18—The DS1 tie trunk has been busied out by a **busyout trunk** grp/mbr command. No calls can be made on this trunk except for the Facility Access Test Call. Facility Access Test Calls are described in Chapter 6 and in *DEFINITY Enterprise Communications Server Release 5.4 Administration and Feature Description*.
- d. Error Type 130—This error type indicates that the circuit pack has been removed or has been insane for more than 11-minutes. To clear the error, reinsert or replace the circuit pack.
- e. Error Type 257—The DS1 Interface circuit pack detects a hardware error on the DS1 tie trunk. The trunk cannot communicate with the far end because it is unable to interpret digits sent from the far-end switch. The Aux Data field indicates the following:

57473	The rotary dial rate is below 8 pulses per second.
57474	The rotary dial rate is above 12 pulses per second.

Check with the far-end switch or operating company for proper trunk connection.

- f. Error Type 513—DS1 Interface circuit pack detects a hardware error on the DS1 tie trunk. The trunk is in-service/active and waiting for an “on-hook” from the far-end switch. No calls can be routed over the trunk while it is in this state. Aux Data 57392 indicates no external release on PBX disconnect. Check with the far-end switch or operating company for proper trunk connection.
- g. Error Type 769—The DS1 Interface circuit pack detects a hardware error on the DS1 tie trunk. This error usually occurs after an occurrence of error type 513. The trunk has received the belated “on-hook” that it has been waiting for from the far-end switch. The trunk is restored to in-service/idle and can be used for calls. Aux Data 57393 indicates delayed external release on PBX disconnect. This error can be ignored.
- h. Error Type 1793—The DS1 Interface circuit pack is out-of-service. See the appropriate DS1-BD/UDS1-BD (DS1/UDS1 Interface Circuit Pack) Maintenance documentation for details.
- i. Error Type 2305—Reorder message. The trunk could not be seized. This error causes the Trunk Seizure Test (#136) to run and is only a problem if the Seizure Test fails (in which case Error Type 1025 also appears). In this case, the trunk may be put in “Ready-for-Service” state (shown as “disconnected” by the status command), which allows only incoming calls. Run the Trunk Seizure Test (#136) and follow its procedures.
- j. Error Type 2562—Retry Failure error. This error is logged only. It is not a hardware failure and hence does not start any testing or generate any alarms. This error comes from call processing and is generated when a second attempt (retry) to seize an outgoing trunk fails.
- k. Error Type 2817—Glare error. This error is logged only. It is not a hardware failure and hence does not start any testing or generate any alarms. This error is the result of a simultaneous seizure of a two-way trunk from both the near-end and the far-end. Attempt to place the call again. If the error persists, execute the DS1 Tie Trunk Seizure Test (#136) and follow its outlined procedures.
- l. Error Type 3840—Port Audit and Update Test (#36) failed due to an internal system error. Enter **status trunk** command and verify the status of the trunk. If the trunk is out-of-service, then enter **release trunk** command to put it back to in-service. Retry the test command.

## System Technician-Demanded Tests: Descriptions and Error Codes

Always investigate tests in the order presented in the table below when inspecting errors in the system. By clearing error codes associated with the *NPE Crosstalk Test*, for example, you may also clear errors generated from other tests in the testing sequence.

Order of Investigation	Short Test Sequence	Long Test Sequence	D/ND <sup>1</sup>
NPE Crosstalk Test (#6)		X	ND
Conference Circuit Test (#7)		X	ND
DS1 Tie Trunk Seizure Test (#136)	X	X	ND
Port Audit and Update Test (#36)	X	X	ND

1. D = Destructive; ND = Nondestructive

For TN767B vintage 8 or 9 circuit packs, a failure of Test #136 causes a subsequent failure of Test #7. Test #136 is part of the short sequence and generates off-board alarms. Test #7 is part of the long sequence and generates on-board alarms. Before entering **busyout**, **release**, **reset** or **test board long** commands, check the vintage number of the circuit pack with **list configuration board UUCSS**. If it is TN767B vintage 8 or 9, do not use the above commands until first making sure that Test #136 passes via **test board short**. Otherwise, extraneous on-board alarms may be generated.

### NPE Crosstalk Test (#6)

The NPE Crosstalk Test verifies that this port's NPE channel talks on the selected time slot and never crosses over to time slots reserved for other connections. If the NPE is not working correctly, one-way and noisy connections may be observed. This test is usually only part of a port's Long Test Sequence and takes on the order of 20 to 30 seconds to complete.

**Table 9-653. TEST #6 NPE Crosstalk Test**

Error Code	Test Result	Description/ Recommendation
	ABORT	System resources required for this test are not available. 1. Retry the command at 1-minute intervals a maximum of 5 times.

*Continued on next page*

**Table 9-653. TEST #6 NPE Crosstalk Test — Continued**

Error Code	Test Result	Description/ Recommendation
1000	ABORT	<p>System resources required to run this test were not available. The port may be busy with a valid call.</p> <ol style="list-style-type: none"> <li>1. Use the <b>display port UUCSSpp</b> command to determine the trunk group/member number of the port. Use the <b>status trunk</b> command to determine the service state of the port. If the service state indicates that the port is in use, then the port is unavailable for certain tests. You must wait until the port is idle before retesting.</li> <li>2. If the port status is active but the port is not in use (no calls), check the error log for error type 1025 (see the error log table for a description of this error and required actions). The port may be locked up.</li> <li>3. If the port status is idle, retry the command at 1-minute intervals for a maximum of 5 times.</li> </ol>
1001	ABORT	<p>System resources required to run this test are not available.</p> <ol style="list-style-type: none"> <li>1. Retry the command at 1-minute intervals for a maximum of 5 times.</li> </ol>
1002	ABORT	<p>The system could not allocate time slots for the test. The system may be under heavy traffic conditions, or it may have time slots out of service due to TDM-BUS errors.</p> <ol style="list-style-type: none"> <li>1. If the system has no TDM-BUS errors and is not handling heavy traffic and the port status is idle, retry the command at 1-minute intervals for a maximum of 5 times.</li> </ol>
1003	ABORT	<p>The system could not allocate a tone receiver for the test. The system may be oversized for the number of tone detectors present or some of the tone detectors may be out of service. Issue the <b>list measurements tone-receiver</b> command to display basic information about the system's tone receivers.</p> <ol style="list-style-type: none"> <li>1. Resolve any TTR-LEV errors.</li> <li>2. Resolve any TONE-PT errors.</li> <li>3. If neither condition exists, retry the test at 1-minute intervals for a maximum of 5 times.</li> </ol>
1004	ABORT	<p>The port was seized by a user for a valid call.</p> <ol style="list-style-type: none"> <li>1. Use the <b>display port UUCSSpp</b> command to determine the trunk group/member number of the port. Use the <b>status trunk</b> command to determine the service state of the port. If the service state indicates that the port is in use, then the port is unavailable for certain tests. You must wait until the port is idle before retesting.</li> <li>2. If the port status is idle, retry the command at 1-minute intervals for a maximum of 5 times.</li> </ol>

*Continued on next page*

**Table 9-653. TEST #6 NPE Crosstalk Test — Continued**

Error Code	Test Result	Description/ Recommendation
1020	ABORT	The test did not run because of a previously existing error on the specific port or a more general circuit pack error. <ol style="list-style-type: none"> <li>1. Examine the Error Log for existing errors against this port or the circuit pack and attempt to diagnose the already existing error.</li> </ol>
2000	ABORT	Response to the test request was not received within the allowable time period.
2100	ABORT	System resources required for this test are not available. <ol style="list-style-type: none"> <li>1. Retry the command at 1-minute intervals a maximum of 5 times.</li> </ol>
2053	ABORT	At least one of the following errors is found on the DS1 circuit pack: <ul style="list-style-type: none"> <li>■ 1281—Loss of signal</li> <li>■ 1793—Blue Alarm</li> <li>■ 2049—Red Alarm</li> <li>■ 2305—Yellow Alarm</li> <li>■ 1537—Hyperactivity</li> </ul> Look for the above error types in the Hardware Error Log and follow the procedures given in the appropriate DS1-BD or UDS1-BD maintenance documentation for the listed error types.
	FAIL	This can be due to on-board or off-board problems. Off-board problems of concern include EXP-PN and EXP-INTF faults, TDM-BUS faults, and faults associated with the tone detectors/tone generators. Clear all off-board problems before replacing the board. Keep in mind that a TDM-BUS problem is usually the result of a faulty board connected to the backplane or bent pins on the backplane. <ol style="list-style-type: none"> <li>1. Resolve any EXP-PN and/or EXP-INTF errors.</li> <li>2. Resolve any TDM-BUS errors.</li> <li>3. Resolve any TONE-BD and/or TONE-PT errors.</li> <li>4. Retest when the faults from steps 1, 2, and 3 are cleared. Replace the board only if the test fails.</li> </ol>
	PASS	The port is correctly using its allocated time slots. User-reported troubles on this port should be investigated using other port tests and by examining station, trunk, or external wiring.

*Continued on next page*



**Table 9-653. TEST #6 NPE Crosstalk Test — Continued**

Error Code	Test Result	Description/ Recommendation
0	NO BOARD	<p>The test could not relate the internal ID to the port (no board). This could be due to incorrect translations, no board is inserted, an incorrect board is inserted, or an insane board is inserted.</p> <ol style="list-style-type: none"> <li>1. Check to ensure that the board translations are correct. Use the <b>list config</b> command, and resolve any problems that are found.</li> <li>2. If the board was found to be correctly inserted in step 1, issue the <b>busyout board</b> command.</li> <li>3. Issue the <b>reset board</b> command.</li> <li>4. Issue the <b>release busy board</b> command.</li> <li>5. Issue the <b>test board long</b> command. This should re-establish the linkage between the internal ID and the port. If this is not the case, check to see that there is a valid board inserted.</li> </ol>

**Conference Circuit Test (#7)**

One or more Network Processing Elements (NPEs) reside on each circuit pack with a TDM Bus interface. (The TN464C/D UDS1 circuit pack has one SCOTCH-NPE chip instead of several NPE chips). The NPE controls port connectivity and gain, and provides conferencing functions on a per-port basis. The Conference Circuit Test verifies that the NPE channel for the port being tested can correctly perform the conferencing function. The NPE is instructed to listen to several different tones and conference the tones together. The resulting signal is then measured by a Tone Detector port. If the level of the tone is within a certain range, the test passes.

**Table 9-654. TEST #7 Conference Circuit Test**

Error Code	Test Result	Description/ Recommendation
	ABORT	<p>System resources required for this test are not available.</p> <ol style="list-style-type: none"> <li>1. Retry the command at 1-minute intervals a maximum of 5 times.</li> </ol>

*Continued on next page*

**Table 9-654. TEST #7 Conference Circuit Test — Continued**

Error Code	Test Result	Description/ Recommendation
1000	ABORT	<p>System resources required to run this test were not available. The port may be busy with a valid call.</p> <ol style="list-style-type: none"> <li>1. Use the <b>display port UUCSSpp</b> command to determine the trunk group/member number of the port. Use the <b>status trunk</b> command to determine the service state of the port. If the service state indicates that the port is in use, then the port is unavailable for certain tests. You must wait until the port is idle before retesting.</li> <li>2. If the port status is active but the port is not in use (no calls), check the error log for error type 1025 (see the error log table for a description of this error and required actions). The port may be locked up.</li> <li>3. If the port status is idle, retry the command at 1-minute intervals for a maximum of 5 times.</li> </ol>
1002	ABORT	<p>The system could not allocate time slots for the test. The system may be under heavy traffic conditions, or it may have time slots out of service due to TDM-BUS errors. The <b>status health</b> command can be used to determine if the system is experiencing heavy traffic.</p> <ol style="list-style-type: none"> <li>1. If the system has no TDM-BUS errors and is not handling heavy traffic and the port status is idle, retry the command at 1-minute intervals for a maximum of 5 times.</li> </ol>
1003	ABORT	<p>The system could not allocate a tone receiver for the test. The system may be oversized for the number of tone detectors present or some of the tone detectors may be out of service. Issue the <b>list measurements tone-receiver</b> command to display basic information about the system's tone receivers.</p> <ol style="list-style-type: none"> <li>1. Resolve any TTR-LEV errors.</li> <li>2. Resolve any TONE-PT errors.</li> <li>3. If neither condition exists, retry the test at 1-minute intervals for a maximum of 5 times.</li> </ol>
1004	ABORT	<p>The port was seized by a user for a valid call.</p> <ol style="list-style-type: none"> <li>1. Use the <b>display port UUCSSpp</b> command to determine the trunk group/member number of the port. Use the <b>status trunk</b> command to determine the service state of the port. If the service state indicates that the port is in use, then the port is unavailable for certain tests. You must wait until the port is idle before retesting.</li> <li>2. If the port status is idle, retry the command at 1-minute intervals for a maximum of 5 times.</li> </ol>
1018	ABORT	<p>Test disabled via administration. This only applies to analog stations.</p> <ol style="list-style-type: none"> <li>1. To enable test, set the Test field on the station administration screen for the particular analog station being tested to "y." Use the <b>change station extension</b> command.</li> </ol>

**Table 9-654. TEST #7 Conference Circuit Test — Continued**

Error Code	Test Result	Description/ Recommendation
1020	ABORT	The test did not run due to a previously existing error on the specific port or because of a more general circuit pack error.  1. Examine the Error Log for existing errors against this port or circuit pack, and attempt to diagnose the previously existing error.
2000 2100	ABORT ABORT	Response to the test request was not received within the allowable time period.  System resources required to run this test are not available.  1. Retry the command at 1-minute intervals a maximum of 5 times.
2053	ABORT	At least one of the following errors is found on the DS1 circuit pack: 1281—Loss of signal, 1793—Blue Alarm, 2049—Red Alarm, 2305—Yellow Alarm, or 1537—Hyperactivity.  Look for the above error types in the Hardware Error Log and follow the procedures given in the appropriate DS1-BD or UDS1-BD maintenance documentation for the listed error types.

*Continued on next page*

**Table 9-654. TEST #7 Conference Circuit Test — Continued**

Error Code	Test Result	Description/ Recommendation
	FAIL	<p>The NPE of the tested port did not conference the tones correctly. This can cause noisy and unreliable connections.</p> <ol style="list-style-type: none"> <li>1. Enter the <b>list configuration board UUCSS</b> command. If the circuit pack is a TN767B vintage 8 or 9, replace the circuit pack with a TN767C V3 or later. The error log may have error type 1281 entries.</li> <li>2. Test all administered trunks on the board. If one fails, this could be an off-board problem (such as an incoming seizure or an off-hook port seizure during the test). Retest the board.</li> <li>3. If all of the ports fail, check the CARR-POW (see note below).</li> <li>4. If several ports fail, check the error log for TONE-BD or TONE-PT errors. If there are such errors, take the appropriate action. When the TONE errors have cleared, rerun the test.</li> <li>5. If the retry passes and troubles have been reported, coordinate isolation with the far-end PBX. Make sure that the near-end and far-end switches and any NTCE equipment (the CSUs) have the correct administration.</li> <li>6. Replace the circuit pack.</li> </ol> <p><b>⇒ NOTE:</b>                      If the conference circuit test fails for all ports on a circuit pack, a -5 volt power problem is indicated. If a TN736 or TN752 power unit circuit pack is present, either the 631DB AC power unit or the 676B DC power unit may be defective. (The 631DB power unit is used in a medium cabinet powered by an AC source. The 645B power unit is used in a medium cabinet powered by a DC power source.) The system may contain a TN736 or TN752 power unit or a 631DB AC power unit, but not both types of power units. To investigate problems with a 631DB AC power unit, refer to the CARR-POW (carrier port power unit for AC-powered systems) Maintenance documentation. To investigate problems with a 645B DC power unit, refer to the CARR-POW (carrier port power unit for DC-powered systems) Maintenance documentation. If a red LED on TN736 or TN752 power unit circuit pack is on, replace the pack.</p>
	PASS	<p>The port can correctly conference multiple connections. User-reported troubles on this port should be investigated using other port tests and by examining station, trunk, or external wiring.</p>

*Continued on next page*

Table 9-654. TEST #7 Conference Circuit Test — *Continued*

Error Code	Test Result	Description/ Recommendation
0	NO BOARD	<p>The test could not relate the internal ID to the port (no board). This could be due to incorrect translations, no board is inserted, an incorrect board is inserted, or an insane board is inserted.</p> <ol style="list-style-type: none"><li>1. Check to ensure that the board translations are correct. Use the <b>list config</b> command, and resolve any problems that are found.</li><li>2. If the board was found to be correctly inserted in step 1, issue the <b>busyout board</b> command.</li><li>3. Issue the <b>reset board</b> command.</li><li>4. Issue the <b>release busy board</b> command.</li><li>5. Issue the <b>test board long</b> command. This should re-establish the linkage between the internal ID and the port. If this is not the case, check to see that there is a valid board inserted.</li></ol>

### Port Audit and Update Test (#36)

This test sends port level translation data from switch processor to the DS1 Interface circuit pack to ensure that the trunk's translation is correct. Translation updates include the following data: trunk type (in/out), dial type, timing parameters, and signaling bits enabled. The port audit operation verifies the consistency of the current state of the trunk kept by the DS1 Interface circuit pack and the switch software.

Table 9-655. TEST #36 Audit and Update Test

Error Code	Test Result	Description/ Recommendation
	ABORT	<p>Internal system error</p> <ol style="list-style-type: none"><li>1. Retry the command at 1-minute intervals a maximum of 5 times.</li></ol>

*Continued on next page*

Table 9-655. TEST #36 Audit and Update Test — Continued

Error Code	Test Result	Description/ Recommendation
1000	ABORT	<p>System resources required to run this test were not available. The port may be busy with a valid call.</p> <ol style="list-style-type: none"> <li>1. Use the <b>display port UUCSSpp</b> command to determine the trunk group/member number of the port. Use the <b>status trunk</b> command to determine the service state of the port. If the service state indicates that the port is in use, then the port is unavailable for certain tests. You must wait until the port is idle before retesting.</li> <li>2. If the port status is active but the port is not in use (no calls), check the error log for error type 1025 (see the error log table for a description of this error and required actions). The port may be locked up.</li> <li>3. If the port status is idle, retry the command at 1-minute intervals for a maximum of 5 times.</li> </ol>
1006	ABORT	<p>The test was aborted because the trunk is out of service.</p> <ol style="list-style-type: none"> <li>1. Use the <b>status trunk</b> command to verify that the trunk is out of service.</li> <li>2. If the trunk is out of service, determine why.</li> <li>3. If it is OK to put the trunk back in service, issue the <b>release trunk</b> command to put the trunk back in service, and then retry the test.</li> </ol>
2000	ABORT	<p>Response to the test request was not received within the allowable time period.</p>
2100	ABORT	<p>Could not allocate the necessary system resources to run this test.</p> <ol style="list-style-type: none"> <li>1. Retry the command at 1-minute intervals a maximum of 5 times.</li> </ol>
	FAIL	<p>Internal system error.</p> <ol style="list-style-type: none"> <li>1. Retry the command at 1-minute intervals a maximum of 5 times.</li> </ol>
	PASS	<p>Trunk translation has been updated successfully. The current trunk states kept in the DS1 Interface circuit pack and switch software are consistent. If the trunk is busied out, the test will not run but will return PASS. To verify that the trunk is in-service:</p> <ol style="list-style-type: none"> <li>1. Enter the <b>status trunk</b> command to verify that the trunk is in-service. If the trunk is in-service, no further action is necessary. If the trunk is out-of-service, continue to step 2.</li> <li>2. Enter the <b>release trunk</b> command to put the trunk back into in-service.</li> <li>3. Retry the test command.</li> </ol>

Continued on next page

Table 9-655. TEST #36 Audit and Update Test — Continued

Error Code	Test Result	Description/ Recommendation
0	NO BOARD	<p>The test could not relate the internal ID to the port (no board). This could be due to incorrect translations, no board is inserted, an incorrect board is inserted, or an insane board is inserted.</p> <ol style="list-style-type: none"><li>1. Check to ensure that the board translations are correct. Use the <b>list config</b> command, and resolve any problems that are found.</li><li>2. If the board was found to be correctly inserted in step 1, issue the <b>busyout board</b> command.</li><li>3. Issue the <b>reset board</b> command.</li><li>4. Issue the <b>release busy board</b> command.</li><li>5. Issue the <b>test board long</b> command. This should re-establish the linkage between the internal ID and the port. If this is not the case, check to see that there is a valid board inserted.</li></ol>

### DS1 Tie Trunk Seizure Test (#136)

The DS1 Tie Trunk Seizure Test is run to verify the trunk's signaling capability. The test is composed of two parts. The first part queries the circuit pack for the following errors: Loss of Signal, Red Alarm, Blue Alarm, Yellow Alarm, and Hyperactivity Alarm. The second part of the test is performed by sending a seizure message to the DS1 Interface circuit pack and expecting an active reply by the DS1 Interface circuit pack. If maintenance software does not receive any reply and the timer expires, the test fails. Once the active message is received, a dial pause message is sent to the DS1 Interface circuit pack. If the DS1 Interface circuit pack replies with a dial pulse tone message when the far end responds to the seizure, then the DS1 tie trunk Seizure Test passes. If the far end does not respond to the seizure and the timer expires, and the DS1 Interface circuit pack sends a reorder message back to the maintenance software, then the test fails.

This second part of this test *cannot* be run on a trunk if one of the following cases is true:

1. The trunk direction is administered as an incoming only trunk.
2. The trunk is the 24th port on a DS1 Interface circuit pack which is administered using 24th Common Channel Signaling.
3. The trunk has been seized by a normal trunk call.
4. The trunk is administered with maintenance test disabled.
5. The outgoing signal type of the trunk is either automatic or immediate-start.

6. This test always passes if the associated board is the TN802 IP trunk circuit pack.

**Table 9-656. TEST #136 DS1 Tie Trunk Seizure Test**

Error Code	Test Result	Description/ Recommendation
	ABORT	Internal system error <ol style="list-style-type: none"><li>1. Retry the command at 1-minute intervals a maximum of 5 times.</li></ol>
1000	ABORT	System resources required to run this test were not available. The port may be busy with a valid call. <ol style="list-style-type: none"><li>1. Use the <b>display port UUCSSpp</b> command to determine the trunk group/member number of the port. Use the <b>status trunk</b> command to determine the service state of the port. If the port is in use, wait until the port is idle before testing.</li><li>2. If the port status is active but the port is not in use (no calls), check the error log for error type 1025 (see the error log table for a description of this error and required actions). The port may be locked up.</li><li>3. If the port status is idle, retry the command at 1-minute intervals for a maximum of 5 times.</li></ol>
1004	ABORT	Far end is seizing the trunk while the test is ongoing. A glare situation is detected. Current test is designed to be aborted. <ol style="list-style-type: none"><li>1. Use the <b>display port UUCSSpp</b> command to determine the trunk group/member number of the port. Use the <b>status trunk</b> command to determine the service state of the port. If the port is in use, wait until the port is idle before testing.</li><li>2. If the port status is idle, retry the command at 1-minute intervals for a maximum of 5 times.</li></ol>
1005	ABORT	Test failed due to incompatible configuration administered in trunk group form. <ol style="list-style-type: none"><li>1. Verify the following fields on the trunk group administration screen:<ol style="list-style-type: none"><li>a. Is trunk direction incoming only?</li><li>b. Is trunk outgoing type either automatic or immediate-start?</li><li>c. Is trunk the 24th port of the DS1 Interface circuit pack while common control channel signaling is specified?</li></ol></li><li>2. If the trunk has been administered using the above information, then this test should abort.</li></ol>

*Continued on next page*



**Table 9-656. TEST #136 DS1 Tie Trunk Seizure Test — Continued**

Error Code	Test Result	Description/ Recommendation
1018	ABORT	The test was disabled via translation. You may want to determine why the test has been disabled before you enable it. <ol style="list-style-type: none"> <li>1. Verify that the 'Maintenance Test' field on the 'Trunk Administration' screen is set to 'n.' To enable the test, change the trunk administration and enter 'y' into the 'Maintenance Test' field.</li> <li>2. Repeat the test.</li> </ol>
1020	ABORT	The test did not run due to an already existing error on the specific port or due to a more general circuit pack error. <ol style="list-style-type: none"> <li>1. Examine the error log for existing errors against this port or the circuit pack and attempt to diagnose the already existing error.</li> <li>2. Retry the test.</li> </ol>
1040	ABORT	The test is invalid for this trunk port because it is administered as an access endpoint. <ol style="list-style-type: none"> <li>1. Use <b>display port</b> to verify that this port is administered as an access endpoint. In this case the test should abort.</li> </ol>
2000	ABORT	Response to the test request was not received within the allowable time period. <ol style="list-style-type: none"> <li>1. Retry the command at 1-minute intervals for a maximum of 5 times.</li> </ol>
2053	ABORT/ FAIL <sup>1</sup>	At least one of the following errors is found on the DS1 circuit pack: 1281: Loss of Signal 1793: Blue Alarm 2049: Red Alarm 2305: Yellow Alarm 1537: Hyperactivity <ol style="list-style-type: none"> <li>1. Look for the above error types in the Hardware Error Log and follow the procedures given in the appropriate DS1-BD/UDS1-BD Maintenance documentation for the listed error types.</li> </ol>
2100	ABORT	Could not allocate the necessary system resources to run this test. <ol style="list-style-type: none"> <li>1. Retry the command at 1-minute intervals for a maximum of 5 times.</li> </ol>

*Continued on next page*

**Table 9-656. TEST #136 DS1 Tie Trunk Seizure Test — Continued**

Error Code	Test Result	Description/ Recommendation
	FAIL	<p>The far-end trunk did not respond to the seizure of the near-end trunk within the allowable time period. This test could have associated in-line errors in the error log.</p> <ol style="list-style-type: none"> <li>1. Enter the <b>list configuration board UUCSS</b> command. If the circuit pack is a TN767B vintage 8 or 9, a failure of test 136 causes a subsequent failure of test 7 due to a firmware bug. Eventually, the board and all of its ports will be taken out of service and extraneous on-board alarms will be generated. Replace the circuit pack with a TN767C V3 or later.</li> <li>2. Verify that the 'Trunk Type' field on the 'Trunk Administration' screen matches the trunk type administered on far-end switch.</li> <li>3. Look for DS1-BD or UDS1-BD errors in the hardware error log. If present, refer to the DS1-BD (DS1 trunk circuit pack) Maintenance documentation or to the UDS1-BD (UDS1 trunk circuit pack) Maintenance documentation.</li> <li>4. Retry the test at 1-minute intervals for a maximum of 5 times.</li> </ol>
2000	FAIL	<p>Response to the seizure message was not received within the allowable time period.</p> <ol style="list-style-type: none"> <li>1. Enter the <b>list configuration board UUCSS</b> command. If the circuit pack is a TN767B vintage 8 or 9, a failure of test 136 causes a subsequent failure of test 7 due to a firmware bug. Eventually, the board and all of its ports will be taken out of service and extraneous on-board alarms will be generated. Replace the circuit pack with a TN767C V3 or later.</li> <li>2. Verify that the 'Trunk Type' field on the 'Trunk Administration' screen matches the trunk type administered on far-end switch.</li> <li>3. Look for DS1-BD or UDS1-BD errors in the hardware error log. If present, refer to the DS1-BD (DS1 trunk circuit pack) Maintenance documentation or to the UDS1-BD (UDS1 trunk circuit pack) Maintenance documentation.</li> <li>4. Retry the test at 1-minute intervals for a maximum of 5 times.</li> </ol>
	PASS	The trunk can be seized for an outgoing call.

*Continued on next page*

Table 9-656. TEST #136 DS1 Tie Trunk Seizure Test — *Continued*

Error Code	Test Result	Description/ Recommendation
0	NO BOARD	<p>The test could not relate the internal ID to the port (no board). This could be due to incorrect translations, no board is inserted, an incorrect board is inserted, or an insane board is inserted.</p> <ol style="list-style-type: none"> <li>1. Check to ensure that the board translations are correct. Use the <b>list config</b> command, and resolve any problems that are found.</li> <li>2. If the board was found to be correctly inserted in step 1, issue the <b>busyout board</b> command.</li> <li>3. Issue the <b>reset board</b> command.</li> <li>4. Issue the <b>release busy board</b> command.</li> <li>5. Issue the <b>test board long</b> command. This should re-establish the linkage between the internal ID and the port. If this is not the case, check to see that there is a valid board inserted.</li> </ol>

---

1. Earlier G1 Software Versions reported Error Code 2053 as a FAIL

## TIE-TRK (Analog Tie Trunk)

MO Name (in Alarm Log)	Alarm Level	Initial Command to Run <sup>12</sup>	Full Name of MO
TIE-TRK	MAJOR <sup>3</sup>	test port UUCSSpp l	Tie Trunk
TIE-TRK	MINOR	test port UUCSSpp l	Tie Trunk
TIE-TRK	WARNING	test port UUCSSpp sh	Tie Trunk

1. *UU* is the universal cabinet number (1 for PPN, 2 - 44 for EPNs). *C* is the carrier designation (A, B, C, D, or E). *SS* is the number of the slot in which the circuit pack resides (01 to 21). *pp* is the two digit port number (01, 02, ...).
2. If ATMS testing is enabled, check the error log for ATMS errors 3840 and 3841. If the error log indicates that measurements exceeded acceptable thresholds, and no other trouble is found with **test trunk**, run the ATMS test call with **test analog-testcall port UUCSSpp full**.
3. A Major alarm on a trunk indicates that alarms on these trunks are not downgraded by the **set options** command and that at least 75 percent of the trunks in this trunk group are alarmed.

This alarm does not apply to TN497.

### ⇒ NOTE:

Many trunk problems are caused by incorrect settings of parameters on the trunk group administration form. Settings must be compatible with the local environment and with parameter settings on the far-end. Refer to *DEFINITY Communications System Generic 3 V2 Implementation, 555-230-653*, for information on how to administer trunks. The Application Notes section of that book shows the correct settings for administrable timers and other parameters on a country-by-country basis.

The following circuit packs, including all suffixes such as TN760D, support analog tie trunks:

**Table 9-657. Analog Tie Trunk Circuit Packs**

Code	Trunk Type	Signaling Leads
TN760	4-wire	E&M
TN437	4-wire	E&M
TN439	2-wire	A&B (two-way circuits only)
TN458	4-wire	E&M
TN497	2-wire	A&B
TN2140	4-wire	E&M

Each tie trunk circuit pack occupies a port circuit pack slot and contains 4 port circuits. Each port circuit supports 1 analog tie trunk used to connect the switch to another PBX across one-way or two-way dedicated circuits (see preceding list).

A tie trunk port can also be administered as an access endpoint which is a non-signaling channel with a voice-grade data bandwidth. Tie trunk maintenance employs up to 6 tests, depending on the hardware involved, to monitor the operating condition of the trunk and its connections. These are described in the following sections on each test. The port must be idle for these tests to run. If an incoming call seizes the port while a test is in progress, the test aborts and the call proceeds (except for TN497).

Additional in-line testing is performed whenever a call is in progress, logging errors that occur during operation. You can reproduce these types of errors by making a call over the trunk and then checking the Hardware Error Log.

By making translation and cross-connect changes, circuit packs (except for TN497) can be configured for back-to-back testing, also known as connectivity testing. Port operation is tested by connecting two tie trunk ports together in either E&M or simplex modes. See the section *Analog Tie Trunk Back-to-Back Testing*.

## Error Log Entries and Test to Clear Values

Table 9-658. TIE Trunk Error Log Entries

Error Type	Aux Data	Associated Test	Alarm Level	On/Off Board	Test to Clear Value
0 <sup>1</sup>	0	Any	Any	Any	test port <i>UUCSSpp sh r 1</i>
1(a)	16384	None	WARNING	OFF	
1(b)	57476	None	WARNING	OFF	
1(c)	57477	None	WARNING	OFF	
1(d)	57483	None	WARNING	OFF	
1(e)	57485	None	WARNING	OFF	
15(f)	Any	Port Audit Update Test (#36)			
18(g)	0	busyout trunk <i>grp/mbr</i>	WARNING	OFF	release trunk <i>grp/mbr</i>
130(h)		None	WARNING	ON	test trunk <i>grp/mbr</i>
257(i)	57473	None	WARNING	OFF	

**Table 9-658. TIE Trunk Error Log Entries — Continued**

Error Type	Aux Data	Associated Test	Alarm Level	On/Off Board	Test to Clear Value
257(j)	57474	None	WARNING	OFF	
257(k)	57475	None	WARNING	OFF	
513(l)	Any	EPF M and E Lead (#74)	MAJ/MIN/ WRN <sup>2</sup>	OFF	test port UUCSSpp sh r 3
769(l)	57481	EPF M and E Lead (#74)	MAJ/MIN/ WRN <sup>2</sup>	ON	test port UUCSSpp sh r 3
1025(m)	Any	None	MAJ/MIN/ WRN <sup>2</sup>	OFF	
1281(l)	Any	EPF M and E Lead (#74)	MAJ/MIN/ WRN <sup>2</sup>	ON	test port UUCSSpp sh r 3
1537		Looparound and Conference (#33)	MAJ/MIN/ WRN <sup>2</sup>	ON	test port UUCSSpp l r 3
1793		Tie Trunk Seizure (#73) (Dial Test #747 for TN439)	MAJ/MIN/ WRN <sup>2</sup>	OFF	test port UUCSSpp sh r 2
2049		NPE Crosstalk (#6)	MAJ/MIN/ WRN <sup>2</sup>	ON	test port UUCSSpp l r 3
2305(n)	57424 50944	None (I)			
2561(o)	0	None	WARNING	OFF	
2562(p)	16665				
2817(o)	0	None	MINOR	OFF	
2817(q)	52992				
3073(o)	0	None			
3840(r)	8000	Transmission Tests (ATMS)(#844-848)		OFF	test analog-testcall
3841(r)		Transmission Tests (ATMS)(#844-848)	MINOR	OFF	test analog-testcall UUCSSpp r 2

1. Run the Short Test Sequence first. If all tests pass, run the Long Test Sequence. Refer to the appropriate test description and follow the recommended procedures.
2. Minor alarms on this MO may be downgraded to Warning alarms based on the values used in the **set options** command. If the MINOR alarm is not downgraded by the **set options** values, then the MINOR alarm will be upgraded to a MAJOR alarm if 75% of the trunks in this trunk group are alarmed. These errors, if applicable, always log a MINOR alarm for TN439 and TN497.

Notes:

- a. Digit time-out. This occurs when the far-end PBX began transmitting digits too late (10 seconds) after receiving the signal indicating ready to receive digits (if any). This can occur on an incoming immediate, wink, or delay dial line. Check the far-end PBX to ensure a translation match at both ends. This error does not apply to TN497.
- b. Rotary dial before wink. This occurs when the far-end PBX starts dialing before the PBX sends the wink on a wink-start or delay-dial trunk. Check the far-end PBX to ensure a translation match at both ends. This error does not apply to TN497.
- c. Rotary dial too early. This occurs when the far-end PBX starts dialing too soon (about 50ms) after seizure on a wink start or delay dial line. Check the far-end PBX to ensure a translation match at both ends. This error does not apply to TN497.
- d. On hook before wink. This occurs when the far end goes on hook before a wink. Check the far-end PBX to ensure a translation match at both ends. This error applies only to TN439.
- e. On an outgoing wink-start or delay-dial trunk, the wink time was too short (less than 80ms) for a valid signal. Check the far-end PBX to ensure a translation match at both ends. This error does not apply to TN497.
- f. This is a software audit error that does not indicate any hardware malfunction. Run Short Test Sequence and investigate associated errors (if any).
- g. This indicates that the trunk in question has been busied-out by maintenance personnel.
- h. The circuit pack has been removed or has been insane for more than 11-minutes. To clear the error, reinsert or replace the circuit pack. TN439 does not alarm this error. This error does not apply to TN497.
- i. The rotary dial rate was too slow — less than 8 pulses per second. Check the far-end PBX to ensure a translation match at both ends.
- j. The rotary dial rate was too fast — above 12 pulses per second. Check the far-end PBX to ensure a translation match at both ends.
- k. The time between digits was too short (less than 300ms). Check the far-end PBX to ensure a translation match at both ends.
- l. These errors do not apply to TN439 and TN497.
- m. This indicates that the trunk is still seized with an incoming call. The far-end PBX is not releasing the trunk after the call was dropped. Check the far-end PBX for problems.

Once the trunk is released from the call, the severity of this problem is decreased. If Error Type 1025 does not appear again, this means that the problem has been corrected. Verify that Error Type 1025 does not reappear in the Error Log.

- n. Reorder message. The trunk could not be seized. This error causes the Tie Trunk Seizure Test (#73) to run and is considered a problem only if that test fails, logging error 1793. In this case, the trunk may be placed in the ready-for-service state, allowing only incoming calls. This service state shows up as `disconnected` on the trunk status screen. Run the Tie Trunk Seizure Test and follow recommended procedures.

TN439 logs aux data 57424 or 50944. Other circuit packs log 50944. This error is associated with Test #747 for TN439, Test #73 for TN497, and no test for the others.

- o. These errors apply only to TN497.
- p. Retry Failure error. This error is logged only. It is not a hardware failure and hence does not start any testing or generate any alarms. This error comes from call processing and is generated when a second attempt (retry) to seize an outgoing trunk fails.
- q. Glare error. This error is logged only. It is not a hardware failure and hence does not start any testing or generate any alarms. This error is the result of a simultaneous seizure of a two-way trunk from both the near-end and the far-end. Attempt to place the call again. If the error persists, execute the Tie Trunk Seizure Test (#73) and follow its outlined procedures.
- r. Error 3841 indicates that test calls made by the Automatic Transmission Measurement System (ATMS) returned measurements in the unacceptable range. Error 3840 indicates measurements were in the marginal range. Use **list testcall detail** to examine the specific transmission parameters which are out of spec, and investigate the trunk for that kind of noise. If the noise is acceptable, then the AMTS thresholds administered on page 4 of the trunk group form should be changed.

### System Technician-Demanded Tests: Descriptions and Error Codes

---

Always investigate tests in the order presented in [Table 9-659](#) when inspecting errors in the system. By clearing error codes associated with the *NPE Crosstalk Test* for example, you may also clear errors generated from other tests in the testing sequence.

**Table 9-659. System Technician-Demanded Tests: TIE-TRK**

Order of Investigation	Short Test Sequence	Long Test Sequence	D/ND <sup>1</sup>
NPE Crosstalk Test (#6)		X	ND
Looparound and Conference Circuit Test (#33)		X	ND
Tie Trunk Seizure Test (#73)	X	X	ND

*Continued on next page*



**Table 9-659. System Technician-Demanded Tests: TIE-TRK — Continued**

Order of Investigation	Short Test Sequence	Long Test Sequence	D/ND <sup>1</sup>
Dial Test #747	X	X	ND
Tie Trunk EPF Test (#74)	X	X	ND
Port Audit and Update Test (#36)	X	X	ND
Transmission Test - ATMS (#844-848)	2	†	ND

1. D = Destructive, ND = Non-destructive
2. ATMS tests are not part of either sequence. They are run either on demand with **test analog-testcall**, or by the ATMS schedule.

### NPE Crosstalk Test (#6)

The NPE Crosstalk Test verifies that a port's NPE channel talks on the time slot assigned to it and does not cross over to time slots reserved for other connections. If the NPE is not working correctly, one-way and noisy connections may be observed. The test takes 20 to 30 seconds to complete.

**Table 9-660. TEST #6 NPE Crosstalk Test**

Error Code	Test Result	Description/ Recommendation
	ABORT	Could not allocate the necessary system resources to run this test. 1. Retry the command at 1-minute intervals a maximum of 5 times.
1000	ABORT	System resources required to run this test are not available. The trunk may be busy with a valid call. Use the <b>display trunk xx</b> command to determine the trunk group/member number of the port. Use the <b>status trunk</b> command to determine the service state of the port. If the service state indicates that the port is in use, then the port is unavailable for certain tests. You must wait until the port is idle before retesting.  1. If the port status is active, but the port is not in use (no connected ports), then check the Error Log for Error Type 1025 (see Error Log table for description of this error and required actions). The port may be locked up.  2. If the port status is idle, then retry the command at 1-minute intervals a maximum of 5 times.

*Continued on next page*

**Table 9-660. TEST #6 NPE Crosstalk Test — Continued**

Error Code	Test Result	Description/ Recommendation
1001	ABORT	System resources required to run this test are not available. This could be due to a failure to seize the port. <ol style="list-style-type: none"> <li>1. Retry the command at 1-minute intervals a maximum of 5 times.</li> </ol>
1002	ABORT	The system could not allocate time slots for the test. The system may be under heavy traffic conditions or it may have time slots out-of-service due to TDM-BUS errors. <ol style="list-style-type: none"> <li>1. If system has no TDM-BUS errors and is not handling heavy traffic, repeat test at 1-minute intervals a maximum of 5 times.</li> </ol>
1003	ABORT	The system could not allocate a tone receiver for the test. The system may be oversized for the number of Tone Detectors present or some Tone Detectors may be out-of-service. <ol style="list-style-type: none"> <li>1. Resolve any TTR-LEV errors.</li> <li>2. Resolve any TONE-PT errors.</li> <li>3. If neither condition exists, retry the test at 1-minute intervals a maximum of 5 times.</li> </ol>
1004	ABORT	The port was seized by a valid call during the test. The test has been aborted. Use the <b>display trunk xx</b> command to determine the trunk group/member number of the port. Use the <b>status trunk</b> command to determine the service state of the port. If the service state indicates that the port is in use, then the port is unavailable for certain tests. You must wait until the port is idle before retesting.
2000 2100	ABORT ABORT	Response to the test request was not received within the allowable time period. Could not allocate the necessary system resources to run this test. This could be due to a failure to seize the port. <ol style="list-style-type: none"> <li>1. Retry the command at 1-minute intervals a maximum of 5 times.</li> </ol>
Any	FAIL	This test can fail due to on-board or off-board problems. Off-board problems of concern include EXP-PN and EXP-INTF faults, TDM-BUS faults, and faults associated with the tone detectors/tone generators. Clear all off-board problems before replacing the board. Keep in mind that a TDM-BUS problem is usually the result of a faulty board connected to the backplane or bent pins on the backplane. <ol style="list-style-type: none"> <li>1. Resolve any EXP-PN and/or EXP-INTF errors. i</li> <li>2. Resolve any TDM-BUS errors.</li> <li>3. Resolve any TONE-BD and/or TONE-PT errors.</li> <li>4. Test the board when the faults from steps 1, 2, and 3 are cleared. Replace the board only if the test fails.</li> </ol>

*Continued on next page*

**Table 9-660. TEST #6 NPE Crosstalk Test — Continued**

Error Code	Test Result	Description/ Recommendation
	PASS	The port is correctly using its allocated time slots. User-reported troubles on this port should be investigated using other port tests and examining station, trunk or external wiring.
0	NO BOARD	The test could not relate the internal ID to the port (no board). <ol style="list-style-type: none"> <li>1. Check to ensure that the board translations are correct. Translate the board, if necessary.</li> <li>2. Issue the <b>busyout board</b> command.</li> <li>3. Issue the <b>reset board</b> command.</li> <li>4. Issue the <b>release busy board</b> command.</li> <li>5. Issue the <b>test board</b> command. This should re-establish the linkage between the internal ID and the port.</li> </ol>

**Looparound and Conference Circuit Test (#33)**

This test verifies signal transmission and conferencing capabilities of a port using 404-Hz, 1004-Hz, and 2804-Hz tones. This is an on-board test only: each tone is transmitted to and looped around within the port and then returned.

This test can fail due to noise induced by adjacent electric power lines. If this is the case, the customer must resolve it with their local power company. To temporarily alleviate an alarm caused by failure of this test, you can disable it via the `Test` field on the trunk administration form.

**Table 9-661. TEST #33 Looparound and Conference Circuit Test**

Error Code	Test Result	Description/ Recommendation
	ABORT	Could not allocate the necessary system resources to run this test. This could be due to a failure to seize the port. <ol style="list-style-type: none"> <li>1. Retry the command at 1-minute intervals a maximum of 5 times.</li> </ol>
7	ABORT	The conference circuit test was aborted. <ol style="list-style-type: none"> <li>1. Retry the command at 1-minute intervals a maximum of 5 times.</li> </ol>

*Continued on next page*

**Table 9-661. TEST #33 Looparound and Conference  
 Circuit Test — Continued**

Error Code	Test Result	Description/ Recommendation
129	ABORT	The 404-Hz reflective loop around test aborted. Response to the test request was not received within the allowable time period.
131		The 1004-Hz reflective loop around test aborted. Response to the test request was not received within the allowable time period.
133		The 2804-Hz reflective loop around test aborted. Response to the test request was not received within the allowable time period.  1. Retry the command at 1-minute intervals for a maximum of 5 times.
1000	ABORT	System resources required to run this test are not available. The trunk may be busy with a valid call. Use the <b>display trunk xx</b> command to determine the trunk group/member number of the port. Use the <b>status trunk</b> command to determine the service state of the port. If the service state indicates that the port is in use, then the port is unavailable for certain tests. You must wait until the port is idle before retesting.  1. If the port status is active, but the port is not in use (no calls), then check the Error Log for Error Type 1025 (see Error Log table for description of this error and required actions). The port may be locked up.  2. If the port status is idle, then retry the command at 1-minute intervals a maximum of 5 times.
1002	ABORT	The system could not allocate time slots for the test. The system may be under heavy traffic conditions or it may have time slots out-of-service due to TDM-BUS errors.  1. If system has no TDM-BUS errors and is not handling heavy traffic, repeat test at 1-minute intervals a maximum of 5 times.
1003	ABORT	The system could not allocate a tone receiver for the test. The system may be oversized force.  1. Resolve any TTR-LEV errors.  2. Resolve any TONE-PT errors.  3. If neither condition exists, retry the command at 1-minute intervals a maximum of 5 times.
1004	ABORT	The port was seized by a valid call during the test. The test has been aborted. Use the <b>display trunk xx</b> command to determine the trunk group/member number of the port. Use the <b>status trunk</b> command to determine the service state of the port. If the service state indicates that the port is in use, then the port is unavailable for certain tests. You must wait until the port is idle before retesting.

*Continued on next page*

**Table 9-661. TEST #33 Looparound and Conference  
 Circuit Test — Continued**

Error Code	Test Result	Description/ Recommendation
1018	ABORT	The test has been disabled via administration.  Verify that the 'Maintenance Test' field on the 'Trunk Group' form is set to 'n.' To enable the test, issue the 'change trunk-group x' command (x equals the number of the trunk group to be tested). Then, change the entry in the 'Maintenance Test' field on the form to 'y.'
2000	ABORT	Response to the test request was not received within the allowable time period.
2100	ABORT	Could not allocate the necessary system resources to run this test. This could be due to a failure to seize the port.  1. Retry the command at 1-minute intervals a maximum of 5 times.
7, 129, 131, or 133	FAIL	The conference capabilities of the port failed (Error Code 7).  The reflective 404-Hz Tone Test failed. No transmission was detected to or from the port (Error Code 129).  The reflective 1004-Hz Tone Test failed. No transmission was detected to or from the port (Error Code 131).  The reflective 2804-Hz Tone Test failed. No transmission was detected to or from the port (Error Code 133).  FAULT ISOLATION: Proceed as follows unless power or tone problems are suspected (see notes on the next page).  1. To make sure the problem is on-board, disconnect the port from the CO and retry the test. Coordinate this with the CO, or do it after busy hours; otherwise, the CO may put the connection out of service.  2. If the retry fails, replace the circuit pack.  3. If the retry passes and no troubles have been reported, disable the test. If the retry passes and troubles have been reported, refer the problem to the CO.  <i>More information continues on the next page.</i>

*Continued on next page*

**Table 9-661. TEST #33 Looparound and Conference  
 Circuit Test — Continued**

Error Code	Test Result	Description/ Recommendation
7, 129, 131, or 133 (cont'd.)	FAIL (cont'd.)	<p><b>⇒ NOTE:</b>                      If the loop around and conference circuit test fails for all ports on a circuit pack, a -5 volt power problem is indicated. If a TN736 or TN752 power unit circuit pack is present, either the 631DB AC power unit or the 676B DC power unit may be defective. (The 631DB power unit is used in a medium cabinet powered by an AC source. The 645B power unit is used in a medium cabinet powered by a DC power source.) The system may contain a TN736 or TN752 power unit circuit pack or a 631DB AC power unit, but not both types of power units. To investigate problems with a 631DB AC power unit, refer to the CARR-POW (carrier port power unit for AC-powered systems) Maintenance documentation. To investigate problems with a 645B DC power unit, refer to the CARR-POW (carrier port power unit for DC-powered systems) Maintenance documentation. If a red LED on TN736 or TN752 power unit circuit pack is on, replace the pack.</p> <p>If the test fails on more than 1 port, check for errors on the TONE-BD or the TONE-PT. If errors, take appropriate actions. When the tone errors are cleared, rerun the test. If the test fails again, see FAULT ISOLATION above.</p>
	PASS	<p>Tie trunk Looparound and Conference Test is successful. This port is functioning properly.</p> <ol style="list-style-type: none"> <li>1. If users are reporting troubles, examine loop connections to the port.</li> </ol>
0	NO BOARD	<p>The test could not relate the internal ID to the port (no board).</p> <ol style="list-style-type: none"> <li>1. Check to ensure that the board translations are correct. Translate the board, if necessary.</li> <li>2. Issue the <b>busyout board</b> command.</li> <li>3. Issue the <b>reset board</b> command.</li> <li>4. Issue the <b>release busy board</b> command.</li> <li>5. Issue the <b>test board</b> command. This should re-establish the linkage between the internal ID and the port.</li> </ol>

**Audit Update Test (#36)**

This test sends to the circuit pack updates of translations for all administered ports on the circuit pack. It is non-disruptive and guards against possible corruption of translation data contained on the circuit pack. No response is expected from the circuit pack. Port translation data includes:

- Start type: immediate, automatic, wink-start, or delay dial
- Rotary or DTMF senderization in or out
- Disconnect timing: 10 to 2550ms in 10ms increments
- DMTF time slot
- Continuous-seize-ack? (TN2140)

**Table 9-662. TEST #36 Audit Update Test**

Error Code	Test Result	Description/ Recommendation
	ABORT	Could not allocate the necessary system resources to run this test. 1. Retry the command at 1-minute intervals a maximum of 5 times.
2100	ABORT  FAIL	Could not allocate the necessary system resources to run the test. This could be due to a failure to seize the port. 1. Retry the command at 1-minute intervals a maximum of 5 times.  Internal system error 1. Retry the command at 1-minute intervals a maximum of 5 times.
	PASS	This test passed. Translation information was successfully updated on the circuit pack. If the trunk is busied out, the test will not run, but will return PASS (except on TN439 and TN497).  1. If signaling troubles are reported, verify translation information for this port. 2. To verify that the trunk is in-service, enter <b>status trunk</b> command to verify that the trunk is in-service. If the trunk is in-service, no further action is necessary. If the trunk is out-of-service, continue to Step 2. 3. Enter <b>release trunk</b> command to put trunk back into in-service. 4. Retry the test command.
0	NO BOARD	The test could not relate the internal ID to the port (no board). 1. Check to ensure that the board translations are correct. Translate the board, if necessary. 2. Issue the <b>busyout board</b> command. 3. Issue the <b>reset board</b> command. 4. Issue the <b>release busy board</b> command. 5. Issue the <b>test board</b> command. This should re-establish the linkage between the internal ID and the port.

## Tie Trunk Seizure Test (#73) and Tie Trunk Dial Test (#747)

For wink-start, delay-dial and TN2140 (cont-seize-ack or discont-seize-ack) trunks, this test activates the M lead and checks for a response from the far end within 10 seconds.

For TN497, the test seizes a trunk and outputs a pause. The port reports uplink the result of the seizure. This test can be disabled via the `Test` field on the trunk group administration form.

For TN439, Test #747 is run instead of #73. This test seizes a trunk and outputs a pause digit. This test aborts on ports administered as access endpoints.

**Table 9-663. TEST #73,#747 Tie Trunk Seizure Test**

Error Code	Test Result	Description/ Recommendation
	ABORT	Could not allocate the necessary system resources to run this test. 1. Retry the command at 1-minute intervals a maximum of 5 times.
1000	ABORT	System resources required to run this test are not available. The trunk may be busy with a valid call. Use the <b>display trunk xx</b> to determine the trunk group/member number of the port. Use the <b>status trunk</b> command to determine the service state of the port. If the service state indicates that the port is in use, then the port is unavailable for certain tests. You must wait until the port is idle before retesting.  1. If the port status is active, but the port is not in use (no calls), then check the Error Log for Error Type 1025 (see Error Log table for description of this error and required actions). The port may be locked up. The far-end PBX may not be releasing.  2. If the port status is idle, then retry the command at 1-minute intervals a maximum of 5 times.
1004	ABORT	The port was seized by a valid call during the test. The test has been aborted. Use the <b>display trunk xx</b> to determine the trunk group/member number of the port. Use the <b>status trunk</b> command to determine the service state of the port. If the service state indicates that the port is in use, then the port is unavailable for certain tests. You must wait until the port is idle before retesting.  1. Retry the command at 1-minute intervals a maximum of 5 times.
1005	ABORT	This test is not valid for this trunk translation. Must be a wink-start or delay dial trunk and must be outgoing or two-way for this test to run. For the TN2140, the trunk must also be continuous-seize-ack or discontinuous-seize-ack.  1. Check trunk translation. If it is not a wink-start or delay dial trunk, this abort message should be ignored.

*Continued on next page*



Table 9-663. TEST #73,#747 Tie Trunk Seizure Test — *Continued*

Error Code	Test Result	Description/ Recommendation
1018	ABORT	Test disabled via administration. <ol style="list-style-type: none"><li>1. Verify that the "Maintenance Tests?" field on the Trunk Group Form is set to "n". To enable the test, issue the <b>change trunk-group x</b> command where "x" equals the number of the trunk group to be tested. Then change the entry in the "Maintenance Tests?" field on the form to "y."</li></ol>
1040	ABORT	This test is not performed for trunk ports administered as access endpoints. <ol style="list-style-type: none"><li>1. Verify this port is an access endpoint by using the <b>display port</b> command.</li><li>2. If the port has been administered as an access endpoint, then this test should abort.</li></ol>
2100	ABORT	Could not allocate the necessary system resources to run the test. This could be due to a failure to seize the port. <ol style="list-style-type: none"><li>1. Retry the command at 1-minute intervals a maximum of 5 times.</li></ol>
3	FAIL	No dial tone detected from the other end. (TN439 circuit packs only.) <ol style="list-style-type: none"><li>1. Retry the command at one minute intervals a maximum of five times.</li><li>2. If the test continues to fail, check the far-end PBX to ensure a translation match at both ends.</li><li>3. Check the facility.</li></ol>
2000	FAIL	Seizure message is not received back within 10 seconds. <ol style="list-style-type: none"><li>1. Retry the command at 1-minute intervals a maximum of 5 times.</li><li>2. If the test continues to fail, check the far-end PBX to ensure a translation match at both ends.</li><li>3. Check the facility.</li></ol>
	PASS	The Tie Trunk Seizure Test passes. This port is functioning properly. <ol style="list-style-type: none"><li>1. If users are reporting troubles, examine loop connections to the port, wiring, and stations.</li></ol>
0	NO BOARD	The test could not relate the internal ID to the port (no board). <ol style="list-style-type: none"><li>1. Check to ensure that the board translations are correct. Translate the board, if necessary.</li><li>2. Issue the <b>busyout board</b> command.</li><li>3. Issue the <b>reset board</b> command.</li><li>4. Issue the <b>release busy board</b> command.</li><li>5. Issue the <b>test board</b> command. This should re-establish the linkage between the internal ID and the port.</li></ol>

## Tie Trunk EPF Test (#74)

The first part of this test checks for proper activation and deactivation of the port's E lead. The second part checks the M lead electronic power feed current flow.

**Table 9-664. TEST #74 Tie Trunk EPF Test**

Error Code	Test Result	Description/ Recommendation
	ABORT	Could not allocate the necessary system resources to run the test. This could be due to a failure to seize the port.  1. Retry the command at 1-minute intervals a maximum of 5 times.
1	ABORT	Internal system error  1. Retry the command at 1-minute intervals a maximum of 5 times.
1000	ABORT	System resources required to run this test are not available. The trunk may be busy with a valid call. Use the <b>display trunk xx</b> to determine trunk group/member number of the port. Use the <b>status trunk</b> command to determine the service state of the port. If the service state indicates that the port is in use, then the port is unavailable for certain tests. You must wait until the port is idle before retesting.  1. If the port status is active, but the port is not in use (no calls), then check the Error Log for Error Type 1025 (see Error Log table for description of this error and required actions). The port may be locked up. The far-end PBX may not be releasing.  2. If the port status is idle, then retry the command at 1-minute intervals a maximum of 5 times.
1004	ABORT	The port was seized by a valid call during the test. The test has been aborted. Use the <b>display trunk xx</b> to determine the trunk group/member number of the port. Use the <b>status trunk</b> command to determine the service state of the port. If the service state indicates that the port is in use, then the port is unavailable for certain tests. You must wait until the port is idle before retesting.  1. Retry the command at 1-minute intervals a maximum of 5 times.
1005	ABORT	This test is not valid for this trunk translation. Must be a type-1 standard trunk for this test to run.  1. Check trunk configuration. If it is not a type-1 standard trunk, this abort message should be ignored.
1014	ABORT	The test was aborted because the circuit pack has not been inserted into the system.  1. Use the <b>list configuration board</b> command to make sure the circuit pack is inserted in the carrier.  2. If the board is not inserted, make sure the circuit pack is inserted in the carrier and fully seated.

**Table 9-664. TEST #74 Tie Trunk EPF Test — Continued**

Error Code	Test Result	Description/ Recommendation
1040	ABORT	This test is not performed for trunk ports administered as access endpoints. <ol style="list-style-type: none"> <li>1. Verify this port is an access endpoint by using the <b>display port</b> command.</li> <li>2. If the port has been administered as an access endpoint, then this test should abort.</li> </ol>
2000	ABORT	Response to the test request was not received within the allowable time period.
2100	ABORT	Could not allocate the necessary system resources to run the test. This could be due to a failure to seize the port. <ol style="list-style-type: none"> <li>1. Retry the command at 1-minute intervals a maximum of 5 times.</li> </ol>
1	FAIL	The E lead test failed due to an on-board port problem. <ol style="list-style-type: none"> <li>1. Replace the circuit pack.</li> </ol>
2	FAIL	The M lead test failed. The EPF has experienced an overcurrent condition, perhaps due to the external M lead. <ol style="list-style-type: none"> <li>1. To make sure the problem is on-board, disconnect the facility from the pack and retry the test.</li> <li>2. If the test fails, replace the circuit pack. Otherwise, check the external wiring toward the far-end PBX.</li> </ol>
	PASS	Tie Trunk EPF test is successful. This port is functioning properly. <ol style="list-style-type: none"> <li>1. If users are reporting troubles, examine loop connections to the port.</li> </ol>
0	NO BOARD	The test could not relate the internal ID to the port (no board). <ol style="list-style-type: none"> <li>1. Check to ensure that the board translations are correct. Translate the board, if necessary.</li> <li>2. Issue the <b>busyout board</b> command.</li> <li>3. Issue the <b>reset board</b> command.</li> <li>4. Issue the <b>release busy board</b> command.</li> <li>5. Issue the <b>test board</b> command. This should re-establish the linkage between the internal ID and the port.</li> </ol>

**Transmission Test (#844-848)**

This test is non-destructive.



**NOTE:**

Tests #844-848 are not supported on a International switch.

These tests are run by the Automatic Transmission Measurement System (ATMS). They are not part of the long or short trunk test sequences. Instead, they are run on demand with the **test analog-testcall** command or as part of ATMS scheduled testing. For more information, see [“Automatic Transmission Measurement System \(ATMS\)”](#) in Chapter 6.

The test call is run from an analog port on a TN771 Maintenance/Test circuit pack. It attempts to seize a port and make a call to a terminating test line (TTL) on the trunk's far end. Transmission performance measurements are made and compared to administered thresholds. Errors are generated when results fall outside of “marginal” or “unacceptable” thresholds. Detail and summary measurement reports are obtainable via the **list testcalls** command.

**Table 9-665. TEST #844-848 Transmission Test**

Error Code	Test Result	Description/ Recommendation
1000	ABORT	System resources required to run this test are not available. The port may be busy with a valid call.  1. Use <b>display port UUCSSpp</b> to determine the trunk group/member number of the port. Use the "status trunk" command to determine the service state of the port. If the service state indicates that the port is in use, then the port unavailable for this test. (Refer to section on "status" commands for a full description all possible states). You must wait until the port is idle before retesting.  2. If the port status is idle, then retry the command at 1-minute intervals for a maximum of 5 retries.
1001	ABORT	Could not allocate the necessary system resources to run this test.  1. Retry the command at 1-minute intervals for a maximum of 5 retries.
1002	ABORT	The system could not allocate timeslots for the test. The system may be under heavy traffic conditions or it may have timeslots out of service due to TDM bus errors.  1. If system has no TDM bus errors and is not handling heavy traffic, repeat test at 1-minute intervals for a maximum of 5 retries.
1004	ABORT	The port has been seized by a user for a valid call. Use status trunk to determine when the port is available for testing.  1. Retry the command at 1-minute intervals for a maximum of 5 retries.
1005	ABORT	Trunk has been administered as incoming-only; transmission tests can only be run on outgoing trunks.
1115	ABORT	The near end test line on the TN771 circuit pack could not be allocated.  1. Verify that the TN771 circuit pack is in service and that port 1 is administered and in service with the <b>status port</b> command.  2. Retry the command at 1-minute intervals for a maximum of 5 retries.

*Continued on next page*

**Table 9-665. TEST #844-848 Transmission Test — Continued**

Error Code	Test Result	Description/ Recommendation
1900	ABORT	The test completion message was not received from the TN771 circuit pack. 1. Test the TN771 circuit packs.
1901	ABORT	This error occurs when the TN771 circuit pack uplinks a message that is not the proper response for this test. The anticipated uplink messages are seize, ring or answer. 1. Verify that the Trunk is administered properly.
1905	ABORT	Intercept tone detected from far end. 1. Get the test line data and verify it with the far end. Dial the test number manually to see if the TTL is reached. If it is not, then either the number is wrong, or the far end is administered incorrectly.
1906	ABORT	Reorder tone detected from far end. 1. See actions for error code 1905.
1907	ABORT	Other unexpected tone detected from far end. 1. See actions for error code 1905.
1913	ABORT	Audible Ring detected from far end. 1. See actions for error code 1905.
1914	ABORT	Unidentified interrupted tone detected from far end. 1. See actions for error code 1905
1915	ABORT	Busy tone detected from far end. 1. Since the test line at the far end was busy. Try the test again. 2. If the test continues to abort, the problem is with the far end system.
1918	ABORT	Test progress tone not removed from far end (type 105 test line only). 1. The problem is with the far end system; a technician at the far end should test the test line (TN771 or ADFTC).
1919	ABORT	Unexpected far end release 1. The problem is with the far end system; a technician at the far end should test the test line (TN771 or ADFTC).
1920	ABORT	No response from far end. 1. The problem is with the far end system; a technician at the far end should test the test line (TN771 or ADFTC).
1921	ABORT	No data returned from far end. 1. The problem is with the far end system; a technician at the far end should test the test line (TN771 or ADFTC).

*Continued on next page*

**Table 9-665. TEST #844-848 Transmission Test — Continued**

Error Code	Test Result	Description/ Recommendation
1922	ABORT	Steady, unidentifiable tone from far end 1. See actions for error code 1905.
1923	ABORT	Broadband energy detected from far end (such as voice or announcement). 1. See actions for error code 1905.
1924	ABORT	No test tone from far end 1. See actions for error code 1905.
1938	ABORT	Near-end self test failed. 1. Test the TN771 circuit packs.
1939	ABORT	Loss self check at 0dBm at 1004 Hz failed. 1. Test the TN771 circuit packs.
1940	ABORT	Far end noise self check failed. 1. The problem is with the far end system; a technician at the far end should test the test line (TN771 or ADFTC).
1941	ABORT	High frequency singing return loss self check failed. 1. Test the TN771 circuit packs.
1942	ABORT	Echo return loss self check failed. 1. Test the TN771 circuit packs.
1943	ABORT	Singing return loss self check failed. 1. Test the TN771 circuit packs.
1944	ABORT	Loss self check at -16 dBm at 1004 Hz failed. 1. Test the TN771 circuit packs
1945	ABORT	Loss self check at -16 dBm at 404 Hz failed. 1. Test the TN771 circuit packs.
1946	ABORT	Loss self check at -16 dBm at 2804 Hz failed. 1. Test the TN771 circuit packs.
1947	ABORT	Noise with tone self check failed. 1. Test the TN771 circuit packs.
2000	ABORT	The test timed out while waiting for a response from the TN771 circuit pack. 1. Retry the command at 1-minute intervals for a maximum of 5 retries.
2012	ABORT	An internal software error occurred. 1. Retry the command at 1-minute intervals for a maximum of 5 retries.

Table 9-665. TEST #844-848 Transmission Test — *Continued*

Error Code	Test Result	Description/ Recommendation
2053	ABORT	The test call could not be established, but no information on why is available. 1. Retry the command at 1-minute intervals for a maximum of 5 retries.
2056	ABORT	An error occurred while trying to obtain results from the TN771 circuit pack. 1. Test the TN771 circuit packs.
	FAIL	Measured transmission performance was in the unacceptable range as administered on the trunk group form. Retrieve a measurement report via the <b>list testcalls</b> command. Make sure that ATMS thresholds are set properly on page 4 of the trunk group form. Besides the facility, test failures can be caused by faulty test lines or switch paths. If the measurements point to a facility problem, report the results to the trunk vendor.
8000	FAIL	Measured transmission performance was in the marginal range as administered on the trunk group form. This generally means that the trunk is usable but has an undesirable amount of noise or loss. If the user does not report unacceptable effects, it may not be necessary to take any action. Retrieve a measurement report via the <b>list testcalls</b> command. Make sure that ATMS thresholds are set properly on page 4 of the trunk group form.

## TIME-DAY (Time of Day)

---

MO Name (in Alarm Log)	Alarm Level	Initial Command To Run	Full Name of MO
TIME-DAY	MINOR	set time	Time of Day

The time of day contains the current year, month, day of the week, day of the month, hour, minute, and second. The Time of Day maintenance object is responsible for monitoring the time-of-day clock and raising an alarm if the time-of-day clock is not set or cannot be read by the software. If the time-of-day clock is not set or cannot be read by the software, many features such as Time-of-Day Routing, CDR, ISDN Call-by-Call, Duplication, and so on will be either inoperative or incorrect. The time-of-day clock should be set using the **set time** command whenever the system is initially powered up or the TN1648 SYSAM circuit pack is replaced.

The time-of-day clock can be read with the **display time** command and set via the **set time** command. The time-of-day clock resides on the TN1648 SYSAM circuit pack and has a backup battery to save the time of day during power failures. If the TN1648 SYSAM circuit pack is physically removed from the carrier, the contents of the time-of-day clock is lost and the time of day must be set when the TN1648 SYSAM circuit pack is re-inserted.

### Error Log Entries and Test to Clear Values

---

Table 9-666. Time of Day Error Log Entries

Error Type	Aux Data	Associated Test	Alarm Level	On/Off Board	Test to Clear Value
0	0	Any	Any	Any	display time
247 <sup>1</sup>	0	none	MINOR	OFF	set time

1. This error indicates that software cannot read the time-of-day clock on the TN1648 SYSAM circuit pack. During this condition, all time stamps on Alarm Log entries, Hardware Error Log entries, and Software Error Log entries are potentially inaccurate. In addition, any features that are sensitive to the time of day (such as SMDR, Time-of-Day Routing, ISDN Call-by-Call) will not function correctly.

To resolve the alarm, do the following:

1. Use the **set time** command to set the time of day.
2. Use the **display time** command to display the time of day. If the time of day is displayed correctly, wait 15 minutes and verify that the alarm is retired. If the alarm has not been retired, continue with Step 3.



3. Test the active TN1648 SYSAM circuit pack using the **test maintenance [a | b] sh** command. If any tests fail, refer to the repair procedures for the SYSAM circuit pack before further investigating time-of-day problems. If all tests PASS and the alarm has not been retired, proceed to Step 4.
4. Replace the active TN1648 SYSAM circuit pack must be replaced. See "Replacing SPE Circuit Packs" in Chapter 5. The alarm should be resolved within 15 minutes of replacing the SYSAM and resetting the time with **set time**.

## TONE-BD (Tone-Clock Circuit Pack)

MO Name (in Alarm Log)	Alarm Level	Initial Command to Run <sup>1</sup>	Full Name of MO
TONE-BD	MAJOR	test tone-clock UUC short	Tone-Clock Circuit Pack
TONE-BD	MINOR	test tone-clock UUC short	Tone-Clock Circuit Pack
TONE-BD	WARNING	release tone-clock UUC	Tone-Clock Circuit Pack

1. UU is the universal cabinet number (1 for PPN, 2 -44 for EPNs). C is the carrier designation (A, B, C, D, or E).

The Tone-Clock circuit packs house two independent components. The tone generator provides all the tones needed by the system, and the clock generates the system clocks for the Time Division Multiplex (TDM) Bus and the LAN Bus, and aids in monitoring and selecting internal synchronization references.

When resolving errors/alarms on the Tone-Clock circuit pack, the following sections should also be consulted:

- Use the **set tone-clock PC** command to establish the tone and synchronization resources for the system.
- TONE-PT (Tone Generator)
- TDM-CLK (TDM Bus Clock)
- SYNC (Synchronization)

The TN2182 is a combined Tone-Clock-Detector circuit pack which contains a third independent function not available on the TN768 or TN780. The TN2182 contains 8 ports used for all-purpose tone detection. These ports are called Enhanced Tone Receiver ports (ETR-PT) and are described in the documentation for ETR-PT.

### Tone-Clock Circuit Packs and System Reliability Options

The following sections describe the relationship between the various System Reliability Options and Tone-Clock circuit pack configurations.

#### **Standard Reliability Option**

Systems with the Standard Reliability Option (no duplication options) have one Tone-Clock circuit pack in each port network (PPN and EPN). For the PPN or the first EPN of a cabinet this is in the A carrier. Cabinets containing a second EPN

will also have a Tone-Clock circuit pack in the E carrier. This Tone-Clock circuit pack generates clocks and provides system tones for all carriers of the port network it resides on.

## High Reliability Option

Systems with the High Reliability Option (duplicated SPE, simplex PNC) have one Tone-Clock circuit pack in each PPN control carrier, A and B. One Tone-Clock circuit pack will be actively generating system clock signals for PPN components, while the other will be in standby mode, ready to take over in the event of a Tone-Clock interchange. Similarly, one Tone-Clock circuit pack will be actively providing system tones for the PPN, while the other will be in standby mode. Normally, the same Tone-Clock circuit pack will be active for both tones and clock signals, but these responsibilities may be divided if neither circuit pack is able to perform both functions. The **status port-network** PN# command will indicate which Tone-Clock circuit pack is actively performing each function.

For systems using the TN2182 Tone-Clock-Detector circuit pack, tone generation and clock generation behaves the same as other clock boards with one being active and one being standby. But the tone detector ports (ETR-PTs) of the TN2182 are always considered available and in-service regardless of the active/standby state of the tones or clock for a specific circuit pack.

EPN Tone-Clock circuit pack configuration is the same as for the Standard Reliability Option. Each EPN Tone-Clock circuit pack will be active for both tones and clock signals for its port network.

## Critical Reliability Option

Systems with the Critical Reliability Option (SPE duplication and PNC duplication) have two Tone-Clock circuit packs associated with the PPN, as in the High Reliability Option case, and two more Tone-Clock circuit packs for each EPN. For the first EPN in a cabinet, these are in carriers A and B; for the second EPN, where configured, they are in carriers D and E. As in the previous case, one Tone-Clock in each Port Network is active, supplying system clocks and tones, and the other is in standby mode.

## Tone-Clock Interchange Strategy

Tone-Clock circuit pack interchanges are controlled both by manual intervention and by maintenance software strategies.

The manual interchange strategy for Tone-Clock circuit packs differs slightly between the PPN and any EPNs on a system.

## Manual PPN Tone-Clock Interchange

In a PPN with more than one Tone-Clock circuit pack, the intention is to assure that the one considered most healthy is active at any given time. *This is independent of the SPE Duplication strategy*, in the sense that the active Tone-Clock circuit pack need not change with an interchange of SPE carriers. Rather, except for the effect of the manual intervention discussed earlier, Tone-Clock interchanges occur only as a result of changes in the health of Tone-Clock circuit packs, as perceived by maintenance software. When both Tone-Clock circuit packs are equally healthy, no preference is given to one over the other, regardless of which SPE carrier is active.

It is possible to manually control Tone-Clock interchanges in three ways.

1. The **standby** Tone-Clock circuit pack may be made unavailable for most purposes by using the **busyout tone-clock UUC** command. Such a Tone-Clock may not be selected with console commands, nor with normal maintenance software activities, until it has been made available again with the **restore tone-clock UUC** command.



### NOTE:

**busyout tone-clock** is not allowed for active Tone-Clock circuit packs.

2. The SPE processor lock switches may be used to force a particular SPE to be active. *This method overrides all other Tone-Clock interchange controls*. If there is a Tone-Clock circuit pack in the same carrier as the active SPE, it will become active, regardless of its health. If the Tone-Clock circuit pack in the selected SPE was in the *busyout* state (see item 1 above), it will automatically be released and made active. While the lock switches are set for a particular carrier, *no manual intervention or software error detection* will cause an interchange of Tone-Clocks; the Tone-Clock circuit pack in the standby SPE carrier can never become active. If there is no Tone-Clock circuit pack in the selected SPE at the time the switches are set, but one is later installed, the system will interchange to it regardless of its health. If the Tone-Clock circuit pack is removed from an SPE while the switches are set, *no interchange will occur*; the system will have no active tone-clock. When the lock switches are restored to the neutral position, a tone clock interchange will occur only if the standby Tone-Clock circuit pack is healthier than the active one.
3. A particular Tone-Clock circuit pack can be made active by issuing the **set tone-clock UUC [override]** command. If the Tone-Clock to be made active is less healthy than the currently active one, no interchange will occur unless the **override** option is specified; without it a message will inform the user that it is required.

Once a Tone-Clock circuit pack is made active by the **set tone-clock UUC** command, it will stay active until either the **set tone-clock UUC** command is issued again to make the other circuit pack active, or until a fault occurs in the active Tone-Clock circuit pack, which causes the system to interchange Tone-Clocks.

## Manual EPN Tone-Clock Interchange

In an EPN with duplicated Tone-Clock circuit packs, one circuit pack is always *preferred* over the other. For the first Port Network in a cabinet, this is the Tone-Clock circuit pack in carrier **A**. If a second Port Network is configured in a cabinet, its preferred Tone-Clock is the one in carrier **E**. The intention is that the preferred circuit pack be active whenever it is healthy. Once a failing preferred Tone-Clock circuit pack has been replaced or repaired, the system will make it active as soon as possible.

Control over interchanges for an EPN is accomplished in essentially the same ways as items 1 and 3 in the PPN case above. In addition, when the non-preferred Tone-Clock circuit pack in an EPN is active, and the preferred circuit pack is repaired and proven capable of filling its roles, the system will automatically interchange back to it as soon as possible.

## Software Maintenance Interchange

Interchanges may be instigated by software Tone-Clock maintenance in two ways.

1. A scheduled Tone-Clock circuit pack interchange occurs according to the parameters set by the **change system-parameters maintenance** command. This can be disabled or set to run weekly, but the standard (default) situation is for it to occur daily, at the time specified in the system-parameters list for scheduled maintenance to begin. This interchange will be blocked if the lock switches are set, if the non-preferred Tone-Clock circuit pack in an EPN has been selected with the **set tone-clock** command, if the standby Tone-Clock has been set to the busyout state, or if the clock generation capability of the standby Tone-Clock circuit pack is known to be impaired. When this scheduled interchange occurs, the standby Tone-Clock circuit pack becomes active for a period of 20 seconds to test its ability to generate clock signals, and then is returned to standby mode.
2. Unscheduled interchanges occur when on-board Tone-Clock circuit pack maintenance, or ongoing switch maintenance tests of **TONE-BD**, **TONE-PT**, or **TDM-CLK** uncover failures serious enough to raise any MAJOR or MINOR alarm against the active Tone-Clock circuit pack.

## International Settings [G3r V2]

The TN780 Tone-Clock circuit pack uses three firmware configuration parameters for international support [G3r V2]. The following two are automatically set by the software load for the targeted country:

- The circuit pack's country-code (USA, ITALY, AUSTRALIA, etc.)
- The circuit pack's companding mode (mu-Law or A-Law)

The third configuration parameter is used only for Italy (country code: ITALY), and selects whether *new* versus *old* ISPT (Istituto Superiore Poste Telegrafi) tones will be used for dial and confirmation tones. Values for dial confirmation tone can be set independently on the **change system-parameters miscellaneous** form. Whenever such changes are made, the effects are immediately enforced on all TN780 Tone-Clock circuit packs without disrupting tone or timing services.

Tone	New ISPT Value(default)	Old ISPT Value
Dial	continuous	cadenced
Confirmation	cadenced	continuous

In addition the TN780 allows customization of up to six system tones in order to meet specific country needs. These changes are made via the **change system-parameters country-options** form.

The TN2182 allows the same internation changes as the TN780 but allows the customization of up to 24 system tones in order to meet specific country needs. These changes are made via the **change system-parameters country-options** form.

## How to Replace the Tone-Clock Circuit Pack

Replacing the Tone-Clock circuit pack is a service-disrupting procedure on Port Networks with a single Tone-Clock, because the Tone-Clock circuit pack is always needed to generate clocks for its network. For EPN Tone-Clock replacement where no second Tone-Clock circuit pack exists, only that EPN is affected. When the circuit pack is removed, all calls are dropped immediately, the EPN enters emergency transfer within one minute, and no calls can be set up from or to that EPN. However, if the PPN Tone-Clock is removed for replacement in a Standard Reliability Option system, the System Emergency Transfer feature is activated within milliseconds, and the entire system is disrupted; no calls can be placed, and existing calls are dropped.

When replacing the Tone-Clock circuit pack, always make sure to replace it with the appropriate Tone-Clock circuit pack for the system. Three circuit pack codes are supported by G3r systems:

- |        |  |
|--------|--|
| TN768  | This is the general purpose Tone-Clock circuit pack for port networks on a G3r switch. It can be used in every situation except as the Master Tone-Clock circuit pack when a Stratum 3 Clock is administered.  |
| TN780  | The Stratum 3 Clock feature requires the use of this circuit pack code for the PPN (in both carriers of High and Critical Reliability systems). The Stratum 3 Clock will operate only with this code as the Master Tone-Clock circuit pack. The TN780 circuit pack is upward compatible with the TN768 code, and can be used in any place a TN768 would be allowed. The TN780 is used in many countries outside the U.S. where the TN768 does not provide local tones. |
| TN2182 | This Tone-Clock-Detector may be used anywhere a TN768 or TN780 is used with the exception of configurations requiring Stratum 3 Clock. The TN2182 may be used in all country configurations.   |

## Port Networks with a Single Tone-Clock Circuit Pack:

**This procedure is destructive.**

1. Pull out the defective Tone-Clock circuit pack. This will remove the clocks and cause the system to activate emergency measures:
  - For the PPN Tone-Clock, the system will immediately go into the Emergency Transfer state.
  - For an EPN Tone-Clock, all calls to and from the EPN will drop and the EPN will activate Emergency Transfer within about one minute, but the rest of the system should operate normally.
2. Insert a new Tone-Clock circuit pack. The system will detect the return of the clocks and will automatically recover as follows:
  - If the Tone-Clock circuit pack being replaced is in the Processor Port Network, the system will perform a **reset system 2 (system cold 2 restart)** automatically. First, all red LEDs of the PPN will come on and off within 30 seconds. Then, all red LEDs of any Expansion Port Networks will come on and go off within the next 30 seconds.
  - If the Tone-Clock circuit pack being replaced is in an Expansion Port Network, the system will reset the EPN (**EPN cold restart**) and all the red LEDs of the EPN will come on and go off within 30 seconds.
3. If the red LEDs come on but do not go off within 30 seconds, pull the circuit pack out and reseat it. If the LEDs perform as expected this time, continue with step 6. Otherwise, there may be a problem with the TDM Bus; possibly a bent pin in the Tone-Clock circuit pack slot. Follow the directions in the TDM-BUS maintenance section.

4. If the red LEDs did light, as explained above, then go to Step 6. If the red LEDs do NOT light, as explained above, then go on to Step 5.
5. Restart the affected Port Network:
  - In the PPN, restart the system via the **reset system 2** command.
  - In an EPN, restart the EPN by resetting its Expansion Interface circuit pack via the **reset port-network PN# 2** command, using the Port Network number of the affected EPN. (Use the **list cabinet UU** command to determine the Port Network number for a given cabinet and carrier.)
6. Test the new Tone-Clock circuit pack to verify that it is functioning properly, using the **test tone-clock UUC long** command, and verify that the system is operational by placing several phone calls. Where possible, try calls into, out from, and within the affected Port Network.

### Port Networks with Two Tone-Clock Circuit Packs:

**Table 9-667. LED Condition/Tone-Clock Circuit States (Two Tone-Clock Pack)**

Condition	Tone-Clock Circuit State	Explanation
flashing yellow 2.7 seconds on .3 seconds off	active	An external timing source is being used as a synchronization reference <sup>1</sup> .
flashing yellow .3 seconds on 2.7 seconds off	active	The local oscillator on the Tone-Clock circuit pack is being used as a synchronization reference.
yellow on continuously	active	The circuit pack has been reset but has not been told which synchronization source to use.
yellow LED off	standby	The circuit pack is in standby mode, (neither generating tones nor supplying clocks).
"jingle bells" green and yellow .1 sec on, .2 sec off, .1 sec on, .4 sec off, .4 sec on, .4 sec off	standby	Maintenance software is testing the standby circuit pack (the standby Tone-Clock is providing tones).

*Continued on next page*



**Table 9-667. LED Condition/Tone-Clock Circuit States  
 (Two Tone-Clock Pack) — Continued**

Condition	Tone-Clock Circuit State	Explanation
"double blink" yellow .3 sec on, .3 sec off, .3 sec on, 2.4 sec off,	active	TN2182 has lost all external references and is in holdover mode.
other green and yellow patterns	active	Maintenance software is testing the active circuit pack.
random yellow	standby	If the circuit pack is a TN2182, the yellow LED may come on and off intermittently as ETR-PTs on the board are used for tone detection services.

- For a Tone-Clock in the master port network, the external source is the primary or secondary DS1 source, or a Stratum 3 clock. For a Tone-Clock in a slave port network, the external source is the Expansion Interface circuit pack.

- Use the **list cabinet** command to determine the Port Network number of the cabinet and carrier containing the Tone-Clock circuit pack to be replaced. If both Tone-Clock circuit packs in a Port Network need to be replaced, first replace and test the one that is in standby mode. Make sure that it is healthy and active before replacing the second one. Make sure the Tone-Clock circuit pack to be replaced is in Standby Mode by displaying its status via the **status port-network** command or making sure its yellow LED is off.

The active/standby state of a Tone-Clock circuit pack may also be determined by looking at its LED. A continuously lit red LED on the Tone-Clock circuit pack indicates a reported fault on one or more of the maintenance objects on the circuit pack. Flashing patterns of the yellow and green LEDs correspond to the following service states:

- If the Tone-Clock circuit pack to be replaced is active, then switch to the other Tone-Clock circuit pack by doing the following:
  - **set tone-clock UUC**—Where UUC is the Standby Tone-Clock circuit pack.

**⇒ NOTE:**

When Port Network Connectivity Duplication is active, the system generally expects an EPN to have its "preferred" Tone-Clock circuit pack active. For the first Port Network in a given cabinet, this is carrier A. For a second PN in a given

cabinet this is carrier E. There is no "preferred" tone clock for the PPN, regardless of reliability options.

- **status system**—Verify the Tone-Clock circuit pack switched to the other Tone-Clock circuit pack or check the LEDs. The yellow LED of the new Standby Tone-Clock circuit pack should be off (provided maintenance is not running on it) and the yellow LED of the active Tone-Clock circuit pack should be blinking.
  - If the interchange was not successful, the standby Tone-Clock circuit pack may be defective. In particular, if the error message "must use override" is displayed, fix the standby Tone-Clock circuit pack before attempting to replace the active one.
3. If the Tone-Clock circuit pack to be replaced is in the PPN, it is recommended, but not required, that the SPE carrier containing it be locked in standby mode by executing an interchange if necessary, and locking the SPE-Select switches. This protects you from disrupting service in case of inadvertent errors in replacing the circuit pack. See "Repairing SPE Components" in [Chapter 5, "Alarms, Errors, and Troubleshooting"](#).

 **NOTE:**

If the SPE-Select switches are locked, be sure to release them at the conclusion of the replacement procedure.

4. Pull out the defective Tone-Clock circuit pack. No calls should be affected. If this is a TN2182 circuit pack, some ETR-PTs may be in use and removal of the pack will affect some individual users. It may be less disruptive to busyout the standby TN2182 before removing it.
5. Insert a new Tone-Clock circuit pack of the appropriate code in the same slot where the defective Tone-Clock circuit pack was removed.
6. Test the new Tone-Clock circuit pack via the **test tone-clock UUC long** command to make sure it is functioning properly. If the Tone-Clock circuit pack is being replaced due to loss of c locks, the Clock Health Inquiry (#46) will still report a failure, proceed with the next step.

7. To verify that the new Tone-Clock circuit pack can generate clocks for the system, switch to the new Tone-Clock with **set tone-clock UUC override**, and execute **test tone-clock UUC**. (In a PPN, the SPE-Select switches must be in the auto position.)



**CAUTION:**

*If the new Tone-Clock circuit pack is not able to generate system clocks, this procedure becomes destructive. The system will detect a loss of clock and recover accordingly.*

*In this case if the Tone-Clock circuit pack being replaced is in the PPN the system will perform a reset system 2 (cold 2 restart) automatically. If the Tone-Clock circuit pack being replaced is in an EPN, the system will reset the EPN (EPN cold restart). After either type of restart, the faulty Tone-Clock circuit pack will be in standby mode.*

**If the new Tone-Clock circuit pack is able to generate system clocks, there will be no system disruption.**

8. Place several phone calls.
9. After replacing a Tone-Clock circuit pack in an SPE, if the SPE lock switches were set during the procedure, they should be released. Additionally, after repairs in an EPN, the **set tone-clock UUC** command should be used if required to make the preferred Tone-Clock circuit pack active.

## Error Log Entries and Test to Clear Values

**Table 9-668. Tone-Clock Circuit Pack Error Log Entries**

Error Type	Aux Data	Associated Test	Alarm Level	On/Off Board	Test to Clear Value
0 <sup>1</sup>	0	Any	Any	Any	test tone-clock PC sh
1(a)	0	Circuit pack removed or SAKI Sanity Test (#53)	MINOR	ON	
18(b)	0	busyout tone-clock PC	WARNING	OFF	release tone-clock PC
23(c)	0	None	WARNING	OFF	
125(d)		None	MINOR	ON	
126(e)		None	MINOR	ON	
257	65535	Control Channel Test (#52)	MINOR	ON	test tone-clock PC r 20
257(f)	Any	None			
513(g)	Any	None			
769(h)	4358	None			
1025(i)	4363	NPE Audit Test (50)			test tone-clock PC sh
1538(j)	Any	None	MINOR	ON	
2049(k)	0	Clock Health Inquiry Test (#46)	MAJOR	ON	set tone-clock PC override
2305(k)	0	Clock Health Inquiry Test (#46)	MAJOR	ON	set tone-clock PC override
2561(l)	Any	None	MAJOR	ON	
3329(m)	0	None	MINOR/ WARNING <sup>2</sup>	OFF	set tone-clock PC
3840(n)	Any	None			
3848(o)	0	Clock Health Inquiry Test (#46)			set tone-clock PC override
3872(p)	0	None			set tone-clock PC override
3999 (q)	Any	None			

1. Run the Short Test Sequence first. If all tests pass, run the Long Test Sequence. Refer to the appropriate test description and follow the recommended procedures.
2. Minor alarms on this MO may be downgraded to Warning alarms based on the value used in the **set options** command.

Notes:

- a. Error Type 1—This error indicates the circuit pack totally stopped functioning or it was physically removed from the system.

 **NOTE:**

The alarm is logged approximately 11-minutes after the circuit pack is removed/SAKI Sanity Test (#53) fails.

If the circuit pack is not present in the system, insert a circuit pack in the slot indicated by the error to resolve the error.

If the circuit pack is present in the system, it is faulty and must be replaced. See the preceding section, *How to Replace the Tone-Clock Circuit Pack*.

If the faulty circuit pack is in standby mode, a MINOR alarm is raised, but no other system action is taken. If the circuit pack is the active Tone-Clock, further effects of this error depend on the Reliability Option for the switch.

**Table 9-669. Location of Tone-Clock Circuit Pack**

Reliability Option	PPN	EPN
Standard	System Emergency Transfer (entire system affected)	Emergency Transfer in the affected EPN
High	Interchange to standby Tone-Clock in the PPN	Emergency Transfer in the affected EPN
Critical	Interchange to standby Tone-Clock in the PPN	Interchange to standby Tone-Clock in the affected EPN

If an interchange is attempted and the system is unable to activate the standby Tone-Clock, Emergency Transfer is activated. If the problem is in the PPN the entire system is affected. Otherwise only the EPN in question is affected. When this happens, both circuit packs are faulty and must be replaced. See the preceding section, *How to Replace the Tone-Clock Circuit Pack*.

If a successful interchange occurs in response to a failure of the active Tone-Clock, or if a standby Tone-Clock fails, the faulty Tone-Clock should be replaced.

- b. Error Type 18—The indicated Tone-Clock circuit pack has been made unavailable via the **busyout tone-clock PC** command. This error applies only to High or Critical Reliability systems (an active Tone-Clock may not be busied out). To resolve this error, execute **release tone-clock PC**.
- c. Error Type 23—The circuit pack has been logically administered but not physically installed. Installing the circuit pack will resolve the alarm.

- d. Error Type 125—A wrong circuit pack is inserted in the slot where this circuit pack is logically administered. To resolve this problem, either remove the wrong circuit pack and insert the logically administered circuit pack OR use the **change circuit-pack** command to readminister this slot to match the circuit pack inserted.
- e. Error Type 126—The port network specified in the PORT field of the error log entry booted up without a Tone-Clock circuit pack, or with a one that cannot communicate at all with the system. The error is logged five minutes after the port network is restarted. If no circuit pack is present, install one of the proper code. If there is a circuit pack present, replace it. See the preceding section, *How to Replace the Tone-Clock Circuit Pack*.
- f. Error Type 257—This error indicates transient communication problems with this circuit pack. This error is not service-affecting and no action is required.
- g. Error Type 513—This circuit pack has an on-board hardware failure. Replace the circuit pack using the procedure described in preceding section, *How to Replace the Tone-Clock Circuit Pack*.
- h. Error Type 769—This error can be ignored, but look for other errors on this circuit pack.
- i. Error Type 1025—This error is not service-affecting and no action is required.
- j. Error Type 1538—The circuit pack was taken out of service because of an excessive rate of uplink messages. Use **test tone-clock PC long** to reset the circuit pack and put it back into service. If the command is not successful, replace the circuit pack using the procedure described in the preceding section, *How to Replace the Tone-Clock Circuit Pack*. If the alarmed circuit pack is the active Tone-Clock of a duplicated pair, first interchange Tone-Clocks via the **set tone-clock PC** command to avoid a service outage. If the error occurs again within 15 minutes, follow normal escalation procedures.
- k. Error Type 2049 or 2305—These errors indicate the loss of one or more clock signals from the reported Tone-Clock circuit pack, which was active at the time of the error. The effect of any of these errors is described in the table for error type 1. Diagnosis of the problem is the same for all four error types, with the exception noted below.
  - 1. Examine the Hardware Error Log for errors reported against circuit packs in the same Port Network, especially TDM-CLK, TONE-BD, DUPINT, SW-CTL, and EXP-INTF. Follow the repair or replacement procedures indicated for any such errors found.
  - 2. If the error is not corrected by resolving errors found in step 1, the Tone-Clock circuit pack should be replaced. See the preceding section, *How to Replace the Tone-Clock Circuit Pack*.

**⇒ NOTE:**

Replacing the circuit pack and retesting it with the **test tone-clock** command is not adequate to retire this alarm and return the Tone-Clock Circuit Pack to full service; the Clock Health Inquiry test (#46) will continue to fail. Because the ability to generate clocks was considered lost, once any repairs have been made it is necessary to execute the **set tone-clock PC override** command, forcing the circuit pack to become active. If the problem has not actually been corrected, this action may cause a disruption in service for active digital facilities users.

3. If error 2305 or 3848 persists, all clock signals from the indicated board were lost. If the reported Tone-Clock circuit pack is in a Port Network with duplicated Tone-Clocks, the problem may lie with the circuit pack responsible for selecting the active Tone-Clock circuit pack (the *t/c selector*).
  - For a PPN, the *t/c selector* is the DUPINT circuit pack on carrier A.
  - For an EPN, the *t/c selector* is the active EXP-INTF circuit pack that is connected to the PPN. This is EXP-INTF 2A01 or 2B02 for EPN1 and 3A01 or 3B02 for EPN2.

The *t/c selector* circuit pack of interest is the one which was active at the time the error was logged. This is the currently active *t/c selector* unless there has been an SPE interchange for PPN problem, or an EXP-INTF link switch for EPN problem. In order to determine whether an interchange has occurred since the TONE-BD error, examine the **display initcauses** log for SPE interchanges, and EXP-LNK entries in the hardware error log for expansion link interchanges.

If the *t/c selector* circuit pack was not replaced as part of the previous step, replace it now. Follow procedures described in "Replacing SPE Circuit Packs" in Chapter 5; [Chapter 7, "LED Interpretation"](#), for the DUPINT circuit pack, or in the EXP-INTF section of this chapter for the Expansion Interface.

4. If the error has not been corrected at this point, there is a problem with the TDM Bus within the Port Network containing the reported Tone-Clock circuit pack. This may include TDM Bus intercarrier cables, Bus terminators, bent pins on the backplane, and errors on any circuit pack plugged into the same Port Network. Refer to the TDM-BUS section.
- I. Error Type 2561—This error indicates that a Tone-Clock circuit pack, with a different circuit pack code as required for this system, has been inserted in the port slot as shown in the Hardware Error Log. To resolve this error, refer to the "How to Replace the Tone-Clock Circuit Pack" section for an

appropriate circuit pack code and replace the Tone-Clock circuit pack according to the procedures indicated for this system. The meanings of the aux data values are as follows:

- 1001 A TN756 Tone-Clock circuit pack is in the PPN of a one port network system without High or Critical Reliability (Multicarrier Cabinet).
  - 1002 A TN756 Tone-Clock circuit pack is in the EPN of a one port network system without High or Critical Reliability (Multicarrier Cabinet).
  - 1003 Either a TN741 or TN714 Tone-Clock circuit pack (instead of a TN768, TN780 or TN2182) is in a one port network system without High or Critical Reliability (Multicarrier Cabinet).
  - 1004 Either a TN741 or TN714 Tone-Clock circuit pack (instead of a TN768, TN780 or TN2182) is in a High or Critical Reliability system.
  - 1005 Same as for aux value 1004.
- m. Error Type 3329—The system attempted but failed to interchange Tone-Clock circuit packs. (This error occurs only in Port Networks with duplicated Tone-Clocks.) The fault may lie in the standby Tone-Clock or in the circuit pack that controls selection of the active Tone-Clock (the *t/c selector*). The goal of the following procedure is to ensure that both Tone-Clocks can be interchanged into while either *t/c-selector* circuit pack is active.
1. Examine the Error Log for errors reported against circuit packs in the same Port Network, paying special attention to TDM-CLK, TONE-BD, DUPINT, SW-CTL, and EXP-INTF. Follow the procedures indicated for any such errors found. After eliminating the above potential problem sources, proceed with the following steps.
  2. Determine which circuit pack was controlling the choice of Tone-Clock at the time the error occurred.
    - For a PPN, the *t/c selector* is the DUPINT circuit pack on the A-carrier.
    - For an EPN, the *t/c selector* is the active EXP-INTF circuit pack that is connected to the PPN. This is EXP-INTF 2A01 or 2B02 for EPN1 and 3A01 or 3B02 for EPN2.
- The *t/c-selector* circuit pack of interest is the one which was active at the time the error was logged. An EXP-LNK interchange since the time of the error may have made that circuit pack the current standby. Determine whether an interchange affecting the *t/c selector* has occurred since the TONE-BD error. When investigation an EPN Tone-Clock, look for EXP-LNK entries in the hardware error log for PNC interchanges, which would affect the EXP-INTF.
3. If the *t/c selector* has not undergone an interchange since the error occurred, go to the next step. If such an interchange has taken place, interchange back to the formerly active *t/c selector*. Use the



**set expansion-interface** command when investigating an EPN Tone-Clock.) If the interchange attempt fails due to other errors, resolve those problems first.

4. Interchange the Tone-Clock circuit packs using the **set tone-clock PC** command. If the command succeeds, the interchange which previously failed has been accomplished and the problem has been satisfactorily resolved. If it fails, proceed to the next step. (You may want to proceed in any case to definitively test all relevant components.)
5. Interchange the t/c selector using **set expansion-interface** if investigating an EPN. If errors prevent this interchange, resolve them first.
6. Attempt again to interchange Tone-Clocks with the **set tone-clock PC** command.
  - If the Tone-Clock interchange failed for both t/c selectors:

Replace the standby Tone-Clock circuit pack which could not be interchanged into and return to this step. (See *How to Replace the Tone-Clock Circuit Pack*.) Test the new circuit pack as follows:

    - a. Execute the **set tone-clock PC** command.
    - b. Execute a **set expansion-interface**, if this is an EPN Tone-Clock.
    - c. Execute the **set tone-clock PC** command again.

If these commands successfully complete, the problem has been resolved.
  - If these commands successfully complete, the problem has been resolved.
  - If the Tone-Clock circuit packs successfully interchange when one EXP-INTF is active, but not when the other one is:

The t/c-selector circuit pack on the failing side is suspect.

    - a. Replace the A carrier DUPINT or EXP-INTF board that is active when the Tone-Clock interchange fails. (Follow procedures in "Replacing SPE Circuit Packs" in Chapter 5 for the DUPINT circuit pack; for the Expansion Interface, see ["EXP-INTF \(Expansion Interface Circuit Pack\)"](#).)
    - b. Make sure the new t/c selector is active and execute the **set tone-clock PC** command.
  - If both Tone-Clocks can be interchanged into, and interchanges succeed when either t/c selector is active, the problem has been resolved.

- n. Error Type 3840—This error is not service-affecting and can be ignored. It indicates that the circuit pack has received a bad control message from the switch.
- o. Error Type 3848—This error indicates that the Tone/Clock circuit pack had a loss of clock. If error 2305 is also logged, see note (j).
- p. Error Type 3872—These errors indicate this Tone/Clock circuit pack had a loss of Data Clocks. This error will impact mainly users on station connected to Digital circuit packs. These users could be with out service. If error 2049 is also logged see note (i).
- q. Error type 3999 indicates that the circuit pack sent a large number of control channel messages to the switch within a short period of time. If error type 1538 is also present, then the circuit pack was taken out-of-service due to hyperactivity. If error type 1538 is not present, then the circuit pack has not been taken out-of-service, but it has generated 50% of the messages necessary to be considered hyperactive. This may be completely normal during heavy traffic periods. However, if this error type is logged when the circuit pack is being lightly used, it may indicate a problem with the circuit pack or the equipment attached to it.

### System Technician-Demanded Tests: Descriptions and Error Codes

Always investigate tests in the order presented in the table below when inspecting errors in the system. By clearing error codes associated with the *SAKI Reset Test* for example, you may also clear errors generated from other tests in the testing sequence.

Order of Investigation	Short Test Sequence	Long Test Sequence	Reset Board Sequence	D/ND <sup>1</sup>
SAKI Reset Test (#53) (a)		X		D
Clock Health Test (#46)	X	X		ND
Control Channel Looparound Test (#52)(a)	X	X		ND
Tone Generator Crosstalk Test (#90) (b)		X		ND
Tone Generator Transmission Test (#40)(b)	X	X		ND
Tone Generator Audit/Update Test (#41)(b)	X	X		ND
TDM Bus Clock Circuit Status Inquiry Test (#148) (c)	X	X		ND
TDM Bus Clock Slip Inquiry Test (#149)(c)(e)	X	X		ND

9 Maintenance Object Repair Procedures  
TONE-BD (Tone-Clock Circuit Pack)

9-1795

Order of Investigation	Short Test Sequence	Long Test Sequence	Reset Board Sequence	D/ND <sup>1</sup>
TDM Bus Clock PPM Inquiry Test (#150)(c)	X	X		ND
TDM Bus Clock Parameter Update Test (#151) (c)	X	X		ND
Board Type Check Test (#574) (c)	X	X		ND
Standby Reference Health Check Test (#651) (c,d)		X		ND

1. D = Destructive; ND = Nondestructive

## Notes:

- a. Refer to XXX-BD for descriptions of these tests.
- b. Refer to TONE-PT for descriptions of these tests.
- c. Refer to TDM-CLK for descriptions of these tests.
- d. This test runs only on the standby Tone-Clock circuit pack in a Port Network with duplicated Tone-Clocks (High or Critical Reliability systems). The circuit pack must be a TN780 with firmware version 2 or above.

**Clock Health Inquiry Test (#46)**

This inquiry reads special data stored in memory to determine if this Tone-Clock circuit pack had a loss of any of three clock types:

- SYSCLK
- SYSFM
- SYSDCLK

If this data indicates this Tone-Clock circuit pack had a loss of any of these clocks, the inquiry reports FAIL. In addition, if TDM-CLK error 1 is at threshold, this test will FAIL. TDM-CLK error 1 indicates a suspect clock is at the edge of its specified frequency. If the circuit pack did not have a loss of clock or TDM-CLK error 1 at threshold, the inquiry reports PASS.

This is not really a test, in the sense that it simply reports status held by the system, and does not generate new information or raise alarms. If this test fails with no error code, there is at least one Major alarm against a Tone-Clock circuit pack. If this test fails with an error code of 1, there is at least one Minor off-board alarm against a TDM-CLK.

**Table 9-670. TEST #46 Clock Health Inquiry Test**

Error Code	Test Result	Description/ Recommendation
	ABORT	Internal system error. 1. Retry the command at 11-minute intervals for a maximum of 5 times.
none	FAIL	This Tone-Clock circuit pack had an apparent loss of clock. One or more of error types 2049, 2305, 3834, and 3872 will appear in the error log. Correct the problem according to the appropriate error log entries.  Once this test fails, the only way to make it pass, and to retire the associated alarm, is to repair the problem and to execute the <b>set tone-clock UUC override</b> command against the indicated Tone-Clock circuit pack.
1	FAIL	This Tone-Clock circuit pack is suspect of having a clock at the edge of its specified frequency. A Tone-Clock circuit pack with this problem can cause Expansion Interface circuit packs and SNI circuit packs to go out-of-frame or report no neighbor conditions, thus causing EPNs, Expansion Archangel Links (EALs), Remote Neighbor Links (RNLs), and/or Local Neighbor Links LNLs) to go down.  1. Replace the Tone-Clock circuit pack identified in the error log. Refer to the "How to Replace the Tone-Clock Circuit Pack" section.
	PASS	This Tone-Clock circuit pack has not reported a loss of clock.

## TONE-PT (Tone Generator)

---

MO Name (in Alarm Log)	Alarm Level	Initial Command To Run <sup>1</sup>	Full Name of MO
TONE-PT	MAJOR	test tone-clock UUC short	Tone Generator
TONE-PT	MINOR	test tone-clock UUC short	Tone Generator
TONE-PT	WARNING	release tone-clock UUC	Tone Generator

1. UU is the universal cabinet number (1 for PPN, 2 -44 for EPNs). C is the carrier designation (A, B, C, D, or E).

### NOTE:

Replacing the tone/clock circuit pack requires a special procedure which is described in the documentation for TONE-BD. That section also describes the LED display for this board.

The tone generator resides on the Tone/Clock circuit pack and provides all system tones such as dial tone, busy tone, and so on. If an active tone generator fails, its port network may not have tones (see the Tone Generator Transmission Test #40). For instance, a user may go off-hook and hear no dial tone. This problem will affect only users on the same port network in which the faulty Tone-Clock circuit pack resides. The system will be able to process certain type of calls (that is, internal calls will succeed while outgoing calls will not).

The Tone-Clock circuit pack also provides the clocks for the system and can serve as the synchronization reference. Therefore, when resolving alarms on the Tone-Clock circuit pack, the TDM-CLK (TDM Bus Clock) and SYNC (Synchronization) Maintenance documentation should be utilized as well as the TONE-BD (Tone-Clock Circuit Pack) Maintenance documentation.

See the section on TONE-BD Maintenance in this manual for a discussion of the relationship of Tone-Clock circuit packs with the various Reliability Options.

## Error Log Entries and Test to Clear Values

Table 9-671. Tone Generator Error Log Entries

Error Type	Aux Data	Associated Test	Alarm Level	On/Off Board	Test to Clear Value
0 <sup>1</sup>	0	Any	Any	Any	test tone-clock UUC r 1
1(a)	17664	Tone Generator Audit/ Update Test (#41)	MAJOR/ MINOR <sup>2</sup>	ON	test tone-clock UUC r 2
18(b)	0	busyout tone-clock UUC	WARNING	OFF	release tone-clock UUC
130(c)		None	MINOR	ON	test tone-clock UUC Sh
257(d,f)	17667	None	MINOR	ON	
513(e,f)	17666	Tone Generator Audit/ Update Test (#41)	MINOR	ON	test tone-clock UUC r 3
769	Any	Transmission Test (#40)	MAJOR/ MINOR <sup>2</sup>	ON	test tone-clock UUC r 3
1025		Crosstalk Test (#90)	MAJOR/ MINOR <sup>2</sup>	ON	test tone-clock UUC l r 2
1281(g)	Any	Tone Generator Audit/ Update Test (#41)	MINOR	ON	test tone-clock UUC r 3

1. Run the Short Test Sequence first. If all tests pass, run the Long Test Sequence. Refer to the appropriate test description and follow the recommended procedures.
2. MAJOR alarm if the alarmed Tone-Clock circuit pack is not duplicated; MINOR if it duplicated within the same Port Network.

### Notes:

- a. A failure in the tone generation facility on the indicated circuit pack has been detected. Replace the circuit pack. See *How to Replace the Tone-Clock Circuit Pack* in the TONE-BD section.
- b. The indicated Tone-Clock circuit pack has been made unavailable via the **busyout tone-clock UUC** command. It only applies to systems which have the High or Critical Reliability Option administered, because only a standby Tone-Clock circuit pack may be made busy by that command. To resolve this error, execute the **release tone-clock UUC** command for the alarmed circuit pack.
- c. This error type indicates that the circuit pack has been removed or has been insane for more than 11-minutes. To clear the error, reinsert or replace the circuit pack.

- d. The tone generation facility is having problems verifying that tones have been connected as requested.
- e. The tone generation facility may or may not be able to generate tones.
- f. Infrequent errors, at a rate which does not bring up an alarm, probably do not affect service, unless there are customer complaints of no tones, or incorrect tones which can not be explained in any other way. However, if an alarm is raised because this error is being repeatedly logged, then the circuit pack should be replaced. See *How to Replace the Tone-Clock Circuit Pack* in the TONE-BD section.
- g. The system-parameters country-options administration are setup such that a TN780 or TN2182 are required and the existing tone-clock circuit pack will not provide the needed functionality. The Base Tone Generation Set on page 1 or the custom tones beginning on page 2 of the system-parameters country options form may have values not supported by the existing tone-clock.

This error (1281) indicates that the system parameters country-options form has custom tones translated and that the alarmed tone board does not support the customized tones. TN768 tone boards do not support any customized tones. TN780 tone boards support up to 6 customized tones using the following frequencies/levels only:

Silence

350Hz at 17.25 dB

425Hz at 4.0 dB

425Hz at 11.0 dB

425Hz at 17.25 dB

440Hz at 17.25 dB

350Hz+425Hz at 4.0 dB

350Hz+440Hz at 13.75 dB

480Hz at 17.25 dB

620Hz at 17.25 dB

440Hz+480Hz at 19.0 dB

404Hz at 11.0 dB

404Hz at 16.0 dB

480Hz+620Hz at 24.0 dB

404Hz+425Hz at 11.0 dB

375Hz+425Hz at 15.0 dB

404Hz+450Hz at 11.0 dB

1000Hz at 0.0 dB

1000Hz at +3.0 dB

525Hz at 11.0 dB

1400Hz at 11.0 dB

## System Technician-Demanded Tests: Descriptions and Error Codes

Always investigate tests in the order presented in the table below when inspecting errors in the system. By clearing error codes associated with the *SAKI Reset Test* for example, you may also clear errors generated from other tests in the testing sequence.

Order of Investigation	Short Test Sequence	Long Test Sequence	Reset Board Sequence	D/ND <sup>1</sup>
SAKI Reset Test (#53) (a)		X		D
Clock Health Test (#46) (b)	X	X		ND
Control Channel Looparound Test (#52) (a)	X	X		ND
Tone Generator Crosstalk Test (#90)		X		ND
Tone Generator Transmission Test (#40)	X	X		ND
Tone Generator Audit/Update Test (#41)	X	X		ND
TDM Bus Clock Circuit Status Inquiry Test (#148) (c)	X	X		ND
TDM Bus Clock Slip Inquiry Test (#149)(c)(e)	X	X		ND
TDM Bus Clock PPM Inquiry Test (#150) (c)	X	X		ND
TDM Bus Clock Parameter Update Test (#151) (c)	X	X		ND
Board Type Check Test (#574) (c)	X	X		ND
Standby Reference Health Check Test (#651) (c,d)		X		ND

1. D = Destructive; ND = Nondestructive

### Notes:

- a. Refer to XXX-BD (Common Port Circuit Pack) section for descriptions of these tests.



- b. Refer to TONE-BD (Tone-Clock Circuit Pack) section for descriptions of these tests.
- c. Refer to TDM-CLK (TDM Bus Clock) section for descriptions of these tests.
- d. This test only runs on the Standby Tone-Clock circuit pack in a Port Network with more than one Tone-Clock circuit pack (High or Critical Reliability Option). The circuit pack must be a TN780 code with firmware revision 2 or above.
- e. Test #149 does not run on the TN2182.

## Tone Generator Transmission Test (#40)

The purpose of this test is to verify that the tone generation hardware on the tone-clock circuit pack is capable of generating a subset of system tones and a set of test tones. This test does not verify all system tones the tone generator produces during normal system operation.

The test is performed in two parts. For the first part, the Tone Generator is told to generate the touch-tone digits. The digits are received and checked by a Tone Detector touch-tone detector. If any of the digits fail, the test is repeated using a touch-tone detector in another Tone Detector circuit pack.

For the second part, the Tone Generator is told to generate call progress tones that are detected and identified by a tone detector. These tones are:

- 440 Hz
- 2225 Hz
- Digital Count

The tone generator is then told to generate a sequence of test tones whose output levels are measured by a tone detector. These tones are:

- 404 Hz at 0 dB
- 1004 Hz at -16 dB
- 1004 Hz at 0 dB
- 2804 Hz at 0 dB

A Tone Detector general purpose tone detector listens for the tones and measures the quality of the tone. If any of the measured values are not within limits, the test is repeated using a general purpose tone detector in a different Tone Detector circuit pack. If the values are still out of the limits, the test will fail.

For all the failure cases of Test #40, do the following:

1. Check that all Tone Detector circuit packs have the same companding mode as that administered for the system. Correct the situation if there is a mismatch.
2. Run the long test sequence: **test tone-clock PC long repeat 1.**

3. If the problem persists, replace the Tone-Clock circuit pack by following the steps outlined in the "How to Replace the Tone-Clock Circuit Pack" section

**Table 9-672. TEST #40 Tone Generator Transmission Test**

Error Code	Test Result	Description/ Recommendation
None	ABORT	The system was not able to allocate all the resources needed for this test or there was an Internal system error.
1	ABORT	The system could not allocate all the resources needed to test the DTMF tones.
1001	ABORT	The system was not able to put the tone generation facility in the appropriate mode to test it.
1002	ABORT	<p>The system could not allocate time slots for the test connection. This can happen when the system is heavily loaded. If the system is not heavily loaded, then test the TDM Bus via the <b>test tdm port-network PN#</b> command.</p> <ol style="list-style-type: none"> <li>1. Retry the command at 1-minute intervals a maximum of 5 times.</li> </ol>
1003	ABORT	<p>The system could not allocate a tone receiver for the test connection. This can happen when the system is heavily loaded or there is not a Tone Detector circuit pack in the port network where this test is being executed.</p> <ol style="list-style-type: none"> <li>1. Make sure there is a Tone Detector circuit pack in the same port network.</li> <li>2. If a Tone Detector circuit pack is missing, install one in the same port network.</li> <li>3. Allow approximately 1-minute for Tone Detector maintenance to run on the newly inserted Tone Detector circuit pack.</li> <li>4. Retry the command at 1-minute intervals a maximum of 5 times.</li> </ol>
1022	ABORT	<p>[G3r V2] Tone detection for the system is administered as wide broadband (tone detection mode 5), and the Tone Detector used for this test was not a TN420C. (the only circuit packs with this capability). GPTD ports on other types of Tone Detector circuit packs are taken out of service since they cannot provide the administered function.</p> <ol style="list-style-type: none"> <li>1. Change the tone-detection mode administered on the system-parameters country-options form (see <i>DEFINITY Communications System Generic 3 V2 Implementation</i>, 555-230-653,</li> </ol> <p>Or</p> <ol style="list-style-type: none"> <li>2. Remove all non-TN420C circuit packs from the system.</li> </ol>
2000	ABORT	<p>Response to the test request was not received within the allowable time period. System resources required for this test are not available.</p> <ol style="list-style-type: none"> <li>1. Retry the command at 1-minute intervals a maximum of 5 times.</li> </ol>

Table 9-672. TEST #40 Tone Generator Transmission Test — Continued

Error Code	Test Result	Description/ Recommendation
2100	ABORT	System resources required for this test are not available. 1. Retry the command at 1-minute intervals a maximum of 5 times.
1 (a)	FAIL	DTMF generation failed for the active tone generator.
105 (a)	FAIL	Generation of 440-Hz failed.
109 (a)	FAIL	Generation of 2225-Hz failed.
110 (b)	FAIL	Generation of 404-Hz level invalid.
111 (b)	FAIL	Generation of 1004-Hz low level invalid.
112 (b)	FAIL	Generation of 1004-Hz high level invalid.
113 (b)	FAIL	Generation of 2804-Hz level invalid.
115 (b,c)	FAIL	Generation of digital count sequence invalid.
120 (a)	FAIL	Generation of quiet tone failed.
1044 (a)	FAIL	DTMF generation failed to generate Digit 1 for the standby tone generator.
1045 (a)	FAIL	DTMF generation failed to generate Digit 5 for the standby tone generator.
1046 (a)	FAIL	DTMF generation failed to generate Digit 9 for the standby tone generator.
1047 (a)	FAIL	DTMF generation failed to generate Digit D for the standby tone generator.
	PASS	The tone generation facility is able to generate and transmit all the tones.

## Notes:

Except in Port Networks containing more than one Tone-Clock circuit pack, replacing the circuit pack is a service disrupting procedure. The test should be run several times with more than one failure before the replacement policy specified in the following notes is executed. Use the procedure described in *How to Replace the Tone-Clock Circuit Pack* in the TONE-BD section.

- a. All the failure error codes marked with (a) may affect users if the failure is on the active tone generator. When this type failure is detected, the system will attempt to move the tone generation function to the alternate Tone-Clock circuit pack, if one is present in the affected Port Network. When the tone generation facility fails in this way, especially in a Port Network without duplicated Tone-Clock circuit packs, the faulty Tone-Clock should be replaced promptly.
- b. All the failure error codes marked with (b) are almost transparent to the user. Again, when this type failure is detected, the system will attempt to move the tone generation function to the alternate Tone-Clock circuit pack, if one is present in the affected Port Network. Users may or may not hear

any noisy tones. This type of failure affects maintenance on other objects. Maintenance may not be able to run on other objects which use the tone generation facility (that is, Tone Detector Circuit Pack maintenance). In this case, the Tone-Clock circuit pack can be replaced as suitable to the customer.

- c. Error code 115 may also be caused by TDM Bus corruption. This normally means a physical problem with bent backplane pins, TDM/LAN Bus cabling, or TDM/LAN Bus terminators. Such physical problems should especially be suspected if board replacement or other physical activity has occurred just before this error is observed.

Use **display errors** to look for errors on other circuit packs in the carriers of the same Port Network as the indicated Tone-Clock. If any are found, they should be resolved if possible, and the Tone-Clock circuit pack retested. If this does not clear the problem, the Tone-Clock circuit pack should be replaced and the new one tested. If the problem persists, follow instructions for TDM Bus maintenance in this manual.

### Tone Generator Update/Audit Test (#41)

The active tone generation facility is refreshed with all the time slot tone information. This test also triggers in-line error messages the Tone-Clock circuit pack generates when it detects problems by itself.

A check is also made between the type of tone-clock being tested and the type of tone-clock needed based on system administration. The administration on the system-parameters country-options form may imply that a TN780 is required

Table 9-673. TEST #41 Tone Generator Update/Audit Test

Error Code	Test Result	Description/ Recommendation
none	ABORT	The system was not able to allocate all the resources needed for this test.
2100	ABORT	System resources required for this test are not available.

*Continued on next page*

**Table 9-673. TEST #41 Tone Generator Update/Audit Test — Continued**

Error Code	Test Result	Description/ Recommendation
1	FAIL	The system requires a TN780 tone-clock to support the administered country-options tone generation parameters. <ol style="list-style-type: none"> <li>1. Check the administration on the system-parameters country-option form. Specifically, the Base Tone Generation Set on page 1 and any custom tone administration beginning on page 2.</li> <li>2. Replace existing tone-clock circuit packs with TN780.</li> </ol>
	PASS	The tone generation facility has been successfully refreshed with its time-slot translation and system administration is consistent with this type of tone-clock. <ol style="list-style-type: none"> <li>1. Display the Hardware Error Log via the <b>display errors</b> command to make sure this circuit pack did not generate new errors.</li> </ol>

### Tone Generator Crosstalk Test (#90)

This test checks the ability of the Tone Generator to talk on a specific time slot. The tone generator is told to talk on a specific time slot. The other idle time slots are checked to make sure the Tone Generator put the tone on only the specified time slot

**Table 9-674. TEST #90 Tone Generator Crosstalk Test**

Error Code	Test Result	Description/ Recommendation
None	ABORT	Internal system error <ol style="list-style-type: none"> <li>1. Retry the command at 1-minute intervals a maximum of 5 times.</li> </ol>
1001	ABORT	The system was not able to put the tone generation facility in the appropriate mode to test it.
1002	ABORT	The system could not allocate time slots for the test connection. This can happen when the system is heavily loaded. If the system is not heavily loaded, then test the TDM-BUS via the <b>test tdm port-network PN#</b> command.
2000	ABORT	Response to the test request was not received within the allowable time period.
2100	ABORT	Could not allocate the necessary system resources to run this test. <ol style="list-style-type: none"> <li>1. Retry the command at 1-minute intervals a maximum of 5 times.</li> </ol>

*Continued on next page*

**Table 9-674. TEST #90 Tone Generator Crosstalk Test — Continued**

Error Code	Test Result	Description/ Recommendation
	FAIL	<p>The Tone Generator could be defective. In a Port Network with more than one Tone-Clock circuit pack, the system will attempt to move the tone generation function to the alternate one.</p> <ol style="list-style-type: none"> <li>1. Test the Tone-Clock circuit pack again via the <b>test tone-clock UUC</b> command.</li> <li>2. If the test fails again, look at the Hardware Error Log for Tone Detector circuit pack errors.</li> <li>3. If there are Tone Detector circuit pack errors, refer to Tone Detector Maintenance documentation (DTMR-PT, GPTD-PT, CLAS-PT, ETR-PT) to resolve these errors first.</li> <li>4. If there are no Tone Detector circuit pack errors, then the Tone-Clock circuit pack should be replaced. See <i>How to Replace the Tone-Clock Circuit Pack</i> in the TONE-BD section.</li> </ol>
	PASS	<p>The tone generation facility is able to put tones out.</p>

## **TSC-ADM (Administered Temporary Signaling Connections)**

<b>MO Name (in Alarm Log)</b>	<b>Alarm Level</b>	<b>Initial Command to Run</b>	<b>Full Name of MO</b>
TSC-ADM	none	none	Administered Temporary Signaling Connections

No alarms are generated for Administered Temporary Signaling Connections (TSC-ADM, also called ADM TSCs).

Administered temporary signaling connections provide a path through ISDN-PRI networks for supplementary D-channel messages. ISDN-PRI applications such as the Distributed Communications System (DCS) use temporary signaling connections to exchange user information across an ISDN-PRI network. What makes Administered TSCs unique is that these particular TSCs stay active for an extended period of time, similar to a permanent data connection. These ADM TSCs are used for DCS features that require Non-Call Associated (NCA) TSCs, and the ADM TSC provides the logical channel function in a DCS network.

An NCA TSC is a virtual connection established within a D-channel without associating any B-channel connections. The connection provides user-to-user service by exchanging USER INFORMATION messages without associated B-channel connections.

An Administered TSC is a special NCA TSC defined for the DCS over the ISDN-PRI D-channel. The ADM TSC has an administratively defined endpoint and is established for an extended period of time.

There are two types of ADM TSCs:

- **Permanent**

These are established by the originating PBX (Near-end ADM TSC) or by the terminating PBX (Far-end ADM TSC). Once these ADM TSCs are established, they remain active.

- **As-Needed**

These are established only when needed.

ADM TSC maintenance provides a strategy to verify that a far-end can respond to an ISDN-PRI USER INFORMATION TSC heartbeat message, thereby indicating that user-user signaling is functioning. In addition, maintenance can retrieve the status of the ADM TSC's connection state.

Since ADM TSCs are administered on a per signaling group basis, the health of an ADM TSC also depends on the state of the D-channel or D-channel pair administered per signaling group. Refer to ISDN-SGR documentation for details on ISDN-PRI NFAS and D-channel Backup maintenance.

The two administration commands for ADM TSCs are as follows:

- **add signaling group** number
- **change signaling group** number

The two maintenance commands for ADM TSCs are as follows:

- **test tsc-administered signaling group** number [/tsc index]
- **status tsc-administered signaling group** number [/tsc index]

## Error Log Entries and Test to Clear Values

**Table 9-675. ADM TSC Error Log Entries**

<b>Error Type</b>	<b>Aux Data</b>	<b>Associated Test</b>	<b>Alarm Level</b>	<b>On/Off Board</b>	<b>Test to Clear Value</b>
3840-3967 (a)	tsc index #	test tsc-administered			

Note:

- a. There is no Test to Clear Value for error types 3840-3967. These error types provide the following additional data that may prove useful when tracking down problems.

Any of these errors indicates that a TSC Heartbeat Inquiry Test was run on an active far-end Administered TSC from the switch. Upon receiving the heartbeat message, the network communicated that the call was unable to complete. As a result, the error was logged. Check the signaling group status of the D-channel or D-channel pair via the **status signaling-group <group>** command for the Administered TSC. Check the status of the Administered TSC via the **status tsc-administered** command. Also check the administration of the Administered TSC on the switch.

This error may only be affecting service for some DCS customers. Upon receipt of this error condition, the switch will tear down and re-establish the ADM TSC within 20 minutes.



## System Technician-Demanded Tests: Descriptions and Error Codes

Always investigate tests in the order presented in the following tables when inspecting errors in the system. By clearing error codes associated with the *TSC Heartbeat Inquiry Test*, for example, you may also clear errors generated from other tests in the testing sequence.

Order of Investigation	Short Test Sequence	Long Test Sequence	D/ND <sup>1</sup>
TSC Heartbeat Inquiry Test (#604)			ND

1. D = Destructive; ND = Nondestructive

### TSC Heartbeat Inquiry Test (#604)

This test can be invoked by system technician personnel for any ADM TSC administered in the switch. Most of the error conditions on the following table will not log an error, but switched services may take some type of recovery action in certain instances.

This test sends a USER INFORMATION TSC heartbeat message inquiry across an ADM TSC to determine if the far-end can respond to a USER INFORMATION TSC heartbeat message.

**Table 9-676. TEST #604 TSC Heartbeat Inquiry Test**

Error Code	Test Result	Description/ Recommendation
2100	ABORT	Could not allocate the necessary system resources to run this test. 1. Reissue the <b>test tsc-administered</b> command at 1-minute intervals a maximum of 5 times.
1005	ABORT	The Administered TSC does not exist. 1. Display the administration for the Administered TSC. 2. If an Administered TSC exists, reissue the <b>test tsc-administered</b> command.
1113	ABORT	The D-channel is out-of-service. 1. Refer to the "ISDN-LNK".

*Continued on next page*

Table 9-676. TEST #604 TSC Heartbeat Inquiry Test — Continued

Error Code	Test Result	Description/ Recommendation
1145	ABORT	<p>There is congestion in the network.</p> <ol style="list-style-type: none"> <li>Issue the <b>status tsc-administered</b> command at 1-minute intervals a maximum of 5 times.</li> <li>If the congestion does not clear, disable and enable the Administered TSC via the <b>change sig-group &lt;group&gt;</b> command.</li> </ol> <p><b>NOTE:</b> To disable the Administered TSC, display the (administration) Signaling Group Form via the <b>change sig-group &lt;group&gt;</b> command where &lt;group&gt; refers to the number of the signaling group under which the suspect TSC is administered. Change the Enable field to "n." To enable the ADM TSC, change the "Enable" field to "y."</p> <ol style="list-style-type: none"> <li>If the congestion still does not clear, check other nodes in the network.</li> </ol>
1146	ABORT	<p>The congestion just occurred in the network.</p> <ol style="list-style-type: none"> <li>Issue the <b>status tsc-administered</b> command at 1-minute intervals a maximum of 3 times.</li> <li>If congestion does not clear, disable and enable the Administered TSC via the <b>change sig-group &lt;group&gt;</b> command.</li> </ol> <p><b>NOTE:</b> To disable the Administered TSC, display the (administration) Signaling Group Form via the <b>change sig-group &lt;group&gt;</b> command where &lt;group&gt; refers to the number of the signaling group under which the suspect TSC is administered. Change the Enable field to "n." To enable the ADM TSC, change the "Enable" field to "y."</p> <ol style="list-style-type: none"> <li>If congestion still does not clear, check the other nodes in the network.</li> </ol>
1147	ABORT	<p>The ADM TSC is being torn down.</p> <ol style="list-style-type: none"> <li>Issue the <b>status tsc-administered</b> command at 1-minute intervals a maximum of 3 times.</li> <li>If ADM TSC is still down, disable and enable the ADM TSC via the <b>change sig-group &lt;group&gt;</b> command.</li> </ol> <p><b>⇒ NOTE:</b>                      To disable the ADM TSC, display the (administration) Signaling Group Form via the <b>change sig-group &lt;group&gt;</b> command where &lt;group&gt; refers to the number of the signaling group under which the suspect TSC is administered. Change the Enable field to "n." To enable the ADM TSC, change the "Enable" field to "y."</p> <ol style="list-style-type: none"> <li>If the ADM TSC is still down, check the other nodes in the network.</li> </ol>

Continued on next page

**Table 9-676. TEST #604 TSC Heartbeat Inquiry Test — Continued**

Error Code	Test Result	Description/ Recommendation
1148	ABORT	The ADM TSC is enabled, but inactive (near-end). <ol style="list-style-type: none"> <li>1. Disable and enable the ADM TSC.</li> <li>2. Reissue the <b>test tsc-administered</b> command.</li> <li>3. If the ADM TSC is still inactive, check the other nodes in the network.</li> </ol>
1149	ABORT	The ADM TSC is disabled. <ol style="list-style-type: none"> <li>1. Enable the TSC, and see if the status indicates “active.”</li> <li>2. Reissue the <b>test tsc-administered</b> command.</li> <li>3. If the TSC still disabled, remove the ADM TSC from the system.</li> </ol>
1181	ABORT	Ran out of ADM TSC resources. <ol style="list-style-type: none"> <li>1. Reissue the <b>test tsc-administered</b> command at 1-minute intervals a maximum of 3 times.</li> </ol>
1182	ABORT	The BX.25 link is down at the gateway. <ol style="list-style-type: none"> <li>1. Disable the ADM TSC.</li> <li>2. Check the status of the gateway link via the <b>status link link-no</b> command.</li> <li>3. Once the gateway link indicates an “in-service” state, enable the Administered TSC.</li> <li>4. Reissue the <b>test tsc-administered</b> command.</li> </ol>
2000	ABORT	The Administered TSC is not responding to a TSC heartbeat inquiry. <ol style="list-style-type: none"> <li>1. Retry the <b>test tsc-administered</b> command at 1-minute intervals a maximum of 3 times.</li> <li>2. If the problem continues to fail, obtain the status of the D-channel or D-channel pair associated with the ADM TSC via the <b>status sig-group &lt;group&gt;</b> command. If the D-channel is INS (i.e., in-service) and the status of the ADM TSC appears to be active, then disable and enable the ADM TSC through administration.                             <p data-bbox="265 1313 1107 1492">  <b>NOTE:</b>                                  To disable the ADM TSC, display the (administration) Signaling Group Form via the <b>change sig-group &lt;group&gt;</b> command where &lt;group&gt; refers to the number of the signaling group under which the suspect TSC is administered. Change the “Enable” field to “n.” To enable the ADM TSC, change the “Enable” field to “y.”                             </p> </li> <li>3. Reissue the <b>test tsc-administered</b> command.</li> <li>4. If the test fails, check the ADM TSC node on the other side of the network to verify that the ADM TSC is indeed active.</li> </ol>

**Table 9-676. TEST #604 TSC Heartbeat Inquiry Test — Continued**

Error Code	Test Result	Description/ Recommendation
2012	ABORT	Internal system error. 1. Reissue the <b>test tsc-administered</b> command at 1-minute intervals a maximum of 5 times.
1	FAIL	The Administered TSC is not active (far-end). 1. Reissue the <b>test tsc-administered</b> command. 2. Verify that the Administered TSC node on the other side of the network is active. 3. Disable and enable the Administered TSC. 4. Retry the <b>test tsc-administered</b> command.
2	FAIL	Facility IE (Information Element) reject. 1. Check all other nodes in the network, and make sure Administered TSC is active.
	PASS	The Administered TSC responded to a heartbeat.

## TTR-LEV (TTR Level)

MO Name (in Alarm Log)	Alarm Level	Initial Command to Run	Full Name of MO
TTR-LEV	WARNING	1	TTR Level
TTR-LEV	MINOR	<a href="#">1</a>	TTR Level
TTR-LEV	MAJOR	<a href="#">1</a>	TTR Level

- See Repair Procedure for the TTR-LEV below.

TN748 and TN420 Tone Detector circuit packs and TN744 Call Classifier circuit packs provide tone receivers for detecting various types of signaling tones. These circuit packs are shared resources that serve all users of the PBX. This discussion uses the following terms and abbreviations (note that the maintenance-related system parameters form uses different names than the alarm and error logs):

Type of Tone Receiver	Maintenance Object	Also Known As	Alternate Abbreviation	Location
Dual-tone Multifrequency Tone Receiver	DTMR-PT	Touch Tone Receiver	TTR	4 per TN420/TN748
General Purpose Tone Detector	GPTD-PT	Call Progress Tone Receiver	CPTR	2 per TN420/TN748
Call Classifier	CLSFY-PT		CCTR	8 per TN744

TN748s and TN420s each have 4 DTMR-PTs and 2 GPTD-PTs. DTMR-PTs interpret dual-tone multifrequency (DTMF) calling signals and translate them into logical digits 0 through 9, \*, and #. GPTD-PTs detect call progress tones, modem answer tones, and transmission test tones.

TN744 Call Classifier circuit packs have 8 CLSFY-PTs. These ports detect DTMF tones and classify network and MFC (multifrequency compelled) signaling tones. (That is, CLSFY-PTs can function as DTMR-PTs or GPTD-PTs, and have other additional capacities).

When a user goes off-hook to place a call, dial tone is returned to the user, indicating that a tone detector is connected and ready to receive and interpret tones. The tone detector is in use until the total number of digits needed is collected or until a time-out occurs. If all tone detectors in the system are being used simultaneously, the next user to go off-hook will not receive dial tone until a tone detector becomes available. It is therefore necessary to have a sufficient number of tone detectors in the system to prevent delays in receiving dial tone. The **list measurements tone-receiver** command shows the level of tone detector usage. For more information on this command, refer to the following documents:

- *DEFINITY Enterprise Communications Server Release 5.4 Administration and Feature Description*
- *DEFINITY Communications System Generic 3 V2 Traffic Reports, 555-230-511*

In order to prevent dial-tone delays and other shortcomings in system performance, threshold levels for the 3 types of tone receivers are administered on the **change system-parameters maintenance** form. Whenever the number of tone receivers in service falls below the administered threshold for that type of tone receiver, an alarm is logged against the TTR Level maintenance object. At this point, the system is operating properly, but call processing capacity is reduced. Another alarm is logged if the number falls to zero. At this point, system operation is severely compromised.

Typical causes of these events are:

1. The threshold for GPTD-PTs or DTMR-PTs is administered incorrectly on the maintenance-related system parameters form.
2. Too many GPTD-PTs, DTMR-PTs, or CLSFY-PTs have been taken out of service, possibly by maintenance software or a demand busyout.
3. A tone detector circuit pack has been removed or suffered a fatal failure, resulting in the loss of all its ports.
4. The system has an insufficient number of TN748/TN744/TN420 circuit packs.

## Repair Procedure for TTR-LEV

To resolve a TTR-LEV alarm:

1. **Display errors** and use the TTR-LEV Error Log Table to determine which type of tone receiver has fallen below its threshold.
2. Enter **change system-parameters maintenance**, and check the administered value. On the form, TTR represents DTMR-PTs, CPTR represents GPTD-PTs, and Call Classifier represents CLSFY-PTs. If the threshold value is set too high, change it to a lower value and wait a minute for the alarm to clear.

To determine the correct thresholds, first find the total number of TN478/TN420 Tone Detector and TN744 Call Classifier circuit packs in the system using the **list configuration** command. Then calculate the total number of tone receiver ports of each type. Each Tone Detector circuit pack has 4 TTR (DTMR) ports and 2 CPTR (GPTD) ports. Each TN744 Call Classifier circuit pack has 8 Call Classifier (CLSFY-PT) ports.

For each type of tone receiver, if the total number of ports installed in the system is less than the administered threshold, then either add more circuit packs to the system or reduce the threshold to match the number already in the system. If the TTR Level alarm is still present, then proceed to Step 3.

3. **Display errors** for error type 18 and look for GPTD-PTs, DTMR-PTs, or CLSFY-PTs that have been busied out.

For each of the busied-out ports:

- Determine why the port was busied out.
- If the port can be placed back into service, then test the port via the **test port UUCSSpp** command.
- If all tests pass, **release port** and wait 1-minute for the TTR Level alarm to clear.

If this does not clear the TTR Level alarm, proceed to Step 4.

4. **Display alarms** and determine the location of the circuit pack with the alarmed GPTD-PT, DTMR-PT, or GPTD-PT.

**Test board UUCSS** long rep 3 for that circuit pack.

If this does not clear the TTR Level alarm, replace the Tone Detector or Call Classifier circuit pack with the alarmed GPTD-PT, DTMR-PT or CLSFY-PT.

## Error Log Entries and Test to Clear Values

**Table 9-677. TTR Level Error Log Entries**

Error Type	Aux Data	Associated Test	Alarm Level	On/Off Board	Test to Clear Value
1 (a)	1	None			
2 (b)	2		WARNING (See WARNING message below)	OFF	
3 (c)	3	None			
4 (d)	4		WARNING	OFF	
5 (e)	5	None			
6 (f)	6		WARNING	OFF	
7 (g)	7		MAJOR	OFF	
8 (h)	8		MINOR	OFF	
9 (i)	9		MINOR	OFF	

**WARNING:**

*The Alarm is upgraded to MAJOR if the Base Tone Generator is set to 12 (France).*

**Notes:**

- a. Error code 1 does not indicate a current error condition. It indicates that the number of DTMR ports in service was below the administered threshold, but is now equal to or greater than the threshold. These errors are typically generated during boot time or other transitional states when the ports are being brought into service.
- b. The total number of DTMR ports currently in service is below the administered threshold. To clear the alarm, refer to the repair procedure described above.
- c. Error code 3 does not indicate a current error condition. It indicates that the number of GPTD ports in service was below the administered threshold, but is now equal to or greater than the threshold. These errors are typically generated during boot time or other transitional states when the ports are being brought into service.
- d. The total number of GPTD ports currently in service is below the administered threshold. To clear the alarm, refer to the repair procedure describe above.



- e. Error code 5 does not indicate a current error condition. It indicates that the number of Call Classifier ports (CLSFY-PT) service was below the administered threshold, but is now equal to or greater than the threshold. These errors are typically generated during boot time or other transitional states when the ports are being brought into service.
- f. The total number of Call Classifier ports (CLSFY-PT) currently in service is below the administered threshold. To clear the alarm, refer to the repair procedure described above.
- g. There are currently no DTMR ports in service. To clear the alarm, refer to the repair procedure described above.
- h. There are currently no GPTD ports in service. To clear the alarm, refer to the repair procedure described above.
- i. There are currently no Call Classifier ports (CLSFY-PT) in service. To clear the alarm, refer to the repair procedure described above.

## UDS1-BD (UDS1 Interface Circuit Pack)

---

MO Name (in Alarm Log)	Alarm Level	Initial Command to Run <sup>1</sup>	Full Name of MO
UDS1-BD	MAJOR	test board UUCSS sh	UDS1 Interface Circuit Pack
UDS1-BD	MINOR	test board UUCSS I	UDS1 Interface Circuit Pack
UDS1-BD	WARNING	test board UUCSS sh	UDS1 Interface Circuit Pack

1. UU is the universal cabinet number (1 for PPN, 2 - 44 for EPNs). C is the carrier designation (A, B, C, D, or E). SS is the number of the slot in which the circuit pack resides (01 to 21).

### 2Mbit Japan trunk (TN2242)

---

The TN2242 2Mbit, 30-port trunk circuit pack supports Japanese TTC private networking environments. This circuit pack interfaces only with network equipment or other circuit packs of the same model and is incompatible with all other digital trunk circuit packs.

The maintenance strategy for the TN2242 is similar to that of the TN464F DS1 interface circuit pack. The TN2242 circuit pack is functionally the same as the TN464F (without ICSU) with the following exceptions:

- The Blue Alarm Inquiry Test (#139) always passes for the TN2242.
- The **test ds1-loop** command is not executed for the TN2242.
- A different initialization message is sent when the local looparound test (Test #135) is executed when **reset board** is run on a TN2242.
- Any tests associated with an Integrated Channel Service Unit (ICSU) are not executed, since ICSU is not supported on this circuit pack.
- Any tests associated with new functionality available with the video-enabled TN464F are not executed for the TN2242.
- Cyclical Redundancy Check (CRC) is not defined for this circuit pack.
- The D-Channel can be user-assigned to any port 1 - 30 when the signaling mode is ISDN-PRI.
- Wideband is not supported.
- Stations (OPS) are not supported.

The TN2242 circuit pack also supports specialized versions of CAS (Channel Associated Signaling) and ISDN-PRI signaling that pertain to the TTC private networking environment in Japan.

## Upgrading to TN2242

[Figure 9-108](#) shows the hardware connections for public network access in Japan. The upgrade procedure requires removing the JRC (Japan Radio Corporation) external converter in [Figure 9-108](#).

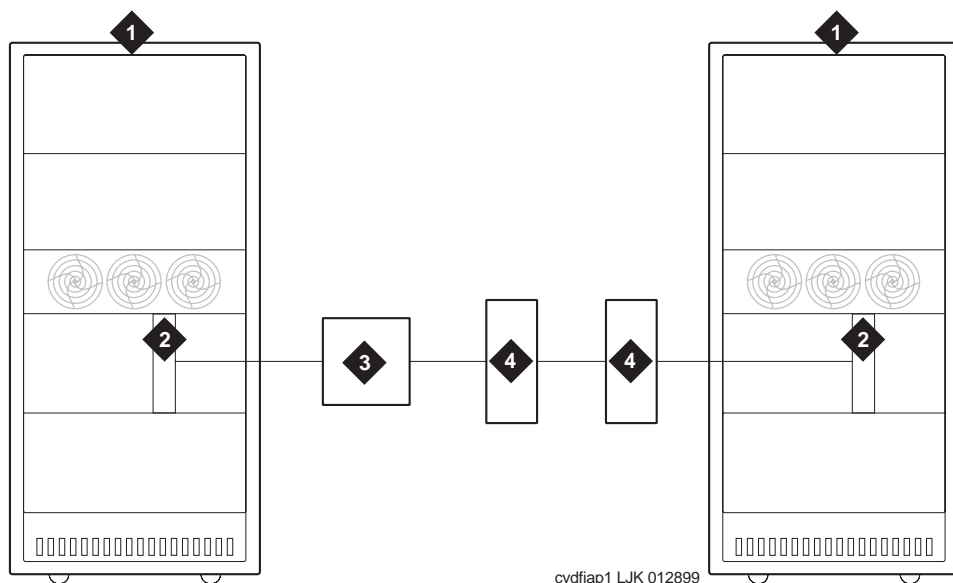

### Figure Notes:

- |   |   |
|---|---|
| 1. DEFINITY Release 7   | 3. JRC (Japan Radio Corporation) external converter |
| 2. TN464F DS1-CONV circuit pack<br>(24-trunk digital tie-trunk) | 4. TDM facilities                                   |

**Figure 9-108. Japanese TTC public network connections**

Figure 9-109 shows the hardware connections for private network access using the TN2242 circuit pack.

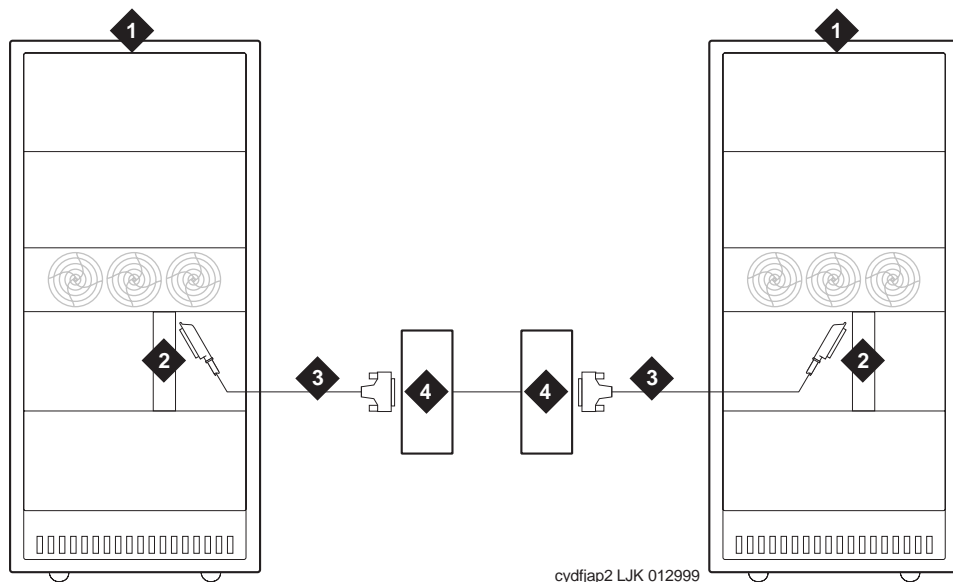

**Figure Notes:**

1. DEFINITY Release 7
2. TN2242 2Mbit Japan trunk circuit pack
3. H600-513 cable assembly cable. (See "[H600-513 cable pinout](#)").
4. TDM facilities

**Figure 9-109. TN2242 Japan trunk TTC private network connections**

To upgrade a system to the TN2242 circuit pack:

1. Busyout the TN464F DS1-CONV circuit pack (**busyout board UUCSS**).
2. Remove the TN464 administration (**change circuit pack, change ds1, and change trunk group n**).
3. Remove the TN464F circuit packs.
4. Remove the JRC (Japan Radio Corporation) external converter and cable.
5. Insert the TN2242 circuit packs.
6. Connect the TN2242 to the TDM with the H600-513 cable assembly.
7. Administer the TN2242 circuit pack (see "[Administration](#)").

## H600-513 cable pinout

[Table 9-678](#) shows the pinout for the H600-513 cable assembly:

**Table 9-678. H600-513 cable assembly pinout**

TN2242			TDM	
50-pin connection pin number	Color	Lead Designation	Color	15-pin connection pin number
22	W-BL	Line in +	W-BL	4
23	W-O	Line out -	W-O	9
47	BI-W	Line in -	BI-W	11
48	O-W	Line out +	O-W	2

## Administration

The TN2242 circuit pack requires board-level translation data. Before administering any ports on the circuit pack, administer the following forms:

- Circuit pack (**change circuit pack**)
- DS1 (**add ds1**)
- Trunk group (**add trunk group n**)

[Table 9-679](#) outlines the trunk group administration parameters that are required for this interface to operate successfully in Japan.

**Table 9-679. TN2242 administration**

Field	Value
<b>Trunk Group form, Page 1</b>	
Trunk Type (in/out)	wink, delay, immed (all permutations)
Trunk Signaling Type	blank
Answer Supervision Timeout	0
Receive Answer Supervision	y
Disconnect Supervision - In?	y
Disconnect Supervision - Out?	y

*Continued on next page*

**Table 9-679. TN2242 administration — Continued**

<b>Field</b>	<b>Value</b>
Incoming Dial Type	tone rotary mf (to other DEFINITYs only)
Wink Timer for wink type	300
Wink Timer for delay type	4500
<b>Trunk Group form, Page 3 (Administrable Timers)</b>	
Incoming Disconnect	100
Incoming Glare Guard	800ms or higher
Incoming Dial Guard	10
Incoming Incomplete Dial Alarm	25 or higher
Incoming Partial Dial	18
PPS	10 or 20
Make (for PPS 10)	35
Break (for PPS 10)	65
Make (for PPS 20)	15
Break (for PPS 20)	35
Outgoing Disconnect	100
Outgoing Glare Guard	800 or higher
Outgoing Rotary Dial Interdigit	800
Outgoing Seizure Response	5

## LEDs

The LEDs on the faceplate of the TN2242 circuit pack indicate its status as described in [Table 9-680](#).

**Table 9-680. TN2242 LED interpretation**

LED	Meaning
Red	<ul style="list-style-type: none"><li>■ MAJOR alarm</li><li>■ MINOR alarm</li><li>■ Firmware initialization during circuit pack insertion</li></ul>
Yellow	A port on the circuit pack is in use.
Green	Maintenance testing is in progress on the circuit pack or its ports.

## Interactions with other MOs

The TN2242 maintenance object directly interacts with these maintenance objects:

- [“Synchronization”](#)
- [“TN2242 trunk ports”](#)
- [“Call processing”](#)

### Synchronization

The DS1 facility plays a vital role in the synchronization subsystem. The Tone/Clock circuit pack uses either the primary or secondary timing reference, whether internal (local -- Tone/Clock circuit pack) or external. TN2242 circuit packs can be administered as “primary” or “secondary” synchronization references.

TN2242 circuit pack sends DS1 link status information to the synchronization reference switching algorithm that determines whether timing references should be switched due to failure or restore conditions.

### TN2242 trunk ports

The TN2242 circuit pack MO is responsible for monitoring the health of the DS1 facility. If a DS1 facility goes down, then that facility’s DS1 circuit pack instructs all DS1 port MOs associated with the facility to place their trunks (or ISDN-PRI signaling link) in an out-of-service state.

### Call processing

The **busyout board** command tears down all calls and signaling links associated with a TN2242 circuit pack.

## **TN2242 serviceability**

---

### **Hardware connections**

This circuit pack can be

- mated to another circuit pack of the same type when interconnecting two DEFINITYs.
- directly-connected to the TDM network device.
- directly-connected to another vendor PBX using ISDN PRI signaling.

### **Loopbacks**

- There is no process to automatically signal the remote end to provide loopbacks for testing purposes. All loopbacks to be tested with a single circuit pack must be local loopbacks on the circuit pack.
- Remote loopbacks may be possible with the TDM network equipment with appropriate coordination between BCS Services Technicians and the service technicians of the TDM equipment (considered a CPE device).

The TN464C, D, E, and F Universal DS1 Interface circuit packs provide an interface to the DS1 facility and are designed to support 24 DS0 channels on a 1.544 Mbps DS1 link or 32 DS0 channels on a 2.048 Mbps link. (The 32-channel interface is not supported on G3r V1 systems.) The DS0 channels can be administered as trunks to other switches, lines to off-premises stations, ports to line-side PRI terminating devices, or ports to other line-side non-PRI terminating devices. (DS0 channels on TN464/Bs can only be administered as trunks to other switches.) For more information on how TN464 ports can be used, see the following sections in this chapter ISDN-SGR, ISDN-TRK, ISDN-LNK, PE-BCHL, TIE-DS1, CO-DS1, DID-DS1, OPS-LINE and WAE-PT. For information on other DS1 circuit packs, see DS1-BD.

Throughout this section on the UDS1-BD MO name, the term TN464 will mean any TN464C or later suffix UDS1 circuit pack. If part of this section refers to a specific suffix TN464 board, it will be noted as such.

The UDS1 maintenance strategy includes logging in-line errors reported by the UDS1 circuit pack, running tests for error diagnosis and recovery, and raising or clearing maintenance alarms.

TN464 circuit packs support the following:

- Digital Tie, CO, and DID trunks
- DS1 off-premises (OPS) lines
- Narrowband and wideband access endpoint ports
- ISDN-PRI trunks and accompanying signaling channel



- PRI endpoint ports (PE-BCHL) and accompanying signaling channel

The TN464 supports digital Tie, CO, and DID trunks, and OPS lines. On-board firmware performs call control signaling for the Tie, CO and DID trunks and OPS lines. ISDN-PRI trunk and PRI endpoint signaling (Q.921, Q.931) is received and generated by system software and is transmitted on a system link through the TN1655 Packet Interface and packet bus to the UDS1 where it is placed on the D-channel. Signaling over the DS1 link has to be synchronized between the transmitting and receiving ends to ensure error-free communication. Refer to [“SYNC \(Synchronization\)”](#) in this chapter for details.

Each trunk, line or endpoint has its own maintenance strategy but all depend on the health of the UDS1 Interface circuit pack. Refer to the following sections for details: TIE-DS1, CO-DS1, DID-DS1, OPS-LINE, ISDN-TRK, ISDN-LNK, ISDN-SGR, WAE-PT and PE-BCHL. The maintenance strategy for the TN464 UDS1 Interface circuit pack (UDS1-BD) is very similar to the maintenance strategy for the TN767 DS1 Interface circuit pack (DS1-BD). The same commands are used for administering and testing the boards. The differences in maintenance strategy between the boards are due to the UDS1 circuit pack's direct interface to the Packet Bus which is used for ISDN-PRI signaling (ISDN-LNK). While both the TN464 and TN767 can support ISDN-PRI B-channels, ISDN-PRI D-channel signaling applications require a TN464 UDS1 circuit pack.

The TN464F or later circuit pack combined with the 120A1 CSU Module forms an Enhanced Integrated CSU. The new 120A1 CSU Module, when combined with the functionality provided by the TN464F hardware and firmware, and new switch software, provides functionality equivalent to an external stand-alone Lucent ESF T1 CSU. The 120A1 CSU Module connects to the TN464F circuit pack on the I/O connector panel on the back of the port carrier. The new CSU Module, thus becomes an integrated part of the DEFINITY. system. Throughout the document, the term 120A1 will mean a 120A1 or later suffix CSU Module.

The Enhanced Integrated CSU is for use in the United States of America with 1.544 Mbps DS1 service. For further details on the 120A1 CSU Module see *DEFINITY Communications System Generic 1, Generic 2, and Generic 3 V1 and V2 - Integrated CSU Module Installation and Operation*.

The TN464F and 120A1 CSU Module support on-demand loopback tests that assist in the detection of faults between the TN464F circuit pack and the CSU Module, between the Integrated CSU and the optional Customer Premises Loopback Jack, or between the Integrated CSU and remote CSU. These loopback tests are explained in detail later in this UDS1-BD section, but [Figure 9-110](#) gives a high level overview of the loopback points.

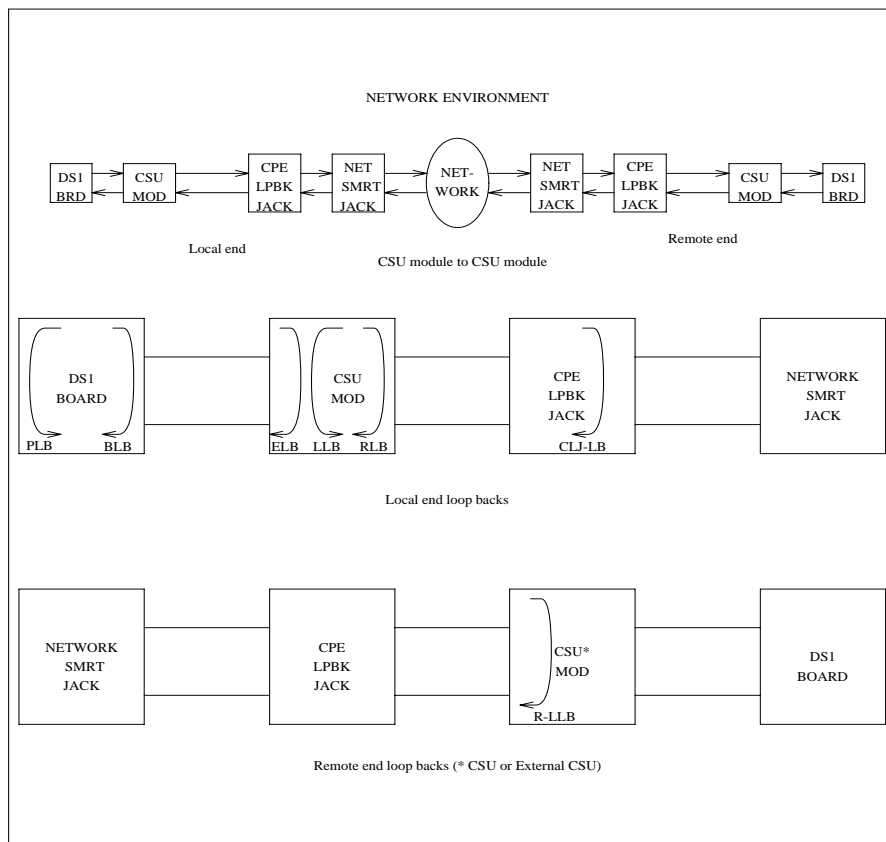

**Figure 9-110. High Level Overview Of Loopback Points**

The following list of acronym definitions are for the [Figure 9-110](#):

- PLB = Payload Loopback
- BLB = Board Loopback
- ELB = Equipment Loopback
- LLB = Line Loopback
- RLB = Repeater Loopback
- CLJ = Loopback Jack Loopback
- R-LLB = Remote Line Loopback
- SMRT = Smart Jack
- LPBK = Loopback

## Circuit Pack Administration and Options

The DS1 configuration for each circuit pack is administered on the DS1 Circuit Pack form. *Bit Rate* is set to 1.544 Mbps for 24-channel systems, and 2.048 Mbps for 32-channel systems. *Country Protocol* is used to drive layer 3 protocol decisions based on PRI specifications specific to a given country (not those related to specific features). This Country Protocol is independent of the *Country* parameter administered on the country-options system-parameters form. Different UDS1 circuit packs may be administered with different Country Protocols, allowing the switch to act as a gateway between two incompatible ISDN-PRI implementations (for example, between two different countries). US systems use country protocol 1. *Near-End CSU Type* is set to *other* for no CSU installed or for an external CSU such as an Lucent ESF T1 CSU, or *integrated* for the 120A1 CSU Module. Answering *integrated* will cause additional fields to be displayed for administering the Enhanced Integrated CSU Module. In addition to the above there are numerous other fields defining such parameters as framing modes, line coding companding mode and so on. For details, see *DEFINITY Communications System Generic 3 V2 Implementation*, 555-230-653, and *DEFINITY Communications System Generic 2.2 and Generic 3 V2 DS1/CEPT/ISDN-PRI Reference*, 555-025-107.

Two option jumpers located on the side of the TN464C/D circuit pack must be installed correctly. The figures on the following page shows how to configure the circuit pack for 24-channel or 32-channel DS1, and for 75\*W (coaxial) or 120\*W trunk connections. The channel selection must match the parameters administered on the corresponding DS1 Circuit Pack Form. (US applications use 24 Channels.)

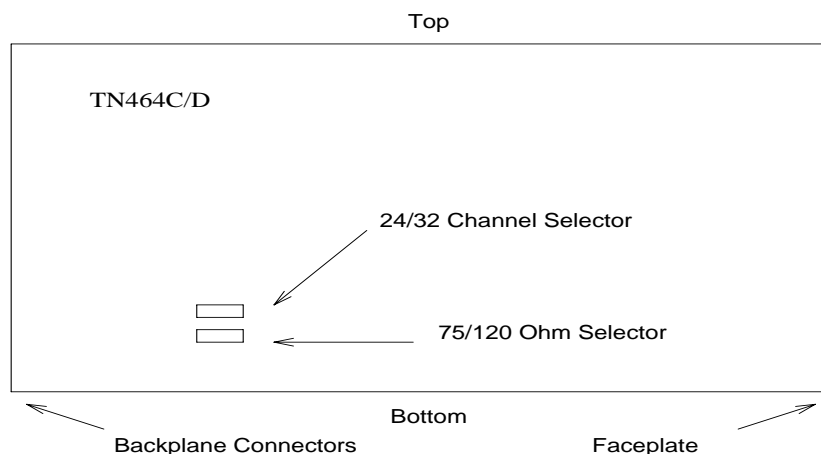

**Figure 9-111.** TN464C/D DS1 Option Jumpers

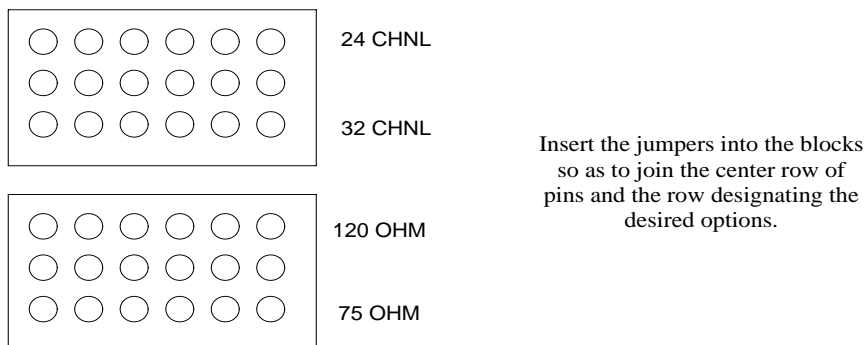

**Figure 9-112. TN464C/D DS1 Option Jumpers (Continued)**

The option switch located on the component side of the TN464E/F circuit pack must be set correctly. [Figure 9-113](#) shows how to configure the circuit pack for 24-channel or 32-channel DS1. The channel selection must match the parameters administered on the corresponding DS1 Circuit Pack Form. (US applications use 24 Channels.)

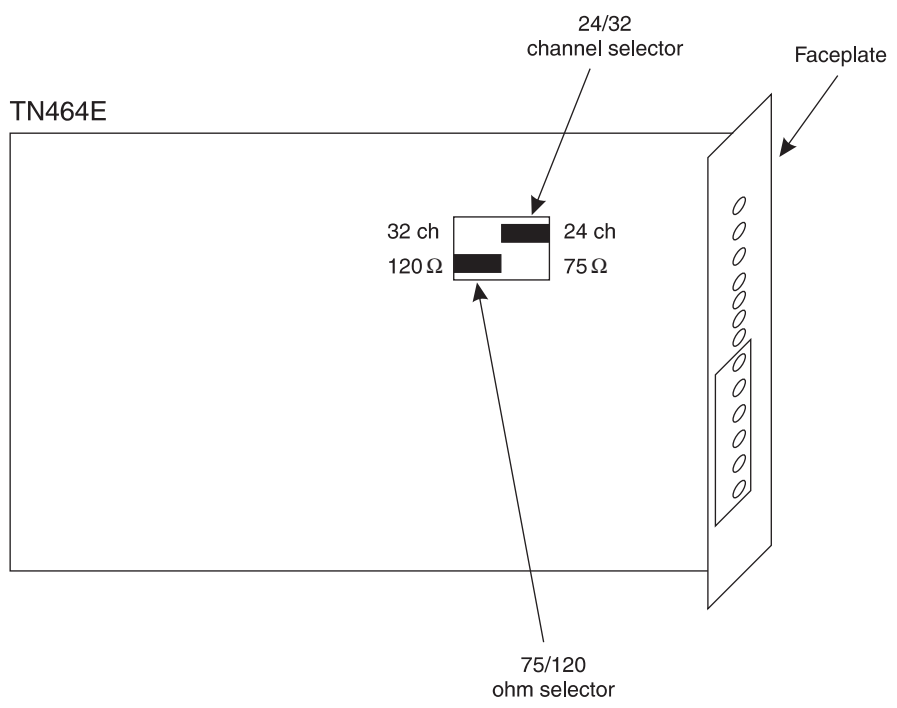

Figure 9-113. TN464E/F DS1 Option switches

## Error Log Entries and Test to Clear Values

**Table 9-681. DS1 Interface Circuit Pack Maintenance Error Log Entries**

Error Type	Aux Data	Associated Test	Alarm Level	On/Off Board	Test to Clear Value
0 <sup>1</sup>	0	Any	Any	Any	test board UUCSS
1(a)	0	Circuit pack removed or SAKI Test (#53)	MIN/WRN <sup>2</sup>	ON	
18(b)	0	busyout board UUCSS	WARNING	OFF	release board UUCSS
23(c)	0		WARNING	OFF	add ds1 UUCSS
125(d)	none 3	None	MIN/WRN <sup>3</sup>	ON	
257	65535	Control Channel Loop Test (#52)	MINOR	ON	test board UUCSS l r 20
257(e)	Any	None			
513(f)	Any		MIN/WRN <sup>3</sup>	ON	
514(g)	46086		MIN/WRN <sup>3</sup>	ON	
769(h)	46085		MIN/WRN <sup>3</sup>	ON	
770(i)	46096		MIN/WRN <sup>3</sup>	ON	
1025(e)	4363	NPE Audit Test (#50)			
1281	Any	Loss of Signal Alarm Inquiry Test (#138)	MIN/WRN <sup>3</sup>	OFF	test board UUCSS
1300(j)	Any	Loss Of Signal Alarm Inquiry Test (#138)	WARNING	OFF	test board UUCSS
1301(k)	Any	Loss Of Signal Alarm Inquiry Test (#138)	WARNING	OFF	test board UUCSS
1302(l)	Any	Loss Of Signal Alarm Inquiry Test (#138)	MIN/WRN <sup>3</sup>	OFF	test board UUCSS
1303(m)	Any	Loss Of Signal Alarm Inquiry Test (#138)	MIN/WRN <sup>3</sup>	ON	test board UUCSS
1310(n)	Any	Board Loopback Test (#1209)	MINOR	ON	test ds1-loop UUCSS ds1/csu-loopback-tests
1311(o)	Any	Equipment Loopback Test (#1210)	MIN/WRN <sup>3</sup>	OFF	test ds1-loop UUCSS ds1/csu-loopback-tests
1312(p)	Any	Repeater Loopback Test (#1211)	MIN/WRN <sup>3</sup>	OFF	test ds1-loop UUCSS ds1/csu-loopback-tests
1313(q)	Any	CPE Loopback Jack Test (#1212)	MIN/WRN <sup>3</sup>	OFF	test ds1-loop UUCSS end-loopback/span-test

*Continued on next page*

**Table 9-681. DS1 Interface Circuit Pack Maintenance Error Log Entries — Continued**

Error Type	Aux Data	Associated Test	Alarm Level	On/Off Board	Test to Clear Value
1314(r)	Any	Far CSU Loopback Test (#1213)	MIN/WRN <sup>3</sup>	OFF	test ds1-loop UUCSS end-loopback/span-test
1320	Any	Loss of Signal Alarm Inquiry Test (#138)	MIN/WRN <sup>3</sup>	OFF	test board UUCSS
1321	Any	Loss of Signal Alarm Inquiry Test (#138)	MIN/WRN <sup>3</sup>	OFF	test board UUCSS
1322	Any	Loss of Signal Alarm Inquiry Test (#138)	MINOR	ON	test board UUCSS
1323	Any	Loss of Signal Alarm Inquiry Test (#138)	MIN/WRN <sup>3</sup>	OFF	test board UUCSS
1324	Any	Loss of Signal Alarm Inquiry Test (#138)	WARNING	OFF	test board UUCSS
1537(s)	46082		MIN/WRN <sup>3</sup>	ON	
1538(t)	Any		MIN/WRN <sup>3</sup>	ON	
1793	Any	Blue Alarm Inquiry Test (#139)	MAJ/MIN/WRN <sup>4</sup>	OFF	test board UUCSS
1794	Any	Blue Alarm Inquiry Test (#139)	MAJ/MIN/WRN <sup>4</sup>	OFF	test board UUCSS
1795	Any	Blue Alarm Inquiry Test (#139)	MAJ/MIN/WNG <sup>4</sup>	OFF	test board UUCSS
2049	Any	Red Alarm Inquiry Test (#140)	MIN/WRN <sup>3</sup>	OFF	test board UUCSS
2305	Any	Yellow Alarm Inquiry Test (#141)	MIN/WRN <sup>3</sup>	OFF	test board UUCSS
2306	Any	Yellow Alarm Inquiry Test (#141)	MIN/WRN <sup>3</sup>	OFF	test Board UUCSS
2561	Any	Major Alarm Inquiry Test (#142)	MIN/WRN <sup>3</sup>	OFF	test board UUCSS
2817		Minor Alarm Inquiry Test (#143)	MIN/WRN <sup>3</sup>	OFF	test board UUCSS
3073 to 3160 (u)	Any	Slip Alarm Inquiry Test (#144)	MIN/WRN <sup>3</sup>	OFF	test board UUCSS r 6
3330(v)	46083		MIN/WRN <sup>3</sup>	ON	
3585 to 3601 (w)	Any	Misframe Alarm Inquiry Test (#145)	MIN/WRN <sup>3</sup>	OFF	test board UUCSS r 6
3840(x)	Any	None			

*Continued on next page*

Table 9-681. DS1 Interface Circuit Pack Maintenance Error Log Entries — *Continued*

Error Type	Aux Data	Associated Test	Alarm Level	On/Off Board	Test to Clear Value
3841(y)	4358				
3842(z)	46097				
3843(aa)	46081				
3900(ab)	Any	CPE Loopback Jack Test (#1212)			
3901(ac)	Any	Far CSU Loopback Test (#1213)			
3902(ad)	Any	One-Way Span Test (#1214)			
3999(ae)	Any	None			

1. Run the Short Test Sequence first. If all tests pass, run the Long Test Sequence. Refer to the appropriate test description and follow the recommended procedures.
2. If ports are assigned to the circuit pack, then a minor alarm is raised. If no ports are assigned to the circuit pack, then a warning alarm is raised. The alarm is raised after the circuit pack has been missing for a period of 15 minutes. Warning alarms are also raised against any ports administered on the circuit pack.
3. Minor alarms on this MO may be downgraded to warning alarms based on values set in the **set options** command.
4. Major alarms on this MO may be downgraded to minor or warning alarms based on values set in the **set options** command.

**Notes:**

- a. Error 1 indicates that the circuit pack has totally stopped functioning or is not fully administered. The alarm is logged about 15 minutes after the circuit pack has been removed or 11-minutes after the SAKI Test (#53) fails.

To be fully administered, a UDS1 circuit pack must meet all of these 3 conditions:

1. Have an entry in the circuit plan via the **change circuit pack** command
2. Be administered via the **add ds1 UUCSS** command
3. Be physically inserted into the correct slot

If the circuit pack has an entry in the circuit plan and either of the other two conditions are *not* met, a MINOR alarm is logged. To resolve the error either



1. Make sure all conditions for administration are met and that a functioning UDS1 circuit pack is inserted in the correct slot, or
2. Completely remove the UDS1-BD from the system using the following steps:
  - a. Remove any administered DS1 trunks, access endpoints or PRI endpoints associated with the circuit pack from their trunk groups.
  - b. Execute the **remove ds1 UUCSS** and **change circuit pack UUCSS** commands.

If all the administration conditions are met for this circuit pack and the red LED is still on, follow the instructions for *LED Alarms with Error Type 1* in Chapter 7.

- b. The UDS1 Interface circuit pack has been busied out by a **busyout board UUCSS** command.
- c. The UDS1-BD circuit pack is not completely administered. To be fully administered, the UDS1 circuit pack must:
  1. Have an entry in the circuit plan via the **change circuit pack** command,
  2. Be administered via the **add ds1 UUCSS** command, and
  3. Be physically inserted into the correct slot.

A DS1 (UDS1-BD and DS1-BD) differs from most circuit packs in that inserting the circuit pack into the switch is not enough to make the board usable. It must also be administered with the **add ds1** command.

- d. No Aux Data: A wrong circuit pack is inserted in the slot where this circuit pack is logically administered. To resolve this problem, either remove the wrong circuit pack and insert the logically administered circuit pack OR use the **change circuit-pack** command to readminister this slot to match the circuit pack inserted.

Aux Data 3: The 24/32-channel option jumper setting on the circuit pack does not match the option set on the DS1 circuit pack administration form. The circuit pack must be physically removed to see the setting of the jumper.

- e. This error is associated with the Common Port Circuit Pack Maintenance Test. Refer to XXX-BD (Common Port Circuit Pack) Maintenance documentation for details.
- f. The UDS1 Interface circuit pack has detected a transient hardware problem. The value in the Aux Data field indicates the type of hardware problem.

4352	External RAM failure
4353	Internal RAM failure
4355	Internal ROM failure

If the UDS1 board detects only one of these hardware problems, then the error will disappear when none of these faults are detected for 10 minutes. If the same Aux Data value is logged more than once in a 24 hour period, the circuit pack should be replaced.

- g. LAN External RAM Error. This error occurs when there is a hardware fault in the PPE external RAM. The RAM is used for message buffering to and from the Packet Bus. This error should not occur regularly. If this error is seen quite frequently (10 times within 30 minutes), the circuit pack should be replaced.
- h. Transmit FIFO Underflow Error. This error occurs when the circuit pack cannot find the "end of frame" bit when transmitting a frame to Packet Bus. An alarm will be raised if this error occurs three times within 10 minutes. Clear the alarm via the following commands: **busyout board UUCSS**, **reset board UUCSS**, **test board UUCSS long**, **release board UUCSS**. If the error recurs within 10 minutes, then replace the circuit pack.
- i. Unable to Write LAN Translation RAM Error. This error occurs when a call is aborted because there are no available translation RAM locations for the call connection attempt. An alarm will be raised if this error occurs two times within 10 minutes. Clear the alarm via the following commands: **busyout board UUCSS**, **reset board UUCSS**, **test board UUCSS long**, **release board UUCSS**. If the error recurs within 10 minutes, then replace the circuit pack.
- j. CSU Module missing. The *Near-End CSU Type* field on the *add ds1* form has been administered as *integrated* but the 120A1 CSU Module is not physically connected (or is improperly connected) to the TN464F board on the back of the port carrier.

If using the 120A1 CSU Module, plug (or replug) the CSU Module into the TN464F circuit pack's connector on the I/O connector panel on back of the carrier. Otherwise, change the *Near-End CSU Type* field using the *change ds1* form to *other*.

If this error remains after plugging the CSU Module into the board's connector, there could be a problem with the I/O connector panel.

- k. CSU Module not expected. The 120A1 CSU Module is physically connected to the TN464F board on the back of the port carrier but the *Near-End CSU Type* field on the *add ds1* form has not been administered as *integrated*.

If the 120A1 CSU Module is to be used, use the *change ds1* command to change the *Near-End CSU Type* field to *integrated*. Otherwise, physically remove the 120A1 CSU Module from the back of the port carrier.

- l. DS1 configuration error. Attempting to use the 120A1 CSU Module with a TN464F circuit pack that is configured for 32-channel (2.048 Mbps) operation. The CSU Module only works with a DS1 board configured for 24-channel (1.544 Mbps) operation in the United States of America.

- m. DS1 circuit pack suffix incorrect for CSU Module. The *Near-End CSU Type* field on the *add ds1* form has been administered as *integrated* but the DS1 circuit pack is not a TN464F or later suffix UDS1 board.

If the 120A1 CSU Module is to be used, remove the circuit pack and replace it with a TN464F or later suffix board. Otherwise, use the *change ds1* command to change the *Near-End CSU Type* field to *other*.

- n. BLB failure. This error occurs when the DS1 Board Loopback (BLB) demand test fails. Repeat the test using the following commands: *busyout board UUCSS, test ds1-loop UUCSS ds1/csu-loopback-tests, release board UUCSS*. If the BLB test continues to fail, then the TN464F circuit pack needs to be replaced.
- o. ELB failure. This error occurs when the Integrated CSU (I-CSU) Module Equipment Loopback (ELB) test fails. This test is executed by the I-CSU during I-CSU power-up/reset (i.e.- TN464F board physically inserted and 120A1 CSU Module already installed) or when the 120A1 CSU Module is plugged on to an already initialized TN464F DS1 board. The ELB test is also executed as part of the command *test ds1-loop UUCSS ds1/csu-loopback-tests*.

Attempt to clear the alarm via the following commands: *busyout board UUCSS, test ds1-loop UUCSS ds1/csu-loopback-tests, release board UUCSS*. If the ELB test continues to fail, then either the TN464F board, the CSU Module, or the I/O cable between the backplane and the CSU module (or any combination thereof) has failed. Attempt to isolate where the failure is occurring by re-executing the test and by replacing one piece of hardware at a time.

- p. RLB failure. This error occurs when the Integrated CSU (I-CSU) Module Repeater Loopback (RLB) test fails. This test is executed by the I-CSU during I-CSU power-up/reset (i.e.- TN464F board physically inserted and 120A1 CSU Module already installed) or when the 120A1 CSU Module is plugged on to an already initialized DS1 board. The RLB test is also executed as part of the command *test ds1-loop UUCSS ds1/csu-loopback-tests*.

Attempt to clear the alarm via the following commands: *busyout board UUCSS, test ds1-loop UUCSS ds1/csu-loopback-tests, release board UUCSS*. If the RLB test continues to fail, then the CSU Module needs to be replaced.

- q. CPE Loopback Jack deactivation error. This error occurs when the TN464F circuit pack could not deactivate a CPE Loopback Jack on power-up/reset or upon software request.

Attempt to clear the alarm via the following commands: *busyout board UUCSS, test ds1-loopback UUCSS end-loopback/span-test, release board UUCSS*. If the attempt to deactivate the CPE Loopback Jack continues to fail, other steps must be taken to deactivate the loopback.

- r. Far CSU Loopback deactivation error. This error occurs when the TN464F circuit pack could not deactivate a far-end CSU loopback on power-up/reset or upon software request.

Attempt to clear the alarm via the following commands: *busyout board UUCSS, test ds1-loop UUCSS end-loopback/span-test, release board UUCSS*. If the attempt to deactivate the Far CSU loopback continues to fail, then escalate the problem.

- s. LAN Bus Timeout Error. This error occurs when the circuit pack transmits too many bytes on the LAN bus for a single frame. This condition may be caused by an on-board fault or by faulty data received on one of the circuit pack's external ports. If any of the ports on this circuit pack are alarmed, refer to the repair procedures for those maintenance objects.

If the error occurs three times within 10 minutes, the board will be isolated from the Packet Bus and the board will be alarmed. To clear the alarm and restore the board to the Packet Bus, use the following commands:  
**busyout board UUCSS, reset board UUCSS, test board UUCSS long, release board UUCSS.**

If the problem persists, and there are no PKT-BUS alarms or port alarms, then replace the circuit pack.

- t. The hyperactive circuit pack is out-of-service and may exhibit one or more of the following symptoms:
  1. The common circuit pack level tests such as Test #50 and/or Test #52 are aborting with error code 2000.
  2. The tests run on the ports of this circuit pack are returning with a NO-BOARD.
  3. A busyout/release of the circuit pack has no affect on test results.
  4. A **list configuration** command shows that the circuit pack and ports are properly installed.

The circuit pack is isolated from the system and all trunks or ports on this circuit pack are placed into the out-of-service state. The system will try to restore the circuit pack within 20-30 minutes. When no faults are detected for 20-30 minutes, the UDS1 Interface circuit pack is restored to normal operation. All trunks or ports of the UDS1 Interface circuit pack are then returned to the in-service state. If the board is not restored to normal operation, or the error recurs after the board was restored to normal operation, escalate the problem.

- u. For later releases of G3V4 and beyond, only error 3073 will show that this board is receiving slips and the AUX data shows the last slip count that was reported.
- v. LAN Critical Error. A critical failure has been detected in the Packet Bus interface of the circuit pack. This failure may be due to an on-board fault or a Packet Bus fault. If the Packet Bus is alarmed, refer to the PKT-BUS Maintenance documentation for recommended repair procedures.

This error will isolate the board from the Packet Bus and raise an alarm. If the Packet Bus is not alarmed, enter the following commands: **busyout board UUCSS**, **reset board UUCSS**, **test board UUCSS**, **release board UUCSS**. This should clear the alarm and restore the board to the Packet Bus.

If the problem persists, and there are no PKT-BUS alarms, then replace the circuit pack.

- w. For later releases of G3V4 and beyond, only error 3585 will show that this board is receiving misframes and the AUX data shows the last misframe count that was reported.
- x. These errors are not service-affecting. No action is required. These errors are reported by the circuit pack when it receives a bad control channel message from the switch. The auxiliary data identifies the following error events:

4096	Bad major heading
4097	Bad port number
4098	Bad data
4099	Bad sub-qualifier
4100	State inconsistency
4101	Bad logical link

- y. The UDS1 Interface circuit pack has detected a transient hardware logic error (for example, program logic inconsistency). This error will disappear when no faults are detected for 100 minutes. The value in Aux Data field indicates the type of hardware problem.
- z. Bad Translation RAM Location Found Error. This error is not service-affecting. No action is required. A Bad Translation RAM is detected, but the call continues by using another translation location.
- aa. LAN Receive Parity Error. This error occurs when the circuit pack detects an error in a received frame from the Packet Bus. These errors are most likely caused by a Packet Bus problem, but may be due to a circuit pack fault.

Refer to the PKT-BUS Maintenance documentation to determine if the problem is isolated to this circuit pack or if the problem is caused by Packet Bus faults.

- ab. Error 3900 is used to give status information on a CPE Loopback Jack Test. The value in the Aux Data field indicates the status of the loopback test.
  - 1. Test is currently running.
  - 2. Test failed because loopback could not be activated.
  - 3. Test failed because test pattern could not be detected.
  - 4. Test has been terminated.

- ac. Error 3901 is used to give status information on a Far CSU Loopback Test. The value in the Aux Data field indicates the status of the loopback test.
  - 1. Test is currently running.
  - 2. Test failed because loopback could not be activated.
  - 3. Test failed because test pattern could not be detected.
  - 4. Test has been terminated.
- ad. Error 3902 is used to give status information on a One-Way Span Test. The value in the Aux Data field indicates the status of the span test.
  - 1. Test is currently running.
  - 2. Test has failed because test could not be activated.
  - 3. Test pattern was not received from the far end.
  - 4. Test has been terminated.
- ae. Error type 3999 indicates that the circuit pack sent a large number of control channel messages to the switch within a short period of time. If error type 1538 is also present, then the circuit pack was taken out-of-service due to hyperactivity. If error type 1538 is not present, then the circuit pack has not been taken out-of-service, but it has generated 50% of the messages necessary to be considered hyperactive. This may be completely normal during heavy traffic periods. However, if this error type is logged when the circuit pack is being lightly used, it may indicate a problem with the circuit pack or the equipment attached to it.

### System Technician-Demanded Tests: Descriptions and Error Codes

Investigate tests in the order they are presented in [Table 9-682](#). By clearing error codes associated with the *NPE Connection Audit Test*, for example, you may also clear errors generated from other tests in the testing sequence.

**Table 9-682. System Technician-Demanded Tests**

Order of Investigation	Short Test Sequence	Long Test Sequence	Reset Board Sequence	test ds1-loop	D/ND <sup>1</sup>
NPE Connection Audit Test (#50)		X			ND
Control Channel Loop Test (#52)		X			ND
Loss of Signal Alarm Inquiry Test (#138)	X	X			ND
Blue Alarm Inquiry Test (#139)	X	X			ND
Red Alarm Inquiry Test (#140)	X	X			ND

*Continued on next page*

**Table 9-682. System Technician-Demanded Tests — Continued**

Order of Investigation	Short Test Sequence	Long Test Sequence	Reset Board Sequence	test ds1-loop	D/ND <sup>1</sup>
Yellow Alarm Inquiry Test (#141)	X	X			ND
Major Alarm Inquiry Test (#142)	X	X			ND
Minor Alarm Inquiry Test (#143)	X	X			ND
Slip Alarm Inquiry Test (#144)	X	X			ND
Misframe Alarm Inquiry Test (#145)	X	X			ND
Translation Update Test (#146)	X	X			ND
ICSU Status LEDs Test (#1227)	X	X			ND
SAKI Sanity Test (#53)			X		D
Internal Looparound Test (#135)			X		D
DS1/CSU Loopback Tests:				X	D
DS1 Board Loopback Test (#1209)				X	D
CSU Equipment Loopback Test (#1210)				X	D
CSU Repeater Loopback Test (#1211)					
CPE Loopback Jack Test (#1212)				X	D
Far CSU Loopback Test (#1213)				X	D
One-Way Span Test (#1214)				X	D
Inject Single Bit Error (#1215)				X	D
End Loopback/Span Test (#1216)				X	D

1. D = Destructive; ND = Nondestructive

**NPE Connection Audit Test (#50)**

The system sends a message to the on-board microprocessor to update the network connectivity translation for the SCOTCH-NPE chip on the circuit pack

**Table 9-683. TEST #50 NPE Connection Audit Test**

Error Code	Test Result	Description/ Recommendation
None 2100	ABORT	System resources required for this test are not available. 1. Retry the command at 1-minute intervals a maximum of 5 times.
1019	ABORT	The test aborted because a test was already running on the port. 1. Retry the command at 1-minute intervals for a maximum of 5 times.
	FAIL	Internal system error 1. Retry the command at 1-minute intervals a maximum of 5 times.
	PASS	The circuit pack's SCOTCH-NPE chip have been updated with its translation.
0	NO BOARD	<p>The test could not relate the internal ID to the port (no board). This could be due to incorrect translations, no board is inserted, an incorrect board is inserted, or an insane board is inserted.</p> <ol style="list-style-type: none"> <li>1. Ensure that the board translations are correct. Execute the <b>add ds1 UUCSS</b> command to administer the UDS1 interface if it is not already administered.</li> <li>2. If the board was already administered correctly, check the error log to determine whether the board is hyperactive. If this is the case, the board is shut down. Reseating the board will re-initialize the board.</li> <li>3. If the board was found to be correctly inserted in step 1, then issue the <b>busyout board</b> command.</li> <li>4. Issue the <b>reset board</b> command.</li> <li>5. Issue the <b>release busy board</b> command.</li> <li>6. Issue the <b>test board long</b> command.</li> </ol> <p>This should re-establish the linkage between the internal ID and the port.</p>

### Control Channel Looparound Test (#52)

This test queries the circuit pack for its circuit pack code and vintage and verifies its records.



**Table 9-684. TEST #52 Control Channel Looparound Test**

Error Code	Test Result	Description/ Recommendation
None 2100	ABORT	System resources required for this test are not available. 1. Retry the command at 1-minute intervals a maximum of 5 times.
	FAIL	The circuit pack failed to return the circuit pack code or vintage. 1. Retry the command a maximum of 5 times. 2. If the problem continues, and if the circuit pack is one of the Port circuit packs, replace the circuit pack. Otherwise, if the circuit pack is part of the SPE, use the procedure described in <i>Replacing SPE Circuit Packs</i> in Chapter 5. 3. Retry the command a few times a maximum of 5 times.
	PASS	Communication with this circuit pack is successful.
0	NO BOARD	The test could not relate the internal ID to the port (no board). This could be due to incorrect translations, no board is inserted, an incorrect board is inserted, or an insane board is inserted. 1. Ensure that the board translations are correct. Execute the <b>add ds1 UUCSS</b> command to administer the UDS1 interface if it is not already administered. 2. If the board was already administered correctly, check the error log to determine whether the board is hyperactive. If this is the case, the board is shut down. Reseating the board will re-initialize the board. 3. If the board was found to be correctly inserted in step 1, then issue the <b>busyout board</b> command. 4. Issue the <b>reset board</b> command. 5. Issue the <b>release busy board</b> command. 6. Issue the <b>test board long</b> command.  This should re-establish the linkage between the internal ID and the port.

### SAKI Sanity Test (#53)

**This test is destructive.**

This test resets the circuit pack. The test is highly destructive and can only be initiated by a system technician-demanded **reset board UUCSS** command.

**Table 9-685. TEST #53 SAKI Sanity Test**

Error Code	Test Result	Description/ Recommendation
None	ABORT	System resources required for this test are not available. 1. Retry the <b>reset board</b> command at 1-minute intervals a maximum of 5 times.
1005	ABORT	Wrong circuit pack configuration to run this test. This error applies only to DS1 Interface circuit packs. It means the DS1 Interface circuit pack is providing timing for the system and, therefore, it cannot be reset without major system disruptions. 1. If the circuit pack needs to be reset, then set synchronization to another DS1 Interface circuit pack or to the Tone-Clock circuit pack and try again. Refer to " <a href="#">SYNC (Synchronization)</a> " Maintenance documentation.
1015	ABORT	Port is not out-of-service. 1. Busyout the circuit pack. 2. Execute the <b>reset board</b> command again.
2100	ABORT	System resources required for this test are not available. 1. Retry the <b>reset board</b> command at 1-minute intervals a maximum of 5 times.
1	FAIL	The circuit pack failed to reset.
2	FAIL	The circuit pack failed to restart. 1. Execute the <b>reset board</b> command again. 2. If the problem persists, replace the circuit pack.
	PASS	The circuit pack initializes correctly. 1. Run the Short Test Sequence.

Table 9-685. TEST #53 SAKI Sanity Test — Continued

Error Code	Test Result	Description/ Recommendation
0	NO BOARD	<p>The test could not relate the internal ID to the port (no board). This could be due to incorrect translations, no board is inserted, an incorrect board is inserted, or an insane board is inserted.</p> <ol style="list-style-type: none"> <li>1. Ensure that the board translations are correct. Execute the <b>add ds1 UUCSS</b> command to administer the UDS1 interface if it is not already administered.</li> <li>2. If the board was already administered correctly, check the error log to determine whether the board is hyperactive. If this is the case, the board is shut down. Reseating the board will re-initialize the board.</li> <li>3. If the board was found to be correctly inserted in step 1, then issue the <b>busyout board</b> command.</li> <li>4. Issue the <b>reset board</b> command.</li> <li>5. Issue the <b>release busy board</b> command.</li> <li>6. Issue the <b>test board long</b> command.</li> </ol> <p>This should re-establish the linkage between the internal ID and the port.</p>

### Internal Looparound Test (#135)

**This test is destructive.**

The Internal Looparound Test is run by looping the transmitted DS1 bit stream back into the UDS1's board receiver. The loop occurs just before the DS1 facility interface. The test is highly destructive and can only be initiated by a system technician-demanded **reset board UUCSS** command.

All trunks or ports on the UDS1 Interface circuit pack must be busied out via the system technician **busyout board** command before running the Internal Looparound Test. When the Internal Looparound Test is initiated, maintenance software sends appropriate messages to the UDS1 Interface circuit pack to start the test. The test uses the Tone Generator and Tone Detector to exercise a bit pattern consistency test for all ports. If the transmitted and received bit patterns on a trunk or port are different, the test fails.

When the test is complete, the maintenance software sends a stop loop around message to the UDS1 Interface circuit pack to put the circuit pack back into the normal operation mode. All trunks or ports of the UDS1 Interface circuit pack are restored to the in-service state after the **release board** command is entered.

**Table 9-686. TEST #135 Internal Looparound Test**

Error Code	Test Result	Description/ Recommendation
1002	ABORT	The system could not allocate time slots for the test. The system may be under heavy traffic conditions or it may have time slots out-of-service due to TDM-BUS errors. <ol style="list-style-type: none"> <li data-bbox="282 422 1094 480">1. If system has no TDM-BUS errors and is not handling heavy traffic, repeat test at 1-minute intervals a maximum of 5 times.</li> </ol>
1003	ABORT	The system could not allocate a tone receiver for the test. The system may be oversized for the number of Tone Detectors present or some Tone Detectors may be out-of-service. <ol style="list-style-type: none"> <li data-bbox="282 598 614 625">1. Resolve any TTR-LEV errors.</li> <li data-bbox="282 641 622 668">2. Resolve any TONE-PT errors.</li> <li data-bbox="282 684 1053 741">3. If neither condition exists, retry the <b>reset board</b> command at 1-minute intervals a maximum of 5 times.</li> </ol>
1004	ABORT	Received an incoming call on a port of the UDS1 circuit pack during the test. <ol style="list-style-type: none"> <li data-bbox="282 804 1094 861">1. Enter the <b>busyout board UUCSS</b> command to put all trunks or ports of the UDS1 Interface circuit pack to out-of-service state.</li> <li data-bbox="282 878 1053 935">2. Retry the <b>reset board</b> command at 1-minute intervals a maximum of 5 times.</li> </ol>
1015	ABORT	Ports on the UDS1 Interface circuit pack have not been busied out to out-of-service. <ol style="list-style-type: none"> <li data-bbox="282 1028 1094 1085">1. Enter the <b>busyout board UUCSS</b> command to put all trunks or ports of the UDS1 Interface circuit pack into the out-of-service state.</li> <li data-bbox="282 1102 665 1128">2. Retry the <b>reset board</b> command.</li> </ol>
1039	ABORT	The UDS1 Interface circuit pack is providing timing for the system. Therefore, it cannot be reset without major system disruption. <p data-bbox="262 1214 1094 1300">If the UDS1 Interface circuit pack needs to be tested, set the synchronization reference to another UDS1 Interface circuit pack or to the Tone-Clock circuit pack via the following command sequence:</p> <ol style="list-style-type: none"> <li data-bbox="282 1317 889 1344">1. Issue the <b>disable synchronization-switch</b> command.</li> <li data-bbox="282 1360 909 1387">2. Next, issue the <b>set synchronization UUCSS</b> command.</li> <li data-bbox="282 1403 955 1430">3. Lastly, issue the <b>enable synchronization-switch</b> command.</li> </ol>
2000	ABORT	Response to the test request was not received within the allowable time period. If Error Type 1538 is present in the Error Log, follow the maintenance strategy recommended for this error type.
2012	ABORT	Internal system error <ol style="list-style-type: none"> <li data-bbox="282 1593 1053 1650">1. Retry the <b>reset board</b> command at 1-minute intervals a maximum of 5 times.</li> </ol>

**Table 9-686. TEST #135 Internal Looparound Test — Continued**

Error Code	Test Result	Description/ Recommendation
2100	ABORT	Could not allocate the necessary system resources to run this test. <ol style="list-style-type: none"> <li>1. Retry the <b>reset board</b> command at 1-minute intervals for a maximum of 5 times.</li> </ol>
	FAIL	The UDS1 Interface circuit pack failed in the Internal Looparound Test. If the UDS1 connects to a T1 network facility or another switch: <ol style="list-style-type: none"> <li>1. Retry the <b>reset board</b> command at 1-minute intervals a maximum of 5 times.</li> <li>2. Enter the <b>list measurement ds1-log UUCSS</b> command to read the error seconds measurement.</li> <li>3. Verify that both endpoints of the DS1 link are administered using the same signaling mode, framing mode, and line coding.</li> <li>4. Check the physical connectivity of DS1 Interface circuit packs and cable.</li> <li>5. Replace the local UDS1 Interface circuit pack and repeat the test.</li> <li>6. Contact T1 Network Service to diagnose the remote DS1 endpoint.</li> </ol>
	FAIL ( <i>cont'd.</i> )	If the UDS1 connects to a line-side terminating device such as a PRI terminal adapter: <ol style="list-style-type: none"> <li>1. Retry the <b>reset board</b> command at 1-minute intervals a maximum of 5 times.</li> <li>2. Enter the <b>list measurement ds1-log UUCSS</b> command to read the error seconds measurement.</li> <li>3. Verify that the switch DS1 and the line-side terminating device are administered using the same signaling mode, framing mode, and line coding.</li> <li>4. Investigate the maintenance status of the line-side terminating device. Obtain the error seconds measurement on the terminating device (if possible). Refer to the line-side terminating device operating manual for information.</li> <li>5. Check the physical connection of the UDS1 Interface circuit pack to the terminating device. Check premise distribution system (or intra-premise wiring) for physical connection failures. If the error seconds measurement is severe, investigate premise distribution system wiring for noise and distance limitation.</li> <li>6. Replace the local UDS1 Interface circuit pack and repeat the test.</li> <li>7. Contact the vendor of the line-side terminating device to diagnose the equipment.</li> </ol>

*Continued on next page*

**Table 9-686. TEST #135 Internal Looparound Test — Continued**

Error Code	Test Result	Description/ Recommendation
	PASS	All administered trunks or ports of the UDS1 Interface circuit pack pass the Internal Looparound Test. The bit pattern consistency test is executed successfully over the path that covers a DS1 port, cable, and the external NCTE device.
0	NO BOARD	<p>The test could not relate the internal ID to the port (no board). This could be due to incorrect translations, no board is inserted, an incorrect board is inserted, or an insane board is inserted.</p> <ol style="list-style-type: none"> <li>1. Ensure that the board translations are correct. Execute the <b>add ds1 UUCSS</b> command to administer the UDS1 interface if it is not already administered.</li> <li>2. If the board was already administered correctly, check the error log to determine whether the board is hyperactive. If this is the case, the board is shut down. Reseating the board will re-initialize the board.</li> <li>3. If the board was found to be correctly inserted in step 1, then issue the <b>busyout board</b> command.</li> <li>4. Issue the <b>reset board</b> command.</li> <li>5. Issue the <b>release busy board</b> command.</li> <li>6. Issue the <b>test board long</b> command.</li> </ol> <p>This should re-establish the linkage between the internal ID and the port.</p>

### Loss of Signal Alarm Inquiry Test (#138)

This test verifies the synchronization status and continuity of the DS1 link. The Loss of Signal alarm indicates that the UDS1 Interface circuit pack is unable to derive the synchronization clock from the DS1 facility. When the UDS1 Interface circuit pack detects a Loss of Signal alarm, it stops providing the synchronization clock for the system if it is administered as a timing source and transmits a Yellow alarm to the remote DS1 endpoint.

When the Loss of Signal alarm is confirmed, the maintenance software places all trunks or ports of the UDS1 Interface circuit pack into the out-of-service state. The inquiry test will run every 10 minutes until the loss of signal has been restored.

The UDS1 Interface circuit pack raises a Loss of Signal alarm after the signal has been lost for about 1 second. It will not retire the alarm until the signal has returned for about 10 seconds.

This test is also used to maintain the new Lucent 120A1 CSU Module. This CSU Module, when combined with the functionality provided by the TN464F circuit pack, provides functionality equivalent to an external stand-alone Lucent ESF T1 CSU. The combination of the TN464F and 120A1 CSU Module is known as an Enhanced Integrated CSU (I-CSU).

If a TN464F circuit pack detects certain I-CSU hardware errors, it will notify maintenance. When the maintenance subsystem receives notification of the I-CSU error, it will execute this Loss of Signal Inquiry test. The test, in addition to querying for a Loss Of Signal alarm condition, will also query the TN464F board to confirm the I-CSU error. A Minor or Warning alarm will be raised depending on the severity of the I-CSU error. The trunks on the board may be taken out of service if the I-CSU error is deemed serious.

If a Loss Of Signal alarm and an I-CSU error co-exist, the Loss Of Signal alarm condition will take priority and the board and all trunks on the board will be put in the out-of-service state. Errors will be logged, however, for both.

When the maintenance subsystem receives notification that the I-CSU hardware error condition no longer exists, maintenance will restore the board and all trunks to their previous service state if the alarm can be cleared (no other I-CSU errors or Loss Of Signal alarm exist).

**Table 9-687. TEST #138 Loss of Signal Alarm Inquiry Test**

Error Code	Test Result	Description/ Recommendation
	ABORT	Internal system error 1. Retry the command at 1-minute intervals for a maximum of 5 times.
2000	ABORT	Response to the test was not received within the allowable time period. This may be due to hyperactivity. Error type 1538 in the error log indicates hyperactivity. The hyperactive circuit pack is out of service and one or more of the following symptoms may be exhibited. <ol style="list-style-type: none"> <li>1. The UDS1-BD tests (such as test 138 and test 139) are aborting with error code 2000.</li> <li>2. The tests run on the ports of this circuit pack are returning a no board result.</li> <li>3. A <b>busyout</b> or a <b>release</b> command has no affect on the test results.</li> <li>4. A <b>list config</b> command shows that the circuit pack and the ports are properly installed.</li> </ol> When hyperactivity occurs, the circuit pack is isolated from the system, and all of the trunks for this circuit pack are placed into the out of service state. The system will try to restore the circuit pack within 15 minutes. When no faults are detected for 15 minutes, the UDS1 interface circuit pack is restored to normal operation. All of the trunks for the UDS1 interface circuit pack are then returned to the in service state. Hyperactivity is often caused by the associated facility. In such a case, faults (such as slips, misframes, or blue alarms) would be entered in the error log. In addition, many hardware errors would be logged against the associated trunk circuits. If the facility is OK and the error occurs again after 15 minutes, replace the circuit pack.
2100	ABORT	Could not allocate the necessary system resources to run this test. <ol style="list-style-type: none"> <li>1. Retry the command at 1-minute intervals for a maximum of 5 times.</li> </ol>

*Continued on next page*



Table 9-687. TEST #138 Loss of Signal Alarm Inquiry Test — Continued

Error Code	Test Result	Description/ Recommendation
	FAIL	<p>UDS1 Interface circuit pack detects a Loss of Signal alarm. The physical link is broken or the remote DS1 endpoint is down. All trunks or ports of this UDS1 interface circuit pack are out-of-service. If the UDS1 Interface circuit pack is designated as the supplier of the system synchronization source, then the system synchronization maintenance will adopt a source elsewhere. Refer to the <a href="#">“SYNC (Synchronization)”</a> section in this chapter for details. If the UDS1 connects to a T1 network facility:</p> <ol style="list-style-type: none"> <li>1. Check the physical connection of the UDS1 Interface circuit pack and the cable. If a 120A1 CSU Module is physically connected to a TN464F board on the back of the port carrier, check the physical connection of the CSU Module and make sure the Network Interface cable is plugged into the CSU Module’s NETWORK jack.</li> <li>2. If the UDS1 Interface circuit pack connects to a T1 facility, call the vendor of the T1 carrier to diagnose the remote DS1 endpoint. If the UDS1 Interface circuit pack connects directly to a switch, call the system technician of the remote switch to diagnose the DS1 endpoint.</li> </ol> <p>If the UDS1 connects to a line-side terminating device such as a PRI terminal adapter:</p> <ol style="list-style-type: none"> <li>1. Check the physical connection of the UDS1 Interface circuit pack to the terminating device. Check premise distribution system (or intra-premise wiring) for physical connection failures. If a 120A1 CSU Module is physically connected to a TN464F board on the back of the port carrier, check the physical connection of the CSU Module and make sure the Network Interface cable is plugged into the CSU Module’s NETWORK jack.</li> <li>2. Contact the vendor of the line-side terminating device to diagnose the equipment.</li> </ol>
1300	FAIL	<p>The CSU Module is missing. The <i>Near-End CSU Type</i> field on the <i>add ds1</i> form has been administered as <i>integrated</i> but the 120A1 CSU Module is not physically connected to the TN464F board on the back of the port carrier.</p> <ol style="list-style-type: none"> <li>1. If using the 120A1 CSU Module, plug the CSU Module into the TN464F circuit pack’s connector on the I/O connector panel on back of the carrier. Otherwise, change the <i>Near-End CSU Type</i> field using the <i>change ds1</i> form to <i>other</i>.</li> <li>2. Run the test again.</li> </ol>

Continued on next page

**Table 9-687. TEST #138 Loss of Signal Alarm Inquiry Test — Continued**

Error Code	Test Result	Description/ Recommendation
1301	FAIL	<p>The 120A1 CSU Module is physically connected to the TN464F board on the back of the port carrier but the <i>Near-End CSU Type</i> field on the <i>add ds1</i> form has not been administered as <i>integrated</i>.</p> <ol style="list-style-type: none"> <li>1. If the 120A1 CSU Module is to be used, use the <i>change ds1</i> command to change the <i>Near-End CSU Type</i> field to <i>integrated</i>. Otherwise, physically remove the 120A1 CSU Module from the back of the port carrier.</li> <li>2. Run the test again.</li> </ol>
1302	FAIL	<p>Attempting to use the 120A1 CSU Module with a TN464F circuit pack that is configured for 32-channel (2.048 Mbps) operation. The CSU Module only works with a DS1 board configured for 24-channel (1.544 Mbps) operation in the United States of America.</p> <ol style="list-style-type: none"> <li>1. If the 120A1 CSU Module is to be used, physically remove the TN464F circuit pack and reconfigure for 24-channel (1.544 Mbps) operation.</li> <li>2. Reinsert the circuit pack and run the test again.</li> </ol>
1303	FAIL	<p>The DS1 circuit pack Suffix is incorrect for CSU Module administration. The <i>Near-End CSU Type</i> field on the <i>add ds1</i> form has been administered as <i>integrated</i> but the DS1 circuit pack is not a TN464F or later suffix UDS1 board.</p> <ol style="list-style-type: none"> <li>1. If the CSU Module is to be used, and the <i>Near-End CSU Type</i> field is set to <i>integrate</i> to allow for CSU Module administration, remove the circuit pack and replace it with a TN464F or later suffix board. Otherwise use the <b><i>change ds1</i></b> command to change the <i>Near-End CSU Type</i> field to <i>other</i>.</li> </ol>
1310	FAIL	<p>The DS1 Board Loopback (BLB) demand test (#1209) failed.</p> <ol style="list-style-type: none"> <li>1. Repeat the test using the <i>test ds1-loop UUCSS ds1/csu-loopback-tests</i> command.</li> <li>2. If the BLB test continues to fail, then replace the TN464F circuit pack.</li> <li>3. Run this test again.</li> </ol>

*Continued on next page*

**Table 9-687. TEST #138 Loss of Signal Alarm Inquiry Test — Continued**

Error Code	Test Result	Description/ Recommendation
1311	FAIL	<p>The Integrated CSU (I-CSU) Module Equipment Loopback (ELB) test (#1210) failed. This test is executed by the I-CSU during I-CSU power-up/reset (i.e.- TN464F board physically inserted and 120A1 CSU Module already installed) or when the 120A1 CSU Module is plugged on to an already initialized DS1 board. The ELB test is also executed as part of the command <i>test ds1-loop UUCSS ds1/csu-loopback-tests</i>.</p> <ol style="list-style-type: none"> <li>1. Execute the <i>test ds1-loop UUCSS ds1/csu-loopback-tests</i> command.</li> <li>2. If the ELB test continues to fail, then either the TN464F board, the CSU Module, or the I/O cable between the backplane and the CSU module (or any combination thereof) has failed. Attempt to isolate the problem to one of these areas. Begin by replacing the CSU Module and running the <i>test ds1-loop UUCSS ds1/csu-loopback-tests</i> command again.</li> <li>3. If the ELB test continues to fail, then replace the TN464F board and run the <i>test ds1-loop UUCSS ds1/csu-loopback-tests</i> command again.</li> <li>4. If the ELB test continues to fail, the problem could be in the I/O cable between the backplane and the CSU module.</li> </ol>
1312	FAIL	<p>The Integrated CSU (I-CSU) Module Repeater Loopback (RLB) test (#1211) failed. This test is executed by the I-CSU during I-CSU power-up/reset (i.e.- TN464F board physically inserted and 120A1 CSU Module already installed) or when the 120A1 CSU Module is plugged on to an already initialized DS1 board. The RLB test is also executed as part of the command <i>test ds1-loop UUCSS ds1/csu-loopback-tests</i>.</p> <ol style="list-style-type: none"> <li>1. Execute the <i>test ds1-loop UUCSS ds1/csu-loopback-tests</i> command.</li> <li>2. If the RLB test continues to fail, then replace the CSU Module.</li> <li>3. Run this test again.</li> </ol>
1313	FAIL	<p>The TN464F circuit pack could not deactivate a CPE Loopback Jack loopback.</p> <ol style="list-style-type: none"> <li>1. Execute the <i>test ds1-loop UUCSS end-loopback/span-test</i> command.</li> <li>2. If the attempt to deactivate the CPE Loopback Jack is not successful, check the cabling and investigate the problem at the CPE Loopback Jack.</li> <li>3. Run the test again.</li> </ol>
1314	FAIL	<p>The TN464F circuit pack could not deactivate a far-end CSU loopback.</p> <ol style="list-style-type: none"> <li>1. Execute the <i>test ds1-loop UUCSS end-loopback/span-test</i> command.</li> </ol>

*Continued on next page*

**Table 9-687. TEST #138 Loss of Signal Alarm Inquiry Test — Continued**

Error Code	Test Result	Description/ Recommendation
1320	FAIL	<p>A 120A1 CSU module hardware failure or an ICSU serial interface audit failure was detected by the TN464F UDS1 circuit pack.</p> <ol style="list-style-type: none"> <li>1. Replace the CSU module, and then run the test again.</li> <li>2. If the test continues to fail with this error code, replace the TN464F and run the test again.</li> <li>3. If the test continues to fail with this error code, then the problem could be in the I/O cable between the backplane and the CSU module.</li> </ol>
1321	FAIL	<p>DTE LOS (loss of signal) was detected between the TN464F UDS1 board and the 120A1 CSU Module. Either the TN464F board, the 120A1 CSU Module, or the I/O cable between the backplane and the CSU module (or any combination thereof) has failed. Attempt to isolate the problem to one of these areas.</p> <ol style="list-style-type: none"> <li>1. Replace the CSU Module and run the test again.</li> <li>2. If the test continues to fail with this error code, then replace the TN464F board and run the test again.</li> <li>3. If the test continues to fail with this error code, the problem could be in the I/O cable between the backplane and the CSU module.</li> </ol>
1322	FAIL	<p>No 5 volts power detected from the TN464F circuit pack to the 120A1 CSU Module. Problem probably due to an open fuse on the DS1 board or a faulty ICSU.</p> <p> <b>NOTE:</b>                      Do not immediately swap DS1 boards as this may blow the fuse on the new board.</p> <ol style="list-style-type: none"> <li>1. If the test continues to fail with this error code, then replace the CSU Module and run the test again.</li> <li>2. Remove the TN464F from the system and reinsert.</li> <li>3. Run the test again once the board has finished its reset.</li> <li>4. If the test continues to fail with this error code, then replace the TN464F board and run the test again.</li> <li>5. If the test continues to fail with this error code, the problem could be in the I/O cable between the backplane and the CSU module.</li> </ol>
1323	FAIL	<p>A service affecting CSU Module audit failure was detected by the TN464F UDS1 circuit pack. All administered ports on the UDS1 circuit pack are affected and maintenance software will place the ports into the out-of-service state.</p> <ol style="list-style-type: none"> <li>1. Replace the 120A1 CSU Module.</li> </ol>

*Continued on next page*

**Table 9-687. TEST #138 Loss of Signal Alarm Inquiry Test — Continued**

Error Code	Test Result	Description/ Recommendation
1324	FAIL	A non-service affecting CSU Module audit failure was detected by the TN464F UDS1 circuit pack. No ports should be affected. No immediate action is required. These errors indicate that the CSU Module hardware may have a problem, and that it should be replaced when practical to avoid further deterioration.
	PASS	DS1 signal is present and the physical link is healthy. In addition, no Integrated CSU errors are detected.
0	NO BOARD	<p>The test could not relate the internal ID to the port (no board). This could be due to incorrect translations, no board is inserted, an incorrect board is inserted, or an insane board is inserted.</p> <ol style="list-style-type: none"> <li>1. Ensure that the board translations are correct. Execute the <b>add ds1 UUCSS</b> command to administer the UDS1 interface if it is not already administered.</li> <li>2. If the board was already administered correctly, check the error log to determine whether the board is hyperactive. If this is the case, the board is shut down. Reseating the board will re-initialize the board.</li> <li>3. If the board was found to be correctly inserted in step 1, then issue the <b>busyout board</b> command.</li> <li>4. Issue the <b>reset board</b> command.</li> <li>5. Issue the <b>release busy board</b> command.</li> <li>6. Issue the <b>test board long</b> command.</li> </ol> <p>This should re-establish the linkage between the internal ID and the port.</p>

### Blue Alarm Inquiry Test (#139)

The Blue Alarm is a signal sent by the remote DS1 endpoint when it is out-of-service. The Blue Alarm Inquiry Test checks the blue alarm status of the remote DS1 endpoint.

When the UDS1 Interface circuit pack detects a Blue Alarm signal from the remote DS1 endpoint, the circuit pack will transmit a Yellow alarm to the remote DS1 endpoint and send a BLUE ALARM message to the maintenance software. When the Blue alarm is confirmed, the maintenance software places all trunks or ports of the UDS1 Interface circuit pack into the out-of-service state. The inquiry test will be run every 10 minutes until the Blue alarm is cleared.

The UDS1 Interface circuit pack takes 1 seconds to recognize and report a Blue alarm and 16 seconds to recognize and report the resolution of a Blue alarm. When the Blue alarm is cleared, the UDS1 Interface circuit pack stops

transmitting the Yellow alarm and places the trunks or ports back into the service state before the Blue alarm occurs.

### **Line Loopback Alarm**

The Line Loopback (LLB) is used by the remote DS1 endpoint to put the ICSU or DS1 board into a loopback mode. When the ICSU or DS1 board is in the LLB mode, the arriving bit pattern is regenerated and sent back. Line Loopback (LLB) Alarm is activated when the in-band activate LLB bit pattern has been arriving continuously for 5 seconds on the DS1 line. LLB is deactivated when the in-band deactivate LLB bit pattern has been arriving continuously for 5 seconds on the DS1 line.

Since LLB is a maintenance condition rendering all DS0 channels unavailable for signaling or bearer traffic, maintenance software treats this the same as a Blue Alarm.

### **Payload Loopback Alarm**

The Payload Loopback (PLB) is used by the remote DS1 endpoint to put the switch DS1 into a loopback mode. PLB Alarm is activated when a network protocol activate bit pattern arrives over the 4Kbps ESF data link on the DS1 line. PLB is deactivated when a network protocol deactivate bit pattern arrives over the 4Kbps ESF data link on the DS1 line.

Since PLB is a maintenance condition rendering all DS0 channels unavailable for signaling or bearer traffic, maintenance software treats this the same as a Blue Alarm

**Table 9-688. TEST #139 Blue Alarm Inquiry Test**

Error Code	Test Result	Description/ Recommendation
	ABORT	Internal system error 1. Retry the command at 1-minute intervals for a maximum of 5 times.
2000	ABORT	Response to the test was not received within the allowable time period. This may be due to hyperactivity. Error type 1538 in the error log indicates hyperactivity. The hyperactive circuit pack is out of service and one or more of the following symptoms may be exhibited. <ol style="list-style-type: none"> <li>1. The UDS1-BD tests (such as test 138 and test 139) are aborting with error code 2000.</li> <li>2. The tests run on the ports of this circuit pack are returning a no board result.</li> <li>3. A <b>busyout</b> or a <b>release</b> command has no affect on the test results.</li> <li>4. A <b>list config</b> command shows that the circuit pack and the ports are properly installed.</li> </ol> When hyperactivity occurs, the circuit pack is isolated from the system, and all of the trunks for this circuit pack are placed into the out of service state. The system will try to restore the circuit pack within 15 minutes. When no faults are detected for 15 minutes, the UDS1 interface circuit pack is restored to normal operation. All of the trunks for the UDS1 interface circuit pack are then returned to the in service state. Hyperactivity is often caused by the associated facility. In such a case, faults (such as slips, misframes, or blue alarms) would be entered in the error log. In addition, many hardware errors would be logged against the associated trunk circuits. If the facility is OK and the error occurs again after 15 minutes, replace the circuit pack.
2100	ABORT	Could not allocate the necessary system resources to run this test. <ol style="list-style-type: none"> <li>1. Retry the command at 1-minute intervals for a maximum of 5 times.</li> </ol>
1 1794	FAIL FAIL	The remote DS1 endpoint is out-of-service. The UDS1 Interface circuit pack detects a Line Loopback Alarm (LLB). If the UDS1 interface circuit pack connects to a T1 facility, call the vendor of the T1 carrier to diagnose the remote DS1 endpoint. If the UDS1 interface circuit pack connects directly to a switch, call the system technician of the remote switch to diagnose the DS1 endpoint. If the UDS1 interface circuit pack connects directly to a line-side terminating device (for example, a PRI terminal adapter), call the vendor of the terminating device to diagnose the equipment.

*Continued on next page*

Table 9-688. TEST #139 Blue Alarm Inquiry Test — *Continued*

Error Code	Test Result	Description/ Recommendation
1795	FAIL	The UDS1 Interface circuit pack detects a Payload Loopback Alarm (PLB). If the UDS1 Interface circuit pack connects to a leased T1 facility, call the vendor of the T1 carrier to diagnose the remote DS1 endpoint. If the UDS1 Interface circuit pack connects directly to another DS1 board, call the system technician of the remote switch to diagnose the DS1 endpoint. If the UDS1 Interface circuit pack connects directly to a line-side terminating device such as a PRI terminal adapter contact the vendor of the terminating device to diagnose the equipment.
	PASS	Remote DS1 endpoint is in-service. Neither a Blue alarm nor a Line Loopback alarm nor a Payload Loopback Alarm is detected by the UDS1 Interface circuit pack.
0	NO BOARD	<p>The test could not relate the internal ID to the port (no board). This could be due to incorrect translations, no board is inserted, an incorrect board is inserted, or an insane board is inserted.</p> <ol style="list-style-type: none"> <li>1. Ensure that the board translations are correct. Execute the <b>add ds1 UUCSS</b> command to administer the UDS1 interface if it is not already administered.</li> <li>2. If the board was already administered correctly, check the error log to determine whether the board is hyperactive. If this is the case, the board is shut down. Reseating the board will re-initialize the board.</li> <li>3. If the board was found to be correctly inserted in step 1, then issue the <b>busyout board</b> command.</li> <li>4. Issue the <b>reset board</b> command.</li> <li>5. Issue the <b>release busy board</b> command.</li> <li>6. Issue the <b>test board long</b> command.</li> </ol> <p>This should re-establish the linkage between the internal ID and the port.</p>

## Red Alarm Inquiry Test (#140)

A UDS1 Interface circuit pack raises a Red alarm when the framing pattern of the incoming DS1 bit stream has been lost. The Red Alarm Inquiry Test checks the framing status of a UDS1 Interface circuit pack. A UDS1 Interface circuit pack takes 3 seconds to recognize and report a Red alarm and 10 seconds to recognize and report the resolution of a Red alarm.

When the UDS1 Interface circuit pack detects a Red alarm, the circuit pack will transmit a Yellow alarm to the remote DS1 endpoint and send a RED ALARM message to the maintenance software. After the Red alarm is confirmed, the maintenance software places all trunks or ports of the circuit pack into the



out-of-service state. The inquiry test will be run every 10 minutes until the Red alarm is cleared.

When the Red alarm is cleared, the UDS1 Interface circuit pack will stop transmitting the Yellow alarm to the remote DS1 endpoint. The maintenance software restores all trunks or ports of the UDS1 Interface circuit pack to the service state before the Red alarm occurs.

### **Loss of Multiframe Alarm**

If the UDS1 Interface circuit pack is administered using DMI-BOS signaling, the UDS1 Interface circuit pack raises a Loss of Multiframe Alarm (LMA) when it cannot interpret the incoming signaling bits to synchronize to the multiframe pattern received in the 24th channel. Once the UDS1 Interface circuit pack detects an LMA, the circuit pack will transmit a Remote Multiframe Alarm (RMA) to the remote DS1 endpoint. Maintenance software handles both Red alarm and LMA alarm(s) using the same mechanism.

**Table 9-689. TEST #140 Red Alarm Inquiry Test**

Error Code	Test Result	Description/ Recommendation
	ABORT	Internal system error 1. Retry the command at 1-minute intervals a maximum of 5 times.
2000	ABORT	Response to the test was not received within the allowable time period. This may be due to hyperactivity. Error type 1538 in the error log indicates hyperactivity. The hyperactive circuit pack is out of service and one or more of the following symptoms may be exhibited. <ol style="list-style-type: none"> <li>1. The UDS1-BD tests (such as test 138 and test 139) are aborting with error code 2000.</li> <li>2. The tests run on the ports of this circuit pack are returning a no board result.</li> <li>3. A <b>busyout</b> or a <b>release</b> command has no affect on the test results.</li> <li>4. A <b>list config</b> command shows that the circuit pack and the ports are properly installed.</li> </ol> <p><b>⇒ NOTE:</b>                      When hyperactivity occurs, the circuit pack is isolated from the system, and all of the trunks for this circuit pack are placed into the out of service state. The system will try to restore the circuit pack within 15 minutes. When no faults are detected for 15 minutes, the UDS1 interface circuit pack is restored to normal operation. All of the trunks for the UDS1 interface circuit pack are then returned to the in service state. Hyperactivity is often caused by the associated facility. In such a case, faults (such as slips, misframes, or blue alarms) would be entered in the error log. In addition, many hardware errors would be logged against the associated trunk circuits. If the facility is OK and the error occurs again after 15 minutes, replace the circuit pack.</p>

*Continued on next page*

**Table 9-689. TEST #140 Red Alarm Inquiry Test — Continued**

Error Code	Test Result	Description/ Recommendation
	FAIL	<p>The UDS1 interface circuit pack detected a red alarm. An out of frame condition occurred on the UDS1 interface circuit pack. The UDS1 interface circuit pack will transmit a yellow alarm to the remote UDS1 endpoint until the red alarm is retired.</p> <p>If the UDS1 connects to a T1 network facility or to another switch, do the following.</p> <ol style="list-style-type: none"> <li>1. Verify that both endpoints of the DS1 link are administered using the same signaling mode, framing mode, and line coding.</li> <li>2. Contact T1 Network Service or a technician at the far-end switch to diagnose the remote DS1 endpoint.</li> <li>3. Check the physical connectivity of the UDS1 packs and of the cable.</li> <li>4. Replace the local UDS1 interface circuit pack, and repeat the test.</li> </ol> <p>If the UDS1 connects to a line-side terminating device (for example, a PRI terminal adapter), do the following.</p> <ol style="list-style-type: none"> <li>1. Verify that the switch DS1 and the line-side terminating device are administered using the same signaling mode, framing mode, and line coding.</li> <li>2. Investigate the maintenance status of the line-side terminating device. Refer to the 'Line-Side Terminating Device Operating Manual' for information.</li> <li>3. Contact the vendor of the line-side terminating device to diagnose the equipment.</li> <li>4. Check the physical connection of the UDS1 interface circuit pack to the terminating device, and check the premise distribution system (or the intra-premise wiring) for physical connection failures.</li> <li>5. Replace the local UDS1 interface circuit pack and repeat the test.</li> </ol>

*Continued on next page*

**Table 9-689. TEST #140 Red Alarm Inquiry Test — Continued**

Error Code	Test Result	Description/ Recommendation
1	FAIL	<p>The test failed. The UDS1 interface circuit pack detected a loss of multiframe alarm (LMA). An out of frame condition occurred on the UDS1 interface circuit pack. The UDS1 interface circuit pack will transmit a remote multiframe alarm (RMA) to the remote UDS1 endpoint until the LMA is retired.</p> <p>If the UDS1 connects to a T1 network facility or to another switch, do the following:</p> <ol style="list-style-type: none"> <li>1. Verify that both endpoints of the DS1 link are administered using the same signaling mode, framing mode, and line coding.</li> <li>2. Contact T1 Network Service or a technician at the far-end switch to diagnose the remote DS1 endpoint.</li> <li>3. Check the physical connectivity of the UDS1 packs and of the cable.</li> <li>4. Replace the local UDS1 interface circuit pack, and repeat the test.</li> </ol> <p>If the UDS1 connects to a line-side terminating device (for example, a PRI terminal adapter), do the following.</p> <ol style="list-style-type: none"> <li>1. Verify that the switch DS1 and the line-side terminating device are administered using the same signaling mode, framing mode, and line coding.</li> <li>2. Investigate the maintenance status of the line-side terminating device. Refer to the 'Line-Side Terminating Device Operating Manual' for information.</li> <li>3. Contact the vendor of the line-side terminating device to diagnose the equipment.</li> <li>4. Check the physical connection of the UDS1 interface circuit pack to the terminating device, and check the premise distribution system (or the intra-premise wiring) for physical connection failures.</li> <li>5. Replace the local UDS1 interface circuit pack and repeat the test.</li> </ol>

*Continued on next page*

**Table 9-689. TEST #140 Red Alarm Inquiry Test — Continued**

Error Code	Test Result	Description/ Recommendation
	PASS	No Red alarm is detected on the UDS1 Interface circuit pack.
0	NO BOARD	<p>The test could not relate the internal ID to the port (no board). This could be due to incorrect translations, no board is inserted, an incorrect board is inserted, or an insane board is inserted.</p> <ol style="list-style-type: none"> <li>1. Ensure that the board translations are correct. Execute the <b>add ds1 UUCSS</b> command to administer the UDS1 interface if it is not already administered.</li> <li>2. If the board was already administered correctly, check the error log to determine whether the board is hyperactive. If this is the case, the board is shut down. Reseating the board will re-initialize the board.</li> <li>3. If the board was found to be correctly inserted in step 1, then issue the <b>busyout board</b> command.</li> <li>4. Issue the <b>reset board</b> command.</li> <li>5. Issue the <b>release busy board</b> command.</li> <li>6. Issue the <b>test board long</b> command.</li> </ol> <p>This should re-establish the linkage between the internal ID and the port.</p>

### Yellow Alarm Inquiry Test (#141)

Receiving a Yellow alarm from remote DS1 endpoint indicates that the remote DS1 endpoint has an out-of-frame condition. The Yellow Alarm Inquiry Test is used to determine whether the remote DS1 endpoint is transmitting a Yellow alarm. The UDS1 Interface circuit pack takes 500 msec to recognize and report a Yellow alarm and 500 msec to recognize and report that a Yellow alarm condition is cleared.

When the UDS1 Interface circuit pack detects a Yellow alarm from the remote DS1 endpoint, it will send a YELLOW-ALARM uplink message to the maintenance software. After the maintenance software receives the YELLOW-ALARM message, the Yellow Alarm Inquiry Test is run to confirm the Yellow alarm. Once the Yellow alarm is confirmed, the maintenance software places all trunks or ports on the circuit pack into the out-of-service state. The Inquiry Test will be run every 10 minutes until the Yellow alarm is cleared.

When the Yellow alarm is cleared, the maintenance software restores all trunks or ports on the UDS1 Interface circuit pack back to their previous service state before the Yellow alarm was raised.

This Yellow alarm corresponds to the yellow F2 state documented in CCITT Recommendation I.431.

### Remote Multiframe Alarm

Remote Multiframe Alarm (RMA) indicates that the remote DS1 endpoint is in a Loss of Multiframe Alarm condition while the UDS1 Interface circuit pack is administered using the DMI-BOS common channel signaling. The RMA is handled as a Yellow alarm.

### Yellow F5 Fault Alarm

For 32-channel E1 operation with CRC4 on, the F5 fault state is defined as a fault in the user-network interface, specifically in the direction from the user (PBX) to the network. Refer to CCITT recommendation I.431.

**Table 9-690. TEST #141 Yellow Alarm Inquiry Test**

Error Code	Test Result	Description/ Recommendation
	ABORT	Internal system error 1. Retry the command at 1-minute intervals a maximum of 5 times.
2000	ABORT	Response to the test was not received within the allowable time period. This may be due to hyperactivity. Error type 1538 in the error log indicates hyperactivity. The hyperactive circuit pack is out of service and one or more of the following symptoms may be exhibited. <ol style="list-style-type: none"> <li>1. The UDS1-BD tests (such as test 138 and test 139) are aborting with error code 2000.</li> <li>2. The tests run on the ports of this circuit pack are returning a no board result.</li> <li>3. A <b>busyout</b> or a <b>release</b> command has no affect on the test results.</li> <li>4. A <b>list config</b> command shows that the circuit pack and the ports are properly installed.</li> </ol> <p> <b>NOTE:</b>                      When hyperactivity occurs, the circuit pack is isolated from the system, and all of the trunks for this circuit pack are placed into the out of service state. The system will try to restore the circuit pack within 15 minutes. When no faults are detected for 15 minutes, the UDS1 interface circuit pack is restored to normal operation. All of the trunks for the UDS1 interface circuit pack are then returned to the in service state. Hyperactivity is often caused by the associated facility. In such a case, faults (such as slips, misframes, or blue alarms) would be entered in the error log. In addition, many hardware errors would be logged against the associated trunk circuits. If the facility is OK and the error occurs again after 15 minutes, replace the circuit pack.</p>

**Table 9-690. TEST #141 Yellow Alarm Inquiry Test — Continued**

Error Code	Test Result	Description/ Recommendation
	FAIL	<p>The UDS1 interface circuit pack detected a yellow alarm sent by the remote DS1 endpoint. An out of frame condition occurred at the DS1 endpoint. If the UDS1 connects to a T1 network facility or to another switch, do the following:</p> <ol style="list-style-type: none"> <li>1. Verify that both endpoints of the DS1 link are administered using the same signaling mode, framing mode, and line coding.</li> <li>2. Contact T1 Network Service or a technician at the far-end switch to diagnose the remote DS1 endpoint.</li> <li>3. Check the physical connectivity of the UDS1 packs and of the cable.</li> <li>4. Replace the local UDS1 interface circuit pack, and repeat the test.</li> </ol> <p>If the UDS1 connects to a line-side terminating device (for example, a PRI terminal adapter), do the following:</p> <ol style="list-style-type: none"> <li>1. Verify that the switch DS1 and the line-side terminating device are administered using the same signaling mode, framing mode, and line coding.</li> <li>2. Investigate the maintenance status of the line-side terminating device. Refer to the 'Line-Side Terminating Device Operating Manual' for information.</li> <li>3. Contact the vendor of the line-side terminating device to diagnose the equipment.</li> <li>4. Check the physical connection of the UDS1 interface circuit pack to the terminating device, and check the premise distribution system (or the intra-premise wiring) for physical connection failures.</li> <li>5. Replace the local UDS1 interface circuit pack and repeat the test.</li> </ol>

*Continued on next page*

**Table 9-690. TEST #141 Yellow Alarm Inquiry Test — Continued**

Error Code	Test Result	Description/ Recommendation
1	FAIL	<p>The UDS1 interface circuit pack detected a remote multiframe alarm (RMA) sent by the remote DS1 endpoint. An out of frame condition occurred at the DS1 endpoint.</p> <p>If the UDS1 connects to a T1 network facility or to another switch, do the following:</p> <ol style="list-style-type: none"> <li>1. Verify that both endpoints of the DS1 link are administered using the same signaling mode, framing mode, and line coding.</li> <li>2. Contact T1 Network Service or a technician at the far-end switch to diagnose the remote DS1 endpoint.</li> <li>3. Check the physical connectivity of the UDS1 packs and of the cable.</li> <li>4. Replace the local UDS1 interface circuit pack, and repeat the test.</li> </ol> <p>If the UDS1 connects to a line-side terminating device (for example, a PRI terminal adapter), do the following:</p> <ol style="list-style-type: none"> <li>1. Verify that the switch DS1 and the line-side terminating device are administered using the same signaling mode, framing mode, and line coding.</li> <li>2. Investigate the maintenance status of the line-side terminating device. Refer to the 'Line-Side Terminating Device Operating Manual' for information.</li> <li>3. Contact the vendor of the line-side terminating device to diagnose the equipment.</li> <li>4. Check the physical connection of the UDS1 interface circuit pack to the terminating device, and check the premise distribution system (or the intra-premise wiring) for physical connection failures.</li> <li>5. Replace the local UDS1 interface circuit pack and repeat the test.</li> </ol>

*Continued on next page*



**Table 9-690. TEST #141 Yellow Alarm Inquiry Test — Continued**

Error Code	Test Result	Description/ Recommendation
2	FAIL	<p>The UDS1 interface circuit pack is reporting a Yellow F5 fault alarm. There is a fault in the User-Network interface from the user (PBX) to the network. An out-of-frame condition occurs on the remote DS1 endpoint.</p> <p>If the UDS1 connects to a T1 network facility:</p> <ol style="list-style-type: none"> <li>1. Verify that both endpoints of the DS1 link are administered using the same signaling mode, framing mode, and line coding.</li> <li>2. Contact T1 Network Service to diagnose the remote DS1 endpoint.</li> <li>3. Check the physical connectivity of the DS1 Interface circuit packs and cable.</li> <li>4. Replace the local UDS1 Interface circuit pack and repeat the test.</li> </ol> <p>If the UDS1 connects to a line-side terminating device such as a PRI terminal adapter:</p> <ol style="list-style-type: none"> <li>1. Verify that the switch DS1 and the line-side terminating device are administered using the same signaling mode, framing mode, and line coding.</li> <li>2. Investigate the maintenance status of the line-side terminating device. Refer to the 'Line-Side Terminating Device Operating Manual' for information.</li> <li>3. Contact the vendor of the line-side terminating device to diagnose the equipment.</li> <li>4. Check the physical connection of the UDS1 Interface circuit pack to the terminating device. Check premise distribution system (or intra-premise wiring) for physical connection failures.</li> <li>5. Replace the local UDS1 Interface circuit pack and repeat the test.</li> </ol>

*Continued on next page*

**Table 9-690. TEST #141 Yellow Alarm Inquiry Test — Continued**

Error Code	Test Result	Description/ Recommendation
	PASS	Neither a Yellow alarm nor a Remote Multiframe Alarm nor a F5 state alarm is being received from the remote DS1 endpoint.
0	NO BOARD	<p>The test could not relate the internal ID to the port (no board). This could be due to incorrect translations, no board is inserted, an incorrect board is inserted, or an insane board is inserted.</p> <ol style="list-style-type: none"> <li>1. Ensure that the board translations are correct. Execute the <b>add ds1 UUCSS</b> command to administer the UDS1 interface if it is not already administered.</li> <li>2. If the board was already administered correctly, check the error log to determine whether the board is hyperactive. If this is the case, the board is shut down. Reseating the board will re-initialize the board.</li> <li>3. If the board was found to be correctly inserted in step 1, then issue the <b>busyout board</b> command.</li> <li>4. Issue the <b>reset board</b> command.</li> <li>5. Issue the <b>release busy board</b> command.</li> <li>6. Issue the <b>test board long</b> command.</li> </ol> <p>This should re-establish the linkage between the internal ID and the port.</p>

### Major Alarm Inquiry Test (#142)

The Major alarm raised by a UDS1 Interface circuit pack indicates that the average bit error rate on the DS1 facility is greater than 1/1000. The Major Alarm Inquiry Test is used to determine that the received DS1 bit error rate is greater than 1/1000. The UDS1 Interface circuit pack takes 10 seconds to recognize and report a Major alarm and 10 seconds to recognize and report that a Major alarm condition is cleared.

When the UDS1 Interface circuit pack detects a Major alarm, it will send a MAJOR-ALARM message to the maintenance software. (32-channel interfaces send a YELLOW alarm to the far end). After the maintenance software receives a MAJOR-ALARM message, the Major Alarm Inquiry Test is initiated to confirm the Major alarm on the UDS1 Interface circuit pack. The Inquiry Test will be run every 10 minutes until the Major alarm is cleared. The maintenance software places all trunks or ports on the circuit pack in the out-of-service state if the Major alarm persists for more than 20 minutes.

When the Major alarm is cleared, the maintenance software restores all trunks or ports on the circuit pack to their previous service state before a Major alarm occurs.

**Table 9-691. TEST #142 Major Alarm Inquiry Test**

Error Code	Test Result	Description/ Recommendation
	ABORT	Internal system error 1. Retry the command at 1-minute intervals a maximum of 5 times.
2000	ABORT	Response to the test was not received within the allowable time period. This may be due to hyperactivity. Error type 1538 in the error log indicates hyperactivity. The hyperactive circuit pack is out of service and one or more of the following symptoms may be exhibited. <ol style="list-style-type: none"> <li>1. The UDS1-BD tests (such as test 138 and test 139) are aborting with error code 2000.</li> <li>2. The tests run on the ports of this circuit pack are returning a no board result.</li> <li>3. A <b>busyout</b> or a <b>release</b> command has no affect on the test results.</li> <li>4. A <b>list config</b> command shows that the circuit pack and the ports are properly installed.</li> </ol> <p><b>⇒ NOTE:</b>                      When hyperactivity occurs, the circuit pack is isolated from the system, and all of the trunks for this circuit pack are placed into the out of service state. The system will try to restore the circuit pack within 15 minutes. When no faults are detected for 15 minutes, the UDS1 interface circuit pack is restored to normal operation. All of the trunks for the UDS1 interface circuit pack are then returned to the in service state. Hyperactivity is often caused by the associated facility. In such a case, faults (such as slips, misframes, or blue alarms) would be entered in the error log. In addition, many hardware errors would be logged against the associated trunk circuits. If the facility is OK and the error occurs again after 15 minutes, replace the circuit pack.</p>
2100	ABORT	Could not allocate the necessary system resources to run this test. <ol style="list-style-type: none"> <li>1. Retry the command at 1-minute intervals for a maximum of 5 times.</li> </ol>

*Continued on next page*

**Table 9-691. TEST #142 Major Alarm Inquiry Test — Continued**

Error Code	Test Result	Description/ Recommendation
	FAIL	<p>If the UDS1 connects to a T1 network facility or to another switch, do the following:</p> <ol style="list-style-type: none"> <li>1. The performance of the DS1 link between the UDS1 interface circuit pack and the remote DS1 endpoint is very poor. Enter the <b>list measurement ds1-log UUCSS</b> command to read the error seconds measurement.</li> <li>2. Verify that both endpoints of the DS1 link are administered using the same signaling mode, framing mode, and line coding.</li> <li>3. Contact T1 Network Service or the technician at the remote switch to diagnose the equipment.</li> <li>4. Check the physical connectivity of the UDS1 interface circuit packs and the cable.</li> <li>5. Replace the local UDS1 interface circuit pack, and repeat the test.</li> </ol>
	FAIL (cont'd.)	<p>If the UDS1 connects to a line-side terminating device (for example, a PRI terminal adapter), do the following:</p> <ol style="list-style-type: none"> <li>1. The performance of the DS1 link between the UDS1 interface circuit pack and the line-side terminating device is very poor. Enter the <b>list measurement ds1-log UUCSS</b> command to read the error seconds measurement.</li> <li>2. Verify that the switch DS1 and the line-side terminating device are administered using the same signaling mode, framing mode, and line coding.</li> <li>3. Investigate the maintenance status of the line-side terminating device. Refer to the 'Line-Side Terminating Device Operating Manual' for information.</li> <li>4. Contact the vendor of the line-side terminating device to diagnose the equipment.</li> <li>5. Check the physical connection of the UDS1 interface circuit pack to the terminating device, and check the premise distribution system (or the intra-premise wiring) for physical connection failures.</li> <li>6. Replace the local UDS1 interface circuit pack and repeat the test.</li> </ol>

*Continued on next page*

**Table 9-691. TEST #142 Major Alarm Inquiry Test — Continued**

Error Code	Test Result	Description/ Recommendation
	PASS	No Major alarm is detected in the UDS1 Interface circuit pack.
0	NO BOARD	<p>The test could not relate the internal ID to the port (no board). This could be due to incorrect translations, no board is inserted, an incorrect board is inserted, or an insane board is inserted.</p> <ol style="list-style-type: none"> <li>1. Ensure that the board translations are correct. Execute the <b>add ds1 UUCSS</b> command to administer the UDS1 interface if it is not already administered.</li> <li>2. If the board was already administered correctly, check the error log to determine whether the board is hyperactive. If this is the case, the board is shut down. Reseating the board will re-initialize the board.</li> <li>3. If the board was found to be correctly inserted in step 1, then issue the <b>busyout board</b> command.</li> <li>4. Issue the <b>reset board</b> command.</li> <li>5. Issue the <b>release busy board</b> command.</li> <li>6. Issue the <b>test board long</b> command.</li> </ol> <p>This should re-establish the linkage between the internal ID and the port.</p>

### Minor Alarm Inquiry Test (#143)

The Minor alarm raised by a UDS1 Interface circuit pack indicates that the average bit error rate on the DS1 facility is greater than 1/1,000,000, but less than 1/1000. The Minor Alarm Inquiry Test is used to determine that the received DS1 bit error rate is greater than 1/1,000,000 and less than 1/1000. When D4 framing mode is selected, the UDS1 Interface circuit pack takes 41-minutes to recognize and report a Minor alarm and 41-minutes to recognize and report that a Minor alarm condition has cleared. If ESF framing mode is selected, the UDS1 Interface circuit pack takes 10 minutes to recognize and report a Minor alarm and 10 minutes to recognize and report that a Minor alarm condition has cleared.

When the UDS1 Interface circuit pack detects a Minor alarm condition, it will send a MINOR-ALARM message to the maintenance software. After the maintenance software receives a MINOR-ALARM message, the Minor Alarm Inquiry Test is initiated to confirm the Minor alarm. All trunks or ports on the circuit pack are kept in the in-service state after the Minor alarm is confirmed. The Minor Alarm Inquiry Test is run every 10 minutes until the Minor alarm is cleared.

**Table 9-692. TEST #143 Minor Alarm Inquiry Test**

Error Code	Test Result	Description/ Recommendation
	ABORT	Internal system error 1. Retry the command at 1-minute intervals a maximum of 5 times.
2000	ABORT	Response to the test was not received within the allowable time period. This may be due to hyperactivity. Error type 1538 in the error log indicates hyperactivity. The hyperactive circuit pack is out of service and one or more of the following symptoms may be exhibited. <ol style="list-style-type: none"> <li>1. The UDS1-BD tests (such as test 138 and test 139) are aborting with error code 2000.</li> <li>2. The tests run on the ports of this circuit pack are returning a no board result.</li> <li>3. A <b>busyout</b> or a <b>release</b> command has no affect on the test results.</li> <li>4. A <b>list config</b> command shows that the circuit pack and the ports are properly installed.</li> </ol> <p><b>⇒ NOTE:</b>                      When hyperactivity occurs, the circuit pack is isolated from the system, and all of the trunks for this circuit pack are placed into the out of service state. The system will try to restore the circuit pack within 15 minutes. When no faults are detected for 15 minutes, the UDS1 interface circuit pack is restored to normal operation. All of the trunks for the UDS1 interface circuit pack are then returned to the in service state. Hyperactivity is often caused by the associated facility. In such a case, faults (such as slips, misframes, or blue alarms) would be entered in the error log. In addition, many hardware errors would be logged against the associated trunk circuits. If the facility is OK and the error occurs again after 15 minutes, replace the circuit pack.</p>
2100	ABORT	Could not allocate the necessary system resources to run this test. <ol style="list-style-type: none"> <li>1. Retry the command at 1-minute intervals for a maximum of 5 times.</li> </ol>

*Continued on next page*

Table 9-692. TEST #143 Minor Alarm Inquiry Test — *Continued*

Error Code	Test Result	Description/ Recommendation
	FAIL	<p>Minor alarms are often accompanied by slip and misframe alarms against the board. Trunk alarms and hardware error logs may occur on the associated trunks.</p> <p>If the UDS1 connects to a T1 network facility or to another switch, do the following:</p> <ol style="list-style-type: none"> <li>1. The performance of the DS1 link between the UDS1 interface circuit pack and the remote DS1 endpoint is poor. Enter the <b>list measurement ds1-log UUCSS</b> command to read the error seconds measurement.</li> <li>2. Verify that both endpoints of the DS1 link are administered using the same signaling mode, framing mode, and line coding.</li> <li>3. Contact T1 Network Service or the technician at the remote switch to diagnose the equipment.</li> <li>4. Check the physical connectivity of the UDS1 interface circuit packs and the cable.</li> <li>5. Replace the local UDS1 interface circuit pack, and repeat the test.</li> </ol>
	FAIL ( <i>cont'd.</i> )	<p>If the UDS1 connects to a line-side terminating device (for example, a PRI terminal adapter), do the following:</p> <ol style="list-style-type: none"> <li>1. The performance of the DS1 link between the UDS1 interface circuit pack and the line-side terminating device is very poor. Enter the <b>list measurement ds1-log UUCSS</b> command to read the error seconds measurement.</li> <li>2. Verify that the switch DS1 and the line-side terminating device are administered using the same signaling mode, framing mode, and line coding.</li> <li>3. Investigate the maintenance status of the line-side terminating device. Obtain the error seconds measurement on the terminating device (if possible). Refer to the 'Line-Side Terminating Device Operating Manual' for information.</li> <li>4. Contact the vendor of the line-side terminating device to diagnose the equipment.</li> <li>5. Check the physical connection of the UDS1 interface circuit pack to the terminating device, and check the premise distribution system (or the intra-premise wiring) for physical connection failures.</li> <li>6. Replace the local UDS1 interface circuit pack and repeat the test.</li> </ol>

*Continued on next page*

**Table 9-692. TEST #143 Minor Alarm Inquiry Test — Continued**

Error Code	Test Result	Description/ Recommendation
	PASS	No Minor alarm is detected in the UDS1 Interface circuit pack.
0	NO BOARD	<p>The test could not relate the internal ID to the port (no board). This could be due to incorrect translations, no board is inserted, an incorrect board is inserted, or an insane board is inserted.</p> <ol style="list-style-type: none"> <li>1. Ensure that the board translations are correct. Execute the <b>add ds1 UUCSS</b> command to administer the UDS1 interface if it is not already administered.</li> <li>2. If the board was already administered correctly, check the error log to determine whether the board is hyperactive. If this is the case, the board is shut down. Reseating the board will re-initialize the board.</li> <li>3. If the board was found to be correctly inserted in step 1, then issue the <b>busyout board</b> command.</li> <li>4. Issue the <b>reset board</b> command.</li> <li>5. Issue the <b>release busy board</b> command.</li> <li>6. Issue the <b>test board long</b> command.</li> </ol> <p>This should re-establish the linkage between the internal ID and the port.</p>

### Slip Alarm Inquiry Test (#144)

Slips occur when transmitter and receiver are not running at precisely the same clock rate. The UDS1 Interface circuit pack can detect both positive and negative slips on the DS1 facility. The Slip Alarm Inquiry Test is used to acquire the total number of slips that have occurred on a DS1 link.

When the UDS1 Interface circuit pack detects a slip condition, the circuit pack will increase the on-board slip counter by 1. A SLIP-COUNT message is spontaneously sent to the system software when the counter reaches a threshold (for example, 88). When the maintenance software receives the SLIP-COUNT message, the Slip Alarm Inquiry Test is initiated to query the slip counters on a UDS1 Interface circuit pack and total the slip counts in the maintenance software.

If the count of slips is over the threshold, a Minor alarm is raised against the UDS1 Interface circuit pack. All trunks or ports of the UDS1 Interface circuit pack remain in the in-service state. If the UDS1 Interface circuit pack is used to supply the system synchronization source, the MINOR alarm will initiate a synchronization source switch. See "TDM-BUS" and "[SYNC \(Synchronization\)](#)" for details.



**Table 9-693. TEST #144 Slip Alarm Inquiry Test**

Error Code	Test Result	Description/ Recommendation
	ABORT	Internal system error 1. Retry the command at 1-minute intervals a maximum of 5 times.
2000	ABORT	Response to the test was not received within the allowable time period. This may be due to hyperactivity. Error type 1538 in the error log indicates hyperactivity. The hyperactive circuit pack is out of service and one or more of the following symptoms may be exhibited. <ol style="list-style-type: none"> <li>1. The UDS1-BD tests (such as test 138 and test 139) are aborting with error code 2000.</li> <li>2. The tests run on the ports of this circuit pack are returning a no board result.</li> <li>3. A <b>busyout</b> or a <b>release</b> command has no affect on the test results.</li> <li>4. A <b>list config</b> command shows that the circuit pack and the ports are properly installed.</li> </ol> <p><b>⇒ NOTE:</b>                      When hyperactivity occurs, the circuit pack is isolated from the system, and all of the trunks for this circuit pack are placed into the out of service state. The system will try to restore the circuit pack within 15 minutes. When no faults are detected for 15 minutes, the UDS1 interface circuit pack is restored to normal operation. All of the trunks for the UDS1 interface circuit pack are then returned to the in service state. Hyperactivity is often caused by the associated facility. In such a case, faults (such as slips, misframes, or blue alarms) would be entered in the error log. In addition, many hardware errors would be logged against the associated trunk circuits. If the facility is OK and the error occurs again after 15 minutes, replace the circuit pack.</p>
2100	ABORT	Could not allocate the necessary system resources to run this test. <ol style="list-style-type: none"> <li>1. Retry the command at 1-minute intervals for a maximum of 5 times.</li> </ol>

*Continued on next page*

**Table 9-693. TEST #144 Slip Alarm Inquiry Test — Continued**

Error Code	Test Result	Description/ Recommendation
1 to 88	FAIL	<p>The test failed because the UDS1 interface circuit pack and the remote DS1 endpoint are not synchronized to the same clock rate. The UDS1 interface circuit pack detected a slip alarm. The error code equals the number of slips detected by the UDS1 interface circuit pack since the last slip alarm inquiry test.</p> <p>If the UDS1 connects to a T1 network facility or to another switch, do the following:</p> <ol style="list-style-type: none"> <li>1. Retry the command at 1-minute intervals for a maximum of 5 times.</li> <li>2. If the DS1 interface circuit pack is a TN464C, enter the <b>list measurement ds1-log UUCSS</b> command to read the error seconds measurement.</li> <li>3. Verify that both endpoints of the DS1 link are administered using the same signaling mode, framing mode, and line coding.</li> <li>4. Check the active alarm and error logs for recent alarms and errors against the synchronization (SYNC). Follow the suggested repair procedure for these errors.</li> <li>5. Contact T1 Network Service or the technician at the remote switch to diagnose the remote DS1 endpoint.</li> <li>6. Check the physical connectivity of the UDS1 interface circuit packs and the cable.</li> <li>7. Replace the local UDS1 interface circuit pack, and repeat the test.</li> </ol> <p><i>Information continues on the next page.</i></p>
1 to 88 (cont'd.)	FAIL (cont'd.)	<p>If the UDS1 connects to a line-side terminating device (for example, a PRI terminal adapter), do the following:</p> <ol style="list-style-type: none"> <li>1. Retry the command at 1-minute intervals for a maximum of 5 times.</li> <li>2. Enter the <b>list measurement ds1-log UUCSS</b> command to read the error seconds measurement.</li> <li>3. Verify that the switch DS1 and the line-side terminating device are administered using the same signaling mode, framing mode, and line coding.</li> <li>4. Investigate the maintenance status of the line-side terminating device. Refer to the 'Line-Side Terminating Device Operating Manual' for information.</li> <li>5. Contact the vendor of the line-side terminating device to diagnose the equipment.</li> <li>6. Check the physical connection of the UDS1 interface circuit pack to the terminating device, and check the premise distribution system (or the intra-premise wiring) for physical connection failures.</li> <li>7) Replace the local UDS1 interface circuit pack and repeat the test.</li> </ol>

**Table 9-693. TEST #144 Slip Alarm Inquiry Test — Continued**

Error Code	Test Result	Description/ Recommendation
	PASS	No Slip alarm is detected on the UDS1 Interface circuit pack.
0	NO BOARD	<p>The test could not relate the internal ID to the port (no board). This could be due to incorrect translations, no board is inserted, an incorrect board is inserted, or an insane board is inserted.</p> <ol style="list-style-type: none"> <li>1. Ensure that the board translations are correct. Execute the <b>add ds1 UUCSS</b> command to administer the UDS1 interface if it is not already administered.</li> <li>2. If the board was already administered correctly, check the error log to determine whether the board is hyperactive. If this is the case, the board is shut down. Reseating the board will re-initialize the board.</li> <li>3. If the board was found to be correctly inserted in step 1, then issue the <b>busyout board</b> command.</li> <li>4. Issue the <b>reset board</b> command.</li> <li>5. Issue the <b>release busy board</b> command.</li> <li>6. Issue the <b>test board long</b> command.</li> </ol> <p>This should re-establish the linkage between the internal ID and the port.</p>

### Misframe Alarm Inquiry Test (#145)

Misframe Alarm indicates that framing bits observed on a UDS1 Interface circuit pack are in error. The Misframe Alarm Inquiry Test queries the total number of misframes that have occurred on a DS1 Interface circuit pack since the last inquiry.

When the DS1 Interface circuit pack detects a misframe error, it will increase its misframe counter by 1. If the counter reaches a specified threshold (i.e.- 17), a MISFRAME-COUNT message is automatically sent to the switch maintenance software. After the maintenance software receives the MISFRAME-COUNT message, the Misframe Alarm Inquiry Test is initiated to collect the misframe counts from the UDS1 Interface circuit pack.

When the threshold of misframes is reached, if the UDS1 Interface circuit pack is supplying the system synchronization source, then a switching synchronization source message is sent to the TDM Bus Clock. See TDM-BUS (TDM Bus) Maintenance documentation for details. A Minor alarm against the UDS1 Interface circuit pack is raised, but all trunks or ports of the UDS1 Interface circuit pack remain in the in-service state.

**Table 9-694. TEST #145 Misframe Alarm Inquiry Test**

Error Code	Test Result	Description/ Recommendation
	ABORT	Internal system error 1. Retry the command at 1-minute intervals a maximum of 5 times.
2000	ABORT	Response to the test was not received within the allowable time period. This may be due to hyperactivity. Error type 1538 in the error log indicates hyperactivity. The hyperactive circuit pack is out of service and one or more of the following symptoms may be exhibited. <ol style="list-style-type: none"> <li>1. The UDS1-BD tests (such as test 138 and test 139) are aborting with error code 2000.</li> <li>2. The tests run on the ports of this circuit pack are returning a no board result.</li> <li>3. A <b>busyout</b> or a <b>release</b> command has no affect on the test results.</li> <li>4. A <b>list config</b> command shows that the circuit pack and the ports are properly installed.</li> </ol> <p><b>⇒ NOTE:</b>                      When hyperactivity occurs, the circuit pack is isolated from the system, and all of the trunks for this circuit pack are placed into the out of service state. The system will try to restore the circuit pack within 15 minutes. When no faults are detected for 15 minutes, the UDS1 interface circuit pack is restored to normal operation. All of the trunks for the UDS1 interface circuit pack are then returned to the in service state. Hyperactivity is often caused by the associated facility. In such a case, faults (such as slips, misframes, or blue alarms) would be entered in the error log. In addition, many hardware errors would be logged against the associated trunk circuits. If the facility is OK and the error occurs again after 15 minutes, replace the circuit pack.</p>
2100	ABORT	Could not allocate the necessary system resources to run this test. <ol style="list-style-type: none"> <li>1. Retry the command at 1-minute intervals for a maximum of 5 times.</li> </ol>

*Continued on next page*

**Table 9-694. TEST #145 Misframe Alarm Inquiry Test — Continued**

Error Code	Test Result	Description/ Recommendation
1 to 17	FAIL	<p>The test failed because the UDS1 interface circuit pack detected errors in the received framing bits pattern. The error code equals the number of misframes detected by the UDS1 interface circuit pack since the last misframe alarm inquiry test. Major bit and minor bit error rate (error types 2561 and 2817) error logs often accompany misframe alarms. Clearing the cause of these error logs may clear the misframes which are occurring.</p> <p>If the UDS1 connects to a T1 network facility or to another switch, do the following:</p> <ol style="list-style-type: none"> <li>1. Retry the command at 1-minute intervals for a maximum of 5 times.</li> <li>2. If the DS1 interface circuit pack is a TN464C, enter the <b>list measurement ds1-log UUCSS</b> command to read the error seconds measurement.</li> <li>3. Verify that both endpoints of the DS1 link are administered using the same signaling mode, framing mode, and line coding.</li> <li>4. Check the active alarm and error logs for recent alarms and errors against the synchronization (SYNC). Follow the suggested repair procedure for these errors.</li> <li>5. Contact T1 Network Service or the technician at the remote switch to diagnose the remote DS1 endpoint.</li> <li>6. Check the physical connectivity of the UDS1 interface circuit packs and the cable.</li> <li>7. Replace the local UDS1 interface circuit pack, and repeat the test.</li> </ol> <p><i>More information continues on the next page.</i></p>

*Continued on next page*

**Table 9-694. TEST #145 Misframe Alarm Inquiry Test — Continued**

Error Code	Test Result	Description/ Recommendation
1 to 17 (cont'd.)	FAIL (cont'd.)	<p>If the UDS1 connects to a line-side terminating device such as a PRI terminal adapter:</p> <ol style="list-style-type: none"> <li>1. Retry the command at 1-minute intervals for a maximum of 5 times.</li> <li>2. Enter the <b>list measurement ds1-log UUCSS</b> command to read the error seconds measurement.</li> <li>3. Verify that the switch DS1 and the line-side terminating device are administered using the same signaling mode, framing mode, and line coding.</li> <li>4. Investigate the maintenance status of the line-side terminating device. Refer to the 'Line-Side Terminating Device Operating Manual' for information.</li> <li>5. Contact the vendor of the line-side terminating device to diagnose the equipment.</li> <li>6. Check the physical connection of the UDS1 interface circuit pack to the terminating device, and check the premise distribution system (or the intra-premise wiring) for physical connection failures.</li> <li>7. Replace the local UDS1 interface circuit pack and repeat the test.</li> </ol>
	PASS	No Misframe alarm is detected on the UDS1 Interface circuit pack.
0	NO BOARD	<p>The test could not relate the internal ID to the port (no board). This could be due to incorrect translations, no board is inserted, an incorrect board is inserted, or an insane board is inserted.</p> <ol style="list-style-type: none"> <li>1. Ensure that the board translations are correct. Execute the <b>add ds1 UUCSS</b> command to administer the UDS1 interface if it is not already administered.</li> <li>2. If the board was already administered correctly, check the error log to determine whether the board is hyperactive. If this is the case, the board is shut down. Reseating the board will re-initialize the board.</li> <li>3. If the board was found to be correctly inserted in step 1, then issue the <b>busyout board</b> command.</li> <li>4. Issue the <b>reset board</b> command.</li> <li>5. Issue the <b>release busy board</b> command.</li> <li>6. Issue the <b>test board long</b> command.</li> </ol> <p>This should re-establish the linkage between the internal ID and the port.</p>

## Translation Update Test (#146)

The Translation Update Test sends the circuit-pack-level information specified by System Administration to the UDS1 Interface circuit pack. Translation includes the following data administered for a UDS1 Interface circuit pack (see output of **display ds1 UUCSS** command): DS1 Link Length between two DS1 endpoints, Synchronization Source Control, All Zero Suppression, Framing Mode, Signaling Mode, Time Slot Number of 697-Hz Tone, Time Slot Number of 700-Hz Tone, etc.

In G3V3, if a TN464F or later UDS1 circuit pack is combined with an Lucent 120A1 CSU Module to form an Integrated CSU Module, this test will also send the administration for this Integrated CSU to the circuit pack to assure the board's translations are correct. The administration of the CSU Module is done using the DS1 circuit pack administration form. Translation for the CSU Module includes the following data: Transmit LBO, Receive ALBO, Supply CPE Loopback Jack Power, etc.

**Table 9-695. TEST #146 Translation Update Test**

Error Code	Test Result	Description/ Recommendation
	ABORT	Internal system error 1. Retry the command at 1-minute intervals a maximum of 5 times.
	FAIL	Internal system software error. 1. Enter the <b>display ds1 UUCSS</b> command to verify the UDS1 Interface circuit pack translation.
	PASS	Translation data has been downloaded to the UDS1 Interface circuit pack successfully.
0	NO BOARD	The test could not relate the internal ID to the port (no board). This could be due to incorrect translations, no board is inserted, an incorrect board is inserted, or an insane board is inserted. 1. Ensure that the board translations are correct. Execute the <b>add ds1 UUCSS</b> command to administer the UDS1 interface if it is not already administered. 2. If the board was already administered correctly, check the error log to determine whether the board is hyperactive. If this is the case, the board is shut down. Reseating the board will re-initialize the board. 3. If the board was found to be correctly inserted in step 1, then issue the <b>busyout board</b> command. 4. Issue the <b>reset board</b> command. 5. Issue the <b>release busy board</b> command. 6. Issue the <b>test board long</b> command.  This should re-establish the linkage between the internal ID and the port.

## DS1 Board Loopback Test (#1209)

**This test is destructive.**

The DS1 Board Loopback (BLB) Test causes a loopback at the TN464F DS1 board edge and tests DS1 board internal circuitry.

The test is destructive and can only be initiated by a system technician demanded *test ds1-loop UUCSS ds1/csu-loopback-tests* command.

All trunks or ports on the UDS1 Interface circuit pack must be busied out via the system technician **busyout board** command before running the BLB Test.

When the BLB Test is initiated, maintenance software sends an appropriate message to the TN464F UDS1 Interface circuit pack to start the test. The board will set up the BLB loopback, transmit a test pattern, and verify that the pattern is received unaltered through the loopback. If the transmitted and received pattern is different, the test fails.

When the test is complete, all trunks or ports on the TN464F UDS1 Interface circuit pack are restored to the in-service state after the **release board** command is entered.

**Table 9-696. TEST #1209 DS1 Board Loopback Test**

Error Code	Test Result	Description/ Recommendation
	ABORT	Internal system error 1. Retry the <i>test ds1-loop UUCSS ds1/csu-loopback-tests</i> command at 1-minute intervals a maximum of 5 times.
1005	ABORT	DS1 Board Loopback Test cannot be executed in the current configuration. To run this, the TN464F or later suffix UDS1 must be administered for 24-channel operation. The "Bit Rate" field on the DS1 circuit pack administration form must be set to "1.544" for 24-channel operation.
1015	ABORT	Ports on the UDS1 Interface circuit pack have not been busied out to out-of-service. 1. Enter the <b>busyout board UUCSS</b> command to put all trunks or ports of the UDS1 Interface circuit pack into the out-of-service state. 2. Retry the command.

*Continued on next page*



**Table 9-696. TEST #1209 DS1 Board Loopback Test — Continued**

Error Code	Test Result	Description/ Recommendation
1039	ABORT	<p>The UDS1 Interface circuit pack is providing timing for the system. Executing this test could cause major system disruption.</p> <p>If the UDS1 Interface circuit pack needs to be tested, set the synchronization reference to another DS1 Interface circuit pack or to the Tone-Clock circuit pack via the following command sequence:</p> <ol style="list-style-type: none"> <li>1. Issue the <b>disable synchronization-switch</b> command.</li> <li>2. Next, issue the <b>set synchronization UUCSS</b> command.</li> <li>3. Lastly, issue the <b>enable synchronization-switch</b> command.</li> </ol>
1950	ABORT	<p>Another loopback/span test is already executing on the DS1 board or the board is in a network requested loopback mode (Line loopback or Payload loopback). The hardware error log will indicate whether a Customer Loopback Jack Test, Far CSU Loopback Test, or the One-Way Span Test is executing or if the board is in line loopback or payload loopback mode. Only one long-duration loopback/span test can be active at a given time. Thus, if a loopback/span test is already active, that test must be terminated via the <b>test ds1-loop UUCSS end-loopback/span-test</b> command in order to execute this test.</p>
2000	ABORT	<p>Response to the test was not received within the allowable time period. This may be due to hyperactivity. Error type 1538 in the error log indicates hyperactivity. The hyperactive circuit pack is out of service and one or more of the following symptoms may be exhibited.</p> <ol style="list-style-type: none"> <li>1. The UDS1-BD tests (such as test 138 and test 139) are aborting with error code 2000.</li> <li>2. The tests run on the ports of this circuit pack are returning a no board result.</li> <li>3. A <b>busyout</b> or a <b>release</b> command has no affect on the test results.</li> <li>4. A <b>list config</b> command shows that the circuit pack and the ports are properly installed.</li> </ol> <p><b>⇒ NOTE:</b></p> <p>When hyperactivity occurs, the circuit pack is isolated from the system, and all of the trunks for this circuit pack are placed into the out of service state. The system will try to restore the circuit pack within 15 minutes. When no faults are detected for 15 minutes, the UDS1 interface circuit pack is restored to normal operation. All of the trunks for the UDS1 interface circuit pack are then returned to the in service state. Hyperactivity is often caused by the associated facility. In such a case, faults (such as slips, misframes, or blue alarms) would be entered in the error log. In addition, many hardware errors would be logged against the associated trunk circuits. If the facility is OK and the error occurs again after 15 minutes, replace the circuit pack.</p>

**Table 9-696. TEST #1209 DS1 Board Loopback Test — Continued**

Error Code	Test Result	Description/ Recommendation
2100	ABORT	Could not allocate the necessary system resources to run this test. 1. Retry the command at 1-minute intervals for a maximum of 5 times.
	FAIL	UDS1 Interface circuit pack failed the DS1 Board Loopback Test. 1. Retry the <i>test ds1-loop UUCSS ds1/csu-loopback-tests</i> command. 2. If the BLB test continues to fail, then replace the UDS1 circuit pack.
	PASS	The BLB test executed successfully. The test pattern was transmitted and received successfully up to the TN464F DS1 board edge.
0	NO BOARD	The test could not relate the internal ID to the port (no board). This could be due to incorrect translations, no board is inserted, an incorrect board is inserted, or an insane board is inserted. 1. Ensure that the board translations are correct. Execute the <b>add ds1 UUCSS</b> command to administer the UDS1 interface if it is not already administered. 2. If the board was already administered correctly, check the error log to determine whether the board is hyperactive. If this is the case, the board is shut down. Reseating the board will re-initialize the board. 3. If the board was found to be correctly inserted in step 1, then issue the <b>busyout board</b> command. 4. Issue the <b>reset board</b> command. 5. Issue the <b>release busy board</b> command. 6. Issue the <b>test board long</b> command. This should re-establish the linkage between the internal ID and the port.

## CSU Equipment Loopback Test (#1210)

**This test is destructive.**

The CSU Equipment Loopback (ELB) Test causes a loopback at the near-edge of the local Lucent 120A1 CSU Module and tests the connection from the TN464F DS1 board to the CSU Module (DS1 board edge interconnecting cable, and CSU Module edge). This test will only be performed if the Lucent 120A1 CSU Module is present, administered, and connected to a 1.544 Mbps TN464F DS1 circuit pack on the back of the port carrier.

The test is destructive and can only be initiated by a system technician demanded *test ds1-loop UUCSS ds1/csu-loopback-tests* command.

All trunks or ports on the UDS1 Interface circuit pack must be busied out via the system technician **busyout board** command before running the ELB Test.

When the ELB Test is initiated, maintenance software sends an appropriate message to the TN464F UDS1 Interface circuit pack to start the test. The board will set up the ELB loopback, transmit a test pattern, and verify that the pattern is received unaltered through the loopback. If the transmitted and received pattern is different, the test fails.

When the test is complete, all trunks or ports on the TN464F UDS1 Interface circuit pack are restored to the in-service state after the **release board** command is entered.

**Table 9-697. TEST #1210 CSU Equipment Loopback Test**

Error Code	Test Result	Description/ Recommendation
	ABORT	Internal system error 1. Retry the <i>test ds1-loop UUCSS ds1/csu-loopback-tests</i> command at 1-minute intervals a maximum of 5 times.
1005	ABORT	CSU Equipment Loopback Test cannot be executed in the current configuration. To run this test, the <i>Near-End CSU Type</i> field on the DS1 circuit pack administration form must be set to <i>integrated</i> and the "Bit Rate" field on the DS1 circuit pack administration form must be set to "1.544" (24-channel configuration). 1. Use the <b>change ds1 UUCSS</b> command to set the <i>Near-End CSU Type</i> field on the DS1 circuit pack administration form to <i>integrated</i> , and/or change the "Bit Rate" field to "1.544" if the board is to be used in 24-channel configuration. 2. Retry the <i>test ds1-loop UUCSS ds1/csu-loopback-tests</i> command.
1015	ABORT	Ports on the UDS1 Interface circuit pack have not been busied out to out-of-service. 1. Enter the <b>busyout board UUCSS</b> command to put all trunks or ports of the UDS1 Interface circuit pack into the out-of-service state. 2. Retry the command.
1039	ABORT	The UDS1 Interface circuit pack is providing timing for the system. Executing this test could cause major system disruption. If the UDS1 Interface circuit pack needs to be tested, set the synchronization reference to another DS1 Interface circuit pack or to the Tone-Clock circuit pack via the following command sequence: 1. Issue the <b>disable synchronization-switch</b> command. 2. Next, issue the <b>set synchronization UUCSS</b> command. 3. Lastly, issue the <b>enable synchronization-switch</b> command.

**Table 9-697. TEST #1210 CSU Equipment Loopback Test — Continued**

Error Code	Test Result	Description/ Recommendation
1950	ABORT	Another loopback/span test is already executing on the DS1 board or the board is in a network requested loopback mode (Line loopback or Payload loopback). The hardware error log will indicate whether a Customer Loopback Jack Test, Far CSU Loopback Test, or the One-Way Span Test is executing or if the board is in line loopback or payload loopback mode. Only one long-duration loopback/span test can be active at a given time. Thus, if a loopback/span test is already active, that test must be terminated via the <i>test ds1-loop UUCSS end-loopback/span-test</i> command in order to execute this test.
1951	ABORT	The CSU Equipment Loopback Test could not be executed because the 120A1 CSU Module was not physically installed. Physically connect the 120A1 CSU Module to the TN464F board on the back of the port carrier.
2000	ABORT	<p>Response to the test was not received within the allowable time period. This may be due to hyperactivity. Error type 1538 in the error log indicates hyperactivity. The hyperactive circuit pack is out of service and one or more of the following symptoms may be exhibited.</p> <ol style="list-style-type: none"> <li>1. The UDS1-BD tests (such as test 138 and test 139) are aborting with error code 2000.</li> <li>2. The tests run on the ports of this circuit pack are returning a no board result.</li> <li>3. A <b>busyout</b> or a <b>release</b> command has no affect on the test results.</li> <li>4. A <b>list config</b> command shows that the circuit pack and the ports are properly installed.</li> </ol> <p><b>⇒ NOTE:</b>                      When hyperactivity occurs, the circuit pack is isolated from the system, and all of the trunks for this circuit pack are placed into the out of service state. The system will try to restore the circuit pack within 15 minutes. When no faults are detected for 15 minutes, the UDS1 interface circuit pack is restored to normal operation. All of the trunks for the UDS1 interface circuit pack are then returned to the in service state. Hyperactivity is often caused by the associated facility. In such a case, faults (such as slips, misframes, or blue alarms) would be entered in the error log. In addition, many hardware errors would be logged against the associated trunk circuits. If the facility is OK and the error occurs again after 15 minutes, replace the circuit pack.</p>
2100	ABORT	<p>Could not allocate the necessary system resources to run this test.</p> <ol style="list-style-type: none"> <li>1. Retry the command at 1-minute intervals for a maximum of 5 times.</li> </ol>

*Continued on next page*

Table 9-697. TEST #1210 CSU Equipment Loopback Test — Continued

Error Code	Test Result	Description/ Recommendation
	FAIL	<p>UDS1 Interface circuit pack failed the CSU Equipment Loopback Test.</p> <ol style="list-style-type: none"> <li>1. Retry the <i>test ds1-loop UUCSS ds1/csu-loopback-tests</i> command.</li> <li>2. If the ELB test continues to fail, then either the TN464F board, the CSU Module, or the I/O cable between the backplane and the CSU module (or any combination thereof) has failed. Attempt to isolate the problem to one of these areas. Begin by replacing the CSU Module and running the <i>test ds1-loop UUCSS ds1/csu-loopback-tests</i> command again.</li> <li>3. If the ELB test continues to fail, then replace the TN464F board and run the <i>test ds1-loop UUCSS ds1/csu-loopback-tests</i> command again.</li> <li>4. If the ELB test continues to fail, the problem could be in the I/O cable between the backplane and the CSU module.</li> </ol>
	PASS	<p>The ELB test executed successfully. The test pattern was transmitted and received successfully over the connection from the TN464F DS1 board to the near-edge of the 120A1 CSU Module.</p>
0	NO BOARD	<p>The test could not relate the internal ID to the port (no board). This could be due to incorrect translations, no board is inserted, an incorrect board is inserted, or an insane board is inserted.</p> <ol style="list-style-type: none"> <li>1. Ensure that the board translations are correct. Execute the <b>add ds1 UUCSS</b> command to administer the UDS1 interface if it is not already administered.</li> <li>2. If the board was already administered correctly, check the error log to determine whether the board is hyperactive. If this is the case, the board is shut down. Reseating the board will re-initialize the board.</li> <li>3. If the board was found to be correctly inserted in step 1, then issue the <b>busyout board</b> command.</li> <li>4. Issue the <b>reset board</b> command.</li> <li>5. Issue the <b>release busy board</b> command.</li> <li>6. Issue the <b>test board long</b> command.</li> </ol> <p>This should re-establish the linkage between the internal ID and the port.</p>

## CSU Repeater Loopback Test (#1211)

**This test is destructive.**

The CSU Repeater Loopback (RLB) Test causes a loopback at the far-edge of the local Lucent 120A1 CSU Module and tests the connection from the TN464F DS1 board to and including the CSU Module circuitry. This test will only be performed if the Lucent 120A1 CSU Module is present, administered, and connected to a 1.544 Mbps TN464F DS1 circuit pack on the back of the port carrier.

The test is destructive and can only be initiated by a system technician demanded *test ds1-loop UUCSS ds1/csu-loopback-tests* command.

All trunks or ports on the UDS1 Interface circuit pack must be busied out via the system technician **busyout board** command before running the RLB Test.

When the RLB Test is initiated, maintenance software sends an appropriate message to the TN464F UDS1 Interface circuit pack to start the test. The board will set up the RLB loopback, transmit a test pattern, and verify that the pattern is received unaltered through the loopback. If the transmitted and received pattern is different, the test fails.

When the test is complete, all trunks or ports on the TN464F UDS1 Interface circuit pack are restored to the in-service state after the **release board** command is entered.

**Table 9-698. TEST #1211 CSU Repeater Loopback Test**

Error Code	Test Result	Description/ Recommendation
	ABORT	Internal system error 1. Retry the <i>test ds1-loop UUCSS ds1/csu-loopback-tests</i> command at 1-minute intervals a maximum of 5 times.
1005	ABORT	CSU Repeater Loopback Test cannot be executed in the current configuration. To run this test, the <i>Near-End CSU Type</i> field on the DS1 circuit pack administration form must be set to <i>integrated</i> and the "Bit Rate" field on the DS1 circuit pack administration form must be set to "1.544" (24-channel configuration). 1. Use the <b>change ds1 UUCSS</b> command to set the <i>Near-End CSU Type</i> field on the DS1 circuit pack administration form to <i>integrated</i> , and/or change the "Bit Rate" field to "1.544" if the board is to be used in 24-channel configuration. 2. Retry the <i>test ds1-loop UUCSS ds1/csu-loopback-tests</i> command.

*Continued on next page*

Table 9-698. TEST #1211 CSU Repeater Loopback Test — *Continued*

Error Code	Test Result	Description/ Recommendation
1015	ABORT	Ports on the UDS1 Interface circuit pack have not been busied out to out-of-service. <ol style="list-style-type: none"><li>1. Enter the <b>busyout board UUCSS</b> command to put all trunks or ports of the UDS1 Interface circuit pack into the out-of-service state.</li><li>2. Retry the command.</li></ol>
1039	ABORT	The UDS1 Interface circuit pack is providing timing for the system. Executing this test could cause major system disruption.  If the UDS1 Interface circuit pack needs to be tested, set the synchronization reference to another DS1 Interface circuit pack or to the Tone-Clock circuit pack via the following command sequence: <ol style="list-style-type: none"><li>1. Issue the <b>disable synchronization-switch</b> command.</li><li>2. Next, issue the <b>set synchronization UUCSS</b> command.</li><li>3. Lastly, issue the <b>enable synchronization-switch</b> command.</li></ol>
1950	ABORT	Another loopback/span test is already executing on the DS1 board or the board is in a network requested loopback mode (Line loopback or Payload loopback). The hardware error log will indicate whether a Customer Loopback Jack Test, Far CSU Loopback Test, or the One-Way Span Test is executing or if the board is in line loopback or payload loopback mode. Only one long-duration loopback/span tests can be active at a given time. Thus, if a loopback/span test is already active, that test must be terminated via the <i>test ds1-loop UUCSS end-loopback/span-test</i> command in order to execute this test.
1951	ABORT	The CSU Repeater Loopback Test could not be executed because the 120A1 CSU Module was not physically installed. Physically connect the 120A1 CSU Module to the TN464F board on the back of the port carrier.

*Continued on next page*

**Table 9-698. TEST #1211 CSU Repeater Loopback Test — Continued**

Error Code	Test Result	Description/ Recommendation
2000	ABORT	<p>Response to the test was not received within the allowable time period. This may be due to hyperactivity. Error type 1538 in the error log indicates hyperactivity. The hyperactive circuit pack is out of service and one or more of the following symptoms may be exhibited.</p> <ol style="list-style-type: none"> <li>1. The UDS1-BD tests (such as test 138 and test 139) are aborting with error code 2000.</li> <li>2. The tests run on the ports of this circuit pack are returning a no board result.</li> <li>3. A <b>busyout</b> or a <b>release</b> command has no affect on the test results.</li> <li>4. A <b>list config</b> command shows that the circuit pack and the ports are properly installed.</li> </ol> <p><b>⇒ NOTE:</b>                      When hyperactivity occurs, the circuit pack is isolated from the system, and all of the trunks for this circuit pack are placed into the out of service state. The system will try to restore the circuit pack within 15 minutes. When no faults are detected for 15 minutes, the UDS1 interface circuit pack is restored to normal operation. All of the trunks for the UDS1 interface circuit pack are then returned to the in service state. Hyperactivity is often caused by the associated facility. In such a case, faults (such as slips, misframes, or blue alarms) would be entered in the error log. In addition, many hardware errors would be logged against the associated trunk circuits. If the facility is OK and the error occurs again after 15 minutes, replace the circuit pack.</p>
2100	ABORT	<p>Could not allocate the necessary system resources to run this test.</p> <ol style="list-style-type: none"> <li>1. Retry the command at 1-minute intervals for a maximum of 5 times.</li> </ol>
	FAIL	<p>UDS1 Interface circuit pack failed the CSU Repeater Loopback Test.</p> <ol style="list-style-type: none"> <li>1. Retry the <i>test ds1-loop UUCSS ds1/csu-loopback-tests</i> command.</li> <li>2. If the RLB test continues to fail, and the CSU Equipment Loopback Test (#1210) passed, then replace the CSU Module.</li> </ol>

*Continued on next page*



**Table 9-698. TEST #1211 CSU Repeater Loopback Test — Continued**

Error Code	Test Result	Description/ Recommendation
	PASS	The RLB test executed successfully. The test pattern was transmitted and received successfully over the connection from the TN464F DS1 board to the far-edge of the 120A1 CSU Module.
0	NO BOARD	<p>The test could not relate the internal ID to the port (no board). This could be due to incorrect translations, no board is inserted, an incorrect board is inserted, or an insane board is inserted.</p> <ol style="list-style-type: none"> <li>1. Ensure that the board translations are correct. Execute the <b>add ds1 UUCSS</b> command to administer the UDS1 interface if it is not already administered.</li> <li>2. If the board was already administered correctly, check the error log to determine whether the board is hyperactive. If this is the case, the board is shut down. Reseating the board will re-initialize the board.</li> <li>3. If the board was found to be correctly inserted in step 1, then issue the <b>busyout board</b> command.</li> <li>4. Issue the <b>reset board</b> command.</li> <li>5. Issue the <b>release busy board</b> command.</li> <li>6. Issue the <b>test board long</b> command.</li> </ol> <p>This should re-establish the linkage between the internal ID and the port.</p>

### CPE Loopback Jack Test (#1212)

**This test is destructive.**

The CPE Loopback Jack (CLJ-LB) Test causes a loopback at the CPE Loopback Jack and tests the building wiring connection between the TN464F DS1 board and the CPE Loopback Jack.

The test is highly destructive and can only be initiated by a system technician demanded **test ds1-loop UUCSS cpe-loopback-jack-test-begin [number-of-bits bit-pattern]** command. The System technician has the choice of entering a loopback activation code on the command line or using the default code *0x47F*.

All trunks or ports on the UDS1 Interface circuit pack must be busied out via the system technician **busyout board** command before running the CPE Loopback Jack Test.

The CPE Loopback Jack Test has the TN464F UDS1 Interface circuit pack transmit a loopback activation code to the CPE Loopback Jack, waits up to 10

seconds for return of the code to verify the loopback has been established, transmits a framed 3-in-24 test pattern, begins counting bit errors in the received test pattern, and returns a PASS result to indicate that the pattern was successfully sent. If the loopback is not established within the 10 seconds, the test returns FAIL or abort.

The status of the CPE Loopback Jack test will be available in the hardware error log via error type 3900. Several distinct aux values will be used to give the user information of the status of the test.

The *list measurements ds1 summary* command will display the length of time the test has been running (*Test Duration* field) and number of bit errors detected (*Loopback/Span Test Bit-Error Count* field). If the test pattern is being passed through the loopback cleanly, the number of bit errors should be very low. The command will also display the type of Loopback/Span test executing (*Test* field), the type of pattern generated for the Loopback/Span test (*Pattern* field), and whether the pattern (*i.e. 3-in-24 Pattern*) is synchronized (*Synchronized* field).

To terminate the test, enter the *test ds1-loop UUCSS end-loopback/span-test* command or the **release board** command. Using the **release board** command will restore all trunks or ports on the TN464F UDS1 Interface circuit pack to the in-service state.

**Table 9-699. TEST #1212 CPE Loopback Jack Test**

Error Code	Test Result	Description/ Recommendation
	ABORT	Internal system error 1. Retry the <i>test ds1-loop UUCSS cpe-loopback-jack-test-begin</i> command at 1-minute intervals a maximum of 5 times.
1005	ABORT	CPE Loopback Jack Test cannot be executed in the current configuration. To run this test, the TN464F or later suffix UDS1 must be administered for 24-channel operation. The "Bit Rate" field on the DS1 circuit pack administration form must be set to "1.544" for 24-channel operation.
1015	ABORT	Ports on the UDS1 Interface circuit pack have not been busied out to out-of-service. 1. Enter the <b>busyout board UUCSS</b> command to put all trunks or ports of the UDS1 Interface circuit pack into the out-of-service state. 2. Retry the command.

*Continued on next page*

**Table 9-699. TEST #1212 CPE Loopback Jack Test — Continued**

Error Code	Test Result	Description/ Recommendation
1039	ABORT	<p>The UDS1 Interface circuit pack is providing timing for the system. Executing this test could cause major system disruption.</p> <p>If the UDS1 Interface circuit pack needs to be tested, set the synchronization reference to another DS1 Interface circuit pack or to the Tone-Clock circuit pack via the following command sequence:</p> <ol style="list-style-type: none"> <li>1. Issue the <b>disable synchronization-switch</b> command.</li> <li>2. Next, issue the <b>set synchronization UUCSS</b> command.</li> <li>3. Lastly, issue the <b>enable synchronization-switch</b> command.</li> </ol>
1950	ABORT	<p>Another loopback/span test is already executing on the DS1 board or the board is in a network requested loopback mode (Line loopback or Payload loopback). The hardware error log will indicate whether a Customer Loopback Jack Test, Far CSU Loopback Test, or the One-Way Span Test is executing or if the board is in line loopback or payload loopback mode. Only one long-duration loopback/span test can be active at a given time. Thus, if a loopback/span test is already active, that test must be terminated via the <i>test ds1-loop UUCSS end-loopback/span-test</i> command in order to execute this test.</p>
2000	ABORT	<p>Response to the test was not received within the allowable time period. This may be due to hyperactivity. Error type 1538 in the error log indicates hyperactivity. The hyperactive circuit pack is out of service and one or more of the following symptoms may be exhibited.</p> <ol style="list-style-type: none"> <li>1. The UDS1-BD tests (such as test 138 and test 139) are aborting with error code 2000.</li> <li>2. The tests run on the ports of this circuit pack are returning a no board result.</li> <li>3. A <b>busyout</b> or a <b>release</b> command has no affect on the test results.</li> <li>4. A <b>list config</b> command shows that the circuit pack and the ports are properly installed.</li> </ol> <p><b>⇒ NOTE:</b></p> <p>When hyperactivity occurs, the circuit pack is isolated from the system, and all of the trunks for this circuit pack are placed into the out of service state. The system will try to restore the circuit pack within 15 minutes. When no faults are detected for 15 minutes, the UDS1 interface circuit pack is restored to normal operation. All of the trunks for the UDS1 interface circuit pack are then returned to the in service state.</p> <p>Hyperactivity is often caused by the associated facility. In such a case, faults (such as slips, misframes, or blue alarms) would be entered in the error log. In addition, many hardware errors would be logged against the associated trunk circuits. If the facility is OK and the error occurs again after 15 minutes, replace the circuit pack.</p>

**Table 9-699. TEST #1212 CPE Loopback Jack Test — Continued**

Error Code	Test Result	Description/ Recommendation
2100	ABORT	Could not allocate the necessary system resources to run this test. 1. Retry the command at 1-minute intervals for a maximum of 5 times.
2	FAIL	The CLJ-LB test failed because it was not set up properly. The UDS1 interface pack could not successfully put the CPE loopback jack into loopback mode. 1. Rerun the <b>test ds1-loop UUCSS cpe-loopback-jack-test-begin</b> command. 2. If the test continues to fail, the problem could be with the TN464F board, the CPE loopback jack equipment, or somewhere between. Run the <b>test ds1-loop UUCSS ds1/csu-loopback-tests</b> command to determine if the loopback tests that are closer to the TN464F board are successful. If any of these tests fail, follow the maintenance strategy that is associated with the test that fails.
3	FAIL	The CPE Loopback Jack Test was not set up properly. The framed 3-in-24 test pattern, generated by the UDS1 Interface circuit pack and looped back through the CPE Loopback Jack, could not be detected properly by the UDS1 circuit pack. 1. Retry the <i>test ds1-loop UUCSS cpe-loopback-jack-test-begin</i> command. 2. If the CPE Loopback Jack test continues to fail, the problem could be with the TN464F board, the CPE Loopback Jack equipment, or somewhere in between. Run the <i>test ds1-loop UUCSS ds1/csu-loopback-tests</i> command to see if the loopback tests closer to the TN464F board are successful. If any of those loopback tests fail, follow the maintenance strategy associated with those loopbacks.

*Continued on next page*

**Table 9-699. TEST #1212 CPE Loopback Jack Test — Continued**

Error Code	Test Result	Description/ Recommendation
	PASS	The CPE Loopback Jack test has successfully began executing. The test will continue to run until the system technician enters the <i>test ds1-loop UUCSS end-loopback/span-test</i> command or the <i>release board UUCSS</i> command.
0	NO BOARD	<p>The test could not relate the internal ID to the port (no board). This could be due to incorrect translations, no board is inserted, an incorrect board is inserted, or an insane board is inserted.</p> <ol style="list-style-type: none"> <li>1. Ensure that the board translations are correct. Execute the <b>add ds1 UUCSS</b> command to administer the UDS1 interface if it is not already administered.</li> <li>2. If the board was already administered correctly, check the error log to determine whether the board is hyperactive. If this is the case, the board is shut down. Reseating the board will re-initialize the board.</li> <li>3. If the board was found to be correctly inserted in step 1, then issue the <b>busyout board</b> command.</li> <li>4. Issue the <b>reset board</b> command.</li> <li>5. Issue the <b>release busy board</b> command.</li> <li>6. Issue the <b>test board long</b> command.</li> </ol> <p>This should re-establish the linkage between the internal ID and the port.</p>

### Far CSU Loopback Test (#1213)

**This test is destructive.**

The Far CSU Loopback (R-LLB) Test causes a loopback at the far-end CSU and tests all circuitry and facilities from the local TN464F DS1 board to the far-end CSU.

The test is destructive and can only be initiated by a system technician demanded *test ds1-loop UUCSS far-csu-loopback-test-begin* command.

All trunks or ports on the UDS1 Interface circuit pack must be busied out via the system technician **busyout board** command before running the Far CSU Loopback Test.

If the far-end CSU is not an Lucent 120A1 CSU Module, and the DS1 is administered for ami-zcs line coding, one's density protection must be disabled on the CSU during the test due to the large number of zero's in the 3-in-24 test pattern.

The Far CSU Loopback Test has the TN464F UDS1 Interface circuit pack transmit a loopback activation code to the remote CSU, waits up to 15 seconds for return of the code to verify the loopback has been established, transmits a framed 3-in-24 test pattern, begins counting bit errors in the received test pattern, and returns a PASS result. If the loopback is not established within the 15 seconds, the test fails.

The status of the Far CSU Loopback test will be available in the hardware error log via error type 3901. Several distinct aux values will be used to give the user information of the status of the test.

The *list measurements ds1 summary* command will display the length of time the test has been running (*Test Duration* field) and number of bit errors detected (*Loopback/Span Test Bit-Error Count* field). If the test pattern is being passed through the loopback cleanly, the number of bit errors should be very low. The command will also display the type of Loopback/Span test executing (*Test* field), the type of pattern generated for the type of Loopback/Span test (*Pattern* field), and whether the pattern (*i.e. 3-in-24 Pattern*) is synchronized (*Synchronized* field).

To terminate the test, enter the *test ds1-loop UUCSS end-loopback/span-test* command or the **release board** command. Using the **release board** command will restore all trunks or ports on the TN464F UDS1 Interface circuit pack to the in-service state.

**Table 9-700. TEST #1213 Far CSU Loopback Test**

Error Code	Test Result	Description/ Recommendation
	ABORT	Internal system error 1. Retry the <i>test ds1-loop UUCSS far-csu-loopback-test-begin</i> command at 1-minute intervals a maximum of 5 times.
1005	ABORT	Far CSU Loopback Test cannot be executed in the current configuration. To run this, the TN464F or later suffix UDS1 must be administered for 24-channel operation. The "Bit Rate" field on the DS1 circuit pack administration form must be set to "1.544" for 24-channel operation.
1015	ABORT	Ports on the UDS1 Interface circuit pack have not been busied out to out-of-service. 1. Enter the <b>busyout board UUCSS</b> command to put all trunks or ports of the UDS1 Interface circuit pack into the out-of-service state. 2. Retry the command.

*Continued on next page*

**Table 9-700. TEST #1213 Far CSU Loopback Test — Continued**

Error Code	Test Result	Description/ Recommendation
1039	ABORT	<p>The UDS1 Interface circuit pack is providing timing for the system. Executing this test could cause major system disruption.</p> <p>If the UDS1 Interface circuit pack needs to be tested, set the synchronization reference to another DS1 Interface circuit pack or to the Tone-Clock circuit pack via the following command sequence:</p> <ol style="list-style-type: none"> <li>1. Issue the <b>disable synchronization-switch</b> command.</li> <li>2. Next, issue the <b>set synchronization UUCSS</b> command.</li> <li>3. Lastly, issue the <b>enable synchronization-switch</b> command.</li> </ol>
1950	ABORT	<p>Another loopback/span test is already executing on the DS1 board or the board is in a network requested loopback mode (Line loopback or Payload loopback). The hardware error log will indicate whether a Customer Loopback Jack Test, Far CSU Loopback Test, or the One-Way Span Test is executing or if the board is in line loopback or payload loopback mode. Only one long-duration loopback/span test can be active at a given time. Thus, if a loopback/span test is already active, that test must be terminated via the <i>test ds1-loop UUCSS end-loopback/span-test</i> command in order to execute this test.</p>
2000	ABORT	<p>Response to the test was not received within the allowable time period. This may be due to hyperactivity. Error type 1538 in the error log indicates hyperactivity. The hyperactive circuit pack is out of service and one or more of the following symptoms may be exhibited.</p> <ol style="list-style-type: none"> <li>1. The UDS1-BD tests (such as test 138 and test 139) are aborting with error code 2000.</li> <li>2. The tests run on the ports of this circuit pack are returning a no board result.</li> <li>3. A <b>busyout</b> or a <b>release</b> command has no affect on the test results.</li> <li>4. A <b>list config</b> command shows that the circuit pack and the ports are properly installed.</li> </ol> <p><b>⇒ NOTE:</b></p> <p>When hyperactivity occurs, the circuit pack is isolated from the system, and all of the trunks for this circuit pack are placed into the out of service state. The system will try to restore the circuit pack within 15 minutes. When no faults are detected for 15 minutes, the UDS1 interface circuit pack is restored to normal operation. All of the trunks for the UDS1 interface circuit pack are then returned to the in service state. Hyperactivity is often caused by the associated facility. In such a case, faults (such as slips, misframes, or blue alarms) would be entered in the error log. In addition, many hardware errors would be logged against the associated trunk circuits. If the facility is OK and the error occurs again after 15 minutes, replace the circuit pack.</p>

**Table 9-700. TEST #1213 Far CSU Loopback Test — Continued**

Error Code	Test Result	Description/ Recommendation
2100	ABORT	Could not allocate the necessary system resources to run this test. 1. Retry the command at 1-minute intervals for a maximum of 5 times.
2	FAIL	The test failed because it was not set up properly. The UDS1 pack could not successfully put the far-end CSU into loopback mode. 1. Rerun the <b>test ds1-loop UUCSS far-csu-loopback-test-begin</b> command. 2. If the test continues to fail, the problem could be with the TN464F board, the CPE loopback jack equipment, or somewhere between. Run the <b>test ds1-loop UUCSS cpe-loopback-jack-test-begin</b> command to determine if the CPE loopback jack loopback test is successful. If a CPE loopback jack device is not being used, issue the <b>test ds1-loop UUCSS ds1/csu-loopback-tests</b> command instead. If the closer loopback test fails, follow the maintenance strategy associated with that test.
3	FAIL	The Far CSU Loopback Test was not set up properly. The framed 3-in-24 test pattern, generated by the UDS1 Interface circuit pack and looped back through the far-end CSU, could not be detected properly by the UDS1 circuit pack. 1. Retry the <i>test ds1-loop UUCSS far-csu-loopback-test-begin</i> command. 2. If the Far CSU Loopback test continues to fail with this error code, the problem could be with the TN464F board, the far-end CSU equipment, or somewhere in between. Run the <i>test ds1-loop UUCSS cpe-loopback-jack-test-begin</i> command to see if the CPE Loopback Jack test which is closer to the TN464F board is successful. (If a CPE Loopback Jack device is not being used, then run the <i>test ds1-loop UUCSS ds1/csu-loopback-tests</i> command to see if these even closer loopback tests succeed). If the closer loopback test fails, follow the maintenance strategy associated with that loopback.

*Continued on next page*



Table 9-700. TEST #1213 Far CSU Loopback Test — *Continued*

Error Code	Test Result	Description/ Recommendation
	PASS	The Far CSU Loopback test has successfully begun executing. The test will continue to run until the system technician enters the <i>test ds1-loop UUCSS end-loopback/span-test</i> command or the <i>release board UUCSS</i> command.
0	NO BOARD	<p>The test could not relate the internal ID to the port (no board). This could be due to incorrect translations, no board is inserted, an incorrect board is inserted, or an insane board is inserted.</p> <ol style="list-style-type: none"> <li>1. Ensure that the board translations are correct. Execute the <b>add ds1 UUCSS</b> command to administer the UDS1 interface if it is not already administered.</li> <li>2. If the board was already administered correctly, check the error log to determine whether the board is hyperactive. If this is the case, the board is shut down. Reseating the board will re-initialize the board.</li> <li>3. If the board was found to be correctly inserted in step 1, then issue the <b>busyout board</b> command.</li> <li>4. Issue the <b>reset board</b> command.</li> <li>5. Issue the <b>release busy board</b> command.</li> <li>6. Issue the <b>test board long</b> command.</li> </ol> <p>This should re-establish the linkage between the internal ID and the port.</p>

## One-Way Span Test (#1214)

**This test is destructive.**

The One-Way Span Test allows one-way span testing to and from remote test equipment or another DEFINITY communications system. This will test all circuitry and facilities from the local TN464F DS1 board to the remote test equipment or other DEFINITY communications system.

The test is destructive and can only be initiated by a system technician demanded *test ds1-loop UUCSS one-way-span-test-begin* command.

All trunks or ports on the UDS1 Interface circuit pack must be busied out via the system technician **busyout board** command before running the One-Way Span Test.

The One-Way Span Test has the TN464F UDS1 Interface circuit pack transmit a framed 3-in-24 test pattern and attempt to receive and verify the pattern. If the TN464F board receives a framed 3-in-24 test pattern sent from another DEFINITY G3V3 or test equipment at the far-end of the DS1, it will begin counting bit errors within the received pattern.

The status of the One-Way Span test will be available in the hardware error log via error type 3902. Several distinct aux values will be used to give the user information of the status of the test.

The *list measurements ds1 summary* command will display the length of time the test has been running (*Test Duration* field) and number of bit errors detected (*Loopback/Span Test Bit-Error Count* field). If the test pattern is being sent cleanly over the span from the far-end, the number of bit errors should be very low. The *Test Duration* field will show 0 until the test pattern is received from the far-end. Upon receiving the test pattern, the board will begin calculating the test duration and number of bit errors. The command will also display the Loopback/Span test executing (*Test* field), the type of pattern generated for the Loopback/Span test (*Pattern* field), and whether the pattern (*i.e. 3-in-24 Pattern*) is synchronized (*Synchronized* field).

To terminate the test, enter the *test ds1-loop UUCSS end-loopback/span-test* command or the **release board** command. Using the **release board** command will restore all trunks or ports on the TN464F UDS1 Interface circuit pack to the in-service state.

**Table 9-701. TEST #1214 One-Way Span Test**

Error Code	Test Result	Description/ Recommendation
	ABORT	Internal system error 1. Retry the <i>test ds1-loop UUCSS one-way-span-test-begin</i> command at 1-minute intervals a maximum of 5 times.
1005	ABORT	One-Way Span Test cannot be executed in the current configuration. To run this, the TN464F or later suffix UDS1 must be administered for 24-channel operation. The "Bit Rate" field on the DS1 circuit pack administration form must be set to "1.544" for 24-channel operation.
1015	ABORT	Ports on the UDS1 Interface circuit pack have not been busied out to out-of-service. 1. Enter the <b>busyout board UUCSS</b> command to put all trunks or ports of the UDS1 Interface circuit pack into the out-of-service state. 2. Retry the command.
1039	ABORT	The UDS1 Interface circuit pack is providing timing for the system. Executing this test could cause major system disruption. If the UDS1 Interface circuit pack needs to be tested, set the synchronization reference to another DS1 Interface circuit pack or to the Tone-Clock circuit pack via the following command sequence: 1. Issue the <b>disable synchronization-switch</b> command. 2. Next, issue the <b>set synchronization UUCSS</b> command. 3. Lastly, issue the <b>enable synchronization-switch</b> command.
1950	ABORT	Another loopback/span test is already executing on the DS1 board or the board is in a network requested loopback mode (Line loopback or Payload loopback). The hardware error log will indicate whether a Customer Loopback Jack Test, Far CSU Loopback Test, or the One-Way Span Test is executing or if the board is in line loopback or payload loopback mode. Only one long-duration loopback/span test can be active at a given time. Thus, if a loopback/span test is already active, that test must be terminated via the <i>test ds1-loop UUCSS end-loopback/span-test</i> command in order to execute this test.

*Continued on next page*

**Table 9-701. TEST #1214 One-Way Span Test — Continued**

Error Code	Test Result	Description/ Recommendation
2000	ABORT	<p>Response to the test was not received within the allowable time period. This may be due to hyperactivity. Error type 1538 in the error log indicates hyperactivity. The hyperactive circuit pack is out of service and one or more of the following symptoms may be exhibited.</p> <ol style="list-style-type: none"> <li>1. The UDS1-BD tests (such as test 138 and test 139) are aborting with error code 2000.</li> <li>2. The tests run on the ports of this circuit pack are returning a no board result.</li> <li>3. A <b>busyout</b> or a <b>release</b> command has no affect on the test results.</li> <li>4. A <b>list config</b> command shows that the circuit pack and the ports are properly installed.</li> </ol> <p><b>⇒ NOTE:</b>                      When hyperactivity occurs, the circuit pack is isolated from the system, and all of the trunks for this circuit pack are placed into the out of service state. The system will try to restore the circuit pack within 15 minutes. When no faults are detected for 15 minutes, the UDS1 interface circuit pack is restored to normal operation. All of the trunks for the UDS1 interface circuit pack are then returned to the in service state. Hyperactivity is often caused by the associated facility. In such a case, faults (such as slips, misframes, or blue alarms) would be entered in the error log. In addition, many hardware errors would be logged against the associated trunk circuits. If the facility is OK and the error occurs again after 15 minutes, replace the circuit pack.</p>
2100	ABORT	<p>Could not allocate the necessary system resources to run this test.</p> <ol style="list-style-type: none"> <li>1. Retry the command at 1-minute intervals for a maximum of 5 times.</li> </ol>

*Continued on next page*

**Table 9-701. TEST #1214 One-Way Span Test — Continued**

Error Code	Test Result	Description/ Recommendation
	PASS	The One-Way Span test has successfully began transmitting a framed 3-in-24 test pattern. The test will continue to run until the system technician enters the <i>test ds1-loop UUCSS end-loopback/span-test</i> command or the <i>release board UUCSS</i> command.
0	NO BOARD	<p>The test could not relate the internal ID to the port (no board). This could be due to incorrect translations, no board is inserted, an incorrect board is inserted, or an insane board is inserted.</p> <ol style="list-style-type: none"> <li>1. Ensure that the board translations are correct. Execute the <b>add ds1 UUCSS</b> command to administer the UDS1 interface if it is not already administered.</li> <li>2. If the board was already administered correctly, check the error log to determine whether the board is hyperactive. If this is the case, the board is shut down. Reseating the board will re-initialize the board.</li> <li>3. If the board was found to be correctly inserted in step 1, then issue the <b>busyout board</b> command.</li> <li>4. Issue the <b>reset board</b> command.</li> <li>5. Issue the <b>release busy board</b> command.</li> <li>6. Issue the <b>test board long</b> command.</li> </ol> <p>This should re-establish the linkage between the internal ID and the port.</p>

**Inject Single Bit Error Test (#1215). This test is destructive.**

The Inject Single Bit Error Test will cause a single bit error to be sent within an active framed 3-in-24 test pattern.

The test is highly destructive and can only be initiated by a system technician demanded *test ds1-loop UUCSS inject-single-bit-error* command. An attempt to use this command will be rejected if none of the three long-duration DS1 loopback/span tests (CPE Loopback Jack Test, Far CSU Loopback Test, One-Way Span Test) are active on a TN464F circuit pack.

All trunks or ports on the UDS1 Interface circuit pack must be busied out via the system technician **busyout board** command before running the Inject Single Bit Error Test.

The *list measurements ds1 summary* command displays the number of bit errors detected (*Loopback/Span Test Bit-Error Count* field). Injecting this single bit error should increment the bit error count of the loopback/span test by one.

**Table 9-702. TEST #1215 Inject Single Bit Error Test**

Error Code	Test Result	Description/ Recommendation
	ABORT	Internal system error 1. Retry the <i>test ds1-loop UUCSS inject-single-bit-error</i> command at 1-minute intervals a maximum of 5 times.
1015	ABORT	Ports on the UDS1 Interface circuit pack have not been busied out to out-of-service. 1. Enter the <b>busyout board UUCSS</b> command to put all trunks or ports of the UDS1 Interface circuit pack into the out-of-service state. 2. Retry the command.
2000	ABORT	Response to the test was not received within the allowable time period. This may be due to hyperactivity. Error type 1538 in the error log indicates hyperactivity. The hyperactive circuit pack is out of service and one or more of the following symptoms may be exhibited. 1. The UDS1-BD tests (such as test 138 and test 139) are aborting with error code 2000. 2. The tests run on the ports of this circuit pack are returning a no board result. 3. A <b>busyout</b> or a <b>release</b> command has no affect on the test results. 4. A <b>list config</b> command shows that the circuit pack and the ports are properly installed.  <b>⇒ NOTE:</b> When hyperactivity occurs, the circuit pack is isolated from the system, and all of the trunks for this circuit pack are placed into the out of service state. The system will try to restore the circuit pack within 15 minutes. When no faults are detected for 15 minutes, the UDS1 interface circuit pack is restored to normal operation. All of the trunks for the UDS1 interface circuit pack are then returned to the in service state. Hyperactivity is often caused by the associated facility. In such a case, faults (such as slips, misframes, or blue alarms) would be entered in the error log. In addition, many hardware errors would be logged against the associated trunk circuits. If the facility is OK and the error occurs again after 15 minutes, replace the circuit pack.
2100	ABORT	Could not allocate the necessary system resources to run this test. 1. Retry the command at 1-minute intervals for a maximum of 5 times.

*Continued on next page*

Table 9-702. TEST #1215 Inject Single Bit Error Test — *Continued*

Error Code	Test Result	Description/ Recommendation
	PASS	A single bit error has been successfully injected into an active framed 3-in-24 test pattern.
0	NO BOARD	<p>The test could not relate the internal ID to the port (no board). This could be due to incorrect translations, no board is inserted, an incorrect board is inserted, or an insane board is inserted.</p> <ol style="list-style-type: none"> <li>1. Ensure that the board translations are correct. Execute the <b>add ds1 UUCSS</b> command to administer the UDS1 interface if it is not already administered.</li> <li>2. If the board was already administered correctly, check the error log to determine whether the board is hyperactive. If this is the case, the board is shut down. Reseating the board will re-initialize the board.</li> <li>3. If the board was found to be correctly inserted in step 1, then issue the <b>busyout board</b> command.</li> <li>4. Issue the <b>reset board</b> command.</li> <li>5. Issue the <b>release busy board</b> command.</li> <li>6. Issue the <b>test board long</b> command.</li> </ol> <p>This should re-establish the linkage between the internal ID and the port.</p>

## End Loopback/Span Test (#1216)

**This test is destructive.**

The End Loopback/Span Test will terminate an active loopback or span test on a TN464F UDS1 circuit pack. Bit error counting against the received test pattern stream is terminated and sending of the framed 3-in-24 test pattern is halted. If either the CPE Loopback Jack or the far-end CSU is looped, the appropriate loopback deactivate code is sent. If the loopback could not be deactivated, then the test will FAIL and a MINOR alarm will be noted in the alarm log until the loopback is cleared.

The test is highly destructive and can only be initiated by a system technician demanded *test ds1-loop UUCSS end-loopback/span-test* command. Since only one of these three different long-duration loopback/span tests can be active at a time, the TN464F circuit pack knows which loopback/span test to terminate.

All trunks or ports on the UDS1 Interface circuit pack must be busied out via the system technician **busyout board** command before running this End Loopback/Span Test.

The *list measurements ds1 summary* command will display the length of time the test ran (*Test Duration* field) and number of bit errors detected (*Loopback/Span Test Bit-Error Count* field).

To restore the trunks or ports on the TN464F UDS1 Interface circuit pack to the in-service state, execute the **release board** command.

**Table 9-703. TEST #1216 End Loopback/Span Test**

Error Code	Test Result	Description/ Recommendation
	ABORT	Internal system error 1. Retry the <i>test ds1-loop UUCSS end-loopback/span-test</i> command at 1-minute intervals a maximum of 5 times.
1005	ABORT	End Loopback/Span Test cannot be executed in the current configuration. To run this test, the TN464F or later suffix DS1 board must be administered for 24-channel operation. The "Bit Rate" field on the DS1 circuit pack administration form must be set to "1.544" for 24-channel operation.
1015	ABORT	Ports on the UDS1 Interface circuit pack have not been busied out to out-of-service. 1. Enter the <b>busyout board UUCSS</b> command to put all trunks or ports of the UDS1 Interface circuit pack into the out-of-service state. 2. Retry the command.

*Continued on next page*



**Table 9-703. TEST #1216 End Loopback/Span Test — Continued**

Error Code	Test Result	Description/ Recommendation
2000	ABORT	<p>Response to the test was not received within the allowable time period. This may be due to hyperactivity. Error type 1538 in the error log indicates hyperactivity. The hyperactive circuit pack is out of service and one or more of the following symptoms may be exhibited.</p> <ol style="list-style-type: none"> <li>1. The UDS1-BD tests (such as test 138 and test 139) are aborting with error code 2000.</li> <li>2. The tests run on the ports of this circuit pack are returning a no board result.</li> <li>3. A <b>busyout</b> or a <b>release</b> command has no affect on the test results.</li> <li>4. A <b>list config</b> command shows that the circuit pack and the ports are properly installed.</li> </ol> <p><b>⇒ NOTE:</b>                      When hyperactivity occurs, the circuit pack is isolated from the system, and all of the trunks for this circuit pack are placed into the out of service state. The system will try to restore the circuit pack within 15 minutes. When no faults are detected for 15 minutes, the UDS1 interface circuit pack is restored to normal operation. All of the trunks for the UDS1 interface circuit pack are then returned to the in service state. Hyperactivity is often caused by the associated facility. In such a case, faults (such as slips, misframes, or blue alarms) would be entered in the error log. In addition, many hardware errors would be logged against the associated trunk circuits. If the facility is OK and the error occurs again after 15 minutes, replace the circuit pack.</p>
2100	ABORT	<p>Could not allocate the necessary system resources to run this test.</p> <ol style="list-style-type: none"> <li>1. Retry the command at 1-minute intervals for a maximum of 5 times.</li> </ol>
1313	FAIL	<p>The TN464F UDS1 circuit pack could not deactivate the loopback through the Customer Loopback Jack.</p> <ol style="list-style-type: none"> <li>1. Retry the <i>test ds1-loop UUCSS end-loopback/span-test</i> command at 1-minute intervals for a maximum of 5 times.</li> </ol>
1314	FAIL	<p>The TN464F UDS1 circuit pack could not deactivate the loopback through the far-end CSU.</p> <ol style="list-style-type: none"> <li>1. Make sure that the far-end DS1 is installed if the far-end CSU is a 120A1 Lucent CSU Module.</li> <li>2. Retry the <i>test ds1-loop UUCSS end-loopback/span-test</i> command at 1-minute intervals for a maximum of 5 times.</li> </ol>

*Continued on next page*

**Table 9-703. TEST #1216 End Loopback/Span Test — Continued**

Error Code	Test Result	Description/ Recommendation
	PASS	The active long-duration loopback or span test on the TN464F circuit pack was successfully terminated.
0	NO BOARD	<p>The test could not relate the internal ID to the port (no board). This could be due to incorrect translations, no board is inserted, an incorrect board is inserted, or an insane board is inserted.</p> <ol style="list-style-type: none"> <li>1. Ensure that the board translations are correct. Execute the <b>add ds1 UUCSS</b> command to administer the UDS1 interface if it is not already administered.</li> <li>2. If the board was already administered correctly, check the error log to determine whether the board is hyperactive. If this is the case, the board is shut down. Reseating the board will re-initialize the board.</li> <li>3. If the board was found to be correctly inserted in step 1, then issue the <b>busyout board</b> command.</li> <li>4. Issue the <b>reset board</b> command.</li> <li>5. Issue the <b>release busy board</b> command.</li> <li>6. Issue the <b>test board long</b> command.</li> </ol> <p>This should re-establish the linkage between the internal ID and the port.</p>

**ICSU Status LEDs Test (#1227)**

The TN464F UDS1 circuit pack has four status LEDs on the faceplate in addition to the three standard faceplate LEDs. These four status LEDs are associated with the 120A1 Channel Service Unit (CSU) Module that can be connected to the TN464F board via the I/O connector panel on the back of the port carrier. The TN464F circuit pack combined with the 120A1 CSU Module forms an Integrated CSU (ICSU).

This test is a visual test. It will light the four status LEDs red for 5 seconds, then light them green for 5 seconds, then light them yellow for 5 seconds, then turn the LEDs off and returns control of the status LEDs to the circuit pack.

This test will only be executed on TN464F or later suffix UDS1 circuit packs administered for 24-channel operation (1.544 bit rate).

If the 120A1 CSU Module is not physically installed, the status LEDs are always off and this test will abort.

**Table 9-704. TEST #1227 ICSU Status LEDs Test**

Error Code	Test Result	Description/ Recommendation
	ABORT	Internal system error 1. Retry the command at 1-minute intervals a maximum of 5 times.
1005	ABORT	The ICSU Status LEDs test can not be executed for the current configuration. The test applies only to TN464F or later UDS1 circuit packs administered for 24-channel operation (1.544 bit rate). 1. If the circuit pack is a TN464F or later suffix UDS1 circuit pack, then retry the command.
1951	ABORT	The ICSU Status LEDs Test can not be executed because a 120A1 or later suffix CSU Module is not physically installed. If using a 120A1 CSU Module, physically connect it to the TN464F board on the back of the port carrier. Otherwise, ignore this abort.
2100	ABORT	Could not allocate the necessary system resources to run this test. 1. Retry the command at 1-minute intervals for a maximum of 5 times.
2500	ABORT	Internal system error. 1. Retry the command.

*Continued on next page*

**Table 9-704. TEST #1227 ICSU Status LEDs Test — Continued**

Error Code	Test Result	Description/ Recommendation
	PASS	<p>The ICSU Status LEDs test executed successfully. A PASS result, however, does not necessarily mean that the status LEDs behaved properly. It only means that the software successfully attempted to light the status LEDs. This is a visual test. The service technician must visually exam the behavior of the LEDs while the test is running. The LEDs are functioning properly if the four status LEDs are lit red for 5 seconds, then lit green for 5 seconds, then lit yellow for 5 seconds. If the LEDs behave differently, the board should be replaced at the customer's convenience.</p>
0	NO BOARD	<p>The test could not relate the internal ID to the port (no board). This could be due to incorrect translations, no board is inserted, an incorrect board is inserted, or an insane board is inserted.</p> <ol style="list-style-type: none"> <li>1. Ensure that the board translations are correct. Execute the <b>add ds1 UUCSS</b> command to administer the UDS1 interface if it is not already administered.</li> <li>2. If the board was already administered correctly, check the error log to determine whether the board is hyperactive. If this is the case, the board is shut down. Reseating the board will re-initialize the board.</li> <li>3. If the board was found to be correctly inserted in step 1, then issue the <b>busyout board</b> command.</li> <li>4. Issue the <b>reset board</b> command.</li> <li>5. Issue the <b>release busy board</b> command.</li> <li>6. Issue the <b>test board long</b> command.</li> </ol> <p>This should re-establish the linkage between the internal ID and the port.</p>

## VC-BD

MO Name (in Alarm Log)	Alarm Level	Initial Command to Run <sup>1</sup>	Full Name of MO
VC-BD	MAJOR	test board UUCSS I r#	Voice Conditioner Circuit Pack
VC-BD	MINOR	test board UUCSS I r#	Voice Conditioner Circuit Pack
VC-BD	WARNING <sup>2</sup>	test board UUCSS s r#	Voice Conditioner Circuit Pack

- Where UU is the universal cabinet number (1 for PPN and 2-44 for EPN); C is the carrier designation (for example, A, B, C, D, or E); SS is the address of the slot in the carrier where the circuit pack is located (for example, 01, 02, ...); and pp is the two digit port number (01, 02, 03, ...).
- Refer to XXX-BD (Common Port Board) Maintenance documentation.



### CAUTION:

*If the TN788 Voice Conditioner Circuit Pack (VC-BD) is not Vintage 2 or later, it must be replaced.*

The TN788 Voice Conditioner Circuit Pack (VC-BD) is a service circuit pack that provides conditioning for the audio signals from multimedia equipment based on the CCITT H.221 standard. The TN788 transcodes, gain adjusts, and bridges the audio bit streams demultiplexed by the TN787 (MMI) circuit pack and transmits encoded, exclusive audio conference sums onto the TDM bus so that the MMI can multiplex the audio, video, and data streams for the H.221 endpoints.

## Error Log Entries and Test to Clear Values

Table 9-705. VC-BD Error Log Entries

Error Type	Aux Data	Associated Test	Alarm Level	On/Off Board	Test to Clear Value
0 <sup>1</sup>	0	Any	Any	Any	test board UUCSS sh r 1
1 (a)	Any	None	MIN	ON	
18 (b)	0	busyout board UUCSS	WNG	OFF	release board UUCSS
257 (c)	Any	Control Channel Loop Test (#52)	MIN	ON	test board UUCSS r 20
513 (d)	4352 to 4357				
769 (e)	4358				

*Continued on next page*

**Table 9-705. VC-BD Error Log Entries — Continued**

Error Type	Aux Data	Associated Test	Alarm Level	On/Off Board	Test to Clear Value
1025 (f)	4363	NPE Audit Test (#50)			
1281 (g)	Any	SAKI Sanity Test (#53)	MAJ	On	
1293 to 1294 (h)	46088 to 46096	SAKI Sanity Test (#53)	MIN	ON	
1538 (i)	46082		MIN	ON	

1. Run the short test sequence first. If all tests pass, run the long test sequence. Refer to the appropriate test description and follow the recommended procedures.

Notes:

- a. The circuit pack stopped functioning or it was removed from the system. This alarm is logged approximately 11-minutes after the circuit pack is removed and/or the SAKI Sanity Test (#53) fails.

To resolve this error, insert a circuit pack in the same slot as the error indicates, if the circuit pack is not already in the system. Or, if the circuit pack is in the system and the red LED is on, then follow instructions for Red alarms.



**CAUTION:**

*If the TN788 Voice Conditioner Circuit Pack (VC-BD) is not Vintage 2 or later, it must be replaced.*

- b. This circuit pack is busied out by the **busyout board UUCSS** command.
- c. Transient communication problems exist between the switch and this circuit pack. Execute the **test board UUCSS** command and refer to the repair procedures for the Control Channel Looparound Test (#52).
- d. The circuit pack detected an on-board hardware failure. The reported aux data values correspond to the following detected errors:

Error	Description
4352	External RAM error
4353	Internal RAM error
4355	ROM Checksum error
4357	Instruction set error

Reset the circuit pack by executing the **busyout board UUCSS**, **reset board UUCSS**, and **release board UUCSS** commands. When it is reset, the circuit pack executes a set of tests to detect the presence of any of the above faults. The detection of one these errors during initialization causes the circuit pack to lock-up and appear insane to the system. See the repair procedures in footnote (a) for error type 1.

- e. The circuit pack detects a program logic error. While no action is required, this error may lead to errors of other types being reported against this circuit pack.
- f. The circuit pack cannot update NPE memory and read it back. This error type can be ignored, but it may lead to other error types being reported against this circuit pack.
- g. A critical hardware failure has been detected on the circuit pack. Use **busyout board UUCSS**, **reset board UUCSS**, followed by **release board UUCSS**. If test #53 passes, the on-board circuitry is healthy. Use **test board UUCSS long clear** to retire the alarm. If test #53 fails, replace the circuit pack.
- h. The circuit pack detected a critical hardware failure. Reset the circuit pack by issuing the **busyout board UUCSS**, **reset board UUCSS**, and **release board UUCSS** commands. If the Circuit Pack Restart Test (#594) passes, then the on-board circuitry is healthy. Retire the alarm by issuing the **test board UUCSS long clear** command. If the Circuit Pack Restart Rest (#594) fails, replace the circuit pack.

The reported error types correspond to the following detected errors:

Error	Description
1293	On-board auxiliary processor insane
1294	Internal memory access error

- i. The circuit pack is hyperactive — it is flooding the switch with messages sent over the control channel. The circuit pack is taken out of service when a threshold number of these errors is reported to the switch. Clear the alarm by using **busyout board UUCSS**, **reset board UUCSS**, **test board UUCSS long clear**, and **release board UUCSS**. If the error recurs within 10 minutes, then replace the circuit pack.

## System Technician-Demanded Tests: Descriptions and Error Code

---

Order of Investigation	Short Test Sequence	Long Test Sequence	D/ND <sup>1</sup>
Control Channel Loop-Around Test (#52) <sup>2</sup>	X	X	ND

- 
1. D = Destructive; ND = Nondestructive
  2. Refer to the repair procedure described in the XXX-BD (Common Port Circuit Pack) maintenance documentation for a description of this test.



### CAUTION:

*If the TN788 Voice Conditioner Circuit Pack (VC-BD) is not Vintage 2 or later, it must be replaced.*

### Control Channel Looparound Test (#52)

Refer to the repair procedure described in the XXX-BD (Common Port Circuit Pack) maintenance documentation as Control Channel Looparound Test (#52).



## VC-DSPPT

---

MO Name (in Alarm Log)	Alarm Level	Initial Command to Run <sup>1</sup>	Full Name of MO
VC-DSPPT	MAJOR	test port UUCSSpp	Voice Conditioner DSP Port
VC-DSPPT	MINOR	test port UUCSSpp	Voice Conditioner DSP Port
VC-DSPPT	WARNING	test port UUCSSpp	Voice Conditioner DSP Port

1. Where UU is the universal cabinet number (1 for PPN and 2-44 for EPN); C is the carrier designation (for example, A, B, C, D, or E); SS is the address of the slot in the carrier where the circuit pack is located (for example, 01, 02, ...); and pp is the two digit port number (01, 02, 03, ...).

Each Voice Conditioner Circuit Pack (VC-BD) provides two types of resources:

1. Transcoder Resources used for encoding and decoding audio formats
2. Summer Resources used for summing audio from different sources

The eight Voice Conditioner DSP ports are the transcoder resources on the VC-BD.

## Error Log Entries and Test to Clear Values

**Table 9-706. VC-DSPPT Error Log Entries**

Error Type	Aux Data	Associated Test	Alarm Level	On/ Off Board	Test to Clear Value
0 <sup>1</sup>	0	Any	Any	Any	test port UUCSSpp sh r 1
18 (a)	0	busyout port UUCSSpp	WNG	OFF	release port UUCSSpp
257 (b)	Any	NPE Crosstalk Test (#6)	MIN	ON	test port UUCSSpp 1 r 3
513 (c)	Any	VC DSP Port Local TDM Loopback Test (#1104)	MIN	ON	test port UUCSSpp sh r 3
778 to 781 (d)	Any	VC Port Reset DSP Test (#1106)	MAJ	ON	See note (d)
1025 (e)			WNG	ON	
1281 (f)	Any	VC DSP Port DSP Loopback Test #(1105)	MIN	ON	test port UUCSSpp sh r 3
3840 (g)					

1. Run the short test sequence first. If all test pass, run the long test sequence. Refer to the appropriate test description and follow the recommended procedures.

### Notes:

- a. This port has been busied out by the **busyout port UUCSSpp** command.
- b. The VC DSP Port NPE Crosstalk Test(#1103) failed.
- c. The VC DSP Port Local TDM Loopback Test(#1104) failed. Run the Long Test Sequence.
- d. A critical hardware failure has been detected on the circuit pack. Reset the port by the **busyout port UUCSSpp** and **reset port UUCSSpp** commands. If the VC Reset DSP Test (#1106) passes, then the on-board circuitry is healthy. Retire the alarm with the **test port UUCSSpp long clear** command.
- e. The VC DSP port reported loss of framing on the Service Channel between the VC and MMI circuit packs.
- f. The VC DSP Port DSP Loopback Test (#1105) failed.
- g. The DSP corresponding to this port on the VC circuit pack reported a firmware error. No action is required.

## System Technician-Demanded Tests: Descriptions and Error Codes

Always investigate tests in the order presented in the table below. By clearing error codes associated with the DSP NPE Crosstalk Test, for example, you may also clear errors generated from other tests in the testing sequence.

Order of Investigation	Short Test Sequence	Long Test Sequence	D/ND <sup>1</sup>
DSP NPE Crosstalk Test (#1103)		X	D
TDM Loopback Test (#1104)	X	X	D
DSP Loopback Test (#1105)	X	X	D

1. D = Destructive; ND = Nondestructive

### DSP NPE Crosstalk Test (#1103)

**This test is destructive.**

The NPE Crosstalk test verifies that this port's NPE channel talks on the selected time slot and never crosses over to time slots reserved for other connections. If the NPE is not working correctly, one-way and noisy connections may be observed. This test is part of the port's long test sequence and takes approximately 20 to 30 seconds to complete.

**Table 9-707. TEST #1103 NPE Crosstalk Test**

Error Code	Test Result	Description/Recommendation
1000	ABORT	System resources required to run this test are not available. The port may be busy with a valid call. 1. Retry the command at 1-minute intervals a maximum of 5 times.
2012	ABORT	Internal system error 1. Retry the command at 1-minute intervals a maximum of 5 times.
2100	ABORT	Could not allocate the necessary resources for this test. 1. Retry the command at 1-minute intervals a maximum of 5 times.
	FAIL	The NPE of the tested port was transmitting in error, causing noisy and unreliable connections. 1. Replace the circuit pack.

**Table 9-707. TEST #1103 NPE Crosstalk Test — Continued**

Error Code	Test Result	Description/Recommendation
	PASS	The port is correctly using its allocated time slots. <ol style="list-style-type: none"> <li>1. To be sure that this is not an intermittent problem, repeat this test a maximum of 10 times.</li> <li>2. If complaints still persist, examine the station, connections, and wiring.</li> </ol>

### VC DSP Port Local TDM Loopback Test (#1104)

**This test is destructive.**

This test verifies the connectivity of a VC DSP Port across the TDM bus. It aborts if calls associated with the port are in progress. Failure of this test indicates an on-board fault associated with the port hardware on the circuit pack. The Loopback Test runs the following tests:

1. A Looparound test across the TDM bus.
2. A conference Circuit Test.

The tests are run in the above order; if one test fails, an error code is returned and the remaining tests in the sequence are not executed.

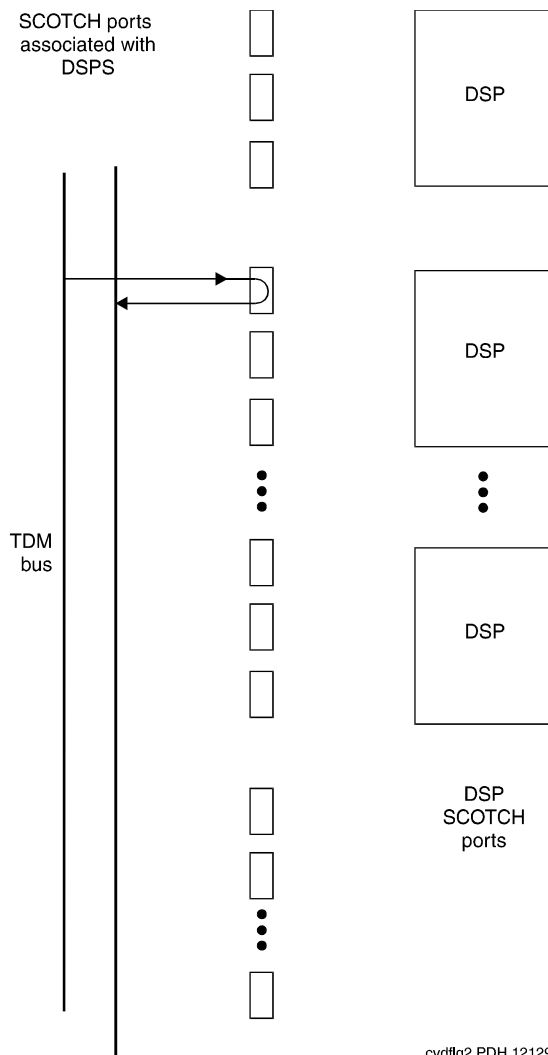

cydfiq2 PDH 121296

**Figure 9-114. VC Circuit Pack DSP Port Local TDM Loopback Test**

**Table 9-708. TEST #1104 VC DSPPT Local TDM Loopback Test**

Error Code	Test Result	Description/Recommendation
1000 1001	ABORT	System resources required to run this test are not available, or the port is busy with a valid call.  1. Retry the command at 1-minute intervals a maximum of 5 times.
1002	ABORT	The system could not allocate time slots for the test. The traffic load on the system is very high, or time slots may be out-of-service due to TDM-BUS errors.  1. If the system has no TDM-BUS errors and is not handling heavy traffic, repeat the test at 1-minute intervals a maximum of 5 times.
1003	ABORT	The system could not allocate a Tone Detector for the test. The system is oversized for the number of Tone Detectors present, or some Tone Detectors are out-of-service.  1. Resolve any TTR-LEV errors. 2. Resolve any TONE-PT errors. 3. If neither condition exists, retry the command at 1-minute intervals a maximum of 5 times.
1004	ABORT	The port is seized by a user for a valid call. Use the <b>status station</b> command for the station associated with this port and determine if the port is available for testing.  1. Retry the command at 1-minute intervals a maximum of 5 times.
2000	ABORT	Response to the test was not received from the VC-BD circuit pack within the allowable time period.  1. If this result occurs repeatedly, attempt to reset the port by using the <b>busyout port UUCSSpp</b> and <b>reset port UUCSSpp</b> commands. 2. If this result occurs again, replace the circuit pack.
2012	ABORT	Internal system error  1. Retry the command at 1-minute intervals a maximum of 5 times.
2100	ABORT	Could not allocate the necessary resources to run this test.  1. Retry the command at 1-minute intervals a maximum of 5 times.
2103	ABORT	The system could not make the conference connection for the test.  1. Retry the command at 1-minute intervals a maximum of 5 times.
0-3	FAIL	The TDM Looparound Test failed.  1. Replace circuit pack.
4-7	FAIL	The Conference Circuit Test failed.  1. Replace circuit pack.
	PASS	The VC DSP Port Local TDM Looparound Test passed.

## VC-DSP Port DSP Loopback Test (#1105)

**This test is destructive.**

This test verifies the connectivity of a VC-DSPPT across the TDM bus. It aborts if calls associated with the port are in progress. Failure of this test indicates an on-board fault associated with the port hardware on the circuit pack.

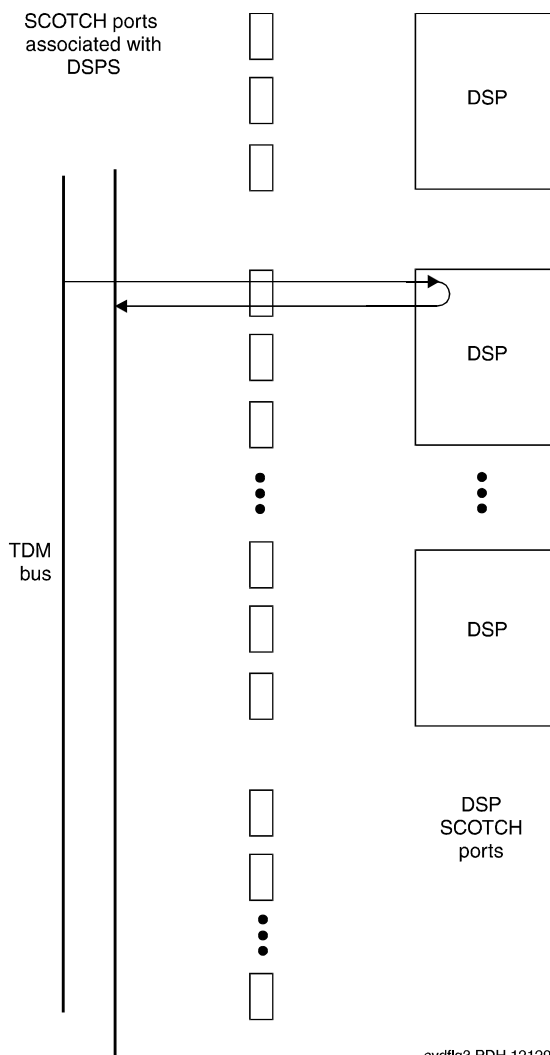

Figure 9-115. VC Circuit pack DSP Port DSP Looparound Test

**Table 9-709. TEST #1105 VC-DSP Port DSP Loopback Test**

Error Code	Test Result	Description/Recommendation
1000	ABORT	System resources required to run this test are not available, or the port is busy with a valid call.  1. Retry the command at 1-minute intervals a maximum of 5 times.
1002	ABORT	The system could not allocate time slots for the test, the traffic load on the system is very high, or time slots are out-of-service due to TDM-BUS errors.  1. If the system has no TDM-BUS errors and is not handling heavy traffic, retry the command at 1-minute intervals a maximum of 5 times.
1003	ABORT	The system could not allocate a Tone Detector for the test, the system is oversized for the number of Tone Detectors present, or some Tone Detectors are out-of-service.  1. Resolve any TTR-LEV errors. 2. Resolve any TONE-PT errors. 3. If neither condition exists, retry the command at 1-minute intervals a maximum of 5 times.
1004	ABORT	The port has been seized by a user for a valid call. Use the <b>status station</b> command for the station associated with this port and determine if the port is available for testing  1. Retry the command at 1-minute intervals a maximum of 5 times.
2000	ABORT	Response to the test request was not received from the VC-BD circuit pack within the allowable time period.  1. If this result occurs repeatedly, reset the circuit pack if the other ports are not in use by using the <b>busyout port UUCSSpp</b> and <b>reset port UUCSSpp</b> commands. 2. If this result occurs again, replace the circuit pack.
2012	ABORT	Internal system error  1. Retry the command at 1-minute intervals a maximum of 5 times.
2100	ABORT	Could not allocate the necessary system resources to run this test.  1. Retry the command at 1-minute intervals a maximum of 5 times.
0, 1	FAIL	The VC-DSPPT DSP Loopback Test failed.  1. Replace the circuit pack.
	PASS	The VC DSPPT DSP Loopback Test passed

**VC Port Reset DSP Test (#1106)**

**This test is destructive.**



This test resets the VC-DSPPT and the DSP associated with it. As part of the reset procedure, the VC-DSPPT will execute a series of self- tests on the hardware. If these self- tests fail, the test will fail; otherwise the test will pass.

Before executing the test, the VC-DSPPT must be busied out by executing the **busy port UUCSSpp** command. After the completion of the test, the VC-DSPPT must be released by executing the **release port UUCSSpp** command.

**Table 9-710. TEST #1106 VC Port Reset DSP Test**

Error Code	Test Result	Description/Recommendation
1000	ABORT	System resources required to run this test are not available, or the port may be busy with a call. 1. Retry the command at 1-minute intervals a maximum of 5 times.
1015	ABORT	The VC-DSPPT is not busied out. 1. Busy out the VC-DSPPT by executing the <b>busy port UUCSSpp</b> command and then retry the test.
2000	ABORT	Response to the test was not received from the VC-DSPPT within the allowable time period. 1. Retry the command at 1-minute intervals a maximum of 5 times. 2. If this result occurs again, replace the circuit pack.
2012	ABORT	Internal system error 1. Retry the command at 1-minute intervals a maximum of 5 times.
2100	ABORT	Could not allocate the necessary resources to run this test. 1. Retry the command at 1-minute intervals a maximum of 5 times.
	FAIL	The reset of the VC-DSPPT was unsuccessful. 1. Replace circuit pack.
	PASS	The VC-DSPPT was successfully reset. 1. Release the VC-DSPPT by executing the <b>reset port UUCSSpp</b> command.

## VC-LEV (Voice Conditioner DSP Port Level)

---

MO Name (in Alarm Log)	Alarm Level	Initial Command to Run	Full Name of MO
VC-LEV	MAJOR	See <a href="#">"Resolving VC-LEV Errors/Alarms"</a>	VC-LEV

Enable the MMCH feature on the *system-parameters customer-options* form before changing the fields.

The Voice Conditioner (VC) Port Level MO monitors VC efficiency by tracking the number of VC ports that are in-service, and then comparing that number with the value entered in the VC field on the System-Parameters Maintenance form. This `VCs` field is located under the Minimum Maintenance Thresholds section. The `VCs` field contains the minimum number of VC ports needed for the Multimedia Call Handling (MMCH) feature, and is an administrable field. The `VCs` field must contain a number between 0 and 126, and is entered by the system administrator. The MMCH feature must be enabled on the System-Parameters Customer-Options form before the `VCs` field can be changed to a number greater than 0. For example, administering 8 in that field means 1 circuit pack. The algorithm for determining that a low level of VC resources exists uses the number entered in the `VCs` field, and the number of VCs that are in-service in the system.

Each VC circuit pack contains 16 physical ports: 8 ports are reserved for VC-DSPPT ports, and the remaining 8 ports are designated as VC-SUMPT ports. The 8 DSP ports are made up of 4 encoder and 4 decoder resources that encode and decode audio formats. Thus, *one VC circuit pack is required for every 8 ports of MMCH port capacity*. If the number of in-service VC ports falls below the MMCH port capacity (value entered on the System-Parameters Maintenance form under the Minimum Maintenance Thresholds section and in the `VCs` field), a VEC-LEV error is logged. If this outage continues for 15 minutes a MAJOR alarm is raised.

### Resolving VC-LEV Errors/Alarms

VC ports are a key part of the MMCH feature, any loss in the number of ports available for use degrades the MMCH customer defined service level.

If a VC circuit pack or port is busied out using the **busyout board** or **busyout port** command, these out-of-service ports are not included in the VC level calculation, thus allowing a technician to busy out a VC circuit pack for maintenance reasons without causing a MAJOR alarm to be raised.

**⇒ NOTE:**

When diagnosing a VC-LEV problem, resolve any alarms raised against VC-BD or VC-DSPPT maintenance objects. Clearing VC-BD or VC-DSPPT alarms may clear the VC-LEV alarm.

The VC circuit pack is maintained by the software similarly to the Tone Detector circuit pack. Tone Detector circuit packs may be removed and reinserted in any port board slot without administration. The same rule applies to VC circuit packs. If a VC circuit pack is removed from service logically (by failing the Archangel sanity scan test) or is removed from service physically (by physically removing the circuit pack from the carrier), no error/alarm is raised against VC-BD or VC-DSPPT maintenance objects. Therefore, if a VC-LEV error/alarm exists, and none has been raised against VC-BD or VC-DSPPT maintenance objects, a VC circuit pack may have been removed from service causing the VC-LEV error/alarm. To resolve a VC-LEV MAJOR alarm, restore the number of VC ports available for service to be equal to or more than the calculated port capacity (value entered in the `VCs` field).

To determine how many VC circuit packs are needed for the MMCH feature:

1. Display the System-Parameters Maintenance form by executing the command **display system-parameters maintenance**.
2. Locate the number listed in the Minimum Maintenance Threshold (`VCs`) field. The MMCH feature requires one VC circuit pack for each four ports listed in the Minimum Maintenance Threshold (`VCs`) field.
3. Divide the Minimum Maintenance Threshold value by 8 to determine the number of VC circuit packs needed. For example, a port capacity of 12 listed in the Minimum Maintenance Threshold (`VCs`) field would require 2 VC circuit packs.
4. Use the **list configuration** command to verify that the number of VC circuit packs listed agrees with the required number of VC circuit packs (determined in step 3). If the number of VC circuit packs listed in the step 3 differs from the calculated number, restore the number of VC circuit packs to the correct value, in order to resolve the VC-LEV alarm.

## Error Log Entries and Test to Clear Values

**Table 9-711. VC-LEV Error Log Entries**

<b>Error Type</b>	<b>Aux Data</b>	<b>Associated Test</b>	<b>Alarm Level</b>	<b>On/ Off Board</b>	<b>Test to Clear Value</b>
1 (a)	Any	None	MAJOR	OFF	

**Notes:**

- a. The number of VC resources in the system that are in service has fallen below the calculated minimum value. If the number of in-service VC ports falls below the MMCH port capacity (value entered in the Minimum Maintenance Threshold  $VC_S$  field on the system parameters maintenance form), a VEC-LEV error is logged. If this outage continues for 15 minutes a MAJOR alarm is raised. To resolve this alarm, correct the out-of-service problem by following the procedures below:
  1. See "VC-DSPPT" and "VC-BD" and resolve any associated alarms.
  2. If a VC-LEV error/alarm exist and none has been raised against VC-BD or VC-DSPPT maintenance objects, a VC circuit pack may have been removed from service causing the VC-LEV error/alarm. To resolve a VC-LEV MAJOR alarm, restore the number of VC ports available for service to be equal to or more than the calculated port capacity. See "Resolving VC-LEV ERRORS/ALARMS" for details.

### System Technician-Demanded Tests: Descriptions and Error Code

There are no System Technician-Demanded test for VC-LEV.

## VC-SUMPT

---

MO Name (in Alarm Log)	Alarm Level	Initial Command to Run <sup>1</sup>	Full Name of MO
VC-SUMPT	MAJOR	test port UUCSSpp	Voice Conditioner Summer Port
VC-SUMPT	MINOR	test port UUCSSpp	Voice Conditioner Summer Port
VC-SUMPT	WARNING	test port UUCSSpp	Voice Conditioner Summer Port

- 
1. Where UU is the universal cabinet number (1 for PPN and 2-44 for EPN); C is the carrier designation (for example, A, B, C, D, or E); SS is the address of the slot in the carrier where the circuit pack is located (for example, 01, 02, ...); and pp is the two digit port number (01, 02, 03, ...).

Each Voice Conditioner Circuit Pack (VC-BD) provides two types of resources:

1. Transcoder Resources that are used for encoding and decoding audio formats
2. Summer Resources that are used for summing audio formats from different sources.

The Voice Conditioner Summer ports (VC-SUMPT) are the summer resources on the VC-BD. There are 8 such ports on a VC-BD.

## Error Log Entries and Test to Clear Values

**Table 9-712. VC-SUMPT Error Log Entries**

Error Type	Aux Data	Associated Test	Alarm Level	On/Off Board	Test to Clear Value
0 <sup>1</sup>	0	Any	Any	Any	test port UUCSSpp sh r 1
18 (a)	0	busyout port UUCSS	WNG	OFF	release port UUCSSpp
130 (b)			WNG	ON	test port UUCSSpp sh
257 (c)	Any	Control Channel Loop Test (#52)	MIN	ON	test board UUCSSpp 1 r 3
513 (d)	Any	VC Summer Port Local Loopback Test # (1100)	MIN	ON	test board UUCSSpp sh r 3

1. Run the short test sequence first. If all test pass, run the long test sequence. Refer to the appropriate test description and follow the recommended procedures.

### Notes:

- a. This port has been busied out with the **busyout port UUCSSpp** command.
- b. The circuit pack has been removed or has been insane for more than 11-minutes. To clear the error, replace or reinsert the circuit pack.
- c. The NPE Crosstalk Test(#1103) failed.
- d. The VC Summer Port Local TDM Loopback Test(#1100) failed.

## System Technician-Demanded Tests: Descriptions and Error Codes

Always investigate tests in the order presented in the table below. By clearing error codes associated with the NPE Crosstalk Test, for example, you may also clear errors generated from other tests in the testing sequence.

Order of Investigation	Short Test Sequence	Long Test Sequence	D/ND <sup>1</sup>
NPE Crosstalk Test (#6) (a)		X	D
TDM Loopback Test (#1100)	X	X	D

1. D = Destructive; ND = Nondestructive

## VC-SUMPT Port NPE Crosstalk Test (#6)

**This test is destructive.**

The NPE controls port connectivity and gain and provides conferencing functions. The NPE Crosstalk test verifies that this port's NPE channel talks on the selected time slot and never crosses over to time slots reserved for other connections. If the NPE is not working correctly, one-way and noisy connections may be observed. This test is part of the port's long test sequence and takes approximately 20 to 30 seconds to complete.

**Table 9-713. TEST #6 VC-SUMPT Port NPE Crosstalk Test**

Error Code	Test Result	Description/ Recommendation
1000 1001	ABORT	System resources required to run this test are not available. The port may be busy with a valid call.  1. Retry the command at 1-minute intervals a maximum of 5 times.
2012 2100	ABORT ABORT	Internal system error  Could not allocate the necessary resources for this test.  1. Retry the command at 1-minute intervals a maximum of 5 times.
0-3	FAIL	The NPE of the tested port was transmitting in error. This causes noisy and unreliable connections.  1. Replace circuit pack.
	PASS	The port is correctly using its allocated time slots.  1. Verify that this is not an intermittent problem by repeating this test a maximum of 10 times.  2. If complaints continue, examine the station, connections, and wiring.

## VC Summer Port Local TDM Loopback Test (#1100)

**This test is destructive.**

This test verifies the connectivity of a VC Summer Port across the TDM bus. It aborts if calls associated with the port are in progress. Failure of this test indicates an on-board fault associated with the port hardware on the circuit pack. The Loopback Test runs the following tests:

- A Looparound test across the TDM bus.
- A conference circuit test.

The tests are run in the above order. If the first test fails, the switch returns an error code, and the second test is not executed.

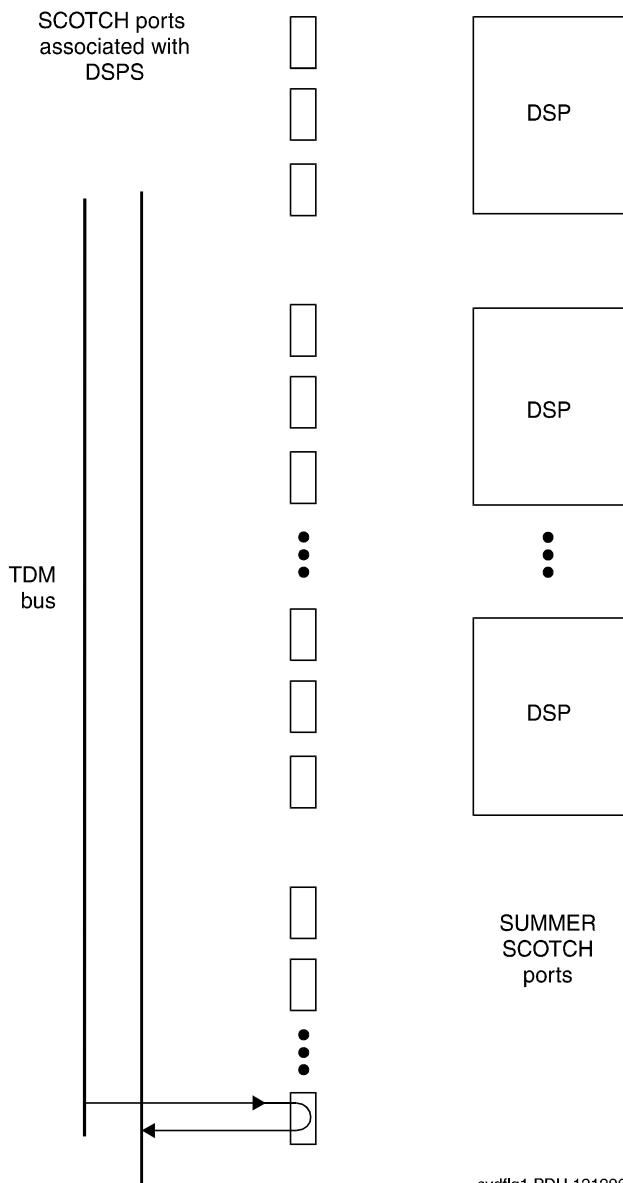

cydfflq1 PDH 121296

Figure 9-116. VC Circuit Pack Summer Port Loopback Test



**Table 9-714. TEST #1100 VC Summer Port Local TDM Loopback Test**

Error Code	Test Result	Description/Recommendation
1000	ABORT	System resources required to run this test are not available, or the port may be busy with a valid call.  1. Retry the command at 1-minute intervals a maximum of 5 times.
1002	ABORT	The system could not allocate time slots for the test. The traffic load on the system is very high or time slots are out-of-service due to TDM-BUS errors.  1. If the system has no TDM-BUS errors and is not handling heavy traffic, retry the command at 1-minute intervals a maximum of 5 times.
1003	ABORT	The system could not allocate a Tone Detector for the test, the system is oversized for the number of Tone Detectors present, or some Tone Detectors are out-of-service.  1. Resolve any TTR-LEV errors. 2. Resolve any TONE-PT errors. 3. If neither condition exists, retry the command at 1-minute intervals a maximum of 5 times.
1004	ABORT	The port has been seized by a user for a valid call. Use the <b>status station</b> command for the station associated with this port to determine whether the port is available for testing.  1. Retry the command at 1-minute intervals a maximum of 5 times.
2000	ABORT	Response to the test request was not received from the VC-BD circuit pack within the allowable time period.  1. If this result occurs repeatedly, reset the circuit pack if the other ports are not in use. Reset the circuit pack by issuing the <b>busyout board UUCSS</b> and the <b>reset board UUCSS</b> commands. 2. If this result occurs again, replace the circuit pack.
2012	ABORT	Internal system error  1. Retry the command at 1-minute intervals a maximum of 5 times.
2100	ABORT	Could not allocate the necessary system resources to run this test.  1. Retry the command at 1-minute intervals a maximum of 5 times.
2103	ABORT	The system could not make the conference connection for the test.  1. Retry the command at 1-minute intervals a maximum of 5 times.
0	FAIL	The TDM Looparound Test failed.
1	FAIL	The Conference Circuit Test failed.  1. Replace circuit pack.
	PASS	The VC Summer Port Local TDM Loopback Test passed.

## WAE-PORT (Wideband Access Endpoint Port)

---

MO Name (in Alarm Log)	Alarm Level	Initial Command to Run <sup>1</sup>	Full Name of MO
WAE-PORT (a)	MINOR	test access-endpoint <i>extension</i> l	Wideband Access
WAE-PORT	WARNING	test access-endpoint <i>extension</i>	Endpoint Port

1. For additional repair information, see also DS1-BD (DS1 Interface Circuit Pack).

Wideband Switching supports end-to-end connectivity between customer endpoints at data rates from 128 to 1536 kbps over T1 facilities and to 1984 kbps over E1 facilities. DEFINITY switching capabilities are extended to support wideband calls comprised of multiple DS0s that are switched end-to-end as a single entity.

Wideband Switching extends the Administered Connections feature to include non-signaling wideband access endpoints. Endpoint application equipment with direct T1 or E1 interfaces may connect directly to the switch's line-side facilities; application equipment without T1 or E1 interfaces requires a terminal adapter such as a DSU/CSU. The terminal adapter or endpoint application equipment is connected to the TN464C Universal DS1 circuit pack.

These endpoints are administered as wideband access endpoints and have no signaling interface to switch; they simply transmit and receive data. (Some applications detect and respond to the presence or absence of data). Calls are initiated from these endpoints using the Administered Connections feature.

Multiple access endpoints on one line-side UDS1 circuit pack facility are separate and distinct within the facility. Endpoint application equipment must be administered to send and receive the correct data rate over the correct DS0s. All Administered Connections originating from wideband access endpoints use the entire bandwidth administered for the endpoint. An incoming call of a different data rate than that administered of the endpoint cannot be routed to the endpoint.

Although Wideband Access Endpoints are used primarily for line-side facilities, these endpoints can also be administered on network DS1 facilities to connect DEFINITY to non-switched network services, such as the Lucent fractional T-1 service. An example of this is the Lucent Static Integrated Network Access, where a trunk group to AT&T 4ESS Switched Services shares an access T-1 facility with a Wideband Access Endpoint. In this case, the Wideband Access Endpoint is connected to the AT&T fractional T-1 service, and it does not terminate on local endpoint equipment but is connected to a far-end CPE (for example, another DEFINITY PBX) via the dedicated fractional T-1. All Wideband Access Endpoint functionality and operation is identical on both line-side and

network facilities. However, because maintenance capabilities are limited to the Wideband Access Endpoint interface, and because faults can occur end-to-end, troubleshooting procedures based on an end-to-end view of the network is required.

Wideband access endpoint port maintenance provides a strategy to maintain a wideband access endpoint port via a port on the Universal DS1 interface circuit pack hardware. The maintenance strategy covers logging wideband access endpoint port hardware errors, running tests for port initialization, periodic and scheduled maintenance, demand tests, and alarm escalation and resolution. Two different port service states are specified in the wideband access endpoint port maintenance:

- *out-of-service*: the port is in a deactivated state and cannot be used for calls
- *in-service*: the port is in an activated state and can be used for calls

If the UDS1 Interface circuit pack is out of service, all ports on it are taken out of service and a Warning alarm is raised.

## Error Log Entries and Test to Clear Values

**Table 9-715. Wideband Access Endpoint Maintenance Error Log Entries**

Error Type	Aux Data	Associated Test	Alarm Level	On/Off Board	Test to Clear Value
0 <sup>1</sup>	0	Any	Any	Any	test access-endpoint extension sh r 1
18(a)	0	busyout access-endpoint	WARNING	OFF	release access-endpoint extension
130(b)		None	WARNING	ON	test access-endpoint extension
1281(c)		Conference Circuit (Test #7)	MINOR	ON	test access-endpoint extension l r 4
1537(d)		NPE Crosstalk Test (#6)	MINOR	ON	test access-endpoint extension l r 3
1793(e)		None			test board UUCSS long
3840(f)	Any	Port Audit and Update (Test #36)			

1. Run the Short Test Sequence first. If all tests pass, run the Long Test Sequence. Refer to the appropriate test description and follow the recommended procedures.

Notes:

- a. The wideband access endpoint has been busied out by a **busyout access-endpoint** extension command. No calls can be made to this extension.
- b. The circuit pack has been removed or has been insane for more than 11-minutes. To clear the error, reinsert or replace the circuit pack.
- c. The Conference Circuit Test (#7) failed on this port. See Test #7 for repair procedures.
- d. The NPE Crosstalk Test (#6) failed on this port. See Test #6 for repair procedures.
- e. The TN464C UDS1 Interface circuit pack has failed. See UDS1-BD.
- f. The Port Audit and Update Test (#36) failed due to an internal system error. Enter **status access-endpoint** extension and verify the status of the port. If the wideband access endpoint port is out of service, enter **release access-endpoint** extension to put it back into service. Retry the test command.

## Technician-Demand Tests: Descriptions and Error Codes

---

Always investigate tests in the order presented in the table below when inspecting errors in the system. By clearing error codes associated with the *NPE Crosstalk Test*, for example, you may also clear errors generated from other tests in the testing sequence.

Order of Investigation	Short Test Sequence	Long Test Sequence	D/ND <sup>1</sup>
NPE Crosstalk Test (#6)		X	ND
Conference Circuit Test (#7)		X	ND
Port Audit and Update Test (#36)	X	X	ND

---

1. D = Destructive; ND = Nondestructive

## NPE Crosstalk Test (#6)

The NPE Crosstalk Test verifies that this port's NPE channel talks on the selected time slot, and does not cross over to time slots reserved for other connections. If the NPE is not working correctly, one-way and noisy connections may be observed. This test is usually part of a port's long test sequence and takes 20 to 30 seconds to complete.

**Table 9-716. TEST #6 NPE Crosstalk Test**

Error Code	Test Result	Description/ Recommendation
	ABORT	System resources required for this test are not available. <ol style="list-style-type: none"><li>1. Retry the command at 1-minute intervals a maximum of 5 times.</li></ol>
1000	ABORT	System resources required to run this test are not available. The port may be in use on a valid call. Use the <b>status access-endpoint</b> extension or command to determine when the port is available for testing. <ol style="list-style-type: none"><li>1. Retry the command at 1-minute intervals a maximum of 5 times.</li></ol>
1001	ABORT	System resources required for this test are not available. <ol style="list-style-type: none"><li>1. Retry the command at 1-minute intervals a maximum of 5 times.</li></ol>
1002	ABORT	The system could not allocate time slots for the test. The system may be under heavy traffic conditions or it may have time slots out-of-service due to TDM-BUS errors. Use <b>status health</b> to determine if the system is experiencing heavy traffic. <ol style="list-style-type: none"><li>1. If system has no TDM-BUS errors and is not handling heavy traffic, retry the command at 1-minute intervals a maximum of 5 times.</li></ol>
1003	ABORT	The system could not allocate a tone receiver for the test. The system may be too big for the number of Tone Detectors present, or some Tone Detectors may be out of service. <b>List measurement tone-receiver</b> displays information on the system's tone receivers. <ol style="list-style-type: none"><li>1. Resolve any TTR-LEV errors.</li><li>2. Resolve any TONE-PT errors.</li><li>3. If neither condition exists, retry the command at 1-minute intervals a maximum of 5 times.</li></ol>
1004	ABORT	The port has been seized by a user for a valid call. Use <b>status access-endpoint</b> extension to determine when the port is available for testing. The port is available when it is in the <b>in-service/idle</b> state. <ol style="list-style-type: none"><li>1. Retry the command at 1-minute intervals a maximum of 5 times.</li></ol>
1020	ABORT	The test did not run because of a previously existing error on the specific port or a more general circuit pack error. <ol style="list-style-type: none"><li>1. Examine the Error Log for existing errors against this port or the circuit pack and attempt to diagnose the already existing error.</li></ol>

**Table 9-716. TEST #6 NPE Crosstalk Test — Continued**

Error Code	Test Result	Description/ Recommendation
2000	ABORT	Response to the test request was not received within the allowable time period.
2100	ABORT	System resources required for this test are not available. 1. Retry the command at 1-minute intervals a maximum of 5 times.
	FAIL	The NPE of the tested port was found to be transmitting in error. This causes noisy and unreliable connections. 1. Replace the circuit pack.
	PASS	The port is correctly using its allocated time slots. 1. Investigate user-reported troubles on this port using other port tests and by examining the terminal adapter or external wiring.

### Conference Circuit Test (#7)

The Conference Circuit Test verifies that the NPE channel for the port being tested can correctly perform the conferencing function. The NPE is instructed to listen to several different tones and conference the tones together. The resulting signal is then measured by a Tone Detector port. If the level of the tone is within a certain range, the test passes

**Table 9-717. TEST #7 Conference Circuit Test**

Error Code	Test Result	Description/ Recommendation
	ABORT	System resources required for this test are not available. 1. Retry the command at 1-minute intervals a maximum of 5 times.
1000	ABORT	System resources required to run this test are not available. The port may be in use on a valid call. Use the <b>status access-endpoint</b> extension command to determine when the port is available for testing.
1004	ABORT	The port has been seized by a user for a valid call. Use the <b>status access-endpoint</b> extension command to determine when the port is available for testing. The port is available when it is in the <b>in-service/idle</b> state. 1. Retry the command at 1-minute intervals a maximum of 5 times.

*Continued on next page*

**Table 9-717. TEST #7 Conference Circuit Test — Continued**

Error Code	Test Result	Description/ Recommendation
1020	ABORT	The test did not run due to a previously existing error on the specific port or because of a more general circuit pack error.  1. Examine the Error Log for existing errors against this port or circuit pack, and attempt to diagnose the previously existing error.
2000	ABORT	Response to the test was not received within the allowable time period.
2100	ABORT	System resources required for this test are not available.  1. Retry the command at 1-minute intervals a maximum of 5 times.
	FAIL	The NPE of the tested port did not conference the tones correctly. This causes noisy and unreliable connections. Even though wideband calls do not use the conferencing feature on the NPE, this failure indicates problems with the circuit pack hardware.  1. Replace the circuit pack.
	PASS	The port can correctly conference multiple connections.  1. Investigate user-reported troubles on this port using other port tests and by examining the terminal adapter or external wiring.

### **Port Audit and Update Test (#36)**

This test sends port level translation data from switch processor to the UDS1 Interface circuit pack to ensure that the wideband access endpoint port's translation is correct.

**Table 9-718. TEST #36 Audit and Update Test**

Error Code	Test Result	Description/ Recommendation
	ABORT	Internal system error 1. Retry the command at 1-minute intervals a maximum of 5 times.
1006	ABORT	The port is out-of-service. If the port is busied out: 1. Issue <b>release access-endpoint &lt;extension&gt;</b> command to put the port back into in-service. 2. Retry the test command. If the port is not busied out: a. Check the error and alarm logs for WAE-PORT and UDS1-BD errors and alarms and follow the recommended repair procedures.
2000	ABORT	Response to the test request was not received within the allowable time period.
2100	ABORT	Could not allocate the necessary system resources to run this test. 1. Retry the command at 1-minute intervals a maximum of 5 times.
	FAIL	Internal system error 1. Retry the command at 1-minute intervals a maximum of 5 times.
	PASS	Port translation has been updated successfully.



## XXX-BD (Common Port Circuit Pack)

MO Name (in Alarm Log)	Alarm Level	Initial Command to Run <sup>1</sup>	Full Name of MO
XXX-BD <sup>2</sup>	MAJOR	test board UUCSS	Common Port Circuit Pack Maintenance
XXX-BD <sup>2</sup>	MINOR	test board UUCSS	Common Port Circuit Pack Maintenance
XXX-BD <sup>2</sup>	WARNING	test board UUCSS	Common Port Circuit Pack Maintenance

1. UU is the universal cabinet number (1 for PPN, 2-44 for EPNs). C is the carrier designation (A, B, C, D, or E). SS is the number of the slot in which the circuit pack resides (01 to 21).
2. Refer to the appropriate circuit pack documentation for the correct MO name displayed in this field. It usually ends with BD.

Common Port Circuit Pack Maintenance is a set of common tests used by all the circuit packs listed in the tables below. The common portion of these circuit packs is the generic hardware that interfaces with the TDM Bus. The XXX-BD designation is also used on G3-MT displays when **reset board** is entered with an empty circuit pack slot, or with a circuit pack type that is in conflict with the actual board type administered for that slot. All circuit pack suffixes (B,C, D, and so forth) are supported by "XXX-BD."

When any of the Common Port Circuit Packs are physically removed from the backplane, no alarm will be logged for approximately 11-minutes. (In the case of the TN754 Digital Line, TN566 DEFINITY AUDIX, and TN758 Pooled Modem circuit packs, Digital Line and Pooled Modem circuit packs, approximately 21-minutes will elapse before an alarm is logged.) When a circuit pack that has been removed is alarmed, the alarm type is minor and is classified as an on-board alarm. The time delay permits maintenance activity to be performed without triggering an additional alarm.

Alarms are logged against only those common port circuit packs on which ports have been administered. In a heavily loaded system, the interval between the removal of a Common Port Circuit Pack and the logging of the alarm may be several minutes longer. The circuit packs in the following list contain ports on the TDM bus. Suffixes are not shown; for a list of all circuit packs supported, see the table in Chapter 2. Those that appear in **bold** type are documented separately under their own maintenance object name. Only those with an asterisk are supported by G3r V1 systems

**XXX-BD Common Circuit Packs**

The following list of circuit packs are listed by apparatus code.

**Table 9-719. XXX-BD Common Circuit Packs**

<b>Apparatus Code</b>	<b>Name</b>	<b>Type</b>
CPP1	Memory Expansion	Control
ED-1E546 (TN2169) (TN2170) (TN566) (TN567)	DEFINITY AUDIX R3 System	Port Assembly
ED-1E546 (TN2208) (TN2170)	Call Visor ASAI over the DEFINITY (LAN) Gateway R1	Port Assembly
TN417	Auxiliary Trunk	Port
TN419B	Tone-Clock	Control
TN420B/C	Tone Detector	Service
TN429	Direct Inward/Outward Dialing (DIOD) Trunk	Port
TN433	Speech Synthesizer	Service
TN436B	Direct Inward Dialing Trunk	Port
TN437	Tie Trunk	Port
TN438B	Central Office Trunk	Port
TN439	Tie Trunk	Port
TN447	Central Office Trunk	Port
TN457	Speech Synthesizer	Service
TN458	Tie Trunk	Port
TN459B	Direct Inward Dialing Trunk	Port
TN464C/D/E/F	DS1/E1 Interface - T1, 24 Channel - E1, 32 Channel	Port
TN465/B/C	Central Office Trunk	Port
TN467	Analog Line	Port
TN468B	Analog Line	Port
TN479	Analog Line	Port
TN497	Tie Trunk	Port

***Continued on next page***

**Table 9-719. XXX-BD Common Circuit Packs — Continued**

Apparatus Code	Name	Type
TN553	Packet Data Line	Port
TN556/B	ISDN-BRI 4-Wire S/T-NT Line (A-Law)	Port
TN570/B/C	Expansion Interface	Port
TN572	Switch Node Clock	Control
TN573/B	Switch Node Interface	Control
TN574	DS1 Converter - T1, 24 Channel	Port
TN577	Packet Gateway	Port
TN722B	Digital Signal Level 1 Tie Trunk	Port
TN725B	Speech Synthesizer	Service
TN726/B	Data Line	Port
TN735	MET Line	Port
TN742	Analog Line	Port
TN744/B	Call Classifier	Service
TN744/C/D	Call Classifier - Detector	Service
TN746/B	Analog Line	Port
TN747B	Central Office Trunk	Port
TN748/B/C/D	Tone Detector	Service
TN750/B/C	Announcement	Service
TN753	Direct Inward Dialing Trunk	Port
TN754/B	Digital Line 4-Wire DCP	Port
TN755B	Neon Power Unit	Power
TN756	Tone Detector	Service
TN758	Pooled Modem	Port
TN760B/C/D	Tie Trunk	Port
TN762B	Hybrid Line	Port
TN763B/C/D	Auxiliary Trunk	Port
TN765	Processor Interface	Control
TN767B/C/D/E	DS1 Interface - T1, 24 Channel	Port
TN768	Tone-Clock	Control
TN769	Analog Line	Port

*Continued on next page*

**Table 9-719. XXX-BD Common Circuit Packs — Continued**

<b>Apparatus Code</b>	<b>Name</b>	<b>Type</b>
TN771D	Maintenance/Test	Service
TN772	Duplication Interface	Control
TN773	Processor	Control
TN775/B	Maintenance	Service
TN776	Expansion Interface	Port
TN777/B	Network Control	Control
TN778	Packet Control	Control
TN780	Tone-Clock	Control
TN786	Processor	Control
TN786B	Processor	Control
TN787F	Multimedia Interface	Service
TN788/B	Multimedia Voice Conditioner	Service
TN789	Radio Controller	Control
TN790	Processor	Control
TN793	Analog Line, 24-Port, 2-Wire	Port
TN796B	Processor	Control
TN800	Multi-Application Platform for DEFINITY (MAPD)	Service
TNPRI/BRI	PRI to BRI Converter	Port
TN1648	System Access/Maintenance	Control
TN1650B	Memory	Control
TN1654	DS1 Converter - T1, 24 Channel/E1, 32 Channel	Port
TN1655	Packet Interface	Control
TN1656	Tape Drive	Control
TN1657	Disk Drive	Control
TN2135	Analog Line	Port
TN2136	Digital Line 2-Wire DCP	Port
TN2138	Central Office Trunk	Port
TN2139	Direct Inward Dialing Trunk	Port
TN2140/B	Tie Trunk	Port
TN2144	Analog Line	Port

***Continued on next page***

**Table 9-719. XXX-BD Common Circuit Packs — *Continued***

<b>Apparatus Code</b>	<b>Name</b>	<b>Type</b>
TN2146	Direct Inward Dialing Trunk	Port
TN2147/C	Central Office Trunk	Port
TN2149	Analog Line	Port
TN2180	Analog Line	Port
TN2181	Digital Line 2-Wire DCP	Port
TN2182/B	Tone-Clock -Tone Detector and Call Classifier	Control
TN2183	Analog Line	Port
TN2184	DIOD Trunk	Port
TN2198	ISDN-BRI 2-Wire U Interface	Port
TN2199	Central Office Trunk	Port
TN2202	Ring Generator	Power
TN2224	Digital Line, 24-Port, 2-Wire DCP	Port

## Error Log Entries and Test to Clear Values

**Table 9-720. Common Port Circuit Pack Maintenance Error Log Entries**

Error Type	Aux Data	Associated Test	Alarm Level	On/Off Board	Test to Clear Value
0 <sup>1</sup>	0	Any	Any	Any	test board UUCSS sh r 1
1(a)	0	Circuit pack removed or SAKI Sanity Test (#53)	MINOR	ON	
18(b)	0	busy-out board UUCSS	WARNING	OFF	release board UUCSS
23(c)	0	None	WARNING	OFF	
36 (d)	4368	none			
125 (e)		None	MINOR	ON	
217 (f)	0	None	WARNING	ON	
257	65535	Control Channel Test (#52)	MINOR	ON	test board UUCSS sh r 20
257 (g)	Any	None			
267 (f)	0	None	WARNING	ON	
513 (h)	Any	None	MINOR	ON	test board UUCSS sh
769 (i)	4358	None			
1025 (j)	4363	NPE Audit Test (#50)			test board UUCSS l r 20
1281 (k)		Ring Application Test (#51)	MINOR	ON	test board UUCSS r 2
1538 (l)	Any	None	WARNING/ MINOR	ON	
1793 (m)		Neon Test (#220)	MINOR	ON	test board UUCSS r 2
3840 (n)	Any	None			
3999 (o)	Any	None			

1. Run the Short Test Sequence first. If all tests pass, run the Long Test Sequence. Refer to the appropriate test description and follow the recommended procedures.

**Notes:**

- a. Error type 1 indicates the circuit pack has stopped functioning or has been physically removed from the system. This error type does not apply to ANN-BD, DETR-BD, S-SYN-BD, M/T-BD, or CLSFY-BD. The alarm is logged approximately 11 minutes after removal of the circuit pack or failure of the SAKI Sanity Test (#53).

Check for the physical presence of the circuit pack in the slot indicated by the alarm. If the circuit pack is not present, insert one of the proper type. If the circuit pack is present and its red LED is lit, see *LED Alarm Without Alarm Log Entry* in Chapter 7.

- b. This error indicates the circuit pack has been busied out. Release the circuit pack via **release board UUCSS**.
- c. The circuit pack has been logically administered but not physically installed. The alarm should clear when the circuit pack is installed.

If the circuit pack is already installed:

1. Run **test board UUCSS long** and look at any test failures or error codes generated.
  2. If the test does not clear error 23, then execute **reset board UUCSS** and run the long test again.
  3. If the reset/test does not clear error 23, replace the circuit pack.
- d. This error applies only to the Maintenance/Test circuit pack (TN771B or TN771C). The error indicates that the hardware associated with the Analog Trunk Testing port of the circuit pack failed to initialize. Note that when this error occurs, the Maintenance/Test circuit pack may report an invalid vintage. Although this error is not service-affecting, the Maintenance/Test circuit pack should be replaced.
  - e. The circuit pack physically installed in the slot does not match the type that is administered for that slot. Do one of the following:
    - Remove the incorrect circuit pack and replace it with one of the type that is administered for that slot.
    - Use **change circuit pack** to readminister the slot so that it matches the board that is installed, and follow with **reset board**.
  - f. This error applies to the Maintenance/Test circuit pack (TN771D), Tone Detector (TN748B, TN748C, or TN748D), and Call Classifier (TN748) circuit packs. For the Maintenance/Test circuit pack, the error indicates that there is more than one Maintenance/Test circuit pack in the port network. For the Tone Detector or Call Classifier packs, the error indicates that there are more than 10 circuit packs in the system. Remove the circuit pack against which the error is logged.
  - g. This error indicates transient communication problems with this circuit pack. This error is not service-affecting and no action is required.
  - h. This error, when reported with Aux data in the range of 4352 to 4358, indicates that the circuit pack has reported an on-board hardware failure. The circuit pack will continuously test the hardware and report the results approximately every 10 minutes. If the hardware problem is resolved, the "leaky bucket" strategy should clear the alarm in approximately 30 minutes. However, if the alarm does NOT clear in 30 minutes, then the circuit pack should be replaced.
  - i. This error can be ignored, but look for other errors on this circuit pack.

- j. This error is not service-affecting and no action is required.
- k. This error indicates that no ringing current is detected. Run Test #51, Ringing Application Test, and follow the procedures for Test #51. This error is only applicable to Analog Line circuit packs.
- l. The hyperactive circuit pack is out-of-service and may exhibit one or more of the following symptoms:
  - 1. The common circuit pack level tests such as Test #51 and/or Test #220 are aborting with error code 2000.
  - 2. The tests run on the ports of this circuit pack are returning with a NO-BOARD.
  - 3. A busy-out/release of the circuit pack has no affect on test results.
  - 4. A **list configuration** command shows that the circuit pack and ports are properly installed.

If the XXX-BD is not a TN754 Digital Line Circuit Pack (DIG-BD), and if this error happens again within 15 minutes, then replace the circuit pack. If the XXX-BD is a TN754 Digital Line Circuit Pack (DIG-BD), then check the alarm level. If the alarm level is a WARNING, this indicates that users are probably causing the hyperactivity by playing with their digital stations. If the circuit pack is really hyperactive then this alarm will be upgrade to a MINOR alarm within 1 hour. If the alarm level is a MINOR alarm, then replace the circuit pack. To replace the circuit pack, refer to Replacing Circuit Packs in Chapter 5.

- m. This error indicates that no neon current is detected. Run **test board UUCSS short** and follow the procedures for Test #220. This error is only applicable to TN769 and TN746 Analog Line circuit packs.
- n. This error is not service-affecting and no action is required.
- o. Error type 3999 indicates that the circuit pack sent a large number of control channel messages to the switch within a short period of time. If error type 1538 is also present, then the circuit pack was taken out-of-service due to hyperactivity. If error type 1538 is not present, then the circuit pack has not been taken out-of-service, but it has generated 50% of the messages necessary to be considered hyperactive. This may be completely normal during heavy traffic periods. However, if this error type is logged when the circuit pack is being lightly used, it may indicate a problem with the circuit pack or the equipment attached to it.



## Technician-Demand Tests: Descriptions and Error Codes

---

Always investigate tests in the order presented in the table below when inspecting errors in the system. By clearing error codes associated with the *NPE Audit*, for example, you may also clear errors generated from other tests in the testing sequence.

Order of Investigation	Short Test Sequence	Long Test Sequence	Reset Board Sequence	D/ND <sup>1</sup>
NPE Audit Test (#50)		X		ND
Ringing Application Test (#51) (a)	X	X		ND
Control Channel Looparound Test (#52)	X	X		ND
SAKI Sanity Test (#53) (b)		X	D	
Neon Test (#220) (c)	X	X		ND

---

1. D = Destructive; ND = Nondestructive

### Notes;

- a. Only applicable to Analog Line circuit packs.
- b. The SAKI Sanity Test is run in the Long Test Sequence for the Tone/Clock circuit packs (TN768, TN780) **only**. The test is run on other circuit packs only when they are reset via the **reset board** command.
- c. Only applicable to TN746 and TN769 Analog Line circuit packs.

## NPE Audit Test (#50)

The system sends a message to the on-board microprocessor to update the network connectivity translation for all the Network Processing Elements (NPEs) on the circuit pack.

**Table 9-721. TEST #50 NPE Audit Test**

Error Code	Test Result	Description/ Recommendation
None 2100	ABORT	System resources required for this test are not available.
1019	ABORT	Test already in progress.
	FAIL	Internal system error 1. Retry the command at 1-minute intervals a maximum of 5 times.
	PASS	The circuit pack's NPEs have been updated with their translation.
	EXTRA BD	Certain circuit packs have limitations on how many circuit packs can be in the system or port network such as the Maintenance/Test circuit pack (TN771B or TN771C), the Tone Detector circuit pack (TN748B, TN748C or TN748D) and the Call Classifier (TN744). The Maintenance/Test circuit pack allows only one circuit pack per port network. The Tone Detector and Call Classifier allow only 10 circuit packs in each system. All additional circuit packs will return EXTRA-BD and should be removed.
Any	NO BOARD	This is normal if the test is being done when (a) the board is not physically in the system or (b) the system is booting up. Otherwise, there is some inconsistency between the physical configuration and the data kept in the system. 1. Verify that the board is physically in the system. 2. Verify that the system is not in a stage of booting up. 3. Retry the command at 1-minute intervals for a maximum of 5 times.

## Ringling Application Test (#51)

This test checks the ringling application circuitry common to all ports on an Analog Line circuit pack.

**Table 9-722. TEST #51 Ringling Application Circuit Test**

Error Code	Test Result	Description/ Recommendation
1000 2100	ABORT	Could not allocate the necessary system resources to run test.
2000	ABORT	<p>Could not allocate the necessary system resources to run test. The circuit pack is not installed. Internal system error</p> <p>There was no response from the board.</p> <ol style="list-style-type: none"> <li>1. If error type 1538 (hyperactivity) is present in the error log, follow the maintenance strategy that is recommended for this error type.</li> <li>2. Run the <b>busyout board</b>, <b>reset board</b>, and <b>release busy board</b> commands, and then retest.</li> <li>3. If the test still aborts, dispatch with the circuit pack.</li> <li>4. Check the off-board wiring and the terminal, and, if there are no problems found, replace the circuit pack.</li> </ol>
1004	ABORT	<p>The port was seized by a valid call during the test. The test has been aborted.</p> <ol style="list-style-type: none"> <li>1. Use the <b>display port UUCSSpp</b> command to determine the station extension. Use the <b>status station</b> command to determine the service state of the port. If the service state indicates that the port is in use, then the port is unavailable for certain tests. (Refer to Chapter 8, for a full description of all possible states). You must wait until the port is idle before retesting.</li> <li>2. Retry the command at 1-minute intervals a maximum of 5 times.</li> </ol>

*Continued on next page*

**Table 9-722. TEST #51 Ringing Application Circuit Test — Continued**

Error Code	Test Result	Description/ Recommendation
1008	ABORT	<p>Could not allocate a ringing circuit for one of the following reasons: all the ringing circuits are in use; the ringing generator is defective; ringing generator is not wired correctly.</p> <ol style="list-style-type: none"> <li>1. If the test continues to abort, look for RING-GEN error in Error Log.                             <ol style="list-style-type: none"> <li>a. If there are RING-GEN errors, refer to RING-GEN Maintenance documentation and try to resolve any problem(s). Then, go to Step 2.</li> <li>b. If there are no RING-GEN errors, and the test continues to abort, issue the <b>test board UUCSS</b> command on other TN742, TN769, or TN746 Analog circuit packs. If an ABORT with error code 1008 occurs for this test on other circuit packs as well, then the ringing generator may be defective or may not be wired properly. Refer to RING-GEN Maintenance documentation for details. If an ABORT with error code 1008 does NOT occur on the other ports, then all four ring generators are in use. Exit from this documentation.</li> </ol> </li> <li>2. Retry the command.</li> </ol>
	FAIL	<p>No ringing current is detected. The ringing application circuitry on this circuit pack probably is not healthy.</p> <ol style="list-style-type: none"> <li>1. Retry the command again.</li> <li>2. If the test continues to fail, look for RING-GEN error in Error Log.                             <ol style="list-style-type: none"> <li>a. If there are RING-GEN errors, refer to the RING-GEN Maintenance documentation and try to resolve any problem(s).</li> <li>b. If there are no RING-GEN errors, then replace the circuit pack.</li> </ol> </li> <li>3. Retry the command again.</li> </ol>
	PASS	<p>Ringing current is detected or this vintage of the Analog Line circuit pack does not support the Ringing Application Circuit Test. Analog Line circuit packs that DO NOT support Test #51 include TN712 Vintage 13 and earlier and TN742 Vintage 3 and earlier.</p>
Any	NO BOARD	<p>This is normal if the test is being done when (a) the board is not physically in the system or (b) the system is booting up. Otherwise, there is some inconsistency between the physical configuration and the data kept in the system.</p> <ol style="list-style-type: none"> <li>1. Verify that the board is physically in the system.</li> <li>2. Verify that the system is not in a stage of booting up.</li> <li>3. Retry the command at 1-minute intervals for a maximum of 5 times.</li> </ol>

## Control Channel Looparound Test (#52)

This test queries the circuit pack for its circuit pack code and vintage and verifies its records.

**Table 9-723. TEST #52 Control Channel Looparound Test**

Error Code	Test Result	Description/ Recommendation
None 2100	ABORT	System resources required for this test are not available. <ol style="list-style-type: none"><li>1. Retry the command at 1-minute intervals a maximum of 5 times.</li></ol>
	FAIL	The test failed because the circuit pack failed to return the circuit pack code or vintage. <ol style="list-style-type: none"><li>1. Retry the command for a maximum of 5 times.</li><li>2. If the test still fails, issue the <b>busyout board</b>, <b>reset board</b>, and <b>release busy board</b> commands, and then retest.</li><li>3. If the problem continues, replace the circuit pack.</li><li>4. Run the test again.</li></ol>
	PASS	Communication with this circuit pack is successful.
	EXTRA BD	This result should only appear when more than one TN771D Maintenance/Test circuit pack has been installed in this port network. Remove this circuit pack.
Any	NO BOARD	This is normal if the test is being done when (a) the board is not physically in the system or (b) the system is booting up. Otherwise, there is some inconsistency between the physical configuration and the data kept in the system. <ol style="list-style-type: none"><li>1. Verify that the board is physically in the system.</li><li>2. Verify that the system is not in a stage of booting up.</li><li>3. Retry the command at 1-minute intervals for a maximum of 5 times.</li></ol>

## SAKI Sanity Test (#53)

**This test is destructive.**

This test resets the circuit pack. It is executed as part of the long test sequence only for the Tone-Clock circuit pack and DS1 interface circuit packs. Other common circuit packs can be reset with the **reset board UUCSS** command which also executes this test.

**Table 9-724. TEST #53 SAKI Sanity Test**

Error Code	Test Result	Description/ Recommendation
None	ABORT	System resources required for this test are not available. 1. Retry the command at 1-minute intervals a maximum of 5 times.
1005	ABORT	Wrong circuit pack configuration to run this test. This error applies only to DS1 interface circuit packs. It means the DS1 interface circuit pack is providing timing for the system and, therefore, it cannot be reset without major system disruptions. 1. If the circuit pack needs to be reset, then set synchronization to another DS1 interface circuit pack or the Tone-Clock circuit pack and try again. Refer to SYNC (Synchronization) Maintenance documentation.
1015	ABORT	Port is not out-of-service. 1. Busy out the circuit pack. 2. Execute command again.
2100	ABORT	System resources required for this test are not available. 1. Retry the command at 1-minute intervals a maximum of 5 times.
1	FAIL	The circuit pack failed to reset.
2	FAIL	The circuit pack failed to restart. 1. Execute command again. 2. If the problem persists, replace the circuit pack.
	PASS	The circuit pack initializes correctly. 1. Run the short test sequence.
Any	NO BOARD	This is normal if the test is being done when (a) the board is not physically in the system or (b) the system is booting up. Otherwise, there is some inconsistency between the physical configuration and the data kept in the system. 1. Verify that the board is physically in the system. 2. Verify that the system is not in a stage of booting up. 3. Retry the command at 1-minute intervals for a maximum of 5 times.

## Neon Test (#220)

This test checks the voltage required to light the neon lamp on an analog terminal. A relay connects a 150V DC source from the backplane of the circuit pack onto the voltage bus, and another relay connects a 2K shunt from the bus to ground. Current in the line is then monitored to determine if the voltage is present. The neon test runs only for TN746 and TN769 Analog circuit packs. If the circuit pack is not a TN746 or TN769, the test will return PASS, but the test is not actually run.

**Table 9-725. TEST #220 Neon Test**

Error Code	Test Result	Description/ Recommendation
	ABORT	Cannot get the list of translated ports on the circuit pack.
1004	ABORT	The port was seized by a valid call during the test. The test has been aborted. <ol style="list-style-type: none"> <li>1. Use the <b>display port UUCSSpp</b> command to determine the station extension. Use the <b>status station</b> command to determine the service state of the port. If the service state indicates that the port is in use, then the port is unavailable for certain tests. Refer to the status commands described in Chapter 8 for a full description of all possible states.) You must wait until the port is idle before retesting.</li> <li>2. Retry the command at 1-minute intervals a maximum of 5 times.</li> </ol>
1008	ABORT	Could not allocate a ringing circuit. Either all the ringing circuits are in use, or the ringing generator is defective or is not wired correctly. <ol style="list-style-type: none"> <li>1. Retry the command at 1-minute intervals a maximum of 5 times.</li> <li>2. If the test continues to abort, look for RING-GEN errors in the Error Log. If an ABORT 1008 occurs for this test on other circuit packs as well, then the ringing generator may be defective or is not wired correctly (see errors for RING-GEN). If it does not occur on port test 48 for ANL-16-L, then all four ring phases are in use.</li> </ol>
2000	ABORT	Response to the request was not received within the allowable time period.
2100	ABORT	Could not allocate the necessary system resources to run this test.
	ABORT	Could not allocate the necessary system resources to run this test. Internal system error. <ol style="list-style-type: none"> <li>1. If Error Type 1538 is present in the Error Log, follow the recommended maintenance strategy.</li> </ol>

*Continued on next page*

**Table 9-725. TEST #220 Neon Test — Continued**

Error Code	Test Result	Description/ Recommendation
	FAIL	The test failed because no neon current was detected. <ol style="list-style-type: none"> <li>1. Determine if there is a TN755 or TN752 power unit circuit pack installed in the same carrier as the TN746 or TN769 analog line circuit pack that failed the test. Look for the failure of test 220 on other TN746 or TN769 circuit packs in the carrier. If test 220 fails on the other circuit packs, replace the TN755 or TN752 power unit circuit pack.</li> <li>2. Retry the command again.</li> <li>3. If the test continues to fail, replace the circuit pack.</li> <li>4. Retry the command again.</li> </ol>
	PASS	This circuit pack is a TN746 or TN769 Analog Line circuit pack and the neon current is detected. If this test passes, it can also mean that this circuit pack is not a TN746 or TN769 Analog Line circuit pack.
Any	NO BOARD	This is normal if the test is being done when (a) the board is not physically in the system or (b) the system is booting up. Otherwise, there is some inconsistency between the physical configuration and the data kept in the system. <ol style="list-style-type: none"> <li>1. Verify that the board is physically in the system.</li> <li>2. Verify that the system is not in a stage of booting up.</li> <li>3. Retry the command at 1-minute intervals for a maximum of 5 times.</li> </ol>



# Index

---

## Numerics

- 120A ICSU, [6-14](#)
  - 513 BCTs, [3-27](#)
  - 715 BCTs, [3-25](#)
  - 8-port analog line (ANL-LINE, ANL-NE-L), [9-77](#)
- 

## A

- AC power
  - distribution in multi-carrier cabinets, [9-371](#)
- AC Power Distribution Unit, [9-372](#)
- AC-powered systems, [9-3](#), [9-1312](#)
- administered temporary signaling connections (TSC-ADM), [9-1807](#)
- administration
  - circuit packs, [7-3](#), [9-1827](#)
  - customer logins, [3-10](#)
  - Forced Password Aging, [3-10](#)
  - login command permissions, [3-13](#)
  - logins, [3-12](#)
  - super-users, [3-12](#)
  - user access, [3-1](#)
- air filters, [6-31](#)
- Alarm Origination to OSS Numbers, [8-59](#)
- alarms
  - categories, [7-1](#)
  - classifications, [1-11](#)
  - external leads, [1-28](#)
  - levels, [7-1](#)
  - maintenance objects (MOs), [1-11](#)
  - spontaneous interchanges, [5-12](#)
  - Terminal Alarm Notification, [7-2](#)
  - warning, [7-1](#)
- American National Standards Institute, see ANSI
- analog
  - carrier signal, [1-32](#)
- analog port
  - insertion loss, [1-40](#)
- analog ring generator (RING-GEN), [9-1354](#)
- analog transmission by a modem, [1-32](#)
- analog-to-analog
  - echo path delay, [1-42](#)
  - frequency response, [1-39](#)
  - intermodulation distortion, [1-40](#)
  - peak noise level, [1-42](#)
  - quantization distortion loss, [1-41](#)
- analog-to-digital
  - coder/decoder, [1-32](#)
  - frequency response, [1-39](#)
  - intermodulation distortion, [1-40](#)
  - peak noise level, [1-42](#)
  - quantization distortion loss, [1-41](#)
- ANSI, [1-38](#)

application protocols, [1-36](#) to [1-42](#)  
ASAI ISDN-BRI port (ABRI-PORT), [9-306](#)  
Asynchronous Data Unit  
    proprietary signal, [1-32](#)  
ATM (Asynchronous Transfer Mode)  
    B-channel, [9-235](#)  
    circuit emulation service (CES), [9-235](#)  
    D-channel, [9-235](#)  
    signaling group, [9-235](#)  
    trunking, [9-235](#)  
ATMS, see Automatic Transmission Measurement System  
attendant console, LEDs, [7-2](#)  
audits (tests), see tests and audits  
AUDIX circuit pack (ADXDP-BD), [9-14](#)  
AUDIX digital port (ADXDP-PT), [9-15](#)  
Automatic Transmission Measurement System (ATMS), [6-40](#)  
auxiliary error codes, [5-13](#)

---

## B

backup, [9-375](#)  
backup power, [9-375](#)  
batteries, preventative maintenance, [6-32](#)  
battery  
    charger, [9-373](#)  
BIU, [5-6](#)  
bulletin boards, [3-5](#)

---

## C

cabling  
    DS1 connectors, [5-27](#)  
    DS1 CONV, [2-10](#)  
    fiber optic, [2-8](#)  
    metallic, [2-10](#)  
call-dropping updates, [6-3](#)  
call-preserving updates, [6-3](#)  
capabilities, system, [1-28](#) to [1-42](#)  
carriers  
    multi-carrier cabinets, [2-3](#)  
    multicarrier cabinets, [2-3](#)  
center stage switches, [9-784](#)  
CEPT1, [1-32](#)  
channel associated signaling (CAS), [9-1818](#)  
character code  
    8-bit, [1-32](#)  
characteristics, transmission, [1-38](#) to [1-42](#)  
charger, battery, [9-373](#)  
circuit breaker, [9-372](#), [9-377](#)  
circuit packs  
    administration, [7-3](#), [9-1827](#)  
    combined tone/generators, [9-773](#)  
    DS1 CONV, [5-6](#)  
    DS1 CONV LEDs, [7-9](#)  
    duplication interface LEDs, [7-7](#)

- electrostatic discharge (ESD), [5-3](#)
- expansion interface (EI), [9-792](#)
- expansion interface (IE) LEDs, [7-4](#)
- expansion port networks (EPNs), [7-5](#)
- expansion port networks (EPNs) maintenance, [3-25](#)
- Generic 3r, [2-12](#)
- green LEDs, [7-3](#)
- hyperactive, [9-1141](#)
- LEDs, [7-3](#)
- maintenance LEDs, [7-5](#)
- maintenance/test LEDs, [7-13](#)
- packet bus failures, [5-83](#)
- red LEDs, [7-3](#)
- replacing, [5-5](#)
- requiring special procedures, [5-6](#)
- reseating, [5-5](#)
- switch processing elements (SPEs), [1-16](#), [5-7](#)
- SYSAM, [7-14](#)
- system access-maintenance (SYSAM), [7-5](#)
- TN1648, [5-6](#)
- TN1650B, [5-6](#)
- TN1655, [5-6](#)
- TN1656, [5-6](#)
- TN1657, [5-6](#)
- TN2182, [9-1778](#)
- TN2242, [9-1818](#)
- TN2305, [9-235](#)
- TN2306, [9-235](#)
- TN464, [9-564](#)
- TN464F, [9-1818](#)
- TN570, [7-4](#), [9-780](#)
- TN572, [5-6](#)
- TN573, [5-6](#)
- TN722, [9-564](#)
- TN750, [5-6](#)
- TN767, [9-564](#)
- TN768, [9-1720](#), [9-1778](#), [9-1797](#)
- TN775, [9-790](#), [9-791](#)
- TN780, [9-1720](#), [9-1778](#)
- TN802 MAPD, [9-996](#)
- TONE-BD, tone-clock, [9-1778](#)
- tone-clock, [9-792](#), [9-1778](#)
- tone-clock LEDs, [7-13](#)
- UN330B, [5-6](#)
- UN331B, [5-6](#)
- UN332, [5-6](#)
- universal DS1 (UDS1) interface, [9-564](#), [9-996](#), [9-1818](#)
- using the packet bus, [5-82](#)
- yellow LEDs, [7-3](#)
- clocks, system, [9-1720](#), [9-1778](#)
- CODEC, [1-32](#)
- coder/decoder, analog-to-digital, see CODEC
- codes
  - service, [1-42](#)
- cold restarts, [4-5](#), [4-6](#)
- combined tone generator/detectors, circuit packs, [9-773](#)
- command interfaces, SPE-down, [4-9](#)
- command lines, [3-28](#)
  - syntax, [8-1](#)
- Command Permissions Categories form, [3-13](#)

- commands
    - error messages, [8-2](#)
    - reboots, [4-15](#)
    - release, [8-8](#), [8-174](#)
    - reset pnc interchange, [5-101](#)
    - reset system interchange, [5-101](#)
    - set tone-clock, [5-101](#)
    - SPE-down interface, [4-13](#)
    - status, [5-96](#)
    - status port-network, [5-100](#)
    - testing, [4-13](#)
  - companding, [9-773](#), [9-1781](#)
  - Conference, Transfer, and Call-Forwarding Denial, [1-36](#)
  - connecting/connectivity
    - G3-MT, [3-24](#)
    - ISDN-BRI/packet bus, [5-71](#)
    - management terminal to system, [3-24](#)
    - packet bus, [5-81](#)
  - connectivity
    - rules, [1-34](#)
  - CO-trunk-to-digital interface frequency response, [1-39](#)
  - country codes, [9-1781](#)
- 

## D

- data
  - service unit, [1-31](#)
- Data Communications Equipment, see DCE
- data terminal equipment, [1-28](#)
- data-link layer, OSI, [1-29](#)
- DC power
  - distribution unit, [9-377](#)
  - relay, [9-373](#)
- DCE, [1-28](#)
- D-channel
  - protocol, [1-28](#)
- DCP, [1-31](#)
- DC-powered systems, [9-8](#), [9-1321](#)
- DEC VT220, [3-27](#)
- delay, echo path, [1-42](#)
- Digital Multiplexed Interface, [1-32](#)
- digital port
  - insertion loss, [1-40](#)
- Digital Signal Level 1 (DS1), [1-32](#)
- digital-to-analog
  - peak noise level, [1-42](#)
  - quantization distortion loss, [1-41](#)
- digital-to-digital
  - echo path delay, [1-42](#)
- Disconnect Supervision, [1-35](#)
- distortion
  - intermodulation, [1-40](#)
  - quantization loss, [1-41](#)
- distribution unit, power, [9-377](#)
- DS0 channels, [9-1824](#)
- DS1
  - cable connectors, [5-27](#)

- CO trunk (CO-DS1), [9-411](#), [9-519](#)
- converter (DS1 CONV-BD), [9-660](#)
- convertor complex, [9-786](#)
- facility LEDs, [7-10](#)
- interface circuit packs, [9-564](#), [9-996](#), [9-1818](#)
- option jumpers, [9-1827](#)
- signaling, [9-564](#)
- trunks, [9-996](#), [9-1818](#)

#### DS1 CONV

- cabling, [2-10](#)
- circuit pack LEDs, [7-9](#)
- circuit packs, [5-6](#)
- loopbacks, [5-26](#)

#### DS1 loopback, [6-10](#)

#### DS1 span, [6-11](#)

#### DS1 span test, [6-11](#)

#### DS1 span, T1, [6-10](#)

#### DSO frequency response, [1-39](#)

#### DSO Loop-Around Test Call, [6-24](#)

DSU, see Data Service Unit

DTE, see data terminal equipment

#### DTMR Test Call, [6-25](#)

duplicated PNCs, [9-783](#)

duplicated SPEs, [4-16](#), [6-2](#), [7-7](#)

duplication

- reliability options, [2-17](#)
- tone-clocks, [9-1778](#)

Duplication-Related System Parameters form, ?? to [8-101](#)

---

## E

echo path delay, [1-42](#)

Echo-Return Loss, [1-42](#)

EIA, [1-38](#)

EIA RS-232C, [9-1139](#)

electrical components in power distribution unit, [9-372](#)

electromagnetic interference filter, [9-372](#)

Electronic Industries Association, see EIA

electrostatic discharge (ESD), circuit packs, [5-3](#)

Emergency Transfer, [5-7](#)

Emergency Transfer (ET), [9-755](#)

EMI filter, [9-372](#)

enhanced integrated CSU, [9-1825](#)

enhanced tone receiver (ETR) ports, [9-773](#)

enhanced tone receiver port (ETR-PT), [9-1778](#)

EPN, see expansion port networks (EPNs)

ERL, see Echo-Return Loss

error

- control, [1-29](#)

error logs

- hardware, [1-11](#)

- spontaneous interchanges, [5-12](#)

error type 1, [9-1140](#)

errors

- 605, [5-16](#)

- codes, auxiliary, [5-13](#)

- codes, busyout commands, [8-10](#)

codes, release commands, [8-10](#)  
codes, reset commands, [8-10](#)  
codes, test commands, [8-10](#)  
messages, commands, [8-2](#)  
reporting, maintenance objects (MOs), [1-11](#)

ESD, See electrostatic discharge

European conference of postal and telecommunications rate 1, see CEPT1

expansion control carrier (J58890AF), [2-6](#)

expansion interface (EI)

  circuit packs, [9-792](#)

  fiber links, viability, [9-792](#)

  TN570 circuit packs, [7-4](#), [9-780](#)

  tone-clock interactions, [9-792](#)

expansion port networks (EPNs), [9-790](#), [9-791](#)

  maintenance circuit packs, [3-25](#), [7-5](#)

  multi-carrier cabinets, [2-3](#)

  single-carrier cabinets, [2-3](#)

  troubleshooting packet bus, [5-109](#)

---

## F

Facility Interface Code, [1-43](#)

Facility Test Calls, [6-23](#)

fan units

  power converter 631DA, [9-377](#)

FCC, [1-42](#)

feature capacities, [1-28](#) to [1-42](#)

Federal Communications Commission, see FCC

fiber administration, [2-8](#)

fiber connections, metallic cabling, [2-10](#)

fiber fault isolation procedure, [5-21](#)

fiber hardware, [2-8](#)

fiber link (FIBER-LK), [9-848](#)

fiber links, DS1 converter complex, [9-786](#), [9-848](#)

fiber optic cables, [2-8](#)

FIC, see Facility Interface Code

FIFO overflow, [9-1141](#)

filter

  circuits, [9-377](#)

First OSS, [8-58](#)

First OSS Telephone Number, [8-106](#)

flow control, [1-29](#)

Forced Password Aging, [3-6](#), [3-10](#)

frequency response

  analog-to-analog, [1-39](#)

  analog-to-digital, [1-39](#)

fuses

  20 Amp, [9-372](#)

---

## G

G3-MT terminals

  connecting, [3-24](#)

  description, [3-1](#)

Generic 3 management terminal (G3-MT), [3-1](#)

Global AC MCC (J58890CH), [9-1319](#)  
global AC/DC power  
    distribution in multi-carrier cabinets, [9-375](#)  
grounding jacks, [5-3](#)

---

## H

handshake communication  
    definition, [1-21](#)  
    path, [1-22](#)  
hot restarts, [4-3](#)  
hyperactive circuit packs, [9-1141](#)

---

## I

impedances  
    loop in, [1-42](#)  
    termination, [1-42](#)  
INADS, see Initialization and Administration System (INADS)  
initialization  
    and recovery, [4-1](#)  
    diagnostics, [4-7](#)  
    diagnostics for reset levels, [4-8](#)  
    reboots, [4-1](#)  
    standby switch processing elements (SPEs), [1-21](#)  
Initialization and Administration System (INADS)  
    alarm notification, [5-1](#)  
    alarms, [1-11](#)  
    maintenance objects (MOs), [9-928](#)  
insertion loss, [1-40](#)  
install a BIU or Rectifier, [5-6](#)  
interchanges, tone-clocks, [9-1779](#)  
interface  
    physical, [1-31](#)  
intermodulation distortion, [1-40](#)  
Internet Telephony Server (ITS-E), [9-996](#)  
intervening switching systems, [1-34](#)  
ISDN  
    BRI definition, [1-31](#)  
    D-channel treatment, [1-28](#)  
    PRI definition, [1-31](#)  
ISDN-BRI data module (BRI-DAT), [9-305](#)  
ISDN-BRI line circuit pack (BRI-BD), [9-297](#)  
ISDN-BRI port (BRI-PORT), [9-306](#)  
ISDN-BRI/ASAI, troubleshooting, [5-71](#)  
ISDN-PRI  
    DS0 channels, [9-996](#), [9-1818](#)  
    signaling link port (ISDN-LNK), [9-936](#)  
    troubleshooting, [5-66](#)

---

## J

jacks, network, [1-43](#)

Japan Radio Corporation external converter, [9-1819](#), [9-1820](#)  
journal printers  
    command permissions, [3-18](#)

---

## L

layers, protocol, [1-31](#)  
LEDs  
    attendant consoles, [7-2](#)  
    circuit packs, [7-3](#)  
    DS1 CONV circuit packs, [7-9](#)  
    DS1 facility, [7-10](#)  
    electrostatic discharge (ESD), [5-3](#)  
    expansion interface (IE) circuit packs, [7-4](#)  
    indicators, [7-1](#)  
    interface circuit packs, [7-7](#)  
    maintenance circuit packs, [7-5](#)  
    maintenance/test circuit packs, [7-13](#)  
    standby components, [7-14](#)  
    switch node interface, [7-8](#)  
    TN573 circuit packs, [7-8](#)  
    tone-clock circuit packs, [7-13](#)  
    yellow, [7-13](#)  
logging in, [3-5](#), [3-7](#), [3-26](#)  
logging off, [3-8](#), [3-28](#)  
login administration, [3-12](#)  
Login Administration screen, [3-12](#)  
Login Kill after "N" Attempts, [3-1](#)  
Login Security Violation Notification Following a Security Violation, [3-1](#)  
logins, [3-5](#)  
    adding, [3-10](#)  
    administrable, [3-6](#)  
    changing attributes, [3-12](#)  
    displaying, [3-9](#)  
    listing, [3-9](#)  
    maintenance, [3-2](#)  
    removing, [3-10](#)  
    security, [3-1](#)  
    testing, [3-10](#)  
Logoff Notification (G3V4), [3-2](#), [3-28](#)  
Logoff screen, [3-9](#)  
logoff screen, [8-151](#)  
loop input impedances, [1-42](#)  
loopback jack, [6-10](#)  
loopback tests  
    fiber fault isolation procedure, [5-25](#)  
loopbacks  
    DS1 CONV, [5-26](#)  
    DS1 CONV tests, [5-26](#)  
loss  
    echo return, [1-42](#)  
    insertion, [1-40](#)  
    quantization distortion, [1-41](#)  
    single-frequency, [1-42](#)



---

## M

### maintenance

- circuit pack LEDs, [7-5](#)
- common port circuit pack, [9-1937](#)
- logins, [3-2](#)
- packet bus, [5-85](#)
- preventative, [6-31](#)
- standby components, [1-22](#)
- test circuit pack LEDs, [7-13](#)
- user access, [3-1](#)
- wideband access endpoint port, [9-1931](#)

### maintenance object repair procedures

- ADXDP-PT (AUDIX Digital Port), [9-15](#)
- BRI-DAT (ISDN-BRI Data Module), [9-305](#)
- BRI-PORT (ISDN-BRI Port), ABRI-PORT (ASAI ISDN-BRI Port), [9-306](#)
- BRI-SET, ASAI-ADJ, BRI-DAT, [9-331](#)
- ISDN-LNK (ISDN-PRI Signaling Link Port), [9-936](#)
- M/T-DIG (Maintenance/Test Digital Port), [9-1108](#)
- M/T-PKT (Maintenance/Test Packet Bus Port), [9-1120](#)
- TIE-BD (Tie Trunk Circuit Pack), [9-1736](#)

### maintenance objects (MOs)

- alarms, [1-11](#)
- circuit pack codes, [1-16](#)
- circuit pack names, [1-16](#)
- definition, [1-10](#)
- display alarms commands, [8-13](#)
- display errors commands, [8-13](#)
- error conditions, [1-11](#)
- INADS, [9-928](#)
- SPE circuit packs, [1-16](#)

### maintenance/test circuit pack (M/T-BD), [9-1104](#)

### maintenance/test digital port, [9-1108](#)

### maintenance/test packet bus port (M/T-PKT), [9-1120](#)

### major alarms, [7-1](#)

### management information system (MIS), [9-1057](#)

### management terminals

- connecting to system, [3-24](#)
- Generic 3, [3-1](#)

### mass storage system (MSS), [9-1630](#), [9-1657](#)

### memory shadowing, switch processing elements (SPEs), [1-21](#)

### MET line (MET-LINE), [9-1039](#)

### metallic cabling, [2-10](#), [2-17](#)

### minor alarms, [7-1](#)

### mismatch of signals, [1-35](#)

### MO, see maintenance objects (MOs), [1-12](#)

### Modem Connection, [8-64](#), [8-111](#)

### multi-carrier cabinets

- (J58890A), [2-1](#)
- carriers, [2-3](#)
- expansion port networks (EPNs), [2-3](#)

---

## N

### network

- jacks, [1-43](#)
  - network interface, [6-14](#)
  - noise
    - peak level, [1-42](#)
- 

## O

- Off-Premises Station (OPS) Line, [9-1125](#)
  - Open System Interconnect model, [1-29](#)
    - data-link layer, [1-29](#)
    - physical layer, [1-29](#)
  - option jumpers
    - TN464, [9-1827](#)
    - universal DS1 (UDS1) interface circuit packs, [9-1827](#)
  - OSI, see Open System Interconnect model
  - OSS Numbers field, [8-55](#)
- 

## P

- packet bus
  - circuit pack failures, [5-83](#)
  - circuit packs, [5-82](#)
  - connectivity, [5-81](#)
  - correcting faults, [5-100](#)
  - definition, [5-80](#)
  - duplicated systems, [5-101](#)
  - fault detection, [9-1120](#)
  - faults, [5-81](#)
  - ISDN-BRI connectivity, [5-71](#)
  - maintenance, [5-85](#)
  - reconfiguration, [9-1120](#)
  - repair, [5-78](#)
  - reset pnc interchange, [5-101](#)
  - reset system interchange, [5-101](#)
  - set tone-clock, [5-101](#)
  - TDM bus comparison, [5-85](#)
  - troubleshooting, [5-97](#), [5-102](#)
- Password Aging, [3-6](#)
- Password Expiration screen, [3-8](#)
- passwords, [3-5](#)
  - assigning, [3-10](#)
  - security, [3-1](#)
- PBX standard RS-464A, [1-38](#)
- pcANYWHERE, [9-1002](#)
- PCM-encoded analog signal, [1-32](#), [1-35](#)
- PDATA-PT, [9-1139](#)
- peak noise level, [1-42](#)
- performance, [1-28](#) to [1-42](#)
  - echo-return loss, [1-42](#)
  - single-frequency return loss, [1-42](#)
- PGATE, [9-1224](#)
- physical
  - layer, OSI, [1-29](#)
- pinout
  - H600-513 cable, [9-1821](#)

- PMS printer link (PMS-PRNT/JN), [9-1289](#)
- PNC duplication (PNC-DUP), [9-224](#), [9-1294](#)
- port carrier (J58890BB), [2-5](#)
- port network connectivity (PNC), [8-100](#)
  - configurations, [1-13](#)
  - definition, [1-12](#)
- port-to-port insertion loss, [1-40](#)
- power, [9-375](#)
  - distribution in multi-carrier cabinets
    - AC, [9-371](#)
    - AC/DC, [9-375](#)
  - distribution unit, [9-377](#)
    - electrical components, [9-372](#)
  - distribution units, [6-32](#)
  - removing, [6-39](#)
  - restoring, [6-39](#)
  - single-carrier cabinets, [9-3](#)
- power converter
  - 631DA, [9-377](#)
- power interruptions, [1-26](#)
- power units
  - 397B, [9-373](#)
  - 397C, [9-373](#)
  - electrical components, [9-372](#)
- PPN, see processor port networks (PPNs)
- precautions, safety, [xix](#)
- preventative maintenance, [6-31](#)
  - air filters, [6-31](#)
  - batteries, [6-32](#)
  - logs, [6-31](#)
  - procedures, [6-31](#)
  - tape drives, [6-32](#)
- PRI, [1-31](#)
- PRI endpoint port (PE-BCHL), [9-1177](#)
- printers
  - 715 BCTs, [3-26](#)
  - journal, [3-18](#)
- private line service codes, [1-42](#)
- procedures
  - fiber fault isolation, [5-21](#)
  - SNI/EI manual loop back, [5-24](#)
- process sanity audits (PROC-SAN), [9-1342](#)
- processor port networks (PPNs)
  - cabinets, [2-2](#)
  - control carriers (J58890AP), [2-3](#)
  - troubleshooting packet bus, [5-109](#)
- property management system (PMS), [9-1281](#), [9-1289](#)
- property management system link (PMS-LINK), [9-1281](#)
- protocols
  - 8-bit character code, [1-32](#)
  - ADU, [1-32](#)
  - analog, [1-32](#)
  - BRI, [1-31](#)
  - CEPT
  - DCP, [1-31](#)
  - Digital Multiplexed Interface, [1-32](#)
  - for applications, [1-36](#) to [1-42](#)
  - layers, [1-31](#)
  - PRI, [1-31](#)

summary of states, [1-33](#)

system, [1-28](#)

voice-grade data, [1-32](#)

PSTN fallback, [9-1000](#)

---

## Q

quantization distortion loss, [1-41](#)

---

## R

R2-MFC signaling, [9-773](#)

rear panel connector, [1-43](#)

reboots, [4-2](#)

  commands, [4-15](#)

  initialization, [4-1](#)

  reset level 4, [4-6](#)

  reset level 5, [4-7](#)

  switch processing elements (SPEs), [4-16](#)

Rectifier, [5-6](#)

relay, DC power, [9-373](#)

release commands, [8-8](#), [8-174](#)

reliability options

  critical, [2-18](#)

  duplication, [2-17](#)

  high, [2-17](#)

  standard, [2-17](#)

Remote Access, [3-12](#)

REN, see ringer equivalency numbers

replacement procedures, tone-cock circuit packs, [9-1782](#)

reset levels

  1 (warm restarts), [4-3](#)

  2 (cold-2 restarts), [4-5](#)

  3 (cold-1 restarts), [4-6](#)

  4 (reboots), [4-6](#)

  5 (extended reboots), [4-7](#)

  initialization diagnostics, [4-8](#)

  reboots, [4-1](#)

reset pnc interchange command, [5-101](#)

reset system command, [5-15](#)

reset system interchange command, [5-101](#)

ringer equivalency numbers, [1-43](#)

RISC processor circuit pack (PROCR), [9-1343](#)

RS-232

  interface, [1-31](#)

RS-232 connector, [9-372](#)

RS-232C, [9-1139](#)

RS-449

  physical interface, [1-31](#)

RS-464A, [1-38](#)

rules, connectivity, [1-34](#)

## S

- safety precautions, [xix](#), [5-1](#), [5-5](#)
- sanity audits, [9-1342](#)
- Second OSS, [8-58](#)
- Second OSS Telephone Number, [8-106](#)
- security
  - logins, [3-1](#)
  - password, [3-1](#)
- service
  - codes, [1-42](#)
- service slot (SVC-SLOT), [9-1548](#)
- set tone-clock command, [5-101](#)
- SFRL, see single-frequency return loss, [1-42](#)
- signals
  - mismatch, [1-35](#)
  - PCM-encoded analog, [1-35](#)
- simplex SPEs, [4-16](#), [6-2](#)
- single carrier cabinet environment (DC-POWER), [9-466](#)
- single-carrier cabinets
  - expansion port networks (EPNs), [2-3](#)
  - power system, [9-3](#)
- single-frequency return loss, [1-42](#)
- SNI circuit pack (SNI-BD), [9-1426](#)
- SNI peer link (SNI-PEER), [9-1487](#)
- SNI, see switch node interface (SNI)
- SNI/EI manual loop back procedure, [5-24](#)
- software
  - standby maintenance monitor (SMM), [1-20](#)
  - updates, duplicated SPEs, [6-7](#)
  - updates, simplex SPEs, [6-5](#)
  - version numbers, [6-1](#)
- SPE interchange, [4-3](#)
- SPE locked standby interface, [4-10](#)
- SPE select switch (SPE-SELE), [9-1491](#)
- SPE, see switch processing elements (SPEs)
- specifications, [1-28](#) to [1-42](#)
- SPE-down
  - command interface, [4-9](#)
  - interface, [4-12](#)
  - interface commands, [4-13](#)
  - mode, [4-10](#)
- spontaneous interchanges, [5-10](#), [5-11](#)
- standby components
  - LEDs, [7-14](#)
- standby maintenance monitor (SMM) software, [1-20](#)
- standby SPE
  - availability, [1-17](#)
  - down interface, [4-10](#)
  - initialization, [1-21](#)
  - maintenance architecture, [1-19](#)
  - state of health, [1-18](#)
- station-to-CO trunk frequency response, [1-39](#)
- station-to-digital interface frequency response, [1-39](#)
- station-to-station frequency response, [1-39](#)
- status commands, [5-96](#)
- status commands, diagnosing ISDN-BRI problems, [5-72](#)

- status port-network command, [5-100](#)
- status spe command, [4-17](#)
- summary of protocol states, [1-33](#)
- switch
  - transmission characteristics, [1-38](#) to [1-42](#)
- switch node carrier (J58890SA), [2-7](#)
- switch node interface (SNI), LEDs, [7-8](#)
- switch processing elements (SPE), [8-100](#)
- switch processing elements (SPEs), [2-3](#)
  - circuit packs, [1-16](#), [5-7](#)
  - down interface, [4-10](#)
  - duplicated, [6-2](#)
  - duplicated, troubleshooting, [5-10](#)
  - interchange, prerequisites, [5-15](#)
  - interchanges, failures, [5-15](#)
  - locked standby, [4-11](#)
  - locked states, [1-21](#)
  - memory shadowing, [1-21](#)
  - rebooting, [4-16](#)
  - spontaneous interchanges, [5-10](#)
  - standby connection, [3-26](#)
  - standby, testing, [5-14](#)
  - upgrade software command, [6-2](#)
- Switch-Based Bulletin Board, [3-2](#)
- synchronization, [1-29](#)
- synchronization (SYNC), [9-246](#), [9-1562](#)
- SYSAM circuit packs, [7-14](#)
- system
  - insertion loss, [1-40](#)
  - protocols, [1-28](#)
  - quantization distortion loss, [1-41](#)
  - specifications, [1-28](#) to [1-42](#)
- system access and maintenance (SYSAM), [9-1600](#)
- system access ports (SAPs), [3-25](#)
- system access-maintenance (SYSAM) circuit pack, [7-5](#)
- system errors, 605, [5-16](#)
- system login procedure, [3-26](#)
- system resets, [7-3](#)
- System Tone Test Call, [6-28](#)

---

## T

- T1 DS1 span, [6-10](#)
- tape drives, preventative maintenance, [6-32](#)
- TDM bus
  - clocks, [9-1720](#), [9-1778](#)
  - packet bus comparison, [5-85](#)
  - time slots, [6-26](#)
- TDM bus (TDM-BUS), [9-1703](#)
- TDM bus clock (TDM-CLK), [9-1720](#)
- TDM Bus Time Slot Test Call, [6-25](#)
- technical specifications, [1-28](#) to [1-42](#)
- terminal
  - blocks, [9-377](#)
  - equipment port wiring, [1-42](#)
- Terminal Alarm Notification
  - alarms, [7-2](#)

description, [7-1](#)

terminals

513 BCTs, [3-27](#)

610 BCTs, [3-25](#)

715 BCTs, [3-27](#)

G3-MT, [3-24](#)

system access ports (SAPs), [3-25](#)

system ports, [3-25](#)

Terminating Trunk Transmission (TTT), [6-38](#)

termination impedances, [1-42](#)

test commands, [4-13](#)

testing

analog tie trunk back-to-back, [6-34](#)

commands, [4-13](#)

common port circuit pack maintenance, [9-1937](#)

fiber fault isolation, [5-25](#)

standby SPEs, [5-14](#)

standby switch processing elements (SPEs), [5-14](#)

system technician-demanded, [9-268](#), [9-805](#), [9-1838](#)

tests and audits

#0 Dial Tone Test, [9-434](#)

#106 Sanity Handshake Test, [9-986](#)

#11 Digital Line Electronic Power Feed Test, [9-511](#)

#115 Customer-Provided Alarming Device Test, [9-456](#)

#117 Analog Ring Generator Initialization Test, [9-1357](#)

#118 Analog Ring Generator Query Test, [9-1357](#)

#120 External Device Alarm Test, [9-847](#)

#1201 Digital Terminal Remote Loop Around Test, [9-506](#)

#1209 Board Loopback Test, [9-607](#)

#1209 DS1 Board Loopback Test, [9-607](#), [9-1880](#)

#1210 CSU Equipment Loopback Test, [9-610](#), [9-611](#), [9-1883](#)

#1211 CSU Repeater Loopback Test, [9-613](#), [9-614](#), [9-1886](#)

#1212 CPE Loopback Jack Test, [9-618](#), [9-1890](#)

#1213 Far CSU Loopback Test, [9-622](#), [9-1894](#)

#1214 One-Way Span Test, [9-625](#), [9-1899](#)

#1215 Inject Single Bit Error Test, [9-629](#), [9-1902](#)

#1216 End Loopback/Span Test, [9-631](#), [9-1904](#)

#122 Cabinet Temperature Query Test, [9-365](#)

#1227 ICSU Status LEDs Test, [9-634](#), [9-1907](#)

#124 Emergency Transfer Query Test, [9-759](#)

#126 OLS Recycle Test, [9-383](#)

#127 OLS Query Test, [9-384](#)

#13 Analog Port Digital Loop Around Test, [9-1099](#)

#13 Information and Control Channel Local Loop Test, [9-1169](#)

#13 Voice and Control Channel Local Loop Test, [9-20](#), [9-21](#), [9-512](#), [9-751](#)

#135 Customer-Provided Alarming Device Test, [9-456](#)

#135 Internal Loop Around Test, [9-579](#), [9-1844](#)

#136 DS1 Tie Trunk Seizure Test, [9-1752](#)

#138 Loss of Signal Alarm Inquiry Test, [9-581](#), [9-582](#), [9-1848](#)

#139 Blue Alarm Inquiry Test, [9-588](#), [9-1855](#)

#139 Red Alarm Inquiry Test, [9-591](#)

#140 Red Alarm Inquiry Test, [9-590](#), [9-1858](#)

#141 Yellow Alarm Inquiry Test, [9-593](#), [9-594](#), [9-1862](#)

#142 Major Alarm Inquiry Test, [9-596](#), [9-1867](#)

#143 Minor Alarm Inquiry Test, [9-599](#), [9-1870](#)

#144 Slip Alarm Inquiry Test, [9-601](#), [9-1692](#), [9-1873](#)

#145 Misframe Alarm Inquiry Test, [9-603](#), [9-1876](#)

#146 Translation Update Test, [9-606](#), [9-1025](#), [9-1879](#)

#148 TDM Bus Clock Circuit Status Inquiry Test, [9-1727](#)

#149 TDM Bus Clock Slip Inquiry Test, [9-1729](#)

- #150 TDM Bus Clock PPM Inquiry Test, [9-1730](#)
- #151 TDM Bus Clock Parameter Update Test, [9-1732](#)
- #16 DIG-LINE Station Lamp Updates Test, [9-514](#), [9-753](#)
- #161 Loop Around Test, [9-959](#), [9-1681](#)
- #163 Speech Synthesis DTMF Receiver, [9-1366](#)
- #164 Speech Synthesis DTMF Receiver Inquiry Test, [9-1367](#)
- #165 Speech Synthesis DSP Tone Test, [9-1368](#)
- #166 Speech Synthesis Memory Test, [9-1369](#)
- #167 Speech Synthesis SSD Inquiry Test, [9-1370](#)
- #168 Speech Synthesis PSS Handshake Test, [9-1371](#)
- #169 Speech Synthesis Parameter Update Test, [9-1372](#)
- #17 Data Module Audits Test, [9-1171](#)
- #17 Station (Digital) Audits Test, [9-516](#)
- #171 Digital Loop Around Test, [9-462](#)
- #175 Data Module Internal Loop Around Test, [9-1174](#)
- #205 Channel Administration Memory Array (CAMA) Test, [9-115](#)
- #206 Playback Speech Memory Array (PSMA) Test, [9-117](#)
- #208 Angel-Speech Processor (SP) Handshake Test, [9-104](#)
- #209 Announcement Checksum Test, [9-105](#)
- #210 140AY Loop Around Test, [9-109](#)
- #211 Super Frame Match Inquiry, [9-111](#)
- #213 Link Tear Down Test, [9-1287](#), [9-1292](#), [9-1339](#), [9-1599](#)
- #215 Link Retry Test, [9-1287](#), [9-1293](#), [9-1340](#), [9-1599](#)
- #220 Neon Test, [9-1951](#)
- #228 Management Terminal Channel Local Loop-Around Test, [9-989](#)
- #229 Serial Channel Local Loop Around Test, [9-990](#)
- #237 Expansion Interface Neighbor Query Test, [9-806](#), [9-854](#)
- #238 Expansion Interface Fiber Out-of-Frame Query Test, [9-808](#), [9-855](#)
- #240 Expansion Interface Local Looparound, [9-197](#), [9-212](#), [9-242](#), [9-282](#), [9-810](#)
- #241 Expansion Interface 2-way Transmission Test, [9-187](#), [9-813](#)
- #242 Expansion Interface Lightwave Transceiver Looparound, [9-203](#), [9-277](#), [9-819](#)
- #252 Circuit Pack Restart Test, [9-395](#), [9-396](#), [9-1200](#), [9-1202](#)
- #255 Signaling Link State Check Test, [9-154](#), [9-967](#)
- #256 Service State Audit Test, [9-156](#), [9-969](#), [9-1190](#), [9-1192](#)
- #257 Call State Audit Test, [9-157](#), [9-970](#), [9-1193](#)
- #258 ISDN Test Call, [9-158](#), [9-973](#)
- #270 Clear Error Counters, [9-146](#), [9-1680](#)
- #294 Idle Time Slot Test on TDM Bus A or TDM Bus B, [9-1717](#)
- #296 Control Channel Test, [9-1718](#)
- #297 Digit Detection Test, [9-1719](#)
- #3 CO Demand Diagnostic Test, [9-437](#)
- #303 EPN Maintenance Circuit Pack Sanity Maze Test, [9-992](#)
- #306 EPN Maintenance Circuit Pack Reset Test, [9-993](#)
- #312 DS1 OPS Switchhook Inquiry Test, [9-1137](#)
- #314 DS1 CO Dial Tone Seizure Test, [9-424](#), [9-528](#)
- #316 Expansion Interface Control Channel Test, [9-193](#), [9-194](#), [9-271](#), [9-824](#)
- #33 Loop Around and Conference Circuit Test, [9-441](#), [9-490](#), [9-1763](#)
- #33 Loop Around and Conference Circuit Test, [9-537](#)
- #336 Expansion Interface Reset Test, [9-826](#)
- #337 EPN Maintenance Circuit Pack Serial Link Test, [9-995](#)
- #35 Battery Feed Test, [9-42](#)
- #35 Battery Feed Test Results, [9-83](#)
- #35 Port Diagnostic Test, [9-492](#), [9-1045](#)
- #36 Audit and Update Test, [9-967](#), [9-1135](#), [9-1749](#), [9-1936](#)
- #36 Audit Update Test, [9-295](#), [9-461](#), [9-1767](#)
- #36 Port Audit and Update Test, [9-422](#), [9-481](#), [9-527](#)
- #36 Port Audit Update Test, [9-444](#), [9-494](#), [9-538](#)
- #36 Station Status and Translation Audits and Updates, [9-54](#), [9-70](#)
- #36 Station Status and Translation Audits and Updates Test, [9-43](#), [9-86](#)
- #40 Tone Generator Transmission Test, [9-1802](#)



- #41 Tone Generator Update/Audit Test, [9-1804](#)
- #417 Test Synchronization Test, [9-252](#), [9-1588](#)
- #42 Tone Detection Verification Test, [9-407](#), [9-696](#), [9-776](#), [9-888](#)
- #43 Tone Detector Audit/Update Test, [9-408](#), [9-697](#), [9-778](#), [9-890](#)
- #46 Clock Health Inquiry Test, [9-1796](#)
- #47 Loop Around and Conference Test, [9-90](#)
- #48 Station Present Test, [9-56](#), [9-72](#), [9-94](#)
- #5 Battery & Battery Charger Query Test, [9-1316](#), [9-1324](#)
- #50 NPE Audit Test, [9-1946](#)
- #50 NPE Connection Audit Test, [9-270](#), [9-574](#), [9-1018](#), [9-1840](#)
- #51 Ringing Application Circuit Test, [9-1947](#)
- #52 Control Channel Loop Around Test, [9-575](#), [9-1019](#), [9-1841](#), [9-1949](#)
- #52 Control Channel Loop-Around Test, [9-217](#), [9-396](#), [9-1201](#)
- #53 SAKI Sanity Test, [9-577](#), [9-1021](#), [9-1842](#), [9-1950](#)
- #558 LAPD Connectivity Test, [9-1155](#)
- #56 Hybrid Electronic Power Feed Test, [9-913](#)
- #56 MFAT Electronic Power Feed Test, [9-1047](#)
- #565 Digital Port Sanity Test, [9-1117](#)
- #567 Consistency Test, [9-1124](#)
- #57 Hybrid Circuit and Conference Circuit Test, [9-914](#), [9-1049](#)
- #572 Maintenance/Test Circuit Pack Query Test, [9-1240](#)
- #573 Packet Circuit Pack Audit Test, [9-1243](#)
- #574 Board Type Check Test, [9-1733](#)
- #58 Hybrid Line Local Digital Loop Around Test, [9-918](#)
- #589 Expansion Interface Packet Interface Test, [9-830](#)
- #59 Hybrid Line Remote Digital Loop Around Test, [9-919](#)
- #595 LANBIC Receive Parity Error Counter Test, [9-304](#), [9-397](#), [9-1203](#), [9-1672](#)
- #595 LANHO Receive Parity Error Counter Test, [9-1143](#)
- #596 Receive FIFO Overflow Error Counter Test, [9-398](#), [9-1204](#)
- #597 Invalid LAPD Frame Error Counter Test, [9-400](#), [9-1205](#)
- #598 Packet Interface Test, [9-400](#), [9-1205](#)
- #599 Packet Gateway Switched Port Loop-Around Test, [9-1222](#), [9-1329](#)
- #6 NPE Crosstalk Test, [9-35](#), [9-80](#), [9-291](#), [9-415](#), [9-439](#), [9-459](#), [9-476](#), [9-487](#), [9-523](#), [9-536](#), [9-910](#),  
[9-964](#), [9-1042](#), [9-1128](#), [9-1187](#), [9-1742](#), [9-1761](#), [9-1933](#)
- #60 Hybrid Line Lamp Updates Test, [9-921](#)
- #60 MET Line Station Lamp Updates Test, [9-1051](#)
- #600 Congestion Query Test, [9-401](#), [9-1206](#)
- #601 Link Status Test, [9-253](#), [9-403](#), [9-1208](#), [9-1335](#)
- #602 PDATA Port Local Loop-Around Test, [9-1157](#)
- #603 System Port Connectivity Test, [9-1158](#)
- #604 TSC Heartbeat Inquiry Test, [9-1809](#)
- #61 Hybrid Line Audits Test, [9-923](#)
- #61 MET Line Station Audits Test, [9-1053](#)
- #610 Packet Gateway Port Local Loop-Around Test, [9-767](#), [9-768](#), [9-1223](#), [9-1330](#)
- #611 Packet Gateway Port Remote Loop-Around Test, [9-1227](#)
- #613 Level 1 State Inquiry Test, [9-769](#), [9-771](#), [9-1229](#), [9-1333](#)
- #617 NPE Crosstalk Test, [9-314](#)
- #618 BRI Port Local LAN Loop Around, [9-139](#), [9-1683](#)
- #619 BRI Port Local TDM Loop Around, [9-1684](#)
- #62 Hybrid Line Ringer Update Test, [9-926](#)
- #620 Electronic Power Feed Restoral, [9-322](#)
- #621 Level 1 Status Inquiry, [9-141](#), [9-1688](#)
- #624 Layer 1 Transmission Error Counter Test, [9-143](#), [9-144](#), [9-145](#)
- #625 Receive FIFO Overflow Error Counter Test, [9-1686](#), [9-1687](#)
- #626 Signaling Link Status Test, [9-133](#)
- #629 BRI Layer 3 Query, [9-353](#), [9-1690](#)
- #630 BRI Set Audits, [9-357](#)
- #637 Remote Layer 3 Query, [9-244](#), [9-949](#)
- #639 Secondary Signaling Link Hardware Check, [9-952](#)
- #643 Signaling Link Board Check, [9-164](#), [9-934](#), [9-939](#)

- #651 Standby Reference Health Check Test, [9-1733](#)
- #7 Conference Circuit Test, [9-50](#), [9-66](#), [9-418](#), [9-461](#), [9-478](#), [9-525](#), [9-966](#), [9-1131](#), [9-1189](#),  
[9-1365](#), [9-1745](#), [9-1934](#)
- #73 Tie Seizure Test, [9-1768](#)
- #747 Tie Trunk Dial Test, [9-1768](#)
- #755 SNI Circuit Path Test, [9-1441](#)
- #756 SNI Off-Board Destructive Facility Test, [9-856](#), [9-1451](#)
- #757 SNI Destructive Facility Test, [9-859](#), [9-1453](#)
- #759 Configuration Audit, [9-861](#), [9-1457](#)
- #760 Processor Route Audit Test, [9-1379](#), [9-1408](#)
- #767 Packet Neighbor Link Test, [9-1468](#)
- #768 Fiber Link Reset Test, [9-877](#)
- #777 Failure Audit, [9-878](#), [9-1410](#), [9-1479](#)
- #778 SNC On-Board Test, [9-1412](#)
- #779 TPN Test, [9-1413](#)
- #78 Power Query Test, [9-6](#), [9-10](#)
- #780 Switch Node Clock Reset Test, [9-1415](#)
- #787 Reset Board, [9-682](#)
- #788 Far-end DS1 Converter Board Loopback Test, [9-683](#)
- #789 Far-end FOT (Lightwave Transceiver) Loopback Test, [9-686](#)
- #79 Single Carrier Cabinet Power Query Test, [9-469](#)
- #790 DS1 Facilities Connectivity Loopback Test, [9-688](#)
- #795 Board Options Audit, [9-691](#)
- #797 Far-End Internal Loopback Test, [9-654](#)
- #798 DS1 Interface Options Audit, [9-656](#)
- #799 Near-end External Loopback Test, [9-658](#)
- #809 Disk Reset Test, [9-547](#)
- #809/#894 Tape Reset Test, [9-1638](#)
- #810 Disk Write-Read Test, [9-550](#)
- #810 Tape Write-Read Test, [9-1641](#)
- #811 Disk Audit Test, [9-552](#)
- #811 Tape Audit Test, [9-1643](#)
- #812 Disk Firmware Error Counters Read and Clear Test, [9-554](#)
- #812 Tape Firmware Error Counters Read and Clear Test, [9-1646](#)
- #813 Disk Diagnostic Test, [9-556](#)
- #813 Tape Diagnostic Test, [9-1650](#)
- #814 Disk Loop-Around Test, [9-558](#)
- #814 Tape Loop-around Test, [9-1652](#)
- #815 Disk Status Test, [9-560](#)
- #815 Tape Status Test, [9-1654](#)
- #820/#893 Host Adapter Reset Test, [9-896](#)
- #822 Host Adapter Read and Clear Firmware Error Counters Test, [9-898](#)
- #823 Host Adapter Diagnostic Test, [9-900](#)
- #824 Host Adapter Loop Around Test, [9-902](#)
- #825 Host Adapter Status Test, [9-904](#)
- #844-848 Transmission Test, [9-445](#), [9-1772](#)
- #855 Standby SPE Status Query Test, [9-1509](#)
- #858 Standby SPE Time-of-Day Comparison Test, [9-1512](#)
- #865 Control Register Test, [9-735](#)
- #866 Mailbox Loop-around Test, [9-736](#)
- #867 Local Loop-around Test, [9-737](#)
- #868 Memory Shadowing Bounds Test, [9-739](#)
- #869 Remote Loop-Around Test, [9-706](#)
- #871 FIFO Full Interrupt Test, [9-708](#)
- #873 State-Of-Health Test, [9-713](#)
- #874 Duplication Channel Test, [9-715](#)
- #875 Remote SPE Error Interrupt Test, [9-717](#)
- #876 Memory Shadowing Test, [9-720](#)
- #884 Memory Checksum Test, [9-1259](#)
- #885 Private Loop Around Tests, [9-1263](#)

- #886 Maintenance Loop Around Test, [9-1266](#)
- #887 Read and Clear Board Counters, [9-1269](#)
- #888 Active-Standby Peer Link Test, [9-1273](#)
- #893 Host Adapter Reset Test, [9-905](#)
- #895 Processor Cache Test, [9-1347](#)
- #896 Processor Cache Parity Audit, [9-1348](#)
- #897 Processor BOOTPROM Checksum Test, [9-1350](#)
- #899 Processor Parity Checker Test, [9-1351](#)
- #9 Digital Line NPE Crosstalk Test, [9-508](#), [9-749](#)
- #9 NPE Cross Talk Test, [9-1097](#), [9-1112](#)
- #9 NPE Crosstalk Test, [9-19](#), [9-28](#), [9-1167](#)
- #90 Tone Generator Crosstalk Test, [9-1805](#)
- #900 Processor Write Buffer Test, [9-1352](#)
- #902 Memory Single/Multiple Bit Error Audit, [9-1030](#)
- #903 RAM Checksum Test, [9-1032](#)
- #906 Memory Parity Checker Test, [9-1033](#)
- #907 Memory Error Detection/ Correction Test, [9-1035](#)
- #908 Memory Burst Read Test, [9-1036](#)
- #909 SYSAM Reset Test, [9-1604](#)
- #910 SYSAM Dual Port RAM Test, [9-1606](#)
- #911 Sanity Handshake Test, [9-1607](#)
- #912 SYSAM Refresh Test, [9-1609](#)
- #913 Time-Of-Day Clock Test, [9-1611](#)
- #915 SYSAM G3-MT Loop Around Test, [9-1614](#)
- #916 SYSAM Outpulse Relay Test, [9-1616](#), [9-1621](#)
- #917 SYSAM Analog Loop Around Test, [9-1618](#)
- #919 Standby SPE Handshake Test, [9-1513](#)
- #92 Control Channel Interface Test, [9-1556](#)
- #920 Standby SPE Configuration Matchup Test, [9-1514](#)
- #93 Switch Control Reset Test, [9-1558](#)
- #939 Signaling Port LAN Loopback, [9-935](#), [9-940](#)
- #94 Control Channel Transmission Test, [9-1560](#)
- #949 Failure Audit, [9-659](#), [9-692](#)
- #955 EPN Cold Restart, [9-843](#)
- #956 EPN Warm Restart, [9-844](#)
- #96 Modem Pool NPE Crosstalk Test, [9-1086](#)
- #97 Modem Pool Conference Test, [9-1088](#)
- #976 Session Status Query Test, [9-252](#), [9-1232](#), [9-1233](#), [9-1331](#)
- #98 Modem Pool Conversion Resource Loop Around Test, [9-1091](#)
- #980 Status Register Comparison Test, [9-722](#)
- #985 System Link Status, [9-1594](#)
- #989 SNI Fiber Out of Frame Query, [9-880](#), [9-1482](#)
- 114 Diagnostic Test—Auxiliary Trunk Test, [9-296](#)
- 761 Switch Node Interface Reset Test, [9-1466](#)
- Test #833 (A Carrier) and #834 (B Carrier) Tape to Disk Consistency Tests, [9-1530](#)

tie trunk circuit pack (TIE-BD), [9-1736](#)

time slots, TDM bus, [6-26](#)

time-division multiplex (TDM), [9-1703](#)

TN1648 circuit packs, [5-6](#)

TN1650B circuit packs, [5-6](#)

TN1655 circuit packs, [5-6](#), [9-195](#), [9-817](#), [9-828](#)

TN1656 circuit packs, [5-6](#)

TN1657 circuit packs, [5-6](#)

TN2182 circuit packs

description, [9-773](#)

duplication, [9-1778](#)

enhanced tone receiver (ETR) ports, [9-773](#)

interchanges, [9-1779](#)

international settings, [9-1781](#)

replacing, [9-1782](#)

- time division multiplex (TDM) bus clocks, [9-1720](#)
- tone-clock, [9-1778](#)
- TN264 circuit packs, [9-1125](#)
- TN464 circuit packs
  - DS1 interface, [9-564](#), [9-996](#), [9-1818](#)
  - option jumpers, [9-1827](#)
  - trunks, [9-1824](#)
- TN553 circuit packs, [9-1139](#)
- TN570 circuit packs, [9-780](#)
- TN572 circuit packs, [5-6](#)
- TN573 circuit packs, [5-6](#)
  - LEDs, [7-8](#)
  - switch node interface (SNI), [7-8](#)
- TN722 circuit packs, [9-564](#)
- TN750 circuit packs, [5-6](#)
- TN767 circuit packs, [9-564](#), [9-1125](#)
- TN768 circuit packs
  - description, [9-1778](#)
  - duplication, [9-1778](#)
  - interchanges, [9-1779](#)
  - international settings, [9-1781](#)
  - replacing, [9-1782](#)
  - time division multiplex (TDM) bus clocks, [9-1720](#)
  - tone generator, [9-1797](#)
- TN775, [9-791](#)
- TN775 circuit packs
  - expansion port network (EPN) maintenance, [7-5](#)
  - expansion port networks (EPNs), [9-790](#), [9-791](#)
- TN775C, [9-790](#)
- TN780 circuit packs
  - duplication, [9-1778](#)
  - interchanges, [9-1779](#)
  - international settings, [9-1781](#)
  - replacing, [9-1782](#)
  - time division multiplex (TDM) bus clocks, [9-1720](#)
  - tone generator, [9-1797](#)
- tone clocks, circuit packs, [9-792](#)
- tone detectors, enhanced tone receiver ports, [9-773](#)
- tone generators, [9-1778](#), [9-1797](#)
- tone-clock circuit packs
  - duplication, [9-1778](#)
  - interchanges, [9-1779](#)
  - international settings, [9-1781](#)
  - LEDs, [7-13](#)
  - replacing, [9-1782](#)
  - time division multiplex (TDM) bus clocks, [9-1720](#)
- TN2182, [9-1778](#)
  - tone generators, [9-1797](#)
- tones, Italian, [9-1781](#)
- Transfer on Ringing, [1-36](#)
- transmission
  - characteristics, [1-38](#) to [1-42](#)
  - errors, [1-29](#)
  - stream, [1-29](#)
- troubleshooting
  - duplicated switch processing element (SPE), [5-10](#)
  - ISDN-BRI/ASAI problems, [5-71](#)
  - ISDN-PRI endpoints (wideband), [5-69](#)
  - ISDN-PRI problems, [5-66](#)
  - ISDN-PRI test call problems, [5-75](#)

outgoing ISDN-testcall command, [5-77](#)  
packet bus, [5-97](#), [5-102](#)  
trunk data module (TDMODULE), [9-1735](#)  
trunk speed, [1-35](#)  
Trunk Test Call, [6-23](#)  
trunking facilities, [1-34](#)  
trunks, DS1, [9-996](#), [9-1818](#)  
TTC private networking (Japan), [1-4](#), [9-1818](#)  
TTT. See Terminating Trunk Transmission

---

## U

UN330B circuit packs, [5-6](#)  
UN331B circuit packs, [5-6](#)  
UN332 circuit packs, [5-6](#)  
uninterruptible power supply (UPS), [1-26](#)  
uninterruptible power supply, see UPS  
universal DS1 (UDS1) interface circuit packs, [9-564](#), [9-996](#), [9-1818](#), [9-1827](#)  
updates, software, [6-1](#)  
UPS, [9-375](#)  
users, multiple access, [3-1](#)

---

## V

V.35, [1-31](#)  
voice-grade  
data, [1-32](#)

---

## W

warm restarts, reset level 1, [4-3](#)  
warning alarms, [7-1](#)  
wideband access endpoints, [9-1930](#)  
wiring  
premises, [1-42](#)  
terminal equipment ports, [1-42](#)