

RINGERS—C-TYPE MAINTENANCE

1. GENERAL

1.01 This section contains procedures, methods, and requirements recommended for maintenance of C-type ringers.

1.02 This section is reissued to:

- Update Fig. 1, 2, and 3 to show latest version of C4A ringer
- Add information on C4B, C5A, and C5B ringers

1.03 The C4A ringer has a straight armature hinge of phosphor bronze, a portion of which projects into the airgap to act as a stopplate; and the armature has a single stop pin located on opposite side. The coil has two windings. The inner winding (1000 ohm tap) is connected between the slate and black leads and the outer winding (2650 ohm tap) between the red and slate-red leads. Four lead ringers are required for tip party identification installations.

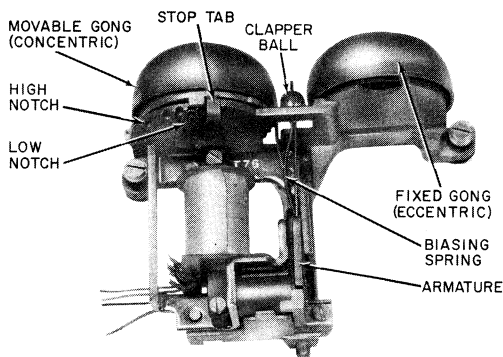

Fig. 1—C4A Ringer

1.04 Development of network-type wall telephone sets and network-type subscriber sets made it necessary to change the frame of C4A ringer. This change provides clearance for volume-adjusting arm.

1.05 The C4B ringer is the same as the C4A except the coil is a single winding coil, and the slate and slate-red leads have been eliminated.

1.06 The C4B ringer can be used as a direct replacement for the C4A in all locations where tip party identification is not required.

1.07 Current model C4-type ringers are equipped with a handset cord retainer (boss) to hold the handset cord in place in nonmodular equipped telephone sets. These ringers are used in most 0- and 1-button 500- and 2500-series telephone sets.

1.08 The C5A ringer is a single coil, two winding, four lead ringer; similar to the C4A except it has longer leads for solder termination. Not furnished with gongs, resonators volume control wheel and cord tips. Has a movable cam which can be operated manually. Intended for use in PBX and central office installations for alarm and signaling purposes.

1.09 The C5B ringer is mechanically and electrically the same as the C5A ringer, except it has two lead coil and a plastic clapper ball. Intended for use in central office alarm only.

2. MAINTENANCE

2.01 Armature of C4- and C5-type ringers, when manually operated shall restore to nonoperate position when bias spring is low notch and volume control wheel in high position. Should armature fail to restore, replace ringer.

Caution: Never bend bias spring or stop rod or adjust armature clearance.

NOTICE

Not for use or disclosure outside the
Bell System except under written agreement

2.02 With ringer lying flat (as mounted in 500-type set) or mounted vertically (gongs down, as in 685-type subscriber set mounted on wall), armature in nonoperated position, and volume control wheel in low position, the clapper shall clear movable gong by a minimum 1/64 inch, maximum 1/32 inch. If this requirement is outside its limits, ringer should be replaced. Clearance between clapper and fixed gong shall be 1/64 inch. Fixed gong may be repositioned to meet this clearance. Both these clearances may be gauged visually.

Volume Control

2.03 Volume control wheel (Fig. 2) may be adjusted for ringer cutoff when requested by customer or in accordance with local instructions.



When ringer cutoff feature is requested, bend stop tab up and out to clear stop on ringer frame (Fig. 3) and rotate volume control wheel to maximum clockwise position.

shall have a positive detent action at each position of wheel. Lubricate detent spring by rubbing graphite from a soft lead pencil onto bearing surface.

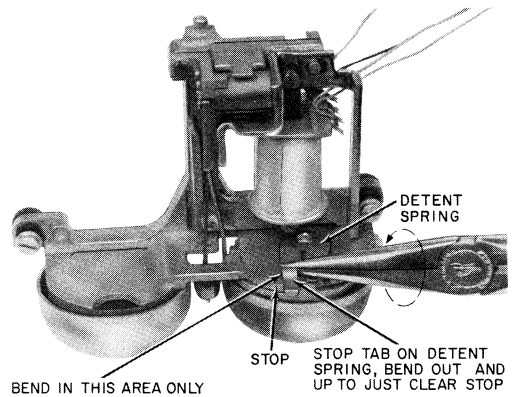

Fig. 3—Procedure for Ringer Cutoff

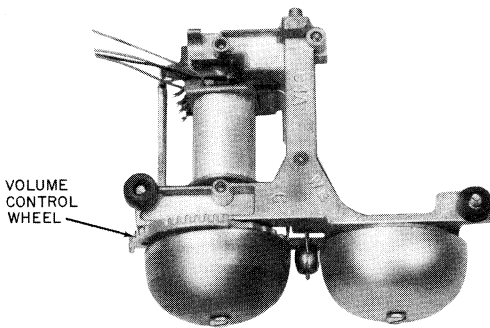

Fig. 2—C4A Ringer (Rear View)

2.04 Ringers manufactured prior to March, 1962 reportedly did not silence properly. A new cam design was developed to correct this situation. If trouble is encountered, replace ringer with newer type.

2.05 The volume control wheel shall operate smoothly over entire range. Detent spring

Bias Spring Position

2.06 Bias spring settings for class of service and number of ringing bridges are shown in Table A. High tension notch of bias bracket is adjacent to fixed gong. The low notch is adjacent to movable gong.



Correct bias spring tension has been set at factory. Do not bend bias spring. Use KS-6320 orange stick when relocating biasing spring.

Inspection

2.07 Table B is a guide for requirements, tests, and procedures for C-type ringers when they are placed in service and on maintenance visits.

2.08 After completing work, test ringer according to local instructions. Check for bell tap while dialing.

2.09 If bell taps with bias spring in low notch and ringer ***properly poled***, move bias spring to high notch. Repeat ringer test. If ringer fails to operate properly, change ringer.

2.10 When replacing C-type ringer, see that locating pin is inserted into rubber grommet before captive mounting screws are tightened. Check that ringer lead connections are tight.

2.11 When replacing ringer in wall telephone set or subscriber set, equipped with a network, a C4-type ringer equipped with later model frame ***must be used***.

Distinctive Tones

2.12 A series of different tone gongs are available for field use at installations involving customers with impaired hearing. ♦Also where telephone sets are closely spaced, it may be necessary to arrange for distinctive ringing signals. Refer to Section 500-128-180 for aids to customers with impaired hearing.♦



Even numbered gongs 52A, 54A, etc, have concentric mounting holes and are to be mounted on movable mounting post. The odd numbered gongs 53A,

55A, etc, have eccentric mounting holes and are installed on fixed mounting post.

2.13 Table C shows seven gong combinations that may be provided to obtain distinctive ringing signals.

2.14 Combination number 1 or 2 is recommended as first choice for customers with impaired hearing.

2.15 Combination number 5, 6, and 7 is recommended for locations where noise level is higher than average.

2.16 All gongs in this series may be mounted over resonator shells without mechanical interference, with exception of the 59A gong. The resonator shell must be removed from fixed post before 59A gong is installed. Should ringer have a staked resonator, insert screwdriver in post opening and pry resonator off.

2.17 When 59A gong is replaced by 55A gong, a removable resonator shall be installed. When replaced by 53A or 57A gong, installation of resonator is not necessary.

◆ TABLE A ◆

**BIAS SPRING POSITION
FOR C4- AND C5-TYPE RINGERS**

CLASS OF SERVICE	BIAS SPRING NOTCH
Bridge Ringing Services Individual Line and PBX Stations* Nonselective Party Lines	 High Low
Grounded Ringing Services 2-party Flat and Message Rate 4-party Semiselective† 4-party Full Selective 8-party Semiselective Divided Code	 High High Low Low Low

*When three or more ringers are bridged across line and operation is not satisfactory, bias spring may be placed in low notch on all ringers. If condition is not corrected, change ringer.

†Where five ringers are connected between same side of line and ground and operation is not satisfactory, bias spring may be placed in low notch on all ringers on that side of line. If condition is not corrected, change ringer.

◆ TABLE B ◆

C-TYPE RINGER TESTS AND REQUIREMENTS

SUBJECT	REMARKS
Volume Control Wheel	See 2.03, 2.04 and 2.05.
Bias Spring	See 2.06 and Table A.
Ringer	<ol style="list-style-type: none"> 1. Leads dressed properly and connections tight. 2. Positioned properly; mounting screws tight. 3. Clean (see section entitled Ringers, General Maintenance and Ringing Tests). 4. Gong mounting screws tight and clapper to gong clearance in accordance with 2.02. 5. Ringer shall produce a steady ring on at least one gong when volume control wheel is in low notch and on both gongs as wheel is advanced to high notch.
Airgap	<p>With volume control wheel in high notch, displace armature manually toward inner pole piece; check for stop pins and see that they make contact with adjacent pole pieces. If stop pins are missing, replace ringer (C4-type ringers have only one stop pin). If stop pins are present but fail to make contact, determine cause. Remove dirt if found (see section entitled Ringers, General Maintenance and Ringing Tests.) If stop rod is deformed, replace ringer.</p>

◆ TABLE C ◆

DISTINCTIVE GONGS

GONG PAIR COMBINATION NUMBER	MOUNTED ON			
	CAM		FIXED POST	
	CODE	FREQ*	CODE	FREQ*
1	52A	805	53A	1015
2	54A	1280	53A	1015
3†	54A	1280	55A	1610
4	56A	2025	55A	1610
5	56A	2025	57A	2555
6	58A	3220	57A	2555
7	58A	3220	59A	4060

*Nominal frequency in hertz.

†Standard gongs as furnished from factory.

Note: The 64A plastic gong may be used to replace the 54A and 55A gongs on a C4-type ringer that is mounted in a 687A subscriber set. When this substitution is made, clapper-to-gong clearance may need to be readjusted so as to permit the ringer to meet its operating requirements.