



**MULTIFUNCTION EQUIPMENT
SERVICE MANUAL**

**MODELS: DCP750CW
DCP540CN
DCP330C
DCP130C**

© Copyright Brother 2007, 2006

All rights reserved.

No part of this publication may be reproduced in any form or by any means without permission in writing from the publisher.

Specifications are subject to change without notice.

Confidential

Preface

This Service Manual is intended for use by service personnel and details the specifications, construction, theory of operation, and maintenance for the Brother machines noted on the front cover. It includes information required for troubleshooting and service--disassembly, reassembly, and lubrication--so that service personnel will be able to understand equipment function, repair the equipment in a timely manner and order spare parts as necessary.

To perform appropriate maintenance so that the machine is always in the best possible condition for the customer, service personnel must adequately understand and apply this manual.

The table below shows the functional comparison between the models covered by this manual.

Model	DCP750CW	DCP540CN	DCP330C	DCP130C
RAM	32 MB			16 MB
LCD	2.5-inch color	2.0-inch color		16 characters x 1 line
ADF	---	√	---	---
Wired LAN	√	√	---	---
Wireless LAN	√	---	---	---
PhotoCapture Center	√	√	√	√
PictBridge	√	√	√	√
Movable platen	√	√	√	---
Photo tray	√	√	√	---

This manual describes the models and their versions destined for major countries. The specifications and functions are subject to change depending upon each destination.

How this manual is organized

This manual is made up of nine chapters and appendices.

CHAPTER 1 PARTS NAMES AND FUNCTIONS

Contains external views and names of components and describes their functions. Information about the keys on the control panel is included to help you check operation or make adjustments.

CHAPTER 2 SPECIFICATIONS

Lists the specifications of each model, which enables you to make a comparison of different models.

CHAPTER 3 THEORY OF OPERATION

Gives an overview of the scanning and printing mechanisms as well as the sensors, actuators, and control electronics. It aids in understanding the basic principles of operation as well as locating defects for troubleshooting.

CHAPTER 4 ERROR INDICATION AND TROUBLESHOOTING

Details error messages and codes that the incorporated self-diagnostic functions display if any error or malfunction occurs. If any error message appears, refer to this chapter to find which components should be checked or replaced.

The latter half of this chapter provides sample problems that could occur in the main sections of the machine and related troubleshooting procedures. This will help service personnel pinpoint and repair defective components.

CHAPTER 5 TRANSFER OF DATA LEFT IN THE MACHINE TO BE SENT FOR REPAIR

Not applicable.

CHAPTER 6 DISASSEMBLY/REASSEMBLY AND LUBRICATION

Details procedures for disassembling and reassembling the machine together with related notes. The disassembly order flow provided enables you to see at a glance the quickest way to get to component(s) involved.

At the start of a disassembly job, you check the disassembly order flow that guides you through a shortcut to the target components.

This chapter also covers screw tightening torques and lubrication points to which the specified lubricants should be applied during reassembly jobs.

CHAPTER 7 ADJUSTMENTS AND UPDATING OF SETTINGS, REQUIRED AFTER PARTS REPLACEMENT

Details adjustments and updating of settings, which are required if the head/carriage unit, main PCB and some other parts have been replaced.

CHAPTER 8 CLEANING

Provides cleaning procedures not covered by the User's Guide. Before starting any repair work, clean the machine as it may solve the problem concerned.

CHAPTER 9 MAINTENANCE MODE

Describes the maintenance mode which is exclusively designed for the purpose of checks, settings and adjustments of the machine using the keys on the control panel.

In the maintenance mode, you can update memory (EEPROM: electrically erasable programmable read-only memory) contents for optimizing the drive conditions of the head/carriage unit or the paper feed roller and paper ejection roller in the engine unit, if those units have been replaced, or for setting the CIS scanner area, for example. You can also customize the EEPROM according to the shipment destination of the machine concerned. In addition, you can perform operational checks of the LCD, control panel PCB or sensors, perform a print test, display the log information or error codes, and modify firmware switches (WSW).

Appendix 1 Reading Labels

Shows the location of labels put on some parts and describes the coding information for serial number, property data, and manufacturing information.

Appendix 2 Firmware Installation

Provides instructions on how to change firmware stored in the flash ROM on the main PCB or load firmware to a new main PCB from the host PC.

Appendix 3 EEPROM Customizing Codes

Provides instructions on how to set up the EEPROM customizing codes for the various preferences exclusively designed for each destination. The specified customizing code is stored in the EEPROM mounted on the main PCB. If the main PCB is replaced, therefore, you need to set up the proper customizing code with the machine in the maintenance mode.

Customizing codes customize firmware for individual models, enabling the common firmware to be used for various models. A list of EEPROM customizing codes comes with the firmware data provided by Brother Industries.

Appendix 4 Firmware Switches (WSW)

Describes the functions of the firmware switches, which can be divided into two groups: one is for customizing preferences designed for the shipping destination (as described in [Appendix 3](#)) and the other is for modifying preferences that match the machine to the environmental conditions. Use the latter group if the machine malfunctions due to mismatching.

Appendix 5 Wiring Diagrams

Provides the wiring diagrams that help you understand the connections between PCBs.

Appendix 6 Circuit Diagrams







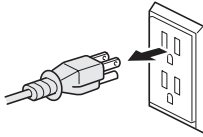

Provides the circuit diagrams of the power supply PCB.

SAFETY PRECAUTIONS

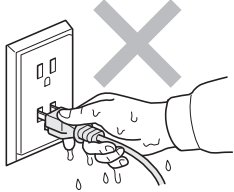
To use the machine safely

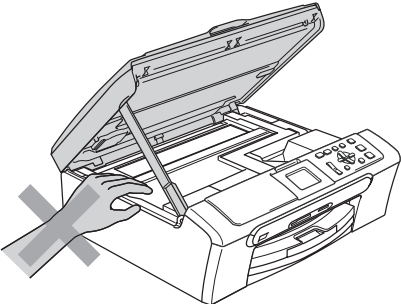
Please refer to these instructions for later reference and before attempting any maintenance.

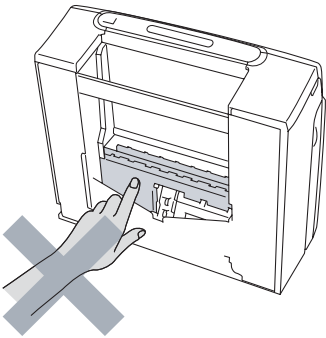
WARNING

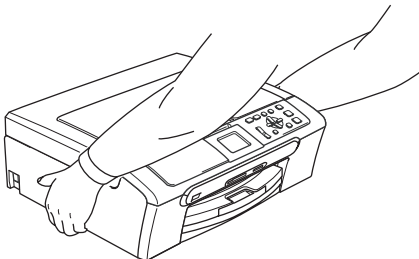
	<p>There are high voltage electrodes inside the machine. Before you clean the machine, make sure you have unplugged the power cord from the AC power outlet.</p>  <p>(Safety_1)</p>	 <p>Do not handle the plug with wet hands. Doing this might cause an electrical shock.</p>  <p>(Safety_2)</p>
	<p>To prevent injuries, be careful not to put your hands on the edge of the machine under the scanner cover.</p>  <p>(Safety_3)</p>	 <p>To prevent injuries, be careful not to touch the area shaded in the illustration.</p>  <p>(Safety_4)</p>
	<p>When moving the machine you must lift it from the base, by placing a hand at each side of the unit as shown in the illustration. Do NOT carry the machine by holding the scanner cover.</p>  <p>(Safety_5)</p>	

 **WARNING**

- This product must be installed near an AC power outlet that is easily accessible. In case of emergencies, you must disconnect the power cord from the AC power outlet in order to shut off power completely.

 **Caution**

- Lightning and power surges can damage this product! We recommend that you use a quality surge protection device on the AC power line, or unplug the cords during a lightning storm.
- When lifting up the machine, hold it from the base. Holding the scanning cover (scanner unit) leaves the machine body inclined, disengaging the scanner cover from the machine body or letting the machine body fall.

	<p>IMPORTANT SAFETY INSTRUCTIONS</p> <p>When using the machine, basic safety precautions should always be followed to reduce the risk of fire, electric shock and injury to persons, including the following:</p> <ol style="list-style-type: none">1. Do not use this product near water, for example, near a bath tub, wash bowl, kitchen sink or washing machine, in a wet basement or near a swimming pool.2. Avoid using this product during a lightning storm. There may be a remote risk of electric shock from lightning.3. Do not use this product to report a gas leak in the vicinity of the leak.4. Use only the power cord provided with the machine. <p>SAVE THESE INSTRUCTIONS</p>
---	---

Choosing a location

Place the machine on a flat, stable surface that is free of vibration and shocks, such as a desk. Put the machine near a standard, grounded AC power outlet. Choose a location where the temperature remains between 50°F and 95°F (10°C and 35°C).

Caution

- Avoid placing the machine in a high-traffic area.
- Avoid placing the machine on the carpet.
- Do not place the machine near heaters, air conditioners, water, chemicals, or refrigerators.
- Do not expose the machine to direct sunlight, excessive heat, moisture, or dust.
- Do not connect the machine to electrical outlets controlled by wall switches or automatic timers.
- Disruption of power can wipe out information in the machine's memory.
- Do not connect the machine to electrical outlets on the same circuit as large appliances or other equipment that might disrupt the power supply.

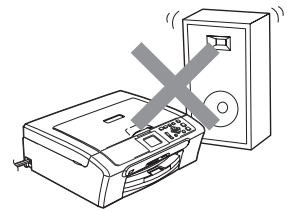
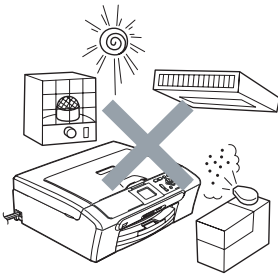

(Location)

Legal limitations for copying

Color reproductions of certain documents are illegal and may result in either criminal or civil liability. This memorandum is intended to be a guide rather than a complete listing of every possible prohibition. In case of doubt, we suggest that you check with relevant authorities as to any particular questionable documents.

The following are examples of documents which should not be copied:

- Money
- Bonds or other certificates of indebtedness
- Certificates of Deposit
- Armed Forces Service or Draft papers.
- Passports
- Postage Stamps (cancelled or uncanceled)
- Immigration Papers
- Welfare documents
- Cheques or Drafts drawn by Governmental Agencies
- Identification Documents, badges or insignias
- Licences and Certificates of Title to motor vehicles

Copyrighted works cannot be copied. Sections of a copyrighted work can be copied for 'fair use'. Multiple copies would indicate improper use.

Works of art should be considered the equivalent of copyrighted works.

Licenses and Certificates of Title to motor vehicles may not be copied under certain state/provincial laws.

CHAPTER 1

PARTS NAMES AND FUNCTIONS

CHAPTER 1 PARTS NAMES AND FUNCTIONS

This chapter contains external views and names of components and describes their functions. Information about the keys on the control panel is included to help you check operation or make adjustments.

CONTENTS

1.1	OUTLINE	1-1
1.2	CONTROL PANEL.....	1-5
1.3	COMPONENTS	1-9

1.1 OUTLINE

■ Models with ADF

Front view

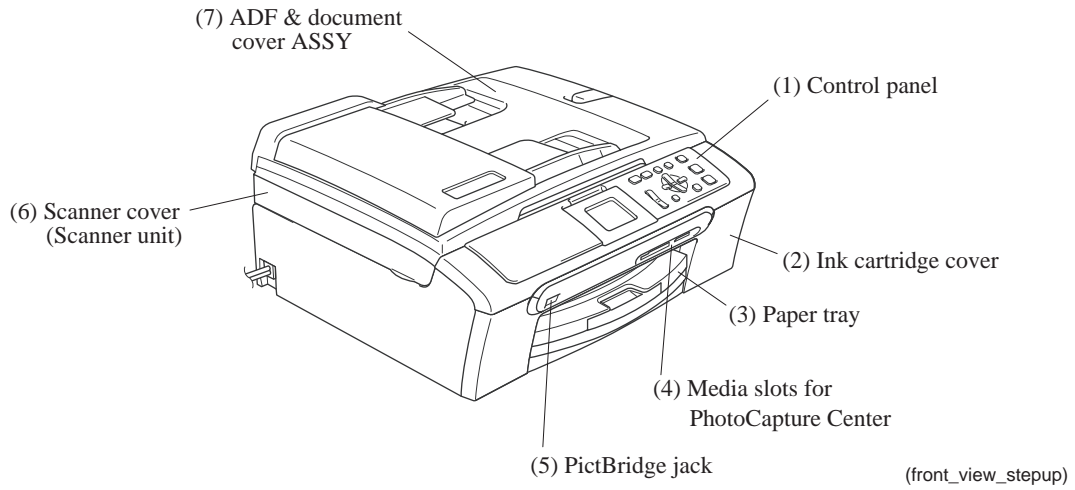

Back view

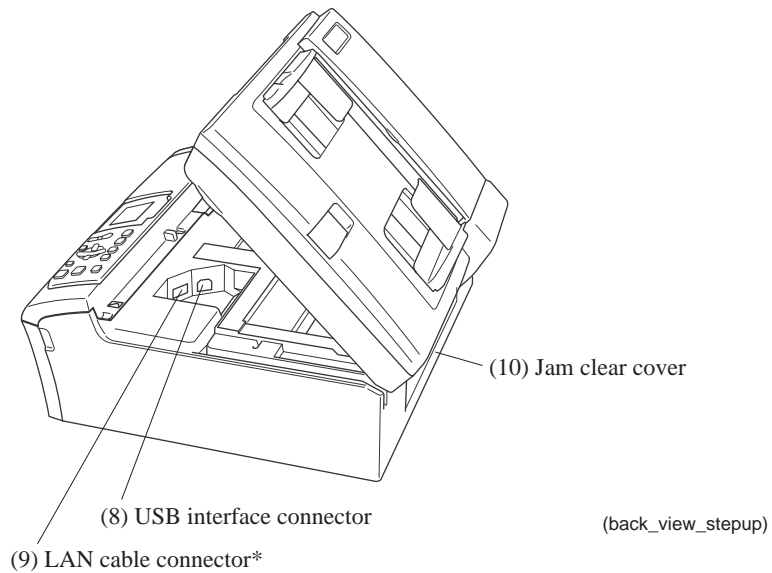

*For wired LAN-enabled models

No.	Name	Description
(1)	Control panel	Use the keys to operate the machine. The liquid crystal display (LCD) shows the machine operation status.
(2)	Ink cartridge cover	Open to replace ink cartridges.
(3)	Paper tray	Load paper here. Paper will be fed into the machine, sheet by sheet.
(4)	Media slots for PhotoCapture Center	Insert a memory card here.
(5)	PictBridge jack	Connect a digital camera to this jack using the USB cable.
(6)	Scanner cover (Scanner unit)	Open to remove jammed paper.
(7)	ADF & document cover ASSY	ADF: Load documents (originals) here. Documents will be fed into the machine, page by page. Document cover: Open to place the document (original) on the scanner glass.
(8)	USB interface connector	Connect the USB cable here.
(9)	LAN cable connector*	Connect the LAN cable here.
(10)	Jam clear cover	Open to remove paper jammed inside the machine.

*For wired LAN-enabled models

■ Models without ADF

Front view

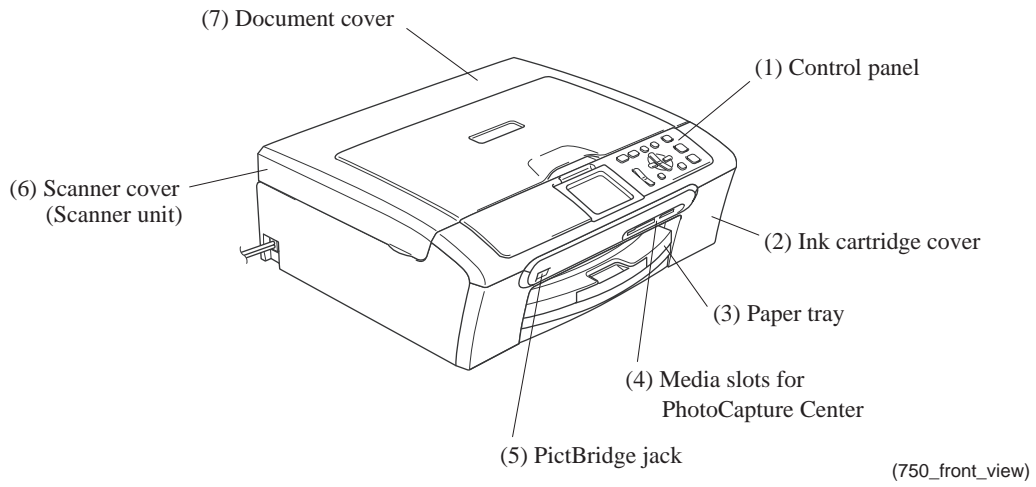

Back view

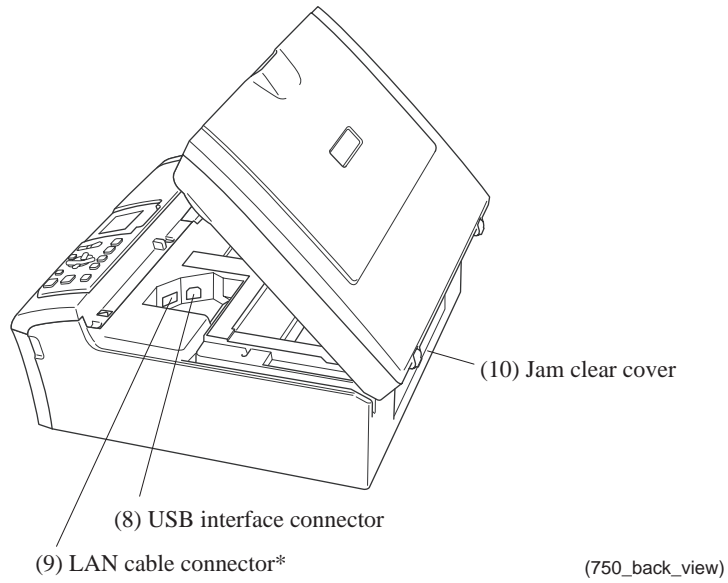

*For wired LAN-enabled models

No.	Name	Description
(1)	Control panel	Use the keys to operate the machine. The liquid crystal display (LCD) shows the machine operation status.
(2)	Ink cartridge cover	Open to replace ink cartridges.
(3)	Paper tray	Load paper here. Paper will be fed into the machine, sheet by sheet.
(4)	Media slots for PhotoCapture Center	Insert a memory card here.
(5)	PictBridge jack	Connect a digital camera to this jack using the USB cable.
(6)	Scanner cover (Scanner unit)	Open to remove jammed paper.
(7)	Document cover	Open to place the document (original) on the scanner glass.
(8)	USB interface connector	Connect the USB cable here.
(9)	LAN cable connector*	Connect the LAN cable here.
(10)	Jam clear cover	Open to remove paper jammed inside the machine.

*For wired LAN-enabled models

1.2 CONTROL PANEL

■ Models with color LCD

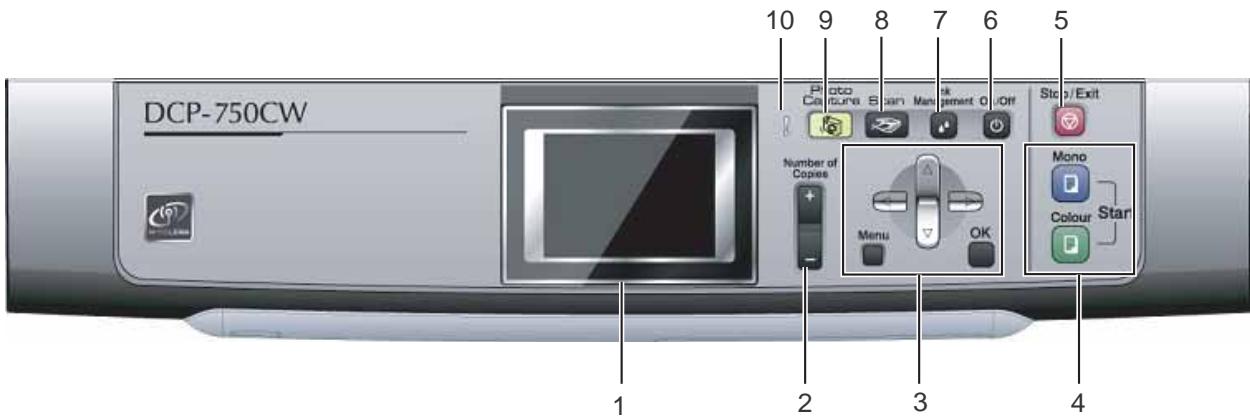

1 LCD (liquid crystal display)

Displays messages on the screen to help you set up and use your machine.

Also, you can adjust the angle of the LCD display by lifting it.

2 Number of Copies

Use this key to make multiple copies.

3 Menu keys:

- ◀ or ▶

Press to scroll backward or forward to a menu selection.

- ▲ or ▼

Press to scroll through the menus and options.

- **Menu**

Lets you access the Menu to program your settings in the machine.

- **OK**

Lets you choose and store your settings in the machine.

4 Start keys:

- **Colour (Color)**

Lets you start making copies in full colour. Also lets you start a scanning operation (in colour or mono, depending on the scanning setting in the ControlCenter software).

- **Mono (Black)**

Lets you start making copies in monochrome. Also lets you start a scanning operation (in colour or mono, depending on the scanning setting in the ControlCenter software).

5  **Stop/Exit**

Stops an operation or exits from a menu.

6 **On/Off**

You can turn the machine on or off.

If you turn the machine off, it will still periodically clean the print head to maintain print quality.

7 **Ink Management (Ink)**

Lets you clean the print head, check the print quality, and check the available ink volume.

8  **Scan**

Lets you access Scan mode.

9  **PhotoCapture**

Lets you access PhotoCapture Center™ mode.

10 **Warning LED**

Turns red when the LCD displays an error or an important status message.

■ **Models with monochrome LCD**

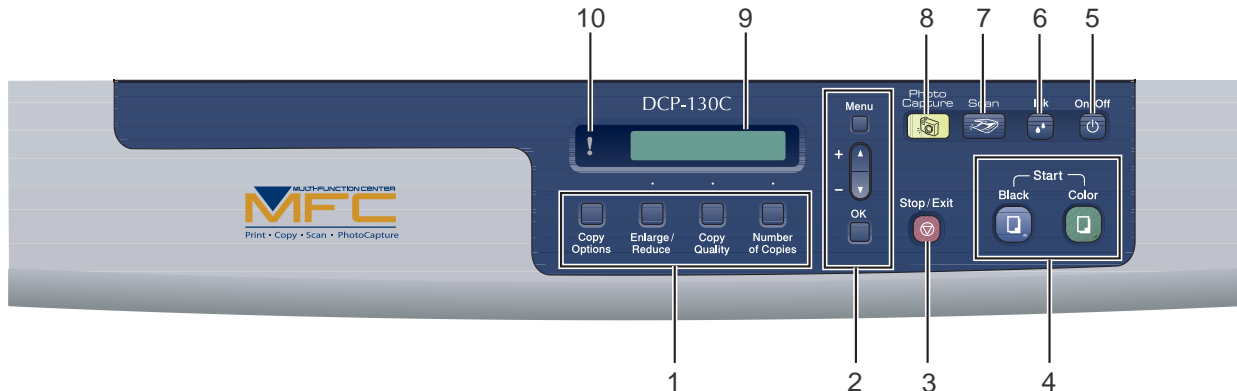

1 Copy keys

Lets you temporarily change the copy settings when in copy mode.

■ **Copy Options**

You can quickly and easily select temporary settings for copying.

■ **Enlarge/Reduce**

Lets you enlarge or reduce copies depending on the ratio you select.

■ **Copy Quality**

Use this key to temporarily change the quality of your copies.

■ **Number of Copies**

Use this key to make multiple copies.

2 Menu keys:

■ **Menu**

Lets you access the Menu to program your settings in the machine.

■ **+▲ or -▼**

Press to scroll through the menus and options.

■ **OK**

Lets you choose and store your settings in the machine.

3  **Stop/Exit**

Stops an operation or exits from a menu.

4 Start keys:

■  **Black Start**

Lets you start making copies in black & white. Also lets you start a scanning operation (in color or black, depending on the scanning setting in the ControlCenter software).

■  **Color Start**

Lets you start making copies in full color. Also lets you start a scanning operation (in color or black & white, depending on the scanning setting in the ControlCenter software).

5 On/Off

You can turn the machine on or off.

If you turn the machine off, it will periodically clean the print head to maintain print quality.

6 Ink

Lets you clean the print head, check the print quality, and check the available ink volume.

7  **Scan**

Lets you access Scan mode.

8  **PhotoCapture**

Lets you access PhotoCapture Center™ mode.

9 LCD (liquid crystal display)

Displays messages on the screen to help you set up and use your machine.

10  **Warning LED**

Turns red when the LCD displays an error or an important status message.

1.3 COMPONENTS

The machine consists of the following major components:

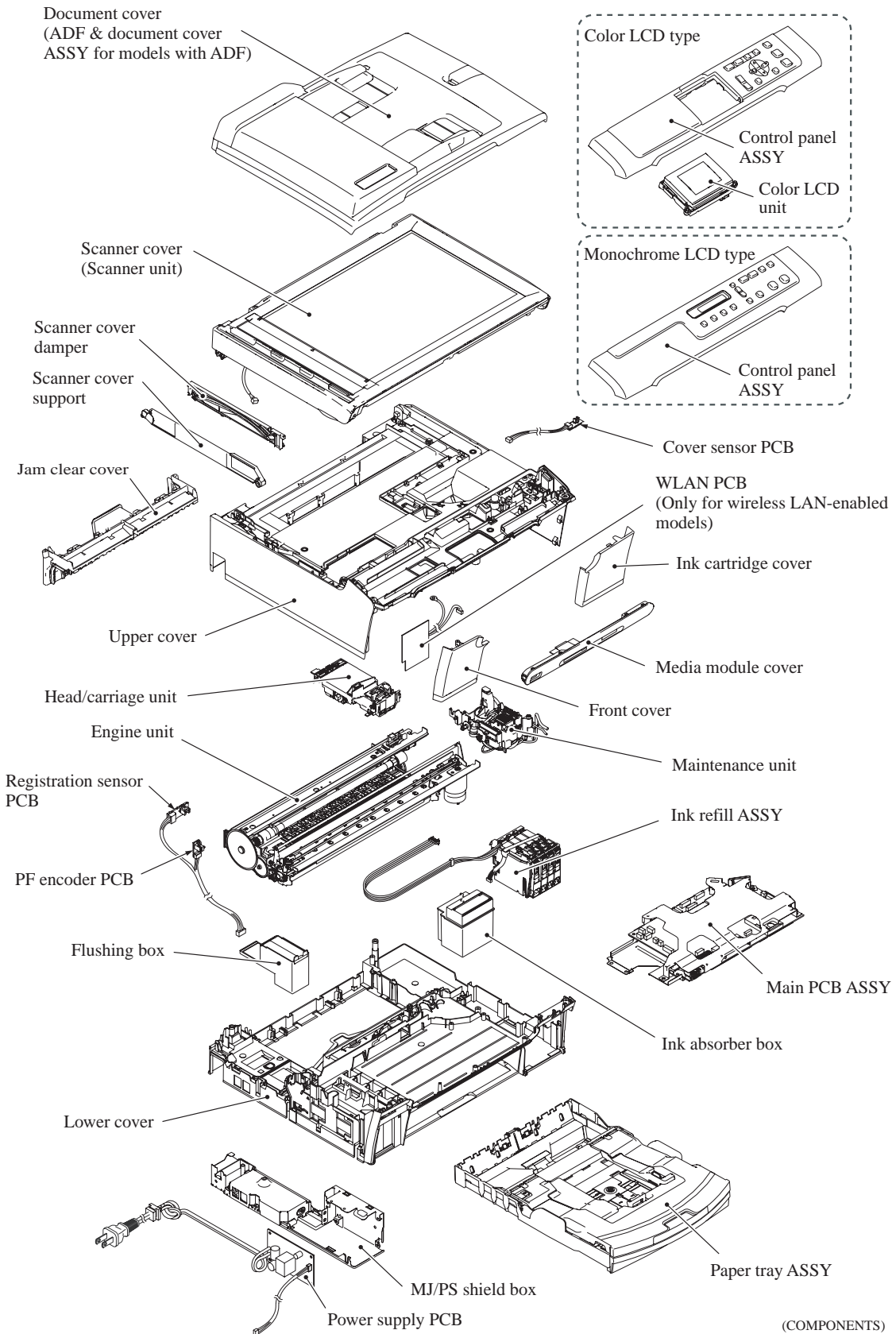

(COMPONENTS)

CHAPTER 2

SPECIFICATIONS

CHAPTER 2 SPECIFICATIONS

This chapter lists the specifications of each model, which enables you to make a comparison of different models.

CONTENTS

2.1	GENERAL	2-1
2.1.1	General Specifications.....	2-1
2.1.2	Paper Specifications.....	2-3
2.1.3	Printable Area.....	2-6
2.2	SPECIFICATIONS LIST	2-7

2.1 GENERAL

2.1.1 General Specifications

Memory Capacity	
Models with color LCD:	32 MB
Models with monochrome LCD:	16 MB
Automatic Document Feeder (ADF)	Up to 10 pages
Paper Tray	100 sheets, 80 g/m ² (20 lb)
Printer Type	Ink Jet
Print Method	Piezoelectric, 376 nozzles (47 nozzles x 2 lines staggered, for each color)
Liquid Crystal Display (LCD)	
DCP750CW:	2.5-inch color
DCP540CN/330C:	2.0-inch color
DCP130C:	16 characters x 1 line, monochrome
Operating Environment	50 to 95°F (10 to 35°C)
Best Print Quality	68 to 91°F (20 to 33°C)
Power Source	100 to 120 VAC, 50/60 Hz (U.S.A./Canada) 230 VAC, 50/60 Hz (Europe/Asia)
Power Consumption	

		Minimum	Standby	Peak
DCP750CW	European models	5.5 W	7.0 W	21.0 W
DCP540CN	U.S.A./Canadian models	4.0 W	6.0 W	29.0 W
	European/Asian models	5.5 W	7.0 W	21.0 W
DCP330C	U.S.A./Canadian models	3.0 W	5.0 W	17.0 W
	European/Asian models	5.5 W	7.0 W	21.0 W
DCP130C	U.S.A./Canadian models	3.0 W	5.0 W	17.0 W
	European/Asian models	4.0 W	6.0 W	20.0 W

Dimensions (W x D x H)

Models with ADF

398 x 370 x 180 mm (15.7 x 14.6 x 7.1 inches)
 (with paper tray flap and document stopper opened) 410 x 433 x 189 mm (16.1 x 17.4 x 7.4 inches)

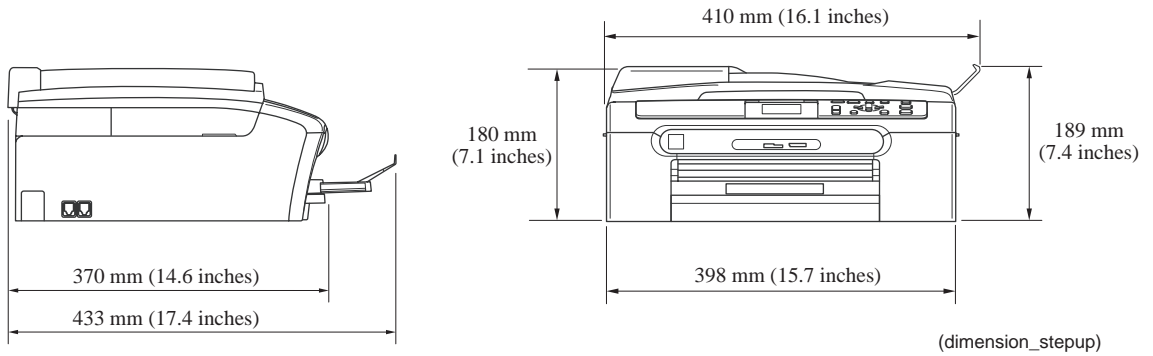

Models without ADF

398 x 360 x 150 mm (15.7 x 14.2 x 5.9 inches)
 (with paper tray flap opened) 398 x 433 x 150 mm (15.7 x 17.4 x 5.9 inches)

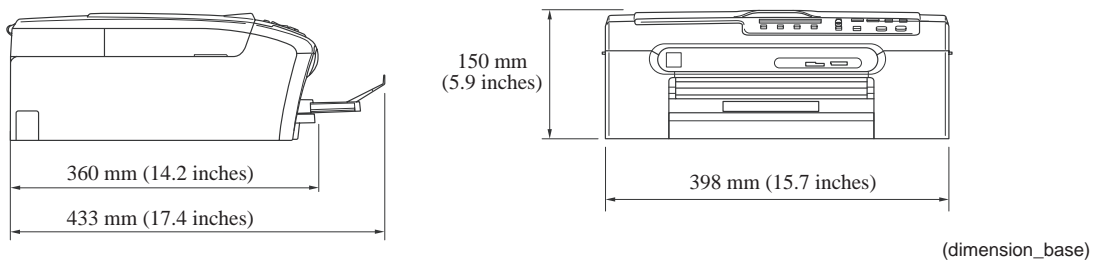

Weight

DCP750CW: 7.3 kg (16.1 lb)
 DCP540CN: 7.9 kg (17.4 lb)
 DCP330C: 7.2 kg (15.8 lb)
 DCP130C: 7.0 kg (15.4 lb)

2.1.2 Paper Specifications

Recommended Paper

Brother Paper

Paper Type	Item	Paper Type	Item
Letter Plain	BP60PL	A4 Plain	BP60PA
Letter Glossy	BP61GLL	A4 Glossy	BP61GLA
Letter Inkjet (Photo Matte)	BP60ML	A4 Inkjet (Photo Matte)	BP60MA
4 x 6 inch Glossy Photo	BP61GLP	10 x 15 cm Glossy Photo	BP61GLP

Transparencies: 3M Transparency Film

Paper Type and Size for Each Operation

Paper Type	Paper Size mm (inches)		Usage		
			Copy	PhotoCapture	Printer
Cut Sheet	Letter	216 x 279 (8 1/2 x 11)	Yes	Yes	Yes
	A4	210 x 297 (8.3 x 11.7)	Yes	Yes	Yes
	Legal	216 x 356 (8 1/2 x 14)	Yes	-	Yes
	Executive	184 x 267 (7 1/4 x 10 1/2)	-	-	Yes
	JIS B5	182 x 257 (7.2 x 10.1)	-	-	Yes
	A5	148 x 210 (5.8 x 8.3)	Yes	-	Yes
	A6	105 x 148 (4.1 x 5.8)	-	-	Yes
Cards	Photo	102 x 152 (4 x 6)	Yes	Yes	Yes
	Photo 2L	127 x 178 (5 x 7)	-	Yes	Yes
	Index Card	127 x 203 (5 x 8)	-	-	Yes
	Post Card 1	100 x 148 (3.9 x 5.8)	-	-	Yes
	Post Card 2 (Double)	148 x 200 (5.8 x 7.9)	-	-	Yes
Envelopes	C5 Envelope	162 x 229 (6.4 x 9)	-	-	Yes
	DL Envelope	110 x 220 (4.3 x 8.7)	-	-	Yes
	COM-10	105 x 241 (4 1/8 x 9 1/2)	-	-	Yes
	Monarch	98 x 191 (3 7/8 x 7 1/2)	-	-	Yes
	JE4 Envelope	105 x 235 (4.1 x 9.3)	-	-	Yes
Transparencies	Letter	216 x 279 (8 1/2 x 11)	Yes	-	Yes
	A4	210 x 297 (8.3 x 11.7)	Yes	-	Yes

Paper Weight, Thickness and Capacity

Paper Type		Weight	Thickness	No. of sheets
Cut Sheet	Plain Paper	64 to 120 g/m ² (17 to 32 lb)	0.08 to 0.15 mm (0.003 to 0.006 inch)	100*
	Inkjet Paper	64 to 200 g/m ² (17 to 53 lb)	0.08 to 0.25 mm (0.003 to 0.01 inch)	20
	Glossy Paper	Up to 220 g/m ² (Up to 58 lb)	Up to 0.25 mm (Up to 0.01 inch)	20
Cards	Photo 4 x 6 inches	Up to 240 g/m ² (Up to 64 lb)	Up to 0.28 mm (Up to 0.01 inch)	20
	Index Card	Up to 120 g/m ² (Up to 32 lb)	Up to 0.15 mm (Up to 0.006 inch)	30
	Post Card	Up to 200 g/m ² (Up to 53 lb)	Up to 0.23 mm (Up to 0.01 inch)	30
Envelopes		75 to 95 g/m ² (20 to 25 lb)	Up to 0.52 mm (Up to 0.02 inch)	10
Transparencies		-	-	10

* Up to 100 sheets for paper of 80 g/m² (20 lb)
Up to 50 sheets for Legal size paper of 80 g/m² (20 lb)

Output Paper Capacity of the Paper Tray Cover*

Paper Tray Cover*	Up to 50 sheets of 80 g/m ² (20 lb) (Letter) - Transparencies or glossy paper must be picked up from the paper tray cover* one page at a time to avoid smudging.
-------------------	--

*Photo tray on some models

⊘ Do not use paper or envelopes:

- that are damaged, curled, wrinkled, or irregularly shaped

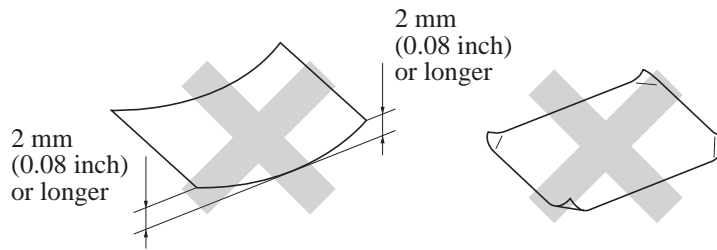

- that are extremely shiny or highly textured
- that were previously printed by a printer
- that cannot be arranged uniformly when stacked
- that are made with a short grain

⊘ Do not use envelopes:

- that are of a baggy construction
- that are embossed (have raised writing on them)
- that have clasps on them
- that are not sharply creased
- that are preprinted on the inside

2.1.3 Printable Area

The printable area depends on the settings in the application you are using. The figures below show the unprintable areas on cut sheet paper and envelopes.

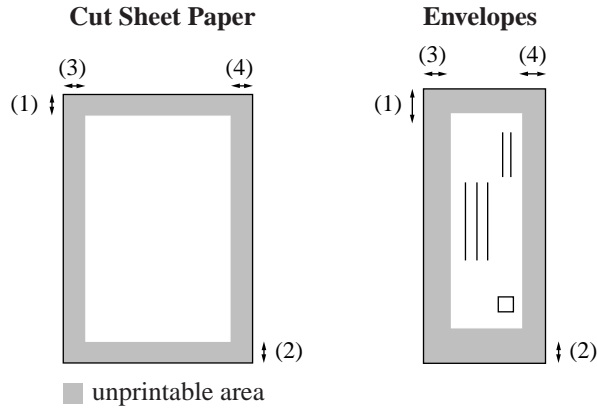

Paper	(1) Top	(2) Bottom	(3) Left	(4) Right
Cut sheet	3 mm (0.12 inch) 0 mm (0 inch)*	3 mm (0.12 inch) 0 mm (0 inch)*	3 mm (0.12 inch) 0 mm (0 inch)*	3 mm (0.12 inch) 0 mm (0 inch)*
Envelopes	12 mm (0.47 inch)	24 mm (0.95 inch)	3 mm (0.12 inch)	3 mm (0.12 inch)

* When you set the borderless printing feature to ON.

Printable area depends on the printer driver settings.

The figures above are approximate and the printable area may vary depending on the type of cut sheet paper you are using.

The borderless feature is not available for envelopes.

2.2 SPECIFICATIONS LIST

AREA	USA / Canada	Europe	Asia / Oceania	USA / Canada	Europe	Asia / Oceania	USA / Canada	Europe	Asia / Oceania	Europe
Model name	DCP-130C	DCP-130C	DCP-130C	DCP-330C	DCP-330C	DCP-330C	DCP-540CN	DCP-540CN	DCP-540CN	DCP-750CW
GENERAL										
Print Head	BH7(KKCC MMY) 94 nozzles/line	BH7(KKCC MMY) 94 nozzles/line	BH7(KKCC MMY) 94 nozzles/line	BH7(KKCC MMY) 94 nozzles/line	BH7(KKCC MMY) 94 nozzles/line	BH7(KKCC MMY) 94 nozzles/line	BH7(KKCC MMY) 94 nozzles/line	BH7(KKCC MMY) 94 nozzles/line	BH7(KKCC MMY) 94 nozzles/line	BH7(KKCC MMY) 94 nozzles/line
Technology	Inkjet	Inkjet	Inkjet	Inkjet	Inkjet	Inkjet	Inkjet	Inkjet	Inkjet	Inkjet
Scanning Method	CIS	CIS	CIS	CIS	CIS	CIS	CIS	CIS	CIS	CIS
CPU Speed	RISC 133MHZ	RISC 133MHZ	RISC 133MHZ	RISC 133MHZ	RISC 133MHZ	RISC 133MHZ	RISC 133MHZ	RISC 133MHZ	RISC 133MHZ	RISC 133MHZ
Back up Clock	Yes	Yes	Yes	Yes	Yes	Yes	Yes	Yes	Yes	Yes
Operating Environment Temperature (BestPrintQuality)	5 - 35 (20-33) degrees Centigrade	5 - 35 (20-33) degrees Centigrade	5 - 35 (20-33) degrees Centigrade	5 - 35 (20-33) degrees Centigrade	5 - 35 (20-33) degrees Centigrade	5 - 35 (20-33) degrees Centigrade	5 - 35 (20-33) degrees Centigrade	5 - 35 (20-33) degrees Centigrade	5 - 35 (20-33) degrees Centigrade	5 - 35 (20-33) degrees Centigrade
Humidity	20 - 80 % (without condensation)	20 - 80 % (without condensation)	20 - 80 % (without condensation)	20 - 80 % (without condensation)	20 - 80 % (without condensation)	20 - 80 % (without condensation)	20 - 80 % (without condensation)	20 - 80 % (without condensation)	20 - 80 % (without condensation)	20 - 80 % (without condensation)
On/Off Switch	Yes	Yes	Yes	Yes	Yes	Yes	Yes	Yes	Yes	Yes
Demo Model	-	-	-	-	-	-	-	-	-	-
Panel Key for demo sheet	-	-	-	-	-	-	-	-	-	-
Simultaneous Operation	Yes	Yes	Yes	Yes	Yes	Yes	Yes	Yes	Yes	Yes
Test Sheet	Yes:Print Quality/Alignment(in Ink Key)	Yes:Print Quality/Alignment(in Ink Key)	Yes:Print Quality/Alignment(in Ink Key)	Yes:Print Quality/Alignment(in Ink Key)	Yes:Print Quality/Alignment(in Ink Key)	Yes:Print Quality/Alignment(in Ink Key)	Yes:Print Quality/Alignment(in Ink Key)	Yes:Print Quality/Alignment(in Ink Key)	Yes:Print Quality/Alignment(in Ink Key)	Yes:Print Quality/Alignment(in Ink Key)
Minimum Input of ADF (Width/Height)	-	-	-	-	-	-	-	148mm/148mm(5.8"/5.8")	148mm/148mm(5.8"/5.8")	-
Maximum Input of ADF (Width/Height)	-	-	-	-	-	-	-	215.9mm/35.6mm(8.5"/14")	215.9mm/35.6mm(8.5"/14")	-
Maximum Input of Glass (Width/Height)	215.9mm/297mm(8.5"/11.7")	215.9mm/297mm(8.5"/11.7")	215.9mm/297mm(8.5"/11.7")	215.9mm/297mm(8.5"/11.7")	215.9mm/297mm(8.5"/11.7")	215.9mm/297mm(8.5"/11.7")	215.9mm/297mm(8.5"/11.7")	215.9mm/297mm(8.5"/11.7")	215.9mm/297mm(8.5"/11.7")	215.9mm/297mm(8.5"/11.7")
Minimum Output of Auto Cut sheet Feeder (Width/Height)	89mm/127mm(3.5"/5.0")	89mm/127mm(3.5"/5.0")	89mm/127mm(3.5"/5.0")	89mm/127mm(3.5"/5.0")	89mm/127mm(3.5"/5.0")	89mm/127mm(3.5"/5.0")	89mm/127mm(3.5"/5.0")	89mm/127mm(3.5"/5.0")	89mm/127mm(3.5"/5.0")	89mm/127mm(3.5"/5.0")
Maximum Output of Auto Cut sheet Feeder (Width/Height)	216mm/356mm(8.5"/14.0")	216mm/356mm(8.5"/14.0")	216mm/356mm(8.5"/14.0")	216mm/356mm(8.5"/14.0")	216mm/356mm(8.5"/14.0")	216mm/356mm(8.5"/14.0")	216mm/356mm(8.5"/14.0")	216mm/356mm(8.5"/14.0")	216mm/356mm(8.5"/14.0")	216mm/356mm(8.5"/14.0")
Minimum Output PhotoTray (Width/Height)	-	-	-	89mm/127mm(3.5"/5.0")	89mm/127mm(3.5"/5.0")	89mm/127mm(3.5"/5.0")	89mm/127mm(3.5"/5.0")	89mm/127mm(3.5"/5.0")	89mm/127mm(3.5"/5.0")	89mm/127mm(3.5"/5.0")

AREA	USA / Canada	Europe	Asia / Oceania	USA / Canada	Europe	Asia / Oceania	USA / Canada	Europe	Asia / Oceania	Europe
Model name	DCP-130C	DCP-130C	DCP-130C	DCP-330C	DCP-330C	DCP-330C	DCP-540CN	DCP-540CN	DCP-540CN	DCP-750CW
Maximum Output PhotoTray (Width/Height)	-	-	-	101.6mm/152.4mm (4.0"/6.0")	101.6mm/152.4mm (4.0"/6.0")	101.6mm/152.4mm (4.0"/6.0")	101.6mm/152.4mm (4.0"/6.0")	101.6mm/152.4mm (4.0"/6.0")	101.6mm/152.4mm (4.0"/6.0")	101.6mm/152.4mm (4.0"/6.0")
Minimum Output LowerTray (Width/Height)	-	-	-	176/250mm	176/250mm	176/250mm	176/250mm	176/250mm	176/250mm	176/250mm
Maximum Output LowerTray (Width/Height)	-	-	-	216mm/356mm (8.5"/14.0")	216mm/356mm (8.5"/14.0")	216mm/356mm (8.5"/14.0")	216mm/356mm (8.5"/14.0")	216mm/356mm (8.5"/14.0")	216mm/356mm (8.5"/14.0")	216mm/356mm (8.5"/14.0")
Sheet Weight (Paper tray)	64-220 g/m2 (17-58 lb.)	64-220 g/m2 (17-58 lb.)	64-220 g/m2 (17-58 lb.)	64-220 g/m2 (17-58 lb.)	64-220 g/m2 (17-58 lb.)	64-220 g/m2 (17-58 lb.)	64-220 g/m2 (17-58 lb.)	64-220 g/m2 (17-58 lb.)	64-220 g/m2 (17-58 lb.)	64-220 g/m2 (17-58 lb.)
Sheet Weight (Lower tray)	-	-	-	-	-	-	-	-	-	-
Sheet Weight (ADF)	-	-	-	-	-	-	-	64-90g/mm2 (17-24lb.)	64-90g/mm2 (17-24lb.)	-
Sheet Weight (Photo Tray)	-	-	-	64-220 g/m2 (17-58 lb.)	64-220 g/m2 (17-58 lb.)	64-220 g/m2 (17-58 lb.)	64-220 g/m2 (17-58 lb.)	64-220 g/m2 (17-58 lb.)	64-220 g/m2 (17-58 lb.)	64-220 g/m2 (17-58 lb.)
ADF(pages)	-	-	-	-	-	-	-	Yes(10)	Yes(10)	-
Paper Capacity (sheets)	100 (80 g/m2)	100 (80 g/m2)	100 (80 g/m2)	100 (80 g/m2)	100 (80 g/m2)	100 (80 g/m2)	100 (80 g/m2)	100 (80 g/m2)	100 (80 g/m2)	100 (80 g/m2)
Output Paper Capacity(sheets)	50	50	50	50	50	50	50	50	50	50
Brother Paper (for Plain,Glossy and Inkjet)	LTR Plain LTR Glossy LTR Inkjet 4x6in Glossy	A4 Plain A4 Glossy A4 Inkjet 4x6in Glossy	A4 Plain A4 Glossy A4 Inkjet 4x6in Glossy	LTR Plain LTR Glossy LTR Inkjet 4x6in Glossy	A4 Plain A4 Glossy A4 Inkjet 4x6in Glossy	A4 Plain A4 Glossy A4 Inkjet 4x6in Glossy	LTR Plain LTR Glossy LTR Inkjet 4x6in Glossy	A4 Plain A4 Glossy A4 Inkjet 4x6in Glossy	A4 Plain A4 Glossy A4 Inkjet 4x6in Glossy	A4 Plain A4 Glossy A4 Inkjet 4x6in Glossy
Recommended Paper Only for Transparency	3M 3410 Transparency film	3M 3410 Transparency film	3M 3410 Transparency film	3M 3410 Transparency film	3M 3410 Transparency film	3M 3410 Transparency film	3M 3410 Transparency film	3M 3410 Transparency film	3M 3410 Transparency film	3M 3410 Transparency film
LCD Size	16x1line	16x1line	16x1line	2.0 inch ColorLCD	2.0 inch ColorLCD	2.0 inch ColorLCD	2.0 inch ColorLCD	2.0 inch ColorLCD	2.0 inch ColorLCD	2.5 inch ColorLCD
LCD Back Light & Color	-	-	-	Yes	Yes	Yes	Yes	Yes	Yes	Yes
LCD Language	English French for Canada model	Depend on each country	English	English French for Canada model	Depend on each country	English	English French for Canada model	Depend on each country	English	Depend on each country
Selectable Wallpaper	-	-	-	-	-	-	-	-	-	-
Illuminated Mode Key	PCC	PCC	PCC	PCC	PCC	PCC	PCC	PCC	PCC	PCC
Illuminated Mode Key Color	Yellow green for Mode key, TAD key	Yellow green for Mode key, TAD key	Yellow green for Mode key, TAD key	Yellow green for Mode key, TAD key	Yellow green for Mode key, TAD key	Yellow green for Mode key, TAD key	Yellow green for Mode key, TAD key	Yellow green for Mode key, TAD key	Yellow green for Mode key, TAD key	Yellow green for Mode key, TAD key
Memory Capacity (physical: Mbytes)	RAM 16MB	RAM 16MB	RAM 16MB	RAM 32MB	RAM 32MB	RAM 32MB	RAM 32MB	RAM 32MB	RAM 32MB	RAM 32MB
Memory Backup (with battery 24hour)	-	-	-	-	-	-	-	-	-	-

AREA	USA / Canada	Europe	Asia / Oceania	USA / Canada	Europe	Asia / Oceania	USA / Canada	Europe	Asia / Oceania	Europe
Model name	DCP-130C	DCP-130C	DCP-130C	DCP-330C	DCP-330C	DCP-330C	DCP-540CN	DCP-540CN	DCP-540CN	DCP-750CW
Back Up Print:ON/OFF (in function Menu)	-	-	-	-	-	-	-	-	-	-
Memory Security	-	-	-	-	-	-	-	-	-	-
Transmission Lock	-	-	-	-	-	-	-	-	-	-
Power Source	AC 120 V 50/60Hz	AC 220-240 V 50/60Hz	AC 220-240 V 50/60Hz	AC 120 V 50/60Hz	AC 220-240 V 50/60Hz	AC 220-240 V 50/60Hz	AC 120 V 50/60Hz	AC 220-240 V 50/60Hz	AC 220-240 V 50/60Hz	AC 220-240 V 50/60Hz
Power Consumption (Peak/Minimum/Standby)	17W/3W/5W	20W/4W/6W	20W/4W/6W	17W/3W/5W	21W/5.5W/7W	21W/5.5W/7W	29W/4W/6W	21W/5.5W/7W	21W/5.5W/7W	21W/5.5W/7W
Energy Star Compliant (USA Only)	Yes	Yes	Yes	Yes	Yes	Yes	Yes	Yes	Yes	Yes
Machine Noise (Operating)	50dB	50dB	50dB	50dB	50dB	50dB	50dB	50dB	50dB	50dB
Ink Gauge Indication	Yes 2) 3) Only	Yes 2) 3) Only	Yes 2) 3) Only	Yes 1)Icon in standby mode 2)In ink key 3)Status Monitor	Yes 1)Icon in standby mode 2)In ink key 3)Status Monitor	Yes 1)Icon in standby mode 2)In ink key 3)Status Monitor	Yes 1)Icon in standby mode 2)In ink key 3)Status Monitor	Yes 1)Icon in standby mode 2)In ink key 3)Status Monitor	Yes 1)Icon in standby mode 2)In ink key 3)Status Monitor	Yes 1)Icon in standby mode 2)In ink key 3)Status Monitor
LIST/REPORT										
Activity Report /Journal Report	-	-	-	-	-	-	-	-	-	-
Help List	Yes	Yes	Yes	Yes	Yes	Yes	Yes	Yes	Yes	Yes
System Setup (User Setting) List	Yes	Yes	Yes	Yes	Yes	Yes	Yes	Yes	Yes	Yes
Order Form	-	-	-	-	-	-	-	-	-	-
Network Config	-	-	-	-	-	-	Yes	Yes	Yes	Yes
INTERFACE										
Host Interface	2.0(FULL)	2.0(FULL)	2.0(FULL)	2.0(FULL)	2.0(FULL)	2.0(FULL)	2.0(FULL)	2.0(FULL)	2.0(FULL)	2.0(FULL)
LAN	-	-	-	-	-	-	Yes	Yes	Yes	Yes
Wireless LAN	-	-	-	-	-	-	-	-	-	Yes
Cable included	-	-	-	-	-	-	-	-	-	-
PictBridge	Yes	Yes	Yes	Yes	Yes	Yes	Yes	Yes	Yes	Yes
Acceptable Media Card	CF/MS/SD(MMC)/xD	CF/MS/SD(MMC)/xD	CF/MS/SD(MMC)/xD	CF/MS/SD(MMC)/xD	CF/MS/SD(MMC)/xD	CF/MS/SD(MMC)/xD	CF/MS/SD(MMC)/xD	CF/MS/SD(MMC)/xD	CF/MS/SD(MMC)/xD	CF/MS/SD(MMC)/xD
SUPPLIES / OPTIONS										
Ink Cartridge	LC51BK LC51C LC51M LC51Y	LC1000BK LC1000C LC1000M LC1000Y	LC57BK LC57C LC57M LC57Y	LC51BK LC51C LC51M LC51Y	LC1000BK LC1000C LC1000M LC1000Y	LC57BK LC57C LC57M LC57Y	LC51BK LC51C LC51M LC51Y	LC1000BK LC1000C LC1000M LC1000Y	LC57BK LC57C LC57M LC57Y	LC1000BK LC1000C LC1000M LC1000Y
Bundled Ink (Life / Yield)	370/240 (Normal @5%)	370/240 (Normal @5%)	370/240 (Normal @5%)	370/240 (Normal @5%)	370/240 (Normal @5%)	370/240 (Normal @5%)	370/240 (Normal @5%)	370/240 (Normal @5%)	370/240 (Normal @5%)	370/240 (Normal @5%)

AREA	USA / Canada	Europe	Asia / Oceania	USA / Canada	Europe	Asia / Oceania	USA / Canada	Europe	Asia / Oceania	Europe	
Model name	DCP-130C	DCP-130C	DCP-130C	DCP-330C	DCP-330C	DCP-330C	DCP-540CN	DCP-540CN	DCP-540CN	DCP-750CW	
Supply Ink Cartridge (Life / Yield)	500/400 (Normal @5%)	500/400 (Normal @5%)	500/400 (Normal @5%)	500/400 (Normal @5%)	500/400 (Normal @5%)	500/400 (Normal @5%)	500/400 (Normal @5%)	500/400 (Normal @5%)	500/400 (Normal @5%)	500/400 (Normal @5%)	
Supply Ink Black Cartridge (Life / Yield) *HighCapacity	-	-	-	-	-	-	-	-	-	-	
Supply Ink Color Cartridge (Life / Yield) *HighCapacity	-	-	-	-	-	-	-	-	-	-	
SERVICE INFORMATION											
Monthly Volume	2500 pages	2500 pages	2500 pages	2500 pages	2500 pages	2500 pages	2500 pages	2500 pages	2500 pages	2500 pages	
Machine Life (year)	30000 pages or 5years	30000 pages or 5years	30000 pages or 5years	30000 pages or 5years	30000 pages or 5years	30000 pages or 5years	30000 pages or 5years	30000 pages or 5years	30000 pages or 5years	30000 pages or 5years	
MTBF (Mean Time Between Failures)	4000 hours	4000 hours	4000 hours	4000 hours	4000 hours	4000 hours	4000 hours	4000 hours	4000 hours	4000 hours	
MTTR (Mean Time To be Repaired)	30 minutes	30 minutes	30 minutes	30 minutes	30 minutes	30 minutes	30 minutes	30 minutes	30 minutes	30 minutes	
COLOR PRINTER											
Color / Mono	Color	Color	Color	Color	Color	Color	Color	Color	Color	Color	
Resolution (horizontal x vertical)	up to 1200 x6000dpi	up to 1200 x6000dpi	up to 1200 x6000dpi	up to 1200 x6000dpi	up to 1200 x6000dpi	up to 1200 x6000dpi	up to 1200 x6000dpi	up to 1200 x6000dpi	up to 1200 x6000dpi	up to 1200 x6000dpi	
Speed (ppm)	25/20ppm(Mono/Color:60x150dpi)	25/20ppm(Mono/Color:60x150dpi)	25/20ppm(Mono/Color:60x150dpi)	25/20ppm(Mono/Color:60x150dpi)	25/20ppm(Mono/Color:60x150dpi)	25/20ppm(Mono/Color:60x150dpi)	25/20ppm(Mono/Color:60x150dpi)	25/20ppm(Mono/Color:60x150dpi)	25/20ppm(Mono/Color:60x150dpi)	27/22ppm(Mono/color:600x150dpi)	
Fonts CD Based	yes(35 True Type)	yes(35 True Type)	yes(35 True Type)	yes(35 True Type)	yes(35 True Type)	yes(35 True Type)	yes(35 True Type)	yes(35 True Type)	yes(35 True Type)	yes(35 True Type)	
Paper Handling Size (Paper Tray)	A4, LTR, LGL, EXE, JISB5, A5, A6, Photo(102mmx152mm/4"x6"), Indexcard(127mmx203mm/5"x8"), Photo L (89mmx127mm/3.5"x5"), Photo2L(127mmx178mm/5"x7"), Post Card 1(100mmx148mm/3.9"x5.8"), Post Card 2 (Double)(148mmx200mm/5.8"x7.8"), C5 Envelope, Com-10, DL Envelope, Monarch, JE4 Envelope.	A4, LTR, LGL, EXE, JISB5, A5, A6, Photo(102mmx152mm/4"x6"), Indexcard(127mmx203mm/5"x8"), Photo L (89mmx127mm/3.5"x5"), Photo2L(127mmx178mm/5"x7"), Post Card 1(100mmx148mm/3.9"x5.8"), Post Card 2 (Double)(148mmx200mm/5.8"x7.8"), C5 Envelope, Com-10, DL Envelope, Monarch, JE4 Envelope.	A4, LTR, LGL, EXE, JISB5, A5, A6, Photo(102mmx152mm/4"x6"), Indexcard(127mmx203mm/5"x8"), Photo L (89mmx127mm/3.5"x5"), Photo2L(127mmx178mm/5"x7"), Post Card 1(100mmx148mm/3.9"x5.8"), Post Card 2 (Double)(148mmx200mm/5.8"x7.8"), C5 Envelope, Com-10, DL Envelope, Monarch, JE4 Envelope.	A4, LTR, LGL, EXE, JISB5, A5, A6, Photo(102mmx152mm/4"x6"), Indexcard(127mmx203mm/5"x8"), Photo L (89mmx127mm/3.5"x5"), Photo2L(127mmx178mm/5"x7"), Post Card 1(100mmx148mm/3.9"x5.8"), Post Card 2 (Double)(148mmx200mm/5.8"x7.8"), C5 Envelope, Com-10, DL Envelope, Monarch, JE4 Envelope.	A4, LTR, LGL, EXE, JISB5, A5, A6, Photo(102mmx152mm/4"x6"), Indexcard(127mmx203mm/5"x8"), Photo L (89mmx127mm/3.5"x5"), Photo2L(127mmx178mm/5"x7"), Post Card 1(100mmx148mm/3.9"x5.8"), Post Card 2 (Double)(148mmx200mm/5.8"x7.8"), C5 Envelope, Com-10, DL Envelope, Monarch, JE4 Envelope.	A4, LTR, LGL, EXE, JISB5, A5, A6, Photo(102mmx152mm/4"x6"), Indexcard(127mmx203mm/5"x8"), Photo L (89mmx127mm/3.5"x5"), Photo2L(127mmx178mm/5"x7"), Post Card 1(100mmx148mm/3.9"x5.8"), Post Card 2 (Double)(148mmx200mm/5.8"x7.8"), C5 Envelope, Com-10, DL Envelope, Monarch, JE4 Envelope.	A4, LTR, LGL, EXE, JISB5, A5, A6, Photo(102mmx152mm/4"x6"), Indexcard(127mmx203mm/5"x8"), Photo L (89mmx127mm/3.5"x5"), Photo2L(127mmx178mm/5"x7"), Post Card 1(100mmx148mm/3.9"x5.8"), Post Card 2 (Double)(148mmx200mm/5.8"x7.8"), C5 Envelope, Com-10, DL Envelope, Monarch, JE4 Envelope.	A4, LTR, LGL, EXE, JISB5, A5, A6, Photo(102mmx152mm/4"x6"), Indexcard(127mmx203mm/5"x8"), Photo L (89mmx127mm/3.5"x5"), Photo2L(127mmx178mm/5"x7"), Post Card 1(100mmx148mm/3.9"x5.8"), Post Card 2 (Double)(148mmx200mm/5.8"x7.8"), C5 Envelope, Com-10, DL Envelope, Monarch, JE4 Envelope.	A4, LTR, LGL, EXE, JISB5, A5, A6, Photo(102mmx152mm/4"x6"), Indexcard(127mmx203mm/5"x8"), Photo L (89mmx127mm/3.5"x5"), Photo2L(127mmx178mm/5"x7"), Post Card 1(100mmx148mm/3.9"x5.8"), Post Card 2 (Double)(148mmx200mm/5.8"x7.8"), C5 Envelope, Com-10, DL Envelope, Monarch, JE4 Envelope.	A4, LTR, LGL, EXE, JISB5, A5, A6, Photo(102mmx152mm/4"x6"), Indexcard(127mmx203mm/5"x8"), Photo L (89mmx127mm/3.5"x5"), Photo2L(127mmx178mm/5"x7"), Post Card 1(100mmx148mm/3.9"x5.8"), Post Card 2 (Double)(148mmx200mm/5.8"x7.8"), C5 Envelope, Com-10, DL Envelope, Monarch, JE4 Envelope.	A4, LTR, LGL, EXE, JISB5, A5, A6, Photo(102mmx152mm/4"x6"), Indexcard(127mmx203mm/5"x8"), Photo L (89mmx127mm/3.5"x5"), Photo2L(127mmx178mm/5"x7"), Post Card 1(100mmx148mm/3.9"x5.8"), Post Card 2 (Double)(148mmx200mm/5.8"x7.8"), C5 Envelope, Com-10, DL Envelope, Monarch, JE4 Envelope.
Paper Handling Size (Lower Tray)	-	-	-	-	-	-	-	-	-	-	
Paper Handling Size (Photo Tray)	-	-	-	4x6, Post Card, Photo L	4x6, Post Card, Photo L	4x6, Post Card, Photo L	4x6, Post Card, Photo L	4x6, Post Card, Photo L	4x6, Post Card, Photo L	4x6, Post Card, Photo L	
Media Type (Paper Tray)	Plain, Inkjet, Glossy, Transparency	Plain, Inkjet, Glossy, Transparency	Plain, Inkjet, Glossy, Transparency	Plain, Inkjet, Glossy, Transparency	Plain, Inkjet, Glossy, Transparency	Plain, Inkjet, Glossy, Transparency	Plain, Inkjet, Glossy, Transparency	Plain, Inkjet, Glossy, Transparency	Plain, Inkjet, Glossy, Transparency	Plain, Inkjet, Glossy, Transparency	

AREA	USA / Canada	Europe	Asia / Oceania	USA / Canada	Europe	Asia / Oceania	USA / Canada	Europe	Asia / Oceania	Europe	
Model name	DCP-130C	DCP-130C	DCP-130C	DCP-330C	DCP-330C	DCP-330C	DCP-540CN	DCP-540CN	DCP-540CN	DCP-750CW	
Media Type (Photo Tray)	-	-	-	Plain, Inkjet, Glossy	Plain, Inkjet, Glossy	Plain, Inkjet, Glossy	Plain, Inkjet, Glossy	Plain, Inkjet, Glossy	Plain, Inkjet, Glossy	Plain, Inkjet, Glossy	
Print Paper Margin (upper, lower, left, right)	Borderless ON:0,0,0,0* OFF:3,3,3,3mm**/0.12, 0.12, 0.12, 0.12* * Borderless For A4 /LTR/A6/Photo(102mmx152mm/4"x6"), Indexcard(127mmx203mm/5"x8"), Photo L (89mmx127mm/3.5"x5"), Photo 2L(127mmx178mm/5"x7"), Post Card 1(100mmx148mm/3.9"x5.8")only ** 12,24,3,3mm/0.47x0.95x0.12x0.12*for Envelops	Borderless ON:0,0,0,0* OFF:3,3,3,3mm**/0.12, 0.12, 0.12, 0.12* * Borderless For A4 /LTR/A6/Photo(102mmx152mm/4"x6"), Indexcard(127mmx203mm/5"x8"), Photo L (89mmx127mm/3.5"x5"), Photo 2L(127mmx178mm/5"x7"), Post Card 1(100mmx148mm/3.9"x5.8")only ** 12,24,3,3mm/0.47x0.95x0.12x0.12*for Envelops	Borderless ON:0,0,0,0* OFF:3,3,3,3mm**/0.12, 0.12, 0.12, 0.12* * Borderless For A4 /LTR/A6/Photo(102mmx152mm/4"x6"), Indexcard(127mmx203mm/5"x8"), Photo L (89mmx127mm/3.5"x5"), Photo 2L(127mmx178mm/5"x7"), Post Card 1(100mmx148mm/3.9"x5.8")only ** 12,24,3,3mm/0.47x0.95x0.12x0.12*for Envelops	Borderless ON:0,0,0,0* OFF:3,3,3,3mm**/0.12, 0.12, 0.12, 0.12* * Borderless For A4 /LTR/A6/Photo(102mmx152mm/4"x6"), Indexcard(127mmx203mm/5"x8"), Photo L (89mmx127mm/3.5"x5"), Photo 2L(127mmx178mm/5"x7"), Post Card 1(100mmx148mm/3.9"x5.8")only ** 12,24,3,3mm/0.47x0.95x0.12x0.12*for Envelops	Borderless ON:0,0,0,0* OFF:3,3,3,3mm**/0.12, 0.12, 0.12, 0.12* * Borderless For A4 /LTR/A6/Photo(102mmx152mm/4"x6"), Indexcard(127mmx203mm/5"x8"), Photo L (89mmx127mm/3.5"x5"), Photo 2L(127mmx178mm/5"x7"), Post Card 1(100mmx148mm/3.9"x5.8")only ** 12,24,3,3mm/0.47x0.95x0.12x0.12*for Envelops	Borderless ON:0,0,0,0* OFF:3,3,3,3mm**/0.12, 0.12, 0.12, 0.12* * Borderless For A4 /LTR/A6/Photo(102mmx152mm/4"x6"), Indexcard(127mmx203mm/5"x8"), Photo L (89mmx127mm/3.5"x5"), Photo 2L(127mmx178mm/5"x7"), Post Card 1(100mmx148mm/3.9"x5.8")only ** 12,24,3,3mm/0.47x0.95x0.12x0.12*for Envelops	Borderless ON:0,0,0,0* OFF:3,3,3,3mm**/0.12, 0.12, 0.12, 0.12* * Borderless For A4 /LTR/A6/Photo(102mmx152mm/4"x6"), Indexcard(127mmx203mm/5"x8"), Photo L (89mmx127mm/3.5"x5"), Photo 2L(127mmx178mm/5"x7"), Post Card 1(100mmx148mm/3.9"x5.8")only ** 12,24,3,3mm/0.47x0.95x0.12x0.12*for Envelops	Borderless ON:0,0,0,0* OFF:3,3,3,3mm**/0.12, 0.12, 0.12, 0.12* * Borderless For A4 /LTR/A6/Photo(102mmx152mm/4"x6"), Indexcard(127mmx203mm/5"x8"), Photo L (89mmx127mm/3.5"x5"), Photo 2L(127mmx178mm/5"x7"), Post Card 1(100mmx148mm/3.9"x5.8")only ** 12,24,3,3mm/0.47x0.95x0.12x0.12*for Envelops	Borderless ON:0,0,0,0* OFF:3,3,3,3mm**/0.12, 0.12, 0.12, 0.12* * Borderless For A4 /LTR/A6/Photo(102mmx152mm/4"x6"), Indexcard(127mmx203mm/5"x8"), Photo L (89mmx127mm/3.5"x5"), Photo 2L(127mmx178mm/5"x7"), Post Card 1(100mmx148mm/3.9"x5.8")only ** 12,24,3,3mm/0.47x0.95x0.12x0.12*for Envelops	Borderless ON:0,0,0,0* OFF:3,3,3,3mm**/0.12, 0.12, 0.12, 0.12* * Borderless For A4 /LTR/A6/Photo(102mmx152mm/4"x6"), Indexcard(127mmx203mm/5"x8"), Photo L (89mmx127mm/3.5"x5"), Photo 2L(127mmx178mm/5"x7"), Post Card 1(100mmx148mm/3.9"x5.8")only ** 12,24,3,3mm/0.47x0.95x0.12x0.12*for Envelops	Borderless ON:0,0,0,0* OFF:3,3,3,3mm**/0.12, 0.12, 0.12, 0.12* * Borderless For A4 /LTR/A6/Photo(102mmx152mm/4"x6"), Indexcard(127mmx203mm/5"x8"), Photo L (89mmx127mm/3.5"x5"), Photo 2L(127mmx178mm/5"x7"), Post Card 1(100mmx148mm/3.9"x5.8")only ** 12,24,3,3mm/0.47x0.95x0.12x0.12*for Envelops
Variable Dot Print	Yes (3 sizes)	Yes (3 sizes)	Yes (3 sizes)	Yes (3 sizes)	Yes (3 sizes)	Yes (3 sizes)	Yes (3 sizes)	Yes (3 sizes)	Yes (3 sizes)	Yes (3 sizes)	
Minimum Droplet Size	1.5 pl	1.5 pl	1.5 pl	1.5 pl	1.5 pl	1.5 pl	1.5 pl	1.5 pl	1.5 pl	1.5 pl	
Color Enhancement	Yes	Yes	Yes	Yes	Yes	Yes	Yes	Yes	Yes	Yes	
COLOR COPY											
Color / Mono	Color	Color	Color	Color	Color	Color	Color	Color	Color	Color	
Speed (cpm) *time calculated including paper feeding **EU's default is calculated by "normal mode"speed.	18/16cpm	18/16cpm	18/16cpm	18/16cpm	18/16cpm	18/16cpm	18/16cpm	18/16cpm	18/16cpm	20/18cpm	
Multi Copy (Stack)	Yes(99)	Yes(99)	Yes(99)	Yes(99)	Yes(99)	Yes(99)	Yes(99)	Yes(99)	Yes(99)	Yes(99)	
Multi Copy(Sort)	-	-	-	-	-	-	Yes	Yes	Yes	-	
Reduction/Enlargement(%)	25 -- 400 in 1% increments	25 -- 400 in 1% increments	25 -- 400 in 1% increments	25 -- 400 in 1% increments	25 -- 400 in 1% increments	25 -- 400 in 1% increments	25 -- 400 in 1% increments	25 -- 400 in 1% increments	25 -- 400 in 1% increments	25 -- 400 in 1% increments	
Resolution (horizontal x vertical)	Print: Maximum 600x1200dpi Scan: Maximum 600x1200dpi	Print: Maximum 600x1200dpi Scan: Maximum 600x1200dpi	Print: Maximum 600x1200dpi Scan: Maximum 600x1200dpi	Print: Maximum 600x1200dpi Scan: Maximum 600x1200dpi	Print: Maximum 600x1200dpi Scan: Maximum 600x1200dpi	Print: Maximum 600x1200dpi Scan: Maximum 600x1200dpi	Print: Maximum 600x1200dpi Scan: Maximum 600x1200dpi	Print: Maximum 600x1200dpi Scan: Maximum 600x1200dpi	Print: Maximum 600x1200dpi Scan: Maximum 600x1200dpi	Print: Maximum 600x1200dpi Scan: Maximum 600x1200dpi	
N in 1	2in1/4in1 A4/LTR only *Mono only	2in1/4in1 A4/LTR only *Mono only	2in1/4in1 A4/LTR only *Mono only	2in1/4in1, A4/LTR, Mono&Color	2in1/4in1, A4/LTR, Mono&Color	2in1/4in1, A4/LTR, Mono&Color	2in1/4in1, A4/LTR, Mono&Color	2in1/4in1, A4/LTR, Mono&Color	2in1/4in1, A4/LTR, Mono&Color	2in1/4in1, A4/LTR, Mono&Color	
Poster	Yes(3x3)	Yes(3x3)	Yes(3x3)	Yes(3x3)	Yes(3x3)	Yes(3x3)	Yes(3x3)	Yes(3x3)	Yes(3x3)	Yes(3x3)	
Image Enhancement	-	-	-	-	-	-	-	-	-	-	
Paper Handling Size (Paper Tray)	Letter/Legal/A4/A5/10cm (Width)x15cm(Height)(4"x6")	Letter/Legal/A4/A5/10cm (Width)x15cm(Height)(4"x6")	Letter/Legal/A4/A5/10cm (Width)x15cm(Height)(4"x6")	Letter/Legal/A4/A5/10cm (Width)x15cm(Height)(4"x6")	Letter/Legal/A4/A5/10cm (Width)x15cm(Height)(4"x6")	Letter/Legal/A4/A5/10cm (Width)x15cm(Height)(4"x6")	Letter/Legal/A4/A5/10cm (Width)x15cm(Height)(4"x6")	Letter/Legal/A4/A5/10cm (Width)x15cm(Height)(4"x6")	Letter/Legal/A4/A5/10cm (Width)x15cm(Height)(4"x6")	Letter/Legal/A4/A5/10cm(Width)x15cm(Height)(4"x6")	
Paper Handling Size (Photo Tray)	-	-	-	4x6, Post Card, Photo L	4x6, Post Card, Photo L	4x6, Post Card, Photo L	4x6, Post Card, Photo L	4x6, Post Card, Photo L	4x6, Post Card, Photo L	4x6, Post Card, Photo L	

AREA	USA / Canada	Europe	Asia / Oceania	USA / Canada	Europe	Asia / Oceania	USA / Canada	Europe	Asia / Oceania	Europe
Model name	DCP-130C	DCP-130C	DCP-130C	DCP-330C	DCP-330C	DCP-330C	DCP-540CN	DCP-540CN	DCP-540CN	DCP-750CW
Media Type (Paper Tray)	Plain, Inkjet, Glossy, Transparency	Plain, Inkjet, Glossy, Transparency	Plain, Inkjet, Glossy, Transparency	Plain, Inkjet, Glossy, Transparency	Plain, Inkjet, Glossy, Transparency	Plain, Inkjet, Glossy, Transparency	Plain, Inkjet, Glossy, Transparency	Plain, Inkjet, Glossy, Transparency	Plain, Inkjet, Glossy, Transparency	Plain, Inkjet, Glossy, Transparency
Media Type (Photo Tray)	-	-	-	Plain, Inkjet, Glossy	Plain, Inkjet, Glossy	Plain, Inkjet, Glossy	Plain, Inkjet, Glossy	Plain, Inkjet, Glossy	Plain, Inkjet, Glossy	Plain, Inkjet, Glossy
Print Paper Margin (upper, lower, left, right)	3,3,3,3mm (0.12, 0.12, 0.12, 0.12")	3,3,3,3mm (0.12, 0.12, 0.12, 0.12")	3,3,3,3mm (0.12, 0.12, 0.12, 0.12")	3,3,3,3mm (0.12, 0.12, 0.12, 0.12")	3,3,3,3mm (0.12, 0.12, 0.12, 0.12")	3,3,3,3mm (0.12, 0.12, 0.12, 0.12")	3,3,3,3mm (0.12, 0.12, 0.12, 0.12")	3,3,3,3mm (0.12, 0.12, 0.12, 0.12")	3,3,3,3mm (0.12, 0.12, 0.12, 0.12")	3,3,3,3mm (0.12, 0.12, 0.12, 0.12")
Resolution Indication	LCD	LCD	LCD	LCD	LCD	LCD	LCD	LCD	LCD	LCD
COLOR SCANNER										
Color / Mono	Color	Color	Color	Color	Color	Color	Color	Color	Color	Color
Resolution (horizontal x vertical)	600x2400dpi	600x2400dpi	600x2400dpi	600x2400dpi	600x2400dpi	600x2400dpi	600x2400dpi	600x2400dpi	600x2400dpi	600x2400dpi
Interpolated Resolution (dpi)	up to 19200x19200dpi (For XP, with special tool. 1200x1200dpi for XP without special tool)	up to 19200x19200dpi (For XP, with special tool. 1200x1200dpi for XP without special tool)	up to 19200x19200dpi (For XP, with special tool. 1200x1200dpi for XP without special tool)	up to 19200x19200dpi (For XP, with special tool. 1200x1200dpi for XP without special tool)	up to 19200x19200dpi (For XP, with special tool. 1200x1200dpi for XP without special tool)	up to 19200x19200dpi (For XP, with special tool. 1200x1200dpi for XP without special tool)	up to 19200x19200dpi (For XP, with special tool. 1200x1200dpi for XP without special tool)	up to 19200x19200dpi (For XP, with special tool. 1200x1200dpi for XP without special tool)	up to 19200x19200dpi (For XP, with special tool. 1200x1200dpi for XP without special tool)	up to 19200x19200dpi (For XP, with special tool. 1200x1200dpi for XP without special tool)
Gray Scale	256	256	256	256	256	256	256	256	256	256
Document Scanning width	210mm	210mm	210mm	210mm	210mm	210mm	210mm	210mm	210mm	210mm
Scan Image	Yes(Scan Key)	Yes(Scan Key)	Yes(Scan Key)	Yes(Scan Key)	Yes(Scan Key)	Yes(Scan Key)	Yes(Scan Key)	Yes(Scan Key)	Yes(Scan Key)	Yes(Scan Key)
Scan / OCR	Yes(Scan Key)	Yes(Scan Key)	Yes(Scan Key)	Yes(Scan Key)	Yes(Scan Key)	Yes(Scan Key)	Yes(Scan Key)	Yes(Scan Key)	Yes(Scan Key)	Yes(Scan Key)
Scan to E-mail	Yes(Scan Key)	Yes(Scan Key)	Yes(Scan Key)	Yes(Scan Key)	Yes(Scan Key)	Yes(Scan Key)	Yes(Scan Key)	Yes(Scan Key)	Yes(Scan Key)	Yes(Scan Key)
Scan to File	Yes(Scan Key)	Yes(Scan Key)	Yes(Scan Key)	Yes(Scan Key)	Yes(Scan Key)	Yes(Scan Key)	Yes(Scan Key)	Yes(Scan Key)	Yes(Scan Key)	Yes(Scan Key)
Scan to Card	Yes(Scan Key)	Yes(Scan Key)	Yes(Scan Key)	Yes(Scan Key)	Yes(Scan Key)	Yes(Scan Key)	Yes(Scan Key)	Yes(Scan Key)	Yes(Scan Key)	Yes(Scan Key)
Scan speed (Mono/Color) *@100dpi	Maximum .3.59/5.66 seconds @Letter Maximum 3.82/6.02 seconds @A4	Maximum .3.59/5.66 seconds @Letter Maximum 3.82/6.02 seconds @A4	Maximum .3.59/5.66 seconds @Letter Maximum 3.82/6.02 seconds @A4	Maximum .3.59/5.66 seconds @Letter Maximum 3.82/6.02 seconds @A4	Maximum .3.59/5.66 seconds @Letter Maximum 3.82/6.02 seconds @A4	Maximum .3.59/5.66 seconds @Letter Maximum 3.82/6.02 seconds @A4	Maximum .3.59/5.66 seconds @Letter Maximum 3.82/6.02 seconds @A4	Maximum .3.59/5.66 seconds @Letter Maximum 3.82/6.02 seconds @A4	Maximum .3.59/5.66 seconds @Letter Maximum 3.82/6.02 seconds @A4	Maximum .3.59/5.66 seconds @Letter Maximum 3.82/6.02 seconds @A4
Color Depth (Input/Output)	36/24bit color processing (Actual In/Out 30/24bit)	36/24bit color processing (Actual In/Out 30/24bit)	36/24bit color processing (Actual In/Out 30/24bit)	36/24bit color processing (Actual In/Out 30/24bit)	36/24bit color processing (Actual In/Out 30/24bit)	36/24bit color processing (Actual In/Out 30/24bit)	36/24bit color processing (Actual In/Out 30/24bit)	36/24bit color processing (Actual In/Out 30/24bit)	36/24bit color processing (Actual In/Out 30/24bit)	36/24bit color processing (Actual In/Out 30/24bit)

AREA	USA / Canada	Europe	Asia / Oceania	USA / Canada	Europe	Asia / Oceania	USA / Canada	Europe	Asia / Oceania	Europe	
Model name	DCP-130C	DCP-130C	DCP-130C	DCP-330C	DCP-330C	DCP-330C	DCP-540CN	DCP-540CN	DCP-540CN	DCP-750CW	
PHOTO CAPTURE CENTER											
Acceptable Media Card & Size	Compact Flash (Type-1only, - for Type2&Micro-Drive):4MB-2GB Memory Stick:16MB-128MB (Duo with Adopter) Memory Stick Pro:256MB-1GB (MagicGate:Yes if not use MG function) Secure Digital (SD & MMC):16MB-1GB (MiniSD with Adopter) xD Picture Card:16-512MB xD Picture Card Type M/Type H: 256MB-1GB	Compact Flash (Type-1only, - for Type2&Micro-Drive):4MB-2GB Memory Stick:16MB-128MB (Duo with Adopter) Memory Stick Pro:256MB-1GB (MagicGate:Yes if not use MG function) Secure Digital (SD & MMC):16MB-1GB (MiniSD with Adopter) xD Picture Card:16-512MB xD Picture Card Type M/Type H: 256MB-1GB	Compact Flash (Type-1only, - for Type2&Micro-Drive):4MB-2GB Memory Stick:16MB-128MB (Duo with Adopter) Memory Stick Pro:256MB-1GB (MagicGate:Yes if not use MG function) Secure Digital (SD & MMC):16MB-1GB (MiniSD with Adopter) xD Picture Card:16-512MB xD Picture Card Type M/Type H: 256MB-1GB	Compact Flash (Type-1only, - for Type2&Micro-Drive):4MB-2GB Memory Stick:16MB-128MB (Duo with Adopter) Memory Stick Pro:256MB-1GB (MagicGate:Yes if not use MG function) Secure Digital (SD & MMC):16MB-1GB (MiniSD with Adopter) xD Picture Card:16-512MB xD Picture Card Type M/Type H: 256MB-1GB	Compact Flash (Type-1only, - for Type2&Micro-Drive):4MB-2GB Memory Stick:16MB-128MB (Duo with Adopter) Memory Stick Pro:256MB-1GB (MagicGate:Yes if not use MG function) Secure Digital (SD & MMC):16MB-1GB (MiniSD with Adopter) xD Picture Card:16-512MB xD Picture Card Type M/Type H: 256MB-1GB	Compact Flash (Type-1only, - for Type2&Micro-Drive):4MB-2GB Memory Stick:16MB-128MB (Duo with Adopter) Memory Stick Pro:256MB-1GB (MagicGate:Yes if not use MG function) Secure Digital (SD & MMC):16MB-1GB (MiniSD with Adopter) xD Picture Card:16-512MB xD Picture Card Type M/Type H: 256MB-1GB	Compact Flash (Type-1only, - for Type2&Micro-Drive):4MB-2GB Memory Stick:16MB-128MB (Duo with Adopter) Memory Stick Pro:256MB-1GB (MagicGate:Yes if not use MG function) Secure Digital (SD & MMC):16MB-1GB (MiniSD with Adopter) xD Picture Card:16-512MB xD Picture Card Type M/Type H: 256MB-1GB	Compact Flash (Type-1only, - for Type2&Micro-Drive):4MB-2GB Memory Stick:16MB-128MB (Duo with Adopter) Memory Stick Pro:256MB-1GB (MagicGate:Yes if not use MG function) Secure Digital (SD & MMC):16MB-1GB (MiniSD with Adopter) xD Picture Card:16-512MB xD Picture Card Type M/Type H: 256MB-1GB	Compact Flash (Type-1only, - for Type2&Micro-Drive):4MB-2GB Memory Stick:16MB-128MB (Duo with Adopter) Memory Stick Pro:256MB-1GB (MagicGate:Yes if not use MG function) Secure Digital (SD & MMC):16MB-1GB (MiniSD with Adopter) xD Picture Card:16-512MB xD Picture Card Type M/Type H: 256MB-1GB	Compact Flash (Type-1only, - for Type2&Micro-Drive):4MB-2GB Memory Stick:16MB-128MB (Duo with Adopter) Memory Stick Pro:256MB-1GB (MagicGate:Yes if not use MG function) Secure Digital (SD & MMC):16MB-1GB (MiniSD with Adopter) xD Picture Card:16-512MB xD Picture Card Type M/Type H: 256MB-1GB	
Paper Handling Size & Type (Paper Tray)	Letter Glossy /10cmx15cm(4"x6") Glossy /13cmx18cm(5"x7") Glossy /A4 Glossy /Letter Plai-4 Plain /Letter Inkjet /A4 Inkjet /10cmx15cm(4"x6") Inkjet	Letter Glossy /10cmx15cm(4"x6") Glossy /13cmx18cm(5"x7") Glossy /A4 Glossy /Letter Plai-4 Plain /Letter Inkjet /A4 Inkjet /10cmx15cm(4"x6") Inkjet	Letter Glossy /10cmx15cm(4"x6") Glossy /13cmx18cm(5"x7") Glossy /A4 Glossy /Letter Plai-4 Plain /Letter Inkjet /A4 Inkjet /10cmx15cm(4"x6") Inkjet	Letter Glossy /10cmx15cm(4"x6") Glossy /13cmx18cm(5"x7") Glossy /A4 Glossy /Letter Plai-4 Plain /Letter Inkjet /A4 Inkjet /10cmx15cm(4"x6") Inkjet	Letter Glossy /10cmx15cm(4"x6") Glossy /13cmx18cm(5"x7") Glossy /A4 Glossy /Letter Plai-4 Plain /Letter Inkjet /A4 Inkjet /10cmx15cm(4"x6") Inkjet	Letter Glossy /10cmx15cm(4"x6") Glossy /13cmx18cm(5"x7") Glossy /A4 Glossy /Letter Plai-4 Plain /Letter Inkjet /A4 Inkjet /10cmx15cm(4"x6") Inkjet	Letter Glossy /10cmx15cm(4"x6") Glossy /13cmx18cm(5"x7") Glossy /A4 Glossy /Letter Plai-4 Plain /Letter Inkjet /A4 Inkjet /10cmx15cm(4"x6") Inkjet	Letter Glossy /10cmx15cm(4"x6") Glossy /13cmx18cm(5"x7") Glossy /A4 Glossy /Letter Plai-4 Plain /Letter Inkjet /A4 Inkjet /10cmx15cm(4"x6") Inkjet	Letter Glossy /10cmx15cm(4"x6") Glossy /13cmx18cm(5"x7") Glossy /A4 Glossy /Letter Plai-4 Plain /Letter Inkjet /A4 Inkjet /10cmx15cm(4"x6") Inkjet	Letter Glossy /10cmx15cm(4"x6") Glossy /13cmx18cm(5"x7") Glossy /A4 Glossy /Letter Plai-4 Plain /Letter Inkjet /A4 Inkjet /10cmx15cm(4"x6") Inkjet	Letter Glossy /10cmx15cm(4"x6") Glossy /13cmx18cm(5"x7") Glossy /A4 Glossy /Letter Plai-4 Plain /Letter Inkjet /A4 Inkjet /10cmx15cm(4"x6") Inkjet
Paper Handling Size & Type (Photo Tray)	-	-	-	4x6, Post Card, L, Photo L	4x6, Post Card, L, Photo L	4x6, Post Card, L, Photo L	4x6, Post Card, L, Photo L	4x6, Post Card, L, Photo L	4x6, Post Card, L, Photo L	4x6, Post Card, L, Photo L	
Print Paper Margin (upper, lower, left, right)	Borderless (For all size) ON:0,0,0,0 OFF:3,3,3,3mm /0.12, 0.12, 0.12, 0.12"	Borderless (For all size) ON:0,0,0,0 OFF:3,3,3,3mm /0.12, 0.12, 0.12, 0.12"	Borderless (For all size) ON:0,0,0,0 OFF:3,3,3,3mm /0.12, 0.12, 0.12, 0.12"	Borderless (For all size) ON:0,0,0,0 OFF:3,3,3,3mm /0.12, 0.12, 0.12, 0.12"	Borderless (For all size) ON:0,0,0,0 OFF:3,3,3,3mm /0.12, 0.12, 0.12, 0.12"	Borderless (For all size) ON:0,0,0,0 OFF:3,3,3,3mm /0.12, 0.12, 0.12, 0.12"	Borderless (For all size) ON:0,0,0,0 OFF:3,3,3,3mm /0.12, 0.12, 0.12, 0.12"	Borderless (For all size) ON:0,0,0,0 OFF:3,3,3,3mm /0.12, 0.12, 0.12, 0.12"	Borderless (For all size) ON:0,0,0,0 OFF:3,3,3,3mm /0.12, 0.12, 0.12, 0.12"	Borderless (For all size) ON:0,0,0,0 OFF:3,3,3,3mm /0.12, 0.12, 0.12, 0.12"	Borderless (For all size) ON:0,0,0,0 OFF:3,3,3,3mm /0.12, 0.12, 0.12, 0.12"
Available paper size for full (Maximum) size printing	All size	All size	All size	All size	All size	All size	All size	All size	All size	All size	
Direct Print Size for A4/LTR	10cmx8cm(4"x3")/ 13cmx9cm(5"x3.5")/ 15cmx10cm(6"x4")/ 18cmx13cm(7"x5")/ 20cmx15cm(8"x6")/ Maximum Size	10cmx8cm(4"x3")/ 13cmx9cm(5"x3.5")/ 15cmx10cm(6"x4")/ 18cmx13cm(7"x5")/ 20cmx15cm(8"x6")/ Maximum Size	10cmx8cm(4"x3")/ 13cmx9cm(5"x3.5")/ 15cmx10cm(6"x4")/ 18cmx13cm(7"x5")/ 20cmx15cm(8"x6")/ Maximum Size	10cmx8cm(4"x3")/ 13cmx9cm(5"x3.5")/ 15cmx10cm(6"x4")/ 18cmx13cm(7"x5")/ 20cmx15cm(8"x6")/ Maximum Size	10cmx8cm(4"x3")/ 13cmx9cm(5"x3.5")/ 15cmx10cm(6"x4")/ 18cmx13cm(7"x5")/ 20cmx15cm(8"x6")/ Maximum Size	10cmx8cm(4"x3")/ 13cmx9cm(5"x3.5")/ 15cmx10cm(6"x4")/ 18cmx13cm(7"x5")/ 20cmx15cm(8"x6")/ Maximum Size	10cmx8cm(4"x3")/ 13cmx9cm(5"x3.5")/ 15cmx10cm(6"x4")/ 18cmx13cm(7"x5")/ 20cmx15cm(8"x6")/ Maximum Size	10cmx8cm(4"x3")/ 13cmx9cm(5"x3.5")/ 15cmx10cm(6"x4")/ 18cmx13cm(7"x5")/ 20cmx15cm(8"x6")/ Maximum Size	10cmx8cm(4"x3")/ 13cmx9cm(5"x3.5")/ 15cmx10cm(6"x4")/ 18cmx13cm(7"x5")/ 20cmx15cm(8"x6")/ Maximum Size	10cmx8cm(4"x3")/ 13cmx9cm(5"x3.5")/ 15cmx10cm(6"x4")/ 18cmx13cm(7"x5")/ 20cmx15cm(8"x6")/ Maximum Size	10cmx8cm(4"x3")/ 13cmx9cm(5"x3.5")/ 15cmx10cm(6"x4")/ 18cmx13cm(7"x5")/ 20cmx15cm(8"x6")/ Maximum Size
Borderless / Cropping (Full Auto)	Yes/Yes	Yes/Yes	Yes/Yes	Yes/Yes	Yes/Yes	Yes/Yes	Yes/Yes	Yes/Yes	Yes/Yes	Yes/Yes	
Media Format	DPOF, Exif DCF	DPOF, Exif DCF	DPOF, Exif DCF	DPOF, Exif DCF	DPOF, Exif DCF	DPOF, Exif DCF	DPOF, Exif DCF	DPOF, Exif DCF	DPOF, Exif DCF	DPOF, Exif DCF	

AREA	USA / Canada	Europe	Asia / Oceania	USA / Canada	Europe	Asia / Oceania	USA / Canada	Europe	Asia / Oceania	Europe
Model name	DCP-130C	DCP-130C	DCP-130C	DCP-330C	DCP-330C	DCP-330C	DCP-540CN	DCP-540CN	DCP-540CN	DCP-750CW
Image Format Print by PCC Scan to Card	Photo Print: JPEG Scan to Card: JPEG/PDF (Color), TIFF/PDF (B&W)	Photo Print: JPEG Scan to Card: JPEG/PDF (Color), TIFF/PDF (B&W)	Photo Print: JPEG Scan to Card: JPEG/PDF (Color), TIFF/PDF (B&W)	Photo Print: JPEG Scan to Card: JPEG/PDF (Color), TIFF/PDF (B&W)	Photo Print: JPEG Scan to Card: JPEG/PDF (Color), TIFF/PDF (B&W)	Photo Print: JPEG Scan to Card: JPEG/PDF (Color), TIFF/PDF (B&W)	Photo Print: JPEG Scan to Card: JPEG/PDF (Color), TIFF/PDF (B&W)	Photo Print: JPEG Scan to Card: JPEG/PDF (Color), TIFF/PDF (B&W)	Photo Print: JPEG Scan to Card: JPEG/PDF (Color), TIFF/PDF (B&W)	Photo Print: JPEG Scan to Card: JPEG/PDF (Color), TIFF/PDF (B&W)
Color Enhancement	Yes	Yes	Yes	Yes	Yes	Yes	Yes	Yes	Yes	Yes
Removable Disk	Yes(read & write)	Yes(read & write)	Yes(read & write)	Yes(read & write)	Yes(read & write)	Yes(read & write)	Yes(read & write)	Yes(read & write)	Yes(read & write)	Yes(read & write)
Scan to Card	Yes	Yes	Yes	Yes	Yes	Yes	Yes	Yes	Yes	Yes
Network PCC	-	-	-	-	-	-	Yes(read & write)	Yes(read & write)	Yes(read & write)	Yes(read & write)
Rotate Function	-	-	-	Yes	Yes	Yes	Yes	Yes	Yes	Yes
NETWORK										
COMMON										
Standard/Option (User Option or Dealer Option)	-	-	-	-	-	-	Yes: Standard	Yes: Standard	Yes: Standard	Yes: Standard
ITU SUB Addressing	-	-	-	-	-	-	-	-	-	-
Printer	-	-	-	-	-	-	Yes	Yes	Yes	Yes
Scanner	-	-	-	-	-	-	Yes	Yes	Yes	Yes
Format (Scan to E-mail server)	-	-	-	-	-	-	-	-	-	-
Support OS version (Windows)	-	-	-	-	-	-	Windows98(SE)/Me/2000/XP/XP Professional X64	Windows98(SE)/Me/2000/XP/XP Professional X64	Windows98(SE)/Me/2000/XP/XP Professional X64	Windows98(SE)/Me/2000/XP/XP Professional X64
Support OS version (Mac)	-	-	-	-	-	-	Mac OS X 10.2.4 (greater)	Mac OS X 10.2.4 (greater)	Mac OS X 10.2.4 (greater)	Mac OS X 10.2.4 (greater)
Support OS version (Novell NetWare)	-	-	-	-	-	-	-	-	-	-
Network connection (Ethernet)	-	-	-	-	-	-	Ethernet 10/100BAS E-TX Auto Negotiation	Ethernet 10/100BAS E-TX Auto Negotiation	Ethernet 10/100BAS E-TX Auto Negotiation	Ethernet 10/100BASE -TX Auto Negotiation
Support Protocols	-	-	-	-	-	-	TCP/IP (IPv4)	TCP/IP (IPv4)	TCP/IP (IPv4)	TCP/IP (IPv4)
Protocols	-	-	-	-	-	-	ARP/RARP, BOOTP, DHCP, APIPA, NetBIOS, WINS	ARP/RARP, BOOTP, DHCP, APIPA, NetBIOS, WINS	ARP/RARP, BOOTP, DHCP, APIPA, NetBIOS, WINS	ARP/RARP, BOOTP, DHCP, APIPA, NetBIOS, WINS
Protocols	-	-	-	-	-	-	LPR/LPD, Port9100	LPR/LPD, Port9100	LPR/LPD, Port9100	LPR/LPD, Port9100

AREA	USA / Canada	Europe	Asia / Oceania	USA / Canada	Europe	Asia / Oceania	USA / Canada	Europe	Asia / Oceania	Europe
Model name	DCP-130C	DCP-130C	DCP-130C	DCP-330C	DCP-330C	DCP-330C	DCP-540CN	DCP-540CN	DCP-540CN	DCP-750CW
Protocols	-	-	-	-	-	-	mDNS, FTP, TELNET, SNMP, TFTP, Scanner port	mDNS, FTP, TELNET, SNMP, TFTP, Scanner port	mDNS, FTP, TELNET, SNMP, TFTP, Scanner port	mDNS, FTP, TELNET, SNMP, TFTP, Scanner port
LDAP	-	-	-	-	-	-	-	-	-	-
Network Management (BRAdmin Professional)	-	-	-	-	-	-	Yes	Yes	Yes	Yes
Network Management (Network Remote Setup)	-	-	-	-	-	-	-	-	-	-
Network Management (MIB-II as well as Brother private MIB)	-	-	-	-	-	-	Yes	Yes	Yes	Yes
Network reset	-	-	-	-	-	-	Yes (for WLAN & WIRED at once) (in LAN Menu)	Yes (for WLAN & WIRED at once) (in LAN Menu)	Yes (for WLAN & WIRED at once) (in LAN Menu)	Yes (for WLAN & WIRED at once) (in LAN Menu)
<i>WIRED</i>										
Model name (Ethernet)	-	-	-	-	-	-	Embedded (NC-130h)	Embedded (NC-130h)	Embedded (NC-130h)	Embedded (NC-130h)
<i>WIRELESS</i>										
Model name (Wireless)	-	-	-	-	-	-	-	-	-	Embedded (NC-140w)
Network connection (Wireless)	-	-	-	-	-	-	-	-	-	IEEE 802.11b/g
Wireless Security	-	-	-	-	-	-	-	-	-	SSID (32 characters) WEP 64/128bit WPA- TKIP/AES **NO LEAP**
Wi-Fi Certification	-	-	-	-	-	-	-	-	-	Wi-Fi B and G N/A for first production
Secure EZ Setup	-	-	-	-	-	-	-	-	-	Yes(for W-LAN model)
AOSS	-	-	-	-	-	-	-	-	-	-

AREA	USA / Canada	Europe	Asia / Oceania	USA / Canada	Europe	Asia / Oceania	USA / Canada	Europe	Asia / Oceania	Europe
Model name	DCP-130C	DCP-130C	DCP-130C	DCP-330C	DCP-330C	DCP-330C	DCP-540CN	DCP-540CN	DCP-540CN	DCP-750CW
Auto Switch W-LAN/WIRED LAN	-	-	-	-	-	-	-	-	-	Yes [When No LAN Cable connected and link up, MFC will use Wireless LAN / otherwise use WIRED LAN]
<i>Others</i>										
Optional I/F	-	-	-	-	-	-	-	-	-	-
Remote Set Up (USB)	-	-	-	-	-	-	-	-	-	-
Bundled Software	-	Yes	-	-	Yes	-	-	Yes	-	Yes

CHAPTER 3

THEORY OF OPERATION

CHAPTER 3 THEORY OF OPERATION

This chapter gives an overview of the scanning and printing mechanisms as well as the sensors, actuators, and control electronics. It aids in understanding the basic principles of operation as well as locating defects for troubleshooting.

CONTENTS

3.1	OVERVIEW	3-1
3.2	MECHANICAL COMPONENTS	3-2
3.2.1	Scanner Mechanism	3-5
3.2.2	Printing Mechanism	3-8
3.2.2.1	Ink supply and ink jet mechanism	3-9
[1]	Overview.....	3-9
[2]	Features.....	3-10
[3]	Head/carriage unit	3-11
[4]	Ink cartridges	3-18
[5]	Ink refill assembly	3-20
[6]	Ink supply tubes.....	3-21
3.2.2.2	Head maintenance mechanism.....	3-22
[1]	Overview.....	3-22
[2]	Maintenance unit components	3-22
[3]	Mechanisms constituting the head maintenance mechanism.....	3-24
[4]	Purge mechanism details	3-29
3.2.2.3	Carriage drive mechanism	3-34
3.2.2.4	Paper pulling-in, registration, feeding and ejecting mechanisms.....	3-38
3.2.3	Sensors and Actuators	3-44
3.3	CONTROL ELECTRONICS	3-47
3.3.1	Components	3-47

3.1 OVERVIEW

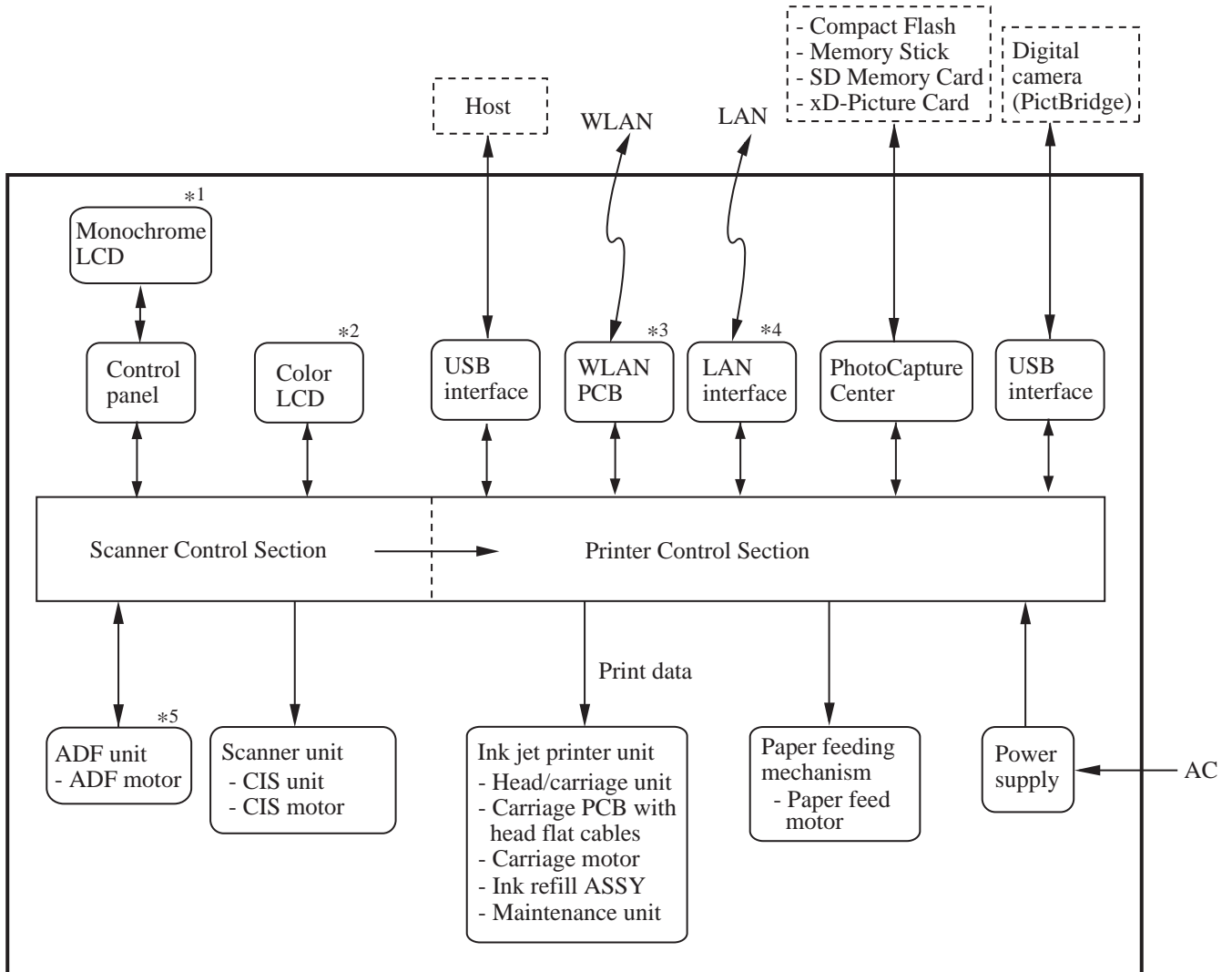

(DCP_Overview)

- *1 For models with monochrome LCD
- *2 For models with color LCD
- *3 For wireless LAN-enabled models
- *4 For wired LAN-enabled models
- *5 For models with ADF

3.2 MECHANICAL COMPONENTS

This machine consists of the following mechanisms and uses motors (four in models with ADF and three in models without ADF), two encoders, various sensors, and thermistors.

■ Scanner Mechanism

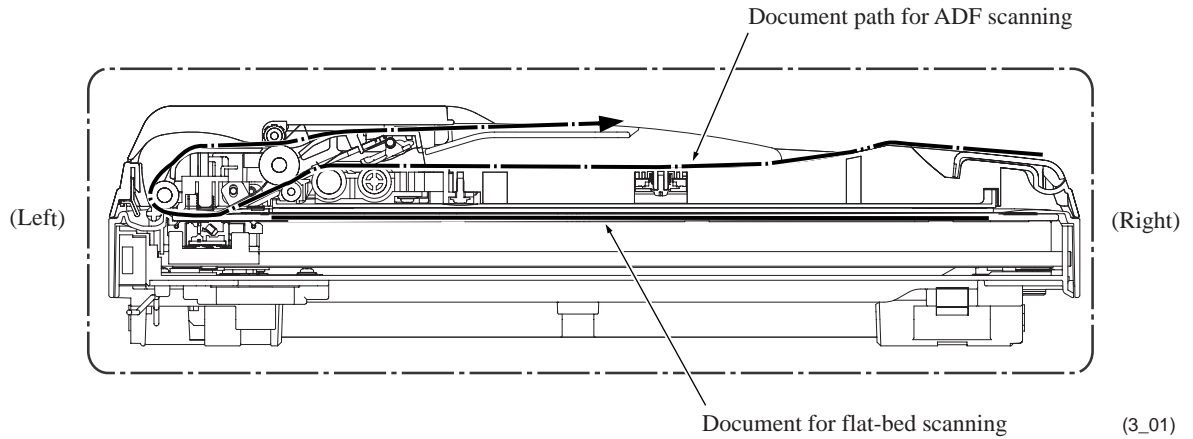

■ Printing Mechanism

Ink supply and ink jet mechanism, head maintenance mechanism, and carriage drive mechanism.

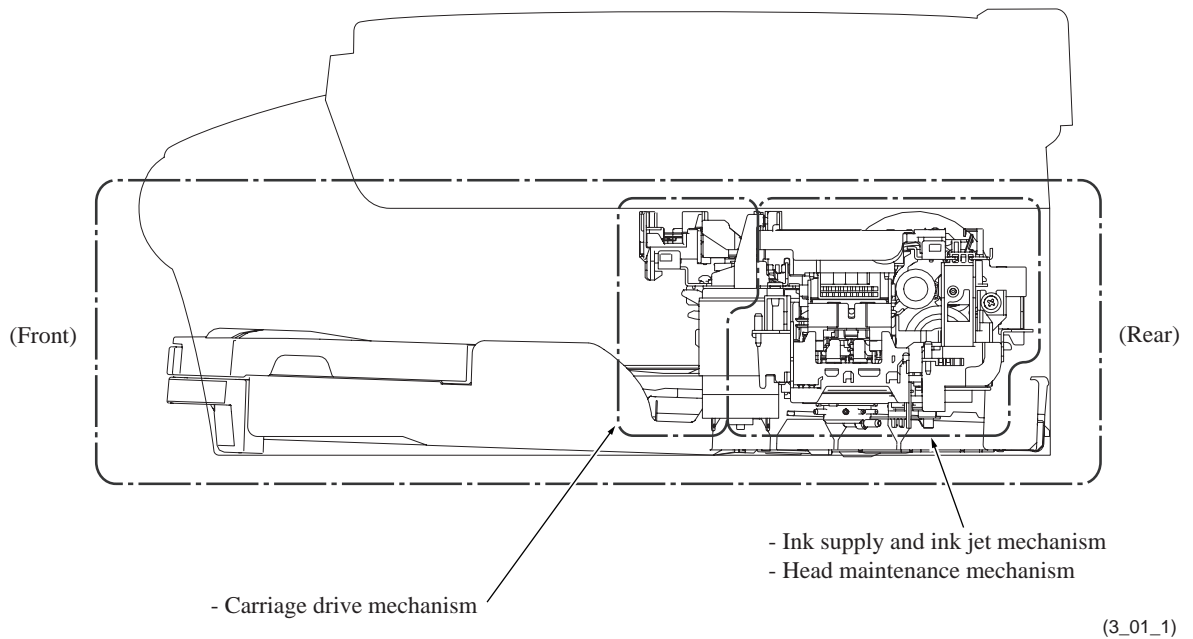

Paper pulling-in, registration, feeding and ejecting mechanisms

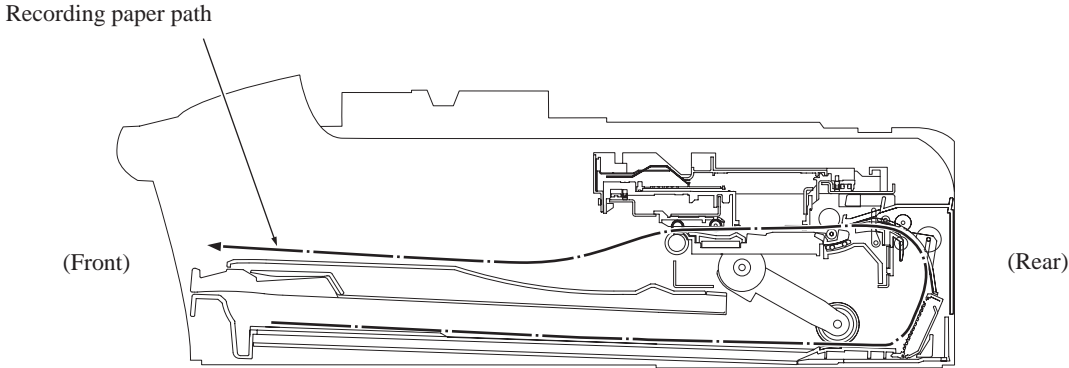

(Section_PF)

■ Scanner Mechanism (See Section 3.2.1.)	- Document scanning mechanism	CIS motor (stepping motor)
	- Automatic document feeder (ADF) mechanism*	ADF motor* (stepping motor)
■ Printing Mechanism (See Section 3.2.2.)	- Ink supply and ink jet mechanism (See Section 3.2.2.1.)	
	- Head maintenance mechanism (head capping, carriage lock, purge, head wiper, and air removing) (See Section 3.2.2.2.)	Paper feed motor (DC motor)
	- Carriage drive mechanism (See Section 3.2.2.3.)	Carriage motor (DC motor)
	- Paper pulling-in, registration, feeding and ejecting mechanisms (See Section 3.2.2.4.)	Paper feed motor (DC motor)
■ Encoders (See Section 3.2.3.)	- Carriage motor (CR) encoder	
	- Paper feed motor (PF) encoder	
■ Sensors (See Section 3.2.3.)	- Document front and rear sensors*	
	- Scanner/ink cartridge cover sensor	
	- Registration sensor	
	- Paper width (media) sensor	
	- Ink cartridge sensors	
	- Purge cam switch	
■ Thermistors (See Section 3.2.3.)	- Head thermistor	
	- Casing internal temperature thermistor	

*For models with ADF

3.2.1 Scanner Mechanism

This mechanism consists of the automatic document feeder (ADF)*, document cover, and scanner unit (scanner cover).

The scanner unit consists of a scanner top cover, CIS unit, CIS drive assembly, and scanner base.

The detailed illustration on the next page shows the components making up the ADF: document pull-in roller, document separation roller, document feed rollers, ADF motor, and document front and rear sensors.

For further details on the sensors, see [Section 3.2.3](#).

*For models with ADF

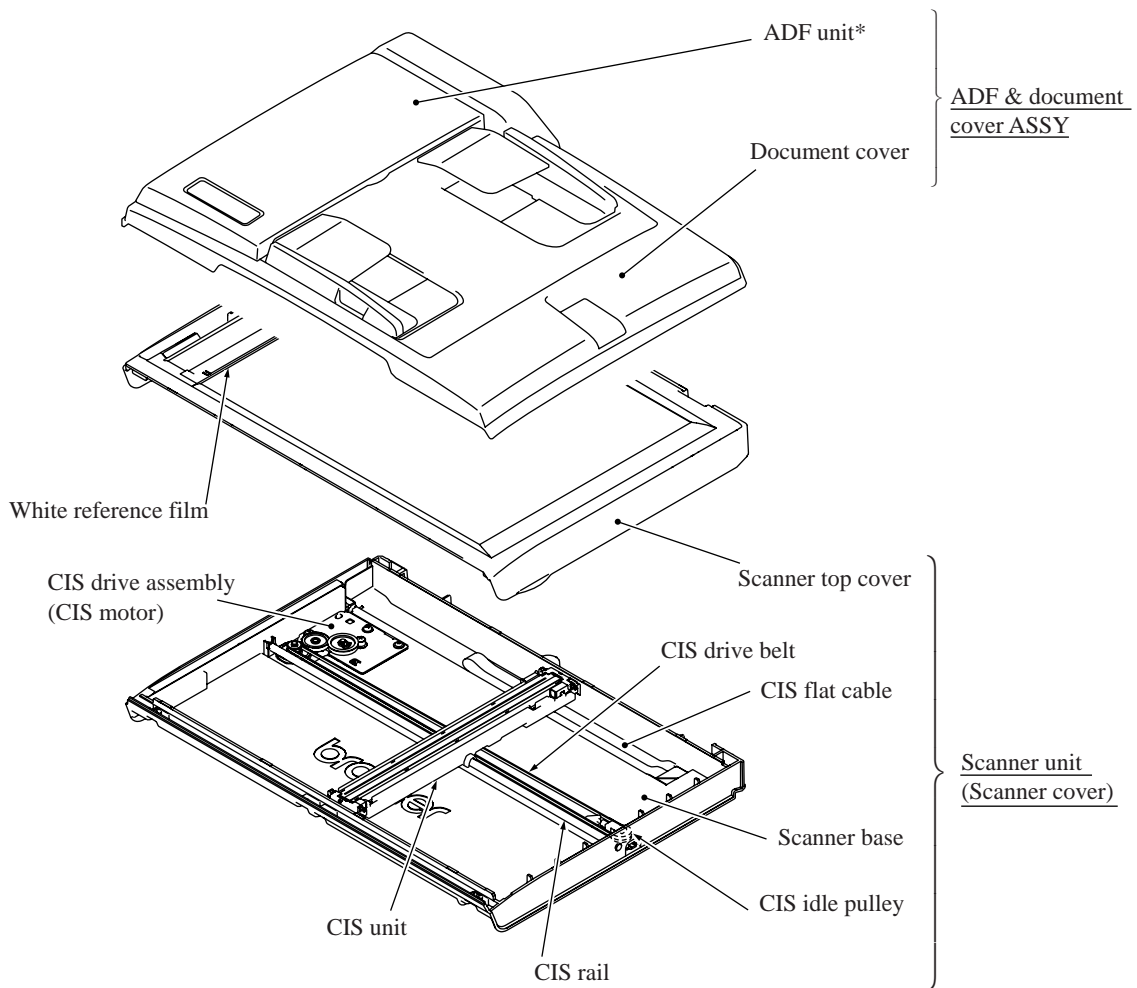

(3_02)

Models with ADF

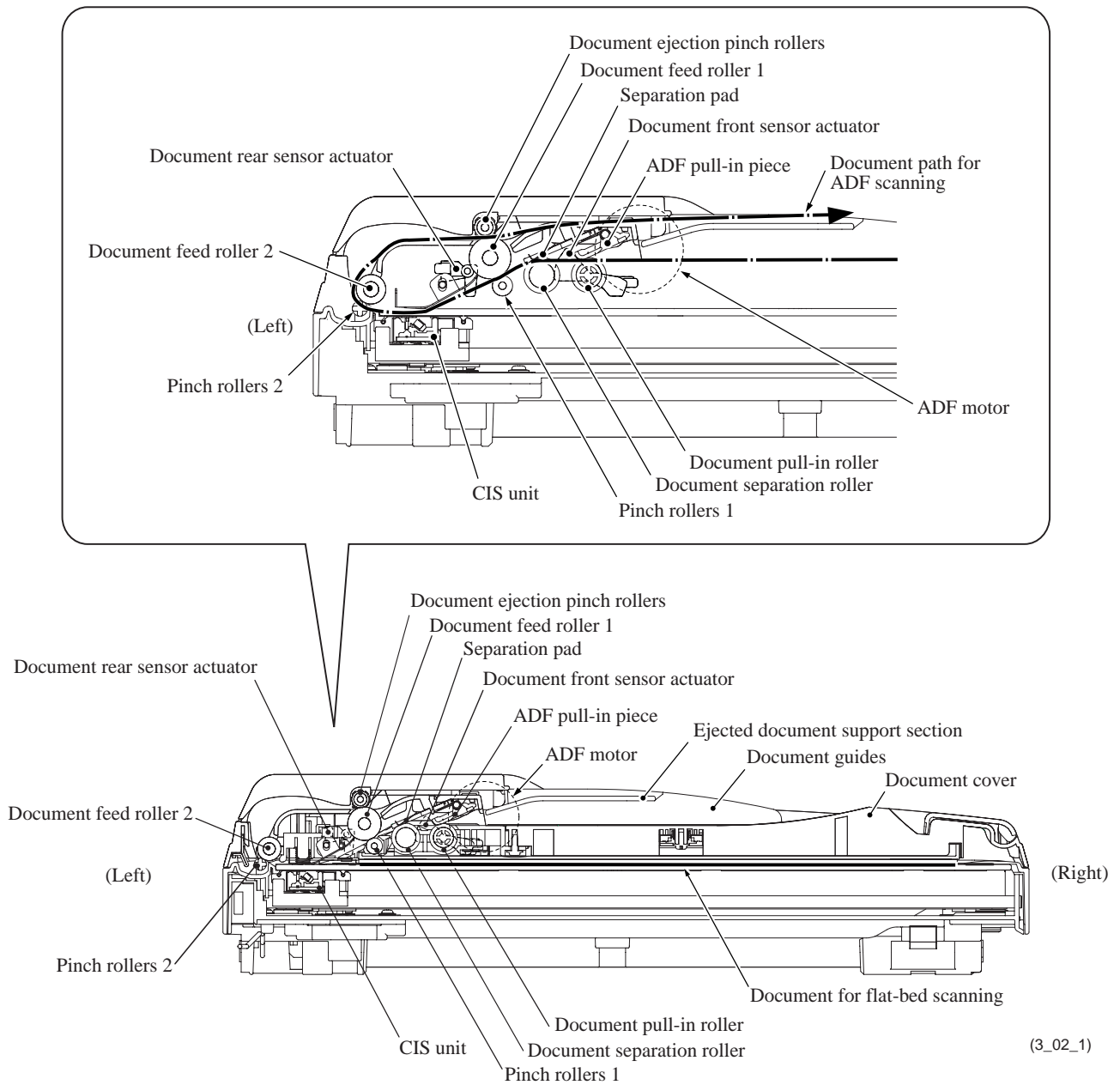

Models with ADF offer two types of scanning: ADF scanning and flat-bed scanning. They automatically switch to the former at the start of a scan operation if the document front sensor inside the ADF detects a document. Models without ADF offer only flat-bed scanning.

(1) ADF scanning: Document moves across stationary CIS unit (Only for models with ADF)

Placing a document *face down* in the ADF activates the document front sensor, switching to ADF scanning.

The CIS drive mechanism (details below) operates for each scanning command executed. First, the CIS motor moves the CIS unit to the white reference film for white level compensation. Secondly, the ADF motor rotates the document pull-in roller* to pull the document into the ADF. (*This roller is added to this series of machines in order to pull in documents horizontally placed.) Thirdly, the CIS motor again moves the CIS unit to the ADF scanning position.

The document separation roller feeds the pages one at a time, *starting from the bottom*, to the document feed rollers (1 and 2), which rotate to move the page in a curve left, up, and right. The page is scanned as it passes over the CIS unit. It then leaves the machine *face up* onto the ejected document support section of the document guides. The machine ejects subsequent pages under this one to preserve the document page order.

(2) Flat-bed scanning: CIS unit moves under stationary document

The user lifts the document cover, places a page (or open book) *face down* on the glass plate, and closes the document cover.

The CIS drive mechanism (details below) operates for each scanning command executed. The CIS unit first moves to the white reference film for white level compensation. It then moves right, scanning as it goes. It returns to its home position after the scan.

CIS drive mechanism

The contact image sensor (CIS) unit rides along the CIS rail, driven by the CIS drive belt. Clockwise motion of the CIS motor moves the unit to the right; counterclockwise motion, to the left. This unit consists of the document illumination LED array, the lens array gathering the light reflected from the scanned image, and the CIS PCB converting the light input to pixel data output.

3.2.2 Printing Mechanism

The printing mechanism consists of the following.

- Ink supply and ink jet mechanism (Section 3.2.2.1)
- Head maintenance mechanism (Section 3.2.2.2)
- Carriage drive mechanism (Section 3.2.2.3)
- Paper pulling-in, registration, feeding and ejecting mechanisms (Section 3.2.2.4)

The **ink supply mechanism** supplies ink to the head/carriage unit, in which the **ink jet mechanism** sprays ink droplets from the head nozzles onto paper.

The major components of the ink supply mechanism are:

- Ink refill assembly: This secures the ink cartridges and connects them to the corresponding ink supply tubes.
- Ink supply tubes: These supply the head/carriage unit with ink fed from the ink cartridges via the ink refill assembly.

The major components of the ink jet mechanism (head/carriage unit) are:

- Front end: This is an ink-jet head consisting of piezoelectric plate (PZT), metal plates, nozzle plate, and head driver. It jets out ink to produce images on paper.
- Back end: This consists of damper assemblies and an air vent unit. Each damper assembly dampens the ink pressure fluctuations in the corresponding ink supply tube and collects air bubbles that result from pressure changes on the ink.

To keep the optimum head performance, the **head maintenance mechanism** caps the head nozzles to prevent them from drying up, purges for removing air bubbles from the head/maintenance unit, and wipes off any ink remaining on the head nozzle surface.

The **carriage drive mechanism** moves the head/carriage unit with a DC motor (carriage motor) along the recording paper. It has a CR encoder sensor that scans the CR encoder strip and monitors the current head position relative to the home position and the current travel speed.

The **paper pulling-in, registration, feeding and ejecting mechanisms** are driven by a single DC motor (paper feed motor).

The major components are:

- Paper tray: Recording paper is stored in this tray.
- Paper pull-in rollers and their holder: These pull in paper into the machine.
- Bank ASSY: This separates paper, sheet by sheet, to feed it into the printer section.
- Jam clear cover: Removing this cover allows the user to access paper jammed. It also guides paper pulled in from the paper tray into the printer section.
- Paper feed roller: This roller performs paper registration and feeds paper to the printer section precisely.
- Paper ejection roller: This roller ejects paper and keeps paper tension tight.
- Paper feed motor: This motor is the drive source for rollers.
- Clutch gear: This gear switches the transmission route of the paper feed motor rotation torque between three gears--SF changeover gear, HS changeover gear, and purge gear, enabling the torque to be applied to the various mechanisms.
- PF rotary encoder: This generates a signal indicating the rotation speed of the PF roller gear. The signal is sent to the controller and used for controlling the paper feed position and speed.

3.2.2.1 Ink supply and ink jet mechanism

[1] Overview

The ink supply and ink-jet mechanism consists of the head/carriage unit, four ink cartridges, ink refill assembly, and ink supply tubes.

The head/carriage unit scans the surface of the recording paper, jetting out ink supplied through the ink supply tubes onto the paper to produce images. For further details, see "[3] Head/carriage unit" below.

The four ink cartridges (black, yellow, cyan, and magenta) are mounted on the ink refill assembly. For further details, see "[4] Ink cartridges" below.

The ink refill assembly secures the ink cartridges and connects them to the corresponding ink supply tubes. For further details, see "[5] Ink refill assembly" below.

The ink supply tubes supply the head/carriage unit with ink fed from the ink cartridges via the ink refill assembly. For further details, see "[6] Ink supply tubes" below.

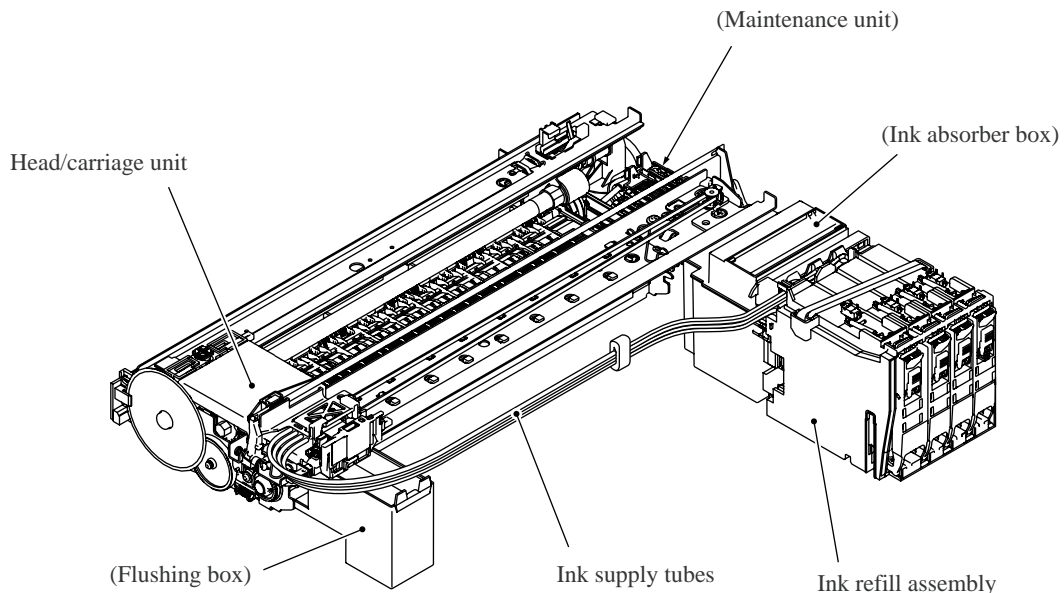

(3_03)

[2] Features

A distinct feature of this machine is the use of ink supply tubes between the ink cartridges and the head/carriage unit. Relieving the head/carriage unit of the task of carrying heavy ink cartridges back and forth across the page, the approach generally adopted by other ink-jet printers, offers the following advantages.

- Smaller unit size--lower height, in particular
- Lower power consumption
- Lower noise levels
- Lower vibration

During print operation, the ink-jet mechanism inside the head/carriage unit sprays ink droplets from the head nozzles. The loss of this ink from the head produces a negative pressure that replenishes the head with ink from the ink tank through the supply tubes.

Note, however, that the above ink flow is only possible when the ink supply tubes are full of ink. The factory therefore primes the ink supply path by applying strong suction to the head nozzles with the maintenance unit to suck both air and ink through the ink supply tubes.

Leaving too long interval between this priming and actual use, however, risks air bubbles, increased viscosity, and other quality issues with the ink in the supply tubes. Before using this machine for the first time, therefore, this machine automatically replaces the ink supply path contents with fresh ink using an initial purge, a repeat of this priming operation.

When the machine is on standby, a constant negative pressure (which is produced according to the difference in height between the head/carriage unit and ink cartridges) is applied to the rear of the print head, thus preventing ink from leading out of those nozzles.

NOTE: The above applies only as long as this machine rests on a horizontal surface. Standing this machine on end or even just tilting it backwards with the print head uncapped risks overcoming this slight negative pressure preventing ink leakage from the head nozzles.

Piezoelectric ceramic actuators inside the print head convert this ink to droplets sprayed onto the paper. For further details, see "[3] Head/carriage unit" below.

[3] Head/carriage unit

The head/carriage unit consists of a front end (ink-jet head) and a back end (buffer and air vent unit) as shown below.

The front end consists of metal plates laminated together and etched to form ink flow channels.

Piezoelectric ceramic actuators generate the spray pressure. The response of individual front ends to applied voltages and waveforms varies, however, because of the nature of piezoelectric materials, fluctuation in manufacturing accuracy, and other factors. The front end therefore leaves the production line with head property labels giving property data. The manufacturer writes this data to the EEPROM on the main PCB incorporating this unit to insure consistent performance without fluctuations.

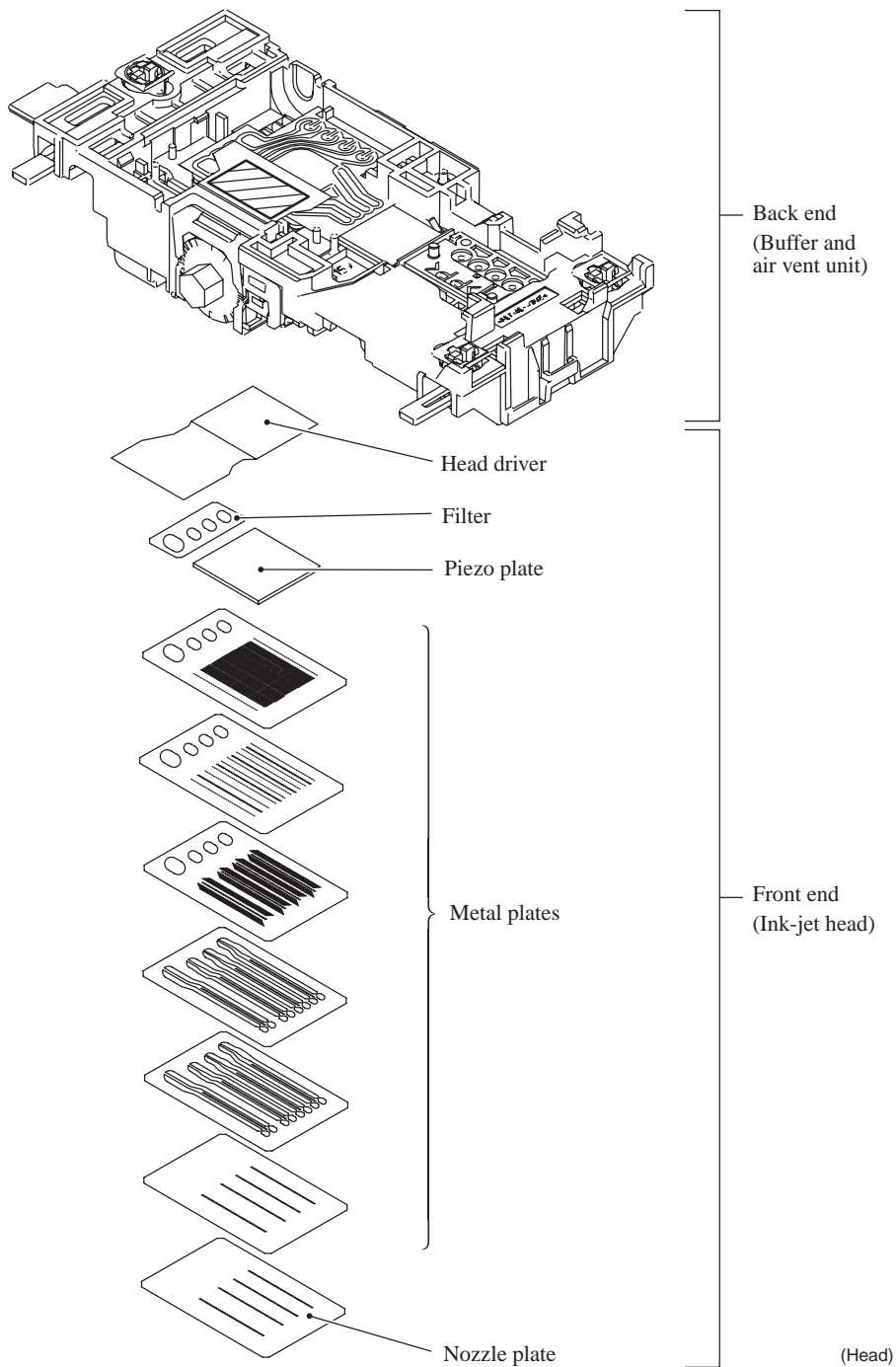

■ **Front end**

Front end components and their main roles

- Piezoelectric plate
Applying a voltage stretches the plate, serving as the actuator for spraying ink. Consisting of thin piezoelectric plates laminated together, this plate can be driven even by a low voltage.
- Filter
This removes foreign materials from the ink.
- Metal plates
These form the head nozzle pressure chambers, ink flow paths, and manifolds.
- Nozzle plate
This plate has a total of 376 nozzles, 47 nozzles x 2 lines staggered x 4 colors (black, yellow, cyan, and magenta).
- Head driver
This flexible circuit board holds the piezoelectric driver chip.

Nozzle array (head bottom plate viewed from the top)

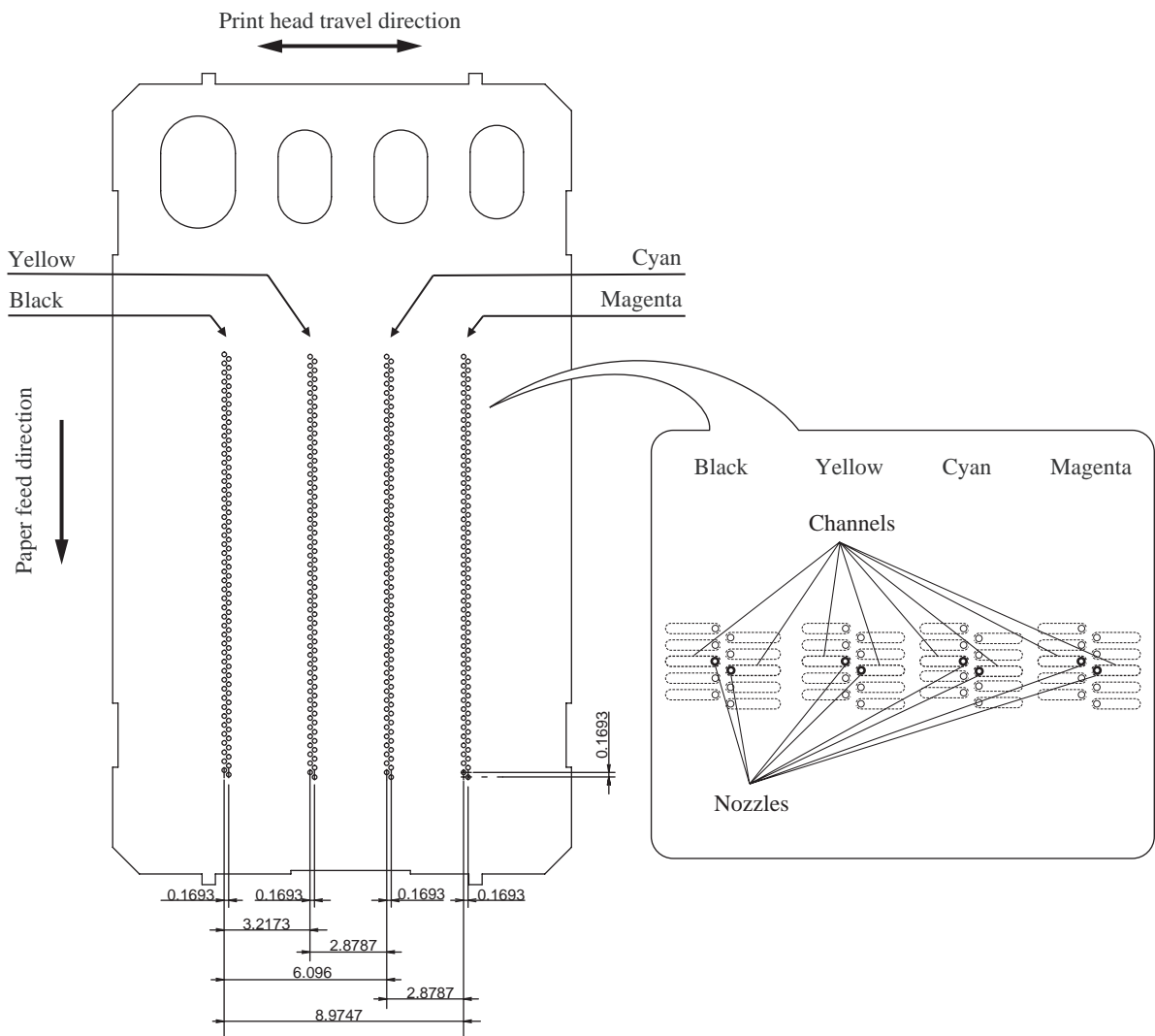

Ink-jet unit (Viewed from the top)

(Nozzle)

Ink spray function

The head employs drop-on-demand ink-jet printing.

Print commands to the drive circuit apply a bias voltage to the layer electrodes on the piezoelectric ceramic surface stretching the elements perpendicular to that surface. Drive signals removing this voltage for specific channel electrodes allow the piezoelectric elements to return to their original shape, sucking ink into the corresponding channels*. Reapplying the bias voltage stretches the elements once again, applying pressure to the ink, spraying it from the head nozzle. The ink drop hits the paper on the platen, forming a dot.

* Pressure chambers for individual nozzles

■ **Back end**

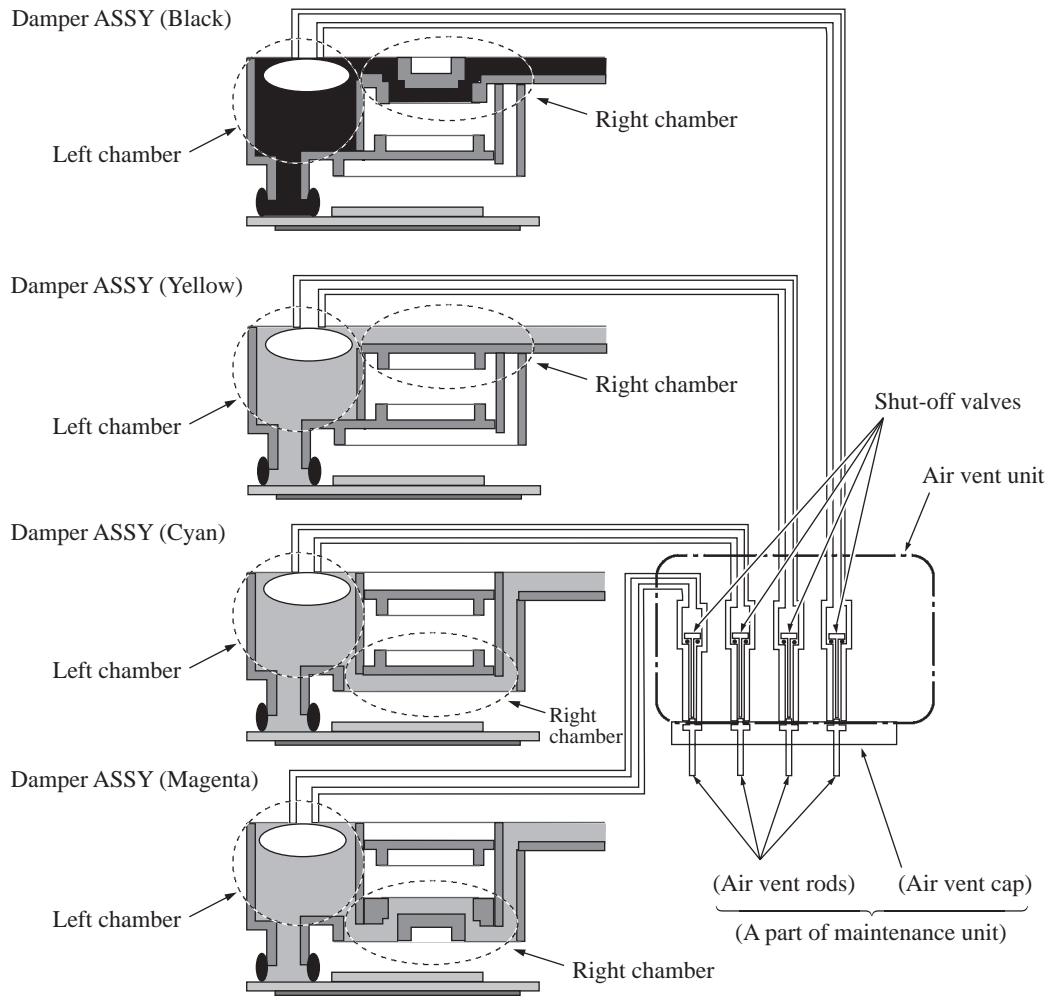

(BackEnd)

Back end components and their main roles

- Damper assemblies

Each assembly has two roles: dampening the ink pressure fluctuations* in the ink supply tube as the carriage moves and collecting air bubbles that grow in the ink flow path.

* Ink pressure fluctuations: As the head/carriage unit travels, inertia means that the ink remains in the same place, temporarily raising or lowering the pressure in the right chamber.

- Air vent unit

At regular scheduled intervals, this vents any air bubbles that have accumulated in the damper assemblies. The air vent rods in the maintenance unit push up the shut-off valves, opening the air vent flow paths.

Damping

Without damping, ink pressure fluctuations directly affect the size of ink-jet head droplets, risking lower print quality.

Each damper assembly has two chambers. The one on the right in the illustration below has a loose film across its top and serves as a damper. The film immediately flexes in and out in response to falls and rises in pressure, adjusting the chamber volume to counteract pressure fluctuations in the ink supply tubes.

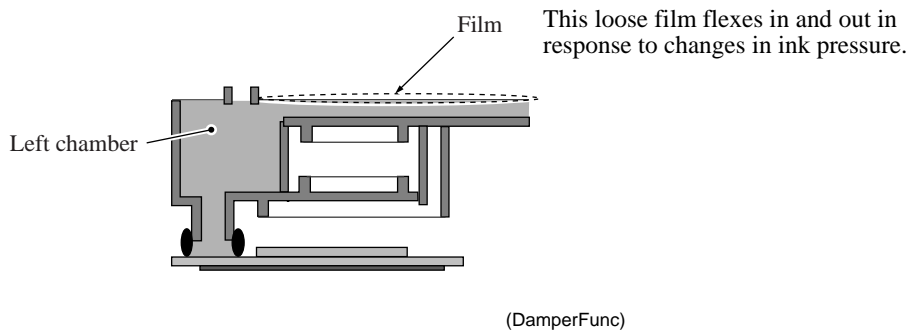

Air buffering

Liquid ink contains trace amounts of air. These molecules coalesce into air bubbles as the piezoelectric ceramic actuators vary the pressure on the ink in the ink-jet head channel. (See the illustration on [page 3-12](#).) Removing as many of these bubbles as possible before the ink reaches the ink-jet head is essential to maintaining proper print quality. The above illustration shows how the damper assemblies provide air buffers, the chambers on the left, for consolidating these air bubbles away from the ink-jet head and vent flow paths for purging them at regular scheduled intervals.

[**Tip: Air bubble growth**]

Liquid ink contains trace amounts of air. The amount varies with the pressure on the ink because increasing the pressure raises the ink's ability to absorb air from its surroundings and lowering the pressure forces the ink to give up some of this air.

The ink pressure fluctuations caused by the piezoelectric ceramic actuators repeatedly expand and contract any air bubbles, growing them larger gradually. This is because the amount of the air per unit area passing through the boundary surface between the ink and the bubble is always constant but the boundary surface area decreases or increases when the bubble contracts or expands, respectively.

That is, when the pressure becomes high, the bubble contracts so that the amount of air moving from the bubble to the ink decreases in proportion to the boundary surface area decreased. On the contrary, when the pressure becomes low, the bubble expands so that the amount of air moving from the ink to the bubble increases in proportion to the boundary surface area increased.

The design therefore compensates by allowing the purging/flushing of air bubbles during printing to keep the amount of air dissolved in the ink to a minimum.

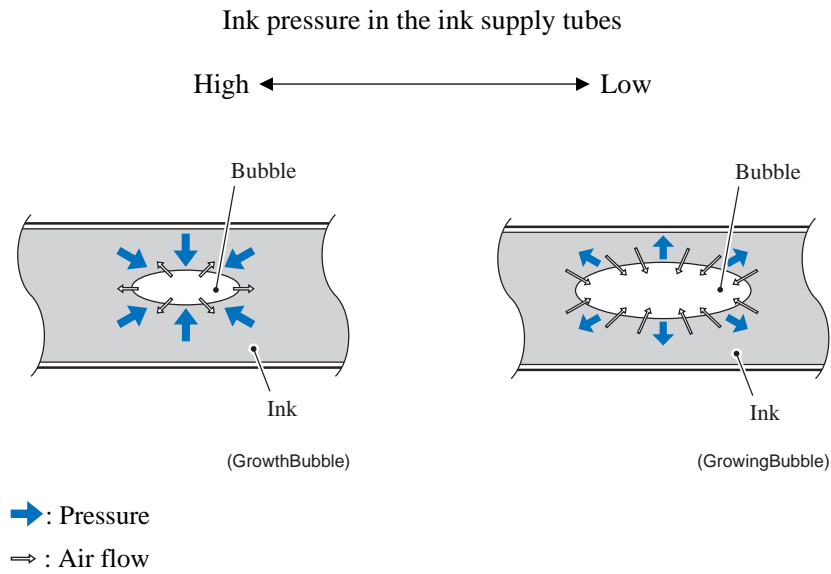

[**Tip: What's so bad about air bubble growth?**]

Pressure fluctuations do not affect the volume of a liquid (ink), but Boyle's Law says that the volume of a gas (air) varies with the pressure on it. The main issue with air bubbles in the ink flow path is their damping effect, absorbing the pressure from the piezoelectric ceramic actuators and thus degrading ink-jet performance.

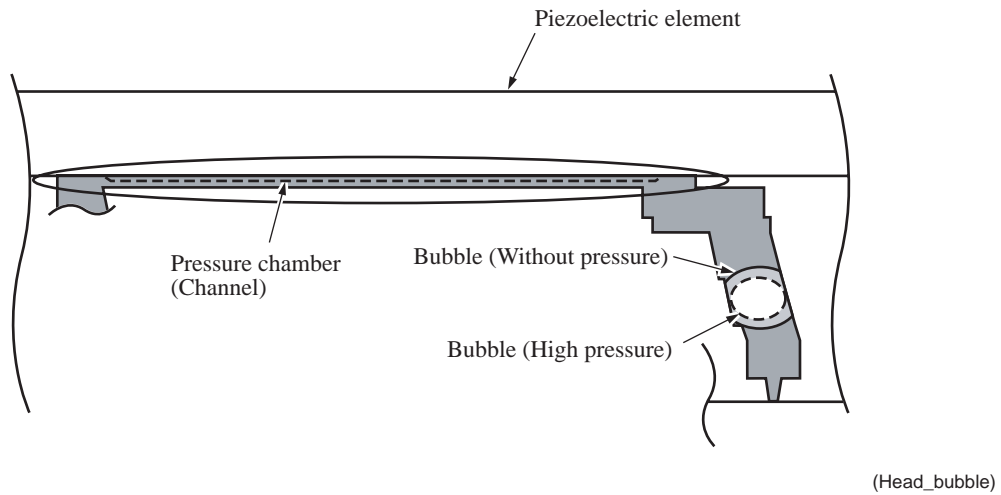

The above illustration shows an example of an extremely large air bubble reaching the head nozzle from the channel ink flow path; the dotted line, the changes resulting from applying a voltage to the laminated electrode, expanding the piezoelectric ceramic actuator. Note how contraction of the air bubble absorbs the pressure from the piezoelectric ceramic actuator, preventing ink ejection.

[4] Ink cartridges

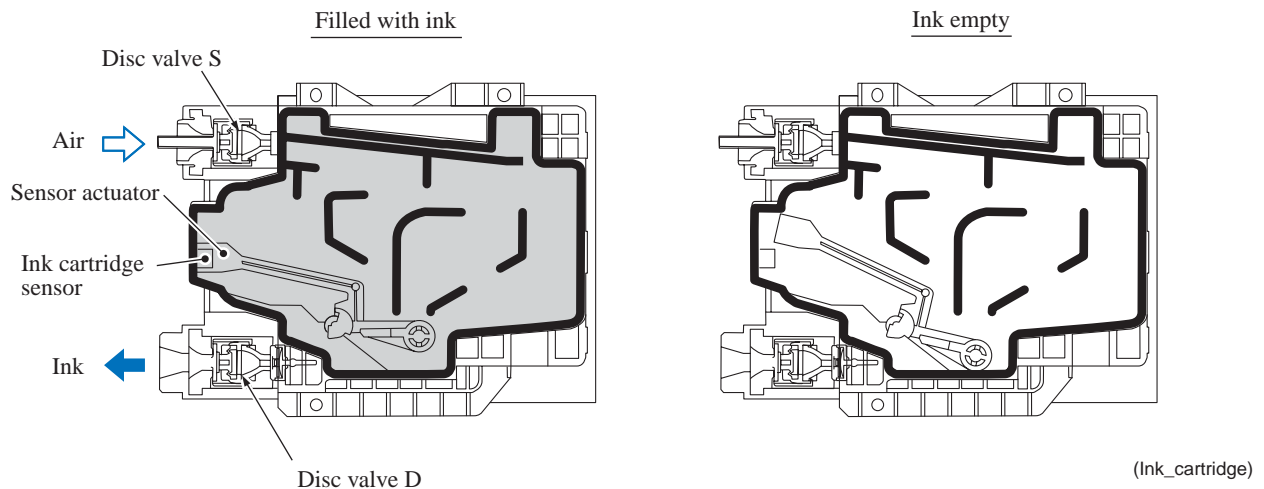

Ink cartridge features

This machine uses four ink cartridges: a black one and three color ones with a slightly lower capacity. It features horizontal insertion in the ink refill base over plastic needles.

Each cartridge has two ports: one supplying the ink for printing and another supplying air to replace that ink. Both ports have a disc valve preventing ink leakage. Mounting a cartridge over the plastic needles in the ink refill base forces these valves open to secure flow paths for both the ink and the air.

Inks

"Removing air"

An earlier page explained how too much air in the ink risks air bubbles degrading ink-jet performance. The manufacturing process prevents such air bubbles with a step, deaeration, that removes air from the ink before injection into the cartridge. Vacuum packaging then prevents air contamination during shipping and storage.

"Pigment-based ink"

Previous Brother machines used only dye-based inks. This one switches to a pigment-based ink for black only, reducing fuzziness from print character outlines, boosting resolution for black dots, and producing clearer images on plain paper.

This machine provides separate head caps and individual vent unit drive mechanisms for this black pigment-based ink and its dye-based color counterparts. Such special design measures are necessary because any mixing of the two types triggers a chemical reaction producing residue clogging head nozzles, filters, maintenance unit piping, and other components, degrading print performance.

Ink cartridge components and their main roles

- Disc valve S
A plastic needle in the refill base opens this valve to supply air to the ink cartridge. Removing the ink cartridge closes this valve to prevent leakage due to ink backflow.
- Disc valve D
A plastic needle in the refill base opens this valve to allow ink to flow out of the ink cartridge. Removing the ink cartridge closes this valve to prevent leakage.
- Sensor actuator
This actuator indicates the amount of ink remaining. Certain positions cut the light beam to the ink cartridge sensor on the ink cartridge PCB inside the ink refill assembly.

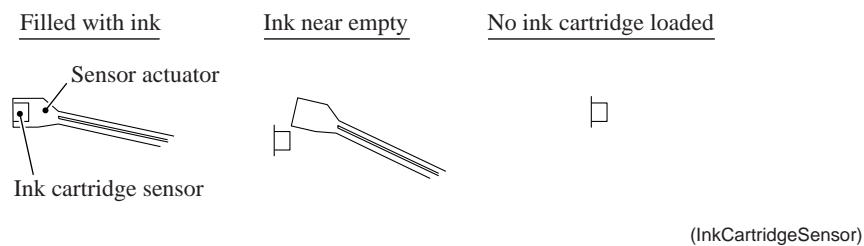

These ink cartridges are single-use affairs. There is no provision for refilling them. The design reduces environment load by using no metals and only burnable materials yielding no toxic substances.

Ink near-empty detection

The ink refill assembly has four ink cartridge sensors (photosensors of transparent type) that monitor the ink levels with sensor actuators inside the ink cartridges.

Attached to one end of the sensor actuator is a float. When there is ink in the cartridge, buoyancy lifts the float, rotating the sensor actuator about a pivot near the center of the actuator to block the light beam to the sensor, indicating that there is ink. As the ink level in the ink cartridge drops, however, the float falls, eventually moving the sensor actuator out of the beam.

Light hitting the sensor is the signal that ink is running low ("Ink near-empty"), activating a firmware counter tracking ink usage during ink-jet printing, purges, and other operations. When this counter reaches a predetermined limit, the firmware considers the "ink empty" and prompts the user to replace it.

[5] Ink refill assembly

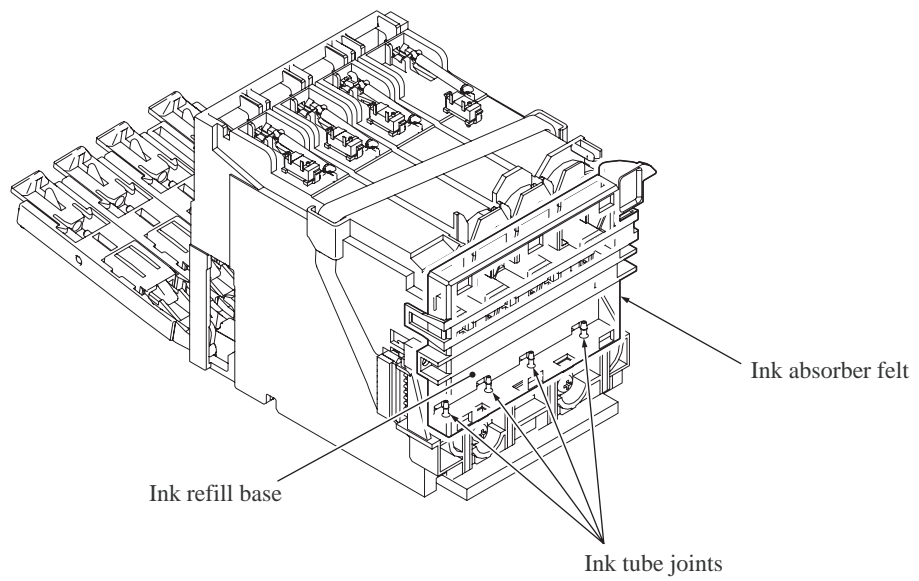
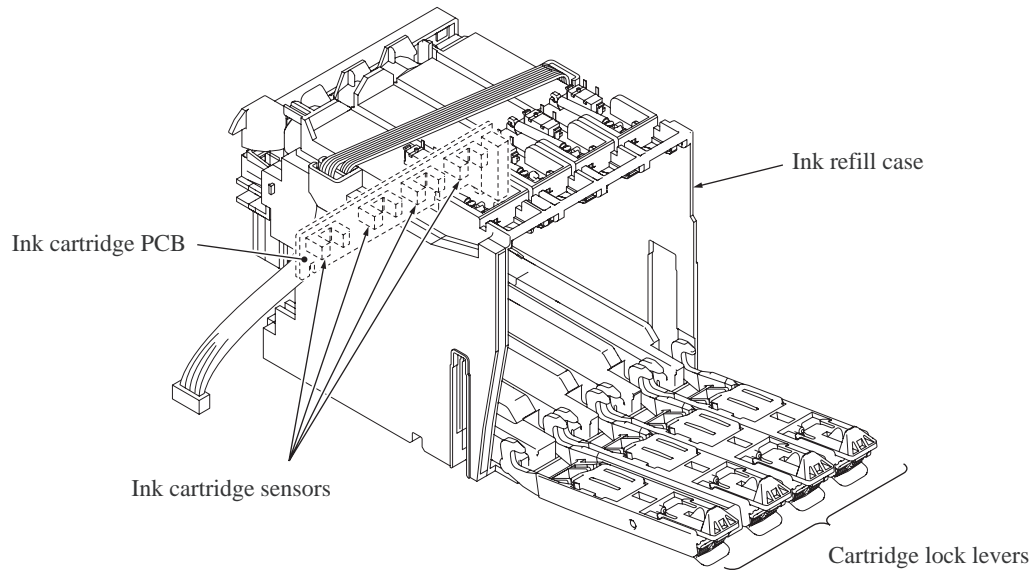

(3_04)

Ink refill assembly components and their main roles

- Ink refill case
- Cartridge lock levers
- Ink refill base
- Ink tube joints
- Ink cartridge sensors (on the ink cartridge PCB)
- Ink absorber felts

Inserting the ink cartridges into the ink refill case and securing them with the cartridge lock levers forces the cartridges' ink supply ports into close contact with the ink refill base to prevent ink leakage.

The ink from the ink cartridges flows through the ink refill base into the ink supply tubes connected to the ink tube joints. As the ink level in an ink cartridge drops, the pressure inside falls, drawing air in the ink cartridge.

An ink cartridge sensor actuator blocking light to an ink cartridge sensor indicates that there is ink in the ink cartridge. When ink runs low, the actuator moves out of the beam, activating the sensor ("Ink near-empty"). (Note that the firmware also interprets a missing ink cartridge as running low on ink.)

At the back of and beneath the ink refill case are ink absorber felts that absorb any ink that leaks from the ink cartridges, limiting its spread and thus reducing the risk of damage to other components.

[6] Ink supply tubes

These are made of an elastomer providing a highly impermeable barrier against air ingress and drying out of the ink during extended periods of nonuse. This material is also soft and highly flexible to better withstand the sharp and frequent bending associated with high-speed head operation repeated over extended periods.

3.2.2.2 Head maintenance mechanism

[1] Overview

The head maintenance mechanism consists of the maintenance unit and the ink absorber box. (See the illustration below.)

The maintenance unit has the following mechanisms.

- Head capping mechanism (See page 3-24.)
- Carriage lock mechanism (See page 3-25.)
- Purge mechanism (See page 3-25.)
- Head wiper mechanism (See page 3-27.)
- Air removing mechanism (See page 3-28.)

The ink absorber box absorbs the ink sucked out by purge operations.

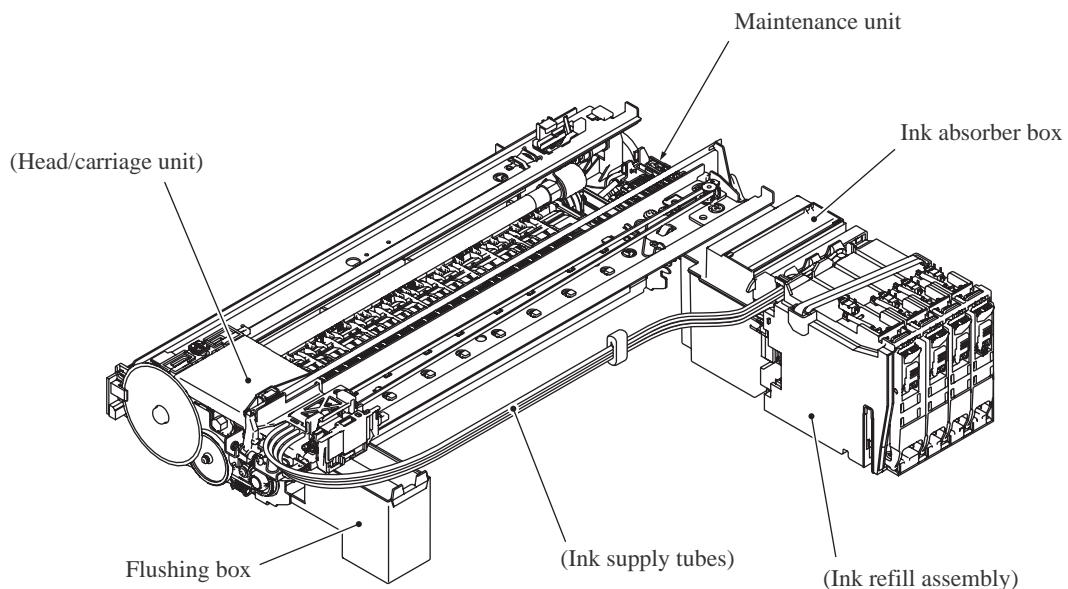

(3_05)

[2] Maintenance unit components

See the illustration given on the next page.

- Pump switching unit
This switches the application target of the negative pressure generated by the tube pump (see the next page) between the head cap for black ink, the one for color ink, and the air vent cap. Usually the pump switching unit is switched to the opening tube to the atmospheric air so that the pressure in the head caps and air vent cap is equal to the normal atmospheric pressure.
- Purge cam
This rotating cam drives the carriage lock, the pump switching unit, the air vent rods, the head wiper, etc.
- Head/carryage lock
This locks the head/carryage unit in its home position so that the head cap unit (see the next page) protects the head nozzles.

- Purge gear and purge bevel gear
These gears transmit the power from the clutch gear (detailed in [4] later) to the planetary arm.
- Planetary arm
This switches power to the tube pump or pump switching unit depending on the direction of paper feed motor rotation.
- Tube pump
A roller squeezes the main drain tube looped inside, forcing their contents toward the ink absorber box and creating negative pressure.
- Head cap unit
When the power is off or the machine is not printing, the head cap unit fits tightly over the print head to prevent the head nozzles from drying up and to seal the head nozzles for purge operations to suck up old ink.
- Air vent cap and rods
During air venting with the tube pump, the air vent cap fits tightly over the air vent unit in the head/carriage unit so that the negative pressure applies to the air vent unit. Pushing up the air vent rods opens the shut-off valves inside the air vent unit, removing air trapped in the damper assemblies. (For the air vent unit, see [Section 3.2.2.1, \[3 \]](#).)
- Head wiper
As the head/carriage unit moves, this wipes off any ink remaining on the head nozzle surface.
- Head cap holder
This moves to the right together with the head/carriage unit as the latter returns to its home position. Rightward motion of the head cap holder turns the lift arms, fitting the head cap unit tightly over the print head to seal the head nozzles.

Viewed from the top

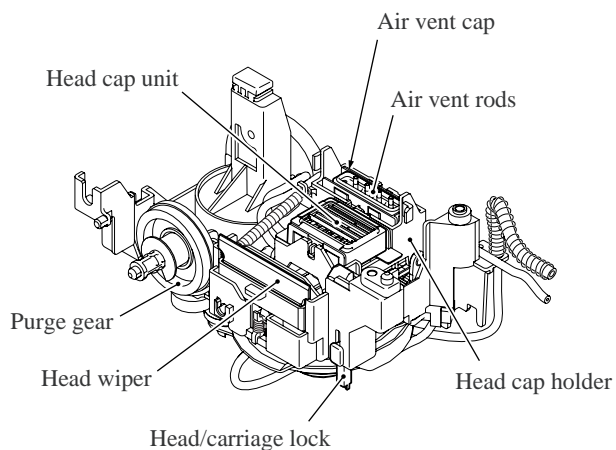

(3_05_1)

Viewed from the bottom

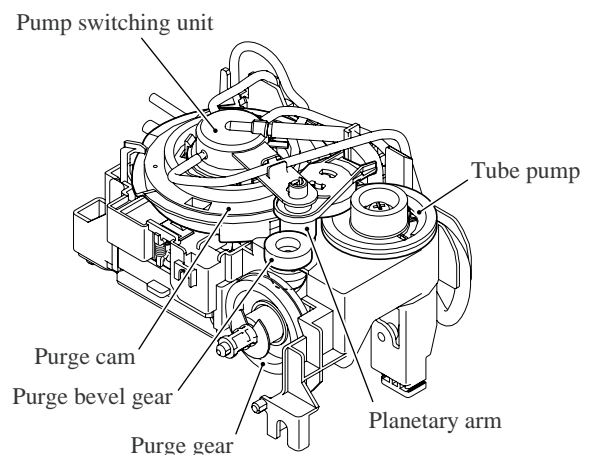

(3_05_2)

[3] Mechanisms constituting the head maintenance mechanism

(1) Head capping mechanism

When the power is off or the machine is not printing, this mechanism fits the head cap unit (which contains two head caps) tightly over the print head to prevent the head nozzles from drying up and to keep dust off the head nozzle surface.

This mechanism is driven by the head/carriage unit. When the head/carriage unit returns to its home position, it presses against the head cap holder in the maintenance unit. The lift arms in the maintenance unit raise the head cap unit, fitting it tightly over the head nozzle surface to protect it.

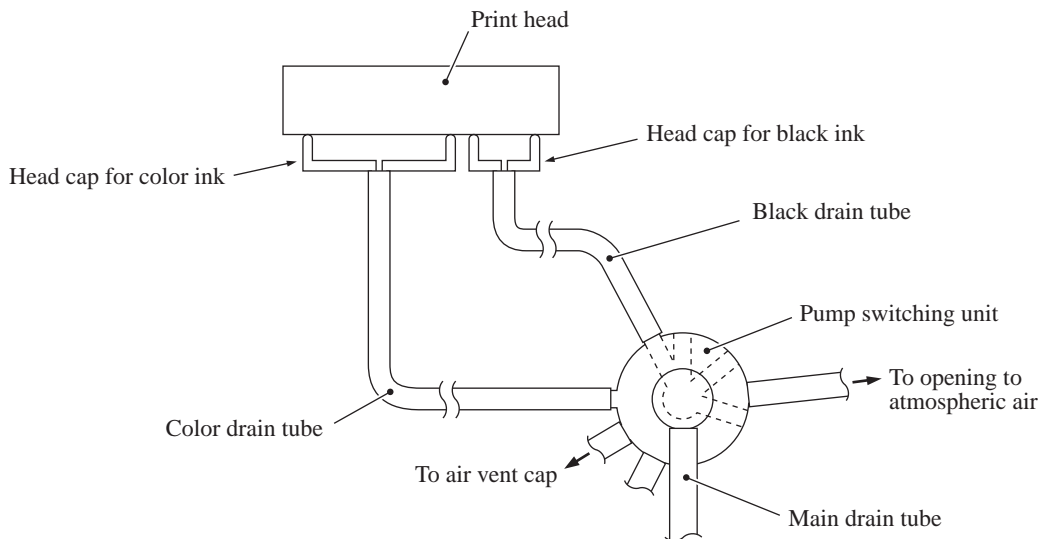
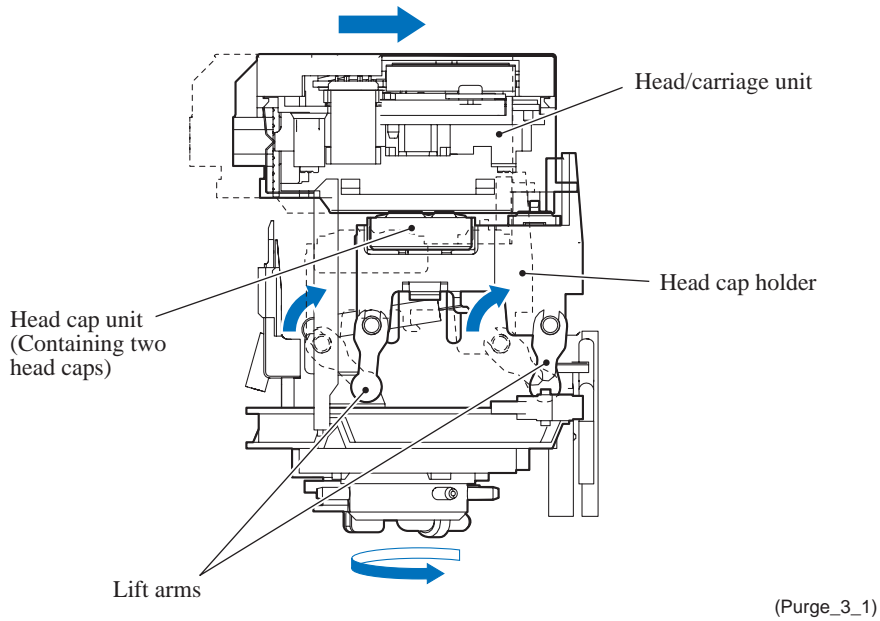

(2) Carriage lock mechanism

This mechanism locks the head/carriage unit to prevent the head nozzles from getting out of the head cap unit accidentally due to external vibration or impact when the machine is not printing, when the power is off, or during transport.

Driving the purge cam causes the carriage lock to pop up in order to lock the head/carriage unit when the head caps are tightly pressed against the ink-jet units.

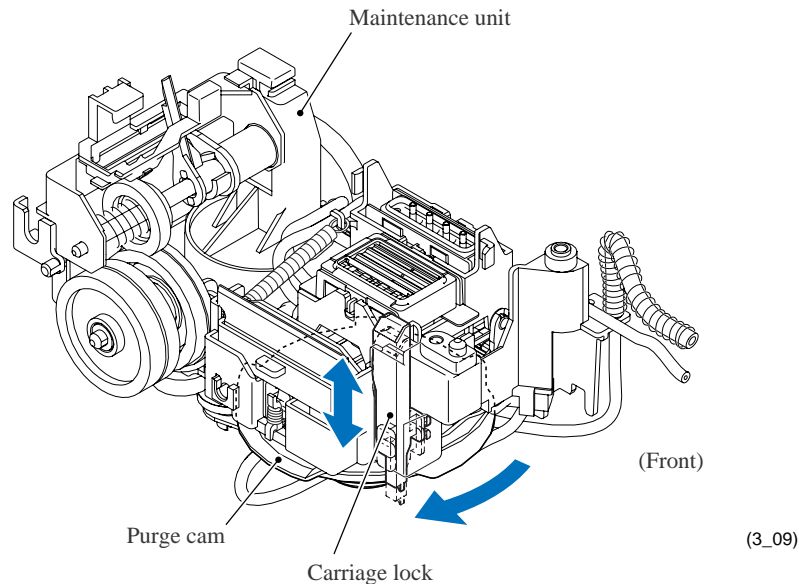

(3) Purge mechanism

Driving the purge cam to the pump switching unit's black or color ink drain position reverses the paper feed motor and activates the tube pump, producing negative pressure to drain the air and old ink from the head nozzles and channels into the ink absorber box.

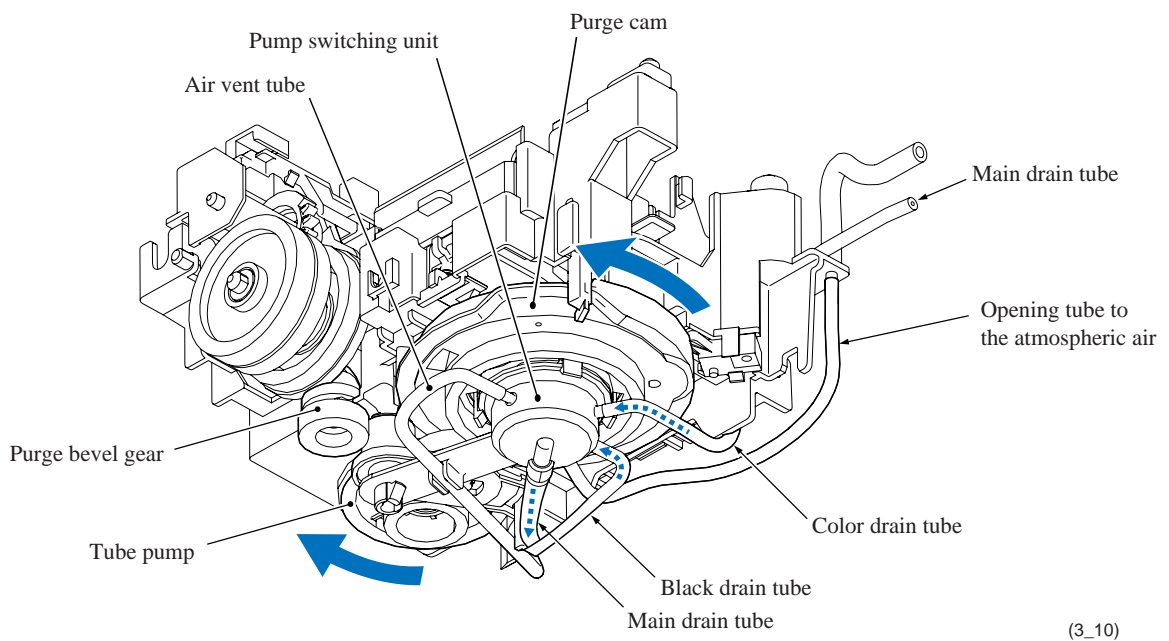

(3.1) Switching pump

The pump switching unit switches the application target of the negative pressure generated by the pump between the head cap for black ink, the one for color ink, and the air vent cap.

When the purge cam is in a head capping position and the carriage lock fits the head cap unit tightly over the print head, the pump switching unit is switched to the opening tube to the atmospheric air so that the pressure in the head caps and air vent cap returns to the normal atmospheric pressure.

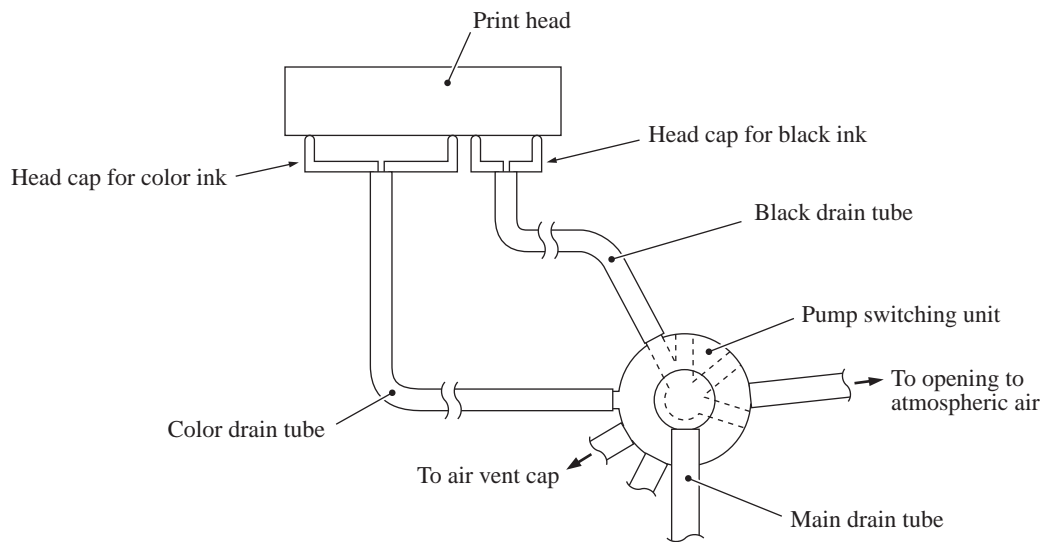

(Purge_3_2)

(3.2) Draining ink

The tube pump consists of a pump gear and tube roller. As the pump gear rotates, the tube roller on its circumference squeezes the main drain tube looped around the pump gear, forcing its content toward the ink absorber box and creating negative pressure.

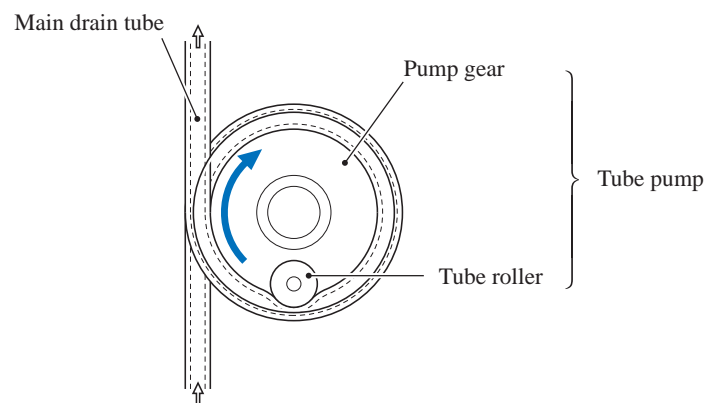

(TubePump)

For details about the purge mechanism, see [4] below.

(4) Head wiper mechanism

After the purge operation, the purge cam pushes up the head wiper, wiping off any ink remaining on the head nozzle surface as the head/carriage unit moves from right to left.

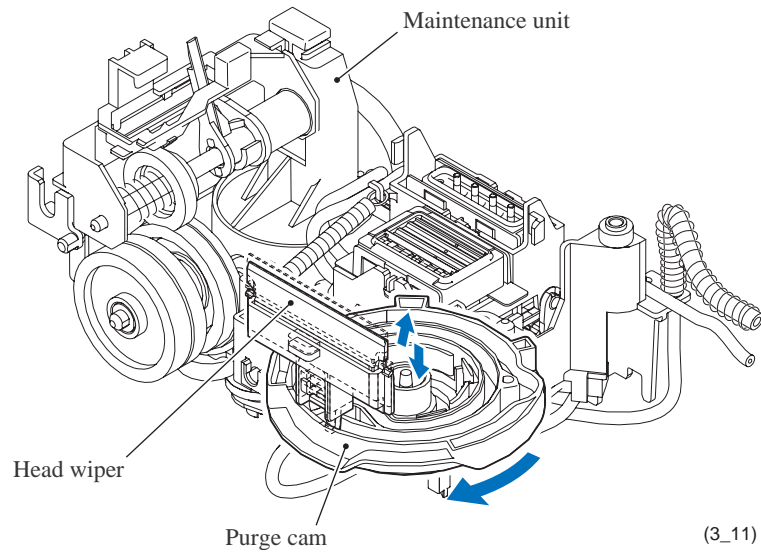

(5) Air removing mechanism

Another position of the purge cam shifts the slide cams, producing vertical motion of the air vent rods. Pushing up the air vent rods opens the shut-off valves inside the air vent unit of the head/carriage unit. Simultaneously adding negative pressure from the tube pump removes air trapped in the damper assemblies.

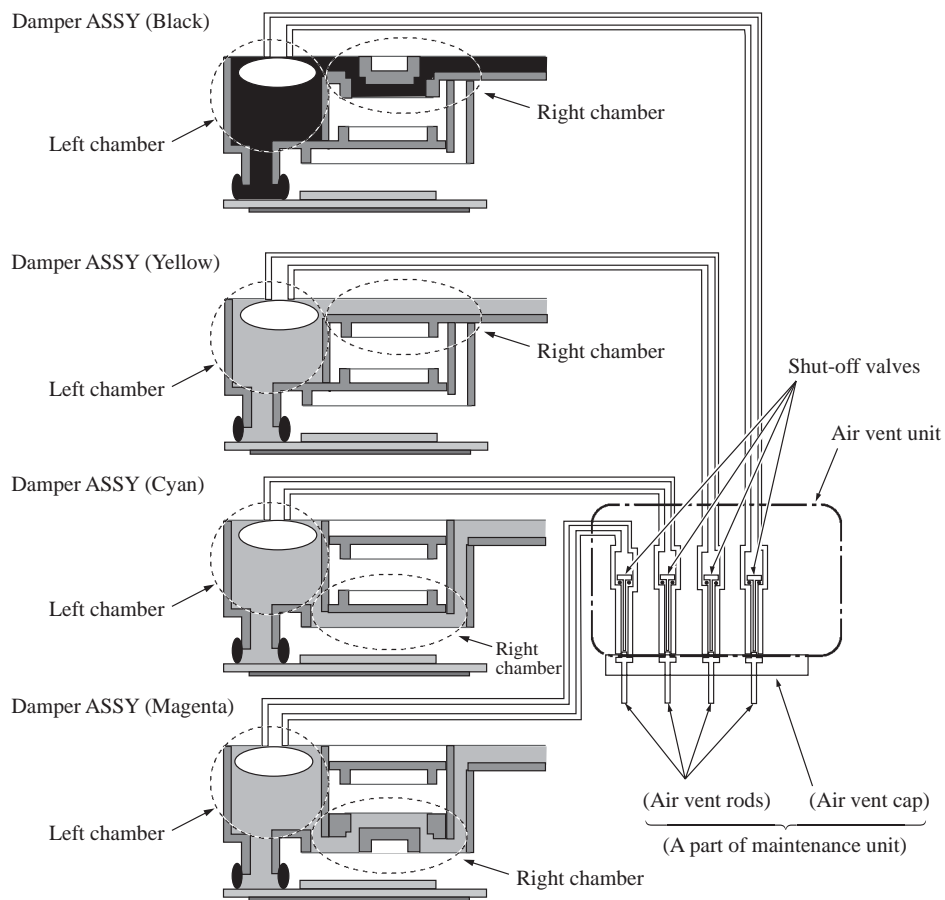
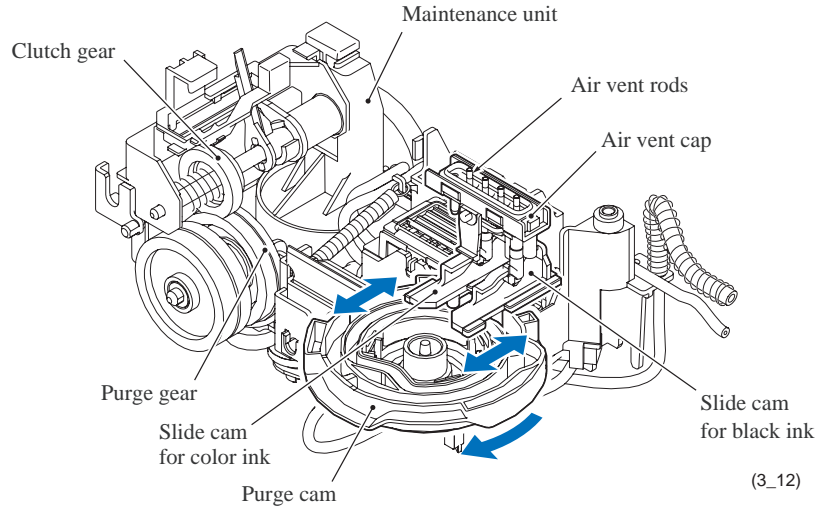

(BackEnd)

[4] Purge mechanism details

This mechanism draws its power from the paper feed motor on the left side of the engine chassis.

Power transmission route from paper feed motor to maintenance unit

The paper feed motor drives the PF roller gear L that rotates the paper feed roller. At the right end of the roller (left in the illustration because the view is from the rear) is the PF roller gear R which always meshes with the clutch gear.

The clutch gear also meshes with the SF changeover gear when the mode switching lever is in the leftmost position (as viewed from the front). When the head/carriage unit travels from the left to right to reach the purge position, a tab on the carriage rear panel pushes the mode switching lever to the right (left in the illustration). The clutch gear spring pushes the clutch gear to the right, away from the SF changeover gear and HS changeover gear, to mesh with the purge gear. This way, the clutch gear switches the operation mode to the purge mode.

The power transmission route and operation mode switching are detailed in [Section 3.2.2.4](#).

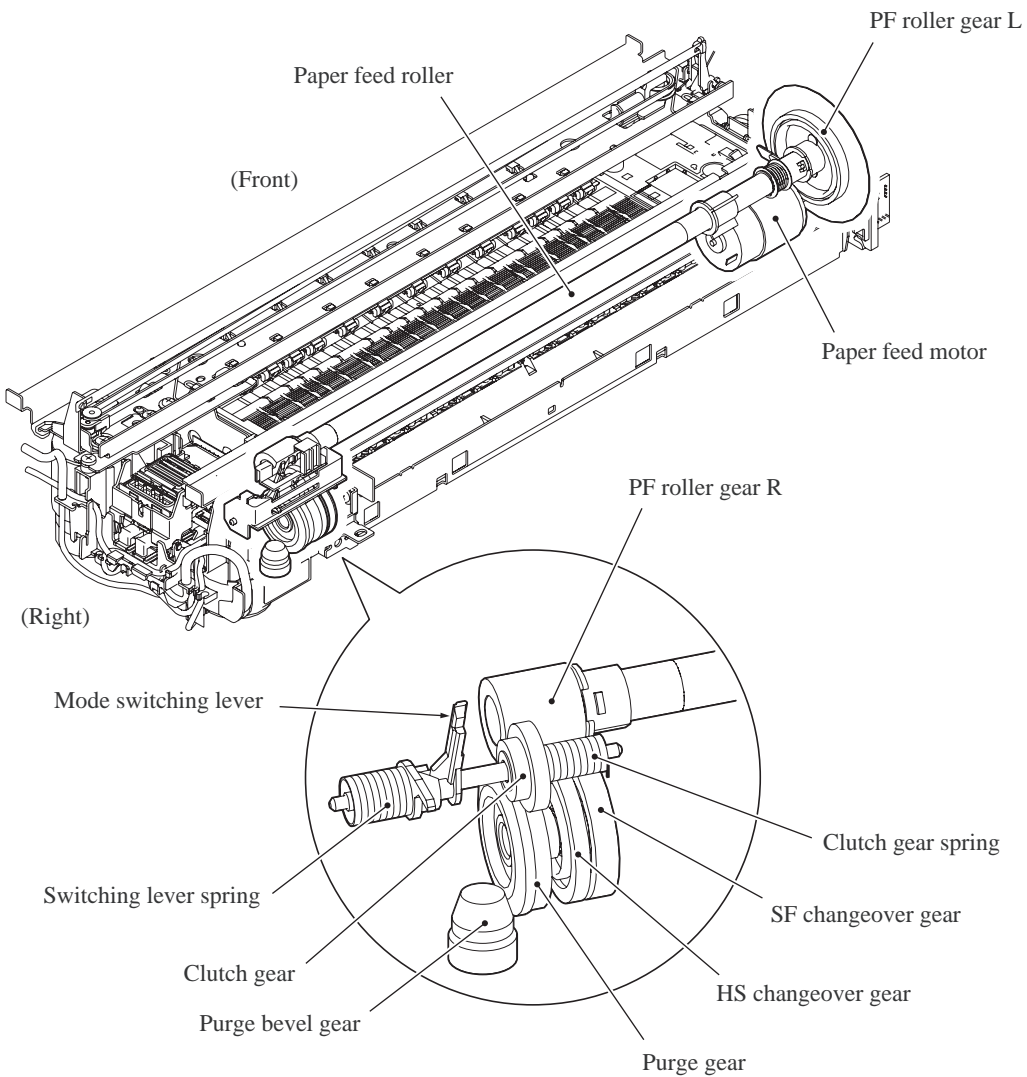

(3_06)

Purge mode

In the purge mode, the motor rotational torque is transmitted to the purge gear, purge bevel gear, and planetary arm to drive the pump switching unit or tube pump (depending upon the motor rotational direction).

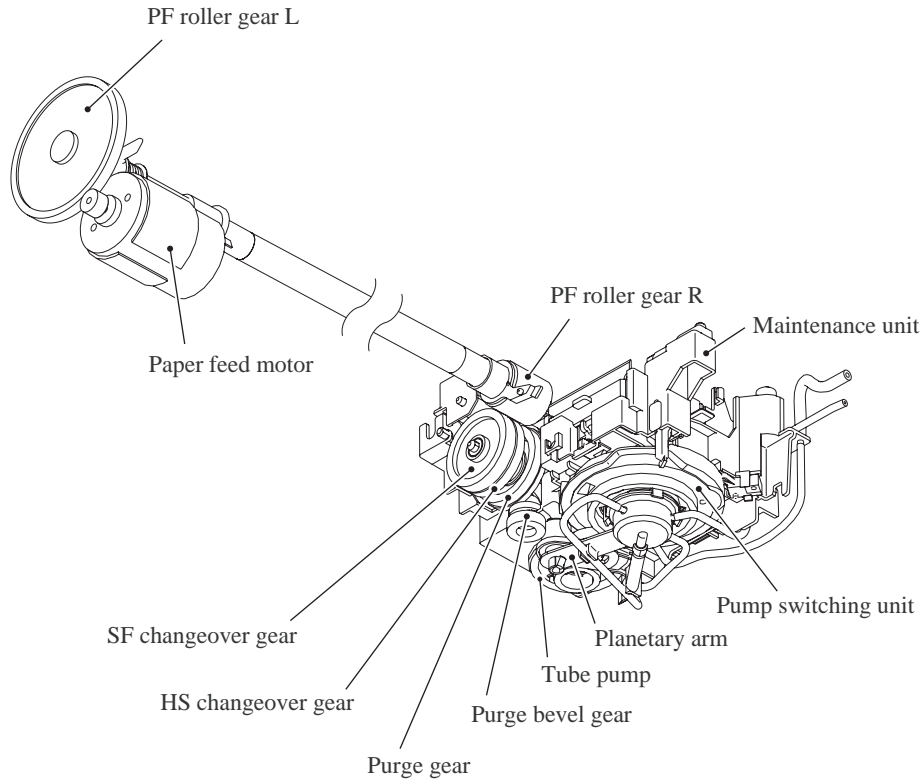

(3_07)

When the head/carriage unit moves left from the purge position, the tab on the carriage rear panel releases the mode switching lever, allowing the switching lever spring to force the mode switching lever and the clutch gear to the left (see the illustration on the previous page). The switching lever spring is stronger, so forces the clutch gear spring back, disengaging it from the purge gear.

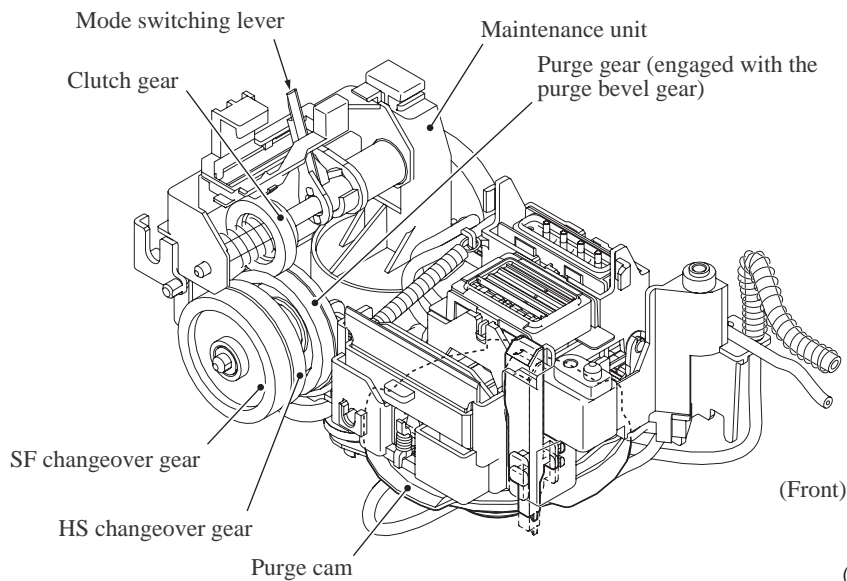

(3_09_1)

Switching the power transmission with the planetary arm in the maintenance unit

When the paper feed motor is driving the maintenance unit, the counterclockwise (when viewed from the output gear side) rotation meshes the planetary arm with the tube pump; the clockwise rotation, with the purge cam.

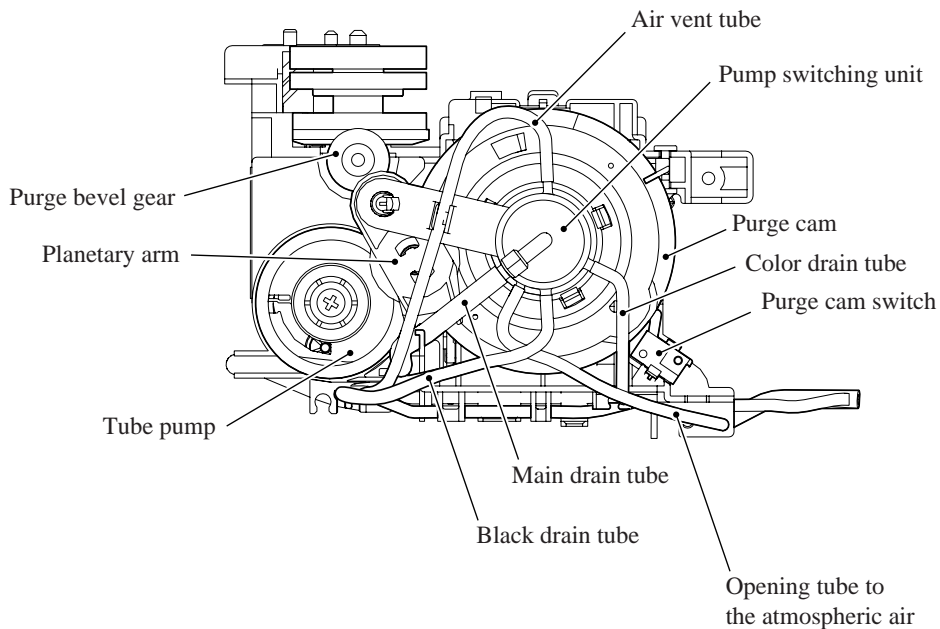

(3_08)

Purge cam mechanism

The purge cam is so designed that:

- the carriage lock pops out to lock the head/carriage unit before purging and pops in before cleaning with the head wiper (this lock also secures the head/carriage unit during transportation),
- the pump switching unit switches the application target of the negative pressure generated by the pump between the head cap for black ink, the one for color ink, the air vent cap, and the opening tube to the atmospheric air,
- the head wiper comes out to clean the nozzle surface, and
- the air vent rods are pushed up via the slide cams to remove air trapped.

The purge cam switch detects the cam drive positions. (See [Section 3.2.3.](#))

Purge types, ink usage, purge counts, and purge codes

Purge Types	Description	Ink Usage	Purge Counts	Purge Codes (In the maintenance mode, Function code 76)*
Normal purge	This purge operation removes dried ink sticking to the head nozzles.	Black: 0.21 mL Per color: 0.13 mL	Black: 11 Total of colors: 21	1
Periodical reset purge	This purge operation removes any bubbles that have accumulated in the ink supply tubes.	Black: 0.44 mL Per color: 0.32 mL	Black: 24 Total of colors: 54	2
Power purge	More powerful than a periodical reset purge, this purge operation is for removing stubborn clogging from the head nozzles and ink supply tubes.	Black: 0.59 mL Per color: 0.38 mL	Black: 32 Total of colors: 64	3
Initial purge	When the user loads ink cartridges for the first time, this purge operation automatically runs to refill the ink supply tubes and print head with fresh ink.	Black: 2.92 mL Per color: 2.59 mL	Black: 163 Total of colors: 432	4
User reset purge	This purge operation should be performed if the print quality problem persists after a user has performed the purge operation repeatedly by pressing the Ink (Ink Management) key.	Black: 0.50 mL Per color: 0.32 mL	Black: 28 Total of colors: 54	5
Engine setup purge	This purge operation refills the ink supply tubes with ink when there is no ink in those tubes.	Black: 2.92 mL Per color: 2.59 mL	Black: 163 Total of colors: 432	6

* To enter a numerical code on models having no numerical keypad, press the ▲/▼ key several times to display the numerical code to be entered on the LCD and then press the **OK** key. After that, press the **Black Start (Mono Start)** key.

Ink cartridge capacities

Ink Cartridge Type		Contents	Usable Portion
Starter and spare ink cartridges	Black ink cartridge	18.2 mL	Approx. 16.7 mL
	Color ink cartridges	9.0 mL	Approx. 7.5 mL

Number of printable pages per ink cartridge

Print conditions: 600 x 600 dpi ("Normal" print quality), continuous printing, 5% coverage

Ink Cartridge Type	Number of Printable Pages per Ink Cartridge*
Black ink cartridge	Approx. 500 pages
Color ink cartridge	Approx. 400 pages

*When the ink cartridge is not used for an initial purge

- The contents and usable portion of ink cartridges are subject to change without notice.
- The ink consumption differs depending on individual machines and ambient environmental conditions. The numbers of printable pages per ink cartridge listed above are typical values under ordinary conditions.

3.2.2.3 Carriage drive mechanism

The head/carriage unit, which integrates the print head unit and carriage, is supported and guided by the CR guide rail and CR support chassis. The CR timing belt transmits the carriage motor rotation to the head/carriage unit. Clockwise motor rotations move the head/carriage unit to the right; counterclockwise ones to the left.

The CR encoder sensor on the top of the head/carriage unit scans the CR encoder strip above the CR support chassis to monitor the current head position relative to the home position. The controller uses this signal for robust control ensuring uniform speed.

The CR encoder strip is a clear film striped in a 1/150 inch cycle. It offers a choice of two travel speeds of the head/carriage unit, 43.3 and 21.7 ips, to match the print resolution.

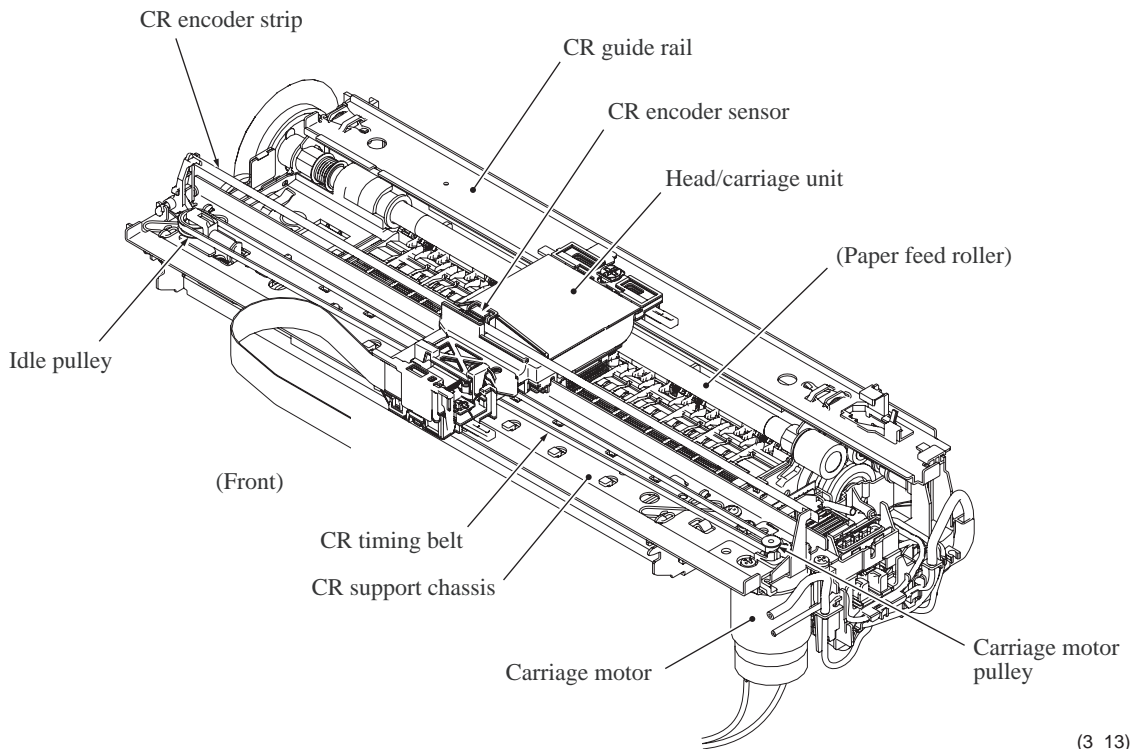

Adjusting the print head angle relative to carriage

For optimal image printing, the print head nozzle array must be perpendicular to the head/carriage unit's line of travel. Manufacturing limitations, however, make perfect alignment impossible during mass production. The angle must be adjusted at the individual machine level.

The following describes this adjustment mechanism's components and their roles.

Slider L, the slider, and the rib attach the head/carriage unit to the CR support chassis. The rib acts as a pivot for the slider's damping springs pressing the head/carriage unit to the rear. Slider L has a head skew adjuster knob that shifts the slider back and forth, adjusting the angle of this backward pressure. Rotating the head skew adjuster knob tilts the entire head/carriage unit, thus adjusting the head nozzle vertical angle relative to the carriage unit's line of travel.

This knob offers 15 settings, from -7 to +7.

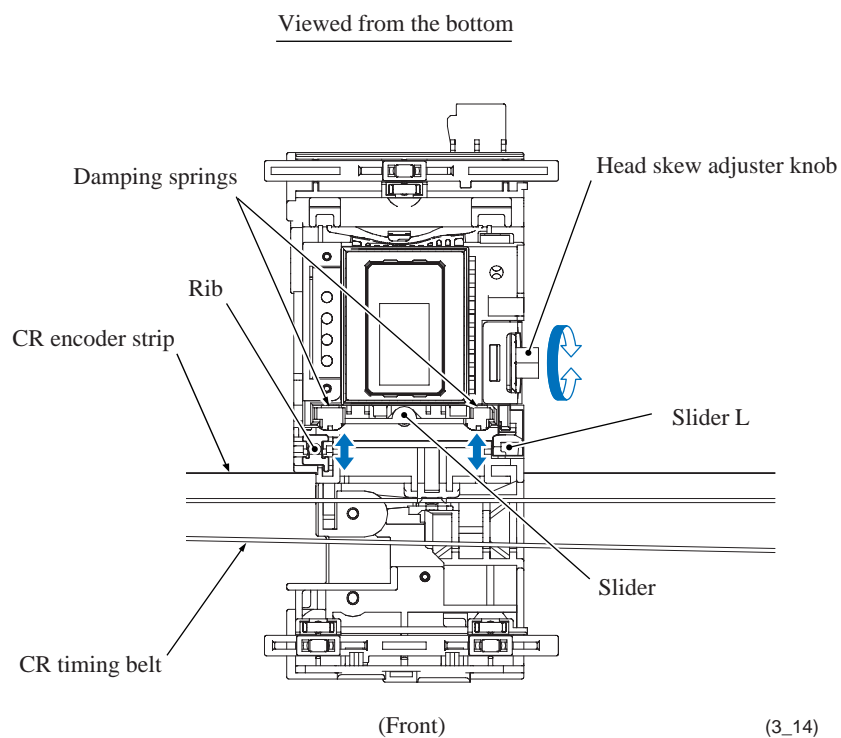

Height adjustment of the head/carriage unit

For optimal image printing, a pair of slider cams mounted on the head/carriage unit switches the height of the head/carriage unit against the CR guide rail and support chassis between three levels for "Brother premium glossy photo paper," "thick paper and envelopes" and "other types of paper" in order to bring the optimum distance between the head nozzle surface and paper.

The slider cams can be switched by hitting against the stoppers at the right and left ends of the CR guide rail and CR support chassis.

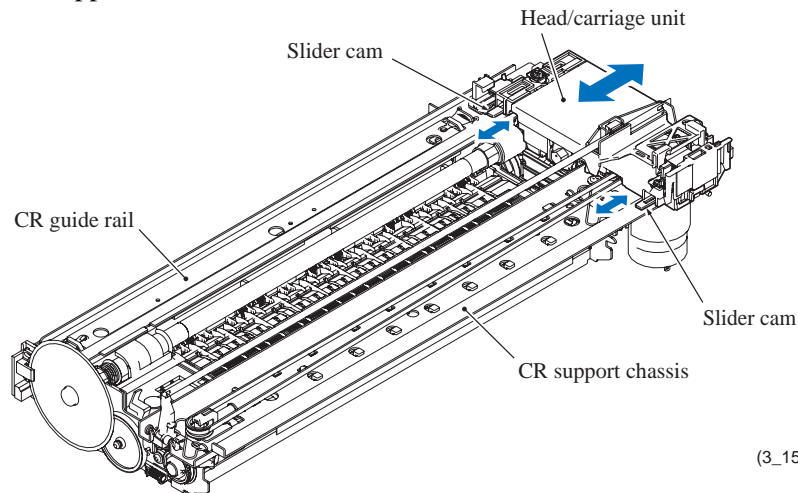

(3_15_1)

For "Brother premium glossy photo paper":

When printing on Brother premium glossy photo paper, the machine uses ink droplets of 1.5 picoliters (pL) and switches the head/carriage unit to the lowest position to make the distance ("a" in the illustration below) narrower than the one ("b") specified for other types of paper. This enables jetted minimal ink droplets to accurately hit the target position on paper.

For "thick paper and envelopes" and "other types of paper":

The machine adjusts the height of the head/carriage unit to keep the distance ("b") constant.

For "Brother premium glossy photo paper"	For "other types of paper" (Paper except Brother premium glossy photo paper, thick paper and envelopes)	For "thick paper and envelopes"
<p>Head nozzle surface</p> <p>"a"</p> <p>Paper</p> <p>Platen</p>	<p>Head nozzle surface</p> <p>"b"</p> <p>Paper</p> <p>Platen</p>	<p>Head nozzle surface</p> <p>"b"</p> <p>Paper</p> <p>Platen</p>
<p>Head/carriage unit (top view)</p> <p>Slider cam</p> <p>(Front)</p> <p>Slider cam</p>		

(3_15_2)

(3_15_3)

As listed below, the printer driver on the connected PC or the paper type setting on the machine controls the slider cams to determine the height of the head/carriage unit.

Controlled by:	Adjustment for:	
	Brother premium glossy photo paper	Thick paper and envelopes
Printer driver (in printing from PC)	Yes	Yes
Paper type setting (in copying and printing via PhotoCapture Center)	Yes	No

3.2.2.4 Paper pulling-in, registration, feeding and ejecting mechanisms

These mechanisms are driven by a single paper feed motor located on the left side of the engine chassis via a gear train. (See the illustration on the next page.)

The following illustration is a cross-sectional view of the machine viewed from the right. Place the recording paper *face down* in the paper tray. This paper first proceeds to the rear, bends upward, heads back toward the front, passes under the head/carriage unit for printing, and finally comes out onto the top of the paper tray cover.

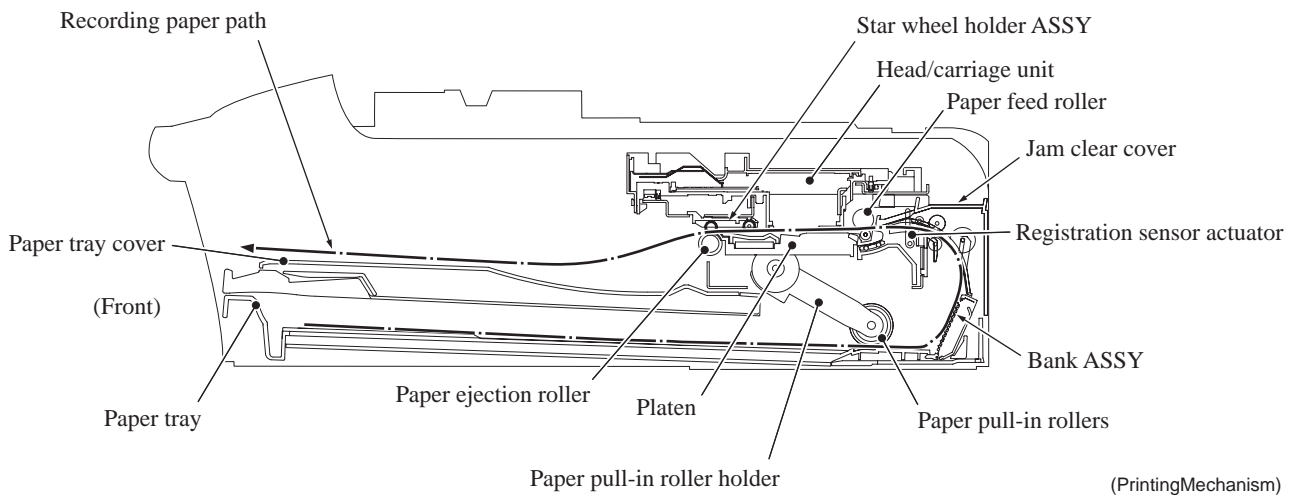

The machine supports two paper feed modes--"normal SF mode" and "high-speed feed mode." The latter mode applies when the "Fast" print quality is selected and the former mode, when any other print quality is selected.

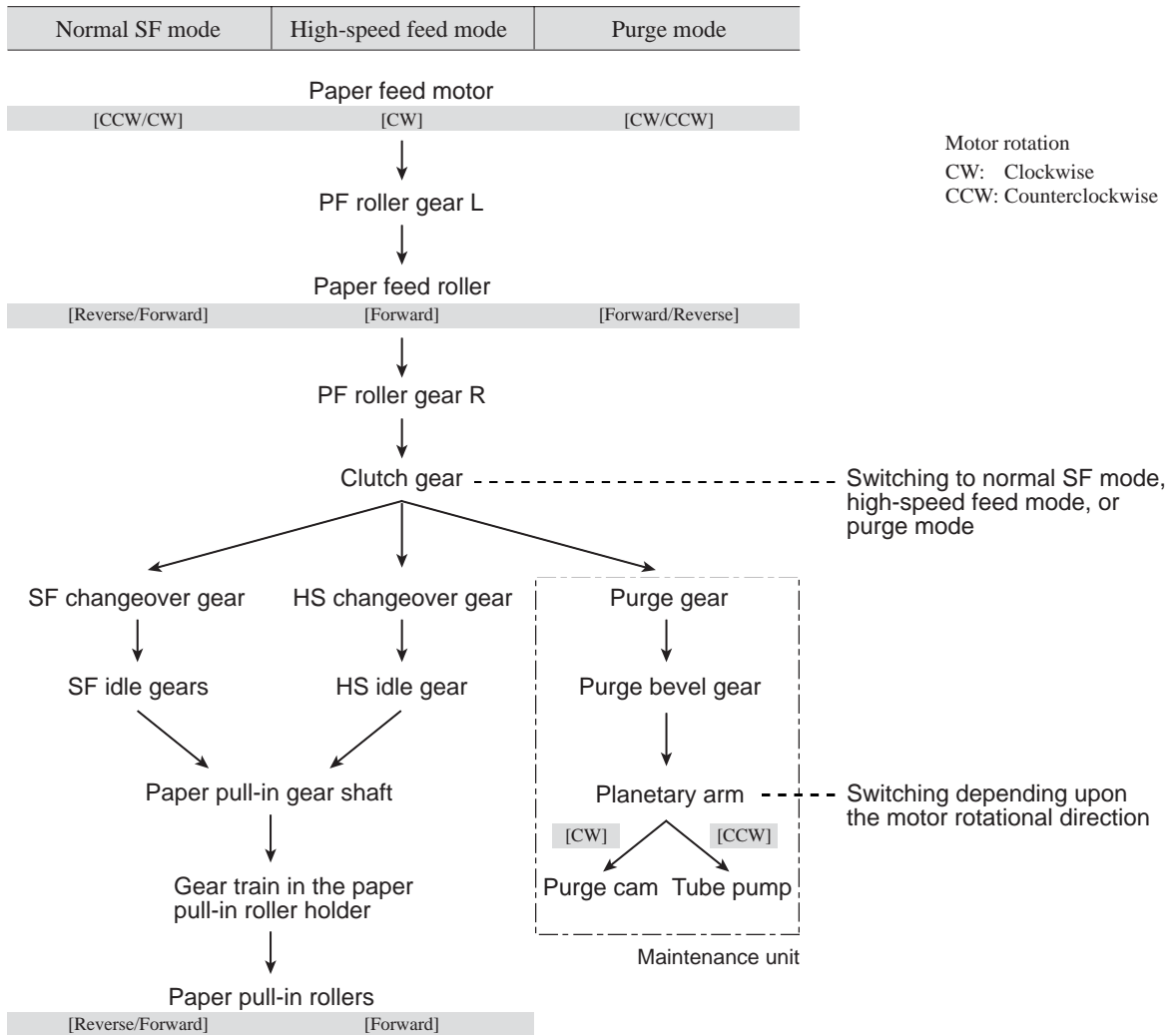

Switching operation modes--Normal SF, high-speed feed, and purge modes

The table below shows the relationship between the position of the mode switching lever, the rotational directions of the paper feed motor, paper feed roller, and paper pull-in rollers, and the maintenance unit components driven.

Position of mode switching lever	Operation	Paper feed motor (viewed from the output gear side)	Paper feed roller	Paper pull-in rollers	Component driven in maintenance unit
Leftmost position (Normal SF mode)	Paper feeding	Counterclockwise	Reverse	Forward	---
	Printing	Clockwise	Forward	(Reverse)*	---
2nd position from the left (High-speed feed mode)	High-speed paper feeding & printing	Clockwise	Forward	Forward	---
	Paper reversing	Counterclockwise	Reverse	Reverse	---
Right position (Purge mode)	Purging	Clockwise	---	---	Purge cam
		Counterclockwise	---	---	Tube pump

*The paper pull-in rollers are idling in the reverse direction.

Normal SF mode

1st stage The paper feed motor rotates *counterclockwise* (when viewed from the output gear side) and its rotational torque is transmitted to the PF roller gear L that rotates the paper feed roller in the *reverse* direction. (See the illustration on [page 3-39](#).)

At the right end of the paper feed roller is the PF roller gear R that always meshes with the clutch gear. The clutch gear also meshes with the SF changeover gear when the mode switching lever is placed in the normal SF mode position (Leftmost position).

The rotational torque is further transmitted from the SF changeover gear via the SF idle gears to the paper pull-in gear shaft and gear train in the paper pull-in roller holder. Consequently, the paper pull-in rollers turn in the *forward* direction to pull in a sheet of paper loaded in the paper tray.

2nd stage After the pulled-in paper pushes the registration sensor actuator to turn the sensor on, the motor further rotates *counterclockwise* for the predetermined period to align (register) the leading edge of the paper with the paper feed roller rotating in the *reverse* direction.

3rd stage The paper feed motor changes the rotational direction to *clockwise* to rotate the paper feed roller in the *forward* direction to feed the paper to the printing start position.

The rotational torque of the PF roller gear L is also transmitted via the ejection idle gear and PF timing belt to the paper ejection roller that rotates in the *forward* direction to eject the paper printed.

High-speed feed mode

1st stage The paper feed motor rotates *clockwise* (when viewed from the output gear side) and its rotation is transmitted to the PF roller gear L that rotates the paper feed roller in the *forward* direction.

At the right end of the paper feed roller is the PF roller gear R that always meshes with the clutch gear. The clutch gear also meshes with the HS changeover gear when the mode switching lever is placed in the high-speed feed mode position (2nd position from the left).

The rotational torque is further transmitted from the HS changeover gear via the HS idle gear to the paper pull-in gear shaft and gear train in the paper pull-in roller holder. Just as in the normal SF mode, the paper pull-in rollers turn in the *forward* direction to pull in a sheet of paper loaded in the paper tray.

Registration sensor activation has no effect on the paper feeding operation in the high-speed feed mode.

The paper feed roller keeps rotating in the *forward* direction; therefore, the paper continues to advance to the printing start position.

Just as in the normal SF mode, the rotational torque of the PF roller gear L is also transmitted via the ejection idle gear and PF timing belt to the paper ejection roller that rotates in the *forward* direction to eject the first sheet of paper printed.

Even after the first sheet of paper leaves the paper tray, the paper pull-in rollers keep rotating in the *forward* direction to continuously pull in paper sheet by sheet. At the completion of the first printing sequence, another sheet of paper has been halfway pulled in. The paper feed roller always rotates faster than the paper pull-in rollers; therefore, the trailing edge of the preceding sheet will not overlap with the leading edge of the subsequent one.

2nd stage When the registration sensor actuator returns to the no-paper state after completion of a sequence of printing operation, the paper feed motor starts rotating *counterclockwise* to rotate the paper pull-in rollers in the *reverse* direction so that the halfway-pulled-in paper goes back into the paper tray. The paper hits the paper length guide provided in the paper tray and goes back into place.

Movable platen*

*Only for models with movable platen

The movable platen has movable ribs that move in synchronization with the leading or trailing edge of advancing paper. It realizes the following.

- Increased printing speed in borderless printing
- Eliminating paper deflection that could occur in printing on the trailing edge of paper

Synchronization with leading edge of paper

When the leading edge of the paper reaches the movable rib drive position, the head/carriage unit moves to the left end of its travel and pushes the upper end of the movable platen lever, releasing its lower end that blocks the rotation of the movable platen cam gear. This triggers driving the movable platen mechanism.

The mechanism transmits the paper feed motor rotation to the movable ribs. They move from the home position (center) to the upstream limit of the movable range to wait for the leading edge of the paper to come. They move in synchronization with the leading edge of the paper advancing. When they reach the downstream limit, they return to the home position. This is a sequence of the movable rib operation.

Synchronization with trailing edge of paper

When the registration sensor detects the trailing edge of the paper, the motor further feeds the paper for the predetermined amount. After that, the head/carriage unit pushes the upper end of movable platen lever again. Just as for the leading edge of paper, the movable ribs move to the upstream limit of the movable range to wait for the trailing edge of the paper advancing to come and then move in synchronization with the trailing edge. When the movable ribs have reached the downstream limit and the printing operation has completed, they return to the home position.

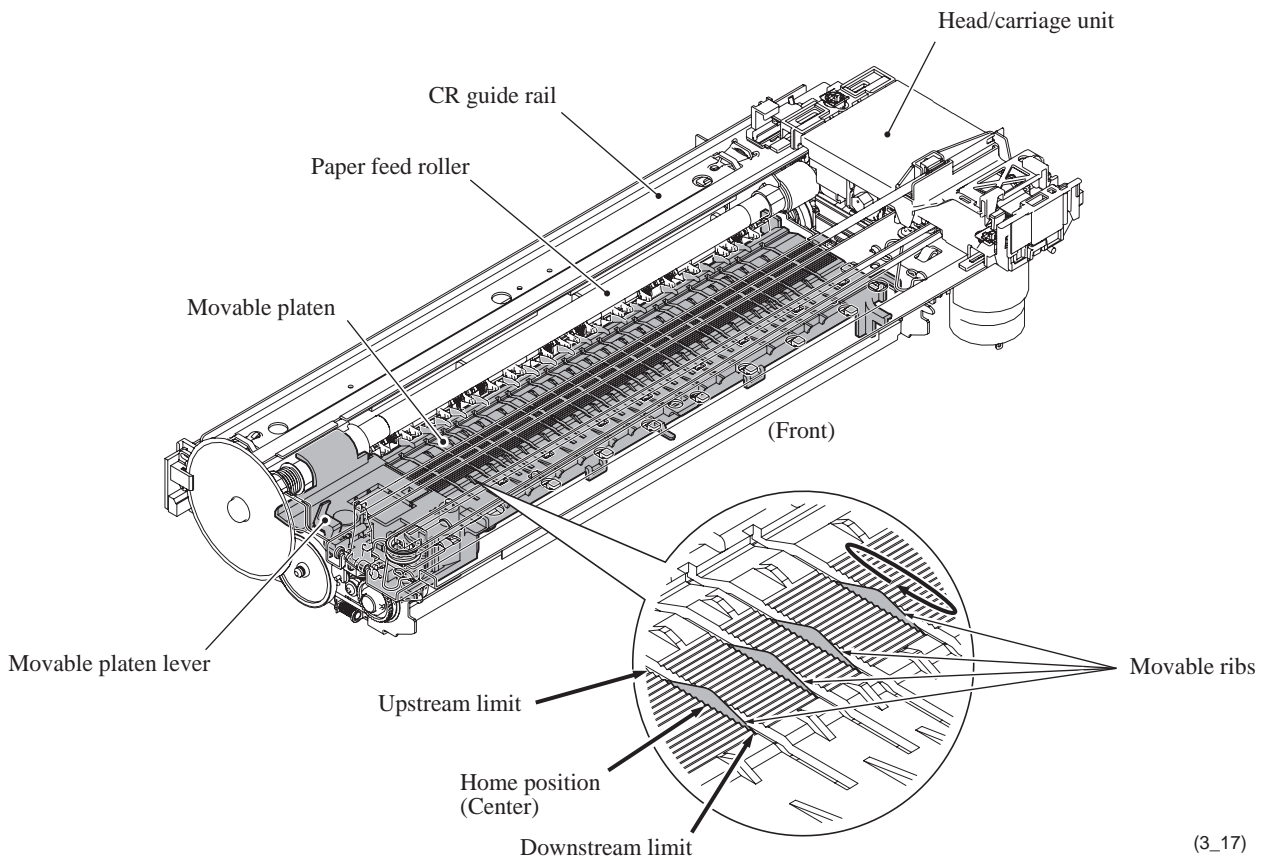

Other controls

Paper feed position and speed control

A PF encoder disk with the resolution of 300 dpi (0.084 mm pitch) is mounted on the PF roller gear L. The PF encoder sensor uses it to generate a signal indicating the gear rotation speed--in other words, the paper feed roller speed--to the controller for use in controlling paper feed position and speed.

Paper stop position control

The controller uses the PF encoder signal for proportional, integration, differential (PID) control of the paper feed motor to produce high-resolution precision paper positioning during printing. This signal also determines the motor parameters for rapidly and precisely positioning the paper.

Fixed-speed paper feed

This operation rotates the paper feed roller to feed the paper at a constant speed regardless of load fluctuations. The primary application is ejecting paper when printing is complete--in other words, in situations where precision stop position control is not needed.

Paper feeding amount control

There is variation in the head nozzle pitch of individual head/carriage units, as well as in the shape of the paper feed and ejection rollers. To make those parts match each other, therefore, updating the paper feeding correction value and correcting the positioning error of the head/carriage unit are necessary (see [Chapter 7](#)).

3.2.3 Sensors and Actuators

This machine uses the following sensors and thermistors.

Sensor Name	Sensor Type	Location
Document front sensor*	Photosensor	In the ADF unit*
Document rear sensor*	Photosensor	
Scanner/ink cartridge cover sensor	Photosensor	On the cover sensor PCB
Paper width sensor (media sensor)	Photosensor	On the carriage PCB
Head thermistor	Thermistor	
CR encoder sensor	Photosensor	
Registration sensor	Photosensor	On the registration sensor PCB
PF encoder sensor	Photosensor	On the PF encoder PCB
Purge cam switch	Mechanical switch	On the maintenance unit
Ink cartridge sensors (four)	Photosensor	On the ink cartridge PCB inside the ink refill assembly
Casing internal temperature thermistor	Thermistor	

*For models with ADF

- The document front sensor detects whether there is a document in the ADF.
- The document rear sensor detects the leading and trailing edges of document pages, indicating to the control circuitry the point at which to start reading and when page scanning is complete.
- The scanner/ink cartridge cover sensor detects whether the scanner cover (scanner unit) and the ink cartridge cover are properly closed.
- The paper width (media) sensor detects the size of recording paper. With this sensor signal, the controller prevents the print head from printing on the outside of paper in borderless printing. It also protects the platen from no-paper printing when a paper jam occurs, preventing stains on the platen and the back side of paper.
- The head thermistor detects the temperature of the print engine. According to the sensor information, the controller adjusts the head driver to compensate for changes in ink viscosity.
- The carriage motor (CR) encoder sensor monitors the head/carriage unit's current position and speed. If the controller detects a head's travel speed error, it interprets the error state as a paper jam and stops the operation.
- The registration sensor detects the leading and trailing edges of paper for use in determining print start and end timings and detecting paper jams.
- The paper feed motor (PF) encoder sensor monitors the PF roller rotation angle and speed for use in optimizing paper feed amount and speed.
- The purge cam switch detects the drive positions of the purge cam.
- There are four ink cartridge sensors, one for each color. The sensor actuator inside the ink cartridge usually blocks the light path to indicate the presence of ink. When ink runs low (near-empty), the arm moves out of the beam, activating the sensor. The same signal also indicates whether there is an ink cartridge present.
- The casing internal temperature thermistor monitors the temperature inside the machine. With this thermistor signal, the controller determines the periodical automatic purge interval since the casing internal temperature is almost equal to the ambient temperature of ink inside the ink cartridges.

Most sensors are photointerrupters consisting of a light-emitting diode and a light-sensitive transistor as shown below. The only exception is the paper width sensor, which uses reflective type. The illustration on the next page gives the sensor and actuator locations.

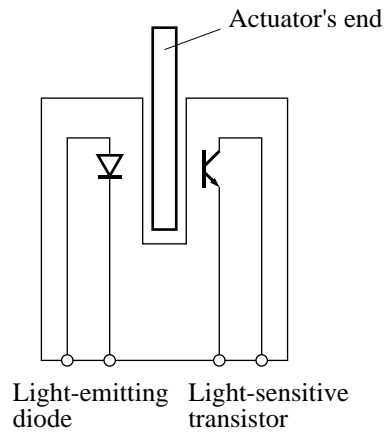

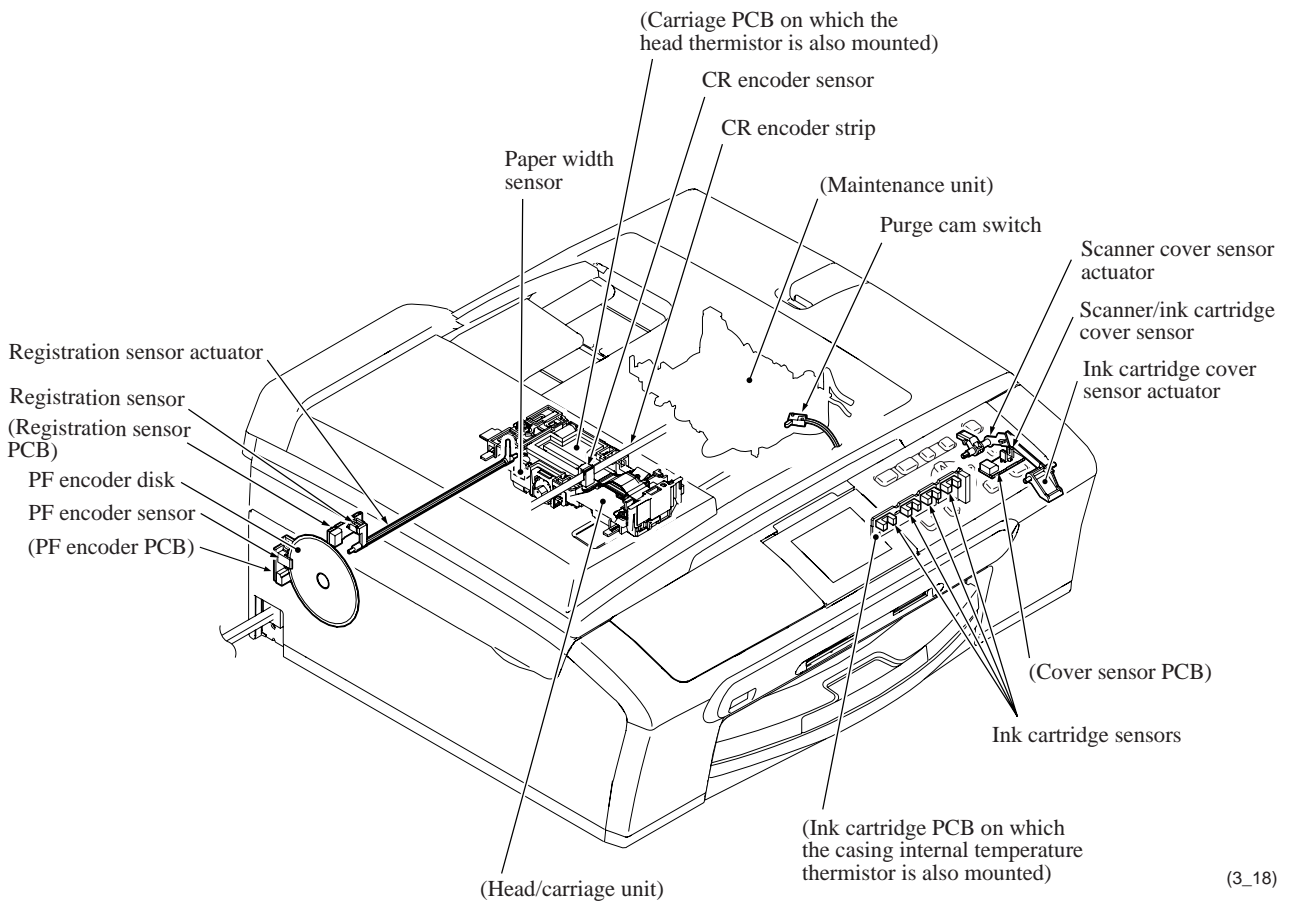
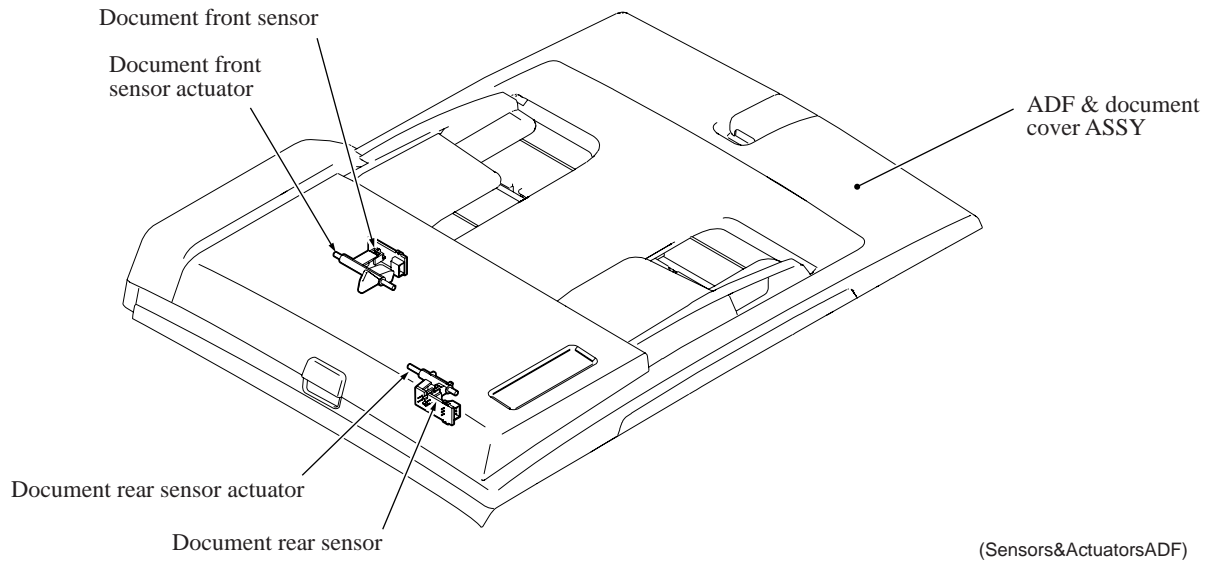

Sensors and Actuators Locations

3.3 CONTROL ELECTRONICS

3.3.1 Components

The following illustration shows the hardware components. The corresponding wiring diagrams appear in [Appendix 5](#).

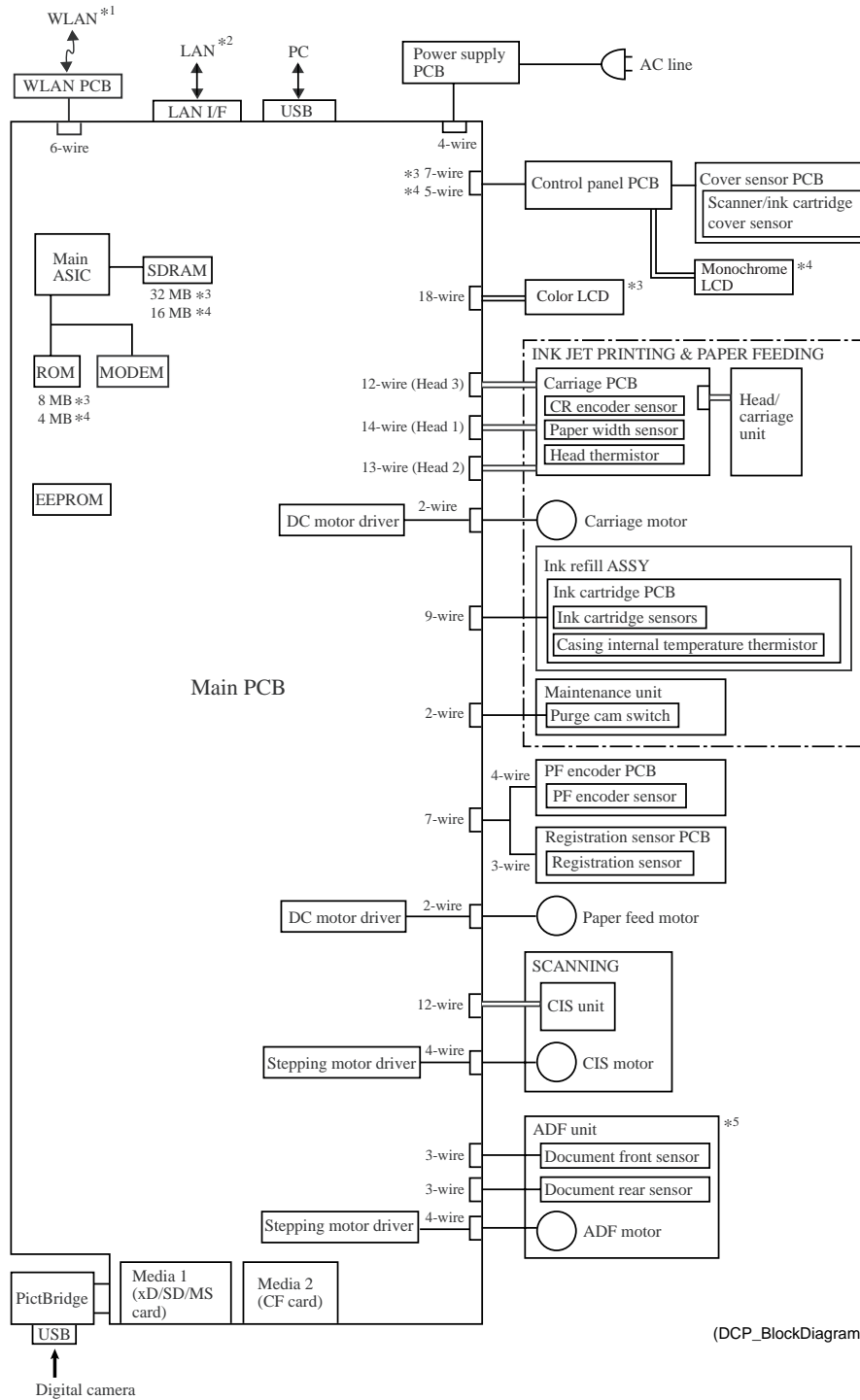

(DCP_BlockDiagram)

- *1 For wireless LAN-enabled models
- *2 For wired LAN-enabled models
- *3 For models with color LCD
- *4 For models with monochrome LCD
- *5 For models with ADF

CHAPTER 4

ERROR INDICATION AND TROUBLESHOOTING

CHAPTER 4 ERROR INDICATION AND TROUBLESHOOTING

This chapter details error messages and codes that the incorporated self-diagnostic functions display if any error or malfunction occurs. If any error message appears, refer to this chapter to find which components should be checked or replaced.

The latter half of this chapter provides sample problems that could occur in the main sections of the machine and related troubleshooting procedures. This will help service personnel pinpoint and repair defective components.

CONTENTS

4.1	ERROR INDICATION	4-1
4.1.1	Equipment Errors.....	4-1
[1]	Error messages appearing on the LCD.....	4-1
[2]	Error codes contained in "MACHINE ERROR X X" messages.....	4-4
4.2	TROUBLESHOOTING	4-18
4.2.1	Introduction	4-18
4.2.2	Precautions	4-18
4.2.3	Checking Prior to Troubleshooting	4-18
4.2.4	Troubleshooting Based on Problem Type	4-19
[1]	Control panel and LCD problems	4-19
[2]	Paper/document feeding problems	4-20
[3]	Print-image problems	4-21
[4]	PC-driven printing problems.....	4-26
[5]	Printing from memory cards--Compact Flash, Memory Stick, SD Memory Card, or xD-Picture Card.....	4-26
[6]	Wireless LAN (WLAN)*	4-27
[7]	Others	4-27
4.2.5	Problems Encountered Frequently in the Past.....	4-28
[1]	Paper jams.....	4-28
[2]	"MACHINE ERROR 4F" error message.....	4-29
[3]	Ink-related problems.....	4-29
[4]	Auto document feeder (ADF) malfunction (For models with ADF).....	4-30
4.2.6	Possible Component Defects and Resulting Problems.....	4-32
[1]	ADF mechanism (For models with ADF).....	4-32
[2]	Scanner mechanism.....	4-33

[3]	Head/carriage unit drive and purge mechanisms.....	4-34
[4]	Print head mechanism.....	4-35
[5]	Sheet feeder (SF) mechanism	4-36
[6]	Paper feeding mechanism.....	4-36
[7]	Control panel and LCD	4-37
[8]	PCBs.....	4-37
[9]	Adjustments/data in the memories	4-38

4.1 ERROR INDICATION

To help the user or the service personnel promptly locate the cause of a problem (if any), the machine incorporates the self-diagnostic functions which display error messages for equipment errors.

4.1.1 Equipment Errors

If an equipment error occurs, the machine shows the error message on the LCD. For the error messages, see [1] below.

To display detailed error information, use Function code 82 described in [Chapter 9, Section 9.4.22](#) (that is, make the machine enter the maintenance mode and then enter 8 and 2 using the ▲/▼ and **OK** keys). Following the MACHINE ERROR, one of the error codes listed in [2] will appear on the LCD.

[1] Error messages appearing on the LCD

Error Message	Cause	Action
Cover is Open	The scanner cover (scanner unit) or ink cartridge cover is not closed completely.	Lift the scanner cover and then close it again.
Data Remaining	Print data is left in the machine's memory.	Re-start printing from your computer.
	Print data is left in the machine's memory. The USB cable was unplugged while the computer was sending the data to the machine. The computer hung up.	Press Stop/Exit . The machine will cancel the job and clear it from the memory. Try to print again.
Document Jam	The document was not inserted or fed properly, or the document scanned from the ADF was too long.	Remove the jammed document. (Only for models with ADF.)
High Temperature	The ambient temperature is too high.	Lower the ambient temperature *

* When the ambient temperature is too high or low, the print quality may deteriorate.

Error Message	Cause	Action
Ink Empty	One or more of the ink cartridges is empty. The machine will stop all print operations.	Replace the ink cartridges.
Low Temperature	The ambient temperature is too low.	Raise the ambient temperature. *
Media Error	The memory card is either corrupted, improperly formatted, or there is a problem with the memory card.	Put the card firmly into the slot again to make sure it is in the correct position. If the error remains, check the media drive by putting in another memory card that you know is working.
Near Empty	One or more of the ink cartridges are running out of ink.	Order a new ink cartridge.
No Cartridge	An ink cartridge is not installed properly.	Take out the ink cartridge and put it in again seating it properly.
No File	The memory card in the media drive does not contain a .JPG file.	Put the correct memory card into the slot again.
No Paper Fed	The machine is out of paper or paper is not properly loaded in the paper tray.	Do one of the following: <ul style="list-style-type: none"> • Refill the paper in the paper tray, and then press Black Start (Mono Start) or Color Start. • Remove the paper and load it again and then press Black Start (Mono Start) or Color Start.
	The jam clear cover is not set in place.	Set the jam clear cover into place.
Out of Memory	Paper is jammed in the machine.	Remove the jammed paper.
	The machine's memory is full.	Reduce print resolution.
	The data size of the memory card is too large.	Reduce the size of the image data stored in the memory card.
Paper Jam	Paper is jammed in the machine.	Remove the jammed paper.

* When the ambient temperature is too high or low, the print quality may deteriorate.

Error Message	Cause	Action
(On color LCD) * Unable to Change XX Unable to Clean XX Unable to Init XX Unable to Print XX Unable to Scan XX (On monochrome LCD) * Change Unable XX Clean Unable XX Init Unable XX Print Unable XX Scan Unable XX	The machine has a mechanical problem. or A foreign object such as a clip or ripped paper is in the machine.	Open the scanner cover and remove any foreign objects inside the machine. If the error message continues, disconnect the machine from the electrical outlet, wait several minutes, then reconnect it.
Wrong Paper Size	Paper is not the correct size.	Load the correct size of paper (Letter, Legal or A4), and then press Black Start (Mono Start) or Color Start .
Wrong USB Device	The machine has been overloaded due to a wrong or broken device plugged in the PictBridge direct print slot.	Unplug the USB cable from the PictBridge direct print slot. Turn the machine off and then on. If this message appears even with a PictBridge compatible digital camera being connected, the USB setting on the camera may not be PictBridge compatible. Check the setting.

* XX represents one of the error codes shown in "[2] Error codes contained in "MACHINE ERROR X" messages."

[2] Error codes contained in "MACHINE ERROR XX" messages

Using Function code 82 (described in [Chapter 9, Section 9.4.22](#)) displays the most recent error in the format of "MACHINE ERROR XX." The XX represents one of the error codes listed in this section.

XX in error messages "Unable to Change XX" to "Unable to Scan XX" and "Change Unable XX" to "Scan Unable XX" given in item [1] also represents one of these error codes.

NOTE: When checking a PCB as instructed in the "Solution" column, also check its harness.

NOTE: To check sensors, use Function code 32 described in [Chapter 9, Section 9.4.8](#) (that is, enter 3 and 2 in the maintenance mode).

Error Code (Hex)	Symptom	Probable Cause	Solution
25	Not used.		
26 27 28 29	Cannot detect ink cartridges.	Running out of ink or the ink cartridge not set in place 26: Black ink 27: Yellow ink 28: Cyan ink 29: Magenta ink	Replace or reload ink cartridges, referring to the User's Guide.
		Ink cartridge PCB defective	Replace the ink refill ASSY.
		Main PCB defective	Replace the main PCB.
2A-2F	Not used.		
3*	Head/carriage unit travel error.	Software malfunction	Open and close the scanner cover. Unplug and plug the AC cord.
		Any obstacles on the travel path of the head/carriage unit	Clean and lubricate the CR guide rail and CR support chassis.
		CR timing belt come off	Set the CR timing belt into place.
		CR encoder strip stained or scratched	Replace the CR encoder strip.
		Carriage PCB defective	Replace the carriage PCB ASSY.
		Head/carriage unit broken	Replace the head/carriage unit.
		Carriage motor defective	Replace the carriage motor.
		Main PCB defective	Replace the main PCB.
		Power supply PCB defective	Replace the power supply PCB.
		Maintenance unit defective	Replace the maintenance unit.

Error Code (Hex)	Symptom	Probable Cause	Solution
40	The casing internal temperature thermistor has detected abnormal temperature in the machine.	Main PCB defective	Replace the main PCB.
		Casing internal temperature thermistor defective	Replace the ink refill ASSY.
41	Not used.		
42	The head drive voltage has not dropped from the high to low level within the specified period.	Piezoelectric ceramic actuator or head driver defective	Replace the head/carriage unit.
		Carriage PCB defective	Replace the carriage PCB ASSY.
		Main PCB defective	Replace the main PCB.
43	The head thermistor has been opened or shorted abnormally.	Head flat cables not connected correctly	Correct those flat cables.
		Head flat cables broken	Replace the carriage PCB ASSY.
		Carriage PCB defective	Replace the carriage PCB ASSY.
		Main PCB defective	Replace the main PCB.
44	The temperature of the print head driver has risen abnormally. The head driver chip temperature sensor in the head driver detects abnormally high temperature.	Head property parameters incorrect in the EEPROM	Enter the correct parameter values.
		Air bubbles in the head/carriage unit	Perform the initial purge.
		Head flat cables and carriage-head flat cable not connected correctly	Correct those flat cables.
		Head flat cables broken	Replace the carriage PCB ASSY.
		Carriage-head flat cable broken	Replace the head/carriage unit.
		Head/carriage unit broken	Replace the head/carriage unit.
		Main PCB defective	Replace the main PCB.
45	Not used.		

Error Code (Hex)	Symptom	Probable Cause	Solution
46	The number of performed purge sequences has reached the limit. The ink absorber box may be filled with drained ink.	Purge counter overflown	Replace both the ink absorber box and flushing box and reset their counters. (When you need to replace the ink absorber box or flushing box, replace both.)
	The number of flushing operations has reached the limit. The flushing box may be filled with drained ink.	Flushing counter overflown	
47	Not used.		
48	Weak connection of the head flat cables.	Head flat cables or carriage-head flat cable broken or not connected	Correct the connection of the head flat cables.
			Replace the carriage PCB ASSY.
			Replace the head/carriage unit.
			Replace the main PCB.
49	The head drive voltage has not risen to the specified level.	Head flat cables and carriage-head flat cable not connected correctly	Correct those flat cables.
		Head/carriage unit defective	Replace the carriage PCB ASSY.
			Replace the head/carriage unit.
		Main PCB defective	Replace the main PCB.
Power supply PCB defective	Replace the power supply PCB.		
4A-4E	Not used.		
4F	The head drive voltage has dropped from the high to low level in an abnormally short period. The head drive voltage has not risen to the specified level within the specified period in the self-diagnosis.	Piezoelectric ceramic actuator defective (Cracks or rare short)	Replace the carriage PCB ASSY.
			Replace the head/carriage unit.
		Main PCB defective	Replace the main PCB.

Error Code (Hex)	Symptom	Probable Cause	Solution
50 51	The purge cam switch does not come ON or OFF even after the purge cam has been driven by the specified number of pulses.	Planetary arm assembly not engaged correctly	Set the maintenance unit into place. If the planetary arm does not move smoothly, clean it.
		Purge cam switch harness not connected correctly	Correct the connection.
		Purge cam switch broken	Replace the purge cam switch.
		Gear(s) on the maintenance unit broken	Replace the maintenance unit.
		Paper feed motor broken	Replace the paper feed motor.
		Power supply PCB defective	Replace the power supply PCB.
		Main PCB defective	Replace the main PCB.
52	The purge cam switch does not come ON at each detection point.	Planetary arm assembly not engaged correctly	Set the maintenance unit into place. If the planetary arm does not move smoothly, clean it.
		Purge cam switch harness not connected correctly	Correct the connection.
		Purge cam switch broken	Replace the purge cam switch.
		Gear(s) on the maintenance unit broken Abnormal load applied to the purge cam	Replace the maintenance unit.
		Paper feed motor broken	Replace the paper feed motor.
		Main PCB defective	Replace the main PCB.
		53	Not used.

Error Code (Hex)	Symptom	Probable Cause	Solution
54 55	The tube pump rotates abnormally.	Foreign materials in the machine	Remove foreign materials.
		Clutch gear broken	Replace the clutch gear.
		PF encoder disk being in contact with the upper cover and deformed	Replace the PF encoder disk.
		PF encoder PCB defective	Replace the PF encoder PCB.
		Main drain tube bent	Replace the main drain tube.
		Purge cam gear broken Abnormal load applied to the purge cam	Replace the maintenance unit.
		Planetary arm assembly broken	Replace the maintenance unit.
		Main PCB defective	Replace the main PCB.
		Power supply PCB defective	Replace the power supply PCB.
		Paper feed motor defective	Replace the paper feed motor.
		PF roller gear L broken	Replace the engine unit.
56	Not used.		
57	After a purging operation, the head/carriage unit will not return to the home position (capping position).	Head cap unit, head wiper or other parts on the maintenance unit interfering with the head/carriage unit	Set these parts back into place. If any part on the maintenance unit does not operate smoothly, replace the unit.
		CR encoder strip stained	Clean the CR encoder strip.
		Any obstacles on the travel path of the head/carriage unit	Clean the CR guide rail and CR support chassis.
		Carriage motor defective	Replace the carriage motor.
		Head/carriage unit defective	Replace the head/carriage unit.
		Main PCB defective	Replace the main PCB.
		Power supply PCB defective	Replace the power supply PCB.

Error Code (Hex)	Symptom	Probable Cause	Solution
58, 59	Not used.		
5A	The purge cam stops abnormally when it is in operation.	Foreign materials in the machine	Remove foreign materials.
5B	The tube pump stops abnormally during air venting.	Clutch gear broken	Replace the clutch gear.
		PF encoder disk being in contact with the upper cover and deformed	Replace the PF encoder disk.
5C	The tube pump stops abnormally during purging operation.	PF encoder PCB defective	Replace the PF encoder PCB.
		Main drain tube bent	Replace the main drain tube.
5D	Current protection for the driver IC activated when the purge cam was being driven.	Purge cam gear broken	Replace the maintenance unit.
		Abnormal load applied to the purge cam	Replace the maintenance unit.
		Planetary arm assembly broken	Replace the maintenance unit.
		Main PCB defective	Replace the main PCB.
5E	Current protection for the driver IC activated when the pump was in operation.	Power supply PCB defective	Replace the power supply PCB.
		Paper feed motor defective	Replace the paper feed motor.
		PF roller gear L broken	Replace the engine unit.

Error Code (Hex)	Symptom	Probable Cause	Solution
5F	Not used.		
60 61 62	Paper width sensor (media sensor) error.	Paper width sensor defective	Replace the carriage PCB ASSY.
		Head flat cables broken	Replace the carriage PCB ASSY.
		Main PCB defective	Replace the main PCB.
63-7D	Not used.		
7E	No head parameters stored in the EEPROM. (This code may appear only in the maintenance mode.)	No head property data has been entered	Enter the head property data.
		Main PCB defective	Replace the main PCB.
7F	Not used.		
80	Not used. (At the start of FAX message printing, the controller detects that paper is smaller than A4 size in width.)	Paper smaller than the specified size loaded in the paper tray	Load the correct size of paper.
		Paper width sensor defective	Replace the carriage PCB ASSY.
		Paper width sensor not adjusted	Adjust the margin for borderless printing with Function code 66 in the maintenance mode.
		Main PCB defective	Replace the main PCB.
81	Not used.		
82	Recording paper jam in paper pull-in operation. (The paper width sensor fails to detect the leading edge of paper.)	Foreign materials in the paper path	Remove foreign materials.
		Paper not loaded correctly in the paper tray	Reload paper.
		Head flat cable connection failure	Insert the head flat cables correctly.
		Paper width sensor defective	Replace the carriage PCB ASSY.
		Main PCB defective	Replace the main PCB.

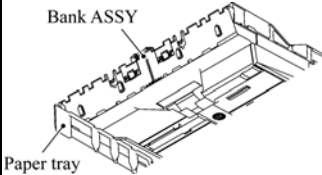
Error Code (Hex)	Symptom	Probable Cause	Solution
83	Recording paper jam. (The registration sensor detects paper abnormally early in paper feeding operation in the normal SF mode.) (The registration sensor sticks to ON in high-speed feed mode.)	Paper is not correctly set in the paper tray	Reload paper.
		Bank ASSY deformed 	Replace the bank ASSY.
		Registration sensor actuator unhooked	Set the registration sensor actuator into place.
		Main PCB defective	Replace the main PCB.
		Registration sensor defective	Replace the registration sensor PCB.
84	Recording paper jam. (The registration sensor sticks to ON after completion of paper ejection operation.)	Foreign materials in the paper path	Remove foreign materials.
		Registration sensor actuator caught on the surrounding parts	Correct the surrounding parts on which the actuator caught.
		Registration sensor defective	Replace the registration sensor PCB.
		PF timing belt come off	Set the PF timing belt into place.
		The paper ejection roller does not rotate correctly	Replace the engine unit.
		Main PCB defective	Replace the main PCB.
85-87	Not used.		

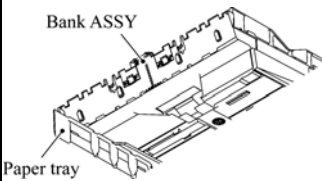
Error Code (Hex)	Symptom	Probable Cause	Solution
88	Recording paper jam. (Even after paper pulling-in operation, the registration sensor is still OFF.)	Recording paper not loaded correctly	Instruct the user to load the recording paper correctly.
		Jam clear cover not set correctly	Set the jam clear cover into place.
		Registration sensor defective	Replace the registration sensor PCB.
		Bank ASSY deformed 	Replace the bank ASSY.
		Paper pull-in roller holder defective	Replace the paper pull-in roller holder.
		Mode switching lever (at the right end of CR guide rail) not sliding smoothly	Clean the mode switching lever.
		At the ends of the paper feed roller shaft, any gear(s) damaged	Replace the engine unit.
		Main PCB defective	Replace the main PCB.
		Paper feed motor defective	Replace the paper feed motor.
89	Not used.		
8A	The paper feed motor does not rotate.	Paper feed motor harness not connected correctly	Reconnect the paper feed motor harness.
		Abnormal load applied to the paper feed roller PF-related gear(s) broken	Replace the PF-related gear(s).
		PF encoder disk stained or scratched	Replace the PF encoder disk.
		PF encoder sensor defective	Replace the PF encoder PCB.
		Main PCB defective	Replace the main PCB.
		Paper feed motor defective	Replace the paper feed motor.

Error Code (Hex)	Symptom	Probable Cause	Solution
8B	The paper feed motor stops suddenly.	Abnormal load applied to the paper feed roller	Replace the PF-related gear(s).
		PF-related gear(s) broken	
		PF encoder disk stained or scratched	Replace the PF encoder disk.
		PF encoder sensor defective	Replace the PF encoder PCB.
		Main PCB defective	Replace the main PCB.
		Paper feed motor defective	Replace the paper feed motor.
8C	Current protection for the driver IC activated in paper feeding operation.	The driving current has exceeded the limit due to an abnormal load applied to the PF-related gears and rollers.	Replace the PF-related gears.
			Replace the PF encoder disk.
			Replace the PF encoder PCB.
			Replace the main PCB.
			Replace the paper feed motor.
8D	The paper feed motor rotates in the reverse direction.	PF encoder disk stained or scratched	Replace the PF encoder disk.
		PF encoder disk dislocated	Replace the PF encoder disk.
		PF encoder sensor defective	Replace the PF encoder PCB.
		Abnormal load applied to the paper feed roller	Check the PF roller gear and its related gears.
		Main PCB defective	Replace the main PCB.
		Paper feed motor defective	Replace the paper feed motor.
8E	Not used.		
8F	The paper feed motor is being driven and cannot be stopped.	Software malfunction	Open and close the scanner cover. Unplug and plug the AC cord.
90-A0	Not used.		

Error Code (Hex)	Symptom	Probable Cause	Solution
A1	Scanner cover (scanner unit) or ink cartridge cover is open.	Scanner/ink cartridge cover sensor broken	Replace the cover sensor PCB.
		Scanner cover sensor actuator or ink cartridge cover sensor actuator unhooked	Set the scanner cover sensor actuator or ink cartridge cover sensor actuator into place.
		Control panel PCB defective	Replace the control panel PCB.
		Main PCB defective	Replace the main PCB.
A2	Document length exceeding the scan limitation. During scanning, a document of 90 cm or longer is detected. During document feeding or ejecting, a document of 400 cm or longer is detected.	Document jam	Remove the jammed document.
		Foreign materials in the machine	Remove foreign materials.
		Document rear sensor actuator caught on the surrounding parts	Correct the surrounding parts on which the actuator caught.
		Document rear sensor broken	Replace the document rear sensor PCB.
		Main PCB defective	Replace the main PCB.
A3	The document rear sensor does not come ON during document pull-in operation.	Document jam	Remove the jammed document.
		Foreign materials in the machine	Remove foreign materials.
		Document rear sensor actuator caught on the surrounding parts	Correct the surrounding parts on which the actuator caught.
		Document rear sensor broken	Replace the document rear sensor PCB.
		Main PCB defective	Replace the main PCB.
A4	Not used.		

Error Code (Hex)	Symptom	Probable Cause	Solution
A5	Not used. (FAX scanning failure (1st time).)	CIS defective	Replace the scanner cover (scanner unit).
A6	Not used. (FAX scanning failure (retry).)	White reference film stained in the scanner cover	
A6		Main PCB defective	Replace the main PCB.
A7	Mismatch between the type of the CIS mounted and EEPROM data.	Scanner cover containing the improper CIS type mounted at repair.	Check the CIS type mounted and enter the new CIS type into the EEPROM with Function code 59 in the maintenance mode. (Refer to Chapter 9, Section 9.4.12).
A8	Color parameter matching error. (Used for monitoring bugs at the factory.)		Install the latest firmware.
A9-AE	Not used.		
AF	CIS positioning error.	Mismatch between the type of the CIS mounted and EEPROM data	Check the CIS type mounted and enter the new CIS type into the EEPROM with Function code 59 in the maintenance mode. (Refer to Chapter 9, Section 9.4.12).
		CIS flat cable broken or not connected properly	Correct the cable connection. Replace the scanner cover (scanner unit).
		CIS motor harness not connected properly	Correct the harness connection.
		CIS motor defective	Replace the scanner cover (scanner unit).
		CIS drive unit defective	Replace the scanner cover (scanner unit).
		CIS defective	Replace the scanner cover (scanner unit).
		Main PCB defective	Replace the main PCB.
B0-BC	Not used.		

Error Code (Hex)	Symptom	Probable Cause	Solution
BD	Black level data error.	CIS defective	Replace the scanner cover (scanner unit).
		Main PCB defective	Replace the main PCB.
BE-DE	Not used.		
DF	Not used. (Modem error.)	Main PCB defective	Replace the main PCB.
E0, E1	Not used.		
E2	Wired LAN MAC address not registered. *1	MAC address not registered correctly	Replace the main PCB.
E3	Wireless LAN MAC address not registered. *2	MAC address not registered correctly	Replace the WLAN PCB.
E4	Not used.		
E5	Not used. (Write error in EEPROM of the cordless handset.)	The base ID code and cordless handset ID code registered are mismatched.	Reregister the cordless handset ID code.
			Replace the cordless handset
			Replace the cordless PCB.
E6	Write error in EEPROM.	Main PCB defective	Replace the main PCB.
E7	Not used. (No response from the cordless handset.)	The base ID code and cordless handset ID code registered are mismatched.	Reregister the cordless handset ID code.
			Replace the cordless handset
			Replace the cordless PCB.
E8	Data scanning error during transmission.	CIS defective	Replace the scanner cover (scanner unit).
		Main PCB defective	Replace the main PCB.
E9	Not used.		

*1 For wired LAN-enabled models

*2 For wireless LAN-enabled models

Error Code (Hex)	Symptom	Probable Cause	Solution
EA	Not used. (Document removed at phase B. *)	Document front sensor actuator caught on the surrounding parts	Correct the surrounding parts on which the actuator caught.
		Document front sensor defective	Replace the document front sensor PCB.
		Main PCB defective	Replace the main PCB.
EB-F6	Not used.		
F7	Media module detection failure.	Main PCB defective	Replace the main PCB.
F8	Not used. (Battery harness connection failure) (For models with backup battery) (Available in the maintenance mode only)	Battery harness not inserted correctly.	Correct the connection.
F9-FF	Not used.		

* Phase B: FAX negotiation stage between sending machine and receiving machine

4.2 TROUBLESHOOTING

4.2.1 Introduction

This section gives the service personnel some of the troubleshooting procedures to be followed if an error or malfunction occurs with the machine. It is impossible to anticipate all of the possible problems which may occur in future and determine the troubleshooting procedures, so this section covers some sample problems. However, those samples will help service personnel pinpoint and repair other defective elements if he/she analyzes and examines them well.

4.2.2 Precautions

Be sure to observe the following to prevent the secondary troubles from happening:

- (1) Always unplug the AC power cord from the outlet when removing the covers and PCBs, adjusting the mechanisms, or conducting continuity testing with a circuit tester.
- (2) When disconnecting the connectors, do not pull the lead wires but hold the connector housings.
- (3)
 - Before handling the PCBs, touch a metal portion of the machine to discharge static electricity charged in your body.
 - When repairing the PCBs, handle them with extra care.

After repairing the defective section, be sure to check again if the repaired section works correctly. Also record the troubleshooting procedure so that it would be of use for future trouble occurrence.

4.2.3 Checking Prior to Troubleshooting

Prior to proceeding to the troubleshooting procedures given in [Section 4.2.4](#), make the following initial checks:

Environmental conditions

Check that:

- (1) The machine is placed on a flat, firm surface.
- (2) The machine is used in a clean environment at or near normal room temperature (10°C to 35°C) with normal relative humidity (20 to 80%).
- (3) The machine is not exposed to direct sunlight or harmful gases.

Power requirements

Check that:

- (1) The power supply specified on the rating plate on the machine is used. The supply voltage stays within the rating $\pm 10\%$.
- (2) Each voltage level on AC input lines and DC lines is correct.
- (3) All cables and harnesses are firmly connected.

Recording paper

Check that:

- (1) A recommended type of recording paper is used.
- (2) The recording paper is not dampened.

Ink cartridges

- (1) Check that all of four ink cartridges are loaded.

Head/carriage unit

- (1) Repeat the purging operation (Function code 76) several times. (Refer to [Chapter 9, Section 9.4.20.](#))
- (2) Clean the print surface of the head/carriage unit.

4.2.4 Troubleshooting Based on Problem Type

[1] Control panel and LCD problems

Problem	Check:
(1) LCD shows nothing.	<u>Models with color LCD</u> <ul style="list-style-type: none">• Color LCD and its flat cable• Power supply PCB• Main PCB <u>Models with monochrome LCD</u> <ul style="list-style-type: none">• Monochrome LCD and its flat cable• Panel-main harness• Control panel PCB• Power supply PCB• Main PCB
(2) Control panel inoperative.	<ul style="list-style-type: none">• Panel-main harness• Control panel PCB• Rubber keypad• Main PCB

[2] Paper/document feeding problems

Problem	Check:
(1) The "ADF Ready" message does not appear although documents are set.*	<ul style="list-style-type: none"> • Sensors by using Function code 32 in the maintenance mode (Refer to Chapter 9, Section 9.4.8.) • Document front sensor actuator • Document front sensor PCB • Main PCB
(2) Document not fed.*	<ul style="list-style-type: none"> • ADF and its related sections • Foreign materials in the document path • ADF motor and its harness • Document feed rollers and their related gears • Document front and rear sensor PCBs • Main PCB
(3) Document double feeding*	<ul style="list-style-type: none"> • ADF parts
(4) Document jam*	<ul style="list-style-type: none"> • Document rear sensor actuator • Foreign materials in the document path • Sensors by using Function code 32 in the maintenance mode (Refer to Chapter 9, Section 9.4.8.) • ADF motor • Main PCB
(5) Recording paper not fed.	<ul style="list-style-type: none"> • Paper pull-in roller holder • Base pad in the paper tray • Jam clear cover • PF-related gears • Main PCB • Paper feed motor
(6) Recording paper jam	<ul style="list-style-type: none"> • Paper feeding mechanism • Foreign materials in the paper path • Check that the carriage-head flat cable is connected to the carriage PCB. • Carriage PCB • Main PCB







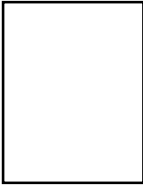

*For models with ADF

[3] Print-image problems

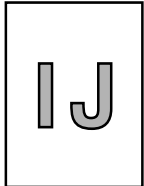
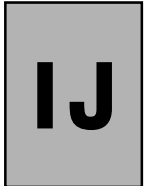
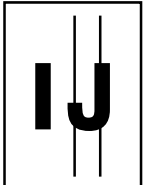
If there is any problem with any image printed, first make a copy using the machine.

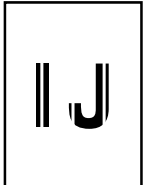
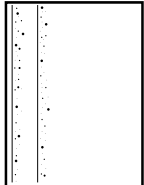
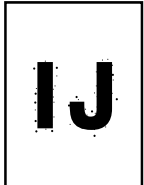
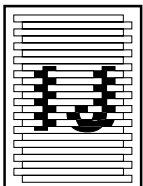

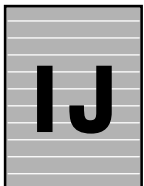
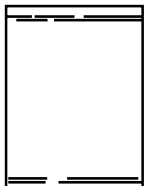
If the copied image is normal, the cause of the problem may be the sending station (e.g., PC and digital camera) or the memory card inserted; if it is abnormal, proceed with the following checks:

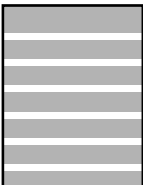
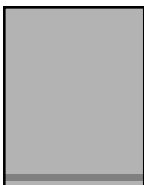
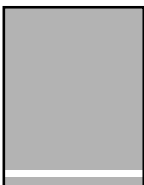
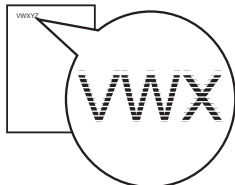

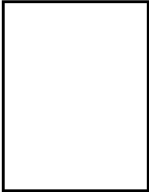
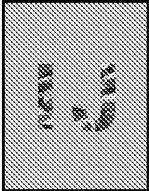
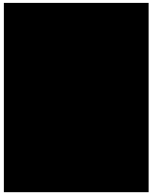
Examples of Defective Images

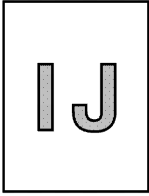
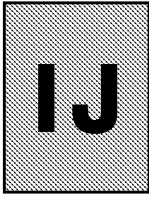
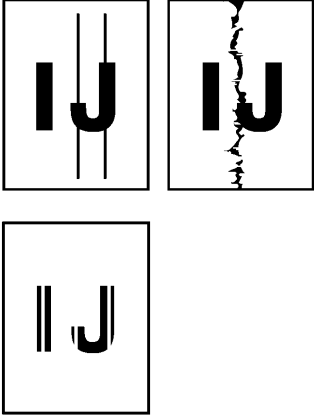
Completely blank	All black	Random color	Light	Dark
				
Straight vertical stripes	Blurred vertical stripes	White vertical streaks	Ink splash	Ink splash
				
Print edges not aligned	Random missing dots	White horizontal streaks	Stained leading edge of recording paper	Overlapping lines over the whole page
				
Separated lines over the whole page	Overlapping lines at the trailing edge of the recording paper	Separated lines at the trailing edge of the recording paper	Characters having shadows (ghost)	
				

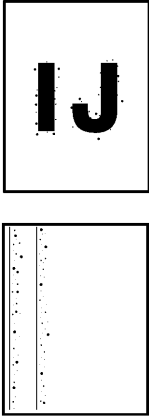
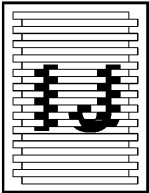
Problem	Action to be taken
<p>(1) Completely blank</p> 	<p><u>At the scanner</u></p> <p>Check that the document is placed facing in the correct direction. In ADF scanning (available only in models with ADF units), is the document placed <i>face down</i> in the document tray? In flat-bed scanning also, is the document placed <i>face down</i> on the scanner glass?</p> <p>Check the following components:</p> <ul style="list-style-type: none"> - Scanner cover (CIS flat cable) - Main PCB
<p>(2) Random color</p> 	<p><u>At the printer</u></p> <ul style="list-style-type: none"> • Check the ink cartridges. If any cartridges have run out of ink, replace them. • Press the Ink (Ink Management) key to perform a head cleaning operation. • Check the connection of the head flat cables on the main PCB. (If either of those cables is broken or damaged, replace it.) • Check the head property data. (Refer to Chapter 9, Section 9.4.16.) • Replace the head/carriage unit. • Replace the main PCB. • Clean the head caps and wiper of the maintenance unit with a Rubycel stick. For the cleaning procedure, refer to Chapter 8, Section 8.2 "CLEANING THE MAINTENANCE UNIT." • Replace the maintenance unit. • Check that the drain tubes are not bent.
<p>(3) All black</p> 	<p><u>At the scanner</u></p> <p>Check the following components:</p> <ul style="list-style-type: none"> - Scanner cover (CIS flat cable) - Main PCB <p><u>At the printer</u></p> <p>Check the following components:</p> <ul style="list-style-type: none"> - Head/carriage unit and carriage PCB ASSY - Main PCB

Problem	Action to be taken
<p>(4) Light</p> 	<p><u>At the scanner</u></p> <p>Check the following components:</p> <ul style="list-style-type: none"> - Scanner cover (CIS unit) - Main PCB <p><u>At the printer</u></p> <p>Check the following components:</p> <ul style="list-style-type: none"> - Ink cartridges - Head/carriage unit and carriage PCB ASSY - Main PCB - Power supply PCB - Head property info (Refer to Chapter 9, Section 9.4.16.) - Maintenance unit
<p>(5) Dark</p> 	<p><u>At the scanner</u></p> <p>Check the following components:</p> <ul style="list-style-type: none"> - Scanner cover (CIS unit) - Main PCB <p><u>At the printer side</u></p> <ul style="list-style-type: none"> • Perform the purging operation (Function code 76) several times to remove dust or air bubbles from its nozzles. If the problem persists, replace the head/carriage unit. (Refer to Chapter 9, Section 9.4.20.) <p>Check the following components:</p> <ul style="list-style-type: none"> - Ink cartridges - Head/carriage unit and carriage PCB ASSY - Main PCB - Power supply PCB - Head property info (Refer to Chapter 9, Section 9.4.16.) - Maintenance unit
<p>(6) Straight or blurred vertical stripes</p> 	<p><u>Scanner</u></p> <p>Check the following components:</p> <ul style="list-style-type: none"> - Scanner cover (CIS unit) - Scanner glass <p><u>Printer</u></p> <ul style="list-style-type: none"> • Check whether paper is coming into contact with any components other than the ones it should during ejecting. • Check the CR encoder strip for stains or scratches. (If the CR encoder strip is not hooked properly, correct it.)

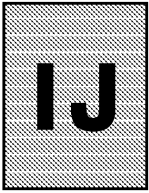
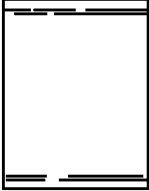
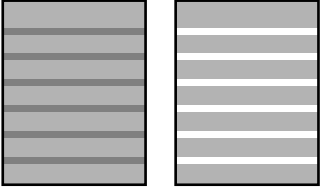
Problem	Action to be taken
<p>(7) Ink splash</p> 	<p><u>Printer</u></p> <ul style="list-style-type: none"> • Perform the purging operation (Function code 76) several times to remove dust or air bubbles from its nozzles. (Refer to Chapter 9, Section 9.4.20.) • Check the ink cartridges. Any of them has run out of ink or the ink viscosity has been increased, so replace it. • Check the head property data (Refer to Chapter 9, Section 9.4.16.) • Check that the main drain tube is not bent. • Replace the head/carriage unit. • Replace the main PCB. • Replace the power supply PCB. • Replace the maintenance unit.
<p>(8) Print edges not aligned</p> 	<p><u>Printer</u></p> <ul style="list-style-type: none"> • Check the alignment of vertical print lines with Function code 65 in the maintenance mode. (Refer to Chapter 9, Section 9.4.14.) • Perform the print head skew compensation with the head skew adjuster knob. Refer to Chapter 7, Section 7.2, [4]. • Check the head/carriage unit. • Check the CR encoder strip for stains or scratches. (If the CR encoder strip is not hooked properly, correct it.) • Correct the positioning error of the head/carriage unit. (Refer to Chapter 7, Section 7.2, [4].) • Check the height adjustment mechanism of the head/carriage unit (Refer to Chapter 3, Section 3.2.2.3.) • If the "head-platen gap offset" is enabled with assurance mode switch AMS 02 (Function code 88), align the vertical print lines (Function code 65). (Refer to Chapter 9, Sections 9.4.23 and 9.4.14.)
<p>(9) Random missing dots</p> 	<p><u>Printer</u></p> <ul style="list-style-type: none"> • Perform the purging operation (Function code 76) several times to remove dust or air bubbles from its nozzles. (Refer to Chapter 9, Section 9.4.20.) • Check the ink cartridges. If any cartridges have run out of ink, replace them. • Check that the carriage-head flat cable is connected to the carriage PCB. • Replace the head/carriage unit. • Check the connection of the head flat cables on the main PCB. (If either of those cables is broken or damaged, replace it.) • Replace the main PCB. • Clean the head caps and wiper of the maintenance unit with a Rubycel stick. For the cleaning procedure, refer to Chapter 8, Section 8.2 "CLEANING THE MAINTENANCE UNIT." • Replace the maintenance unit.

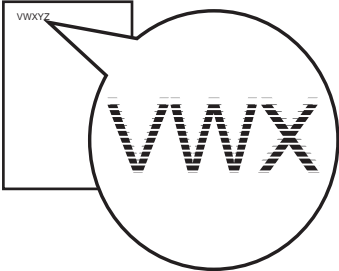
Problem	Action to be taken
<p>(10) White horizontal streaks</p> 	<ul style="list-style-type: none"> • Perform the purging operation (Function code 76) several times to remove dust or air bubbles from its nozzles. (Refer to Chapter 9, Section 9.4.20.) • Replace the head/carriage unit. • Check the paper feed-related rollers. • Perform the print head skew compensation with the head skew adjuster knob. Refer to Chapter 7, Section 7.2, [4]. • Clean the head caps and wiper of the maintenance unit with a Rubycel stick. For the cleaning procedure, refer to Chapter 8, Section 8.2 "CLEANING THE MAINTENANCE UNIT."
<p>(11) Stained leading edge of recording paper</p> 	<p><u>Printer</u></p> <ul style="list-style-type: none"> • Press the Ink (Ink Management) key to perform a head cleaning operation. • Check that the head/carriage unit is set into place. • Check the height adjustment mechanism of the head/carriage unit (Refer to Chapter 3, Section 3.2.2.3.) • If the "head-platen gap offset" is enabled with assurance mode switch AMS 02 (Function code 88), align the vertical print lines (Function code 65). (Refer to Chapter 9, Sections 9.4.23 and 9.4.14.)
<p>(12) Overlapping or separated lines over the whole page</p> 	<ul style="list-style-type: none"> • Adjust the paper feeding correction value of the paper feed roller with Function code 58 in the maintenance mode. (Refer to Chapter 7, Section 7.2, [5].) • Perform the print head skew compensation with the head skew adjuster knob. Refer to Chapter 7, Section 7.2, [4].
<p>(13) Overlapping or separated lines at the trailing edge of the recording paper</p> 	<ul style="list-style-type: none"> • Adjust the paper feeding correction value of the paper ejection roller with Function code 58 in the maintenance mode. (Refer to Chapter 7, Section 7.2, [5].)
<p>(14) Characters having shadows (ghost)</p> 	<ul style="list-style-type: none"> • Adjust the paper feeding correction value of the paper feed roller and paper ejection roller with Function code 58 in the maintenance mode. (Refer to Chapter 7, Section 7.2, [5].) • Correct the positioning error of the head/carriage unit with Function code 63 in the maintenance mode. (Refer to Chapter 7, Section 7.2, [4].) • Replace the PF encoder disk. • Replace the PF encoder PCB.

[4] PC-driven printing problems

Problem	Action to be taken
(1) PC-driven printing is impossible.	<ul style="list-style-type: none"> • Interface with the host computer • PC interface cable • Main PCB • USB interface • Network interface

[5] Printing from memory cards--Compact Flash, Memory Stick, SD Memory Card, or xD-Picture Card

Problem	Action to be taken
(1) No image data can be read.	<ul style="list-style-type: none"> • Insertion direction of memory cards <ul style="list-style-type: none"> - Insert a Compact Flash card, SD Memory Card, or xD-Picture Card with the label side facing up. - Insert a Memory Stick card with the cutout corner leading and facing towards the left. • Memory cards <ul style="list-style-type: none"> - Formatted? - Any data in the memory card? - Images stored in the memory card are in EXIF2.0-compliant JPEG file format (having extension .JPG)? • Main PCB
(2) More than one memory card cannot be recognized.	<ul style="list-style-type: none"> • The machine can recognize only a single memory card at a time even if it has two cards in the two slots. Only the first inserted one can be recognized. <p>If only a single memory card is inserted, refer to item (1) above.</p>
(3) Media printing is impossible.	<ul style="list-style-type: none"> • Check whether the memory is full.

[6] Wireless LAN (WLAN)*

Problem	Action to be taken
(1) PC-driven printing via the wireless LAN is impossible.	Check the following: <ul style="list-style-type: none">- The address has not been changed at both the machine and PC.- Connection between the WLAN PCB and the main PCB- WLAN PCB

*For wireless LAN-enabled models

[7] Others

Problem	Action to be taken
(1) When the power is turned on (when the power cord is plugged into an electrical outlet), the scanner makes a grating noise.	Check the following components: <ul style="list-style-type: none">- Scanner cover (CIS flat cable)- Main PCB

4.2.5 Problems Encountered Frequently in the Past

This section lists the four problems most frequently encountered during on-site service in the past.

- Paper jams
- Error message "MACHINE ERROR 4F"
- Ink-related problems
- Auto document feeder (ADF) failure (For models with ADF)

[1] Paper jams

A paper jam may occur not only due to machine malfunction but also to the user's actions.

IMPORTANT: In some cases, foreign material that has found its way into the machine without the user realizing can be the cause of a paper jam. Instruct the user to place nothing on top of the machine that might fall into it.

Problems due to the user's actions

Check	Possible causes	Problems that may result
Recording paper	Paper not suited to use with the machine was used.	Paper with labels attached, for example, may leave labels inside the machine.
For foreign materials	Fragments of paper that were left behind when previous paper jams occurred. Foreign materials such as tacks have found their way into the machine.	Foreign materials can hinder the paper feed.

Problems due to machine malfunction

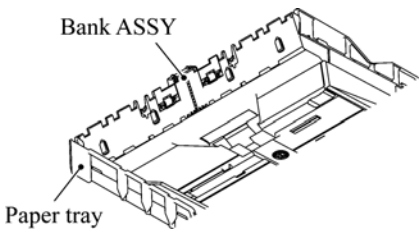
Check	Possible causes	Problems that may result
Star wheels on star wheel support	Star wheels became dislocated when paper jam occurred.	Dislocated star wheels can hinder paper feed.
Sensors and actuators	Any sensor(s) not working.	If a sensor does not turn on, the related roller(s) will not rotate.
Bank ASSY	The bank ASSY is deformed. 	A deformed section on the bank ASSY can cause double-feeding.
CR encoder strip	The CR encoder strip is stained.	A stained CR encoder strip can cause a carriage drive error during printing that will stop the printing operation.

[2] "MACHINE ERROR 4F" error message

The error message "MACHINE ERROR 4F" appears if the head drive voltage drops from the high to low level in an abnormally short period. The source of the problem is mainly the head/carriage unit.

Check	Possible causes	Problems that may result
Head/carriage unit	<ul style="list-style-type: none"> - The carriage-head flat cable is disconnected from the carriage PCB. - Piezoelectric ceramic actuator defective. (Cracks or rare short) 	At the start of printing or head cleaning operation, correct voltage will not be applied to the electrodes on the surface of the piezoelectric ceramic actuator (described in Chapter 3, Section 3.2.2.1).
Main PCB	<ul style="list-style-type: none"> - A power failure when the machine was in operation resulted in a damaged part. - The drive voltage and current supplied are too low to drive the head/carriage unit. - Voltage detection circuit defective. 	<p>The head drive voltage drops from the high to low level in an abnormally short period.</p> <p>The head drive voltage becomes too high or low.</p>
Carriage PCB ASSY	Head power circuit insulation failure.	

[3] Ink-related problems

Problems of this nature may arise not only due to machine malfunction but also to the user's actions.

IMPORTANT: In many cases, the user fails to set ink cartridges in place.

Problems due to the user's actions

Check	Possible causes	Problems that may result
Ink cartridges	<ul style="list-style-type: none"> - Ink cartridges are not inserted fully into the ink refill ASSY. - One or more of the ink cartridges are not loaded. - One or more of the ink cartridges has run out of ink. 	The machine will not be able to print.

Problems due to machine malfunction

Check	Possible causes	Problems that may result
Head/carriage unit	<ul style="list-style-type: none"> - Air bubbles, high viscosity ink, or foreign materials have found their way into the head/carriage unit. - Head flat cables are broken. - The carriage-head flat cable has not been inserted into the carriage PCB. 	<p>Dot missing occurs on the printout.</p> <p>The machine will not be able to print or drive the head/carriage unit.</p>
Maintenance unit	<ul style="list-style-type: none"> - Air bubbles, high viscosity ink, or foreign materials get into the maintenance unit. - Torque not transmitted. - Drain tube bent or pinched. 	Head cleaning operation will not be possible and/or the maintenance unit will not work.
CIS unit	The CIS unit is weak in identifying colors.	The quality of print colors in copying operation will be low.

[4] Auto document feeder (ADF) malfunction (For models with ADF)

An ADF failure may occur not only due to machine malfunction but also to the user's actions.

Problems due to the user's actions

Check	Possible causes	Problems that may result
Document guides	The document guides are not positioned to match the width of document(s) loaded.	Documents will skew.
Inside the ADF	<ul style="list-style-type: none"> - Foreign materials have found their way into ADF. - The size of the document loaded is smaller than the specified size. 	<p>Foreign materials can hinder document feeding.</p> <p>The document will jam inside the ADF.</p>

Problems due to machine malfunction

Check	Possible causes	Problems that may result
ADF	The spring plates of the ADF parts are deformed.	Documents will stop halfway through feeding.
	The ADF parts are deformed or worn.	Two or more sheets of documents will be fed through at once.
Document rear sensor	<ul style="list-style-type: none">- The document rear sensor is defective.- The document rear sensor actuator is deformed.	Documents will stop halfway through feeding or the machine will not be able to recognize them.
ADF motor	The ADF motor does not rotate.	Documents will not be able to be drawn in.
Main PCB	The motor driver IC is defective.	Documents will not be able to be drawn in.

4.2.6 Possible Component Defects and Resulting Problems

This section lists possible component defects and what happens due to them. It also describes what happens if the necessary adjustments or data settings into the memories is not made.

[1] ADF mechanism (For models with ADF)

Defective component	Result	Error codes
ADF motor	- Document will not be able to be fed.	---
Document feed rollers 1, 2	- Documents will jam. - Documents will skew. - Documents will not be able to be fed.	A2, A3
Separation pad	- Two or more sheets of documents will be fed at once.	---
Document front sensor actuator	- Document draw-in operation will not start even though documents have been set.	A3
Document rear sensor actuator	- Document draw-in operation will continue even though all documents have been fed into the machine.	A2, A3

[2] Scanner mechanism

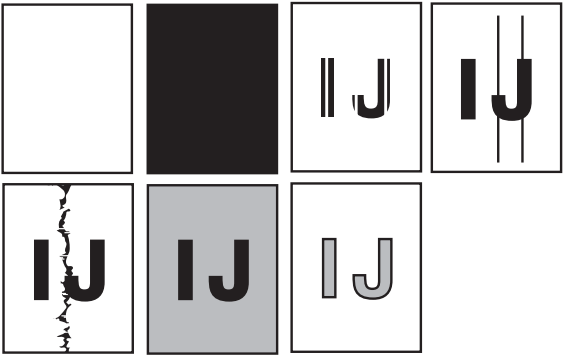
Defective component	Result	Error codes
CIS unit	<p>- Any of the following images may appear on the printout:</p>  <p>- When the power is turned on, abnormal noises will be heard from the machine.</p> <p>- Any of the following errors occurs:</p> <ul style="list-style-type: none"> - Dark level offset data level error for scanning - Gain control data level error for scanning - Scan area right/left edge detection error - Horizontal scanning edge reduction/enlargement detection error in scanning area setting - White/black level data error - Scan starting edge detection error 	BD
CIS flat cable	<p>- When the power is turned on, the "Unable to Init AF" (for models with color LCD) or "Init Unable AF" (for models with monochrome LCD) appears on the LCD.</p>	---
Scanner drive unit	<p>- When the power is turned on, abnormal noises will be heard from the machine.</p>	---

[3] Head/carriage unit drive and purge mechanisms

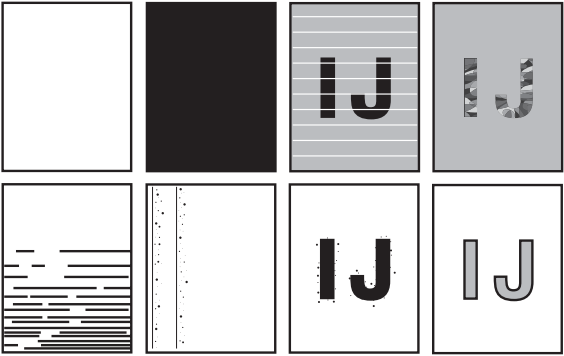
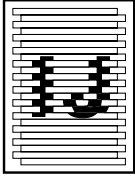
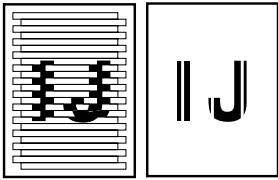
Defective component	Result	Error codes
Head/carriage unit	<ul style="list-style-type: none"> - Any of the following images may appear on the printout: 	---
Carriage motor	<ul style="list-style-type: none"> - The head/carriage unit will not be able to travel normally. - When the power is turned on, the following appears on the LCD. "Unable to Init 3*" (for models with color LCD) "Init Unable 3*" (for models with monochrome LCD) - The following image may appear on the printout: 	30, 31, 32, 33
CR encoder strip	<ul style="list-style-type: none"> - The head/carriage unit will not be able to travel normally. - Any of the following images may appear on the printout: 	30, 31, 32, 33
Ink cartridge PCB	<ul style="list-style-type: none"> - The "Ink Empty XX" message will appear even though there is ink. - Even though the ink has run out, the "Ink Empty XX" message will not appear. 	26, 27, 28, 29
Paper width sensor	- A paper jam will occur.	80, 82
	- Print on the platen without paper.	---

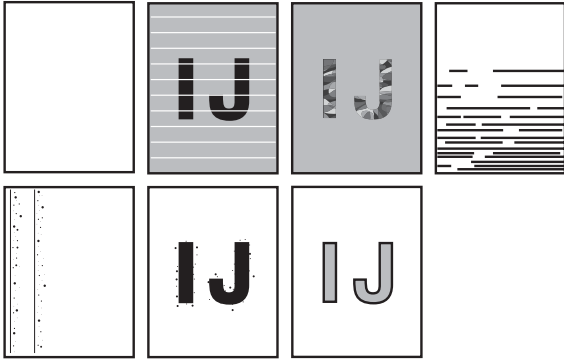
Defective component	Result	Error codes
Maintenance unit Head caps or wiper	- Any of the following images may appear on the printout: 	---
Tube pump	- The tube pump will not draw out ink from the head nozzles.	---
Purge cam switch	- The purge cam switch will not detect the purge cam ON/OFF timing.	50, 51, 52

[4] Print head mechanism

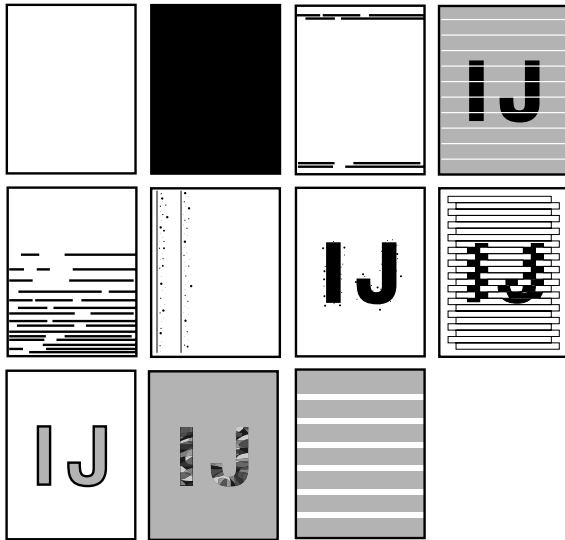
Defective component	Result	Error codes
Head/carriage unit and carriage PCB ASSY	- Any of the following images may appear on the printout: 	---

[5] Sheet feeder (SF) mechanism

Defective component	Result	Error codes
Bank ASSY (shown on page 4-28)	<ul style="list-style-type: none"> - Two or more sheets of paper will be fed at once. - No paper will be fed. 	82, 83, 88

[6] Paper feeding mechanism

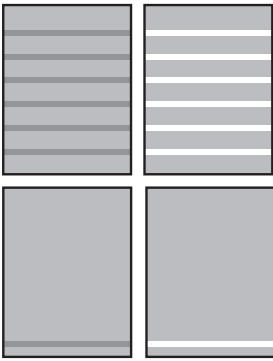
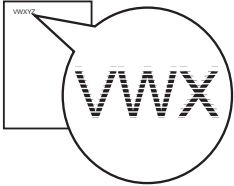
Defective component	Result	Error codes
Paper feed roller Paper ejection roller (If the paper feed roller or paper ejection roller is defective, it is necessary to replace the engine unit.)	<ul style="list-style-type: none"> - Any of the following images may appear on the printout: 	---
PF encoder disk PF encoder sensor	<ul style="list-style-type: none"> - The following image may appear on the printout: 	---

[7] Control panel and LCD

Defective component	Result	Error codes
Rubber keypad	- Keys will not work.	---
Control panel PCB	- The monochrome LCD will show nothing. *1 - Keys will not work. - The LED will not light.	---
Color LCD *2	The color LCD will show nothing.	---

*1 For models with monochrome LCD

*2 For models with color LCD

[8] PCBs

Defective component	Result	Error codes
Main PCB	- Copying will not be possible. - PC-driven printing will not be possible. - Scanning will not be possible. - The machine will not be able to be turned on. - Any of the following images may appear on the printout: 	---
Power supply PCB	- The machine will not be able to be turned on. - The LED will not light. - The LCD will show nothing.	---

[9] Adjustments/data in the memories

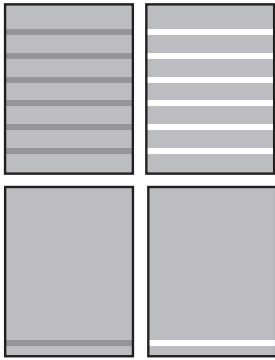
Adjustment/data setting error in the following components:	Result	Refer to:	Error codes
EEPROM customizing code	- The machine will not work as specified for that model or that shipping destination.	- Chapter 9, Section 9.4.18 - Appendix 3	
ID code	- The machine will not be able to be identified by the PC connected to it via USB.	- Chapter 7, Section 7.3, [8]	
Head property data (in the EEPROM)	- The print quality will deteriorate.	- Chapter 7, Section 7.2, [1] - Chapter 9, Section 9.4.16	
Correction of head positioning error	<p>- Any of the following images may appear on the printout:</p> 	- Chapter 7, Section 7.2, [4]	
Updating of the paper feeding correction value for the paper feed roller/paper ejection roller (Function code 58)	<p>- Any of the following images may appear on the printout:</p> 	- Chapter 7, Section 7.2, [5] - Chapter 9, Section 9.4.11	
Setting of the CIS scanner area	<p>- The white and black level data will not be compensated properly.</p> <p>- The scanning center position will not be centered.</p> <p>- The enlargement/reduction ratio of copies will go wrong.</p>	- Chapter 9, Section 9.4.10	

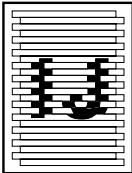
Adjustment/data setting not performed	Result	Refer to:	Error codes
Alignment of vertical print lines	<p data-bbox="555 383 1011 450">- The following image may appear on the printout:</p> 	<ul style="list-style-type: none"> <li data-bbox="1054 383 1278 450">- Chapter 7, Section 7.2, [6] <li data-bbox="1054 456 1251 524">- Chapter 9, Section 9.4.14 	

CHAPTER 5

TRANSFER OF DATA LEFT IN THE MACHINE TO BE SENT FOR REPAIR

This chapter is not applicable to the models covered by this manual.

CHAPTER 6

DISASSEMBLY/REASSEMBLY AND LUBRICATION

CHAPTER 6 DISASSEMBLY/REASSEMBLY AND LUBRICATION

This chapter details procedures for disassembling and reassembling the machine together with related notes. The disassembly order flow provided enables you to see at a glance the quickest way to get to component(s) involved.

At the start of a disassembly job, you check the disassembly order flow that guides you through a shortcut to the target components.

This chapter also covers screw tightening torques and lubrication points to which the specified lubricants should be applied during reassembly jobs.

◆The illustrations in this chapter are based on models with ADF.

CONTENTS

6.1	DISASSEMBLY/REASSEMBLY	6-1
	■ Safety Precautions	6-1
	■ Tightening Torque	6-2
	■ Preparation	6-3
	■ How to Access the Target Component	6-3
	■ Disassembly Flowchart	6-4
6.1.1	Jam Clear Cover	6-5
6.1.2	Scanner Cover (Scanner Unit).....	6-6
6.1.3	Document Cover (ADF & Document Cover ASSY*).....	6-12
6.1.4	Disassembly of ADF & Document Cover ASSY (Only for models with ADF) ...	6-15
6.1.5	Control Panel ASSY, Scanner Cover Sensor Actuator, Ink Cartridge Cover Sensor Actuator, and Cover Sensor PCB	6-23
6.1.6	Components of Control Panel ASSY	6-25
6.1.7	Upper Cover.....	6-29
6.1.8	Ink Cartridge Cover, Media Module Cover, Front Cover, and WLAN PCB*	6-30
6.1.9	Main PCB.....	6-32
6.1.10	MJ/PS Shield Box and Power Supply PCB	6-37
6.1.11	Head/Carriage Unit and Ink Refill ASSY	6-40
6.1.12	Ink Absorber Box, Ink Absorber Felt, and PF Encoder Disk	6-52
6.1.13	Engine Unit and Flushing Box	6-54
6.1.14	Components on the Engine Unit (Maintenance unit, Mode switching lever & clutch gear ASSY, Carriage motor, Inner chute ASSY, Registration sensor PCB, PF encoder PCB, Paper feed motor, Paper pull-in gear shaft, and Paper pull-in roller holder)	6-58
6.1.15	Paper Tray ASSY.....	6-64

6.1.16 Routing of the Harnesses, Flat Cables, and Ink Supply Tubes.....	6-66
6.2 LUBRICATION	6-73

6.1 DISASSEMBLY/REASSEMBLY

■ Safety Precautions

To prevent the creation of secondary problems by mishandling, observe the following precautions during maintenance work.

- (1) Before replacing parts or units, unplug the power cord.

In particular, when having access to the power supply or main PCB inside the machine, make sure that the power cord is unplugged from the electrical outlet.

- (2) Be careful not to lose screws, washers, or other parts removed for parts replacement.
- (3) When using soldering irons and other heat-generating tools, take care not to damage the resin parts such as wires, PCBs, and covers.
- (4) Static electricity charged in your body may damage electronic parts.

Before handling the PCBs, touch a metal portion of the machine to discharge static electricity charged in your body. When transporting PCBs, be sure to wrap them in conductive sheets.

When replacing the head/carriage unit, put on a grounding wrist band and perform the job on a static mat. Also take care not to touch the conductor sections on the flat cables.

- (5) Be sure to reinsert self-tapping screws correctly, if removed.
- (6) Tighten screws to the torque values listed on the next page.
- (7) When connecting or disconnecting cable connectors, hold the connector bodies not the wires. If the connector has a lock, always slide the connector lock to unlock it.
- (8) Before reassembly, apply the specified lubricant to the specified points. (Refer to [Section 6.2](#) in this chapter.)
- (9) After repairs, check not only the repaired portion but also that the connectors and other related portions function properly before operation checks.
- (10) Once the head/carriage unit prints, it will start head locking operation after five seconds from the end of printing. The head locking operation will take 5 to 10 seconds. NEVER unplug the power cord before the machine completes the head locking operation; doing so will make the head/carriage unit unusable and require replacement with a new head/carriage unit.

When you receive the machine from the user or when you pack it for sending it back to the user, check the head locking state.

■ Tightening Torque

Location of screw	Screw type	Q'ty	Tightening torque N•m (kgf•cm)
Grounding wire* ¹ (for ADF motor)	Screw, bind M3x6	1	0.40 ±0.1 (4 ±1)
ADF reinforcement plate* ¹	Taptite, cup B M3x8	1	0.50 ±0.1 (5 ±1)
ADF unit* ¹	Taptite, bind B M4x12	3	0.70 ±0.1 (7 ±1)
	Taptite, cup B M3x8	1	0.50 ±0.1 (5 ±1)
ADF motor* ¹ (Together with grounding wire* ¹ using one screw)	Screw, pan (s/p washer) M3x6	2	0.70 ±0.1 (7 ±1)
Document roller holder * ¹	Taptite, cup B M3x10	1	0.50 ±0.1 (5 ±1)
Control panel ASSY	Taptite, cup B M3x10	3	0.40 ±0.1 (4 ±1)
Color LCD support cover* ²	Taptite, bind B M3x8	2	0.40 ±0.1 (4 ±1)
Upper cover	Taptite, bind B M4x12	6	0.70 ±0.1 (7 ±1)
	Taptite, cup B M3x10	1	0.40 ±0.1 (4 ±1)
Grounding wire (for WLAN PCB)* ³ (Together with main PCB shield frame)	Screw, pan (s/p washer) M3x8	1	0.40 ±0.1 (4 ±1)
Main PCB shield	Taptite, cup B M3x10	2	0.40 ±0.1 (4 ±1)
	Taptite, cup S M3x6* ²	2	0.40 ±0.1 (4 ±1)
Main PCB	Taptite, cup S M3x6	4 (2)* ⁴	0.40 ±0.1 (4 ±1)
Main PCB shield frame (Together with MJ/PS shield box)	Screw, pan (s/p washer) M3x8	1	0.40 ±0.1 (4 ±1)
MJ/PS shield box	Screw, pan (s/p washer) M3x8	1	0.40 ±0.1 (4 ±1)
	Taptite, cup S M3x6	1	0.40 ±0.1 (4 ±1)
Power cord holder* ⁵	Taptite, cup B M3x12	1	0.60 ±0.1 (6 ±1)
Power supply PCB	Taptite, cup S M3x6	4	0.40 ±0.1 (4 ±1)
Flat cable support plate	Taptite, bind B M4x12	1	0.70 ±0.1 (7 ±1)
Chassis support	Taptite, cup B M3x12	1	0.60 ±0.1 (6 ±1)
Engine unit	Taptite, cup B M3x12	1	0.60 ±0.1 (6 ±1)
Maintenance unit (top) (right side)	Taptite, bind B M3x8	2	0.40 ±0.1 (4 ±1)
	Taptite, cup S M3x6	1	0.80 ±0.1 (8 ±1)
Carriage motor	Screw, bind M3x6	2	0.70 ±0.1 (7 ±1)
PF encoder PCB	Screw, bind M2x12	1	0.20 ±0.1 (2 ±1)
Paper feed motor	Screw, bind M2.6x4	2	0.40 ±0.1 (4 ±1)

*¹ For models with ADF

*² For models with color LCD

*³ For wireless LAN-enabled models

*⁴ Four screws for models with color LCD
Two screws for models with monochrome LCD

*⁵ For 120V series

■ Preparation

Prior to proceeding with the disassembly procedure,

- (1) Unplug the following:
 - Power cord from the electrical outlet
 - USB cable, if connected
 - LAN cable*, if connected
 - USB cable from the PictBridge jack, if connected

*For wired LAN-enabled models

- (2) Remove the paper tray ASSY.
- (3) Remove memory cards if inserted in the machine.

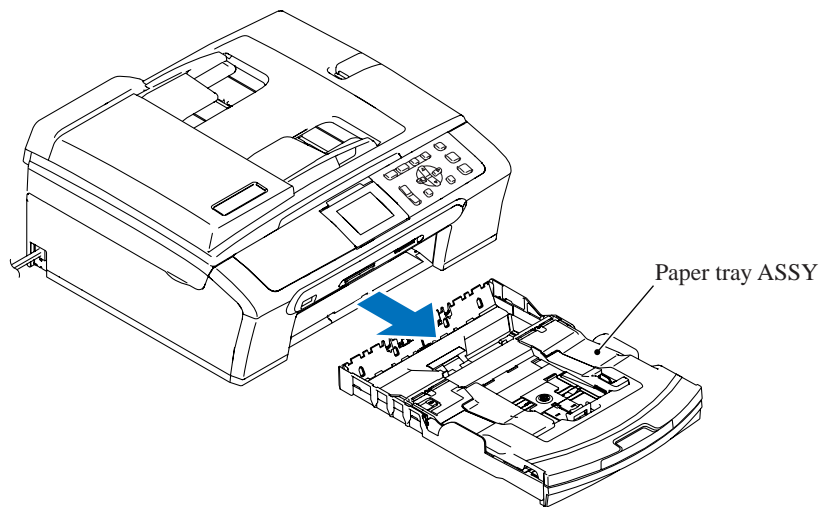

(6_01)

- (4) Remove all four ink cartridges and set the protective part instead.

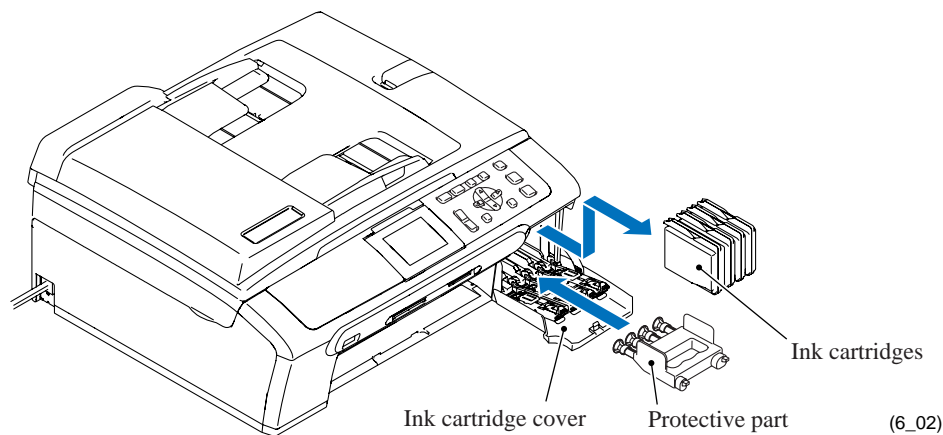

(6_02)

■ How to Access the Target Component

- On the next page is a disassembly flowchart which helps you access the target components. To remove the maintenance unit, first find it on the flowchart and note its number (6.1.14 in this case). To access it, you need to remove all the parts above the maintenance unit on the flowchart (6.1.1, 6.1.2, 6.1.5, 6.1.7, 6.1.11 and 6.1.13 in this case) before the unit itself can be removed.
- Unless otherwise specified, all parts should be replaced in the opposite order to which they were removed to reassemble the machine.

Disassembly Flowchart

Disassembly/reassembly
standard time (seconds)

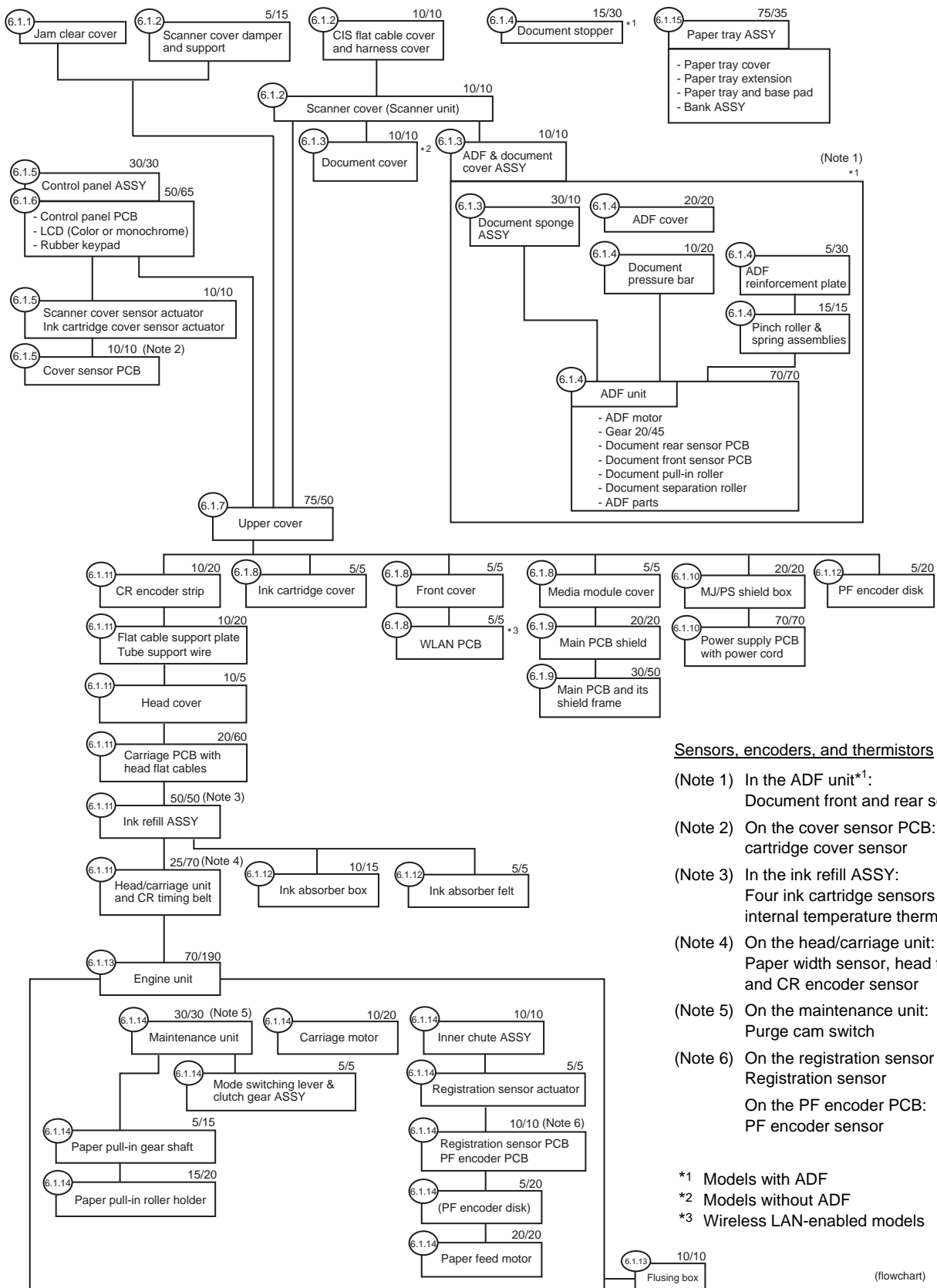

6.1.1 Jam Clear Cover

- (1) Pull the jam clear cover to unlatch the two lock arms at both sides.

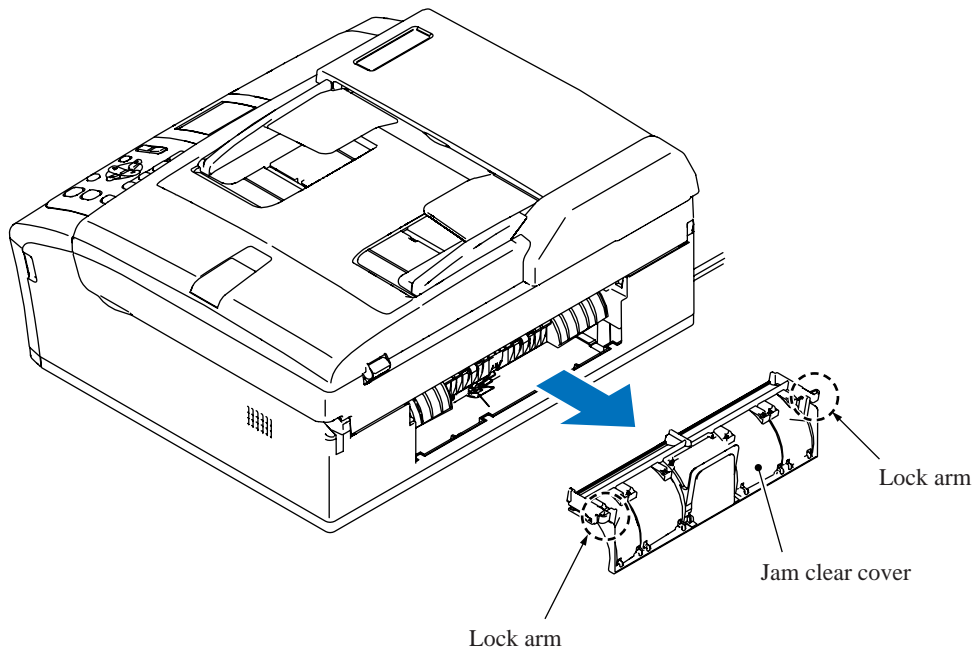

(6_03)

6.1.2 Scanner Cover (Scanner Unit)

The scanner cover should be removed together with the document cover (ADF & document cover ASSY*) whose removal procedure is given in [Section 6.1.3](#). The disassembly of the ADF & document cover ASSY* is detailed in [Section 6.1.4](#).

*For models with ADF

- (1) Open the scanner cover until it locks.
- (2) Remove the CIS flat cable cover and the harness cover by inserting the tip of a flat screwdriver into the slots and releasing the latches.

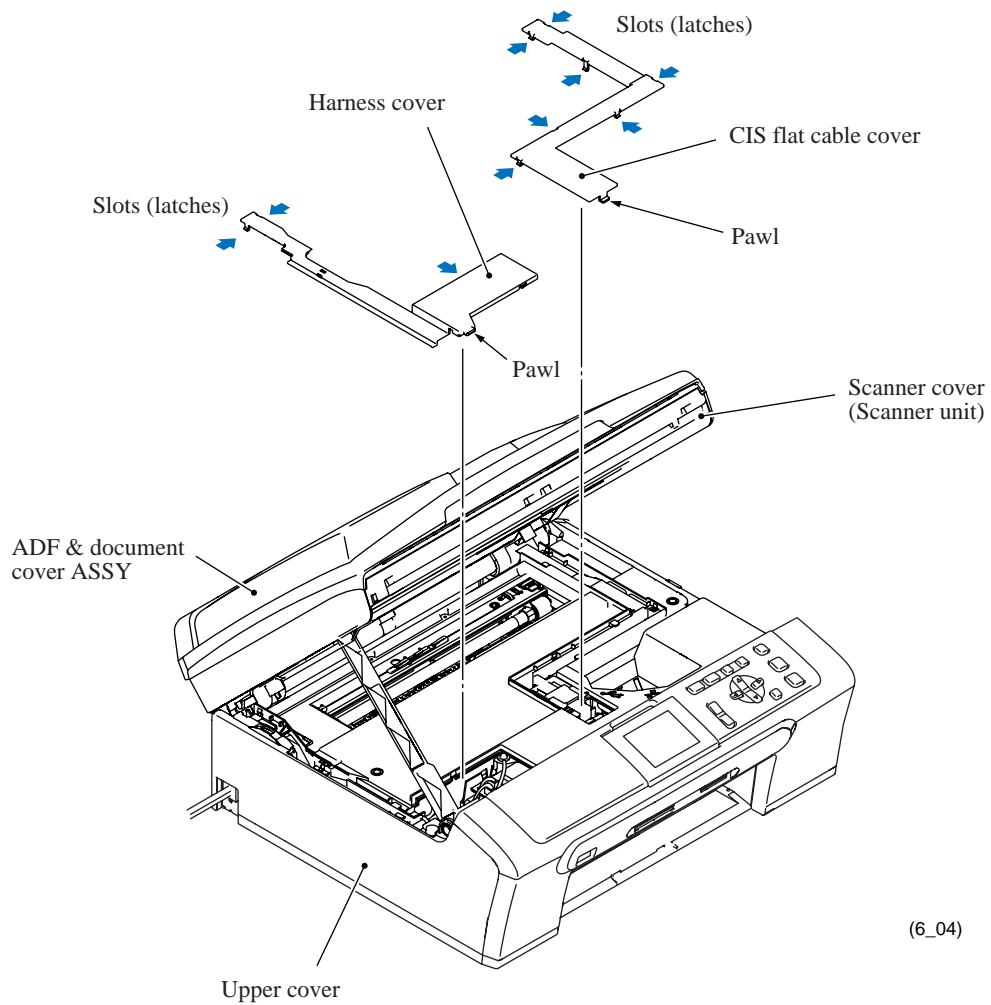

(6_04)

- (3) Disconnect the CIS flat cable from the main PCB, pull it to the rear through the flat core, and then release it from the cable guides. Unlatch the flat core and take it out of the upper cover.
- (4) Disconnect the following harnesses from the main PCB.
 - CIS motor harness
 - ADF motor harness*
 - Document front sensor harness*
 - Document rear sensor harness*
- (5) Release the grounding wire* by removing the screw.

*For models with ADF

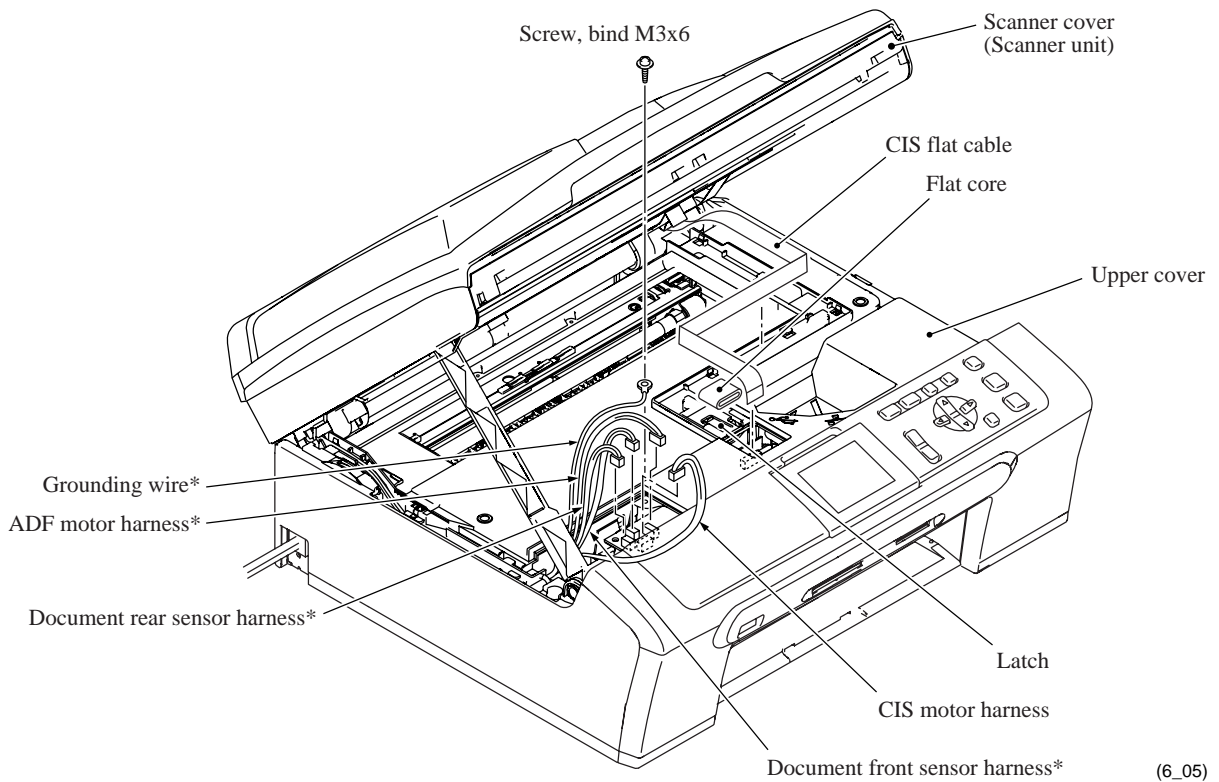

(6_05)

DCP750CW

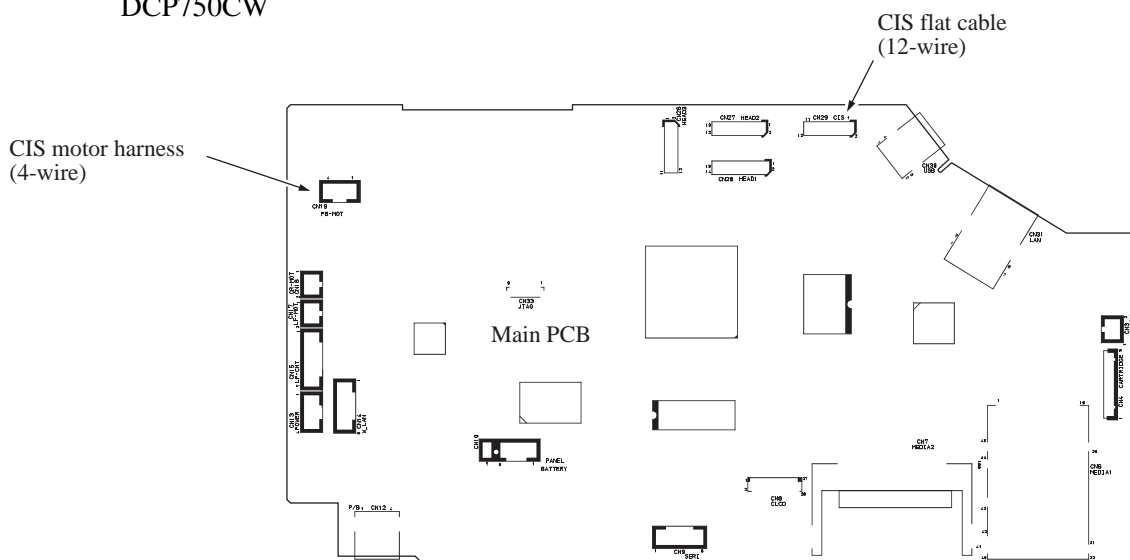

(6_06_750CW)

DCP540CN/330C

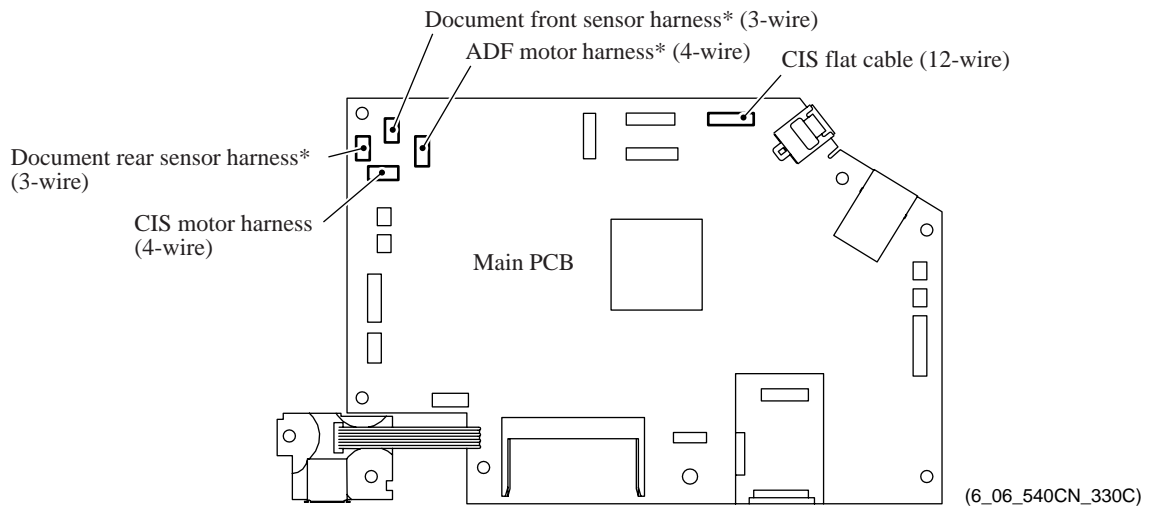

*For models with ADF

DCP130C

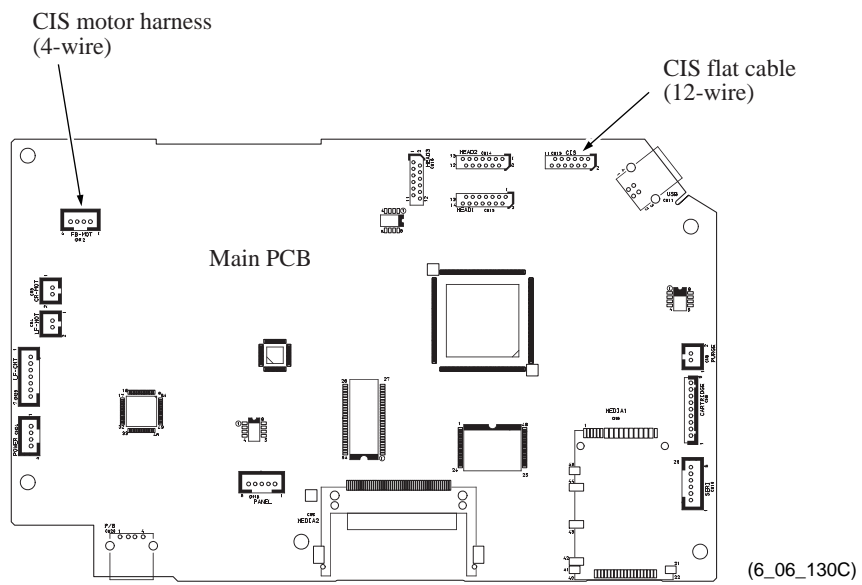

- (6) While supporting the scanner cover by hand, press the lock arm and release the front end of the scanner cover support from the upper cover.
- (7) Release the harnesses from the cable guides provided at the left end of the upper cover.

*For models with ADF

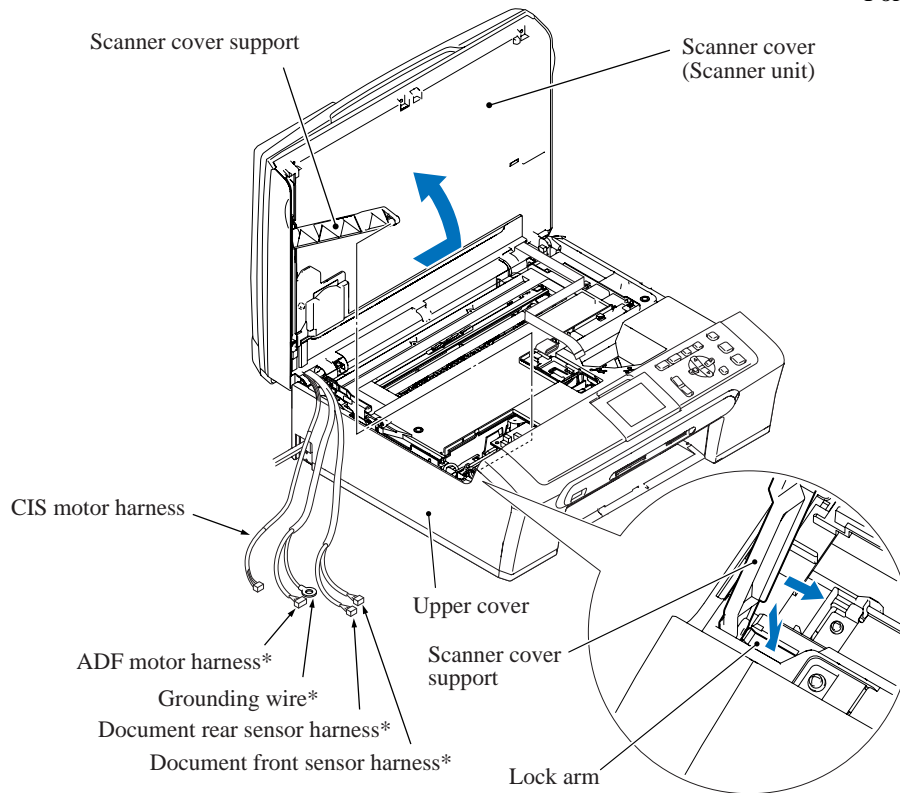

(6_07)

- (8) Open the scanner cover at approx. 90° and pull it to the rear and off the machine.

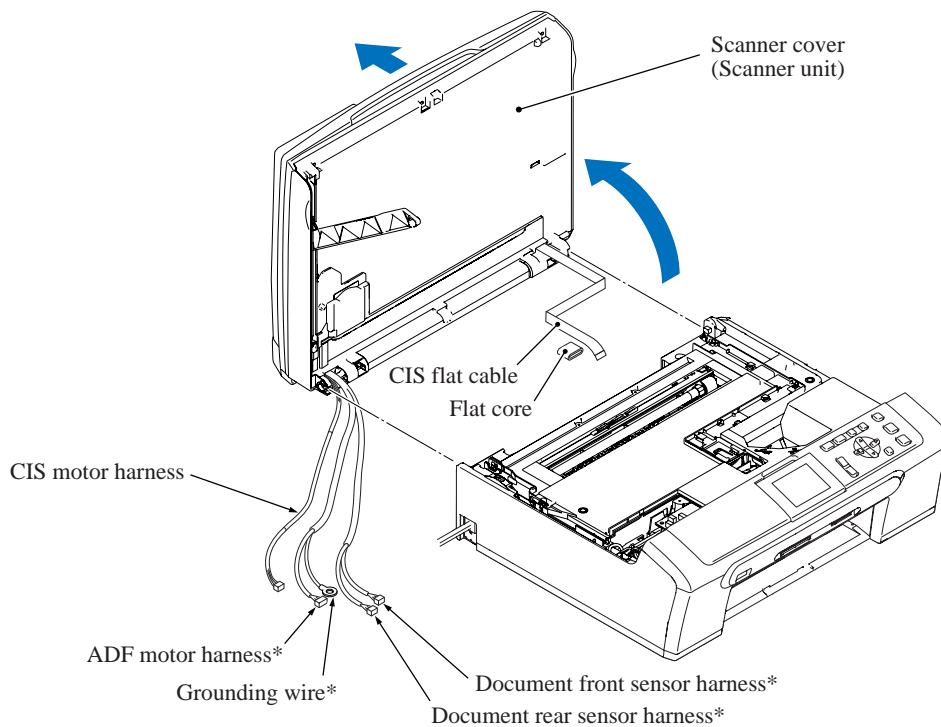

(6_08)

- (9) Place the scanner cover upside down.
- (10) To prevent the scanner cover support and damper from getting broken, remove them from the scanner cover as follows.
Release the lock arm of the scanner cover damper from the scanner cover and pull out the damper in the direction of arrows shown below. The scanner cover support also comes off.

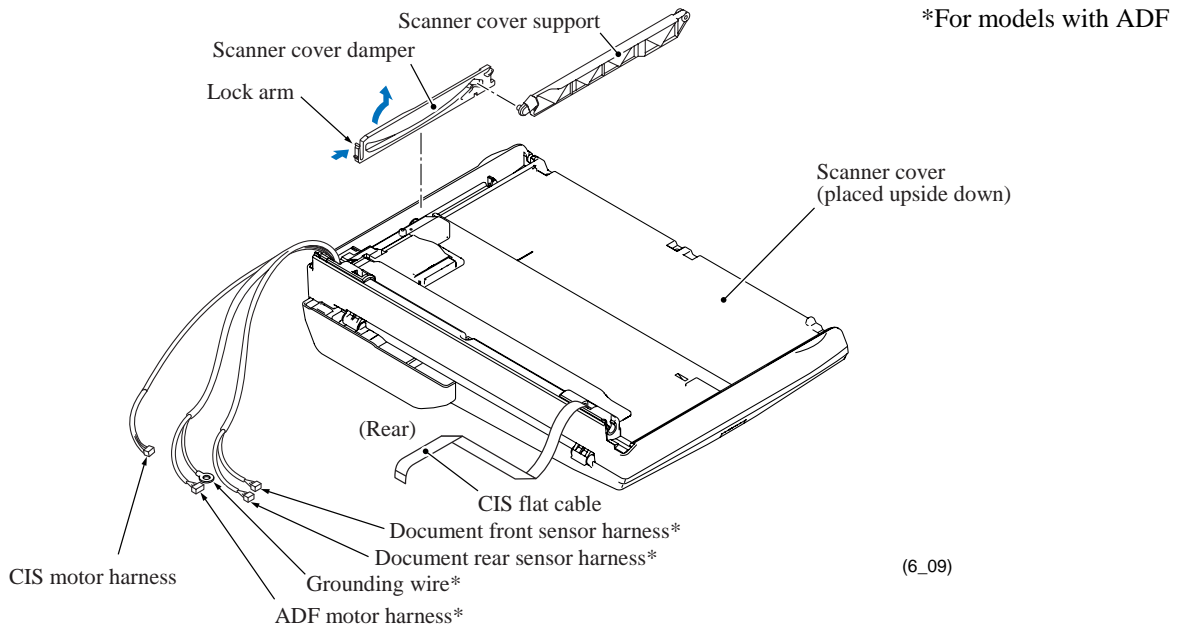

■ Assembling Notes

- Route the CIS motor harness, document front and rear sensor harnesses*, ADF motor harness* and grounding wire* as shown below and on the next page. (*For models with ADF)
- If you replace the scanner cover, check the CIS type (Canon, Rohm, or Lite-On) printed on the CIS bar code label on the new scanner cover and enter it to the EEPROM (Function code 59), referring to [Chapter 9, Section 9.4.12](#).

After that, acquire the white level data and set the CIS scanner area (Function code 55), referring to [Chapter 9, Section 9.4.10](#).

DCP750CW

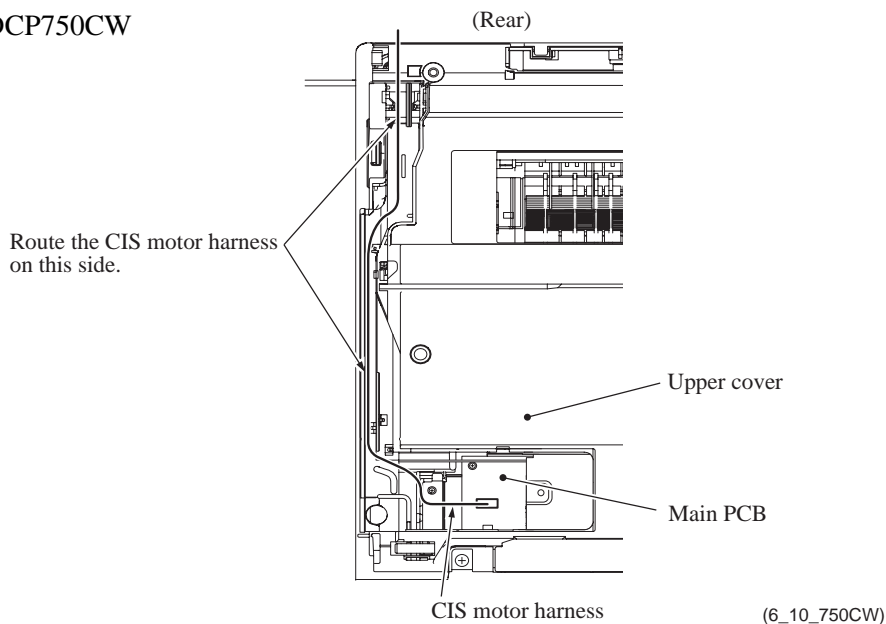

DCP540CN/330C

*For models with ADF

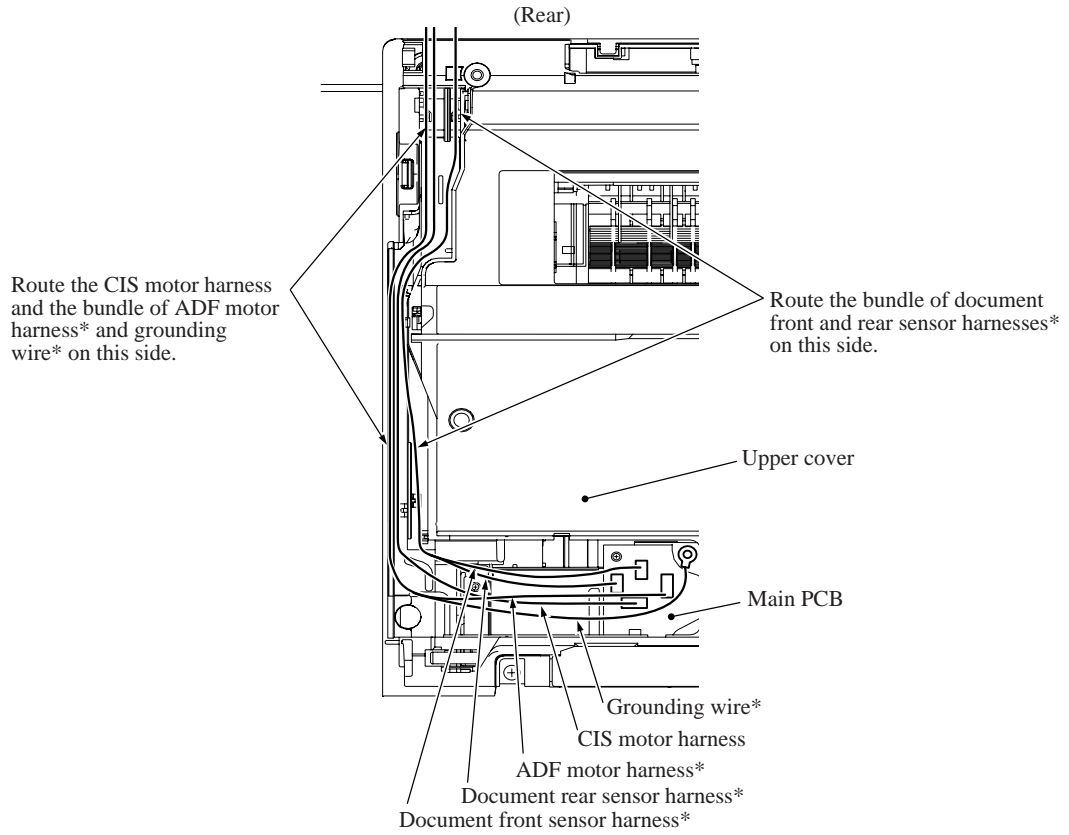

(6_10_540CN_330C)

DCP130C

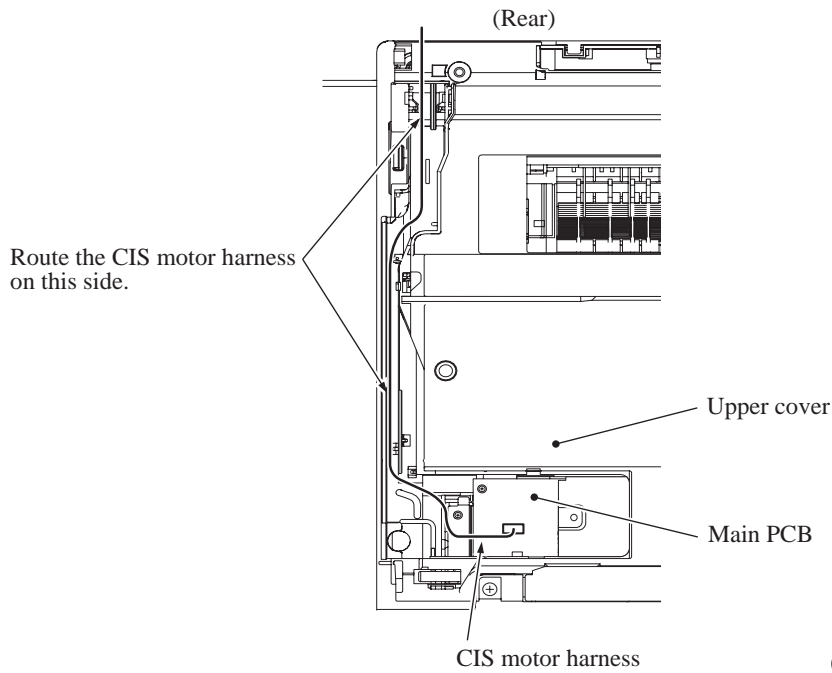

(6_10_130C)

6.1.3 Document Cover (ADF & Document Cover ASSY*)

- (1) Release the bundle of harnesses (ADF motor harness*, grounding wire*, and document front and rear sensor harnesses*) from the cable guide in the rear corner of the scanner cover as shown below.

*For models with ADF

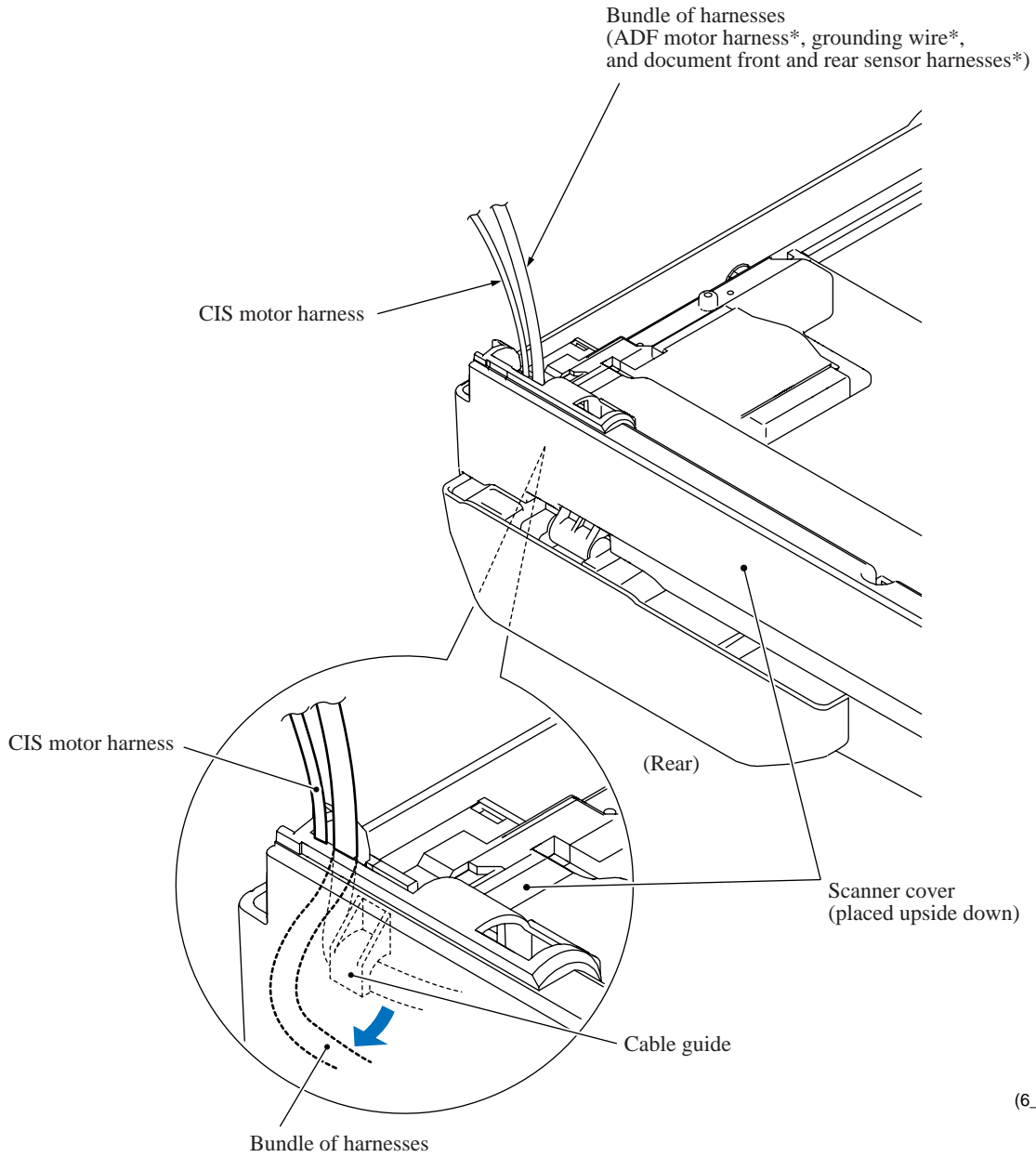

(6_12)

(2) Place the scanner cover right side up.

(3) **Models with ADF:** Turn the ADF & document cover ASSY upright. Slightly lift up the ASSY and press both ends of hinge R inwards to separate hinge R from the scanner cover.

Slightly lift up the ASSY and unlatch hinge L from the scanner cover with the tip of a flat screwdriver as shown below.

To remove those hinges from the ASSY, turn them slightly.

NOTE: Hinge L holds the bundle of harnesses (ADF motor harness*, grounding wire*, and document front and rear sensor harnesses*) even if it is removed from the ASSY. If it is not easy to remove hinge L from the bundle of harnesses, try it after separating the ADF unit from the document cover (see [page 6-17](#)).

Other models: Turn the document cover upright, unlatch the two hinges, and lift up the cover.

*For models with ADF

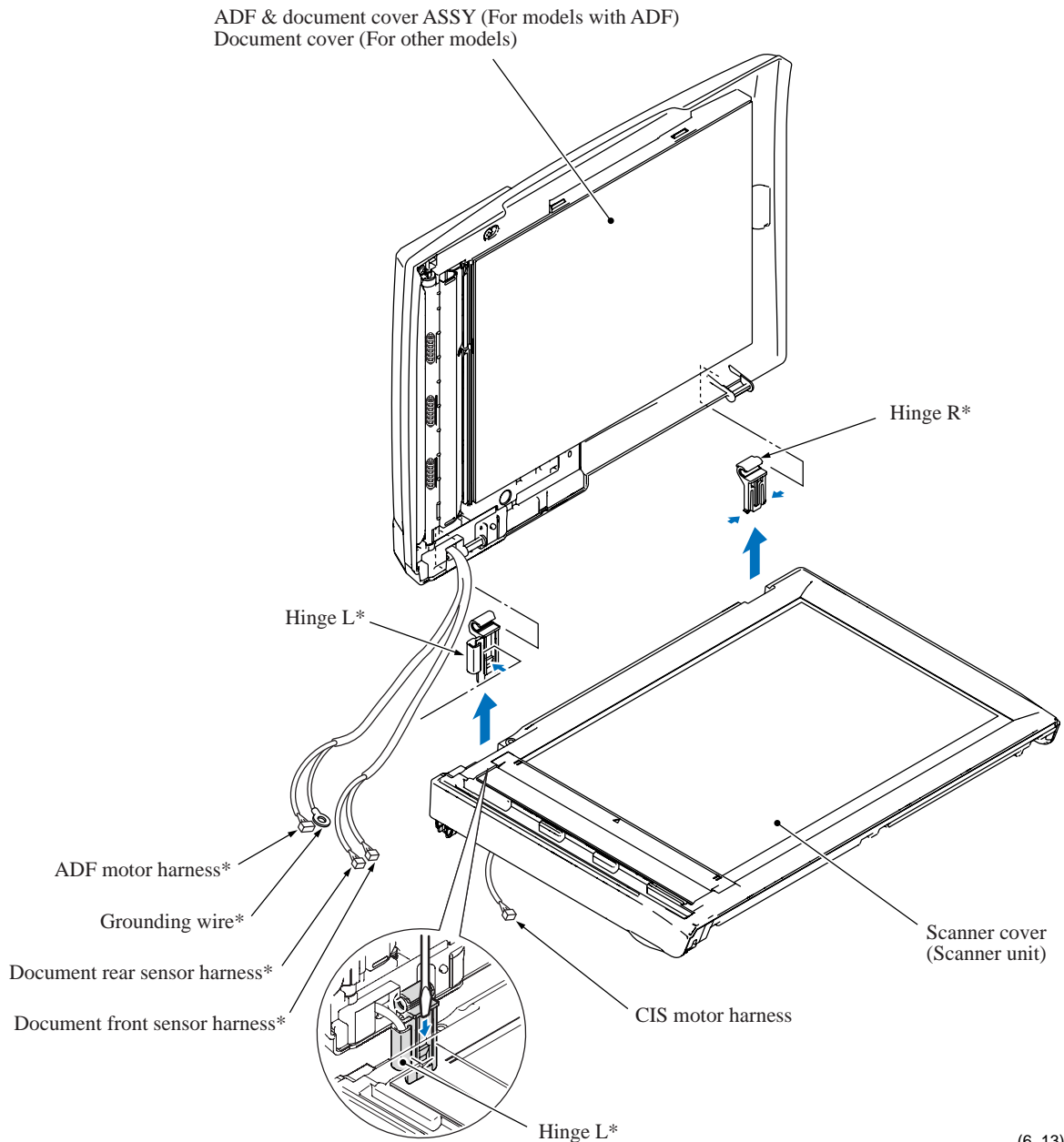

(6_13)

- (4) **Models with ADF:** Remove the document sponge ASSY by releasing the four latches with a flat screwdriver.

*For models with ADF

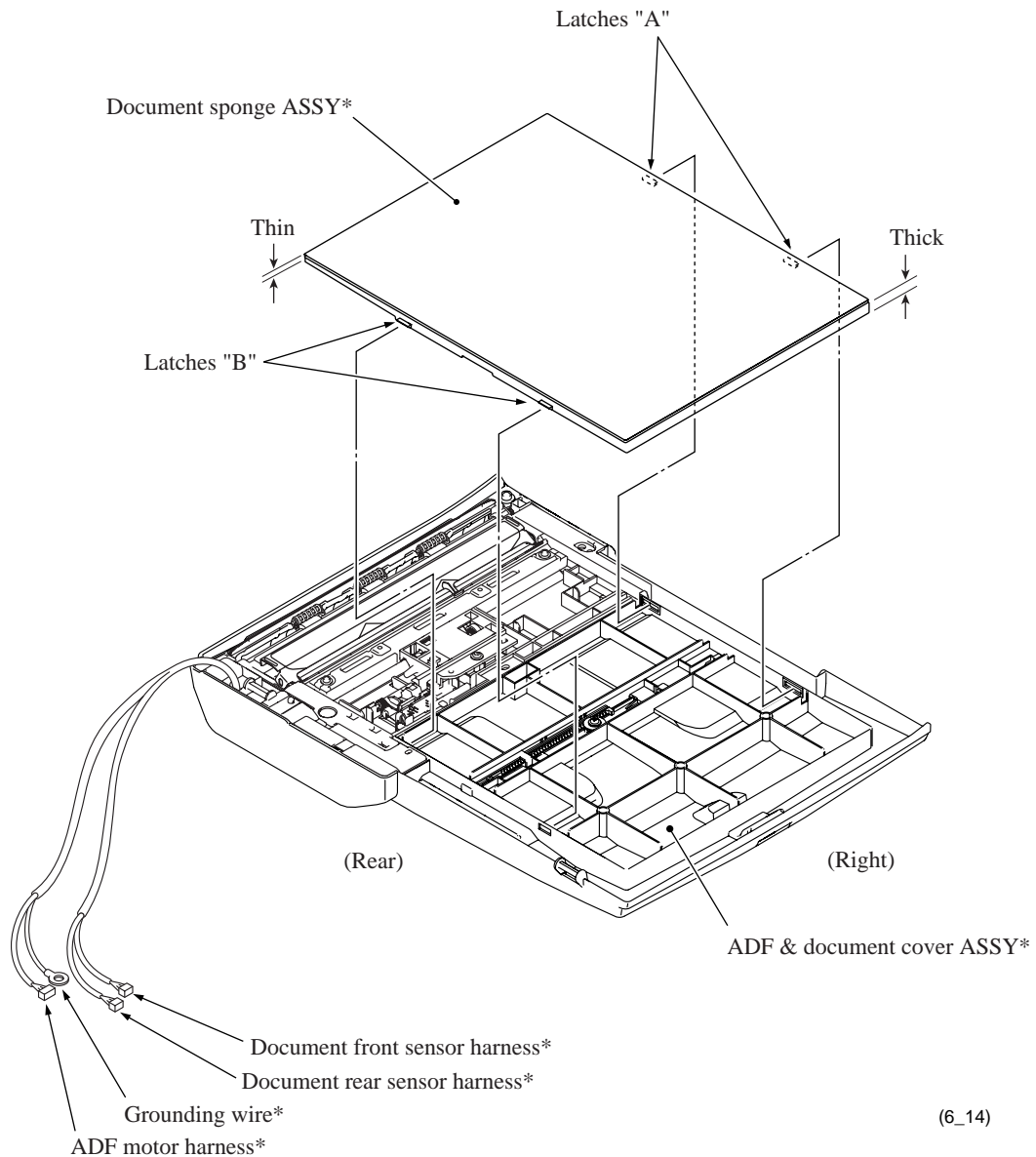

■ **Assembling Notes**

- **Models with ADF:** When mounting the document sponge ASSY on the ADF & document cover ASSY, face the thick side towards the right and insert latches "A" into the document cover first, and then set latches "B" as shown above.
- **Models with ADF:** When mounting the ADF & document cover ASSY on the scanner cover, be sure to route a bundle of harnesses (ADF motor harness*, grounding wire*, and document front and rear sensor harnesses*) through the cable guide provided in the left rear corner of the scanner cover as shown on [page 6-12](#).

6.1.4 Disassembly of ADF & Document Cover ASSY (Only for models with ADF)

ADF cover and document stopper

- (1) Place the ADF & document cover ASSY right side up as shown below.
- (2) Pull up the left end of the ADF cover to open and turn it upright.
- (3) Pull the front end of the ADF cover outwards to release it from the front boss provided on the document cover.
- (4) Turn the front end of the ADF cover to the left slightly and release the rear end from the rear boss on the document cover.
- (5) Remove the document stopper.

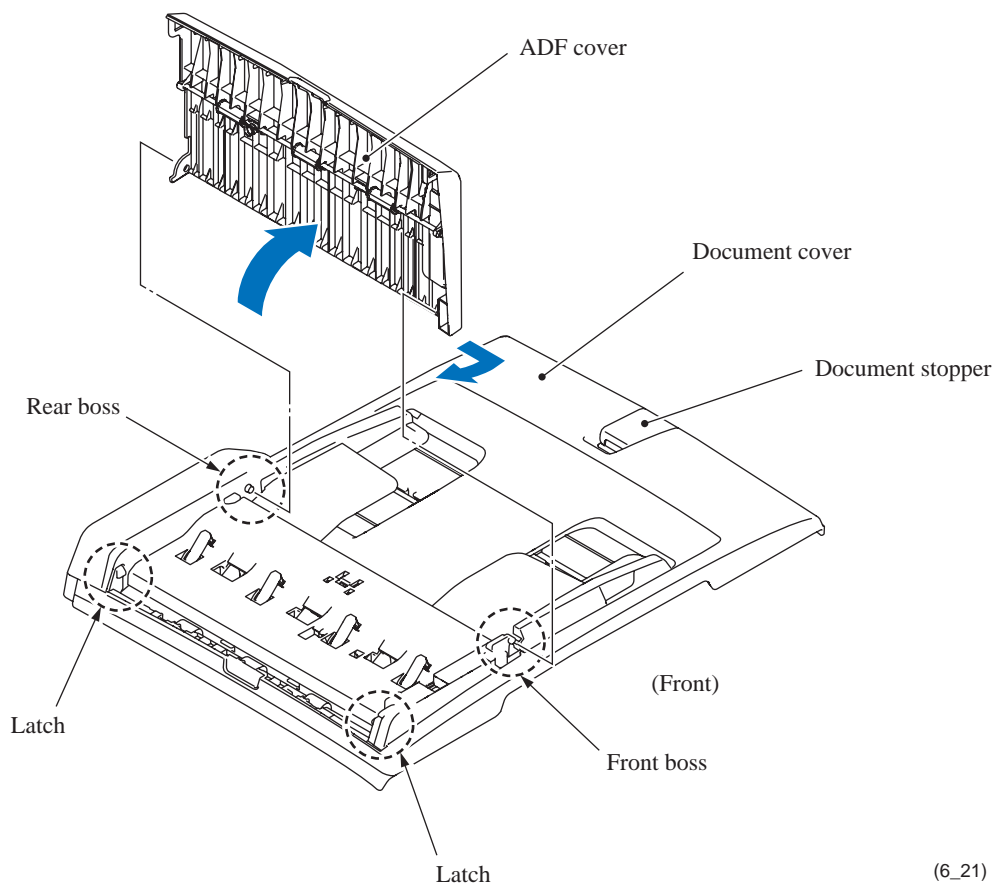

(6_21)

Document pressure bar

- (6) Place the ADF & document cover ASSY upside down.
- (7) Press the lock arms on the ADF unit outwards, push the document pressure bar once to release the two tabs from the square openings, and pull it out. The spring also comes off.

NOTE: When handling the document pressure bar, take care not to stain or scratch the white reference film on the bar.

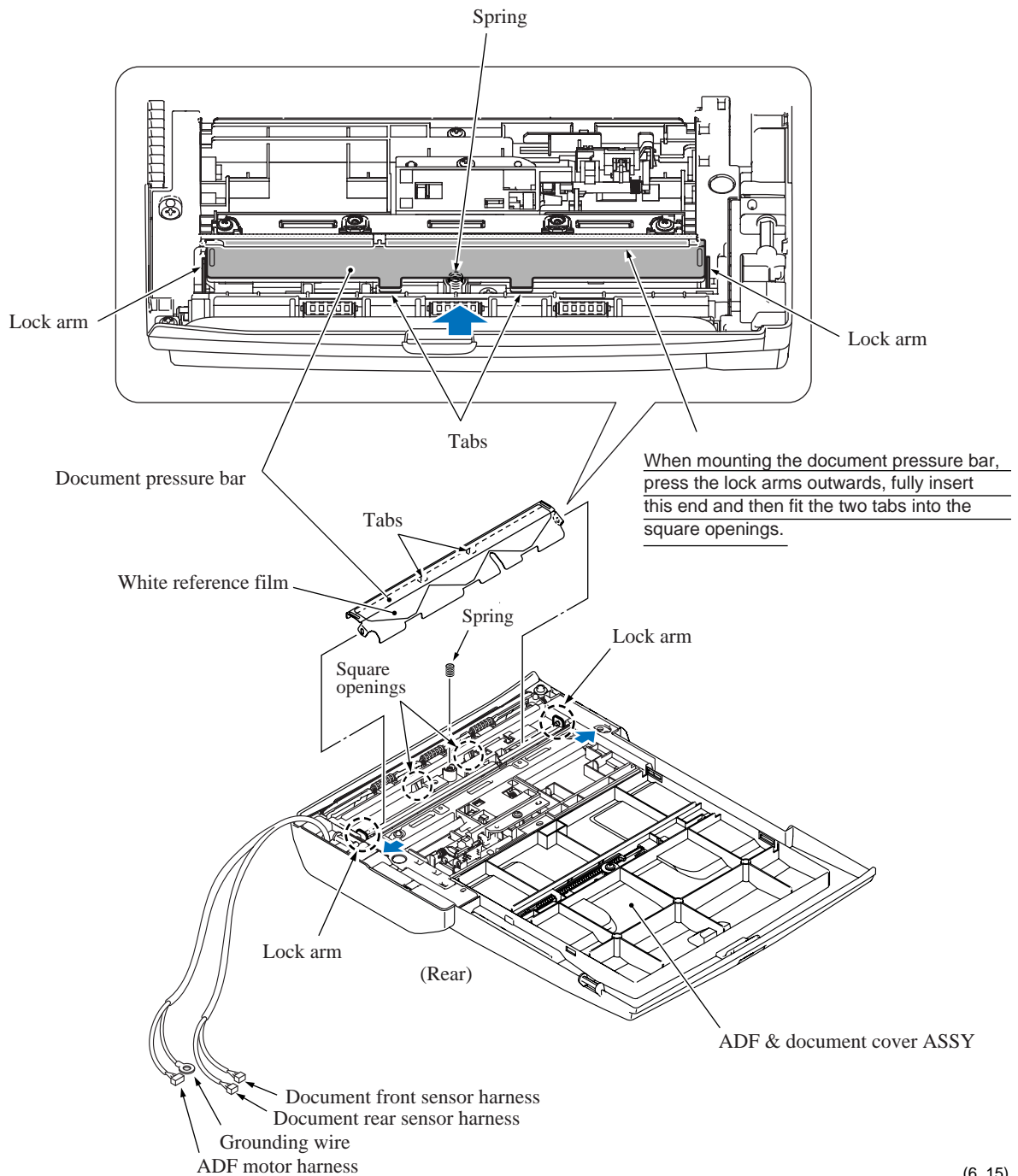

(6_15)

ADF reinforcement plate and pinch roller & spring assemblies

- (8) Remove the screw that secures the ADF reinforcement plate and pull out the plate.
- (9) Remove the three pinch roller & spring assemblies.

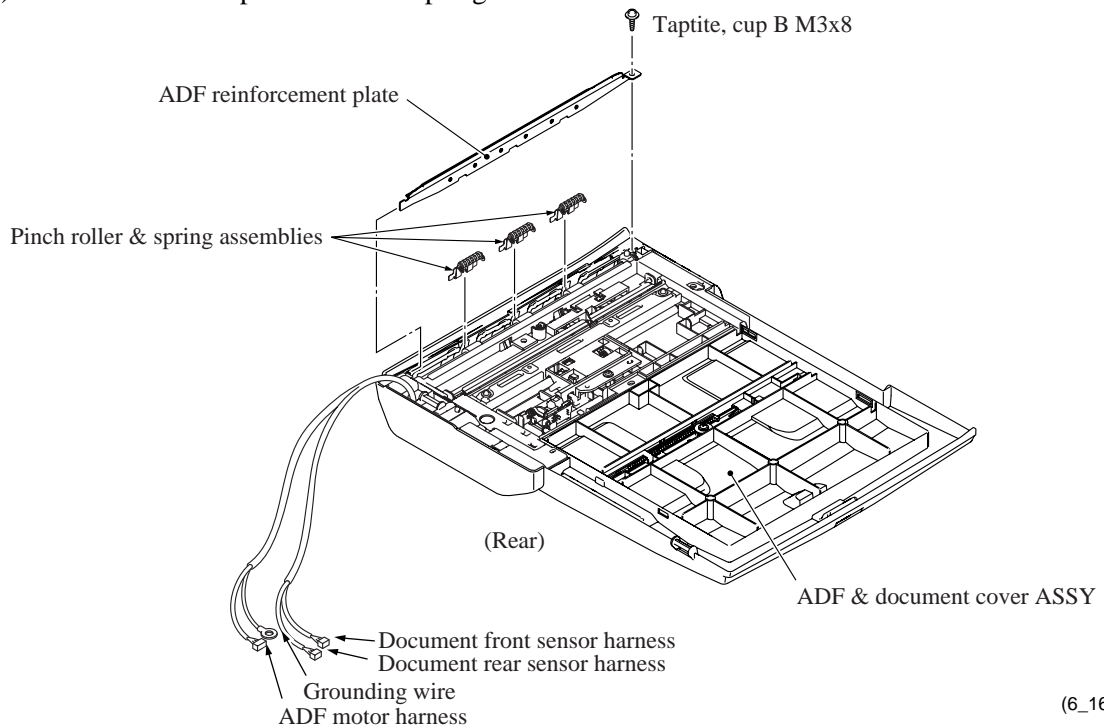

Separating the ADF unit from the document cover

- (10) Remove four screws (three "a" and one "b" screws) from the ADF unit.
- (11) Pull the rear side of the document cover outwards and take the ADF unit out of the document cover.

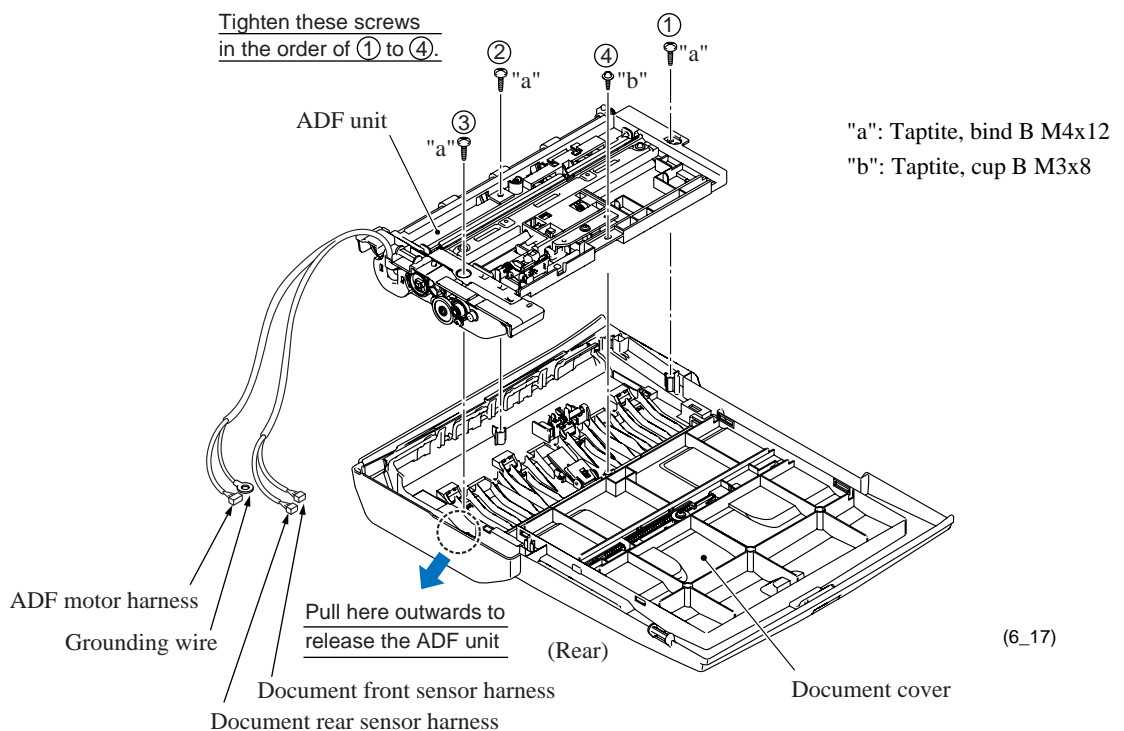

ADF motor and document rear sensor PCB

- (12) Place the ADF unit right side up as shown below.
- (13) Remove the ADF motor with the following steps.
 - 1) Remove the gear 20/45 by releasing the latch.
NOTE: The gear 21/46 and planet gear 23 become freed. Take care not to lose them.
 - 2) Remove the two screws.
 - 3) Disconnect the ADF motor harness from the ADF motor.
- (14) Push down the two lock arms and take out the document rear sensor PCB. Then disconnect the document rear sensor harness from the PCB.

Routing the ADF motor harness and grounding wire

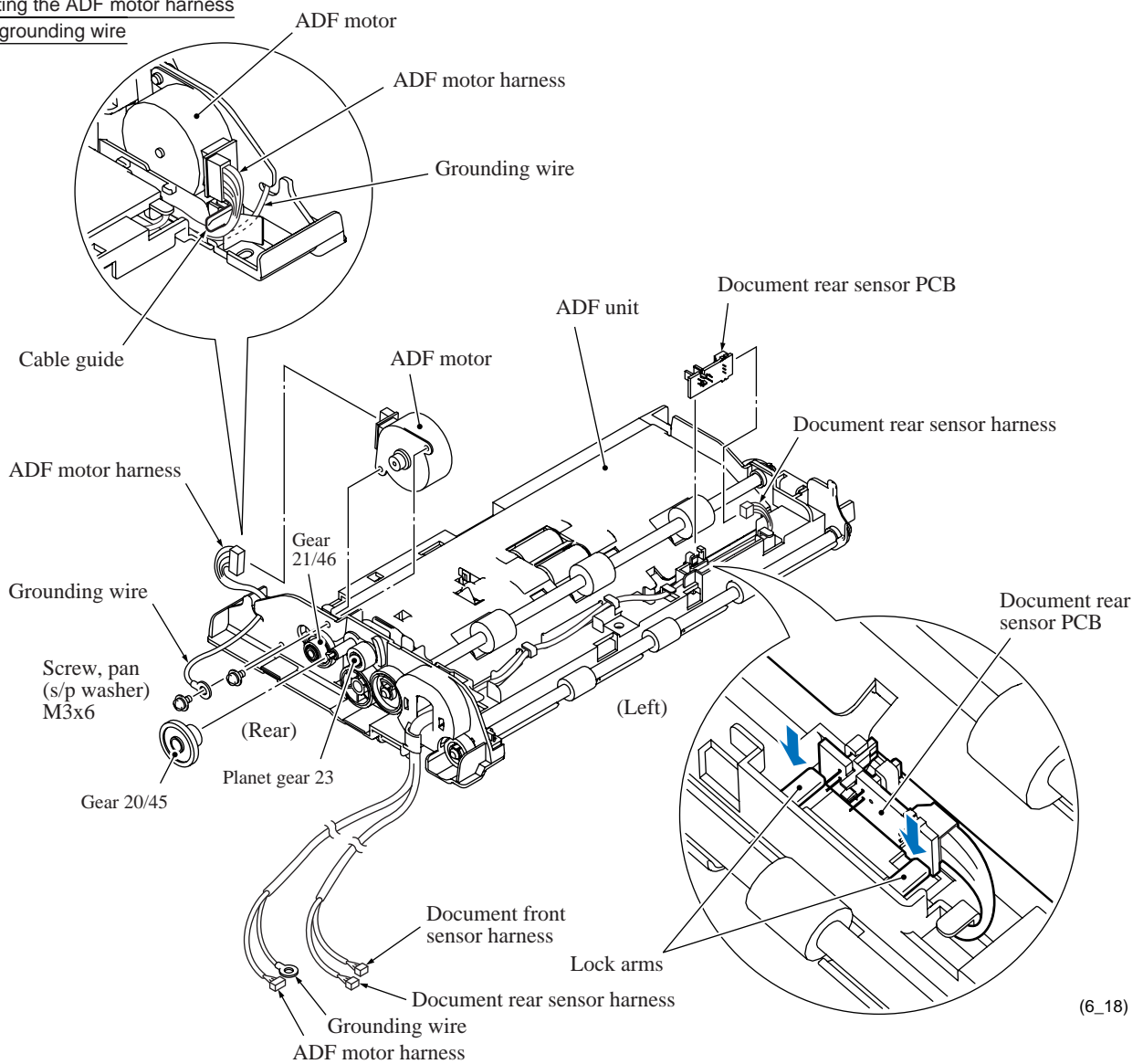

Document front sensor PCB

- (15) Place the ADF unit upside down.
- (16) Pull the lock arm outwards and take out the document front sensor PCB. Then disconnect the document front sensor harness from the PCB.

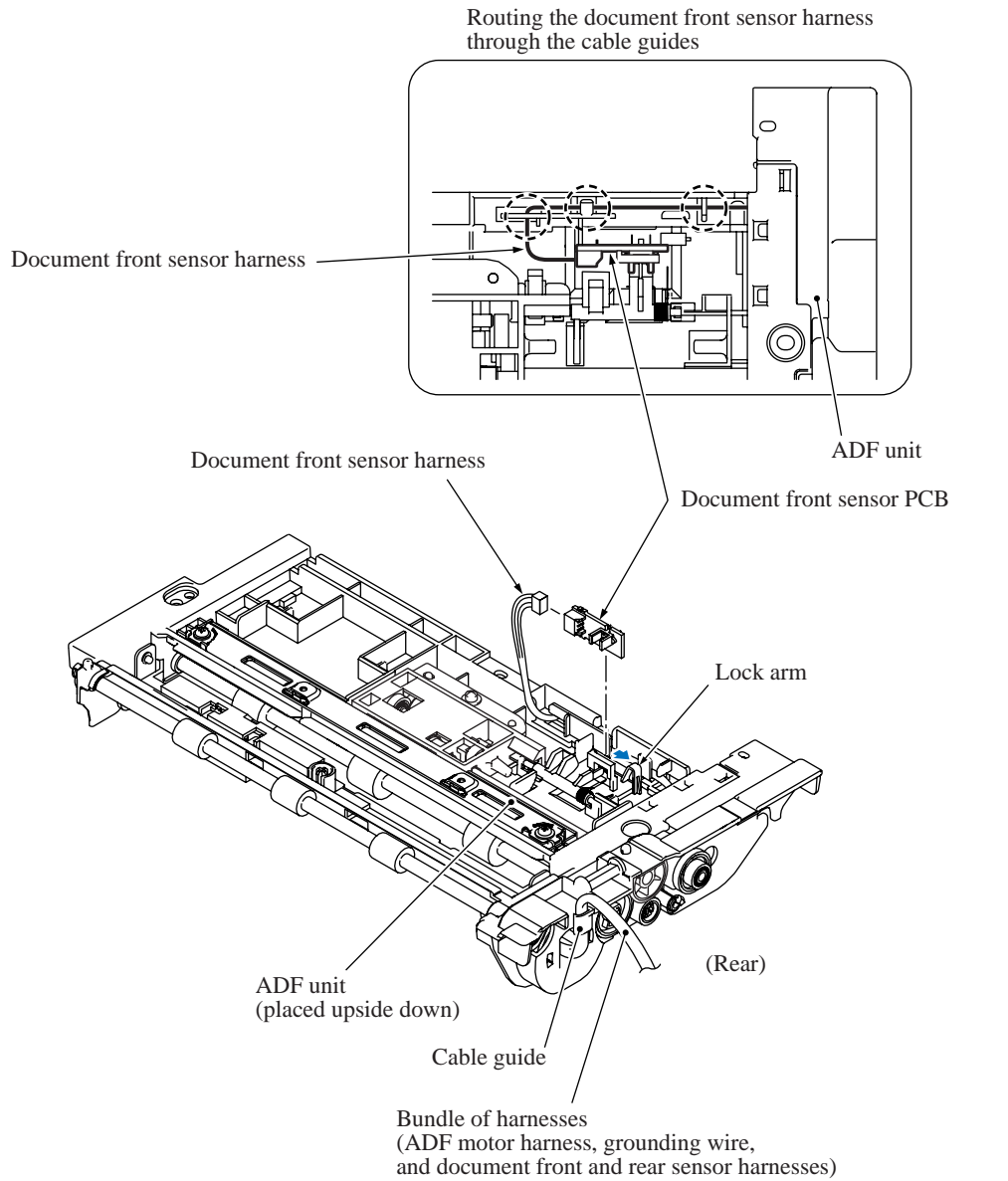

(6_19)

Document pull-in roller and document separation roller

- (17) Press the lock arm on the document roller holder and pull out the separation roller gear.
- (18) Remove the screw that secures the document roller holder.
- (19) Release the two tabs on the left end of the document roller holder from the ADF unit and take it out.
- (20) Remove the document pull-in roller and document separation roller from the document roller holder.

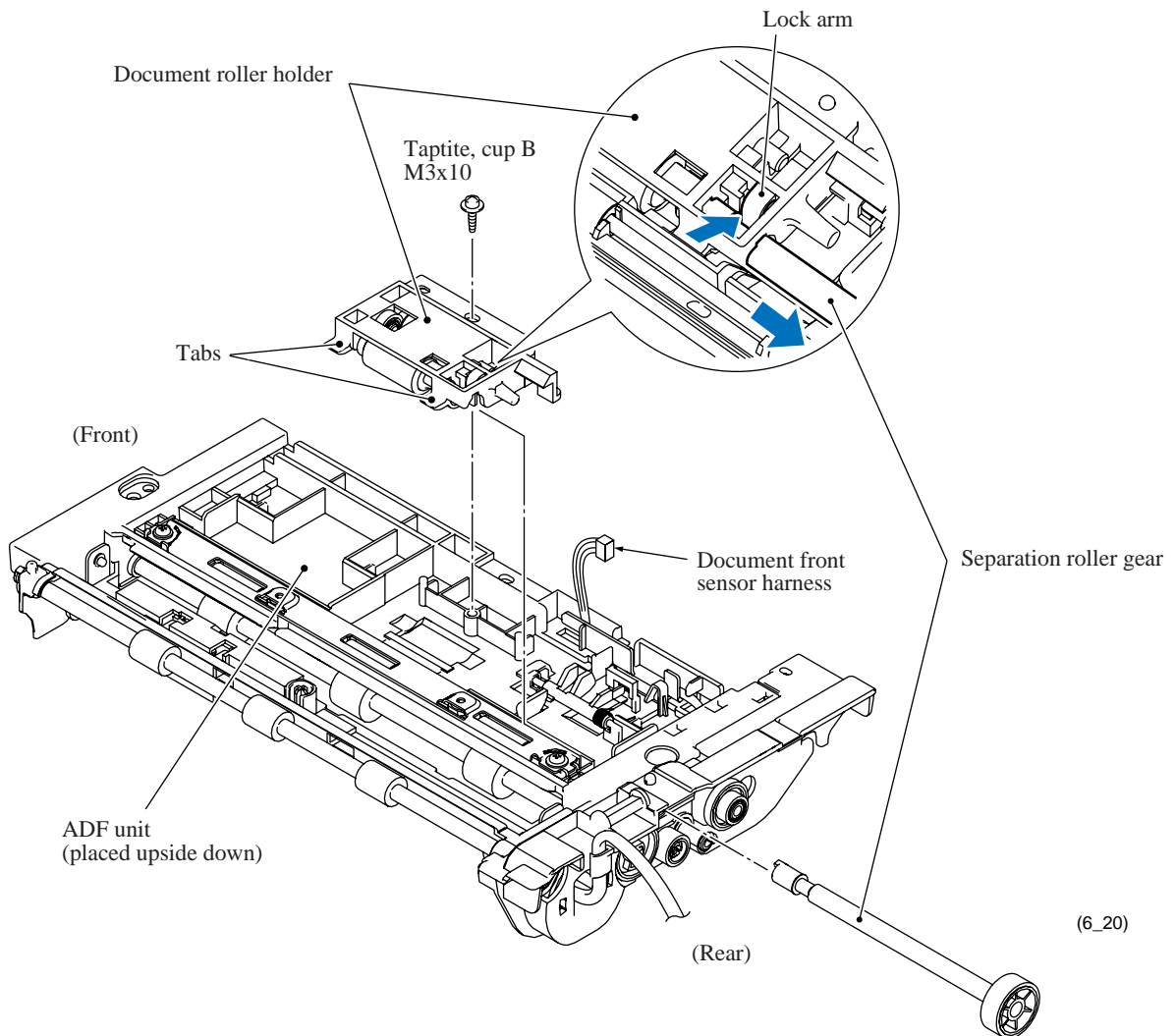
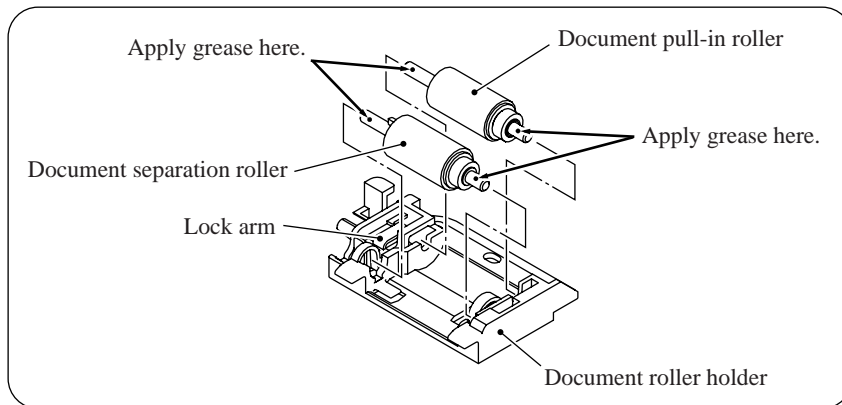

ADF parts

- (21) Place the document cover upside down.
- (22) Remove the ADF pull-in piece and its spring from the document cover.
- (23) Remove the separation pad from the document cover.

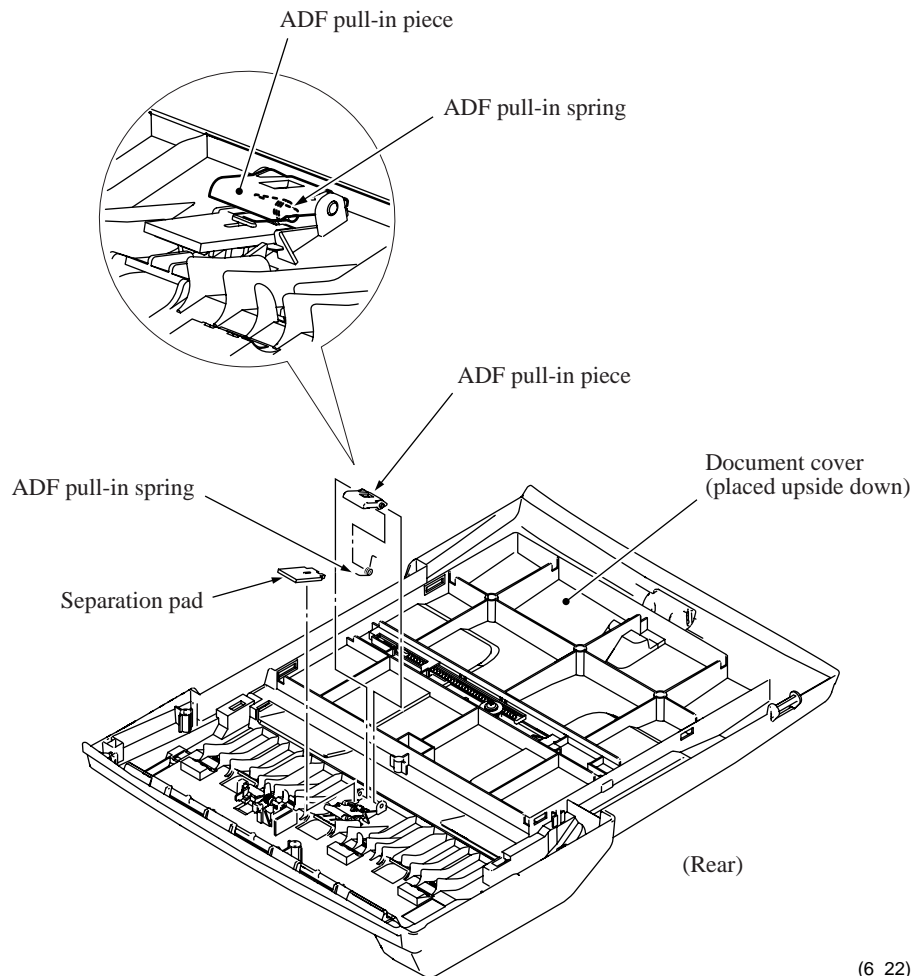

(6_22)

■ Assembling Notes

- When mounting the ADF pull-in piece on the document cover, be sure to set the ADF pull-in spring as shown above.
- Before mounting the document roller holder onto the ADF unit (see [page 6-20](#)), apply the specified lubricant to the specified points, referring to [Section 6.2](#).
- When mounting the ADF motor onto the ADF unit, route the ADF motor harness and the grounding wire as shown on [page 6-18](#). When securing the motor with two screws, be sure to secure the grounding wire also with one of those screws (see [page 6-18](#)).

- Before mounting the ADF unit on the document cover, make sure that the ADF motor harness, grounding wire, and document front and rear sensor harnesses are routed on the top of the ADF unit as shown below. Also make sure that the bundle of those harnesses is routed through the cable guide (shown on [page 6-19](#)) provided at the rear of the ADF unit.

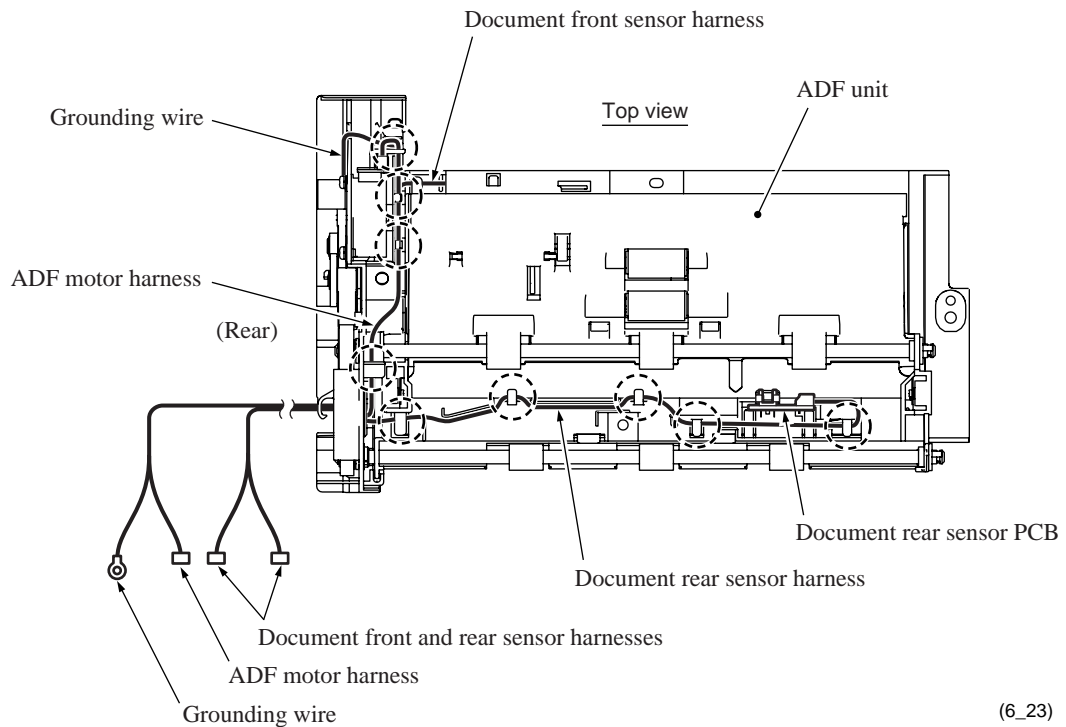

(6_23)

- When securing the ADF unit on the document cover, tighten four screws (three "a" and one "b" screws) in the order of ① through ④ as shown at the bottom of [page 6-17](#).

When mounting the ADF reinforcement plate and three pinch roller & spring assemblies, first secure the ADF reinforcement plate with the screw. Then insert the pinch roller & spring assemblies between the plate and document cover until they snap into place.

- When handling the document pressure bar, be careful not to stain or scratch the white reference film on the bar. (See [page 6-16](#).)

When mounting the document pressure bar on the ADF unit, set the spring, press the lock arms on the ADF unit outwards, fully insert the no-tab end of the document pressure bar into the ADF unit, and then fit the two tabs into the square openings. After that, make sure that the document pressure bar is supported by the two lock arms. (See [page 6-16](#).)

6.1.5 Control Panel ASSY, Scanner Cover Sensor Actuator, Ink Cartridge Cover Sensor Actuator, and Cover Sensor PCB

Control panel ASSY

- (1) Remove the three screws from the control panel ASSY.
- (2) Pull up the rear end of the control panel ASSY and turn it up slightly.

NOTE: Do not pull the control panel ASSY away from the machine since it is connected to the machine with a short LCD flat cable* and harnesses.

- (3) While holding the control panel ASSY at an angle of approx. 45°, disconnect the LCD flat cable* and panel-main harness from the main PCB, and the cover sensor harness from the control panel PCB.

*For models with color LCD

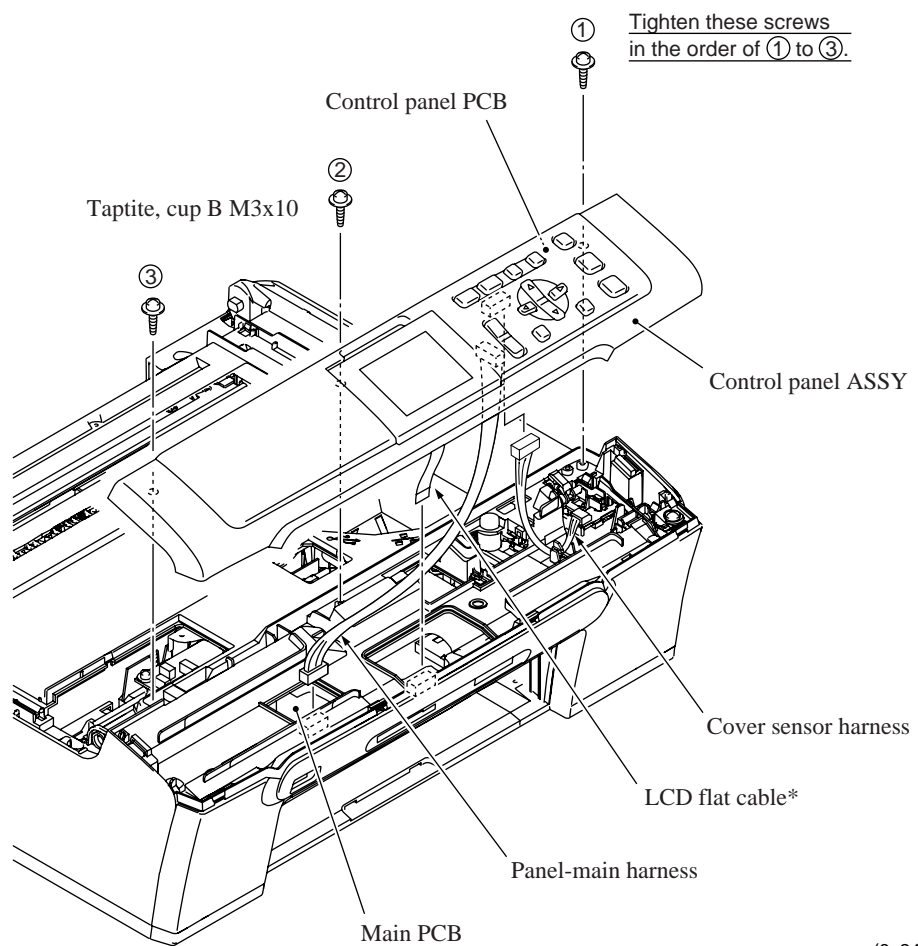

(6_24)

Scanner cover sensor actuator, ink cartridge cover sensor actuator, and cover sensor PCB

- (4) Remove the scanner cover sensor actuator from the upper cover, pulling the lock arms outwards. The actuator spring also comes off.
- (5) Open the ink cartridge cover. Remove the ink cartridge cover sensor actuator, pulling the lock arms outwards. The actuator spring also comes off.
- (6) Remove the cover sensor PCB by pulling the two lock arms outwards that hold the photosensor.

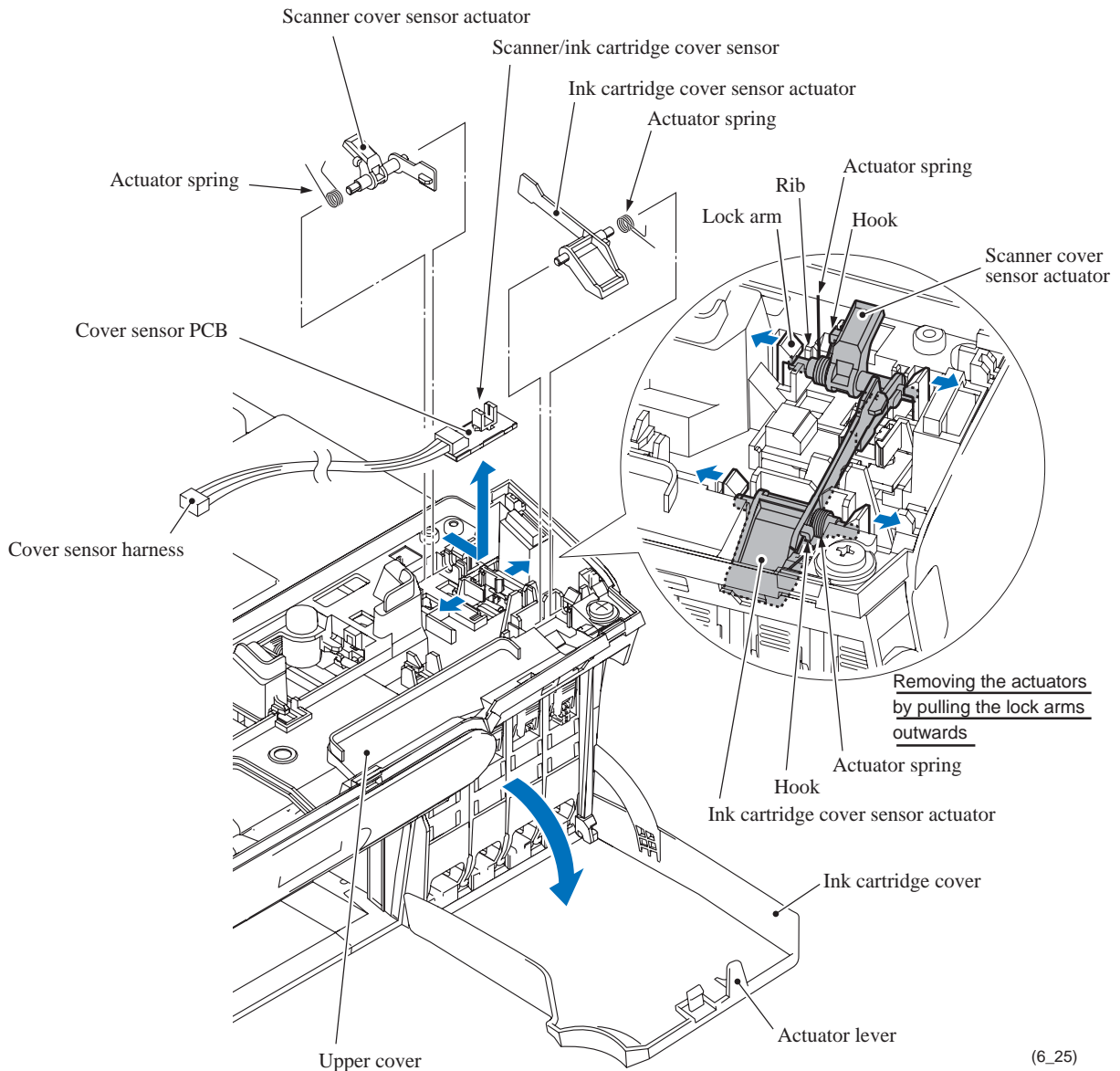

(6_25)

■ Assembling Notes

- Mount the ink cartridge cover sensor actuator with the ink cartridge cover being opened. When setting its spring, fit the bent end under the hook on the actuator, and the straight end on the upper cover as shown above. After closing the cover, check that the cover's actuator lever pushes down the sensor actuator.
- When mounting the scanner cover sensor actuator, fit the bent end under the hook on the actuator, and the straight end between the rib and boss on the upper cover.
- When securing the control panel ASSY to the upper cover, tighten the three screws in the order of ① to ③ as shown on the previous page. After mounting the control panel ASSY, check that there is no gap between the front end of the control panel ASSY and that of the upper cover.

6.1.6 Components of Control Panel ASSY

For models with color LCD

- (1) Place the control panel ASSY upside down.
- (2) Remove the two screws and lift up the LCD support cover.
- (3) Take the color LCD unit out of the control panel.
- (4) Warp the cable protection plate and release it from the color LCD.

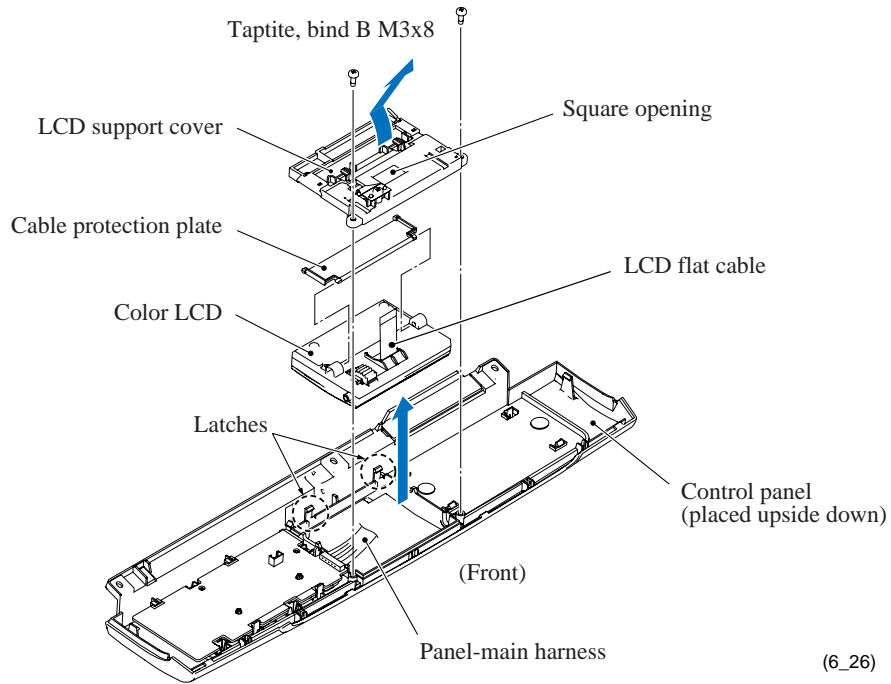

- (5) Pull the two latches outwards and remove the control panel PCB to the front.
- (6) Remove the rubber keypad and keys.

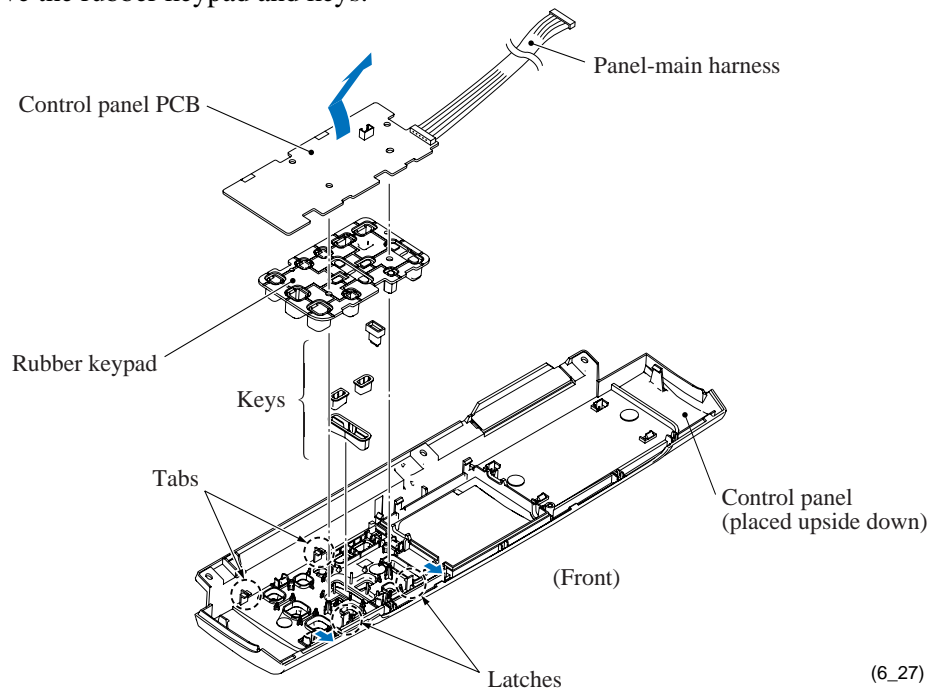

- (7) Remove the control panel R by releasing the four latches.
- (8) Remove the control panel L by releasing the five latches.

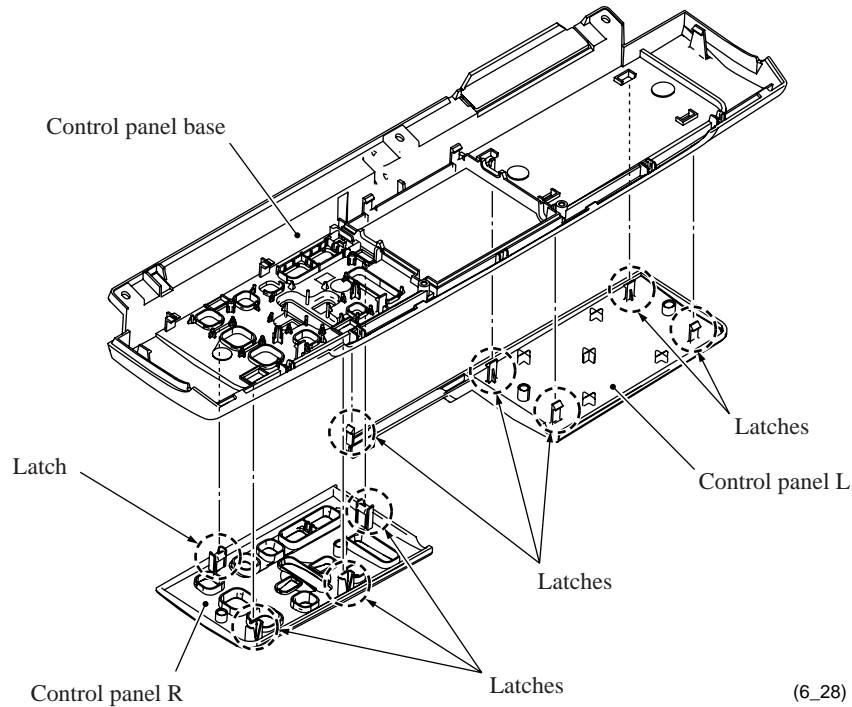

■ **Assembling Notes**

- Mount the control panels L and R in this order.
- A new LCD is covered with a protection sheet. Before setting it, remove the protection sheet.
- When setting the cable protection plate on the color LCD, take care not to pinch the LCD flat cable between the plate and LCD.
- When mounting the LCD support cover, route the LCD flat cable through the square opening.
- After setting the color LCD back into place, wipe fingerprints or dust off the LCD surface with a soft cloth.

For models with monochrome LCD

- (1) Place the control panel ASSY upside down.
- (2) Pull three latches "x" and remove the control panel PCB.
NOTE: Do not pull the control panel PCB away from the control panel base since it is connected to the monochrome LCD mounted on the control panel base with a short panel-LCD flat cable.
- (3) Disconnect the panel-LCD flat cable from the control panel PCB after releasing the connector lock.
- (4) Remove the rubber keypad.
- (5) Remove the monochrome LCD by releasing the two lock arms.
- (6) Remove the control panel from the control panel base by releasing six latches "y."

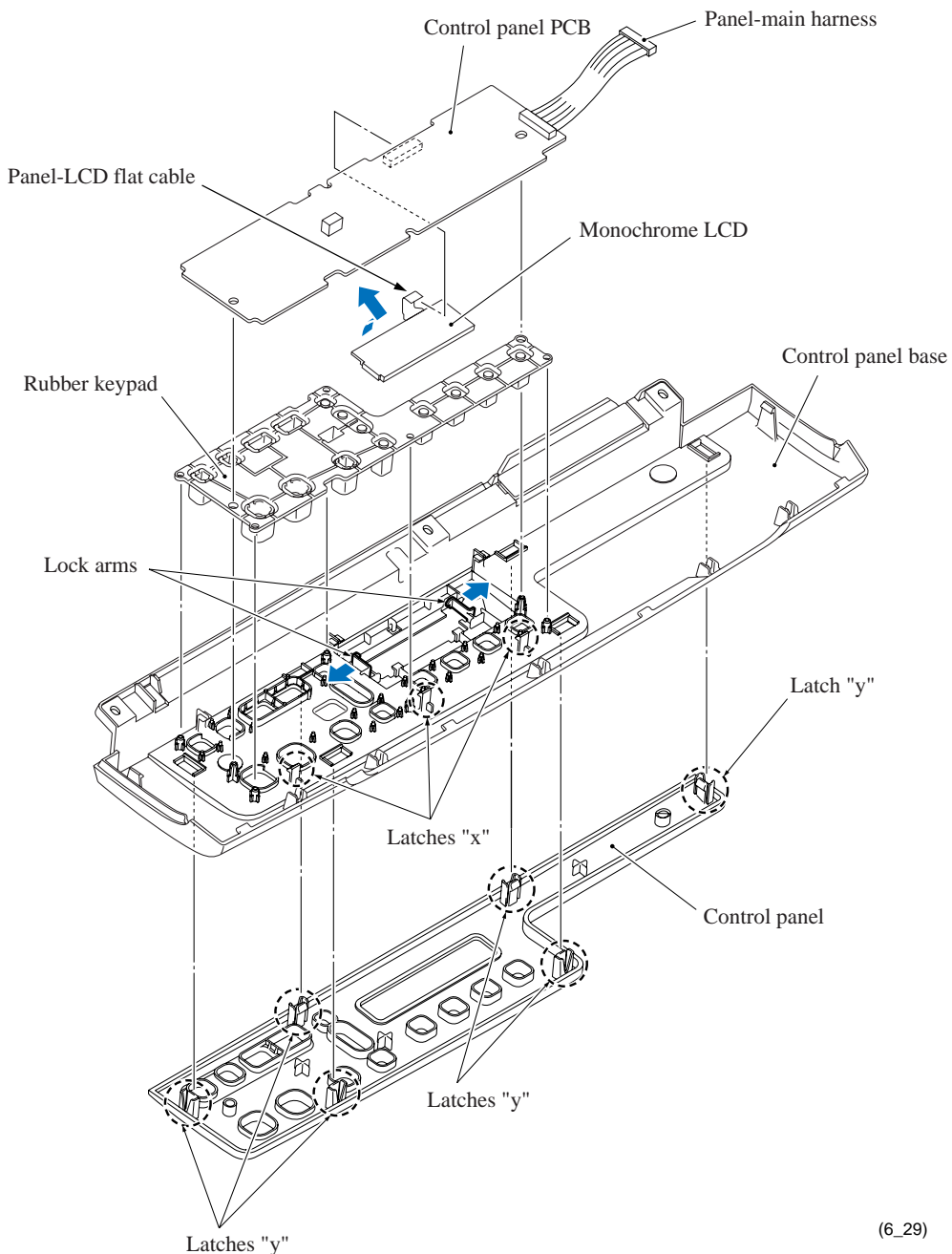

(6_29)

■ Assembling Notes

- Before setting the monochrome LCD back into place, wipe fingerprints or dust off the LCD surface and control panel window with a soft cloth.
- A new LCD is covered with a protection sheet. Before setting it, remove the protection sheet.

6.1.7 Upper Cover

NOTE: Make sure that the jam clear cover has been removed.

- (1) Open the ink cartridge cover.
- (2) Remove the seven screws (six "a" and one "b" screws) from the upper cover.
- (3) Insert the tip of a small flat screwdriver into the two openings provided in the front end of the upper cover, release the upper cover from the bosses on the lower cover, and lift it up.

NOTE: Do not put your hands in the opening above the platen (shown below). Doing so may damage or stain the CR encoder strip inside.

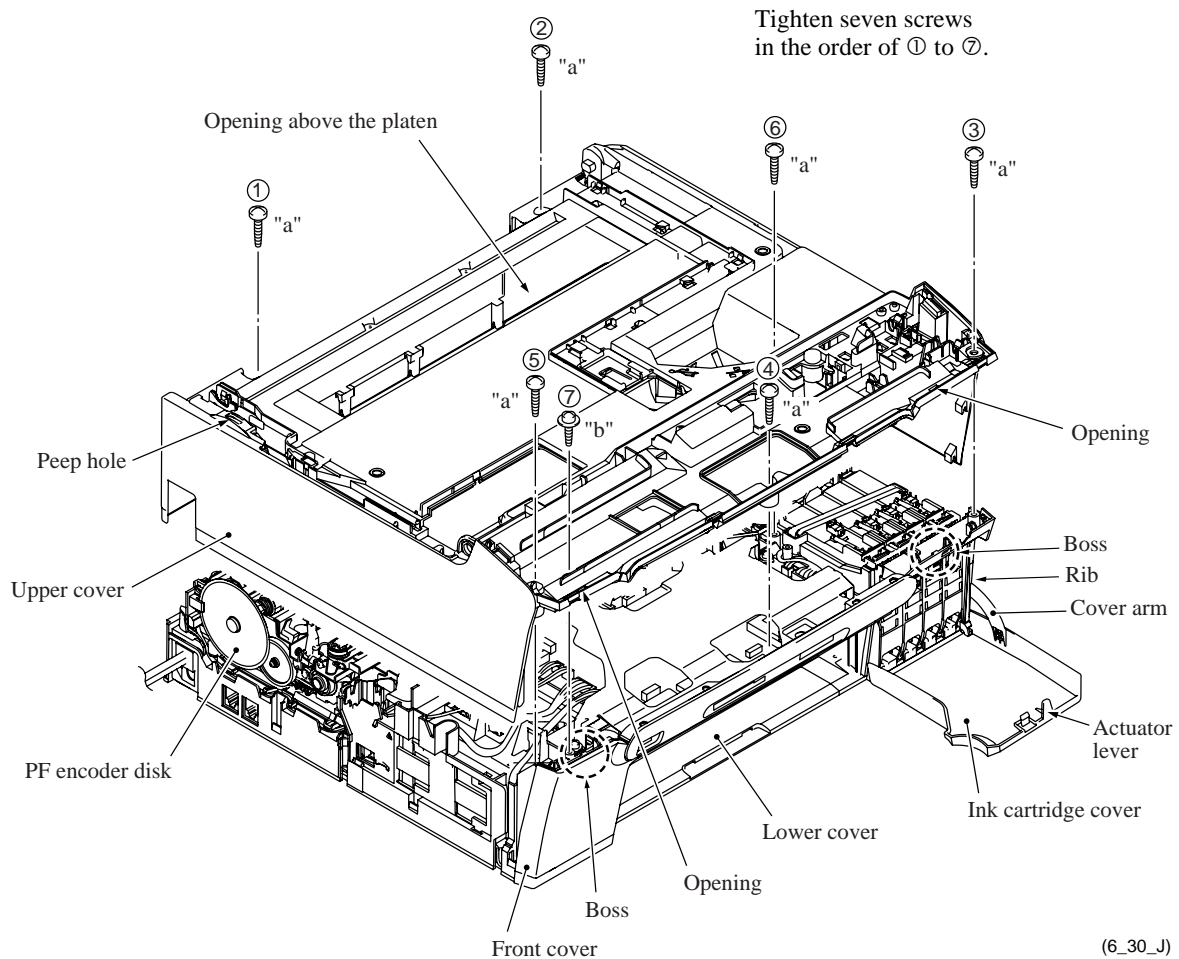

(6_30_J)

"a": Taptite, bind B M4x12

"b": Taptite, cup B M3x10

■ Assembling Notes

- When mounting the upper cover:
 - Make sure that the jam clear cover is not mounted.
 - Make sure that the head/carriage unit is placed in the head capping position (home position). This prevents the ink supply tubes from getting crushed between the upper and lower covers.
 - Make sure that the ink cartridge cover is opened if the ink cartridge cover sensor actuator has been mounted. (Mounting the upper cover with the ink cartridge cover being closed will dislocate the ink cartridge cover sensor actuator.)
 - Take care not to deform the PF encoder disk.
 - Tighten seven screws ① to ⑦ in this order as shown above.
- After mounting the upper cover, check that the PF encoder disk is not bent or deformed through the peep hole. (See the illustration above.)

6.1.8 Ink Cartridge Cover, Media Module Cover, Front Cover, and WLAN PCB*

*For wireless LAN-enabled models

- (1) Lightly lift up the front end of the lower cover and remove the ink cartridge cover.
- (2) Remove the media module cover.
- (3) For wireless LAN-enabled models: Proceed to step (4).

For models not supporting wireless LAN: Lightly pull up the retainer on the inside of the front cover to release it from the lower cover. Then lightly lift up the front end of the lower cover and remove the front cover.

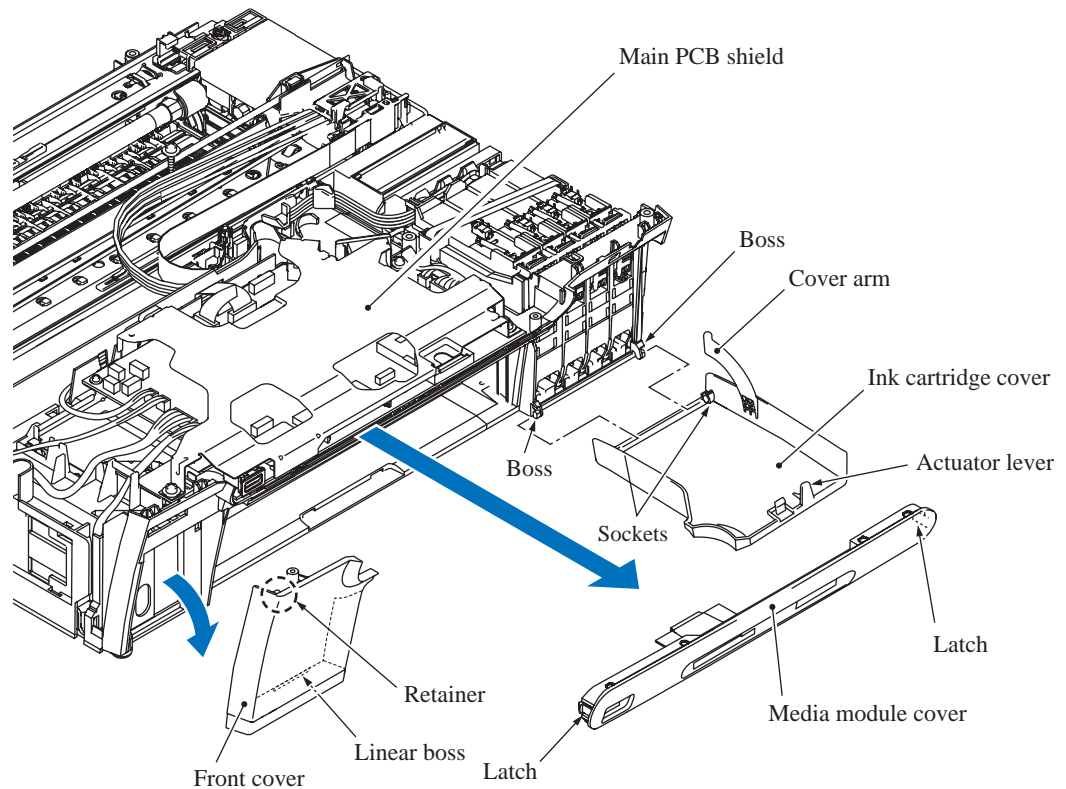

(6_31)

For wireless LAN-enabled models, remove the front cover and WLAN PCB using the following steps.

- (4) Release the grounding wire by removing the screw.
- (5) Disconnect the WLAN PCB harness from the main PCB.
- (6) Lightly pull up the retainer on the inside of the front cover to release it from the lower cover. Then lightly lift up the front end of the lower cover and remove the front cover together with the WLAN PCB.
- (7) Release the two latches on the front cover and take out the WLAN PCB.

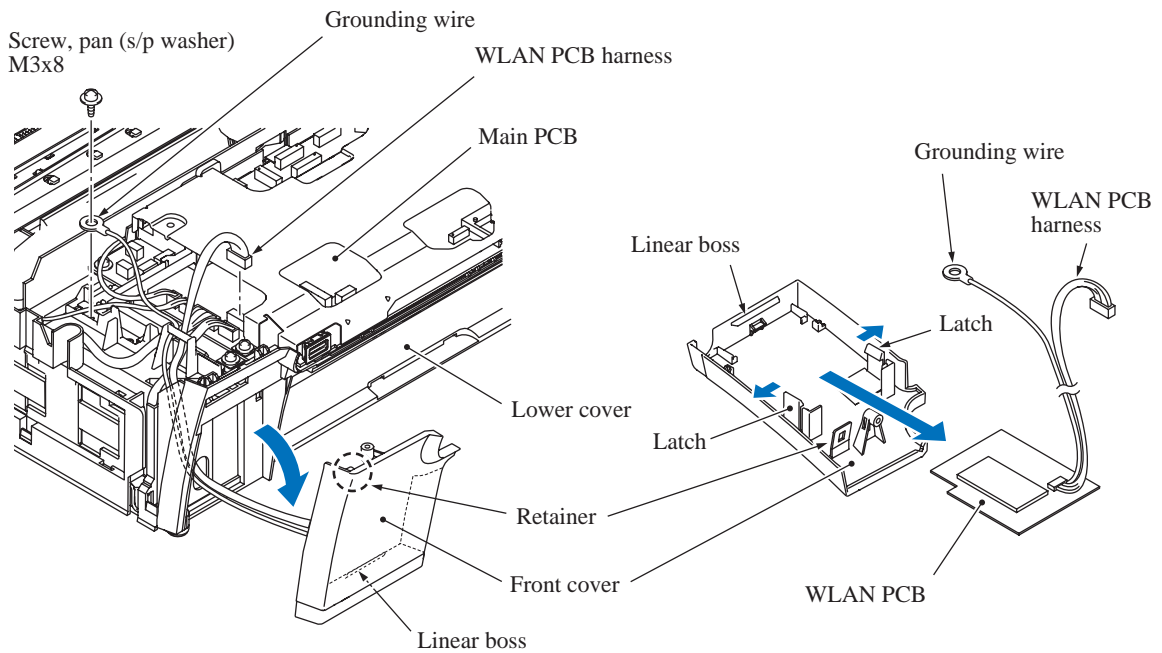

(6_32)

■ **Assembling Notes**

- For wireless LAN-enabled models: When mounting the front cover and WLAN PCB onto the lower cover, route the WLAN PCB harness and grounding wire as shown above.
- When mounting the front cover, lightly lift up the front end of the lower cover and fit the linear boss provided on the inside bottom of the front cover on the bottom of the lower cover.
- When mounting the ink cartridge cover, lightly lift up the front end of the lower cover, fit the two sockets over the bosses on the lower cover at the angle shown below and rotate the ink cartridge cover. Then, set the cover arm on the rib on the right side of the lower cover (see the illustration on the previous page).

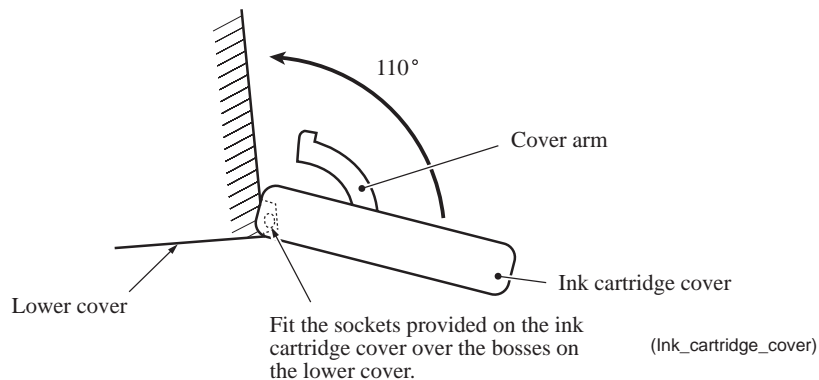

6.1.9 Main PCB

CAUTION: Before accessing the main PCB, make sure that the power cord is unplugged from the electrical outlet; otherwise, an electric shock could occur.

CAUTION: At the time of removal of the main PCB, untightening screws should be preceded by disconnection of the harnesses and flat cables, and at the time of installation, connection of the harnesses and flat cables, by tightening of screws. Observing this sequence prevents harnesses and flat cables from getting crushed or damaged by screws or screwdrivers.

- (1) **Models with color LCD:** Remove the four screws (two "a" and two "b" screws) from the main PCB shield and lift it up.

Models with monochrome LCD: Remove the two screws "a" from the main PCB shield and lift it up.

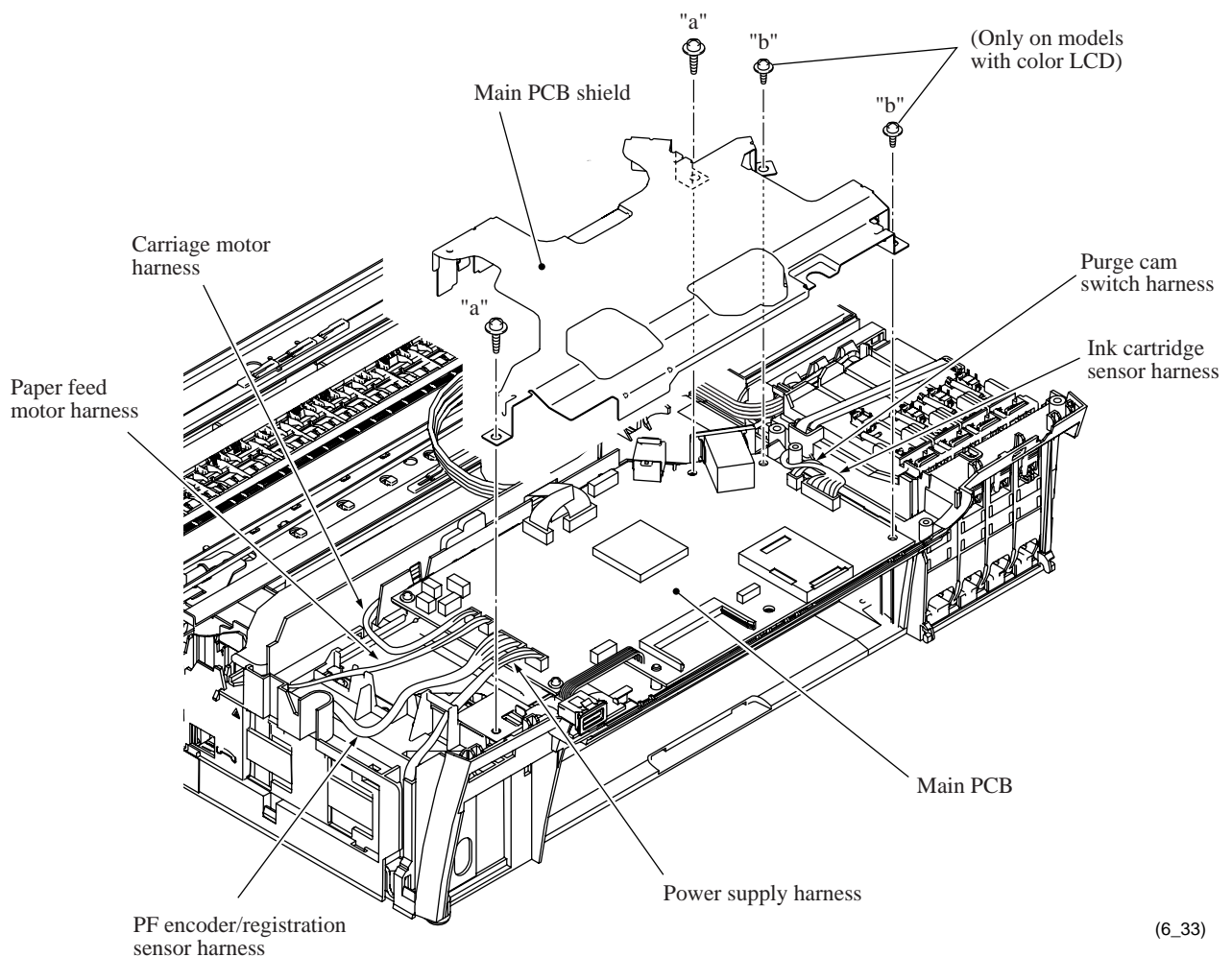

"a": Taptite, cup B M3x10

"b": Taptite, cup S M3x6 (Only on models with color LCD)

(2) Disconnect the following harnesses and flat cables from the main PCB.

CAUTION: Do not remove the screws from the main PCB before disconnecting harnesses and flat cables.

- Purge cam switch harness (2-wire)
- Ink cartridge sensor harness (9-wire)
- Power supply harness (4-wire)
- PF encoder/registration sensor harness (7-wire)
- Paper feed motor harness (2-wire)
- Carriage motor harness (2-wire)
- Head flat cable 1 (14-wire)
- Head flat cable 2 (13-wire)
- Head flat cable 3 (12-wire)

■ DCP750CW

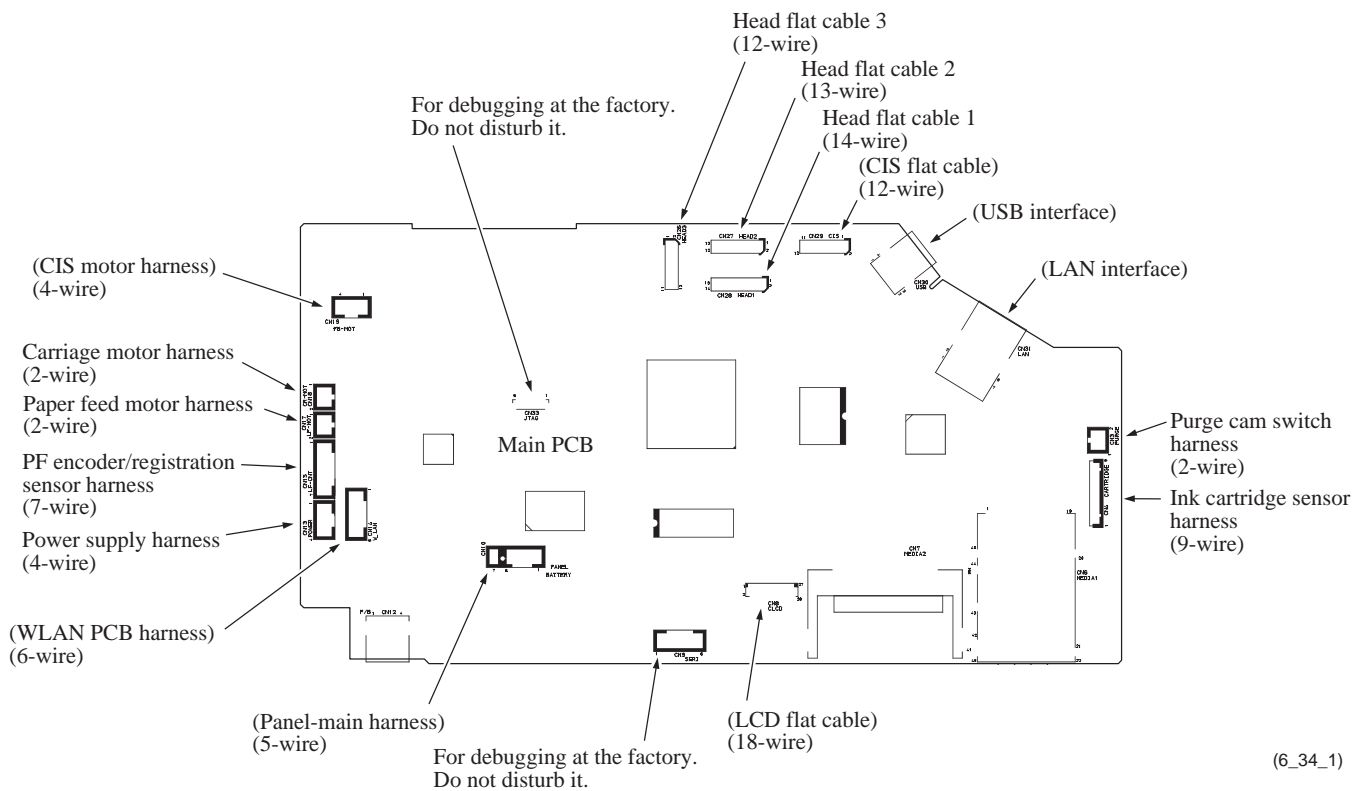

■ DCP540CN/330C

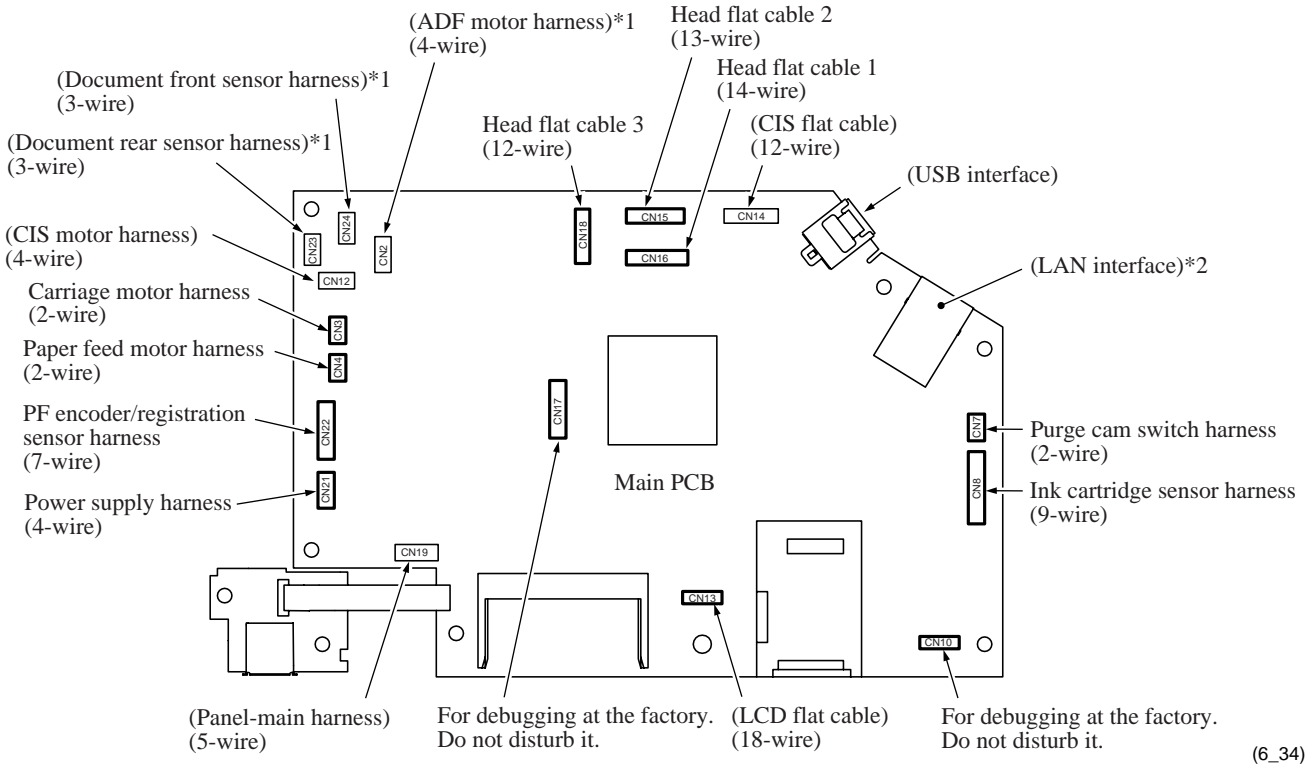

*1 For models with ADF

*2 For wired LAN-enabled models

■ DCP130C

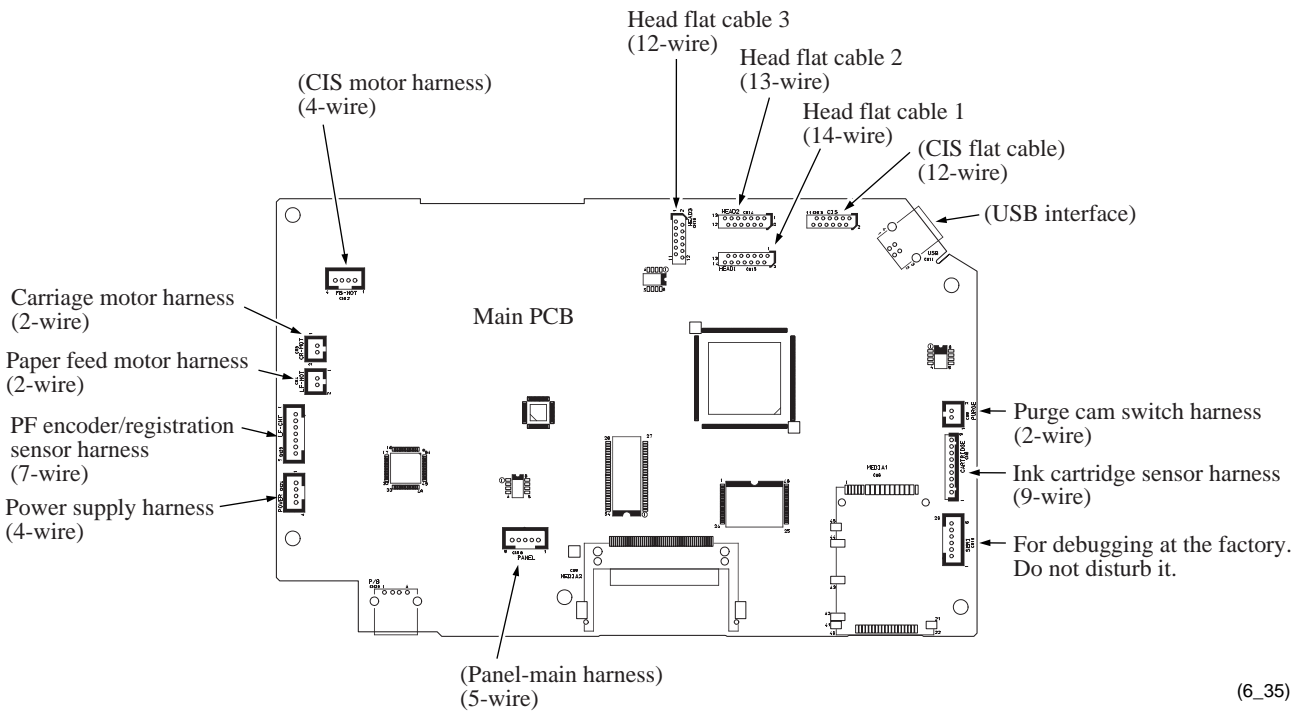

- (3) Remove screws "c" (four for models with color LCD, two for models with monochrome LCD) from the main PCB, then lift up the main PCB together with the PictBridge PCB.
- (4) Remove screw "d" from the main PCB shield frame, then lift up the shield frame. (This screw also secures the MJ/PS shield box.)

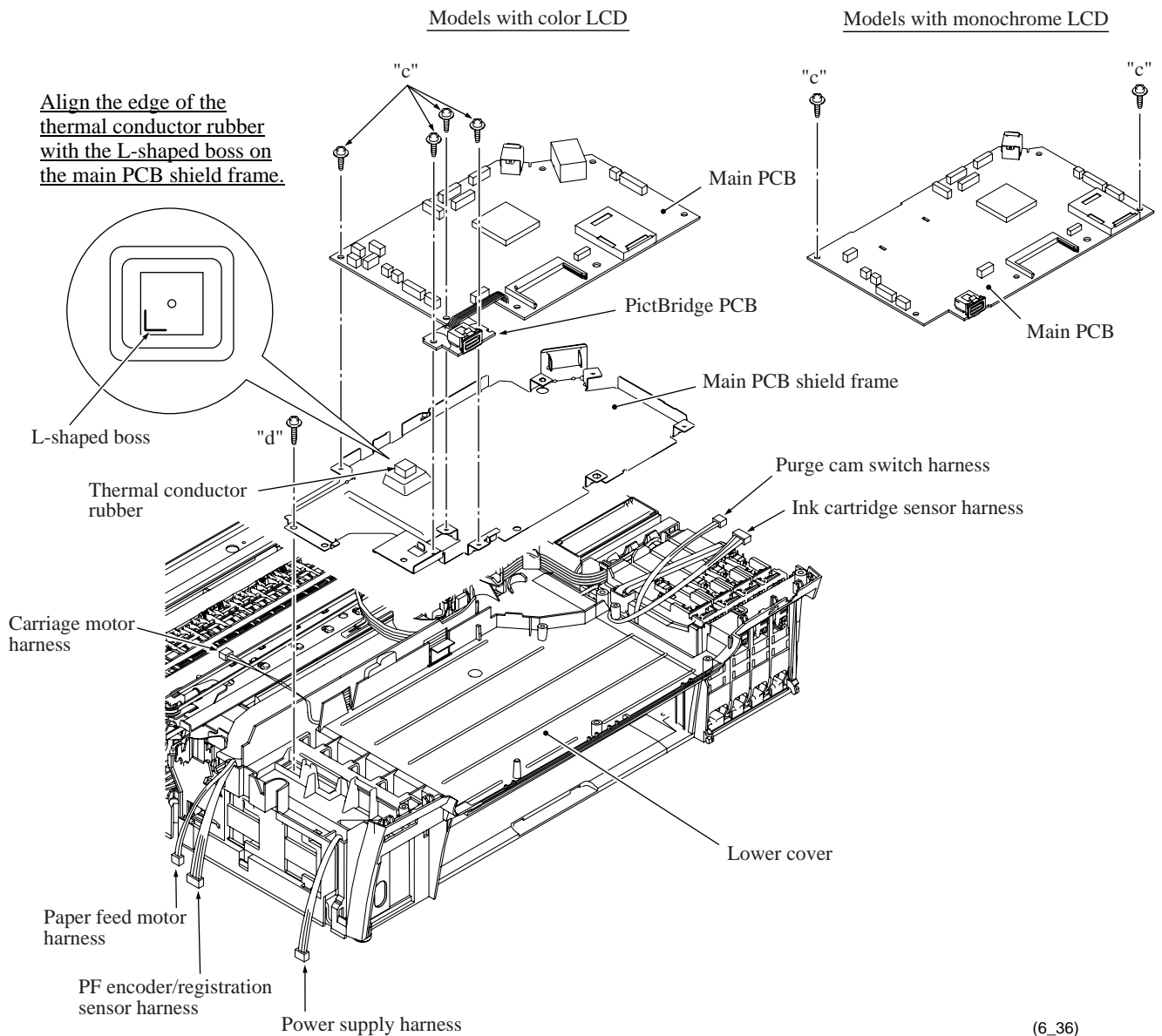

(6_36)

"c": Taptite, cup S M3x6

"d": Screw, pan (s/p washer) M3x8

■ Assembling Notes

- Before mounting the main PCB, check that the thermal conductor rubber is set on the main PCB shield frame. If it has come off, attach it to the main PCB shield frame so that it becomes aligned with the L-shaped boss on the shield frame as shown on the previous page.
- When replacing the main PCB, check that the thermal conductor rubber is on the main PCB shield frame, not on the bottom of the main PCB. Take care not to remove the old PCB with the conductor rubber being attached.
- If you replace the main PCB, also replace the ink absorber box and flushing box. Otherwise, drained ink may overflow after long-term use.
- If you replace the main PCB, you need to make the specified adjustments and updating of settings stored in the flash ROM, referring to [Chapter 7, Section 7.3](#). Before starting, make sure that the head/carriage unit is mounted.

6.1.10 MJ/PS Shield Box and Power Supply PCB

- (1) If the main PCB shield frame has not been removed, disconnect the power supply harness from the main PCB and remove screw "d" (shown on [page 6-35](#)) from the main PCB shield frame.
- (2) Remove the two screws ("e" and "f").
- (3) Remove the MJ/PS shield box from the underside of the lower cover.

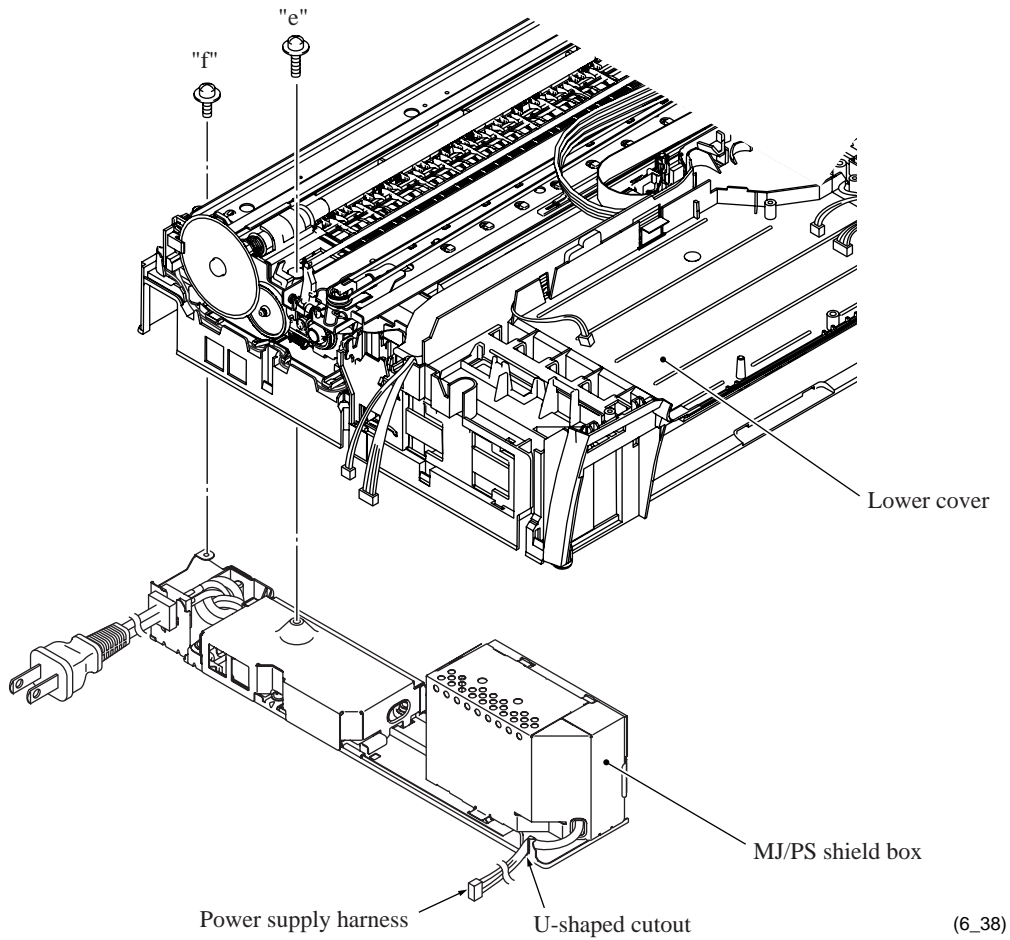

"e": Screw, pan (s/p washer) M3x8

"f": Taptite, cup S M3x6

- (4) For 120V series: Remove the power cord holder by removing the screw.
- (5) Release the power cord from the cable guides (shown on the next page).
- (6) Remove the power supply shield from the lower MJ/PS shield.
- (7) Remove the four screws from the power supply PCB.

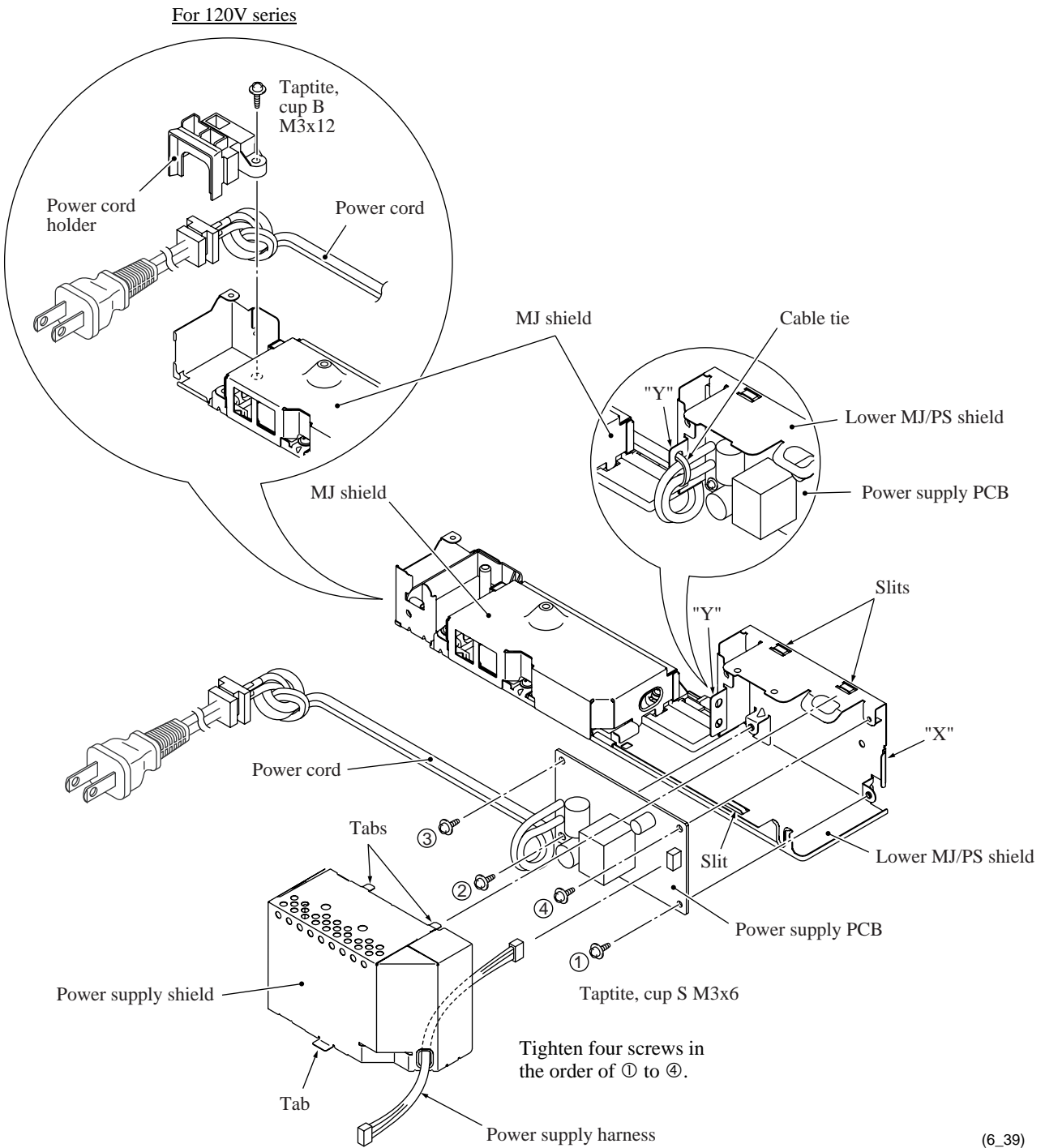

(6_39)

■ Assembling Notes

- When securing the power supply PCB, tighten four screws in the order of ①, ②, ③ and ④ as shown on the previous page.
- Secure the power cord to the two holes provided in section "Y" (shown on the previous page) of the lower MJ/PS shield with a cable tie. After that, route the power cord through the cable guides as shown below.

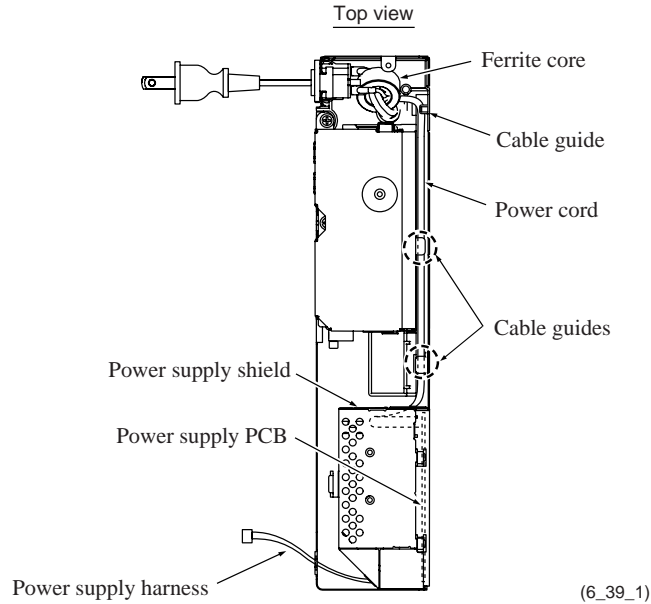

- When mounting the power supply shield on the lower MJ/PS shield, insert three tabs into three slits. Make sure that section "X" of the lower MJ/PS shield is fitted *over* the power supply shield. (See the previous page.)
- When mounting the MJ/PS shield box, route the power supply harness through the U-shaped cutout (shown on [page 6-37](#)) in the lower MJ/PS shield. After mounting the MJ/PS shield box, route the power supply harness through the channel as shown below.

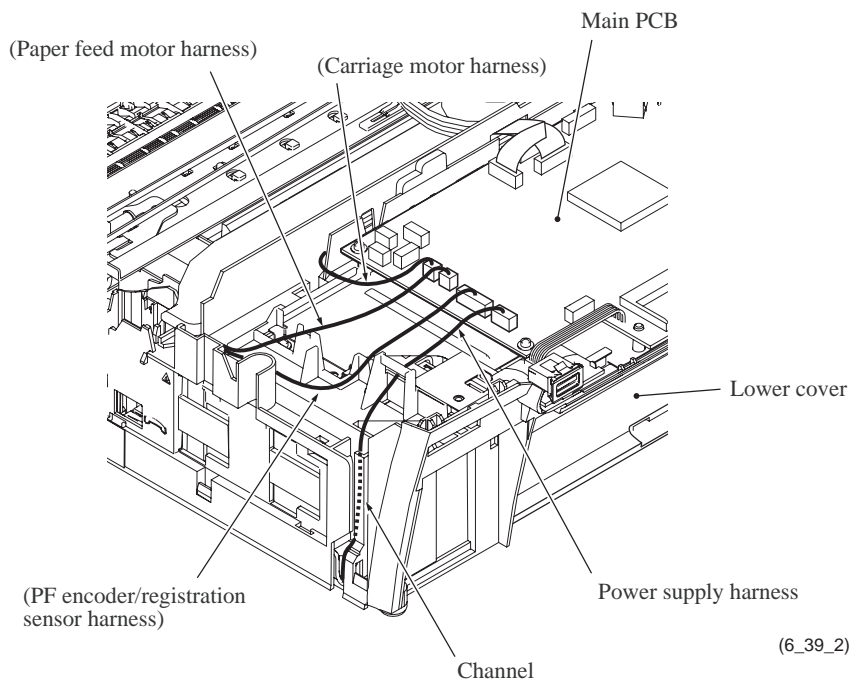

6.1.11 Head/Carriage Unit and Ink Refill ASSY

During disassembly jobs, except when removing the ink refill ASSY or engine unit (including the maintenance unit), leave the head/carriage unit in the machine.

Before removing the head/carriage unit, ink refill ASSY or engine unit, you need to remove all four ink cartridges and set the protective part instead (see [page 6-3](#)). Be sure to insert the protective part into place to prevent ink remaining in the ink supply tubes from leaking and the machine from getting stained with leaked ink.

NOTE: Make sure that the power cord is unplugged from the electrical outlet.

NOTE: When replacing the head/carriage unit, put on a grounding wrist band and perform the job on a static mat. Also take care not to touch the conductor sections on the flat cables.

NOTE: During the removal or installation job for the head/carriage unit, take care not to contaminate the CR encoder strip or PF encoder disk with ink or grease.

NOTE: If you replace the head/carriage unit, also replace the ink cartridges. This is because sufficient ink volume is necessary for refilling the ink supply tubes after replacement of the head/carriage unit.

CR encoder strip

- (1) While lightly pushing the CR encoder strip support on the left end of the engine unit inwards, unhook the right end of the CR encoder strip from the hook.
- (2) At the left end of the CR encoder strip, align the rectangular hole in the strip with the boss of the strip support and take the strip off.

NOTE: Take care not to scratch or damage the encoder strip. If it becomes dirty, wipe it with a soft, dry cloth. If it is stained with ink, replace it.

Flat cable support plate, tube support wire and its spring

- (3) Unhook the spring from the tube support wire.
- (4) Release the four ink supply tubes from the tube support wire.
- (5) Remove the screw from the flat cable support plate.
- (6) Unlatch the support plate from the lower cover and remove it together with the tube support wire and its spring.
- (7) Remove the spring and tube support wire from the flat cable support plate.

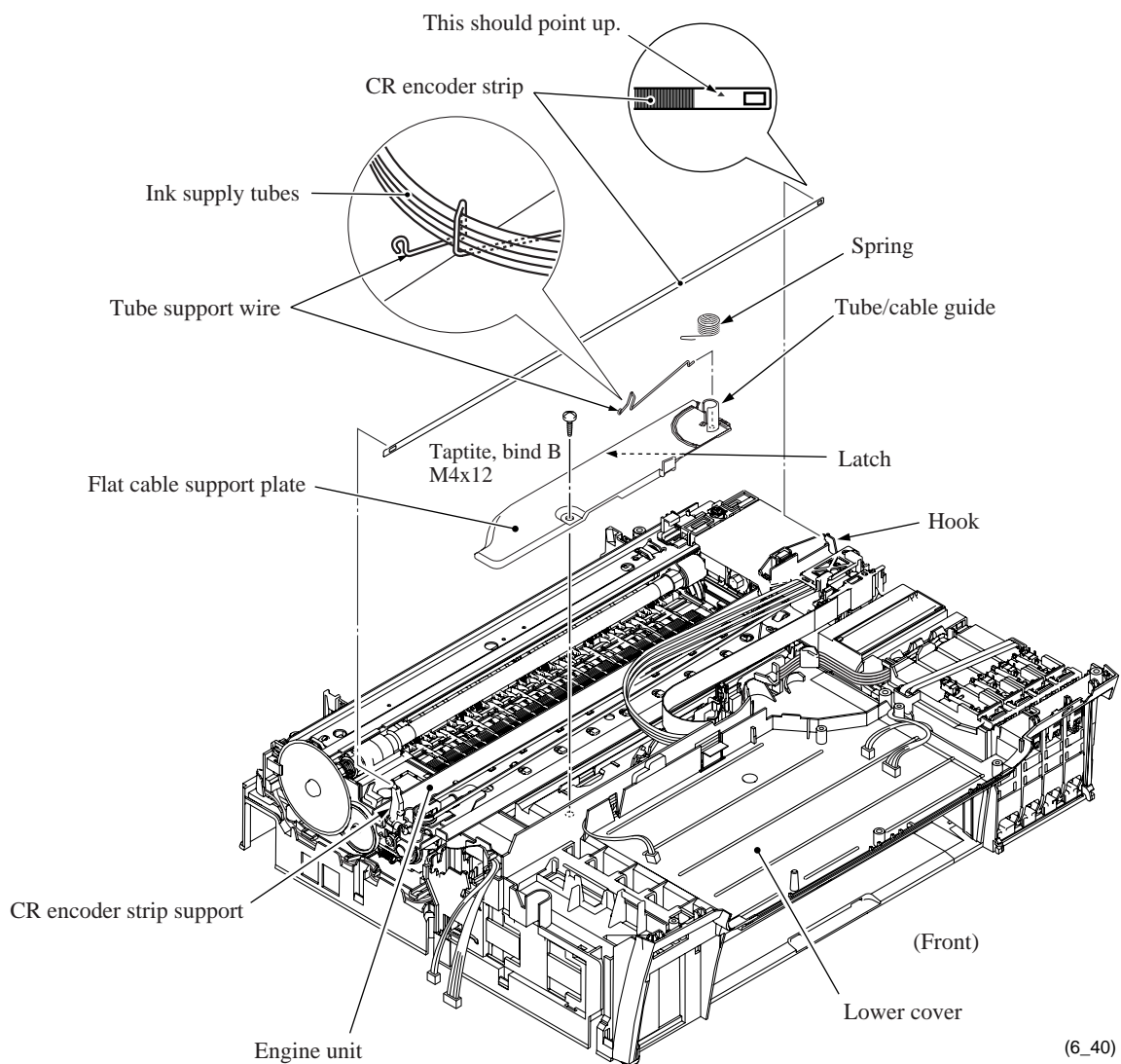

(6_40)

Head cover

(8) Move the head/carriage unit to position "P" (shown below) by hand.

NOTE: If the head/carriage unit does not move, rotate the ejection idle gear clockwise (viewed from the left) by hand to unlock the head/carriage unit and move it to position "P."

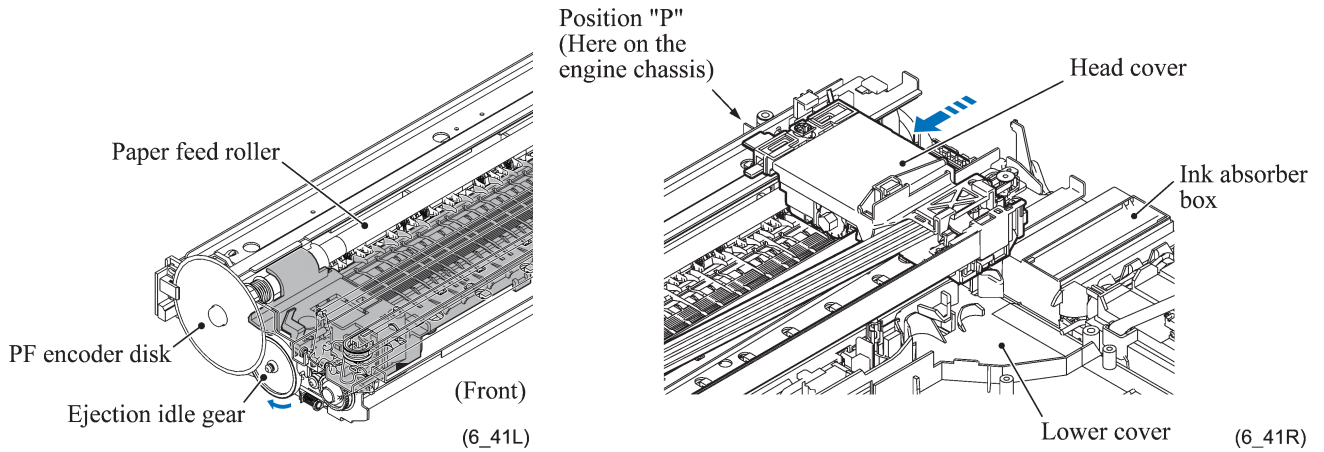

(9) Unlatch the head cover from the head/carriage unit and pull it up.

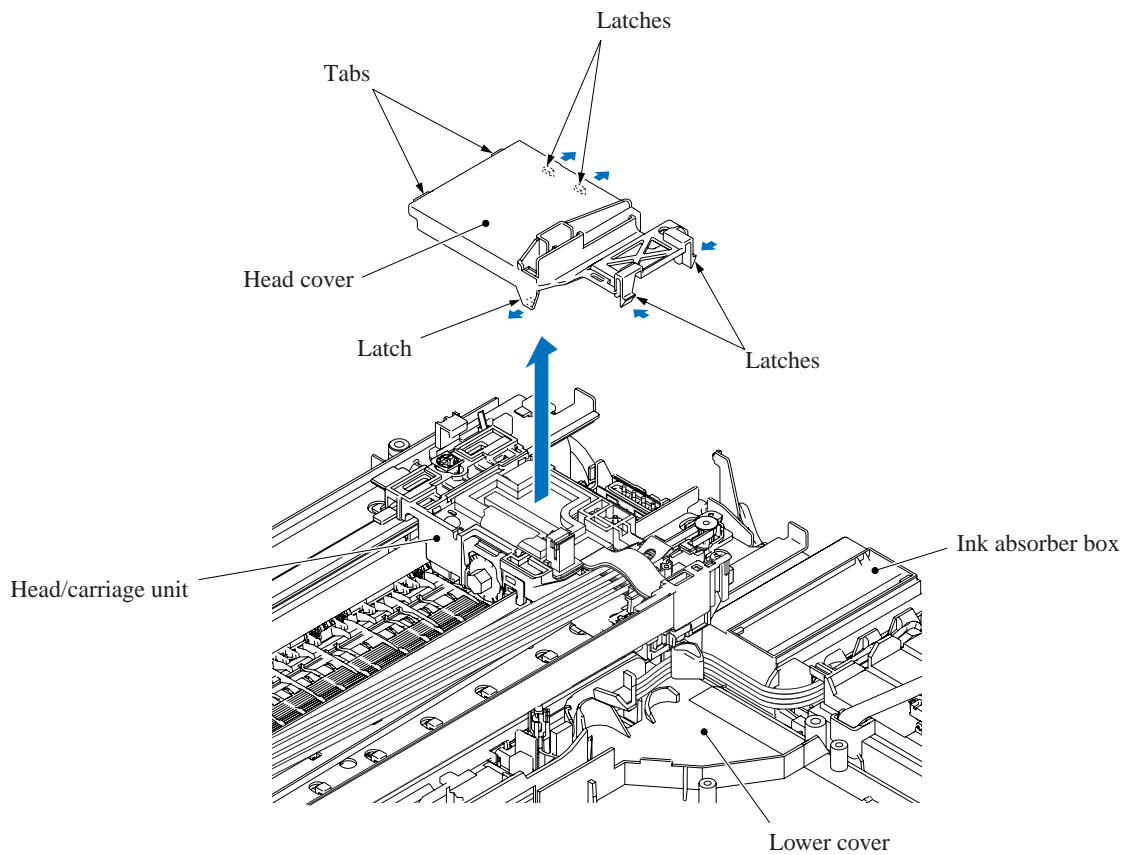

(6_42)

Carriage PCB ASSY (carriage PCB with head flat cables)

- (10) Unlock the connector on the carriage PCB and disconnect the carriage-head flat cable.
- (11) Release the head flat cables out of the cable guides and pull them out (together with the flat core) to the rear through the opening provided in the lower cover as shown below.

NOTE: When replacing the carriage PCB ASSY, remove the flat core from the old head flat cables and set it to the new ones.

- (12) Unlatch the FFC support, which holds the three head flat cables, from the head/carriage unit.
- (13) Lift up the carriage PCB ASSY.
- (14) Remove the FFC support from the head flat cables.

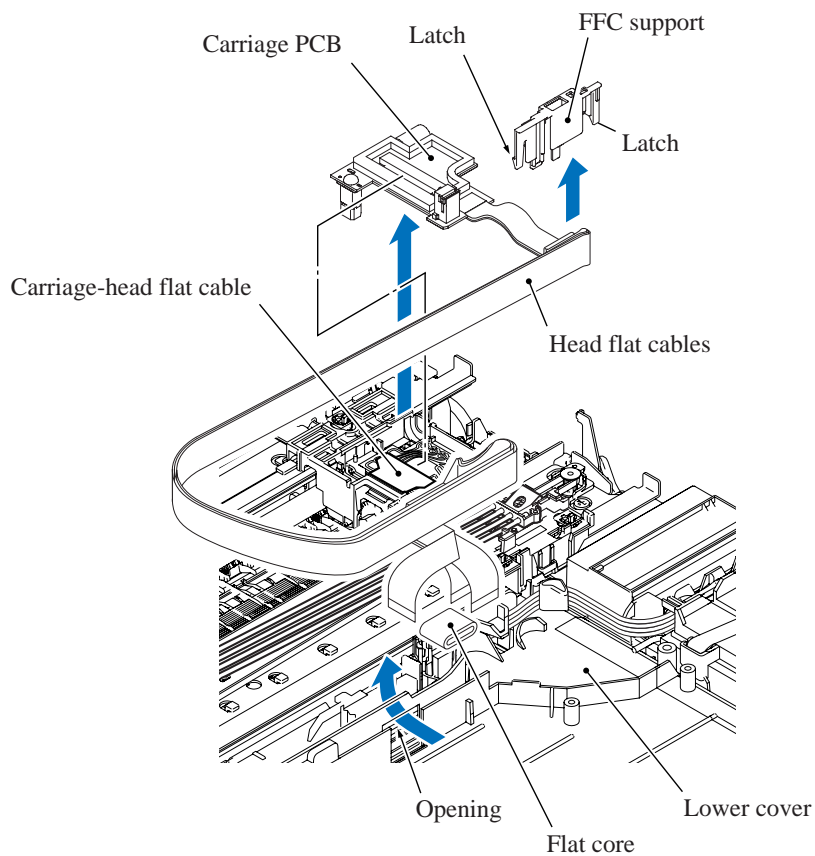

(6_43)

Head joint and ink refill ASSY

(15) Pull out the joint leaf spring to the right to release the head joint.

(16) Pull the head joint up and off the head/carriage unit.

Remove the head joint rubber (that is a part of the head/carriage unit but may come off with the head joint) and put it on a clean vinyl sheet while taking care not to contaminate it.

NOTE: Wipe off the ink remaining on the section where the head joint was mounted with a clean, lint-free cloth.

NOTE: Wrap the head joint in a clean, lint-free cloth and keep it higher than the ink supply tubes to prevent ink remaining in the ink supply tubes from leaking and the machine from getting stained with leaked ink.

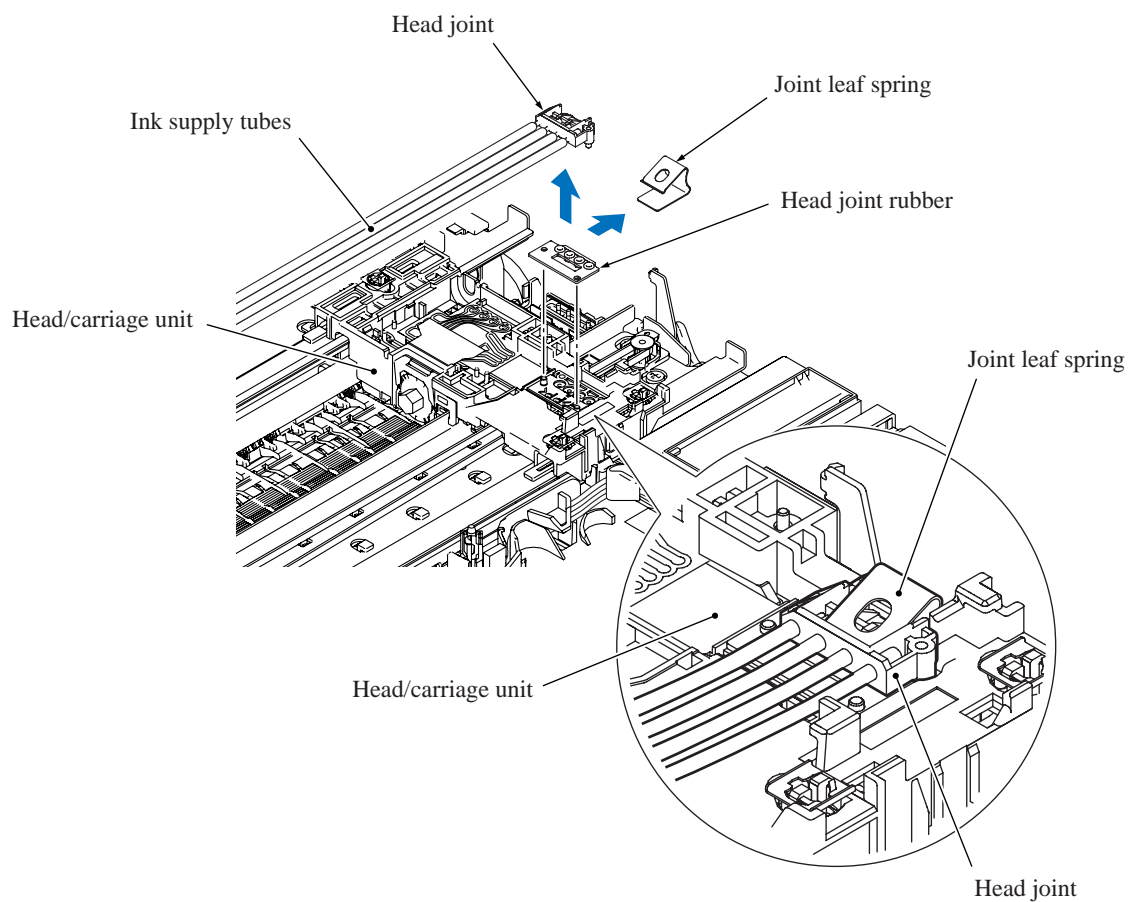

(6_45)

- (17) Take out the ink supply tubes routed on the lower cover.
- (18) While pressing the four lock release levers with your fingers, lift the ink refill ASSY up and out of the lower cover.

NOTE: On the back of the ink refill ASSY is an ink absorber felt that may be stained with ink. If it is excessively stained, replace it.

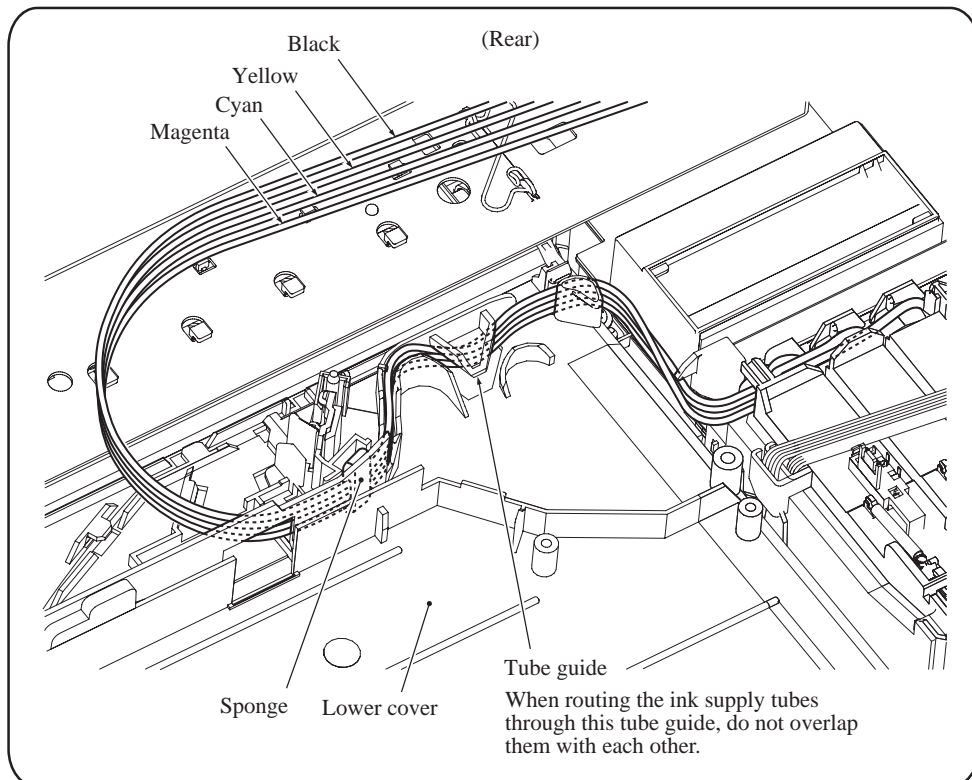
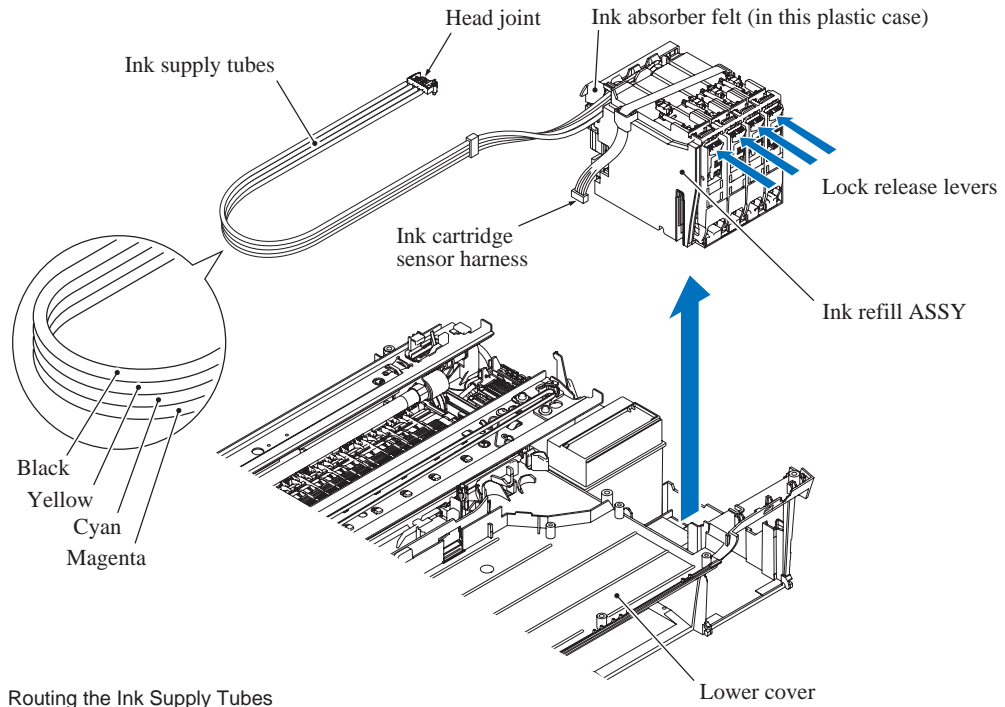

(6_46)

Head/carriage unit and CR timing belt

NOTE: During the removal or installation job for the head/carriage unit, take care not to contaminate the PF encoder disk with ink or grease.

- (19) While pressing the idle pulley holder to the right, remove the CR timing belt from the carriage motor pulley and idle pulley.
- (20) Move the head/carriage unit to the left end of its travel by hand.
- (21) Lift the head/carriage unit (with the CR timing belt) up and off the engine unit in the direction of the arrow shown below.

NOTE: Do not touch the head nozzles (the printing ends) or ink supply ports (to which ink supply tubes are connected) of the head/carriage unit; doing so will not only stain your hands with ink but also damage the nozzles and supply ports. If you do touch them though, clean them with a special-purpose cleaning stick and liquid.

NOTE: Do not remove the CR timing belt from the head/carriage unit unless it needs to be replaced. Once removed, the belt will become unusable and a new one will have to be put back in. For the early version of machines which has a spacer film between the CR timing belt and the head/carriage unit, be sure to sandwich the film inbetween when setting a new belt to the head/carriage unit as shown below.

NOTE: If the head/carriage unit needs to be replaced, replace not only that unit but also the CR timing belt. In this case, do not sandwich the spacer film any more even on the early version of machines.

For the early version of machines:
Spacer film for the CR timing belt (viewed from the bottom)

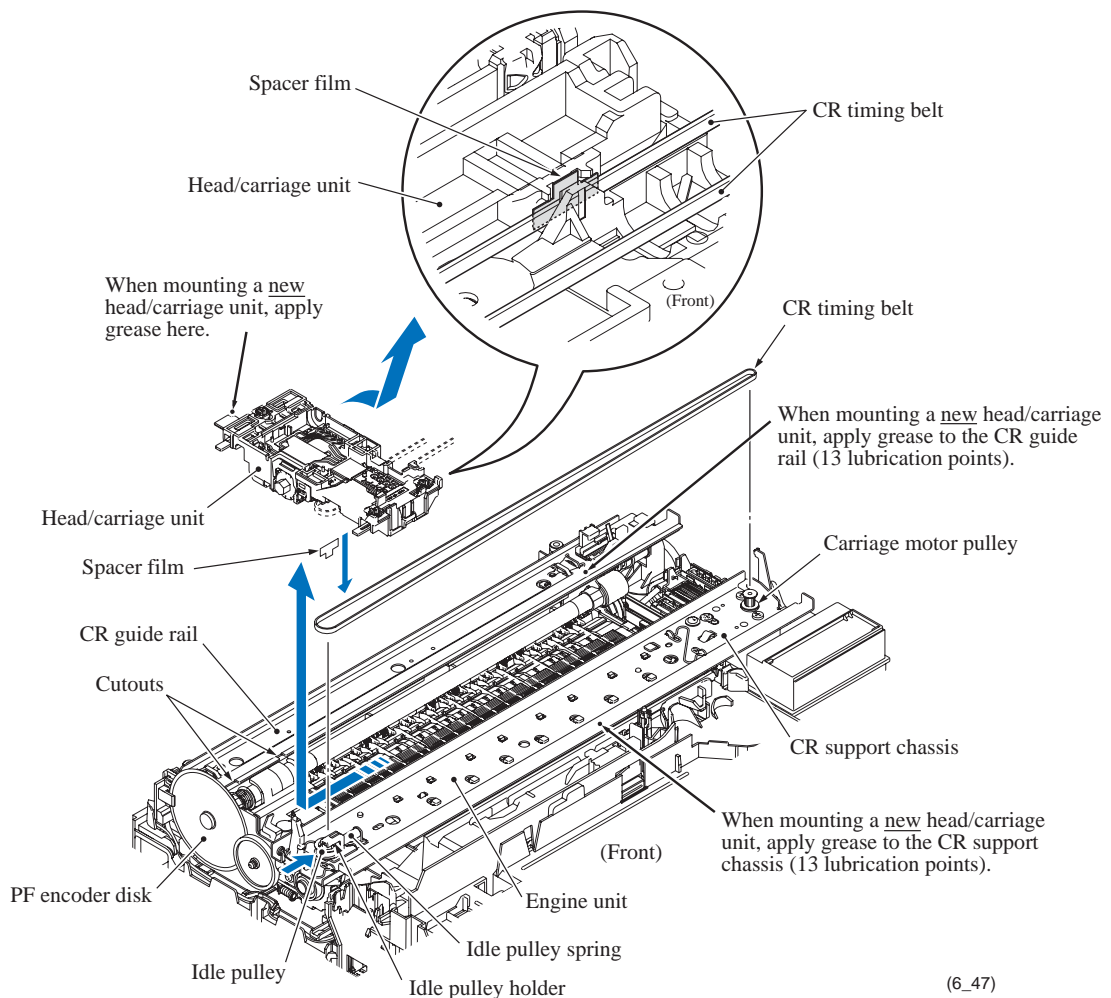

(6_47)

(22) A head/carriage unit is assigned a property code that represents the properties unique to that head/carriage unit. The property code is printed on head property labels--bar code label and QR code label, each of which is attached to the lower cover and carriage-head flat cable, respectively.

When you remove the head/carriage unit and store it separately from the machine, remove the property label (bar code label) from the lower cover and store it together with the head/carriage unit.

If you replace the head/carriage unit, attach the property label (bar code label) that comes with the new head/carriage unit to the lower cover as shown below.

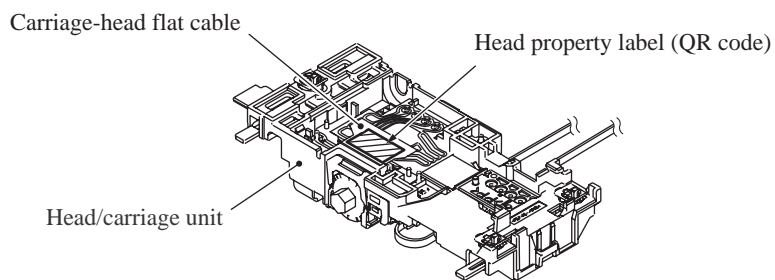
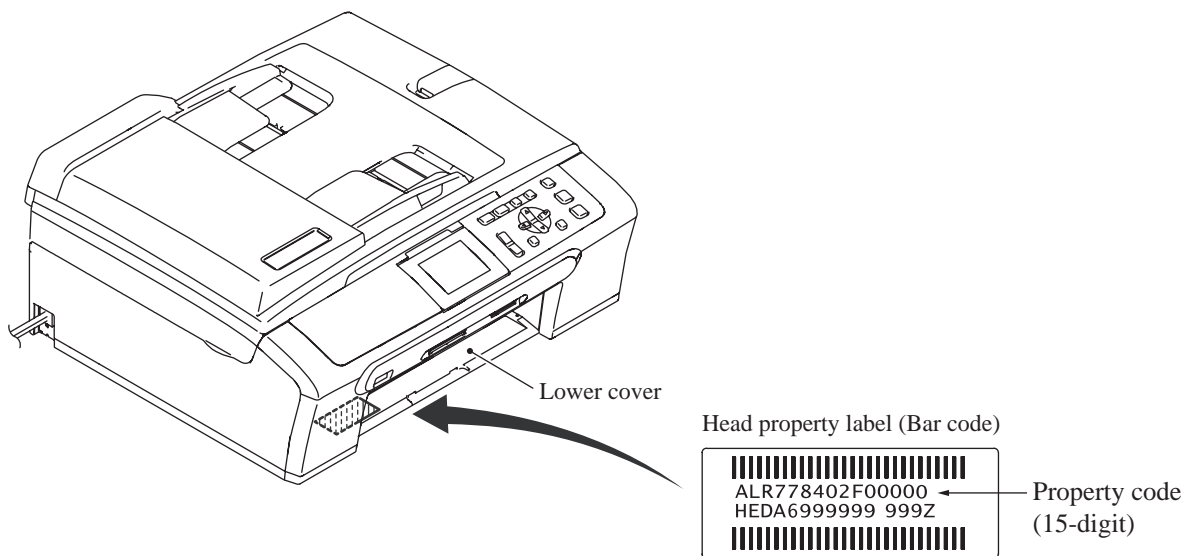

(6_48)

NOTE: When storing the head/carriage unit for a long period, be sure to put an air buffer cap on the head/carriage unit and store the unit in the head casing, as shown below. Leaving the head/carriage unit out of the casing will cause the head nozzles and ink supply ports to dry up, resulting in a damaged head.

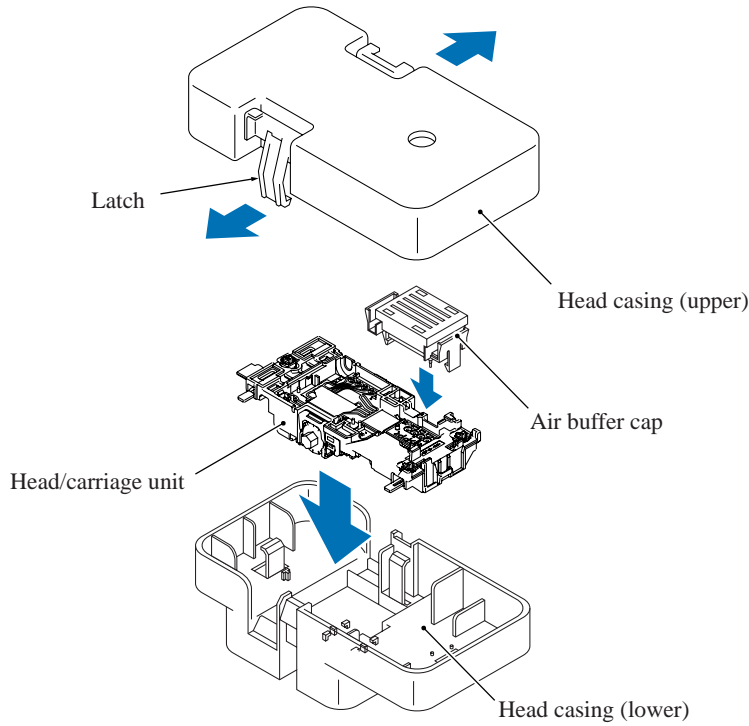

(6_49)

■ **Assembling Notes**

- When handling the head/carriage unit, put on a grounding wrist band and perform the job on a static mat. Also take care not to touch the conductor sections on the flat cables.
- When accessing the head/carriage unit placed on the engine unit, put the head/carriage unit in position "P" (on the right edge of the engine chassis) as shown on [page 6-42](#).
- For the early version of machines that has a spacer film between the CR timing belt and the head/carriage unit, when setting a new CR timing belt to the head/carriage unit, be sure to sandwich the film inbetween as shown on [page 6-46](#). Once the head/carriage unit is replaced, do not sandwich it any more.
- When replacing the head/carriage unit, replace not only that unit but also the CR timing belt. Refer to [page 6-46](#). In this case, do not use the spacer film any more even on the early version of machines.
- When mounting a new head/carriage unit, apply the specified lubricant to the specified point, referring to [Section 6.2](#).

Also, after mounting a new head/carriage unit, apply the specified lubricant to the specified points on the sliding surfaces of the CR guide rail and CR support chassis, referring to [Section 6.2](#).

- Before mounting the head/carriage unit on the engine unit, be sure to move the front and rear slider cams to the rightmost position to prevent them from scratching or damaging the PF encoder disk.

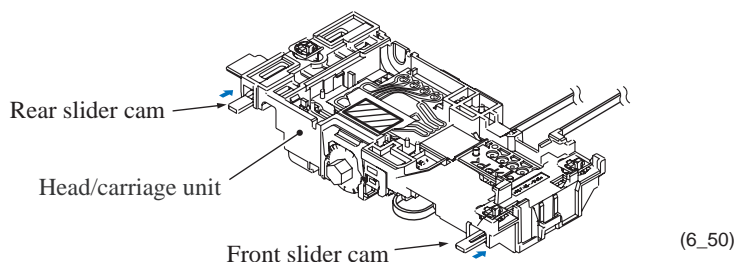

- When mounting the head/carriage unit on the left end of the engine unit, first fit the front end over the CR support chassis (shown on [page 6-46](#)) and then set the rear end onto the CR guide rail. Make sure that the two front bosses (see below) provided on the bottom of the head/carriage unit catch the front edge of the CR support chassis and the two rear bosses are fitted in the two cutouts (on [page 6-46](#)) in the CR guide rail.

Viewed from the bottom

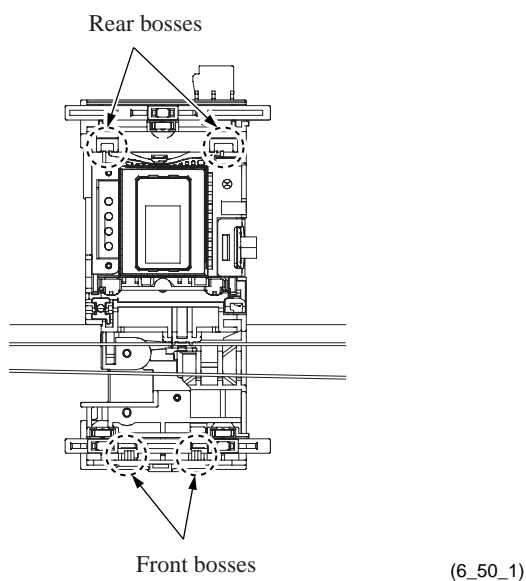

- After mounting the head/carriage unit, slide it by hand to check that it smoothly moves to the right and left ends of its travel.
- After mounting the ink refill ASSY, route the ink supply tubes on the lower cover, aligning magenta, cyan, yellow, and black ones in this order from the bottom, as shown on [page 6-45](#).
- Before setting the head joint, make sure that the head joint rubber is set on the head/carriage unit as shown on [page 6-44](#). Then secure the head joint to the head/carriage unit with the joint leaf spring.
- When mounting the carriage PCB ASSY, route the head flat cables, observing instructions given on the next page.

Routing the Head Flat Cables When Mounting the Carriage PCB ASSY

1) Set the FFC support on the head flat cables.

- Fit the loop of the head flat cables over the small boss inside the FFC support as shown below.

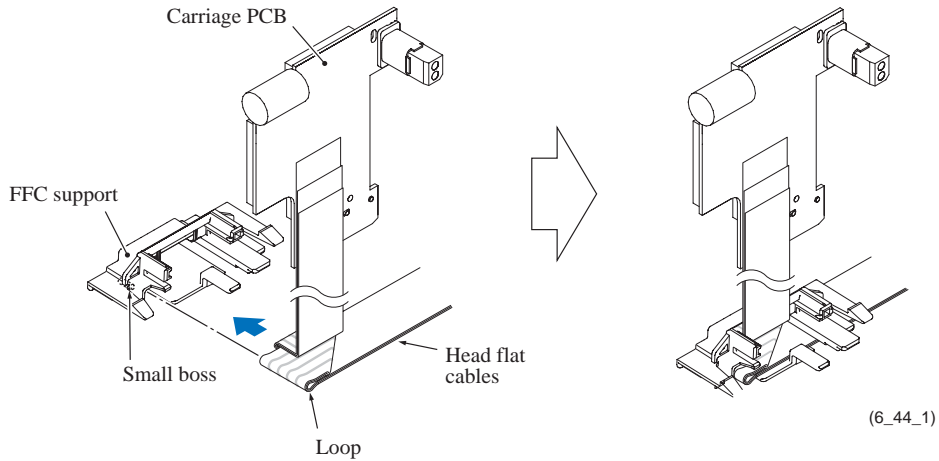

2) Mount the carriage PCB on the head/carriage unit (see [page 6-43](#)).

3) Latch the FFC support onto the head/carriage unit (see [page 6-43](#)).

4) Route the head flat cables through the cable guides and pass them through the flat core and the opening provided in the lower cover.

5) Set the tube support wire and spring onto the flat cable support plate. Fit the bent end of the spring on the tube/cable guide as shown below, turn the spring clockwise once and hook it on the tube support wire so that the spring pulls the wire to the front.

Then, mount the flat cable support plate so that the head flat cables (and ink supply tubes) pass between the tube/cable guide on the support plate and the lower cover.

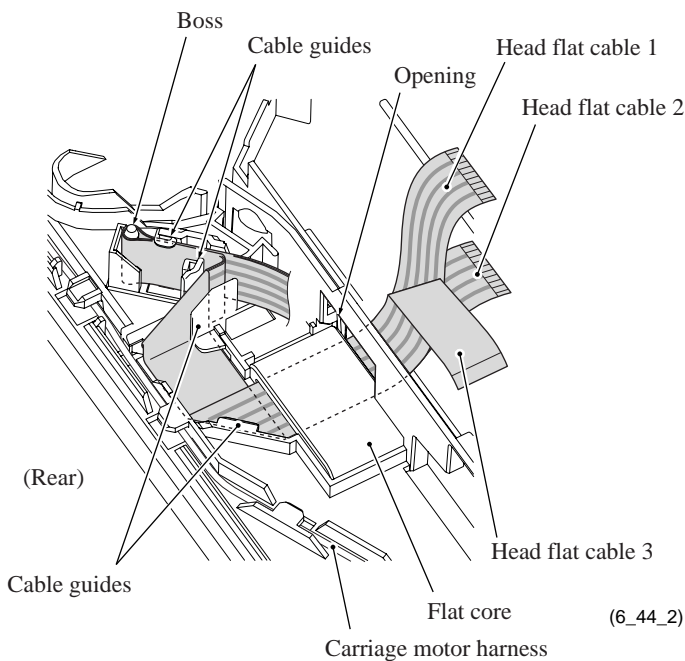

(6_44_2)

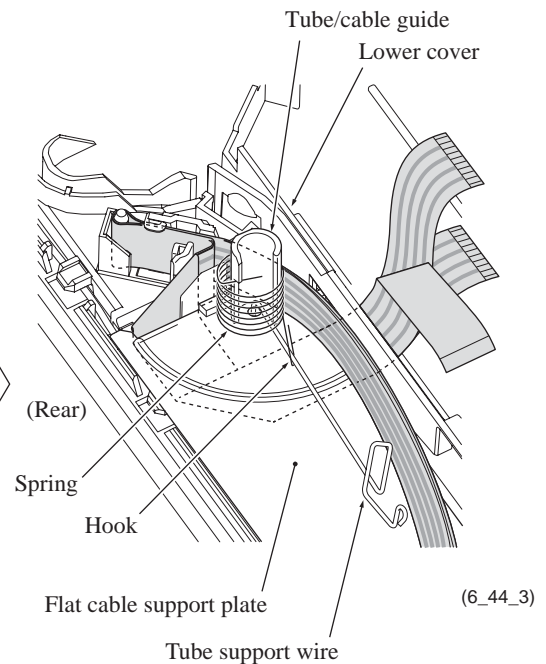

(6_44_3)

- After mounting the flat cable support plate, pass the ink supply tubes between the tube/cable guide and the lower cover and then through the bent section of the tube support wire as shown below.

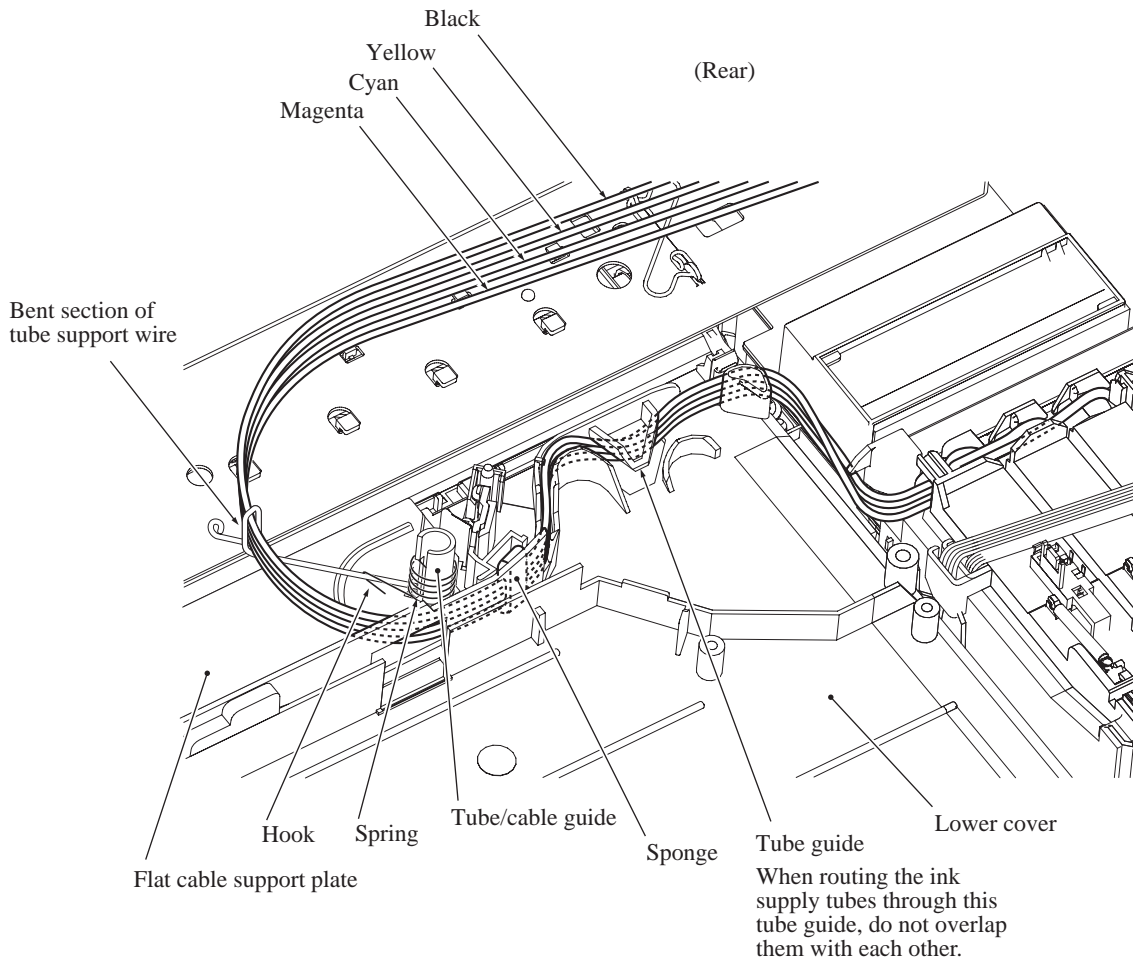

(6_46_A)

- After mounting the head cover, set the CR encoder strip so that the ▲-marked end is to the right (carriage motor side) and the ▲ mark points upwards as shown on [page 6-41](#).
Hook the left end of the strip on the CR encoder strip support first, pass it through the CR encoder sensor located on the head/carriage unit, then hook the right end while pushing the CR encoder strip support inwards.
- After replacement of the head/carriage unit, check that the CR encoder strip and PF encoder disk are free of grease and ink. If they are stained with grease or ink, replace them.
- If you replace the head/carriage unit, make adjustments specified in [Chapter 7, Section 7.2](#).

6.1.12 Ink Absorber Box, Ink Absorber Felt, and PF Encoder Disk

NOTE: Do not remove the ink absorber box unless it needs to be replaced.

NOTE: Once the two tubes (main drain tube and opening tube to the atmospheric air) are removed from the ink absorber box for the replacement of the ink absorber box, they will become unusable and new parts will have to be put back in. Using the removed tubes again may result in an ink leakage.

- (1) Pull out the two tubes (main drain tube and opening tube to the atmospheric air) from the ink absorber box.

NOTE: Pinch the end of the main drain tube with a clip and wrap the end of the opening tube to the atmospheric air in tissue paper in order to prevent drained ink from leaking and the machine from getting stained with leaked ink.

- (2) Pull the ink absorber box up and out of the lower cover.
- (3) Immediately set a new ink absorber box. Then replace these two tubes; that is, pull them off their joints on the maintenance unit and connect new tubes to the joints and new ink absorber box as shown below.

NOTE: If the ink absorber box or its surroundings are stained with ink, wipe them off with a cloth.

- (4) Take the ink absorber felt out of the lower cover.

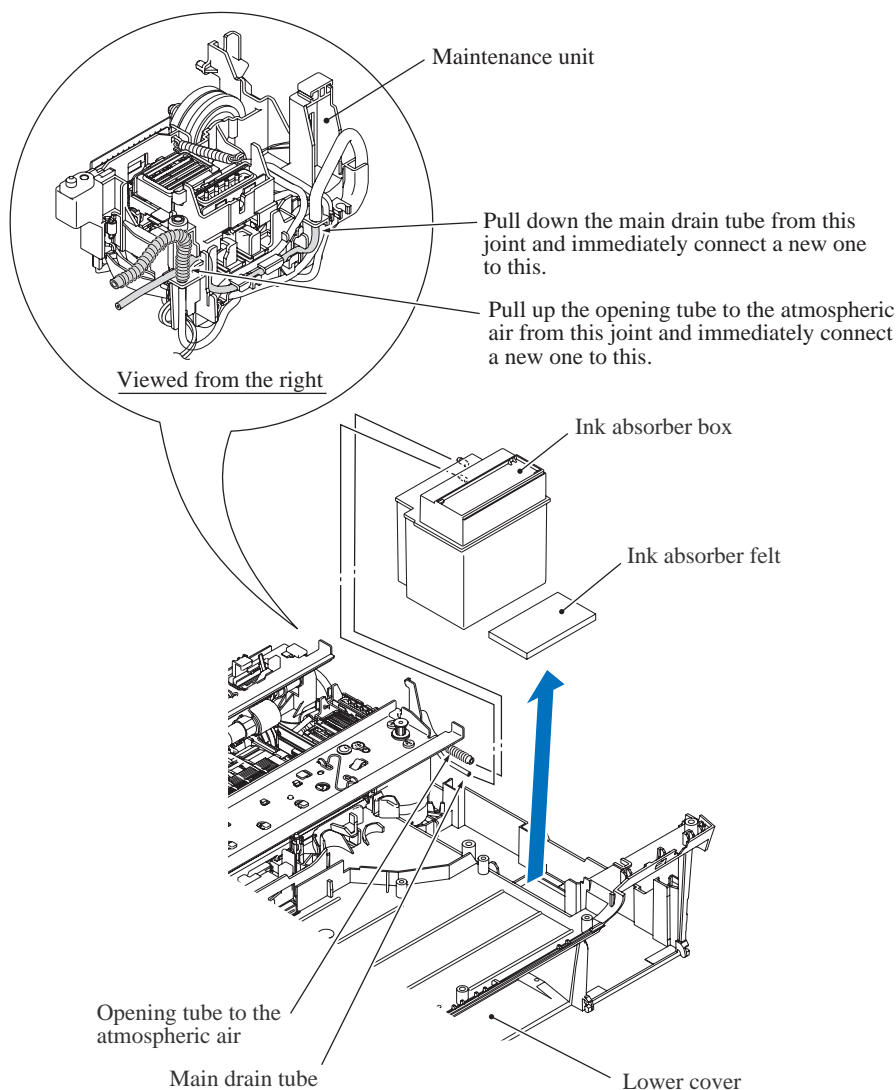

(6_51)

(5) Peel the PF encoder disk off the PF roller gear L only when it should be replaced.

NOTE: Once removed, the PF encoder disk will become unusable and a new disk will have to be put back in.

NOTE: Remove any adhesive remaining left on the PF roller gear L.

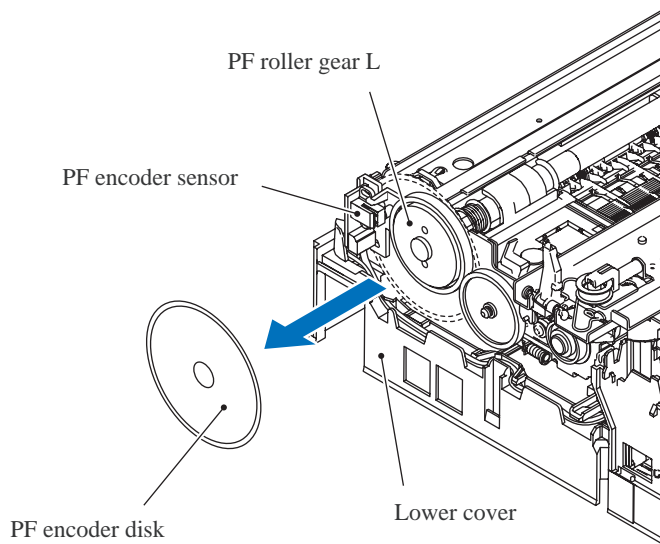

(6_52)

■ Assembling Notes

- When attaching the PF encoder disk to the PF roller gear L, using a spatular tool makes the job easier. Put on clean gloves to protect the disk surface from dust or fingerprints.
- If you replace the ink absorber box (without replacing the main PCB), you also need to replace the flushing box (see [Section 6.1.13](#)) and reset both the purge and flushing counters as specified in [Chapter 7, Section 7.4](#).

6.1.13 Engine Unit and Flushing Box

During disassembly jobs, except when removing the ink refill ASSY or engine unit (including the maintenance unit), leave the head/carriage unit in the machine.

Before removing the head/carriage unit, ink refill ASSY or engine unit, you need to replace all four ink cartridges with the protective part (see [page 6-3](#)).

- (1) If the MJ/PS shield box has not been removed, you need to remove screw "e" shown on [page 6-37](#).
- (2) Remove the chassis support by removing the screw.
- (3) Remove the screw from the rear of the engine unit.
- (4) Take the carriage motor harness and purge cam switch harness out of the cable guides provided on the lower cover.

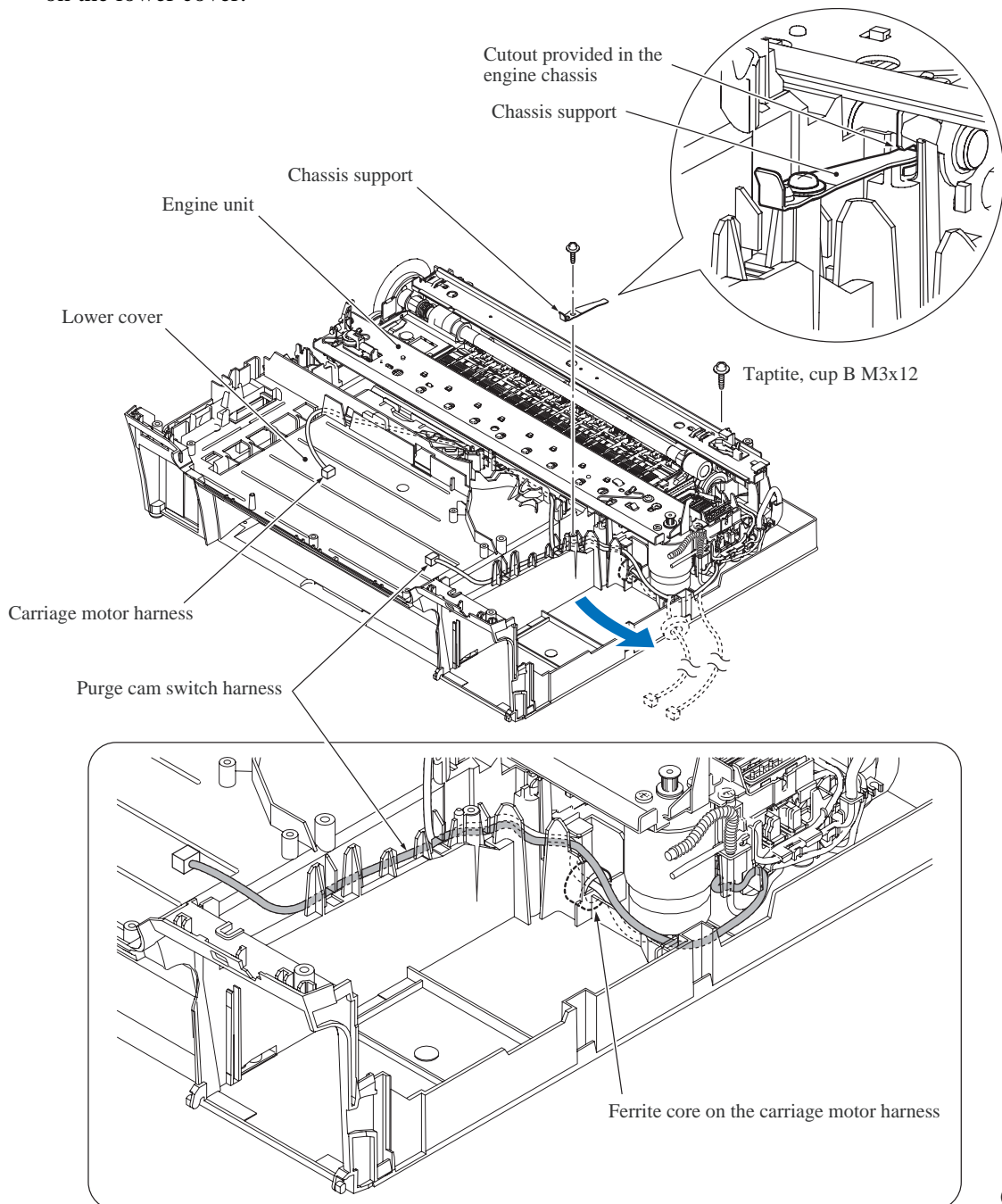

(6_53)

- (5) Take the paper feed motor harness and PF encoder/registration sensor harness out of the harness guides on the lower cover.
- (6) Lift the engine unit up and out of the lower cover in the direction of the arrow shown below, holding the inner chute located beneath the CR guide rail.

NOTE: Do not hold the CR guide rail.

NOTE: Take care not to touch the PF encoder disk.

NOTE: If the ink absorber box does not need to be replaced, be sure to take it out of the lower cover together with the engine unit. Do not disconnect the two tubes (main drain tube and opening tube to the atmospheric air) from the ink absorber box. Once disconnected, those tubes will become unusable and new parts will have to be put back in.

NOTE: Do not place the engine unit directly on a flat surface; doing so may break the PF encoder disk and gears. Be sure to place a support pad under the engine unit as shown below.

- (7) Take the flushing box out of the lower cover.

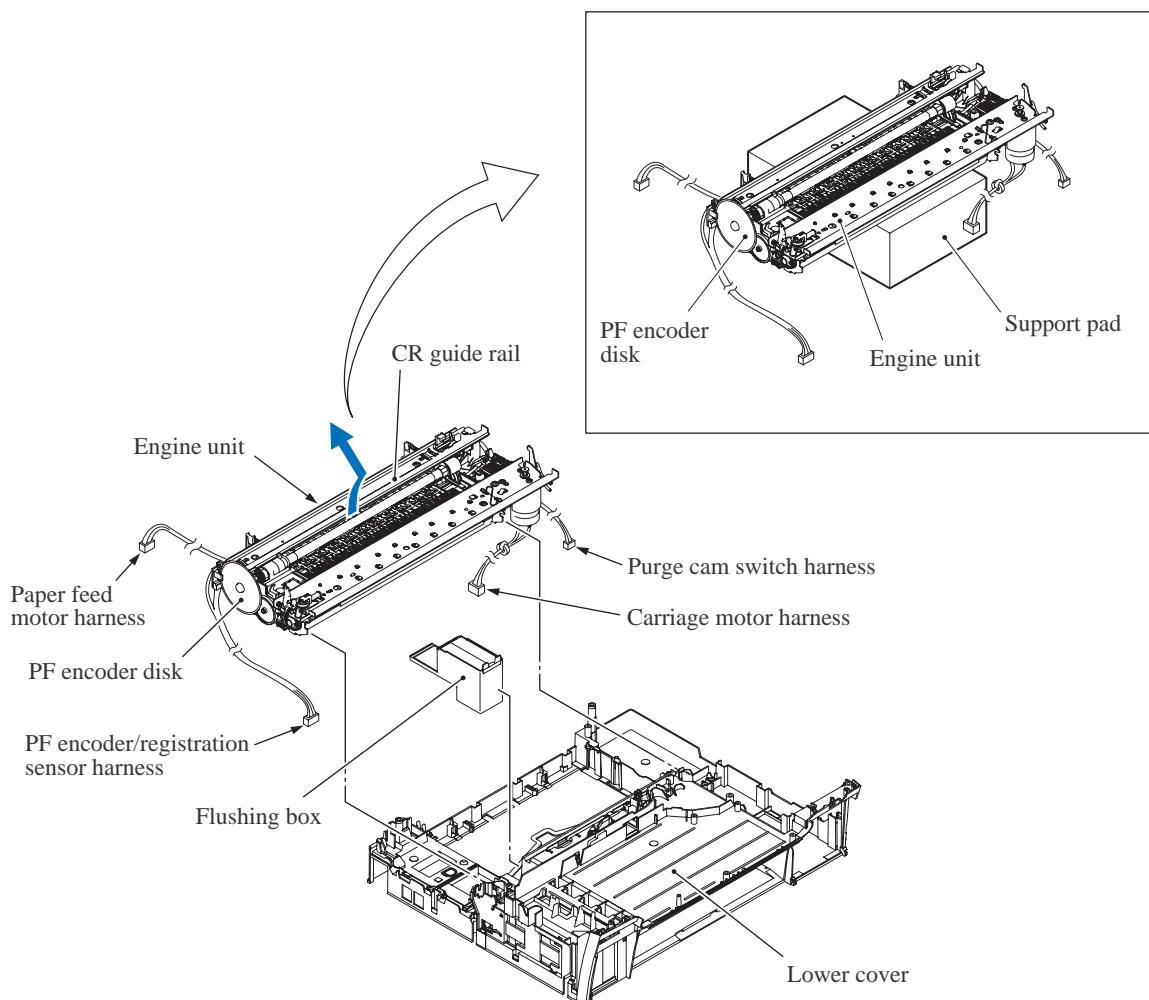

(6_54)

■ **Assembling Notes**

- Before mounting the engine unit on the lower cover, make sure that the PF encoder/registration sensor harness and the paper feed motor harness are routed through the cable guides on the inner chute as shown on [page 6-60](#).
- When mounting the engine unit on the lower cover, be careful not to crush the harnesses between the unit and the cover. Mount the engine unit parallel to the lower cover so that the screws are tightened securely.
- Route the harnesses as shown below.

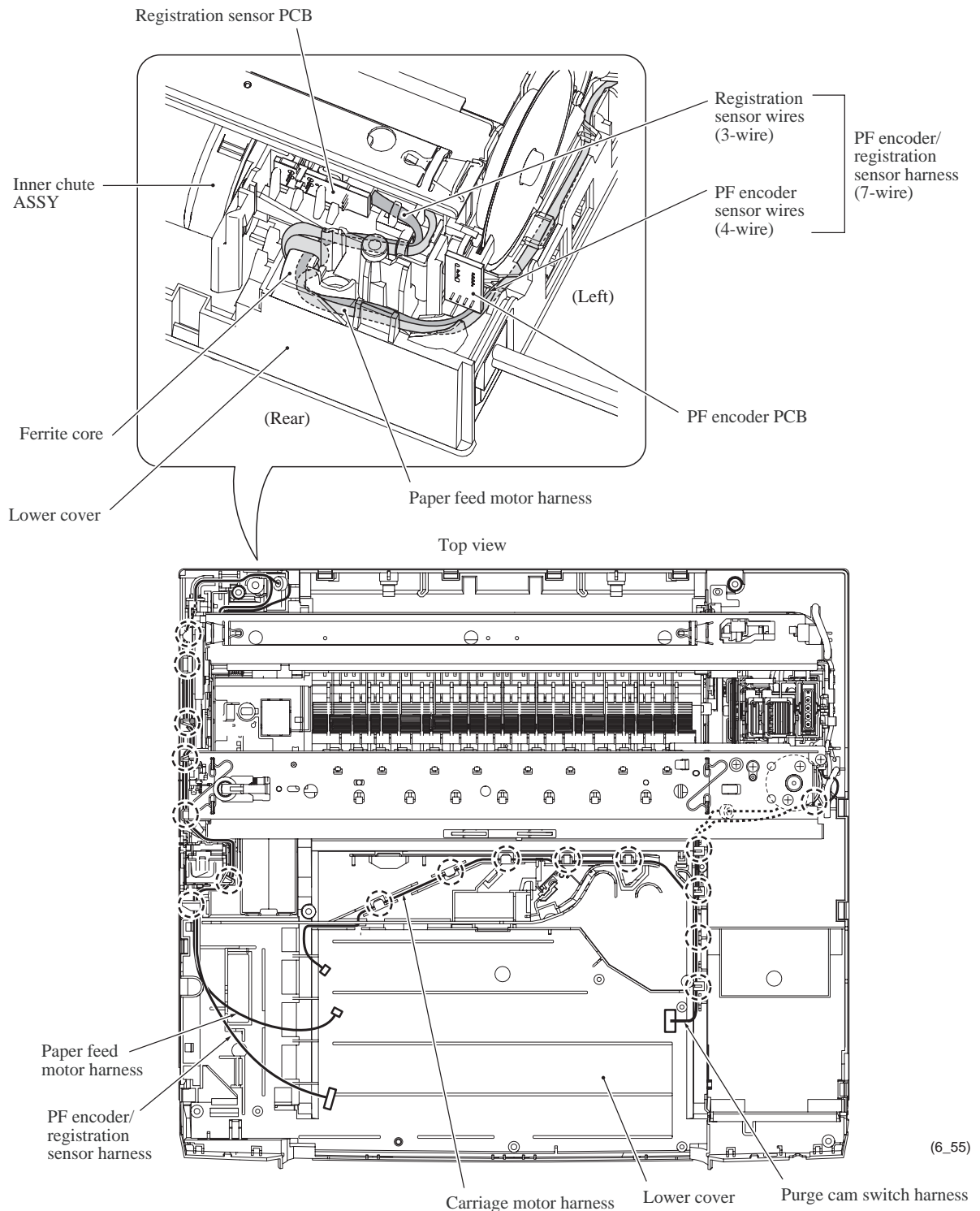

- Insert the chassis support into the cutout provided in the right end of the engine chassis (see [page 6-54](#)), not between the chassis and the lower cover.
- If you replace the engine unit, make adjustments specified in [Chapter 7, Section 7.2](#).
- If you replace the flushing box (without replacing the main PCB), you also need to replace the ink absorber box (see [Section 6.1.12](#)) and reset both the flushing and purge counters as specified in [Chapter 7, Section 7.4](#).

6.1.14 Components on the Engine Unit

(Maintenance unit, Mode switching lever & clutch gear ASSY, Carriage motor, Inner chute ASSY, Registration sensor PCB, PF encoder PCB, Paper feed motor, Paper pull-in gear shaft, and Paper pull-in roller holder)

Maintenance unit and mode switching lever & clutch gear ASSY

- (1) Remove the three screws from the maintenance unit--two "a" screws from the top and one "b" screw from the right side.
- (2) Take the maintenance unit off the engine unit.
- (3) Remove the SF changeover gear, HS changeover gear, and HS gear plate (which is used only in the early version of machines) from the maintenance unit.
- (4) Slide the mode switching lever & clutch gear ASSY outwards to remove it.
- (5) Unlatch the switching lever guide from the CR guide rail.

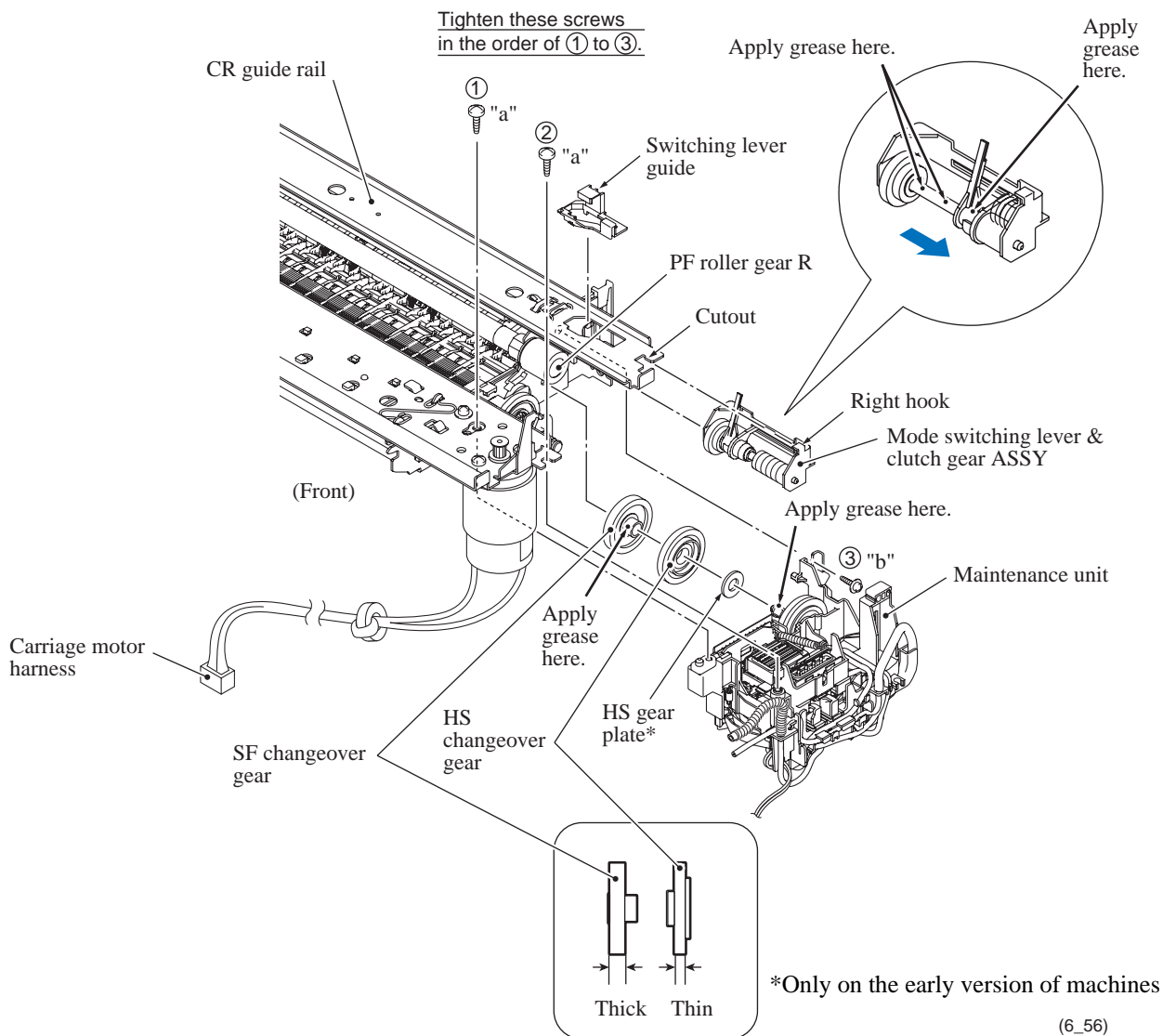

(6_56)

"a": Taptite, bind B M3x8

"b": Taptite, cup S M3x6

Carriage motor

- (6) Remove the carriage motor from the engine unit by removing the two screws.

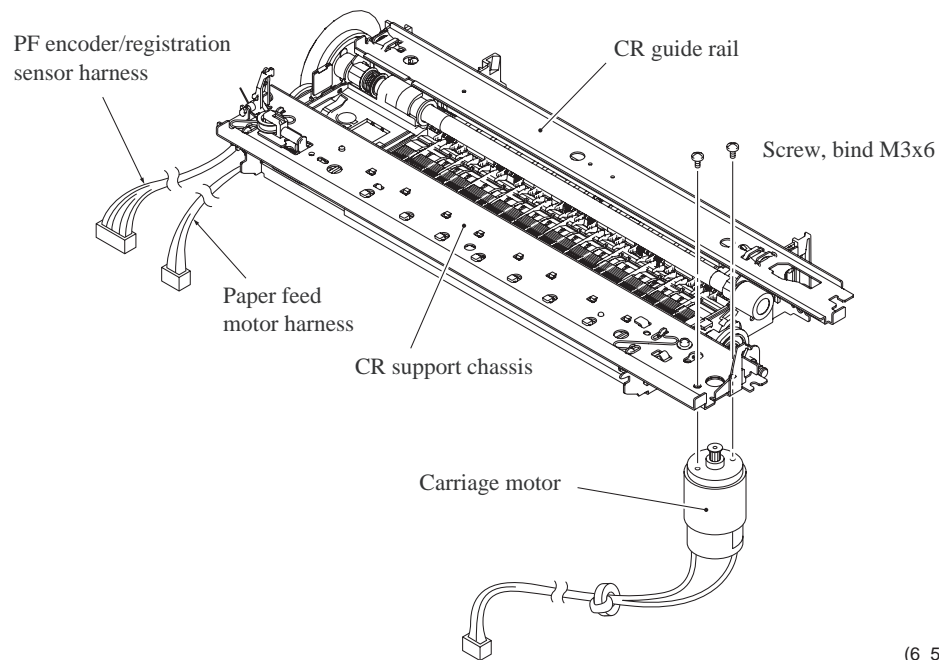

(6_57)

Inner chute ASSY, registration sensor actuator, registration sensor PCB, and PF encoder PCB

- (7) Release the three latches of the inner chute ASSY from the engine unit.

NOTE: Do not pull the inner chute ASSY away from the engine unit since it is connected to the engine unit with the PF encoder/registration sensor harness and the paper feed motor harness.

- (8) Release the PF encoder/registration sensor harness and the paper feed motor harness from the cable guides on the inner chute ASSY. (The routing detail is shown on the next page.)

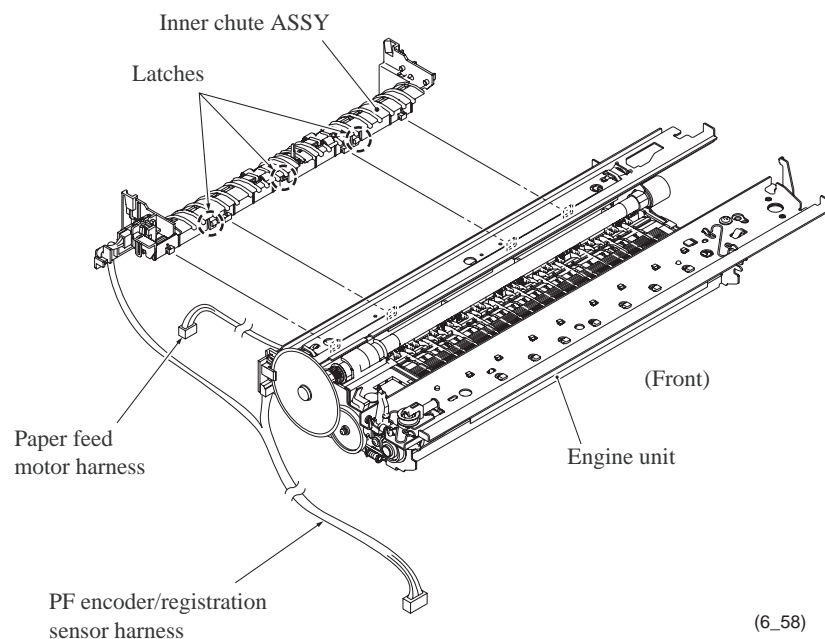

(6_58)

- (9) Turn the registration sensor actuator in the direction of the arrow shown below and take it off the inner chute ASSY. The sensor actuator spring comes off.
- (10) Take the registration sensor PCB out of the support arms.

NOTE: The registration sensor PCB and the PF encoder PCB are assembled with their harnesses. To completely release the registration sensor PCB from the engine unit, therefore, you need to remove the PF encoder PCB at the next step.

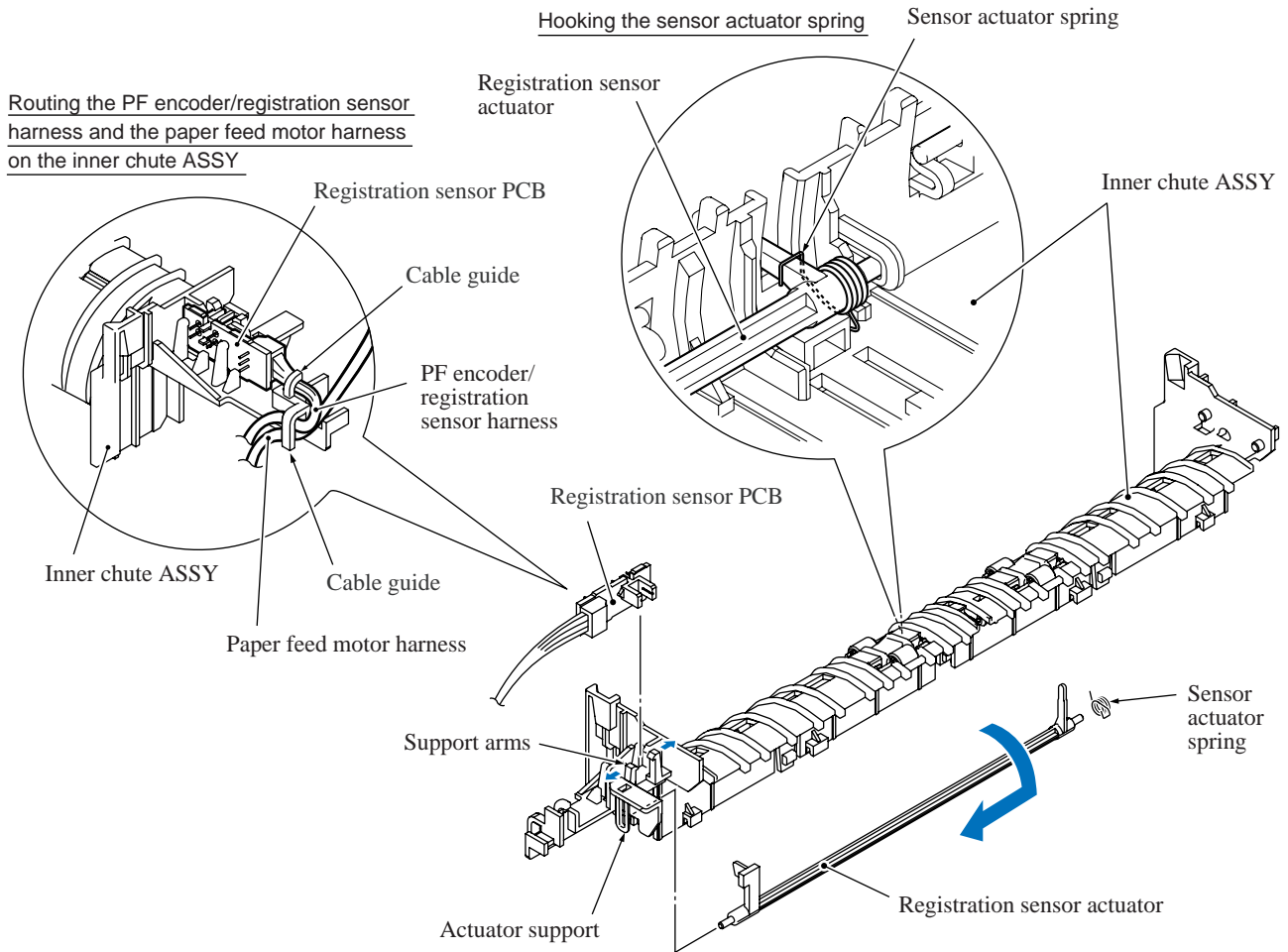

(6_59)

(11) At the left end of the engine unit, remove the screw that secures the PF encoder PCB and its support to the engine unit, taking care not to touch the PF encoder disk (if it has not been removed in [Section 6.1.12](#)).

(12) If the PF encoder disk needs to be replaced, peel it off the PF roller gear L.

NOTE: Once removed, the PF encoder disk will become unusable and a new disk will have to be put back in.

NOTE: Remove any adhesive remaining left on the PF roller gear L.

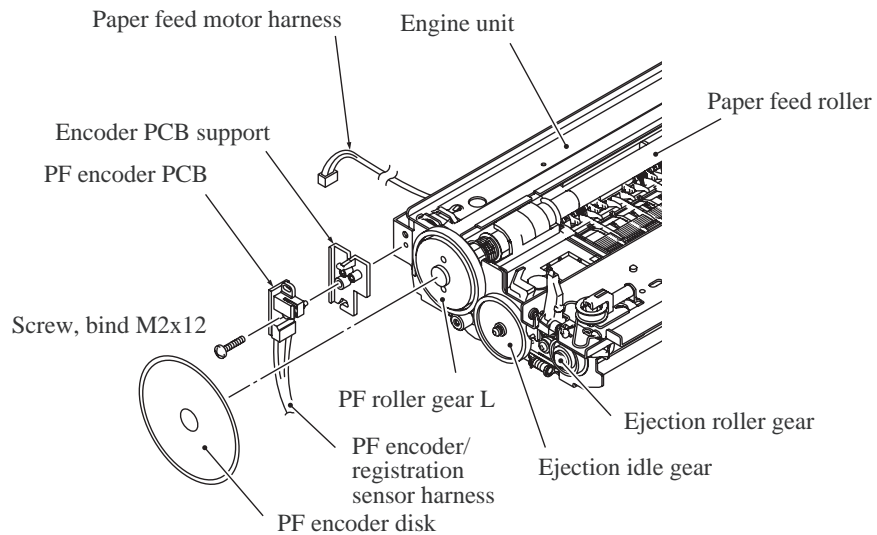

(6_60)

Paper feed motor

(13) Remove the two screws from the left end of the engine unit and remove the paper feed motor in the direction of the arrow.

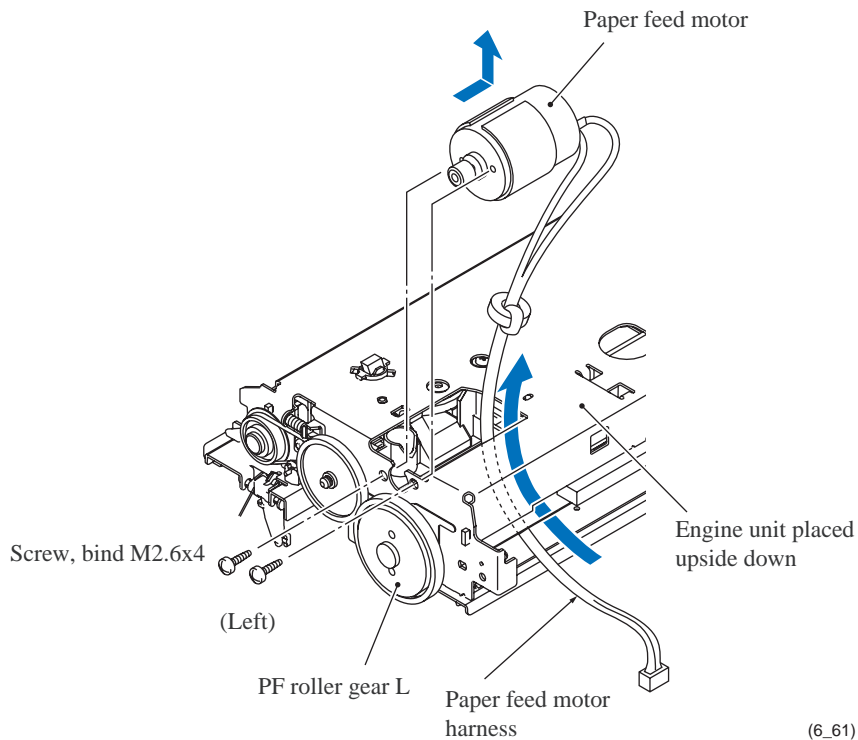

(6_61)

Paper pull-in gear shaft and paper pull-in roller holder

(14) Press the lock arm and pull out the paper pull-in gear shaft to the right.

(15) Lift the paper pull-in roller holder up and out of the engine unit, together with its spring.

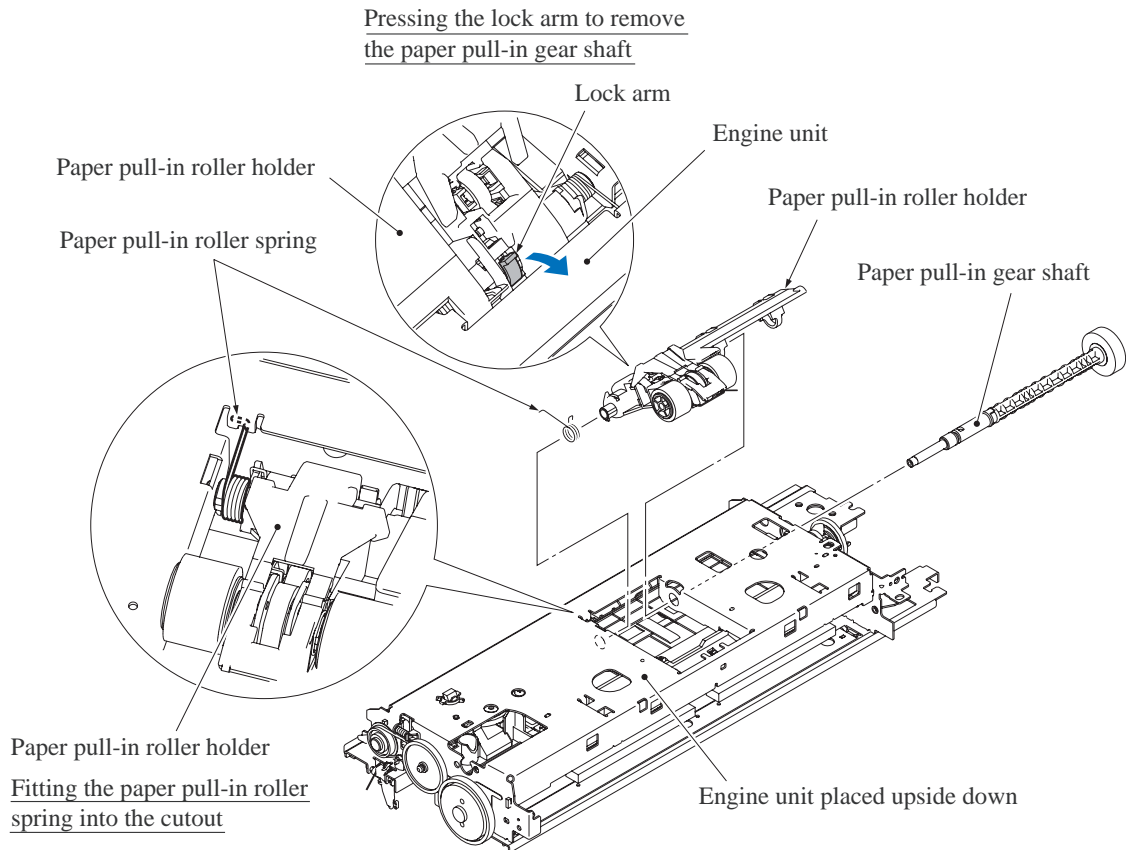

(6_62)

■ Assembling Notes

- When setting the paper pull-in roller holder back into place, fit the longer end of the paper pull-in roller spring into the cutout provided in the engine chassis.
While holding down the paper pull-in roller holder lightly, insert the paper pull-in gear shaft from the right until it locks.
- When mounting the paper feed motor, route its harness as shown on the previous page and secure the motor with two screws with the label facing towards the front.
- When attaching the PF encoder disk to the PF roller gear L, using a spatular tool makes the job easier. Put on clean gloves to protect the disk surface from dust or fingerprints.
- Before mounting the inner chute on the engine unit, set the registration sensor actuator and its spring. Also set the registration sensor PCB and route the PF encoder/registration sensor harness and the paper feed motor harness. See [page 6-60](#).
- When mounting the carriage motor, face the label outwards (see [page 6-59](#)).

- Mount the switching lever guide and the mode switching lever & clutch gear ASSY onto the engine unit in this order.

Before mounting the ASSY, apply the specified lubricant to the specified points, referring to [Section 6.2](#).

When mounting the ASSY, insert the shaft end into the hole provided in the CR guide rail and fit the right hook over the cutout (see [page 6-58](#)).

The ASSY should be mounted immediately before you mount the maintenance unit.

- Before mounting the maintenance unit onto the engine unit:
 - Apply the specified lubricant to the SF changeover gear and the purge gear shaft, referring to [Section 6.2](#).
 - For the early version of machines that has an HS gear plate: Set the plate onto the purge gear shaft before mounting the HS changeover gear and SF changeover gear. Once the maintenance unit is replaced, do not use the HS gear plate any more.
 - Put the two gears (SF changeover gear and HS changeover gear) together so that there is a gap between those gears as shown on [page 6-58](#). Then set them onto the purge gear shaft with the HS changeover gear (thinner one) facing towards the maintenance unit.
- When securing the maintenance unit with three screws (two "a" and one "b" screws), tighten these screws in the order of ① to ③ as shown on [page 6-58](#).

6.1.15 Paper Tray ASSY

- (1) While pulling each of the left and right sides of the paper tray outwards, release each of the left and right rear corners of the paper tray cover, respectively.

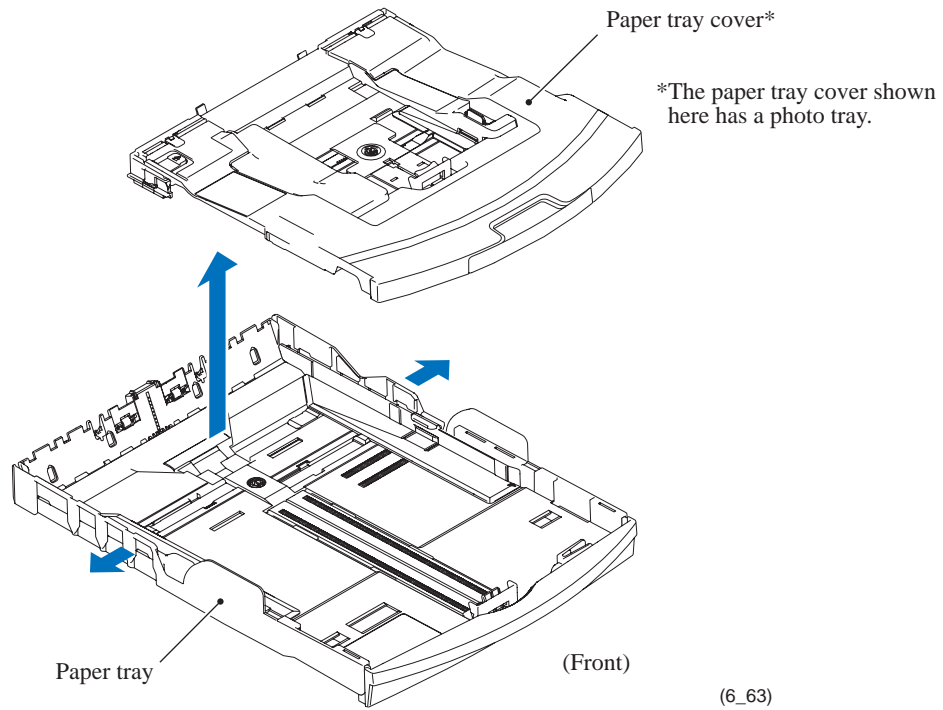

- (2) While pressing the universal guide release button (shown below), slide the paper tray extension to the front until it clicks.
- (3) While pulling sections "x" of the paper tray outwards, push down the paper tray extension and slide it to the front and out of the paper tray.

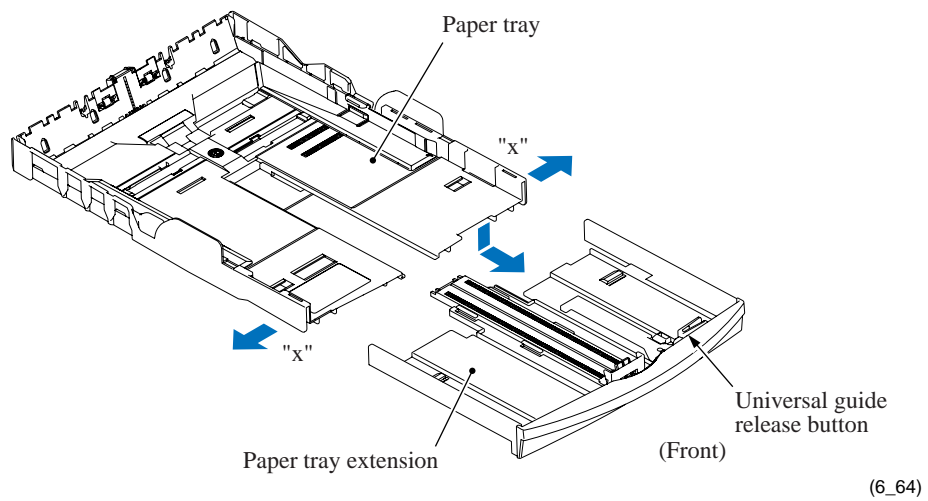

- (4) Pull the four lock arms on the rear of the paper tray outwards and release the four latches of the bank ASSY. Then pull the bank ASSY up and out of the paper tray.
- (5) If the base pad needs to be replaced, peel it off the bottom of the paper tray.

NOTE: Once removed, the base pad will become unusable and a new pad will have to be put back in.

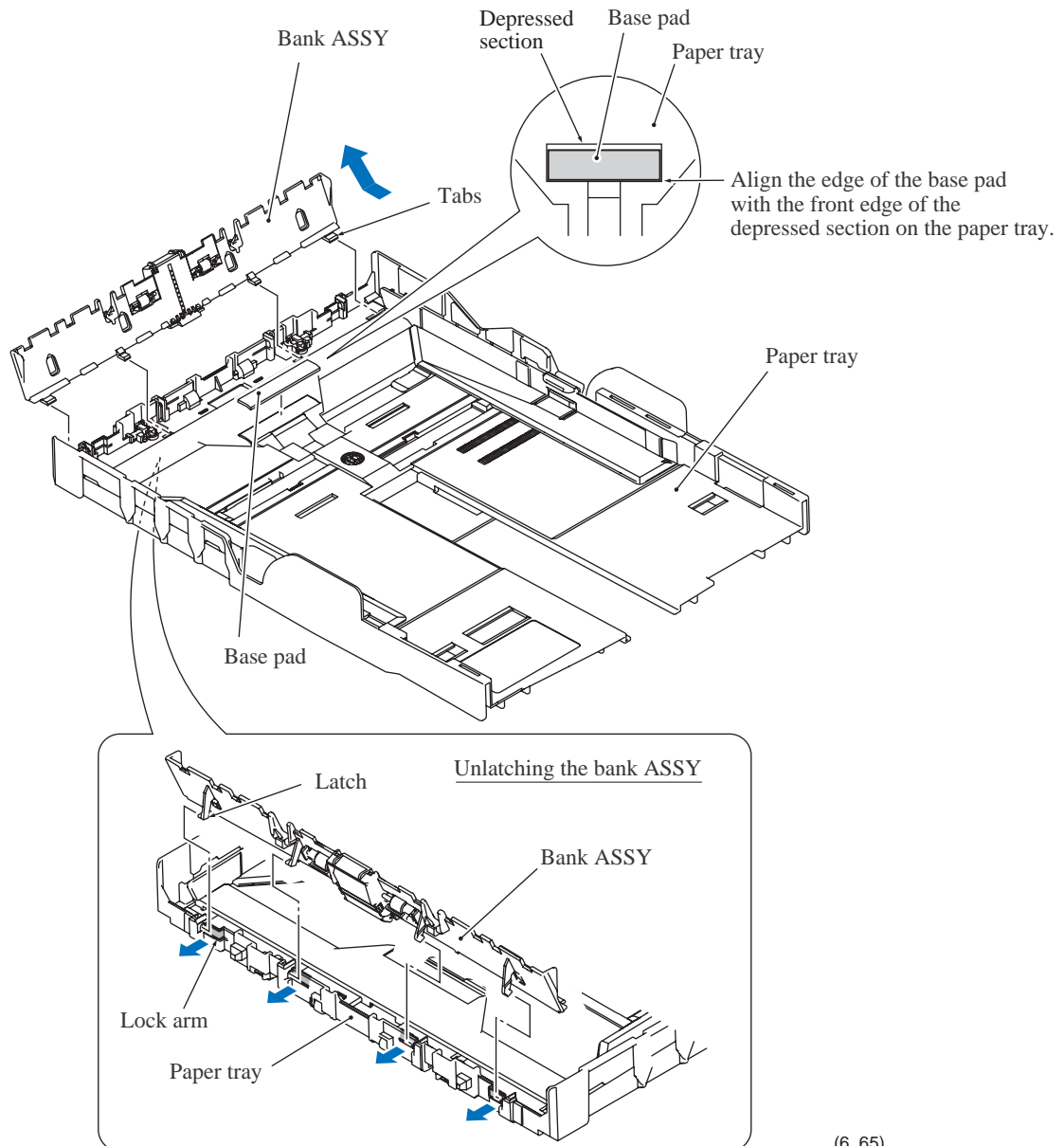

(6_65)

■ **Assembling Notes**

- When attaching a new base pad to the paper tray, align the edge of the base pad with the front edge of the depressed section on the paper tray as shown above.
- When mounting the bank ASSY, first insert the four tabs into the openings in the paper tray and then press the inside of the bank ASSY so that the latches snap into place.

6.1.16 Routing of the Harnesses, Flat Cables, and Ink Supply Tubes

*For models with ADF

Routing A: CIS motor harness, document front and rear sensor harnesses*, ADF motor harness* and grounding wire*

- On the upper cover

DCP750CW

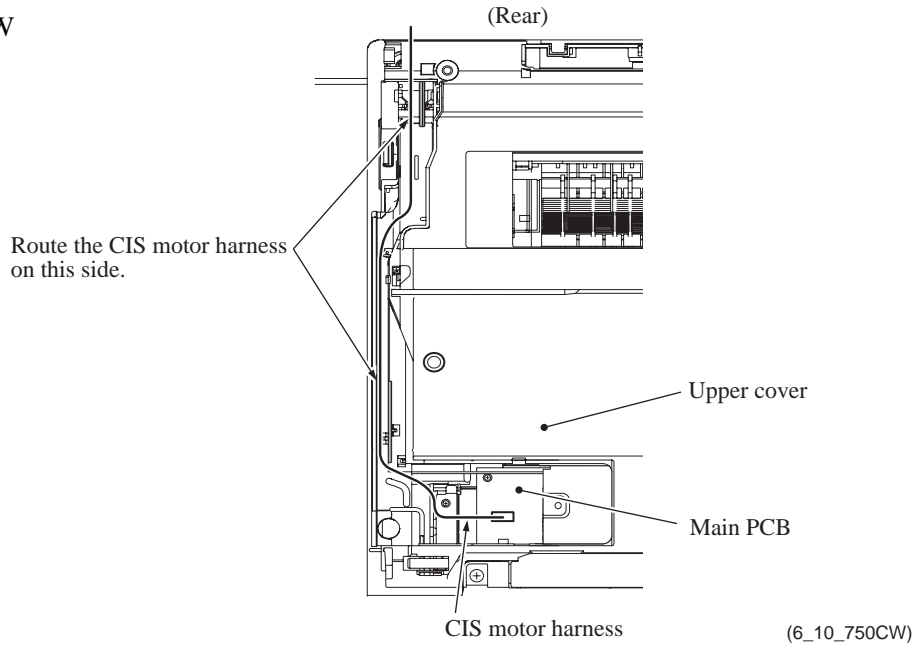

DCP540CN/330C

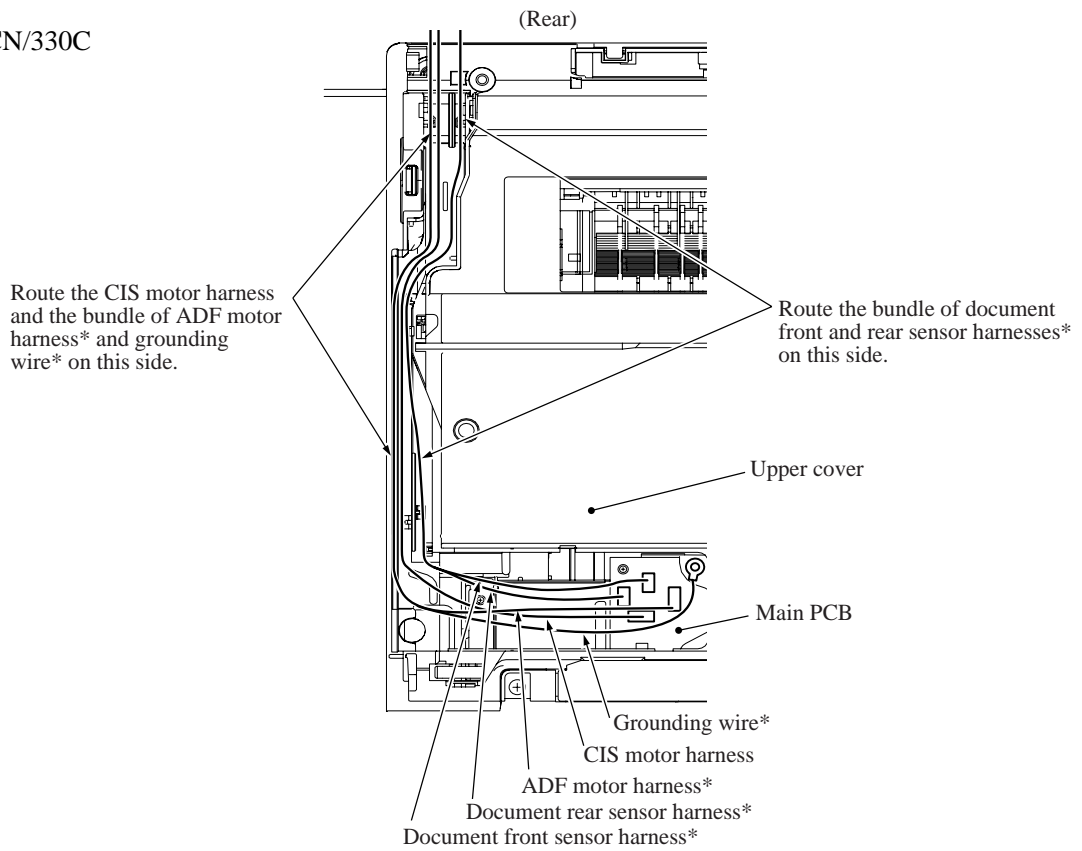

DCP130C

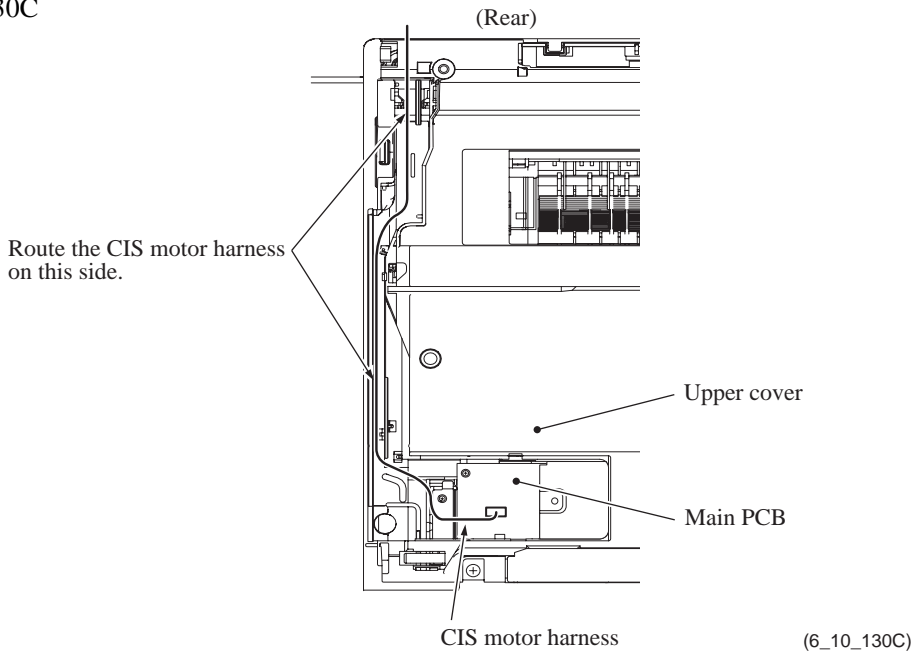

■ On the ADF unit*

*For models with ADF

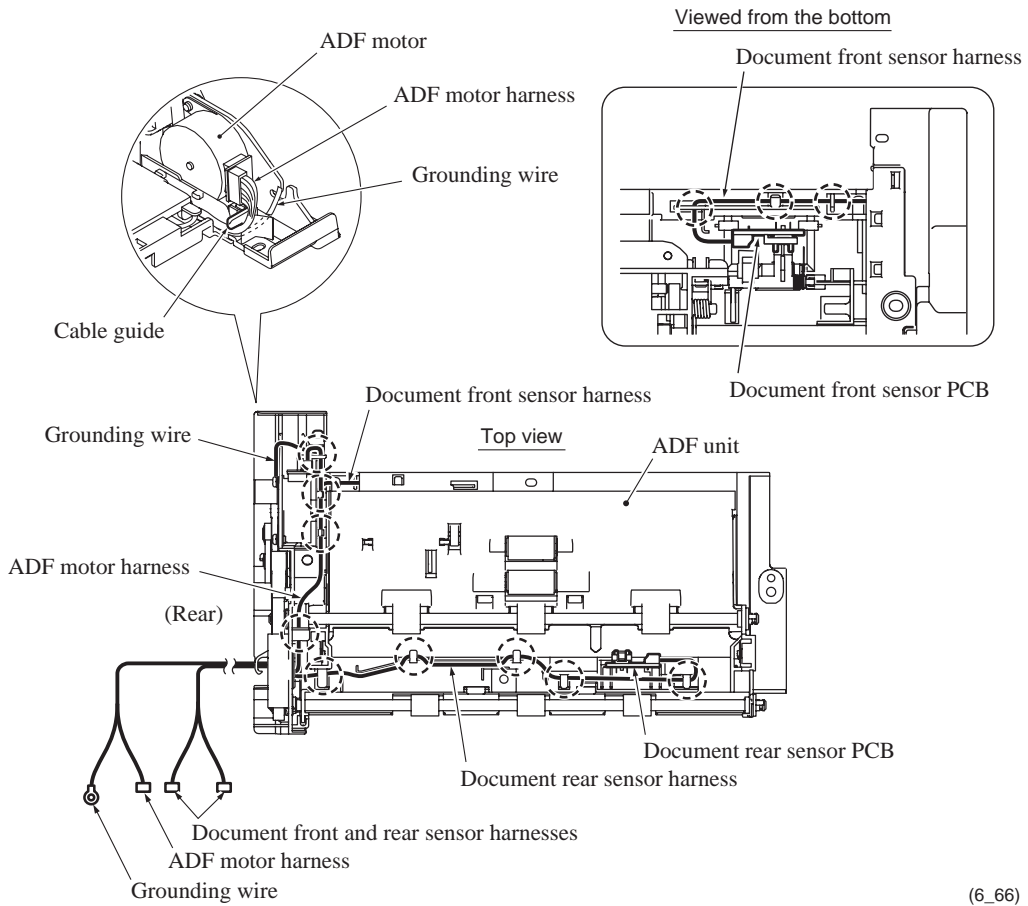

Routing B: WLAN PCB harness*

*For wireless LAN-enabled models

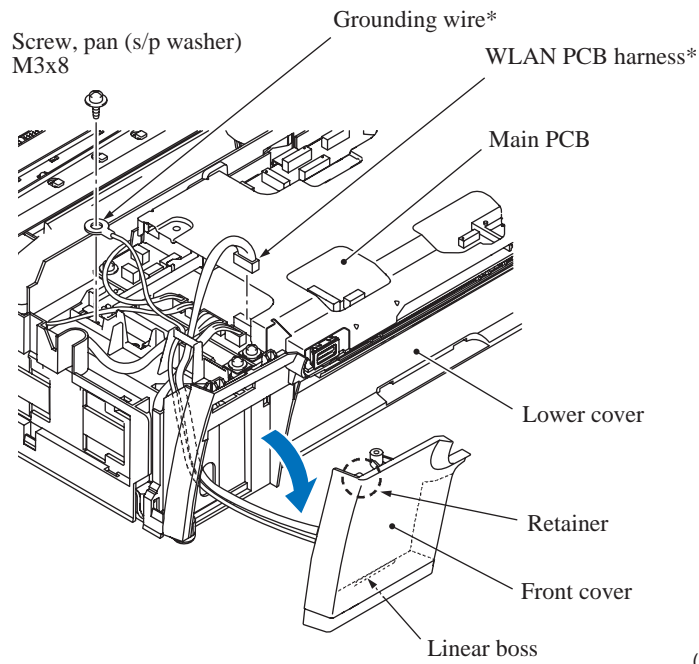

(6_67)

Routing C: Carriage motor harness, paper feed motor harness, PF encoder/registration sensor harness, and power supply harness on the lower cover

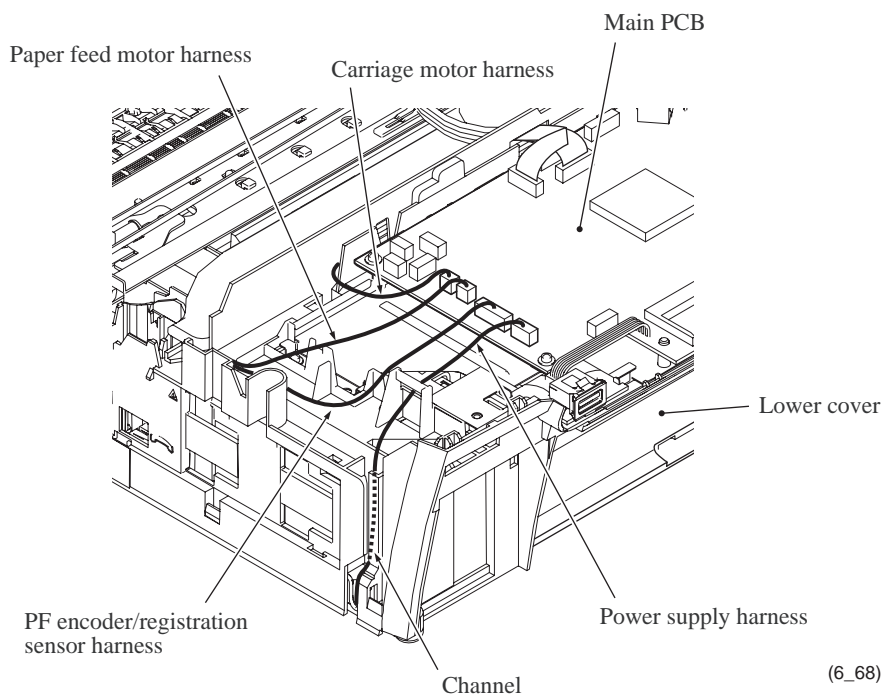

(6_68)

Routing D: Power supply harness and power cord in the MJ/PS shield box

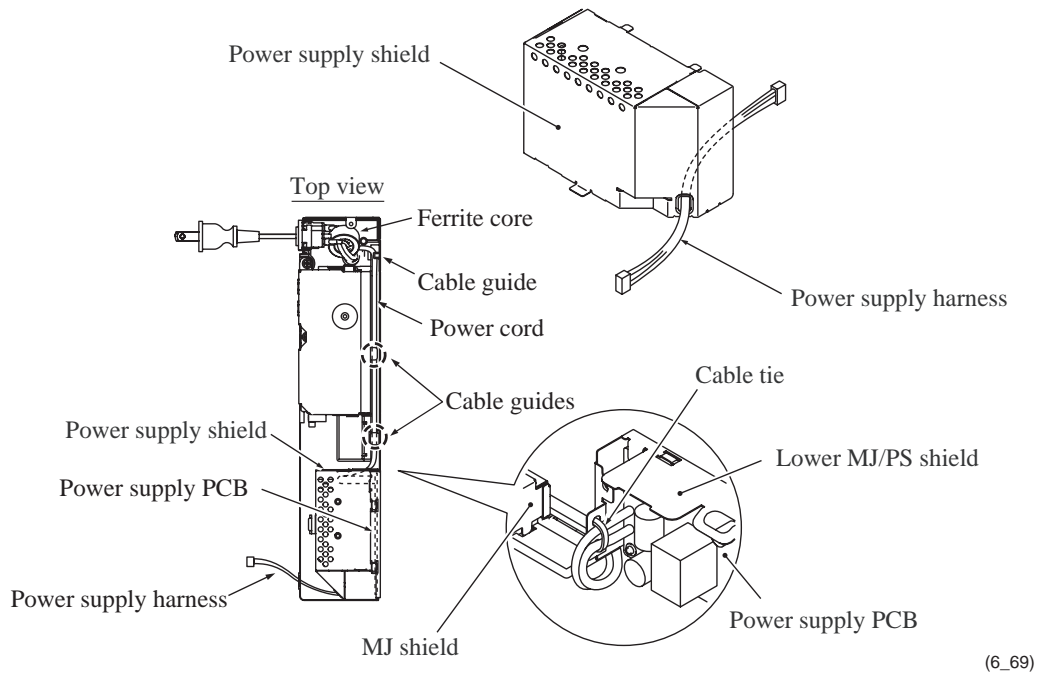

Routing E: Ink supply tubes

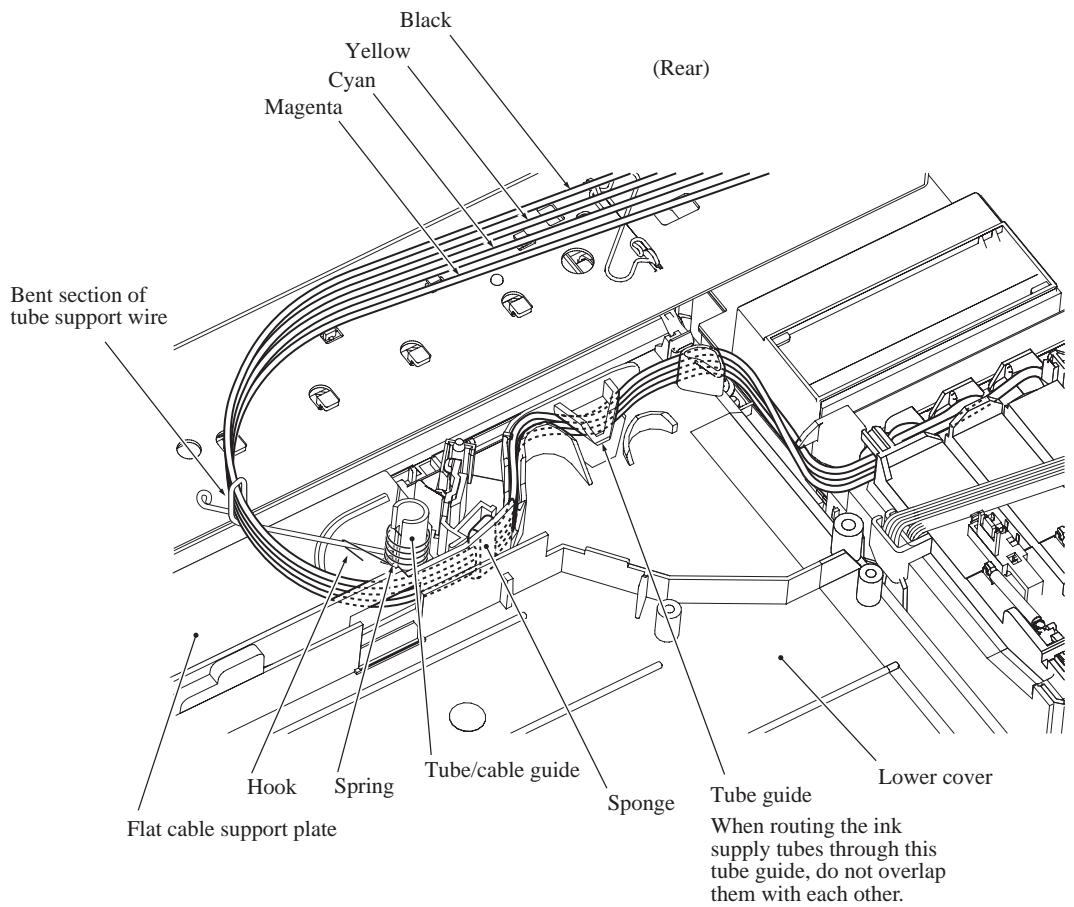

Routing F: Head flat cables

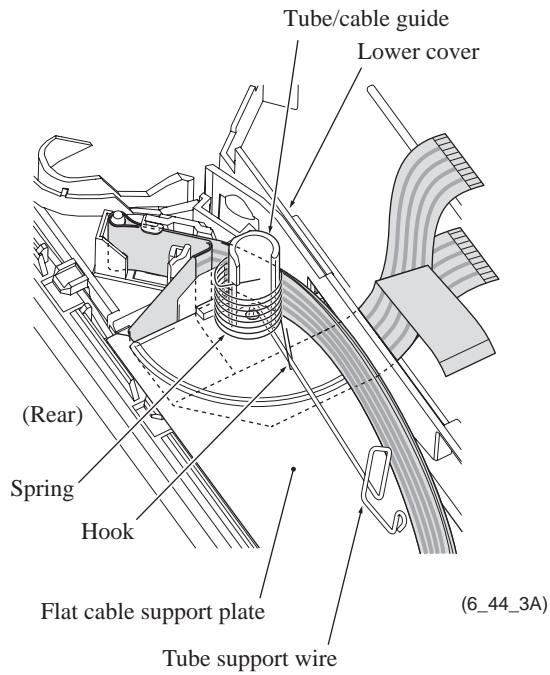

Routing G: Purge cam switch harness and carriage motor harness on the lower cover

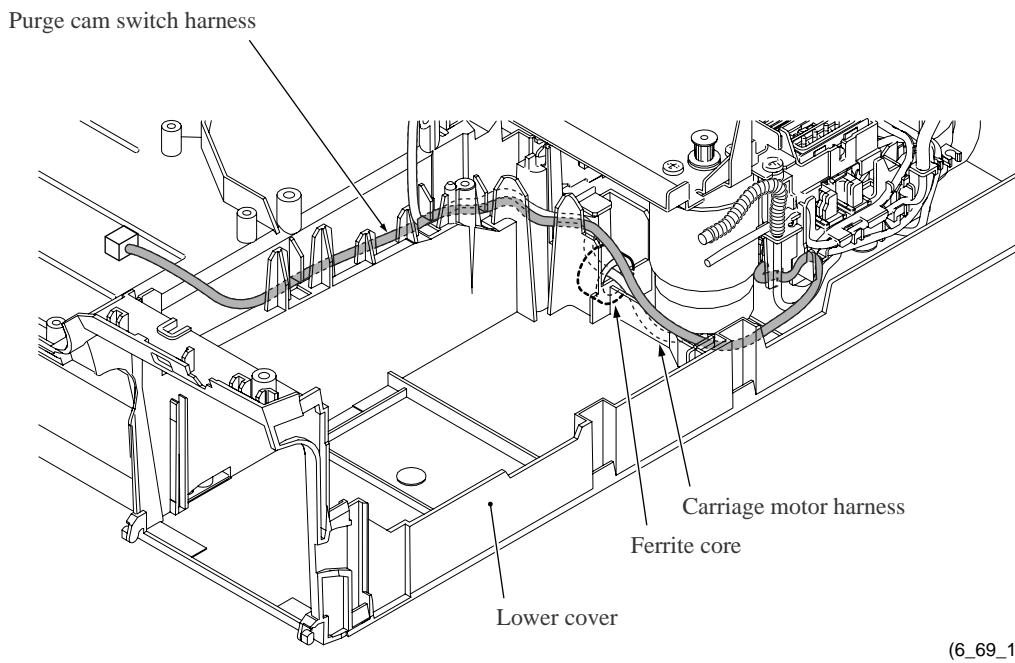

Routing H: PF encoder/registration sensor harness and paper feed motor harness

■ On the inner chute ASSY

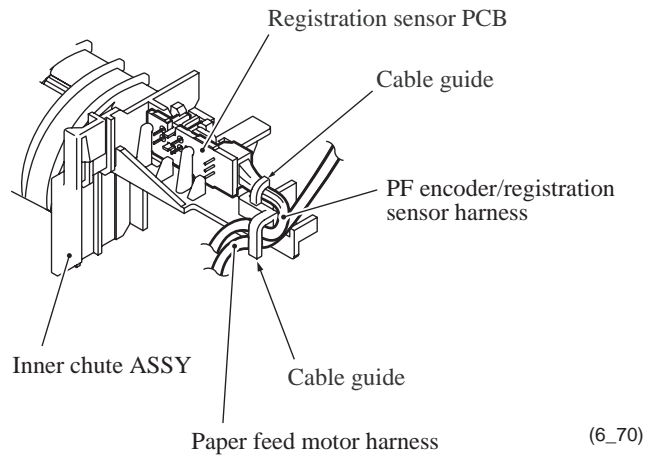

■ On the lower cover

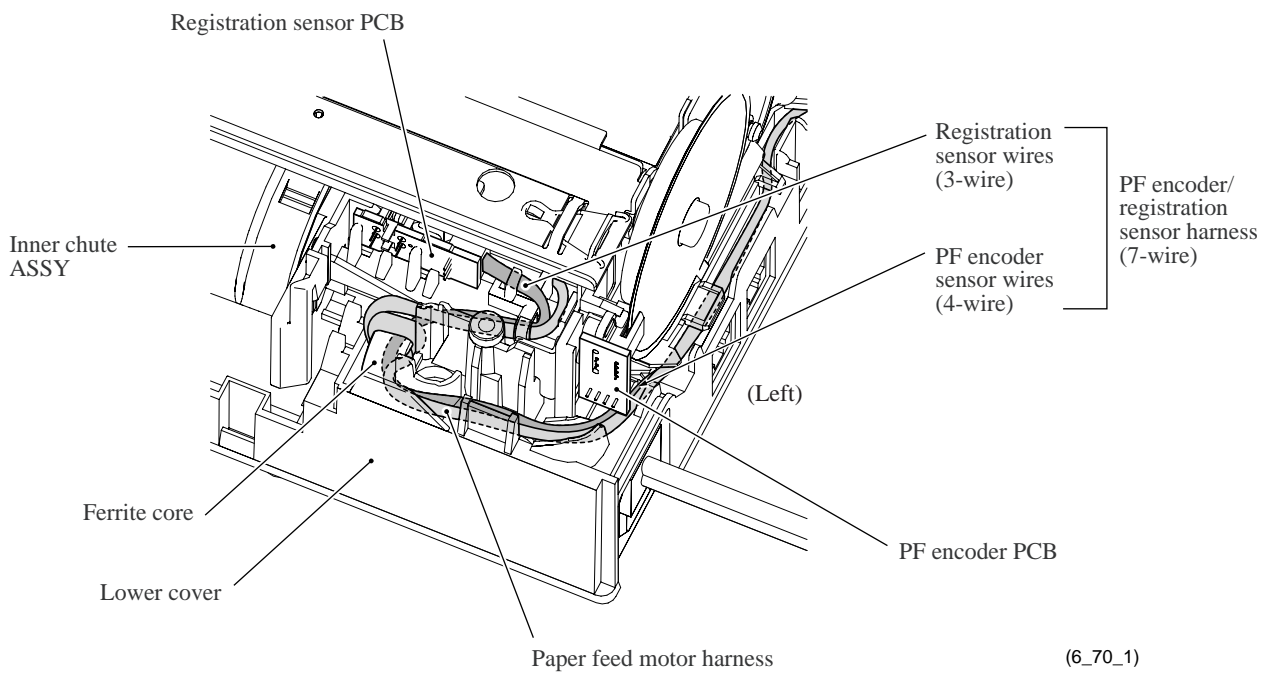

Routing I: Harnesses, flat cables and ink supply tubes on the lower cover

Top view

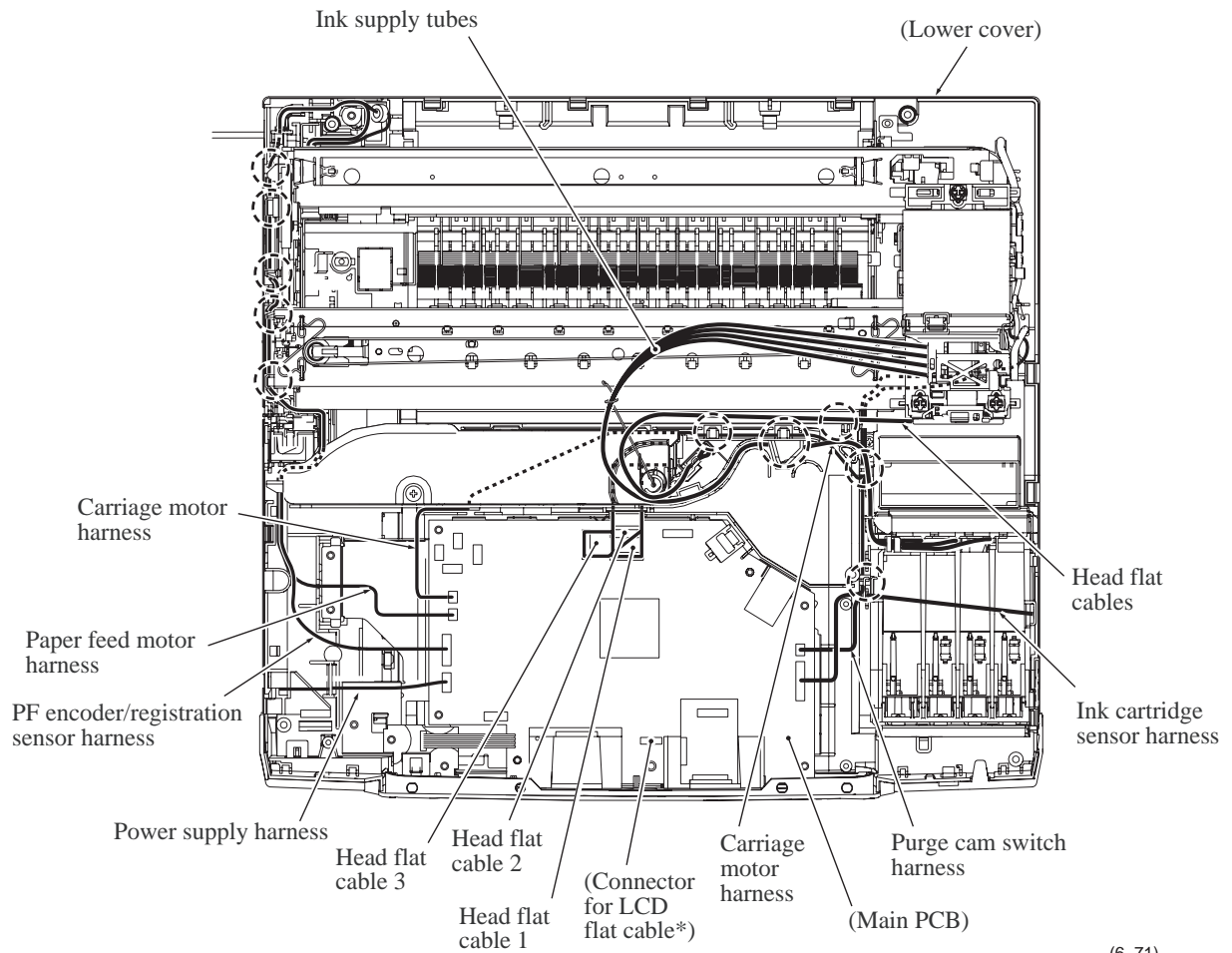

(6_71)

*For models with color LCD

6.2 LUBRICATION

Apply the specified lubricants to the lubrication points as shown below.

Lubricant type (Manufacturer)	Lubrication points	No. of points	Lubricant amount per point
Molykote EM-30LG (Dow Corning)	Document pull-in roller*	1	4 mm diameter ball
	Document separation roller*	1	
Molykote EM-60L (Dow Corning)	Head/carriage unit	1	1.5 mm diameter ball
	CR guide rail	13	1.5 mm diameter ball
	CR support chassis	13	
	Mode switching lever	1	2 mm diameter ball
	Clutch gear shaft	2	
Silicone G-501 (Shin-Etsu Chemical)	SF changeover gear	1	3 mm diameter ball
	Purge gear shaft	1	

*For models with ADF

■ Document pull-in roller and document separation roller in the document roller holder (For models with ADF)

Apply a 4 mm diameter ball of grease (Molykote EM-30LG) to each of the lubrication points below.

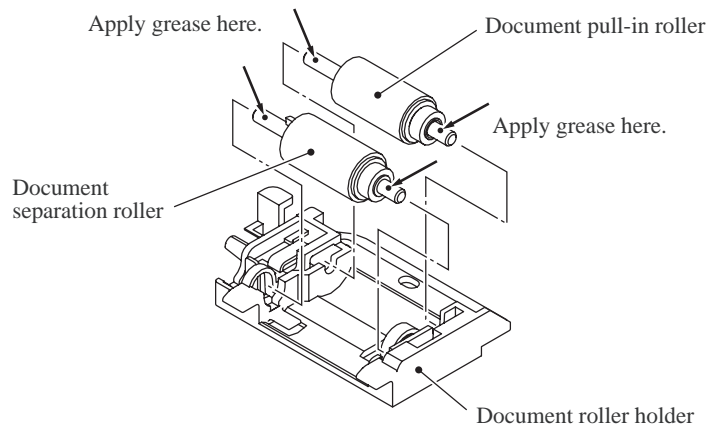

(6_72)

■ Head/carriage unit

Apply a 1.5 mm diameter ball of grease (Molykote EM-60L) to the lubrication point below.

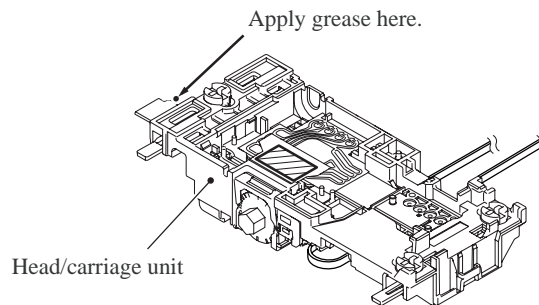

(6_73)

■ CR guide rail and CR support chassis

Apply a 1.5 mm diameter ball of grease (Molykote EM-60L) to the 26 lubrication points below.

Lubrication procedure

- (1) Move the head/carriage unit to the right end of its travel and hit it against the stoppers provided at the right end of the CR guide rail and support chassis. This is to make the pair of slider cams protrude to the left from the head/carriage unit, raising the head/carriage unit to the highest position.
- (2) Move the head/carriage unit close to the left end of its travel, taking care not to hit the slider cams against the left stoppers to prevent the slider cams from protruding to the right.
- (3) Apply grease to the 24 lubrication points on the CR guide rail and support chassis as specified below.

As for the leftmost two lubrication points, apply grease after moving the head/carriage unit to the right and out of those points.

- (4) Move the head/carriage unit from the left to the right ends of its travel to spread the applied grease on the CR guide rail and chassis.

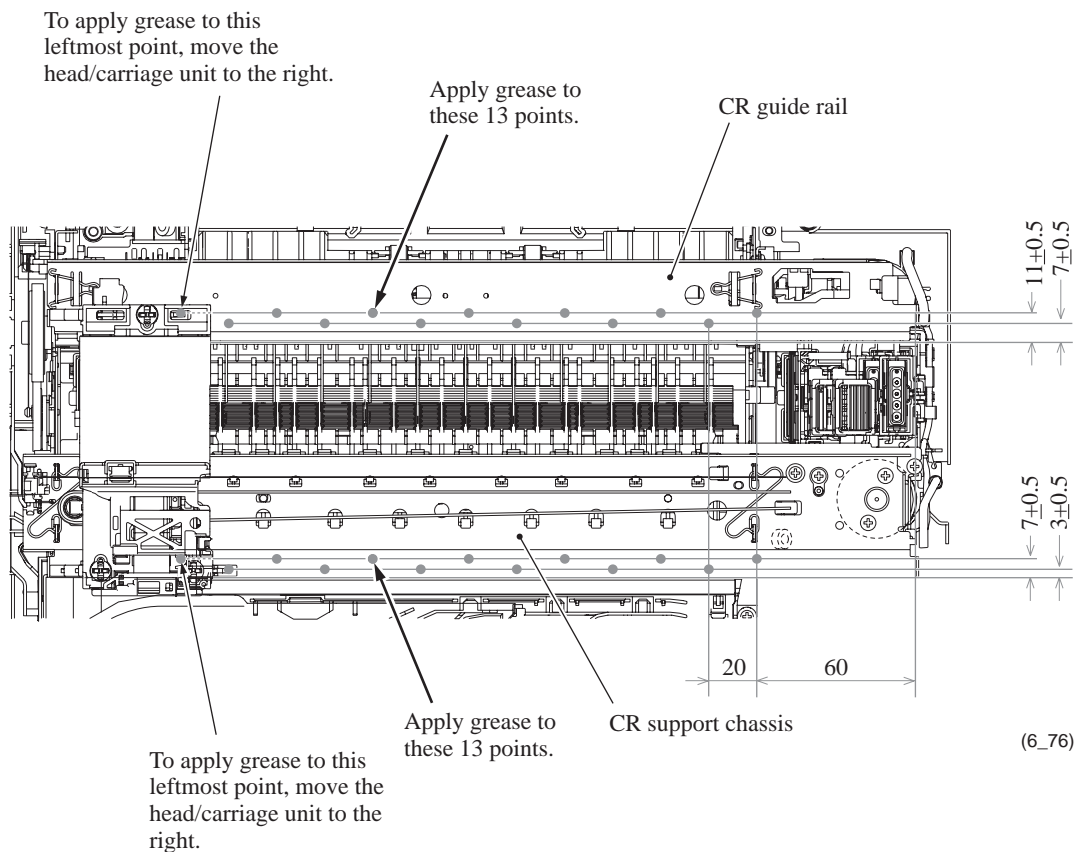

■ **Mode switching lever and clutch gear shaft**

Apply a 2 mm diameter ball of grease (Molykote EM-60L) to each of the lubrication points below.

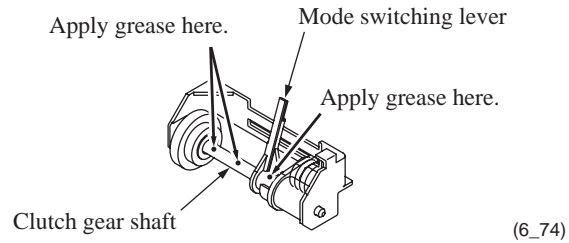

■ **SF changeover gear and purge gear shaft**

Apply a 3 mm diameter ball of grease (Silicone G-501) to each of the lubrication points below.

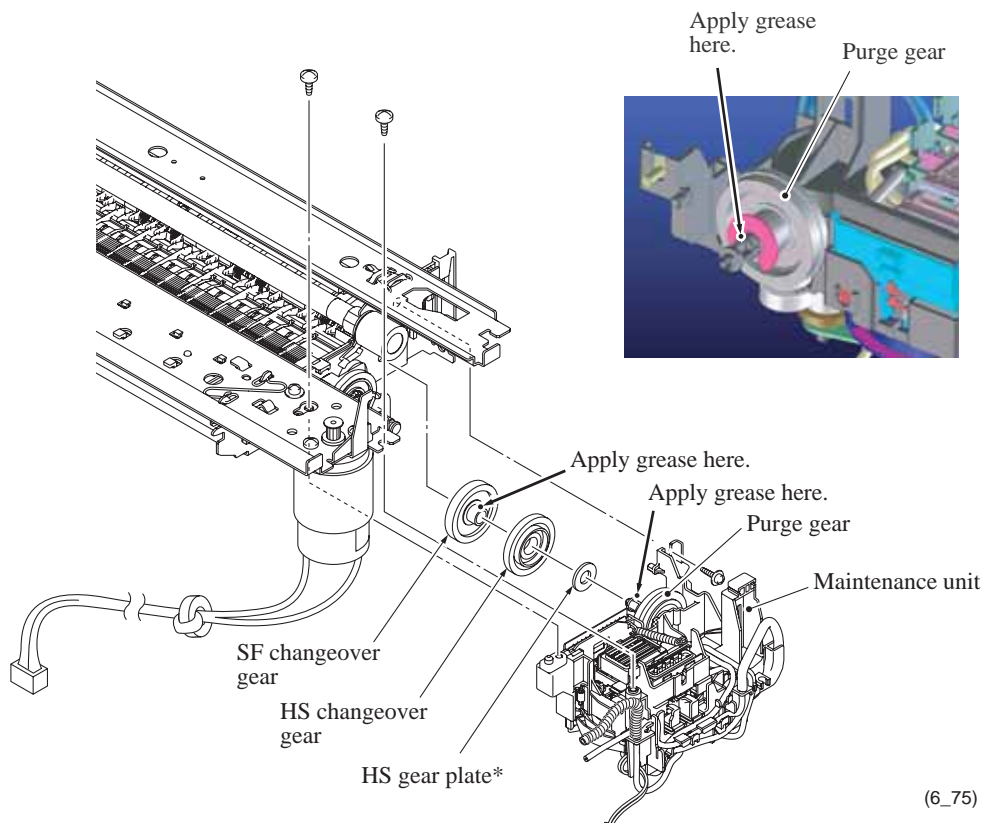

*Only on the early version of machines

CHAPTER 7

ADJUSTMENTS AND UPDATING OF SETTINGS, REQUIRED AFTER PARTS REPLACEMENT

CHAPTER 7 ADJUSTMENTS AND UPDATING OF SETTINGS, REQUIRED AFTER PARTS REPLACEMENT

This chapter details adjustments and updating of settings, which are required if the head/carriage unit, main PCB and some other parts have been replaced.

CONTENTS

7.1 PREPARATION.....	7-1
7.1.1 Requirements.....	7-1
7.1.2 Loading the Programs to the Machine	7-2
7.2 IF YOU REPLACE THE HEAD/CARRIAGE UNIT OR ENGINE UNIT	7-6
[1] Update the head property information stored in the EEPROM on the main PCB.....	7-6
[2] Clean the new head/carriage unit (Function code 76)	7-9
[3] Print out a test pattern (Function code 09).....	7-9
[4] Correct the positioning error of the head/carriage unit	7-10
[5] Update the paper feeding correction value (Function code 58)	7-13
[6] Align vertical print lines (Function code 65)	7-17
[7] Margin adjustment in borderless printing (Function code 66)	7-19
[8] Print out a total check pattern.....	7-22
[9] Switch back to standby.....	7-24
[10] Replace the ink cartridges with the protective part.....	7-24
7.3 IF YOU REPLACE THE MAIN PCB.....	7-25
[1] Load programs	7-25
[2] Initialize the EEPROM on the main PCB (Function code 01)	7-25
[3] Specify the CIS type (Function code 59).....	7-25
[4] Customize the EEPROM on the main PCB (Function code 74)	7-25
[5] Check the control panel PCB for normal operation (Function code 13) ...	7-25
[6] Check the sensor operation (Function code 32).....	7-25
[7] Acquire white level data and set CIS scanner area (Function code 55) ...	7-26
[8] Set an ID code and update the head property information	7-26
[9] Update the paper feeding correction value (Function code 58)	7-28
[10] Align vertical print lines (Function code 65)	7-28
[11] Margin adjustment in borderless printing (Function code 66)	7-28
[12] Switch back to standby.....	7-28
7.4 IF YOU REPLACE THE INK ABSORBER BOX OR FLUSHING BOX.....	7-29

[1]	Reset each of the purge and flushing counters	7-29
7.5	IF YOU REPLACE THE SCANNER COVER (SCANNER UNIT).....	7-29
[1]	Specify the CIS type (Function code 59).....	7-29
[2]	Acquire white level data and set CIS scanner area (Function code 55) ...	7-29

Entering numerical codes

To enter numerical codes, press the ▲/▼ key several times to display the numerical code to be entered and then press the **OK** key. Repeat this operation for each numerical code.

7.1 PREPARATION

7.1.1 Requirements

Before proceeding to perform any adjustments or update any settings, you need the executables, data files, spare parts and supplies (provided by Brother Industries) and must set up your PC.

NOTE: Use a PC/AT-compatible computer running Windows 98SE/Me, Windows 2000 Professional, or Windows XP Home/Professional.

Executables and Data Files Required for Adjustments and Updating of Settings

	BHL2-Maintenance Printer driver	brusbsn.exe	brusbsn.ini	filedg32.exe	incline.prn
Head/carriage unit, Engine unit (Section 7.2)	√	√	√	√	√
Main PCB (Section 7.3)	√	√	√	√	√
Ink absorber box, Flushing box (Section 7.4)					
Scanner cover (Section 7.5)					

	pfadj.prn	exitadj.prn	media.prn	qualbh7.prn
Head/carriage unit, Engine unit (Section 7.2)	√	√	√	√
Main PCB (Section 7.3)	√	√	√	
Ink absorber box, Flushing box (Section 7.4)				
Scanner cover (Section 7.5)				

NOTE: Executables and data files listed above should be saved in an arbitrary folder in your PC beforehand.

Spare Parts and Supplies Required for Adjustments and Updating of Settings

	Recording paper*	Ink cartridges	Protective part
Head/carriage unit, Engine unit (Section 7.2)	√	√	√
Main PCB (Section 7.3)	√	√	
Ink absorber box, Flushing box (Section 7.4)			
Scanner cover (Section 7.5)			

* Letter-size paper is necessary to correctly print check patterns in "updating the paper feeding correction value" and "adjusting the margins in borderless printing."

7.1.2 Loading the Programs to the Machine

If you want to change the programs stored in the flash ROM on the main PCB or after you replace the main PCB, load the desired programs to the flash ROM.

Loading requires a PC/AT-compatible computer running Windows 98SE/Me, Windows 2000 Professional, or Windows XP Home/Professional.

CAUTION: During loading, never turn off your PC or the machine, unplug the USB interface cable, interrupt loading, or load invalid data. If you do so, loading will fail, causing the PCB to be unusable. You will have to replace the main PCB and load programs to a new PCB.

Preparation

You need the BHL2-Maintenance Printer driver and filedg32.exe (provided by Brother Industries). Save them in an arbitrary folder in your PC.

Installing the BHL2-Maintenance Printer driver

To identify terminals connected via USB interface, a PC requires the corresponding virtual USB devices to be implemented by driver/software. If you connect any number of machines to your PC, therefore, the same number of virtual USB devices will be automatically configured on your PC. To prevent virtual USB devices from being configured limitlessly, use the unique driver installation procedure described below that enables your PC to identify terminals via a single virtual USB device.

NOTE: Once this installation procedure is carried out for a PC, no more driver/software installation will be required for that PC to identify machines. If the BHL2-Maintenance Printer driver has been already installed to your PC according to this procedure, skip this section.

NOTE: Before proceeding to the procedure given below, make sure that the BHL2-Maintenance Printer driver (listed in [Chapter 7, Section 7.1.1](#)) is stored in your PC.

- (1) Make sure that the machine's power cord is unplugged from an electrical outlet.

If the machine is connected to a PC, unplug the USB cable.

- (2) Switch on your PC.
- (3) Plug the machine's power cord into an electrical outlet.
- (4) Press the **Menu** and **Black Start (Mono Start)** keys. Next press the **▲** key four times to make the machine enter the maintenance mode. (Refer to [Chapter 9](#).)

The machine displays "■■ MAINTENANCE ■■■" on the LCD, indicating that it is placed in the initial stage of the maintenance mode, a mode in which the machine is ready to accept entry from the keys.

- (5) Connect the machine to your PC using the USB cable.

The following window appears.



- (6) The following screen appears, indicating the detection of new hardware device by the system. Click **Next** to proceed.



- (7) Select "Search for a suitable driver for my device (recommended)" and click **Next**.

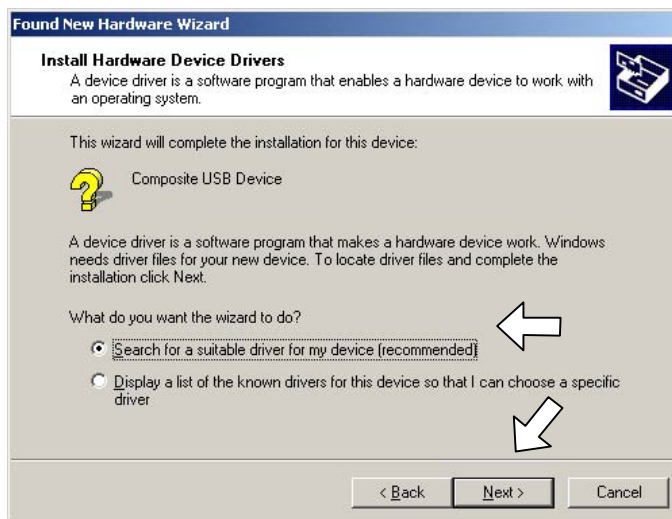

- (8) Select "Specify a location" and click **Next**.

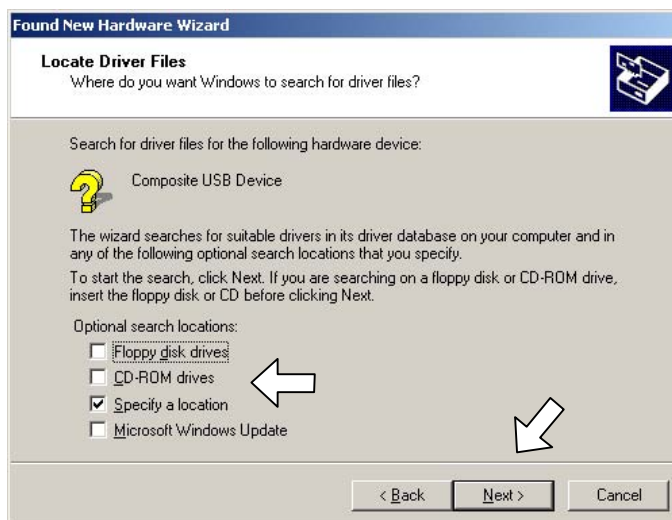

- (9) Select the folder where the copy of the BHL2-Maintenance Printer driver is located (or click **Browse** to specify it), then click **OK**.

(This sample screen is captured on the Windows 2000 desktop.)



- (10) Click **Next**.



- (11) To proceed, click **Yes**.



(12) If the driver is successfully installed, the following message window appears. Click **Finish** to return to Windows.

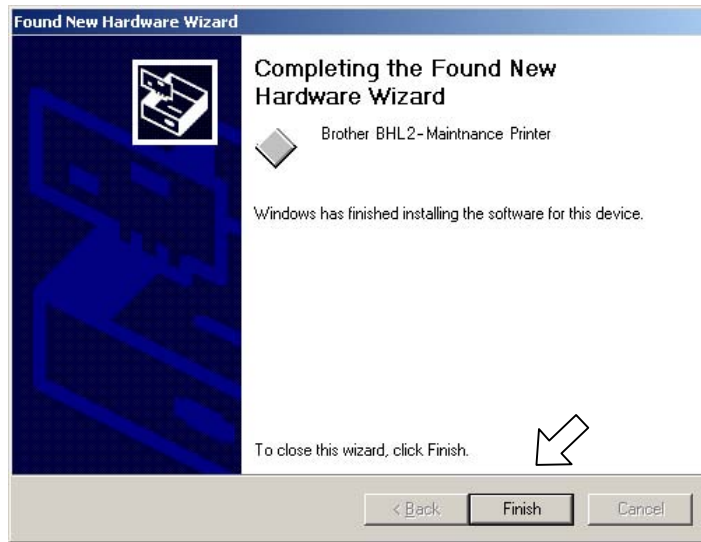

NOTE: After completion of the driver installation, if the machine exits the maintenance mode, the "Found New Hardware Wizard" screen in step (6) appears again. Click **Cancel**.

NOTE: To check that the printer driver is successfully installed, click **Start|Settings|Printers** to call up the Printers window as shown below and confirm that the BHL2-Maintenance Printer icon is displayed.

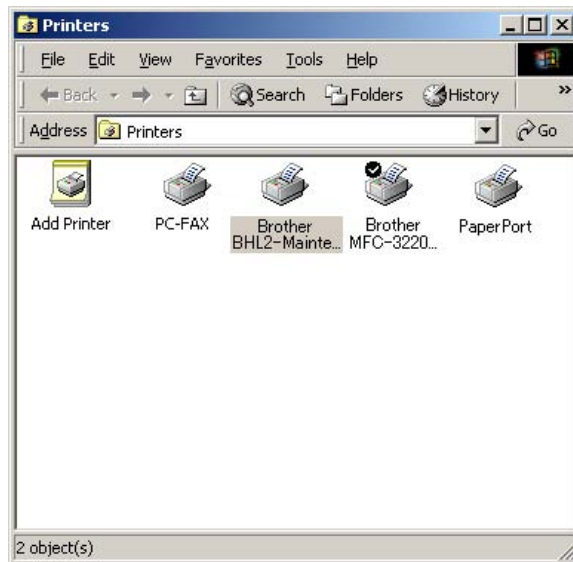

7.2 IF YOU REPLACE THE HEAD/CARRIAGE UNIT OR ENGINE UNIT

[1] Update the head property information stored in the EEPROM on the main PCB

- (1) Make sure that the machine's power cord is unplugged from an electrical outlet.
If the machine is connected to a PC, unplug the USB cable.
- (2) Switch on the PC.
- (3) Plug the machine's power cord into an electrical outlet.
- (4) Press the **Menu** and **Black Start (Mono Start)** keys. Next press the **▲** key four times to make the machine enter the maintenance mode.

The machine displays "■■ MAINTENANCE ■■" on the LCD, indicating that it is placed in the initial stage of the maintenance mode, a mode in which the machine is ready to accept entry from the keys.

- (5) Connect the machine to the PC using a USB cable.
- (6) On the PC, run the ID/head property setup utility (brusbsn.exe) in the folder created. The following window appears.

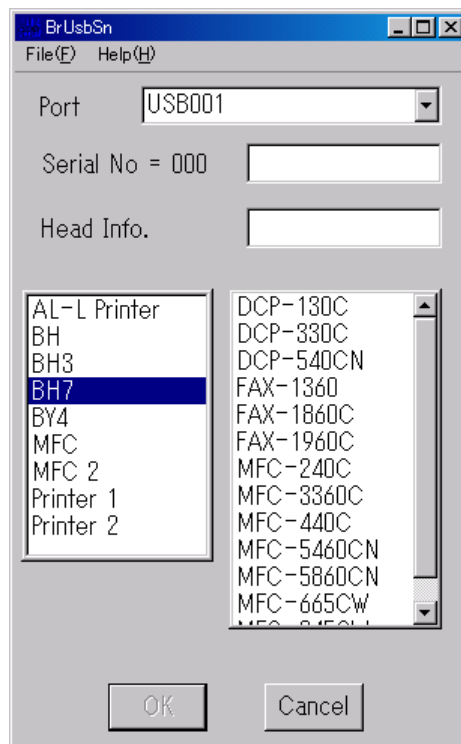

- (7) On the model menu, click **BH7**.

(8) In **Port** on the BrUsbSn screen, select the port number assigned to the BHL2-Maintenance Printer. If the port number is unknown, follow steps 1) through 4) below.

1) Click **Start | Settings | Printers**.

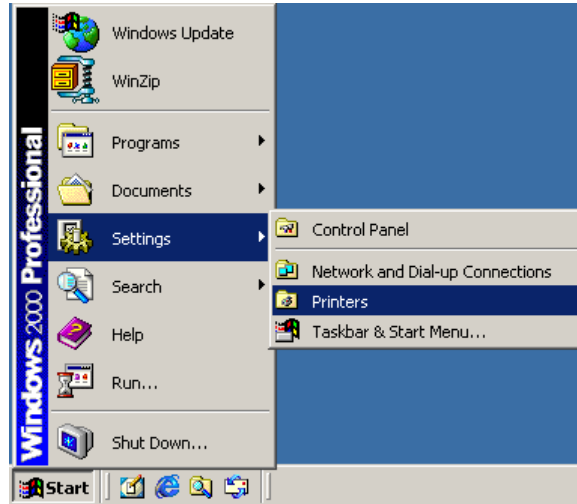

The Printers window appears as shown below.

2) Right-click the BHL2-Maintenance Printer icon.



3) Click **Properties**.

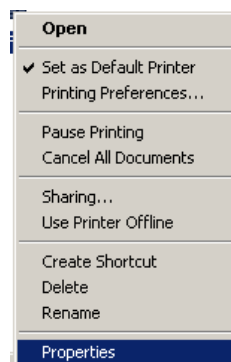

The BHL2-Maintenance Printer Properties window appears as shown below.

- 4) Click the **Ports** tab.

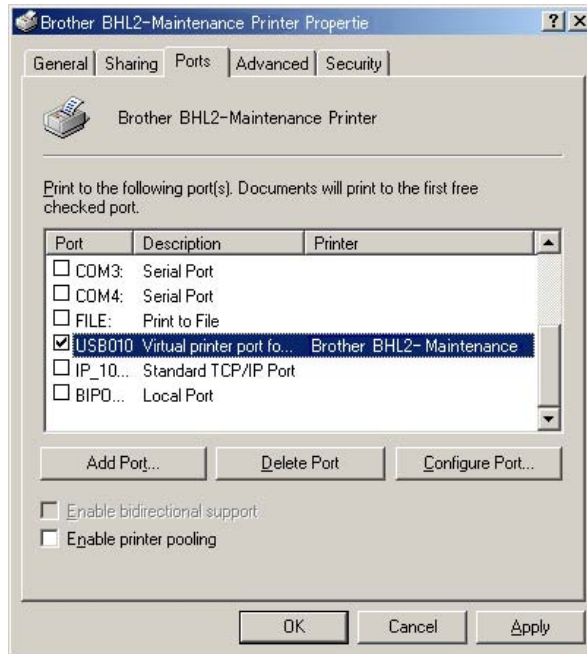

In this example, the port number assigned to the Brother BHL2-Maintenance Printer is USB010.

- (9) In the **Head Info.** box on the BrUsbSn screen (page 7-6), type the 15-digit property code (e.g., ALR778402F00000) which is printed on the bar code label attached to the lower cover. Click the **OK** button.
- (10) To check that the entered head property code is correct (using function code 68 in Chapter 9, Section 9.4.16), enter 6, 8, 2, 5, 8, and 0 using the ▲/▼ and **OK** keys.

The LCD shows the current head property information (15-digit code) stored in the EEPROM on the main PCB.

- (11) Check that the character string entered in step (9) appears.

If it is OK, press the **Stop/Exit** key.

If something other than that appears, check the connection between the PC and machine and go back to step (6).

[2] Clean the new head/carriage unit (Function code 76)

- (1) Open the ink cartridge cover, set new ink cartridges into the ink refill ASSY, and close the ink cartridge cover.
- (2) Carry out "Initial purge" (with function code 76) using the steps below. (See [Chapter 9, Section 9.4.20.](#))

Enter 7 and 6 using the ▲/▼ and **OK** keys.

The machine displays "CLEANING ALL" on the LCD and enters the purge mode.

Enter 4 using the ▲/▼ and **OK** keys.

The machine starts an initial purge that refills the ink supply tubes and the new print head with fresh ink.

[3] Print out a test pattern (Function code 09)

To check that the head/carriage unit normally sprays ink droplets from *all* head nozzles, print out a test pattern with function code 09 (see [Chapter 9, Section 9.4.4](#)) with the following steps.

- (1) Enter 0 and 9 using the ▲/▼ and **OK** keys.
- (2) If a missing dot or any other print problem is found, go back to [2] above to clean the head/carriage unit again.

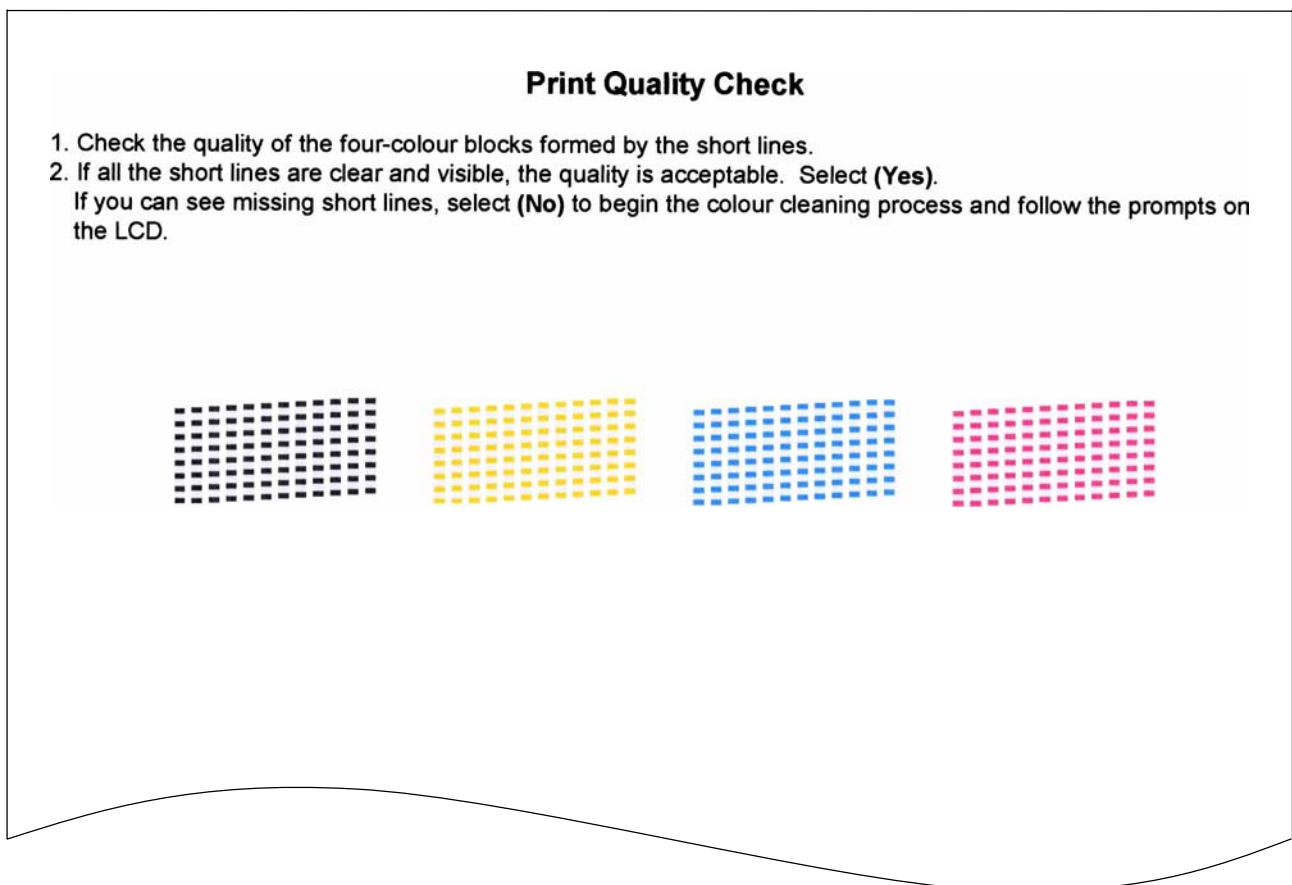

Test Pattern

[4] Correct the positioning error of the head/carriage unit

- (1) Run "filedrg32.exe" in the folder created.

The Filedrgs window appears as shown below.

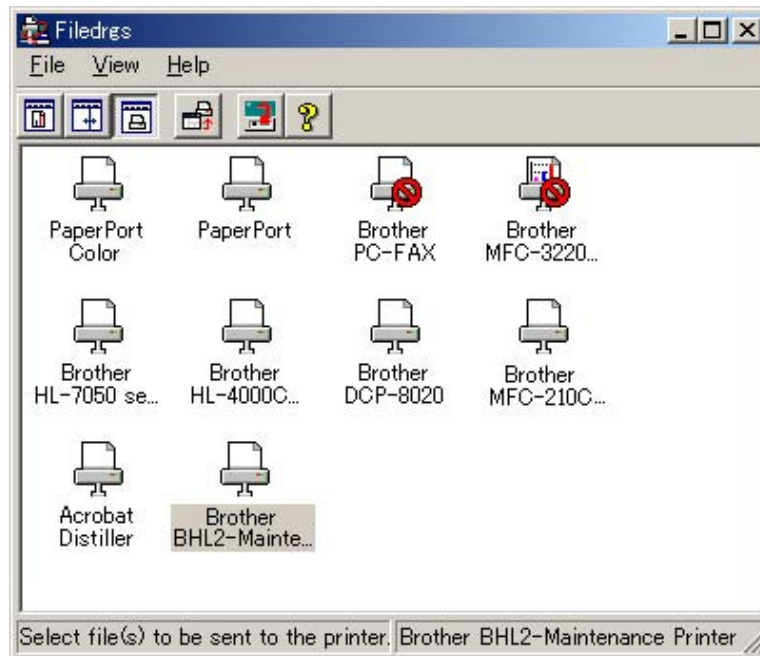

- (2) Drag and drop the "incline.prn" icon onto the BHL2-Maintenance Printer icon in the Filedrgs window shown above.

The machine displays the "RECEIVING DATA" on the LCD and prints out the "Incline Adjust" test pattern shown on the next page.

- (3) Out of the three rows of the "Incline Adjust" test pattern (on the next page), check the middle row and select the block that is the least uneven print. Make a note of that block number.

NG
-7
-6
-4
-3
-1
0
+1
+3
+4
+6
+7
NG

NG
-7
-6
-4
-3
-1
0
+1
+3
+4
+6
+7
NG

NG
-7
-6
-4
-3
-1
0
+1
+3
+4
+6
+7
NG

Head Positioning Test Pattern

- (4) Move the head/carriage unit to the center of its travel with function code 63 (see [Chapter 9, Section 9.4.13](#)) using the following key operation.

Enter 6, 3, and * using the ▲/▼ and **OK** keys.

- (5) Turn the head skew adjuster knob by the number of divisions specified by the pattern number you recorded in step (3), using a spanner.

If block +1 is the least uneven print, for example, turn the head skew adjuster knob to the front by one division; if block -1, turn it to the rear by one division.

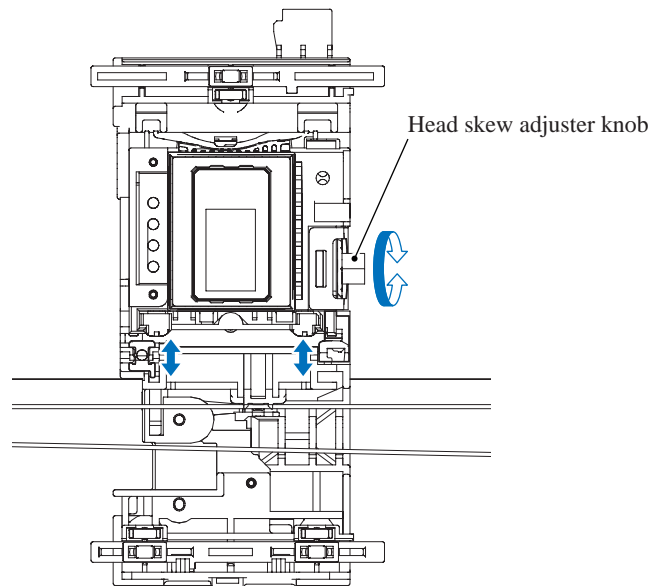

[5] Update the paper feeding correction value (Function code 58)

Before starting the operation below, be sure to set letter-size paper for printing check patterns.

- (1) On your PC, run "filedrgs.exe" in the folder created in [Section 7.1.1](#).

The Filedrgs window appears as shown below.

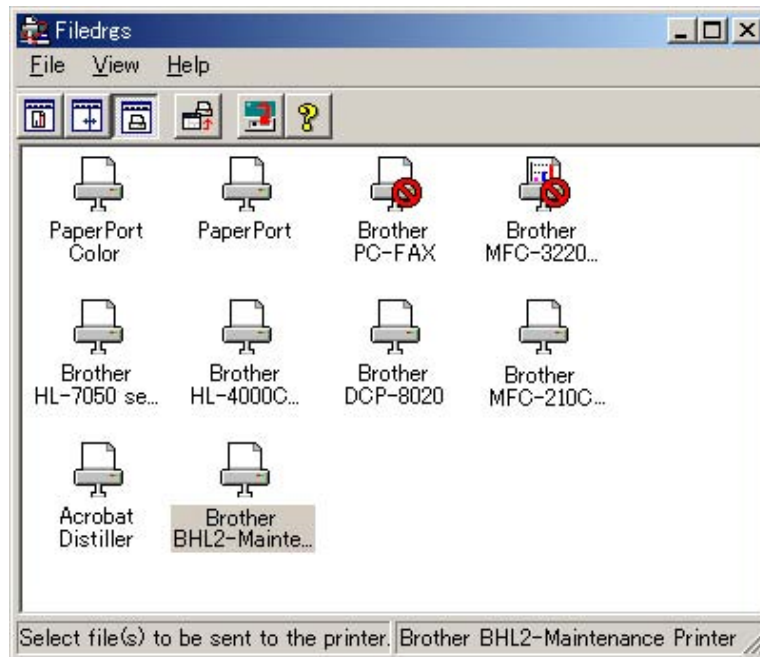

- (2) Drag and drop the "pfadj.prn" onto the BHL2-Maintenance Printer icon in the Filedrgs window shown above.

The machine displays the "RECEIVING DATA" on the LCD and prints out "PF adjust check" patterns (see [page 7-15](#) for a sample printout).

- (3) On the machine, enter 5 and 8 using the ▲/▼ and **OK** keys.
The "1.PF 2.EXIT" appears on the LCD.
- (4) To select the paper feed roller adjustment, enter 1 using the ▲/▼ and **OK** keys.
The "PF ADJ NO. +0" appears on the LCD.
- (5) Out of the three rows of the "PF adjust check" pattern (on [page 7-15](#)), check the middle row and select the block that is the least uneven print. Make a note of that block number.

If the least unevenness seems to be far to the left of -8, regard it as -8; if it seems to be far to the right of +8, regard it as +8. In this case, you need to check whether the paper feed roller and head/carriage unit are set into place.

- (6) Enter the number of the least uneven block found in step (5).

For example, if the number of the least uneven block is +4, enter 4 using the ▲/▼ and **OK** keys when the "PF ADJ NO. +0" is displayed on the LCD.

If the number is -4, display ▼ using the ▲/▼ key and press the **OK** key to display the "PF ADJ NO. -0." Enter 4 using the ▲/▼ and **OK** keys.

Then press the **OK** key, and the machine returns to the initial stage of the maintenance mode.

- (7) On your PC, drag and drop the "exitadj.prn" onto the BHL2-Maintenance Printer icon in the Filedrgs window.

The machine displays the "RECEIVING DATA" on the LCD and prints out three sheets of "EXIT adjust check" patterns (on [page 7-16](#) for a sample printout).

- (8) On the machine, enter 5 and 8 using the ▲/▼ and **OK** keys.

The "1.PF 2.EXIT" appears on the LCD.

- (9) To select the paper ejection roller adjustment, enter 2 using the ▲/▼ and **OK** keys.

The "EXIT ADJ NO. +0" appears on the LCD.

- (10) Out of the three sheets of the "EXIT adjust check" patterns (on [page 7-16](#)), check the middle sheet and select the block that is the least uneven print. Make a note of that block number.

- (11) Enter the number of the least uneven block found in step (10) in the same way as in step (6).

Then press the **OK** key, and the machine returns to the initial stage of the maintenance mode.

* BH7 PF adjust check - Ver 005 *

(NG)-8 -6 -4 -2 0 +2 +4 +6 +8(NG)



(NG)-8 -6 -4 -2 0 +2 +4 +6 +8(NG)



(NG)-8 -6 -4 -2 0 +2 +4 +6 +8(NG)



Paper Feeding Check Pattern for the Paper Feed Roller

BH7 EXIT adjust check 2/3 = Ver 005

(NG)-S -6 -4 -2 0 +2 +4 +6 +S(NG)



Paper Feeding Check Pattern for the Paper Ejection Roller

[6] Align vertical print lines (Function code 65)

- (1) Enter 6,5, and 1 using the ▲/▼ and **OK** keys on the machine.

The machine prints out two sets of vertical alignment check patterns in monochrome for 600 dpi and 1200 dpi (see the next page), each of which consists of #0 through #8 blocks. If the vertical alignment is ON, #5 block shows vertically aligned lines.

The "600DPI NO.(1-8)" appears on the LCD.

- (2) For 600 dpi, check the printed vertical alignment check patterns and find which number block shows full alignment.

If the full alignment block is other than #5, enter that block number using the ▲/▼ and **OK** keys.

The "1200DPI NO.(1-8)" appears.

- (3) For 1200 dpi, perform the same operation as in step (2).

The machine automatically returns to the initial stage of the maintenance mode.

NOTE: If #1 or #8 block is fully aligned so that you enter 1 or 8 in the above procedure, then go back to step (1) to confirm that #5 block becomes aligned.

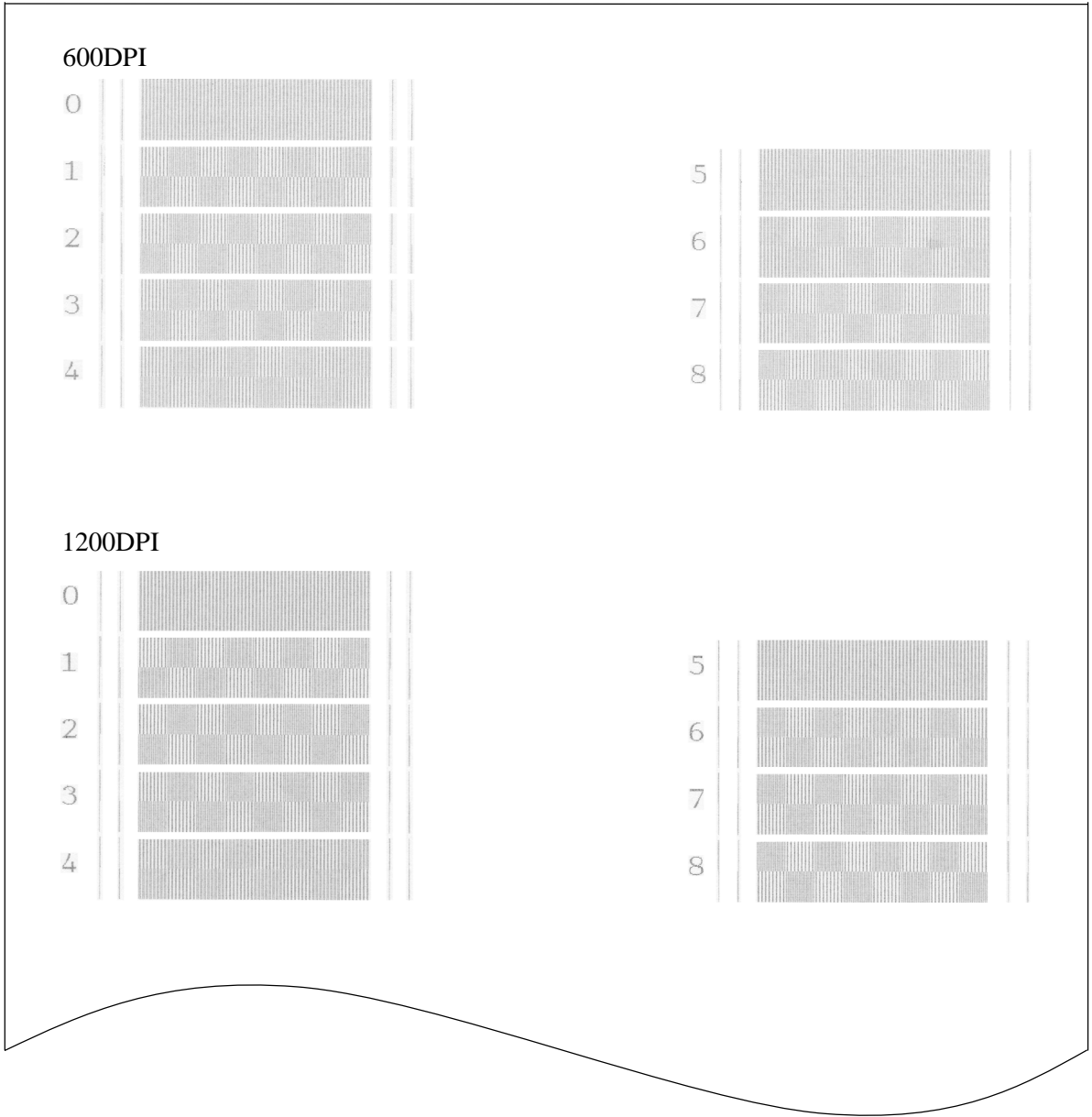

Vertical Alignment Check Patterns

[7] Margin adjustment in borderless printing (Function code 66)

Before starting the operation below, be sure to set letter-size paper for printing a check pattern.

- (1) On the PC, run "filedrg32.exe" in the folder created in [Section 7.1.1](#).

The Filedrgs window appears as shown below.

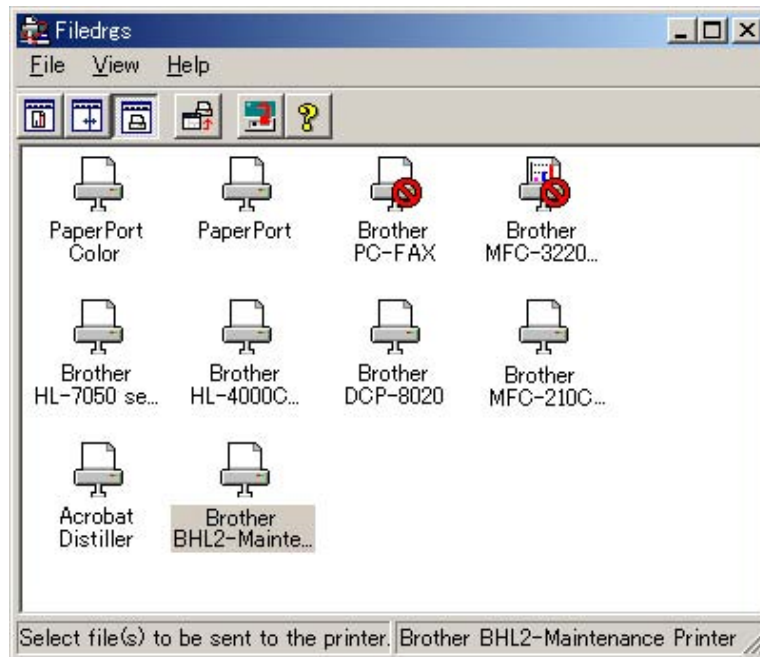

- (2) Drag and drop the "media.prn" onto the BHL2-Maintenance Printer icon in the Filedrgs window shown above.

The machine displays the "RECEIVING DATA" on the LCD and prints out the "MEDIA CHECK" pattern (see [page 7-21](#) for a sample printout).

- (3) Measure the left and right margins on the printout.

(Example) Left: 1.3 mm, Right: 1.4 mm

If both margins are within the range from 0.9 to 1.1 mm, no adjustment is required.

- (4) If either margin is out of the specified range, enter 6 twice using the ▲/▼ and **OK** keys on the machine.

The "MEDIA SENSOR ADJ" appears. (Note: The Media Sensor refers to the paper width sensor.)

- (5) To make the machine ready for data entry, enter * using the ▲/▼ and **OK** keys.

The "LEFT: 10" appears on the LCD.

- (6) To adjust the left margin, enter the measured value (in units of 0.1 mm) multiplied by 10.

In this example, the left margin measured in step (3) is 1.3 mm, so enter 1 and 3 using the ▲/▼ and **OK** keys. Then press the **OK** key again.

- (7) The "RIGHT: 10" appears on the LCD.

To adjust the right margin, enter the measured value (in units of 0.1 mm) multiplied by 10.

In this example, the right margin measured in step (3) is 1.4 mm, so enter 1 and 4 using the ▲/▼ and **OK** keys. Then press the **OK** key again.

- (8) Upon completion of the entry, the machine automatically returns to the initial stage of the maintenance mode.

Go back to step (2) and print out the margin check pattern again.

- (9) Measure the left and right margins on the printout.

If both margins are within the range from 0.9 to 1.1 mm, the adjustment is completed.

* BH7 MEDIA CHECK - Ver. 003 *

LEFT:0.9-1.1mm

RIGHT:0.9-1.1mm



Margin Check Pattern

7-21

Confidential

[8] Print out a total check pattern

Before starting the operation below, be sure to set letter-size paper for printing a check pattern.

- (1) On your PC, run "filedrg32.exe" in the folder created in [Section 7.1.1](#).

The Filedrgs window appears as shown below.

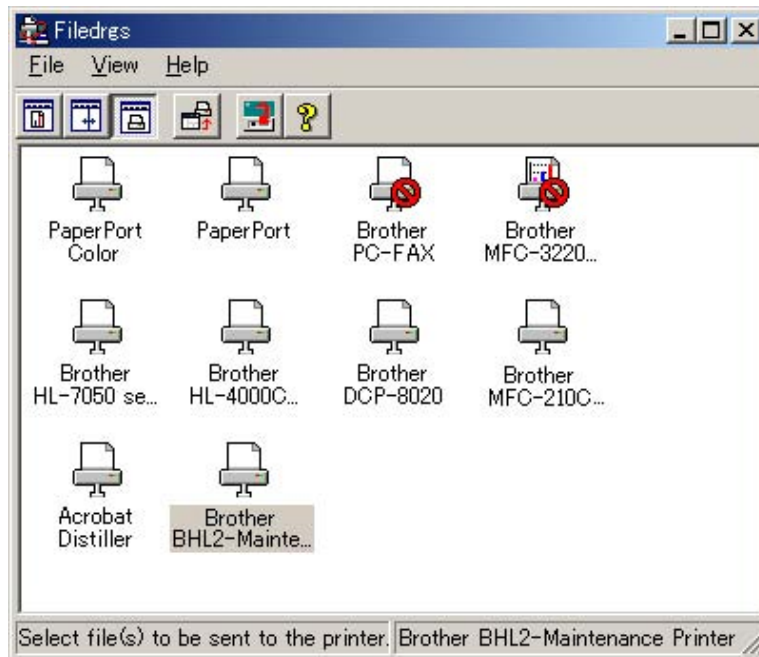

- (2) Drag and drop the "qualbh7.prn" onto the BHL2-Maintenance Printer icon in the Filedrgs window shown above.

The machine displays the "RECEIVING DATA" on the LCD and prints out the "Total Quality Check Pattern" (see the next page for a sample printout).

- (3) Check the printed check pattern. If any problem is found, go back to the related item (any of [4] through [7] above) and make adjustments again.

- | | |
|--|--|
| A: Margin adjustment for borderless printing | Go back to Section 7.2 [7] . |
| B: Paper feed roller adjustment | Go back to Section 7.2 [5] . |
| C: Vertical print lines adjustment | Go back to Section 7.2 [6] . |
| D: Head positioning adjustment | Go back to Section 7.2 [4] . |
| E: Paper ejection roller adjustment | Go back to Section 7.2 [5] . |

- (4) Repeat steps (2) and (3) until no problem is found.

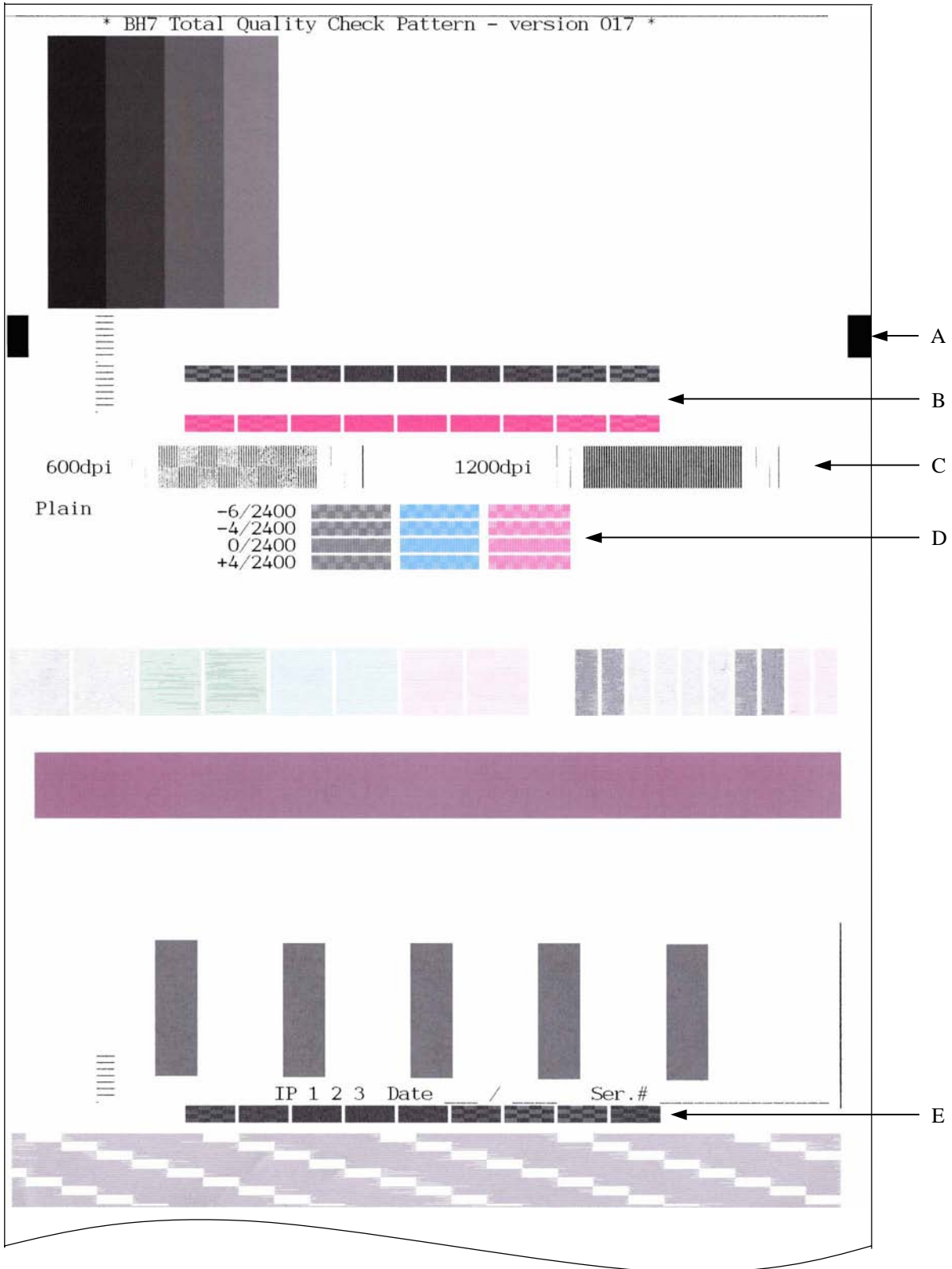

Total Check Pattern

- A: Margin adjustment for borderless printing
- B: Paper feed roller adjustment
- C: Vertical print lines adjustment
- D: Head positioning adjustment
- E: Paper ejection roller adjustment

[9] Switch back to standby

After completion of the adjustment, disconnect the USB cable and then enter 9 twice using the ▲▼ and OK keys to return to the standby state.

NOTE: Be sure to disconnect the USB cable first. Returning to standby without disconnecting the USB cable runs "Found New Hardware Wizard" that starts USB driver installation (as described in [Section 7.1.2](#)).

NOTE: Enable the initial setup mode (see [Chapter 9, Section 9.4.13](#)).

[10] Replace the ink cartridges with the protective part

Remove all four ink cartridges and set the protective part instead.

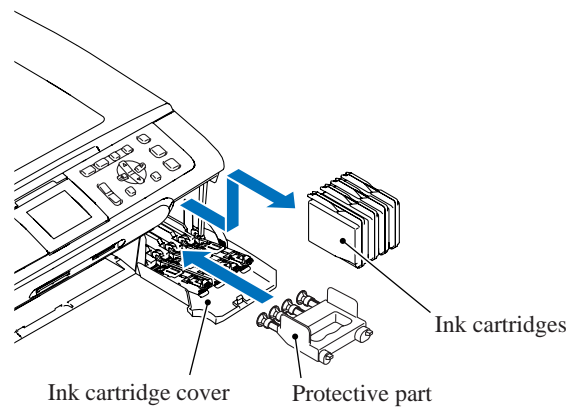

7.3 IF YOU REPLACE THE MAIN PCB

NOTE: If the main PCB is replaced, you should also replace both of the ink absorber box and flushing box. Using the machine without replacing them for a long period may cause an overflow of drained ink from them, thereby staining the machine.

[1] Load programs

- If the main PCB is replaced with a new one, load the desired programs onto the flash ROM. Refer to [Appendix 2, page App. 2-5](#).
- If the main PCB is replaced with the one used for any other machine, follow the steps below.
 - (1) Change the firmware stored in the flash ROM. Refer to [Appendix 2, page App. 2-7](#).
 - (2) Reset each of the purge and flushing counters with the following procedure.
 - 1) Press the **Menu** and **Black Start (Mono Start)** keys in this order. Next press the **▲** key four times to make the machine enter the maintenance mode.

The machine displays "■■■ MAINTENANCE ■■■" on the LCD, indicating that it is placed in the initial stage of the maintenance mode, a mode in which the machine is ready to accept entry from the keys.
 - 2) Enter 8 and 0 using the **▲/▼** and **OK** keys.
 - 3) Press the **Black Start (Mono Start)** key several times until the purge (or flushing) count appears on the LCD.
 - 4) Enter 2, 7, 8, and 3 using the **▲/▼** and **OK** keys to reset the purge (or flushing) count.
 - 5) Press the **Stop/Exit** key to return to the initial stage of the maintenance mode.
 - 6) Enter 9 twice using the **▲/▼** and **OK** keys to exit from the maintenance mode.

[2] Initialize the EEPROM on the main PCB (Function code 01)

Refer to [Chapter 9, Section 9.4.1](#).

[3] Specify the CIS type (Function code 59)

Refer to [Chapter 9, Section 9.4.12](#).

[4] Customize the EEPROM on the main PCB (Function code 74)

Refer to [Chapter 9, Section 9.4.18](#).

[5] Check the control panel PCB for normal operation (Function code 13)

Refer to [Chapter 9, Section 9.4.7](#).

[6] Check the sensor operation (Function code 32)

Refer to [Chapter 9, Section 9.4.8](#).

[7] Acquire white level data and set CIS scanner area (Function code 55)

Refer to [Chapter 9, Section 9.4.10](#).

[8] Set an ID code and update the head property information

NOTE: Make sure that the BHL2-Maintenance Printer driver has been installed to your PC. To do it, click **Start|Settings|Printers** to call up the Printers window and confirm that the BHL2-Maintenance Printer icon (shown on the sample window on [page 7-5](#)) is displayed. If the driver has not been installed, install it referring to [Section 7.1.2](#).

- (1) Make sure that your PC is turned off, then connect the machine to your PC using a USB cable.
- (2) Switch your PC on.
- (3) On your PC, run the ID/head property utility (brusbsn.exe) in the folder created in [Section 7.1.1](#). The following window appears.

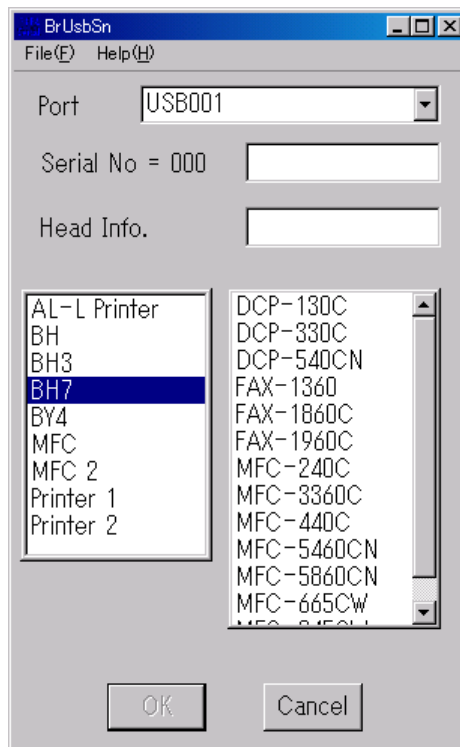

- (4) On the model menu, click **BH7**.

- (5) In **Port** on the BrUsbSn screen (on the previous page), select the port number assigned to the BHL2-Maintenance Printer. If the port number is unknown, follow the instructions given in [Section 7.2 \[1 \], step \(8\)](#).
- (6) In the **Serial No** box on the BrUsbSn screen, type the 9-digit serial number (e.g., D6F111101) printed on the nameplate labeled to the machine as an ID code.

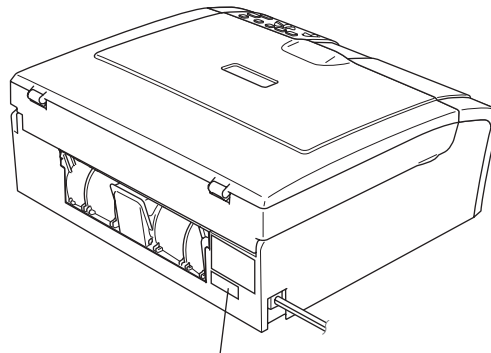

Serial number label

(app01b)

- (7) In the **Head Info.** box, type the 15-digit property code (e.g., ALR778402F00000) which is printed on the bar code label attached to the lower cover. Click the **OK** button.

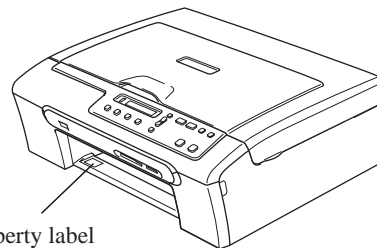

Head property label
(Bar code label)

(app01d)

- (8) Check whether the entered character strings (ID code and head property information) are correct with the following procedure.

Enter 8 and 0 using the ▲/▼ and **OK** keys. Then press the **Black Start (Mono Start)** key several times, and the ID code appears on the LCD. Check that the displayed code is that string entered in step (6).

Next, enter 6, 8, 2, 5, 8, and 0 using the ▲/▼ and **OK** keys, and the head property code appears on the LCD. Check that the displayed code is that string entered in step (7).

- (9) If both are OK, proceed to [9] below.

If something wrong is displayed, check the connection between the PC and machine and go back to step (2).

[9] Update the paper feeding correction value (Function code 58)

Refer to [Section 7.2, \[5 \]](#).

[10] Align vertical print lines (Function code 65)

Refer to [Section 7.2, \[6 \]](#).

[11] Margin adjustment in borderless printing (Function code 66)

Refer to [Section 7.2, \[7 \]](#).

[12] Switch back to standby

Refer to [Section 7.2, \[9 \]](#).

7.4 IF YOU REPLACE THE INK ABSORBER BOX OR FLUSHING BOX

When either the ink absorber box or flushing box is replaced, you should replace both of them.

[1] Reset each of the purge and flushing counters

- (1) Press the **Menu** and **Black Start (Mono Start)** keys. Next press the **▲** key four times to make the machine enter the maintenance mode.

The machine displays "■■ MAINTENANCE ■■■" on the LCD, indicating that it is placed in the initial stage of the maintenance mode, a mode in which the machine is ready to accept entry from the keys.

- (2) Enter 8 and 0 using the **▲/▼** and **OK** keys.
- (3) Press the **Black Start (Mono Start)** key several times until the purge (or flushing) count appears on the LCD.
- (4) Enter 2, 7, 8, and 3 using the **▲/▼** and **OK** keys to reset the purge (or flushing) count.
- (5) Press the **Stop/Exit** key to return to the initial stage of the maintenance mode.
- (6) Enter 9 twice using the **▲/▼** and **OK** keys to exit from the maintenance mode.

TIP: This machine counts all purge operations performed since produced in order to prevent the ink absorber box from overflowing with drained ink. An initial purge, for example, advances the counter by $163 + 432 = 595$.

When the purge or flushing counter approaches 9600 or 475852272, respectively, "MACHINE ERROR 46" appears, and further purge or flushing operations are prohibited. Replace both the ink absorber box and flushing box and reset their counters.

7.5 IF YOU REPLACE THE SCANNER COVER (SCANNER UNIT)

[1] Specify the CIS type (Function code 59)

Refer to [Chapter 9, Section 9.4.12](#).

[2] Acquire white level data and set CIS scanner area (Function code 55)

Refer to [Chapter 9, Section 9.4.10](#).

CHAPTER 8

CLEANING

CHAPTER 8 CLEANING

This chapter provides cleaning procedures not covered by the User's Guide. Before starting any repair work, clean the machine as it may solve the problem concerned.

CONTENTS

8.1	CLEANING THE EXTERNAL AND INTERNAL SURFACES OF THE MACHINE	8-1
8.2	CLEANING THE MAINTENANCE UNIT	8-2

For the cleaning procedures of the head/carriage unit, scanner unit, and platen, refer to the User's Guide.

Entering numerical codes

To enter numerical codes, press the ▲/▼ key several times to display the numerical code to be entered and then press the **OK** key. Repeat this operation for each numerical code.

8.1 CLEANING THE EXTERNAL AND INTERNAL SURFACES OF THE MACHINE

- (1) If the external surface of the machine is stained, clean it with a soft, clean and lint-free cloth.
NOTE: Do not use isopropyl alcohol (IPA) to remove dirt or stains from the molding parts. Doing so may cause cracks in those parts.
- (2) If the inside of the machine is stained, first unplug the power cord from the electrical outlet and then clean it with a soft, clean and lint-free cloth.
NOTE: Do not use liquid or aerosol cleaners.
- (3) If the PF encoder disk or encoder strip is stained, replace it with a new one. Do not try to clean it.

8.2 CLEANING THE MAINTENANCE UNIT

- (1) Plug the power cord of the machine into an electrical outlet.
- (2) Press the **Menu** and **Black Start (Mono Start)** keys. Next press the **▲** key four times to make the machine enter the maintenance mode.

The machine displays "■■ MAINTENANCE ■■■" on the LCD, indicating that it is placed in the initial stage of the maintenance mode, a mode in which the machine is ready to accept entry from the keys.

- (3) Move the head/carriage unit to the center of its travel (function code 63 in [Chapter 9, Section 9.4.13](#)) by entering 6, 3, and * with the **▲▼** and **OK** keys.
- (4) Unplug the power cord of the machine from the electrical outlet.
- (5) Open the scanner cover (scanner unit).
- (6) Clean the two head caps and wiper of the maintenance unit with a "Rubycel" stick that is a head cleaner stick provided as a spare part.

NOTE: Do not use a cotton swab that may leave lint on the cleaned sections. Lint left on the maintenance unit will affect the print performance.

NOTE: Use a new Rubycel stick and do not use the used one for any other maintenance units.

NOTE: During the cleaning jobs, take care not to touch the head caps or wiper directly by hand or scratch their surfaces. Do not remove them from the head cap holder.

- (7) Close the scanner cover.
- (8) Plug the power cord of the machine into an electrical outlet.
- (9) Hear the head/carriage unit moving. After the moving sound stops, unplug the machine's power cord from the electrical outlet.

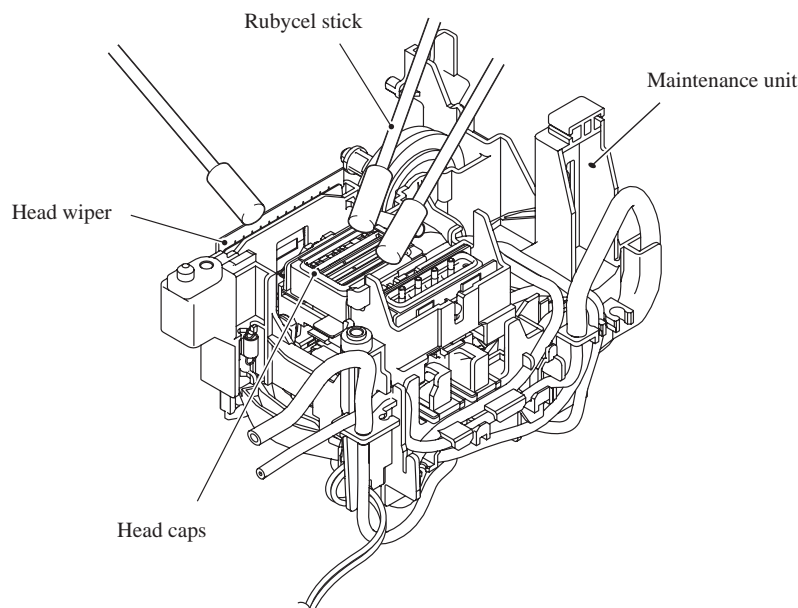

CHAPTER 9

MAINTENANCE MODE

CHAPTER 9 MAINTENANCE MODE

This chapter describes the maintenance mode which is exclusively designed for the purpose of checks, settings and adjustments of the machine using the keys on the control panel.

In the maintenance mode, you can update memory (EEPROM: electrically erasable programmable read-only memory) contents for optimizing the drive conditions of the head/carriage unit or the paper feed roller and paper ejection roller in the engine unit, if those units have been replaced, or for setting the CIS scanner area, for example. You can also customize the EEPROM according to the shipment destination of the machine concerned. In addition, you can perform operational checks of the LCD, control panel PCB or sensors, perform a print test, display the log information or error codes, and modify firmware switches (WSW).

CONTENTS

9.1	ENTRY INTO THE MAINTENANCE MODE	9-1
9.2	LIST OF MAINTENANCE-MODE FUNCTIONS	9-2
9.3	USER-ACCESS TO THE MAINTENANCE MODE	9-3
9.4	DETAILED DESCRIPTION OF MAINTENANCE-MODE FUNCTIONS	9-4
9.4.1	EEPROM Parameter Initialization (Function code 01, 91)	9-4
9.4.2	Printout of Scanning Compensation Data (Function code 05)	9-5
9.4.3	ADF Performance Test (Function code 08)	9-7
9.4.4	Test Pattern (Function code 09)	9-8
9.4.5	Firmware Switch Setting and Printout (Function codes 10 and 11)	9-10
9.4.6	Operational Check of LCD (Function code 12)	9-15
9.4.7	Operational Check of Control Panel PCB (Function code 13)	9-16
9.4.8	Sensor Operational Check (Function code 32)	9-17
9.4.9	Fine Adjustment of Scanning Start/End Position (Function code 54)	9-18
9.4.10	Acquisition of White Level Data and CIS Scanner Area Setting (Function code 55)	9-19
9.4.11	Updating of Paper Feeding Correction Value (Function code 58)	9-20
9.4.12	Checking of CIS Travel and Specifying of CIS Type (Function code 59)	9-24
9.4.13	Travel Check of the Head/Carriage Unit and Initial Setup Mode (Function code 63)	9-26
9.4.14	Alignment of Vertical Print Lines in Monochrome (Function code 65)	9-27
9.4.15	Margin Adjustment in Borderless Printing (Function code 66)	9-29
9.4.16	Updating of Property Data (Function code 68)	9-32
9.4.17	Head/Carriage Unit Traveling Speed Check (Function code 69)	9-33
9.4.18	EEPROM Customizing (Function code 74)	9-34

9.4.19	Travel of Head/Carriage Unit (for removing paper particles and dust accumulated on the maintenance unit) (Function code 75)	9-36
9.4.20	Purging Operation (Function code 76)	9-37
9.4.21	Display of the Equipment's Log (Function code 80)	9-40
9.4.22	Equipment Error Code Indication (Function code 82)	9-42
9.4.23	Assurance Mode Switch Setting (Function code 88).....	9-43

Entering numerical codes

To enter numerical codes, press the ▲/▼ key several times to display the numerical code to be entered and then press the **OK** key. Repeat this operation for each numerical code.

9.1 ENTRY INTO THE MAINTENANCE MODE

Press the **Menu** and **Black Start (Mono Start)** keys. Next press the **▲** key four times to make the machine enter the maintenance mode.

The machine displays "■■ MAINTENANCE ■■■" on the LCD, indicating that it is placed in the initial stage of the maintenance mode, a mode in which the machine is ready to accept entry from the keys.

To select one of the maintenance-mode functions listed in [Section 9.2](#), enter the corresponding 2-digit function code using the **▲/▼** and **OK** keys on the control panel. (The details of each maintenance-mode function are described in [Section 9.4](#).)

- NOTES**
- To exit from the maintenance mode and switch to standby, enter 9 twice using the **▲/▼** and **OK** keys in the initial stage of the maintenance mode.
 - Pressing the **Stop/Exit** key after entering only one digit restores the machine to the initial stage of the maintenance mode.
 - If an invalid function code is entered, the machine resumes the initial stage of the maintenance mode.

9.2 LIST OF MAINTENANCE-MODE FUNCTIONS

Maintenance-mode Functions

Function Code	Function	Reference Section (Page)
01	EEPROM Parameter Initialization	9.4.1 (9-4)
05	Printout of Scanning Compensation Data	9.4.2 (9-5)
08	ADF Performance Test	9.4.3 (9-7)
09	Test Pattern	9.4.4 (9-8)
10	Firmware Switch Setting	9.4.5 (9-10)
11	Printout of Firmware Switch Data	9.4.5 (9-13)
12	Operational Check of LCD	9.4.6 (9-15)
13	Operational Check of Control Panel PCB (Check of Keys)	9.4.7 (9-16)
32	Sensor Operational Check	9.4.8 (9-17)
54	Fine Adjustment of Scanning Start/End Position	9.4.9 (9-18)
55	Acquisition of White Level Data and CIS Scanner Area Setting	9.4.10 (9-19)
58	Updating of Paper Feeding Correction Value	9.4.11 (9-20)
59	Checking of CIS Travel and Specifying of CIS Type	9.4.12 (9-24)
63	Travel Check of the Head/Carriage Unit and Initial Setup Mode	9.4.13 (9-26)
65	Alignment of Vertical Print Lines in Monochrome	9.4.14 (9-27)
66	Margin Adjustment in Borderless Printing	9.4.15 (9-29)
68	Updating of Property Data	9.4.16 (9-32)
69	Head/Carriage Unit Traveling Speed Check	9.4.17 (9-33)
74	EEPROM Customizing	9.4.18 (9-34)
75	Travel of Head/Carriage Unit (for removing paper particles and dust accumulated on the maintenance unit)	9.4.19 (9-36)
76	Purging Operation	9.4.20 (9-37)
80	Display of the Equipment's Log	9.4.21 (9-40)
82	Equipment Error Code Indication	9.4.22 (9-42)
88	Assurance Mode Switch Setting	9.4.23 (9-43)
91	EEPROM Parameter Initialization	9.4.1 (9-4)
99	Exit from the Maintenance Mode	----- (9-1)

9.3 USER-ACCESS TO THE MAINTENANCE MODE

Basically, the maintenance-mode functions listed on the previous page should be accessed by service personnel only. However, you can allow end users to access some of these under the guidance of service personnel (e.g., by telephone).

The user-accessible functions (codes 10, 11, 12, 66, 75, 76, 80, 82, 88, and 91) are *shaded* in the table given on the previous page. Function code 10 accesses the firmware switches, each of which has eight selectors. You should not allow end users to access all of those selectors, but you can allow them to access user-accessible selectors which are *shaded* in the firmware switch tables in [Appendix 4](#).

The service personnel should instruct end users to follow the procedure given below.

- (1) Press the **Menu**, **Black Start (Mono Start)**, **Menu**, and **Black Start (Mono Start)** keys in this order.

The "MAINTENANCE 10" appears on the LCD.

- (2) To access function code 10, press the **OK** key.

To access any other function code, press the **▲** or **▼** key several times until the desired code appears. Then press the **OK** key.

For function code 10, access the desired firmware switch according to the operating procedure described in [Appendix 4](#).

- (3) To make the machine return to standby, press the **Stop/Exit** key. When each of the user-accessible functions is completed, the machine automatically returns to standby.

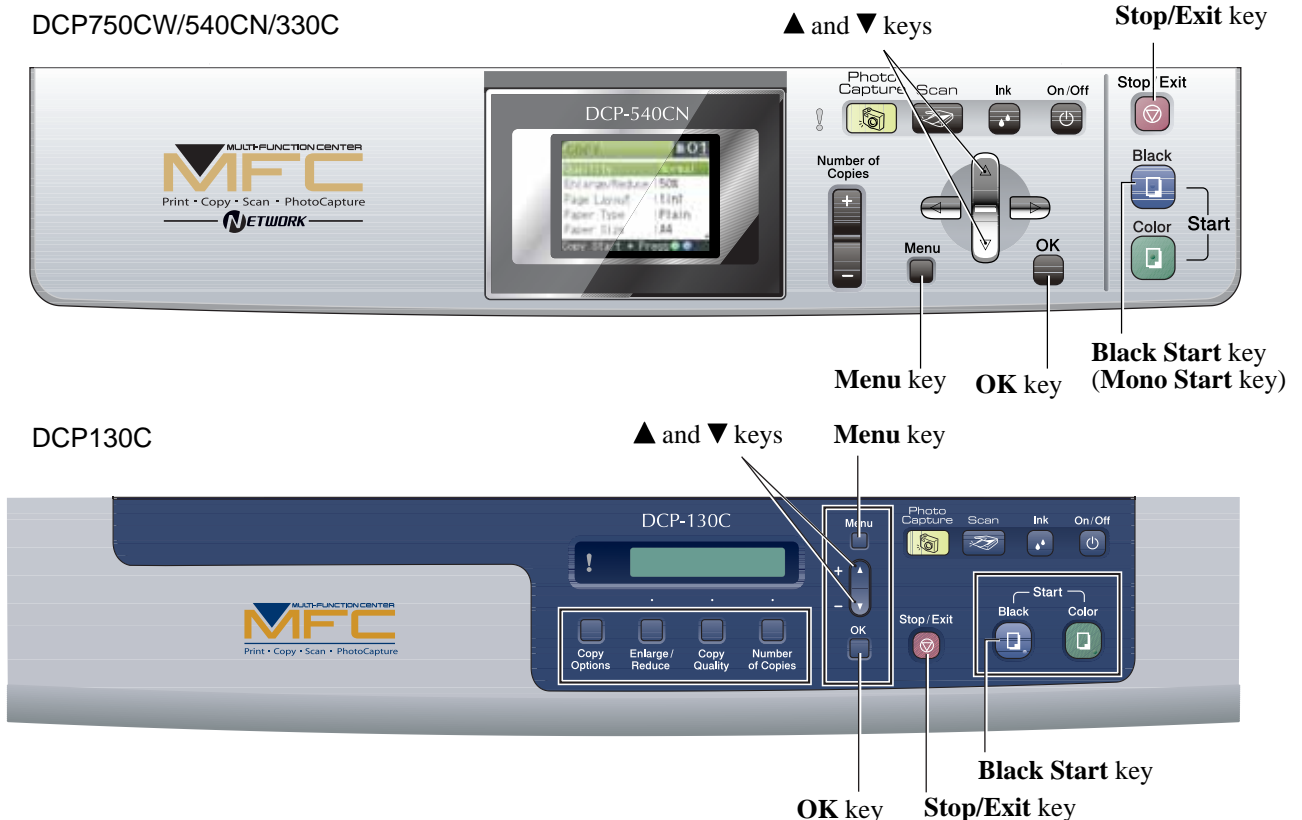

9.4 DETAILED DESCRIPTION OF MAINTENANCE-MODE FUNCTIONS

9.4.1 EEPROM Parameter Initialization (Function code 01, 91)

■ Function

The machine initializes the parameters, user switches, firmware switches, and assurance mode switch settings registered in the EEPROM, to the initial values.

Function code	01/91
Data item	
Maintenance-mode functions	} All of these will be initialized.
User switches	
Firmware switches	
Assurance mode switch settings	
EEPROM customizing code (4-digit)	This will <u>not</u> be initialized. (Note that the first digit of the 4-digit code will be initialized to "0." If the code is <u>1</u> 001, for example, it will be initialized to <u>0</u> 001.)

NOTE: If you replace the main PCB with the one used for any other machine, carry out this procedure and then customize the EEPROM (function code 74 in [Section 9.4.18](#)).

■ Operating Procedure

- (1) Enter 0 and 1 in the initial stage of the maintenance mode using the ▲/▼ and OK keys. The "PARAMETER INIT" appears on the LCD.
- (2) Upon completion of parameter initialization, the machine returns to the initial stage of the maintenance mode.

9.4.2 Printout of Scanning Compensation Data (Function code 05)

■ Function

The machine prints out the white and black level data for scanning compensation.

■ Operating Procedure

Do not start this function merely after powering on the machine but start it after carrying out a sequence of scanning operation. Unless the machine has carried out any scanning operation, this function cannot print out correct scanning compensation data. This is because at the start of scanning operation, the machine initializes white and black level data and takes in the scanning compensation reference data.

NOTE: Be sure to disconnect the USB cable from the machine before proceeding to the procedure below.

- (1) Enter 0 and 5 in the initial stage of the maintenance mode using the ▲/▼ and OK keys.
The "PRINTING" appears on the LCD.
- (2) The machine prints out the scanning compensation data list containing the following:
 - a) Black/white data graph
 - b) LED light intensity pulse data for green image (2 bytes)
 - c) LED light intensity pulse data for blue image (2 bytes)
 - d) LED light intensity pulse data for red image (2 bytes)
 - e) Compensation data for background color (1 byte)
 - f) Black level data (4970 bytes)
 - g) White level data for red image (4970 bytes)
 - h) White level data for green image (4970 bytes)
 - i) White level data for blue image (4970 bytes)
- (3) Upon completion of recording of the compensation data list, the machine returns to the initial stage of the maintenance mode.

NOTE: When the machine prints monochrome images after monochrome scanning, only the green data is valid.

NOTE: If any data is abnormal, its code will be printed in inline style.

9.4.3 ADF Performance Test (Function code 08)

■ Function

The machine counts the documents fed by the automatic document feeder (ADF) and displays the count on the LCD for checking the ADF performance.

■ Operating Procedure

- (1) Set documents. (Allowable up to the ADF capacity.)

The "DOC. READY" appears on the LCD.

- (2) Enter 0 and 8 in the initial stage of the maintenance mode using the ▲/▼ and OK keys.

The machine feeds the documents in and out while counting them and displaying the current count on the LCD as shown below.

ADF CHECK P.01

└─ Current count (1st page in this example)

- (3) After counting all documents, the machine shows the final count. To return the machine to the initial stage of the maintenance mode, press the **Stop/Exit** key.

9.4.4 Test Pattern (Function code 09)

■ Function

This function prints out a test pattern (Print Quality Check sheet) to allow the service personnel to check the print quality.

■ Operating Procedure

Enter 0 and 9 in the initial stage of the maintenance mode using the ▲/▼ and **OK** keys.

The figure on the next page shows a test pattern which is printed on the Print Quality Check sheet. According to the instructions printed on the sheet, you can check or correct the print quality.

Print Quality Check

1. Check the quality of the four-colour blocks formed by the short lines.
2. If all the short lines are clear and visible, the quality is acceptable. Select **(Yes)**.
If you can see missing short lines, select **(No)** to begin the colour cleaning process and follow the prompts on the LCD.



Test Pattern

9.4.5 Firmware Switch Setting and Printout (Function codes 10 and 11)

[A] Firmware switch setting

■ Function

The machine incorporates the following firmware switch functions which can be activated with the procedures using the control panel keys.

The firmware switches have been set at the factory in conformity to the communications standards and codes of each country. Do not disturb them unless necessary. Some firmware switches may not be applicable in some versions. The firmware switch data list indicates "Not used." for those inapplicable switches.

Firmware Switches (WSW01 through WSW58)

WSW No.	Function
WSW01	Dial pulse setting <i>(Not used.)</i>
WSW02	Tone signal setting <i>(Not used.)</i>
WSW03	PBX mode setting <i>(Not used.)</i>
WSW04	TRANSFER facility setting <i>(Not used.)</i>
WSW05	1st dial tone and busy tone detection <i>(Not used.)</i>
WSW06	Pause key setting and 2nd dial tone detection <i>(Not used.)</i>
WSW07	Dial tone setting 1 <i>(Not used.)</i>
WSW08	Dial tone setting 2 <i>(Not used.)</i>
WSW09	Protocol definition 1 <i>(Not used.)</i>
WSW10	Protocol definition 2 <i>(Not used.)</i>
WSW11	Busy tone setting <i>(Not used.)</i>
WSW12	Signal detection condition setting <i>(Not used.)</i>
WSW13	Modem setting <i>(Not used.)</i>
WSW14	AUTO ANS facility setting <i>(Not used.)</i>
WSW15	REDIAL facility setting <i>(Not used.)</i>
WSW16	Function setting 1
WSW17	Function setting 2
WSW18	Function setting 3 <i>(Not used.)</i>
WSW19	Transmission speed setting <i>(Not used.)</i>
WSW20	Overseas communications mode setting <i>(Not used.)</i>
WSW21	TAD setting 1 <i>(Not used.)</i>
WSW22	ECM and call waiting caller ID <i>(Not used.)</i>
WSW23	Communications setting <i>(Not used.)</i>
WSW24	TAD setting 2 <i>(Not used.)</i>
WSW25	TAD setting 3 <i>(Not used.)</i>
WSW26	Function setting 4 <i>(Not used.)</i>
WSW27	Function setting 5 <i>(Not used.)</i>
WSW28	Function setting 6 <i>(Not used.)</i>
WSW29	Function setting 7 <i>(Not used.)</i>
WSW30	Function setting 8 <i>(Not used.)</i>
WSW31	Function setting 9 <i>(Not used.)</i>
WSW32	Function setting 10
WSW33	Function setting 11 <i>(Not used.)</i>

Firmware Switches (WSW01 through WSW58) Continued

WSW No.	Function
WSW34	Function setting 12 <i>(Not used.)</i>
WSW35	Function setting 13 <i>(Not used.)</i>
WSW36	Function setting 14
WSW37	Function setting 15
WSW38	V.34 transmission settings <i>(Not used.)</i>
WSW39	V.34 transmission speed <i>(Not used.)</i>
WSW40	V.34 modem settings <i>(Not used.)</i>
WSW41	ON-duration of the scanning light source
WSW42	Internet mail settings <i>(Not used.)</i>
WSW43	Function setting 21
WSW44	Speeding up scanning-1 <i>(Not used.)</i>
WSW45	Speeding up scanning-2
WSW46	Monitor of power ON/OFF state and parallel port kept at high
WSW47	Switching between high- and full-speed USB
WSW48	USB setup latency
WSW49	End-of-copying beep and black ink print mode
WSW50	SDAA settings <i>(Not used.)</i>
WSW51	Function setting 16 <i>(Not used.)</i>
WSW52	Function setting 17 <i>(Not used.)</i>
WSW53	Function setting 18
WSW54	Function setting 19
WSW55	Function setting 20 <i>(Not used.)</i>
WSW56	Function setting 21 <i>(Not used.)</i>
WSW57	Function setting 22 <i>(Not used.)</i>
WSW58	Function setting 23 <i>(Not used.)</i>

■ Operating Procedure

- (1) Enter 1 and 0 in the initial stage of the maintenance mode using the ▲/▼ and **OK** keys.
The machine displays the "WSW00" on the LCD and becomes ready to accept a firmware switch number.
- (2) Enter the numbers at the ten's place and unit's place of the desired number from the firmware switch numbers (01 through 58) using the ▲/▼ and **OK** keys.

The following appears on the LCD:

Selector 1 Selector 8
 ↓ ↓
WSWXX = 0 0 0 0 0 0 0 0

- (3) Move the cursor to the selector position to be modified, using the ▲/▼ and **OK** keys.*
(*Press the ▲/▼ key several times to display ► or ◀ and press the **OK** key, and the cursor moves to the right- or left-hand digit, respectively. Repeat this operation to move the cursor to the target digit.)
- (4) Enter the desired number (0 or 1) using the ▲/▼ and **OK** keys.
- (5) Press the **OK** key. This operation saves the newly entered selector values onto the EEPROM and readies the machine for accepting a firmware switch number.
- (6) Repeat steps (2) through (5) until the modification for the desired firmware switches is completed.
- (7) Press the **Stop/Exit** key to return the machine to the initial stage of the maintenance mode.

NOTES:

- To cancel this operation and return the machine to the initial stage of the maintenance mode during the above procedure, press the **Stop/Exit** key.
- If there is a pause of more than one minute after a single-digit number is entered for double-digit firmware switch numbers, the machine will automatically return to the initial stage of the maintenance mode.

■ Details of Firmware Switches

The details of the firmware switches are described in [Appendix 4](#) in which the user-accessible selectors of the firmware switches are shaded.

[B] Printout of firmware switch data

■ Function

The machine prints out the setting items of the firmware switches and their contents specified.

■ Operating Procedure

- (1) Enter 1 twice in the initial stage of the maintenance mode using the ▲▼ and **OK** keys.
The "PRINTING" appears on the LCD.
- (2) The machine prints out the configuration list as shown on the next page.
- (3) Upon completion of printing, the machine returns to the initial stage of the maintenance mode.

CONFIGURATION LIST

MODEL : 8CA-A05-001
 TIME : 01/01/2005 00:14
 REV. : L0001010000VER.T
 PCI : 5.00
 SUM : 0000
 SER.# : BROM5F000446

WSW40 = 1-8. = Z WSW41 = 1-3. = Z0 4-8. = WSW42 = 1-8. = Z WSW43 = 2-3. = Z 4-7. = Z 8. = Z WSW44 = 1-5. = Z 6-8. = Z WSW45 = 1-3. = Z 4-6. = Z 7. = Z WSW46 = 1-2. = Z 3. = Z 4. = Z 5-8. = Z WSW47 = 1. = Z 2-7. = Z 8. = Z WSW48 = 1-2. = Z 3-8. = Z WSW49 = 1-2. = Z 3. = Z 4-5. = Z 6-7. = Z 8. = Z WSW50 = 1-2. = Z 3. = Z 4. = Z 5-6. = Z 7-8. = Z WSW51 = 1. = Z 2-8. = Z WSW52 = 1-6. = Z 7. = Z 8. = Z WSW53 = 00000000 1-6. NOT USED 7. ILLEGAL CNG DETECT 8. NOT USED	WSW25 = 1-4. = Z 5-7. = Z WSW26 = 1-2. = Z 3-4. = Z 4-5. = Z 6-7. = Z WSW27 = 1. = Z 2-3. = Z 4-7. = Z 8. = Z WSW29 = 1-8. = Z WSW30 = 1-8. = Z WSW31 = 1. = Z 2. = Z 3. = Z 4. = Z 5-8. = Z WSW32 = 1-2. = Z 3. = Z 4. = Z 5-8. = Z WSW33 = 1-5. = Z 6. = Z 7-8. = Z WSW34 = 1-5. = Z 6-7. = Z WSW35 = 1-3. = Z 4-8. = Z WSW36 = 1. = Z 2. = Z 3. = Z 4. = Z 5. = Z 6-8. = Z WSW37 = 1. = Z 2. = Z 3-8. = Z WSW38 = 1-3. = Z 4. = Z 5. = Z 6-8. = Z WSW39 = 11110000 1-8. NOT USED	WSW13 = 1-2. = I 3-4. = A 5-8. = A WSW14 = 1-2. = I 3-4. = I 5-8. = I WSW15 = 1-2. = I 3-6. = I 7. = I 8. = I WSW16 = 1. = I 2. = I 3-6. = I 7. = I 8. = I WSW17 = 1-2. = I 3-4. = I 5. = I 6. = I 7. = I 8. = I WSW18 = 1. = I 2-3. = I 4-5. = I 6. = I 7-8. = I WSW19 = 1-3. = I 4-6. = I 7. = I 8. = I WSW20 = 1. = I 2. = I 3. = I 4-5. = I 6-7. = I 8. = I WSW21 = 1-7. = I 8. = I WSW22 = 1. = I 2. = I 3. = I 4-8. = I WSW23 = 1. = I 2-3. = I 4-5. = I 6-7. = I 8. = I WSW24 = 01000010 1-2. NOT USED 3-4. DELAY OF CML ON-OGM : 4 SEC 5-8. NOT USED	WSW01 = 00000000 1-2. DIAL FORMAT : NORMAL 3-4. BREAK TIME : 60 MS 5-5. INTERDIGIT PAUSE : 800 MS 7. DP/PB CHANGE IN USER SW : YES 8. DP/PB FIXING SELECTION : PB WSW02 = 1111010 1-2. ON TIME : 100 MS 3-4. OFF TIME : 140 MS 5-8. LINE BEEP ATTENUATOR : 10 DB WSW03 = 10110000 1. PARA. CNG DETECTION1 : B 2-4. NOT USED 5. PARA. CNG DETECTION2 : A 6-8. NOT USED WSW04 = 00010110 1-4. NOT USED 5. ADDITIONAL DELAY OF CML ON-OGM : 0 SEC 6-8. FLASHING TIME : 500 MS WSW05 = 00000110 1-3. DIAL TONE DETECTION : 3.5 SEC WAITING 4. REMOTE ID DETECTION TIMEOUT : 2 SEC 5-5. BUSY TONE DETECTION (CALLING) : AFTER DIALING 7. BUSY TONE DETECTION (CALLED) : OFF 8. NOT USED WSW06 = 00101100 1-3. PAUSE KEY : 3.5 SEC WAITING 4-6. 2ND DT DETECTION TIME : 800 MS 7. 2ND DT DETECTION CYCLE : 1 CYCLE 8. 2ND DT INTERRUPT DETECTION TIME : 30 MS WSW07 = 01001100 1-2. FREQUENCY RANGE : INITIAL DATA 3. NOT USED 4-5. 2ND DT DETECTION LEVEL : -30 DBM 7. 1ST DT INTERRUPT DETECTION TIME : 30 MS WSW08 = 01100111 1-3. 1ST DT DETECTION TIME : 800 MS 4-5. 1ST/2ND DT TIME OUT : 10 SEC 6-8. 1ST DT DETECTION LEVEL : -42 DBM WSW09 = 00000000 1. ECM FRAME : 256 OCTET 2. NON STANDARD FACILITIES : ON 3-4. TIMES OF FALL BACK : 4 5. T5 TIMER : 300 SEC 6. T1 TIMER : 35 SEC 7-8. CALLING TIMEOUT : 55 SEC WSW10 = 00010100 1. NOT USED 2. TIMING OF LAST DIGIT-MODEM CHANGE : 100 MS 3. TIMING OF CML ON CNG TRANSMISSION : 2 SEC 4. TIMING OF CML ON CED TRANSMISSION : 2 SEC 5-6. TRAINING RETRIES : 2 7. CODING METHOD MR : ON 8. CODING METHOD MMR : ON WSW11 = 01011000 1-2. FREQUENCY RANGE : INITIAL DATA 3-8. ON/OFF TIME : 175 - 600 / 175 - 600 MS WSW12 = 10011001 1-2. OFF DETECTION TIME : 700 MS 3-4. AUTO ANS OFF DETECTION TIME : 7 SEC 5-6. ON DETECTION TIME : 250 MS 7-8. NOT USED
---	--	---	--

Configuration List

9.4.6 Operational Check of LCD (Function code 12)

■ Function

This function allows you to check whether the LCD on the control panel works normally.

■ Operating Procedure

Checking the display state of the LCD:

(1) Enter 1 and 2 in the initial stage of the maintenance mode, using the ▲/▼ and **OK** keys.

(2) Models with color LCD

Press the ▲ key.

The LCD shows the screen given at right. Each time you press the ▲ key, the LCD cycles through the displays as shown at right.

Models with monochrome LCD

Press the **Black Start** key.

The LCD shows the screen given at right. Each time you press **Black Start** key, the LCD cycles through the displays as shown at right.

(3) Press the **Stop/Exit** key in any process of the above display cycle. The machine returns to the initial stage of the maintenance mode.

For models with color LCD

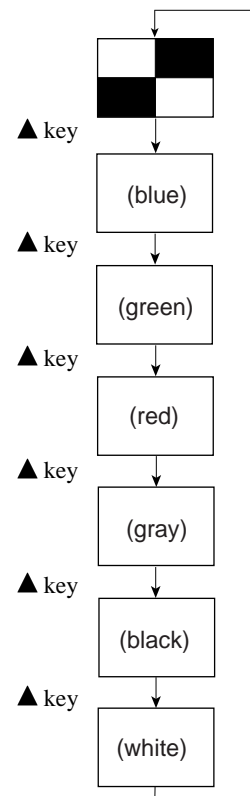

For models with monochrome LCD

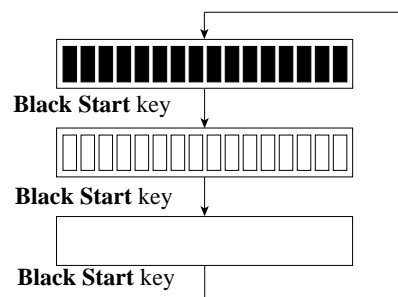

9.4.7 Operational Check of Control Panel PCB (Function code 13)

■ Function

This function allows you to check the control panel PCB for normal operation.

■ Operating Procedure

(1) Enter 1 and 3 in the initial stage of the maintenance mode using the ▲/▼ and OK keys. The "00 " will appear on the LCD.

(2) Press the keys in the order designated in the illustration shown below.

The LCD shows the corresponding number in decimal notation each time a key is pressed. Check that the displayed number is correct by referring to the illustration below.

If a key is pressed out of order, the machine displays the "INVALID OPERATE" on the LCD. To return to the status ready to accept key entry for operational check, press the **Stop/Exit** key.

(3) After the last number key is pressed, the machine returns to the initial stage of the maintenance mode.

To terminate this operation, press the **Stop/Exit** key. The machine returns to the initial stage of the maintenance mode.

For models with color LCD



For models with monochrome LCD

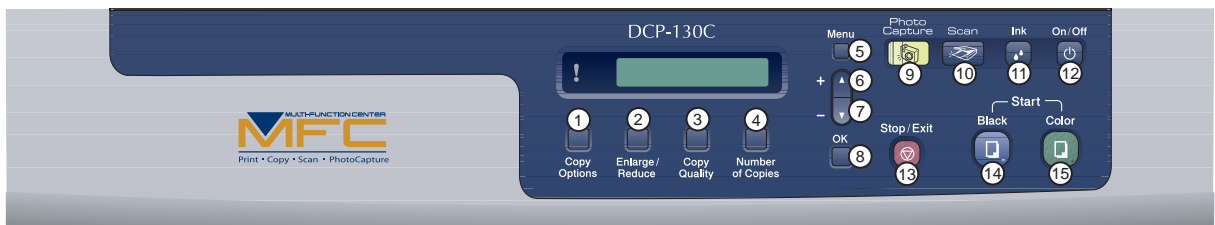

Key Entry Order

9.4.8 Sensor Operational Check (Function code 32)

■ Function

This function allows you to check the following:

- Document front sensor
- Document rear sensor
- Scanner/ink cartridge cover sensor
- Registration sensor
- Purge cam switch
- Black ink cartridge sensor
- Yellow ink cartridge sensor
- Cyan ink cartridge sensor
- Magenta ink cartridge sensor
- Head thermistor (in the head driver chip)
- Casing internal temperature thermistor (in the complex IC)

■ Operating Procedure

- (1) Enter 3 and 2 in the initial stage of the maintenance mode using the ▲/▼ and OK keys.

If the sensing status are as listed below, the LCD will show "DFDRCVRSCCP1*****" and "IKIYICIMVT LKTH," which can be switched by pressing the **Black Start (Mono Start)** key.

Given below is the relationship between the LCD indication, sensor name and sensor status.

LCD	Sensors	Sensing status
DF	Document front sensor*1	No document detected.
DR	Document rear sensor*1	No document detected.
CV	Scanner cover sensor*2	Scanner cover and ink cartridge cover closed.
RS	Registration sensor	No recording paper detected.
CC	Ink cartridge cover sensor*2	Scanner cover and ink cartridge cover closed.
P1	Purge cam switch	Purge cam switch ON.
IK	Black ink cartridge sensor	Black ink cartridge loaded (Black ink present).
IY	Yellow ink cartridge sensor	Yellow ink cartridge loaded (Yellow ink present).
IC	Cyan ink cartridge sensor	Cyan ink cartridge loaded (Cyan ink present).
IM	Magenta ink cartridge sensor	Magenta ink cartridge loaded (Magenta ink present).
VT	Head thermistor	Driver chip temperature within the allowable range.
LK	High yield ink cartridge sensor*3	High yield ink cartridge not loaded.
TH	Casing internal temperature thermistor	Normal temperature detected.

*1 For models with ADF

*2 Sensor sharing: Two sensor actuators share a single photosensor (scanner/ink cartridge cover sensor) so that the sensor acts as a scanner cover sensor and ink cartridge cover sensor. If either the scanner cover or ink cartridge cover is open, both "CV" and "CC" disappear.

*3 The "LK" is always displayed even on models not equipped with a high yield ink cartridge sensor.

- (2) Change the detecting conditions (e.g., open the scanner cover or insert paper through the registration sensor or remove the ink cartridges), and then check that the indication on the LCD changes according to the sensor states.
- (3) To stop this operation and return the machine to the initial stage of the maintenance mode, press the **Stop/Exit** key.

9.4.9 Fine Adjustment of Scanning Start/End Position (Function code 54)

This function allows you to adjust the scanning start/end position.

For models without an ADF, selecting "1.ADF" in steps (2) and (3) below produces nothing. Select "2.FB" to adjust the start/end position of flat-bed scanning.

■ Function

This function allows you to adjust the scanning start/end position.

■ Operating Procedure

- (1) Enter 5 and 4 in the initial stage of the maintenance mode using the ▲/▼ and **OK** keys. The "SCAN START ADJ." appears on the LCD.
- (2) Wait for the LCD to display the "1.ADF 2.FB."
- (3) Enter 1 or 2 using the ▲/▼ and **OK** keys, and the current scanning position correction value appears. You can adjust the correction value to 11 levels from +5 to -5 (mm).
- (4) To increase the correction value, press the right arrow key; to decrease it, press the left arrow key. If you press the **Stop/Exit** key, the machine returns to the initial stage of the maintenance mode without making change of the correction value.
- (5) Press the **OK** key. The "ACCEPTED" appears on the LCD. After one second, the LCD returns to the "1.ADF 2.FB" screen.
- (6) Press the **Stop/Exit** key to return to the initial stage of the maintenance mode.

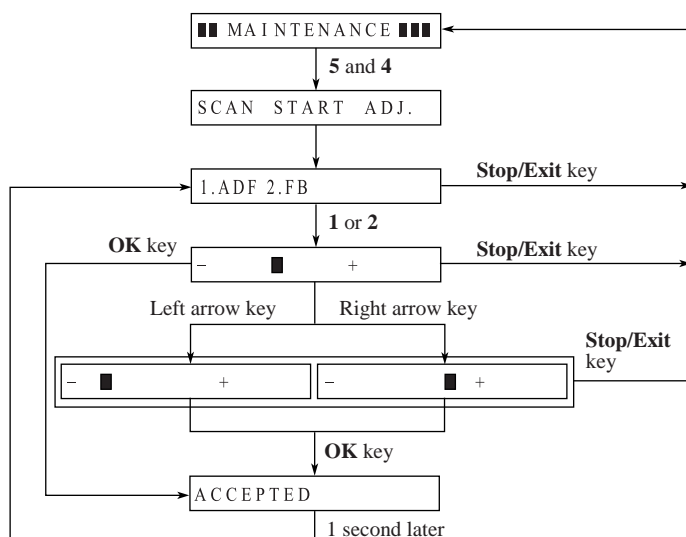

NOTE: The relationship between the scanning start/end positions and their correction values is shown below.

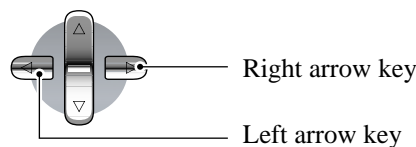
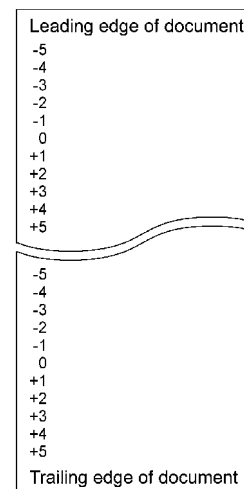

9.4.10 Acquisition of White Level Data and CIS Scanner Area Setting (Function code 55)

■ Function

This function allows the machine to obtain white level data for the CIS scanner and save it together with the CIS scanner area into the EEPROM on the main PCB.

■ Operating Procedure

- (1) Enter 5 twice in the initial stage of the maintenance mode using the ▲/▼ and **OK** keys.
The "SCANNER AREA SET" will appear on the LCD.

The machine automatically obtains white level data.

- (2) If this operation completes normally, the machine returns to the initial stage of the maintenance mode.

If any error is detected, the "SCANNER ERROR" appears on the LCD. To return the machine to the initial stage of the maintenance mode, press the **Stop/Exit** key.

9.4.11 Updating of Paper Feeding Correction Value (Function code 58)

■ Function

To keep the paper feeding performance in the best condition for quality print, the controller optimizes the rotation of the paper feed roller, using the correction value stored in the EEPROM on the main PCB.

If you replace the engine unit or head/carriage unit, you need to update the paper feeding correction value according to the procedure given here.

■ Operating Procedure

- (1) Switch on your PC.
- (2) Place the machine in the maintenance mode (see [Section 9.1](#)) and set letter-size paper to print check patterns.
- (3) Connect the machine to your PC using a USB cable.
- (4) On your PC, run "filedrgs.exe" in the folder created in [Section 7.1.1](#).

The Filedrgs window appears as shown below.

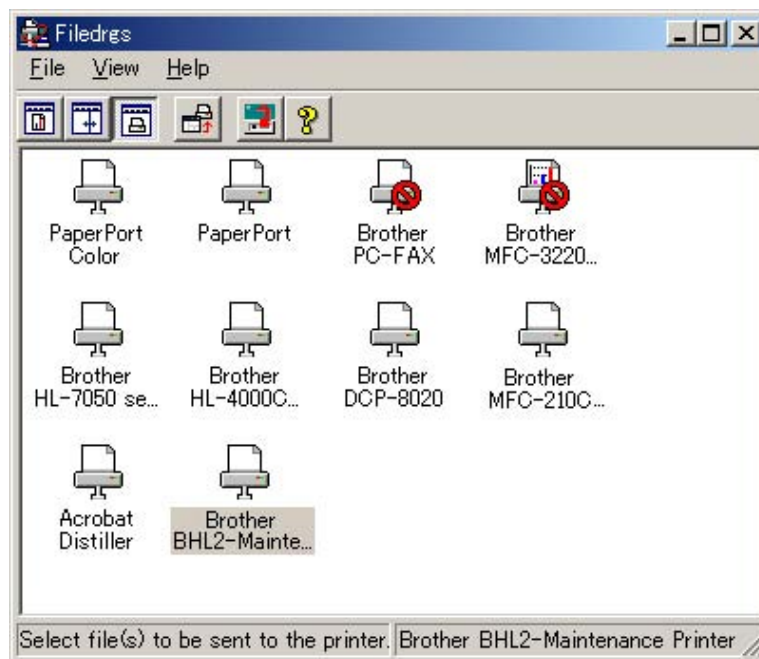

- (5) Drag and drop the "pfadj.prn" onto the BHL2-Maintenance Printer icon in the Filedrgs window shown above.

The machine displays the "RECEIVING DATA" on the LCD and prints out "PF adjust check" pattern (see [page 9-22](#) for a sample printout).

- (6) On the machine, enter 5 and 8 using the ▲/▼ and OK keys.

The "1.PF 2.EXIT" appears on the LCD.

- (7) To select the paper feed roller adjustment, enter 1 using the ▲/▼ and **OK** keys.
The "PF ADJ NO. +0" appears on the LCD.
- (8) Out of the three rows of the "PF adjust check" pattern (on the next page), check the middle row and select the block that is the least uneven print. Make a note of that block number.
If the least unevenness seems to be far to the left of -8, regard it as -8; if it seems to be far to the right of +8, regard it as +8. In this case, you need to check whether the paper feed roller and head/carriage unit are set into place.
- (9) Enter the number of the least uneven block found in step (8).
For example, if the number of the least uneven block is +4, enter 4 using the ▲/▼ and **OK** keys while the "PF ADJ NO. +0" is displayed on the LCD.
If the number is -4, display ▼ using the ▲/▼ key and press the **OK** key to display the "PF ADJ NO. -0." Enter 4 using the ▲/▼ and **OK** keys.
Then press the **OK** key, and the machine returns to the initial stage of the maintenance mode.
- (10) On your PC, drag and drop the "exitadj.prn" onto the BHL2-Maintenance Printer icon in the Filedrgs window.
The machine displays the "RECEIVING DATA" on the LCD and prints out three sheets of "EXIT adjust check" pattern (on [page 9-23](#) for a sample printout).
- (11) On the machine, enter 5 and 8 using the ▲/▼ and **OK** keys.
The "1.PF 2.EXIT" appears on the LCD.
- (12) To select the paper ejection roller adjustment, enter 2 using the ▲/▼ and **OK** keys.
The "EXIT ADJ NO. +0" appears on the LCD.
- (13) Out of the three sheets of the "EXIT adjust check" pattern (on [page 9-23](#)), check the middle sheet and select the block that is the least uneven print. Make a note of that block number.
- (14) Enter the number of the least uneven block found in step (13) in the same way as in step (9).
Then press the **OK** key, and the machine returns to the initial stage of the maintenance mode.

* BH7 PF adjust check - Ver 005 *

(NG)-8 -6 -4 -2 0 +2 +4 +6 +8(NG)



(NG)-8 -6 -4 -2 0 +2 +4 +6 +8(NG)



(NG)-8 -6 -4 -2 0 +2 +4 +6 +8(NG)



Paper Feeding Check Pattern for the Paper Feed Roller

PH7 EXIT adjust check 2/3 - Ver 005 *

(NG)-S -6 -4 -2 0 +2 +4 +6 +S(NG)



Paper Feeding Check Pattern for the Paper Ejection Roller

9.4.12 Checking of CIS Travel and Specifying of CIS Type (Function code 59)

■ Function

This procedure allows you to check the movement of the CIS unit integrated in the scanner cover (scanner unit). The CIS unit travels to the three positions--the white reference film position, scanning start and end positions.

It also allows you to enter the CIS type (Canon, Rohm, or Lite-On) into the EEPROM on the main PCB. If you replace the scanner cover or the main PCB, you need to specify the CIS type according to the procedure given below.

■ Operating Procedure

-- Check the movement of the CIS unit --

- (1) Enter 5 and 9 in the initial stage of the maintenance mode using the ▲/▼ and **OK** keys.

The "1:MO 2:CO 3:CHG?" appears on the LCD.

- (2) To call up the CIS travel menu, enter 1 using the ▲/▼ and **OK** keys.

(The "3:CHG" is for specifying the CIS type, as described on the next page. The "2:CO" is for checking scanning clocks at the factory, so do not access it.)

The "LED PWM: " appears on the LCD.

- (3) Press the **OK** key.

The "1:WHT 2:FRT 3:MV" appears.

- (4) Enter 3, 1, or 2 using the ▲/▼ and **OK** keys, then press the **OK** key.

The CIS unit moves to the scanning end position, white reference film position, or scanning start position, respectively.

- (5) Press the **Stop/Exit** key, and the CIS unit returns to the home position.

The machine returns to the initial stage of the maintenance mode.

-- Specify the CIS type --

- (1) Open the scanner cover and check the CIS bar code label on the scanner cover.

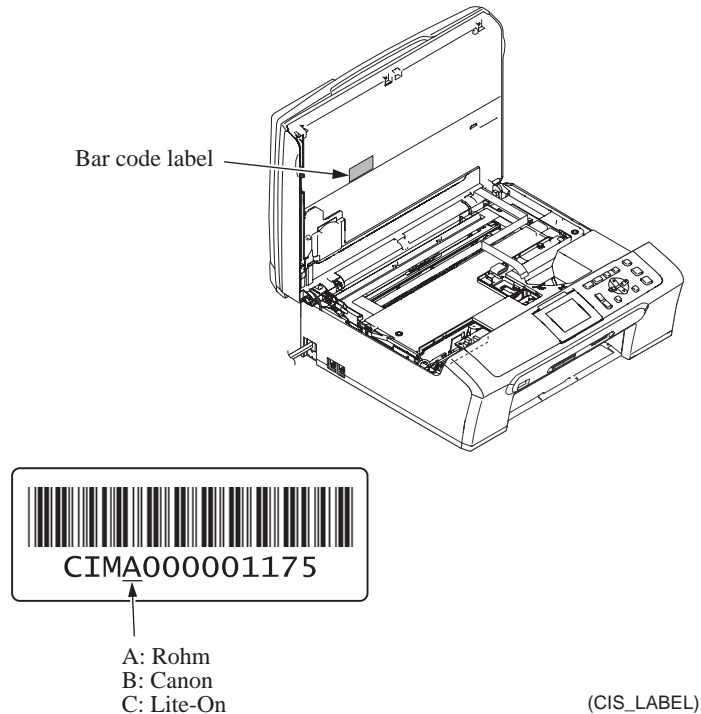

- (2) Enter 5 and 9 in the initial stage of the maintenance mode using the ▲/▼ and **OK** keys.
The "1:MO 2:CO 3:CHG?" appears on the LCD.
- (3) To call up the CIS type menu, enter 3 using the ▲/▼ and **OK** keys.
(The "1:MO" is for checking the CIS travel, as described on the previous page. The "2:CO" is for checking scanning clocks at the factory, so do not access it.)
The "CIS C:0 R:1 L:2" appears on the LCD.
- (4) If the CIS type is "B" (Canon), enter 0 using the ▲/▼ and **OK** keys; if "A" (Rohm), enter 1; if "C" (Lite-On), enter 2.
Upon completion of the entry, the machine returns to the initial stage of the maintenance mode.

9.4.13 Travel Check of the Head/Carriage Unit and Initial Setup Mode (Function code 63)

■ Function

This procedure moves the head/carriage unit to the center of its travel (Function code 63 + *).

It can also enable or disable the initial setup mode when the power is applied at the next time (Function code 63 + 1 or Function code 63 +3).

■ Operating Procedure

- (1) Enter 6 and 3 in the initial stage of the maintenance mode using the ▲/▼ and **OK** keys.
The "MAINTENANCE 63" appears on the LCD.
- (2) To move the head/carriage unit to the center of its travel, enter * using the ▲/▼ and **OK** keys.
After completion of head replacement or adjustment jobs, press the **Stop/Exit** key. The head/carriage unit returns to the home position where the head/carriage unit will be locked.
- (3) To enable or disable the initial setup mode when the power is applied at the next time, enter 1 or 3, respectively, using the ▲/▼ and **OK** keys.

If you enable the initial setup mode, wait until the "INIT" appears on the LCD and the head/carriage unit becomes locked. When the "HEAD LOCKED" appears, turn the power off.

NOTE: Enabling the initial setup mode resets all counts which can be displayed with Function code 80 (described in [Section 9.4.21 "Display of the Equipment's Log"](#)).

If you disable the initial setup mode, the machine displays the "NOT INIT" on the LCD and returns to the initial stage of the maintenance mode.

9.4.14 Alignment of Vertical Print Lines in Monochrome (Function code 65)

■ Function

This function allows you to align vertical lines printed in the forward and backward direction of the head/carriage unit.

If the head/carriage unit or main PCB is replaced with a new one, you need to make the adjustment given in this section.

NOTE: If the head/carriage unit is replaced, you need to make other adjustments in addition. Refer to [Chapter 7, Section 7.2](#).

■ Operating Procedure

- (1) Enter 6, 5, and 1 in the initial stage of the maintenance mode using the ▲/▼ and **OK** keys.

The machine displays the "MAINTENANCE 65" on the LCD and prints two sets of vertical alignment check patterns (shown on the next page) in monochrome for 600 dpi and 1200 dpi, each of which consists of #0 through #8 blocks. If the vertical alignment is ON, #5 block shows vertically aligned lines.

The "600DPI NO. (1-8)" appears on the LCD.

- (2) Check the printed vertical alignment check patterns and find which number block shows full alignment.

If the full alignment block is other than #5, enter that block number using the ▲/▼ and **OK** keys.

The "1200DPI NO.(1-8)" appears on the LCD.

- (3) For 1200 dpi, perform the same operation as in step (2).

The machine automatically returns to the initial stage of the maintenance mode.

NOTE: If #1 or #8 block is fully aligned so that you enter 1 or 8 in the above procedure, then go back to step (1) to confirm that #5 block becomes aligned.

600DPI

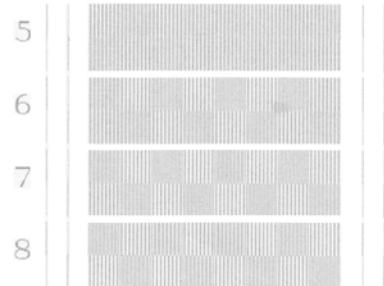
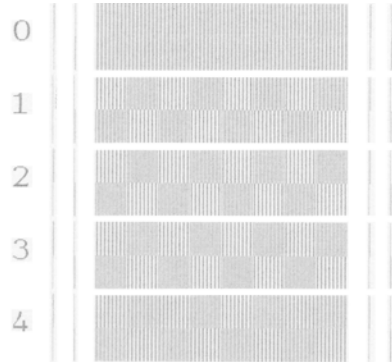

1200DPI

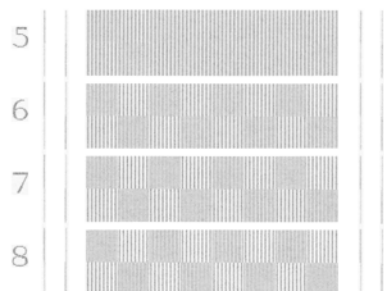
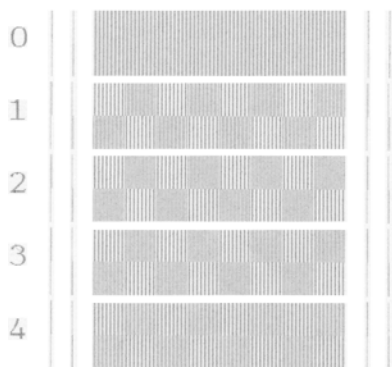

Vertical Alignment Check Patterns

9.4.15 Margin Adjustment in Borderless Printing (Function code 66)

■ Function

This function allows you to adjust the left and right margins for borderless printing. You print out a margin check pattern, measure the left and right margins, and enter the correction values.

■ Operating Procedure

- (1) Switch on your PC.
- (2) Place the machine in the maintenance mode (see [Section 9.1](#)) and set letter-size paper to print a margin check pattern.
- (3) Connect the machine to your PC using a USB cable.
- (4) On the PC, run "filedrg32.exe" in the folder created in [Section 7.1.1](#).

The Filedrgs window appears as shown below.

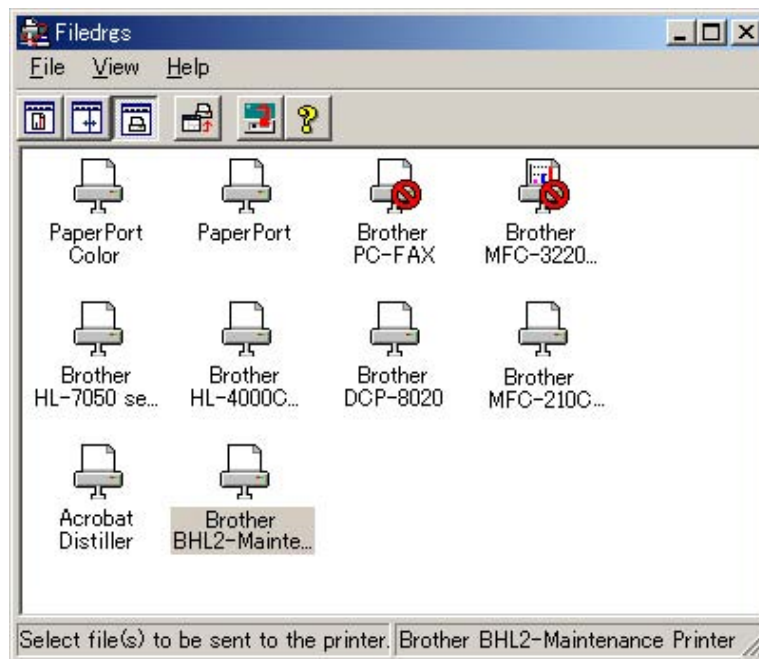

- (5) Drag and drop the "media.prn" onto the BHL2-Maintenance Printer icon in the Filedrgs window shown above.

The machine displays the "RECEIVING DATA" on the LCD and prints out the "MEDIA CHECK" pattern (see [page 9-31](#) for a sample printout).

- (6) Measure the left and right margins on the printout.

(Example) Left: 1.3 mm, Right: 1.4 mm

If both margins are within the range from 0.9 to 1.1 mm, no adjustment is required.

- (7) If either margin is out of the specified range, enter 6 twice using the ▲/▼ and **OK** keys on the machine.
The "MEDIA SENSOR ADJ" appears. (Note: The Media Sensor refers to the paper width sensor.)
- (8) To make the machine ready for data entry, enter * using the ▲/▼ and **OK** keys.
The "LEFT: 10" appears on the LCD.
- (9) To adjust the left margin, enter the measured value (in units of 0.1 mm) multiplied by 10.
In this example, the left margin measured in step (6) is 1.3 mm, so enter **1** and **3**, using the ▲/▼ and **OK** keys. Then press the **OK** key again.
- (10) The "RIGHT: 10" appears on the LCD.
To adjust the right margin, enter the measured value (in units of 0.1 mm) multiplied by 10.
In this example, the right margin measured in step (6) is 1.4 mm, so enter **1** and **4**, using the ▲/▼ and **OK** keys. Then press the **OK** key again.
- (11) Upon completion of the entry, the machine automatically returns to the initial stage of the maintenance mode.
Go back to step (5) and print out the margin check pattern again.
- (12) Measure the left and right margins on the printout.
If both margins are within the range from 0.9 to 1.1 mm, the adjustment is completed.

* BH7 MEDIA CHECK - Ver. 003 *

LEFT:0.9-1.1mm

RIGHT:0.9-1.1mm



Margin Check Pattern

9.4.16 Updating of Property Data (Function code 68)

■ Function

To keep the print quality, the controller optimizes the drive conditions of individual head/carriage units according to the property data. For instance, the controller optimizes the head drive strength, ink jet-out timing and other drive conditions according to the electromechanical properties unique to individual head/carriage units and ambient temperature.

The property data is stored in the EEPROM on the main PCB and its property code is printed on the property labels attached to the machine and the head/carriage unit.

If you replace the head/carriage unit with a new spare part, you need to enter its property code printed on the property label (that comes with the new spare part) and replace the old property label on the machine (see [Appendix 1](#) for the label location) with the new one. If the old part may be used in future, store the old property label also with the old part.

■ Operating Procedure

- (1) Enter 6 and 8 in the initial stage of the maintenance mode using the ▲/▼ and **OK** keys.
- (2) Enter 2, 5, 8, and 0 using the ▲/▼ and **OK** keys.

The current property data stored in the EEPROM appears on the LCD and the machine is ready for entry.

- (3) Check the property label that comes with a new head/carriage unit and then enter the property code.

The code to be entered is 12 digits excluding the heading alphabets.

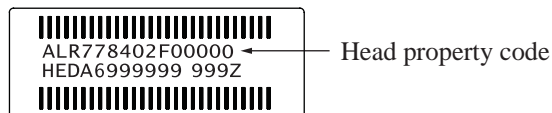

To enter letters "A" through "F," use the ▲/▼ and **OK** keys.

- (4) Press the **OK** key.

The machine shows the "INPUT ACCEPTED" on the LCD, and writes the entered property code into the EEPROM. Then it returns to the initial stage of the maintenance mode.

NOTE: If the entered data contains any checksum error, the machine shows the "INPUT ERROR" and returns to the ready-to-enter state. Go back to step (3).

9.4.17 Head/Carriage Unit Traveling Speed Check (Function code 69)

■ Function

This function checks whether or not the traveling speed of the head/carriage unit is within the specified range.

This procedure should be performed when you replace the head/carriage unit or carriage motor, or when you loosen the CR timing belt.

■ Operating Procedure

- (1) Enter 6 and 9 in the initial stage of the maintenance mode using the ▲/▼ and **OK** keys.
The machine starts aging the head/carriage unit, showing the "CR AGING" on the LCD.
In each of travel speeds 43.3 and 21.7 inches/sec, the machine checks whether the maximum and minimum speeds are within the specified range.
 - If both are within the range, the "43O 21O" appears on the LCD.
 - If either one is out of the range, the machine shows some message, e.g., "43O 21X" on the LCD. This sample message indicates that the speed variation is within the allowable range when the head/carriage unit travels at 43.3 inches/sec.; however, it is out of the range at 21.7 inches/sec.
- (2) Press the **Stop/Exit** key to return to the initial stage of the maintenance mode.

9.4.18 EEPROM Customizing (Function code 74)

The "EEPROM Customizing Codes List" is given on the next page.

■ Function

This function allows you to customize the EEPROM according to language, function settings, and firmware switch settings.

NOTE: If you replace the main PCB, be sure to carry out this procedure.

■ Operating Procedure

(1) Enter 7 and 4 in the initial stage of the maintenance mode using the ▲/▼ and **OK** keys.
The current customizing code appears on the LCD.

(2) Enter the desired customizing code using the ▲/▼ and **OK** keys.

Letters "A" through "F" can also be entered using the ▲/▼ and **OK** keys.

The newly entered code appears.

***NOTE:** If a wrong 4-digit code is entered, the machine will malfunction.*

(3) Press the **Black Start (Mono Start)** key.

The machine saves the setting and returns to the initial stage of the maintenance mode.

If you press the **Stop/Exit** key or no keys are pressed for one minute in the above procedure, the machine stops the procedure and returns to the initial stage of the maintenance mode.

EEPROM Customizing Codes List

Destination	US	Canada	Brazil	UK	Germany	France	Italy	Spain
Country code	01	02	42	04	03	05	16	15
DCP130C	0002	0002	0015	0004	0004	0004	0015	0015
DCP330C	0002	0002	---	0004	0004	0004	0015	0115
DCP540CN	0002	0002	---	0004	0004	0004	0015	0115
DCP750CW	---	---	---	0004	0004	0004	0015	0115

Destination	Portugal	Switzerland	Netherlands	Belgium	Norway Sweden Finland Denmark	Austria	Ireland	Czech Hungary Poland Rumania Bulgaria Turkey
Country code	18	10	09	08	57	14	11	54
DCP130C	0015	0004	0004	0004	0007	0004	0004	0054
DCP330C	0115	0004	0004	0004	0007	0004	0004	0054
DCP540CN	0115	0004	0004	0004	0007	0004	0004	0054
DCP750CW	0115	0004	0004	0004	0007	---	0004	---

Destination	Russia	S. Africa	Singapore Gulf	Australia New Zealand	China
Country code	48	24	40	56	20
DCP130C	0048	0004	0004	0004	0020
DCP330C	0054	0004	0004	0004	0020
DCP540CN	0054	0004	0004	0004	0020
DCP750CW	---	---	---	---	---

The above information is as of March 30, 2006. The up-to-date information is available from your local Brother Customer Service.

9.4.19 Travel of Head/Carriage Unit (for removing paper particles and dust accumulated on the maintenance unit) (Function code 75)

■ Function

This function is used to remove paper particles and dust accumulated between the maintenance unit and head/carriage unit. Using this function moves the head/carriage unit to the flushing position, allowing you to easily remove the paper particles and dust accumulated.

■ Operating Procedure

- (1) Enter 7 and 5 in the initial stage of the maintenance mode using the ▲/▼ and **OK** keys.
The head/carriage unit moves to the flushing position and the "PLS COVER OPEN" appears on the LCD.
- (2) Open the scanner cover.
The "PLS COVER CLOSE" appears on the LCD. Remove the paper particles and dust accumulated.
- (3) Close the scanner cover.
The head/carriage unit moves back to the home position.
The machine returns to the initial stage of the maintenance mode.

9.4.20 Purging Operation (Function code 76)

■ Function

The machine can carry out several types of purging operations--normal purge, periodical reset purge, power purge, initial purge, user reset purge, and engine setup purge. This function allows you to select the desired purge type and carry it out.

TIP: The purge types and their details are described on the next page.

■ Operating Procedure

- (1) Enter 7 and 6 in the initial stage of the maintenance mode using the ▲/▼ and **OK** keys. The machine displays the "CLEANING ALL" on the LCD and enters the purge mode.

- (2) Models with color LCD

Press the ◀ or ▶ key to display the target color for purge.

Models with monochrome LCD

Enter ◀ or ▶ using the ▲/▼ and **OK** keys to display the target color for purge.

Each time the ◀ or ▶ key is pressed (◀ or ▶ is entered), the "CLEANING ALL," "CLEANING BLACK," "CLEANING MAGENTA," "CLEANING CYAN," or "CLEANING YELLOW" appears cyclically.

"CLEANING ALL": Purge for all four color inks

"CLEANING BLACK": Purge for black ink

"CLEANING MAGENTA" / "CLEANING CYAN" / "CLEANING YELLOW":

Any color choice performs purge for all three color inks.

- (3) Enter the purge code according to the table on the next page.

- (4) Press the **Black Start (Mono Start)** key.

Upon completion of purging, the machine automatically returns to the initial stage of the maintenance mode.

Purge types, ink usage, purge counts, and purge codes

Purge Types	Description	Ink Usage	Purge Counts (See Note 2.)	Purge Codes (In the maintenance mode, Function code 76) (See Note 1.)
Normal purge	This purge operation removes dried ink sticking to the head nozzles.	Black: 0.21 mL Per color: 0.13 mL	Black: 11 Total of colors: 21	1
Periodical reset purge	This purge operation removes any bubbles that have accumulated in the ink supply tubes.	Black: 0.44 mL Per color: 0.32 mL	Black: 24 Total of colors: 54	2
Power purge	More powerful than a periodical reset purge, this purge operation is for removing stubborn clogging from the head nozzles and ink supply tubes.	Black: 0.59 mL Per color: 0.38 mL	Black: 32 Total of colors: 64	3
Initial purge	When the user loads ink cartridges for the first time, this purge operation automatically runs to refill the ink supply tubes and print head with fresh ink.	Black: 2.92 mL Per color: 2.59 mL	Black: 163 Total of colors: 432	4
User reset purge	This purge operation should be performed if the print quality problem persists after a user has performed the purge operation repeatedly by pressing the Ink (Ink Management) key.	Black: 0.50 mL Per color: 0.32 mL	Black: 28 Total of colors: 54	5
Engine setup purge	This purge operation refills the ink supply tubes with ink when there is no ink in those tubes.	Black: 2.92 mL Per color: 2.59 mL	Black: 163 Total of colors: 432	6

(Note 1) To enter a numerical code on models having no numerical keypad, press the ▲/▼ key several times to display the numerical code to be entered and then press the **OK** key. After that, press the **Black Start (Mono Start)** key.

(Note 2) This machine counts all purge operations and flushing operations performed since produced in order to prevent the ink absorber box and flushing box from overflowing with drained and flushed ink, respectively. An initial purge, for example, advances the counter by $163 + 432 = 595$. When the purge or flushing counter approaches 9600 or 475852272, respectively, the "MACHINE ERROR 46" appears, and further purge or flushing operations are prohibited. Replace the ink absorber box and flushing box, and then reset their counters with the following procedure.

■ **Resetting purge or flushing counter**

- 1) Press the **Menu** and **Black Start (Mono Start)** keys. Next press the **▲** key four times to make the machine enter the maintenance mode.
The machine displays "**■■ MAINTENANCE ■■■**" on the LCD, indicating that it is placed in the initial stage of the maintenance mode, a mode in which the machine is ready to accept entry from the keys.
- 2) Enter 8 and 0 using the **▲/▼** and **OK** keys in the initial stage of the maintenance mode to call up the machine's log information. (Function code 80. Refer to [Section 9.4.21](#).)
- 3) Press the **Black Start (Mono Start)** key several times until the purge or flushing count appears on the LCD.
- 4) To reset the purge or flushing count, enter 2, 7, 8, and 3 using the **▲/▼** and **OK** keys.
- 5) Press the **Stop/Exit** key to return the machine to the initial stage of the maintenance mode.
- 6) To exit from the maintenance mode, enter 9 twice using the **▲/▼** and **OK** keys.

9.4.21 Display of the Equipment's Log (Function code 80)

■ Function

The machine can display its log information on the LCD.

This procedure allows you to reset the purge count. It is necessary to reset the purge count when the ink absorber box is replaced with a new one without replacing the main PCB.

■ Operating Procedure

- (1) Enter 8 and 0 in the initial stage of the maintenance mode using the ▲/▼ and OK keys.
The calendar clock appears on the LCD.
- (2) Press the **Black Start (Mono Start)** key. Pressing the key more than ten times calls up the following log information items on the LCD, one by one. (The following list does not include all items.)
 - Head property code
 - PictBridge information
 - Ink drop count, indicating how many droplets have been jetted out from each of the ink cartridges*¹
 - Ink drop count after near-empty, indicating how many droplets have been jetted out from each of the ink cartridges*¹ after the ink cartridge sensor detects near-empty.
 - Total ink drop count, indicating how many droplets the machine has jetted out from each of the ink cartridges*¹ since produced
 - Ink cartridge change count, indicating how many times ink cartridge replacement has been made for each color*¹
 - Jam count, indicating how many times a paper jam has occurred
 - Total page count, indicating how many pages have been printed since the machine was produced
 - PC print page count, indicating how many pages the machine has printed as an output device of the connected PC
 - Color copy page count, indicating how many copies in color have been made
 - Black copy page count, indicating how many copies in monochrome have been made
 - Memory card print page count, indicating how many pages have been printed from the memory card data
 - FAX page count, indicating how many received FAX pages have been printed
(This item is not applicable to the models covered by this manual. This counter is always fixed to "0000000000.")
 - Purge count, indicating how many times the purge operation has been carried out
(With the purge count displayed, entering 2, 7, 8, and 3 using the ▲/▼ and OK keys resets the purge count.)
 - Purging record for each purge type
 - Wiper count, indicating how many times the wiper operation has been carried out
 - Flushing count, indicating how many times the flushing operation has been carried out
(With the flushing count displayed, entering 2, 7, 8, and 3 using the ▲/▼ and OK keys resets the flushing count.)

- Total power-ON time
- Error code of the most recent machine error*²
- ADF paper jam count, indicating how many times a paper jam has occurred*³
- ADF page count, indicating how many pages the ADF has fed*³
- Flat-bed page count, indicating how many documents have been scanned

After all of the log information items above are displayed, pressing the **Black Start (Mono Start)** key returns the screen to the calendar clock in step (1) above.

- (3) To stop this operation and return the machine to the initial stage of the maintenance mode, press the **Stop/Exit** key.

*¹ To check each of the four ink cartridges, press the **OK** key. Pressing the key cycles through black, yellow, cyan, and magenta.

*² When a machine error code is displayed, pressing the **OK** key cycles through recent nine errors that have occurred.

*³ For models with ADF

9.4.22 Equipment Error Code Indication (Function code 82)

■ Function

This function displays an error code of the last error on the LCD.

■ Operating Procedure

- (1) Enter 8 and 2 in the initial stage of the maintenance mode using the ▲/▼ and **OK** keys.
The LCD shows the "MACHINE ERROR X X."
- (2) To stop this operation and return the machine to the initial stage of the maintenance mode, press the **Stop/Exit** key.

9.4.23 Assurance Mode Switch Setting (Function code 88)

■ Function

The machine incorporates four assurance mode switches (AMS01 through AMS04) that are firmware switches just like the ones described in [Section 9.4.5](#).

When the machine does not function normally because the usage environments or operating conditions are not usual, the assurance mode switches provide workarounds to make the machine usable by changing the machine settings to untypical ones.

The user is allowed to access the assurance mode switches under the guidance of service personnel (e.g., by telephone).

The details about AMS01 through AMS04 are described on the following pages.

■ Operating Procedure

- (1) Enter 8 twice in the initial stage of the maintenance mode using the ▲▼ and OK keys.
The machine displays "AMS00" on the LCD and becomes ready to accept an assurance mode switch number.
- (2) Enter the desired number from the assurance mode switch numbers (01 through 04) using the ▲▼ and OK keys.

The following appears on the LCD:

Selector 1 Selector 8
 ↓ ↓
AMSXX = 0 0 0 0 0 0 0 0

- (3) Models with color LCD
Move the cursor to the selector position to be modified, using the ◀ and ▶ keys.

Models with monochrome LCD
Move the cursor to the selector position to be modified, using the ▲▼ and OK keys.*
(*Press the ▲▼ key several times to display ▶ or ◀ and press the OK key, and the cursor moves to the right- or left-hand digit, respectively. Repeat this operation to move the cursor to the target digit.)
- (4) Enter the desired number (0 or 1) using the ▲▼ and OK keys.
- (5) Press the OK key. This operation saves the newly entered selector values onto the EEPROM and readies the machine for accepting an assurance mode switch number.
- (6) Repeat steps (2) through (5) until the modification for the desired assurance mode switches is completed.
- (7) Press the **Stop/Exit** key to return the machine to the initial stage of the maintenance mode.

- NOTES:**
- To cancel this operation and return the machine to the initial stage of the maintenance mode during the above procedure, press the **Stop/Exit** key.
 - If there is a pause of more than one minute after a single-digit number is entered for double-digit assurance mode switch numbers, the machine will automatically return to the initial stage of the maintenance mode.
 - Initializing the EEPROM with Function code 01 or 91 initializes the AMS switch settings.

AMS01 (Printing assurance 1)

Selector No.	Function	Setting and Specifications
1	Prevention of stains on back side of leading edge of paper in borderless printing	0: Disable (default) 1: Enable
2	Reduction of banding in borderless printing (Limit of the number of head nozzles to be used)	0: Disable (No limit) 1: Enable (Limit)
3 4	Protection of platen from no-paper printing to prevent stains (Functional restriction on the paper width sensor)	No. 3 4 0 0 : Enable (Determine the sensor function depending upon the print resolution selected) (default) 0 1 : Enable (Detect the leading edge plus right and left edges of paper) 1 0 : Enable (Detect the leading edge of paper) 1 1 : Disable (No paper detection)
5	Assurance print 1 (Printing with black and cyan inks in monochrome copy)	0: Disable (default) 1: Enable
6	Assurance print 2 (Printing with black and cyan inks in list output)	0: Disable (default) 1: Enable
7 8	Workaround for false jam detection (Functional restriction on the paper width sensor)	No. 7 8 0 0 : Detect both the leading edge and width of paper (default) 0 1 : Detect both the leading edge and width of paper 1 0 : Detect only the leading edge of paper 1 1 : No detection

- **Selector 1: Prevention of stains on back side of leading edge of paper in borderless printing**

Setting this selector to "1" reduces the protruding amount of the leading edge of recording paper to the platen groove to minimize stains that could be caused by ink mist on the back side of the leading edge. Enabling this function reduces the throughput than disabling it.

- **Selector 2: Reduction of banding in borderless printing (Limit of the number of head nozzles to be used)**

Setting this selector to "1" limits the number of head nozzles to be used in borderless printing to reduce banding.

The default setting of this selector is "0" for models with movable platen, and "1" for models without movable platen.

- **Selectors 3 and 4: Protection of platen from no-paper printing to prevent stains (Functional restriction on the paper width sensor)**

The setting made by these selectors applies to such printing that is assumed to be at a high resolution, that is, printing from a PC or media card, copying, and printing via PictBridge.

If these selectors are set to "0, 0," the machine automatically determines the functions of the paper width sensor depending upon the print resolution selected. Therefore, in low resolution printing, e.g. when the "Fast" print quality is selected, the paper width sensor is automatically disabled. On the contrary, in high resolution printing, e.g. when the "Highest" print quality is selected, the sensor is automatically enabled.

Setting these selectors to "1, 1" disables the paper width sensor to save the sensing time for higher throughput.

- **Selectors 5 and 6: Assurance print 1 and 2**

Enabling assurance print 1 or 2 causes the machine to mix black ink (pigment-based) and a little of cyan ink (dye-based) to use in monochrome copy or in list output, respectively.

If black ink is not jetted out normally, cyan ink can be substituted for black ink in printing. This ensures that in list printing (in which data once printed will be deleted) the data will be preserved as a printout.

- **Selectors 7 and 8: Workaround for false jam detection (Functional restriction on the paper width sensor)**

The setting made by these selectors applies to the list and index printing and test printing.

When logo printed recording paper is used, for example, the paper width sensor might misdetect the paper present state as "no paper loaded" due to the logo's color. Limiting the paper width sensor functions with these selectors avoids detecting such a false paper jam.

AMS02 (Printing assurance 2)

Selector No.	Function	Setting and Specifications
1	Head-platen gap offset (Prevention of stains on recording paper)	For glossy paper 0: Disable (default) 1: Enable
2		For recording paper except glossy paper 0: Disable (default) 1: Enable
3 5	Paper feed amount compensation (for preventing banding at the leading edge of recording paper fed from the photo tray)	No. 3 4 5 0 0 0 : Enable for 4 x 6 postcards (default) 1 0 0 : Enable for Photo L-size paper in Japan Others : Disable
6		Registration time offset to slipping in plain paper feeding 0: Disable (default) 1: Enable
7	Unidirectional print for higher print quality 0: Disable (default) 1: Enable	
8	Improvement of paper feeding reliability 0: Disable (default) 1: Enable	

● **Selectors 1 and 2: Head-platen gap offset (Prevention of stains on recording paper)**

If using curled or thick recording paper results in a stained print face of the paper, increase the gap between the head nozzles and the platen with these selectors to reduce the production of stains.

Enabling the head-platen gap offset increases the gap to 1.6 or 2.3 mm if it was 1.3 or 1.6 mm, respectively. (The details are given in the table below.)

In borderless printing, even if enabled by these selectors, the head-platen gap offset becomes disabled except when the Brother premium glossy photo paper is used with the "Photo" or "Highest" print quality selected.

Recording paper	Print quality selected	Head-platen gap offset (specified by selector 1 or 2)				
		OFF	ON for glossy paper		ON for recording paper except glossy paper	
			Using A4, letter, or legal paper in borderless printing	In printing with borderless printing OFF, or using paper except A4, letter, and legal paper	Using A4, letter, or legal paper in borderless printing	In printing with borderless printing OFF, or using paper except A4, letter, and legal paper
Brother premium glossy photo paper	"Highest"	1.3 mm	1.6 mm	1.6 mm		
	"Photo"	1.3 mm	1.6 mm	1.6 mm		
	"Fine"	1.6 mm	(1.6 mm)	2.3 mm	---	---
Other glossy paper	"Highest"	1.6 mm	(1.6 mm)	2.3 mm		
	"Photo"	1.6 mm	(1.6 mm)	2.3 mm		
	"Fine"	1.6 mm	(1.6 mm)	2.3 mm		
Inkjet paper	"Photo"	1.6 mm			(1.6 mm)	2.3 mm
	"Fine"	1.6 mm			(1.6 mm)	2.3 mm
Plain paper (except the above)	"Fine"	1.6 mm	---	---	(1.6 mm)	2.3 mm
	"Normal"	1.6 mm			(1.6 mm)	2.3 mm
	"Fast Normal"	1.6 mm			(1.6 mm)	2.3 mm
	"Fast"	1.6 mm			(1.6 mm)	2.3 mm

In the above table, values in parentheses are not changed since the offset is automatically disabled.

- **Selectors 3 to 5: Paper feed amount compensation (for preventing banding at the leading edge of recording paper fed from the photo tray)**

This compensation function is usually enabled for preventing banding (horizontal streaks) from occurring at the leading edge of recording paper fed from the photo tray.

When postcards or small size paper are fed from the standard paper tray, however, this compensation function can be counterproductive. If so, disable the function, and the print quality may be improved.

- **Selector 6: Registration time offset to slipping in plain paper feeding**

Enabling the registration time offset with this selector increases the registration time (during which the paper feed roller rotates in the reverse direction), avoiding the occurrence of a paper feeding timeout error even if the paper cannot reach the registration sensor actuator within the predetermined registration time due to slipping of the paper pull-in rollers against paper in the paper tray.

Selecting the "Fast" print quality disables the registration time offset even if it is enabled with this selector.

NOTE: Selecting the "Glossy paper" automatically enables the registration time offset.

- **Selector 7: Unidirectional print for higher print quality**

The machine prints bidirectionally by default. To get higher print quality, set this selector to "1" to switch to the unidirectional print mode in which printing is performed only when the head/carriage unit travels from left to right. Note that the unidirectional print mode sacrifices the print speed.

Print object	Unidirectional print
Copy	Yes
Print from PC	No
Print from memory cards or via PictBridge	Yes
Print memory card index or PictBridge index	Yes
Print a list	Yes
Print a test pattern	No

- **Selector 8: Improvement of paper feeding reliability**

Setting this selector to "1" improves the paper feeding reliability, sacrificing the print speed.

AMS03 (Maintenance assurance 1)

Selector No.	Function	Setting and Specifications
1	Protection of head caps from drying	0: Disable (default) 1: Enable
2 3	Auto capping start time	No. 2 3 0 0 : 30 seconds (default) 0 1 : 5 seconds 1 0 : 15 seconds 1 1 : 300 seconds
4	Purge more powerful than normal purge	0: Disable (default) 1: Enable
5 6	Not used.	
7	Automatic purging interval programmed for matching the ambient temperature (for color ink)	0: Enable (default) 1: Disable
8	Automatic purging interval programmed for matching the ambient temperature (for black ink)	0: Enable (default) 1: Disable

- **Selector 1: Protection of head caps from drying**

If the protection function is enabled with this selector, the head/carriage unit automatically returns to the home position (head capping position) for flushing each time the machine prints the specified number of pages in order to protect the inside of the head caps from drying up. This function is useful in a dry environment or for heavy duty print per printing cycle.

- **Selectors 2 and 3: Auto capping start time**

If data transfer from the PC stops midway through printing for some reason in the PC, the head/carriage unit automatically returns to the home position (head capping position) after the specified auto capping start time (default: 30 seconds) to prevent the head surface from drying up. At the restart of printing after the auto capping operation, print image unevenness could occur. To avoid it, increase the auto capping start time with these selectors.

- **Selector 4: Purge more powerful than normal purge**

Setting this selector to "1" automatically selects a purge more powerful than the normal purge from the first if the purge is initiated immediately after printing.

- **Selectors 7 and 8: Automatic purging interval programmed for matching the ambient temperature**

The "automatic purging interval programmed for matching the ambient temperature" is enabled by default. If the machine is set in an excessively hot or cold place, therefore, the automatic purging interval becomes short, resulting in increased ink waste.

Disabling this interval enables the one programmed for the ordinary temperature. In the first printing after a long no-print period, however, the print quality may lower.

AMS04 (Maintenance assurance 2)

Selector No.	Function	Setting and Specifications
1	Line monitor volume (<i>Not used.</i>)	0: Normal (default) 1: Extra-high
2	Not used.	
3	Black ink print mode	0: Disable (default) 1: Enable
4	Automatic purging for color ink	0: Enable (default) 1: Disable
5	Not used.	
6 7	Automatic purging interval	No. 6 7 0 0 : 30 days (black and color) 0 1 : 20 days (black), 30 days (color) 1 0 : 30 days (black), no purge (color) 1 1 : No purge (black and color)
8	Automatic purging for black ink	0: Enable (default) 1: Disable

- **Selector 3: Black ink print mode**

If any color ink runs out, printing is no longer possible by default. Setting this selector to "1" allows the machine to function as a monochrome printer, making it possible to print with black ink only even in an ink empty state as listed below.

Printing from a PC	Monochrome printing only possible.
Copying	Monochrome printing only possible. The Black Start (Mono Start) key is enabled, but the Color Start key is disabled.
Printing from memory cards	No printing possible.
Printing via PictBridge	No printing possible.
Printing lists	Monochrome printing only possible.
Purge operation	Purge operation possible for black ink only, not possible for all-color or any specific color.

Tip: Difference between selector 3 on AMS04 and selector 8 on WSW49 (See [page App. 4-53.](#))

Both selector 3 on AMS04 and selector 8 on WSW49 specify the similar black ink print mode that applies if any color ink runs out. The difference is that the former allows the machine to print all data received as a monochrome printer with black ink only; the latter to ignore the ink empty state, receive both color and black data, and print it, resulting in a printout missing color components.

- **Selectors 4 and 8: Automatic purging for color ink and for black ink**

The machine periodically performs an automatic purge by default. The automatic purge, however, wastes ink when no printing has occurred. To avoid it, disable the automatic purge with these selectors. In the first printing after a long no-print period, disabling it may lower the print quality.

Setting selector 4 or 8 to "1" disables the setting made by selectors 6 and 7.

- **Selectors 6 and 7: Automatic purging interval**

These selectors allow you to select the automatic purging interval to reduce ink consumption.

Setting these selectors to "1, 1" (No purge) disables the setting made by selectors 4 and 8.

Appendix 1. Reading Labels

This appendix shows the location of labels put on some parts and describes the coding information for serial number, property data, and manufacturing information.

Reading Labels

An individual machine has a "serial number label" for the machine itself and "property labels" for the head/carriage unit. An individual ink cartridge also has a "manufacturing information label."

This section lists the coding information for those serial number, property data, and manufacturing information.

(1) Serial number label for the machine itself

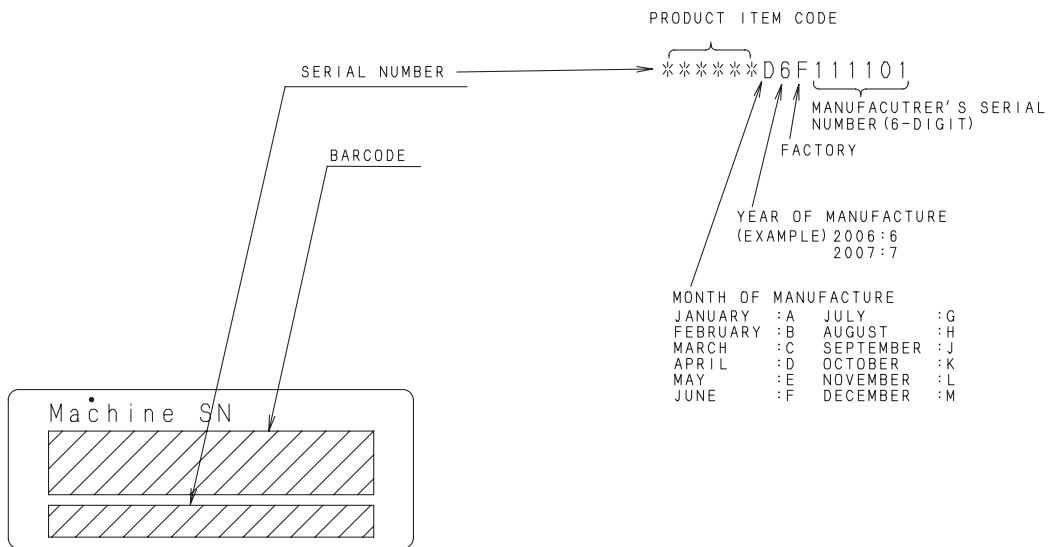

(app01a)

Location

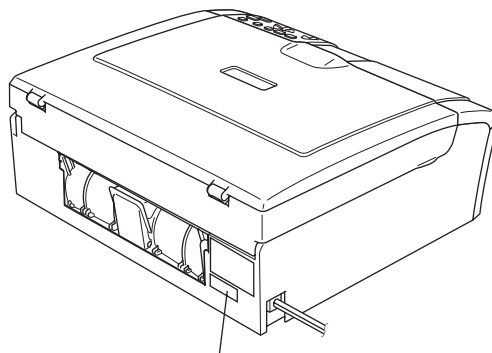

Serial number label

(app01b)

(2) Head property labels

The property code of the head/carriage unit is printed on head property labels--bar code label and QR code label, each of which is attached to the lower cover and the head/carriage unit, respectively.

■ On the lower cover

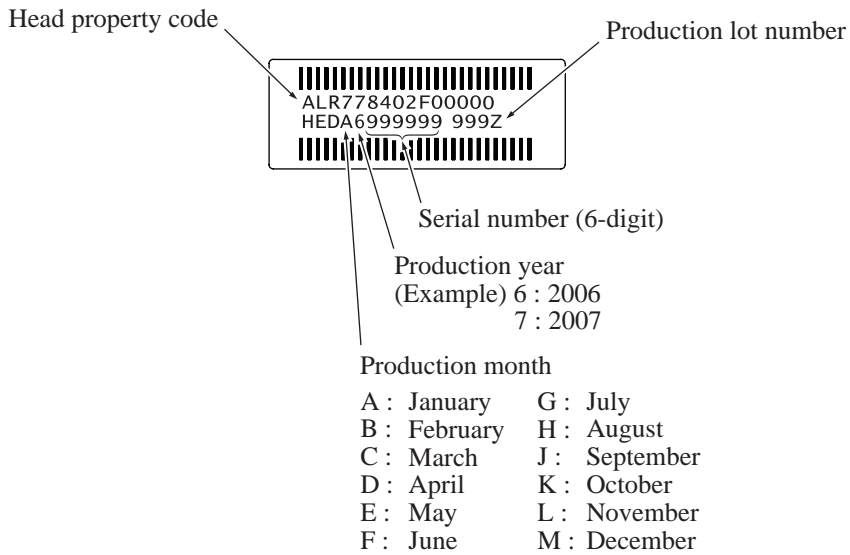

(bar_code_label)

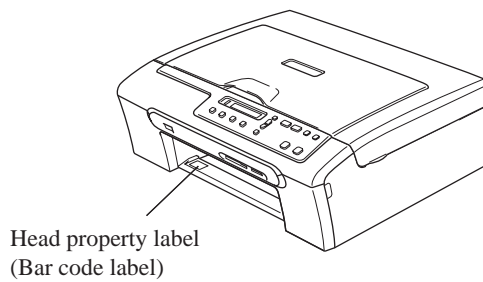

(app01d)

■ On the head/carriage unit

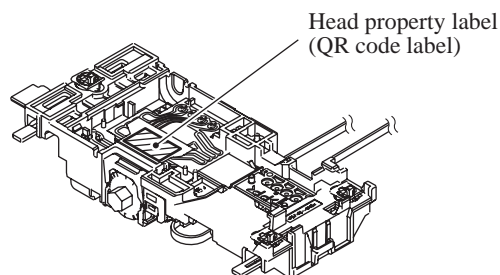

(app01f)

(3) Manufacturing information label for an ink cartridge

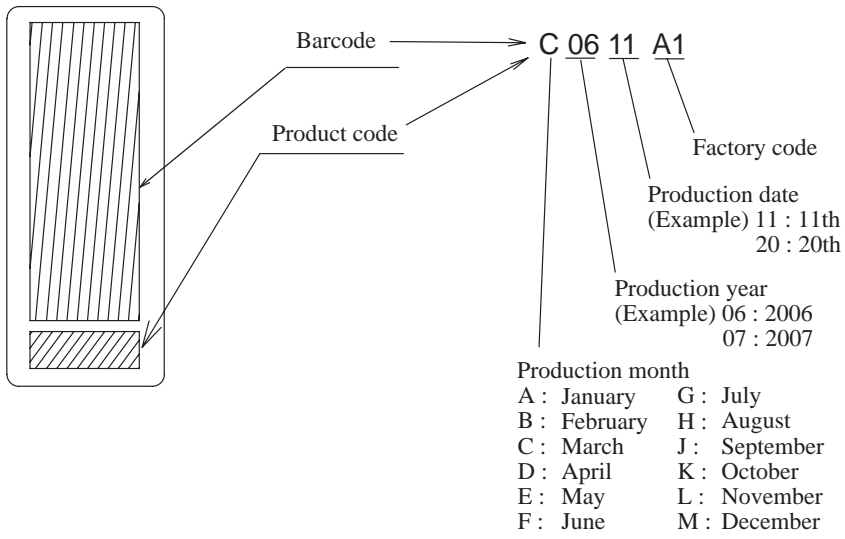

(app01g)

Location

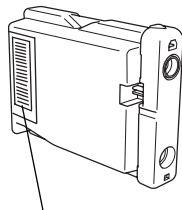

Manufacturing information label

(app01h)

Appendix 2. Firmware Installation

This appendix provides instructions on how to change firmware stored in the flash ROM on the main PCB or load firmware to a new main PCB from the host PC.

A2.1 Loading the Programs to the Flash ROM	App. 2-1
---	-----------------

A2.1 Loading the Programs to the Flash ROM

If you want to change the programs stored in the flash ROM on the main PCB or after you replace the main PCB, load the desired programs to the flash ROM.

Loading requires a PC/AT-compatible computer running Windows 98SE/Me, Windows 2000 Professional, or Windows XP Home/Professional.

CAUTION: During loading, never turn off your PC or the machine, unplug the USB interface cable, interrupt loading or load invalid data. If you do so, loading will fail, causing the PCB to be unusable. You will have to replace the main PCB and load programs to a new PCB.

Preparation

You need the BHL2-Maintenance Printer driver and filedg32.exe (provided by Brother Industries). Save them in an arbitrary folder in your PC.

Installing the BHL2-Maintenance Printer driver

To identify terminals connected via USB interface, a PC requires the corresponding virtual USB devices to be implemented by driver/software. If you connect any number of machines to your PC, therefore, the same number of virtual USB devices will be automatically configured on your PC. To prevent virtual USB devices from being configured limitlessly, use the unique driver installation procedure described below that enables your PC to identify terminals via a single virtual USB device.

NOTE: Once this installation procedure is carried out for a PC, no more driver/software installation will be required for that PC to identify machines. If the BHL2-Maintenance Printer driver has been already installed to your PC according to this procedure, skip this section.

NOTE: Before proceeding to the procedure given below, make sure that the BHL2-Maintenance Printer driver (listed in [Chapter 7, Section 7.1.1](#)) is stored in your PC.

- (1) Make sure that the power cord of the machine is unplugged from the electrical outlet.
If the machine is connected to your PC, unplug the USB cable.
- (2) Switch on your PC.
- (3) Plug the power cord of the machine into an electrical outlet.
- (4) Press the **Menu** and **Black Start (Mono Start)** keys. Next press the **▲** key four times to make the machine enter the maintenance mode. (Refer to [Chapter 9](#).)

The machine displays "■■ MAINTENANCE ■■■" on the LCD, indicating that it is placed in the initial stage of the maintenance mode, a mode in which the machine is ready to accept entry from the keys.

- (5) Connect the machine to your PC using a USB cable.

The following window appears.



- (6) The following screen appears, indicating the detection of new hardware device by the system. Click **Next** to proceed.



- (7) Select "Search for a suitable driver for my device (recommended)" and click **Next**.

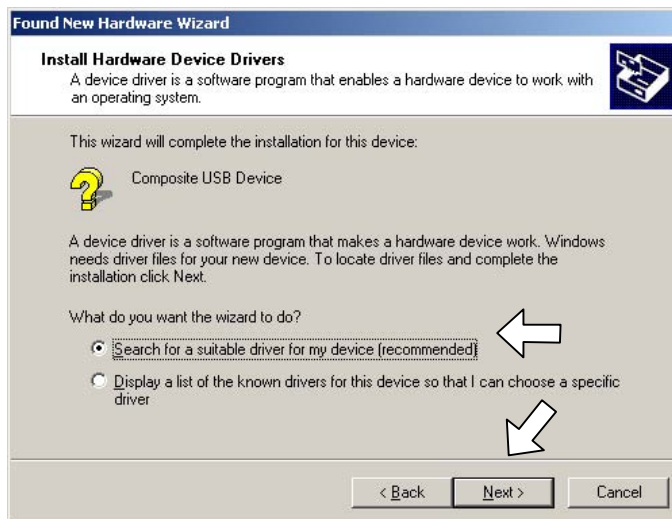

- (8) Select "Specify a location" and click **Next**.



- (9) Select the folder where the copy of the BHL2-Maintenance Printer driver is located (or click **Browse** to specify it), then click **OK**.

(This sample screen is captured on the Windows 2000 desktop.)

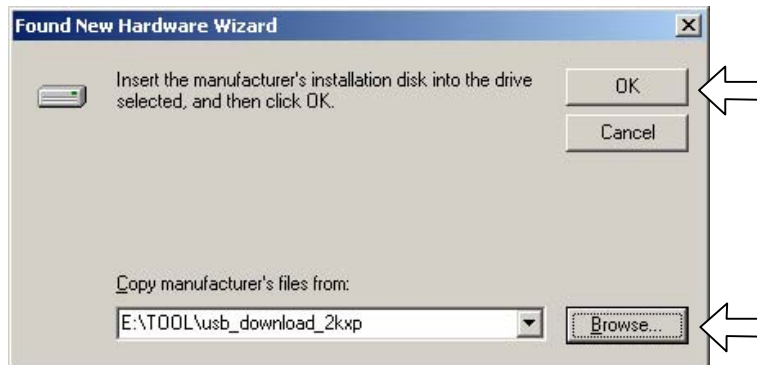

- (10) Click **Next**.



- (11) To proceed, click **Yes**.



(12) If the driver is successfully installed, the following message window appears. Click **Finish** to return to Windows.

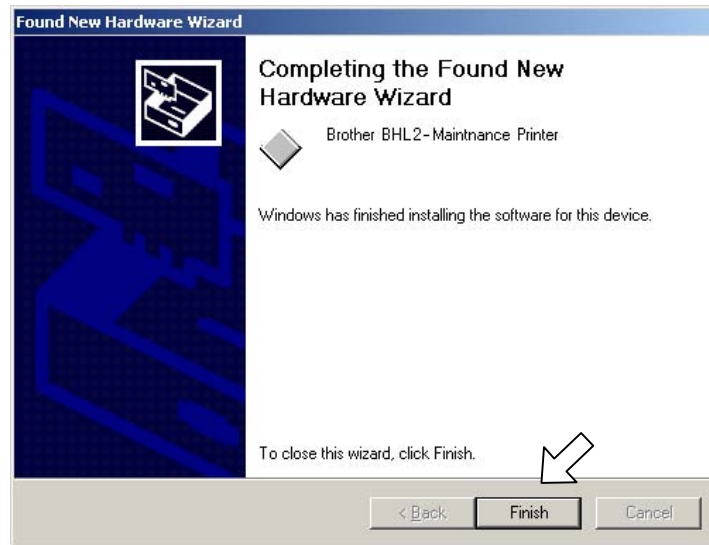

NOTE: After completion of the driver installation, if the machine exits the maintenance mode, the "Found New Hardware Wizard" screen in step (6) appears again. Click **Cancel**.

NOTE: To check that the printer driver is successfully installed, click **Start|Settings|Printers** to call up the Printers window as shown below and confirm that the Brother BHL2-Maintenance Printer icon is displayed.

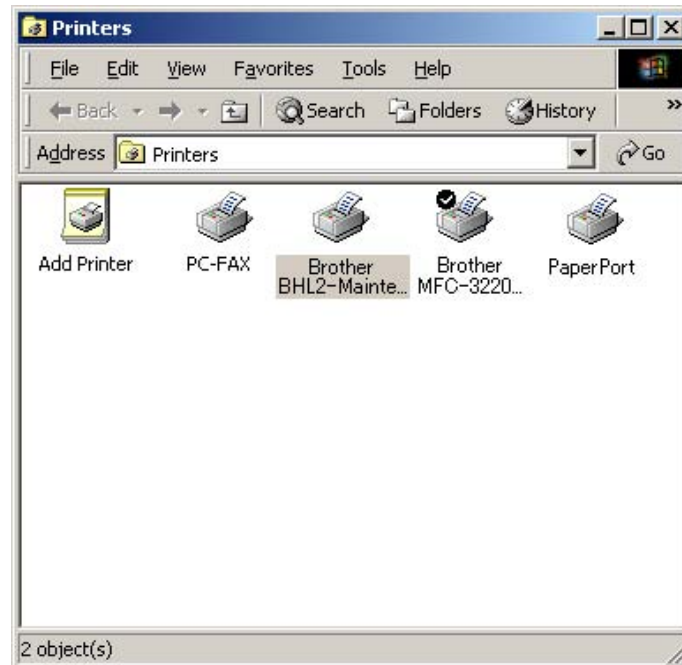

Loading the programs onto the flash ROM of the machine

■ After replacing the main PCB with a new one

Unplug the power cord of the machine from the electrical outlet and disconnect the USB cable that connects the machine with your PC.

- (1) On your PC, run "filedrg32.exe."

The Filedrgs window will appear as shown below.

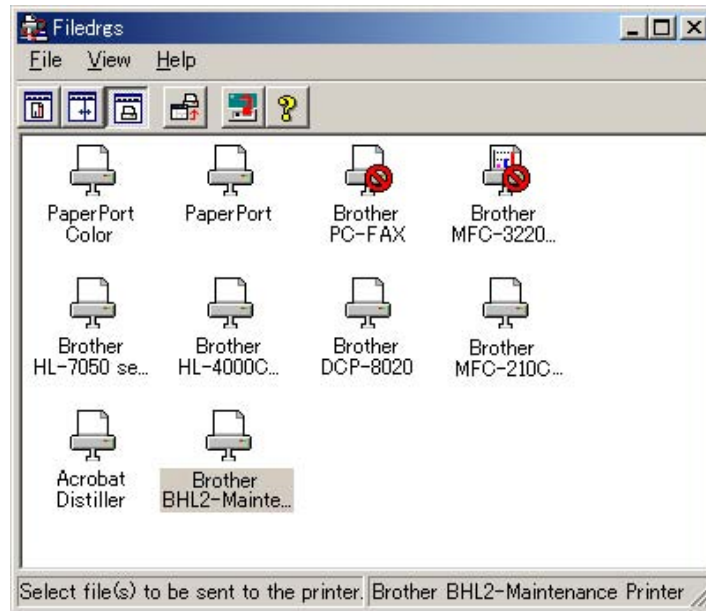

- (2) Connect the machine to your PC using a USB cable.

- (3) On the machine, follow the steps below to enter the firmware loading mode.

- 1) Plug the power cord into an electrical outlet with the ◀ (**Copy Options**) key held down and keep holding it down until the following appears on the LCD.

Color LCD



Monochrome LCD

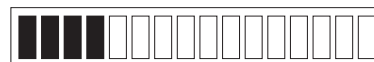

- 2) Hold down the ▲ (**Enlarge/Reduce**) key until the following appears on the LCD.

Color LCD



Monochrome LCD



3) Hold down the ► (**Copy Quality**) key until the following appears on the LCD.



4) Hold down the **OK** key until the following appears on the LCD.



When the black and white pattern shown above is displayed, the machine is ready to receive programs or data for firmware installation from the connected PC.

NOTE: Pressing a wrong key or no key within the specified time in steps 1) through 4) above causes an error. If it happens, unplug the power cord and go back to step (1) above.

(4) Drag and drop the firmware (e.g., lz0023_a.pmu) onto the BHL2-Maintenance Printer icon in the Filedrags window.

NOTE: To use a firmware file, extract it beforehand by double-clicking. It is a self-extracting file having the extension .exe.

After approx. 2 to 5 minutes, the loading operation is complete and the machine automatically reboots and returns to the standby state.

(5) Check the version of the firmware installed, with the following steps.

Press the ▲ and **Stop/Exit** keys at the same time to display the firmware version on the LCD.

- Sample version number shown on the monochrome LCD: A0307252244:CF30
- Sample version number shown on the color LCD: 0A63061910:FE46
(The top line shows the version number.) P0601242005:4123
B0601242005:1C8D

If the displayed version number is identical with the firmware version you installed, the loading operation has been successfully finished.

NOTE: If loading operation ends abnormally, turn the machine off and on. Wait for the machine to automatically enter the firmware loading mode, and then perform the loading procedure above again.

■ **After replacing the main PCB with the one used for any other machine or when changing programs**

Unplug the power cord from the electrical outlet and make sure that the machine is connected with your PC using a USB cable.

Models with color LCD: While holding down the ▼ key, plug the power cord into an electrical outlet.
Models with monochrome LCD: While holding down the **Number of Copies** key, plug the power cord into an electrical outlet.

The black and white pattern appears on the LCD as shown on the previous page. The machine is ready to receive programs or data for firmware installation from the connected PC.

(1) On your PC, run "filedrg32.exe."

The Filedrgs window will appear as shown below.

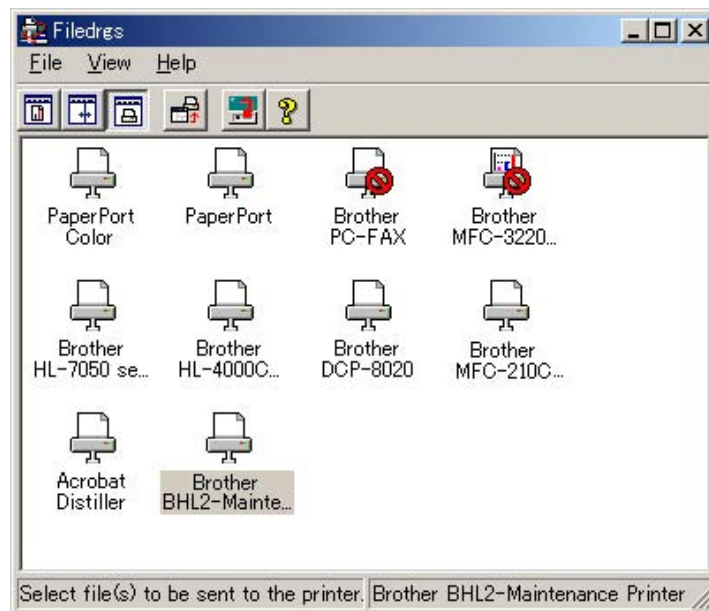

(2) Drag and drop the firmware (e.g., lz0023_a.pmu) onto the BHL2-Maintenance Printer icon in the Filedrgs window shown above.

NOTE: To use a firmware file, extract it beforehand by double-clicking. It is a self-extracting file having the extension .exe.

After approx. 2 to 5 minutes, the loading operation is complete and the machine automatically reboots and returns to the standby state.

(3) On the machine, check the version of the firmware installed, with the following steps.

Press the **▲** and **Stop/Exit** keys at the same time to display the firmware version on the LCD.

- Sample version number shown on the monochrome LCD: A0307252244:CF30

- Sample version number shown on the color LCD: 0A63061910:FE46
(The top line shows the version number.) P0601242005:4123
B0601242005:1C8D

If the displayed version number is identical with the firmware version you installed, the loading operation has been successfully finished.

NOTE: If loading operation ends abnormally, turn the machine off and on. Wait for the machine to automatically enter the firmware loading mode, and then perform the loading procedure above again.

Appendix 3. EEPROM Customizing Codes

This appendix provides instructions on how to set up the EEPROM customizing codes for the various preferences exclusively designed for each destination. The specified customizing code is stored in the EEPROM mounted on the main PCB. If the main PCB is replaced, therefore, you need to set up the proper customizing code with the machine in the maintenance mode.

NOTE: Customizing codes customize firmware for individual models, enabling the common firmware to be used for various models. A list of EEPROM customizing codes comes with the firmware data provided by Brother Industries.

Entering numerical codes

To enter numerical codes, press the ▲/▼ key several times to display the numerical code to be entered and then press the **OK** key. Repeat this operation for each numerical code.

EEPROM CUSTOMIZING CODES

This function allows you to customize the EEPROM according to language, function settings, and firmware switch settings.

Refer to the "EEPROM Customizing Codes List" on the next page.

■ Operating Procedure

- (1) Press the **Menu** and **Black Start (Mono Start)** keys. Next press the **▲** key four times to make the machine enter the maintenance mode.

The machine displays "■■ MAINTENANCE ■■■" on the LCD, indicating that it is placed in the initial stage of the maintenance mode, a mode in which the machine is ready to accept entry from the keys.

- (2) Start customizing the EEPROM (with Function code 74) as follows:

Enter 7 and 4 in the initial stage of the maintenance mode using the **▲/▼** and **OK** keys.

The current customizing code appears on the LCD.

- (3) Enter the desired customizing code using the **▲/▼** and **OK** keys.

Letters "A" through "F" can also be entered using the **▲/▼** and **OK** keys.

The newly entered code appears.

***NOTE:** If a wrong 4-digit code is entered, the machine will malfunction.*

- (4) Press the **Black Start (Mono Start)** key.

The machine saves the setting and returns to the initial stage of the maintenance mode.

If you press the **Stop/Exit** key or no keys are pressed for one minute in the above procedure, the machine stops the procedure and returns to the initial stage of the maintenance mode.

■ EEPROM Customizing Codes List

Destination	US	Canada	Brazil	UK	Germany	France	Italy	Spain
Country code	01	02	42	04	03	05	16	15
DCP130C	0002	0002	0015	0004	0004	0004	0015	0015
DCP330C	0002	0002	---	0004	0004	0004	0015	0115
DCP540CN	0002	0002	---	0004	0004	0004	0015	0115
DCP750CW	---	---	---	0004	0004	0004	0015	0115

Destination	Portugal	Switzerland	Netherlands	Belgium	Norway Sweden Finland Denmark	Austria	Ireland	Czech Hungary Poland Rumania Bulgaria Turkey
Country code	18	10	09	08	57	14	11	54
DCP130C	0015	0004	0004	0004	0007	0004	0004	0054
DCP330C	0115	0004	0004	0004	0007	0004	0004	0054
DCP540CN	0115	0004	0004	0004	0007	0004	0004	0054
DCP750CW	0115	0004	0004	0004	0007	---	0004	---

Destination	Russia	S. Africa	Singapore Gulf	Australia New Zealand	China
Country code	48	24	40	56	20
DCP130C	0048	0004	0004	0004	0020
DCP330C	0054	0004	0004	0004	0020
DCP540CN	0054	0004	0004	0004	0020
DCP750CW	---	---	---	---	---

The above information is as of March 30, 2006. The up-to-date information is available from your local Brother Customer Service.

Appendix 4. Firmware Switches (WSW)

This appendix describes the functions of the firmware switches, which can be divided into two groups: one is for customizing preferences designed for the shipping destination (as described in [Appendix 3](#)) and the other is for modifying preferences that match the machine to the environmental conditions. Use the latter group if the machine malfunctions due to mismatching.

NOTE: Each of the firmware switches has eight selectors. You should not allow end users to access all of those selectors, but you can allow them to access user-accessible selectors which are *shaded* in the firmware switch tables in this appendix.

NOTE: The firmware switch setting procedure is given in [Chapter 9, Section 9.4.5](#) (Function code 10).

WSW No.	Function	Refer to:
WSW01	Dial pulse setting <i>(Not used.)</i>	App. 4-3
WSW02	Tone signal setting <i>(Not used.)</i>	App. 4-4
WSW03	PBX mode setting <i>(Not used.)</i>	App. 4-5
WSW04	TRANSFER facility setting <i>(Not used.)</i>	App. 4-6
WSW05	1st dial tone and busy tone detection <i>(Not used.)</i>	App. 4-7
WSW06	Pause key setting and 2nd dial tone detection <i>(Not used.)</i>	App. 4-9
WSW07	Dial tone setting 1 <i>(Not used.)</i>	App. 4-11
WSW08	Dial tone setting 2 <i>(Not used.)</i>	App. 4-12
WSW09	Protocol definition 1 <i>(Not used.)</i>	App. 4-13
WSW10	Protocol definition 2 <i>(Not used.)</i>	App. 4-14
WSW11	Busy tone setting <i>(Not used.)</i>	App. 4-15
WSW12	Signal detection condition setting <i>(Not used.)</i>	App. 4-16
WSW13	Modem setting <i>(Not used.)</i>	App. 4-17
WSW14	AUTO ANS facility setting <i>(Not used.)</i>	App. 4-18
WSW15	REDIAL facility setting <i>(Not used.)</i>	App. 4-19
WSW16	Function setting 1	App. 4-20
WSW17	Function setting 2	App. 4-21
WSW18	Function setting 3 <i>(Not used.)</i>	App. 4-22
WSW19	Transmission speed setting <i>(Not used.)</i>	App. 4-23
WSW20	Overseas communications mode setting <i>(Not used.)</i>	App. 4-24
WSW21	TAD setting 1 <i>(Not used.)</i>	App. 4-25
WSW22	ECM and call waiting caller ID <i>(Not used.)</i>	App. 4-26
WSW23	Communications setting <i>(Not used.)</i>	App. 4-27
WSW24	TAD setting 2 <i>(Not used.)</i>	App. 4-28
WSW25	TAD setting 3 <i>(Not used.)</i>	App. 4-29
WSW26	Function setting 4 <i>(Not used.)</i>	App. 4-30
WSW27	Function setting 5 <i>(Not used.)</i>	App. 4-31
WSW28	Function setting 6 <i>(Not used.)</i>	App. 4-32
WSW29	Function setting 7 <i>(Not used.)</i>	App. 4-33
WSW30	Function setting 8 <i>(Not used.)</i>	App. 4-34
WSW31	Function setting 9 <i>(Not used.)</i>	App. 4-35
WSW32	Function setting 10	App. 4-36
WSW33	Function setting 11 <i>(Not used.)</i>	App. 4-37
WSW34	Function setting 12 <i>(Not used.)</i>	App. 4-38
WSW35	Function setting 13 <i>(Not used.)</i>	App. 4-39
WSW36	Function setting 14	App. 4-40
WSW37	Function setting 15	App. 4-41
WSW38	V.34 transmission settings <i>(Not used.)</i>	App. 4-42
WSW39	V.34 transmission speed <i>(Not used.)</i>	App. 4-43
WSW40	V.34 modem settings <i>(Not used.)</i>	App. 4-44
WSW41	ON-duration of the scanning light source	App. 4-46
WSW42	Internet mail settings <i>(Not used.)</i>	App. 4-47
WSW43	Function setting 21	App. 4-47
WSW44	Speeding up scanning-1 <i>(Not used.)</i>	App. 4-48
WSW45	Speeding up scanning-2	App. 4-49
WSW46	Monitor of power ON/OFF state and parallel port kept at high	App. 4-50

WSW47	Switching between high- and full-speed USB		App. 4-51
WSW48	USB setup latency		App. 4-52
WSW49	End-of-copying beep and black ink print mode		App. 4-53
WSW50	SDAA settings	<i>(Not used.)</i>	App. 4-54
WSW51	Function setting 16	<i>(Not used.)</i>	App. 4-55
WSW52	Function setting 17	<i>(Not used.)</i>	App. 4-56
WSW53	Function setting 18		App. 4-57
WSW54	Function setting 19		App. 4-58
WSW55	Function setting 20	<i>(Not used.)</i>	App. 4-59
WSW56	Function setting 21	<i>(Not used.)</i>	App. 4-59
WSW57	Function setting 22	<i>(Not used.)</i>	App. 4-60
WSW58	Function setting 23	<i>(Not used.)</i>	App. 4-61

WSW01 (Dial pulse setting) (Not used.)

Selector No.	Function	Setting and Specifications
1 2	Dial pulse generation mode	No. 1 2 0 0 : N 0 1 : N+1 1 0 : 10-N 1 1 : N
3 4	Break time length in pulse dialing	No. 3 4 0 0 : 60 ms 0 1 : 67 ms 1 0 : 40 ms (for 16 PPS) 1 1 : 64 ms (at 106-ms intervals)
5 6	Inter-digit pause	No. 5 6 0 0 : 800 ms 0 1 : 850 ms 1 0 : 950 ms 1 1 : 600 ms
7	Switching between pulse (DP) and tone (PB) dialing, by the function switch	0: Yes 1: No
8	Default dialing mode, pulse (DP) or tone (PB) dialing	0: PB 1: DP

ms: millisecond(s)

● **Selectors 1 and 2: Dial pulse generation mode**

These selectors set the number of pulses to be generated in pulse dialing.

N: Dialing "N" generates "N" pulses. (Dialing "0" generates 10 pulses.)

N + 1: Dialing "N" generates "N + 1" pulses.

10 - N: Dialing "N" generates "10 - N" pulses.

● **Selectors 3 and 4: Break time length in pulse dialing**

These selectors set the break time length in pulse dialing.

(Example: If "1," "2," and "3" are dialed when N is set by selectors 1 and 2.)

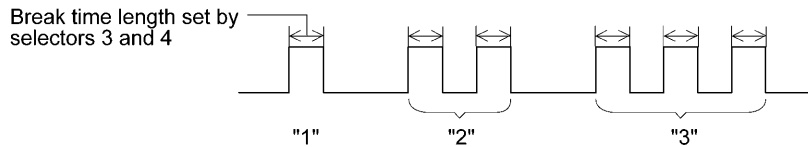

● **Selectors 5 and 6: Inter-digit pause**

These selectors set the inter-digit pause in pulse dialing.

(Example: If "1," "2," and "3" are dialed when N is set by selectors 1 and 2.)

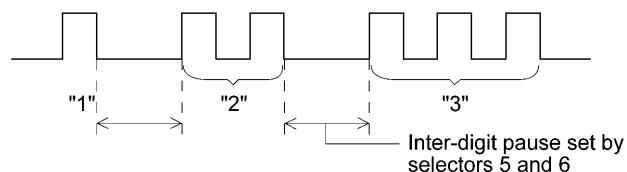

- **Selector 7: Switching between pulse (DP) and tone (PB) dialing, by the function switch**

This selector determines whether or not the dialing mode can be switched between the pulse (DP) and tone (PB) dialing by using the function switch.

- **Selector 8: Default dialing mode, pulse (DP) or tone (PB) dialing**

This selector sets the default dialing mode (pulse dialing or tone dialing) which can be changed by the function switch. If the user switches it with the function switch when selector 7 is set to "0," the setting specified by this selector will also be switched automatically.

WSW02 (Tone signal setting) (Not used.)

Selector No.	Function	Setting and Specifications
1 2	Tone signal transmission time length	No. 1 2 0 0 : 70 ms 0 1 : 80 ms 1 0 : 90 ms 1 1 : 100 ms
3 4	Min. pause in tone dialing	No. 3 4 0 0 : 70 ms 0 1 : 80 ms 1 0 : 90 ms 1 1 : 140 ms
5 8	Attenuator for pseudo ring backtone to the line (selectable in the range of 0-15 dB, in 1 dB increments)	0: 0 dB 1: 8 dB 0: 0 dB 1: 4 dB 0: 0 dB 1: 2 dB 0: 0 dB 1: 1 dB

ms: millisecond(s)

- **Selectors 1 through 4: Tone signal transmission time length and Min. pause in tone dialing**

These selectors set the tone signal transmission time length and minimum pause in tone dialing. (Example: If "1," "2," "3," "4," and "5" are dialed.)

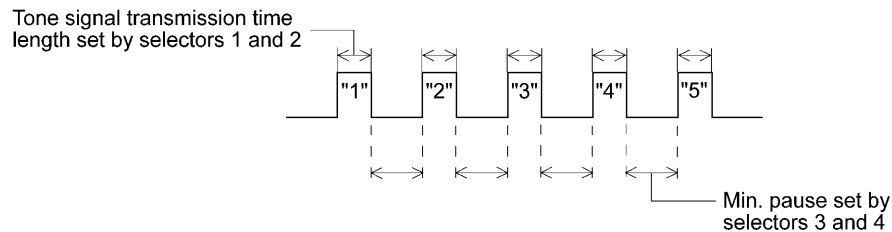

- **Selectors 5 through 8: Attenuator for pseudo ring backtone to the line**

These selectors are used to adjust the sound volume of a ring backtone in the F/T mode, an on-hold sound, or a beep generated as a signal during remote control operation or at the start of ICM recording.

The larger the value specified by these selectors, the greater the attenuation.

WSW03 (PBX* mode setting) (Not used.)

Selector No.	Function	Setting and Specifications
1	CNG detection when sharing a modular wall socket with a telephone	0: A 1: B
2 4	Detection time length of PBX* dial tone, required for starting dialing	No. 2 3 4 0 0 0 : 50 ms 0 0 1 : 210 ms 0 1 0 : 500 ms 0 1 1 : 800 ms 1 0 0 : 900 ms 1 0 1 : 1.5 sec. 1 1 0 : 2.0 sec. 1 1 1 : 2.5 sec.
5	CNG detection when sharing a modular wall socket with a telephone	0: A 1: B
6 7	Dial tone detection in PBX*	No. 6 7 0 0 : No detection (3.5 sec. WAIT) 0 1 : No detection (5 sec. WAIT) 1 0 : No detection (7 sec. WAIT) 1 1 : Detection (Frequency only)
8	Not used.	

sec.: second(s), ms: millisecond(s)
* PBX: Private branch exchange

NOTE: Selectors 2 through 4, 6 and 7 are not applicable where no PBX is installed.

• **Selectors 1 and 5: CNG detection when sharing a modular wall socket with a telephone**

These selectors determine whether or not the machine detects a CNG signal when a line is connected to a telephone sharing a modular wall socket with the machine. Upon detection of CNG signals by the number of cycles specified by these selectors, the machine interprets CNG as an effective signal and then starts FAX reception.

Selector		Cycle
No. 1	No. 5	
0 (A)	0 (A)	0.5 cycle
0 (A)	1 (B)	1.0 cycle
1 (B)	0 (A)	1.5 cycles
1 (B)	1 (B)	2.0 cycles

• **Selectors 2 through 4: Detection time length of PBX dial tone, required for starting dialing**

Upon detection of the PBX dial tone for the time length set by these selectors, the machine starts dialing.

These selectors are effective only when both selectors 6 and 7 are set to "1" (Detection).

● **Selectors 6 and 7: Dial tone detection in PBX**

These selectors activate or deactivate the dial tone detection function which detects a dial tone when a line is connected to the PBX.

Setting both of these selectors to "1" activates the dial tone detection function so that the machine starts dialing upon detection of a dial tone when a line is connected.

Other setting combinations deactivate the dial tone detection function so that the machine starts dialing after the specified WAIT (3.5, 5.0, or 7.0 seconds) without detection of a dial tone when a line is connected.

WSW04 (TRANSFER facility setting) (Not used.)

Selector No.	Function	Setting and Specifications
1	Earth function in transfer facility	0: Provided 1: Not provided
2 3	Dual tone detection frequency in ICM recording	No. 2 3 0 0 : 350 and 440 Hz (A) 0 1 : 440 and 480 Hz (B) 1 0 : } 1 1 : } 480 and 620 Hz (C)
4	Dual tone detection sensitivity in ICM recording	0: Normal 1: High
5	Time to be added to the setting specified by selectors 3 and 4 of WSW24 (Time length from CML ON to start of pseudo ring backtone transmission)	0: Not added 1: +4 seconds added
6 8	Break time length for flash function	No. 6 7 8 No. 6 7 8 0 0 0 : 80 ms 1 0 1 : 250 ms 0 0 1 : 100 ms 1 1 0 : 500 ms 0 1 0 : 110 ms 1 1 1 : 700 ms 0 1 1 : 120 ms 1 0 0 : 200 ms

ms: millisecond(s)

NOTE: Selectors 1 and 5 through 8 are not applicable in those countries where no transfer facility is supported.

NOTE: Selectors 2 through 4 are applicable to models with built-in TAD.

- **Selector 1: Earth function in transfer facility**

This selector determines whether or not the earth function is added to the transfer setting menu to be accessed by the function switch.

- **Selectors 2 and 3: Dual tone detection frequency in ICM recording**

If the machine detects either of the frequencies set by these selectors in ICM recording, it disconnects the line. For example, if these selectors are set to “0, 0,” the machine disconnects the line upon detection of 350 or 440 Hz.

- **Selector 4: Dual tone detection sensitivity in ICM recording**

Setting this selector to "1" increases the tone detection sensitivity in ICM recording.

- **Selectors 6 through 8: Break time length for flash function**

These selectors set the break time length.

This setting is effective only when the flash function is selected for the Speed Dial key by using the function switch.

WSW05 (1st dial tone and busy tone detection) (Not used.)

Selector No.	Function	Setting and Specifications
1 3	1st dial tone detection	No. 1 2 3 0 0 0 : 3.5 sec. WAIT 0 0 1 : 7.0 sec. WAIT 0 1 0 : 10.5 sec. WAIT 0 1 1 : 14.0 sec. WAIT 1 0 0 : 17.5 sec. WAIT 1 0 1 : 21.0 sec. WAIT 1 1 0 : 2.5 sec. WAIT 1 1 1 : Detection (Without WAIT)
4	Max. pause time allowable for remote ID code detection	0 : 2 seconds 1: 1 second
5 6	Busy tone detection in auto- matic sending mode	No. 5 6 0 0 : No detection 0 1 : Detection only after dialing 1 0 : No detection 1 1 : Detection before and after dialing
7	Busy tone detection in auto- matic receiving mode	0: Yes 1: No
8	Not used.	

sec.: second(s)

NOTE: Selectors 5 through 7 are not applicable in those countries where no busy tone detection is supported.

- **Selectors 1 through 3: 1st dial tone detection**

These selectors activate or deactivate the 1st dial tone detection function which detects the 1st dial tone issued from the PSTN when a line is connected to the PSTN.

Setting all of these selectors to "1" activates the dial tone detection function so that the machine starts dialing upon detection of a dial tone when a line is connected. (However, in those countries which support no dial tone detection function, e.g., in the U.S.A., setting these selectors to "1" makes the machine start dialing after a WAIT of 3.5 seconds.) For the detecting conditions of the 1st dial tone, refer to WSW07 and WSW08.

Other setting combinations deactivate the dial tone detection function so that the machine starts dialing after the specified WAIT (2.5, 7.0, 10.5, 14.0, 17.5, or 21.0 seconds) without detection of a dial tone when a line is connected to the PSTN.

- **Selector 4: Max. pause time allowable for remote ID code detection**

This selector sets the maximum pause time allowable for detecting the second digit of a remote ID code after detection of the first digit in remote reception.

If selector 4 is set to "0" (2 seconds), for instance, only a remote ID code whose second digit is detected within 2 seconds after detection of the first digit will become effective so as to activate the remote function.

- **Selectors 5 and 6: Busy tone detection in automatic sending mode**

These selectors determine whether or not the machine automatically disconnects a line upon detection of a busy tone in automatic sending mode.

Setting selector 6 to "0" ignores a busy tone so that the machine does not disconnect the line.

Setting selectors 5 and 6 to "0" and "1," respectively, makes the machine detect a busy tone only after dialing and disconnect the line.

Setting both of selectors 5 and 6 to "1" makes the machine detect a busy tone before and after dialing and then disconnect the line.

- **Selector 7: Busy tone detection in automatic receiving mode**

This selector determines whether or not the machine automatically disconnects the line upon detection of a busy tone in automatic receiving mode.

WSW06 (Pause key setting and 2nd dial tone detection) (Not used.)

Selector No.	Function	Setting and Specifications
1 3	Pause key setting and 2nd dial tone detection	No.1 2 3 0 0 0 : No pause 0 0 1 : 3.5 sec. WAIT 0 1 0 : 7 sec. WAIT 0 1 1 : 10.5 sec. WAIT 1 0 0 : 2.5 sec. WAIT 1 1 0 : 2nd dial tone detection only in pulse dialing (DP) system 1 0 1 : } 2nd dial tone detection 1 1 1 : } both in DP and push-button (PB) dialing system
4 6	Detection of international tone	No.4 5 6 0 0 0 : 50 ms 0 0 1 : 250 ms 0 1 0 : 500 ms 0 1 1 : 620 ms 1 0 0 : 800 ms 1 0 1 : 1.5 sec. 1 1 0 : 2.0 sec. 1 1 1 : 2.5 sec.
7	No. of 2nd dial tone detection cycles	0: 1 cycle 1: 2 cycles
8	Allowable instantaneous interrupt during reception of 2nd dial tone	0: 30 ms 1: 50 ms

sec.: second(s), ms: millisecond(s)

NOTE: Selectors 4 through 8 are not applicable in those countries where no dial tone detection is supported, e.g., U.S.A.

- **Selectors 1 through 3: Pause key setting and 2nd dial tone detection**

Selectors			
1	2	3	
0	0	0	No WAIT is inserted even if the Pause key is pressed.
0	0	1	If you press the Pause key during dialing, the machine will insert WAIT as defined in the above table. If the Pause key is pressed repeatedly, the machine inserts the specified WAIT multiplied by the number of depressions. It applies also in hook-up dialing.
0	1	0	
0	1	1	
1	0	0	
1	0	1	When these selectors are set to "1, 0, 1": Each time you press the Pause key in dialing, the machine will wait for the 2nd dial tone to be sent via the communications line regardless of pulse dialing or tone dialing. When these selectors are set to "1, 1, 0": If you press the Pause key in pulse dialing, the machine will first wait for the 2nd dial tone to be sent via the communications line. After that, pressing the Pause key will cause the machine to insert a WAIT of 3.5 seconds. In tone dialing, the machine will insert a WAIT of 3.5 seconds. When these selectors are set to "1, 1, 1": If you press the Pause key, the machine will first wait for the 2nd dial tone to be sent via the communications line regardless of pulse dialing or tone dialing. After that, pressing the Pause key will cause the machine to insert a WAIT of 3.5 seconds. (In those countries where no dial tone detection function is supported, setting these selectors to "1, 0, 1," "1, 1, 0," or "1, 1, 1" inserts a WAIT of 3.5 seconds.)
1	1	0	
1	1	1	

- **Selectors 4 through 6: Detection of international tone**

Upon detection of the 2nd dial tone for the time length specified by these selectors, the machine starts dialing.

This setting is effective only when the 2nd dial tone detection function is activated by selectors 1 through 3 (Setting 101, 110, or 111).

This function does not apply in those countries where no dial tone detection function is supported.

- **Selector 7: No. of 2nd dial tone detection cycles**

This selector sets the number of dial tone detection cycles required for starting dialing.

- **Selector 8: Allowable instantaneous interrupt during reception of 2nd dial tone**

This selector sets the allowable instantaneous interrupt period that should be ignored during reception of the 2nd dial tone.

WSW07 (Dial tone setting 1) (Not used.)

Selector No.	Function	Setting and Specifications
1 2	Dial tone frequency band control	No. 1 2 0 0 : Narrows by 10 Hz 0 1 : Initial value 1 0 : Widens by 10 Hz 1 1 : Widens by 10 Hz
3	Line current detection	0: No 1: Yes
4 6	2nd dial tone detection level (Z = 600Ω)	No. 4 5 6 0 0 0 : -21 dBm 0 0 1 : -24 dBm 0 1 0 : -27 dBm 0 1 1 : -30 dBm 1 0 0 : -33 dBm 1 0 1 : -36 dBm 1 1 0 : -39 dBm 1 1 1 : -42 dBm
7	Allowable instantaneous interrupt during reception of 1st dial tone	0: 30 ms 1: 50 ms
8	Not used.	

ms: millisecond(s)

NOTE: Selectors 1, 2, 4 through 7 are not applicable in those countries where no dial tone or line current detection is supported, e.g., U.S.A.

NOTE: Selector 3 is not applicable to those models having no loop current detection function.

- **Selectors 1 and 2: Dial tone frequency band control**

These selectors set the frequency band for the 1st dial tone and busy tone (before dialing) to be detected.

This setting is effective only when selectors 1 through 3 of WSW05 are set to "1,1,1."

- **Selector 3: Line current detection**

This selector determines whether or not to detect a line current before starting dialing.

- **Selectors 4 through 6: 2nd dial tone detection level**

These selectors set the detection level of the 2nd dial tone.

- **Selector 7: Allowable instantaneous interrupt during reception of 1st dial tone**

This selector sets the allowable instantaneous interrupt period that should be ignored during reception of the 1st dial tone.

WSW08 (Dial tone setting 2) (Not used.)

Selector No.	Function	Setting and Specifications
1 3	1st dial tone detection time length	No. 1 2 3 0 0 0 : 50 ms 0 0 1 : 250 ms 0 1 0 : 500 ms 0 1 1 : 620 ms 1 0 0 : 800 ms 1 0 1 : 1.5 sec. 1 1 0 : 2.0 sec. 1 1 1 : 2.5 sec.
4 5	Time-out length for 1st and 2nd dial tone detection	No. 4 5 0 0 : 10 sec. 0 1 : 20 sec. 1 0 : 15 sec. 1 1 : 30 sec.
6 8	Detection level of 1st dial tone and busy tone before dialing	No. 6 7 8 0 0 0 : -21 dBm 0 0 1 : -24 dBm 0 1 0 : -27 dBm 0 1 1 : -30 dBm 1 0 0 : -33 dBm 1 0 1 : -36 dBm 1 1 0 : -39 dBm 1 1 1 : -42 dBm

sec.: second(s), ms: millisecond(s)

NOTE: The WSW08 is not applicable in those countries where no dial tone detection is supported, e.g., U.S.A.

- **Selectors 1 through 3: 1st dial tone detection time length**

Upon detection of the 1st dial tone for the time length set by these selectors, the machine starts dialing.

This setting is effective only when selectors 1 through 3 of WSW05 are set to "1,1,1."

- **Selectors 4 and 5: Time-out length for 1st and 2nd dial tone detection**

These selectors set the time-out length for the 1st and 2nd dial tone detection so that the machine waits dial tone input for the specified time length and disconnects itself from the line when no dial tone is inputted.

WSW09 (Protocol definition 1) (Not used.)

Selector No.	Function	Setting and Specifications
1	Frame length selection	0: 256 octets 1: 64 octets
2	Use of non-standard commands	0: Allowed 1: Prohibited
3 4	No. of retries	No. 3 4
		0 0 : 4 times
		0 1 : 3 times
		1 0 : 2 times
		1 1 : 1 time
5	T5 timer	0: 300 sec. 1: 60 sec.
6	T1 timer	0: 35 sec. 1: 40 sec.
7 8	Timeout for response from the called station in automatic sending mode	No. 7 8
		0 0 : { 55 sec. (in U.S.A. and Canadian models) 60 sec. (in other models)
		0 1 : 140 sec.
		1 0 : 90 sec.
		1 1 : 35 sec.

sec.: second(s)

NOTE: Selectors 1 through 5 are not applicable in those models which do not support ECM.

- **Selector 1: Frame length selection**

Usually a single frame consists of 256 octets (1 octet = 8 bits). For communications lines with higher bit error rate, however, set selector 1 to "1" so that the machine can divide a message into 64-octet frames.

Remarks: The error correction mode (ECM) is a facsimile transmission manner in which the machine divides a message into frames for transmission so that if any data error occurs on the transmission line, the machine retransmits only those frames containing the error data.

- **Selector 2: Use of non-standard commands**

If this selector is set to "0," the machine can use non-standard commands (the machine's native-mode commands, e.g., NSF, NSC, and NSS) for communications. If it is set to "1," the machine will use standard commands only.

- **Selectors 3 and 4: No. of retries**

These selectors set the number of retries in each specified modem transmission speed.

- **Selector 5: T5 timer**

This selector sets the time length for the T5 timer.

- **Selector 6: T1 timer**

This selector sets the time length for the T1 timer.

- **Selectors 7 and 8: Timeout for response from the called station in automatic sending mode**

If the machine (calling station) receives no response (no G3 command) from the called terminal in automatic sending mode for the period specified by these selectors, it disconnects the line.

WSW10 (Protocol definition 2) (Not used.)

Selector No.	Function	Setting and Specifications
1	Not used.	
2	Time length from transmission of the last dial digit to CML ON	0: 100 ms 1: 50 ms
3	Time length from CML ON to CNG transmission	0: 2 sec. 1: 4 sec.
4	Time length from CML ON to CED transmission (except for facsimile-to-telephone switching)	0: 0.5 sec. 1: 2 sec.
5 6	No. of training retries	No. 5 6 0 0 : 1 time 0 1 : 2 times 1 0 : 3 times 1 1 : 4 times
7	Encoding system (Compression)	MR 0: Allowed 1: Not allowed
8		MMR 0: Allowed 1: Not allowed

sec.: second(s), ms: millisecond(s)

- **Selector 2: Time length from transmission of the last dial digit to CML ON**
This selector sets the time length from when the machine transmits the last dial digit until the CML relay comes on.
- **Selector 3: Time length from CML ON to CNG transmission**
This selector sets the time length until the machine transmits a CNG after it turns on the CML relay.
- **Selector 4: Time length from CML ON to CED transmission**
This selector sets the time length until the machine transmits a CED after it turns on the CML relay. This setting does not apply to switching between facsimile and telephone.
- **Selectors 5 and 6: No. of training retries**
These selectors set the number of training retries to be repeated before automatic fallback.
- **Selectors 7 and 8: Encoding system (Compression)**
This selector determines whether or not to allow the use of the MR/MMR coding system.

WSW11 (Busy tone setting) (Not used.)

Selector No.	Function	Setting and Specifications
1 2	Busy tone frequency band control	No. 1 2 0 0 : Narrows by 10 Hz 0 1 : Initial value 1 0 : Widens by 10 Hz 1 1 : Widens by 10 Hz
3	ON/OFF time length ranges for busy tone (More than one setting allowed)	1: 250-750/250-750 ms
4		1: 400-600/400-600 ms
5		1: 175-440/175-440 ms
6		1: 100-1000 ms/17-660 ms
7		1: 110-410/320-550 ms
8		1: 100-660/100-660 ms

ms: millisecond(s)

NOTE: WSW11 is not applicable in those countries where no busy tone detection is supported.

NOTE: The setting of WSW11 is effective only when selectors 5 and 6 of WSW05 are set to "0, 1" or "1, 1" (Busy tone detection).

- **Selectors 1 and 2: Busy tone frequency band control**

These selectors set the frequency band for busy tone to be detected.

- **Selectors 3 through 8: ON/OFF time length ranges for busy tone**

These selectors set the ON and OFF time length ranges for busy tone to be detected. If more than one selector is set to "1," the ranges become wider. For example, if selectors 4 and 5 are set to "1," the ON and OFF time length ranges are from 175 to 600 milliseconds.

WSW12 (Signal detection condition setting) (Not used.)

Selector No.	Function	Setting and Specifications
1 2	Min. detection period required for interpreting incoming calling signal (CI) as OFF	No. 1 2 0 0 : 1500 ms 0 1 : 500 ms 1 0 : 700 ms 1 1 : 900 ms
3 4	Max. detection period for incoming calling signal (CI) being OFF	No. 3 4 0 0 : 6 sec. 0 1 : 7 sec. 1 0 : 9 sec. 1 1 : 11 sec.
5 6	Min. detection period required for acknowledging incoming calling signal (CI) as ON	No. 5 6 0 0 : 800 ms (1000 ms*) 0 1 : 200 ms 1 0 : 250 ms 1 1 : 150 ms
7	Line connection timing	0: Ringer-OFF period (default) 1: Ringer-ON period
8	Not used.	

sec.: second(s), ms: millisecond(s)
*1000 milliseconds in Chinese models.

- **Selectors 1 through 4: Min. detection period required for interpreting incoming calling signal (CI) as OFF**
Max. detection period for incoming calling signal (CI) being OFF

If the machine detects the OFF state of a CI signal for the period greater than the value set by selectors 1 and 2 and less than the value set by selectors 3 and 4, it interprets the CI signal as OFF.

- **Selectors 5 and 6: Min. detection period required for acknowledging incoming calling signal (CI) as ON**

These selectors set the period required to make the machine acknowledge itself to be called. That is, if the machine continuously detects a CI signal with the frequency set by selectors 1 through 4 of WSW14 during the period set by these selectors 5 and 6, then it acknowledges the call.

- **Selector 7: Line connection timing**

If a line is connected in a ringer-ON period, FAX models equipped with SDAA circuits may malfunction due to the ringer voltage. To make the line connection stable, this selector should be set to "0" so that a line is connected in a ringer-OFF period.

WSW13 (Modem setting) (Not used.)

Selector No.	Function	Setting and Specifications
1 2	Cable equalizer	No. 1 2 0 0 : 0 km 0 1 : 1.8 km 1 0 : 3.6 km 1 1 : 5.6 km
3 4	Reception level	No. 3 4 0 0 : -43 dBm 0 1 : -47 dBm 1 0 : -49 dBm 1 1 : -51 dBm
5 8	Modem attenuator	0: 0 dB 1: 8 dB 0: 0 dB 1: 4 dB 0: 0 dB 1: 2 dB 0: 0 dB 1: 1 dB

The modem should be adjusted according to the user's line conditions.

- **Selectors 1 and 2: Cable equalizer**

These selectors are used to improve the pass-band characteristics of analogue signals on a line. (Attenuation in the high-band frequency is greater than in the low-band frequency.)

Set these selectors according to the distance from the telephone switchboard to the machine.

- **Selectors 3 and 4: Reception level**

These selectors set the optimum receive signal level.

- **Selectors 5 through 8: Modem attenuator**

These selectors are used to adjust the transmitting level attenuation of the modem when the reception level at the remote station is improper due to line loss. This function applies for G3 protocol signals.

Setting two or more selectors to "1" produces addition of attenuation assigned to each selector.

If selector 8 of WSW23 is set to "0," this setting is so limited that 10 dB (1 dB in France) or higher setting only is effective. Note that in Japan and China, 9 dB or higher and 2 dB or higher settings only are effective, respectively, regardless of whether selector 8 of WSW23 is set to "0."

WSW14 (AUTO ANS facility setting) (Not used.)

Selector No.	Function	Setting and Specifications
1 2	Frequency band selection (lower limit) for incoming calling signal (CI)	No. 1 2 0 0 : 13 Hz 0 1 : 15 Hz 1 0 : 23 Hz 1 1 : 20 Hz
3 4	Frequency band selection (upper limit) for incoming calling signal (CI)	No. 3 4 0 0 : 30 Hz 0 1 : 55 Hz 1 0 : 70 Hz 1 1 : 200 Hz
5 8	No. of rings in AUTO ANS mode	No. 5 6 7 8 0 0 0 0 : Fixed to once 0 0 0 1 : 1 to 6 times 0 0 1 0 : 1 to 8 times 0 0 1 1 : 2 to 8 times 0 1 0 0 : 1 to 2 times 0 1 0 1 : 1 to 3 times 0 1 1 0 : 1 to 4 times 0 1 1 1 : 1 to 5 times 1 0 0 0 : 2 to 3 times 1 0 0 1 : 2 to 4 times 1 0 1 0 : 2 to 5 times 1 0 1 1 : 2 to 6 times 1 1 0 0 : 1 to 10 times 1 1 0 1 : 2 to 10 times 1 1 1 0 : 3 to 5 times 1 1 1 1 : 4 to 10 times

- **Selectors 1 through 4: Frequency band selection for incoming calling signal (CI)**

These selectors are used to select the frequency band of CI for activating the AUTO ANS facility.

In the French models, if the user sets the PBX to OFF from the control panel, the setting made by selectors 1 and 2 will take no effect and the frequency's lower limit will be fixed to 32 Hz. (Even if the setting made by these selectors does not apply, it will be printed on the configuration list.)

- **Selectors 5 through 8: No. of rings in AUTO ANS mode**

These selectors set the number of rings to initiate the AUTO ANS facility.

WSW15 (REDIAL facility setting) (Not used.)

Selector No.	Function	Setting and Specifications
1 2	Redial interval	No. 1 2 0 0 : 5 minutes 0 1 : 1 minute 1 0 : 2 minutes 1 1 : 3 minutes
3 6	No. of redialings	No. 3 4 5 6 0 0 0 0 : 16 times 0 0 0 1 : 1 times 0 0 1 0 : 2 times 0 0 1 1 : 3 times 1 1 1 1 : 15 times
7	Not used.	
8	CRP option	0: Disable 1: Enable

- **Selectors 1 through 6: Redial interval and No. of redialings**

The machine redials by the number of times set by selectors 3 through 6 at intervals set by selectors 1 and 2.

- **Selector 8: CRP option**

If a command error occurs in the machine (calling station), the machine usually waits for three seconds and then makes a retry three times. This CRP option is a request command that can be sent from the called station for requesting the calling station to retry the failed command immediately.

WSW16 (Function setting 1)

Selector No.	Function	Setting and Specifications
1	Not used.	
2	ITU-T (CCITT) superfine recommendation	0: OFF 1: ON
3 6	Not used.	
7	Max. document length limitation	0: 400 cm 1: 90 cm
8	Stop key pressed during reception (<i>Not used.</i>)	0: Not functional 1: Functional

NOTE: Selector 7 is applicable to models with ADF unit.

- **Selector 2: ITU-T (CCITT) superfine recommendation**

If this selector is set to "1," the machine communicates in ITU-T (CCITT) recommended superfine mode (15.4 lines/mm). If it is set to "0," it communicates in native superfine mode.

- **Selector 7: Max. document length limitation**

This selector is used to select the maximum length of a document to be sent.

- **Selector 8: Stop key pressed during reception (*Not used.*)**

If this selector is set to "1," pressing the **Stop** key can stop the current receiving operation. The received data will be lost.

WSW17 (Function setting 2)

Selector No.	Function	Setting and Specifications
1 2	Off-hook alarm (<i>Not used.</i>)	No. 1 2 0 0 : No alarm 0 1 : Always valid 1 0 : } Valid except when 1 1 : } 'call reservation' is selected.
3 4	Not used.	
5	Calendar clock type	0: U.S.A. type 1: European type
6	Not used.	
7	Non-ring reception (<i>Not used.</i>)	0: OFF 1: ON
8	Not used.	

- **Selectors 1 and 2: Off-hook alarm** (*Not used.*)

These selectors activate or deactivate the alarm function which sounds an alarm when the communication is completed with the handset being off the hook.

- **Selector 5: Calendar clock type**

If this selector is set to "0" (USA), the MM/DD/YY hh:mm format applies; if it is set to "1" (Europe), the DD/MM/YY hh:mm format applies: DD is the day, MM is the month, YY is the last two digits of the year, hh is the hour, and mm is the minute.

- **Selector 7: Non-ring reception** (*Not used.*)

Setting this selector to "1" makes the machine receive calls without ringer sound if the Ring Delay is set to 0.

WSW18 (Function setting 3) (Not used.)

Selector No.	Function	Setting and Specifications
1	Not used.	
2 3	Detection enabled time for CNG or no tone	No. 2 3 0 0 : 40 sec. 0 1 : 0 sec. (No detection) 1 0 : 5 sec. 1 1 : 80 sec.
4 5	Not used.	
6	Registration of station ID	0: Permitted 1: Prohibited
7 8	Tone sound monitoring	No. 7 8 0 0 : No monitoring 0 1 : No monitoring 1 0 : Up to phase B at the calling station only 1 1 : All transmission phases both at the calling and called stations

sec.: second(s)

- **Selectors 2 and 3: Detection enabled time for CNG or no tone**

After the line is connected via the external telephone or by picking up the handset of the machine, the machine can detect a CNG signal or no tone for the time length specified by these selectors. The setting specified by these selectors becomes effective only when selector 8 of WSW20 is set to "1."

- **Selector 6: Registration of station ID**

Setting this selector to "0" permits the registration of station ID for Austrian and Czech models.

- **Selectors 7 and 8: Tone sound monitoring**

These selectors set monitoring specifications of the tone sound inputted from the line.

WSW19 (Transmission speed setting) (Not used.)

Selector No.	Function	Setting and Specifications
1 3	First transmission speed choice for fallback	No. 1 2 3 No. 4 5 6 0 0 0 : 2,400 bps 0 0 1 : 4,800 bps 0 1 0 : 7,200 bps 0 1 1 : 9,600 bps 1 0 0 : 12,000 bps 1 0 1 : } 1 1 0 : } 14,400 bps 1 1 1 : }
4 6	Last transmission speed choice for fallback	
7	V.34 mode	0: Permitted 1: Prohibited
8	V.17 mode	0: Permitted 1: Prohibited

NOTE: Selector 7 takes effect only in models supporting V.34 mode.

- **Selectors 1 through 6: First and last choices of transmission speed for fallback**

These selectors are used to set the MODEM speed range. With the first transmission speed choice specified by selectors 1 through 3, the machine attempts to establish the transmission link via the MODEM. If the establishment fails, the machine automatically steps down to the next lowest speed and attempts to establish the transmission link again. The machine repeats this sequence while stepping down the transmission speed to the last choice specified by selectors 4 through 6.

If the MODEM always falls back to a low transmission speed (e.g., 4,800 bps), set the first transmission speed choice to the lower one (e.g., modify it from 12,000 bps to 7,200 bps) in order to deactivate the high-speed MODEM function and reduce the training time for shorter transmission time.

Generally, to save the transmission time, set the last transmission speed choice to a higher one.

- **Selector 7: V.34 mode**

Permitting the V.34 mode with this selector makes WSW38 to WSW40, and WSW41 (selectors 5 to 8) effective.

WSW20 (Overseas communications mode setting) (Not used.)

Selector No.	Function	Setting and Specifications
1	EP* tone prefix	0: OFF 1: ON
2	Overseas communications mode (Reception)	0: 2100 Hz 1: 1100 Hz
3	Overseas communications mode (Transmission)	0: OFF 1: Ignores DIS once.
4 5	Min. time length from reception of CFR to start of transmission of video signals	No. 4 5 0 0 : 100 ms 0 1 : 200 ms 1 0 : 300 ms 1 1 : 400 ms
6 7	At CNG detection, elimination of chattering noise	No. 6 7 0 0 : Yes, at both ON/OFF timings 0 1 : Yes, at OFF timing 1 0 : No 1 1 : No
8	Limitation on CNG detection	0: OFF 1: ON

ms: millisecond(s)

* EP: Echo protection

NOTE: Selectors 6 and 7 are applicable to models equipped with an SDAA circuit.

● **Selector 1: EP tone prefix**

Setting this selector to "1" makes the machine transmit a 1700 Hz echo protection (EP) tone immediately preceding training in V.29 modulation system to prevent omission of training signals.

Prefixing an EP tone is useful when the machine fails to transmit at the V.29 modem speed and always has to fall back to 4,800 bps transmission.

The setting made by this selector takes effect only when the Overseas Mode is set to ON.

● **Selectors 2 and 3: Overseas communications mode**

These selectors should be used if the machine malfunctions in overseas communications. According to the communications error state, select the signal specifications.

Setting selector 2 to "1" allows the machine to use 1100 Hz CED signal instead of 2100 Hz in receiving operation. This prevents malfunctions resulting from echoes, since the 1100 Hz signal does not disable the echo suppressor (ES) while the 2100 Hz signal does.

Setting selector 3 to "1" allows the machine to ignore a DIS signal sent from the called station once in sending operation. This operation suppresses echoes since the first DIS signal immediately follows a 2100 Hz CED (which disables the ES) so that it is likely to be affected by echoes in the disabled ES state. However, such a disabled ES state will be removed soon so that the second and the following DIS signals are not susceptible to data distortion due to echoes. Note that some models when called may cause error by receiving a self-outputted DIS.

The setting made by selector 3 takes effect only when the Overseas Communications Mode is set to ON. (The setting made by selector 2 is always effective.)

- **Selectors 8: Limitation on CNG detection**

If this selector is set to "1," the machine detects a CNG signal according to the condition preset by selectors 2 and 3 of WSW18 after a line is connected. If it is set to "0," the machine detects a CNG signal as long as the line is connected.

WSW21 (TAD setting 1) (Not used.)

Selector No.	Function	Setting and Specifications
1 5	"No tone" detection period during recording of ICM (Max. waiting time for voice signal)	No. 1 2 3 4 5 0 0 0 0 0 : No detection 0 0 0 0 1 : 1 sec. 0 0 0 1 0 : 2 sec. 0 0 0 1 1 : 3 sec. 0 0 1 1 0 : 6 sec. (default) 1 1 1 1 1 : 31 sec.
6 7	Taping the call	No. 6 7 0 0 : Enable (signaling for U.S.A.) (A) 0 1 : Enable (signaling for countries except U.S.A.) (B) 1 0 : Enable (without signaling) (C) 1 1 : Disable (D)
8	Erasure of message stored in the memory after the message transfer	0: Yes 1: No

sec.: second(s)

NOTE: Selectors 1 through 5 are applicable to models equipped with ICM recorder.

NOTE: Selectors 6 through 8 are applicable to models with a built-in TAD.

- **Selectors 1 through 5: "No tone" detection period during recording of ICM (Max. waiting time for voice signal)**

If the machine detects "no tone"* during recording of ICM for the time length specified by these selectors, it automatically stops recording ICM and disconnects the line. (*Tone whose level is less than the threshold specified by selectors 1 through 3 on WSW33 is interpreted as "no tone.")

- **Selectors 6 and 7: Taping the call**

These selectors select whether or not to tape the call. Setting them to "1, 0" enables taping the call without signaling to the calling station that the call is being taped.

- **Selector 8: Erasure of message stored in the memory after the message transfer**

Setting this selector to "0" will erase the message recorded in the memory after the document retrieval feature transfers the message.

WSW22 (ECM and call waiting caller ID) (Not used.)

Selector No.	Function	Setting and Specifications	
1	ECM* in sending	0: ON	1: OFF
2	ECM* in receiving	0: ON	1: OFF
3	Call Waiting Caller ID	0: ON	1: OFF
4	Not used.		
5 8	Acceptable TCF bit error rate (%) (Only at 4,800 bps)	0: 0%	1: 8%
		0: 0%	1: 4%
		0: 0%	1: 2%
		0: 0%	1: 1%

* ECM: Error correction mode

NOTE: Selector 3 is applicable to the American models.

NOTE: Selectors 5 through 8 are applicable to the Chinese, Taiwanese and Asian models only.

- **Selector 3: Call Waiting Caller ID**

Setting this selector to "0" allows the user to decide whether or not to interrupt the current call when a new call comes in. If Call Waiting Caller ID service is available in the area and the user subscribes to it, he/she can see information about his/her incoming call on the LCD.

- **Selectors 5 through 8: Acceptable TCF bit error rate (%)**

Setting two or more selectors to "1" produces addition of percent assigned to each selector. If you set selectors 7 and 8 to "1," the acceptable TCF bit error rate will be 3%.

WSW23 (Communications setting) (Not used.)

Selector No.	Function	Setting and Specifications
1	Starting point of training check (TCF)	0: From the head of a series of zeros 1: From any arbitrary point
2 3	Allowable training error rate	No. 2 3 0 0 : 0% 0 1 : 0.5% 1 0 : 1% 1 1 : 2%
4 5		No. 4 5 0 0 : 16% 0 1 : 14% 1 0 : 10% 1 1 : 8%
6 7	Not used.	
8	Limitation of attenuation level	0: Yes 1: No

NOTE: Selector 8 is not applicable to the French models.

- **Selector 1: Starting point of training check (TCF)**

At the training phase of receiving operation, the called station detects for 1.0 second a training check (TCF) command, a series of zeros which is sent from the calling station for 1.5 seconds to verify training and give the first indication of the acceptability of the line.

This selector sets the starting point from which the called station should start counting those zeros. If this selector is set to "0," the called station starts counting zeros 100 milliseconds after the head of a series of zeros is detected.

If it is set to "1," the called station starts counting zeros upon detection of 10-millisecond successive zeros 50 milliseconds after the head of a series of zeros is detected. In this case, if the detection of 10-millisecond successive zeros is too late, the data counting period will become less than 1.0 second, making the called station judge the line condition unacceptable.

- **Selectors 2 and 3: Allowable training error rate**

The called station checks a series of zeros gathered in training (as described in Selector 1) according to the allowable training error rate set by these selectors. If the called station judges the line condition to be accepted, it responds with CFR; if not, it responds with FTT.

- **Selectors 4 and 5: Decoding error rate for transmission of RTN**

The machine checks the actual decoding errors and then transmits an RTN according to the decoding error rate (Number of lines containing an error per page ÷ Total number of lines per page) set by these selectors.

- **Selector 8: Limitation of attenuation level**

Setting this selector to "0" limits the transmitting level of the modem to 10 dB (1 dB in France).

This setting has priority over the settings selected by WSW02 (selectors 5 through 8) and WSW13 (selectors 5 through 8).

WSW24 (TAD setting 2) (Not used.)

Selector No.	Function	Setting and Specifications
1 2	Maximum OGM recording time	No. 1 2 0 0 : 15 sec. 0 1 : 20 sec. 1 0 : 30 sec. 1 1 : 50 sec.
3 4	Time length from CML ON to start of pseudo ring backtone transmission	No. 3 4 0 0 : 4 sec. 0 1 : 3 sec. 1 0 : 2 sec. 1 1 : 1 sec.
5 8	Attenuator for playback of ICM/OGM to the line (Selectable from the range of 0-15 dB)	0: 0 dB 1: 8 dB 0: 0 dB 1: 4 dB 0: 0 dB 1: 2 dB 0: 0 dB 1: 1 dB

sec.: second(s)

- **Selectors 1 and 2: Maximum OGM recording time**

These selectors specify the allowable maximum recording time for an OGM.

- **Selectors 3 and 4: Time length from CML ON to start of pseudo ring backtone transmission**

These selectors specify the length of time from CML-ON up to the start of pseudo ring backtone transmission.

In models with OGM facilities, the settings made by these selectors also apply to the length of time from CML-ON up to the start of OGM transmission.

- **Selectors 5 through 8: Attenuator for playback of ICM/OGM to the line**

Setting two or more selectors to "1" produces addition of attenuation assigned to each selector.

This setting is not limited by selector 8 of WSW23.

WSW25 (TAD setting 3) (Not used.)

Selector No.	Function	Setting and Specifications
1 2	Delay time for starting "no tone" detection in the external TAD mode	No. 1 2 0 0: 0 sec. 0 1: 8 sec. 1 0: 16 sec. 1 1: 24 sec.
3 4	Threshold level of "no tone" detection in the external TAD mode	No. 3 4 0 0: -43 dB (A) 0 1: -46 dB (B) 1 0: -49 dB (C) 1 1: -51 dB (D)
5 7	Pause between paging number and PIN	No. 5 6 7 0 0 0 : 2 sec. 0 0 1 : 4 sec. 0 1 0 : 6 sec. 0 1 1 : 8 sec. 1 0 0 : 10 sec. 1 0 1 : 12 sec. 1 1 0 : 14 sec. 1 1 1 : 16 sec.
8	Not used.	

sec.: second(s)

NOTE: Selectors 1 through 4 are not applicable to the U.S.A. models, models without "no tone" detecting function in the external TAD mode, or models with Rockwell modem V24.

NOTE: Selectors 5 through 7 are applicable to the U.S.A. models only.

- **Selectors 1 and 2: Delay time for starting "no tone" detection in the external TAD mode**

These selectors take effect only in the external TAD mode. The machine delays starting detection of "no tone" by the time length specified by these selectors.

The total length of the delay time specified by these selectors and the maximum waiting time specified by WSW21 (selectors 1 through 5) should not exceed 40 seconds.

- **Selectors 3 and 4: Threshold level of "no tone" detection in the external TAD mode**

These selectors specify the threshold level of "no tone" detection in the external TAD mode.

- **Selectors 5 through 7: Pause between paging number and PIN**

These selectors set the pause time between a telephone number being paged and PIN (personal identification number) for the paging feature.

WSW26 (Function setting 4) (Not used.)

Selector No.	Function	Setting and Specifications
1 2	Not used.	
3	Dialing during document reading into the temporary memory in in-memory message transmission	0: Disable 1: Enable
4 5	No. of CNG cycles to be detected (when the line is connected via the external telephone except in the external TAD mode or via the built-in telephone)	No.4 5 0 0 : 0.5 (A) 0 1 : 1 (B) 1 0 : 1.5 (C) 1 1 : 2 (D)
6 7	No. of CNG cycles to be detected (when the line is connected via the external telephone in the external TAD mode, via the built-in telephone in the TAD mode, or via the machine in the automatic reception of the F/T mode)	No.6 7 0 0 : 0.5 (A) 0 1 : 1 (B) 1 0 : 1.5 (C) 1 1 : 2 (D)
8	Not used.	

- **Selector 3: Dialing during document reading into the temporary memory in in-memory message transmission**

If this selector is set to "0," the machine waits for document reading into the memory to complete and then starts dialing. This enables the machine to list the total number of pages in the header of the facsimile message.

- **Selectors 4 and 5: No. of CNG cycles to be detected (when the line is connected via the external telephone except in the external TAD mode or via the built-in telephone)**

The machine interprets a CNG as an effective signal if it detects the CNG by the number of cycles specified by these selectors when the line is connected via the external telephone except in the external TAD mode or via the built-in telephone.

- **Selectors 6 and 7: No. of CNG cycles to be detected (when the line is connected via the external telephone in the external TAD mode, via the built-in telephone in the TAD mode, or via the machine in the automatic reception of the F/T mode)**

The machine interprets a CNG as an effective signal if it detects the CNG by the number of cycles specified by these selectors when the line is connected via the external telephone in the external TAD mode, via the built-in telephone in the TAD mode, or via the machine in the automatic reception of the F/T mode.

WSW27 (Function setting 5) (Not used.)

Selector No.	Function	Setting and Specifications
1	Not used.	
2	Ringer OFF setting	0: Yes 1: No
3	Automatic playback of OGM when switched to the TAD mode	0: No 1: Yes
4	Detection of distinctive ringing pattern	0: Yes 1: No
5	Not used.	
6	Recording quality	0: Normal 1: High
7	Recording time for high recording quality	0: Short (9.6 kbps) 1: Long (8.8 kbps)
8	Not used.	

NOTE: Selectors 4 and 5 are applicable to the U.S.A. models only.

- **Selector 2: Ringer OFF setting**

This selector determines whether or not the ringer can be set to OFF.

- **Selector 3: Automatic playback of OGM when switched to the TAD mode**

This selector determines whether or not to automatically play back an OGM the moment the machine switches to the TAD mode.

- **Selector 4: Detection of distinctive ringing pattern**

If this selector is set to "1," the machine detects only the number of rings; if it is set to "0," the machine detects the number of rings and the ringing time length to compare the detected ringing pattern with the registered distinctive one.

- **Selector 6: Recording quality**

This selector determines the recording quality for the OGM and ICM. Selecting "1" (High) increases the quality, sacrificing the recording time.

- **Selector 7: Recording time for high recording quality**

This setting takes effect when selector 6 is set to "1" (High). Setting this selector to "0" (Short) further increases the recording quality, sacrificing the recording time.

The recording quality and time to be applied when this selector is set to "1" (Long) are higher and shorter than the ones to be applied when selector 6 is set to "0" (Normal).

The recording quality and time determined by this selector being set to "1" (Long) are higher and shorter than the ones determined by selector 6 being set to "0" (Normal).

WSW28 (Function setting 6) (Not used.)

Selector No.	Function	Setting and Specifications
1 3	Transmission level of DTMF high-band frequency signal	No. 1 2 3 0 0 0 : 0 dB 0 0 1 : +1 dB 0 1 0 : +2 dB 0 1 1 : +3 dB 1 0 0 : 0 dB 1 0 1 : -1 dB 1 1 0 : -2 dB 1 1 1 : -3 dB
4 6	Transmission level of DTMF low-band frequency signal	No. 4 5 6 0 0 0 : 0 dB 0 0 1 : +1 dB 0 1 0 : +2 dB 0 1 1 : +3 dB 1 0 0 : 0 dB 1 0 1 : -1 dB 1 1 0 : -2 dB 1 1 1 : -3 dB
7 8	Not used.	

- **Selectors 1 through 6: Transmission level of DTMF high-/low-band frequency signal**

These selectors are intended for the manufacturer who tests the machine for the Standard. Never access them.

WSW29 (Function setting 7) (Not used.)

Selector No.	Function	Setting and Specifications
1 3	Compression threshold level for voice signals inputted via the telephone line in the built-in TAD operation	No. 1 2 3 0 0 0 : -47.0 dBm (A) 0 0 1 : -48.5 dBm (B) 0 1 0 : -50.0 dBm (C) 0 1 1 : -51.5 dBm (D) 1 0 0 : -53.0 dBm (E) 1 0 1 : -54.5 dBm (F) 1 1 0 : -56.0 dBm (G) 1 1 1 : OFF (H)
4 6	Compression threshold level for voice signals inputted via the handset in the built-in TAD operation	No. 4 5 6 0 0 0 : -44.0 dBm (A) 0 0 1 : -45.5 dBm (B) 0 1 0 : -47.0 dBm (C) 0 1 1 : -48.5 dBm (D) 1 0 0 : -50.0 dBm (E) 1 0 1 : -51.5 dBm (F) 1 1 0 : -53.0 dBm (G) 1 1 1 : OFF (H)
7	Impedance switching control in pulse dialing	0: OFF 1: ON
8	Prompt beep when the memory area for the activity report becomes full	0: No 1: Yes

NOTE: Selectors 1 through 6 are applicable to models with built-in TAD.

NOTE: Selectors 7 and 8 are applicable only to the European versions.

- **Selectors 1 through 6: Compression threshold level for voice signals inputted via the telephone line in the built-in TAD operation**

If voice signals inputted via the telephone line are below the level specified by these selectors, the TAD interprets those received voice signals as no signal, compressing the recording time.

- **Selector 8: Prompt beep for activity report**

This selector determines whether or not to beep if the memory area for the activity report becomes full, for prompting you to print out the report. (Printing it out will clear the memory area.)

WSW30 (Function setting 8) (Not used.)

Selector No.	Function	Setting and Specifications
1 3	Dial tone/busy tone detection level during recording of ICM	No. 1 2 3 0 0 0 : -38.0 dBm (A) 0 0 1 : -39.5 dBm (B) 0 1 0 : -41.0 dBm (C) 0 1 1 : -42.5 dBm (D) 1 0 0 : -44.0 dBm (E) 1 0 1 : -45.5 dBm (F) 1 1 0 : -47.0 dBm (G) 1 1 1 : -48.5 dBm (H)
4 8	Not used.	

NOTE: Selectors 1 through 3 are applicable to models with built-in TAD.

- **Selectors 1 through 3: Dial tone/busy tone detection level during recording of ICM**

If the machine (called station) detects dial tone (400 Hz continuously) or busy tone (400 Hz intermittently) exceeding the detection level specified by these selectors for the period specified by selectors 1 through 4 of WSW35, then it interprets the calling station as being disconnected. The machine stops TAD recording and disconnects the line.

WSW31 (Function setting 9) (Not used.)

Selector No.	Function	Setting and Specifications
1	Not used.	
2	Default reduction rate for failure of automatic reduction during recording	0: 100% 1: 70%
3	Not used.	
4	(Do not disturb this selector.)	
5	Minimum ON and OFF duration of ringer signals effective in distinctive ringing	0: 130 ms 1: 90 ms
6 8	Not used.	

ms: millisecond(s)

NOTE: Selector 5 is applicable only to the U.S.A. models.

- **Selector 2: Default reduction rate for failure of automatic reduction during recording**

This selector sets the default reduction rate to be applied if the automatic reduction function fails to record one-page data sent from the calling station in a single page of the current recording paper.

If it is set to "0," the machine records one-page data at full size (100%) without reduction; if it is set to "1," the machine records it at 70% size.

- **Selector 5: Minimum ON and OFF duration of ringer signals effective in distinctive ringing**

The ringer pattern consists of short and long rings, e.g., short-short-long rings. This selector sets the minimum ON and OFF duration of ringer signals that are required for the machine to interpret ringer signals as being ON or OFF. This is to prevent components of a ringer pattern from being misinterpreted due to chattering in distinctive ringing.

The machine monitors ringer signals at 10-millisecond intervals. If the signal is ON, the machine counts +1; if it is OFF, it counts -1. If the counter increments up to +5 or +13 when this selector is set to "1" (90 milliseconds) or "0" (130 milliseconds), respectively, the machine interprets the current signal as being ON.

If the counter returns to zero, the machine interprets the signal as being OFF.

If the Distinctive Ring is set to OFF, this selector is not effective.

WSW32 (Function setting 10)

Selector No.	Function	Setting and Specifications
1 4	Not used.	
5 6	Default resolution	No. 5 6 0 0 : Standard 0 1 : Fine 1 0 : Super fine 1 1 : Photo
7 8	Default contrast	No. 7 8 0 0 : Automatic 0 1 : Automatic 1 0 : Super light 1 1 : Super dark

- **Selectors 5 and 6: Default resolution**

These selectors set the default resolution which applies when the machine is turned on or completes a transaction.

- **Selectors 7 and 8: Default contrast**

These selectors set the default contrast which applies when the machine is turned on or completes a transaction.

WSW33 (Function setting 11) (Not used.)

Selector No.	Function	Setting and Specifications
1 3	Threshold level of "no tone" detection during recording of ICM	No. 1 2 3 0 0 0 : -48 dBm (A) 0 0 1 : -50 dBm (B) 0 1 0 : -52 dBm (C) 0 1 1 : -54 dBm (D) 1 0 0 : -56 dBm (E) 1 0 1 : -58 dBm (F) 1 1 0 : -60 dBm (G) (default) 1 1 1 : -62 dBm (H)
4 5	FAX receiving speed to be kept within the transmission speed limit to the PC	No. 4 5 0 0 : 14,400 bps 0 1 : 12,000 bps 1 0 : 9,600 bps 1 1 : 7,200 bps
6	Report output of polled transmission requests	0: Yes 1: No
7 8	Comfortable noise level	No. 7 8 0 0 : OFF 0 1 : Low (A) 1 0 : Medium (B) 1 1 : High (C)

NOTE: Selectors 1 through 3 are applicable to models with built-in TAD.

- **Selectors 1 through 3: Threshold level of "no tone" detection during recording of ICM**

If the tone level during recording of ICM is less than the threshold setting made by these selectors, the tone is interpreted as "no tone." When the "no tone" state is kept for the period specified by selectors 1 through 5 of WSW21, the machine stops recording of ICM and disconnects the line.

- **Selectors 4 and 5: FAX receiving speed to be kept within the transmission speed limit to the PC**

To transmit FAX data being received from other machine to the connected PC, you may need to keep the FAX receiving speed within the transmission speed limit specified for the PC. In an initial negotiation sequence for transmission, the machine responds to the calling station with the allowable FAX receiving speed specified by these selectors.

- **Selectors 7 and 8: Comfortable noise level**

These selectors set the level of noise to be added during playing-back of voice signals recorded with no-signal compression.

If they are set to "0, 0," no noise will be added.

WSW34 (Function setting 12) (Not used.)

Selector No.	Function	Setting and Specifications
1 3	Erasing time length of ICM tone recorded preceding the tone detection starting point in the case of automatic line disconnection due to no voice signal received	No. 1 2 3 0 0 0 : 0 sec. 0 0 1 : 1 sec. 0 1 0 : 2 sec. 0 1 1 : 3 sec. 1 0 0 : 4 sec. 1 0 1 : 5 sec. 1 1 0 : 6 sec. 1 1 1 : 7 sec.
4 5	No. of CNG cycles to be detected (when the line is connected via the external telephone in the external TAD mode or via the machine in F/T mode)	No. 4 5 0 0 : 0.5 (A) 0 1 : 1 (B) 1 0 : 1.5 (C) 1 1 : 2 (D)
6 7	Number of DTMF tone signals for inhibiting the detection of CNG during external TAD operation	No. 6 7 0 0 : 3 0 1 : 2 1 0 : 1 1 1 : OFF
8	Not used.	

sec.: second(s)

NOTE: Selectors 1 through 5 are applicable to models with built-in TAD.

- **Selectors 1 through 3: Erasing time length of ICM tone recorded preceding the tone detection starting point in the case of automatic line disconnection due to no voice signal received**

If the machine has disconnected the line after detection of disconnection tone in ICM recording, it erases tone recorded preceding the tone detection starting point for the time length set by these selectors.

- **Selectors 4 and 5: No. of CNG cycles to be detected (when the line is connected via the external telephone in the external TAD mode or via the machine in F/T mode)**

The machine interprets a CNG as an effective signal if it detects a CNG signal by the number of cycles specified by these selectors when the line is connected via the external telephone in the external TAD mode or via the machine in F/T mode.

- **Selectors 6 and 7: Number of DTMF tone signals for inhibiting the detection of CNG during external TAD operation**

If the machine receives this specified number of DTMF tone signals during external TAD operation, it will not detect CNG afterwards.

If these selectors are set to "1, 1," the CNG detection will not be inhibited.

WSW35 (Function setting 13) (Not used.)

Selector No.	Function	Setting and Specifications
1 4	Max. detection period of dial tone/busy tone during recording of ICM	No. 1 2 3 4 0 0 0 0 : No detection 0 0 0 1 : 1 sec. 0 0 1 0 : 2 sec. 0 1 0 0 : 4 sec. 1 1 1 1 : 15 sec.
5 8	Not used.	

sec.: second(s)

NOTE: Selectors 1 through 4 are applicable to models with built-in TAD.

- **Selectors 1 through 4: Max. detection period of dial tone/busy tone during recording of ICM**

If the machine (called station) detects dial tone or busy tone exceeding the detection level specified by selectors 1 through 3 of WSW30 for the period specified by these selectors, then it interprets the state as the calling station's breaking the connection, stops recording the ICM, and disconnects the line.

WSW36 (Function setting 14)

Selector No.	Function	Setting and Specifications
1	ECP mode* (<i>Not used.</i>)	0: ON 1: OFF
2	Recovery from Inactive PC Interface	0: Disable 1: Enable
3	PC Power-off Recognition Time	0: Normal 1: Long
4	Not used.	
5	Escape from phase C (<i>Not used.</i>)	0: Yes 1: No
6 8	Extension of incoming calling signal (CI) frequency band specified by selectors 1 through 4 on WSW14 (<i>Not used.</i>)	No. 6 7 8 0 0 0 : 0 (Ignored) 0 0 1 : 4 (448 Hz) 0 1 0 : 8 (244 Hz) 0 1 1 : 12 (162 Hz) 1 0 0 : 16 (122 Hz) 1 0 1 : 20 (97 Hz) 1 1 0 : 24 (81 Hz) 1 1 1 : 28 (69 Hz)

*ECP (Enhanced Capabilities Port)

NOTE: Selectors 2 and 3 on WSW36 take effect only when the "Monitoring the PC ON/OFF state" is enabled with selectors 1 and 2 on WSW46.

- **Selector 1: ECP mode** (*Not used.*)

The ECP mode enhances the normal bidirectional communications between the machine and the connected PC for higher transmission speed.

- **Selector 2: Recovery from Inactive PC Interface**

If the machine recognizes via the STB signal line that the connected PC is powered off, it will turn the PC interface outputs Low to protect the PC from hazards that could be caused by weak electric current accidentally flown from the machine.

This selector determines whether or not the machine should recover from the inactive PC interface to normal interfacing state upon receipt of data from the PC.

- **Selector 3: PC Power-off Recognition Time**

This selector sets the time length from when the machine detects the PC powered off until it recognizes the detected state as power-off.

If selector 2 is set to "0," it is recommended that selector 3 be set to "1"; otherwise, the machine may mistakenly detect PC powered off.

- **Selector 5: Escape from phase C** (*Not used.*)

This selector determines whether or not the machine will escape from phase C when it detects an RTC (Return to Control) in non-ECM mode or an RCP (Return to Control Partial page) in ECM mode.

- **Selectors 6 through 8: Extension of incoming calling signal (CI) frequency band specified by selectors 1 through 4 on WSW14 (Not used.)**

At the start of reception, if the machine detects the frequency of a CI signal specified by selectors 1 through 4 of WSW14, it starts the ringer sounding. However, the machine may fail to detect the CI signal normally due to noise superimposed at the time of reception. To prevent it, use selectors 6 through 8 on WSW36.

If the machine detects higher frequencies than the setting made here, it regards them as noise and interprets the detecting state as being normal, allowing the ringer to keep sounding according to the preset number of ringers (until it starts automatic reception of FAX data in the FAX mode or enters the TAD mode in the TEL mode).

WSW37 (Function setting 15)

Selector No.	Function	Setting and Specifications
1	Printout of the stored image data of an unsent document onto an error report	0: No 1: Yes
2	Erasure of the stored image data of an unsent document at the time of the subsequent in-memory message transmission	0: No 1: Yes
3 8	Not used.	

- **Selector 1: Printout of the stored image data of an unsent document onto an error report**

This selector determines whether or not to print out the 1st-page image data of a document onto the error report if the document image data stored in the temporary memory cannot be transmitted normally.

- **Selector 2: Erasure of the stored image data of an unsent document at the time of the subsequent in-memory message transmission**

If in-memory message transmission fails repeatedly when selector 1 is set to "1," the temporary memory will be occupied with image data. Setting selector 2 to "1" will automatically erase the stored 1st-page image data of an unsent document at the time of the subsequent in-memory message transmission only when recording paper or toner runs out.

WSW38 (V.34 transmission settings) (Not used.)

Selector No.	Function	Setting and Specifications
1 2	Setting of the equalizer	No. 1 2 0 0 : Automatic 0 1 : Automatic 1 0 : Fixed to 4 points 1 1 : Fixed to 16 points
3	Sending level of guard tone at phase 2	0: Normal - 7 db 1: Normal
4	Stepping down the transmission speed at fallback each	0: 2,400 bps 1: 4,800 bps
5 6	Automatic control of modem's EQM gain for proper transmission speed choice	No. 5 6 0 0 : For higher transmission speed than the current setting 0 1 : No change from the current setting 1 0 : For lower transmission speed than the current setting 1 1 : For further lower transmission than the setting made by 1, 0
7	Redialing when a communications error occurs	0: ON 1: OFF
8	Detection of CED for stopping CNG	0: ON 1: OFF

NOTE: WSW38 takes effect only when the V.34 mode is permitted (WSW19, selector 7) in models supporting V.34 mode.

- **Selectors 1 and 2: Setting of the equalizer**

These selectors set the equalizer's training level to be applied if the machine fails to send training due to weak line connection. If these selectors are set to "0, 0" or "0, 1," the modem will automatically set the appropriate training level.

- **Selector 3: Sending level of guard tone at phase 2**

This selector sets the sending level of guard tone for 1800 Hz to be sent at Phase 2 in the V. 34 mode.

- **Selector 4: Stepping down the transmission speed at fallback each**

This selector determines how much the modem steps down the transmission speed at fallback when called by the remote station. If this selector is set to "1," the modem may step down the transmission speed from 33,600 bps to 28,800 bps by one-time fallback.

- **Selectors 5 and 6: Automatic control of modem's EQM gain for proper transmission speed choice**

These selectors determine how the modem controls the EQM (Eye Quality Monitor) gain for proper choice of the transmission speed, which applies if the modem selects higher transmission speed than the possible speed so that it always repeats falling back.

- **Selector 8: Detection of CED for stopping CNG**

If this selector is set to "0," the detection time of CED specified by WSW43, selectors 4 and 5 will apply.

WSW39 (V.34 transmission speed) (Not used.)

Selector No.	Function	Setting and Specifications
1 4	First transmission speed choice for fallback	No. 1 2 3 4 No. 5 6 7 8 0 0 0 0 : 2,400 bps 0 0 0 1 : 4,800 bps 0 0 1 0 : 7,200 bps 0 0 1 1 : 9,600 bps 0 1 0 0 : 12,000 bps 0 1 0 1 : 14,400 bps 0 1 1 0 : 16,800 bps 0 1 1 1 : 19,200 bps
5 8	Last transmission speed choice for fallback	1 0 0 0 : 21,600 bps 1 0 0 1 : 24,000 bps 1 0 1 0 : 26,400 bps 1 0 1 1 : 28,800 bps 1 1 0 0 : 31,200 bps 1 1 0 1 : 33,600 bps 1 1 1 0 : 33,600 bps 1 1 1 1 : 33,600 bps

NOTE: WSW39 takes effect only when the V.34 mode is permitted (WSW19, selector 7) in models supporting V.34 mode. For the transmission speed setting in other modes, refer to WSW19.

• **Selectors 1 through 8: First and last choices of transmission speed for fallback**

These selectors are used to set the modem speed range. With the first transmission speed choice specified by selectors 1 through 4, the machine attempts to establish the transmission link via the modem. If the establishment fails, the machine automatically steps down to the next highest speed and attempts to establish the transmission link again. The machine repeats this sequence while stepping down the transmission speed to the last choice specified by selectors 5 through 8.

If the modem always falls back to a low transmission speed (e.g., 24,000 bps), set the first transmission speed choice to the lower one (e.g., modify it from 31,200 bps to 26,400 bps) in order to deactivate the high-speed modem function and reduce the training time for shorter transmission time.

WSW39 will be limited by selectors 3 through 8 of WSW40.

WSW40 (V.34 modem settings) (Not used.)

Selector No.	Function	Setting and Specifications			
1 2	Not used.				
3 8	Masking of symbol rate(s)	Not masking Masking			
		No. 3	0	1	3429 symbols/sec
		No. 4	0	1	3200 symbols/sec
		No. 5	0	1	3000 symbols/sec
		No. 6	0	1	2800 symbols/sec
		No. 7	-	-	Not used.
		No. 8	0	1	2400 symbols/sec

sec: second(s)

NOTE: WSW40 takes effect only when the V.34 mode is permitted (WSW19, selector 7) in models supporting V.34 mode.

- **Selectors 3 through 8: Masking of symbol rate(s)**

These selectors allow you to limit the transmission speed range in V.34 mode by masking the desired symbol rate(s). Transmission speeds assigned to the symbol rates are listed on the next page. The setting made by these selectors will limit the setting made by selectors 1 through 4 of WSW39.

If selector 3 is set to "1" to mask the 3429 symbols/second when the first transmission speed choice is 33,600 bps (specified by selectors 1 through 4 of WSW39), for example, then the allowable maximum transmission speed will be limited to 31,200 bps. If selector 8 is set to "1" to mask the 2400 symbols/second when the first transmission speed choice is 33,600 bps, then the allowable maximum transmission speed remains 33,600 bps.

If selector 8 is set to "1" to mask the 2400 symbols/second when the first transmission speed choice is 21,600 bps (specified by selectors 1 through 4 of WSW39), then the allowable maximum transmission speed remains 21,600 bps but the minimum transmission speed will be limited to 4,800 bps.

Symbol rate	Transmission speed (bps)	Symbol rate	Transmission speed (bps)	Symbol rate	Transmission speed (bps)
2400	2,400	3000	4,800	3429	4,800
	4,800		7,200		7,200
	7,200		9,600		9,600
	9,600		12,000		12,000
	12,000		14,400		14,400
	14,400		16,800		16,800
	16,800		19,200		19,200
	19,200		21,600		21,600
	21,600		24,000		24,000
	21,600		26,400		28,800
2800	4,800	3200	4,800		33,600
	7,200		7,200		
	9,600		9,600		
	12,000		12,000		
	14,400		14,400		
	16,800		16,800		
	19,200		19,200		
	21,600		21,600		
	24,000		24,000		
	26,400		26,400		
	26,400		28,800		
	26,400		31,200		

WSW41 (ON-duration of the scanning light source)

Selector No.	Function	Setting and Specifications
1 3	ON-duration of the scanning light source at room temperature <i>(Not used.)</i>	No. 1 2 3 0 0 0 : 16 hours 0 0 1 : 24 hours 0 1 0 : 12 hours 0 1 1 : 8 hours 1 0 0 : 4 hours 1 0 1 : 2 hours 1 1 0 : 10 minutes 1 1 1 : 0 minute
4	I-FAX Relay Report <i>(Not used.)</i>	0: ON 1: OFF
5 8	Modem attenuator <i>(Not used.)</i>	No. 5 6 7 8 0 0 0 0 : -10 dBm 0 0 0 1 : -11 dBm 0 0 1 0 : -12 dBm 0 0 1 1 : -13 dBm 0 1 0 0 : -14 dBm 1 1 1 1 : -25 dBm

NOTE: Selectors 1 through 3 are applicable to CCD models.

- **Selectors 1 through 3: ON-duration of the scanning light source at room temperature** *(Not used.)*

If the scanning operation is started when the scanning light source is off, then it will come on for scanning. These selectors determine how long the light source is ON after scanning.

If these selectors are set to "1, 1, 1," the light source goes off immediately after the scanning sequence.

- **Selectors 5 through 8: Modem attenuator** *(Not used.)*

These selectors are used to adjust the transmitting level of the modem when the reception level at the remote station is improper due to line loss. This function applies to super G3 protocol signals.

WSW42 (Internet mail settings) (Not used.)

Selector No.	Function	Setting and Specifications
1	Access to the incoming mail (POP3) server (Periodical or on-demand)	0: Disable 1: Enable
2	Access to the outgoing mail (SMTP) server	0: Disable 1: Enable
3	I-FAX relay	0: Disable 1: Enable
4 8	Not used.	

NOTE: WSW42 is applicable to models equipped with LAN interface.

WSW43 (Function setting 21)

Selector No.	Function	Setting and Specifications
1	Not used.	
2 3	Wait time for PC-Fax reception (Class 2) and FPTS command transmission (Not used.)	No. 2 3 0 0 : 50 ms 0 1 : 100 ms 1 0 : 150 ms 1 1 : 0 ms
4 5	Detection time of 2100 Hz CED or ANSam (Not used.)	No. 4 5 0 0 : 200 ms 0 1 : 300 ms 1 0 : 400 ms 1 1 : 500 ms
6	Not used.	
7	Automatic start of remote maintenance (Not used.)	0: No 1: Yes
8	JPEG coding	0: Disable 1: Enable

ms: millisecond(s)

● **Selector 8: JPEG coding**

Setting this selector to "0" disables the machine from sending/receiving JPEG color images and from receiving JPEG monochrome images.

WSW44 (Speeding up scanning-1) (Not used.)

Selector No.	Function	Setting and Specifications
1 5	Not used.	
6 8	Effective time length of the white level compensation data obtained beforehand	No. 6 7 8 0 0 0 : Obtained compensation data ineffective 0 0 1 : 1 min. 0 1 0 : 3 min. 0 1 1 : 5 min. 1 0 0 : 10 min. 1 0 1 : 15 min. 1 1 0 : 20 min. 1 1 1 : 30 min.

min.: minute(s)

NOTE: Selectors 6 through 8 are applicable only to models equipped with flat-bed scanner.

- **Selectors 6 through 8: Effective time length of the white level compensation data obtained beforehand**

If you set documents in the ADF and the document front sensor detects them, the controller will make correction of the reference voltage to be applied to white level compensation for document scanning before the **Copy** key is pressed.

These selectors determine how long compensation data obtained beforehand will keep effective.

WSW45 (Speeding up scanning-2)

Selector No.	Function	Setting and Specifications
1 3	Delay time from when documents are set until the ADF starts drawing them in	No. 1 2 3 0 0 0 : No automatic drawing-in 0 0 1 : 1 sec. 0 1 0 : 2 sec. 0 1 1 : 3 sec. 1 0 0 : 4 sec. 1 0 1 : 5 sec. 1 1 0 : 6 sec. 1 1 1 : 7 sec.
4 6	Periodical correction intervals of the reference voltage to be applied to white level compensation for document scanning, during standby	No. 4 5 6 0 0 0 : No correction of reference voltage during standby 0 0 1 : 10 sec. 0 1 0 : 30 sec. 0 1 1 : 1 min. 1 0 0 : 3 min. 1 0 1 : 5 min. 1 1 0 : 10 min. 1 1 1 : 30 min.
7	Standby position of the CIS unit	0: CIS home position 1: Location of the white reference film
8	Line polarity reversal detector (<i>Not used.</i>)	0: Disable 1: Enable

sec.: second(s), min: minute(s)

NOTE: WSW45 is applicable only to models equipped with flat-bed scanner.

- **Selectors 1 through 3: Delay time from when documents are set until the ADF starts drawing them in**

These selectors determine how long the ADF will delay automatic drawing-in of documents (to the scanning standby position) after you set them in the ADF, as well as determining whether or not the ADF automatically draws in documents.

- **Selectors 4 through 6: Periodical correction intervals of the reference voltage applied to white level compensation for document scanning, during standby**

These selectors set the correction intervals (in seconds) of the reference voltage to be applied to white level compensation for document scanning during standby, as well as determining whether or not the controller makes the reference voltage correction during standby. (Conventionally, the correction has been made immediately before the start of actual scanning)

This function takes effect in copying. Making the correction during standby may shorten the preparation time for copying.

NOTE: Do not access these selectors.

- **Selector 7: Standby position of the CIS unit**

This selector determines whether the standby position of the CIS unit should be the home position or the location of the white reference film (attached to the inside of the scanner top cover). If the location of the reference film is selected, the CIS unit will not return to the home position so as to shorten the travel time, decreasing the preparation time for copying.

- **Selector 8: Line polarity reversal detector** (*Not used.*)

When the remote station breaks the connection, a line polarity reversal occurs. Enabling the polarity reversal detector with this selector allows the machine to detect the polarity reversal if detected when the user is leaving a message on the station's answering machine.

WSW46 (Monitor of power ON/OFF state and parallel port kept at high)

Selector No.	Function	Setting and Specifications
1 2	Monitoring the PC ON/OFF state	No. 1 2 0 0 : Disable 0 1 : Monitor SELECT IN 1 0 : Monitor STROBE 1 1 : Monitor both SELECT IN and STROBE
3	Parallel port output pins kept at high level	0: Enable 1: Disable
4	Previous filtering parameters for white level compensation	0: Enable 1: Disable
5 8	Not used.	

NOTE: Selector 4 is not applicable to models equipped with flat-bed scanner.

- **Selectors 1 and 2: Monitoring the PC ON/OFF state**

For the related functions, refer to WSW36, selectors 2 and 3.

- **Selector 3: Parallel port output pins kept at high level**

Setting this selector to "0" will keep all parallel output pins of the machine at high level. Use this setting if Resource Manager (bundled with MFC models) installed to WindowsNT running on the connected PC fails to monitor the power ON/OFF state of the machine.

- **Selector 4: Previous filtering parameters for white level compensation**

At the start of scanning operation, the machine usually initializes white and black level data stored in the EEPROM by scanning the white reference film attached to the inside of the scanner top cover. After long use of the machine, however, the film may be contaminated with dust or dirt. Accordingly, incorrect white level data will be set up so that white vertical streaks will be brought on the scanning result.

Setting this selector to "0" (Enabled) will apply previously saved white level data instead of new incorrect compensation.

WSW47 (Switching between high- and full-speed USB)

Selector No.	Function	Setting and Specifications
1	Handling paper at the occurrence of a paper feed timing error	0: Eject paper w/o print 1: Print on the current paper
2	Not used.	
3 4	Delay of FAX line disconnection when switching to the pseudo-ringing external telephone (<i>Not used.</i>)	No. 3 4 0 0 : 200 ms 0 1 : 400 ms 1 0 : 700 ms 1 1 : 1000 ms
5	Disable the ringer of external telephone at non-ring reception (<i>Not used.</i>)	0: No 1: Yes
6	Not used.	
7	Disable the ringer of external telephone with CAR signal when caller ID service is available (<i>Not used.</i>)	0: No 1: Yes
8	Switching between high-speed USB and full-speed USB	0: Auto switching between high-speed USB (ver. 2.0) and full-speed USB (ver. 1.1) 1: Fixed to full-speed USB (ver. 1.1)

ms: millisecond(s)

NOTE: Selector 1 is applicable only to models equipped with flat-bed scanner.

NOTE: Selectors 3 and 4 are applicable only to models supporting pseudo-ringing of a connected external telephone.

- **Selector 1: Handling paper at the occurrence of a paper feed timing error**

When feeding paper to the print start position, the machine might cause a feed timing error so that the registration sensor goes ON signaling the presence of paper. This selector determines whether the machine prints on the current paper or ejects the current paper without printing and prints on the next paper.

- **Selectors 3 and 4: Delay of FAX line disconnection when switching to the pseudo-ringing external telephone (*Not used.*)**

When the machine receives a phone call, it can make the connected external telephone ring (so called pseudo-ringing). During pseudo-ringing, if you pick up the handset of the external telephone, the line might be disconnected due to cut-off of the line current.

To hold the line, the machine may supply line current by making use of the pulse generator circuit that forms a parallel loop. This way the FAX line disconnection may be delayed. These selectors determine the delay period.

WSW48 (USB setup latency)

Selector No.	Function	Setting and Specifications
1 2	Not used.	
3 5	Number of PCs registrable to each of TWAIN-enabled applications over a network	No. 3 4 5 0 0 0 : 25 0 0 1 : 50 0 1 0 : 75 0 1 1 : 100 1 0 0 : 125 1 0 1 : 150 1 1 0 : 175 1 1 1 : 200
6 8	USB setup latency (<i>Not used.</i>)	No. 6 7 8 0 0 0 : Default period 0 0 1 : Shorter 1 0 1 0 : Longer 1 0 1 1 : Longer 2 1 0 0 : Longer 3 1 0 1 : Longer 4 1 0 0 : Shorter 2 1 1 1 : Shorter 3

- **Selectors 6 through 8: USB setup latency** (*Not used.*)

These selectors should not be disturbed.

WSW50 (SDAA settings) (Not used.)

Selector No.	Function	Setting and Specifications
1 2	Percentage voltage for interpreting the external telephone as being hooked up (based on the network's standard voltage)	No. 1 2 0 0 : 50% 0 1 : 80% 1 0 : 30% 1 1 : No detection
3	DC mask curve table to be applied when the line is connected	0: Apply the initial value specified by local regulations 1: Apply table DC5 prepared specially
4	AC impedance to be applied when the line is connected	0: 600Ω termination 1: ZR termination
5 6	Current control to be applied immediately after connection of the line	No. 5 6 0 0 : Standard 0 1 : Increase start-up current for termination 1 0 : Fine current control for termination 1 1 : Not used. (equal to "0, 0")
7 8	AC voltage threshold for detection of ring	No. 7 8 0 0 : 19 V 0 1 : 11 V 1 0 : 25 V 1 1 : 31 V

NOTE: WSW50 is applicable to models equipped with an SDAA circuit.

• **Selectors 5 and 6: Current control to be applied immediately after connection of the line**

FAX models equipped with an SDAA circuit (on which an NTU chip is mounted) might not be connected to a broad band line such as an ADSL (Asynchronous Digital Subscriber Line) in a stable condition. If those models fail to connect to such a line, try to change the current control to be applied immediately after connection of the line by using selectors 5 and 6.

If selectors 5 and 6 are set to "0" and "1," respectively, the SDAA draws more current, decreasing the period required to terminate the current control. If they are set to "1" and "0," the SDAA finely controls precision of the termination current against the voltage to approach nearer to the specified DC curve that specifies the current vs. voltage characteristics of the network termination. Selecting either control may solve an unstable connection problem.

WSW51 (Function setting 16) (Not used.)

Selector No.	Function	Setting and Specifications
1	Output of communications error report when transmission verification report is disabled	0: Enable 1: Disable
2	CR motor control for reducing torque fluctuation	0: Activate 1: Deactivate
3 4	Cordless handset transmitter volume	No. 3 4 0 0 : Middle (default) 0 1 : Low 1 0 : High 1 1 : Very high
5 7	Transmitter level and echo suppression	No. 5 6 7 0 0 0 : Transmitter level 0 & echo suppression OFF 0 0 1 : Transmitter level 1 & echo suppression ON 0 1 0 : Transmitter level 2 & echo suppression ON 0 1 1 : Transmitter level 3 & echo suppression ON
8	Switching from ink near-empty to ink empty when opening the scanner cover	0: Yes 1: No (No change from ink near-empty)

NOTE: Selectors 3 and 4 are applicable to models equipped with cordless handset.

- **Selector 2: CR motor control for reducing torque fluctuation**

When the CR motor runs, the motor torque may vary so as to cause the head/carriage unit travel velocity to fluctuate, affecting the print quality. Setting this selector to "0" activates the CR motor control that regulates the motor drive current to reduce torque fluctuation, running the CR motor smoothly.

- **Selectors 5 through 7: Transmitter level and echo suppression**

Transmitter level 0 sets the transmitter volume to a maximum. As the level increases, the volume decreases. The transmitter level can also be changed by the user switch and its setting is interlocked with the setting made by these selectors.

Enabling the echo suppression suppresses echoes in both the receiver and transmitter.

- **Selector 8: Switching from ink near-empty to ink empty when opening the scanner cover**

If this selector is set to "0," opening the scanner cover switches from ink near-empty (if detected) to ink empty state, prompting the user to replace the near-empty ink cartridge(s) immediately.

WSW52 (Function setting 17) (Not used.)

Selector No.	Function	Setting and Specifications
1 3	Transmitter level and echo suppression for cordless handsets	No. 1 2 3 0 0 0 : Transmitter level 0 & echo suppression OFF 0 0 1 : Transmitter level 1 & echo suppression ON 0 1 0 : Transmitter level 2 & echo suppression ON 0 1 1 : Transmitter level 3 & echo suppression ON
4 6	External telephone pseudo ring signal frequency	No. 4 5 6 0 0 0 : 16 Hz 0 0 1 : 20 Hz 0 1 0 : 24 Hz 0 1 1 : 28 Hz 1 0 0 : 32 Hz 1 0 1 : 16 Hz 1 1 0 : 16 Hz 1 1 1 : 16 Hz
7	Caller ID display (number display) being kept ON even after switching back to TEL from FAX mode	0: Enable 1: Disable
8	Dial number being displayed during faxing	0: Enable 1: Disable

- **Selectors 4 through 6: External telephone pseudo ring signal frequency**

These selectors provide a choice of pseudo ring sounds of the external telephone.

- **Selector 7: Caller ID display (number display) being kept ON even after switching back to TEL from FAX mode**

Enabling this function keeps the caller ID display ON even after the machine switches back to the TEL mode from the FAX mode.

- **Selector 8: Dial number being displayed during faxing**

Setting this selector to "0" enables the machine to keep displaying the dial number of the FAX receiver on the LCD until the end of faxing.

WSW53 (Function setting 18)

Selector No.	Function	Setting and Specifications
1 2	Not used.	
3 4	FSK receive timing delay for caller ID (<i>Not used.</i>)	No. 3 4 0 0 : 0 ms 0 1 : 100 ms 1 0 : 150 ms 1 1 : 200 ms
5 6	Allowable instantaneous interrupt period during reception of caller ID (<i>Not used.</i>)	No. 5 6 0 0 : 20 ms 0 1 : 10 ms 1 0 : 30 ms 1 1 : 0 ms
7	CNG detection retry after detection of invalid CNG (<i>Not used.</i>)	0: Yes 1: No
8	JPEG decompressor	0: ASIC (default) 1: Software

NOTE: Selector 8 is applicable to models equipped with PhotoCapture Center.

- **Selectors 3 through 6: FSK receive timing delay for caller ID (*Not used.*)**
Allowable instantaneous interrupt period during reception of caller ID (*Not used.*)

If a communications error occurs during a telephone conversation when the user has subscribed to the caller ID service, change the settings of these selectors, and it may improve the communications state. First, change the settings of selectors 3 and 4. If the error persists, change the settings of selectors 5 and 6.

- **Selector 8: JPEG decompressor**

By default, the ASIC (Application specified integrated circuit) in the machine decompresses the compressed JPEG data in a memory card inserted. If it fails to decompress the data and reproduce the image normally, switch from the ASIC to any proven decompressor software with this selector.

WSW54 (Function setting 19)

Selector No.	Function	Setting and Specifications
1 2	PictBridge command delay time	No. 1 2 0 0 : 100 ms (default) 0 1 : 0 ms 1 0 : 50 ms 1 1 : 200 ms
3	Extension of the "No. of CNG cycles to be detected" for Easy Receive mode <i>(Not used.)</i>	0: No 1: + 2 cycles
4	Recovery of cordless handset ID <i>(Not used.)</i>	0: Enable 1: Disable
5 6	Caller ID tone alert detection period <i>(Not used.)</i>	No. 5 6 0 0 : 10 ms (default) 0 1 : 20 ms 1 0 : 30 ms 1 1 : 40 ms
7	Transmission of caller ID wetting pulse <i>(Not used.)</i>	0: Enable (default) 1: Disable
8	Switching between DTMF and FSK for caller ID <i>(Not used.)</i>	0: DTMF (default) 1: FSK

ms: millisecond(s)

NOTE: Selectors 1 and 2 are applicable to PictBridge-enabled models.

NOTE: Selector 4 is applicable to models with cordless handset.

NOTE: Selectors 5 through 7 are applicable to the UK models.

NOTE: Selector 8 is applicable to the Chinese models.

- **Selectors 1 and 2: PictBridge command delay time**

These selectors specify the PictBridge command delay time that applies when the machine responds to the digital camera connected via PictBridge during negotiation. If the machine fails to receive data from the digital camera, change the delay time.

- **Selector 3: Extension of the "No. of CNG cycles to be detected" for Easy Receive mode *(Not used.)***

In Easy Receive mode, if the machine fails to detect the CNG even after the setting made by selectors 4 and 5 on WSW26, extend the "No. of CNG cycles to be detected" by two cycles.

- **Selector 4: Recovery of cordless handset ID *(Not used.)***

Enabling this function automatically writes the cordless handset ID registered on the main PCB onto the cordless PCB when the power is turned on if the ID on the cordless PCB is discrepant with the one on the main PCB.

- **Selectors 5 and 6: Caller ID tone alert detection period** *(Not used.)*

If the machine misdetects a tone alert for a caller ID, adjust the detection period with these selectors.

- **Selector 7: Transmission of caller ID wetting pulse** *(Not used.)*

If the machine fails to display a caller ID due to a wetting pulse transmitted after the detection of a tone alert, disable the transmission of caller ID wetting pulse.

- **Selector 8: Switching between DTMF and FSK for caller ID** *(Not used.)*

If the machine fails to receive a caller ID, switch from DTMF to FSK. This setting is equivalent to the DTMF/FSK setting made from the menu.

WSW55 (Function setting 20) *(Not used.)*

Selector No.	Function	Setting and Specifications
1 8	_____	

WSW56 (Function setting 21) *(Not used.)*

Selector No.	Function	Setting and Specifications
1 8	_____	

WSW57 (Function setting 22) (Not used.)

Selector No.	Function	Setting and Specifications
1 3	Caller ID judgment voltage level to discriminate caller ID event from ring event	No. 1 2 3 0 0 0 : 0 V 0 0 1 : 5 V (default) 0 1 0 : 10 V 0 1 1 : 15 V 1 0 0 : 20 V 1 0 1 : 25 V 1 1 0 : 30 V 1 1 1 : Maximum
4 6	Caller ID judgment voltage level to detect line polarity reversal	No. 4 5 6 0 0 0 : 0 V 0 0 1 : 5 V (default) 0 1 0 : 10 V 0 1 1 : 15 V 1 0 0 : 20 V 1 0 1 : 25 V 1 1 0 : 30 V 1 1 1 : Maximum
7	Time limit for judging a caller ID burst ring	0: Enable (default) 1: Disable
8	Start key on the machine after dialing with cordless handset	0: Disable (default) 1: Enable

NOTE: Selectors 1 through 7 are applicable to the European models.

- **Selectors 1 through 3: Caller ID judgment voltage level to discriminate caller ID event from ring event**

If the machine misdetects a caller ID event as a ring event due to voltage variation, it fails to display a caller ID. If it happens, increase the judgment voltage level provided that the setting made by these selectors is equal to or more than the setting made by selectors 4 through 6.

- **Selectors 4 through 6: Caller ID judgment voltage level to detect line polarity reversal**

If the machine fails to detect a line polarity reversal for a caller ID due to a great difference between the line voltage when a polarity reversal occurs and the one at the steady state, it fails to display a caller ID. If it happens, increase the judgment voltage level provided that the setting made by these selectors is equal to or less than the setting made by selectors 1 through 3.

- **Selector 7: Time limit for judging a caller ID burst ring**

The time limit for judging a caller ID burst ring is enabled by default so that receiving a burst ring out of the specified time limit causes the machine to interpret it as an ordinary call involving no caller ID signal, resulting in no caller ID display.

When the machine fails to display a caller ID if you have the caller ID subscriber service from your telephone company, disable the time limit with this selector to receive a caller ID burst ring independent of the burst ring time.

- **Selector 8: Start key on the machine after dialing with cordless handset**

Pressing the **Start** key on the machine to send a fax during a telephone conversation with the cordless handset cannot start a sending operation by default. Setting this selector to "1" enables the **Start** key pressed even after dialing with cordless handset.

WSW58 (Function setting 23) (Not used.)

Selector No.	Function	Setting and Specifications
1 3	Prevention against line disconnection during ICM recording (Percentage of guard tone response time relative to end-of-call tone ON time)	No. 1 2 3 0 0 0 : Disable 0 0 1 : 10% 0 1 0 : 20% 0 1 1 : 30% (default) 1 0 0 : 40% 1 0 1 : 50% 1 1 0 : 60% 1 1 1 : 70%
4	Trimming of R key signal issued from cordless handset--For connection to base unit with PBX OFF	0: Disable (default) 1: Enable
5	Call transfer to cordless handset from telephone(s) connected in parallel with the machine (base unit)	0: Enable (default) 1: Disable
6 8	Not used.	

NOTE: Selectors 1 through 3 are applicable to models equipped with TAD.

NOTE: Selector 4 is applicable to European models with a cordless handset.

NOTE: Selector 5 is applicable to U.S.A. models with a cordless handset.

- **Selectors 1 through 3: Prevention against line disconnection during ICM recording (Percentage of guard tone response time relative to end-of-call tone ON time)**

If the machine misdetects an ICM tone as an end-of-call tone, it disconnects the line even during recording of the ICM. If it happens, change the percentage of the guard tone response time relative to the end-of-call tone ON time with these selectors.

If the percentage of the actual guard tone response time is more than the setting made by these selectors, the machine interprets it as no detection of end-of-call tone, continuing recording the ICM.

- **Selector 4: Trimming of R key signal issued from cordless handset--For connection to base unit with PBX OFF**

For European models, a cordless handset can be registered to up to four base units.

On the cordless handset registered to more than one base unit, if you have programmed an **R** key press as part of a number stored in a Speed-Dial location, you can dial using a Speed-Dial location stored in the handset when connected to the base unit in which *PBX is set to ON*.

When the cordless handset is connected to any other base unit in which *PBX is set to OFF*, however, using a Speed-Dial location may dial an unintended telephone number or cause a malfunction due to the programmed **R** key signal preceding the intended number. To avoid such problems, enable the **R** key signal trimming function with this selector so that the base unit dials trimming the received **R** key signal.

- **Selector 5: Call transfer to cordless handset from telephone(s) connected in parallel with the machine (base unit)**

Enabling this function allows the machine (base unit) to transfer a call transferred from telephone(s) connected in parallel with the machine to the cordless handset.

Appendix 5. Wiring Diagrams

This appendix provides the wiring diagrams that help you understand the connections between PCBs.

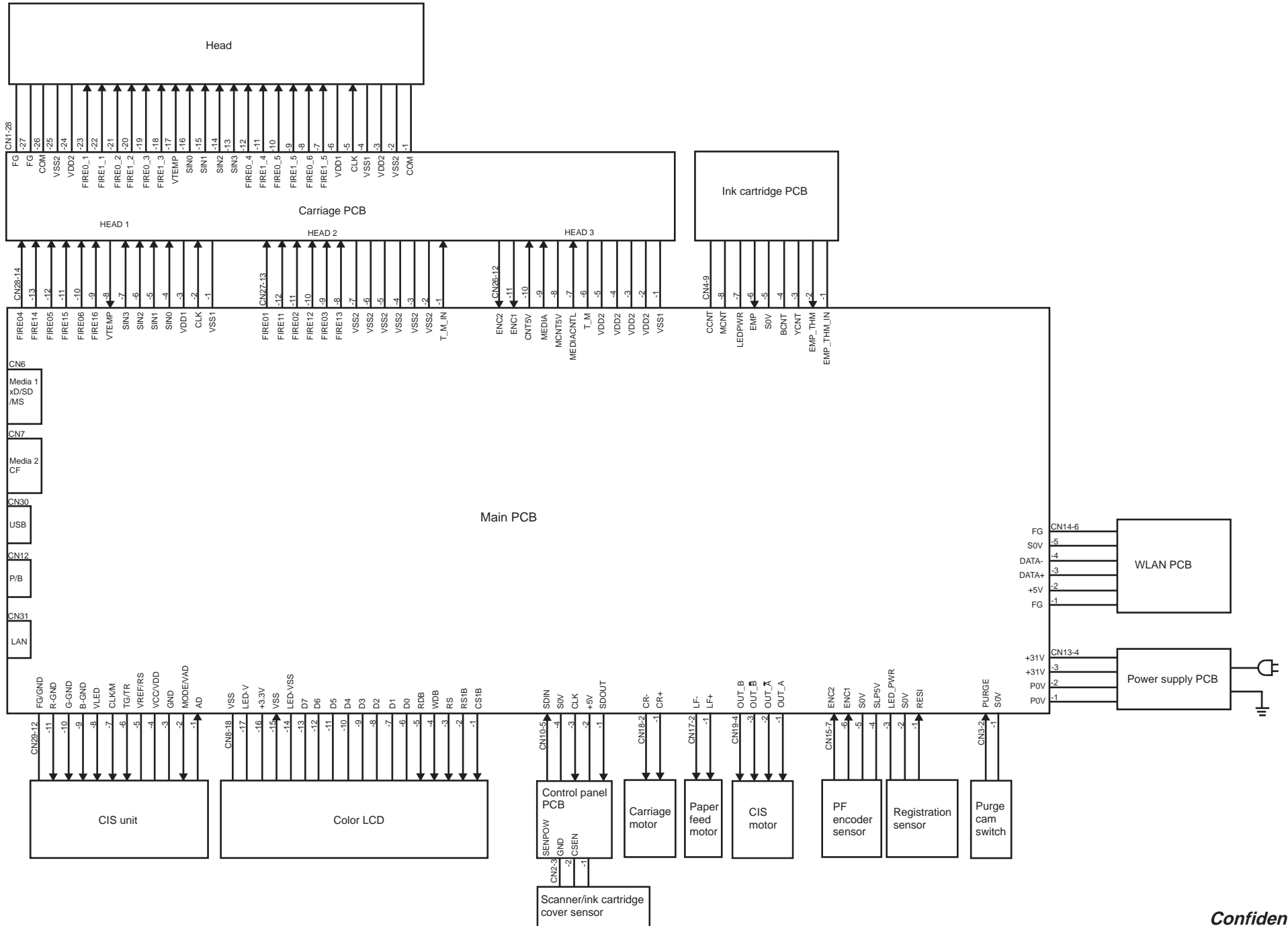

DCP130C

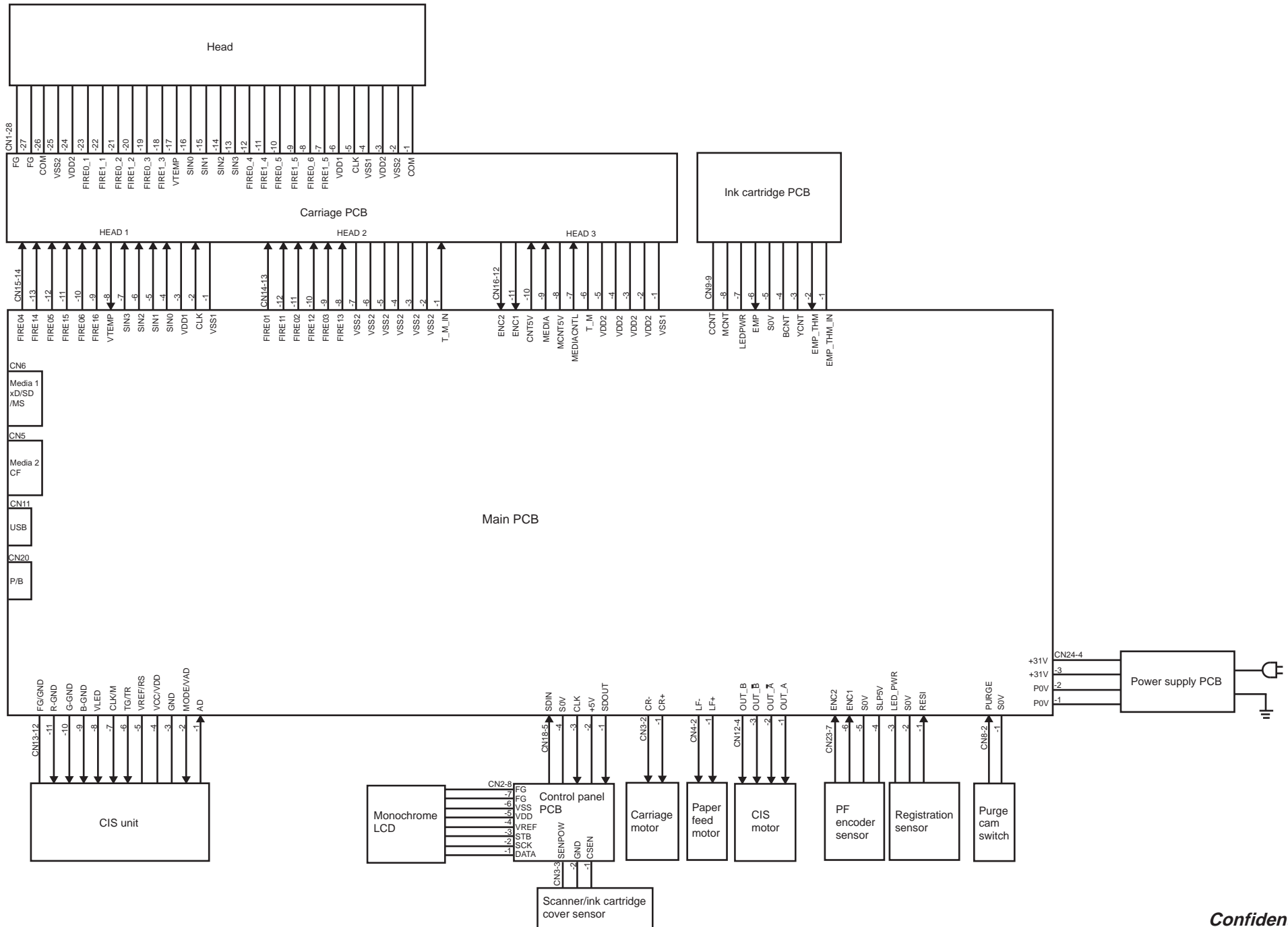

Appendix 6. Circuit Diagrams

This appendix provides the circuit diagrams of the power supply PCB.

Power supply PCB (U.S.A. and Canadian models)

Power supply PCB (European, Asian and Oceanian models)

Power supply PCB (European, Asian and Oceanian models)

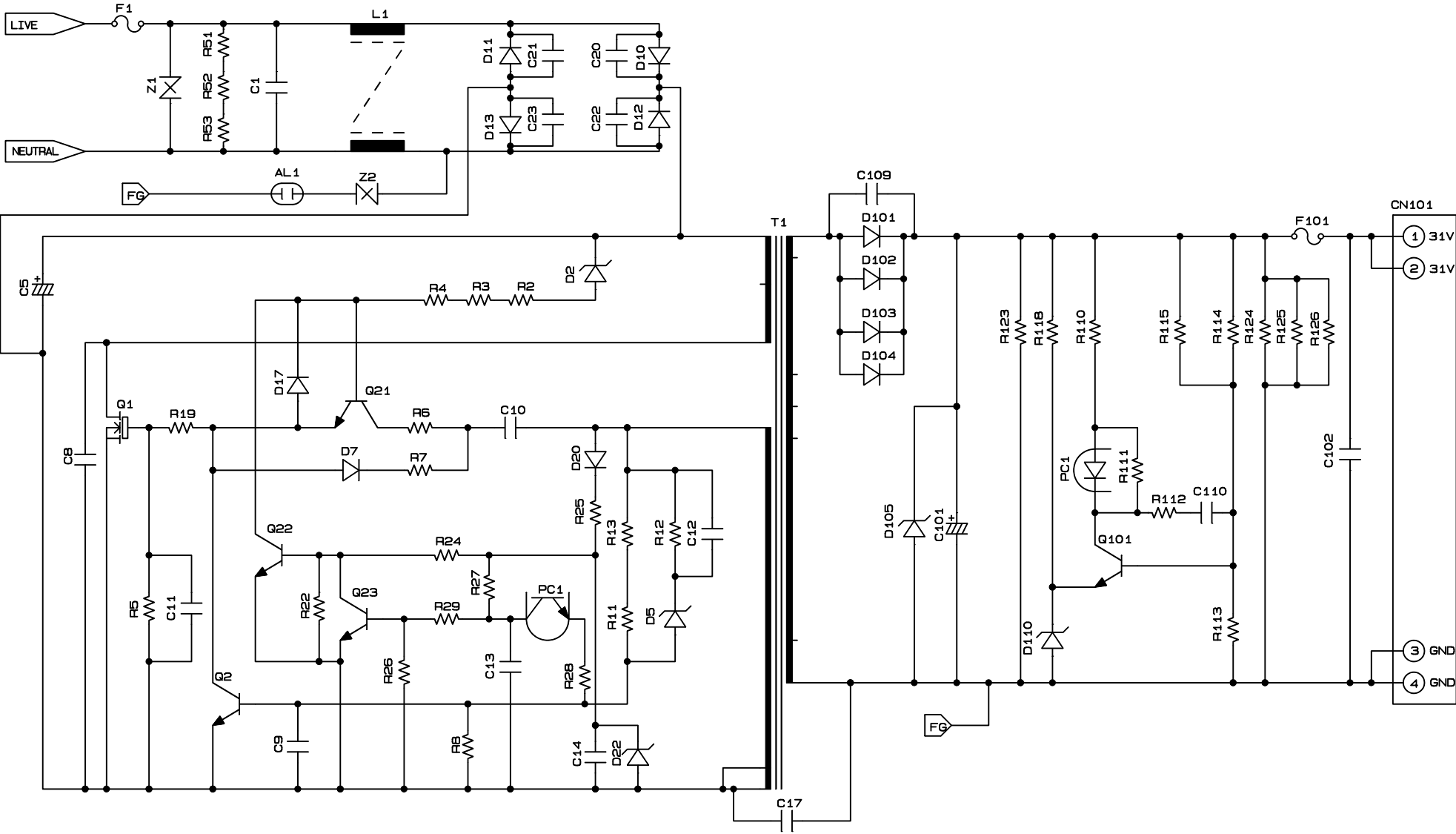

MPW6629

brother®

January '07
SM-FAX054
8CAA01 (2)
Printed in Japan

Confidential