



**FACSIMILE EQUIPMENT
SERVICE MANUAL**

**MODEL: FAX235/FAX236/
FAX335MC/
FAX218/
FAX228MC**

© Copyright Brother 2003

All rights reserved.

No part of this publication may be reproduced in any form or by any means without permission in writing from the publisher.

Specifications are subject to change without notice.

PREFACE

This publication is a Service Manual covering the specifications, construction, theory of operation, and maintenance of the Brother facsimile equipment. It includes information required for field troubleshooting and repair—disassembly, reassembly, and adjustment—so that service personnel will be able to understand equipment function, to rapidly repair the equipment and order any necessary spare parts.

To perform appropriate maintenance so that the facsimile equipment is always in best condition for the customer, the service personnel must adequately understand and apply this manual.

This manual is made up of six chapters and appendices.

CHAPTER I.	GENERAL DESCRIPTION
CHAPTER II.	INSTALLATION
CHAPTER III.	THEORY OF OPERATION
CHAPTER IV.	DISASSEMBLY/REASSEMBLY AND LUBRICATION
CHAPTER V.	MAINTENANCE MODE
CHAPTER VI.	ERROR INDICATION AND TROUBLESHOOTING
APPENDICES	EEPROM Customizing Codes & Circuit Diagrams

This manual describes the model and its versions to be destined for major countries. The specifications and functions are subject to change depending upon each destination.

CHAPTER I.

GENERAL DESCRIPTION

CHAPTER I. GENERAL DESCRIPTION

CONTENTS

1. EQUIPMENT OUTLINE	I-1
1.1 External Appearance and Weight	I-1
1.2 Components	I-1
2. SPECIFICATIONS	I-2

1. EQUIPMENT OUTLINE

1.1 External Appearance and Weight

The figure below shows the equipment appearance and approximate dimensions.

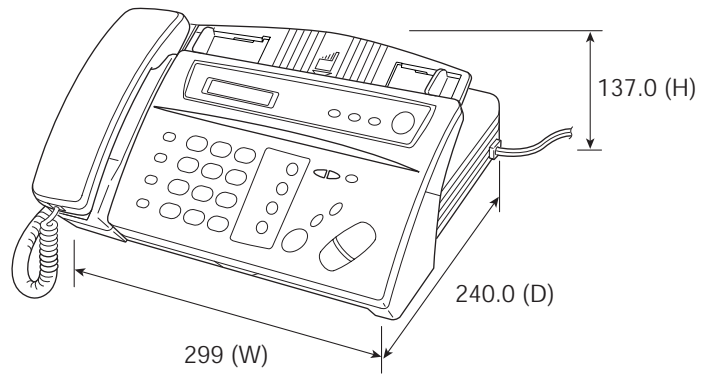

(Unit: mm)

Weight: Machine proper	Approx. 2.9 kg (excluding a paper roll)
In package	Approx. 4.0 kg

1.2 Components

The equipment consists of the following major components:

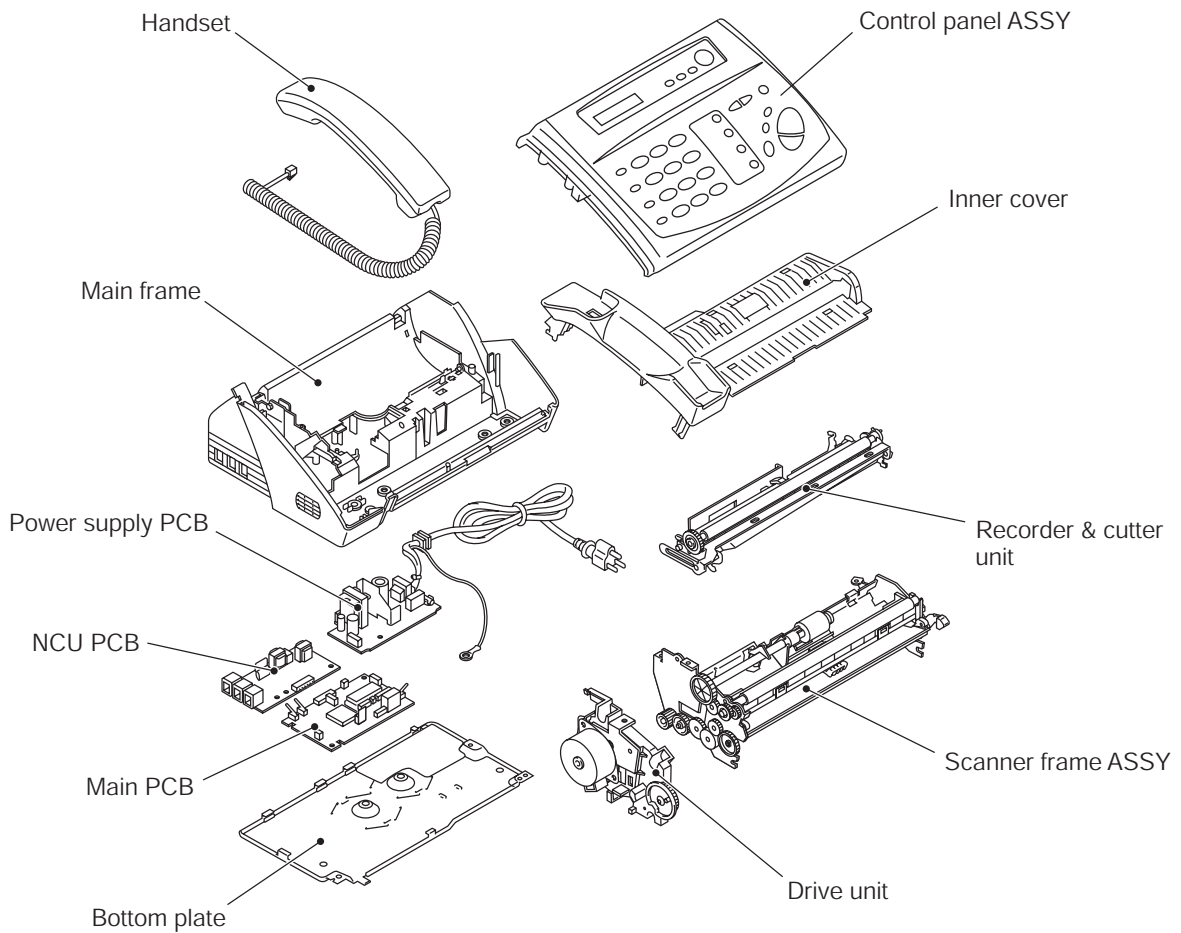

2. SPECIFICATIONS

Model	FAX235	FAX236/218
Color	White(1517)	White (1517)
Modem Speed	9600 bps	9600 bps
Coding Method	MH	MH
Transmission Speed	15 sec.	15 sec.
CCITT Group	G3	G3
Input/Output Width	Max. 8.5" x 8.5"	Max. 8.5" x 8.5"
Handset	Yes	Yes
Automatic Cutter	Yes	Yes
ADF Capacity (pages)	10 pages	10 pages
Anti-curl System	Yes	Yes
Roll Paper Size (Standard thermal/Therma PLUS)	164/98' (1"-core)	164/98' (1"-core)
LCD Size	16 x 1	16 x 1
On-screen Programming	Yes	Yes
Memory Capacity	No	No
Super Fine	Yes	Yes
Smoothing	Yes	Yes
Gray Scale (levels)	64 by Dithered Method	64 by Dithered Method
One-touch Dialing	4 locations	4 locations
Speed Dialing	60 locations	100 locations
Telephone Index	Yes	Yes
Super Telephone Index	No	No
Hook Key (TEL Key)	Yes	Yes
Fax/Tel Switch	Yes	Yes
TAD Interface	Yes	Yes
Enlargement/Reduction	No	No
Enhanced Remote Activation	Yes	Yes
Distinctive Ringing (FAX Ability)	Yes (ASIA Only)	Yes (ASIA, CHINA Only)
Next-fax Reservation	No	Yes
Help	Yes	Yes
Caller ID (Caller Display)	Yes	Yes
Automatic Redialing	Yes	Yes
Auto Reduction	No	No
Multi-resolution Transmission	Yes	Yes
Polling	Yes	Yes
Delayed Transmission	Yes, 1 timer	Yes, 1 timer
Delayed Polling	Yes	Yes
Coverpage	No	Yes
Call Reservation	No	Yes
Call-back Message	No	Yes
Activity Report	Yes	Yes
Auto CNG Detection (New)	Yes	Yes
Transmission Verification Report	Yes	Yes
ECM	No	No
Broadcasting	No	No
Quick Scanning	No	No
Out-of-paper Reception	No	No
Multi Copy	No	No
Multi Transmission	No	No
PCI (Missing link)	No	Yes
Confidential Mailbox	No	No

Model	FAX335MC/FAX228MC
Color	White (1517)
Modem Speed	14400 bps
Coding Method	MH
Transmission Speed	9 sec.
CCITT Group	G3
Input/Output Width	8.5"/8.5"
Hold Key (Mute Key)	Yes
Automatic Cutter	Yes
ADF Capacity	10 pages
Anti-curl System	Yes
Roll Paper Size (Standard thermal/Therma PLUS)	164'/98' (1"-core)
LCD Size	16 x 1
On-screen Programming	Yes
Memory Capacity	512 KB
Super Fine	Yes
Smoothing	Yes
Gray Scale (levels)	64 by Dithered Method
One-touch Dialing	4 locations
Speed Dialing	100 locations
Telephone Index	Yes
Super Telephone Index	No
Speaker Phone	Yes (Full Duplex)
Fax/Tel Switch	Yes
TAD Interface	Yes
Enlargement/Reduction	No
Enhanced Remote Activation	Yes
Distinctive Ringing (FAX Ability)	Yes
Next-fax Reservation	Yes
Help	Yes
Caller ID (Caller Display)	Yes
Automatic Redialing	Yes
Auto Reduction	No
Multi-resolution Transmission	Yes
Polling	Yes
Delayed Transmission	Yes, 3 timers
Delayed Polling	Yes
Coverpage	Yes
Call Reservation	Yes
Call-back Message	Yes
Activity Report	Yes
Auto CNG Detection (New)	Yes
Transmission Verification Report	Yes
ECM	Yes
Broadcasting	Yes
Quick Scanning	Yes
Out-of-paper Reception	Yes
Multi Copy	Yes
Multi Transmission	No
PCI (Missing link)	No
Fax Forwarding	Yes
Fax-on-demand	No
Fax Retrieval	Yes
ICM Recording Time	15 minutes
Memo/2-way Recording	Yes
Page Memory	Yes, 20 pages
Paging	Yes
Personal Fax Mail box (5)	No
Personal Voice Mail Box (5)	No
Remote Control	Yes
TAD Type	DSP type
Toll Saver	Yes
Voice-on-demand	No

CHAPTER II.

INSTALLATION

CHAPTER **III**.
THEORY OF OPERATION

CHAPTER III. THEORY OF OPERATION

CONTENTS

1. OVERVIEW	III-1
2. MECHANISMS	III-2
2.1 Transmitting Mechanism (Feeding and scanning documents)	III-2
2.1.1 Automatic document feeder (ADF)	III-2
2.1.2 Scanner	III-3
2.2 Receiving Mechanism (Feeding recording paper and printing data)	III-4
2.2.1 Anti-curl system (ACS)	III-4
2.2.2 Automatic cutter	III-4
2.2.3 Recorder	III-4
2.3 Power Transmission Mechanism	III-5
2.3.1 Structure of the gear train	III-5
2.3.2 Description of planetary gear system	III-7
2.3.3 Power transmission for four operation modes	III-8
[1] Recording mode (Solenoid: OFF, Motor rotation: Forward)	III-9
[2] Scanning mode (Solenoid: OFF, Motor rotation: Reverse)	III-10
[3] Copying mode (Solenoid: ON→OFF, Motor rotation: Forward) ...	III-11
[4] Cutter driving mode (Solenoid: ON, Motor rotation: Reverse)	III-12
2.3.4 Power transmission route	III-14
2.4 Sensors and Actuators	III-15
3. CONTROL ELECTRONICS	III-17
3.1 Configuration	III-17
3.2 Main PCB	III-18
3.3 NCU PCB	III-20
3.4 Control Panel PCB	III-21
3.5 Power Supply PCB	III-22

1. OVERVIEW

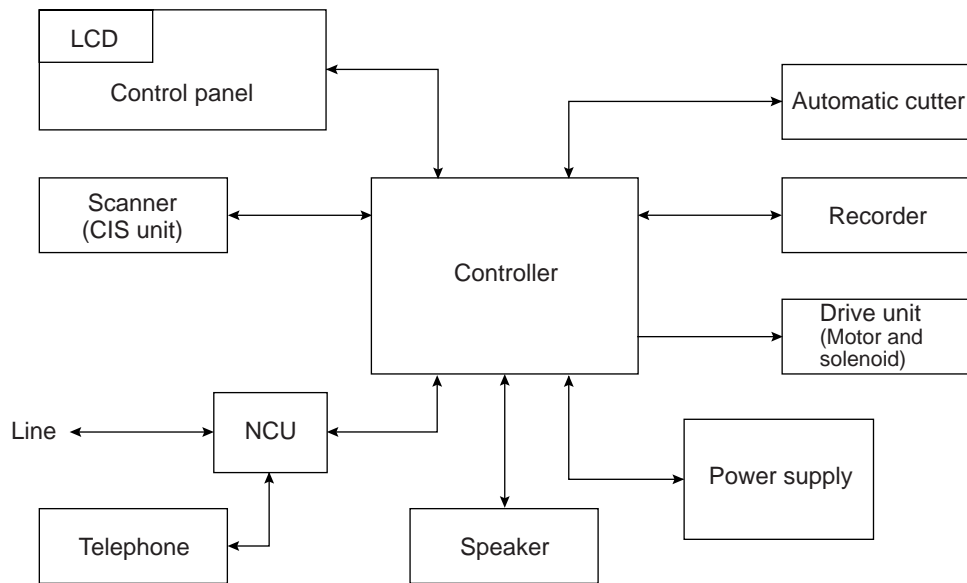

2. MECHANISMS

The equipment is classified into the following mechanisms:

- Transmitting Mechanism Feeding and scanning documents
- Receiving Mechanism Feeding recording paper and printing data
- Power Transmission Mechanism Switching the power transmission route
- Sensors and Actuators

2.1 Transmitting Mechanism (Feeding and scanning documents)

The transmitting mechanism consists of the document stacker, automatic document feeder (ADF), document feeding related rollers, scanner, and document sensors. (For details about the sensors, refer to Section 2.4.)

For the drive power source, refer to Section 2.3.

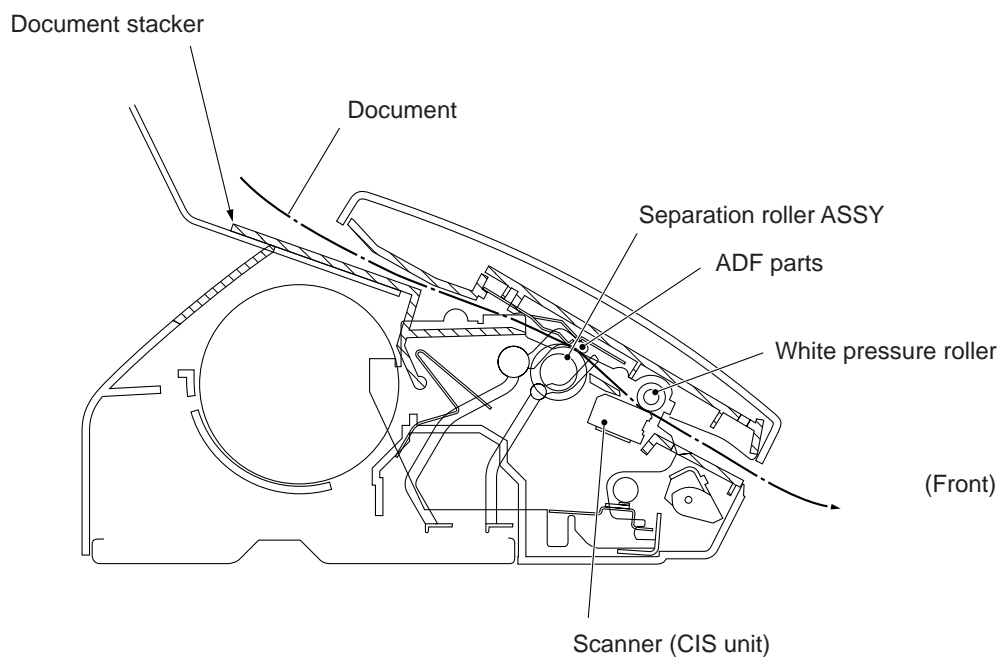

2.1.1 Automatic document feeder (ADF)

If the operator sets documents on the stacker and starts the transmitting operation, the ADF (consisting of the separation roller ASSY and ADF parts) feeds those documents into the equipment, starting from the bottom sheet to the top, page by page. Each document advances to the scanner, and then it is fed out of the equipment with the white pressure roller.

2.1.2 Scanner

The scanner uses a contact image sensor (CIS) unit which consists of an LED array illuminating documents, a self-focus lens array collecting the reflected light, a CIS PCB carrying out photoelectric conversion to output picture element data, and a cover glass on which a document advances. When the document passes between the white pressure roller and the cover glass, it is scanned.

2.2 Receiving Mechanism (Feeding recording paper and printing data)

The receiving mechanism consists of the recording paper roll holder, anti-curl system (ACS) plate, platen, thermal recording head, automatic cutter, and sensors. (For details about the sensors, refer to Section 2.4.)

The recording paper is routed on the ACS plate to the recording head which prints onto the heat-sensitive recording paper pressed by the platen according to received image signals. The printed paper is further fed through the cutter chute and cut by the automatic cutter page by page.

For the drive power source, refer to Section 2.3.

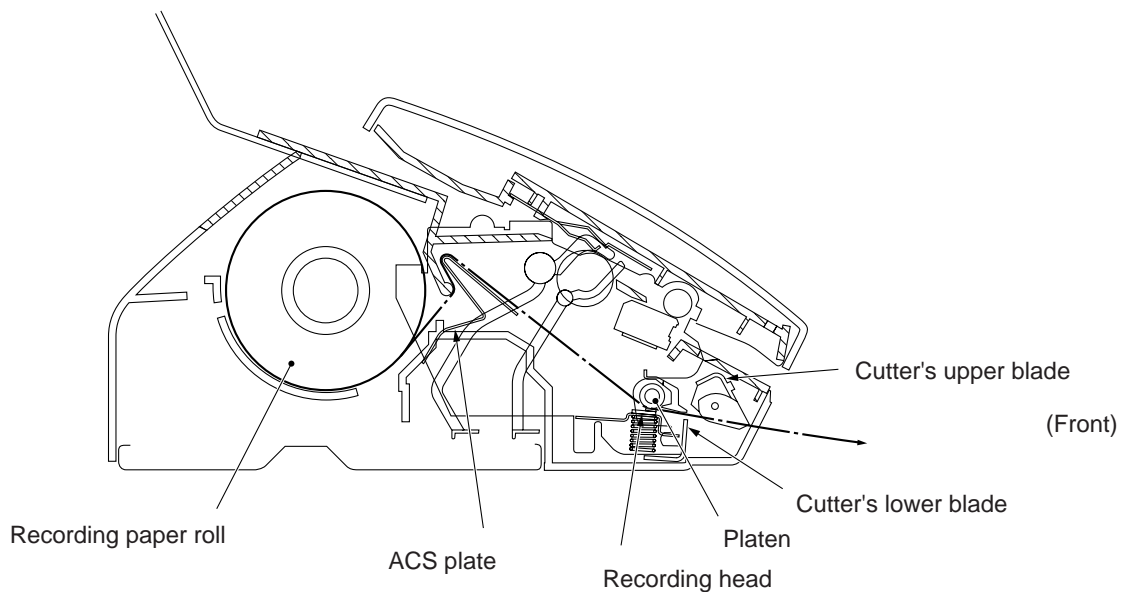

2.2.1 Anti-curl system (ACS)

The ACS eliminates curl peculiar to rolled recording paper by curving the paper towards the opposite side of the curl with the ACS plate.

2.2.2 Automatic cutter

The automatic paper cutter consists of an upper blade (rotary) and a lower blade (stationary). As the upper blade rotates around the left end hub, the recording paper will be cut. Upon completion of cutting, the upper blade returns to its home position which is detected by the cutter HP sensor.

2.2.3 Recorder

The recorder, which is incorporated in the middle of the machine, consists of the recording head unit, coil spring, and platen. It prints according to received image signals.

2.3 Power Transmission Mechanism

The equipment has a single drive motor whose power transmission route can be switched by the planetary gear train and the solenoid. This switching allows the equipment to function in four operation modes (recording, scanning, copying, and cutter driving modes).

2.3.1 Structure of the gear train

The gear train consists of two groups of gears: one group on the drive unit and the other on the scanner frame ASSY. Mounting the drive unit onto the scanner frame ASSY makes those two groups of gears engage with each other so that the rotation torque of the motor on the drive unit is transmitted to the separation roller, white pressure roller, and platen.

Shown below are a group of gears, the motor and solenoid on the drive unit. The cutter gear (Q) is integrated in the cutter flange (R) whose boss is placed in the hole provided in the cutter's upper blade.

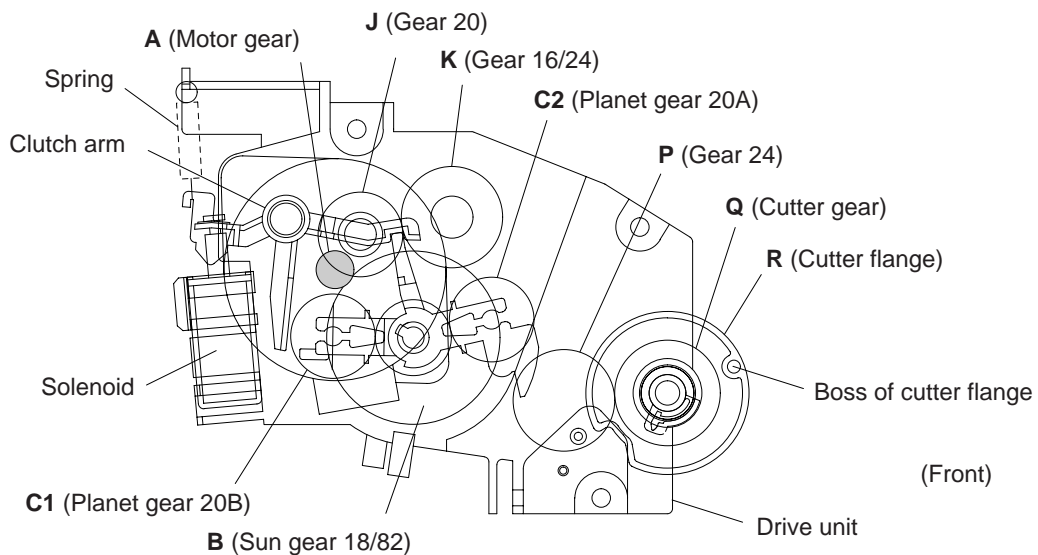

Drive Unit (viewed from the motor mounting side)

Shown below is a group of gears on the scanner frame ASSY.

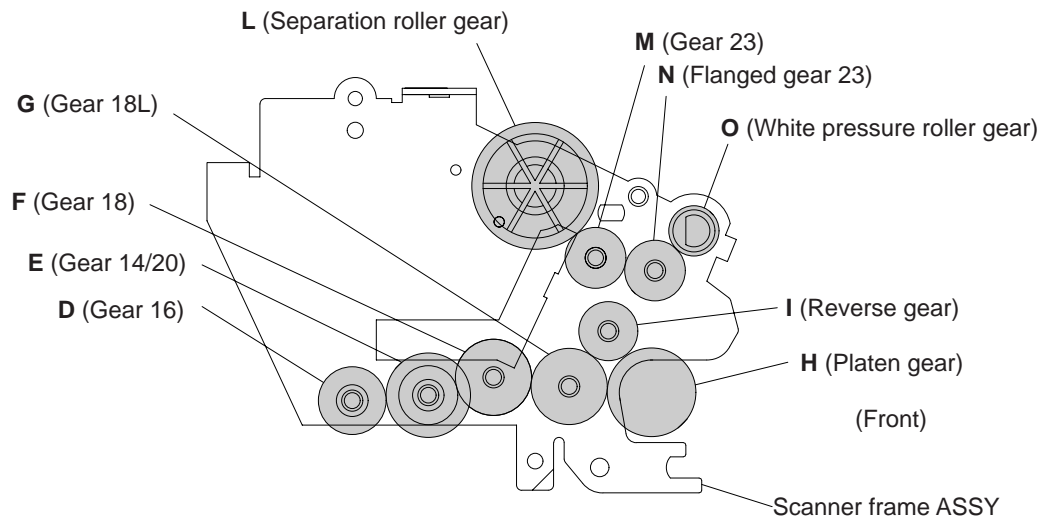

Scanner Frame ASSY

Shown below is a gear train constructed by combining the drive unit and scanner frame ASSY. The motor rotation is transmitted via the planet gear 20B (C1) to the gear 16 (D) and via the gear 16/24 (K) to the separation roller gear (L).

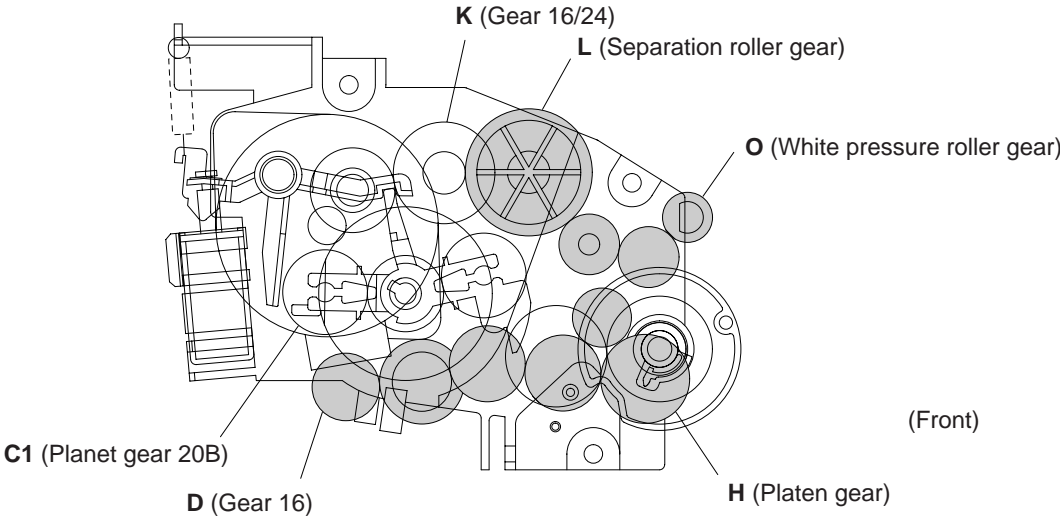

Combination of Drive Unit and Scanner Frame ASSY

2.3.2 Description of planetary gear system

The planetary gear train consists of the sun gear 18/82, two planet gears 20, arm A, and arm B, as shown below.

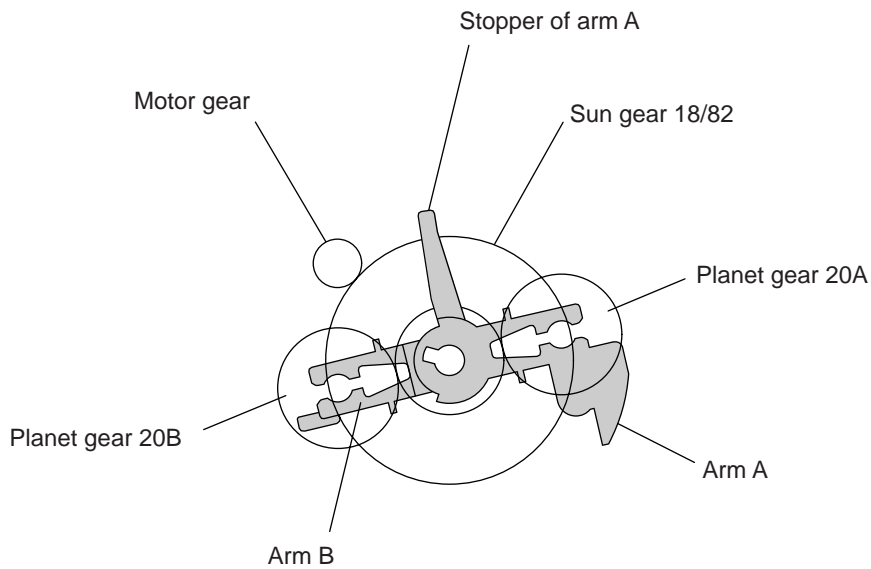

Planetary Gear System

If the motor rotates, the sun gear 18/82 rotates so that the rotational torque is transmitted to the engagement between the sun gear and the planet gears 20. Since the arms and planet gears are so designed that the moment of the arms is less than that of the planet gears, the arms turn around the center shaft in the same direction as the sun gear 18/82.

If the planet gear(s) becomes engaged with any other gear so that the arm cannot turn any more, the rotational torque of the sun gear 18/82 is transmitted to that planet gear. Accordingly, the planet gear starts rotation in the opposite direction of the sun gear 18/82.

2.3.3 Power transmission for four operation modes

Depending upon the solenoid ON/OFF state and the motor rotation direction, the planetary gear train switches the power transmission route for the four operation modes.

Solenoid ON/OFF state

Motor rotation direction

Solenoid: OFF

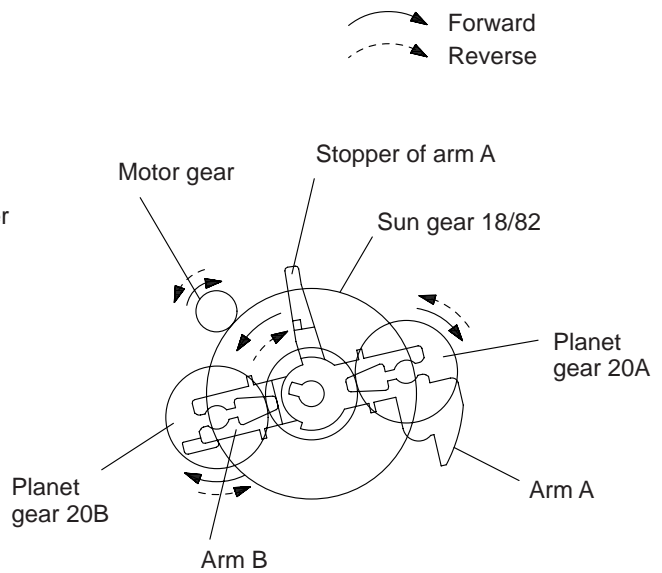
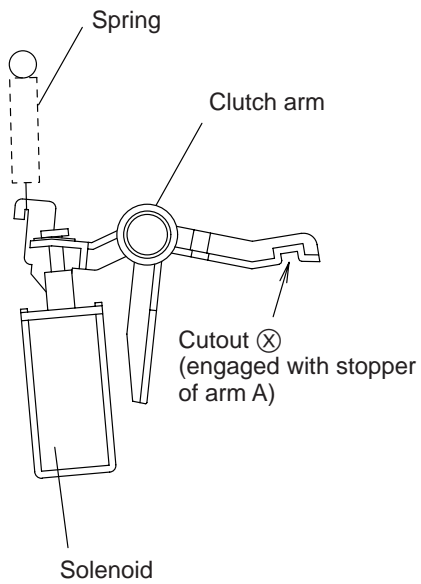

Solenoid: ON

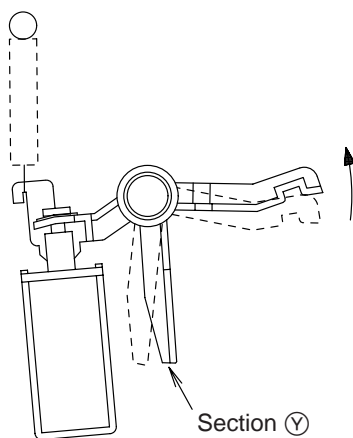

[1] Recording mode (Solenoid: OFF, Motor rotation: Forward)

In the recording mode, the control electronics deactivates the solenoid. When the motor rotates in the forward direction, the clutch arm turns clockwise with the spring and its cutout (⊗) becomes engaged with the stopper of arm A. Once arm A is locked, the planet gear 20A (C2) will not be engaged with any other gear but simply idle.

The motor rotation turns the sun gear 18/82 (B) counterclockwise so that the planet gear 20B (C1) transmits the rotation via the gears D through G to the platen gear (H).

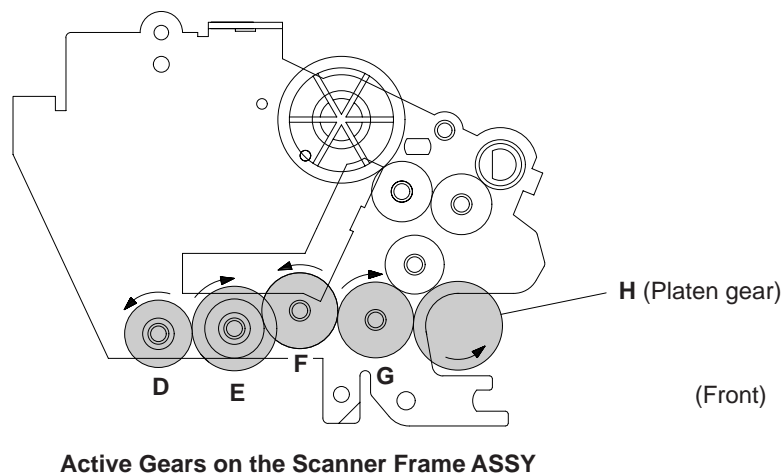
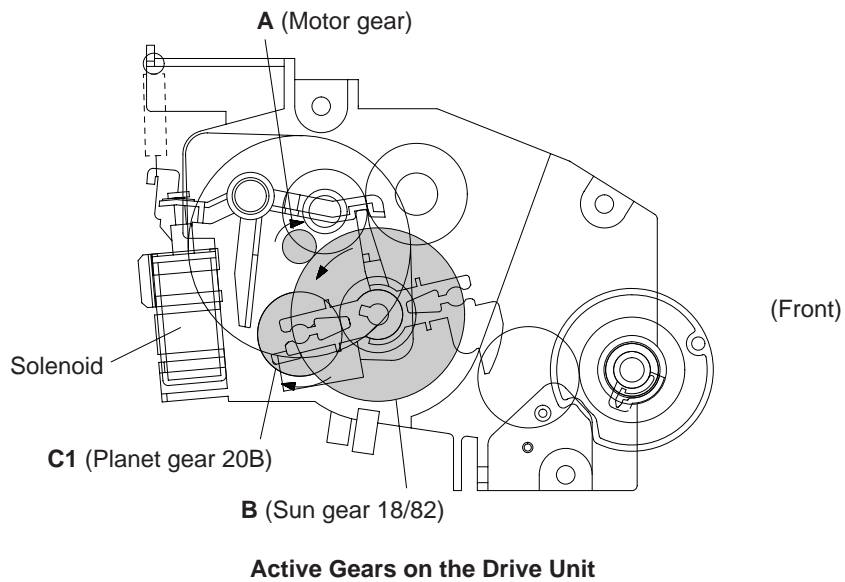
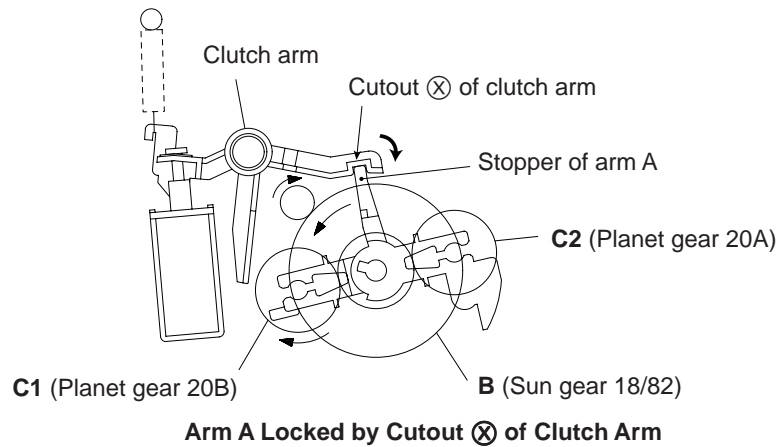

[2] Scanning mode (Solenoid: OFF, Motor rotation: Reverse)

Just as in the recording mode, the control electronics deactivates the solenoid in the scanning mode to lock arm A.

The motor rotates in the reverse direction and the sun gear 18/82 (B) rotates clockwise so that the planet gear 20B (C1) transmits the rotation to the separation roller gear (L) and white pressure roller gear (O) via the several gears.

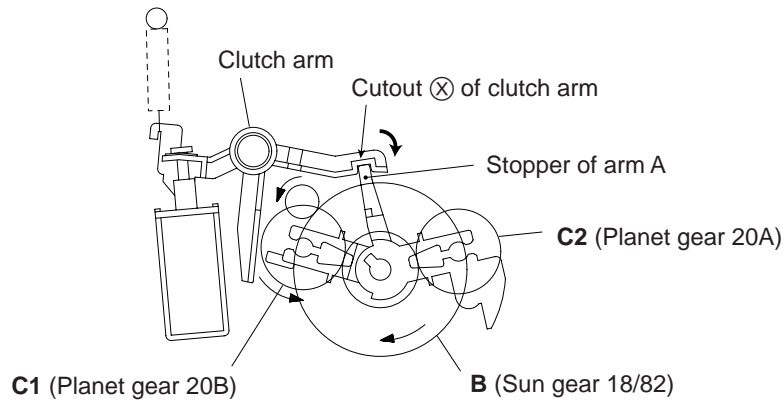

Arm A Locked by Cutout ⊗ of Clutch Arm

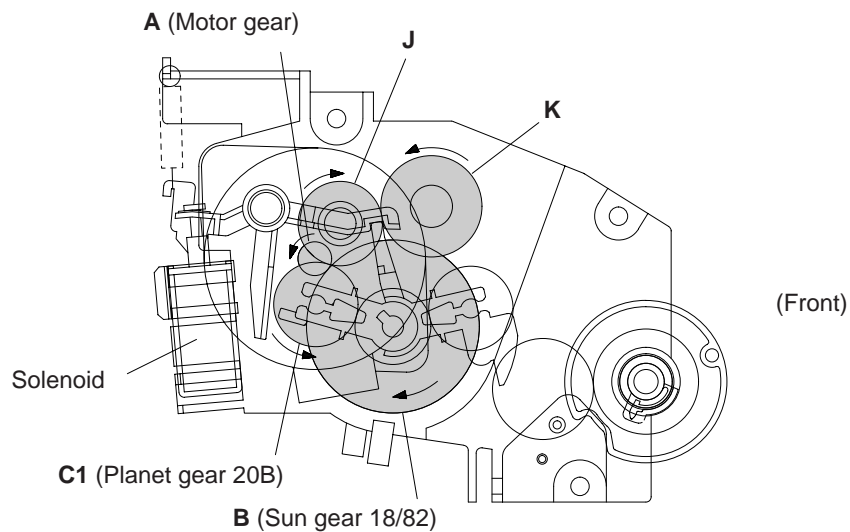

Active Gears on the Drive Unit

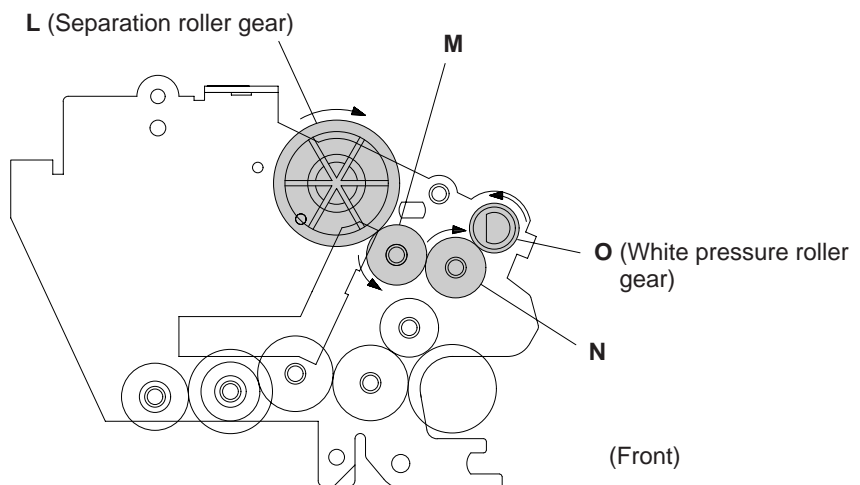

Active Gears on the Scanner Frame ASSY

[3] Copying mode (Solenoid: ON→OFF, Motor rotation: Forward)

The control electronics at first activates the solenoid to release the stopper of arm A from the cutout ⊗ of the clutch arm while rotating the motor in the forward direction. Accordingly, the sun gear 18/82 (B) rotates counterclockwise so that both the planet gears 20B (C1) and 20A (C2) transmit the rotation; C1 rotation to the platen gear (H) and C2 rotation to the separation roller gear (L) and white pressure roller gear (O).

Once the planet gear 20A (C2) becomes engaged with gear K, the control electronics deactivates the solenoid.

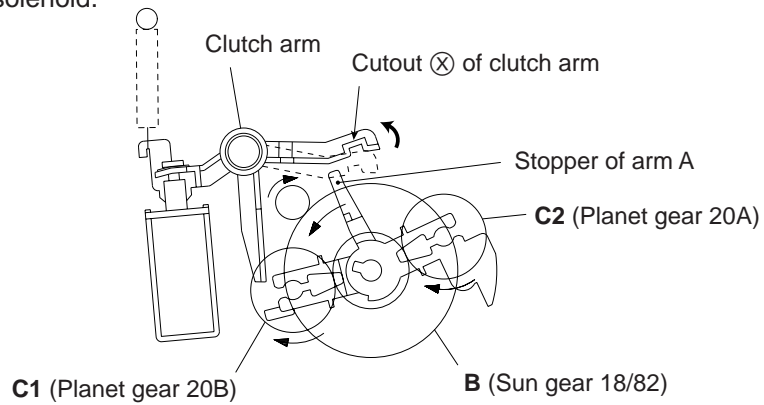

Arm A Released from Cutout ⊗ of Clutch Arm

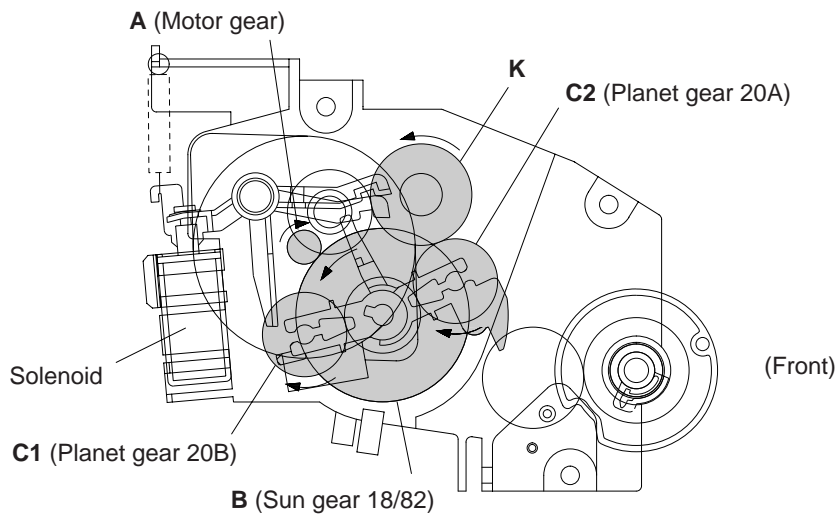

Active Gears on the Drive Unit

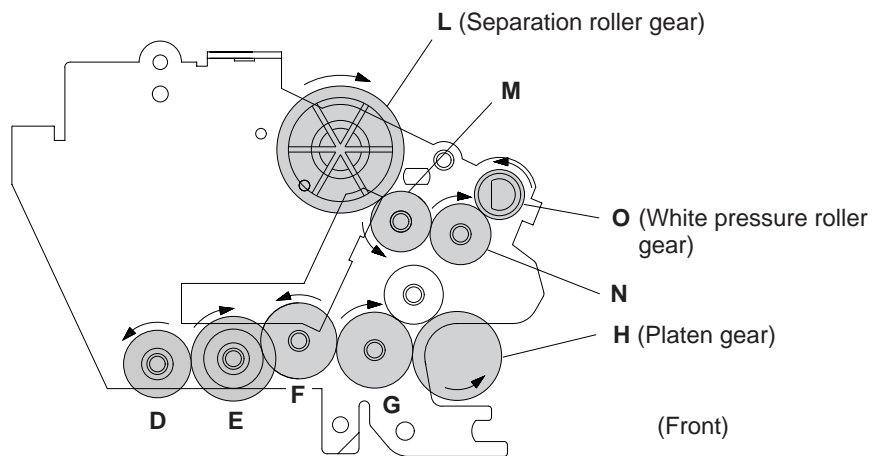

Active Gears on the Scanner Frame ASSY

[4] Cutter driving mode (Solenoid: ON, Motor rotation: Reverse)

The control electronics activates the solenoid to release the stopper of arm A from the clutch arm. When the motor rotates in the reverse direction, the sun gear 18/82 (B) rotates clockwise so that the planet gear 20A (C2) transmits the rotation to the cutter gear (Q) via gear P.

Since the planet gear 20B (C1) is blocked by the section Ⓢ of the clutch arm, it is merely idle without engaging with any other gear.

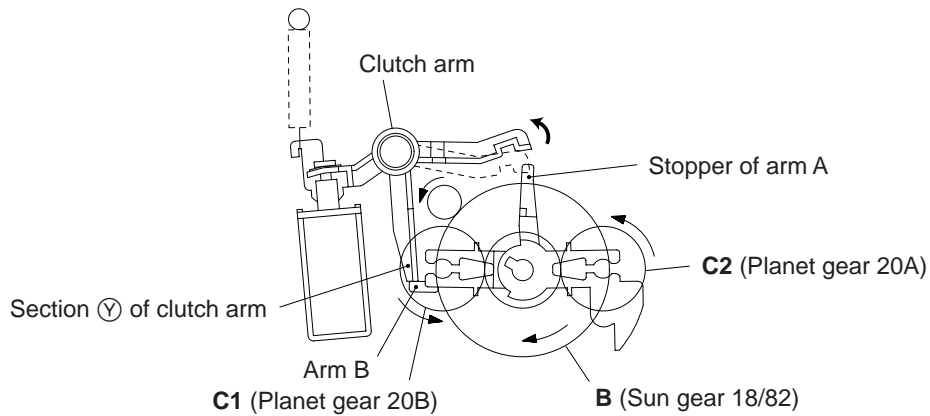

Arm B Blocked by Section Ⓢ of Clutch Arm

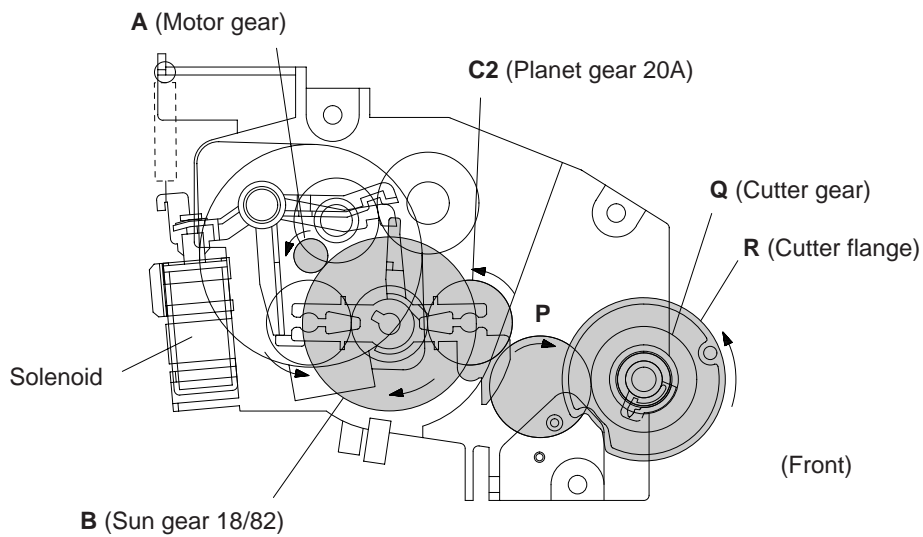

Active Gears on the Drive Unit

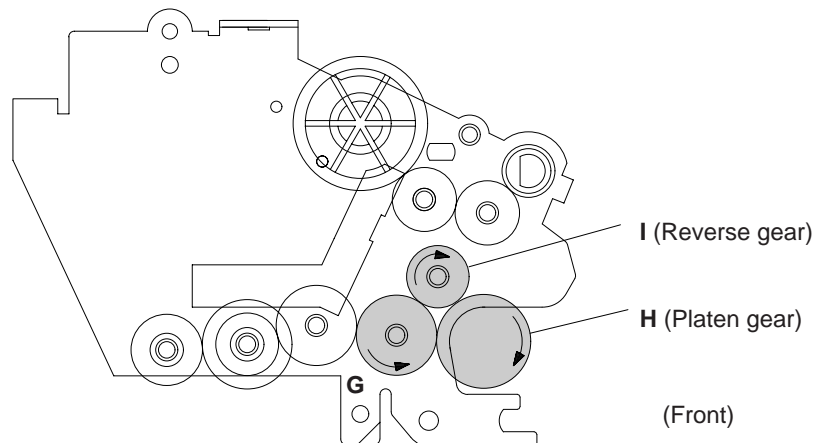

Active Gears on the Scanner Frame ASSY

The cutter gear (Q) is a two-stepped gear whose inside gear is a one-tooth sector gear. While the cutter gear (Q) rotates by one turn for one stroke of the upper blade of the cutter, the one-tooth sector gear slightly turns the platen gear (H) clockwise via the reverse gear (I) to feed the recording paper back into the equipment. This prevents the upper blade of the cutter from scratching the leading edge of the remaining paper.

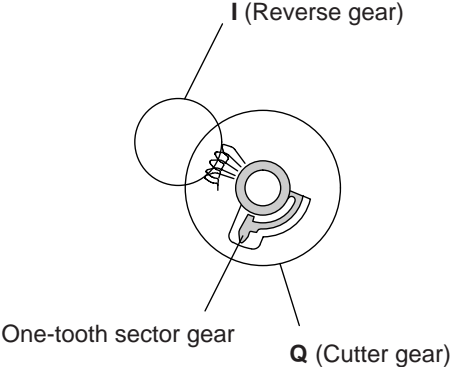

2.3.4 Power transmission route

Rotation of the motor gear is transmitted as shown below.

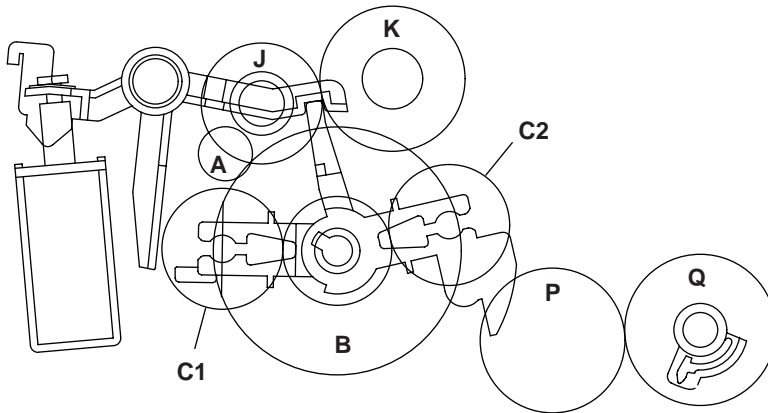

Gears on the Drive Unit

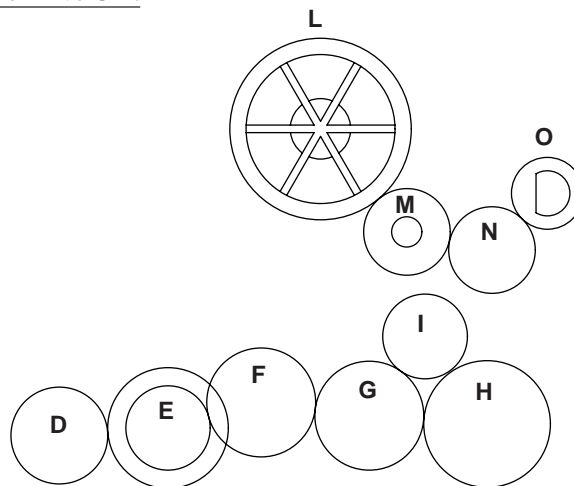

Gears on the Scanner Frame ASSY

- A: Motor gear
- B: Sun gear 18/82
- C1: Planet gear 20B
- C2: Planet gear 20A
- D: Gear 16
- E: Gear 14/20
- F: Gear 18
- G: Gear 18L
- H: Platen gear
- I: Reverse gear
- J: Gear 20
- K: Gear 16/24
- L: Separation roller gear
- M: Gear 23
- N: Flanged gear 23
- O: White pressure roller gear
- P: Gear 24
- Q: Cutter gear

[1] Recording Mode (Solenoid: OFF, Motor rotation: forward)

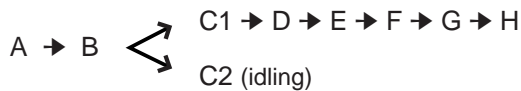

[2] Scanning Mode (Solenoid: OFF, Motor rotation: reverse)

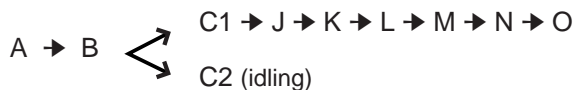

[3] Copying Mode (Solenoid: ON→OFF, Motor rotation: forward)

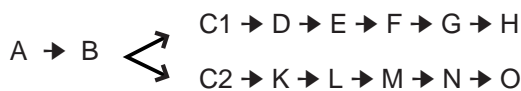

[4] Cutter Driving Mode (Solenoid: ON, Motor rotation: reverse)

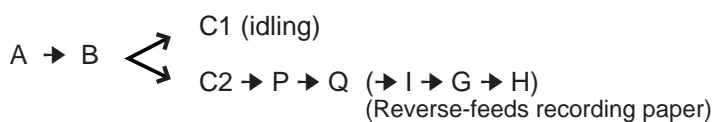

2.4 Sensors and Actuators

This equipment has two photosensors and four mechanical switches as described below.

Sensor name	Type	Located on
Document front sensor	Photosensor (PH1)	Main PCB
Document rear sensor	Photosensor (PH2)	Main PCB
Paper empty (PE) sensor	Mechanical switch (SW1)	Main PCB
Cover sensor	Mechanical switch (SW2)	Main PCB
Hook switch sensor	Mechanical switch (SW3)	Main PCB
Cutter home position (HP) sensor	Mechanical switch	Drive unit

- Document front sensor which detects the presence of documents.
- Document rear sensor which detects the leading and trailing edges of pages to tell the control circuitry when the leading edge of a new page has reached the starting position and when the scan for that page is over.

These photosensors are of a reflection type consisting of a light-emitting diode and a light-sensitive transistor. Each of them has an actuator separately arranged (see the next page). When an actuator is not activated, its white end lies in the path of light issued from the light-emitting diode and reflects its light into the light-sensitive transistor. If a document is fed in so as to activate the actuator, the actuator's white end goes out of the light path. With no reflected light to go into the light-sensitive transistor, the sensor detects the presence of documents.

- PE sensor which detects when the recording paper runs out.
- Cover sensor which detects whether the control panel is closed.
- Hook switch sensor which detects whether the handset is placed on the handset mount.
- Cutter HP sensor which detects the home position of the upper rotary blade of the automatic cutter.

Each of these four sensors has an actuator separately arranged (see the next page). If an actuator is activated, its lower end releases or pushes down the lever provided on the corresponding sensor so that the sensor signals the detection.

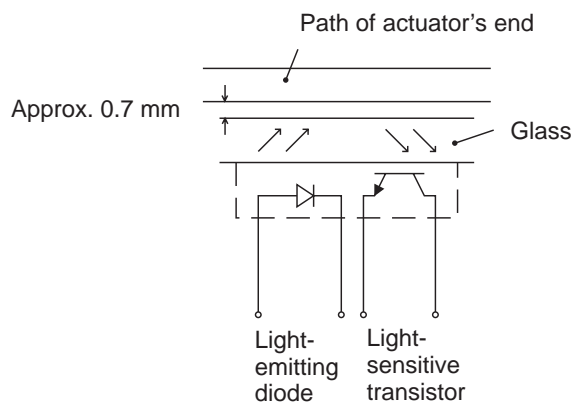

Photosensor

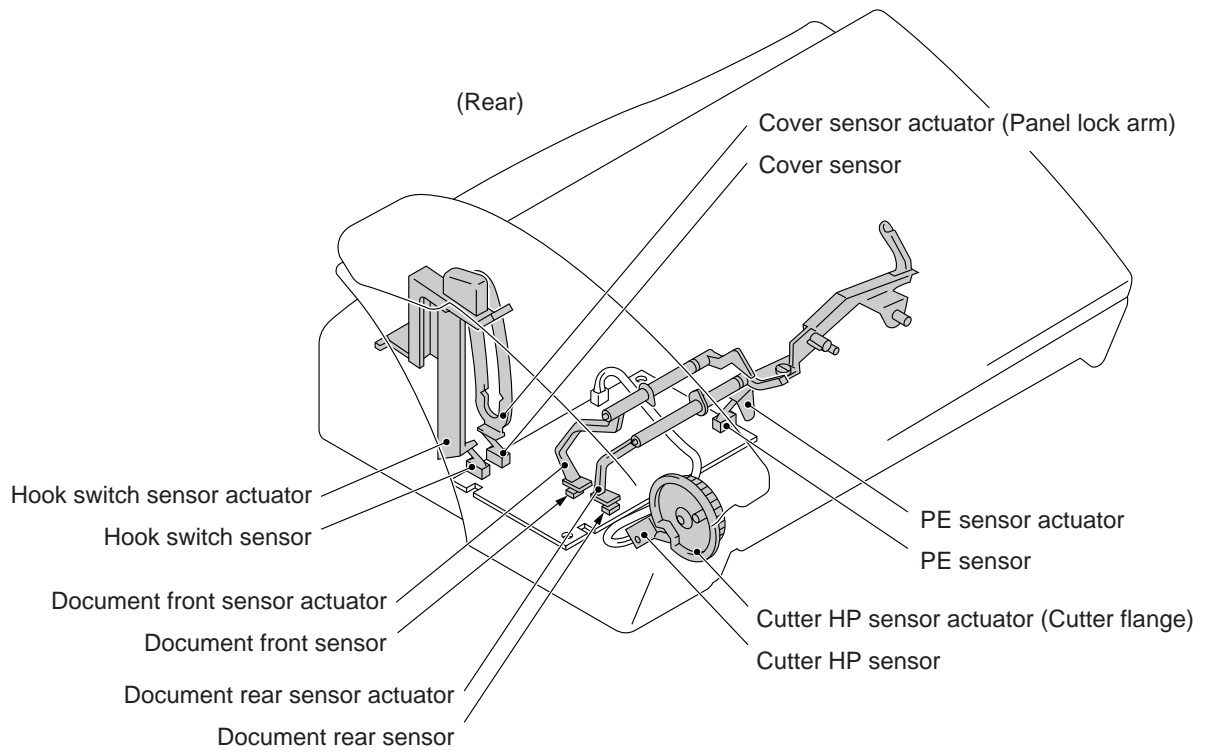

Location of Sensors and Actuators

3. CONTROL ELECTRONICS

3.1 Configuration

The hardware configuration of the facsimile equipment is shown below.

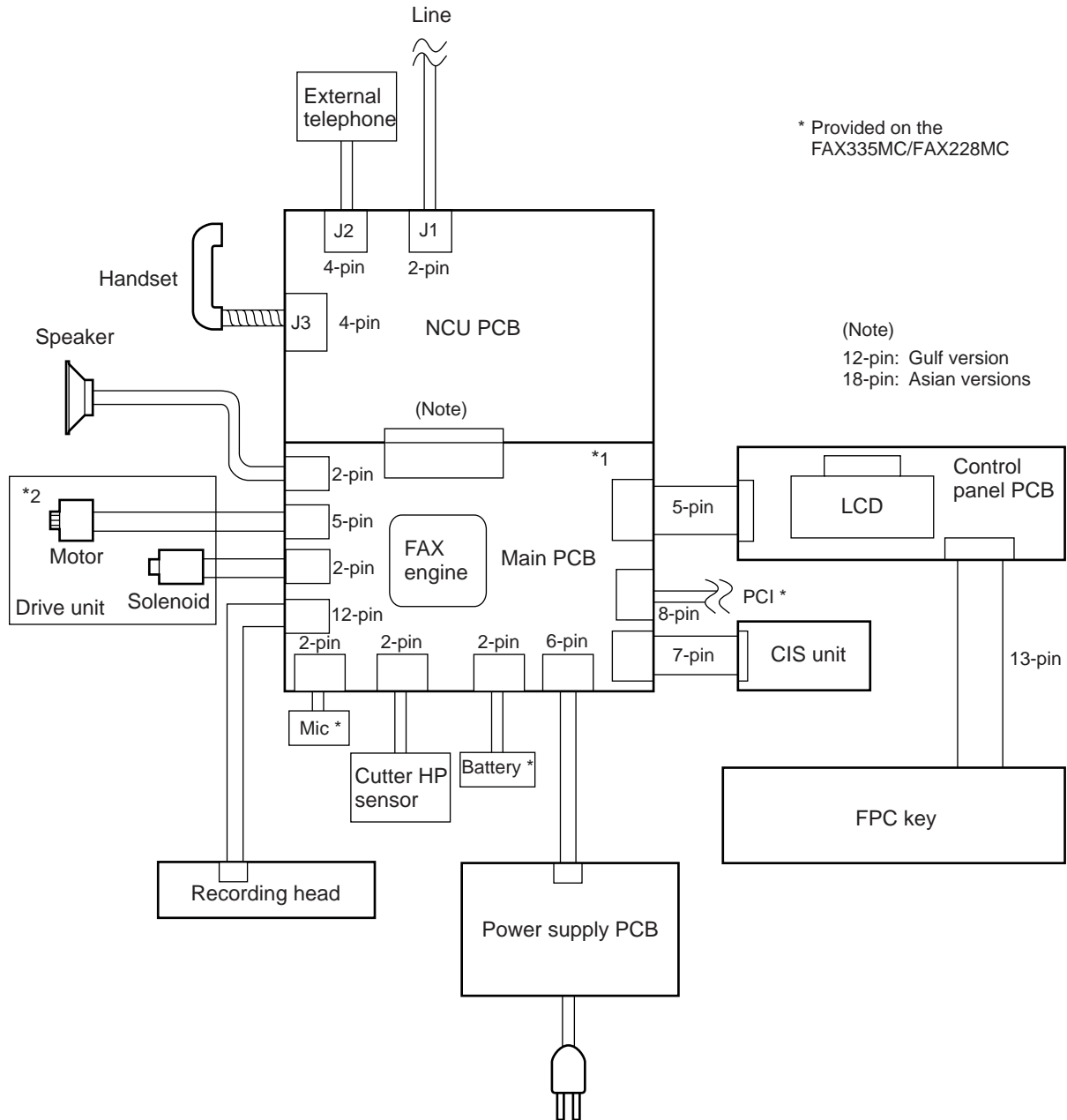

*1 On the main PCB are these sensors:

- PE sensor (SW1)
- Cover sensor (SW2)
- Hook switch sensor (SW3)
- Document front sensor (PH1)
- Document rear sensor (PH2)

*2 On the drive unit is the cutter HP sensor.

Configuration of Facsimile Equipment

3.2 Main PCB

The main PCB, which is the nucleus controlling the entire operation of the equipment, consists of a FAX engine (ASIC), memories, MODEM, motor drive circuitry, sensor detection circuitry, and analog circuits for scanning, recording, and power transmission shifting.

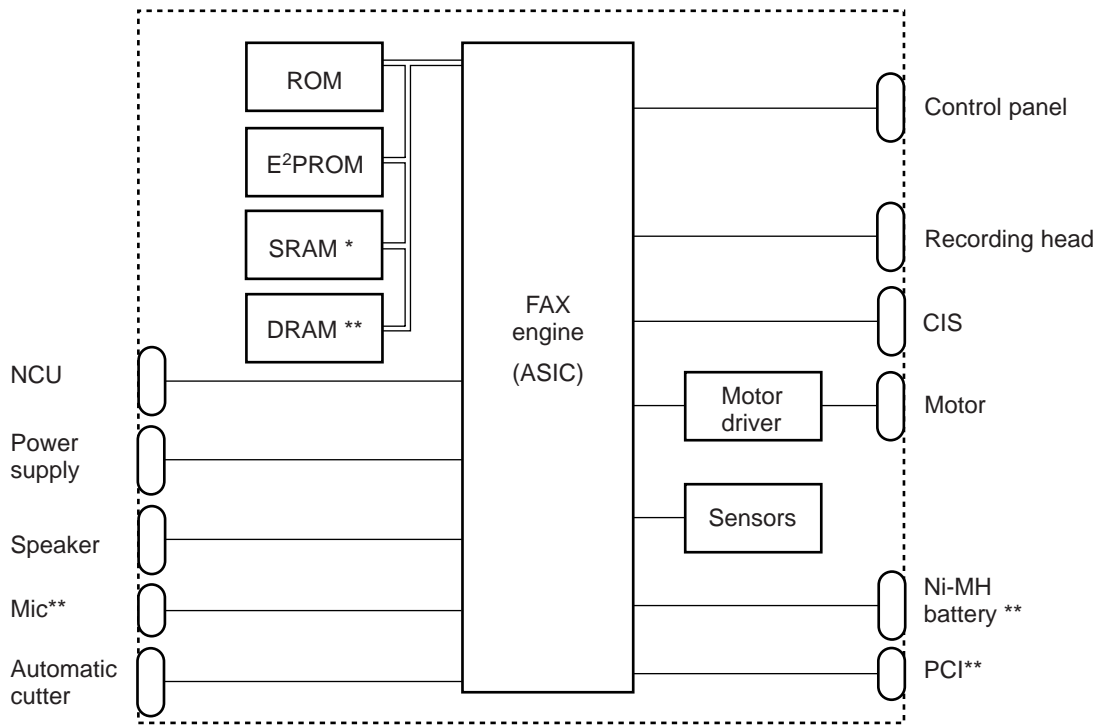

E²PROM: Electrically Erasable Programmable Read-only Memory

* Provided on the FAX235/FAX236/FAX218

** Provided on the FAX335MC/FAX228MC

Block Diagram of Main PCB

FAX235/FAX236/218

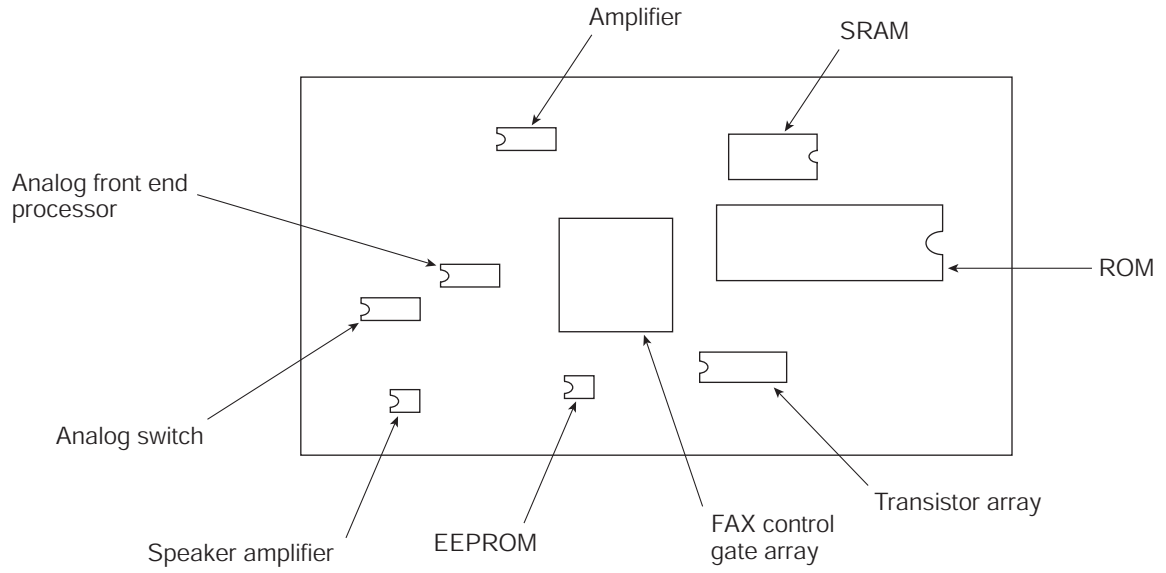

FAX335MC/228MC

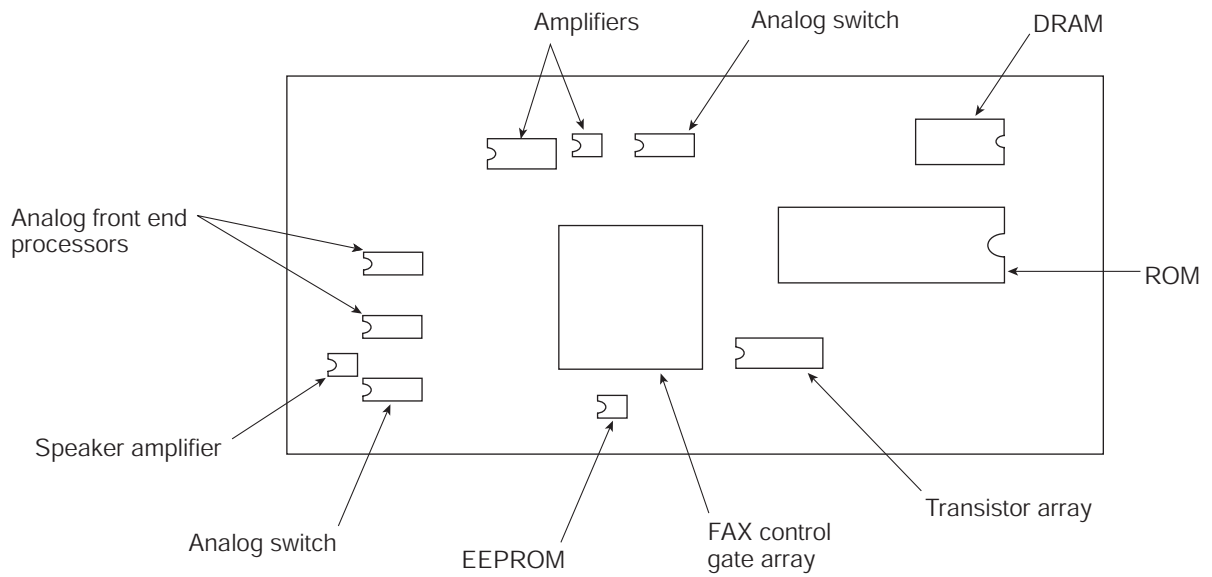

3.3 NCU P CB

The NCU PCB switches the communications line to telephone or built-in MODEM, under the control of the main PCB.

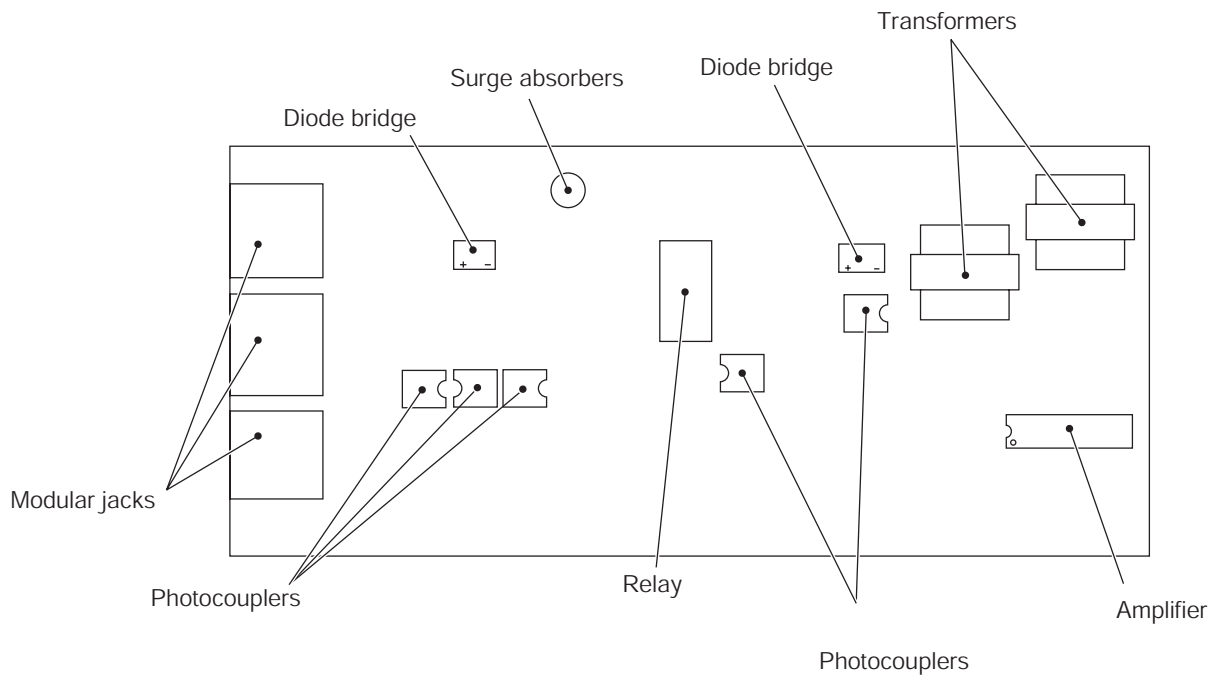
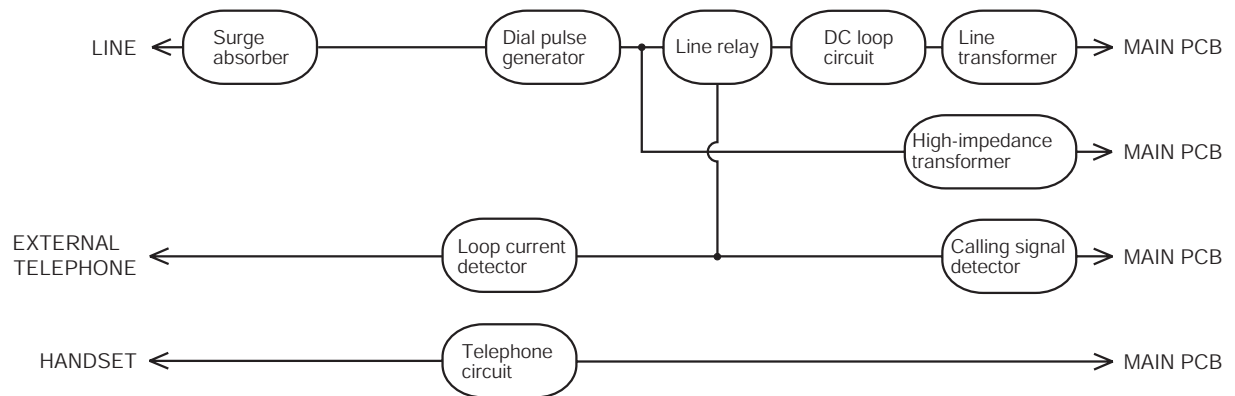

3.4 Control Panel PCB

The control panel PCB and the main PCB communicate with each other by serially transmitting commands and data.

The control panel unit consists of a gate array and LCD, which are controlled by the gate array according to commands issued from the FAX engine on the main PCB.

The calendar clock is backed up by the backup circuit on the main PCB.

The panel FPC is a flexible keyboard PCB which integrates the key matrix having rubber keytops.

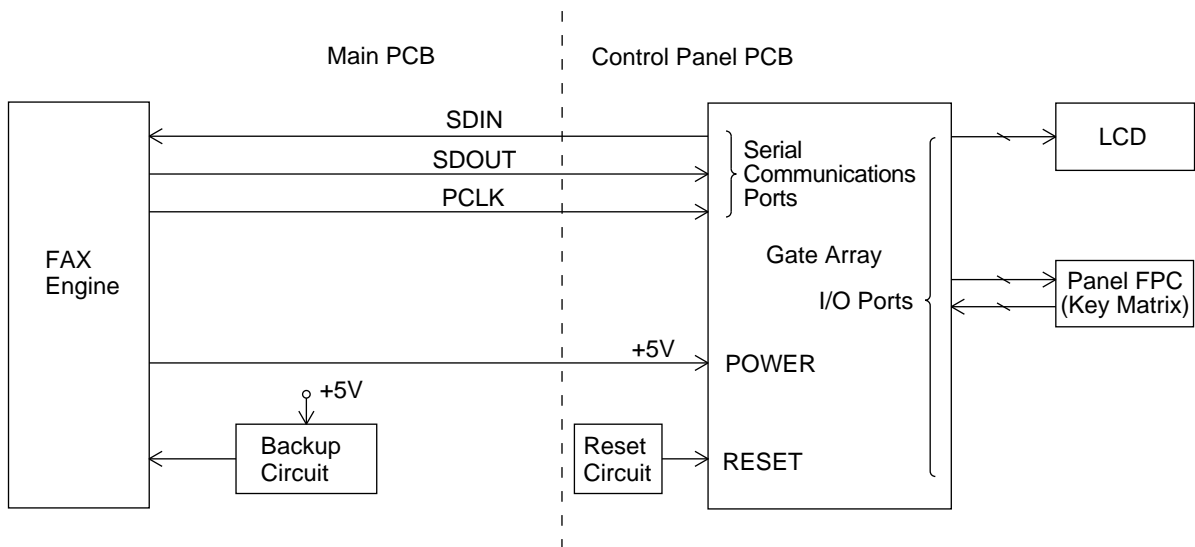

Control Panel PCB and its Related Circuit

3.5 Power Supply PCB

The power supply uses the switching regulation system to generate DC power (+26.6V and +8V) from a commercial AC power supply.

The +26.6V source is stabilized and fed to the motor and solenoid for feeding documents and recording paper or activating the automatic cutter, and also fed to the CIS LED array. It is also fed to the main PCB where the H26.6V source is generated. The H26.6V source outputs 26.6V only when the H26.6V ON/OFF control signal is High, for driving the recording head.

The +8V source is not stabilized and fed to the speaker. It is also fed to the main PCB where the 3-terminal regulator eliminates unstabilized components of the +8V source to generate stabilized +5V source. The +5V source is fed to the logic, control panel, and sensors.

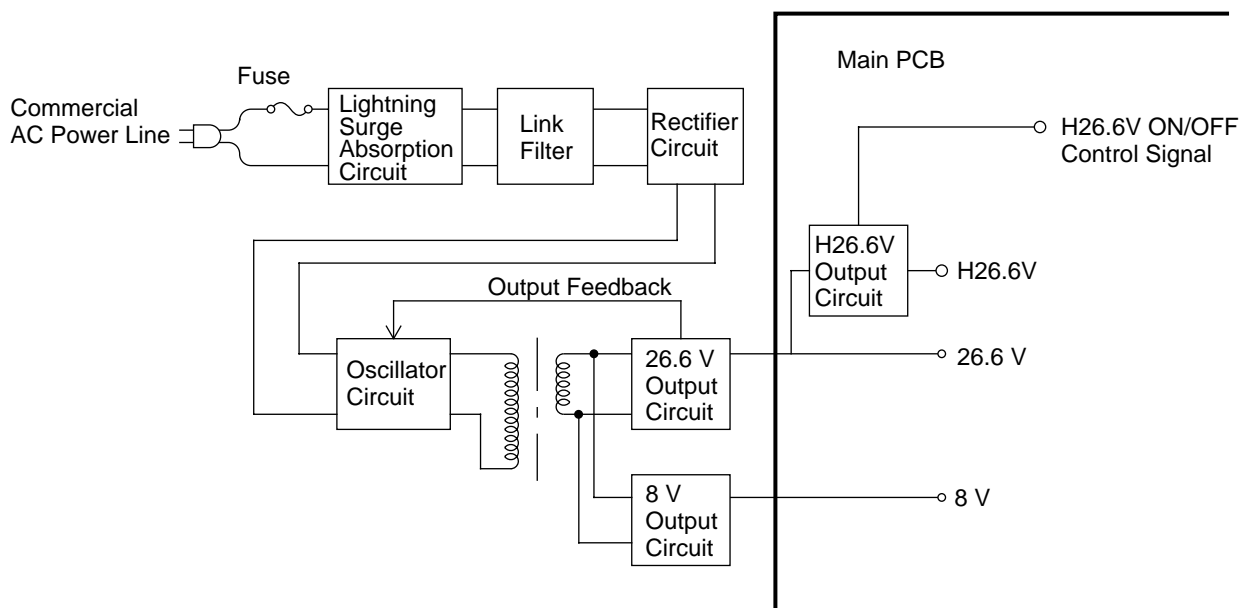

Power Supply Circuit

CHAPTER **IV**.
DISASSEMBLY/REASSEMBLY
AND LUBRICATION

CHAPTER IV. DISASSEMBLY/REASSEMBLY AND LUBRICATION

CONTENTS

1. DISASSEMBLY/REASSEMBLY	IV-1
■ Safety Precautions	IV-1
■ Preparation	IV-3
■ How to Access the Object Component	IV-3
■ Disassembly Order Flow	IV-4
1.1 ACS Plate	IV-5
1.2 ROM Cover and Battery ASSY	IV-6
1.3 Inner Cover	IV-8
1.4 Control Panel ASSY	IV-9
1.5 Recording Paper Cover, Panel Rear Cover, Control Panel and Microphone	IV-11
1.6 Scanner Frame ASSY	IV-14
1.7 White Pressure Roller and CIS Unit	IV-17
1.8 Drive Unit (Main Motor and Cutter HP Sensor)	IV-18
1.9 Separation Roller ASSY	IV-21
1.10 Document Front and Rear Sensor Actuators	IV-22
1.11 Recording Head Release Lever	IV-23
1.12 Recorder & Cutter ASSY	IV-24
1.13 Platen and Cutter Chute	IV-25
1.14 Recording Head and Cutter Unit	IV-26
1.15 Hook Switch Sensor Actuator	IV-27
1.16 Speaker	IV-27
1.17 Bottom Plate	IV-28
1.18 Main PCB, NCU PCB and Power Supply PCB	IV-29
1.19 Paper Empty Sensor Actuator	IV-33
2. LUBRICATION	IV-34

1. DISASSEMBLY/REASSEMBLY

■ Safety Precautions

To prevent the creation of secondary problems by mishandling, observe the following precautions during maintenance work.

- (1) Always turn off the power before replacing parts or units. When having access to the power supply, be sure to unplug the power cord from the power outlet.
- (2) Be careful not to lose screws, washers, or other parts removed for parts replacement.
- (3) When using soldering irons and other heat-generating tools, take care not to damage the resin parts such as wires, PCBs, and covers.
- (4) Before handling the PCBs, touch a metal portion of the equipment to discharge static electricity; otherwise, the electronic parts may be damaged due to the electricity charged in your body.
- (5) When transporting PCBs, be sure to wrap them in conductive sheets such as aluminum foil.
- (6) Be sure to reinsert self-tapping screws correctly, if removed.
- (7) Tighten screws to the torque values listed on the next page.
- (8) When connecting or disconnecting cable connectors, hold the connector bodies not the cables. If the connector has a lock, always slide the connector lock to unlock it.
- (9) Before reassembly, apply the specified lubricant to the specified points. (Refer to Section 2 in this chapter.)
- (10) After repairs, check not only the repaired portion but also that the connectors and other related portions function properly before operation checks.

Tightening Torque List

Location	Screw type	Q'ty	Tightening torque kgf•cm (N•cm)
Recording paper cover	Taptite, cup B M3x8	2	5 ±2 (49 ±20)
Panel rear cover	Taptite, cup B M3x8	4	5 ±2 (49 ±20)
Control panel PCB	Taptite, cup B M3x8	1*	5 ±2 (49 ±20)
Scanner frame ASSY	Taptite, cup B M3x8	2	5 ±2 (49 ±20)
Drive unit	Taptite, cup S M3x6 Taptite, cup S M3x8	3 1	7 ±2 (69 ±20) 7 ±2 (69 ±20)
Motor	Taptite, cup S M3x6	1	6 ±2 (59 ±20)
Cutter HP sensor	Taptite, pan B M1.6x8	1	1 ±0.5 (10 ±5)
Recorder & cutter unit	Taptite, cup S M3x8	1	7 ±2 (69 ±20)
Bottom plate	Taptite, cup B M3x8	4	5 ±2 (49 ±20)
Grounding wire	Screw, pan (washer) 4x6DB	1	7 ±2 (69 ±20)

* Provided on the FAX335MC/FAX228MC

■ Preparation

Prior to proceeding to the disassembly procedure,

- (1) Unplug
 - the modular jack of the telephone line,
 - the modular jack of the curled cord (and remove the handset), and
 - the modular jack of an external telephone set if mounted. (Not shown below.)
- (2) Remove
 - the document support.

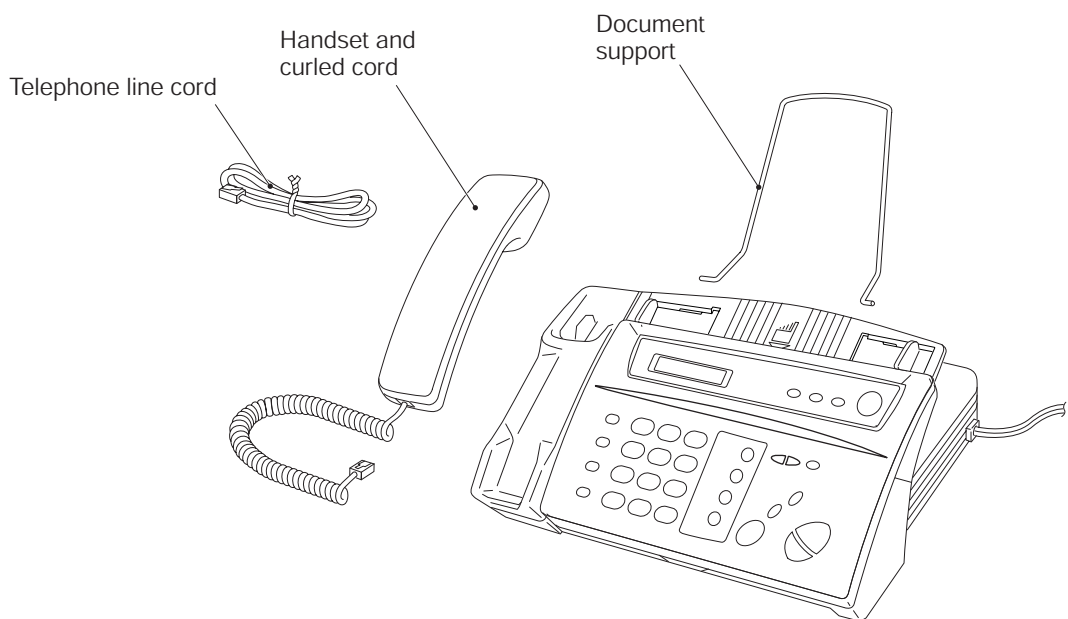

■ How to Access the Object Component

- On the next page is a disassembly order flow which helps you access the object component. To remove the recording head, for example, first find it on the flow and learn its number (14 in this case). You should remove parts numbered 1 through 4, 6, 8, 11, 12, and 13 so as to access the recording head.
- Unless otherwise specified, the disassembled parts or components should be reassembled in the reverse order of removal.

■ **Disassembly Order Flow**

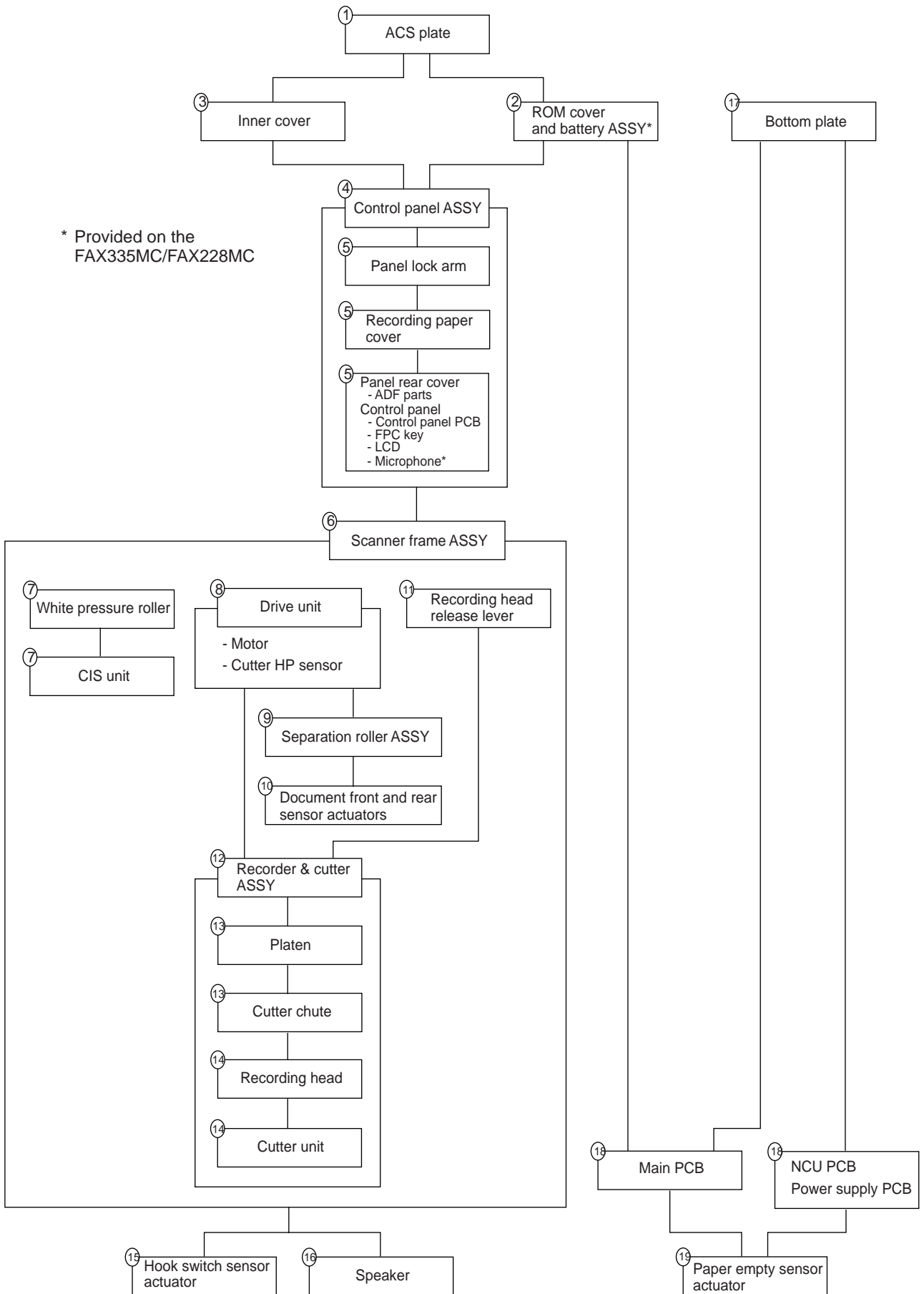

1.1 ACS Plate

- (1) Open the control panel ASSY.
- (2) Push down the locking pawl of the main frame with the tip of a flat screwdriver and move the ACS plate to the left.

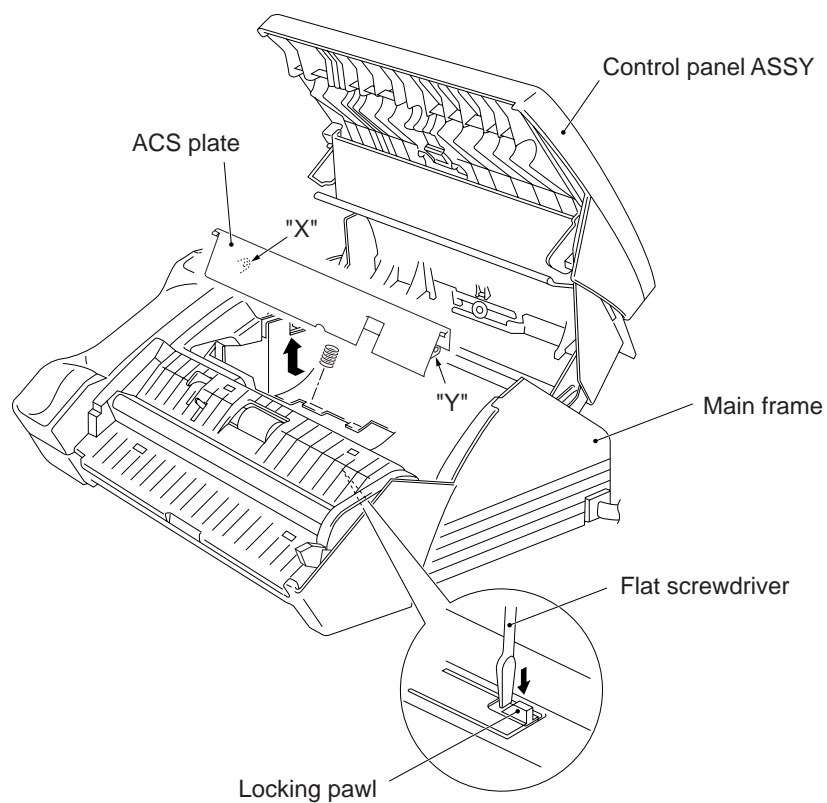

■ Reassembling Notes

- When installing the ACS plate, first fit hole "X" at the left end of the ACS plate over the left-hand boss provided on the main frame and then fit hole "Y" at the right end over the right-hand boss.

1.2 ROM Cover and Battery ASSY*

(*FAX335MC/FAX228MC)

- (1) Insert the tip of the spring hook at the center or left half of the locking arm as shown below, then lift up the hook to release and move the ROM cover to the right.
- (2) For the FAX335MC/FAX228MC: Slightly lift up the ROM cover and disconnect the battery harness from the main PCB, then take out the ROM cover together with the battery ASSY.
- (3) For the FAX335MC/FAX228MC: Remove the battery ASSY from the ROM cover.

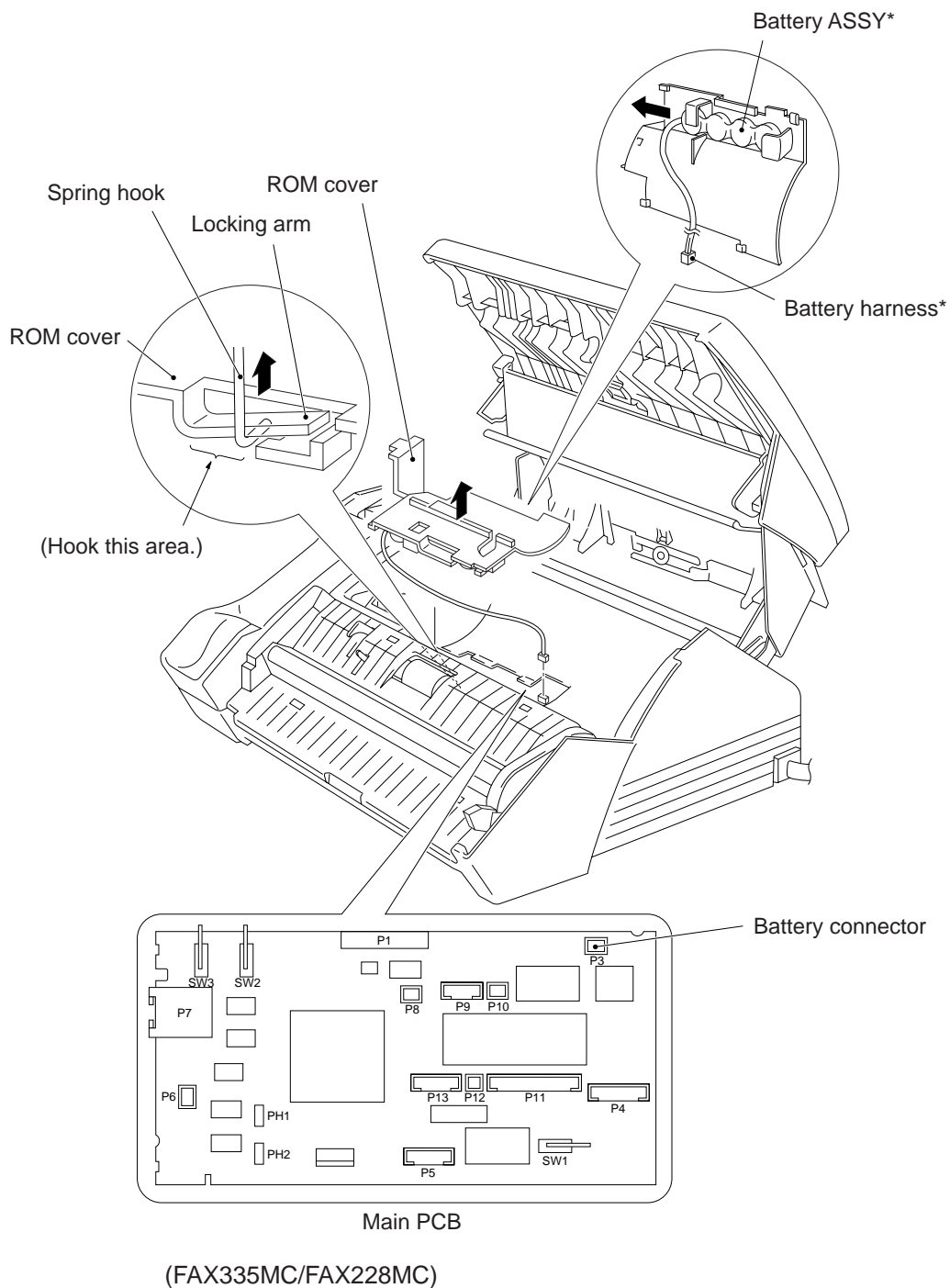

- (4) For the FAX335MC/FAX228MC: To take out the main PCB or the power supply PCB in Section 1.18, unhook the battery harness core and cutter HP sensor harness core from bosses "C" and "D," respectively, at this stage.

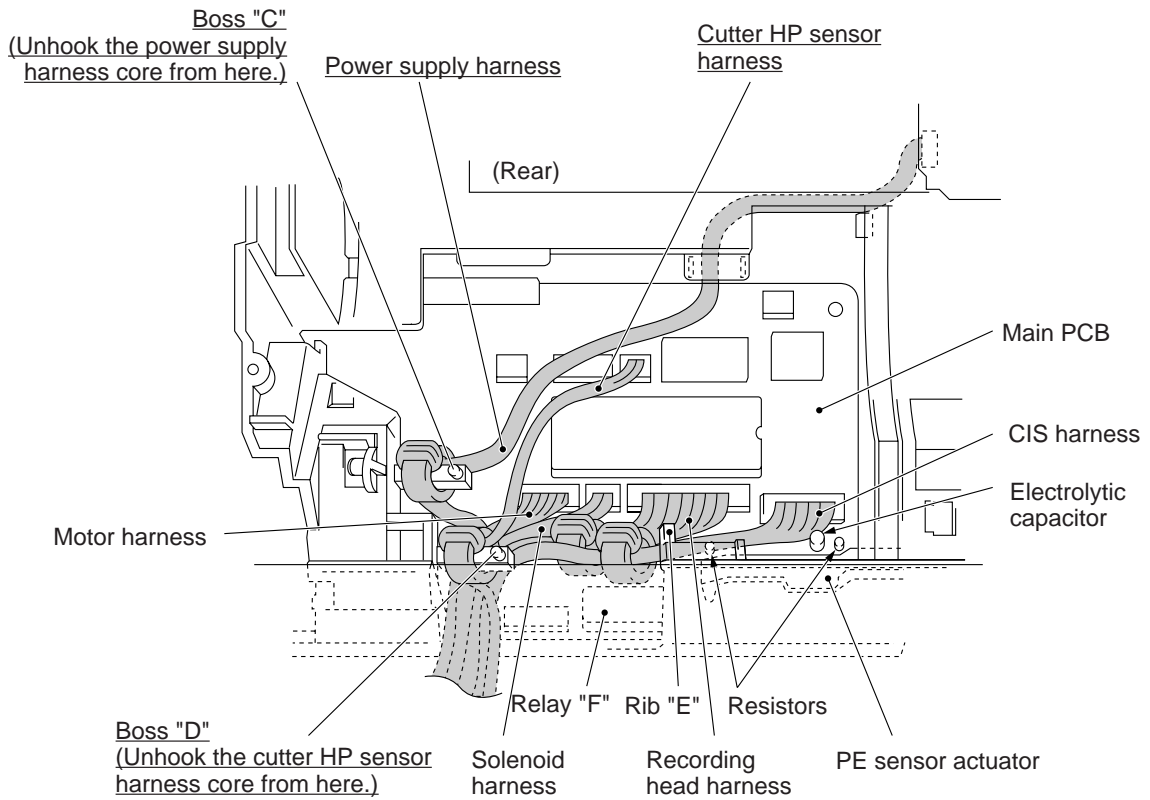

1.3 Inner Cover

- (1) Swing the recording head release lever (blue lever) up to the head release position.
- (2) While lifting up the inner cover slightly, release the four latches with the tip of a flat screwdriver in the order (① to ④) shown below.

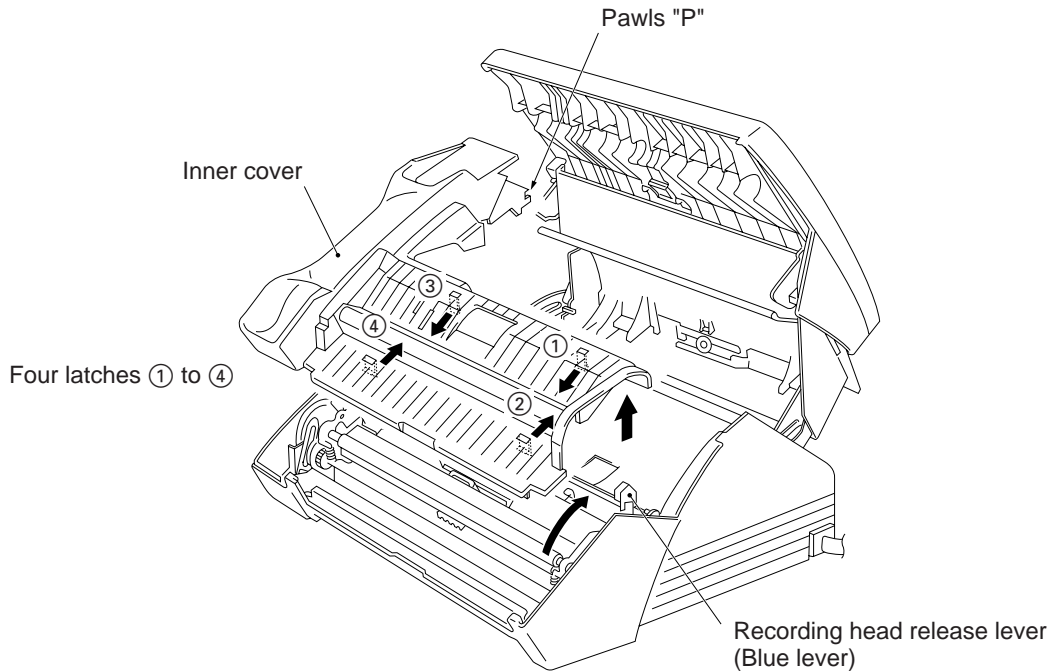

■ Reassembling Notes

- Before installing the inner cover, swing the recording head release lever up for greater ease.
- Fit the pawls "P" of the inner cover into the square hole provided in the left rear corner of the main frame and then push the inner cover down into place.

1.4 Control Panel ASSY

- (1) Disconnect the main-panel harness and the main-mic harness* from the main PCB, and then take out those harnesses from the groove of the main frame.
- (2) Slightly bring the control panel ASSY back up towards you so that you can release the panel lock arm from the boss of the main frame. Pull out the panel lock arm to the left and fully open the control panel ASSY.

* The main-mic harness is provided on the FAX335MC/FAX228MC.

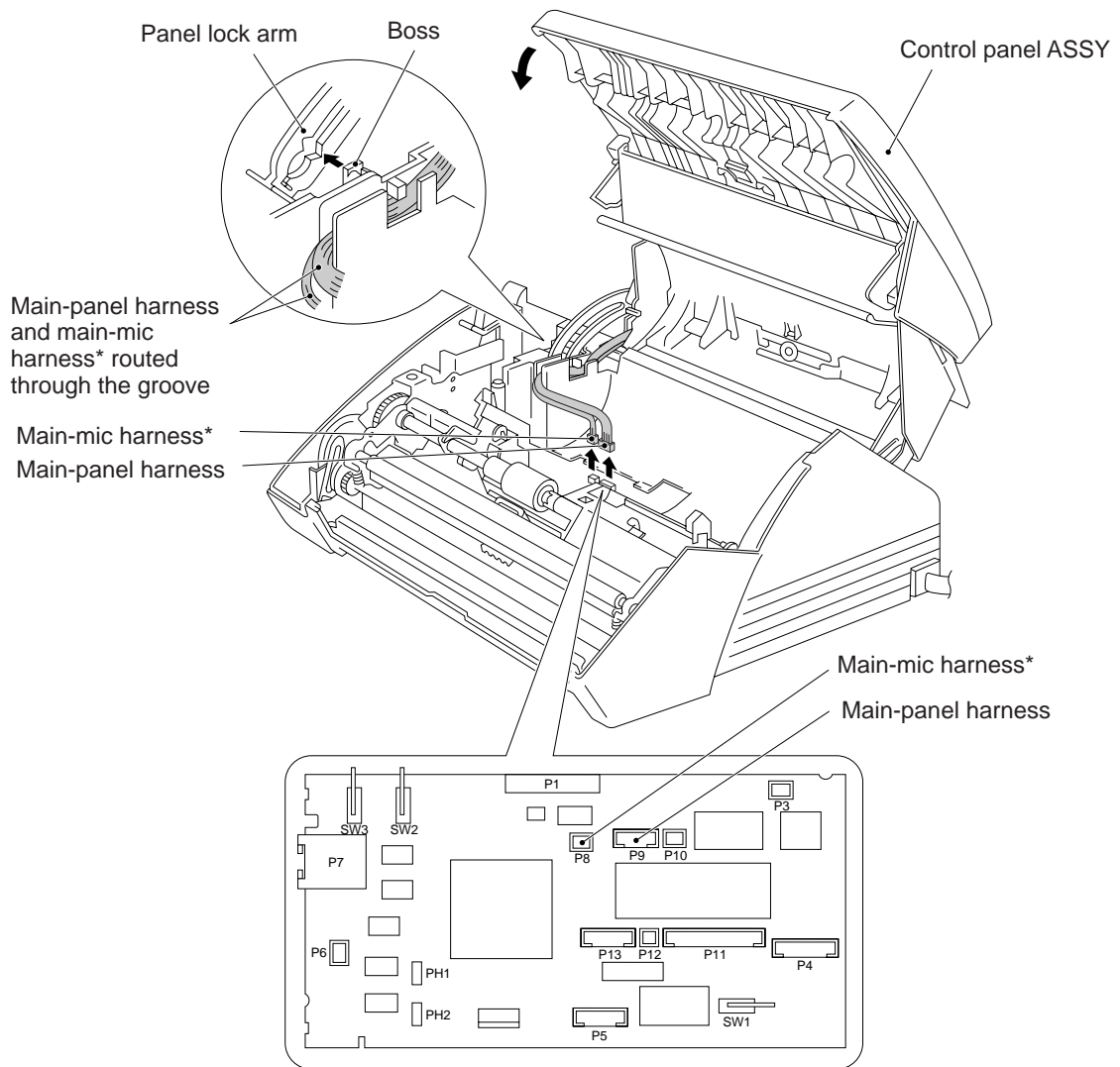

(Main PCB)

(FAX335MC/FAX228MC)

- (3) Push the control panel ASSY back and remove it.

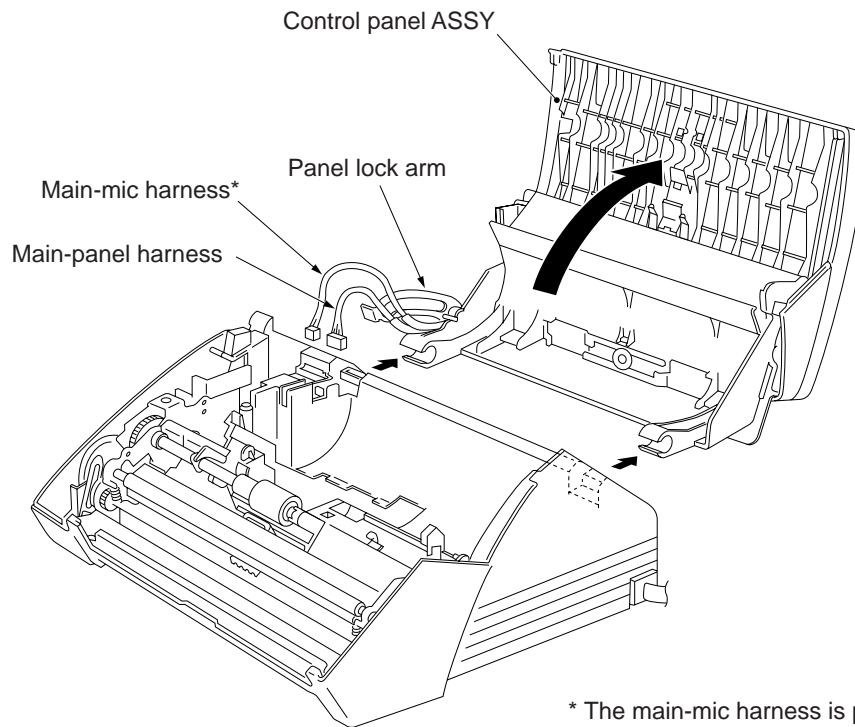

* The main-mic harness is provided on the FAX335MC/FAX228MC.

■ Reassembling Notes

- Make sure that the main-panel harness and main-mic harness* are routed through the groove provided on the recording paper cover and are kept in place with the panel lock arm, as illustrated on page IV-13.

1.5 Recording Paper Cover, Panel Rear Cover, Control Panel and Microphone* (*FAX335MC/228MC)

- (1) Place the control panel ASSY upside down.
- (2) Turn the panel lock arm until the cutout provided in it becomes aligned with the boss of the arm support, then pull it out to the left.
- (3) Remove the two screws "a" from the recording paper cover and lift up the rear edge of the cover.
- (4) Remove the ADF parts (ADF film, separator and leaf spring), using the spring hook and a flat screwdriver. Once removed, they will become unusable and new parts should have to be put back in.
- (5) Remove the four screws "b" from the panel rear cover, then unhook the latches "L" and lift up the cover.
- (6) For the FAX335MC/228MC: Remove the screw "c" from the control panel PCB.

Unlock the LCD cable connector and disconnect the LCD flat cable to take out the control panel PCB and the FPC key.

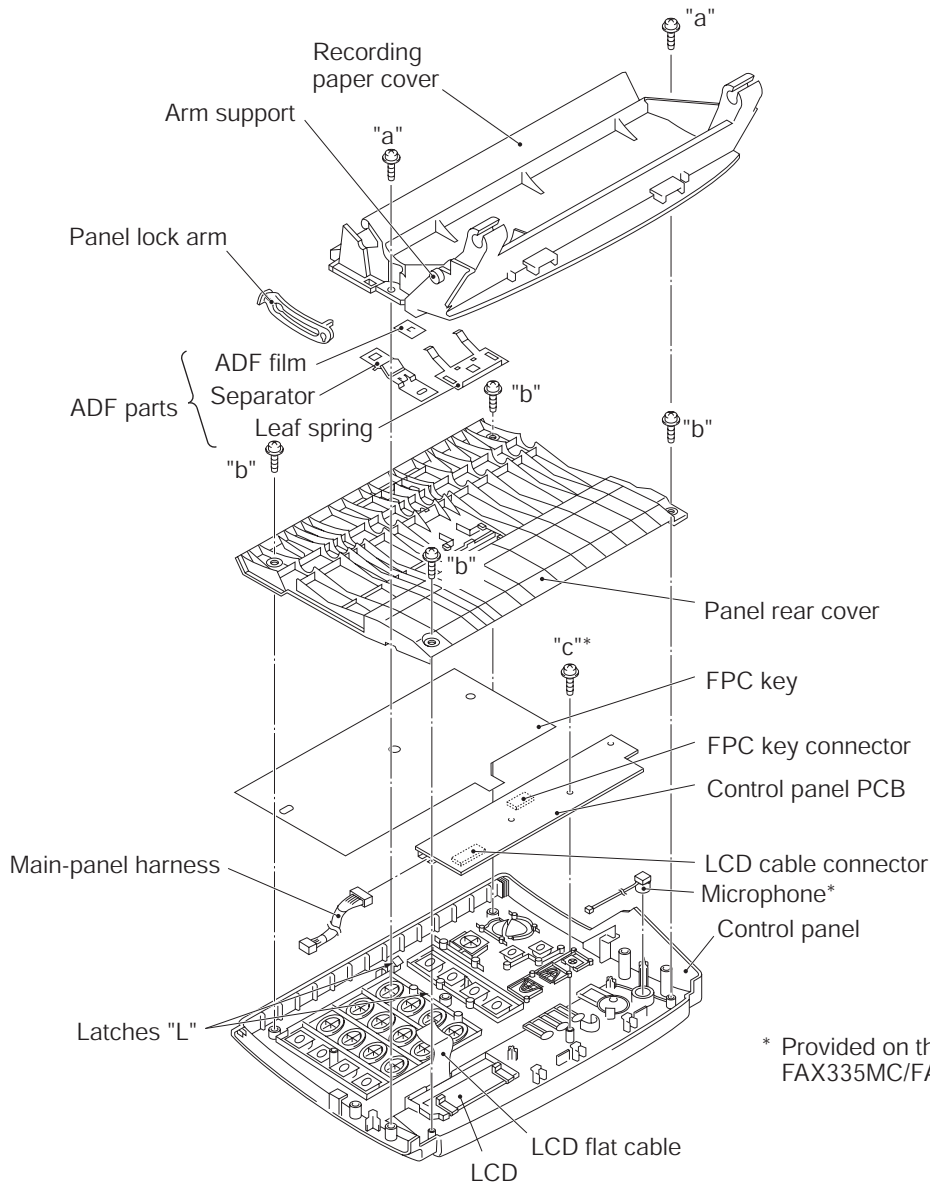

* Provided on the FAX335MC/FAX228MC.

- (7) To separate the FPC key from the control panel PCB, unlock the FPC key connector and disconnect the FPC key.
- (8) For the FAX335MC/FAX228MC: Take out the microphone* and its harness* from from the control panel.

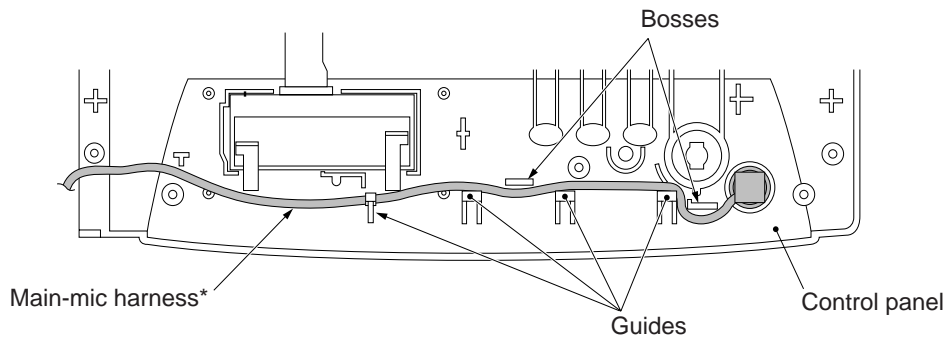

* Provided on the FAX335MC/FAX228MC.

- (9) To take out the LCD, remove the control panel PCB and the FPC key in step (6). Pull up the clamps with your fingers and take out the LCD to the front, as shown below.

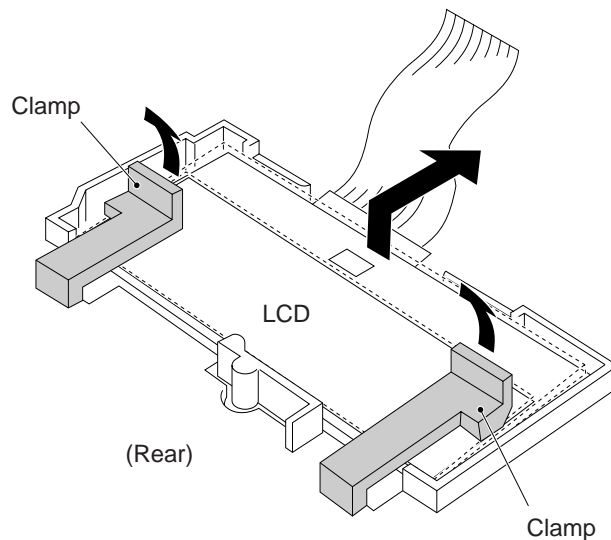

■ Reassembling Notes

- When installing the LCD, take care not to scratch or damage the cover sheet. Replace it if scratched or damaged.
- A new LCD is covered with a protection sheet. Before installing it, remove the protection sheet.

- When setting the recording paper cover on the control panel, first insert the right and left front corners under sections "X" of the control panel and put the cover into place. Make sure that the main-panel harness and main-mic harness* are routed as shown below.

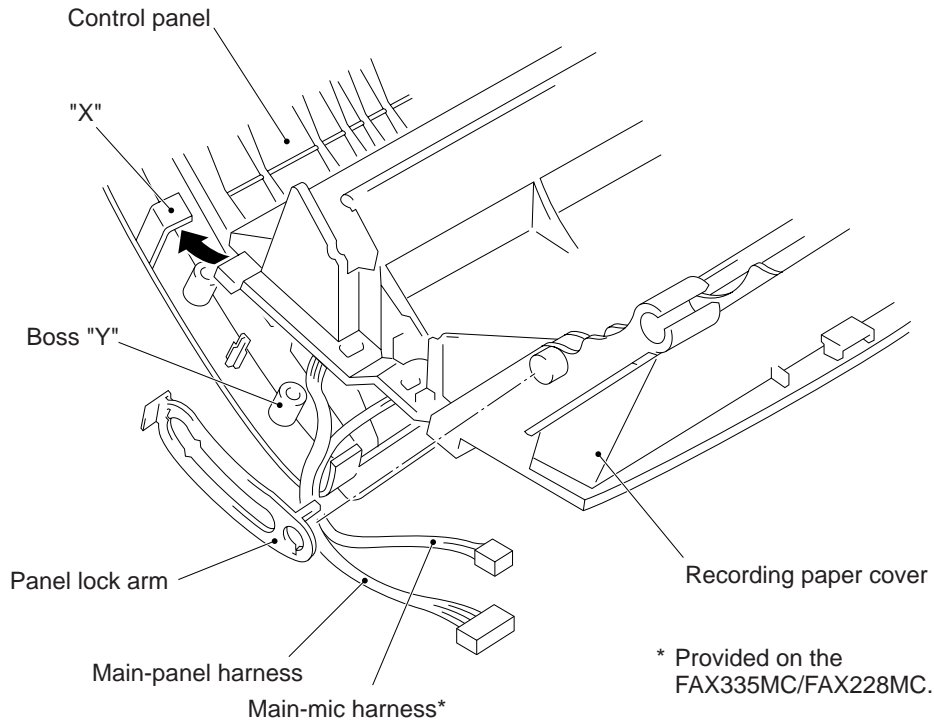

- After securing the recording paper cover with the screws, be sure to route the main-panel harness and the main-mic harness* through the groove provided on the recording paper cover and then set the panel lock arm to keep those harnesses in place, as illustrated below.

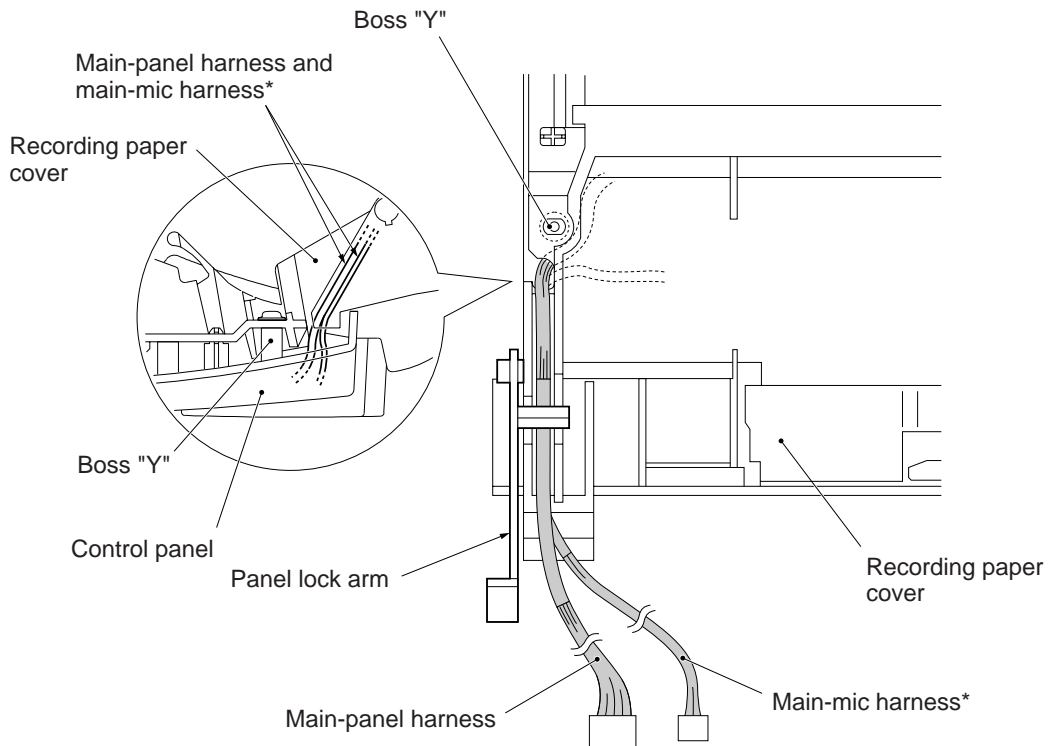

1.6 Scanner Frame ASSY

- (1) Be sure to swing the recording head release lever (blue lever) down to the front position.
 - (2) Remove the two screws.
 - (3) Slightly lift up the rear edge of the scanner frame ASSY and disconnect the following five harnesses from the main PCB:
 - Cutter home position (HP) sensor harness (2-pin)
 - CIS harness (7-pin)
 - Recording head harness (12-pin)
 - Solenoid harness (2-pin)
 - Motor harness (6-pin)
 - (4) Lift up the scanner frame ASSY from the rear and take it out from the main frame.
- NOTE: Do not hold the lower paper chute but the upper paper chute. The lower paper chute is easily deformed.

FAX235/FAX236/FAX218

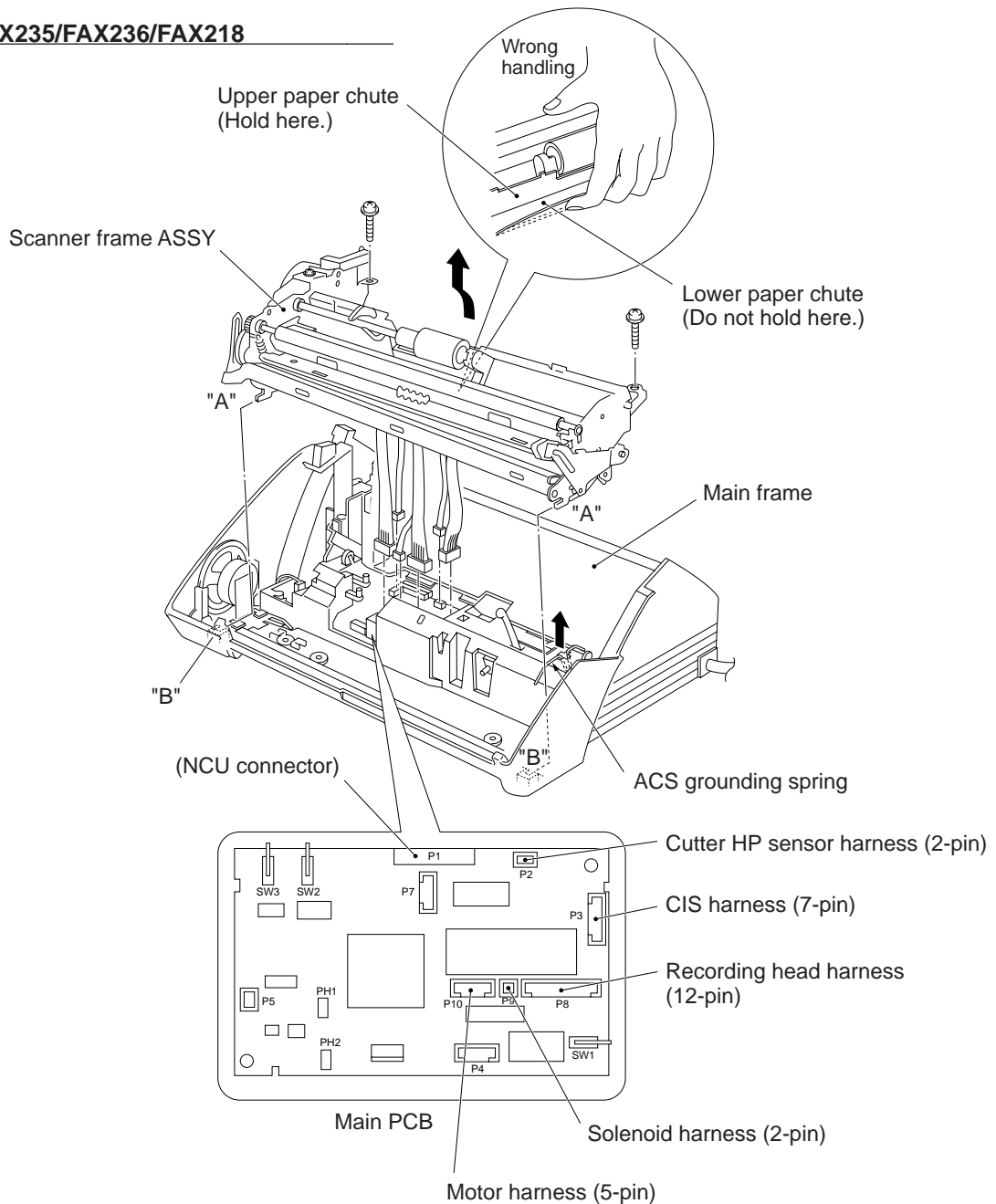

FAX335MC/FAX228MC

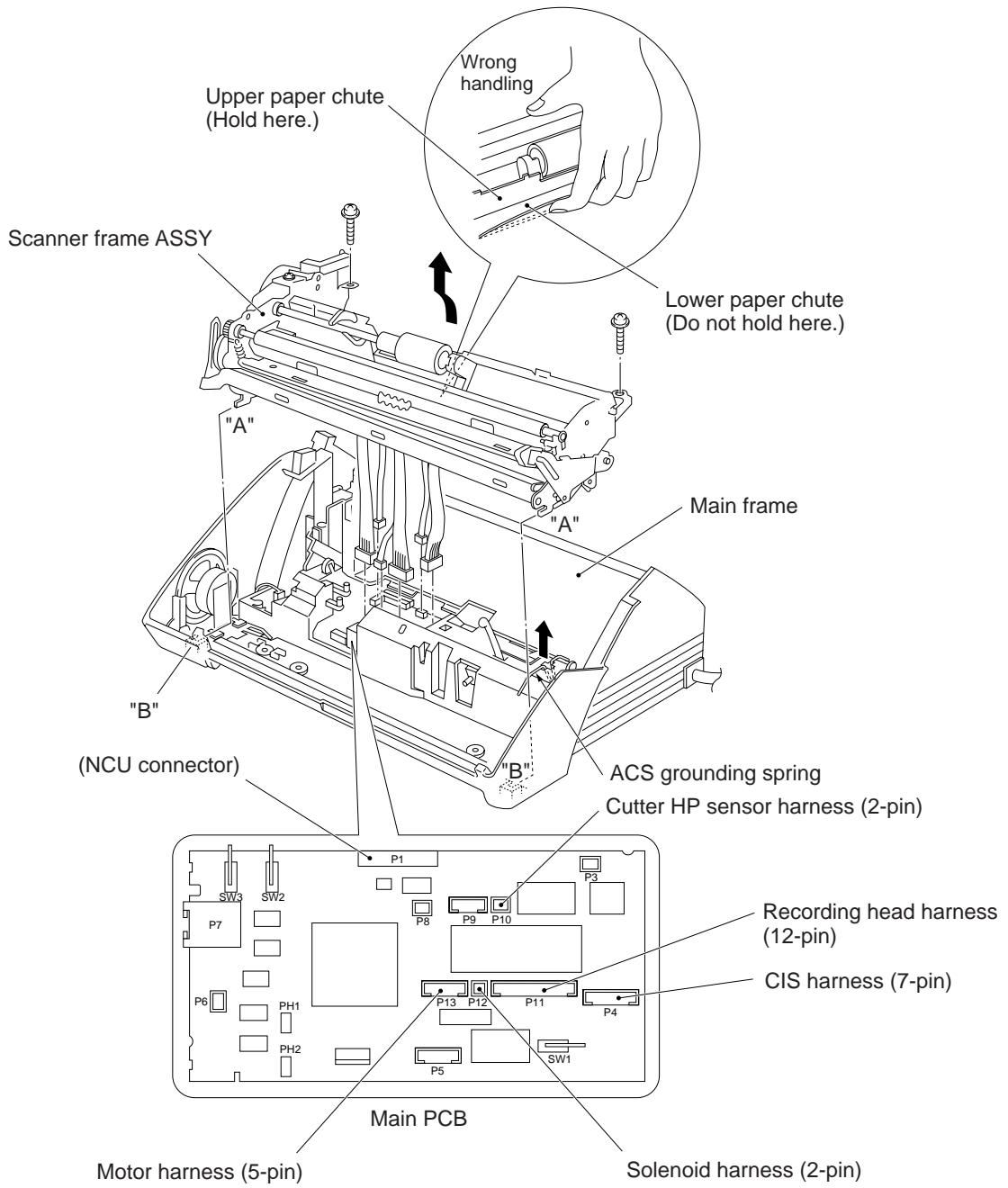

- (5) Lift up the ACS grounding spring.

■ **Reassembling Notes**

- Before putting the scanner frame ASSY back onto the main frame, be sure to set the ACS grounding spring as illustrated on the previous page.
- Make sure that tabs "A" of the scanner frame ASSY are fitted in cutouts "B" provided in the main frame. (See the illustration on the previous page.)
- For the FAX335MC/FAX228MC: After putting the scanner frame ASSY back onto the main frame, route the harnesses and arrange the cores as follows, referring to the illustration below.
 - Hook the power supply harness core on boss "C."
 - Check that the cutter HP sensor harness runs through a core, and then hook the core on boss "D."
 - Push the CIS harness core and the recording head harness core into position, to the left of rib "E" and behind relay "F."
 - Route all these harnesses under boss "D."

If any of these harnesses and cores are out of the specified position, the scanner frame ASSY or ROM cover may not be put back into place.

- For the FAX335MC/FAX228MC: After connecting these harnesses, check that neither the electrolytic capacitor nor resistors are tilted towards the PE sensor actuator. If tilted, they may interfere with normal operation of the sensor actuator.

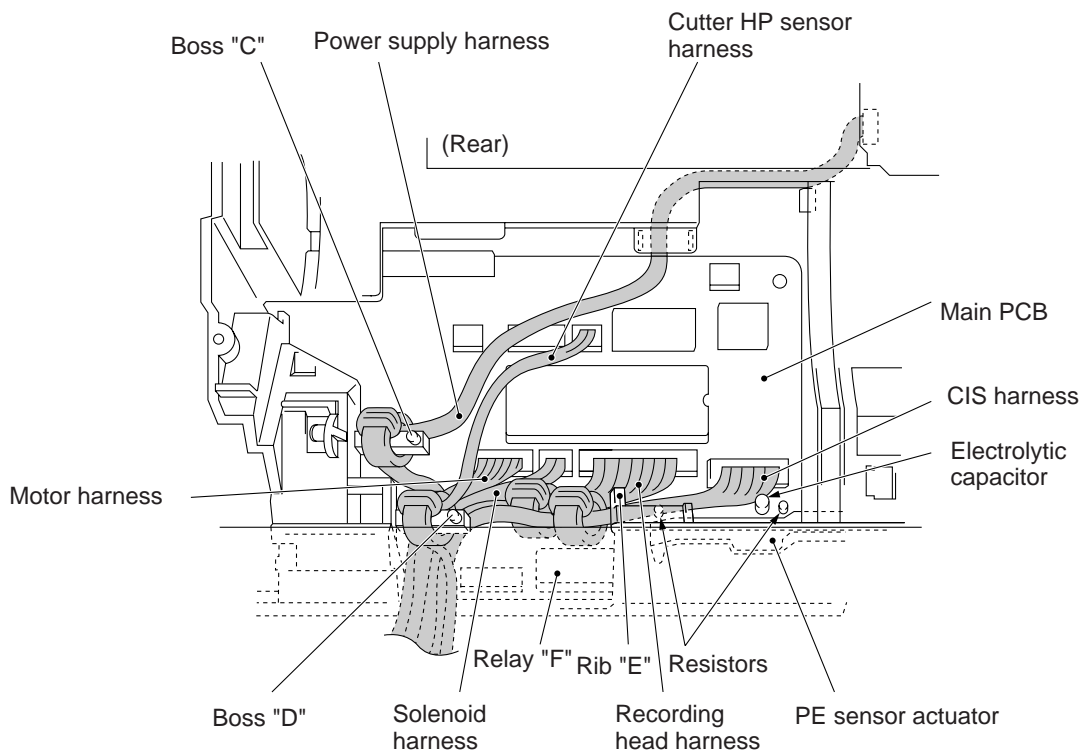

(FAX335MC/FAX228MC)

1.7 White Pressure Roller and CIS Unit

- (1) Turn the bushing of the white pressure roller clockwise approx. 90° and pull it out to the right.
- (2) Lift up the left end of the white pressure roller and push it to the right.

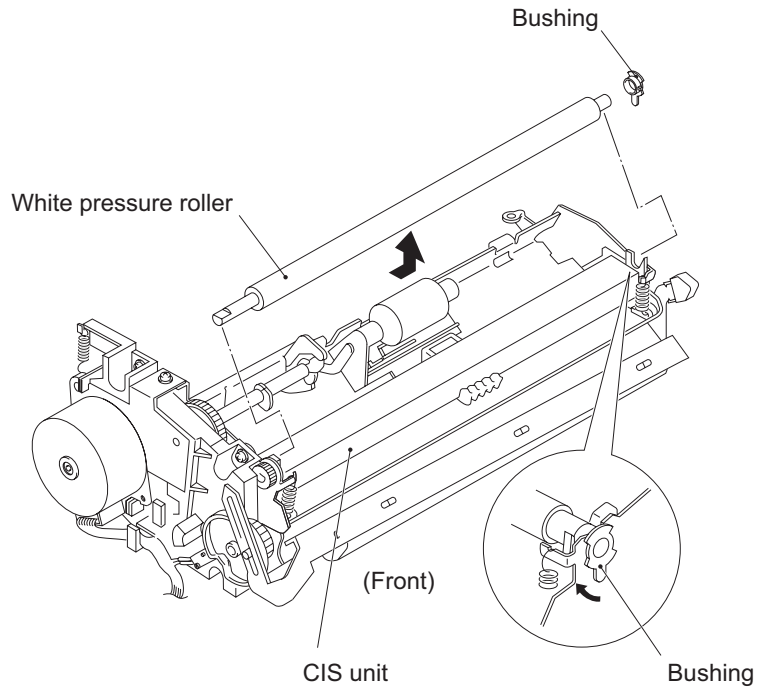

- (3) Unhook the two springs, using the spring hook.
- (4) Slightly lift up the CIS unit and disconnect the CIS harness. The CIS support also comes off.

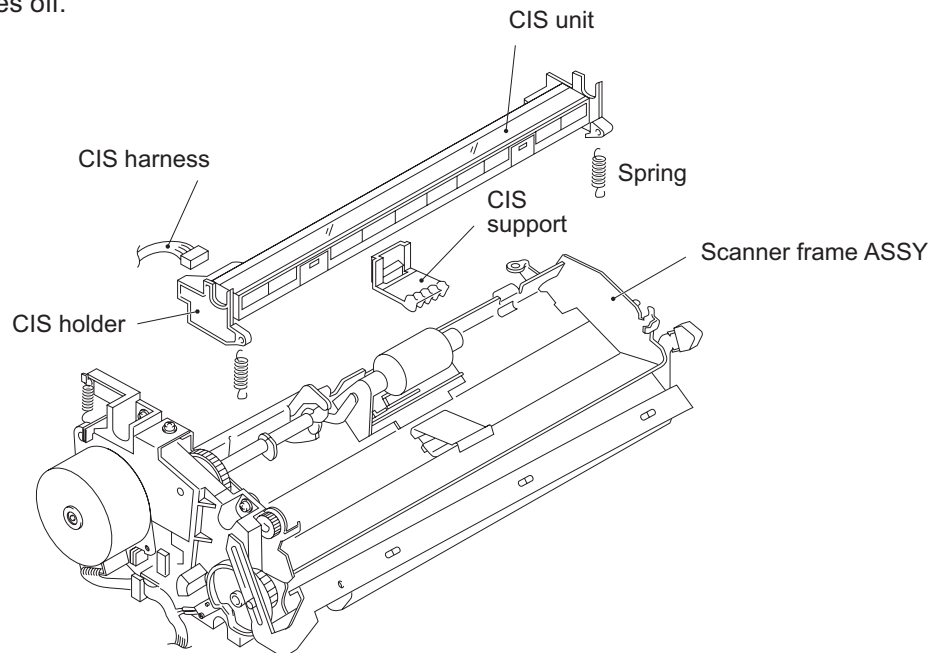

■ Reassembling Notes

- Before putting the white pressure roller back into place, wipe it with an alcohol-dampened cloth.
- When replacing the CIS unit, remove the CIS holders (secured with screws) from the old CIS unit and install them to a new CIS unit.

1.8 Drive Unit (Main Motor and Cutter HP Sensor)

- (1) Turn the scanner frame ASSY upside down.
- (2) Remove the adhesive tape to release the CIS harness, motor harness, solenoid harness, and cutter HP sensor harness.

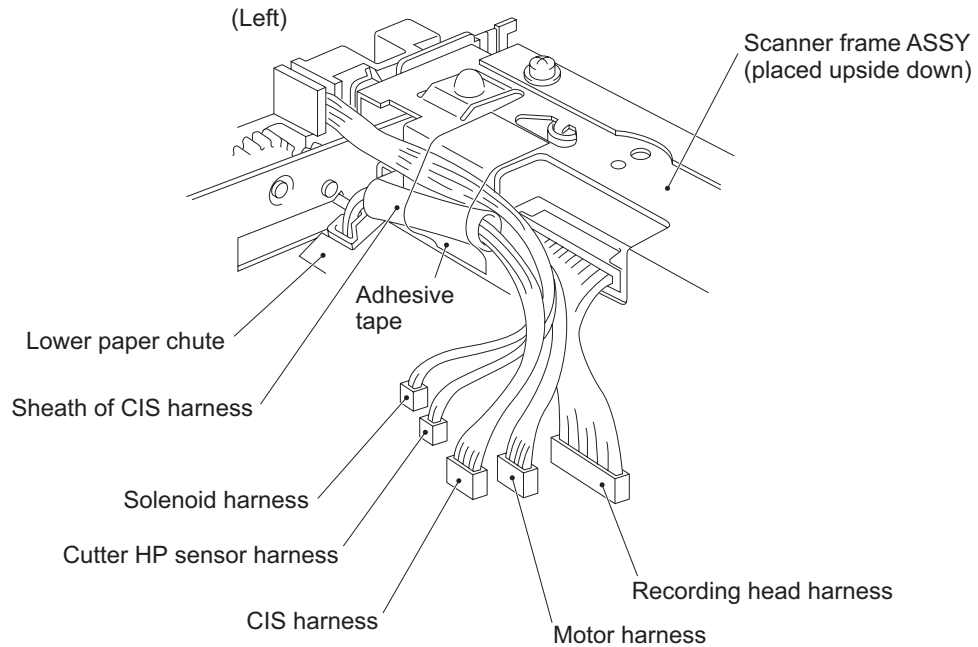

- (3) Place the scanner frame ASSY rightside up.
- (4) Remove the four screws.
- (5) Fully turn the cutter flange clockwise. Hold the drive unit with your left hand and then slightly separate its rear edge from the scanner frame ASSY in the direction of arrow "X" in order to release the boss of the cutter flange from the upper blade.

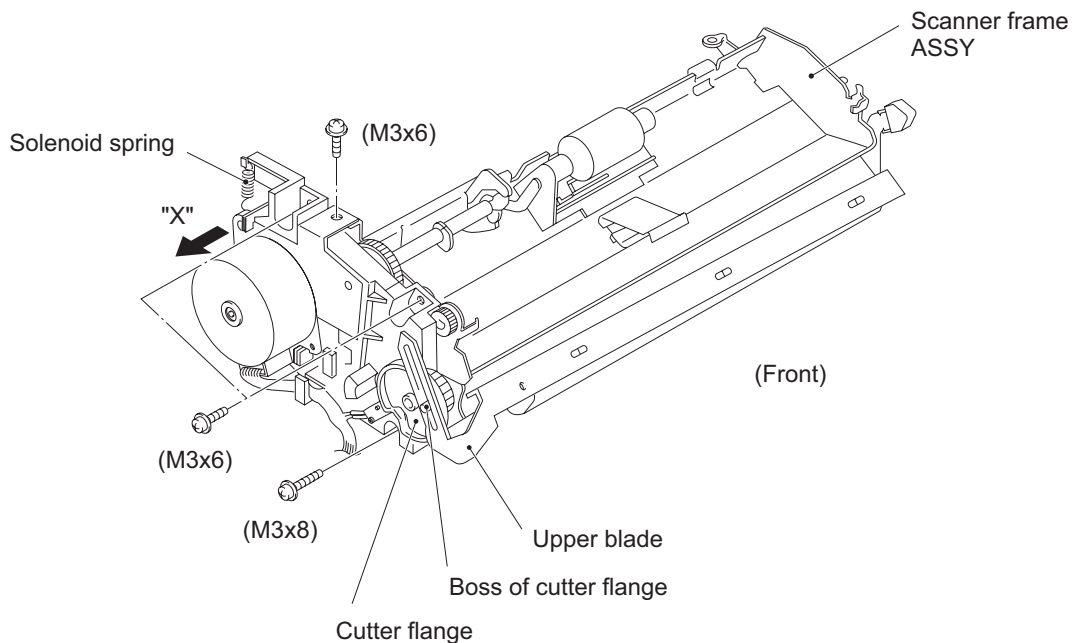

- (6) After releasing the boss of the cutter flange from the upper blade, turn the upper blade clockwise as shown below and take the drive unit off from the scanner frame ASSY.

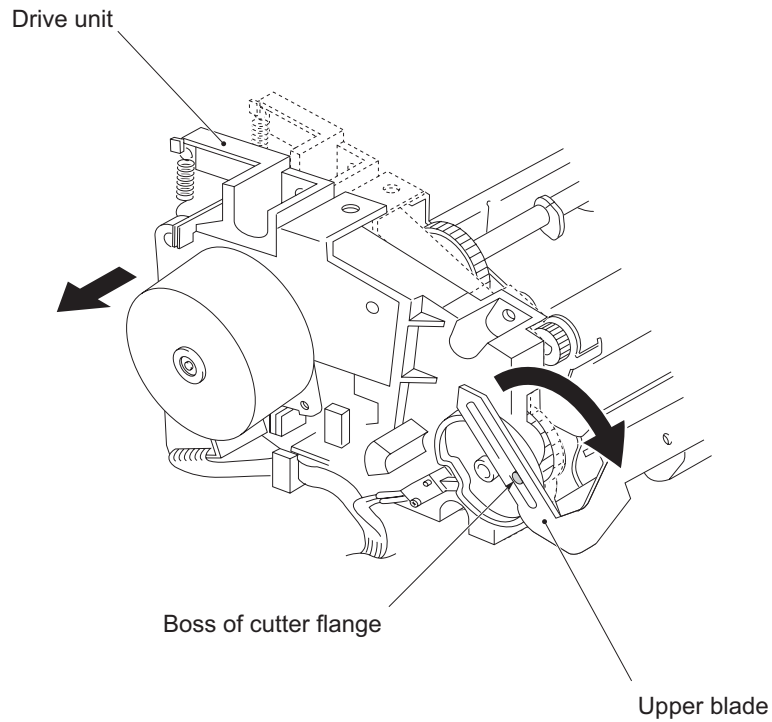

- (7) To take out the motor, remove the screw, lightly press the locking arm and turn the motor counterclockwise. The motor bracket also comes off.

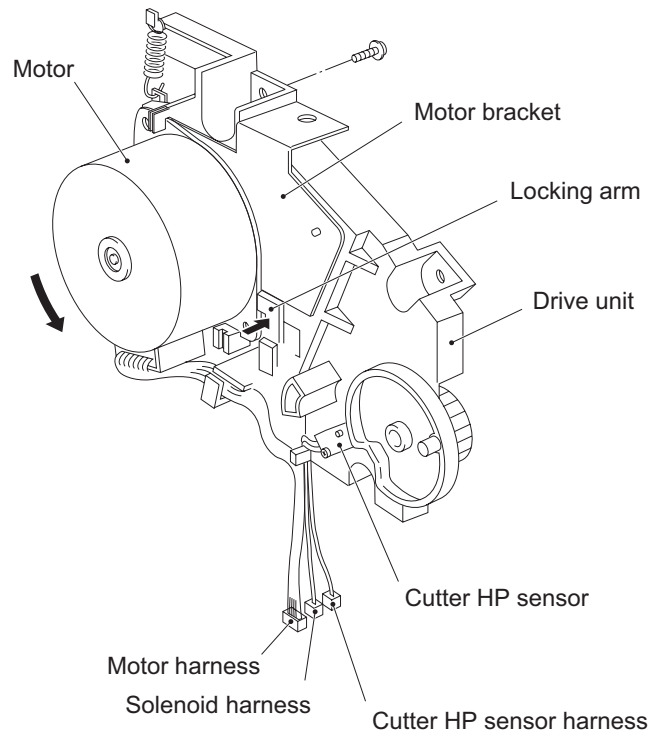

- (8) To take out the cutter HP sensor, remove the screw.

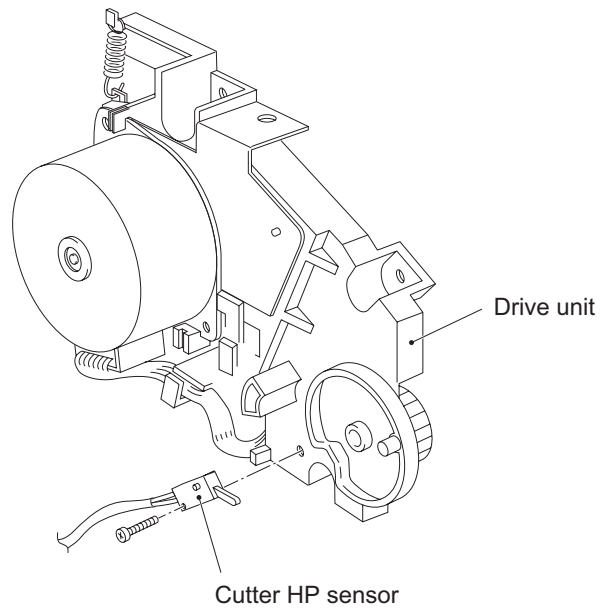

■ Reassembling Notes

- When installing the motor bracket, fit the two holes "a" over the positioning bosses provided on the drive unit.
- Make sure that the locking arm clamps the motor.
- When installing the drive unit to the scanner frame ASSY, hold the resin part of the drive unit, taking care not to grip the solenoid spring. Fully turn the cutter flange clockwise and turn the upper blade to the angle shown below, and then fit the boss of the cutter flange into the hole of the upper blade.

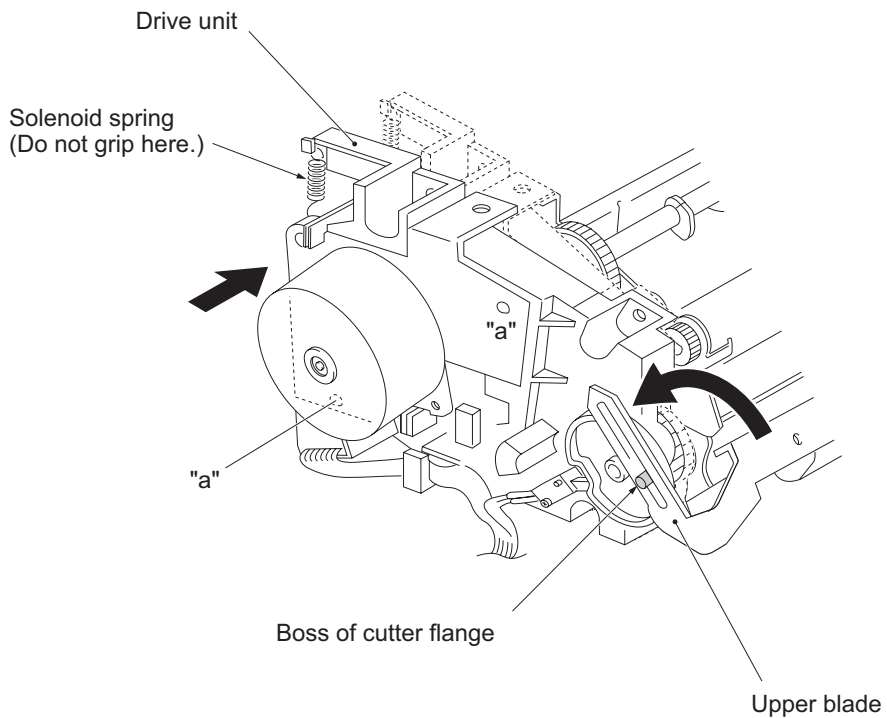

1.9 Separation Roller ASSY

- (1) Push down the latch with the tip of a flat screwdriver and move the separation roller ASSY to the left. Then remove the roller to the right and pull out the roller shaft to the left.

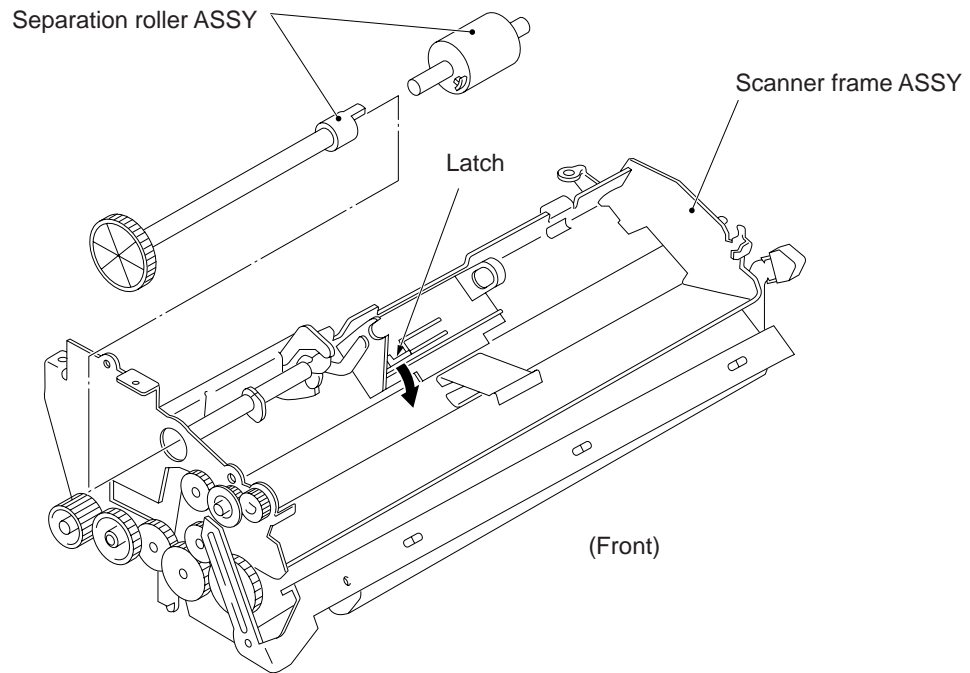

1.10 Document Front and Rear Sensor Actuators

- (1) Turn the document front sensor actuator as shown below and move it to the left (viewed from the rear).

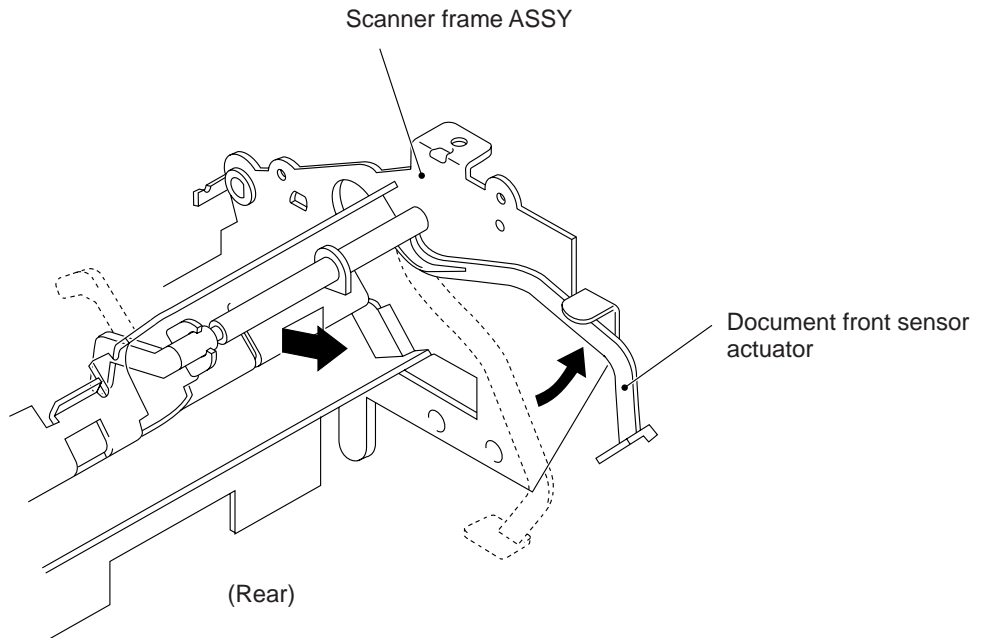

- (2) Turn the document rear sensor actuator as shown below and move it to the right (viewed from the front).

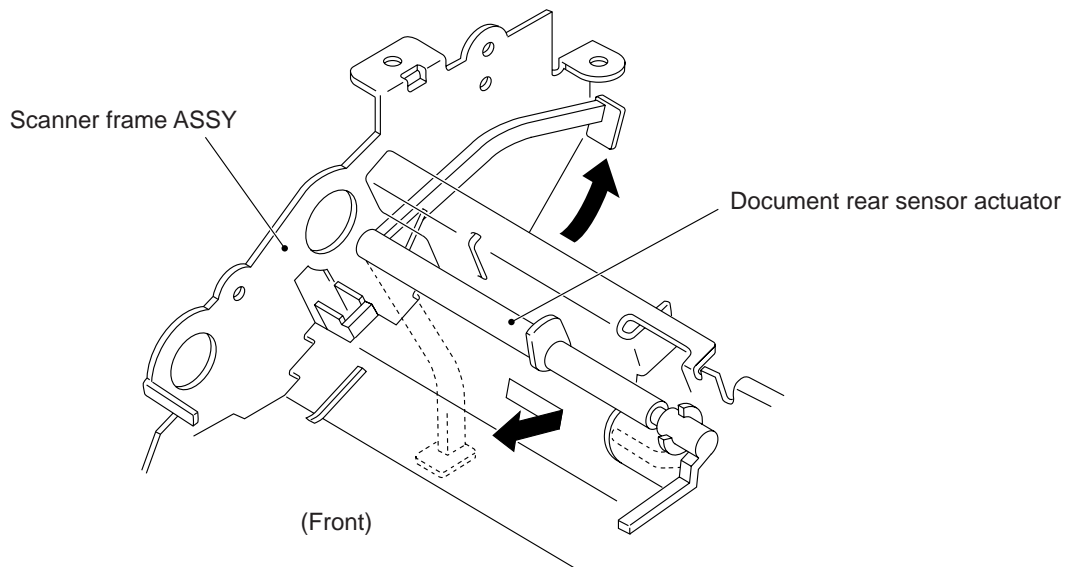

1.11 Recording Head Release Lever

- (1) Place the scanner frame ASSY upside down.
- (2) Swing the recording head release lever as shown below.
- (3) Release the latch and remove the recording head release lever.

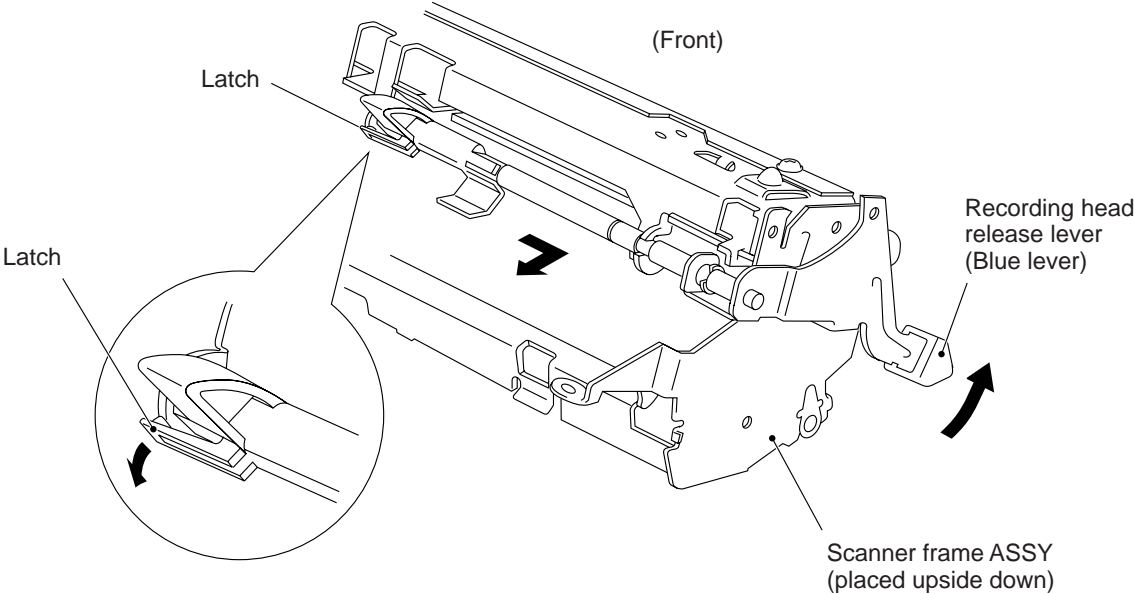

1.12 Recorder & Cutter ASSY

- (1) Place the scanner frame ASSY upside down.
- (2) Remove the screw.
- (3) Press the warped sections of the scanner frame ASSY outwards at both sides with the tip of a flat screwdriver and take out the recorder & cutter ASSY.

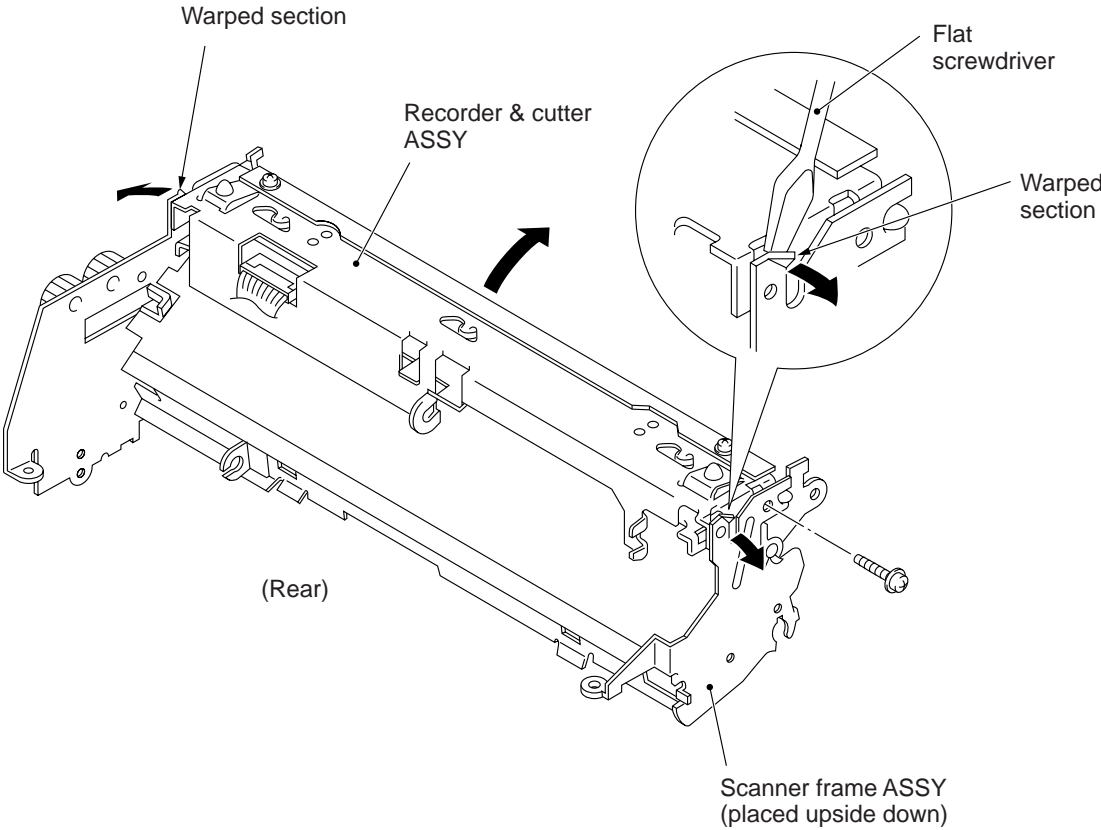

1.13 Platen and Cutter Chute

- (1) Release the latch of the bushing (R) and pull out the bushing to the right.
- (2) Pull out the platen gear to the left together with the platen and then lift up.

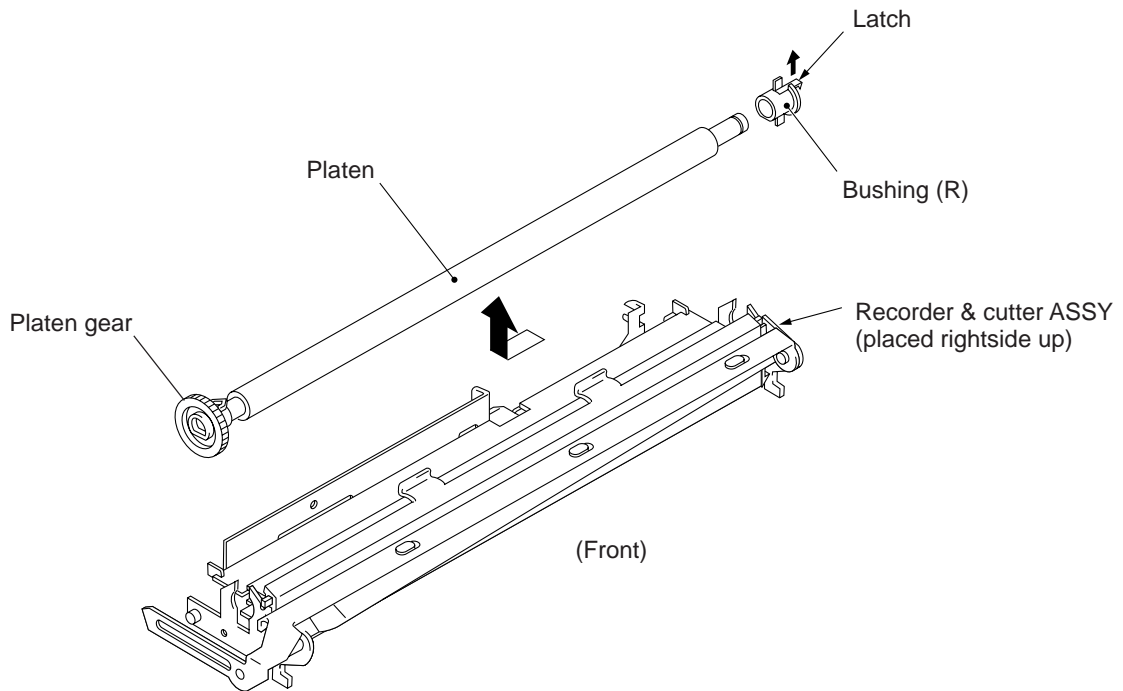

- (3) Press the two latches of the cutter chute inwards to release and then lift up the cutter chute straight, taking care not to let it catch on other parts.

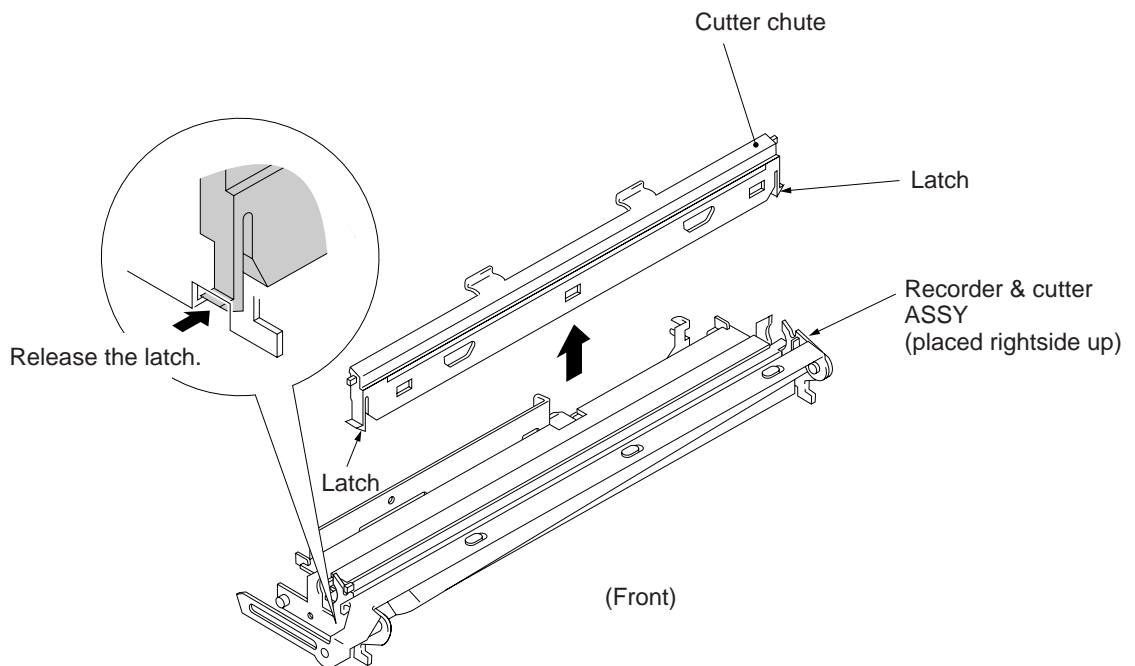

1.14 Recording Head and Cutter Unit

- (1) Push down the front edge of the recording head and move it back to the rear to release the tabs from the cutter unit.

NOTE: Take care not to lose the three springs placed under the recording head.

NOTE: Never disassemble the cutter unit.

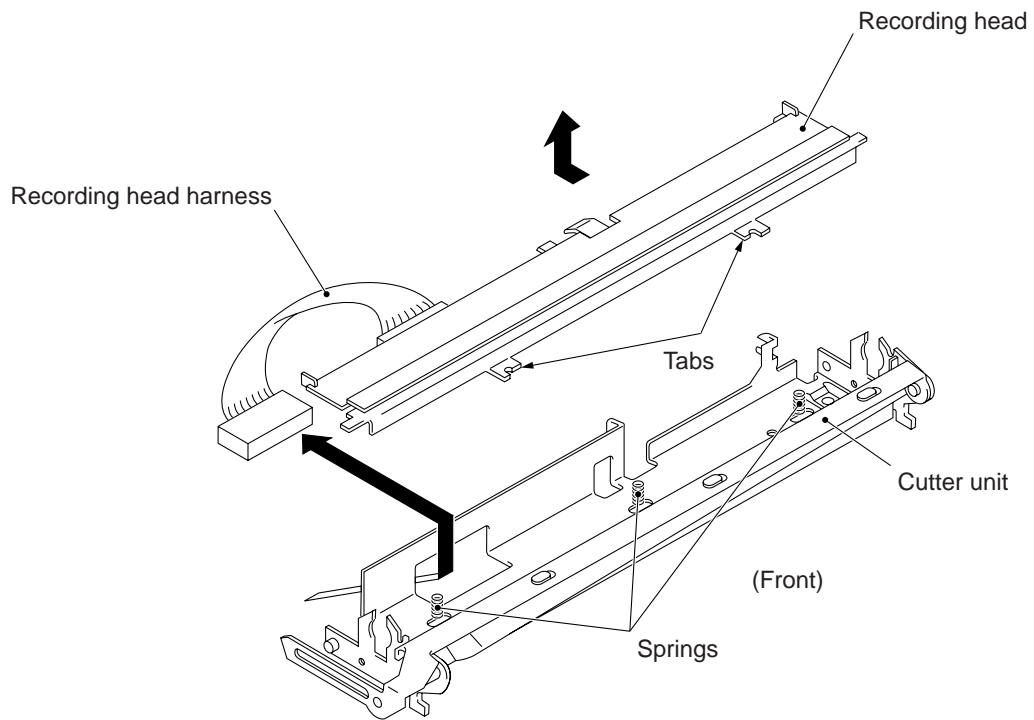

■ Reassembling Notes

- When installing the recording head, make sure that the three springs are set on the bosses of the cutter unit.
- Make sure the recording head harness goes through the cutout provided in the cutter unit.
- It is recommended that you install the platen right after putting the recording head back into place. If not secured by the platen, the recording head could easily come out with any impact.

1.15 Hook Switch Sensor Actuator

- (1) Press the lower section of the hook switch sensor actuator to the left to release the latch from the main frame, then swing it upwards.
- (2) Remove the spring.

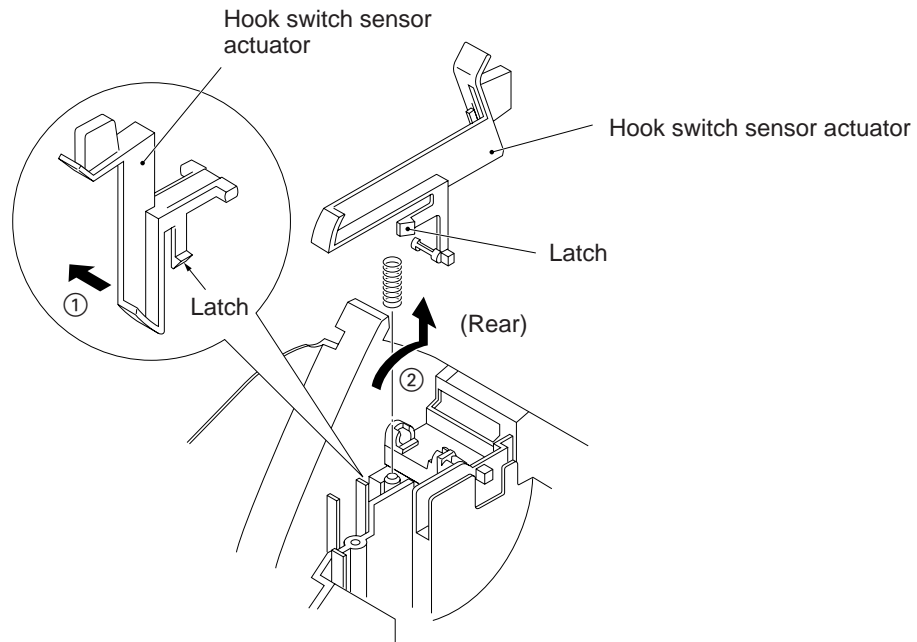

1.16 Speaker

- (1) Disconnect the speaker harness from the main PCB.
- (2) Lift up the speaker.

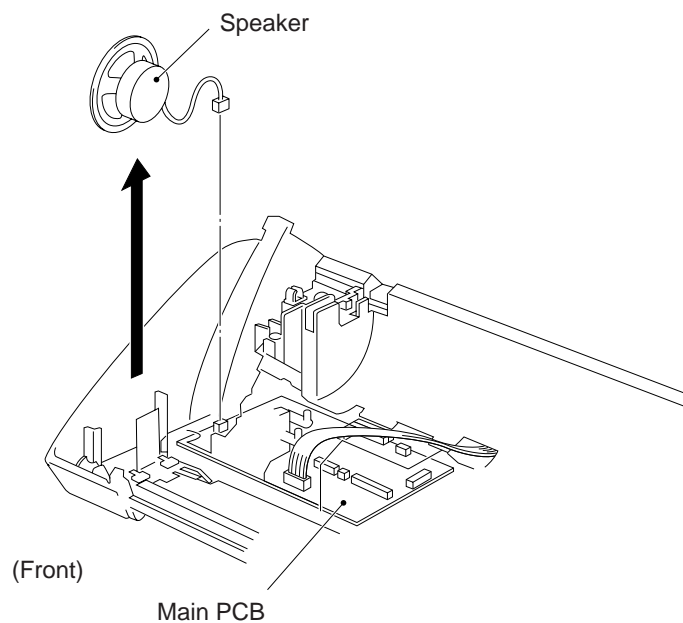

1.17 Bottom Plate

- (1) Place the main frame upside down.
- (2) Remove the five screws.
- (3) Slightly lift up the bottom plate and disconnect the grounding terminal.
- (4) Remove the insulation sheet from the bottom plate.

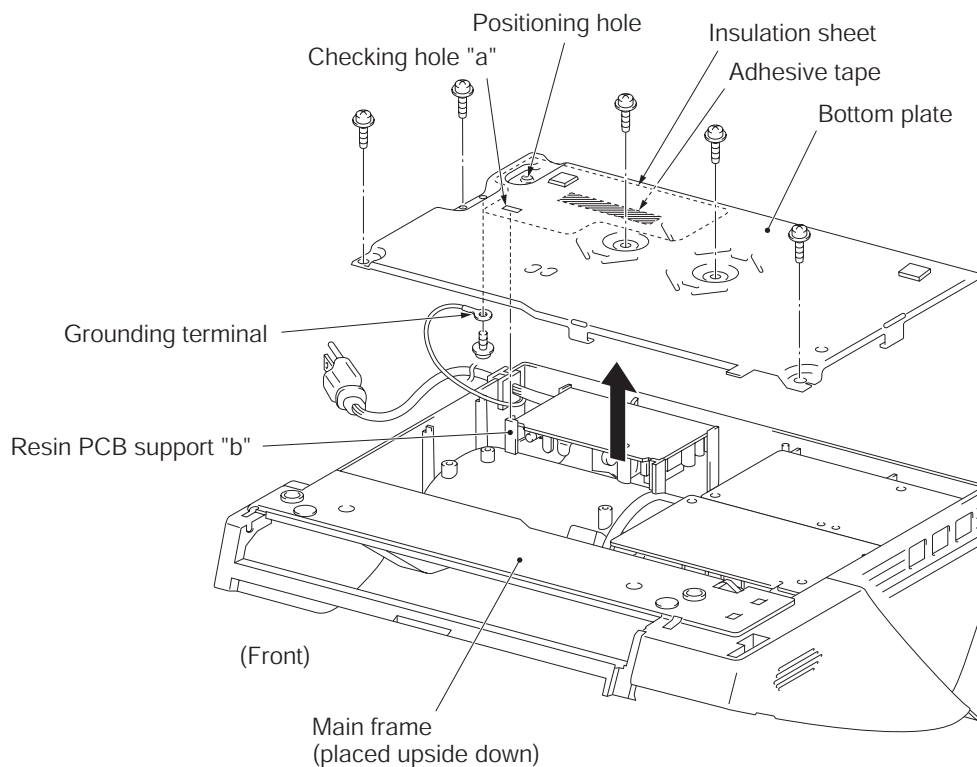

■ Reassembling Notes

- Once removed, the insulation sheet will become unusable and a new one should have to be put back in. When attaching it to the bottom plate, align the rear edge with that of the bottom plate and fit the positioning hole with that provided in the bottom plate, as shown above.

Before putting the bottom plate back into place, make sure that the power supply PCB is completely fitted in the resin PCB supports without any gap.

- After installing the bottom plate, check that resin PCB support "b" of the main frame appears from the checking hole "a" provided in the bottom plate and that the bottom plate is fitted in the main frame without any gap.

If the power supply PCB comes into contact with the bottom plate, a short circuit may occur.

1.18 Main PCB, NCU PCB and Power Supply PCB

If you have already removed the scanner frame ASSY and speaker, slightly lift up the main PCB together with the NCU PCB and then disconnect the power supply harness from the main PCB. If the scanner frame ASSY and speaker are not yet removed, follow the steps below:

FAX235/FAX236/FAX218

- (1) Slightly lift up the rear edge of the NCU PCB and disconnect it from the main PCB.
- (2) Slightly lift up the rear edge of the main PCB and disconnect the following harnesses from the main PCB:
 - Main-panel harness (5-pin)
 - Cutter home position (HP) sensor harness (2-pin)
 - CIS harness (7-pin)
 - Recording head harness (12-pin)
 - Solenoid harness (2-pin)
 - Motor harness (5-pin)
 - Speaker harness (2-pin)
 - Power supply harness (6-pin)
- (3) Lift up the power supply PCB.

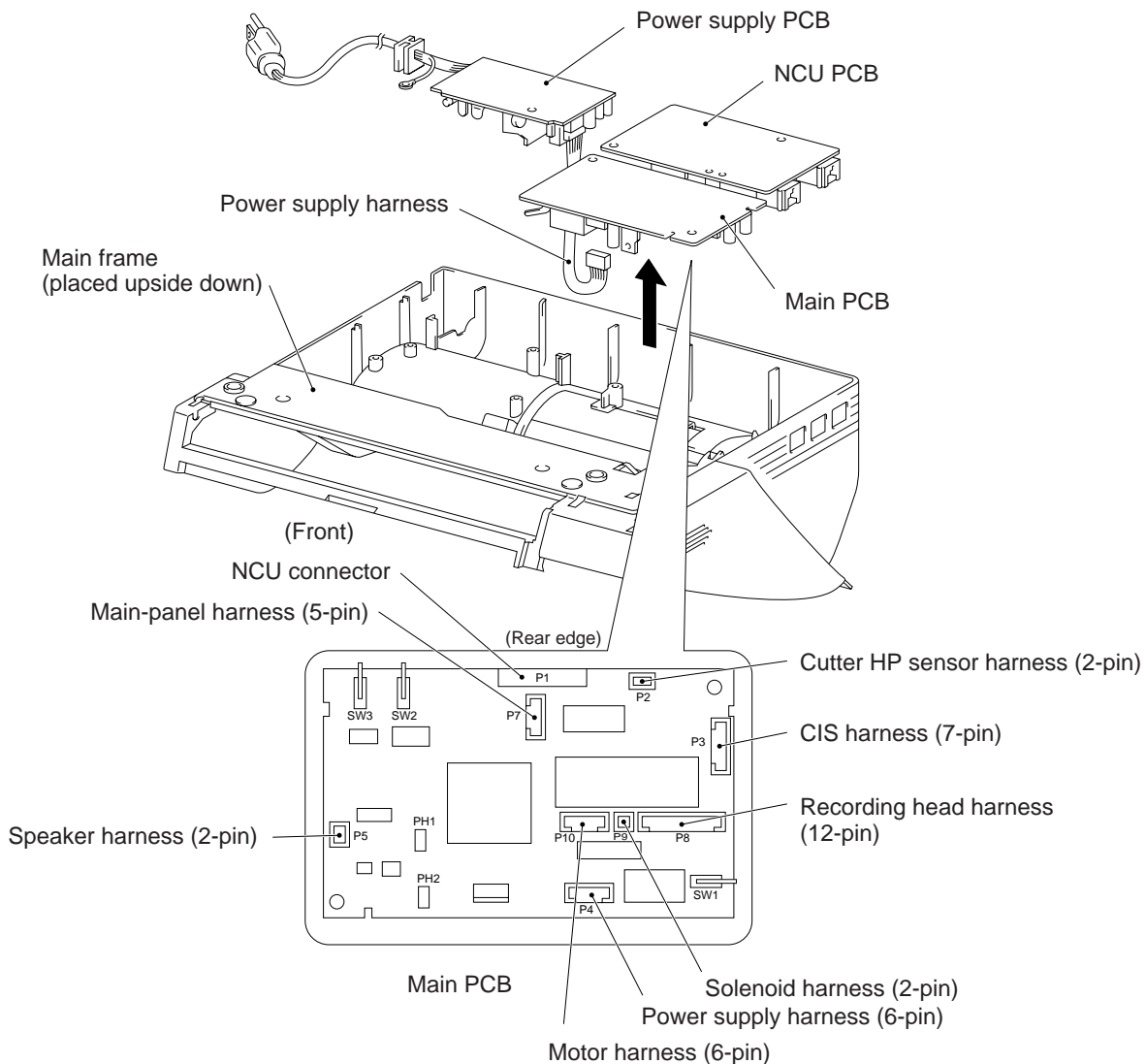

FAX335MC/FAX228MC

- (1) Slightly lift up the rear edge of the NCU PCB and disconnect it from the main PCB.

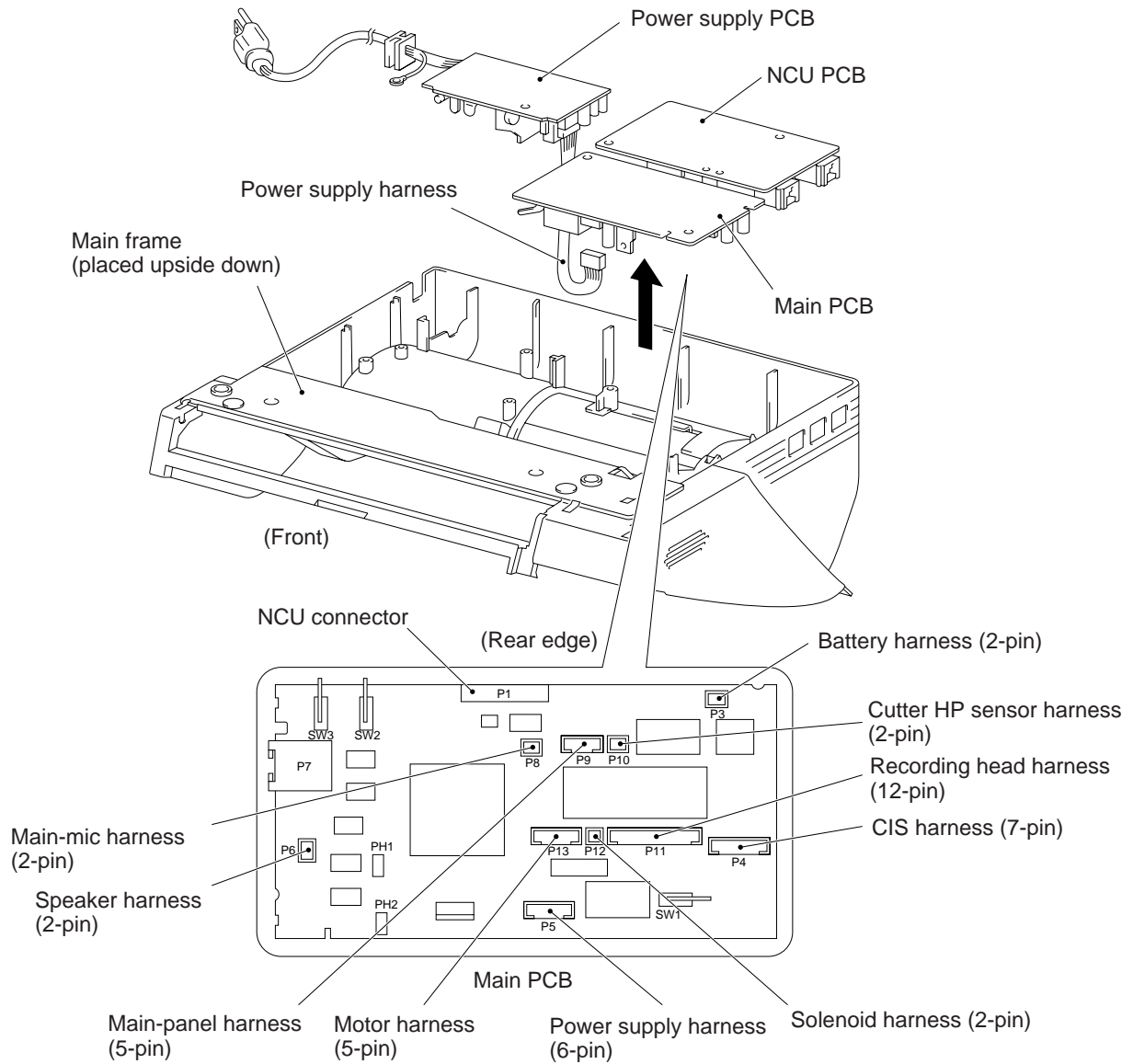

- (2) Attempt to lift up the main PCB slightly. If it is impossible to lift up the PCB to an extent which allows you to disconnect the harnesses, you may not have unhooked the power supply harness core or cutter HP sensor harness core from bosses "C" or "D," respectively. Remove the ROM cover (refer to Section 1.2) and unhook those cores from bosses "C" and "D" illustrated below.

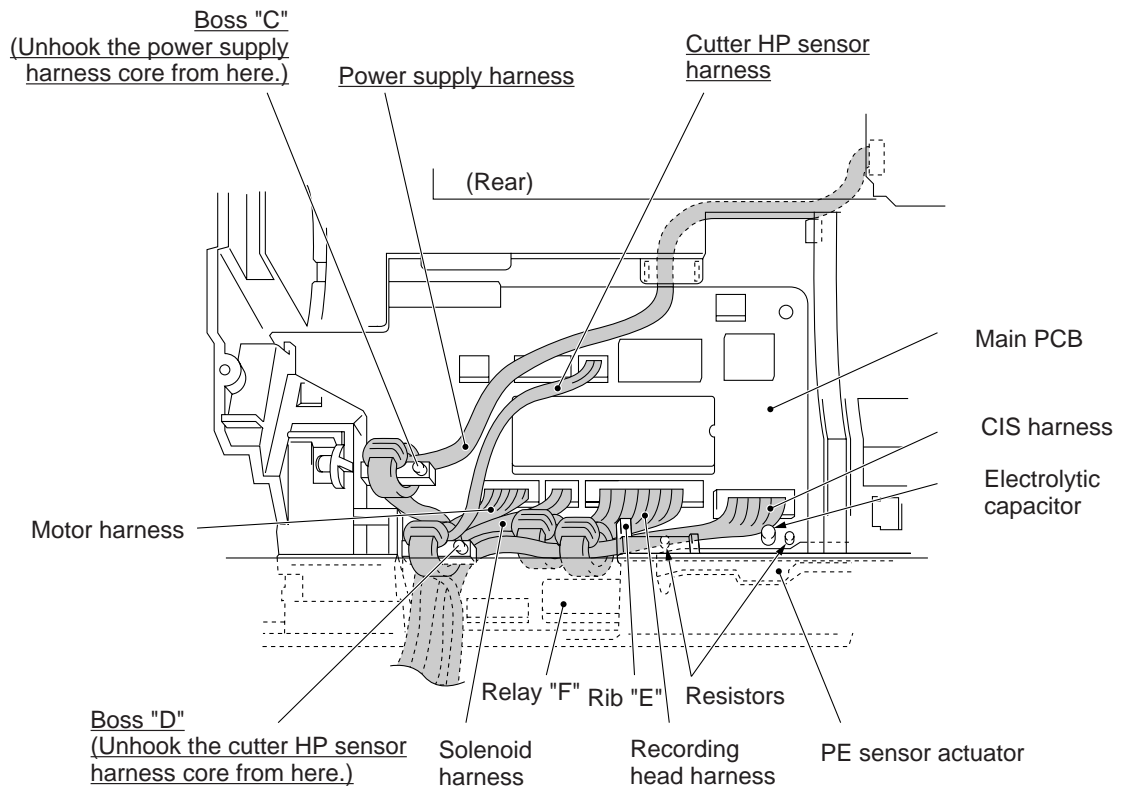

- (3) Slightly lift up the rear edge of the main PCB and disconnect the following harnesses from the main PCB:
- Cutter home position (HP) sensor harness (2-pin)
 - Main-panel harness (5-pin)
 - Main-mic harness (2-pin)
 - Speaker harness (2-pin)
 - Motor harness (5-pin)
 - Power supply harness (6-pin)
 - Solenoid harness (2-pin)
 - Recording head harness (12-pin)
 - CIS harness (7-pin)
- (4) Lift up the power supply PCB.

■ Reassembling Notes

- Make sure that the power supply PCB is completely fitted in the resin PCB supports of the main frame. If it is loosely mounted so that it comes into contact with the bottom plate, a short circuit may occur.
- For the FAX335MC/FAX228MC: After putting the scanner frame ASSY back onto the main frame, route the harnesses and arrange the cores as follows, referring to the illustration given on the previous page.
 - Hook the power supply harness core on boss "C."
 - Check that the cutter HP sensor harness runs through a core, and then hook the core on boss "D."
 - Push the CIS harness core and the recording head harness core to the left of rib "E" and behind relay "F."
 - Route all these harnesses under boss "D."

If any of these harnesses and cores are out of the specified position, the scanner frame ASSY or ROM cover may not be put back into place.

- For the FAX335MC/FAX228MC: After connecting these harnesses, check that neither the electrolytic capacitor nor resistors are tilted towards the PE sensor actuator. If tilted, they may interfere with normal operation of the sensor actuator.

1.19 Paper Empty Sensor Actuator

- (1) Press the actuator support outwards and lift up the paper empty sensor actuator. The spring also comes off.

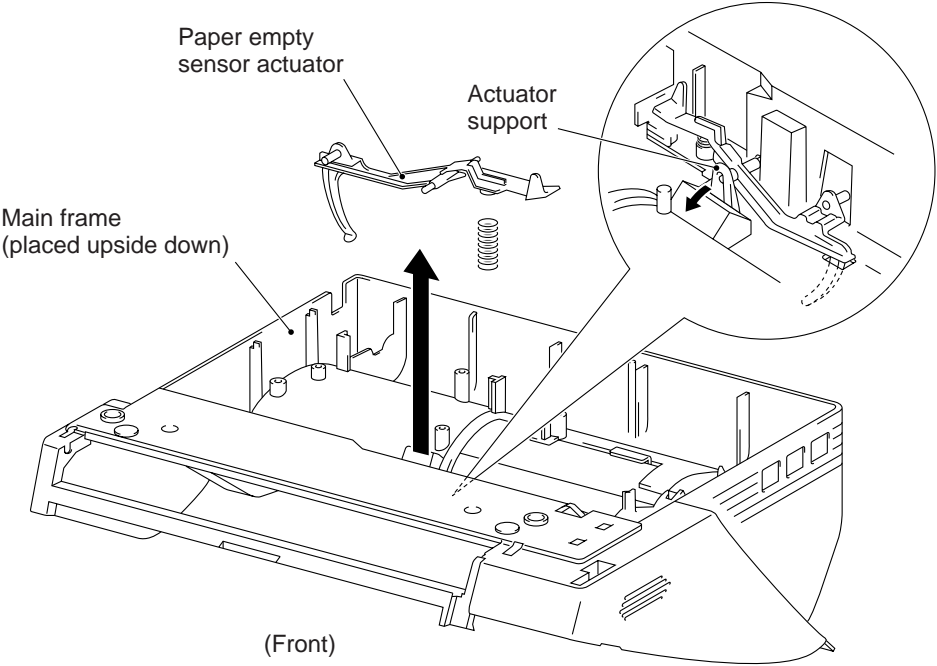

2. LUBRICATION

Apply Molykote EM-30L to the lubrication points as illustrated below.

For points (A), apply a rice-sized pinch of grease (6 mm³).

For points (B), apply a bean-sized pinch of grease (12 mm³).

[1] Scanner frame ASSY

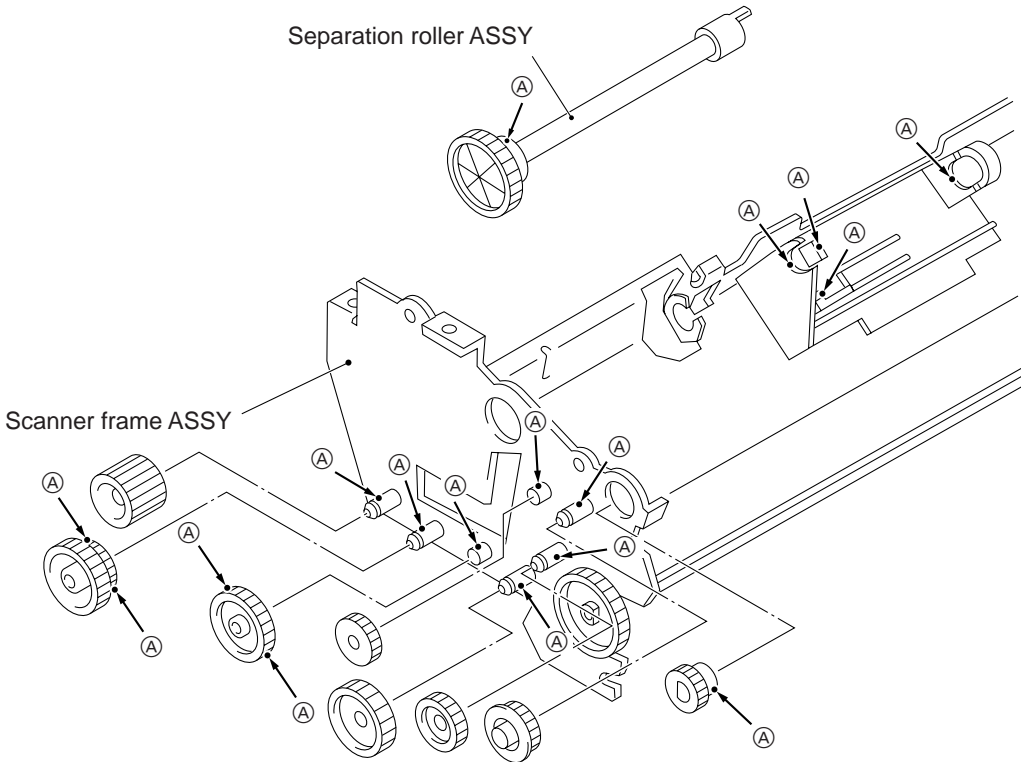

[2] Drive unit

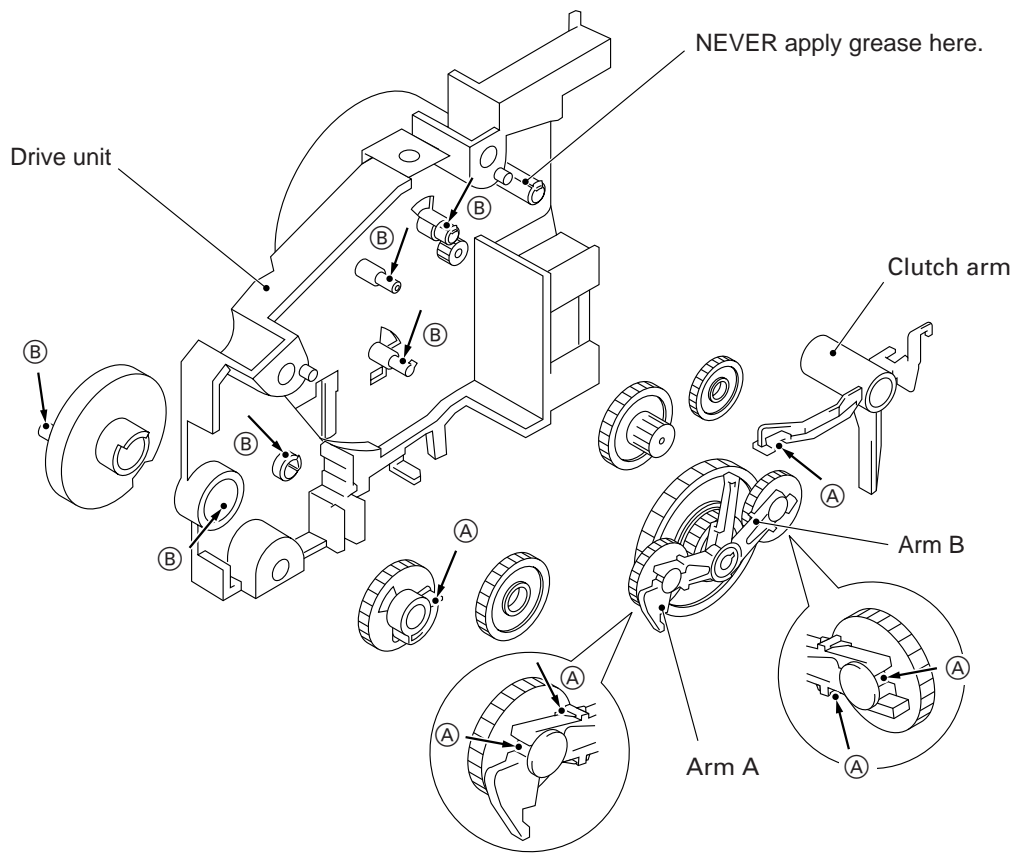

[3] Recording head

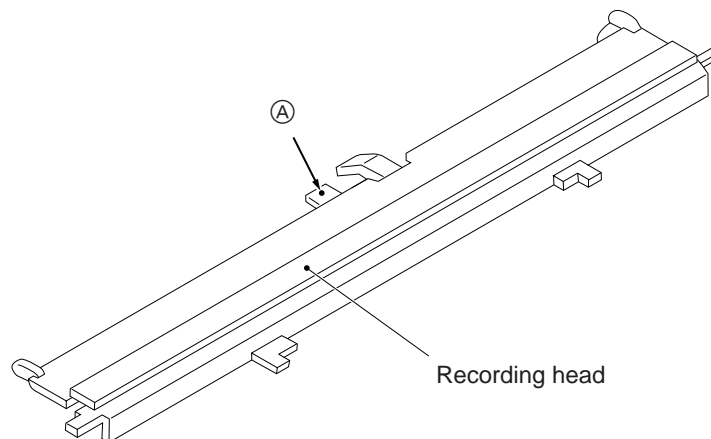

[4] Cutter unit

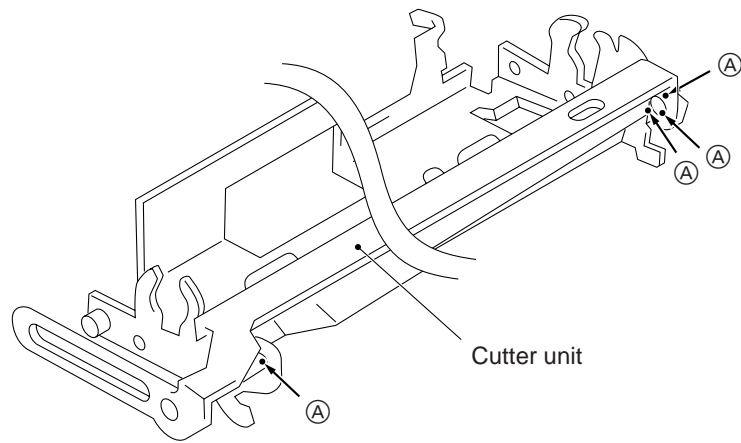

CHAPTER V.

MAINTENANCE MODE

CHAPTER V. MAINTENANCE MODE

CONTENTS

1.	ENTRY INTO THE MAINTENANCE MODE.....	V-1
2.	LIST OF MAINTENANCE-MODE FUNCTIONS	V-2
3.	DETAILED DESCRIPTION OF MAINTENANCE-MODE FUNCTIONS	V-4
3.1	EEPROM Parameter Initialization.....	V-4
3.2	Printout of Scanning Compensation Data	V-5
3.3	ADF Performance Test.....	V-7
3.4	Test Pattern 1.....	V-8
3.5	Firmware Switch Setting and Printout	V-9
3.6	Operational Check of LCD.....	V-51
3.7	Operational Check of Control Panel PCB	V-51
3.8	Sensor Operational Check.....	V-53
3.9	Fine Adjustment of Scanning Start/End Position.....	V-54
3.10	CIS Scanner Area Setting.....	V-55
3.11	EEPROM Customizing	V-55
3.12	Equipment Error Code Indication	V-56
3.13	Output of Transmission Log to the Telephone Line	V-56
3.14	Document Draw Adjustment	V-57

1. ENTRY INTO THE MAINTENANCE MODE

To make the facsimile equipment enter the maintenance mode, press the

Function, *, **2**, **8**, **6**, and **4** keys in this order.

|← Within 2 seconds →|

The equipment beeps for approx. one second and displays " ■■ MAINTENANCE ■■■ " on the LCD, indicating that it is placed in the initial stage of the maintenance mode, a mode in which the equipment is ready to accept entry from the keys.

To select one of the maintenance-mode functions listed in Section 2, enter the corresponding 2-digit function code with the numerical keys on the control panel. (The details of each maintenance-mode function are described in Section 3.)

- NOTES:**
- Pressing the **9** key twice in the initial stage of the maintenance mode makes the equipment exit from the maintenance mode, restoring it to the standby state.
 - Pressing the **Stop** button after entering only one digit restores the equipment to the initial stage of the maintenance mode.
 - If an invalid function code is entered, the equipment resumes the initial stage of the maintenance mode.

2. LIST OF MAINTENANCE-MODE FUNCTIONS

Maintenance-mode Functions

Function Code	Function	Reference Subsection (Page)
01	EEPROM Parameter Initialization	3.1 (V-4)
02	_____	_____
03	_____	_____
04	_____	_____
05	Printout of Scanning Compensation Data	3.2 (V-5)
06	_____	_____
07	_____	_____
08	ADF* Performance Test	3.3 (V-7)
09	Test Pattern 1	3.4 (V-8)
10	Firmware Switch Setting	3.5 (V-9)
11	Printout of Firmware Switch Data	3.5 (V-50)
12	Operational Check of LCD	3.6 (V-51)
13	Operational Check of Control Panel PCB (Check of Keys and Buttons)	3.7 (V-51)
32	Sensor Operational Check	3.8 (V-53)
54	Fine Adjustment of Scanning Start/End Position	3.9 (V-54)
55	CIS Scanner Area Setting	3.10 (V-55)
74	EEPROM Customizing	3.11 (V-55)
82	Equipment Error Code Indication	3.12 (V-56)
87	Output of Transmission Log to the Telephone Line	3.13 (V-56)
91	EEPROM Parameter Initialization (except the telephone number storage area)	3.1 (V-4)
99	Exit from the Maintenance Mode	---- (V-1)
-----	Document Draw Adjustment	3.14 (V-57)

* ADF: Automatic document feeder

----- **IMPORTANT** -----

Basically, the maintenance-mode functions listed on the previous page should be accessed by service personnel only. However, you may allow end users to access some of these under the guidance of service personnel (e.g., by telephone).

The user-accessible functions (codes 10, 11, 12, 82, 87 and 91) are shaded in the table given on the previous page. Function code 10 accesses the firmware switches WSW01 to WSW37, each of which has eight selectors. You should not allow end users to access all of those selectors, but you may allow them to access user-accessible selectors which are shaded in the firmware switch tables in Subsection 3.5.

The service personnel should instruct end users to follow the procedure given below.

- (1) Press the **Function** and **Mode** keys in this order.
The LCD clears the current display.
NOTE: The **Mode** key is inoperable during standby for redialing and timer.
- (2) Press the **0** key.
- (3) Enter the desired function code (10, 11, 12, 82, 87, or 91) with the numerical keys.
For function code 10, access the desired firmware switch according to the operating procedure described in Subsection 3.5.
NOTE: 87 is invalid when the line is used.
- (4) To make the equipment return to the standby state, press the **Stop** key.



3. DETAILED DESCRIPTION OF MAINTENANCE-MODE FUNCTIONS

3.1 EEPROM Parameter Initialization

■ Function

The equipment initializes the parameters, user switches, and firmware switches registered in the EEPROM, to the initial values. Entering the function code 01 initializes all of the EEPROM areas, but entering 91 does not initialize some areas, as listed below.

Function code	01	91
Data item		
Maintenance-mode functions User switches Firmware switches Remote activation code Activity report Distinctive ringing patterns registered	All of these will be initialized	These will be initialized
Station ID data Outside line number Remote access code FAX forwarding/paging Telephone function registration One-touch dialing Speed dialing Group dialing		These will <u>not</u> be initialized
EEPROM customizing code (4-digit)	This will <u>not</u> be initialized. (Note that the first digit of the 4-digit code will be initialized to "0." If the code is <u>1</u> 001, for example, it will be initialized to <u>0</u> 001.)	

NOTE: If you replace the main PCB with one used for other facsimile equipment, carry out this procedure and then customize the EEPROM (maintenance-mode function code 74 in Section 3.11).

■ Operating Procedure

- (1) Press the **0** and **1** keys (or the **9** and **1** keys according to your need) in this order in the initial stage of the maintenance mode.
The "PARAMETER INIT" will appear on the LCD.
- (2) Upon completion of parameter initialization, the equipment returns to the initial stage of the maintenance mode.

3.2 Printout of Scanning Compensation Data

■ Function

The equipment prints out the white and black level data for scanning compensation.

■ Operating Procedure

Do not start this function merely after powering on the equipment but start it after carrying out a sequence of scanning operation. Unless the equipment has carried out any scanning operation, this function cannot print out correct scanning compensation data. This is because at the start of scanning operation, the equipment initializes white and black level data and takes in the scanning compensation reference data.

- (1) Press the **0** and **5** keys in this order in the initial stage of the maintenance mode.
The "WHITE LEVEL 1" will appear on the LCD.
- (2) The equipment prints out the scanning compensation data list containing the following:
 - a) White level data (208 bytes)
 - b) Black level data (1 byte)
 - c) White level data for compensation operation of background color (100 bytes)
 - d) Initial clamp PWM value (1 byte)
 - e) Clamp PWM value (1 byte)
 - f) Compensation data for background color (1 byte)
 - g) Upper and lower limit data for the compensation factor of background color (2 bytes)
 - h) Initial LED light intensity value (1 byte)
 - i) LED light intensity value (1 byte)
 - j) LED light intensity value on the white film of the document pressure bar ASSY and documents (2 bytes)
 - k) Threshold value on the platen (1 byte)
 - l) Document rear sensor adjustment value (1 byte)
- (3) Upon completion of recording of the compensation data list, the equipment returns to the initial stage of the maintenance mode.

NOTE: If any data is abnormal, its code will be printed in inline style, as shown on the next page.

- a) 5F00 : 22 24 25 24 25 25 25 27 25 29 29 29 27 29 2B 2B
5F10 : 27 29 25 25 25 2B 2D 2D 2B 29 29 29 2D 2D 2B 2B
5F20 : 29 2D 2B 2B 2B 2D 2E 2D 2B 2B 27 25 25 2B 2B 2B
5F30 : 29 29 29 29 29 27 25 24 25 2B 29 27 29 29 27 29
5F40 : 27 29 25 25 25 2B 2B 2B 2B 29 2B 29 29 2B 2B 29
5F50 : 27 2B 27 29 2B 2B 29 29 27 29 25 25 25 2B 2D 2D
5F60 : 2B 2B 2B 2B 2B 2D 2D 2B 29 2B 2D 2E 2D 2D 2B 2B
5F70 : 2B 2B 29 29 27 2E 2E 2E 2D 2D 2D 2D 2D 2D 2B 2B
5F80 : 2D 32 32 34 32 32 32 32 30 30 2E 2B 29 2E 2E 30
5F90 : 30 2E 2E 2D 2B 2B 2B 2B 2D 30 2E 2E 2E 2D 2D 30
5FA0 : 2D 2E 2D 2B 29 2D 2D 2E 2E 2D 2D 2B 27 29 2B 29
5FB0 : 2D 2E 2D 2D 2E 2D 2D 2E 2D 2D 2D 2B 27 30 30 32
5FC0 : 34 32 32 30 30 30 30 2E 2E 30 32 2E 2E 2E 2E 3F
- b) 5F00 : 00
- c) 5F00 : 09 32 35 37 37 38 32 08 07 07 06 07 05 05 05 08
5F10 : 08 09 37 39 3A 39 3A 3B 04 07 07 0A 36 39 3B 3B
5F20 : 3B 3C 0F 08 08 07 09 3B 3B 3B 3B 39 34 0E 08 0A
5F30 : 08 1A 39 3B 3C 3C 3C 1D 08 09 09 08 37 3A 3A 3F
5F40 : 3E 3E 0A 0A 0A 3B 3F 3F 3F 3E 3E 3F 00 0B 0B 00
5F50 : 0C 0E 3F 3F 3E 3C 33 0A 0A 09 08 08 08 07 07 07
5F60 : 07 08 07 0A
- d) 5F00 : AF
- e) 5F00 : AF
- f) 5F00 : 79
- g) 5F00 : 3A 80
- h) 5F00 : 81
- i) 5F00 : 81
- j) 5F00 : 77 7A
- k) 5F00 : AD
- l) 5F00 : 80

Scanning Compensation Data List

3.3 ADF Performance Test

■ Function

The equipment counts the documents fed by the automatic document feeder (ADF) and displays the count on the LCD for checking the ADF performance.

■ Operating Procedure

- (1) Set documents (Allowable up to the ADF capacity) in the initial stage of the maintenance mode.
The "DOC. READY" will appear on the LCD.
- (2) Press the **0** and **8** keys in this order.
The equipment
 - i) copies the 1st document and displays "COPY P.01 STD" on the LCD.
 - ii) feeds in and out the 2nd through 4th documents while counting without copying them as the LCD shows the corresponding count,
 - iii) copies the 5th document and displays "COPY P.05 STD" on the LCD,
 - iv) feeds in and out the 6th through 9th documents while counting without copying them as the LCD shows the corresponding count, and
 - v) copies the 10th document and displays "COPY P.10 STD" on the LCD.
- (3) Upon completion of feeding in and out all of the documents, the final count appears on the LCD.
- (4) Press the **Stop** key to return the equipment to the initial maintenance mode.

3.5 Firmware Switch Setting and Printout

[A] Firmware switch setting

■ Function

The facsimile equipment incorporates the following firmware switch functions (WSW01 through WSW37) which may be activated with the procedures using the control panel keys and buttons. The firmware switches have been set at the factory in conformity to the communications standards and codes of each country. Do not disturb them unless necessary. Some firmware switches may not be applicable in some versions. The firmware switch data list indicates "Not used." for those inapplicable switches.

Firmware Switches (WSW01 through WSW37)

WSW No.	Function	Reference Page
WSW01	Dial pulse setting	V-11
WSW02	Tone signal setting	V-12
WSW03	PABX mode setting	V-13
WSW04	TRANSFER facility setting	V-15
WSW05	1st dial tone and busy tone detection	V-16
WSW06	Pause key setting and 2nd dial tone detection	V-18
WSW07	Dial tone setting 1	V-20
WSW08	Dial tone setting 2	V-21
WSW09	Protocol definition 1	V-22
WSW10	Protocol definition 2	V-23
WSW11	Busy tone setting	V-24
WSW12	Signal detection condition setting	V-25
WSW13	Modem setting	V-26
WSW14	AUTO ANS facility setting	V-27
WSW15	REDIAL facility setting	V-28
WSW16	Function setting 1	V-29
WSW17	Function setting 2	V-30
WSW18	Function setting 3	V-31
WSW19	Transmission speed setting	V-32
WSW20	Overseas communications mode setting	V-33
WSW21	TAD setting 1	V-34
WSW22	ECM setting	V-35
WSW23	Communications setting	V-36
WSW24	TAD setting 2	V-37
WSW25	TAD setting 3	V-38
WSW26	Function setting 4	V-39
WSW27	Function setting 5	V-40
WSW28	Function setting 6	V-41
WSW29	Function setting 7	V-42
WSW30	Function setting 8	V-43
WSW31	Function setting 9	V-44
WSW32	Function setting 10	V-45
WSW33	Function setting 11	V-46
WSW34	Function setting 12	V-47
WSW35	Function setting 13	V-48
WSW36	Function setting 14	V-48
WSW37	Function setting 15	V-49

■ Operating Procedure

- (1) Press the **1** and **0** keys in this order in the initial stage of the maintenance mode.
The equipment displays the "WSW00" on the LCD and becomes ready to accept a firmware switch number.
- (2) Enter the desired number from the firmware switch numbers (01 through 37).
The following appears on the LCD:
WSWXX = 0 0 0 0 0 0 0
- (3) Use the ◀ and ▶ keys to move the cursor to the selector position to be modified.
- (4) Enter the desired number using the **0** and **1** keys.
- (5) Press the **Set** key. This operation saves the newly entered selector values onto the EEPROM and readies the equipment for accepting a firmware switch number.
- (6) Repeat steps (2) through (5) until the modification for the desired firmware switches is completed.
- (7) Press the **Set** or **Stop** key to return the equipment to the initial stage of the maintenance mode.

- NOTES:**
- To cancel this operation and return the equipment to the initial stage of the maintenance mode during the above procedure, press the **Stop** key.
 - If there is a pause of more than one minute after a single-digit number is entered for double-digit firmware switch numbers, the equipment will automatically return to the initial stage of the maintenance mode.

■ Note

The user-accessible selectors of the firmware switches are shaded in the tables given on the following pages.

■ Detailed Description for the Firmware Switches

WSW01 (Dial pulse setting)

Selector No.	Function	Setting and Specifications
1 2	Dial pulse generation mode	No. 1 2 0 0 : N 0 1 : N+1 1 0 : 10-N 1 1 : N
3 4	Break time length in pulse dialing	No. 3 4 0 0 : 60 ms 0 1 : 67 ms 1 0 : 40 ms (for 16 PPS) 1 1 : 64 ms (at 106-ms intervals)
5 6	Inter-digit pause	No. 5 6 0 0 : 800 ms 0 1 : 850 ms 1 0 : 950 ms 1 1 : 600 ms
7	Switching between pulse (DP) and tone (PB) dialing, by the function switch	0: Yes 1: No
8	Default dialing mode, pulse (DP) or tone (PB) dialing	0: PB 1: DP

● **Selectors 1 and 2: Dial pulse generation mode**

These selectors set the number of pulses to be generated in pulse dialing.

N: Dialing "N" generates "N" pulses. (Dialing "0" generates 10 pulses.)

N + 1: Dialing "N" generates "N + 1" pulses.

10 - N: Dialing "N" generates "10 - N" pulses.

● **Selectors 3 and 4: Break time length in pulse dialing**

These selectors set the break time length in pulse dialing.

(Example: If "1," "2," and "3" are dialed when N is set by selectors 1 and 2.)

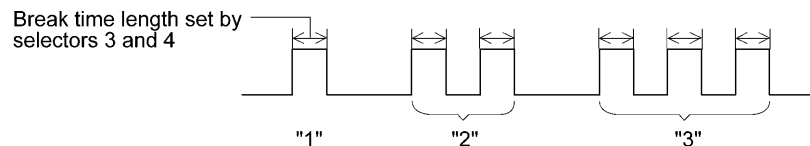

● **Selectors 5 and 6: Inter-digit pause**

These selectors set the inter-digit pause in pulse dialing.

(Example: If "1," "2," and "3" are dialed when N is set by selectors 1 and 2.)

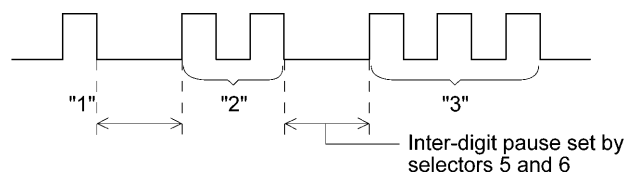

- **Selector 7: Switching between pulse (DP) and tone (PB) dialing, by the function switch**

This selector determines whether or not the dialing mode may be switched between the pulse (DP) and tone (PB) dialing by using the function switch.

- **Selector 8: Default dialing mode, pulse (DP) or tone (PB) dialing**

This selector sets the default dialing mode (pulse dialing or tone dialing) which may be changed by the function switch. If the user switches it with the function switch when selector 7 is set to "0," the setting specified by this selector will also be switched automatically.

WSW02 (Tone signal setting)

Selector No.	Function	Setting and Specifications
1 2	Tone signal transmission time length	No. 1 2 0 0 : 70 ms 0 1 : 80 ms 1 0 : 90 ms 1 1 : 100 ms
3 4	Min. pause in tone dialing	No. 3 4 0 0 : 70 ms 0 1 : 80 ms 1 0 : 90 ms 1 1 : 140 ms
5 8	Attenuator for pseudo ring backtone to the line (selectable in the range of 0-15 dB)	0: 0 dB 1: 8 dB 0: 0 dB 1: 4 dB 0: 0 dB 1: 2 dB 0: 0 dB 1: 1 dB

- **Selectors 1 through 4: Tone signal transmission time length and Min. pause in tone dialing**

These selectors set the tone signal transmission time length and minimum pause in tone dialing.

(Example: If "1," "2," "3," "4," and "5" are dialed.)

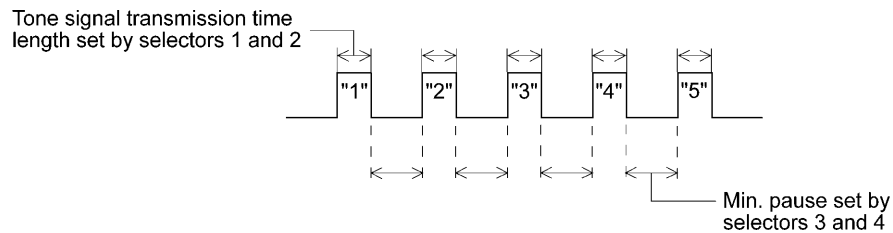

- **Selectors 5 through 8: Attenuator for pseudo ring backtone to the line**

These selectors are used to adjust the sound level of beep generated as a ring backtone in the F/T mode or as a signal during remote control operation or at the start of ICM recording.

Setting two or more selectors to "1" produces addition of attenuation assigned to each selector. This setting will be limited if selector 8 of WSW23 is set to "0."

WSW03 (PABX* mode setting)

Selector No.	Function	Setting and Specifications
1	CNG detection when sharing a modular wall socket with a telephone	0: A 1: B
2 4	Min. detection time length of PABX* dial tone, required for starting dialing	No. 2 3 4 0 0 0 : 50 ms 0 0 1 : 210 ms 0 1 0 : 500 ms 0 1 1 : 800 ms 1 0 0 : 900 ms 1 0 1 : 1.5 sec. 1 1 0 : 2.0 sec. 1 1 1 : 2.5 sec.
5	CNG detection when sharing a modular wall socket with a telephone	0: A 1: B
6 7	Dial tone detection in PABX*	No. 6 7 0 0 : No detection (3.5 sec. WAIT) 0 1 : No detection (5 sec. WAIT) 1 0 : No detection (7 sec. WAIT) 1 1 : Detection (Frequency only)
8	"R" key function	0: 1st dial tone detection add 1: No 1st dial tone detection

* PABX: Private automatic branch exchange

NOTE: Selectors 2 through 4 and 6 through 8 are not applicable where no PABX is installed.

● **Selectors 1 and 5: CNG detection when sharing a modular wall socket with a telephone**

These selectors determine whether or not the equipment detects a CNG signal when a line is connected to a telephone sharing a modular wall socket with the equipment. Upon detection of CNG signals by the number of cycles specified by these selectors, the equipment interprets CNG as an effective signal and then starts FAX reception.

Selector No. 1 No. 5		Cycle
0 (A)	0 (A)	0.5 cycle
0 (A)	1 (B)	1.0 cycle
1 (B)	0 (A)	1.5 cycles
1 (B)	1 (B)	2.0 cycles

● **Selectors 2 through 4: Min. detection time length of PABX dial tone, required for starting dialing**

Upon detection of the PABX dial tone for the time length set by these selectors, the equipment starts dialing.

These selectors are effective only when both selectors 6 and 7 are set to "1" (Detection).

- **Selectors 6 and 7: Dial tone detection in PABX**

These selectors activate or deactivate the dial tone detection function which detects a dial tone when a line is connected to the PABX.

Setting both of these selectors to "1" activates the dial tone detection function so that the equipment starts dialing upon detection of a dial tone when a line is connected.

Other setting combinations deactivate the dial tone detection function so that the equipment starts dialing after the specified WAIT (3.5, 5.0, or 7.0 sec.) without detection of a dial tone when a line is connected.

- **Selector 8: "R" key function**

This selector determines whether or not the 1st dial tone detection function (specified by selectors 1 through 3 of WSW05) is added to the R key.

If this selector is set to "0," pressing the R key automatically activates the 1st dial tone detection function when the PABX and the automatic calling are selected by using the function switch. If you press the R key and a dial number in succession, the equipment will automatically carry out the 1st dial tone detection function following the original transfer function as shown below.

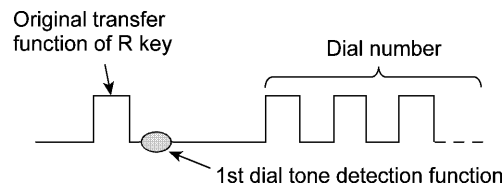

WSW04 (TRANSFER facility setting)

Selector No.	Function	Setting and Specifications
1	Earth function in transfer facility	0: Provided 1: Not provided
2 3	Dual tone detection frequency in ICM recording	No. 2 3 0 0 : 350 and 440 Hz (A) 0 1 : 440 and 480 Hz (B) 1 x : 480 and 620 Hz (C)
4	Tone detection sensitivity in ICM recording	0: OFF 1: High
5 6	Earth time length for earth function	No. 5 6 0 0 : 200 ms 0 1 : 300 ms 1 0 : 500 ms 1 1 : 700 ms
7 8	Break time length for flash function	No. 7 8 0 0 : 80 ms 0 1 : 110 ms 1 0 : 250 ms 1 1 : 500 ms

NOTE: Selectors 1 and 5 through 8 are not applicable in those countries where no transfer facility is supported.

NOTE: Selectors 2 through 4 are applicable to those models equipped with a built-in TAD.

NOTE: Selectors 2 and 3 are applicable in the U.S.A.

- **Selector 1: Earth function in transfer facility**

This selector determines whether or not the earth function is added to the transfer setting menu to be accessed by the function switch.

- **Selectors 2 and 3: Dual tone detection frequency in ICM recording**

If the equipment detects either of the frequencies set by these selectors in ICM recording, it will disconnect the line. For example, if these selectors are set to "0, 0," the equipment will disconnect the line upon detection of 350 Hz or 440 Hz.

- **Selectors 4: Tone detection sensitivity in ICM recording**

Setting this selector to "1" increases the tone detection sensitivity in ICM recording.

- **Selectors 5 and 6: Earth time length for earth function**

These selectors set the short-circuiting time length of the telephone line (La or Lb) to ground.

This setting is effective only when the earth function is selected for the R key by using the function switch.

- **Selectors 7 and 8: Break time length for flash function**

These selectors set the break time length.

This setting is effective only when the flash function is selected for the R key by using the function switch.

WSW05 (1st dial tone and busy tone detection)

Selector No.	Function	Setting and Specifications
1 3	1st dial tone detection	No. 1 2 3 0 0 0 : 3.5 sec. WAIT 0 0 1 : 7.0 sec. WAIT 0 1 0 : 10.5 sec. WAIT 0 1 1 : 14.0 sec. WAIT 1 0 0 : 17.5 sec. WAIT 1 0 1 : 21.0 sec. WAIT 1 1 0 : 24.5 sec. WAIT 1 1 1 : Detection (Without WAIT)
4	Max. pause time allowable for remote ID code detection	0 : 2 seconds 1: 1 second
5 6	Busy tone detection in automatic sending mode	No. 5 6 0 0 : No detection 0 1 : Detection only after dialing 1 0 : No detection 1 1 : Detection before and after dialing
7	Busy tone detection in automatic receiving mode	0: Yes 1: No
8	Not used.	

NOTE: Selectors 5 through 7 are not applicable in those countries where no busy tone detection is supported, e.g., China.

- **Selectors 1 through 3: 1st dial tone detection**

These selectors activate or deactivate the 1st dial tone detection function which detects the 1st dial tone issued from the PSTN when a line is connected to the PSTN.

Setting all of these selectors to "1" activates the dial tone detection function so that the equipment starts dialing upon detection of a dial tone when a line is connected. (However, in those countries which support no dial tone detection function, e.g., in the U.S.A., setting these selectors to "1" makes the equipment start dialing after a WAIT of 3.5 seconds.) For the detecting conditions of the 1st dial tone, refer to WSW07 and WSW08.

Other setting combinations deactivate the dial tone detection function so that the equipment starts dialing after the specified WAIT (3.5, 7.0, 10.5, 14.0, 17.5, 21.0, or 24.5 seconds) without detection of a dial tone when a line is connected to the PSTN.

- **Selector 4: Max. pause time allowable for remote ID code detection**

This selector sets the maximum pause time allowable for detecting the second digit of a remote ID code after detection of the first digit in remote reception.

If selector 4 is set to "0" (2 seconds), for instance, only a remote ID code whose second digit is detected within 2 seconds after detection of the first digit will become effective so as to activate the remote function.

- **Selectors 5 and 6: Busy tone detection in automatic sending mode**

These selectors determine whether or not the equipment automatically disconnects a line upon detection of a busy tone in automatic sending mode.

Setting selector 6 to "0" ignores a busy tone so that the equipment does not disconnect the line.

Setting selectors 5 and 6 to "0" and "1," respectively, makes the equipment detect a busy tone only after dialing and disconnect the line.

Setting both of selectors 5 and 6 to "1" makes the equipment detect a busy tone before and after dialing and then disconnect the line.

- **Selector 7: Busy tone detection in automatic receiving mode**

This selector determines whether or not the equipment automatically disconnects a line upon detection of a busy tone in automatic receiving mode.

WSW06 (Pause key setting and 2nd dial tone detection)

Selector No.	Function	Setting and Specifications
1 3	Pause key setting and 2nd dial tone detection	No. 1 2 3 0 0 0 : No pause 0 0 1 : 3.5 sec. WAIT 0 1 0 : 7 sec. WAIT 0 1 1 : 10.5 sec. WAIT 1 0 0 : 14 sec. WAIT 1 1 0 : 2nd dial tone detection only in pulse dialing (DP) system 1 0 1 : 2nd dial tone detection 1 1 1 : both in DP and push-button (PB) dialing system
4 6	Detection of international tone	No. 4 5 6 0 0 0 : 50 ms 0 0 1 : 210 ms 0 1 0 : 500 ms 0 1 1 : 800 ms 1 0 0 : 900 ms 1 0 1 : 1.5 sec. 1 1 0 : 2.0 sec. 1 1 1 : 2.5 sec.
7	No. of 2nd dial tone detection times	0: Once 1: Twice
8	2nd dial tone interrupt detecting time	0: 30 ms 1: 50 ms

NOTE: Selectors 4 through 8 are not applicable in those countries where no dial tone detection is supported, e.g., U.S.A.

- **Selectors 1 through 3: Pause key setting and 2nd dial tone detection**

Selectors			
1	2	3	
0	0	0	No WAIT is inserted even if the Pause key is pressed.
0	0	1	If you press the Pause key during dialing, the facsimile equipment will insert WAIT as defined in the above table. If the Pause key is pressed repeatedly, the equipment inserts the specified WAIT multiplied by the number of depressions. It applies also in hook-up dialing.
0	1	0	
0	1	1	
1	0	0	
1	0	1	When these selectors are set to "1, 0, 1": If you press the Pause key during dialing, the equipment will wait for the 2nd dial tone to be sent via the communications line. When these selectors are set to "1, 1, 0" or "1, 1, 1": If you press the Pause key during dialing, the equipment will first wait for the 2nd dial tone to be sent via the communications line. After that, the equipment will insert a WAIT of 3.5 seconds. If no 2nd dial tone is received within the specified time length (set by WSW08), the equipment will disconnect the line if in automatic dialing, or it will start transmitting the dial signal if given after depression of the Pause key in hook-up dialing. (In those countries where no dial tone detection function is supported, setting these selectors to "1, 1, 0," "1, 0, 1," or "1, 1, 1" inserts a WAIT of 3.5 seconds.)
1	1	0	
1	1	1	

- **Selectors 4 through 6: Detection of international tone**

Upon detection of the 2nd dial tone for the time length specified by these selectors, the equipment starts dialing.

This setting is effective only when the 2nd dial tone detection function is activated by selectors 1 through 3 (Setting 1 0 1, 1 1 0, or 1 1 1).

This function does not apply in those countries where no dial tone detection function is supported.

- **Selector 7: No. of 2nd dial tone detection times**

This selector sets the number of dial tone detection times required for starting dialing.

- **Selector 8: 2nd dial tone interrupt detecting time**

This selector sets the allowable time length of an interrupt which should not be interpreted as an interrupt in the 2nd tone dialing.

WSW07 (Dial tone setting 1)

Selector No.	Function	Setting and Specifications
1 2	Frequency band range	No. 1 2 0 0 : Narrows by 10 Hz 0 1 : Initial value 1 X : Widens by 10 Hz
3	Line current detection	0: No 1: Yes
4 6	2nd dial tone detection level (Z = 600 Ω)	No. 4 5 6 0 0 0 : -21 dBm 0 0 1 : -24 dBm 0 1 0 : -27 dBm 0 1 1 : -30 dBm 1 0 0 : -33 dBm 1 0 1 : -36 dBm 1 1 0 : -39 dBm 1 1 1 : -42 dBm
7	1st dial tone interrupt detecting time	0: 30 ms 1: 50 ms
8	PABX loop current control	0: Disabled 1: Enabled

NOTE: The WSW07 is not applicable in those countries where no dial tone or line current detection is supported, e.g., U.S.A.

- **Selectors 1 and 2: Frequency band range**

These selectors set the frequency band for the 1st dial tone and the busy tone (before dialing) to be detected.

This setting is effective only when selectors 1 through 3 of WSW05 are set to "1,1,1."

- **Selector 3: Line current detection**

This selector determines whether or not the equipment should detect a line current before starting dialing.

- **Selectors 4 through 6: 2nd dial tone detection level**

These selectors set the detection level of the 2nd dial tone.

- **Selector 7: 1st dial tone interrupt detecting time**

This selector sets the allowable time length of an interrupt which should not be interpreted as an interrupt in the 1st dial tone dialing.

- **Selector 8: PABX loop current control**

This selector determines whether the PABX loop current control will be enabled or disabled. Setting this selector to "1" enables the loop current control that automatically switches the internal resistance inserted in series with the communications line on and off depending upon the loop current amount. Setting this selector to "0" disables the loop current control and keeps the internal resistance on.

For some PABXs that are not compatible with the facsimile equipment in voltage rating, set this selector to "0."

The setting made by this selector takes effect only when the user selects the PABX. If no PABX is selected, the PABX loop current control will be enabled independent of this setting.

WSW08 (Dial tone setting 2)

Selector No.	Function	Setting and Specifications
1 3	1st dial tone detection time length	No. 1 2 3 0 0 0 : 50 ms 0 0 1 : 210 ms 0 1 0 : 500 ms 0 1 1 : 800 ms 1 0 0 : 900 ms 1 0 1 : 1.5 sec. 1 1 0 : 2.0 sec. 1 1 1 : 2.5 sec.
4 5	Time-out length for 1st and 2nd dial tone detection	No. 4 5 0 0 : 10 sec. 0 1 : 20 sec. 1 0 : 15 sec. 1 1 : 30 sec.
6 8	Detection level of 1st dial tone and busy tone before dialing	No. 6 7 8 0 0 0 : -21 dBm 0 0 1 : -24 dBm 0 1 0 : -27 dBm 0 1 1 : -30 dBm 1 0 0 : -33 dBm 1 0 1 : -36 dBm 1 1 0 : -39 dBm 1 1 1 : -42 dBm

NOTE: The WSW08 is not applicable in those countries where no dial tone detection is supported, e.g., U.S.A.

- **Selectors 1 through 3: 1st dial tone detection time length**

Upon detection of the 1st dial tone for the time length set by these selectors, the equipment starts dialing.

This setting is effective only when selectors 1 through 3 of WSW05 are set to "1,1,1."

- **Selectors 4 and 5: Time-out length for 1st and 2nd dial tone detection**

These selectors set the time-out length for the 1st and 2nd dial tone detection so that the equipment waits dial tone input for the specified time length and disconnects itself from the line when no dial tone is inputted.

WSW09 (Protocol definition 1)

Selector No.	Function	Setting and Specifications
1	Frame length selection	0: 256 octets 1: 64 octets
2	Use of non-standard commands	0: Allowed 1: Prohibited
3 4	No. of retries	No. 3 4
		0 0 : 4 times
		0 1 : 3 times
		1 0 : 2 times
		1 1 : 1 time
5	T5 timer	0: 300 sec. 1: 60 sec.
6	T1 timer	0: 35 sec. 1: 40 sec.
7 8	Elapsed time for time-out control for no response from the called station in automatic sending mode	No. 7 8
		0 0 : 60 sec.
		0 1 : 140 sec. (in the French versions) 70 sec. (in other versions)
		1 0 : 90 sec.
		1 1 : 35 sec.

NOTE: Selectors 1 through 5 are not applicable in those models which do not support ECM.

- **Selector 1: Frame length selection**

Usually a single frame consists of 256 octets (1 octet = 8 bits). For communications lines with higher bit error rate, however, set selector 1 to "1" so that the facsimile equipment can divide a message into 64-octet frames.

Remarks: The error correction mode (ECM) is a facsimile transmission manner in which the equipment divides a message into frames for transmission so that if any data error occurs on the transmission line, the equipment retransmits only those frames containing the error data.

- **Selector 2: Use of non-standard commands**

If this selector is set to "0," the equipment may use non-standard commands (the machine's native-mode commands, e.g., NSF, NSC, and NSS) for communications. If it is set to "1," the equipment will use standard commands only.

- **Selectors 3 and 4: No. of retries**

These selectors set the number of retries in each specified modem transmission speed.

- **Selector 5: T5 timer**

This selector sets the time length for the T5 timer.

- **Selector 6: T1 timer**

This selector sets the time length for the T1 timer.

- **Selectors 7 and 8: Elapsed time for time-out control**

If the equipment receives no response (no G3 command) from the called terminal in automatic sending during the time set by these selectors, it disconnects the line.

WSW10 (Protocol definition 2)

Selector No.	Function	Setting and Specifications
1	Switching of DPS, following the CML ON/OFF	0: No 1: Yes
2	Time length from transmission of the last dial digit to CML ON	0: 100 ms 1: 50 ms
3	Time length from CML ON to CNG transmission	0: 2 sec. 1: 4 sec.
4	Time length from CML ON to CED transmission (except for facsimile-to-telephone switching)	0: 0.5 sec. 1: 2 sec.
5 6	No. of training retries	No. 5 6 0 0 : 1 time 0 1 : 2 times 1 0 : 3 times 1 1 : 4 times
7 8	Not used.	

- **Selector 1: Switching of DPS, following the CML ON/OFF**
Setting this selector to "1" automatically switches DPS following the CML ON/OFF operation.
- **Selector 2: Time length from transmission of the last dial digit to CML ON**
This selector sets the time length from when the equipment transmits the last dial digit until the CML relay comes on.
- **Selector 3: Time length from CML ON to CNG transmission**
This selector sets the time length until the equipment transmits a CNG after it turns on the CML relay.
- **Selector 4: Time length from CML ON to CED transmission**
This selector sets the time length until the equipment transmits a CED after it turns on the CML relay. This setting does not apply to switching between facsimile and telephone.
- **Selectors 5 and 6: No. of training retries**
These selectors set the number of training retries to be repeated before automatic fallback.

WSW11 (Busy tone setting)

Selector No.	Function	Setting and Specifications
1 2	Frequency band range	No. 1 2 0 0 : Narrows by 10 Hz 0 1 : Initial value 1 x : Widens by 10 Hz
3	ON/OFF time length ranges (More than one setting allowed)	1: 250-750/250-750 ms
4		1: 400-600/400-600 ms
5		1: 175-440/175-440 ms
6		1: 100-1000/17-660 ms
7		1: 110-410/320-550 ms
8		1: 100-660/100-660 ms

NOTE: WSW11 is not applicable in those countries where no busy tone detection is supported.

NOTE: The setting of WSW11 is effective only when selectors 5 and 6 of WSW05 are set to "0, 1" or "1, 1" (Busy tone detection).

Selectors 1 and 2: Frequency band range

These selectors set the frequency band for busy tone to be detected.

Selectors 3 through 8: ON/OFF time length ranges

These selectors set the ON and OFF time length ranges for busy tone to be detected. If more than one selector is set to "1," the ranges become wider. For example, if selectors 4 and 5 are set to "1," the ON and OFF time length ranges are from 175 to 600 ms.

WSW12 (Signal detection condition setting)

Selector No.	Function	Setting and Specifications
1 2	Min. OFF time length of calling signal (Ci)	No. 1 2 0 0 : 1500 ms 0 1 : 500 ms 1 0 : 700 ms 1 1 : 900 ms
3 4	Max. OFF time length of calling signal (Ci)	No. 3 4 0 0 : 6 sec. 0 1 : 7 sec. 1 0 : 9 sec. 1 1 : 11 sec.
5 6	Detecting time setting	No. 5 6 0 0 : 800 ms (1000 ms*) 0 1 : 200 ms 1 0 : 250 ms 1 1 : 150 ms
7	Delay	0: Yes 1: No
8	Not used.	

* 1000 ms in Chinese versions.

- **Selectors 1 through 4: Min. and max. OFF time length of calling signal (Ci)**

If the equipment detects the OFF state of calling signal (Ci) for a time length which is greater than the value set by selectors 1 and 2 and less than the value set by selectors 3 and 4, it interprets the Ci signal as OFF.

- **Selectors 5 and 6: Detecting time setting**

These selectors set the time length required to make the equipment acknowledge itself to be called. That is, if the equipment continuously detects calling signals with the frequency set by selectors 1 through 4 of WSW14 during the time length set by these selectors 5 and 6, it acknowledges the call.

- **Selector 7: Delay**

Setting this selector to "0" allows the equipment to insert a 900 ms WAIT after acknowledgment of the call until the equipment turns on the CML relay to start receiving operation.

WSW13 (Modem setting)

Selector No.	Function	Setting and Specifications
1 2	Cable equalizer	No. 1 2 0 0 : 0 km 0 1 : 1.8 km 1 0 : 3.6 km 1 1 : 5.6 km
3 4	Reception level	No. 3 4 0 0 : -43 dBm 0 1 : -47 dBm 1 0 : -49 dBm 1 1 : -51 dBm
5 8	Modem attenuator	0: 0 dB 1: 8 dB 0: 0 dB 1: 4 dB 0: 0 dB 1: 2 dB 0: 0 dB 1: 1 dB

The modem should be adjusted according to the user's line conditions.

- **Selectors 1 and 2: Cable equalizer**

These selectors are used to improve the pass-band characteristics of analogue signals on a line. (Attenuation in the high-band frequency is greater than in the low-band frequency.)

Set these selectors according to the distance from the telephone switchboard to the facsimile equipment.

- **Selectors 3 and 4: Reception level**

These selectors set the optimum receive signal level.

- **Selectors 5 through 8: Modem attenuator**

These selectors are used to adjust the transmitting level of the modem when the reception level at the remote station is improper due to line loss. This function applies for G3 protocol signals.

Setting two or more selectors to "1" produces addition of attenuation assigned to each selector.

This setting will be limited if selector 8 of WSW23 is set to "0."

WSW14 (AUTO ANS facility setting)

Selector No.	Function	Setting and Specifications
1 2	Frequency band selection (Lower limit)	No. 1 2 0 0 : 13 Hz 0 1 : 15 Hz 1 0 : 23 Hz 1 1 : 20 Hz
3 4	Frequency band selection (Upper limit)	No. 3 4 0 0 : 30 Hz 0 1 : 55 Hz 1 X : 70 Hz
5 8	No. of rings in AUTO ANS mode	No. 5 6 7 8 0 0 0 0 : Fixed to once 0 0 0 1 : Fixed to 2 times 0 0 1 0 : Fixed to 3 times 0 0 1 1 : Fixed to 4 times 0 1 0 0 : 1 to 2 times 0 1 0 1 : 1 to 3 times 0 1 1 0 : 1 to 4 times 0 1 1 1 : 1 to 5 times 1 0 0 0 : 2 to 3 times 1 0 0 1 : 2 to 4 times 1 0 1 0 : 2 to 5 times 1 0 1 1 : 2 to 6 times 1 1 0 0 : 1 to 10 times 1 1 0 1 : 2 to 10 times 1 1 1 0 : 3 to 5 times 1 1 1 1 : 4 to 10 times

● **Selectors 1 through 4: Frequency band selection**

These selectors are used to select the frequency band of calling signals for activating the AUTO ANS facility.

In the French versions, if the user sets the PBX to OFF from the control panel, the setting made by selectors 1 and 2 will take no effect and the frequency's lower limit will be fixed to 32 Hz. (Even if the setting made by these selectors does not apply, it will be printed on the configuration list.)

● **Selectors 5 through 8: No. of rings in AUTO ANS mode**

These selectors set the number of rings to initiate the AUTO ANS facility.

WSW15 (REDIAL facility setting)

Selector No.	Function	Setting and Specifications
1 2	Selection of redial interval	No. 1 2 0 0 : 5 minutes 0 1 : 1 minute 1 0 : 2 minutes 1 1 : 3 minutes
3 6	No. of redialings	No. 3 4 5 6 0 0 0 0 : 16 times 0 0 0 1 : 1 times 0 0 1 0 : 2 times 0 0 1 1 : 3 times 1 1 1 1 : 15 times
7	Redialing for no response sent from the called terminal	0: Redialing 1: No redialing
8	CRP option	0: Disable 1: Enable

Selectors 1 through 6: Selection of redial interval and No. of redialings

The equipment redials by the number of times set by selectors 3 through 6 at intervals set by selectors 1 and 2.

Selectors 7: Redialing for no response sent from the called terminal

This selector determines whether or not the equipment redials if no G3 command response comes from the called station after dialing within the time length set by selectors 7 and 8 of WSW09.

Selectors 8: CRP option

If a command error occurs in the equipment (calling station), the equipment usually waits for three seconds and then makes a retry three times. This CRP option is a request command that can be sent from the called station for requesting the calling station to retry the failed command immediately.

WSW16 (Function setting 1)

Selector No.	Function	Setting and Specifications	
1	Automatic cutter	0: ON	1: OFF
2	CCITT superfine recommendation	0: OFF	1: ON
3 6	Not used.		
7	Max. document length limitation	0: 400 cm	1: 90 cm
8	Stop key pressed during reception	0: Not functional	1: Functional

- **Selector 1: Automatic cutter**

This selector activates or deactivates the automatic cutter.

- **Selector 2: CCITT superfine recommendation**

If this selector is set to "1," the equipment communicates in CCITT recommended superfine mode (15.4 lines/mm). If it is set to "0," it communicates in native superfine mode.

- **Selector 7: Max. document length limitation**

This selector is used to select the maximum length of a document to be sent.

- **Selector 8: Stop key pressed during reception**

If this selector is set to "1," pressing the **Stop** key can stop the current receiving operation. The received data will be lost.

WSW17 (Function setting 2)

Selector No.	Function	Setting and Specifications												
1 2	Off-hook alarm	<table border="0"> <tr> <td>No. 1</td> <td>2</td> <td></td> </tr> <tr> <td>0</td> <td>0</td> <td>: No alarm</td> </tr> <tr> <td>0</td> <td>1</td> <td>: Always valid</td> </tr> <tr> <td>1</td> <td>X</td> <td>: Valid except when 'call reservation' is selected.</td> </tr> </table>	No. 1	2		0	0	: No alarm	0	1	: Always valid	1	X	: Valid except when 'call reservation' is selected.
No. 1	2													
0	0	: No alarm												
0	1	: Always valid												
1	X	: Valid except when 'call reservation' is selected.												
3	Power failure report output	0: ON 1: OFF												
4	Calendar clock/prompt alternate display	0: No 1: Yes												
5	Calendar clock type	0: U.S.A. type 1: European type												
6	Error indication in activity report	0: No 1: Yes												
7	Non-ring reception	0: OFF 1: ON												
8	Not used.													

NOTE: Selector 3 is not applicable to the U.S.A. versions.

- **Selectors 1 and 2: Off-hook alarm**

These selectors activate or deactivate the alarm function which sounds an alarm when the communication is completed with the handset being off the hook.

- **Selector 3: Power failure report output**

This selector determines whether or not the equipment outputs a power failure report when the power comes back on.

- **Selector 4: Calendar clock/prompt alternate display**

If this selector is set to "1," the calendar clock and the prompt "INSERT DOCUMENT" appear alternately on the LCD while the equipment is on standby; if it is set to "0," only the calendar clock appears.

- **Selector 5: Calendar clock type**

If this selector is set to "0" (USA), the MM/DD/YY hh:mm format applies; if it is set to "1" (Europe), the DD/MM/YY hh:mm format applies: DD is the day, MM is the month, YY is the last two digits of the year, hh is the hour, and mm is the minute.

- **Selector 6: Error indication in activity report**

This selector determines whether or not a communications error code will be printed in the activity report.

- **Selector 7: Non-ring reception**

Setting this selector to "1" makes the equipment receive calls without ringer sound if the ring delay is set to 0.

WSW18 (Function setting 3)

Selector No.	Function	Setting and Specifications
1	Not used.	
2 3	Detection enabled time for CNG and no tone	No. 2 3 0 0 : 40 sec. 0 1 : 0 sec. (No detection) 1 0 : 5 sec. 1 1 : 80 sec.
4	ACS* check sheet output function on/off key	0: Operative 1: Inoperative
5	ACS* check sheet output function	0: ON 1: OFF
6	Registration of station ID	0: Permitted 1: Prohibited
7 8	Tone sound monitoring	No. 7 8 0 X : No monitoring 1 0 : Up to phase B at the calling station only 1 1 : All transmission phases both at the calling and called stations

*ACS: Anti-curl system

- **Selectors 2 and 3: Detection enabled time for CNG and no tone**

After the line is connected via the external telephone or by picking up the handset of the facsimile equipment, the equipment can detect a CNG signal or no tone for the time length specified by these selectors. The setting specified by these selectors becomes effective only when selector 8 of WSW20 is set to "1."

- **Selector 4: ACS check sheet output function on/off key**

If this selector is set to "0" (Operative), the user can toggle the ACS check sheet output function on and off by pressing one-touch keys **01** and **05** simultaneously. If it is set to "1" (Inoperative), the user cannot toggle the ACS check sheet output function from the control panel so that the setting specified by selector 5 takes effect.

- **Selector 5: ACS check sheet output function**

When selector 4 is set to "0," the setting specified by this selector becomes the default state of the ACS check sheet output function. When selector 4 is set to "1," the setting specified by this selector permanently takes effect.

- **Selector 6: Registration of station ID**

Setting this selector to "0" permits the registration of station ID for Austrian and Czech versions.

- **Selectors 7 and 8: Tone sound monitoring**

These selectors set monitoring specifications of the tone sound inputted from the line.

WSW19 (Transmission speed setting)

Selector No.	Function	Setting and Specifications
1 3	First transmission speed choice for fallback	No. 1 2 3 No. 4 5 6 0 0 0 : 2,400 bps 0 0 1 : 4,800 bps 0 1 0 : 7,200 bps 0 1 1 : 9,600 bps 1 0 0 : 12,000 bps * 1 0 1 : } 14,400 bps * 1 1 0 : } 1 1 1 : }
4 6	Last transmission speed choice for fallback	
7	Not used.	
8	V. 17 mode	0: Permitted 1: Prohibited

- In those models with a maximum of 9600 bps capability, selection of 12,000 bps or 14,400 bps will still only produce a set speed automatically reduced to 9600 bps.

NOTE: Selector 8 is applicable only to those models that support 14,400 bps.

• **Selectors 1 through 6: First and last choices of transmission speed for fallback**

These selectors are used to set the MODEM speed range. With the first transmission speed choice specified by selectors 1 through 3, the equipment attempts to synchronize the data transmission via the MODEM. If the synchronization fails, the equipment automatically steps down to the next lowest speed and attempts to synchronize the data transmission again. The equipment repeats this sequence while stepping down the transmission speed to the last choice specified by selectors 4 through 6.

If the MODEM always falls back to a low transmission speed (e.g., 4,800 bps), set the first transmission speed choice to the lower one (e.g., modify it from 12,000 bps to 7,200 bps) in order to deactivate the high-speed MODEM function and reduce the training time for shorter transmission time.

Generally, to save the transmission time, set the last transmission speed choice to a higher one.

WSW20 (Overseas communications mode setting)

Selector No.	Function	Setting and Specifications
1	EP* tone prefix	0: OFF 1: ON
2	Overseas communications mode (Reception)	0: 2100 Hz 1: 1100 Hz
3	Overseas communications mode (Transmission)	0: OFF 1: Ignores DIS once.
4 5	Min. time length from reception of CFR to start of transmission of video signals	No. 4 5 0 0 : 100 ms 0 1 : 200 ms 1 0 : 300 ms 1 1 : 400 ms
6 7	Chattering elimination for CNG detection	No. 6 7 0 0 : A (During CNG ON and OFF) 0 1 : B (During CNG OFF only) 1 X : C (No elimination)
8	CNG detection on/off	0: OFF 1: ON

* EP: Echo protection

- **Selector 1: EP tone prefix**

Setting this selector to "1" makes the equipment transmit a 1700 Hz echo protection (EP) tone immediately preceding training in V.29 modulation system to prevent omission of training signals.

Prefixing an EP tone is effective when the equipment fails to transmit at the V.29 modem speed and always has to fall back to 4800 bps transmission.

- **Selectors 2 and 3: Overseas communications mode**

These selectors should be used if the facsimile equipment malfunctions in overseas communications. According to the communications error state, select the signal specifications.

Setting selector 2 to "1" allows the equipment to use 1100 Hz CED signal instead of 2100 Hz in receiving operation. This prevents malfunctions resulting from echoes, since the 1100 Hz signal does not disable the echo suppressor (ES) while the 2100 Hz signal does.

Setting selector 3 to "1" allows the equipment to ignore a DIS signal sent from the called station once in sending operation. This operation suppresses echoes since the first DIS signal immediately follows a 2100 Hz CED (which disables the ES) so that it is likely to be affected by echoes in the disabled ES state. However, such a disabled ES state will be removed soon so that the second and the following DIS signals are not susceptible to data distortion due to echoes. Note that some models when called may cause error by receiving a self-outputted DIS.

- **Selectors 8: CNG detection on/off**

If this selector is set to "1," the equipment detects a CNG signal according to the condition preset by selectors 2 and 3 of WSW18 after a line is connected. If it is set to "0," the equipment detects a CNG signal as long as the line is connected.

WSW21 (TAD setting 1)

Selector No.	Function	Setting and Specifications
1 5	Max. waiting time for voice signal	No. 1 2 3 4 5 0 0 0 0 0 : No detection 0 0 0 0 1 : 1 sec. 0 0 0 1 0 : 2 sec. 0 0 0 1 1 : 3 sec. 0 1 0 0 0 : 8 sec. 1 1 1 1 1 : 31 sec.
6 7	Two-way recording	No. 6 7 0 0 : For U.S.A. (A) 0 1 : Except for U.S.A. (B) 1 0 : Without beep (C) 1 1 : OFF (D)
8	Erasure of message stored in the memory after the message transfer	0: Yes 1: No

NOTE: Selectors 1 through 8 are applicable to those models equipped with a built-in TAD.

- **Selectors 1 through 5: Max. waiting time for voice signal**

In the TAD mode, the equipment waits for voice signal for the time length specified by these selectors before it automatically shifts to the facsimile message receive mode or disconnects the line.

- **Selectors 6 and 7: Two-way recording**

These selectors select the specifications of the two-way recording feature.

- **Selector 8: Erasure of message**

Setting this selector to "0" will erase the message recorded in the memory after the document retrieval feature transfers the message.

WSW22 (ECM)

Selector No.	Function	Setting and Specifications	
1	ECM* in sending	0: ON	1: OFF
2	ECM* in receiving	0: ON	1: OFF
3 4	Not used.		
5 8	Acceptable TCF bit error rate (%) (Only at 4800 bps)	0: 0%	1: 8%
		0: 0%	1: 4%
		0: 0%	1: 2%
		0: 0%	1: 1%

* ECM: Error correction mode

NOTE: Selectors 5 through 8 are applicable to the Chinese, Taiwanese and Asian versions only.

● **Selectors 5 through 8: Acceptable TCF bit error rate (%)**

Setting two or more selectors to "1" produces addition of percent assigned to each selector. If you set selectors 7 and 8 to "1," the acceptable TCF bit error rate will be 3%.

WSW23 (Communications setting)

Selector No.	Function	Setting and Specifications
1	Starting point of training check (TCF)	0: From the head of a series of zeros 1: From any arbitrary point
2 3	Allowable training error rate	No. 2 3 0 0 : 0% 0 1 : 0.5% 1 0 : 1% 1 1 : 2%
4 5		No. 4 5 0 0 : 16% 0 1 : 14% 1 0 : 10% 1 1 : 8%
6 7	Not used.	
8	Limitation of attenuation level	0: Yes 1: No

NOTE: Selector 8 is not applicable to the French and Chinese versions.

- **Selector 1: Starting point of training check (TCF)**

At the training phase of receiving operation, the called station detects for 1.0 second a training check (TCF) command, a series of zeros which is sent from the calling station for 1.5 seconds to verify training and give the first indication of the acceptability of the line.

This selector sets the starting point from which the called station should start counting those zeros. If this selector is set to "0," the called station starts counting zeros 100 ms after the head of a series of zeros is detected.

If it is set to "1," the called station starts counting zeros upon detection of 10-ms successive zeros 50 ms after the head of a series of zeros is detected. In this case, if the detection of 10-ms successive zeros is too late, the data counting period will become less than 1.0 second, making the called station judge the line condition unacceptable.

- **Selectors 2 and 3: Allowable training error rate**

The called station checks a series of zeros gathered in training (as described in Selector 1) according to the allowable training error rate set by these selectors. If the called station judges the line condition to be accepted, it responds with CFR; if not, it responds with FTT.

- **Selectors 4 and 5: Decoding error rate for transmission of RTN**

The facsimile equipment checks the actual decoding errors and then transmits an RTN according to the decoding error rate (Number of lines containing an error per page ÷ Total number of lines per page) set by these selectors.

- **Selector 8: Limitation of attenuation level**

Setting this selector to "0" limits the transmitting level of the modem to 10 dB.

This setting has priority over the settings selected by WSW02 (selectors 5 through 8) and WSW13 (selectors 5 through 8).

WSW24 (TAD setting 2)

Selector No.	Function	Setting and Specifications
1 2	Maximum OGM recording time	No. 1 2 0 0 : 15 sec. 0 1 : 20 sec. 1 0 : 30 sec. 1 1 : 50 sec.
3 4	Time length from CML ON to start of pseudo ring backtone transmission	No. 3 4 0 0 : 4 sec. 0 1 : 3 sec. 1 0 : 2 sec. 1 1 : 1 sec.
5 8	Attenuator for playback of ICM/OGM to the line (Selectable from the range of 0-15 dB)	0: 0 dB 1: 8 dB 0: 0 dB 1: 4 dB 0: 0 dB 1: 2 dB 0: 0 dB 1: 1 dB

NOTE: Selectors 1 and 2 are applicable to those models equipped with a built-in TAD.

- **Selectors 1 and 2: Maximum OGM recording time**

These selectors set the allowable maximum recording time for an OGM.

- **Selectors 3 and 4: Time length from CML ON to start of pseudo ring backtone transmission**

These selectors set the length of time from CML-ON up to the start of pseudo ring backtone transmission.

In those versions which have an OGM facility, the settings made by these selectors also apply to the length of time from CML-ON up to the start of OGM transmission.

- **Selectors 5 through 8: Attenuator for playback of ICM/OGM to the line**

Setting two or more selectors to "1" produces addition of attenuation assigned to each selector.

This setting will not be limited by selector 8 of WSW23.

WSW25 (TAD setting 3)

Selector No.	Function	Setting and Specifications
1 8	Not used.	

WSW26 (Function setting 4)

Selector No.	Function	Setting and Specifications
1 3	Not used.	
4 5	No. of CNG cycles to be detected (when the line is connected via the external telephone except in the external TAD mode)	No. 4 5 0 0 : 0.5 (A) 0 1 : 1 (B) 1 0 : 1.5 (C) 1 1 : 2 (D)
6 7	No. of CNG cycles to be detected (when the line is connected via the external telephone in the external TAD mode or via the facsimile equipment in F/T mode)	No. 6 7 0 0 : 0.5 (A) 0 1 : 1 (B) 1 0 : 1.5 (C) 1 1 : 2 (D)
8	FAX reception after the time-out of pseudo ring backtones in F/T mode	0: Yes 1: No

NOTE: Selectors 6 and 7 are not applicable to those models equipped with a built-in TAD.

Selectors 4 and 5: No. of CNG cycles to be detected

The equipment interprets a CNG as an effective signal if it detects a CNG signal by the number of cycles specified by these selectors when the line is connected via the external telephone except in the external TAD mode.

Selectors 6 and 7: No. of CNG cycles to be detected

The equipment interprets a CNG as an effective signal if it detects a CNG signal by the number of cycles specified by these selectors when the line is connected via the external telephone in the external TAD mode or via the facsimile equipment in F/T mode.

Selector 8: FAX reception after the time-out of pseudo ring backtones in F/T mode

If this selector is set to "0," the equipment starts receiving FAX messages when it receives a CNG signal within 10-second no-tone period provided after the time-out of pseudo ring backtones. If no CNG is received within the period, the equipment disconnects the line.

If this selector is set to "1," the equipment disconnects the line after issuing pseudo ring backtones.

WSW27 (Function setting 5)

Selector No.	Function	Setting and Specifications
1	Definition of programmable key	0: TEL key 1: TEL/POLLING key
2	Ringer OFF setting	0: Yes 1: No
3	Automatic playback of OGM at the start time of OGM ON mode	0: No 1: Yes
4	Detection of distinctive ringing pattern	0: Yes 1: No
5 7	Not used.	
8	Motor overheating error indication	0: No 1: Yes

NOTE: Selector 1 is not applicable to the U.S.A. versions.

NOTE: Selectors 3 and 6 are applicable to those models equipped with a built-in TAD.

- **Selector 1: Definition of programmable key**

This selector defines a programmable key as a TEL key or TEL/POLLING key.

Setting this selector to "1" allows the programmable key to function as either a TEL or POLLING key if pressed when the handset is off or on the hook, respectively.

This setting is effective only for those models having a programmable key.

- **Selector 2: Ringer OFF setting**

This selector determines whether or not the ringer can be set to OFF.

- **Selector 3: Automatic playback of OGM at the start time of OGM ON mode**

This selector determines whether or not the equipment automatically plays back an OGM the moment it switches to the OGM ON mode in the MC mode.

- **Selector 4: Detection of distinctive ringing pattern**

If this selector is set to "1," the equipment detects only the number of rings; if it is set to "0," the equipment detects the number of rings and the ringing time length to compare the detected ringing pattern with the registered distinctive one.

- **Selector 8: Motor overheating error indication**

If this selector is set to "0," the equipment displays the message "PRINTER FAULT" on the LCD whenever a motor overheating error occurs so that any of the following happens and the equipment aborts recording:

- The number of printed documents is five or less although the receiving operation continues for 15 minutes or more.
- The number of printed documents is 10 or less although the receiving operation continues for 20 minutes or more.

WSW28 (Function setting 6)

Selector No.	Function	Setting and Specifications
1 3	Transmission level of DTMF high-band frequency signal	No. 1 2 3 0 0 0 : 0 dB 0 0 1 : +1 dB 0 1 0 : +2 dB 0 1 1 : +3 dB 1 0 0 : 0 dB 1 0 1 : -1 dB 1 1 0 : -2 dB 1 1 1 : -3 dB
4 6	Transmission level of DTMF low-band frequency signal	No. 4 5 6 0 0 0 : 0 dB 0 0 1 : +1 dB 0 1 0 : +2 dB 0 1 1 : +3 dB 1 0 0 : 0 dB 1 0 1 : -1 dB 1 1 0 : -2 dB 1 1 1 : -3 dB
7 8	Not used.	

● **Selectors 1 through 6: Transmission level of DTMF high-/low-band frequency signal**

These selectors are intended for the manufacturer who tests the equipment for the Standard. Never access them.

WSW29 (Function setting 7)

Selector No.	Function	Setting and Specifications
1 3	Compression threshold level for voice signals inputted via the telephone line in the built-in TAD operation	No. 1 2 3 0 0 0 : -47.0 dBm (A) 0 0 1 : -48.5 dBm (B) 0 1 0 : -50.0 dBm (C) 0 1 1 : -51.5 dBm (D) 1 0 0 : -53.0 dBm (E) 1 0 1 : -54.5 dBm (F) 1 1 0 : -56.0 dBm (G) 1 1 1 : OFF (H)
4 6	Compression threshold level for voice signals inputted via the handset in the built-in TAD operation	No. 4 5 6 0 0 0 : -44.0 dBm (A) 0 0 1 : -45.5 dBm (B) 0 1 0 : -47.0 dBm (C) 0 1 1 : -48.5 dBm (D) 1 0 0 : -50.0 dBm (E) 1 0 1 : -51.5 dBm (F) 1 1 0 : -53.0 dBm (G) 1 1 1 : OFF (H)
7	Not used.	
8	Not used.	

NOTE: Selectors 1 through 6 are applicable to those models equipped with a built-in TAD.

NOTE: Selector 8 is not applicable to the U.S.A. versions.

Selectors 1 through 6: Compression threshold level for voice signals inputted via the telephone line in the built-in TAD operation

If voice signals inputted via the telephone line are below the level specified by these selectors, the TAD interprets those received voice signals as no signal, compressing the recording time.

WSW30 (Function setting 8)

Selector No.	Function	Setting and Specifications																																																						
1 3	Detection level of dial tone or busy tone for the built-in TAD operation	<table border="0"> <tr> <td>No.</td> <td>1</td> <td>2</td> <td>3</td> <td></td> <td></td> </tr> <tr> <td></td> <td>0</td> <td>0</td> <td>0</td> <td>:</td> <td>-38.0 dBm (A)</td> </tr> <tr> <td></td> <td>0</td> <td>0</td> <td>1</td> <td>:</td> <td>-39.5 dBm (B)</td> </tr> <tr> <td></td> <td>0</td> <td>1</td> <td>0</td> <td>:</td> <td>-41.0 dBm (C)</td> </tr> <tr> <td></td> <td>0</td> <td>1</td> <td>1</td> <td>:</td> <td>-42.5 dBm (D)</td> </tr> <tr> <td></td> <td>1</td> <td>0</td> <td>0</td> <td>:</td> <td>-44.0 dBm (E)</td> </tr> <tr> <td></td> <td>1</td> <td>0</td> <td>1</td> <td>:</td> <td>-45.5 dBm (F)</td> </tr> <tr> <td></td> <td>1</td> <td>1</td> <td>0</td> <td>:</td> <td>-47.0 dBm (G)</td> </tr> <tr> <td></td> <td>1</td> <td>1</td> <td>1</td> <td>:</td> <td>-48.5 dBm (H)</td> </tr> </table>	No.	1	2	3				0	0	0	:	-38.0 dBm (A)		0	0	1	:	-39.5 dBm (B)		0	1	0	:	-41.0 dBm (C)		0	1	1	:	-42.5 dBm (D)		1	0	0	:	-44.0 dBm (E)		1	0	1	:	-45.5 dBm (F)		1	1	0	:	-47.0 dBm (G)		1	1	1	:	-48.5 dBm (H)
No.	1	2	3																																																					
	0	0	0	:	-38.0 dBm (A)																																																			
	0	0	1	:	-39.5 dBm (B)																																																			
	0	1	0	:	-41.0 dBm (C)																																																			
	0	1	1	:	-42.5 dBm (D)																																																			
	1	0	0	:	-44.0 dBm (E)																																																			
	1	0	1	:	-45.5 dBm (F)																																																			
	1	1	0	:	-47.0 dBm (G)																																																			
	1	1	1	:	-48.5 dBm (H)																																																			
4 8	Not used.																																																							

NOTE: Selectors 1 through 3 are applicable to those models equipped with a built-in TAD.

- **Selectors 1 through 3: Detection level of dial tone or busy tone for built-in TAD operation**

If dial tone or busy tone inputted during ICM recording is below the level specified by these selectors, the TAD stops recording and disconnects the line.

WSW31 (Function setting 9)

Selector No.	Function	Setting and Specifications
1 4	Not used.	
5	Minimum short-OFF duration in distinctive ringing	0: 130 ms 1: 90 ms
6 8	Not used.	

NOTE: Selector 5 is applicable in those areas where the distinctive ringing is supported.

- **Selector 5 Minimum short-OFF duration in distinctive ringing**

The ringer pattern consists of short and long rings, e.g., short-short-long rings. This selector sets the minimum OFF duration following a short ring in order to avoid missing ringer tones in distinctive ringing.

If this selector is set to "1," when the short-OFF duration is a minimum of 90 ms long, then the equipment will interpret the short-OFF as OFF.

WSW32 (Function setting 10)

Selector No.	Function	Setting and Specifications
1 4	Not used.	
5 6	Default resolution	No. 5 6 0 0 : Standard 0 1 : Fine 1 0 : Super fine 1 1 : Photo
7 8	Default contrast	No. 7 8 0 X : Automatic 1 0 : Super light 1 1 : Super dark

NOTE: Selectors 5 through 8 are applicable to those models equipped with a built-in TAD.

- **Selectors 5 and 6 Default resolution**

These selectors set the default resolution which applies when the equipment is powered up or completes a transaction.

- **Selectors 7 and 8 Default contrast**

These selectors set the default contrast which applies when the equipment is powered up or completes a transaction.

WSW33 (Function setting 11)

Selector No.	Function	Setting and Specifications
1 3	Detection threshold level for voice signals inputted via the telephone line in the built-in TAD operation	No. 1 2 3 0 0 0 : -42.5 dBm (A) 0 0 1 : -44.0 dBm (B) 0 1 0 : -45.5 dBm (C) 0 1 1 : -47.0 dBm (D) 1 0 0 : -48.5 dBm (E) 1 0 1 : -50.0 dBm (F) 1 1 0 : -51.5 dBm (G) 1 1 1 : -53.0 dBm (H)
4 5	Not used.	
6	Report output of polled transmission requests	0: Yes 1: No
7 8	Comfortable noise level	No. 7 8 0 0 : OFF 0 1 : Low (A) 1 0 : Medium (B) 1 1 : High (C)

NOTE: WSW33 is applicable to those models equipped with a built-in TAD.

NOTE: Selector 6 is not applicable to the U.S.A. versions.

Selectors 1 through 3: Detection threshold level for voice signals inputted via the telephone line in the built-in TAD operation

If the equipment detects voice signals exceeding the threshold level set by these selectors, it will interpret them as effective voice.

Selectors 7 and 8: Comfortable noise level

These selectors set the level of noise to be added during playing-back of voice signals recorded with no-signal compression.

If they are set to "0, 0," no noise will be added.

WSW34 (Function setting 12)

Selector No.	Function	Setting and Specifications																																													
1 3	Erasing time length of ICM tone recorded preceding the tone detection starting point in the case of automatic line disconnection due to no voice signal received	<table> <tr><td>No. 1</td><td>2</td><td>3</td><td></td><td></td></tr> <tr><td>0</td><td>0</td><td>0</td><td>:</td><td>0 sec.</td></tr> <tr><td>0</td><td>0</td><td>1</td><td>:</td><td>1 sec.</td></tr> <tr><td>0</td><td>1</td><td>0</td><td>:</td><td>2 sec.</td></tr> <tr><td>0</td><td>1</td><td>1</td><td>:</td><td>3 sec.</td></tr> <tr><td>1</td><td>0</td><td>0</td><td>:</td><td>4 sec.</td></tr> <tr><td>1</td><td>0</td><td>1</td><td>:</td><td>5 sec.</td></tr> <tr><td>1</td><td>1</td><td>0</td><td>:</td><td>6 sec.</td></tr> <tr><td>1</td><td>1</td><td>1</td><td>:</td><td>7 sec.</td></tr> </table>	No. 1	2	3			0	0	0	:	0 sec.	0	0	1	:	1 sec.	0	1	0	:	2 sec.	0	1	1	:	3 sec.	1	0	0	:	4 sec.	1	0	1	:	5 sec.	1	1	0	:	6 sec.	1	1	1	:	7 sec.
No. 1	2	3																																													
0	0	0	:	0 sec.																																											
0	0	1	:	1 sec.																																											
0	1	0	:	2 sec.																																											
0	1	1	:	3 sec.																																											
1	0	0	:	4 sec.																																											
1	0	1	:	5 sec.																																											
1	1	0	:	6 sec.																																											
1	1	1	:	7 sec.																																											
4 5	No. of CNG cycles to be detected (when the line is connected via the external telephone in the external TAD mode or via the facsimile equipment in F/T or TAD mode)	<table> <tr><td>No. 4</td><td>5</td><td></td><td></td><td></td></tr> <tr><td>0</td><td>0</td><td>:</td><td>0.5</td><td>(A)</td></tr> <tr><td>0</td><td>1</td><td>:</td><td>1</td><td>(B)</td></tr> <tr><td>1</td><td>0</td><td>:</td><td>1.5</td><td>(C)</td></tr> <tr><td>1</td><td>1</td><td>:</td><td>2</td><td>(D)</td></tr> </table>	No. 4	5				0	0	:	0.5	(A)	0	1	:	1	(B)	1	0	:	1.5	(C)	1	1	:	2	(D)																				
No. 4	5																																														
0	0	:	0.5	(A)																																											
0	1	:	1	(B)																																											
1	0	:	1.5	(C)																																											
1	1	:	2	(D)																																											
6 7	Number of DTMF tone signals for inhibiting the detection of CNG during external TAD operation	<table> <tr><td>No. 6</td><td>7</td><td></td><td></td><td></td></tr> <tr><td>0</td><td>0</td><td>:</td><td>3</td><td></td></tr> <tr><td>0</td><td>1</td><td>:</td><td>2</td><td></td></tr> <tr><td>1</td><td>0</td><td>:</td><td>1</td><td></td></tr> <tr><td>1</td><td>1</td><td>:</td><td>OFF</td><td></td></tr> </table>	No. 6	7				0	0	:	3		0	1	:	2		1	0	:	1		1	1	:	OFF																					
No. 6	7																																														
0	0	:	3																																												
0	1	:	2																																												
1	0	:	1																																												
1	1	:	OFF																																												
8	Not used.																																														

NOTE: Selectors 1 through 5 are applicable to those models equipped with a built-in TAD.

- **Selectors 1 through 3: Erasing time length of ICM tone recorded preceding the tone detection starting point in the case of automatic line disconnection due to no voice signal received**

If the equipment has disconnected the line after detection of disconnection tone in ICM recording, it erases tone recorded preceding the tone detection starting point for the time length set by these selectors.

- **Selectors 4 and 5: No. of CNG cycles to be detected**

The equipment interprets a CNG as an effective signal if it detects a CNG signal by the number of cycles specified by these selectors in any of the following cases:

- when the line is connected via the external telephone in the external TAD mode.
- when the line is connected via the facsimile equipment in F/T or TAD mode.

- **Selectors 6 and 7: Number of DTMF tone signals for inhibiting the detection of CNG during external TAD operation**

If the equipment receives this specified number of DTMF tone signals during external TAD operation, it will not detect CNG afterwards.

If these selectors are set to "1, 1," the CNG detection will not be inhibited.

WSW35 (Function setting 13)

Selector No.	Function	Setting and Specifications
1 4	Detection time length of the disconnection tone in ICM recording	No. 1 2 3 4 0 0 0 0 : No detection 0 0 0 1 : 1 sec. 0 0 1 0 : 2 sec. 0 1 0 0 : 4 sec. 1 1 1 1 : 15 sec.
5 8	Not used.	

NOTE: Selectors 1 through 4 are applicable to those models equipped with a built-in TAD.

- Selectors 1 through 4: Detection time length of the disconnection tone in ICM recording**
 If the equipment detects disconnection tone for the time length set by these selectors, it will disconnect the line.

WSW36 (Function setting 14)

Selector No.	Function	Setting and Specifications
1 5	Not used.	
6 8	Lower limit of frequency to be ignored after detection of calling signals (Ci)	No. 6 7 8 0 0 0 : 0 (Not ignored) 0 0 1 : 4 (448 Hz) 0 1 0 : 8 (244 Hz) 0 1 1 : 12 (162 Hz) 1 0 0 : 16 (122 Hz) 1 0 1 : 20 (97 Hz) 1 1 0 : 24 (81 Hz) 1 1 1 : 28 (69 Hz)

- Selectors 6 through 8: Lower limit of frequency to be ignored after detection of calling signals (Ci)**
 At the start of reception, if the equipment detects the frequency of calling signals (Ci) specified by selectors 1 through 4 of WSW14, it will start the ringer sounding. When doing so, the equipment may fail to detect the calling signals normally due to noises superimposed at the time of reception. To prevent it, use selectors 6 through 8 of WSW36.

 If the equipment detects higher frequencies than the lower limit specified by these selectors, it will regard them as noise and interpret that detecting state as being normal, allowing the ringer to keep sounding (until the equipment starts automatic reception of FAX data if in the FAX mode or enters the TAD mode if set in the TEL mode, according to the preset number of ringers).

WSW37 (Function setting 15)

Selector No.	Function	Setting and Specifications
1 8	Not used.	

[B] Printout of firmware switch data

Function

The equipment prints out the setting items and contents specified by the firmware switches.

Operating Procedure

- (1) Press the **1** key twice in the initial stage of the maintenance mode.
The "PRINTING" will appear on the LCD.
- (2) The equipment prints out the configuration list as shown in the figure below.
- (3) Upon completion of printing, the equipment returns to the initial stage of the maintenance mode.

CONFIGURATION LIST

MODEL : 8X1-U43
TIME : 01/01/200 05:33
REV. : LG0383040 VER.A
SUM : 4806

```
WSW01 = 00000000
1-2. DIAL FORMAT : NORMAL
3-4. BREAK TIME : 60 MS
5-6. INTERDIGIT PAUSE : 800 MS
7. DP/PB CHANGE IN USER SW : YES
8. DP/PB FIXING SELECTION : PB
WSW02 = 1111010
1-2. ON TIME : 100 MS
3-4. OFF TIME : 140 MS
5-8. LINE BEEP ATTENUATOR : 10 DB
WSW03 = 10000000
1. PARA. CNG DETECTION1 : B
2-4. NOT USED
5. PARA. CNG DETECTION2 : A
6-8. NOT USED
WSW04 = 00010111
1-8. NOT USED
WSW05 = 00000110
1-3. DIAL TONE DETECTION : 3.5 SEC WAITING
4. REMOTE ID DETECTION TIMEOUT : 2 SEC
5-6. BUSY TONE DETECTION (CALLING) : AFTER DIALING
7. BUSY TONE DETECTION (CALLED) : OFF
8. NOT USED
WSW06 = 00101100
1-3. PAUSE KEY : 3.5 SEC WAITING
4-8. NOT USED
WSW07 = 01001100
1-8. NOT USED
WSW08 = 01100100
1-8. NOT USED
WSW09 = 00000000
1. NOT USED
2. NON STANDARD FACILITIES : ON
3-5. NOT USED
6. T1 TIMER : 35 SEC
7-8. CALLING TIMEOUT : 60 SEC
WSW10 = 00010111
1. DPS LINK WITH CML : NO
2. TIMING OF LAST DIGIT-MODEM CHANGE : 100 MS
3. TIMING OF CML ON CNG TRANSMISSION : 2 SEC
4. TIMING OF CML ON CFB TRANSMISSION : 2 SEC
: 2

WSW34 = 00010000
1-5. NOT USED
6-7. DTMF DIGIT FOR CNG DETECTION
8. NOT USED
WSW35 = 01000000
1-8. NOT USED
WSW36 = 00000000
1-5. NOT USED
6-8. IGNORE CI COUNT : 0
WSW37 = 00000101
1-8. NOT USED
```

Configuration List

3.6 Operational Check of LCD

■ Function

This function allows you to check whether the LCD on the control panel works normally.

■ Operating Procedure

- (1) Press the **1** and **2** keys in this order in the initial stage of the maintenance mode.

The LCD shows

- (2) Press the **Start** key. Each time you press the **Start** key, the LCD cycles through the displays shown at right.

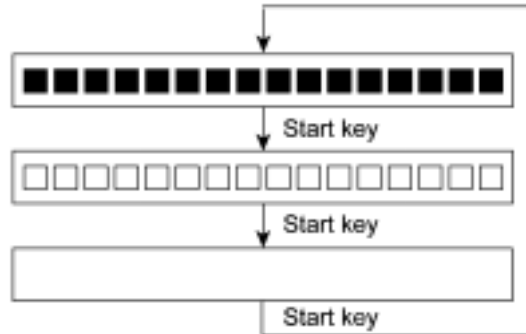

- (3) Press the **Stop** key in any process of the above display cycle. The equipment beeps for one second and returns to the initial stage of the maintenance mode.

3.7 Operational Check of Control Panel PCB

■ Function

This function allows you to check the control panel PCB for normal operation.

■ Operating Procedure

- (1) Press the **1** and **3** keys in this order in the initial stage of the maintenance mode.

The "00 " will appear on the LCD.

- (2) Press the keys and buttons in the order designated in the illustration shown below.

The LCD shows the corresponding number in decimal notation each time a key or button is pressed. Check that the displayed number is correct by referring to the illustration below.

If a key or button is pressed out of order, the equipment beeps and displays the "INVALID OPERATE" on the LCD. To return to the status ready to accept key & button entry for operational check, press the **Stop** key.

- (3) After the last number key or button is pressed, the equipment beeps and returns to the initial stage of the maintenance mode.

To terminate this operation, press the **Stop** key. The equipment returns to the initial stage of the maintenance mode.

FAX335MC/228MC

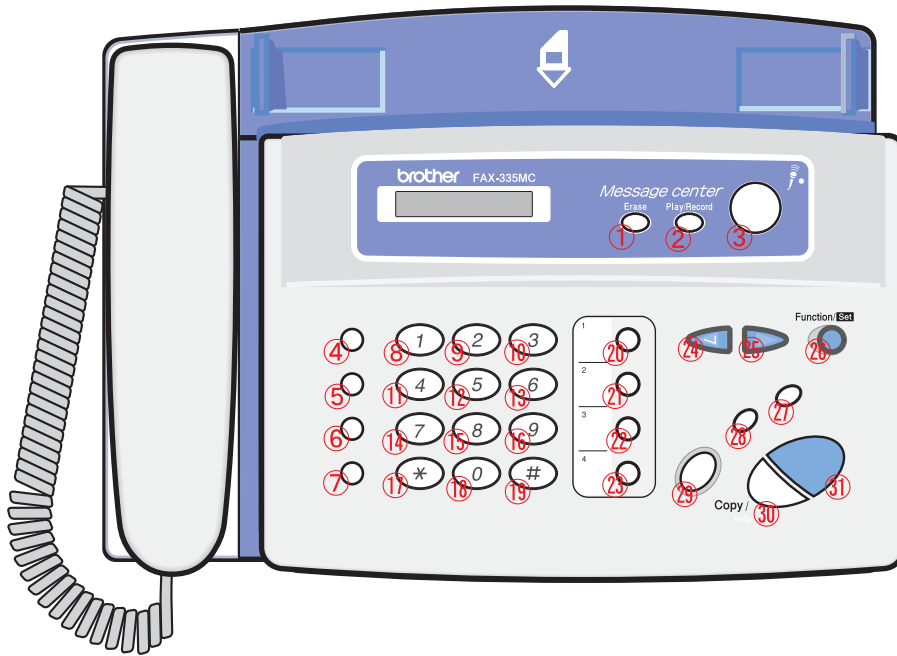

FAX235/236/218

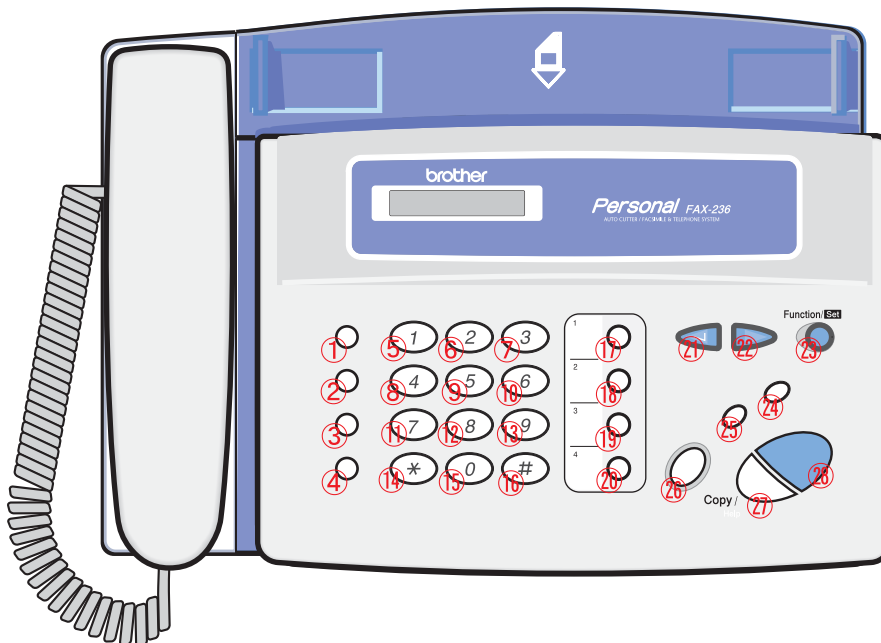

Key & Button Entry Order

3.8 Sensor Operational Check

■ Function

This function allows you to check that the six sensors (document front sensor, document rear sensor, cover sensor, paper empty (PE) sensor, cutter home position (HP) sensor, and hook switch sensor) operate correctly.

■ Operating Procedure

- (1) Press the **3** and **2** keys in this order in the initial stage of the maintenance mode. The equipment sounds 1100 Hz and 400 Hz tones cyclically through the following volumes for testing the speaker.

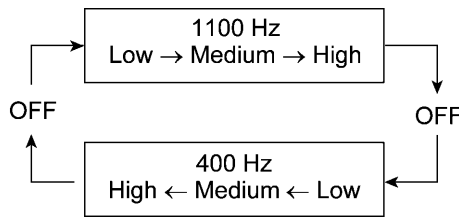

To disable the speaker, press the **Function** key . With the key, you may toggle the speaker on and off.

If the sensing status are as listed below, the LCD will show the following:

FRE RC PE CHK

Given below is the relationship between the LCD indication, sensor name and sensor status.

LCD	Sensors	Sensing status
FRE	Document front and rear sensors	No document detected.
RC	Cover sensor	Recording paper cover ASSY closed.
PE	PE sensor	Recording paper loaded.
CH	Cutter HP sensor	Cutter placed in the home position.
K	Hook switch sensor	On-hook state.

- (2) Change the detecting conditions and check that the displayed letters disappear. For example, insert a document through the document front (or rear) sensor and check that the "F" (or "E") of the FRE disappears.
- (3) To stop this operation, press the **Stop** key. The equipment beeps for one second and returns to the initial stage of the maintenance mode.

3.9 Fine Adjustment of Scanning Start/End Position

■ Function

This function allows you to adjust the scanning start/end position.

■ Operating Procedure

- (1) Press the **5** and **4** keys in this order in the initial stage of the maintenance mode.

The LCD shows the current scanning position correction value as shown at right.

- (2) Press the **Start** key. Each time you press the **Start** key, the LCD cycles through the displays shown at right.

That is, pressing this key cycles through the correction values (mm) as shown below.

0 → -1 → -2 → +1

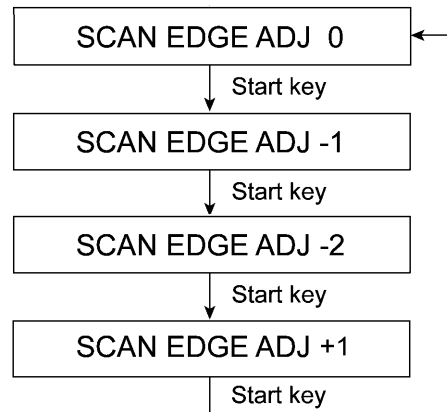

- (3) To stop this operation, press the **Stop** key. The equipment beeps for one second and returns to the initial stage of the maintenance mode.

NOTE: The relationship between the scanning start/end positions and their correction values is shown below.

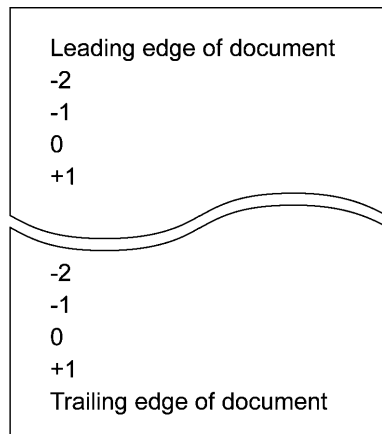

3.10 CIS Scanner Area Setting

■ Function

The equipment sets the CIS scanner area and stores it into the EEPROM.

■ Operating Procedure

(1) In the initial stage of the maintenance mode, set the "adjusting sheet A" on the document stacker.

(2) Press the **5** key twice.

The "SCANNER AREA SET" will appear on the LCD.

The equipment checks and sets the area to be scanned.

If no error is noted, the equipment returns to the initial stage of the maintenance mode.

If any error is noted, the "SCANNER ERROR" will appear on the LCD. To return the equipment to the initial stage of the maintenance mode, press the **Stop** key.

3.11 EEPROM Customizing

■ Function

This function allows you to customize the EEPROM according to language, function settings, and firmware switch settings. The customizing codes list is given in Appendix 1.

NOTE: If you replace the main PCB or CIS, be sure to carry out this procedure.

■ Operating Procedure

(1) Press the **7** and **4** keys in this order in the initial stage of the maintenance mode.

The current customizing code (e.g., 0040 in the case of FAX202 Asian version) appears.

(2) Enter the desired customizing code (e.g., 0140 in the case of FAX222 Asian version).

The newly entered code appears.

NOTE: If a wrong 4-digit code is entered, the equipment will malfunction.

(3) Press the **Start** key.

The equipment saves the setting and returns to the initial stage of the maintenance mode.

If you press the **Stop** key or no keys are pressed for one minute in the above procedure, the equipment stops the procedure and returns to the initial stage of the maintenance mode.

3.12 Equipment Error Code Indication

■ Function

This function displays an error code of the last error on the LCD.

■ Operating Procedure

- (1) Press the **8** and **2** keys in this order in the initial stage of the maintenance mode.
The LCD shows the "MACHINE ERROR _ _".
- (2) To stop this operation and return the equipment to the initial stage of the maintenance mode, press the **Stop** key.

3.13 Output of Transmission Log to the Telephone Line

■ Function

This function outputs the transmission log (that the equipment has stored about the latest transmission) to the telephone line. It allows the service personnel to receive the transmission log of the user's equipment at a remote location and use it for analyzing problems arising in the user's equipment.

■ Operating Procedure

- (1) If the user's equipment has a transmission-related problem, call the user's equipment at a remote location from your equipment.
- (2) If the line is connected, have the user perform the following:
 - 1) Press the **Function**, **Mode**, and **0** keys in this order.
 - 2) Press the **8** and **7** keys.
The above operation makes the user's equipment send CNG to your equipment for sending the transmission log.
- (3) If you hear the CNG sent from the user's equipment, press the **Start** key of your equipment.
Your equipment will start to receive the transmission log from the user's equipment.

3.14 Document Draw Adjustment

After replacement of the main PCB or CIS, or if data stored in the EEPROM is damaged, you need to carry out this procedure by using the TC-027 chart.

■ Function

This function adjusts how much the document is drawn in, starting at the point when the document rear sensor is turned on until the leading edge of the document reaches the scanning start position.

■ Operating Procedure

- (1) In the initial stage of the maintenance mode, set the TC-027 chart on the document stacker.
The message "DOC. READY" appears on the LCD.

- (2) Press the **Function** key.

The equipment beeps and draws in the TC-027 chart to the scanning start position. While drawing it in, the equipment counts patterns on the chart to determine the amount of draw.

Upon completion of normal counting, the equipment shows the message "COPY P.01 SUP" on the LCD and begins copying the TC-027 chart. The message "REAR SENSOR IS ADJUSTED." and the copied image will be printed out on recording paper as shown below.

If any error occurs during counting, the message "MACHINE ERROR AB" appears on the LCD, with no copying of the TC-027 chart onto the recording paper. However, only the message "REAR SENSOR IS ADJUSTED." will be printed out.

REAR SENSOR IS ADJUSTED.

TC-027

1997.6.2

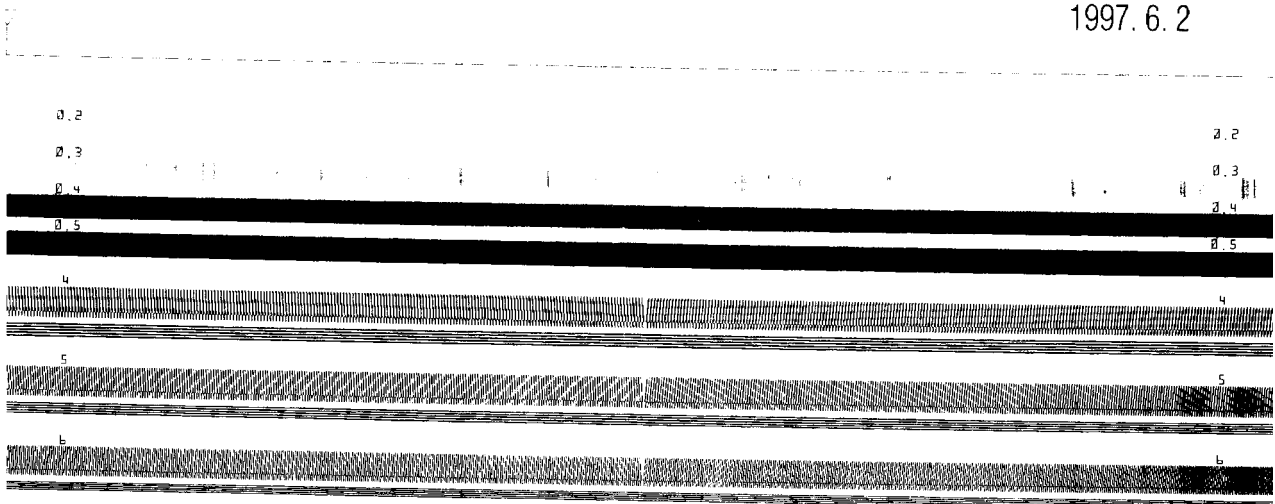

Printout after Normal Completion of Document Draw Adjustment

CHAPTER VI.
ERROR INDICATION AND
TROUBLESHOOTING

CHAPTER VI. ERROR INDICATION AND TROUBLESHOOTING

CONTENTS

1. ERROR INDICATION	VI-1
1.1 Equipment Errors	VI-1
[1] Error messages on the LCD	VI-1
[2] Error codes shown in the "MACHINE ERROR <u>XX</u> " message	VI-3
1.2 Communications Errors.....	VI-4
2. TROUBLESHOOTING	VI-11
2.1 Introduction	VI-11
2.2 Precautions	VI-11
2.3 Checking prior to Troubleshooting	VI-11
2.4 Troubleshooting Procedures	VI-12
[1] Control panel related.....	VI-12
[2] Telephone related	VI-12
[3] Communications related	VI-13
[4] Paper/document feeding related	VI-13
[5] Print-image related.....	VI-14

1. ERROR INDICATION

To help the user or the service personnel promptly locate the cause of a problem (if any), the facsimile equipment incorporates the self-diagnostic functions which display error messages for equipment errors and communications errors.

For the communications errors, the equipment also prints out the transmission verification report and the communications list.

1.1 Equipment Errors

If an equipment error occurs, the facsimile equipment emits an audible alarm (continuous beeping) for approximately 4 seconds and shows the error message on the LCD. For the error messages, see [1] below. As one of the error messages, "MACHINE ERROR XX" includes an error code which indicates the detailed error causes listed in [2]. To display an error code for the other latest error message, make the equipment enter the maintenance mode and press [8] and [2] keys (for details, refer to Chapter V, Section 3.12).

[1] Error messages on the LCD

Messages on the LCD	Probable Cause
PAPER ROLL EMPTY	The paper empty (PE) sensor detects that no recording paper is present.
PAPER JAM	The recording paper failed to return to the printing position after it had been cut.
COVER OPEN	The cover sensor detects that the control panel ASSY is not closed.
CHECK DOCUMENT	<ul style="list-style-type: none">■ Document jam(1) The document length exceeds the limitation (400 or 90 cm) registered by firmware switch WSW16. (Refer to Chapter V, Section 3.5.) (Both the document front and rear sensors stay ON even after the document has been fed by the registered length.)(2) The document rear sensor detects no trailing edge of a document after the document has been fed by 400 cm. (The document rear sensor stays ON even after the document has been fed when the document front and rear sensors were OFF and ON, respectively.)

Messages on the LCD	Probable Cause
CHECK DOCUMENT	<ul style="list-style-type: none"> ■ Document loading error (1) The document rear sensor detects no leading edge of a document within 10 seconds from the start of document loading operation. (The document rear sensor stays OFF even after the document has been fed when the document front sensor was ON.) (2) The loaded document is too short. (Since the document is shorter than the distance between the document front and rear sensors, the document front sensor is turned OFF before the document rear sensor is turned ON.)
CUTTER JAM	The upper rotary blade of the automatic cutter failed to return to the home position within the specified time after cutting the recording paper.
CLEAN UP SCANNER	In the scanning compensation data list printed by the maintenance-mode function No. 05, less than fifty percent of the white level data is faulty. (This message may appear only in the maintenance mode.)
SCANNER ERROR	In the scanning compensation data list printed by the maintenance-mode function No. 05, fifty percent or more of the white level data is faulty. (This message may appear only in the maintenance mode.)
COOLING DOWN WAIT FOR A WHILE	The thermistor in the recording head caused a heat error
MACHINE ERROR XX	"XX" indicates an error code. Refer to Section [2] on the next page.

If only an alarm beep is heard without any message on the LCD when the equipment is powered up, the ROM or RAM will be defective.

[2] Error codes shown in the "MACHINE ERROR XX" message

Error Code <u>XX</u> (Hex.)	Error factor
(87	Fails to complete the sequence of recording operation.)
(89	Cutter jam.)
8A	Wrong or weak contact of the recording head connectors.
(8B	Recording head overheat.)
(A1	Recording paper cover opened.)
(A2	Document too long to scan.)
(A3	Document not detected by the document rear sensor.)
(A4	50% or more faulty of white level data.) *
(A5	Faulty operation of DMA0 during scanning.)
(A6	Faulty operation of DMA1 during scanning.)
(A7	One-line feeding time-out error.)
(A8	One-line scanning time-out error.)
(A9	Abnormal scanning reference voltage.)
(AB	Document feed-in amount measuring error.) *
(AC	Less than 50% faulty of white level data.) *
(B9	Light emission intensity error of the LED array.)
(BE	Abnormal clamp PWM value)
(BF	Light emission intensity error of the LED array at the setting time of initial values.) *
(D5	The MODEM fails to complete the command transmission sequence.)
(D6	No MODEM interrupt for 60 seconds.)
(E4	Out of recording paper.)
E6	Write error in E ² PROM.
(E8	Data scanning error during transmission.)
F3	Voice message recording or playing-back not started.
(F5	EOL not found in page memory transmission mode.)
(F6	PC interface error.)
(F7	Optional handy scanner interface error.)

Error codes in parentheses do not appear in the "MACHINE ERROR XX", since those errors are displayed as messages described in "[1] Error messages on the LCD." You can display those error codes in the maintenance mode (Function code 82). Those error codes appear in the communications error list if an equipment error occurs during communications. Refer to Section 1.2, (13).

* Those codes marked with an asterisk can appear only in the maintenance mode.

1.2 Communications Errors

If a communications error occurs, the facsimile equipment

- (1) emits an audible alarm (intermittent beeping) for approximately 4 seconds,
- (2) displays the corresponding error message, and
- (3) prints out the transmission verification report if the equipment is in sending operation.

■ Definition of Error Codes on the Communications List

(1) Calling

Code 1	Code 2	Causes
10	08	Wrong number called.
11	01	No dial tone detected before start of dialing.
11	02	Busy tone detected before dialing.
11	03	2nd dial tone not detected.
11	05	No loop current detected. *
11	06	Busy tone detected after dialing or called.
11	07	No response from the remote station in sending.
11	10	No tone detected after dialing.
17	07	No response from the calling station in receiving.

* Available in Germany and Austria only.

(2) Command reception

Code 1	Code 2	Causes
20	01	Unable to detect a flag field.
20	02	Carrier was OFF for 200 ms or longer.
20	03	Abort detected ("1" in succession for 7 bits or more).
20	04	Overrun detected.
20	05	A frame for 3 seconds or more received.
20	06	CRC error in answer back.
20	07	Undefined command received.
20	08	Invalid command received.
20	09	Command ignored once for document setting or for dumping-out at turn-around transmission.
20	0A	T5 time-out error
20	0B	CRP received.
20	0C	EOR and NULL received.

(3) Compatibility [checking the NSF and DIS]

Code 1	Code 2	Causes
32	01	Remote terminal only with V.29 capability in 2400 or 4800 bps transmission.
32	02	Remote terminal not ready for polling.
32	10	Remote terminal not equipped with password function or its password switch OFF.
32	11	Remote terminal not equipped with or not ready for confidential mail box function.
32	12	Remote terminal not equipped with or not ready for relay broadcasting function.
32	13	No confidential mail in the remote terminal.
32	14	The available memory space of the remote terminal is less than that required for reception of the confidential or relay broadcasting instruction.

(4) Instructions received from the remote terminal [checking the NSC, DTC, NSS, and DCS]

Code 1	Code 2	Causes
40	02	Illegal coding system requested.
40	03	Illegal recording width requested.
40	05	ECM requested although not allowed.
40	06	Polled while not ready.
40	07	No document to send when polled.
40	10	Nation code or manufacturer code not coincident.
40	11	Unregistered group code entered for relay broadcasting function, or the specified number of broadcasting subscribers exceeding the limit.
40	12	Retrieval attempted when not ready for retrieval.
40	13	Polled by any other manufacturers' terminal while waiting for secure polling.
40	17	Invalid resolution selected.

(5) Command reception [checking the NSF and DIS after transmission of NSS and DCS]

Code 1	Code 2	Causes
50	01	Vertical resolution capability changed after compensation of background color.

(6) ID checking

Code 1	Code 2	Causes
63	01	Password plus "lower 4 digits of telephone number" not coincident.
63	02	Password not coincident.
63	03	Polling ID not coincident.
63	04	Entered confidential mail box ID uncoincident with the mail box ID.
63	05	Relay broadcasting ID not coincident.
63	06	Entered retrieval ID uncoincident with that of the mail box ID.

(7) DCN reception

Code 1	Code 2	Causes
74		DCN received.

(8) TCF transmission/reception

Code 1	Code 2	Causes
80	01	Fallback impossible.

(9) Signal isolation

Code 1	Code 2	Causes
90	01	Unable to detect video signals and commands within 6 seconds after CFR is transmitted.
90	02	Received PPS containing invalid page count or block count.

(10) Video signal reception

Code 1	Code 2	Causes
A0	03	Error correction sequence not terminated even at the final transmission speed for fallback.
A0	11	Receive buffer empty. (5-second time-out)
A0	12	Receive buffer full during operation except receiving into memory.
A0	13	Decoding error continued on 500 lines.
A0	14	Decoding error continued for 10 seconds.
A0	15	Time-out: Five seconds or more for one-line transmission.
A0	16	RTC not found and carrier OFF signal detected for 6 seconds.
A0	17	RTC found and command detected for 60 seconds.
A8	01	RTN, PIN, or ERR received at the calling terminal. *
A9	01	RTN, PIN, or ERR received at the called terminal. *
AA	18	Receive buffer full during receiving into memory.

* Available in Germany and Austria only.

(11) General communications-related

Code 1	Code 2	Causes
B0	01	Polarity inversion detected.
B0	02	Unable to receive the next-page data.
B0	03	Unable to receive polling even during turn-around transmission due to call reservation.
B0	04	PC interface error.

(12) Maintenance mode

Code 1	Code 2	Causes
E0	01	Failed to detect 1300 Hz signal in burn-in operation.
E0	02	Failed to detect PB signals in burn-in operation.
E0	03	Failed to detect any command from the RS-232C interface in burn-in operation.

(13) Equipment error

Code 1	Code 2	Causes
FF	XX	Equipment error (For XX, refer to Subsection 1.1 [2].)

2. TROUBLESHOOTING

2.1 Introduction

This section gives the service personnel some of the troubleshooting procedures to be followed if an error or malfunction occurs with the facsimile equipment. It is impossible to anticipate all of the possible problems which may occur in future and determine the troubleshooting procedures, so this section covers some sample problems. However, those samples will help service personnel pinpoint and repair other defective elements if he/she analyzes and examines them well.

2.2 Precautions

Be sure to observe the following to prevent the secondary troubles from happening:

- (1) Always unplug the AC power cord from the outlet when removing the covers and PCBs, adjusting the mechanisms, or conducting continuity testing with a circuit tester.
- (2) When disconnecting the connectors, do not pull the lead wires but hold the connector housings.
- (3)
 - Before handling the PCBs, touch a metal portion of the machine to discharge static electricity charged in your body.
 - When repairing the PCBs, handle them with extra care.

After repairing the defective section, be sure to check again if the repaired section works correctly. Also record the troubleshooting procedure so that it would be of use for future trouble occurrence.

2.3 Checking prior to Troubleshooting

Prior to proceeding to the troubleshooting procedures, check that:

- (1) Each voltage level on AC input lines and DC lines is correct.
- (2) All cables and harnesses are firmly connected.
- (3) None of the fuses are blown.

2.4 Troubleshooting Procedures

[1] Control panel related

Trouble	Check:
(1) LCD shows nothing.	<ul style="list-style-type: none"> • Main-panel harness between the main PCB and the control panel PCB • Interfaces between the main PCB, NCU PCB and power supply PCB • Control panel PCB • Power supply PCB • Main PCB
(2) Control panel inoperative.	<ul style="list-style-type: none"> • Main-panel harness between the main PCB and the control panel PCB • Interfaces between the main PCB, NCU PCB and power supply PCB • Control panel PCB • FPC key • Main PCB

[2] Telephone related

Trouble	Check:
(1) No phone call can be made.	<ul style="list-style-type: none"> • FPC key • Control panel PCB by using the maintenance-mode function No. 13. If any defective keys are found, replace them. (Refer to Chapter V, Section 3.7.) • NCU PCB • Main PCB
(2) Speed dialing or one-touch dialing will not work.	<ul style="list-style-type: none"> • Ordinary dialing function (other than the speed and one-touch dialing) <p>If it works normally, check the main PCB; if not, refer to item (1) above.</p>
(3) Speaker silent during on-hook dialing.	<ul style="list-style-type: none"> • Ordinary dialing function (other than the on-hook dialing with the hook key) <p>If it works normally, proceed to the following checks; if not, refer to item (1) above.</p>
(4) Dial does not switch between tone and pulse.	<ul style="list-style-type: none"> • Main PCB

Trouble	Check:
(5) Telephone does not ring.	<ul style="list-style-type: none"> • Speaker • NCU PCB • Main PCB

[3] Communications related

Trouble	Check:
(1) No tone is transmitted.	<ul style="list-style-type: none"> • Main PCB • NCU PCB

[4] Paper/document feeding related

Trouble	Check:
(1) Neither "COPY: PRESS COPY" nor "FAX: NO. & START" message appears although documents are set.	<ul style="list-style-type: none"> • Sensors by using the maintenance-mode function No. 32. (Refer to Chapter V, Section 3.8.) • Actuators of the document front and rear sensors • Main PCB
(2) Document not fed.	<ul style="list-style-type: none"> • ADF and its related sections • Drive motor and its harness • White pressure roller and its related gears • Solenoid and the planetary gear train • Main PCB
(3) Recording paper not fed.	<ul style="list-style-type: none"> • ADF and its related sections • Drive motor and its harness • Platen and its related gears • Solenoid and the planetary gear train • Main PCB
(4) The "CUTTER JAM" message cannot be removed.	<ul style="list-style-type: none"> • Drive motor and its harness • Cutter HP sensor and its position • Cutter gear • Solenoid and the planetary gear train • Main PCB

[5] Print-image related

If the received or sent image has any problem, first make a copy with the facsimile equipment.

If the copied image is normal, the problem may be due to the remote terminal; if it is abnormal, proceed to the following checks:

Trouble	Check:
(1) Completely blank <u>At the scanner</u> <u>At the recorder</u>	<ul style="list-style-type: none"> • Main PCB • Recording head harness • Compression springs beneath the recording head • Recording head • Main PCB
(2) White vertical streaks <u>At the scanner</u> <u>At the recorder</u>	<ul style="list-style-type: none"> • CIS unit • Recording head
(3) All black <u>At the scanner</u> <u>At the recorder</u>	<ul style="list-style-type: none"> • CIS harness • CIS unit • Main PCB • Recording head harness • Recording head • Main PCB
(4) Black vertical streaks <u>At the scanner</u> <u>At the recorder</u>	<ul style="list-style-type: none"> • CIS unit • Recording head
(5) Light or dark <u>At the scanner</u> <u>At the recorder</u>	<ul style="list-style-type: none"> • CIS unit • Main PCB • Compression springs beneath the recording head

brother®

**FAX235/FAX236/FAX335MC
FAX218/FAX228MC**

Appendix 1. EEPROM Customizing Codes

EEPROM Customizing Codes

This function allows you to customize the EEPROM according to language, function settings, and firmware switch settings. The customizing codes list is given on the next page.

■ Operating Procedure

←Within 2 seconds →

- (1) Press the **Function**, *, **2**, **8**, **6**, and **4** keys in this order to make the equipment enter the maintenance mode.

The equipment beeps for approx. one second and displays " ■■ MAINTENANCE ■■■ " on the LCD.

- (2) Press the **7** and **4** keys in this order in the initial stage of the maintenance mode.

The current customizing code (e.g., 0040 in the case of FAX235 Asian version) appears.

- (3) Enter the desired customizing code (e.g., 0140 in the case of FAX236 Asian version).

The newly entered code appears.

NOTE: *If a wrong 4-digit code is entered, the equipment will malfunction.*

- (4) Press the **Start** key.

The equipment saves the setting and returns to the initial stage of the maintenance mode.

If you press the **Stop** key or no keys are pressed for one minute in the above procedure, the equipment stops the procedure and returns to the initial stage of the maintenance mode.

■ EEPROM Customizing Codes List

Versions	Model		
	FAX235	FAX236(218)	FAX335MC(228MC)
CHINA	---	0120	0020
TAIWAN	---	0123	0023
HONG KONG	---	0140	0040
ASIA	0040	0140	0040
GULF	0040	0140	0040
RUSSIA	---	0140	0040
POLAND	---	0139	---

**FAX235/FAX236/FAX335MC
FAX218/FAX228MC**

Appendix 2. Circuit Diagrams

- A. Main PCB
- B. Network Control Unit (NCU) PCB
- C. Control Panel PCB
- D. Power Supply PCB

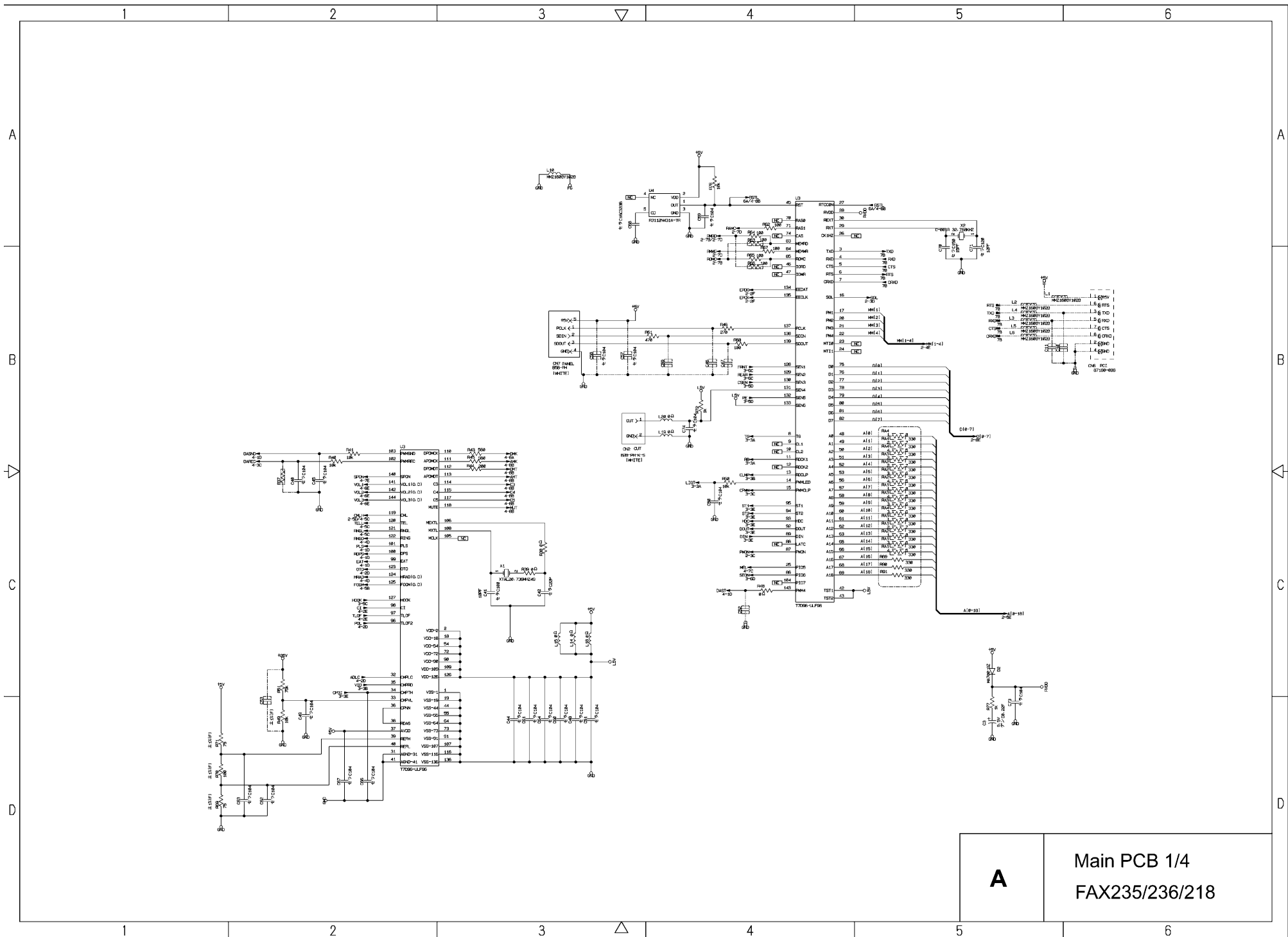

A Main PCB 1/4
FAX235/236/218

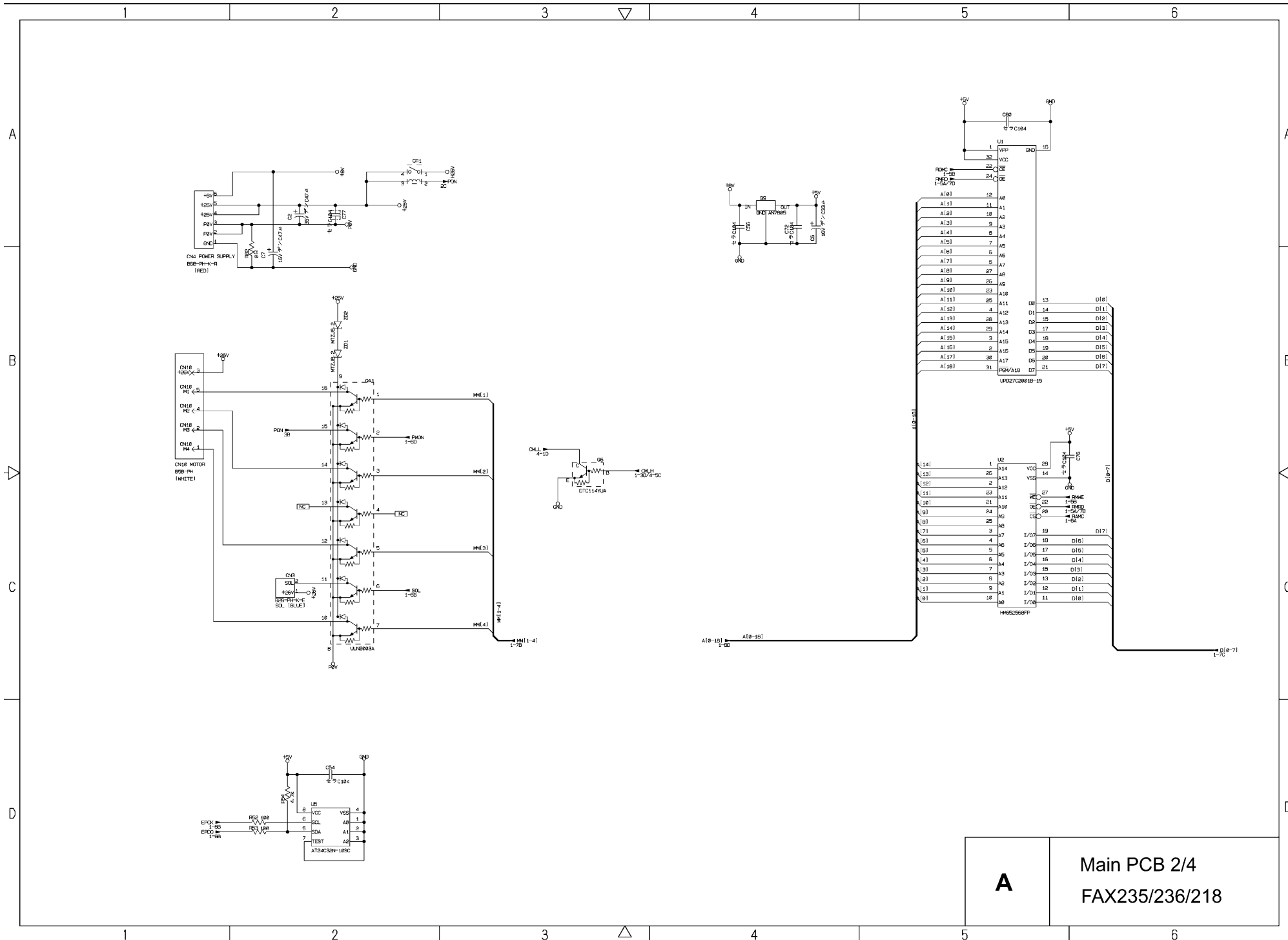

A

Main PCB 2/4
FAX235/236/218

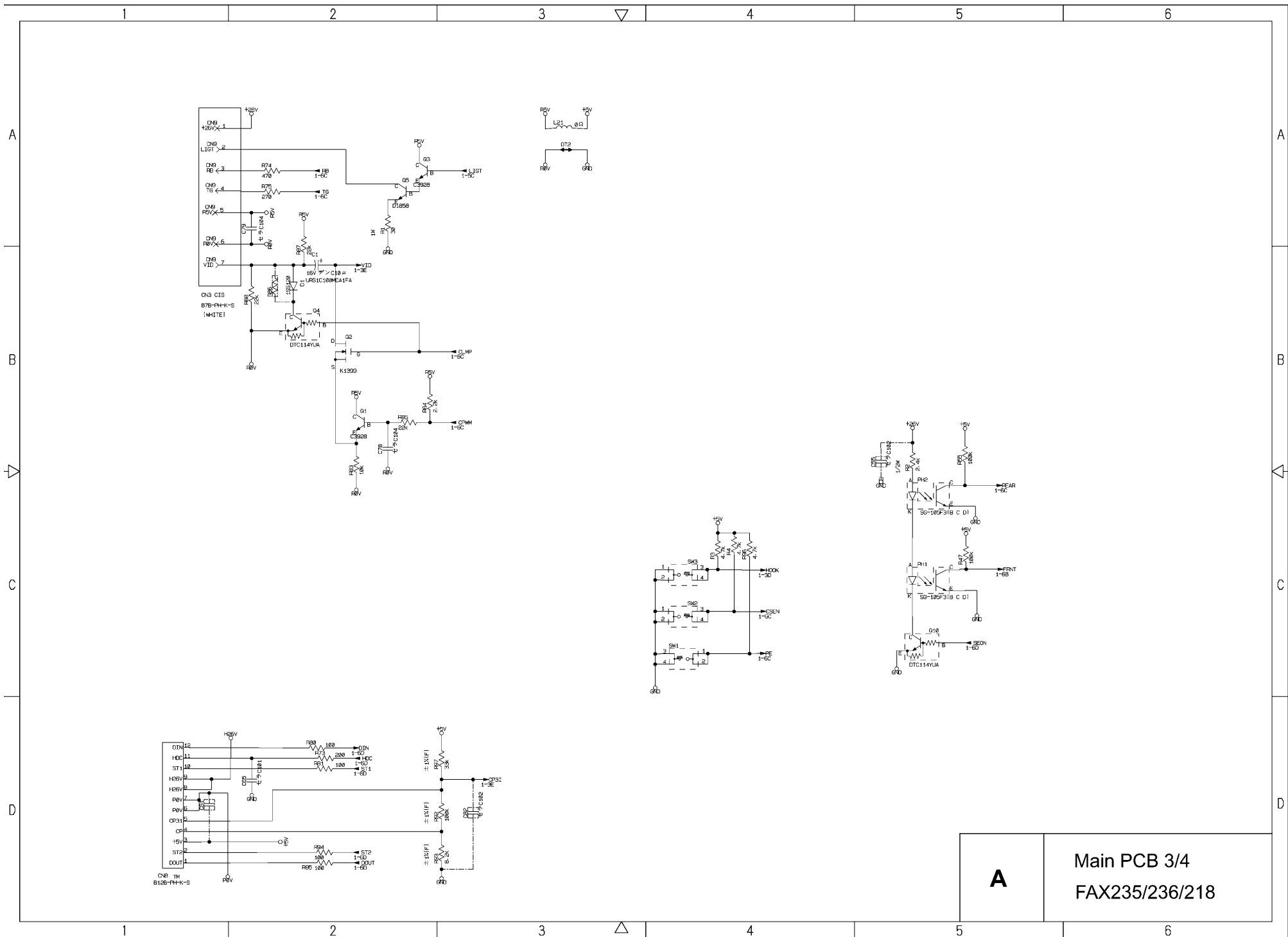

A Main PCB 3/4
FAX235/236/218

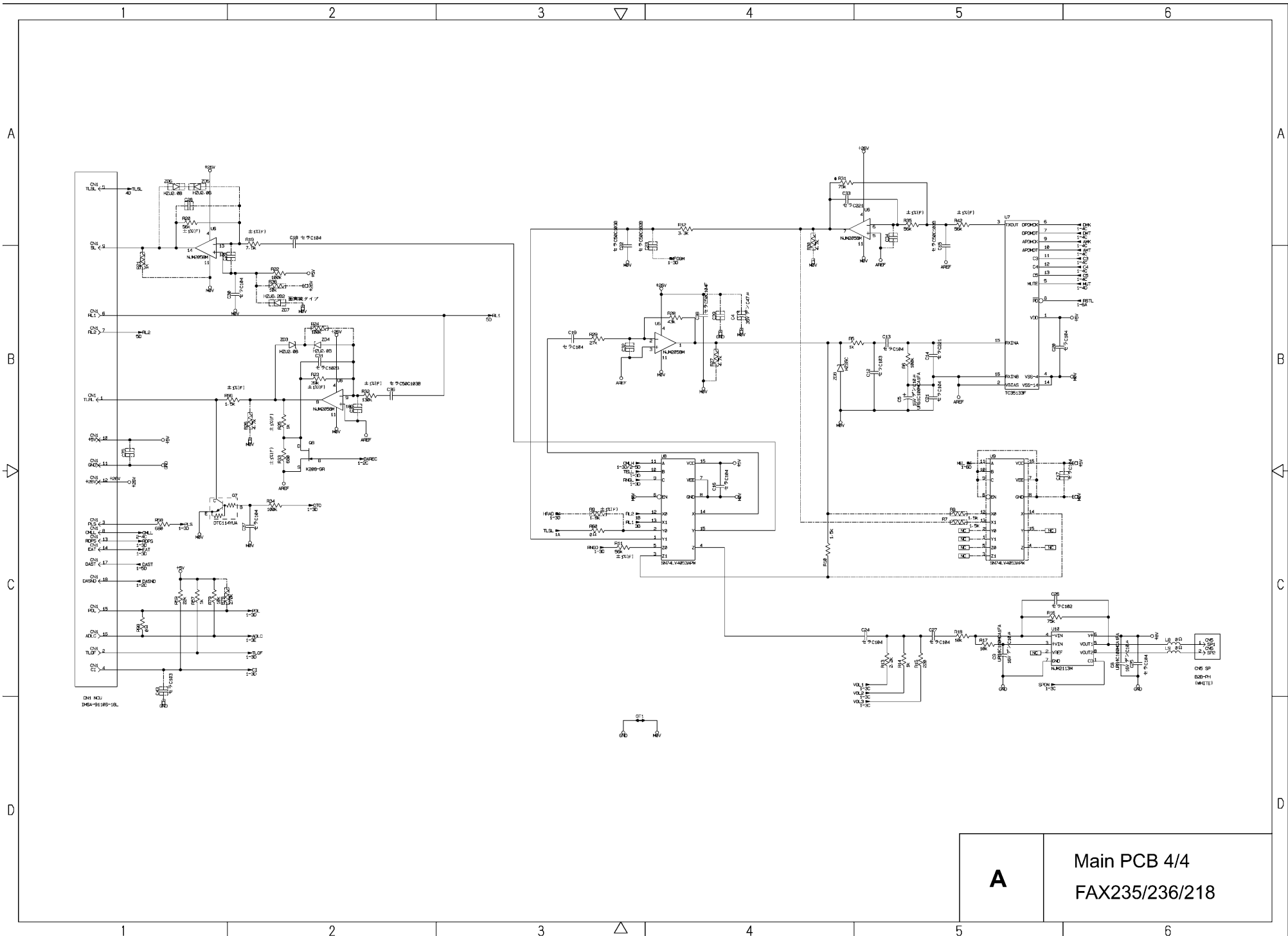

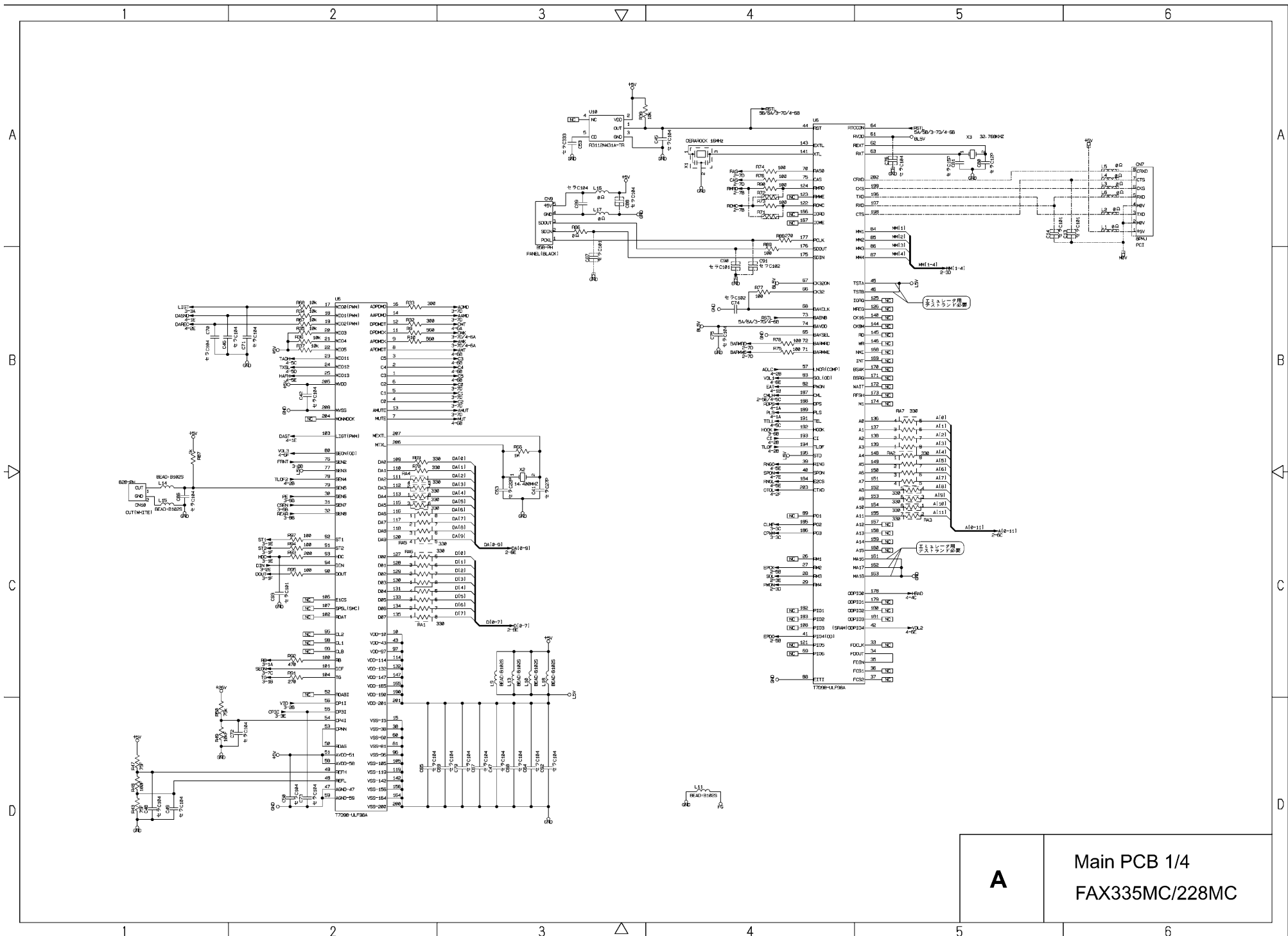

A Main PCB 1/4
FAX335MC/228MC

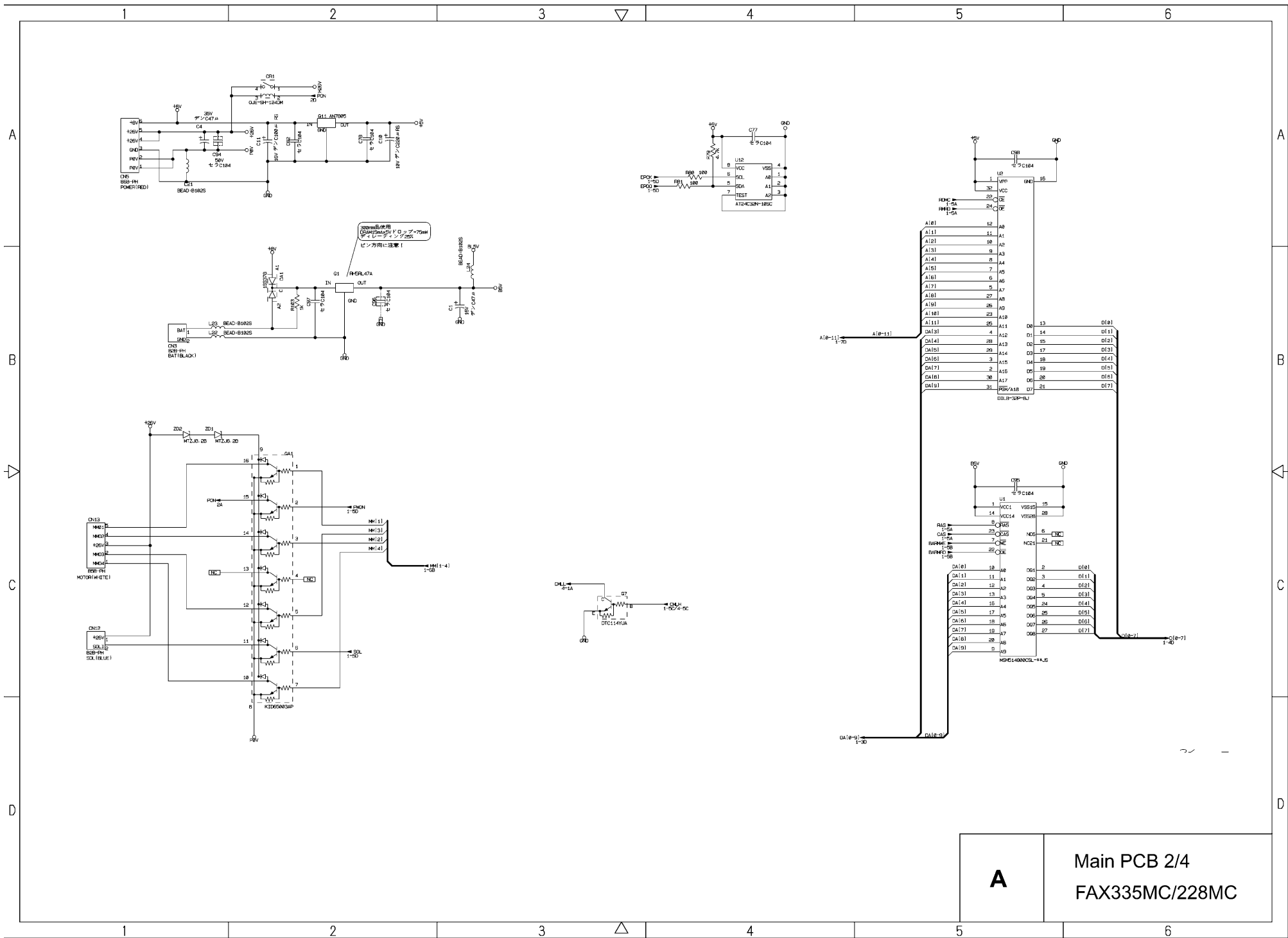

A Main PCB 2/4
FAX335MC/228MC

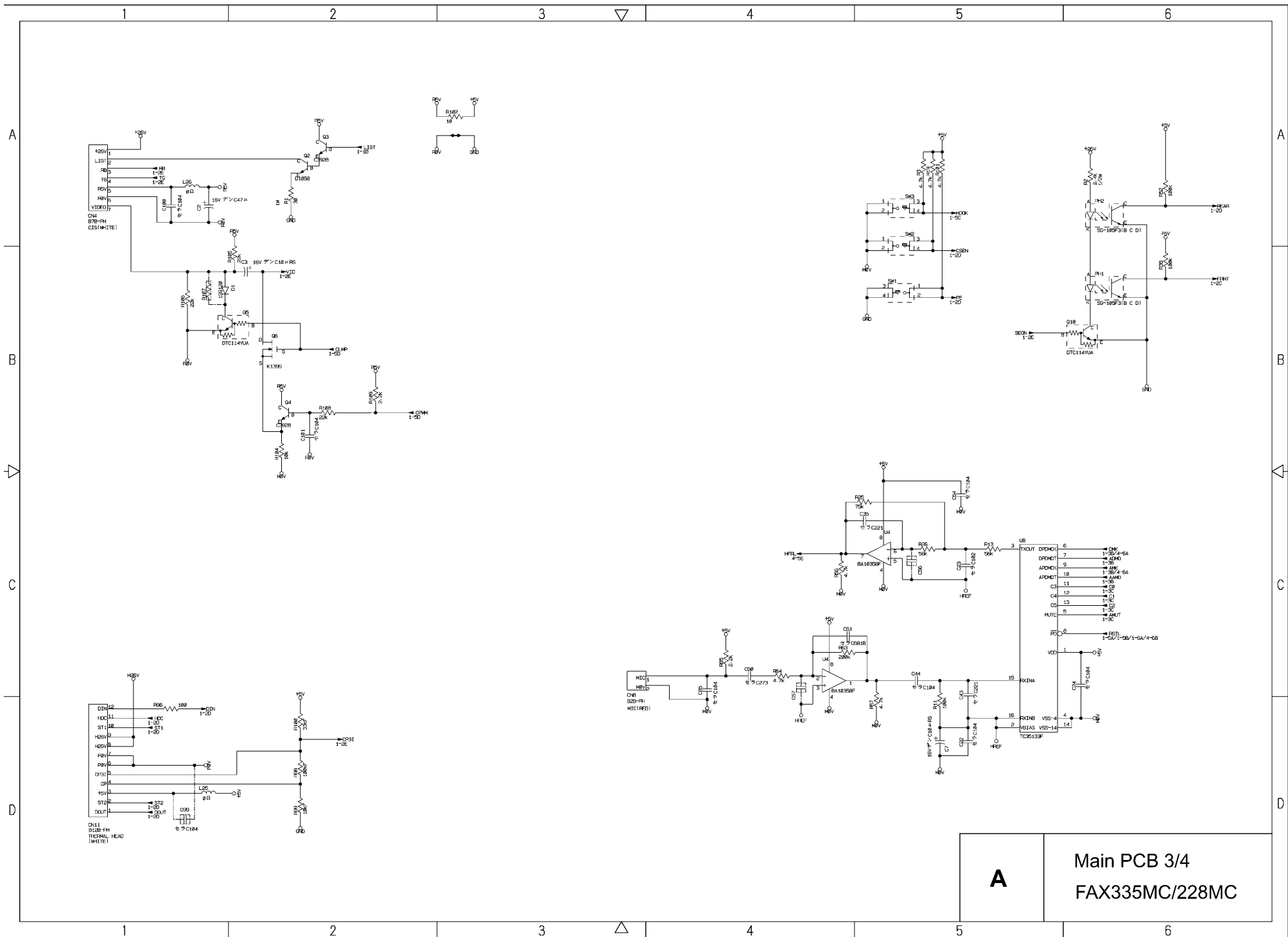

A Main PCB 3/4 FAX335MC/228MC

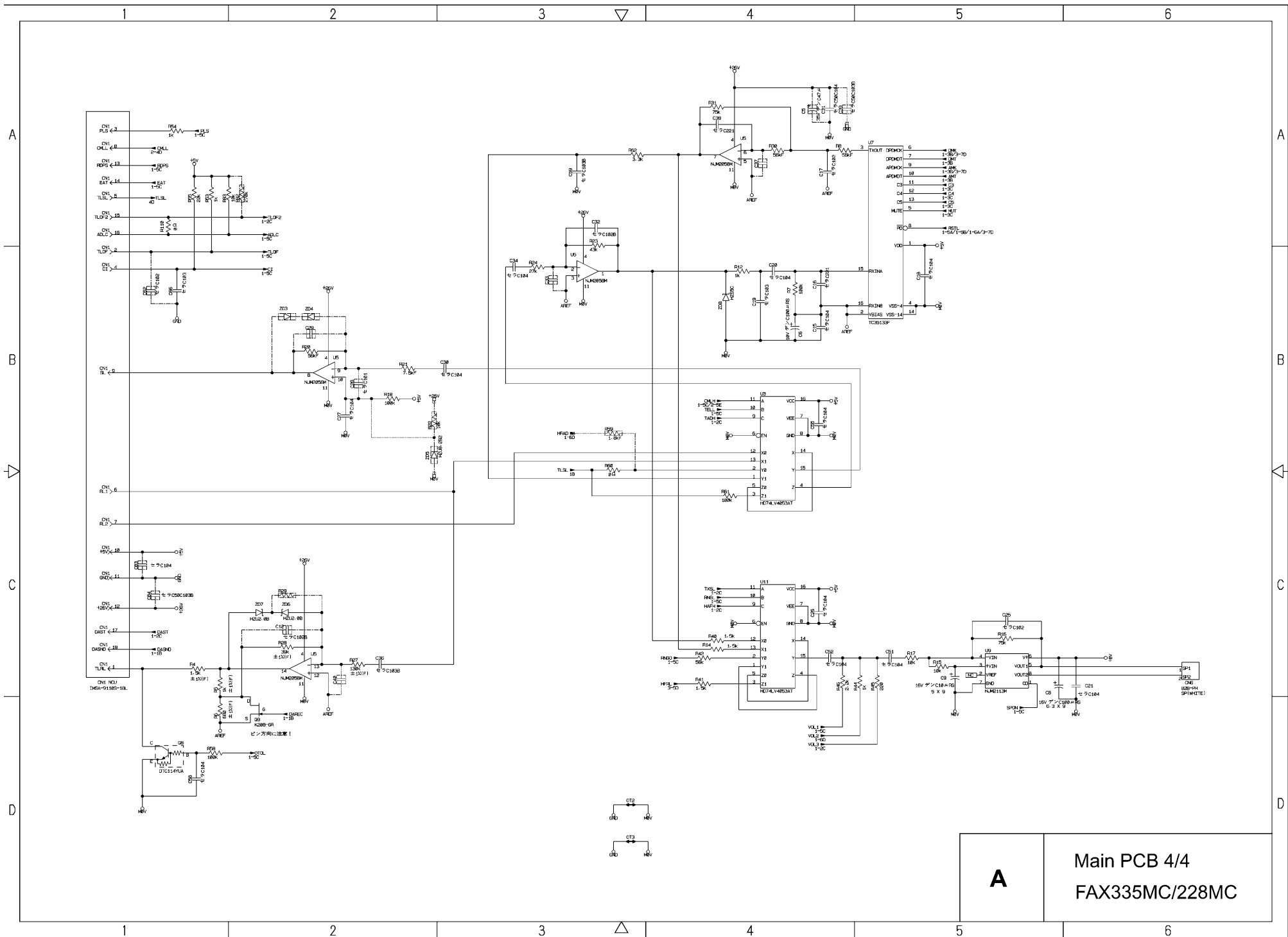

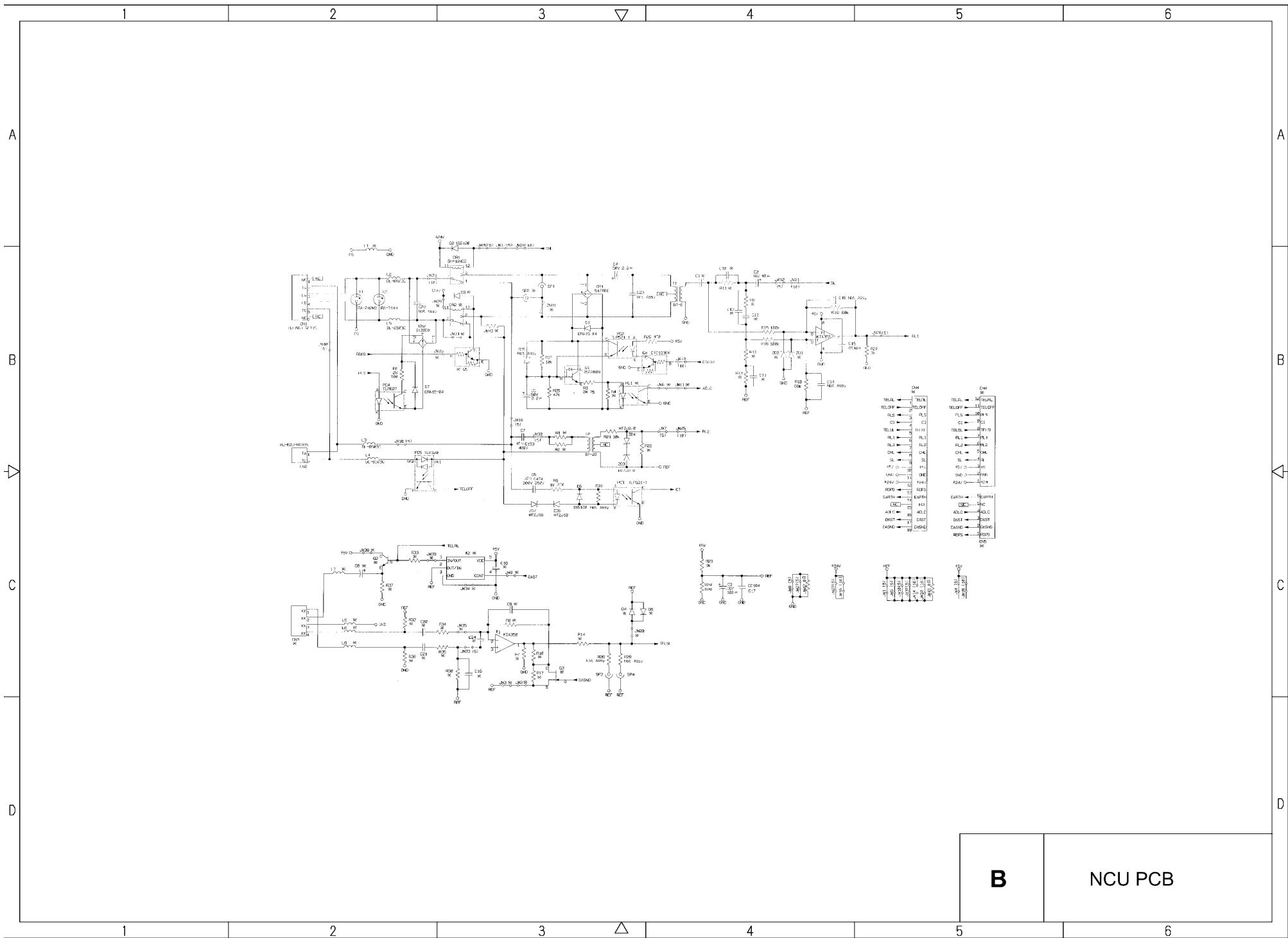

B NCU PCB

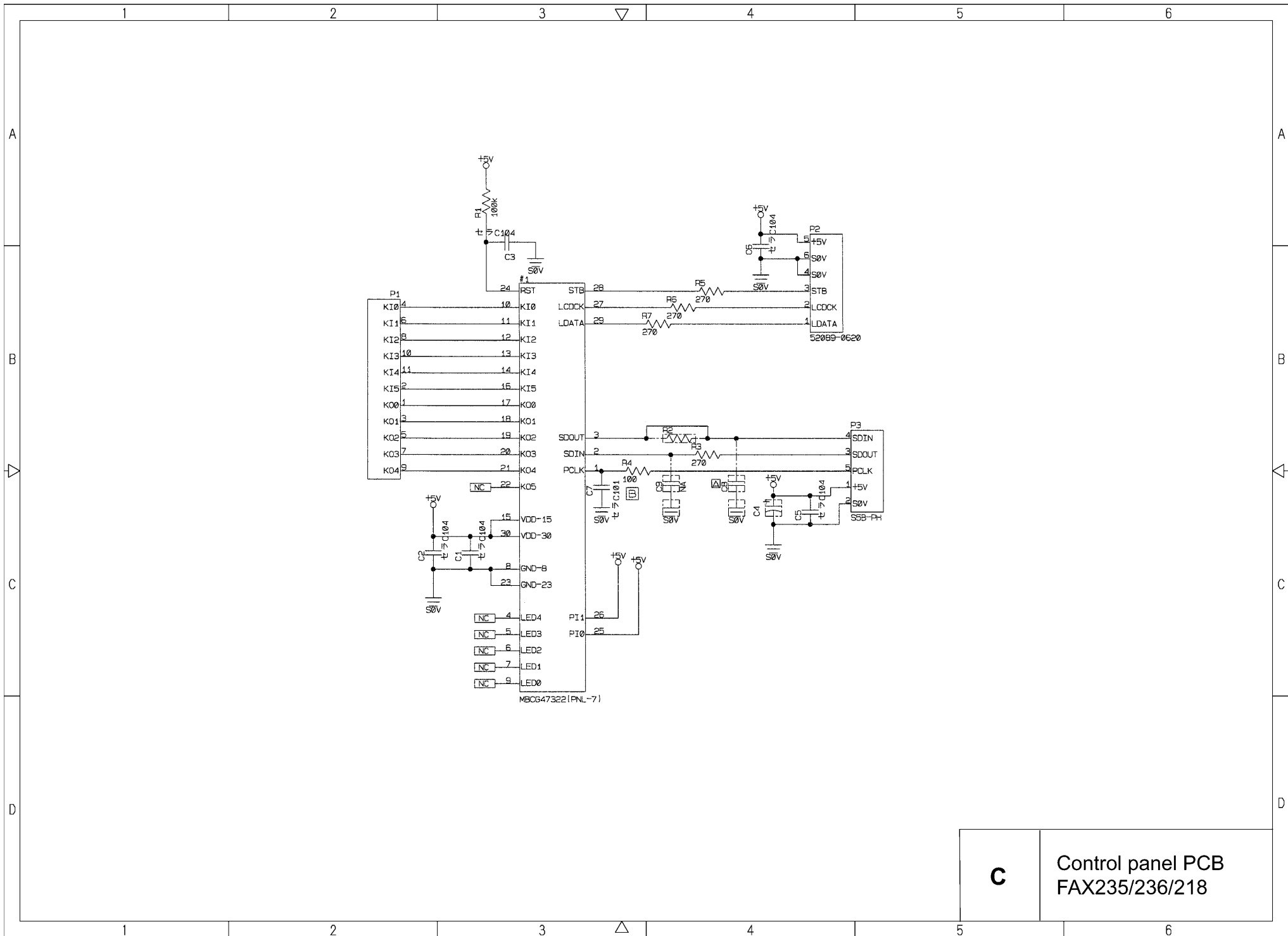

C	Control panel PCB FAX235/236/218
----------	-------------------------------------

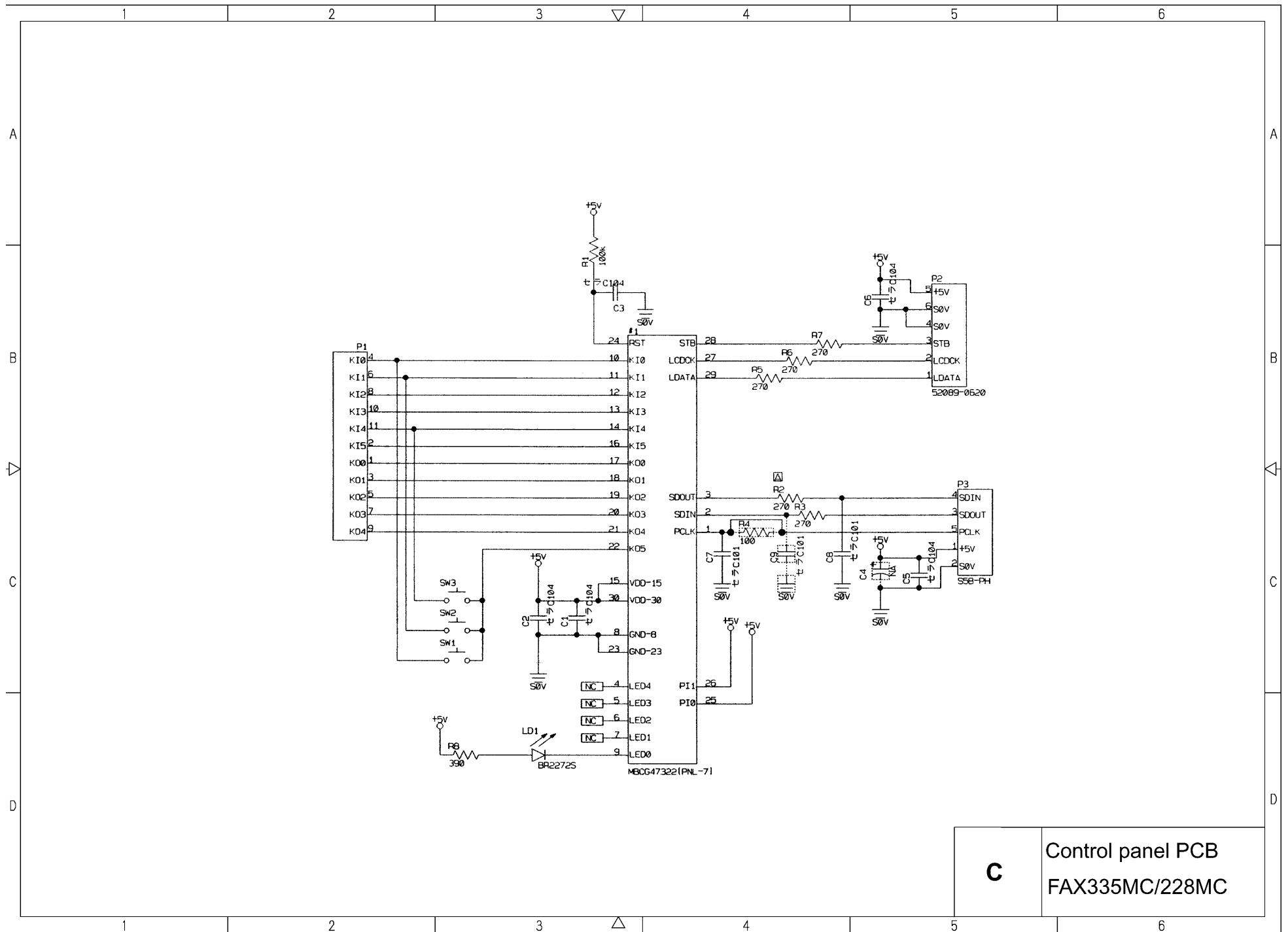

C	Control panel PCB FAX335MC/228MC
----------	-------------------------------------

PS3 PANEL KEY MATRIX REFERENCE TABLE 1

KEY NO.	KEY NAME	KEY COE
1	Hold/Caller ID	01
2	10key-1	21
3	10key-2	11
4	10key-3	09
5	Redial/Pause	19
6	10key-4	02
7	10key-5	12
8	10key-6	0A
9	Speed Dial/Search	1E
10	10key-7	22
11	10KEY-8	1A
12	10KEY-9	0B
13	Speaker Phone	06
14	10key-*	26
15	10key-0	16
16	10key-#	0E
17	1touch-01	04
18	1touch-02	1B
19	1touch-03	23
20	1touch-04	05
21	←	24
22	→	14
23	Function/Set	1C
24	Resolution	03
25	Mode	13
26	Stop	25
27	Copy/Help	15
28	Start	1D
SW1	MC ON/OFF	29
SW2	Play	2A
SW3	Erase	2D

PS3 PANEL KEY MATRIX REFERENCE TABLE 2

	K00 P1-1P	K01 P1-3P	K02 P1-5P	K03 P1-7P	K04 P1-9P	K05 -
K10 P1-4P	1	4	3	5	2	* SW1
K11 P1-6P	6	8	7	11	10	* SW2
K12 P1-8P	24	12	25	18	19	-
K13 P1-10P	17	-	22	23	21	-
K14 P1-11P	20	-	27	28	26	* SW3
K15 P1-2P	13	16	15	9	14	-

*MC ONLY

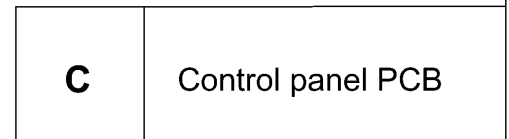

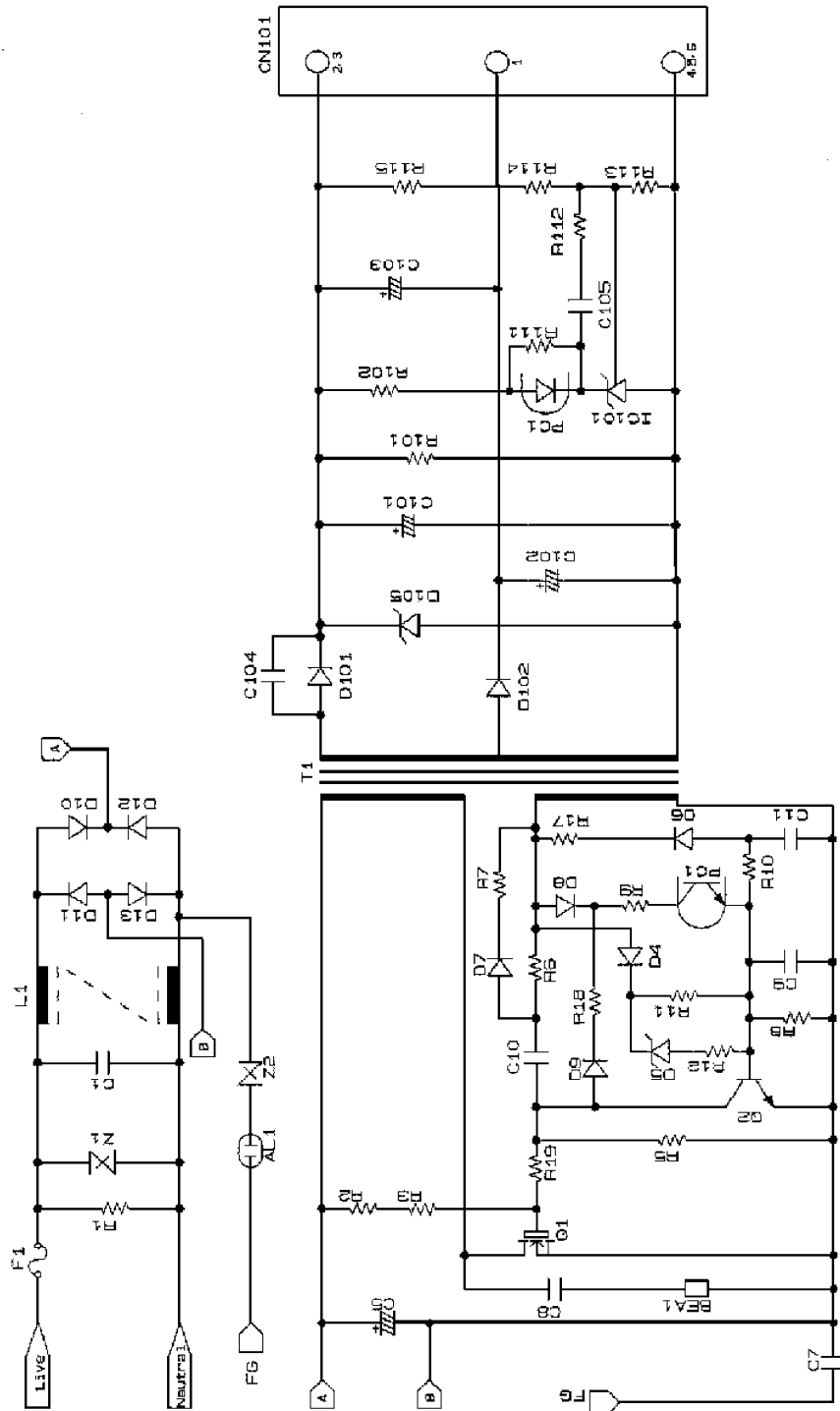

D

Power Supply PCB

brother®

Oct. '03
SM-FAX024
8X1U41
Printed in Japan