

brother®

ADVANCED USER'S GUIDE

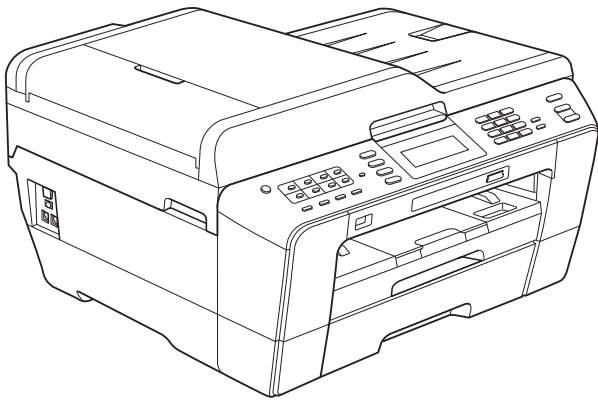

MFC-J6910DW

Version 0

USA/CAN

User's Guides and where do I find it?

Which manual?	What's in it?	Where is it?
Safety and Legal	Read this Guide first. Please read the Safety Instructions before you set up your machine. See this Guide for trademarks and legal limitations.	Printed / In the box
Quick Setup Guide	Follow the instructions for setting up your machine and installing the drivers and software for the operating system and connection type you are using.	Printed / In the box
Basic User's Guide	Learn the basic Fax, Copy, Scan and PhotoCapture Center™ operations and how to replace consumables. See troubleshooting tips.	Printed / In the box
Advanced User's Guide	Learn more advanced operations: Fax, Copy, security features, printing reports and performing routine maintenance.	PDF file / Documentation CD-ROM
Software User's Guide	Follow these instructions for Printing, Scanning, Network Scanning, PhotoCapture Center™, Remote Setup, PC-Fax, and using the Brother ControlCenter utility.	PDF file / Documentation CD-ROM
Network Glossary	This Guide provides basic information about advanced network features of Brother machines along with explanations about general networking and common terms.	PDF file / Documentation CD-ROM
Network User's Guide	This Guide provides useful information about wired and wireless network settings and security settings using the Brother machine. You can also find supported protocol information for your machine and detailed troubleshooting tips.	PDF file / Documentation CD-ROM

Table of Contents

1	General setup	1
	Memory storage.....	1
	Volume Settings.....	1
	Ring Volume	1
	Beeper Volume.....	2
	Speaker Volume	2
	Automatic Daylight Saving Time.....	3
	Sleep Mode	3
	LCD screen.....	4
	Setting the backlight brightness.....	4
	Setting the Dim Timer for the backlight	4
	Dial Prefix	4
	Setting up or changing the prefix number.....	4
	Mode Timer.....	5
2	Security features	6
	Secure Function Lock 2.0.....	6
	Before you begin to use Secure Function Lock 2.0.....	6
	Setting and changing the Administrator Password.....	7
	Setting up restricted users.....	8
	Turning Secure Function Lock on/off.....	8
	Switching users	9
	Changing to the Public mode	9
3	Sending a fax	10
	Additional sending options.....	10
	Sending faxes using multiple settings	10
	Stop faxing.....	10
	Contrast.....	10
	Changing fax resolution.....	11
	Setting your changes as the new default.....	11
	Restoring fax settings to the factory settings.....	11
	Additional sending operations.....	12
	Sending a duplex (2-sided) fax from the ADF	12
	Sending a fax manually	12
	Sending a fax at the end of a conversation	13
	Dual Access (Black & White only)	13
	Broadcasting (Black & White only)	13
	Real Time Transmission.....	15
	Overseas Mode	15
	Delayed Faxing (Black & White only)	15
	Delayed Batch Transmission (Black & White only)	16
	Checking and canceling waiting jobs.....	16
	Polling overview.....	17
	Polled Transmit (Black & White only)	17

4 Receiving a fax 18

Memory Receive (Black & White only)	18
Receiving faxes into memory when paper tray is empty	18
Fax Forwarding.....	18
Paging	19
Fax Storage	20
Printing a fax from the memory	20
PC-Fax Receive (Windows® only).....	21
Turning off Memory Receive operations.....	22
Changing Memory Receive operations	22
Remote Retrieval	23
Setting a Remote Access Code.....	23
Using your Remote Access Code.....	23
Remote Fax commands	24
Retrieving fax messages	25
Changing your Fax Forwarding number	25
Additional receiving operations	26
Printing a reduced incoming fax	26
Receiving a fax at the end of a conversation.....	26
Polling overview.....	27
Polling receive	27

5 Dialing and storing numbers 29

Voice operations	29
Tone or Pulse (Canada only).....	29
Fax/Tel mode.....	29
Caller ID.....	29
Special line considerations	30
Additional dialing operations.....	32
Outgoing Call.....	32
Caller ID history	32
Dialing access codes and credit card numbers	33
Additional ways to store numbers.....	34
Storing One Touch numbers from Outgoing Calls.....	34
Storing One Touch numbers from the Caller ID history.....	34
Storing Speed Dial numbers from Outgoing Calls.....	35
Storing Speed Dial numbers from the Caller ID history.....	36
Setting up groups for Broadcasting	37

6 Printing reports 39

Fax reports.....	39
Transmission Verification Report.....	39
Fax Journal (activity report)	39
Reports	40
How to print a report	40

7 Making copies 41

Copy settings	41
Stop copying	41
Changing copy quality	41
Enlarging or reducing the copied image	42
Making N in 1 copies or a poster (Page Layout)	43
2 in 1 ID Copy	46
Sorting copies using the ADF	46
Adjusting Density	47
Ink Save Mode	47
Thin Paper Copy	48
Skew Adjustment	48
Book Copy	49
Watermark Copy	49
Duplex (2-sided) copying	50
Setting your favorites	53

8 PhotoCapture Center™: Printing photos from a memory card or USB Flash memory drive 54

PhotoCapture Center™ operations	54
Memory cards, USB Flash memory drive and folder structures	54
Movie printing	55
Print Images	55
Print Index (Thumbnails)	55
Printing Photos	56
Enhance Photos	56
DPOF printing	58
PhotoCapture Center™ print settings	59
Print Quality	59
Paper options	59
Adjusting Brightness, Contrast and Color	60
Cropping	61
Borderless printing	62
Print Date	62
Setting your changes as the new default	62
Restoring all settings to the factory settings	62
Scan to a memory card or USB Flash memory drive	63
Glass Scan Size	63
Auto Crop	63
How to set a new default	64
How to reset to the factory settings	65

9	Printing photos from a camera	66
	Printing photos directly from a PictBridge camera	66
	PictBridge requirements	66
	Setting your digital camera	67
	Printing Images.....	68
	DPOF printing.....	68
	Printing photos directly from a digital camera (without PictBridge).....	69
	Printing Images.....	69
A	Routine maintenance	70
	Cleaning and checking the machine	70
	Cleaning the outside of the machine	70
	Cleaning the machine's printer platen	71
	Cleaning the paper feed rollers	72
	Cleaning the paper pick-up rollers.....	73
	Cleaning the paper pick-up rollers for paper tray #2	74
	Checking the ink volume	74
	Packing and shipping the machine	75
B	Glossary	77
C	Index	81

Memory storage

Even if there is a power failure, you will not lose the settings you have chosen using the **MENU** button because they are stored permanently. Also, you will not lose your settings in the **FAX**, **SCAN**, **COPY** and **PHOTO CAPTURE** mode key menus if you have chosen **Set New Default** or **Favorite Settings**. You may have to reset the date and time.



Note

During a power failure the machine will retain messages that are in the memory for approximately 24 hours.

Volume Settings

Ring Volume

You can choose a range of ring volume levels, from **High** to **Off**. The machine will keep your new default setting until you change it.

Setting the Ring Volume from the menu

- 1 Press **MENU**.
- 2 Press **▲** or **▼** to display **General Setup**.
- 3 Press **General Setup**.
- 4 Press **▲** or **▼** to display **Volume**.
- 5 Press **Volume**.
- 6 Press **Ring**.
- 7 Press **Low**, **Med**, **High** or **Off**.
- 8 Press **Stop/Exit**.

Beeper Volume

When the beeper is on, the machine will beep when you press a key, make a mistake, or after you send or receive a fax.

You can choose a range of beeper volume levels, from *High* to *Off*.

- 1 Press **MENU**.
- 2 Press **▲** or **▼** to display *General Setup*.
- 3 Press *General Setup*.
- 4 Press **▲** or **▼** to display *Volume*.
- 5 Press *Volume*.
- 6 Press *Beeper*.
- 7 Press *Low*, *Med*, *High* or *Off*.
- 8 Press **Stop/Exit**.

Speaker Volume

You can choose a range of speaker volume levels, from *High* to *Off*.

- 1 Press **MENU**.
- 2 Press **▲** or **▼** to display *General Setup*.
- 3 Press *General Setup*.
- 4 Press **▲** or **▼** to display *Volume*.
- 5 Press *Volume*.
- 6 Press *Speaker*.
- 7 Press *Low*, *Med*, *High* or *Off*.
- 8 Press **Stop/Exit**.

You can also adjust the speaker volume by pressing **Hook**.

- 1 Press **Hook** on the control panel.
- 2 Press **◀** or **▶** on the Touchscreen to display the *Volume* button.
- 3 Press *Volume*.
- 4 Press **◀** or **▶** on the Touchscreen. Each button press changes the volume to the next setting.
- 5 Press **Hook** on the control panel.

Automatic Daylight Saving Time

You can set the machine to change automatically for daylight saving time. It will reset itself forward one hour in the Spring and backward one hour in the Fall. Make sure you have set the correct date and time in the `Date&Time` setting.

The factory setting is `Off`, so you will have to turn on Automatic Daylight Saving Time as follows.

- 1 Press `MENU`.
- 2 Press `▲` or `▼` to display `General Setup`.
- 3 Press `General Setup`.
- 4 Press `▲` or `▼` to display `Auto Daylight`.
- 5 Press `Auto Daylight`.
- 6 Press `On` (or `Off`).
- 7 Press **Stop/Exit**.

Sleep Mode

You can choose how long the machine must be idle (from 1 to 60 minutes) before it goes into Sleep Mode. The timer will restart if any operation is carried out on the machine.

- 1 Press `MENU`.
- 2 Press `▲` or `▼` to display `General Setup`.
- 3 Press `General Setup`.
- 4 Press `▲` or `▼` to display `Sleep Mode`.
- 5 Press `Sleep Mode`.
- 6 Press `1 Min`, `2 Mins`, `3 Mins`, `5 Mins`, `10 Mins`, `30 Mins` or `60 Mins`, which is the length of time the machine is idle before entering sleep mode.
- 7 Press **Stop/Exit**.

LCD screen

Setting the backlight brightness

You can adjust the brightness of the LCD backlight. If you are having difficulty reading the LCD, try changing the brightness setting.

- 1 Press **MENU**.
- 2 Press **▲** or **▼** to display **General Setup**.
- 3 Press **General Setup**.
- 4 Press **▲** or **▼** to display **LCD Settings**.
- 5 Press **LCD Settings**.
- 6 Press **Backlight**.
- 7 Press **Light**, **Med** or **Dark**.
- 8 Press **Stop/Exit**.

Setting the Dim Timer for the backlight

You can set how long the LCD backlight stays on after you go back to the Ready screen.

- 1 Press **MENU**.
- 2 Press **▲** or **▼** to display **General Setup**.
- 3 Press **General Setup**.
- 4 Press **▲** or **▼** to display **LCD Settings**.
- 5 Press **LCD Settings**.
- 6 Press **Dim Timer**.
- 7 Press **10 Secs**, **20 Secs**, **30 Secs** or **Off**.
- 8 Press **Stop/Exit**.

Dial Prefix

The Dial Prefix setting will automatically dial a predefined number before every fax number you dial. For example, if your telephone system requires you to dial 9 before dialing an outside number use this setting to automatically dial 9 for every fax you send.

Setting up or changing the prefix number

- 1 Press **MENU**.
- 2 Press **▲** or **▼** to display **Initial Setup**.
- 3 Press **Initial Setup**.
- 4 Press **▲** or **▼** to display **Dial Prefix**.
- 5 Press **Dial Prefix**.
- 6 Press **On** (or **Off**).
- 7 Press **Dial Prefix**.
- 8 Enter the prefix number (up to 5 digits) by pressing the buttons on the Touchscreen.
- 9 Press **OK**.



Note

- If your telephone system requires a timed break recall (hookflash), press **!** to enter the break.
- You cannot use **!** with any other numbers or characters.
- (Canada only) If the pulse dialing mode is on, **#** and ***** are not available to use.

- 10 Press **Stop/Exit**.

Mode Timer

The machine has four temporary mode keys on the control panel: **FAX**, **SCAN**, **COPY** and **PHOTO CAPTURE**. You can change the amount of time the machine takes after the last Scan, Copy or PhotoCapture operation before it returns to FAX mode. If you choose **Off**, the machine stays in the mode you used last.



- 1 Press **MENU**.
- 2 Press **▲** or **▼** to display General Setup.
- 3 Press General Setup.
- 4 Press **▲** or **▼** to display Mode Timer.
- 5 Press Mode Timer.
- 6 Press **0 Sec**, **30 Secs**, **1 Min**, **2 Mins**, **5 Mins** or **Off**.
- 7 Press **Stop/Exit**.

2

Security features

Secure Function Lock 2.0

Secure Function Lock lets you restrict public access to certain machine functions:

- Fax Tx (Fax Transmit)
- Fax Rx (Fax Receive)
- Copy
- Scan
- PCC
- PC Print
- Color Print
- Page Limit

This feature also prevents users from changing the default settings of the machine by limiting access to the menu settings.

Before using the security features, you must first enter an administrator password.

Access to restricted operations can be enabled by creating a restricted user. Restricted users must enter a user password to use the machine.

Make a careful note of your password. If you forget it, please call Brother Customer Service.

Note

- Only administrators can set limitations and make changes for each user.
- If Fax Tx is disabled, you cannot use any functions in the Fax menu.
- Polling Receive is enabled only when both Fax Tx and Fax Rx are enabled.

Before you begin to use Secure Function Lock 2.0

You can configure Secure Function Lock 2.0 settings using a Web browser. Before configuration, following preparations are needed.

- 1 Start your Web browser.
- 2 Type "http://machine's IP address/" into your browser's address bar (where "machine's IP address" is the machine's IP address).

- For example:

http://192.168.1.2/

Note

You can find the machine's IP address in the Network Configuration List. (See *Printing the Network Configuration List* in the *Network User's Guide*.)

- 3 Enter a password in the **Login** box. (This is a password to log into the machine's Web page, not the administrator password for Secure Function Lock.) Click .

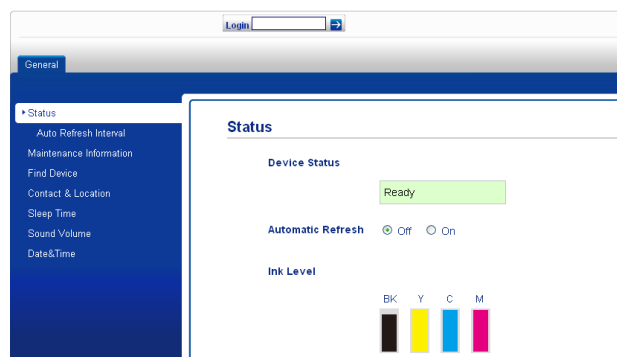

**Note**

If you are using a Web browser to configure the machine's setting for the first time, set a password.

- 1 Click **Please configure the password.**
- 2 Enter a password you want to use (up to 32 characters).
- 3 Re-enter the password in **Confirm new password** box.
- 4 Click **Submit.**

Setting and changing the Administrator Password

You can configure these settings using a Web browser. To set up the Web page, see *Before you begin to use Secure Function Lock 2.0* on page 6. Then follow the instructions below.

Setting the administrator password

The password you set in these steps is for the administrator. This password is used to set up users and to turn Secure Function Lock on or off. (See *Setting up restricted users* on page 8 and *Turning Secure Function Lock on/off* on page 8.)

- 1 Click **Administrator.**
- 2 Click **Secure Function Lock.**

- 3 Enter a four-digit number for the password in the **New Password** box.

D Number/Name	PIN	PC Print	PC Copy	Print Option		Page Limit	Fax TX	Fax RX	Other	Page Counter		
				Color Print	Full Screen					Total	Black	Color
Public Mode		<input checked="" type="checkbox"/>	<input checked="" type="checkbox"/>	<input checked="" type="checkbox"/>	<input checked="" type="checkbox"/>	<input checked="" type="checkbox"/>	<input checked="" type="checkbox"/>	<input checked="" type="checkbox"/>	<input checked="" type="checkbox"/>	0	0	0
1		<input checked="" type="checkbox"/>	<input checked="" type="checkbox"/>	<input checked="" type="checkbox"/>	<input checked="" type="checkbox"/>	<input checked="" type="checkbox"/>	<input checked="" type="checkbox"/>	<input checked="" type="checkbox"/>	<input checked="" type="checkbox"/>	0	0	0
2		<input checked="" type="checkbox"/>	<input checked="" type="checkbox"/>	<input checked="" type="checkbox"/>	<input checked="" type="checkbox"/>	<input checked="" type="checkbox"/>	<input checked="" type="checkbox"/>	<input checked="" type="checkbox"/>	<input checked="" type="checkbox"/>	0	0	0
3		<input checked="" type="checkbox"/>	<input checked="" type="checkbox"/>	<input checked="" type="checkbox"/>	<input checked="" type="checkbox"/>	<input checked="" type="checkbox"/>	<input checked="" type="checkbox"/>	<input checked="" type="checkbox"/>	<input checked="" type="checkbox"/>	0	0	0

- 4 Re-enter the password in the **Retype Password** box.
- 5 Click **Submit.**

Changing the administrator password

- 1 Click **Administrator.**
- 2 Click **Secure Function Lock.**
- 3 Enter a four-digit number for the new password in the **New Password** box.
- 4 Re-enter the new password in the **Retype Password** box.
- 5 Click **Submit.**

Setting up restricted users

You can set up users with restrictions and a password. You can set up to 10 restricted users.

You can configure these settings using a Web browser.

To set up the Web page, see *Before you begin to use Secure Function Lock 2.0* on page 6. Then follow the instructions below.

- 1 Click **Administrator**.
- 2 Click **Secure Function Lock**.
- 3 Enter an alphanumeric Group name or User name (up to 15 characters) in the **ID Number/Name** box and then enter a four-digit password in the **PIN** box.

- 4 Uncheck the functions that you want to restrict in the **Print** box or the **Others** box. If you want to configure the maximum page count, check the **On** box in **Page Limit**, and then enter the number in the **Max.** box. Then click **Submit**.

Note

- You cannot use the same password as another user's password.
- You can set up one Public user. Public users do not need to enter a password. For more information, see the *Network User's Guide*.

Turning Secure Function Lock on/off

Note

Make a careful note of the administrator password. If you enter the wrong password, the LCD will show `Wrong Password`. Enter the correct password. If you forget it, please call Brother Customer Service.

Turning Secure Function Lock on



- 1 Press `MENU`.
- 2 Press `General Setup`.
- 3 Press `▲` or `▼` to display `Function Lock`.
- 4 Press `Function Lock`.
- 5 Press `Lock Off→On`.
- 6 Enter your four-digit administrator password by pressing the buttons on the Touchscreen. Press `OK`.

Turning Secure Function Lock off

- 1 Press `Public`.
- 2 Press `Lock On→Off`.
- 3 Enter your four-digit administrator password by pressing the buttons on the Touchscreen. Press `OK`.

Switching users

This setting allows a restricted user to log on the machine when Secure Function Lock is turned on.

- 1 Hold down **Shift** as you press *****.
Or, on the Touchscreen, press  or  (where xxxxx is the user's name). Then press **Change User**.
- 2 Press **▲** or **▼** to display your user name.
- 3 Press your user name.
- 4 Enter your four-digit user password by pressing the buttons on the Touchscreen.
Press **OK**.

Changing to the Public mode

- 1 Press  (where xxxxx is the user's name).
- 2 Press **Go to Public**.



Note

After a restricted user has finished using the machine, it will return to the Public setting within the same time as the Mode Timer setting. (See *Mode Timer* on page 5.)

3

Sending a fax

Additional sending options

Sending faxes using multiple settings

When you send a fax you can choose a combination of settings, such as Fax Resolution, Contrast, Duplex Fax, Glass Scan Size, Real Time TX, and Preview.

You can also choose: Call History, Phone Book, Broadcasting, Delayed Fax, Batch TX, Polled TX, Polling RX, Overseas Mode, Set New Default, and Factory Reset.

Some settings are only available when sending black & white faxes.

- 1 Press  (FAX).
The LCD shows:

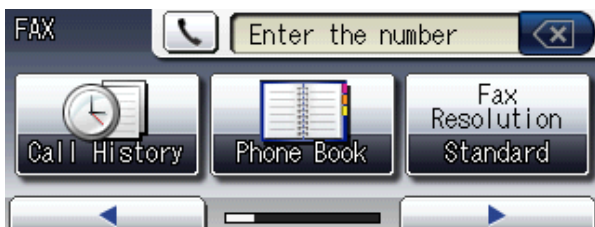

- 2 Press ◀ or ▶ to display a setting you want to change. When the setting is displayed, press it.
- 3 Press an option.
- 4 Repeat steps 2 to 3 to change more settings.

Note

- Most settings are temporary and the machine returns to its default settings after you send a fax.
- You can save some of the settings you use most often by setting them as the default. These settings will stay until you change them again. (See *Setting your changes as the new default* on page 11.)

Stop faxing

To stop faxing, press **Stop/Exit**.

Contrast

If your document is very light or very dark, you may want to change the contrast. For most documents the factory setting **Auto** can be used. It automatically chooses the suitable contrast for your document.

Choose **Light** when sending a light document. Choose **Dark** when sending a dark document.

- 1 Press  (FAX).
- 2 Press ◀ or ▶ to display Contrast.
- 3 Press Contrast.
- 4 Press Auto, Light or Dark.

Note

Even if you choose **Light** or **Dark**, the machine will send the fax using the **Auto** setting in any of the following conditions:

- When you send a color fax.
- When you choose **Photo** as the Fax Resolution.

Changing fax resolution

The quality of a fax can be improved by changing the fax resolution.

- 1 Press  (**FAX**).
- 2 Press ◀ or ▶ to display Fax Resolution.
- 3 Press Fax Resolution.
- 4 Press the resolution you want.



Note

You can choose four different resolution settings for black & white faxes and two for color faxes.

Black & White	
Standard	Suitable for most typed documents.
Fine	Good for small print and transmits a little slower than Standard resolution.
S.Fine	Good for small print or artwork and transmits slower than Fine resolution.
Photo	Use when the document has varying shades of gray or is a photograph. Photo has the slowest transmission.

Color	
Standard	Suitable for most typed documents.
Fine	Use when the document is a photograph. The transmission time is slower than Standard resolution.

If you choose **S.Fine** or **Photo** and then use the **Color Start** key to send a fax, the machine will send the fax using the **Fine** setting.

Setting your changes as the new default

You can save the fax settings for Fax Resolution, Contrast, Glass Scan Size, Preview and Real Time TX you use most often by setting them as default. These settings will stay until you change them again.

- 1 Press  (**FAX**).
- 2 Press ◀ or ▶ to choose the setting you want to change, and then press your new option.

Repeat this step for each setting you want to change.

- 3 After changing the last setting, press ◀ or ▶ to display Set New Default.
- 4 Press Set New Default.
- 5 Press Yes.
- 6 Press **Stop/Exit**.

Restoring fax settings to the factory settings

You can restore all the fax settings you have changed to the factory settings. These settings will stay until you change them again.

- 1 Press  (**FAX**).
- 2 Press ◀ or ▶ to display Factory Reset.
- 3 Press Factory Reset.
- 4 Press Yes.
- 5 Press **Stop/Exit**.

Additional sending operations

Sending a duplex (2-sided) fax from the ADF

You can send 2-sided documents up to Legal size from the ADF.

- 1 Press **Duplex** on the machine's control panel.
- 2 Load your document in the ADF.
- 3 Press **Fax**.
- 4 Do one of the following:
 - If your document is flipped on the Long edge, press
`DuplexScan :LongEdge`.

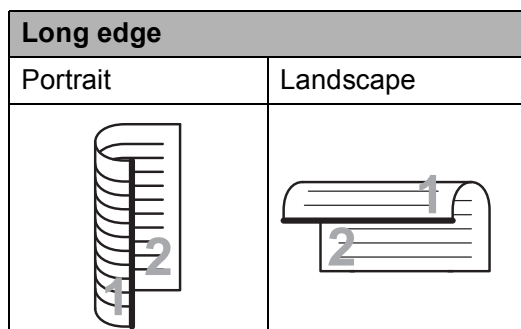

- If your document is flipped on the Short edge, press
`DuplexScan :ShortEdge`.

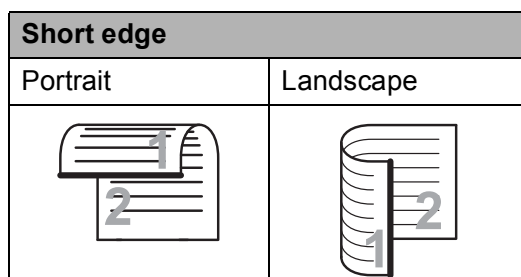

- 5 Enter the fax number.
- 6 Press **Black Start** or **Color Start**.

The machine will now scan and send your document.

Sending a fax manually

Manual transmission lets you hear the dialing, ringing and fax-receiving tones while sending a fax.



Note

To send a multiple page fax, use the ADF.

- 1 Press  (**FAX**).
- 2 Load your document.
- 3 To listen for a dial tone, press **Hook** or pick up the handset of the external telephone.
- 4 Dial the fax number.



Note

If your network supports the LDAP protocol you can search for fax numbers and E-mail addresses on your server. (See *LDAP operation* in the *Network User's Guide*.)

- 5 When you hear the fax tone, press **Black Start** or **Color Start**.
If you are using the scanner glass, press **Send** on the Touchscreen to send the fax.
If you pressed **Color Start**, go to step 6.
- 6 If you picked up the handset of an external telephone, replace it.

Sending a fax at the end of a conversation

At the end of a conversation, you can send a fax to the other party before you both hang up.

- 1 Ask the other party to wait for fax tones (beeps) and then to press the Start or Send key before hanging up.
- 2 Press  (**FAX**).
- 3 Load your document.
- 4 Press **Black Start** or **Color Start**.
 - If you are using the scanner glass, press **Send** to send the fax.
- 5 Replace the handset of the external phone.

Dual Access (Black & White only)

You can dial a number and start scanning the fax into memory—even when the machine is sending from memory, receiving faxes or printing PC data. The LCD shows the new job number and available memory.

The number of pages you can scan into the memory will vary depending on the data that is printed on them.



Note

If the **Out of Memory** message appears while scanning a document, press **Stop/Exit** to cancel or **Black Start** to send the scanned pages.

Broadcasting (Black & White only)

Broadcasting is when the same fax message is automatically sent to more than one fax number. You can include Groups, One Touch numbers, Speed Dial numbers, and up to 50 manually dialed numbers in the same broadcast.

After the broadcast is finished, a Broadcast Report will be printed.

Before you begin the broadcast

One Touch and Speed Dial numbers must be stored in the machine's memory before they can be used in a broadcast. (See *Storing One Touch Dial numbers* and *Storing Speed Dial numbers* in chapter 7 of the *Basic User's Guide*.)

Group numbers must also be stored in the machine's memory before they can be used in a broadcast. Group numbers include many stored One Touch Dial and Speed Dial numbers for easier dialing. (See *Setting up groups for Broadcasting* on page 37.)

How to broadcast a fax

- 1 Press  (**FAX**).
- 2 Load your document.
- 3 Press ◀ or ▶ to display **Broadcasting**.
- 4 Press **Broadcasting**.
- 5 You can add numbers to the broadcast in the following ways:
 - Press **Add Number** and enter a number by pressing the buttons on the Touchscreen.
Press **OK**.

**Note**

If you downloaded Internet Fax:

If you want to broadcast using an E-mail address, press , enter the E-mail address, and press **OK**. (See *Entering Text* in appendix C of the *Basic User's Guide*.)

- Press **Phone Book**.
Press  to search by Alphabetical Order or Numerical Order. Press the locations where you want to send a fax.
Press **OK**.

**Note**

If you chose Numerical Order:

One Touch Dial locations begin with *.
Speed Dial locations begin with #.

- 6 After you have entered all the fax numbers by repeating step 5, press **OK**.
- 7 Press **Black Start**.

Faxing from the ADF

- The machine starts scanning and sending the document.

Faxing from the scanner glass

When the LCD asks you **Next Page?**, do one of the following:

- To send a single page, press **No** (or press **Black Start** again).
The machine starts sending the document.
- To send more than one page, press **Yes** and place the next page on the scanner glass.
Press **Black Start**.

The machine starts scanning the page. (Repeat this step for each additional page.)

**Note**

- If you did not use up any of the numbers for Groups, you can broadcast faxes to as many as 266 different numbers.
- The machine's available memory will vary depending on the types of jobs in the memory and the number of locations used for broadcasting. If you broadcast to the maximum number available, you will not be able to use dual access and delayed fax.
- If the **Out of Memory** message appears, press **Stop/Exit** to stop the job. If more than one page has been scanned, press **Black Start** to send the portion that is in the machine's memory.

Canceling a Broadcast in progress

- 1 Press **Stop/Exit**.
- 2 Do one of the following:
 - To cancel the entire broadcast, press **Entire Broadcast**. Go to step 3.
 - To cancel the current job, press the button that displays the number being dialed. Go to step 4.
 - To exit without canceling, press **Stop/Exit**.
- 3 When the LCD asks if you want to cancel the entire broadcast, do one of the following:
 - Press **Yes** to confirm.
 - To exit without canceling, press **No** or **Stop/Exit**.
- 4 Do one of the following:
 - To cancel the current job, press **Yes**.
 - To exit without canceling, press **No** or **Stop/Exit**.

Real Time Transmission

When you are sending a fax, the machine will scan the document into the memory before sending it. Then, as soon as the telephone line is free, the machine will start dialing and sending.

Sometimes, you may want to send an important document immediately, without waiting for memory transmission. You can do this by turning on `Real Time TX`.

- 1 Press  (**FAX**).
- 2 Load your document.
- 3 Press ◀ or ▶ to display `Real Time TX`.
- 4 Press `Real Time TX`.
- 5 Press `On`.



Note

- If you are sending a color fax or the memory is full and you are sending a black & white fax from the ADF, the machine will send the document in real time (even if `Real Time TX` is set to `Off`). Faxes from the scanner glass cannot be sent until you clear some of the memory.
- In Real Time Transmission, the automatic redial feature does not work when you are using the scanner glass.

Overseas Mode

If you are having difficulty sending a fax overseas due to possible interference on the telephone line, we recommend that you turn on Overseas Mode. After you send a fax using this feature, the feature will turn itself off.

- 1 Press  (**FAX**).
- 2 Load your document.
- 3 Press ◀ or ▶ to display `Overseas Mode`.
- 4 Press `Overseas Mode`.
- 5 Press `On` (or `Off`).

Delayed Faxing (Black & White only)

You can store up to 50 faxes in the memory to be sent within 24 hours. These faxes will be sent at the time of day you enter in step 6.

- 1 Press  (**FAX**).
- 2 Load your document.
- 3 Press ◀ or ▶ to display `Delayed Fax`.
- 4 Press `Delayed Fax`.
- 5 Press `On`.
- 6 Enter the time you want the fax to be sent (in 24-hour format) by pressing the buttons on the Touchscreen. (For example, enter 19:45 for 7:45 PM.) Press `OK`.



Note

- When you set `12h Clock` in the `Date&Time` setting, enter the time in 12-hour format.
- The number of pages you can scan into the memory depends on the amount of data that is printed on each page.

Delayed Batch Transmission (Black & White only)

Before sending the delayed faxes, your machine will help you economize by sorting all the faxes in the memory by destination and scheduled time. All delayed faxes that are scheduled to be sent at the same time to the same fax number will be sent as one fax to save transmission time.

- 1 Press  (FAX).
- 2 Press ◀ or ▶ to display Batch TX.
- 3 Press Batch TX.
- 4 Press On.
- 5 Press **Stop/Exit**.

Checking and canceling waiting jobs

You can check which jobs are still waiting in the memory to be sent and cancel a job. (If there are no jobs, the LCD shows No Jobs Waiting.)

- 1 Press MENU.
- 2 Press ▲ or ▼ to display Fax.
- 3 Press Fax.
- 4 Press ▲ or ▼ to display Remaining Jobs.
- 5 Press Remaining Jobs. Any waiting jobs appear on the LCD.
- 6 Press ▲ or ▼ to scroll through the jobs and press the job you want to cancel. Press OK.
- 7 Do one of the following:
 - To cancel, press Yes.
If you want to cancel another job go to step 6.
 - To exit without canceling, press No.
- 8 When you are finished, press **Stop/Exit**.

Polling overview

Polling lets you set up your machine so other people can receive faxes from you, but they pay for the call. It also lets you call somebody else's fax machine and receive a fax from it, so you pay for the call. The polling feature needs to be set up on both machines for this to work. Not all fax machines support polling.

Polled Transmit (Black & White only)

Polled transmit lets you set up your machine to wait with a document so another fax machine can call and retrieve it.

The document will be stored and can be retrieved by any other fax machine until you delete it from the memory. (See *Checking and canceling waiting jobs* on page 16.)

Setup for polled transmit

- 1 Press  (FAX).
- 2 Load your document.
- 3 Press ◀ or ▶ to display Polled TX.
- 4 Press Polled TX.
- 5 Press On (or Off).
- 6 Press ◀ or ▶ to display any settings you want to change, and press it. Then choose your option. After each setting is accepted, you can continue to change more settings.
- 7 Press **Black Start**.

- 8 If you are using the scanner glass, the LCD will prompt you to choose one of the following options:
 - Press **Yes** to scan another page. Go to step 9.
 - Press **No** or **Black Start** to send the document.
- 9 Place the next page on the scanner glass and press **Black Start**. Repeat steps 8 and 9 for each additional page. Your machine will automatically send the fax.

4

Receiving a fax

Memory Receive (Black & White only)

You can only use one Memory Receive operation at a time:

- Fax Forwarding
- Paging
- Fax Storage
- PC-Fax Receive
- Off

You can change your selection at any time. If received faxes are still in the machine's memory when you change the Memory Receive operation, a question will appear on the LCD. (See *Changing Memory Receive operations* on page 22.)

Receiving faxes into memory when paper tray is empty

As soon as the paper tray becomes empty during fax reception, the LCD shows *No Paper Fed.* Put some paper in the paper tray. (See *Loading paper and other print media* in chapter 2 of the *Basic User's Guide.*)

If you don't put paper in the paper tray, the machine will carry on receiving the fax, with the remaining pages being stored in memory, if enough memory is available.

Further incoming faxes will also be stored in memory until the memory is full. When the memory is full the machine will stop automatically answering calls. To print the faxes, put fresh paper in the tray.

Fax Forwarding

When you choose Fax Forward, your machine stores the received fax in the memory. The machine will then dial the fax number you have programmed and forward the fax message.

- 1 Press **MENU**.
- 2 Press **▲** or **▼** to display **Fax**.
- 3 Press **Fax**.
- 4 Press **▲** or **▼** to display **Setup Receive**.
- 5 Press **Setup Receive**.
- 6 Press **▲** or **▼** to display **Memory Receive**.
- 7 Press **Memory Receive**.
- 8 Press **Fax Forward**.
- 9 Do one of the following:
 - To forward faxes to another machine, enter the forwarding number (up to 20 digits) by pressing the buttons on the Touchscreen.
Press **OK**.
 - To forward faxes to an E-mail address, press , enter the E-mail address and press **OK**. (See *Entering Text* in appendix C of the *Basic User's Guide.*)

- 10 Press **Backup Print:On** or **Backup Print:Off**.

! IMPORTANT

- If you choose **Backup Print:On**, the machine will also print the fax at your machine so you will have a copy. This is a safety feature in case there is a power failure before the fax is forwarded or a problem at the receiving machine.
- When you receive a color fax, your machine prints the color fax at your machine but does not send the fax to the fax forwarding number you programmed.

- 11 Press **Stop/Exit**.

Paging

When you choose Paging, your machine dials the cell phone or pager number you have programmed. This activates your cell phone or pager so you will know that you have a fax message in the memory.

If you have set Paging, a backup copy of the received fax will automatically be printed at the machine.

- 1 Press **MENU**.
- 2 Press **▲** or **▼** to display **Fax**.
- 3 Press **Fax**.
- 4 Press **▲** or **▼** to display **Setup Receive**.
- 5 Press **Setup Receive**.
- 6 Press **▲** or **▼** to display **Memory Receive**.
- 7 Press **Memory Receive**.
- 8 Press **Paging**.

- 9 Enter your cell phone or pager number followed by **##** (up to 20 digits). Press **OK**. Do not include the area code if it is the same as that of your machine. For example, press:
1 8 0 0 5 5 5 1 2 3 4 ##.

- 10 Do one of the following:
- If you are programming your cell phone number and do not need to enter a PIN, press **OK**.
 - If your pager needs a PIN, enter the PIN, press **#**, press **Pause**, and then enter your fax number followed by **##**.

Press **OK**.

For example, press:

1 2 3 4 5 # Pause 1 8 0 0 5 5 5 6 7 8 9 ##

- If you do not need a PIN, press: **Pause**, and then enter your fax number followed by **##**. Press **OK**.

For example, press:

Pause 1 8 0 0 5 5 5 6 7 8 9 ##

- 11 Press **Stop/Exit**.



Note

You cannot change a paging number or PIN remotely.

Fax Storage

If you choose Fax Storage, your machine stores the received fax in the memory. You will be able to retrieve fax messages from another location using the remote retrieval commands.

If you have set Fax Storage, a backup copy will automatically be printed at the machine.

- 1 Press **MENU**.
- 2 Press **▲** or **▼** to display **Fax**.
- 3 Press **Fax**.
- 4 Press **▲** or **▼** to display **Setup Receive**.
- 5 Press **Setup Receive**.
- 6 Press **▲** or **▼** to display **Memory Receive**.
- 7 Press **Memory Receive**.
- 8 Press **Fax Storage**.
- 9 Press **Stop/Exit**.



Note

Color faxes cannot be stored in the memory. When you receive a color fax your machine prints the color fax at your machine.

Printing a fax from the memory

If you have chosen Paging or Fax Storage, you can still print a fax from the memory when you are at your machine. (See *Memory Receive (Black & White only)* on page 18.)

- 1 Press **MENU**.
- 2 Press **▲** or **▼** to display **Fax**.
- 3 Press **Fax**.
- 4 Press **▲** or **▼** to display **Print Fax**.
- 5 Press **Print Fax**.
- 6 Press **Black Start**.
- 7 Press **Stop/Exit**.



Note

When you print a fax from the memory, the fax data will be erased.

PC-Fax Receive (Windows® only)

If you turn on the PC-Fax Receive feature your machine will store received faxes in memory and send them to your PC automatically. You can then use your PC to view and store these faxes.

Even if you have turned off your PC (at night or on the weekend, for example), your machine will receive and store your faxes in its memory. The number of received faxes that are stored in the memory will appear on the LCD.

When you start your PC and the PC-FAX Receiving software runs, your machine transfers your faxes to your PC automatically.

To transfer the received faxes to your PC you must have the PC-FAX Receiving software running on your PC. (For details, see *PC-FAX receiving* in the *Software User's Guide*.)

If you choose `Backup Print:On` the machine will also print the fax.

- 1 Press `MENU`.
- 2 Press `▲` or `▼` to display `Fax`.
- 3 Press `Fax`.
- 4 Press `▲` or `▼` to display `Setup Receive`.
- 5 Press `Setup Receive`.
- 6 Press `▲` or `▼` to display `Memory Receive`.
- 7 Press `Memory Receive`.
- 8 Press `PC Fax Receive`.
- 9 The LCD shows the message `Run PC-Fax on your computer. Press OK`.
- 10 Press `<USB>` or the PC you want to receive faxes.

- 11 Press `OK`.
- 12 Press `Backup Print:On` or `Backup Print:Off`.
- 13 Press **Stop/Exit**.



Note

- PC-Fax Receive is not supported in the Mac OS.
- Before you can set up PC-Fax Receive you must install the MFL-Pro Suite software on your PC. Make sure your PC is connected and turned on. (For details see *PC-FAX receiving* in the *Software User's Guide*.)
- If you get an error message and the machine cannot print the faxes in memory, you can use this setting to transfer your faxes to your PC. (For details, see *Transferring your faxes or Fax Journal report* in *appendix B* of the *Basic User's Guide*.)
- When you receive a color fax, your machine prints the color fax at your machine but does not send the fax to your PC.

Changing the destination PC

- 1 Press `MENU`.
- 2 Press `▲` or `▼` to display `Fax`.
- 3 Press `Fax`.
- 4 Press `▲` or `▼` to display `Setup Receive`.
- 5 Press `Setup Receive`.
- 6 Press `▲` or `▼` to display `Memory Receive`.
- 7 Press `Memory Receive`.
- 8 Press `PC Fax Receive`.

- 9 The LCD shows the message
Run PC-Fax on your computer.
Press OK.
- 10 Press <USB>, or the PC you want to
receive faxes.
- 11 Press OK.
- 12 Press Backup Print:On or
Backup Print:Off.
- 13 Press **Stop/Exit**.

Turning off Memory Receive operations

- 1 Press MENU.
- 2 Press ▲ or ▼ to display Fax.
- 3 Press Fax.
- 4 Press ▲ or ▼ to display
Setup Receive.
- 5 Press Setup Receive.
- 6 Press ▲ or ▼ to display
Memory Receive.
- 7 Press Memory Receive.
- 8 Press Off.
- 9 Press **Stop/Exit**.



Note

The LCD will give you more options if there are received faxes still in the machine's memory. (See *Changing Memory Receive operations* on page 22.)

Changing Memory Receive operations

If received faxes remain in your machine's memory when you change the Memory Receive Operations, the LCD will ask you one of the following questions:

- Erase All Fax?
- Print All Fax?
 - If you press Yes, faxes in the memory will be erased or printed before the setting changes. If a backup copy has already been printed it will not be printed again.
 - If you press No, faxes in the memory will not be erased or printed and the setting will be unchanged.

If received faxes are left in the machine's memory when you change to PC Fax Receive from another option [Fax Forward, Paging or Fax Storage], press ▲ or ▼ to choose the PC.

The LCD will ask you the following question:

- Send Fax to PC?
 - If you press Yes, faxes in the memory will be sent to your PC before the setting changes. You will be asked if you want to turn on Backup Print. (For details, see *PC-Fax Receive (Windows® only)* on page 21.)
 - If you press No, faxes in the memory will not be erased or transferred to your PC and the setting will be unchanged.

Remote Retrieval

You can call your machine from any touch-tone telephone or fax machine and then use the remote access code and remote commands to retrieve fax messages.

Setting a Remote Access Code

The Remote Access Code lets you access the remote retrieval features when you are away from your machine. Before you can use the remote access and retrieval features, you have to set up your own code. The factory default code is the inactive code (---*).

- 1 Press **MENU**.
- 2 Press **▲** or **▼** to display **Fax**.
- 3 Press **Fax**.
- 4 Press **▲** or **▼** to display **Remote Access**.
- 5 Press **Remote Access**.
- 6 Enter a three-digit code using numbers 0-9, *, or # by pressing the buttons on the Touchscreen.
Press **OK**.
(The preset '*' cannot be changed.)



Note

Do not use the same code as your Fax Receive Code (* 5 1) or Telephone Answer Code (# 5 1). (See *Using external and extension telephones* in chapter 6 of the *Basic User's Guide*.)

- 7 Press **Stop/Exit**.



Note

You can change your code at any time by entering a new one. If you want to make your code inactive, press **Clear** in step 6 to restore the inactive setting (---*) and press **OK**.

Using your Remote Access Code

- 1 Dial your fax number from a touch-tone telephone or another fax machine.
- 2 When your machine answers, enter your remote access code (3 digits followed by *) at once.
- 3 The machine signals if it has received messages:
 - 1 long beep — Fax messages
 - No beeps — No messages
- 4 When the machine gives two short beeps, enter a command.
The machine will hang up if you wait longer than 30 seconds to enter a command.
The machine will beep three times if you enter an invalid command.
- 5 Press **9 0** to stop Remote Access when you have finished.
- 6 Hang up.



Note

If your machine is set to **Manual** mode and you want to use the remote retrieval features, wait for about 100 seconds after it starts ringing, and then enter the remote access code within 30 seconds.

Remote Fax commands

Follow the commands below to access features when you are away from the machine. When you call the machine and enter your remote access code (3 digits followed by *), the system will give two short beeps and you must enter a remote command.

Remote commands		Operation details
95	Change the Fax Forwarding, Paging or Fax Storage settings	
	1 OFF	You can choose OFF after you have retrieved or erased all your messages.
	2 Fax Forwarding	One long beep means the change is accepted. If you hear three short beeps, you cannot make a change because something has not been set up (for example, a Fax Forwarding or Paging number has not been registered).
	3 Paging	
	4 Fax Forwarding number	
6 Fax Storage	You can register your Fax Forwarding number by entering 4. (See <i>Changing your Fax Forwarding number</i> on page 25.) Once you have registered the number, Fax Forwarding will work.	
96	Retrieve a fax	
	2 Retrieve all faxes	Enter the number of a remote fax machine to receive stored fax messages. (See <i>Retrieving fax messages</i> on page 25.)
	3 Erase faxes from the memory	If you hear one long beep, fax messages have been erased from the memory.
97	Check the receiving status	
	1 Fax	You can check whether your machine has received any faxes. If yes, you will hear one long beep. If no, you will hear three short beeps.
98	Change the Receive Mode	
	1 External TAD	If you hear one long beep, your change has been accepted.
	2 Fax/Tel	
3 Fax Only		
90	Exit	Pressing 9 0 allows you to exit remote retrieval. Wait for the long beep, then replace the handset.

Retrieving fax messages

You can call your machine from any touch-tone telephone and have your fax messages sent to another machine. Before you use this feature, you have to turn on Fax Storage.

- 1 Dial your fax number.
- 2 When your machine answers, enter your remote access code (3 digits followed by *) at once. If you hear one long beep, you have messages.
- 3 When you hear two short beeps, press **9 6 2**.
- 4 Wait for a long beep, and then use the dial pad to enter the number of the remote fax machine where you want your fax messages sent, followed by **# #** (up to 20 digits).



Note

You cannot use * and # as dial numbers. However, press # if you want to create a pause.

- 5 Hang up after you hear your machine beep. Your machine will call the other fax machine, which will then print your fax messages.

Changing your Fax Forwarding number

You can change the default setting of your fax forwarding number from another touch-tone telephone or fax machine.

- 1 Dial your fax number.
- 2 When your machine answers, enter your remote access code (3 digits followed by *) at once. If you hear one long beep, you have messages.
- 3 When you hear two short beeps, press **9 5 4**.
- 4 Wait for the long beep, enter the new number (up to 20 digits) of the remote fax machine you want your fax messages forwarded to using the dial pad, then enter **# #**.



Note

You cannot use * and # as dial numbers. However, press # if you want to create a pause.

- 5 Press **9 0** to stop Remote Access when you have finished.
- 6 Hang up after you hear your machine beep.

Additional receiving operations

Printing a reduced incoming fax

If you choose **On**, the machine automatically reduces each page of an incoming fax to fit on one page of Letter, Legal, Ledger, A4 or A3 size paper. The machine calculates the reduction ratio by using the page size of the fax and your Paper Size setting. (See *Paper Size and Type* in chapter 2 of the *Basic User's Guide*.)

- 1 Press **MENU**.
- 2 Press **▲** or **▼** to display **Fax**.
- 3 Press **Fax**.
- 4 Press **▲** or **▼** to display **Setup Receive**.
- 5 Press **Setup Receive**.
- 6 Press **▲** or **▼** to display **Auto Reduction**.
- 7 Press **Auto Reduction**.
- 8 Press **On** (or **Off**).
- 9 Press **Stop/Exit**.

Receiving a fax at the end of a conversation

At the end of a conversation, you can ask the other party to fax you information before you both hang up.

- 1 Ask the other party to place the document in their machine and to press the **Start** or **Send** key.
- 2 When you hear the other machine's CNG tones (slowly repeating beeps), press **Black Start** or **Color Start**.
- 3 Press **Receive** to receive the fax.
- 4 Replace the handset of the external telephone.

Polling overview

Polling lets you set up your machine so other people can receive faxes from you, but they pay for the call. It also lets you call somebody else's fax machine and receive a fax from it, so you pay for the call. The polling feature needs to be set up on both machines for this to work. Not all fax machines support polling.

Polling receive

Polling receive lets you call another fax machine to receive a fax.

Setup to receive polling

- 1 Press  (**FAX**).
- 2 Press ◀ or ▶ to display **Polling RX**.
- 3 Press **Polling RX**.
- 4 Press **On** (or **Off**).
- 5 Enter the fax number you are polling using **One Touch**, **Speed Dial** or the dial pad on the control panel.
- 6 Press **Black Start** or **Color Start**.
The LCD shows **Dialing**.

Sequential polling (Black & White only)

Sequential polling lets you request documents from several fax machines in one operation. Afterwards, a Sequential Polling Report will be printed.

- 1 Press  (**FAX**).
- 2 Press ◀ or ▶ to display **Polling RX**.
- 3 Press **Polling RX**.
- 4 Press **On** (or **Off**).
- 5 Press ◀ or ▶ to display **Broadcasting**.

- 6 Press **Broadcasting**.
- 7 Do one of the following:
 - Press **Add Number** and enter a number by pressing the buttons on the Touchscreen.
Press **OK**.
 - Press **Phone Book**. Press  to choose **Alphabetical Order** or **Numerical Order**. Press ▲ or ▼ to select a number.
Press **OK**.



Note

If you chose Numerical Order:

One Touch Dial locations begin with *.
Speed Dial locations begin with #.

- 8 After you have entered all the fax numbers by repeating step 7, press **OK**.
- 9 Press **Black Start**.
The machine polls each number or Group number in turn for a document.

Press **Stop/Exit** while the machine is dialing to cancel the polling process.

To cancel all sequential polling receive jobs, see *Checking and canceling waiting jobs* on page 16.

Canceling a Sequential Polling Job

- 1 Press **Stop/Exit**.
- 2 Do one of the following:
 - To cancel the entire sequential polling job, press `Entire Seq. Poll.` Go to step 3.
 - To cancel the current job, press the button that displays the number being dialed. Go to step 4.
 - To exit without canceling, press **Stop/Exit**.
- 3 When the LCD asks if you want to cancel the entire sequential polling job, do one of the following:
 - Press `Yes` to confirm.
 - To exit without canceling, press `No` or **Stop/Exit**.
- 4 Do one of the following:
 - To cancel the current job, press `Yes`.
 - To exit without canceling, press `No` or **Stop/Exit**.

Voice operations

Voice calls can be made either with an external telephone by dialing manually or by using Quick Dial numbers.

Tone or Pulse (Canada only)

If you have a Pulse dialing service, but need to send tone signals (for example, for telephone banking), follow the instructions below:

- 1 Pick up the handset of an external telephone or press **Hook**.
- 2 Press **#** on the machine's control panel. Any digits dialed after this will send tone signals.

When you hang up, the machine will return to the Pulse dialing service.

Fax/Tel mode

When the machine is in Fax/Tel mode, it will use the F/T Ring (pseudo/double-ringing) to alert you to pick up a voice call.

If you are at the extension telephone, you'll need to lift the handset during the F/T Ring and then press **# 5 1** between the pseudo/double-rings. If no one is on the line, or if someone wants to send you a fax, send the call back to the machine by pressing *** 5 1**.

If you are at the machine, lift the external telephone's handset, and then press **Hook** to answer.

Caller ID

The Caller ID feature lets you use the Caller ID subscriber service offered by many local telephone companies. Call your telephone company for details. This service shows the telephone number, or name if it is available, of your caller as the line rings.

After a few rings, the LCD shows the telephone number of your caller (and name, if available). Once you answer a call, the Caller ID information disappears from the LCD, but the call information stays stored in the Caller ID memory.

You can view the list or choose one of these numbers to fax to, add to One Touch or Speed Dial, or delete from the history. (See *Caller ID history* on page 32.)

- You can see the first 20 characters of the number (or name).
- The # `Unavailable` message means the call originated outside your Caller ID service area.
- The `Private Call` message means the caller has intentionally blocked transmission of Caller ID information.

You can print a list of the Caller ID information received by your machine. (See *How to print a report* on page 40.)



Note

- This feature may not be available in certain areas of the USA and Canada.
- The Caller ID service varies with different carriers. Call your local telephone company to find out about the kind of service available in your area.

Setting up your area code (USA only)

When returning calls from the Caller ID history your machine will automatically dial “1” plus the area code for all calls. If your local dialing plan requires that the “1” not be used for calls within your area code, enter your area code in this setting. With the area code setting, calls returned from the Caller ID history to numbers *within* your area code will be dialed using 10 digits (area code + 7-digit number). If your dialing plan does not follow the standard 1 + area code + 7-digit number dialing system for calling *outside* your area code, you may experience problems returning calls automatically from the Caller ID history. If this is not the procedure followed by your dialing plan, you will not be able to return calls automatically.

- 1 Press **MENU**.
- 2 Press **▲** or **▼** to display **Fax**.
- 3 Press **Fax**.
- 4 Press **▲** or **▼** to display **Miscellaneous**.
- 5 Press **Miscellaneous**.
- 6 Press **▲** or **▼** to display **Area Code**.
- 7 Press **Area Code**.
- 8 Enter your Area Code (3-digit number), and press **OK**.
- 9 Press **Stop/Exit**.

Special line considerations

Roll-over telephone lines

A roll-over telephone system is a group of two or more separate telephone lines that pass incoming calls to each other if they are busy. The calls are usually passed down or “rolled over” to the next available telephone line in a preset order.

Your machine can work in a roll-over system as long as it is the last number in the sequence so the call cannot roll away. Do not put the machine on any of the other numbers; when the other lines are busy and a second fax call is received, the fax call will be sent to a line that does not have a fax machine. **Your machine will work best on a dedicated line.**

Two-line telephone system

A two-line telephone system is nothing more than two separate telephone numbers on the same wall outlet. The two telephone numbers can be on separate jacks (RJ11) or mixed into one jack (RJ14). Your machine must be plugged into an RJ11 jack. RJ11 and RJ14 jacks may be equal in size and appearance and both may contain four wires (black, red, green, yellow). To test the type of jack, plug in a two-line telephone and see if it can access both lines. If it can, you must separate the line for your machine.

Converting telephone wall outlets

There are three ways to convert to an RJ11 jack. The first two ways may require help from the telephone company. You can change the wall outlets from one RJ14 jack to two RJ11 jacks. Or, you can have an RJ11 wall outlet installed and slave or jump one of the telephone numbers to it.

The third way is the easiest: Buy a triplex adapter. You can plug a triplex adapter into an RJ14 outlet. It separates the wires into two separate RJ11 jacks (Line 1, Line 2) and a third RJ14 jack (Lines 1 and 2). If your machine is on Line 1, plug the machine into L1 of the triplex adapter. If your machine is on Line 2, plug it into L2 of the triplex adapter.

Triplex Adapter

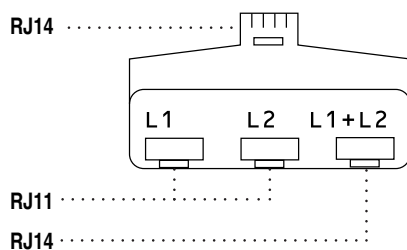

Installing machine, external two-line TAD and two-line telephone

When you are installing an external two-line telephone answering device (TAD) and a two-line telephone, your machine must be isolated on one line at both the wall jack and at the TAD. The most common connection is to put the machine on Line 2, which is explained in the following steps. The back of the two-line TAD must have two telephone jacks: one labeled L1 or L1/L2, and the other labeled L2. You will need at least three telephone line cords: the one that came with your machine and two for your external two-line TAD. You will need a fourth line cord if you add a two-line telephone.

- 1 Put the two-line TAD and the two-line telephone next to your machine.

- 2 Plug one end of the telephone line cord for your machine into the L2 jack of the triplex adapter. Plug the other end into the LINE jack on the back of the machine.
- 3 Plug one end of the first telephone line cord for your TAD into the L1 jack of the triplex adapter. Plug the other end into the L1 or L1/L2 jack of the two-line TAD.
- 4 Plug one end of the second telephone line cord for your TAD into the L2 jack of the two-line TAD. Plug the other end into the EXT. jack on the left side of the machine.

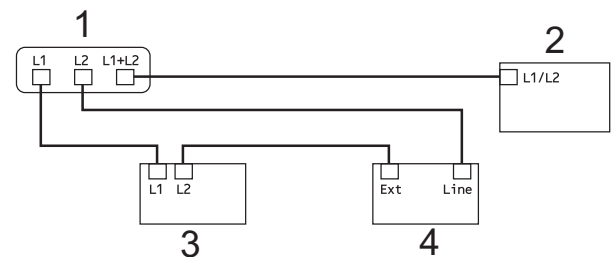

- 1 Triplex Adapter
- 2 Two Line Telephone
- 3 External Two Line TAD
- 4 Machine

Your additional two-line telephones on other wall outlets do not require adapters. There are two ways to add a two-line telephone to the machine's wall outlet. You can plug the telephone line cord from the two-line telephone into the L1+L2 jack of the triplex adapter. Or, you can plug the two-line telephone into the TEL jack of the two-line TAD.

Additional dialing operations

Outgoing Call

The last 30 numbers you sent a fax to will be stored in the outgoing call history. You can choose one of these numbers to fax to, add to One Touch or Speed Dial, or delete from the history.

- 1 Press **Redial/Pause**.
You can also press  (Call History).
- 2 Press the **Outgoing Call** tab.
- 3 Press the number you want.
- 4 Do one of the following:
 - To send a fax, press **Send a fax**.
 - If you want to store the number, press **More** and then press **Add to Speed Dial** or **Add to One Touch Dial**.
(See *Storing One Touch numbers from Outgoing Calls* on page 34 or *Storing Speed Dial numbers from Outgoing Calls* on page 35.)
 - If you want to delete the number from the Outgoing Call history list, press **More** and then press **Delete**.
Press **Yes** to confirm.
- 5 Press **Stop/Exit**.

Caller ID history

This feature requires the Caller ID subscriber service offered by many local telephone companies. (See *Caller ID* on page 29.)

The number, or name if available, from the last 30 fax and telephone calls you received will be stored in the Caller ID history. You can view the list or choose one of these numbers to fax to, add to One Touch or Speed Dial, or delete from the history. When the thirty-first call comes into the machine, it replaces information about the first call.

Note

If you are not a Caller ID subscriber, Caller ID history only allows you to view and delete the dates of calls.

- 1 Press  (Call History).
- 2 Press **Caller ID hist.**
- 3 Press **▲** or **▼** to display the number or the name you want to call.
- 4 Press the number or the name you want to call.
- 5 Do one of the following:
 - To send a fax, press **Send a fax**.
 - If you want to store the number, press **More** and then press **Add to Speed Dial** or **Add to One Touch Dial**.
(See *Storing One Touch numbers from the Caller ID history* on page 34 and *Storing Speed Dial numbers from the Caller ID history* on page 36.)
 - If you want to delete the number from the Caller ID history list, press **More** and then press **Delete**.
Press **Yes** to confirm.
- 6 Press **Stop/Exit**.

**Note**

- (USA only) If you redial from the Caller ID history outside your area code, you must set up your AREA CODE in advance. (See *Setting up your area code (USA only)* on page 30.)
- You can print the Caller ID List. (See *How to print a report* on page 40.)

Dialing access codes and credit card numbers

Sometimes, you may want to choose from several long distance carriers when you send a fax. Rates may vary depending on the time and destination. To take advantage of low rates, you can store the access codes of long-distance carriers and credit card numbers as One Touch and Speed Dial numbers. You can store these long dialing sequences by dividing them and setting them up as separate One Touch and Speed Dial numbers in any combination. You can even include manual dialing using the dial pad. (See *Storing One Touch Dial numbers* or *Storing Speed Dial numbers* in chapter 7 of the *Basic User's Guide*.)

For example, you might have stored '555' on Speed Dial: 03 and '7000' on One Touch: 02. You can use them both to dial '555-7000' if you press the following buttons on the Touchscreen:

- 1 Press  (Phone Book).
- 2 Press #03.

**Note**

One Touch Dial locations begin with *.
Speed Dial locations begin with #.

- 3 Press Send a fax.
- 4 Press Phone Book.
- 5 Press *02.

- 6 Press Send a fax.

- 7 Press **Black Start** or **Color Start**.
You will dial '555-7000'.

To temporarily change a number, you can substitute part of the number with manual dialing using the dial pad. For example, to change the number to 555-7001 you could press  (Phone Book), press #03, press Send a fax and then press **7001** using the dial pad.

**Note**

If you must wait for another dial tone or signal at any point in the dialing sequence, create a pause in the number by pressing **Redial/Pause**. Each key press adds a 3.5-second delay.

Additional ways to store numbers

Storing One Touch numbers from Outgoing Calls

You can store One Touch numbers from the Outgoing Call history.

- 1 Press **Redial/Pause**.
You can also choose by pressing  (Call History).
- 2 Press **Outgoing Call** tab.
- 3 Press the number you want to store.
- 4 Press **More**.
- 5 Press **Add to One Touch Dial**.
- 6 To choose where the number will be stored, do one of the following:
 - To accept the displayed next available One Touch location, press **OK**.
 - To enter a different One Touch location, press a number by pressing the buttons on the Touchscreen.
Press **OK**.



Note

If the One Touch location you choose is already taken, the **OK** button on the LCD will not work. Choose a different location.

- 7 Do one of the following:
 - Enter the name by pressing the buttons on the Touchscreen (up to 16 characters).
Press **OK**.

(To help you enter letters, see *Entering Text* in appendix C of the *Basic User's Guide*.)
 - To store the number without a name, press **OK**.

- 8 Press **OK** to accept the displayed telephone or fax number.
- 9 When the LCD shows your settings, press **OK** to confirm.
- 10 Press **Stop/Exit**.

Storing One Touch numbers from the Caller ID history

If you have the Caller ID subscriber service from your telephone company, you can also store One Touch numbers from incoming calls in the Caller ID History. (See *Caller ID* on page 29.)

- 1 Press  (Call History).
- 2 Press the **Caller ID hist. tab**.
- 3 Press **▲** or **▼** to display the number you want to store.
- 4 Press the number you want to store.
- 5 Press **More**.
- 6 Press **Add to One Touch Dial**.
- 7 To choose where the number will be stored, do one of the following:
 - To accept the displayed next available One Touch location, press **OK**.
 - To enter a different One Touch location, press a number by pressing the buttons on the Touchscreen.
Press **OK**.



Note

If the One Touch location you choose is already taken, the **OK** button on the LCD will not work. Choose a different location.

- 8 Do one of the following:
 - If you want to store the displayed name, press **OK**.
 - Enter the name (up to 16 characters) by pressing the buttons on the Touchscreen.
Press **OK**.
(To help you enter letters, see *Entering Text* in appendix C of the *Basic User's Guide*.)
 - To store the number without a name, press **OK**.
- 9 Press **OK** to confirm the fax or telephone number.
- 10 When the LCD shows your settings, press **OK** to confirm.
- 11 Press **Stop/Exit**.

Storing Speed Dial numbers from Outgoing Calls

You can also store Speed Dial numbers from the Outgoing Call history.

- 1 Press **Redial/Pause**.
You can also choose the number by pressing  (**Call History**).
- 2 Press the **Outgoing Call** tab.
- 3 Press the name or number you want to store.
- 4 Press **More**.
- 5 Press **Add to Speed Dial**.

- 6 Do one of the following:
 - Enter the name (up to 16 characters) by pressing the buttons on the Touchscreen.
Press **OK**.
(To help you enter letters, see *Entering Text* in appendix C of the *Basic User's Guide*.)
 - To store the number without a name, press **OK**.
- 7 Press **OK** to confirm the fax or telephone number you want to store.
- 8 Do one of the following:
 - Enter the second fax or telephone number (up to 20 digits) by pressing the buttons on the Touchscreen.
Press **OK**.
 - If you do not want to store a second number, press **OK**.
- 9 To choose where the number will be stored, do one of the following:
 - To accept the displayed next available Speed Dial location, press **OK**.
 - To enter a different Speed Dial location, press a 2-digit number by pressing the buttons on the Touchscreen.
Press **OK**.



Note

- Speed Dial locations begin with **#** (for example, **# 0 2**).
- If the 2-digit Speed Dial location you choose is already taken, the **OK** button on the LCD will not work. Choose a different location.

- 10 When the LCD shows your settings, press **OK** to confirm.
- 11 Press **Stop/Exit**.

Storing Speed Dial numbers from the Caller ID history

If you have the Caller ID subscriber service from your telephone company, you can also store Speed Dial numbers from incoming calls in the Caller ID History. (See *Caller ID* on page 29.)

- 1 Press  (Call History).
- 2 Press the `Caller ID hist.` tab.
- 3 Press `▲` or `▼` to display the number you want to store.
- 4 Press the number you want to store.
- 5 Press `More`.
- 6 Press `Add to Speed Dial`.
- 7 Do one of the following:
 - If you want to store the displayed name, press `OK`.
 - Enter the name (up to 16 characters) by pressing the buttons on the Touchscreen.
Press `OK`.
(To help you enter letters, see *Entering Text* in appendix C of the *Basic User's Guide*.)
 - To store the number without a name, press `OK`.
- 8 Press `OK` to confirm the fax or telephone number you want to store.
- 9 Do one of the following:
 - Enter a second fax or telephone number (up to 20 digits) by pressing the buttons on the Touchscreen.
Press `OK`.
 - If you do not want to store a second number, press `OK`.

- 10 To choose where the number will be stored, do one of the following:
 - To accept the displayed next available Speed Dial location, press `OK`.
 - To enter a different Speed Dial location, press a 2-digit number by pressing the buttons on the Touchscreen.
Press `OK`.

Note

- Speed Dial locations begin with # (for example, # 0 2).
- If the 2-digit Speed Dial location you choose is already taken, the `OK` button on the LCD will not work. Choose a different location.

- 11 When the LCD shows your settings, press `OK` to confirm.
- 12 Press **Stop/Exit**.

Setting up groups for Broadcasting

Groups, which can be stored on a One Touch key or Speed Dial location, allow you to send the same fax message to many fax numbers by pressing only a One Touch key or a Speed Dial location by pressing

 (Phone Book), the two-digit location, Send a fax and **Black Start**.

First, you'll need to store each fax number in a One Touch key or Speed Dial location. Then you can include them as numbers in the Group. Each Group uses up a One Touch key or Speed Dial location. You can have up to six Groups, or you can assign up to 215 numbers to a large Group.

(See *Broadcasting (Black & White only)* on page 13 and *Storing One Touch Dial numbers* and *Storing Speed Dial numbers* in chapter 7 of the *Basic User's Guide*.)

- 1 Press  (Phone Book).
- 2 Press **More**.
- 3 Press **Setup Groups**.
- 4 Press **Set Speed Dial** or **Set One Touch Dial**.
If you choose **Set Speed Dial** go to step 6.
- 5 To accept the next available One Touch key number press **OK**.
- 6 Enter the group name (up to 16 characters) by pressing the buttons on the Touchscreen.
Press **OK**.
- 7 When the LCD shows the next available Group number, press **OK**.
This Group number and name will automatically be assigned to the next available Speed Dial location.

- 8 Add One Touch or Speed Dial numbers to the Group by pressing them to display a red checkmark. Press **OK**.
If you want to list the numbers in alphabetical order, press .



Note

One Touch Dial locations begin with *.
Speed Dial locations begin with #.

- 9 When the LCD shows the Group Name and numbers, press **OK** to confirm.
- 10 Do one of the following:
 - To store another Group for broadcasting, repeat steps 2 to 9.
 - To finish storing Groups for broadcasting, press **Stop/Exit**.



Note

You can print a list of all the One Touch and Speed Dial numbers. Group numbers will be marked in the GROUP column. (See *Reports* on page 40.)

Changing a Group name

- 1 Press  (Phone Book).
- 2 Press **More**.
- 3 Press **Change**.
- 4 Press **▲** or **▼** to display the Group you want to change.
- 5 Press the Group.
- 6 Press **Name : .**
- 7 Enter the new name (up to 16 characters) by pressing the buttons on the Touchscreen.
Press **OK**.
(See *Entering Text* in *appendix C* of the *Basic User's Guide*. For example, type **NEW CLIENTS**.)

Note

How to change the stored name or number:

If you want to change a character, press **◀** or **▶** to position the cursor under the character you want to change, and then press . Re-enter the character.

- 8 Press **OK**.
- 9 Press **Stop/Exit**.

Deleting a Group

- 1 Press  (Phone Book).
- 2 Press **More**.
- 3 Press **Delete**.
- 4 Press **▲** or **▼** to display the Group you want to delete.
- 5 Press the Group Name.
- 6 Press **OK**.
Press **Yes** to confirm.
- 7 Press **Stop/Exit**.

Deleting a number from a Group

- 1 Press  (Phone Book).
- 2 Press **More**.
- 3 Press **Change**.
- 4 Press **▲** or **▼** to display the Group you want to change.
- 5 Press the Group.
- 6 Press **Add/Del .**
- 7 Press **▲** or **▼** to display the number you want to delete from the Group.
- 8 Press the check box of the number you want to delete to uncheck it.
Press **OK** to confirm.
- 9 Press **OK**.
- 10 Press **Stop/Exit**.

Fax reports

Use the **MENU** button on the LCD to set up the Transmission Verification Report and the Journal Period.

Transmission Verification Report

You can use the Transmission Verification Report as proof that you sent a fax. (For details about how to set up the type of report you want, see *Transmission Verification Report* in chapter 4 of the *Basic User's Guide*.)

Fax Journal (activity report)

You can set the machine to print a journal at specific intervals (every 50 faxes, 6, 12 or 24 hours, 2 or 7 days). If you set the interval to **Off**, you can still print the report by following the steps in *How to print a report* on page 40. The factory setting is **Every 50 Faxes**.

- 1 Press **MENU**.
- 2 Press **▲** or **▼** to display **Fax**.
- 3 Press **Fax**.
- 4 Press **▲** or **▼** to display **Report Setting**.
- 5 Press **Report Setting**.
- 6 Press **Journal Period**.

- 7 Press **◀** or **▶** to choose an interval. If you choose **Every 50 Faxes**, go to step 10.

- **6, 12, 24 hours, 2 or 7 days**

The machine will print the report at the chosen time and then erase all jobs from its memory. If the machine's memory becomes full with 200 jobs before the time you chose has passed, the machine will print the Journal early and then erase all jobs from the memory. If you want an extra report before it is due to print, you can print it without erasing the jobs from the memory.

- **Every 50 Faxes**

The machine will print the Journal when the machine has stored 50 jobs.

- 8 Enter the time to start printing in 24-hour format. Press **OK**. (For example: enter 19:45 for 7:45 PM.)



Note

When you set **12h Clock** in the **Date&Time** setting, enter the time in 12-hour format.

- 9 If you choose **Every 7 Days**, the LCD will ask you to choose the first day for the 7-day countdown.
- 10 Press **Stop/Exit**.

Reports

The following reports are available:

- **Transmission**
Prints a Transmission Verification Report for your last transmission.
- **Help List**
A help list showing how to program your machine.
- **Quick Dial**
Lists names and numbers stored in the One Touch and Speed Dial memory, in alphabetical or numerical order.
- **Fax Journal**
Lists information about the last incoming and outgoing faxes.
(TX: Transmit.) (RX: Receive.)
- **User Settings**
Lists your settings.
- **Network Config**
Lists your Network settings.
- **WLAN Report**
Prints the result of the WLAN connection.
- **Caller ID hist.**
Lists the available Caller ID information about the last 30 received faxes and telephone calls.

How to print a report

- 1 Press **MENU**.
- 2 Press **▲** or **▼** to display **Print Reports**.
- 3 Press **Print Reports**.
- 4 Press the report you want.
- 5 (Quick Dial Only) Press **Alphabetical Order** or **Numerical Order**.
- 6 Press **Black Start**.
- 7 Press **Stop/Exit**.

Copy settings

You can change the copy settings for the next copy.

These settings are temporary. The machine returns to its default settings 1 minute after copying unless you have set the Mode Timer to 30 seconds or less. (See *Mode Timer* on page 5.)

To change a setting, press **COPY** and then press ◀ or ▶ to scroll through the copy settings. When the setting you want is displayed, press it and choose your option.

When you are finished choosing settings, press **Black Start** or **Color Start**.

Note

- You can save some of the settings that you use most often by setting them as default. These settings will stay until you change them again. (See *Setting your favorites* on page 53.)
- The Ink Save Mode, Thin Paper Copy, Book Copy and Watermark Copy features are supported by technology from Reallusion,

Inc.  **REALLUSION**

Stop copying

To stop copying, press **Stop/Exit**.

Changing copy quality

You can choose from a range of quality. The factory setting is **Normal**.

■ Fast

Fast copy speed and lowest amount of ink used. Use to save time printing documents to be proof-read, large documents or many copies.

■ Normal

Normal is the recommended mode for ordinary printouts. This produces good copy quality with good copy speed.

■ Best

Use Best mode to copy precise images such as photographs. This provides the highest resolution and slowest speed.

- 1 Press  (**COPY**).
- 2 Load your document.
- 3 Enter the number of copies you want.
- 4 Press ◀ or ▶ to display **Quality**.
- 5 Press **Quality**.
- 6 Press **Fast**, **Normal** or **Best**.
- 7 If you do not want to change additional settings, press **Black Start** or **Color Start**.

Enlarging or reducing the copied image

You can choose an enlargement or reduction ratio. If you choose **Fit to Page**, your machine will adjust the size automatically to the paper size you set.

- 1 Press  (**COPY**).
- 2 Load your document.
- 3 Enter the number of copies you want.
- 4 Press ◀ or ▶ to display **Enlarge/Reduce**.
- 5 Press **Enlarge/Reduce**.
- 6 Press **100%**, **Enlarge**, **Reduce**, **Fit to Page** or **Custom (25-400%)**.
- 7 Do one of the following:
 - If you chose **Enlarge** or **Reduce**, press the enlargement or reduction ratio you want.
 - If you chose **Custom (25-400%)**, enter an enlargement or reduction ratio from 25% to 400%. Press **OK**.
 - If you chose **100%** or **Fit to Page**, go to step 8.

198% 4"x6"→A4
186% 4"x6"→LTR
130% LTR→LGR
104% EXE→LTR
100%
97% LTR→A4
93% A4→LTR
85% LTR→EXE
83% LGL→A4
78% LGL→LTR
64% LGR→LTR
46% LTR→4"x6"
Fit to Page
Custom (25-400%)

- 8 If you do not want to change additional settings, press **Black Start** or **Color Start**.



Note

- Page Layout is not available with **Enlarge/Reduce**.
- Page Layout, Book Copy, Sort, Thin Paper Copy and Watermark Copy are not available with **Fit to Page**.
- **Fit to Page** does not work properly when the document on the scanner glass is skewed more than 3 degrees. Using the document guidelines on the left and top, place your document in the upper left hand corner, with the document face down on the scanner glass.
- **Fit to Page** is not available for a Legal size document.
- When using Ledger or A3 size paper, 1side→2side and 2side→2side of Duplex Copy is not available with **Enlarge/Reduce**.

Making N in 1 copies or a poster (Page Layout)

The N in 1 copy feature can help you save paper by letting you copy two or four pages onto one printed page.

The 1 to 2 feature copies one Ledger or A3 size page onto two Letter or A4 size pages. If you use this setting, use the scanner glass.

You can also produce a poster. When you use the poster feature your machine divides your document into sections, then enlarges the sections so you can assemble them into a poster. If you want to print a poster, you must use the scanner glass and Tray #1.

! IMPORTANT

- Make sure the paper size is set to Letter, Ledger, A4, A3 or Executive.
- If you are producing multiple color copies, N in 1 copy is not available.
- (P) means Portrait and (L) means Landscape.
- You can only make one poster copy and 1 to 2 copy at a time.
- Poster copy is not available when using transparencies or Executive size paper.
- Poster copy is not available when you feed paper from Tray #2.

Note

- Watermark Copy, Book Copy, Sort, Thin Paper Copy, Ink Save Mode and Enlarge/Reduce are not available with Page Layout.
- Skew Adjustment is not available with Poster and 1 to 2 copy.
- Duplex Copy is not available with Poster copy.
- 2side→2side and 2side→1side of Duplex Copy are not available with 1 to 2.

- 1 Press  (COPY).
- 2 Load your document.
- 3 Enter the number of copies you want.
- 4 Press ◀ or ▶ to display Page Layout.
- 5 Press Page Layout.
- 6 Press ◀ or ▶ to display Off (1in1), 2in1 (P), 2in1 (L), 4in1 (P), 4in1 (L), 1 to 2, Poster (2 x 1), Poster (2 x 2), Poster (3 x 3) or 2 in 1 (ID)¹.

¹ For details about 2 in 1 (ID), see *2 in 1 ID Copy* on page 46.

If you chose 2in1 or Poster (2 x 2) with Ledger or A3, go to step 7 to choose the paper size of your document.

If you choose another setting, go to step 8.
- 7 Do one of the following:
 - If you chose 2in1 (P) or 2in1 (L), press LGRx2 → LGRx1, LTRx2 → LGRx1, A3x2 → A3x1 or A4x2 → A3x1.
 - If you chose Poster (2 x 2), press LGRx1 → LGRx4, LTRx1 → LGRx4, A3x1 → A3x4 or A4x1 → A3x4.

- 8 If you do not want to change additional settings, press **Black Start** or **Color Start** to scan the page. If you placed the document in the ADF or are making a poster, the machine scans the pages and starts printing.

If you are using the scanner glass, go to step 9.

- 9 After the machine scans the page, press **Yes** to scan the next page.
- 10 Place the next page on the scanner glass. Press **Black Start** or **Color Start** to scan the document. Repeat steps 9 and 10 for each page of the layout.
- 11 After all the pages have been scanned, press **No** to finish.



Note

If you have chosen photo paper as the Paper Type for N in 1 copies, the machine will print the images as if plain paper had been chosen.

If you are copying from the ADF, insert the document face up in the direction shown below:

■ 2in1 (P)



■ 2in1 (L)



■ 4in1 (P)

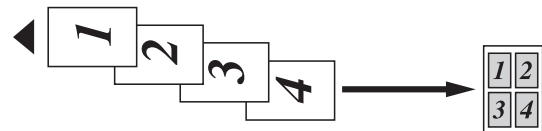

■ 4in1 (L)

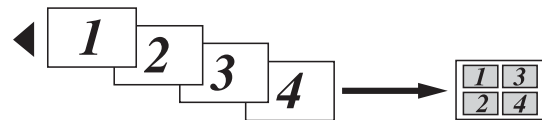

If you are copying from the scanner glass, place the document face down in the direction shown below:

■ 2in1 (P)



■ 2in1 (L)

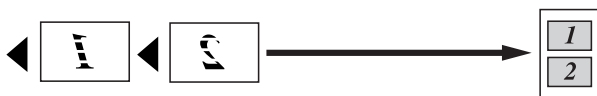

■ 4in1 (P)



■ 4in1 (L)



■ 1 to 2



■ Poster (2 x 1)

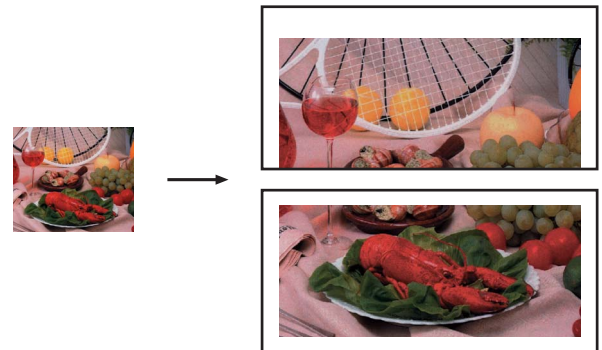

■ Poster (2 x 2)

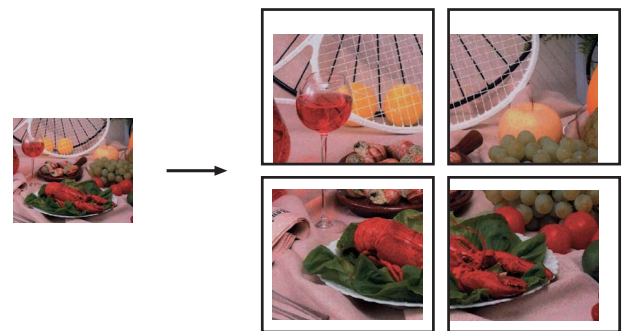

■ Poster (3 x 3)

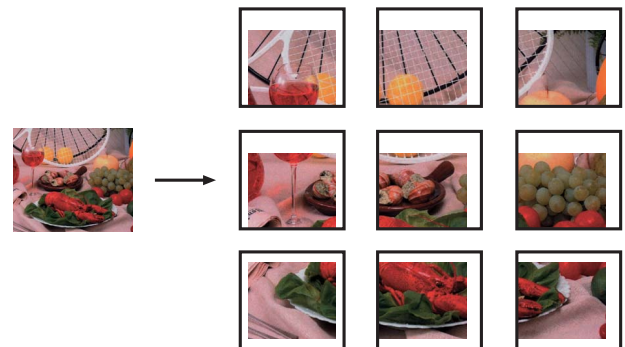

2 in 1 ID Copy

You can copy both sides of your identification card onto one page, keeping the original card size. Make sure the paper size is set to Letter or A4.

Note

You can copy an identification card to the extent permitted under applicable laws. See *Legal limitations for copying* in the *Safety and Legal Booklet*.

- 1 Press  (**COPY**).
- 2 Place your identification card face down at the left corner of the scanner glass.

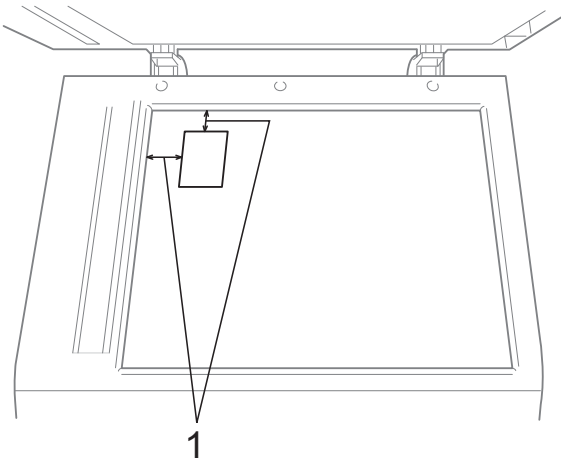

1 0.12 in. (3 mm) or greater (top, left)

- 3 Enter the number of copies you want.
- 4 Press ◀ or ▶ to display *Page Layout*.
- 5 Press *Page Layout*.
- 6 Press ◀ or ▶ to display *2 in 1 (ID)*.
- 7 Press *2 in 1 (ID)*.
- 8 Press **Black Start** or **Color Start**.
The machine starts scanning the first page.

- 9 After the machine copies the one side, press *Yes*. Turn over the identification card and press **Black Start** or **Color Start** to scan the another side.

Note

- *Watermark Copy, Book Copy, Sort, Duplex Copy, Thin Paper Copy, Ink Save Mode* and *Enlarge/Reduce* are not available with *2 in 1 (ID)*.
- If you are producing multiple color copies, *2 in 1 (ID)* copy is not available.

Sorting copies using the ADF

You can sort multiple copies. Pages will be stacked in the order 321, 321, 321, and so on.

- 1 Press  (**COPY**).
- 2 Load your document.
- 3 Enter the number of copies you want.
- 4 Press ◀ or ▶ to display *Stack/Sort*.
- 5 Press *Stack/Sort*.
- 6 Press *Sort*.
- 7 If you do not want to change additional settings, press **Black Start** or **Color Start**.

Note

Fit to Page, Page Layout and *Book Copy* are not available with *Sort*.

Adjusting Density

You can adjust the copy density to make copies darker or lighter.

- 1 Press  (**COPY**).
- 2 Load your document.
- 3 Enter the number of copies you want.
- 4 Press ◀ or ▶ to display *Density*.
- 5 Press *Density*.
- 6 Press ▶ to make the copy darker or press ◀ to make the copy lighter. Press **OK**.
- 7 If you do not want to change additional settings, press **Black Start** or **Color Start**.

Ink Save Mode

Ink Save Mode can help you save some ink. Your machine detects the edges of the image and prints the outline of the image.

The amount of ink saved will vary depending on the document.

Ink Save Mode: Off

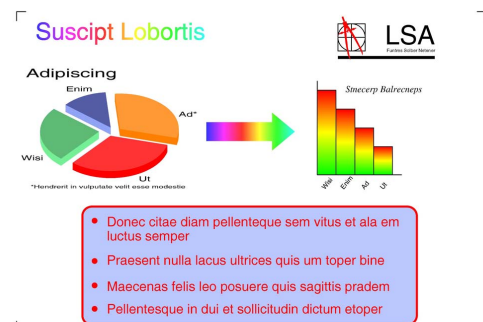

Ink Save Mode: On

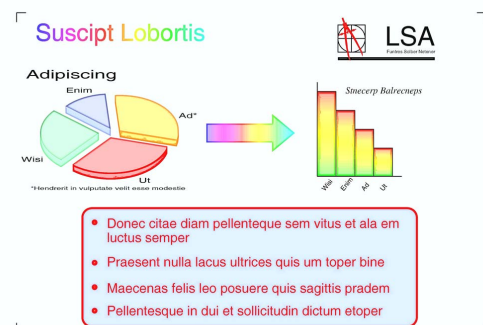

- 1 Press  (**COPY**).
- 2 Load your document.
- 3 Enter the number of copies you want.
- 4 Press ◀ or ▶ to display *Advanced Settings*.
- 5 Press *Advanced Settings*.
- 6 Press *Ink Save Mode*.

- 7 If you do not want to change any additional settings, press **Black Start** or **Color Start**.

Note

- Watermark Copy, Book Copy, Skew Adjustment, Thin Paper Copy and Page Layout are not available with Ink Save Mode.
- Ink Save Mode may make your printouts look different from your original document.

Thin Paper Copy

If your document is a duplex copy on thin paper, choose **Thin Paper Copy** so the print on the other side does not bleed through.

- 1 Press  (**COPY**).
- 2 Load your document.
- 3 Enter the number of copies you want.
- 4 Press ◀ or ▶ to display Advanced Settings.
- 5 Press Advanced Settings.
- 6 Press Thin Paper Copy.
- 7 Press **Black Start** or **Color Start**.

Note

Fit to Page, Page Layout, Skew Adjustment, Ink Save Mode, Book Copy and Watermark Copy are not available with Thin Paper Copy.

Skew Adjustment

If your scanned copy is skewed, your machine can correct the data automatically. This setting is only available when using the scanner glass.

- 1 Press  (**COPY**).
- 2 Load your document.
- 3 Enter the number of copies you want.
- 4 Press ◀ or ▶ to display Skew Adjustment.
- 5 Press Skew Adjustment.
- 6 Press Auto (or Off).
- 7 If you do not want to change additional settings, press **Black Start** or **Color Start**.

Note

- 1 to 2, Poster, Ink Save Mode, Thin Paper Copy, Book Copy, Watermark Copy, 2side→2side and 2side→1side of Duplex Copy are not available with Skew Adjustment.
- You cannot use this setting with Ledger, A3 or paper that is smaller than 2.52 in. × 3.58 in. (64 mm × 91 mm).
- This setting is only available for paper that is rectangular or square.
- You cannot use this setting with a thick document, such as a book.
- Skew Adjustment is only available if the document is skewed by less than 3 degrees.

Book Copy

Book copy corrects dark borders and skew when copying from the scanner glass. Your machine can correct the data automatically or you can make specific corrections.

- 1 Press  (**COPY**).
- 2 Load your document.
- 3 Enter the number of copies you want.
- 4 Press ◀ or ▶ to display Advanced Settings.
- 5 Press Advanced Settings.
- 6 Press Book Copy.
- 7 If you are finished making corrections, press **Black Start** or **Color Start**.



Note

Page Layout, Sort, Duplex Copy, Skew Adjustment, Ink Save Mode, Fit to Page, Thin Paper Copy and Watermark Copy are not available with Book Copy.

Watermark Copy

You can place a logo or text into your document as a Watermark. You can select one of the template watermarks, data from your media cards or USB Flash memory drive, or scanned data.



Note

Fit to Page, Page Layout, Thin Paper Copy, Skew Adjustment, Ink Save Mode and Book Copy are not available with Watermark Copy.

Using a template

- 1 Press  (**COPY**).
- 2 Load your document.
- 3 Enter the number of copies you want.
- 4 Press ◀ or ▶ to display Advanced Settings.
- 5 Press Advanced Settings.
- 6 Press Watermark Copy.
- 7 Press Edit Template.
- 8 Change the settings from the options displayed on the LCD if required.
- 9 Press OK to confirm to use watermark.
- 10 If you do not want to change additional settings, press **Black Start** or **Color Start**.

Using a media card or USB Flash memory drive

- 1 Press  (**COPY**).
- 2 Load your document.
- 3 Enter the number of copies you want.
- 4 Press ◀ or ▶ to display Advanced Settings.
- 5 Press Advanced Settings.
- 6 Press Watermark Copy.
- 7 Press Use Image.
- 8 Insert a media card or USB Flash memory drive. Press Media.
- 9 Press the data you want to use for the watermark.

- 10 Change any additional settings from the options shown on the LCD.
- 11 Press **OK** to confirm to use watermark.
- 12 If you do not want to change additional settings, press **Black Start** or **Color Start**.

! IMPORTANT

DO NOT take out the memory card or USB Flash memory drive while **PHOTO CAPTURE** is blinking to avoid damaging the card, USB Flash memory drive, or the data stored on them.

Using a scanned paper document as your watermark

- 1 Press  (**COPY**).
- 2 Enter the number of copies you want.
- 3 Press **◀** or **▶** to display Advanced Settings.
- 4 Press **Advanced Settings**.
- 5 Press **Watermark Copy**.
- 6 Press **Use Image**.
- 7 Press **Scan**. Place the page that you want to use as a watermark on the scanner glass.
- 8 Press **Black Start** or **Color Start**.
- 9 Take out the watermark document you scanned and load the document you want to copy.
- 10 Press **Transparency**, and then press **◀** or **▶** to change the Transparency of the watermark. Press **OK**.
- 11 Press **OK**.

- 12 Press **OK** to confirm to use watermark.
- 13 If you do not want to change any additional settings, press **Black Start** or **Color Start**.



Note

You cannot enlarge or reduce the scanned watermark.

Duplex (2-sided) copying

You can reduce the amount of paper used for copies by copying on both sides of the paper.

We recommend you load your document in the ADF for duplex copying.



Note

- You can copy 2-sided documents up to Legal size using the ADF.
- You can only use plain paper sizes Letter, Legal, Ledger, A4, A5, A3 or Executive

- 1 Press **Duplex** on the machine's panel.
- 2 Load your document.
If you want to copy a 2-sided document, load your document in the ADF.
- 3 Press **Copy**.
- 4 Do one of the following:
 - If you are copying Ledger or A3 size document, go to step 5.
 - If you are copying Letter, Legal, A4, A5 or Executive size document, go to step 8.
- 5 Press **More**.
- 6 Press **A3/LGR Duplex Copy Setting**.



Note

N in 1 copy is not available with A3/LGR Duplex Copy Setting.

- 7 Press **Fit to Page** or **Keep Scale**.



Note

If you choose **Fit to Page**, your machine will reduce the document size automatically to fit the printable area.
If you choose **Keep Scale**, your machine will not change the document size. The top and bottom might be cut off depending on the document size.

- 8 Press ◀ or ▶ to display the duplex copy type you want, and press it. (See *Duplex copying type* on page 52.)

- 9 Enter the number of copies you want.



Note

If you want to sort multiple copies, press ◀ or ▶ to display **Stack/Sort**, then press **Sort**.

- 10 Press **Black Start** or **Color Start**.
If you placed the document in the ADF, the machine scans the pages and starts printing.
If you are using the scanner glass, go to step 11.

- 11 Press **Scan** and place the next page on the scanner glass. Press **Black Start** or **Color Start**.
The machine starts printing.

- 12 If you pressed **Sort** for multiple copies, repeat step 11 for each additional page. After all the pages have been scanned, press **Complete**.
The machine starts printing.

DO NOT touch the printed page until it is ejected the second time. The machine will print the first side and eject the paper and then pull the paper in to print the second side.



Note

- If you get a paper jam, press **More** after step 3. Press **Advanced**, and then press one of the jam prevention settings: **DX1** or **DX2**.
DX1 uses a longer print time for the ink to dry.
DX2 uses a longer print time and will also print in lighter colors.
- DX1 is not available for Ledger or A3 size paper.
- 2 in 1 (ID), Poster and Book Copy are not available with Duplex Copy.
- 1 to 2 and Skew Adjustment are not available with 2side→2side and 2side→1side.
- When using Ledger or A3 size paper, Enlarge/Reduce is not available with 1side→2side and 2side→2side.
- Fit to Page is not available with 1side→2side and 2side→2side.

Duplex copying type

■ 1 sided → 2 sided (long edge flip)

Portrait

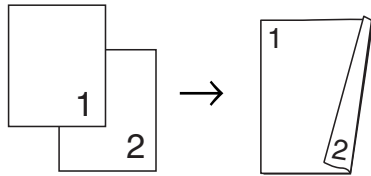

Landscape

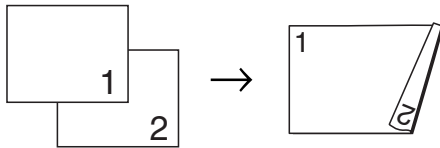

(short edge flip)

Portrait

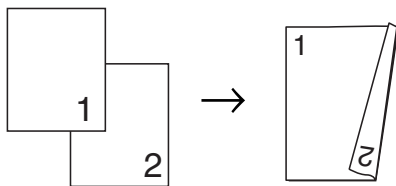

Landscape

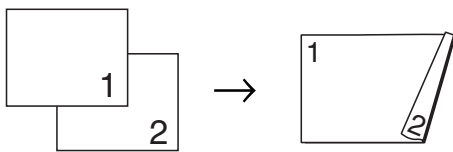

■ 2 sided → 2 sided

Portrait

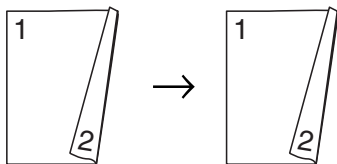

Landscape

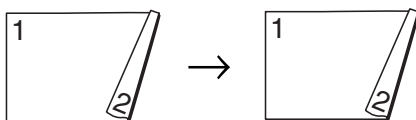

■ 2 sided → 1 sided (long edge flip)

Portrait

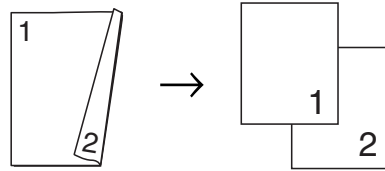

Landscape

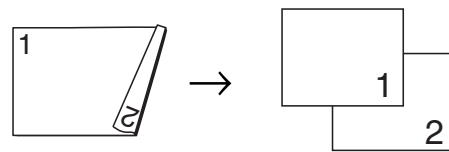

(short edge flip)

Portrait

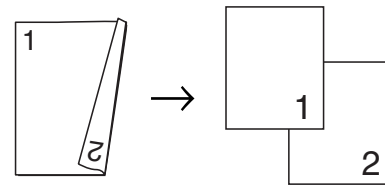

Landscape

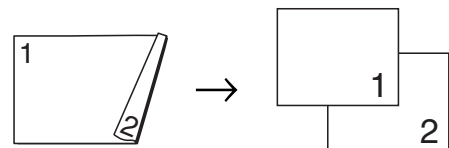

Setting your favorites

You can store the copy settings that you use most often by setting them as a favorite. You can set up to three favorites.

- 1 Press  (**COPY**).
- 2 Choose the copy option and settings you want to store.
- 3 Press ◀ or ▶ to display Favorite Settings.
- 4 Press Favorite Settings.
- 5 Press Store.



Note

Set Watermark Copy to Off or Template when storing Favorite Settings.

- 6 Press the location where you want to store your setting for Favorite:1, Favorite:2 or Favorite:3.
- 7 Do one of the following:
 - If you want to rename your setting, press  to delete characters. Then enter the new name (up to 12 characters).
Press OK. (See *Entering Text* in appendix C of the *Basic User's Guide*.)
 - If you do not want to rename your setting, press OK.

Retrieving your favorite setting

When you are ready to use one of your favorite set of settings, you can recall it.

- 1 Press  (**COPY**).
- 2 Press ◀ or ▶ to display Favorite.
- 3 Press Favorite.
- 4 Press the favorite setting you want to retrieve.

Rename your favorite setting

After you stored your favorite setting, you can rename it.

- 1 Press  (**COPY**).
- 2 Press ◀ or ▶ to display Favorite Settings.
- 3 Press Favorite Settings.
- 4 Press Rename.
- 5 Press the favorite setting you want to rename.
- 6 Enter the new name (up to 12 characters). (See *Entering Text* in appendix C of the *Basic User's Guide*.)
- 7 Press OK.

PhotoCapture Center™: Printing photos from a memory card or USB Flash memory drive

PhotoCapture Center™ operations

Memory cards, USB Flash memory drive and folder structures

Your machine is designed to be compatible with modern digital camera image files, memory cards and USB Flash memory drives; however, please read the points below to avoid errors:

- The image file extension must be .JPG (other image file extensions like .JPEG, .TIF, .GIF and so on will not be recognized).
- Direct PhotoCapture Center™ printing must be performed separately from PhotoCapture Center™ operations using the PC. (Simultaneous operation is not available.)
- The machine can read up to 999 files on a memory card or USB Flash memory drive.
- The DPOF file on the memory cards must be in a valid DPOF format. (See *DPOF printing* on page 58.)

Please be aware of the following:

- When printing an index or image, the PhotoCapture Center™ will print all valid images, even if one or more images have been corrupted. Corrupted images will not be printed.

■ (memory card users)

Your machine is designed to read memory cards that have been formatted by a digital camera.

When a digital camera formats a memory card it creates a special folder into which it copies image data. If you need to modify the image data stored on a memory card with your PC, we recommend that you do not modify the folder structure created by the digital camera. When saving new or modified image files to the memory card, we also recommend you use the same folder your digital camera uses. If the data is not saved to the same folder, the machine may not be able to read the file or print the image.

■ (USB Flash memory drive users)

This machine supports USB Flash memory drives that have been formatted by Windows®.

Movie printing

You can print images from movie files that are stored on a memory card or USB Flash memory drive.

A movie file is automatically divided into 9 parts by movie recording times and is placed in 3 lines, then you can see and print the scenes that have been automatically divided.

Note

- You cannot choose a particular movie scene.
- You can use AVI or MOV movie file formats (Motion JPEG only). However, if an AVI file size is 1 GB or more (the shooting time is about 30 minutes) or a MOV file size is 2 GB or more (the shooting time is about 60 minutes), these files cannot be printed.

Print Images

Print Index (Thumbnails)

The PhotoCapture Center™ assigns numbers for images (such as No.1, No.2, No.3, and so on).



→ NO.1
DEL.JPG 01.01.2009
100KB

The PhotoCapture Center™ does not recognize any other numbers or file names that your digital camera or computer has used to identify the pictures. You can print a thumbnail page. This will show all the pictures on the memory card or USB Flash memory drive.

Note

Only file names that are 8 characters or less will be printed correctly on the index sheet.

- 1 Make sure you have put the memory card or USB Flash memory drive in the proper slot.
Press  (**PHOTO CAPTURE**).
- 2 Press **Index Print**.
- 3 Press **Index Sheet** and choose **6 Images/Line** or **5 Images/Line**.

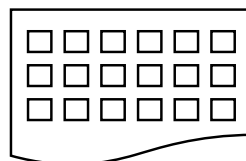

6 Images/Line

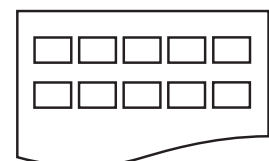

5 Images/Line

Print time for 5 Images/Line will be slower than 6 Images/Line, but the quality is better.

- 4 Do one of the following:
 - Press **Print Setting** to change the paper type or the paper size you are using.
 - If you do not want to change the paper settings, go to 7.
- 5 Press **Paper Type**. Choose the paper type you are using, Plain Paper, Inkjet Paper, Brother BP71, Brother BP61 or Other Glossy.
- 6 Press **Paper Size**. Choose the paper size you are using, Letter or A4.
- 7 Press **Color Start** to print.

Printing Photos

Before you can print an individual image, you have to know the image number.

- 1 Make sure you have put the memory card or USB Flash memory drive in the proper slot.
Press  (**PHOTO CAPTURE**).
- 2 Print the Index. (See *Print Index (Thumbnails)* on page 55.)
- 3 Press **Index Print**.
- 4 Press **Print Photos**.
- 5 Enter the image number that you want to print from the Index page (Thumbnails). After you have chosen the image numbers, press **OK**.



Note

- You can enter multiple numbers at one time by using a comma or a hyphen. For example, Enter 1,3,6 to print images No.1, No.3 and No.6. Enter 1-5 to print images No.1 to No.5.
- You can enter up to 12 characters (including commas) for the image numbers you want to print.

- 6 Enter the number of copies you want either by pressing the number box directly and entering the number you want or by pressing **+** or **-**.
- 7 Do one of the following:
 - Press **Print Setting** to change the print settings. (See page 59.)
 - If you do not want to change any settings, press **Color Start** to print.

Enhance Photos

You can edit and add effects to your photos and view them on the LCD before printing.



Note

The **Enhance Photo** feature is supported by technology from Reallusion,

Inc.  **REALLUSION**

- 1 Make sure you have put a memory card or USB Flash memory drive in the proper slot.
Press  (**PHOTO CAPTURE**).

- 2 Press **Enhance Photo**.



Note

- Four thumbnails are displayed at a time with the current page number and total number of pages listed under the thumbnails.
- Press **◀** or **▶** repeatedly to scroll through all photos. Hold down **◀** or **▶** to fast-forward and fast-rewind through the thumbnail pages.
- Press  to start Slide Show.

- 3 Press a photo from the thumbnails.
- 4 Press **Enhance** or **Trim**. You can also choose both together.
Press **OK**.

- 5** Do one of the following:
- If you chose **Enhance**, go to step **6**.
 - If you chose **Trim**, go to step **7**.
- 6** Press the effect you wish to add.
Press **OK**.
Go to step **8**.



Note

- You have 10 ways to add effects to your photo.

	(Auto Correct) The machine decides the suitable effect for your photo.
	(Enhance Skin) Best used for adjusting portrait photographs. It adjusts human skin color. Press ◀ or ▶ to adjust the level of contrast.
	(Enhance Scenery) Best used for adjusting landscape photographs. It highlights green and blue areas in your photo. Press ◀ or ▶ to adjust the level of contrast.
	(Remove Red-Eye) The machine will attempt to remove red-eye from your photo. If red-eye detection fails, you can press the Try Again button to re-detect.
	(Night Scene) Night Scene is best used for adjusting night view photographs to make them more vivid.
	(Fill Light) Fill Light is best used for adjusting photographs against the light.
	(Whiteboard) Whiteboard is best used for adjusting photographs. It detects letters on a whiteboard in your photo and makes them more legible.
	(Monochrome) You can convert your photo to black & white.

	(Sepia) You can convert the color of your photo to sepia.
	(Auto Correct & Remove Red-Eye) The machine decides the suitable effects for your photo. Also, it will attempt to remove red-eye from your photo.

- There are some cases when red-eye may not be removed.
 - When the face is too small in the image.
 - When the face is turning too far up, down, left or right.
- After adding each effect, you can enlarge the view of the image by pressing . To go back to the original size, press .
- While the image is enlarged, you can move around the image with **up** (), **down** () , **left** () and **right** ().
- Press **Cancel** to return to the list of effects.

- 7** Adjust the red frame around your photo. The part inside of the red frame will be printed.
- Press **+** or **-** to enlarge or reduce the frame size.
 - Press **▲**, **▼**, **◀** or **▶** to move the position of the frame.
 - Press to rotate the frame.
- Press **OK** when you have finished adjusting the frame setting.
Press **OK** to confirm.



Note

If your photo is very small or has irregular proportions you may not be able to trim the photo. The LCD will display **Image Too Small.** or **Image Too Long.**

- 8 Enter the number of copies you want either by pressing the number box directly and entering the number you want or by pressing + or -. Press **OK**.
- 9 Do one of the following.
 - Press **Print Setting** and change the print settings. (See page 59.)
 - If you do not want to change any settings, press **Color Start** to print.

DPOF printing

DPOF stands for Digital Print Order Format.

Major digital camera manufacturers (Canon Inc., Eastman Kodak Company, FUJIFILM Corporation, Panasonic Corporation and Sony Corporation) created this standard to make it easier to print images from a digital camera.

If your digital camera supports DPOF printing, you will be able to choose on the digital camera display the images and number of copies you want to print.

When a memory card (Memory Stick™, Memory Stick PRO™, Memory Stick Duo™, Memory Stick PRO Duo™ SD or SDHC) containing DPOF information is put into your machine, you can print the chosen image easily.

- 1 Make sure you have put the memory card in the proper slot.
Press  (**PHOTO CAPTURE**). The machine will ask you if you want to use DPOF settings.
- 2 Press **Yes**.
- 3 Do one of the following:
 - Press **Print Setting** to change the print settings. (See page 59.)
 - If you do not want to change any settings, press **Color Start** to print.



Note

An Invalid DPOF File error can occur if the print order that was created on the camera has been corrupted. Delete and recreate the print order using your camera to correct this problem. For instructions on how to delete or recreate the print order, refer to your camera manufacturer's support Web site or accompanying documentation.

PhotoCapture Center™ print settings

You can change the print settings for the next printing.

These settings are temporary, and the machine returns to its default settings 3 minutes after printing, unless you have set the Mode Timer to 2 minutes or less. (See *Mode Timer* on page 5.)



Note

You can save the print settings you use most often by setting them as the default. (See *Setting your changes as the new default* on page 62.)

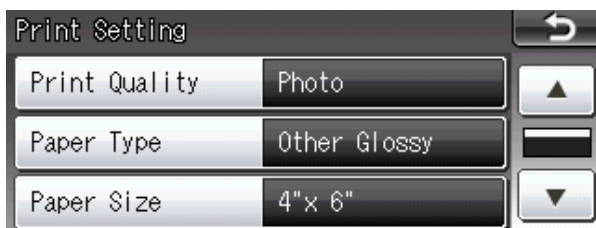

Print Quality

- 1 Press Print Setting.
- 2 Press ▲ or ▼ to display Print Quality.
- 3 Press Print Quality.
- 4 Press Normal or Photo.
- 5 If you do not want to change additional settings, press . Press **Color Start** to print.

Paper options



Paper Type

- 1 Press Print Setting.
- 2 Press ▲ or ▼ to display Paper Type.
- 3 Press Paper Type.
- 4 Press the paper type you are using, Plain Paper, Inkjet Paper, Brother BP71, Brother BP61 or Other Glossy.
- 5 If you do not want to change additional settings, press . Press **Color Start** to print.

Paper and print size

- 1 Press Print Setting.
- 2 Press ▲ or ▼ to display Paper Size.
- 3 Press Paper Size.
- 4 Press the paper size you are using, 4"x 6", 5"x 7", Letter, Ledger, A4 or A3.
Do one of the following:
 - If you chose Letter or A4, go to step 5.
 - If you chose another size of paper, go to step 6.

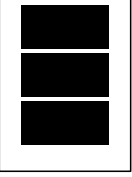
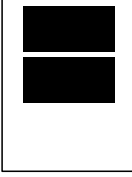
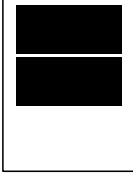
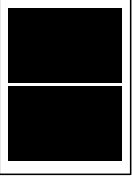
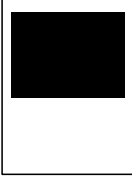
5 Press the Print Size.

Example: Printed position for Letter paper		
1 3"x 4"	2 3.5"x 5"	3 4"x 6"
		
4 5"x 7"	5 6"x 8"	6 Max. Size
		

- 6 If you do not want to change additional settings, press . Press **Color Start** to print.

Adjusting Brightness, Contrast and Color

Brightness

- 1 Press **Print Setting**.
- 2 Press **▲** or **▼** to display **Brightness**.
- 3 Press **Brightness**.
- 4 Press **◀** to make a darker print or press **▶** to make a lighter print. Press **OK**.
- 5 If you do not want to change additional settings, press . Press **Color Start** to print.

Contrast

You can choose the contrast setting. Increasing the contrast will make an image look sharper and more vivid.

- 1 Press **Print Setting**.
- 2 Press **▲** or **▼** to display **Contrast**.
- 3 Press **Contrast**.
- 4 Press **▶** to increase the contrast or press **◀** to decrease the contrast. Press **OK**.
- 5 If you do not want to change additional settings, press . Press **Color Start** to print.

Color Enhancement (True2Life™)

You can turn on the color enhancement (True2Life™) feature to print more vivid images. Printing time will be slower.

- 1 Press **Print Setting**.
- 2 Press **▲** or **▼** to display **True2Life**.
- 3 Press **True2Life**.
- 4 Do one of the following:
 - If you want to customize the **White Balance**, **Sharpness** or **Color Density**, press **On**, and then go to step 5.
 - If you do not want to customize, press **Off**. Go to step 8.
- 5 Press **White Balance**, **Sharpness** or **Color Density**.
- 6 Press **◀** or **▶** to adjust the degree of the setting. Press **OK**.

- 7** Do one of the following:
- If you want to customize another color enhancement, repeat steps **5** to **6**.
 - If you want to change other settings, press  to display the print setting menu and press the setting you want to change. (See page 59.)

- 8** If you do not want to change additional settings, press . Press **Color Start** to print.



Note

- **White Balance**

This setting adjusts the hue of the white areas of an image. Lighting, camera settings and other influences will affect the appearance of white. The white areas of a picture may be slightly pink, yellow or some other color. By using this setting, you can correct that effect and bring the white areas back to pure white.

- **Sharpness**

This setting enhances the detail of an image, similar to adjusting the fine focus on a camera. If the image is not in true focus and you cannot see the fine details of the picture, then adjust the sharpness.

- **Color Density**

This setting adjusts the total amount of color in the image. You can increase or decrease the amount of color in an image to improve a washed out or weak picture.

Cropping

If your photo is too long or wide to fit the available space on your chosen layout, part of the image will automatically be cropped.

The factory setting is **On**. If you want to print the whole image, turn this setting to **Off**. When you set **Cropping** to **Off**, also set **Borderless** to **Off**. (See *Borderless printing* on page 62.)

- 1** Press **Print Setting**.
- 2** Press **▲** or **▼** to display **Cropping**.
- 3** Press **Cropping**.
- 4** Press **Off** (or **On**).
- 5** If you do not want to change additional settings, press . Press **Color Start** to print.

Cropping: On

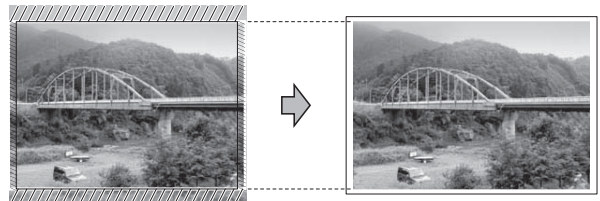

Cropping: Off

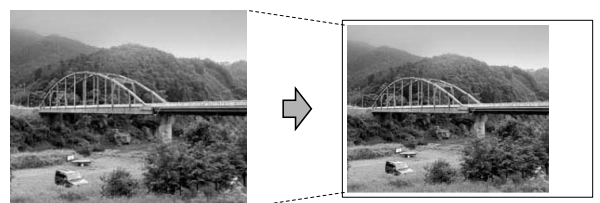

Borderless printing

This feature expands the printable area to the edges of the paper. Printing time will be slightly slower.

- 1 Press **Print Setting**.
- 2 Press **▲** or **▼** to display **Borderless**.
- 3 Press **Borderless**.
- 4 Press **Off** (or **On**).
- 5 If you do not want to change additional settings, press . Press **Color Start** to print.

Print Date

You can print the date if it is already in the data on your photo. The date will be printed on the lower right corner. If the data doesn't have the date information, you cannot use this function.

- 1 Press **Print Setting**.
- 2 Press **▲** or **▼** to display **Print Date**.
- 3 Press **Print Date**.
- 4 Press **On** (or **Off**).
- 5 If you do not want to change additional settings, press . Press **Color Start** to print.



Note

The DPOF setting on your camera must be turned off to use the **Print Date** feature.

Setting your changes as the new default

You can save the print settings you use most often by setting them as the default settings. These settings will stay until you change them again.

- 1 Press your new setting. Repeat this step for each setting you want to change.
- 2 After changing the last setting, press **▲** or **▼** to choose **Set New Default**.
- 3 Press **Set New Default**.
- 4 Press **Yes** to confirm.
- 5 Press **Stop/Exit**.

Restoring all settings to the factory settings

You can restore the PhotoCapture settings

Print Quality, Paper Type, Paper Size, Brightness, Contrast, True2Life, Cropping, Borderless and Print Date, that you have changed, to the factory settings.

- 1 Press **Print Setting**.
- 2 Press **▲** or **▼** to display **Factory Reset**.
- 3 Press **Factory Reset**.
- 4 Press **Yes** to confirm.
- 5 Press **Stop/Exit**.

Scan to a memory card or USB Flash memory drive

Glass Scan Size

To scan a Legal, Ledger, A3 or A4 size document, you need to change the **Glass Scan Size** setting. The default setting is Letter.

- 1 Press  (**SCAN**).
- 2 Press to Media.
- 3 Press ◀ or ▶ to display Glass Scan Size.
- 4 Press Glass Scan Size.
- 5 Press Letter, Legal, Ledger, A3 or A4.

Note

- You can save the setting you use most often by setting it as the default. (See *Setting your changes as the new default* on page 62.)
- This setting is only available for scanning documents from the scanner glass.

Auto Crop

You can scan multiple documents placed on the scanner glass. An individual document can be previewed on the LCD before you save it. When you choose **Auto Crop**, the machine will scan each document and create separate files. For example, if you place three documents on the scanner glass, the machine will scan and create three separate files. If you want to create a three-page file, choose **PDF** or **TIFF** for **File Type**.

(If you choose **JPEG**, each document is created as three separate files.)

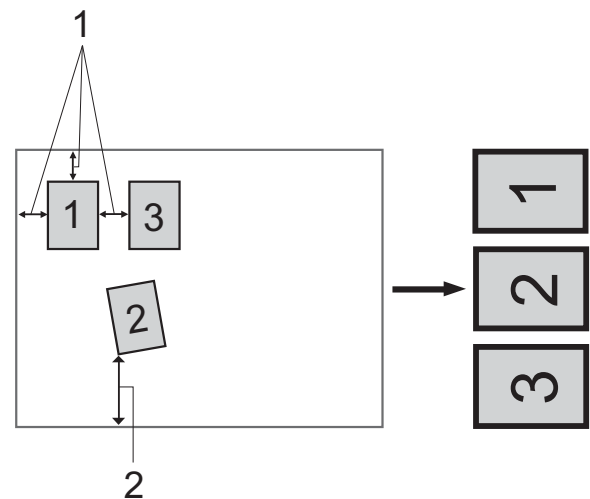

- 1 0.4 in. (10 mm) or greater (top, left, right)
- 2 0.8 in. (20 mm) or greater (bottom)

Note

- Auto Crop works properly for all Glass Scan Size settings.
- Auto Crop is supported by technology from Reallusion, Inc.



- 1 Make sure you have put the memory card or USB Flash memory drive in the proper slot.
- 2 Load your document.
- 3 Press  (**SCAN**).

- 4 Press to Media.
- 5 Press ◀ or ▶ to display Auto Crop.
- 6 Press Auto Crop.
- 7 Press On.
- 8 If you do not want to change additional settings, press **Black Start** or **Color Start** to start scanning.
- 9 The number of the scanned documents appears on the LCD.
Press OK.
- 10 Press ◀ or ▶ to preview each document data.
- 11 Press Save All to save the data.



Note

- Auto Crop is available for paper with right angles of 90 degrees at all four corners. If one of the angles is not square, Auto Crop cannot detect the document.
- If your document is too long or wide, this setting does not work properly.
- You must place the documents away from the edges of the scanner glass as shown in the illustration.
- You must place the documents at least 0.4 in. (10 mm) apart from each other.
- Auto Crop adjusts the skew of the document on the scanner glass, but if your document is skewed more than 10 degrees, this setting will not work.
- The ADF must be empty to use the Auto Crop.
- The Auto Crop feature is available for up to a maximum of 16 documents depending on the size of your documents.

! IMPORTANT

DO NOT take out the memory card or USB Flash memory drive while **PHOTO CAPTURE** is blinking to avoid damaging the card, USB Flash memory drive or the data stored on them.

How to set a new default

You can save the Scan to Media settings (Quality, File Type, Glass Scan Size and Auto Crop) you use most often by setting them as the default settings. These settings will stay until you change them again.

- 1 Press  (**SCAN**).
- 2 Press to Media.
- 3 Press ◀ or ▶ to display Set New Default.
- 4 Press Set New Default.
- 5 Press Yes to confirm.
- 6 Press **Stop/Exit**.

How to reset to the factory settings

You can restore all the Scan to Media settings (Quality, File Type, Glass Scan Size and Auto Crop), that you have changed, to the factory settings.

- 1 Press  (**SCAN**).
- 2 Press to Media.
- 3 Press ◀ or ▶ to choose Factory Reset.
- 4 Press Factory Reset.
- 5 Press Yes to confirm.
- 6 Press **Stop/Exit**.

Printing photos directly from a PictBridge camera



Your Brother machine supports the PictBridge standard, allowing you to connect to and print photos directly from any PictBridge compatible digital camera.

If your camera is using the USB Mass Storage standard, you can also print photos from a digital camera without PictBridge. (See *Printing photos directly from a digital camera (without PictBridge)* on page 69.)

PictBridge requirements

To avoid errors, remember the following points:

- The machine and the digital camera must be connected using a suitable USB cable.
- The image file extension must be .JPG (other image file extensions like .JPEG, .TIF, .GIF and so on will not be recognized).
- PhotoCapture Center™ operations are not available when using the PictBridge feature.

Setting your digital camera

Make sure your camera is in PictBridge mode. The following PictBridge settings may be available from the LCD of your PictBridge compatible camera.

Depending on your camera some of these settings may not be available.

Camera Menu Selections	Options
Paper Size	Ledger, Letter, A3, A4, 4" × 6", Printer Settings (Default setting) ²
Paper Type	Plain Paper, Glossy Paper, Inkjet Paper, Printer Settings (Default setting) ²
Layout	Borderless: On, Borderless: Off, Printer Settings (Default setting) ²
DPOF setting ¹	-
Print Quality	Normal, Fine, Printer Settings (Default setting) ²
Color Enhancement	On, Off, Printer Settings (Default setting) ²
Print Date	On, Off, Printer Settings (Default setting) ²

¹ See *DPOF printing* on page 68 for more details.

² If your camera is set to use the Printer Settings (Default setting), the machine will print your photo using the following settings.

Settings	Options
Paper Size	4" × 6"
Paper Type	Glossy Paper
Layout	Borderless: On
Print Quality	Fine
Color Enhancement	Off
Print Date	Off

- When your camera does not have any menu selections, these settings are also used.
- The name and availability of each setting depends on the specification of your camera.

Please refer to the documentation supplied with your camera for more detailed information on changing PictBridge settings.

Printing Images



Note

Remove any memory cards or USB Flash memory drive from the machine before connecting a digital camera.

- 1 Make sure that your camera is turned off. Connect your camera to the USB direct interface (1) on the machine using the USB cable.

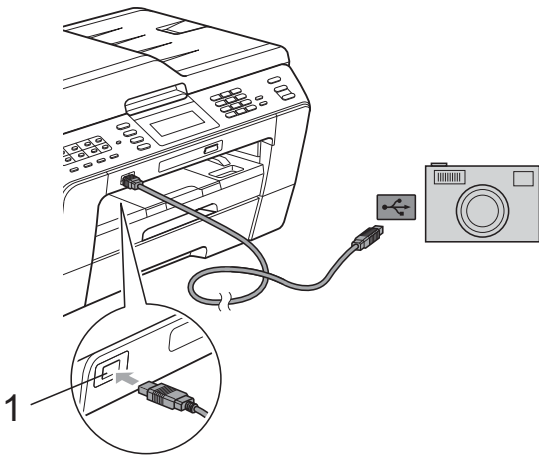

1 USB direct interface

- 2 Turn on the camera. When the machine has recognized the camera, the LCD shows *Camera Connected*.
- 3 Choose the photo you want to print following the instructions from your camera. When the machine starts printing a photo, the LCD will show *Printing*.

! IMPORTANT

To prevent damage to your machine, do not connect any device other than a digital camera or USB Flash memory drive to the USB direct interface.

DPOF printing

DPOF stands for Digital Print Order Format.

Major digital camera manufacturers (Canon Inc., Eastman Kodak Company, FUJIFILM Corporation, Panasonic Corporation and Sony Corporation) created this standard to make it easier to print images from a digital camera.

If your digital camera supports DPOF printing, you will be able to choose on the digital camera display the images and number of copies you want to print.



Note

An Invalid DPOF File error can occur if the print order that was created on the camera has been corrupted. Delete and recreate the print order using your camera to correct this problem. For instructions on how to delete or recreate the print order, refer to your camera manufacturer's support Web site or accompanying documentation.

Printing photos directly from a digital camera (without PictBridge)

If your camera is using the USB Mass Storage standard, you can connect your camera in storage mode. This enables you to print photos from your camera.

(If you would like to print photos in PictBridge mode, see *Printing photos directly from a PictBridge camera* on page 66.)

Note

The name, availability and operation differ among digital cameras. Please refer to the documentation supplied with your camera for detailed information, such as how to switch from PictBridge mode to USB mass storage mode.

Printing Images

Note

Remove any memory cards or USB Flash memory drive from the machine before connecting a digital camera.

- 1 Make sure that your camera is turned off. Connect your camera to the USB direct interface (1) on the machine using the USB cable.

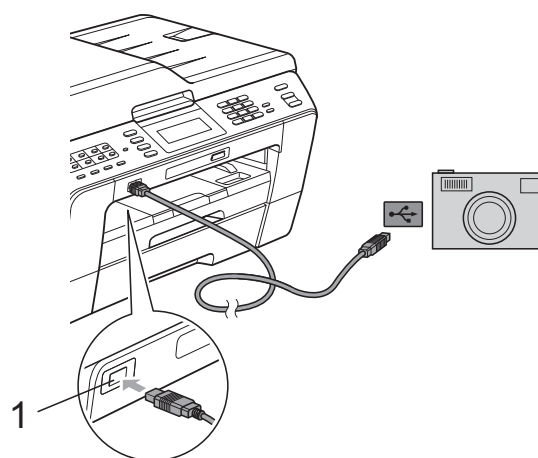

1 USB direct interface

- 2 Turn on the camera.
- 3 Follow the steps in *Print Images* on page 55.

! IMPORTANT

To prevent damage to your machine, do not connect any device other than a digital camera or USB Flash memory drive to the USB direct interface.

A

Routine maintenance

Cleaning and checking the machine

Cleaning the outside of the machine

Clean the Touchscreen as follows:

! IMPORTANT

- Turn off the power switch when you clean the Touchscreen.
- DO NOT use any type of liquid cleaners (including ethanol).

- 1 Clean the Touchscreen with a *dry*, soft lint-free cloth.

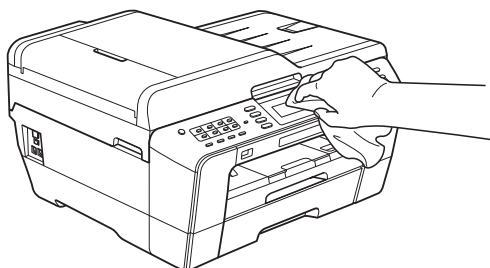

Clean the outside of the machine as follows:

! IMPORTANT

- Use neutral detergents. Cleaning with volatile liquids such as thinner or benzene will damage the outside surface of the machine.
- DO NOT use cleaning materials that contain ammonia.
- DO NOT use isopropyl alcohol to remove dirt from the control panel. It may crack the panel.

- 1 Pull the paper trays (1) completely out of the machine.

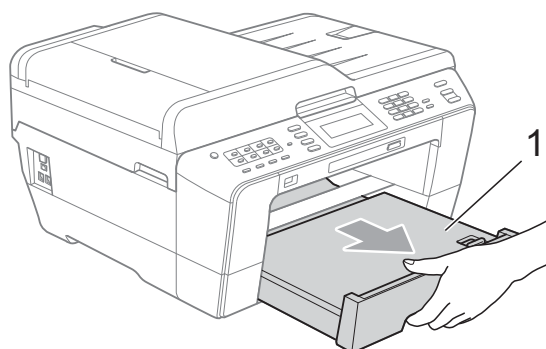
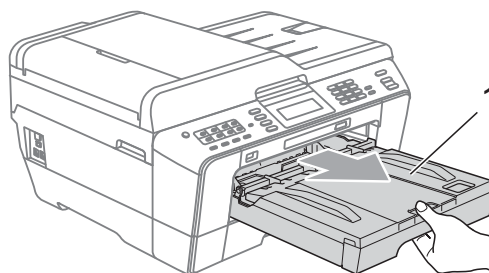

- Wipe the outside of the machine with a *dry*, soft lint-free cloth to remove dust.

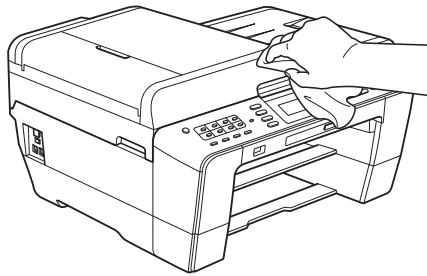

- Lift the output paper tray cover and remove anything that is stuck inside the paper tray.
- Wipe the inside and outside of the paper tray with a *dry*, soft lint-free cloth to remove dust.

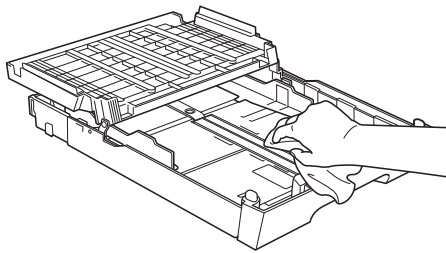

- Close the output paper tray cover and put the output paper tray firmly back in the machine.

Cleaning the machine's printer platen

⚠ CAUTION

Be sure to unplug the machine from the AC power outlet before cleaning the printer platen to avoid an electrical shock.

- Using both hands, use the finger holds on each side of the machine to lift the scanner cover into the open position.
- Clean the machine's printer platen (1) and the area around it, wiping off any scattered ink with a *dry*, soft lint-free cloth.

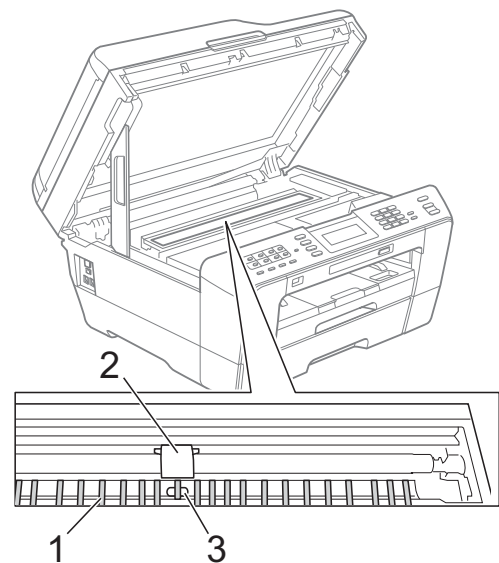

⚠ IMPORTANT

DO NOT touch the plate (2) and lever (3). Doing this may cause damage to the machine.

Cleaning the paper feed rollers

If the paper feed rollers are stained with ink, it may cause paper feed problems.

- 1 Unplug the machine from the AC power outlet. Pull the paper tray completely out of the machine.

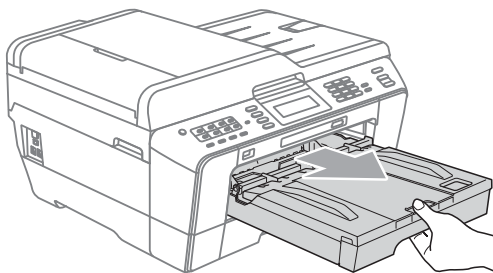

Note

If the paper support flap is open, close it, and then close the paper support.

- 2 Clean the front side of the Paper Feed Rollers (1) with a soft lint-free cloth moistened with water, using a side-to-side motion. After cleaning, wipe the rollers with a *dry*, soft lint-free cloth to remove all moisture.

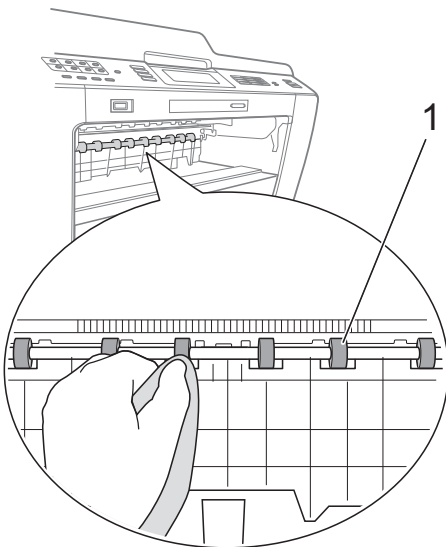

- 3 Lift the Jam Clear flap (2), and then clean the back side of the Paper Feed Rollers (1) with a soft lint-free cloth moistened with water. After cleaning, wipe the rollers with a *dry*, soft lint-free cloth to remove all moisture.

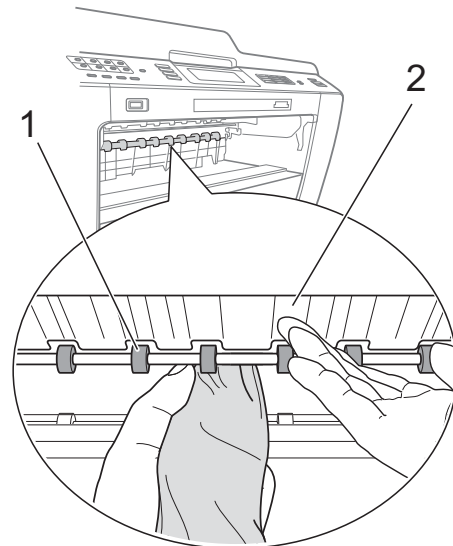

- 4 Put the paper tray firmly back in the machine.
- 5 Re-connect the power cord.

Note

Do not use the machine again until the rollers are dry. Using the machine before the rollers are dry may cause paper feed problems.

Cleaning the paper pick-up rollers

- 1 Unplug the machine from the AC power outlet.
- 2 Pull the paper tray completely out of the machine.



Note

If the machine starts multiple-feeding the last few sheets of paper in the tray, clean the Base Pad (1) with a soft lint-free cloth moistened with water.

After cleaning, wipe the pad with a *dry*, soft lint-free cloth to remove all moisture.

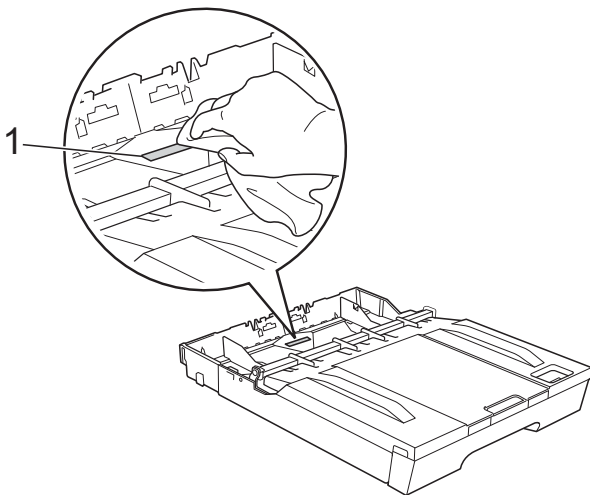

- 3 Open the Jam Clear Cover (1) at the back of the machine.

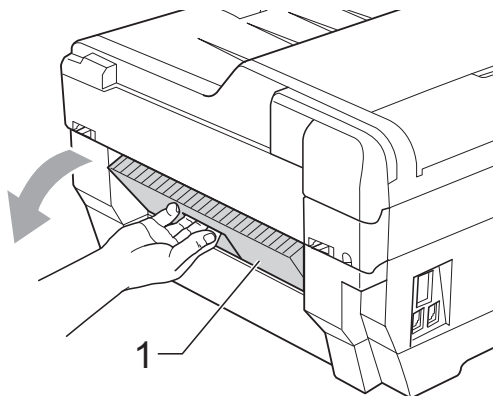

- 4 Clean the Paper Pick-up Rollers (1) with a soft lint-free cloth moistened with water. Slowly turn the rollers so that the whole surface is cleaned. After cleaning, wipe the rollers with a *dry*, soft lint-free cloth to remove all moisture.

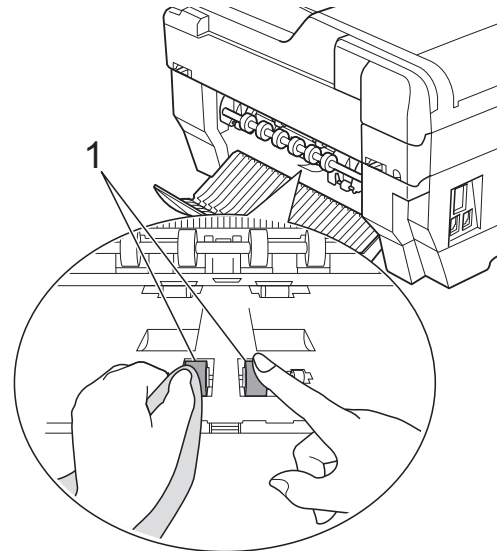

- 5 Clean the Back Paper Feed Rollers (1) with a soft lint-free cloth moistened with water. Slowly turn the rollers so that the whole surface is cleaned. After cleaning, wipe the rollers with a *dry*, soft lint-free cloth to remove all moisture.

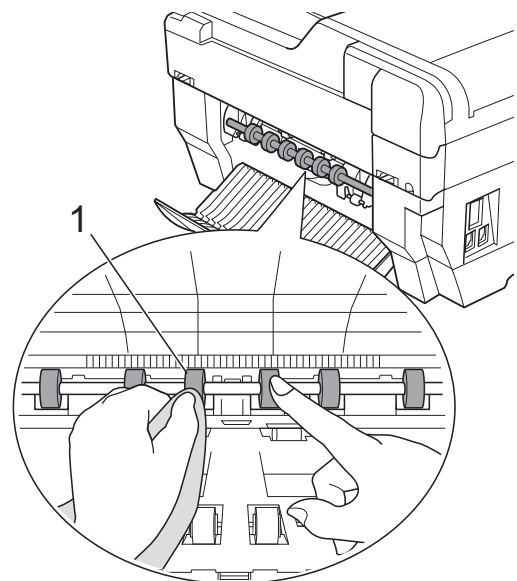



Note

Do not touch the metal shaft.

- 6 Close the Jam Clear Cover. Make sure the cover is closed completely.
- 7 Put the paper tray firmly back in the machine.
- 8 Re-connect the power cord.

Cleaning the paper pick-up rollers for paper tray #2

- 1 Unplug the machine from the AC power outlet. Pull tray #2 completely out of the machine.



Note

If the paper support flap is open, close it, and then close the paper support.

- 2 Clean the paper pick-up rollers for tray #2 (1) with a soft lint-free cloth moistened with water. Slowly turn the rollers so that the whole surface is cleaned. After cleaning, wipe the rollers with a *dry*, soft lint-free cloth to remove all moisture.

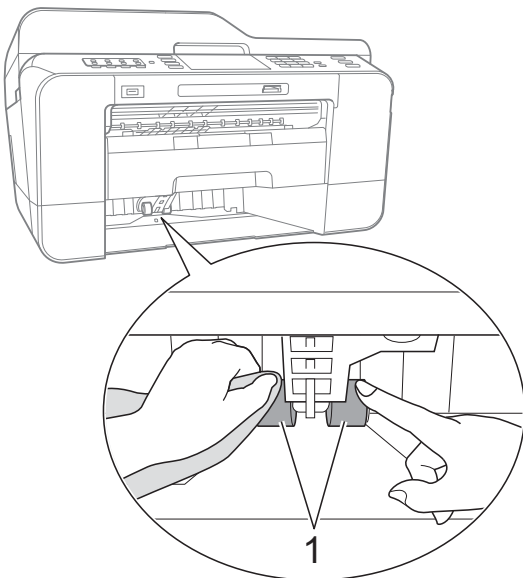

- 3 Put tray #2 firmly back in the machine.
- 4 Re-connect the power cord.

Checking the ink volume

Although an ink volume icon appears on the LCD, you can use the ink menu to see a large graph showing the ink that is left in each cartridge.

- 1 Press .
- 2 Press **Ink Volume**. The LCD shows the ink volume.
- 3 Press **Stop/Exit**.



Note

You can check the ink volume from your computer. (See *Printing for Windows*[®] or *Printing and Faxing for Macintosh* in the *Software User's Guide*.)

Packing and shipping the machine

When you transport the machine, use the packing materials that came with your machine. If you do not pack the machine properly, any damage that may occur in transit may not be covered by your warranty.

! IMPORTANT

It is important to allow the machine to “park” the print head after a print job. Listen carefully to the machine before unplugging it to make sure that all mechanical noise has stopped. Not allowing the machine to finish this parking process may lead to print problems and possible damage to the print head.

- 1 Unplug the machine from the telephone wall jack and take the telephone line cord out of the machine.
- 2 Unplug the machine from the AC power outlet.
- 3 Using both hands, use the finger holds on each side of the machine to lift the scanner cover into the open position. Then unplug the interface cable from the machine, if it is connected.
- 4 Remove the orange protective part from the inside right corner of the machine.

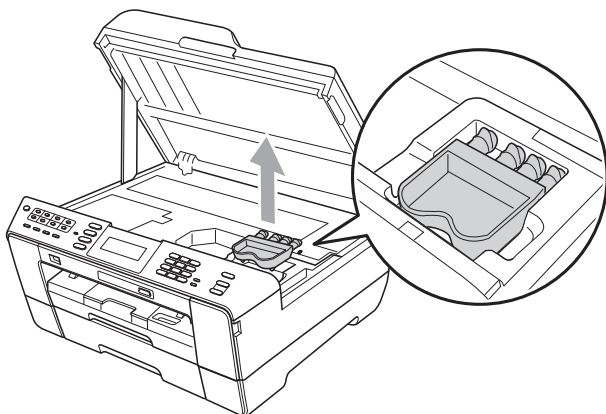

- 5 Gently close the scanner cover using the finger holds on each side.

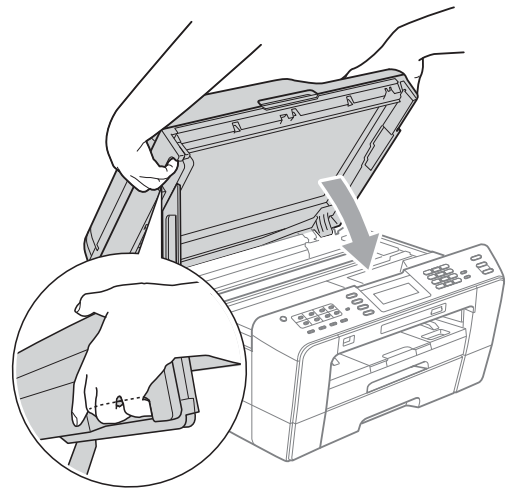

! WARNING

Be careful not to trap your fingers under the scanner cover.

Always use the finger holds provided on each side of the scanner cover when opening and closing it.

- 6 Open the ink cartridge cover.
- 7 Press the ink release levers to release the ink cartridges and then take out the ink cartridges. (See *Replacing the ink cartridges* in appendix A of the *Basic User's Guide*.)
- 8 Install the orange protective part and then close the ink cartridge cover.

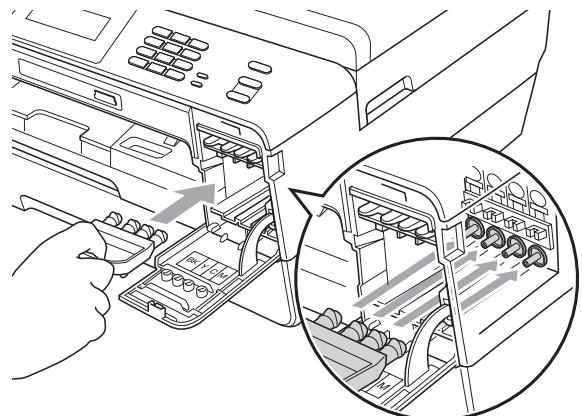

A

! IMPORTANT

- Make sure the plastic tab on the right side of the orange protective part (1) clicks securely into place (2).

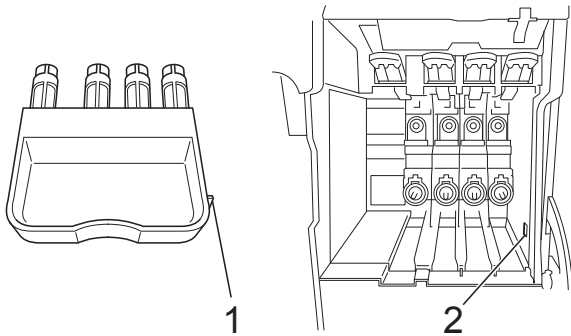

- If you are not able to find the orange protective part, DO NOT remove the ink cartridges before shipping. It is essential that the machine be shipped with either the orange protective part or the ink cartridges in position. Shipping without them will cause damage to your machine and may void your warranty.

- 9 Wrap the machine in the bag.

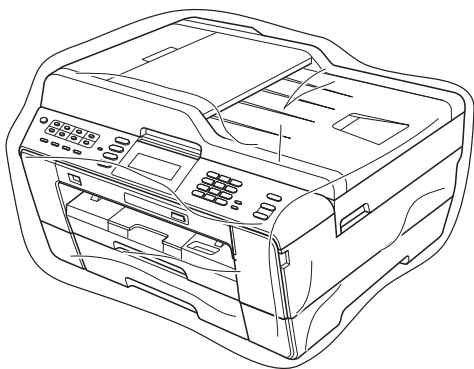

- 10 Pack the machine and the printed materials in the original carton with the original packing material as shown below. Do not pack the used ink cartridges in the carton.



Note

If you are returning your machine to Brother as part of the Exchange Service, pack *only* the machine. Keep all separate parts and printed materials to use with your "Exchange" machine.

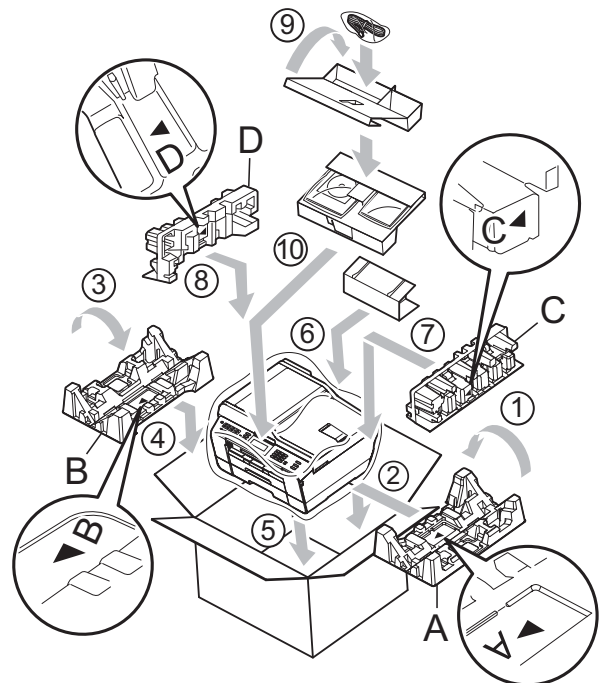

- 11 Close the carton and tape it shut.

This is a comprehensive list of features and terms that appear in Brother manuals. Availability of these features depends on the model you purchased.

ADF (automatic document feeder)

The document can be placed in the ADF and scanned one page at a time automatically.

Auto Reduction

Reduces the size of incoming faxes.

Automatic Redial

A feature that enables your machine to redial the last fax number after five minutes if the fax did not go through because the line was busy.

Backup Print

Your machine prints a copy of every fax that is received and stored in memory. This is a safety feature so you will not lose messages during a power failure.

Batch Transmission

(Black & white faxes only) As a cost saving feature, all delayed faxes to the same fax number can be sent as one transmission.

Beeper Volume

Volume setting for the beep when you press a key or make an error.

Brightness

Changing the Brightness makes the whole image lighter or darker.

Broadcasting

The ability to send the same fax message to more than one location.

Caller ID

A service purchased from the telephone company that lets you see the number (or name) of the party calling you.

CNG tones

The special tones (beeps) sent by fax machines during automatic transmission to tell the receiving machine that a fax machine is calling.

Coding method

Method of coding the information contained in the document. All fax machines must use a minimum standard of Modified Huffman (MH). Your machine is capable of greater compression methods, Modified Read (MR), Modified Modified Read (MMR) and JPEG, if the receiving machine has the same capability.

Communication error (Comm. Error)

An error during fax sending or receiving, usually caused by line noise or static.

Compatibility group

The ability of one fax unit to communicate with another. Compatibility is assured between ITU-T Groups.

Contrast

Setting to compensate for dark or light documents, by making faxes or copies of dark documents lighter and light documents darker.

Delayed Fax

Sends your fax at a specified time later.

Density

Changing the Density makes the whole image lighter or darker.

Distinctive Ring

A subscriber service purchased from the telephone company that gives you another telephone number on an existing telephone line. The Brother machine uses the new number to simulate a dedicated fax line.

Dual Access

Your machine can scan outgoing faxes or scheduled jobs into memory at the same time it is sending a fax from memory or receiving or printing an incoming fax.

Easy Receive

Enables your machine to respond to CNG tones if you interrupt a fax call by answering it.

ECM (Error Correction Mode)

Detects errors during fax transmission and resends the pages of the fax that had an error.

Extension telephone

A telephone using the same line as your fax but plugged into a separate wall jack.

External telephone

A telephone that is plugged into the EXT. jack of your machine.

F/T Ring Time

The length of time that the Brother machine rings (when the Receive Mode setting is Fax/Tel) to notify you to pick up a voice call that it answered.

Fax Forwarding

Sends a fax received into the memory to another pre-programmed fax number.

Fax Journal

Lists information about the last 200 incoming and outgoing faxes. TX means Transmit. RX means Receive.

Fax Preview

If you turn on Fax Preview you will be able to view incoming faxes on the LCD by pressing the **Fax Preview** key on the control panel or the **Fax Preview** button on the Touchscreen.

Fax Receive Code

Press this code (* 5 1) when you answer a fax call on an extension or external telephone.

Fax Storage

You can store received faxes in memory.

Fax tones

The signals sent by sending and receiving fax machines while communicating information.

Fax/Tel

You can receive faxes and telephone calls. Do not use this mode if you are using a telephone answering device (TAD).

Fine resolution

Resolution is 203 × 196 dpi. It is used for small print and graphs.

Gray Scale

The shades of gray available for copying, scanning and faxing photographs.

Group number

A combination of One Touch and Speed Dial numbers that are stored on a One Touch key or in a Speed Dial location for Broadcasting.

Help list

A printout of the complete Menu table that you can use to program your machine when you do not have the Basic User's Guide with you.

Innobella™

Innobella™ is a range of genuine consumables offered by Brother. For best quality results Brother recommends Innobella™ Ink and Paper.

Journal Period

The pre-programmed time period between automatically printed Fax Journal Reports. You can print the Fax Journal on demand without interrupting the cycle.

LCD (Liquid Crystal Display)

The LCD screen on the machine that shows interactive messages during On-Screen Programming and shows the date and time when the machine is idle.

Manual fax

You can lift the handset of the external telephone or you can press **Hook** to hear the receiving fax machine answer before you press **Black Start** or **Color Start** to begin sending.

Memory Receive

Receives faxes into the machine's memory when the machine is out of paper.

Menu mode

Programming mode for changing your machine's settings.

OCR (optical character recognition)

ScanSoft™ PaperPort™ 12SE with OCR or Presto! PageManager software application converts an image of text to text you can edit.

One Touch

Keys on the machine's control panel where you can store numbers for easy dialing. You can store a second number on each key if you hold down **Shift** as you press the One Touch key.

Overseas Mode

Makes temporary changes to the fax tones to accommodate noise and static on overseas telephone lines.

Paging

This feature enables your machine to call your pager when a fax is received into its memory. The machine will also page for voice messages.

Pause

Allows you to place a 3.5 second delay in the dialing sequence while you are dialing using the dial pad or while you are storing One Touch and Speed Dial numbers. Press the **Redial/Pause** key on the control panel or the **Pause** button on the Touchscreen as many times as needed for longer pauses.

PhotoCapture Center™

Allows you to print digital photos from your digital camera at high resolution for photo quality printing.

Photo resolution (B&W only)

A resolution setting that uses varying shades of gray for the best representation of photographs.

PictBridge

Allows you to print photos directly from your digital camera at high resolution for photo quality printing.

Polling

The process of a fax machine calling another fax machine to retrieve waiting fax messages.

Pulse (Canada only)

A form of rotary dialing on a telephone line.

Quick Dial List

A listing of names and numbers stored in One Touch and Speed Dial memory, in numerical order.

Real Time Transmission

When memory is full, you can send faxes in real time.

Remaining jobs

You can check which jobs are waiting in memory and cancel jobs individually.

Remote Access Code

Your own four-digit code (---*) that allows you to call and access your machine from a remote location.

Remote Retrieval Access

The ability to access your machine remotely from a touch-tone telephone.

Resolution

The number of vertical and horizontal lines per inch. See: Standard, Fine, Super Fine and Photo.

Ring Delay

The number of rings before the machine answers in **Fax Only** and **Fax/Tel** modes.

Ring Volume

Volume setting for the machine's ring.

Scanning

The process of sending an electronic image of a paper document into your computer.

Scan to Media

You can scan a black & white or color document into a memory card or USB Flash memory drive. Black & white images can be in TIFF or PDF file format and color images can be in PDF or JPEG file format.

Search

An electronic, numerical or alphabetical listing of stored One Touch, Speed Dial and Group numbers.

Speed Dial

A pre-programmed number for easy dialing.

Standard resolution

203 × 97 dpi. It is used for regular size text and quickest transmission.

Station ID

The stored information that appears on the top of faxed pages. It includes the sender's name and fax number.

Super Fine resolution (B&W)

392 × 203 dpi. Best for very small print and line art.

TAD (telephone answering device)

You can connect an external telephone answering device or answering machine to the EXT. jack of your machine.

Telephone Answer Code (For Fax/Tel mode only)

When the machine answers a voice call, it pseudo/double-rings. You can pick up at an extension telephone by pressing this code (**# 5 1**).

Temporary settings

You can choose certain options for each fax transmission and copy without changing the default settings.

Tone

A form of dialing on the telephone line used for touch-tone telephones.

Transmission

The process of sending faxes over the phone lines from your machine to the receiving fax machine.

Transmission Verification Report

A listing for the last fax sent, that shows its date, time and number.

True2Life™

Adjusts the color in the image for better print quality by improving sharpness, white balance and color density.

User Settings

A printed report that shows the current settings of the machine.

WLAN Report

A printed report that shows the result of the WLAN Connection.

Numerics

2 in 1 ID Copy46

A

Access codes, storing and dialing33

Apple Macintosh

See Software User's Guide.

B

Broadcasting13

setting up Groups for37

C

Caller ID29

Caller ID history32

Add to One Touch Dial32

Add to Speed Dial32

Delete32

Send a fax32

Caller ID History report40

Setting up your area code30

Canceling

Fax Forwarding22, 24

Fax Storage22

jobs awaiting redial16

Paging22, 24

Cleaning

paper feed roller72

paper pick-up roller73

printer platen71

Connecting

two-line external TAD or telephone31

ControlCenter

See Software User's Guide.

Copy

2 in 1 ID46

book49

density47

duplex50

enlarge/reduce42

Favorite settings53

ink save mode47

page layout (N in 1)43

poster43

quality41

skew adjustment48

sort (ADF only)46

thin paper48

using ADF46

Watermark49

using a media card49

using a paper document50

using a template49

using a USB Flash memory drive49

D

Dialing

access codes and credit card

numbers33

Caller ID history32

dial prefix4

Groups (Broadcasting)13

Outgoing Call32

Direct printing

from a non-PictBridge camera69

from a PictBridge camera66

Dual Access13

Duplex (2-sided)

copy50

fax12

F

Fax codes	
changing	23
Remote Access Code	23
Fax Forwarding	
changing remotely	24, 25
programming a number	18
Fax Storage	20
printing from memory	20
turning off	22
turning on	20
Fax, from PC	
See Software User's Guide.	
Fax, stand-alone	
receiving	
at end of conversation	26
Fax Forwarding	24
into PC	21
into the memory	18
out of paper reception	18
Paging	19
printing from memory	20
reducing to fit on paper	26
retrieving from a remote site	24, 25
sending	10
at end of conversation	13
Broadcasting	13
canceling from memory	16
contrast	10
delayed batch transmission	16
delayed fax	15
duplex (2-sided)	12
from memory (Dual Access)	13
manual	12
overseas	15
Real Time Transmission	15
Resolution	11
return to factory setting	11
set new default	11
Function Lock	6

G

Groups for Broadcasting	37
-------------------------------	----

I

ID Copy	46
Ink cartridges	
checking ink volume	74

J

Jacks	
Convert to RJ11 jack triplex adapter	31
EXT	
TAD	31

L

LCD (Liquid Crystal Display)	
Brightness	4
Dim Timer	4
Help List	40

M

Macintosh	
See Software User's Guide.	
Manual	
transmission	12
Memory Storage	1
Mode, entering	
Timer	5
Movie printing	55

N

Network	
Printing	
See Network User's Guide.	
Scanning	
See Software User's Guide.	

O

One Touch	
setting up from Caller ID history	34
setting up from outgoing calls	34
Outgoing Call	
Add to One Touch Dial	32
Add to Speed Dial	32
Delete	32
Send a fax	32

P

Packing and shipping the machine	75
Paging	19
PaperPort™ 12SE with OCR	
See Software User's Guide. See also Help in the PaperPort™ 12SE application.	
PhotoCapture Center™	
Adding Effect	56
DPOF printing	58
from PC	
See Software User's Guide.	
Photo Effects	
Auto Correct	56
Enhance Scenery	56
Enhance Skin	56
Fill Light	56
Monochrome	56
Night Scene	56
Remove Red-Eye	56
Sepia	56
Trim	56
Whiteboard	56
Print settings	
Borderless	62
Brightness	60
Contrast	60
Cropping	61
Paper type & size	59
Print Date	62
Quality	59
Return to factory setting	62
Set new default	62
Printing	
index	55
photos	56
Scan to Media	
auto crop	63
memory card	63
USB Flash memory	63
PictBridge	
DPOF Printing	68
Power failure	1
Presto! PageManager	
See Software User's Guide. See also Help in the Presto! PageManager application.	
Print	
fax from memory	20
report	40

Printing

See Software User's Guide.

Q

Quick Dial

Access codes and credit card numbers	33
Broadcasting	13
deleting Groups	38
using Groups	13
Group dial	
changing	38
setting up Groups for Broadcasting	37
One Touch	
setting up from Caller ID history	34
setting up from outgoing calls	34
Speed Dial	
setting up from Caller ID history	36
setting up from outgoing calls	35

R

Reducing

copies	42
incoming faxes	26
Remote Retrieval	23
commands	24
getting your faxes	25
remote access code	23

Remote Setup

See Software User's Guide.

Reports	39
Caller ID History Report	40
Fax Journal	40
Journal Period	39
Help List	40
how to print	40
Network Configuration	40
Quick Dial List	40
Transmission Verification	39, 40
User Settings	40
WLAN Report	40

Resolution

setting for next fax	11
----------------------------	----

Restricted users	8
------------------------	---

S

Scanning

See Software User's Guide.

Security

Secure function lock

administrator password7

restricted users8

Shipping the machine75

Sleep Mode3

Speed Dial

setting up from Caller ID history36

setting up from outgoing calls35

T

TAD (telephone answering device),

external31

with two-line jack31

Telephone line

roll over lines30

two-line telephone system30

Troubleshooting

checking ink volume74

Two-line telephone system30

V

Volume, setting

beeper2

ring1

speaker2

W

Warranties (Printed / In the box)

Windows®

See Software User's Guide.

Wireless Network

See Quick Setup Guide and Network User's Guide.

Brother International Corporation
100 Somerset Corporate Boulevard
P.O. Box 6911
Bridgewater, NJ 08807-0911 USA

Brother International Corporation (Canada) Ltd.
1 rue Hôtel de Ville,
Dollard-des-Ormeaux, QC, Canada H9B 3H6

brother®

Visit us on the World Wide Web
<http://www.brother.com/>

This machine is approved for use in the country of purchase only. Local Brother companies or their dealers will only support machines purchased in their own countries.