

*Color*   
*LaserJet™*

*8550, 8550N, 8550DN, 8550GN,  
8550MFP Printer*

**User Guide**



English

# HP Color LaserJet 8550, 8550N, 8550DN, 8550GN, 8550MFP Printer

## **User Guide**

**Use of this electronic document indicates that you accept the Terms of Use.**

© 2000 Hewlett-Packard Company

## Copyright Information

© Copyright 2001  
Hewlett-Packard Company

All Rights Reserved.  
Reproduction, adaptation, or translation without prior written permission is prohibited, except as allowed under the copyright laws.

A user of an HP Color LaserJet 8550 printer is granted a license to: a) print hard copies of this HP Color LaserJet 8550 printer user guide for PERSONAL, INTERNAL or COMPANY use subject to the restriction not to sell, re-sell or otherwise distribute the hard copies; and b) place an electronic copy of this HP Color LaserJet 8550 printer user guide on a network server provided access to the electronic copy is limited to PERSONAL, INTERNAL users of the HP Color LaserJet 8550 printer.

Part number: C7096-online  
Edition 3, 4/2009

## Warranty

The information contained in this document is subject to change without notice.

Hewlett-Packard makes no warranty of any kind with respect to this information. HEWLETT-PACKARD SPECIFICALLY DISCLAIMS THE IMPLIED WARRANTY OF MERCHANTABILITY AND FITNESS FOR A PARTICULAR PURPOSE.

Hewlett-Packard shall not be liable for any direct, indirect, incidental, consequential, or other damage alleged in connection with the furnishing or use of this information.

## Trademark Credits

*Adobe*<sup>™</sup> and *PostScript*<sup>™</sup> are trademarks of Adobe Systems Incorporated which may be registered in certain jurisdictions.

*Arial*<sup>®</sup> and *Times New Roman*<sup>®</sup> are U.S. registered trademarks of the Monotype Corporation.

*CompuServe*<sup>™</sup> is a U.S. trademark of CompuServe, Inc.

*dBASE*<sup>®</sup> is a U.S. registered trademark of Borland International, Inc.

ENERGY STAR<sup>®</sup> is a U.S. registered service mark of the United States Environmental Protection Agency.

HP-UX 9.\* and 10.0 for HP 9000 Series 700 and 800 computers are X/Open Company UNIX 93 branded products.

*Lotus*<sup>®</sup> 1-2-3<sup>®</sup> and *Lotus*<sup>®</sup> *Symphony*<sup>®</sup> are U.S. registered trademarks of Lotus Development Corporation.

*Microsoft*<sup>®</sup>, *Windows*<sup>®</sup>, *MS Windows*<sup>®</sup>, *Windows NT*<sup>®</sup>, and *MS-DOS*<sup>®</sup> are U.S. registered trademarks of Microsoft Corporation.

*PANTONE*<sup>®\*</sup> is Pantone, Inc.s check-standard trademark for color.

*TrueType*<sup>™</sup> is a U.S. trademark of Apple Computer, Inc.

*UNIX*<sup>®</sup> is a registered trademark in the United States and other countries, licensed exclusively through X/Open Company Limited.

All other products mentioned herein may be trademarks of their respective companies.

# HP Customer Care

Thank you for your purchase. Along with your product, you receive a variety of support services from Hewlett-Packard and our support partners. These services are designed to give you the results you need, quickly and professionally.

## Online Services:

For 24 hour access to information over your modem, we suggest these services:

## World Wide Web

Printer drivers, updated HP printer software, plus product and support information may be obtained from the following URLs:

in the U.S.	<a href="http://www.hp.com">http://www.hp.com</a>
in Europe	<a href="http://www2.hp.com">http://www2.hp.com</a>

Printer drivers may be obtained from the following sites:

in Japan	<a href="ftp://www.jpn.hp.com/drivers/">ftp://www.jpn.hp.com/drivers/</a>
in Korea	<a href="http://www.hp.co.kr">http://www.hp.co.kr</a>
in Taiwan	<a href="http://www.hp.com.tw">http://www.hp.com.tw</a>
or the local driver website	<a href="http://www.dds.com.tw">http://www.dds.com.tw</a>

## America Online

America Online/Bertelsmann is available in the U.S., France, Germany, and U.K. Printer drivers, updated HP printer software, and support documentation to help answer your questions about HP products are available. Use Keyword HP to start your tour or call 1 800-827-6364 preferred customer # 1118 to subscribe. In Europe, call the appropriate number below:

Austria	0222 58 58 485
France	++353 1 704 90 00
Germany	0180 531 31 64
Switzerland	0848 80 10 11
United Kingdom	0800 279 1234

## **CompuServe**

Printer drivers, updated HP printer software, and interactive sharing of technical information with other members is available on CompuServe's "HP User's forums" (GO HP), or call 1 800-524-3388 and ask for representative #51 to subscribe. (CompuServe is also available in the U.K., France, Belgium, Switzerland, Germany, and Austria.)

## **Obtaining software utilities and electronic information:**

### **For U.S. and Canada:**

**Phone:**

(661) 257-5565

**Fax:**

(661) 257-6995

**Mail:**

Hewlett-Packard  
P.O. Box 907  
Santa Clarita, CA  
91380-9007  
U.S.A.

### **For Asia-Pacific Countries/Regions:**

Contact Fulfill Plus at (65) 740-4477 (Hong Kong SAR, Indonesia, Philippines, Malaysia, or Singapore). For Korea, call (82) (2) 3270-0805 or (82) (2) 3270-0893.

### **For Australia, New Zealand, and India:**

For Australia and New Zealand, call (61) (2) 565-6099. For India, call (91) (11) 682-6035.

### **For European English:**

For U.K., call (44) (142) 986-5511. For Ireland and outside U.K., call (44) (142) 986-5511.

### **HP direct ordering for accessories or supplies:**

Call (800) 538-8787 (U.S.) or (800) 387-3154 (Canada).

### **HP Support Assistant compact disc:**

This support tool offers a comprehensive online information system designed to provide technical and product information on HP products. To subscribe to this quarterly service in the U.S. or Canada, call (800) 457-1762. In Hong Kong SAR, Indonesia, Philippines, Malaysia, or Singapore, call Fulfill Plus at (65) 740-4477.

### **HP Service Information:**

To locate HP-Authorized Dealers, call (800) 243-9816 (U.S.) or (800) 387-3867 (Canada).

### **HP Service Agreements:**

Call (800) 835-4747 (U.S.) or (800) 268-1221 (Canada). Extended Service (800) 446-0522.

### **HP FIRST:**

HP FIRST Fax will deliver detailed troubleshooting information on common software and troubleshooting tips for your HP product. Call from any touch tone phone and request up to three documents per call. These documents will be sent to the fax of your choice.

### **North and Latin America**

Outside the U.S. and Canada	(208) 344-4809
U.S. and Canada	(800) 333-1917

## Asia-Pacific Countries/Regions

Australia	61 (0)3 9272 2627
China	86 (0)10 6505 5280
Hong Kong SAR	85 (0)2 2506 2422
India	91 (0)11 682 6031
Indonesia	21 (0)352 2044
Japan	81 (0)3 3335 8622
Korea	82 (0)02 769 0543
Malaysia	03 (0)298 2478
New Zealand	64 (0)09 356 6642
Philippines	65 (0)275 7251
Singapore	65 (0)275 7251
Thailand	66 (0)02 661 3511

# Customer support options worldwide

## **Customer Support and Product Repair Assistance for the U.S. and Canada**

Call (208) 323-2551 Monday through Friday from 6 am to 6 pm free of charge during the warranty period. However, your standard long-distance phone charges still apply. Have your system nearby and your serial number ready when calling.

If you know your printer needs repair, call (800) 243-9816 to locate your nearest HP Authorized service provider, or call (208) 323-2551 for HP centralized service dispatch.

Post-warranty telephone assistance is available to answer your product questions. Call (900) 555-1500 (\$2.50\* per minute, U.S. only) or call (800) 999-1148 (\$25\* per call, Visa or MasterCard, U.S. and Canada) Monday through Friday from 7 am to 6 pm and Saturday from 9 am to 3 pm (Mountain Time). Charges begin only when you connect with a support technician. \*Prices subject to change.



## European Customer Support Center Language and In-country/region Options Available

Open Monday through Friday 8:30–18:00 CET

HP provides a free telephone support service during the warranty period. By calling a telephone number listed below, you will be connected to a responsive team waiting to help you. If you require support after your warranty has expired, you can receive support for a fee through the same telephone number. The fee is charged on a per incident basis. When calling HP, have the following information ready: product name and serial number, date of purchase, and description of the problem.

English	Ireland: (353) (1) 662-5525 U.K.: (44) (171) 512-5202 International: (44) (171) 512-5202
Dutch	Belgium: (32) (2) 626-8806 Netherlands: (31) (20) 606-8751
French	France: (33) (01) 43-62-3434 Belgium: (32) (2) 626-8807 Switzerland: (41) (84) 880-1111
German	Germany: (49) (180) 532-6222 Austria: (43) (1) 0660-6386
Norwegian	Norway: (47) 2211-6299
Danish	Denmark: (45) 3929-4099
Finnish	Finland: (358) (9) 0203-47288
Swedish	Sweden: (46) (8) 619-2170
Italian	Italy: (39) (2) 264-10350
Spanish	Spain: (34) (90) 232-1123
Portuguese	Portugal: (351) (1) 441-7199

### In-country/region support numbers

If you require support after your warranty has expired, additional repair services, or if your country/region is not listed below, see the [HP Customer Care Centers](#) section.

Argentina	787-8080
Australia	(61) (3) 2728000
Brazil	022-829-6612
Canada	(208) 3232551
Chile	800-360999
China	(86) (10) 65053888-5959
Czech Republic	(42) (2) 4717321
Greece	(30) (1) 6896411
Hong Kong SAR	(852) 800-96-7729

Hungary	(36) (1) 382-1111
India	(91) (11) 6826035
	(91) (11) 6826069
Indonesia	(62) (21) 3503408
Korea	(82) (2) 32700700
Korea outside Seoul	(82) (080) 9990700
Japan	(81) (3) 33358333
Malaysia	(60) (3) 2952566
Mexico (Mexico City)	01 800-22147
Mexico (outside MexicoCity)	01 800-90529
New Zealand	(64) (9) 3566640
Philippines	(63) (2) 8941451
Poland	(48) (22) 375065
Portugal	(351) (1) 3017330
Russia	(7) (95) 9235001
Singapore	(65) 2725300
Taiwan	(886) (02) 7170055
Thailand	+66 (0) 2 661-4011
Turkey	(90) (1) 2245925

# HP Customer Care Centers

## Asia Pacific Countries/Regions

Australia	+ 61 3 8877 8000
China	+ 86 10 6564 5959
Hong Kon SAR	800 96 7729
India	+ 91 11 682 6035
Indonesia	+ 62 21 350 3408
Japan	+ 81 3 5346 1891
Korea	+ 82 2 3270 0805
Outside Seoul only	080 999 0700
Malaysia	+ 60 3 295 2566
New Zealand	+64 (9) 356 6640
Penang	1 300 88 0028
Philippines	+ 63 2 867 3551
Singapore	+ 65 272 5300
Taiwan	+ 886 2 2717 0055
Thailand	+ 66 2 661 4000
Viet Nam	+84 8 823 4530

## North & Latin America

Argentina	(54 11) 4778 8380
Brazil	(011) 829 6612
Canada	905-206-4663
Chile	800 360 999
Mexico	800 427 6684
United States	(208) 323-2551
Venezuela	800 47 888
Caracas	207 8488

## Europe, Middle East, and Africa

Austria	+ 43 (0)7114 201080
Belgium	
Dutch	+ 32 (0)2 626 8806
French	+ 32 (0)2 626 8807
Denmark	+ 45 39 29 4099
English International	+ 44 (0)171 512 52 02
Finland	+ 358 (0)203 47 288
France	+ 33 (0)1 43 62 34 34
Germany	+ 49 (0)180 52 58 143

Ireland	+ 353 (0)1 662 5525
Israel	
Tel.	+ 972 (0)9 9524848
Fax	+ 972 (0)9 9524849
Italy	+ 39 02 264 10350
Netherlands	+ 31 (0)20 606 8751
Norway	+ 47 22 11 6299
Poland	+ 48 22 519 06 00
	+ 48 22 519 06 01
Portugal	+ 351 (0)1 318 00 65
Russian Federation	+ 7 095 916 98 21
	+ 7 095 916 98 35
South Africa	+27 (0)11 8061030
Spain	+ 34 902 321 123
Sweden	+ 46 (0)8 619 2170
Switzerland	+ 41 (0)848 80 11 11
Turkey	+ 90 212 224 59 25
United Kingdom	+ 44 (0)171 512 52 02



# Contents

## **1 The HP Color LaserJet 8550 Printer**

<a href="#">Features</a>	<a href="#">17</a>
<a href="#">Printer Information</a>	<a href="#">20</a>
<a href="#">Configurations</a>	<a href="#">20</a>
<a href="#">Locating the Printer's Parts</a>	<a href="#">22</a>
<a href="#">Optional Paper Handling Accessories and Status Lights</a>	<a href="#">24</a>

## **2 Using the Printer Control Panel**

<a href="#">Overview</a>	<a href="#">27</a>
<a href="#">Printer Control Panel Keys and Indicator Lights</a>	<a href="#">28</a>
<a href="#">When to Use the Printer Control Panel Menus</a>	<a href="#">30</a>
<a href="#">Using the Printer Control Panel in Shared Environments</a>	<a href="#">30</a>
<a href="#">Resetting the Printer</a>	<a href="#">31</a>
<a href="#">Factory Defaults</a>	<a href="#">32</a>
<a href="#">Printing Menu Maps</a>	<a href="#">37</a>
<a href="#">Changing Settings in the Printer Control Panel</a>	<a href="#">38</a>
<a href="#">Configuring Menu Selections</a>	<a href="#">38</a>
<a href="#">Auto Continue</a>	<a href="#">39</a>
<a href="#">Tray 1 Auto</a>	<a href="#">39</a>
<a href="#">Configuring Media Type and Size</a>	<a href="#">40</a>
<a href="#">Selecting an Output Bin</a>	<a href="#">42</a>
<a href="#">Setting Media Type and Size Overrides</a>	<a href="#">43</a>
<a href="#">Selecting the A4 Override</a>	<a href="#">44</a>
<a href="#">Selecting Toner Low Response</a>	<a href="#">45</a>
<a href="#">Setting the Power Save Mode</a>	<a href="#">46</a>
<a href="#">Selecting Parallel Advanced Function</a>	<a href="#">46</a>
<a href="#">Selecting the Default Printer Personality</a>	<a href="#">47</a>
<a href="#">Setting the I/O Timeout</a>	<a href="#">48</a>
<a href="#">Locking the Printer Control Panel</a>	<a href="#">49</a>
<a href="#">Selecting the Display Language</a>	<a href="#">50</a>
<a href="#">Printing Internal Pages</a>	<a href="#">51</a>
<a href="#">Interpreting the Configuration Page</a>	<a href="#">52</a>
<a href="#">Duplex Registration</a>	<a href="#">54</a>
<a href="#">Managing Memory</a>	<a href="#">56</a>
<a href="#">Resource Saving</a>	<a href="#">57</a>
<a href="#">Configuring the Printer for the Network</a>	<a href="#">57</a>

## **3 Common Printing Tasks**

<u>Selecting Media</u>	<u>59</u>
<u>Supported Media Weights and Sizes for Input Trays</u>	<u>60</u>
<u>Supported Media Weights and Sizes for the Optional Multi-bin Mailbox</u>	<u>63</u>
<u>Supported Media Weights and Sizes for the Optional Duplexer</u>	<u>65</u>
<u>Supported Media Weights and Sizes for the Optional 3000-sheet         Stapler/Stacker and Optional 3000-sheet Stacker</u>	<u>66</u>
<u>Preprinted Forms and Letterhead</u>	<u>68</u>
<u>Recycled Media</u>	<u>69</u>
<u>Envelopes</u>	<u>69</u>
<u>Transparencies</u>	<u>70</u>
<u>Heavy Paper Stock</u>	<u>70</u>
<u>Labels</u>	<u>71</u>
<u>Colored Media</u>	<u>72</u>
<u>Media to Avoid</u>	<u>72</u>
<u>Controlling Your Print Job</u>	<u>73</u>
<u>Changing Page Orientation</u>	<u>73</u>
<u>Printing from Tray 1</u>	<u>74</u>
<u>Printing Tips for Tray 1</u>	<u>77</u>
<u>Orienting Media</u>	<u>78</u>
<u>Printing from Trays 2 (some printer models only) and 3</u>	<u>80</u>
<u>Printing Tips for Trays 2 and 3</u>	<u>83</u>
<u>Printing from Tray 4 (some printer models only)</u>	<u>84</u>
<u>Printing Tips for Tray 4 (some printer models only)</u>	<u>86</u>

## **4 Advanced Printing Features**

<u>Overview</u>	<u>87</u>
<u>Using the HP TonerGauge</u>	<u>88</u>
<u>Printing by Type and Size of Paper</u>	<u>89</u>
<u>Benefits of Printing by Type and Size of Paper</u>	<u>89</u>
<u>Different First Page</u>	<u>91</u>
<u>Printing Multiple Pages on One Sheet of Paper</u>	<u>92</u>
<u>Creating and Using Quick Sets</u>	<u>93</u>
<u>Quick Copying a Job</u>	<u>95</u>
<u>Printing Additional Copies of a Quick Copy Job</u>	<u>95</u>
<u>Deleting a Stored Quick Copy Job</u>	<u>96</u>
<u>Proofing and Holding a Job</u>	<u>97</u>
<u>Printing the Remaining Copies of a Held Job</u>	<u>97</u>
<u>Deleting a Held Job</u>	<u>97</u>
<u>Printing a Private Job</u>	<u>99</u>
<u>Specifying a Private Job</u>	<u>99</u>
<u>Releasing a Private Job</u>	<u>99</u>
<u>Deleting a Private Job</u>	<u>100</u>

<a href="#">Storing a Print Job</a>	<a href="#">101</a>
<a href="#">Printing a Stored Job</a>	<a href="#">101</a>
<a href="#">Deleting a Stored Job</a>	<a href="#">101</a>
<a href="#">Variable Data Printing</a>	<a href="#">102</a>
<a href="#">Booklet Printing</a>	<a href="#">103</a>
<a href="#">Print on Backside of Heavy Media</a>	<a href="#">104</a>
<a href="#">HP JetSend Communications Technology</a>	<a href="#">105</a>
<a href="#">How the JetSend Communications Technology Works</a>	<a href="#">105</a>
<a href="#">Managing Fonts and Forms on Disk</a>	<a href="#">106</a>
<a href="#">HP LaserJet Resource Manager (Windows)</a>	<a href="#">106</a>
<a href="#">HP LaserJet Utility (Macintosh)</a>	<a href="#">107</a>

## **[5 Using Color](#)**

<a href="#">Controlling Color Output with Printer Drivers</a>	<a href="#">109</a>
<a href="#">Using Color</a>	<a href="#">110</a>
<a href="#">Manual Mode</a>	<a href="#">111</a>
<a href="#">ICC/CMS</a>	<a href="#">112</a>
<a href="#">Black and White</a>	<a href="#">112</a>
<a href="#">Automatic PANTONE® Matching</a>	<a href="#">113</a>
<a href="#">CMYK Ink Set Emulation</a>	<a href="#">113</a>
<a href="#">Adjusting the Print Color and Quality Settings</a>	<a href="#">114</a>
<a href="#">Selecting Colors</a>	<a href="#">115</a>
<a href="#">PANTONE Colors</a>	<a href="#">115</a>
<a href="#">Color Swatch</a>	<a href="#">115</a>
<a href="#">Resolution Considerations for Graphics, Images, and Photographs</a>	<a href="#">116</a>
<a href="#">Using Digital Cameras</a>	<a href="#">116</a>
<a href="#">Using Scanners</a>	<a href="#">117</a>
<a href="#">Adjusting the Color Balance</a>	<a href="#">118</a>

## **[6 Maintaining the Printer](#)**

<a href="#">Making Room for Printer Maintenance</a>	<a href="#">123</a>
<a href="#">Replacing Printer Consumables</a>	<a href="#">124</a>
<a href="#">Locating Printer Consumables</a>	<a href="#">124</a>
<a href="#">Frequency for Replacing Printer Consumables</a>	<a href="#">125</a>
<a href="#">Recycling Consumables</a>	<a href="#">127</a>
<a href="#">Resetting the HP TonerGauge</a>	<a href="#">127</a>

## **[7 Printer Control Panel Messages](#)**

<a href="#">Printer Messages</a>	<a href="#">129</a>
<a href="#">Using the Printer Online Help System</a>	<a href="#">129</a>



## **8 Solving Printer Problems**

<a href="#"><u>Performing Basic Troubleshooting Steps</u></a>	<a href="#"><u>161</u></a>
<a href="#"><u>Working with Toner</u></a>	<a href="#"><u>162</u></a>
<a href="#"><u>Media Jam Locations</u></a>	<a href="#"><u>163</u></a>
<a href="#"><u>Media Handling Problems</u></a>	<a href="#"><u>165</u></a>
<a href="#"><u>Printer Response Problems</u></a>	<a href="#"><u>173</u></a>
<a href="#"><u>Printer Control Panel and Configuration Problems</u></a>	<a href="#"><u>179</u></a>
<a href="#"><u>Application Problems</u></a>	<a href="#"><u>181</u></a>
<a href="#"><u>Incorrect Printer Output</u></a>	<a href="#"><u>183</u></a>
<a href="#"><u>Color Printing Problems</u></a>	<a href="#"><u>185</u></a>
<a href="#"><u>Print Quality Problems</u></a>	<a href="#"><u>187</u></a>
<a href="#"><u>Cleaning the Transfer Drum</u></a>	<a href="#"><u>198</u></a>
<a href="#"><u>Accessories, Options, and Related Products</u></a>	<a href="#"><u>204</u></a>

## **A DIMM Installation**

<a href="#"><u>Supported DIMMs</u></a>	<a href="#"><u>207</u></a>
<a href="#"><u>Installing DIMMs</u></a>	<a href="#"><u>207</u></a>

## **B Specifications**

<a href="#"><u>Electrical Specifications</u></a>	<a href="#"><u>211</u></a>
<a href="#"><u>Operating Environmental Specifications</u></a>	<a href="#"><u>212</u></a>
<a href="#"><u>Environmental Product Stewardship Program</u></a>	<a href="#"><u>213</u></a>
<a href="#"><u>Protecting the Environment</u></a>	<a href="#"><u>213</u></a>
<a href="#"><u>Regulatory Statements</u></a>	<a href="#"><u>217</u></a>
<a href="#"><u>FCC Regulations</u></a>	<a href="#"><u>217</u></a>
<a href="#"><u>Canadian DOC Regulations</u></a>	<a href="#"><u>217</u></a>
<a href="#"><u>Declaration of Conformity</u></a>	<a href="#"><u>218</u></a>
<a href="#"><u>VCCI Statement (Japan)</u></a>	<a href="#"><u>224</u></a>
<a href="#"><u>Korean EMI Statement</u></a>	<a href="#"><u>224</u></a>
<a href="#"><u>Safety Information</u></a>	<a href="#"><u>225</u></a>
<a href="#"><u>Laser Safety</u></a>	<a href="#"><u>225</u></a>
<a href="#"><u>Product Information Sheet</u></a>	<a href="#"><u>225</u></a>
<a href="#"><u>Laser Statement for Finland</u></a>	<a href="#"><u>226</u></a>

## **C Warranty Information**

<a href="#"><u>Hewlett-Packard Limited Warranty Statement</u></a>	<a href="#"><u>229</u></a>
---	----------------------------

# 1 The HP Color LaserJet 8550 Printer

## Features

Congratulations on your purchase of the HP Color LaserJet 8550, 8550N, 8550DN, 8550GN, or 8550MFP printer. This printer is designed to produce high-quality, high-speed color printouts for business environments.

This printer provides the quality and reliability of Hewlett-Packard printers as well as these specific features:

---

### Performance

- 24 pages per minute (ppm) black and white printing
- 6 ppm color printing
- Provides the ability to mopy (multiple original prints)

---

### Approximate Print Speeds

- **Letter-, A4-sized media:** 24 ppm black and white; 6 ppm color
- **Legal-, Executive-, 11-by-17 inch sized media:** 12 ppm black and white; 3 ppm color
- **Transparencies:** 2.8 ppm black and white; 2.1 ppm color
- **Labels:** 12 ppm black and white; 3 ppm color

---

## Paper Handling

**Note:** See "[Printer Information](#)" for printer configurations.

- Prints on up to 12-by-18.50 inch (304.80-by-469.90 mm) sized media
- Printing on heavy media up to 58 lb (216 g/m<sup>2</sup>) bond
- A 500-sheet input tray (tray 3) that supports letter-, legal-, A4-, 11-by-17 inch and A3-sized media
- A 500-sheet input tray (tray 2) that supports letter-, legal-, and A4-sized media; standard on some printer models
- 2,000-sheet input tray (tray 4); standard on some printer models
- Optional duplexer, which provides two-sided printing; standard on some printer models
- A 100-sheet multipurpose tray that supports letter-, legal-, executive-, A3-, A4-, B4-, 11-by-17 inch, B5-, and custom-sized media, as well as envelopes, labels, and card stock
- Face-down (top) output bin
- Printer driver selectable face-up (left) output bin with straight-through paper path

---

## Font and Memory

- 32 MB minimum DIMM (dual inline memory module) memory, expandable to 512 MB
- HP LaserJet 45 TrueType font set and 65 additional TrueType fonts for Microsoft® Windows 3.1, Windows 9x, Windows NT 4.0, Windows 2000, and Macintosh
- Supports forms and fonts on the disk using HP Resource Manager

---

## Printer Personality Support

- PCL 5 color extension support in the printer
- PostScript 3™ support (includes PDF)
- Automatic printer personality switching

---

## User Interface and EIO

- Standard ECP or bidirectional parallel cable interface (IEEE-1284 compliant)
- 2 enhanced input/output (EIO) slots
- Automatic I/O (input/output) switching
- HP Web JetAdmin software
- HP LaserJet Utility (Macintosh only)

---

## Accessories

**Note:** See “[Printer Information](#)” for printer configurations.

- Printer hard disk, which provides storage for fonts and macros as well as proof and hold, private jobs, quick copy jobs, and mopying capabilities
  - Optional ROM (read-only memory) or synchronous DRAM (dynamic random-access memory) DIMM device memory
  - Optional multi-bin mailbox, which provides multiple output destinations
  - Optional 3000-sheet Stapler/Stacker
  - Optional 3000-sheet Stacker
  - Optional HP JetDirect internal print server for network connection
- 

For more information on supported media, see “[Selecting Media](#)” in chapter [3](#).

The approximate print speeds offered by this printer might vary from those listed above because the following factors affect processing time:

- Complex graphics or large graphics
- I/O configuration
- Type of computer
- Computer configuration
- Amount of printer memory
- Network operating system
- Network configuration
- Print media

# Printer Information

## Configurations

This printer is available in five configurations, as described below:

### HP Color LaserJet 8550



The HP Color LaserJet 8550 comes standard with a 100-sheet tray 1, a 500-sheet tray 3, a printer stand, and 32 MB RAM.

### HP Color LaserJet 8550N



The HP Color LaserJet 8550N comes standard with a 100-sheet tray 1, a 500-sheet tray 2, a 500-sheet tray 3, a printer stand, 32 MB RAM, an HP JetDirect print server (10/100 Base-TX), and an internal hard disk.

### HP Color LaserJet 8550DN

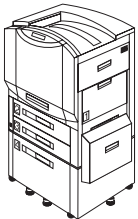

The HP Color LaserJet 8550DN comes standard with a 100-sheet tray 1, a 500-sheet tray 2, a 500-sheet tray 3, a (tray 4) 2000-sheet input tray, a duplexer, 64 MB RAM, an HP JetDirect print server (10/100 Base-TX), an internal hard disk, and five stabilizing legs.

### HP Color LaserJet 8550GN

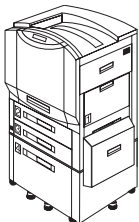

The HP Color LaserJet 8550GN comes standard with a 100-sheet tray 1, a 500-sheet tray 2, a 500-sheet tray 3, a (tray 4) 2000-sheet input tray, a duplexer, 128 MB RAM, an HP JetDirect print server (10/100 Base-TX), an internal hard disk, five stabilizing legs, and a higher performance processor.

## HP Color LaserJet 8550MFP



The HP Color LaserJet 8550MFP comes standard with a 100-sheet tray 1, a 500-sheet tray 2, a 500-sheet tray 3, a duplexer, 64 MB RAM, an HP JetDirect print server (10/100 Base-TX), an internal hard disk, a printer/copy module stand, and a copy module.

# Locating the Printer's Parts

The following figures show the locations of the printer's parts. (HP Color LaserJet 8550 shown below.)

Figure 1

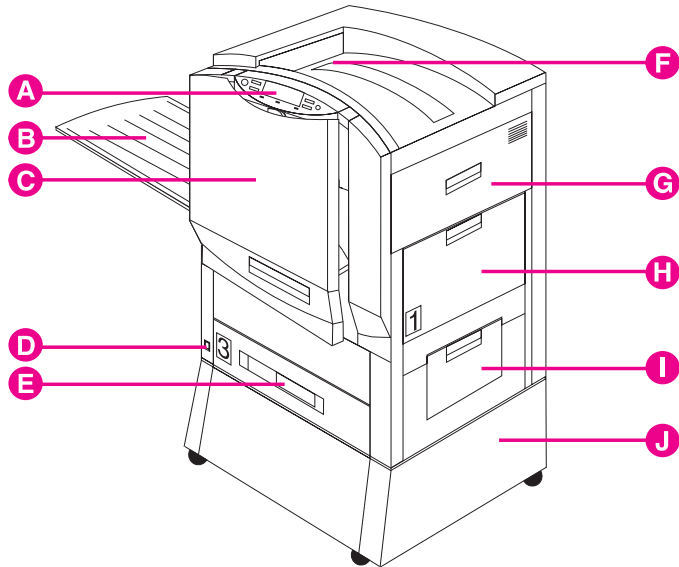

- A Printer Control Panel
- B Left Output Bin (face up)
- C Front Door
- D Power Button
- E Input Tray 3
- F Top Output Bin (face down)
- G Upper Right Door
- H Input Tray 1
- I Lower Right Door
- J Printer Stand

**Figure 2**

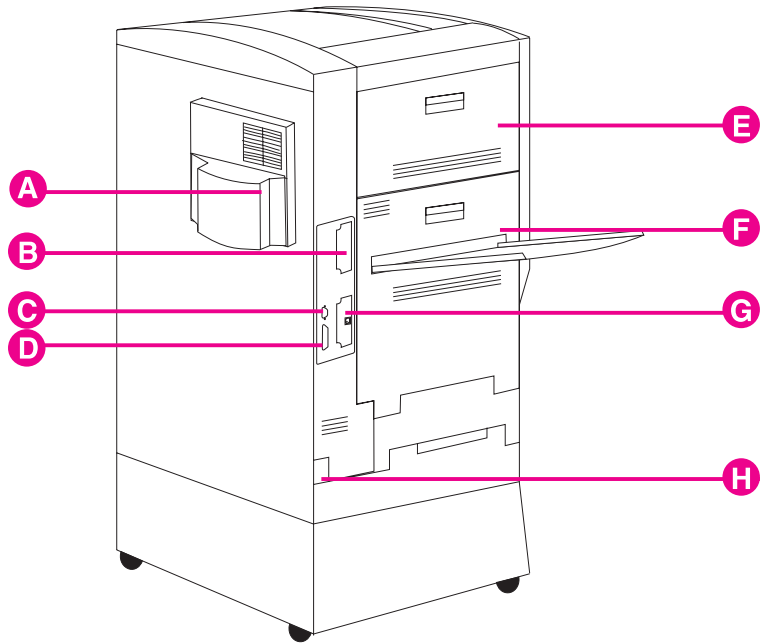

- A** Air Filter Door
- B** EIO Slot 2
- C** Tray 4 Connector (C-Link Connector)
- D** Parallel Connector
- E** Upper Left Door
- F** Lower Left Door
- G** EIO Slot 1 (shown with optional HP JetDirect internal print server)
- H** Power Connector

---

**Note**

For information on the locations of printer consumables, see [“Locating Printer Consumables”](#) in chapter [6](#).

---



## Optional Paper Handling Accessories and Status Lights

The following figure shows the locations of optional or packaged accessories and their status lights (if applicable).

Figure 3

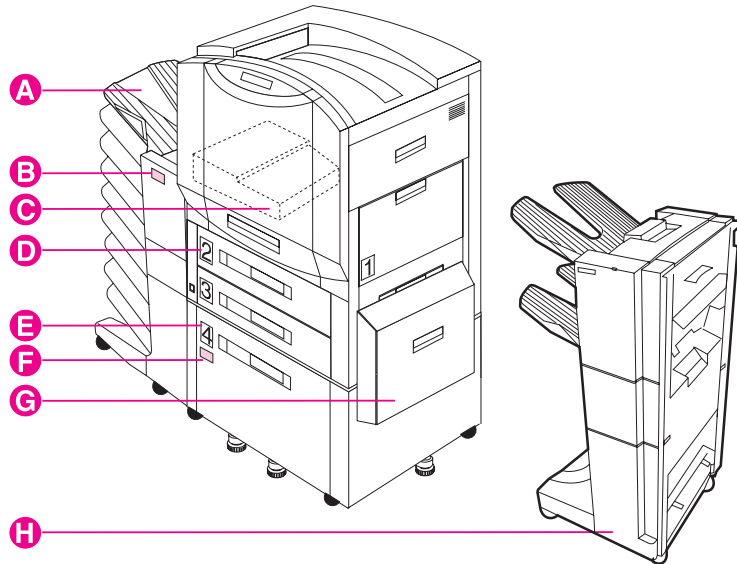

- A Multi-bin Mailbox
- B Multi-bin Mailbox Status Light
- C Duplexer (some printer models only)
- D Tray 2 (some printer models only)
- E Tray 4 (some printer models only)
- F Tray 4 Status Light
- G Media Transfer Door
- H 3000-sheet Stapler/Stacker (optional) or 3000-sheet Stacker (optional)

Use the following table to interpret the status lights on tray 4 and the multi-bin mailbox.

Light	Tray 4	Multi-Bin Mailbox
Solid Green	The accessory is on and ready.	The accessory is on and ready.
Solid Amber	The accessory is experiencing a hardware malfunction.	The accessory is experiencing a hardware malfunction.
Flashing Amber	<p>The accessory has a media jam or a page needs to be removed from tray 4, even if the page is not jammed.</p> <p>The lower right door might be open.</p>	<p>The accessory has a media jam or a page needs to be removed from the multi-bin mailbox, even if the page is not jammed.</p> <p>The accessory is not correctly attached to the printer.</p>
Off	<p>The printer might be in Power Save mode. Press <b>Go</b>.</p> <p>The accessory is not receiving power. Check both the power supply and the power cables.</p>	<p>The printer might be in Power Save mode. Press <b>Go</b>.</p> <p>The accessory is not receiving power. Check both the power supply and the power cables.</p>



# 2 Using the Printer Control Panel

## Overview

The most convenient way to control the printer is through your application or the printer driver. The commands in your application override the printer control panel settings. For more information on changing the printer settings from within an application or printer driver, see the associated online help files.

Use the printer control panel to configure the default settings for the printer or to obtain printer status information. Also, use the printer control panel to access printer features not supported by the application.

---

### Note

Unless otherwise specified, *control panel* refers to the control panel on the printer. Keys on the printer control panel are indicated by the **KEY** font.

---

---

### Note

For more information on controlling the printer in a network environment, see the HP JetDirect software installation guide and the HP Web JetAdmin online help.

---

# Printer Control Panel Keys and Indicator Lights

The following figure shows the locations of printer control panel features.

Figure 4

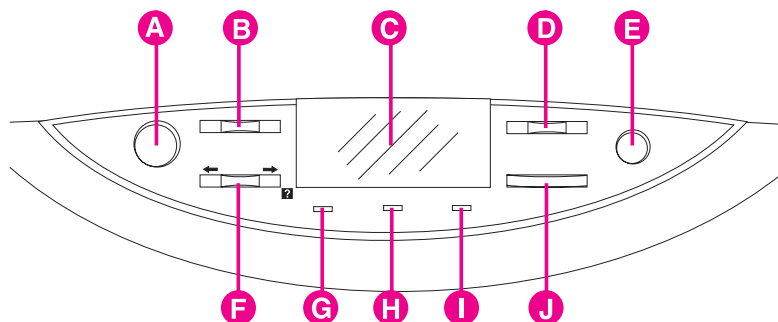

- A Go**  
Brings the printer online or offline, and exits menus.
- B Menu**  
Accesses the printer control panel menus to set the printer defaults. This key permits both forward and backward movement through the list of available menus.
- C Display**  
Presents data about the printer (such as printer status, required actions, or data and print errors) in one or two lines of characters.
- D -Value+**  
Steps through the value choices for a particular menu item using -/+. This key permits both forward and backward movement through the values.
- E Cancel Job**  
Stops the currently printing job from printing. If no job is printing and the display indicates that a job is processing, **CANCEL JOB** cancels the currently processing job and the next job begins printing. While the job is being canceled, **CANCELING JOB** is displayed.

**F Item**

Steps through the items in a particular menu. This key permits both forward and backward movement through the available items. The **ITEM** key also steps through the control panel help messages.

**G Ready Indicator** (green)

- On—The printer is online and able to accept and process data.
- Off—The printer is offline and unable to process data.
- Flashing—The printer is going from online to offline, or from offline to online.

**H Data Indicator** (green)

- On—Data is in the printer buffer, or the printer is processing data.
- Off—The printer buffer is empty.
- Flashing—The printer is receiving or processing data.

**I Attention Indicator** (amber)

- On—An error has occurred in the printer.
- Off—The printer does not require attention.
- Flashing—The printer requires attention.

**J Select**

Selects the item or value currently shown on the printer control panel display. An asterisk (\*) is displayed when an item has been selected.

For information on the status lights for the multi-bin mailbox and tray 4, see "[Optional Paper Handling Accessories and Status Lights](#)" in chapter [1](#).

# When to Use the Printer Control Panel Menus

The printer control panel menus allow you to select items such as the number of copies and test pages. Use the printer control panel to perform the following tasks:

- Set the media type for each input tray and the size for tray 1
- Job management:
  - Continue a proof and hold job
  - Quick copy a job
  - Job storage
  - Private printing
- Step through the control panel help messages
- Switch between online and offline status
- Print configuration pages
- Set the printer defaults when the application does not support the option
- Change the printer's EIO configuration
- Print a file directory page to identify the fonts and macros available on the printer hard disk
- Adjust duplex registration

## Using the Printer Control Panel in Shared Environments

The printer control panel functions in a network or other shared-printer environment in the same way as it does when it is connected to a standalone computer. Follow these guidelines before you change printer control panel settings:

- See the system administrator before making printer control panel changes. Any printer control panel changes could affect other print jobs.
- Coordinate setting the default printer font and downloading fonts with other users. Coordinating these operations conserves memory and reduces the chances of unexpected printer output.

# Resetting the Printer

Use the procedures below to reset the printer to the factory defaults listed in the table following this section.

## To reset the printer to factory defaults

- 1 Press **MENU** until INFORMATION MENU appears on the printer control panel display.
- 2 Press **ITEM** until PRINT CONFIG PAGE appears on the display.
- 3 Press **SELECT** to print the page.
- 4 Press **MENU** until RESETS MENU appears on the display.
- 5 Press **ITEM** until FACTORY DEFAULT RESET appears on the display.
- 6 Press **SELECT**. The printer will reset all factory defaults.

---

### Note

---

Resetting the printer to factory defaults clears all print jobs from the print buffer. After resetting the defaults, reprint any lost print jobs.

- 7 Reset the EIO type and configure the printer, if necessary.
- 8 Press **Go** to bring the printer online.
- 9 Use the printer configuration page to reconfigure the printer.



## Factory Defaults

The following table lists factory defaults for printer settings.

Menu	Item	Factory Default
INFORMATION MENU	PRINT MENU MAP	
	PRINT CONFIG PAGE	
	PRINT PCL FONT LIST	
	PRINT PS FONT LIST	
	PRINT LASERJET DEMONSTRATION	
	PRINT FILE DIRECTORY <sup>a</sup>	
	PRINT EIO PAGE <sup>b</sup>	
	PRINT CONTINUOUS CONFIG PAGES	
	PRINT EVENT LOG	
QUICK COPY JOBS MENU <sup>c</sup>		COPIES=nn
PRIVATE/STORED JOBS MENU		COPIES=nn

Menu	Item	Factory Default
PAPER HANDLING MENU	TRAY 1 TYPE =	AUTO
	TRAY 1 SIZE =	AUTO
	TRAY 2 TYPE = <sup>d</sup>	PLAIN
	TRAY 3 TYPE =	PLAIN
	TRAY 4 TYPE = <sup>e</sup>	PLAIN
	PAPER DEST =	TOP OUTPUT BIN
	DUPLEX = <sup>f</sup>	OFF
	BINDING <sup>g</sup>	LONG EDGE
	MANUAL FEED	OFF
	OVERRIDE A4 WITH LETTER	NO
	AUTO PAPER OVERRIDE	OFF
CONFIGURATION MENU	POWERSAVE =	1 HOUR
	PERSONALITY	AUTO
	CLEARABLE WARNINGS	ON
	TONER LOW	CONTINUE
	NEW TONER CARTRIDGE=	NO
	NEW TONER= <sup>h</sup>	BLACK YELLOW MAGENTA CYAN
	QUICK COPY JOBS	32
	PRINT PS ERRORS	OFF
	INITIALIZE DISK <sup>i</sup>	

<b>Menu</b>	<b>Item</b>	<b>Factory Default</b>
PRINTING MENU	COPIES=	1
	PAPER	LETTER <sup>j</sup>
	CONFIGURE CUSTOM PAPER= <sup>k</sup>	NO
	UNIT OF MEASURE=	INCHES
	X DIMENSION=	12.00 RANGE 3.87 - 12.00
	Y DIMENSION=	18.50 RANGE 7.48 - 18.50
	ORIENTATION	PORTRAIT
	FORM LENGTH	60 LINES
	PCL FONT SOURCE	INTERNAL
	PCL FONT NUMBER	0 (Courier)
	PCL PITCH	10.00
	PCL POINT SIZE	12.00
	PCL SYMBOL SET	PC-8
	COURIER	REGULAR
	WIDE A4	NO
APPEND CR TO LF	NO	

<b>Menu</b>	<b>Item</b>	<b>Factory Default</b>
REGISTRATION DUPLEX MENU	TRAY 1 PRINT TEST PAGE	
	TRAY 1 X =	0
	TRAY 1 Y =	0
	TRAY 2 <sup>l</sup> PRINT TEST PAGE	
	TRAY 2 X =	0
	TRAY 2 Y =	0
	TRAY 3 PRINT TEST PAGE	
	TRAY 3 X =	0
	TRAY 3 Y =	0
	TRAY 4 <sup>m</sup> PRINT TEST PAGE	
	TRAY 4 X =	0
	TRAY 4 Y =	0
I/O MENU	I/O TIMEOUT	30 (seconds)
	PARALLEL ADV FUNCTIONS =	ON
RESETS MENU	FACTORY DEFAULT RESET	
	RESET ACTIVE I/O	
	RESET ALL I/O	
	RESET TRANSFER LIFE COUNT	
	RESET FUSER LIFE COUNT	
<other menus> <sup>n</sup>	supplied by installed devices	

Menu	Item	Factory Default
COLOR ADJUST MENU	PRINT TEST PAGE	
	BLACK SMOOTH VALUE=	0
	CYAN SMOOTH VALUE=	0
	MAGENTA SMOOTH VALUE=	0
	YELLOW SMOOTH VALUE=	0
	BLACK DETAIL VALUE=	0
	CYAN DETAIL VALUE=	0
	MAGENTA DETAIL VALUE=	0
	YELLOW DETAIL VALUE=	0

- a. Appears only if the printer has a disk installed.
- b. Appears only if an EIO card is installed and an EIO page exists.
- c. QUICK COPYJOBS MENU and PRIVATE/JOBS MENU only appear if disk is installed and at least one job is in the queue.
- d. Appears only if tray 2 is properly installed.
- e. Appears only if tray 4 is properly installed.
- f. Appears only if the optional duplexer is installed.
- g. Appears only if the optional duplexer is installed and DUPLEX is set to ON.
- h. Appears only if NEW TONER = YES.
- i. Initialize functions only appear if appropriate disk is installed.
- j. This setting will default to A4 in some countries/regions.
- k. UNIT OF MEASURE, X DIMENSION, and Y DIMENSION only appear if CONFIGURE CUSTOM is set to YES.
- l. Tray 2 items appear only if tray 2 is installed.
- m. Tray 4 items appear only if tray 4 is installed.
- n. Appears only if appropriate device (EIO) menu exists.

# Printing Menu Maps

Print menu maps from the printer control panel, and then use the menu maps to view printer settings and to help navigate the printer control panel menus.

## To print menu maps

- 1 Press **MENU** until INFORMATION MENU appears on the printer control panel display.
- 2 Press **ITEM** until PRINT MENU MAP appears on the display.
- 3 Press **SELECT** to print. The printer will automatically bring itself online.

# Changing Settings in the Printer Control Panel

Use the printer control panel to configure the default printer selections and to obtain printer status information. Also, use the printer control panel to access printer features not supported by your application. For more information on navigating the printer control panel, see [“Printing Menu Maps”](#) on the previous page.

## Configuring Menu Selections

Use the following instructions to configure all printer control panel settings, including the default printer settings.

### To configure menu selections in the printer control panel

- 1 Press **MENU** until the menu you want appears on the printer control panel display.
- 2 Press **ITEM** until the item you want appears on the display.
- 3 Press **-VALUE+** until the value you want appears on the display.
- 4 Press **SELECT** to save the selection. An asterisk (\*) appears to the right of the selection.
- 5 Repeat steps 1 through 4 until all of your changes are complete.
- 6 Press **GO** to bring the printer online.

---

#### Note

---

Changes to the printer control panel will not take effect until all current data in the print buffer prints or until the next print job.

## Auto Continue

The Auto Continue feature allows the printer to continue printing when certain warnings or conditions occur (such as `TONER LOW`). The printer message will be displayed on the printer control panel, but the printer will continue printing. Auto Continue is always on, and most printer control panel messages that do not disable the printer will not stop subsequent jobs from printing. However, the job where the error occurred might not print correctly.

If in the Configuration Menu `CLEARABLE WARNINGS` is set to `ON`, many printer control panel messages can be cleared by pressing **Go**. If `CLEARABLE WARNINGS` is set to `JOB`, the clearable messages will be cleared from the display automatically when the job where the error occurred finishes printing.

## Tray 1 Auto

From the control panel, you can also set the media size and type for tray 1 to `AUTO`. The printer tries to match the media size and/or type specified for the current print job in the print driver to the settings in the control panel and prints from tray 1 if it can. For example, if you set the media size and type for tray 1 to `AUTO` in the control panel, load letter-size transparencies into tray 1, and send a job to the printer specifying plain Letter in the print driver, the printer prints from tray 1 even if other trays are configured for plain Letter. You can use the `AUTO` setting to override the printer's tray selection process, forcing the printer to print from tray 1 regardless of the media size and/or type specified in the print driver or loaded in tray 1.

---

### Note

---

Although tray 1 does not fully sense the media size, the printer will not print on media that it senses is the wrong width.



## Configuring Media Type and Size

Configure the media type (such as plain paper, letterhead, or transparencies) for each of the input trays. If the media type and size have been correctly configured for the input trays, the printer will print based on the type and size of media and will automatically use the correct input tray. Configuring the media type is beneficial for several reasons:

- Setting the media type prevents printing on the wrong, possibly expensive, media.
- The printer will automatically adjust its print speed to accommodate special media (such as card stock, labels, and transparencies). These adjustments will give the best quality output, saving time and resources.

---

### Note

If the media type is not set properly, the printer might not print on the correct media or at the correct speed for the media type, which can result in poor print quality.

---

## To configure the input trays

Follow the steps below to configure the media type.

- 1 Press **MENU** until PAPER HANDLING MENU appears on the printer control panel display.
- 2 Press **ITEM** until TRAY [number] TYPE = appears on the display.
- 3 Press **-VALUE+** until the correct media type appears on the display.
- 4 Press **SELECT** to save the selection. An asterisk (\*) appears to the right of the selection.

To configure the media size in tray 1, repeat steps 1-4 ("size" will replace references to "type").

---

### Note

---

Trays 2, 3, and the optional tray 4 will automatically sense the media size.

- 5 Repeat steps 2 through 4 to configure the media type in another input tray.  
- Or -  
Press **Go** to bring the printer online.

## Selecting an Output Bin

Select the top output bin (face down) or the left output bin (face up) in the printer control panel. The top output bin stacks the pages in sequential order, so that the first page is on top and the last page is on bottom. The left output bin provides a straight paper path which is useful to prevent curling when printing on card stock, labels, or other special media.

If you have an optional multi-bin mailbox, an optional 3000-sheet Stacker, or an optional 3000-sheet Stapler/Stacker, then select the appropriate output bin as your default. To configure other available modes, see your network administrator.

---

### Note

For more information on the optional multi-bin mailbox, the optional 3000-sheet Stacker, and the optional 3000-sheet Stapler/Stacker modes, see the guides that came with them.

Select the default destination for print jobs in the printer control panel. The printer will send print jobs to the default destination if a destination is not selected in the printer driver, or if your printing environment does not use printer drivers. For more information on using the HP Web JetAdmin software, see the online help.

---

### Note

Changes made to the multi-bin mailbox mode settings in the printer driver will **not** override the multi-bin mailbox mode set in the HP Web JetAdmin software or through PJI commands.

## To select an output bin

- 1 Press **MENU** until PAPER HANDLING MENU appears on the printer control panel display.
- 2 Press **ITEM** until PAPER DEST = appears on the display.
- 3 Press **-VALUE+** until the correct destination appears on the display.
- 4 Press **SELECT** to save the selection. An asterisk (\*) appears to the right of the selection.
- 5 Press **GO** to bring the printer online.

## Setting Media Type and Size Overrides

Set the media override option to select the media on which a job will print if the selected media is not available.

### To set the media override

- 1 Press **MENU** until PAPER HANDLING MENU appears on the printer control panel display.
- 2 Press **ITEM** until AUTO PAPER OVERRIDE appears on the display.
- 3 Press **-VALUE+** until the ON or OFF appears on the display.
  - **ON**—If the requested media is not found, TRAY X LOAD <Type> <Size> will appear on the display. There will be a delay before the printer automatically prints on plain paper on the default media size (set in the PRINTING MENU on the printer control panel). The delay time can be configured through the HP Web JetAdmin software. For more information on configuring HP Web JetAdmin software, see the associated online help file.
  - **OFF**—TRAY X LOAD <Type> <Size> will appear on the display. The printer will not print until it detects the correct media type and size or **Go** is pressed.

---

**Note**

---

If the requested media size is larger than the default paper size (for example, 11-by-17 inch size is requested, but the default is letter size), then the image will be cropped to fit on the smaller page size.

- 4 Press **SELECT** to save the selection. An asterisk (\*) appears to the right of the selection.
- 5 Press **Go** to bring the printer online.

## Selecting the A4 Override

Enabling `VERRIDE A4 WITH LETTER` will print A4-sized documents on letter-sized media, **or** letter-sized documents on A4-sized media. However if an input tray is configured for the size you want to override (letter or A4), even if the tray is empty, then the printer will continue to try and print on the correct size of media regardless of the override setting.

### To select the A4 override

- 1 Press **MENU** until `PAPER HANDLING MENU` appears on the printer control panel display.
- 2 Press **ITEM** until `VERRIDE A4 WITH LETTER` appears on the display.
- 3 Press **-VALUE+** to display `ON` or `OFF`.
- 4 Press **SELECT** to save the selection. An asterisk (\*) appears to the right of the selection.
- 5 Press **Go** to bring the printer online.

## Selecting Toner Low Response

Selecting the toner low response allows you to determine how the printer will behave when the printer detects a toner level is low.

---

### Note

The printer uses the toner low response setting as the setting for TRANSFER KIT LOW REPLACE KIT, FUSER LIFE LOW REPLACE KIT, TONER LOW, and DRUM LIFE LOW REPLACE DRUM KIT messages. For example, if the toner low response is set to STOP, then when the TRANSFER KIT LOW REPLACE KIT message appears on the printer control panel the printer will stop printing until the transfer kit is replaced or Go is pressed.

---

### To select the toner low response

- 1 Press MENU until CONFIGURATION MENU appears on the printer control panel display.
- 2 Press ITEM until TONER LOW appears on the display.
- 3 Press -VALUE+ until the option you want appears on the display. The available options include the following:
  - STOP will take the printer offline. Pressing Go will bring the printer online and allow printing to continue until the toner cartridge is empty. When the toner cartridge is empty, the message TONER OUT REPLACE <Color> will be displayed.
  - CONTINUE will display the TONER LOW REPLACE <Color> warning until the toner cartridge is empty.
- 4 Press SELECT to save the selection. An asterisk (\*) appears to the right of the selection.
- 5 Press Go to bring the printer online.

---

### Note

Although this option allows you to configure the printer behavior when the consumable lives are low, print quality will eventually degrade after a consumable's life has reached low, regardless of how you have configured the printer response. These print quality problems can be fixed by replacing the consumable.

---

## Setting the Power Save Mode

The Power Save mode conserves electricity by reducing the amount of power the printer uses when it has been idle for a length of time specified in the printer control panel. The default setting is 60 minutes (60 MIN). However, the Power Save mode can be adjusted to start between 10 seconds and 8 hours after the last print job finishes. The printer fans will run for 30 minutes after entering Power Save mode to cool the printer.

---

### Note

---

The 10 seconds setting is for use by service personnel and is not recommended for daily use.

### To set the Power Save mode

- 1 Press **MENU** until CONFIGURATION MENU appears on the printer control panel display.
- 2 Press **ITEM** until POWERSAVE appears on the display.
- 3 Press **-VALUE+** until the interval you want (between 30 minutes and 8 hours) appears on the display.
- 4 Press **SELECT** to save the selection. An asterisk (\*) appears to the right of the selection.
- 5 Press **GO** to bring the printer online.

## Selecting Parallel Advanced Function

If the printer is not correctly interpreting data transmitted across the ECP (enhanced capability parallel) port, turn the parallel advanced functions off to send the printer into compatibility mode. Compatibility mode turns the bidirectional communication off so that an HP LaserJet fax or other peripheral between the host computer and the printer will work correctly.

---

### Note

---

You must have the parallel advanced functions turned off for a peripheral connected between the host computer and the printer to work correctly.

## To select the parallel advanced function

- 1 Press **MENU** until I/O MENU appears on the printer control panel display.
- 2 Press **ITEM** until PARALLEL ADV FUNCTIONS = appears on the display.
- 3 Press **-VALUE+** to display ON or OFF.
- 4 Press **SELECT** to save the selection. An asterisk (\*) appears to the right of the selection.
- 5 Press **GO** to bring the printer online.

## Selecting the Default Printer Personality

Select the default printer personality for multi-platform environments, or select a personality if your printer driver does not send the PJI header with the print job. AUTO is the default setting.

## To select the printer personality

- 1 Press **MENU** until CONFIGURATION MENU appears on the printer control panel display.
- 2 Press **ITEM** until PERSONALITY appears on the display.
- 3 Press **-VALUE+** until the option you want appears on the display. The available options include the following:
  - AUTO enables switching by file type or PJI description. This is the default setting and the best setting to maintain all printer capabilities.
  - PCL selects printer control language (PCL) as the printer personality.
  - POSTSCRIPT selects the PostScript language as the printer personality.
- 4 Press **SELECT** to save the selection. An asterisk (\*) appears to the right of the selection.
- 5 Press **GO** to bring the printer online.



## Setting the I/O Timeout

The I/O timeout sets the amount of time the printer waits after receiving print data before switching I/O ports. The default time is 30 seconds.

### To set the I/O timeout

- 1 Press **MENU** until I/O MENU appears on the printer control panel display.
- 2 Press **ITEM** until I/O TIMEOUT appears on the display.
- 3 Press **-VALUE+** until the interval you want (between 5 and 300 seconds) appears on the display.
- 4 Press **SELECT** to save the selection. An asterisk (\*) appears to the right of the selection.
- 5 Press **GO** to bring the printer online.

---

#### Note

If the I/O timeout is too short, print jobs might be incomplete. If the I/O timeout is too long, print jobs might be unnecessarily delayed.

## Locking the Printer Control Panel

You can prevent users from changing the printer control panel settings by establishing a password, thus enabling the printer control panel lock. When locked, unauthorized users who try to change settings in the printer control panel will receive an `ACCESS DENIED` message.

If you are using Microsoft Windows, use either the HP Web JetAdmin software or a PJI Command. The easier of the two methods is through the HP Web JetAdmin software. For more information on using the HP Web JetAdmin software to perform this function, see the HP Web JetAdmin online help.

If you are using Mac OS, use the HP LaserJet utility. From the HP LaserJet utility, on the Security tab select **Lock Control Panel**.

---

### Note

If you have forgotten the password for the printer control panel, print a configuration page, an EIO page, and a menu map page, then reset the printer with a cold reset. To perform a cold reset, turn the printer off then hold down the green **Go** button and turn the printer on. When the front panel displays `COLD RESET`, release the green **Go** button. **All** printer settings (including internal print server card settings) will return to the factory defaults, all passwords will be cleared, and the printer control panel will be unlocked. Use the pages listed above to restore the printer settings. For more information on printing these pages, see "[Printing Internal Pages](#)" later in this chapter.

---

## Selecting the Display Language

Using the printer control panel, you can set the printer to display printer messages and print test pages in a variety of supported languages.

### To select the display language

- 1 Hold down **SELECT** while turning the printer off and then on. `CONFIG LANGUAGE` (in English) appears on the printer control panel display for approximately one second. Once the printer has restarted, `LANGUAGE=ENGLISH` will appear.

---

#### Note

Only **-VALUE+**, **SELECT**, and **Go** are active while the display language is being configured. All other keys are ignored.

If you press **Go** without selecting a language, the printer will bring itself online and all subsequent messages will be displayed in English. However, since no display language was selected, the `LANGUAGE=ENGLISH` message will reappear (after the power-on self test) when the printer is next turned on. This message will be displayed every time the printer is turned on until you select a language through the configure language mode.

- 
- 2 Press **-VALUE+** until the language you want appears on the display.
  - 3 Press **SELECT** to save the selection. An asterisk (\*) appears to the right of the selection. The language selected will be the default language until another selection is made by restarting the printer in the configure language mode.
  - 4 Press **Go** to bring the printer online.

# Printing Internal Pages

Print a configuration page to verify that the printer is set up correctly or to verify information about the printer's configuration.

## To print an internal page

- 1 Press **MENU** until `INFORMATION MENU` appears on the printer control panel display.
- 2 Press **ITEM** until the option you want appears on the display. The available options include the following:
  - `PRINT MENU MAP`
  - `PRINT CONFIG PAGE`
  - `PRINT PCL FONT LIST`
  - `PRINT PS FONT LIST`
  - `PRINT LASERJET DEMONSTRATION`
  - `PRINT FILE DIRECTORY PAGE` (appears only if the disk is installed)
  - `PRINT CONTINUOUS CONFIG PAGES`
  - `PRINT EVENT LOG`
  - `PRINT EIO PAGE` (appears only if the EIO card is installed)
- 3 Press **SELECT** to print the page. The printer will automatically bring itself online.
- 4 If you want to print another page, repeat steps 1 through 3.

# Interpreting the Configuration Page

The following figure is an example of a configuration page.

Figure 5

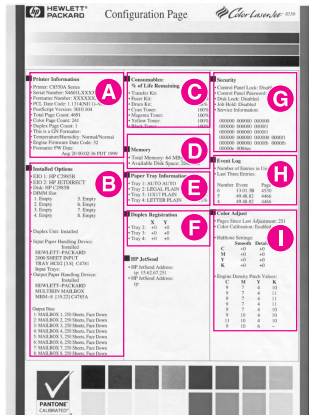

- A Printer Information**—Lists the printer product number, serial number, PCL firmware date code, PostScript version, total pages printed during the life of the printer, number of color pages printed during the life of the printer, HP JetSend ID, processor installed, and number of duplex pages printed during the life of the printer.
- B Installed Options**—Shows whether options have been installed, such as the printer hard disk, DIMMs, duplexer, multi-bin mailbox, and optional input trays.
- C Consumables:% of Life Remaining**—Shows the percentage of life remaining for consumable kits in the printer.
- D Memory**—Shows the total memory installed in the printer (including a printer hard disk) and the settings that affect how the memory is used.
- E Paper Tray Configuration**—Lists the types and sizes of media configured for each input tray.
- F Duplex Registration**—Lists the offset values set for each input tray.
- G Security**—Shows whether the security features have been activated, such as the printer control panel lock, printer control panel password, and printer hard disk lock. There also is a service information code for service personnel.
- H Event Log**—Lists the last five printer events, including printer jams, service errors, and other printer actions.

- I **Color Adjust**—Lists the number of pages since the last color adjustment and the color calibration information.

---

**Note**

---

Print the Menu Map from the printer control panel to view the current color adjustment values.

## Duplex Registration

The duplex registration feature allows precise alignment of images on the front and back of a duplexed page. Image placement varies slightly for each input tray. The alignment procedure must be performed for each tray.

Figure 6

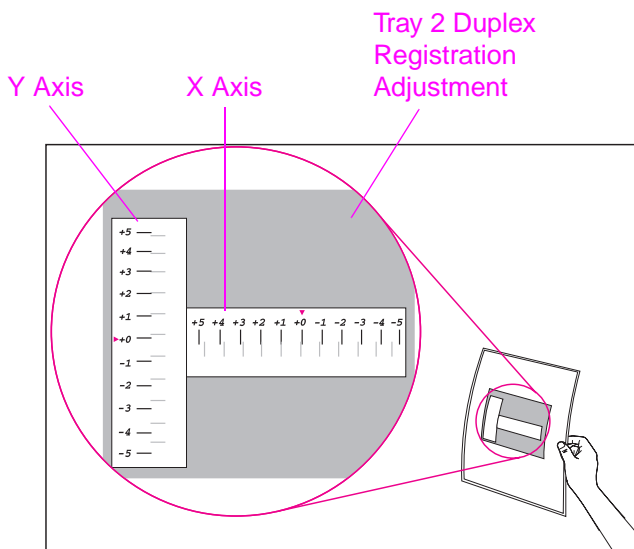

- 1 Press **MENU** until DUPLEX REGISTRATION MENU appears on the printer control panel display.
- 2 Press **ITEM** until PRINT TEST PAGE appears for the tray you want.
- 3 Press **SELECT** to print the page.
- 4 Hold the printed page up to a light source and choose the number on each axis where the lines on the front and back of the page align most accurately.
- 5 Repeat step 1.
- 6 Press **ITEM** until TRAY *n* X= appears and use **-VALUE+** to enter the number you selected from the test page in step 4.
- 7 Repeat step 6 for the y axis.
- 8 Press **ITEM** to scroll up through the duplex registration menu until PRINT TEST PAGE appears for the tray you want.

- 9 Press **SELECT** to print the page.
- 10 Repeat step 4 to verify that the lines on the front and back of the page are now properly aligned.

---

**Note**

---

If the lines on the front and back of the page do not properly align, then repeat steps 4-9 until they are properly aligned.



## Managing Memory

The printer supports an optional printer hard disk as well as ROM (read-only memory) and synchronous DRAM (dynamic random-access memory) DIMMs (dual inline memory modules). DRAM DIMMs must be installed in synchronized pairs (two DIMMs) with the same amount of memory installed in slots such as 1 and 2 (see task 5 on page 209). For more information on DIMMs, see appendix A, “[DIMM Installation](#).”

The printer comes with a minimum of 32 MB of RAM and can be expanded with additional DIMMs. The printer has four available DIMM slots for additional 8, 16, 32, or 64 MB DIMMs.

An optional printer hard disk is available for storing downloaded fonts and forms in the printer. Unlike standard printer memory, information stored on the printer hard disk is permanently downloaded and can remain in the printer even when the printer is turned off. A printer hard disk also enables proof and hold and mopying features (which can significantly decrease the processing time for multiple copies, or large or complex jobs). For information on ordering a printer hard disk, see “[Accessories, Options, and Related Products](#)” in chapter 8.

---

### Note

A printer hard disk is required to mopy or proof and hold.

## Resource Saving

Resource Saving allows PCL and PostScript fonts and macros downloaded to the printer's RAM when the printer switches between PCL and PostScript personalities. The printer determines the amount of RAM allocated to save each of the printer personality environments. Resource Saving is always enabled.

---

**Note**

---

All data downloaded to the printer's RAM will be lost when the printer is turned off.

## Configuring the Printer for the Network

For information on configuring the printer for the network, see your getting started guide or the *HP JetDirect Print Server Software Installation Guide*.



# 3 Common Printing Tasks

## Selecting Media

Many types of paper and other print media can be used with the printer, within certain specifications. Using media that does not meet the specifications outlined in this chapter can increase the incidence of media jams, contribute to repair and maintenance costs, and cause premature wear, print quality problems, and problems requiring service. This service might not be covered by the HP warranty or service agreements.

Before purchasing media or specialized forms, test a small quantity in the printer. Make sure your media supplier obtains and understands the media and print media specifications in the *HP LaserJet Printer Family Paper Specifications Guide*. (For ordering information, see [“Accessories, Options, and Related Products”](#) in chapter 8.)

---

### Note

It is possible that media could meet all of the specifications in this chapter and still not print satisfactorily. This might be caused by abnormal characteristics of the printing environment or other variables over which HP has no control, such as extremes in temperature and humidity.

---

- Use only print media that meets the specifications outlined in this chapter.
- Do not attempt to print unsupported sizes or weights of media or other unsupported media. For more information on supported media, see [“Supported Media Weights and Sizes for Input Trays”](#) on the next page.
- Always handle transparencies and glossy media by their edges to avoid fingerprints in the image area.

- Do not use media that has already passed through the printer or through a copy machine, even if there is no printing on the page.
- Recycled media can be used with this printer. Recycled media must meet the specifications shown in this chapter.

## Supported Media Weights and Sizes for Input Trays

The following table lists the types and sizes of media supported by each input tray. For best results, use HP LaserJet paper or conventional white xerographic paper. The media should be good quality and free of cuts, nicks, tears, spots, loose particles, dust, wrinkles, voids, perforations, and curled or bent edges. For a complete list of media specifications, see the *HP LaserJet Printer Family Paper Specifications Guide*.

For more information on orienting the media in each of the input trays, see the appropriate section later in this chapter.

Tray Location	Media Type	Media Size (Common Name and Dimensions)	Media Weight	Maximum Capacity
Tray 1	Paper: Plain Preprinted Letterhead Prepunched Bond Recycled Color Card Stock Heavy (greater than 28 lb/105 g/m <sup>2</sup> bond) Glossy	Executive (7.25 by 10.50 in, 184.15 by 266.70 mm) Letter (8.50 by 11 in, 215.90 by 279.40 mm) Legal (8.50 by 14 in, 215.90 by 355.60 mm) 11 by 17 in (279.40 by 431.80 mm)  A5 (148 by 210 mm, 5.83 by 8.27 in) ISO B5 (176 by 250 mm, 6.93 by 9.85 in) JIS B5 (182 by 257 mm, 7.17 by 10.13 in) A4 (210 by 297 mm, 8.27 by 11.70 in) JIS B4 (257 by 364 mm, 10.13 by 14.34 in) A3 (297 by 420 mm, 11.70 by 16.55 in)  12 by 18.50 in (304.80 by 469.90 mm) 312 by 440 mm (12.29 by 17.33 in) Custom minimum 99 by 190 mm (3.90 by 7.49 in), maximum 304 by 469 mm (11.98 by 18.48 in)	16 to 58 lb (60 to 216 g/m <sup>2</sup> ) bond	100 sheets of 20 lb (75 g/m <sup>2</sup> ) bond  Limit to media-fill mark on the media width guides

Tray Location	Media Type	Media Size (Common Name and Dimensions)	Media Weight	Maximum Capacity
	Envelopes	Monarch (3.90 by 7.50 in, 99.06 by 90.50 mm) Commercial #10 (Com10) (4.10 by 9.50 in, 104.14 by 241.30 mm)  DL (110 by 220 mm, 4.33 by 8.67 in) Double Post Card (JPOSTD) (148 by 200 mm, 5.83 by 7.88 in) C5 (162 by 229 mm, 6.38 by 9.02 in) B5 (176 by 250 mm, 6.93 by 9.85 in)	Maximum 24 lb (90 g/m <sup>2</sup> ) bond	Approximately 10  Limit to media-fill mark on the media width guides
	Labels	Letter (8.50 by 11 in, 215.90 by 279.40 mm) A4 (210 by 297 mm, 8.27 by 11.70 in)	—	Limit to media-fill mark on the media width guides
	Transparencies	Letter (8.50 by 11 in, 215.90 by 279.40 mm) A4 (210 by 297 mm, 8.27 by 11.70 in)	4 to 5 mils (0.10 to 0.13 mm) thick <sup>a</sup>	Limit to media-fill mark on the media width guides
Trays 2 and 3	Paper: Plain Preprinted Letterhead Prepunched Bond Recycled Color Glossy	Letter (8.50 by 11 in, 215.90 by 279.40 mm) Legal (8.50 by 14 in, 215.90 by 355.60 mm)  A4 (210 by 297 mm, 8.27 by 11.70 in)  <b>Tray 3 only</b> 11 by 17 in (279.40 by 431.80 mm) A3 (297 by 420 mm, 11.70 by 16.55 in)	16 to 28 lb (60 to 105 g/m <sup>2</sup> ) bond	500 sheets of 20 lb (75 g/m <sup>2</sup> ) bond  Limit to media-fill mark on the media width guides
	Transparencies	Letter (8.50 by 11 in, 215.90 by 279.40 mm) A4 (210 by 297 mm, 8.27 by 11.70 in)	4 to 5 mils (0.10 to 0.13 mm) thick <sup>a</sup>	Limit to media-fill mark on the media width guides

<b>Tray Location</b>	<b>Media Type</b>	<b>Media Size (Common Name and Dimensions)</b>	<b>Media Weight</b>	<b>Maximum Capacity</b>
Tray 4	Paper: Plain Preprinted Letterhead Prepunched Bond Recycled Color Glossy	Letter (8.50 by 11 in, 215.90 by 279.40 mm) Legal (8.50 by 14 in, 215.90 by 355.60 mm) 11 by 17 in (279.40 by 431.80 mm)  A4 (210 by 297 mm, 8.27 by 11.70 in) JIS B4 (257 by 364 mm, 10.13 by 14.34 in) A3 (297 by 420 mm, 11.70 by 16.55 in)	16 to 28 lb (60 to 105 g/m <sup>2</sup> ) bond	2,000 sheets of 20 lb (75 g/m <sup>2</sup> ) bond  Limit to media-fill mark on the media width guides

- a. HP recommends using 5 mil (0.13 mm) thick transparencies with this printer.

## Supported Media Weights and Sizes for the Optional Multi-bin Mailbox

The following table lists the types and sizes of media supported by multi-bin mailbox output bins.

<b>Bin</b>	<b>Media Type</b>	<b>Media Size (Common Name and Dimensions)</b>	<b>Media Weight</b>	<b>Maximum Capacity</b>
Mailboxes	Paper: Plain Preprinted Letterhead Prepunched Bond Recycled Color	Letter (8.50 by 11 in, 215.90 by 279.40 mm) Legal (8.50 by 14 in, 215.90 by 355.60 mm) 11 by 17 inch (279.40 by 431.80 mm)  A4 (210 by 297 mm, 8.27 by 11.70 in) A3 (297 by 420 mm, 11.70 by 16.55 in) JIS B4 (257 by 364 mm, 10.13 by 14.34 in)	16 to 28 lb (60 to 105 g/m <sup>2</sup> ) bond	250 sheets of 20 lb (75 g/m <sup>2</sup> ) bond



<b>Bin</b>	<b>Media Type</b>	<b>Media Size (Common Name and Dimensions)</b>	<b>Media Weight</b>	<b>Maximum Capacity</b>
Left (face-up) Output Bin	Paper: Plain Preprinted Letterhead Prepunched Bond Recycled Color Card Stock Heavy (greater than 28 lb/105 g/m <sup>2</sup> bond) Glossy	Letter (8.50 by 11 in, 215.90 by 279.40 mm) Legal (8.50 by 14 in, 215.90 by 355.60 mm) 11 by 17 in (279.40 by 431.80 mm) Executive (7.25 by 10.50 in, 184.15 by 266.70 mm)  A4 (210 by 297 mm, 8.27 by 11.70 in) A5 (148 by 210 mm, 5.83 by 8.27 in) A3 (297 by 420 mm, 11.70 by 16.55 in) JIS B5 (182 by 257 mm, 7.17 by 10.13 in) JIS B4 (257 by 364 mm, 10.13 by 14.34 in) ISO B5 (176 by 250 mm, 6.93 by 9.85 in)  12 by 18.50 in (304.80 by 469.90 mm) 312 by 440 mm (12.29 by 17.33 in) Custom minimum 99 by 190 mm (3.90 by 7.49 in), maximum 304 by 469 mm 11.98 by 18.48 in)	16 to 58 lb (60 to 216 g/m <sup>2</sup> ) bond	125 sheets of 20 lb (75 g/m <sup>2</sup> ) bond
	Labels	Letter (8.50 by 11 in, 215.90 by 279.40 mm) A4 (210 by 297 mm, 8.27 by 11.70 in)	—	
	Transparencies	Letter (8.50 by 11 in, 215.90 by 279.40 mm) A4 (210 by 297 mm, 8.27 by 11.70 in)	4 to 5 mils (0.10 to 0.13 mm) thick <sup>a</sup>	

<b>Bin</b>	<b>Media Type</b>	<b>Media Size (Common Name and Dimensions)</b>	<b>Media Weight</b>	<b>Maximum Capacity</b>
	Envelopes	Commercial #10 (Com10) (4.10 by 9.50 in, 104.14 by 241.30 mm) Monarch (3.90 by 7.50 in, 99.06 by 190.50 mm)  C5 (162 by 229 mm, 6.38 by 9.02 in) DL (110 by 220 mm, 4.33 by 8.67 in) B5 (176 by 250 mm, 6.93 by 9.85 in) Double Post Card (JPOSTD) (148 by 200 mm, 5.83 by 7.88 in)	Maximum 24 lb (90 g/m <sup>2</sup> ) bond	30 Monarch-sized envelopes

- a. HP recommends using 5 mil (0.13 mm) thick transparencies with this printer.

## Supported Media Weights and Sizes for the Optional Duplexer

The following table lists the types and sizes of media supported by the optional duplexer.

	<b>Media Type</b>	<b>Media Size (Common Name and Dimensions)</b>	<b>Media Weight</b>	<b>Maximum Capacity</b>
Duplexer	Paper: Plain Preprinted Letterhead Prepunched Bond Recycled Glossy	Letter (8.50 by 11 in, 215.90 by 279.40 mm) Legal (8.50 by 14 in, 215.90 by 355.60 mm) 11 by 17 inch (279.40 by 431.80 mm)  A4 (210 by 297 mm, 8.27 by 11.70 in) A3 (297 by 420 mm, 11.70 by 16.55 in) JIS B4 (257 by 364 mm, 10.13 by 14.34 in) B5 (176 by 250 mm, 6.93 by 9.85 in)	16 to 28 lb (60 to 105 g/m <sup>2</sup> ) bond	

## Supported Media Weights and Sizes for the Optional 3000-sheet Stapler/Stacker and Optional 3000-sheet Stacker

The following table lists the types and sizes of media supported by the optional 3000-sheet Stapler/Stacker and 3000-sheet Stacker tray, bin, or stapler.

Tray, Bin, or Stapler	Media Type	Media Size (Common Name and Dimensions)	Media Weight	Maximum Capacity
Left (face-up) Output Bin	Paper: Plain Preprinted Letterhead Prepunched Bond Recycled Color Card Stock Heavy (greater than 28 lb/105 g/m <sup>2</sup> bond) Glossy	<ul style="list-style-type: none"> <li>● Letter, ISO A4 (landscape orientation only)</li> <li>● Legal, Ledger (11 x 17 in.), A3, JIS B4, JIS Double Postcard, JPostD, JIS B5, A5, Executive, JIS Exec, 8K, 16K (portrait orientation only) Custom: Minimum - 190 mm length x 98 mm width Maximum - 460 mm length x 305 mm width</li> <li>● Universal</li> </ul> Envelopes: COM 10, C5, DL, Monarch, B5 (portrait orientation only)	16 to 53 lb bond (60 to 199 g/m <sup>2</sup> )	Up to 125 sheets Letter (20 lb bond) A4 (80 g/m <sup>2</sup> )

Tray, Bin, or Stapler	Media Type	Media Size (Common Name and Dimensions)	Media Weight	Maximum Capacity
Stacker Bin (Optional Bin 1)	Paper: Plain Preprinted Letterhead Prepunched Bond Recycled Color	<ul style="list-style-type: none"> <li>● Letter, ISO A4 (landscape orientation only)</li> <li>● Legal, Ledger (11 x 17 in.), A3, JIS B4, JIS B5, A5, Executive, JIS Exec, 8K, 16K (portrait orientation only)</li> <li>● Custom: Minimum - 190 mm length x 148 mm width Maximum - 460 mm length x 297 mm width</li> </ul> <p><b>Note</b> Envelopes, transparencies, and labels are ONLY supported in the Face-up Bin.</p>	16 to 28 lb bond (60 to 110 g/m <sup>2</sup> )	Up to 3,000 sheets Letter (20 lb bond) A4 (80 g/m <sup>2</sup> )  <b>Note</b> The Stacker Bin's capacity varies depending on the paper's size and weight. For example, using 11 x 17 in. (20 lb bond), the capacity can be approximately 1,500 sheets.
Stapler	Paper: Plain Preprinted Letterhead Prepunched Bond Recycled Color	<ul style="list-style-type: none"> <li>● Letter, ISO A4 (landscape orientation only)</li> <li>● Legal, Ledger (11 x 17 in.), A3, JIS B4, JIS B5, A5, Executive, JIS Executive, 8K, 16K (portrait orientation only)</li> </ul> <p><b>Note</b> Envelopes, transparencies, and labels are ONLY supported in the Face-up Bin.</p>	16 to 28 lb bond (60 to 110 g/m <sup>2</sup> )	Maximum 5 mm stack height. For example, 50 sheets of 20 lb bond.  <b>Note</b> The stapling capacity varies depending on the paper's thickness.

## Preprinted Forms and Letterhead

Observe the following guidelines to avoid problems with preprinted forms and letterhead.

- Forms and letterhead must have been printed with heat-resistant inks that will not melt, vaporize, or release hazardous emissions when subjected to the printer's fusing temperatures (approximately 374° F, or 190° C).
- The inks must be non-flammable and must not adversely affect any printer rollers.
- Forms and letterhead should be sealed in a moisture-proof wrapping to prevent moisture damage during storage.
- Inks must be completely dry on forms and letterhead before they are used in the printer. Ink that is not completely dry can come off the page during the fusing process.

## Recycled Media

Choose recycled media that meets the same specifications as standard paper (see “[Supported Media Weights and Sizes for Input Trays](#)” earlier in this chapter). HP recommends that recycled media contain no more than five percent ground wood.

## Envelopes

Envelopes can only be printed from tray 1. The weight of the envelope paper should not exceed 24 lb (90 g/m<sup>2</sup>) bond; otherwise, jamming might occur. For more information on printing envelopes, see “[Printing Envelopes from Tray 1](#)” later in this chapter.

- Envelopes should lie flat, with less than 0.25 inches (6.35 mm) curl.
- Output envelopes to the left (face-up) output bin rather than to the top (face-down) output bin to reduce curl.
- The optional multi-bin mailbox does not support envelopes except in its left (face-up) output bin.
- Do not use envelopes with windows or clasps.
- Make sure envelopes are not wrinkled, nicked, or otherwise damaged.
- Envelopes with a peel-off adhesive strip or with more than one flap must use adhesives compatible with the printer's fusing temperatures (approximately 374° F, or 190° C). Extra flaps or strips can result in wrinkling or creasing, and can cause jamming.
- All folds must be well scored and sharply creased.
- Envelopes must be tightly constructed and should not contain air. Envelopes that contain air may wrinkle as they pass through the printer.

# Transparencies

---

## CAUTION

---

Use only transparencies supported for use in this printer, such as HP Color LaserJet transparencies (for ordering information, see “[Accessories, Options, and Related Products](#)” in chapter 8). Using transparencies that do not meet the specifications for this printer can cause poor print quality, media jams, and damage to the printer.

Although this printer supports transparencies between 4 and 5 mils (0.10 to 0.13 mm) thick, HP recommends using 5-mil (0.13-mm) thick transparencies.

To prevent damage to the printer, transparencies must be able to withstand the printer’s fusing temperature (approximately 374° F, or 190° C).

Handle transparencies by the edges. Oils from your fingers can be deposited on the transparencies, causing print quality problems.

## Heavy Paper Stock

Heavy paper stock is any paper heavier than 28 lb up to 58 lb (105 to 216 g/m<sup>2</sup>) bond. Always print heavy paper stock from tray 1. In the printer driver, select **Heavy Paper** as the paper type on the Paper tab to ensure the correct finish on the media. Also, use the left (face-up) output bin to prevent media jams. For more information on changing the printer driver settings, see the online help.

*Do not* use extremely heavy paper stock (greater than 58 lb, or 216 g/m<sup>2</sup> bond). Misfeeds, mis-stacking, media jams, poor toner fusing, poor print quality, and excessive mechanical wear can result.

## Labels

Labels consist of three parts: the top or face sheet that the printer prints on, the adhesive, and the carrier sheet (also referred to as the backing or liner). When printing on labels with this printer, observe the following:

- Top sheets, which are the printing surface, are usually composed of xerographic paper. Label top sheets must provide good toner adhesion.
- Carrier sheets must be compatible with the printer's fusing temperature (approximately 374° F, or 190° C) and the pressure of the fusing process. The carrier sheet also must be coated for easy release of the top sheet.

---

### CAUTION

---

Do not remove labels from the carrier sheet and then print on the remaining labels; printer damage can result.

- Adhesives must be able to withstand the printer's fusing temperature (approximately 374° F, or 190° C). The adhesives must not produce emissions that exceed exposure levels or threshold limits established by the U.S. Occupational Safety and Health Administration and other safety agencies. Adhesives must not come in direct contact with any part of the printer. No adhesive should be pressed out of the edges or between die-cuts (the cuts between individual labels).
- Labels should be arranged so that the carrier sheet is not exposed. Using label stock with spaces between the horizontal rows of labels might result in labels peeling off during printing, causing jams and possible printer damage. Labels might be specifically manufactured to leave a margin around the outside edges that correspond to the outer margins of the printable area. *Do not remove* the excess top sheet material from the carrier sheet.

---

### Note

---

Labels could meet all of the guidelines in this chapter and still not print satisfactorily because of the printing environment or other variables over which HP has no control.



## Colored Media

Colored media should be of the same high quality as white xerographic paper. Pigments used must be able to withstand the printer's fusing temperature (approximately 374° F, or 190° C). Do not use media with colored coating that was added after the media was produced.

The printer cannot detect the color of media you are using. Varying the shade or color of the media can change the shades of the printed colors.

## Media to Avoid

Follow these guidelines to avoid poor print quality or damage to the printer:

- Do not use media that contains embossing.
- Do not use media with cutouts or perforations.
- Do not use multi-part forms.
- Do not use media with irregularities, such as tabs or staples.
- Do not use preprinted media that contains thermography or inks that melt, vaporize, or release hazardous emissions when subjected to the fusing temperature (approximately 374° F, or 190° C).
- Do not use any media that produces hazardous emissions, melts, offsets, or discolors when heated to the printer's fusing temperatures (approximately 374° F, or 190° C).
- Do not use media that has already been through a photocopier or printer, even if there is no printing on the page.
- Do not use media with a watermark if solid fill areas are to be printed.
- Do not use transparencies designed for ink jet printers.

# Controlling Your Print Job

Control your print jobs from the printer or your computer. Changes to the printer setup made from the printer control panel become default settings for all print jobs. Changes to the printer setup made through the printer driver on the computer will override settings in the printer control panel and affect only the print jobs initiated from that computer. Changes made from an application will remain in effect for the current print job or until changed, depending on the application. Most changes made to the printer should be made from the computer so that the changes do not affect other users' print jobs.

## Changing Page Orientation

The following figure shows different page orientations:

Figure 7



**A** Portrait

**B** Landscape

Control the page orientation from your application, the printer driver, or the printer control panel (PCL print jobs only):

- To print across the width (short edge) of the media, select portrait page orientation from your application or the printer driver.
- To print across the length (long edge) of the media, select landscape page orientation from your application or the printer driver.

For more information on changing the page orientation, see the online help for your application or the printer driver.

# Printing from Tray 1

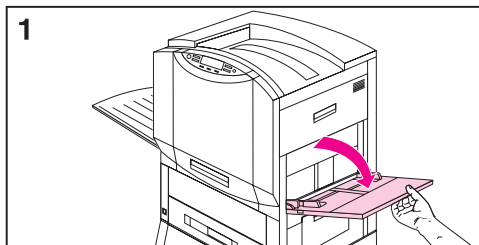

Load up to 100 sheets of 20 lb (75 g/m<sup>2</sup>) bond paper in tray 1.

---

## CAUTION

To avoid media jams, never add or remove media from tray 1 while the printer is printing from tray 1.

---

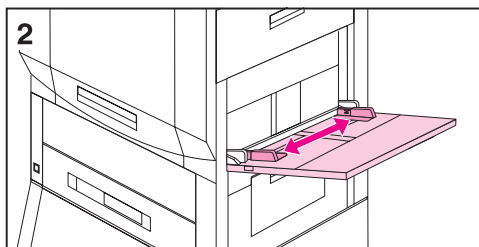

## To load media into tray 1

- 1 Open tray 1.
- 2 Slide the media width guides to the size that matches the media.
- 3 Load up to 100 sheets of 20 lb (75 g/m<sup>2</sup>) bond paper into the input tray face up, with the long edge of the letter- or A4-sized media toward the printer. For more information on loading other sizes into tray 1, see [“Orienting Media”](#) later in this chapter.

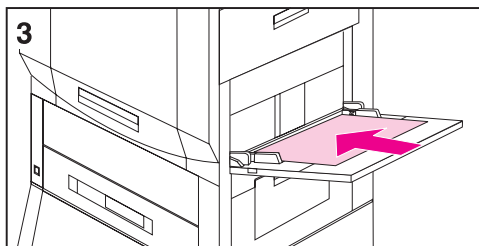

---

## Note

Do not fill the input tray above the media-fill mark on the media guides.

---

- 4 Slide the media into the printer as far as it will go (until the leading edge rests lightly against the printer) and adjust the media width guides until the media fits squarely and firmly between the media width guides without bending the media.
- 5 Use the control panel to select the size and type of media in tray 1 (see [Configuring Media Type and Size](#) in chapter 2).

# Printing Envelopes from Tray 1

Load up to ten envelopes in tray 1.

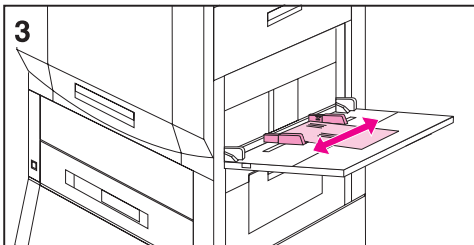
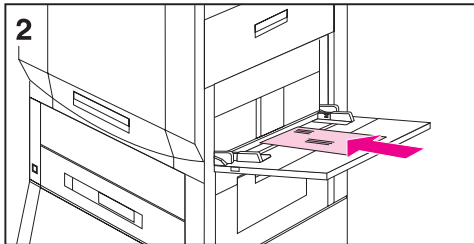
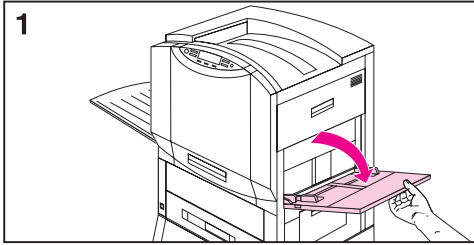

---

## CAUTION

Never use envelopes with clasps, snaps, windows, coated linings, or self-stick adhesives. These items can damage the printer. Never try to print on both sides of an envelope. Media jams and printer damage can result.

---

## To load envelopes in tray 1

- 1 Open tray 1.
- 2 Place up to ten envelopes in tray 1 between the media width guides, face up, with the back flap against the input tray and the return address area (short edge of the envelope) towards the printer.
- 3 Slide the media width guides until they touch both sides of the envelopes without bending the envelopes.
- 4 Set the envelope size in the printer control panel. For more information on configuring the printer control panel, see "[Configuring Media Type and Size](#)" in chapter 2.

## To print envelopes from tray 1

- 1 Select envelope in your application or in the printer driver if your application does not support printing on envelopes. For more information on printing on envelopes, see the online help.
- 2 Set the envelope size and type in your application or the printer driver.
- 3 If your application does not have an option to automatically format an envelope, select Landscape for the page orientation.
- 4 Use the following table to set the margins for a return and mailing address on a Commercial #10- (Com10) or DL-sized envelope.

Type of Address	Left Margin	Top Margin
Return	0.50 in (12.70 mm)	0.50 in (12.70 mm)
Mailing	4 in (101.60 mm)	2 in (50.80 mm)

For other sizes of envelopes, adjust the margins as necessary. Avoid printing over the area where the envelope's three back flaps (seams) meet.

- 5 Print the file from your application.

## Printing Tips for Tray 1

- For letter- or A4-sized media, load the media with the **long edge** of the media toward the printer.
- For legal-, executive-, 11-by-17 inch, or A3-sized media, load the media with the **short edge** of the media toward the printer.
- Heavy paper stock is any paper heavier than 28 lb up to 58 lb (105 to 216 g/m<sup>2</sup>) bond. Always print heavy paper stock from tray 1. In the printer driver, select **Heavy Paper** as the paper type on the Paper tab to ensure the correct finish on the media. Also, use the left (face-up) output bin to prevent media jams.
- To print on custom-sized media, set the media size in your application or the printer driver. The printer will accept custom sizes between 3.90 by 7.49 in (99 by 190 mm) and 12 by 18.50 in (304.80 by 469.90 mm). If the media size set in your application or the printer driver does not match the size of the media being fed into the printer, then the printer might not feed the media or the media might jam.
- Do not use media heavier than 58 lb (216 g/m<sup>2</sup>) bond.
- Handle transparencies by the edges to avoid leaving fingerprints on the transparency.

---

### CAUTION

Use only transparencies and glossy media that meet the specifications for this printer. Using an incorrect type of media can damage the printer. For more information on glossy media, see “[Supported Media Weights and Sizes for Input Trays](#)” earlier in this chapter.

---

# Orienting Media

## Orienting Media in Tray 1

Figure 8

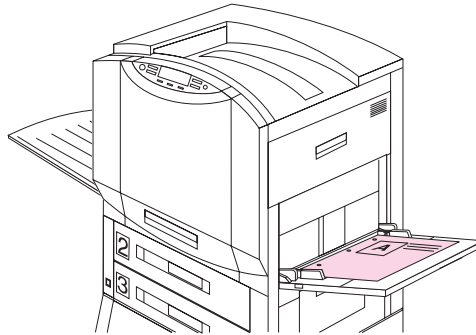

Place media into the input tray with the side to be printed on face up for single-sided printing (see figure 8). For letter- or A4-sized media, place the top of the page toward the rear of the printer and the long edge toward the printer. For media sizes larger than letter and A4, place the top (short) edge of the page toward the printer.

Load letterhead and preprinted forms face up.

Figure 9

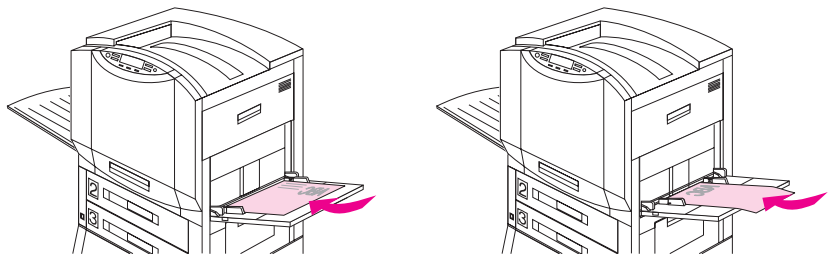

The duplexer prints the second side of the paper first, so paper such as letterhead and preprinted paper needs to be oriented as shown.

- Load letter and A4 paper with the front side down and the top, short edge toward the rear of the printer for double-sided printing.
- Load other sizes of paper with the front side down and the top, short edge toward the printer for double-sided printing.

## Orienting Media for All Other Trays

Figure 10

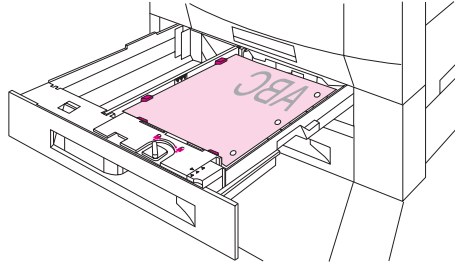

Place the media into the input tray with the side to be printed on face down (see figure [10](#)) for single-sided printing.

Load letterhead with the top toward the rear of the input tray.

Figure 11

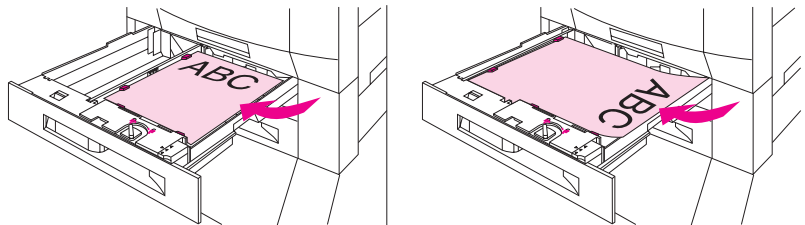

- Load letter and A4 paper with the front side up and the top, short edge toward the rear of the tray for double-sided printing.
- Load other sizes with the front side up and the top, short edge toward the right of the tray for double-sided printing.

## Media Orientation for Printing Prepunched Paper

When printing with prepunched paper, always load the paper with the holes toward the printer for tray 1 (see figure [8](#)). Load the prepunched paper with the holes toward the right of the printer for trays 2, 3, and 4 (see figure [10](#)). When printing on both sides of prepunched paper, you must select prepunched paper as the paper type in the Paper Handling menu from the control panel and select prepunched paper from your printer driver.

---

### Note

When printing on both sides of prepunched paper with stapling enabled, the staple will be in the lower right corner of your print job.



# Printing from Trays 2 (some printer models only) and 3

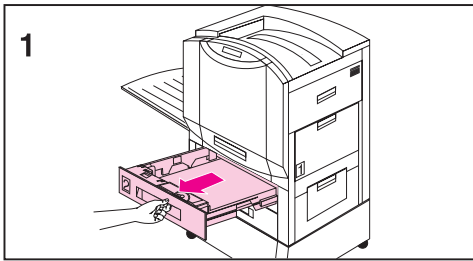

Load up to 500 sheets of 20 lb (75 g/m<sup>2</sup>) bond paper in trays 2 and 3.

## To load media into trays 2 and 3

### CAUTION

To avoid media jams, never open an input tray while the printer is printing from that input tray.

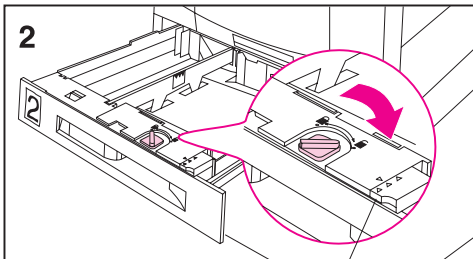

- 1 Firmly grip the handle in the center of the input tray, squeeze the release lever, and pull the input tray out until it stops.

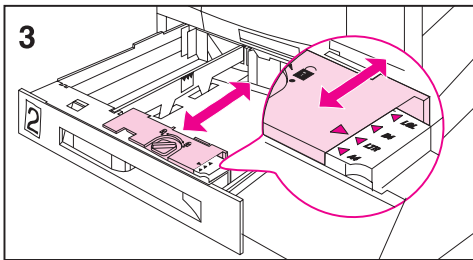

### Note

To use the media size currently configured in the input tray, go to step 8. To use a media size different from the current setting, go to step 2 to reconfigure the input tray.

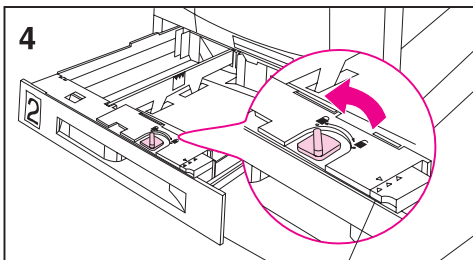

- 2 Turn the media guide lock to the unlocked position.
- 3 Slide the media width guides to the size that matches the media.
- 4 Turn the media guide lock to the locked position.

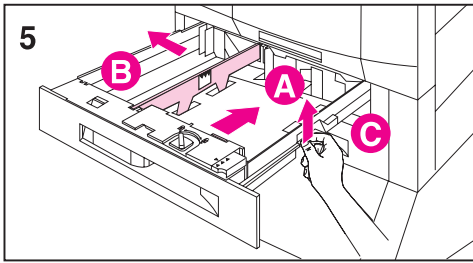

- 5 Adjust the left media guide by pushing it in (A) and lifting up and out (B).

---

**Note**

Lift here (C) to remove paper from the tray.

---

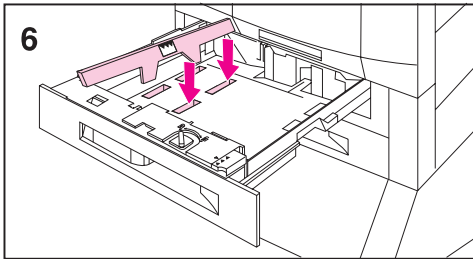

- 6 Position the left media guide over the correct media size marked on the input tray.

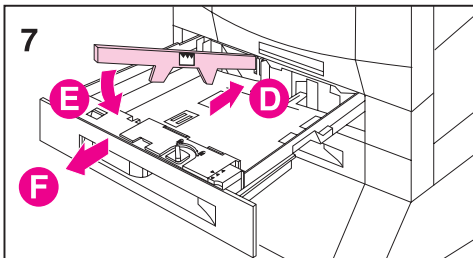

- 7 Press the left media guide into the rear slot (D), and then lower it down (E) into the front slot (F). Verify the guide is not skewed.

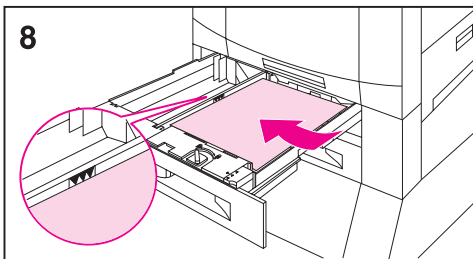

- 8 Load up to 500 sheets of 20 lb (75 g/m<sup>2</sup>) bond paper in the input tray. For information on loading different types of media, see [“Orienting Media for All Other Trays”](#) later in this chapter.

---

**CAUTION**

Do not fill the input tray above the media-fill mark. Excessive media in the input trays can cause media jams.

---

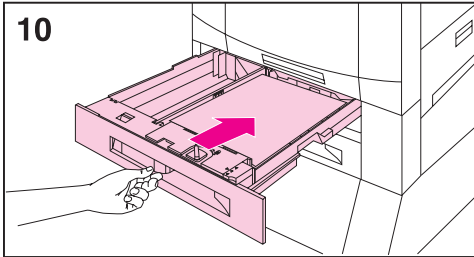
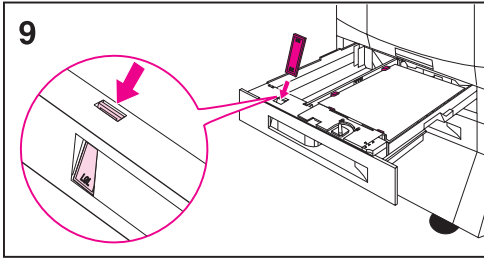

- 9 Ensure that the media size tab on the front of the input tray is set to the correct media size.
- 10 Slide the input tray back into the printer.
- 11 Set the media type in the printer control panel. For more information on configuring the printer control panel, see [“Configuring Media Type and Size”](#) in chapter 2.

---

**Note**

Always configure the media type in the printer control panel to prevent users from printing on the wrong media type (such as transparencies instead of plain paper).

---

**Note**

If media curls or skews excessively during printing, open the input tray and turn the stack of media over. To avoid media jams, never open the input tray while the printer is printing.

---

## To print from trays 2 and 3

- 1 Select the media type and size from your application or the printer driver. To set the media type and size in the printer control panel, see [“Configuring Media Type and Size”](#) in chapter 2.
- 2 Print the file from your application.

## Printing Tips for Trays 2 and 3

- Handle transparencies by the edges to avoid leaving fingerprints on the transparencies.
- Use transparencies that meet the media specifications for this printer. Using the incorrect type of transparencies can damage the printer. For more information on transparencies, see [“Supported Media Weights and Sizes for Input Trays”](#) earlier in this chapter.
- Use letterhead that meets the media specifications for this printer. For more information on letterhead specifications, see [“Preprinted Forms and Letterhead”](#) earlier in this chapter.

# Printing from Tray 4 (some printer models only)

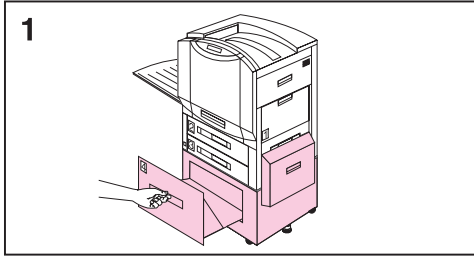

Load up to 2,000 sheets of 20 lb (75 g/m<sup>2</sup>) bond paper in tray 4.

## To load media into tray 4

- 1 Firmly grip the handle in the center of the input tray, squeeze the release lever, and pull the input tray out until it stops.

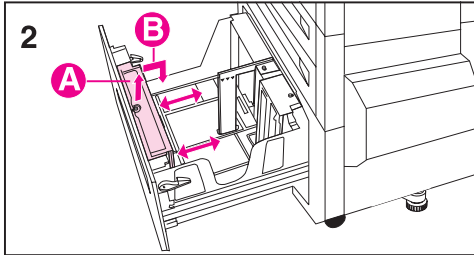

### Note

To use the media size currently configured in the input tray, go to step 5. To use a different size, go to step 2.

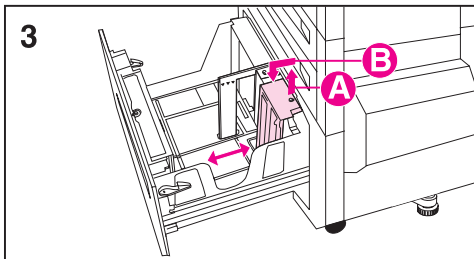

- 2 Adjust the front media guide by pulling up on the pin (A), placing the media guide into the slots on the top and bottom of the input tray that correspond to the media size you are loading (B), and pushing in the pin.
- 3 Repeat step 2 to adjust the back media guide.
- 4 Repeat step 2 to adjust the left media guide.

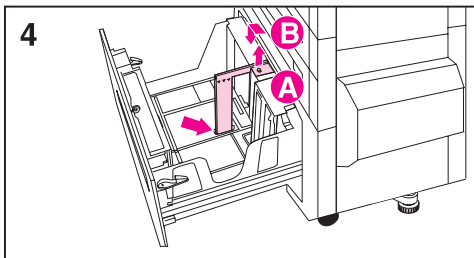

### Note

For 11-by-17 inch media, move the left media guide to the back of the input tray.

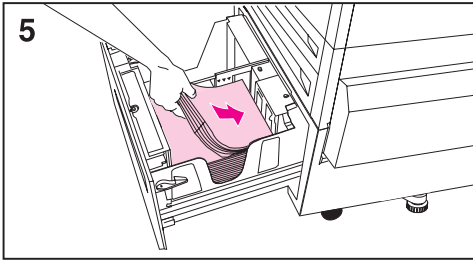

- 5 Load up to 2,000 sheets of 20 lb (75 g/m<sup>2</sup>) bond paper into the input tray. For information on loading different types of media, see [“Orienting Media for All Other Trays”](#) later in this chapter.

---

### CAUTION

Do not place anything in the input tray to the left of the media guides because the input tray will not be able to lift the media to print and could damage the input tray. Also, do not fill the input tray above the media-fill mark on the left media guide. Excessive media can cause media jams.

---

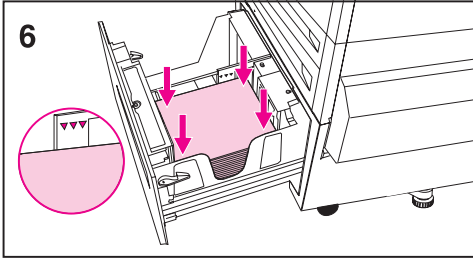

- 6 Press down on all four corners of the media stack to ensure the media rests flat in the input tray.

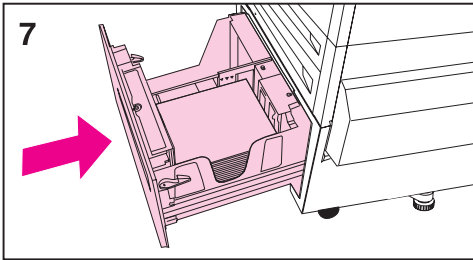

- 7 Close tray 4.
- 8 Set the media type in the printer control panel. For more information on configuring the printer control panel, see [“Configuring Media Type and Size”](#) in chapter 2.

---

### Note

Always configure the media type in the printer control panel to prevent printing on the wrong media type (such as transparencies instead of plain paper).

---

## To print from tray 4

- 1 Select the media type and size from your application or the printer driver. To set the media type and size in the printer control panel, see [“Configuring Media Type and Size”](#) in chapter 2.
- 2 Print the file from your application.

## **Printing Tips for Tray 4 (some printer models only)**

Use letterhead that meets the media specifications for this printer (see "[Preprinted Forms and Letterhead](#)" earlier in this chapter).

# 4 Advanced Printing Features

## Overview

This chapter introduces some **advanced printing tasks** to help you take full advantage of the printer's features. These tasks are "advanced" because they require you to change settings from a software application, the printer driver, or the printer's control panel.



## Using the HP TonerGauge

The HP TonerGauge feature allows the user to estimate how much toner is left in the cartridges. The HP TonerGauge indicator appears on the configuration page, on the status tab of the driver, and in HP Web JetAdmin (for the network administrator). The toner level indicated by the gauge may be used to estimate whether enough toner remains in the cartridges to complete a print job.

---

### Note

The user must reset the HP TonerGauge each time a new cartridge is installed to ensure that the HP TonerGauge reports accurate information. See “[Resetting the HP TonerGauge](#)” on page [127](#).

---

# Printing by Type and Size of Paper

You can configure the printer to select paper by **type** (such as plain or letterhead) and **size** (such as letter or A4), as opposed to **source** (a paper tray).

## Benefits of Printing by Type and Size of Paper

If you frequently use several different kinds of paper, once trays are set up correctly, you do not have to check which paper is loaded in each tray before you print. This is especially helpful when the printer is shared and more than one person loads or removes paper.

Printing by type and size of paper is a way to be sure that print jobs always print on the desired paper. (Some printers have a feature that “locks out” trays to prevent printing on the wrong paper. Printing by type and size of paper eliminates the need to lock out trays.)

### To print by type and size of paper, do the following:

- 1 Be sure to adjust and load the trays correctly. (See the sections on loading paper, starting on page [77](#).)
- 2 From the Paper Handling Menu in the printer's control panel, select the paper **type** for each tray. If you are unsure what type you are loading (such as bond or recycled), check the label on the package of paper. For supported types, see page [60](#).
- 3 Select the paper size settings from the control panel.
  - **Tray 1:** If custom paper is loaded, set the size of custom paper from the Printing Menu to match the paper loaded in tray 1.
  - **Other trays:** Paper size settings are adjusted when paper is properly loaded into the printer. (See the sections on loading paper, starting on page [77](#).)

- 4 From the software or printer driver, select the desired type and size of paper.

---

**Note**

The type and size settings can also be configured from HP Web JetAdmin for networked printers. See the printer software help.

Settings in the printer driver and software application override control panel settings. (Software application settings override printer driver settings.)

---

## Different First Page

- 1 For Windows, select “Use different paper for first page” in your printer driver. Choose a tray or type under First Page for the first page and then select a tray or type from Other Pages for the remaining pages. Place the paper with the side-to-be-printed up, the top of the page facing the rear of the printer, and the long edge leading into the printer.

For Macintosh, select “First from” and “Remaining from” in the print dialog box.

---

### Note

Where and how you make selections depends on your software application or associated printer driver. (Some options may only be available through the printer driver.)

- 2 Load the paper for the remaining pages of the document into another tray. You may select the first and remaining pages by type of paper. For more information, see [Printing by Type and Size of Paper](#) on page [89](#).

---

### Note

The paper size must be the same for the first and remaining pages.

## Printing Multiple Pages on One Sheet of Paper

You can print more than one page on a single sheet of paper. This feature is available in some printer drivers and provides a cost-effective way to print draft pages.

To print more than one page on a sheet of paper, look for the Pages Per Sheet option in the Finishing Tab of the printer driver. (This is sometimes called 2-up, 4-up, or n-up printing.)

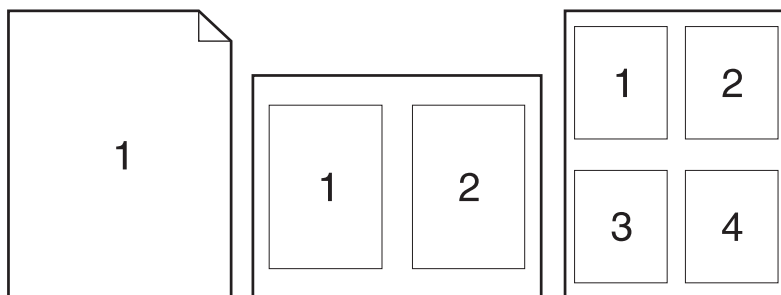

# Creating and Using Quick Sets

Quick Sets allow you to save the current driver settings (for example, page orientation, n-up printing or paper source) for reuse. For convenience, Quick Sets can be selected and saved from most printer driver tabs. You can also restore printer driver default settings by selecting Defaults from the Quick Sets drop-down list.

---

**Note**

---

Quick Sets are available only for Windows.

## Quick Sets

---

Printer Driver	Procedure
----------------	-----------

---

(Windows 3.1/9x/  
NT 4.0/Windows  
2000)

### Creating Quick Sets

**Note:** If you are using NT 4.0 or Windows 2000 and are running the printer driver from the server, you need administrator rights to save new Quick Sets.

- 1 Access the printer driver.
- 2 Select the desired print settings.
- 3 In the Quick Sets box, type a name for the selected settings (for example “Quarterly Report” or “My Project Status”).
- 4 Click Save.
- 5 When you save Quick Sets, all current driver settings are saved. The printer driver will now remember these settings.
- 6 Click OK.

## Quick Sets (continued)

---

Printer Driver	Procedure
----------------	-----------

---

### Using Quick Sets

- 1 Access the printer driver.
  - 2 Select the desired item from the Quick Sets drop-down list.
  - 3 Click OK. The printer is now set to print according to the settings in the Quick Sets you selected.
-

## Quick Copying a Job

The quick copy feature prints the requested number of copies of a job and stores a copy of the job on the printer's hard disk. Additional copies of the job can be printed later.

---

### CAUTION

---

The quick copy feature allows every user to print the last 32 jobs. This feature can be turned off in the driver.

This feature is the default for every job. This feature can be turned off from the driver. For more information about specifying the number of quick copy jobs that can be stored, see the `QUICK COPY JOBS` control panel item described on page [32](#).

## Printing Additional Copies of a Quick Copy Job

To print additional copies of a job stored on the printer's hard disk from the control panel:

- 1 Press **MENU** repeatedly until `QUICK COPY JOBS MENU` appears.
- 2 Press **ITEM** until the desired job name appears.
- 3 Press **SELECT** to select the job. `COPIES=1` appears.
- 4 Press **- VALUE +** until the desired number of copies appears.
- 5 Press **SELECT** to print the job.



## Deleting a Stored Quick Copy Job

When a user sends a quick copy job, the printer overwrites any previous jobs with the same name. If there is not a quick copy job already stored under the job name and the printer needs additional space, the printer may delete other stored quick copy jobs starting with the oldest job. The default number of quick copy jobs that can be stored is 32. The number of quick copy jobs that can be stored is set from the control panel.

---

### Note

---

If you turn the printer off and then back on, all quick copy, proof and hold, and private jobs are deleted.

A stored quick copy job can also be deleted from the control panel.

- 1 Press **MENU** repeatedly until `QUICK COPY JOBS MENU` appears.
- 2 Press **ITEM** until the desired job name appears.
- 3 Press **SELECT** to select the job. `COPIES=1` appears.
- 4 Press **- VALUE** until `DELETE` appears.
- 5 Press **SELECT** to delete the job.

# Proofing and Holding a Job

The proof and hold feature provides a quick and easy way to print and proof one copy of a job and then print the additional copies.

To permanently store the job and prevent the printer from deleting it when space is needed for something else, select the Stored Job option in the driver.

## Printing the Remaining Copies of a Held Job

The user can print the remaining copies of a job held on the printer's hard disk from the control panel.

- 1 Press **MENU** repeatedly until `QUICK COPY JOBS MENU` appears.
- 2 Press **ITEM** until the desired job name appears.
- 3 Press **SELECT** to select the job. `COPIES=1` appears.
- 4 Press **- VALUE +** until the desired number of copies appears.
- 5 Press **SELECT** to print the job.

## Deleting a Held Job

When a user sends a proof and hold job, the printer automatically deletes that user's previous stored proof and hold job. If there is not a proof and hold job already stored for that job name and the printer needs additional space, the printer may delete other stored proof and hold jobs starting with the oldest one.

---

### Note

---

If you turn the printer off and then back on, all quick copy, proof and hold, and private jobs are deleted.

A stored proof and hold job can also be deleted from the control panel.

- 1 Press **MENU** repeatedly until `QUICK COPY JOBS MENU` appears.
- 2 Press **ITEM** until the desired job name appears.
- 3 Press **SELECT** to select the job. `COPIES=1` appears.
- 4 Press **- VALUE** until `DELETE` appears.
- 5 Press **SELECT** to delete the job.

# Printing a Private Job

The private printing feature lets a user specify that a job is not printed until that user releases it using a 4-digit Personal Identification Number (PIN) through the printer's control panel. The user specifies the PIN in the driver and it is sent to the printer as part of the print job.

## Specifying a Private Job

To specify that a job is private from the driver, select the Private Job option and type a 4-digit PIN.

## Releasing a Private Job

The user can print a private job from the control panel.

- 1 Press **MENU** repeatedly until PRIVATE/STORED JOBS MENU appears.
- 2 Press **ITEM** until the desired job name appears.
- 3 Press **SELECT**. PIN:0000 appears.
- 4 Press **- VALUE +** to change the first number of the PIN, and then press **SELECT**. An \* appears in place of the number. Repeat these steps to change the remaining three numbers of the PIN.  
COPIES=1 appears.
- 5 Press **- VALUE +** until the desired number of copies appears.
- 6 Press **SELECT** to print the job.

## Deleting a Private Job

A private job is automatically deleted from the printer's hard disk after the user releases it for printing, unless the user selects the Stored Job option in the driver.

---

### Note

---

If you turn the printer off and then back on, all quick copy, proof and hold, and private jobs are deleted.

A private job can also be deleted from the printer's control panel before it is ever printed.

- 1 Press **MENU** repeatedly until PRIVATE/STORED JOBS MENU appears.
- 2 Press **ITEM** until the desired job name appears.
- 3 Press **SELECT** to select the job. PIN:0000 appears.
- 4 Press - **VALUE** + to change the first number of the PIN, and then press **SELECT**. An \* appears in place of the number. Repeat these steps to change the remaining three numbers of the PIN. COPIES=1 appears.
- 5 Press - **VALUE** until DELETE appears.
- 6 Press **SELECT** to delete the job.

## Storing a Print Job

The user can download a print job to the printer's hard disk without printing it. The user can then print the job at any time through the printer's control panel. For example, a user may want to download a personnel form, calendar, time sheet, or accounting form that other users can access and print.

To store a print job permanently on the hard disk, select the Stored Job option in the driver when printing the job.

## Printing a Stored Job

The user can print a job stored on the printer's hard disk from the control panel.

- 1 Press **MENU** repeatedly until PRIVATE/STORED JOBS MENU appears.
- 2 Press **ITEM** until the desired job name appears.
- 3 Press **SELECT** to select the job name. COPIES=1 appears.
- 4 Press **- VALUE +** until the desired number of copies appears.
- 5 Press **SELECT** to print the job.

## Deleting a Stored Job

Jobs stored on the printer's hard disk can be deleted from the control panel.

- 1 Press **MENU** repeatedly until PRIVATE/STORED JOBS MENU appears.
- 2 Press **ITEM** until the desired job name appears.
- 3 Press **SELECT** to select the job. COPIES=1 appears.
- 4 Press **- VALUE** until DELETE appears.
- 5 Press **SELECT** to delete the job.

# Variable Data Printing

Some applications produce documents containing two types of information: static information like background patterns, and variable information that changes from page to page. In a print job, variable data printing separates the static and dynamic information and sends the static information to the printer only once. Pages print faster because repetitive information does not have to be processed separately for each page.

---

**Note**

---

This feature is automatic. No user interaction is required.

# Booklet Printing

Booklet printing allows the pages of a print job to be arranged so that the document can be folded and stapled or bound into a book. Booklet printing is supported in PostScript and PCL5c in Windows 3.x, 9x, NT 4.0, Windows 2000, and using the Booklet Maker for Macintosh.

---

## Note

---

Duplex printing must be selected in order to use the Booklet Printing feature.

**Offline Booklet Printing** delivers the job to the top (face-down) output bin. The user can remove the job from the printer and bind or staple it. (Right and left binding options are provided for Asian languages.) The user may also insert one full blank page (2 booklet pages) at any location in the booklet.

**Inline Booklet Printing** uses a finishing device like a multi-bin mailbox to staple or bind the booklet. (Booklet Printing requires the document be sent to the left (face-up) output bin instead of the top (face-down) output bin.) The user selects the destination of the print job, and the software places the pages in the proper order for binding.

**Custom Order** allows the user to specify the page sequence.



## Print on Backside of Heavy Media

Print on Backside of Heavy Media allows you to print on both sides of media that is not supported in the automatic duplexer accessory.

- 1 Make sure that the appropriate media type is selected in the driver.
- 2 Select the face-up output bin for the destination.
- 3 Print the odd pages of the desired document from the software application.
- 4 Turn the media over (blank-side up) and place it in tray 1.
- 5 Select Print on Backside of Heavy Media from the Print Quality tab of the driver.
- 6 Select the face-up output bin for the destination.
- 7 Click OK, then print the even pages of the document.

# HP JetSend Communications Technology



HP JetSend is a new technology from Hewlett-Packard that allows devices to communicate with each other simply and directly. HP JetSend is built into your printer, allowing it to receive information from any JetSend-enabled sending device anywhere on your network, whether it is in the same office or at a remote location. Examples of JetSend sending devices include PCs or laptops running JetSend software or scanners with JetSend built in. JetSend uses simple IP addressing between networked devices.

You can visit the JetSend web site to learn which other devices are available to communicate easily and directly with your JetSend-enabled printer.

## How the JetSend Communications Technology Works

### Networked Devices

To use the JetSend capability between networked devices, print a configuration page to find your JetSend IP address, and give your address to anyone who wants to send information to your printer via JetSend.

From a JetSend sending device, a person only needs to enter the printer's IP address and press "send."

# Managing Fonts and Forms on Disk

## HP LaserJet Resource Manager (Windows)

The HP LaserJet Resource Manager should be installed only on the network administrator's computer. The HP LaserJet Resource Manager allows you to control hard disk features not found in the drivers. Bidirectional communication is required.

---

**Note**

---

HP LaserJet Resource Manager is not available for the Macintosh.

Use the HP LaserJet Resource Manager to do the following:

- Initialize disk.
- Download, delete, and manage fonts to disk across networks.
  - PostScript Type 1, PostScript Type 42 (True Type fonts converted to PostScript format), TrueType, and PCL bitmap fonts.

---

**Note**

---

To download Type 1 fonts, Adobe Type Manager must be loaded and turned on.

## HP LaserJet Utility (Macintosh)

HP LaserJet Utility allows control of features that are not available in the driver. The illustrated screens make selecting printer features from the Macintosh computer easier than ever. Use the HP LaserJet Utility to do the following:

- Customize the printer's control panel messages.
- Name the printer, assign it to a zone on the network, download files and fonts, and change most of the printer settings.
- Set a password for the printer.
- From the computer, lock out functions on the printer's control panel to prevent unauthorized access. (See the printer software help.)
- Configure and set the printer for IP printing.



# 5 Using Color

## Controlling Color Output with Printer Drivers

By varying the amount and pattern of the four toner colors applied to a page, the printer can produce more than 16 million colors. Use the printer drivers (the software installed with the printer) to control the color output for text, graphics, and photographs. The printer drivers enable computer applications to communicate with the printer and to use all of its features.

Access to the printer drivers depends on the computer system. For example, in a system using Microsoft Windows, use the application's Print Setup command to access your printer driver. For specific instructions on accessing the printer driver, see the online help files for your operating system.

---

**Note**

Applications override most printer settings, such as media size, copies, and media source. When possible, use application settings for adjustments.

---

## Using Color

The color features of the driver are available on the properties page. Access the driver properties as it pertains to the specific operating system or application in use, then select the Color tab.

### ColorSmart II

HP ColorSmart II technology optimizes the color and halftoning for each element in a document (such as text, graphics, and photographs).

- HP ColorSmart II uses the **Screen Match** setting to reproduce all elements in a document. HP ColorSmart II uses a smooth halftone for photographs and raster graphics, and uses a detail halftone for text and vector graphics. This setting provides consistent color treatment for everything on a page.
- When **Transparency** is selected in the Paper tab of the printer driver, HP ColorSmart II chooses specialized colors to provide the best projection quality.
- HP ColorSmart II is also the most reliable setting for PANTONE®\* color reproduction. For more information on using PANTONE colors, see "[PANTONE Colors](#)" later in this chapter.

## Manual Mode

For custom color printing jobs, you can turn off HP ColorSmart II defaults and set color adjustments manually. The Manual mode allows you to adjust the color settings for text, graphics, and photographs separately by manipulating the available settings. The following settings apply to all types of media:

- **Halftone**—Changes the method used to produce lighter shades of solid colors.
  - **Smooth**—Works well for solid areas, gradients, and photographs by smoothing out fine color gradations and providing accurate color reproduction.
  - **Detail**—Works well for text, multiple-colored text, line art, and detail-oriented graphics by providing sharper edges.
- **Color Adjustment**—Changes the color settings for elements on the page.
  - **Screen Match**—Color is optimized for reproducing of sRGB monitor colors. (The term sRGB is generally used to define RGB, red/green/blue, color output for monitors.) This setting maximizes the similarities between the appearance of the printed document and the document as it appears on the monitor. Screen Match is the printer default input color source.
  - **Vivid**—Saturation of colors is enhanced to produce high-impact color appearance.
  - **OHT**—(Overhead Transparency) For optimized color quality for projection.

All settings in the printer driver will remain in effect until they are changed. The online help describes in more detail the printer color settings and options, and their effect on your output.



## ICC/CMS

Some applications and operating systems support specific color management systems (CMS):

- ICC (International Color Consortium) is an international standard for color profiles that describe the color characteristics of devices, such as printers.
- ColorSync 2.x is Macintosh's color management system for System 7 and 8.
- ICM is Microsoft's color management system for Windows.

For information on downloading and selecting color profiles, see the online help.

If you are generating customized color profiles, use the same printer driver settings for both generating the profiles and printing.

## Black and White

Selecting **Black and White** in the Color tab allows your color documents to be printed as black and white documents with shades of gray. This setting allows you to view preliminary copies of slides and hard copy output quickly and still interpret your color information. Printing in black and white also works well for color information that you wish to photocopy or fax.

## **Automatic PANTONE® Matching**

The printer has a PANTONE Spot Name color matching utility. PANTONE has certified the printer and has mapped the PANTONE Spot Color names to the printer's CMYK values. This color matching utility uses the certified mapping to provide the best PANTONE color matching for the printer.

For the color matching utility to function, applications must pass the PANTONE names to the printer. Some applications substitute CMYK values to the printer if they cannot provide PANTONE names. If your application does not pass the PANTONE names to the printer, then the utility will be bypassed and color matching will depend on proper ink emulation. Selection of the proper ink emulation depends on the source of the palette (SWOP (Standard Web Offset Printing), EuroStandard, DIC, or None). The palette used for obtaining PANTONE CMYK values and the driver emulation mode setting should match.

## **CMYK Ink Set Emulation**

You can select a CMYK ink emulation (SWOP, EuroStandard, DIC, or None - no emulation, device CMYK) from the dropdown menu to provide output similar to an offset press ink set. If color management is active in an application or OS, the ink emulation selected must be the same as when the printer was profiled.

## Adjusting the Print Color and Quality Settings

For most color printing needs, HP ColorSmart II default settings will handle your color adjustments. For some print jobs, you might want to turn off HP ColorSmart II defaults and set color controls manually.

The following table shows default color settings in the printer driver and recommended printer driver settings for various types of printed output:

Printer Driver Setting/Desired Treatment	Page Objects				All Page Objects on Transparencies
	Text	Vector Graphics and Line Art	Raster Data (Text, Graphics, and Line Art)	Photographs	
<b>HP ColorSmart II Default Setting</b>	Screen Match Detail	Screen Match Detail	Screen Match Smooth	Screen Match Smooth	Color optimized for transparencies
<b>Recommended Resolution of Input Data</b>	N/A	N/A	600 dpi <sup>a</sup>	200 dpi or 300 dpi preferred (after scaling in your application)	N/A

a. The recommended input data resolution for raster data is 600 dpi.

For more information on choosing the color settings to produce the most accurate color reproduction, see [“Selecting Colors”](#) on the next page or see the online help.

# Selecting Colors

The computer and printer use different color processing methods. Other factors, such as print media and lighting, also influence and limit your ability to match colors from the screen to your output.

In addition to the printer driver color controls described in this chapter and the media you choose for printing, the following tools can help you to control the color output.

## PANTONE Colors

PANTONE colors are certified CMYK (cyan, magenta, yellow, and black) and sRGB color values in the PANTONE color matching system. This option affects your output only if your application supports PANTONE colors. See the application's instructions for using these colors. The color and halftone settings and the media you use will affect the appearance of printed PANTONE colors.

For the best PANTONE color reproduction, set the printer driver to **ColorSmart II** or make the selections shown in the table in "[Adjusting the Print Color and Quality Settings](#)" on the previous page. Or, if you are using the **Manual** setting, select **Screen Match** for the most accurate color reproduction. The device profiles for PANTONE Maps are created using the **Screen Match** setting; select this setting for best results. For more information on printer driver settings, see the online help or the readme file.

## Color Swatch

With HP ColorSmart II selected, the Color Swatch program will send several pages of example colors and their accompanying RGB and CMYK values to the printer. These pages are useful for selecting or matching colors in applications that allow you to specify RGB or CMYK color values.

If you are using the RGB values, select **ColorSmart II** on the Color tab in the printer driver.

For information on using the Color Swatch utility, see the associated readme file.

# Resolution Considerations for Graphics, Images, and Photographs

Graphics, images and photographs can come from many different sources such as digital cameras, scanners, and photograph CD-ROMs. Typical file extensions for images and photographs are .bmp, .fpx, .gif, .jpg, .png, and .tif. For these images, resolution decisions should be made based on the content of the image. When possible, import images at the size you plan to use (actual size).

- Graphics and line art should be imported at the maximum resolution. For best reproduction of raster graphics and line art, the printer driver halftone settings should be configured to enhance the critical feature. If the fill smoothness is critical, select **Smooth**. If the edge detail is critical, select **Detail**.
- Images should be at least 200 dpi, and preferably 300 dpi. The printer driver settings should be set to **ColorSmart II**. Or, if you are using the **Manual** setting, select **Smooth Halftone** and **Screen Match** color mode.

---

## Note

Image resolutions of higher than 300 dpi will produce significantly larger files, but the print quality of the image will not necessarily improve.

---

## Using Digital Cameras

When printing images captured by a digital camera, you might have to adjust the image quality. Adjust the images with the imaging software that came with the digital camera. Generally, for the most accurate color rendering, leave the digital image color mode in RGB. When you print the image, the printer will convert the RGB information to CMYK. For more information on adjusting the image quality of digital photographs, see the imaging software documentation.

For photographs, use **ColorSmart II** setting in the Color tab. Or, if you are using the **Manual** setting, select **Smooth Halftone** and **Screen Match** color mode. For more information on printer driver settings, see the online help.

## Using Scanners

For the best image quality, make as many adjustments as possible in the scanner imaging software before scanning. These adjustments, many of which are listed below, can increase the resolution of the image, resulting in higher quality images:

- Select the appropriate image type (for example, color photograph, line art, or text).
- Select the optimum image resolution based on image type, at least 300 dpi for most images; however, select 600 dpi for line art, graphics, and text.
- Crop the image to scan only what you need. Scale the image for the optimum resolution when it is reproduced.
- Adjust the image sharpness, contrast, and brightness.
- Set the gamma correction to 2.2. For more information on scanner gamma correction, see the scanner's documentation.
- When possible, import images at the size you plan to use (actual size).

# Adjusting the Color Balance

## CAUTION

Adjusting the color balance will change the printer's calibration. Because this procedure adjusts parameters within the printer hardware, it will affect all print jobs. Check with your system administrator before making any changes to the color balance.

The printer automatically recalibrates the color settings. However, you can adjust the color manually from the default settings by changing the densities of the four toners (black, cyan, magenta, and yellow). Changing the Detail Halftone Adjust and Smooth Halftone Adjust allow you to independently adjust the color of objects on a page that use the smooth and detail halftones (such as text and graphics).

Any settings you change remain in effect until you change them again or restore the factory defaults.

Do not perform the color balance adjustment procedure until all of the following troubleshooting methods have been completed:

- Experiment with the printer driver and application settings to adjust the color output. For more information on application settings, see the previous sections on printer driver settings in this chapter or the online help.
- Clean the density sensor in the printer. For more information, see [“Cleaning the Density Sensor”](#) in chapter 8.
- Complete the troubleshooting solutions in chapter 8 for the color printing problem you are experiencing.

## To adjust the color balance

### 1 Print the color adjust page.

- a Press **MENU** until `COLOR ADJUST MENU` appears on the printer control panel display.
- b Press **ITEM** until `PRINT TEST PAGE` appears on the display.
- c Press **SELECT** to print the color adjust page.
- d Press **Go** to exit the color adjust menu.

The color adjust page allows you to adjust the printer's two halftone screens for each of the four colors (cyan, magenta, yellow, and black) for a total of eight adjustments. Make these adjustments after examining the color adjust page.

The color adjust page consists of two sections: the Detail Halftone Adjust section and the Smooth Halftone Adjust section. Each section shows the adjustment ramps for black, cyan, magenta, and yellow and a neutral axis check ramp which can be used to verify the adjustment after the correction values have been entered for each of the primary colors. An example of the color adjust page is shown below.

Figure 12

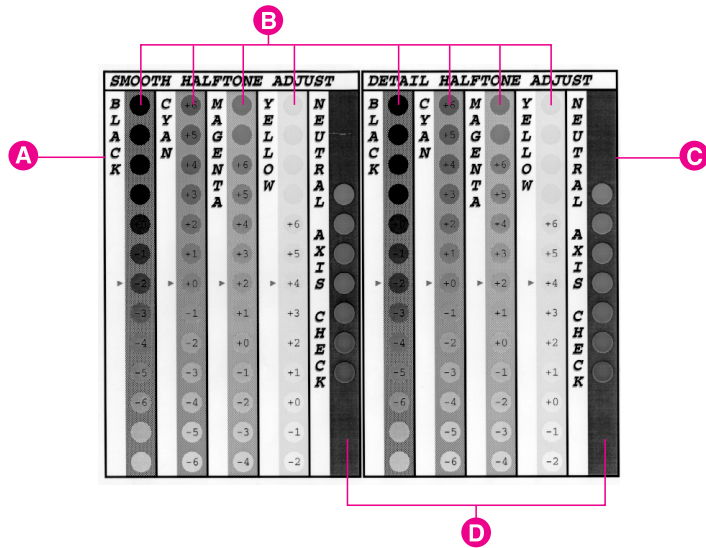

- A Smooth Halftone Adjust section
- B Color Ramps
- C Detail Halftone Adjust section
- D Neutral Axis

**2 Note the numbers beside the red arrows for later reference.** The color adjust page indicates the last set of saved color settings with a red arrow next to the saved setting. The default for each color is 0 (other possible settings include -6 through 6).



- 3 Determine the color adjustment numbers for each color in the high and low resolution screen adjusts.**
  - a Examine the color adjust page from a distance of 3 ft. (approximately 1 m).
  - b Find the circle of each color that most closely matches the background color. It might be necessary to squint slightly to match the colors.
  - c Record the number in the circle.
  
- 4 Enter the color adjustment numbers in the printer control panel.**
  - a Press **MENU** until COLOR ADJUST MENU appears on the printer control panel display.
  - b Press **ITEM** until the option you want appears on the display. The options are listed below:
    - BLACK SMOOTH VALUE =
    - CYAN SMOOTH VALUE =
    - MAGENTA SMOOTH VALUE =
    - YELLOW SMOOTH VALUE =
    - BLACK DETAIL VALUE =
    - CYAN DETAIL VALUE =
    - MAGENTA DETAIL VALUE =
    - YELLOW DETAIL VALUE =
  - c Press **-VALUE+** until the number recorded in step 3c appears on the display.
  - d Press **SELECT** to enter the number into the printer memory. An asterisk (\*) appears to the right of the selection.
  - e Repeat steps 4a through 4d to adjust the color screens, as necessary.

## 5 Reprint the color adjust page.

- a Press **ITEM** until PRINT TEST PAGE appears on the display.
- b Press **SELECT** to print the color adjust page.
- c Re-examine the test page and verify that the color adjustment is correct.
  - Verify that the circles with the arrows beside them match their background for each of the color ramps (cyan, magenta, yellow, and black). If another circle matches the background more closely, return to step 4 to reset the values on the printer control panel to the number shown in that circle.
  - Verify that the circles in the neutral axis areas of the test page are neutral gray (gray without a color tint when illuminated by D55 or diffuse sunlight), and then verify that one of the circles in the ramp is a color very close to the background. If the circles are not neutral gray, additional corrections to cyan, magenta, or yellow might be necessary. If there is an overall tint of color in the circles, make the adjustments suggested by the following table. However, the most accurate correction is determined by the circles in the individual black, cyan, magenta, and yellow ramps.

<b>Overall Color of Circles</b>	<b>Correction if all Circles are Darker than Background</b>	<b>Correction if all Circles are Lighter than Background</b>
Cyan tint	Reduce cyan	Increase magenta and yellow
Magenta tint	Reduce magenta	Increase cyan and yellow
Yellow tint	Reduce yellow	Increase magenta and cyan
Green tint	Reduce yellow and cyan	Increase magenta
Red tint	Reduce yellow and magenta	Increase cyan
Purple or blue tint	Reduce cyan and magenta	Increase yellow

For example, if the circles in the neutral axes show a green tint and the circle appears lighter than the background, the magenta ramp should be examined closely to determine if magenta should be increased.

---

**Note**

If the color settings are less accurate when you finish the color adjustment than when you started, reset all color values to 0 (zero) in the printer control panel and try the adjustment again.

---

# 6 Maintaining the Printer

## Making Room for Printer Maintenance

### CAUTION

To prevent damage to the printer, remove the imaging drum and all toner cartridges before moving or shipping the printer.

Sufficient space is required on all sides of the printer for removing consumables when performing printer maintenance. For more information on maintenance procedures, see the installation guide with each consumable. The following figure shows the space required around the printer for maintenance.

Figure 13

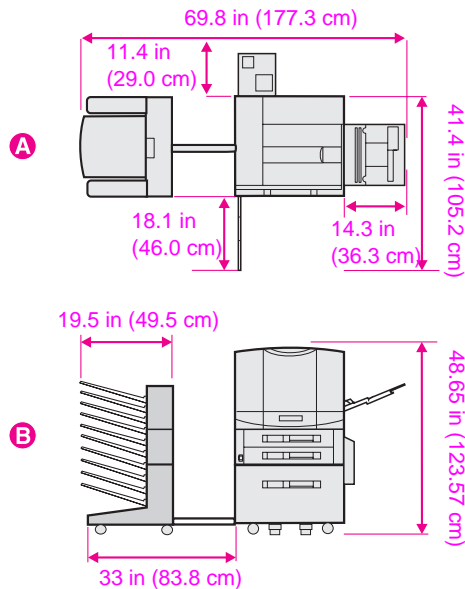

A Top View (with the optional multi-bin mailbox and tray 4)

B Side View (with the optional multi-bin mailbox and tray 4)

# Replacing Printer Consumables

## Locating Printer Consumables

The following figure shows the location of each printer consumable. A consumable is any part of the printer that can be replaced after its useful life has been exceeded.

Figure 14

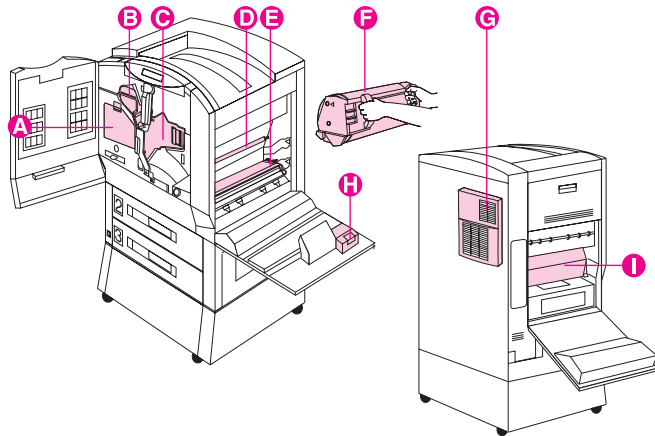

- A** Color Toner Cartridges
- B** Black Toner Cartridge
- C** Imaging Drum
- D** Cleaning Roller
- E** Transfer Belt
- F** Transfer Drum
- G** Air Filters
- H** Charcoal Filter
- I** Fuser
- J** Transfer Charger

For information on replacing the consumables, see the instructions included with each consumable.

---

**Note**

---

The color toner carousel will not rotate unless the clear door is closed, the imaging drum and black toner cartridge are installed (including removing the orange seal from the black toner cartridge and swinging the upper lever to the left), and the upper right door is closed.

## Frequency for Replacing Printer Consumables

The following table lists the approximate schedule for replacing consumables and the printer messages that appear when each of the consumables should be replaced. Part numbers for each consumable can be found in “[Accessories, Options, and Related Products](#)” in chapter 8. For best print quality output, use HP consumables that have been designed to work together in this printer.

---

**Note**

---

Do not shake the toner cartridge in attempts to extend the cartridge life. For more information on replacing the toner cartridge, see the installation guide included with the toner cartridge.

<b>Consumable</b>	<b>Printer Message</b>	<b>Page Count</b>	<b>Approximate Time Period<sup>a</sup></b>
Black Toner Cartridge	TONER LOW REPLACE BLACK	17,000 pages <sup>b</sup>	2.5 months
Color Toner Cartridges Cyan Magenta Yellow	TONER LOW REPLACE <color>	8,500 pages <sup>b</sup>	1.1 to 1.6 months
Drum Kit Imaging Drum Air Filters (2) Hand Wipe	DRUM LIFE LOW REPLACE DRUM KIT	50,000 black-and-white only pages, or 12,500 color pages <sup>c</sup>	8.3 months black-and-white only pages, or 2.1 months color pages
Transfer Kit Transfer Drum Transfer Belt Transfer Charger Cleaning Roller Charcoal Filter Hand Wipe	TRANSFER KIT LOW REPLACE KIT	150,000 black-and-white only pages, or 75,000 color pages	25 months black-and-white only pages, or 12.5 months color pages
Fuser Kit (110 Volt) Fuser Paper Rollers (6) Hand Wipe	FUSER LIFE LOW REPLACE KIT	100,000 black-and-white only pages, or 50,000 color pages	16.7 months black-and-white only pages, or 8.3 months color pages
Fuser Kit (220 Volt) Fuser Paper Rollers (6) Hand Wipe	FUSER LIFE LOW REPLACE KIT	100,000 black-and-white only pages, or 50,000 color pages	16.7 months black-and-white only pages, or 8.3 months color pages

- a. Approximate life based on printing 6,000 pages per month.
- b. Approximate average letter-size page count based on 5% coverage of individual toner colors. This value can be used to estimate other levels of coverage from 2% to 35%. For example, 5,000 pages at 5% coverage is approximately 2,500 pages at 10% coverage. Estimates made in this manner are only approximate, and usage conditions and print patterns can cause the results to vary.
- c. Drum life is stated in terms of Letter/A-4-size images. The number of images printed for each sheet of media varies, depending on the mix of color, duplexing, and large-format printing. An image is a layer of toner. A Letter-size, color (CMYK) sheet printed on one side contains four Letter/A4 images. A duplexed sheet (printed on both sides) counts as two images. In color duplex mode, there are eight Letter-size images per Letter/A4 sheet. An 11 x 17 (or A3) page sheet contains twice as many Letter-size images as a Letter-size sheet.

For an explanation of printer control panel messages, see chapter [7](#), “[Printer Control Panel Messages](#).”

## Recycling Consumables

HP encourages responsible disposal of HP Color LaserJet printer consumables through its printing supplies recycling program. For details on this program, see “[Environmental Product Stewardship Program](#)” in appendix B. All consumables listed above can be disposed of through the printing supplies recycling program.

## Resetting the HP TonerGauge

After a new toner cartridge is installed, the user must reset the HP TonerGauge from the control panel. When the top cover is closed after the printer has detected a toner low condition, the NEW TONER CARTRIDGE=NO message is displayed on the control panel for approximately 30 seconds. To reset the HP TonerGauge:

---

### Note

If the NEW TONER CARTRIDGE=NO message is no longer displayed on the control panel and you have replaced one or more of the toner cartridges, then press **MENU** repeatedly until CONFIGURATION MENU appears. When you replace an empty or low toner cartridge, press **ITEM** repeatedly until NEW TONER CARTRIDGE=NO appears.

---

- 1 Press **- VALUE +** until YES appears.
- 2 Press **SELECT** to save the selection.
- 3 NEW TONER=BLACK will appear. Press **- VALUE +** until the correct color appears.
- 4 Press **SELECT** to save the selection.
- 5 Repeat steps 2 through 4 if other cartridges have been replaced.
- 6 Press **Go** to exit the menu.





# 7 Printer Control Panel Messages



## Printer Messages

The following table lists the printer messages. If a printer message has a numeric prefix, it is listed in order of the number beside the printer message. Printer messages without numeric prefixes are listed in alphabetical order following the numeric messages.

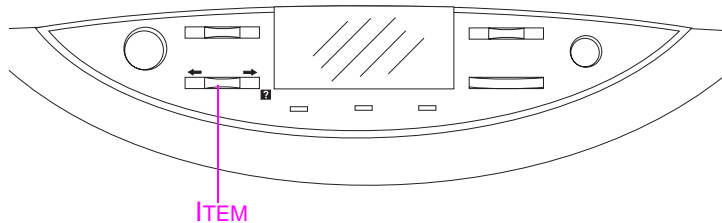
## Using the Printer Online Help System



This printer features an online Help system that provides instructions for resolving most printer errors. Certain control panel error messages alternate with instructions on accessing the online help system.

Whenever a  appears in an error message or a message alternates with FOR HELP PRESS THE  KEY, press the **ITEM** key to navigate through a sequence of instructions. If there is more than one message alternating on the control panel, press **MENU+** to display the Help for the first message. Continue to press **MENU+** to display the other Help messages. When the desired Help message is displayed, press **ITEM+** to scroll through the Help messages.

To exit the online Help system, press **Go**.

Message	Description	Recommended Action
*****	Displayed during startup as the individual tasks begin initializing.	No action is required.
13.xx Paper Jam alternates with STKR: DETACH AND CLEAR STAPLE JAM	A staple jam occurred.	Open the Stapler door, and clear the paper or staple jam.
20 INSUFFICIENT MEMORY	More data has been received from the computer than fits in the printer's internal memory.	To continue printing, press <b>Go</b> . Only the amount of data that fits in the printer's internal memory is printed. Reduce the page complexity or add more memory, then print the page again.
22 EIO [n] BUFFER OVERFLOW	The EIO buffer has overflowed during a busy state.	The current data in the print buffer will be lost. No action is required.
22 PARALLEL IO BUFFER OVERFLOW	Indicates the parallel buffer has overflowed.	Printing can continue, but some data might be lost.
40 EIO N BAD TRANSMISSION	An EIO accessory connection has been abnormally broken.  <b>N = EIO Slot Number</b> 1 = Bottom EIO Slot 2 = Top EIO Slot	Check that all cables are connected to the EIO ports and that the EIO board is seated properly. If possible, print to another network printer to verify the network is working properly. All data in the print buffer will be lost.
41.2 PRINTER ERROR	Indicates that a laser scanner error has occurred.	Open and close the front door of the printer to remove any remaining pages from the printer. Reprint the job. If the problem persists, turn the printer off and on to reset the printer.

Message	Description	Recommended Action
<p>41.3 UNEXPECTED PAPER SIZE LOAD TRAY 1 &lt;Type&gt; &lt;Size&gt;</p>	<p>Tray 1 is configured for one media size, but the printer detects a different size being fed from the tray 1.</p> <p>&lt;Type&gt; is the media type specified in the printer driver or application. &lt;Size&gt; is the media size specified in the printer driver or application.</p>	<p>Load the proper size media into tray 1. For more information on configuring input trays, see “<a href="#">Configuring Media Type and Size</a>” in chapter 2.</p>
<p>41.3 UNEXPECTED PAPER SIZE LOAD TRAY 1 &lt;Width&gt; &lt;Length&gt;</p>	<p>Tray 1 is configured for a custom media size, but the printer detects a different size being fed from the tray 1.</p> <p>&lt;Width&gt; is the media width selected in the application or printer driver. &lt;Length&gt; is the media length selected in the application or printer driver.</p>	<p>Load the requested size media into tray 1. For more information on configuring input trays, see “<a href="#">Configuring Media Type and Size</a>” in chapter 2.</p>
<p>41.5 UNEXPECTED PAPER TYPE LOAD TRAY X &lt;Type&gt; &lt;Size&gt;</p>	<p>The printer was expecting one type of media to be fed from an input tray and a different type was fed. For example, the printer was expecting transparencies and plain paper was fed.</p> <p>X is the input tray number. &lt;Type&gt; is the media type specified in the printer driver or application. &lt;Size&gt; is the media size specified in the printer driver or application.</p>	<p>Open and close the front door to remove the page from the printer. Verify that the correct media is loaded in the input tray and the printer control panel is configured correctly. For more information on configuring input trays, see “<a href="#">Configuring Media Type and Size</a>” in chapter 2.</p>

Message	Description	Recommended Action
49. XXXX ERROR CYCLE POWER	Indicates that a firmware error has occurred, or corrupt data was sent to the printer.	Verify that all cables are connected. Turn the printer off and on to reset the printer. If the condition persists, contact a local authorized HP dealer or service representative for service.
50. X FUSER ERROR CYCLE POWER	<p>Indicates that a fusing assembly malfunction has occurred.</p> <p><b>X = Description</b>            1 = Low Temperature Error            2 = Warmup Error            3 = High Temperature Error            4 = Fuser Drive/Power Unit Error            6 = Heater Error</p>	<p>Turn the printer off and on to reset the printer.</p> <p>For a 50.3 error, turn the printer off for 30 minutes to allow the fuser to cool, and then turn the printer on.</p> <p>If the condition persists, contact a local authorized HP dealer or service representative for service.</p>
51 LASER ERROR CYCLE POWER	Indicates that a laser malfunction has occurred.	Turn the printer off and on to reset the printer. If the condition persists, contact a local authorized HP dealer or service representative for service.
52 SCANNER ERROR CYCLE POWER	Indicates that the scanner motor is not turning properly.	Turn the printer off and on to reset the printer. If the condition persists, contact a local authorized HP dealer or service representative for service.

Message	Description	Recommended Action
<p>53.XY.ZZ ERROR DIMM SLOT Y</p>	<p>Indicates that a memory error occurred during the configuration and validation of DIMM memory.</p> <p><b>X Hardware Type</b> 0 ROM 1 RAM</p> <p><b>Y Hardware Device</b> 0 Onboard ROM/RAM 1 DIMM slot 1 2 DIMM slot 2 3 DIMM slot 3 4 DIMM slot 4 5 DIMM slot 5 6 DIMM slot 6 7 DIMM slot 7 8 DIMM slot 8</p> <p><b>ZZ Error</b> 0 Unsupported memory 1 Unrecognized memory 2 Unsupported memory size 3 Failed RAM test 4 Exceeded maximum RAM size 5 Exceeded maximum ROM size 6 Invalid DIMM speed, check DRAM 7 DIMM is reporting information incorrectly 10 DIMM address conflict 11 PDC XROM out of bounds 12 Could not make temporary mapping 13 Invalid RAM type 14 DIMM not paired properly</p>	<p>Verify that the DIMM board is installed correctly and the DIMMs are configured correctly. Turn the printer off and on to reset the printer. If necessary, remove and replace the DIMM that caused the error. For more information about installing and configuring DIMMs, see appendix A, "<a href="#">DIMM Installation</a>."</p> <p>If the condition persists, contact a local authorized HP dealer or service representative for service.</p>

Message	Description	Recommended Action
54.1 TEMPERATURE SENSOR ERROR CYCLE POWER	Indicates that the humidity and temperature sensor in the printer has malfunctioned.	Turn the printer off and on to reset the printer. If the condition persists, contact a local authorized HP service representative for service. <b>Do not operate the printer in this condition or the printer can be damaged.</b>
54.2 CAROUSEL ERROR CYCLE POWER	Indicates that the color toner carousel is not working correctly.	Open the color toner clear door and look for an obstruction. If the message does not clear after closing the doors, turn the printer off and on to reset the printer. If the condition persists, contact a local authorized HP dealer or service representative for service.
54.3 DENSITY SENSOR ERROR CYCLE POWER	Indicates a density sensor error, or the printer is not receiving data back from the density sensor.	Turn the printer off and on to reset the printer. If the condition persists, contact a local authorized HP dealer or service representative for service.
55 PRINTER ERROR CYCLE POWER	Indicates a printer command error. The commands cannot be exchanged between the printer and its controller.	Turn the printer off and on to reset the printer. If the condition persists, contact a local authorized HP dealer or service representative for service.
56.1 ERROR CYCLE POWER	Indicates an input feed error (such as requesting to feed transparencies through the duplexer), or the input tray is not installed.	If the input tray you are trying to print from is not installed, install the input tray. Turn the printer off and on to reset the printer. If the condition persists, contact a local authorized HP dealer or service representative for service.

Message	Description	Recommended Action
56.2 ERROR CYCLE POWER	Indicates an illegal output error. For example, the multi-bin mailbox is not installed and it was selected as the output destination, or there are transparencies in the duplexer.	Open the printer and remove media from the paper path. Verify that the media type is set in the printer control panel. Turn the printer off and on to reset the printer. If the condition persists, contact a local authorized HP dealer or service representative for service. For more information on configuring input trays, see <a href="#">“Configuring Media Type and Size”</a> in chapter 2.
57.X FAN FAILURE	One of the cooling fans has failed.  <b>X = Fan Type</b> 1 = Rear Output Fan (Motor 1) 2 = Rear Input Fan (Motor 2) 3 = Left Output Fan (Motor 3)	Turn the printer off and then on to reset the printer. If the message reappears, contact a local authorized HP dealer or service representative for service. <b>Do not operate the printer in this condition or the printer can be seriously damaged.</b>
58.1 ERROR CYCLE POWER	Indicates that the paper diverter inside the upper right door is out of position, causing an error feeding media from tray 1.	Open the upper right door and check for a media jam or misfed media. Turn the printer off and on to reset the printer. If the message reappears, contact a local authorized HP dealer or service representative for service.
59.X MOTOR ERROR CYCLE POWER	Indicates that the main printer motor is not working properly.  <b>X = Description</b> 0 = General Error 1 = Startup Error 2 = Rotation Error	Turn the printer off and on to reset the printer. If the condition persists, contact a local authorized HP dealer or service representative for service.



Message	Description	Recommended Action
62.X SERVICE CYCLE POWER	Indicates that a problem exists with the internal memory.  <b>X = Description</b> 0 = Internal ROM or RAM 1-8 = DIMM slots 1-8	Turn the printer off and on to reset the printer. If the condition persists, contact a local authorized HP dealer or service representative for service.
63 SERVICE CYCLE POWER	Indicates that the internal RAM memory test failed.	Turn the printer off and on to reset the printer. If the condition persists, contact a local authorized HP dealer or service representative for service.
64 PRINTER ERROR CYCLE POWER	Indicates a scan buffer error.	Turn the printer off and on to reset the printer. If the condition persists, contact a local authorized HP dealer or service representative for service.
65 PRINTER ERROR CYCLE POWER	Indicates a dynamic RAM controller error.	Turn the printer off and on to reset the printer. If the condition persists, contact a local authorized HP dealer or service representative for service.
66.X0.YY C-LINK COMM ERROR CHECK CABLES AND CYCLE POWER	Indicates a communication error between tray 4 and the printer.  <b>X/YY Description</b> X = Device number in the link YY = Error code from the optional device	Verify that the communication and power cables are connected. Press <b>Go</b> to continue printing. If the message persists, turn the printer off and on to reset the printer.
66.X1.YY INPUT DEVICE FAILURE CHECK CABLES AND CYCLE POWER	Indicates a tray 4 error.  <b>X/YY Description</b> X = Device number in the link YY = Error code from the optional device	Verify that the communication and power cables are connected. Press <b>Go</b> to continue printing. If the message persists, turn the printer off and on to reset the printer.

Message	Description	Recommended Action
<p>66.X2.YY OUTPUT DEVICE FAILURE CHECK CABLES AND CYCLE POWER</p>	<p>Indicates a multi-bin mailbox error.</p> <p><b>X/YY Description</b> X = Device number in the link YY = Error code from the optional device</p>	<p>Verify that the communication and power cables are connected. Press <b>Go</b> to continue printing. If the message persists, turn the printer off and on to reset the printer.</p>
<p>67.X PRINTER ERROR POWER CYCLE</p>	<p>Indicates an electronic controller error.</p> <p><b>X = Description</b> 1 = DC Controller Error 2 = DC Controller IC Malfunction 3 = Internal Communication Malfunction</p>	<p>Turn the printer off and on to reset the printer. If the condition persists, contact a local authorized HP dealer or service representative for service.</p>
<p>68 NVRAM ERROR SETTINGS CHANGED</p>	<p>Indicates that a recoverable error has been detected in the NVRAM (nonvolatile random-access memory).</p>	<p>Verify the printer control panel settings. One or more fields might have been reset to their factory defaults during the error recovery. For more information on factory defaults, see "<a href="#">Factory Defaults</a>" in chapter 2.</p>
<p>68 NVRAM FULL SETTINGS LOST</p>	<p>Indicates that the NVRAM is full, and the printer is unable to write new data to the NVRAM.</p>	<p>Verify the printer control panel settings. One or more fields might have been reset to their factory defaults during error recovery. The next time the printer is turned off and on, NVRAM will be cleared and all factory defaults will be restored. For more information on factory defaults, see "<a href="#">Factory Defaults</a>" in chapter 2.</p>

Message	Description	Recommended Action
79 SERVICE (XXXX) CYCLE POWER	The firmware has detected an unrecoverable error.  <b>X Description</b> 01XX = IO ASIC Register Error 02XX = Video ASIC Register Error 03XX = IDE ASIC Register Error	Turn the printer off and on to reset the printer. If the condition persists, contact a local authorized HP dealer or service representative for service.
ACCESS DENIED	A user has attempted to select a menu value while the printer control panel locking is enabled.	See the system administrator for access to the printer control panel.
CALIBRATING	The printer is adjusting the density sensor.	No action is required.
CANCELING JOB	The printer is canceling the current print job.	No action is required.
CHECK STAPLER DEVICE  alternates with  CLEAR JAMMED STAPLE	A staple jam occurred.	Clear the staple jam.
CLEAN DENSITY SENSOR CYCLE POWER	The density sensor values are out of range or inconsistent. The density sensor might be dirty or the transfer drum might be damaged.	Clean the density sensor. Then turn the printer off and on to reset the printer. If the problem is not resolved, clean the transfer drum. If the condition persists, contact a local authorized HP dealer or service representative for service. For information on cleaning the printer, see <a href="#">“Cleaning the Density Sensor”</a> and <a href="#">“Cleaning the Transfer Drum”</a> in chapter 8.

Message	Description	Recommended Action
CLEAR DUPLEX JAM LOWER LEFT DOOR	The printer senses a media jam in the duplexer.	<p>Open the lower left door. Remove the duplexer. Remove the jammed media. Replace the duplexer. Close the lower left door, and wait for the printer to warm up before resuming printing.</p> <p><b>WARNING!</b> Do not touch the fuser; it might be very hot and could cause burns.</p> <p>For more information on clearing jams, see the quick reference guide.</p>
CLEAR FUSER JAM LOWER LEFT DOOR	The printer senses a media jam in the fuser area.	<p>Open the lower left door. Remove the duplexer if installed. Remove the jammed media. Replace the duplexer if necessary. Close the lower left door, and wait for the printer to warm up before resuming printing.</p> <p><b>WARNING!</b> Do not touch the fuser; it might be very hot and could cause burns.</p> <p>For more information on clearing jams, see the quick reference guide.</p>

<b>Message</b>	<b>Description</b>	<b>Recommended Action</b>
CLEAR INPUT JAM	The printer senses a media jam in the transfer and registration area or in an input tray.	Open the front door, press the white button on the lower (green) lever, and swing the lever to the right. Open the upper right door, remove the transfer drum, and remove the jammed media from under the metal paper guide. Swing the lower (green) lever to the left, and close the front door. If the message still appears on the control panel display, open the input tray, remove any jammed media, and close the input tray. Close the printer, and wait for the printer to warm up before resuming printing. For more information on clearing jams, see the quick reference guide.
CLEAR MAILBOX JAM	The printer senses a media jam in the multi-bin mailbox.	Detach the multi-bin mailbox from the printer, remove the jammed media, reattach the multi-bin mailbox, and wait for the printer to warm up before resuming printing. For more information on clearing jams, see the quick reference guide.
CLEAR OUTPUT JAM UPPER LEFT DOOR	The printer senses a media jam in the top output bin.	Open the upper left door, remove the jammed media, close the upper left door, and wait for the printer to warm up before resuming printing. For more information on clearing jams, see the quick reference guide.

<b>Message</b>	<b>Description</b>	<b>Recommended Action</b>
CLEAR PAPER JAM	The printer senses a media jam.	Open and shut the front door of the printer to clear any paper from the printer. If the message still appears on the printer, check all areas of the printer for jammed media since the printer is unable to determine the location of the media jam. For more information on clearing jams, see the quick reference guide.
CLEAR TRANSFER JAM	The printer senses a media jam in the transfer drum area.	Open the upper right door. Lift the metal strip with the green corner and remove all of the media. Remove the transfer drum, remove the jammed media, reinstall the transfer drum, close the upper right door, and wait for the printer to warm up before resuming printing. For more information on clearing jams, see the quick reference guide.
CLEAR TRAY 4 JAM	The printer senses a media jam in tray 4.	Open tray 4, remove the jammed media, close tray 4, and wait for the printer to warm up before resuming printing. For more information on clearing jams, see the quick reference guide.
CLEAR TRAY X JAM	The printer senses a media jam in one of the optional paper trays.	Open the indicated tray and remove the jammed media. Close the tray and wait for the printer to warm up before resuming printing. For more information on clearing jams, see the quick reference guide.

Message	Description	Recommended Action
CLEAR UNEXPECTED PAPER SIZE JAM THEN LOAD TRAY 1 <Type> <Size>	<p>The printer senses a media jam in tray 1.</p> <p>&lt;Type&gt; is the media type specified in the printer driver or application.</p> <p>&lt;Size&gt; is the media size specified in the printer driver or application.</p> <p>The &lt;Type&gt; and &lt;Size&gt; can be the default media type and size if an automatic paper override has occurred.</p>	<p>Open the upper right door, remove the jammed media, and close the door. Load the media type and size indicated on the printer control panel. For more information on loading media into tray 1, see <a href="#">“Printing from Tray 1”</a> in chapter 3. For more information on clearing jams, see the quick reference guide.</p>
CLEARING PAPER FROM PRINTER	<p>The printer is attempting to remove unusable media (such as a misfed page or media damaged in a media jam).</p>	<p>No action is required.</p>
CLOSE <Location> DOOR	<p>The printer senses that one of the doors is not closed properly.</p> <p>&lt;Location&gt; is one of the printer doors.</p>	<p>Close the door indicated in the message.</p>
COLD RESET	<p>The printer has recognized the key sequence for performing a cold reset. The printer will reset to the factory default settings.</p>	<p>No action is required. For more information on factory default settings, see <a href="#">“Factory Defaults”</a> in chapter 2.</p>
CONFIG LANGUAGE	<p>The printer has recognized the key sequence for selecting the display language.</p>	<p>Wait for the display language options to appear and select the appropriate language. For more information on selecting the display language, see <a href="#">“Selecting the Display Language”</a> in chapter 2.</p>

Message	Description	Recommended Action
CONTINUOUS TEST PRESS CANCEL JOB	A continuous configuration page is printing.	Press <b>CANCEL JOB</b> to exit the configuration page printout mode. If the printer is in the process of printing when <b>CANCEL JOB</b> is pressed, the printer finishes printing the buffered pages before returning online.
DATA RECEIVED PRESS GO KEY	The printer has received and processed data and is waiting for a form feed.	Press <b>Go</b> to form feed a page. The printer will feed the page from one of the input trays.
DISK DEVICE FAILURE	The printer detected a printer hard disk failure.	If access to the printer hard disk is not required, printer operation can continue. Contact a local authorized HP dealer or service representative to replace the printer hard disk.
DISK FILE OPERATION FAILED	The printer has received an illogical PJL command (such as download to non-existent directory).	No action is required.
DISK IS FULL	The printer hard disk is full.	From the host computer, delete data from the printer hard disk using the printer drivers or a disk management application. Or, to clear <b>all</b> data from the printer hard disk, reformat the printer hard disk from the printer control panel. To reformat the printer hard disk, press <b>MENU</b> until CONFIGURATION MENU appears on the printer control panel display. Press <b>ITEM</b> until INITIALIZE DISK appears on the display. Press <b>SELECT</b> and the printer hard disk will be reformatted.



Message	Description	Recommended Action
DISK IS WRITE PROTECTED	A user has attempted to save to the printer hard disk or send a proof and hold job to the printer while the printer hard disk is write-protected.	See the system administrator for access to the printer hard disk.
DRUM ERROR REPLACE KIT	The printer has detected an error in the imaging drum.	Open the front door. Raise the green and blue levers. Remove the imaging drum. Reinstall the drum, lower both of the levers, and close the front door. If the problem persists, contact a local authorized HP dealer or service representative for service.
DRUM LIFE LOW REPLACE KIT	The imaging drum is almost past its specified life.	Although printing can continue, the drum kit should be replaced for optimum printer operation. For more information on replacing the drum kit, see the installation guide included with the drum kit. For more information on configuring the printer response to this message, see <a href="#">“Selecting Toner Low Response”</a> in chapter 2.
DRUM LIFE OUT REPLACE DRUM KIT	The imaging drum is past its specified life.	Printing cannot continue until the drum kit has been replaced. For more information on replacing the drum kit, see the installation guide included with the drum kit.

Message	Description	Recommended Action
DUPLEX ERROR CHECK DUPLEXER	The printer has detected an error in the duplexer.	Open the lower left door, press the green tab on the right side of the duplexer, and pull the duplexer out of the printer. Check for and remove any jammed media from the duplexer. Reinstall the duplexer. Turn the printer off and then on. If the problem persists, contact a local authorized HP dealer or service representative for service.
EIO N INITIALIZING	An EIO accessory is initializing.  <b>N = EIO Slot Number</b> 1 = Bottom EIO Slot 2 = Top EIO Slot	No action is required.
EIO N NOT FUNCTIONAL	Indicates an EIO card error. The error is logged to the event log with more detail.  <b>N = EIO Slot Number</b> 1 = Bottom EIO Slot 2 = Top EIO Slot	Turn the printer off and on to reset the printer. If the condition persists, replace the offending EIO accessory.
ENGINE TEST	The printer is running an internal test to verify operation. When the printer is finished, the printer returns to the ready state but remains offline.	Press <b>Go</b> to bring the printer online.
FACE UP OUTPUT BIN FULL	The top output bin (face up) on the multi-bin mailbox is full.	Remove all media from the top output bin on the multi-bin mailbox to continue printing.

Message	Description	Recommended Action
FUSER LIFE LOW REPLACE KIT	The fuser and paper rollers are almost past their specified life.	Although printing can continue, the fuser should be replaced for optimum printer operation. For more information on replacing the fuser, see the installation guide included with the fuser kit.
FUSER LIFE OUT REPLACE KIT	The fuser and paper rollers are past their specified life.	Replace the fuser kit and reset the fuser counter before attempting to print. For more information on replacing the fuser kit and resetting the counter, see the installation guide included with the fuser kit. For more information on configuring the printer response to this message, see <a href="#">“Selecting Toner Low Response”</a> in chapter 2.
INCORRECT FUSER LOWER LEFT DOOR	The printer has detected that an incompatible fuser (possibly the wrong voltage of fuser for the printer) has been installed.	Remove the fuser and install the fuser specified for use with this printer. Printing cannot continue until the correct fuser is installed in the printer. For information on ordering a fuser kit, see <a href="#">“Accessories, Options, and Related Products”</a> in chapter 8.
INPUT DEVICE PAPER PATH OPEN	The media transfer door on tray 4 is open.	Close the media transfer door.

Message	Description	Recommended Action
<p>INSTALL &lt;Color&gt; TONER</p>	<p>The toner cartridge is either not installed or not correctly installed in the printer.</p> <p>&lt;Color&gt; can be cyan, magenta, yellow, or black.</p>	<p>Insert the cartridge or make sure the installed cartridge is correctly seated in the printer.</p> <p><b>Note:</b> The color toner carousel will not rotate unless the clear door is closed, the imaging drum and black toner cartridge are installed completely (including removing the orange seal from the black toner cartridge and swinging the upper lever to the left), and the upper right door is closed.</p> <p>For more information on installing toner cartridges, see the installation guide included with the toner cartridge.</p>
<p>INSTALL FUSER LOWER LEFT DOOR</p>	<p>The printer has detected that the fuser is not installed.</p>	<p>Install the fuser and verify that it is correctly seated in the printer before attempting to print. For more information on installing the fuser, see the installation guide included with the fuser kit.</p>

Message	Description	Recommended Action
INSTALL IMAGING DRUM OPEN FRONT DOOR	The printer has detected that the imaging drum is not installed.	<p>Install the imaging drum before attempting to print. If the condition persists, take the imaging drum out and reinstall it.</p> <p><b>Note:</b> The imaging drum must be installed and the upper lever must be to the left in order for the color toner carousel to rotate.</p> <p>For more information on installing the imaging drum, see the getting started guide or the installation guide included with the drum kit.</p>
INSTALL TRANSFER DRUM OPEN RIGHT DOOR	The printer has detected that the transfer drum is not installed.	<p>Install the transfer drum before attempting to print. If the condition persists, take the transfer drum out and reinstall it. For more information on installing the transfer drum, see the getting started guide or the installation guide included with the transfer kit.</p>
LANGUAGE = <XXXX>	<p>Displayed during start up.</p> <p>&lt;XXXX&gt; is the printer control panel display language.</p>	<p>No action is required. For more information on changing the printer control panel display language, see <a href="#">“Selecting the Display Language”</a> in chapter 2.</p>
LEFT OUTPUT BIN FULL	The left output bin on the printer is full.	Remove all media from the left output bin of the printer to continue printing.

Message	Description	Recommended Action
LOCK TONER LEVER	The blue lever inside the clear door is not locked.	Open the front door of the printer, open the clear door, and swing the blue toner lock lever to the right. Remove the toner cartridge, and then reinstall it, making sure the cartridge is all the way in the printer. Swing the blue toner lock lever to the left until it clicks, and then close the clear and front doors.
MAILBOX X OUTPUT BIN FULL	A mailbox on the multi-bin mailbox is full.  X indicates mailbox 1 through 8.	Remove all media from the mailbox to continue printing.
MAILBOX COMM ERROR CHECK CABLES AND CYCLE POWER	Indicates a communication error between the multi-bin mailbox and the printer.	Verify that the communication and power cables are connected. Press <b>Go</b> to continue printing. If the message persists, turn the printer off and on to reset the printer. If the condition still persists, contact a local authorized HP dealer or service representative for service.
MAILBOX NOT ATTACHED	The multi-bin mailbox is not correctly attached to the printer.	Push the mailbox up against printer. Verify that the wheels on the multi-bin mailbox are not hitting tray 4 and preventing the multi-bin mailbox (optional) from attaching to the printer.

Message	Description	Recommended Action
MANUALLY FEED <Type> <Size>	The printer is requesting a sheet of media or envelope to be manually fed.  <Type> is the media type specified in the printer driver or application. <Size> is the media size specified in the printer driver or application.	Load the requested media type and size into tray 1. If the proper media size is already loaded into tray 1, press <b>Go</b> to initiate printing. For more information on loading media in tray 1, see " <a href="#">Printing from Tray 1</a> " in chapter 3.
MEMORY SHORTAGE PAGE SIMPLIFIED	The printer is compressing the print job so that all of the job will fit into the available printer memory. The print job's appearance might be altered by the compression of the data.	If possible, simplify the print job by lowering the resolution of graphics. Or, install more printer memory. For more information on printer memory options, see " <a href="#">Accessories, Options, and Related Products</a> " in chapter 8.
NEW TONER CARTRIDGE? = NO	This message will appear if the printer senses that a TONER LOW or TONER OUT message has appeared and then gone away, indicating that a new toner cartridge may have been installed.	Change to YES and press <b>SELECT</b> if you just installed a toner cartridge.  Press <b>ITEM+</b> until you see NEW TONER=BLACK. Press <b>VALUE+</b> until the new cartridge appears, then press <b>SELECT</b> .
NO JOB TO CANCEL	<b>CANCEL JOB</b> was pressed and there is no job to cancel.	No action is required.
OFFLINE	The printer is offline. No error messages are pending.	Press <b>Go</b> to bring the printer online.
OUT OF MEMORY JOB CLEARED	The printer personality for the current job could not be run in the available memory. The job was canceled, and no pages were printed.	Reprint the job. If the message still appears, turn the printer off and on to reset the printer before sending the print job again.

Message	Description	Recommended Action
OUTPUT BIN FULL alternates with CLEAR PAPER FROM FACE UP	The bin-full sensor in the left Face-up Bin has been reached.	Empty the Face-up Bin.
OUTPUT BIN FULL alternates with CLEAR PAPER FROM OPTIONAL BIN 1	The Stacker Bin is full.	Empty the Stacker Bin.
PCL MEMORY FULL STORED DATA LOST	The resource save area for the printer personality is full. Fonts downloaded to the printer's RAM might have been deleted.	Turn the printer off and on to clear the printer's RAM.
PJL OPERATIONS FAILED	The requested PJL operation could not be completed because the option is unavailable or the PJL data was corrupt.	No action is required.
PLEASE WAIT	The printer is in the process of going offline or into the menus.	No action is required.
POWERSAVE ON	The printer is in Power Save mode.	Clear this message by pressing any key.
PRESS SELECT IF FUSER IS NEW	The printer has detected that a new fuser has been installed.	If the fuser has been replaced, press <b>SELECT</b> to reset the internal counter. If the fuser has not been replaced, press <b>Go</b> .
PRESS SELECT IF TRANSFER IS NEW	The printer has detected that a new transfer drum has been installed.	If the transfer drum has been replaced, press <b>SELECT</b> to reset the internal counter. If the transfer drum has not been replaced, press <b>Go</b> .



Message	Description	Recommended Action
PRESS SELECT TO INITIALIZE DISK	The printer hard disk is new or has been formatted for another file system.	Press <b>SELECT</b> to reformat the printer hard disk. All data currently on the printer hard disk will be lost. If you don't want to initialize the printer hard disk, turn the printer off and remove the printer hard disk.
PRESS SELECT TO LOSE DISK DATA PRESS GO KEY TO CANCEL	Request to confirm initialization of the printer hard disk.	If you want to proceed with initialization, press <b>SELECT</b> .  If you do not want to initialize the printer hard disk, press <b>Go</b> .
PRINTER LANGUAGE NOT AVAILABLE JOB CANCELED	PJL encountered a request for a printer personality that does not exist in the printer. The job was canceled and no pages were printed.	Try reprinting the job using PCL or PS.
PRINTING CONFIGURATION	The printer is printing the configuration page. When the configuration page is printed, the printer returns to an online and ready state.	No action is required.
PRINTING DEMONSTRATION	The printer is printing a demonstration page. When the demonstration page is printed, the printer returns to an online and ready state.	No action is required.
PRINTING EVENT LOG	The printer is printing the event log page. When the event log page is printed, the printer returns to an online and ready state.	No action is required.
PRINTING FILE DIRECTORY	The printer is printing the file directory page. When the file directory page is printed, the printer returns to an online and ready state.	No action is required.

<b>Message</b>	<b>Description</b>	<b>Recommended Action</b>
PRINTING FONT LIST	The printer is printing the font list page. When the font list page is printed, the printer returns to an online and ready state.	No action is required.
PRINTING MENU MAP	The printer is printing the menu map page. When the menu map page is printed, the printer returns to an online and ready state.	No action is required.
PROCESSING COPY X OF Y	The printer is processing a proof and print or mopy print job.  X is the number of copies completed. Y is the total number of copies.	No action is required.
PROCESSING JOB	The printer is actively processing a print job.	No action is required.
PROCESSING JOB FROM TRAY X	The printer is actively processing a print job.  X is the input tray that the job will be printed from.	No action is required.
PS MEMORY FULL STORED DATA LOST	The resource save area for the printer personality is full. Fonts downloaded to the printer's RAM might have been deleted.	Turn the printer off and on to clear the printer's RAM.
READY	The printer is online and ready for data. No status or printer attention messages are pending.	No action is required.
RESETTING ACTIVE IO	The printer is resetting active I/O ports.	No action is required.
RESETTING ALL IO	The printer is resetting all I/O ports.	No action is required.

Message	Description	Recommended Action
RESTORING FACTORY SETTINGS	The printer is resetting the printer's factory defaults. The printer is in the process of completing a cold reset. When the reset is completed, the printer returns to the ready state but remains offline.	Reset the EIO type and configure the printer before bringing the printer online. For more information on factory defaults and configuring the printer control panel, see chapter 2, " <a href="#">Using the Printer Control Panel.</a> "
SEPARATOR OUTPUT BIN FULL	The multi-bin mailbox output bins are full.	Remove all media from the output bins on the multi-bin mailbox to continue printing.
STACKER OUTPUT BIN FULL	The multi-bin mailbox output bins are full.	Remove all media from the output bins on the multi-bin mailbox to continue printing.
STAPLER LOW ON STAPLES	The Stapler Cartridge has 20 to 50 staples remaining.	No action required.
STKR: ATTACH TO PRINTER	The device is not attached to the printer properly.	Make sure that there is a proper attachment between the device and the printer, and wait for a solid green status light on the user LED on the device.
STKR: CLOSE STAPLER DOOR	The Stapler door is open or it is not closed properly.	Close the Stapler door properly.
STKR: DETACH AND CLEAR JAM	A paper jam occurred in the device.	Clear the paper jam.
STKR: TRAY OVERLOAD  alternates with  CLEAR PAPER FROM OPTIONAL BIN 1	The weight capacity of the stacker bin has been reached.	Clear the paper from the Stacker Bin.

Message	Description	Recommended Action
TONER LOW REPLACE <Color>	The printer is almost out of the specified toner. The printer remains online.  <Color> can be cyan, magenta, yellow, or black.	Although printing can continue, the toner cartridge should be replaced for optimum printer operation. <b>Do not shake the toner cartridge in attempts to extend the cartridge life.</b> For more information on replacing the toner cartridge, see the installation guide included with the toner cartridge. For more information on configuring the printer response to this message, see " <a href="#">Selecting Toner Low Response</a> " in chapter 2.
TONER OUT REPLACE <Color>	The printer is out of the specified toner and cannot continue.  <Color> can be cyan, magenta, yellow, or black.	Printing cannot continue until the specified toner cartridge has been replaced. For more information on replacing the toner cartridge, see the installation guide included with the toner cartridge.
TOO MANY FILE STORAGE DEVICES REMOVE EITHER DISK	The printer can only support one printer hard disk at a time.	Turn the printer off and remove either printer hard disk. Printing will not continue until one printer hard disk is removed.
TOO MANY PAGES IN JOB TO STAPLE	The job height is greater than the stapler capacity. The height of the job to be stapled should not exceed 5 mm.	See the stapling specifications on page 67 for more information.
TOP OUTPUT BIN FULL	The top (face-down) output bin of the printer is full.	Remove all media from the top (face-down) output bin on the printer to continue printing.

Message	Description	Recommended Action
TRANSFER KIT LOW REPLACE KIT	The transfer drum, transfer belt, cleaning roller, and charcoal filter are almost past their specified life.	Although printing can continue, the transfer kit should be replaced for optimum printer operation. For more information on replacing the transfer kit, see the installation guide included with the transfer kit.
TRANSFER KIT OUT REPLACE KIT	The transfer drum, transfer belt, cleaning roller, and charcoal filter are past their specified life.	Replace the transfer kit and reset the transfer counter before attempting to print. For more information on replacing the transfer kit and resetting the counter, see the installation guide included with the transfer kit. For more information on configuring the printer response to this message, see <a href="#">“Selecting Toner Low Response”</a> in chapter 2.
TRAY 1 CONTAINS UNKNOWN MEDIA	Media was stacked in tray 1 for continuous manual feed printing, and the job has been completed. However, there is still media in the input tray. The printer considers the input tray not to be configured.	Configure the media type for tray 1 or remove the remaining media. For more information on configuring the media type, see <a href="#">“Printing from Tray 1”</a> in chapter 3.
TRAY 1 LOAD <Type> <Size>	A user has requested a media size that is not currently installed in tray 1.  <Type> is the last media type configured for the input tray. <Size> is the last media size configured for the input tray.	Load the media type and size specified on the printer control panel display. After the tray 1 is loaded, the printer automatically brings itself online.  For more information on configuring the printer control panel or checking printer control panel settings, see chapter 2, <a href="#">“Using the Printer Control Panel.”</a>

Message	Description	Recommended Action
TRAY 1 SIZE = <Size>	This message is displayed when media is placed in tray 1.  <Size> is the last media size configured for the input tray.	Press <b>-VALUE+</b> to view the choices. Press <b>SELECT</b> when the choice you want is displayed, and then press <b>Go</b> to bring the printer online. If no key is pressed for 30 seconds after the media is detected in the input tray, the displayed size will automatically be selected, the message will be cleared, and printing will begin.
TRAY 4 COMM ERROR CHECK CABLES AND CYCLE POWER	Indicates a communication error between tray 4 and the printer.	Verify that the communication and power cables are connected. Press <b>Go</b> to continue printing. If the message persists, turn the printer off and on to reset the printer. If the condition still persists, contact a local authorized HP dealer or service representative for service.
TRAY X EMPTY <Type> <Size>	An input tray not currently selected has run out of media.  X is the input tray number. <Type> is the last media type configured for the input tray. <Size> is the last media size configured for the input tray.	Load the media type and size specified on the printer control panel display. For more information on loading media, see chapter 3, " <a href="#">Common Printing Tasks</a> ."
TRAY X LIFTING	The specified input tray is lifting the media into position for printing.  X is the input tray number.	No action is required.

Message	Description	Recommended Action
<p>TRAY X LOAD            &lt;Type&gt; &lt;Size&gt;            CHECK CONTROL            PANEL SETTING</p>	<p>A user has requested a media size that is not currently installed or configured in the printer. This message is also generated when the current input tray runs out of media and no other auto-selectable input trays contain that size of media.</p> <p>X is the input tray number.            &lt;Type&gt; is the last media type configured for the input tray.            &lt;Size&gt; is the last media size configured for the input tray.</p>	<p>Load the media type and size specified on the printer control panel display, and configure the media type in the printer control panel. After the requested input tray is loaded, the printer automatically goes online.</p> <p>Pressing <b>Go</b> will cause the printer to attempt to print the page on the default type and size media.</p> <p>If the condition persists, check the input tray type and size configuration in the printer control panel. The correct media type and size might be loaded in the input tray, but the printer will not recognize that the media is loaded if the printer control panel settings do not match the media type and size requested.</p> <p>For more information on configuring input trays, see <a href="#">“Configuring Media Type and Size”</a> in chapter 2.</p>
<p>TRAY X OPEN</p>	<p>An input tray is open.</p> <p>X is the input tray number.</p>	<p>Close the input tray before resuming printing.</p>

Message	Description	Recommended Action
TRAY X TYPE = <Type>	This message is displayed when media is placed in an input tray.  X is the input tray number. <Type> is the last media type configured for the input tray.	Press <b>-VALUE+</b> to view the choices. Press <b>SELECT</b> when the choice you want is displayed, and then press <b>Go</b> to bring the printer online. If no key is pressed for 30 seconds after the media is detected in the input tray, the displayed type will automatically be selected, the message will be cleared, and printing will begin.
WARMING UP	The fuser is warming up.	No action is required.





# 8 Solving Printer Problems

## Performing Basic Troubleshooting Steps

This chapter suggests steps to solve common problems that you might encounter while using the printer. If the printer does not work properly, check the following items first:

- Is the printer connected to a live power source?
- Is the printer online?
- Are the communications cables from the printer to the network or the host computer connected?
- Are the parallel cables IEEE-1284 compliant?
- Are any messages displayed on the printer control panel?
- If you recently replaced a toner cartridge, did you remove the orange tab?
- Were the printer and its software installed correctly?

For more information on installation and set up, see the getting started guide. If you have questions that you do not find the answers to in this chapter, see the [HP Customer Care](#) information in the front of this manual.

## Working with Toner

HP recommends that you use HP LaserJet toner cartridges. HP has designed the printer, toner cartridges, and toner formula to work together to give you optimal image quality from the printer.

If toner gets on clothing or carpet, wipe the toner off with a dry cloth and then wash with cold water. Warm water or the heat of a dryer will set the toner into the clothing or carpet.

# Media Jam Locations

The following figure shows the locations of media jams in the printer paper path.

Figure 15

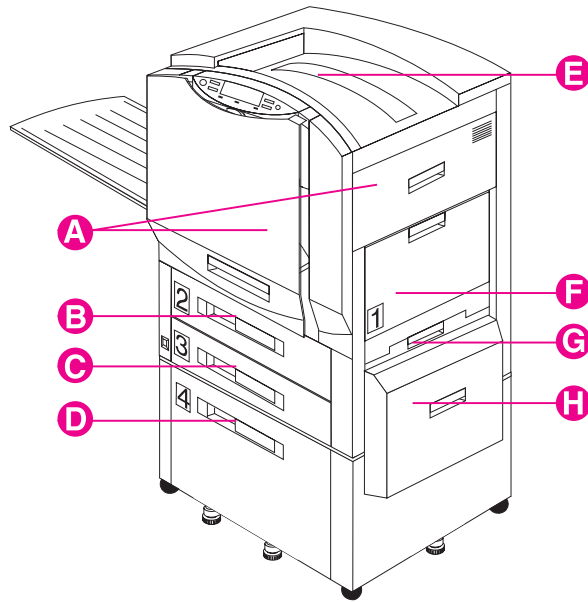

- A** Registration and Transfer Area
- B** Tray 2 (some printer models only)
- C** Tray 3
- D** Tray 4 (some printer models only)
- E** Top Output Bin (face down)
- F** Tray 1
- G** Lower Right Door
- H** Media Transfer Door (part of tray 4)

**Figure 16**

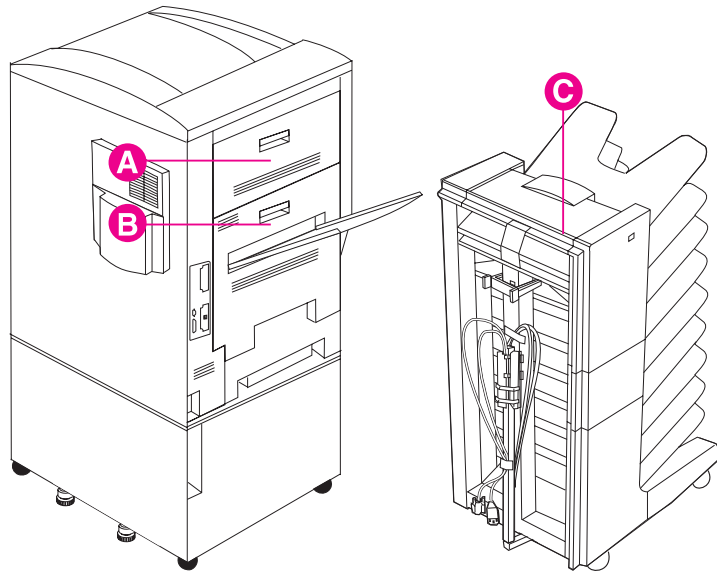

- A** Upper Left Door
- B** Fuser and Duplexer (optional) area
- C** Multi-bin Mailbox (optional)

For information on clearing jams, see the quick reference guide.

**CAUTION**

Resetting the transfer life count without replacing the transfer kit can cause print quality problems and may damage the printer.

# Media Handling Problems

Problem	Cause and Solution
Media jams	The media does not meet the specifications for this printer. For media specifications, see <a href="#">“Supported Media Weights and Sizes for Input Trays”</a> in chapter 3.
	The paper or other media is in poor condition. Replace the media.
	The media was not stored correctly. Replace the media. Media should be stored in its original packaging in a dry area.
	The media type is set incorrectly. Select the correct media type in the printer control panel. For more information, see chapter 2, <a href="#">“Using the Printer Control Panel.”</a>
	You are using media that has already passed through the printer or a copier. Do not re-feed media.
	The input tray is loaded incorrectly. Remove any excess media from the input tray. Press the media down under the tabs in the input tray. For more information on loading media, see chapter 3, <a href="#">“Common Printing Tasks.”</a>
	The media guides are not adjusted correctly. Adjust the media guides so that they are firmly against the media but not bending the media.
	If you are printing on heavy media and the media is jamming repeatedly in the top output bin, switch to the left output bin.
	If you are printing from tray 1 and the size set in your application does not match the size of media fed into tray 1, the printer will sense the difference in size and stop printing to prevent damage to the printer. Remove any remaining media, ensure the size set in your application and the size of the media match, and reprint.
	Print media is binding or sticking together. Remove any remaining media, rotate it 180 degrees or flip it over, and then set it back in the input tray.

Problem	Cause and Solution
<i>(Media jams, continued)</i>	If you are using the optional multi-bin mailbox, do not remove pages from the output bins until the printer is finished printing.
	Repeated jams in the fuser area might indicate that the fuser is not installed correctly. Press down on the large green lever on the left side to lock it into place. Also, rotate the blue levers on either side of the fuser up until they snap into place.
	Repeated jams in the transfer area might indicate that the transfer drum is not installed correctly. Remove the transfer drum and reinstall it, making sure the knobs on the sides of the transfer drum are in the guides inside the printer.
	Repeated jams in the multi-bin mailbox area might indicate that the printer and multi-bin mailbox are set up on an uneven floor. Remove the toner cartridges, and then move the printer to a level location. Reinstall the toner cartridges.
	Repeated paper jams between the printer and the optional 3000-sheet Stapler/Stacker or optional 3000-sheet Stacker might mean that the printer and the optional 3000-sheet Stapler/Stacker or 3000-sheet Stacker are set up on an uneven floor. Level the device. See the installation guide that came with the device for instructions.
	The printer consumables are wearing out. Check the printer control panel for messages prompting you to replace consumables, or print a configuration page to verify the current status of the consumables. For the consumable replacement schedule, see <a href="#">“Frequency for Replacing Printer Consumables”</a> in chapter 6.
	CLEAR INPUT JAM displays on the front panel and will not clear even though there is no paper in the path. Or, tray 2, 3, or 4 misfeeds or continually jams when feeding. Inspect the feed rollers. Ensure that they are completely installed on the shaft (they should click into place).

Problem	Cause and Solution
Printer feeds multiple sheets	The input tray is overfilled. Remove the excess media from the input tray. For more information on input tray capacity, see <a href="#">“Supported Media Weights and Sizes for Input Trays”</a> in chapter 3.
	Verify that the media is under the tabs in the input tray. Pull out the input tray, press the media down under the tabs in the input tray, and then close the input tray.
	The media is sticking together. Remove any remaining media, rotate it 180 degrees or flip it over, and then set it back in the input tray.
	There is more than one type of media, such as paper and transparencies, in the input tray. Remove all media except the type you want to print on.
	The media does not meet the specifications for this printer. For media specifications, see <a href="#">“Supported Media Weights and Sizes for Input Trays”</a> in chapter 3.
Printer feeds the incorrect media type or size	The correct media size is not selected in your application. Select the correct media size in your application.
	The media types for each input tray are not configured correctly in the printer control panel. Verify the requested media is installed in the printer, and reconfigure the media type for the input tray in the printer control panel. For information on configuring the media type in the input trays, see <a href="#">“Configuring Media Type and Size”</a> in chapter 2.
	If the requested media type and size are not available, then the printer displays a message on the printer control panel requesting that the media type and size be loaded. If Auto Paper Override is enabled in the printer control panel, then after the set time, or if <b>Go</b> is pressed, the printer will print on the default type and size.



Problem	Cause and Solution
Media does not feed automatically	<b>Manual Feed (Tray 1)</b> is not selected in the printer driver. Select the correct media source.
	The input tray is empty. Load media into the input tray.
	Media is still in the paper path after removing the previous media jam. Open the printer doors and remove any media from the paper path. Check the fuser area carefully for any jams. For information on removing media jams, see the quick reference guide.
Media does not feed from tray 1	<b>Manual Feed (Tray 1)</b> is not selected in the printer driver. Select the correct media source.
	If the size set in your application does not match the size of media fed into tray 1, the printer will sense the difference in size and stop printing to prevent damage to the printer. Remove any remaining media, verify the size set in your application and the size of the media match, adjust the media width guides so they are firmly against the edges of the media, and reprint.
	Verify that the media is being inserted far enough into the tray 1. Insert the media into the tray 1 until the media is tight against the printer, and slide the media width guides until they touch both sides of the media without bending the media.
	Media is still in the paper path after removing the previous media jam. Open the printer doors and remove any media from the paper path. For information on removing media jams, see the quick reference guide.

Problem	Cause and Solution
Media does not feed from tray 2 or 3	The media type selected from the application has not been configured for the input tray. Configure the media type for the input tray in the printer control panel. For more information on configuring media types, see <a href="#">“Configuring Media Type and Size”</a> in chapter 2.
	If trays 2 and 3 are configured for the same media type and size, the printer will only feed from a specific input tray if that input tray is selected in your application. For more information on selecting a input tray from your application, see the online help for the application.
	Media is still in the paper path after removing the previous media jam. Open the printer doors and remove any media from the paper path. For information on removing media jams, see the quick reference guide.
Media does not feed from tray 4	Remove the media and verify the media guides in the front, back, and left of the input tray are configured to the correct media size. For more information on configuring the media guides, see <a href="#">“Printing from Tray 4 (some printer models only)”</a> in chapter 3.
	Verify the media type configured in the printer control panel for tray 4 matches the media loaded in tray 4. For more information on configuring the media type, see <a href="#">“Configuring Media Type and Size”</a> in chapter 2.

Problem	Cause and Solution
<p><i>(Media does not feed from tray 4, continued)</i></p>	<p>The input tray is overfilled. Remove excess media from the input tray. For more information on input tray capacity, see “<a href="#">Supported Media Weights and Sizes for Input Trays</a>” in chapter 3.</p>
	<p>The power cord is not firmly plugged into the printer, tray 4, and the power receptacle. Remove and reconnect the power cord.</p>
	<p>Verify that the cables are firmly attached between tray 4 and the printer. Also, verify that the cables are connected to the correct connector. For more information on connecting the cables between tray 4 and the printer, see the getting started guide.</p>
	<p>The paper rollers might need to be cleaned. Open the lower right door, pinch together the release levers on the end of the rollers, and slide the rollers off their spindles. Clean the rollers with a hand wipe. Reinstall the rollers by holding the roller by the levers and sliding the rollers onto the spindle until the rollers click into place.</p>
	<p>The media does not meet the specifications for this printer. For media specifications, see “<a href="#">Supported Media Weights and Sizes for Input Trays</a>” in chapter 3.</p>
<p>Transparencies or glossy paper will not feed from trays 1, 2, or 3</p>	<p>Verify the correct media type is selected in the printer driver or application. Or, if you are trying to print from a particular input tray, verify that the input tray from which you are trying to print is selected in the printer driver or application.</p>
	<p>Verify the media type configured in the printer control panel for the input tray matches the media loaded in the input tray. For more information on configuring the media type, see “<a href="#">Configuring Media Type and Size</a>” in chapter 2.</p>
	<p>The input tray is overfilled. Remove the excess media from the input tray. For more information on input tray capacity, see “<a href="#">Supported Media Weights and Sizes for Input Trays</a>” in chapter 3.</p>

Problem	Cause and Solution
<p><i>(Transparencies or glossy paper will not feed from trays 1, 2, or 3, continued)</i></p>	<p>Verify that the media is being inserted far enough into the tray 1. Insert the media into the tray 1 until the media is tight against the printer, and slide the media width guides until they touch both sides of the media without bending the media.</p>
	<p>Only one sheet is loaded in the input tray. Load more than one sheet in the input tray.</p>
	<p>The media does not meet the specifications for this printer. For media specifications, see “<a href="#">Supported Media Weights and Sizes for Input Trays</a>” in chapter 3.</p>
<p>Envelopes jam or will not feed in the printer</p>	<p>Envelopes can only be printed from tray 1. If the envelopes are in another input tray, remove the envelopes and place them in tray 1.</p>
	<p>Envelopes can only be printed on the front (smooth) side. If the envelopes are loaded upside-down in tray 1, remove the envelopes and place them flap down on tray 1 with the return address area (short edge of the envelope) toward the printer.</p>
	<p>Verify that the envelopes are being inserted far enough into the tray 1. Insert the envelopes into the tray 1 until the envelopes are tight against the printer, and slide the media width guides until they touch both sides of the envelopes without bending the envelopes.</p>
	<p>The envelope does not meet the specifications for this printer. For envelope specifications, see “<a href="#">Supported Media Weights and Sizes for Input Trays</a>” in chapter 3.</p>
<p>Media is not going to the correct output bin</p>	<p>Verify that the correct output bin is selected in the printer driver. For more information on changing printer driver settings, see the online help.</p>
	<p>The media does not meet the specifications for the output bin. For media specifications, see “<a href="#">Supported Media Weights and Sizes for Input Trays</a>” in chapter 3.</p>
	<p>If you are trying to send print jobs to an optional multi-bin mailbox, optional 3000-sheet Stapler/Stacker, or optional 3000-sheet Stacker, verify that the specific device has been installed on the printer and in the printer driver. Also verify the multi-bin mailbox mode, which will affect the print job destination.</p>

Problem	Cause and Solution
Curled or wrinkled output	The media does not meet the specifications for this printer. For media specifications, see “ <a href="#">Supported Media Weights and Sizes for Input Trays</a> ” in chapter 3.
	The current media is damaged or in poor condition. Remove the damaged media from the input tray, and then replace with undamaged media.
	You are operating the printer in excessively humid conditions. Make sure the printer is operating within the environmental specifications listed in appendix B.
	If you are printing heavy, solid fill areas, the excessive toner can cause excessive curl. Try printing different halftone patterns (a lighter shade of the same color), a lighter color, or a lighter pattern.
	The paper path might be curling the page. Change the paper path by printing from a different input tray to a different output bin.
	You are using media that was not stored correctly and could have absorbed water. Remove and replace with media from a fresh, unopened package.
	The media has a poorly cut edge. Remove any remaining media, rotate the media 180 degrees or flip it over, and then set it back in the input tray.

## Printer Response Problems

Problem	Cause and Solution
No display message	The printer might be in Power Save mode. Press <b>Go</b> to bring the printer online.
	The printer control panel display appears blank or is not lit, even when the fan is running. The printer is in standby mode (off). Turn the printer on (button in).
	The power cord is not firmly plugged into both the printer and the power receptacle. Remove and reconnect the power cord.
	The line voltage is incorrect for the printer power configuration. Connect the printer to the correct line voltage as specified on the Power Rating label on the back of the printer.
	The power cord is damaged or excessively worn. Replace the power cord.
	The power source receptacle is not working correctly. Connect the printer to a different power receptacle.
	If you recently installed DIMMs or a printer hard disk, verify the communications board was reinstalled correctly. For more information on installing DIMMs, see appendix A, " <a href="#">DIMM Installation</a> ;" for more information on installing a printer hard disk, see the installation guide included with the printer hard disk.
Tray 4 will not power on	The power cord is not firmly plugged into both the printer and the power receptacle. Remove and reconnect the power cord.
	Verify that the cables are firmly attached between tray 4 and the printer. Also, verify that the cables are connected to the correct connector. For more information on connecting the cables between tray 4 and the printer, see the getting started guide.

<b>Problem</b>	<b>Cause and Solution</b>
The multi-bin mailbox will not power on	Verify that the power cord is firmly plugged into both the multi-bin mailbox and the power receptacle. Remove and reconnect the power cord.
	Verify that the cables are firmly attached between the multi-bin mailbox and tray 4. Also, verify that the cables are connected to the correct connector. For more information on connecting the cables between the multi-bin mailbox and tray 4, see the getting started guide.
	Verify that the multi-bin mailbox is firmly attached to the printer.
The printer does not recognize the multi-bin mailbox	Verify that the power cord is firmly plugged into both the multi-bin mailbox and the power receptacle. Remove and reconnect the power cord.
	Verify that the multi-bin mailbox is firmly attached to the printer.
	Verify that the cables are firmly attached between the multi-bin mailbox and tray 4. Also, verify that the cables are connected to the correct connector. For more information on connecting the cables between the multi-bin mailbox and tray 4, see the getting started guide.
Printer does not recognize the optional paper handling device or the user LED on the device is off.	Check the power cords.
	Check the C-link cables.
	Make sure that the device has been configured in the printer driver.
	If the printer still does not recognize the device, contact a dealer or authorized HP service provider. See the user guide for your specific HP LaserJet printer for service and support information.

Problem	Cause and Solution
Color toner carousel will not rotate	The power cord is not firmly plugged into both the printer and the power receptacle. Remove and reconnect the power cord. The printer must be turned on.
	Verify the clear door is closed, the imaging drum and black toner cartridge are installed (including removing the orange seal from the black toner cartridge and swinging the upper lever to the left), and the upper right door is closed.
The printer is on, but not receiving data (Data light does not blink and nothing prints)	READY is not displayed on the printer control panel. Press <b>Go</b> to bring the printer online.
	The printer has lost communication with the network. Turn the printer off and then turn the printer on to re-establish the connection.
	The network cable is not correct for the network operating system. Select the correct network cable for the network operating system. For more information, see the getting started guide.



<b>Problem</b>	<b>Cause and Solution</b>
<p><i>(The printer is on, but not receiving data (Data light does not blink and nothing prints), continued)</i></p>	<p>The interface cable is not securely connected to both the printer and the computer. Remove and reconnect the interface cable.</p>
	<p>The network cable might be old or not working correctly. Replace the network cable with a new cable.</p>
	<p>The parallel cable might not be working correctly. Verify that the cable is IEEE-1284 compliant and no longer than 10 feet (approximately 3 meters), and that the parallel advanced function in the printer control panel is on. If necessary, turn the parallel advanced function off through the printer control panel and replace the cable.</p>
	<p>The network configurations on the configuration page do not match the configurations on the host computer. Configure the printer to match the computer configuration, or configure the host computer to match the printer. For network configuration information, see the getting started guide.</p>
	<p>If you have more than one LAN (local area network), the computer might be on a different LAN than the printer is on. Change LANs and reprint the job.</p>
	<p>If you are using Windows 9x, Windows NT or Windows 2000, the host computer or the printer might not be shared correctly. For more information on sharing, see the Windows documentation.</p>
	<p>If you are using Novell NetWare, you might not have configured the queues properly. Use the HP Web JetAdmin software to configure the queues. For more information on configuring queues, see the HP Web JetAdmin online help.</p>
	<p>The computer port is not configured or working correctly. Connect another peripheral to this port to check the port operation.</p>
	<p>If you are using AppleTalk, the printer is not selected in the Chooser menu. Go to the Chooser menu. Select the printer type. In the list box, select the printer name. Select the printer port icon. When you close the Chooser menu, the settings will be saved.</p>

Problem	Cause and Solution
<i>(The printer is on, but not receiving data (Data light does not blink and nothing prints), continued)</i>	If you are using AppleTalk, verify that the AppleTalk name matches the name on the configuration page. Print the configuration page. Go to the Chooser menu. Select the printer type. In the list box, select the printer name that matches the printer name on the configuration page. Select the printer port icon. When you close the Chooser menu, the settings will be saved.
The printer is on and receiving data (Data light blinks), but nothing prints	READY is not displayed on the printer control panel. Press <b>Go</b> to bring the printer online.
	The levers inside the front door of the printer might not be latched. Verify all levers inside the front door are properly latched and close the front door.
	The Data indicator is flashing. Wait for the Data indicator to stop flashing. The printer is still receiving data.
	The printer might be out of toner. Check the printer control panel display for TONER OUT REPLACE <Color>. For more information on replacing the toner cartridge, see the installation guide included with the toner cartridge.
	The imaging drum life might be exceeded. Check the printer control panel display for DRUM LIFE OUT REPLACE DRUM KIT. For more information on replacing the drum kit, see the installation guide included with the drum kit.
	Check the printer control panel for messages. For more information on resolving printer control panel messages, see chapter 7, " <a href="#">Printer Control Panel Messages</a> ."
	The parallel port might have an MS-DOS timeout error. Add a MODE command to the autoexec.bat file. For example, in MS-DOS 4.0 or later, use <code>MODE LPT1: B</code> . For earlier versions of MS-DOS, use <code>MODE LPT1: P</code> . Both examples are for a printer connected to LPT1. See the MS-DOS documentation for more information.

Problem	Cause and Solution
<p>The printer is on, but cannot print a PostScript file</p>	<p>You are using the MS-DOS copy command with the /B option (COPY /B &lt;filename&gt; PRN: or COPY &lt;filename&gt; PRN: /B). Try the same command without the /B option.</p>
	<p>The PostScript printer driver is not selected in your application. Select the PostScript printer driver for this printer in your application.</p>
	<p>The PostScript file might contain an error. Turn the PRINT PS ERRORS option on in the printer control panel to determine the error. Try printing the PostScript file from another application. If necessary, update the PostScript printer driver. For more help, see the Adobe documentation.</p>
<p>Cannot select the printer from the computer</p>	<p>READY is not displayed on the printer control panel. Press <b>Go</b> to bring the printer online.</p>
	<p>The correct printer driver is not loaded in the computer. Load the correct printer driver.</p>
	<p>The correct printer and port are not selected on the computer. See the getting started guide to verify that the printer is connected to the network correctly, and then select the correct printer and port.</p>
	<p>Print a configuration page to verify that the TCP/IP address in the EIO settings and the printer name matches the information in the network settings on the host computer. Change the settings as necessary.</p>
	<p>Verify that the network permissions have been set correctly. For more information on network permissions, see the network operating system documentation.</p>
	<p>If you are on an AppleTalk network or using a Mac OS computer, the printer is not selected correctly. Go to the Chooser menu. Select the printer type. In the list box, select the printer name. Select the printer port icon. When you close the Chooser menu, the settings will be saved.</p>

# Printer Control Panel and Configuration Problems

Problem	Cause and Solution
Printer control panel settings work incorrectly	The printer control panel display appears blank or is not lit even when the fan is running. The printer is in standby mode (off). Turn the printer on (button in).
	The printer settings in the application are different from the printer control panel settings. The settings in your application override the settings in the printer control panel.
	The settings were not correctly saved after changing them. Re-select the setting, then press <b>SELECT</b> . An asterisk (*) should appear to the right of the setting.
	The data indicator was lit and the settings were not activated after changing them. Re-select the printer control panel settings. Then, if the data indicator is lit, press <b>SELECT</b> to activate the settings and clear the print buffer.
	The Data indicator is lit. Buffered data exist in the printer. Pressing <b>SELECT</b> activates the printer control panel settings, but erases the buffered data. Pressing <b>Go</b> prints the buffered data in the current printer control panel settings, then activates the new printer control panel settings.
	If you are on a network, another user might have changed the printer control panel settings. See the system administrator to coordinate changes to printer control panel settings.
Cannot select the information menu	The Ready indicator is lit. Press <b>Go</b> to take the printer offline.
	The Data indicator is lit. Press <b>Go</b> to reset the printer.

Problem	Cause and Solution
Cannot print a configuration page	You did not press <b>SELECT</b> after selecting the configuration page. Re-select the configuration page. Then press <b>SELECT</b> to print the configuration page.
	You pressed <b>GO</b> before pressing <b>SELECT</b> or before the printer self-test was completed. Re-select the configuration page, and then press <b>SELECT</b> once to print the configuration page. Pressing <b>GO</b> after the printer self-test is started, or before pressing <b>SELECT</b> , stops the printer self-test and brings the printer online.
	The selected input tray is empty. Load the correct media size in the input tray.

# Application Problems

Problem	Cause and Solution
Cannot change system selections through software	The correct printer driver is not loaded. Load the correct printer driver.
Cannot select a font in the application	The correct printer driver is not selected. Select the correct printer driver.
	The font is not available in your application. Use a font manager utility to add the font.
	If you have downloaded a font on the printer hard disk and you do not see the font in the application, see the download program (such as EuroForm or other font management utilities) help for more information.
	Print a disk directory page to see if the font has been downloaded to the printer hard disk. If the font is on the printer hard disk, install the font in Windows using a font management utility or through the Windows control panel. For more information on installing a font using the Windows control panel, see the appropriate online help.
	The font might have been downloaded to the printer RAM rather than to the printer hard disk. When the printer is turned off and on, all data in the printer's RAM is lost. Download the font to RAM again. For more information on downloading fonts, see the online help.
If you selected one font and another font prints out, the font is not available and the application has substituted the font. Make sure the selected font has been downloaded to the printer hard disk or printer RAM. For more information on downloading fonts, see the online help.	

<b>Problem</b>	<b>Cause and Solution</b>
Cannot select colors in the application	Your application does not support color. See the documentation for your application for help.
	The color mode is not selected in your application. Select the color mode instead of the grayscale or black and white output mode.
	The correct printer driver is not loaded. Load the correct printer driver.

# Incorrect Printer Output

Problem	Cause and Solution
Incorrect fonts on the printout	The font has not been correctly selected in your application. Re-select the font in your application. For more information on selecting fonts, see the online help for your application.
	The font is not available to the printer. Use a different font or download the font you want. For more information on downloading fonts, see the online help for the printer driver.
	The correct printer driver is not selected. Select the correct printer driver. For more information on selecting printer drivers, see the online help for the printer driver for your application.
Cannot print all characters in a symbol set	The correct font is not selected. Select the correct font. For more information on selecting fonts, see the online help for your application.
	The correct symbol set is not selected. Select the correct symbol set. For more information on selecting symbol sets, see the online help for your application.
	The selected character is not supported by your application. For more information, see the online help for your application.
	The selected symbol set is not supported by the printer. Use a font that supports the symbol set or download fonts that support the symbol set. For more information on downloading fonts, see the online help.
Erratic or interrupted printout	The interface cable is loose. Remove and reconnect the interface cable.
	The interface cable is damaged or bad. Connect a new IEEE-1284 compliant interface cable.
	The power cable is loose. Remove the cables, and then firmly plug the power cord into both the printer and the power receptacle.



Problem	Cause and Solution
Partial printout	The media was loaded in tray 1 incorrectly. Load letter- or A4-sized media with the long edge toward the printer. Load media sizes larger than letter or A4 with the short edge toward the printer.
	Verify that the media size set in the printer driver and the actual size of the media match. For information on configuring the printer driver, see the online help.
	A memory error message appears on the printer control panel display. Delete from the printer memory any unwanted downloaded fonts, style sheets, macros, and forms, or add more memory to the printer.
	If there are missing random characters, the parallel cable might be old or bad. Replace the cable with an IEEE-1284 compliant parallel cable.
	The printer files contain errors. Check your application to make sure the print files are error free by 1) trying to print another file that you know is error free from within the same application or 2) printing the file in question from another application.
Drifting text between consecutive pages	Your application is not resetting the printer to the top of the page. See the software application notes or the <i>PCL Technical Reference Manual</i> for specific information.
PostScript job prints as text	If you are using a non-Windows or custom-built application, it is possible that the PostScript job header is not being sent down to the printer with the file. For more information about sending a PostScript job header with your file, see the application's documentation.
	Your file might have an error in the PostScript code. Try reprinting the document. For more information on printing PostScript files, see the application's documentation.

# Color Printing Problems

Problem	Cause and Solution
Printed colors do not match the screen colors	The computer and printer use different color processing methods. Other factors, such as print media and lighting, also influence and limit your ability to match colors from the screen to your output. For more information on printer driver color controls, see chapter 5, " <a href="#">Using Color</a> ."
	Turn the printer off and on to reset the printer's color calibration. If the problem persists, clean the density sensor as described in " <a href="#">Cleaning the Density Sensor</a> " later in this chapter.
	Extremely light screen colors are not being printed. Avoid extremely light colors. Your application is interpreting extremely light colors as white. For more information, see the online help for your application.
	Extremely dark screen colors are being printed as black. Avoid extremely dark colors. Your application is interpreting extremely dark colors as black. For more information, see the online help for your application.
	The screen colors differ from the printer output. Select <b>ColorSmart II</b> in the Color tab of the printer driver. For information on using the Color Swatch utility to help match colors or another color matching system, see " <a href="#">Selecting Colors</a> " in chapter 5 or see the online help.
	Each application processes colors differently. Change applications. For more information on how a particular application handles color, see the documentation for the application.
	The color density and balance are not set properly. For information on changing the color density and balance, see " <a href="#">Adjusting the Color Balance</a> " in chapter 5.
Missing colors	Turn the printer off and on to reset the printer's color calibration.
	The media does not meet the specifications for this printer. For media specifications, see " <a href="#">Supported Media Weights and Sizes for Input Trays</a> " in chapter 3.

Problem	Cause and Solution
<p><i>(Missing colors, continued)</i></p>	<p>You might be operating the printer in excessively humid conditions. Make sure the printer is operating within the environmental specifications listed in appendix <a href="#">B</a>.</p>
	<p>A new toner cartridge was installed without removing all of the toner packaging. Remove the toner cartridge. Remove all packaging, verify that the orange tab has been pulled and the seal has been removed. Reinstall the toner cartridge.</p>
	<p>The printer might not be recognizing that the toner levels are low. Open the front door, and remove and reinstall each toner cartridge. Close the front door. Replace the toner cartridges if <code>TONER LOW REPLACE &lt;Color&gt;</code> or <code>TONER OUT REPLACE &lt;Color&gt;</code> appears on the printer control panel display.</p>
<p>Print is black instead of color</p>	<p>The color mode is not selected in your application or printer driver. Select the color mode instead of the grayscale or black and white mode in your application or printer driver. For more information, see the online help for the application or printer driver.</p>
	<p>The correct printer driver is not selected in your application. Select the printer driver for this printer. For more information, see the online help for the printer driver.</p>
	<p>The printer is not working correctly. Verify the printer operation by printing a configuration page from the printer control panel. If no color appears on the configuration page, contact a local authorized HP dealer for service.</p>
<p>Inconsistent colors after replacing the toner cartridges</p>	<p>You are not using the correct toner cartridges. Use only the HP toner cartridges that were designed for this printer. HP has designed the printer, toner cartridges, and toner formula to work together to give you optimal image quality from the printer. For part number information, see "<a href="#">Accessories, Options, and Related Products</a>" later in this chapter.</p>
	<p>A new toner cartridge was installed without removing all of the toner packaging. Remove the toner cartridge. Remove all packaging, verify that the orange tab has been pulled and the seal has been removed. Reinstall the toner cartridge.</p>

# Print Quality Problems

Unless otherwise specified, all references in this section to horizontal or vertical directions of print quality problems refer to problems found on letter- and A4-sized media. These media sizes are fed into the printer long edge first.

Because media sizes other than letter or A4 are fed into the printer short edge first, the orientations of print quality problems are the opposite of those on letter or A4-sized media. Print quality problems that appear horizontally on a letter- or A4-sized page when it is held with the short edge up will run vertically on other media sizes when the page is held with the short edge up. The same is true for a vertical defect on a letter- or A4- sized page: it will appear as a horizontal defect on other sizes of media.



The following figure shows a print quality problem printed on both a letter- or A4-sized page and the same defect on an 11-by-17 inch or A3-sized page (or any other size of media).

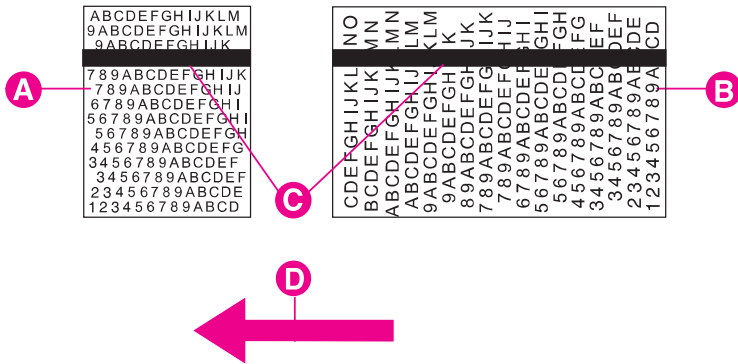

Figure 17

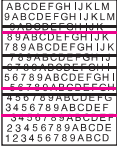

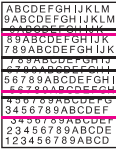
- A Letter- or A4-sized media
- B 11-by-17 inch or A3-sized media (or any other size of media)
- C Print quality problem
- D Direction media moves through printer



Problem	Cause and Solution
<p>Toner smear</p> 	<p>Toner smears appear on the back of the page. The transfer belt is dirty or the transfer belt assembly may not be seated properly. Open and close the front door to complete a printer self-cleaning cycle.</p>
	<p>There might be an undetected jam in the printer. Open and close the front door to allow the printer to clear the jam. If the problem persists, remove the transfer drum. Look between the drum surface and the drum handles for the piece of media. Remove any media, and then reinstall the transfer drum.</p>
	<p>You recently had a media jam or the printer fed multiple sheets of media. Open and close the front door to complete a printer self-cleaning cycle.</p>
	<p>If you are printing on media heavier than 28 lb (105 g/m<sup>2</sup>) bond, you must select <b>Heavy Paper</b> as the paper type on the Paper tab in the printer driver to ensure the correct finish on the media. For more information on changing the printer driver settings, see the online help.</p>



Problem	Cause and Solution
<p data-bbox="129 163 354 222">Horizontal lines or streaks</p>  	<p data-bbox="463 163 1122 456">A toner cartridge might be running out of toner. Check the printer control panel display for a TONER LOW REPLACE &lt;Color&gt; or TONER OUT REPLACE &lt;Color&gt; message. Replace the toner cartridge indicated on the printer control panel display. <b>Do not shake the toner cartridge in attempts to extend the cartridge life.</b> For more information on replacing the toner cartridge, see the installation guide included with the toner cartridge.</p>
	<p data-bbox="463 479 1122 605">Dark or light lines or streaks appear in colors, except black. A toner cartridge might be defective. If the problem persists, contact a local authorized HP dealer or service representative for service.</p>
	<p data-bbox="463 628 1122 855">White lines or streaks only appear in the black areas of print, but not in color areas. Print the configuration page five times. The defect should clear with continued printing. Then reprint the print job. If the problem persists, replace the black toner cartridge. If the problem persists, contact a local authorized HP dealer or service representative for service.</p>
	<p data-bbox="463 878 1122 1203">Dark or white lines or streaks in all colors, including black. Print the configuration page five times. The defect should clear with continued printing. If the defect does not clear, turn the printer off and on to reset the printer's density calibration. Make sure that the transfer belt is seated properly (rest the ends of the belt into the notches inside the printer). If the problem persists, replace the imaging drum. For more information on replacing the imaging drum, see the installation guide included with the drum kit.</p>
	<p data-bbox="463 1225 1122 1446">Light streaks in dark solid fill areas might indicate that the post charger on the transfer drum needs to be cleaned. Open and close the front door to complete a printer self-cleaning cycle. If the defect does not clear, clean the post charger. For information on cleaning the post charger, see <a href="#">“Cleaning the Post Charger”</a> later in this chapter.</p>



Problem	Cause and Solution
<p>Vertical bands or very dark background</p> 	<p>Vertical colored bands or dark black or brown backgrounds appear on the page. If the problem persists after printing 10 pages, contact a local authorized HP dealer or service representative for service.</p> <p>The new imaging drum might have a temporary charging problem. Print several configuration pages to clear the drum.</p>
<p>Faded print, or random faded areas</p> 	<p>A toner cartridge is running out of toner. Check for a TONER LOW REPLACE &lt;Color&gt; or TONER OUT REPLACE &lt;Color&gt; message on the printer control panel. Replace the toner cartridge indicated on the display.</p> <p>The media does not meet the specifications for this printer. For media specifications, see <a href="#">“Supported Media Weights and Sizes for Input Trays”</a> in chapter 3.</p> <p>The moisture content of the media is uneven or too high. Try media from a different source or from an unopened ream of media.</p> <p>If you are trying to duplex on paper heavier than 28 lb (105 g/m<sup>2</sup>) bond, at your computer select <b>Heavy</b> or <b>Cardstock</b> as the media type in the printer driver. Print side one of your document from tray 1. To print side two, at your computer select <b>Manually Print on 2nd Side</b> in the printer driver. Then, using tray 1 again, turn the page over and print.</p> <p><b>Note:</b> If you use the <b>Manually Print on 2nd Side</b> setting when you are not printing on the second side of heavy media, you might see sharp, inconsistent patches of color on your output.</p> <p>Some areas of some media might reject toner. Try media from a different source or from an unopened ream of media.</p> <p>Your media is excessively rough. Change to a smooth xerographic paper. For media specifications, see <a href="#">“Supported Media Weights and Sizes for Input Trays”</a> in chapter 3.</p>



Problem	Cause and Solution
<p><i>(Faded print, or random faded areas, continued)</i></p>	<p>The letterhead you are using is printed on rough paper. Try a smooth xerographic paper. If this solves the problem, make sure the letterhead vendor is using paper that meets the specifications for this printer. For media specifications, see "<a href="#">Supported Media Weights and Sizes for Input Trays</a>" in chapter 3.</p>
	<p>You are operating the printer in excessively humid or dry conditions. Make sure the printer is operating within the environmental specifications listed appendix <a href="#">B</a>.</p>
	<p>The media was creased or wrinkled when it was loaded in the input tray. Try media from a different source or from an unopened ream of media.</p>
	<p>The print on the entire page is light or faded. Remove the transfer assembly. Reinstall the transfer assembly. Be sure to align the arrows and then reseal the assembly.</p>
	<p>If you recently removed the imaging drum from the printer, it might have been damaged by light. Turn the printer off and on to reset the printer's density calibration. If the problem persists, replace the imaging drum or contact a local authorized HP dealer or service representative for service. For more information on replacing the imaging drum, see the installation guide included with the drum kit.</p>
	<p>If the print or the background is too dark, turn the printer off and on to allow the printer to adjust its color settings. If the problem persists, clean the density sensor as described in "<a href="#">Cleaning the Density Sensor</a>" later in this chapter.</p>



Problem	Cause and Solution
<p data-bbox="131 166 429 227">Irregular, raised spots or stray toner</p> 	<p data-bbox="463 166 1127 354">If you are printing on heavy media (28 to 58 lb, or 105 to 216 g/m<sup>2</sup> bond), you must select <b>Heavy Paper</b> as the paper type in the Paper tab in the printer driver to ensure the correct finish on the media. For more information on changing printer driver settings, see the online help.</p>
	<p data-bbox="463 383 1097 571">Toner is smudged on the back of the page. Toner collected on the transfer belt will cause smudging on the back of a page. The belt is self-cleaning and the smudging will normally clear within a few pages. Or, open and close the front door to complete a printer self-cleaning cycle.</p>
	<p data-bbox="463 600 1126 690">You recently had a media jam or the printer fed multiple sheets of media. Open and close the front door to complete a printer self-cleaning cycle.</p>
	<p data-bbox="463 718 1103 840">You are refeeding media that has already passed through the printer or through a copier. Do not refeed media. Refeeding media contaminates the fuser, causing stray toner defects.</p>
	<p data-bbox="463 871 1122 923">The fuser roller is contaminated. Print 5 to 10 pages to clean the fuser roller.</p>
<p data-bbox="131 956 234 982">Banding</p> 	<p data-bbox="463 956 1122 1107">Consumables might be past their rated life. Check the printer control panel display for any messages. If no messages appear, print a configuration page to check the life of the consumables. Replace any consumables that are past their rated life.</p>
	<p data-bbox="463 1142 1068 1225">Certain halftone patterns (lighter shades of a solid color) exaggerate banding. Try a different halftone pattern.</p>

Problem	Cause and Solution
<p data-bbox="129 163 391 222">Dull or dark colors on transparencies</p>  	<p data-bbox="463 163 1126 288">The printer is not correctly fusing the toner to the transparency. Check <b>Transparency</b> in Paper tab in the printer driver. For more information on changing the printer driver settings, see the online help.</p>
	<p data-bbox="463 315 1126 440">The media input tray is not correctly configured for transparencies. For more information on configuring the input tray, see “<a href="#">Configuring Media Type and Size</a>” in chapter <a href="#">2</a>.</p>
	<p data-bbox="463 468 1126 725"><b>Transparency</b> is not selected as the media type on the Paper tab in the printer driver. When <b>Transparency</b> is selected as the media type and <b>ColorSmart II</b> is selected on the Color tab, the printer will use a color treatment optimized for projection. To choose different color treatments for transparencies, use the <b>Manual</b> setting on the Color tab. For more information on using color, see chapter <a href="#">5</a>, “<a href="#">Using Color</a>.”</p>
	<p data-bbox="463 753 1126 808">Turn the printer off and on to reset the printer's density calibration.</p>
	<p data-bbox="463 836 1126 1031">Reflective overhead projectors reflect light through the transparency twice, causing excessive light scattering and producing colors that appear dark or dull on the screen. If you are using a reflective overhead projector (usually a portable overhead projector), use a standard overhead projector, if available.</p>
	<p data-bbox="463 1058 1126 1211">You are using a transparency that is outside the specifications for this printer. Use HP brand transparencies to produce the best image quality for the printer. For media specifications, see “<a href="#">Supported Media Weights and Sizes for Input Trays</a>” in chapter <a href="#">3</a>.</p>
	<p data-bbox="463 1239 1126 1295">The selected colors give an undesirable appearance when printed. Select different colors in your application.</p>
	<p data-bbox="463 1322 1126 1510">Spots and smudges appear in the background areas of transparencies when they are projected on the screen. Reprint the transparencies, being careful not to touch the surface of transparencies. Oil from your fingers and hands can contaminate transparencies, leaving oil spots or smudges on the transparencies.</p>

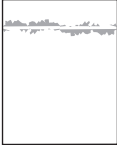
Problem	Cause and Solution
<i>(Dull or dark colors on transparencies, continued)</i>	Verify that the printer is operating in an environment consistent with the specifications listed appendix <a href="#">B</a> .
Rippled or wavy transparencies  	<p>You are using a transparency that is outside the specifications for this printer. Use HP brand transparencies to produce the best image quality for the printer. For media specifications, see “<a href="#">Supported Media Weights and Sizes for Input Trays</a>” in chapter <a href="#">3</a>.</p> <p>There is a wave or ripple in the background when printing a solid color. Choose a background pattern that uses less toner.</p> <p>The paper path you are using might be rippling or waving the page. Change the paper path by printing from a different input tray to a different output bin.</p>
Horizontal streaks on transparencies  	<p>You are using a transparency that is outside the specifications for this printer. Use HP brand transparencies to produce the best image quality for the printer. For media specifications, see “<a href="#">Supported Media Weights and Sizes for Input Trays</a>” in chapter <a href="#">3</a>.</p> <p>Reflective overhead projectors reflect light through the transparency twice, causing excessive light scattering and producing colors that appear dark or dull on the screen. If you are using a reflective overhead projector (usually a portable overhead projector), use a standard overhead projector, if available.</p>

Problem	Cause and Solution
<p>Smudges</p> 	<p>The printer recently had a media jam. Open and close the front door to complete a printer self-cleaning cycle.</p> <p>You recently changed to a different media size. Open and close the front door to complete a printer self-cleaning cycle.</p> <p>If the previous page printed was a prepunched media and there was an image in the location of the prepunched holes, then this toner is deposited on the back of the next page printed. Open and close the front door to complete a printer self-cleaning cycle.</p> <p>There might be an undetected jam in the printer. Open and close the front door to allow the printer to clear the jam. If the problem persists, remove the transfer drum. Look between the drum surface and the drum handles for a piece of media. Remove any media, and then reinstall the transfer drum.</p>
<p>Uneven dark areas or lines in solid fill areas on transparencies</p> 	<p>You are using a transparency that is outside the specifications for this printer. Use HP brand transparencies to produce the best image quality for the printer. For media specifications, see <a href="#">“Supported Media Weights and Sizes for Input Trays”</a> in chapter 3.</p>
<p>Repetitive defects</p> 	<p>The printer should be cleaned. Open and shut the front door of the printer to complete a printer self-cleaning cycle. If the problem persists, see <a href="#">“Cleaning the Transfer Drum”</a> later in this chapter.</p> <p>If the previous page printed was a prepunched media and there was an image in the location of the prepunched holes, then toner will be deposited on the back of the next page printed. Open and close the front door to complete a printer self-cleaning cycle.</p>

Problem	Cause and Solution
<p data-bbox="132 164 365 225"><i>(Repetitive defects, continued)</i></p>	<p data-bbox="463 164 1127 711">Repeating spots or specks of the same size and shape appear on almost all pages in the same area of the page. The repeating defects will generally be dark gray or black. If the defect is not acceptable, cleaning or replacing the imaging drum or the transfer drum might be necessary. If the defect occurs one or more times on each letter- or A4-sized page, the imaging drum should be replaced. If the defect occurs on every other letter- or A4-sized page, then the transfer drum should be cleaned. For information on cleaning the transfer drum, see <a href="#">“Cleaning the Transfer Drum”</a> later in this chapter. If cleaning the transfer drum does not correct the problem, replace the transfer drum or contact a local authorized HP dealer or service representative for service. For more information on replacing the imaging drum or the transfer drum, see the installation guide included with the drum kit or transfer kit.</p> <p data-bbox="463 737 1102 920">Unwanted marks of the same size and shape appear more than once in the same vertical area on transparencies only. The fuser roller is damaged. Replace the fuser. For more information on replacing the fuser, see the installation guide included with the fuser kit.</p>
<p data-bbox="132 954 409 980">Irregular wavy patterns</p> 	<p data-bbox="463 954 1115 1111">Irregular wavy patterns in solid fill backgrounds might indicate that the transfer charger needs to be cleaned. For more information on cleaning the transfer charger, see <a href="#">“Cleaning the Transfer Charger”</a> later in this chapter.</p>

## Cleaning the Density Sensor

Clean the density sensor after replacing the imaging drum and when printed colors are inaccurate.

### To clean the density sensor and erase lamp

- 1 Open the upper door on the right side of the printer.
- 2 On the inside of the door, locate the density sensor and the density sensor brush. Use the brush to brush off toner particles from the density sensor and the erase lamp. Then replace the brush.

---

#### Note

You can also use a hand wipe to clean the density sensor. To prevent scratches on the sensor, do not use any paper products, such as tissue or paper towels, to clean the sensor.

---

- 3 Close the upper right door.

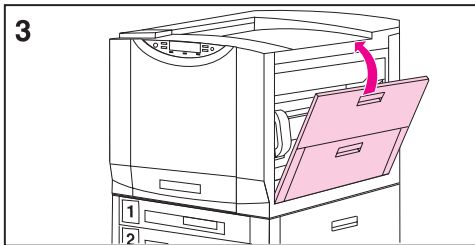
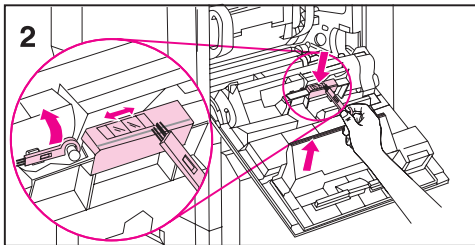
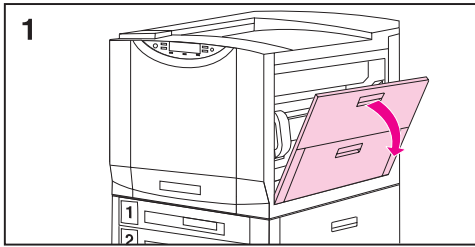

## Cleaning the Transfer Drum

Perform these procedures only when there is an unacceptable repetitive defect and the only other solution is replacing the transfer drum. Many, but not all, repetitive defects can be removed using the following procedures. Defects that appear as light spots in dark areas of print are more likely to be corrected by this procedure than dark spots in unprinted areas. **If the procedures are performed incorrectly or without proper care, the transfer drum can be permanently damaged.**

These procedures require the following items:

- A print sample showing the repetitive defect
- A clean, flat surface to work on
- Isopropyl alcohol
- A hand wipe

---

### CAUTION

You can also use a dry, clean, soft, lint-free cloth, such as cheesecloth, to clean the transfer drum. To prevent scratches on the drum, do not use any paper products, such as tissue or paper towels, to clean the drum.

Make sure you have a clean work area free of sharp or rough objects that might damage the drum. To avoid damaging the drum, remove all jewelry and watches before continuing. Contact with any of these items can cause permanent damage.

---

## To clean the transfer drum

- 1 Leave the printer powered on and open the printer's front door.
- 2 Push the white button on the lower (green) lever and swing the lever to the right.
- 3 Open the upper door on the right side of the printer.
- 4 Using the handles, gently pull out the transfer drum until it stops.

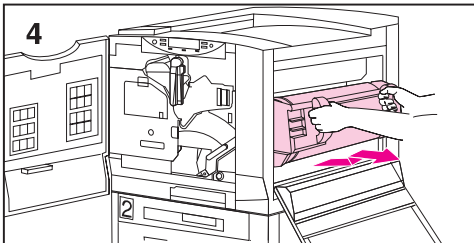
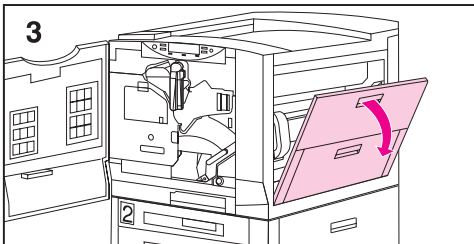
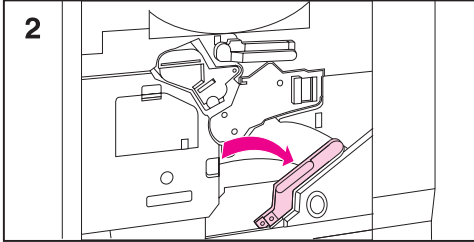
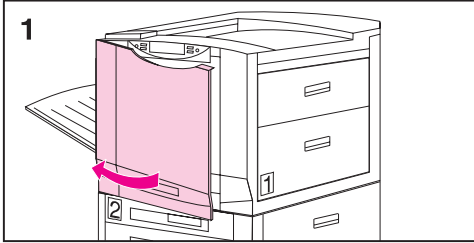



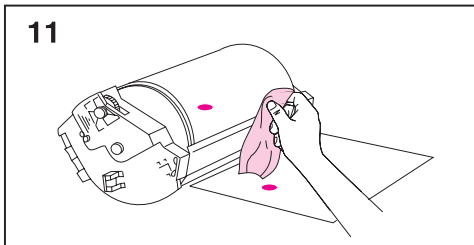
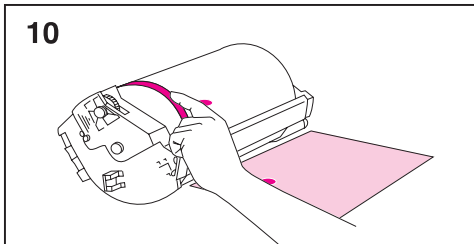
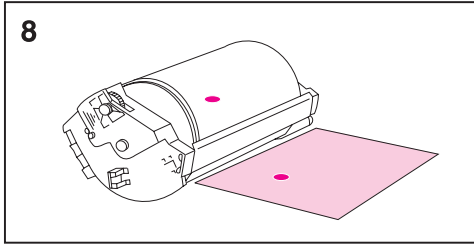
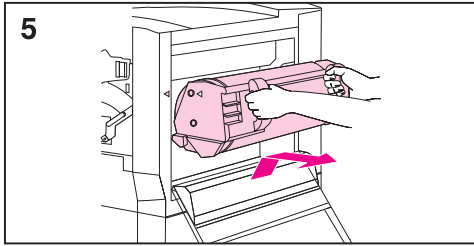

- 5 Lift the drum out of the printer.
- 6 Place the drum on a clean, smooth surface that is free of sharp or rough objects.
- 7 Face the drum surface towards you (the handles will be away from you).
- 8 Center the print sample beside the transfer drum with the top of the page toward the transfer drum.
- 9 Using the print sample as a reference, inspect the transfer drum for a small spot or speck that might be causing the repetitive defects.
- 10 To locate the spot or speck, you might have to rotate the transfer drum by turning the shiny metal area on either side of the transfer drum surface with your fingers.

---

**CAUTION**

Use extreme care when removing a defect from the transfer drum. Using a sharp object to remove the defect or allowing fingernails or jewelry to touch the transfer drum can scratch the drum, causing permanent damage. Do not clean the transfer drum using force. Do not use any water-based cleaners or excessive alcohol. These actions can permanently damage the transfer drum.

---

- 11 Gently rub the spot or speck with a hand wipe.

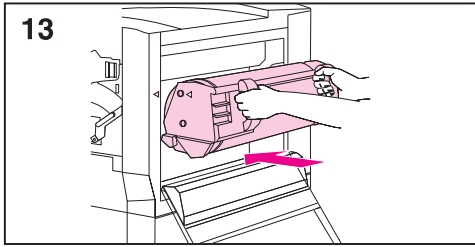

**12** If the speck does not come off, dampen the hand wipe with isopropyl alcohol. Use the hand wipe to remove the spot or speck from the transfer drum.

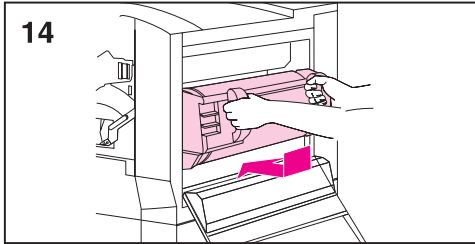

---

**Note**

If you used isopropyl alcohol to clean the transfer drum, you might need to print 50 to 100 pages to clean any residual isopropyl alcohol from the transfer drum.

---

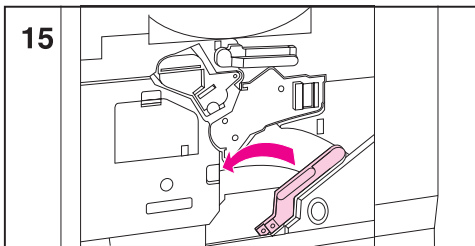

**13** To reinstall the transfer drum, align the arrows on the ends of the drum with the matching arrows on the tracks inside the printer.

**14** Push the drum into the printer. Be sure both sides are inserted completely.

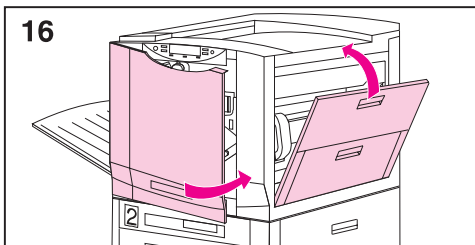

**15** Swing the lower (green) lever to the left, making sure it clicks into place.

**16** Close the right and front doors.

**17** When the printer control panel displays **READY**, reprint the print job to verify the repetitive defect has been eliminated.

If cleaning does not eliminate the repetitive defect, contact a local authorized HP dealer or service representative for service.

---

**Note**

In certain areas of California, air pollution control regulations restrict the use of liquid Isopropyl Alcohol (IPA) as a cleaning agent. In those areas of California, please disregard the previous recommendations and use a dry, lint-free cloth. The cloth may be moistened with water if desired.

---

## Cleaning the Post Charger

Clean the post charger on the transfer drum if there are light streaks in halftone areas.

### To clean the post charger

- 1 Open the right upper door.
- 2 Locate the post charger unit cleaner by the transfer drum handle.
- 3 Slide the post charger unit cleaner across the bar several times.
- 4 Push the cleaner back into place.
- 5 Close the right upper door.

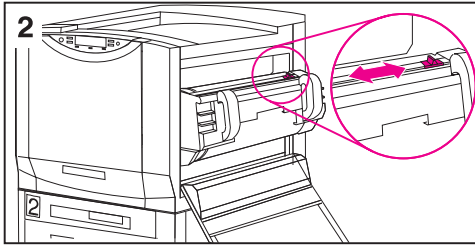
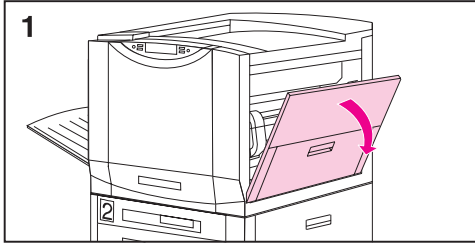

## Cleaning the Transfer Charger

Clean the transfer charger when irregular wavy patterns appear in solid backgrounds.

### To clean the transfer charger

- 1 Open the front door.
- 2 Find the knob below the transfer charger.
- 3 Pull the knob out and push it back in.
- 4 Close the front door.

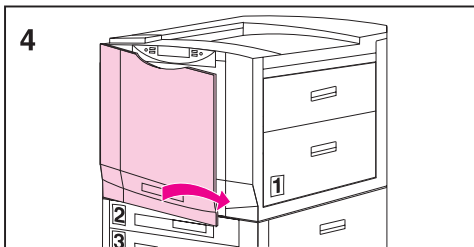
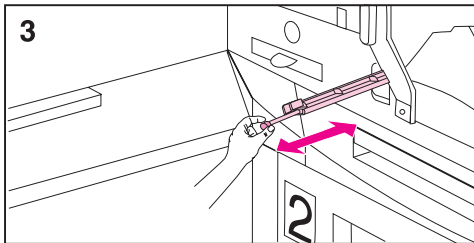
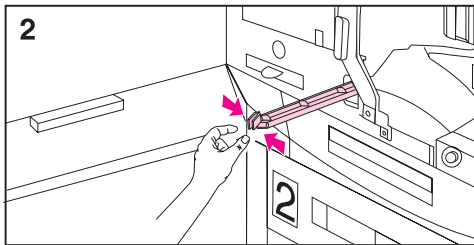
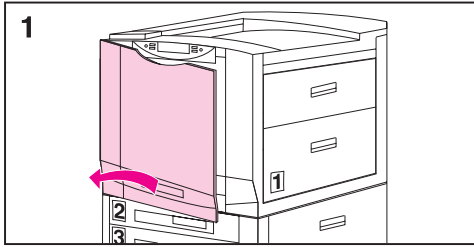

## Accessories, Options, and Related Products

As your printing and networking needs grow, you can increase the printer's capabilities by adding accessories and options. To order accessories or options for the printer, call HP's Direct Marketing Division (see the front of this guide for ordering information).

<b>Part</b>	<b>Part Number</b>	<b>Type / Size</b>
<b>Memory</b>	C2985A	Printer Hard Disk
	C7842A	Synchronous 8 MB DIMM <sup>a</sup> (SDRAM)
	C7843A	Synchronous 16 MB DIMM <sup>a</sup> (SDRAM)
	C7845A	Synchronous 32 MB DIMM <sup>a</sup> (SDRAM)
	C7846A	Synchronous 64 MB DIMM <sup>a</sup> (SDRAM)
<b>EIO Accessories</b>	J3110A	Ethernet 10 Base-T
	J3111A	Ethernet Combo (10 Base-T, BNC, and LocalTalk)
	J3112A	Token Ring
	J3113A	10/100 Base-TX
<b>Paper Handling Accessories</b>	C4782A	Duplexer
	C4785A	Multi-bin Mailbox <sup>b</sup>
	C4788A	Optional 3000-sheet Stapler/Stacker
	C4779A	Optional 3000-sheet Stacker

<b>Part</b>	<b>Part Number</b>	<b>Type / Size</b>
<b>Printer Supplies</b>	C4149A	Black Toner Cartridge
	C4150A	Cyan Toner Cartridge
	C4151A	Magenta Toner Cartridge
	C4152A	Yellow Toner Cartridge
	C4153A	Drum Kit Imaging Drum 2 Air Filters Hand Wipe
	C4154A	Transfer Kit Transfer Drum Transfer Belt Cleaning Roller Charcoal Filter Hand Wipe
	C4155A	110-Volt Fuser Kit Fuser Paper Rollers Hand Wipe
	C4156A	220-Volt Fuser Kit Fuser Paper Rollers Hand Wipe
<b>Cables</b>	C2946A	IEEE-1284 compliant parallel cable of 3 m (approximately 10 ft.) with 25-pin male/micro 36-pin male ("C" size) connector
	92215S	Macintosh DIN-8 printer cable
	92215N	HP LocalTalk Cable Kit
<b>Media</b>	C2934A	HP Color LaserJet Transparency (letter), 50 sheets
	C2936A	HP Color LaserJet Transparency (A4), 50 sheets
	C4179A	HP SoftGloss paper (letter), 200 sheets
	C4179B	HP SoftGloss paper (A4), 200 sheets

<b>Part</b>	<b>Part Number</b>	<b>Type / Size</b>
<b>Reference Materials</b>	5010-6394	<i>HP LaserJet Printer Family Paper Specifications Guide</i>
	5021-0337	PCL/PJL Technical Reference Package <sup>c</sup>

- a. You must install DRAM DIMMs in synchronized pairs, for example two 8 MB DIMMs.
- b. You must have a 2,000 sheet input tray (tray 4) installed in the printer in order to install a multi-bin mailbox.
- c. This package contains information on PCL and PJL.

# A DIMM Installation

## Supported DIMMs

The printer supports the following types of DIMMs (dual inline memory modules):

- ROM
- Synchronous DRAM

EDO (extended data out) or Fast Page Mode DIMMs are not supported.

## Installing DIMMs

The printer supports ROM (font) and synchronous DRAM (memory) DIMMs. ROM (font) DIMMs need not be installed in a specific configuration. DRAM (memory) DIMMs must be installed in synchronized pairs: two DIMMs with the same amount of DRAM (memory) are installed in slots such as 1 and 2 (see task [5](#) on page [209](#)). A ROM (font) DIMM can be installed in slots 1 and 3, and slot 2 should be empty. However, ROM (font) DIMMs cannot be installed as pairs (in corresponding left and right slots).



## To install a DIMM

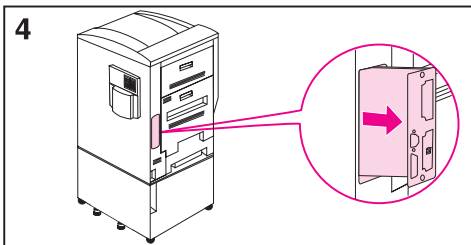
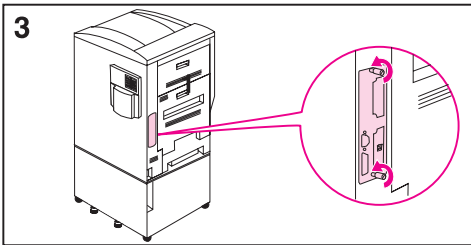
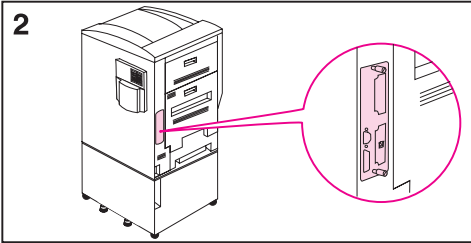
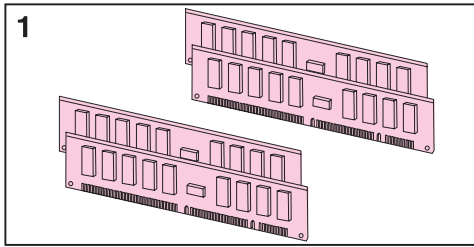

- 1 Synchronous DRAM (memory) DIMMs must be installed in pairs.
- 2 Print a configuration page. Next turn the printer off and disconnect it from its power source. Locate the formatter board on the left rear of the printer.
- 3 Loosen the two thumb screws by hand or with a #2 Phillips screwdriver.
- 4 Slide the formatter board out and lay it on a flat, grounded surface.

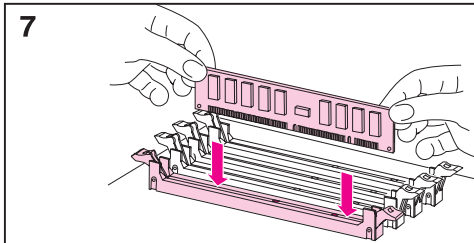
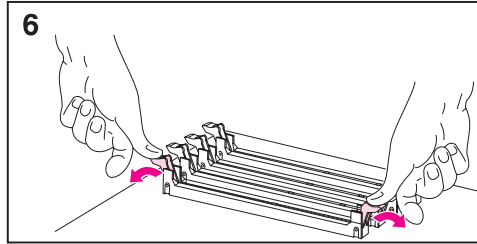
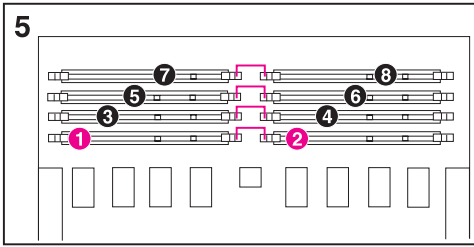

- 5 The DIMM slots are paired: 1-2, 3-4, 5-6, and 7-8. The ROM (font) DIMMs are placed in odd numbered slots. Place DIMMs in the next available slots.
- 6 Push the levers down as shown.
- 7 Match the notches on the DIMMs with the tabs on the connectors. Firmly push the DIMM into the slot until the levers lock. Repeat for each DIMM.

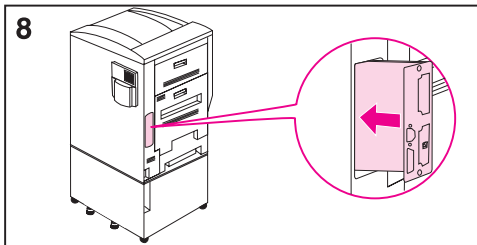

**8** Insert the formatter board into the printer, ensuring that the edges of the board line up with the guides in the printer.

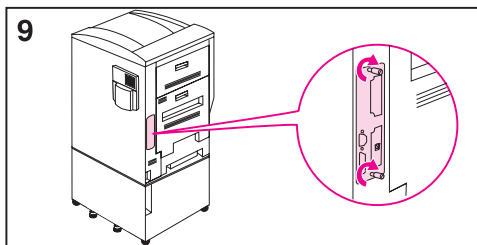

**9** Tighten the thumb screws, reconnect the power, and turn on the printer.

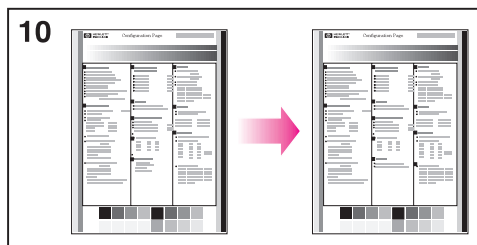

**10** Confirm installation: print a configuration page and compare it with the previous configuration page.

# B Specifications

## Electrical Specifications

	<b>110-Volt Models</b>	<b>220-Volt Models</b>
<b>Power Requirements</b>	100-127 V (+/- 10%) 50/60 Hz (+/- 2 Hz)	220-240 V (+/- 10%) 50/60 Hz (+/- 2 Hz)
<b>Power Consumption (typical)</b> <ul style="list-style-type: none"><li>● <b>During printing (black &amp; white)</b></li><li>● <b>During printing (color)</b></li><li>● <b>During idle<sup>a</sup></b></li><li>● <b>During Power Save mode</b></li></ul>	750 W (average) 375 W (average) 190 W (average) < 45 W	750 W (average) 375 W (average) 190 W (average) < 45 W
<b>Minimum recommended circuit capacity for typical product</b>	12.0 A at 120 V	6.0 A at 220 V

- a. When the printer is in standby (off) mode, a minimal amount of energy is still consumed. Energy consumption can be eliminated by disconnecting the printer power cord from the power source.

## Operating Environmental Specifications

<b>Temperature</b> <ul style="list-style-type: none"><li>● Recommended</li><li>● Allowed</li></ul>	68 to 79° F (20 to 26° C) 59 to 86° F (15 to 30° C)
<b>Humidity</b> <ul style="list-style-type: none"><li>● Recommended</li><li>● Allowed</li></ul>	20 to 50% RH 10 to 80% RH
<b>Altitude</b> Allowed	0 to 10,000 ft (0 to 3,048 m)

# Environmental Product Stewardship Program

## Protecting the Environment

Hewlett-Packard Company is committed to providing quality products in an environmentally sound manner. This HP LaserJet printer has been designed with several attributes to minimize impacts on our environment.

### This HP LaserJet printer design eliminates:

- **Ozone Production**

This HP LaserJet printer contains an ozone filter to protect office air quality. See the maintenance section of this user guide for suggested replacement intervals.

### This HP LaserJet printer design reduces:

- **Energy Consumption**

Energy usage drops to less than 45 W while in low-power (Power Save) mode. Not only does this save natural resources, but it also saves money without affecting the high performance of this printer. This product qualifies for the ENERGY STAR program. ENERGY STAR is a voluntary program established to encourage the development of energy-efficient office products. ENERGY STAR is a U.S. registered service mark of the U.S. EPA.

As an ENERGY STAR partner, Hewlett-Packard Company has determined that this product meets ENERGY STAR Guidelines for energy efficiency.



- **Toner Consumption**

EconoMode/Toner Miser uses significantly less toner, which may extend the life of the toner cartridge.

- **Paper Usage**

This printer either has an optional duplexing accessory or one already built in. The printer's duplexing feature, which provides for two-sided printing, reduces paper usage and the resulting demands on natural resources. Depending on the type of software program in use, you can request for a number of pages of your document to be printed on one page of paper. This N-up printing practice and the printer's automatic/manual duplexing feature, which provides two-sided printing, can reduce paper usage and the resulting demands on natural resources.

## **The design of this HP LaserJet printer facilitates the recycling of:**

- **Plastics**

Plastic parts have markings according to international standards that enhance the ability to identify plastics for recycling purposes at the end of the printer's life.

- **HP Toner Cartridges/Photoconductive Drum**

In many countries/regions, this product's toner cartridge, photoconductive drum, transfer assembly, and fuser can be returned to HP at the end of each item's useful life. A prepaid shipping label and instructions on how to return the toner cartridge/drum are included with the replacement toner cartridge/drum. If your country/region is not listed in the replacement's brochure, see the [HP Customer Care](#) information in the front of this guide.

## **HP LaserJet Printing Supplies**

In many countries/regions, this product's printing supplies (e.g., toner cartridge, drum, fuser) can be returned to HP through the HP Planet Partners Printing Supplies Environmental Program. An easy to use and free takeback program is available in over 20 countries. Multi-lingual program information and instructions are included in every new HP LaserJet toner cartridge and consumables package.

## HP Planet Partners Printing Supplies Environmental Program Information

Since 1990, the HP LaserJet Toner Cartridge Recycling Program has collected more than 25 million used LaserJet toner cartridges that otherwise may have been discarded in the world's landfills. The HP LaserJet toner cartridges and consumables are collected and bulk shipped to our resource and recovery partners who disassemble the cartridge. After a thorough quality inspection, selected parts such as nuts, screws, and clips are reclaimed for use in new cartridges. Remaining materials are separated and converted into raw materials for use by other industries to make a variety of useful products.

### US Returns

For a more environmentally responsible return of used cartridges and consumables, HP encourages the use of bulk returns. Simply bundle two or more cartridges together and use the single, pre-paid, pre-addressed UPS label that is supplied in the package. For more information in the U.S., call (1) (800) (340-2445) or visit the HP LaserJet Supplies website at <http://www.ljsupplies.com/planetpartners/>. For more information in Mexico, call 258-40-44 (Mexico City) or (1) (800) 900-7200 (outside Mexico City). Or, visit the website at <http://www.hp.com/latinamerica>. Non-US customers should call the local HP Sales and Service Office or visit the following websites for further information regarding availability of the HP Planet Partners LaserJet Toner Cartridge and Consumables Recycling Program.

Latin America: <http://www.hp.com/latinamerica>

Asia Pacific countries/regions: <http://www.asiapac.hp.com/planp1.htm>

Europe:

[http://www.hp.com/pays/eur\\_supplies/english/planetpartners/](http://www.hp.com/pays/eur_supplies/english/planetpartners/)

#### ● Paper

- This printer is suited for the use of recycled papers when the paper meets the guidelines outlined in the *HP LaserJet Printer Family Paper Specifications Guide*, HP part number 5010-6394. This printer is suited for the use of recycled paper according to DIN 19 309.
- The user guide is provided on CD-ROM, which allows the same high-quality information to be provided without consuming the large quantities of energy and natural resources required to produce traditional paper manuals.



## **Material safety data sheet**

Material Safety Data Sheets (MSDS) can be obtained by contacting the HP LaserJet Supplies website at <http://www.hp.com/go/msds>. If you do not have access to the internet, call the U.S. HP FIRST (fax-on-demand service) at (1) (800) 231-9300. Use Index number 7 for a listing of the material safety data sheets. Non-US customers should refer to the front of this manual for appropriate HP FIRST phone numbers and information.

# Regulatory Statements

## FCC Regulations

This equipment has been tested and found to comply with the limits for a Class A digital device, pursuant to Part 15 of the FCC rules. These limits are designed to provide reasonable protection against harmful interference in a residential installation. This equipment generates, uses, and can radiate radio frequency energy, and if not installed and used in accordance with the instructions, may cause harmful interference to radio communications. However, there is no guarantee that interference will not occur in a particular installation. If this equipment does cause harmful interference to radio or television reception, which can be determined by turning the equipment off and on, the user is encouraged to try to correct the interference by one or more of the following measures:

- Reorient or relocate the receiving antenna.
- Increase separation between equipment and receiver.
- Connect equipment to an outlet on a circuit different from that to which the receiver is located.
- Consult your dealer or an experienced radio/TV technician.

---

### Note

Any changes or modifications to the printer not expressly approved by HP could void the user's authority to operate this equipment.

Use of a shielded interface cable is required to comply with the FCC rules.

---

## Canadian DOC Regulations

Complies with Canadian EMC Class A requirements.

<<Conforme à la classe A des normes canadiennes de compatibilité électromagnétiques. << CEM>>.>>

# Declaration of Conformity

---

## DECLARATION OF CONFORMITY

according to ISO/IEC Guide 22 and EN 45014

---

Manufacturer's Name: Hewlett-Packard Company  
Manufacturer's Address: 11311 Chinden Boulevard  
Boise, Idaho 83714-1021, USA

declares, that the product

Product Name: HP Color LaserJet 8550, 8550N, 8550DN, 8550GN, 8550MFP  
Model Number: C7096A, C7097A, C7098A, C7099A, C7835A, C7836A  
Product Options: ALL

### conforms to the following Product Specifications:

Safety: IEC 950:1991+A1+A2+A3+A4 / EN  
60950:1992+A1+A2+A3+A4+A11  
IEC 825-1:1993+A1 / EN 60825-1:1994+A11 Class 1 (Laser/LED)

EMC: CISPR 22:1997 / EN 55022:1998 Class A  
EN 61000-3-2:1995  
EN61000-3-3:1995  
EN55024:1998  
FCC Title 47 CFR, Part 15 Class A/ ICES-002, Issue 2  
AS / NZS 3548:1995

### Supplementary Information:

The product herewith complies with the requirements of the EMC Directive 89/336/EEC and the Low Voltage Directive 73/23/EEC, and carries the CE-Marking accordingly.

---

<sup>1</sup> The product was tested in a typical configuration with Hewlett-Packard Personal Computer Systems.

<sup>2</sup> This Device complies with Part 15 of the FCC Rules. Operation is subject to the following two Conditions: (1) this device may not cause harmful interference, and (2) this device must accept any interference received, including interference that may cause undesired operation.

---

**WARNING!**

This is a Class A product. In a domestic environment this product may cause radio interference in which case the user may be required to take adequate measures.

---

Boise, Idaho USA  
May 1999

**For regulatory topics only:**

Australia Contact: Product Regulations Manager, Hewlett-Packard Australia Ltd., 31-41 Joseph Street, Blackburn, Victoria 3130, Australia

European Contact: Your Local Hewlett-Packard Sales and Service Office or Hewlett-Packard GmbH, Department HQ-TRE / Standards Europe, Herrenberger Strasse 110-140, D-71034 Böblingen (FAX: +49-7031-14-3143)

USA Contact: Product Regulations Manager, Hewlett-Packard Company, P.O. Box 15 Mail Stop 160, Boise, ID 83707-0015 (Phone: 208-396-6000)

---

---

## DECLARATION OF CONFORMITY

according to ISO/IEC Guide 22 and EN 45014

---

Manufacturer's Name: Hewlett-Packard Company  
Manufacturer's Address: Montemorelos #299  
Guadalajara Jalisco, 45060  
México

declares, that the  
product

Product Name: Duplexer  
Model Number: C4782A  
Product Options: ALL

### conforms to the following Product Specifications:

Safety: IEC 950:1991+A1+A2+A3+A4 / EN  
60950:1992+A1+A2+A3+A4+A11  
IEC 825-1:1993+A1 / EN 60825-1:1994+A11 Class 1  
(Laser/LED)

EMC: CISPR 22:1997 / EN 55022:1998 Class B<sup>1</sup>  
EN 61000-3-2:1995  
EN 61000-3-3:1995  
EN 55024:1998  
FCC Title 47 CFR, Part 15 Class B<sup>2</sup> / ICES-002, Issue 2  
AS / NZS 3548:1995

### Supplementary Information:

The product herewith complies with the requirements of the EMC Directive 89/336/EEC and the Low Voltage Directive 73/23/EEC, and carries the CE-Marking accordingly.

<sup>1</sup> The product was tested in a typical configuration with Hewlett-Packard Personal Computer Systems.

<sup>2</sup> This Device complies with Part 15 of the FCC Rules. Operation is subject to the following two Conditions: (1) this device may not cause harmful interference, and (2) this device must accept any interference received, including interference that may cause undesired operation.

---

Guadalajara, Jalisco México  
May 1999

**For regulatory topics only:**

Australia Contact: Product Regulations Manager, Hewlett-Packard  
Australia Ltd., 31-41 Joseph Street, Blackburn, Victoria  
3130, Australia

European Contact: Your Local Hewlett-Packard Sales and Service Office or  
Hewlett-Packard GmbH, Department HQ-TRE /  
Standards Europe, Herrenberger Strasse 110-140,  
D-71034 Böblingen (FAX: +49-7031-14-3143)

USA Contact: Product Regulations Manager, Hewlett-Packard  
Company, P.O. Box 15 Mail Stop 160, Boise, ID  
83707-0015 (Phone: 208-396-6000)

---

---

## DECLARATION OF CONFORMITY

according to ISO/IEC Guide 22 and EN 45014

---

Manufacturer's Name: Hewlett-Packard Company  
Manufacturer's Address: Montemorelos #299  
Guadalajara Jalisco, 45060  
México

declares, that the  
product

Product Name: 2000-Sheet Input Tray  
Model Number: C4781A  
Product Options: All

### conforms to the following Product Specifications:

Safety: IEC 950:1991+A1+A2+A3+A4 / EN  
60950:1992+A1+A2+A3+A4+A11  
IEC 825-1:1993+A1 / EN 60825-1:1994+A11 Class 1  
(Laser/LED)

EMC: CISPR 22:1997 / EN 55022:1998 Class B<sup>1</sup>  
EN 61000-3-2:1995  
EN 61000-3-3:1995  
EN 55024:1998  
FCC Title 47 CFR, Part 15 Class B<sup>2</sup> / ICES-002, Issue 2  
AS / NZS 3548:1995

### Supplementary Information:

The product herewith complies with the requirements of the EMC Directive 89/336/EEC and the Low Voltage Directive 73/23/EEC, and carries the CE-Marking accordingly.

<sup>1</sup> The product was tested in a typical configuration with Hewlett-Packard Personal Computer Systems.

<sup>2</sup> This Device complies with Part 15 of the FCC Rules. Operation is subject to the following two conditions: (1) this device may not cause harmful interference, and (2) this device must accept any interference received, including interference that may cause undesired operation.

---

Guadalajara, Jalisco México  
May 1999

**For regulatory topics only:**

Australia Contact: Product Regulations Manager, Hewlett-Packard  
Australia Ltd., 31-41 Joseph Street, Blackburn, Victoria  
3130, Australia

European Contact: Your Local Hewlett-Packard Sales and Service Office or  
Hewlett-Packard GmbH, Department HQ-TRE /  
Standards Europe, Herrenberger Strasse 110-140,  
D-71034 Böblingen (FAX: +49-7031-14-3143)

USA Contact: Product Regulations Manager, Hewlett-Packard  
Company, P.O. Box 15 Mail Stop 160, Boise, ID  
83707-0015 (Phone: 208-396-6000)

---



## VCCI Statement (Japan)

この装置は、情報処理装置等電波障害自主規制協議会（VCCI）の基準に基づくクラスA情報技術装置です。この装置を家庭環境で使用すると電波妨害を引き起こすことがあります。この場合には使用者が適切な対策を講ずるよう要求されることがあります。

## Korean EMI Statement

사용자 안내문 (A급 기기)

이 기기는 업무용으로 전자파장애 검정을 받은 기기 이오니, 만약 잘못 구입하셨 을 때에는구입한 곳에 세 비업무용으로 교환하시기 바랍니다.

# Safety Information

## Laser Safety

The Center for Devices and Radiological Health (CDRH) of the U.S. Food and Drug Administration has implemented regulations for laser products manufactured since August 1, 1976. Compliance is mandatory for products marketed in the United States. This printer is certified as a "Class 1" laser product under the U.S. Department of Health and Human Services (DHHS) Radiation Performance Standard according to the Radiation Control for Health and Safety Act of 1968. Since radiation emitted inside this printer is completely confined within protective housings and external covers, the laser beam cannot escape during any phase of normal user operation.

---

### **WARNING!**

---

Using controls, making adjustments, or performing procedures other than those specified in this manual may result in exposure to hazardous radiation.

## Product Information Sheet

The Toner Product Information Sheet can be obtained by calling the U.S. HP FIRST (Fax Information Retrieval Support Technology) at (1) (800) 333-1917. International customers should see the front of this manual for appropriate phone numbers and information.

# Laser Statement for Finland

## Luokan 1 laserlaite

### Klass 1 Laser Apparat

HP Color LaserJet 8550, 8550N, 8550DN, 8550GN, 8550MFP laserkirjoitin on käyttäjän kannalta turvallinen luokan 1 laserlaite. Normaalisissa käytöissä kirjoittimen suojakotelointi estää lasersäteen pääsyn laitteen ulkopuolelle. Laitteen turvallisuusluokka on määritetty standardin EN 60825-1 (1994) mukaisesti.

### Varoitus!

Laitteen käyttäminen muulla kuin käyttöohjeessa mainitulla tavalla saattaa altistaa käyttäjän turvallisuusluokan 1 ylittävälle näkymättömälle lasersäteilylle.

### Varning!

Om apparaten används på annat sätt än i bruksanvisning specificerats, kan användaren utsättas för osynlig laserstrålning, som överskrider gränsen för laserklass 1.

## HUOLTO

HP Color LaserJet 8550, 8550N, 8550DN, 8550GN, 8550MFP -kirjoittimen sisällä ei ole käyttäjän huollettavissa olevia kohteita. Laitteen saa avata ja huoltaa ainoastaan sen huoltamiseen koulutettu henkilö. Tällaiseksi huoltotoimenpiteeksi ei katsota väriainekasetin vaihtamista, paperiradan puhdistusta tai muita käyttäjän käsikirjassa lueteltuja, käyttäjän tehtäväksi tarkoitettuja ylläpitotoimia, jotka voidaan suorittaa ilman erikoistyökaluja.

### Varo!

Mikäli kirjoittimen suojakotelo avataan, olet alttiina näkymättömälle lasersäteilylle laitteen ollessa toiminnassa. Älä katso säteeseen.

## **Varning!**

Om laserprinterns skyddshölje öppnas då apparaten är i funktion, utsätts användaren för osynlig laserstrålning. Betrakta ej strålen.

Tiedot laitteessa käytettävän laserdiodin säteilyominaisuuksista:

Aallonpituus 775-795 nm

Teho 5 mW

Luokan 3B laser



# C Warranty Information

## Hewlett-Packard Limited Warranty Statement

HP PRODUCT	DURATION OF WARRANTY
HP Color LaserJet 8500, 8550N, 8550DN, 8550GN	1-year, on-site

---

### Note

---

This section does not cover warranty specifications for the 8550MFP product. Please refer to the *HP Color LaserJet 8550MFP Copy Module User Guide*.

1. HP warrants HP hardware, accessories and supplies against defects in materials and workmanship for the period specified above. If HP receives notice of such defects during the warranty period, HP will, at its option, either repair or replace products which prove to be defective. Replacement products may be either new or like-new.
2. HP warrants that HP software will not fail to execute its programming instructions, for the period specified above, due to defects in material and workmanship when properly installed and used. If HP receives notice of such defects during the warranty period, HP will replace software media which does not execute its programming instructions due to such defects.
3. HP does not warrant that the operation of HP products will be uninterrupted or error free. If HP is unable, within a reasonable time, to repair or replace any product to a condition as warranted, customer will be entitled to a refund of the purchase price upon prompt return of the product.
4. HP products may contain remanufactured parts equivalent to new in performance or may have been subject to incidental use.

5. The warranty period begins on the date of delivery or on the date of installation if installed by HP. If customer schedules or delays HP installation more than 30 days after delivery, warranty begins on the 31st day from delivery.
6. Warranty does not apply to defects resulting from (a) improper or inadequate maintenance or calibration, (b) software, interfacing, parts or supplies not supplied by HP, (c) unauthorized modification or misuse, (d) operation outside of the published environmental specifications for the product, or (e) improper site preparation or maintenance.
7. TO THE EXTENT ALLOWED BY LOCAL LAW, THE ABOVE WARRANTIES ARE EXCLUSIVE AND NO OTHER WARRANTY OR CONDITION, WHETHER WRITTEN OR ORAL, IS EXPRESSED OR IMPLIED AND HP SPECIFICALLY DISCLAIMS THE IMPLIED WARRANTIES OR CONDITIONS OF MERCHANTABILITY, SATISFACTORY QUALITY, AND FITNESS FOR A PARTICULAR PURPOSE.
8. HP will be liable for damage to tangible property per incident up to the greater of \$300,000 or the actual amount paid for the product that is the subject of the claim, and for damages for bodily injury or death, to the extent that all such damages are determined by a court of competent jurisdiction to have been directly caused by a defective HP product.
9. TO THE EXTENT ALLOWED BY LOCAL LAW, THE REMEDIES IN THIS WARRANTY STATEMENT ARE THE CUSTOMER'S SOLE AND EXCLUSIVE REMEDIES. EXCEPT AS INDICATED ABOVE, IN NO EVENT WILL HP OR ITS SUPPLIERS BE LIABLE FOR LOSS OF DATA OR FOR DIRECT, SPECIAL, INCIDENTAL, CONSEQUENTIAL (INCLUDING LOST PROFIT OR DATA), OR OTHER DAMAGE, WHETHER BASED IN CONTRACT, TORT, OR OTHERWISE.

FOR CONSUMER TRANSACTIONS IN AUSTRALIA AND NEW ZEALAND: THE WARRANTY TERMS CONTAINED IN THIS STATEMENT, EXCEPT TO THE EXTENT LAWFULLY PERMITTED, DO NOT EXCLUDE, RESTRICT OR MODIFY AND ARE IN ADDITION TO THE MANDATORY STATUTORY RIGHTS APPLICABLE TO THE SALE OF THIS PRODUCT TO YOU.

# Index

- Value + key, illustration [28](#)

## Numerics

11-by-17 inch size, print speeds [17](#)  
11-by-17 inch size, weights/types [61](#)  
12-by-18.5 inch size, weights/types [62](#)  
2,000 sheet input tray, default type [33](#)  
2,000 sheet input tray, features [18](#)  
2,000 sheet input tray, letterhead [86](#)  
2,000 sheet input tray, lights [24](#)  
2,000 sheet input tray, loading media [84](#)  
2,000 sheet input tray, media capacity [63](#)  
2,000 sheet input tray, media weights/sizes [63](#)  
2,000 sheet input tray, orienting media [79](#)  
2,000 sheet input tray, printing from [85](#)  
2,000 sheet input tray, printing tips [86](#)  
2,000 sheet input tray, verifying installation [52](#)  
3000-sheet stacker, lights [24](#)  
3000-sheet stacker, media types [66](#) [67](#)  
3000-sheet stapler/stacker, lights [24](#)  
3000-sheet stapler/stacker, media types [67](#)  
312-by-440 mm size, weights/types [61](#)

## A

A3 size, weights/types [61](#)  
A4 size, overriding with letter [44](#)  
A4 size, print speeds [17](#)  
A4 size, weights/types [61](#)  
A5 size, types/sizes [61](#)  
abort, print job [28](#)  
access, denied [138](#)  
accessories, features [19](#)  
accessories, ordering [204](#)  
adjusting color balance [118](#)  
adjusting paper guides in tray 4 [84](#)  
adjusting paper guides in trays 2 or 3 [80](#)  
air filters, illustration [124](#)  
air filters, ordering [204](#)  
air filters, replace frequency [126](#)  
Attention light, illustration [29](#)  
auto continue, setting [39](#)  
automatic PANTONE matching [113](#)  
automatic paper override setting [33](#)  
automatic switching of personalities [47](#)

## B

B4 size, weights/types [61](#)  
B5 size, weights/types [61](#)

background, dark [190](#)  
beam error [132](#)  
belt, illustration [124](#)  
belt, replace frequency [126](#)  
bidirectional, turn off communication [46](#)  
bins, configuring output [42](#)  
bins, face-down output [42](#)  
bins, face-up output [42](#)  
bins, face-up output, illustration [22](#)  
bins, left output [42](#)  
bins, left output, illustration [22](#)  
bins, selecting output [42](#)  
bins, top output [42](#)  
black and white, print color as [112](#)  
black and white, print speeds [17](#)  
black toner cartridges, illustration [124](#)  
black toner cartridges, ordering [204](#)  
black toner cartridges, replace frequency [126](#)  
bond paper, weights/sizes [61](#)  
booklet printing [103](#)  
buttons, control panel [28](#)  
buttons, power, illustration [22](#)

## C

C5 size, weights [62](#)  
cables, connection, illustration [23](#)  
Canada, DOC regulations [217](#)  
Cancel Job key, illustration [28](#)  
canceling print job, key [28](#)  
canceling print job, message [138](#)  
card stock, duplexing [190](#)  
card stock, printing from tray 1 [77](#)  
card stock, weights/sizes [61](#)  
carousel, will not rotate [175](#)  
cartridges, error [147](#)  
cartridges, ordering [204](#)  
cartridges, recycling [214](#)  
cartridges, replace [155](#)  
changing control panel settings [29](#)  
changing orientation [73](#)  
charcoal filter, illustration [124](#)  
charcoal filter, ordering [204](#)  
charcoal filter, replacement frequency [126](#)  
cleaning roller, illustration [124](#)  
cleaning roller, ordering [204](#)  
cleaning roller, replace frequency [126](#)  
cleaning, density sensor [197](#)  
cleaning, post charger [202](#)  
cleaning, toner from fabric [162](#)



cleaning, transfer charger [203](#)  
cleaning, transfer drum [198](#)  
clearable warnings defaults [33](#)  
C-Link connector, illustration [23](#)  
CMS [112](#)  
CMYK ink set emulation [113](#)  
cold reset, message [142](#)  
cold reset, performing [49](#)  
color adjustments, verifying [53](#)  
color balance test page, printing [118](#)  
color calibration [53](#)  
color carousel, will not rotate [175](#)  
Color Management Systems [112](#)  
Color Swatch, printing [115](#)  
Color Test Page, printing [118](#)  
color toner carousel, will not rotate [175](#)  
color toner cartridges, illustration [124](#)  
color toner cartridges, replace frequency [126](#)  
colors, adjusting balance [118](#)  
colors, adjusting settings [111](#)  
colors, adjustment [111](#)  
colors, cannot select in application [182](#)  
colors, ColorSmart II settings [110](#)  
colors, ColorSync [112](#)  
colors, controlling output with drivers [109](#)  
colors, dark transparencies [193](#)  
colors, Detail settings [111](#)  
colors, do not match screen colors [185](#)  
colors, dull transparencies [193](#)  
colors, Halftone settings [111](#)  
colors, ICC [112](#)  
colors, management systems [112](#)  
colors, Manual settings [111](#)  
colors, media [61](#)  
colors, media specifications [72](#)  
colors, missing [185](#)  
colors, PANTONE settings [115](#)  
colors, print as black [186](#)  
colors, print speeds [17](#)  
colors, printing problems [185](#)  
colors, ramps [119](#)  
colors, Screen Match settings [111](#)  
colors, selecting [115](#)  
colors, settings [114](#)  
colors, Smooth settings [111](#)  
colors, sRGB [111](#)  
colors, transparency settings [111](#)  
colors, using colors [110](#)  
colors, verifying color adjustment settings [53](#)  
colors, Vivid settings [111](#)  
ColorSmart II, settings [110](#)  
ColorSync, settings [112](#)  
commands, printer error [134](#)  
Commercial 10 size, weights/sizes [62](#)  
communication cables, illustration [23](#)  
communication, turn off bidirectional [46](#)

compatibility mode, switching to [46](#)  
configuration page, cannot print [180](#)  
configuration page, consumables percent remaining, [52](#)  
configuration page, interpreting [52](#)  
configuration page, printing [51](#)  
configuration page, printing continuous [51](#)  
configuration, verifying color adjustments [53](#)  
configuration, verifying control panel lock [52](#)  
configuration, verifying control panel password [52](#)  
configuration, verifying DIMMs [52](#)  
configuration, verifying duplexer [52](#)  
configuration, verifying hard disk [52](#)  
configuration, verifying hard disk lock [52](#)  
configuration, verifying input trays [52](#)  
configuration, verifying memory [52](#)  
configuration, verifying multi-bin mailbox [52](#)  
configuration, verifying tray 1 [52](#)  
configuration, verifying tray 4 [52](#)  
configuration, verifying trays 2 and 3 [52](#)  
configurations, printer [20](#)  
configuring the printer, network [57](#)  
configuring, consumable out response [45](#)  
configuring, control panel [38](#)  
configuring, control panel display language [50](#)  
configuring, display language [50](#)  
configuring, input trays [40](#)  
configuring, media trays [40](#)  
configuring, media type/size [40](#)  
configuring, menus [38](#)  
configuring, multi-bin mailbox [42](#)  
configuring, output bin [42](#)  
configuring, paper type/size [40](#)  
configuring, parallel advanced functions [46](#)  
configuring, Power Save [46](#)  
configuring, RAM [57](#)  
configuring, toner low response [45](#)  
connector, C-Link, illustration [23](#)  
connector, parallel, illustration [23](#)  
connector, tray 4, illustration [23](#)  
connectors, communication cable, illustration [23](#)  
connectors, EIO [23](#)  
connectors, network [23](#)  
connectors, power, illustration [23](#)  
consumables, continue if low [45](#)  
consumables, illustration [124](#)  
consumables, ordering [204](#)  
consumables, recycling [127](#)  
consumables, replace frequency [125](#)  
consumables, selecting out response [45](#)  
consumables, stop if low [45](#)  
continue, consumables if low [45](#)  
control panel, buttons [28](#)  
control panel, changing values [28](#)  
control panel, display language [50](#)  
control panel, features [28](#)

- control panel, forgotten password [49](#)
- control panel, illustration [28](#)
- control panel, keys [28](#)
- control panel, lights [28](#)
- control panel, locking [49](#)
- control panel, menus [28](#)
- control panel, message display [28](#)
- control panel, messages [129](#)
- control panel, messages not showing [173](#)
- control panel, moving through items [29](#)
- control panel, setting password [49](#)
- control panel, settings work incorrectly [179](#)
- control panel, using menus [30](#)
- control panel, verifying lock [52](#)
- control panel, verifying password [52](#)
- copies, default setting [33](#)
- curled output, causes [171](#), [172](#)
- customer support [3](#)
- custom-sized media, printing from tray 1 [77](#)
- custom-sized media, weights/types [61](#)
- cyan toner cartridges, ordering [204](#)
- cyan toner cartridges, replace frequency [126](#)

## D

- Data light, illustration [29](#)
- data, printer not receiving [175](#)
- declaration of conformity [218](#)
- defaults, binding [33](#)
- defaults, clearable warnings [33](#)
- defaults, Color Adjust Menu [36](#)
- defaults, Configuration Menu [33](#)
- defaults, control panel messages [33](#)
- defaults, copies [34](#)
- defaults, Courier [34](#)
- defaults, duplex [33](#)
- defaults, factory [32](#)
- defaults, font number [34](#)
- defaults, font source [34](#)
- defaults, I/O Menu [35](#)
- defaults, I/O timeout [35](#)
- defaults, Information Menu [32](#)
- defaults, manual feed [33](#)
- defaults, media types/sizes [33](#)
- defaults, orientation [34](#)
- defaults, override A4 with letter [33](#)
- defaults, override letter with A4 [33](#)
- defaults, paper destination [33](#)
- defaults, Paper Handling Menu [33](#)
- defaults, paper override [33](#)
- defaults, paper types/sizes [34](#)
- defaults, parallel advanced functions [35](#)
- defaults, PCL as personality [47](#)
- defaults, PCL font number [34](#)
- defaults, PCL font source [34](#)
- defaults, PCL pitch [34](#)
- defaults, PCL point size [34](#)

- defaults, PCL settings [34](#)
- defaults, PCL symbol set [34](#)
- defaults, personality [33](#)
- defaults, pitch [34](#)
- defaults, point size [34](#)
- defaults, PostScript as personality [47](#)
- defaults, Power Save [33](#)
- defaults, print errors [33](#)
- defaults, printer personality [33](#)
- defaults, Printing Menu [34](#)
- defaults, Private/Stored Jobs Menu [32](#)
- defaults, Quick Copy Jobs Menu [32](#)
- defaults, Registration Duplex Menu [35](#)
- defaults, Resets Menu [35](#)
- defaults, resolution [32](#)
- defaults, selecting printer personality [47](#)
- defaults, settings [34](#)
- defaults, symbol set [34](#)
- defaults, toner low response [33](#)
- defects, repeated printed [195](#)
- deleting a held job [97](#)
- demonstration page, printing [51](#)
- density sensor, cleaning [197](#)
- density settings, verifying [53](#)
- depth, printer [123](#)
- Detail Halftone Adjust page, printing [118](#)
- Detail settings [111](#)
- digital cameras, using images [116](#)
- DIMMs, EDO [207](#)
- DIMMs, errors [133](#)
- DIMMs, Fast Page Mode [207](#)
- DIMMs, features [18](#)
- DIMMs, increasing printer memory [56](#)
- DIMMs, installation [208](#)
- DIMMs, supported [207](#)
- DIMMs, types supported [207](#)
- DIMMs, verifying configuration [52](#)
- DL size, weights [62](#)
- DOC regulations, Canadian [217](#)
- doors, front, illustration [22](#)
- doors, lower left, illustration [23](#)
- doors, lower right, illustration [22](#)
- doors, media transfer, illustration [24](#)
- doors, upper left, illustration [23](#)
- doors, upper right, illustration [22](#)
- dots per inch, digital cameras [116](#)
- dots per inch, graphics [116](#)
- dots per inch, printer default [32](#)
- dots per inch, scanners [117](#)
- Double Post Card size, weights [62](#)
- double-sided printing, default [33](#)
- double-sided printing, error [145](#)
- double-sided printing, orienting in tray 1 [78](#)
- double-sided printing, orienting in tray 4 [79](#)
- double-sided printing, orienting in trays 2 and 3 [79](#)
- dpi, digital cameras [116](#)

- dpi, graphics [116](#)
- dpi, printer default [32](#)
- dpi, scanners [117](#)
- DRAM, DIMMs [207](#)
- DRAM, error [136](#)
- drum kit, errors [144](#)
- drum kit, ordering [204](#)
- drum kit, replace frequency [126](#)
- drums, imaging, illustration [124](#)
- drums, transfer, illustration [124](#)
- dual inline memory modules, EDO [207](#)
- dual inline memory modules, errors [133](#)
- dual inline memory modules, Fast Page Mode [207](#)
- dual inline memory modules, features [18](#)
- dual inline memory modules, increasing printer memory [56](#)
- dual inline memory modules, slot configuration [207](#)
- dual inline memory modules, supported [207](#)
- dual inline memory modules, types supported [207](#)
- dual inline memory modules, verify configuration [52](#)
- duplex registration [52](#), [54](#)
- duplexer, error [145](#)
- duplexer, features [18](#)
- duplexer, illustration [24](#)
- duplexer, media types [65](#)
- duplexer, media weights/sizes [65](#)
- duplexer, ordering [204](#)
- duplexer, verify installation [52](#)
- duplexing, card stock [190](#)
- duplexing, default [33](#)
- duplexing, error [145](#)
- duplexing, heavy paper [190](#)
- duplexing, manual [190](#)
- duplexing, orienting in tray 1 [78](#)
- duplexing, orienting in tray 4 [79](#)
- duplexing, orienting in trays 2 and 3 [79](#)
- dynamic random-access memory, DIMMs [207](#)
- dynamic random-access memory, error [136](#)

## E

- ECP port, transmitting data across [46](#)
- EDO, DIMMs [207](#)
- EIO slot 1, illustration [23](#)
- EIO slot 2, illustration [23](#)
- EIO, connection [23](#)
- EIO, features [18](#)
- EIO, numbered errors [130](#)
- EIO, unnumbered errors [145](#)
- electrical specifications [211](#)
- EMI statement, Korean regulations [224](#)
- emulation, CMYK ink set emulation [113](#)
- energy consumption [213](#)
- Energy Star program [213](#)
- engine test [145](#)
- enhanced input/output slot 1, illustration [23](#)
- enhanced input/output slot 2, illustration [23](#)

- enhanced input/output, connection [23](#)
- enhanced input/output, features [18](#)
- enhanced input/output, numbered errors [130](#)
- enhanced input/output, unnumbered errors [145](#)
- envelopes, jam [171](#)
- envelopes, loading in tray 1 [75](#)
- envelopes, printing on [76](#)
- envelopes, specifications [69](#)
- envelopes, weights/sizes [62](#)
- envelopes, will not feed [171](#)
- Environmental Product Stewardship Program [213](#)
- environments, saving printer [57](#)
- error log, printing [51](#)
- error messages [129](#)
- error messages, not showing [173](#)
- error, internal memory [136](#)
- error, memory [150](#)
- errors, print PostScript [33](#)
- event log, printing [51](#)
- executive size, print speeds [17](#)
- executive size, weights/types [61](#)
- expanding, memory [56](#)
- extended data out, DIMMs [207](#)

## F

- face-up output bin, illustration [22](#)
- factory defaults [32](#)
- fan, failure [135](#)
- Fast Page Mode, DIMMs [207](#)
- FCC, regulations [217](#)
- features, accessories [19](#)
- features, control panel [28](#)
- features, DIMMs [18](#)
- features, duplexer [18](#)
- features, EIO [18](#)
- features, hard disk [19](#)
- features, memory [18](#)
- features, multi-bin mailbox [19](#)
- features, print speeds [17](#)
- features, printer [17](#)
- features, printer personalities [18](#)
- features, tray 4 [18](#)
- features, user interface [18](#)
- file directory page, printing [51](#)
- filters, air, illustration [124](#)
- filters, charcoal, illustration [124](#)
- filters, replace frequency [126](#)
- Finland, laser statement [226](#)
- fonts, cannot select in application [181](#)
- fonts, incorrect on printout [183](#)
- fonts, numbers, PCL defaults [34](#)
- fonts, printer features [18](#)
- fonts, saving downloaded [57](#)
- fonts, sources, PCL defaults [34](#)
- frequency, air filter replacement [125](#)
- frequency, charcoal filter replacement [125](#)

frequency, cleaning roller replacement [125](#)  
frequency, drum kit replacement [125](#)  
frequency, fuser kit replacement [126](#)  
frequency, fuser replacement [126](#)  
frequency, imaging drum replacement [125](#)  
frequency, paper rollers replacement [126](#)  
frequency, toner cartridges replacement [126](#)  
frequency, transfer belt replacement [125](#)  
frequency, transfer drum replacement [125](#)  
frequency, transfer kit replacement [125](#)  
front door, illustration [22](#)  
fuser kit, ordering [204](#)  
fuser kit, replace frequency [126](#)  
fuser, error [132](#)  
fuser, illustration [124](#)  
fuser, ordering [204](#)  
fuser, replacement frequency [126](#)

## G

gauge, HP TonerGauge [88](#)  
glossy media, printing from tray 1 [77](#)  
glossy media, weights/sizes [61](#)  
glossy media, will not feed [170](#)  
Go key, illustration [28](#)  
graphics, resolution [116](#)  
graphics, using scanners [117](#)

## H

halftone, settings [111](#)  
hand wipe, ordering [204](#)  
hard disk, failure [143](#)  
hard disk, features [19](#)  
hard disk, increasing printer memory [56](#)  
hard disk, initializing [152](#)  
hard disk, ordering [204](#)  
hard disk, storing data on [56](#)  
hard disk, verifying installation [52](#)  
hard disk, verifying lock [52](#)  
heavy media, printing on backside [104](#)  
heavy paper, duplexing [190](#)  
heavy paper, printing from tray 1 [77](#)  
heavy paper, specifications [70](#)  
heavy paper, weights/sizes [61](#)  
height, printer [123](#)  
help, using online [129](#)  
HP ColorSmart II, settings [110](#)  
HP Customer Care Centers [10](#)  
HP LaserJet Resource Manager [106](#)  
HP LaserJet Utility [107](#)  
HP support services [3](#)  
HP TonerGauge [88](#)  
HP TonerGauge, resetting [127](#)  
HP Web JetAdmin, locking control panel from [49](#)

## I

I/O, default timeout [35](#)  
I/O, resetting [153](#)  
I/O, setting timeout [48](#)  
ICC, settings [112](#)  
images, using digital camera [116](#)  
imaging drum, error [148](#)  
imaging drum, illustration [124](#)  
imaging drum, ordering [204](#)  
imaging drum, recycling [214](#)  
imaging drum, replace frequency [126](#)  
Information Menu, cannot select [179](#)  
input trays, illustration [22](#)  
input trays, lights [24](#)  
input trays, paper sizes supported [18](#)  
input trays, verifying configuration [52](#)  
input/output, default timeout [35](#)  
input/output, resetting [153](#)  
input/output, setting timeout [48](#)  
ISO B5 size, weights/types [61](#)

## J

Japan, VCCI statement [224](#)  
JetSend, installing [105](#)  
JIS B4 size, weights/types [61](#)  
JIS B5 size, weights/types [61](#)  
JPOSTD size, weights [62](#)

## K

keys, control panel [28](#)  
Korea, EMI statement [224](#)

## L

labels, print speeds [17](#)  
labels, specifications [71](#)  
labels, weights/sizes [62](#)  
languages, control panel display [50](#)  
laser, safety [225](#)  
laser, statement for Finland [226](#)  
LaserJet Resource Manager [106](#)  
ledger size, print speeds [17](#)  
ledger size, weights/types [61](#)  
left doors, lower, illustration [23](#)  
left doors, upper, illustration [23](#)  
left output bin, illustration [22](#)  
legal size, print speeds [17](#)  
legal size, weights/types [61](#)  
letter size, override with A4 [44](#)  
letter size, print speeds [17](#)  
letter size, weights/types [61](#)  
letterhead, printing from tray 4 [86](#)  
letterhead, printing from trays 2 and 3 [83](#)  
letterhead, specifications [68](#)  
letterhead, weights/sizes [61](#)  
lights, 3000-sheet Stacker [24](#)

lights, 3000-sheet Stapler/Stacker [24](#)  
lights, Attention [29](#)  
lights, Data [29](#)  
lights, multi-bin mailbox [24](#)  
lights, Ready [29](#)  
lights, tray 4 [24](#)  
loading, envelopes in tray 1 [75](#)  
loading, media in tray 1 [74](#)  
loading, media in tray 4 [84](#)  
loading, media in trays 2 and 3 [80](#)  
locating, consumables [124](#)  
locking, control panel [49](#)  
locking, verifying control panel [52](#)  
log, printing error [51](#)  
log, printing event [51](#)  
lower left door, illustration [23](#)  
lower right door, illustration [22](#)

## M

Mac OS, color settings [112](#)  
Mac OS, ColorSync [112](#)  
Macintosh, color settings [112](#)  
Macintosh, ColorSync [112](#)  
magenta toner cartridges, ordering [204](#)  
magenta toner cartridges, replace frequency [126](#)  
maintenance, density sensor [197](#)  
maintenance, making room for [123](#)  
manual feed, default [33](#)  
maps, printing menu [37](#)  
Material safety data sheet, obtaining [216](#)  
measurements, printer [123](#)  
measurements, space for printer [123](#)  
media guides, adjusting in tray 4 [84](#)  
media guides, adjusting in trays 2 or 3 [80](#)  
media jams, causes [165](#)  
media jams, duplexer [139](#)  
media jams, fuser [139](#)  
media jams, locations [163](#)  
media jams, transfer [141](#)  
media jams, troubleshooting [165](#)  
media transfer door, illustration [24](#)  
media trays, illustration [22](#)  
media trays, lights [24](#)  
media trays, paper sizes supported [18](#)  
media trays, verifying configuration [52](#)  
media trays, verifying installation [52](#)  
media, capacity of trays [60](#)  
media, clearing from printer [142](#)  
media, configuring types/sizes [40](#)  
media, default destination [33](#)  
media, default override [33](#)  
media, default size [34](#)  
media, incorrect size fed [167](#)  
media, loading in tray 1 [74](#)  
media, loading in tray 4 [84](#)  
media, loading in trays 2 and 3 [80](#)

media, maximum size [18](#)  
media, ordering [204](#)  
media, orienting in tray 1 [78](#)  
media, orienting in tray 4 [79](#)  
media, orienting in trays 2 and 3 [79](#)  
media, printing from tray 1 [74](#)  
media, printing from trays 2 and 3 [82](#)  
media, request types/sizes [157](#)  
media, specifications [59](#)  
media, to avoid [72](#)  
media, type/size override [43](#)  
media, types supported [60](#)  
media, unexpected size [131](#)  
media, using recycled [215](#)  
media, weights/sizes [60](#)  
media, will not feed [168](#)  
memory, error [150](#)  
memory, expanding [56](#)  
memory, features [18](#)  
memory, insufficient [130](#)  
memory, internal error [136](#)  
memory, optional hard disk [56](#)  
memory, standard printer [56](#)  
memory, verifying installation [52](#)  
Menu key, illustration [28](#)  
menu maps, printing [51](#)  
menus, control panel [28](#)  
menus, printing maps [37](#)  
menus, restoring settings [154](#)  
menus, using control panel [30](#)  
messages, control panel [129](#)  
messages, display [28](#)  
messages, not showing [173](#)  
missing colors [185](#)  
Monarch size, weights [62](#)  
multi-bin mailbox, configuring [42](#)  
multi-bin mailbox, features [19](#)  
multi-bin mailbox, lights [24](#)  
multi-bin mailbox, media capacity [63](#)  
multi-bin mailbox, media types [63](#)  
multi-bin mailbox, media weights/sizes [63](#)  
multi-bin mailbox, ordering [204](#)  
multi-bin mailbox, verifying installation [52](#)  
multiple pages on one sheet [92](#)  
multiple sheets, causes of feeding [167](#)

## N

network, configuring the printer [57](#)  
networking, connections [23](#)  
neutral axis [119](#)  
nonvolatile random-access memory, full [137](#)  
n-up printing [92](#)  
NVRAM, full [137](#)

## O

on/off switch, illustration [22](#)

- online help, using [129](#)
- online, bringing printer [28](#)
- operating environmental specifications [212](#)
- ordering, accessories and options [204](#)
- ordering, consumables [204](#)
- ordering, supplies [204](#)
- orientation, changing [73](#)
- orientation, default [34](#)
- orienting, media in tray 1 [78](#)
- orienting, media in tray 4 [79](#)
- orienting, media in trays 2 and 3 [79](#)
- output bins, face-down [42](#)
- output bins, face-up [42](#)
- output bins, left [42](#)
- output bins, selecting [42](#)
- output bins, top [42](#)
- output, curled or wrinkled [171](#), [172](#)
- overriding, A4 with letter [44](#)
- overriding, A4 with letter default [33](#)
- overriding, letter with A4 [44](#)
- overriding, letter with A4 default [33](#)
- overriding, media type/size [43](#)

## P

- pages per minute, for media types/sizes [17](#)
- pages, number printed [52](#)
- pages, printed since color adjustment [53](#)
- PANTONE settings [115](#)
- PANTONE, automatic matching [113](#)
- paper guides, adjusting in tray 4 [84](#)
- paper guides, adjusting in trays 2 or 3 [80](#)
- paper jams, causes [165](#)
- paper jams, duplexer [139](#)
- paper jams, fuser [139](#)
- paper jams, locations [163](#)
- paper jams, transfer [141](#)
- paper jams, troubleshooting [165](#)
- paper rollers, replacement frequency [126](#)
- paper trays, illustration [22](#)
- paper trays, lights [24](#)
- paper trays, paper sizes supported [18](#)
- paper trays, verifying configuration [52](#)
- paper, capacity of trays [60](#)
- paper, clearing from printer [142](#)
- paper, configuring types/sizes [40](#)
- paper, default destination [33](#)
- paper, default override [33](#)
- paper, default size [34](#)
- paper, incorrect size fed [167](#)
- paper, loading in tray 1 [74](#)
- paper, loading in tray 4 [84](#)
- paper, loading in trays 2 and 3 [80](#)
- paper, multiple pages on one sheet [92](#)
- paper, ordering [204](#)
- paper, orienting in tray 1 [78](#)
- paper, orienting in tray 4 [79](#)
- paper, orienting in trays 2 and 3 [79](#)
- paper, printing from tray 1 [74](#)
- paper, printing from trays 2 and 3 [82](#)
- paper, request types/sizes [157](#)
- paper, selecting by size and type [89](#)
- paper, specifications [59](#)
- paper, to avoid [72](#)
- paper, type/size override [43](#)
- paper, types supported [60](#)
- paper, unexpected size [131](#)
- paper, using recycled [215](#)
- paper, weights/sizes [60](#)
- paper, will not feed [168](#)
- parallel connector, illustration [23](#)
- parallel, default advanced functions [35](#)
- parallel, ordering cable [204](#)
- parallel, setting advanced functions [46](#)
- parts, consumables, illustration [124](#)
- passwords, forgotten [49](#)
- passwords, setting control panel [49](#)
- passwords, verifying configuration [52](#)
- PCL, default settings [34](#)
- PCL, firmware date code [52](#)
- PCL, font list, printing [51](#)
- PCL, font number [34](#)
- PCL, font source [34](#)
- PCL, pitch [34](#)
- PCL, point size [34](#)
- PCL, selecting [47](#)
- PCL, symbol sets [34](#)
- personality, defaults [33](#)
- photoconductive drum, error [148](#)
- photoconductive drum, illustration [124](#)
- photoconductive drum, ordering [204](#)
- photoconductive drum, recycling [214](#)
- photoconductive drum, replace frequency [126](#)
- photographs, using digital cameras [116](#)
- pitch, PCL default settings [34](#)
- PJL, error [151](#)
- plain paper, weights/sizes [60](#)
- plastics, recycling [214](#)
- point sizes, PCL default settings [34](#)
- post charger, cleaning [202](#)
- PostScript, file will not print [178](#)
- PostScript, selecting [47](#)
- power button, illustration [22](#)
- power connector, illustration [23](#)
- Power Save, defaults [33](#)
- Power Save, setting time [46](#)
- power switch, illustration [22](#)
- power, consumption [213](#)
- PPM, for media types/sizes [17](#)
- preprinted forms, specifications [68](#)
- preprinted forms, weights/sizes [61](#)
- prepunched paper, weights/sizes [61](#)
- print jobs, canceling [28](#)

print jobs, delayed [48](#)  
print jobs, incomplete [48](#)  
print quality, problems [187](#)  
print speeds, factors affecting [19](#)  
print speeds, for media types/sizes [17](#)  
printer driver, different first page [91](#)  
printer driver, multiple pages on one sheet [91](#), [92](#)  
printer driver, selecting paper by size and type [89](#), [91](#)  
printer messages [129](#)  
printer messages, not showing [173](#)  
printer personalities, features [18](#)  
printer personalities, selecting default [47](#)  
printer stand, illustration [22](#)  
printer, configurations [20](#)  
printing, backside of heavy media [104](#)  
printing, booklet [103](#)  
printing, cannot print symbol set [183](#)  
printing, color balance test page [119](#)  
printing, color problems [185](#)  
printing, Color Swatch [115](#)  
printing, configuration page [51](#)  
printing, continuous configuration pages [51](#)  
printing, demonstration page [51](#)  
printing, Detail Halftone Adjust page [119](#)  
printing, drifting text [184](#)  
printing, envelopes [76](#)  
printing, erratic [183](#)  
printing, error log [51](#)  
printing, event log [51](#)  
printing, file directory page [51](#)  
printing, fonts incorrect [183](#)  
printing, from tray 1 [74](#)  
printing, from tray 4 [85](#)  
printing, from trays 2 or 3 [82](#)  
printing, interrupted [183](#)  
printing, menu maps [37](#)  
printing, partial pages [184](#)  
printing, PCL font list [51](#)  
printing, PostScript font list [51](#)  
printing, private job [99](#)  
printing, PS font list [51](#)  
printing, quick copying [95](#)  
printing, repeated defects on page [195](#)  
printing, Smooth Halftone Adjust page [119](#)  
printing, storing print job [101](#)  
printing, tips for tray 1 [77](#)  
printing, tips for tray 4 [86](#)  
printing, tips for trays 2 and 3 [83](#)  
printing, variable data [102](#)  
private job, printing [99](#)  
product information sheets, obtaining [225](#)  
product numbers, verifying [52](#)  
proof and hold, continuing jobs [97](#)  
PS, file will not print [178](#)  
PS, printing font list [51](#)  
PS, selecting [47](#)

punched paper, weights/sizes [61](#)

## Q

quick copying, print job [95](#)  
quick sets, creating and using [93](#)

## R

RAM, configuring [57](#)  
RAM, internal error [136](#)  
ramp, color [119](#)  
random-access memory, configuring [57](#)  
random-access memory, internal error [136](#)  
read-only memory, DIMMs [207](#)  
Ready light, illustration [29](#)  
recycled media, specifications [69](#)  
recycled media, weights/sizes [61](#)  
recycled, paper using [215](#)  
recycling, parts and supplies [214](#)  
recycling, used consumables [127](#)  
regulations, Canadian DOC [217](#)  
regulations, declaration of conformity [218](#)  
regulations, FCC [217](#)  
regulations, Korean EMI statement [224](#)  
regulations, VCCI statement (Japan) [224](#)  
replacing air filters, frequency [126](#)  
replacing charcoal filter, frequency [126](#)  
replacing cleaning roller, frequency [126](#)  
replacing consumables, frequency [125](#)  
replacing drum kit, frequency [126](#)  
replacing fuser kit, frequency [126](#)  
replacing fuser, frequency [126](#)  
replacing imaging drum, frequency [126](#)  
replacing paper rollers, frequency [126](#)  
replacing toner cartridge, frequency [126](#)  
replacing transfer belt, frequency [126](#)  
replacing transfer drum, frequency [126](#)  
replacing transfer kit, frequency [126](#)  
reset, cold, message [142](#)  
reset, cold, performing [49](#)  
resolution, digital cameras [116](#)  
resolution, graphics [116](#)  
resolution, printer default [32](#)  
resolution, scanners [117](#)  
Resource Manager, HP LaserJet [106](#)  
resource saving, configuring RAM [57](#)  
resource saving, setting [57](#)  
resource saving, using [47](#)  
returning parts [215](#)  
right doors, lower, illustration [22](#)  
right doors, upper, illustration [22](#)  
rollers, cleaning, illustration [124](#)  
rollers, cleaning, ordering [204](#)  
rollers, cleaning, replace frequency [126](#)  
rollers, paper, replace frequency [126](#)  
rollers, paper, replacement frequency [126](#)  
ROM DIMMs [207](#)



rotate, color toner carousel [175](#)

## S

safety, laser [225](#)  
saving, downloaded fonts [57](#)  
saving, printer environments [57](#)  
scan buffer error [136](#)  
scanner error [132](#)  
scanners, using images from [117](#)  
Screen Match settings [111](#)  
Select key, illustration [29](#)  
selecting Color Swatch [115](#)  
selecting colors [115](#)  
selecting consumable out response [45](#)  
selecting control panel display language [50](#)  
selecting default printer personality [47](#)  
selecting output bin [42](#)  
selecting PANTONE [115](#)  
selecting PCL personality [47](#)  
selecting PostScript personality [47](#)  
selecting Power Save [46](#)  
sensor, cleaning density [197](#)  
serial numbers, verifying [52](#)  
service code, verifying [52](#)  
settings, adjusting color [114](#)  
settings, auto continue [39](#)  
settings, black and white printing [112](#)  
settings, changing control panel [29](#)  
settings, color adjustment [111](#)  
settings, ColorSync [112](#)  
settings, consumable out response [45](#)  
settings, control panel display language [50](#)  
settings, default printer personality [47](#)  
settings, Detail [111](#)  
settings, Halftone [111](#)  
settings, HP ColorSmart II [110](#)  
settings, I/O timeout [48](#)  
settings, ICC [112](#)  
settings, Manual color [111](#)  
settings, parallel advanced functions [46](#)  
settings, Power Save [46](#)  
settings, resource saving [57](#)  
settings, Screen Match [111](#)  
settings, Smooth [111](#)  
settings, toner low response [45](#)  
settings, transparencies [111](#)  
settings, troubleshooting transparencies [193](#)  
settings, verifying memory [52](#)  
settings, Vivid [111](#)  
simplex, orienting in tray 1 [78](#)  
simplex, orienting in tray 4 [79](#)  
simplex, orienting in trays 2 and 3 [79](#)  
single-sided printing, orienting in tray 1 [78](#)  
single-sided printing, orienting in tray 4 [79](#)  
single-sided printing, orienting in trays 2 and 3 [79](#)  
sizes, configuring media [40](#)

sizes, printer [123](#)  
sizes, selecting media [40](#)  
sizes, supported media [60](#)  
smears, toner [188](#)  
Smooth Halftone Adjust page, printing [118](#)  
Smooth settings [111](#)  
smudges toner [195](#)  
software, JetSend [105](#)  
software, LaserJet Resource Manager [105](#), [106](#)  
space, required for printer [123](#)  
specifications, colored media [72](#)  
specifications, electrical [211](#)  
specifications, envelopes [69](#)  
specifications, heavy paper [70](#)  
specifications, labels [71](#)  
specifications, letterhead [68](#)  
specifications, media [59](#)  
specifications, operating environmental [212](#)  
specifications, preprinted forms [68](#)  
specifications, recycled media [69](#)  
specifications, transparencies [70](#)  
speeds, print [17](#)  
speeds, print, factors affecting [19](#)  
spots, toner [192](#)  
sRGB, colors [111](#)  
stand, printer, illustration [22](#)  
stop, consumables low [45](#)  
stopping print job [28](#)  
storing print job [101](#)  
streaks, toner [189](#)  
streaks, transparencies [194](#)  
supplies, ordering [204](#)  
support services [3](#)  
switch, power, illustration [22](#)  
switching, compatibility mode [46](#)  
switching, printer personalities [47](#)  
symbol sets, cannot print [183](#)  
symbol sets, PCL default settings [34](#)

## T

tabloid size, print speeds [17](#)  
tabloid size, weights/types [61](#)  
takeback program [214](#)  
time, setting Power Save [46](#)  
timeout, I/O default [35](#)  
toner cartridge, resetting HP TonerGauge [127](#)  
toner cartridges, error [147](#)  
toner cartridges, ordering [204](#)  
toner cartridges, recycling [214](#)  
toner cartridges, replace [155](#)  
toner wipe, ordering [204](#)  
toner, banding [192](#)  
toner, carousel will not rotate [175](#)  
toner, cleaning from fabric [162](#)  
toner, dark background [190](#)  
toner, irregular spots [192](#)



toner, lines [189](#)  
 toner, low response default [33](#)  
 toner, raised spots [192](#)  
 toner, setting low response [45](#)  
 toner, smears [188](#)  
 toner, smudges [195](#)  
 toner, stray spots [192](#)  
 toner, streaks [189](#)  
 transfer belt, illustration [124](#)  
 transfer belt, ordering [204](#)  
 transfer belt, replace frequency [126](#)  
 transfer charger, cleaning [203](#)  
 transfer drum, cleaning [198](#)  
 transfer drum, error [148](#)  
 transfer drum, illustration [124](#)  
 transfer drum, ordering [204](#)  
 transfer drum, replace frequency [126](#)  
 transfer kit, ordering [204](#)  
 transfer kit, replace frequency [126](#)  
 transfer kit, replacing [156](#)  
 transmitting data across ECP port [46](#)  
 transparencies, dark areas [195](#)  
 transparencies, dark colors [193](#)  
 transparencies, dull colors [193](#)  
 transparencies, lines [195](#)  
 transparencies, ordering [204](#)  
 transparencies, print speeds [17](#)  
 transparencies, printing from tray 1 [77](#)  
 transparencies, printing from trays 2 and 3 [83](#)  
 transparencies, rippled [194](#)  
 transparencies, settings [111](#)  
 transparencies, specifications [70](#)  
 transparencies, streaks [194](#)  
 transparencies, supported [60](#)  
 transparencies, using color [193](#)  
 transparencies, wavy [194](#)  
 transparencies, weights/sizes [60](#), [62](#)  
 transparencies, will not feed [170](#)  
 Tray 1 Auto [39](#)  
 tray 1, card stock [77](#)  
 tray 1, custom-sized media [77](#)  
 tray 1, default type [33](#)  
 tray 1, glossy paper [77](#)  
 tray 1, heavy paper [77](#)  
 tray 1, illustration [22](#)  
 tray 1, loading envelopes [75](#)  
 tray 1, loading media [74](#)  
 tray 1, media capacity [61](#)  
 tray 1, media weights/sizes [61](#)  
 tray 1, orienting media [78](#)  
 tray 1, printing envelopes from [76](#)  
 tray 1, printing from [74](#)  
 tray 1, printing tips [77](#)  
 tray 1, request type/size [157](#)  
 tray 1, transparencies [77](#)  
 tray 2, adjusting media guides [80](#)  
 tray 2, default type [33](#)  
 tray 2, letterhead [83](#)  
 tray 2, loading media [80](#)  
 tray 2, media capacity [62](#)  
 tray 2, media weights/sizes [62](#)  
 tray 2, orienting media [79](#)  
 tray 2, printing from [82](#)  
 tray 2, tips for printing [83](#)  
 tray 2, transparencies [83](#)  
 tray 3, adjusting media guides [80](#)  
 tray 3, default type [33](#)  
 tray 3, illustration [22](#)  
 tray 3, letterhead [83](#)  
 tray 3, loading media [80](#)  
 tray 3, media capacity [62](#)  
 tray 3, orienting media [79](#)  
 tray 3, printing from [82](#)  
 tray 3, tips for printing [83](#)  
 tray 3, transparencies [83](#)  
 tray 4 connector, illustration [23](#)  
 tray 4, default type [33](#)  
 tray 4, features [18](#)  
 tray 4, letterhead [86](#)  
 tray 4, lights [24](#)  
 tray 4, loading media [84](#)  
 tray 4, media capacity [63](#)  
 tray 4, media weights/sizes [63](#)  
 tray 4, orienting media [79](#)  
 tray 4, printing from [85](#)  
 tray 4, tips for printing [86](#)  
 tray 4, verifying installation [52](#)  
 trays, illustration [22](#)  
 trays, lights [24](#)  
 trays, paper sizes supported [18](#)  
 trays, verifying configuration [52](#)  
 troubleshooting, basic steps [161](#)  
 TrueType fonts, supported [18](#)  
 typefaces, cannot select in application [181](#)  
 typefaces, incorrect on printout [183](#)  
 typefaces, numbers, PCL defaults [34](#)  
 typefaces, printer features [18](#)  
 typefaces, saving downloaded [57](#)  
 typefaces, sources, PCL defaults [34](#)  
 types, configuring media [40](#)  
 types, media [60](#)  
 types, selecting media [40](#)

**U**

upper left door, illustration [23](#)  
 user interface, features [18](#)  
 using control panel menus [30](#)

**V**

Value key, illustration [28](#)  
 variable data printing [102](#)  
 VCCI statement (Japan) [224](#)

verifying, color adjustments [53](#)  
verifying, consumable percent remaining [52](#)  
verifying, control panel lock [52](#)  
verifying, control panel password [52](#)  
verifying, DIMM configuration [52](#)  
verifying, duplexer installation [52](#)  
verifying, hard disk installation [52](#)  
verifying, hard disk lock [52](#)  
verifying, input tray configuration [52](#)  
verifying, input tray installation [52](#)  
verifying, memory installed [52](#)  
verifying, memory settings [52](#)  
verifying, multi-bin mailbox installation [52](#)  
verifying, number of pages printed [52](#)  
verifying, PCL firmware date code [52](#)  
verifying, product number [52](#)  
verifying, serial number [52](#)  
verifying, service code [52](#)  
verifying, tray 4 installation [52](#)  
Vivid, settings [111](#)

## W

warnings, control panel [129](#)  
warnings, not showing [173](#)  
warranties, printer [229](#)  
Web JetAdmin, locking control panel from [49](#)  
weights, media [60](#)  
width, printer [123](#)  
World Wide Web support [3](#)  
wrinkled output, causes [171](#), [172](#)

## Y

yellow toner cartridges, ordering [204](#)  
yellow toner cartridges, replace frequency [126](#)