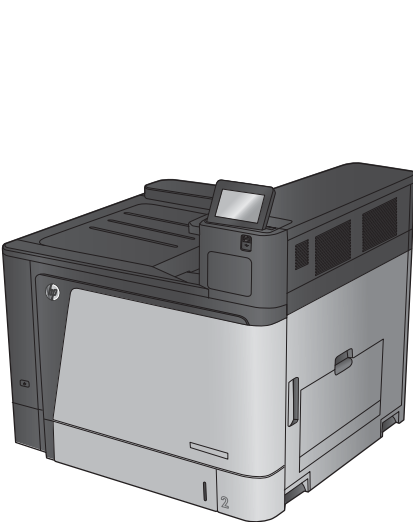


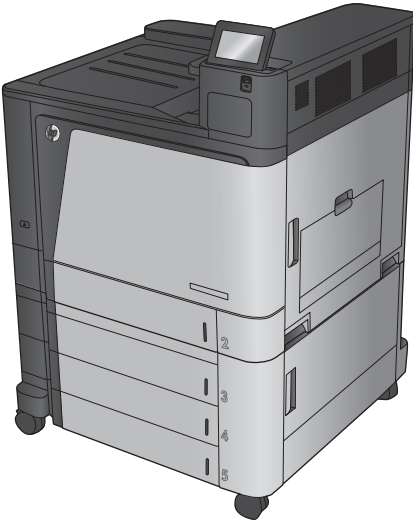


# COLOR LASERJET ENTERPRISE M855

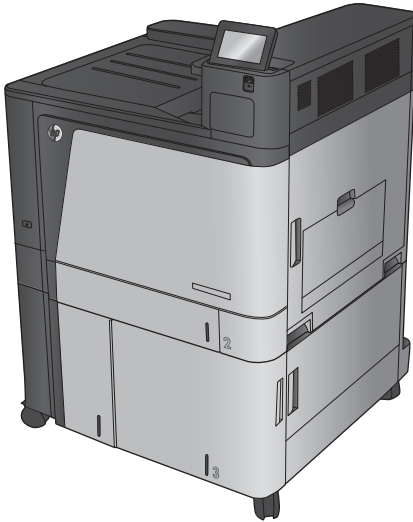
## User Guide



M855dn



M855xh



M855x+





# HP Color LaserJet Enterprise M855

User Guide

**Copyright and License**

© Copyright 2015 HP Development Company, L.P.

Reproduction, adaptation, or translation without prior written permission is prohibited, except as allowed under the copyright laws.

The information contained herein is subject to change without notice.

The only warranties for HP products and services are set forth in the express warranty statements accompanying such products and services. Nothing herein should be construed as constituting an additional warranty. HP shall not be liable for technical or editorial errors or omissions contained herein.

Edition 1, 11/2015

**Trademark Credits**

Adobe®, Adobe Photoshop®, Acrobat®, and PostScript® are trademarks of Adobe Systems Incorporated.

Apple and the Apple logo are trademarks of Apple Computer, Inc., registered in the U.S. and other countries. iPod is a trademark of Apple Computer, Inc. iPod is for legal or rightholder-authorized copying only. Don't steal music.

Microsoft®, Windows®, Windows® XP, and Windows Vista® are U.S. registered trademarks of Microsoft Corporation.

UNIX® is a registered trademark of The Open Group.

---

# Table of contents

|   |           |
|---|-----------|
| <b>1 Product introduction</b>                       | <b>1</b>  |
| Product comparison                                  | 2         |
| Product views                                       | 5         |
| Product front view                                  | 5         |
| Product back view                                   | 6         |
| Interface ports                                     | 7         |
| Control-panel view                                  | 8         |
| Finishing accessory views                           | 10        |
| Stapler/stacker and stapler/stacker with hole punch | 10        |
| Booklet maker and booklet maker with hole punch     | 11        |
| Product hardware setup and software installation    | 12        |
| <b>2 Paper trays</b>                                | <b>13</b> |
| Configure trays for paper type and size             | 14        |
| Configure a tray when loading paper                 | 14        |
| Configure a tray to match print job settings        | 14        |
| Configure a tray by using the control panel         | 14        |
| Load Tray 1   | 15        |
| Load Tray 2   | 19        |
| Load the 3x500-sheet trays                          | 23        |
| Load the 3,500-sheet high-capacity tray             | 27        |
| Configure the default staple location               | 29        |
| Configure the default hole punch location           | 29        |
| <b>3 Parts, supplies, and accessories</b>           | <b>31</b> |
| Order parts, accessories, and supplies              | 32        |
| Ordering  | 32        |
| Parts and supplies                                  | 32        |
| Accessories   | 34        |
| Replace the toner cartridges                        | 35        |
| Replace the imaging drums                           | 38        |

|  |           |
|--|-----------|
| <b>4 Print</b> .....                                 | <b>41</b> |
| Print tasks (Windows) .....                          | 42        |
| How to print (Windows) .....                         | 42        |
| Automatically print on both sides (Windows) .....    | 43        |
| Manually print on both sides (Windows) .....         | 45        |
| Print multiple pages per sheet (Windows) .....       | 47        |
| Select the paper type (Windows) .....                | 49        |
| Print tasks (Mac OS X) .....                         | 52        |
| How to print (Mac OS X) .....                        | 52        |
| Automatically print on both sides (Mac OS X) .....   | 52        |
| Manually print on both sides (Mac OS X) .....        | 52        |
| Print multiple pages per sheet (Mac OS X) .....      | 52        |
| Select the paper type (Mac OS X) .....               | 53        |
| Store print jobs on the product .....                | 54        |
| Create a stored job (Windows) .....                  | 54        |
| Create a stored job (Mac OS X) .....                 | 56        |
| Print a stored job .....                             | 57        |
| Delete a stored job .....                            | 57        |
| Mobile printing .....                                | 58        |
| HP Wireless Direct printing .....                    | 58        |
| HP ePrint via email .....                            | 58        |
| HP ePrint software .....                             | 59        |
| AirPrint .....                                       | 60        |
| Print from the USB port .....                        | 61        |
| Enable the USB port for printing .....               | 61        |
| Print USB documents .....                            | 61        |
| <br>   |           |
| <b>5 Manage the product</b> .....                    | <b>63</b> |
| HP Embedded Web Server .....                         | 64        |
| How to access the HP Embedded Web Server (EWS) ..... | 64        |
| HP Utility for Mac OS X .....                        | 65        |
| Open HP Utility .....                                | 65        |
| HP Utility features .....                            | 65        |
| HP Web Jetadmin .....                                | 67        |
| Economy settings .....                               | 68        |
| Optimize speed or energy usage .....                 | 68        |
| Set Sleep mode .....                                 | 68        |
| Set the Sleep Schedule .....                         | 68        |
| Product security features .....                      | 70        |
| Security statements .....                            | 70        |
| IP Security .....                                    | 70        |

|   |    |
|---|----|
| Sign in to the product .....                                    | 70 |
| Assign a system password .....                                  | 70 |
| Encryption support: HP High Performance Secure Hard Disks ..... | 71 |
| Software and firmware updates .....                             | 72 |

## **6 Solve problems ..... 73**

|   |     |
|---|-----|
| Restore factory-set defaults .....  | 74  |
| Control panel help system .....   | 75  |
| A “Cartridge is low” or “Cartridge is very low” message displays on the product control panel ..... | 76  |
| Change the “Very Low” settings .....  | 76  |
| For products with fax capability .....  | 76  |
| Order supplies .....  | 77  |
| Product does not pick up paper or misfeeds .....  | 78  |
| The product does not pick up paper .....  | 78  |
| The product picks up multiple sheets of paper .....   | 78  |
| The document feeder jams, skews, or picks up multiple sheets of paper .....                         | 78  |
| Clear jams .....  | 80  |
| Auto-navigation for clearing jams .....   | 80  |
| Experiencing frequent or recurring paper jams? .....  | 80  |
| Clear jams in Tray 1, the right door, and the fuser .....   | 81  |
| Clear jams in Tray 2 .....  | 85  |
| Clear jams in the 3x500-sheet feeder and the lower-right door .....                                 | 88  |
| Clear jams in the 3,500-sheet high-capacity input tray and the lower-right door .....               | 90  |
| Clear output jams in the output-accessory bridge .....  | 93  |
| Clear jams in the stapler/stacker accessory or the stapler/stacker with hole punch accessory .....  | 95  |
| Clear top left door jams in the stapler/stacker .....   | 95  |
| Clear Stapler 1 jams in the stapler/stacker .....   | 98  |
| Clear stapler/stacker connection jams (hole-punch models only) .....                                | 101 |
| Clear jams in the booklet maker accessory or the booklet maker with hole punch accessory .....      | 105 |
| Clear top left door jams in the booklet maker .....   | 105 |
| Clear Stapler 1 jams in the booklet maker .....   | 108 |
| Clear front left door jams in the booklet maker .....   | 111 |
| Clear stapler 2 or 3 jams in the booklet maker .....  | 117 |
| Improve print quality .....   | 122 |
| Print from a different software program .....   | 122 |
| Check the paper-type setting for the print job .....  | 122 |
| Check the paper type setting (Windows) .....  | 122 |
| Check the paper type setting (Mac OS X) .....   | 122 |
| Check toner-cartridge status .....  | 123 |
| Calibrate the product to align the colors .....   | 123 |
| Print a cleaning page .....   | 124 |

|   |            |
|---|------------|
| Visually inspect the imaging-drum .....                                       | 124        |
| Check paper and the printing environment .....                                | 124        |
| Step one: Use paper that meets HP specifications .....                        | 124        |
| Step two: Check the environment .....   | 125        |
| Check other print job settings .....  | 125        |
| Adjust color settings (Windows) .....   | 125        |
| Try a different print driver .....  | 126        |
| Set the individual tray alignment .....                                       | 127        |
| Solve wired network problems .....  | 128        |
| Poor physical connection .....  | 128        |
| The computer is using the incorrect IP address for the product .....          | 128        |
| The computer is unable to communicate with the product .....                  | 128        |
| The product is using incorrect link and duplex settings for the network ..... | 129        |
| New software programs might be causing compatibility problems .....           | 129        |
| The computer or workstation might be set up incorrectly .....                 | 129        |
| The product is disabled, or other network settings are incorrect .....        | 129        |
| <b>Index .....</b>  | <b>131</b> |



---

# 1 Product introduction

- [Product comparison](#)
- [Product views](#)
- [Finishing accessory views](#)
- [Product hardware setup and software installation](#)

## For more information:

In the US, go to [www.hp.com/support/colorljM855](http://www.hp.com/support/colorljM855).

Outside the US, go to [www.hp.com/support](http://www.hp.com/support). Select your country/region. Click **Product Support & Troubleshooting**. Enter the product name, and then select **Search**.

HP's all-inclusive help for your product includes the following information:

- Install and configure
- Learn and use
- Solve problems
- Download software updates
- Join support forums
- Find warranty and regulatory information

## Product comparison

|  |   | M855dn | M855xh | M855x+ | M855x+ |
|--|---|--------|--------|--------|--------|
|  |   | A2W77A | A2W78A | A2W79A | D7P73A |
| <b>Paper handling</b>  | Tray 1 (100-sheet capacity)   | ✓      | ✓      | ✓      | ✓      |
|  | Tray 2 (500-sheet capacity)   | ✓      | ✓      | ✓      | ✓      |
|  | 3x500-sheet paper feeder  |        | ✓      |        |        |
|  | <b>NOTE:</b> Optional for the M855dn model. If this input accessory is installed, then any of the optional finishing accessories can also be installed with the M855dn model. |        |        |        |        |
|  | 3,500-sheet high-capacity input trays   |        |        | ✓      | ✓      |
|  | <b>NOTE:</b> Optional for the M855dn model. If this input accessory is installed, then any of the optional finishing accessories can also be installed with the M855dn model. |        |        |        |        |
|  | Automatic duplex printing   | ✓      | ✓      | ✓      | ✓      |
|  | Optional 1x500-sheet feeder with cabinet. Available in Europe, the Middle East, Africa, and Asia-Pacific Countries/Regions  | ✓      |        |        |        |
|  | <b>NOTE:</b> If this input accessory is installed, then any of the optional finishing accessories can also be installed with the M855dn model.                                |        |        |        |        |
|  | Optional stapler/stacker finishing accessory  |        | ✓      | ✓      | ✓      |
| Optional stapler/stacker with 2/4 hole punch finishing accessory                 |   | ✓      | ✓      | ✓      |        |
| Available in Europe, the Middle East, Africa, and Asia-Pacific Countries/Regions |   |        |        |        |        |
| Optional booklet maker finishing accessory                                       |   | ✓      | ✓      | ✓      |        |
| Available in Europe, the Middle East, Africa, and Asia-Pacific Countries/Regions |   |        |        |        |        |
| Optional booklet maker with 2/3 hole punch finishing accessory                   |   | ✓      | ✓      | ✓      |        |
| Available in North America and Latin America                                     |   |        |        |        |        |

|   |   | M855dn | M855xh | M855x+ | M855x+ |
|---|---|--------|--------|--------|--------|
|   |   | A2W77A | A2W78A | A2W79A | D7P73A |
|   | Optional booklet maker with 2/4 hole punch finishing accessory  |        | ✓      | ✓      | ✓      |
|   | Available in Europe, the Middle East, Africa, and Asia-Pacific Countries/Regions  |        |        |        |        |
| <b>Connectivity</b>                                       | 10/100/1000 Ethernet LAN connection with IPv4 and IPv6  | ✓      | ✓      | ✓      | ✓      |
|   | Easy-access USB port for printing without a computer and upgrading the firmware   | ✓      | ✓      | ✓      | ✓      |
|   | HP near-field communications (NFC) and Wireless Direct accessory for printing from mobile devices   |        |        |        | ✓      |
|   | Optional HP NFC and Wireless Direct accessory for printing from mobile devices  | ✓      | ✓      | ✓      |        |
| <b>Storage</b>  | HP High-Performance Secure Hard Disk  |        | ✓      | ✓      | ✓      |
| <b>Control-panel display and input</b>                    | Touchscreen control panel   | ✓      | ✓      | ✓      | ✓      |
| <b>Print</b>  | Prints 46 pages per minute (ppm) on A4 and 45 ppm on letter-size paper  | ✓      | ✓      | ✓      | ✓      |
|   | Easy-access USB printing (no computer required)   | ✓      | ✓      | ✓      | ✓      |
| <b>Mobile printing solutions</b>                          | <ul style="list-style-type: none"> <li>• HP ePrint via email</li> </ul>   | ✓      | ✓      | ✓      | ✓      |
| For more information about Mobile printing solutions see: | <ul style="list-style-type: none"> <li>• HP ePrint software<sup>1</sup></li> <li>• HP ePrint app</li> <li>• HP ePrint Enterprise</li> <li>• HP ePrint Home &amp; Biz</li> <li>• HP Printer Control app</li> <li>• Google Cloud Print</li> <li>• AirPrint</li> </ul> |        |        |        |        |
|   | <a href="http://www.hpconnected.com">www.hpconnected.com</a>  |        |        |        |        |
|   | <a href="http://www.hp.com/go/LaserJetMobilePrinting">www.hp.com/go/LaserJetMobilePrinting</a> (English only)   |        |        |        |        |
|   | <a href="http://www.hp.com/go/eprintsoftware">www.hp.com/go/eprintsoftware</a>  |        |        |        |        |
|   | <a href="http://www.hp.com/go/eprintenterprise">www.hp.com/go/eprintenterprise</a>  |        |        |        |        |
|   | <a href="http://www.google.com/cloudprint/learn">www.google.com/cloudprint/learn</a>  |        |        |        |        |
|   | <a href="http://www.hp.com/go/airprint">www.hp.com/go/airprint</a>  |        |        |        |        |

|  |   | M855dn | M855xh | M855x+ | M855x+ |
|--|---|--------|--------|--------|--------|
|  |   | A2W77A | A2W78A | A2W79A | D7P73A |
| <b>Supported operating systems</b> <sup>2, 3</sup> | Windows XP SP3 or later, 32-bit and 64-bit<br><br><b>NOTE:</b> The software installer does not support the 64-bit version, but the print driver supports it.<br><br><b>NOTE:</b> Microsoft retired mainstream support for Windows XP in April 2009. HP will continue to provide best-effort support for the discontinued XP operating system.                           | ✓      | ✓      | ✓      | ✓      |
|  | Windows Vista, 32-bit and 64-bit<br><br><b>NOTE:</b> Windows Vista Starter is not supported by the software installer or the print driver.  | ✓      | ✓      | ✓      | ✓      |
|  | Windows 7 SP1 or later, 32-bit and 64-bit   | ✓      | ✓      | ✓      | ✓      |
|  | Windows 8, 32-bit and 64-bit  | ✓      | ✓      | ✓      | ✓      |
|  | Windows 2003 Server SP2 or later, 32-bit and 64-bit<br><br><b>NOTE:</b> The software installer does not support the 64-bit version, but the print driver supports it.<br><br><b>NOTE:</b> Microsoft retired mainstream support for Windows Server 2003 in July 2010. HP will continue to provide best-effort support for the discontinued Server 2003 operating system. | ✓      | ✓      | ✓      | ✓      |
|  | Windows Server 2008, 32-bit and 64-bit  | ✓      | ✓      | ✓      | ✓      |
|  | Windows Server 2008 R2, 64-bit  | ✓      | ✓      | ✓      | ✓      |
|  | Windows Server 2012, 64-bit   | ✓      | ✓      | ✓      | ✓      |
|  | Mac OS X 10.6, 10.7 Lion, and 10.8 Mountain Lion  | ✓      | ✓      | ✓      | ✓      |

<sup>1</sup> The HP ePrint Software supports the following operating systems: Windows® XP SP3 or greater (32-bit) up to ePrint Software version 3; Windows Vista® (32-bit and 64-bit); Windows 7 SP 1 or later (32-bit and 64-bit); Windows 8 (32-bit and 64-bit); and Mac OS X versions 10.6, 10.7 Lion, and 10.8 Mountain Lion.

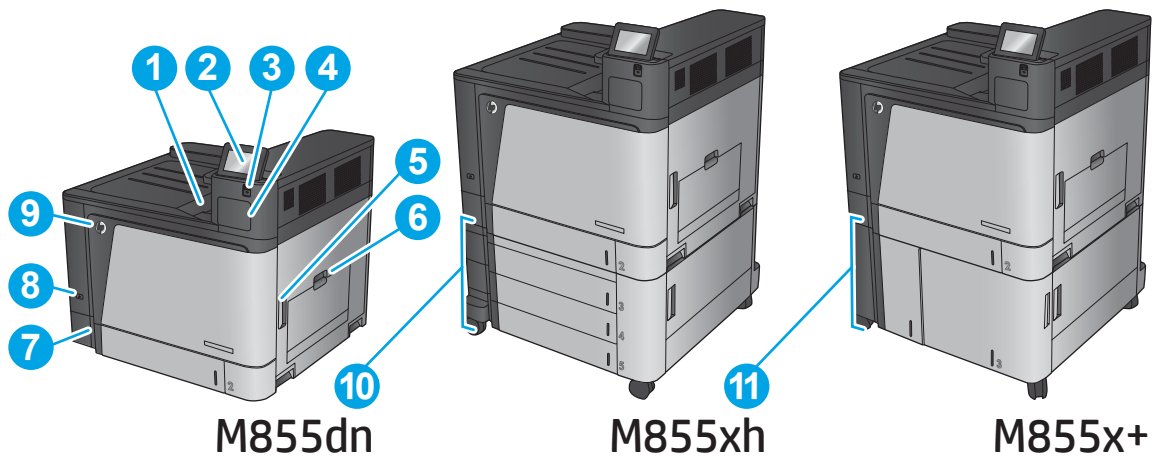
<sup>2</sup> The list of supported operating systems applies to the Windows PCL 6, UPD PCL 6, UPD PCL 5, UPD PS, and Mac print drivers and to the in-box software installation CD. For a current list of supported operating systems, go to [www.hp.com/support/colorljM855](http://www.hp.com/support/colorljM855) for HP's all-inclusive help for your product. If you are located outside the US, go to [www.hp.com/support](http://www.hp.com/support), select a country/region, and then click **Drivers & Software**. Enter a product name or number. In the **Download Options** area, click **Drivers, Software & Firmware**. Click the operating system version, and then click the **Download** button.

<sup>3</sup> The HP Software Installer CD installs the HP PCL 6 discrete driver for Windows operating systems along with other optional software. Mac installer software is not included on the CD. The CD provides steps to download the Mac installer software from [www.hp.com](http://www.hp.com). The steps to download the Mac installer software are as follows: Go to [www.hp.com/support](http://www.hp.com/support), select the country/region, and then click **Drivers & Software**. Enter a product name or number. In the **Download Options** area, click **Drivers, Software & Firmware**. Click the operating system version, and then click the **Download** button.

## Product views

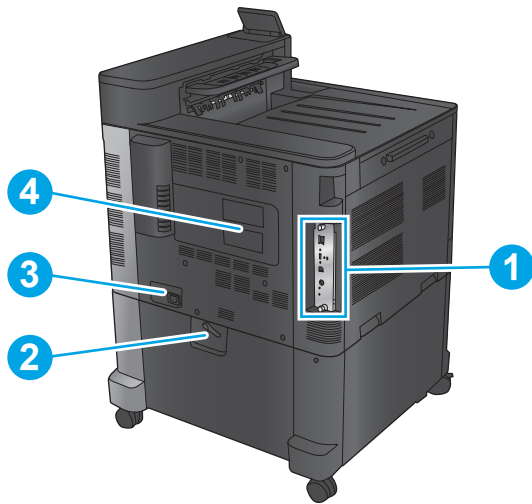
- [Product front view](#)
- [Product back view](#)
- [Interface ports](#)
- [Control-panel view](#)

### Product front view



|    |   |
|----|---|
| 1  | Output bin  |
| 2  | Control panel with color touchscreen display (tilts up for easier viewing)  |
| 3  | Easy-access USB port (for printing without a computer)<br><b>NOTE:</b> An administrator must enable this port before use. |
| 4  | Hardware integration pocket (for connecting accessory and third-party devices)  |
| 5  | Right door (access to the fuser and for clearing jams)  |
| 6  | Tray 1  |
| 7  | Tray 2  |
| 8  | On/off button   |
| 9  | Front door (access to the toner cartridges and imaging drums)   |
| 10 | 3x500-sheet paper feeder  |
| 11 | 3,500-sheet high-capacity input tray  |

## Product back view

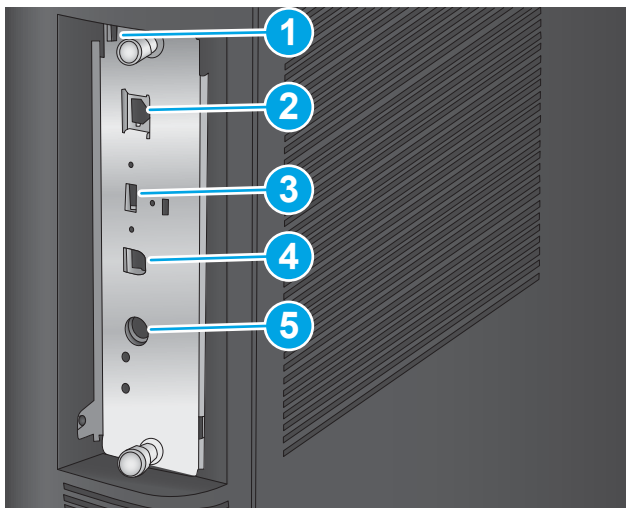


---

|   |   |
|---|---|
| 1 | Formatter (contains the interface ports)                                |
| 2 | Lever to lock the product to the 3x500-sheet feeder (M855xh model only) |
| 3 | Power connection  |
| 4 | Model and serial number label   |

---

## Interface ports



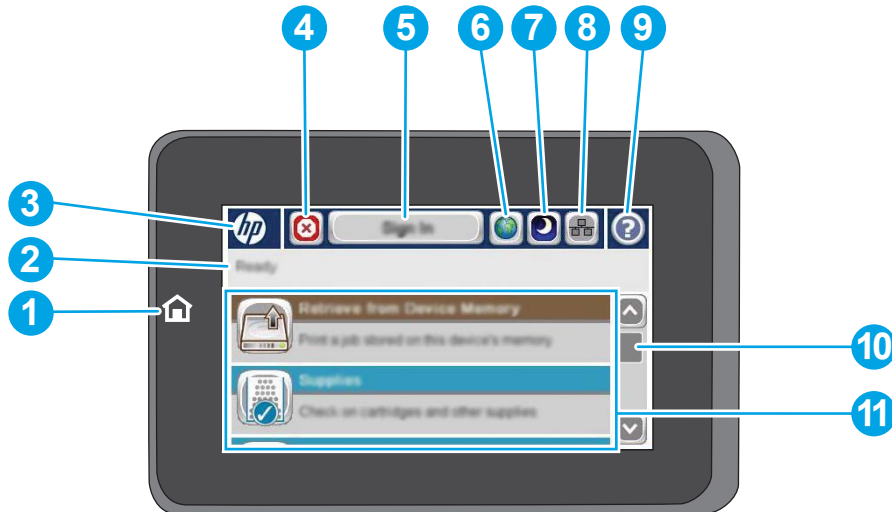
- 
- |   |   |
|---|---|
| 1 | Slot for a cable-type security lock   |
| 2 | Local area network (LAN) Ethernet (RJ-45) network port                              |
| 3 | USB port for connecting external USB devices (this port might be covered)           |
| 4 | Hi-Speed USB 2.0 printing port  |
|   | <b>NOTE:</b> For Easy-access USB printing, use the USB port near the control panel. |
| 5 | Foreign interface harness (for connecting third-party devices)                      |
-



## Control-panel view

The Home screen provides access to the product features and indicates the current status of the product.

You can return to the Home screen at any time by touching the Home button on the left side of the product control panel. You can also touch the Home button in the upper-left corner of most screens.

 **NOTE:** The features that appear on the Home screen can vary, depending on the product configuration.



|   |  |   |
|---|--|---|
| 1 | Home button and light                                      | Touch to return to the product Home screen at any time.   |
| 2 | Product status   | The status line provides information about the overall product status.  |
| 3 | HP logo or Home button                                     | On any screen other than the Home screen, the HP logo changes to a Home  button. Touch the Home  button to return to the Home screen. |
| 4 | Stop button  | Touch the Stop button to pause the current job. The <a href="#">Job Status</a> screen opens, and then you can cancel or continue the job.   |
| 5 | <a href="#">Sign In</a> or <a href="#">Sign Out</a> button | Touch the <a href="#">Sign In</a> button to access secured features.<br><br>Touch the <a href="#">Sign Out</a> button to sign out of the product if you have signed in for access to secured features. After you sign out, the product restores all options to the default settings.                          |
| 6 | Language Selection button                                  | Touch the Language Selection button to select the language for the control-panel display.   |
| 7 | Sleep button   | Touch the Sleep button to put the product into Sleep mode.  |
| 8 | Network button   | Touch the Network button to find information about the network connection.  |
| 9 | Help button  | Touch the Help button to open the embedded help system.   |



---

|    |            |   |
|----|------------|---|
| 10 | Scroll bar | Touch the up or down arrows on the scroll bar to see the complete list of available features.   |
| 11 | Features   | <p>Depending on the product configuration, the features that appear in this area can include any of the following items:</p> <ul style="list-style-type: none"><li>• <a href="#">Quick Sets</a></li><li>• <a href="#">Retrieve from USB</a></li><li>• <a href="#">Retrieve from Device Memory</a></li><li>• <a href="#">Job Status</a></li><li>• <a href="#">Supplies</a></li><li>• <a href="#">Trays</a></li><li>• <a href="#">Administration</a></li><li>• <a href="#">Device Maintenance</a></li></ul> |

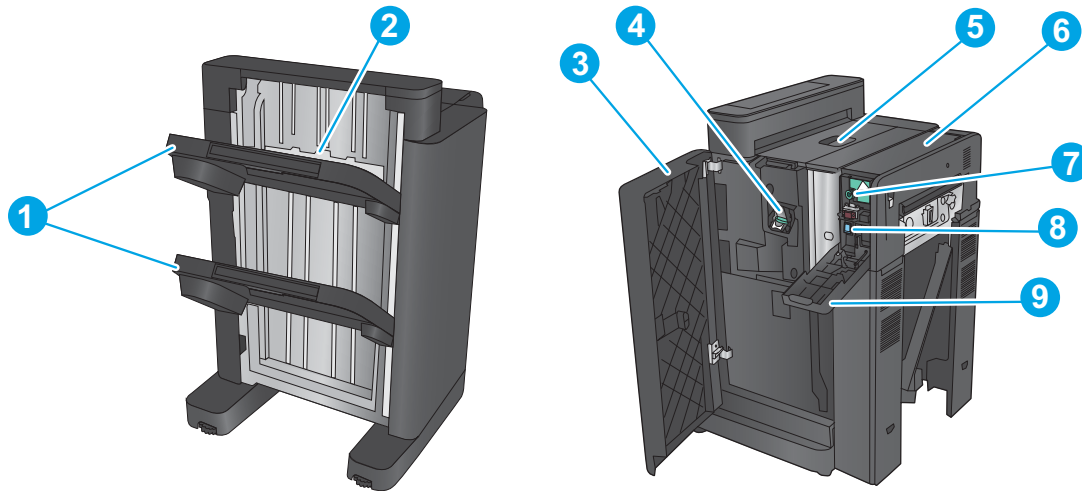
---

## Finishing accessory views

These finishing devices are available as accessories for this product.

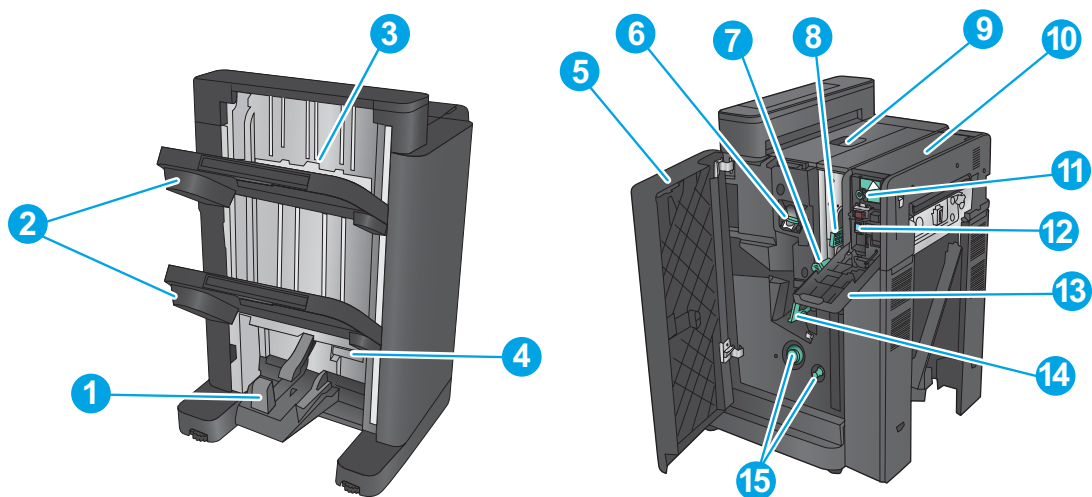
- [Stapler/stacker and stapler/stacker with hole punch](#)
- [Booklet maker and booklet maker with hole punch](#)

### Stapler/stacker and stapler/stacker with hole punch



|   |  |
|---|--|
| 1 | Stapler/stacker output bins                        |
| 2 | Stapler/stacker output slot                        |
| 3 | Front door   |
| 4 | Stapler 1  |
| 5 | Top left door                                      |
| 6 | Hole-punch unit (hole punch models only)           |
| 7 | Hole-punch alignment knob (hole punch models only) |
| 8 | Chad collector (hole punch models only)            |
| 9 | Hole-punch door (hole punch models only)           |

## Booklet maker and booklet maker with hole punch



|    |   |
|----|---|
| 1  | Booklet output bin  |
| 2  | Stapler/stacker output bins                               |
| 3  | Stapler/stacker output slot                               |
| 4  | Lower booklet door (access for clearing jams)             |
| 5  | Front left door   |
| 6  | Stapler 1   |
| 7  | Lower paper delivery guide                                |
| 8  | Upper paper delivery guide                                |
| 9  | Top left door   |
| 10 | Hole-punch unit (hole punch models only)                  |
| 11 | Hole-punch alignment knob (hole punch models only)        |
| 12 | Chad collector (hole punch models only)                   |
| 13 | Hole-punch door (hole punch models only)                  |
| 14 | Paper-advancement knobs for clearing jams                 |
| 15 | Saddle-stitch carriage, access to stapler 2 and stapler 3 |

## Product hardware setup and software installation

For basic setup instructions, see the Hardware Installation Guide that came with the product. For additional instructions, go to HP support on the Web.

In the US, go to [www.hp.com/support/colorljM855](http://www.hp.com/support/colorljM855) for HP's all-inclusive help for your product.

Outside the US, follow these steps:

1. Go to [www.hp.com/support](http://www.hp.com/support).
2. Select your country/region.
3. Click **Product Support & Troubleshooting**.
4. Enter the product name (HP Color LaserJet Enterprise M855), and then select **Search**.

Find the following support:

- Install and configure
- Learn and use
- Solve problems
- Download software updates
- Join support forums
- Find warranty and regulatory information

---

## 2 Paper trays

- [Configure trays for paper type and size](#)
- [Load Tray 1](#)
- [Load Tray 2](#)
- [Load the 3x500-sheet trays](#)
- [Load the 3,500-sheet high-capacity tray](#)
- [Configure the default staple location](#)
- [Configure the default hole punch location](#)

### For more information:

In the US, go to [www.hp.com/support/colorljM855](http://www.hp.com/support/colorljM855).

Outside the US, go to [www.hp.com/support](http://www.hp.com/support). Select your country/region. Click **Product Support & Troubleshooting**. Enter the product name, and then select **Search**.

HP's all-inclusive help for your product includes the following information:


- Install and configure
- Learn and use
- Solve problems
- Download software updates
- Join support forums
- Find warranty and regulatory information

## Configure trays for paper type and size

The product automatically prompts you to configure a tray for type and size in the following situations:

- When you load paper into the tray
- When you specify a particular tray or paper type for a print job through the print driver or a software program and the tray is not configured to match the print-job's settings

---

 **NOTE:** The prompt does not display if you are printing from Tray 1, and Tray 1 is configured for the [Any Size](#) paper size and the [Any Type](#) paper type settings. In this situation, if the print job does not specify a tray, the product prints from Tray 1, even if the paper type and size settings in the print job do not match the paper loaded in Tray 1.

---

### Configure a tray when loading paper

1. Load paper in the tray.
2. The tray configuration message displays on the product control panel.
3. Touch the **OK** button to accept the detected type and size, or touch the **Modify** button to choose a different paper size or type.
4. Select the correct type and size, and then touch the **OK** button.

### Configure a tray to match print job settings

1. In the software program, specify the source tray, the paper size, and the paper type.
2. Send the job to the product.  
If the tray needs to be configured, a tray configuration message displays on the product control panel.
3. Load the tray with the specified type and size of paper, and then close the tray.
4. Touch the **OK** button to accept the detected type and size, or touch the **Modify** button to choose a different paper size or type.
5. Select the correct type and size, and then touch the **OK** button.

### Configure a tray by using the control panel

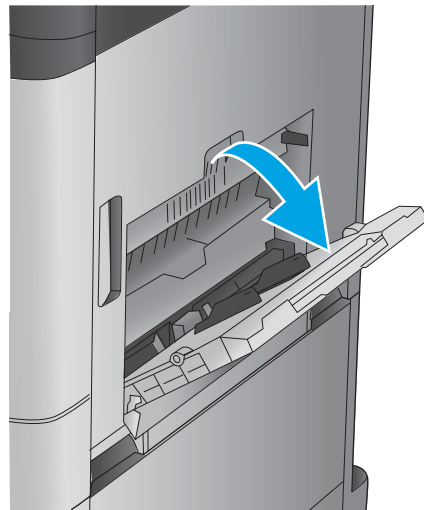
You can also configure the trays for type and size without a prompt from the product.

1. From the Home screen on the product control panel, scroll to and touch the **Trays** button.
2. Touch the line for the tray that you want to configure, and then touch the **Modify** button.
3. Select the paper type and size from the lists of options.
4. Touch the **OK** button to save your selection.

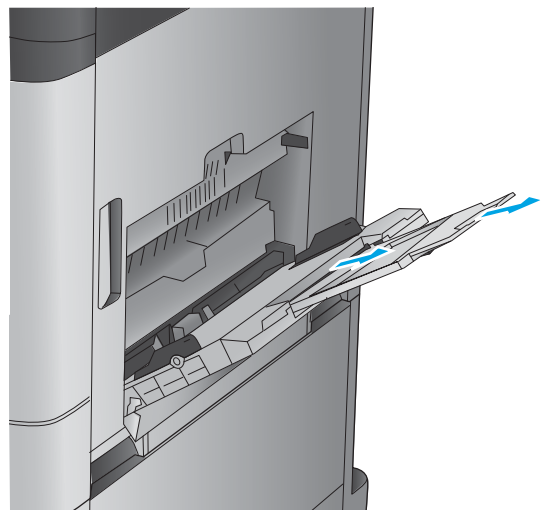
# Load Tray 1

**CAUTION:** To avoid jams, never add or remove paper from Tray 1 during printing.

1. Open Tray 1.

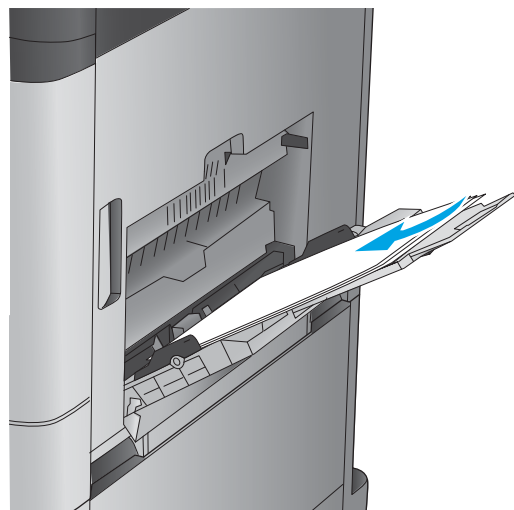


2. Pull out the tray extension to support the paper.

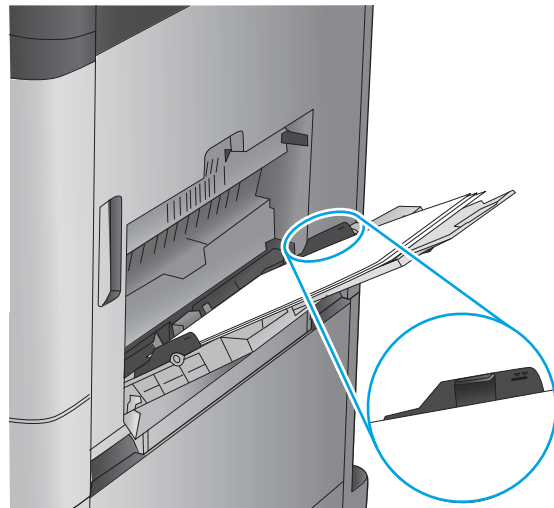


3. Load paper in the tray. See [Table 2-1 Tray 1 paper orientation on page 16](#).

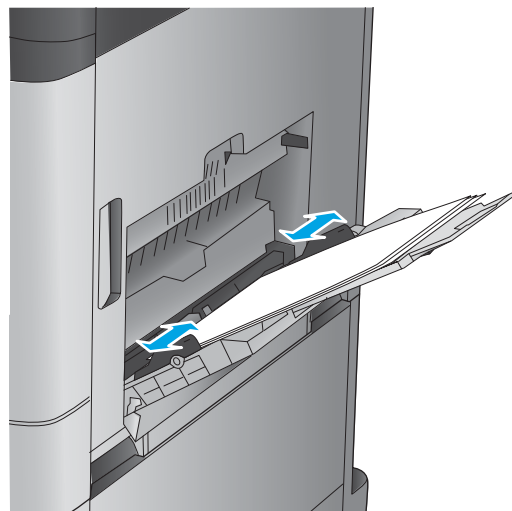
**TIP:** To achieve the highest print-quality, HP recommends that you load the paper long-edge first.



- 4. Make sure that the paper fits under the fill line on the paper guides.

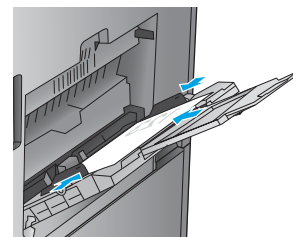


- 5. Adjust the side guides so that they lightly touch the paper stack, but do not bend it.



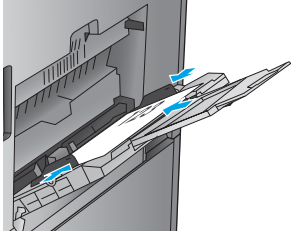
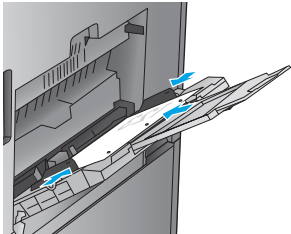
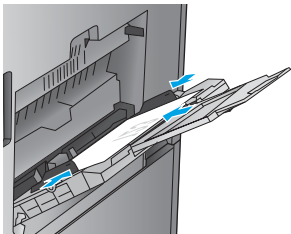
**Table 2-1 Tray 1 paper orientation**

| Paper type                        | Image orientation | Duplex mode      | How to load paper                                    |
|-----------------------------------|-------------------|------------------|--|
| Preprinted, letterhead, or labels | Portrait          | 1-sided printing | Face-down<br>Top edge toward the back of the product |

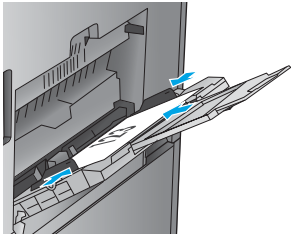
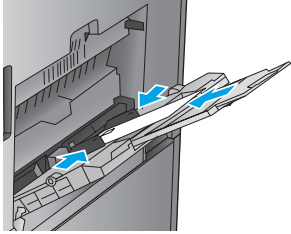




**Table 2-1 Tray 1 paper orientation (continued)**

| Paper type               | Image orientation | Duplex mode                | How to load paper   |
|--------------------------|-------------------|----------------------------|---|
|                          |                   | Automatic 2-sided printing | Face-up<br>Top edge toward the back of the product                                    |
|                          |                   |                            |    |
| Prepunched               | Portrait          | 1-sided printing           | Face-down<br>Holes towards the right of the tray                                      |
|                          |                   |                            |    |
| Preprinted or letterhead | Landscape         | 1-sided printing           | Face-down<br>Top edge toward the right  |
|                          |                   |                            |  |

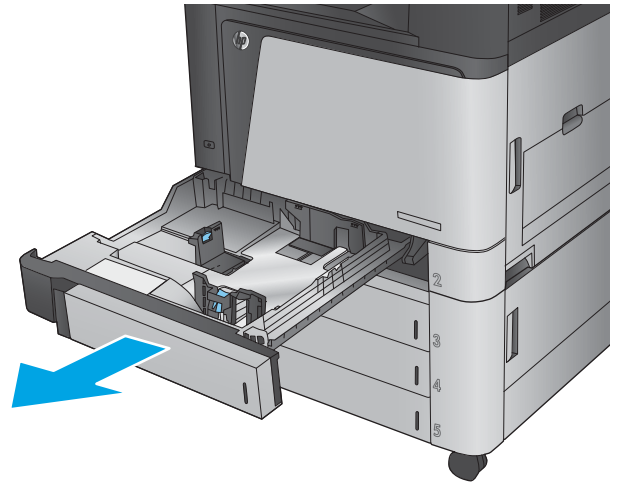
**Table 2-1 Tray 1 paper orientation (continued)**

| Paper type | Image orientation                                   | Duplex mode                | How to load paper   |
|------------|---|----------------------------|---|
|            |   | Automatic 2-sided printing | Face-up<br>Top edge toward the left   |
|            |   |                            |  |
| Envelopes  | Short edge of the envelope feeding into the product | 1-sided printing           | Face-down<br>Top edge toward the back of the product                                |
|            |   |                            |  |

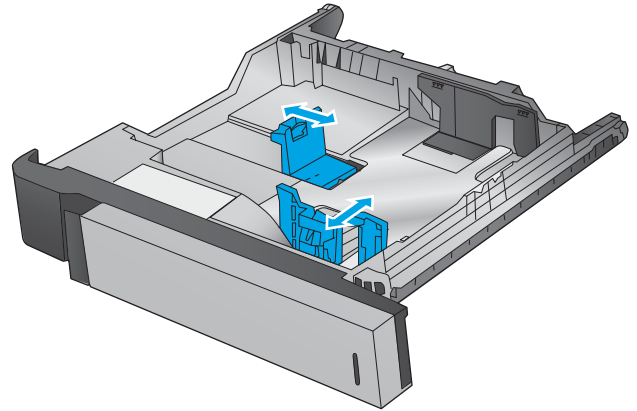
## Load Tray 2

1. Open the tray.

**NOTE:** Do not open this tray while it is in use.



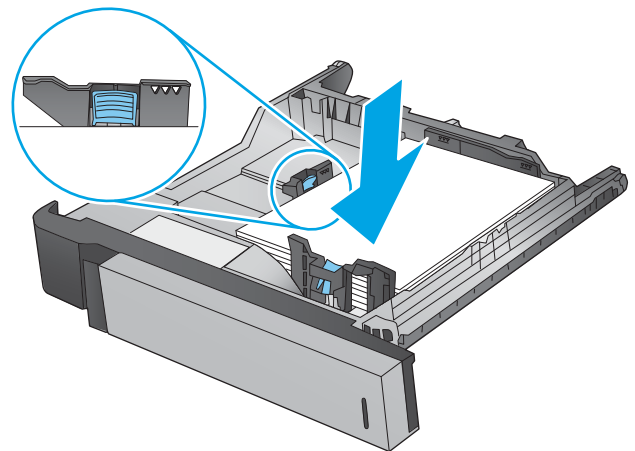
2. Adjust the paper-length and paper-width guides by squeezing the adjustment latches and sliding the guides to the size of the paper being used.



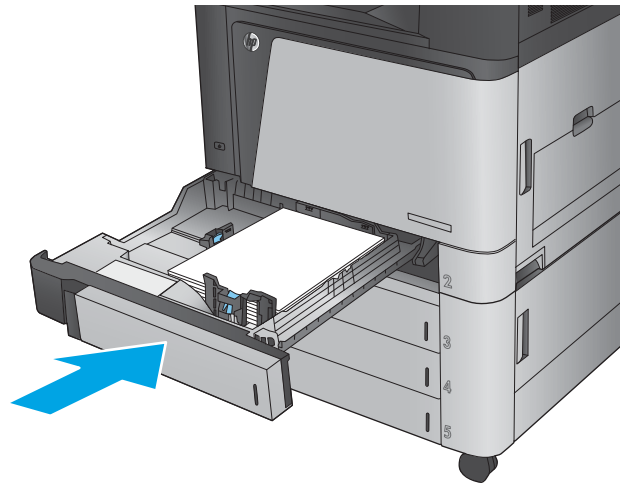
3. Load paper into the tray. Check the paper to verify the guides lightly touch the stack, but do not bend it.

**NOTE:** To prevent jams, do not overfill the tray. Be sure that the top of the stack is below the tray full indicator.

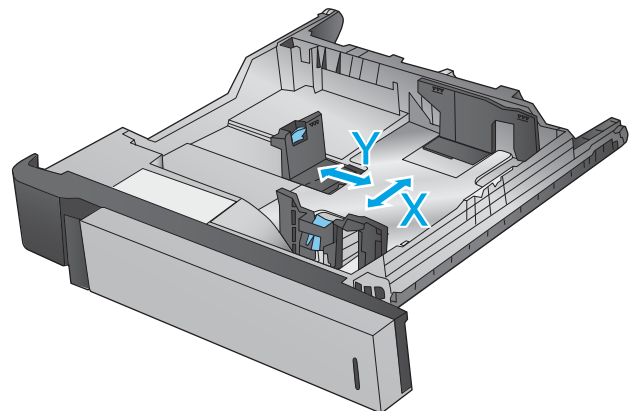
**NOTE:** If the tray is not adjusted correctly, an error message might appear during printing or the paper might jam.



4. Close the tray.

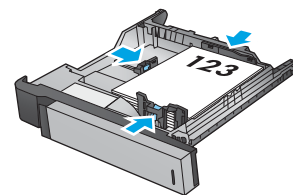


5. The control panel shows the tray's paper type and size. If the configuration is not correct, follow the instructions on the control panel to change the type or size.
6. For custom-size paper, you need to specify the X and Y dimensions for the paper when the prompt displays on the product control panel.

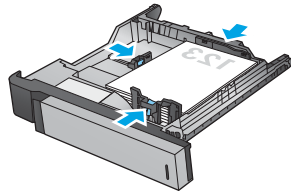
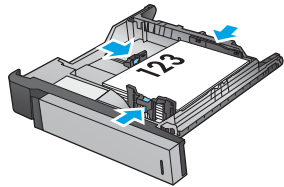
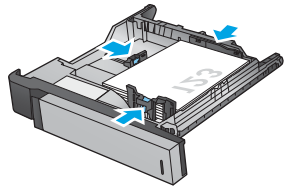


**Table 2-2 Tray 2 paper orientation**

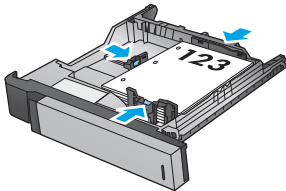
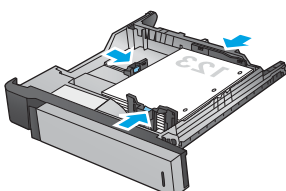
| Paper type               | Image orientation | Duplex mode      | How to load paper                           |
|--------------------------|-------------------|------------------|---|
| Preprinted or letterhead | Portrait          | 1-sided printing | Face-up<br>Top edge at the back of the tray |



**Table 2-2 Tray 2 paper orientation (continued)**

| Paper type | Image orientation | Duplex mode                | How to load paper   |
|------------|-------------------|----------------------------|---|
|            |                   | Automatic 2-sided printing | Face-down<br>Top edge at the back of the tray   |
|            |                   |                            |    |
|            | Landscape         | 1-sided printing           | Face-up<br>Bottom edge toward the right side of the tray                              |
|            |                   |                            |    |
|            |                   | Automatic 2-sided printing | Face-down<br>Top edge toward the right side of the tray                               |
|            |                   |                            |  |

**Table 2-2 Tray 2 paper orientation (continued)**

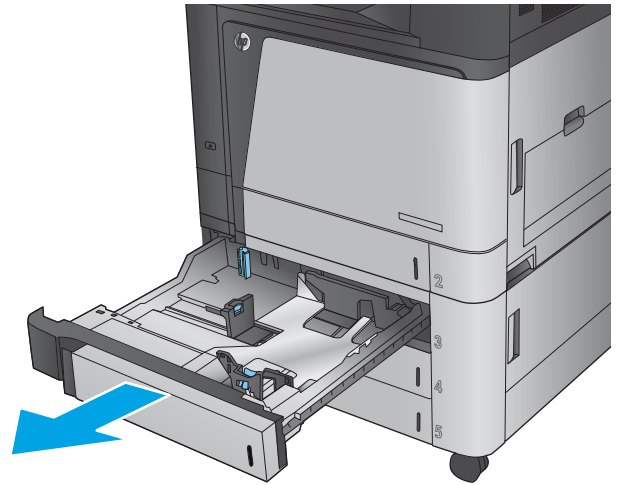
| Paper type | Image orientation | Duplex mode                | How to load paper   |
|------------|-------------------|----------------------------|---|
| Prepunched | Portrait          | 1-sided printing           | Holes toward the left side of the tray  |
|            |                   |                            |  |
|            |                   | Automatic 2-sided printing | Holes toward the right side of the tray   |
|            |                   |                            |  |

# Load the 3x500-sheet trays

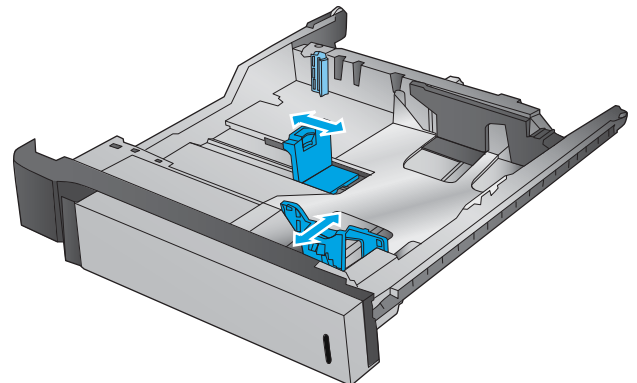
Use the following information to load paper in any of the trays in the 3x500-sheet feeder.

1. Open the tray.

**NOTE:** Do not open this tray while it is in use.

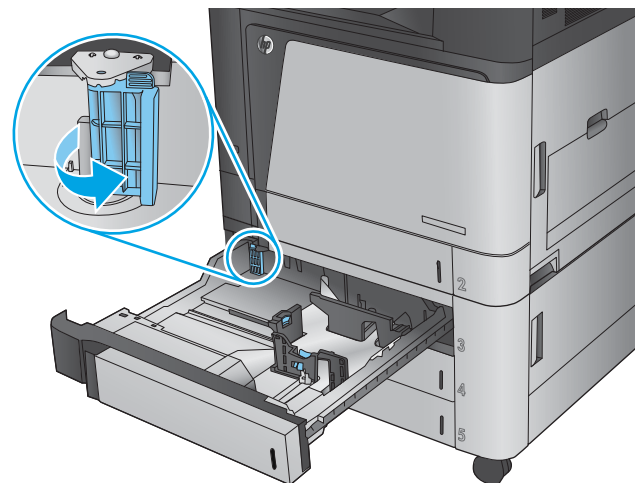


2. Adjust the paper-length and paper-width guides by squeezing the adjustment latches and sliding the guides to the size of the paper being used.



3. For any of the following paper sizes, also adjust the blue paper-stop lever in the left rear corner of the tray to the correct position, as indicated by the label in the tray:

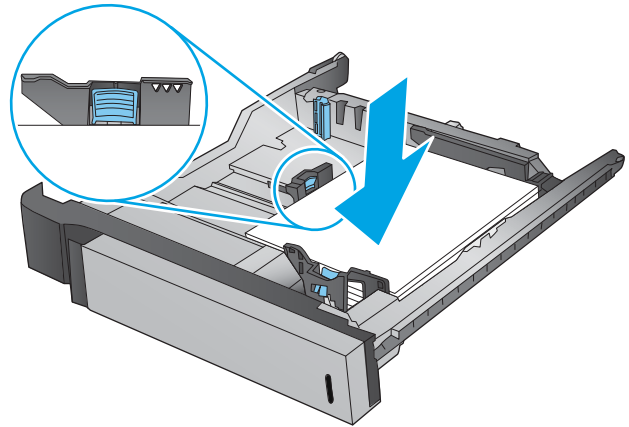
- 12 x 18
- RA3
- 11 x 17
- A3
- SRA3



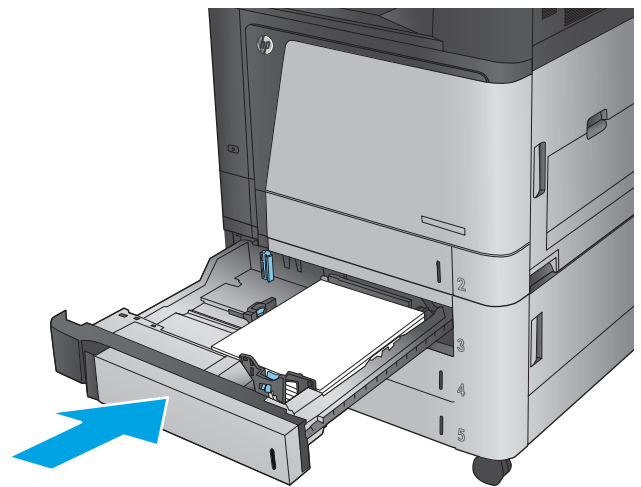
4. Load paper into the tray. Check the paper to verify the guides lightly touch the stack, but do not bend it.

**NOTE:** To prevent jams, do not overfill the tray. Be sure that the top of the stack is below the tray full indicator.

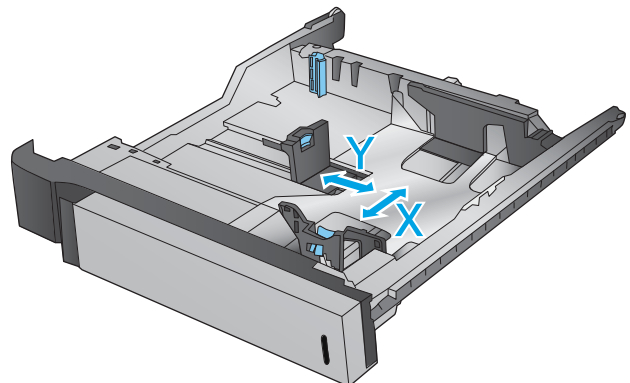
**NOTE:** If the tray is not adjusted correctly, an error message might appear during printing or the paper might jam.



5. Close the tray.



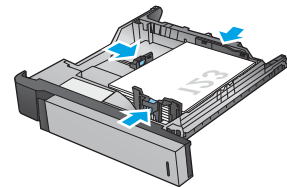
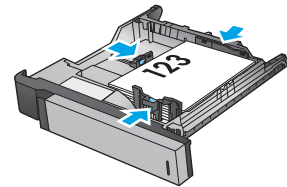
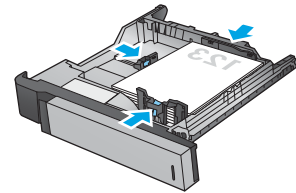
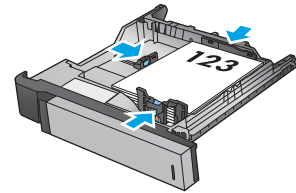
6. The control panel shows the tray's paper type and size. If the configuration is not correct, follow the instructions on the control panel to change the type or size.
7. For custom-size paper, you need to specify the X and Y dimensions for the paper when the prompt displays on the product control panel.



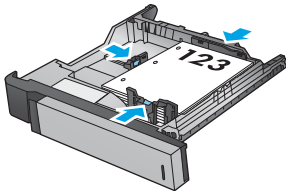
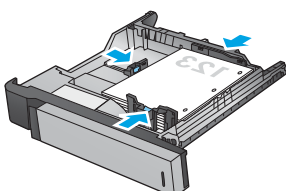


**Table 2-3 3x500-sheet tray paper orientation**

| Paper type               | Image orientation | Duplex mode                | How to load paper  |
|--------------------------|-------------------|----------------------------|--|
| Preprinted or letterhead | Portrait          | 1-sided printing           | Face-up<br>Top edge at the back of the tray              |
|                          |                   | Automatic 2-sided printing | Face-down<br>Top edge at the back of the tray            |
|                          | Landscape         | 1-sided printing           | Face-up<br>Bottom edge toward the right side of the tray |
|                          |                   | Automatic 2-sided printing | Face-down<br>Top edge toward the right side of the tray  |



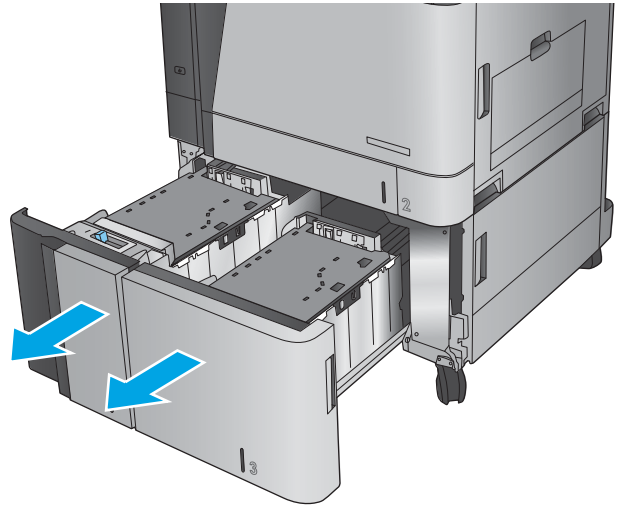
**Table 2-3 3x500-sheet tray paper orientation (continued)**

| Paper type | Image orientation | Duplex mode                | How to load paper   |
|------------|-------------------|----------------------------|---|
| Prepunched | Portrait          | 1-sided printing           | Holes toward the left side of the tray  |
|            |                   |                            |  |
|            |                   | Automatic 2-sided printing | Holes toward the right side of the tray   |
|            |                   |                            |  |

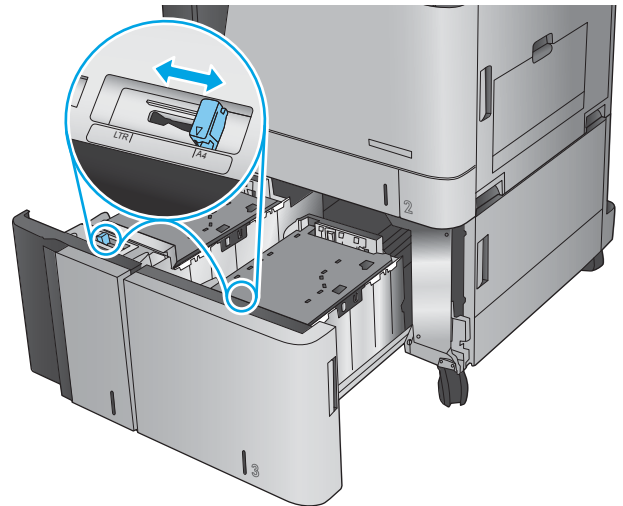
## Load the 3,500-sheet high-capacity tray

The 3,500-sheet high-capacity tray supports only A4 and Letter-size paper.

1. Open the right and left sides of the tray.

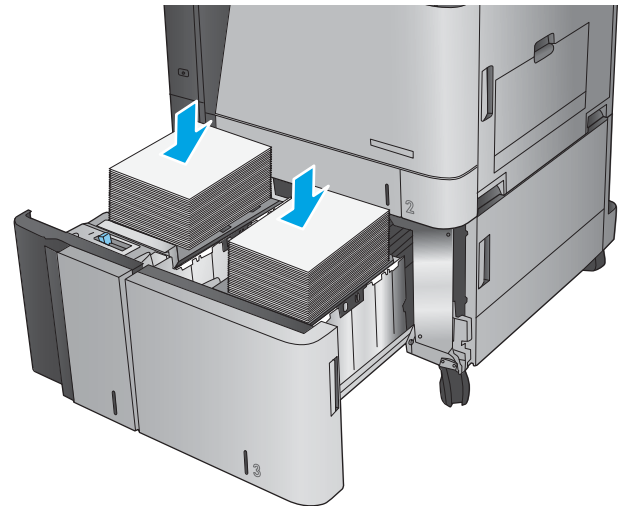


2. On each side, adjust the paper-size lever to the correct position for the paper you are using.

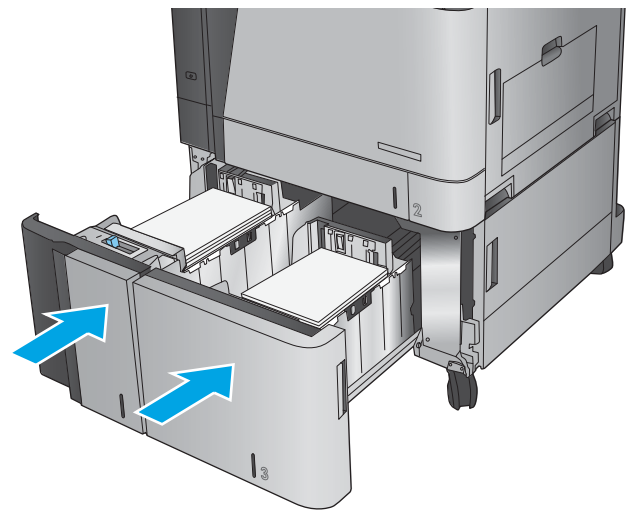


3. Load full reams of paper into each side of the tray. The right side holds 1,500 sheets of paper. The left side holds 2,000 sheets of paper.

**NOTE:** For best results, load full reams of paper. Avoid dividing reams into smaller sections.



4. Close the right and left sides of the tray.



## Configure the default staple location

1. From the Home screen on the product control panel, scroll to and touch the [Administration](#) button.
2. Open the following menus:
  - [Stapler/Stacker Settings](#)
  - [Stapling](#)
3. Select a staple location from the list of options, and then touch the [Save](#) button. The following options are available:
  - [None](#)
  - [Top left](#)
  - [Top right](#)
  - [Two left](#)
  - [Two right](#)
  - [Two top](#)
  - [Two top or left](#)



---

**NOTE:** For documents with portrait orientation, the staples are on the left. For documents with landscape orientation, the staples are on the top.

---

## Configure the default hole punch location

1. From the Home screen on the product control panel, scroll to and touch the [Administration](#) button.
2. Open the following menus:
  - [Stapler/Stacker Settings](#)
  - [Hole Punching](#)
3. Select a hole punch location from the list of options, and then touch the [Save](#) button. The following options are available:
  - [None](#)
  - [Two left or top](#)
  - [Two left](#)
  - [Top right](#)
  - [Two top](#)
  - [Two bottom](#)
  - [Three left](#)
  - [Three right](#)

- Three top
- Three bottom



---

**NOTE:** For documents with portrait orientation, the holes are on the left. For documents with landscape orientation, the holes are on the top.

---

---

## 3 Parts, supplies, and accessories

- [Order parts, accessories, and supplies](#)
- [Replace the toner cartridges](#)
- [Replace the imaging drums](#)

### For more information:

In the US, go to [www.hp.com/support/colorljM855](http://www.hp.com/support/colorljM855).

Outside the US, go to [www.hp.com/support](http://www.hp.com/support). Select your country/region. Click **Product Support & Troubleshooting**. Enter the product name, and then select **Search**.

HP's all-inclusive help for your product includes the following information:

- Install and configure
- Learn and use
- Solve problems
- Download software updates
- Join support forums
- Find warranty and regulatory information

# Order parts, accessories, and supplies

## Ordering

|  |  |
|--|--|
| Order supplies and paper                     | <a href="http://www.hp.com/go/suresupply">www.hp.com/go/suresupply</a>   |
| Order genuine HP parts or accessories        | <a href="http://www.hp.com/buy/parts">www.hp.com/buy/parts</a>   |
| Order through service or support providers   | Contact an HP-authorized service or support provider.  |
| Order using the HP Embedded Web Server (EWS) | To access, in a supported Web browser on your computer, enter the product IP address or host name in the address/URL field. The EWS contains a link to the HP SureSupply Web site, which provides options for purchasing Original HP supplies. |

## Parts and supplies

The following parts are available for the product.

- Parts listed as **Mandatory** self-replacement are to be installed by customers, unless you are willing to pay HP service personnel to perform the repair. For these parts, on-site or return-to-depot support is not provided under the HP product warranty.
- Parts listed as **Optional** self-replacement can be installed by HP service personnel at your request for no additional charge during the product warranty period.

| Item                                   | Description  | Self-replacement options | Part number |
|--|--|--------------------------|-------------|
| HP 826A Black toner cartridge          | Replacement toner cartridge  | Mandatory                | CF310A      |
| HP 826A Cyan toner cartridge           | Replacement toner cartridge  | Mandatory                | CF311A      |
| HP 826A Yellow toner cartridge         | Replacement toner cartridge  | Mandatory                | CF312A      |
| HP 826A Magenta toner cartridge        | Replacement toner cartridge  | Mandatory                | CF313A      |
| HP 828A Black imaging drum             | Replacement imaging drum   | Mandatory                | CF358A      |
| HP 828A Cyan imaging drum              | Replacement imaging drum   | Mandatory                | CF359A      |
| HP 828A Yellow imaging drum            | Replacement imaging drum   | Mandatory                | CF364A      |
| HP 828A Magenta imaging drum           | Replacement imaging drum   | Mandatory                | CF365A      |
| Staple Cartridge Refill Kit            | Replacement staple cartridge for Stapler 1 in all optional finishing accessories   | Mandatory                | C8091A      |
| 2000-Staple Cartridge Kit (2-pack)     | Replacement set of staple cartridges for Stapler 2 and 3 in the optional booklet maker and booklet maker with hole punch finishing accessories | Mandatory                | CC383A      |
| 1x500 Sheet Feeder                     | 1x500-sheet feeder (available in Europe, the Middle East, Africa, and Asia-Pacific Countries/Regions)  | Mandatory                | C2H56A      |
| 3x500 Sheet Feeder Stand               | 3x500 Sheet Feeder Stand   | Mandatory                | C1N63A      |
| 1x3,500 Sheet high-capacity input tray | 3,500-sheet high-capacity input tray   | Mandatory                | C1N64A      |



| <b>Item</b>                              | <b>Description</b>   | <b>Self-replacement options</b> | <b>Part number</b> |
|--|--|---------------------------------|--------------------|
| Booklet Maker/Finisher                   | Booklet maker (available in Europe, the Middle East, Africa, and Asia-Pacific Countries/Regions)                       | Mandatory                       | A2W83A             |
| Booklet Maker with 2/3 hole punch        | Booklet maker with 2/3 hole punch (available in North America and Latin America)                                       | Mandatory                       | A2W84A             |
| Booklet Maker with 2/4 hole punch        | Booklet maker with 2/4 hole punch (available in Europe, the Middle East, Africa, and Asia-Pacific Countries/Regions)   | Mandatory                       | CZ999A             |
| Stapler/stacker                          | Stapler/stacker  | Mandatory                       | A2W80A             |
| Stapler/stacker with 2/4 hole punch      | Stapler/stacker with 2/4 hole punch (available in Europe, the Middle East, Africa, and Asia-Pacific Countries/Regions) | Mandatory                       | A2W82A             |
| Fuser Kit 110V                           | Maintenance 110V fuser kit   | Mandatory                       | C1N54A             |
| Fuser Kit 220V                           | Maintenance 220V fuser kit   | Mandatory                       | C1N58A             |
| Transfer & Roller Kit                    | Replacement transfer unit and secondary transfer roller, feed rollers, and pick rollers                                | Mandatory                       | D7H14A             |
| Control Panel Assembly Kit               | Replacement control-panel assembly   | Mandatory                       | 5851-5950          |
| Secondary Transfer Roller Kit            | Replacement secondary transfer roller  | Mandatory                       | D7H14-67902        |
| ITB Service Kit                          | Replacement transfer belt and secondary transfer roller  | Mandatory                       | A2W77-67904        |
| Cassette Tray 2 Kit                      | Replacement paper tray for Tray 2  | Mandatory                       | A2W75-67906        |
| Tray 2-X Roller Kit                      | Replacement rollers for Tray 2, the 3x500-sheet trays, and the 3,500-sheet high-capacity trays                         | Mandatory                       | A2W77-67905        |
| Tray 1 Roller Kit                        | Replacement rollers for Tray 1   | Optional                        | A2W77-67906        |
| Formatter Assembly Kit                   | Replacement formatter  | Optional                        | A2W77-67902        |
| Formatter Assembly Kit (China and India) | Replacement formatter  | Optional                        | A2W77-67903        |
| SSM Drive Kit                            | Replacement solid-state memory drive   | Mandatory                       | A2W77-67909        |
| HDD Drive Kit                            | Replacement HP High-Performance Secure Hard Disk   | Optional                        | A2W75-67905        |
| FIPS HDD 500GB                           | Replacement hard drive for US government models  | Optional                        | S2W79-67901        |

## Accessories

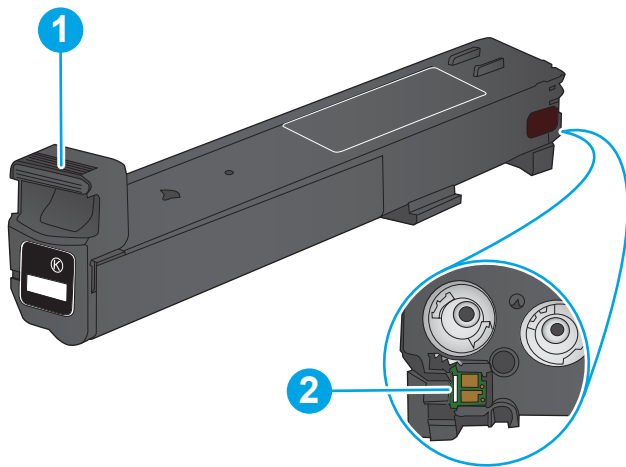
| Item  | Description  | Part number |
|---|--|-------------|
| 1x500-sheet feeder (available in Europe, the Middle East, Africa, and Asia-Pacific Countries/Regions)                                     | Input accessory with one 500-sheet tray, and a storage cabinet and stand.      | C2H56A      |
| HP LaserJet 3x500 Sheet Feeder Stand  | Input tray accessory with three 500-sheet trays.                               | C1N63A      |
| HP LaserJet 1x3500 Sheet Feeder   | 3,500-sheet high-capacity input tray accessory, holds letter and A4-size paper | C1N64A      |
| HP LaserJet Stapler/Stacker   | Stapler/stacker finishing accessory  | A2W80A      |
| HP LaserJet Stapler/Stacker with 2/4 hole punch (available in Europe, the Middle East, Africa, and Asia-Pacific Countries/Regions)        | Stapler/stacker with hole punch finishing accessory                            | A2W82A      |
| HP LaserJet Booklet Maker/Finisher (available in Europe, the Middle East, Africa, and Asia-Pacific Countries/Regions)                     | Booklet maker finishing accessory  | A2W83A      |
| HP LaserJet Booklet Maker/Finisher with 2/3 hole punch (available in North America and Latin America)                                     | Booklet maker with hole punch finishing accessory                              | A2W84A      |
| HP LaserJet Booklet Maker/Finisher with 2/4 hole punch (available in Europe, the Middle East, Africa, and Asia-Pacific Countries/Regions) | Booklet maker with hole punch finishing accessory                              | CZ999A      |
| HP Jetdirect ew2500 Wireless Print Server   | USB wireless print server  | J8026A      |
| HP Jetdirect 2800w NFC & Wireless Direct Accessory  | Wireless direct accessory for “touch” printing from mobile devices             | J8029A      |

## Replace the toner cartridges

The product uses four colors and has a different toner cartridge for each color: black (K), cyan (C), magenta (M), and yellow (Y). The product also has four imaging drums that are separate from the toner cartridges. The toner cartridges are above the imaging drums. The toner cartridges and imaging drums are inside the front door. A toner cartridge and its associated imaging drum are replaced independently of each other.

This product indicates when the toner cartridge level is low. The actual toner cartridge life remaining can vary. The toner cartridge does not need to be replaced at this time. Consider having a replacement cartridge available to install when print quality is no longer acceptable.

The following illustration shows the toner-cartridge components.

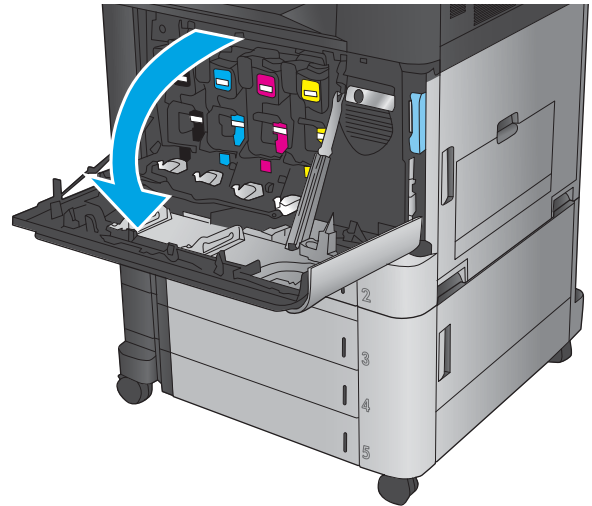


|   |                        |
|---|------------------------|
| 1 | Toner-cartridge handle |
| 2 | Memory chip            |

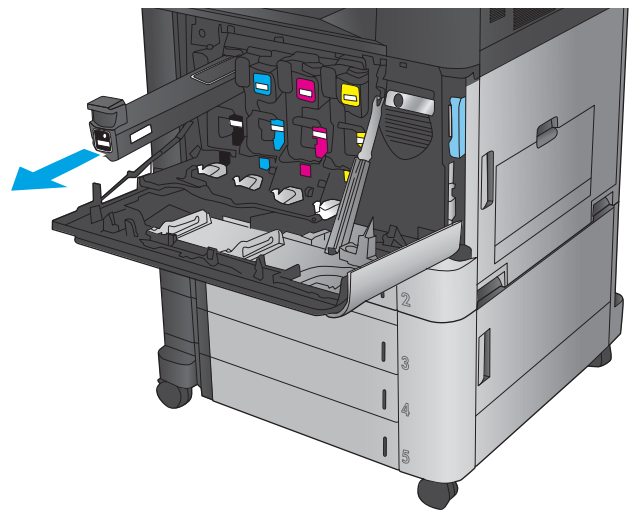
**CAUTION:** If toner gets on clothing, wipe it off by using a dry cloth and wash the clothes in cold water. Hot water sets toner into fabric.

**NOTE:** Information about recycling used toner cartridges is on the toner cartridge box.

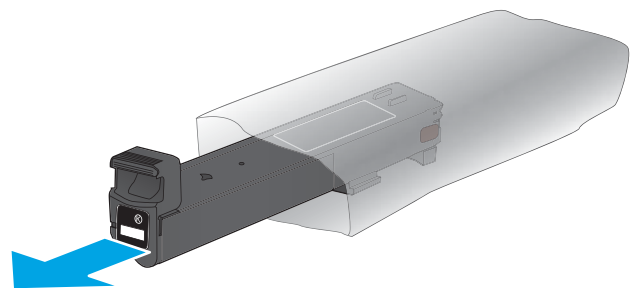
1. Open the front door.



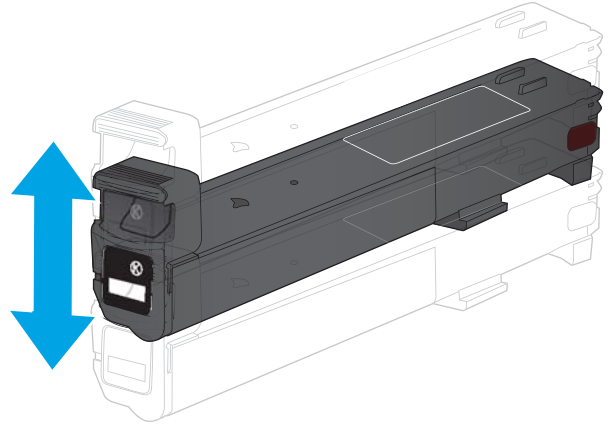
2. Grasp the handle of the used toner cartridge and pull out to remove it.



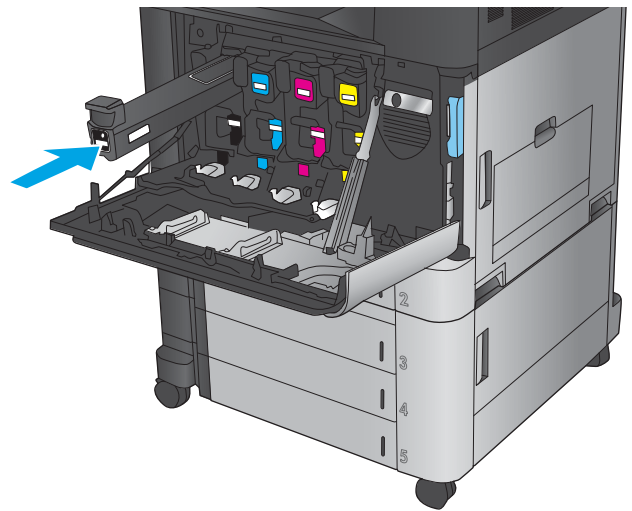
3. Remove the new toner cartridge from its protective bag.



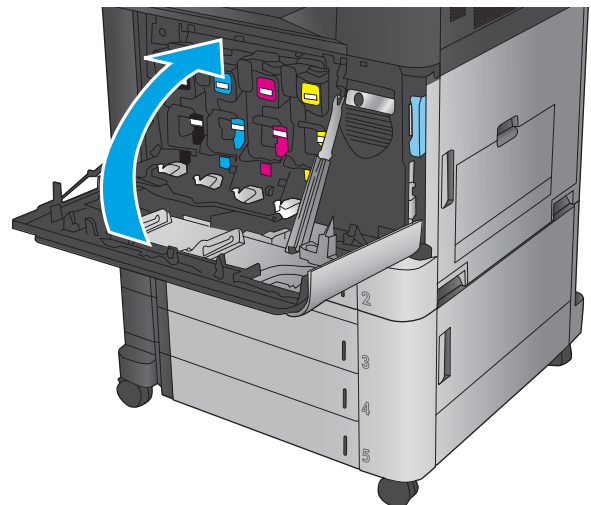
4. Hold both sides of the toner cartridge and shake it up and down 5-6 times.



5. Align the toner cartridge with its slot, and then insert the toner cartridge into the product.



6. Close the front door.

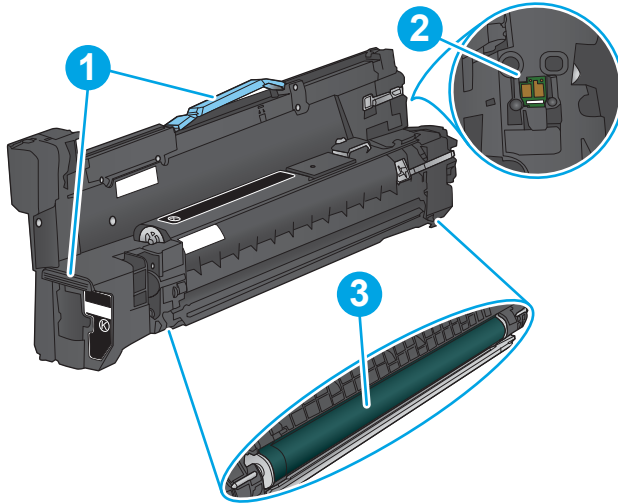


## Replace the imaging drums

The product uses four colors and has a different imaging drum for each color: black (K), cyan (C), magenta (M), and yellow (Y). The product also has four toner cartridges that are separate from the imaging drums. The toner cartridges are above the imaging drums. The toner cartridges and imaging drums are inside the front door. A toner cartridge and its associated imaging drum are replaced independently of each other.

This product indicates when the imaging drum life is low. The actual imaging drum life remaining can vary. The imaging drum does not need to be replaced at this time. Consider having a replacement imaging drum available to install when print quality is no longer acceptable.

The following illustration shows the imaging-drum components.



---

|   |                      |
|---|----------------------|
| 1 | Imaging-drum handles |
| 2 | Memory chip          |
| 3 | Photosensitive drum  |

---

**CAUTION:** Do not touch the photosensitive drum. Fingerprints on the drum can cause print defects.

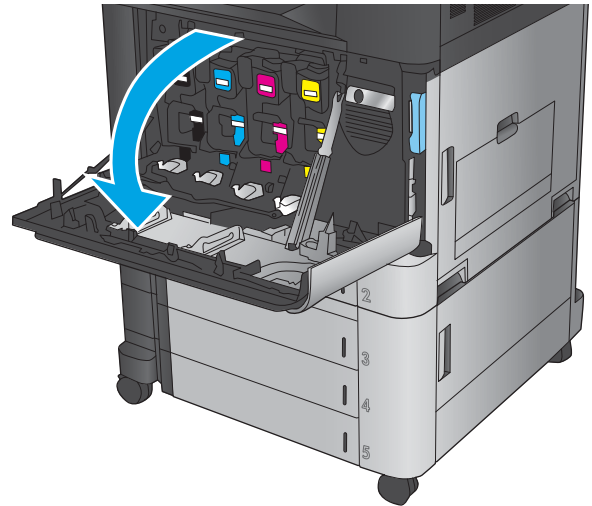
---

**CAUTION:** If toner gets on clothing, wipe it off by using a dry cloth and wash the clothes in cold water. Hot water sets toner into fabric.

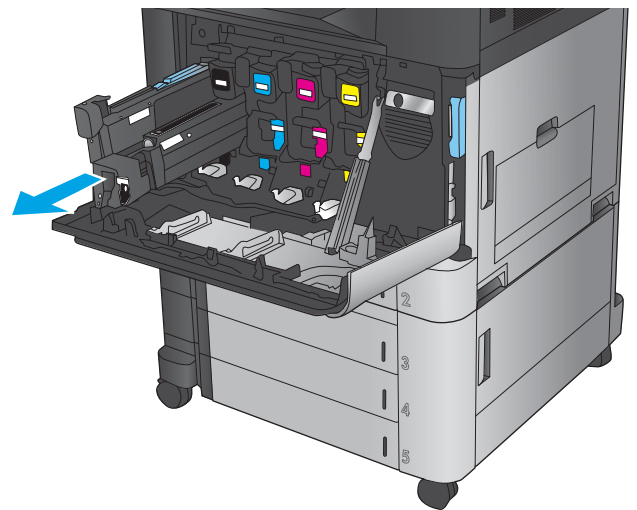
**NOTE:** Information about recycling used imaging drums is on the imaging-drum box.

---

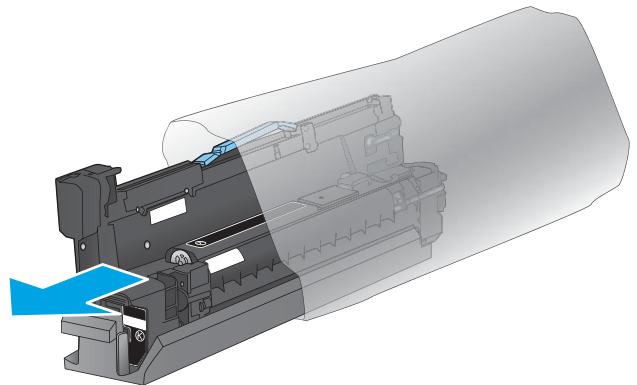
1. Open the front door.



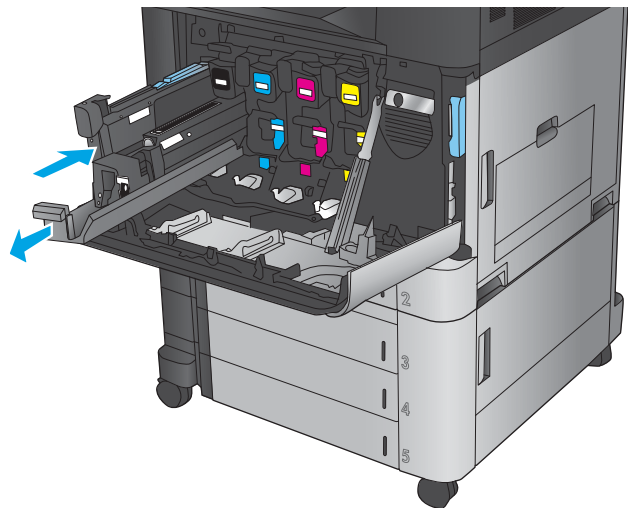
2. Grasp the handle of the used imaging drum and pull out to remove it. Grasp the blue handle on the top of the imaging drum to support it.



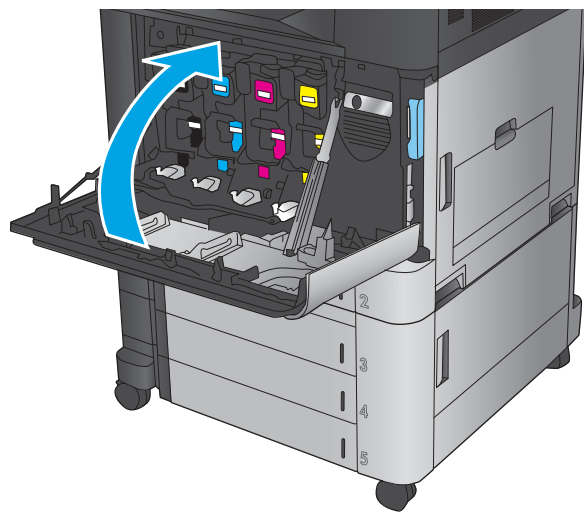
3. Remove the new imaging drum from its protective bag.



- 4. Align the imaging drum with its slot, and then insert the imaging drum into the product. The protective cover on the bottom of the drum automatically slides off as the imaging drum is inserted. Recycle this cover with the used imaging drum.



- 5. Close the front door.





---

# 4 Print

- [Print tasks \(Windows\)](#)
- [Print tasks \(Mac OS X\)](#)
- [Store print jobs on the product](#)
- [Mobile printing](#)
- [Print from the USB port](#)

## For more information:

In the US, go to [www.hp.com/support/colorljM855](http://www.hp.com/support/colorljM855).

Outside the US, go to [www.hp.com/support](http://www.hp.com/support). Select your country/region. Click **Product Support & Troubleshooting**. Enter the product name, and then select **Search**.

HP's all-inclusive help for your product includes the following information:

- Install and configure
- Learn and use
- Solve problems
- Download software updates
- Join support forums
- Find warranty and regulatory information

# Print tasks (Windows)

## How to print (Windows)

The following procedure describes the basic printing process for Windows.

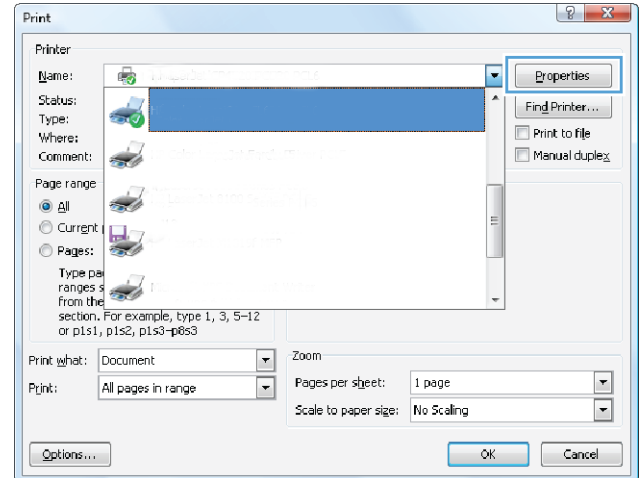
1. From the software program, select the **Print** option.
2. Select the product from the list of printers, and then select **Properties** or **Preferences** (the name varies for different software programs).
3. Click or tap the tabs in the print driver to configure the available options.
4. Click or tap the **OK** button to return to the **Print** dialog box. Select the number of copies to print from this screen.
5. Click or tap the **OK** button to print the job.

## Automatically print on both sides (Windows)

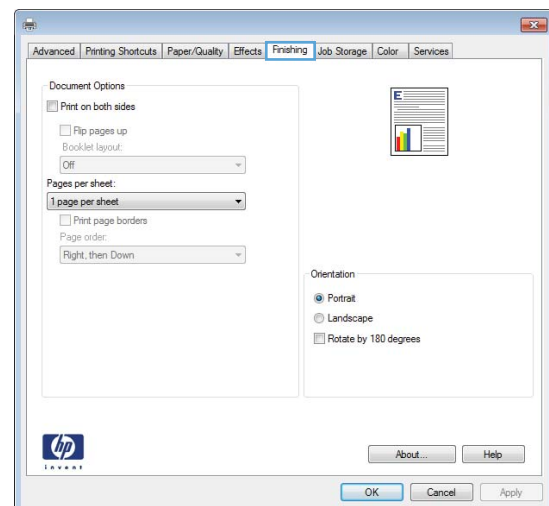


**NOTE:** Your print driver might look different than what is shown here, but the steps are the same.

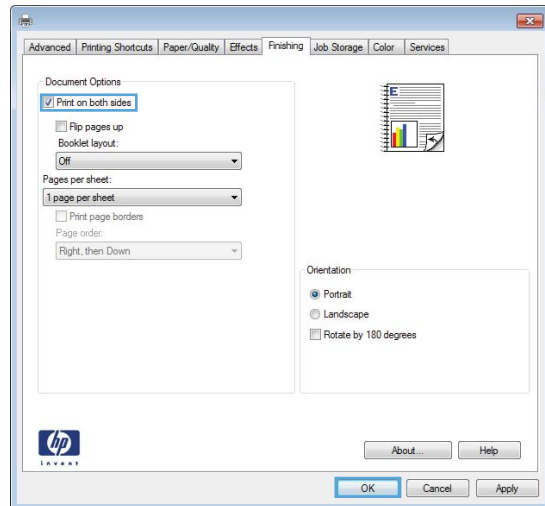
1. From the software program, select the **Print** option.
2. Select the product from the list of printers, and then select **Properties** or **Preferences** (the name varies for different software programs).



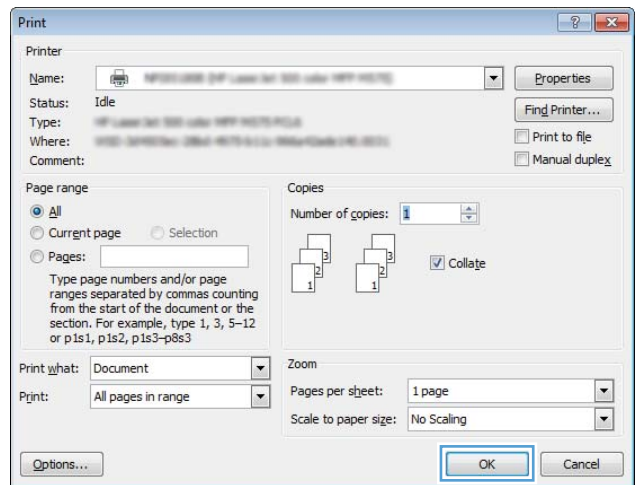
3. Click the **Finishing** tab.



4. Select the **Print on both sides** check box. Click the **OK** button to close the **Document Properties** dialog box.



5. In the **Print** dialog box, click the **OK** button to print the job.

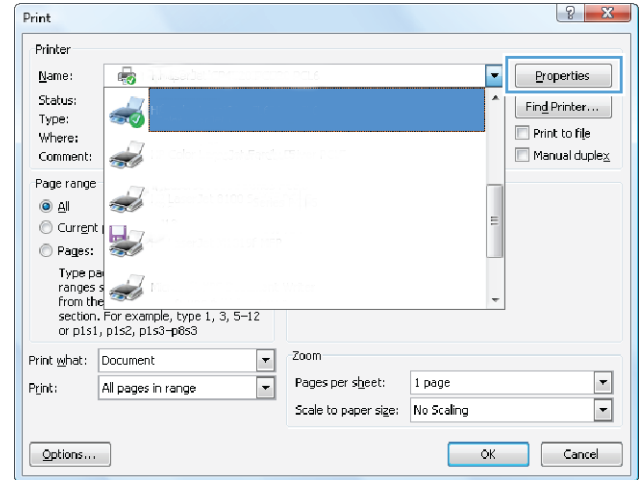


## Manually print on both sides (Windows)

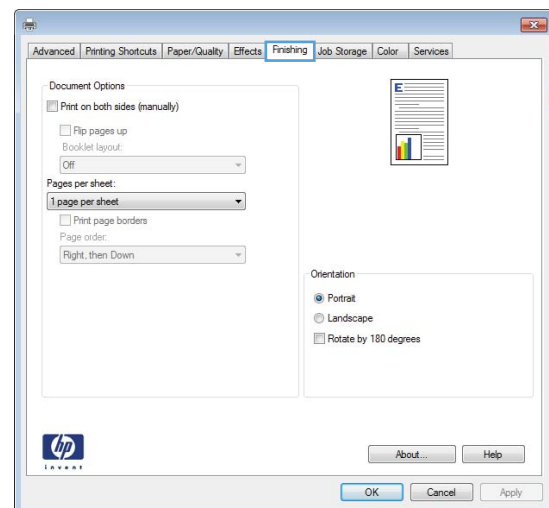


**NOTE:** Your print driver might look different than what is shown here, but the steps are the same.

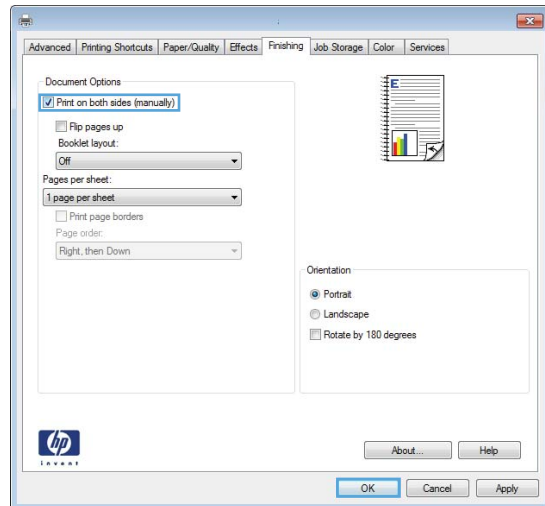
1. From the software program, select the **Print** option.
2. Select the product from the list of printers, and then select **Properties** or **Preferences** (the name varies for different software programs).



3. Click the **Finishing** tab.



4. Select the **Print on both sides** check box. Click the **OK** button to print the first side of the job.



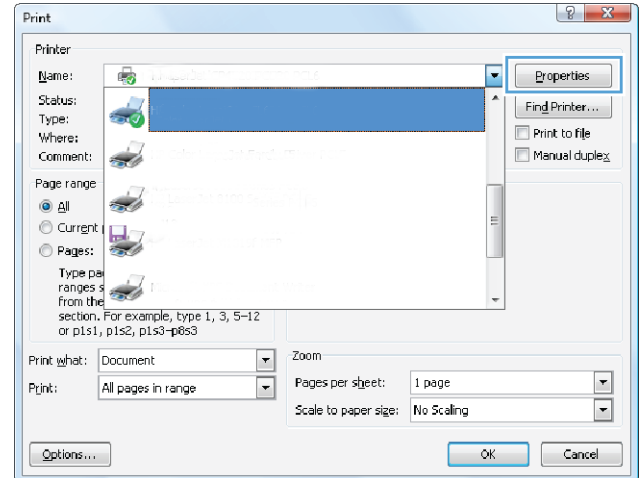
5. Retrieve the printed stack from the output bin, and then place it with the printed-side facing up in Tray 1.
6. If prompted, touch the appropriate control panel button to continue.

## Print multiple pages per sheet (Windows)

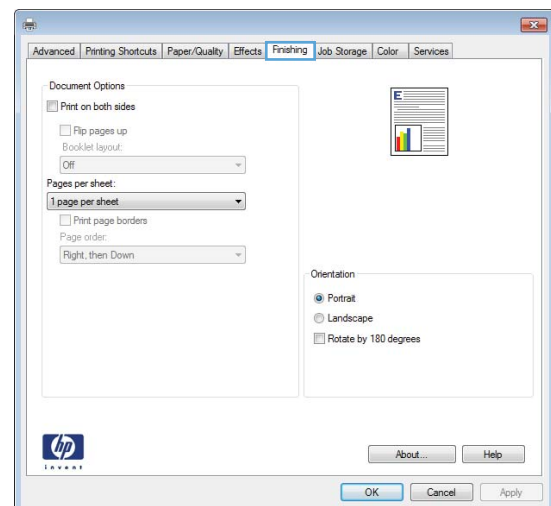


**NOTE:** Your print driver might look different than what is shown here, but the steps are the same.

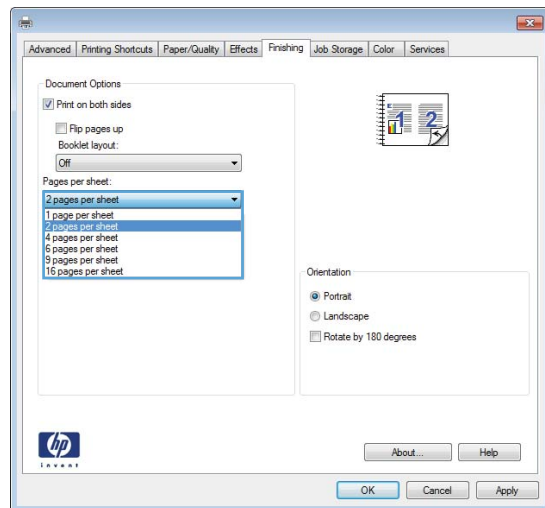
1. From the software program, select the **Print** option.
2. Select the product from the list of printers, and then select **Properties** or **Preferences** (the name varies for different software programs).



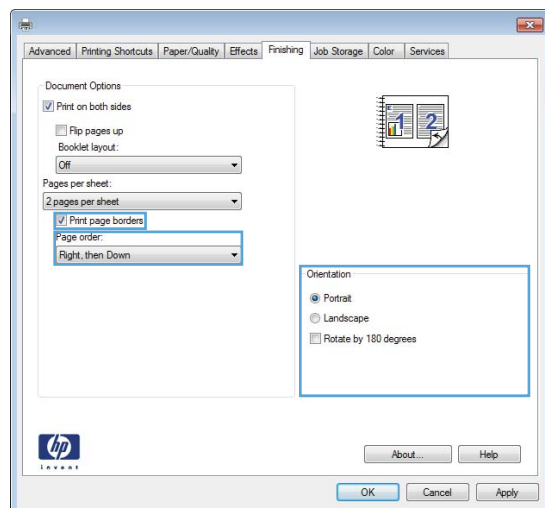
3. Click the **Finishing** tab.



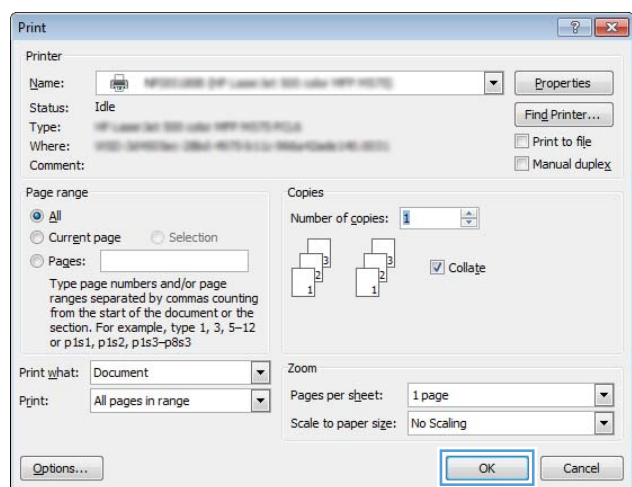
- 4. Select the number of pages per sheet from the **Pages per sheet** drop-down list.



- 5. Select the correct **Print page borders**, **Page order**, and **Orientation** options. Click the **OK** button to close the **Document Properties** dialog box.




- 6. In the **Print** dialog box, click the **OK** button to print the job.

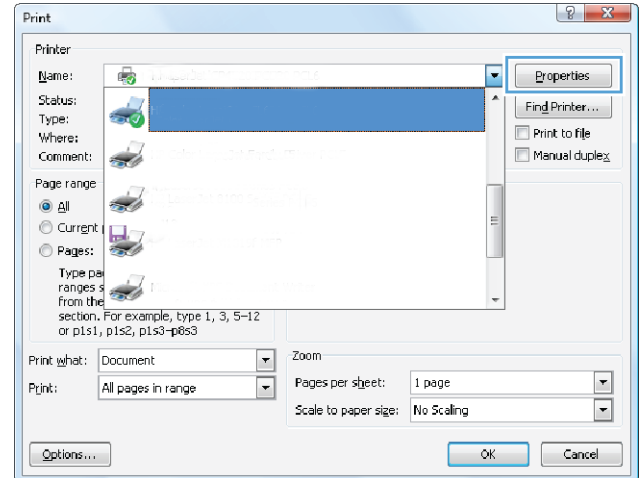




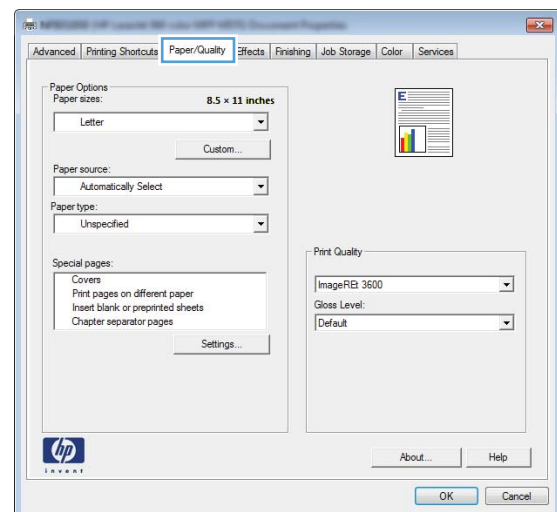
## Select the paper type (Windows)

 **NOTE:** Your print driver might look different than what is shown here, but the steps are the same.

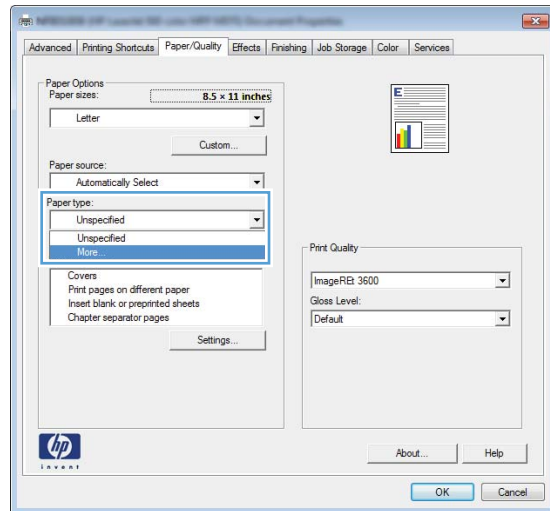
1. From the software program, select the **Print** option.
2. Select the product from the list of printers, and then select **Properties** or **Preferences** (the name varies for different software programs).



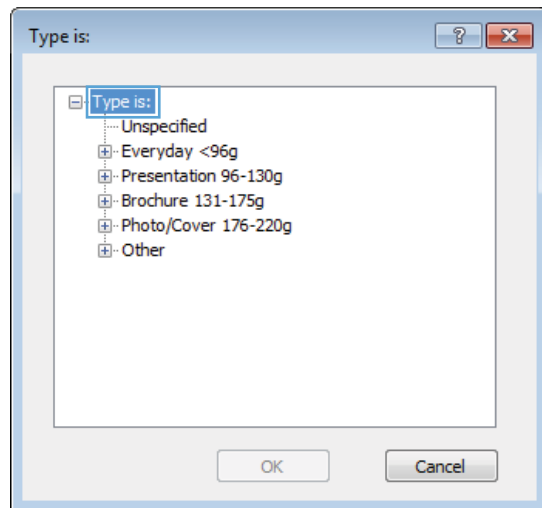
3. Click the **Paper/Quality** tab.



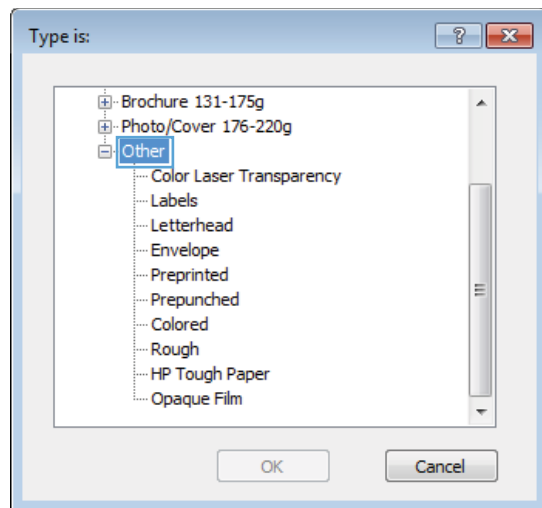
- 4. From the **Paper type** drop-down list, click the **More...** option.



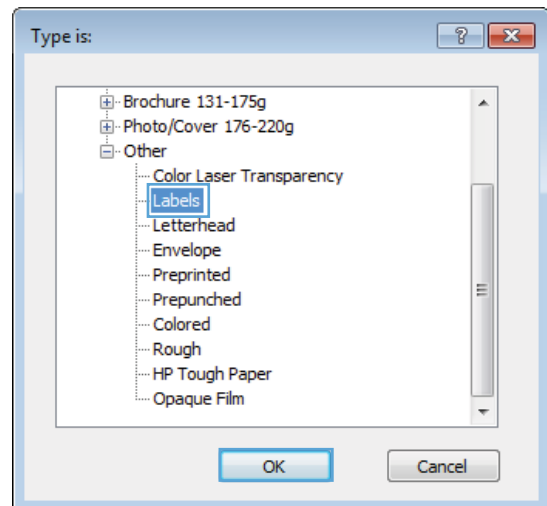
- 5. Expand the list of **Type is:** options.



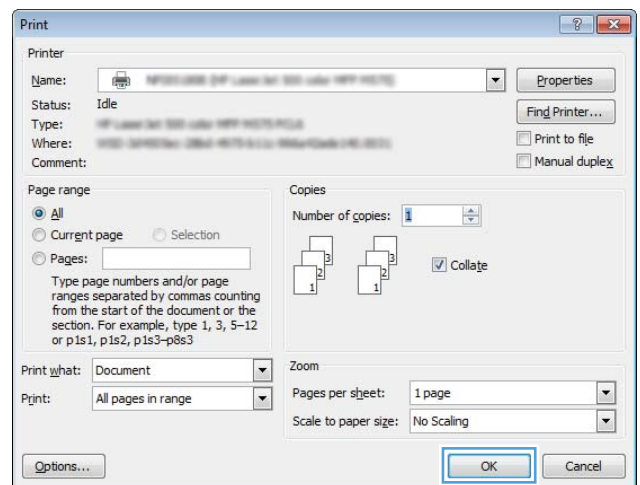
- 6. Expand the category of paper types that best describes your paper.



7. Select the option for the type of paper you are using, and then click the **OK** button.



8. Click the **OK** button to close the **Document Properties** dialog box. In the **Print** dialog box, click the **OK** button to print the job.



## Print tasks (Mac OS X)

### How to print (Mac OS X)

The following procedure describes the basic printing process for Mac OS X.

1. Click the **File** menu, and then click the **Print** option.
2. In the **Printer** menu, select the product.
3. Open the menus drop-down list or click **Show Details**, and then select other menus to adjust the print settings.
4. Click the **Print** button.

### Automatically print on both sides (Mac OS X)



---

**NOTE:** This feature is available if you install the HP print driver. It might not be available if you are using AirPrint.

---

1. Click the **File** menu, and then click the **Print** option.
2. In the **Printer** menu, select the product.
3. Open the menus drop-down list or click **Show Details**, and then click the **Layout** menu.
4. Select a binding option from the **Two-Sided** drop-down list.
5. Click the **Print** button.

### Manually print on both sides (Mac OS X)



---

**NOTE:** This feature is available if you install the HP print driver. It might not be available if you are using AirPrint.

---

1. Click the **File** menu, and then click the **Print** option.
2. In the **Printer** menu, select this product.
3. Open the menus drop-down list or click **Show Details**, and then click the **Manual Duplex** menu.
4. Click the **Manual Duplex** box, and select a binding option.
5. Click the **Print** button.
6. Go to the product, and remove any blank paper that is in Tray 1.
7. Retrieve the printed stack from the output bin and place it with the printed-side facing down in the input tray.
8. If prompted, touch the appropriate control panel button to continue.

### Print multiple pages per sheet (Mac OS X)

1. Click the **File** menu, and then click the **Print** option.
2. In the **Printer** menu, select the product.

3. Open the menus drop-down list or click **Show Details**, and then click the **Layout** menu.
4. From the **Pages per Sheet** drop-down list, select the number of pages that you want to print on each sheet.
5. In the **Layout Direction** area, select the order and placement of the pages on the sheet.
6. From the **Borders** menu, select the type of border to print around each page on the sheet.
7. Click the **Print** button.


### Select the paper type (Mac OS X)

1. Click the **File** menu, and then click the **Print** option.
2. In the **Printer** menu, select the product.
3. Open the menus drop-down list or click **Show Details**, and then click the **Finishing** menu.
4. Select a type from the **Media-type** drop-down list.
5. Click the **Print** button.

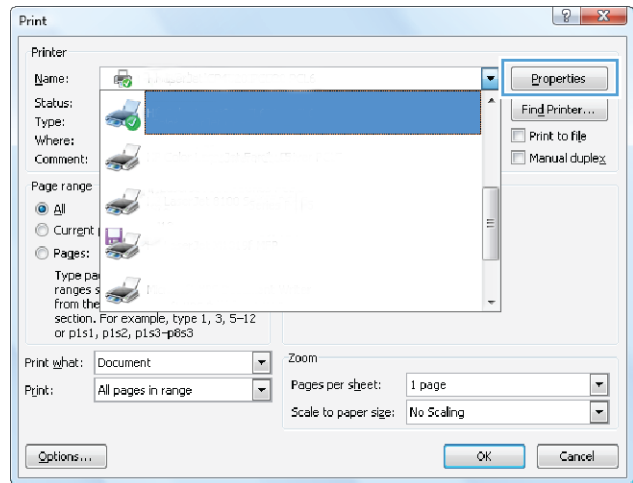
# Store print jobs on the product

## Create a stored job (Windows)

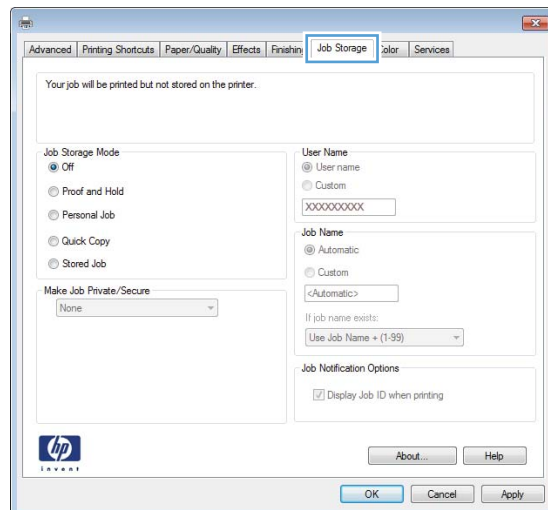
You can store jobs on the product so you can print them at any time.

 **NOTE:** Your print driver might look different than what is shown here, but the steps are the same.

1. From the software program, select the **Print** option.
2. Select the product from the list of printers, and then select **Properties** or **Preferences** (the name varies for different software programs).

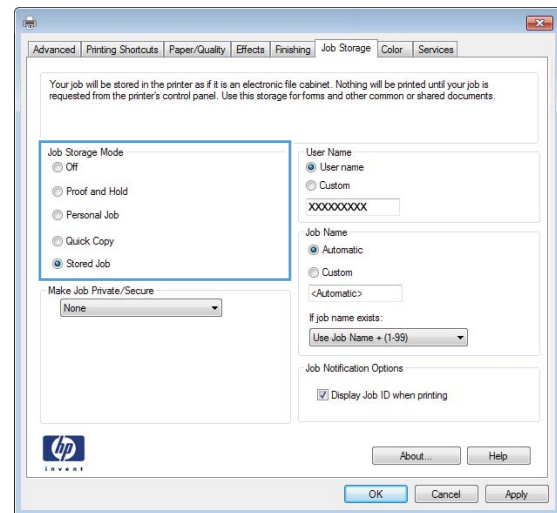


3. Click the **Job Storage** tab.



#### 4. Select a **Job Storage Mode** option.

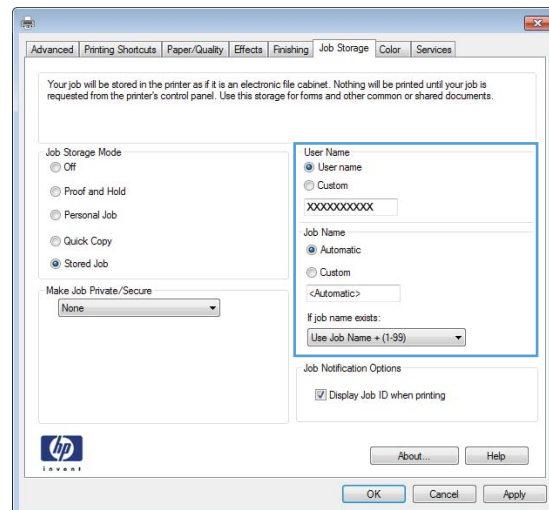
- **Proof and Hold:** Print and proof one copy of a job, and then print more copies.
- **Personal Job:** The job does not print until you request it at the product control panel. For this job-storage mode, you can select one of the **Make Job Private/Secure** options. If you assign a personal identification number (PIN) to the job, you must provide the required PIN at the control panel. If you encrypt the job, you must provide the required password at the control panel.
- **Quick Copy:** Print the requested number of copies of a job and store a copy of the job in the product memory so you can print it again later.
- **Stored Job:** Store a job on the product and allow other users to print the job at any time. For this job-storage mode, you can select one of the **Make Job Private/Secure** options. If you assign a personal identification number (PIN) to the job, the person who prints the job must provide the required PIN at the control panel. If you encrypt the job, the person who prints the job must provide the required password at the control panel.



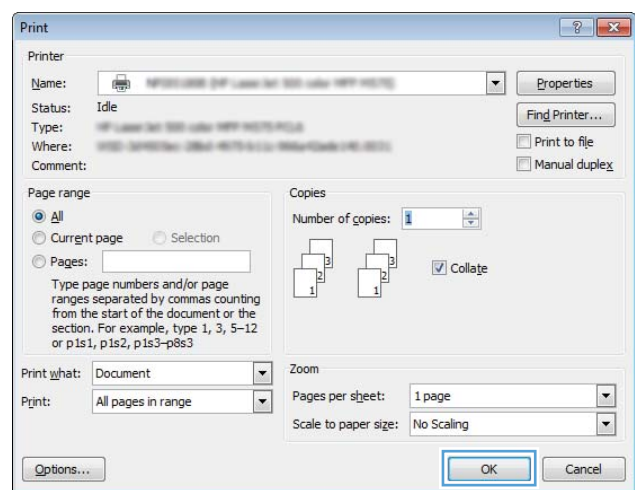
- To use a custom user name or job name, click the **Custom** button, and then enter the user name or the job name.

Select which option to use if another stored job already has that name:

- **Use Job Name + (1-99):** Append a unique number to the end of the job name.
- **Replace Existing File:** Overwrite the existing stored job with the new one.



- Click the **OK** button to close the **Document Properties** dialog box. In the **Print** dialog box, click the **OK** button to print the job.



## Create a stored job (Mac OS X)

You can store jobs on the product so you can print them at any time.

- Click the **File** menu, and then click the **Print** option.
- In the **Printer** menu, select the product.
- By default, the print driver displays the **Copies & Pages** menu. Open the menus drop-down list, and then click the **Job Storage** menu.
- In the **Mode** drop-down list, select the type of stored job.
  - **Proof and Hold:** Print and proof one copy of a job, and then print more copies.
  - **Personal Job:** The job does not print until you request it at the product control panel. If you assign a personal identification number (PIN) to the job, you must provide the required PIN at the control panel.




- **Quick Copy:** Print the requested number of copies of a job and store a copy of the job in the product memory so you can print it again later.
  - **Stored Job:** Store a job on the product and allow other users to print the job at any time. If you assign a personal identification number (PIN) to the job, the person who prints the job must provide the required PIN at the control panel.
5. To use a custom user name or job name, click the **Custom** button, and then enter the user name or the job name.

Select which option to use if another stored job already has that name.

    - **Use Job Name + (1-99):** Append a unique number to the end of the job name.
    - **Replace Existing File:** Overwrite the existing stored job with the new one.
  6. If you selected the **Stored Job** or **Personal Job** option in step 3, you can protect the job with a PIN. Type a 4-digit number in the **Use PIN to Print** field. When other people attempt to print this job, the product prompts them to enter this PIN number.
  7. Click the **Print** button to process the job.

## Print a stored job

Use the following procedure to print a job that is stored in the product memory.

1. From the Home screen on the product control panel, scroll to and touch the **Retrieve from Device Memory** button.
2. Select the name of the folder where the job is stored.
3. Select the name of the job. If the job is private or encrypted, enter the PIN or password.
4. Adjust the number of copies, and then touch the Start  button to print the job.

## Delete a stored job

When you send a stored job to the product memory, the product overwrites any previous jobs with the same user and job name. If a job is not already stored under the same user and job name, and the product needs additional space, the product might delete other stored jobs starting with the oldest. You can change the number of jobs that the product can store from the **General Settings** menu on the product control panel.

Use this procedure to delete a job that is stored in the product memory.

1. From the Home screen on the product control panel, scroll to and touch the **Retrieve from Device Memory** button.
2. Select the name of the folder where the job is stored.
3. Select the name of the job, and then touch the **Delete** button.
4. If the job is private or encrypted, enter the PIN or the password, and then touch the **Delete** button.

## Mobile printing

HP offers multiple Mobile and ePrint solutions to enable wireless printing to an HP printer from a laptop, tablet, smartphone, or other mobile device. To determine the best choice, go to [www.hp.com/go/LaserJetMobilePrinting](http://www.hp.com/go/LaserJetMobilePrinting) (English only).

## HP Wireless Direct printing

HP provides HP Wireless Direct and NFC (Near Field Communication) printing for printers with the HP Jetdirect 2800w NFC & Wireless Direct Accessory (part number: J8029-90901) as well as certain other HP LaserJet printers (check the printer's documentation). See [www.hp.com/go/jd2800wSupport](http://www.hp.com/go/jd2800wSupport) for more information on the HP Jetdirect 2800w NFC & Wireless Direct Accessory.

HP Wireless Direct printing enables printing from a wireless mobile device directly to an HP Wireless Direct-enabled printer without requiring a connection to a network or the Internet.

Use HP Wireless Direct to print wirelessly from the following devices:

- iPhone, iPad, or iPod touch using Apple AirPrint or the HP ePrint App
- Android mobile devices using the HP ePrint App or the Android embedded print solution
- Symbian mobile devices using the HP ePrint Home & Biz App
- PC and Mac devices using the HP ePrint Software

For more information on HP Wireless Direct printing, go to [www.hp.com/go/wirelessprinting](http://www.hp.com/go/wirelessprinting) and click **HP wireless direct** on the left navigation bar.

## HP ePrint via email

Use HP ePrint to print documents by sending them as an email attachment to the product's email address from any email enabled device.




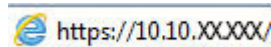
**NOTE:** The product might require a firmware update to use this feature.

To use HP ePrint, the product must meet these requirements:

- The product must be connected to a wired or wireless network and have Internet access.
- HP Web Services must be enabled on the product, and the product must be registered with HP Connected.

Follow this procedure to enable HP Web Services and register with HP Connected:

1. Open the HP Embedded Web Server (EWS):
  - a. From the Home screen on the product control panel, touch the Network  button to display the IP address or host name.
  - b. Open a Web browser, and in the address line, type the IP address or host name exactly as it displays on the product control panel. Press the **Enter** key on the computer keyboard. The EWS opens.

A screenshot of a web browser address bar. The address bar contains the text "https://10.10.XX.XXX/" with a blue underline. To the left of the text is a small icon of a globe with a blue and yellow border.

2. Click the **HP Web Services** tab.

3. Select the option to enable Web Services.

---

 **NOTE:** Enabling Web Services might take several minutes.

---

4. Go to [www.hpconnected.com](http://www.hpconnected.com) to create an HP ePrint account and complete the setup process.

## HP ePrint software

The HP ePrint software makes it easy to print from a Windows or Mac desktop or laptop computer to any HP ePrint-capable product. This software makes it easy to find HP ePrint-enabled products that are registered to your HP Connected account. The target HP printer can be located in the office or at locations across the globe.

- **Windows:** After installing the software, open the **Print** option from within your application, and then select **HP ePrint** from the installed printers list. Click the **Properties** button to configure print options.
- **Mac:** After installing the software, select **File, Print**, and then select the arrow next to **PDF** (in the bottom left of the driver screen). Select **HP ePrint**.

For Windows, the HP ePrint software supports TCP/IP printing to local network printers on the network (LAN or WAN) to products that support UPD PostScript®.

Windows and Mac both support IPP printing to LAN or WAN network-connected products that support ePCL.


Windows and Mac also both support printing PDF documents to public print locations and printing using HP ePrint via email through the cloud.

Go to [www.hp.com/go/eprintsoftware](http://www.hp.com/go/eprintsoftware) for drivers and information.

---

 **NOTE:** The HP ePrint software is a PDF workflow utility for Mac, and is not technically a print driver.

---

 **NOTE:** HP ePrint Software does not support USB printing.

---

## AirPrint

Direct printing using Apple's AirPrint is supported for iOS 4.2 or later. Use AirPrint to print directly to the product from an iPad, iPhone (3GS or later), or iPod touch (third generation or later) in the following applications:

- Mail
- Photos
- Safari
- iBooks
- Select third-party applications

To use AirPrint, the product must be connected to the same wireless network as the Apple device. For more information about using AirPrint and about which HP products are compatible with AirPrint, go to [www.hp.com/go/airprint](http://www.hp.com/go/airprint).



**NOTE:** AirPrint does not support USB connections.

---

## Print from the USB port

This product features easy-access USB printing, so you can quickly print files without sending them from a computer. The product accepts standard USB flash drives in the USB port on the front of the product. You can print the following types of files:

- .pdf
- .prn
- .pcl
- .ps
- .cht

### Enable the USB port for printing

Before you can use this feature, you must enable the USB port. Use the following procedure to enable the port from the product control-panel menus:

1. From the Home screen on the product control panel, scroll to and touch the [Administration](#) button.
2. Open the following menus:
  - [General Settings](#)
  - [Enable Retrieve from USB](#)
3. Select the [Enable](#) option, and then touch the [Save](#) button.

### Print USB documents


1. Insert the USB flash drive into the easy-access USB port.


---

 **NOTE:** You might need to remove the cover from the USB port. Pull the cover straight out to remove it.

2. The product detects the USB flash drive. Touch the [OK](#) button to access the drive, or, if prompted, select the [Retrieve from USB](#) option from the list of available applications. The [Retrieve from USB](#) screen opens.
3. Select the name of the document that you want to print.

---

 **NOTE:** The document might be in a folder. Open folders as necessary.

4. To adjust the number of copies, touch the [Copies](#) field, and then use the keypad to select the number of copies.
5. Touch the Start  button to print the document.



---

## 5 Manage the product

- [HP Embedded Web Server](#)
- [HP Utility for Mac OS X](#)
- [HP Web Jetadmin](#)
- [Economy settings](#)
- [Product security features](#)
- [Software and firmware updates](#)

### For more information:

In the US, go to [www.hp.com/support/colorljM855](http://www.hp.com/support/colorljM855).

Outside the US, go to [www.hp.com/support](http://www.hp.com/support). Select your country/region. Click **Product Support & Troubleshooting**. Enter the product name, and then select **Search**.

HP's all-inclusive help for your product includes the following information:

- Install and configure
- Learn and use
- Solve problems
- Download software updates
- Join support forums
- Find warranty and regulatory information

## HP Embedded Web Server

Use the HP Embedded Web Server to manage printing functions from your computer instead of the product control panel.

- View product status information
- Determine the remaining life for all supplies and order new ones
- View and change tray configurations
- View and change the product control-panel menu configuration
- View and print internal pages
- Receive notification of product and supplies events
- View and change network configuration

The HP Embedded Web Server works when the product is connected to an IP-based network. The HP Embedded Web Server does not support IPX-based product connections. You do not have to have Internet access to open and use the HP Embedded Web Server.

When the product is connected to the network, the HP Embedded Web Server is automatically available.




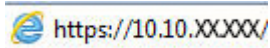
---

**NOTE:** The HP Embedded Web Server is not accessible beyond the network firewall.

---

### How to access the HP Embedded Web Server (EWS)

1. From the Home screen on the product control panel, touch the Network  button to display the IP address or host name.
2. Open a Web browser, and in the address line, type the IP address or host name exactly as it displays on the product control panel. Press the **Enter** key on the computer keyboard. The EWS opens.

A screenshot of a web browser address bar showing the URL <https://10.10.XX.XXX/>. The address bar has a blue border and a small globe icon on the left.

To use the HP Embedded Web Server, your browser must meet the following requirements:

- Windows: Microsoft Internet Explorer 5.01 or later or Netscape 6.2 or later
- Mac OS X: Safari or Firefox using Bonjour or an IP address
- Linux: Netscape Navigator only
- HP-UX 10 and HP-UX 11: Netscape Navigator 4.7



# HP Utility for Mac OS X


Use the HP Utility for Mac OS X to check product status or to view or change product settings from your computer.

You can use the HP Utility when the product is connected with a USB cable or is connected to a TCP/IP-based network.

## Open HP Utility

From the Finder, click **Applications**, click **HP**, and then click **HP Utility**.

If HP Utility is not included in the **Utilities** list, use the following procedure to open it:

1. At the computer, open the Apple  menu, click the **System Preferences** menu, and then click the **Print & Fax** icon or the **Print & Scan** icon.
2. Select the product in the left side of the window.
3. Click the **Options & Supplies** button.
4. Click the **Utility** tab.
5. Click the **Open Printer Utility** button.

## HP Utility features

The HP Utility toolbar is at the top of every page. It includes these items:

- **Devices:** Click this button to show or hide Mac products found by the HP Utility in the **Printers** pane at the left side of the screen.
- **All Settings:** Click this button to return to the HP Utility main page.
- **Applications:** Click this button to manage which HP tools or utilities appear in the Dock.
- **HP Support:** Click this button to open a browser and go to the HP support Web site for the product.
- **Supplies:** Click this button to open the HP SureSupply Web site.
- **Registration:** Click this button to open the HP registration Web site.
- **Recycling:** Click this button to open the HP Planet Partners Recycling Program Web site.

HP Utility consists of pages that you open by clicking in the **All Settings** list. The following table describes the tasks that you can perform with HP Utility.

| Menu                           | Item                      | Description  |
|--------------------------------|---------------------------|--|
| <b>Information and Support</b> | <b>Supplies Status</b>    | Shows the product supplies status and provides links for ordering supplies online. |
|                                | <b>Device Information</b> | Shows information about the currently selected product.                            |
|                                | <b>File Upload</b>        | Transfers files from the computer to the product.                                  |
|                                | <b>Upload Fonts</b>       | Transfers font files from the computer to the product.                             |
|                                | <b>HP Connected</b>       | Accesses the HP Connected Web site.  |

| Menu                    | Item                        | Description  |
|-------------------------|-----------------------------|--|
|                         | <b>Update Firmware</b>      | Transfers a firmware update file to the product.<br><br><b>NOTE:</b> This option is available only after you open the <b>View</b> menu and select the <b>Show Advanced Options</b> item.                               |
|                         | <b>Commands</b>             | Sends special characters or print commands to the product after the print job.<br><br><b>NOTE:</b> This option is available only after you open the <b>View</b> menu and select the <b>Show Advanced Options</b> item. |
| <b>Printer Settings</b> | <b>Supplies Management</b>  | Configures how the product should behave when supplies are nearing the end of their estimated life.  |
|                         | <b>Trays Configuration</b>  | Changes the default tray settings.   |
|                         | <b>Output Devices</b>       | Manages settings for optional output accessories.  |
|                         | <b>Duplex Mode</b>          | Turns on the automatic two-sided printing mode.  |
|                         | <b>Protect Direct Ports</b> | Disables printing over USB or parallel ports.  |
|                         | <b>Stored Jobs</b>          | Manages print jobs that are stored on the product hard disk.   |
|                         | <b>Network Settings</b>     | Configures the network settings, such as the IPv4 and IPv6 settings.   |
|                         | <b>Additional Settings</b>  | Provides access to the HP Embedded Web Server.   |

## HP Web Jetadmin

HP Web Jetadmin is an award-winning, industry-leading tool for efficiently managing a wide variety of networked HP products, including printers, multifunction products, and digital senders. This single solution allows you to remotely install, monitor, maintain, troubleshoot, and secure your printing and imaging environment — ultimately increasing business productivity by helping you save time, control costs, and protect your investment.

HP Web Jetadmin upgrades are periodically made available to provide support for specific product features. Go to [www.hp.com/go/webjetadmin](http://www.hp.com/go/webjetadmin) and click the **Self Help and Documentation** link to learn more about upgrades.

## Economy settings

- [Optimize speed or energy usage](#)
- [Set Sleep mode](#)
- [Set the Sleep Schedule](#)

### Optimize speed or energy usage

By default the product stays warm between jobs to optimize speed and print the first page of jobs faster. To conserve energy, set the product to cool between jobs. The product has four incremental settings to optimize for speed or energy usage.

1. From the Home screen on the product control panel, scroll to and touch the [Administration](#) button.
2. Open the following menus:
  - [General Settings](#)
  - [Energy Settings](#)
  - [Optimum Speed/Energy Usage](#)
3. Select the option that you want to use, and then touch the [Save](#) button.

### Set Sleep mode

1. From the Home screen on the product control panel, scroll to and touch the [Administration](#) button.
2. Open the following menus:
  - [General Settings](#)
  - [Energy Settings](#)
  - [Sleep Timer Settings](#)
3. Touch [Sleep/Auto Off After](#) to select the option.
4. Select the appropriate time period, and then touch the [Save](#) button.

### Set the Sleep Schedule




---

**NOTE:** You must configure the date and time settings before you can use the [Sleep Schedule](#) feature.

---

1. From the Home screen on the product control panel, scroll to and touch the [Administration](#) button.
2. Open the following menus:
  - [General Settings](#)
  - [Date/Time Settings](#)
3. Open the [Date/Time Format](#) menu and configure the following settings:
  - [Date Format](#)
  - [Time Format](#)

4. Touch the [Save](#) button.
5. Open the [Date/Time](#) menu and configure the following settings:
  - [Date/Time](#)
  - [Time Zone](#)

If you are in an area that uses daylight savings time, select the [Adjust for Daylight Savings](#) box.
6. Touch the [Save](#) button.
7. Touch the back-arrow button to return to the [Administration](#) screen.
8. Open the following menus:
  - [General Settings](#)
  - [Energy Settings](#)
  - [Sleep Schedule](#)
9. Touch the Add  button, and then select the type of event to schedule: [Wake](#) or [Sleep](#).
10. Configure the following settings:
  - [Time](#)
  - [Event Days](#)
11. Touch the [OK](#) button, and then touch the [Save](#) button.

# Product security features

- [Security statements](#)
- [IP Security](#)
- [Sign in to the product](#)
- [Assign a system password](#)
- [Encryption support: HP High Performance Secure Hard Disks](#)

## Security statements

The product supports security standards and recommended protocols that help you keep the product secure, protect critical information on your network, and simplify the way you monitor and maintain the product.

For in-depth information about HP's secure imaging and printing solutions, visit [www.hp.com/go/secureprinting](http://www.hp.com/go/secureprinting). The site provides links to white papers and FAQ documents about security features.

## IP Security

IP Security (IPsec) is a set of protocols that control IP-based network traffic to and from the product. IPsec provides host-to-host authentication, data integrity, and encryption of network communications.

For products that are connected to the network and have an HP Jetdirect print server, you can configure IPsec by using the **Networking** tab in the HP Embedded Web Server.

## Sign in to the product

Some features on the product control panel can be secured so that unauthorized people cannot use them. When a feature is secured, the product prompts you to sign in before you can use it. You can also sign in without waiting for a prompt by touching the [Sign In](#) button on the Home screen.

Typically, you use the same user name and password that you use to sign in to your computer on the network. Consult the network administrator for this product if you have questions about which credentials to use.

After you have signed in to the product, a [Sign Out](#) button displays on the control panel. To maintain security for the product, touch the [Sign Out](#) button when you have finished using the product.

## Assign a system password

Assign an administrator password for access to the product and the HP Embedded Web Server so that unauthorized users cannot change the product settings.

1. Open the HP Embedded Web Server by entering the product IP address into the address line of a Web browser.
2. Click the **Security** tab.
3. Open the **General Security** menu.
4. In the **Username** field, enter the name to associate with the password.
5. Enter the password in the **New Password** field, and then enter it again in the **Verify Password** field.



---

**NOTE:** If you are changing an existing password, you must first enter the existing password in the **Old Password** field.

---

6. Click the **Apply** button. Make note of the password and store it in a safe place.

## Encryption support: HP High Performance Secure Hard Disks

The hard disk provides hardware-based encryption so you can securely store sensitive data without impacting product performance. This hard disk uses the latest Advanced Encryption Standard (AES) and has versatile time-saving features and robust functionality.

Use the **Security** menu in the HP Embedded Web Server to configure the disk.

## Software and firmware updates

HP regularly updates features that are available in the product firmware. To take advantage of the most current features, update the product firmware. Download the most recent firmware update file from the Web:

In the US, go to [www.hp.com/support/colorljM855](http://www.hp.com/support/colorljM855). Click **Drivers & Software**.

Outside the US, follow these steps:

1. Go to [www.hp.com/support](http://www.hp.com/support).
2. Select your country/region.
3. Click **Drivers & Software**.
4. Enter the product name (HP Color LaserJet Enterprise M855), and then select **Search**.



---

## 6 Solve problems

- [Restore factory-set defaults](#)
- [Control panel help system](#)
- [A “Cartridge is low” or “Cartridge is very low” message displays on the product control panel](#)
- [Product does not pick up paper or misfeeds](#)
- [Clear jams](#)
- [Improve print quality](#)
- [Solve wired network problems](#)

### For more information:

In the US, go to [www.hp.com/support/colorljM855](http://www.hp.com/support/colorljM855).

Outside the US, go to [www.hp.com/support](http://www.hp.com/support). Select your country/region. Click **Product Support & Troubleshooting**. Enter the product name, and then select **Search**.

HP's all-inclusive help for your product includes the following information:

- Install and configure
- Learn and use
- Solve problems
- Download software updates
- Join support forums
- Find warranty and regulatory information


## Restore factory-set defaults

1. From the Home screen on the product control panel, scroll to and touch the [Administration](#) button.
2. Open the following menus:
  - [General Settings](#)
  - [Restore Factory Settings](#)
3. A verification message advises that completing the reset function might result in loss of data. Touch the [Reset](#) button to complete the process.



**NOTE:** The product restarts automatically after the reset operation completes.


## Control panel help system

The product has a built-in Help system that explains how to use each screen. To open the Help system, touch the Help  button in the upper-right corner of the screen.

For some screens, the Help opens to a global menu where you can search for specific topics. You can browse through the menu structure by touching the buttons in the menu.

Some Help screens include animations that guide you through procedures, such as clearing jams.

For screens that contain settings for individual jobs, the Help opens to a topic that explains the options for that screen.

If the product alerts you of an error or warning, touch the Help  button to open a message that describes the problem. The message also contains instructions to help solve the problem.

## A “Cartridge is low” or “Cartridge is very low” message displays on the product control panel

**Cartridge is low:** The product indicates when a toner cartridge level is low. Actual toner cartridge life remaining may vary. Consider having a replacement available to install when print quality is no longer acceptable. The toner cartridge does not need to be replaced now.

**Cartridge is very low:** The product indicates when the toner cartridge level is very low. Actual toner cartridge life remaining may vary. Consider having a replacement available to install when print quality is no longer acceptable. The toner cartridge does not need to be replaced now unless the print quality is no longer acceptable.

Once an HP toner cartridge has reached **Very Low**, HP’s Premium Protection Warranty on that toner cartridge has ended.

### Change the “Very Low” settings

You can change the way the product reacts when supplies reach the Very Low state. You do not have to re-establish these settings when you install a new toner cartridge.

1. From the Home screen on the product control panel, scroll to and touch [Supplies](#).
2. Open the following menus:
  - [Manage Supplies](#)
  - [Supply Settings](#)
  - [Black Cartridge](#) or [Color Cartridges](#)
  - [Very Low Settings](#)
3. Select one of the following options:
  - Select the [Stop](#) option to set the product to stop printing when the cartridge reaches the **Very Low** threshold.
  - Select the [Prompt to continue](#) option to set the product to stop printing when the cartridge reaches the **Very Low** threshold. You can acknowledge the prompt or replace the cartridge to resume printing.
  - Select the [Continue](#) option to set the product to alert you that the cartridge is very low, and to continue printing beyond the **Very Low** setting without interaction. This can result in unsatisfactory print quality.

### For products with fax capability

When the product is set to the [Stop](#) or [Prompt to continue](#) option, there is some risk that faxes will not print when the product resumes printing. This can occur if the product has received more faxes than the memory can hold while the product is waiting.

The product can print faxes without interruption when it passes the Very Low threshold if you select the [Continue](#) option for the toner cartridge, but print quality might degrade.

## Order supplies

---

|  |  |
|--|--|
| Order supplies and paper                     | <a href="http://www.hp.com/go/suresupply">www.hp.com/go/suresupply</a>   |
| Order through service or support providers   | Contact an HP-authorized service or support provider.  |
| Order using the HP Embedded Web Server (EWS) | To access, in a supported Web browser on your computer, enter the product IP address or host name in the address/URL field. The EWS contains a link to the HP SureSupply Web site, which provides options for purchasing Original HP supplies. |

---

## Product does not pick up paper or misfeeds

- [The product does not pick up paper](#)
- [The product picks up multiple sheets of paper](#)
- [The document feeder jams, skews, or picks up multiple sheets of paper](#)

### The product does not pick up paper

If the product does not pick up paper from the tray, try these solutions.

1. Open the product and remove any jammed sheets of paper.
2. Load the tray with the correct size of paper for your job.
3. Make sure the paper size and type are set correctly on the product control panel.
4. Make sure the paper guides in the tray are adjusted correctly for the size of paper. Adjust the guides to the appropriate indentation in the tray.
5. Check the product control panel to see if the product is waiting for you to acknowledge a prompt to feed the paper manually. Load paper, and continue.
6. The rollers above the tray might be contaminated. Clean the rollers with a lint-free cloth dampened with warm water.

### The product picks up multiple sheets of paper

If the product picks up multiple sheets of paper from the tray, try these solutions.

1. Remove the stack of paper from the tray and flex it, rotate it 180 degrees, and flip it over. *Do not fan the paper.* Return the stack of paper to the tray.
2. Use only paper that meets HP specifications for this product.
3. Use paper that is not wrinkled, folded, or damaged. If necessary, use paper from a different package.
4. Make sure the tray is not overfilled. If it is, remove the entire stack of paper from the tray, straighten the stack, and then return some of the paper to the tray.
5. Make sure the paper guides in the tray are adjusted correctly for the size of paper. Adjust the guides to the appropriate indentation in the tray.
6. Make sure the printing environment is within recommended specifications.

### The document feeder jams, skews, or picks up multiple sheets of paper



**NOTE:** This information applies to MFP products only.

- The original might have something on it, such as staples or self-adhesive notes, that must be removed.
- Check that all rollers are in place and that the roller-access cover inside the document feeder is closed.
- Make sure that the top document-feeder cover is closed.
- The pages might not be placed correctly. Straighten the pages and adjust the paper guides to center the stack.

- The paper guides must be touching the sides of the paper stack to work correctly. Make sure that the paper stack is straight and the guides are against the paper stack.
- The document feeder input tray or output bin might contain more than the maximum number of pages. Make sure the paper stack fits below the guides in the input tray, and remove pages from the output bin.
- Verify that there are no pieces of paper, staples, paper clips, or other debris in the paper path.
- Clean the document-feeder rollers and the separation pad. Use compressed air or a clean, lint-free cloth moistened with warm water. If misfeeds still occur, replace the rollers.
- From the Home screen on the product control panel, scroll to and touch the [Supplies](#) button. Check the status of the document-feeder kit, and replace it if necessary.

# Clear jams

## Auto-navigation for clearing jams

The auto-navigation feature assists you in clearing jams by providing step-by-step instructions on the control panel. When you complete a step, the product displays instructions for the next step until you have completed all steps in the procedure.

## Experiencing frequent or recurring paper jams?

To reduce the number of paper jams, try these solutions.

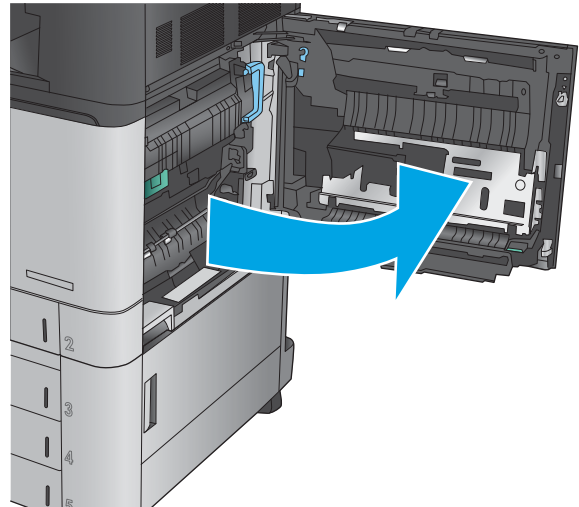
1. Use only paper that meets HP specifications for this product.
2. Use paper that is not wrinkled, folded, or damaged. If necessary, use paper from a different package.
3. Use paper that has not previously been printed or copied on.
4. Make sure the tray is not overfilled. If it is, remove the entire stack of paper from the tray, straighten the stack, and then return some of the paper to the tray.
5. Make sure the paper guides in the tray are adjusted correctly for the size of paper. Adjust the guides so they are touching the paper stack without bending it.
6. Make sure that the tray is fully inserted in the product.
7. If you are printing on heavy, embossed, or perforated paper, use the manual feed feature and feed sheets one at a time.
8. From the Home screen on the product control panel, scroll to and touch the [Trays](#) button. Verify that the tray is configured correctly for the paper type and size.
9. Make sure the printing environment is within recommended specifications.



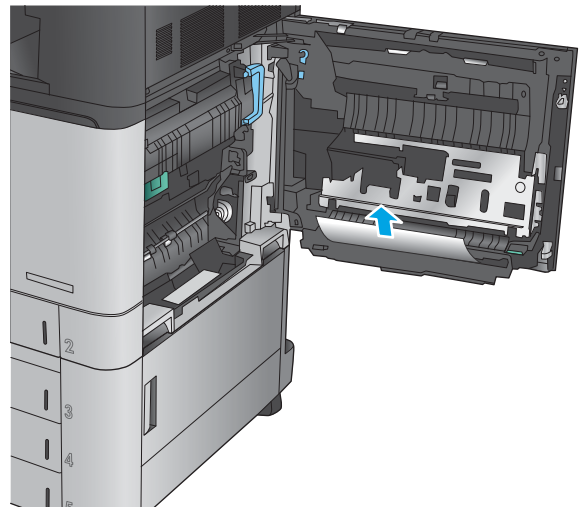
## Clear jams in Tray 1, the right door, and the fuser

Clear jams in Tray 1, the right door, and the fuser by opening the right door of the product. Use the following procedure to check for paper in all possible jam locations inside the right door. When a jam occurs, the control panel displays an animation that assists in clearing the jam.

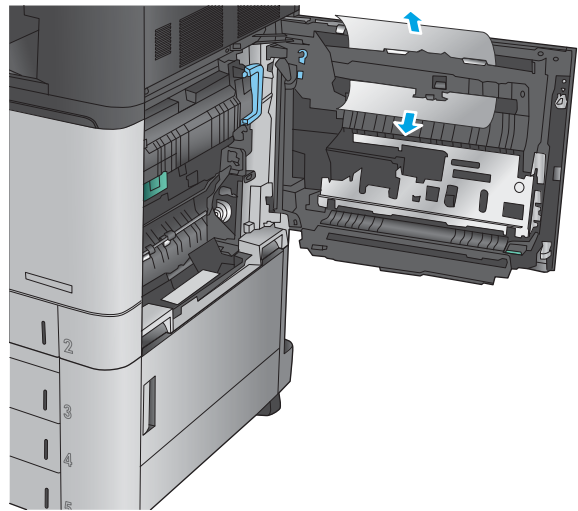
1. Open the right door.



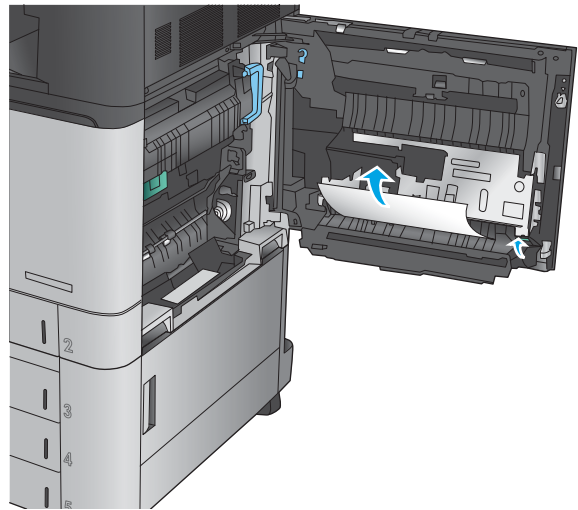
2. If paper is jammed in Tray 1, gently pull the paper from the bottom of the right door.



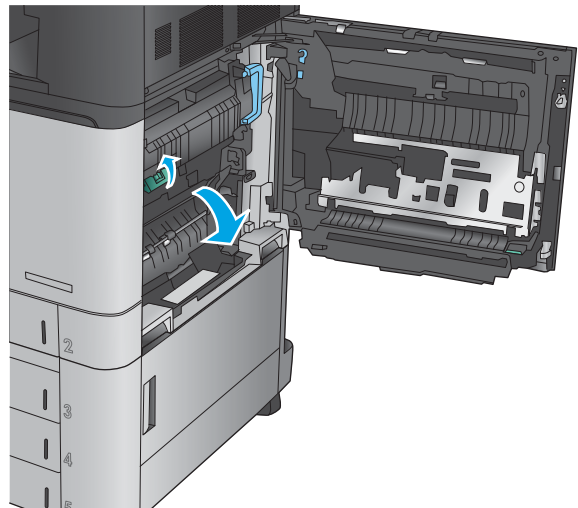
3. Check for paper in the duplex-printing path inside the right door. If paper is near the top of the duplex-printing path, gently pull it out to remove it.



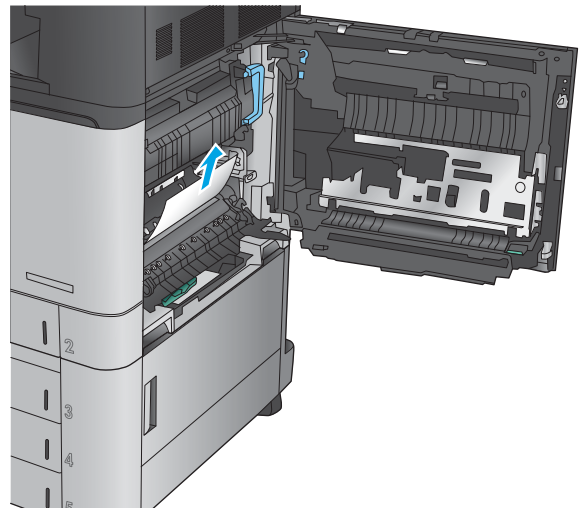
4. Lift the jam-access cover at the bottom of the duplex printing path, and remove any jammed paper.



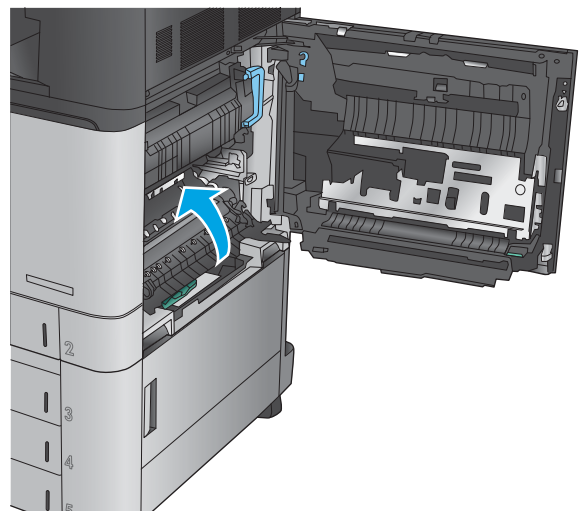
5. Lift the green handle on the transfer-access panel and open the panel.



6. Gently pull out any jammed paper.

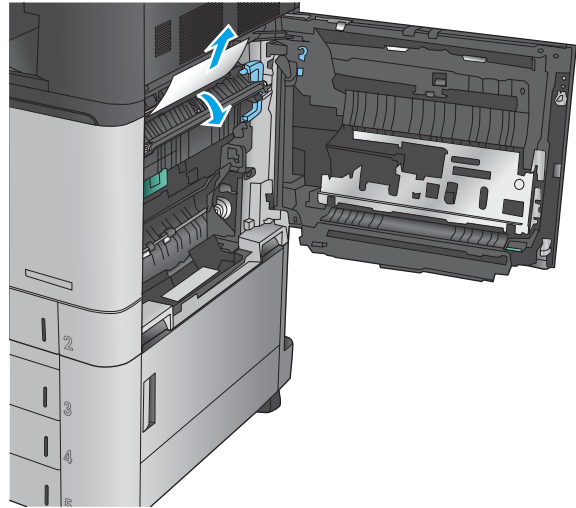


7. Close the transfer-access panel.

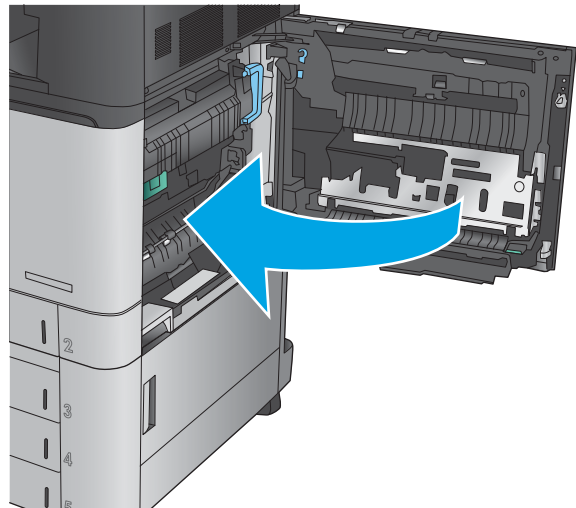


8. If paper is jammed in the fuser, lift the jam-access cover on top of the fuser, and gently pull out the paper.

**WARNING!** The fuser can be hot while the product is in use.



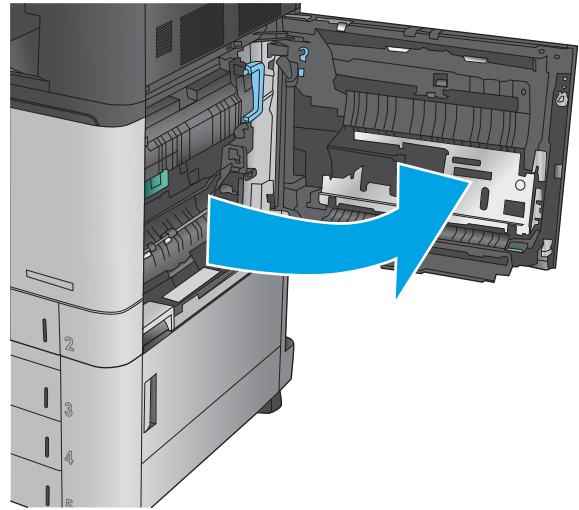
9. Close the right door.



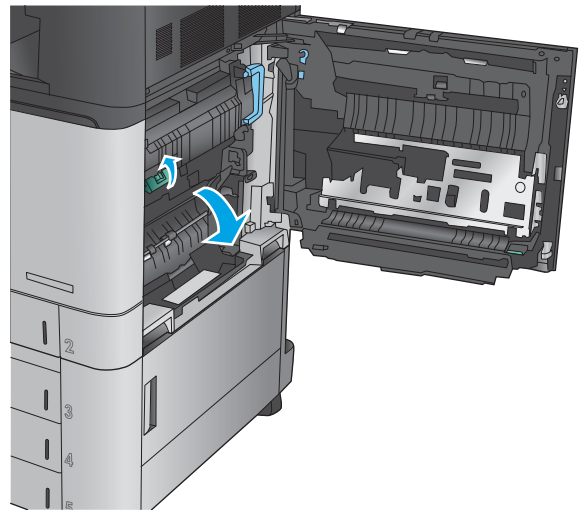
## Clear jams in Tray 2

Use the following procedure to check for paper in all possible jam locations related to Tray 2. When a jam occurs, the control panel displays an animation that assists in clearing the jam.

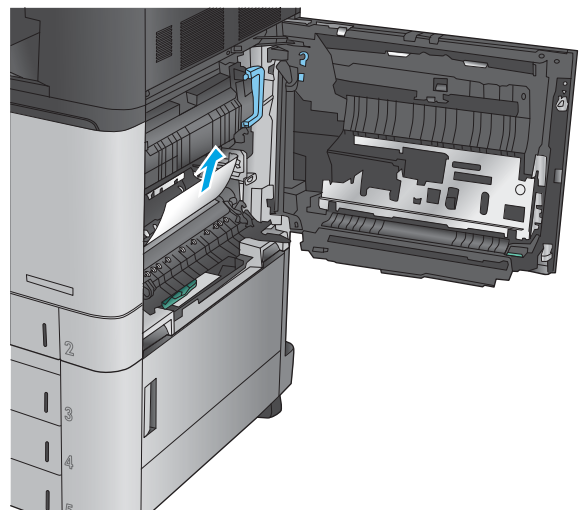
1. Open the right door.



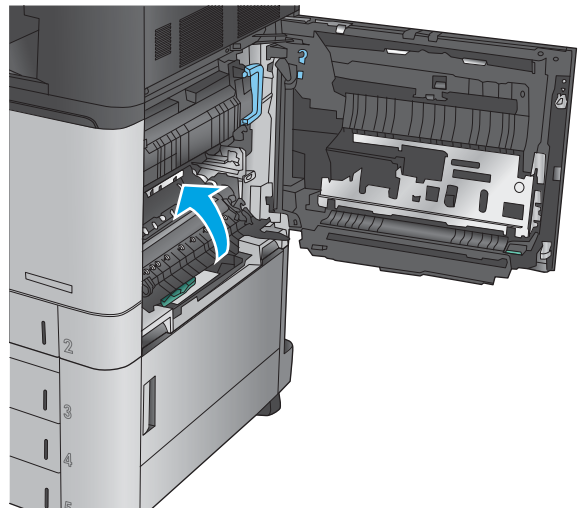
2. Lift the green handle on the transfer-access panel and open the panel.



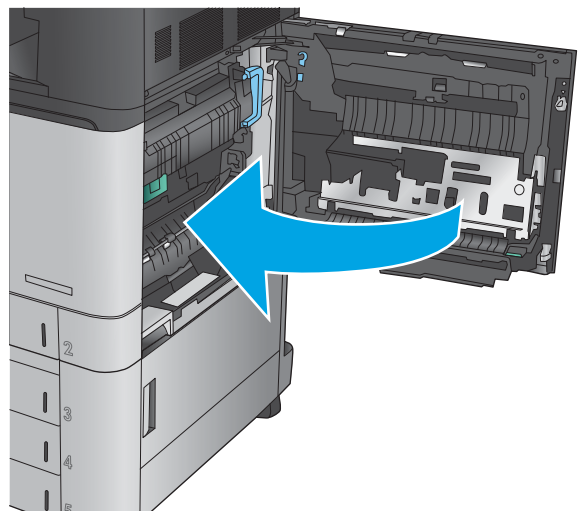
3. Gently pull out any jammed paper.



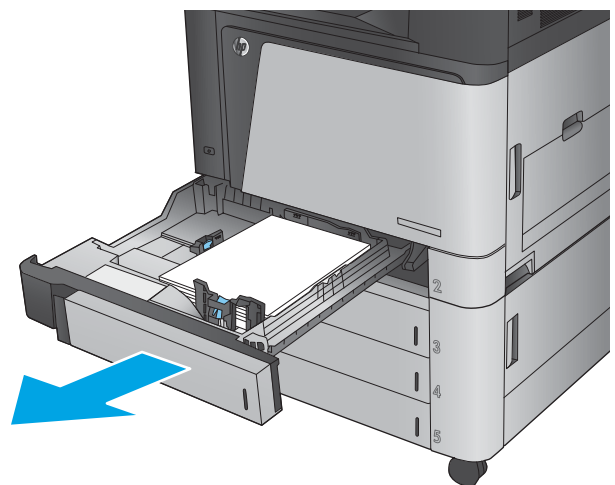
4. Close the transfer-access panel.



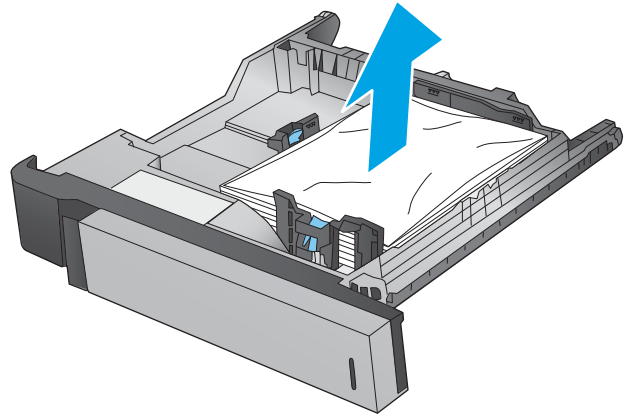
5. Close the right door.



6. Pull the tray completely out of the product by pulling and lifting it up slightly.



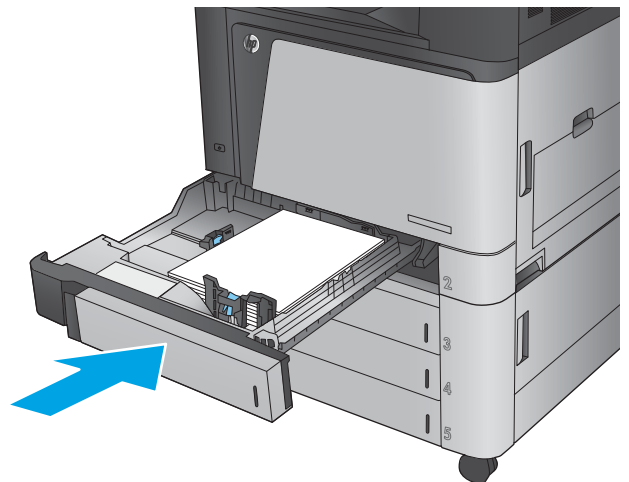
7. Remove any jammed or damaged sheets of paper.



8. Remove any paper from the feed rollers inside the product.



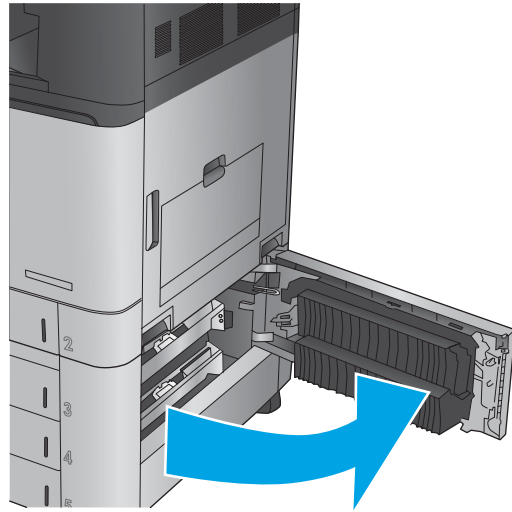
9. Reinsert and close the tray.



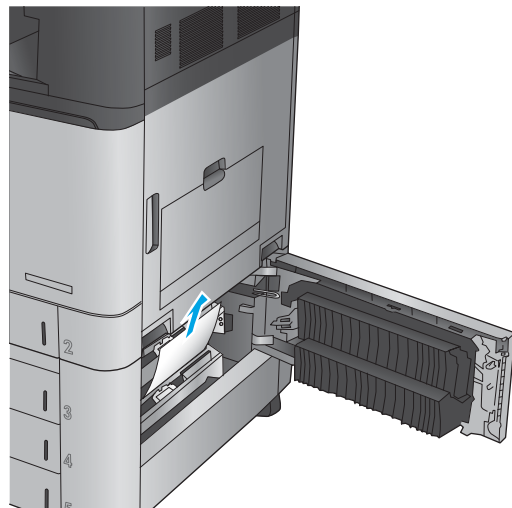
## Clear jams in the 3x500-sheet feeder and the lower-right door

Use the following procedure to check for paper in all possible jam locations related to the 3x500-sheet feeder. When a jam occurs, the control panel displays an animation that assists in clearing the jam.

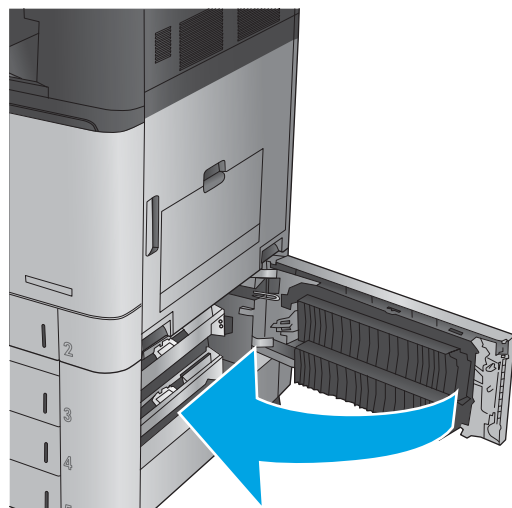
1. Open the lower-right door.



2. Gently pull out any jammed paper.



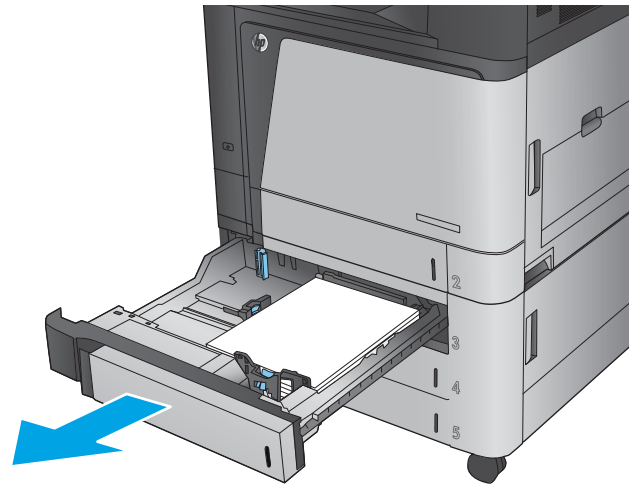
3. Close the lower-right door.



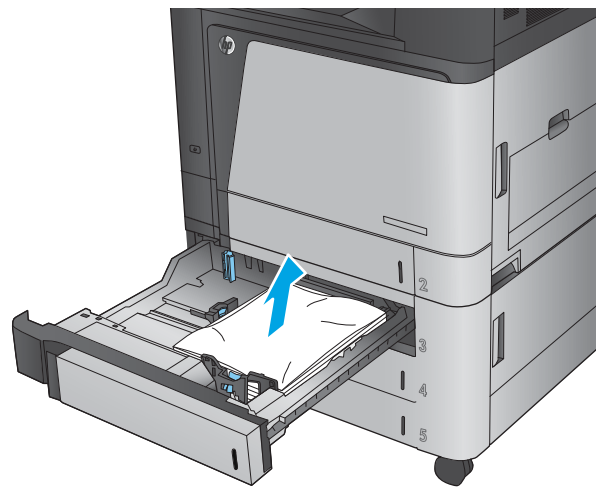


4. Open the tray.

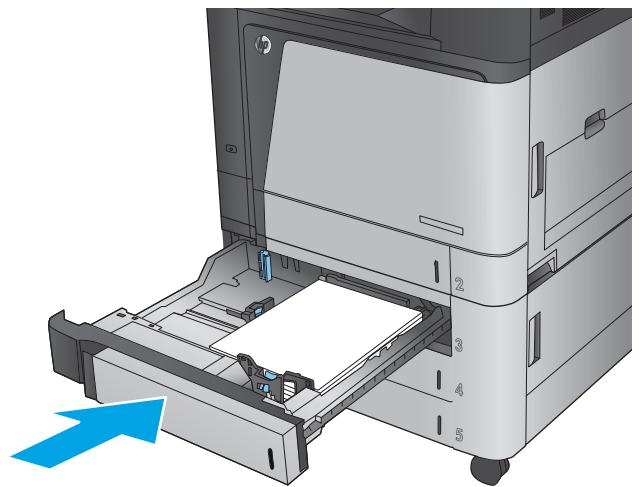
**NOTE:** The message on the product control panel indicates which tray has the jam. The following steps show removing a jam from the top tray, but the procedure is the same for all three trays.



5. Remove any jammed or damaged sheets of paper.



6. Close the tray.

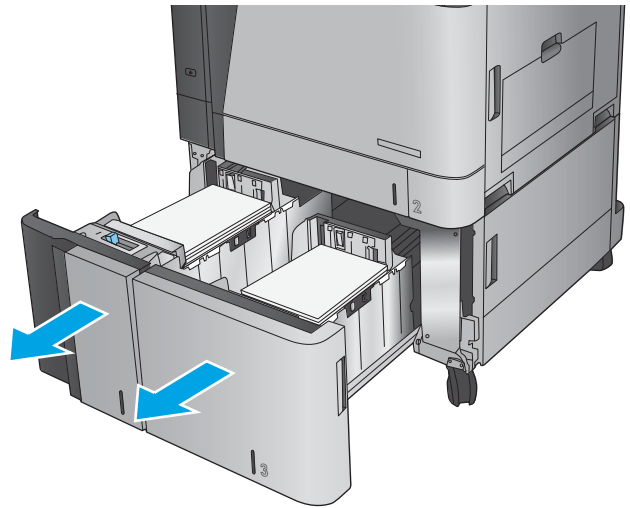


## Clear jams in the 3,500-sheet high-capacity input tray and the lower-right door

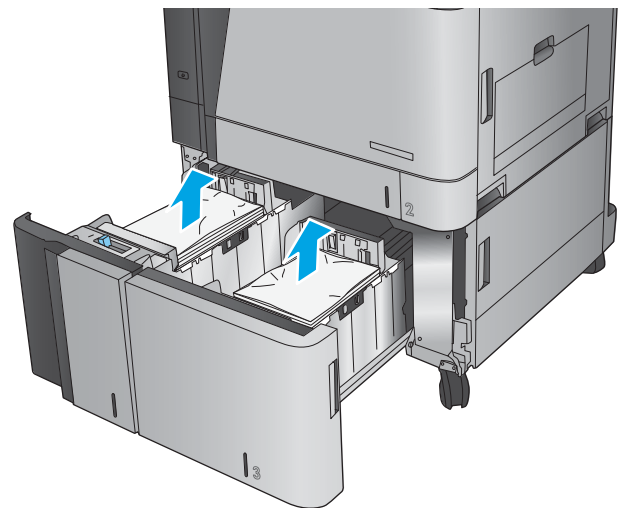
Use the following procedure to check for paper in all possible jam locations related to the 3,500-sheet high-capacity tray. When a jam occurs, the control panel displays an animation that assists in clearing the jam.

1. Open the right and left trays.

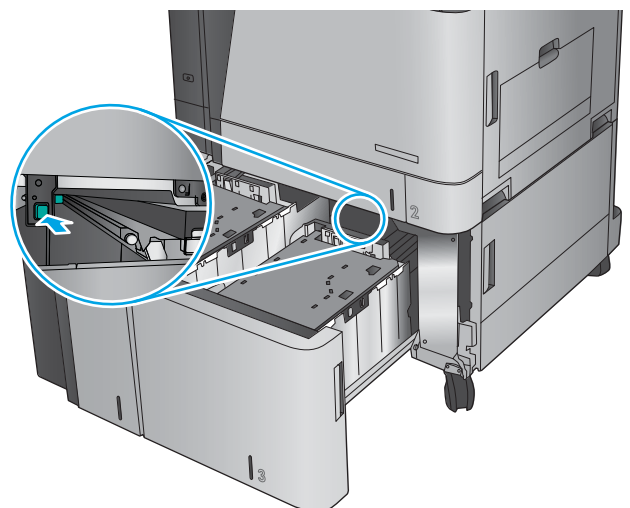
**NOTE:** You do not need to open both trays at the same time.



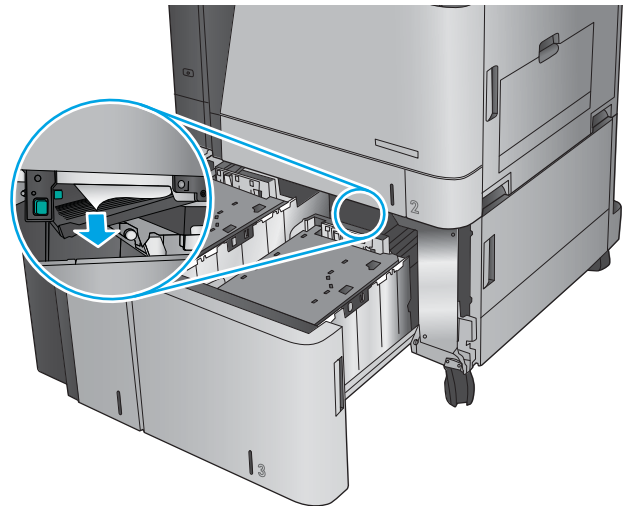
2. Remove the paper from the trays and discard any damaged sheets.



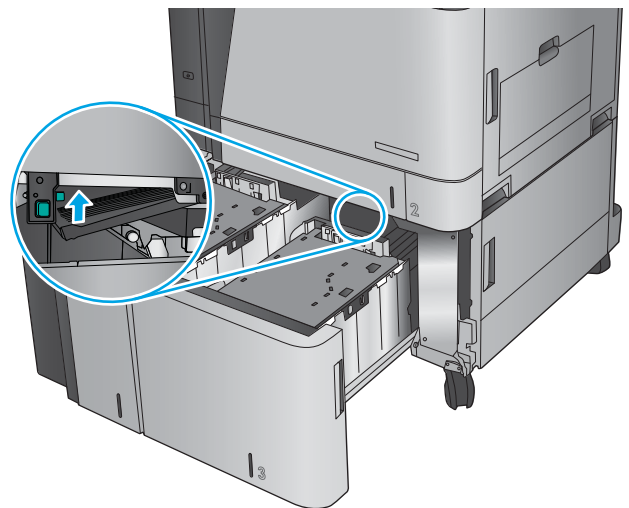
3. Above the right-side tray, press the green button to release the jam-access plate.



4. If jammed paper is in the feed area, pull it down to remove it.

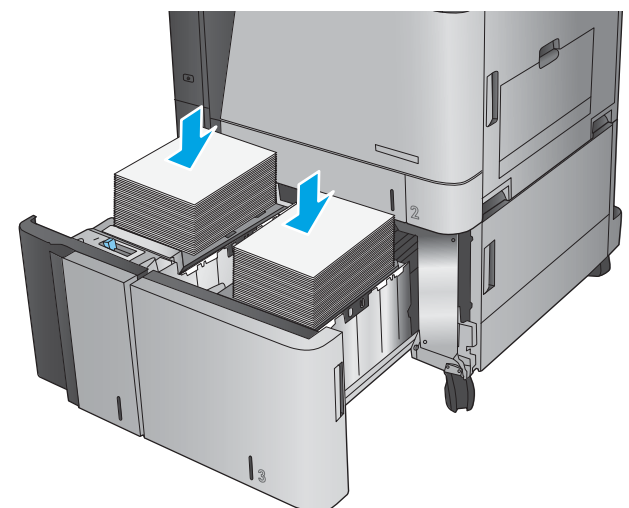


5. Push up on the jam-access plate to close it.

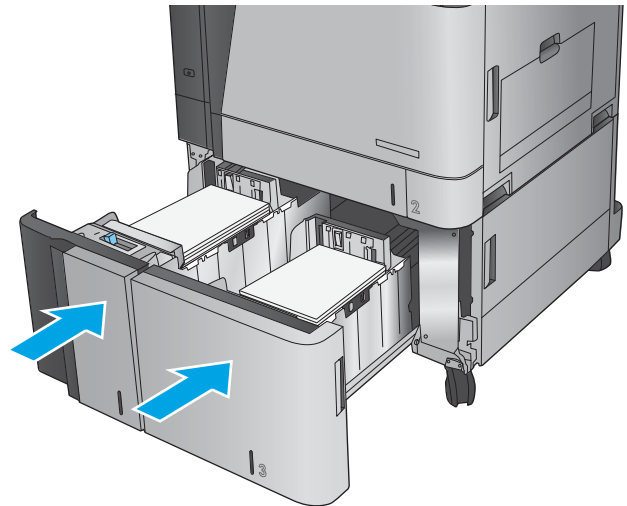


6. Load full reams of paper into each side of the tray. The right side holds 1,500 sheets of paper. The left side holds 2,000 sheets of paper.

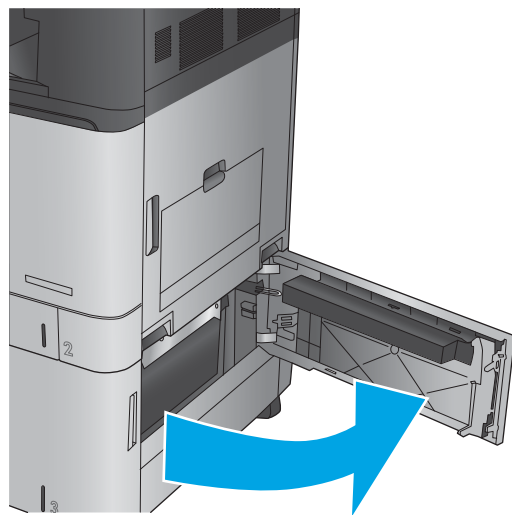
**NOTE:** For best results, load full reams of paper. Avoid dividing reams into smaller sections.



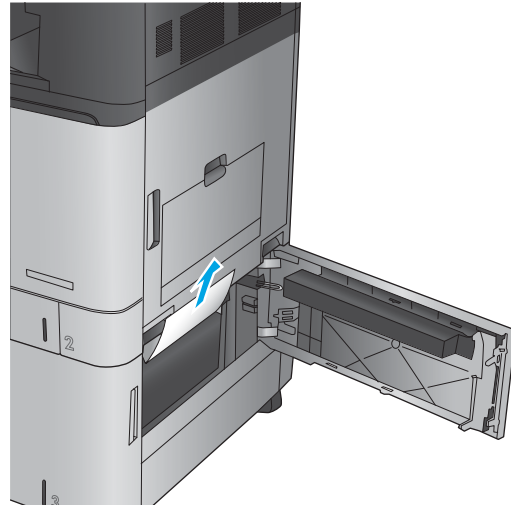
7. Close the right and left trays.



8. Open the jam-access door on the right side of the high-capacity tray cabinet.

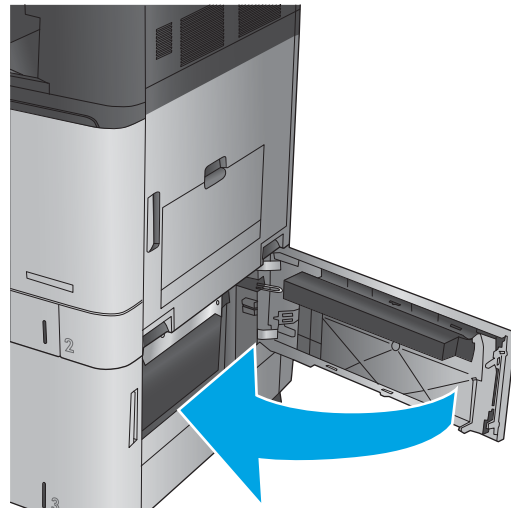


9. Remove any jammed paper.



10. Close the jam-access door on the right side of the high-capacity tray cabinet.

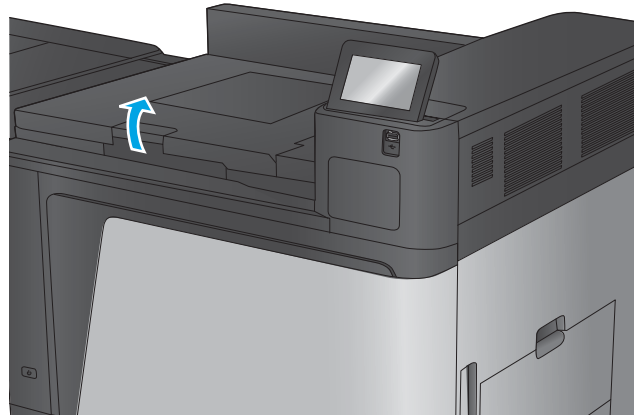
**NOTE:** If after clearing the jam the product control panel displays a message that there is no paper in the tray or the tray is over filled, remove the tray and look behind it for any remaining paper.



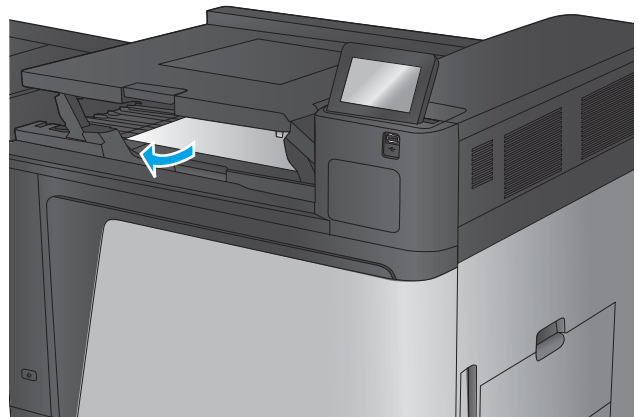
## Clear output jams in the output-accessory bridge

The output-accessory bridge is installed on products with an optional finishing accessory. The output-accessory bridge transfers paper from the output slot near the control panel, across the top of the product, and into the finishing accessory. Use the following procedure to clear jams in this area.

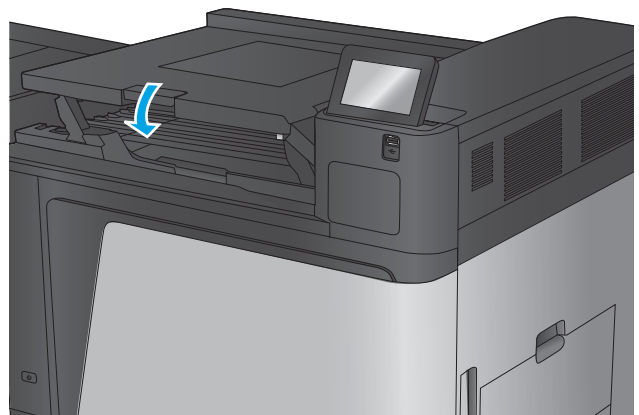
1. Lift the latch on the top cover of the output-accessory bridge and open the top cover.



2. Gently pull the jammed paper to remove it.



3. Close the top cover of the output-accessory bridge.



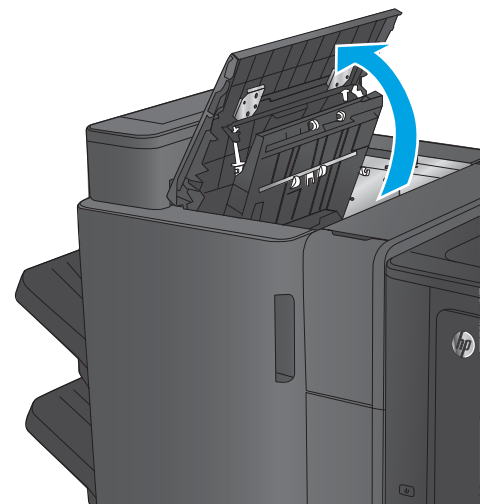
## Clear jams in the stapler/stacker accessory or the stapler/stacker with hole punch accessory

The procedures to clear paper jams and staple jams in the stapler/stacker accessory and the stapler/stacker with hole punch accessory are similar. Use the following procedures to check for jams in all possible locations inside the finishing accessory. When a jam occurs, the control panel displays an animation that assists in clearing the jam. Only the stapler/stacker with hole punch accessory is shown in the following tasks. Steps that apply only to the hole-punch model are clearly indicated.

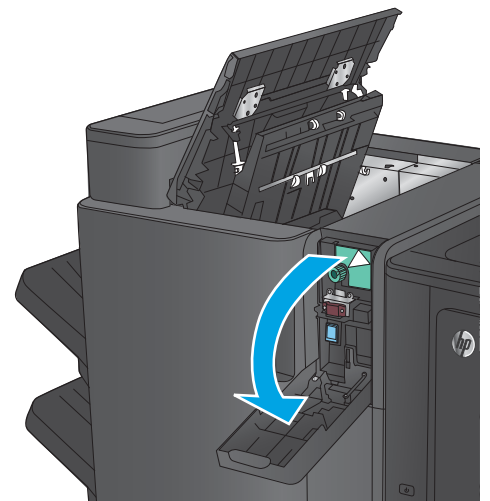
- [Clear top left door jams in the stapler/stacker](#)
- [Clear Stapler 1 jams in the stapler/stacker](#)
- [Clear stapler/stacker connection jams \(hole-punch models only\)](#)

### Clear top left door jams in the stapler/stacker

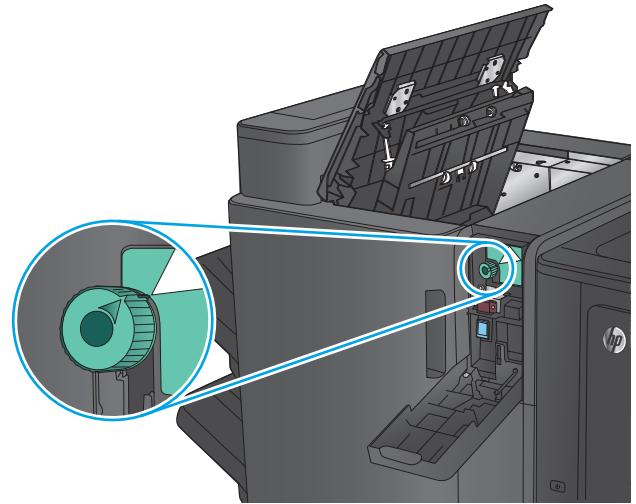
1. Open the top left door.



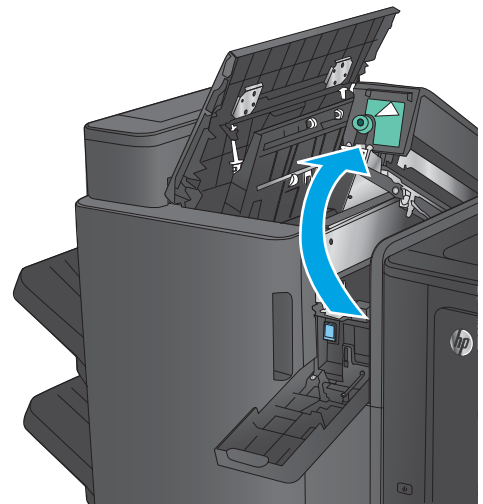
2. **Hole punch models only:** Open the hole-punch door.



- 3. **Hole punch models only:** Turn the knob to align the arrows.

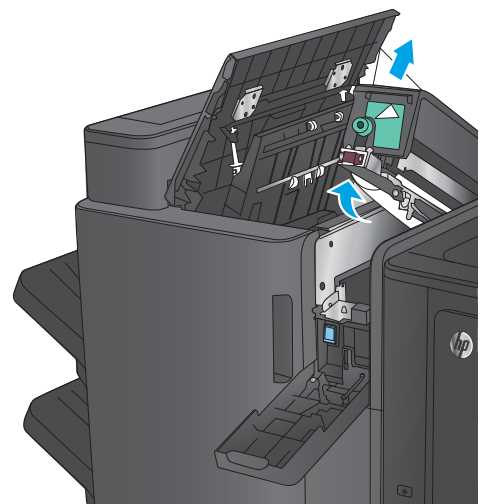


- 4. **Hole punch models only:** Lift the hole-punch unit.



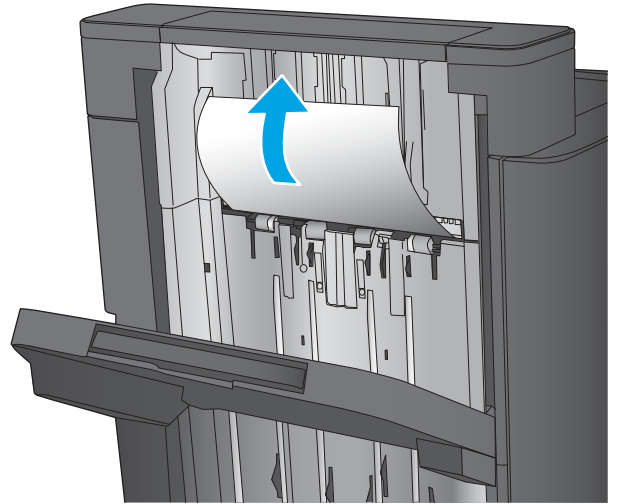
- 5. **Hole punch models only:** If paper is jammed in the bottom of the hole-punch unit, carefully remove it.

**NOTE:** Do not close the hole-punch unit yet.

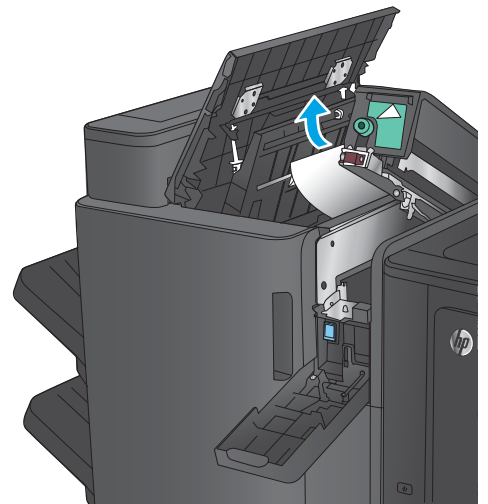




6. Lift the jam access cover for the output slot, and gently remove any jammed paper.

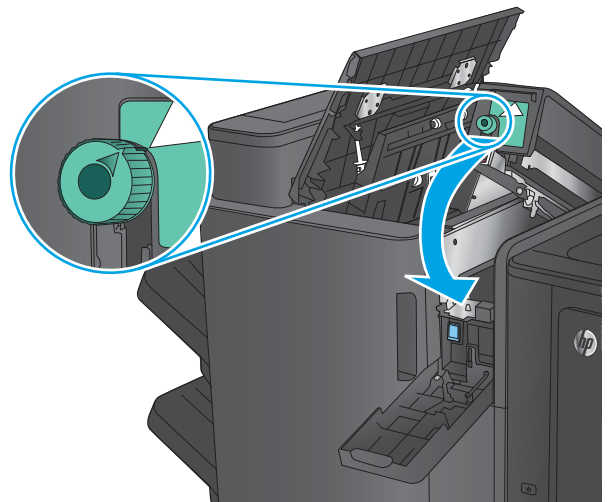


7. Remove all paper from the top left door area.

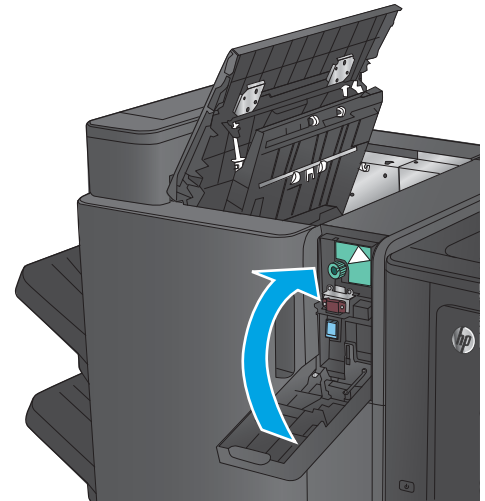


8. **Hole punch models only:** Close the hole-punch unit.

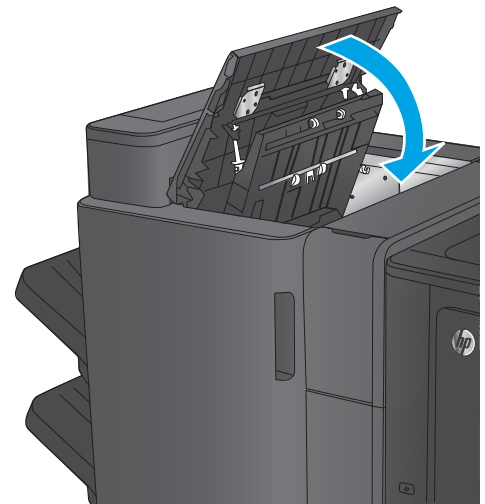
**NOTE:** Ensure the arrows on the hole punch are positioned as shown in the graphic.



9. **Hole punch models only:** Close the hole-punch door.

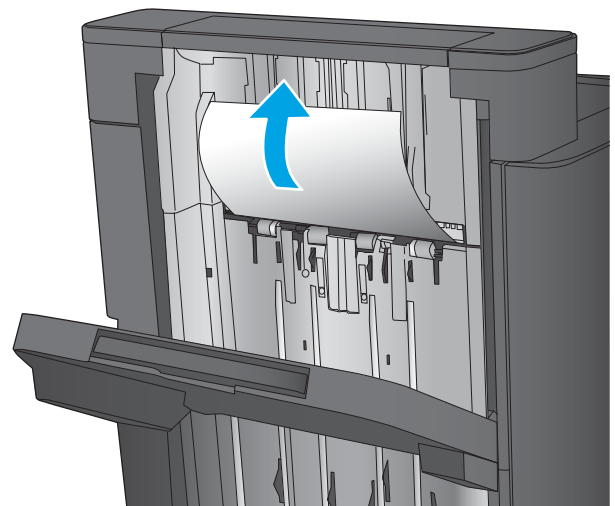


10. Close the top left door.

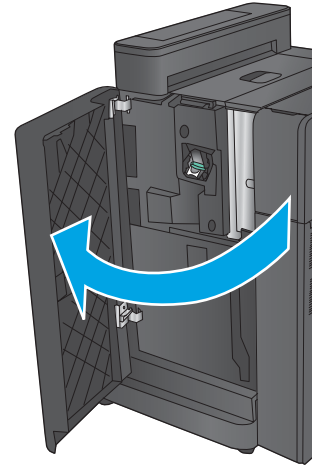


### Clear Stapler 1 jams in the stapler/stacker

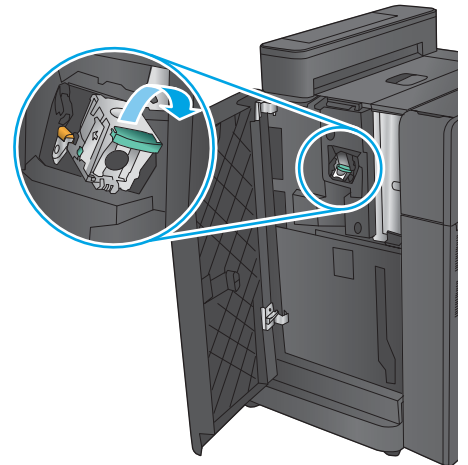
1. Lift the jam access cover for the output slot, and gently remove any jammed paper.



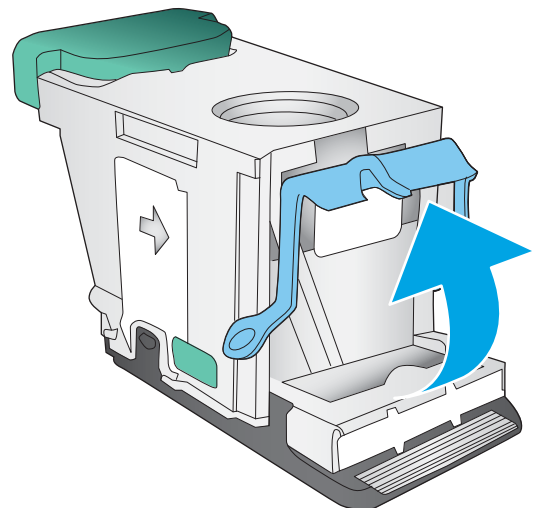
2. Wait three seconds, and then open the front left door.



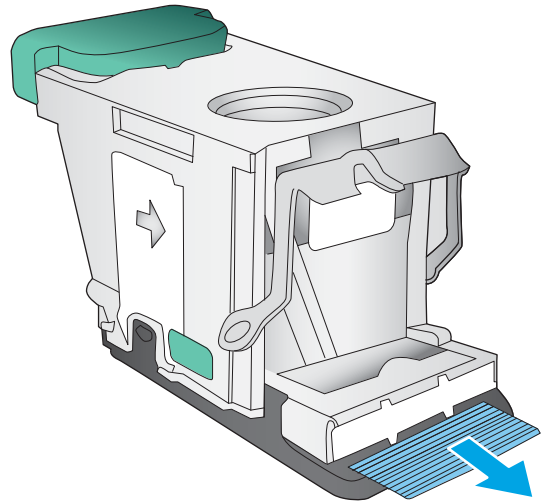
3. Pull the staple cartridge up and out to remove it.



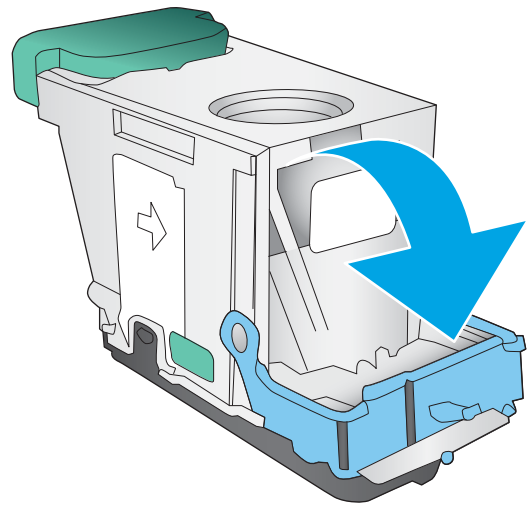
4. Lift up the metal handle on the front of the staple cartridge.



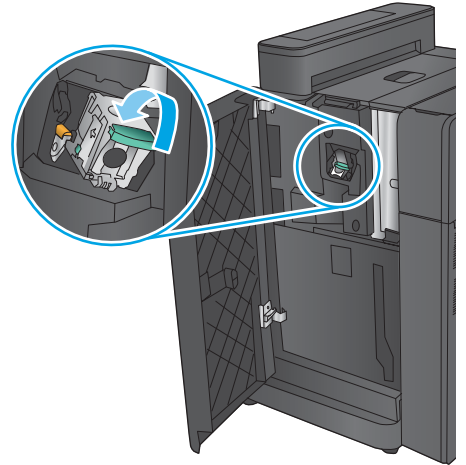
- 5. Remove any jammed staples from the staple cartridge.



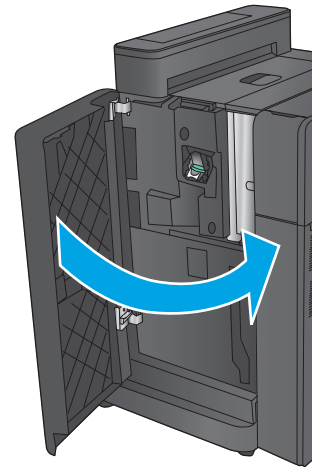
- 6. Push down the metal handle on the front of the staple cartridge.



7. Insert the staple cartridge. Press down on the top of the staple cartridge until it clicks into place.

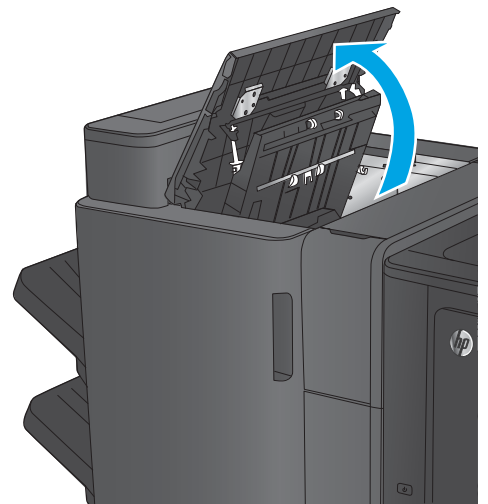


8. Close the front left door.

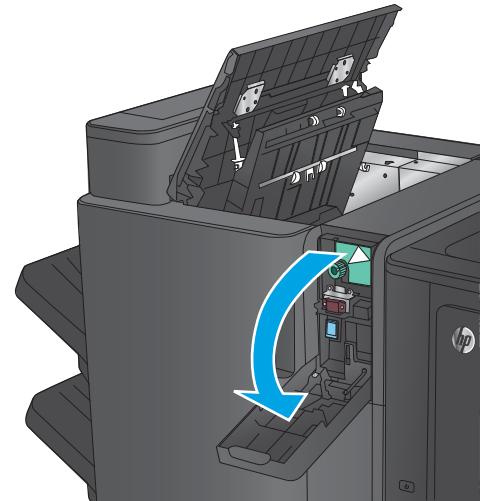


### Clear stapler/stacker connection jams (hole-punch models only)

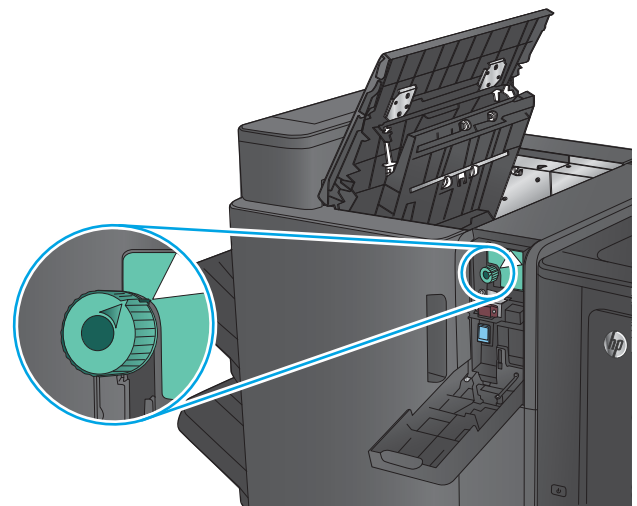
1. Open the top left door.



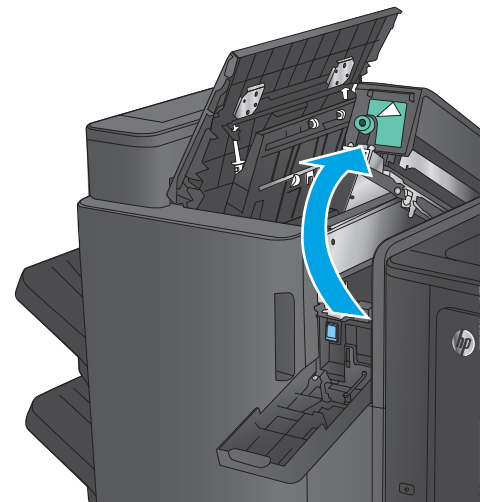
2. Open the hole-punch door.



3. Turn the knob to align the arrows.

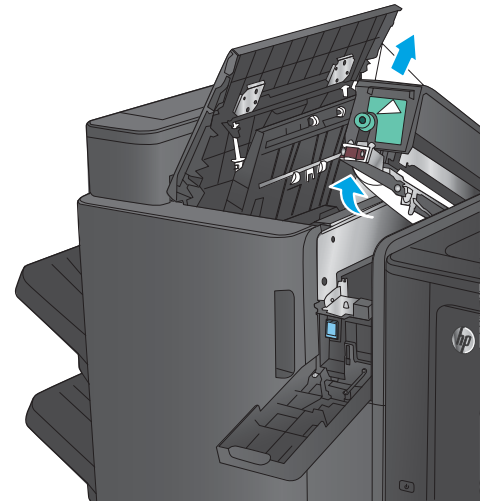


4. Lift the hole-punch unit.

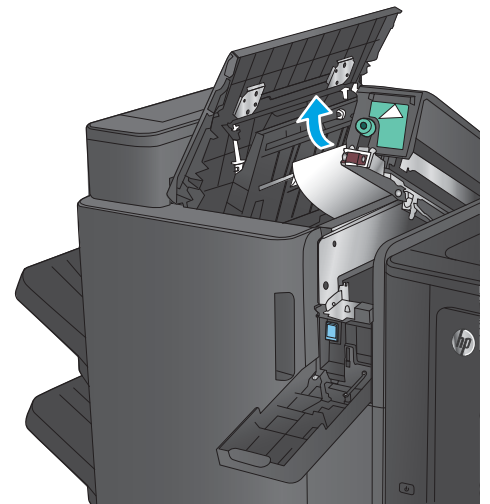


5. If paper is jammed in the bottom of the hole-punch unit, carefully remove it.

**NOTE:** Do not close the hole-punch unit yet.

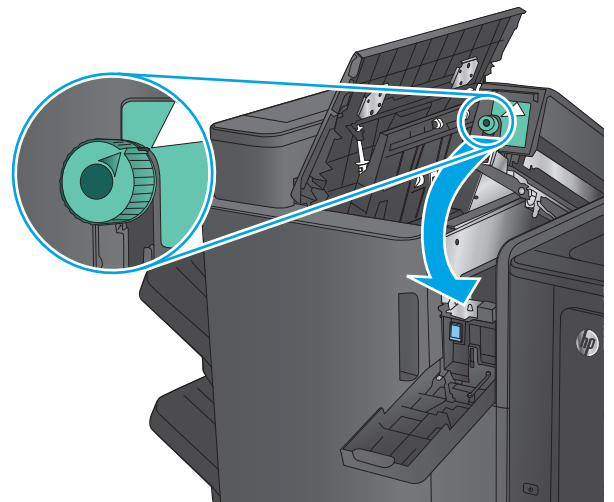


6. Remove all paper from the top left door area.

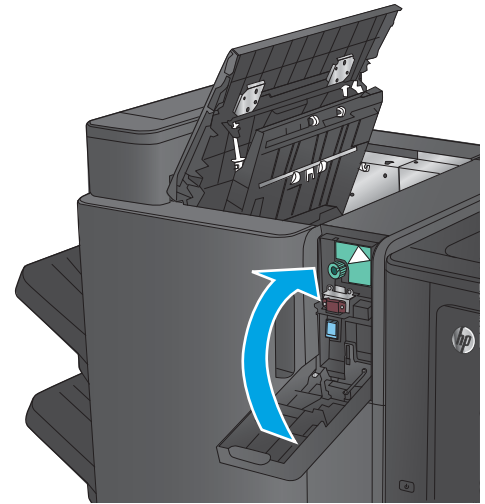


7. Close the hole-punch unit.

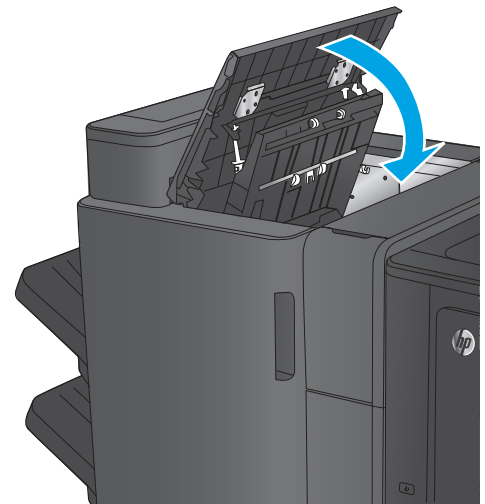
**NOTE:** Ensure the arrows on the hole punch are positioned as shown in the graphic.



8. Close the hole-punch door.



9. Close the top left door.





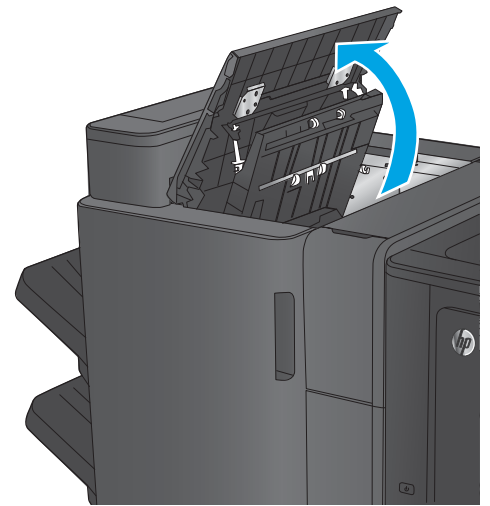
## Clear jams in the booklet maker accessory or the booklet maker with hole punch accessory

The procedures to clear paper jams and staple jams in the booklet maker accessory and the booklet maker with hole punch accessory are similar. Use the following procedures to check for jams in all possible locations inside the finishing accessory. When a jam occurs, the control panel displays an animation that assists in clearing the jam. Only the booklet maker with hole punch accessory is shown in the following tasks. Steps that apply only to the hole-punch model are clearly indicated.

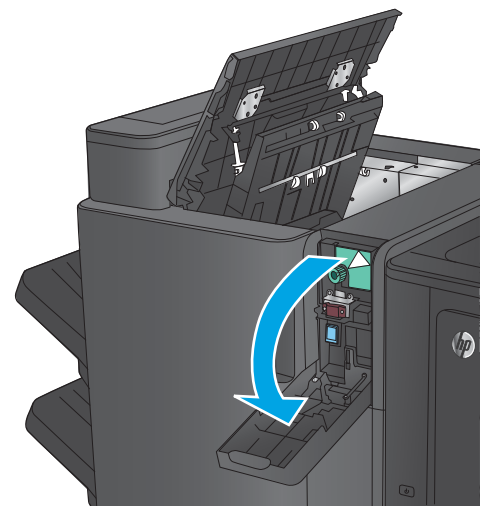
- [Clear top left door jams in the booklet maker](#)
- [Clear Stapler 1 jams in the booklet maker](#)
- [Clear front left door jams in the booklet maker](#)
- [Clear stapler 2 or 3 jams in the booklet maker](#)

### Clear top left door jams in the booklet maker

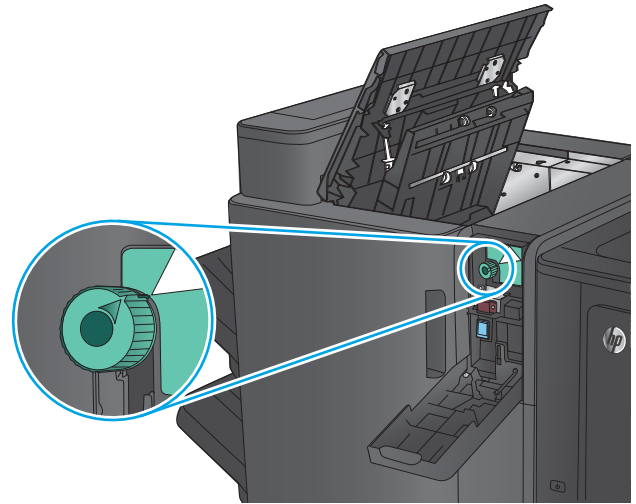
1. Open the top left door.



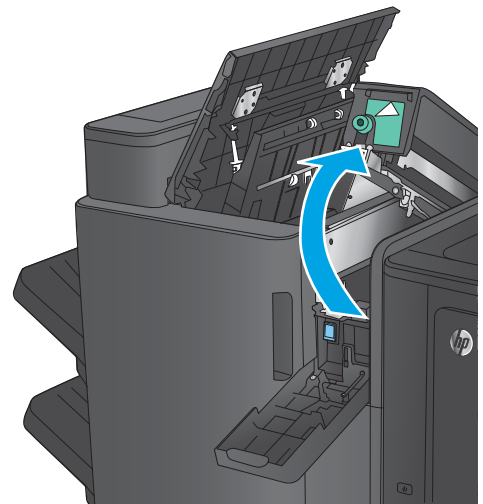
2. **Hole punch models only:** Open the hole-punch door.



- 3. **Hole punch models only:** Turn the knob to align the arrows.

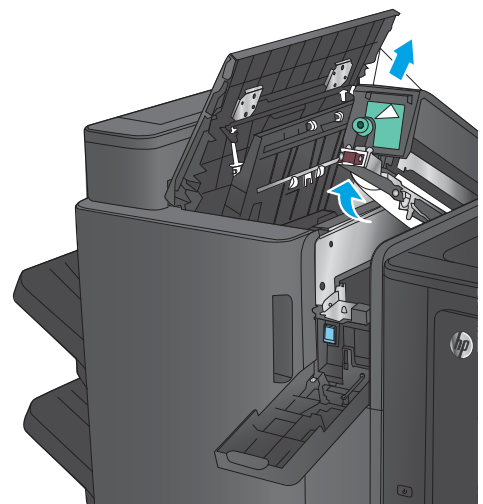


- 4. **Hole punch models only:** Lift the hole-punch unit.

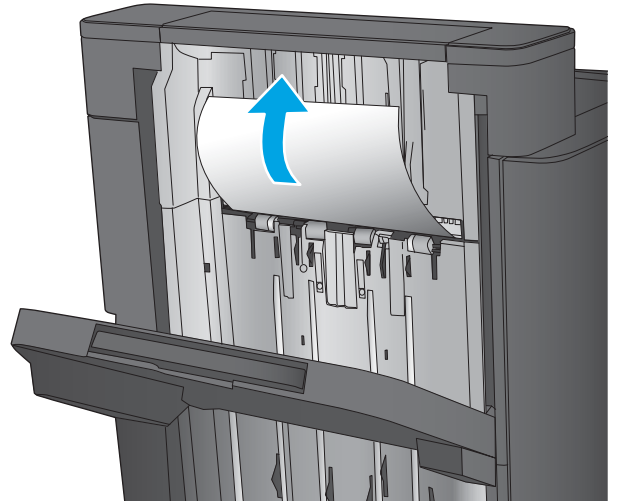


- 5. **Hole punch models only:** If paper is jammed in the bottom of the hole-punch unit, carefully remove it.

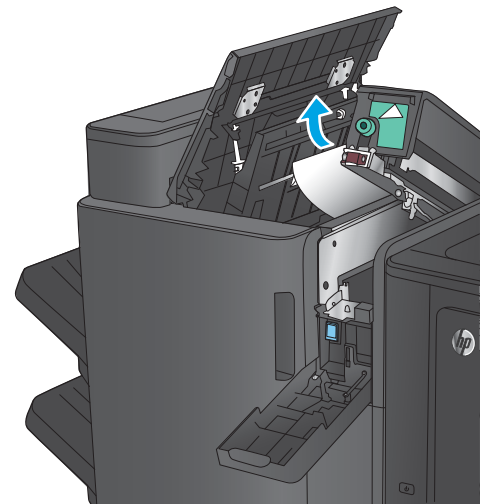
**NOTE:** Do not close the hole-punch unit yet.



6. Lift the jam access cover for the output slot, and gently remove any jammed paper.

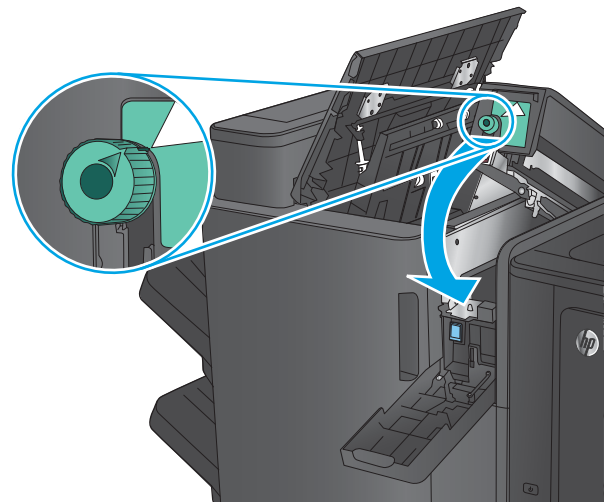


7. Remove all paper from the top left door area.

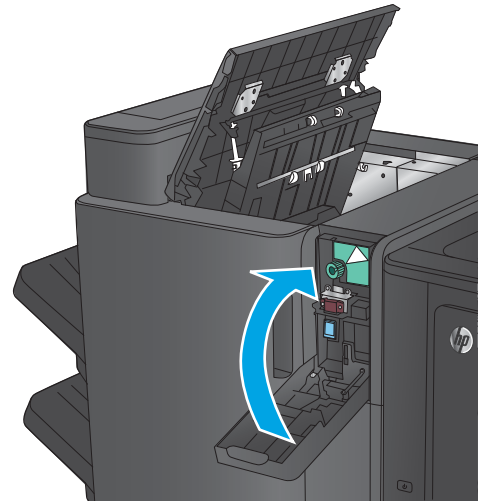


8. **Hole punch models only:** Close the hole-punch unit.

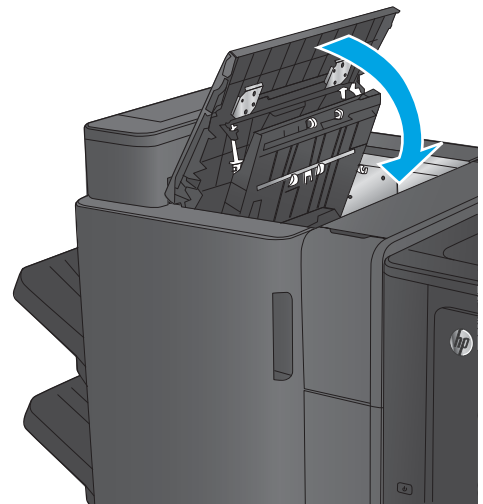
**NOTE:** Ensure the arrows on the hole punch are positioned as shown in the graphic.



9. **Hole punch models only:** Close the hole-punch door.

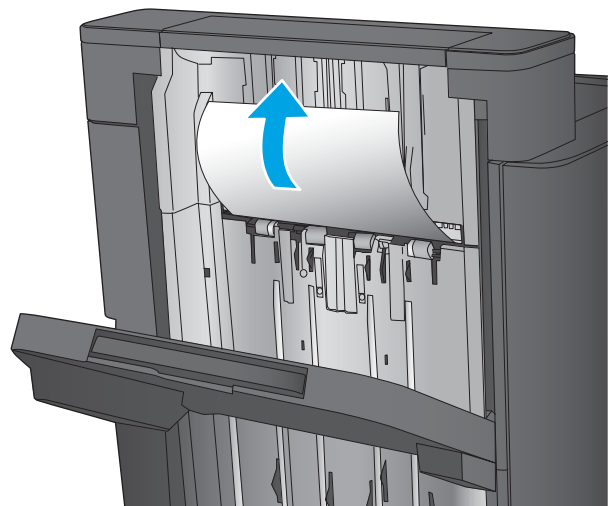


10. Close the top left door.

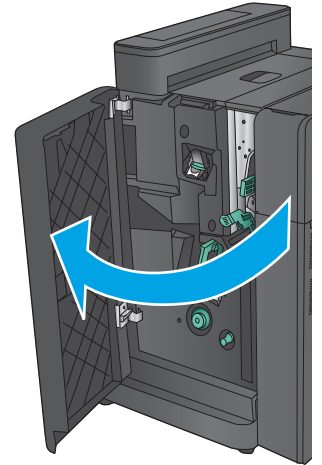


### Clear Stapler 1 jams in the booklet maker

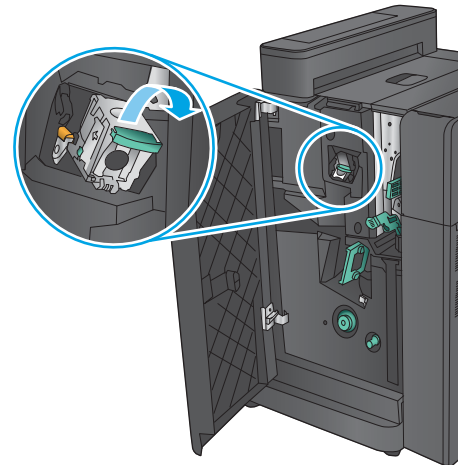
1. Lift the jam access cover for the output slot, and gently remove any jammed paper.



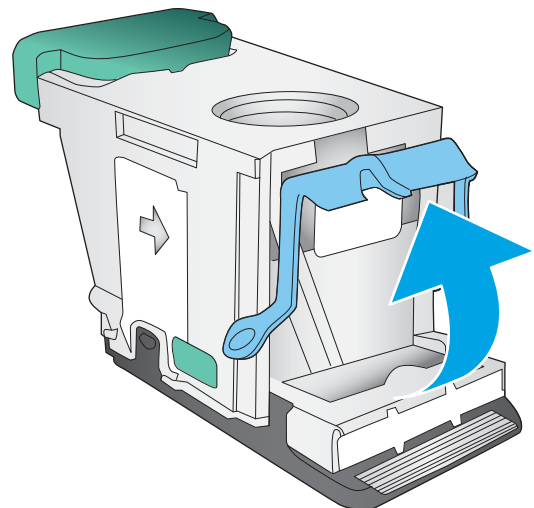
2. Wait three seconds, and then open the front left door.



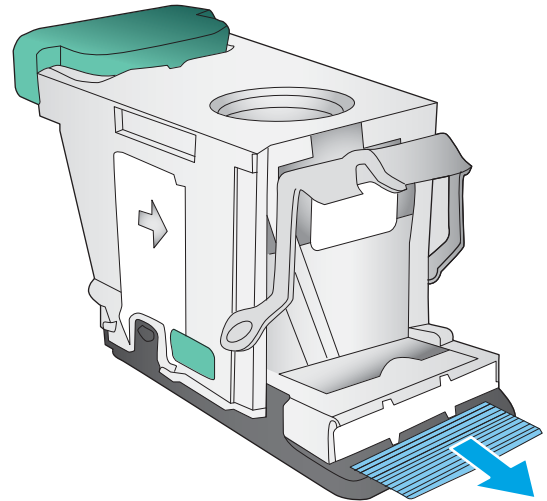
3. Pull the staple cartridge up and out to remove it.



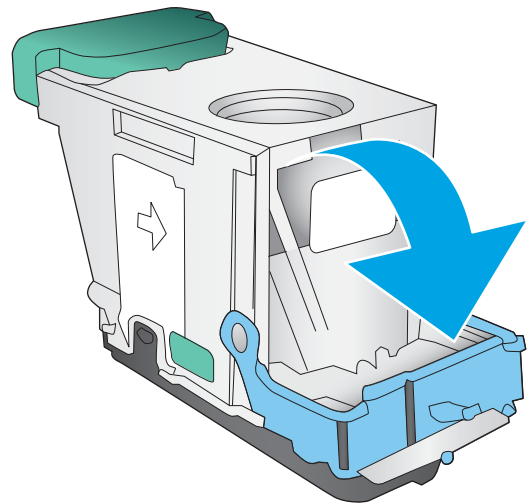
4. Lift up the metal handle on the front of the staple cartridge.



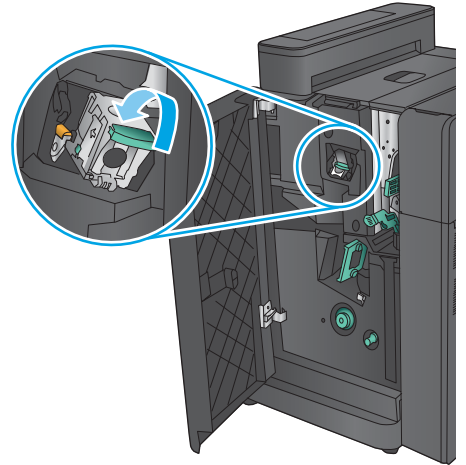
- 5. Remove any jammed staples from the staple cartridge.



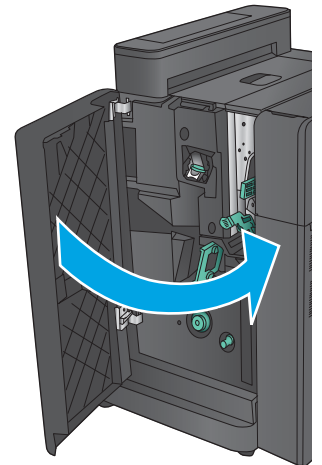
- 6. Push down the metal handle on the front of the staple cartridge.



7. Insert the staple cartridge. Press down on the top of the staple cartridge until it clicks into place.

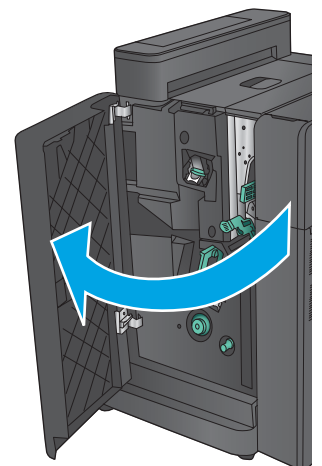


8. Close the front left door.

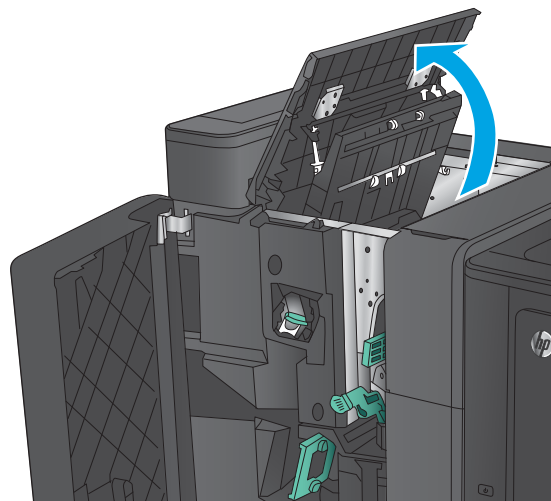


### Clear front left door jams in the booklet maker

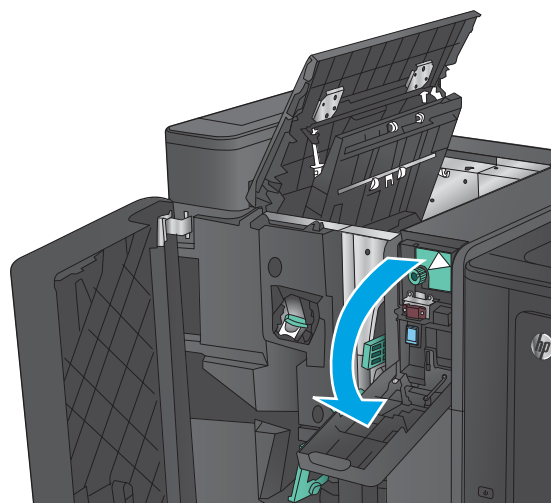
1. Open the front left door.



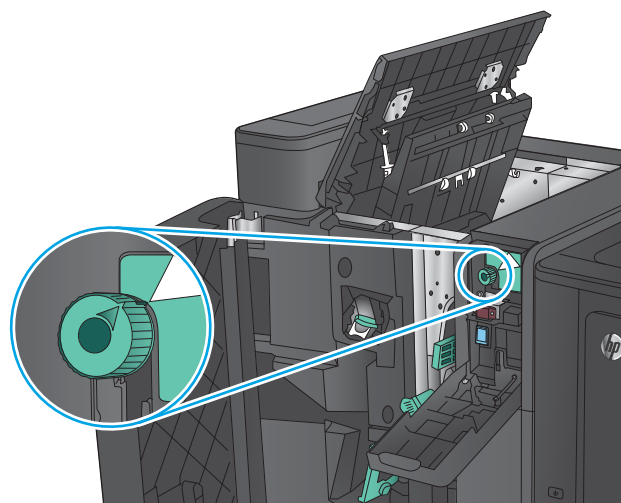
2. **Hole punch models only:** Open the top left door.



3. **Hole punch models only:** Open the hole-punch door.

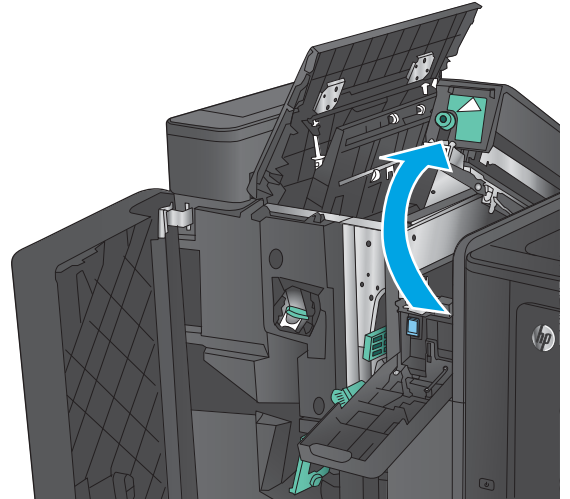


4. **Hole punch models only:** Turn the knob to align the arrows.

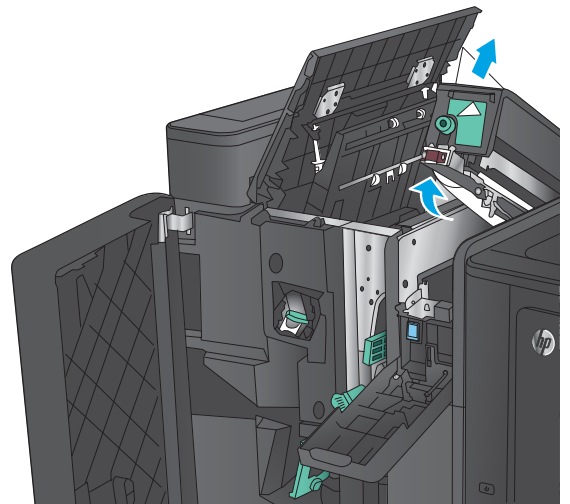




5. **Hole punch models only:** Lift the hole-punch unit.

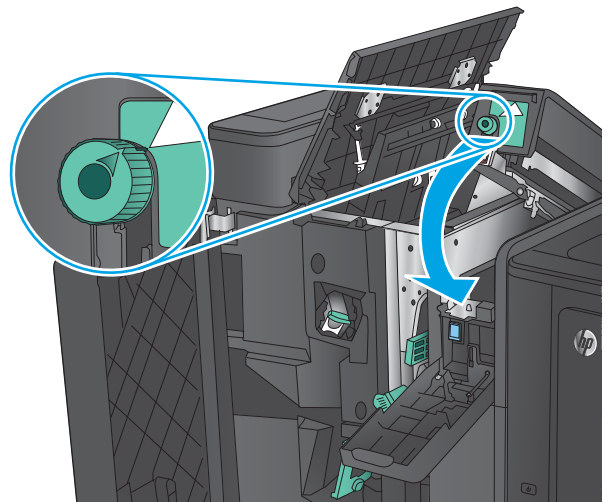


6. **Hole punch models only:** If paper is jammed in the bottom of the hole-punch unit, carefully remove it.

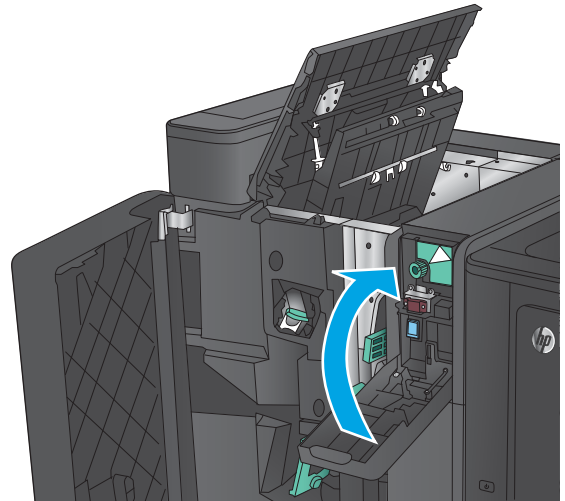


7. **Hole punch models only:** Close the hole-punch unit.

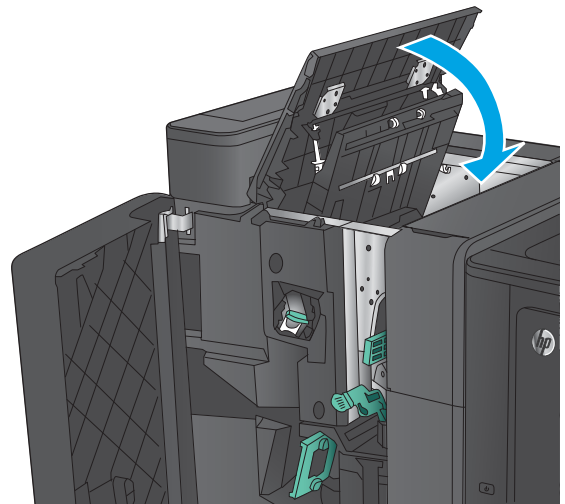
**NOTE:** Ensure the arrows on the hole punch are positioned as shown in the graphic.



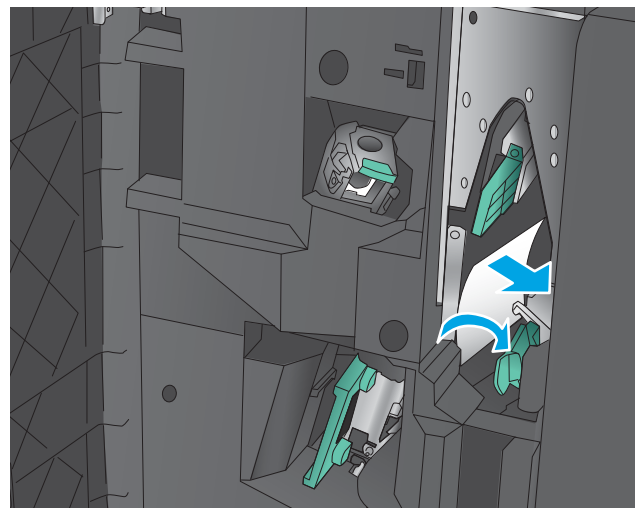
8. **Hole punch models only:** Close the hole-punch door.



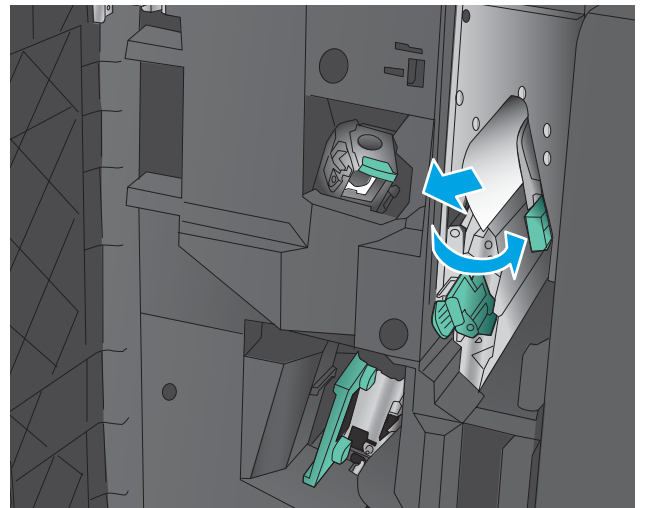
9. **Hole punch models only:** Close the top left door.



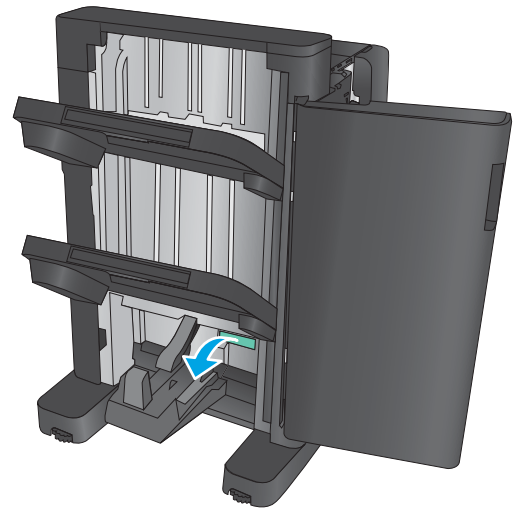
10. Move the lower jam-release lever to the right, and then remove any paper. Move the lower jam-release handle to the left.



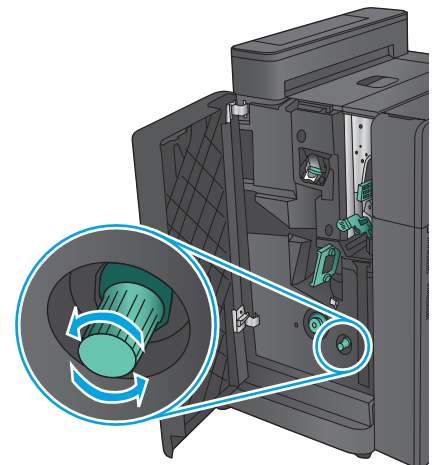
- 11.** Move the upper jam-release lever to the right, and then remove any paper. Move the upper jam-release handle to the left.



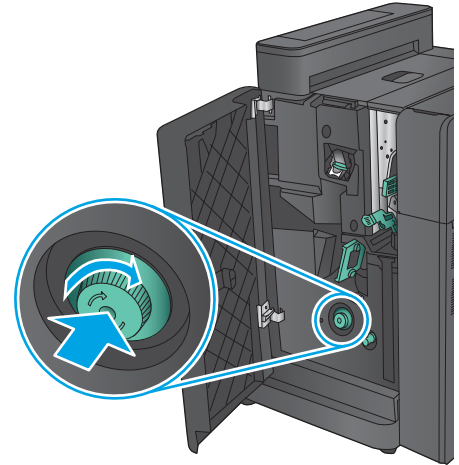
- 12.** Open the lower booklet door.



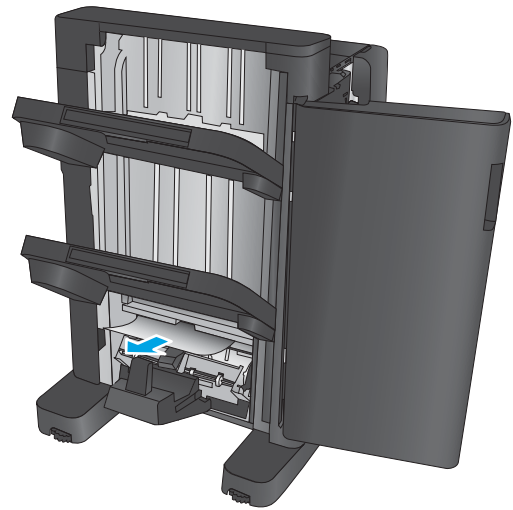
- 13.** Turn the small jam-release knob counterclockwise.



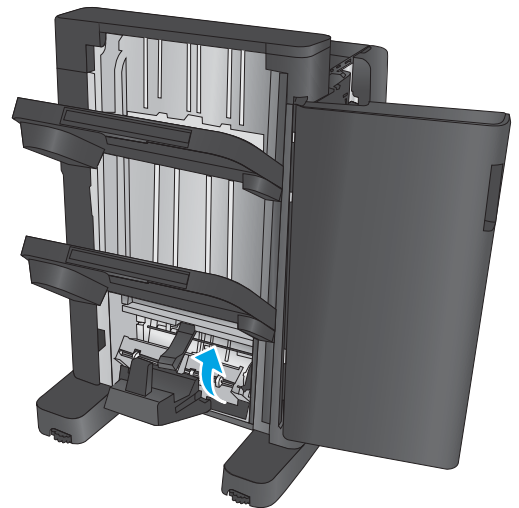
14. Press the large jam-release knob, and then turn it clockwise.



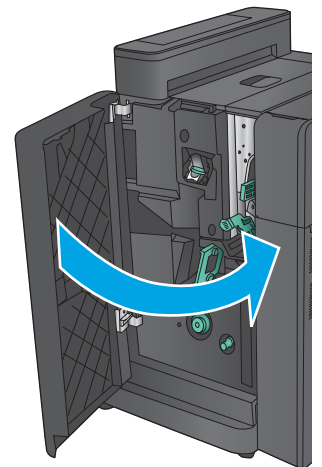
15. Remove all paper from the lower booklet door area.



16. Close the lower booklet door.

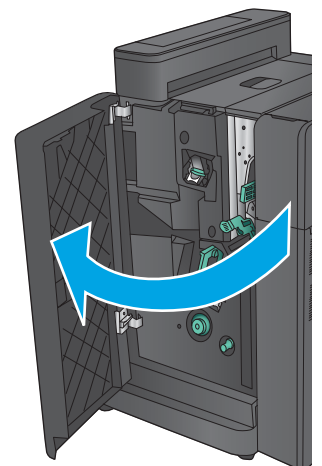


17. Close the front left door.

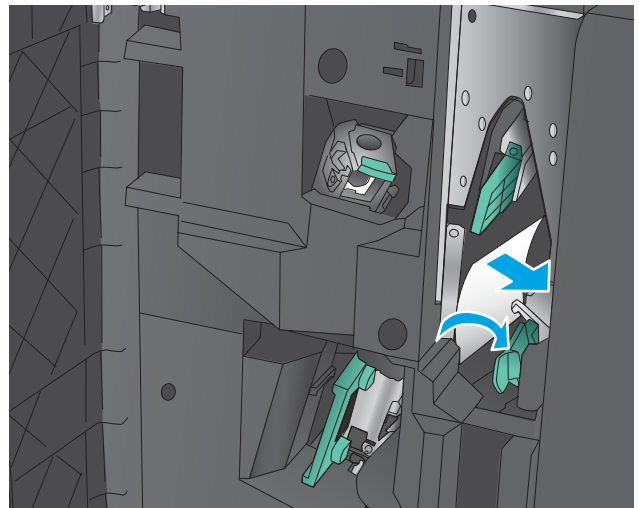


### Clear stapler 2 or 3 jams in the booklet maker

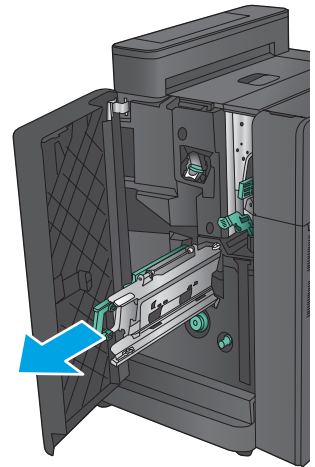
1. Open the front left door.



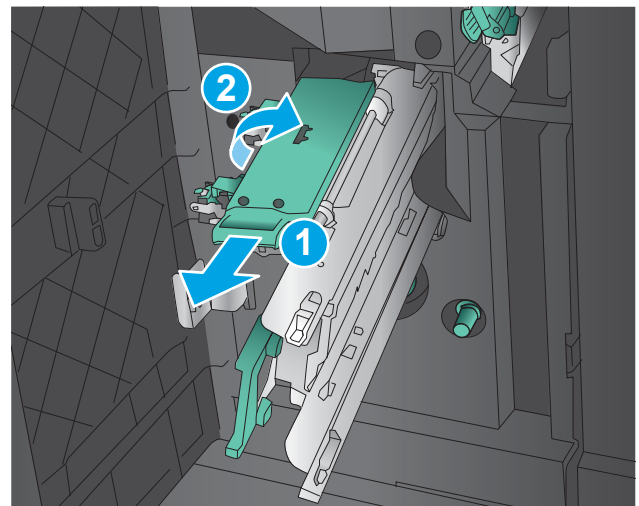
2. Move the lower jam-release lever to the right, and then remove any paper. Move the lower jam-release handle to the left.



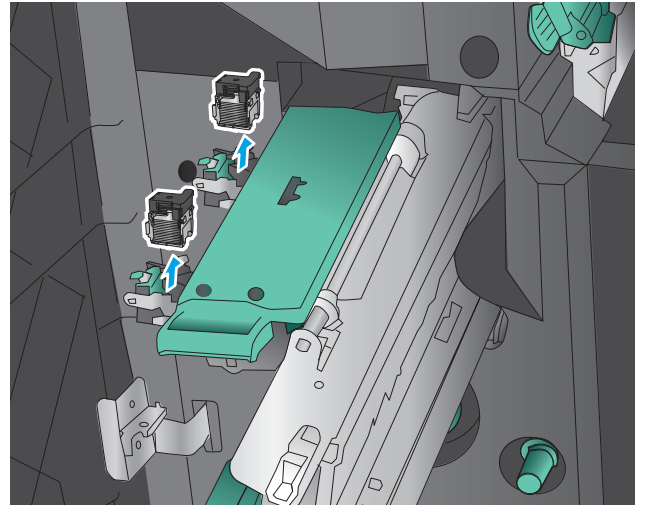
3. Grasp the green handle and pull the staple carriage out.



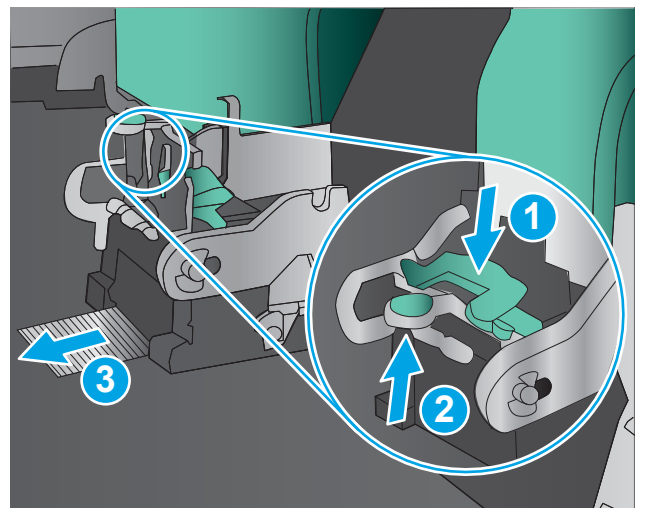
4. Pull the green handle of the stapler unit toward you and rotate it upward. Push the handle in to lock it in the open position.



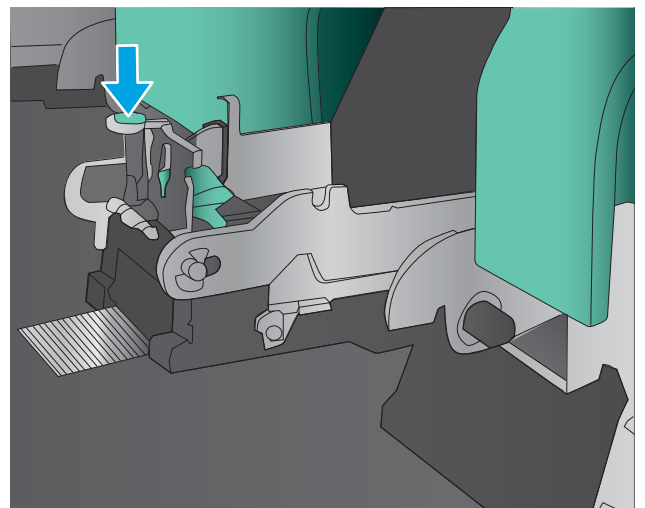
5. Grasp the edges of each staple cartridge and firmly pull up to remove the staple cartridges from the staple cartridge unit.



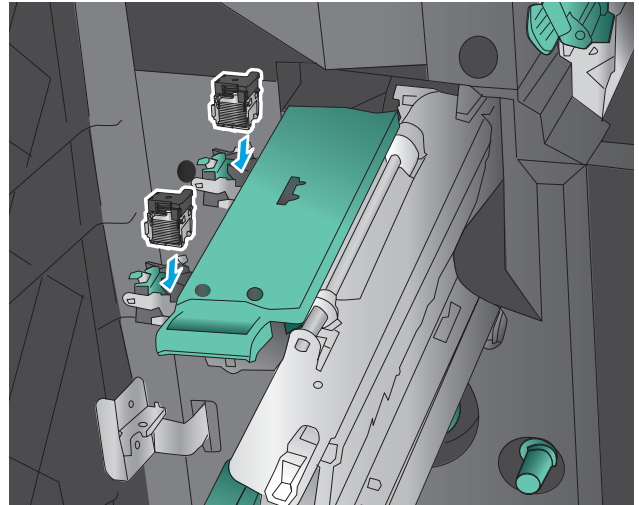
6. Press down on the jam-release at the back of the saddle-staple cartridge, push up on the plate at the front of the cartridge, and then remove any jammed staples.



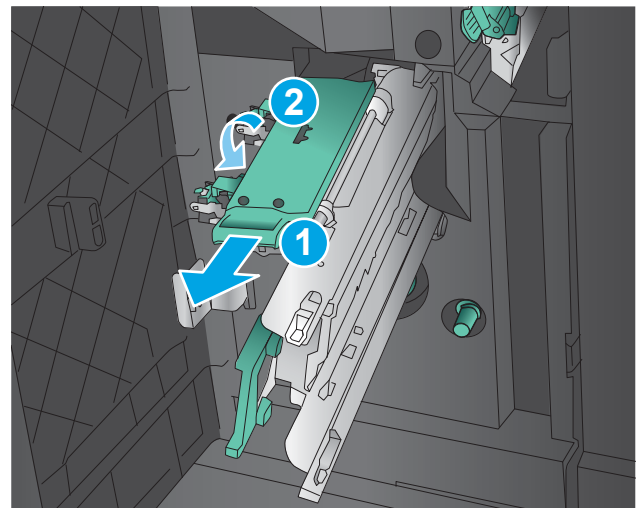
7. Press down on the front of the saddle-staple cartridge close it.



8. Insert the staple cartridges.



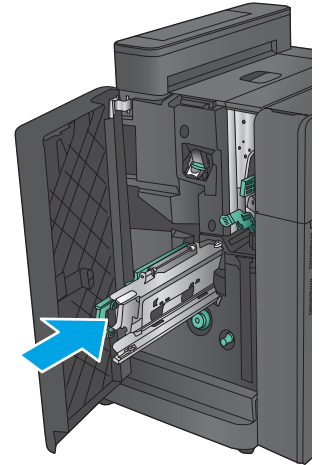
9. Pull the handle of the staple cartridge unit toward you and rotate it downward to its original position. Lock it into position by pushing in the handle.



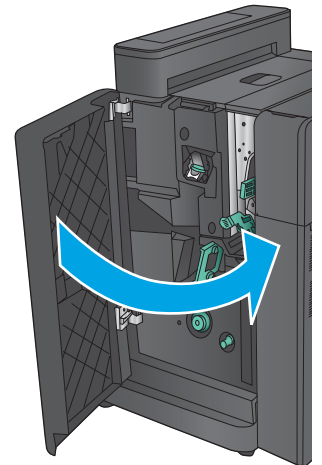


10. Push the saddle-stitch carriage in.

**NOTE:** If the saddle-stitch carriage does not easily slide into the finisher, the staple unit is not closed properly. Pull the saddle-stitch carriage out of the finisher and reseal the stapler unit.



11. Close the front left door.



## Improve print quality

If the product is having print-quality problems, try the following solutions in the order presented to resolve the issue.

- [Print from a different software program](#)
- [Check the paper-type setting for the print job](#)
- [Check toner-cartridge status](#)
- [Calibrate the product to align the colors](#)
- [Print a cleaning page](#)
- [Visually inspect the imaging-drum](#)
- [Check paper and the printing environment](#)
- [Check other print job settings](#)
- [Try a different print driver](#)
- [Set the individual tray alignment](#)

### Print from a different software program

Try printing from a different software program. If the page prints correctly, the problem is with the software program from which you were printing.

### Check the paper-type setting for the print job

Check the paper type setting when printing from a software program and the printed pages have smears, fuzzy or dark print, curled paper, scattered dots of toner, loose toner, or small areas of missing toner.

#### Check the paper type setting (Windows)

1. From the software program, select the **Print** option.
2. Select the product, and then click the **Properties** or **Preferences** button.
3. Click the **Paper/Quality** tab.
4. From the **Paper Type** drop-down list, click the **More...** option.
5. Expand the list of **Type is:** options.
6. Expand the category of paper types that best describes your paper.
7. Select the option for the type of paper you are using, and click the **OK** button.
8. Click the **OK** button to close the **Document Properties** dialog box. In the **Print** dialog box, click the **OK** button to print the job.

#### Check the paper type setting (Mac OS X)

1. Click the **File** menu, and then click the **Print** option.
2. In the **Printer** menu, select the product.

3. By default, the print driver displays the **Copies & Pages** menu. Open the menus drop-down list, and then click the **Finishing** menu.
4. Select a type from the **Media Type** drop-down list.
5. Click the **Print** button.

## Check toner-cartridge status

Follow these steps to check the estimated life remaining in the toner cartridges and if applicable, the status of other replaceable maintenance parts.

### Step one: Print the supplies status page

1. From the Home screen on the product control panel, scroll to and touch the [Supplies](#) button.
2. The status of all supply items is listed on the screen.
3. To print or view a report of the status of all supply items, including the genuine HP part number for reordering the supply, touch the [Manage Supplies](#) button. Touch the [Supplies Status](#) button, and then touch either the [Print](#) or [View](#) button.

### Step two: Check supplies status

1. Look at the supplies status report to check the percent of life remaining for the toner cartridges and if applicable, the status of other replaceable maintenance parts.

Print quality problems can occur when using a toner cartridge that is at its estimated end of life. The supplies status page indicates when a supply level is very low. After an HP supply has reached the very low threshold, HP's premium protection warranty on that supply has ended.

The toner cartridge does not need to be replaced now unless the print quality is no longer acceptable. Consider having a replacement available to install when print quality is no longer acceptable.

If you determine that you need to replace a toner cartridge or other replaceable maintenance parts, the supplies status page lists the genuine HP part numbers.

2. Check to see if you are using a genuine HP cartridge.

A genuine HP toner cartridge has the words "HP" on it, or has the HP logo on it. For more information on identifying HP cartridges go to [www.hp.com/go/learnaboutsupplies](http://www.hp.com/go/learnaboutsupplies).

## Calibrate the product to align the colors

Calibration is a product function that optimizes print quality.

Follow these steps to resolve print print-quality problems such as misaligned color, colored shadows, blurry graphics, or other print-quality issues.

1. From the Home screen on the product control panel, scroll to and touch the [Device Maintenance](#) button.
2. Open the following menus:
  - [Calibration/Cleaning](#)
  - [Full Calibration](#)

3. Touch the **Start** button to start the calibration process.

A **Calibrating** message will display on the product control panel. The calibration process takes a few minutes to complete. Do not turn the product off until the calibration process has finished.

4. Wait while the product calibrates, and then try printing again.

## Print a cleaning page

During the printing process paper, toner, and dust particles can accumulate inside the product and can cause print-quality issues such as toner specks or spatter, smears, streaks, lines, or repeating marks.

Follow these steps to clean the product's paper path.

1. From the Home screen on the product control panel, scroll to and touch the **Device Maintenance** button.
2. Touch **Calibration/Cleaning**, touch **Cleaning Page**, and then touch **Print** to print the page.

A **Cleaning** message displays on the product control panel. The cleaning process takes a few minutes to complete. Do not turn the product off until the cleaning process has finished. When it is finished, discard the printed page.

## Visually inspect the imaging-drum

Follow these steps to inspect each imaging drum.

1. Remove the imaging drum from the product.
2. Check the memory chip for damage.
3. Examine the surface of the green imaging drum.

---

 **CAUTION:** Do not touch the imaging drum. Fingerprints on the imaging drum can cause print-quality problems.

---

4. If you see any scratches, fingerprints, or other damage on the imaging drum, replace it.
5. Reinstall the imaging drum, and print a few pages to see if the problem has resolved.

## Check paper and the printing environment

### Step one: Use paper that meets HP specifications

Some print-quality problems arise from using paper that does not meet HP specifications.

- Always use a paper type and weight that this product supports.
- Use paper that is of good quality and free of cuts, nicks, tears, spots, loose particles, dust, wrinkles, voids, staples, and curled or bent edges.
- Use paper that has not been previously printed on.
- Use paper that does not contain metallic material, such as glitter.
- Use paper that is designed for use in laser printers. Do not use paper that is designed only for use in Inkjet printers.
- Use paper that is not too rough. Using smoother paper generally results in better print quality.

## Step two: Check the environment

The environment can directly affect print quality and is a common cause for print-quality or paper-feeding issues. Try the following solutions:

- Move the product away from drafty locations, such as open windows or doors, or air-conditioning vents.
- Make sure the product is not exposed to temperatures or humidity outside of product specifications.
- Do not place the product in a confined space, such as a cabinet.
- Place the product on a sturdy, level surface.
- Remove anything that is blocking the vents on the product. The product requires good air flow on all sides, including the top.
- Protect the product from airborne debris, dust, steam, grease, or other elements that can leave residue inside the product.

## Check other print job settings

When printing from a software program, follow these steps to try to resolve the issue by adjusting other print-driver settings.

### Adjust color settings (Windows)


Follow these steps if colors on the printed page do not match colors on the computer screen, or if the colors on the printed page are not satisfactory.

#### Change the color theme

1. From the software program, select the **Print** option.
2. Select the product, and then click the **Properties** or **Preferences** button.
3. Click the **Color** tab.
4. Select the **HP EasyColor** check box to clear it.
5. Select a color theme from the **Color Themes** drop-down list.
  - **Default (sRGB):** This theme sets the product to print RGB data in raw device mode. When using this theme, manage color in the software program or in the operating system for correct rendering.
  - **Vivid (sRGB):** The product increases the color saturation in the midtones. Use this theme when printing business graphics.
  - **Photo (sRGB):** The product interprets RGB color as if it were printed as a photograph using a digital mini lab. The product renders deeper, more saturated colors differently than with the Default (sRGB) theme. Use this theme when printing photos.
  - **Photo (Adobe RGB 1998):** Use this theme with printing digital photos that use the AdobeRGB color space rather than sRGB. Turn off color management in the software program when using this theme.

- **None:** No color theme is used.
  - **Custom Profile:** Select this option to use a custom input profile to accurately control color output (for example, to emulate a specific HP Color LaserJet product). Download custom profiles from [www.hp.com](http://www.hp.com).
6. Click the **OK** button to close the **Document Properties** dialog box. In the **Print** dialog box, click the **OK** button to print the job.

### Change the color options

1. From the software program, select the **Print** option.
  2. Select the product, and then click the **Properties** or **Preferences** button.
  3. Click the **Color** tab.
  4. Select the **HP EasyColor** check box to clear it.
  5. Click the **Automatic** or **Manual** setting.
    - **Automatic** setting: Select this setting for most color print jobs
    - **Manual** setting: Select this setting to adjust the color settings independently from other settings. Click the **Settings** button to open the manual color-adjustment window.
- 
-  **NOTE:** Changing color settings manually can impact output. HP recommends that only color graphics experts change these settings.
- 
6. Click the **Print in Grayscale** option to print a color document in black and shades of gray. Use this option to print color documents for photocopying or faxing. Also use this option to print draft copies or to save color toner.
  7. Click the **OK** button to close the **Document Properties** dialog box. In the **Print** dialog box, click the **OK** button to print the job.

### Try a different print driver

You might need to use a different print driver when printing from a software program and the printed pages have unexpected lines in graphics, missing text, missing graphics, incorrect formatting, or substituted fonts.

Download any of the following drivers from the HP Web site. In the US, go to [www.hp.com/support/colorljM855](http://www.hp.com/support/colorljM855). Outside the US, go to [www.hp.com/support](http://www.hp.com/support). Select your country/region. Click **Download Drivers & Software**. Enter the product name, and then select **Search**.

---

#### HP PCL 6 driver

- Provided as the default driver on the product CD. This driver is automatically installed unless you select a different one.
  - Recommended for all Windows environments
  - Provides the overall best speed, print quality, and product-feature support for most users
  - Developed to align with the Windows Graphic Device Interface (GDI) for the best speed in Windows environments
  - Might not be fully compatible with third-party and custom software programs that are based on PCL 5
-

---

|                         |   |
|-------------------------|---|
| <b>HP UPD PS driver</b> | <ul style="list-style-type: none"><li>• Recommended for printing with Adobe® software programs or with other highly graphics-intensive software programs</li><li>• Provides support for printing from postscript emulation needs, or for postscript flash font support</li></ul>  |
| <b>HP UPD PCL 5</b>     | <ul style="list-style-type: none"><li>• Recommended for general office printing in Windows environments</li><li>• Compatible with previous PCL versions and older HP LaserJet products</li><li>• The best choice for printing from third-party or custom software programs</li><li>• The best choice when operating with mixed environments, which require the product to be set to PCL 5 (UNIX, Linux, mainframe)</li><li>• Designed for use in corporate Windows environments to provide a single driver for use with multiple product models</li><li>• Preferred when printing to multiple product models from a mobile Windows computer</li></ul> |
| <b>HP UPD PCL 6</b>     | <ul style="list-style-type: none"><li>• Recommended for printing in all Windows environments</li><li>• Provides the overall best speed, print quality, and printer feature support for most users</li><li>• Developed to align with Windows Graphic Device Interface (GDI) for best speed in Windows environments</li><li>• Might not be fully compatible with third-party and custom software programs that are based on PCL 5</li></ul>   |

---

## Set the individual tray alignment

Follow these steps when text or images are not centered or aligned correctly on the printed page when printing from specific trays.

1. From the Home screen on the product control panel, scroll to and touch the [Administration](#) button.
2. Open the following menus:
  - [General Settings](#)
  - [Print Quality](#)
  - [Image Registration](#)
3. Select the tray that you want to adjust.
4. Touch the [Print Test Page](#) button, and then follow the instructions on the printed pages.
5. Touch the [Print Test Page](#) button to verify the results, and then make further adjustments if necessary.
6. When you are satisfied with the results, touch the [Save](#) button to save the new settings.

## Solve wired network problems

Check the following items to verify that the product is communicating with the network. Before beginning, print a configuration page from the product control panel and locate the product IP address that is listed on this page.

- [Poor physical connection](#)
- [The computer is using the incorrect IP address for the product](#)
- [The computer is unable to communicate with the product](#)
- [The product is using incorrect link and duplex settings for the network](#)
- [New software programs might be causing compatibility problems](#)
- [The computer or workstation might be set up incorrectly](#)
- [The product is disabled, or other network settings are incorrect](#)



**NOTE:** HP does not support peer-to-peer networking, as the feature is a function of Microsoft operating systems and not of the HP print drivers. For more information, go to Microsoft at [www.microsoft.com](http://www.microsoft.com).

### Poor physical connection

1. Verify that the product is attached to the correct network port using a cable of the correct length.
2. Verify that cable connections are secure.
3. Look at the network port connection on the back of the product, and verify that the amber activity light and the green link-status light are lit.
4. If the problem continues, try a different cable or port on the hub.

### The computer is using the incorrect IP address for the product

1. Open the printer properties and click the **Ports** tab. Verify that the current IP address for the product is selected. The product IP address is listed on the product configuration page.
2. If you installed the product using the HP standard TCP/IP port, select the box labeled **Always print to this printer, even if its IP address changes**.
3. If you installed the product using a Microsoft standard TCP/IP port, use the hostname instead of the IP address.
4. If the IP address is correct, delete the product and then add it again.

### The computer is unable to communicate with the product

1. Test network communication by pinging the network.



- a. Open a command-line prompt on your computer. For Windows, click **Start**, click **Run**, type `cmd`, and then press **Enter**.
  - b. Type `ping` followed by the IP address for your product.  
  
For Mac OS X, open the Network Utility, and then supply the IP address in the correct field in the **Ping** pane.
  - c. If the window displays round-trip times, the network is working.
2. If the ping command failed, verify that the network hubs are on, and then verify that the network settings, the product, and the computer are all configured for the same network.

## The product is using incorrect link and duplex settings for the network

HP recommends leaving these settings in automatic mode (the default setting). If you change these settings, you must also change them for your network.

## New software programs might be causing compatibility problems

Verify that any new software programs are correctly installed and that they use the correct print driver.

## The computer or workstation might be set up incorrectly

1. Check the network drivers, print drivers, and the network redirection settings.
2. Verify that the operating system is configured correctly.

## The product is disabled, or other network settings are incorrect

1. Review the configuration page to check the status of the network protocol. Enable it if necessary.
2. Reconfigure the network settings if necessary.



# Index

## Symbols/Numerics

- 3,500-sheet high-capacity input tray
  - clear jams 90
- 3,500-sheet high-capacity tray
  - loading 27
- 3x500-sheet feeder
  - jams 88
- 3x500-sheet trays
  - loading 23

## A

- accessories
  - ordering 32
  - part number 34
- AirPrint 60

## B

- bins, output
  - locating 5
- Bonjour
  - identifying 64
- booklet maker
  - delivery guides, locating 11
  - front left door, locating 11
  - hole punch, locating 11
  - jams 105
  - output bins, locating 11
  - output slot, locating 11
  - part number 34
  - staple jams 108, 117
  - stapler, locating 11
  - top left door, locating 11
- browser requirements
  - HP embedded Web Server 64

## C

- calibrate
  - colors 123

- cartridge
  - replacing 35
- cleaning
  - paper path 124
- color options
  - changing, Windows 125
- color theme
  - changing, Windows 125
- colors
  - calibrate 123
- control panel
  - help 75
  - locating 5
  - locating features 8
- covers
  - locating 5

## D

- deleting
  - stored jobs 57
- document feeder
  - paper-feeding problems 78
- double-sided printing
  - Mac 52
- duplex printing
  - Mac 52
- duplex printing (double-sided)
  - settings (Windows) 43
- duplexer
  - locating 6
- duplexing
  - manually (Mac) 52
  - manually (Windows) 45

## E

- easy-access USB printing 61
- Embedded Web Server (EWS)
  - assigning passwords 70

- features 64
  - network connection 64
- energy use, optimizing 68
- envelopes
  - loading in Tray 1 15
  - orientation 16
- Ethernet (RJ-45)
  - locating 7
- Explorer, versions supported
  - HP Embedded Web Server 64

## F

- FIH (foreign interface harness)
  - locating 7
- file upload, Mac 65
- firmware
  - update, Mac 66
- fonts
  - upload, Mac 65
- foreign interface harness (FIH)
  - locating 7
- formatter
  - locating 6
- front door
  - locating 5
- fuser
  - jams 81
  - locating 5, 6

## H

- hard disks
  - encrypted 71
- hardware integration pocket (HIP)
  - locating 5
- Help button
  - locating 8
- help, control panel 75
- Hi-Speed USB 2.0 printing port
  - locating 7

- HP (hardware integration pocket)
  - locating 5
- hole punch
  - setting default location 29
- Home button
  - locating 8
- HP Embedded Web Server (EWS)
  - features 64
  - network connection 64
- HP ePrint 58
- HP ePrint software 59
- HP Utility 65
- HP Utility for Mac
  - Bonjour 65
  - features 65
- HP Utility, Mac 65
- HP Web Jetadmin 67
- HP Wireless Direct printing 58

## I

- imaging drums
  - components 38
  - locating 5
  - replacing 38
- interface ports
  - locating 7
- Internet Explorer, versions supported
  - HP Embedded Web Server 64
- IP Security 70
- IPsec 70

## J

- jams
  - 3,500-sheet high-capacity input tray 90
  - 3x500-sheet feeder 88
  - auto-navigation 80
  - booklet maker 105
  - causes of 80
  - fuser 81
  - output-accessory bridge 93
  - right door 81
  - staple in hole punch accessory 98
  - stapler/stacker 95, 101, 111
  - staples in booklet maker 117
  - Tray 1 81
  - Tray 2 85
- Jetadmin, HP Web 67

- jobs, stored
  - creating (Windows) 54
  - deleting 57
  - Mac settings 56
  - printing 57

## L

- labels
  - printing (Windows) 49
- LAN port
  - locating 7
- Language Selection button
  - locating 8
- left door
  - locating 6
- loading
  - paper in 3x500-sheet trays 23
  - paper in the 3,500-sheet high-capacity tray 27
  - paper in Tray 1 15
  - paper in Tray 2 19
- local area network (LAN)
  - locating 7

## M

- Mac driver settings
  - Job Storage 56
- Macintosh
  - HP Utility 65
- manual duplex
  - Mac 52
  - Windows 45
- memory
  - included 2
- memory chip (imaging drum)
  - locating 38
- memory chip (toner)
  - locating 35
- mobile printing solutions 2
- model number
  - locating 6
- multiple pages per sheet
  - printing (Mac) 52
  - printing (Windows) 47

## N

- Netscape Navigator, versions supported
  - HP embedded Web Server 64
- Network button
  - locating 8

- networks
  - HP Web Jetadmin 67
  - supported 2

## O

- on/off button
  - locating 5
- online help, control panel 75
- operating systems (OS)
  - supported 2
- ordering
  - supplies and accessories 32
- OS (operating system)
  - supported 2
- output bins
  - locating 5
- output-accessory bridge
  - jams 93

## P

- pages per minute 2
- pages per sheet
  - selecting (Mac) 52
  - selecting (Windows) 47
- paper
  - 3,500-sheet high-capacity tray 27
  - jams 80
  - loading 3x500-sheet trays 23
  - loading Tray 1 15
  - loading Tray 2 19
  - selecting 124
  - Tray 1 paper orientation 16
  - Tray 2 orientation 20, 25
- paper jams
  - 3,500-sheet high-capacity input tray 90
  - 3x500-sheet feeder 88
  - booklet maker 105
  - fuser 81
  - output-accessory bridge 93
  - right door 81
  - stapler/stacker 95, 101, 111
  - Tray 1 81
  - Tray 2 85
- paper pickup problems
  - solving 78
- paper types
  - selecting (Mac) 53
  - selecting (Windows) 49

- paper, ordering 32
- part numbers
  - accessories 34
  - replacement parts 32
  - staple cartridges 32
  - supplies 32
  - toner cartridge 32
- ports
  - locating 7
- power connection
  - locating 6
- power switch
  - locating 5
- print on both sides
  - Mac 52
  - Windows 45
- printing
  - from USB storage accessories 61
  - stored jobs 57
- printing on both sides
  - settings (Windows) 43

## R

- replacement parts
  - part numbers 32
- replacing
  - imaging drums 38
  - toner cartridges 35
- restore factory settings 74
- right door
  - jams 81
  - locating 5
- RJ-45 port
  - locating 7

## S

- security
  - encrypted hard disk 71
- serial number
  - locating 6
- settings
  - restore factory 74
- Sign in
  - control panel 70
- Sign In button
  - locating 8
- Sign Out button
  - locating 8

- Sleep button
  - locating 8
- software
  - HP Utility 65
- special paper
  - printing (Windows) 49
- speed, optimizing 68
- stacker
  - staple jams 98
- staple cartridges
  - part numbers 32
- staple jams
  - booklet maker 108, 117
  - stapler/stacker 98
- stapler
  - locating 10
  - setting default staple location 29
- stapler/stacker
  - front left door, locating 10
  - hole punch, locating 10
  - jams 95, 101, 111
  - output bins, locating 10
  - output slot, locating 10
  - part number 34
  - staple jams 98
  - top left door, locating 10
- stapling
  - setting default location 29
- status
  - HP Utility, Mac 65
- status of product 8
- Stop button
  - locating 8
- storage, job
  - Mac settings 56
- stored jobs
  - creating (Mac) 56
  - creating (Windows) 54
  - deleting 57
  - printing 57
- storing jobs
  - with Windows 54
- supplies
  - low threshold settings 76
  - ordering 32
  - part numbers 32
  - replacing imaging drums 38
  - replacing toner cartridges 35

- status, viewing with HP Utility for
  - Mac 65
  - using when low 76
- supplies status 123
- system requirements
  - HP Embedded Web Server 64

## T

- toner cartridge
  - low threshold settings 76
  - part numbers 32
  - using when low 76
- toner cartridges
  - components 35
  - locating 5
  - replacing 35
- toner-cartridge status 123
- transparencies
  - printing (Windows) 49
- Tray 1
  - jams 81
  - paper orientation 16
- Tray 2
  - jams 85
  - loading 19
  - paper orientation 20, 25
- trays
  - capacity 2
  - configure 14
  - included 2
  - locating 5
- troubleshooting
  - jams 80
  - network problems 128
  - paper feed problems 78
  - wired network 128
- two-sided printing
  - settings (Windows) 43

## U

- USB port
  - enabling 61
  - locating 7
- USB storage accessories
  - printing from 61

## W

- Web browser requirements
  - HP Embedded Web Server 64

Web sites

HP Web Jetadmin, downloading

67