

Service Manual

HP DesignJet 230,  
HP DesignJet 250C,  
HP DesignJet 330 and  
HP DesignJet 350C  
Plotters

---

**For HP Internal Use Only**

© Copyright Hewlett-Packard Company 1996

This document contains proprietary information that is protected by copyright. All rights are reserved. No part of this document may be photocopied, reproduced, or translated into another language without the prior written consent of Hewlett-Packard Company.

HP internal order number C4699-90000

Second edition, March 1996

Printed in U.S.A.

**Warranty**

The information contained in this document is subject to change without notice.

**Hewlett-Packard makes no warranty of any kind with regard to this material, including, but not limited to, the implied warranties of merchantability and fitness for a particular purpose.**

Hewlett-Packard shall not be liable for errors contained herein or for incidental or consequential damages in connection with the furnishing, performance, or use of this material.

**WARNING**

The procedures described in this manual are to be performed by HP-qualified service personnel only.

**Electrical Shock Hazard**

Serious shock hazard leading to death or injury may result if you do not take the following precautions:

- Ensure that the ac power outlet (mains) has a protective earth (ground) terminal.
- Disconnect the plotter from the power source prior to performing any maintenance.
- Prevent water or other liquids from running onto electrical components or circuits, or through openings in the enclosure.

**Electrostatic Discharge**

Refer to the beginning of Chapter 6 of this manual, for precautions you should take to prevent damage to the plotter circuits from electrostatic discharge.

**Safety Symbols**

General definitions of safety symbols are given immediately after the table of contents.

---

Learning Products, Barcelona Division

Hewlett-Packard Española, S.A.

Avda. Graells, 501

08190 Sant Cugat del Vallès

Spain

---

# Service Manual

---

HP DesignJet 230,  
HP DesignJet 250C,  
HP DesignJet 330 and  
HP DesignJet 350C  
Plotters

---

## Using this Manual

### Purpose

This manual contains information necessary to test, calibrate and service:

- HP DesignJet 230 plotters (models C4694A and C4695A)
- HP DesignJet 250C plotters (models C3190A and C3191A)
- HP DesignJet 330 plotters (models C4701A and C4702A)
- HP DesignJet 350C plotters (models C4699A and C4700A)

For information about using these plotters, refer to the corresponding user and quick-reference guides.

### Readership

The procedures described in this manual are to be performed by HP-certified service personnel only.

### Training

The HP ongoing training course CEV2-TIJ provides training for HP Customer Engineers and Authorized Dealers, on servicing the complete HP DesignJet series of large-format, thermal-inkjet plotters.

### Part Numbers

Part numbers for plotter options, accessories and service parts are located in chapter 10.

### Conventions

This manual contains information for the monochrome HP DesignJet 230 and 330 plotters and the color HP DesignJet 250C and 350C plotters. To highlight the differences between the various plotters the following symbols will be used in the left margin:

230  
250C

This symbol indicates the information specific only to the HP DesignJet 230 and 250C.

330  
350C

This symbol indicates the information specific only to the HP DesignJet 330 and 350C.

All other information not marked by these symbols is applicable to all plotters.

The term **D/A1-size plotters** refers generically to models C3190A, C4694A, C4699A and C4701A. The term **E/A0-size plotters** refers generically to models C3191A, C4695A, C4700A and C4702A.

A small arrow **▶** is used to indicate other parts of the Service Manual or User's Guide where you can find information related to the topic you are consulting.

The **§** symbol is used to indicate the name of a referenced paragraph.

---

# Contents

Using this Manual .....	ii
Safety Symbols .....	x

## 1 Product Information

Applications .....	1-2
Drivers .....	1-2
Graphic Languages .....	1-2
Device-Control Languages .....	1-2
Interfaces .....	1-3
Network Connections .....	1-3
Memory .....	1-3
Accuracy .....	1-3
Resolution .....	1-4
Legs .....	1-4
Roll-feed .....	1-4
Upgrading a DesignJet 330 .....	1-4
Media .....	1-4

## 2 Site Planning and Requirements

Power Requirements .....	2-2
Choosing an Interface Cable (more ▶ User's Guide) .....	2-2
Choosing a Suitable Plotter Environment (more ▶ User's Guide) .....	2-3
Environmental Specifications .....	2-3
Plotter Dimensions and Weight .....	2-3

### 3 Installation and Configuration

Unpacking and Assembling the Plotter .....	3-2
Inspecting the Plotter for Damage .....	3-4
Repacking the Plotter .....	3-4
Assembling the Legs (Optional) .....	3-5
Assembling the Roll-Feed Assembly (Optional) .....	3-8
Installing the Plotter (more ♦ User's Guide) .....	3-12
Using the Plotter (more ♦ Quick Reference Guide) .....	3-12
DesignJet 230 Front Panel .....	3-12
DesignJet 250C Front Panel .....	3-12
DesignJet 330 Front Panel .....	3-13
DesignJet 350C Front Panel .....	3-13
Third-Party Inks and Off-Axis Ink Systems .....	3-14
Configuring the Plotter .....	3-14
Verifying Plotter Operation .....	3-14
Power-On Self-Tests .....	3-14
Demonstration Plot .....	3-14
Example of Setup Sheet (DesignJet 250C) .....	3-15
Example of Setup Sheet (DesignJet 350C) .....	3-16

### 4 Preventive Maintenance

Moisture on Plotter .....	4-2
Level of Plotter Usage .....	4-2
Friction on Slider Rod .....	4-2
Noisy Carriage Wheel .....	4-2
Ink Spilling .....	4-3
Belt Swelling .....	4-3
Cleaning the Roll-feed Assembly .....	4-3
Cleaning the Plotter .....	4-4
General Cleaning .....	4-4
Cleaning the Drive Roller .....	4-4

## 5 Functional Overview (more ▶ HP DesignJet 200/220 Service Manual)

Introduction	5-2
Loading Sheet Media	5-2
Loading Roll Media on the DesignJet 330 and 350C	5-4
Roll Media	5-5
Removing Static Charge from the Media	5-5
Gripping the Media	5-5
Pinch-Arm Sensor	5-5
Providing a Force on Top of the Media	5-6
Bail	5-6
Bail-Lift Mechanism	5-6
Moving the Carriage	5-6
Carriage-Drive Mechanics	5-6
Motor, Belt and Pulley	5-6
Carriage Guidance	5-6
Positional Feedback	5-6
Detecting the Lines and Media Edges	5-7
Line Sensor	5-7
Providing Ink	5-7
Print Cartridges	5-7
Distance between Carriage and Media	5-7
Producing an Image	5-8
Print-Mode Characteristics	5-8
Servicing the Cartridges	5-11
Service Station	5-11
Spittoon	5-11
Primer	5-11
Plotter Architecture	5-12
Electronics Module	5-13
Main-PCA Connections	5-13
Sensors	5-13
ROM	5-14
RAM	5-14
EEROM	5-14
Input/Output Interfaces	5-14
Bi-Tronics	5-14
RS-232-C	5-14
Power Supply	5-15
Water Condensation	5-15
Memory Usage	5-15
Plot Orientation	5-15
Raster Image Processor	5-15
Carriage PCA	5-16
Front Panel PCA	5-16

## 6 Removal and Replacement

Safety Precautions	6-2
ESD Precautions	6-2
Reassembly	6-2
Required Tools	6-3
Repair Procedures	6-4
Installing a RAM or ROM SIMM	6-4
Removing the Bail	6-5
Removing the Cartridge Caps and Wiper Blades	6-6
Removing the Top Cover	6-7
Removing the Roll-feed Assembly	6-8
Removing the Left End-Cover	6-9
Removing the Right End-Cover	6-10
Disconnecting the Front-Panel Assembly	6-12
Removing the Electronics Module	6-13
Removing the Media-Sensor Assembly	6-15
Replacing the Media-Sensor Assembly	6-16
Removing the Encoder Strip	6-17
Reinstalling the Encoder Strip	6-19
Removing the Right Bracket	6-21
Removing the Carriage Motor	6-21
Removing the Spittoon	6-23
Removing the Spittoon	6-24
Removing the Pinch-Arm Sensor	6-25
Removing the Drive-Roller Gear	6-25
Removing the Media Motor	6-26
Removing the Pinch-Arm-Lever Linkage	6-27
Removing the Primer	6-27
Removing the Service Station	6-28
Removing the Bail-Lift Mechanism	6-29
Removing the Engaging-Lever Support	6-31
Removing the Overdrive Roller	6-32
Removing the Back Cover	6-33
Removing the Trailing Cable	6-34
Repositioning the Trailing Cable	6-35
Removing the Trailing-Cable Guide	6-36
Removing the Cartridge Carriage	6-37
Removing the Drive Belt	6-39
Removing the Drive-Belt Pulley	6-40
Removing the Drive Roller	6-41
Reinstalling the Drive Roller	6-42
Removing the Pinch-Arm Lift Mechanism	6-44
Reinstalling the Pinch-Arm Lift Mechanism	6-45
Removing the Overdrive Enclosure	6-46
Reinstalling the Overdrive Enclosure	6-47
Removing the Entry Platen	6-48
Reinstalling the Entry Platen	6-49



## 7 Calibrations and Adjustments

When to Calibrate the Plotter	7-2
Black Cartridge Alignment (See ♦ User's Guide, chapter 1)	7-2
Color Cartridge Test (See ♦ User's Guide, chapter 3)	7-2
Service Modes	7-3
Entering Service Mode 1	7-3
Entering Service Mode 2	7-4
Stopping a Test	7-4
Front-Panel Keys in Service Mode	7-5
Pressing Two Keys Together	7-5
Software Diagnostics and Hardware Tools	7-5
Service-Mode 1 (DesignJet 230)	7-6
Service-Mode 2 (DesignJet 250C)	7-6
Service-Mode 1 (DesignJet 330)	7-7
Service-Mode 2 (DesignJet 350C)	7-7
Accuracy Calibrations	7-8
Adjusting the Carriage-to-Media Distance	7-11

## 8 Troubleshooting

Power-On	8-2
Self Test and Initialization	8-2
What You Should See and Hear	8-3
Front-Panel LEDs	8-5
Error Codes for the DesignJet 230 and 250C Plotters	8-6
No LEDs On	8-6
LEDs On (Error Off)	8-6
LEDs Flashing	8-7
Error LED On	8-9
Error Codes for the DesignJet 330 and 350C Plotters	8-13
No LEDs On	8-13
LEDs On (Error Off)	8-13
LEDs On or Flashing	8-13
LEDs Flashing	8-14
Error LED On	8-15
System Errors for the DesignJet 230 and 250C Plotters	8-19
System Errors for the DesignJet 330 and 350C Plotters	8-23
EEROM Errors	8-27
EEROM Model ID Configuration Procedure for the DesignJet 330 and 350C	8-28
Troubleshooting Tips	8-30
Service Tests	8-35
Which Service Test to Perform	8-35
Viewing Test Output on an HP Palmtop PC	8-36
Bail Cycle Test	8-37
Bench Run	8-38
Carriage-Axis Test	8-38

Carriage Test for the DesignJet 230 and 250C .....	8-39
Carriage Test for the DesignJet 330 and 350C .....	8-40
Electrical Test .....	8-41
Front-Panel Test .....	8-42
Input/Output Test for the DesignJet 230/250C Only .....	8-43
Media-Axis Test .....	8-44
Modular Test .....	8-45
Print-Quality Plot .....	8-46
Sensors Test for the DesignJet 230 and 250C .....	8-47
Sensors Test for the DesignJet 330 and 350C .....	8-48
Service Configuration Plot for the DesignJet 230 and 250C .....	8-49
Service Configuration Plot for the DesignJet 330 and 350C .....	8-50
Printing the Service Configuration Plot .....	8-51
Service Monitor (Data Display) .....	8-52
Servo/Encoder Test .....	8-53
Clearing the EEROM for the DesignJet 230 and 250C .....	8-54
Clearing the EEROM for the DesignJet 330 and 350C .....	8-55
Print-Quality Troubleshooting .....	8-56
Print-Quality Plot .....	8-56
Banding .....	8-57
Uneven Fill Density .....	8-58
Lightfastness .....	8-58
Spray .....	8-58
Vertical-Line Straightness (VLS) .....	8-59
Ink Smearing .....	8-60
Hue Changes .....	8-60
Starwheel Marks .....	8-60
Misaligned Colors .....	8-61
Bleeding, Blooming and Wicking .....	8-61

## **9 Product History and Service Notes**

Introduction .....	9-2
Serial-Number Format .....	9-2
Firmware Revision Level .....	9-3
Obtaining Service Notes with Graphics .....	9-4
From a PC .....	9-4
From a UNIX Workstation .....	9-4
Problem Reading the Setup Sheet .....	9-5

## **10 Parts and Diagrams**

Exchange Assemblies .....	10-2
Replacement Parts .....	10-3
Part Lists and Exploded-View Diagrams .....	10-4
Legs .....	10-4
Top and Back Covers, Electronics, Trailing Cable .....	10-6
End Covers .....	10-8
Carriage-Axis (Left End) .....	10-10
Carriage-Axis (Right End) .....	10-12
Service Station, Primer, Spittoon .....	10-14
Media Entry Path .....	10-16
Bail and Overdrive .....	10-18
Pinch-Arm Assembly .....	10-22
Roll-Feed Assembly .....	10-24
Accessories .....	10-26
Interface Cables .....	10-29

## **11 Support Services**

Hewlett-Packard support services in the United States .....	11-2
Hewlett-Packard support services in Europe .....	11-4
Hewlett-Packard support services in Asia-Pacific .....	11-8

---

## General Definition of Safety Symbols



International caution symbol (refer to manual): the product is marked with this symbol when it is necessary for the user to refer to the instruction manual in order to protect themselves and the instrument against damage.



Indicates dangerous voltage (terminals fed from the interior by voltage exceeding 1000 volts must also be marked).

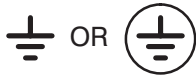

Protective conductor terminal. For protection against electrical shock in case of a fault. Used with field wiring terminals to indicate the terminal that must be connected to ground before operating equipment.



Low-noise or noiseless, clean ground (earth) terminal. Used for a signal common, as well as providing protection against electrical shock in case of a fault. A terminal marked with this symbol must be connected to ground in the manner described in the installation (operating) manual, and before operating the equipment.

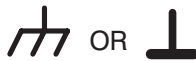

Frame or chassis terminal. A connection to the frame (chassis) of the equipment, which normally includes all exposed metal.



Alternating current



Direct current



Alternating or direct current

---

**WARNING**

---

The WARNING sign denotes a hazard. It calls attention to a procedure, practice, or the like, which, if not correctly performed or adhered to, could result in personal injury.



Take care not to cut yourself on the encoder strip inside the plotter.

---

**CAUTION**

---

The CAUTION sign denotes a hazard. It calls attention to an operating procedure, practice, or the like, which, if not correctly performed or adhered to, could result in damage to or destruction of part or all of the product.

---

1

---

Product  
Information

---

## Description

### Applications

HP DesignJet 230 and 330 (monochrome) and HP DesignJet 250C and 350C (color) plotters are large-format, ink-jet plotters that print output from software applications, on paper and other media.

The plotters produce large-format plots of high resolution and quality for the following sectors:

- Computer-aided design (CAD)
- Computer-aided manufacturing (CAM)
- Mapping
- Mechanical and architectural drawing
- General drafting

### Drivers

Software drivers for the following applications are supplied with the plotters:

- AutoCAD for DOS
- AutoCAD for Windows
- MicroSoft Windows Applications

(Other application software ▶ User's Guide, chapter 1.)

### Graphic Languages

The plotters accept drawing data in the following graphic languages:

- Hewlett-Packard Graphics Language (HP-GL), a vector language
- HP-GL/2, an enhanced version of HP-GL
- Hewlett-Packard Raster Transfer Language (HP-RTL), a raster language

When receiving HP-GL/2 data, the plotters can recognize and output the Kana-8, Kanji, and Roman character sets.

### Device-Control Languages

The plotters support the following languages, enabling the user to read certain plotter settings from the computer:

- Printer Job Language (PJM)
- Printer Management Language (PML)

## Interfaces

The plotters operate with a variety of computer systems through either the serial, RS-232-C port or the parallel, Bi-Tronics, extended-capability port (ECP).

An autoswitching feature enables the plotter to detect from which interface it is receiving data, so you can send data through either interface without having to change the plotter settings. (More on interfaces ▶ chapter 5, § *Input/Output Interfaces*.)

## Network Connections

You can connect the plotters to a network through an optional *HP JetDirect EX* or *HP JetDirect EX Plus3* external print server. The range of network operating systems that are supported are as follows:

Local Area Network	Network Operating System	Computer Operating System
Ethernet	Novell Netware	DOS, Windows
	LAN Manager	DOS, Windows
	TCP/IP	HP-UX, Sun OS, Solaris
	TCP/IP	IBM AIX
	EtherTalk	Macintosh, Apple Products
Token Ring	Novell Netware	DOS, Windows
	LAN Manager	DOS, Windows
	TCP/IP	HP-UX, Sun OS, Solaris, IBM AIX

The print server includes a network autoswitching feature and can detect from which network it is receiving data. This enables you to send data through different networks without having to change the interface settings.

## Memory

The plotters have a standard 4 megabytes of on-board random access memory (RAM). They also have one RAM-expansion socket, which can hold an optional 4-, 8-, 16- or 32-megabyte, single in-line memory module (SIMM). The maximum RAM is 36 MB.

## Accuracy

The accuracy of the plotters in drawing a vector is  $\pm 0.38$  mm (0.015 in) or  $\pm 0.2\%$  of the specified vector length, whichever is greater, at 23 °C (73 °F) at 50-60% relative humidity, on HP Inkjet 0.012-cm (0.0048-inch) polyester film.

## Resolution

The resolution of the plotter output is measured in dots per inch (dpi). The plotter resolutions for different plot-quality settings are as follows (see also [chapter 5](#)):

Print Quality	Monochrome Plotting	Color Plotting
Fast	300 x 300 dpi	300 x 300 dpi
Normal	Addressable 600 x 600 dpi	300 x 300 dpi
Best	Addressable 600 x 600 dpi	300 x 300 dpi

230  
250C

### Legs

The plotter legs are optional. The E/A0-size legs include a media diverter to prevent large media sizes from hitting the ground. The D/A1-size legs have no media diverter.

330  
350C

### Roll-feed and Legs

The roll-feed assembly and legs are optional. The E/A0-size legs include a media diverter to prevent large media sizes from hitting the ground. The D/A1-size legs have no media diverter. For additional information on the roll-feed assembly [chapter 5](#).

330  
350C

### Upgrading a DesignJet 330

Users can order an upgrade kit to upgrade a DesignJet 330 to a Designjet 350C. The kit can be installed by the user. For additional information [User's Guide, chapter 6](#).

## Media Types (See also [HP Media Reference Guide](#))

Monochrome Plotting	Color Plotting
Plain paper and plotter paper	HP special inkjet paper
Plain vellum (HP preferred)	or equivalent non-HP media
Plain translucent paper (HP preferred)	
HP single-matte polyester film	

330  
350C

For additional media types available [User's Guide, chapter 2, § \*Choosing media\*](#).



## Media Sizes

230  
250C

The DesignJet 230 and 250C plotters handle only sheet media, not roll media.

330  
350C

The DesignJet 330 and 350C plotters handle sheet media **and** roll media.

Sheet media must not exceed the maxima and minima shown here:

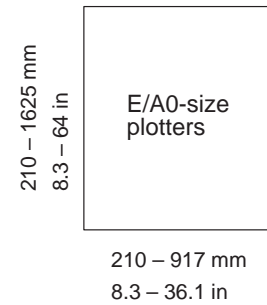
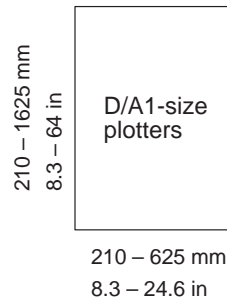

## Media Margins

The media margins define the real available plotting area on the media:

17 mm = 0.67 in  
5 mm = 0.2 in  
All measurements +/- 2mm (0.08 in)

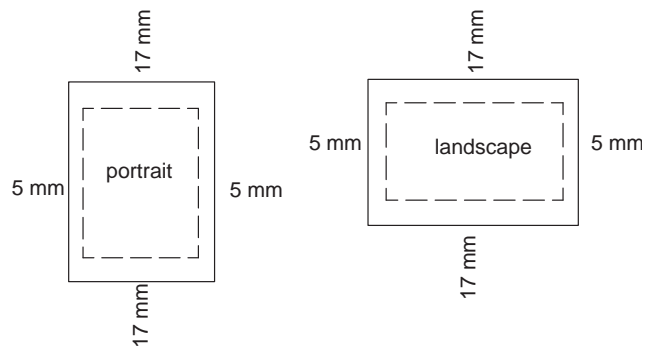

**Notes**

---

Site Planning and  
Requirements

---

## Power Requirements

HP DesignJet 230 and 330 and HP DesignJet 250C and 350C plotters have self-adjusting power supplies and do not require a voltage selector or switch settings prior to use. The table below lists the power requirements for the plotters.

Power Requirements

Source Voltage Requirements:	Voltage	Max current (rms)
	100 V ac	1.40 A
	120 V ac	1.17 A
	220 V ac	0.64 A
	240 V ac	0.60 A
Normal Operating Range:	90 to 264 V ac	
Frequency:	47-63 Hz	
Consumption:	140 watts maximum	

---

### WARNING

**The ac power outlet (mains) must have a protective earth (ground) terminal. Serious shock hazard leading to death or injury may result if the plotter is not properly grounded.**

---

---

## Choosing an Interface Cable

(Instructions ▶ User's Guide, chapter 1, § *Connect the plotter to your computer.*)

**Serial (RS-232-C) Interface** A short cable (less than 15 meters or 50 feet) is recommended for the RS-232-C interface. A longer cable is permissible, provided the load capacitance does not exceed 2500 picofarads.

**Parallel (Bi-Tronics/Centronics) Interface** Use a short cable (less than 2 meters or 6.6 feet) for the parallel interface.

(Interface descriptions ▶ Service Manual, chapter 5, § *Input/Output Interfaces.*)

230  
250C

(Pin specifications ▶ User's Guide, chapter 5, § *Interface specifications.*)

330  
350C

(Pin specifications ▶ User's Guide, chapter 10, § *Interface specifications.*)

(Cable part numbers ▶ Service Manual, chapter 10.)

## Choosing a Suitable Plotter Environment

(Instructions ▶ User's Guide, chapter 1, § *Position the plotter.*)

### Environmental Specifications

Hardware:		Environmental Class B2	
<b>Operating environment:</b>		<b>Temperature</b>	<b>Relative Humidity</b>
Plotter		0 to 55°C (32 to 131°F)	5-25%
With cartridges and media:		15 to 35°C (59 to 95°F)	20-80%
<b>Storage environment:</b>		<b>Temperature</b>	<b>Relative Humidity</b>
Plotter/media		-40 to +70°C (-40 to +158°F)	5-95%
Cartridges		-40 to +40°C (-40 to +104°F)	
<b>Acoustics:*</b>		<b>Sound Pressure</b>	<b>Sound Power</b>
Operating	D/A1-size plotters E/A0-size plotters	43 dB (Acoustic) 45 dB (A)	6.0 bels (A)
Idle		< 20 dB (A)	< 3.6 bels (A)

\*These specifications are typical sound pressures at a one-meter bystander position. Idle specification assumes fan is off.

### Plotter Dimensions and Weight

Plotter Model:	D/A1-size plotters	E/A0-size plotters
Length	1028 mm (40.5 in)	1327 mm (52.2 in)
Depth	237 mm (9.3 in)	237 mm (9.3 in)
Height (window closed)	327 mm (12.9 in)	327 mm (12.9 in)
Weight	26 kg (57.2 lb)	31 kg (68.2 lb)

**Notes**

---

Installation and  
Configuration

## Unpacking and Assembling the Plotter

When the plotter arrives at the user site:

- 1 Inspect the shipping container for damage.

*If the shipping container shows signs of damage, retain it until you have checked the contents of the shipment and verified the performance of the plotter.*

- 2 Unpack and assemble the plotter, following the series of illustrations below.

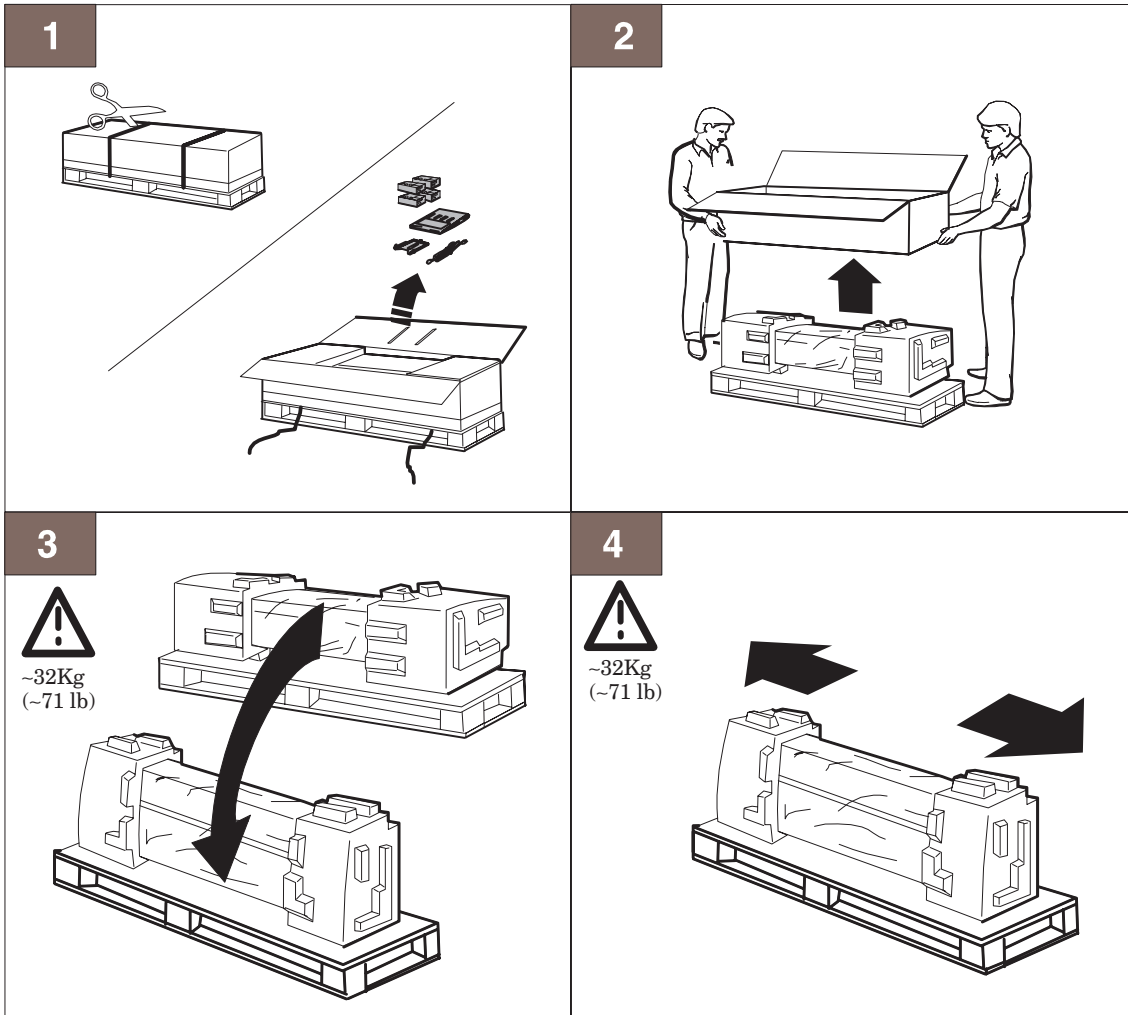



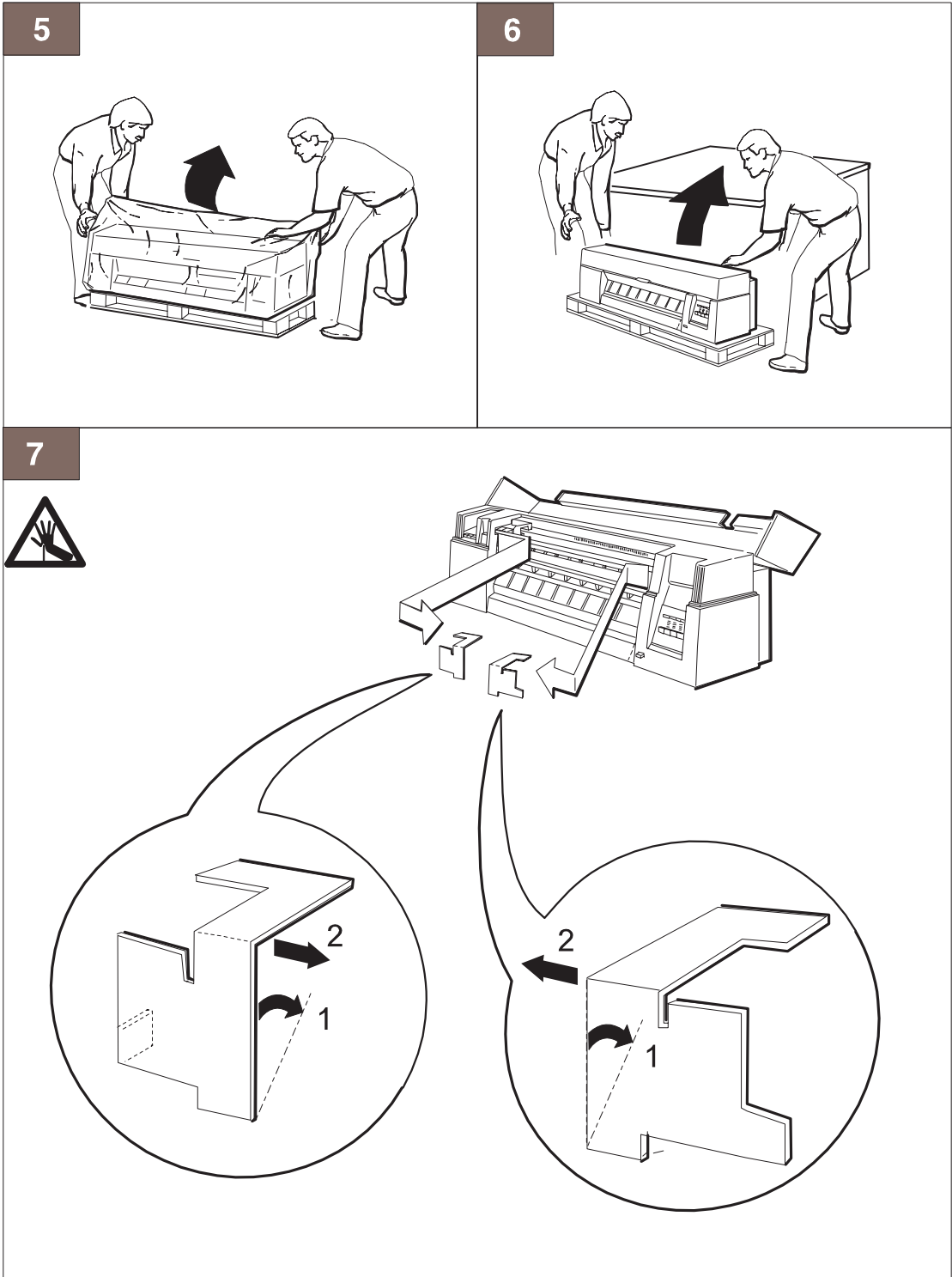

8

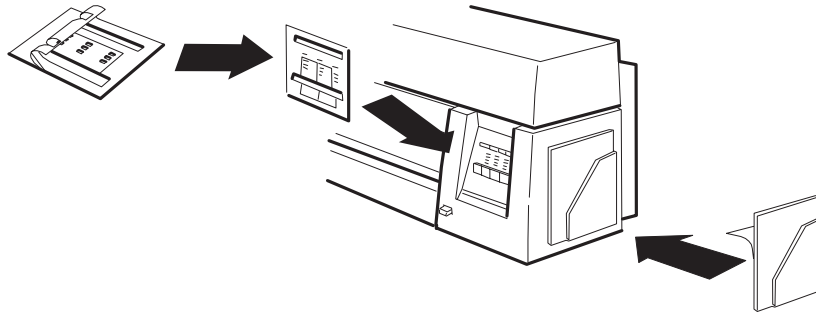

---

## Inspecting the Plotter for Damage

Visually inspect the plotter for damage, scratches, dents, or other mechanical defects. If the plotter is damaged in transit, notify the carrier and the nearest HP Sales and Support Office. Retain the shipping container and insulation material for the carrier's inspection. The Sales and Support Office will arrange for the repair or replacement of the plotter.

## Repacking the Plotter

You can order a repacking kit if you need to repack the plotter and don't have the shipping container and insulation material. (Part numbers ▶ chapter 10.)

## Assembling the Legs (Optional)

If the user has purchased the optional legs for the plotter, assemble them following the series of illustrations below:

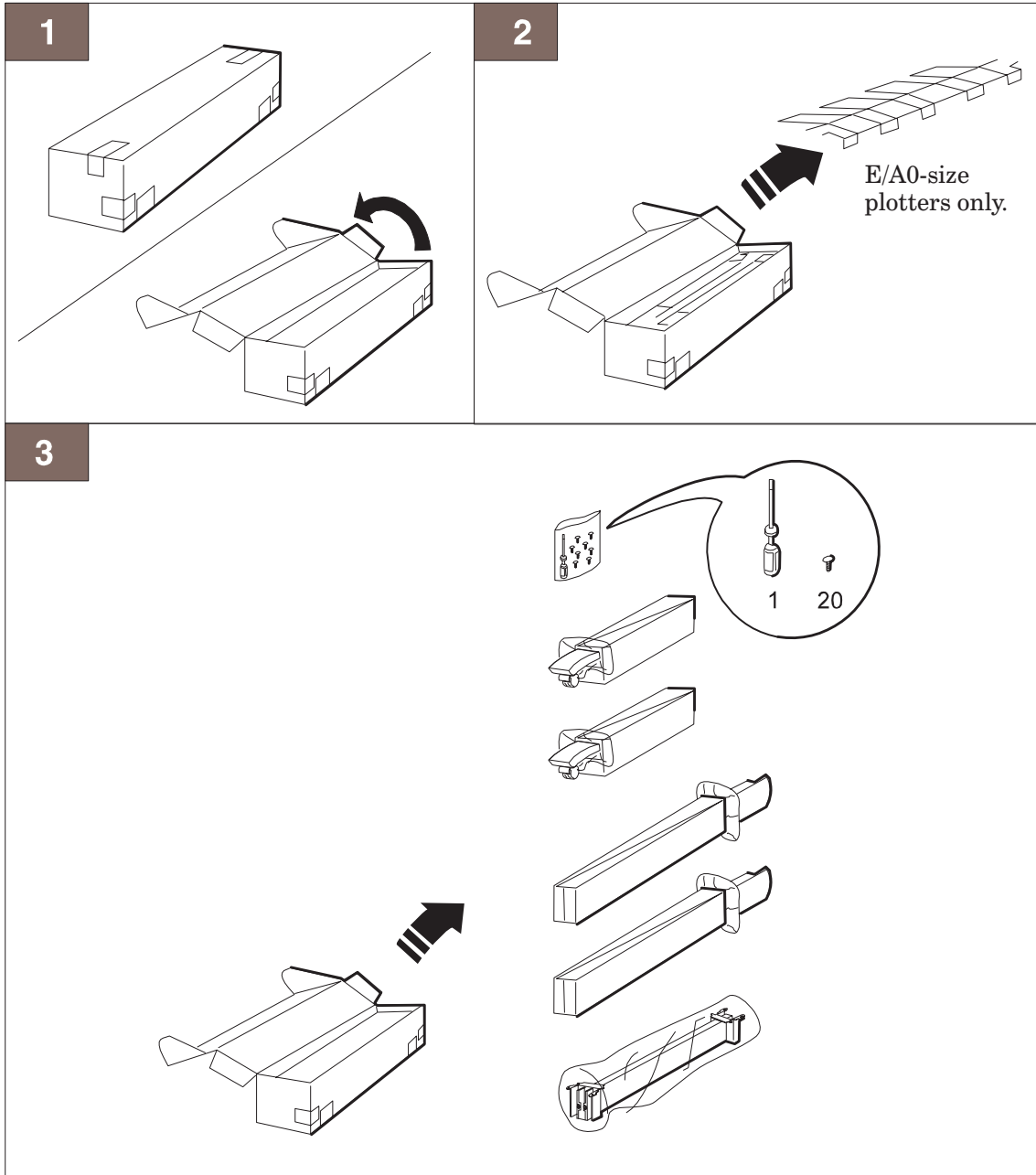

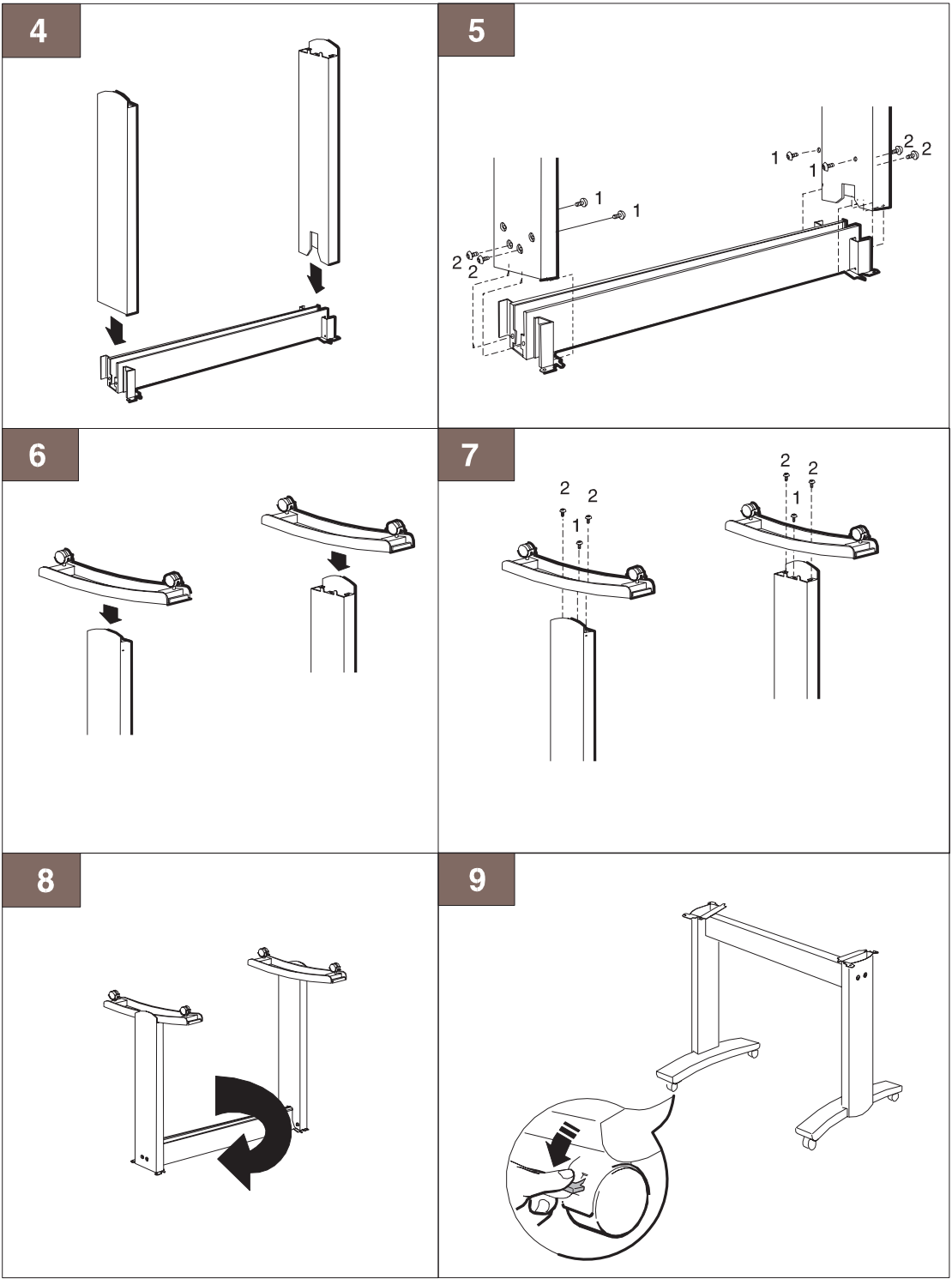

10



~32Kg  
(~71 lb)

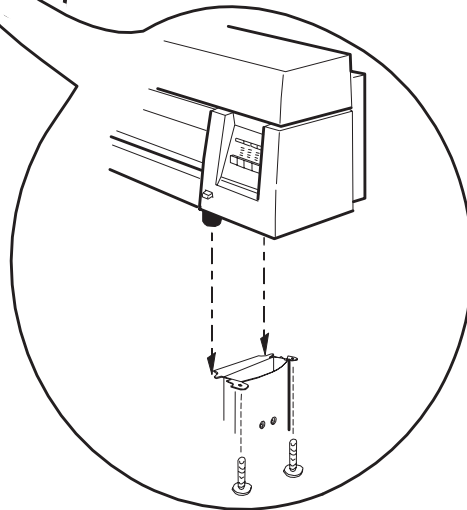
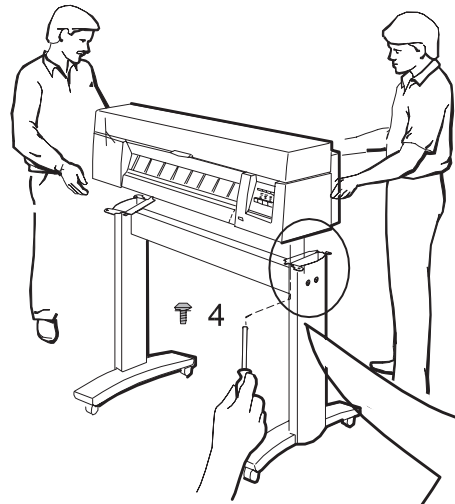

11

E/A0-size  
plotters only.

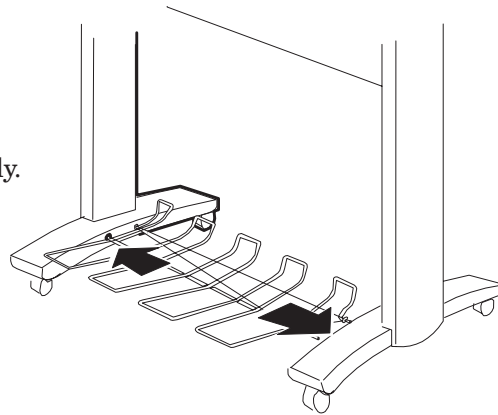

330  
350C

## Assembling the Roll-Feed Assembly (Optional)

If the user has purchased the optional roll-feed assembly for the plotter, assemble it following the series of illustrations below:

1

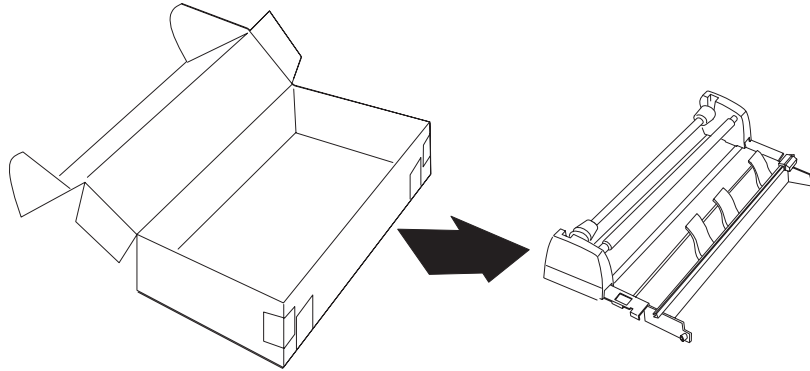

2

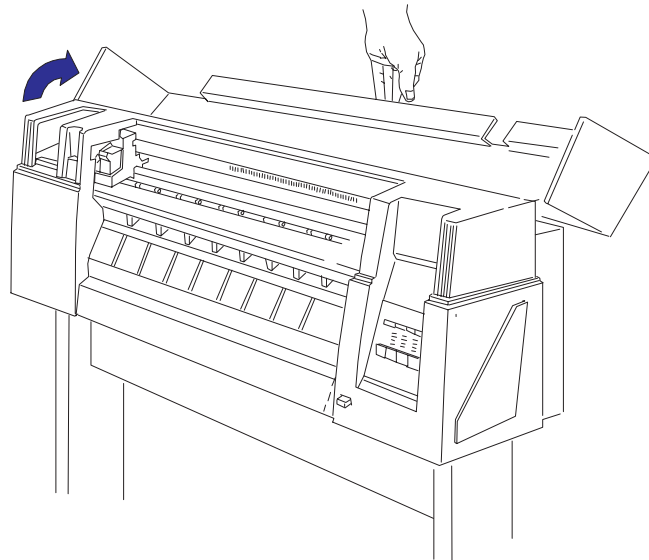

3

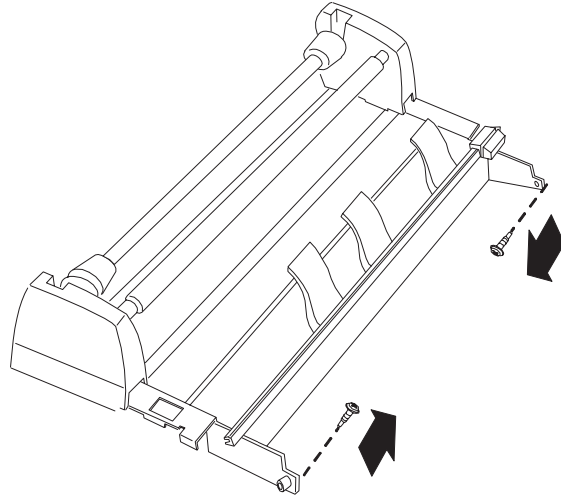

4

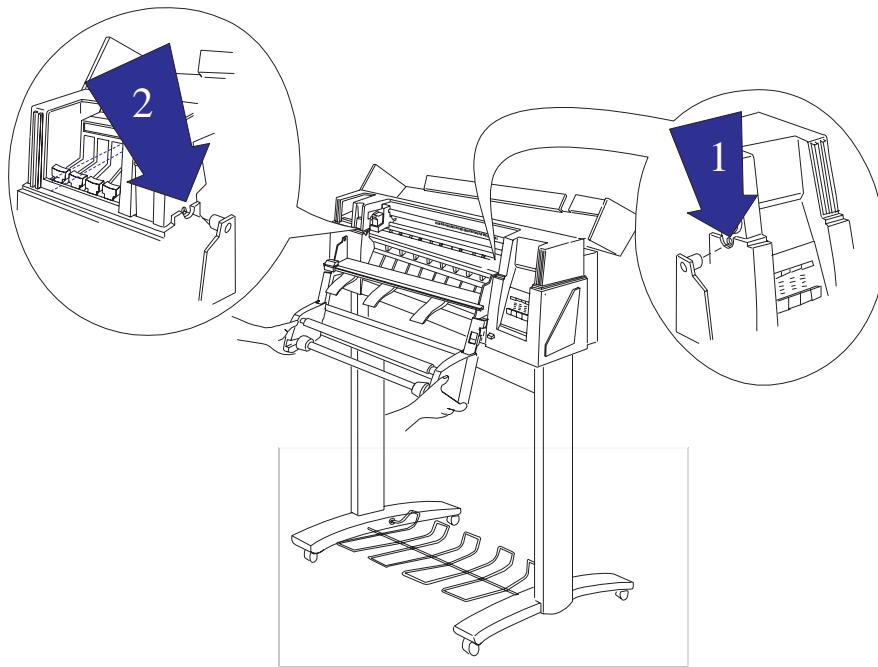

5

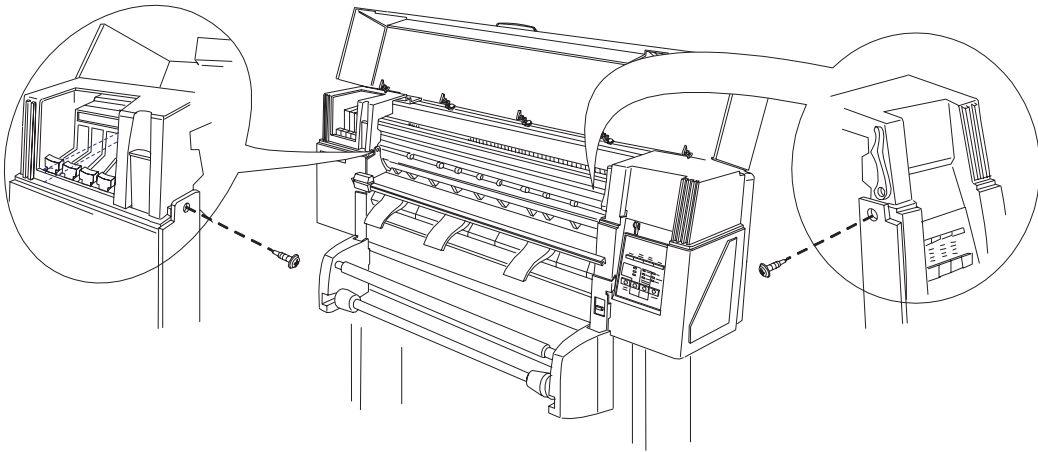

6

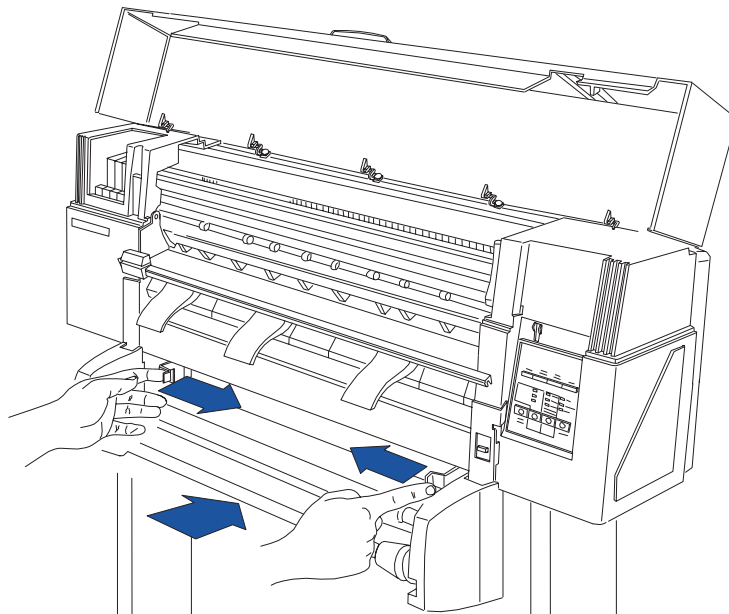



7

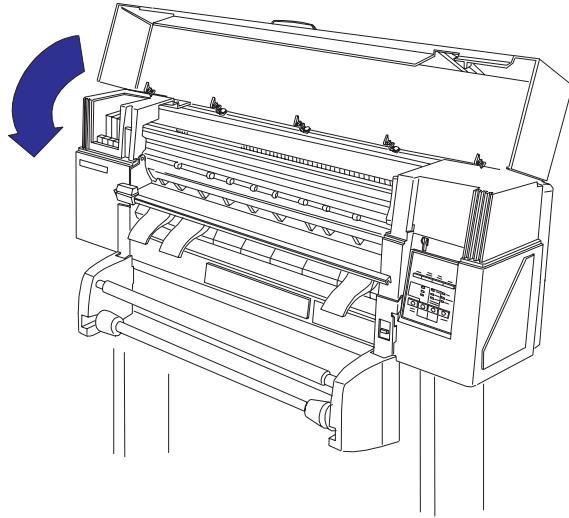

8

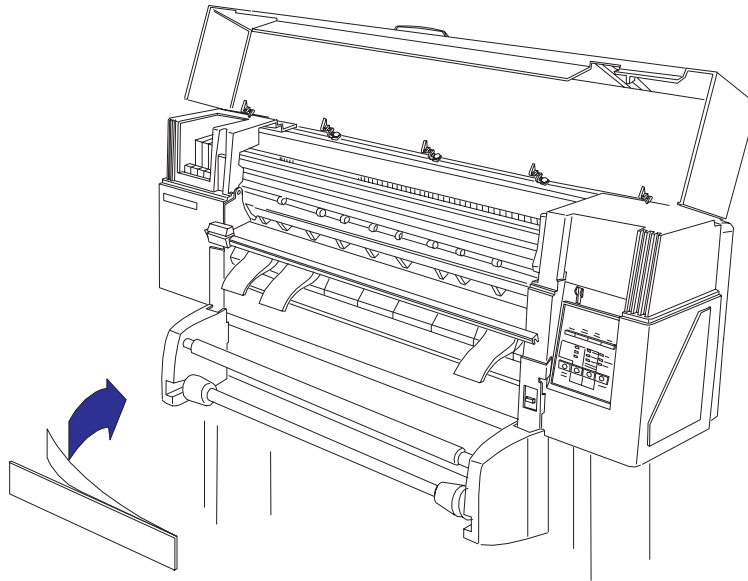

---

## Installing the Plotter

(Instructions ▶ User's Guide, chapter 1, *Setting up the plotter.*)

---

## Using the Plotter

(Instructions ▶ *Quick Reference Guide.*)

### DesignJet 230 Front Panel

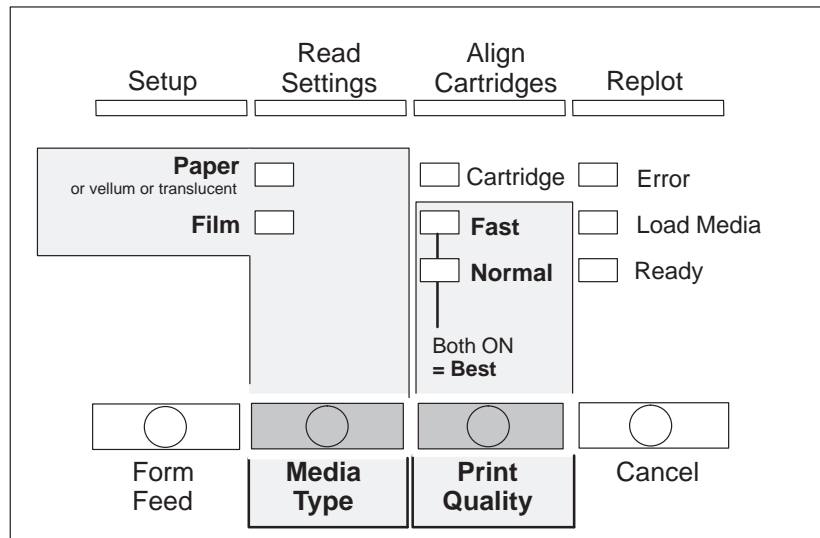

### DesignJet 250C Front Panel

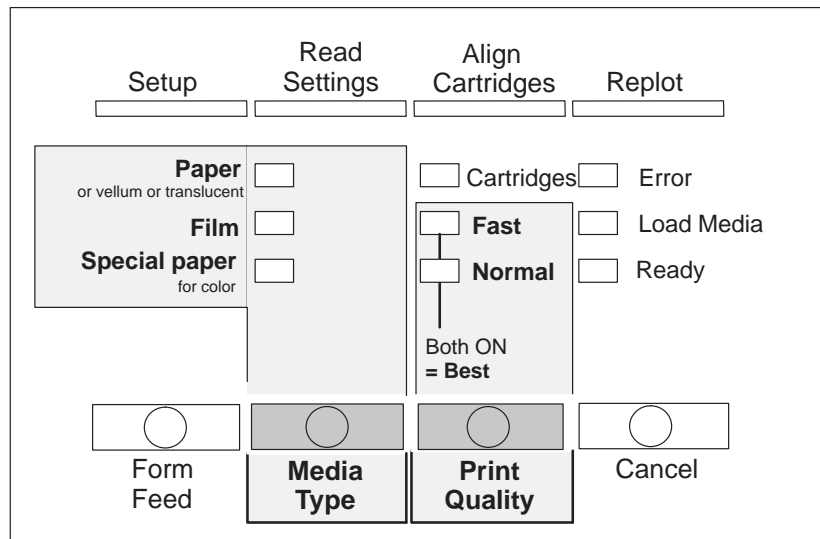

## DesignJet 330 Front Panel

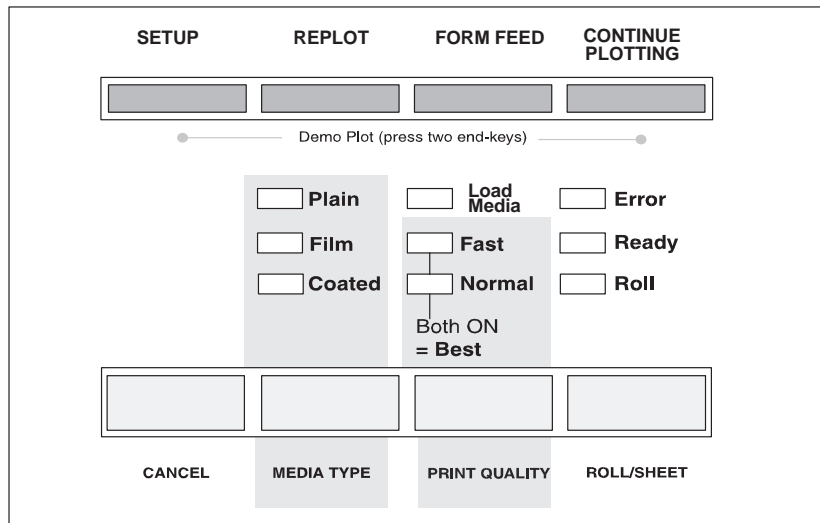

## DesignJet 350C Front Panel

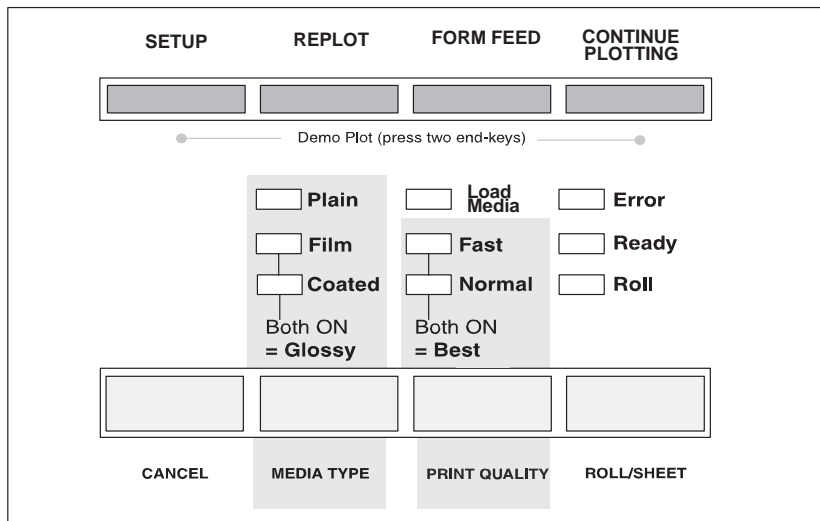

## Third-Party Inks and Off-Axis Ink Systems

HP does not support third-party inks or off-axis ink systems for use with any of its DesignJet series plotters or printers. If a failure or damage to such HP products is found to be directly attributed to the use of third-party inks or off-axis ink systems (or any other non-supported HP supply or accessory), the repair will NOT be covered under HP's warranty or maintenance contract. In such cases, standard time and material charges will be applied to service the plotter or printer.

---

## Configuring the Plotter

The User's Guide describes how to configure the following settings using a *setup sheet* :

- Language of demonstration plot, setup sheet and cartridge-alignment sheet
- Baud rate and parity of serial interface
- Graphics language
- Input/output timeout period
- Plot orientation (rotate and mirror) and line merging
- Color/monochrome
- Page size
- Pen-palette settings (width and density)

330  
350C

Examples of the setup sheets are given on the following pages.

You can change between pattern, scatter and cluster half-toning by means of a software driver.

---

## Verifying Plotter Operation

The plotters contain several types of internal operational checks and tests to ensure that the plotter is properly functioning and to help identify problems if any are detected.

### Power-On Self-Tests

Whenever you switch the plotter on, it automatically performs a series of internal self-tests and mechanical initialization sequences. If a failure occurs, an error is indicated on the front-panel LEDs. You can perform a failure analysis by interpreting the LED error code. (Details ▶ chapter 8.)

### Demonstration Plot

You can check proper plotter operation by plotting and examining the demonstration plot, which is resident in the plotters. This plot shows different plotter capabilities including pen line widths and shading. You can set the demonstration plot, to plot in any of the languages listed in the **Language** box of the setup sheet on the following page.

(Instructions ▶ User's Guide, chapter 1, § *Change the language*,  
▶ User's Guide, chapter 1, § *Send a sample plot or demo plot*.)

230  
250C

## Example of Setup Sheet

The following is a scaled version of a DesignJet 250C setup sheet (setup sheet for Designjet 230 is very similar):

# HP DesignJet 250C Setup Sheet

Current setting=   
Desired setting=  Pencil or black pen

<b>1. Language</b> <input checked="" type="radio"/> English <input type="radio"/> Français <input type="radio"/> Deutsch <input type="radio"/> Español <input type="radio"/> Italiano <input type="radio"/> Português <input type="radio"/> 日本語	<b>2. Serial Interface</b> <table style="width: 100%;"> <tr> <th style="text-align: left;">Baud Rate</th> <th style="text-align: left;">Parity</th> </tr> <tr> <td><input type="radio"/> 1200</td> <td><input checked="" type="radio"/> None</td> </tr> <tr> <td><input type="radio"/> 2400</td> <td><input type="radio"/> Even</td> </tr> <tr> <td><input type="radio"/> 4800</td> <td><input type="radio"/> Odd</td> </tr> <tr> <td><input checked="" type="radio"/> 9600</td> <td></td> </tr> <tr> <td><input type="radio"/> 19200</td> <td></td> </tr> <tr> <td><input type="radio"/> 38400</td> <td></td> </tr> </table>	Baud Rate	Parity	<input type="radio"/> 1200	<input checked="" type="radio"/> None	<input type="radio"/> 2400	<input type="radio"/> Even	<input type="radio"/> 4800	<input type="radio"/> Odd	<input checked="" type="radio"/> 9600		<input type="radio"/> 19200		<input type="radio"/> 38400		<b>3. Graphics Language</b> <input checked="" type="radio"/> HP-GL(7586B) <input type="radio"/> HP-GL/2 <b>4. I/O Timeout</b> <input type="radio"/> 0.5 min <input type="radio"/> 1 min <input type="radio"/> 5 min <input checked="" type="radio"/> 30 min	<b>5. Plot Appearance</b> <input checked="" type="radio"/> Rotate off <input type="radio"/> Rotate 90° <hr/> <input checked="" type="radio"/> Mirror off <input type="radio"/> Mirror on <hr/> <input checked="" type="radio"/> Merge off <input type="radio"/> Merge on
Baud Rate	Parity																
<input type="radio"/> 1200	<input checked="" type="radio"/> None																
<input type="radio"/> 2400	<input type="radio"/> Even																
<input type="radio"/> 4800	<input type="radio"/> Odd																
<input checked="" type="radio"/> 9600																	
<input type="radio"/> 19200																	
<input type="radio"/> 38400																	

<b>6. Color/Mono</b> <input checked="" type="radio"/> Print color as color <input type="radio"/> Print color as grayscale	<b>7. Pen Settings</b> <input checked="" type="radio"/> Use settings from software <input type="radio"/> Use settings from tables below <p style="font-size: small; text-align: center;"><i>If you want these pen settings to take effect, don't forget to mark the oval above.</i></p> <table border="1" style="width: 100%; border-collapse: collapse; text-align: center;"> <thead> <tr> <th style="text-align: left;">Width (mm)</th> <th colspan="8">Pen Number</th> </tr> <tr> <th></th> <th>1</th><th>2</th><th>3</th><th>4</th><th>5</th><th>6</th><th>7</th><th>8</th> </tr> </thead> <tbody> <tr><td>0.13</td><td><input type="radio"/></td><td><input type="radio"/></td><td><input type="radio"/></td><td><input type="radio"/></td><td><input type="radio"/></td><td><input type="radio"/></td><td><input type="radio"/></td><td><input type="radio"/></td></tr> <tr><td>0.18</td><td><input type="radio"/></td><td><input type="radio"/></td><td><input type="radio"/></td><td><input type="radio"/></td><td><input type="radio"/></td><td><input type="radio"/></td><td><input type="radio"/></td><td><input type="radio"/></td></tr> <tr><td>0.25</td><td><input type="radio"/></td><td><input type="radio"/></td><td><input type="radio"/></td><td><input type="radio"/></td><td><input type="radio"/></td><td><input type="radio"/></td><td><input type="radio"/></td><td><input type="radio"/></td></tr> <tr><td>0.35</td><td><input type="radio"/></td><td><input type="radio"/></td><td><input type="radio"/></td><td><input type="radio"/></td><td><input type="radio"/></td><td><input type="radio"/></td><td><input type="radio"/></td><td><input type="radio"/></td></tr> <tr><td>0.50</td><td><input type="radio"/></td><td><input type="radio"/></td><td><input type="radio"/></td><td><input type="radio"/></td><td><input type="radio"/></td><td><input type="radio"/></td><td><input type="radio"/></td><td><input type="radio"/></td></tr> <tr><td>0.70</td><td><input type="radio"/></td><td><input type="radio"/></td><td><input type="radio"/></td><td><input type="radio"/></td><td><input type="radio"/></td><td><input type="radio"/></td><td><input type="radio"/></td><td><input type="radio"/></td></tr> <tr><td>1.00</td><td><input type="radio"/></td><td><input type="radio"/></td><td><input type="radio"/></td><td><input type="radio"/></td><td><input type="radio"/></td><td><input type="radio"/></td><td><input type="radio"/></td><td><input type="radio"/></td></tr> </tbody> </table> <table border="1" style="width: 100%; border-collapse: collapse; text-align: center;"> <thead> <tr> <th style="text-align: left;">Grayscale</th> <th>1</th><th>2</th><th>3</th><th>4</th><th>5</th><th>6</th><th>7</th><th>8</th> <th style="text-align: left;">Color</th> </tr> </thead> <tbody> <tr> <td>100% </td> <td><input type="radio"/></td><td><input type="radio"/></td><td><input type="radio"/></td><td><input type="radio"/></td><td><input type="radio"/></td><td><input type="radio"/></td><td><input type="radio"/></td><td><input type="radio"/></td> <td>Black</td> </tr> <tr> <td>80% </td> <td><input type="radio"/></td><td><input type="radio"/></td><td><input type="radio"/></td><td><input type="radio"/></td><td><input type="radio"/></td><td><input type="radio"/></td><td><input type="radio"/></td><td><input type="radio"/></td> <td>Red</td> </tr> <tr> <td>60% </td> <td><input type="radio"/></td><td><input type="radio"/></td><td><input type="radio"/></td><td><input type="radio"/></td><td><input type="radio"/></td><td><input type="radio"/></td><td><input type="radio"/></td><td><input type="radio"/></td> <td>Green</td> </tr> <tr> <td>40% </td> <td><input type="radio"/></td><td><input type="radio"/></td><td><input type="radio"/></td><td><input type="radio"/></td><td><input type="radio"/></td><td><input type="radio"/></td><td><input type="radio"/></td><td><input type="radio"/></td> <td>Yellow</td> </tr> <tr> <td>20% </td> <td><input type="radio"/></td><td><input type="radio"/></td><td><input type="radio"/></td><td><input type="radio"/></td><td><input type="radio"/></td><td><input type="radio"/></td><td><input type="radio"/></td><td><input type="radio"/></td> <td>Blue</td> </tr> <tr> <td>10% </td> <td><input type="radio"/></td><td><input type="radio"/></td><td><input type="radio"/></td><td><input type="radio"/></td><td><input type="radio"/></td><td><input type="radio"/></td><td><input type="radio"/></td><td><input type="radio"/></td> <td>Magenta</td> </tr> <tr> <td>5% </td> <td><input type="radio"/></td><td><input type="radio"/></td><td><input type="radio"/></td><td><input type="radio"/></td><td><input type="radio"/></td><td><input type="radio"/></td><td><input type="radio"/></td><td><input type="radio"/></td> <td>Cyan</td> </tr> </tbody> </table>	Width (mm)	Pen Number									1	2	3	4	5	6	7	8	0.13	<input type="radio"/>	<input type="radio"/>	<input type="radio"/>	<input type="radio"/>	<input type="radio"/>	<input type="radio"/>	<input type="radio"/>	<input type="radio"/>	0.18	<input type="radio"/>	<input type="radio"/>	<input type="radio"/>	<input type="radio"/>	<input type="radio"/>	<input type="radio"/>	<input type="radio"/>	<input type="radio"/>	0.25	<input type="radio"/>	<input type="radio"/>	<input type="radio"/>	<input type="radio"/>	<input type="radio"/>	<input type="radio"/>	<input type="radio"/>	<input type="radio"/>	0.35	<input type="radio"/>	<input type="radio"/>	<input type="radio"/>	<input type="radio"/>	<input type="radio"/>	<input type="radio"/>	<input type="radio"/>	<input type="radio"/>	0.50	<input type="radio"/>	<input type="radio"/>	<input type="radio"/>	<input type="radio"/>	<input type="radio"/>	<input type="radio"/>	<input type="radio"/>	<input type="radio"/>	0.70	<input type="radio"/>	<input type="radio"/>	<input type="radio"/>	<input type="radio"/>	<input type="radio"/>	<input type="radio"/>	<input type="radio"/>	<input type="radio"/>	1.00	<input type="radio"/>	<input type="radio"/>	<input type="radio"/>	<input type="radio"/>	<input type="radio"/>	<input type="radio"/>	<input type="radio"/>	<input type="radio"/>	Grayscale	1	2	3	4	5	6	7	8	Color	100%	<input type="radio"/>	<input type="radio"/>	<input type="radio"/>	<input type="radio"/>	<input type="radio"/>	<input type="radio"/>	<input type="radio"/>	<input type="radio"/>	Black	80%	<input type="radio"/>	<input type="radio"/>	<input type="radio"/>	<input type="radio"/>	<input type="radio"/>	<input type="radio"/>	<input type="radio"/>	<input type="radio"/>	Red	60%	<input type="radio"/>	<input type="radio"/>	<input type="radio"/>	<input type="radio"/>	<input type="radio"/>	<input type="radio"/>	<input type="radio"/>	<input type="radio"/>	Green	40%	<input type="radio"/>	<input type="radio"/>	<input type="radio"/>	<input type="radio"/>	<input type="radio"/>	<input type="radio"/>	<input type="radio"/>	<input type="radio"/>	Yellow	20%	<input type="radio"/>	<input type="radio"/>	<input type="radio"/>	<input type="radio"/>	<input type="radio"/>	<input type="radio"/>	<input type="radio"/>	<input type="radio"/>	Blue	10%	<input type="radio"/>	<input type="radio"/>	<input type="radio"/>	<input type="radio"/>	<input type="radio"/>	<input type="radio"/>	<input type="radio"/>	<input type="radio"/>	Magenta	5%	<input type="radio"/>	<input type="radio"/>	<input type="radio"/>	<input type="radio"/>	<input type="radio"/>	<input type="radio"/>	<input type="radio"/>	<input type="radio"/>	Cyan
Width (mm)	Pen Number																																																																																																																																																																	
	1	2	3	4	5	6	7	8																																																																																																																																																										
0.13	<input type="radio"/>	<input type="radio"/>	<input type="radio"/>	<input type="radio"/>	<input type="radio"/>	<input type="radio"/>	<input type="radio"/>	<input type="radio"/>																																																																																																																																																										
0.18	<input type="radio"/>	<input type="radio"/>	<input type="radio"/>	<input type="radio"/>	<input type="radio"/>	<input type="radio"/>	<input type="radio"/>	<input type="radio"/>																																																																																																																																																										
0.25	<input type="radio"/>	<input type="radio"/>	<input type="radio"/>	<input type="radio"/>	<input type="radio"/>	<input type="radio"/>	<input type="radio"/>	<input type="radio"/>																																																																																																																																																										
0.35	<input type="radio"/>	<input type="radio"/>	<input type="radio"/>	<input type="radio"/>	<input type="radio"/>	<input type="radio"/>	<input type="radio"/>	<input type="radio"/>																																																																																																																																																										
0.50	<input type="radio"/>	<input type="radio"/>	<input type="radio"/>	<input type="radio"/>	<input type="radio"/>	<input type="radio"/>	<input type="radio"/>	<input type="radio"/>																																																																																																																																																										
0.70	<input type="radio"/>	<input type="radio"/>	<input type="radio"/>	<input type="radio"/>	<input type="radio"/>	<input type="radio"/>	<input type="radio"/>	<input type="radio"/>																																																																																																																																																										
1.00	<input type="radio"/>	<input type="radio"/>	<input type="radio"/>	<input type="radio"/>	<input type="radio"/>	<input type="radio"/>	<input type="radio"/>	<input type="radio"/>																																																																																																																																																										
Grayscale	1	2	3	4	5	6	7	8	Color																																																																																																																																																									
100%	<input type="radio"/>	<input type="radio"/>	<input type="radio"/>	<input type="radio"/>	<input type="radio"/>	<input type="radio"/>	<input type="radio"/>	<input type="radio"/>	Black																																																																																																																																																									
80%	<input type="radio"/>	<input type="radio"/>	<input type="radio"/>	<input type="radio"/>	<input type="radio"/>	<input type="radio"/>	<input type="radio"/>	<input type="radio"/>	Red																																																																																																																																																									
60%	<input type="radio"/>	<input type="radio"/>	<input type="radio"/>	<input type="radio"/>	<input type="radio"/>	<input type="radio"/>	<input type="radio"/>	<input type="radio"/>	Green																																																																																																																																																									
40%	<input type="radio"/>	<input type="radio"/>	<input type="radio"/>	<input type="radio"/>	<input type="radio"/>	<input type="radio"/>	<input type="radio"/>	<input type="radio"/>	Yellow																																																																																																																																																									
20%	<input type="radio"/>	<input type="radio"/>	<input type="radio"/>	<input type="radio"/>	<input type="radio"/>	<input type="radio"/>	<input type="radio"/>	<input type="radio"/>	Blue																																																																																																																																																									
10%	<input type="radio"/>	<input type="radio"/>	<input type="radio"/>	<input type="radio"/>	<input type="radio"/>	<input type="radio"/>	<input type="radio"/>	<input type="radio"/>	Magenta																																																																																																																																																									
5%	<input type="radio"/>	<input type="radio"/>	<input type="radio"/>	<input type="radio"/>	<input type="radio"/>	<input type="radio"/>	<input type="radio"/>	<input type="radio"/>	Cyan																																																																																																																																																									

**2** →

**3** →

330  
350C

## Example of Setup Sheet

The following is a scaled version of a DesignJet 350C setup sheet (setup sheet for Designjet 330 is very similar):

# HP DesignJet 350C Setup Sheet

Current setting =    
 Desired setting =  Pencil or black pen

<b>1. Language</b> <input checked="" type="radio"/> English <input type="radio"/> Français <input type="radio"/> Deutsch <input type="radio"/> Español <input type="radio"/> Italiano <input type="radio"/> Português <input type="radio"/> 日本語	<b>2. Serial Interface</b> <table style="width: 100%;"> <tr> <td>Baud Rate</td> <td>Parity</td> </tr> <tr> <td><input type="radio"/> 1200</td> <td><input checked="" type="radio"/> None</td> </tr> <tr> <td><input type="radio"/> 2400</td> <td><input type="radio"/> Even</td> </tr> <tr> <td><input type="radio"/> 4800</td> <td><input type="radio"/> Odd</td> </tr> <tr> <td><input checked="" type="radio"/> 9600</td> <td></td> </tr> <tr> <td><input type="radio"/> 19200</td> <td></td> </tr> <tr> <td><input type="radio"/> 38400</td> <td></td> </tr> </table>	Baud Rate	Parity	<input type="radio"/> 1200	<input checked="" type="radio"/> None	<input type="radio"/> 2400	<input type="radio"/> Even	<input type="radio"/> 4800	<input type="radio"/> Odd	<input checked="" type="radio"/> 9600		<input type="radio"/> 19200		<input type="radio"/> 38400		<b>3. Graphics Language</b> <input checked="" type="radio"/> HP-GL (7586B) <input type="radio"/> HP-GL/2 <b>4. I/O Timeout</b> <input type="radio"/> 0.5 min <input type="radio"/> 1 min <input type="radio"/> 5 min <input checked="" type="radio"/> 30 min	<b>5. Plot Appearance</b> <input type="radio"/> Auto rotate <input checked="" type="radio"/> Rotate off <input type="radio"/> Rotate 90° <input checked="" type="radio"/> Mirror off <input type="radio"/> Mirror on <input checked="" type="radio"/> Merge off <input type="radio"/> Merge on	<b>6. Color/Mono</b> <input checked="" type="radio"/> Print color as color <input type="radio"/> Print color as grayscale
Baud Rate	Parity																	
<input type="radio"/> 1200	<input checked="" type="radio"/> None																	
<input type="radio"/> 2400	<input type="radio"/> Even																	
<input type="radio"/> 4800	<input type="radio"/> Odd																	
<input checked="" type="radio"/> 9600																		
<input type="radio"/> 19200																		
<input type="radio"/> 38400																		

**7. Page Size**  

Inked Area Software <input checked="" type="radio"/> Over-size <input type="radio"/> A1 <input type="radio"/> A2	JIS <input type="radio"/> Best <input type="radio"/> B1 <input type="radio"/> B2 <input type="radio"/> B3 <input type="radio"/> B4	ANSI <input type="radio"/> Best <input type="radio"/> E <input type="radio"/> D <input type="radio"/> C <input type="radio"/> B <input type="radio"/> A	ISO <input type="radio"/> Best <input type="radio"/> A0 <input type="radio"/> A1 <input type="radio"/> A2 <input type="radio"/> A3 <input type="radio"/> A4
---------------------------------------------------------------------------------------------------------------------	------------------------------------------------------------------------------------------------------------------------------------	---------------------------------------------------------------------------------------------------------------------------------------------------------	-------------------------------------------------------------------------------------------------------------------------------------------------------------

**8. Pen Settings**  
 Use settings from software  
 Use settings from tables below  

If you want these pen settings to take effect, don't forget to mark the oval above.

Width (mm)	Pen Number							
	1	2	3	4	5	6	7	8
0.13	<input type="radio"/>	<input type="radio"/>	<input type="radio"/>	<input type="radio"/>	<input type="radio"/>	<input type="radio"/>	<input type="radio"/>	<input type="radio"/>
0.18	<input type="radio"/>	<input type="radio"/>	<input type="radio"/>	<input type="radio"/>	<input type="radio"/>	<input type="radio"/>	<input type="radio"/>	<input type="radio"/>
0.25	<input type="radio"/>	<input type="radio"/>	<input type="radio"/>	<input type="radio"/>	<input type="radio"/>	<input type="radio"/>	<input type="radio"/>	<input type="radio"/>
0.35	<input checked="" type="radio"/>	<input checked="" type="radio"/>	<input checked="" type="radio"/>	<input checked="" type="radio"/>	<input checked="" type="radio"/>	<input checked="" type="radio"/>	<input checked="" type="radio"/>	<input checked="" type="radio"/>
0.50	<input type="radio"/>	<input type="radio"/>	<input type="radio"/>	<input type="radio"/>	<input type="radio"/>	<input type="radio"/>	<input type="radio"/>	<input type="radio"/>
0.70	<input type="radio"/>	<input type="radio"/>	<input type="radio"/>	<input type="radio"/>	<input type="radio"/>	<input type="radio"/>	<input type="radio"/>	<input type="radio"/>
1.00	<input type="radio"/>	<input type="radio"/>	<input type="radio"/>	<input type="radio"/>	<input type="radio"/>	<input type="radio"/>	<input type="radio"/>	<input type="radio"/>

Grayscale	1	2	3	4	5	6	7	8	Color
100%	<input checked="" type="radio"/>	<input checked="" type="radio"/>	<input checked="" type="radio"/>	<input checked="" type="radio"/>	<input checked="" type="radio"/>	<input checked="" type="radio"/>	<input checked="" type="radio"/>	<input checked="" type="radio"/>	Black
80%	<input type="radio"/>	<input type="radio"/>	<input type="radio"/>	<input type="radio"/>	<input type="radio"/>	<input type="radio"/>	<input type="radio"/>	<input type="radio"/>	Red
60%	<input type="radio"/>	<input type="radio"/>	<input type="radio"/>	<input type="radio"/>	<input type="radio"/>	<input type="radio"/>	<input type="radio"/>	<input type="radio"/>	Green
40%	<input type="radio"/>	<input type="radio"/>	<input type="radio"/>	<input type="radio"/>	<input type="radio"/>	<input type="radio"/>	<input type="radio"/>	<input type="radio"/>	Yellow
20%	<input type="radio"/>	<input type="radio"/>	<input type="radio"/>	<input type="radio"/>	<input type="radio"/>	<input type="radio"/>	<input type="radio"/>	<input type="radio"/>	Blue
10%	<input type="radio"/>	<input type="radio"/>	<input type="radio"/>	<input type="radio"/>	<input type="radio"/>	<input type="radio"/>	<input type="radio"/>	<input type="radio"/>	Magenta
5%	<input type="radio"/>	<input type="radio"/>	<input type="radio"/>	<input type="radio"/>	<input type="radio"/>	<input type="radio"/>	<input type="radio"/>	<input type="radio"/>	Cyan

3

Ready

Setup

---

Preventive Maintenance

---

## Moisture on Plotter

Users should use the plotter in an environment between 5% and 95% relative humidity. To recover from moisture condensation, turn the plotter off, and, using the main roller as a reference, wait until the plotter is completely dry before using it again. (Other environmental specifications ▶ chapter 2.)

---

## Level of Plotter Usage

To achieve good performance and long lifetime of the HP DesignJet 230/250C and HP DesignJet 330/350C plotters, users should limit use to the following recommendations (duty cycle):

Average number of plots per day	Maximum number of plots per day
10 E/A0 CAD plots	20 E/A0 CAD plots

The service configuration plot gives an indication of how much the plotter has been used: number of plots, number of cartridges, number of times the plotter has been turned on. (Details ▶ page 8-49/8-50.)

---

## Friction on Slider Rod

The carriage bushings are made of a porous composite material. Oil stays inside them by means of capillary action. Never place the bushings on an absorbant material. To prevent friction of the bushings on the slider rod, remove dirt from the slider rod and chassis beam. Apply oil (Anderol 4068, HP part number: 6040-0858) to the slider rod ( $\pm 3$  drops) and to the bushings if they are running dry.

---

## Noisy Carriage Wheel

To prevent noisy movement of the carriage, remove aluminum or dust particles from the wheel at the back of the carriage, and from the slider path along which the wheel moves.



---

## Ink Spilling

The service configuration plot gives an estimation of the amount of ink in the plotter's spittoon. (Details ▶ page 8-49 or 8-50.) To prevent ink spilling, replace both the spittoon and the ink-separator when the spittoon is almost full. About 880 primes are needed to fill up the ink-separator.

Note that if you clear the EEROM or replace the electronics module, the factory spittoon value is reset to 0% used. Keep in mind that the value printed on the service configuration plot may greatly underestimate the amount of ink in the spittoon. Future PC-based plotter diagnostics will enable you to download information from the old EEROM and upload it to the new EEROM.

---

## Belt Swelling

To prevent new belts from swelling incorrectly, keep them in their bags with dessicant until you need to install them.

---

## Cleaning the Roll-feed Assembly

Always clean the rubber diverter of the roll-feed assembly with a dry cloth. Never clean it with water or alcohol based substances.

---

## Cleaning the Plotter

To maintain the plotter in good operating condition, keep it free of dust accumulation, ink, and other contamination. Cleaning intervals are determined by the plotter environment and by the types of plotter supplies used.

---

### WARNING

**Disconnect the plotter from the power source prior to performing any cleaning. DO NOT allow liquid to run on to electrical components or circuits, or through openings in the enclosure, as this can create a shock hazard leading to death or injury.**

---

## General Cleaning

Proper general cleaning should include the following:

- 1 Blow away dust accumulation with compressed air if available.
- 2 Clean the outer surface of the plotter with a damp sponge or cloth. Use a mild soap and water solution if necessary. Do not use abrasive cleaners.
- 3 Wipe the plotter dry with a soft lint-free cloth.

## Cleaning the Drive Roller

Due to the ink's reflectance, ink spilled on the roller can disrupt the plotter's edge-sensing function. To remove any ink from the roller, perform the following procedure:

- 1 Connect the plotter to the ac power source.
- 2 Switch the plotter ON, and wait for it to finish initialization.
- 3 Open the top cover.
- 4 Keep the cover switch pressed while pressing **Form Feed** repeatedly until the stained area of the drive roller is positioned at the top where it can be cleaned.
- 5 Turn the plotter OFF, and **disconnect it** from the ac power source.
- 6 Apply IPA (alcohol) to a soft, lint-free rag.
- 7 Use the rag to clean the roller surface.
- 8 Allow the drive roller to dry.
- 9 If other areas of the roller have been stained by ink, repeat the above steps.
- 10 Reconnect the plotter to the ac source, turn the plotter on, and load paper to test that no ink reflections disrupt operation of media loading.

---

## Functional Overview

---

## Introduction

The HP DesignJet 330 and 350C follow on from and replace the DesignJet 230 and 250C. The HP DesignJet 230 and 250C originally replaced the DesignJet 220 but are now no longer produced.

The HP DesignJet 330 and 350C (like the DesignJet 230 and 250C) have inherited much of the system architecture and features of the DesignJet 220. Their writing system, however, is based on that of the DesignJet 650C.

This chapter describes only the main features new to the DesignJet 230 and 250C and DesignJet 330 and 350C. Before reading it, read the functional overview of the DesignJet 220 ♦ “*HP DesignJet 220 and HP DesignJet 200 Plotters – Service Manual*,” part number C3187-90000.

(Information on the DesignJet 650C ♦ “*HP C2858B/C2859B DesignJet 650C Service Manual*,” part number C2858-90000 Rev B).

---

## Loading Sheet Media

The actions performed by the plotters in loading sheet media are similar to those of the DesignJet 220. (There are some differences due to the different position of the media sensor.) The following diagram shows the sheet media-loading sequence. The vertical arrows represent movement of the media. The thick horizontal bars represent movement of the carriage to sense the media edges.

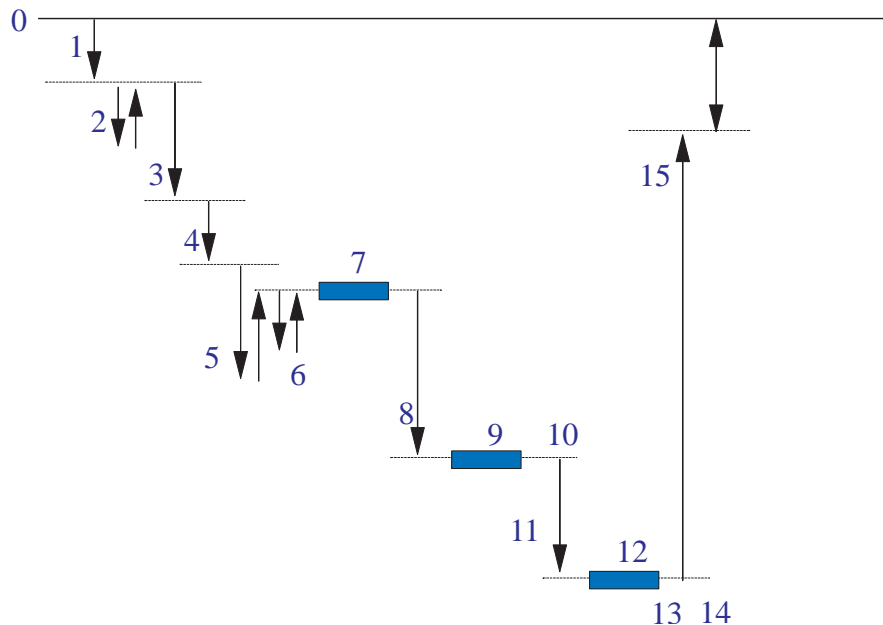

During sheet media loading, the plotter:

- 0** Detects the front edge of the media. (Media sensor located before pinch-arm stops.)
- 1** Grips and advances the media.
- 2** Moves the media forwards and backwards to check whether it is still present and correctly gripped.
- 3** Advances the media and rechecks media presence. (The loading process fails if the media sensor detects no media.)
- 4** Actuates the bail so that the media can advance under it.
- 5** Moves the media to a given absolute position.
- 6** Again moves the media forwards and backwards to check for its presence. (The loading process fails if the media sensor detects no media.)
- 7** Moves the carriage to sense the right and left edges and to check dimensions.
- 8** Advances the media six inches.
- 9** Checks the right edge of the media for skew (misalignment). (The loading process fails if the skew is greater than the allowed limits.)
- 10** If the media is slightly misaligned, the plotter gives you the opportunity to realign it. After realigning, the right edge of the media is checked again for skew (misalignment). (The loading process fails if the skew is greater than the allowed limits or if the aligned media is too far away from the load line.)
- 11** Advances the media until the media sensor detects the end of the media.
- 12** Checks the position of the right edge of the media.
- 13** Extrapolates the skew to the upper and lower edges of the media.
- 14** Calculates the media dimensions: print margin, length and width.
- 15** Moves the sheet to the printing position and resets the media-axis servo position.

330  
350C

## Loading Roll Media on the DesignJet 330 and 350C

The following diagram shows the Roll media-loading sequence. The vertical arrows represent movement of the media. The thick horizontal bars represent movement of the carriage to sense the media edges.

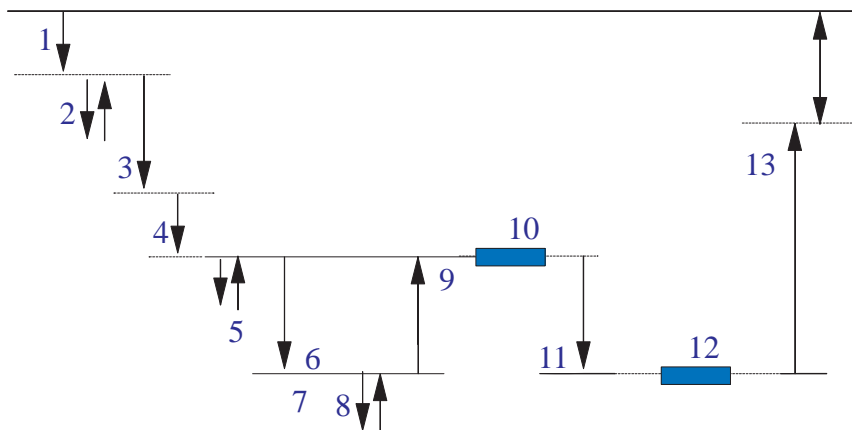

During roll media loading, the plotter:

- 1 Grips and advances the media.
- 2 Moves the media forwards and backwards to check whether it is still present and correctly gripped.
- 3 Advances the media and rechecks media presence. (The loading process fails if the media sensor detects no media.)
- 4 Actuates the bail so that the media can advance under it.
- 5 Again moves the media forwards and backwards to check for its presence. (The loading process fails if the media sensor detects no media.)
- 6 Advances the media several inches and rechecks media presence. (The loading process fails if the media sensor detects no media.)
- 7 The plotter stops and allows you to realign the media.
- 8 Again moves the media forwards and backwards to check for its presence. (The loading process fails if the media sensor detects no media.)
- 9 Moves the media backwards several inches.
- 10 Moves the carriage to sense the right and left edges and to check dimensions.
- 11 Advances the media several inches.

- 12 Checks the right edge of the media for skew (misalignment). (The loading process fails if the skew is greater than the allowed limits.)
- 13 Moves the sheet to the printing position and resets the media-axis servo position.

330  
350C

---

## Roll Media

When a roll-feed assembly is installed on the DesignJet 330 and 350C roll media can be used. The roll-feed assembly consists of:

- A roll-feed frame
- A spindle
- Two media stops
- A built-in cutter

The roll-feed assembly is installed below the sheet media entry path, to allow the ease of loading for sheet media. When roll media is loaded into the plotter, it is passed around a diverter roll, which optimizes the infeed path to the plotter. Once a plot is completed, the built-in cutter is manually slid across the paper to cut the plot from the roll.

For further information ▶ User's Guide, chapter 2.

---

## Removing Static Charge from the Media

An anti-static brush located under the entry platen prevents static charge from building up on the media. A charge can cause the media to stick to itself and jam the plotter.

---

## Gripping the Media

When you load the media, it is gripped by the pinch-arms. There is no pinch-arm sensor on the DesignJet 230 and 250C but there is one on the DesignJet 330 and 350C.

330  
350C

### Pinch-Arm Sensor

The pinch-arm sensor is a switch sensor that is attached to the spittoon. It detects the position of the pinch-arm lever. Linkage, attaching the lever to a cam, causes the cam to release the switch as the pinch-arms are raised. The pinch-arm sensor is electrically connected to the main PCA.

---

## Providing a Force on Top of the Media

### Bail

The bail provides a normal force on top of the media. Unlike on the DesignJet 220, there is no bail sensor on the DesignJet 230 and 250C and DesignJet 330 and 350C.

### Bail-Lift Mechanism

The bail features an automatic lift mechanism driven by the media motor using a series of gears and actuated by the cartridge carriage. The mechanism is different from that used in the DesignJet 220. The new cable-based design eliminates the torque on the axle of the bail-lift cam and thus improves reliability. The new mechanism is also more accessible. (Removal ▶ page 6-29.)

---

## Moving the Carriage

### Carriage-Drive Mechanics

#### Motor, Belt and Pulley

- The carriage (Y-axis) drive consists of a DC motor directly driving a single belt and the carriage. This replaces the dual-belt system of the DesignJet 220.
- The motor assembly itself provides the tension needed on the belt, eliminating the need for a separate pulley tensioner.
- The belt clamps itself to the carriage; there are no separate belt clamps.
- The interface between the motor shaft and belt is friction based.
- You can remove the belt without having to remove the pulley on the left end of the belt.

#### Carriage Guidance

The carriage moves along on just one stainless steel slider rod. It is guided by two integrated bronze bushings, which are self-lubricating, and a back wheel.

#### Positional Feedback

An encoder strip, similar to that on the DesignJet 650C, provides feedback on the position of the carriage. The strip does not require adjustment.



Take care not to cut yourself on the encoder strip inside the plotter.



---

## Detecting the Lines and Media Edges

### Line Sensor

The line sensor on the cartridge carriage is used to:

- Detect the left and right media edges.
- Detect and measure lines drawn on media when performing accuracy calibration.
- Scan the setup and alignment sheets.
- Find the platen roller reference mark.

330  
350C

---

## Providing Ink

### Print Cartridges

The DesignJet 250C uses the same four print cartridges as does the DesignJet 650C. The DesignJet 350C uses the same three color print cartridges as does the DesignJet 750C and 755CM plotters and the same black cartridge as the DesignJet 650C. The DesignJet 230 and 330 plotters use only the black cartridge which is used in the DesignJet 650C.

### Distance between Carriage and Media

The distance between the carriage and the writing surface can determine image sharpness. As the distance increases, the drop shape and directionality degrade and are more difficult to predict. You can change the distance using the adjusting screw on the carriage. (Details ▶ chapter 7.)

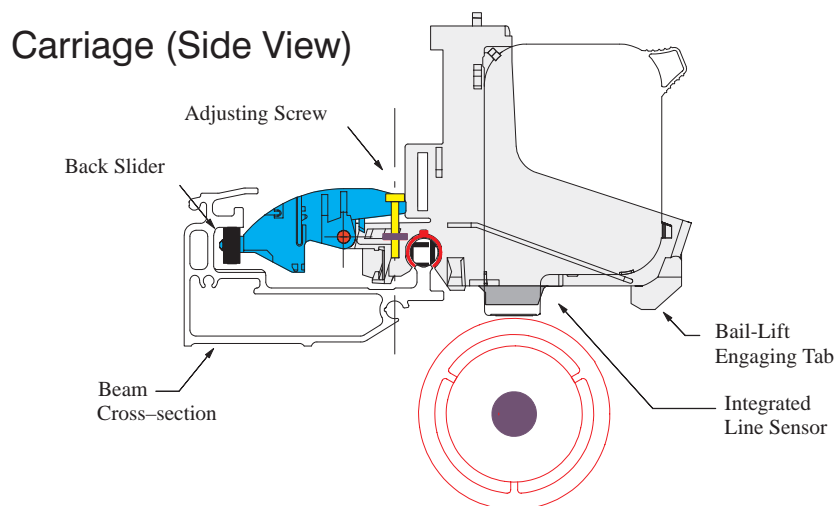

---

## Producing an Image

### Print-Mode Characteristics

Note that the firmware can recognize from the plot data whether a plot is color or monochrome. You do not set this parameter on the front panel.

230  
250C

#### Monochrome Plots on Paper (or vellum or translucent)

	Fast	Normal	Best
<b>Resolution (dpi)</b>	300x300	600x600 addressable	600x600 addressable
<b>Passes per Swath (#)</b>	1	2	2
<b>Carriage Speed (ips)</b>	26.67	26.67	26.67
<b>Carriage-Axis Depletion</b>	No	Yes	Yes
<b>Media-Axis Depletion</b>	No	Yes	Yes
<b>Pass Advance (swaths)</b>	1	~ 0.5	~ 0.5
<b>Bidirectional</b>	Yes	Yes	No
<b>Minimum Pass Time (sec)</b>	0.5	0.75	0.75

230  
250C

#### Monochrome Plots on Film

The characteristics for monochrome plots on film are the same as for monochrome plots on paper, except for the minimum pass time:

<b>Minimum Pass Time (sec)</b>	7.6	3.8	3.8
--------------------------------	-----	-----	-----

230  
250C

#### Monochrome Plots on Special Paper

	Fast	Normal	Best
<b>Resolution (dpi)</b>	300x300	600x600 addressable	600x600 addressable
<b>Passes per Swath (#)</b>	1	2	2
<b>Carriage Speed (ips)</b>	26.67	26.67	26.67
<b>Carriage-Axis Depletion</b>	No	Yes	Yes
<b>Media-Axis Depletion</b>	No	Yes	Yes
<b>Pass Advance (swaths)</b>	1	~ 0.5	~ 0.5
<b>Bidirectional</b>	Yes	Yes	No
<b>Minimum Pass Time (sec)</b>	0	0	0

230  
250C

**Color Plots on Special Paper**

	<b>Fast</b>	<b>Normal</b>	<b>Best</b>
<b>Resolution (dpi)</b>	300x300	300x300	300x300
<b>Passes per Swath (#)</b>	1	1	2
<b>Carriage Speed (ips)</b>	16.67	16.67	16.67
<b>Carriage-Axis Depletion</b>	No	No	No
<b>Media-Axis Depletion</b>	No	No	No
<b>Pass Advance (swaths)</b>	1	1	~ 0.5
<b>Bidirectional</b>	Yes	No	No
<b>Minimum Pass Time (sec)</b>	0	0	0

330  
350C

**Monochrome Plots on Paper and Film Media**

	<b>Fast</b>	<b>Normal</b>	<b>Normal</b>	<b>Best</b>	<b>Best</b>
<b>Resolution (dpi)</b>	300x300	600x600 addressable	300x300 addressable	600x600 addressable	300x300 addressable
<b>Passes per Swath (#)</b>	1	2	2	2	1
<b>Carriage Speed (ips)</b>	26.67	26.67	26.67	26.67	26.67
<b>Carriage-Axis Depletion</b>	No	Yes	Yes	Yes	Yes
<b>Media-Axis Depletion</b>	No	Yes	Yes	Yes	Yes
<b>Pass Advance (swaths)</b>	1	~ 0.5	~ 0.5	~ 0.5	~ 0.5
<b>Bidirectional</b>	Yes	Yes	Yes	No	No
<b>Minimum Pass Time (sec):</b>					
<b>Paper</b>	0.5	.75	.75	.75	.75
<b>Film</b>	7.6	3.8	3.8	3.8	3.8

330  
350C**Monochrome Plots on Coated Media**

	<b>Fast</b>	<b>Normal</b>	<b>Normal</b>	<b>Best</b>	<b>Best</b>
<b>Resolution (dpi)</b>	300x300	600x600 addressable	300x300 addressable	600x600 addressable	300x300 addressable
<b>Passes per Swath (#)</b>	1	2	1	2	1
<b>Carriage Speed (ips)</b>	26.67	26.67	26.67	26.67	26.67
<b>Carriage-Axis Depletion</b>	No	Yes	No	Yes	No
<b>Media-Axis Depletion</b>	No	Yes	No	Yes	No
<b>Pass Advance (swaths)</b>	1	~ 0.5	1	~ 0.5	1
<b>Bidirectional</b>	Yes	Yes	No	No	No
<b>Minimum Pass Time (sec)</b>	0	0	0	0	0

330  
350C**Color Plots on Paper and Coated Media**

	<b>Fast</b>	<b>Normal</b>	<b>Best</b>
<b>Resolution (dpi)</b>	300x300	300x300	300x300
<b>Passes per Swath (#)</b>	1	1	2
<b>Carriage Speed (ips)</b>	16.67	16.67	16.67
<b>Carriage-Axis Depletion</b>	No	No	No
<b>Media-Axis Depletion</b>	No	No	No
<b>Pass Advance (swaths)</b>	1	1	~ 0.5
<b>Bidirectional</b>	Yes	No	No
<b>Minimum Pass Time (sec)</b>	0	0	0

330  
350C**Color Plots on Film**

The characteristics for color plots on film are the same as for color plots on paper, except for the passes per swath (#) and pass advance (swaths):

<b>Passes per Swath (#)</b>	1	2	4
<b>Pass Advance (swaths)</b>	1	~ 0.5	~ 0.25

330  
350C

### Color Plots on Glossy Paper

The characteristics for color plots on glossy media are the same as for color plots on paper, except for the passes per swath (#), pass advance (swaths) and bidirectional abilities:

	Fast	Normal	Best
<b>Passes per Swath (#)</b>	4	4	6
<b>Pass Advance (swaths)</b>	~ 0.25	~ 0.25	~ 0.167
<b>Bidirectional</b>	No	No	No

---

## Servicing the Cartridges

### Service Station

The service station is based on that of the DesignJet 650C, with some differences.

- The service station is easier to access and remove, and is replaceable as one unit.
- The absence of a drop detector implies a different cartridge-maintenance algorithm to guarantee correct nozzle conditions. The plotter warms the nozzles and spits ink:
  - Before each plot.
  - After each cartridge change.
  - While printing, depending on: cartridge, humidity, temperature, and plot ink density.
- The ventilation holes, which were located on the service-station sled on the DesignJet 650C, are now located on the ink separator to prevent them from becoming clogged.

### Spittoon

A single, redesigned spittoon is located on the right side of the plotter.

### Primer

The plotters feature a manual primer, based on that of the DeskJet 1200, instead of the automatic one of the DesignJet 650C. (See ♦ User's Guide, § *Cleaning the cartridge nozzles.*)

- A bellows assembly provides a vacuum to suck ink from the nozzles. The suction tubes have a wider diameter than those of the DesignJet 650C, to help prevent clogging.
- An ink separator isolates the bellows from the cartridges, preventing ink contamination of the bellows.

Although the primers for the DesignJet 230/250C and DesignJet 330/350C look identical, their characteristics are different. Installing the incorrect primer can damage the cartridges or reduce the servicing of the cartridges. For the correct part numbers for the primers ♦ chapter 10.

## Plotter Architecture

The plotters have a multiprocessor architecture similar to that of the DesignJet 650C. The following diagram gives an overview of the architecture:

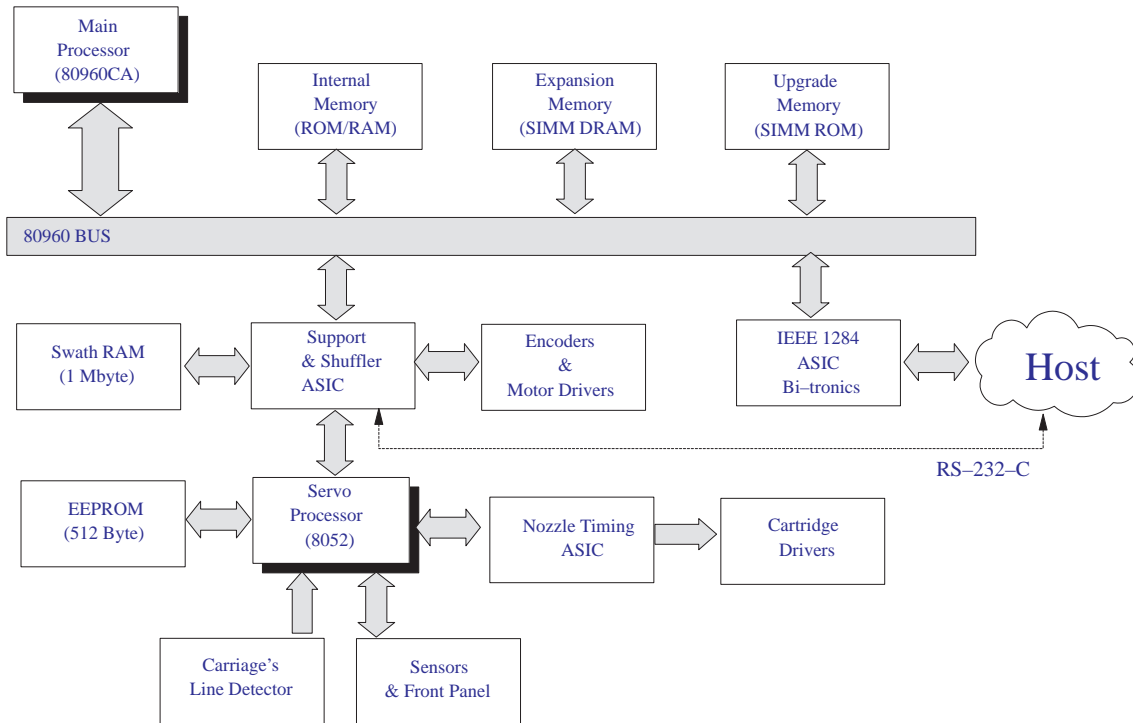

---

## Electronics Module

The electronics module includes the main PCA, power supply and fan. It is one exchangeable part; you do not need to open it. If you replace the electronics module, remember to swop any SIMMs from the old module to the new one.

### Main-PCA Connections

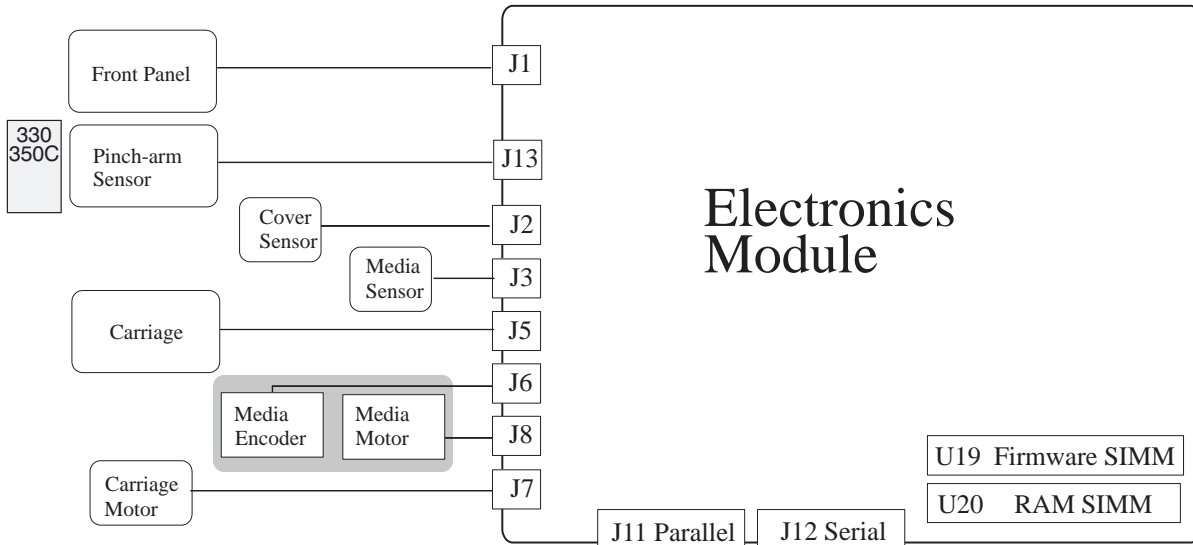

### Sensors

There is no bail sensor for the DesignJet 230 and 250C and DesignJet 330 and 350C. There is no pinch-arm sensor on the DesignJet 230 and 250C but there is one on the DesignJet 330 and 350C. The following sensors connect to the main PCA:

- The **cover sensor** is a mechanical switch that detects if the plotter cover has been raised. If you open the cover while the plotter is plotting, the plot is cancelled!
- The **media sensor** detects the presence of media. It is also used to determine media size.
- The **pinch-arm sensor** detects whether the pinch-arms have been raised. The servo processor uses the sensor to determine the pinch-arm position during the initialization sequence.

330  
350C

## ROM

The plotter firmware code is contained on either an in-built masked ROM (soldered to the main PCA) or a flash ROM SIMM (installed in the inner-most socket at the back of the plotter). If both are present, the plotter recognizes the code on the ROM SIMM instead of that on the in-built ROM. The power-on LED sequence tells you whether the plotter is using code from in-built ROM or from a ROM SIMM. (Details ♦ page 8-3.) To find out the firmware-code revision level that the plotter is using, print a user setup sheet or a service configuration plot.

## RAM

The plotters have a standard four megabytes of on-board RAM. They also have one RAM-expansion socket, which can hold an optional 4-, 8-, 16- or 32- megabyte DRAM SIMM. The socket is the outer-most one at the back of the plotter.

## EEROM

EEROM is used as nonvolatile storage for calibration and configuration data. Useful information from the EEROM is printed on the service configuration plot ♦ page 8-49 (DesignJet 230/250C) or page 8-50 (DesignJet 330/350C). The EEROM is soldered to the Main PCA in both new and rebuilt electronic modules.

If you clear the EEROM or replace the electronics module, perform all calibrations. Also note that the factory spittoon value on the cleared or new EEROM is 0%. Keep in mind that the value printed on the service configuration plot may greatly underestimate the amount of ink in the spittoon. Future PC-based plotter diagnostics will enable you to download information from the old EEROM and upload it to the new EEROM. (Clearing the EEROM ♦ page 8-54/8-55.)

## Input/Output Interfaces

Like the DesignJet 220, the plotters have both a parallel (Bi-Tronics) and a serial (RS-232-C) interface. Unlike the DesignJet 650C, they have no modular input/output (MIO). You can connect the plotters to a network by means of an *HP JetDirect EX* or *HP JetDirect EX Plus3* external print server. (See also ♦ chapter 1, § *Network Connections*, and chapter 10, § *Accessories*.)

### Bi-Tronics

In addition to the operating modes of the DesignJet 220, the Bi-Tronics interfaces of the DesignJet 230 and 250C and DesignJet 330 and 350C feature the extended-capability-port (ECP) forward and reverse operating modes, providing for faster communication.

### RS-232-C

The supported baudrates are 1200, 2400, 4800, 9600, 19200 and 38400, with eight bits and no parity, or seven bits with either odd or even parity. Mark parity is not supported. Both XON/XOFF and DTR handshaking are supported. ENQ/ACK handshake is not supported.



## Power Supply

An auto-ranging power supply is located in the electronics module. (Specifications ▶ chapter 1, “Power Requirements.”)

---

### WARNING

**The primary side of the power supply contains rectified line voltage that can be lethal when touched even if the ON/OFF switch is OFF.**

**In any case, you should not need to open the electronics module. It is one exchangeable part.**

---

## Water Condensation

In humid environments, water may condense on the side-plates. A wick attached to the underside of the right side-plate routes water drops away from the main-PCA electronics.

---

## Memory Usage

It is difficult to calculate the amount of plotter memory needed to plot a drawing of any given file size. Memory is used, not just to hold the input data, but also for system overhead, processing work-space, and storage of the internal representation of the plot. Some types of graphics require relatively large amounts of memory. Examples are wide lines, raster fill patterns, polygons, and user-defined lines.

## Plot Orientation

The output orientation of the drawing also has an impact on memory usage. Compare a plot of horizontal lines with one of vertical lines. Lines plotted parallel to the carriage axis take up considerably less memory than those plotted perpendicular to it. The plotter builds graphic display objects on a swath-by-swath basis. A horizontal line can be contained in one swath. A vertical line spans many swaths and therefore requires more entries in the plotter's internal display list.

## Raster Image Processor

The raster transfer language (RTL) provides a solution to insufficient memory on the plotter. When all the data is sent to the plotter in the order left-to-right and top-to-bottom, the plotter is able to plot the data as it receives it. For this to happen, software (a raster-image processor) in the computer must first rasterize all the data. The software issues a command (referred to in RTL as **no negative motion**) telling the plotter that it will not receive data for any media location on which it has already plotted.

The use of no negative motion is called **flow mode**. Data flows through the plotter without being stored in a display list, so the size of the file that you can send is almost unlimited.

---

## Carriage PCA

The carriage PCA is based on that of the DesignJet 650C. It connects to the main PCA through a long 60-conductor (2x30) trailing cable. The carriage PCA contains:

- Optical line sensor
- Thermistor circuit
- Linear encoder
- Cartridge nozzle firing circuit

Some electronic components on the DesignJet 250C and 350C carriage PCA are not present on the DesignJet 230 and 330 carriage PCA. At power-on the plotter firmware identifies whether the carriage is for a color or a monochrome model, and behaves accordingly.

---

## Front Panel PCA

The plotters use the same front-panel PCA as the DeskJet 550 and DesignJet 220.

---

Removal and  
Replacement

---

## Safety Precautions

(Safety symbols ▶ Immediately after the table of contents.)

Review WARNING and CAUTION symbols and instructions before you service the plotters. Follow these warnings and cautions for your protection and to avoid damaging the plotter.

---

### WARNING

**Serious shock hazard leading to death or injury may result if you do not take the following precautions:**

**Ensure that the ac power outlet (mains) has a protective earth (ground) terminal.**

**Switch the plotter off, and disconnect it from the power source prior to performing any maintenance.**

**Prevent water or other liquids from running onto electrical components or circuits, or through openings in the enclosure.**

---

---

## ESD Precautions

To prevent damage to the plotter circuits from high-voltage electrostatic discharge (ESD)

- 1 Do not wear clothing that is subject to static build-up.
  - 2 Do not handle integrated circuits (ICs) in carpeted areas.
  - 3 Do not remove an IC or a printed circuit assembly (PCA) from its conductive foam pad or conductive packaging until you are ready to install it.
  - 4 Ground your body while disassembling and working on the plotter.
  - 5 After removing a cover from the plotter, attach a clip lead between the PCA common and earth ground. Touch all tools to earth ground to remove static charges before using them on the plotter.
  - 6 After removing any PCA from the plotter, place it on a conductive foam pad or into its conductive packaging to prevent ESD damage to any ICs on the PCA.
- 

## Reassembly

Most of the procedures in this chapter describe how to disassemble the plotter. Unless otherwise specified, reassemble the parts in the reverse order of disassembly.

---

---

## Required Tools

The following are the tools required to disassemble and repair the plotters.

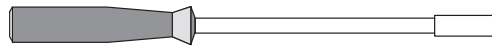

Long Torx screwdriver with the indicated attachments.

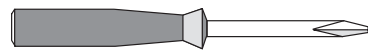
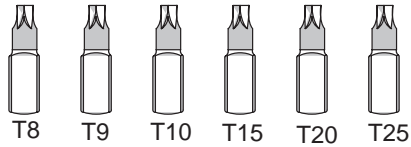

Poizdrive PZ1 screwdriver.



Small flat-blade screwdriver.

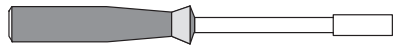

Nut driver with the indicated attachments.

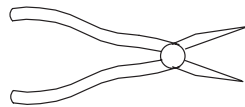
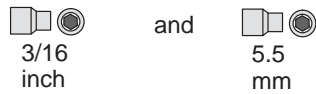

Needle-nose pliers.



Spring hook.



10X Magnifier.

Loopback connector  
(HP Part Number 07440-60302).

## Installing a RAM or ROM SIMM

A RAM SIMM provides the plotter with extra memory. A ROM SIMM contains new firmware code to override the internal firmware code.

- 1 Make sure that the plotter is switched OFF and that neither the power cord nor an interface cable is connected.

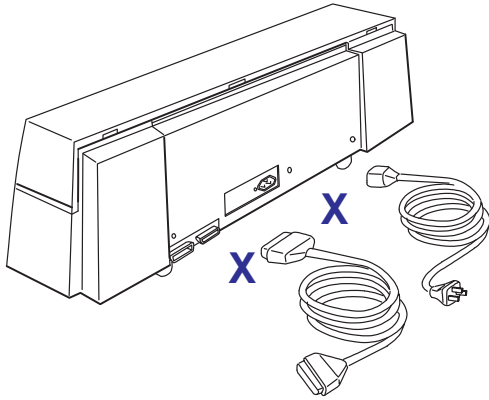

- 2 Unscrew the cover plate at the back of the plotter, and remove it.

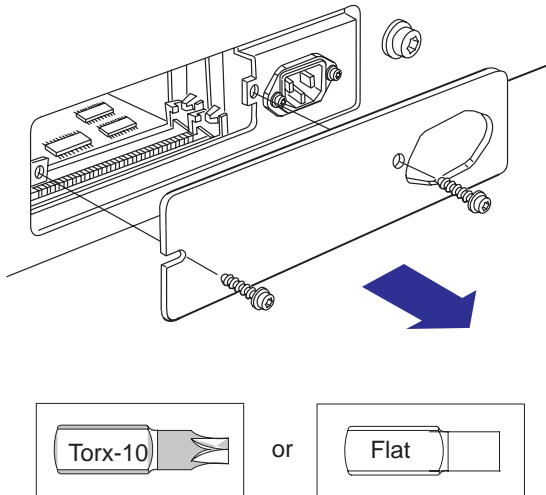

## CAUTION

Before handling a SIMM, either put on a grounding wrist strap and attach the end to the metal chassis of the plotter, or touch the outer metal surface of the plotter with your hand. Otherwise, static electricity from your body could damage the SIMM.

- 3 Take the SIMM out of its bag, holding the SIMM only by the edges.
- 4 With the SIMM's small notch on the left and the metallic edge away from you, load the SIMM into the slot
  - nearest to you (RAM SIMM)
  - furthest from you (ROM SIMM)

To do this, first hold the SIMM at an angle, and then gradually push it back until it clicks vertically into place.

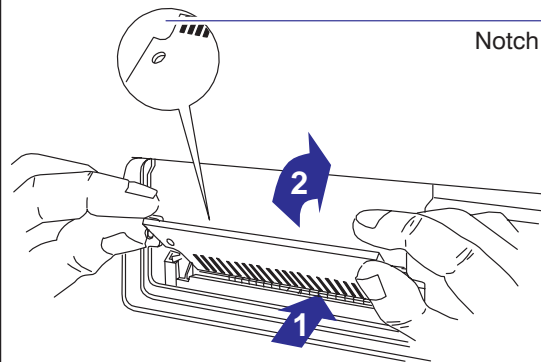

- 5 Replace the cover plate and the screws.

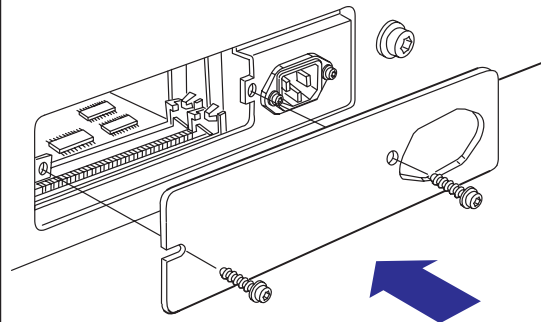

---

## Removing the Bail

- 1 Open the top cover.

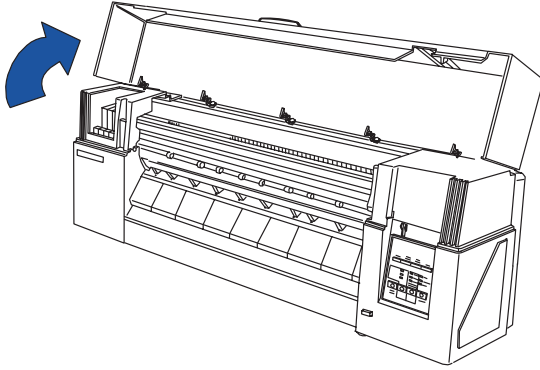

- 2 Move the carriage to the extreme left.

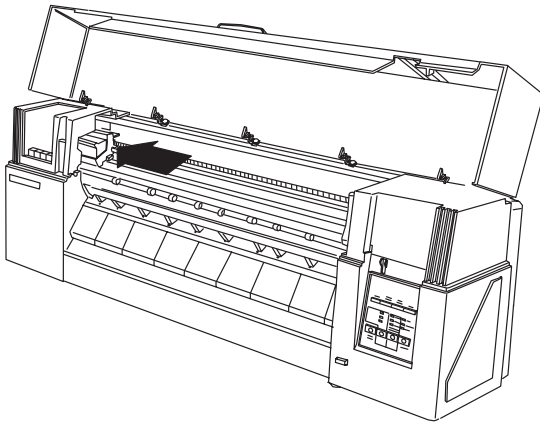

---

### WARNING



**In the following step, take care neither to cut yourself on the encoder strip, nor to damage the strip.**

- 3 Push one of the plastic ends of the bail towards the center of the plotter to release it from the hole in the sideplate, and lift the bail out of the plotter.

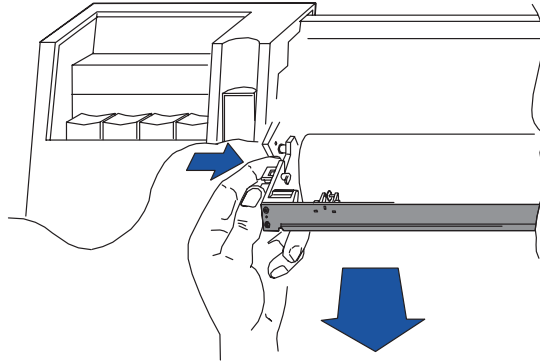

---

## Removing the Cartridge Caps and Wiper Blades

---

### WARNING

You are likely to get ink on your hands while performing the following procedure.

---

- 1 Open the top cover of the plotter.

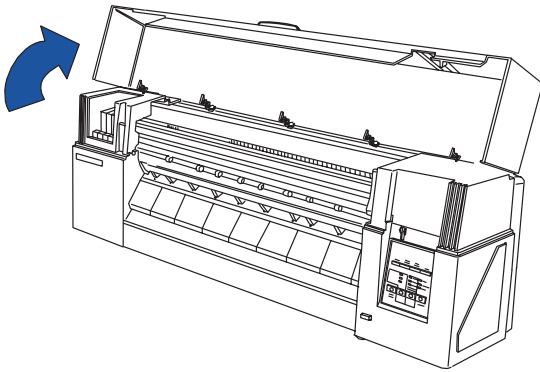

- 2 Move the cartridge carriage to the right, out of the service-station area.

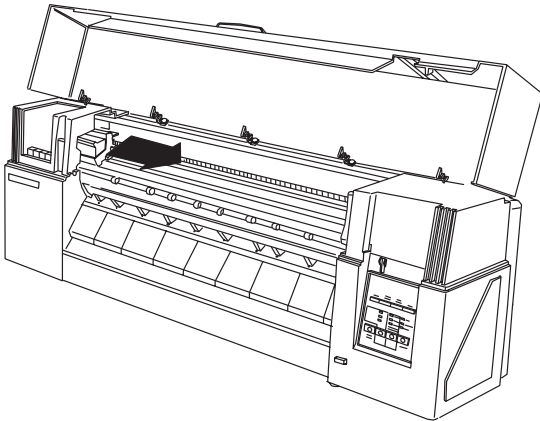

- 3 Peel the cartridge caps and/or the wiper blades from the top of the service station, and remove them from the plotter.

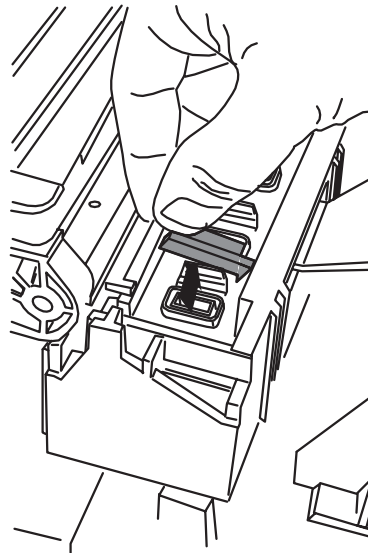
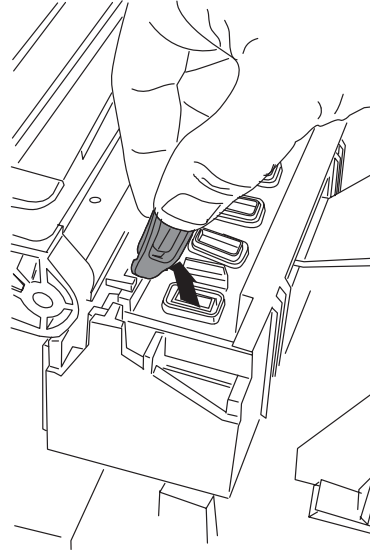

**Reassembling:** Ensure that the cartridge caps are clean, the wipers straight, and the openings clear.



## Removing the Top Cover

- 1 Open the top cover.

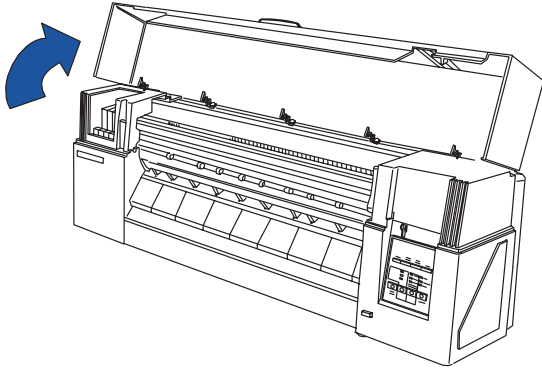

- 2 Push the right-hand side of the cover slightly back, so that the rightmost hinge uncouples.

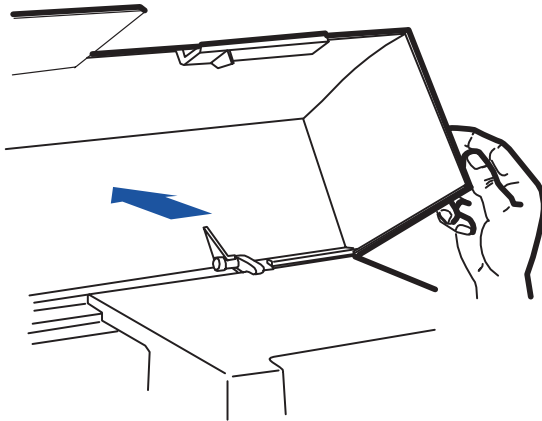

- 3 Slide the cover to the left, so that the other hinges uncouple.

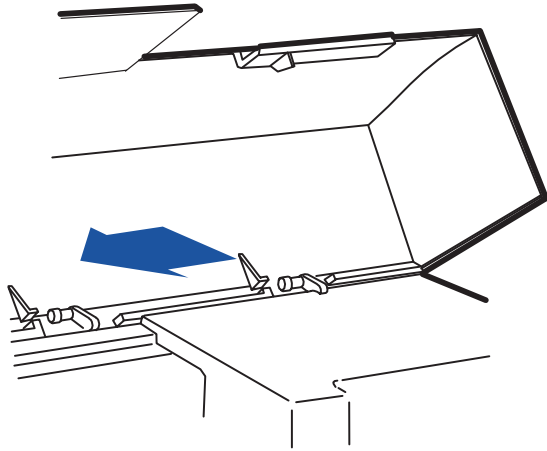

**Reassembling:** Close the cover and click each hinge into place.

- 4 Remove the cover from the plotter.

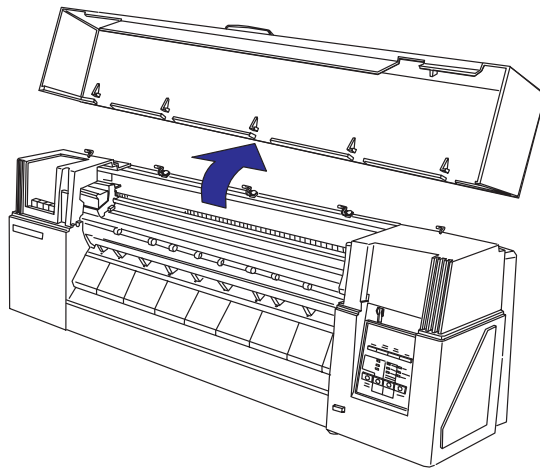

330  
350C

## Removing the Roll-feed Assembly

- 1 Open the top cover.

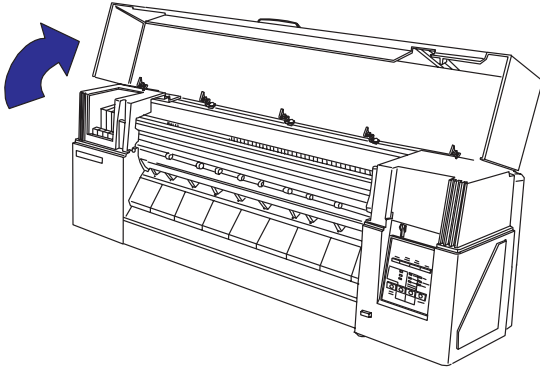

- 2 While pressing the tabs on the locking bracket toward the center of the plotter, pull up on the roll-feed assembly.

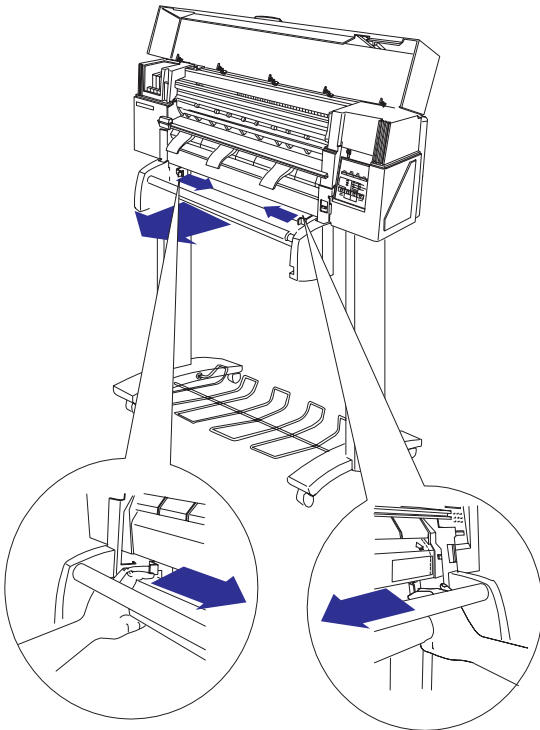

- 3 Remove the two screws that attach the roll-feed brackets to the plotter.

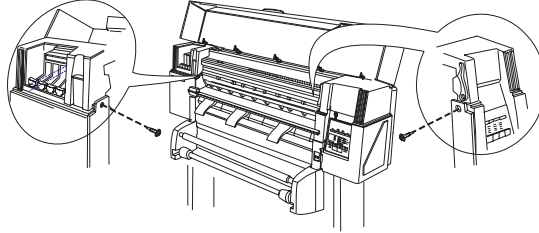

- 4 Remove the roll-feed assembly from the plotter by first removing the left mounting bracket and then the right mounting bracket.

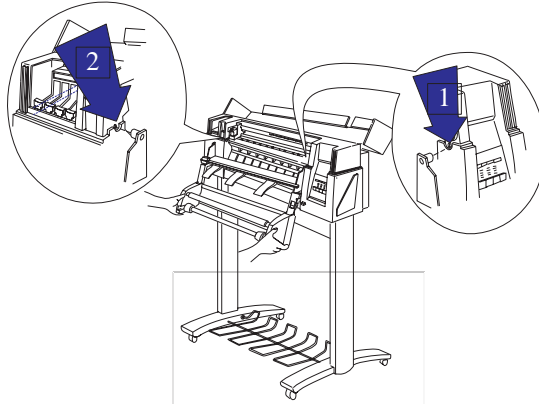

## Removing the Left End-Cover

- 1 Remove the top cover ▶ page 6-7.

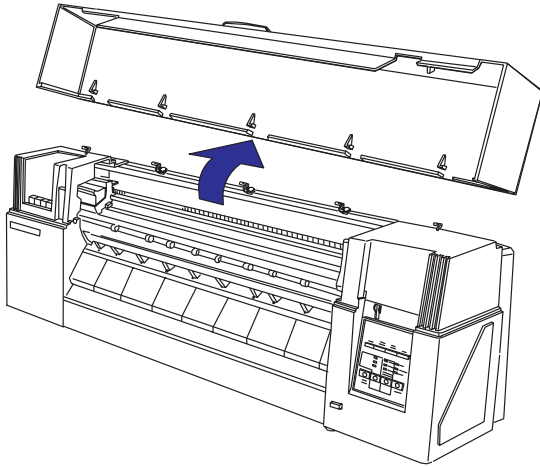

330  
350C

- 2 Remove the roll-feed assembly ▶ page 6-8.
- 3 Release the three clips at the bottom of the end-cover: first the side clip, then the front and back clips.

*These may be stiff.*

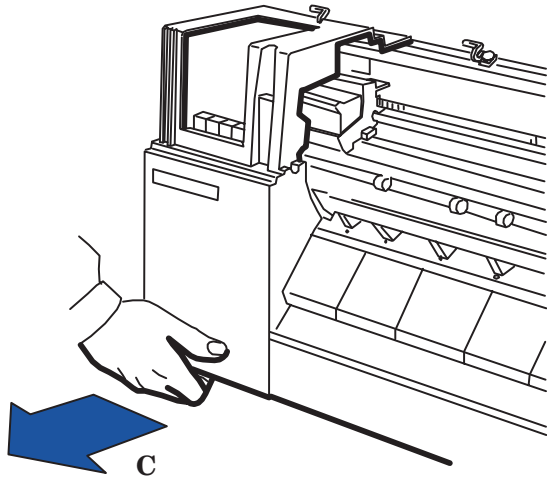
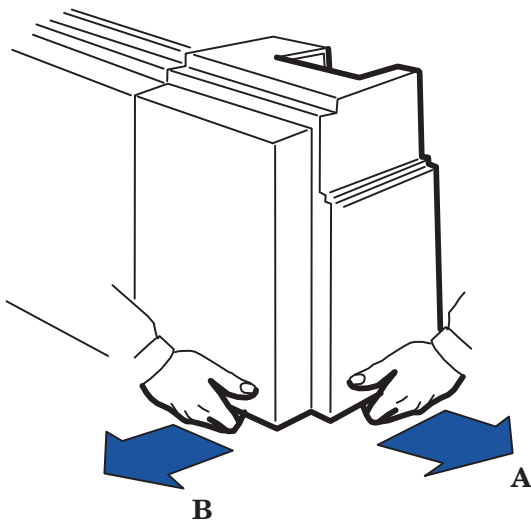

- 4 Pull the end-cover up, and remove it from the plotter.

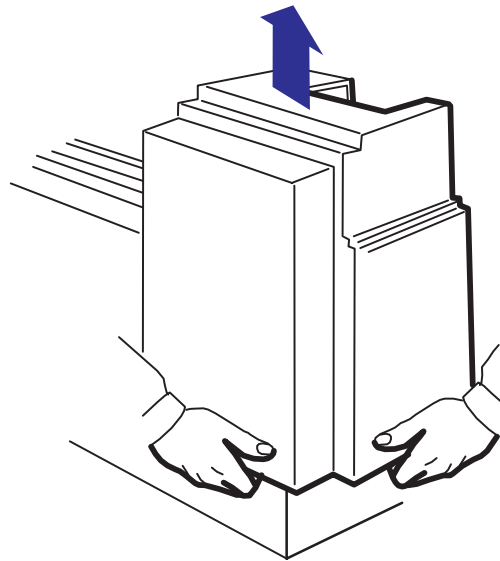

**Reassembling:** *It's not easy to reinstall the end-covers on the plotter. With some practice, you should learn the knack. As a guide, before you replace an end-cover, take a look at the various clips on its inside, and identify where they fit on the plotter.*

*Make sure that the primer plunger is installed properly when reinstalling the end-cover.*

## Removing the Right End-Cover

- 1 Remove the top cover ▶ page 6-7.

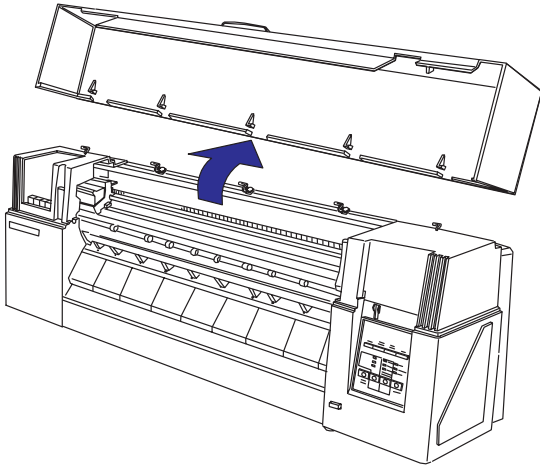

330  
350C

- 2 Remove the roll-feed assembly ▶ page 6-8.
- 3 Remove the pinch-wheel lever and screw.

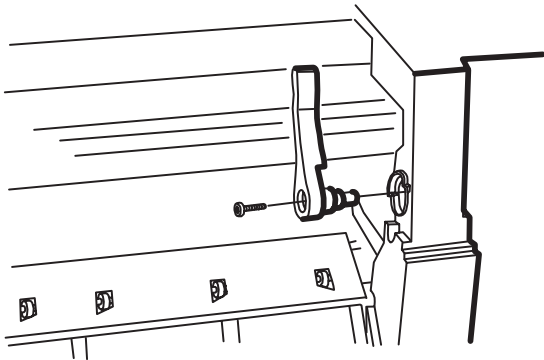
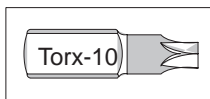

- 4 Pull the plotter on/off switch out of the end-cover.

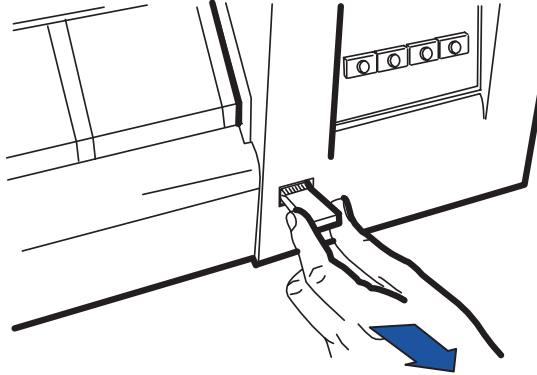

- 5 Release the three clips at the bottom of the end-cover: first the side clip, then the front and back clips.

*These may be stiff.*

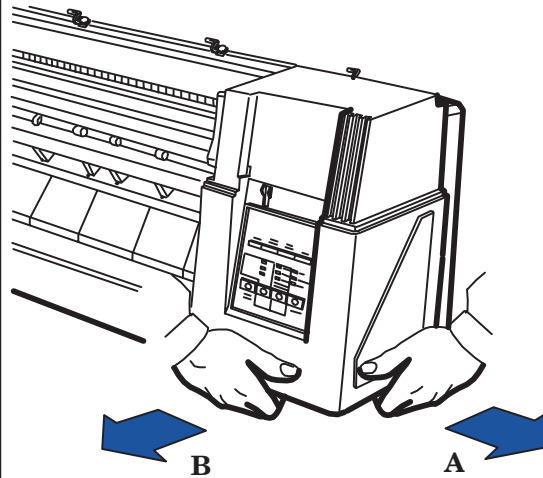

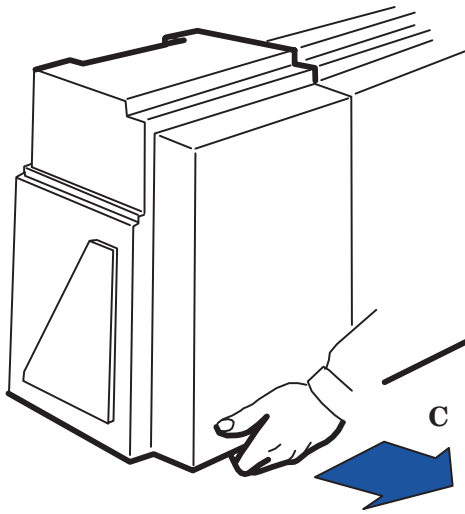

### CAUTION

In the following step, be careful not to damage the two electronic cables attached inside the end-cover.

- 6 Pull the end-cover up.

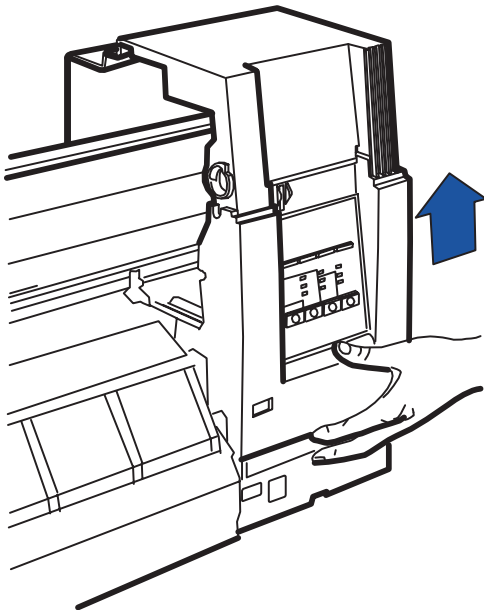

- 7 Inside the end-cover, press the two indicated tabs towards each other, and remove the front-panel assembly from the end-cover.

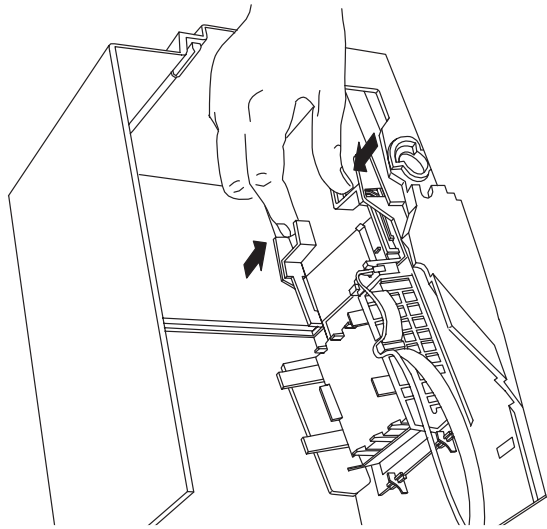

- 8 To be able to easily use the front-panel, when the right end-cover has been removed, slide the front-panel assembly onto the metal base of the plotter as shown.

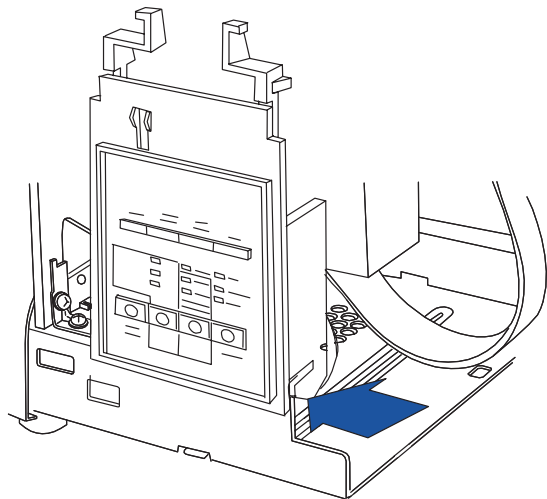

**Reinstalling the front-panel assembly:**  
 Insert the bottom of the assembly into the two indicated notches, inside the right end-cover. Then **firmly** reinsert the top two tabs.

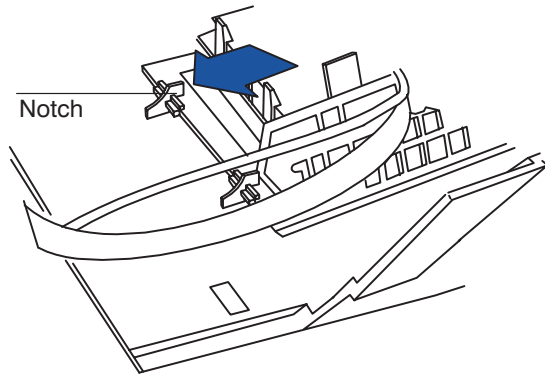

Push the front panel from the outside, to check whether it is correctly installed.

**Reinstalling the right end-cover:** Before replacing the end-cover, make sure that

- a** The black plastic piece at the front end of the pinch-arm linkage is correctly attached to the side-plate.
- b** The lever nut is positioned inside the slot on the black plastic piece.

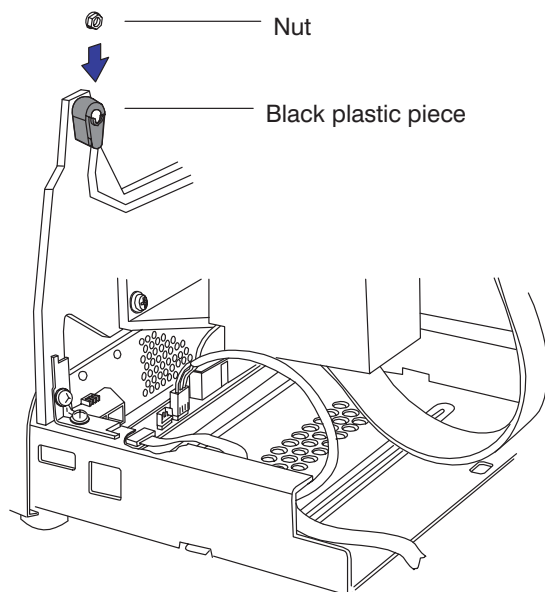

## Disconnecting the Front-Panel Assembly

- 1 Remove the right end-cover ▶ page 6-10.
- 2 On the main PCA, gently pull the front-panel connector clamp (FP) to the right to release the flat, white cable.
- 3 Pull the cable easily out of the clamp, and release it from the clip on the side of the electronics module.

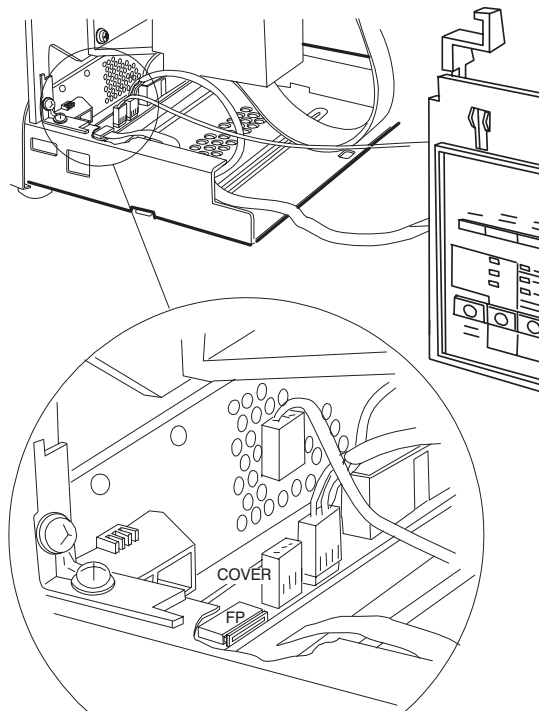

**Reassembling:** The contact part of the cable faces down. Prevent tugging of the cable at the point of connection by leaving slack between the connector and the clip.

- 4 Detach the top-cover-sensor cable from the COVER connector, and release it from the clip on the side of the electronics module.

## Removing the Electronics Module

*The electronics module is a field-replaceable part. You do not need to open it. If it is faulty, exchange it for a new one.*

- 1 Remove the right end-cover ▶ page 6-10.
- 2 Disconnect the front-panel assembly from the main PCA ▶ page 6-12.
- 3 Unscrew the cover plate at the back of the plotter, and remove it.

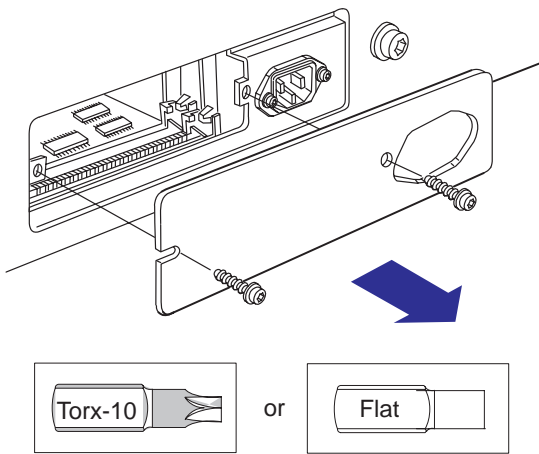

- 4 Remove the indicated two screws from the back cover.

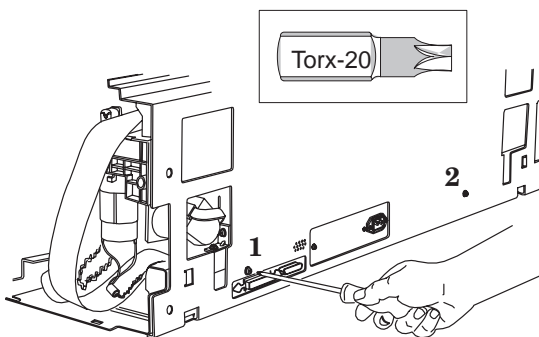

- 5 Remove the indicated screw from the floor of the electronics module.

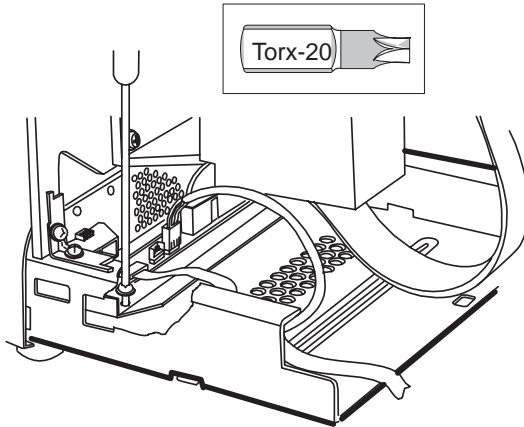

- 6 At the back of the plotter, ensure that the two small wire clamps of the parallel port are positioned flush against the electronics module

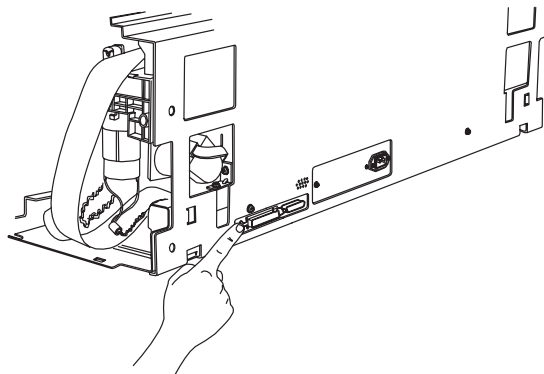

- 7 Push the electronics module towards the front of the plotter.

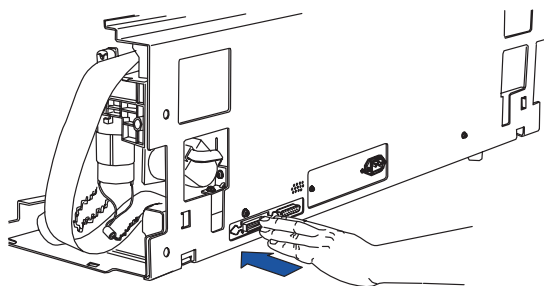

- 8 Pull the electronics module to the right, in order to easily access the connectors.

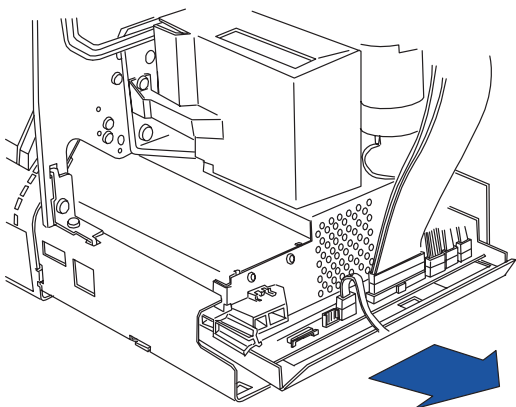

- 9 Disconnect all cables from the visible part of the main PCA.

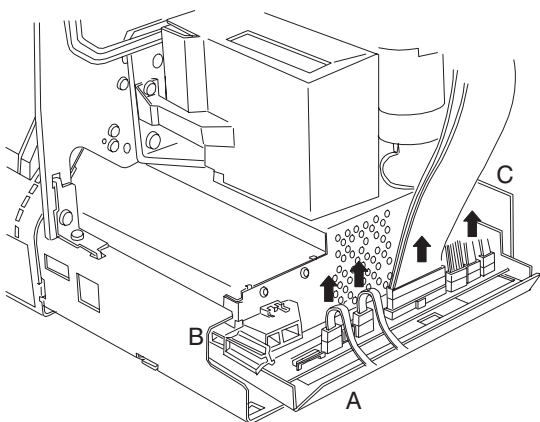

**Reassembling:** The connectors and cables correspond as follows:

Connector	Cable	Clip
FP	Front Panel	A
PINCH	Pinch-Arm Sensor	A
COVER	Top-Cover Sensor	A
MEDIA	Media Sensor	B
P1	Trailing Cable	B
ENC X	Media Motor Encoder	C
MOT X	Media Motor	C
MOT Y	Carriage Motor	C

Prevent tugging on the cables at the point of connection by leaving slack between the connectors and the clips.

- 10 Pull the electronics module further to the right and out of the plotter.

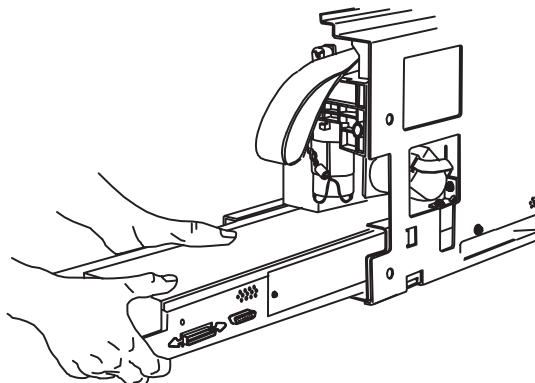

**Reassembling:** Slide the module into the plotter until it is stopped by its location hook on the floor of the plotter. Be careful not to damage the parallel-port clamps.

- 11 If you are changing the electronics module for a new one, remove the DRAM SIMM (if installed) from the old module and install it into the new one. Refer to Chapter 9 before installing the ROM SIMM from the old module into the new module.

**Calibrations:** After having installed a new electronics module, perform the following calibrations. (Details ▶ chapter 7.)

1. Black Cartridge Alignment
2. Color Cartridge Test
3. Accuracy Calibration

Note also that the factory spittoon value on the EEROM of the new electronics module is reset to 0% used. Keep in mind that the value printed on the service configuration plot may greatly underestimate the amount of ink in the spittoon. Future PC-based plotter diagnostics will enable you to download information from the old EEROM and upload it to the new EEROM.

**Reassembling:** After reinstalling the electronics module, the plotter must be configured with the correct model ID. To configure plotter ▶ page 8-28.

330  
350C



## Removing the Media-Sensor Assembly

- 1 Remove the electronics module [▶ page 6-13](#).

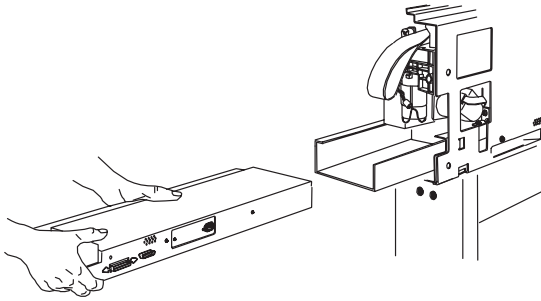

- 2 Pull the media-sensor assembly down from the underside of the entry platen.

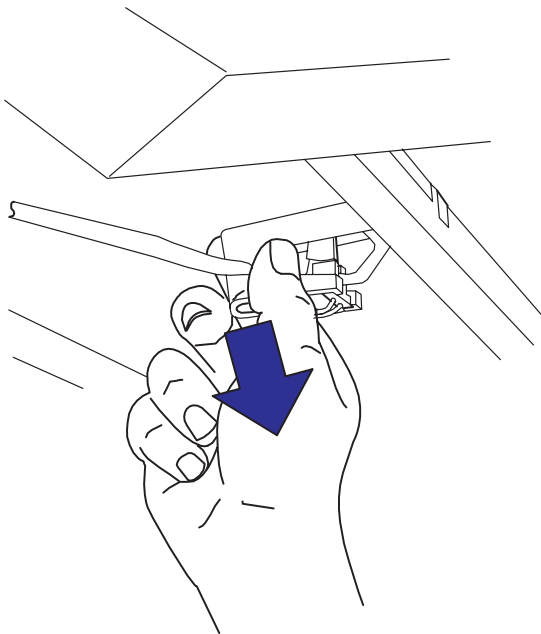

- 3 Release the media-sensor cable from the indicated clip.

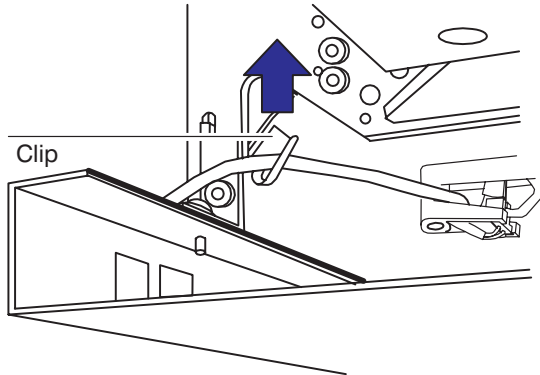

- 4 Remove the media-sensor assembly from the plotter.

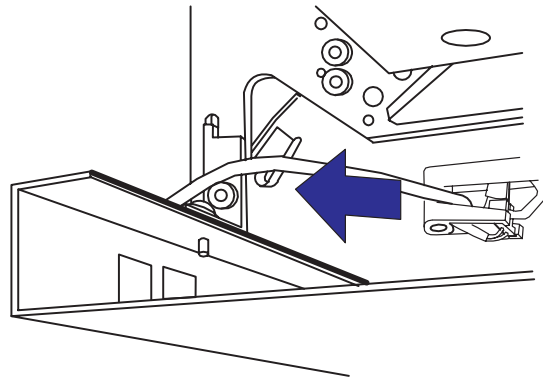

## Replacing the Media-Sensor Assembly

- 1 Insert the t-shaped flag in the indicated position.
- 2 Let the t-shaped flag rotate to its correct position.

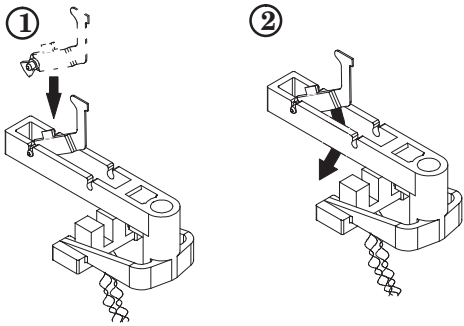

- 3 Insert the bell-shaped flag in the indicated position.
- 4 Let the bell-shaped flag rotate to its correct position.

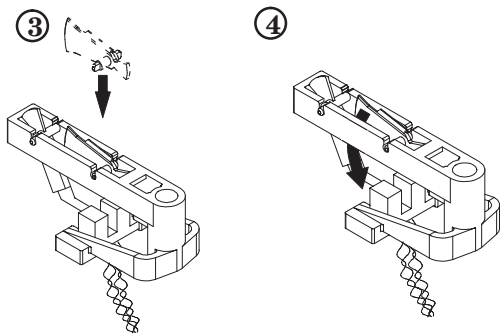

- 5 Insert the long arm of the media-sensor assembly into the slot at the back of the entry platen as shown.

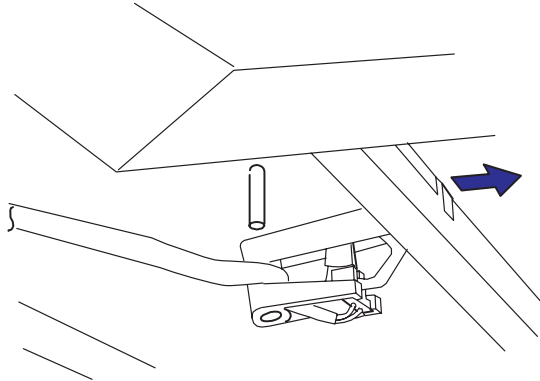

- 6 Ensure that the two flags have not been mispositioned.
- 7 Press the media-sensor assembly up onto the post on the underside of the entry platen, until it clicks into place.

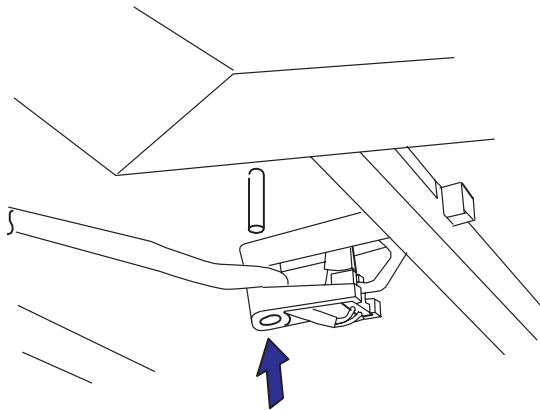

- 8 Refasten the media-sensor cable in its clip, making sure that it does not obstruct motion of the media-sensor flags.

## Removing the Encoder Strip

- 1 Move the cartridge carriage to the left, over the service station.

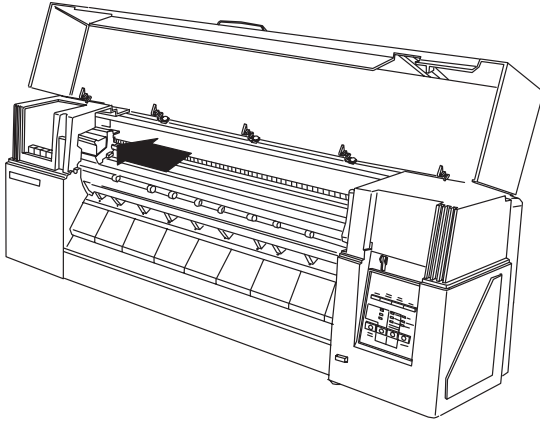

- 2 Remove the right end-cover ▶ page 6-10.
- 3 Remove the left end-cover ▶ page 6-9.
- 4 Disconnect the trailing cable from the main PCA.

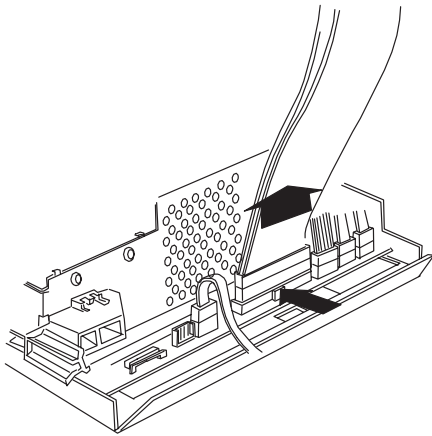

**Reassembling:** The cable connects to the connector marked P1 on the main PCA.

- 5 Disconnect the trailing cable from the guides on the right bracket

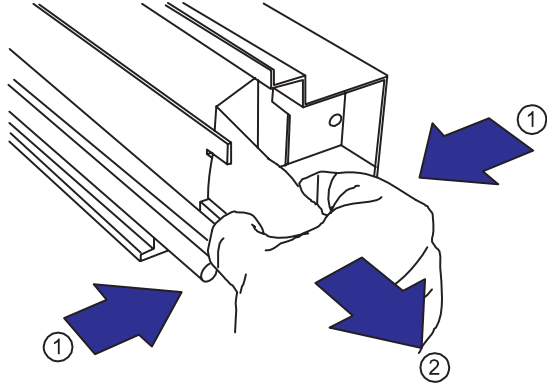

- 6 Fold the trailing cable upwards and store it on the trailing-cable guide.

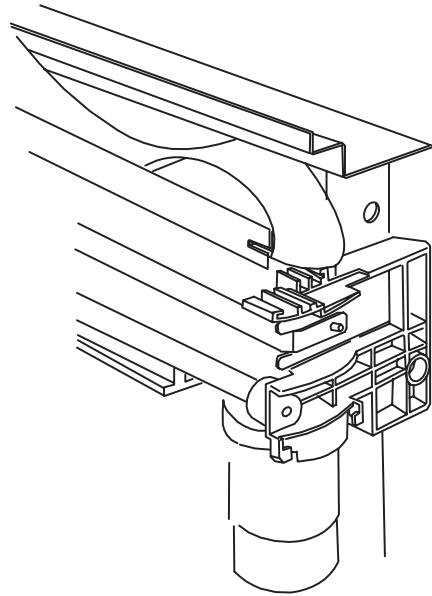

## WARNING



**In the following steps, take care neither to cut yourself on the encoder strip, nor to damage the strip.**

- 7** On the right-hand side, remove the nut and washer that secure the encoder strip to the encoder-strip spring.

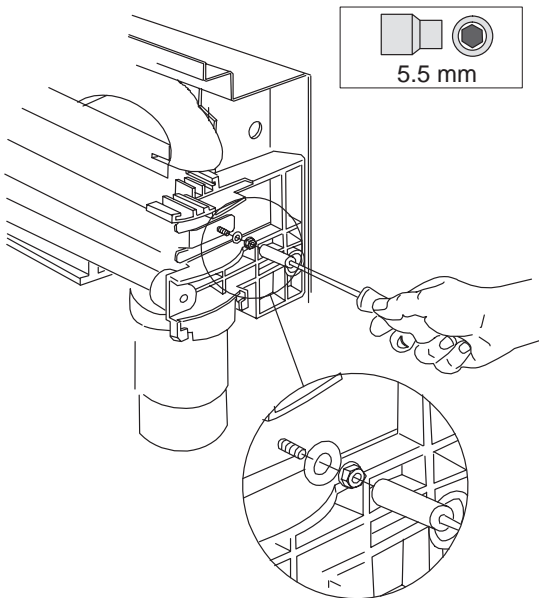

- 8** Remove the screw and washer that secure the encoder strip to the left bracket.

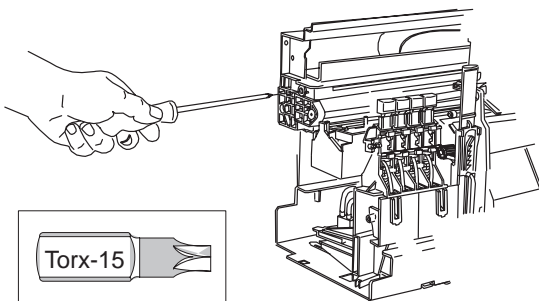

- 9** Compressing the encoder-strip spring to release tension on the encoder strip, carefully release the encoder strip from the pin on the spring.

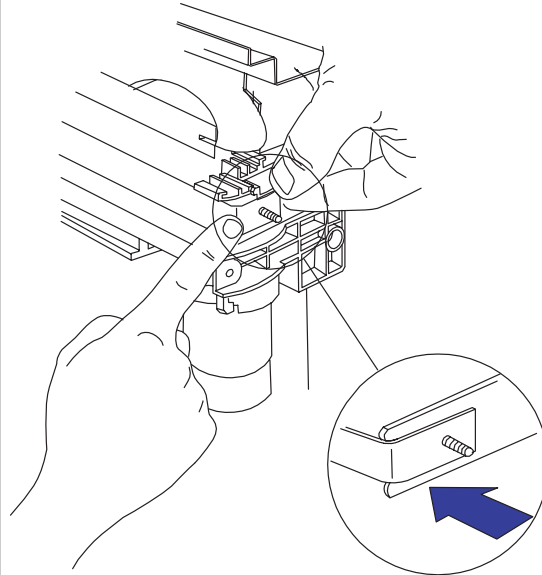

- 10** Carefully release the encoder strip from the left bracket.

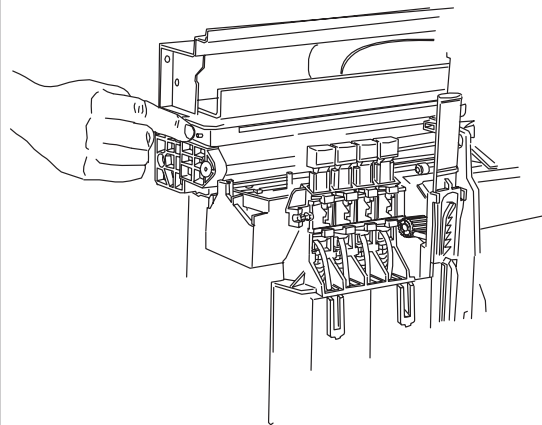

- 11 Carefully pull the encoder strip to the right, through and out of the carriage assembly.

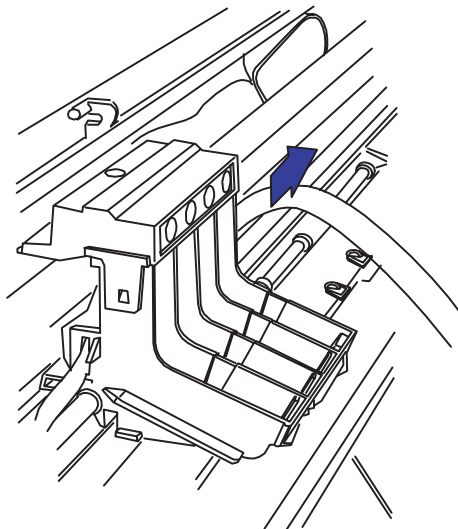

- 12 Lay the encoder strip on a flat surface.

## Reinstalling the Encoder Strip

- 1 Move the carriage carriage to the left, over the service station.
- 2 Ensure that the encoder strip is oriented with the transparent area up, and with two holes on the left side and one hole on the right side.

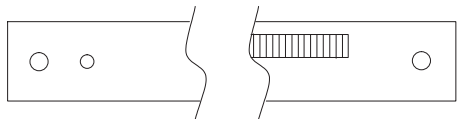

## WARNING



In the following steps, take care neither to cut yourself on the encoder strip, nor to damage the strip.

- 3 Feed the encoder strip through the cartridge carriage from right to left.

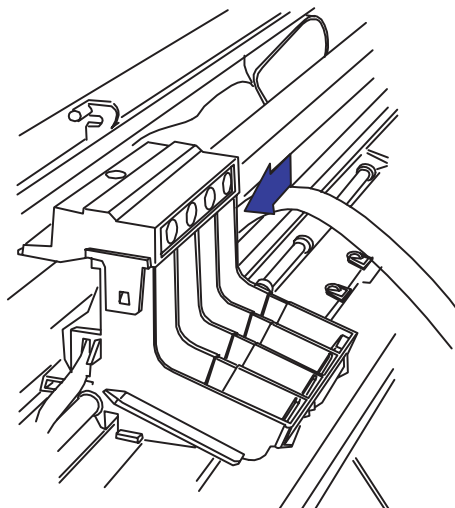

- 4 Temporarily, rest the loose strip safely on the drive roller.
- 5 Slip the left end of the strip over the plastic pin on the left bracket, and press it right to the base of the pin.

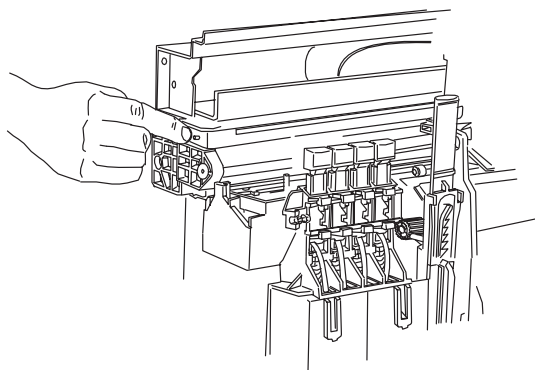

**6** Loosely fit, but do not tighten, the washer and screw to retain the encoder strip.

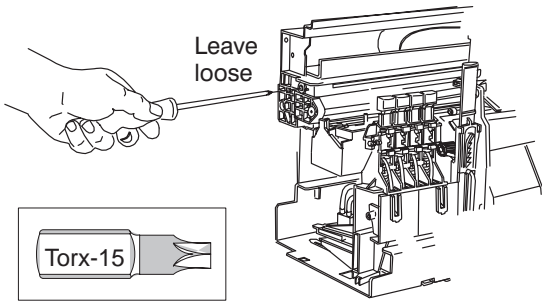

**7** Press the encoder spring to the left, and slip the right end of the strip over the pin. Press the strip right to the base of the pin and slowly release the spring.

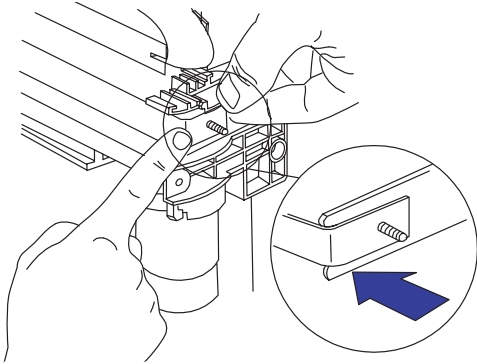

---

### CAUTION

In the following two steps, avoid distorting the encoder strip while you tighten it.

---

**8** Replace the washer and nut on the right side, and slightly tighten the nut.

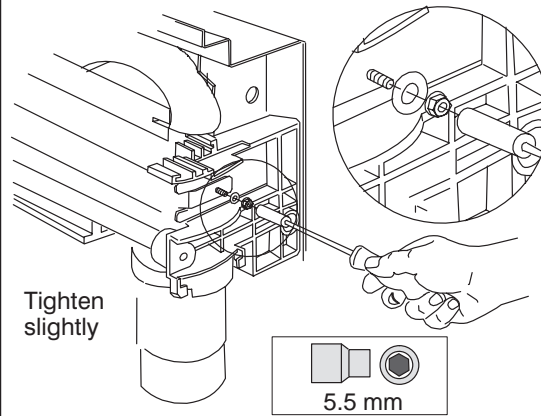

**9** Slightly tighten the screw on the left side.

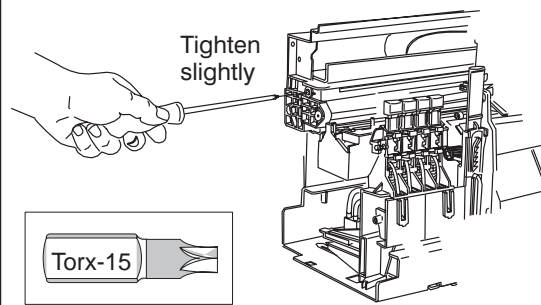

**10** Slide the carriage back and forth the length of its travel to ensure free movement. The encoder strip should not bind or rub on the carriage.

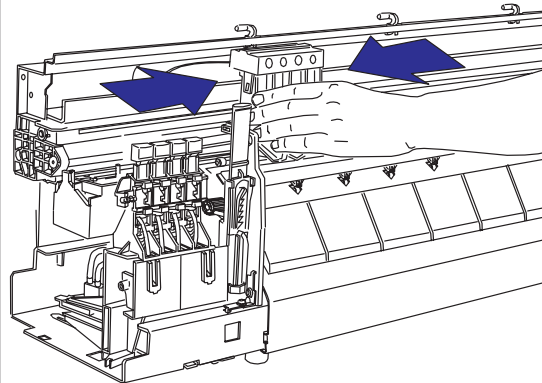

## Removing the Right Bracket

- 1 Remove the encoder strip [▶](#) page 6-17.
- 2 Remove the screw that attaches the right bracket to the plotter chassis.

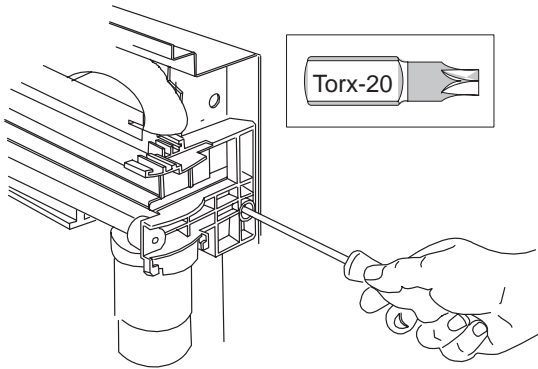

**Reassembling:** Use the long screw.  
Threaded length  $\cong$  3 cm (~1.2 inch).

- 3 Pull the right bracket to the right, and remove it from the plotter,

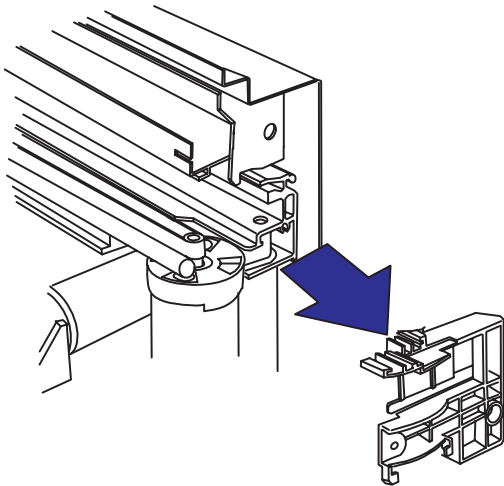

**Reassembling:** Insert the right-bracket tab into the slot on the right of the trailing-cable guide.

## Removing the Carriage Motor

- 1 Remove the right bracket [▶](#) page 6-21.
- 2 Disconnect the carriage-motor cable from the main PCA (connector MOT Y), and from the clip at the back of the plotter.

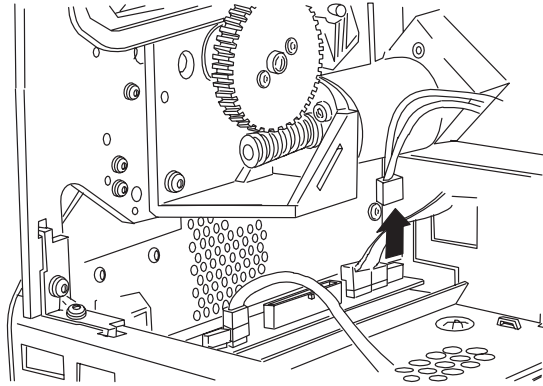

### CAUTION

In the following step, take care not to break the black plastic tab on top of the motor.

- 3 Press the carriage motor towards the left, and remove the belt from the motor shaft.

*If you need greater maneuverability of the motor, press the black plastic tab on top very **slightly** downwards.*

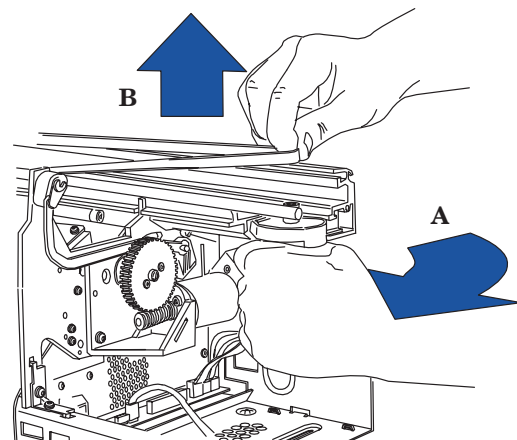

- 4 Slightly rotate the motor on its hinge until the indicated part of the black plastic is parallel with the side of the chassis beam.

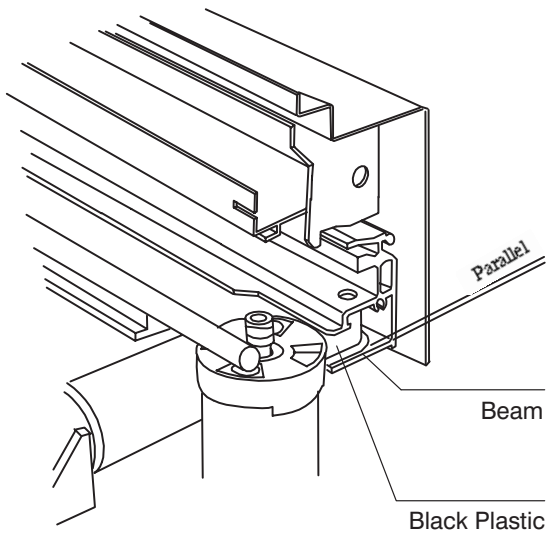

- 5 Pull the motor out to the right of the plotter.

*The motor may be stiff.*

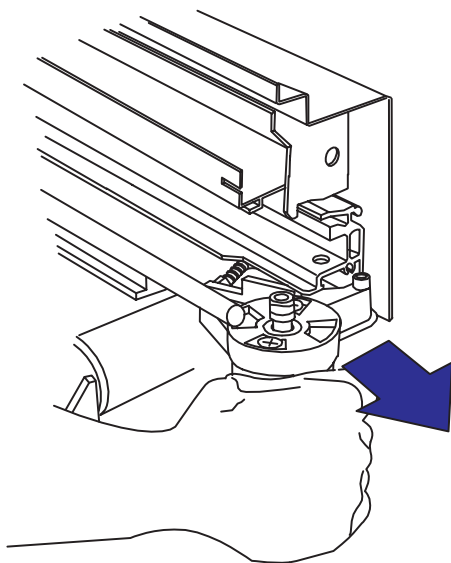

**Reassembling:** There are two springs on the motor assembly:

- One fits onto the protruding plastic part on top of the motor. Position this part **inside** the chassis beam.

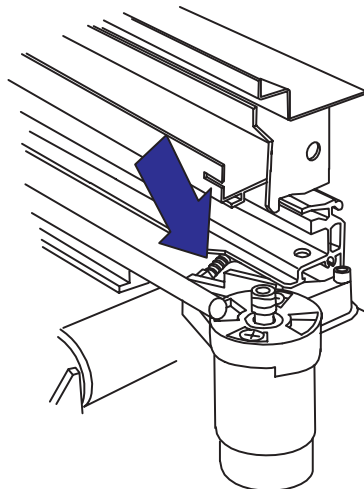

- The other is a flat metal spring attached underneath the motor. Position it **underneath** the chassis beam.

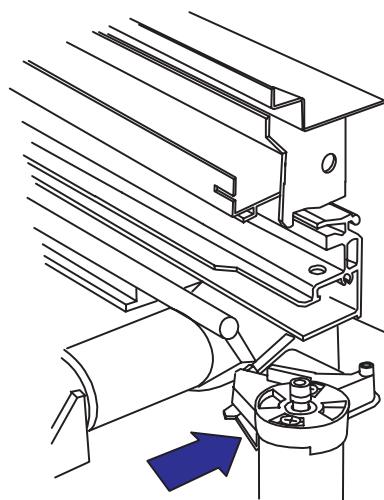

*Also, make sure the belt is correctly positioned on the grooves of the shaft.*



230  
250C

## Removing the Spittoon

- 1 Remove the right end-cover ▶ page 6-10.

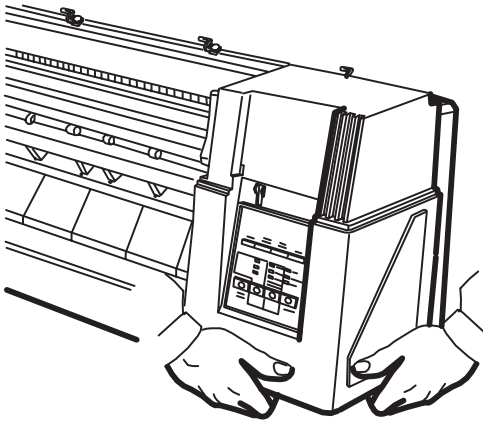

- 2 Remove the screw that attaches the spittoon to the right side-plate.

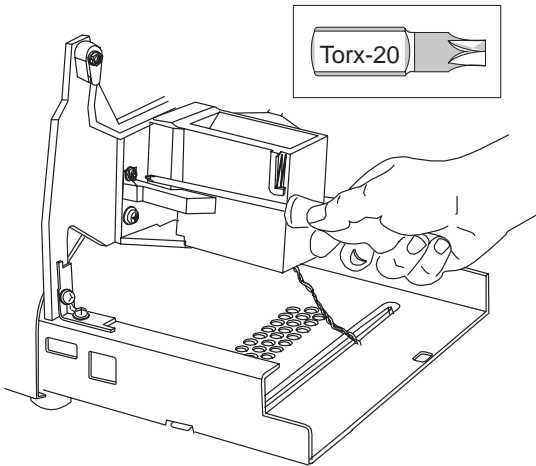

- 3 Slide the spittoon to the right, and remove it from the plotter.

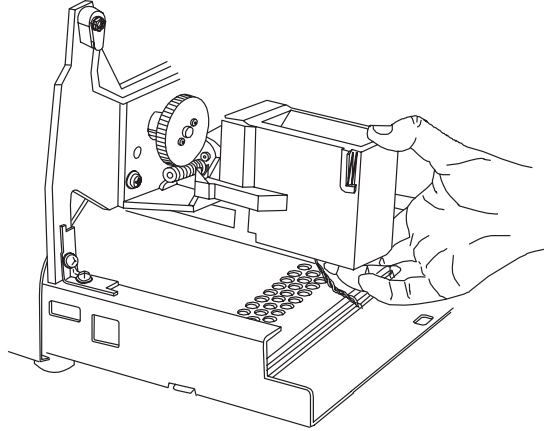

330  
350C

## Removing the Spittoon

- 1 Remove the right end-cover ▶ page 6-10.
- 2 Move the pinch-arm lever linkage upwards so you can access the screw that attaches the spittoon to the right side-plate.

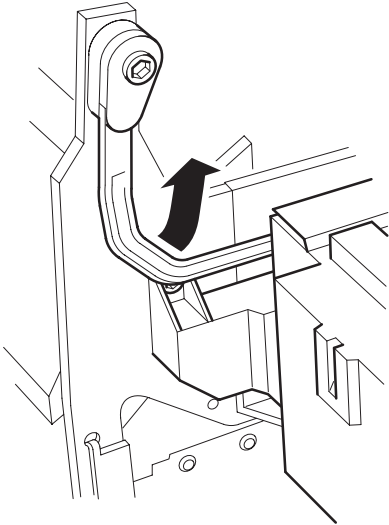

- 3 Remove the screw that attaches the spittoon to the right side-plate.

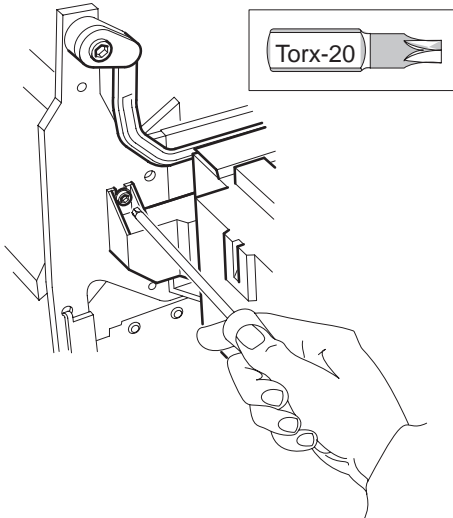

- 4 Disconnect the pinch-arm sensor cable from the main PCA (connector PINCH).

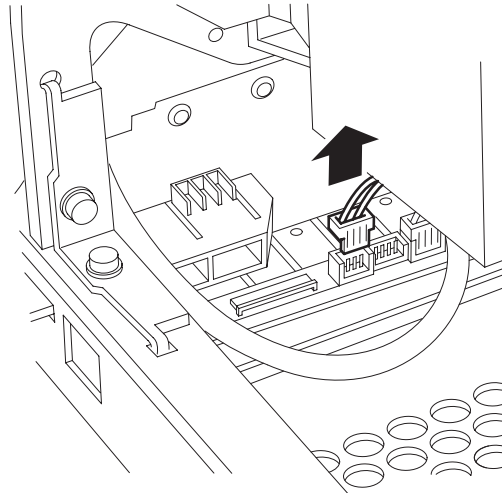

- 5 Slide the spittoon to the right, and remove it from the plotter.

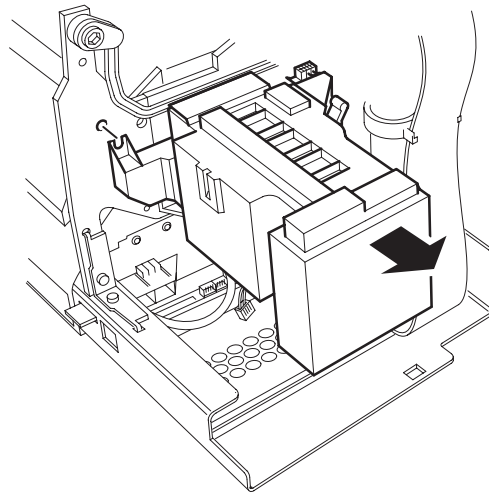

330  
350C

## Removing the Pinch-Arm Sensor

- 1 Remove the spittoon ▶ page 6-24.
- 2 Release the pinch-arm sensor cable from the indicated clip on the spittoon.

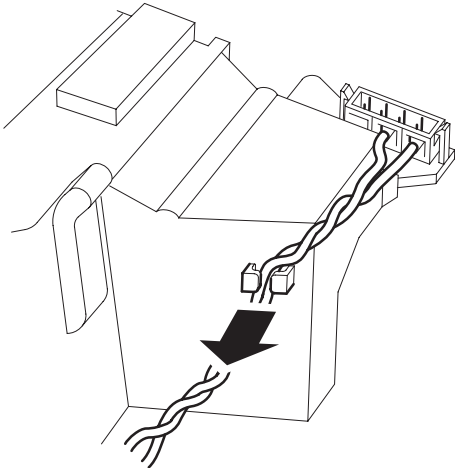

- 3 Gently press the two indicated tabs to the side and lift the pinch-arm sensor from the spittoon.

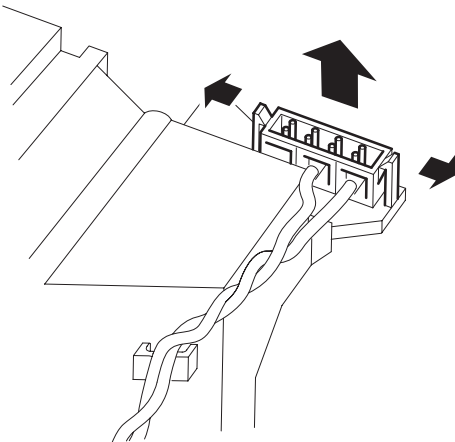

## Removing the Drive-Roller Gear

- 1 Remove the spittoon ▶ page 6-23/6-24.
- 2 Remove the two screws that secure the drive-roller gear to the drive-roller shaft.

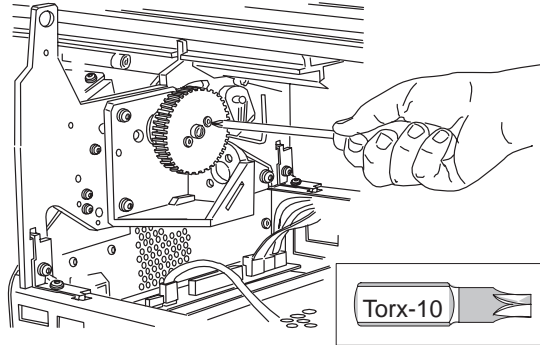

- 3 Remove the drive-roller gear from the drive-roller shaft.

*The gear may be stiff.*

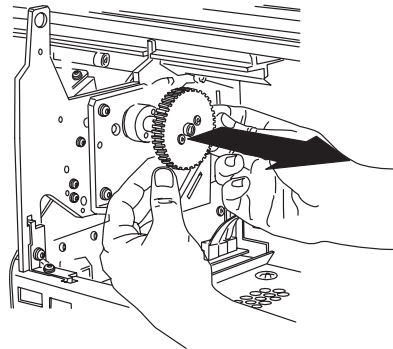

**Reassembling:** *The worm pinion and drive-roller gear mesh slightly during use. Don't install a new motor and an old gear, or vice versa: **install the gear that comes with the motor.** Apply the grease that comes with the new motor to the worm pinion and drive-roller gear.*

**Reassembling:** *Push the gear onto the shaft as far as it will go. Align the holes on the gear with the holes on the shaft.*

330  
350C

*Always calibrate the X-axis after reassembling the motor or the gear ▶ page 7-8.*

## Removing the Media Motor

- 1 Remove the spittoon [page 6-23/6-24](#).
- 2 Disconnect the media-motor cable and the flat media-axis-encoder cable from the main PCA (connectors labeled MOT X and ENC X respectively), and from the clip at the back of the plotter.

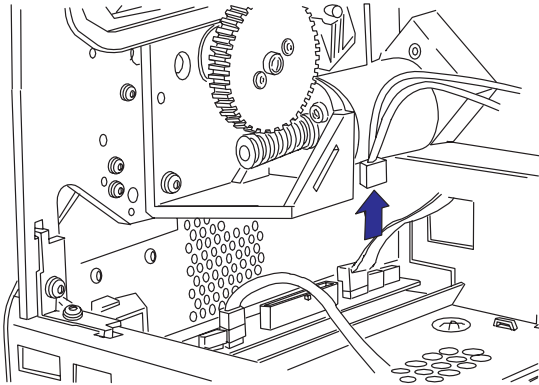

- 3 Remove the two screws that secure the media motor to the media-motor mount.

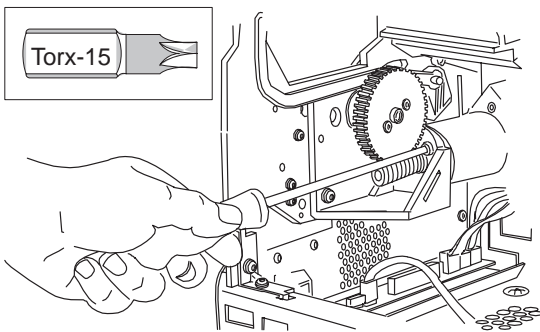

- 4 Pull the media motor out through the back of the plotter.

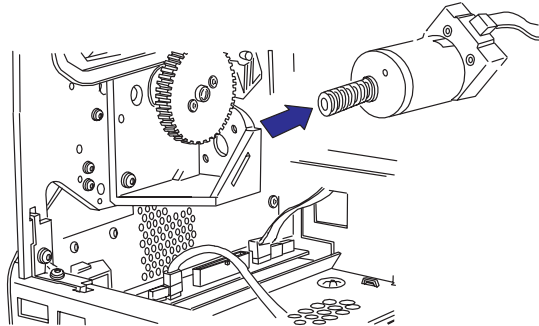

**Reassembling:** The worm pinion and drive-roller gear mesh slightly during use. Don't install a new motor and an old gear, or vice versa: **install the gear that comes with the motor.** Apply the grease that comes with the new motor to the worm pinion and drive-roller gear.

**Calibration:** After having reassembled the plotter, perform the accuracy calibration (Details [page 7](#).)

## Removing the Pinch-Arm-Lever Linkage

- 1 Remove the right end-cover ▶ page 6-10.
- 2 Ease the front plastic part of the linkage to the right, out from the hole in the right side-plate.

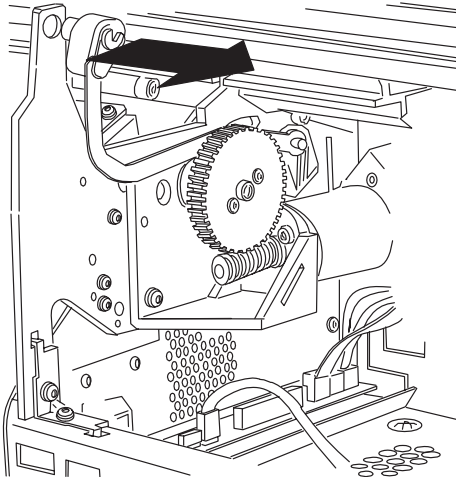

- 3 Remove the linkage from the cam journal on the right side-plate.

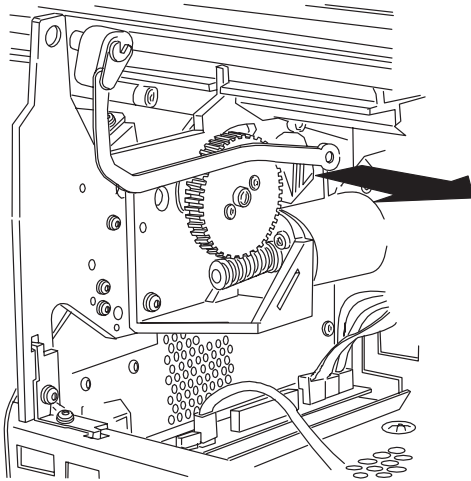

## Removing the Primer

- 1 Remove the left end-cover ▶ page 6-9.
- 2 Disconnect the four **short** tubes from the ink separator.

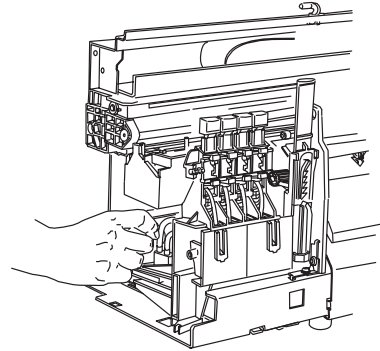

- 3 Remove the screw that attaches the primer to the left side-plate.

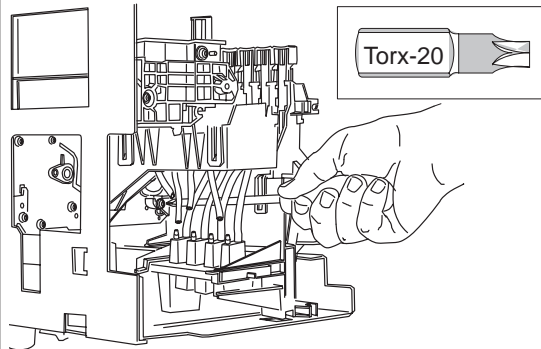

- 4 Slide the primer to the left, and remove it from the plotter.

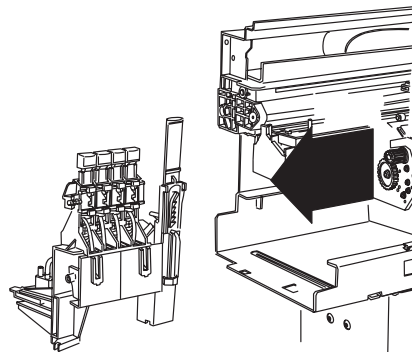

## Removing the Service Station

- 1 Remove the left end-cover ▶ page 6-9.
- 2 Disconnect the four **short** tubes from the primer ink separator.

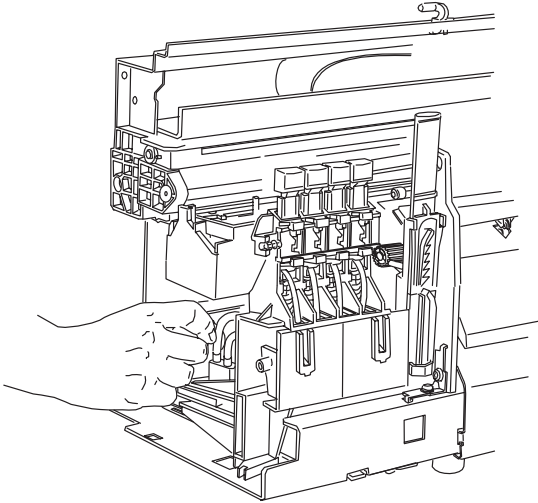

- 3 Remove the screw that attaches the service station to the left side-plate.

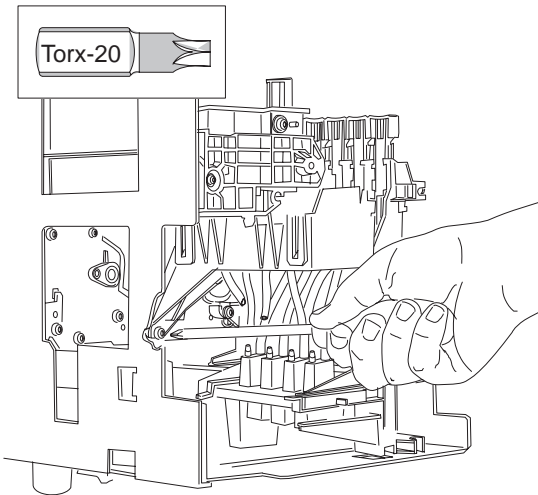

- 4 Slide the service station to the left, and remove it from the plotter.

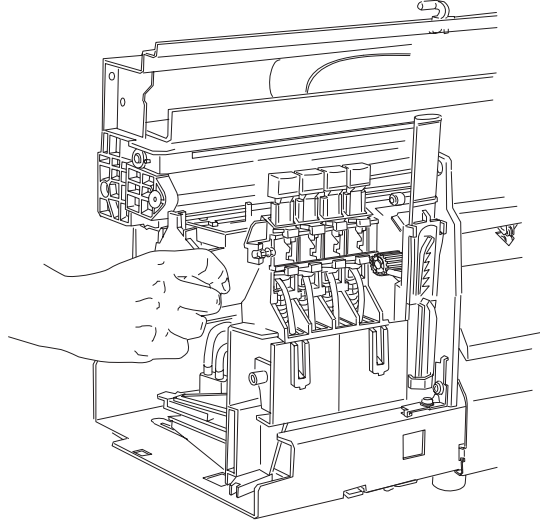

*The service station is one orderable assembly. Do not open it.*

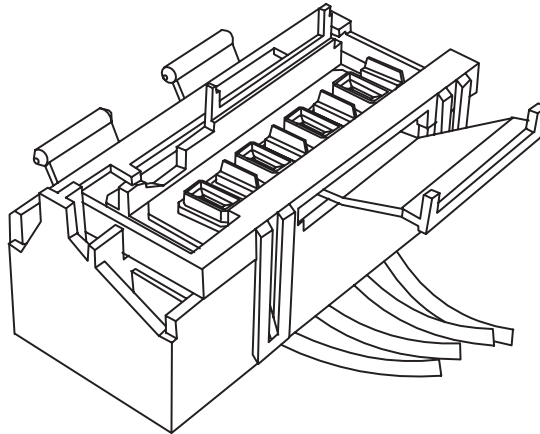

**Reassembling:** *Ensure that the cartridge caps are clean, the wipers straight, and the openings clear.*

## Removing the Bail-Lift Mechanism

- 1 Remove the bail ▶ page 6-5.
- 2 Remove the primer ▶ page 6-27.
- 3 Remove the service station ▶ page 6-28.
- 4 **While** pushing the top of the bail-gear assembly towards the front of the plotter,

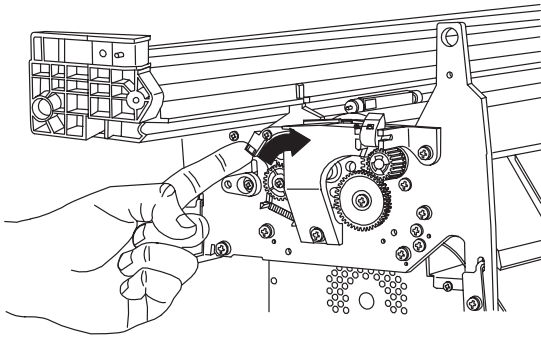

**do** the following:

- a On the engaging lever, move the cable ball slightly towards the back of the plotter.

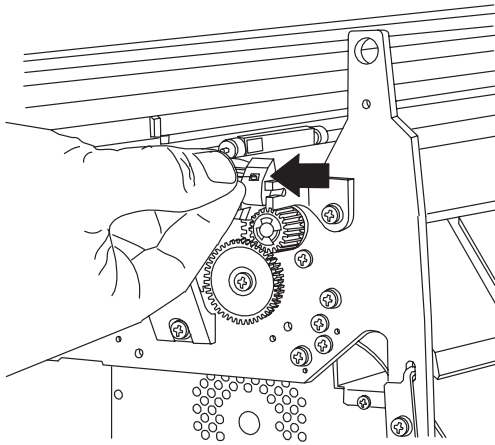

- b Allow the engaging lever to move towards the left of the plotter, so that the cable comes free of the lever.

- 5 Release the cable from the engaging-lever support.

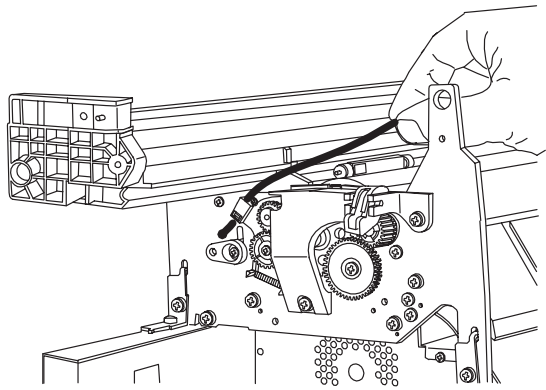
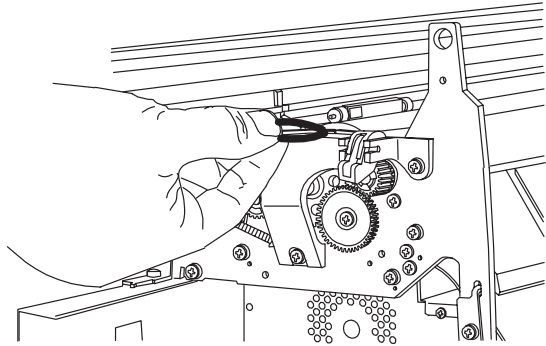

- 6 Release the cable from the bail-gear assembly.

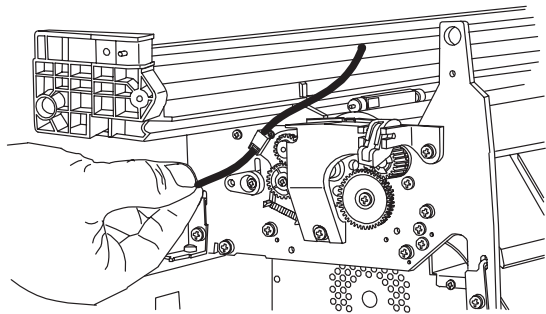

**7** Remove the engaging lever.

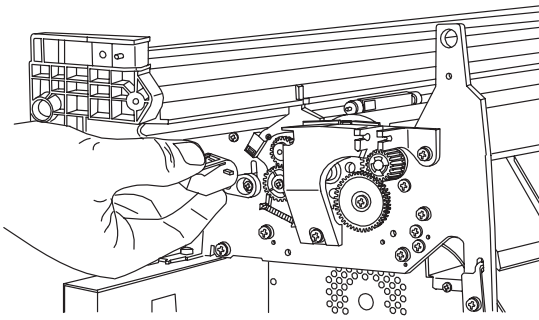

**8** Remove the spring from the bail-gear assembly.

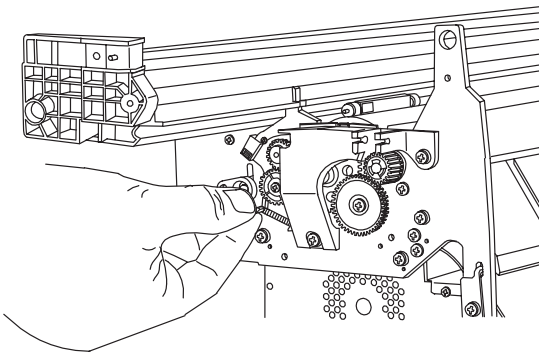

**9** Loosen the screw from the top of the bail-gear assembly.

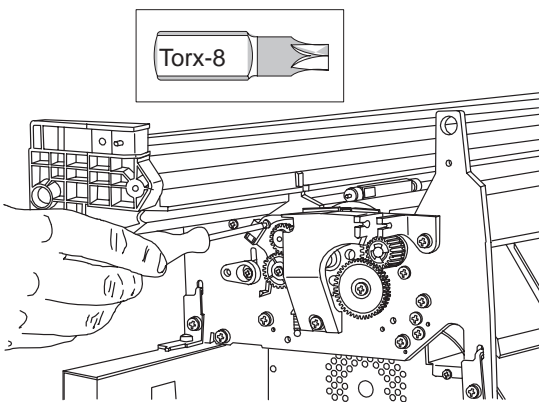

**10** Remove the screw from the plastic bail gear.

*You may need to hold the bail cam steady inside the side-plate at the same time. You can access the cam through the hole underneath the side-plate.*

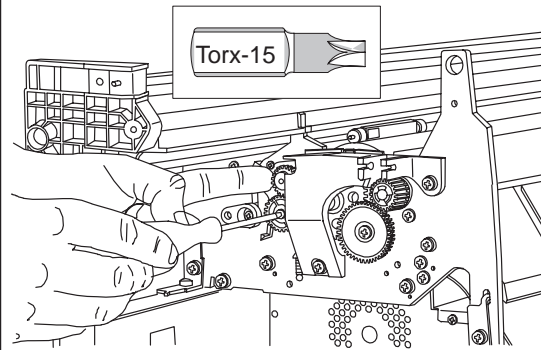

**11** Pull the bail gear assembly out from the plotter.

*The cam falls to the floor of the plotter.*

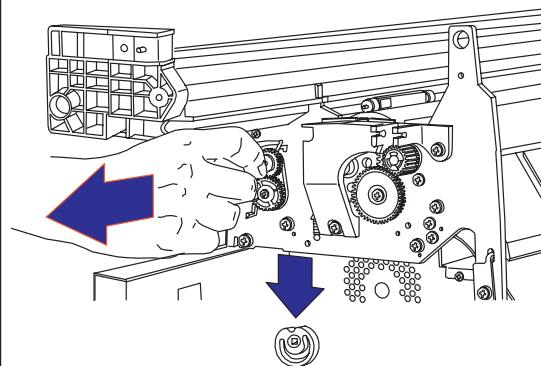



## Removing the Engaging-Lever Support

- 1 Remove the primer ▶ page 6-27.
- 2 Remove the service station ▶ page 6-28.
- 3 Release the cable from the engaging lever support ▶ page 6-29.

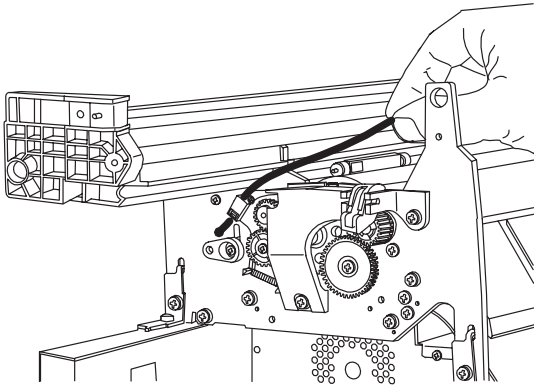

- 4 Remove the engaging lever.

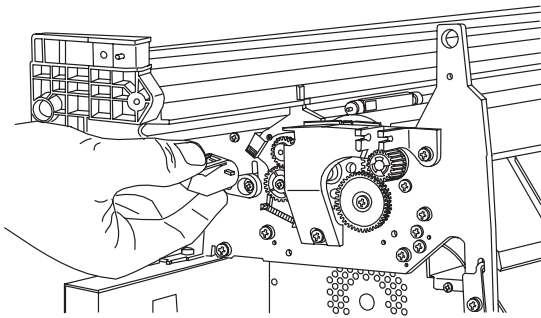

- 5 Remove the spring from the engaging-lever support.

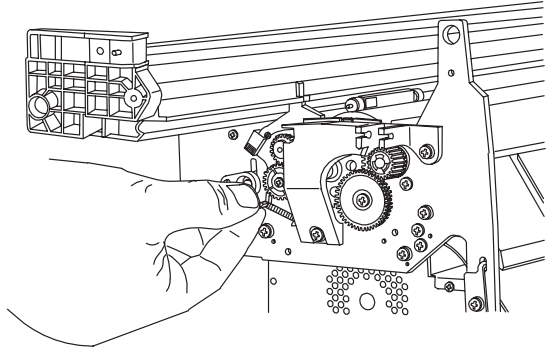

- 6 Remove the three screws that attach the support to the left side-plate.

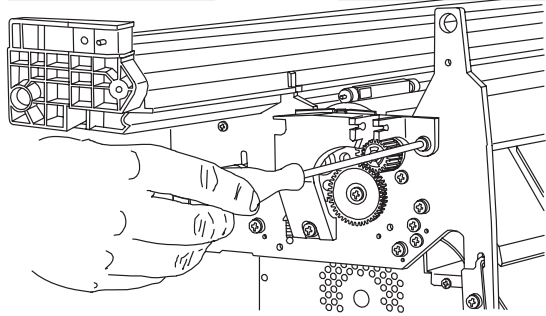

- 7 Pull the support upwards and remove it from the plotter.

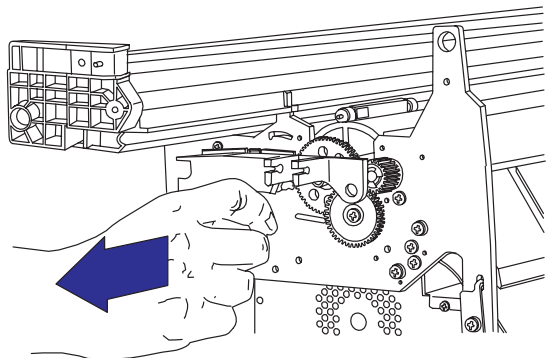

## Removing the Overdrive Roller

- 1 Remove the primer ▶ page 6-27.
- 2 Remove the service station ▶ page 6-28.
- 3 Remove the clutch retaining ring that secures the overdrive clutch to the overdrive roller.

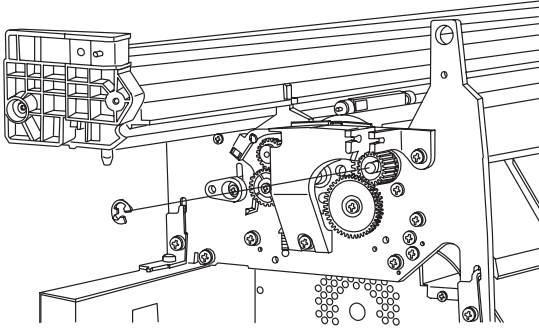

*Note the position and orientation of the overdrive clutch. When correctly installed, the overdrive roller can be manually rotated forward only.*

- 4 While flexing the media separator upwards, ...

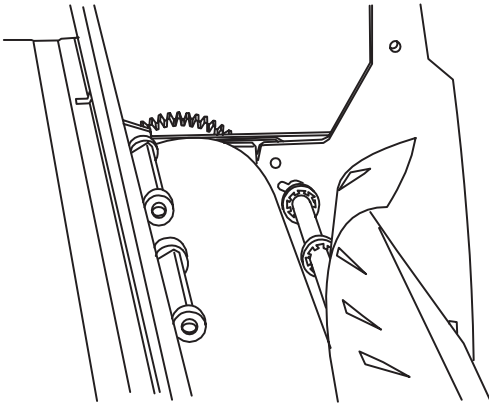

... slide the overdrive roller horizontally to the right until the overdrive clutch can drop free of the roller.

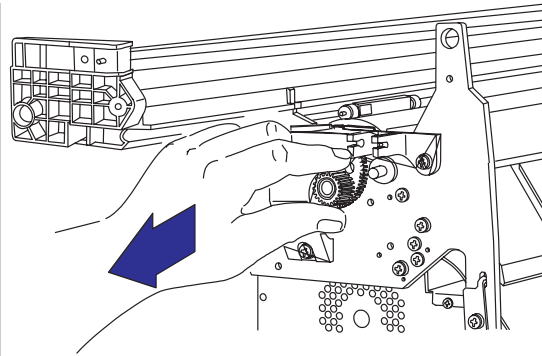

- 5 Move the overdrive roller to the right until it has completely cleared the left sideplate but not entered the hole in the right sideplate.
- 6 Release the overdrive roller from the small black clips underneath the media separator, and remove the overdrive roller from the plotter.

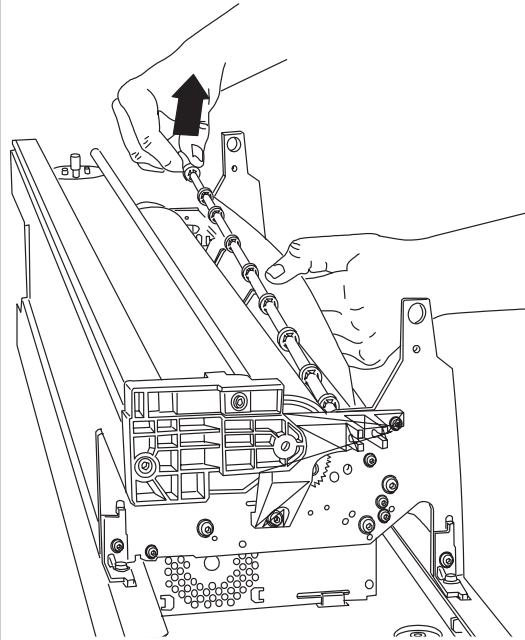

**Reassembling:** Position the C-clips and bushings on the overdrive roller from **left to right** as follows:

*C-clip – clutch – bushing – sideplate – bushing – C-clip.*

---

## Removing the Back Cover

- 1 Remove the left and right end-covers  
▶ pages 6-9 and 6-10.
- 2 Remove the screws that attach the back cover to the plotter.

*D/A1-size plotters have 2 screws.  
E/A0-size plotters have 3 screws.*

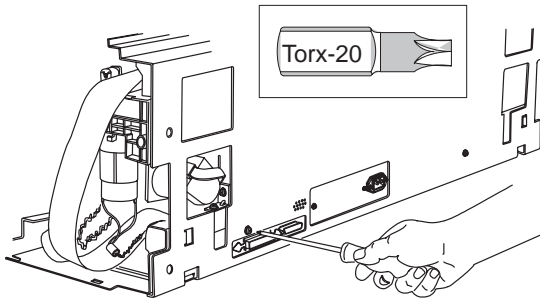

**Reassembling:** Before replacing the screws, ensure that the electronics module is flush against the inside back of the plotter.

---

### CAUTION

In the following steps, take care not to damage the parallel-port clips.

- 3 Pull the bottom of the cover slightly back and out from the plotter.

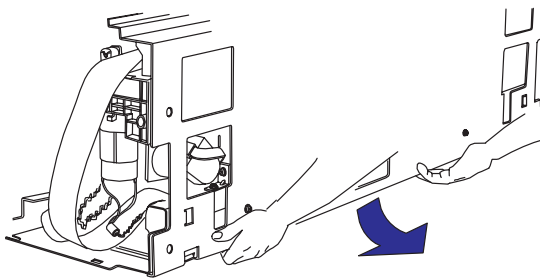

- 4 Lift the cover up, and remove it from the plotter.

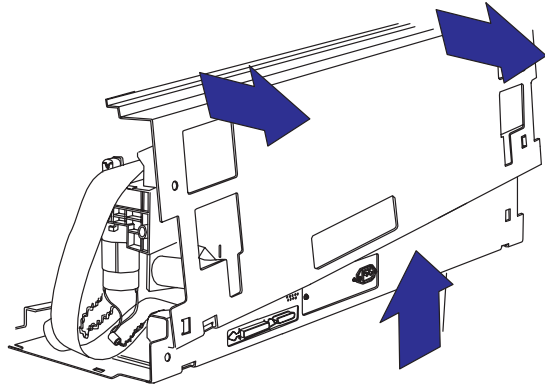

## Removing the Trailing Cable

- 1 Remove the right end-cover ▶ page 6-10.
- 2 Disconnect the trailing cable from the connector marked P1 on the main PCA, and from the guides on the right bracket.

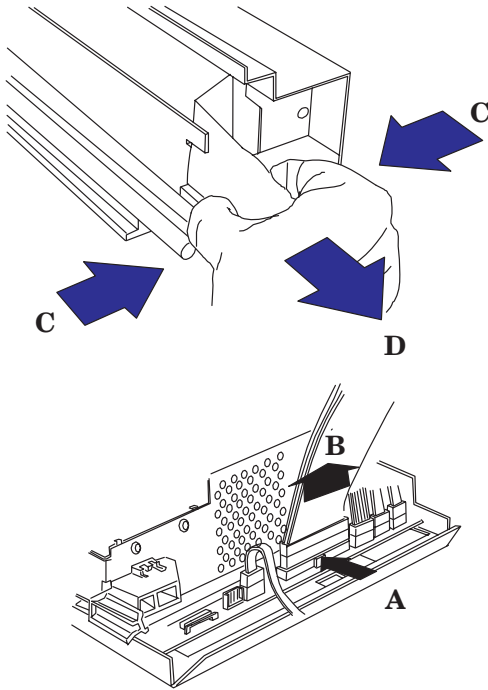

- 3 Move the carriage out of the service station.

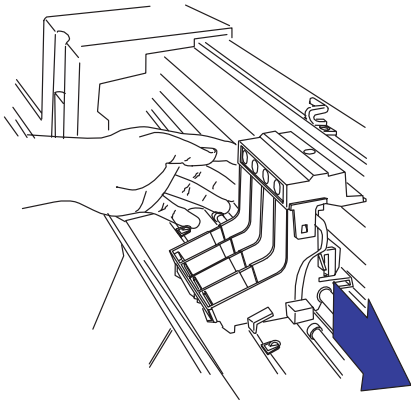

- 4 Release the two indicated clips on the top of the cartridge carriage by pulling them slightly outwards.

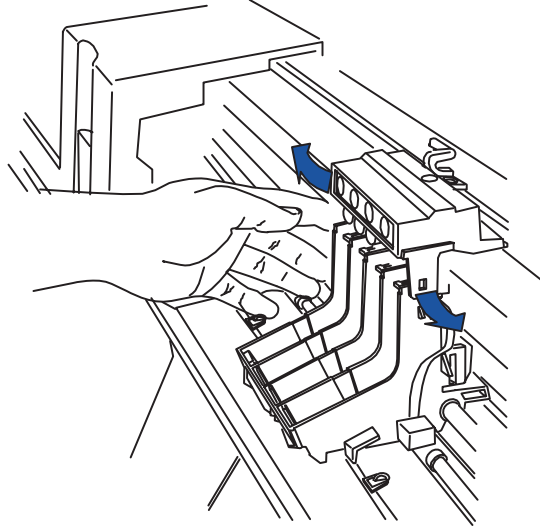

### WARNING



**In the following step, take care neither to cut yourself on the encoder strip, nor to damage the strip.**

*For DesignJet 230 only, it is also necessary to release two clips at the bottom of the cartridge carriage.*

230  
250C

5 Pull the top of the carriage up.

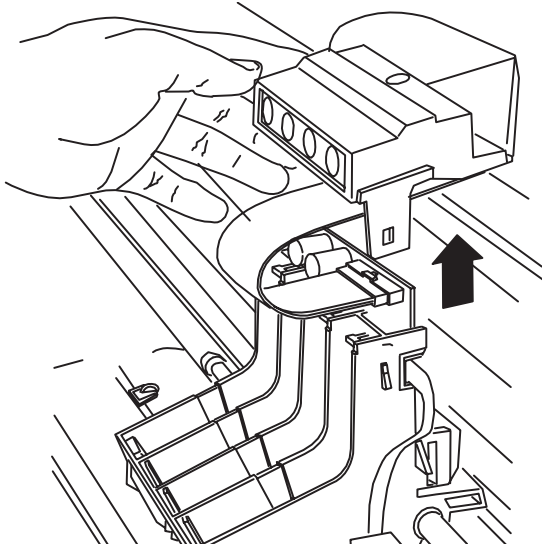

6 Disconnect the trailing cable from the connector on the carriage.

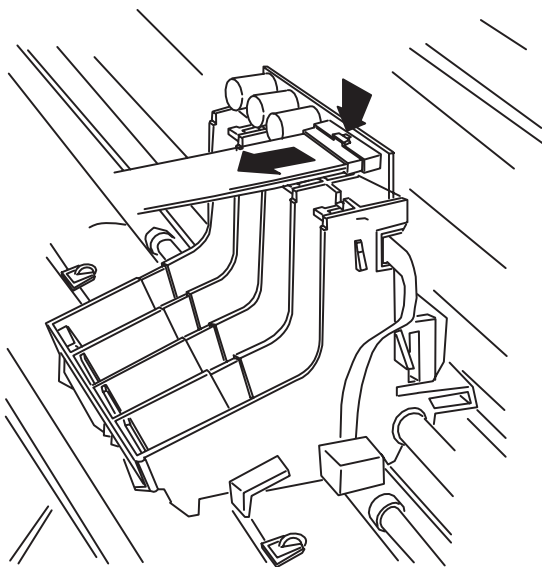

7 Release the trailing cable from the clips on the trailing-cable guide, and remove the trailing cable from the plotter.

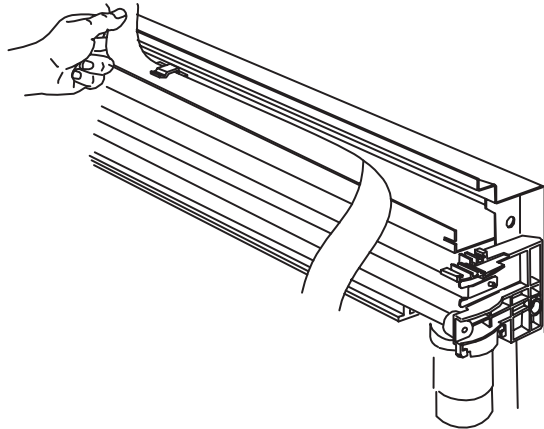

## Repositioning the Trailing Cable

### IMPORTANT

When you reinstall the trailing cable, make sure that you position it under the plastic tabs at the back of the carriage cover, and not above them.

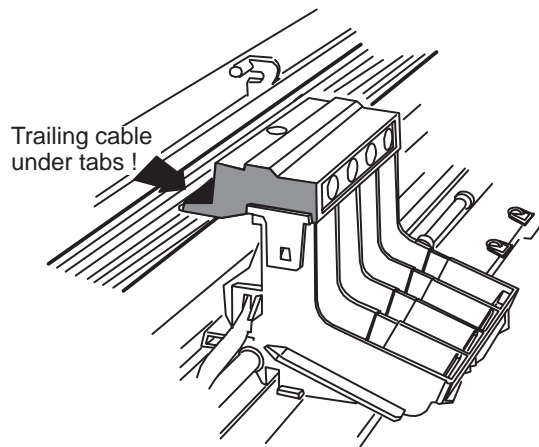

Otherwise, the plotter will not be able to load media.

## Removing the Trailing-Cable Guide

- 1 Remove the right bracket [▶ page 6-21](#).

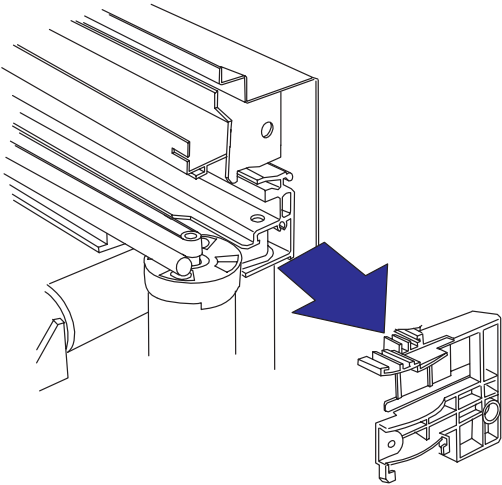

- 2 Remove the back cover [▶ page 6-33](#).
- 3 Remove the trailing cable [▶ page 6-34](#).
- 4 Slide the trailing-cable guide to the right, releasing it from the left-bracket tab.

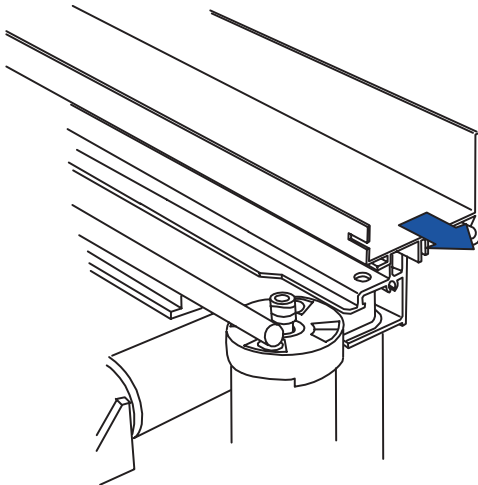

- 5 Rotate the trailing-cable guide back on its hinge, until it clicks off from the chassis beam.

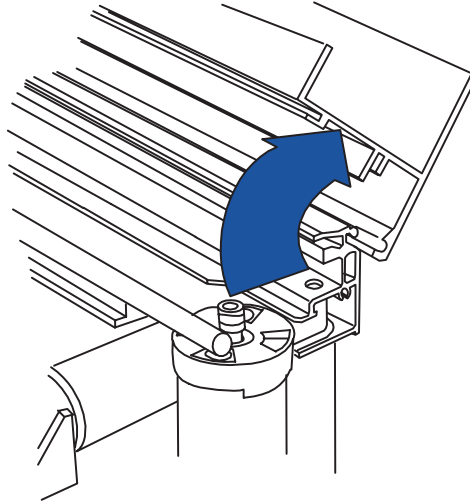

- 6 Remove the trailing-cable guide from the plotter.

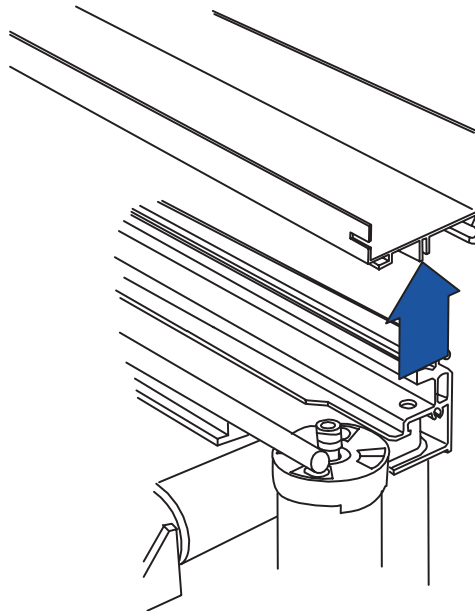

---

## Removing the Cartridge Carriage

- 1 Remove the encoder strip ▶ page 6-17.
  - 2 Remove the right bracket ▶ 6-21.
- 

### CAUTION

In the following step, take care not to break the black plastic tab on top of the motor.

---

- 3 Press the carriage motor towards the left, and remove the belt from the motor shaft.

*If you need greater maneuverability of the motor, press the black plastic tab on top very **slightly** downwards.*

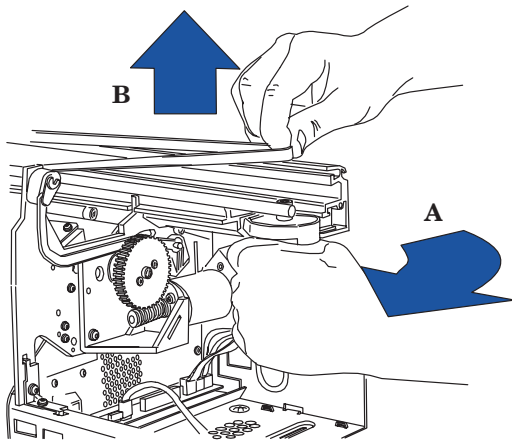

**Reassembling:** Make sure the belt is correctly positioned on the grooves of the shaft.

- 4 Rotate the motor on its hinge out towards the back of the plotter.

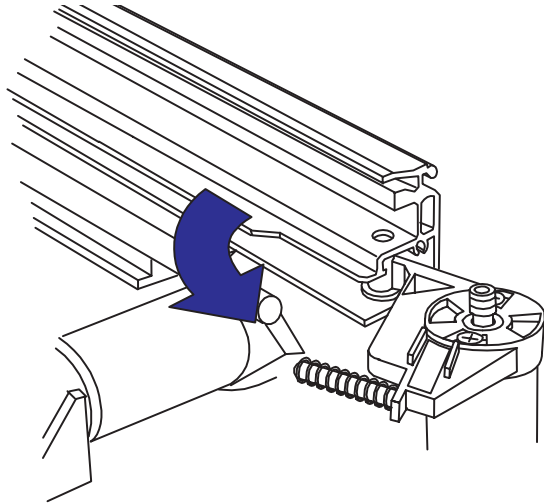

- 5 Release the belt from the pulley on the left of the plotter.

**Reassembling:** Make sure the belt is correctly positioned on the grooves of the pulley.

---

### WARNING



**In the following steps, take care neither to cut yourself on the encoder strip, nor to damage the strip.**

---

- 6 Release the two indicated clips on the top of the cartridge carriage by pulling them slightly outwards.

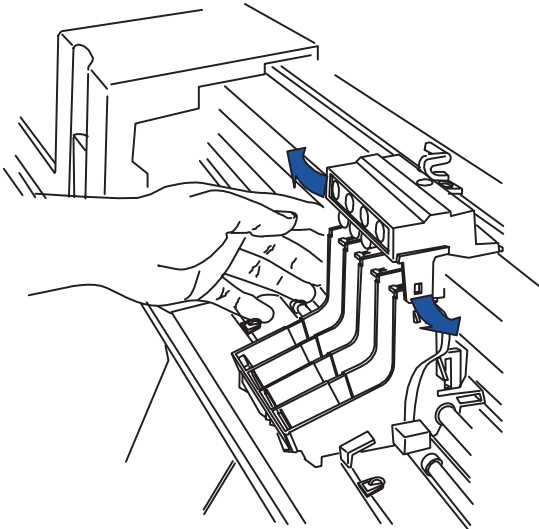

- 7 Pull the top of the carriage up.

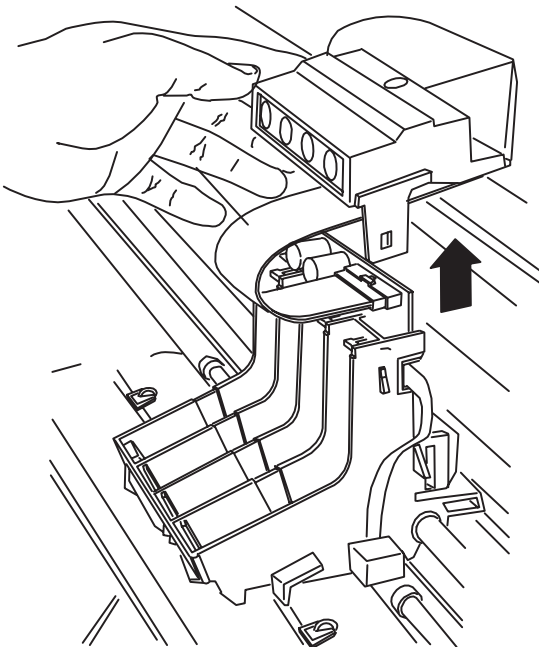

- 8 Disconnect the trailing cable from the connector on the carriage.

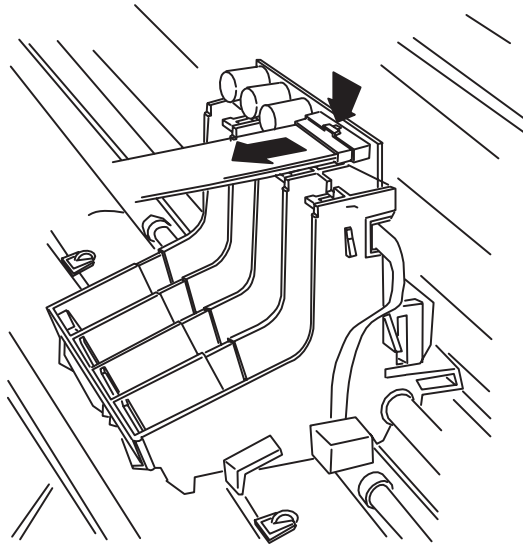

- 9 Rest the top of the carriage on the trailing-cable guide.

---

#### WARNING

In the following step, take care not to spill ink from the carriage.

---



- 10 Slide the carriage to the right, and remove it with the belt from the plotter.

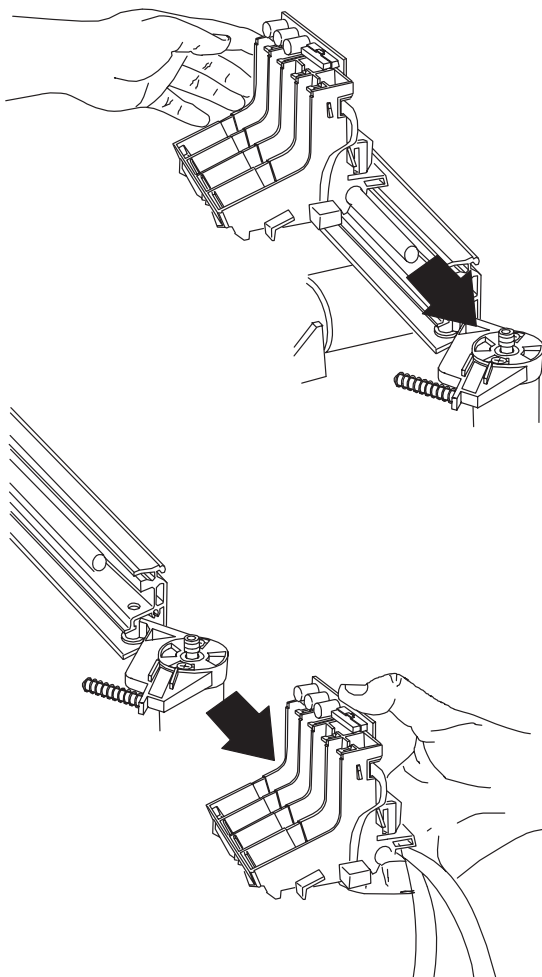

**Reassembling:** Position the belt **under** the back extrusion of the carriage.

Make sure that you correctly reconnect the trailing cable ▶ page 6-35.

After reassembling, make sure that you check the carriage-to-media distance ▶ page 7-11.

**Calibration:** After having reassembled the plotter, perform the black cartridge-alignment. (Details ▶ User's Guide.)

## Removing the Drive Belt

- 1 Remove the cartridge carriage ▶ page 6-37.

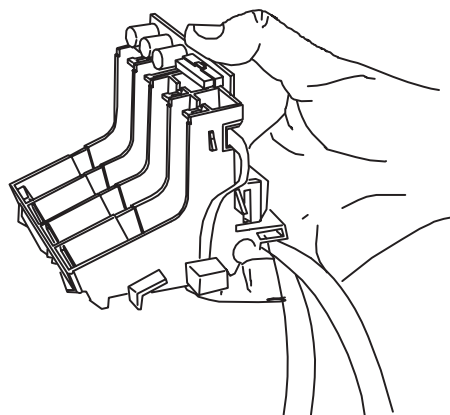

- 2 Release the belt from the clips on the underside of the carriage.

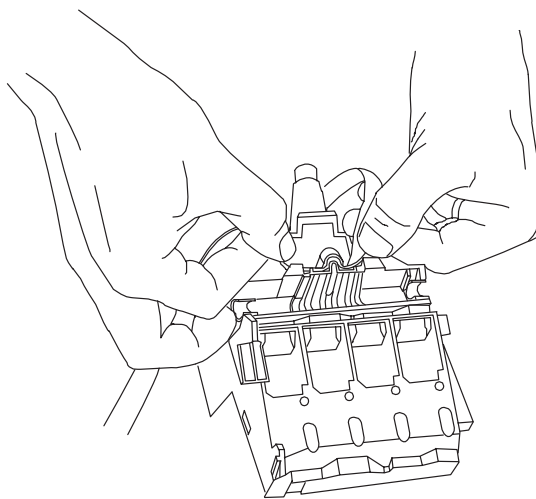

**Reassembling:** Clip the belt to the carriage, using the same part of the belt as was originally used. Also, match the vertical lines on the belt with the vertical grooves on the carriage. The horizontal lines on the belt face outwards.

## Removing the Drive-Belt Pulley

- 1 Remove the encoder strip.

### CAUTION

In the following step, take care not to break the black plastic tab on top of the motor.

- 2 Press the carriage motor towards the left, and remove the belt from the motor shaft.

*If you need greater maneuverability of the motor, press the black plastic tab on top very slightly downwards.*

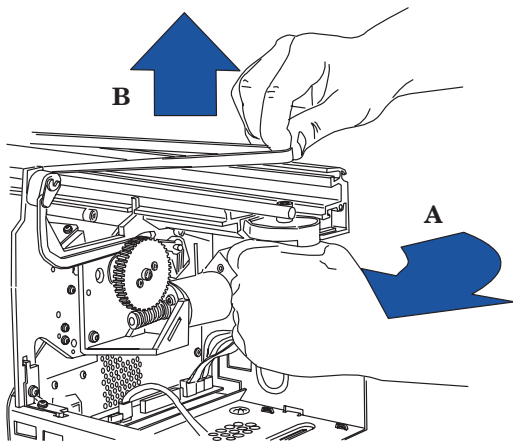

**Reassembling:** Make sure the belt is correctly positioned on the shaft grooves.

- 3 On the left of the plotter, remove the belt from the pulley.

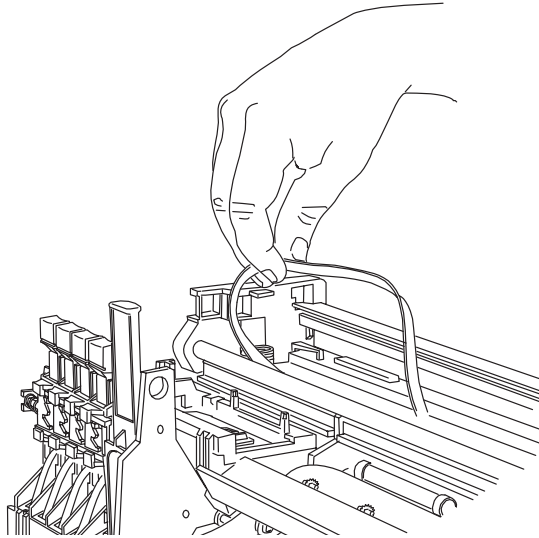

**Reassembling:** Make sure the belt is correctly positioned on the pulley grooves.

- 4 Underneath the left side of the chassis beam, release the black plastic clip and push the pulley shaft upwards.
- 5 Remove the pulley, shaft, and bushing from the plotter.

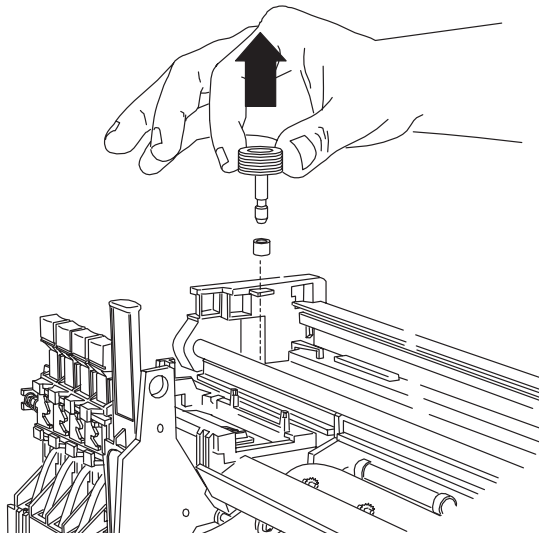

## Removing the Drive Roller

- 1 Remove the drive-roller gear ▶ page 6-25.
- 2 Remove the media motor ▶ page 6-26.
- 3 Remove the pinch-arm-lever linkage ▶ page 6-27.
- 4 Remove the engaging-lever support ▶ page 6-31.
- 5 Remove the large black plastic gear from the left side-plate.

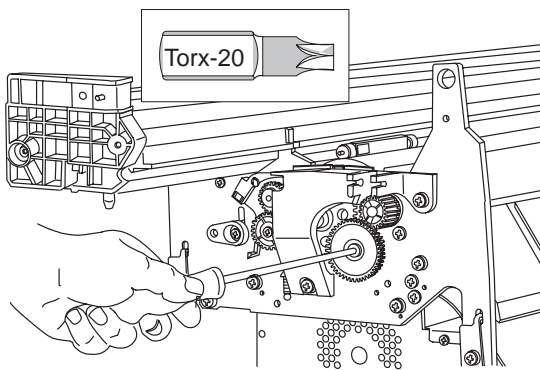

- 6 Remove the overdrive roller ▶ page 6-32.
- 7 Remove the three screws that attach the media-motor mount to the right sideplate.

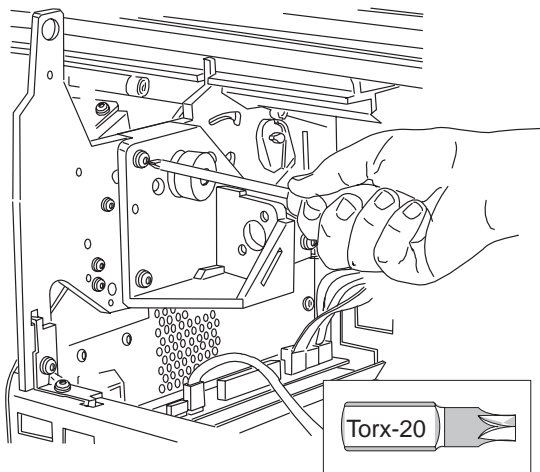

- 8 Remove the media-motor mount.

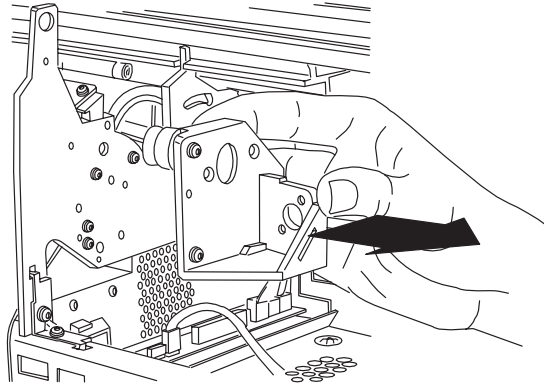

- 9 Snap the overdrive clips to the right, and remove them from under the media separator.

*D/A1-size plotters have two clips.  
E/A0-size plotters have three clips.*

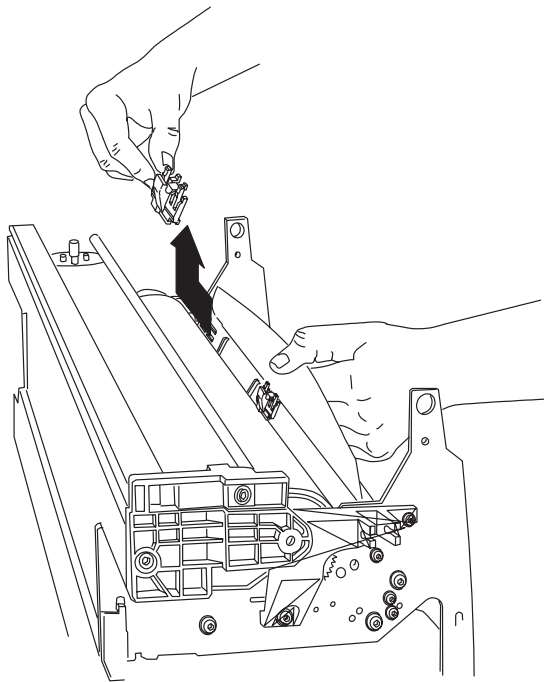

- 10 Use the right cam journal to raise the pinch-wheels, and lift the right side of the drive roller up.

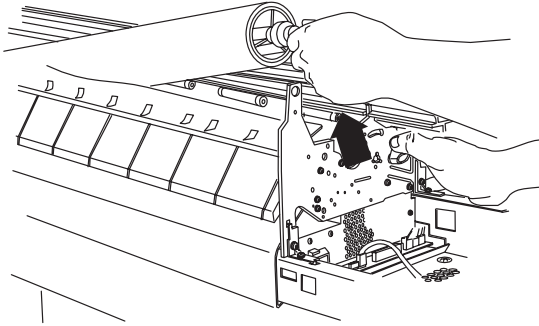

- 11 Lift the roller out of the plotter.

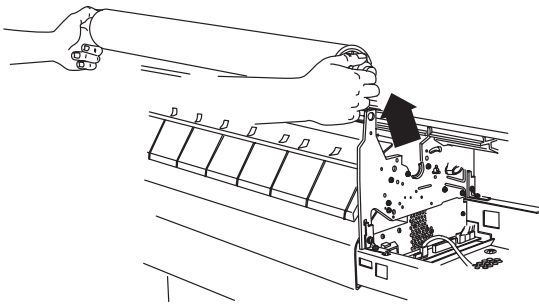

## WARNING

**Reassembling: See following procedure.**

**After reassembling, make sure that you check the carriage-to-media distance** ▶ page 7-11

## Reinstalling the Drive Roller

### WARNING

**In the following procedure, take care not to injure your fingers if you let the drive roller snap into place.**

### CAUTION

In the following procedure

- Take care not to damage the media separator. Don't let it slip under the drive roller.
- Take care that the edge of the media separator does not damage the rubber surface of the drive roller.

- 1 Flex the media separator upwards and position the roller behind it and on top of the pinch wheels.

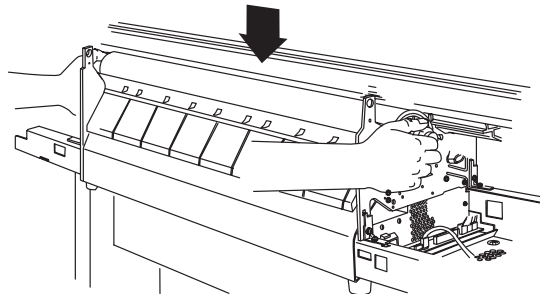

- 2 Make sure that the gear on the left side of the roller is positioned immediately to the left of the side-plate.

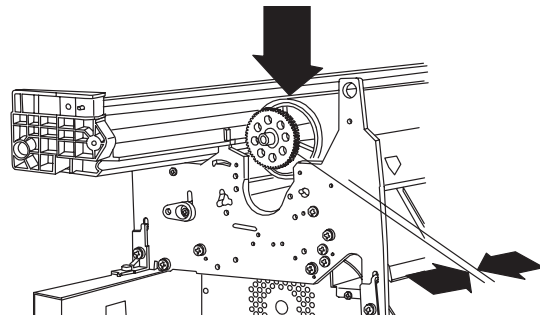

- 3** Use the right cam journal to lift the pinch-wheels, and let the roller drop into place.

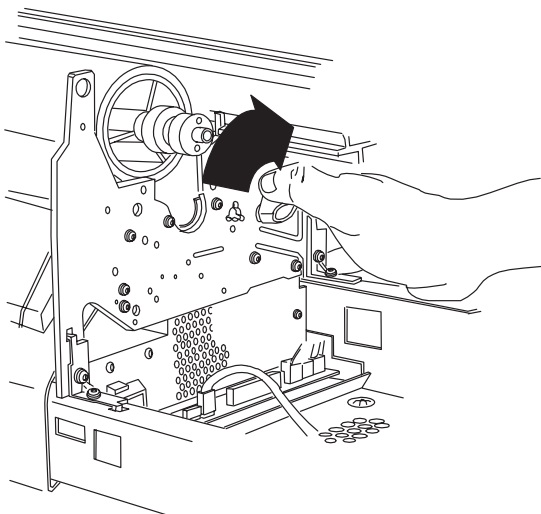

- 4** Ensure that the bearing assembly at the right end of the drive roller is seated in the right sideplate and completely on the right side of the axial bias plate.

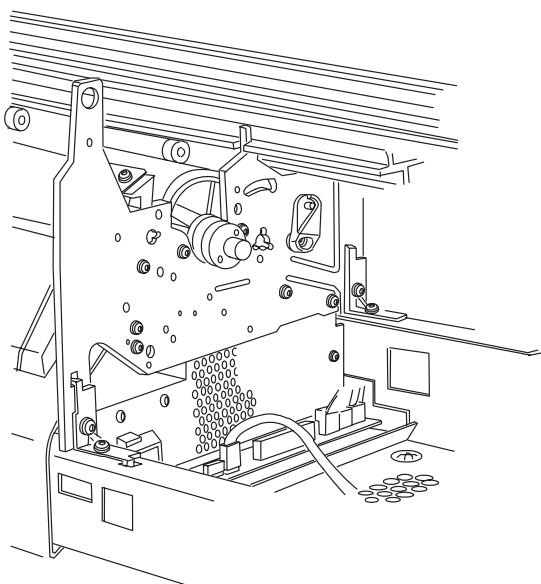

- 5** Replace the overdrive clips underneath the media separator.

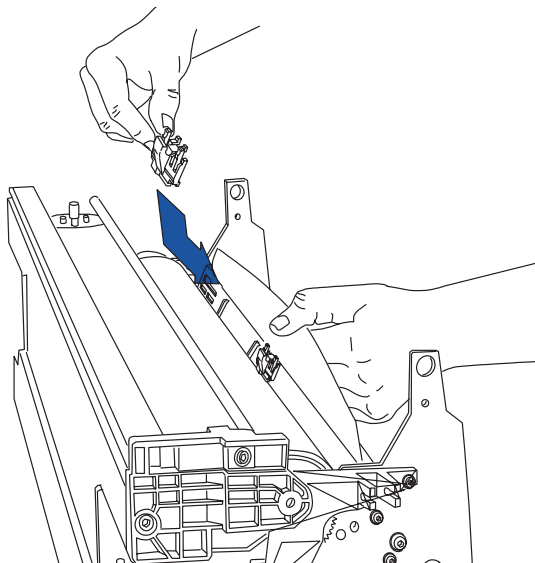

- 6** Replace the media mount.

*Press down on the media mount as you replace the three screws. This is to ensure correct spacing between the drive roller and the cartridge nozzles.*

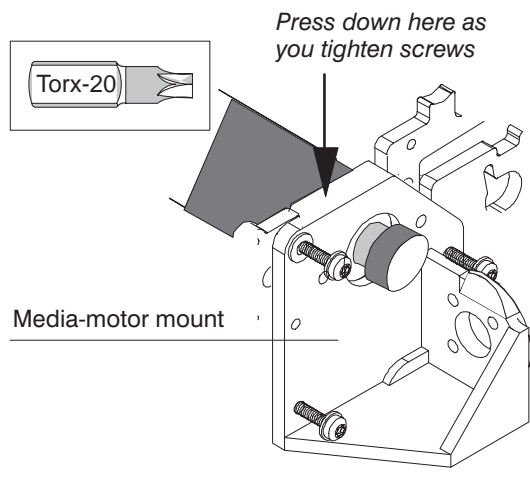

**Calibration:** Perform the accuracy calibration after reassembling the plotter. (Details ▶ chapter 7.)

## Removing the Pinch-Arm Lift Mechanism

- 1 Remove the drive roller ▶ page 6-41.
- 2 Little by little, unscrew the cam-journal screw on the right side, at the same time continually pushing the screw in towards the center of the plotter, until you feel that you have pushed the cam-journal **nut** out of the journal.

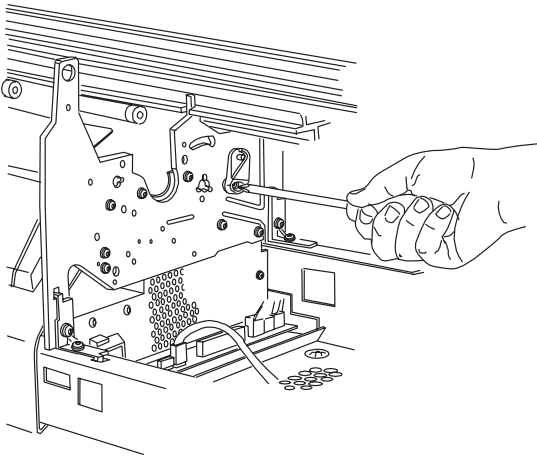

- 3 Pull the journal out of the bar cam.

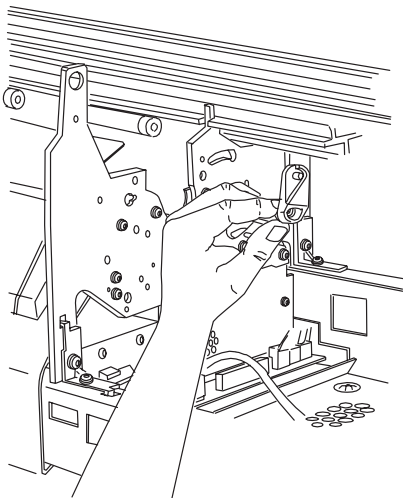

- 4 Grasp the cam journal on the left side of the plotter.
- 5 Reach around to the front of the plotter and push the top of the bar cam slightly towards the rear of the plotter, simultaneously pulling the cam journal to the left, so that the cam can begin to slide out of the left sideplate.

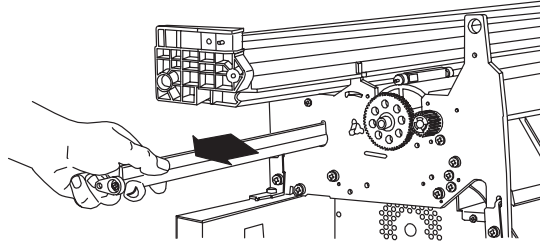

- 6 Slide the bar cam to the left until it clears the pinch-arm assembly you want to replace.
- 7 Remove the pinch-arm assembly and spring from the chassis.

*Take care that the spring does not fall.*

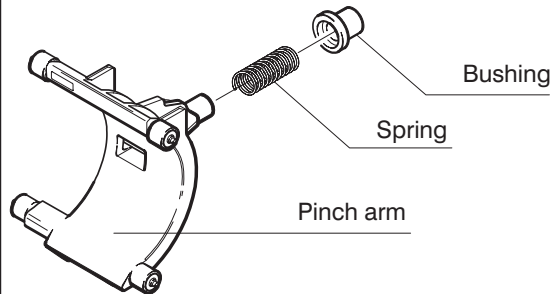

### CAUTION

**Reassembling:** See following procedure

---

## Reinstalling the Pinch-Arm Lift Mechanism

- 1 Reinsert the pinch-arm assemblies into the chassis. Make sure that the bushings are correctly inserted in the holes.

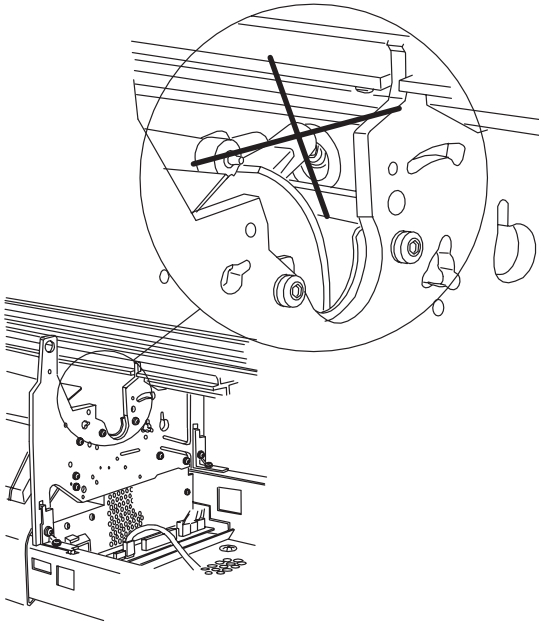

- 2 Slide the bar cam to the right. You must position it *between* the left and right side-plates, or the lift mechanism will not work.

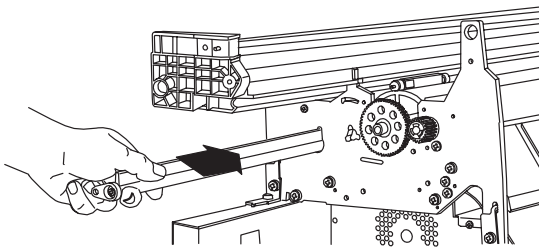

---

## CAUTION

In the following step, do not overtighten the cam-journal screw. Doing so could break the journal, cause the bar cam to enter the side-plate hole, and thus restrict the action of the pinch-arm lever.

- 3 Before repositioning the right cam journal, tighten its nut just to the point where the nut is inside the journal. Reinstall the journal and slightly tighten the screw.

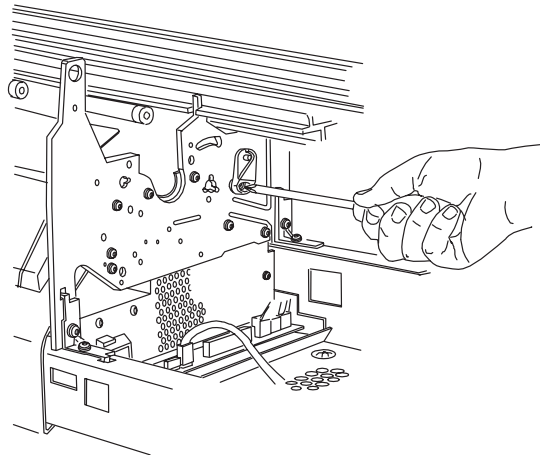
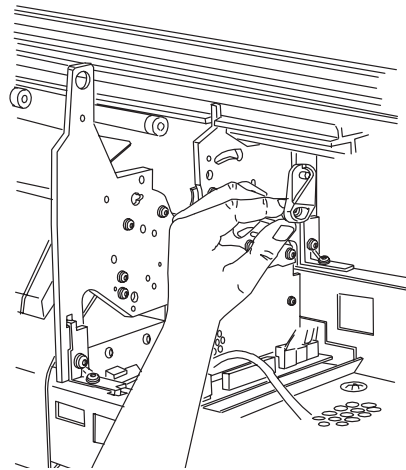

## Removing the Overdrive Enclosure

230  
250C

- 1 Remove the right end-cover ▶ page 6-10.

330  
350C

Remove the spittoon ▶ page 6-24.

- 2 Remove the overdrive roller ▶ page 6-32.
- 3 Remove the indicated two screws from the right side-plate.

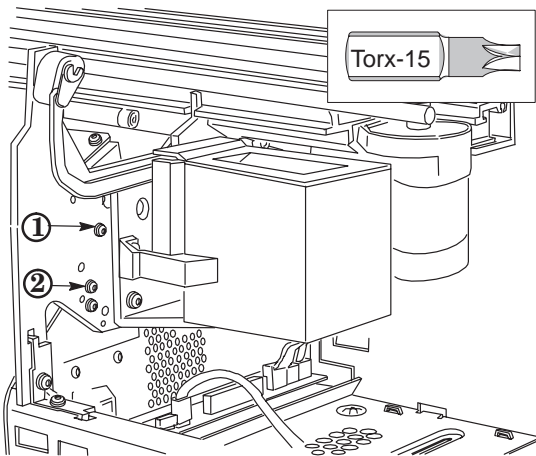

*This illustration shows the configuration for the DesignJet 230/250C. The removal procedure for DesignJet 330/350C is exactly the same except that the spittoon has been removed to access the indicated screws.*

- 4 Remove the indicated three screws from the left side-plate.

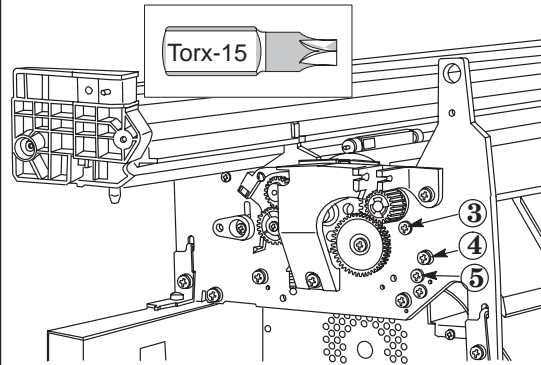

- 5 Lift the overdrive enclosure out from the plotter.

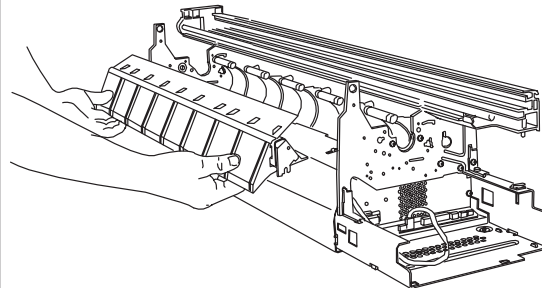

**Reassembling:** See following procedure.



## Reinstalling the Overdrive Enclosure

*The order in which you replace the screws on the overdrive enclosure is important.*

### CAUTION

Take care not to damage the media-sensor flags. The overdrive enclosure should not touch them.

- 1 Replace the two indicated screws. (**Short** dog-point screws.)

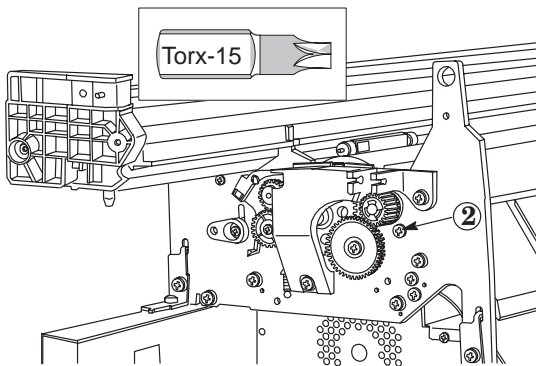
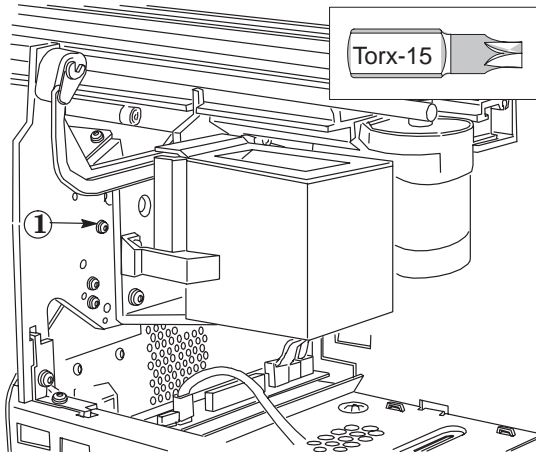

- 2 Insert the two indicated screws, but do not tighten them. (**Long** dog-point screws.)

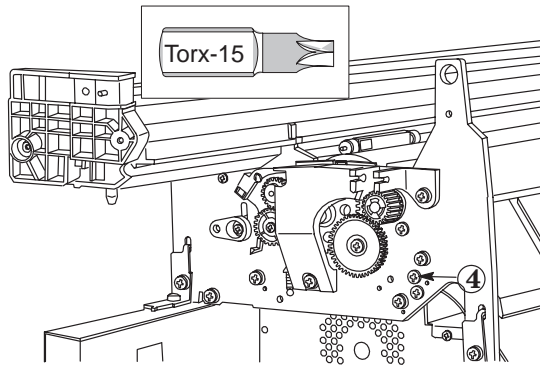
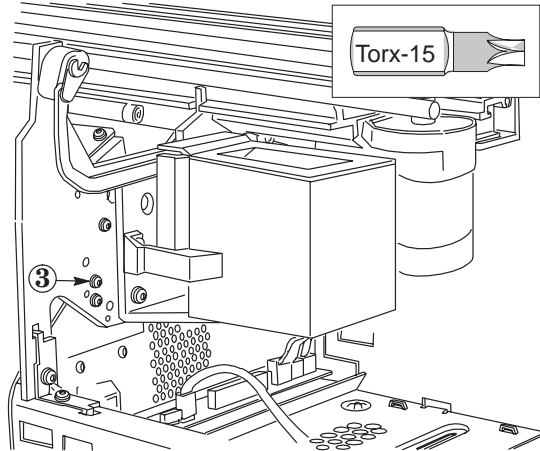

- 3 Replace the indicated screw and tighten it, thus aligning the overdrive enclosure with the left side-plate.

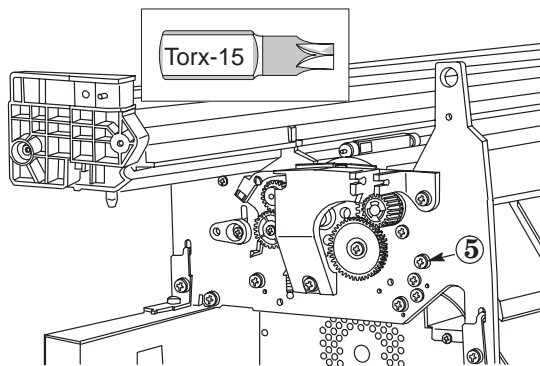

- 4 Tighten the screws you inserted in step 2.

## Removing the Entry Platen

- 1 Remove the overdrive enclosure ▶ page 6-46.
- 2 Disconnect the media-sensor cable from the main PCA (connector labeled MEDIA).

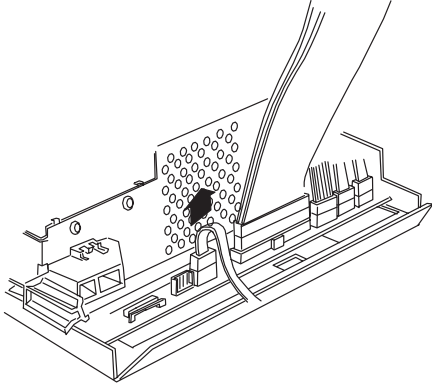

- 3 Remove the indicated screw from the right side-plate.

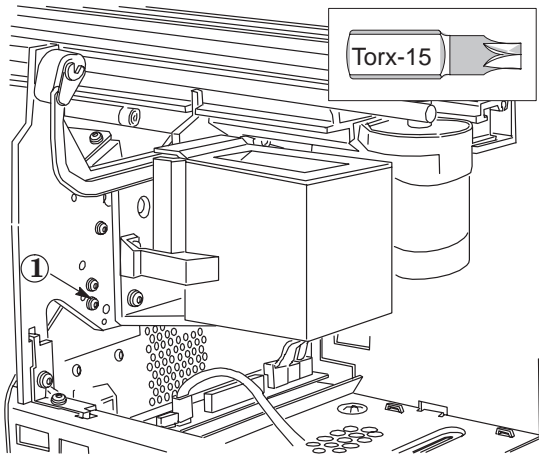

- 4 Remove the indicated two screws from the left side-plate.

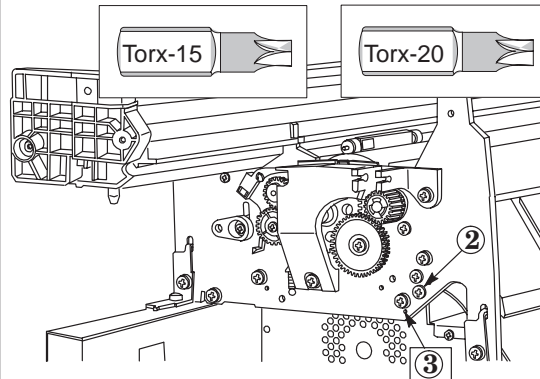

- 5 Release the indicated entry-platen clips by pushing the bottom front corners of the entry platen up.

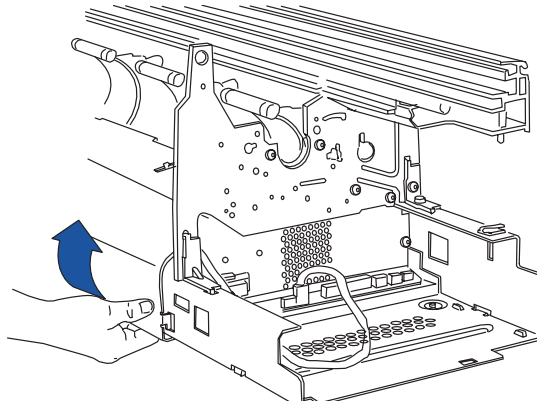

- 6 Pull the entry platen horizontally out from the plotter.

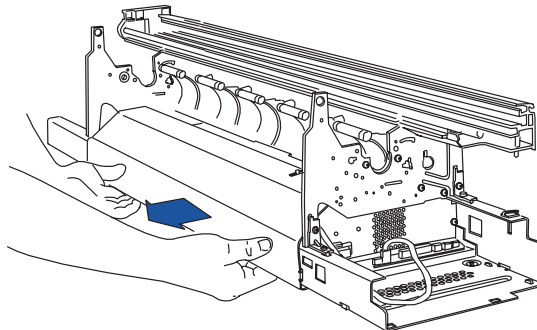

**Reassembling:** See the following procedure.

## Reinstalling the Entry Platen

*The order in which you replace the screws on the entry platen is important.*

- 1 Position the entry platen between the two side-plates, feeding the media sensor cable under the right side-plate.

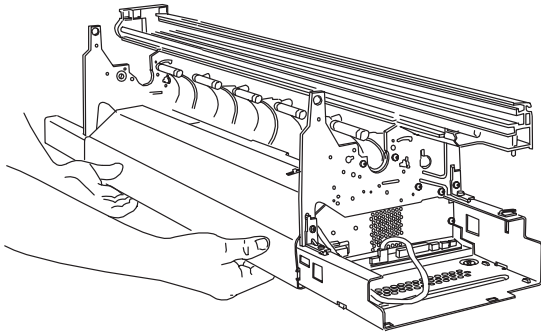

- 2 Make sure that the media-sensor cable is not obstructing the movement of the media-sensor flags.

- 3 Slide the top of the entry platen in, and correctly position it on the inside of each side-plate.

*On each side-plate, the **upper** two pins should touch the entry platen above it.*

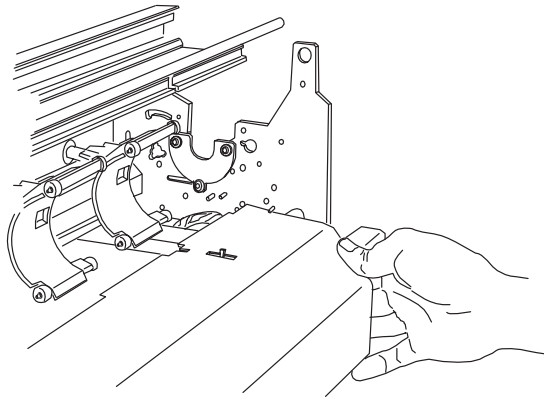
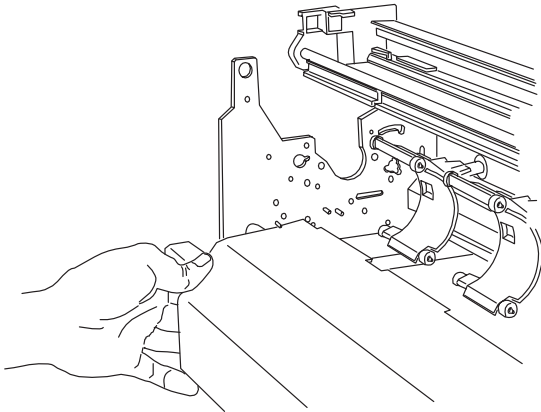

- 4 Refasten the indicated entry-platen clips.

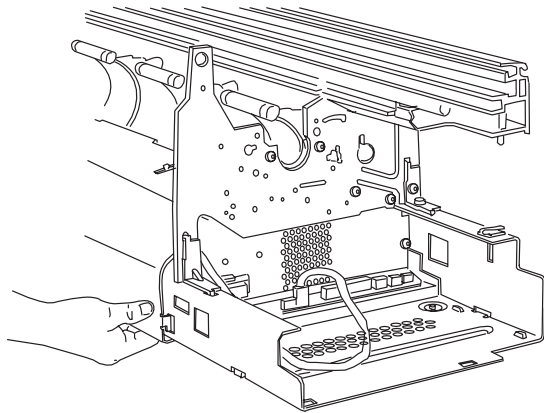

- 5 Inserting a screwdriver under the side-plate on the right of the entry platen, lever the entry platen over to the left, so that it is flush against the left side-plate.

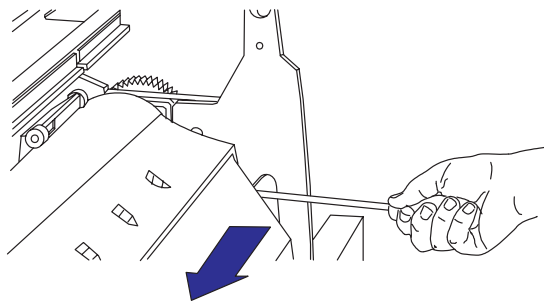

*There must be no space between the entry platen and the **left** side-plate. It doesn't matter if there is a small space between the entry platen and the **right** side-plate.*

- 6 Replace the indicated screw on the left-hand side. (**Long** dog-point screw.) Tighten this screw, making sure that the entry platen is aligned tight against the left side-plate.

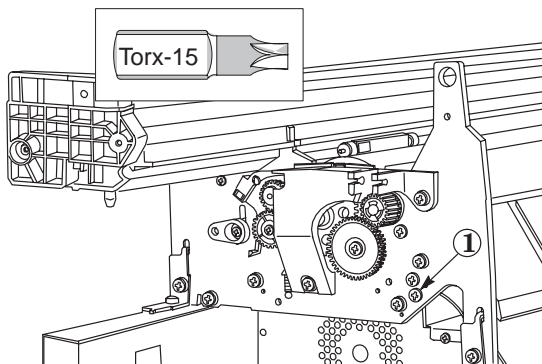

- 7 Replace the indicated screw on the right-hand side. (**Long** dog-point screw.)

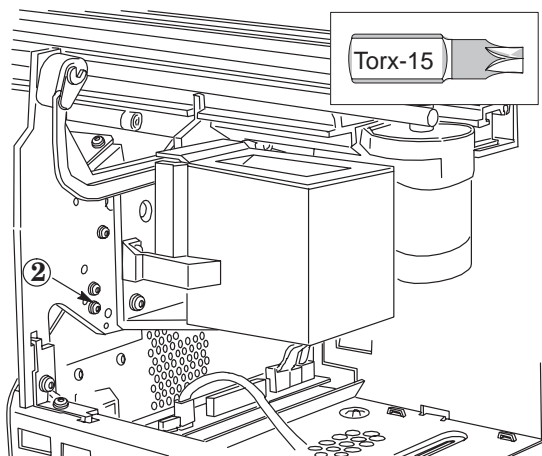

- 8 Replace the indicated clamping screw on the left-hand side.

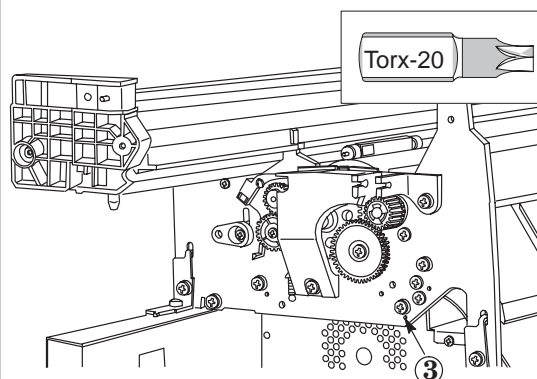

- 9 Reconnect the media-sensor cable to the main PCA (connector labeled MEDIA).

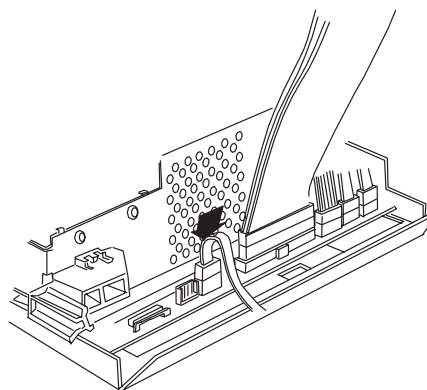

- 10 Before reinstalling the overdrive enclosure, ensure that both flags on the media sensor move freely when you pass a sheet of media over them.

---

Calibrations and  
Adjustments

---

## When to Calibrate the Plotter

---

Indications or Repairs Performed	Calibration Required
You reseated or replaced the black cartridge	Black Cartridge Alignment
You removed or replaced the drive roller	Accuracy Calibration
You removed or replaced the media (X-axis) motor or the drive-roller gear	Accuracy Calibration
The length of plotted lines is not within the accuracy specifications.	Accuracy Calibration
You cleared the EEROM or replaced the electronics module or cartridge carriage or optical sensor.	1. Black Cartridge Alignment 2. Color Cartridge Test 3. Accuracy Calibration
<b>Plot Quality</b> (More ▶ chapter 8):	
Jagged vertical black or gray lines on plots	Black Cartridge Alignment
Jagged color lines on plots	Color Cartridge Test
Shadows appear beside colors	Color Cartridge Test
<span style="border: 1px solid black; padding: 2px;">330 350C</span> Banding	Accuracy Calibration

---

## Black Cartridge Alignment

230  
250C Instructions ▶ User's Guide, chapter 1.

330  
350C Instructions ▶ User's Guide, chapter 5.

---

## Color Cartridge Test

230  
250C Instructions ▶ User's Guide, chapter 3.

330  
350C Instructions ▶ User's Guide, chapter 5.

## Service Modes

The possible states of any LED are:  Off  On  Flashing  Can be On or Off

There are two service modes: Service Mode 1 contains tests that do **not** need carriage-axis initialization; Service Mode 2 contains tests that **do** need carriage-axis initialization.

### Entering Service Mode 1

- 1 Switch the plotter off.
- 2 While holding the following key down, switch the plotter on:

230  
250C

**Align Cartridges**

330  
350C

**Form Feed**

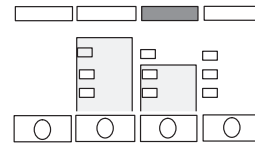

- 3 Once the the LEDs begin to light up one by one (as shown below), release the key.

230  
250C

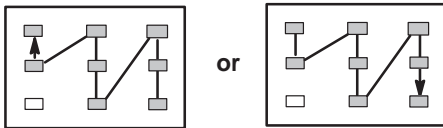

or

330  
350C

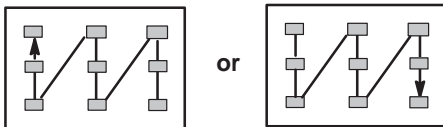

or

*The plotter performs the electrical power-on tests but does not initialize the mechanics. The fan turns on and remains on. All LEDs remain off for a few seconds.*

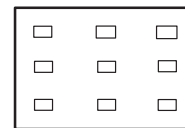

*Then, all LEDs begin to flash, waiting for you to perform a test or calibration.*

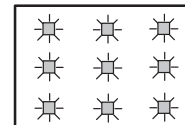

- 4 Place the **Service Mode 1** front-panel overlay over the keys on the plotter.

*The overlay is supplied with this manual. The front-panel keys in service mode are described on page 7-5.*

## Entering Service Mode 2

- 1 Switch the plotter off.
- 2 While holding the **Print Quality** key down, switch the plotter on.
- 3 Once the the LEDs begin to light up one by one (as shown below), release the **Print Quality** key.

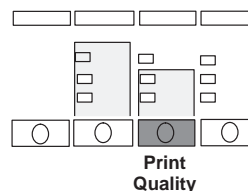

230  
250C

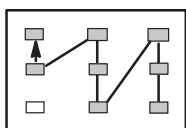

or

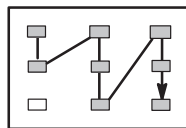

330  
350C

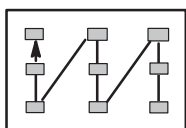

or

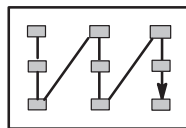

*The plotter performs the electrical power-on tests and initializes the mechanics as in normal user mode. (Details ▶ chapter 8.)*

- 4 Place the **Service Mode 2** front-panel overlay over the keys on the plotter.

*The overlay is supplied with this manual. The front-panel keys in service mode are described on page 7-5.*

## Stopping a Test

Some of the service tests are continuously repeated until you stop them. To stop a test, press the **Shift** key.

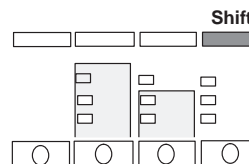



## Front-Panel Keys in Service Mode

The functions of the front-panel keys change when the plotter goes into service mode. You use the keys to perform the various service tests and calibrations. Some of the tests and calibrations require you to press two keys. For this reason the following keys will act as the **SHIFT** and **ALT** keys:

**230**  
**250C** **Replot** key acts as a **SHIFT** key.  
**Cancel** key acts as an **ALT** key.

**330**  
**350C** **Continue Plotting** key acts as a **SHIFT** key.  
**Roll/Sheet** key acts as an **ALT** key.

The following illustrations indicate which service tests and calibrations are assigned to which front-panel keys. Two front-panel overlays are provided with this manual, one for each service mode; you can place either over the actual keys on the plotter.

**230**  
**250C** The designation of keys for service mode 2 is also shown on the service configuration plot.

## Pressing Two Keys Together

When you have to press two keys together, first keep the **SHIFT** or **ALT** key pressed, and then press the second key.

## Software Diagnostics and Hardware Tools

**230**  
**250C** PC-based diagnostics for the plotters have been developed and are now available on the HP Barcelona server. The diagnostics will enable you to perform service tests from a PC connected to the plotter.

**330**  
**350C** PC-based diagnostics for the plotters are being developed at the time of printing of this manual. The diagnostics will enable you to perform service tests from a PC connected to the plotter. The program should be available on the HP Barcelona server in the very near future. It will be announced in one of the "Product Line 30, Newsletters."

230  
250C

### Service-Mode 1

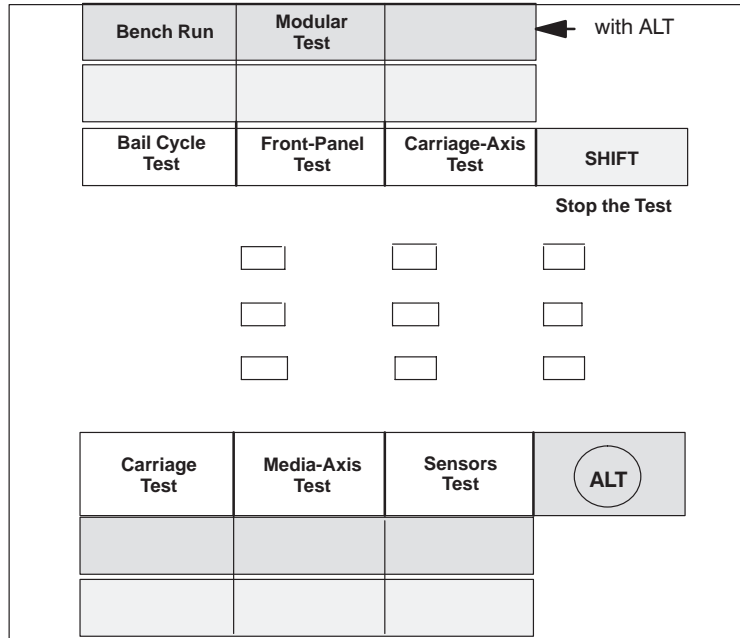
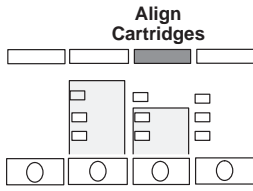

230  
250C

### Service-Mode 2

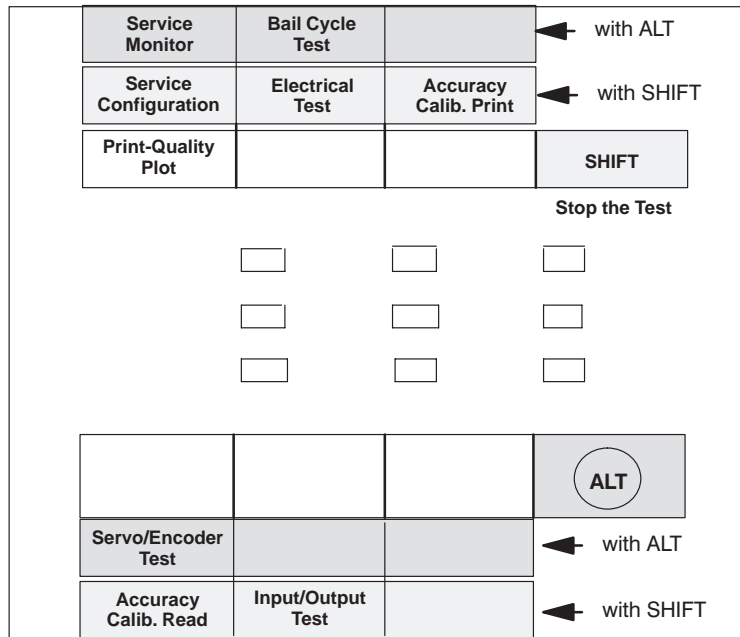
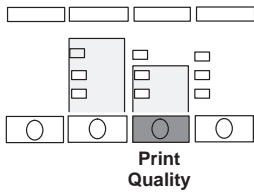

330  
350C

### Service-Mode 1

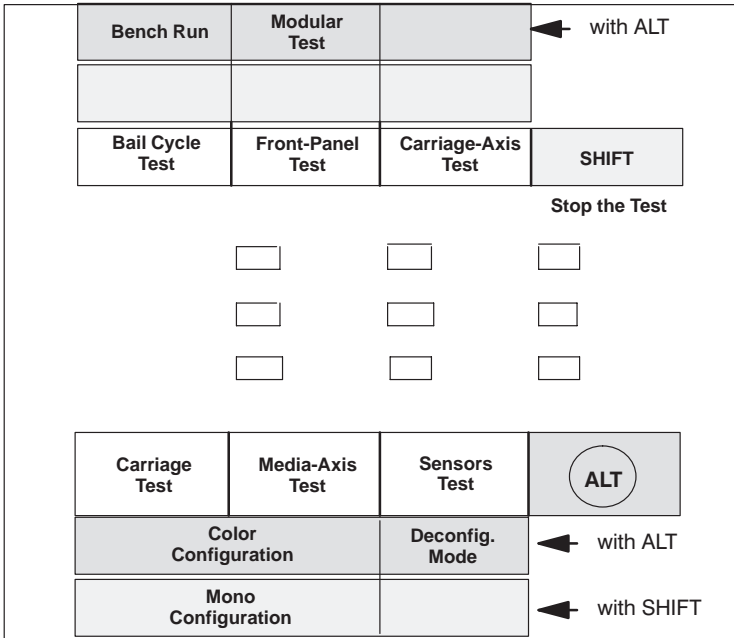
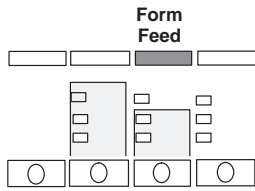

330  
350C

### Service-Mode 2

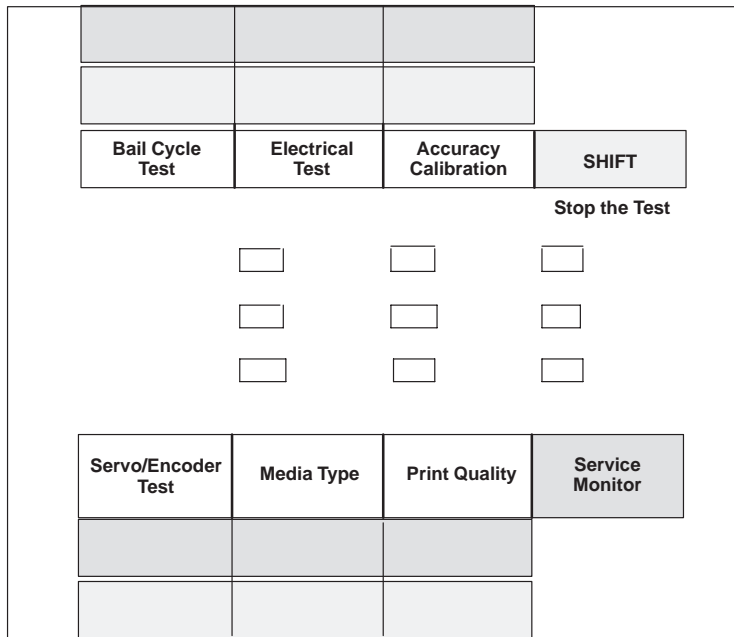
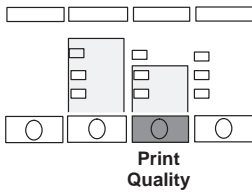

---

## Accuracy Calibration

### Purpose

The accuracy calibration (X-axis calibration) procedure is used to correct the end-point accuracy of the media axis. The carriage axis does not require calibration and is used to calibrate the media axis. The accuracy calibration also includes calibration of the optical line sensor on the carriage.

330  
350C

The accuracy calibration is also used to correct the error of the X-axis movement to avoid banding.

Perform the accuracy calibration whenever the:

- EEROM is erased
- Electronics module is replaced
- Drive roller is removed or replaced
- Media (X-axis) motor is removed or replaced
- Drive-roller gear is removed or replaced
- Cartridge carriage is replaced

330  
350C

- Mark encoder is removed or replaced
- Optical sensor is removed or replaced

### What is the End-Point Accuracy Specification ?

The end-point accuracy specifies how accurately a plotter can draw a given length of line. The end-point accuracy specification for the plotters is  $\pm 0.38$  mm (0.015 in) or  $\pm 0.2\%$  of the specified vector length, whichever is greater, at  $23^{\circ}\text{C}$  ( $73^{\circ}\text{F}$ ), at 50-60% relative humidity on HP special polyester film. Use the following formula to calculate the plotter's accuracy:

$$\frac{\text{Measured length} - \text{Desired length}}{\text{Desired length}} \times 100 = \% \text{Error}$$

### What can Affect the End-Point Accuracy ?

Various part tolerances inside the plotter affect the accuracy (in particular the drive roller). Other outside influences include:

- Media thickness. Thicker media creates longer lines.
- Media expansion. As the media grows, so do the lines.
- The application software may be instructing the plotter to draw an incorrect line length.
- The EEROM has been cleared. The accuracy constants are stored in this non-volatile memory component.

## Before Performing the Accuracy Calibration

- 1 Under normal environmental conditions and on HP inkjet polyester D/A1-size media, plot a drawing that contains two “X” marks nominally positioned 500 mm (19.69 in.) apart.
- 2 Measure the distance between the centers of the “X” marks on the plot.

Accuracy calibration is needed if this distance is not 500 mm (19.69 in)  $\pm$ 1 mm (0.04 in).

If the measured accuracy, media thickness, or environmental conditions vary greatly from the factory standards, recalibrate the plotter by continuing with the following procedure.

230  
250C

## Performing the Accuracy Calibration on the DesignJet 230 and 250C

- 1 Read § *Before Performing the Accuracy Calibration* above.
- 2 Place a sheet of HP inkjet polyester film over the top of the plotter for 10 minutes to let the sheet stabilize to the environmental conditions.

Use a sheet of approximate size A1 or D.

***You must use polyester film.*** Otherwise the optical sensor on the carriage will be calibrated incorrectly, and the plotter will have problems loading some types of media.

- 3 In **service mode 2**, set the **Media Type** on the front panel to **Film**.

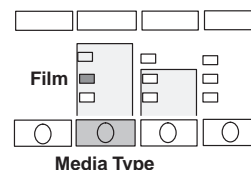

- 4 Load the film, with the matte (dull) side down, in portrait orientation into the plotter.

- 5 When the **Ready LED** lights up, hold down the **SHIFT** key and press **Accuracy Calib. Print**.

The **Ready LED** begins to flash and the plotter plots a calibration plot. The plotter ejects the sheet, and the **Load Media LED** lights up.

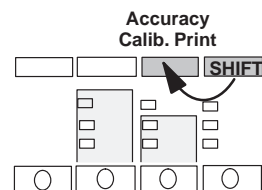

- 6 Unload the sheet.

- 7 Cut the blank end off the film by cutting along the long dashed line on the plot; the cut must be very straight.

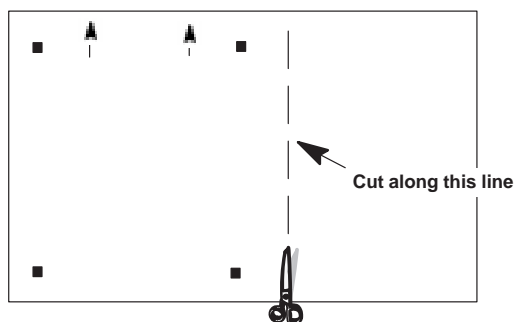

- 8 Wait until the ink on the sheet is dry.
- 9 Reload the sheet **facedown** into the plotter, in the direction indicated by the arrows on the calibration plot.
- 10 When the **Ready** LED lights up, hold down the **SHIFT** key and press **Accuracy Calib. Read**,

*The **Ready** LED begins to flash. The plotter takes less than 1 minute to: read the calibration sheet; calculate the calibration data; save the data in the EEROM; and eject the sheet.*

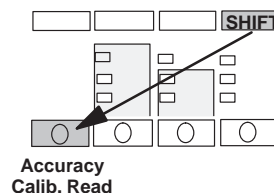

- 11 Unload the sheet.

330  
350C

## Performing the Accuracy Calibration on the DesignJet 330 and 350C

- 1 Read § *Before Performing the Accuracy Calibration* on page 7-9.
- 2 Place a sheet of HP inkjet polyester film over the top of the plotter for 10 minutes to let the sheet stabilize to the environmental conditions.

*Use a sheet of approximate size A1 or D.*

***You must use polyester film.*** Otherwise the optical sensor on the carriage will be calibrated incorrectly, and the plotter will have problems loading some types of media.

- 3 In **service mode 2**, set the **Media Type** on the front panel to **Film**.

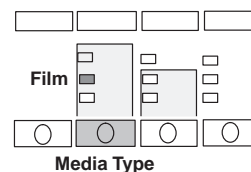

- 4 Load the film, with the matte (dull) side down, in portrait orientation into the plotter.

- 5 When the **Ready** LED lights up, press **Accuracy Calibration**.

*The **Ready** LED begins to flash and the plotter takes several minutes to plot the calibration plot. The plotter ejects the sheet, and the **Load Media** LED lights up.*

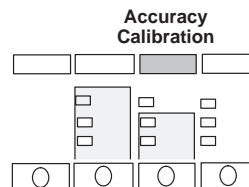

- 6 Unload the sheet.
- 7 Wait until the ink on the sheet is dry.
- 8 Reload the sheet **facedown** into the plotter, in the direction indicated by the arrows on the calibration plot.

*The **Ready** LED begins to flash. The plotter takes less than 1 minute to: read the calibration sheet; calculate the calibration data; save the data in the EEROM; and eject the sheet.*

- 9 Unload the sheet.

---

## Adjusting the Carriage-to-Media Distance

It is very important that the distance between the carriage and the media is within certain limits. If the distance between the cartridge nozzles and the media is **too small**, ink smears on the media. If the distance is **too big**, unwanted spray appears around the ink dots, and vertical lines are not straight. (A big distance may also prevent the carriage from actuating the bail lever.)

Whenever you remove the Drive Roller or the Carriage Carriage, take care to reinstall them correctly. Incorrect installation may result in the carriage being too close or too far from the media. For the correct installation procedure ▶ Chapter 6.

### To check the carriage-to-media distance

A *Gauge* (included with the carriage assembly) has been produced to check the carriage-to-media distance to make sure it is within the tolerances allowed. Use this gauge to check the carriage-to-media distance as follows:

- 1 Open the top cover.
- 2 Move the carriage out of the service station.

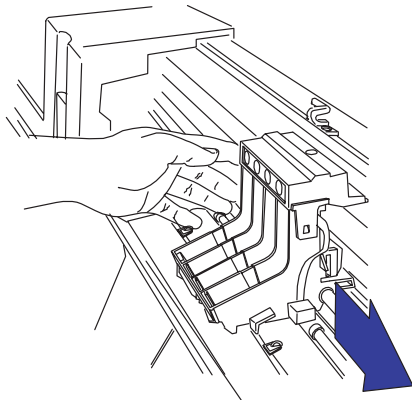

- 3 Remove the **Yellow** cartridge from the carriage.
- 4 Check the gauge to determine the *GO* and *NO GO* sides:



- 5 Place the gauge on the drive roller on the left-hand side of the carriage, with the *GO* side facing the carriage, in the position shown below:

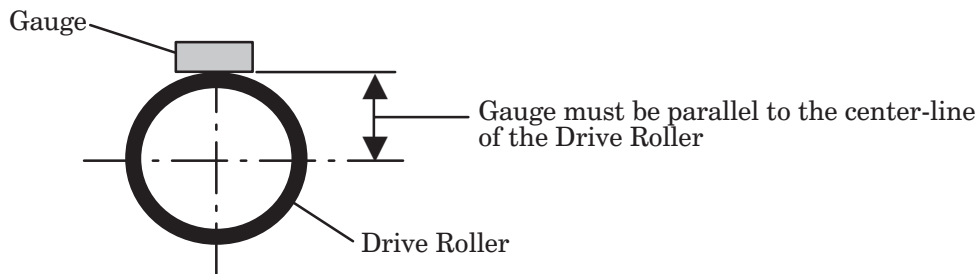

- 6 With the gauge held in place, manually move the carriage over the *GO* side of the gauge. The ledge, indicated below, should easily pass over the *GO* side of the gauge.

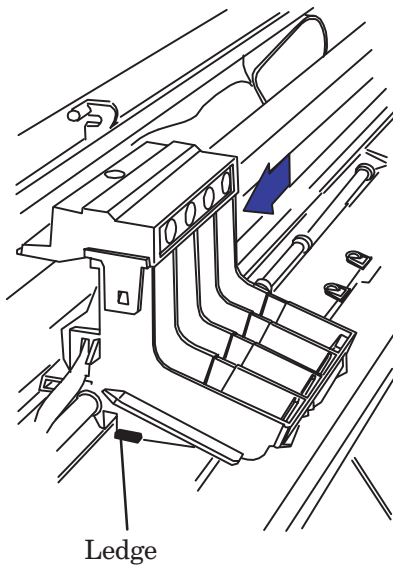

---

#### WARNING

**Make sure that the carriage is in the down position at all times when passing over the gauge.**

---

If the ledge **does not** go over the *GO* side of the gauge, adjust the carriage-to-media distance ▶ page 7-13.

- 7 Remove the gauge and replace it on the drive roller with the *NO GO* side facing the carriage.
- 8 With the gauge held in place, manually try to pass the carriage over the *NO GO* side of the gauge. The ledge, indicated above, should not pass over the *NO GO* side of the gauge.

If the ledge **does** go over the *NO GO* side of the gauge, adjust the carriage-to-media distance ▶ page 7-13.

- 9 Replace the **Yellow** cartridge in the carriage.



10 Move the carriage back into the service station.

11 Close the top cover.

### To adjust the carriage-to-media distance

You will need to adjust the carriage-to-media distance if:

- The ledge on the carriage **did not** pass over the *GO* side of the gauge. This means that the carriage is positioned too close to the drive roller.
- The ledge on the carriage **did** pass over the *NO GO* side of the gauge. This means that the carriage is positioned too far from the drive roller.

Adjust the carriage-to-media distance as follows:

- 1 Release the two indicated clips on the top of the cartridge carriage by pulling them slightly outwards.

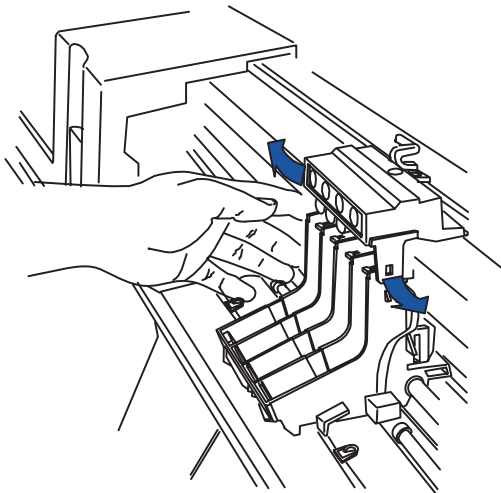

---

#### WARNING



Take care neither to cut yourself on the encoder strip, nor to damage the strip.

---

- 2 Pull the top of the carriage up.

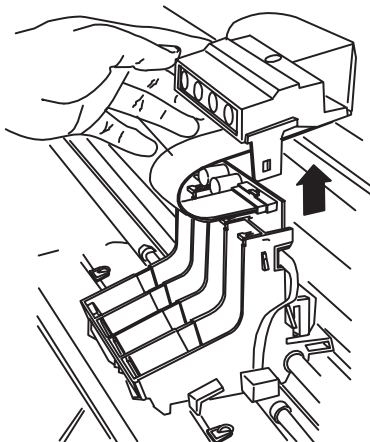

- 3 Tighten or loosen the indicated screw on the carriage. This will adjust the carriage angle on the slider rod, thus increasing or decreasing the carriage-to-media distance.

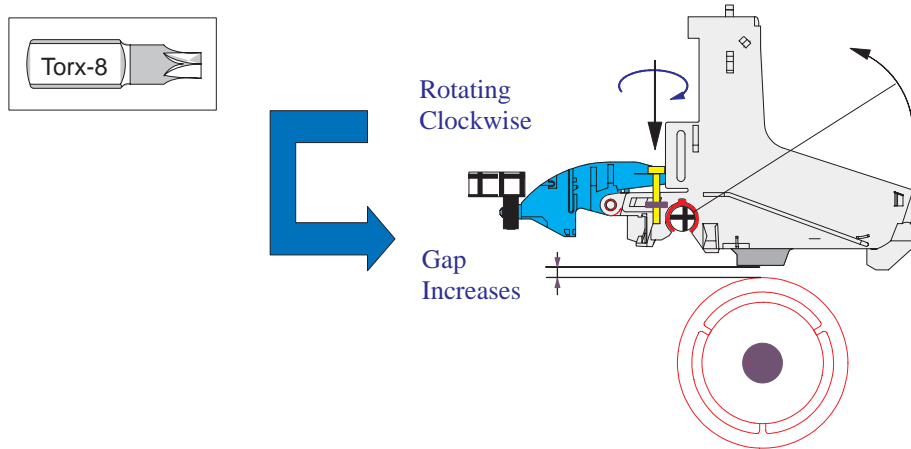

- 4 Check the carriage-to-media distance → page 7-11.
- 5 Reinstall the top of the carriage.
- 6 Check the trailing cable to make sure that it is positioned under the plastic tabs at the back of the carriage cover, and not above them.

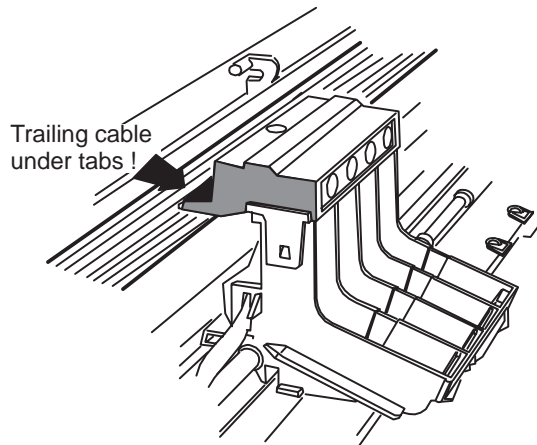

Otherwise, the plotter will not be able to load media.

Print-Quality Plot Service Configuration (+ SHIFT) Service Monitor (+ALT)	Electrical Test (+ SHIFT) Bail Cycle Test (+ ALT)	Accuracy Cal. Print (+Shift)	<b>SHIFT</b> Stop the Test
---------------------------------------------------------------------------------	------------------------------------------------------	------------------------------	-------------------------------

Bail Cycle Test Bench Run (+ ALT)	Front-Panel Test Modular Test (+ ALT)	Carriage-Axis Test	<b>SHIFT</b> Stop the Test
--------------------------------------	------------------------------------------	--------------------	-------------------------------

**[Deutsch] [HP DesignJet 230/250C]**

Setup [Einstellung]	Read Settings [Einstellungen einlesen]	Align Cartridges [Patronen ausrichten] <b>Service Mode 1 (+ ON)</b>	Replot [Neuploten]
------------------------	-------------------------------------------	---------------------------------------------------------------------------	-----------------------

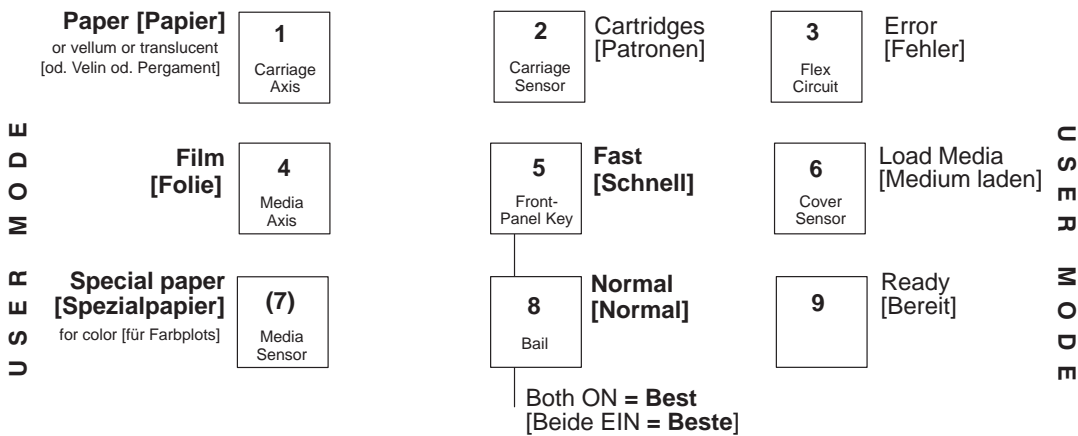

Form Feed [Vorschub]	Media Type [Medienart]	Print Quality [Druckqualität] <b>Service Mode 2 (+ ON)</b>	Cancel [Abbrechen]
-------------------------	---------------------------	------------------------------------------------------------------	-----------------------

Carriage Test	Media-Axis Test	Sensors Test	<b>ALT</b>
---------------	-----------------	--------------	------------

Servo/Encoder Test (+ ALT) Accuracy Calib Read (+ SHIFT)	Input/Output Test (+ SHIFT)	<b>ALT</b>
-------------------------------------------------------------	-----------------------------	------------

SERVICE MODE 2  
SERVICE MODE 1

USER MODE

USER MODE

USER MODE

SERVICE MODE 1

SERVICE MODE 2

Bail Cycle Test	Electrical Test	Accuracy Calibration	<b>SHIFT</b> Stop the Test
-----------------	-----------------	----------------------	-------------------------------

Bail Cycle Test Bench Run (+ ALT)	Front-Panel Test Modular Test (+ ALT)	Carriage-Axis Test	<b>SHIFT</b> Stop the Test
--------------------------------------	------------------------------------------	--------------------	-------------------------------

**[Deutsch] [HP DesignJet 330/350C]**

Setup [Einstellung]	Replot [Neuploten]	Form Feed [Vorschub] <b>Service Mode 1 (+ ON)</b>	Continue Plotting [Plotten Fortsetzen]
------------------------	-----------------------	---------------------------------------------------------	-------------------------------------------

SERVICE MODE 2  
SERVICE MODE 1

USER MODE

**Plain**  
[Papier]

**1**  
Carriage Axis

**2**  
Carriage Sensor

Load Media  
[Medium Laden]

**3**  
Flex Circuit

Error  
[Fehler]

**Film**  
[Folie]

**4**  
Media Axis

**5**  
Front-Panel Key

**Fast**  
[Schnell]

**6**  
Cover Sensor

Ready  
[Bereit]

**Coated**  
[Gestrich Papier]

**(7)**  
Media Sensor

**8**  
Bail

**Normal**  
[Normal]

**9**  
Pinch-arm Sensor

Roll  
[Rolle]

Both ON = **Glossy**  
[Beide EIN = Gläzend]  
for color [für Farbplots]

Both ON = **Best**  
[Beide EIN = Beste]

USER MODE

SERVICE MODE 1

SERVICE MODE 2

Cancel [Abbrechen]	Media Type [Mediumart]	Print Quality [Druckqualität] <b>Service Mode 2 (+ ON)</b>	Roll/Sheet [Rolle/Blatt]
-----------------------	---------------------------	------------------------------------------------------------------	-----------------------------

Carriage Test Color Configuration (+ ALT) Mono Configuration (+ SHIFT)	Media-Axis Test	Sensors Test Deconfig. Mode (+ Alt)	<b>ALT</b>
------------------------------------------------------------------------------	-----------------	-------------------------------------------	------------

Servo/Encoder Test	Media Type	Print Quality	Service Monitor
--------------------	------------	---------------	-----------------

Print-Quality Plot Service Configuration (+ SHIFT) Service Monitor (+ ALT)	Electrical Test (+ SHIFT) Bail Cycle Test (+ ALT)	Accuracy Cal. Print (+ Shift)	<b>SHIFT</b> Stop the Test
----------------------------------------------------------------------------------	------------------------------------------------------	-------------------------------	-------------------------------

Bail Cycle Test Bench Run (+ ALT)	Front-Panel Test Modular Test (+ ALT)	Carriage-Axis Test	<b>SHIFT</b> Stop the Test
--------------------------------------	------------------------------------------	--------------------	-------------------------------

**[English] [HP DesignJet 230/250C]**

Setup	Read Settings	Align Cartridges <b>Service Mode 1 (+ ON)</b>	Replot
-------	---------------	--------------------------------------------------	--------

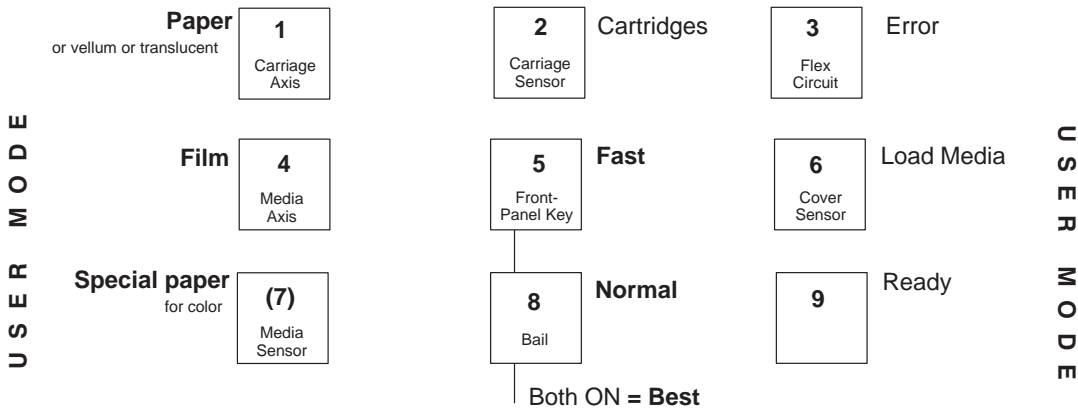

Form Feed	Media Type	Print Quality <b>Service Mode 2 (+ ON)</b>	Cancel
-----------	------------	-----------------------------------------------	--------

Carriage Test	Media-Axis Test	Sensors Test	<b>ALT</b>
---------------	-----------------	--------------	------------

Accuracy Calib Read (+ SHIFT) Servo/Encoder Test (+ ALT)	Input/Output Test (+ SHIFT)		<b>ALT</b>
-------------------------------------------------------------	-----------------------------	--	------------

SERVICE MODE 2  
SERVICE MODE 1

USER MODE

USER MODE

USER MODE

SERVICE MODE 1

SERVICE MODE 2

Bail Cycle Test	Electrical Test	Accuracy Calibration	<b>SHIFT</b> Stop the Test
-----------------	-----------------	----------------------	-------------------------------

Bail Cycle Test Bench Run (+ ALT)	Front-Panel Test Modular Test (+ ALT)	Carriage-Axis Test	<b>SHIFT</b> Stop the Test
--------------------------------------	------------------------------------------	--------------------	-------------------------------

**[English] [HP DesignJet 330/350C]**

Setup	Replot	Form Feed <b>Service Mode 1 (+ ON)</b>	Continue Plotting
-------	--------	-------------------------------------------	-------------------

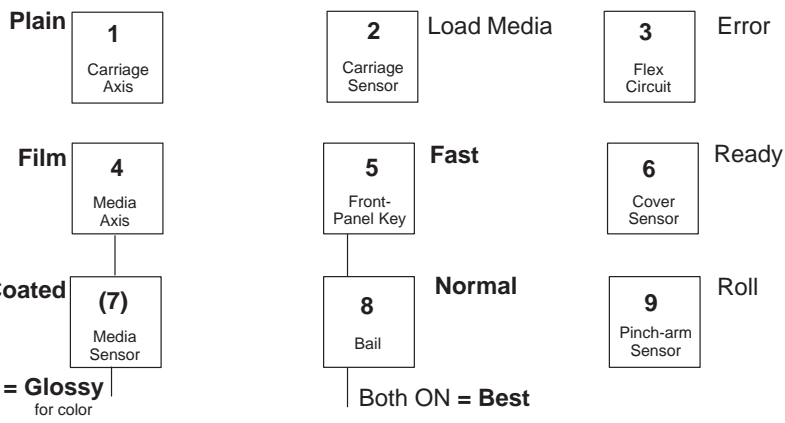

Cancel	Media Type	Print Quality <b>Service Mode 2 (+ ON)</b>	Roll/Sheet
--------	------------	-----------------------------------------------	------------

Carriage Test Color Configuration (+ ALT) Mono Configuration (+ SHIFT)	Media-Axis Test	Sensors Test Deconfig. Mode (+ Alt)	<b>ALT</b>
------------------------------------------------------------------------------	-----------------	----------------------------------------	------------

Servo/Encoder Test	Media Type	Print Quality	Service Monitor
--------------------	------------	---------------	-----------------

SERVICE MODE 2  
SERVICE MODE 1

USER MODE

USER MODE

SERVICE MODE 1  
SERVICE MODE 2

SERVICE MODE 2  
SERVICE MODE 1

Print-Quality Plot Service Configuration (+ SHIFT) Service Monitor (+ALT)	Electrical Test (+ SHIFT) Bail Cycle Test (+ ALT)	Accuracy Cal. Print (+Shift)	<b>SHIFT</b> Stop the Test
---------------------------------------------------------------------------------	------------------------------------------------------	------------------------------	-------------------------------

Bail Cycle Test Bench Run (+ ALT)	Front-Panel Test Modular Test (+ ALT)	Carriage-Axis Test	<b>SHIFT</b> Stop the Test
--------------------------------------	------------------------------------------	--------------------	-------------------------------

**[Español] [HP DesignJet 230/250C]**

Setup [Configurar]	Read Settings [Leer Configuración]	Align Cartridges [Alinear Cartuchos] <b>Service Mode 1 (+ ON)</b>	Replot [Reimprimir]
-----------------------	---------------------------------------	-------------------------------------------------------------------------	------------------------

**Paper [Papel]**  
or vellum or translucent  
[o vellum o translúcido]

**1**  
Carriage  
Axis

**2**  
Carriage  
Sensor

Cartridges  
[Cartuchos]

**3**  
Flex  
Circuit

Error  
[Error]

**Film  
[Película]**

**4**  
Media  
Axis

**5**  
Front-  
Panel Key

**Fast  
[Rápido]**

**6**  
Cover  
Sensor

Load Media  
[Cargar Hoja]

**Special paper  
[Papel especial]**  
for color [para color]

**(7)**  
Media  
Sensor

**8**  
Bail

**Normal  
[Normal]**

**9**

Ready  
[Listo]

Both ON = Best  
[Ambos encendidos = Óptima]

Form Feed [Avanzar Hoja]	Media Type [Tipo Hoja]	Print Quality [Calidad de Impresión] <b>Service Mode 2 (+ ON)</b>	Cancel [Cancelar]
-----------------------------	---------------------------	-------------------------------------------------------------------------	----------------------

Carriage Test	Media-Axis Test	Sensors Test	<b>ALT</b>
---------------	-----------------	--------------	------------

Servo/Encoder Test (+ ALT) Accuracy Calib Read (+ SHIFT)	Input/Output Test (+ SHIFT)		<b>ALT</b>
-------------------------------------------------------------	-----------------------------	--	------------

SERVICE MODE 2

SERVICE MODE 1

USER MODE

USER MODE

SERVICE MODE 1

SERVICE MODE 2

Bail Cycle Test	Electrical Test	Accuracy Calibration	<b>SHIFT</b> Stop the Test
-----------------	-----------------	----------------------	-------------------------------

Bail Cycle Test Bench Run (+ ALT)	Front-Panel Test Modular Test (+ ALT)	Carriage-Axis Test	<b>SHIFT</b> Stop the Test
--------------------------------------	------------------------------------------	--------------------	-------------------------------

**[Español] [HP DesignJet 330/350C]**

Setup [Configurar]	Replot [Reimprimir]	Form Feed [Avanzar Hoja] <b>Service Mode 1 (+ ON)</b>	Continue Plotting [Continuar Trazando]
-----------------------	------------------------	-------------------------------------------------------------	-------------------------------------------

**Plain**  
[Normal]  
**1**  
Carriage Axis

**2**  
Carriage Sensor  
Load Media  
[Cargar Hoja]

**3**  
Flex Circuit  
Error  
[Error]

**Film**  
[Película]  
**4**  
Media Axis

**5**  
Front-Panel Key  
**Fast**  
[Rápido]

**6**  
Cover Sensor  
Ready  
[Listo]

**Coated**  
[Recub.]  
**(7)**  
Media Sensor

**8**  
Bail  
**Normal**  
[Normal]

**9**  
Pinch-arm Sensor  
Roll  
[Rollo]

Both ON = **Glossy**  
[Ambos encendidos = **Óptima**]  
for color [para color]

Both ON = **Best**  
[Ambos encendidos = **Óptima**]

Cancel [Cancelar]	Media Type [Tipo dePapel]	Print Quality [Calidad de Impresión] <b>Service Mode 2 (+ ON)</b>	Roll/Sheet [Rollo/Hoja]
----------------------	------------------------------	-------------------------------------------------------------------------	----------------------------

Carriage Test Color Configuration (+ ALT) Mono Configuration (+ SHIFT)	Media-Axis Test	Sensors Test Deconfig. Mode (+ Alt)	<b>ALT</b>
------------------------------------------------------------------------------	-----------------	-------------------------------------------	------------

Servo/Encoder Test	Media Type	Print Quality	Service Monitor
--------------------	------------	---------------	-----------------

SERVICE MODE 2

SERVICE MODE 1

USER MODE

USER MODE

SERVICE MODE 1

SERVICE MODE 2



Print-Quality Plot Service Configuration (+ SHIFT) Service Monitor (+ALT)	Electrical Test (+ SHIFT) Bail Cycle Test (+ ALT)	Accuracy Cal. Print (+Shift)	<b>SHIFT</b> Stop the Test
---------------------------------------------------------------------------------	------------------------------------------------------	------------------------------	-------------------------------

Bail Cycle Test Bench Run (+ ALT)	Front-Panel Test Modular Test (+ ALT)	Carriage-Axis Test	<b>SHIFT</b> Stop the Test
--------------------------------------	------------------------------------------	--------------------	-------------------------------

**[Italiano] [HP DesignJet 230/250C]**

Setup [Configura]	Read Settings [Leggi Configurazione]	Align Cartridges [Allinea Cartucce] <b>Service Mode 1 (+ ON)</b>	Replot [Ridisegna]
----------------------	-----------------------------------------	------------------------------------------------------------------------	-----------------------

**Paper [Carta]**  
or vellum or translucent  
[o lucido]

**1**  
Carriage  
Axis

**2**  
Carriage  
Sensor

**Cartridges  
[Cartucce]**

**3**  
Flex  
Circuit

**Error  
[Errore]**

**Film  
[Film]**

**4**  
Media  
Axis

**5**  
Front-  
Panel Key

**Fast  
[Veloce]**

**6**  
Cover  
Sensor

**Load Media  
[Carica supporto]**

**Special paper  
[Carta speciale]**  
for color [per colore]

**(7)**  
Media  
Sensor

**8**  
Bail

**Normal  
[Normale]**

**9**

**Ready  
[Pronto]**

**Both ON = Best  
[Entrambi ON = Migliore]**

Form Feed [Avanzamento Carta]	Media Type [Tipo Supporto]	Print Quality [Qualità Stampa] <b>Service Mode 2 (+ ON)</b>	Cancel [Annulla]
----------------------------------	-------------------------------	-------------------------------------------------------------------	---------------------

Carriage Test	Media-Axis Test	Sensors Test	<b>ALT</b>
---------------	-----------------	--------------	------------

Servo/Encoder Test (+ ALT) Accuracy Calib Read (+ SHIFT)	Input/Output Test (+ SHIFT)		<b>ALT</b>
-------------------------------------------------------------	-----------------------------	--	------------

SERVICE MODE 2

SERVICE MODE 1

USER MODE

USER MODE

SERVICE MODE 1

SERVICE MODE 2

Bail Cycle Test	Electrical Test	Accuracy Calibration	<b>SHIFT</b> Stop the Test
-----------------	-----------------	----------------------	-------------------------------

Bail Cycle Test Bench Run (+ ALT)	Front-Panel Test Modular Test (+ ALT)	Carriage-Axis Test	<b>SHIFT</b> Stop the Test
--------------------------------------	------------------------------------------	--------------------	-------------------------------

**[Italiano] [HP DesignJet 330/350C]**

Setup [Configura]	Replot [Ridisegna]	Form Feed [Avanzamento Carta] <b>Service Mode 1 (+ ON)</b>	Continue Plotting [Continua a Stampare]
----------------------	-----------------------	------------------------------------------------------------------	--------------------------------------------

**Plain**  
[Non pat.]

**1**  
Carriage  
Axis

**2**  
Carriage  
Sensor

Load Media  
[Carica supporto]

**3**  
Flex  
Circuit

Error  
[Errore]

**Film**  
[Pellicola]

**4**  
Media  
Axis

**5**  
Front-  
Panel Key

**Fast**  
[Veloce]

**6**  
Cover  
Sensor

Ready  
[Pronto]

**Coated**  
[Patinata]

**(7)**  
Media  
Sensor

**8**  
Bail

**Normal**  
[Normale]

**9**  
Pinch-arm  
Sensor

Roll  
[Rotolo]

Both ON = **Glossy**  
[Entrambi ON = **Lucido**]

Both ON = **Best**  
[Entrambi ON = **Migliore**]

Cancel [Annulla]	Media Type [Tipo Supporto]	Print Quality [Qualità Stampa] <b>Service Mode 2 (+ ON)</b>	Roll/Sheet [Rotolo/Foglio]
---------------------	-------------------------------	-------------------------------------------------------------------	-------------------------------

Carriage Test Color Configuration (+ ALT) Mono Configuration (+ SHIFT)	Media-Axis Test	Sensors Test Deconfig. Mode (+ Alt)	<b>ALT</b>
------------------------------------------------------------------------------	-----------------	-------------------------------------------	------------

Servo/Encoder Test	Media Type	Print Quality	Service Monitor
--------------------	------------	---------------	-----------------

SERVICE MODE 2

SERVICE MODE 1

USER MODE

USER MODE

SERVICE MODE 1

SERVICE MODE 2

Print-Quality Plot Service Configuration (+ SHIFT) Service Monitor (+ALT)	Electrical Test (+ SHIFT) Bail Cycle Test (+ ALT)	Accuracy Cal. Print (+Shift)	<b>SHIFT</b> Stop the Test
---------------------------------------------------------------------------------	------------------------------------------------------	------------------------------	-------------------------------

Bail Cycle Test Bench Run (+ ALT)	Front-Panel Test Modular Test (+ ALT)	Carriage-Axis Test	<b>SHIFT</b> Stop the Test
--------------------------------------	------------------------------------------	--------------------	-------------------------------

**[Français] [HP DesignJet 230/250C]**

Setup [Configurer]	Read Settings [Lire Paramètres]	Align Cartridges [Aligner Cartouches] <b>Service Mode 1 (+ ON)</b>	Replot [Retracer]
-----------------------	------------------------------------	--------------------------------------------------------------------------	----------------------

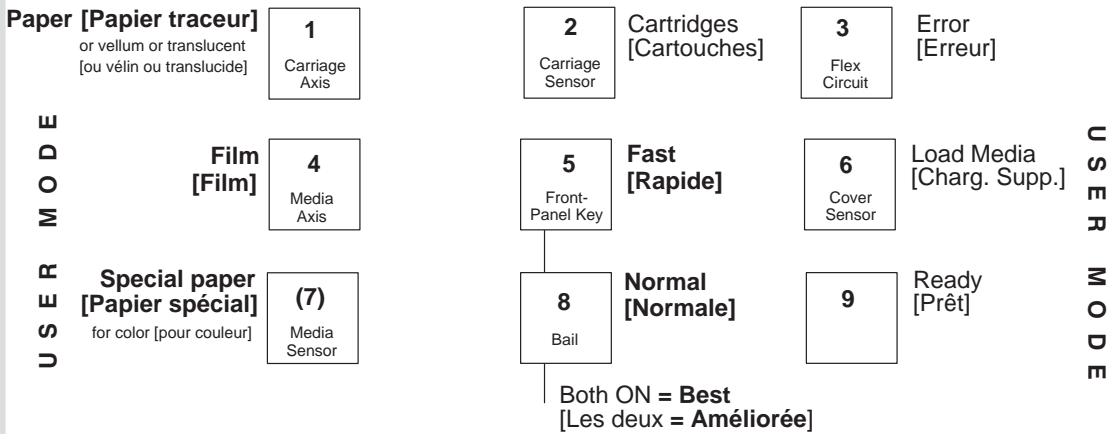

Form Feed [Avancer]	Media Type [Type de Support]	Print Quality [Qualité d'impression] <b>Service Mode 2 (+ ON)</b>	Cancel [Annuler]
------------------------	---------------------------------	-------------------------------------------------------------------------	---------------------

Carriage Test	Media-Axis Test	Sensors Test	<b>ALT</b>
---------------	-----------------	--------------	------------

Servo/Encoder Test (+ ALT) Accuracy Calib Read (+ SHIFT)	Input/Output Test (+ SHIFT)		<b>ALT</b>
-------------------------------------------------------------	-----------------------------	--	------------

Bail Cycle Test	Electrical Test	Accuracy Calibration	<b>SHIFT</b> Stop the Test
-----------------	-----------------	----------------------	-------------------------------

Bail Cycle Test Bench Run (+ ALT)	Front-Panel Test Modular Test (+ ALT)	Carriage-Axis Test	<b>SHIFT</b> Stop the Test
--------------------------------------	------------------------------------------	--------------------	-------------------------------

**[Français] [HP DesignJet 330/350C]**

Setup [Configurer]	Replot [Retracer]	Form Feed [Avancer] <b>Service Mode 1 (+ ON)</b>	Continue Plotting [Continuer Impression]
-----------------------	----------------------	--------------------------------------------------------	---------------------------------------------

**Plain**  
[Ordinaire]

**1**  
Carriage  
Axis

**2**  
Carriage  
Sensor

Load Media  
[Charger Support]

**3**  
Flex  
Circuit

Error  
[Erreur]

**Film**  
[Film]

**4**  
Media  
Axis

**5**  
Front-  
Panel Key

**Fast**  
[Rapide]

**6**  
Cover  
Sensor

Ready  
[Prêt]

**Coated**  
[Couché]

**(7)**  
Media  
Sensor

**8**  
Bail

**Normal**  
[Normale]

**9**  
Pinch-arm  
Sensor

Roll  
[Rouleau]

Both ON = **Glossy**  
[Les deux = **Brilliant**]  
for color [pour couleur]

Both ON = **Best**  
[Les deux = **Améliorée**]

Cancel [Annuler]	Media Type [Type de Support]	Print Quality [Qualité d'impression] <b>Service Mode 2 (+ ON)</b>	Roll/Sheet [Rouleau/Feuille]
---------------------	---------------------------------	-------------------------------------------------------------------------	---------------------------------

Carriage Test Color Configuration (+ ALT) Mono Configuration (+ SHIFT)	Media-Axis Test	Sensors Test Deconfig. Mode (+ Alt)	<b>ALT</b>
------------------------------------------------------------------------------	-----------------	-------------------------------------------	------------

Servo/Encoder Test	Media Type	Print Quality	Service Monitor
--------------------	------------	---------------	-----------------

SERVICE MODE 2

SERVICE MODE 1

USER MODE

USER MODE

SERVICE MODE 1

SERVICE MODE 2

Print-Quality Plot Service Configuration (+ SHIFT) Service Monitor (+ALT)	Electrical Test (+ SHIFT) Bail Cycle Test (+ ALT)	Accuracy Cal. Print (+Shift)	<b>SHIFT</b> Stop the Test
---------------------------------------------------------------------------------	------------------------------------------------------	------------------------------	-------------------------------

Bail Cycle Test Bench Run (+ ALT)	Front-Panel Test Modular Test (+ ALT)	Carriage-Axis Test	<b>SHIFT</b> Stop the Test
--------------------------------------	------------------------------------------	--------------------	-------------------------------

**[Português] [HP DesignJet 230/250C]**

Setup [Config]	Read Settings [Ajustes Leitura]	Align Cartridges [Alinhar Cartuchos] <b>Service Mode 1 (+ ON)</b>	Replot [Replotar]
-------------------	------------------------------------	-------------------------------------------------------------------------	----------------------

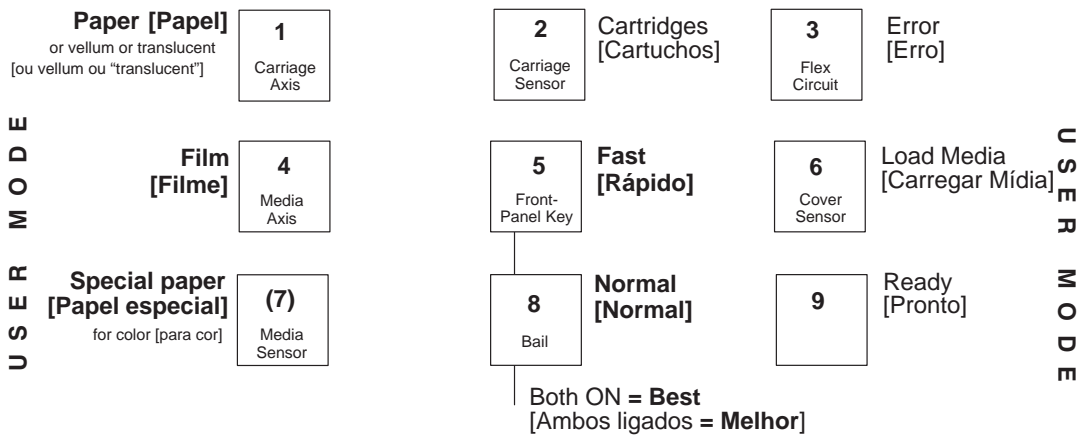

Form Feed [Alimentação de página]	Media Type [Tipo de Mídia]	Print Quality [Qualidade Impressão] <b>Service Mode 2 (+ ON)</b>	Cancel [Cancelar]
-----------------------------------------	-------------------------------	------------------------------------------------------------------------	----------------------

Carriage Test	Media-Axis Test	Sensors Test	<b>ALT</b>
---------------	-----------------	--------------	------------

Servo/Encoder Test (+ ALT) Accuracy Calib Read (+ SHIFT)	Input/Output Test (+ SHIFT)		<b>ALT</b>
-------------------------------------------------------------	-----------------------------	--	------------

Bail Cycle Test	Electrical Test	Accuracy Calibration	<b>SHIFT</b> Stop the Test
-----------------	-----------------	----------------------	-------------------------------

Bail Cycle Test Bench Run (+ ALT)	Front-Panel Test Modular Test (+ ALT)	Carriage-Axis Test	<b>SHIFT</b> Stop the Test
--------------------------------------	------------------------------------------	--------------------	-------------------------------

**[Português] [HP DesignJet 330/350C]**

Setup [Config]	Replot [Replotar]	Form Feed [Alimentação de página] <b>Service Mode 1 (+ ON)</b>	Continue Plotting [Continuar Plotagem]
-------------------	----------------------	----------------------------------------------------------------------	-------------------------------------------

SERVICE MODE 2  
SERVICE MODE 1

USER MODE

USER MODE

USER MODE

SERVICE MODE 1  
SERVICE MODE 2

**Plain**  
[Comuns]

**1**  
Carriage Axis

**2**  
Carriage Sensor

**Load Media**  
[Carregar Mídia]

**3**  
Flex Circuit

**Error**  
[Erro]

**Film**  
[Filme]

**4**  
Media Axis

**5**  
Front-Panel Key

**Fast**  
[Rápido]

**6**  
Cover Sensor

**Ready**  
[Pronto]

**Coated**  
[Coated]

**(7)**  
Media Sensor

**8**  
Bail

**Normal**  
[Normal]

**9**  
Pinch-arm Sensor

**Roll**  
[Rolo]

Both ON = **Glossy**  
[Ambos ligados = **Brilhante**]  
for color [para cor]

Both ON = **Best**  
[Ambos ligados = **Melhor**]

Cancel [Cancelar]	Media Type [Tipo de Mídia]	Print Quality [Qualidade de Impressão] <b>Service Mode 2 (+ ON)</b>	Roll/Sheet [Rolo/Mídia]
----------------------	-------------------------------	---------------------------------------------------------------------------	----------------------------

Carriage Test Color Configuration (+ ALT) Mono Configuration (+ SHIFT)	Media-Axis Test	Sensors Test Deconfig. Mode (+ Alt)	<b>ALT</b>
------------------------------------------------------------------------------	-----------------	----------------------------------------	------------

Servo/Encoder Test	Media Type	Print Quality	Service Monitor
--------------------	------------	---------------	-----------------

---

# Troubleshooting

---

## Power-On

The plotters automatically perform a series of internal self tests and mechanical initialization sequences whenever the user switches the plotter on. These are completed after about 30 seconds. If a failure occurs, an error is indicated on the front-panel LEDs. You can perform a failure analysis by interpreting the LED error code. (Details [▶](#) later in this chapter.)

### Self Test and Initialization

The power-on self test and initialization procedure does the following:

- 1 Initializes the servo processor.
- 2 Initializes the main processor.
- 3 Tests communication between the main processor and the servo processor.
- 4 Tests the EEROM checksum.
- 5 Tests the servo-processor transfer buffer and interrupt tracking.
- 6 Tests the ROM checksum.
- 7 Causes the main processor to initialize certain firmware modules.
- 8 Performs a subset of the electrical service test.
- 9 Checks the cover sensor.

*If the cover is open, nothing further happens until you close it.*

- 10 Initializes the carriage axis (Y-axis).

330  
350C

- 11 Uses the mark encoder to check the start of the drive roller.

- 12 Ejects any loaded sheet.

330  
350C

*Does not eject roll media if loaded.*

- 13 Checks the media sensor.
- 14 Sets the plotter to accept media.



## What You Should See and Hear

The sequence given below is what should happen when you turn on the plotter in **normal** operating mode.

### CAUTION

To observe movement of internal mechanisms, you can keep the cover switch pressed, while the cover is open. However, in doing so, do not block the path of the cartridge carriage with anything you stick into the cover-switch area.

The possible states of any LED are:  Off  On  Flashing  Can be On or Off

- 1 All front-panel LEDs flash together twice; the second flash is very short.
- 2 If a firmware **ROM SIMM** is installed in the plotter, the following will occur:

230  
250C

The LEDs light up one by one as follows, until eight LEDs are on. This happens three times.

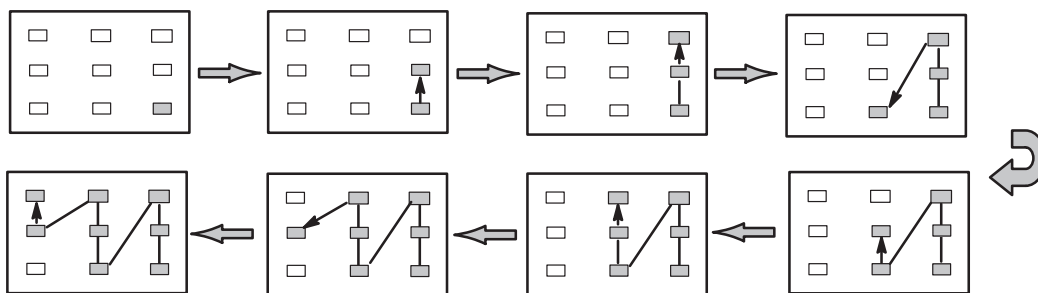

330  
350C

The LEDs light up one by one as follows, until all nine LEDs are on. This happens several times throughout the initialization procedure.

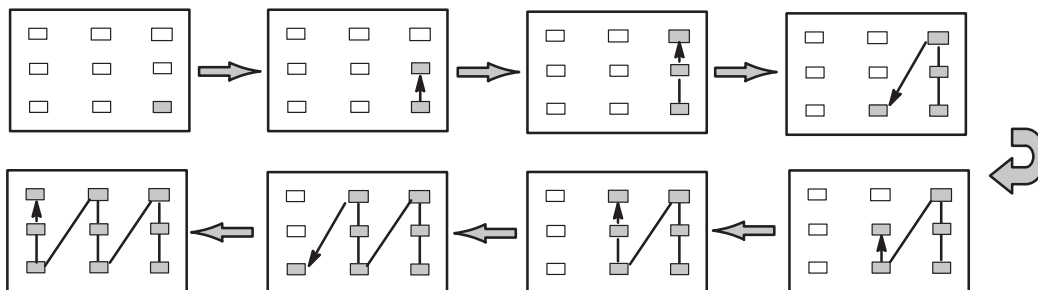

Otherwise, if the plotter is using firmware from the **inbuilt ROM** the following will occur:

230  
250C

The LEDs light up one by one as follows, until eight LEDs are on. This happens three times.

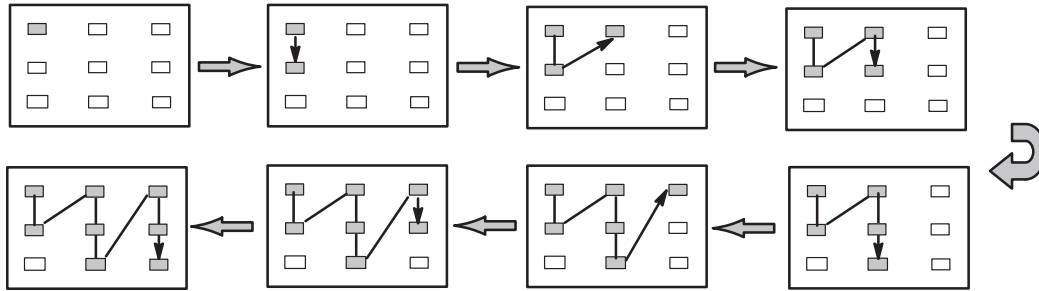

330  
350C

The LEDs light up one by one as follows, until all nine LEDs are on. This happens several times throughout the initialization procedure.

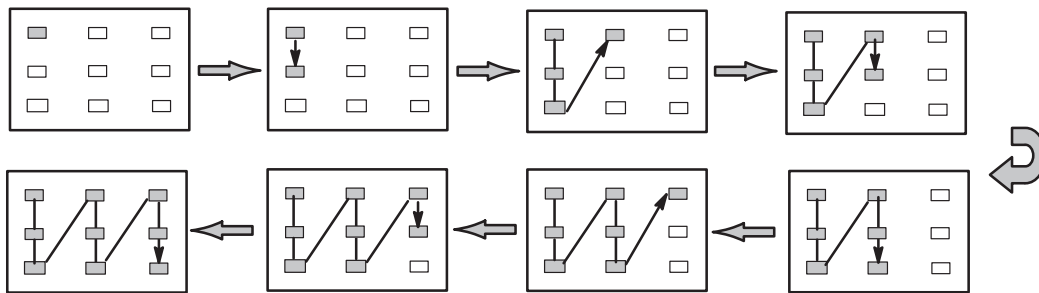

230  
250C

- 3 The front-panel LEDs indicate the current selections for **Media Type** and **Print Quality**.
- 4 The cartridge carriage moves across the plotter and knocks three times against the right-hand side.
- 5 The carriage returns to the left-hand side and enters the service station. The bail jerks slightly as the carriage parks in the service station.
- 6 The top of the drive roller rotates slightly forward and then slightly backward.
- 7 The carriage moves out of, and back into, the service station. Again, the bail jerks slightly as the carriage parks in the service station.
- 8 The plotter ejects any sheet that is already loaded.

330  
350C

*Does not eject roll media if loaded.*

330  
350C

- 9 The optical sensor positions itself over the the mark encoder to check the start of the drive roller.
- 10 The **Load Media** LED lights up to indicate that the plotter is ready for you to load media.

330  
350C

The front-panel LEDs indicate the current selections for **Media Type** and **Print Quality**.

## Front-Panel LEDs

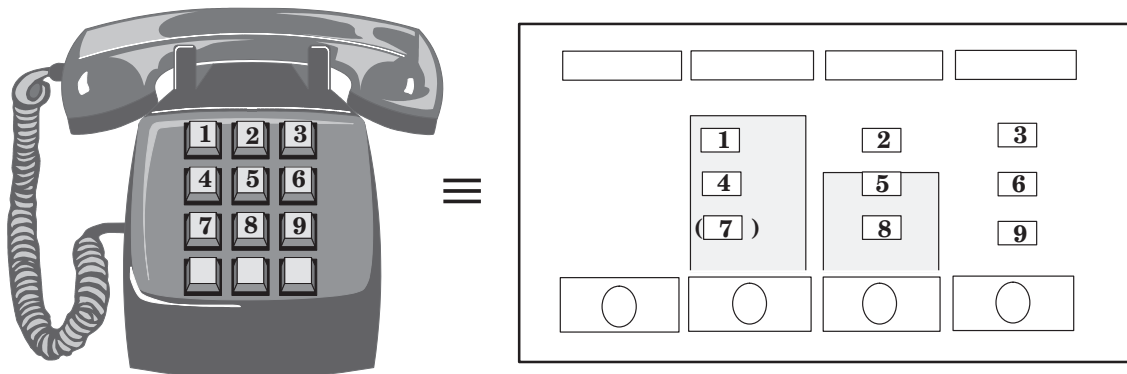

<p>LED Symbols:</p> <p><input type="checkbox"/> Off</p> <p><input checked="" type="checkbox"/> On (Steady)</p> <p><input type="checkbox"/> Flashing</p> <p><input type="checkbox"/> Can be On or Off</p>	<p>LED Numbers:</p> <table border="1" style="margin-left: auto; margin-right: auto;"> <tr><td>1</td><td>2</td><td>3</td></tr> <tr><td>4</td><td>5</td><td>6</td></tr> <tr><td>7</td><td>8</td><td>9</td></tr> <tr><td colspan="3" style="text-align: center;">LED Code</td></tr> </table>	1	2	3	4	5	6	7	8	9	LED Code			<p>LED-Code Examples:</p> <p><b>Flashing 29</b> LEDs 2 and 9 are flashing.</p> <p><b>Steady 1236</b> LEDs 1, 2, 3, and 6 are on.</p> <p><i>DesignJet 230 plotters have <b>no</b> LED number 7.</i></p>
1	2	3												
4	5	6												
7	8	9												
LED Code														

## Error codes

The following pages contain the possible error codes and the instructions necessary to solve the problem.

230  
250C

Turn to page 8-6 for the relevant error codes.

330  
350C

Turn to page 8-13 for the relevant error codes.

## Error Codes for the DesignJet 230 and 250C Plotters

### No LEDs On

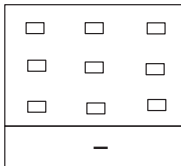

If there is no activity at all from the plotter, you may have a power problem. (Troubleshooting ▶ User's Guide, chapter 4.)

### LEDs On (Error Off)

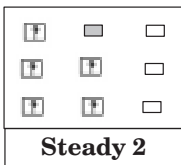

**Cartridges:** One or more of the cartridges is missing or badly positioned. Load or reseat the cartridges. (Instructions ▶ Quick Reference Guide.)

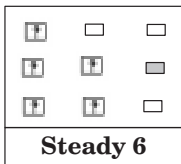

**Load Media:** No sheet is loaded.

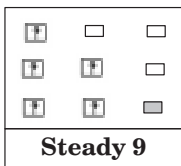

**Ready:** Ready to plot.

Send your plot from your computer or, for a special internal plot, press the appropriate key combination. (Keys ▶ Quick Reference Guide.)

## LEDs Flashing

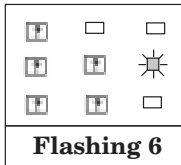

**Load Media:** The plotter has a file in memory, which it is waiting to plot, but no sheet is loaded.

Load a sheet.

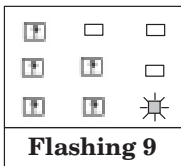

**Ready:** The plotter is busy with a task or is receiving a file.

Wait.

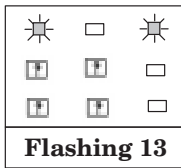

**Paper + Error:** The current plot is too large and does not fit in memory.

- If the plot is a raster plot, try sending it with a **no negative motion** RTL command.
- If it is a vector plot, try using a driver that performs all the rasterization of the plot in the host computer before sending it to the plotter. (See also chapter 5, § *Memory Usage*.)
- Otherwise, add more memory by installing a DRAM SIMM.

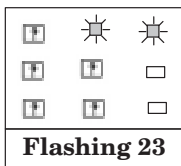

**Cartridges + Error:** One or more of the cartridges missing or making bad contact.

- Remove each cartridge. Ensure that the protective tape has been removed, and look for dirty contacts or wear. Replace each cartridge and run the Black-Cartridge Alignment Procedure. (Instructions in User's Guide, chapter 1.)
- Replace the trailing cable.
- Replace the carriage.
- Replace the electronics module.

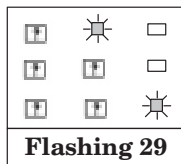

**Cartridges + Ready:** The plotter is testing and servicing the cartridges.

Wait.

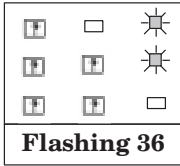

**Error + Load Media:** Media-load error. Try one or more of the following:

- Check that the media is aligned and that the correct media size is loaded. Try to load it again. (Tips ♦ User's Guide, chapter 4, and media-loading guide C3190-90162.) When you begin to load media and push it into the plotter with too much force, too large a buckle forms in the media. The roller is then not able to correctly grasp the media and misaligns it. Instead, load the media so that the sheet buckles only slightly. Neither should you load the media too slowly. Do it in one brisk movement.

- Clear any binding in the media axis. **Caution:** Do not pull media along the carriage axis – you could break the media-sensor flags. • Are both media-sensor flags installed? • Replace the media sensor.

- Reconnect or replace the trailing cable. Make sure that the trailing cable is positioned under the plastic tabs at the back of the carriage cover, and not above them. • Replace the carriage.

---

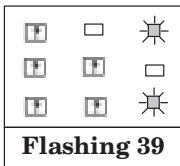

**Error + Ready:** There is a problem with the serial interface. Try one or more of the following:

- Ensure the plotter's settings for baud rate and parity are the same as those of the host computer. To check the plotter settings, use the setup sheet. (Instructions ♦ User's Guide, chapter 1.) • Also check your interface cable and connections. • This error may also occur if you send a drawing for print using a Windows driver when the **Fast Direct to Print** option is turned **OFF** in the Windows Printer Control Panel. You should either turn the **Fast Direct to Print** option **ON**, or send the drawing to a file and print the file from the MS-DOS command line through the serial port. • If the host computer is an HP 712 workstation, you may have some problems using baudrates of 19200 and 38400. Check if recent service notes have a solution.

- Check to see if the Plotter or PC is badly configured. • Check for an error in the host computer. • Replace the electronics module.

---

## Error LED On

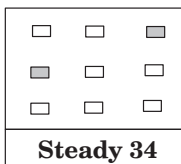

**Steady 34**

**Error + Film:** From firmware revision A.01.04 onwards, this combination of LEDs indicates an error in the EEROM.

See **Steady 135**.

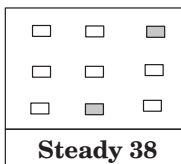

**Steady 38**

**Error + Normal:** Not enough memory to allocate internal data structures.

- Turn the plotter off, and then on again to see if the problem disappears.
- If the problem remains, consult recent service notes for a possible solution.
- If no service note deals with this error, report the problem to your HP Response Center. Note conditions and actions before error occurred. Include setup sheet and service configuration plot in report.

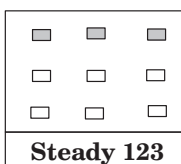

**Steady 123**

**Paper + Cartridges + Error:** Processor fault.

Replace the electronics module.

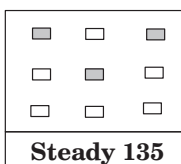

**Steady 135**

**Paper + Error + Fast:** Error detected in the EEROM.

The possible causes could be: • Power failure during the tests. • Faulty carriage PCA. • Faulty or badly connected trailing cable. • Faulty electronics module. • Plotter is operating very near to powerful electrical motors or machines.

For more information ▶ page 8-27, § EEROM Errors.

For more precise troubleshooting ▶ page 8-19, § System Errors.

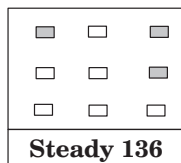

**Steady 136**

**Paper + Error + Load Media:** Servo error in the X-axis (media axis). Try one or more of the following:

- Clear any binding due to a media jam. **Caution:** Do not pull media along the carriage axis – you could break the media-sensor flags.
- Perform the media-axis test and the servo/encoder test to check for problems with the media motor and encoder, and the electronics module.
- The media-motor worm and the right drive-roller gear should have grease on them. (Parts: Silicon grease: C3190-60155) • If necessary, remove the right drive-roller gear from the drive roller. Then, if you cannot manually spin the roller, it is probably jammed.
- Is the plotter located in an environment of high temperature and humidity? Is this causing deformation (flattening) of the pinch-wheels? • Replace the media motor. • Replace the electronics module.

For more precise troubleshooting ▶ page 8-19, § System Errors.

<input type="checkbox"/> <input type="checkbox"/> <input type="checkbox"/> <input type="checkbox"/> <input type="checkbox"/> <input type="checkbox"/> <input type="checkbox"/> <input type="checkbox"/> <input type="checkbox"/>
<b>Steady 139</b>

**Paper + Error + Ready:** RS-232-C data overflow. Data byte was not read before another was entered into the UART. Possible causes are:

- Incorrect configuration in communications speed/protocol.
- Incorrect communications cable.
- Error in host computer.
- Faulty electronics module.

<input type="checkbox"/> <input type="checkbox"/> <input type="checkbox"/> <input type="checkbox"/> <input type="checkbox"/> <input type="checkbox"/> <input type="checkbox"/> <input type="checkbox"/> <input type="checkbox"/>
<b>Steady 234</b>

**Cartridges + Error + Film:** Firmware error.

- Turn the plotter off, and then on again to see if the problem disappears.
- If the problem remains, consult recent service notes for a possible solution.
- If no service note deals with this error, report the problem to your HP Response Center. Note conditions and actions before error occurred. Include setup sheet and service configuration plot in report. For more precise troubleshooting ▶ page 8-23, § System Errors.

<input type="checkbox"/> <input type="checkbox"/> <input type="checkbox"/> <input type="checkbox"/> <input type="checkbox"/> <input type="checkbox"/> <input type="checkbox"/> <input type="checkbox"/> <input type="checkbox"/>
<b>Steady 237</b>

**Cartridges + Error + Special:** Old version of firmware.

This error has occurred in the field when the ROM SIMM at the back of the plotter was not correctly inserted. The plotter did not recognize the presence of the SIMM, and therefore used an old version of the firmware from the in-built ROM on the main PCA. (See page 8-3 for more information.) If correctly inserting the ROM SIMM does not solve the problem, try replacing the electronics module.

<input type="checkbox"/> <input type="checkbox"/> <input type="checkbox"/> <input type="checkbox"/> <input type="checkbox"/> <input type="checkbox"/> <input type="checkbox"/> <input type="checkbox"/> <input type="checkbox"/>
<b>Steady 346</b>

**Error + Film + Load Media:** Servo error in the Y-axis (carriage axis). Try one or more of the following:

- Clear any binding due to a media jam.
  - Turn the plotter off. Manually move the carriage along the carriage axis. Check for any areas where the carriage may be binding.
  - Ensure that the belt and belt pulley are in correct working order. Remove dirt from the pulley that could cause the belt to slip.
  - Perform the carriage-axis test and the servo/encoder test to check for problems with the carriage motor, encoder strip, and electronics module.
  - Remove dirt from the slider rod and chassis beam. Apply oil (Anderol 4068, HP part number: 6040-0858) to the carriage bushings.
  - At high temperatures, and if the fan is not working correctly, the internal resistance of the motor driver may increase, causing a decrease in the voltage between the motor contacts, and a shutdown of the motor.
  - Ensure that the encoder strip is not inverted, damaged or absent.
  - Reconnect or replace the trailing cable.
  - Replace the carriage.
- For more precise troubleshooting ▶ page 8-19, § System Errors.

<input type="checkbox"/> <input type="checkbox"/> <input type="checkbox"/> <input type="checkbox"/> <input type="checkbox"/> <input type="checkbox"/> <input type="checkbox"/> <input type="checkbox"/> <input type="checkbox"/>
<b>Steady 349</b>

**Error + Film + Ready:** Failure of RS-232-C loopback test.

Ensure the loopback connector is the appropriate one. If the problem remains, replace the electronics module.



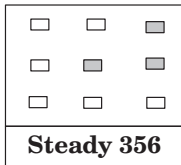

**Error + Fast + Load Media:** Problems in movement in the X-axis (media axis)  
The possible causes could be: ● Something is causing too much friction in the X-axis. ● Paper jam.

---

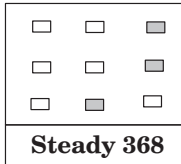

**Error + Load Media + Normal:** Error in X-axis calibration  
Did you load media in correct orientation? ● Are the marks visible on the plot? If not, check cartridges. ● Are cartridges correctly aligned? If so, the problem may be in the electronics module, media motor or drive-roller gear; if alignment is incorrect, the problem may be in the carriage. There could also be a problem with the line sensor.

---

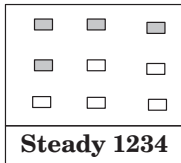

**Paper + Cartridges + Error + Film:** Communication broken between the two processors on the main PCA.  
Replace the electronics module.

---

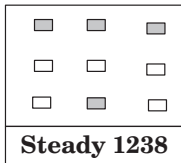

**Paper + Cartridges + Error + Normal:** Electrical error  
The possible causes could be: ● Missing or badly seated cartridge. ● One end of the trailing cable is not connected or is badly connected, or the trailing cable is faulty. ● Faulty fan, or fan is disconnected. ● Faulty carriage PCA. ● Faulty electronics module.  
For more precise troubleshooting ▶ page 8-19, § System Errors.

---

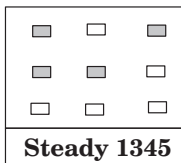

**Paper + Error + Film + Fast:** Not enough memory for the sensor data structure.  
● Turn the plotter off, and then on again to see if the problem disappears.  
● If the problem remains, consult recent service notes for a possible solution.  
● If no service note deals with this error, report the problem to your HP Response Center. Note conditions and actions before error occurred. Include setup sheet and service configuration plot in report.

---

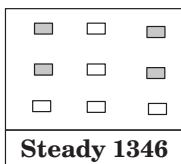

**Paper + Error + Film + Load Media:** Problems in the free movement of the carriage.  
The possible causes could be: ● Something is causing excessive friction in the Y-axis (carriage axis). ● The carriage touches the bail as it moves.  
See also error code **Steady 346**.

---

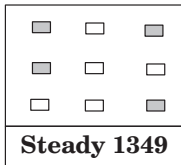

**Paper + Error + Film + Ready:** Failure of centronics READ.  
Firmware error or faulty electronics module.

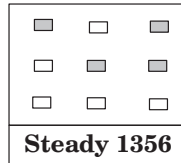

**Paper + Error + Fast + Load Media:** Error in X-axis encoder quadrature (media-axis). Possible causes are:

- Incorrect routing of the motor cables.
- Electrical noise in motors.
- Faulty motor encoder.
- Motor received an electrostatic discharge while operating.

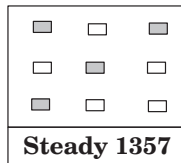

**Paper + Error + Fast + Special:** Contents of the EEROM have been lost.

- Perform the electrical test. If it fails, the main PCA is faulty.
- Don't rule out the fact that any new service test that you perform may corrupt the EEROM.

For more information ▶ page 8-27, § EEROM Errors.

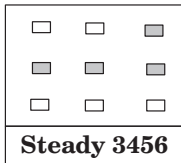

**Error + Film + Fast + Load Media:** Error in encoder-strip quadrature (carriage axis). Possible causes are:

- Incorrect routing of the motor cables.
- Trailing cable is faulty or badly connected.
- Faulty carriage.
- Motor received an electrostatic discharge while operating.

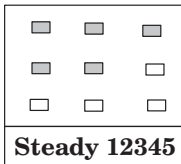

**Paper + Cartridges + Error + Film + Fast:** Cartridge-alignment firmware error. Try one or more of the following:

- Turn the plotter off, and then on again to see if the problem disappears.
- Ensure that the cartridges are correctly seated.
- Replace cartridges.
- If the problem remains, consult recent service notes for a possible solution.
- If no service note deals with this error, report the problem to your HP Response Center. Note conditions and actions before error occurred. Include setup sheet and service configuration plot in report.

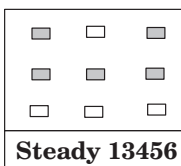

**Paper + Error + Film + Fast + Load Media:** Error in bail-lift mechanism. The bail-lift system is unable to raise or lower the bail. (It is the carriage that tests to see whether the bail is in the correct position by trying to knock against it.)

- Check the bail-lift system to see if it is working correctly.
- Use the bail cycle test to help troubleshoot.

For more precise troubleshooting ▶ page 8-19, § System Errors.

## Error Codes for the DesignJet 330 and 350C Plotters

### No LEDs On

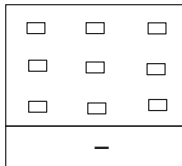

If there is no activity at all from the plotter, you may have a power problem. (Troubleshooting ▶ User's Guide, chapter 9.)

### LEDs Off

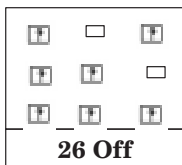

**Load Media + Ready:** Possible causes are:

- Cover is open.
- Plotter is waiting for you to cut the plot. Instructions ▶ User's Guide, chapter 2.

### LEDs On (Error Off)

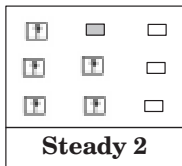

**Load Media:** No sheet is loaded.

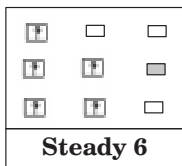

**Ready:** Ready to plot.

Send your plot from your computer or, for a special internal plot, press the appropriate key combination. (Keys ▶ Quick Reference Guide.)

### LEDs Flashing

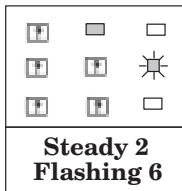

**Load Media + Ready:** The plotter has a file in memory, which it is waiting to plot, but no sheet is loaded.

Load a sheet.

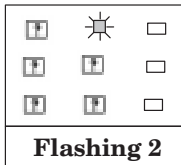

**Load Media:** Media must be re-aligned.

Re-align the media. Instructions ▶ User's Guide, chapter 2.

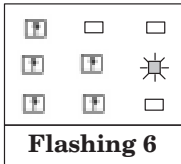

**Ready:** The plotter is busy with a task or is receiving a file.

Wait.

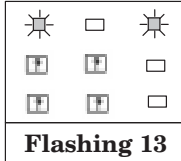

**Plain + Error:** The current plot is too large and does not fit in memory.

- If the plot is a raster plot, try sending it with a **no negative motion** RTL command.
- If it is a vector plot, try using a driver that performs all the rasterization of the plot in the host computer before sending it to the plotter. (See also ▶ chapter 5, § *Memory Usage*.)
- Otherwise, add more memory by installing a DRAM SIMM.

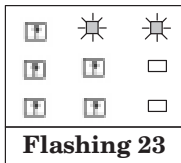

**Load Media + Error:** Media-load error.

- Cover open during start-up.
- Check that the media is aligned and that the correct media size is loaded. Try to load it again. (Tips ▶ User's Guide, chapter 4.)
- Clear any binding in the media axis. **Caution:** Do not pull media along the carriage axis – you could break the media-sensor flags.
- Are both media-sensor flags installed?
- Check for a faulty media sensor.
- Check for a faulty or badly connected trailing cable.
- Check for a faulty carriage PCA.

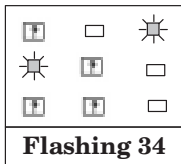

**Error + Film:** One or more of the cartridges is missing, making bad contact or is of the wrong type. Try one or more of the following:

- Remove each cartridge. Ensure that the protective tape has been removed, and look for dirty contacts or wear. Replace each cartridge and run the Black-Cartridge Alignment Procedure. (Instructions ▶ User's Guide, chapter 1.)
- Replace the trailing cable.
- Replace the carriage.
- Replace the electronics module.

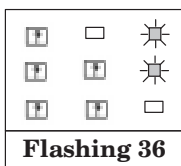

**Error + Ready:** There is a problem with the serial interface.

- Ensure the plotter's settings for baud rate and parity are the same as those of the host computer. To check the plotter settings, use the setup sheet. (Instructions ▶ User's Guide, chapter 1.)
- Also check your interface cable and connections.
- This error may also occur if you send a drawing for print using a Windows driver when the **Fast Direct to Print** option is turned **OFF** in the Windows Printer Control Panel. You should either turn the **Fast Direct to Print** option **ON**, or send the drawing to a file and print the file from the MS-DOS command line through the serial port.
- If the host computer is an HP 712 workstation, you may have some problems using baudrates of 19200 and 38400. Check if recent service notes have a solution.
- Check to see if the Plotter or PC is badly configured.
- Check for an error in the host computer.
- Replace the electronics module.

## Error LED On

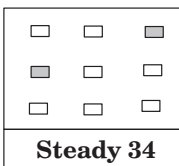

**Error + Film:** DRAM (on-board) or SIMM DRAM failure.

See **Steady 135**.

---

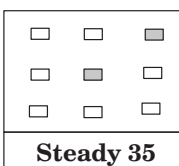

**Error + Fast:** Swath RAM test failure.

Replace the electronics module.

---

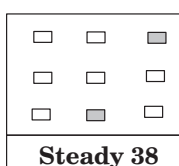

**Error + Normal:** Not enough memory to allocate internal data structures.

- Turn the plotter off, and then on again to see if the problem disappears.
  - If the problem remains, consult recent service notes for a possible solution.
  - If no service note deals with this error, report the problem to your HP Response Center. Note conditions and actions before error occurred. Include setup sheet and service configuration plot in report.
- 

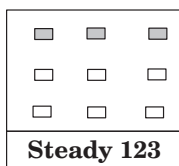

**Plain + Load Media + Error:** Servo error in the X-axis (media axis). Try one or more of the following:

- Clear any binding due to a media jam. **Caution:** Do not pull media along the carriage axis – you could break the media-sensor flags.
- Perform the media-axis test and the servo/encoder test to check for problems with the media motor and encoder, and the electronics module.
- The media-motor worm and the right drive-roller gear should have grease on them. (Parts: Silicon grease: C3190-60155) ● If necessary, remove the right drive-roller gear from the drive roller. Then, if you cannot manually spin the roller, it is probably jammed.
- Is the plotter located in an environment of high temperature and humidity? Is this causing deformation (flattening) of the pinch-wheels?
- Replace the media motor.
- Replace the electronics module.

For more precise troubleshooting ▶ page 8-23, § System Errors.

---

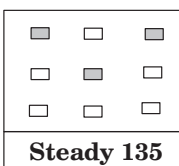

**Plain + Error + Fast:** Error detected in the EEROM. Possible causes are:

- EEROM model ID not configured. Configure the EEROM with the correct model ID (Instructions ▶ page 8-28).
- Power failure during the tests.
- Faulty carriage PCA.
- Faulty or badly connected trailing cable.
- Faulty electronics module.
- Plotter is operating very near to powerful electrical motors or machines.

For more information ▶ page 8-27, § EEROM Errors.

For more precise troubleshooting ▶ page 8-23, § System Errors.

---

<input checked="" type="checkbox"/> <input type="checkbox"/> <input type="checkbox"/> <input type="checkbox"/> <input type="checkbox"/> <input checked="" type="checkbox"/> <input type="checkbox"/> <input type="checkbox"/> <input type="checkbox"/>
<b>Steady 136</b>

**Plain + Error + Ready:** RS-232-C data overflow. Data byte was not read before another was entered into the UART. Possible causes are:

- Incorrect configuration in communications speed/protocol.
- Incorrect communications cable.
- Error in host computer.
- Faulty electronics module.

<input checked="" type="checkbox"/> <input type="checkbox"/> <input type="checkbox"/> <input type="checkbox"/> <input type="checkbox"/> <input type="checkbox"/> <input type="checkbox"/> <input type="checkbox"/> <input checked="" type="checkbox"/>
<b>Steady 139</b>

**Plain + Error + Roll:** Processor fault.

- Turn the plotter off, and then on again to see if the problem disappears.
- If the problem remains, consult recent service notes for a possible solution.
- If no service note deals with this error, report the problem to your HP Response Center. Note conditions and actions before error occurred. Include setup sheet and service configuration plot in report.

<input type="checkbox"/> <input checked="" type="checkbox"/> <input type="checkbox"/> <input checked="" type="checkbox"/> <input type="checkbox"/> <input type="checkbox"/> <input type="checkbox"/> <input type="checkbox"/> <input type="checkbox"/>
<b>Steady 234</b>

**Load Media + Error + Film:** Servo error in the Y-axis (carriage axis). Try one or more of the following:

- Clear any binding due to a media jam.
  - Turn the plotter off. Manually move the carriage along the carriage axis. Check for any areas where the carriage may be binding.
  - Ensure that the belt and belt pulley are in correct working order. Remove dirt from the pulley that could cause the belt to slip.
  - Perform the carriage-axis test and the servo/encoder test to check for problems with the carriage motor, encoder strip, and electronics module.
  - Remove dirt from the slider rod and chassis beam. Apply oil (Anderol 4068, HP part number: 6040-0858) to the carriage bushings.
  - At high temperatures, and if the fan is not working correctly, the internal resistance of the motor driver may increase, causing a decrease in the voltage between the motor contacts, and a shutdown of the motor.
  - Ensure that the encoder strip is not inverted, damaged or absent.
  - Reconnect or replace the trailing cable.
  - Replace the carriage.
- For more precise troubleshooting ▶ page 8-23, § System Errors.

<input type="checkbox"/> <input checked="" type="checkbox"/> <input type="checkbox"/> <input type="checkbox"/> <input type="checkbox"/> <input type="checkbox"/> <input type="checkbox"/> <input checked="" type="checkbox"/> <input type="checkbox"/>
<b>Steady 238</b>

**Load Media + Error + Normal:** Error in X-axis calibration.

- Is X-axis calibration done?
- Did you load media in correct orientation?
- Are the marks visible on the plot? If not, check cartridges.
- Are cartridges correctly aligned? If so, the problem may be in the electronics module, media motor or drive-roller gear; if alignment is incorrect, the problem may be in the carriage.

<input type="checkbox"/> <input type="checkbox"/> <input checked="" type="checkbox"/> <input checked="" type="checkbox"/> <input type="checkbox"/> <input checked="" type="checkbox"/> <input type="checkbox"/> <input type="checkbox"/> <input type="checkbox"/>
<b>Steady 346</b>

**Error + Film + Ready:** Failure of RS-232-C loopback test.

- Ensure the loopback connector is the appropriate one.
- If the problem remains, replace the electronics module.

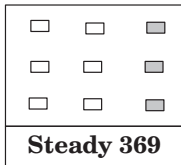

---

**Error + Ready + Roll:** Library Error.  
Special firmware error. See **Steady 1389**.

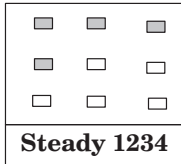

---

**Plain + Load Media + Error + Film:** Problems in the free movement of the carriage.  
The possible causes could be: ● Something is causing excessive friction in the Y-axis (carriage axis). ● The carriage touches the bail as it moves.

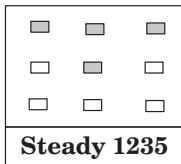

---

**Plain + Load Media + Error + Fast:** Error detected in media-axis servo feedback loop.  
The problem may be with the: ● Media-motor encoder cable ● Media motor ● Electronics module.

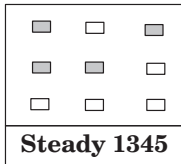

---

**Plain + Error + Film + Fast:** Not enough memory for the sensor data structure.  
● Turn the plotter off, and then on again to see if the problem disappears.  
● If the problem remains, consult recent service notes for a possible solution.  
● If no service note deals with this error, report the problem to your HP Response Center. Note conditions and actions before error occurred. Include setup sheet and service configuration plot in report.

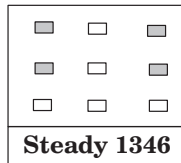

---

**Plain + Error + Film + Ready:** Failure of Centronics READ.  
Firmware error or faulty electronics module.

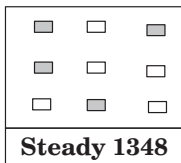

---

**Plain + Error + Film + Normal:** Electrical error  
The possible causes could be: ● Missing or badly seated cartridge. ● One end of the trailing cable is not connected or is badly connected, or the trailing cable is faulty. ● Faulty fan, or fan is disconnected. ● Faulty carriage PCA. ● Faulty main PCA.

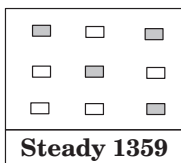

---

**Plain + Error + Fast + Roll:** Communication broken between the two processors on the main PCA.  
Replace the electronics module.

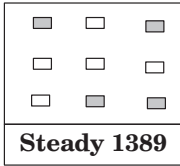

**Plain + Error + Normal + Roll:** Firmware failure (generic).

- Turn the plotter off, and then on again to see if the problem disappears.
  - If the problem remains, consult recent service notes for a possible solution.
  - If no service note deals with this error, report the problem to your HP Response Center. Note conditions and actions before error occurred. Include setup sheet and service configuration plot in report.
- For more precise troubleshooting ▶ page 8-23, § System Errors.
- 

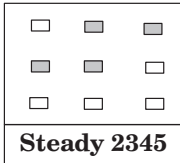

**Load Media + Error + Film + Fast :** Error in Y-axis encoder quadrature (Carriage axis). Possible causes are:

- Broken or damaged encoder strip.
  - Incorrect routing of the motor cables.
  - Electrical noise in motors. • Faulty motor encoder. • Motor received an electrostatic discharge while operating.
- 

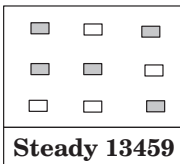

**Plain + Error + Film + Fast + Roll:** Cartridge-alignment firmware error. Try one or more of the following:

- Turn the plotter off, and then on again to see if the problem disappears.
  - Ensure that the cartridges are correctly seated. • Replace cartridges.
  - If the problem remains, consult recent service notes for a possible solution.
  - If no service note deals with this error, report the problem to your HP Response Center. Note conditions and actions before error occurred. Include setup sheet and service configuration plot in report.
- 

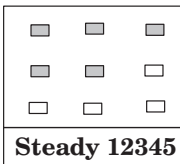

**Plain + Load Media + Error + Film + Fast:** Error in bail-lift mechanism. The bail-lift system is unable to raise or lower the bail. (It is the carriage that tests to see whether the bail is in the correct position by trying to knock against it.)

- Check the bail-lift system to see if it is working correctly • Use the bail cycle test to help troubleshoot.
- For more precise troubleshooting ▶ page 8-23, § System Errors.
-



## System Errors for the DesignJet 230 and 250C Plotters

The DesignJet 230 and 250C plotters have many failure modes that cause system errors. Many are due to electrical problems, others electronic, and some mechanical.

To more precisely troubleshoot the system error, you may be able to find out what line of the firmware code the error appeared, and interpret this line;

- 1 If possible, print the service configuration plot (see [page 8-49](#)). The last system error, and the line number of the system error are printed on this plot.
- 2 See if the line number also appears in the following table. (Make sure that you also know which firmware revision the plotter is using, since a given line number corresponds to different lines in different revisions.)

Filename	Line Number			Failure (and most frequent causes)
	Firmware A.01.03	Firmware A.01.04	Firmware A.01.05	
testmode.c	–	1735	1739	Y-axis servo error during bench run.
testmode.c	–	1907	1973	X/Y-axis servo error during bench run.
testmode.c	3014	3013	3079	Cartridge continuity: <ul style="list-style-type: none"> <li>● Cartridges badly seated.</li> <li>● Faulty or badly connected trailing cable.</li> <li>● Dirty carriage flex circuit.</li> <li>● Faulty carriage.</li> <li>● Faulty electronics module.</li> </ul>
testmode.c	2950 or 2959	2949 or 2958	3015 or 3024	Secondary <i>Fibis</i> test failed: <ul style="list-style-type: none"> <li>● Faulty electronics module.</li> </ul>
testmode.c	2974	2973	3039	Error in swath-RAM test: <ul style="list-style-type: none"> <li>● Faulty electronics module.</li> </ul>
testmode.c	2992	2991	3057	Error in cartridge-voltage regulation: <ul style="list-style-type: none"> <li>● Faulty or badly connected trailing cable.</li> <li>● Faulty carriage.</li> <li>● Faulty electronics module.</li> </ul>

Filename	Line Number			Failure (and most frequent causes)
	Firmware A.01.03	Firmware A.01.04	Firmware A.01.05	
testmode.c	3001	3000	3066	Error in A/D convertor test: <ul style="list-style-type: none"> <li>• Faulty trailing cable.</li> <li>• Faulty carriage.</li> </ul>
testmode.c	3083	3082	3148	Error in DRAM data test: <ul style="list-style-type: none"> <li>• Faulty carriage.</li> </ul>
testmode.c	3090	3089	3155	Error in DRAM addresses test: <ul style="list-style-type: none"> <li>• Faulty electronics module.</li> </ul>
testmode.c	3097	3096	3162	Unknown DRAM error: <ul style="list-style-type: none"> <li>• Faulty electronics module.</li> </ul>
testmode.c	3121	3120	3186	Error in the test of the in-built ROM and ROM SIMM performed at power-on: <ul style="list-style-type: none"> <li>• ROM SIMM badly seated.</li> <li>• Faulty ROM SIMM.</li> <li>• Faulty electronics module.</li> </ul>
testmode.c	3132	3131	3197	Error in the test of the masked ROM: <ul style="list-style-type: none"> <li>• Faulty electronics module.</li> </ul>
main.c	187	187	187	Failure in cartridge initialization: <ul style="list-style-type: none"> <li>• Faulty or badly connected trailing cable.</li> </ul>
main.c	314	314	314	Failure in fan connection test: <ul style="list-style-type: none"> <li>• Faulty electronics module.</li> </ul>
selftest.c	1496	1496	1496	Failure in test to actuate in-built ROM or ROM SIMM: <ul style="list-style-type: none"> <li>• ROM SIMM badly seated.</li> <li>• Faulty ROM SIMM.</li> <li>• Faulty electronics module.</li> </ul>
selftest.c	1500	1500	1500	Failure in masked-ROM test: <ul style="list-style-type: none"> <li>• Faulty electronics module.</li> </ul>
selftest.c	1507	1507	1507	Failure in main-PCA DRAM test: <ul style="list-style-type: none"> <li>• Faulty electronics module.</li> </ul>

Filename	Line Number			Failure (and most frequent causes)
	Firmware A.01.03	Firmware A.01.04	Firmware A.01.05	
selftest.c	1516	1516	1516	Failure in RAM SIMM test: <ul style="list-style-type: none"> <li>● RAM SIMM badly connected.</li> <li>● Faulty RAM SIMM.</li> <li>● Faulty electronics module.</li> </ul>
selftest.c	1520	1520	1520	Failure in RAM SIMM test: <ul style="list-style-type: none"> <li>● RAM SIMM badly connected.</li> <li>● Faulty RAM SIMM.</li> <li>● Faulty electronics module.</li> </ul>
selftest.c	1563	1563	1563	Failure in <i>Fibis</i> test: <ul style="list-style-type: none"> <li>● Faulty electronics module.</li> </ul>
selftest.c	1567	1567	–	Failure in <i>Fibis</i> RAM sequence test: <ul style="list-style-type: none"> <li>● Faulty electronics module.</li> </ul>
selftest.c	1573	1573	1573	Failure in <i>Condor</i> test: <ul style="list-style-type: none"> <li>● If firmware is revision A.01.02 or earlier, then change to latest.</li> <li>● Faulty electronics module.</li> </ul>
ipc.c	824	824	824	The SPROC did not respond within 10 seconds: <ul style="list-style-type: none"> <li>● Faulty electronics module.</li> </ul>
media_load.c	862 or 889 or 993 or 1310	862 or 889 or 993 or 1310	862 or 889 or 993 or 1310	Bail error or Y-axis servo error: <ul style="list-style-type: none"> <li>● Carriage knocked against bail.</li> <li>● Faulty encoder strip.</li> <li>● Faulty trailing cable.</li> <li>● Faulty carriage.</li> </ul>
fpcmain.c	1489	1489	1489	PCA was initialized in a Designjet 250C and used in a DesignJet 230. EEROM needs to be reset.
error.c	537	537	537	Processor error: <ul style="list-style-type: none"> <li>● Faulty electronics module.</li> </ul>

Filename	Line Number			Failure (and most frequent causes)
	Firmware A.01.03	Firmware A.01.04	Firmware A.01.05	
mechanics.c	247	247	247	Mechanical problem when the carriage attempts to position itself over the service station. Check the mechanics.
eerom.c	–	458 or 1232	458 or 1232	EEROM test failed: <ul style="list-style-type: none"> <li>• See page 8-27, § EEROM errors.</li> </ul>
servo.c	–	412	412	Y-axis servo error (carriage movement): <ul style="list-style-type: none"> <li>• Obstacle or friction in Y-axis.</li> <li>• Motor cable disconnected.</li> <li>• Faulty carriage motor, or motor cable pinched.</li> <li>• Faulty encoder strip.</li> <li>• Faulty carriage.</li> <li>• Faulty electronics module.</li> </ul>
servo.c	–	417 or 431	417 or 431	X-axis servo error (roll movement): <ul style="list-style-type: none"> <li>• Obstacle or friction in X-axis.</li> <li>• Motor cable disconnected.</li> <li>• Faulty media motor, or motor cable pinched.</li> <li>• Faulty electronics module.</li> </ul>
bnixsystem.c	–	2729	–	Centronics/Bitronics communication error: <ul style="list-style-type: none"> <li>• Centronics cable badly connected.</li> <li>• Problem with host computer.</li> <li>• Faulty electronics module.</li> </ul>

## System Errors for the DesignJet 330 and 350C Plotters

The DesignJet 330 and 350C plotters have many failure modes that cause system errors. Many are due to electrical problems, others electronic, and some mechanical.

To more precisely troubleshoot the system error, you may be able to find out what line of the firmware code the error appeared, and interpret this line;

- 1 If possible, print the service configuration plot (see [page 8-50](#)). The last system error, and the line number of the system error are printed on this plot.
- 2 See if the line number also appears in the following table. (Make sure that you also know which firmware revision the plotter is using, since a given line number corresponds to different lines in different revisions.)

Filename	Line Number		Failure (and most frequent causes)
	Firmware A.01.00		
testmode.c	–		Y-axis servo error during bench run.
testmode.c	2499		X/Y-axis servo error during bench run.
testmode.c	3614		Cartridge continuity: <ul style="list-style-type: none"> <li>● Cartridges badly seated.</li> <li>● Faulty or badly connected trailing cable.</li> <li>● Dirty carriage flex circuit.</li> <li>● Faulty carriage.</li> <li>● Faulty electronics module.</li> </ul>
testmode.c	3559		Secondary <i>Fibis</i> test failed: <ul style="list-style-type: none"> <li>● Faulty electronics module.</li> </ul>
testmode.c	3574		Error in swath-RAM test: <ul style="list-style-type: none"> <li>● Faulty electronics module</li> </ul>
testmode.c	3592		Error in cartridge-voltage regulation: <ul style="list-style-type: none"> <li>● Faulty or badly connected trailing cable.</li> <li>● Faulty carriage.</li> <li>● Faulty electronics module.</li> </ul>
testmode.c	3601		Error in A/D convertor test: <ul style="list-style-type: none"> <li>● Faulty trailing cable.</li> <li>● Faulty carriage.</li> </ul>

Filename	Line Number	Failure (and most frequent causes)
	Firmware A.01.00	
testmode.c	3684	Error in DRAM data test: <ul style="list-style-type: none"> <li>Faulty carriage.</li> </ul>
testmode.c	3691	Error in DRAM addresses test: <ul style="list-style-type: none"> <li>Faulty electronics module.</li> </ul>
testmode.c	3698	Unknown DRAM error: <ul style="list-style-type: none"> <li>Faulty electronics module.</li> </ul>
testmode.c	3722	Error in the test of the in-built ROM and ROM SIMM performed at power-on: <ul style="list-style-type: none"> <li>ROM SIMM badly seated.</li> <li>Faulty ROM SIMM.</li> <li>Faulty electronics module.</li> </ul>
testmode.c	3733	Error in the test of the masked ROM: <ul style="list-style-type: none"> <li>Faulty electronics module.</li> </ul>
main.c	238	Failure in cartridge initialization: <ul style="list-style-type: none"> <li>Faulty or badly connected trailing cable.</li> </ul>
main.c	381	Failure in fan connection test: <ul style="list-style-type: none"> <li>Faulty electronics module.</li> </ul>
main.c	230 or 354	Model ID configuration incorrect. Reconfigure the plotter <a href="#">▶ page 8-28</a> .
selftest.c	1502	Failure in test to actuate in-built ROM or ROM SIMM: <ul style="list-style-type: none"> <li>ROM SIMM badly seated.</li> <li>Faulty ROM SIMM.</li> <li>Faulty electronics module.</li> </ul>
selftest.c	1506	Failure in masked-ROM test: <ul style="list-style-type: none"> <li>Faulty electronics module.</li> </ul>
selftest.c	1513	Failure in main-PCA DRAM test: <ul style="list-style-type: none"> <li>Faulty electronics module.</li> </ul>

<b>Filename</b>	<b>Line Number</b>	<b>Failure</b> (and most frequent causes)
	Firmware A.01.00	
selftest.c	1522	Failure in RAM SIMM test: <ul style="list-style-type: none"> <li>● RAM SIMM badly connected.</li> <li>● Faulty RAM SIMM.</li> <li>● Faulty electronics module.</li> </ul>
selftest.c	1526	Failure in RAM SIMM test: <ul style="list-style-type: none"> <li>● RAM SIMM badly connected</li> <li>● Faulty RAM SIMM</li> <li>● Faulty electronics module.</li> </ul>
selftest.c	1569	Failure in <i>Fibis</i> test: <ul style="list-style-type: none"> <li>● Faulty electronics module.</li> </ul>
selftest.c	1573	Failure in <i>Fibis</i> RAM sequence test: <ul style="list-style-type: none"> <li>● Faulty electronics module.</li> </ul>
selftest.c	1579	Failure in <i>Condor</i> test: <ul style="list-style-type: none"> <li>● If firmware is revision A.01.02 or earlier, then change to latest.</li> <li>● Faulty electronics module.</li> </ul>
ipc.c	813 or 824	The SPROC did not respond within 10 seconds: <ul style="list-style-type: none"> <li>● Faulty electronics module.</li> </ul>
media_load.c	681 or 2403 or 2430 or 2619	Bail error or Y-axis servo error: <ul style="list-style-type: none"> <li>● Carriage knocked against bail.</li> <li>● Faulty encoder strip.</li> <li>● Faulty trailing cable.</li> <li>● Faulty carriage.</li> </ul>
error.c	536	Processor error: <ul style="list-style-type: none"> <li>● Faulty electronics module.</li> </ul>
miInterface.c	1973 or 1997	Mechanical problem when the carriage attempts to position itself over the service station. Check the mechanics.

<b>Filename</b>	<b>Line Number</b>	<b>Failure</b> (and most frequent causes)
	Firmware A.01.00	
eerom.c	220 or 260 or 291 or 325 or 355 or 399 or 443 or 483 or 527 or 554	EEROM test failed: <ul style="list-style-type: none"> <li>• See page 8-27, § EEROM errors.</li> </ul>
servo.c	412 or 426	Y-axis servo error (carriage movement): <ul style="list-style-type: none"> <li>• Obstacle or friction in Y-axis.</li> <li>• Motor cable disconnected.</li> <li>• Faulty carriage motor, or motor cable pinched.</li> <li>• Faulty encoder strip.</li> <li>• Faulty carriage.</li> <li>• Faulty electronics module.</li> </ul>
servo.c	417 or 431	X-axis servo error (roll movement): <ul style="list-style-type: none"> <li>• Obstacle or friction in X-axis.</li> <li>• Motor cable disconnected.</li> <li>• Faulty media motor, or motor cable pinched.</li> <li>• Faulty electronics module.</li> </ul>
bnixsystem.c	2292 or 2414 or 2449 or 2750	Centronics/Bitronics communication error: <ul style="list-style-type: none"> <li>• Centronics cable badly connected.</li> <li>• Problem with host computer.</li> <li>• Faulty electronics module.</li> </ul>



---

## EEROM Errors

What is an EEROM error?

An EEROM error means that some of the internal tests that the firmware performs have detected that, when re-reading information from the EEROM, it doesn't correspond to the information that had previously been written there, or that the checksum of all the information is incorrect. This failure has five possible causes:

- Faulty electronics module.
- Contact problems with the trailing-cable connections.
- Faulty trailing cable.
- Faulty carriage.
- The plotter was turned off while a test was writing to the EEROM, thus leaving corrupt information (or a communication cable was disconnected while sending information to the EEROM using software diagnostic tools).

It is generally not easy to discover the cause, due to the intermittent character of the failure modes.

If you are sure that the failure occurred just after an electricity power-cut, or after turning off the plotter during the bench run or other service tests, then the plotter is not faulty. You just need to reset the EEROM. In other cases, you need to find the cause:

- There is always an EEROM error when you switch on the plotter:  
If it is easy to reproduce a **Steady 135** error, then try one or all of the following steps for a possible solution:

330  
350C

- 1 Configure the EEROM with the correct model ID (instructions ▶ page 8-28).
  - 2 Ensure that the trailing cable is properly connected at both ends.
  - 3 Connect a new trailing cable outside the plotter to the carriage and electronics module (without installing the cable completely). If the error disappears, install the new trailing cable.
  - 4 Connect a new carriage outside the plotter to the trailing cable, and switch on the plotter. If the error disappears, install the new carriage.
  - 5 Change the electronics module.
- There is sometimes an EEROM error when you switch on the plotter (normally shows up as a **Steady 135** error):
    - 1 Switch on the plotter, allow it to initialize until it has completed the power-on LED sequence, and switch off the plotter. (You are now sure that the EEROM has not been corrupted. If a **Steady 135** error appeared, it also corrects the EEROM contents, and the next time you switch the plotter on, the error should not occur in good units.)
    - 2 Leave the unit off for 15 minutes to detect if the EEROM is losing its information. Then turn it on again and allow it to initialize. If a **Steady 135** error appears during the initialization sequence, and the carriage does not begin to move, then the EEROM is probably faulty. Change the electronics module.

## EEROM Model ID Configuration Procedure for the DesignJet 330 and 350C

The EEROM model ID configuration procedure only needs to be carried out if:

- A pre-configured board is being reused.
- The current board is incorrectly configured to the wrong model ID.
- The plotter shows an unconfigured model ID system error (**Steady 135**).

*It is very rare that these situations will ever occur.*

Configure the plotter model ID as follows:

- 1 Remove the left cover ▶ page 6-10.
- 2 Disconnect the media motor encoder cable from the main PCA (connector ENC X).
- 3 Turn the plotter ON in Service Mode 1.
- 4 Hold the **ALT** key down and press the **Deconfiguration Mode** key.

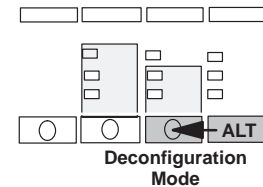

- 5 Once in Deconfiguration Mode, the first and second LED columns should light up.

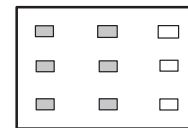

- 6 Using a suitable tool, short-circuit pins 1 and 2 (the first two pins on the right) of the media motor encoder connector (ENC X). The second and third LED columns should light up as you short-circuit the two pins.

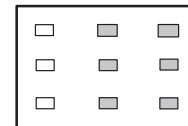

- 7 Once you have short-circuited the two pins, the first and second LED columns should light up again.

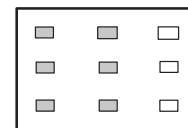

- 8 Press the **Shift** key to exit the Deconfiguration Mode.

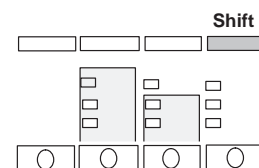

**9** Configure the plotter with the correct model ID as follows:

*Only one opportunity is given to perform this procedure and there is no indication that it was successful.*

If the plotter is to be configured as a DesignJet 350C (Color) plotter, hold the **ALT** key down and press the two **Color Configuration** keys at the same time.

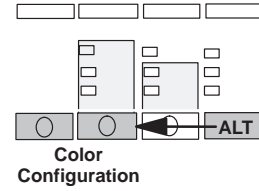

If the plotter is to be configured as a DesignJet 330 (Monochrome) plotter, hold the **SHIFT** key down and press the two **Mono Configuration** keys at the same time.

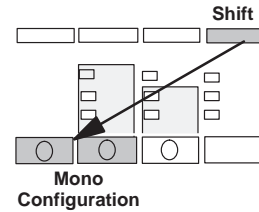

- 10** Turn the plotter OFF.
- 11** Reconnect the media motor encoder cable to the main PCA (connector ENC X).
- 12** Turn the plotter ON and print the Demo Plot to check if the plotter has been correctly configured.  
*If the plotter is still incorrectly configured, repeat the model ID configuration procedure from step 2.*
- 13** Because all plotter calibrations are reset during the model ID configuration procedure, the plotter must be recalibrated. To perform the accuracy calibration [▶ page 7-8](#).

---

## Troubleshooting Tips

---

Diagnosing problems.	<b>Print quality and service configuration plots:</b> You can use these plots to help diagnose problems. (See ♦ pages 8-46 and 8-51).
Firmware-code revision level.	Print a <b>setup sheet</b> or a <b>service configuration plot</b> to check the firmware-code revision level that the plotter is using. The plotter may be using in-built firmware, or firmware from a flash ROM SIMM. (Which firmware? ♦ page 8-3).
Repair and calibrate.	After you have made a repair, consider whether any <b>calibrations</b> have been affected.
Cartridges fail frequently.	<b>Remove tape and align cartridges:</b> One frequent cause of cartridge problems is that the user has forgotten to remove the tape from new cartridges. Remove the tape. <b>Priming cartridges</b> to clear nozzles ♦ User's Guide. <b>Primer tubes:</b> When you prime cartridges, and there seems to be no result, ensure that the primer tubes are not clogged up with ink. <b>Damaged encoder strip:</b> Another frequent cause of apparent cartridge failure may be a damaged encoder strip. If the small slots on the strip are damaged, the plotter cannot position the carriage correctly during cartridge checking. Try replacing the encoder strip. <b>Faulty cartridge:</b> Some black cartridges (51640A) with USE BEFORE dates of April '96 and earlier may have thin-film damage. This means that the material used for channeling ink behind the nozzles can crack with aging. When this happens, ink seepage may cause many nozzles to fail (eight or more). Replace the black cartridge with one with USE BEFORE date of May '96 or later. <b>Dirty pads:</b> The connection between the carriage PCA and the cartridge flex connector is made by means of a gold bubble on the flex connector that touches a gold pad on the PCA. The Carriage Test includes a test of this connection. When nozzle failures occur, try cleaning the pads with isopropilic alcohol (warnings ♦ page 6-2). <b>Worn wipers:</b> If the wipers in the service station are worn down, they do not properly wipe the cartridge heads. Easy to replace.
Carriage sensor does not correctly find media edge.	<b>Ink on roller:</b> Excessive ink deposits on the drive-roller surface can fool the sensor by reflecting the light. (Cleaning roller ♦ chapter 4.) <b>Optical sensor incorrectly calibrated:</b> The accuracy calibration includes calibration of the optical sensor on the carriage. You must use polyester film when performing the accuracy calibration. Otherwise the optical sensor will have problems loading some types of media.

---

Carriage cannot park in service station.	<b>Mispositioned trailing cable:</b> The trailing cable may be preventing the carriage from reaching the left-hand stop. Make sure that the trailing cable is positioned <u>under</u> the plastic tabs at the back of the carriage cover, and not above them.
Drive belts wear out prematurely.	<b>Diazo copiers:</b> The belt may wear prematurely if the plotter is placed near a diazo copier that uses ammonia to produce blue-line copies. The material used in the belt is very reactive to ammonia vapor. The vapor is very corrosive and can damage other parts as well. Move the plotters away from such copiers. <b>Storing:</b> Keep new belts in their bags with dessicant until you need to install them. This is to avoid incorrect swelling.
Noisy carriage movement.	<b>Dirty carriage wheel:</b> Remove aluminum or dust particles from the wheel at the back of the carriage, and from the slider path along which the wheel moves.
Bail mechanism fails.	<b>Wearing of parts:</b> The cam gear and engaging gear may not make correct contact with the left drive-roller gear even though the carriage is actuating the engaging lever. This can happen due to excessive wearing of parts. Another problem may be that the bail cable has broken. <b>Carriage motor control:</b> The carriage may not properly locate the engagement lever, preventing the gears from engaging. Any problems with the carriage-motor control system (for example, the encoder strip) or associated mechanics could cause this problem. Also, if the carriage cannot find the true left stop during initialization (caused by interference), the engaging lever cannot be located. <b>Bail cam:</b> The bail may fall from the up position. This can happen if the cam is over or under-rotated. The notch on the cam, used to engage the left bail bracket, is not properly located for the “bail up” condition, and the bail falls abruptly. Perform a bail cycle test. <b>Adjust carriage:</b> If the carriage moves over the engaging lever without raising it, you may need to adjust the carriage angle on the slider rod. (Details ▶ page 7-11.) However, be careful not to jeopardize the print quality, which is very sensitive to the carriage angle.
Bail starwheels slip off overdrive roller wheels. Media jam.	<b>C-clips:</b> Ensure that the c-clips and bushings are correctly installed on the left end of the overdrive roller, to prevent its movement from side to side.
Ink spilling.	<b>Spittoon and ink separator:</b> You need to replace these parts when they fill up with ink. (See ▶ chapter 4.)
Static charge causing media jams.	<b>Anti-static brush:</b> If this brush (located under the entry platen) is damaged or removed, static charge can build up on the media. A charge can cause the media to stick to itself and jam the plotter.

Plots joined or not plotted.	<p><b>HP-GL timeout:</b> If the user is using an HP 7586B (HP-GL) driver, it may not end files properly with the result that several plots may be joined, or not plotted at all. In this case you need to choose an I/O Timeout period. (Instructions ▶ User's Guide.) The timeout tells the plotter how long to wait before assuming a plot is complete.</p> <p><i>Short timeout period:</i> A timeout setting that is too short results in incomplete plots.</p> <p><i>Long timeout period:</i> If the plotter has finished receiving the plot data (<b>Ready LED</b> stops flashing and remains on) and is waiting for the timeout period to finish before plotting, you can command it to plot immediately by pressing <b>Form Feed</b>.</p>
Damage to electronics module.	<p><b>Condensation:</b> In conditions of high humidity, water may condense on the plotter side-plates. To stop this water dripping onto the main PCA, a wick is attached to the underside of the right side-plate. This wick uses capillary action to route the water away from the electronics. If the wick is damaged, water may damage the main PCA.</p>
Third-party ink and off-axis ink systems.	<p><b>Drawer statement:</b> "HP does not support third-party inks or off-axis ink systems for use with any of its DesignJet series plotters or printers. If a failure or damage to such HP products is found to be directly attributed to the use of third-party inks or off-axis ink systems (or any other non-supported HP supply or accessory), the repair will NOT be covered under HP's warranty or maintenance contract. In such cases, standard time and material charges will be applied to service the plotter or printer."</p>
Troublesome plotters.	<p><b>Duty cycle:</b> Plotters need increased maintenance if users do not limit use to the duty-cycle recommendations. (Details ▶ chapter 4.)</p>
Random or incorrectly ordered LED sequence at power-on.	<p><b>Adjust electronics module:</b> The gasket to the left of the motor/sensor connectors on the electronics module may be short-circuiting the front-panel connector contacts. Push the gasket to the left, away from the connectors.</p>
Failure in RS-232-C communication.	<p><b>Faulty electronics module:</b> Failure of the -12V voltage in the power supply shows up as a failure in RS-232-C communication. The serial port might fail: completely, occasionally, or only with some PC models. See also error codes <b>Flashing 39</b>, <b>Steady 139</b>, and <b>Steady 349</b>.</p>
Changing electronics module or motors.	<p><b>Pinched cables:</b> Before changing an electronics module in which the main PCA has failed, make sure that the cables from the carriage motor and media motor have not been pinched. Pinched cables could have caused a short-circuit and damaged the chips that control the motors. (A faulty motor could also have caused the same to happen.)</p>

230  
250C

---

Media not Loading.

**Mispositioned trailing cable:** Make sure that the trailing cable is positioned under the plastic tabs at the back of the carriage cover, and not above them.

Otherwise, the following happens:

- 1 During plotter initialization, the trailing cable prevents the carriage from reaching the left-hand stop, and all Y-axis references are shifted to the right.
- 2 During media loading, the line sensor on the carriage searches for the right media edge at a position too far to the right, and the plotter rejects the media.
- 3 The plotter does not park the carriage correctly in the service station, so the cartridges are not correctly capped. The ink dries in the nozzles, and the primer has no effect.

**Excessive loading force:** When you begin to load media and push it into the plotter with too much force, too large a buckle forms in the media. The roller is then not able to correctly grasp the media and misaligns it. Instead, load the media so that the sheet buckles only slightly.

**Loading media too slowly:** If you push the media into the entry platen too slowly, the media sensor instructs the roller to move before the media has reached the roller. This can cause misalignment of the media. Instead, push the media in briskly.

See the media-loading guide C3190-90162 for more information on the trick to loading media correctly every time.

---





---

## Service Tests

### Which Service Test to Perform

Use the following table as a rough guide:

Assembly/Feature	Tested by ...
Bail system	Bail cycle test, Bench run
Carriage	Carriage test, Electrical test, Modular test
Carriage motor and drive system (including belt, pulley and slider rod)	Carriage-axis test, Bail cycle test, Modular test, Bench run
Cartridge identification	Carriage test, Modular test
Cartridge nozzles	Carriage test, Modular test
Communication between computer and plotter	Service monitor
Cover sensor	Sensors test, Modular test
DRAM SIMM	Electrical test, Power-on tests, Bench run
EEROM	Electrical test, Power-on tests, Bench run
Electronics module	Electrical test, Power-on tests, Input/output test, Servo/encoder test, Sensors test, Bail cycle test, Front-panel test, Media-axis test, Carriage test, Carriage-axis test, Bench run, Modular test
Encoder strip	Carriage-axis test, Servo/encoder test, Modular test, Bench run
Front-panel keys and LEDs	Front-panel test, Modular test
Media-axis encoder and cable	Servo/encoder test, Media-axis test, Modular test, Bench run
Media motor and drive system (including drive roller and overdrive)	Media-axis test, Modular test, Bench run
Media sensor	Sensors test, Modular test
<span style="border: 1px solid black; padding: 2px;">330 350C</span> Pinch-arm sensor	Sensors test, Modular test
Optical sensor (on carriage)	Carriage test, Modular test
ROM	Electrical test, Power-on tests, Bench run
Service station	Bail cycle test
Trailing cable	Electrical test, Power-on tests, Bench run

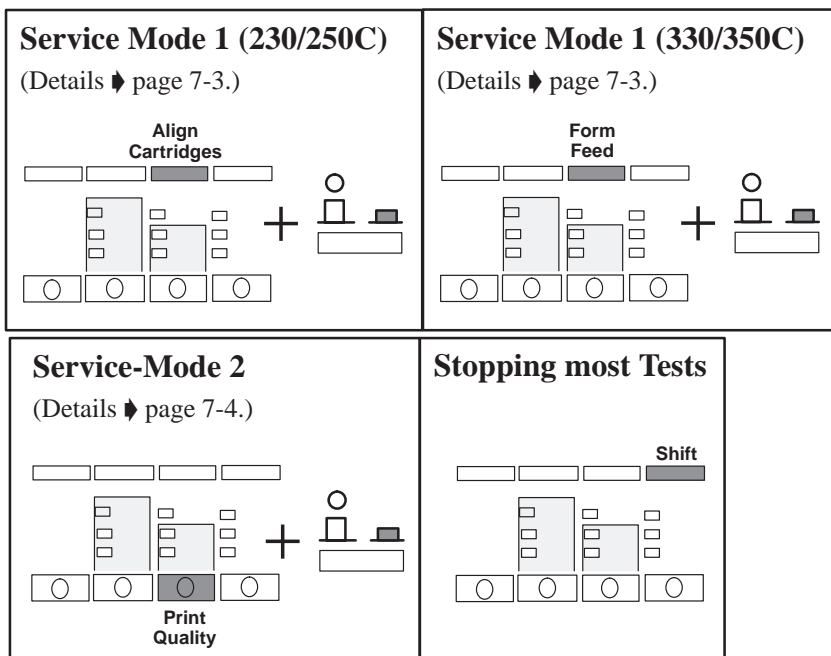

## Viewing Test Output on an HP Palmtop PC

Some of the tests in service mode 1 send test information to the plotter's serial port. To view the information on an HP Palmtop PC, perform the procedure below.

- 1 Turn the plotter and Palmtop off.
- 2 Use HP cable number F1015-80002 and adapter number 5181-6640 to connect the Palmtop to the plotter's serial interface port.  
*Both cable and adaptor are included in the HP F1021B Connectivity Pack.*
- 3 Turn the plotter on in service mode 1.
- 4 Turn the Palmtop on.
- 5 Open the **Data Comm** application on the Palmtop.
- 6 Press **MENU**.
- 7 Move to the **Connect** menu and press **ENTER**.
- 8 Ensure that **settings** are the same for both plotter and Palmtop.
- 9 Again move to the **Connect** menu and press **ENTER**.
- 10 With **connect** highlighted in the **Connect** menu, press **ENTER**.
- 11 Perform the service tests on the plotter.

To stop communication between the plotter and the Palmtop, highlight **Hangup** in the **Connect** menu and press **ENTER**.

## Bail Cycle Test

This tests the operation of the bail system, service station and carriage drive.

- 1 In service mode **1**, press **Bail Cycle Test**.

*All LEDs turn off. If the plotter has not yet initialized the media axis, the carriage moves to the right-hand side of the plotter and back to the service station. The following routine begins:*

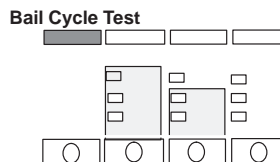

- The carriage moves out of the service station and back in, to position itself over the engaging lever. This causes the bail-lift mechanism gear and the left drive-roller gear to engage.*
- The top of the roller rotates towards you. This causes the bail to be gently raised and then lowered.*
- Again the carriage moves out of, and back into, the service station. However, this time it parks beyond the engaging lever, so that the gears are **not** engaged.*
- The top of the roller rotates slightly forward and then back.*

**Status.** After the first cycle, the **Normal LED** turns on (steady) if the bail-cycle test has not found an error. If an error occurs, the **Normal LED** flashes.

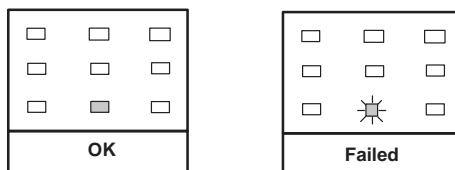



---

### Output to the Serial Port (Viewing Output ▶ 8-36)

---

Error code: If an error has occurred, this code specifies more precisely what has gone wrong during the test. Include this information in the report to your HP Response Center, if the problem cannot be fixed.

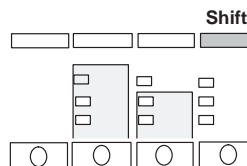
- 2 The test continuously repeats itself until you press the **Shift** key.



*You can also run the bail cycle test in service mode **2**. However, in this case, the **Normal LED** is not used to indicate an error as above. It's better to use service mode **1**.*

## Bench Run

The bench run is a routine that each plotter performs before it leaves the manufacturing site. It attempts to filter out plotters that could have an early breakdown due to a fault in manufacturing. The bench run tests the operation of the electronics, carriage-axis system, media-axis system, bail-lift mechanism, and service station.

The bench run is performed at the manufacturing site by sending special commands to the plotter and then pressing the indicated front-panel keys. Once the PC-based plotter diagnostics are available, Customer Engineers will be able to run the routine at the customer site when they replace critical parts of the plotter.

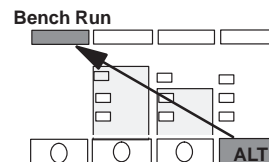

## Carriage-Axis Test

This tests the operation of the carriage motor, belt, tensioner, and encoder strip.

- 1 Ensure that the carriage is parked in the service station.

*The test does not include carriage-axis initialization. If the carriage starts somewhere in the center of the plotter, it will hit the right-hand side of the plotter when the test begins, and the test will fail.*

- 2 In service mode 1, press **Carriage-Axis Test**.

*The carriage moves towards the right-hand side of the plotter. It then begins cycles of moving from side to side over an approximate 50-cm (20-inch) span of the drive roller. The movement alternates between two speeds: 67.73 cm/sec and 33.87 cm/sec (26.67 inches/sec and 13.33 inches/sec).*

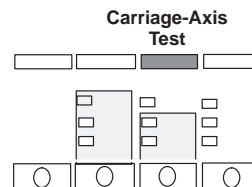

**Status.** After the first cycle, the **Paper LED** turns on (steady) if the carriage-axis test has not found an error. If the test fails, the **Paper LED** flashes.

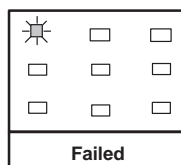
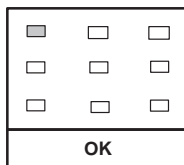

---

### Output to the Serial Port (Viewing Output ▶ 8-36)

---

Error code:	If an error has occurred, this code specifies more precisely what has gone wrong during the test. Include this information in the report to your HP Response Center, if the problem cannot be fixed.
Speed:	Speed for each carriage cycle.
Maximum PWM:	For each carriage cycle, the maximum PWM once the carriage achieves a constant speed. A typical carriage-axis PWM is 75. The maximum allowed is 102.

- 3 The test continuously repeats itself until you press the **Shift** key.

230  
250C

## Carriage Test for the DesignJet 230 and 250C

This tests the operation of the carriage sensor and the connection between the carriage flex circuit and the cartridges.

- 1 Position the sensor over a white surface. (Simply place a piece of white paper under the sensor.)
- 2 In service mode 1, press **Carriage Test**.

*The plotter varies the LED intensity between 255 and 0.*

*The plotter tests the connection between the carriage flex circuit and the cartridges by getting the cartridge identification and checking the electrical continuity for all nozzles.*

**Status.** During the test, the **Cartridges** and **Error** LEDs turn on (steady) if the carriage test has not found an error. If the test fails, one or both of these LEDs flash as indicated below:

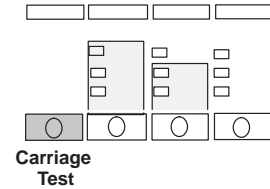
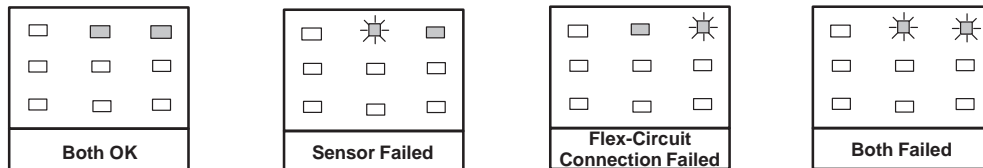

### Output to the Serial Port (Viewing Output ▶ 8-36)

Error code:	If an error has occurred in the sensor test, this code specifies more precisely what has gone wrong. Include this information in the report to your HP Response Center, if the problem cannot be fixed. Pen 0 = Cyan; Pen 1 = Magenta; Pen 2 = Yellow; Pen 3 = Black.
Sensor sensitivity:	The sensitivity measured during the test. The figures should vary from 255 to 0. Failure occurs when the sensitivity does not vary (for example, it stays at 255).
Pen ID:	If a pen does not fail, the plotter outputs the pen ID.

- 3 The test continuously repeats itself until you press the **Shift** key.

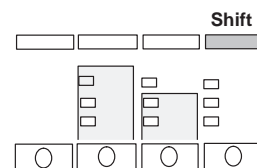

330  
350C

## Carriage Test for the DesignJet 330 and 350C

This tests the operation of the carriage sensor and the connection between the carriage flex circuit and the cartridges.

- 1 Position the sensor over a white surface. (Simply place a piece of white paper under the sensor.)
- 2 In service mode 1, press **Carriage Test**.

The plotter varies the LED intensity between 255 and 0.

The plotter tests the connection between the carriage flex circuit and the cartridges by getting the cartridge identification and checking the electrical continuity for all nozzles.

The plotter also tests the encoder sensor. Because the encoder sensor only detects motion, it is necessary to manually move the carriage along the encoder strip to correctly perform the test.

**Status.** During the test, the **Load Media**, **Error** and **Normal** LEDs turn on (steady) if the carriage test has not found an error. If the test fails, one, two or all of these LEDs flash as indicated below:

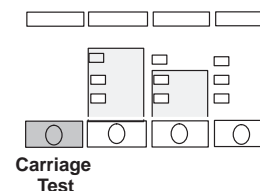
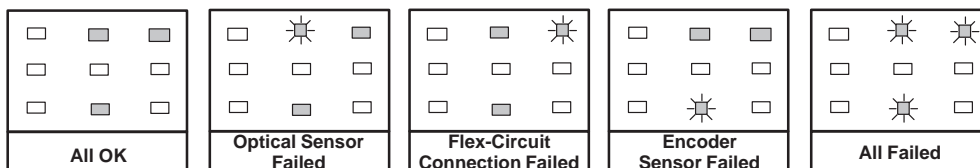

### Output to the Serial Port (Viewing Output ▶ 8-36)

In order to send output to the serial port, it is necessary to set the Verbose mode ON. This can be done using the 'verbose 1;' underware.

- Error code: If an error has occurred in the sensor test, this code specifies more precisely what has gone wrong. Include this information in the report to your HP Response Center, if the problem cannot be fixed.  
Pen 0 = Cyan; Pen 1 = Magenta; Pen 2 = Yellow; Pen 3 = Black.
- Sensor sensitivity: The sensitivity measured during the test. The figures should vary from 255 to 0. Failure occurs when the sensitivity does not vary (for example, it stays at 255).
- Pen ID: If a pen does not fail, the plotter outputs the pen ID.

- 3 The test continuously repeats itself until you press the **Shift** key.

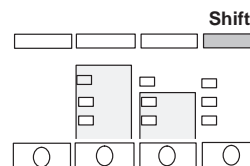

## Electrical Test

This tests the main PCA and carriage PCA electronics.

### 1 In service mode 2:

230  
250C

Hold down the **SHIFT** key and press **Electrical Test**.

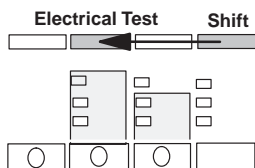

330  
350C

Press **Electrical Test**.

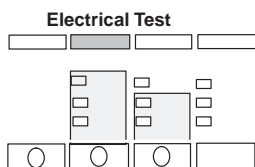

*The **Load Media LED** (or the **Ready LED**, if you have already loaded media) turns off for about 50 seconds while the plotter performs the electrical test.*

*The shift key does **not** act as a **stop-the-test** key for this test.*

**Status.** *If the test does not find an error, the **Load Media LED** (or the **Ready LED**, if you have already loaded media) turns on again. Otherwise, an error is reported by an error code on the front panel. The error code is usually shown as a "Steady 1238" (for DesignJet 230 and 250C) or a "Steady 1389" (for DesignJet 330 and 350C) which indicates a system error. See **System Errors**, page 8-19 (for DesignJet 230 and 250C) or page 8-23 (for DesignJet 330 and 350C), to be able to correctly troubleshoot the failure, and to be able to include the information when you exchange the electronics module.*

## Front-Panel Test

This tests the operation of the front-panel keys.

- 1 In service mode **1**, press **Front-Panel Test**.

*All LEDs flash a further two or three times and then turn OFF.*

- 2 Press any front-panel key except **Shift**.

**Status:** *If the key is operating correctly, the **Fast LED** stays on (steady) until you take your finger off the key*

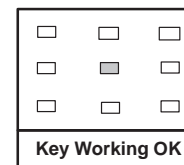
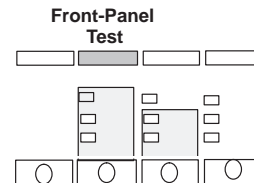

- 3 Repeat step 2 for each key except **Shift**.

- 4 Finally, press the **Shift** key.

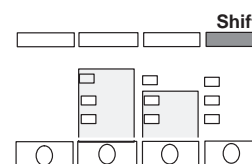

*If this key is working correctly, the **Fast LED** comes on briefly, and then all LEDs begin to flash to indicate that the test has ended.*

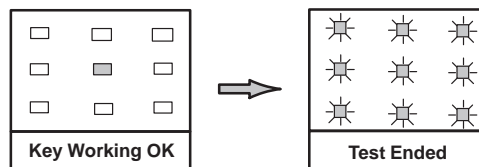



230  
250C

## Input/Output Test for the DesignJet 230/250C Only

The input/output test performs the following:

- Parallel input/output test: Reads the data and status registers of the Bi-Tronics PAL. (Tests only a small portion of the Bi-Tronics input/output functionality.)
- Serial input/output test: Verifies the ability of the RS-232-C interface to send and receive data. This test uses a special loopback connector (part number 07440-60302) to connect the output to the input.

- 1 Connect the loopback connector to the serial port of the plotter.

*If a connector is not available, you can place a jumper between pins 2 and 3 of the serial port for the test.*

- 2 In service mode 2, hold down the **SHIFT** key and press **Input/Output** test.

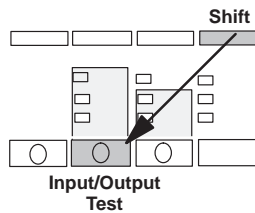

*The **Load Media LED** (or the **Ready LED**, if you have already loaded media) turns off while the plotter performs the input/output test.*

*The shift key does **not** act as a **stop-the-test** key for this test.*

**Status.** *If the test does not find an error, the **Load Media LED** (or the **Ready LED**, if you have already loaded media) turns on again. Otherwise, an error is reported by an error code on the front panel.*

## Media-Axis Test

This tests the operation of the media-axis motor, encoder and gears.

- 1 In service mode **1**, press **Media-Axis Test**.

*The drive roller rotates in steps, each equivalent to one swath advance.*

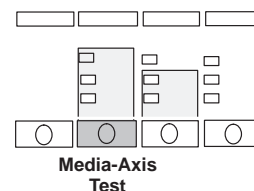

**Status.** The **Film LED** turns on (steady) if the media-axis test has not found an error. If the test fails, the **Film LED** flashes.

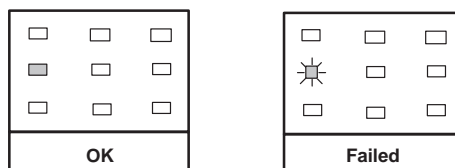



---

### Output to the Serial Port (Viewing Output ▶ 8-36)

---

Maximum PWM: The maximum PWM for each cycle.  
A typical media-axis PWM is 52. The maximum allowed is 65.

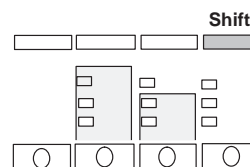
- 2 The test continuously repeats itself until you press the **Shift** key.



## Modular Test

This is a combination of the following tests:

- Carriage-axis test
- Carriage test
- Media-axis test
- Front-panel test
- Sensors test

If one part of the test fails, the other parts continue regardless.

Perform the test as follows:

- 1 Ensure that the carriage is parked in the service station.

*The test does not include carriage-axis initialization. If the carriage starts somewhere in the center of the plotter, it will hit the right-hand side of the plotter when the test begins, and the carriage-axis part of the test will fail.*

- 2 In service mode **1**, hold down the **ALT** key and press **Modular Test**.

*The plotter performs all the above tests in parallel. See details of the individual tests to know what happens in each case.*

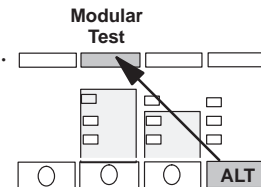

**Status.** After a few seconds, the appropriate LEDs turn on (steady) as each test passes. See the following diagram for LED meanings:

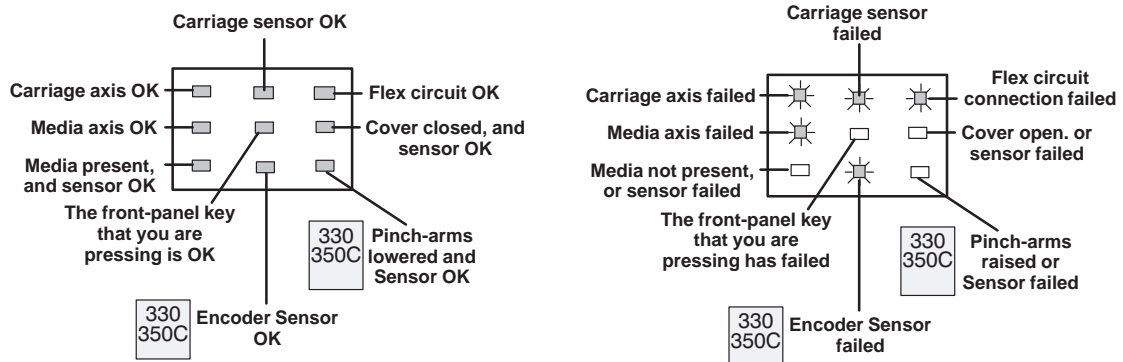



---

### Output to the Serial Port (Viewing Output ▶ 8-36)

---

See Individual tests

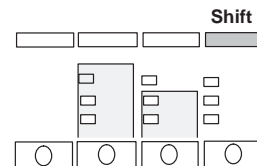
- 3 The test continuously repeats itself until you press the **Shift** key.



## Print-Quality Plot

### Printing the Plot

- 1 Before printing the plot:

230  
250C

In service mode **2**, set the **Media Type** and **Print Quality** on the front panel to the settings that you want to test.

330  
350C

In Normal mode, set the **Media Type** and **Print Quality** on the front panel to the settings that you want to test.

*The print-quality plot can be plotted without the need to enter the service mode. This is because the customer will be requested to plot the print-quality plot and he will be given the following instructions to plot it without entering the service mode.*

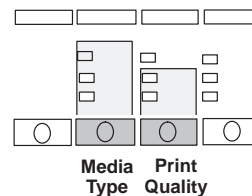

- 2 Load a sheet of media in portrait orientation.

*Use E/A0-size or D/A1-size media if you want to examine vertical-line straightness (VLS) at both ends of the roller. Otherwise, A/A4-size media is sufficient.*

- 3 When the **Ready** LED lights up:

230  
250C

Press **Print-Quality Plot**.



330  
350C

Press the **Print Quality** and **Roll/Sheet** keys together.

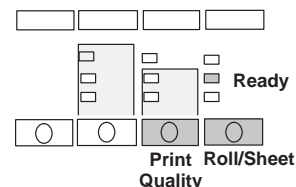

*The **Ready** light begins to flash, and the media moves slightly forward. The carriage moves to the right side of the plotter, and the fan turns on. The plotter plots the print-quality plot and ejects the media.*

- 4 Unload the media.
- 5 At the end of the plot, mark which print-quality setting you used.

For Example:     Fast     Normal     Best

### Interpreting the Plot

See [▶ page 8-56](#), § *Print-Quality Troubleshooting*.

230  
250C

## Sensors Test for the DesignJet 230 and 250C

This tests the operation of the cover sensor and the media sensor.

1 In service mode 1, press **Sensors Test**.

2 Close the cover of the plotter.

*The **Load Media** LED should turn on.*

3 Open the cover.

*The **Load Media** LED should turn off.*

4 Insert media into the right-hand side of the entry platen.

*The **Special Paper** LED should turn on.*

5 Remove the media.

*The **Special Paper** LED should turn off.*

**Status:** *The LED meanings are summarized as follows:*

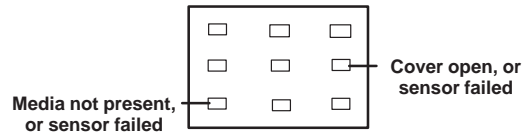
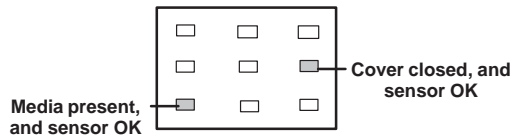

6 Press the **Shift** key when you want to stop the test.

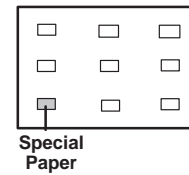
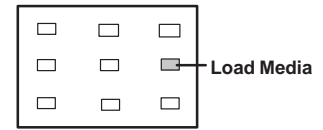
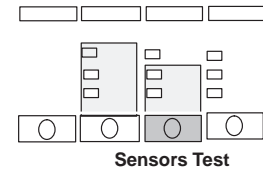
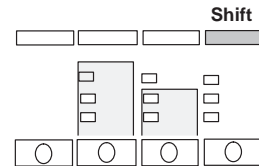

330  
350C

## Sensors Test for the DesignJet 330 and 350C

This tests the operation of the cover sensor and the media sensor.

- 1 In service mode **1**, press **Sensors Test**.  
*The **Roll** LED should turn on.*
- 2 Lower the pinch-arms (raise the green media lever)  
*The **Roll** LED should turn off.*
- 3 Raise the pinch-arms (lower the green media lever)  
*The **Ready** LED should turn on.*
- 4 Close the cover of the plotter.  
*The **Ready** LED should turn off.*
- 5 Open the cover.  
*The **Ready** LED should turn off.*
- 6 Insert media into the right-hand side of the entry platen.  
*The **Coated** LED should turn on.*
- 7 Remove the media.  
*The **Coated** LED should turn off.*

**Status:** The LED meanings are summarized as follows:

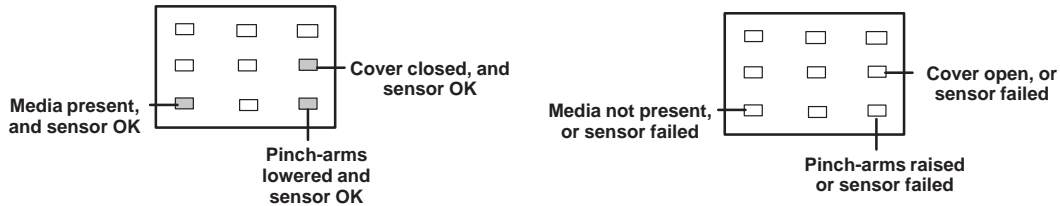

- 8 Press the **Shift** key when you want to stop the test.

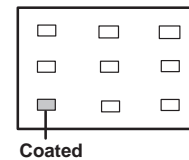
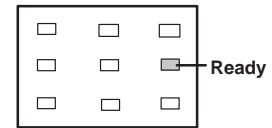
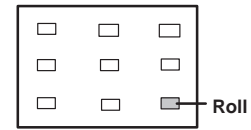
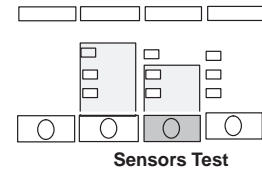
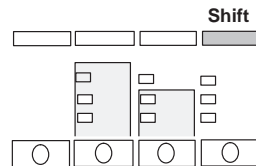

## Service Configuration Plot for the DesignJet 230 and 250C

The service configuration plot contains the following information:

### DesignJet 230/250C Service Configuration Plot

Firmware Release: X.XX.XX

SPROC release: X.X (*Servo-Processor Code revision number.*)

#### EEROM Contents

#### EEROM CONTENTS

*(This is for the plotter design engineers to interpret.)*

NOTE: All EEPROM Parameters are since last EEROM Reset.

Number of Power Cycles: *(Number of times plotter has been switched on.)*

Number of Color Plots:

Number of Black Plots:

Number of Pens: *(Number of times each cartridge has been replaced. Cyan, Magenta, Yellow, Black.)*

Factory Spittoon: *(The estimated level of ink in the spittoon. Incorrect if you have cleared the EEROM.)*

Number of Bail Errors:

Number of System Errors:

Last System Error: *(To correctly interpret this information, refer to page 8-19.)*

Last System Error Data: *(To correctly interpret this information, refer to page 8-19.)*

Bench Run: *(Whether the bench run has been performed.)*

Bench Run Maximum Y-Axis (Carriage-Axis) PWM: *(This should be less than 102. Typical value = 75.)*

Bench Run Maximum X-Axis (Media-Axis) PWM: *(This should be less than 65. Typical value = 52.)*

Encoder-Tests Maximum Y-Axis (Carriage-Axis) PWM: *(This should be less than 102. Typical value = 75.)*

Encoder-Tests Maximum X-Axis (Media-Axis) PWM: *(This should be less than 65. Typical value = 52.)*

Last Accuracy Calibration:

Factory Calibration Factor:

*(This is the drive-roller correction factor, calculated during accuracy calibration. It should be approximately 1.*

*Less than 0.9 means the drive-roller radius is too small. Greater than 1.1 means the drive-roller radius is too big.)*

#### FRONT-PANEL KEYS IN SERVICE MODE 2

## Service Configuration Plot for the DesignJet 330 and 350C

The service configuration plot contains the following information:

### DesignJet 330/350C Service Configuration Plot

Firmware Release: X.XX.XX

SPROC release: X.X (*Servo-Processor Code revision number.*)

#### EEROM Contents

#### EEROM CONTENTS

*(This is for the plotter design engineers to interpret.)*

NOTE: All EEPROM Parameters are since last EEROM Reset.

Number of Power Cycles: *(Number of times plotter has been switched on.)*

Number of Color Plots:

Number of Black Plots:

Number of Pens: *(Number of times each cartridge has been replaced. Cyan, Magenta, Yellow, Black.)*

Factory Spittoon: *(The estimated level of ink in the spittoon. Incorrect if you have cleared the EEROM.)*

Number of Bail Errors:

Number of System Errors:

Last System Error: *(To correctly interpret this information, refer to page 8-23.)*

Last System Error Data: *(To correctly interpret this information, refer to page 8-23.)*

Bench Run: *(Whether the bench run has been performed.)*

Bench Run Maximum Y-Axis (Carriage-Axis) PWM: *(This should be less than 102. Typical value = 75.)*

Bench Run Maximum X-Axis (Media-Axis) PWM: *(This should be less than 65. Typical value = 52.)*

Encoder-Tests Maximum Y-Axis (Carriage-Axis) PWM: *(This should be less than 102. Typical value = 75.)*

Encoder-Tests Maximum X-Axis (Media-Axis) PWM: *(This should be less than 65. Typical value = 52.)*

X-axis Calibration:



## Printing the Service Configuration Plot

### 1 To print the service configuration plot:

230  
250C

In service mode **2**, load a sheet in portrait orientation.

330  
350C

In normal mode, load a sheet in portrait orientation.

*The service configuration plot can be plotted without the need to enter the service mode. This is because the customer will be requested to plot the service configuration plot and he will be given the following instructions to plot it without entering the service mode.*

### 2 When the **Ready** LED lights up:

230  
250C

Hold down the **SHIFT** key and press **Service Configuration**.

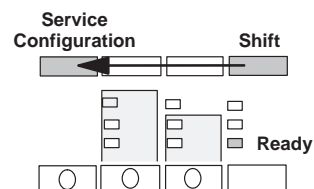

330  
350C

Press the **Cancel** and **Media Type** keys together.

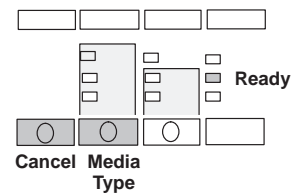

*The **Ready** light begins to flash and then remains on (steady).  
The plotter plots the service configuration plot and ejects the media.*

### 3 Unload the media.

## Service Monitor (Data Display)

The service monitor is useful to find out why the plotter is not plotting what you expect it to plot. It enables you to read the graphics-language instructions that the plotter is receiving from the computer. Instead of plotting the drawing that you send, the plotter prints the beginning and end of the code that would otherwise have been used to plot the drawing.

You need a basic knowledge of the graphics-language instructions to be able to pick out the important information from the printed code. (Basic training is included in the course referenced on page ii.)

- 1 In service mode **2**, load a sheet of media (A3 size or B size minimum) in portrait orientation.
- 2 To enter service monitor:

230  
250C

Hold down the **ALT** key and press **Service Monitor**

*(The front-panel LEDs do not change.)*

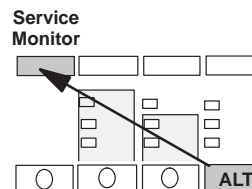

330  
350C

Press **Service Monitor**

*(The front-panel LEDs do not change.)*

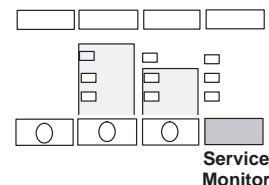

- 3 Send the file from the computer through the serial or parallel ports.  
*The **Ready LED** begins to flash.*
- 4 Wait until the computer has indicated that it has sent the file.  
*The **Ready LED** continues to flash.*
- 5 While the **Ready LED** is flashing, hold down the **ALT** key and press **Service Monitor** again.  
*The **Ready LED** continues to flash. After a minute, the fan turns on, and the carriage moves to the right side of the plotter.*

*Instead of plotting the drawings that you sent, the plotter plots the first and last Kbytes of the code for those drawings. The code is printed in hexadecimal and ASCII format. (If the total size of the file(s) sent is not bigger than one Kbyte, only the first buffer is printed.) The plotter exits the service monitor mode if the file(s) sent contain PJI universal exit language.*

230  
250C

## Servo/Encoder Test

The servo/encoder test performs the following:

- Media-axis encoder test: Verifies the operation of the servo loop (media-axis feedback).
- Carriage-axis encoder test: Verifies the operation of the servo loop (carriage-axis feedback).
- Records the maximum pulse-width modulations used. You can view this information on the service configuration plot.

### 1 In service mode 2:

230  
250C

Hold down the **ALT** key and press **Servo/Encoder Test**.

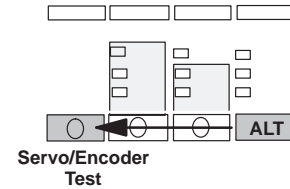

330  
350C

Press **Servo/Encoder Test**.

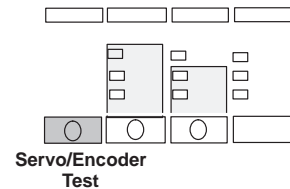

*The **Load Media LED** (or the **Ready LED**, if you have already loaded media) turns off, and the carriage moves over the left end of the roller. The roller rotates slightly.*

*The carriage moves to the center of the plotter. Both the carriage and the roller then move backwards and forwards in cycles of six short steps, changing direction between cycles.*

### 2 Press any front-panel key to stop the test.

**Status.** *If the test does not find an error, the **Load Media LED** (or the **Ready LED**, if you have already loaded media) turns on again. If the test finds an error, it is indicated by an error code on the front panel.*

---

#### Stored in EEROM (and printed on the service configuration plot ♦ page NO TAG)

---

Encoder Tests, Maximum Y-Axis PWM	(Y-Axis = Carriage Axis.) This should be less than 102. Typical value = 75.
Encoder Tests, Maximum X-Axis PWM	(X-Axis = Media Axis.) This should be less than 65. Typical value = 52.

## Clearing the EEROM for the DesignJet 230 and 250C

### CAUTION

If you clear the calibration parameters, you will then need to perform the plotter calibrations. (Details ▶ chapter 7.) Clearing the EEROM also resets the factory spittoon value to 0% used. Keep in mind that the value printed on the service configuration plot may greatly underestimate the amount of ink in the spittoon.

### Clearing Just the Benchrun and Calibration Parameters

- 1 Switch the plotter off.
- 2 While holding both the **Read Settings** and **Media Type** keys down, switch the plotter on.
- 3 Once the the LEDs begin to light up one by one, release the **Read Settings** and **Media Type** keys.

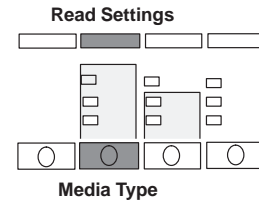

### Clearing Just the User-Defined Setup Parameters

- 1 Switch the plotter off.
- 2 While holding both the **Align Cartridges** and **Print Quality** keys down, switch the plotter on.
- 3 Once the the LEDs begin to light up one by one, release the **Align Cartridges** and **Print Quality** keys.

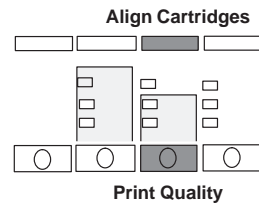

### Clearing All Parameters

- 1 Switch the plotter off.
- 2 While holding both the **Cancel** and **Replot** keys down, switch the plotter on.
- 3 Once the the LEDs begin to light up one by one, release the **Cancel** and **Replot** keys.

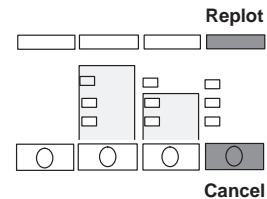

330  
350C

## Clearing the EEROM for the DesignJet 330 and 350C

### CAUTION

If you clear the calibration parameters, you will then need to perform the plotter calibrations. (Details ▶ chapter 7.) Clearing the EEROM also resets the factory spittoon value to 0% used. Keep in mind that the value printed on the service configuration plot may greatly underestimate the amount of ink in the spittoon.

### Clearing Just the Benchrun and Calibration Parameters

- 1 Switch the plotter off.
- 2 While holding both the **Replot** and **Media Type** keys down, switch the plotter on.
- 3 Once the the LEDs begin to light up one by one, release the **Replot** and **Media Type** keys.

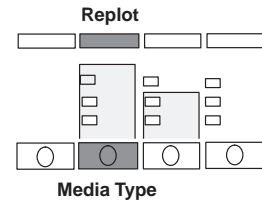

### Clearing Just the User-Defined Setup Parameters

- 1 Switch the plotter off.
- 2 While holding both the **Form Feed** and **Print Quality** keys down, switch the plotter on.
- 3 Once the the LEDs begin to light up one by one, release the **Form Feed** and **Print Quality** keys.

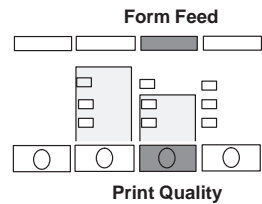

### Clearing All Parameters

- 1 Switch the plotter off.
- 2 While holding both the **Roll/Sheet** and **Continue Plotting** keys down, switch the plotter on.
- 3 Once the the LEDs begin to light up one by one, release the **Roll/Sheet** and **Continue Plotting** keys.

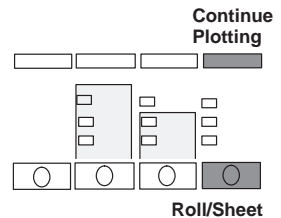

# Print-Quality Troubleshooting

## Print-Quality Plot

The print-quality plot for the HP DesignJet 250C/350C is represented below. (Printing it ▶ page 8-46.) The plot for the HP DesignJet 230/330 is similar, but only the patterns relevant to the black cartridge are printed. Use a 10X magnifier to help identify plot-quality problems.

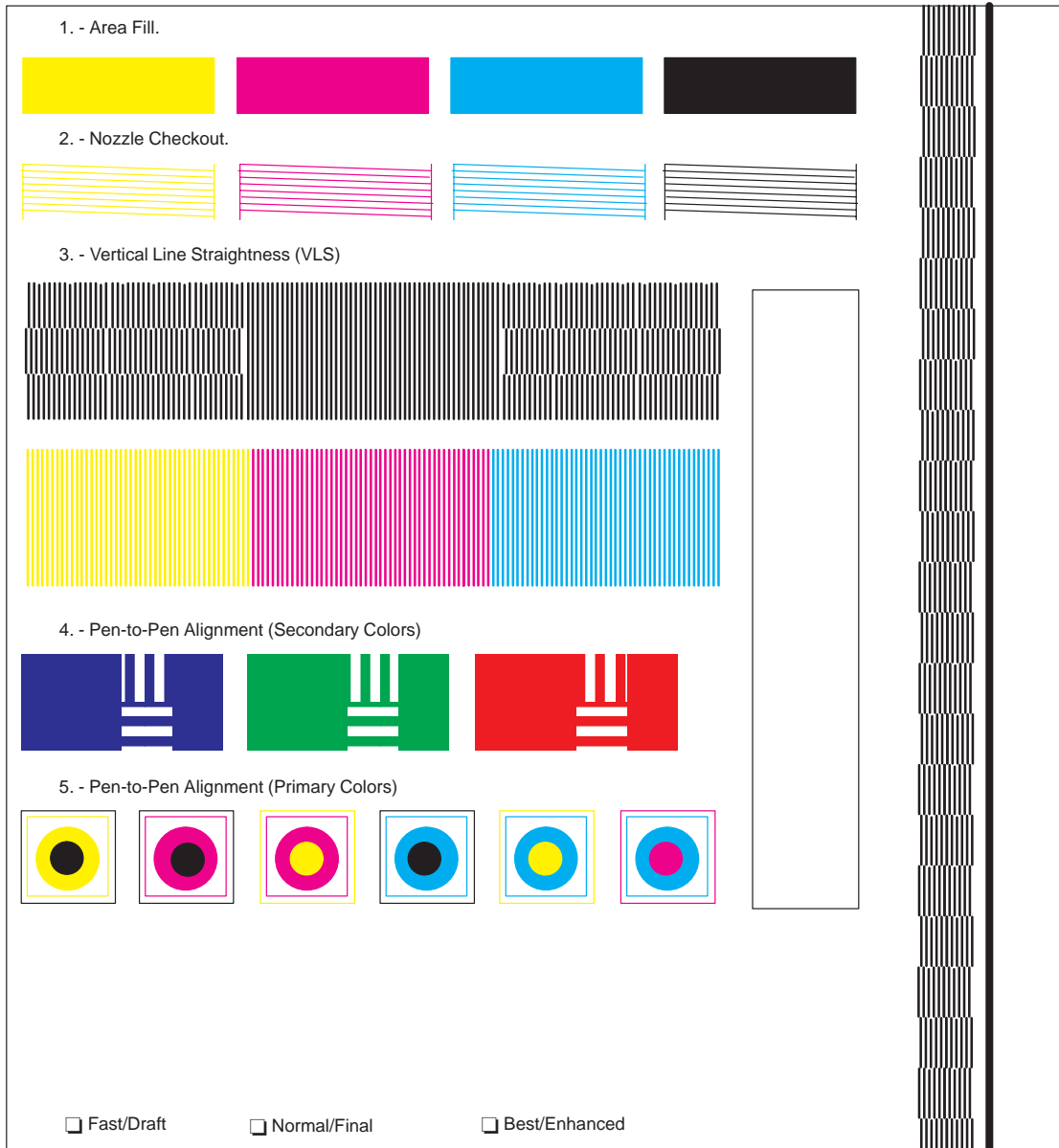

## Banding

### Symptoms

Random dark or light bands in area fills. (Print-Quality Plot ▶ page 8-56, 1. - **Area Fills**, and the offset-swath lines on the right of the plot.) (See also ▶ User's Guide, chapter 4.)

### Cartridge Fault

- A nozzle is blocked or faulty and is not firing ink-drops. (P-Q Plot ▶ 2. - **Nozzle Checkout**.)
- The ink drops of one nozzle are of smaller volume than those of the other nozzles.
- A nozzle's ink drop volume varies while plotting.
- A nozzle's ink drops are misdirected:
  - Defect in manufacture of cartridge
  - Dirt or debris on the nozzle plate
  - Ink puddling on the nozzle plate
- An electrical contact is misaligned or damaged on the cartridge, so that it doesn't make correct contact with the circuit on the carriage. (See ▶ page 8-39, § *Carriage Test*.)

### Plotter Fault

- Incorrect swath-advance angle of the drive roller. This could be caused by a
  - Faulty roller (irregular roller radius / defective bearings)
  - Media-axis inaccuracy (defective media motor or driver circuit / calibration lost)
- An electrical contact is faulty in one of the plotter cartridge chutes, so that it doesn't make correct contact with the circuit on the cartridge. (See ▶ page 8-39, § *Carriage Test*.)
- Nozzles touch the service station, thus causing puddling to occur on the print-head.
- Some of the small slots on the encoder strip are damaged. Therefore the plotter cannot position the carriage correctly during cartridge servicing.
- Cartridges are misaligned with respect to each other.
- Calibration values lost or incorrect.

### Media Fault

Some types of media have a coating that prevents them getting "wet" from the ink drop. The ink doesn't spread out sufficiently around the point where the dot is placed.

Banding may not occur on some poor-quality media, where it is counteracted by another problem: large dot gain. This is where the ink spreads out excessively on the media around the desired dot position. To accurately test for banding, use HP polyester inkjet film.

### Solutions

One or more of the following actions may be appropriate to solve a banding problem:

- Prime/clean cartridges.
- Reseat/replace cartridges.
- Perform cartridge alignment.
- Perform accuracy calibration
- Reseat cartridge caps in service station.
- Replace encoder strip.

## Uneven Fill Density

### Symptoms

Blotchy area fills. (Print-Quality Plot ▶ page 8-56 1. - **Area Fills**.) (See also ▶ User's Guide, chapter 4.)

### Product Fault

- An incorrect media-type setting has been selected on the front panel and does not correspond to the media being used.

### Media Fault

The ink is incompatible with the media and does not spread uniformly through the area fill.

### Solutions

One or both of the following actions may be appropriate to solve an uneven-fill-density problem:

- Change the media-type setting on the front panel.
- Use a more suitable media type.
- If the problem is occurring in black area fills on color plots printed in **Normal** print-quality mode, then use **Best** print-quality mode instead.

230  
250C

## Lightfastness

Drawings plotted with the color cartridges 51650C, 51650M, and 51650Y fade when exposed to light. Colors become less vivid and less bright, and change over time:

- Under direct sunlight: After between 3 and 10 hours.
- Under office light: After about 20 days.
- Laminated and under office light: After about 24 days.

The use of some non-HP media types improves the lightfastness.

Strict lightfastness is NOT necessary for the large majority of HP DesignJet 250C customers, but it will become important in the future for the large-format printing (LFP) market. HP is working on the development of a new set of inks.

## Spray

### Symptoms

Smaller dots of sprayed ink located around the point at which the required dot is placed.

### Product Fault

The cartridges are positioned too far from the media.

### Solution

Adjust the nozzle-to-media distance. (Details ▶ chapter 7.)



## Vertical-Line Straightness (VLS)

### Symptoms

Vertical-line straightness is a measure of the horizontal distance between the segments of a vertical line plotted in two consecutive swaths. If the plotter is working correctly, this distance should be less than 2 mils. (Print-Quality Plot [▶](#) page 8-56 **3. - VLS.**) (See also [▶](#) User's Guide, chapter 4.)

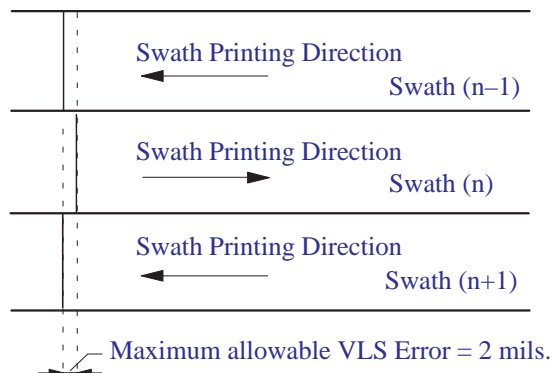

Depending on the causes of the error, lines that are supposed to be vertical may appear as shown below:

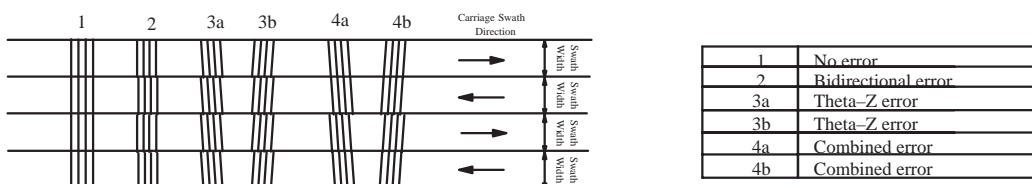

### Customer Expectations

Although the VLS specification satisfies the expectations of most customers, some may complain even when the plotter is working within this specification. If the VLS error is already less than 2 mils, do not try to improve it.

### Bidirectional Error

Error numbered 2 above is called a bidirectional error. If you print the same plot using a unidirectional print mode, the error should not appear. (Print modes [▶](#) chapter 5.)

This error can occur for various reasons, including:

- Incorrect distance between nozzles and media. (Adjustment [▶](#) chapter 7.)
- Encoder-strip slots are damaged or dirty.
- Dirt on the pulley is causing the belt to slip.
- Friction between carriage bushings and slider rod:

230  
250C

(See [▶](#) Error code **Steady 346.**)

330  
350C

(See [▶](#) Error code **Steady 234.**)

## **Theta-Z Error**

Errors numbered 3a and 3b are called Theta-Z errors. They appear when the rows of nozzles on a cartridge are not perpendicular to the carriage axis (Y-axis).

This error can occur for various reasons, including:

- Badly seated cartridge.
- Faulty cartridge.
- Faulty carriage.

## **Ink Smearing**

### **Symptoms**

Ink smears on the media. (See also [User's Guide, chapter 4.](#))

### **Product Fault**

The media touches the print heads. This can occur because:

- The media-holding mechanism is not holding the media correctly, and the media buckles.
- The carriage-to-roller distance is too small. (Adjustment [chapter 7.](#))

## **Hue Changes**

### **Symptoms**

Changes of hue are noticed when printing in color.

### **Cartridge Fault**

One or more of the print cartridges is running out of ink. (Typically the inks of the four cartridges are used at different rates.)

### **Solution**

Replace the print cartridge with a new one.

## **Starwheel Marks**

On some drawings (for example, CAD drawings having a thick-lined frame around them) on some types of media, you may notice some small marks made by the starwheels. These cannot be avoided.

## Misaligned Colors

### Symptoms

The colors on the plot are misaligned. (See also [User's Guide, chapter 4.](#))  
Refer to the print-quality plot [page 8-56](#):

**4. - Pen-to-Pen Alignment Secondary:** The first of these patterns tests alignment between the cyan and magenta cartridges; it should be blue with no cyan or magenta shadows. The second tests alignment between the cyan and yellow cartridges; it should be green with no cyan or yellow shadows. The third tests alignment between the magenta and yellow cartridges; it should be red, with no magenta or yellow shadows.

**5. - Pen-to-Pen Alignment Primary:** These patterns also test alignment between the different cartridges. The inner color in each disk should not overlap the outer color.

### Product Fault

The cartridges are misaligned with respect to each other.

### Solution

Perform a print cartridge alignment.

## Bleeding, Blooming and Wicking

### Symptoms

Blurred lines. (See also [User's Guide, chapter 4.](#))

- **Bleeding:** Different color inks, printed side by side, run into each other.
- **Blooming:** Ink absorbs into the paper, spreading beyond the desired ink dot.
- **Wicking:** Ink spreads along a fiber or fibers in the paper, creating a “spider web” effect.

### Product Fault

Plotting in fast mode.

### Media Fault

- The ink is incompatible with the media type.
- Environmental conditions may affect the media. (Temperature or humidity levels are too high.)

### Solutions

One or more of the following actions may be appropriate to solve the problem:

- Change the plot-quality mode: Plotting in **Best** mode slows plotting but improves quality.
- Use better quality media.
- If you are plotting on vellum or translucent media, try using Hewlett-Packard media.
- Recommended environmental conditions for optimum plot quality are in the range of 15 – 35 degrees Celsius (59 – 95 degrees Fahrenheit) with 20 – 80 % relative humidity.
- Pen problem: TTOE (Thermal Turn-On Energy) has not been performed because of incorrect cartridge change. With the power ON, open the top cover and reseal the cartridge.

330  
350C

## Notes

---

Product History and  
Service Notes

---

## Introduction

This chapter describes the differences between earlier versions of the plotters and the latest version documented in this manual.

---

## Serial-Number Format

The plotter serial number is composed of 10 letters and digits, for example ESA5600248.

- In the first two positions is the code for the country of manufacture of the plotter. In the example above, this is ES, which is the code for Spain.
- In the third position is the revision letter of the plotter. The letter A identifies the original version of the plotter. The next revision would have the letter B and so on.
- In the fourth position is the last digit of the year of manufacture. This is 5 for plotters made in 1995, as in the example above.
- In the fifth position is the month of the year. (October is represented by the letter A, November by B, and December by C.) In the example above, the digit is 6, that is, June.
- The remaining five digits distinguish the plotter from others manufactured in the same country in the same month. In the example above, these are 00248.

---

## Firmware Revision Level

The plotter firmware is contained either on a flash ROM SIMM at the back of the plotter or on a masked ROM inside the electronics module. The firmware-revision level, for example A.01.03, is printed by the plotter on the setup sheet and on the service configuration plot. The revision level is also printed on a label on any flash ROM SIMM. Do not open the electronics module.

**Important:** When replacing the electronics module, always remember to check the firmware revision level of the **new** electronics module. The revision level will be printed on the top surface of the module. Also, check the firmware revision level of the ROM SIMM installed in the **old** electronics module. With this information you must do the following:

1. If the firmware revision level of the ROM SIMM in the old electronics module is **lower** than the firmware revision level of the new electronics module, then you **must not** install the ROM SIMM into the module.
2. If the firmware revision level of the ROM SIMM in the old electronics module is **higher** than the firmware revision level of the new electronics module, then you **must** install the ROM SIMM into the module.

Example 1: The ROM SIMM firmware revision level is A.01.03 and the firmware revision level of the electronics module is A.01.04. You would use the electronics module **without** the ROM SIMM installed.

Example 2: The ROM SIMM firmware revision level is A.01.05 and the firmware revision level of the electronics module is A.01.04. You would use the electronics module **with** the ROM SIMM installed.

---

## Obtaining Service Notes with Graphics

You can access a WCSO (Worldwide Customer Support Operation) server from a PC or UNIX workstation to obtain service notes with graphics.

### From a PC

- 1 Go to the MS-DOS screen.
- 2 Type what is marked in bold letters below, pressing `Enter` at the end of each line:

```
C:\> addname wcsolmx 15.24.176.18
C:\> NET USE j: \\wsolmx\snotes
C:\> j:
J:\> dir
J:\> cd cso_cpo
J:\cso_cpo> dir
```

- 3 See the `readme.txt` file for more information.
- 4 When you have downloaded the files you need, please disconnect from the server, since there are only a limited number of connections available:

```
J:\> c:
C:\> NET USE j: /d
```

### From a UNIX Workstation

- 1 Go to the system prompt.
- 2 Type what is marked in bold letters below, pressing `Enter` at the end of each line:

```
ftp 15.24.176.18
Name (...): snotes
Password: (Just press Enter)
ftp> ls
ftp> cd cso_cpo
ftp> ls
```

- 3 See the `readme.txt` file for more information.
- 4 When you have downloaded the files you need, please disconnect from the server, since there are only a limited number of connections available:

```
ftp> bye
```



## Problem Reading the Setup Sheet

Several HP DesignJet 230 and 250C plotters have failed with the following defect:

- 1 The media is loaded without any problems.
- 2 Any plot you want can be printed, but there is a print quality defect in the first two swaths. The first and second swaths are overprinted (there is no paper advance). If you print the Setup Sheet, the arrow printed in the first two swaths appears as follows:

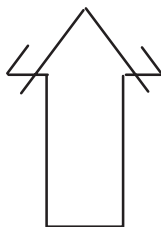

- 3 In order to read the settings (Setup Sheet, Black Cartridge Alignment Sheet or Color Cartridge Test Sheet) the paper is loaded again.
- 4 Once the paper is loaded, the Read Settings button is pressed. Then the carriage goes over the paper and tries to read the left-top corner in order to determine which sheet has been loaded.
- 5 The plotter fails to read the settings and rejects the paper with Error and Load Media LEDs flashing.

### Problem

The problem is caused by the two screws that hold the Helical Gear (Drive Roller Gear) to the Drive Roller. The screws aren't tight enough.

### Solution

Remove the Spittoon (Instructions ♦ page 6-23) and gently tighten the two screws.

**Notes**

---

Parts and Diagrams

---

## Exchange Assemblies

Exchange assemblies are factory-repaired and tested assemblies that you can order; they are listed in the following table. Exchange assemblies are available only on a trade-in basis; therefore, you must return the defective assemblies for credit.

Exchange Assemblies			
	HP Part Number	Qty	Description
<b>230</b> <b>250C</b>	C3190-60139	1	Electronics Module
<b>330</b> <b>350C</b>	C4699-60039	1	Electronics Module

---

## Replacement Parts

Parts shown in the drawings in this chapter are listed in the corresponding part lists. Match the appropriate number on the drawing with the same number in the parts list for information on that part. The total quantity for each part on the drawing is given as well as the part number.

To obtain replacement parts, contact the nearest HP Support Office. You must include the part number and part description in the order you send. Also include the plotter model and serial number.

Legs

---

Reference on Drawing	HP Part Number	Quantity	Description
1	C3192-60003	2	Foot assembly
2	C3192-60001	1	X Brace Assembly (D/A1-size)
	C3193-60001	1	X Brace Assembly (E/A0-size)
3	C3192-60002	2	Legs Assembly
4	C3193-60003	1	Paper Diverter Assembly (E/A0-size plotters only)
5	C3192-00009	14	Screw

---

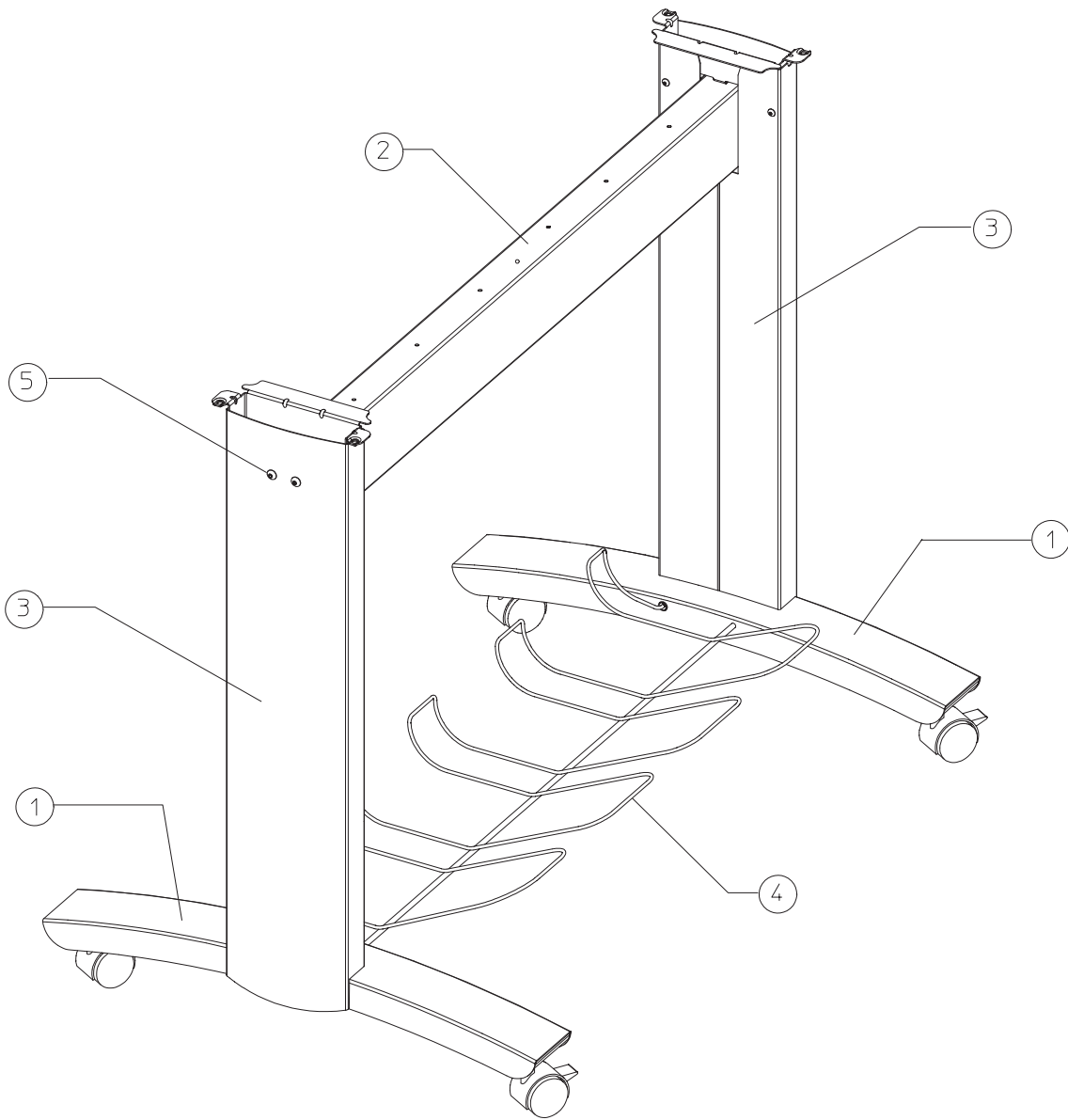

Legs

Top and Back Covers, Electronics, Trailing Cable

Reference on Drawing	HP Part Number		Quantity	Description
	DesignJet 330/350C	DesignJet 230/250C		
1	C4699-40003	C4699-40003	1	Top Cover (D/A1-size)
	C4700-40003	C4700-40003	1	Top Cover (E/A0-size)
2	C3190-60082	C3190-60082	1	Back Cover Assy (D/A1-size)
	C3191-60082	C3191-60082	1	Back Cover Assy (E/A0-size)
3	C3190-20006	C3190-20006	1	Trailing-Cable Guide (D/A1-size)
	C3191-20006	C3191-20006	1	Trailing-Cable Guide (E/A0-size)
4	C1676-00055	C1676-00055	1	Trailing-Cable metal Clip
5	C3190-40024	—	1	Carriage Top
	—	C3190-40024	1	Carriage Top (DesignJet 250C)
	—	C4694-40002	1	Carriage Top (DesignJet 230)
6	C3178-00030	C3178-00030	1	Carriage Label (DesignJet 350C/250C)
6	C4701-00009	—	1	Carriage Label (DesignJet 330)
7	See page 10-2	See page 10-2	1	Electronics Module
8	C3190-60038	C3190-60038	1	Trailing Cable Assy (D/A1-size)
	C3191-60038	C3191-60038	1	Trailing Cable Assy (E/A0-size)
9	C3190-40041	C3190-40041	3	Top-Cover Hinge
10	0515-2282	0515-2282	7	Screw M4 x 10 Tap T20
11	1400-1021	1400-1021	3	Trailing-Cable Plastic Clip
12	C3190-00009	C3190-00009	1	Cover Plate
13	See page 10-28	See page 10-28		DRAM SIMM (Optional)
14	C3178-60002	—		ROM SIMM (DesignJet 350C)
	C4699-60104	—		ROM SIMM (DesignJet 330)
	—	C3190-60152		ROM SIMM
15	0515-2246	0515-2246		Screw M4 Torx



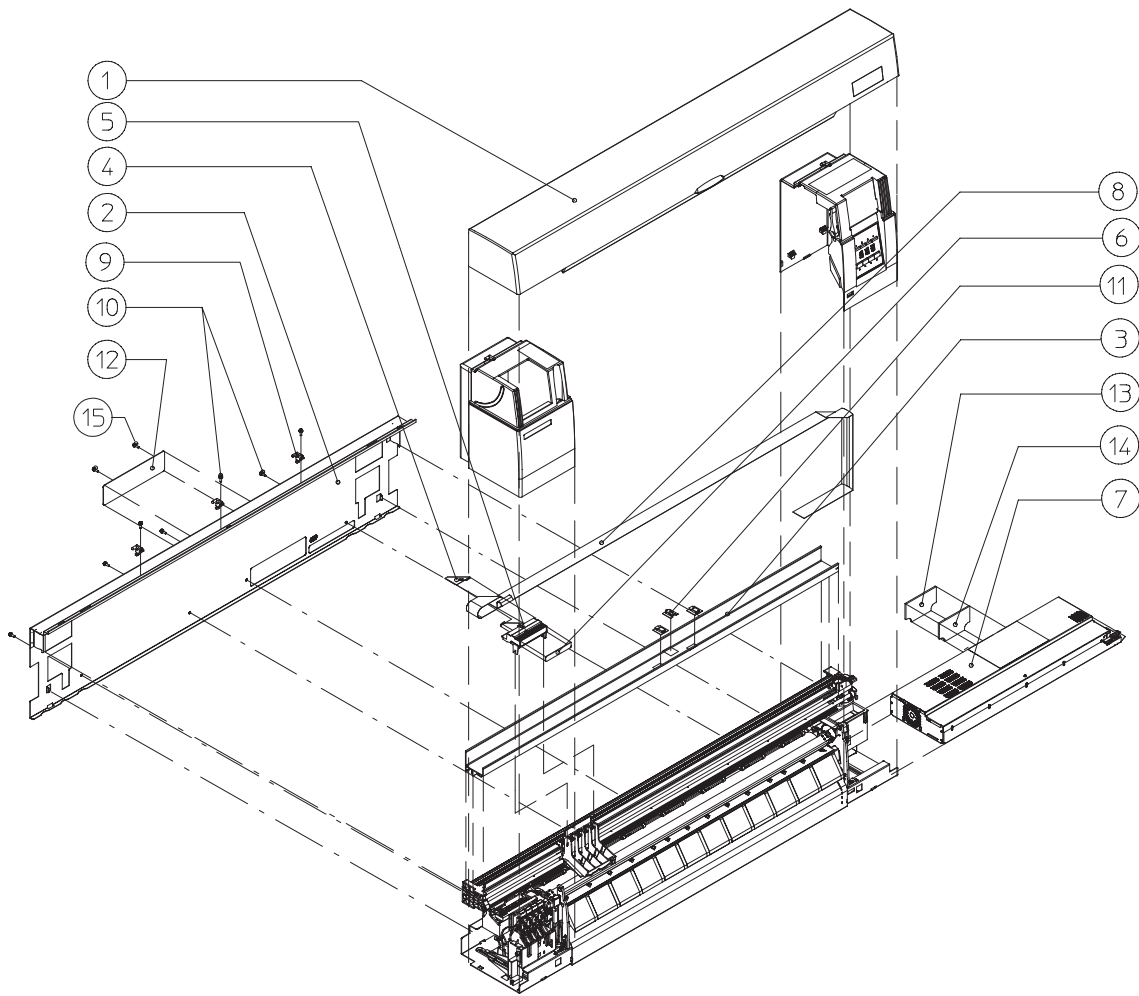

Top and Back Covers, Electronics, Trailing Cable

End Covers

Reference on Drawing	HP Part Number		Quantity	Description
	DesignJet 330/350C	DesignJet 230/250C		
1	C4699-40004	C4699-40004	1	Left End-Cover
2	C4699-00008	–	1	Nameplate (DesignJet 350C)
	C4701-00008	–	1	Nameplate (DesignJet 330)
	–	C3190-00022	1	Nameplate (DesignJet 250C)
	–	C4694-00001	1	Nameplate (DesignJet 230)
3	C4699-00007	C4699-00007	1	Instruction Label
4	C4699-40005	C3190-40016	1	Right End-Cover
5	C3190-40029	C3190-40029	1	Pinch-Arm Lever
6	C3190-40045	C3190-40045	1	Switch Button
7	C3190-60144	C3190-60144	1	Front Panel Assy
8	C4699-00009	C3190-00033	1	Media Label
9	5961-3524	5961-3508	1	Serial Label
10	0515-1349	0515-1349	1	Screw M3 x 30 Mach T10
11	0535-0031	0535-0031	1	Nut HGX M3 x 2.4
12	See page 10-27	See page 10-27	1	Front-Panel Overlay
13	C4701-40001	–	1	Cartridge Cover (DesignJet 330)
14	C3178-00030	C3178-00030	1	Carriage Label (DesignJet 350C/250C)
	C4701-00009	–	1	Carriage Label (DesignJet 330)
15	C3190-40052	C3190-40052	1	QRG Holder

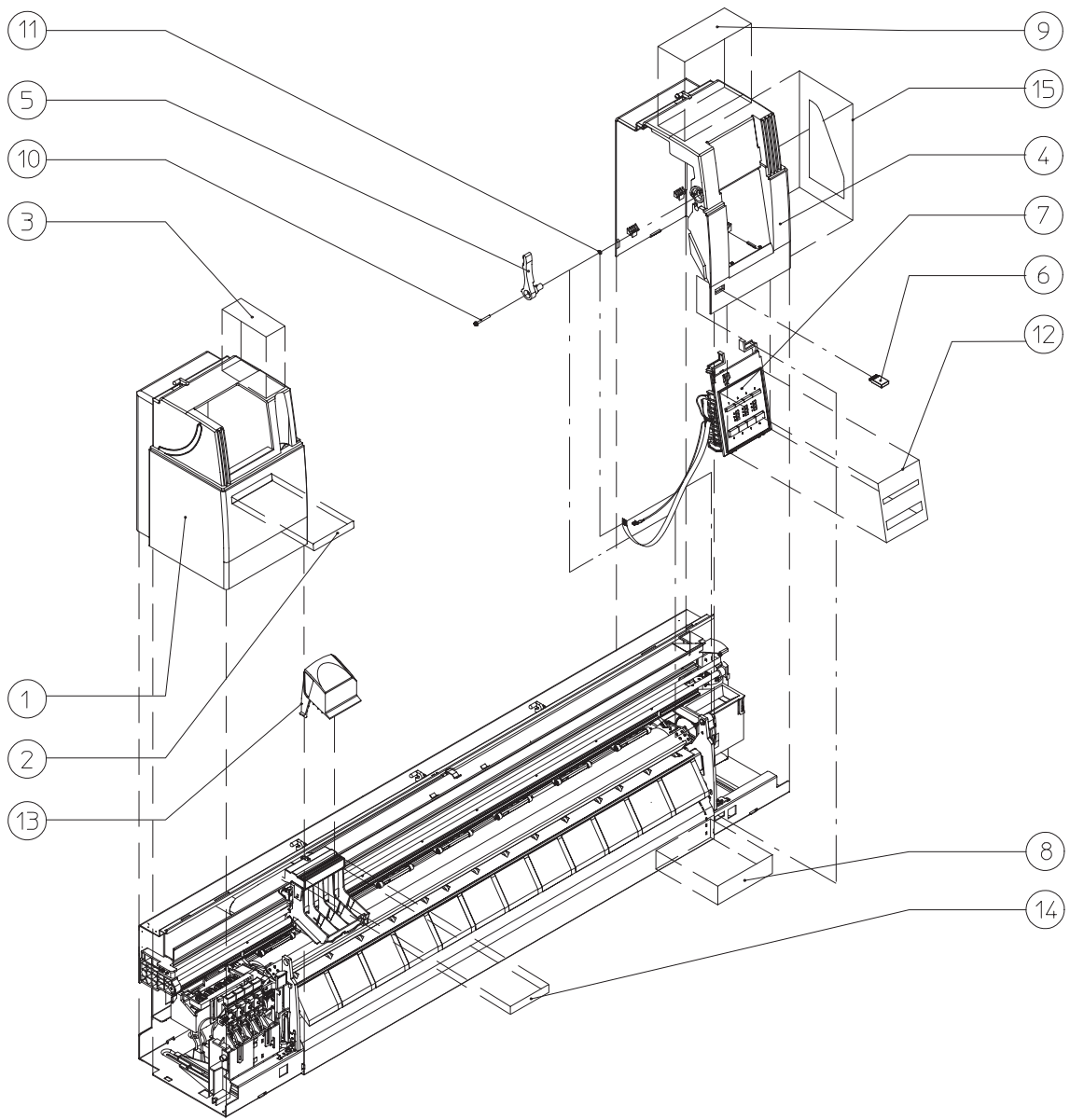

End Covers

Carriage-Axis (Left End)

Reference on Drawing	HP Part Number		Quantity	Description
	DesignJet 330/350C	DesignJet 230/250C		
1	C3190-40040	C3190-40040	1	Left Bracket
2	C3190-00012	C3190-00012	1	Left Strap
3	0515-2765	0515-2765	1	Screw M4.2 x 35 Pan Torx Stl
4	C3190-60106	C3190-60106	1	Encoder Strip (D/A1-size)
	C3191-60106	C3191-60106	1	Encoder Strip (E/A0-size)
5	0624-0704	0624-0704	1	Screw 6-19 .375 Plas T15
6	3050-1267	3050-1267	1	Washer
7	C3190-40048	C3190-40048	1	Carriage Belt (D/A1-size)
	C3191-40048	C3191-40048	1	Carriage Belt (E/A0-size)
8	C4699-60036	—	1	Carriage assembly
	—	C3190-60143	1	Carriage assembly (250C)
	—	C4694-60050	1	Carriage assembly (230)
9	C3190-60132	C3190-60132	1	Pulley Assembly (Incl. pulley, shaft and spacer)

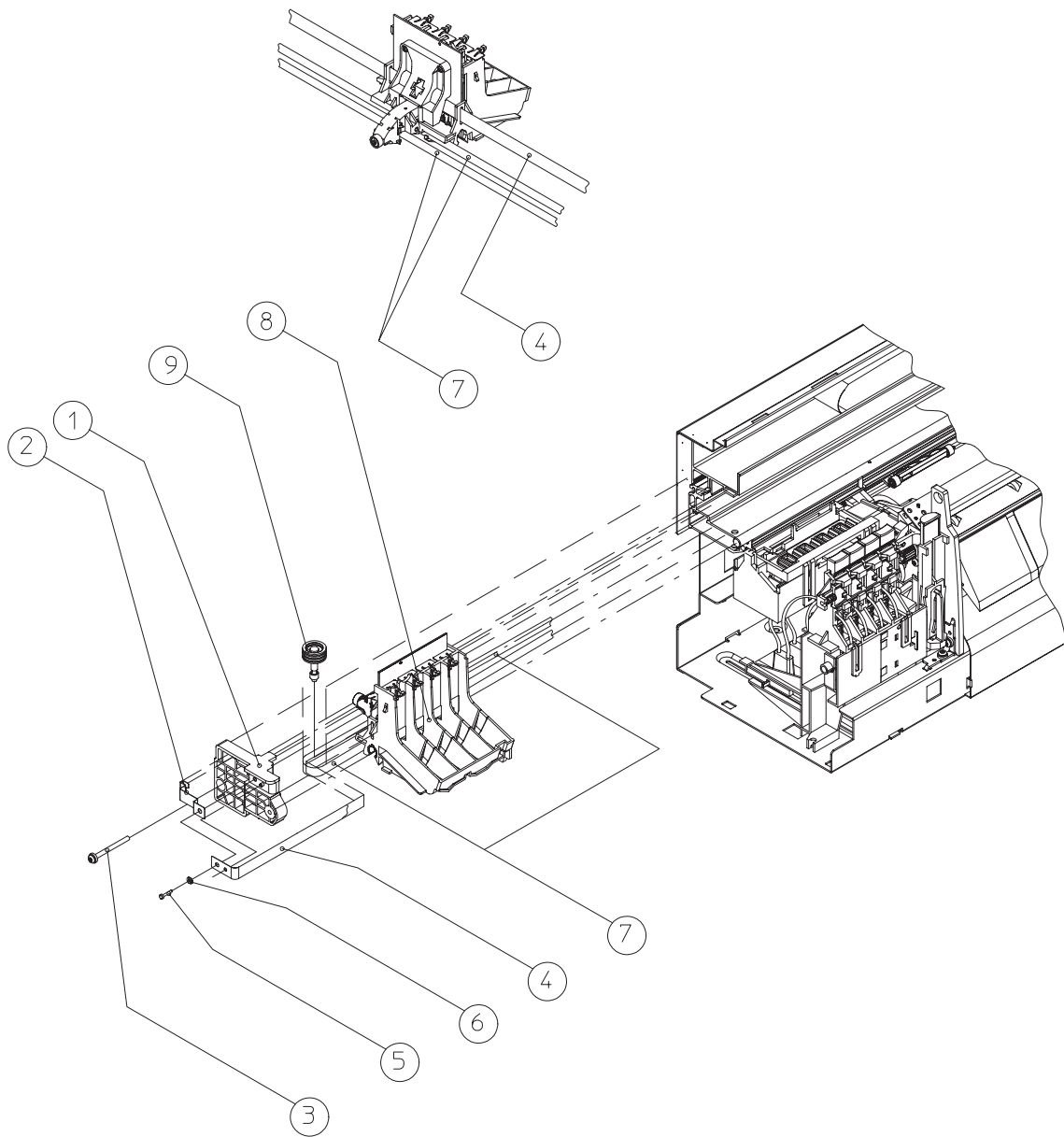

Carriage-Axis (Left End)

Carriage-Axis (Right End)

Reference on Drawing	HP Part Number	Quantity	Description
1	C3190-40039	1	Right Bracket
2	C3190-00015	1	Encoder Spring
3	C3190-00013	1	Right Strap
4	0515-2765	1	Screw M4.2 x 35 Pan Torx Stl
5	0535-0031	1	Nut Hex M3 x .5
6	C3190-80010	1	Tensioner Spring
7	C3190-60145	1	Carriage-Motor Assembly
8	3050-1267	1	Washer
9	C3190-40048	1	Carriage Belt (D/A1-size)
	C3191-40048	1	Carriage Belt (E/A0-size)
10	C3190-60106	1	Encoder Strip (D/A1-size)
	C3190-60106	1	Encoder Strip (E/A0-size)
-	6040-0858	AR	Lubricant

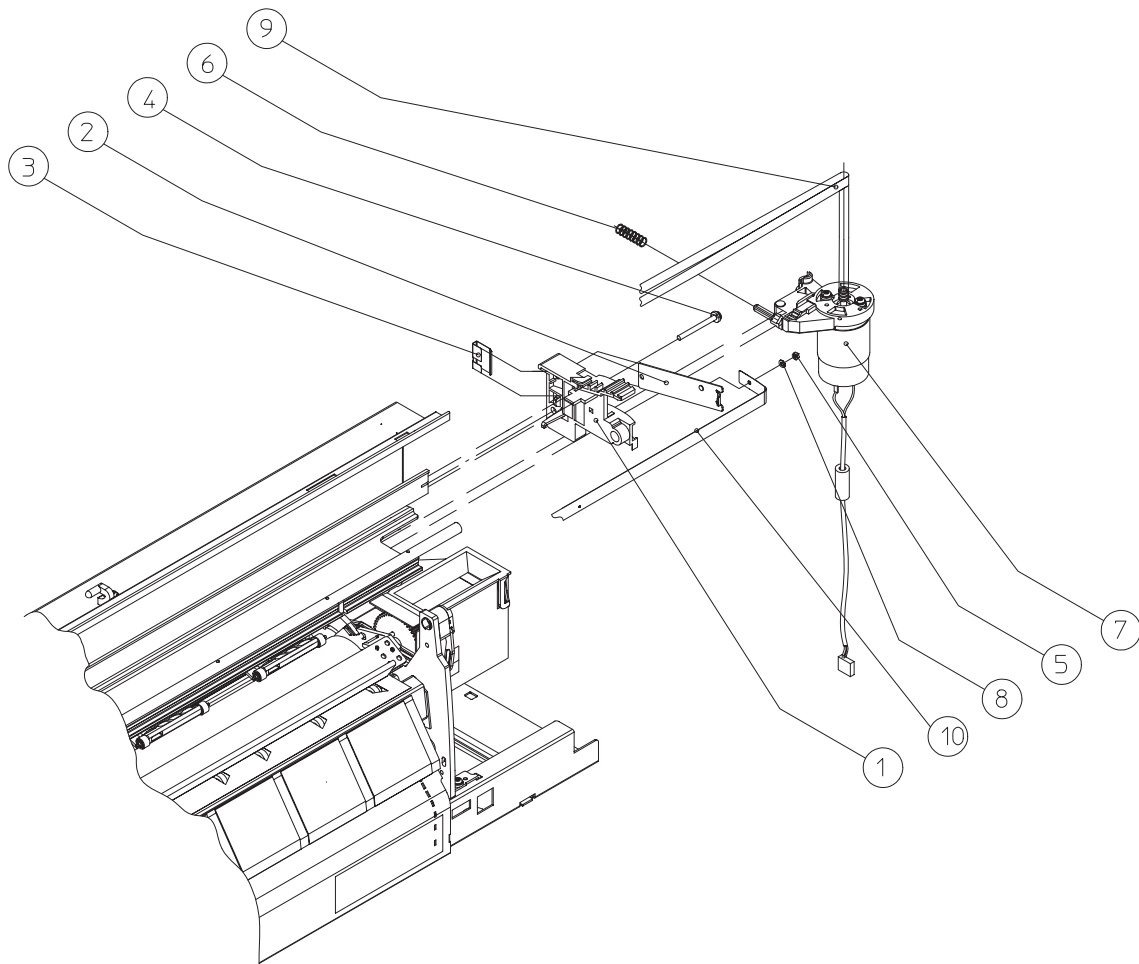

Carriage-Axis (Right End)

Service Station, Primer, Spittoon

Reference on Drawing	HP Part Number		Quantity	Description
	DesignJet 330/350C	DesignJet 230/250C		
1	0515-1743	0515-1743	3	Screw M4 x 17 Tap 20
2	C3190-60142	C3190-60142	1	Service Station Assembly
3	C4699-60002	C3190-60004	1	Spittoon Assembly
4	C4699-60003	C3190-60002	1	Primer Assembly
5	C4701-40002	–	1	Primer Cover (DesignJet 330)
	–	C4694-40001	1	Primer Cover (DesignJet 230)



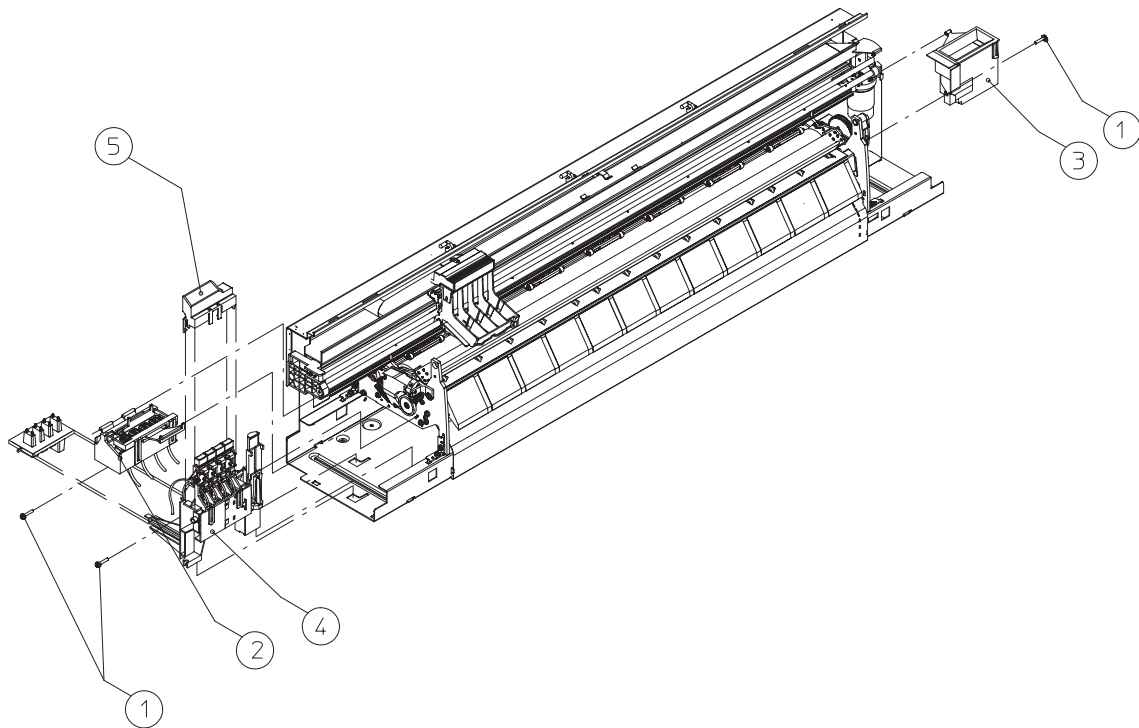

Service Station, Primer, Spittoon

Media Entry Path

Reference on Drawing	HP Part Number		Quantity	Description
	DesignJet 330/350C	DesignJet 230/250C		
1	–	C2858-60054	1	Drive Roller (D/A1-size)
	–	C2859-60004	1	Drive Roller (E/A0-size)
	C4699-60042	–	1	Drive Roller Assembly (D/A1-size)
	C4700-60042	–	1	Drive Roller Assembly (E/A0-size)
–	C3190-60155	C3190-60155	AR	Lubricant
2	C4699-60040	C3190-60090	1	Entry platen Assy (D/A1-size) (Incl. Antistatic Brush)
	C4700-60040	C3191-60090	1	Entry platen Assy (E/A0-size) (Incl. Antistatic Brush)
3	0515-2337	0515-2337	2	Screw M4 Dogpoint Tap
4	C1633-20006	C1633-20006	1	Media-Motor Mount
5	0515-2248	0515-2248	3	Screw M4 x 14 Tap T20
6	C3190-60140	C3190-60140	1	Media Sensor Assembly
7	0515-0382	0515-0382	2	Screw M4 x 15 Mach T15
8	C4699-60038	C3190-60133	1	Media-Motor Assembly (Incl. Helical Gear and Gear Screws)
9	0505-1349	0505-1349	2	Screw M3 x 30 Mach T10
10	C3180-60012	C3180-60012	1	Encoder Cable

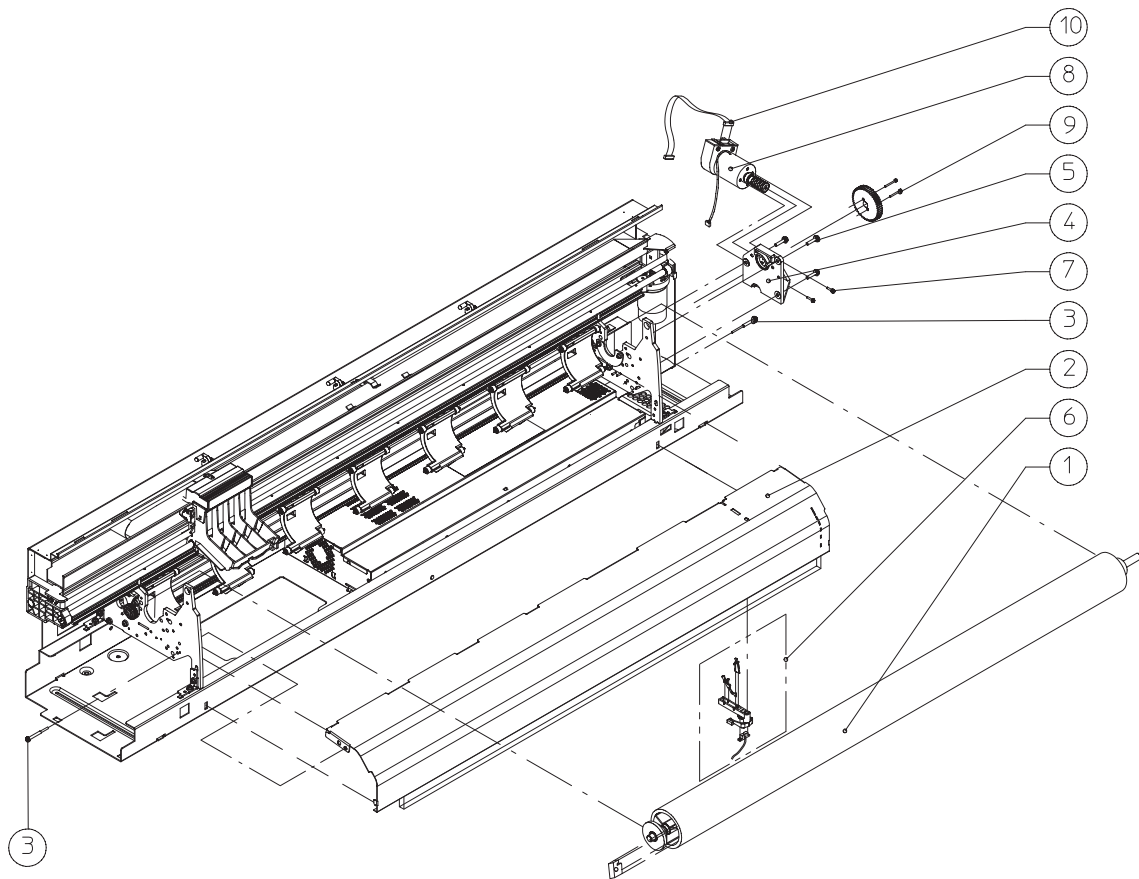

Media Entry Path

Bail and Overdrive

Reference on Drawing	HP Part Number	Quantity	Description
1	0624-0617	1	Screw 6-9 .937 Plast T15
2	0624-0745	2	Screw M4 x 10 Tap T20
3	3050-0026	1	Washer 3.2 mm
4	C3190-40019	1	Cam Gear
5	C1633-40027	1	Engaging Gear
6	C3190-80013	1	Cable Spring
7	C3190-40021	1	Gear Support
8	0510-0083	2	Ring Net .250 OD
9	C3190-60131	1	Clutch Assembly (Incl. Rings and Bushings)
10	C3190-40055	2	Sideplate Bushing
11	C1633-20021	1	Shoulder Screw
12	C1633-40019	1	Overdrive Gear
13	3050-1415	1	Washer Flat
14	0515-1743	1	Screw M4 x 17 Tap T20
15	C3190-40020	1	Bail-Lift Cam
16	0624-0704	6	Screw Plas 6-19 x 375

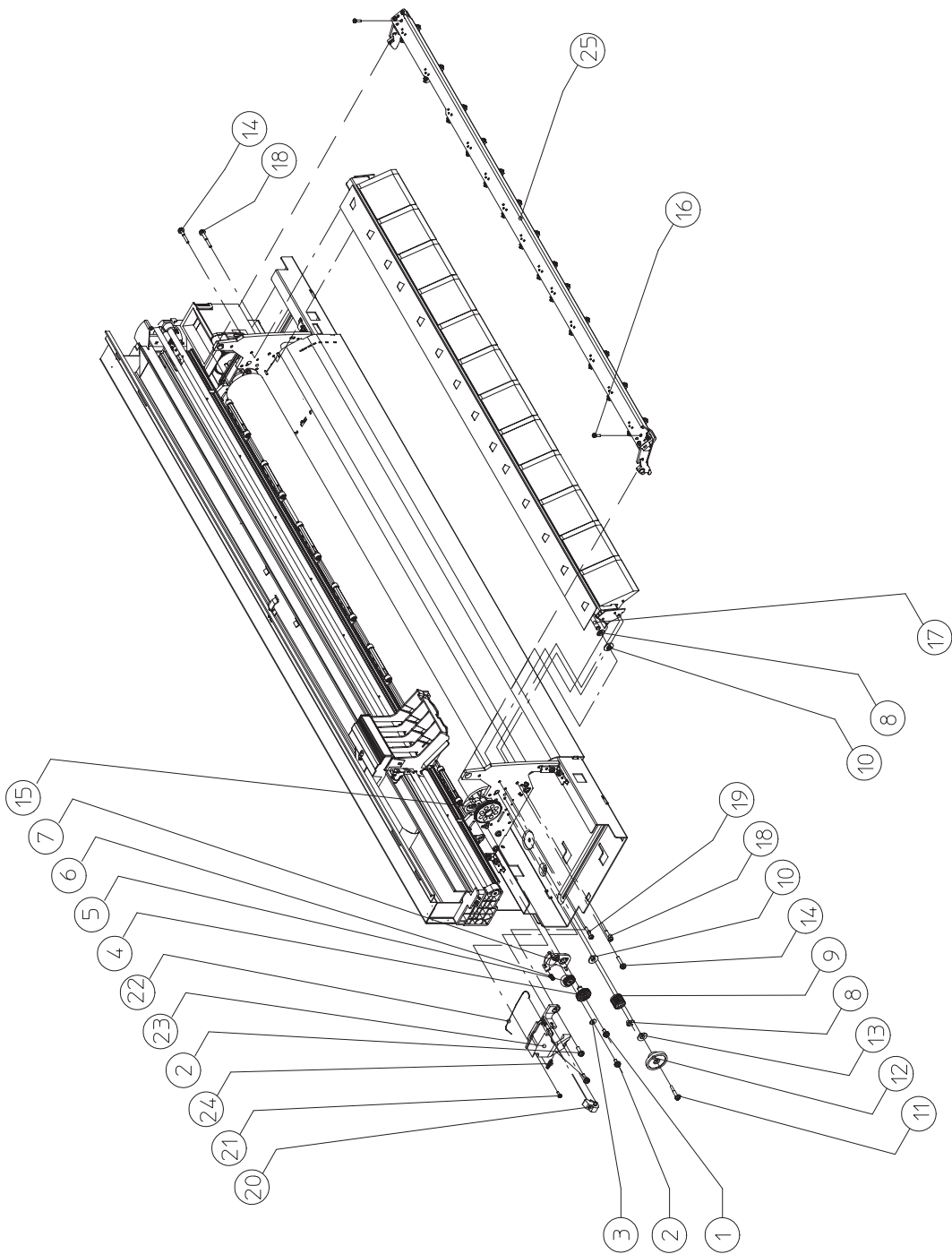

Bail and Overdrive

Bail and Overdrive (Continued)

Reference on Drawing	HP Part Number	Quantity	Description
17	C3190-60096	1	Overdrive Roller (D/A1-size) (Incl. Items 8 & 10)
	C3191-60096	1	Overdrive Roller (E/A0-size) (Incl. Items 8 & 10)
18	C3180-20001	2	Alignment Screw
19	0515-2337	2	Screw M4 Long Dogpoint
20	C3190-40022	1	Engaging Lever
21	0515-2200	1	Screw M3 x 8 Tap T10
22	C3190-60007	1	Bail Cable
23	C3190-40023	1	Engaging-Lever Support
24	07575-80012	1	Gear-Support Spring
25	C3190-60095	1	Bail Assembly (D/A1-size)
	C3191-60095	1	Bail Assembly (E/A0-size)

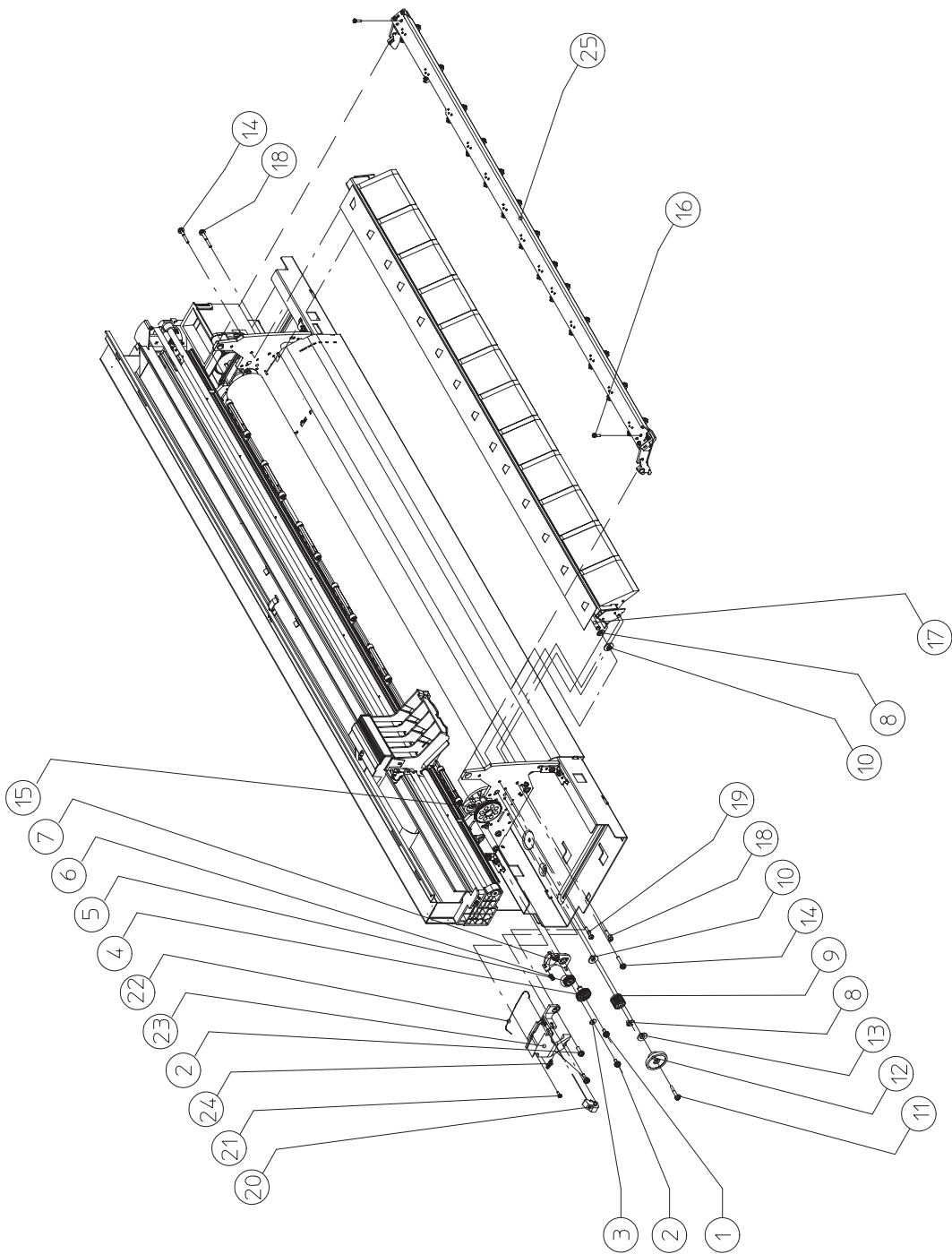

Bail and Overdrive

Pinch-Arm Assembly

Reference on Drawing	HP Part Number	Quantity	Description
1	C2847-20005	1	Pinch-Arm Bar Cam (D/A1-size)
	C1633-20012	1	Pinch-Arm Bar Cam (E/A0-size)
2	C3190-60149	1	Left Cam Journal Assembly
3	C4699-60037	1	Right Cam Journal Assembly
4	C3190-40028	1	Lever Crank
5	C3190-40034	1	Crank Cover
6	C1633-40082	5	Pinch-Arm Bushing (D/A1-size)
	C1633-40082	7	Pinch-Arm Bushing (E/A0-size)
7	C1633-80005	5	Pinch-Arm Spring (D/A1-size)
	C1633-80005	7	Pinch-Arm Spring (E/A0-size)
8	C3190-60029	5	Pinch-Arm Assembly (D/A1-size)
	C3190-60029	7	Pinch-Arm Assembly (E/A0-size)



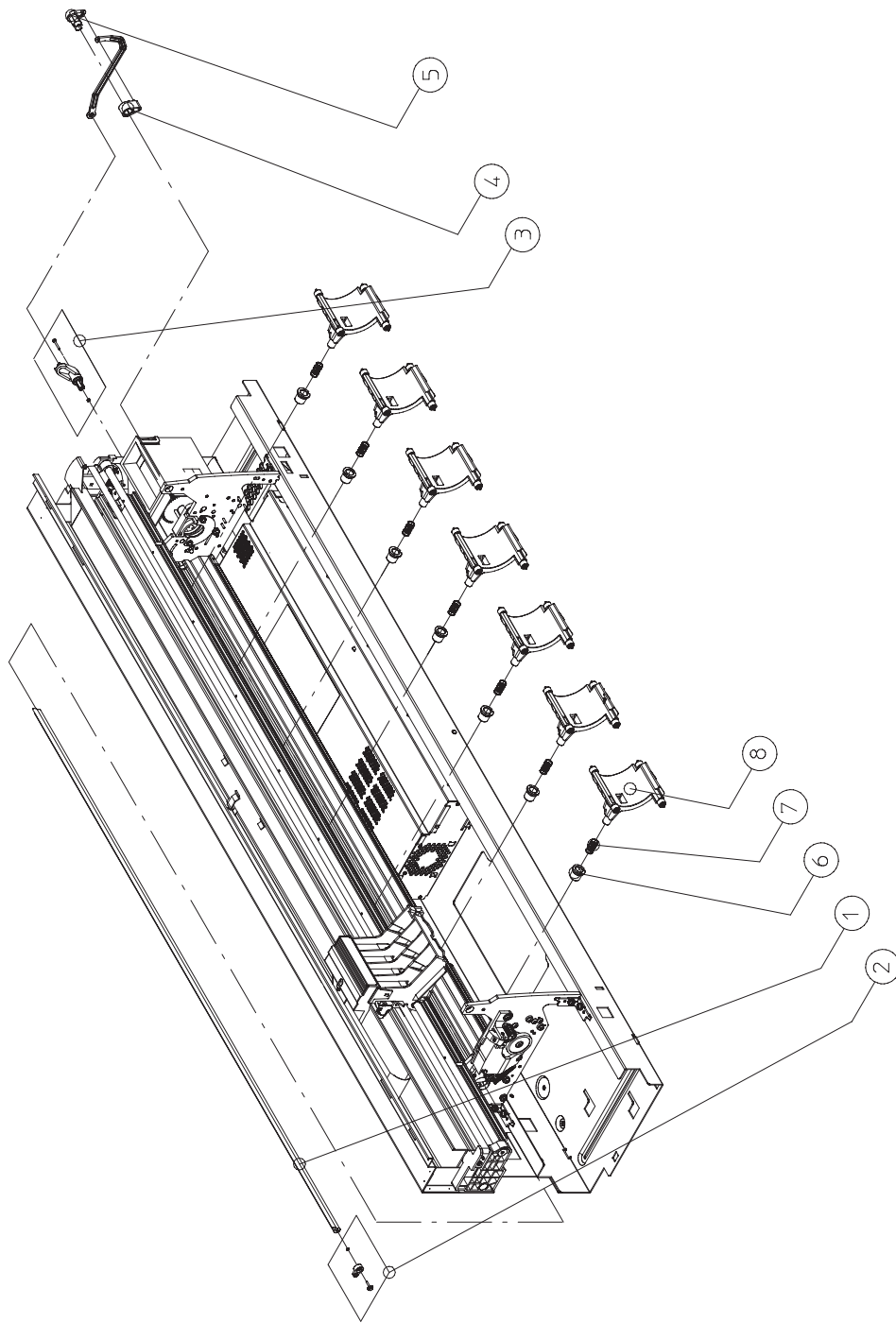

Pinch-Arm Assembly

Roll-Feed Assembly (DesignJet 330 and 350C Only)

Reference on Drawing	HP Part Number	Quantity	Description
1	C3174-60013	1	Roll-Feed Assembly (D/A1-size)
	C3175-60013	1	Roll-Feed Assembly (E/A0-size)
2	C3174-60004	1	Cutter Assembly
3	C3174-60005	1	Spinde (D/A1-size)
	C3175-60005	1	Spindle (E/A0-size)
4	C3174-40011	2	End Cap

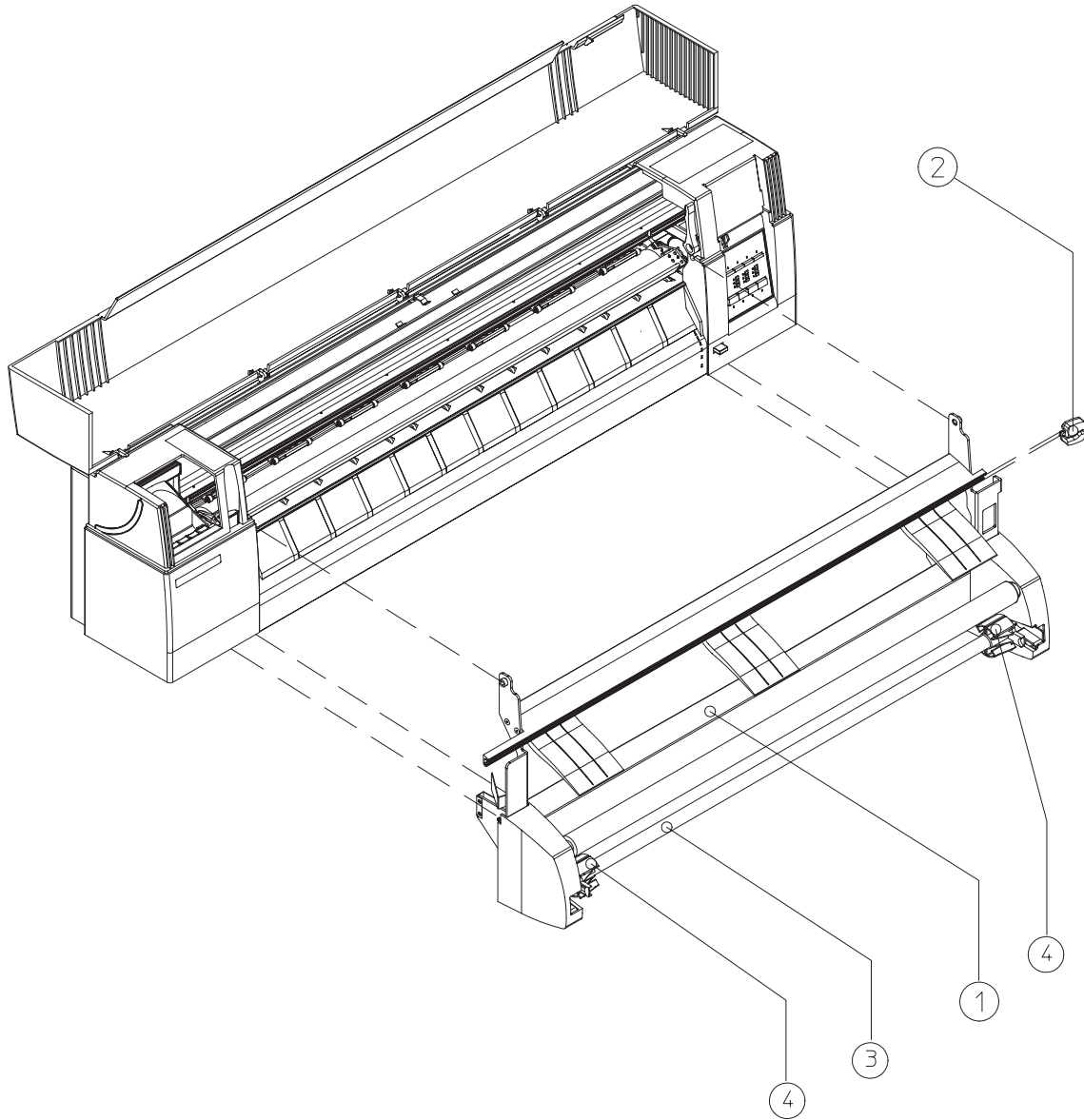

Roll-Feed Assembly

Accessories

Description	HP Part Number	
Repackaging Kit	<b>DesignJet 230/250C and 330/350C</b>	
	D/A1 Size: C3190-60098	E/A0 Size: C3191-60098
<b>User Documentation + Overlay</b>	<b>DesignJet 230</b>	<b>DesignJet 250C</b>
Chinese	C4694-60020	C3190-60060
English	C4694-60011	C3190-60051
French	C4694-60015	C3190-60055
German	C4694-60014	C3190-60054
Italian	C4694-60017	C3190-60057
Japanese	C4694-60018	C3190-60058
Korean	C4694-60012	C3190-60052
Portuguese	C4694-60019	C3190-60059
Spanish	C4694-60016	C3190-60056
Taiwanese	C4694-60013	C3190-60053
<b>User Documentation</b>	<b>DesignJet 330/350C</b>	
Chinese	C4699-90100	
English	C4699-90091	
French	C4699-90095	
German	C4699-90094	
Italian	C4699-90097	
Japanese	C4699-90098	
Korean	C4699-90092	
Portuguese	C4699-90099	
Spanish	C4699-90096	
Taiwanese	C4699-90093	

Description	HP Part Number	
<b>Front-Panel Overlay</b>	<b>DesignJet 230</b>	<b>DesignJet 250C</b>
Chinese	C4694-60010	C3190-60050
English	C4694-60001	C3190-60041
French	C4694-60005	C3190-60045
German	C4694-60004	C3190-60044
Italian	C4694-60007	C3190-60047
Japanese	C4694-60008	C3190-60048
Korean	C4694-60002	C3190-60042
Portuguese	C4694-60009	C3190-60049
Spanish	C4694-60006	C3190-60046
Taiwanese	C4694-60003	C3190-60043
<b>Front-Panel Overlay</b>	<b>DesignJet 330</b>	<b>DesignJet 350C</b>
Chinese	C4701-60020	C4699-60020
English	C4701-60011	C4699-60011
French	C4701-60015	C4699-60015
German	C4701-60014	C4699-60014
Italian	C4701-60017	C4699-60017
Japanese	C4701-60018	C4699-60018
Korean	C4701-60012	C4699-60012
Portuguese	C4701-60019	C4699-60019
Spanish	C4701-60016	C4699-60016
Taiwanese	C4701-60013	C4699-60013
<b>Other Documentation</b>	<b>DesignJet 330/350C</b>	<b>DesignJet 230/250C</b>
HP CAD Plotters Software/Hardware Guide	5964-3839	5963-2170 / 5963-2182
	<b>DesignJet 230/250C and 330/350C</b>	
Software Application Notes	C3190-90080	
HP-GL/2 and HP RTL Reference Guide	5959-9733	
HP-GL/2 and HP RTL Peripherals Product Comparison Guide	5959-9734	
Supplies Source (booklet)	5963-5162E	
Media Reference Guide	5963-5220 / 5963-5224	

Description	HP Part Number		
<b>Print Cartridges</b>	<b>DesignJet 350C</b>	<b>DesignJet 230/330</b>	<b>DesignJet 250C</b>
Black	51640A	51640A	51640A
Cyan	51644C	–	51650C
Magenta	51644M	–	51650M
Yellow	51644Y	–	51650Y
<b>Plug-In Memory (DRAM SIMM)</b>	<b>DesignJet 230/250C and 330/350C</b>		
4-Mbyte SIMM		C3131A	
8-Mbyte SIMM		C3133A	
16-Mbyte SIMM		C3146A	
32-Mbyte SIMM		C3975A <sup>1</sup>	
		C3578A <sup>2</sup>	
<sup>1</sup> 32 bits wide, no parity			
<sup>2</sup> 36 bits wide, parity			
<b>External Print Servers</b>	<b>DesignJet 330/350C</b>	<b>DesignJet 230/250C</b>	
HP JetDirect EX			
Ethernet	J2591A		J2382B
Token Ring	–		J2383B
HP JetDirect EX Plus3			
Ethernet	–		J2593A
Token Ring	J2594A		J2594A
HP JetDirect Software			
For HP-UX	–		J2374C
For Sun UNIX	–		J2375C
<b>Color Upgrade Kit</b>		<b>DesignJet 330</b>	
		C3178A	

## Interface Cables

### Parallel (Bi-Tronics/Centronics) Interface Cables

Computer	HP Part Number		Cable length	Connector type at computer end of cable
	DesignJet 330/350C	DesignJet 230/250C		
HP Vectra with HP 24540A/B serial/parallel interface card using the parallel connector.		92284A	2.1 m (6.9 ft)	25-pin male
	C2950A		2.0 m (6.9 ft)	25-pin male
HP 9000 workstations, series 300, 400, 700.	C2951A		3.0 m (9.8 ft)	25-pin male
IBM AT, IBM PS/2, IBM PC/XT and compatible computers.				

### Serial (RS-232-C) Interface Cables

Computer	HP Part Number		Cable length	Connector type at computer end of cable
	DesignJet 330/350C	DesignJet 230/250C		
HP Vectra or HP 24541A/B serial interface card (9-pin connector).	24542G	24542G	3.0 m (9.8 ft)	9-pin female
HP 9000 workstations using 9-pin connectors.				
IBM AT and compatible computers using 9-pin serial connectors.				
HP Vectra PC with HP 24541A/B dual serial interface card using the 25-pin connector.	17255M	17255M	1.2 m (3.9 ft)	25-pin male
HP Apollo workstation using an SPE (Serial/Parallel Expansion) option and supplied adapter cable.				
DEC VAX.				
Sun workstation.				
IBM PC, PC/XT, IBM PS/2 and compatible computers	C2913A	17255D	1.2 m (3.9 ft)	25-pin female
DEC VAX using DEC BC22D, BC03M, or equivalent	17355M	17355M	3.0 m (9.8 ft)	

Computer	HP Part Number		Cable length	Connector type at computer end of cable
	DesignJet 330/350C	DesignJet 230/250C		
Apple Macintosh Plus, SE, II Series, Classic, LC family, Quadra family, PowerBook, PowerMac	17302A	17302A	1.5 m (4.9 ft)	8-pin male mini-DIN
Apple Macintosh 128K and 512K	92219M	92219M	1.5 m (4.9 ft)	9-pin male
Extension cable	31391A	31391A	5 m (16.4 ft)	25-pin female



---

Support Services



## Hewlett-Packard support services in the United States

Below is a list of Hewlett-Packard support resources for customers in the United States. Use these resources before calling the Customer Support Center, whose details are given after this list.

US Support Resources			
Resource	Support provided and notes	Phone/fax/ftp number	Hours of operation
HP FIRST Fax	Detailed product support information on common software applications and troubleshooting tips. All sent by fax. Must call using a Group 3 fax machine.	(800) 333-1917 (Press 1 for HP FIRST)  or  (208) 344-4809	24 hours. 7 days. Automated support service.
HP Download Service (BBS: Bulletin Board Service)	Electronic downloading of HP product information, troubleshooting hints and updated HP plotter driver information.	(208) 344-1691	24 hours. 7 days. Real-time access over modem.
CompuServe (HP FORUM)	Interactive dialog with worldwide HP customer community for exchange of information. Must be a subscriber. Ask for Agent #51. CompuServe connect charges apply to caller.	(800) 524-3388	24 hours. 7 days. Real-time access over modem.
Internet	Information on products and plotter drivers for anyone with ftp access to the Internet, or who has Worldwide Web access through a hyper-media viewer such as Mosaic.	ftp to: 192.6.71.2, or ftp-boi.external.hp.com Name: anonymous Password: your e-mail address  World-Wide Web: <a href="http://www-dmo.external.hp.com/peripherals/main.html">http://www-dmo.external.hp.com/peripherals/main.html</a>	24 hours. 7 days. Real-time access over modem.
Drivers by mail	HP distributes HP-GL/2 plotter drivers for AutoCAD and Microsoft Windows. Other plotter drivers must be obtained by contacting the software application manufacturer.	(970) 339-7009	24 hours. 6 days (closed Sundays).

<b>US Customer Support Center</b>			
<b>Resource</b>	<b>Support provided</b>	<b>Phone number</b>	<b>Hours of operation</b>
HP Customer Support Center	Technical support with setup, operation and repair information.	(208) 323-2551	6am – 6pm (MST) Weekdays

<b>Other Useful HP Resources in the United States</b>			
<b>Resource</b>	<b>Support provided and notes</b>	<b>Phone number</b>	<b>Hours of operation</b>
HP Customer Information Center	Pre-sales information and literature	(800) 752-0900	6 am – 5 pm (PST) Weekdays
Services Direct Marketing	HP service contract information	(800) 835 4747	730 am – 12 noon 1pm – 4 pm (PST) Weekdays
HP DIRECT Ordering	Ordering of supplies and accessories directly from HP.	(800) 538-8787	6am – 5pm (PST)
Parts Identification	Assistance in identifying service parts.	(916) 783-0804	M Tu W Th: 6am – 3pm (MST) Friday: 6am – 2pm (MST)
Support Materials Organization	Ordering of manuals and service parts directly from HP.  Must have a part number before calling.	(800) 227-8164	M Tu Th F: 6am – 5pm (PST) Wednesday: 6am – 2pm 3pm – 5pm (PST)
HP Support Assistant (CD-ROM)	A quarterly CD-ROM subscription service from HP. This online system provides technical information, product information and software drivers.  This product is designed to run in a Microsoft Windows environment.	(800) 457-1762	24 hours 7 days



## Hewlett-Packard support services in Europe

Below is a list of Hewlett-Packard support resources for customers in Europe. Use these resources before calling the Customer Support Center, whose details are given after this list.

European Support Resources			
Resource	Support provided and notes	Phone/fax/ftp number	Hours of operation
HP FIRST Fax	Detailed product support information on common software applications and troubleshooting tips. All sent by fax. Must call using a Group 3 fax machine.	Europe: (English) (+31) 20 681 5792  Austria: (German) 0660 8128 Belgium: (Dutch) 0800 1 1906 (French) 0800 1 7043 Switzerland: (French) 155 1526 (German) 155 1527 Germany: (German) 0130 810061 Denmark: (Danish) 800 10453 Spain: (Spanish) 900 993123 France: (French) 05 905900 United Kingdom: (English) 0800 960271 Italy: (Italian) 1678 59020 Norway: (Norwegian) 800 11319 Netherlands: (Dutch) 06 0222420 Sweden: (Swedish) 020 795743 Finland: (Finnish) 9800 13134	24 hours. 7 days. Automated support service.
HP Download Service (BBS: Bulletin Board Service)	Electronic downloading of HP product information, troubleshooting hints and updated HP plotter driver information.	UK: (01344) 360880 Outside the UK: (+1) 208 344-1694	24 hours. 7 days. Real-time access over modem.

<b>European Support Resources (continued)</b>			
<b>Resource</b>	<b>Support provided and notes</b>	<b>Phone/fax/ftp number</b>	<b>Hours of operation</b>
CompuServe (HP FORUM)	Interactive dialog with worldwide HP customer community for exchange of information. Must be a subscriber. CompuServe connect charges apply to caller.	UK: (01272) 760680 and ask for Agent #51. Outside the UK: (+1) 614 529-1349	24 hours. 7 days. Real-time access over modem.
Internet	Information on products and plotter drivers for anyone with ftp access to the Internet, or who has Worldwide Web access through a hyper-media viewer such as Mosaic.	ftp to: 192.6.71.2, or ftp-boi.external.hp.com Name: anonymous Password: your e-mail address	24 hours. 7 days. Real-time access over modem.
		World-Wide Web: <a href="http://www-dmo.external.hp.com/peripherals/main.html">http://www-dmo.external.hp.com/peripherals/main.html</a>	
HP Support Assistant (CD-ROM)	A quarterly CD-ROM subscription service from HP. This online system provides technical information, product information and software drivers. This product is designed to run in a Microsoft Windows environment.	UK: (0800) 960274 Outside the UK: (+31) 55 384 2799	09:00 – 18:00 Weekdays
HP Fulfilment Service	Latest drivers.	UK: Tel: (01429) 865511 Fax: (01429) 866000 Outside the UK: Tel: (+44) 1429 865511 Fax: (+44) 1429 866000	

<b>European Customer Support Center</b>			
<b>Resource</b>	<b>Support provided</b>	<b>Phone number</b>	<b>Hours of operation</b>
HP Customer Support Center, Amsterdam, The Netherlands	Technical support with setup, and operation information.	Dutch (+31) 20 681 6473 English (+31) 20 682 8291 or 0891 391 000 French (+31) 20 681 8260 or 3670 39 49 German (+31) 20 681 7174 Italian (+31) 20 581 3318 Spanish (+31) 20 581 3319	M Tu Th F: 08:30–18:00 , Wednesday: 8:30–16:00

<b>European Service Agreements</b>		
<b>Initiated ...</b>	<b>Product</b>	<b>Details</b>
Within 30 days of purchase	HP Support-Pack	HP SupportPack is a three-year on-site service agreement which you can buy within 30 days of purchasing your plotter. With HP SupportPack, you can protect your investment and ensure its maximum availability. Your dealer can supply information about HP SupportPack, as well as a simple registration card.
After 30 days of purchase	Please contact your local HP Sales and Support office for details of other service agreements.	

<b>European Response Centers</b>			
<b>Support provided</b>	<b>Country</b>	<b>Phone number</b>	<b>fax number</b>
Technical support with repair information.	Netherlands	(+31) 20 547 9666	(+31) 20 547 7750
	United Kingdom	(+44) 1344 366366	(+44) 1344 363344
	France	(+33) 1 69 82 60 60	(+33) 1 69 82 60 99
	Germany	(+49) 2102 90 6143	(+49) 2102 90 6300
	Italy	(+39) 2 92 122 778	(+39) 2 92 104 551
	Spain	(+34) 1 631 16 01 /	(+34) 1 631 18 30 or (+34) 1 631 18 31
	Czech Republic	(+42) 2 4743 111 or (+42) 2 4717 321 /	(+42) 2 471 76 11
	Greece	(+30) 1 689 6503 or (+30) 1 689 6504	(+30) 1 689 6508
	Hungary	(+36) 1 252 4505 or (+36) 1 252 4705	(+36) 1 252 7441
	Poland	(+48) 22 37 50 65	(+48) 22 37 47 83
	Turkey	(+90) 212 224 59 37 or (+90) 212 246 78 47	(+90) 212 233 93 49
	Headquarters International Sales Branch (I.S.B.) / Middle East & Africa	(+41) 22 780 41 11	(+41) 22 780 47 70
	Denmark	(+45) 45 99 11 22	(+45) 42 81 39 20
	Austria	(+43) 1 25000 555	(+43) 1 25000 500
	Belgium	(+32) 2 778 38 00	(+32) 2 778 30 43
	Finland	(+358) 0 88721	(+358) 0 887 2477
	Norway	(+47) 22 73 56 01	(+47) 22 75 56 10
	Portugal	(+351) 1 301 73 44	(+351) 1 301 63 32 or (+351) 1 301 63 33
	Sweden	(+46) 8 444 23 20	(+46) 8 444 25 20
	Switzerland	(+41) 31 980 31 11	(+41) 31 980 33 90
Europe	(+41) 22 780 81 11	(+41) 22 780 85 42	

## Hewlett-Packard support services in Asia-Pacific

Asia-Pacific Support Resources			
Resource	Support provided and notes	Phone/fax/ftp number	Hours of operation
HP FIRST Fax	Detailed product support information on common software applications and troubleshooting tips. All sent by fax.	Australia: (03) 9272 2627 Japan: (03) 3335 8622 Korea: (82-2) 769 0543 New Zealand: (09) 356 6642 PRC: (86-10) 505 5280 Singapore (65) 291 7951 Taiwan (886-2) 719 5589 Worldwide: (+1) (208) 344-4809	24 hours. 7 days. Automated support service.
HP Download Service (BBS: Bulletin Board Service))	Electronic downloading of HP product information, troubleshooting hints and updated HP plotter driver information.	Australia: (03) 9890 0276 New Zealand: (09) 356 3660 Taiwan (886-2) 923 3233 (login: hp password: bbs) Worldwide: (+1) (208) 344-1691	24 hours. 7 days. Real-time access over modem.
Internet	Information on products and plotter drivers for anyone with ftp access to the Internet, or who has Worldwide Web access through a hyper-media viewer such as Mosaic.	ftp to: 192.6.71.2, or ftp-boi.external.hp.com Name: anonymous Password: your e-mail address  World-Wide Web: <a href="http://www-dmo.external.hp.com/peripherals/main.html">http://www-dmo.external.hp.com/peripherals/main.html</a>	24 hours. 7 days. Real-time access over modem.
HP Support Assistant (CD-ROM)	A quarterly CD-ROM subscription service from HP. This online system provides technical information, product information and software drivers. This product is designed to run in a Microsoft Windows environment.	(65) 740 4629	24 hours 7 days



<b>Asia-Pacific Support Resources (continued)</b>			
<b>Resource</b>	<b>Support provided and notes</b>	<b>Phone/fax/ftp number</b>	<b>Hours of operation</b>
HP Fulfilment Service	Latest drivers.	Australia: Tel: (612) 565 6099 Fax: (612) 519 5631  Japan Tel: (03) 5346 1891  Korea Tel: (82-2) 3452 7677  New Zealand Tel: (02) 565 6099 Fax: (02) 519 5631  Singapore: Tel: (65) 740 4477 Fax: (65) 740 4499	
For telephone support in the Asia-Pacific region other than for those services listed above, contact your local HP dealer.			



---

---

# Glossary

**#** Number of units.

**°C** Degree(s) Celsius.

**°F** Degree(s) Fahrenheit.

**A** 1. Amp(s).  
2. Acoustic.

**ac** Alternating current.

**accuracy calibration** X-axis calibration.

**addressable dpi** A resolution higher than the nominal value of the cartridges, giving a finer grid on which the plotter can selectively position dots and improve print quality.

**ASIC** Application-Specific Integrated Circuit.

**baud rate** For the RS-232-C interface, the data transmission rate between the computer and the plotter (bits per second).

**bidirectional print mode** A print mode in which plotting is performed while the carriage is moving in either direction.

**binding** Obstruction to movement.

**Bi-Tronics** A parallel interface standard.

**°C** Degree(s) Celsius.

**CAD** Computer-Aided Design.

**calib.** Calibration.

**CAM** Computer-Aided Manufacturing.

**carriage axis** The axis along which the carriage moves. (Y-axis.)

**carriage LED** Line sensor.

**cartridge** Print cartridge (pen).

**centronics** A parallel interface standard.

**checkout** Of nozzles: testing of nozzles by firing them one by one.

**checksum** A programming method used to minimize data errors when data are transferred. ... (Part of a definition from *The Harper Collins Dictionary of Computer Terms*, © Ian R. Sinclair 1991.)

**cm** Centimeter(s).

**Customer Engineers** HP field support engineers.

**D/A1-size plotters** Models C3190A and C4694A.

**data display** Service monitor.

**dB** Decibel(s).

**dc** Direct current.

**depletion** The selective reduction of the number of drops placed on the media, in order to prevent an excess of ink on the media.

**display data** Service monitor.

**display list** An internal logical map, in swath format, containing data representing graphical objects.

**DOS** (MS-DOS.) MicroSoft Disk-Operating System.

**dpi** Dot(s) per inch, the plotter's resolution of raster images on the media.

**DRAM** Dynamic Random-Access Memory.

**drive roller** Platen roller.

**drive-roller gear** Helical gear at right-hand side of drive roller.

**driver** 1. An electronic circuit that provides input to another electronic circuit, (from *Webster's Ninth New Collegiate Dictionary*, © Merriam-Webster 1991).  
2. Configuration data used by software to control input and output between the computer and the plotter.

**DTR** Data Terminal Ready.

**duty cycle** The amount of use a plotter should withstand without undue maintenance.

**E/A0-size plotters** Models C3191A and C4695A.

**ECP** Extended Capability Port. (A Bi-Tronics operating mode.)

**EEROM** Electrically Erasable Read-Only Memory.

**electronics module** The equivalent of the *electronics enclosure* of previous models in the DesignJet series. However, the electronics module is orderable as one part: you should not open it.

**EPROM** Erasable Programmable Read-Only Memory.

**ESD** Electrostatic discharge.

**°F** Degree(s) Fahrenheit.

**film** A type of media.

**flow mode** The plotting of images that have already been rasterized by computer software and do not need to be rasterized by the plotter itself.

**ft** foot/feet

**half-toning** The placement of dots to create a visual effect of different colors or different shades of gray.

**helical gear** Right-hand drive-roller gear.

**HP** Hewlett-Packard.

**HP-GL** Precursor of HP-GL/2.

**HP-GL/2** Hewlett-Packard's standard graphics language for its plotters.

**HP-RTL** Hewlett-Packard Raster Transfer Language.

**Hz** Hertz.

**IC** Integrated Circuit.

**IEEE** Institute of Electrical and Electronics Engineers.

**in** Inch(es).

**I/O** Input/Output

**IPA** Isopropilic alcohol.

**ips** Inch(es) per second.

**K** Kilobyte(s)

**Kana-8** A Japanese character set.

**Kanji** A Japanese character set.

**Kbyte** Kilobyte

**kg** Kilogram(s).

**Kg** Kilogram(s).

**LAN** Local Area Network.

**lb** Pound(s).

**LED** Light-Emitting Diode.

**line sensor** Carriage LED.

**m** Meter(s)

**margin** Part of the media on which the plotter is incapable of printing.

**Mbyte** Megabyte.

**media** (Used instead of medium.) The material on which the graphics are plotted: paper, translucent material, vellum, film, or special paper.

**media axis** The axis along which the media moves. (X-axis; paper axis.)

**media jam** A situation in which media becomes blocked in the plotter mechanisms.

**media-jam lever** Pinch-arm lever.

**media-length calibration** Media-sensor calibration.

**media-sensor calibration** Media-length calibration.

**mil** 1/1000 of an inch.

**minimum pass time** The time necessary for ink to dry sufficiently before the plotter can place more ink adjacent to it.

**MIO** Modular Input/Output.

**mm** Millimeter(s).

**monitor mode** Service monitor.

**MS-DOS** MicroSoft Disk-Operating System

**no negative motion** An RTL command that indicates to the plotter that it will receive all data already in the order in which it should be plotted.

**off-axis ink system** A system whereby ink is pumped to the cartridges from a reservoir that does not move with the carriage.

**PAL** Programmable Array Logic.

**palette** A set of pens for which width and % shading are defined using the setup sheet or the graphics software.

**paper axis** Media axis (X-axis).

**parity** An error-checking method for information transfer between a computer and a peripheral device. Parity is used to check the accuracy of binary data.

**pass** A movement of the carriage from left to right, or from right to left, as it plots the graphic.

**pass advance** The distance that the media advances between carriage passes.

**PC** Personal Computer.

**PCA** Printed Circuit Assembly.

**pen** 1. Even though the inkjet plotter has no physical pens, the lines it draws match the attributes for pens numbered 1 through 8 in the application software. (See also “palette.”)  
2. Sometimes used instead of “print cartridge.”

**pinch-arm lever** Pinch-wheel lever, media-jam lever.

**PJL** Printer Job Language, developed by Hewlett-Packard to give software applications more job-level device control and to provide device status information to the application.

**platen roller** Drive roller.

**plot quality** Print quality.

**PML** Printer Management Language.

**P/N** Part Number.

**power cycle** The switching of the plotter off and then on again.

**primary colors** cyan, magenta, yellow, black.

**print quality** Plot quality

**Product Line 30** Hewlett-Packard’s product line of large-format, pen and thermal-inkjet plotters.

**PWM** Pulse-Width Modulation.

**RAM** Random-Access Memory.

**raster** 1. A matrix of dots, or pixels, where each pixel is defined by a bit. A bit that is “on” will print a dot on the paper. A bit that is “off” will leave the area blank.  
2. A method for defining a plot directly in terms of the pixels rather than as vectors.

**raster image processor** Software that converts graphics data to pixel format.

**relative humidity** The ratio of the amount of water vapor actually present in the air to the greatest amount possible at the same temperature, (from *Webster’s Ninth New Collegiate Dictionary*, © Merriam-Webster 1991).

**resolution** A measure of image sharpness expressed as a number of lines per unit length. When referring to plotters, addressable resolution means the smallest move the plotter can make programmatically.

**rms** Root mean square.

**ROM** Read-Only Memory.

**roman** A character set based on the Latin alphabet.

**RS-232-C interface** A serial interface standardized by the Electronic Industries Association Standard RS-232-C.

**RTL** see “HP-RTL.”

**sec** Second(s).

**secondary colors** Red, blue, green.

**service monitor** Data display; display data; monitor mode.

**SIMM** Single In-line Memory Module.

**skew** Misalignment.

**special paper** A paper specifically developed by HP, for HP inkjet plotters.

**SPROC** Servo-Processor Code.

**swath** That portion of a drawing plotted between advances of the drive roller in **Fast** mode. (In **Best** mode, the drive roller advances half a swath at a time; in **Normal** mode, it may advance a full swath or half a swath, depending on whether the plot is color or monochrome.)

**TCP/IP** Transmission Control Protocol / Internet Protocol.

**theta-Z error** A print-quality error caused when the nozzles on a cartridge are not perpendicular to the carriage axis. The error shows up as jagged vertical lines.

**translucent** Describes a type of media through which light passes.

**TTOE** Thermal Turn-On Energy.

**UART** Universal Asynchronous Receiver Transmitter.

**unidirectional print mode** A print mode in which plotting is performed while the carriage moves in one direction, and no plotting is performed while the carriage moves in the opposite direction.

**vellum** A type of strong paper.

**VLS** Vertical-line straightness.

**X-axis** Media axis.

**X-axis calibration** Accuracy calibration.

**Y-axis** Carriage axis.



---

---

# Index

## A

absorption, ink, 8-61  
ac, Glossary-2  
ac power outlet, 6-2. *See also* power supply  
accessories, 10-26  
accuracy  
  calibration, 7-2, 7-8, 8-57, Glossary-2  
  print  
    DesignJet 230/250C, 7-6  
    DesignJet 330/350C, 7-7  
  read, DesignJet 230/250C, 7-6  
  specification, 1-3  
acoustic specifications, 2-3  
addressable dpi, 5-8, Glossary-2  
adjusting, carriage, 5-7  
  when bail lift mechanism fails, 8-31  
aligning cartridges, 8-30, 8-57  
  Align Cartridge(s) key, 3-12  
alignment, 8-61  
  black cartridge, 7-2  
  error  
    DesignJet 230/250C, 8-12  
    DesignJet 330/350C, 8-18  
ALT key in service mode, 7-5, 7-6, 7-7  
ammonia, causing belt damage, 8-31  
anti-static brush, 5-5, 8-31  
Apple, network connections, 1-3  
application notes, part number, 10-27  
applications, plotter, 1-2  
architecture  
  multiprocessor, 5-12  
  plotter, 5-12  
area fill  
  banding, 8-57  
  blotchy, 8-58  
  print-quality plot, 8-56  
ASIC, 5-12, Glossary-2

assembling. *See also* reinstalling  
  legs, 3-5  
  plotter, 3-2  
  roll-feed, 3-8  
automatic bail lift mechanism, 5-6  
autoswitching, interface and network, 1-3

## B

back cover, removing, 6-33  
bail, 5-6, 8-31  
  cam, 8-31  
  cycle test  
    front-panel keys  
      DesignJet 230/250C, 7-6  
      DesignJet 330/350C, 7-7  
    performing, 8-37  
  lift mechanism, 5-6  
  error, 8-31  
    DesignJet 230/250C, 8-12  
    DesignJet 330/350C, 8-18  
  removing, 6-29  
  number of errors, service configuration  
    plot  
      DesignJet 230/250C, 8-49  
      DesignJet 330/350C, 8-50  
  removing, 6-5  
  system, 8-35  
  testing, 8-37  
banding, 7-2, 8-57  
baud rate, 3-14, Glossary-2  
  and parity, 5-14  
  error  
    DesignJet 230/250C, 8-8  
    DesignJet 330/350C, 8-14  
  setup sheet, 3-15, 3-16  
bellows, primer, 5-11  
belt, 8-35  
  carriage-axis test, 8-38  
  error  
    DesignJet 230/250C, 8-10

- DesignJet 330/350C, 8-16
- moving the carriage, 5-6
- premature wearing, 8-31
- removing, 6-39
- slipping, 8-59
- swelling, 4-3
- bench run, 8-38, 8-49, 8-50
  - front-panel keys
    - DesignJet 230/250C, 7-6
    - DesignJet 330/350C, 7-7
  - parameters, clearing
    - DesignJet 230/250C, 8-54
    - DesignJet 330/350C, 8-55
- Best, print mode, 5-8, 5-9, 5-10
- bidirectional
  - error, 8-59
  - print mode, 5-8, 5-9, 5-10, 5-11, Glossary-2
- binding, Glossary-2
- Bi-Tronics, 8-43, Glossary-2
  - interface, 2-2, 5-14
    - cables, 10-29
  - plotter architecture, 5-12
- black
  - area fills, 8-58
  - cartridge alignment, 7-2
  - number of plots, service configuration
    - plot
      - DesignJet 230/250C, 8-49
      - DesignJet 330/350C, 8-50
- bleeding, 8-61
- blooming, 8-61
- blotchy area fills, 8-58
- brush, anti-static, 5-5
- bushings, 8-31
  - carriage guidance, 5-6
  - friction, 8-59
- buttons, 3-12

## C

- cables, interface, 2-2
  - part numbers, 10-29
- CAD, Glossary-2
- calibrations, 7-1
  - clearing parameters
    - DesignJet 230/250C, 8-54
    - DesignJet 330/350C, 8-55
- CAM, Glossary-2
- cam gear wearing, bail, 8-31
- Cancel, key, 3-12, 3-13. *See also* stopping a test
- carriage, 5-13, 8-11, 8-16, 8-35, 8-60
  - axis, Glossary-2
    - encoder test, 8-53
    - test, 8-38
  - axis test, front-panel keys
    - DesignJet 230/250C, 7-6
    - DesignJet 330/350C, 7-7
  - bushings, 4-2
  - cannot park, 8-31
  - distance to media
    - adjust, 7-13
    - check, 7-11
  - drive, testing, 8-37
  - drive mechanics, 5-6
  - LED, 5-7, Glossary-2
  - motor, 5-6, 8-35
    - connection to main PCA, 5-13
    - control, 8-31
    - error
      - DesignJet 230/250C, 8-10
      - DesignJet 330/350C, 8-16
    - removing, 6-21
    - testing, 8-38
  - noise, 4-2, 8-31
  - PCA, 5-16
  - sensor, testing
    - DesignJet 230/250C, 8-39

- DesignJet 330/350C, 8-40
- speed, 5-8, 5-9, 5-10
- test
  - DesignJet 230/250C, 8-39
  - DesignJet 330/350C, 8-40
- front-panel keys
  - DesignJet 230/250C, 7-6
  - DesignJet 330/350C, 7-7
- carriage-to-media distance, 8-59
- cartridge, Glossary-2
  - caps, removing, 6-6
  - carriage, removing, 6-37
  - part number, 10-28
- cartridges, 2-3, 8-57, 8-60, 8-61
  - fail frequently, 8-30
  - faulty, 8-30
    - DesignJet 230/250C, 8-7
    - DesignJet 330/350C, 8-14
  - flex circuit, 8-39, 8-40
  - identification, 8-35
  - LED, 3-12
  - misaligned, 8-57
  - number of, service configuration plot
    - DesignJet 230/250C, 8-49
    - DesignJet 330/350C, 8-50
  - priming, 8-30
  - print, 5-7
  - servicing, 5-11
- cautions, 6-2
- c-clips, causing media jam, 8-31
- Centronics, Glossary-2.
- centronics interface cables, 10-29
- centronics READ error, 8-12, 8-17
- changing, electronics module, 8-32
- charge, static, 5-5, 8-31
- chassis beam, 8-10, 8-16
- checkout, Glossary-2
- checksum, Glossary-2
- cleaning
  - carriage wheel, 8-31
  - cartridge contacts/pads, 8-30
  - drive roller, 4-4
  - plotter, 4-4
- clearing the EEROM
  - DesignJet 230/250C, 8-54
  - DesignJet 330/350C, 8-55
- clogged tubes, 8-30
- clogging in service station, 5-11
- cluster half-toning, 3-14
- coated, LED, 3-13
- coating, media, 8-57
- code, firmware revision, 8-30, 9-3
- codes, error
  - HP DesignJet 230 and 250C, 8-6 to 8-12
  - HP DesignJet 330 and 350C, 8-13 to 8-18
- color, 3-14
  - cartridge test, 7-2
  - cartridges, 8-58
  - configuration
    - front-panel keys, 7-7
    - key, 8-29
  - hue changes, 8-60
  - inks, 8-61
  - misaligned, 8-61
  - number of plots, service configuration plot
    - DesignJet 230/250C, 8-49
    - DesignJet 330/350C, 8-50
  - print mode
    - DesignJet 230/250C, 5-9
    - DesignJet 330/350C, 5-10
  - upgrade kit, 10-28
- color/mono, setup sheet, 3-15, 3-16
- communication, plotter-computer, 8-35
- condensation, *See* relative humidity
- configuration, plot, service
  - DesignJet 230/250C, 8-49
  - DesignJet 330/350C, 8-50
- configuration procedure, EEROM model ID, DesignJet 330/350C, 8-28
- configuring, plotter, 3-14

- connections
  - flex circuit, testing
    - DesignJet 230/250C, 8-39
    - DesignJet 330/350C, 8-40
  - main PCA, 5-13
- consumption, power, 2-2
- continue plotting, key, 3-13
- copiers, diazo, wearing belt, 8-31
- country of manufacture, 9-2
- cover sensor, 5-13, 8-35, 8-47, 8-48
- current, electrical, 2-2
- customer engineers, Glossary-2
- customer expectations, print quality, 8-59

## D

- D/A1-size plotters, Glossary-2
- damage to plotter, 3-4
- data display, 8-52, Glossary-2
- dB, Glossary-2
- dc, Glossary-2
- deconfiguration mode, 8-28
  - front-panel keys, 7-7
  - key, 8-28
- demonstration plot, 3-14
- density, line, 3-14
- depletion, 5-8, 5-9, 5-10, Glossary-2
- depth of plotter, 2-3
- description of plotter, 1-2
- detecting the media edges, 5-7
- diagnosing problems, 8-30
- diagnostics, software, 7-5
- diagrams and parts, 10-1
- diazo copiers, wearing belt, 8-31
- dimensions, plotter, 2-3
- dirt on
  - carriage wheel, 4-2
  - pulley, 8-10, 8-16
  - slider rod, 4-2
- dirty
  - carriage wheel, 8-31
  - contacts, 8-7, 8-14
  - encoder strip, 8-59
  - pads, 8-30
  - pulley, 8-59
- disconnecting front-panel assembly, 6-12
- display data, 8-52, Glossary-2
- display list, 5-15, Glossary-2
- distance, carriage-to-media, 5-7
- diverter, media, 1-4
- documentation, 10-27
- DOS, Glossary-2
- dot gain, 8-57
- dpi, 1-4, 5-9, 5-10, Glossary-2
- DRAM, 5-12, Glossary-2
- DRAM SIMM, 8-7, 8-14, 8-35, 10-28
- drive belt
  - premature wearing, 8-31
  - removing, 6-39
- drive roller, 7-8, 8-35, 8-57, Glossary-3
  - bearings, 8-57
  - correction factor, DesignJet 230/250C, 8-49
  - faulty, 8-57
  - gear, Glossary-3
  - problem
    - DesignJet 230/250C, 8-11
    - DesignJet 330/350C, 8-16
  - removing, 6-25
  - pulley, removing, 6-40
  - radius, 8-57
  - reinstalling, 6-42
  - removing, 6-41
- drivers, Glossary-3
  - cartridge, 5-12
  - motor, 5-12
  - software, 1-2

drop detector, absence of, 5-11  
drop volume causing banding, 8-57  
DTR, Glossary-3  
duty cycle, 4-2, 8-32

## E

E/A0-size plotters, Glossary-3  
earth, 6-2  
ECP, 1-3, 5-14, Glossary-3  
edge of media not found, 8-30  
edges, detecting media, 5-7  
EEROM, 4-3, 5-12, 5-14, 7-8, 8-35,  
Glossary-3  
clearing  
DesignJet 230/250C, 8-54  
DesignJet 330/350C, 8-55  
contents, service configuration plot  
DesignJet 230/250C, 8-49  
DesignJet 330/350C, 8-50  
error, 8-27  
DesignJet 230/250C, 8-9  
DesignJet 330/350C, 8-15  
model ID, configuration procedure, 8-28  
electrical  
contact, cartridge, 8-57  
error  
DesignJet 230/250C, 8-11  
DesignJet 330/350C, 8-17  
specifications, 2-2  
test, 8-41  
electrical test, front-panel keys  
DesignJet 230/250C, 7-6  
DesignJet 330/350C, 7-7  
electronics module, 4-3, 5-13, 8-10, 8-16,  
8-32, 8-35, Glossary-3  
changing, 8-32  
faulty, 8-32  
removing, 6-13  
electrostatic discharge, 6-2  
encoder

cable, 8-17  
media-axis, 8-35, 8-44  
strip, 8-10, 8-16, 8-31, 8-35, 8-38, 8-57  
damaged, 8-30  
removing, 6-17  
slots, 8-59  
tests, 8-53  
encoders  
carriage axis (encoder strip), 5-6, 5-16  
media axis, connection to main PCA, 5-13  
plotter architecture, 5-12  
end-point accuracy, 7-8  
end-covers, removing  
left, 6-9  
right, 6-10  
engaging gear, 8-31  
engaging lever  
problem, 8-31  
support, removing, 6-31  
entering  
service mode 1, 7-3  
service mode 2, 7-4  
entry platen  
reinstalling, 6-49  
removing, 6-48  
environment, 8-9, 8-15  
environmental conditions, 8-61  
EPROM, Glossary-3  
error  
bail-lift-mechanism  
DesignJet 230/250C, 8-12  
DesignJet 330/350C, 8-18  
EEROM  
DesignJet 230/250C, 8-9  
DesignJet 330/350C, 8-15  
electrical  
DesignJet 230/250C, 8-11  
DesignJet 330/350C, 8-17  
firmware, DesignJet 230/250C, 8-10  
LED, 3-12, 3-13  
library, DesignJet 330/350C, 8-17  
media-load

- DesignJet 230/250C, 8-8
- DesignJet 330/350C, 8-14
- servo
  - X-axis
    - DesignJet 230/250C, 8-9
    - DesignJet 330/350C, 8-15
  - Y-axis
    - DesignJet 230/250C, 8-10
    - DesignJet 330/350C, 8-16
- X-axis calibration
  - DesignJet 230/250C, 8-11
  - DesignJet 330/350C, 8-16
- error codes
  - HP DesignJet 230 and 250C, 8-6
    - flashing 13, 8-7
    - flashing 23, 8-7
    - flashing 29, 8-7
    - flashing 36, 8-8
    - flashing 39, 8-8
    - flashing 6, 8-7
    - flashing 9, 8-7
    - steady 123, 8-9
    - steady 1234, 8-11
    - steady 12345, 8-12
    - steady 1238, 8-11
    - steady 1345, 8-11
    - steady 13456, 8-12
    - steady 1346, 8-11
    - steady 1349, 8-12
    - steady 135, 8-9
    - steady 1356, 8-12
    - steady 1357, 8-12
    - steady 136, 8-9
    - steady 139, 8-10
    - steady 2, 8-6
    - steady 234, 8-10
    - steady 237, 8-10
    - steady 34, 8-9
    - steady 3456, 8-12
    - steady 346, 8-10
    - steady 349, 8-10
    - steady 356, 8-11
    - steady 368, 8-11
    - steady 38, 8-9
    - steady 6, 8-6
    - steady 9, 8-6
  - HP DesignJet 330 and 350C, 8-13
    - 26 off, 8-13
    - flashing 13, 8-14
    - flashing 2, 8-14
    - flashing 23, 8-14
    - flashing 34, 8-14
    - flashing 36, 8-14
    - flashing 6, 8-14
    - steady 123, 8-15
    - steady 1234, 8-17
    - steady 12345, 8-18
    - steady 1235, 8-17
    - steady 1345, 8-17
    - steady 13459, 8-18
    - steady 1346, 8-17
    - steady 1348, 8-17
    - steady 135, 8-15
    - steady 1359, 8-17
    - steady 136, 8-16
    - steady 1389, 8-18
    - steady 139, 8-16
    - steady 2, 8-13
    - steady 2 and flashing 6, 8-13
    - steady 234, 8-16
    - steady 2345, 8-18
    - steady 238, 8-16
    - steady 34, 8-15
    - steady 346, 8-16
    - steady 35, 8-15
    - steady 369, 8-17
    - steady 38, 8-15
    - steady 6, 8-13
- error LED, 8-15
- errors
  - EEROM, 8-27
  - system
    - DesignJet 230/250C, 8-19
    - DesignJet 330/350C, 8-23
- ESD, Glossary-3
  - precautions, 6-2
- Ethernet, 1-3, 10-28
- EtherTalk, 1-3
- exchange assemblies, 10-2

expanding, memory, 1-3. *See also* RAM  
external print servers, 10-28  
extra memory, 6-4

## F

factory calibration factor, 8-49  
factory spittoon, 8-49, 8-50. *See also*  
spittoon  
fading, 8-58  
failure, RS-232-C communication, 8-32  
fan, 5-13  
Fast, LED, 3-12, 3-13  
fast (draft) print mode, 5-8, 5-9, 5-10, 5-11  
Fast Direct to Print, 8-8, 8-14  
faulty, electronics module, 8-32  
feedback, positional, 5-6  
fibers, media, 8-61  
fill density, uneven, 8-58  
film, Glossary-3  
LED, 3-12, 3-13  
polyester, 8-30  
firmware  
code, 6-4  
revision level, 8-30  
connection to main PCA, 5-13  
error  
DesignJet 230/250C, 8-10  
DesignJet 330/350C, 8-18  
release, service configuration plot  
DesignJet 230/250C, 8-49  
DesignJet 330/350C, 8-50  
revision code, 9-3  
flash ROM SIMM, 5-14, 9-3  
flow mode, 5-15, Glossary-3  
form feed, 8-32  
key, 3-12, 3-13  
frequency, 2-2

friction, 8-59  
slider rod, 4-2  
front panel  
assembly, disconnecting, 6-12  
connection to main PCA, 5-13  
keys, 8-35  
DesignJet 230/250C, 3-12  
DesignJet 330/350C, 3-13  
keys and LEDs, service mode, 7-5  
LEDs, 8-35  
DesignJet 230/250C, 3-12  
DesignJet 330/350C, 3-13  
overlay, part numbers, 10-27  
PCA, 5-16  
plotter architecture, 5-12  
test, 8-42  
keys to press  
DesignJet 230/250C, 7-6  
DesignJet 330/350C, 7-7  
functional overview, 5-1

## G

gear  
bail cam, 8-31  
engaging, 8-31  
media axis, testing, 8-44  
graphics language, setup sheet, 3-15, 3-16  
graticule, setup sheet, 3-15, 3-16  
grease, silicon, 8-9, 8-15  
gripping the media, 5-5  
ground, electrical, 6-2

## H

half-toning, 3-14, Glossary-3  
handshaking, 5-14  
hardware tools, 7-5  
height of plotter, 2-3  
helical gear, Glossary-3. *See also* drive roller



history of product, chapter 9  
holes for ventilation, service station, 5-11  
HP 712 workstation, 8-8, 8-14  
HP JetDirect EX, part numbers, 10-28  
HP JetDirect EX Plus3, part numbers,  
10-28  
HP UX, 10-28  
HP-GL, 1-2, 8-32, Glossary-3  
  timeout, 8-32  
HP-GL (7586B), setup sheet, 3-15, 3-16  
HP-GL/2, 1-2, Glossary-3  
  setup sheet, 3-15, 3-16  
HP-GL/2 and HP RTL documentation,  
10-27  
HP-RTL, 1-2, Glossary-3  
HP-UX, 1-3  
hue changes, 8-60  
humidity, relative, 8-61

## I

I/O, Glossary-3  
  timeout, 8-32  
  setup sheet, 3-15, 3-16  
IBM AIX, 1-3  
IC, Glossary-3  
identification, cartridge, 8-35  
IEEE, Glossary-3  
inbuilt ROM, 8-4. *See also* ROM  
incompatible media, 8-58, 8-61  
incorrect LED sequence, 8-32  
initialization  
  mechanical, 8-2  
  plotter, 8-2  
ink  
  color, 8-61  
  off axis, 3-14

  on roller, 4-4, 8-30  
  providing, 5-7  
  separator, 5-11, 4-3, 8-31  
  smearing, 7-11, 8-60  
  spilling, 4-3, 8-31  
  spray, 8-58  
  third-party, 3-14, 8-32  
input/output  
  interfaces, 5-14  
    test, DesignJet 230/250C, 8-43  
    front-panel keys, DesignJet 230/250C, 7-6  
installation and configuration, chapter 3  
installing a RAM or ROM SIMM, 6-4  
interface to networks, part numbers, 10-28  
interfaces  
  baud rate, 3-14  
  Bi-Tronics, 1-3  
  cables, 2-2  
    part numbers, 10-29  
  input/output, 1-3, 5-14  
  parallel, 5-14  
  parity, 3-14  
  RS-232-C, 1-3  
  serial, 5-14  
  timeout, 3-14  
IPA, Glossary-3  
ips, Glossary-3

## J

jagged lines, 7-2  
JetDirect, 1-3, 5-14  
  software, 10-28  
joined plots, 8-32

## K

Kana-8, Glossary-3  
Kanji, Glossary-4  
keys

DesignJet 230/250C, 3-12  
DesignJet 330/350C, 3-13  
front-panel, in service mode, 7-5

## L

lamination, 8-58  
LAN, Glossary-4  
  Manager, 1-3  
languages  
  demonstration plot, 3-14  
  device control, 1-2  
  graphic, 1-2, 3-14  
  setup sheet, 3-14, 3-15, 3-16  
last accuracy calibration, 8-49  
last system error, 8-49, 8-50  
LED, Glossary-4  
  carriage, 5-7  
LEDs, 7-3, 8-3, 8-35  
  DesignJet 230/250C, 3-12  
  DesignJet 330/350C, 3-13  
left end-cover, removing, 6-9  
legs, 1-4  
  assembling, 3-5  
length of lines, 7-8  
length of plotter, 2-3  
letter, plotter revision, 9-2  
library error, DesignJet 330/350C, 8-17  
lifetime, 4-2  
lightfastness, 8-58  
line, 8-59  
  density, 3-14  
  length, 7-8  
  merging, 3-14  
  sensor, 5-7, 5-16, 7-8, Glossary-4  
  plotter architecture, 5-12  
  width, 3-14  
linear encoder (on carriage), 5-16  
liquids, 6-2

load media, LED, 3-12, 3-13

loading  
  roll media, 5-4  
  sheet media, 5-2

loopback  
  connector, 8-43  
  test, failure  
    DesignJet 230/250C, 8-10  
    DesignJet 330/350C, 8-16

## M

Macintosh, 1-3  
main PCA, 5-13  
main processor, 5-12  
mains, 6-2  
margin, Glossary-4  
margins, 1-5  
marks, starwheel, 8-60  
masked ROM, 5-14, 9-3  
mechanical initialization, 8-2  
media, 8-60, 8-61, Glossary-4  
  axis, 7-8, Glossary-4  
  encoder test, 8-53  
  error, 8-17  
  motor, 8-44  
  test, 8-44  
    front-panel keys  
      DesignJet 230/250C, 7-6  
      DesignJet 330/350C, 7-7  
  diverter, 1-4  
  edge not found, 8-30  
  edges, detecting, 5-7  
  encoder, connection to main PCA, 5-13  
  expansion, 7-8  
  fault, 8-57  
  jam, 5-5, 8-9, 8-10, 8-15, 8-16, 8-31,  
    Glossary-4  
  lever, Glossary-4  
  length, calibration, Glossary-4  
  load error, DesignJet 230/250C, 8-8, 8-14

- margins, 1-5
- motor, 8-35
  - connection to main PCA, 5-13
  - defective, 8-57
  - error
    - DesignJet 230/250C, 8-11
    - DesignJet 330/350C, 8-16, 8-17
  - removing, 6-26
- not loading, 8-33
- sensor, 5-13, 8-35
  - connection to main PCA, 5-13
  - testing
    - DesignJet 230/250C, 8-47
    - DesignJet 330/350C, 8-48
- sensor assembly
  - removing, 6-15
  - replacing, 6-16
- sensor calibration, Glossary-4
- sizes, 1-5
- thickness, 7-8
- type
  - incorrect, 8-58
  - key, 3-12, 3-13
- types, 1-4
- memory, 5-12, 8-7, 8-14
  - RAM, 1-3
  - usage, 5-15
- merge, setup sheet, 3-15, 3-16
- merging, lines, 3-14
- minimum pass time, 5-8, 5-9, 5-10, Glossary-4
- MIO, 5-14, Glossary-4
- mirror, 3-14
  - setup sheet, 3-15, 3-16
- misaligned colors, 8-61
- mispositioned, trailing cable, 8-33
- modular test, 8-45
  - front-panel keys
    - DesignJet 230/250C, 7-6
    - DesignJet 330/350C, 7-7
- moisture, on plotter, 4-2

- monitor mode, Glossary-4
- mono configuration
  - front-panel keys, 7-7
  - key, 8-29
- monochrome, 3-14
  - print mode, 5-8
    - DesignJet 230/250C, 5-8
    - DesignJet 330/350C, 5-9, 5-10
- month of manufacture, 9-2
- motor
  - carriage, 5-6
  - connection to main PCA, 5-13
  - plotter architecture, 5-12
- moving the carriage, 5-6
- MS-DOS, 1-3, Glossary-4
- multiprocessor, 5-12

## N

- negative motion, Glossary-4
- network, interfaces, 1-3
  - part numbers, 10-28
- no negative motion, 5-15, 8-7, 8-14, Glossary-4
- noise, carriage wheel, 4-2
- noisy carriage, 8-31
- normal
  - LED, 3-12, 3-13
  - print mode, 5-8, 5-9, 5-10
- Novell Netware, 1-3
- nozzles, 8-35, 8-60
  - blocked, 8-57
  - checkout, 8-56
  - faulty, 8-57
  - misdirected, 8-57
- nozzle-to-media distance, 8-58
- number format, serial, 9-2

## O

- off-axis ink system, 3-14, 8-32, Glossary-4
- office light, 8-58
- oil, 8-10, 8-16
  - slider rod, 4-2
- operating environment, 2-3
- optical line sensor, 5-16
- optical sensor, 8-30, 8-35
- orientation of plot, 3-14, 5-15
- output from tests, 8-36
- overdrive, 8-35
  - enclosure
    - reinstalling, 6-47
    - removing, 6-46
  - roller, 8-31
    - removing, 6-32
- overlay, service, 7-5

## P

- P/N, Glossary-5
- page, size, 3-14
  - setup sheet, 3-16
- PAL, Glossary-4
- palette, 3-14, Glossary-4
- Palmtop PC, HP, 8-36
- paper
  - axis, Glossary-4
  - LED, 3-12
- parallel, interface, 1-3, 2-2, 5-14
  - cables, 10-29
  - connection to main PCA, 5-13
- parity, 3-14, 5-14, Glossary-4
  - error
    - DesignJet 230/250C, 8-8
    - DesignJet 330/350C, 8-14
  - setup sheet, 3-15, 3-16
- parts and diagrams, chapter 10

- pass, Glossary-4
- pass advance, 5-8, 5-9, 5-10, Glossary-4
- passes per swath, 5-8, 5-9, 5-10
- pattern half-toning, 3-14
- PC, Glossary-5
  - HP Palmtop, 8-36
- PCA, Glossary-5
  - carriage, 5-16
  - front-panel, 5-16
- pen, Glossary-5
  - palette, 3-14
  - settings, setup sheet, 3-15, 3-16
- pens
  - alignment, (cartridges), 8-56
  - number of, service configuration plot
    - DesignJet 230/250C, 8-49
    - DesignJet 330/350C, 8-50
- pen-to-pen alignment, 8-61
- pinch-arm
  - lever, Glossary-5
  - lever linkage, removing, 6-27
  - lift mechanism
    - reinstalling, 6-45
    - removing, 6-44
  - sensor, 5-5, 5-13, 8-35
    - connection to main PCA, 5-13
    - removing, 6-25
- pinched cable, 8-32
- PJL, 1-2, Glossary-5
- plain, LED, 3-13
- platen roller, Glossary-5. See also drive roller
- plot
  - appearance, setup sheet, 3-15, 3-16
  - files joined, 8-32
  - files not plotted, 8-32
  - quality, Glossary-5
- plotter architecture, 5-12
- PML, 1-2
- positional feedback, 5-6

positioning the plotter, 2-3

power

- cycles, number of, service configuration plot
  - DesignJet 230/250C, 8-49
  - DesignJet 330/350C, 8-50
- problem, 8-6, 8-13
- requirements, 2-2
- supply, 2-2, 5-15
  - part of electronics module, 5-13

power cycles, Glossary-5

power on, self-test, 8-2

pressing two keys together, 7-5

preventive maintenance, chapter 4

primary colors, 8-56, 8-61, Glossary-5

primer, 5-11

- removing, 6-27

priming

- cartridges, 8-30
- to solve banding, 8-57

print cartridges, 5-7

print heads

- touching media, 8-60
- touching service station, 8-57

print quality, 1-4, 7-2, 8-31, Glossary-5

- key, 3-12, 3-13
- plot, 8-56
  - front-panel keys, DesignJet 230/250C, 7-6
  - printing, 8-46
  - troubleshooting, 8-56

print-mode characteristics, 5-8

problem solving, chapter 8

processor fault, 8-9, 8-16

product

- history, chapter 9
- information, 1-1
- line 30, Glossary-5

protective earth terminal, 6-2

puddling, 8-57

pulley, 5-6, 8-10, 8-16, 8-35

- removing, 6-40

PWM, 8-38, 8-53, Glossary-5

- carriage axis, service configuration plot
  - DesignJet 230/250C, 8-49
  - DesignJet 330/350C, 8-50
- media axis, service configuration plot
  - DesignJet 230/250C, 8-49
  - DesignJet 330/350C, 8-50
- media-axis, 8-44

## R

radius of drive roller, 8-49

RAM, 1-3, Glossary-5

- connection to main PCA, 5-13
- memory usage, 5-14
- plotter architecture, 5-12
- SIMM, installing, 6-4

raster, 5-15, Glossary-5

- image processor, 5-15, Glossary-5

read settings, key, 3-12

ready, LED, 3-12, 3-13

reassembly, 6-2

reinstalling

- drive roller, 6-42
- entry platen, 6-49
- overdrive enclosure, 6-47
- pinch-arm lift mechanism, 6-45

relative humidity, 2-3, 4-2, 8-61, Glossary-5

- bleeding/blooming/wicking, 8-61
- water on main PCA, 5-15, 8-32

release, firmware, 8-49, 8-50

removing

- back cover, 6-33
- bail, 6-5
- bail-lift mechanism, 6-29
- belt, 6-39
- carriage motor, 6-21
- cartridge caps, 6-6
- cartridge carriage, 6-37

- drive belt, 6-39
- drive roller, 6-41
- drive-belt pulley, 6-40
- drive-roller gear, 6-25
- electronics module, 6-13
- encoder strip, 6-17
- engaging-lever support, 6-31
- entry platen, 6-48
- left end-cover, 6-9
- media motor, 6-26
- media-sensor assembly, 6-15
- overdrive enclosure, 6-46
- overdrive roller, 6-32
- pinch-arm lever linkage, 6-27
- pinch-arm lift mechanism, 6-44
- pinch-arm sensor, 6-25
- primer, 6-27
- pulley, 6-40
- right bracket, 6-21
- right end-cover, 6-10
- roller, 6-41
- roll-feed assembly, 6-8
- service station, 6-28
- spittoon
  - DesignJet 230/250C, 6-23
  - DesignJet 330/350C, 6-24
- top cover, 6-7
- trailing cable, 6-34
- trailing-cable guide, 6-36
- wiper blades, 6-6

- repackaging kit, 10-26
- repacking the plotter, plotter, 3-4
- repaired assemblies, 10-2
- replacement parts, 10-3
- replacing, media-sensor assembly, 6-16
- replot, key, 3-12, 3-13
- repositioning, trailing cable, 6-35
- resistance of motor driver, 8-10, 8-16
- resolution, 1-4, 5-8, 5-9, 5-10, Glossary-5
- revision
  - firmware code, 9-3
  - letter
    - plotter, 9-2

- level, firmware code, 8-30
- right bracket, removing, 6-21
- right end-cover, removing, 6-10
- rms, Glossary-5
- roll
  - LED, 3-13
  - media, 5-5
    - loading, 5-4
- roll/sheet, key, 3-13
- roller
  - reinstalling, 6-42
  - removing, 6-41
- roll-feed, 1-4
  - assembling, 3-8
  - assembly, 5-5
    - removing, 6-8
- ROM, 5-12, 5-14, 8-35, Glossary-5
  - SIMM, 9-3
    - firmware, 8-3
    - installing, 6-4
- roman, Glossary-5
- rotate, 3-14
  - setup sheet, 3-15, 3-16
- RS-232-C
- RS-232-C, 5-12, 8-10, 8-16, 8-43, Glossary-5
  - communication failure, 8-32
  - interface, 2-2, 5-14
    - cables, 10-29
  - loopback test failure
    - DesignJet 230/250C, 8-10
    - DesignJet 330/350C, 8-16
- RTL, 5-15, 8-7, 8-14, Glossary-5

## S

- safety
  - precautions, 6-2
  - symbols, x
  - warnings, A-2, 5-15, 6-2
- scatter half-toning, 3-14

- secondary colors, 8-56, 8-61, Glossary-5
- self test, power-on, 8-2
- sensitivity of line sensor
  - DesignJet 230/250C, 8-39
  - DesignJet 330/350C, 8-40
- sensor
  - does not find media edge, 8-30
  - sensitivity
    - DesignJet 230/250C, 8-39
    - DesignJet 330/350C, 8-40
- sensors, 5-13
  - cover, 5-13
  - line, 5-7, 5-16
  - media, 5-13
  - pinch-arm, 5-5, 5-13
  - plotter architecture, 5-12
  - test
    - DesignJet 230/250C, 8-47
    - DesignJet 330/350C, 8-48
  - front-panel keys
    - DesignJet 230/250C, 7-6
    - DesignJet 330/350C, 7-7
- sequences
  - LEDS at start up, 8-3
  - roll media-loading, DesignJet 330/350C, 5-4
  - sheet media-loading, 5-2
- serial, interface, 1-3, 3-14, 5-14, 2-2
  - cables, 10-29
  - connection to main PCA, 5-13
  - problem
    - DesignJet 230/250C, 8-8
    - DesignJet 330/350C, 8-14
  - setup sheet, 3-15, 3-16
- serial-number format, 9-2
- server, WCSO, 9-4
- service
  - configuration, front-panel keys, DesignJet 230/250C, 7-6
  - configuration plot, 4-3
    - DesignJet 230/250C, 8-49
    - DesignJet 330/350C, 8-50
  - printing, 8-51
- mode 1
  - entering, 7-3
  - front-panel keys
    - DesignJet 230/250C, 7-6
    - DesignJet 330/350C, 7-7
- mode 2
  - entering, 7-4
  - front-panel keys
    - DesignJet 230/250C, 7-6
    - DesignJet 330/350C, 7-7
- monitor, 8-52, Glossary-5
  - front-panel keys
    - DesignJet 230/250C, 7-6
    - DesignJet 330/350C, 7-7
- notes, chapter 9
  - with graphics, 9-4
- station, 5-11, 8-35
  - removing, 6-28
  - testing, 8-37
- tests, 8-35
- service station
- servicing cartridges, 5-11
- servo
  - error
    - X-axis
      - DesignJet 230/250C, 8-9
      - DesignJet 330/350C, 8-15
    - Y-axis
      - DesignJet 230/250C, 8-10
      - DesignJet 330/350C, 8-16
  - processor, plotter architecture, 5-12
- servo/encoder test, 8-53
  - front-panel keys
    - DesignJet 230/250C, 7-6
    - DesignJet 330/350C, 7-7
- setup
  - key, 3-12, 3-13
  - sheet, 3-14
    - DesignJet 250C, 3-15
    - DesignJet 350C, 3-16
- shadows, 7-2
- sharpness of image, 5-7
- sheet media, loading, 5-2

SHIFT key in service mode, 7-5, 7-6, 7-7  
SIMM, 1-3, 5-12, 5-13, 9-3, Glossary-6  
site planning, chapter 2  
size, page, 3-14  
sizes, media, 1-5  
skew, Glossary-6  
slider rod, 5-6, 7-14, 8-10, 8-16, 8-31, 8-35, 8-59  
    friction, 4-2  
slipping of belt, 8-10, 8-16, 8-59  
smearing of ink, 8-60  
software, 5-15  
    diagnostics, 7-5  
    drivers, 1-2  
software/hardware guide, part number, 10-27  
Solaris, 1-3  
solving problems, chapter 8  
sound  
    power, 2-3  
    pressure, 2-3  
special paper, Glossary-6  
    LED, 3-12  
    print mode, 5-8  
specifications  
    accuracy, 1-3, 7-8  
    electrical, 2-2  
    environmental, 2-3  
    moisture, 4-2  
    resolution, 1-4  
speed of carriage, 5-8, 5-9, 5-10, 8-38  
spilling of ink, 4-3  
spittoon, 4-3, 5-11, 8-31  
    factory, service configuration plot  
        DesignJet 230/250C, 8-49  
        DesignJet 330/350C, 8-50  
    removing  
        DesignJet 230/250C, 6-23  
        DesignJet 330/350C, 6-24

spray, 8-58  
spreading of ink, 8-61  
SPROC, Glossary-6  
    release, service configuration plot  
        DesignJet 230/250C, 8-49  
        DesignJet 330/350C, 8-50  
starwheel marks, 8-60  
starwheels, 8-31  
static charge, 5-5, 8-31  
stopping a test, 7-4  
storage environment, 2-3  
Sun  
    OS, 1-3  
    UNIX, 10-28  
sunlight, 8-58  
supplies source, part number, 10-27  
support services, 11-1  
    Asia-Pacific, 11-8  
    Europe, 11-4  
    USA, 11-2  
swath, 5-8, 5-9, 5-10, Glossary-6  
    advance angle, incorrect, 8-57  
    RAM, plotter architecture, 5-12  
swelling of belt, 4-3  
system errors  
    DesignJet 230/250C, 8-19  
    DesignJet 330/350C, 8-23  
    number of, service configuration plot  
        DesignJet 230/250C, 8-49  
        DesignJet 330/350C, 8-50

## T

tape on cartridges, 8-30  
TCP/IP, 1-3, Glossary-6  
temperature, 2-3, 8-9, 8-15  
tensioner, 8-38



test  
  bail cycle, 8-37  
  carriage  
    DesignJet 230/250C, 8-39  
    DesignJet 330/350C, 8-40  
  color cartridges, 7-2  
  electrical, 8-41  
  front panel, 8-42  
  input/output, DesignJet 230/250C, 8-43  
  media axis, 8-44  
  modular, 8-45  
  sensors  
    DesignJet 230/250C, 8-47  
    DesignJet 330/350C, 8-48  
  service, 8-35  
  servo/encoder, 8-53  
thermistor circuit, 5-16  
theta-Z error, 8-59, 8-60, Glossary-6  
thin-film damage, 8-30  
third-party ink, 3-14, 8-32  
timeout, 3-14  
  HPGL, 8-32  
Token Ring, 1-3, 10-28  
tools, 6-3, 7-5  
top cover, removing, 6-7  
trailing cable, 5-16, 8-31, 8-35  
  guide, removing, 6-36  
  improvisation, 8-33  
  removing, 6-34  
  repositioning, 6-35  
training, for customer engineers, ii  
translucent, Glossary-6  
  media, 8-61  
troubleshooting, chapter 8  
  print quality, 8-56  
  tips, 8-30  
troublesome plotters, 8-32  
TTOE, 8-61, Glossary-6  
tubes on primer, 8-30  
turning plotter on, 8-3

types, media, 1-4

## U

UART, Glossary-6  
uneven fill density, 8-58  
unidirectional print mode, Glossary-6  
unpacking, plotter, 3-2  
upgrade kit, DesignJet 330, 1-4  
usage, level of, 4-2  
user documentation, part numbers, 10-26  
user-defined parameters, clearing  
  DesignJet 230/250C, 8-54  
  DesignJet 330/350C, 8-55  
using  
  this manual, ii  
  the plotter, 3-12

## V

vacuum, 5-11  
vellum, 8-61, Glossary-6  
ventilation holes, 5-11  
verifying, plotter operation, 3-14  
vertical-line straightness, 7-11, 8-56, 8-59  
viewing test output, 8-36  
VLS, Glossary-6  
voltage, 2-2

## W

warnings, *See* safety  
water, 8-32  
  condensation, 5-15  
  on main PCA, 5-15, 8-32  
  warning, 6-2

WCSO server, 9-4  
wearing of parts, 8-31  
weight, plotter, 2-3  
wick, 5-15, 8-32  
wicking, 8-61  
width of lines, 3-14  
window sensor, *See* cover sensor  
Windows driver, 8-8, 8-14  
wiper blades, removing, 6-6  
wipers blades, worn, 8-30  
workstation, HP 712, 8-8, 8-14

## X

X-axis, Glossary-6. *See also* media axis

X-axis calibration  
X-axis calibration, Glossary-6.  
error  
    DesignJet 230/250C, 8-11  
    DesignJet 330/350C, 8-16  
service configuration plot, DesignJet  
    330/350C, 8-50

## Y

Y-axis, Glossary-6  
year of manufacture, 9-2

---

### **About This Edition**

This is the second edition of this service manual. It updates information in respect to the HP DesignJet 230 and 250C and introduces the HP DesignJet 330 and 350C.

1st edition, titled  
*HP C4694A/C4695A/C3190A/C3191A  
HP DesignJet 230/250C  
Service Manual, June 1995*

2nd edition, titled  
*HP C4694A/C4695A/C3190A/C3191A/  
C4701A/C4702A/C4699A/C4700A  
HP DesignJet 230/250C/330/350C  
Service Manual, March 1996*



### **What's in This Book**

This manual contains information necessary to test, calibrate and service

- HP DesignJet 230 plotters  
(models C4694A and C4695A)
- HP DesignJet 250C plotters  
(models C3190A and C3191A)
- HP DesignJet 330 plotters  
(models C4701A and C4702A)
- HP DesignJet 350C plotters  
(models C4699A and C4700A)

For information about using these plotters, refer to the corresponding user and quick-reference guides.

The procedures described in this manual are to be performed by HP-qualified service personnel only.

**Recycled paper** 

**Printed in U.S.A. 3/96**  
**HP Internal Order Number**  
**C4699-90000.**



**C4699-90000**