



## HP Designjet 4020 Printer series



### High-speed HP Designjet to grow your business

#### Designed for non-stop printing at lower costs

- Double your print capacity and truly maximize productivity with HP Double Swath technology and 160 GB hard disk.
- Experience fast, simultaneous processing and printing thanks to in-printer processing, which also provides built-in HP-GL/2 and PDF support<sup>(1)</sup>.
- Save time and money by producing ready-to-use prints—this series creates CAD prints with 5mm margins, so there's no need for trimming.
- Count on this printer to perform unattended printing with reliable 775-ml black, 400-ml color Original HP ink cartridges.
- Achieve greater cost efficiency with free HP support, HP supplies that deliver a better value.

#### Provides great possibilities to grow your business

- Experience more possibilities to increase your personal productivity with HP Instant Printing Utility 2.0, HP embedded Web server and Serif PosterDesigner Pro for HP.
- Turn your printer into a print workflow management system with optional SCP Reprocontrol for HP<sup>(2)</sup>. The SCP Reprocontrol for HP is powerful software that lets you flexibly automate, standardize, and manage color consistently within your workflow.
- Produce excellent lines and images with patented HP inks, printheads enabling 0.1% line accuracy<sup>(3)</sup>, and HP Professional Color technologies.
- Choose from a broad portfolio of over 35 Original HP media for high-quality results from CAD drawings and renders to presentations and posters.

#### Trusted integration in your IT environment

- Trusted connectivity and security—with built-in Gigabit Ethernet networking, advanced access control and optional HP Jetdirect support for secure IPsec and IPv6<sup>(4)</sup>. A Linux PS driver offers additional support for Linux users<sup>(5)</sup>.
- Manage your HP Designjet, fleet of devices, and your costs with HP Web Jetadmin and the embedded Web server.
- Experience true peace of mind with a printer you know you can trust—from a company with years of experience and expertise.

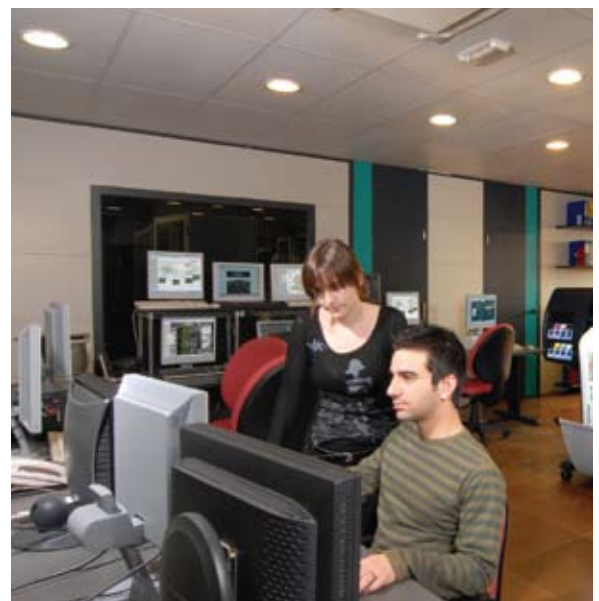

(1) Available on the HP Designjet 4020ps Designjet Printer only. Support in English only.

(2) SCP reprocontrol for HP is an optional feature. Not included, sold separately.

(3) +/-0.1% of the specified vector length or +/-0.1 mm (whichever greater) at 23° C (73° F), 50-60% relative humidity, on E/A0 printing material in Best or Normal mode with HP Matte Film.

(4) IPsec and IPv6 support requires the purchase of the HP Jetdirect 630n or HP Jetdirect 635n.

(5) Serif PosterDesigner Pro for HP is an optional feature. Not included, sold separately.

For enterprise, public sector, and reprographic houses

100 A1/D prints per hour

775-ml black, 400-ml color cartridges

160 GB hard disk

Optional PostScript

SCP reprocontrol for HP

Embedded Web server

608 MB memory (up to 1120 MB)

# HP Designjet 4020 Printer series

1. Ink cartridges of 225 and 400-ml for CMY; 400 and 775-ml for K.
2. Accommodates media rolls up to 90 m (300 ft). It also has a manual sheet feed that supports sizes starting from A3 (B).
3. Front panel with user friendly animations.
4. Color consistency and screen-to-print matching with HP Professional Color technologies.
5. Pairs of staggered printheads in the carriage mean the HP Designjet 4020 Printer series has double the print capacity of earlier models.
6. HP Embedded Web Server for driverless file submission, queue management, preview, supplies and printer status, and error notification.
7. HP Embedded Jetdirect Gigabit Ethernet print server (1000Base-T) + 2 FireWire (IEEE-1394a compliant) ports.
8. EIO port for optional Jetdirect cards.
9. Embedded processor for simultaneous printing and processing. 608 MB Memory (upgradeable to 1120 MB). 160 GB HDD.
10. Equipped with a standard bin that holds 50 E/A0-size prints.

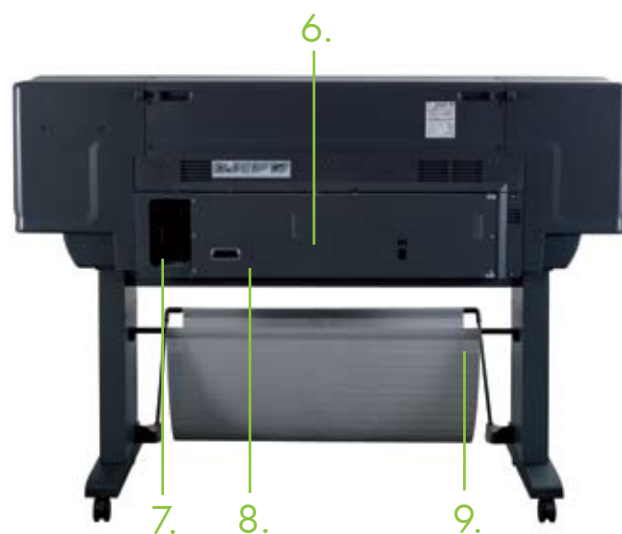
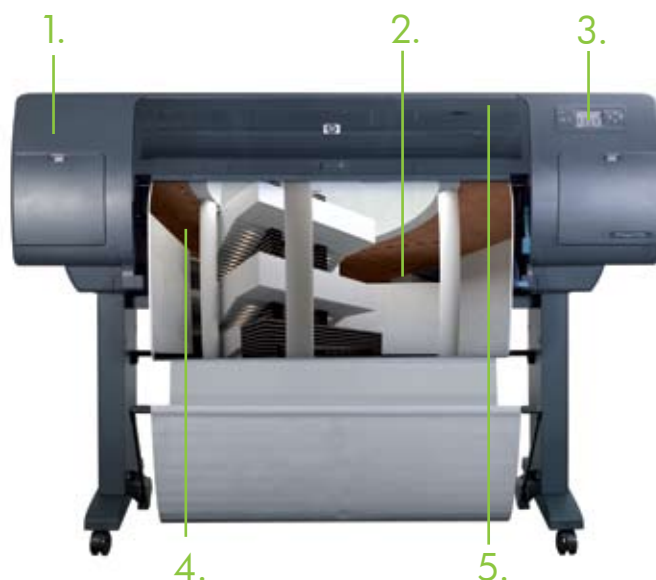

## HP Designjet 4020 Printer series at a glance

### HP Designjet 4020 Printer

- Up to 1067 mm (42 in) wide
- 2400 x1200 dpi maximum resolution
- Rolls up to 90 m (300 ft) long
- Ink supplies of 225 and 400-ml for CMY; 400 and 775-ml for K
- Embedded processor and 608 MB Memory (upgradeable to 1120 MB). 160 GB HDD
- Support for HP-GL/2, HP-RTL, TIFF, JPEG, CALS G4

### Optional accessories

- HP Designjet 4520 Scanner
- HP Designjet 1067 mm (42 in) Roll Feed Spindle
- HP Designjet 512 MB Memory Upgrade
- HP Designjet High Speed USB 2.0 Card
- HP Jetdirect 630n IPv6 Gigabit Print Server
- HP Jetdirect 635n IPv6/IPsec Print Server
- Serif PosterDesigner Pro for HP
- SCP reprocontrol for HP

### HP Designjet 4020ps Printer

All the features of the 4020 model, plus:

- Embedded RIP for Adobe® PostScript 3 and Adobe® PDF 1.5

### Optional accessories

- HP Installation Service (1 unit)
- HP Network Installation Service (1 unit)
- HP Next Business Day Onsite Hardware Support, 3 years
- HP 4 hour response 9x5 Onsite Hardware Support, 3 years
- HP 4 hour response 13x5 Onsite Hardware Support - onsite in 4 hours, 3 years
- HP Next Business Day Onsite Hardware Support, 1 year post warranty
- HP 4 hour response 9x5 Same-Day Onsite Hardware Support, 1 year post warranty
- HP 4 hour response 13x5 Onsite Hardware Support, 1 year post warranty

*HP Designjet 4020 Printer series are ideal for quality, low-cost large-format drawings, graphics, maps, presentations, renders, and posters that you can print in batch<sup>(5)</sup>.*

### HP Double Swath Technology

Pairs of staggered printheads in the carriage double the print swath of the HP Designjet 4020 Printer series resulting in twice the performance of earlier Designjet models.\*

The print swaths overlap each other with 24 nozzles. The nozzles printing in the same scan line (top and bottom printheads) are used together to eliminate swath-to-swath banding. With 1048 nozzles per color, this printer fires an impressive 36,000 drops per second per nozzle.

The printer has been designed to make automatic print mode adjustments if necessary, thus ensuring consistent image quality print after print. In order to maintain media advance accuracy at the increased printing speeds, improvements have been made to keep the media tension constant, regardless of the friction conditions.

Related technologies to HP Double Swath Technology, such as the new vacuum system with dual control and high-precision media advance, ensure fast print speeds without compromising on image quality and line accuracy.



### HP Embedded Web Server

The HP Embedded Web Server enables remote printer management using an ordinary Web browser. Increase your productivity and cost efficiency:

- Preview jobs before printing
- Re-print stored jobs at the touch of a button
- Remotely reset your print job priorities at any time
- Submit multiple files for printing in one go
- View and save accounting information on printheads, ink, and media usage

### HP Professional Color technologies

Get the right colors on the first print. No more trial and error. Get superior color consistency: print-to-screen color matching, print-to-print color consistency, and accurate application color palette reproduction. Get excellent grays: improved gray neutrality and more grayscale levels. The HP Designjet 4020 Printer series includes the latest HP Professional Color technologies:

- Enhanced sRGB printing and Adobe RGB
- Closed Loop Color (CLC)
- TIFF and JPEG with embedded ICC profiles
- Enhanced graphic features: PANTONE calibration<sup>®</sup>, offset emulation, HP CMYK plus, and Black Point compensation



\* Compared to any HP Designjet 600/700/800/1000 Printer

# HP Designjet 4020 Printer series

## Technical specifications

<b>Print speed</b>	25 sec/page on A1/D <sup>6</sup> , 93 m <sup>2</sup> /hr (1000 ft <sup>2</sup> /hr) <sup>7</sup> , 100 A1/D prints per hour <sup>8</sup>
<b>Printing</b>	
Print resolution	Up to 2400 x 1200 optimized dpi
Margins (top x bottom x left right)	Roll: 5 x 5 x 5 x 5 mm (0.2 x 0.2 x 0.2 x 0.2 in) Sheet: 11.5 x 25 x 5 x 5 mm (0.45 x 0.98 x 0.2 x 0.2 in)
Technology	HP Thermal Inkjet
Ink cartridge colors	Black, cyan, magenta, yellow
Ink types	Dye-based (cyan, magenta, yellow), pigment-based (black)
Ink drop	5 pl (cyan, magenta, yellow), 15 pl (black)
Line accuracy	+/- 0.1% <sup>9</sup>
Line width	Minimum line width (HP-GL/2 addressable): 0.02 mm (0.0007 in) Guaranteed minimum line thickness (ISO/IEC 13660:2001(E))*: 0.07 mm (0.0027 in)
<b>Memory</b>	608 MB memory (upgradeable to 1120 MB), 160 GB hard disk
<b>Media</b>	
Handling	Manual single-sheet feed, manual roll feed, automatic cutter
Types	Bond and coated paper, technical paper, film, photographic paper, proofing paper, self-adhesive, banner and sign material, fine art printing material
Thickness	Up to 0.4 mm (15.7 mil)
Weight	50 to 350 g/m <sup>2</sup> (0.11 to 0.77 lb)
Size	Sheets and rolls in sizes A3, A2, A1, A0 (B, C, D, E) and up to 1067 mm (42 in) wide
<b>Connectivity</b>	
Interfaces (standard)	1 Gigabit Ethernet (1000Base-T) port, 2 FireWire (IEEE-1394a compliant) ports, 1 EIO Jetdirect accessory slot
Interfaces (optional)	HP Jetdirect print servers
Drivers (included)	HP-GL/2, HP-RTL, PostScript <sup>®</sup> drivers for Windows; HP PCL 3 GUI, PostScript <sup>®</sup> drivers for Mac OS X; support for Citrix XenApp and Citrix XenServer environments
Print languages (standard)	HP Designjet 4020: HP-GL/2, HP-RTL, TIFF, JPEG, CALS G4 HP Designjet 4020ps: Adobe <sup>®</sup> PostScript 3, Adobe <sup>®</sup> PDF 1.5, HP-GL/2, HP-RTL, TIFF, JPEG, CALS G4
<b>Supported operating systems</b>	
	Windows Vista, Windows Server 2008, Windows XP, Windows Server 2003, Mac OS X v 10.4 and 10.5, Linux <sup>®</sup>
<b>Dimensions</b>	
Printer	1930 x 800 x 1350 mm (76 x 31.5 x 53.2 in)
Shipping	2130 x 710 x 1215 mm (83.9 x 28 x 47.8 in)
<b>Weight</b>	
Printer	115 kg (253.5 lb)
Shipping	175.9 kg (387.8 lb)
<b>What's in the box</b>	
	Printer, 42-in printer stand and bin, printheads (x8), printhead cleaners (x8), introductory ink cartridges, documentation and drivers CD, user maintenance kit, setup poster, Customer Service Guide, Serif PosterDesigner Pro poster, power cord

(6) Mechanical printing time. Line drawing printed in Fast mode on HP Bright White Inkjet Paper (Bond). Speed indicated is maximum printer speed.

(7) Color image (100% color coverage) printed in Fast mode on HP Bright White Inkjet Paper (Bond). Speed indicated is maximum printer speed.

(8) Multi-copy printing; total printing time. Line drawings printed in Fast mode on HP Bright White Inkjet Paper (Bond). Speed indicated is maximum printer speed.

## Environmental ranges

Operating temperature	5 to 40° C (41 to 104° F)
Recommended operating temperature	15 to 30° C (59 to 86° F)
Storage temperature	-20 to 55° C (-4 to 131° F)
Operating humidity	20 to 80% RH

## Acoustic

Sound pressure, active	53 dB(A)
Sound pressure, standby	38 dB(A)
Sound power, active	7.0 B(A)
Sound power, standby	5.7 B(A)

## Power consumption

Maximum	500 watts
Power requirements	Input voltage (auto ranging): 100 to 127 VAC (+/- 10%), 6 A; 220 to 240 VAC (+/- 10%), 3 A; 50/60 Hz (+/- 3 Hz)

## Certification

Safety	USA and Canada (CSA certified), EU (LVD and EN60950-1 compliant), Russia (GOST), Singapore (PSB), China (CCC), Argentina (IRAM), Mexico (NRYE)
Environmental	EU & China RoHS, WEEE, REACH, EuP
Electromagnetic	Compliance for Class A ITE products: EU (EMC Directive), USA (FCC Rules), Canada (ICES), Australia (ACA), New Zealand (MoC), China (CCC), Japan (VCCI); Certified as Class A product: Korea (KCC), Taiwan (BSMI)
Energy Star qualified models	see: <a href="http://www.hp.com/go/energystar">www.hp.com/go/energystar</a>

## Warranty

	One-year limited hardware warranty
--	------------------------------------

## Service and support

H4518E	HP Network Installation
UN412E	HP 3y Next Business Day Onsite
UN411E	HP 4y Next Business Day Onsite
UN406PE	HP 1y Post Warranty Next Business Day Onsite
UN405E	HP 3 year 4 hour 13X5
UN400PE	HP 1 year Post Warranty 4 hour 13X5

## Ordering information

<b>Product</b>	
CM765A	HP Designjet 4020 42-in Printer
CM766A	HP Designjet 4020ps 42-in Printer

## Accessories

Q5675A	HP Designjet 42-in Roll Feed Spindle
Q5680A	HP Designjet High Speed USB 2.0 card
CM973A	HP Designjet 512 MB Memory Upgrade
J7997G	HP Jetdirect 630n IPv6 Gigabit Print Server
J7961G	HP Jetdirect 635n IPv6/IPv4 Print Server
CN088A	Serif PosterDesigner Pro for HP
CN454A	SCP reprocontrol for HP (1 printer)
CN455A	SCP reprocontrol for HP (2 printers)
CM770A	HP Designjet 4520 Scanner

## Original HP ink cartridges

C5054A	HP 90 Black Printhead and Cleaner
C5055A	HP 90 Cyan Printhead and Cleaner
C5056A	HP 90 Magenta Printhead and Cleaner
C5057A	HP 90 Yellow Printhead and Cleaner
C5060A	HP 90 225-ml Cyan Ink Cartridge
C5062A	HP 90 225-ml Magenta Ink Cartridge
C5064A	HP 90 225-ml Yellow Ink Cartridge
C5061A	HP 90 400-ml Cyan Ink Cartridge
C5063A	HP 90 400-ml Magenta Ink Cartridge
C5065A	HP 90 400-ml Yellow Ink Cartridge
C5058A	HP 90 400-ml Black Ink Cartridge
C5059A	HP 90 775-ml Black Ink Cartridge
C5078A	HP 90 Black Printhead/Cleaner & Ink Cartridge, 400-ml, Value Pack
C5079A	HP 90 Cyan Printhead/Cleaner & Ink Cartridge, 400-ml, Value Pack
C5080A	HP 90 Magenta Printhead/Cleaner & Ink Cartridge, 400-ml, Value Pack
C5081A	HP 90 Yellow Printhead/Cleaner & Ink Cartridge, 400-ml, Value Pack
C5082A	HP 90 Black Ink Cartridges, 400-ml, 3-ink Multipack
C5083A	HP 90 Cyan Ink Cartridges, 400-ml, 3-ink Multipack
C5084A	HP 90 Magenta Ink Cartridges, 400-ml, 3-ink Multipack
C5085A	HP 90 Yellow Ink Cartridges, 400-ml, 3-ink Multipack
C5095A	HP 90 Black Ink Cartridges, 775-ml, 3-ink Multipack
C5096A	HP 90 Black Printhead Cleaner

## Original HP large-format printing materials

Q1397A	HP Universal Bond Paper 80 g/m <sup>2</sup> , 36 in. x 150 ft/914 mm x 45.7 m
Q8751A	HP Universal Bond Paper 80 g/m <sup>2</sup> , 36 in. x 574 ft/914 mm x 175 m (NA, LAR, EMEA only)
C6810A	HP Bright White Inkjet Paper 90 g/m <sup>2</sup> , 36 in. x 300 ft/914 mm x 91.4 m
C6020B	HP Coated Paper 90 g/m <sup>2</sup> , 36 in. x 150 ft/914 mm x 45.7 m
C6980A	HP Coated Paper 90 g/m <sup>2</sup> , 36 in. x 300 ft/914 mm x 91.4 m
C6300C	HP Heavyweight Coated Paper 131 g/m <sup>2</sup> , 36 in. x 100 ft/914 mm x 30.5 m
Q1956A	HP Heavyweight Coated Paper 131 g/m <sup>2</sup> , 42 in. x 225 ft/1067 mm x 67.5 m (NA & EMEA only)
C3868A	HP Natural Tracing Paper 90g/m <sup>2</sup> , 36 in. x 150 ft/914 mm x 45.7 m
C3875A	HP Clear Film 174 g/m <sup>2</sup> , 36 in. x 75 ft/914 mm x 22.9 m
51642B	HP Matte Film 160 g/m <sup>2</sup> , 36 in. x 125 ft/914 mm x 38.1 m
Q1427A	HP Universal High-gloss Photo Paper 190 g/m <sup>2</sup> , 36 in. x 100 ft/914 mm x 30.5 m (NA, EMEA, AP only)
Q1421A	HP Universal Semi-gloss Photo Paper 190 g/m <sup>2</sup> , 36 in. x 100 ft/914 mm x 30.5 m (NA, EMEA, AP only)
CG886A	HP Cottle-free Heavyweight Coated Paper 170 g/m <sup>2</sup> , 24 in. x 100 ft/914 mm x 30.5 m (US & EMEA only)
CG887A	HP Cottle-free Heavyweight Coated Paper 170 g/m <sup>2</sup> , 36 in. x 100 ft/914 mm x 30.5 m (US & EMEA only)
CG888A	HP Cottle-free Heavyweight Coated Paper 170 g/m <sup>2</sup> , 42 in. x 100 ft/1067 mm x 30.5 m (US & EMEA only)
CG883A	HP Cottle-free Coated Paper 100 g/m <sup>2</sup> , 24 in. x 150 ft/610 mm x 45.7 m (US & EMEA only)
CG884A	HP Cottle-free Coated Paper 100 g/m <sup>2</sup> , 36 in. x 150 ft/914 mm x 45.7 m (US & EMEA only)
CG885A	HP Cottle-free Coated Paper 100 g/m <sup>2</sup> , 42 in. x 150 ft/1067 mm x 45.7 m (US & EMEA only)
CG889A	HP Recycled Bond Paper 80 g/m <sup>2</sup> , 24 in. x 150 ft/610 mm x 45.7 m (US & EMEA only)
CG890A	HP Recycled Bond Paper 80 g/m <sup>2</sup> , 36 in. x 150 ft/914 mm x 45.7 m (US & EMEA only)
CG891A	HP Recycled Bond Paper 80 g/m <sup>2</sup> , 42 in. x 150 ft/1067 mm x 45.7 m (US & EMEA only)
CG892A	HP Recycled Bond Paper 80 g/m <sup>2</sup> , (A2) 16.5 in. x 150 ft/420 mm x 45.7 m (US & EMEA only)
CG824A	HP Everyday Adhesive Matte Polypropylene 180 g/m <sup>2</sup> , 36 in. x 75 ft/914 mm x 22.9 m
CG825A	HP Everyday Adhesive Matte Polypropylene 180 g/m <sup>2</sup> , 42 in. x 75 ft/1067 mm x 22.9 m
CG843A	HP Everyday Adhesive Matte Polypropylene 180 g/m <sup>2</sup> , 24 in. x 75 ft/610 mm x 22.9 m
CG821A	HP Durable Banner with DuPont <sup>™</sup> Tyvek <sup>®</sup> 140 g/m <sup>2</sup> , 36 in. x 75 ft/914 mm x 22.9 m
CG822A	HP Durable Banner with DuPont <sup>™</sup> Tyvek <sup>®</sup> 140 g/m <sup>2</sup> , 42 in. x 75 ft/1067 mm x 22.9 m
CG823A	HP Durable Banner with DuPont <sup>™</sup> Tyvek <sup>®</sup> 140 g/m <sup>2</sup> , 60 in. x 75 ft/1524 mm x 22.9 m

More HP large-format printing material sizes and weights available at:  
[www.hp.com/go/designjet/supplies](http://www.hp.com/go/designjet/supplies)

## ecoHIGHLIGHTS

### HP DESIGNJET 4020 PRINTER

#### ECO INFORMATION

- Save paper and avoid printing mistakes with HP Instant Printing Utility 2.0
- Less ink wasted thanks to efficient installation and maintenance routine.
- Free, convenient cartridge recycling<sup>1</sup>
- Supports 100% recycled media



ENERGY STAR<sup>®</sup> Qualified Product

1. In countries where the HP's Planet Partner Program operates

[www.hp.com/ecosolutions](http://www.hp.com/ecosolutions)

Please recycle your printing hardware and supplies.  
Find out how at our website.



For more information, visit our website at:  
[www.hp.com/go/designjet4020](http://www.hp.com/go/designjet4020)

