HP DesignJet 755CM Printer

User's Guide



Includes Set Up Instructions
– See Chapter 1 

Manual part number
C3198-90091
First edition, September 1996
Printed in Europe

**Customer re-order number
C3198-60051**

All rights are reserved. No part of the document may be photocopied, reproduced, or translated to another language without the prior written consent of Hewlett-Packard Company.

Adobe™ is a trademark of Adobe Systems Incorporated which may be registered in certain jurisdictions.

Adobe PageMaker™ Adobe Photoshop™ and Aldus PageMaker™ are trademarks of Adobe Systems Incorporated which may be registered in certain jurisdictions.

AutoCAD™ is a trademark of Autodesk Inc.

Bi-Tronics, HP-GL and HP-GL/2 are trademarks of Hewlett-Packard Company.

CorelDRAW!™ is a trademark of Corel Corporation.

Macintosh is a product of Apple Computer Inc.

Microsoft® and MS-DOS® are registered trademarks of Microsoft Corporation.

Microsoft Windows is a registered trademark of Microsoft Corporation.

PANTONE® and PANTONE MATCHING SYSTEM® are licensed trademarks of Pantone, Inc. PANTONE®* Colors generated by the HP DesignJet 650C plotter are four-color process simulations and may not match PANTONE-identified solid color standards. Use current PANTONE Color Reference Manuals for accurate color. PANTONE Color simulations are only obtainable on this product when driven by qualified Pantone-licensed software packages. Contact Pantone, Inc. for a current list of qualified licensees.

*Pantone, Inc.'s check-standard trademark for color. ©Pantone, Inc., 1988

PostScript® is a registered trademark of Adobe Systems Incorporated

QuickDraw™ is a trademark of Apple Computer Inc.

UNIX® is a registered trademark in the United States and other countries, licensed exclusively through X/Open Company Limited.

Notice

The information contained in this document is subject to change without notice and should not be construed as a commitment by Hewlett-Packard Company.

Hewlett-Packard assumes no responsibility for any errors that may appear in this document nor does it make expressed or implied warranty of any kind with regard to this material, including, but not limited to, the implied warranties of merchantability and fitness for a particular purpose.

The Hewlett-Packard Company shall not be liable for incidental or consequential damages in connection with, or arising out of the furnishing, performance, or use of this document and the program material which it describes.

Safety Symbols



The product is marked with this symbol when it is necessary for you to refer to the instruction manual in order to protect against damage to the product.



Hazardous voltage symbol.

WARNING

The Warning symbol calls attention to a procedure, practice, or the like, which, if not correctly performed or adhered to, could result in personal injury. Do not proceed beyond a Warning symbol until the indicated conditions are fully understood and met.

CAUTION

The Caution symbol calls attention to an operating procedure, practice, or the like, which, if not correctly performed or adhered to, could result in damage to or destruction of part or all of the product. Do not proceed beyond a Caution symbol until the indicated conditions are fully understood and met.

Warranty Statement

One-Year On-Site Hardware Warranty

Except when purchased as part of a system, Hewlett-Packard warrants your graphics peripheral hardware product against defects in materials and workmanship for a period of one year from receipt by the end user (proof of purchase required). If HP receives notice of such defects during the warranty period, HP will either, at its option, repair or replace products that prove to be defective.

Should HP be unable to repair or replace the product within a reasonable amount of time, the customer's alternative exclusive remedy shall be refund of the purchase price upon return of the product.

If this product was purchased as part of an HP system in a coordinated shipment or as a system add-on, it is warranted against defects in material and workmanship during the same period as the HP system.

Exclusions

The above warranty shall not apply to defects resulting from: improper or inadequate maintenance by customer; customer-supplied software or interfacing; unauthorized modification or misuse; operation outside of the environmental specifications for the product; operation of non-supported media; or improper site preparation and maintenance. usage exceeding the product warranty limits (see page 8-3).

Warranty Limitations

HP makes no other warranty, either expressed or implied, with respect to this product. HP specifically disclaims the implied warranties of merchantability and fitness for a particular purpose. Some states or provinces do not allow limitations on the duration of an implied warranty, so the above limitation or exclusion may not apply to you. However, any implied warranty of merchantability or fitness is limited to the one-year duration of this written warranty.

This warranty gives you specific legal rights, and you may also have other rights which may vary from state to state, or province to province.

Obtaining Service During Warranty Period

If your hardware should fail during the warranty period, read the "Troubleshooting" section in this guide, then contact your local Hewlett-Packard Sales and Support Office or an Authorized HP Personal Computer Dealer Repair Center and arrange for on-site repair of the product. Retain proof of purchase in order to obtain warranty service.

If a service call is prompted by the "Maintenance advised" message (see page 8-3), it is not covered under this warranty.

After the Warranty Period

If your hardware should fail after the warranty period, read the problem solving sections in this guide, then contact an Authorized HP Personal Computer Dealer Repair Center or call an HP Sales and Support Office for details of the services available. If you have an HP Maintenance Agreement, request service under your agreement.

About this edition

Edition dates are as follows:

1st edition,
September 1996

New editions are complete revisions of the manual. Change sheets, which may be issued between editions, contain additional information. The dates on the title page change only when a new edition is published. Minor corrections that do not affect the function of the product may be made at reprint without a change to the print date.

Many product updates and fixes do not require manual changes and, conversely, manual corrections may be done without accompanying product changes. Therefore, do not expect a one to one correspondence between product updates and manual revisions.



For support details, see the section "Getting help" in chapter 9.

User's Guide



HP DesignJet 755CM Printer
C3198B

Finding Information



This User's Guide Contains:

- A comprehensive explanation of all the printer's features.



The Quick Reference Guide Contains:

- Some information that you are most likely to need on a day-to-day basis. For example, the front-panel menu structure and media-type selections. It is stored in the pocket at the back of the printer.

Where in this manual to find the most commonly needed information	
To find how to ...	go to ...
Install the printer	▶ chapter 1
Connect the printer	▶ page 1-24
Choose media	▶ page 3-2
Load media	▶ page 3-9
Replace the cartridges	▶ page 3-25
See the printer's current configuration	▶ pages 7-2 and 7-3
Clear a media jam	▶ page 9-8
Solve print quality problems	▶ page 9-16
Interpret a front-panel message	▶ page 10-2
Order accessories	▶ page 11-13
To find any other information ...	▶ go to the index <i>at the back of this manual.</i>

On page D-1 at the back of this manual, you will find a **Documentation Map**, listing useful documents to help with:

- Setting Up and Using the Printer
- Using Application Software
- Getting Support
- Programmer's Reference.

Contents

Finding information	ii
Welcome	xi
1 Setting Up The Printer	
<i>Fast Track</i>	1-2
Set Up Checklist	1-3
Task 1: Check that You Have All the Items Required	1-4
Task 2: Switch On and Change the Language from English (<i>Optional</i>)	1-6
Task 3: Load Media	1-8
Task 4: Load the Print Cartridges	1-17
Task 5: Print a Demonstration File (<i>Optional</i>)	1-21
Task 6: Connect the Printer to Your Computer	1-24
Task 7: Configure the Interface (<i>Serial Interface Users Only</i>)	1-26
Task 8: Set Up Your Software	1-32
Task 9: Print a Test File	1-36
Extra Tips for UNIX Users	1-37
2 Learning How To Use the Front-Panel Display (Tutorial)	
The Front Panel	2-2
The Display Section	2-3
Printing the Menus Print	2-4
Description of the Menus Print	2-4
Entering the Menu System	2-5
Navigating the Menu System	2-6
Menu Graphics Used in This Manual	2-8
Other Types of Screen	2-9
Examples	2-10

3 Working With Media and Cartridges

Choosing Media	3-2
Five Important Points about Media Types	3-2
Supported Media Types	3-3
Physical Characteristics of Media types	3-4
Cost and Color Support of Media Types	3-5
Combinations of Media Type and Print Quality	3-6
Typical Media-Type Choices by Application	3-7
Caring for Your Media	3-8
Loading Media	3-9
To Change a Roll	3-9
To Load a Sheet	3-17
Compensating for Badly Cut Media	3-20
To Adjust Skew Tolerance	3-20
Unloading Media	3-21
Drying Time	3-21
To Adjust Drying Time	3-22
To Unload a Sheet after Printing	3-23
To Remove an Unused Sheet	3-24
Replacing Cartridges	3-25
When to Replace Cartridges	3-25
Before Replacing Cartridges	3-26
To Replace One or More Cartridges	3-27

4 Controlling the Page Format

Page Size	4-2
Do You Need to Adjust the Page Size in the Front Panel?	4-3
To Adjust the Page Size in the Front Panel	4-4
Page Size and Clipped Images	4-6
Page Size and Nesting (Roll Media Only)	4-6
Adjusting the Margins (Roll Media Only)	4-7
Margins and Automatic Cutting	4-7
Rotating a Drawing	4-8
Rotating a Drawing from the Front Panel	4-8
To Rotate a Drawing from the Front Panel	4-8
Exactly What is Rotated?	4-9
How Does Rotate Interact with Your Software?	4-10
For PostScript files	4-10
For Non PostScript files	4-11
Printing a Mirror Image	4-12
Changing the Scale of a Printed Image	4-13
Scale and Page Size	4-14

5 Controlling a Print's Overall Appearance

Ways to Control the Print's Appearance	5-2
Why Change the Appearance of the Print Using the Front Panel Rather Than from the Software?	5-3
Changing Pen Widths and Colors Using the Printer's Internal Palettes	5-4
To See the Current Palette Settings	5-4
To See the Colors Available For a Palette	5-5
To Change the Palette Settings	5-6
To Change the Selection of the Current Palette	5-7
Changing the Treatment of Overlapping Lines (Merge Feature)	5-8
Changing the Overall Lightness/Darkness of a Print	5-9
Printing Color Drawings in Monochrome	5-10
To Switch Between Color and Monochrome	5-11
Choosing an Appropriate Print Quality	5-12
To Change the Print Quality	5-13

6 Managing Your Prints

Managing Pages Being Printed or Drying	6-2
To Cancel a Page	6-2
To Cut a Page Before Drying is Complete (Roll Media Only)	6-2
To Pause while Printing a Series of Pages	6-3
Managing Pages Not Yet Printed (The Queue)	6-4
To Start Printing a File That is Waiting For a Timeout	6-4
What is The Queue?	6-5
To Identify a Page In The Queue	6-6
To See the Size of a Page In The Queue	6-7
To Prioritize a Page in The Queue	6-7
To Delete a Page From The Queue	6-7
To Make Copies of a Page in The Queue	6-8
Avoiding Media Waste by Nesting Pages (Roll Media Only)	6-9
What is Nesting?	6-9
When Does the Printer Try to Nest Pages?	6-10
Which Pages Qualify for Nesting?	6-10
Which Pages May be Rotated?	6-10
To Turn Nesting On or Off and Choose the Nesting Method	6-11
What Happens to Nesting if You Turn Queueing Off?	6-11
How Long Does the Printer Wait for Another File?	6-11
Getting the Best From Nesting (Nesting and Margins)	6-12
Nesting and the Rotate Feature	6-12

7	Reconfiguring Your Printer	
	To See the Current Overall Configuration of the Printer	7-2
	To See the Current Configuration of the Front-Panel Settings	7-3
	To Change the Front-Panel Settings	7-4
	Recalibrating the Printer for Accuracy	7-5
	When to Recalibrate the Printer	7-5
	A Quick Guide to Whether Recalibration is Necessary	7-5
	To Recalibrate the Printer	7-6
	To Restore the Factory's Calibration	7-6
	Changing the Graphics Language Setting for a Different Application	7-7
	To Change the Graphics Language Setting	7-7
	Graphics Language and Networks	7-8
	Changing the Interface Settings	7-9
	To Change the Serial Interface Settings	7-9
	To Change the I/O Timeout Setting	7-9
8	Maintaining the Printer	
	Replacing the Print Cartridges	8-2
	Cleaning the Printer	8-2
	“Normal” Printer Use	8-3
	To Print the Service Configuration Print	8-4

9 Troubleshooting

Using the Documentation to Help Solve Problems	9-2
Locating the Source of the Problem	9-3
Solving Media-Handling Problems	9-4
If the Front Panel Keeps Indicating that Media is Misaligned or Mispositioned.	9-4
If Media Crumples When You Load it	9-5
If Prints Do Not Feed Out Properly From the Printer	9-5
If The Automatic Cutter Does Not Cut Immediately When a Print Has Finished	9-5
If the Automatic Cutter Does Not Work	9-6
If Prints Fall on the Floor After Being Cut	9-6
If a Sheet Is Ejected When You Switch On the Printer	9-6
If Prints Do Not Stack Properly in the Bin	9-6
Solving Print Cartridge Problems	9-7
If the Access Cartridges Key Does Not Work	9-7
If the Printer Runs the Cartridge-Alignment Routine Unexpectedly	9-7
If Brand New Cartridges Have Problems	9-7
Clearing a Media Jam	9-8
Solving Communication Problems	9-9
If There is a Problem Communicating between Your Computer and the Printer	9-9
Solving Problems with Image Position or Content	9-10
If the Print Is Completely Blank	9-10
If the Output Contains Only a Partial Print	9-11
If the Image Is Clipped	9-12
If a Long-Axis Print Is Clipped	9-12
If the Entire Image Is in One Quadrant of the Correct Printing Area	9-13
If the Image Is Unexpectedly Rotated	9-13
If the Print Is a Mirror Image of Your Drawing	9-13
If the Print Is Inaccurate	9-13
If the Print Is Distorted or Unintelligible	9-14
If One Image Overlays Another on the Same Sheet	9-14
If Pen Settings Seem To Have No Effect	9-14
If the Printer Produces a Black and White Print When You Expected a Color Print	9-14
If a Gray Box Appears Where an Image Should Be	9-15
If the Printer Has Printed a Different Print Than the One You Were Expecting	9-15
If the Quality Of A Color Print Is Not as Sharp as You Were Expecting ...	9-15

Solving Print-Quality Problems	9-16
If the Color Is Not as Expected	9-16
If there Are White Streaks in Solid Areas	9-16
If There are Other Gaps in Solid Areas Or in Lines	9-17
If There are Jagged Vertical or Horizontal Lines	9-18
If There are Slightly Warped Lines	9-18
If There are Color “Shadows”	9-18
If One or More Cartridges are not Printing at All	9-18
If There are Blurred Lines (Ink “Bleeds” from Lines)	9-19
If There are Blotchy Areas (Uneven Fill Density)	9-19
If the Print Is Too Dark Or the Color Too Saturated	9-19
If There Is Pronounced Banding in Area Fills	9-20
If Ink Smears After You Remove a Print	9-20
Solving Front-Panel Problems	9-21
If the Access Cartridges Key Does Not Work	9-21
If the Cancel key Does Not Work	9-21
If None Of the Front-Panel Keys Work	9-21
If Page Format/Rotate Does Not Work	9-21
If a Display Message Will Not Clear	9-21
If a “System Error” Message Is Displayed	9-22
If an “Out Of Memory/Data Was Lost” Message Is Displayed	9-22
File Size and Memory Usage	9-22
Solving Miscellaneous Problems	9-23
If the Printer Does not Print	9-23
If the Printer Seems Too Slow	9-23
If the Printer Waits Too Long to Print a Nest	9-24
If the Printer Performs the Cartridge-Alignment Routine Unexpectedly	9-24
If the Bail (Black Metal Bar) Does Not Lower All the Way	9-24
Getting Help	9-25
What to Do Before You Call	9-25
If a Repair is Needed	9-25

10 Front-Panel Messages

11 Reference

Printer Specifications	11-2
Interface Specifications	11-7
Interface Cables	11-8
Regulatory Notices	11-10
To Obtain a Material Safety Data Sheet (MSDS)	11-10
Sound	11-10
Electro-Magnetic Compatibility (EMC)	11-10
Telecommunications Statement	11-11
Ordering Accessories	11-13
HP-GL/2 and HP RTL Programming Information	11-16
How to Order Supplies and Accessories	11-16

12 Glossary

Index

Documentation Map

Please Give Us Your Feedback (Removable)

Welcome

A Five-Minute Guide To Your Printer's Main Features

The HP DesignJet 755CM printer is an E/A0 size large-format inkjet printer which can print in color or monochrome.

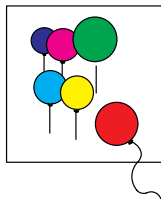

Colors

Your printer uses a set of *four disposable print cartridges* containing yellow, cyan, magenta and black inks. All other supported colors are generated from these four, up to a total of over 16 million different colors for all your needs. Two sets of four cartridges are supplied with the printer. From time to time, you will need to replace them.

Also supplied with the printer is an HP Color Management Kit, which includes software and documentation to help you print the colors you expect on your HP DesignJet 755CM printer. The software in this kit includes various color profiles: PANTONE® process color simulation tables, Adobe™ PhotoShop™ profiles, and Adobe PageMaker™ profiles.

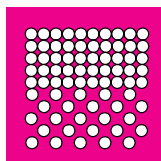

Print Quality

Print resolution can be in true 300 dots per inch or addressable 600 dots per inch depending on the print quality you have selected. You can choose between three levels of print quality – Best, Normal, or Fast – either from your software or from the printer's front panel.

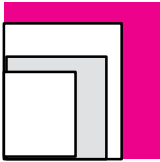

Media

You can print on *rolls or sheets* up to E/A0 size.

A large variety of *media types* are supported:

- High-gloss photo paper*
- Semi-gloss photo paper*
- High-gloss film*
- Matte and clear film
- Coated paper
- Heavy coated paper (one roll is supplied with the printer)
- Opaque bond
- Translucent bond
- Natural tracing paper
- Vellum.

*One roll of one of these glossy media types is supplied with the printer. In addition, a small sample of several of the above is supplied.

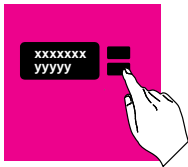

User Interface

The printer's front panel includes an easy-to-use interface with a two-line display, giving you access to a comprehensive set of printer functions and to a number of useful internal prints.

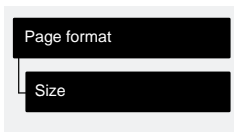

This manual includes a short tutorial to teach you how to navigate around the menus. Wherever a front-panel feature is explained in this manual, a simple graphic shows you how to access that feature in the front-panel menus.



Software Applications and Drivers

To make sure that your printer prints exactly what you were expecting – in terms of size, position, orientation, color and quality – the key is to use the correct driver for the combination of your application software and your printer, and to be confident that it is configured correctly.

Three types of drivers are supplied with your printer:

- HP DesignJet PostScript® drivers for Macintosh® (QuickDraw™ and QuickDraw GX) and Microsoft® Windows™ applications,
- HP driver for users of Microsoft Windows applications,
- HP drivers for AutoCAD™ users.

These drivers come with printed and on line documentation to help you install and configure them correctly. If you are printing using one of these drivers, then refer to *the driver's* documentation, as well as this manual, for advice on the use of this printer.

Generally, software applications include their own drivers too. With this printer we have provided free of charge a set of Software Application Notes for the most popular applications. If you find your own application in these notes, we recommend that you use the information they contain as an overall guide to configuring the software for your printer.

PS Applies *only* to PostScript files

~~**PS**~~ Does *not* apply to PostScript files

The printer behaves differently when it receives a PostScript¹ file than when it receives a file in another “language” (HP-GL, HP-GL2, or RTL). For example, the printer’s ability to scale images applies *only* to PostScript files, while its ability to queue files does *not* apply to PostScript files. Therefore you will see the two symbols on the left used now and then in this manual.

IMPORTANT. The printer does not support PostScript files created in Chinese, Korean and Taiwanese software applications.

If you don’t know whether your application sends PostScript files to a printer, consult your software documentation.

¹ Here, and throughout this manual, references to “PostScript files” mean files sent to the printer using the HP DesignJet PostScript driver supplied with the printer and installed by you on your Macintosh or PC.

Front View

Window

Print Cartridges
(Inside)

ON/OFF Switch

Front Panel Display

Front Panel

Media Lever

Media-Entry Slot

Roll Cover

Media Bin

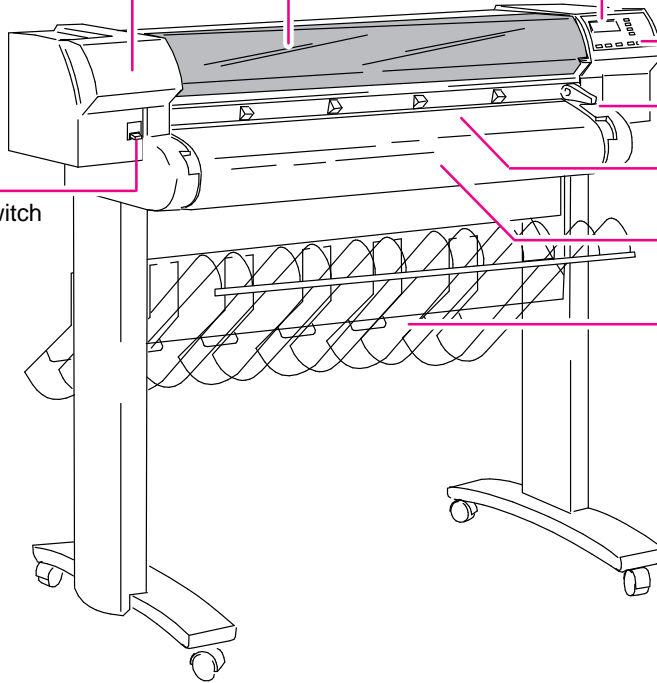

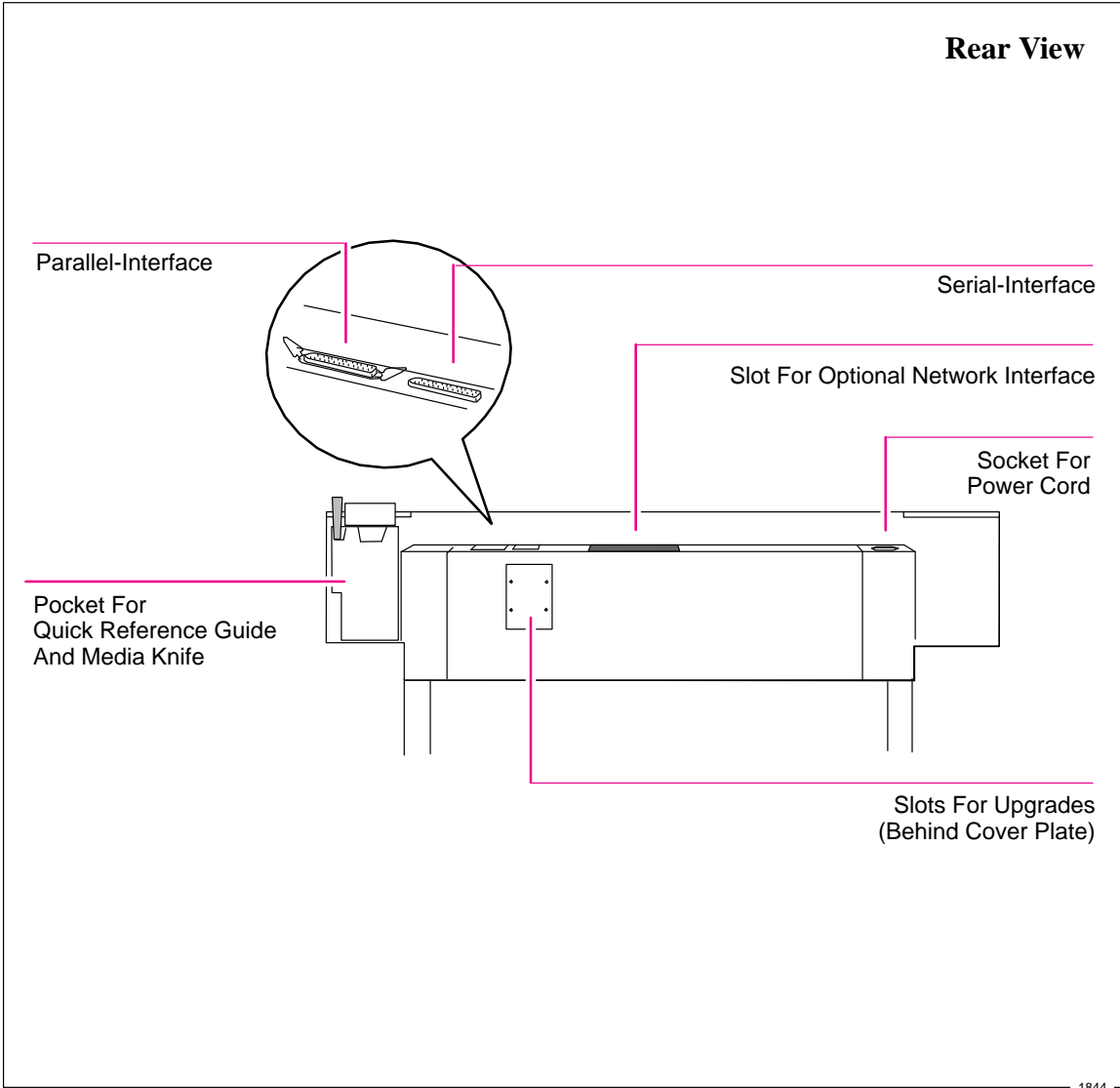

1844

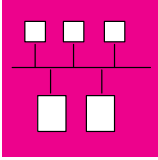

Connections

Your printer comes with an HP JetDirect network interface card, for LAN connections, as well as serial and parallel interfaces for a direct connection to your computer.

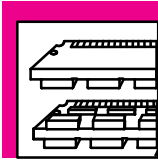

Memory

Your printer comes with a memory of 75 Megabytes (3 Megabytes of internal memory and 72 Megabytes of usable memory). No expansion is possible. For further details of the memory specification, see page 9-22.

Fast Track 1-2

Set Up Checklist 1-3

Task 1: Check that You Have All the Items Required 1-4

Task 2: Switch On and
Change the Language from English (*Optional*) 1-6

Task 3: Load Media 1-8

Task 4: Load the Print Cartridges 1-17

Task 5: Print a Demonstration File (*Optional*) 1-21

Task 6: Connect the Printer to Your Computer 1-24

Task 7: Configure the Interface (*Serial Interface Users Only*) 1-26

Task 8: Set Up Your Software 1-32

Task 9: Print a Test File 1-36

Extra Tips For UNIX Users 1-37

Setting Up the Printer

Installation, Connection,
and Configuration

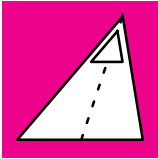

Fast Track

If You Meet All the Following Requirements:

- You want English as the language of the front-panel display and of the printer's sample prints.
- You are experienced at installing printers.
- You are going to use roll media and print in color.
- You know whether to connect the printer directly to your computer or to a network and whether to use the serial or parallel interface, and you already have the right cable.
- (Serial interface users) Your computer's RS-232-C settings are 9600 baud, no parity, 8 data bits and 1 stop bit.

... Just Follow the Six Steps on this Page, and Skip the Rest of this Chapter.

- 1** Connect the power cord and switch on.
- 2** Load the roll of media supplied, following the instructions on the label inside the printer's roll cover. Watch the front-panel display for further instructions.
- 3** Press **Access Cartridges**, open the printer's window, remove the tape from the four cartridges and load them into the carriage on the left side of the printer.
- 4** Close the window and let the printer run its automatic cartridge-alignment procedure.
- 5** Switch off the printer and your computer, connect the interface cable, and then switch them on again.
- 6** Choose your driver disk(s) and color profile disk(s), read the instructions on the label, and follow any printed instructions accompanying the disks. For many Macintosh, Microsoft Windows or AutoCAD applications, the driver is shipped with the printer. For other applications, see page 1-35 for advice, and, if necessary, contact your software vendor.

That's All!



Set Up Checklist

You should already have unpacked and assembled the printer, following the Assembly Instructions in the box. Now you can set up the printer, using the checklist below as you complete each task explained in this chapter.

Task	Done? (✓)
1 Check that you have all the items required.	
2 Switch on and change the language from English (<i>optional</i>).	
3 Load media.	
4 Load the print cartridges.	
5 Print the demonstration print (<i>Optional</i>).	
6 Connect the printer to your computer.	
7 Configure the interface (<i>Serial interface users only</i>).	
8 Set up your software.	
9 Print a test file.	

Task 1: Check that You Have All the Items Required

Supplied

1 You need the following items, which were supplied with the printer.

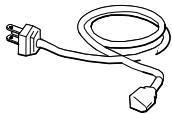

- **Power cord**

The power cord supplied with your printer should meet the plug requirements for your area. However, different power cords (international options) are available. If necessary, contact your dealer or HP Sales and Support Office.

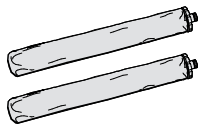

- **A roll of HP glossy paper**

- **A roll of HP Heavyweight Coated Paper**

- **Eight print cartridges:**

- Two yellow
- Two cyan
- Two magenta
- Two black

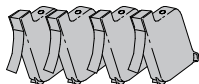

- **Software**

The following software packs were supplied with the printer. Whether you need them depends on which application(s) you intend to use.

- HP DesignJet PostScript Drivers for Macintosh
- HP DesignJet PostScript Driver for Microsoft Windows
- HP Plotter Drivers for AutoCAD
- HP Driver for Microsoft Windows
- HP Color Management Kit



Task 1: Check that you have all the items required

- 2 Inspect the printer itself and the above accessories. If you received any item in a damaged condition, notify the dealer or HP Sales and Support Office where you purchased the printer, and file a claim with the carrier.

Not supplied



- 3 You will also need the following items, which were not supplied with the printer.

- **Interface cable**

For details of suitable cables, see page 11-8.

Task 2: Switch On and Change the Language From English (Optional)

The printer's front-panel menus and all the printer's sample files are available in the following languages¹: English, French, German, Italian, Japanese, Portuguese, and Spanish. By default, the language is English.

WARNING

Be sure that the power cord supplied with your printer matches your ac power connection requirements. Use only three-wire (earth-grounded) power cords with this printer.

- 1 Make sure that the power switch on the front of the printer is OFF.

- 2 Plug the power cord into the socket at the back of the printer, and then into your power outlet.

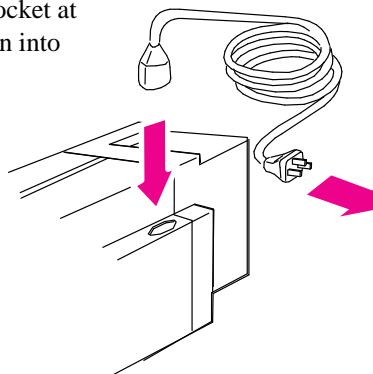

1848

If English OK
or if you have
already
changed the
language

- 3 Switch on the printer by pushing the power switch. Then go to Step 5.

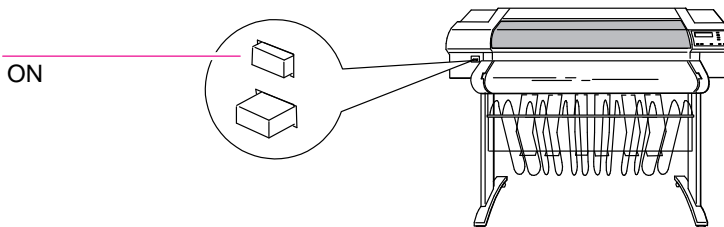

If there is no sound, nor any light on the front panel, you have a power problem.

1843

¹ The physical front-panel overlay is also available in Chinese and Korean.

Task 2: Switch On and (Optional) Change the Language from English

If English not OK 4
or if you want
to change the
language

Hold down the **Enter** key on the front panel and then switch on the printer by pushing the power switch.

1 Press and hold

2 Switch ON

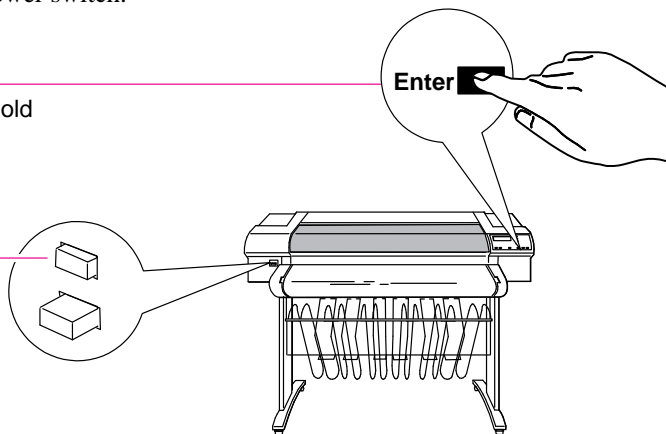

Release the **Enter** key when “STATUS / Initializing” appears on the front-panel screen. If there is no sound, nor any light on the front panel, you have a power problem.

1843a

5 When the word “English” appears on the front-panel screen, press the ↑ or ↓ key until your language appears. Then press **Enter**.

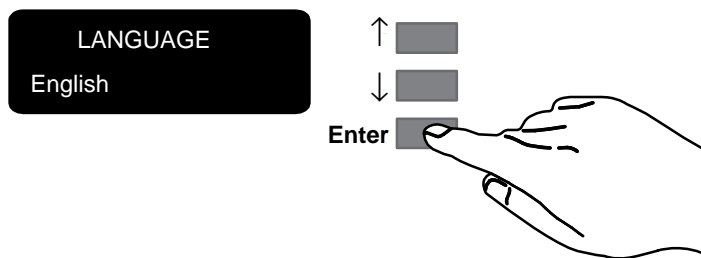

0014

Task 3: Load Media

For advice on the availability and use of different media types, see the section starting on page 3-2.

IMPORTANT Because the next task is to load the cartridges and carry out the automatic cartridge alignment procedure, you *must* load *opaque* media at this stage – for example, coated paper – as this is needed for the alignment procedure. Either of the rolls supplied with the printer is suitable.

To load roll media, start with step 1 below.

To load sheet media, go to page 1-15.

To Load a Roll

- 1 Make sure the printer wheels are locked (the brake levers pressed down) to prevent the printer from moving.
- 2 Open the roll cover and remove the empty spindle by pulling firmly on each end. The two ends are different: end A has a media stop and end B a smaller endcap, as shown on the next page.

Roll cover

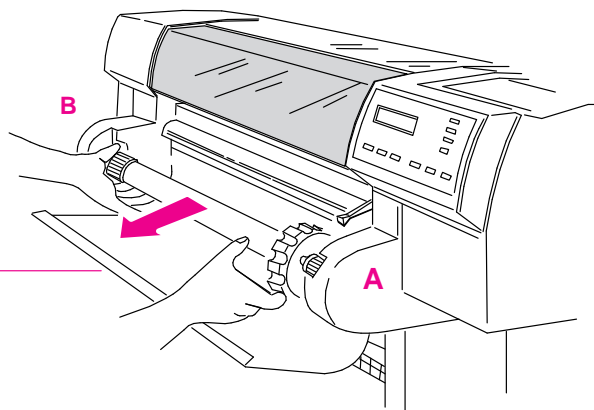

Place the spindle vertically on the floor, with the media stop at the bottom, ready for the new roll.

1865

- 3 Remove the new roll from its wrapping. Remove the endcap from the top of the spindle, and slide the new roll onto the spindle. The leading edge of the media *must* wind clockwise.

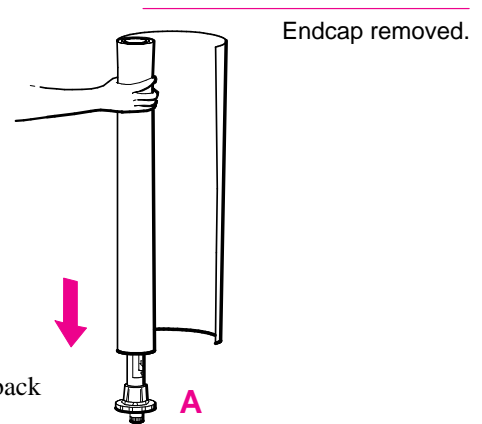

0015

- 4 Push the endcap back in, making sure that the tabs are flush against the ends of the roll. Push it far enough to be firm, but do not use excessive force as this may break the tabs.

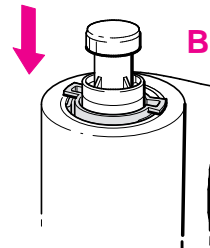

0016

Task 3: Load Media

- 5** Insert the spindle so that the large media stop (A) is to the right and the small endcap (B) to the left. Push in firmly on both ends. Be sure the media remains flush against the media stop.

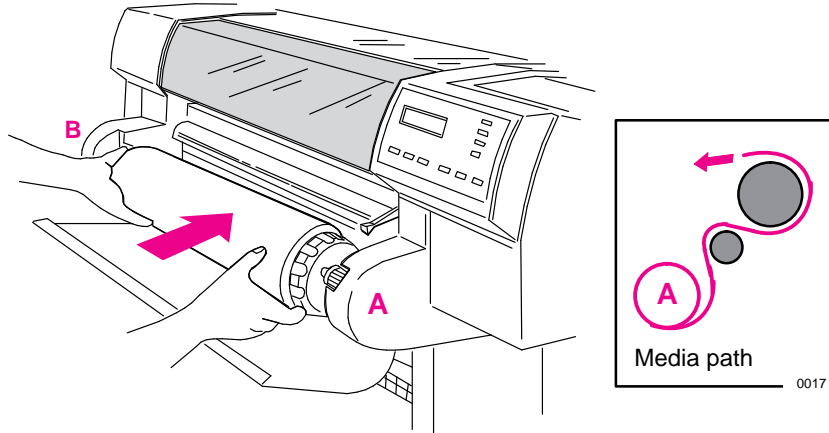

The relationship of the media to the roller must be as shown in the diagram above.

1837

- 6** Check the leading edge as it unwinds from the spool. If it is uneven, trim it as explained in step 7. Otherwise go to step 8.

WARNING

The media cutting knife used in the next step is sharp. Be sure the printer's wheels are locked. Keep fingers clear of the cutting path. Keep media cutting knife away from children.

- 7 Trim the leading edge of the media roll:
- Pull the media over the top of the machine and lay it over the cutting track.
 - Use the media cutting knife in the pocket located at the back of the printer to cut off the first few inches of the media.
 - Retract the blade and return the media cutting knife to its pocket.

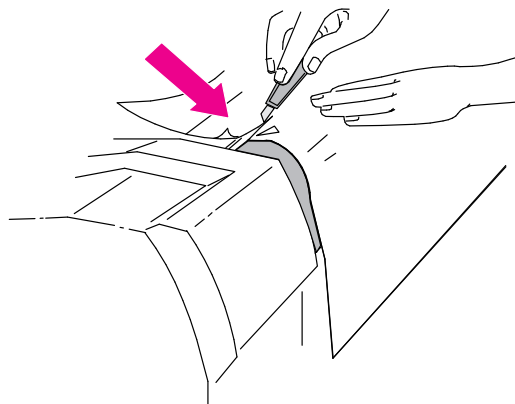

1838

Task 3: Load Media

- 8**
- a** Pull the media towards you and, holding it from the sides, align its right edge with the perforated line on the entry platen.
 - b** Insert the leading edge into the printer, until the page buckles slightly.
 - c** Let go of the media when the printer begins to pull it in.

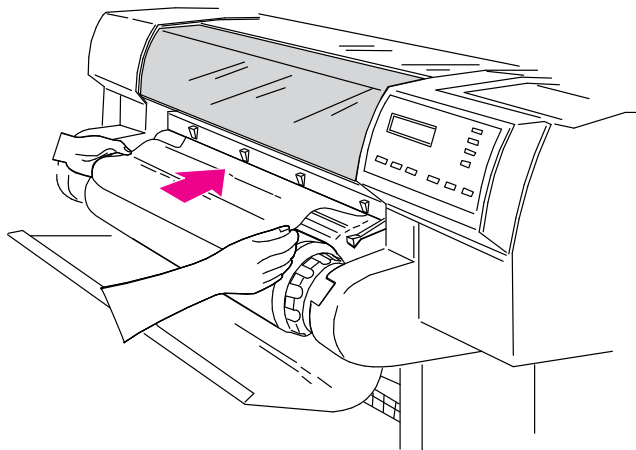

1839

- 9** Press the ↓ key next to the front-panel display to indicate you are loading a roll.

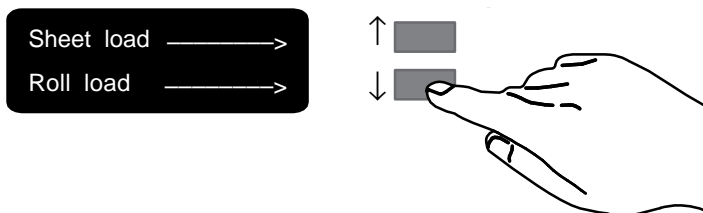

0014

- 10** Press the \uparrow or \downarrow key until the display shows the type of media you are loading (for example, if you are using the roll of HP Heavyweight Coated Paper supplied with the printer, scroll to Heavy coated paper) and then press the **Enter** key.

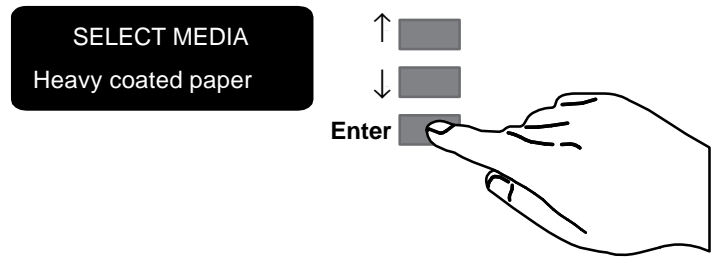

0014

- 11**
- a** When the front panel instructs you, lift the media lever.
 - b** Take hold of the edges of the media now extending from the exit slot and pull the media toward you until taut. Then align the left and right edges of the media so that they are flush with the edges of the roll.

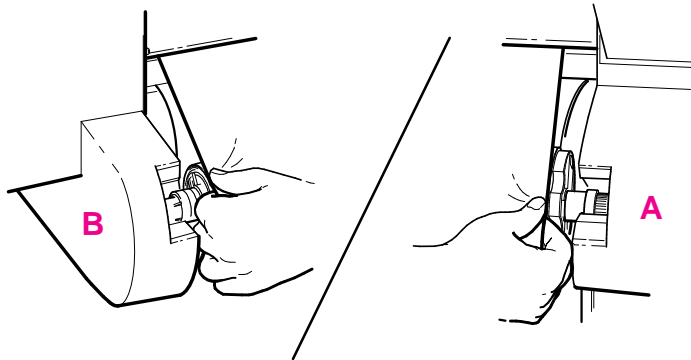

- c** When the front panel instructs you, lower the media lever.

0018

Task 3: Load Media

- 12 a** When the printer instructs you to close the roll cover, rewind the media stop in the direction shown by the large arrow below, to take up any slack in the roll. Make sure that the leading edge of the media is outside the roll cover, and then close the cover.

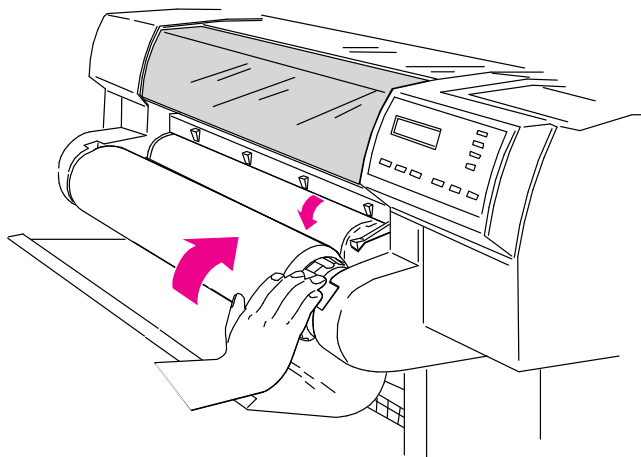

- b** Press the ↓ key to continue. The printer trims off the first few inches of media.
- c** The roll media is now loaded and ready for printing.

1840

To Load Sheet

You can load a sheet in either portrait or landscape orientation. (Your choice of orientation is significant when sending a file from your software, but for the moment it doesn't matter.)

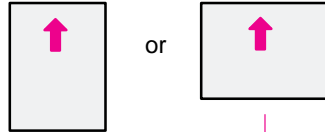

Printing will be on the underside. So, if loading Coated paper, load with the coated side down. For advice on other media types, see page 3-17.

- 1 Make sure the media lever is down and the roll cover is closed.
- 2
 - a Holding the media from the sides, align the right edge with the perforated line on the entry platen.
 - b Insert the media until it buckles slightly, that is, push all the way to the media stops. Let go of the media when the printer begins to pull it in.

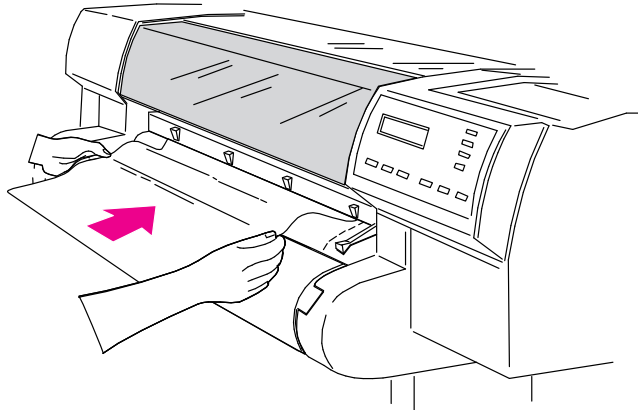

1841

Task 3: Load Media

- 3 Press the ↑ key next to the front-panel display to indicate you are loading a sheet.

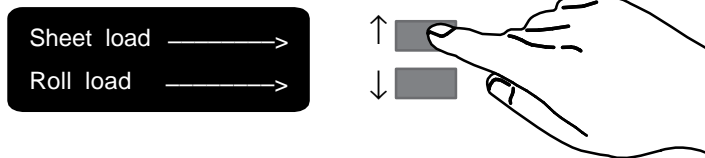

0014

- 4 Press the ↑ or ↓ key until the display shows the type of media you are loading (if you are using heavyweight coated paper, scroll to Heavy coated paper), and then press the **Enter** key.

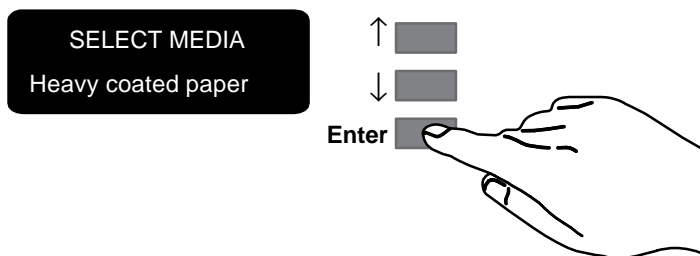

0014

- 5 The printer moves the sheet in and out to check its size and alignment, and then advances it to the start of the page. When sheet loading is complete, STATUS / Ready is displayed.

If you have persistent difficulty loading media, this may indicate poorly cut media – see page 3-20 for advice.

Task 4: Load the Print Cartridges

Eight cartridges are supplied with your printer: two each of yellow, cyan, magenta and black. The printer will operate successfully in monochrome with just the black cartridge loaded (except on glossy media), but these instructions assume that you are loading *all four* cartridges.

Cartridge types

IMPORTANT Your printer is designed to operate only with the four cartridge types whose part numbers are listed on page 11-15, and samples of which are supplied with the printer.

WARNING

Do not touch the stainless steel strip that runs the length of the printer behind the cartridge carriage; its edge is very sharp. Keep hair, jewelry, clothing, and foreign objects away from the printer mechanisms.

- 1
 - a Press the **Access Cartridges** key and wait for the cartridge carriage to come to a complete stop next to the front panel.
 - b When the carriage stops, open the window.

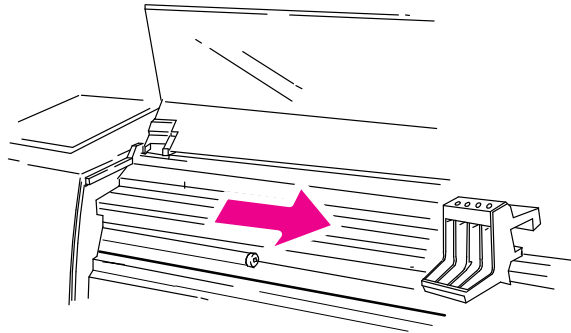

1849

Task 4: Load the Print Cartridges

- 2 Notice that each stall in the empty carriage has a dot indicating the color: you *must* put the correct cartridge in the correct stall.

For users with color-vision deficiencies: You can identify the colors of the cartridges by the part numbers on the boxes – see page 11-15. The sequence of the stalls is, from left to right, yellow, cyan, magenta and black.

CAUTION

It is essential to load the cartridges *with the printer switched ON*, otherwise you will get poor print quality, and the reliability of your cartridges will be impaired.

It is essential to load the cartridges *in the correct stalls*, otherwise not only will your colors be wrong, but also print quality may be impacted.

WARNING

Keep new and used print cartridges out of the reach of children.

3 For each cartridge:

- a** Take the cartridge out of its box.
- b** Remove the colored protective tape and tab from the cartridge's nozzles.

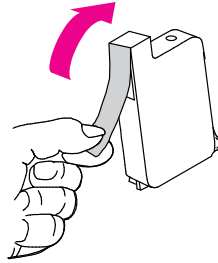

- c** Match the color of the cartridge's label with the color of the dot above the stall.
- d** Insert the cartridge in the correct stall. Press down lightly and push the cartridge away from you until it snaps into place.

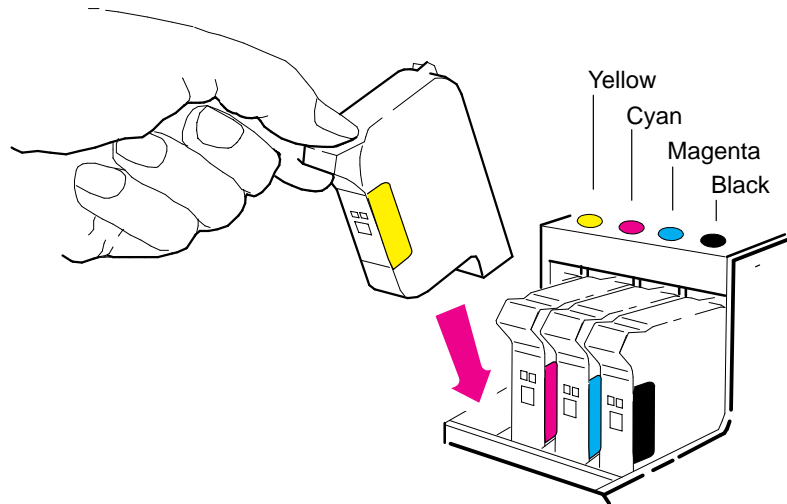

If the front-panel display says **Reseat cartridge**, then remove the cartridge indicated in the display and insert it again. Do so until the message disappears.

Task 4: Load the Print Cartridges

- 4 When all four cartridges are successfully installed, the printer automatically runs the cartridge-alignment procedure. When the front-panel displays STATUS / Ready, the procedure is complete. You can throw away the small print produced during the cartridge alignment procedure.

To make your cartridges last as long as possible, you should not remove them once they are installed, except to replace them.

CAUTION

Now that the cartridges are loaded, *never* turn the printer upside down, or ink will spill.

Task 5: Print a Demonstration File (Optional)

Before you connect your printer to a computer, it is a good idea to print one of the internal sample files. This ensures that the printer itself is operating properly.

- 1 If media is not already loaded, load a roll or a sheet, as explained earlier in task 3. For advice on the availability and use of different media types, see the section starting on page 3-2.

Task 5: (Optional) Print a Demo

2

On the front-panel display, go to Demos, as shown below.

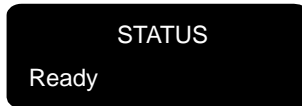

Press **Enter**

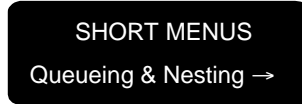

Press ↓

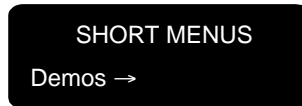

Press **Enter**

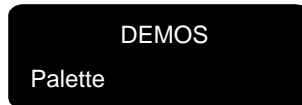

Press **Enter** to choose this or ↓ to get to the next option

Palette prints the **Palette Demo**, which is explained on page 5-5.

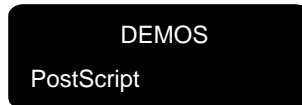

Press **Enter** to choose this or ↓ to get to the next option

PostScript prints a PostScript demo stored in the printer's firmware.

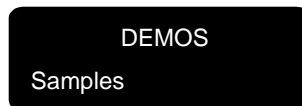

Press **Enter** to choose this or ↓ to get to the next option

Samples prints a CAD demo stored in the printer's firmware.

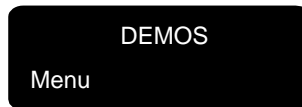

Press **Enter**

Menu prints a menu tree of the entire front-panel menu structure.

If when you choose PostScript or Samples, a further menu is displayed with a choice of demos, select the one you require, by pressing ↑ or ↓, and then press **Enter**.

- 3 The **Receiving** light flashes while the file is being processed, and then the printer starts printing. After it has finished:
 - On roll media, the printer waits for the ink to dry, if necessary, and drops the page into the media bin.
 - On sheet media, wait until the ink is dry, if necessary (see the front-panel display for an ink-drying message), and then gently pull the sheet from the printer. On HP Coated Paper, you don't need to wait at all.
- 4 Examine the print, with the following questions particularly in mind:
 - Are the lines clean and complete?
 - Are the area fills smooth?
 - Is the color of good quality?

Unless you changed it, the print-quality setting on the front panel was Best. If you have any concerns about the print quality of the sample files, use the troubleshooting advice starting on page 9-16.

Task 6: Connect the Printer to Your Computer

For UNIX systems, see also the tips starting on page 1-37.

If You are Connecting the Printer Directly To a Network

You can connect your printer directly to a Local Area Network using its **HP JetDirect Print Server**. Depending on your needs, you may want to use the network interface *instead of, or in addition to*, the parallel and serial interfaces.

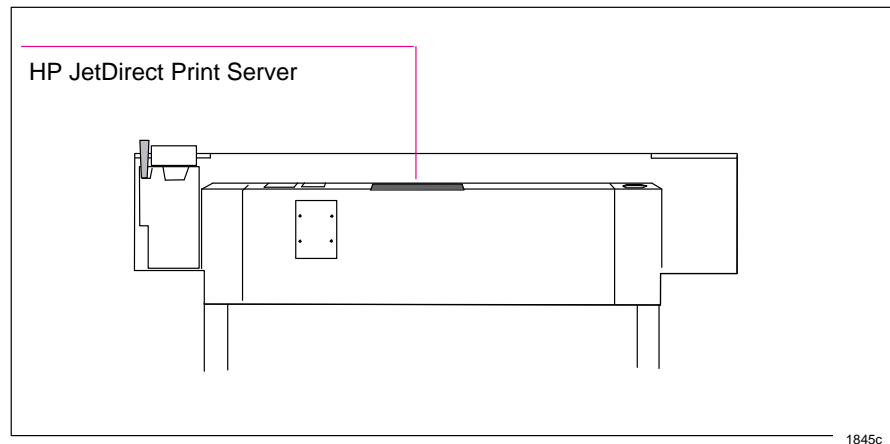

For information concerning your HP JetDirect Print Server, see the *HP JetDirect Print Server Software Installation Guide*, supplied with this printer.

If You are Connecting the Printer Directly to Your Computer

- 1 Decide whether to use the parallel or serial interface.

If your computer and your application software support it, use the parallel interface, as it is faster. You can connect both the parallel and the serial interface simultaneously if you wish: the printer uses the interface that first receives data.

- 2 Choose an interface cable.

A list of recommended HP cables for various computers starts on page 11-8.

AD OLPS ES

To achieve the best performance from your printer, we recommend you only use genuine *Hewlett-Packard* interface cables, whose reliability and performance have been thoroughly tested to give trouble-free performance.

- 3 Switch OFF the printer and then the computer.

- 4 Connect one end of the cable to the appropriate port on the back of the printer.

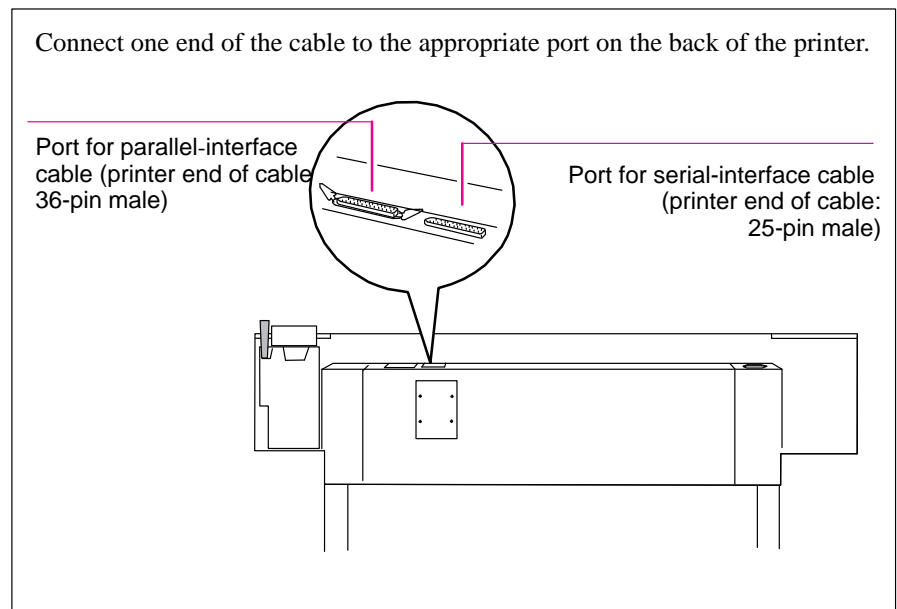

- 5 Connect the other end of the cable to your computer. For help on choosing the correct port on the computer, refer to your computer documentation.
- 6 Switch ON the computer and then the printer.

Task 7: Configure the Interface (*Serial Interface Users Only*)

The following table shows the settings available for the printer's serial interface parameters, the factory defaults and the most likely requirements for different computers.

Serial (RS-232-C) Settings				
Parameter	Available settings	Likely requirement for ...		
		Macintosh	PC	Unix
Baud rate	1200 2400 4800 <i>9600</i> 19200 38400	(²)	<i>9600</i>	<i>9600</i>
Parity ¹	<i>None (0)</i> Even Odd	(²)	<i>None</i>	<i>None</i>
<p><i>Italics = factory default</i></p> <p>¹ Parity of None = 8 data bits, 1 stop bit Parity of Even or Odd = 7 data bits, 1 stop bit</p> <p>² Consult your software documentation.</p>				

The settings on the printer must match those of the computer and software sending the data. Use their documentation to find the requirements. If in doubt, try with the above suggestions. If the printer's defaults already match the requirements, then you can skip the rest of this task.

To Change the Printer's Serial Interface Settings

Through the front-panel display, you can create and save two sets of configurations for the serial interface, called Configurations A and B. By default they are set to the factory defaults shown in the table on page 1-26. The factory default configuration is always available as well, giving you up to three stored configurations to choose from.

The instructions that follow explain how to specify and apply Configuration A. Configuration B can be specified in the same way. To restore the factory default configuration see page 7-6.

Task 7: (Serial Interface Users Only) Configure the Interface

1

On the front-panel display, change the Menu mode from Short to Full.

STATUS
Ready

Press **Enter**

SHORT MENU
Queueing & Nesting →

Press ↓

SHORT MENU
Demos →

Press ↓

UTILITIES
Menu mode=Short →

Press **Enter**

MENU MODE
Short*

Press ↓

MENU MODE
Full

Press **Enter**

UTILITIES
Menu mode=Full →

Press **Previous**

FULL MENU
Utilities →

If FULL MENUS is displayed instead of SHORT MENU, you can skip this step and go to step 2.

Task 7: (Serial Interface Users Only) Configure the Interface

2

Get to the routine for defining a new serial configuration.

FULL MENU
Utilities

Press ↓

FULL MENU
I/O setup →

Press **Enter**

I/O SETUP
Modular →

Press ↓

I/O SETUP
RS-232-C →

Press **Enter**

RS-232-C
Config=Factory →

Press ↓

RS-232-C SETUP
Define config

Press **Enter**

DEFINE CONFIG
Config A →

Press **Enter**

CONFIG A
Baudrate=9600

Task 7: (Serial Interface Users Only) Configure the Interface

3

Configure the serial interface to match your software configuration.

CONFIG A
Baudrate=9600 →

Press **Enter**

BAUDRATE
9600*

Press ↑

BAUDRATE
19200

Press **Enter**

CONFIG A
Baudrate=19200 →

Press ↓

CONFIG A
parity=None(0) →

Press **Enter**

PARITY
none(0)*

Press ↓

PARITY
Even

Press **Enter**

CONFIG A
Parity=Even →

Press **Previous** until you return to ...

This example changes the configuration to 19200 Baud and Even parity.

RS-232-C
Config=Factory →

Task 7: (Serial Interface Users Only) Configure the Interface

4 Switch to the new configuration.

RS-232-C
Config=Factory →

Press **Enter**

CONFIG
Factory*

Press ↓

CONFIG
Config A

Press **Enter**

RS-232-C
Config=A →

Press **Previous** until you return to ...

STATUS
Ready

Task 8: Set Up Your Software

This section gives a **simple overview** of the software-configuration tasks you need to perform and is designed for those users unfamiliar with this type of task. It also points to documents containing detailed, application-specific advice.

More experienced users may prefer to go straight to those documents.

For UNIX systems, see also the tips starting on page 1-37.

Basic Terminology

Application software Application software means the software from which you intend to send files to your printer – for example, a graphics package, a desktop publishing system, a CAD system, etc.

Drivers Your application software needs to know to which type of printer it is sending information. This knowledge, and other configuration information, is held in a “driver.” The driver is a piece of software that handles communications between your application software and your printer.

To make sure that your printer prints exactly what you expect – in terms of size, position, orientation, color and quality – use the correct driver for the combination of your application software and your printer.

Typical Checklist of Tasks to Set Up Your Software

- 1 Identify which driver you need.

Some are supplied with this printer, as listed in the table on page 1-34. Others are supplied with your application software.

- 2 If necessary, install the driver on your computer.

- 3 Add this printer to the device list in the software (Done as part of the installation routine with the PostScript driver.)

This list may be accessed, for example, through Printer type (in Macintosh applications), Printer setup (in Microsoft Windows applications) or CONFIG / Add a Printer (in AutoCAD). In most cases, you don't need to add the printer for each individual software application, but, for example, just once for all Microsoft Windows applications.

- 4 Install any extra color management software on your computer.

For example, you may want to install the software in the Color Management Kit supplied with this printer, in order to be able to print simulations of PANTONE colors. How to do this is explained in the documentation included in the kit.

- 5 Configure the driver and any color management software.

This usually involves a series of dialog boxes where you can specify such items as default media type, print quality etc.

IMPORTANT

In most cases these settings will override any settings you make on the front panel of the printer.

Task 8: Set Up Your Software**Software and Accessories Supplied with This Printer**

Use the information in the table below to decide if you need to install and set up any of the software supplied with this printer.

Item	For use on	Installation and Setup
HP JetDirect Print Server	Macintosh Unix PC	Hardware pre-installed in your printer. Set up the software, as instructed in the HP JetDirect documentation.
HP DesignJet PostScript Drivers ¹	Macintosh PC	Firmware pre-installed in your printer. Install the software on your computer. Set up the software, as instructed in the documentation supplied.
HP Driver for Microsoft Windows 95 and 3.1 Applications ¹	PC	Install the software on your computer. Set up the software, as instructed in the driver documentation.
HP Drivers for AutoCAD ¹	PC	Install the software on your computer. Set up the software, as instructed in the driver documentation.
Color Management Kit	Macintosh PC	Install the profiles on your computer. Set up the software, as instructed in the Color Management Kit documentation.
¹ These items are updated from time to time. For details of which software versions are supported, see the documentation included with them.		

Note for users of Microsoft Windows applications

In most cases, you can use either of the following two drivers:

- HP Driver for Microsoft Windows
- HP DesignJet PostScript Driver for Microsoft Windows

If your files include embedded EPS (encapsulated PostScript) images, use the PostScript driver. To use one, you do not need to install the other as well, but you can install both if you wish.

Other Applications

If you are going to use applications other than AutoCAD, Microsoft Windows or Macintosh applications, first check any Software Application Notes supplied with this printer, to see if the application is covered there. If not, here is some general advice.

The device list in your software may not be up to date with the latest printers available. If the HP DesignJet 755CM is not quoted by name in your application's device list, select an alternative printer as follows:

This table does not apply to PostScript files.



Preference	Device	Comments
1	HP DesignJet 750C	
2	HP DesignJet 350C or HP DesignJet 330	
3	HP DesignJet 250C or HP DesignJet 230	
4	HP DesignJet 220	
5	HP DesignJet 650C	With a preference for C2858B/C2859B rather than C2958A/C2859A
6	HP DesignJet 200	
7	HP DesignJet 600 or HP DesignJet	
8	HP-GL/2 Device	or a similar option including a reference to HP-GL/2
9	HP 7600	
10	HP 7595B DraftMaster SX or HP 7596B DraftMaster RX or HP 7599A DraftMaster MX or HP 7595C DraftMaster SX Plus or HP 7596C DraftMaster RX Plus or HP 7599B DraftMaster MX Plus	
11	HP 7586B	If you choose these devices you may not be able to use your plotter's parallel connection – depending on the application software.
12	HP 7580 or HP 7585	
The devices in the gray boxes support only HP-GL. The others all support HP-GL/2 and HP-GL.		

Task 9: Print a Test File

The sample files explained in task 5 simply verify the operation of the printer itself. Having connected the printer to your computer and configured the drivers or other software for your requirements, you should now be in a position to send a test using one of your own files.

Among the points you should be looking out for are:

- Did the **Receiving** light on the front panel come on?
- Do you see any error message on the front-panel display?
- Does the image appear in the size, orientation and position on the sheet that you expected?
- Is any of the image clipped?
- Are the lines of the correct width?
- Are the colors an exact representation of what you expected?

If you find any problem at all, start by consulting chapter 9 of this manual, “Troubleshooting.” There you will find advice on many different types of problems, from obtaining no output at all, to tracking down the reason for a specific print-quality issue. In case you do not solve your problem with the information supplied there, chapter 9 also contains advice on where else to turn for help.

Extra Tips for UNIX Users

PostScript Applications

The Adobe PostScript drivers supplied with this printer are for Macintosh and Microsoft Windows applications only, and *not* for UNIX applications. Most UNIX applications that output PostScript files include their own embedded PostScript driver. If you have any queries about whether your application supports this printer, or have any output problems that may be linked to a UNIX PostScript driver, first check your software documentation and, if necessary, contact your software vendor for advice.

Which Interface?

You can connect the printer to your workstation in one of two ways:

- Via the UNIX print-spooling system, using any of the interfaces: network, parallel or serial
- Directly using the serial interface

Recommendations

The *print-spooling system* is recommended, so that printing takes place in the background while you continue using your application. A *network interface* is also recommended, as it will give you not only more flexibility in locating the printer, but also the possibility of network integration and centralized printer configurations using BOOTP (Bootstrap Protocol) and TFTP (Trivial File Transfer Protocol).

If you choose the *parallel interface*, you may need a parallel-interface card for your workstation. Contact your workstation supplier for details.

Print Spooler Configuration Examples

Example 1: Configuring the SunOS 4.1.3 print spooler for Sun SPARCstations (parallel interface)

In order to perform the following steps you must be superuser.

- 1 Create a directory for print spooling. All application users need read and write permission for this directory. For example, from the command line of a shell, type:

```
mkdir /usr/spool/cad
chmod 777 /usr/spool/cad
```

- 2 Edit the /etc/printcap file to set up the printer configuration. You must assign a name to each printer managed by the print spooler. Refer to the example below if you need help completing this step.

Add the following lines to your /etc/printcap file. The example assumes:

- your printer is named djet,
- the device name of your parallel port is /dev/bpp0, and
- your spool directory is called /usr/spool/cad.

Entry for an HP printer on a parallel port

```
djet:\
        :mx#0:sf:sh:\
        :lp=/dev/bpp0:\
        :sd=/usr/spool/cad:\
        :lf=/usr/adm/lpd-errs:
```

Example 2: Configuring the SunOS 4.1.3 print spooler for Sun SPARCstations (serial interface)

In order to perform the following steps you must be superuser.

- 1 Create a directory for print spooling. All application users need read and write permissions for this directory. For example, from the command line of a shell, type:

```
mkdir /usr/spool/cad
chmod 777 /usr/spool/cad
```
- 2 Edit the `/etc/printcap` file to set up the printer configuration. You must assign a name to each printer managed by the print spooler. Refer to the example below if you need help completing this step.
- 3 Add the following lines to your `/etc/printcap` file. The example assumes:
 - your printer is named `djet`, and
 - your printer is connected to the device named `/dev/ttya` (usually the first serial port on the workstation), and
 - the spooling directory you created in step 1 is called `/usr/spool/cad`.

```
# Entry for an HP printer on a serial port
djet:\
        :lp=/dev/ttya:sd=/usr/spool/cad:br#9600:\
        :lf=/usr/adm/lpd-errs:\
        :sf:sh:mx#0:xc#0177777:xs#040040:fc#050:\
        :ms=-evenp:
```
- 4 Make sure the printer's baud rate is 9600 and parity is even.

Example 3: Configuring the SunOS 4.1.3 print spooler for Sun SPARCstations (network interface with HP JetDirect)

See the *Configuration Guide* shipped with the HP JetDirect Network Interface.

Example 4: Configuring the Solaris 2.x print spooler for Sun SPARCstations

In order to perform the following steps you must be a superuser or belong to the special sysadmin (GID=14) group. If you are using the NIS+ name service, you may need NIS+ permissions to modify the printer table. Refer to your Sun documentation for details.

- 1 Create a directory for print spooling. All application users need read and write permission for this directory, so you must be a superuser to perform this step. For example, from the command line of a shell, type:

```
mkdir /usr/spool/cad
chmod 777 /usr/spool/cad
```

- 2 Start the Administration Tool utility (from OpenWindows™).

```
% /bin/admintool
```
- 3 Load the Printer Manager window, and, from the Add Printer edit menu, select Add Local Printer.
- 4 In the Add Local Printer dialog box:

Item	Select ...
Printer Name:	For example, HP DesignJet 755CM
Printer Type:	Other, and set it to Unknown.
File Contents:	Any.
Banner:	Not required.

For full details on how to use the Printer Manager option of admintool, consult your Sun documentation.

- 5 Exit admintool.
- 6 For serial connections:
 - a Make sure the printer's baud rate is 9600 and parity is even.
 - b From the command line of a shell, as superuser, enter the following:

```
lpadmin -p pname -o "stty='9600 evenp -cstopb ixon ixoff"
```

where *pname* is the same as Printer Name in step 4. It is assumed that /usr/sbin is in the superuser's path.

The Front Panel 2-2

 The Display Section 2-3

Printing the Menu Print 2-4

 Description of the Menu Print 2-4

Entering the Menu System 2-5

Navigating The Menu System 2-6

 Menu Graphics Used in This Manual 2-8

Other Types of Screen 2-9

Examples 2-10

 Example 1: Changing Margins 2-10

 Example 2: Changing the Drying Time 2-11

Learning How To Use the Front Panel Display

Tutorial

The Front Panel

The Front Panel

The front panel of the HP DesignJet 755CM printer is shown below:

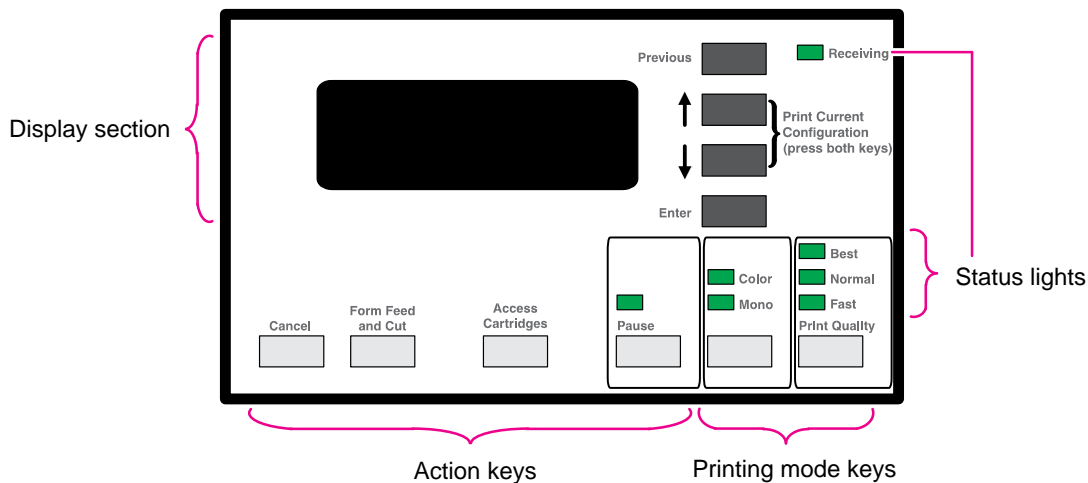

The purpose of this tutorial is to explain the use of the display section. The other sections and their use are described later in this manual.

The display section is used primarily for setting the printer's configuration, so, before the tutorial, print the *current* configuration. You can return to this afterwards.

- 1 Make sure that media is loaded. See page 3-9 for loading information.
- 2 Print the **Current Configuration** print, by pressing the ↑ and ↓ keys simultaneously.

The diagram shows the front panel with the display section displaying 'STATUS Ready'. A callout points to the up and down arrow keys with the text 'Press these two simultaneously'. Below the diagram, it says 'Keep the print for later reference.'

The Display Section

The display section of the front panel consists of the display itself and the four display keys to its right (**Previous**, **↑**, **↓** and **Enter**).

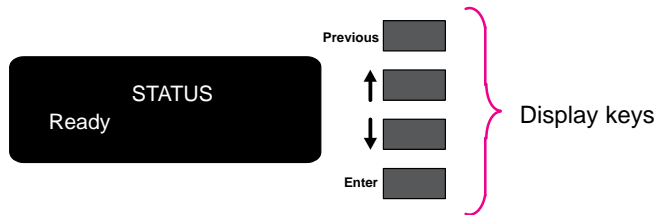

The display can show two lines of text and is used for displaying:

- Menus, for example:



In this case, you can use the display keys to navigate the menu system and select menu options.

- Messages, for example:

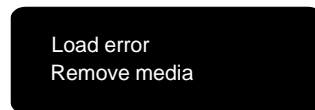

These messages may concern machine status, actions required or errors.

In this case, you can use the display keys to respond to messages. See chapter 10, "Front panel messages" for more information.

Printing the Menu Print

Printing the Menu Print

You can see the complete menu structure available on the printer by printing the Front-Panel Menu print. To help understand the menu structure and its navigation, print it now:

- 1 Check that media is loaded. See page 3-9 for loading information.
- 2 Select the Menu option from the DEMOS menu, as described in chapter 1, task 5. The Front-Panel Menu print will be printed.

Description of the Menu Print

Look at the Front-Panel Menu print . It shows the full menu structure. Here is a sample section of it (concerned with pen settings):

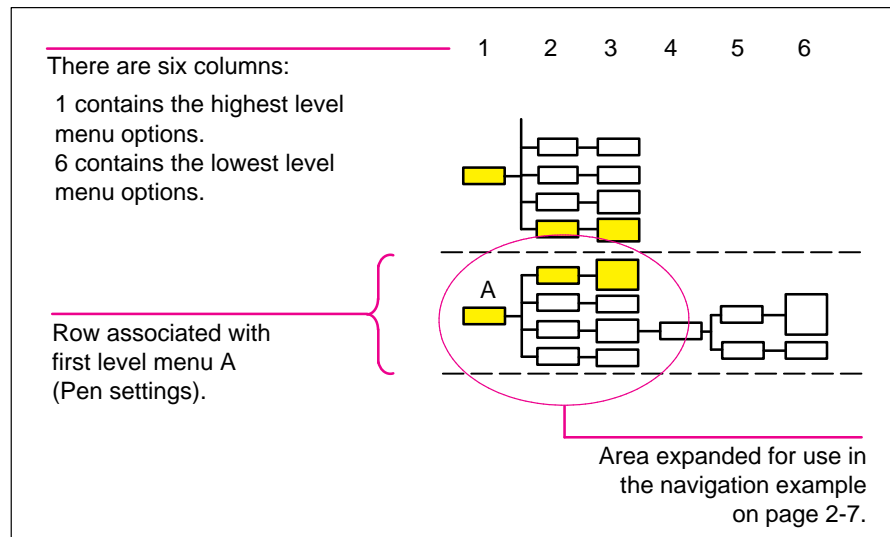

Entering the Menu System

With a STATUS screen displayed, for instance:

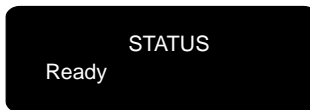

press the Enter key.

Either the SHORT MENU screen:

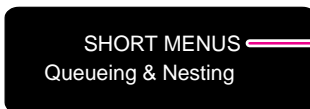

Only menu shaded yellow in Front Panel Menu print accessible (Shaded gray if printing in black only).

or the FULL MENU screen:

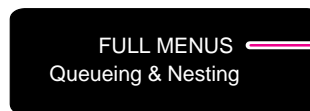

All menus accessible.

is displayed, with the Queueing & Nesting option shown.¹

Change to full menu mode, if necessary. See page 1-28.

You are now in the 1st level menu, shown in the 1st column of the Front-Panel Menu print.

¹ You may not be able to access the menu system *immediately*, if the current task overrides it. If this happens, wait until the task is completed and try again.

Navigating the Menu System

Once in the 1st-level menu, you navigate the system using the display keys.

Press **Previous** to display the previous menu level, without changing any menu selections (equivalent to moving left [←]¹ one column in the Front-Panel Menus print).

Press ↑ to scroll up, or ↓ to scroll down through the options in a menu (equivalent to moving up [↑] or down [↓] a column in the Front-Panel Menus print).

The option list is continuous, allowing you to move from the bottom to the top by pressing ↓ or from the top to the bottom by pressing ↑.

Press **Enter** to:

- select an option and move to the next menu level, when in the menu system (equivalent to moving one column to the right [→] in the Front-Panel Menus print).
- add to the configuration, your displayed choice from the options available in the lowest level menu [↵].

¹ The colored arrows ↑↓↔↵, shown in square brackets above, are used to represent pressing the relevant keys once, in the following navigation example.

Use this example to practice navigating the menu system. It assumes that you have entered the menu system from the STATUS screen and wish to change the Merge setting in Pen settings. The colored arrows on the excerpt of the Front-Panel Menus print below correspond to the numbered instructions.

- 1 Press the ↓ key five times to display the Pen settings option.
- 2 Press the **Enter** key to select the option and move to the Pen settings second-level menu. The Palette option is displayed.
- 3 Press the ↓ key once to display the Merge option.
- 4 Press the **Enter** key to select the option and move to the Merge third-level menu. The option currently selected is displayed with a *.
- 5 Change the displayed option by pressing the ↓ or the ↑ key.
- 6 Press the **Enter** key to set Merge equal to the new displayed value. You will be returned to the Merge second-level menu.
- 7 To exit the menu system, press the **Previous** key twice.

If you now re-enter the menu system and repeat steps 1 to 4, you will see the option that you selected displayed with a *.

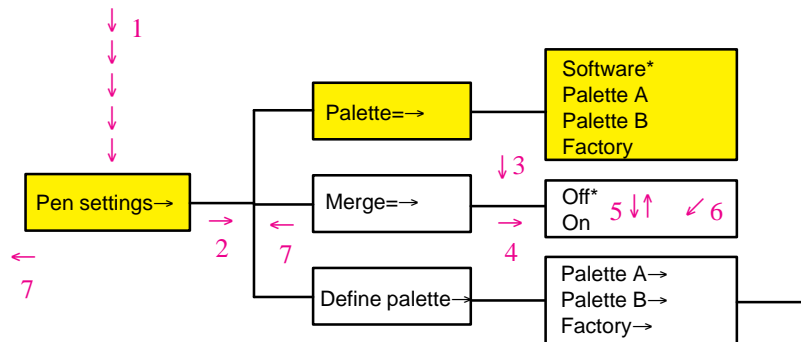

Note: A → character in a menu option box indicates that another level of menu is available.

Navigating the Menu System

Menu Graphics Used in This Manual

At the end of this chapter, there are some examples of navigating the menu system, showing all the menu displays available. In the rest of this manual, when you need to use the menu system, a simple menu graphic will appear in the left margin giving a concise explanation of how to navigate to the exact place.

The graphics look similar to this, but further levels may be shown:

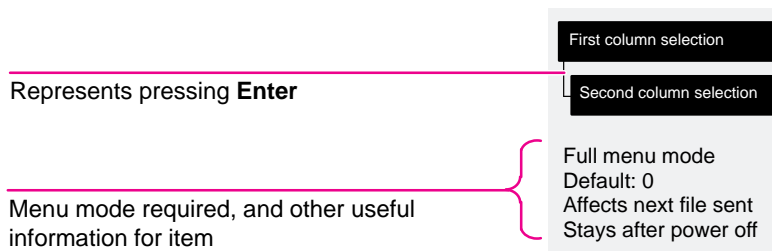

Other Types of Screen

Other screens, such as those displayed for selecting media type during media loading:

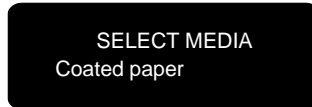

or for changing the language:

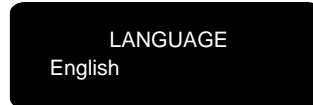

are in fact further examples of selection menus which are not part of the main menu system. These behave in the same way as other menus, in that you can scroll through the options using the ↓ and ↑ keys and select a displayed option using the **Enter** key.

Examples

Examples

Example 1: Changing Margins

In the section of this manual that describes how to adjust the page margins, the icon on the left is shown, indicating that you should go to the MARGINS menu as follows.

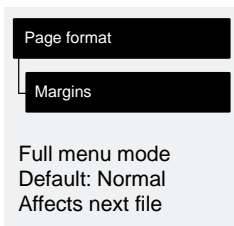

With the STATUS screen displayed:



- 1 Enter the menu system by pressing the **Enter** key.

Either the SHORT MENU screen or the FULL MENU screen is displayed with the Queueing & Nesting option. If necessary, see page 1-28 and change to full menu mode.

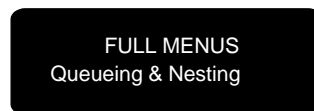

- 2 Press the **↑** key once, or the **↓** key 6 times, to display the required option.

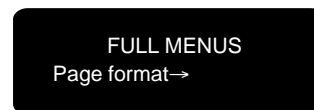

- 3 Press the **Enter** key.



Continued...

- 4 Press the ↓ key twice, or the ↑ key twice, to display the required option.

PAGE FORMAT
Margins=Normal

- 5 Press the **Enter** key to display the MARGINS menu.

MARGINS
Normal

- 6 Use the ↑ and ↓ keys to display the available options and, when the one required is displayed, press the **Enter** key to select it as the value for Margins.

Example 2: Changing the Drying Time

The section on adjusting the drying time, to suit different environmental conditions, contains the icon shown on the left, indicating that you should go to the DRYING TIME menu. This example assumes that the display is in full menu mode following example 1, but can be used in short menu mode.

Device setup

Drying time

All menu modes
Default: Normal

With the STATUS screen displayed:

STATUS
Ready

- 1 Enter the menu system by pressing the **Enter** key.

The FULL MENU screen is displayed with the Queueing & Nesting option.

FULL MENU
Queueing & Nesting

Continued...

Examples

- 2 Press the ↑ key 3 times, or the ↓ key 4 times, to display the required option.

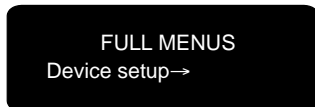

- 3 Press the **Enter** key. (If the display is in short menu mode, you will notice that the screen shown after instruction 4 below is displayed at this point, so go to instruction 5.)

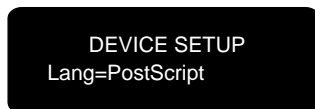

- 4 Press the ↑ key once, or the ↓ key 4 times, to display the required option.

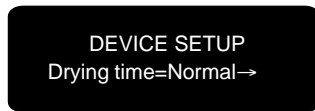

- 5 Press the **Enter** key to display the DRYING TIME menu.

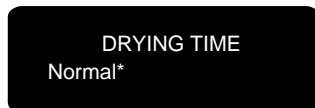

- 6 Use the ↑ and ↓ keys to display the available options and, when the one required is displayed, press the **Enter** key to select it as the value for Drying time.

Choosing Media 3-2
Caring For Your Media 3-8
Loading Media 3-9
Unloading Media 3-21
Replacing Cartridges 3-25



Working With Media and Cartridges

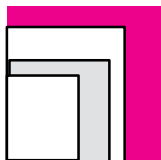

Choosing Media

Your printer supports many types of paper and other media types. Choosing the best media type for your requirements is the first (and most important) step in ensuring good print quality. It is recommended you only use genuine Hewlett-Packard media, whose reliability and performance have been developed and thoroughly tested to give trouble-free performance and optimal print quality.

For details of Hewlett-Packard media, see page 3-3 and the HP DesignJet Papers and Films catalog supplied with the printer.

Five Important Points about Media Types

- When selecting different **opaque paper types**, be aware that you will use significantly less ink printing on coated types than on normal opaque bond.
- Most media types are supported, However the quality of some prints may not be as good if you do not use HP media. For media details, see the table on page 3-5.
- Whenever you load a roll or a sheet, the printer's front-panel display prompts you to specify which **media type** you are loading. It is *absolutely essential* for good print quality to specify this correctly. The table on page 3-3 gives you all the information you need. If media is already loaded and you are unsure which media type was specified, go to Utilities / Statistics in the front panel, as explained on page 7-2.
- You should also be aware of which **print quality** setting (best, normal or fast) you are using. You can set this either from your software or from the printer's front panel (*the software driver setting will override any print quality setting made on the front panel*). The combination of media type and print quality settings automatically tells the printer how to place the ink on the media – for example, in terms of ink density and number of passes of the cartridges. For more details, see the tables on page(s) 3-6 and 3-7. There are print quality improvements which can be made using **sharp lines** on the front panel menu or in the Windows driver, this is described on page 5-15.
- Included with this printer is a **HP DesignJet Papers and Films catalog** which gives ordering details for Hewlett-Packard media supplies. To get the latest version of this document, contact your local HP Sales and Support office.

Supported Media Types

Media Type on the Front-Panel Display	Also Known As	Commercial Name of HP Media ¹
Coated paper	Special paper Special inkjet paper Color inkjet paper Matte paper Presentation	HP Coated Paper for the HP DesignJet 750C Plus and 755CM Note: HP Special Inkjet Paper is <i>not</i> supported on the HP DesignJet 755CM printer.
Heavy coated paper	Heavyweight coated paper Heavyweight special paper Heavyweight inkjet paper Heavyweight color inkjet paper Heavyweight matte paper	HP Coated Heavyweight Paper for the HP DesignJet 750C Plus and 755CM Note: HP Heavyweight Special Inkjet Paper is <i>not</i> supported on the HP DesignJet 755CM printer.
Matte film	Matte polyester Poly matte film Mylar	HP Matte Film
Clear film	Translucent film Clear polyester	HP Clear Film
High-gloss photo	High-gloss photo paper High-gloss paper	HP High-Gloss Photo Paper
Semi-gloss photo	Semi-gloss photo paper Semi-gloss paper	HP Semi-Gloss Photo Paper
High-gloss film	High-gloss white film	HP High-Gloss White Film
Opaque bond	Printer paper	HP Opaque Bond
Translucent bond		HP Translucent Bond
Natural tracing paper	Natural tracing paper Tracing paper Extra translucent bond	HP Natural Tracing Paper YHP Tracing Paper
Vellum		HP Vellum
<p>¹ From time to time, new media types may become available. For up-to-date information, please contact your HP dealer or local HP Sales and Support Office.</p>		

Choosing Media**Physical Characteristics of Media types**

Media Type on the Front-panel Display	Physical Characteristics		
	Opacity	Matte or Glossy	Special coated side for printing?
Coated paper	Opaque	Matte	Yes ¹
Heavy coated paper	Opaque	Matte	Yes
Matte film	Semi-opaque	Matte	Yes
Clear film	Clear	–	Yes
High-gloss photo	Opaque	Glossy	Yes
Semi-gloss photo	Opaque	Glossy	Yes
High-gloss film	Opaque	Glossy	Yes
Opaque bond	Opaque	Matte	No
Translucent bond	Semi-opaque	Matte	No
Natural tracing paper	Semi-opaque	Matte	No
Vellum	Semi-opaque	Matte	No
¹ When loading coated paper into the printer, ensure the coated side is facing downwards.			

Cost and Color Support of Media Types

Media Type on the Front-Panel Display	Cost (Relative to Each Other)	Recommended for Color?
Coated paper	Low / moderate	Yes
Heavy coated paper	Moderate	Yes
Matte film	High	Yes
Clear film	High	Yes
High-gloss photo	High	Yes
Semi-gloss photo	High	Yes
High-gloss film	High	Yes
Opaque bond	Low	CAD drawings only ¹
Translucent bond	Low	No
Natural tracing paper	Moderate	CAD drawings only ¹ HP media only
Vellum	Moderate	
<p>¹ The limitations using non-coated media for color depends on:</p> <ul style="list-style-type: none"> ● the amount of filled area in your drawing (the more there is, the less likely that the print quality on opaque bond will be satisfactory), ● the quality of the media. 		

Choosing Media**Combinations of Media Type and Print Quality**

The table below shows that some combinations of media type and print quality are not recommended.

Media Type on the Front-Panel Display	Print Quality (Set Either on the Front Panel or In the Software)		
	Fast	Normal	Best
Coated paper	OK	OK	OK
Heavy coated paper	OK	OK	OK
Matte film	OK	OK	OK
Clear film	OK	OK	OK
High-gloss photo	Not recommended	OK	OK
Semi-gloss photo	Not recommended	OK	OK
High-gloss film	Not recommended	OK	OK
Opaque bond	OK	OK	OK
Translucent bond	OK in monochrome only	OK in monochrome only	OK in monochrome only
Natural tracing paper	OK	OK	OK
Vellum	OK	OK	OK

IMPORTANT. If you are using an add-on a third-party Raster Image Processor (RIP), in order to create additional print modes on your printer, then the above table may not apply. In this case, consult your RIP vendor for advice on the best settings for your requirements. A clue as to whether you are using a RIP or not is the message on the printer's front panel while it is printing. If the message "STATUS / Printing (special)" appears, then you *are* using a RIP. If the message "STATUS / Printing" appears, then you are probably not using a RIP.

Typical Media-Type Choices by Application

Application	Use	Typical Choice of Media ²	Probable Choice of Print Quality ³
Imaging and graphics packages color	Matte	Opaque bond (for drafts) Coated paper Heavy coated paper (for durability)	Fast, Normal or Best Fast, Normal or Best Normal or Best
	Gloss	High-gloss photo Semi-gloss photo High-gloss film	Normal or Best Normal or Best Normal or Best
	Clear film	Clear film	Best
CAD ¹ and GIS ¹ color	Drafts	Opaque bond Natural tracing paper Vellum Coated paper	Fast or Normal Fast or Normal
	Final versions	Coated paper Heavy coated paper (for durability) Matte film Clear film	Normal or Best Normal or Best Normal or Best Fast or Normal
	Archives	Matte film Clear film	Best Normal
	Overlays	Clear film	Fast or Normal
CAD ¹ monochrome	Drafts	Opaque bond Translucent bond Natural tracing paper Vellum	Fast or Normal Fast or Normal Fast or Normal Fast or Normal
	Final versions	Opaque bond Matte film Clear film	Normal or Best Normal or Best Normal or Best
	Archives	Vellum Matte film Clear film	Best Best Best
	Diazo reproductions	Translucent bond Natural tracing paper Vellum Matte film	Normal or Best Normal or Best Normal or Best Normal or Best
¹ CAD = Computer-Aided Design GIS = Geographical Information or Mapping Systems		² Using the generic media types on the front-panel display ³ Set either on the front panel or in the software	

Caring for Your Media

- Handle *film and glossy media* by the edge(s) or wear cotton gloves. Skin oils can interact with ink and cause it to smear.
- Make sure the media bin is installed between the printer's legs. When the printer finishes each print on roll media, it automatically cuts the page and drops it into the bin. Note that mixing page sizes can cause shorter prints to curl and shuffle in the bin.
- Colors will eventually fade or change if exposed to office light or sunlight over a period of time. Therefore:
 - avoid exposing your prints longer than necessary to direct sunlight.
 - ideally, when not using your prints, store them away from any light, for example, in a drawer.



Loading Media

To Change a Roll

1 Be sure the printer wheels are locked (the brake lever pressed down) to prevent the printer from moving.

2 *If the old roll is not used up*, then to remove the media from the media path:

- a** Raise the media lever to release the media.
- b** Open the roll cover and turn the media stop to wind the media out of the printer and onto the roll.

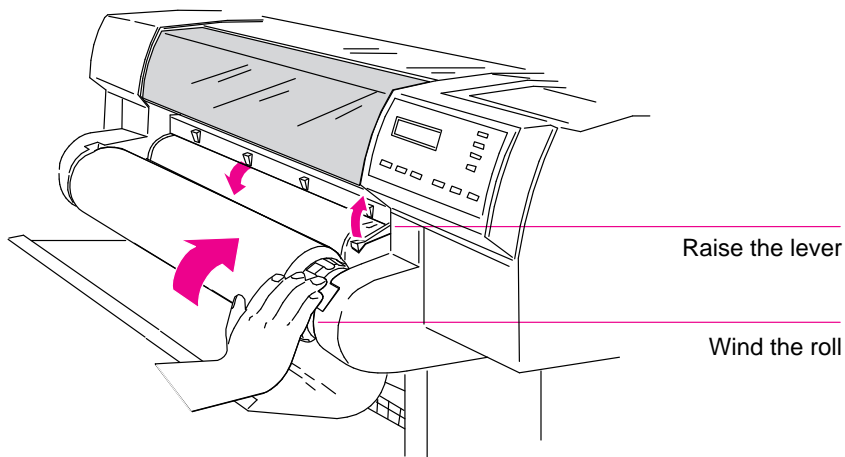

- c** Lower the media lever.

1840a

Loading Media

- 3 Remove the **old roll** by pulling firmly on each end of the spindle.

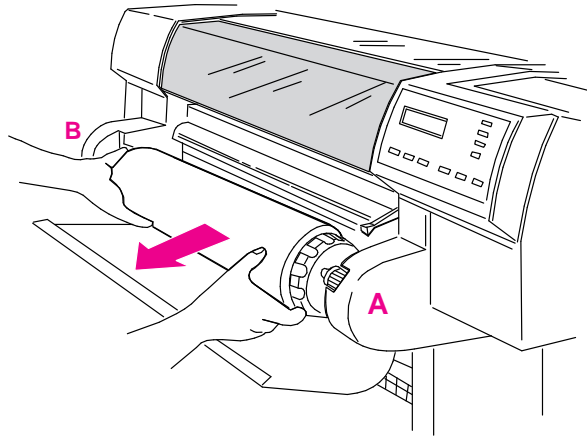

1837a

- 4
- a Rest the old roll upright on the floor so that the media stop (A) is on top.
 - b Pull out the media stop and the spindle and set it aside.

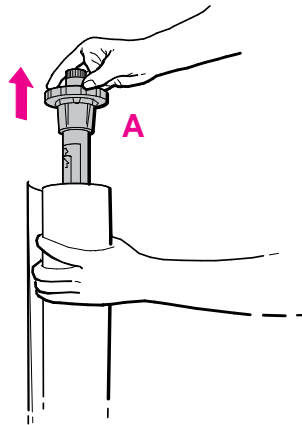

0021

- 5 From the other end of the old roll, pull out the endcap (B).

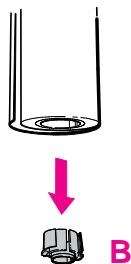

0022

- 6 If you are not immediately loading another roll of media into the printer, replace the endcap on the spindle and place the spindle back in the printer. You can skip the rest of these steps.

- 7
- Remove the **new roll** from its wrapping.
 - Turn the spindle upside down, that is, with the media stop at the bottom (and the end cap still removed)
 - Place the new roll on the spindle, so that the leading edge winds *clockwise*.

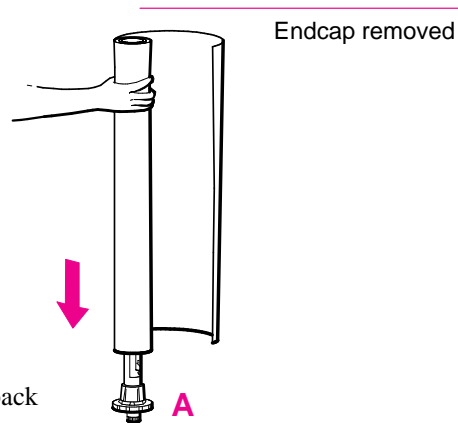

If the media stop falls off, push it back in until it snaps into position.

0015

Loading Media

- 8** Push the endcap back in, making sure that the tabs are flush against the ends of the roll. Push it far enough to be firm, but do not use excessive force as this may result in broken tabs.

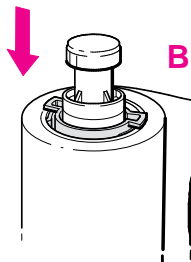

0016

- 9** Insert the spindle so that the media stop (A) is to the right and the endcap (B) to the left. Push in firmly on both ends. Be sure the media remains flush against the media stop.

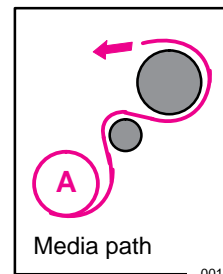
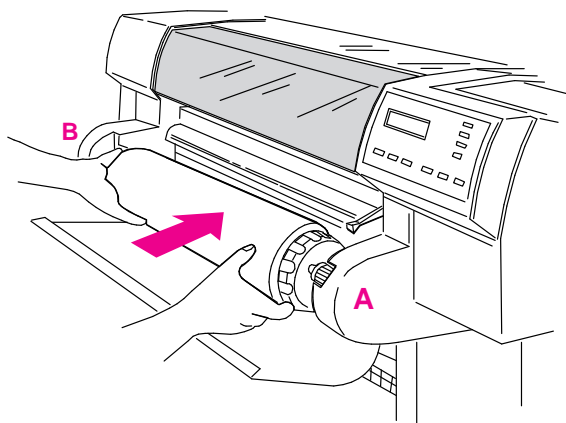

0017

The media should wind up from behind the roll.

1837

- 10** Check the leading edge as it unwinds from the spool. If it is uneven, trim it as explained in step 11. Otherwise go to step 12.

WARNING

The media cutting knife used in the next step is sharp. Be sure the printer's wheels are locked. Keep fingers clear of the cutting path. Keep media cutting knife away from children.

11

To trim the leading edge of the media roll:

- a** Pull the media over the top of the printer and lay it over the cutting track.
- b** Use the media cutting knife in the pocket located at the back of the printer to cut off the first few inches of the media.
- c** Retract the blade and return the media cutting knife to its pocket.

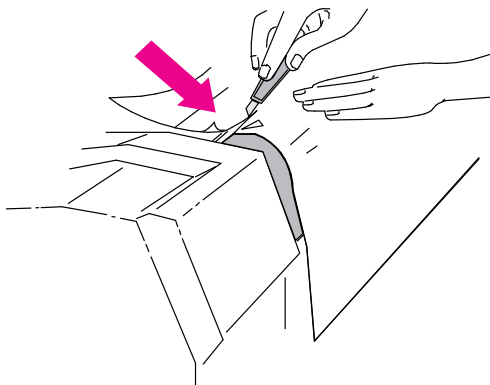

1838

Loading Media

- 12**
- a** Pull the media up and, holding it from the sides, align its right edge with the perforated line on the entry platen.
 - b** Insert the leading edge into the printer, until the page buckles slightly.
 - c** Release the media when the printer begins to pull it in.

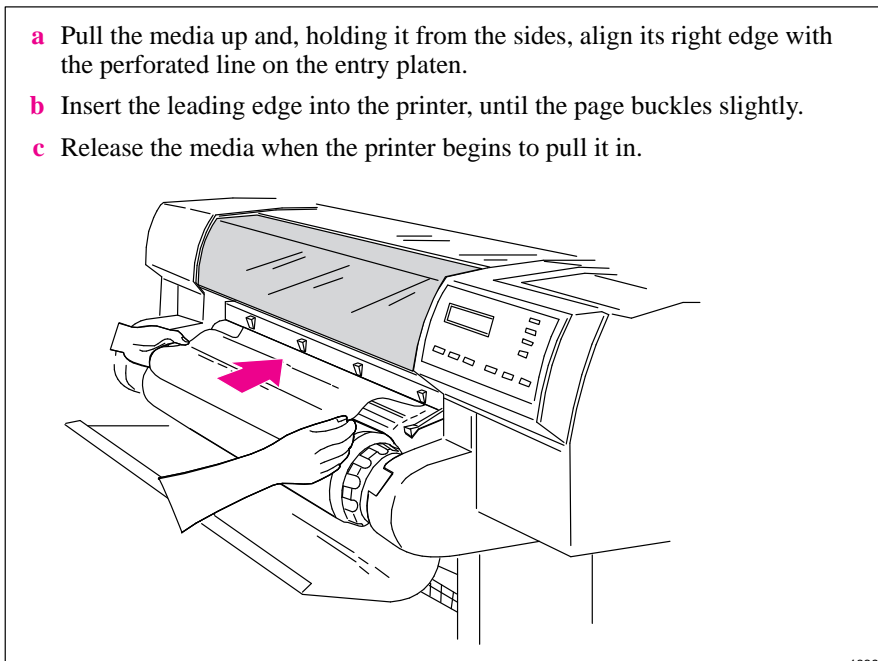

1839

- 13** Press the ↓ key next to the front-panel display to indicate you are loading roll media.

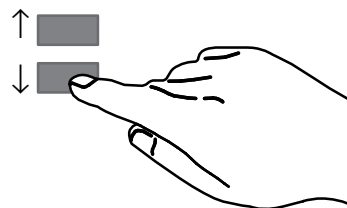
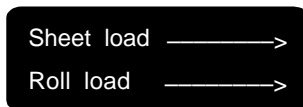

0014

- 14 Use the ↑ and ↓ keys until the display shows the type of media you are loading¹, and then press the **Enter** key.

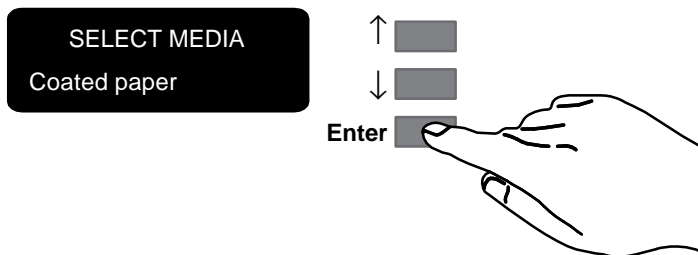

If you are using software that offers a “*special print mode*” for this printer, then simply press **Enter** on the first media type displayed (whatever it is), as in this case it is the software that controls the print mode, not the printer. For more details on special print modes, see page 3-6.

0014

- 15
- When the front panel instructs you, lift the media lever.
 - Take hold of the edge(s) of the media now extending from the exit slot and pull the media toward you until taut. Then align the left and right edges of the media, so that they are flush with the edges of the roll.

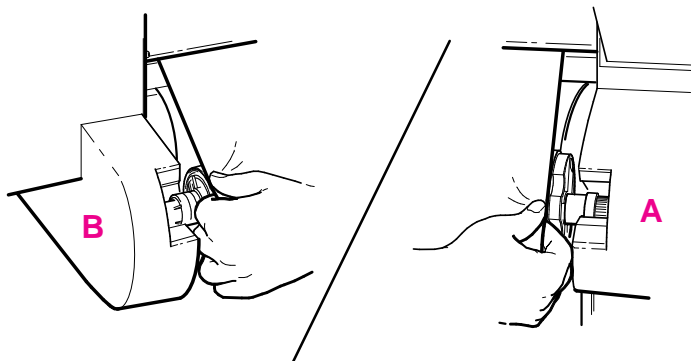

- When the front panel instructs you, lower the media lever.

0018

¹ For advice on media types, see page 3-2.

Loading Media

- 16 a** When the printer instructs you to close the roll cover, rewind the media stop in the direction shown by the large arrow below, to take up any slack in the roll. Make sure the leading edge of the media is outside the roll cover, and then close the cover.

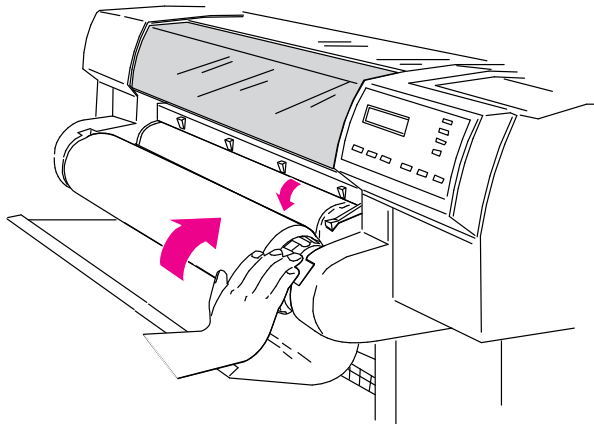

- b** Press ↓ to continue. The printer trims off the first few inches of media.

1840

To Load a Sheet

Which way round?

You can load a sheet in either portrait or landscape orientation. Unless using the Rotate option (see page 4-8), load the sheet in the same orientation as you have specified in your software. If printing a PostScript file, always load the sheet with the short edge first, even if your drawing is landscape.

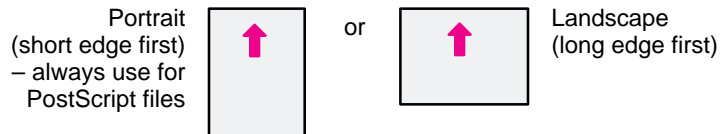

Which way up?

As you load the sheet, it is the *under side* on which the printer will print. With most media types, the two sides are different and so it is important to load the sheet correctly. Refer to the table below.

Media Type	Media-Loading Tips
Coated paper Heavy coated paper	Load with the coated side down. On HP Coated Paper and Heavyweight Coated Paper, look for the small notch in the corner: <ul style="list-style-type: none"> • When loading in a portrait orientation, make sure the notch is on the right side of the leading edge. • When loading in a landscape orientation, make sure the notch is on the left side of the leading edge.
Matte film	Load with the matte side down.
Clear film	Load with the rougher side down.
High-gloss photo paper Semi-gloss photo paper High-gloss film	Load with the glossy side down.
Opaque bond Translucent bond Natural tracing paper Vellum	Both sides are the same. If the sheet is curled, load with the curl <i>up</i> .

Loading Media

- 1 If you need to, unload any roll media (see page 3-9) so that the printing area is clear.
- 2 Make sure the media lever is down and the roll cover is closed.

- 3
 - a Holding the media from the sides, align the right edge with the perforated line on the entry platen.
 - b Insert the media until it buckles slightly. That is, *push all the way to the media stops*. Let go of the media when the printer begins to pull it in.

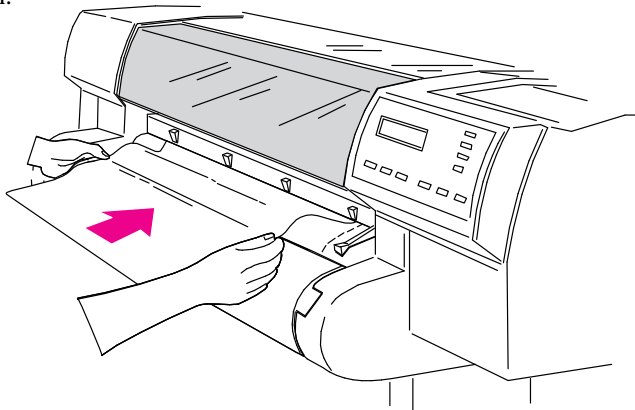

1841

- 4 Press \uparrow next to the front-panel display to indicate you are loading a sheet.

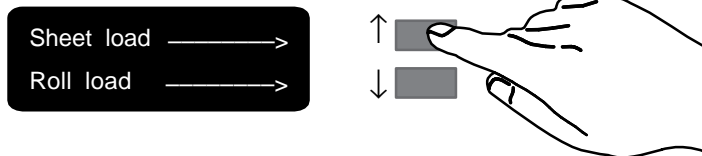

0014

- 5 Scroll until the display shows the type of media you are loading*, and then press the **Enter** key.

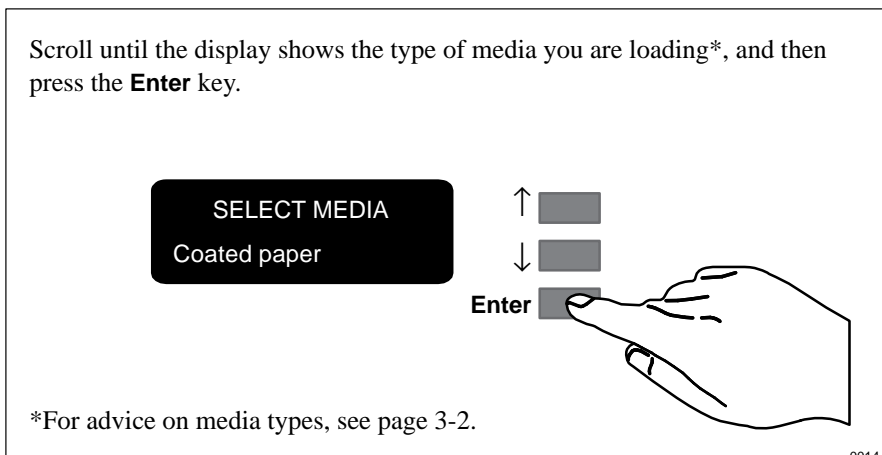

- 6 The printer moves the sheet in and out to check its size and alignment, then advances it to the start of the page. When sheet loading is complete, the "STATUS / Ready" message is displayed.

Loading Media**Compensating for Badly Cut Media**

You can only use this feature when sheet media is selected on the front panel.

If the media is persistently difficult to load, it could be an indication that it has been badly cut. That is, it has been cut unevenly with the media width on the leading edge different to the width of the trailing edge. A front-panel option called **Skew tolerance** helps you compensate for the shape of some poorly cut media. When you properly load the leading edge of poorly cut media along the perforated line on the platen, you may notice the trailing edge displaces from the line by a small distance and the printer will not accept the media. The printer can accept poorly cut media that displaces less than 1.0 cm from the perforated line.

Media that is cut properly should not need the help of the skew tolerance feature. In fact, *using this feature for properly cut media increases the risk of skewing your print on the page.*

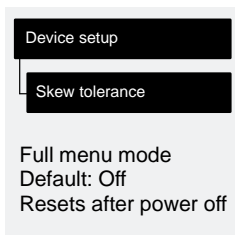
To Adjust Skew Tolerance

Skew Tolerance in Front Panel	Maximum Acceptable Skew of Loaded Sheet
Off	0.4 cm
On	1.0 cm



Unloading Media

Drying Time

On some media types, the ink needs to dry before the media is unloaded. For roll media, the printer automatically allows the appropriate drying time before cutting the page and dropping it into the media bin. For sheet media, you should wait for the times shown in the table below before unloading the media.

Typical Drying Times (minutes)		
Media Type on the Front-Panel Display	Print Quality	
	Fast	Normal or Best
Coated paper	0	0.25
Coated heavy paper	0	0.25
Matte film	Not recommended	2.0
Clear film		2.0
High-gloss photo		4.0
Semi-gloss photo		4.0
High-gloss film		2.0
Opaque bond	0.5	1.0
Translucent bond	0.5	1.0
Natural Tracing paper	0.5	1.0
Vellum	1.0	4.0

In the table above you will see that some media types can be unloaded immediately.

Unloading Media**To Adjust Drying Time**

You can make a global adjustment to the printer's automatic drying times through the front-panel menus.

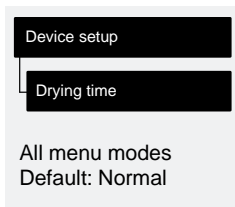

Drying time in front panel	Result
None*	None (printer cuts page without delay).
Less	Adjusted for the driest expected environmental conditions.
Normal	As in the table on page 3-21.
More	Adjusted for the most humid expected environmental conditions.
* Not recommended if you are using roll media and leaving the printer unattended, as the ink may smear when the pages are dropped into the media bin.	

So if you are operating your printer in an extremely dry environment, choose **Less**; in an extremely humid environment, choose **More**. For environmental specifications, see page 11-4.

IMPORTANT. Adjusting drying times purely to speed up the printer is not recommended as the quality of your print can be impaired.

To Unload a Sheet After Printing

- 1 Wait until the appropriate drying time has passed (see table on previous page – *no* drying time is necessary for some media types).
- 2 Gently pull the sheet from the printer.

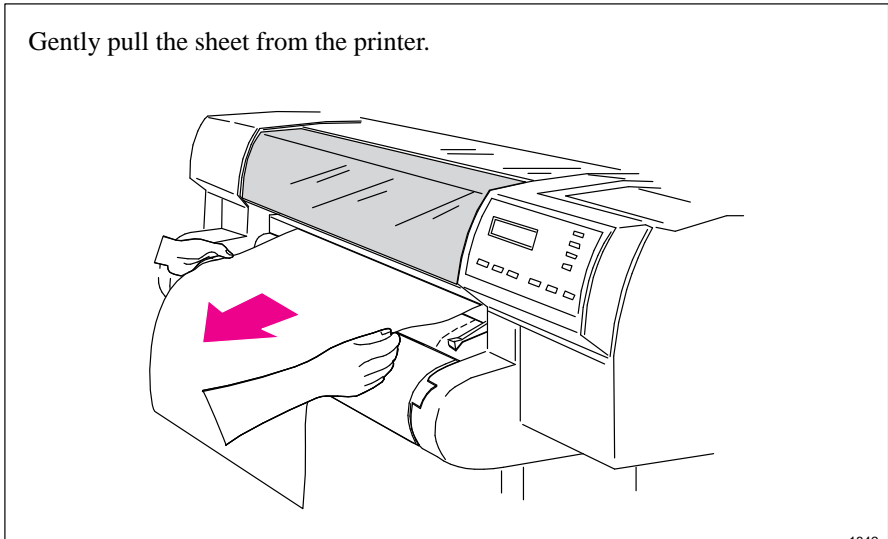

1842

Unloading Media

To Remove an Unused Sheet

Either ...

- 1 Press **Form Feed and Cut**.
- 2 When the printer has finished feeding it out, pull out the sheet.

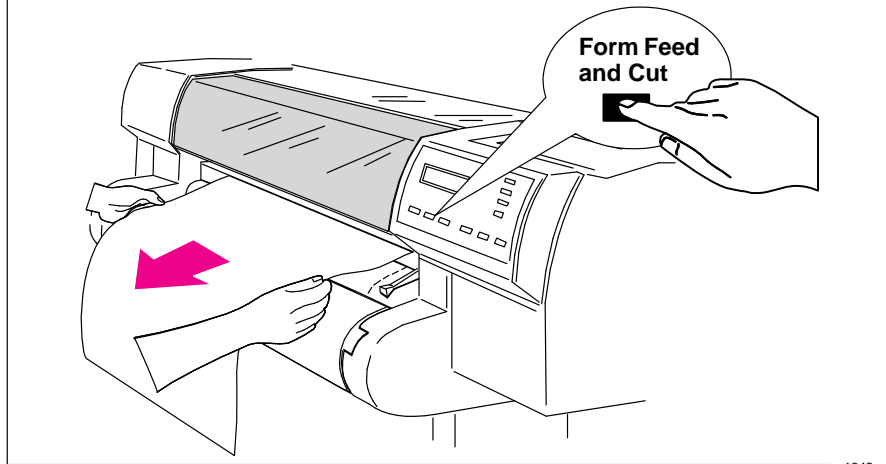

1842a

or ...

- 1 Lift the media lever.
- 2 Pull out the sheet.
- 3 Lower the media lever.

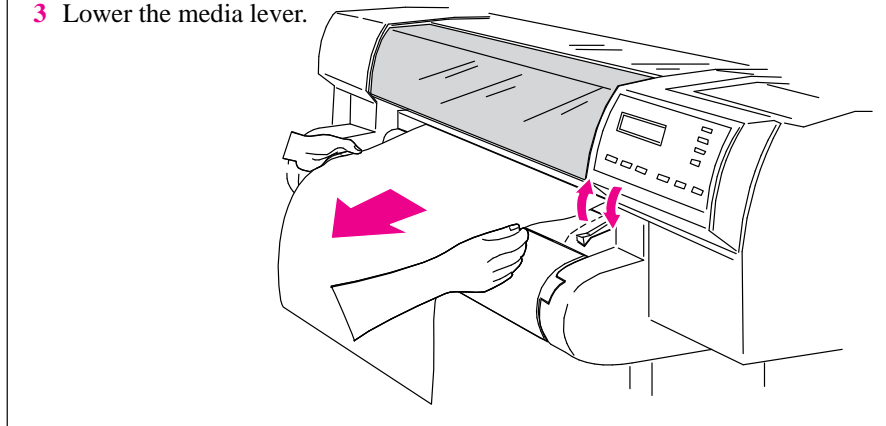

1842b

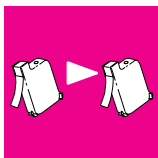

Replacing Cartridges

When to Replace Cartridges

Replace the cartridges in the following three circumstances.

- 1 *When the printer prompts you to replace one or more cartridges (by displaying Service cartridges on the front panel)*

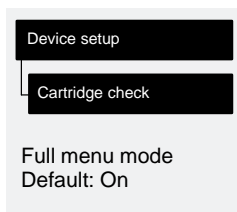



The printer automatically checks before and after every print that the cartridges are seated correctly and that the nozzles are working, this is called automatic checking. You can switch off the automatic checking using the front panel menus.

Note that automatic cartridge checking does *not* check the ink levels.

- 2 *When either poor print quality or the ink-level indicator on the cartridge indicates that the cartridge is out of ink.*

To check a cartridge's ink level:

-  Green = full
-  A considerable portion of ink has been used. Cartridge is close to empty.*
-  Black = empty

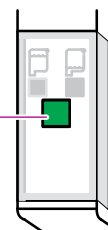

* It is recommended to have a replacement cartridge ready by this time.

Note: The ink-level indicator is *not* an exact gauge of the specific quantity of ink available over the life of the cartridge.

0002

- 3 *When you are troubleshooting print quality problems.* See Chapter 9, page 9-16.

Replacing Cartridges

Before Replacing Cartridges

Four important points:

- 1 Your printer is designed to operate *only* with the four cartridge types whose specific part numbers are listed on page 11-15. Except on glossy media types, the printer will operate successfully in monochrome with just the black cartridge loaded, although the Best print quality may not be as good as if all cartridges were loaded. Otherwise, all four *must* be loaded.
- 2 Every time you replace, or even adjust, a cartridge, the printer afterwards runs an automatic alignment procedure, for which it needs an opaque media type, for example opaque bond (regular printer paper) or coated paper. *So make sure that either a roll or a sheet of the appropriate media is loaded before you replace a cartridge.* If the automatic cartridge alignment procedure is not run on a suitable media type, print quality will be affected.
- 3 Once the cartridges have been installed they should not be removed, except to replace them. This will ensure the best lifetime for your cartridges.
- 4 Make sure you are aware of the general warnings and caution below.

WARNING

Don't touch the stainless steel strip that runs the length of the printer behind the cartridge carriage; its edge is very sharp. Keep hair, jewelry, clothing, and foreign objects away from the printer mechanisms. Keep new and used print cartridges out of the reach of children.

CAUTION

Only touch the plastic parts of the cartridge. Do not touch, wipe, or attempt to clean the cartridge nozzles or contacts as they can become clogged or scratched and are easily damaged.

CAUTION

Each time you access the cartridges to load or reseal them, the nozzles are exposed to air. If the nozzles are exposed to air (except during printing) for more than a few minutes at a time, they are susceptible to clogging and drying.

CAUTION

It is absolutely essential to load the cartridge(s) *in the correct stalls*, or your colors will be wrong and print quality may be impacted.

To Replace One or More Cartridges

If you are responding to a Service cartridges request, go straight to step 4.

- 1 Start with the printer switched ON.
- 2 Make sure the front-panel display reads STATUS / Ready (not STATUS / Ready for media).
- 3
 - a Press the **Access Cartridges** key and wait for the cartridge carriage to come to a complete stop next to the front panel.

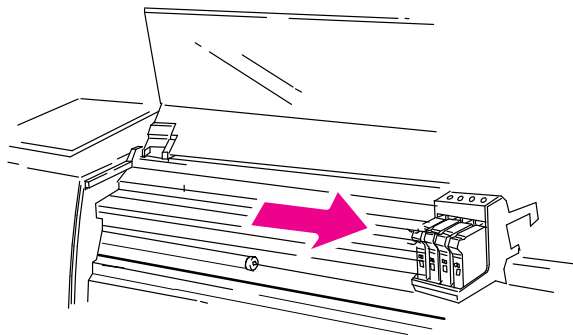

Continued...

1849a

Replacing Cartridges

- 4
- a When the carriage stops, open the window.
 - b Press down lightly on the cartridge you are replacing and pull it toward you. Remove the cartridge from its stall and discard it.

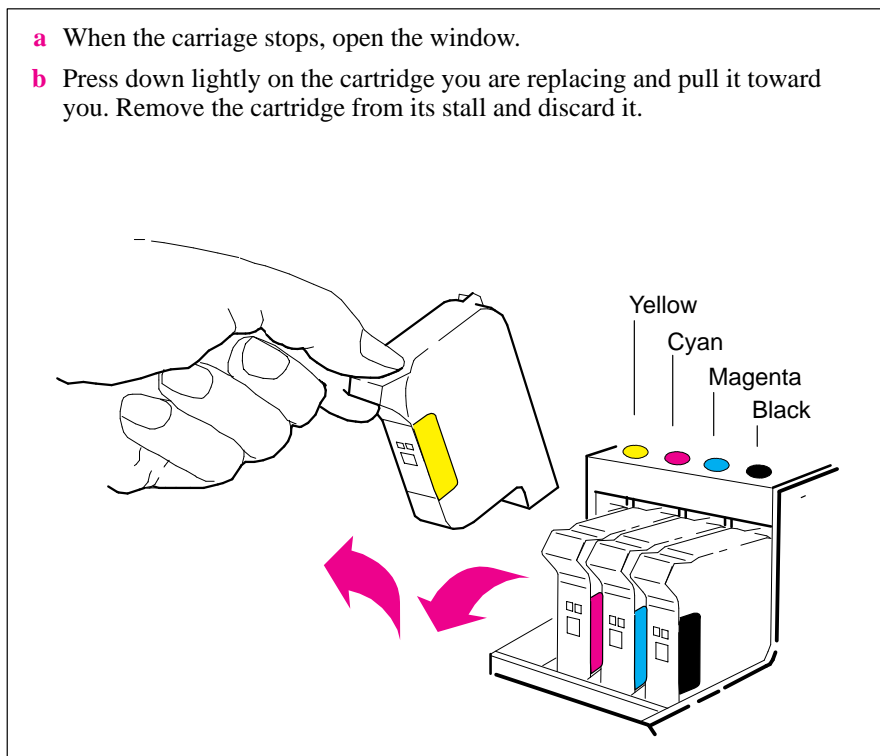

0019

- 5 Notice that each stall in the carriage has a dot indicating the color: when loading the new cartridge you *must* put the correct cartridge in the correct stall.

For users with color-vision deficiencies: You can identify the colors of the cartridges by the part numbers on the boxes – see page 11-15. The sequence of the stalls is, from left to right, yellow, cyan, magenta and black.

CAUTION

It is absolutely essential to load the cartridges *with the printer switched ON*, otherwise you will get poor print quality and the reliability of your cartridges will be impaired.

It is absolutely essential to load the cartridges *in the correct stalls*, otherwise not only will your colors be wrong, but also print quality may be impacted.

6 For each cartridge in the set that needs to be replaced:

- a** Take the new cartridge out of its box.
- b** Remove the colored protective tape and tab from the cartridge's nozzles.

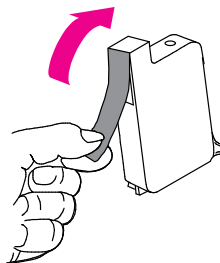

- c** Match the color of the cartridge's label with the color of the dot above the stall.
- d** Insert the cartridge in the correct stall. Press down lightly and push the cartridge away from you until it snaps into place.

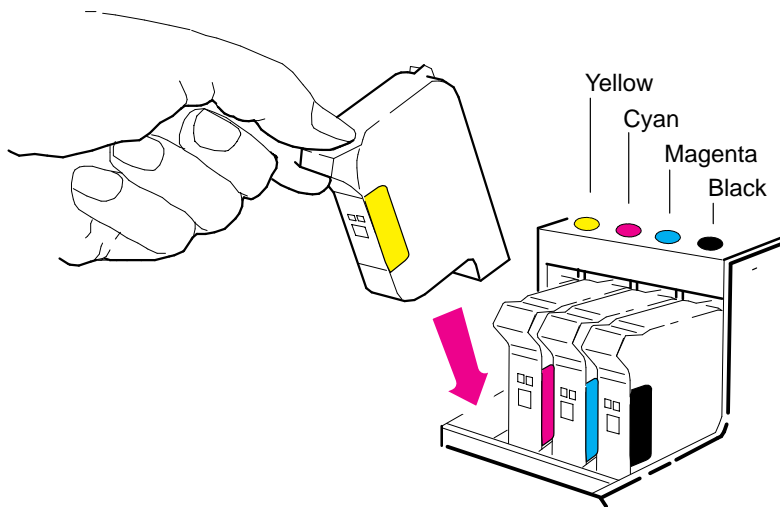

If the front-panel display says **Reseat cartridge**, then remove the cartridge indicated in the display and insert it again. Do so until the message disappears.

Replacing Cartridges

- 7 When you have finished installing the cartridges, the printer runs the automatic cartridge-alignment procedure. When the front-panel displays STATUS / Ready, the procedure is complete. You can throw away the small print produced during the alignment procedure.

Page Size 4-2

Adjusting the Margins (Roll Media Only) 4-7

Rotating a Drawing 4-8

Printing a Mirror Image 4-12

Changing the Scale of a Printed Image 4-13

Controlling the Page Format

Page Size, Margins and Other Controls

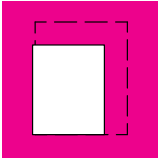

Terminology

Page Size

This chapter explains how to make sure that the printer produces your print in the page size you want.

Media

Page size

Margin

Printing area

Inked area

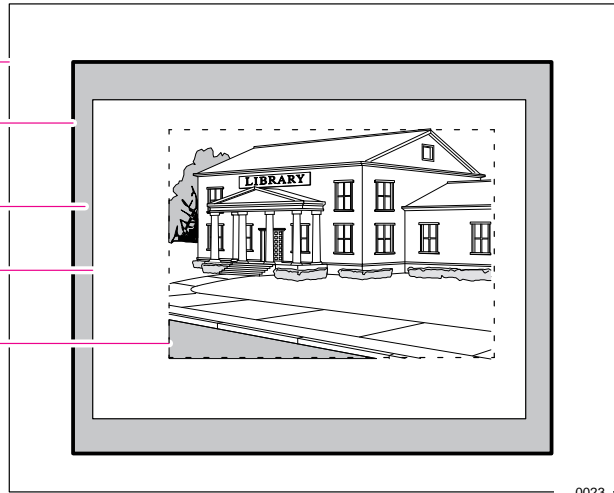

0023

Page size

This can be specified from the front panel or in the software, where it may be called “Page Size”, “Media Size”, “Paper Size” etc., and where the options include, for example, ISO A3, ANSI Letter, Architectural E and Custom. If the drivers setting is “default”, the front panel setting is used. Any other software setting overrides the front panel setting, unless the latter is Inked area and you are sending a PostScript file: in this case the front panel setting takes precedence.

Margins

These are specific to the printer and are normally 17 mm on the leading and trailing edges and 5 mm on the sides. Except with PostScript files, the 17 mm can be adjusted for roll media, as explained on page 11-2.

Printing area

This is the page size minus the margins. For a table showing the printing areas for standard media sizes, see page 11-6.

Inked area

This is the smallest rectangle that contains the entire drawing, while maintaining its relative dimensions.

Do You Need to Adjust the Page Size in the Front Panel?

PS

PostScript files

The answer is normally no, because the page size you have selected in your driver overrides the page size selected in the printer. However, some of the circumstances in which you may want to change the default setting are:

- When you are using the Scale feature. See page 4-14.
- When you are *not* using one of the HP DesignJet PostScript drivers supplied with your printer; for example, if you are sending a PostScript file from a UNIX application.
- When you want to save media by printing only the inked area of your print, plus the margins. In this case set Page format / Size to Inked area.

~~PS~~

Non-PostScript files

Depending on the driver you are using, you may not need to change the page size in the front panel. The default setting of the printer looks to your software for the page size settings: if it is there, the printer uses it.

However, some of the circumstances in which you may want to change the default setting are:

- If you want to print the inked area only, but the driver you are using does not specify “Inked area”.

In this case, set Page format / Size to Inked area.

Note: If you can select Inked area from your driver, any selection you have made in the front panel menu will be overridden by the settings in the driver.

- When the prints you are creating need to be of a specific standard (for example, ISO or ANSI), but the actual size within that standard is not important. For example, your page size may need to conform to a standard ISO page size, but it does not matter whether the final page size is ISO A4 or ISO A3.

In this case, set Page format / Size to ISO > Best... or ANSI > Best ... etc. The printer uses the smallest standard size into which the inked area will fit.

To Adjust the Page Size in the Front Panel

PS

PostScript files

Unless you are using the front-panel **Scale** option (see page 4-13), the front-panel page-size setting has no effect on PostScript files that already contain page size information, which includes all PostScript files sent using one of the HP DesignJet PostScript drivers supplied with this printer.

If you are using the front-panel **Scale** option, then the printer uses the page size set in the printer's front panel. If this is set to **Inked area**, **Software**, or a "Best ..." option, then it takes the page *width* from this, and calculates the page *length* as 1.5 times the width. If this is set to a discrete size, it uses the specified page size.



Non-PostScript files

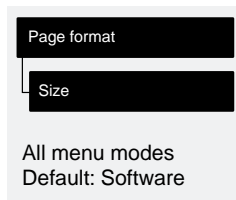

Size in Front Panel		Comments	
Software		The printer looks to the print you have sent for a page size instruction. If it is present the printer uses this. If not, the printed page size is the inked area plus margins.	
Inked area		The printed page size is the inked area plus margins. For a definition of “inked area”, see page 4-2.	
ISO	Best ISO A	“Best ...” options The printer chooses the smallest page size (from the A-series: A4, A3 etc.) that will hold the inked area of the print. For example, if the inked area of the print is between A3 and A4, the printer chooses A3 as the page size. Discrete options ISO A0/1/2/3/4 ANSI E/D/C/B/A JIS B1/2/3/4 ARCH E1/E/D/C/B/A Over A1/2	
	ISO A0/1/2/3/4		
ANSI	Best ANSI		
	ANSI E/D/C/B/A		
JIS	Best JIS B		
	JIS B1/2/3/4		
ARCH	Best ARCH		
	ARCH E1/E/D/C/B/A		
Oversize	(No “Best” option)		The printed page size is exactly the size you specify. The largest discrete page size you can specify is E/A0.
	Over A1/A2		

If you need to adjust the page size from the front panel, do so *before sending the file from your computer*, as the printer determines the size of a print at the time it is received from your application.

Page Size and Clipped Images

If you specify in your software a page size that is larger than the media size loaded in the printer, the printer will still print what it can, but may clip your image.

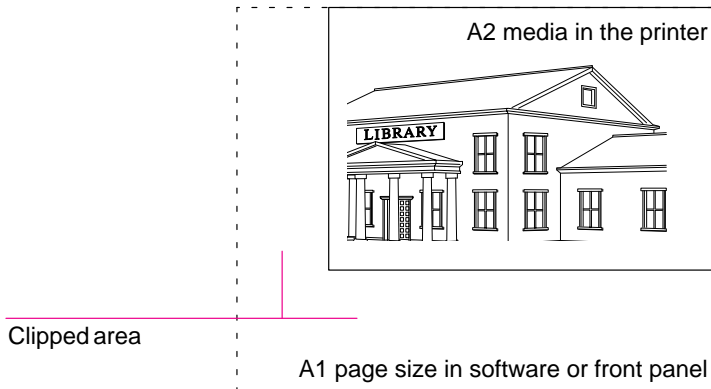

Page Size and Nesting (Roll Media Only)

Nesting means placing two or more pages side-by-side on a roll to save wasting media. There are certain cases when your prints will not be nested, for a complete explanation of nesting see page 6-9.

If you have queueing and nesting switched on, the printer will use the page size to determine which pages are nested and whether the pages can be automatically rotated when nesting.

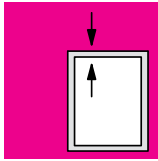

Adjusting the Margins (Roll Media Only)

Besides nesting and setting the page size, you can also change the margin settings and expand the printing area of the page, therefore reducing the amount of media waste. The two side margins are 5.0 mm. By automatic setting of the printer's margin is 17 mm on the leading and trailing edges of the media. By reducing the margins to 10 mm on the leading and trailing edges of the media, you can use 14 mm more printing area along that axis. The adjustment is available in the front panel.

With PostScript files, the margins are always “Normal”.

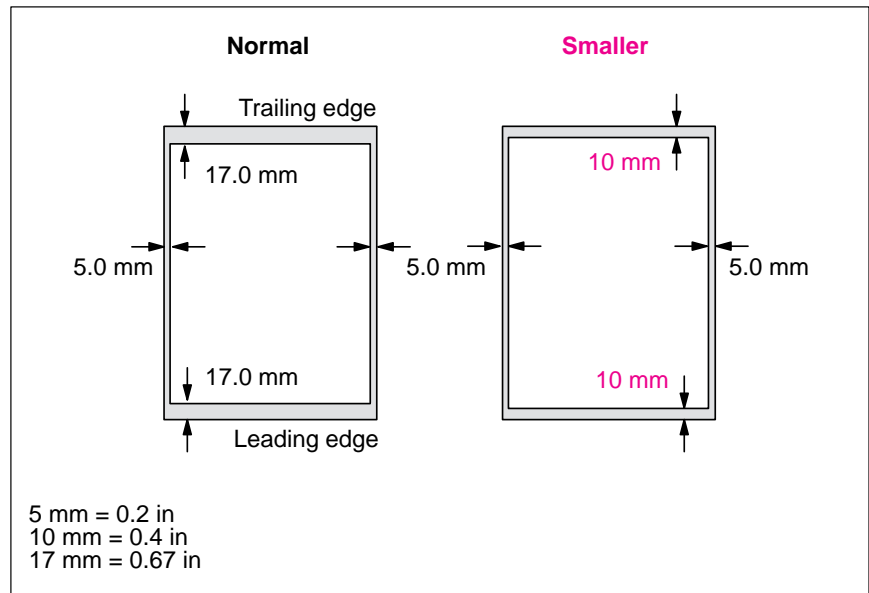
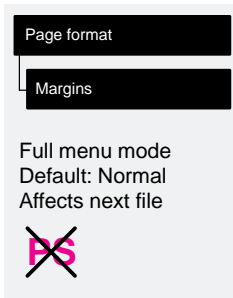

Margins and Automatic Cutting

IMPORTANT.

When **Margins** is set to **Smaller**, the printer waits for the print to dry and the next file to begin printing before cutting the page from the roll. If you press **Form Feed and Cut**, the printer immediately cuts off the current page. When the next file begins, the printer cuts again to give this page the narrow margin.

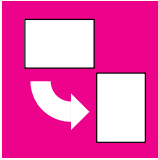

Rotating a Drawing

Rotating a Drawing from the Front Panel

Your Drawings can only be rotated from the Page format / Rotate option in the front panel if:

- Queueing and Nesting are off (see page 6-9), and if
- the file is either a PostScript file or contains no raster data.

If you are using the non-PostScript Microsoft Windows driver supplied with this printer, your files *do* contain raster data and therefore you *cannot* use this Rotate option. The normal line drawings of most CAD software do *not* contain raster data, and therefore you *can* use this Rotate option.

To Rotate a Drawing from the Front Panel

Except in the circumstances stated above, you can rotate a drawing from the printer's front panel, without changing the drawing in your software. The options are 90, 180 or 270 degrees relative to the drawing's orientation in your software. The rotation is *counterclockwise*, as shown below.

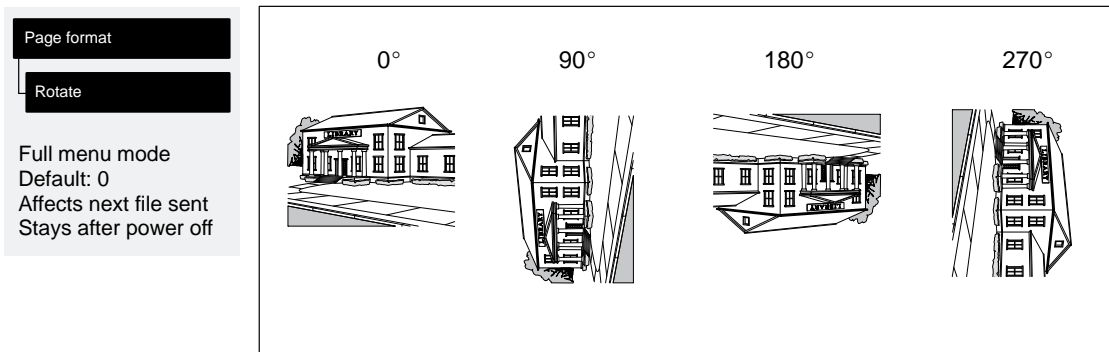

Exactly What is Rotated?

With **roll media**, both the drawing and the page orientation are rotated.

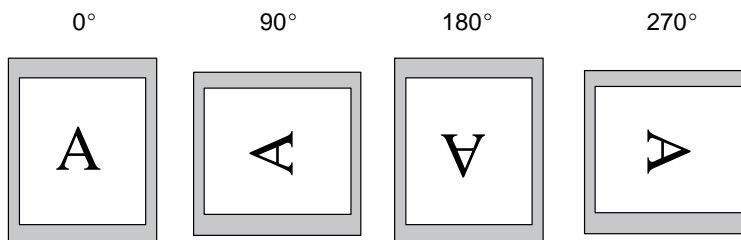

Notice that the narrow margins are always at the side, regardless of the orientation.

0025



With **sheet media**, the drawing is rotated, but the page orientation specified in your software is retained. (You should always load sheet media in the orientation you have specified in the software.)

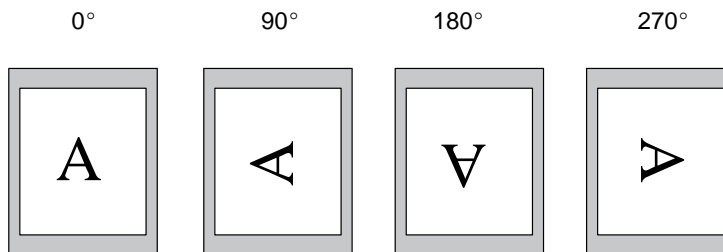

The front panel's **Rotate** feature has no impact on a PostScript file printed on sheet media.

0026

How Does Rotate Interact with Your Software?

PS

For PostScript files

- On sheet media, the front-panel Rotate feature has no impact.
- On roll media the front-panel Rotate feature does work: you may want to use it to save wasting media, by printing the page in landscape orientation, that is, with the short edge parallel to the media path. When rotated by 90° or 270° the page size is enlarged by $17-5 = 12$ mm, i.e.

$$[\text{leading and trailing edges}] - [\text{side margins}] = 12 \text{ mm}$$

at the top and bottom. This is to prevent the larger margins resulting from the rotation encroaching on the image.

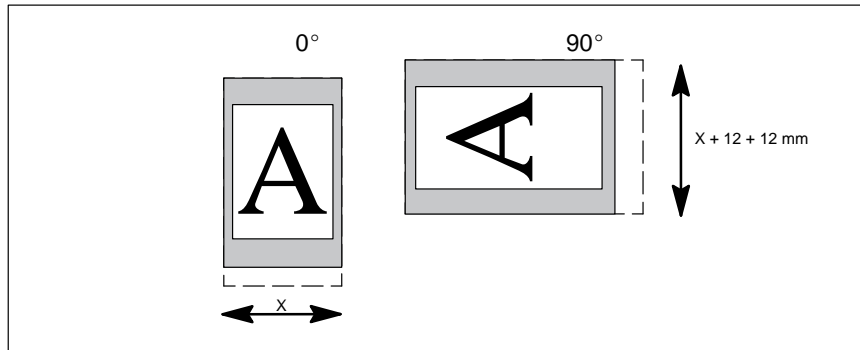



For Non-PostScript Files

The printer *adds* the rotation setting to any rotation angle you specify in your software. For example:

- For software applications which, like the printer, rotate *counter-clockwise* (for example, CorelDRAW!) the result is the *sum*. For example, if your software specifies 180 degrees rotation, and you set Rotate in the front panel to 90, your drawing's final rotation will be 270 degrees.
- For software applications which rotate *clockwise* (for example, AutoCAD) the result is the *difference*. For example, if your software specifies 90 degrees rotation, and you set Rotate in the front panel to 90, there will be no rotation.

For further information on the Rotate feature see page 9-21 in the Troubleshooting chapter which details some of the most common problems.

Possibility of clipped images with rotated non-PostScript files

With either roll or sheet media, if you rotate a portrait drawing, it is possible that the media is not wide enough for the drawing, and so it may be clipped. For example, rotating by 90 degrees a portrait E/A0-size drawing on E/A0-size media will probably result in a clipped image.

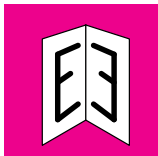

Printing a Mirror Image

You can print a mirror image of the drawing from the printer's front panel, without changing the drawing in your software.

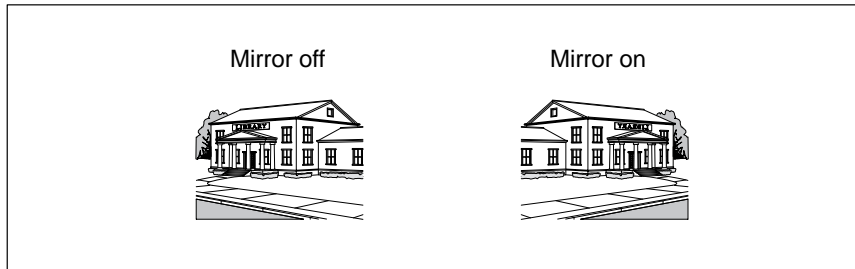
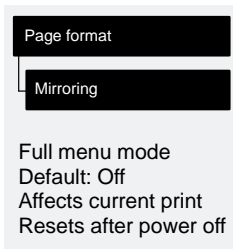

Do not change the setting during a print, as the change becomes effective immediately; that is, if you change the setting in the middle of the current print, the remaining data is printed in the mirrored orientation.

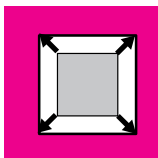

Changing the Scale of a Printed Image

With a PostScript file, you can enlarge your printed image from the printer's front panel by using the Scale option, accessed from the Device setup menu, as shown in the menu graphic, below left. Notice that, in order to use this feature, you have to switch the front-panel graphics language setting from Automatic (the default) to PostScript. If you regularly send non-PostScript files to your printer as well as PostScript files, it is a good idea to switch this back to Automatic after using the Scale feature.

The Scale feature is useful:

- If your software does not support large formats.
- If your file is too large for the printer's memory, and therefore you try reducing the page size in your software and then scaling it up again using this front-panel option.

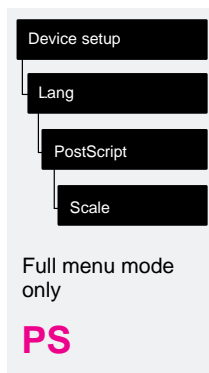

To scale your ANSI A PostScript file to...								
	ANSI B	ANSI C	Arch C	ANSI D	Arch D	Arch E1	ANSI E	Arch E
Use...	129%	200%	210%	258%	282%	352%	400%	419%

To scale your ISO A4 PostScript file to...							
	ISO A3	ISO/JIS A2	OS A2	ISO/JIS A1	OS A1	ISO/JIS A0	OS A0
Use...	141%	200%	210%	282%	352%	400%	419%

The scaling factors are cumulative with software settings. Whatever scale you choose will be used for PostScript files until you choose another scale, *even if you change the graphics language from PostScript and back again.*

Scale and Page Size

If you use this Scale option, the printer ignores the page size you set in your software and instead uses the page size set in the printer's front panel (see page 4-4).

Ways to Control the Print's Appearance 5-2

Changing Pen Widths and Colors Using the
Printer's Internal Palettes 5-4

Changing the Treatment of Overlapping Lines
(Merge Feature) 5-8

Changing the Overall Lightness/Darkness of a Print 5-9

Printing Color Drawings in Monochrome 5-10

Choosing an Appropriate Print Quality 5-12

Controlling a Print's Overall Appearance

Ways to Control the Prints' Appearance

Note. The “pens” discussed throughout this chapter are the “conceptual” pens in a software palette, rather than the printer’s physical print cartridges.

This chapter discusses the ways you can control the overall appearance of your prints from the front panel in terms of:

- pen width
- pen color
- the treatment of overlapping lines
- overall lightness/darkness
- rendering color drawings in monochrome
- overall print quality and resolution.

Some of these front-panel items take effect only on the next file you send from your computer, that is, they do not affect any pages already in the printer’s queue. If this is the case, it is stated in the relevant part of this chapter.

Some of the controls are available using the front-panel menus (pen width, pen color, overlapping lines and lightness). Print quality and color/monochrome print options are controlled from the front-panel keys. This chapter explains them in the sequence of the list at the top of this page.

Why Change the Appearance of the Print Using the Front Panel Rather Than from Your Software?

By default, the printer looks to your software to provide information on all the above attributes. However, you may want to experiment with various effects, or try a temporary change, without the need to change your drawing or your driver settings.

PS

Unless you have specifically indicated in your software that the printer's settings are to be used (by choosing, for example, Printer's Current Setting in a Macintosh Print Options window), the software settings for a PostScript file override all the printer front-panel features described in this chapter.



Changing Pen Widths and Colors Using the Printer's Internal Palettes

The printer has three pen palettes. The factory palette cannot be changed. You can, however, change the line width and color settings for each pen in the remaining two palettes (called *palette A* and *palette B*). Initially, all three palettes are identical. Each palette has 16 pens¹ which can include pens of different widths and any combination of the printer's internal 256 colors.

These internal palettes have no effect on PostScript files.

To See the Current Palette Settings

- 1 Make sure either a roll or a sheet of media is loaded.
- 2 Make sure that the front-panel Color/Mono switch is set to **Color**.
- 3 Print the **Current Configuration Print**, by pressing the ↑ and ↓ keys simultaneously..

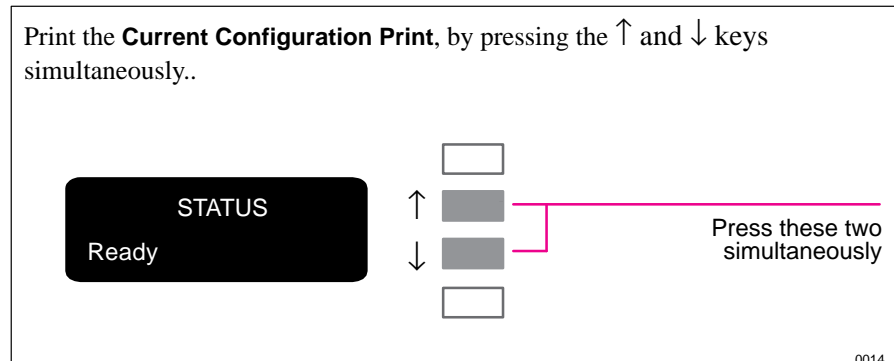

Notice on the Current Configuration Print that the 16 pens are numbered 0 through 15 and the 256 colors are numbered 0 through 255. These colors are specified in the Palette Print, as now explained.

¹ We are discussing "conceptual" pens here.

To See the Colors Available For a Palette

- 1 Make sure that the front-panel Color/Mono switch is set to **Color**.
- 2 To print the Palette Demo, go to the Demos menu and choose Palette.

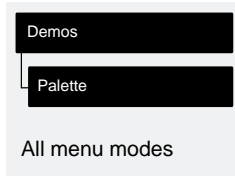

In the **Palette Demo**, you will see 256 squares, numbered 0 through 255, each showing one of the 256 colors available for selection in the printer's internal palettes. The example below is color 6 (magenta), which happens to be assigned to pen 6 in the factory's default palette.

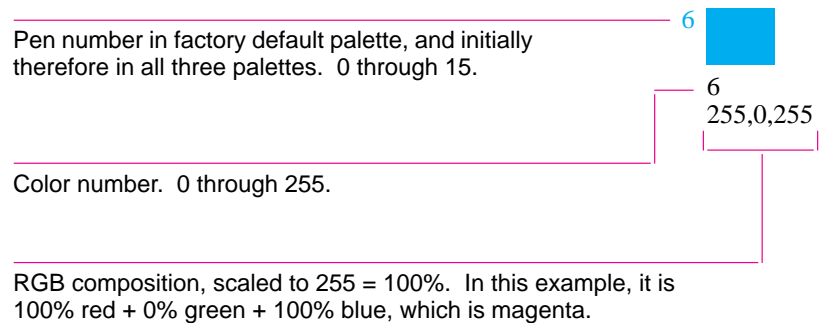

Notice that RGB and CMYK, – plus white – are assigned by default to pens 0 through 7, and that eight grayscales are included in the 256 colors.

The 256 colors shown in the Palette Demo are not the only colors you can print with your printer! Using your software, you can create many more colors and, as long as you are using the correct driver, the printer will reproduce these colors by an appropriate mix of inks from its CMYK cartridges. The Palette Demo merely shows the 256 colors available for use in the printer's internal palettes, should you choose to use them.

To Change the Palette Settings

There are three palettes: Factory, Palette A and Palette B. You cannot change the Factory palette, but you can define Palettes A and B to be whatever you choose.

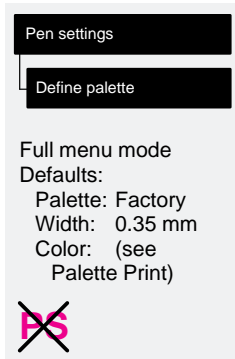

Item	Available Options
Palettes	Factory, A, B.
Pens	0 through 15.
Widths (mm)	0.13, 0.18, 0.25, 0.35, 0.50, 0.65, 0.70, 0.80, 0.90, 1.00, 1.40, 2.00, 3.00, 5.00, 8.00, 12.00. Note that 0.13 mm is a one-pixel line width and renders some colors as a dot pattern.
Colors	0 through 255. As specified on the Palette Print.

The steps below explain how to define Palette A.

- 1 In the front-panel display, go to the Define Palette routine and choose Palette A.
- 2 Scroll to the pen number you want to change and press **Enter**.
- 3 The current width assigned to this pen is displayed, for example Width=0.35mm. If you want to change it, press **Enter**, scroll to the width you want and then press **Enter** again. Otherwise, scroll to Color.
- 4 The current color assigned to the pen is displayed, for example Color=110. If you want to change it, press **Enter**, scroll to the color you want and then press **Enter** again.
- 5 When both width and color are correct, press **Previous**.
- 6 Scroll to the next pen number you want to change, press **Enter** and do steps 3 through 5 again.
- 7 When all pen definitions are correct, press **Previous** until you have exited the menus.

IMPORTANT. The palette you have just defined will take effect only when you select it to be the current palette, as explained next.

To Change the Selection of the Current Palette

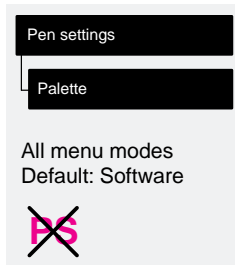

Palette	Comments
Software	The printer looks to your software for pen settings and ignores all three internal palettes.
Palette A	The printer assigns the attributes defined in Palette A to the pens defined in your software as 0 through 15.
Palette B	The printer assigns the attributes defined in Palette B to the pens defined in your software as 0 through 15.
Factory	The printer assigns the attributes defined in the Factory Palette to the pens defined in your software as 0 through 15.

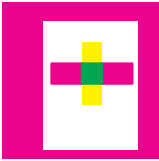

Changing the Treatment of Overlapping Lines (Merge Feature)

There are two alternative settings for controlling overlapping lines. The feature is called **Merge**. This feature has no effect on PostScript files.

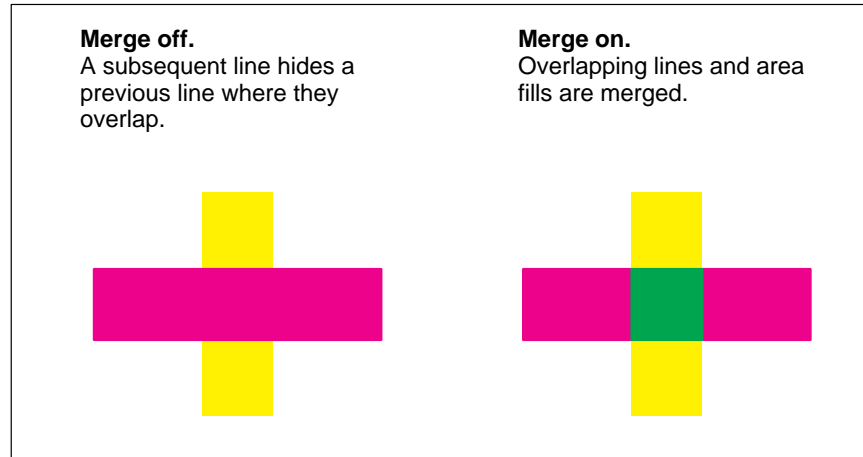
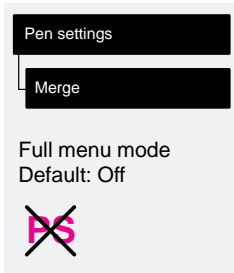

You can set this feature from your software in some applications, for example in AutoCAD.

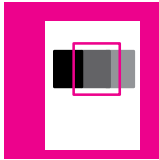

Changing the Overall Lightness/Darkness of a Print

You can change the overall lightness/darkness of a print by adjusting the amount of ink used in your prints.

The feature is called **Lightness** and affects both grayscales and colors.

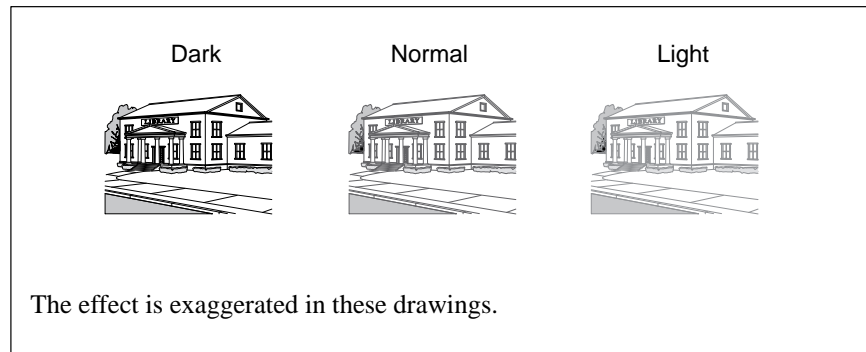
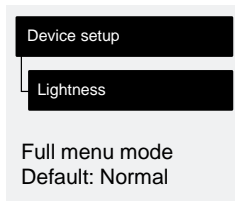

As this is a simple way to change the appearance of your print, you can achieve better results if you use your software for different effects. However, some examples of situations where you may find the feature useful are:

- Where a tracing paper produces better print quality when the printer uses a smaller volume of ink.
- Where a small variation in the amount of ink used produces a significant change in the apparent darkness or color saturation of an image.
- Where you want to reduce the drying time required: for example, for glossy media in extremely humid conditions. (If you need to make a global change to drying times for extreme environmental conditions, refer to page 3-22.)

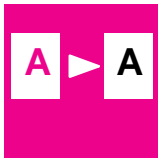

Printing Color Drawings in Monochrome

Examples of why you may want to print a color drawing in monochrome are:

- because you want a draft where color is not important, for example to check that the image is not going to be clipped,
- because you want a version for photocopying in black and white.

Four important points:

- The monochrome print will render colors as *grayscale*s rather than all as black. If you want all colors to be printed as *black*, then you should set all your colors to black in your software. This is most easily achieved in CAD software by using a pen number that is 100% black. Alternatively (except for PostScript files), you could make one of the printer's internal palettes (A or B) all black, and then select this as the current palette (see earlier in this chapter for an explanation of palettes).
- With monochrome printing, you have the option to choose between true 300 and true 600 dpi resolution (see page 5-12). This option does not apply to glossy media types, on which the resolution is always 300 dpi.
- If you send a monochrome drawing with this front-panel option set to Color, the print resolution is 300 dpi, regardless of your Print Quality setting.
- You cannot change the color/monochrome setting for pages already in the printer's queue.

Affects next file sent

To Switch Between Color and Monochrome

- 1 Use the front-panel key shown below to toggle between color and monochrome.

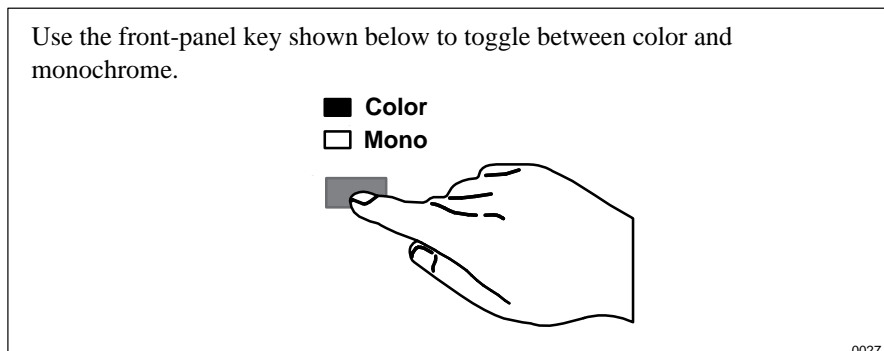

- 2 Send the file from your computer.

The setting also impacts the printer's internal demos.

Affects next print sent

Choosing an Appropriate Print Quality

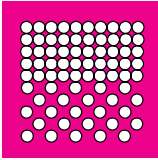

You can set the overall print quality from the front panel. The main effects of your print quality setting are shown in the table below.

Print Quality Setting	Fast	Normal	Best
Speed			
Ink Used			

General tips

By choosing Fast, you will get draft-quality output in the shortest time. By choosing Normal, and a suitable media type, you will get high-quality output in a reasonable time. By choosing Best, you will get the highest possible quality for the media type, but the printing time will be longer.

However, your printer's output speed, quality and particularly its resolution, also varies according to:

- Whether Sharp lines is set to Auto, On or Off (see page 5-15) on the front panel or in your software.
- The specification option when you loaded the media (see page 3-3)

The resolution at which your print will be printed is summarized in the table below.

Print Quality Setting	Resolution in dpi	
	Monochrome	Color
Fast	300 x 300	300 x 300
Normal	600 x 600 ¹	300 x 300
Best	600 x 600 ¹	600 x 600 ²
<p>¹ Or 300 x 300, depending on your driver resolution setting or the software application you have used.</p> <p>² Addressable dpi with Sharp lines On, using opaque bond, coated paper and matte film only. This resolution depends on the type of image created in your software application.</p>		

Recommended combinations of print quality and media type are given in the table on page 3-6.

To get the very best print quality for images and drawings from graphics packages (other than CAD drawings or other line drawings):

- When loading the paper, specify “Heavy coated paper” on the front panel, rather than “Coated paper”.
- Set Print Quality to “Best”.

Affects next file sent.
Software setting
takes priority.

To Change the Print Quality

- 1 Use the front-panel **Print Quality** key to toggle between the three print quality settings.

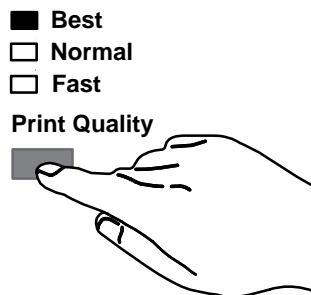

0027

- 2 Send the file from your computer.

The setting also impacts the printer's internal demos.

You cannot change the print quality setting for pages already in the printer's queue.

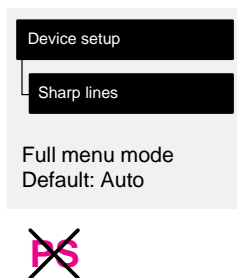

Improving Line Quality and Graphics Detail

The Sharp lines option refines the print quality of line drawings by *smoothing* the fine gradations along the angles and curves of the printed image. This enhancement produces:

- Crisper lines.
- Finer detail.
- Line drawings with a ‘sharp’ appearance.

Only prints that have color content are affected by the Sharp lines option to produce addressable 600 dpi resolution. Monochrome images are not affected by the Sharp lines option as these are produced in true 300 or 600 dpi resolution, depending on the print quality that you have selected.

The Sharp lines option has three settings, Auto, Off and On, and can be set either through the front-panel menu or HP supported Windows drivers. The factory default setting is Auto.

With Sharp lines set to Auto you will always get best quality color prints, except when you send the following files:

- Mixed lines and scanned color images.
- Mixed lines and color photographs.
- CorelDRAW! (with color images).

For these files it is recommended that the Sharp lines default setting is changed, depending on your preference for image or line quality:

- Select On if you have a file which contains line and color images and you want the lines to be printed in Best quality, even if there is possible degradation to the quality of the color image.
- Select Off if you have a file which contains line and color images and you want to optimize the quality of the color images.
- Select Off if the print is a complex vector file, such as a CorelDRAW! The print quality will be optimized for these circumstances.
- Select Off if the output speed of the printer is more important than Best quality.

For further information on Sharp lines see Troubleshooting, page 9-15.

Important

With the Sharp lines set to Auto or On in the front-panel menu, the printer may not always produce an addressable 600 dpi print. This may be because:

- You have not selected Best on the front-panel **Print Quality** key, refer to page 5-14.
 - You are using media other than Coated paper, Opaque bond or Matte film.
 - Your application-software driver is overriding the front-panel selection.
 - You are printing a color raster image or a line drawing combined with a color raster image.
-

Managing Pages Being Printed or Drying 6-2
Managing Pages Not Yet Printed (The Queue) 6-4
Avoiding Media Waste by Nesting Pages (Roll Media Only) .. 6-9

Managing Your Prints

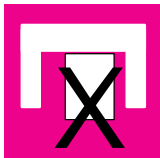

Managing Pages Currently Being Printed or Drying

To Cancel a Page

Press **Cancel** on the front panel.

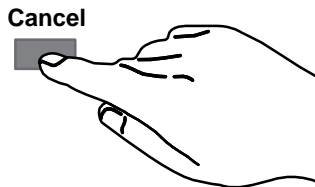

The printer advances the media as though the print were finished. A multi-page or complex PostScript file may take longer to stop printing than other files.

0027



If queueing is on and there are no more pages in the queue, the cancelled page is placed in the queue and you can reprint it as explained on page 6-8. If, in addition to cancelling the page, you want to delete it from the queue, see page 6-7.

To Cut a Page Before Drying Is Complete (Roll Media Only)

Press **Form Feed and Cut** on the front panel.

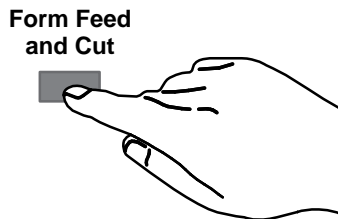

The printer ignores the drying time and immediately drops the page into the media bin.

0027

To Pause while Printing a Series of Pages

You can pause between two pages already sent from your computer, for example to change the media type or replace the cartridges.

- 1 Press **Pause** on the front panel.

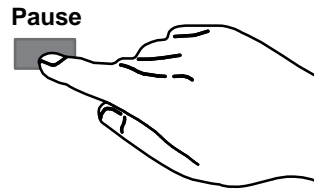

The printer finishes the current page and leaves the printer paused (indicated by the **Pause** light being on) until you press **Pause** again.

While the printer is paused, you can use the front-panel as normal, for example to change a front-panel menu setting or to load and specify a new media type.

0027

- 2 To resume printing, press **Pause** again.



Managing Pages Not Yet Printed (The Queue)

The normal sequence of events is:

- 1 You send a file from your computer (or choose one of the internal sample pages from the Demos menu).
- 2 The printer's Receiving light flashes while it receives and processes the data.
- 3 The printer starts printing or, if queueing is on, places it in the queue until its turn comes round.

IMPORTANT. If you send a PostScript file, you will automatically empty the queue, as PostScript files cannot be queued.

To Start Printing a File That is Waiting for a Timeout

If all is in order (media loaded, cartridges loaded, no file error), there are still two reasons why a file you have sent from your computer may not start printing when expected:

- The print file may lack a proper file terminator and the printer is therefore waiting for the specified I/O timeout period before assuming it is complete. See page 7-9.
- Nesting may be on and the printer is waiting for the specified Nest wait timeout period before calculating the appropriate nests. See page 6-11.

In either case, if you want to override the timeout period and start printing:

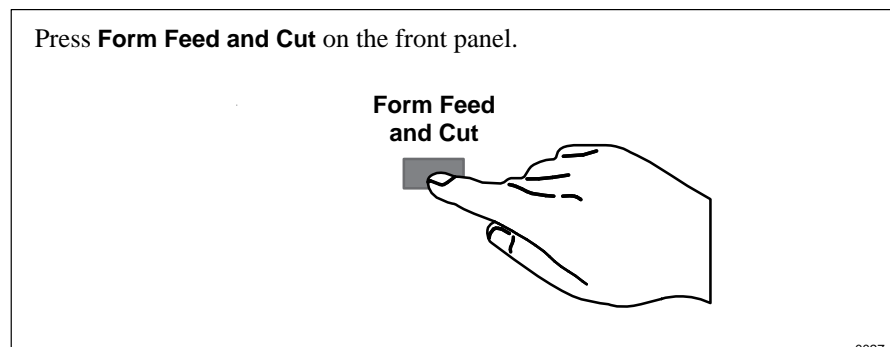

What is the Queue?

Your printer can store files in a queue at the same time as printing the current file. It stores them by *page*, though if you send only single-page files, you can regard these as files. The size of the queue is limited by the number of pages (maximum 32) and the total memory occupied by the queue (67 MB standard memory, being 71 MB less 4 MB main memory). Remember that file size and memory usage are not the same thing, as explained on page 9-22. However, it is clear that the larger are your files, the fewer you can store in the queue.

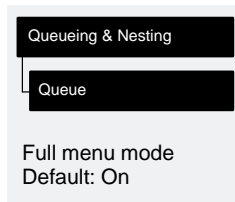

With queuing turned ON:

- You can send one or more pages to the printer without waiting for the current page to finish.
- You can manipulate the pages in the queue, for example prioritizing them and reprinting them.
- You can use nesting, the printer's media-saving feature (see page 6-9).

With queuing turned OFF:

- The printer will not accept a file sent from the computer until the current page has finished printing and the printer is ready.
- You cannot use nesting (see page 6-9).

If you turn queuing off while pages are still in the queue, they will be printed and – if nesting is on – nested, until the queue is empty.

Managing Pages Not Yet Printed (The Queue)

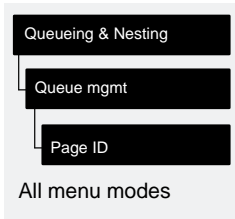

To Identify a Page In The Queue

In Queueing & Nesting, you can scroll through the pages in the queue.

Each has a identifier, comprising:

<position in queue> : <drawing name>

Position in queue

The page currently being printed is in position 0. The next page to be printed is in position 1, the one after in position 2, etc. The previous page printed is position -1, the one before that in position -2, etc.

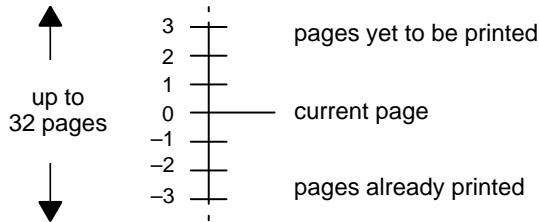

Drawing name

Some applications let you give your drawing a descriptive name which it then sends to the printer – for example “Building 2 Exterior”. *If your software supports this feature*, this drawing name is applied to each page and displayed after its queue position:



If your software does not support this feature, your printer will assign names to the pages in its queue. The printer-assigned name indicates how many thousands of vectors make up the page:



Note that this is not an indication of the amount of memory the page requires. For that, see page 9-22.

To See the Size of a Page In the Queue

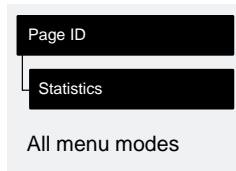

Statistic	Comments
Width	The shorter side of the page, in millimeters.
Length	The longer side of the page, in millimeters.

To Prioritize a Page in the Queue

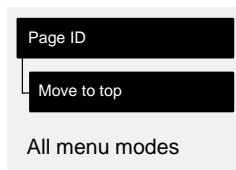

To make any page in the queue the next one to be printed, select it and choose Move to top.

If nesting is turned on (see page 6-9), the prioritized page may still be nested with others. If you really want this page to be printed next *and on its own* on the roll, then first turn nesting off and then use Move to top to move it the top of the queue.

To Delete a Page From The Queue

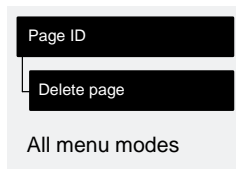

Under normal circumstances, there is no need to delete a page from the queue after printing it, as it will just “fall off the end” of the queue as more files are sent. However, if you have sent a file in error and want to avoid any chance of it being reprinted, you can simply delete it, by selecting it and choosing Delete page.

To remove a page that has not yet been printed, simply identify it by its position in the queue (see page 6-6) and delete it, by choosing Delete page.

If the page is currently being printed (its queue position is 0), and you want both to cancel the page *and* to delete it, first press **Cancel** and then delete it from the queue.

To Make Copies of a Page in The Queue

Has the page already been printed?	Do you want one copy or several?	What to do
Yes	One	Use Move to top (see page 6-7).
	Several	Use Copies (see below) and then use Move to top (see page 6-7).
No	One	Use Copies (see below).
	Several	

In all cases, the page must be still in the queue.

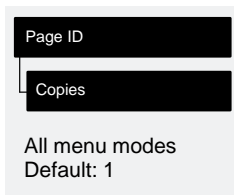

Having selected the page and chosen Copies, use the scrolling keys to specify the number of copies required, and press **Enter**. The number you enter is the actual number of pages to be printed; for example, choosing 2 for a page not yet printed means you will get the one original and one copy. The maximum is 99.

The setting you specify in this option overrides any value set by your software.

Note that, if Rotate (see page 4-8) was on when you sent the file, every copy will be rotated too.

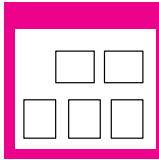

Avoiding Media Waste by Nesting Pages (Roll Media Only)

What is Nesting?

Nesting means placing pages side-by-side on the media (rather than one after the other), to avoid wasting media.

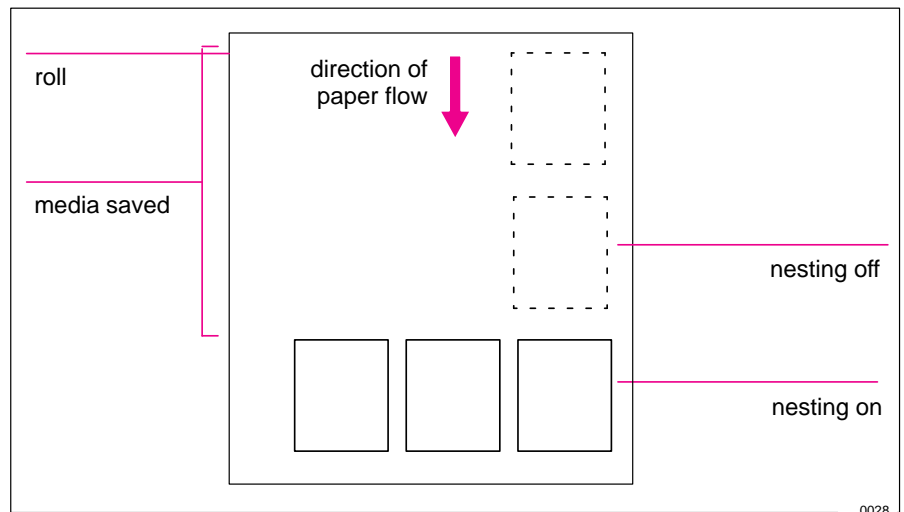

The printer may automatically rotate a page in nesting (see page 6-10). It may do this even with a single page.

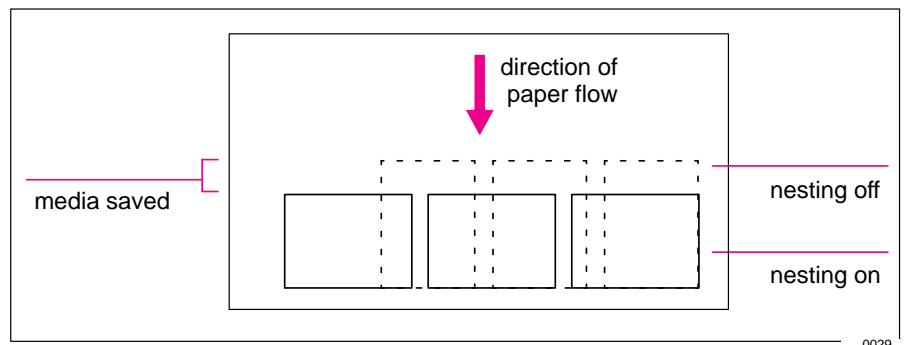

When Does the Printer Try to Nest Pages?

When all the following are true:

- The printer is loaded with roll media rather than sheet media.
- In the front-panel menus, Queue is ON (the default). See page 6-5.
- In the front-panel menus, Nest is ON (that is, set to either Optimal or In order). See page 6-11.

Which Pages Qualify for Nesting?

In order to be in the same nest, the individual pages must be compatible on both the following criteria:

- **Color or monochrome**

Either all are color or all are monochrome. Remember that monochrome may include a color page rendered in grayscales by use of the front-panel Color/Mono key – see page 5-10.

- **Print resolution**

Either all are 300 dpi or all are 600 dpi – see page 5-13.

Which Pages May be Rotated?

Apart from obvious physical limitations on the roll, any page containing raster data will *not* be rotated.

If you are using the Microsoft Windows driver supplied with this printer, your files *do* contain raster data and therefore the pages will *not* be rotated in nesting. The normal line drawings of most CAD software do *not* contain raster data, and therefore *may* be rotated in nesting.

To Turn Nesting On or Off and Choose the Nesting Method

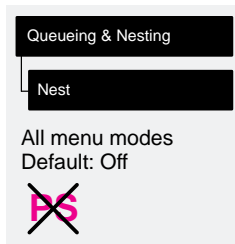

Nest Setting Selected	Printer's Response
Off	The printer will not nest pages.
Optimal	<i>Choose this if you want to use the least amount of media.</i> The printer will search all through the queue for suitable pages. It will nest the pages according to an algorithm that, for most combinations of page sizes, saves the most media. The resulting nesting pattern may still vary, depending on the size of the first page.
In order	<i>Choose this if the speed with which you receive your prints is most important.</i> The printer will try to nest pages in their queue sequence. If it comes across an incompatible page, it will stop searching and print any nest it has already created.

What Happens to Nesting if you Turn Queueing Off?

Turning queueing off does not turn nesting off for pages already in the queue. The printer prints all the pages in the queue before accepting any more files. As soon as you turn queueing off, the nesting setting also changes to *off*. When queueing is turned on again, the printer restores nesting to its previous setting.

How Long Does the Printer Wait for Another File?

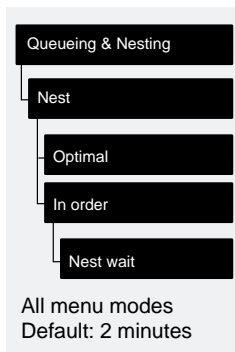

So that the printer can make the best nest possible, it waits after a file has been received to check if a subsequent page will nest with it or with pages already in the queue. This waiting period is the *nest wait* time. The factory default nest wait time is two minutes. This means that the printer waits for up to two minutes after the last file is received before printing the final nest. You can change this waiting time using the front panel menu (as shown opposite). The available range is 1 through to 99 minutes.

Getting the Best from Nesting (Nesting and Margins)

What the printer may do

In order to “squeeze in” one more page, the printer may reduce the right margin of the right-most page by up to 3 mm (0.08 in). This is done only if:

- your Page format / Size is set either to a Best option or to a discrete standard size, and if
- the roll of media loaded is slightly narrower than a standard size.

What you can do

You can reduce the side margins too, for every page, as explained on page 4-7. In order to give the printer the best chance of nesting the most pages, we recommend that you set Page format / Margins to Smaller.

Nesting and the Rotate Feature

Since nesting may automatically rotate pages, the front panel’s Page format / Rotate setting is ignored as long as nesting is on.

To See the Current Overall Configuration of the Printer	7-2
To See the Current Configuration of the Front-Panel Settings .	7-3
To Change the Front-Panel Settings	7-4
Recalibrating the Printer for Accuracy	7-5
Changing the Graphics Language Setting for a Different Application	7-7
Changing the Interface Settings	7-9
To Change The I/O Timeout Setting	7-9

Reconfiguring Your Printer

Reconfiguration and Recalibration

To See the Current Overall Configuration of the Printer

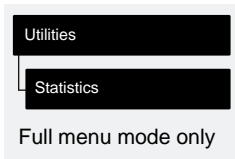

Item	Comments
Max X Max Y	<p>These two figures, in millimeters, give the size of the current printing area, that is, the area in which the printer will print the next page unless it is changed. Normally each file received sets these dimensions with its Page Size command. You can impact it by:</p> <ul style="list-style-type: none"> • the current front-panel setting for Page format / Size. • the media size currently loaded. <p>Remember:</p> <ul style="list-style-type: none"> • Printing area = page size minus margins. • X represents the vertical (paper path) axis. • Y represents the horizontal (carriage path) axis.
Code rev	This is the revision number of the printer's internal code.
RAM present	<p>This is the size, in megabytes, of the printer's main standard memory, plus the amount of memory reserved for printing.</p> <ul style="list-style-type: none"> • This does not correspond directly to the size of your files on the computer, as explained on page 9-22. • This is the total RAM, not the RAM currently free.
Media	<p>This is the media type which the printer thinks is currently loaded (or was last loaded), on the basis of what you specified when you loaded it. For an explanation of media types, see page 3-3.</p> <p>In this display, the following abbreviations are used:</p> <ul style="list-style-type: none"> • Translucent = Translucent bond • High-gl photo = High-gloss photo paper • Semi-gl photo = Semi-gloss photo paper • High-gl film = High-gloss film • Nat. tracing = Natural tracing paper
ROM SIMM	This tells you if a ROM SIMM is installed in the printer, for example PostScript.

To See the Current Configuration of the Front-Panel Settings

1 Make sure either a roll or a sheet of media is loaded.

2 Print the **Current Configuration Print**, by pressing the up-arrow and down-arrow keys simultaneously.

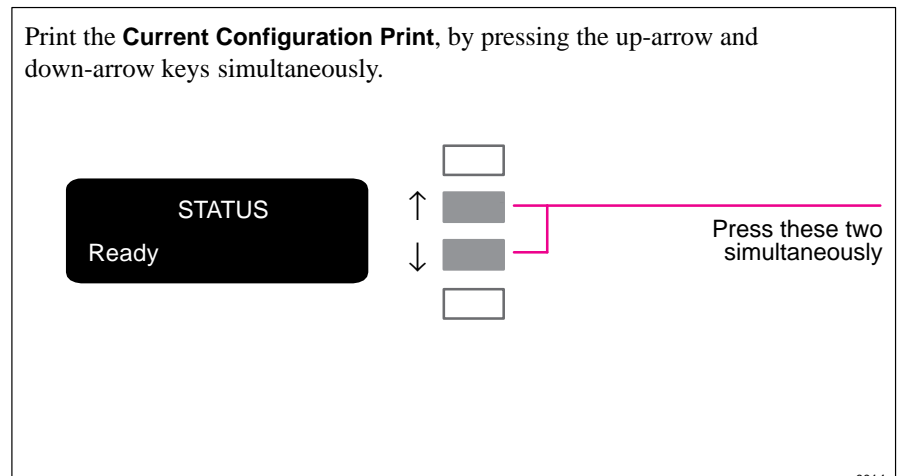

The **Current Configuration Print** lists in an easy-to-read format all the items available in the front-panel menus, together with their current settings (in red italics). Note that some of the items don't appear in the front-panel display unless you have set Utilities / Menu mode to Full (the default is Short, so that they *don't* appear). See the legend at the bottom of the print for details.

NOTE. Don't confuse the **Current Configuration Print** with the **Service Configuration Print**, which you can print by selecting Utilities / Service config. Apart from its use in calibrating the printer, as explained on page 7-5, the **Service Configuration Print** is likely to be needed only by a service engineer.

To Change the Front-Panel Settings

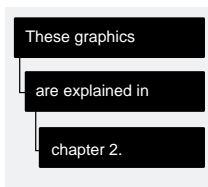

Chapter 2 of this manual explains how to use the front-panel display, including how to change any of the settings. It also explains the small menu graphics that appear in the left margins of this manual whenever a particular menu item is explained.

The meanings of all the items in the front-panel menus are explained at the relevant point in this manual. Refer to the index at the back of the manual for the item you want to change.

Recalibrating the Printer for Accuracy

When to Recalibrate the Printer

Your printer was calibrated at the factory using HP Matte Film, with a thickness of 0.12 mm (0.0048 in);

- at 23°C (73°F),
- with 50-60% relative humidity.

It will operate with greatest accuracy in similar environmental conditions. If you are operating under significantly different conditions, you should recalibrate the printer as explained here. The printer's environmental specifications are given on page 11-4. Also, if you are using a non-standard media type, you should first recalibrate the printer for that media type. For supported media types, see page 3-3. You may also need to recalibrate the printer if you have banding problems, see page 9-20.

A Quick Guide to Whether Recalibration is Necessary

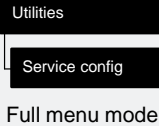

- 1 Make sure E/A0-size or D/A1-size media is loaded.
- 2 Print the **Service Configuration** print, by choosing the option shown in the menu graphic on the left.

- 3 Near the top of this print are a pair of Xs. With a ruler measure the distance between them. It should be 500 mm. If significantly different you will need to recalibrate the printer as described on the following page



Recalibrating Your Printer for Accuracy

To Recalibrate the Printer

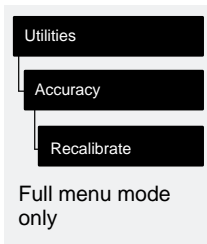

- 1 Choose your media type (*sheet or roll*). If recalibrating for a non-standard media type, use that type. Otherwise HP Matte Film will give greatest accuracy.
- 2 Choose your media size. This must be either E/A0 or D/A1.
- 3 Go to Recalibrate in the front-panel menus, as shown above left.
- 4 Choose Create pattern. The message Calibrating is displayed. If sheet media is loaded, this will be ejected. If roll media is loaded, you are asked to remove it.
- 5 When prompted, load your media, using the normal procedure. If using sheet media, load it in *portrait* orientation, unless you chose D/A1-size media for an E/A0-size printer, in which case load it in landscape orientation.
- 6 When the calibration print is finished, remove it.
- 7 Unload any unprinted media.
- 8 Rotate the sheet 90° counterclockwise and reload it *printed side down*, so that the two black arrows go into the printer first.

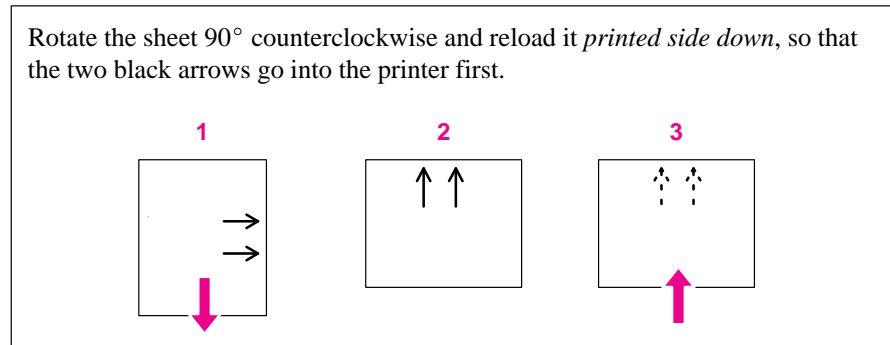

- 9 Go to Recalibrate again, and this time choose Measure pattern.
- 10 When the printer has finished measuring and has ejected the sheet, the recalibration routine is finished.

Once created, you can use this calibration sheet to recalibrate the printer's accuracy again later. Store the sheet flat or rolled with the printed side *out*. If the film takes a curl in the wrong direction it can become impossible to reload.

To Restore the Factory's Calibration

From the Accuracy menu, choose Restore factory. That's all.

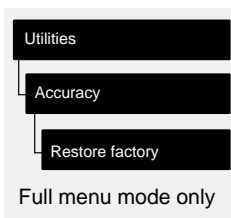

Changing the Graphics Language Setting for a Different Application

Your software application communicates with the printer by a graphics language. The HP DesignJet 755CM printer supports:

- PostScript
- HP-GL/2
- HP-GL (7586B)
- HP RTL

With the printer's default setting, called Automatic, it decides for itself which type of file it is receiving – PostScript, HP-GL/2, HP-GL or RTL – and prints it. Unless you want to change the scale of a PostScript print from the front panel (see page 4-13), or are troubleshooting any of the problems listed under Comments in the table below, then do not change this default.

To Change the Graphics Language Setting

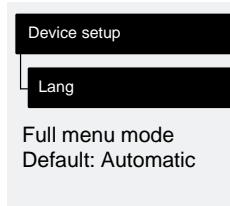

Graphics language	Comments
Automatic	This should work successfully for most software applications.
PostScript	This lets you change the scale of a PostScript print from the front panel. See page 4-13.
7586, HP-GL/2	This should work successfully for most CAD applications. With this graphics language setting another parameter is available: Terminator. Try changing this setting from Normal (the default) to Special: <ul style="list-style-type: none"> • if you are using an obsolete HP 7586 (pen plotter) driver, and your prints are incomplete.
HP-GL/2	Try this setting: <ul style="list-style-type: none"> • if you have experienced image position problems. • if you have experienced timing problems. However, if you choose this setting, you don't have access to the Terminator option.

Graphics Language and Networks

Note for system administrator. If you are using the printer with a network spooler, consider modifying the spooler to insert automatically the PJI language-switching commands at the beginning and end of each file. This allows the printer to switch automatically into the correct graphics language for your current print and returns the printer to the front panel graphics language setting for subsequent prints. For PJI reference information, see page 11-13.

Changing the Interface Settings

Network	With a network interface (such as HP JetDirect Print Server), refer to your network interface documentation for advice on any front-panel configuration. The front-panel menu is I/O Setup / Modular / MIO ...
Serial	With a serial interface, you should have configured it when installing the printer, as explained from page 1-26. However, you may need to reconfigure it: <ul style="list-style-type: none"> • when you connect a new computer to the printer • when you output to the printer from a new application • if you experience problems with distorted or unintelligible prints
Parallel	With a parallel interface, no front-panel configuration is necessary.

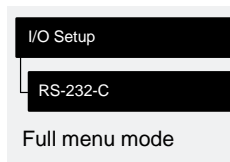

To Change the Serial Interface Settings

This task is explained in detail from page 1-26, including a note of the defaults and likely requirements.

To Change the I/O Timeout Setting

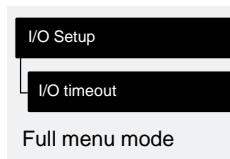

Some software may not write a proper file terminator at the end of the file. In this case, the printer will not know that the file is complete and will wait for more data until the end of the “I/O Timeout” period. By default, this period is 30 minutes, but you can change it in the menu (indicated on the left) to as little as 30 seconds.

Replacing the Print Cartridges 8-2
Cleaning the Printer 8-2
“Normal” Printer Use 8-3



Maintaining Your Printer

Cleaning and Service

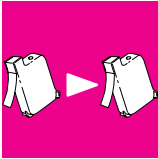

Replacing the Print Cartridges

Replaceable print cartridges have been used in your printer, greatly reducing its user maintenance requirements, as these are the components that experience the greatest wear and tear. Under normal use, you will probably find that you have to replace the black cartridge more often than the rest.

For instructions on when and how to replace cartridges, see the section starting on page 3-25.



Cleaning the Printer

Cleaning is limited to the outside of the machine. Use a damp sponge or a soft cloth and household cleaner.

WARNING

To avoid an electric shock, make sure that the printer is switched OFF and unplugged before you clean it. Do not let water get inside the printer.

CAUTION

Do not use abrasive cleaners on the printer.

Any maintenance or repairs beyond this should be done by a qualified service technician.

“Normal” Printer Use

“Normal” printer use means less than:

- 12 pages per day (if medium-density E/A0 image prints), or
- 20 pages per day (if medium-density E/A0 CAD prints)

If your drawings are smaller than E/A0, the number of pages per day can be higher.

If you use the printer less than this, it is unlikely you will need to get it serviced. If you use the printer more than this, it is possible that, after a period of time, it will need to be serviced. The printer itself keeps an internal count of total pages printed and total passes of the print cartridges. If the front panel periodically displays:

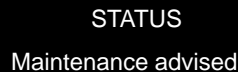

STATUS
Maintenance advised

this means that your use of the printer has exceeded one of the following warranty limits:

- either 20,000 pages printed
- or 4,500,000 passes of the cartridge carriage.

Contact your local HP dealer or HP service engineer to arrange a service. After the service the message will disappear. If you choose to ignore the message, you may continue to use the printer as normal, but may encounter a number of operational or print-quality problems.

You can check your current count of pages printed and passes of cartridge carriage by printing the **Service Configuration Print**.

To Print the Service Configuration Print

- 1 Make sure media is loaded.
- 2 In the front-panel menus, choose the option shown on the left.

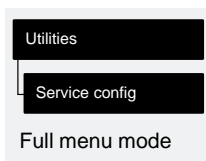

Using the Documentation to Help Solve Problems 9-2

Locating the Source of Your Problem 9-3

Solving Media-Handling Problems 9-4

Solving Print-Cartridge Problems 9-7

Clearing a Media Jam 9-8

Solving Communication Problems 9-9

Solving Problems with Image Position or Content 9-10

Solving Print-Quality Problems 9-16

Solving Front-Panel Problems 9-21

Solving Miscellaneous Problems 9-23

Getting Help 9-25



Troubleshooting

Using the Documentation to Help Solve Problems

- If you are looking for the meaning of an error message, see chapter 10.
- If you know the problem is related to a certain task, first check the relevant section in this manual, for the step-by-step procedures. Use this manual's index to find the section. For example, if you are having difficulty with your page format, refer to chapter 4, titled: Controlling the Page Format.
- If the problem persists, refer to the appropriate section in *this* chapter. The sections are
 - Solving media-handling problems
 - Clearing a media jam
 - Solving problems with image position or content
 - Solving print-quality problems
 - Solving miscellaneous problems.
- If the problem could be related to your software driver, and you are using an HP driver, refer to the drivers' troubleshooting documentation and the 'On-Line-Help' in your application software.
- If the problem has no obvious cause, read "Locating the source of your problem" on the next page.

- **If you still cannot solve the problem, refer to "Getting help" on page 9-25.**

Locating the Source of the Problem

- 1 Look at the front-panel display for any error message. For an explanation, see chapter 10.
- 2 Test the printer.
 - Switch the printer off. Ensure that the power cord is firmly inserted in the printer and plugged in to an outlet that you know works.
 - Switch the printer on. Print a sample file (see page 1-21). If the printer prints this correctly, the problem is probably not with the printer.
- 3 Test your computer hardware and interface.
 - Ensure that you have the correct interface cable between the computer and the printer and that it is firmly connected to the correct ports (see the sections starting on page 1-24).
 - Check that your printer's graphics language setting (in Device setup / Lang) matches the requirements of your software.
 - **Serial interface users only.** Check that your printer's serial interface settings (in I/O Setup / RS-232-C) match the requirements of your computer hardware and application software. See page 1-26 for details. Also, if you have changed your interface, switch the printer off and then on again before trying to print.

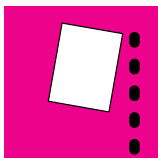

Solving Media-Handling Problems

If the Front Panel Keeps Indicating that Media is Misaligned or Incorrectly Positioned.

Roll media

Have you:

- Loaded the roll the wrong way. The media should load over the roll toward you.
- Loaded the media at an angle. The right-hand edge must be *parallel* to the perforated line on the printer.

Sheet media

Have you:

- Loaded the media at the wrong side of the entry slot. It must be loaded with the right-hand edge against the perforated line on the printer.
- Loaded the media at an angle. The right-hand edge must be *parallel* to the perforated line on the printer.
- Pushed or held the media back as it is loading. You must hold the media only by the edges and immediately release it when the printer is loading.
- It is also possible that the media itself is crumpled or warped or has irregular edges.
- If you are using hand-cut media, perhaps the edges do not form a right-angle or they are rough. It is not recommended to use media that you have cut yourself; use only purchased sheet media.
- If you cannot make your media's leading edge straight, you can turn on the skew tolerance feature (Device setup / Skew tolerance). See page 3-20, but remember that this feature can skew your print on the page.

If Media Crumples When You Load it

- Clear any obstructions in the media path.
- Be sure the leading edge is straight and free of tears. Cut a straight edge with the knife if necessary.
- If your media is curled, and if both sides are the same, load it with the curved (hollow) side towards you (Certain media types – for example coated paper – have a printing side and a non-printing side and these must be loaded printing side down).
- When loading media, hold each edge and push the media into the printer *evenly* against the stops until a slight buckle develops evenly across the media. Let go as soon as it starts to feed into the printer.
- If you have just moved the printer or your media from an environment with a different humidity level, let the media stabilize for at least 15 minutes before loading it.
- **Roll media only.** Open the roll cover and raise the lever. Unload the leading edge of the roll. Push the media all the way to the right so that it is flush against the media stop on the roll core. Then reload the media.

If Prints Do Not Feed Out Properly From the Printer

- Make sure the roll cover is completely closed before you print.

If The Automatic Cutter Does Not Cut Immediately When a Print Has Finished

- Check the Page format / Margins setting. When this is set to Smaller, the printer waits until the next print begins printing so it can create a 10 mm margin between both prints or nesting sets.
- Press the **Form Feed and Cut** key if you need to cut the media before the ink-drying time has passed or before the next print begins printing. Use caution to avoid smearing the ink.
- Check the ink-drying time and change if necessary (Device setup / Drying time).

If the Automatic Cutter Does Not Work

- The automatic cutter is activated only when roll media is loaded.
- Your software application may have disabled the automatic cutter. Refer to your software documentation or contact your software vendor for more information.

If Prints Fall on the Floor After Being Cut

- Do not let more than twenty prints accumulate in the bin.
- Be sure you have loaded roll media properly. If loaded incorrectly, the natural curl of the media may cause it to miss the bin and fall to the floor.

If a Sheet Is Ejected When You Switch On the Printer

- The printer is undertaking an automatic calibration check. Simply wait for the STATUS / Ready message and then reload the sheet.

If Prints Do Not Stack Properly in the Bin

- You may be too close to the end of the roll. The natural curl near the end of the roll can cause stacking problems. Load a new roll or remove prints manually as they are completed.
- If printed media is sagging or wrinkling between the bin wires after it is cut and fed out, try placing a sheet of scrap paper in the bin shelf that is at least the size of the print.
- If you are mixing prints or nesting sets of several different sizes, you are more likely to have stacking problems because of the different sizes of media in the bin.

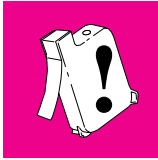

Solving Print-Cartridge Problems

If the Access Cartridges Key Does Not Work

- Make sure the window is closed before you press **Access Cartridges**.

If the Printer Runs the Cartridge-Alignment Routine Unexpectedly

- The printer runs the automatic cartridge alignment procedure every time you load, replace or even reseal a cartridge, whether it is a new cartridge or not. Do not remove the cartridges unnecessarily.
- You can stop the alignment by pressing **Cancel**, but the printer will restart the alignment procedure the next time you try to switch it on.

If Brand New Cartridges Have Problems

- Check the cartridges to be sure you have removed the protective nozzle tape.
- Try reseating cartridges.

Don't forget that, after you remove or reseal a cartridge, the printer will run its automatic cartridge alignment procedure – see page 3-26.

For troubleshooting other problems with the print cartridges, see the section starting on page 9-16.

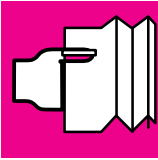

Clearing a Media Jam

- 1 Switch OFF the printer, open the window and raise the media lever.

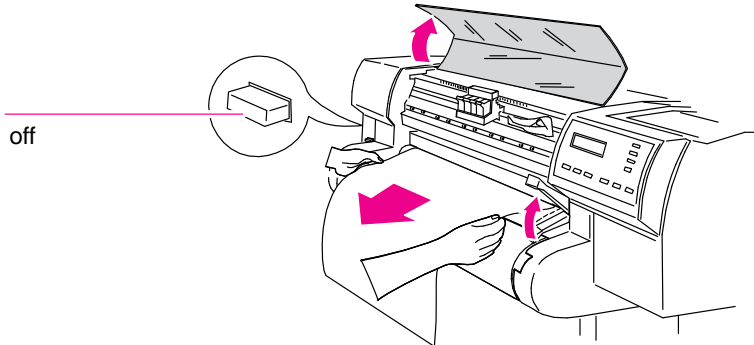

1867

WARNING

Don't touch the stainless steel strip that runs the length of the printer behind the cartridge carriage; its edge is very sharp. Keep hair, jewelry, clothing, and foreign objects away from the printer mechanisms.

When moving the cartridge carriage, touch only the black plastic parts.

- 2 Carefully move the cartridge carriage out of the way – if possible all the way to the enclosed area on the left or the right. Which way you are able to move it depends on where the media is jammed. If the printer was in the process of cutting media at the time of the jam, the cutter carriage will be attached to the cartridge carriage and will move with it.
- 3 Carefully remove any of the jammed media which you can easily lift *up and out from the top of the printer*.
- 4 Carefully pull the rest of the roll or sheet *down and out of the media entry slot*.
- 5 Lower the window and the lever and switch on the printer. Press the **Form Feed and Cut** key to eject any pieces of media that are still in the media path.
- 6 Reload the media as normal – see page 3-9. Remember that, if it's a roll, you may need to trim the edge.

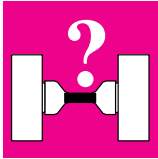

Solving Communication Problems

If There is a Problem Communicating between Your Computer and the Printer

Some symptoms of a communication problem are:

- The front-panel **Receiving** light does not come on.
- The front-panel display does not show STATUS / Receiving.
- Your computer displays an error message when you are trying to print.
- Your computer or printer “hangs” (stays idle) while communication is taking place.
- Your printed output shows random or inexplicable errors (misplaced lines, partial drawings etc.)

Items to start checking are:

- Have you selected the correct interface port in your software?
- Does the printer work correctly when receiving files from other software?
- If the printer is connected to a network, try using it when connected directly to your computer.
- If your printer is connected to your computer via any other intermediate devices, such as switch boxes, buffer boxes, cable adapters, cable converters etc., try using it when connected directly to your computer.
- Try another interface cable. For details of supported cables, see page 11-8.

Solving Problems with Image Position or Content

If you don't find the solution to the problem here, other sources of help are:

- The documentation supplied with the driver that you are using to manage the output from your software application to the printer. For example, the online and printed documentation included in the following drivers supplied with your printer:
 - HP DesignJet PostScript Drivers for Macintosh
 - HP DesignJet PostScript Driver for Microsoft Windows
 - HP Driver for Microsoft Windows
 - HP Printer Drivers for AutoCAD
- The documentation supplied with your application software



If the Print Is Completely Blank

- Check the print cartridges to be sure you have removed the protective nozzle tape from all of them. Do not forget that, after you remove or reseal a cartridge, the printer will run its automatic cartridge alignment procedure – see page 3-26.
- Cartridges may be out of ink. For an explanation of how to check if a cartridge is out of ink, see page 3-25.
- If the front-panel graphics language setting is Automatic (the default), try the other settings (PostScript for a PostScript file, HP-GL/2 for an HP-GL/2 file etc.) and send the file again. See page 7-7.



If the Output Contains Only a Partial Print

- Did you press **Form Feed and Cut** before all the data was received by the printer? If so, you have ended the data transmission and will have to print the page again. (You normally don't need to press **Form Feed and Cut** to unload the print.)
- The I/O Setup / I/O Timeout setting may be too short. Increase the setting and print again. See page 7-9.
- The file may be too big for the printer's memory. See the note on page 9-22.
- There may be a communications problem between your computer and the printer. Check your interface cable.
- Check to make sure that your software settings are correct for your current page size (e.g., long-axis prints).
- If you are using network software, make sure it has not timed out.

See also under "If the image is clipped" on page 9-12.



If the Image Is Clipped

This normally indicates a discrepancy between the actual printing area on the loaded media and the printing area as understood by your software. For general advice on printing areas and page size, see chapter 4.

- Check the actual printing area for the media size you have loaded. printing area = media size minus margins. For media size and margins, see page 11-2. For actual printing areas, see page 11-6.
- Check what your software understands to be the printing area (which it may call “printable area” or “imageable area”). For example, AutoCAD assumes standard printing areas that are larger than those used in this printer.
- Check that the orientation of the media is the same as that assumed by your software. The front-panel Page format / Rotate option changes the orientation of a drawing and, on roll media, the orientation of the page. It is possible that a rotated image on roll media may be slightly clipped in order to retain the correct page size, as explained on page 4-11.
- You may have asked to rotate the page from portrait to landscape on media that is not wide enough, for example a D/A1-size page rotated on a D/A1-size roll.
- If necessary, change the printing area in your software.
- The file may be too big for the printer’s memory. This is the case if the front panel displays “Out of memory – data was lost”. See the note on page 9-22.



If a Long-Axis Print Is Clipped

- Does your software support long-axis prints?
- Have you specified an appropriate media size in your software?
- Unless it is a PostScript file, make sure that the printer’s Page format / Size is set to Inked area.



If the Entire Image Is in One Quadrant of the Correct Printing Area

- Is the page size configured in the software too small?
- Are you sure that your software doesn't believe the drawing to be in one quadrant of the page?

Otherwise, this indicates an incompatibility between the software and the printer:

- Is your software configured for this printer? For general advice, see page 1-32. For advice specific to your software, see either the documentation supplied with the driver or any Software Application Notes supplied with your printer.
- If you still haven't found the solution, try changing the printer's **Graphics Language** setting on the front panel (Device setup / Lang).



If the Image Is Unexpectedly Rotated

- Check the front-panel Page format / Rotate setting. See page 4-8.
- For non-PostScript files: if Queueing and Nesting are both ON, pages may be automatically rotated to save media. See page 6-10.
- For an explanation of rotation for PostScript files, see page 4-10.



If the Print Is a Mirror Image of Your Drawing

- Check the front-panel Page format / Mirror setting.



If the Print Is Inaccurate

- If you notice problems with accuracy, print the **Service Config** print, as explained on page 7-5, to see if the printer needs to be recalibrated.



If the Print Is Distorted or Unintelligible

- The interface cable between your computer and the printer could be faulty. Try another cable to see if the problem is corrected.
- If you are using a serial interface between the printer and your computer, make sure the printer's serial interface settings match the settings and requirements of your software and hardware. See page 1-26.
- If the front-panel graphics language setting is Automatic (the default), try the other settings (PostScript for a PostScript file, HP-GL/2 for an HP-GL/2 file etc.) and send the file again. See page 7-7.



If One Image Overlays Another on the Same Sheet

- The I/O Setup / I/O Timeout setting may be too long. Decrease the setting and print again. See page 7-9.
- If Device setup / Lang is set to 7586,HP-GL/2 (the default), try changing the Terminator setting and send the files again.



If Pen Settings Seem To Have No Effect

- Either you have changed them in Pen settings / Define palette but forgotten to select that palette in Pen settings / Palette,
- or you expected the software-driven pen settings but in the front panel Pen settings / Palette is not set to Software.

See page 5-7.

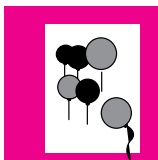

If the Printer Produces a Black and White Print When You Expected a Color Print

- Check the front panel **Color/Mono** setting, and the equivalent setting in your software.



If a Gray Box Appears Where an Image Should Be

- If the image is an embedded EPS (encapsulated PostScript) file, and you printed it using the non-PostScript Microsoft Windows driver, try using the HP DesignJet PostScript driver for Microsoft Windows instead.

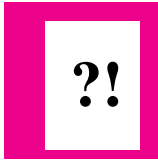

If the Printer Has Printed a Different Print Than the One You Were Expecting

One possibility is that you have accidentally initiated one of the printer's internal prints:

- **The Cartridge Alignment Print.** (A small pattern of colored lines without text.) This is printed automatically every time you replace, or even reseal a cartridge.
- **The Current Configuration Print.** This is printed by simultaneously pressing the two arrow keys on the front-panel.
- **The Demos.** These are printed from the front-panel menu options Demos / PostScript and Demos / Samples.
- **The Front-Panel Menu Print.** This is printed from the front-panel menu Demos / Menu.
- **The Palette Print.** This is printed from the front-panel menu Demos / Palette.
- **The Service Configuration Print.** This is printed from the front-panel menu Demos / Service Config.



If the Quality Of A Color Print Is Not as Sharp as You Were Expecting

- Select Best on the front-panel **Print Quality** key and print again.
- Did you specify the correct media type when loading? The highest line quality is only produced using Opaque Bond, Coated Paper or Matte Film. For details of media types, see page 3-3. To find out the printers' current media type setting, see page 7-2.
- Your application-software driver may be overriding the Sharp lines selection on the front-panel menu.
- Are you printing something other than a line drawing, for example a CorelDRAW! file? If so, you may want to experiment to improve the output quality by setting Sharp lines to Off on the front-panel menu, and print again.
- Are you printing a CAD drawing with small raster images? Try setting Sharp lines to On and print again.
- When loading the paper, specify "Heavy coated paper" on the front panel, rather than "Coated paper".

Solving Print-Quality Problems

To achieve the best performance from your printer, we recommend you only use genuine HP accessories and supplies, whose reliability and performance have been thoroughly tested to give trouble-free performance and best-quality prints. For details of HP media, see page 3-3 and the Supplies Source catalog supplied with the printer.

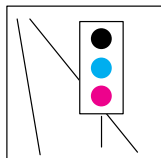

If the Color Is Not as Expected

The means of accurately managing the colors printed by your printer vary with the software application and driver being used. Refer to the following documentation:

- That included as part of the HP Color Management Kit supplied with the printer.
- The *Software Application Note* for your application, in the specific package shipped with your printer.
- Online documentation in the drivers shipped with your printer, for example in the Color Options dialog box of the non-PostScript Microsoft Windows driver.

Additionally, remember that your printer may be configured to use one of its internal pen palettes instead of your software's palette (which is the default). See the section starting on page 5-5. If you cannot find any reason for the discrepancy, before getting help, find out for which CMYK printer inks the colors have been specified.

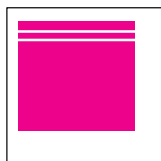

If there Are White Streaks in Solid Areas

This may mean that a cartridge nozzle is blocked. Unless you have switched cartridge check off (see page 3-25), the printer normally detects this problem and tries to clear the nozzle automatically. However, some nozzles may still remain blocked, and in this case, the printer will display **Service cartridges** on the front panel. This means you should replace the problem cartridge, as explained from page 3-25. If you are unsure which cartridge has the problem, refer to the next page.

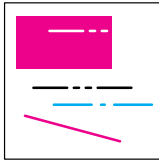

If There are Other Gaps in Solid Areas Or in Lines

- 1 One or more of your cartridges may be out of ink. For an explanation of how to check, see page 3-25.
- 2 If the ink levels are OK, try to assess which cartridge has the problem. Look at your print, if the problem occurs only in one of the following colors – yellow, cyan, magenta, red, green, blue or black – then you can eliminate one or more of the cartridges. Remember that the printer’s cartridges are yellow, cyan, magenta and black, and that “pure” red, green and blue are made up as follows:

	red	=		yellow	+		magenta
---	-----	---	---	--------	---	--	---------

	green	=		cyan	+		yellow
---	-------	---	---	------	---	--	--------

	blue	=		magenta	+		cyan
---	------	---	---	---------	---	--	------

- 3 If you know which cartridge has the problem, then try reseating it to ensure good electrical connections. While it is out of the carriage, check the print nozzles to make sure the protective tape has been removed. Don’t forget that, after you remove or reseal a cartridge, the printer will run its automatic cartridge alignment procedure – see page 3-26.
- 4 If you don’t know which cartridge has the problem, then print the **Service Configuration Print**, by choosing Utilities / Service Config on the front panel. This print contains a pattern for each of the four cartridge colors (yellow, cyan, magenta and black) which you can examine for gaps or streaks. If you can identify a problem cartridge, try the checks in 3 above.
- 5 If the problems persist, try running the recalibration routine. See page 7-5.
- 6 If the problems still persist, replace the cartridge(s). See page 3-25.

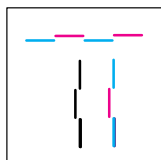

If There are Jagged Vertical or Horizontal Lines

- Did you specify the right media type when loading the media? For details of front-panel media types, see page 3-3. To find out the printer's current type of media setting, see page 7-2.
- Force the automatic cartridge alignment procedure by reseating any one of the print cartridges.
- If the problem persists, replace the print cartridges. See page 3-25.

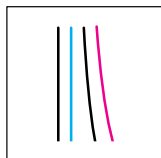

If There are Slightly Warped Lines

- The media itself may be warped. This can happen if it has been used or stored in an extreme environment. For all environmental specifications, see page 11-4.

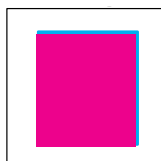

If There are Color “Shadows”

Force the automatic cartridge alignment procedure by reseating any one of the print cartridges.

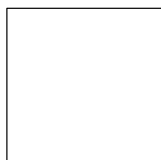

If One or More Cartridges are not Printing at All

- Look to see if the cartridge is out of ink. See 3-25.
- If it is still not printing, remove the faulty cartridge(s) and check the print nozzles to make sure the protective tape has been removed. Do not forget that, after you remove or reseal a cartridge, the printer will run its automatic cartridge alignment procedure – see page 3-26.

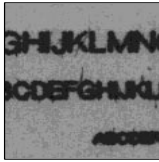

If There are Blurred Lines (Ink “Bleeds” from Lines)

- Perhaps you are not using HP media. For details of HP media, see page 3-3 and the Supplies Source catalog supplied with the printer.
- The printer may be operating in an area where the temperature and humidity are too high. For environmental specifications, see page 11-4. To allow for extremely dry or humid environments within the specification, see page 3-21.
- Did you adjust the drying time in the front-panel menu purely to speed up the printers output? For details of drying time adjustments see page 3-22.

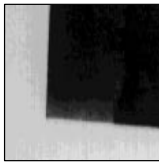

If There are Blotchy Areas (Uneven Fill Density)

- Perhaps you are not using HP media. For details of HP media, see page 3-3 and the Supplies Source catalog supplied with the printer.
- Did you specify the right media type when loading the media? For details of front-panel media types, see page 3-3. To find out the printer’s current type of media setting, see page 7-2.
- Note that some media types are not recommended for color prints with large area fills. See page 3-5.



If the Print Is Too Dark .or the Color Too Saturated

- You can make a global adjustment to the amount of black ink used (which affects most colors too) by adjusting the Lightness setting. See page 5-9. This is also available from some drivers, where the feature may be called “Darkness”.



If There Is Pronounced Banding in Area Fills

Some banding is normal, especially in dark or dense area fills. If the banding is unacceptable try the following:

- Make sure you are using HP media.
- Try changing the Print Quality setting.
- If the banding is in a black or gray area, then try reducing the percentage of black in grayscales, either in your software or in the printer's palette. For details of how to do this using the printer's palette, see page 5-5.
- Force the automatic cartridge alignment procedure by reseating a print cartridges.
- Try accuracy calibration.
- Adjust the drying time, see page 3-21.
- If the problem persists, replace the print cartridges. See page 3-25.

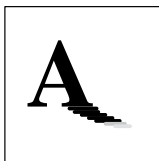

If Ink Smears After You Remove a Print

- Use HP media for best quality.
- This can be caused by extreme environmental conditions. For environmental specifications, see page 11-4.
- *With roll media*, the printer automatically allows a suitable ink-drying time before cutting the roll and dropping the print in the media bin. To allow for extremely dry or humid environments within the specification, see page 3-21.
- *With sheet media*, **you** need to allow for ink-drying time before removing the sheet. For recommended ink-drying times, see page 3-21. For example, with a best-quality monochrome print on opaque bond, you should wait about 90 seconds before unloading the sheet.
- Handle media by the edges. If possible, wear gloves when you handle film. Skin oils can interact with ink and cause it to smear.

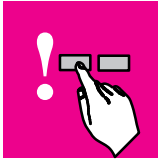

Solving Front-Panel Problems

If the Access Cartridges Key Does Not Work

- Make sure the window is closed before you press **Access Cartridges**.

If the Cancel key Does Not Work

- A PostScript file will carry on printing for a while before implementing a cancel request. Simply wait until the front panel display STATUS / Ready.

If None Of the Front-Panel Keys Work

- Turn the printer off and then on again. If the problem persists, have your printer serviced.

If Page Format/Rotate Does Not Work

- Your print file may be too big for the printer's memory. See the note on page 9-22.
- The printer cannot rotate raster images (except for PostScript files). If your non-PostScript file contains raster data (typically, images with heavy area fill and shading that you have scanned into your software) you will not be able to rotate the print.
- The printer cannot rotate any file sent using the non-PostScript Microsoft Windows driver supplied with the printer, as they contain raster images.

If a Display Message Will Not Clear

- Look up the message in chapter 10. The message description may help you understand and resolve the problem.
- If looking up the message did not help, press **Enter**. If that does not work, turn the power off, then on again. If the message still displays, have the printer serviced. If the message says "System Error" and has an alphanumeric code, refer to the next explanation.

If a “System Error” Message Is Displayed

- Press **Enter**. If the message does not clear, turn the printer off, then on again to try to clear the error message. If media appears to be jammed, clear it. If the message is still displayed, record the alphanumeric code and have the printer serviced. Report the code to the service technician; knowing the code number will help the technician resolve the problem.

If an “Out Of Memory/Data Was Lost” Message Is Displayed

- The current file is too large for the printer’s memory.

File Size and Memory Usage

There is no direct relationship between file size on your computer and memory used in the printer to print that file. In fact, because of file compression (and general complexity) it is often impossible to estimate how much memory will be used. In general, thicker lines (≥ 0.5 mm), complex objects (such as polylines) and fills will all use significantly more memory.

This also means that size of the largest file you can store in the printer’s queue is not the same thing as the amount of memory installed in your printer.

Two tips for PostScript users with file-size problems:

- Try reducing the page size in your software and then scale the print in the printer’s front panel. See page 4-13.
- Try reducing the resolution of any bit-map objects in your file, for example photographs.



Solving Miscellaneous Problems

If the Printer Does not Print

- You may have a power problem. If there is no activity at all from the printer, and no lights on the front panel, check that the power cable is connected correctly and that there is power available at the socket.
- You may have a problem with your application driver. Is your software configured for this printer? For general advice, see page 1-32. For advice specific to your software, see either the documentation supplied with the driver or a relevant Software Application Note supplied with your printer.
- The file may be too big for the printer's memory. Look on your computer screen for any error message: some drivers, for example the Microsoft Windows driver supplied with your printer, allow you to choose a different printing mode and try to send the file again.
- If you continue to have problems, see "Getting help" on page 9-25.

If the Printer Seems Too Slow

- Did you specify **Best Print Quality** level on the front panel? Best quality prints are produced more slowly. See page 5-12.
- Did you specify the right media type when loading the media? For details of front-panel media types, see page 3-3. To find out the printer's current media type setting, see page 7-2.
- If you are using the non-PostScript Microsoft Windows driver shipped with the printer, check the settings in the "Print Setup / Options" dialog box, where some of the settings impact printing speed. If in doubt, use the on-screen help system.
- Is Sharp lines set to Auto on the front panel or in your driver? If so, setting it to Off will speed up your printer but may reduce the quality of your print. See page 5-15.

If the Printer Waits Too Long to Print a Nest

- Change the Nest wait setting. See page 6-11.

If the Printer Performs the Cartridge Alignment Routine Unexpectedly

- This is a normal printer operation. The printer will align the cartridges every time you replace, or even reseal, a cartridge, whether or not it is new.

If the Bail (Black Metal Bar) Does Not Lower All the Way

- If the the bail (the black metal bar just inside the printer's window) will not lower all the way, check for obstructions underneath it.
- Make sure the cutting carriage is pushed all the way to the right.



Getting Help

Hewlett-Packard has support services available to help you in case you have a problem with your printer.

For a list of the support services available, refer to the *Hewlett-Packard Support Services* booklet shipped with this printer.

What to Do *Before* You Call

- 1 Review the troubleshooting suggestions:
 - in this chapter,
 - in the relevant driver documentation supplied with this printer (for users sending PostScript files or those using Microsoft Windows and AutoCAD applications),
 - in any relevant Software Application Note supplied with this printer.
- 2 Print the demo as explained on page 1-21. If the demos work and do not display the problems you have found with your own prints, then the problem is probably not with your printer.
- 3 If the problem appears to be related to your software application, first contact your software vendor.
- 4 If you still have difficulty, refer to the HP Support Services booklet shipped with this printer. This document contains a comprehensive list of various support services available to help solve printer problems.
- 5 If you do call one of the Hewlett-Packard offices, please have the following information available to help us answer your questions more quickly:
 - The printer you are using.
 - The computer you are using.
 - Any special equipment or software you are using (for example, spoolers, networks, switch-boxes, modems, or special software drivers).
 - The cable you are using (by part number) and where you purchased it.
 - The type of interface used on your printer (RS-232-C, parallel, or modular).
 - The software name and version you are currently using.

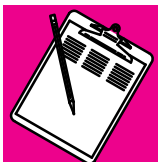

If a Repair Is Needed

Contact the Hewlett-Packard dealer or HP Sales and Support Office nearest to where you purchased the printer for complete service information.



Front-Panel Messages

Front-Panel Messages

This is a list of all possible messages in the front-panel display. If you need to do something, it is shown in *italics* in the **Explanation and Action** column.

The messages are listed in alphabetical order.

Message	Explanation and Action
Alignment error Continue →	The alignment procedure has failed. <i>Check that an opaque media is loaded. Press ↓ to continue and force the automatic alignment procedure again by reseating any of the print cartridges. Do not lift the window while cartridge alignment is being performed.</i>
Calibrate error Continue →	The calibration print was loaded incorrectly and it could not be measured. <i>Press ↓ to continue, then reload the print for measurement. Follow front panel instructions.</i>
Calibration done Continue →	Accuracy calibration is complete. <i>Press ↓ to continue.</i>
Close roll cover Continue →	<i>Rewind the media to take up any slack in the roll, close the roll cover, then press ↓ to continue.</i>
Create pattern →	<i>Press ↑ to create the pattern for automatic calibration.</i>
Measure pattern →	<i>Press ↓ to start the automatic calibration.</i>
Edge not found Reload media	The printer could not find edge of media during loading procedure. <i>Check the leading edge of the media for unevenness or tears; cut a straight edge, if necessary, and reload. Be sure to position the right edge along the perforated line on the entry platen when loading.</i>
Lift lever	<i>Lift the lever at the right of the printer.</i>
Load arrow edge print side down	<i>Remove accuracy calibration print, turn it so that the edge with arrows printed on it is print side down, then load that edge into the printer.</i>
Load cancelled Remove media	You pressed the Cancel button while media loading was in progress. <i>Remove media.</i>
Load error Remove media	You inserted media with the media lever raised. <i>Lower the lever and reload the media.</i>
Load media to align cartridges	<i>Load media to proceed with cartridge alignment.</i>
Lower lever after aligning	<i>When you've finished aligning the roll media as instructed, lower the lever at the right of the printer.</i>

Message	Explanation and Action
Lower lever to continue	You lifted the media lever while the processor was busy. <i>Lower the lever to continue.</i>
Lower window to continue	You opened the window while the processor was busy. <i>Close the window to continue.</i>
Media too small	The media you loaded for accuracy calibration or cartridge alignment is too small. <i>Reload appropriate media.</i> See page 7-5.
Mispositioned Reload roll	The roll is mispositioned. <i>Reload media.</i>
Mispositioned Reload sheet	The sheet is mispositioned. <i>Remove it and reload it with the right edge no more than 0.2 inches (0.5 cm) from either side of the perforated line on the entry platen.</i>
MIO data error	You configured the modular interface incorrectly. <i>Press Enter to clear the message from the front panel display. Recheck the MIO configuration settings.</i>
MIO error Communication break	You prematurely stopped the flow of data from the computer to the printer (e.g., by turning off the computer before all data is sent). <i>Press Enter to clear the message from the front panel display.</i>
Open window to access cartridges	<i>Lift the window to access the cartridges.</i>
Out of memory Data was lost	The current file is too large for the printer's buffer. <i>See the note on page 9-22.</i>
Pull ↓ / Align ↔ edges to roll	<i>Grasp the left and right free edges of the roll media and pull toward you until the media is taut. At the same time, align the left and right edges of the media so that they are flush with the left and right edges of the roll.</i>
Remove media Continue →	The ink is dry. <i>Remove the accuracy calibration print the printer just produced. Press ↓ to continue with accuracy calibration.</i>
Remove media Lower lever	You have attempted to load media while the lever at the right of the printer was raised. <i>Remove the media, lower the lever, and reload media with the lever down.</i>
Replace cartridge(s) ■ ■ ■ ■ ■	The cartridge indicated has a clogged nozzle. <i>Replace it to continue.</i>
Reseat cartridge(s) ■ ■ ■ ■ ■	The cartridge indicated is badly seated. <i>Reseat it to continue.</i>
Roll misaligned Reload roll	Roll media is skewed. <i>Reload media.</i>
RS-232 error Baud, parity	You configured the RS-232-C interface incorrectly. <i>Press Enter to clear the message from the front panel display. Check the baud rate and parity settings in the front panel, in the hardware configuration, and in your software to be sure they are all compatible.</i>

Message	Explanation and Action
Service cartridges Continue →	Cartridge Check is on and an error has been detected. <i>Press ↑ if you want to service the cartridges (replace or reseal). Press ↓ if you want to continue without servicing the cartridges.</i>
Sheet load →	<i>Press ↑ to load sheet media.</i>
Roll load →	<i>Press ↓ to load roll media.</i>
Sheet misaligned Reload sheet	Sheet media is skewed. <i>Remove it and reload it so that the left and right edges being loaded into the printer are square.</i> The leading edge must also be straight.
Sheet / Roll? Reload media	<ul style="list-style-type: none"> • Either: You have chosen Sheet mode while loading roll media. <i>Reload media.</i> • Or: You have loaded a sheet more than 51 inches (130 cm) long. <i>Trim sheet and reload.</i>
STATUS Accessing cartridges	You have pressed the Access cartridges button. The cartridge carriage is moving out so you can access it.
STATUS Aligning cartridges	The printer is aligning cartridges.
STATUS Cancelling	You have pressed the Cancel button and the printer is in the process of cancelling the procedure. <i>Continue when this message is no longer displayed.</i>
STATUS Checking media	The printer is checking to see if media is properly positioned with respect to the perforated line of the entry platen.
STATUS Creating pattern	The printer is performing accuracy calibration.
STATUS Ink drying (xx m xx s)	The ink on your print is drying. <i>Wait before removing the print. If you remove it before the indicated time has passed, avoid smearing the ink.</i>
STATUS Loading roll	The printer is loading roll media.
STATUS Loading sheet	The printer is loading sheet media.
STATUS Maintenance advised	You are using the printer more intensively than the recommended duty cycle and should <i>contact your local HP dealer or HP service engineer to arrange a service.</i> For the duty cycle specification, see page 11-4. If you choose to ignore the message, you may continue to use the printer as normal, but may encounter a number of operational or print-quality problems.
STATUS Measuring pattern	The printer is measuring the accuracy calibration print you just loaded.

Message	Explanation and Action
STATUS Returning cartridges	The cartridge carriage is returning to its station at the left of the printer.
STATUS Roll feed edge trim	The printer is trimming the edge of roll media.
STATUS Initializing	The printer is doing an internal check on power-up.
STATUS Out of media	The printer has received a file, is ready to print, but has no media loaded.
STATUS Printing	The printer is printing.
STATUS Printing (Special)	The printer is printing with a special print mode controlled by your software rather than by the printer.
STATUS Ready for media	The printer is ready for you to load media.
STATUS Ready	The printer is ready to print.
STATUS Receiving	The printer has received data.
STATUS Testing cartridges	The printer is testing the cartridges for problems, i.e., clogged cartridge or bad electrical connection (improper seating).
Switch power off Check cartridge path	<i>Turn off the printer.</i> The cartridge carriage cannot move. The printer may be jammed with media. <i>Check the media path and clear it if necessary. Then turn on the printer.</i>
Switch power off Check paper path	<i>Turn off the printer.</i> The drive roller cannot move or the roll feed spindle cannot freely rotate. The printer may be jammed with media. <i>Check the media path and clear it if necessary. Then turn on the printer.</i>
System error XXXXXX	An internal error has occurred and a system error number is displayed. <i>Press Enter; this may clear the error and allow you to continue. If you cannot continue, turn off the printer, then turn it on again. If you still see the system error message, record the system error number and have the printer serviced. For support details, see page 9-25.</i>
Wrong cartridge type	You have loaded one or more incompatible cartridges. <i>Replace the cartridges with those appropriate for this printer.</i>

Printer Specifications	11-2
Interface Specifications	11-7
Interface Cables	11-8
Regulatory Notices	11-10
Ordering Accessories	11-13



Reference



Printer Specifications

Functional Specifications				
Cartridges	Four: yellow, cyan, magenta and black. For part numbers, see page 11-15.			
Media sizes E/A0-size printer	<i>Width (carriage axis)</i>		<i>Length (paper axis)</i>	
	<i>Minimum</i>	<i>Maximum</i>	<i>Minimum</i>	<i>Maximum</i>
	190 mm (7.5 in)	917 mm (36.1 in)	210 mm (8.3 in)	Maximum length of long axis plot on roll media: 15.2 m (50 ft) Sheet media: 1.32 m (52 in)
Media types See also Supplies Source catalog and (in Europe and USA) Media Reference Guide. For alternative names, HP commercial names and physical characteristics of these media types, see chapter 3.	<i>Monochrome</i>		<i>Color</i>	
	Coated paper		Coated paper	
	Matte film		Matte film	
	Clear film		Clear film	
	Heavy coated paper		Heavy coated paper	
	Opaque bond		Opaque bond (CAD drawings only)	
	Translucent bond			
	Natural tracing paper		Natural tracing paper ¹	
	Vellum		Vellum ¹	
	High-gloss photo paper ²		High-gloss photo paper	
Semi-gloss photo paper ²		Semi-gloss photo paper		
High-gloss film ²		High-gloss film		
¹ CAD drawings only and HP media only. ² To print in monochrome on glossy media, you must have all four cartridges loaded. Note. From time to time, new media types may become available. For up-to-date information, please contact your HP dealer or local HP Sales and Support Office.				
Margins For printing area (media size minus margins), see page 11-6		<i>Normal</i>	<i>Smaller (roll media only)</i>	
	Leading edge:	17 mm (0.67 in)	10 mm (0.39 in)	
	Trailing edge:	17 mm (0.67 in)	10 mm (0.39 in)	
	Sides:	5 mm (0.2 in)	5 mm (0.2 in)	
All measurements ± 2 mm (0.08 in).				



Functional Specifications (continued)				
Resolution by Print Quality setting	<i>Color/Mono set to: Mono</i>		<i>Color/Mono set to: Color</i>	
	Fast	300 x 300 dpi.	Fast	300 x 300 dpi.
	Normal	PS: 300 x 300 dpi. Non-PS: 600 x 600 dpi. ¹	Normal	300 x 300 dpi.
	Best	600 x 600 dpi. ¹	Best	600 x 600 dpi. ²
Accuracy (Maximum accumulated error)	±0.38 mm (0.015 in) or ±0.2% of the specified vector length, whichever is greater, at 23°C (73°F), 50–60% relative humidity, on HP Matte Film.			
Programming languages supported	Adobe PostScript Level 2, HP-GL (7586B), HP-GL/2, HP RTL, P.JL.			
	¹ Except for glossy media types, on which the resolution is always 300 dpi. ² Addressable dpi (depending on the type of image your application software has created). Only on coated paper, matte film and opaque bond media.			

Physical Specifications				
	<i>Weight (packed)</i>	<i>Length (unpacked)</i>	<i>Depth (unpacked)</i>	<i>Height (unpacked)</i>
With stand	61 kg (135 lb)	1370 mm (54.0 in)	675 mm (26.6 in)	1200 mm (47.3 in)
Without stand	43 kg (95 lb)			

Memory Specifications
Your printer comes with a standard memory of 75 MB (3 MB of internal memory and 72 MB of printing memory). Of the 72 MB, 64 MB is provided by two pre-installed 32-MB ROM SIMMs. See also the note on page 9-22.

Printer Specifications

Environmental Specifications		
Operational	Mechanical and electrical:	0 to 55°C (32 to 131°F) @ 5-95% relative humidity
	With cartridges and media:	15 to 35°C (59 to 95°F) @ 20-80% relative humidity
	For optimal print quality and media handling:	15 to 30°C (59 to 86°F) @ 20-80% relative humidity
Storage	Printer and media:	-40 to 70°C (-40 to 158°F) @ 20-80% relative humidity
	Cartridges:	-40 to 70°C (-40 to 158°F) @ 20-90% relative humidity

Power Specifications	
Source	100–240V ac \pm 10%. Autoranging.
Frequency	50–60 Hz.
Consumption	140 W max. (2.0 A max.)
Energy Star rating (USA)	Maximum power in idle state: 45 watts.

Acoustic Specifications		
Operating sound pressure	42 dB(A)	(From a one-meter bystander position and with Print Quality set to Best .)
Idle sound pressure	<20 dB(A)	

Duty Cycle		
Recommended maximum number of prints per day	Medium density E/A0 image prints:	25
	Medium density E/A0 CAD prints:	40

EMC (ElectroMagnetic Compatibility) Specifications	
Canada	Canadian Department of Communications, Radio Interference Regulations Class A and Class B compliant.
European Union	89/336/EEC EMC Directive compliant. Meets EN 55022 Class A and Class B emission limits, prEN 55024-2 ESD, prEN55024-3 Radiated Immunity, prEN 55024-4 Fast Transients.
Japan	Registered VCCI Class 1 and Class 2.
Korea	RRL certified.
South Africa	SABS licensed.
USA	Federal Communications Commission certified. Class A and Class B computing device. CFR 47 Part 15

Safety Specifications	
Information Technology Equipment (ITE), Movable, Class I, Plugable Type A, Installation Category II, Pollution Degree 2. For indoor controlled office environments use.	
Canada	Canadian Standards Association "Certified" ITE, CSA C22.2 No.950
European Union	73/23/EEC Low Voltage Directive compliant. Meets EN 60950
Mexico	DGN, NOM019-SCFI-1993 certified
Norway	NEMKO approved, EN 60950, EMKO TSE(74)DK207/94
USA	Underwriters' Laboratories "Listed" ITE, UL 1950

Printer Specifications

Printing Area (= Media Size Minus Margins).					
	Media Size (and Orientation of Media)	Printing Area (Width x Height) by Orientation of Drawing			
		inches		millimeters	
		landscape	portrait	landscape	portrait
ANSI media	A (portrait)	9.66 x 8.1	8.1 x 9.66	245 x 205	205 x 245
	A (landscape)	10.6 x 7.16	7.16 x 10.6	269 x 182	182 x 269
	B (portrait)	15.7 x 10.6	10.6 x 15.7	397 x 269	269 x 397
	B (landscape)	16.6 x 9.66	9.66 x 16.6	421 x 245	245 x 421
	C (portrait)	20.7 x 16.6	16.6 x 20.7	524 x 421	421 x 524
	C (landscape)	20.6 x 15.7	15.7 x 20.6	549 x 398	398 x 549
	D (portrait)	32.7 x 21.6	21.6 x 32.7	829 x 548	548 x 829
	D (landscape)	33.6 x 20.7	20.7 x 33.6	854 x 525	525 x 854
	E (portrait)	42.7 x 33.6	33.6 x 42.7	1084 x 854	854 x 1084
Architectural media	A (portrait)	10.7 x 8.60	8.6 x 10.7	271 x 219	219 x 271
	A (landscape)	11.6 x 7.66	7.66 x 11.6	295 x 195	195 x 295
	B (portrait)	16.7 x 11.6	11.6 x 16.7	423 x 295	295 x 423
	B (landscape)	17.6 x 10.7	10.7 x 17.6	447 x 271	271 x 447
	C (portrait)	22.7 x 17.6	17.6 x 22.7	576 x 447	447 x 576
	C (landscape)	23.6 x 16.7	16.7 x 23.6	600 x 423	423 x 600
	D (portrait)	34.7 x 23.6	23.6 x 34.7	880 x 600	600 x 880
	D (landscape)	35.6 x 22.7	22.7 x 35.6	904 x 576	576 x 904
		E1 (portrait)	40.7 x 29.6	29.6 x 40.7	1033 x 752
	E (portrait)	46.7 x 35.6	35.6 x 46.7	1185 x 904	904 x 1185
ISO media	A4 (portrait)	10.3 x 7.87	7.87 x 10.3	263 x 200	200 x 263
	A4 (landscape)	11.3 x 6.93	6.93 x 11.3	287 x 176	176 x 287
	A3 (portrait)	15.2 x 11.3	11.3 x 15.2	386 x 287	287 x 386
	A3 (landscape)	16.1 x 10.3	10.3 x 16.1	410 x 263	263 x 410
	A2 (portrait)	22.0 x 16.1	16.1 x 22.0	560 x 410	410 x 560
	A2 (landscape)	23.0 x 15.2	15.2 x 23.0	584 x 386	386 x 584
	A1 (portrait)	31.8 x 23.0	23.0 x 31.8	807 x 584	584 x 807
	A1 (landscape)	32.7 x 22.0	22.0 x 32.7	831 x 560	560 x 831
		A0 (portrait)	45.5 x 32.7	32.7 x 45.5	1155 x 831

For margins, see page 11-2. This table is calculated with normal margins.



Interface Specifications

Below are the parallel and serial interface specifications. For specifications of the HP JetDirect Network interface, see the JetDirect Print Server documentation supplied with this printer.

<p>Parallel (Bi-Tronics/Centronics) Interface</p> <p>The connector on the printer is 36-pin female.</p> <p>Most existing parallel cables support Bi-Tronics communication, but for use with this printer, the cable <i>must</i> meet the specification in this table.</p>	Pin	Wire/Signal Name	Source
	1	$\overline{\text{Strobe}}$	computer
	2 ... 9	D0 ... D7 (data lines)	both
	10	$\overline{\text{Ack}}$	printer
	11	Busy	printer
	12	PError	printer
	13	Select (SelectOut)	printer
	14	$\overline{\text{AutoFd}}$	computer
	16	GND	
	19 ... 30	GND	
	31	$\overline{\text{Init}}$	computer
	32	$\overline{\text{Fault}}$	printer
36	$\overline{\text{SelectIn}}$	computer	
<p>Serial (RS-232-C) Interface</p> <p>The connector on the printer is 25-pin female.</p> <p>The printer is configured as DTE (data terminal equipment).</p> <p>Data is transmitted on Pin 2 and received on Pin 3.</p>	Pin	Wire/Signal Name	Source
	1	Protective Ground	
	2	Transmitted Data	DTE
	3	Received Data	DCE
	4	Request to Send	DTE
	6	Data Set Ready	DCE
	7	Signal Ground	
	20	Data Terminal Ready	DTE

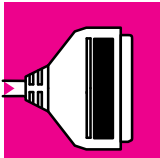

Interface Cables

Cables for Macintoshes

Interface type Computer	HP part number	Cable length	Connector type at computer end of cable
<i>Serial (RS-232-C) Interface</i> Apple Macintosh Plus, SE, II Series, Classic, LC family, Quadra family, PowerBook, PowerMac	17302A	1.5 m (4.9 ft)	8-pin male mini-DIN

Cables for PCs

Interface type Computer	HP part number	Cable length	Connector type at computer end of cable
<i>Parallel (Bi-Tronics/Centronics) Interface</i> All	C2912B	3.0 m (9.8 ft)	25-pin male
	92284A	2.1 m (6.9 ft)	25-pin male
<i>Serial (RS-232-C) Interface</i> HP Vectra or HP 24541A/B serial-interface card (9-pin connector) IBM AT and compatibles using 9-pin serial connectors	24542G	3.0 m (9.8 ft)	9-pin female
HP Vectra PC with HP 24541A/B dual serial-interface card using the 25-pin connector	13242G	5.0 m (16.4 ft)	25-pin male
	17255M	1.2 m (3.9 ft)	25-pin male
IBM PC, PC/XT, PC/AT, PS/1, PS/2 and compatibles	C2913A	1.2 m (3.9 ft)	25-pin female
	17255D	1.2 m (3.9 ft)	25-pin female

Cables for Unix Systems			
Interface type Computer	HP part number	Cable length	Connector type at computer end of cable
<i>Parallel (Bi-Tronics/Centronics) Interface</i>			
All	C2912B 92284A	3.0 m (9.8 ft) 2.1 m (6.9 ft)	25-pin male 25-pin male
<i>Serial (RS-232-C) Interface</i>			
HP 9000 workstations using 9-pin connectors.	24542G	3.0 m (9.8 ft)	9-pin female
HP Apollo workstation using an SPE (Serial/Parallel Expansion) option and supplied adapter cable	13242G 17255M	5.0 m (16.4 ft) 1.2 m (3.9 ft)	25-pin male 25-pin male
Sun workstation Note: You may need a Sun serial adapter cable to convert the DIN connector found on certain Sun SPARCstations to the 25-pin connector on the HP cable. Contact your Sun dealer for part numbers.	13242G 17255M	5.0 m (16.4 ft) 1.2 m (3.9 ft)	25-pin male 25-pin male

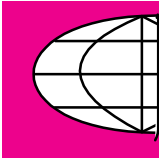

Regulatory Notices

To Obtain a Material Safety Data Sheet (MSDS)

You can obtain current Material Safety Data Sheets for the print cartridges used in the printer (HP Part numbers 51644C [cyan], 51644M [magenta], 51644Y [yellow] and 51645A [black]) by mailing a request to this address: **Hewlett-Packard Customer Information Center**, 19310 Pruneridge Avenue, Dept. MSDS, Cupertino, CA 95014, U.S.A.

Sound

LpA < 70 dB, am Arbeitsplatz, im Normalbetrieb, nach DIN 45635 T. 19.

Geräuschemission
(Germany)

Electro-Magnetic Compatibility (EMC)

The U.S. Federal Communications Commission (in 47 cfr 15.105) has specified that the following notices be brought to the attention of users of this product.

FCC Statements
(U.S.A.)

CAUTION

Pursuant to Part 15.21 of the FCC Rules, any changes or modifications to this equipment not expressly approved by the Hewlett-Packard Company, may cause harmful interference and void the FCC authorization to operate this equipment.

This equipment has been tested and found to comply with the limits for a *Class B* digital device, pursuant to part 15 of the FCC Rules. These limits are designed to provide reasonable protection against harmful interference in a *residential* installation. This equipment generates, uses and can radiate radio frequency energy and, if not installed and used in accordance with the instructions, may cause harmful interference to radio communications. However, there is no guarantee that interference will not occur in a particular installation. If this equipment does cause harmful interference to radio or television reception, which can be determined by turning the equipment off and on, the user is encouraged to try and correct the interferences by one or more of the following measures:

- Reorient the receiving antenna
- Increase the separation between the equipment and the receiver
- Connect the equipment into an outlet on a circuit different from that to which the receiver is connected
- Consult the dealer or an experienced radio/TV technician for help

The user may find useful the following booklet prepared by the FCC: "How to Identify and Resolve Radio/TV Interference Problems". This booklet is available from the US Government Printing Office, Washington, DC 20402, Stock No. 004f((f(())aeafa

When connected to an IEEE 802.3 or Ethernet network ...

This equipment has been tested and found to comply with the limits for a *Class A* digital device, pursuant to part 15 of the FCC Rules. These limits are designed to provide reasonable protection against harmful interference in a *commercial* environment. This equipment generates, uses and can radiate radio frequency energy and, if not installed and used in accordance with the instructions, may cause harmful interference to radio communications. Operation of this equipment in a residential area is likely to cause harmful interference in which case the user will be required to correct the interference at their own expense.

Normes de sécurité (Canada)	<p>Le présent appareil numérique n'émet pas de bruits radioélectriques dépassant les limites applicables aux appareils numériques de <i>Classe B</i> prescrites dans le règlement sur le brouillage radioélectrique édicté par le Ministère des Communications du Canada.</p> <p>Le présent appareil numérique, <i>connecté à un réseau de type IEEE 802.3 ou Ethernet</i>, n'émet pas de bruits radioélectriques dépassant les limites applicables aux appareils numériques de <i>Classe A</i> prescrites dans le règlement sur le brouillage radioélectrique édicté par le Ministère des Communications du Canada.</p>
DOC statement (Canada)	<p>This digital apparatus does not exceed the <i>Class B</i> limits for radio noise emissions from digital apparatus set out in the Radio Interference Regulations of the Canadian Department of Communications.</p> <p><i>When connected to an IEEE 802.3 or Ethernet network</i>, this digital apparatus does not exceed the <i>Class A</i> limits for radio noise emissions from digital apparatus set out in the Radio Interference Regulations of the Canadian Department of Communications.</p>
VCCI Class 1 および Class 2 (Japan)	<p>この装置は、第二種情報装置（住宅地域またはその隣接した地域において使用されるべき情報装置）で住宅地域での電波障害防止を目的とした情報処理装置等電波障害自主規制協議会（VCCI）基準に適合しております。</p> <p>しかし、本装置をラジオ、テレビジョン受信機に近接してご使用になると、受信障害の原因となることがあります。</p> <p>取扱説明書に従って正しい取り扱いをして下さい。</p> <p>IEEE802.3もしくはEthernetに接続されている場合、この装置は、第一種情報装置（商工業地域において使用されるべき情報装置）で商工業地域での電波障害防止を目的とした情報処理装置等電波障害自主規制協議会（VCCI）基準に適合しております。</p> <p>従って、住宅地域またはその隣接した地域において使用すると、ラジオ、テレビジョン受信機等に受信障害を与えることがあります。</p> <p>取扱説明書に従って正しい取り扱いをして下さい。</p>
Korean EMI statement	<p>이 기기는 업무용으로 전자파장애검정을 받은 기기이오니 판매자 또는 사용자는 이점을 주의하시기 바라며, 만약 잘못 구입하였을 때에는 구입한 곳에서 비업무용으로 교환하시기 바랍니다.</p>
Tele-communications General Approval (UK)	<p>Telecommunications Statement</p> <p>The HP DesignJet 755CM printer, model C3198B, is approved under Approval Number NS/G/1234/5/100003 for indirect connection to public telecommunication systems within the United Kingdom.</p>

DECLARATION OF CONFORMITY

according to ISO/IEC Guide 22 and EN 45014

Manufacturer's Name: Hewlett-Packard Española S.A.**Manufacturer's Address:** Hewlett-Packard Española S.A.
BARCELONA DIVISION
Avda. Graells, 501
08190 Sant Cugat del Vallès
Barcelona, Spain**declares that the product****Product Name:** InkJet Printer**Model Number:** HP C3198B**conforms to the following Product Specifications:****Safety:** IEC 950: 1991 + A1, A2 / EN 60950 (1992) + A1, A2
CSA C22.2 No. 950 (1993)
UL 1950 (1993)
EMKO-TSE(74)DK207/94
NOM-019-SCFI-1993**EMC:** CISPR 22: 1993 / EN 55022 (1994): Class B⁽¹⁾
CISPR 22: 1993 / EN 55022 (1994): Class A⁽²⁾
EN 50082-1 (1992)
IEC 801-2: 1991 / prEN 55024-2 (1992): 4KV CD
8KV AD
IEC 801-3: 1984 / prEN 55024-3 (1991): 3 V/m
IEC 801-4: 1988 / prEN 55024-4 (1993): 1KV Power Lines
0.5KV Signal Lines
FCC Part 15 – Class B / DOC-B / VCCI-2 / RRL-A
FCC Part 15 – Class A / DOC-A / VCCI-1 / RRL-A⁽²⁾**Supplementary Information:**

The product herewith complies with the requirements of the Low Voltage Directive 73/23/EEC and the EMC Directive 89/336/EEC, and carries the CE marking accordingly.

(1) The product was tested with a system, consisting of: a Macintosh personal computer for LocalTalk, keyboard, mouse, and an HP Surestore optical disk drive as the second peripheral.

(2) The product was tested with IEEE 802.3 or 802.5 cables.

Sant Cugat del Vallès (Barcelona), September 1st, 1996



Jordi Balderas,
Quality Engineering Manager

European Contact: Your local Hewlett-Packard Sales and Service Office or Hewlett-Packard GmbH, Department HQ/TRE
Europe, Herrenberger Strasse 130, D-71034 Boeblingen, Germany (fax: (+49) 7031 143143).



Ordering Accessories

		HP Part Number
Cables		
		See page 11-8
Documentation		
User's Guide and Quick Reference Guide	Chinese	C3198-60060
	English	C3198-60051
	French	C3198-60055
	German	C3198-60054
	Italian	C3198-60057
	Korean	C3198-60052
	Portuguese	C3198-60059
	Spanish	C3198-60056
Software Application Notes (CAD)	English	C4705-90006
Software Application Notes (graphics packages)	English	C3198-90121
Hewlett-Packard Support Services	Multi	(1)
HP-GL/2 and RTL Programmer's Reference Guide	English	5959-9733 (2)
The Product Comparison Guide for HP-GL/2 and HP RTL Peripherals	English	5959-9734 (2)
PJL Technical Reference Manual	English	5961-0938

¹ This item is updated regularly. For details of the latest version available, please contact your HP dealer or sales representative.

² See note on page 11-16.

Ordering Accessories

To achieve the best performance from your printer, we recommend you only use genuine *Hewlett-Packard* accessories and supplies, whose reliability and performance have been thoroughly tested to give trouble-free performance. For Example:

- HP drivers are developed to support all the latest features and to optimize print quality and your printers performance.
- HP memory expansion modules are thoroughly tested to give you maximum performance.
- HP ink cartridges and media supplies are developed for optimal print quality.

**HP Part
Number**

Drivers

Latest versions of the following were shipped with this printer:

HP DesignJet PostScript Drivers for Macintosh	(1)
HP DesignJet PostScript Driver for Microsoft Windows	(1)
HP Plotter Drivers for AutoCAD for DOS and AutoCAD for Windows	(1)
HP Driver for Microsoft Windows	(1)

Media Supplies

Supplies Source Catalog (The latest edition was shipped with this printer)	(1)
---	-----

Memory Modules

The printer has two 32-MB memory pre-installed modules. Should you need to replace them, you can use any of the part numbers listed on the right.	4 MB	C3132A
	8 MB	C3133A
	16 MB	D2297A or C3146A
	32 MB	D2298A
Specification:	72-pin, 36-bit.	
	4/8 MB: 80 nanoseconds.	
	16/32 MB: 70 nanoseconds.	

¹ This item is updated regularly. For details of the latest version available, please contact your HP dealer or sales representative, or, for drivers, use one of the support resources for your area listed towards the end of chapter 9.

		HP Part Number
Print Cartridges	Yellow	51644Y
Although other cartridges may appear to fit in the stalls, use only these part numbers.	Cyan	51644C
	Magenta	51644M
	Black	51645A
Spindle Assembly		
E/A0-size		C3173A

HP-GL/2 and HP RTL Programming Information

The *HP-GL/2 and HP RTL Reference Guide* provides complete explanations and examples of the HP-GL/2 and HP RTL graphic and interfacing instructions. If you are writing an HP-GL/2 or RTL driver for your printer, you will find this guide an invaluable source of general instruction information. It is published by Addison-Wesley Publishing Company and you can order it through most book stores (ISBN 0-201-56308-8).

For specific parameter information, refer to *The Product Comparison Guide for HP-GL/2 and HP RTL Peripherals*, which you can order through your HP Sales office.

How to Order Supplies and Accessories

You can order supplies and accessories in any of the following ways:

- Call your local authorized HP dealer.
- Contact your local HP Sales and Support office.
- Refer to the *Hewlett-Packard Services* Booklet that was supplied with your printer.



Glossary

Glossary

ac Alternating current.

addressable dpi A resolution higher than nominal value of the cartridges, giving a finer grid on which the plotter can selectively position dots and improve print quality.

ANSI size An American standard paper size; e.g. D, E, etc.

application The software you use to create your drawings.

bail The black metal bar inside the printer, which holds the media in place.

baud rate The data transmission rate in a serial interface between a computer and a device, in bits per second.

Bi-tronics A standard for the parallel interface between computer and device, compatible with Centronics.

CAD Computer-aided design.

cartridge Print cartridge, containing ink.

Centronics A standard for the parallel interface between computer and device.

clear film See-through, polyester media type.

clipping Losing part of a drawing at the edges.

CMYK Cyan, magenta, yellow and black. The colors of the printer's four inks, and also a standard color model.

coated paper Paper coated on one side for inkjet printing.

default A value or condition that is assumed if no other value or condition is specified.

device An external item connected to the computer: printer, plotter, tape drive etc. Your HP DesignJet is a device.

dpi Dots per inch, a measure of print resolution.

driver The software that controls the communication between a computer and a device.

front panel The control panel on the right of the printer.

front-panel menus The structure of options in the front-panel display.

GIS Geographical information system (mapping software).

graphics language A programming language telling a print device how to output graphic data.

grayscale Shades of gray to represent colors.

high-gloss film A glossy, opaque, polyester media type.

-
- high-gloss photo** A glossy, opaque photographic paper.
- HP-GL** One of Hewlett-Packard's standard graphics languages for plotters and printers. Produces vector data. Forerunner to HP-GL/2.
- HP-GL/2** One of Hewlett-Packard's standard graphics languages for plotters and printers. Produces vector data. Newer than HP-GL.
- I/O** Input/output. The transmission of data between a computer and a device.
- inked area** The smallest rectangle that contains all the content of the drawing, while maintaining its relative dimensions.
- ISO size** An international standard paper size; e.g. A1, A2, etc.
- JIS size** A Japanese standard paper size.
- LAN** Local area network.
- long-axis printing** Printing a page whose X-axis (the axis vertical to the printer as you look at it from the front) is longer than a standard page size.
- margin** The space around the page added by the printer to separate one page from another and to avoid printing right to the edge of the media.
- matte** Not glossy.
- matte film** Opaque, polyester media type.
- media** The material, usually paper, onto which the printer prints.
- media bin** The catcher situated below the printer.
- MIO** Modular input/output. Refers to the printer's network interface.
- nesting** Placing two or more pages side-by-side on the media to avoid waste.
- opaque bond** A matte paper media.
- palette** A set of logical pens defined by color and width.
- PJL** Printer Job Language. A programming language that controls jobs going to a printer.
- PML** Printer management language.
- parallel interface** A type of interface between computer and device. Generally faster than a serial interface.
- PANTONE** The PANTONE MATCHING SYSTEM® is an international standard for color communication in the graphics art industry.
- pen** Even though the plotter has no physical pens, the lines it draws match the attributes of a pen.
- platen** The exterior part of the printer on which the media rests before going into the media-entry slot.
- printing area** Page size minus margins.
-

Glossary

PostScript A standard page-markup language, commonly used by graphics and desktop publishing software applications.

queueing Placing each page of each file received by the device in line, before and after printing.

parity An error-checking method in a serial interface between a computer and a device.

raster A method for defining an image, in terms of dots rather than lines. Raster data typically needs more memory than vector data.

RGB Red, green and blue. A standard color model.

RS-232-C A serial interface standard.

RTL One of Hewlett-Packard's standard graphics languages for plotters and printers. Produces raster data.

ROM SIMM A physical module containing read-only data, that can be installed in the back of the printer to provide upgrades.

semi-gloss photo A semi glossy, opaque photographic paper.

serial interface A type of interface between computer and device. Generally slower than a parallel interface.

spindle The rod which holds the roll of media.

tracing paper A semi-opaque matte paper type.

translucent bond A semi-opaque matte paper type.

vector A line. A method for defining an image, in terms of lines rather than dots. Vector data typically needs less memory than raster data.

vellum Cotton-fiber-based, semi-opaque matte media type.

X-axis The vertical axis, as you look at the printer from the front.

Y-axis The horizontal axis, as you look at the printer from the front.

Index

A

Access Cartridges key, 1-17, 3-27
 problems, 9-7
accessories, 1-4–1-6
 list, 11-13
 ordering, 11-16
accuracy, specification, 11-3
acoustic specifications, 11-4
action keys, 2-2
addressable 600 dpi, Sharp lines, 5-16
addressable dpi, 5-15
Apollo, cables to connect, 11-9
Apple
 See also Macintosh
 cables to connect, 11-8
archive prints, 3-8
area fill problems, 9-19
arrow keys, 2-6
AutoCAD, drivers, 11-14
automatic cutter, problems with,
 9-5–9-6

B

banding problems, 9-20
Bi-Tronics interface, 11-7
black cartridge only, operating with,
 1-17–1-20
blank print, 9-10
bleeding lines, 9-19
blurred lines, 9-19
BOOTP, 1-37
buttons. *See* keys

C

cables
 ordering, 11-8–11-9
 power, 1-4
 problems, 9-9
 supplied/not supplied, 1-5
CAD, demo, 1-22
calibration. *See* recalibration
Cancel key, 6-2
cancelling a page, 6-2
cartridge alignment procedure, 3-30
Cartridge check, 3-25
cartridge stalls, 1-18–1-19, 3-28–3-30
cartridges
 before replacing, 3-26

 black only, 1-17
 colors, 1-4, 1-17, 1-18–1-19,
 3-28–3-30
 environmental specifications, 11-4
 ink level, 3-25
 loading, 1-17–1-20
 ordering, 11-15
 part numbers, 11-15
 problems with, 9-7, 9-18
 removing tab, 3-29
 replacing, 3-25–3-30
 supplied, 1-4
 choosing media, 3-2–3-7
 cleaning the printer, 8-2
 clearing the media path, 3-24
 clipped print, 9-12
 clipping, and page size, 4-6
 CMYK, 5-5
 color management, software, 1-33
 Color Management Kit, installation
 and setup, 1-34
 color printing, media type for, 11-2
 color problems, 9-16–9-21
 color-vision deficiencies, advice for
 users with, 1-18, 3-28
 Color/Mono key, 5-11
 color/monochrome switching, 5-11
 colors
 CMYK, 5-5
 RGB, 5-5
 communications, problems, 9-9
 compensating for poorly cut media,
 3-20
 components of printer, xiv–xvi
 computer, connection to, 1-24–1-27
 conceptual pens, settings, 5-2–5-5
 configuration
 changing, 1-27–1-31
 current front-panel, 7-3
 current overall, 7-2
 print current, 2-2
 setting parameter values, 2-7
 connector
 parallel, 1-25
 serial, 1-25
 Copies, 6-8
 Core!DRAW!, 5-15

 color quality, 9-15
 Create pattern, 7-6
 curl, on media, 9-5
 Current Configuration Print, 2-2, 5-4,
 7-3
 cutting
 and margins, 4-7
 immediately after printing, 6-2
 problems with, 9-5–9-6

D

darkness of print, adjusting, 5-9
Declaration of Conformity (EC),
 11-12
default page margins, 4-7
Define palette, 5-6
Delete page, 6-7
demonstration prints, 1-21–1-23
Demos, 1-22
device lists, 1-35
dimensions of printer, 11-3
display, front panel, 2-3
display keys, 2-3, 2-6
documentation, 11-13, 11-16
 map, D-1
down arrow key, 2-6
driver, choice of, 1-34–1-35
drivers, 1-32, 1-34–1-35, 11-14
 supplied, 1-4
drying time, 3-21–3-22
 adjusting, 3-22
duty cycle, 11-4

E

electrical specifications, 11-4
EMC (electromagnetic compatibility),
 11-5, 11-10
enlarging an image, 4-13
Enter key, 2-6
EPS files, 1-34, 9-14

F

fast track, 1-2
file size and memory usage, 9-22,
 11-3
filled area problems, 9-19
film, 11-2
finding information, ii

Index

-
- firmware, supplied, 1-34
 - Form Feed and Cut key, 3-24, 6-2, 6-4
 - to clear the media path, 9-8
 - front panel, 2-2
 - action keys, 2-2
 - display section, 2-3
 - messages, 10-2–10-6
 - printing mode keys, 2-2
 - problems with, 9-21–9-22
 - status lights, 2-2
 - Front Panel Menus print, printing, 2-4
 - front view of printer, xiv
 - G**
 - gaps in lines, 9-16, 9-17
 - gaps in solid areas, 9-16
 - getting help, 9-25
 - graphics languages, 11-3
 - and networks, 7-8
 - changing, 7-7
 - H**
 - heavyweight media, 11-2
 - help, 9-25–9-27
 - HP DesignJets, other, 1-35
 - HP JetDirect, 1-24
 - HP RTL, 7-7
 - documentation, 11-13, 11-16
 - HP Special Inkjet Paper, 3-3
 - HP Special Inkjet paper, 11-2
 - HP-GL (7586B), 7-7
 - HP-GL/2, 7-7
 - documentation, 11-13, 11-16
 - humidity specifications, 11-4
 - I**
 - I/O Setup, 7-9
 - I/O timeout, changing, 7-9
 - images, problems printing, 9-14
 - ink problems, 9-16–9-21
 - installation. *See* setting up interface
 - parallel specifications, 11-7
 - problems, 9-9
 - serial, 9-3
 - serial specifications, 11-7
 - specifications, 11-7–11-8
 - with application software, 9-3
 - introduction to printer, xi
 - J**
 - jagged lines, 9-18
 - jammed media, 9-8–9-9
 - K**
 - keys
 - Access Cartridges, 1-17, 3-27
 - action, 2-2
 - Cancel, 6-2
 - Color/Mono, 5-11
 - display, 2-3, 2-6
 - down arrow, 2-6
 - Enter, 2-6
 - Form Feed and Cut, 3-24, 6-2, 6-4
 - Pause, 6-3
 - Previous, 2-6
 - Print Quality, 5-14
 - printing mode, 2-2
 - up arrow, 2-6
 - L**
 - LAN, 1-24
 - Lang, 7-7
 - languages (graphics), 11-3
 - and networks, 7-8
 - changing, 7-7
 - documentation, 11-16
 - languages (human)
 - changing, 1-6
 - manuals available in, 11-13
 - lever, for media jam, 9-8–9-9
 - light, effect of, 3-8
 - Lightness (of print), adjusting, 5-9
 - line quality problems, 9-16–9-21
 - loading media
 - roll, 3-9–3-16
 - sheet, 3-17–3-20
 - Local Area Network, 1-24
 - long-axis prints, problems with, 9-12
 - M**
 - Macintosh
 - cables to connect, 11-8
 - drivers, 1-34
 - Maintenance advised, 8-3
 - managing prints
 - before printing, 6-4
 - during printing or drying, 6-2
 - manuals, 11-13, 11-16, D-1
 - margins, 4-7, 11-2
 - and cutting, 4-7
 - and nesting, 6-12
 - margins (printing areas), 11-6
 - maximum media sizes, 11-2
 - Measure pattern, 7-6
 - media
 - adjusting drying time, 3-22
 - and print quality, 3-6
 - care of, 3-8
 - cost and color support, 3-5
 - curled, 9-5
 - drying time, 3-21
 - environmental specifications, 11-4
 - guidelines for loading, 3-8
 - handling, 3-8
 - handling problems, 9-4
 - important points, 3-2
 - leading edge, 9-5
 - loading problems, 9-4
 - loading roll, 3-9–3-16
 - loading sheet, 3-17–3-20
 - physical characteristics, 3-4
 - poorly cut, 3-20
 - roll. *See* roll media
 - selecting, 3-2–3-7, 3-14–3-15, 3-18–3-19
 - sheet orientation, 3-17
 - sizes and printing areas, 11-6
 - sizes supported, 11-2
 - skew tolerance, 3-20
 - supplied, xii, 1-4
 - supplies, 11-14
 - trimming roll, 3-13
 - type for application, 3-7
 - types supported, 3-3, 11-2
 - unloading, 3-21–3-24
 - media bin, 3-8
 - stacking problems, 9-6
 - Media bypass. *See* skew tolerance
 - media jam, 9-8–9-9
 - media types supported, 11-2
 - memory, xvi, 11-3, 11-14
 - memory usage and file size, 9-22, 11-3
-



-
- menu graphics, 2-8
 - Menu mode, changing, 1-28
 - menu print, printing, 2-4
 - menu system
 - entering, 2-5
 - navigating, 2-6–2-8
 - navigation examples, 2-10–2-12
 - printing, 2-4
 - Merge, 5-8
 - messages, front panel, 10-2–10-6
 - Microsoft Windows
 - driver, 11-14
 - drivers, 1-34, 11-14
 - notes on use with, 1-34
 - minimum media sizes, 11-2
 - Mirroring an image, 4-12
 - monochrome, printing color in, 5-10
 - monochrome/color switching, 5-11
 - Move to top, 6-7
 - MSDS (Material Safety Data Sheet), 11-10
- N**
- Nest, 6-11
 - Nest wait, 6-11
 - nesting
 - algorithms, 6-11
 - and margins, 6-12
 - and page size, 6-12
 - and Rotate, 6-12
 - interaction with queue, 6-11
 - optimizing, 6-12
 - order, 6-11
 - overview, 6-9
 - requirements, 6-10
 - sets, 6-11
 - network, xvi
 - connections, 1-24
 - no print?, 9-23
 - non-PostScript, drivers, 1-34–1-35, 11-14
 - Normal usage, 8-3
 - nozzle blockages, 9-16
- O**
- options. *See* accessories
 - ordering accessories, 11-13
 - output
 - cancelling, 6-2
 - management before printing, 6-4
 - overlapping lines, treatment of, 5-8
 - overlay of one print on another, 9-14
- P**
- page
 - cancelling, 6-2
 - copying in a queue, 6-8
 - deleting from a queue, 6-7
 - identifying in a queue, 6-6
 - prioritizing in a queue, 6-7
 - Page format, Rotate. *See* solving problems
 - Page ID, 6-6
 - page information, 6-7
 - page margins, 4-7
 - page size, 4-2–4-5
 - adjusting, 4-3–4-4
 - and clipping, 4-6
 - and nesting, 4-6, 6-12
 - Palette, 5-5, 5-7
 - palette
 - changing current selection, 5-7
 - changing settings, 5-6
 - Palette Demo, 5-5
 - PANTONE, 1-33
 - paper, clearing jammed. *See* media
 - parameter values, setting, 2-7
 - part numbers, 11-13
 - Pause key, 6-3
 - pausing between prints, 6-3
 - PCs, cables to connect, 11-8
 - pen, settings, have no effect, 9-14
 - pens, limiting exposure, 3-26
 - pens (conceptual), colors, 5-5
 - pens (logical)
 - current palette settings, 5-4
 - settings, 5-2–5-5
 - pens (physical). *See* cartridges
 - physical specifications, 11-3
 - pin-outs, 11-7–11-10
 - PJL, 7-8
 - documentation, 11-13
 - plot resolution, quality, 9-15
 - polyester film, 11-2
 - ports
 - on printer, 1-25
 - PostScript, 1-34, 7-7
 - demo, 1-22
 - drivers, 1-34, 11-14
 - on UNIX, 1-37
 - PostScript/non-PostScript, features applicable, xiii
 - power
 - cord, 1-4, 1-6
 - socket, 1-6
 - supply, 1-6
 - switch, 1-7
 - power specifications, 11-4
 - Previous key, 2-6
 - print
 - blank, 9-10
 - cancelling, 6-2
 - clipped, 9-12
 - content problems, 9-10–9-16
 - distorted, 9-14
 - management before printing, 6-4
 - management during printing, 6-2
 - position problems, 9-10–9-16
 - unexpected, 9-15
 - print appearance, controlling, 5-2
 - print cartridges. *See* cartridges
 - Print quality, sharpen lines, 5-15
 - print quality
 - and banding, 9-20
 - changing, 5-14
 - choosing, 5-12
 - Print Quality key, 5-14
 - print quality problems, 9-16–9-21
 - print spooler, UNIX, 1-37
 - printer
 - components, xiv–xvi
 - views of, xiv–xvi
 - printing area, 11-6
 - printing mode keys, 2-2
 - problem-solving. *See* troubleshooting
 - programming documentation, 11-16
 - programming languages, 11-3
- Q**
- quality problems, 9-16–9-21
 - Queue, 6-5
 - copy page in, 6-8
 - deleting a page from, 6-7
-

- identifying a page in, 6-6
 - interaction with nesting, 6-11
 - management, 6-4–6-8
 - page information, 6-7
 - prioritizing a page, 6-7
 - queue, cancelling a page, 6-2
 - queueing, 6-5
 - quick setup, 1-2
- R**
- Rear view of printer, xv
 - Recalibrate, 7-6
 - recalibration
 - for accuracy, 7-5–7-7
 - restoring factory settings, 7-6
 - Receiving light, 1-23
 - regulations
 - Declaration of Conformity (EC), 11-12
 - EMC, 11-5
 - notices, 11-10–11-13
 - safety, 11-5
 - regulatory notices, 11-10–11-13
 - replacing cartridges, 3-25
 - reprinting an image, 6-2
 - Restore factory, 7-6
 - RGB, 5-5
 - roll media
 - handling, 3-8
 - loading, 3-9–3-16
 - stacking problems, 9-6
 - trimming, 3-13
 - Rotate
 - and nesting, 6-12
 - interaction with software, 4-10
 - problems with, 9-21
 - Rotating a drawing, 4-8–4-10
 - RS-232-C, 7-9
 - RS-232-C, specifications, 11-7
 - RTL documentation, 11-13, 11-16
- S**
- safety, MSDS, 11-10
 - safety specifications, 11-5
 - Samples, 1-22
 - scaling an image, 4-13
 - selecting media, 3-14–3-15, 3-18–3-19
 - serial interface
 - changing settings, 7-9
 - configuring, 1-26–1-31
 - Service config, 7-5, 8-4
 - print, 8-4
 - setting up
 - checklist, 1-3
 - fast track (quick setup), 1-2
 - full instructions, 1-3–1-40
 - items required, 1-4
 - shadows of color, 9-18
 - Sharp lines, 5-15
 - CorelDRAW!, 5-15
 - troubleshooting, 9-15
 - sheet media
 - loading, 3-17–3-20
 - orientation, 3-17
 - sheet sizes supported, 11-2
 - side-by-side prints. *See* nesting
 - signal specifications, 11-7
 - Size, 4-4
 - size, printer, 11-3
 - size of image, scale, 4-13
 - sizes of media supported, 11-2
 - skew tolerance, 3-20
 - slow printing, 9-23
 - smears, 9-20
 - software
 - setting up, 1-32–1-35
 - supplied, 1-4, 1-34
 - Software Application Notes, 11-13
 - sound levels, 11-4
 - special inkjet paper, 3-3, 11-2
 - specification, accuracy, 11-3
 - specifications, 11-2–11-7
 - acoustic, 11-4
 - electromagnetic, 11-5
 - EMC, 11-5
 - environmental, 11-4
 - functional, 11-2, 11-3
 - interface, 11-7–11-8
 - physical, 11-3
 - power, 11-4
 - safety, 11-5
 - speed problems, 9-23
 - Statistics, 6-7, 7-2
 - status lights, 2-2
 - storing prints, 3-8
 - Sun, cables to connect, 11-9
 - supplies. *See* accessories
 - Supplies Source Catalog, 11-14
 - support, 9-25–9-27
 - support services, 11-13
- T**
- temperature specifications, 11-4
 - test file, printing, 1-36
 - testing the printer, 9-3
 - TFTP, 1-37
 - timeout, overriding, 6-4
 - translucent, 11-2
 - trimming roll media, 3-13
 - troubleshooting, 9-1
 - Access Cartridges key, 9-7
 - automatic cutter, 9-5–9-6
 - lightfastness, 3-8
 - long-axis prints, 9-12
 - media bin, 9-6
 - media handling, 9-4
 - media jam, 9-8–9-9
 - media loading, 9-4
 - miscellaneous problems, 9-23–9-25
 - print content, 9-10–9-16
 - print position, 9-10–9-16
 - print quality problems, 9-16–9-21
 - procedure, 9-2–9-3
 - Rotate, 9-21
 - stacking media in bin, 9-6
- U**
- UNIX systems, cables to connect, 11-9
 - UNIX tips, 1-37
 - unloading media, 3-21–3-24
 - unprinted sheet, removing, 3-24
 - up arrow key, 2-6
- V**
- vellum, 11-2
- W**
- warped lines, 9-18
 - weights, 11-3
 - Windows applications
 - driver, 11-14
 - drivers, 1-34, 11-14
 - workstation, cables to connect, 11-9

Documentation Map

Printed Documentation for Users of the HP DesignJet 755CM Printer

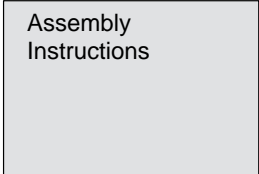
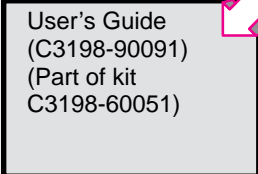
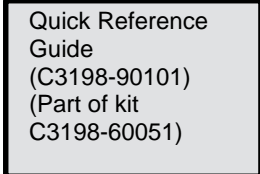
Setting Up and Using the Printer

 Assembly Instructions	 User's Guide (C3198-90091) (Part of kit C3198-60051)	 Quick Reference Guide (C3198-90101) (Part of kit C3198-60051)	 HP JetDirect Print Server Software Installation Guide (J2552-90101)
---	---	--	--



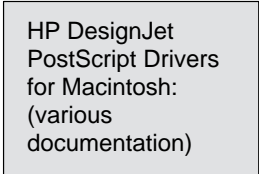
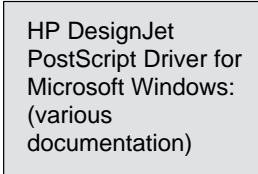
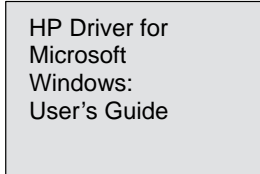
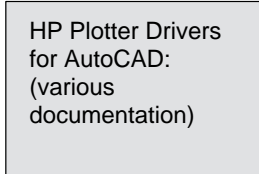
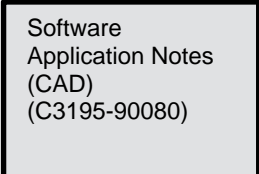
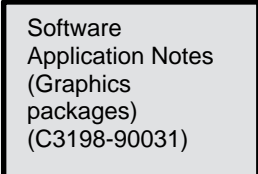
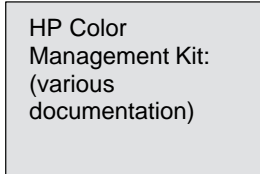

Using Application Software

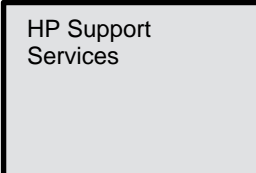
 HP DesignJet PostScript Drivers for Macintosh: (various documentation)	 HP DesignJet PostScript Driver for Microsoft Windows: (various documentation)	 HP Driver for Microsoft Windows: User's Guide	 HP Plotter Drivers for AutoCAD: (various documentation)
 Software Application Notes (CAD) (C3195-90080)	 Software Application Notes (Graphics packages) (C3198-90031)	 HP Color Management Kit: (various documentation)	

Getting Support

 HP Support Services
--

Continued...

-  These documents are supplied with this plotter.
-  These documents can be ordered separately. For details, see page 11-13.
-  These documents are supplied with this plotter and can be ordered separately.
-  This manual.

Documentation Map

Programmer's Reference

HP-GL/2 and RTL
Programmer's
Reference Guide
(5959-9733)

The Product
Comparison Guide
for HP-GL/2 and
HP RTL Peripherals
(5959-9734)

PJL Technical
Reference Manual
(5961-0938)



These documents are supplied with this plotter.



These documents can be ordered separately. For details, see page 11-13.



These documents are supplied with this plotter and can be ordered separately.



This manual.

Please Give Us Your Feedback on the Quality of This Documentation

Name:

Job Title:

Organization:

Address:

Phone:

If mailing to the address in the USA (see over), fill out *this sheet*.

If mailing to the address in Spain, fill out *the other sheet*.

Alternatively, you can fax this form to:
USA (1) 619 655 6640,
Attn: HP DesignJet Marketing Dept. *or*
Spain (34) 3 582 1400,
Attn: Learning Products Dept.

Circle the appropriate score

Poor ► ► ► *Excellent*

Overall ease of use of this manual 1 2 3 4 5

Overall ease of use of the Quick Reference Guide 1 2 3 4 5

Use of language in both documents 1 2 3 4 5

Use of graphics in both documents 1 2 3 4 5

Please explain any low score:

Any other comments on any of the documentation accompanying the printer:



Any comments?

▼ Fold here and then staple or tape the ends together ▼



NO POSTAGE
NECESSARY
IF MAILED
IN THE
UNITED STATES

BUSINESS REPLY MAIL
FIRST CLASS MAIL PERMIT NO. 24343 SAN DIEGO, CA

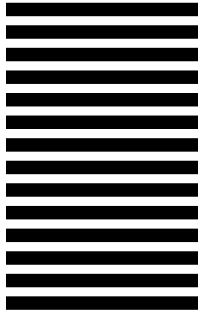

POSTAGE WILL BE PAID BY ADDRESSEE



HP DesignJet Marketing Center
Hewlett-Packard Company
Building #7
16399 West Bernardo Drive
San Diego, CA 92127
U.S.A.



Please Give Us Your Feedback on the Quality of This Documentation

If mailing to the address in Spain (see over), fill out *this sheet*.

If mailing to the address in the USA, fill out *the other sheet*.

Name:

Job Title:

Organization:

Address:

Phone:

Alternatively, you can fax this form to:
USA (1) 619 655 6640,
Attn: HP DesignJet Marketing Dept. *or*
Spain (34) 3 582 1400,
Attn: Learning Products Dept.

Circle the appropriate score

Poor ▶ ▶ ▶ *Excellent*

Overall ease of use of this manual	1	2	3	4	5
Overall ease of use of the Quick Reference Guide	1	2	3	4	5
Use of language in both documents	1	2	3	4	5
Use of graphics in both documents	1	2	3	4	5

Please explain any low score:

Any other comments on any of the documentation accompanying the printer



Any comments?

▼ Fold here and then staple or tape the ends together ▼



Hewlett-Packard Company
Barcelona Division
Attn: Learning Products Dept.
Avda. Graells, 501
08190 Sant Cugat del Vallès
Spain



C3198-60051

Customer re-order number: C3198-60051

Manual Part Number: C3198-90091

Edition 1, September 1996

English

Printed in Europe