



# LaserJet Pro M402, M403 LaserJet Pro M426, M427

## Repair Manual



M402d  
M402n  
M402dn  
M402dw  
M403n  
M403d  
M403dn  
M403dw



M426dw  
M426fdn  
M426fdw  
M427dw  
M427fdn  
M427fdw



[www.hp.com/support/ljM402](http://www.hp.com/support/ljM402)  
[www.hp.com/support/ljM403](http://www.hp.com/support/ljM403)  
[www.hp.com/support/ljM426MFP](http://www.hp.com/support/ljM426MFP)  
[www.hp.com/support/ljM427MFP](http://www.hp.com/support/ljM427MFP)  
For printer theory and troubleshooting information, see the Troubleshooting Manual.





# LaserJet Pro M402, M403 and LaserJet Pro M426, M427

Repair Manual

**Copyright and License**

© Copyright 2015 HP Development Company, L.P.

Reproduction, adaptation, or translation without prior written permission is prohibited, except as allowed under the copyright laws.

The information contained herein is subject to change without notice.

The only warranties for HP products and services are set forth in the express warranty statements accompanying such products and services. Nothing herein should be construed as constituting an additional warranty. HP shall not be liable for technical or editorial errors or omissions contained herein.


Edition 1, 9/2015


## Conventions used in this guide

---


 **TIP:** Helpful hints or shortcuts.

**Reinstallation tip:** Reinstallation helpful hints, shortcuts, or considerations.

 **NOTE:** Information that explains a concept or how to complete a task.

 **IMPORTANT:** Information that help the user to avoid potential printer error conditions.

 **CAUTION:** Procedures that the user must follow to avoid losing data or damaging the printer.

 **WARNING!** Procedures that the user must follow to avoid personal injury, catastrophic loss of data, or extensive damage to the printer.

---



## For additional service and support information

HP service personnel, go to the Service Access Work Bench (SAW) at <http://h41302.www4.hp.com/km/saw/home.do>.

Channel partners, go to HP Channel Services Network (CNS) at <https://h30125.www3.hp.com/hpcsn>.

At these locations, find information on the following topics:

- Install and configure
- Printer specifications
- Up-to-date control panel message (CPMD) troubleshooting
- Solutions for printer issues and emerging issues
- Remove and replace part instructions and videos
- Service advisories
- Warranty and regulatory information

To access HP PartSurfer information from any mobile device, go to <http://partsurfermobile.hp.com/> or scan the Quick Response (QR) code below.







---

# Table of contents

<b>1 Removal and replacement .....</b>	<b>1</b>
For additional service and support .....	2
Removal and replacement strategy .....	3
Introduction .....	3
Considerations during removal and replacement .....	3
Electrostatic discharge .....	4
Required tools .....	4
Fasteners used in this printer .....	5
Service approach .....	6
Before performing service .....	6
After performing service .....	6
Post-service test .....	6
Print-quality test .....	6
Removal and replacement procedures .....	7
Customer self-repair (CSR) A parts and assemblies .....	7
RL2-0656-000CN multipurpose tray roller .....	8
Introduction .....	8
Step 1: Remove the roller .....	8
Step 2: Unpack the replacement assembly .....	10
Step 3: Install the roller .....	11
RM2-5392-000CN 250-sheet paper input tray .....	13
Introduction .....	13
Step 1: Remove Tray 2 .....	13
Step 2: Unpack the replacement assembly .....	14
Step 3: Install Tray 2 .....	14
RM2-5413-000CN optional Tray 3 .....	16
Introduction .....	16
Step 1: Remove optional Tray 3 .....	16
Step 2: Unpack the replacement assembly .....	17
Step 3: Install optional Tray 3 .....	18
RM2-5452-000CN Tray 2 paper pickup roller assembly .....	20
Introduction .....	20

Step 1: Remove Tray 2 .....	20
Step 2: Remove the pickup roller assembly (Tray 2) .....	21
Step 3: Unpack the replacement assembly .....	23
Step 4: Install the pickup roller assembly (Tray 2) .....	24
Step 5: Install Tray 2 .....	25
RM2-5741-000CN optional Tray 3 paper pickup roller assembly .....	27
Introduction .....	27
Step 1: Remove optional Tray 3 .....	27
Step 2: Remove the paper pickup roller assembly (optional Tray 3) .....	28
Step 3: Unpack the replacement assembly .....	30
Step 4: Install the paper pickup roller assembly (optional Tray 3) .....	31
Step 5: Install optional Tray 3 .....	32
RM2-5397-000CN Tray 2 separation roller assembly .....	34
Introduction .....	34
Step 1: Remove Tray 2 .....	34
Step 2: Remove the separation pad roller assembly (Tray 2) .....	35
Step 3: Unpack the replacement assembly .....	36
Step 4: Install the separation pad roller assembly (Tray 2) .....	36
Step 5: Install Tray 2 .....	37
RM2-5745-000CN optional Tray 3 separation roller assembly .....	39
Introduction .....	39
Step 1: Remove Tray 3 .....	39
Step 2: Remove the separation roller assembly (optional Tray 3) .....	40
Step 3: Unpack the replacement assembly .....	41
Step 4: Install the separation roller assembly (optional Tray 3) .....	42
Step 5: Install Tray 3 .....	43
Removal and replacement: External panels, covers, and doors .....	45
Removal and replacement: Damper sheets .....	46
Introduction .....	46
Step 1: Remove the damper sheets .....	46
Step 2: Unpack the replacement assembly .....	47
Step 3: Install the damper sheets .....	47
Removal and replacement: Rear USB cover .....	46
Introduction .....	49
Step 1: Remove the rear USB cover .....	49
Step 2: Unpack the replacement assembly .....	50
Step 3: Install the rear USB cover .....	51
Removal and replacement: Support shaft .....	53
Introduction .....	53
Step 1: Remove the support shaft .....	53
Step 2: Unpack the replacement assembly .....	54

Step 3: Install the support shaft .....	55
Removal and replacement: Cartridge door assembly .....	57
Introduction .....	57
Step 1: Remove the cartridge door assembly .....	57
Step 2: Unpack the replacement assembly .....	60
Step 3: Install the cartridge door assembly .....	61
Removal and replacement: Pressure-release link .....	64
Introduction .....	64
Step 1: Remove the cartridge door assembly .....	64
Step 2: Remove the pressure-release link .....	67
Step 3: Unpack the replacement assembly .....	68
Step 4: Install the pressure-release link .....	68
Step 5: Install the cartridge door assembly .....	69
Removal and replacement: Left cover .....	73
Introduction .....	73
Step 1: Remove the rear USB cover .....	74
Step 2: Remove the rear network cover (M402d and M403d) .....	75
Step 3: Remove Tray 2 .....	75
Step 4: Remove the cartridge door assembly .....	76
Step 5: Remove the left cover .....	78
Step 6: Unpack the replacement assembly .....	80
Step 7: Install the left cover .....	80
Step 8: Install the cartridge door assembly .....	82
Step 9: Install Tray 2 .....	85
Step 10: Install the rear network cover (M402d and M403d) .....	85
Step 11: Install the rear USB cover .....	85
Removal and replacement: Right cover .....	87
Introduction .....	87
Step 1: Remove Tray 2 .....	87
Step 2: Remove the cartridge door assembly .....	88
Step 3: Remove the right cover .....	90
Step 4: Unpack the replacement assembly .....	91
Step 5: Install the right cover .....	92
Step 6: Install the cartridge door assembly .....	94
Step 7: Install Tray 2 .....	97
Removal and replacement: Rear door assembly .....	98
Introduction .....	98
Step 1: Remove Tray 2 .....	99
Step 2: Remove the cartridge door assembly .....	99
Step 3: Remove the left cover .....	102
Step 4: Remove the right cover .....	103

Step 5: Remove the rear door assembly .....	104
Step 6: Unpack the replacement assembly .....	105
Step 7: Install the rear door assembly .....	106
Step 8: Install the right cover .....	107
Step 9: Install the left cover .....	109
Step 10: Install the cartridge door assembly .....	110
Step 11: Install Tray 2 .....	113
Removal and replacement: Cassette rear cover .....	114
Introduction .....	114
Step 1: Remove Tray 2 .....	115
Step 2: Remove the cartridge door assembly .....	115
Step 3: Remove the left cover .....	118
Step 4: Remove the right cover .....	119
Step 5: Remove the rear door assembly .....	120
Step 6: Remove the cassette rear cover .....	121
Step 7: Unpack the replacement assembly .....	123
Step 8: Install the cassette rear door assembly .....	124
Step 9: Install the rear door assembly .....	125
Step 10: Install the right cover .....	125
Step 11: Install the left cover .....	127
Step 12: Install the cartridge door assembly .....	128
Step 13: Install Tray 2 .....	132
Removal and replacement: Top cover (M427/M426) .....	133
Introduction .....	133
Step 1: Remove Tray 2 .....	134
Step 2: Remove the cartridge door assembly .....	134
Step 3: Remove the left cover .....	137
Step 4: Remove the right cover .....	138
Step 5: Remove the integrated scanner assembly (M427/M426) .....	140
Step 6: Remove the control panel (M427/M426) .....	144
Step 7: Remove the top cover (M427/M426) .....	148
Step 8: Unpack the replacement assembly .....	149
Step 9: Remove the cable guide (M427/M426) .....	150
Step 10: Install the cable guide (M427/M426) .....	151
Step 11: Install the top cover (M427/M426) .....	153
Step 12: Install the control panel (M427/M426) .....	155
Step 13: Install the integrated scanner assembly (M427/M246) .....	159
Step 14: Install the right cover .....	164
Step 15: Install the left cover .....	166
Step 16: Install the cartridge door assembly .....	167
Step 17: Install Tray 2 .....	171

Removal and replacement: Cable guide (M427/M426) .....	172
Introduction .....	172
Step 1: Remove Tray 2 .....	173
Step 2: Remove the cartridge door assembly .....	173
Step 3: Remove the left cover .....	176
Step 4: Remove the right cover .....	177
Step 5: Remove the control panel (M427/M426) .....	178
Step 6: Remove the integrated scanner assembly (M427/M246) .....	182
Step 7: Remove the top cover (M427/M426) .....	187
Step 8: Remove the cable guide (M427/M426) .....	188
Step 9: Unpack the replacement assembly .....	190
Step 10: Install the cable guide (M427/M426) .....	190
Step 11: install the top cover (M427/M426) .....	192
Step 12: Install the integrated scanner assembly (M427/M246) .....	194
Step 13: Install the control panel (M427/M426) .....	199
Step 14: Install the right cover .....	203
Step 15: Install the left cover .....	205
Step 16: Install the cartridge door assembly .....	206
Step 17: Install Tray 2 .....	210
Removal and replacement: Top cover (M403/M402) .....	211
Introduction .....	211
Step 1: Remove Tray 2 .....	212
Step 2: Remove the cartridge door assembly .....	212
Step 3: Remove the left cover .....	215
Step 4: Remove the right cover .....	216
Step 5: Remove the top cover (M403/M402) .....	217
Step 6: Remove the 2-line LCD operator and indication covers (M403/ M402) .....	219
Step 7: Unpack the replacement assembly .....	220
Step 8: Install the 2-line LCD operator and indication covers (M403/ M402) .....	221
Step 9: Install the top cover (M403/M402) .....	222
Step 10: Install the right cover .....	224
Step 11: Install the left cover .....	226
Step 12: Install the cartridge door assembly .....	227
Step 13: Install Tray 2 .....	231
Removal and replacement: 2-line LCD operator and indication covers (M403/ M402) .....	232
Introduction .....	232
Step 1: Remove Tray 2 .....	233
Step 2: Remove the cartridge door assembly .....	233

Step 3: Remove the left cover .....	236
Step 4: Remove the right cover .....	237
Step 5: Remove the top cover (M403/M402) .....	238
Step 6: Remove the 2-line LCD operator and indication covers (M403/ M402) .....	240
Step 7: Unpack the replacement assembly .....	241
Step 8: Install the 2-line LCD operator and indication covers (M403/ M402) .....	242
Step 9: Install the top cover (M403/M402) .....	243
Step 10: Install the right cover .....	245
Step 11: Install the left cover .....	247
Step 12: Install the cartridge door assembly .....	248
Step 13: Install Tray 2 .....	252
Removal and replacement: Paper delivery tray (output bin) .....	253
Introduction .....	253
Step 1: Remove Tray 2 .....	254
Step 2: Remove the cartridge door assembly .....	255
Step 3: Remove the left cover .....	257
Step 4: Remove the right cover .....	258
Step 5: Remove the integrated scanner assembly (M427/M246) .....	259
Step 6: Remove the control panel (M427/M246) .....	264
Step 7: Remove the top cover (M427/M426) .....	268
Step 8: Remove the top cover (M403/M402) .....	269
Step 9: Remove the paper delivery tray (output bin) .....	271
Step 10: Unpack the replacement assembly .....	272
Step 11: Install the paper delivery tray (output bin) .....	272
Step 12: Install the top cover (M403/M402) .....	273
Step 13: Install the top cover (M427/M426) .....	275
Step 14: Install the control panel (M427/M246) .....	277
Step 15: Install the integrated scanner assembly (M427/M246) .....	281
Step 16: Install the right cover .....	286
Step 17: Install the left cover .....	288
Step 18: Install the cartridge door assembly .....	289
Step 19: Install Tray 2 .....	293
Removal and replacement: Integrated scanner assembly (M427/M426) .....	294
Introduction .....	294
Step 1: Remove Tray 2 .....	295
Step 2: Remove the cartridge door assembly .....	295
Step 3: Remove the left cover .....	298
Step 4: Remove the ISA (M427/M426) .....	299
Step 5: Unpack the replacement assembly .....	304

Step 6: Install the ISA (M427/M426) .....	305
Step 7: Install the left cover .....	310
Step 8: Install the cartridge door assembly .....	311
Step 9: Install Tray 2 .....	315
Removal and replacement: ISA lift assembly and slider pin (M427/M426) .....	294
Introduction .....	316
Step 1: Remove the slider pin (M427/M426) .....	317
Step 2: Remove the ISA lift assembly (M427/M426) .....	317
Step 3: Unpack the replacement assembly .....	319
Step 4: Install the ISA lift assembly (M427/M426) .....	320
Step 5: Install the slider pin (M427/M426) .....	322
Removal and replacement: Internal parts and assemblies .....	324
Removal and replacement: Fuser .....	325
Introduction .....	325
Step 1: Remove Tray 2 .....	326
Step 2: Remove the cartridge door assembly .....	326
Step 3: Remove the left cover .....	329
Step 4: Remove the right cover .....	330
Step 5: Remove the rear door assembly .....	331
Step 6: Remove the fuser .....	332
Step 7: Unpack the replacement assembly .....	335
Step 8: Install the fuser .....	336
Step 9: Install the rear door assembly .....	339
Step 10: Install the right cover .....	340
Step 11: Install the left cover .....	342
Step 12: Install the cartridge door assembly .....	343
Step 13: Install Tray 2 .....	346
Removal and replacement: Registration assembly .....	347
Introduction .....	347
Step 1: Remove Tray 2 .....	348
Step 2: Remove the cartridge door assembly .....	349
Step 3: Remove the left cover .....	351
Step 4: Remove the right cover .....	353
Step 5: Remove the rear door assembly .....	354
Step 6: Remove the integrated scanner assembly (M427/M246) .....	355
Step 7: Remove the control panel (M427/M426) .....	360
Step 8: Remove the top cover (M427/M426) .....	364
Step 9: Remove the top cover (M403/M402) .....	365
Step 10: Remove the paper delivery tray (output bin) .....	366
Step 11: Remove the fuser .....	367
Step 12: Remove the registration assembly .....	370

Step 13: Unpack the replacement assembly .....	373
Step 14: Install the registration assembly .....	374
Step 15: Install the fuser .....	376
Step 16: Install the paper delivery tray (output bin) .....	379
Step 17: Install the top cover (M403/M402) .....	380
Step 18: Install the top cover (M427/M426) .....	382
Step 19: Install the control panel (M427/M246) .....	384
Step 20: Install the integrated scanner assembly (M427/M246) .....	388
Step 21: Install the rear door assembly .....	393
Step 22: Install the right cover .....	394
Step 23: Install the left cover .....	396
Step 24: Install the cartridge door assembly .....	397
Step 25: Install Install Tray 2 .....	401
Removal and replacement: Main motor (M1) .....	402
Introduction .....	402
Step 1: Remove Tray 2 .....	403
Step 2: Remove the cartridge door assembly .....	403
Step 3: Remove the right cover .....	405
Step 4: Remove the main motor (M1) .....	406
Step 5: Unpack the replacement assembly .....	407
Step 6: Install the main motor (M1) .....	407
Step 7: Install the right cover .....	408
Step 8: Install the cartridge door assembly .....	410
Step 9: Install Tray 2 .....	413
Removal and replacement: Power switch printed circuit assembly .....	414
Introduction .....	414
Step 1: Remove Tray 2 .....	415
Step 2: Remove the cartridge door assembly .....	415
Step 3: Remove the right cover .....	418
Step 4: Remove the power switch PCA .....	419
Step 5: Unpack the replacement assembly .....	421
Step 6: Install the power switch PCA .....	422
Step 7: Install the right cover .....	423
Step 8: Install the cartridge door assembly .....	425
Step 9: Install Tray 2 .....	428
Removal and replacement: Fax PCA (M427/M426) .....	429
Introduction .....	429
Step 1: Remove Tray 2 .....	430
Step 2: Remove the cartridge door assembly .....	430
Step 3: Remove the left cover .....	433
Step 4: Remove the fax PCA (M427/M426) .....	434



Step 5: Unpack the replacement assembly .....	435
Step 6: Install the fax PCA (M427/M426) .....	436
Step 7: Install the left cover .....	437
Step 8: Install the cartridge door assembly .....	438
Step 9: Install Tray 2 .....	442
Removal and replacement: Walkup USB PCA (M427/M426) .....	443
Introduction .....	443
Step 1: Remove Tray 2 .....	444
Step 2: Remove the cartridge door assembly .....	444
Step 3: Remove the left cover .....	447
Step 4: Remove the fax PCA .....	448
Step 5: Remove the walkup USB PCA (M427/M426) .....	449
Step 6: Unpack the replacement assembly .....	451
Step 7: Install the walkup USB PCA (M427/M426) .....	451
Step 8: Install the fax PCA .....	453
Step 9: Install the left cover .....	454
Step 10: Install the cartridge door assembly .....	455
Step 9: Install Tray 2 .....	459
Removal and replacement: Wireless PCA .....	460
Introduction .....	460
Step 1: Remove Tray 2 .....	461
Step 2: Remove the cartridge door assembly .....	461
Step 3: Remove the left cover .....	464
Step 4: Remove the wireless PCA .....	465
Step 5: Unpack the replacement assembly .....	466
Step 6: Install the wireless PCA .....	467
Step 7: Install the left cover .....	468
Step 8: Install the cartridge door assembly .....	469
Step 9: Install Tray 2 .....	473
Removal and replacement: Formatter PCA .....	474
Introduction .....	474
Step 1: Remove Tray 2 .....	475
Step 2: Remove the cartridge door assembly .....	475
Step 3: Remove the left cover .....	478
Step 4: Remove the fax PCA .....	479
Step 5: Remove the wireless PCA .....	480
Step 6: Remove the formatter PCA .....	481
Step 7: Unpack the replacement assembly .....	483
Step 8: Install the formatter PCA .....	483
Step 9: Install the wireless PCA .....	485
Step 10: Install the fax PCA .....	486

Step 11: Install the left cover .....	487
Step 12: Install the cartridge door assembly .....	488
Step 13: Install Tray 2 .....	492
Removal and replacement: Fan (FM1) .....	493
Introduction .....	493
Step 1: Remove Tray 2 .....	494
Step 2: Remove the cartridge door assembly .....	494
Step 3: Remove the left cover .....	496
Step 4: Remove the fan (FM1) .....	498
Step 5: Unpack the replacement assembly .....	499
Step 6: Install the fan (FM1) .....	500
Step 7: Install the left cover .....	501
Step 8: Install the cartridge door assembly .....	502
Step 9: Install Tray 2 .....	506
Removal and replacement: Fan holder (FM1) .....	507
Introduction .....	507
Step 1: Remove Tray 2 .....	508
Step 2: Remove the cartridge door assembly .....	508
Step 3: Remove the left cover .....	511
Step 4: Remove the fan (FM1) .....	512
Step 5: Remove the fan holder (FM1) .....	514
Step 6: Unpack the replacement assembly .....	516
Step 7: Install the fan holder (FM1) .....	517
Step 8: Install the fan (FM1) .....	518
Step 9: Install the left cover .....	519
Step 10: Install the cartridge door assembly .....	521
Step 11: Install Tray 2 .....	524
Removal and replacement: Laser scanner assembly .....	525
Introduction .....	525
Step 1: Remove Tray 2 .....	526
Step 2: Remove the cartridge door assembly .....	526
Step 3: Remove the left cover .....	529
Step 4: Remove the right cover .....	530
Step 5: Remove the integrated scanner assembly (M427/M246) .....	531
Step 6: Remove the control panel (M427/M246) .....	536
Step 7: Remove the top cover (M427/M426) .....	540
Step 8: Remove the top cover (M403/M402) .....	541
Step 9: Remove the paper delivery tray (output bin) .....	543
Step 10: Remove the laser scanner assembly .....	544
Step 11: Unpack the replacement assembly .....	544
Step 12: Install the laser scanner assembly .....	545

Step 13: Install the paper delivery tray (output bin) .....	546
Step 14: Install the top cover (M403/M402) .....	546
Step 15: Install the top cover (M427/M426) .....	548
Step 16: Install the control panel (M427/M246) .....	551
Step 17: Install the integrated scanner assembly (M427/M246) .....	555
Step 18: Install the right cover .....	560
Step 19: Install the left cover .....	562
Step 20: Install the cartridge door assembly .....	563
Step 21: Install Tray 2 .....	566
Removal and replacement: Sheet-metal formatter bracket and formatter PCA .....	567
Step 1: Remove Tray 2 .....	567
Step 2: Remove the cartridge door assembly .....	568
Step 3: Remove the left cover .....	570
Step 4: Remove the right cover .....	572
Step 5: Remove the integrated scanner assembly (M427/M246) .....	573
Step 6: Remove the control panel (M427/M246) .....	578
Step 7: Remove the top cover (M427/M426) .....	582
Step 8: Remove the top cover (M403/M402) .....	583
Step 9: Remove the sheet-metal formatter bracket and formatter PCA ..	584
Step 10: Install the sheet-metal formatter bracket and formatter PCA ...	587
Step 11: Install the top cover (M403/M402) .....	589
Step 12: Install the top cover (M427/M426) .....	590
Step 13: Install the control panel (M427/M246) .....	593
Step 14: Install the integrated scanner assembly (M427/M246) .....	597
Step 15: Install the right cover .....	602
Step 16: Install the left cover .....	604
Step 17: Install the cartridge door assembly .....	605
Step 18: Install Tray 2 .....	608
Removal and replacement: NFC FFC .....	609
Introduction .....	609
Step 1: Remove Tray 2 .....	610
Step 2: Remove the cartridge door assembly .....	611
Step 3: Remove the left cover .....	613
Step 4: Remove the right cover .....	615
Step 5: Remove the integrated scanner assembly (M427/M246) .....	616
Step 6: Remove the control panel (M427/M246) .....	621
Step 7: Remove the top cover (M427/M426) .....	625
Step 8: Remove the NFC PCA cover (M427/M426) .....	626
Step 9: Remove the top cover (M403/M402) .....	627
Step 10: Remove the paper delivery tray (output bin) .....	628
Step 11: Remove the NFC PCA .....	629

Step 12: Remove the NFC FFC .....	629
Step 13: Unpack the replacement assembly .....	631
Step 14: Install the NFC FFC .....	631
Step 15: Install the NFC PCA .....	633
Step 16: Install the paper delivery tray (output bin) .....	635
Step 17: Install the top cover (M403/M402) .....	635
Step 18: Install the NFC PCA cover (M427/M426) .....	637
Step 19: Install the top cover (M427/M426) .....	638
Step 20: Install the control panel (M427/M246) .....	640
Step 21: Install the integrated scanner assembly (M427/M246) .....	644
Step 22: Install the right cover .....	649
Step 23: Install the left cover .....	651
Step 24: Install the cartridge door assembly .....	652
Step 25: Install Tray 2 .....	655
Removal and replacement: Control panel FFC, (M403/M402) .....	656
Introduction .....	656
Step 1: Remove Tray 2 .....	657
Step 2: Remove the cartridge door assembly .....	657
Step 3: Remove the left cover .....	660
Step 4: Remove the right cover .....	661
Step 5: Remove the top cover (M403/M402) .....	662
Step 6: Remove the paper delivery tray (output bin) .....	664
Step 7: Remove the control panel FFC .....	665
Step 8: Unpack the replacement assembly .....	666
Step 9: Install the control panel FFC .....	666
Step 10: Install the paper delivery tray (output bin) .....	668
Step 11: Install the top cover (M403/M402) .....	668
Step 12: Install the right cover .....	670
Step 13: Install the left cover .....	672
Step 14: Install the cartridge door assembly .....	673
Step 15: Install Tray 2 .....	677
Removal and replacement: Formatter FFC .....	678
Introduction .....	678
Step 1: Remove Tray 2 .....	679
Step 2: Remove the cartridge door assembly .....	680
Step 3: Remove the left cover .....	682
Step 4: Remove the right cover .....	683
Step 5: Remove the integrated scanner assembly (M427/M246) .....	684
Step 6: Remove the control panel (M427/M246) .....	689
Step 7: Remove the top cover (M427/M426) .....	693
Step 8: Remove the top cover (M403/M402) .....	694

Step 9: Remove the sheet-metal formatter bracket and formatter PCA ..	696
Step 10: Remove the formatter FFC .....	698
Step 11: Unpack the replacement assembly .....	699
Step 12: Install the formatter FFC .....	700
Step 13: Install the sheet-metal formatter bracket and formatter PCA ...	701
Step 14: Install the top cover (M403/M402) .....	703
Step 15: Install the top cover (M427/M426) .....	705
Step 16: Install the control panel (M427/M246) .....	708
Step 17: Install the integrated scanner assembly (M427/M246) .....	712
Step 18: Install the right cover .....	717
Step 19: Install the left cover .....	719
Step 20: Install the cartridge door assembly .....	720
Step 21: Install Tray 2 .....	723
Removal and replacement: DC controller .....	724
Introduction .....	724
Step 1: Remove Tray 2 .....	725
Step 2: Remove the cartridge door assembly .....	726
Step 3: Remove the left cover .....	728
Step 4: Remove the right cover .....	730
Step 5: Remove the rear door assembly .....	731
Step 6: Remove the integrated scanner assembly (M427/M246) .....	732
Step 7: Remove the control panel (M427/M246) .....	737
Step 8: Remove the top cover (M427/M426) .....	741
Step 9: Remove the top cover (M403/M402) .....	742
Step 10: Remove the paper delivery tray (output bin) .....	743
Step 11: Remove the sheet-metal formatter bracket and formatter .....	744
Step 12: Remove the DC controller .....	746
Step 13: Unpack the replacement assembly .....	748
Step 14: Install the DC controller .....	749
Step 15: Install the sheet-metal formatter bracket and formatter .....	751
Step 16: Install the paper delivery tray (output bin) .....	754
Step 17: Install the top cover (M403/M402) .....	754
Step 18: Install the top cover (M427/M426) .....	756
Step 19: Install the control panel (M427/M246) .....	758
Step 20: Install the integrated scanner assembly (M427/M246) .....	762
Step 21: Install the rear door assembly .....	767
Step 22: Install the right cover .....	768
Step 23: Install the left cover .....	770
Step 24: Install the cartridge door assembly .....	771
Step 25: Install Tray 2 .....	775
Removal and replacement: Tag-cable assembly (toner-cartridge memory) .....	776

Introduction .....	776
Step 1: Remove Tray 2 .....	777
Step 2: Remove the cartridge door assembly .....	778
Step 3: Remove the left cover .....	780
Step 4: Remove the right cover .....	781
Step 5: Remove the integrated scanner assembly (M427/M246) .....	782
Step 6: Remove the control panel (M427/M246) .....	787
Step 7: Remove the top cover (M427/M426) .....	791
Step 8: Remove the top cover (M403/M402) .....	792
Step 9: Remove the paper delivery tray (output bin) .....	794
Step 10: Remove the sheet-metal formatter bracket and formatter PCA .....	795
Step 11: Remove the tag-cable assembly (toner-cartridge memory) .....	797
Step 12: Unpack the replacement assembly .....	798
Step 13: Install the tag-cable assembly (toner-cartridge memory) .....	799
Step 14: Install the sheet-metal formatter bracket and formatter PCA ...	800
Step 15: Install the paper delivery tray (output bin) .....	803
Step 16: Install the top cover (M403/M402) .....	803
Step 17: Install the top cover (M427/M426) .....	805
Step 18: Install the control panel (M427/M246) .....	807
Step 19: Install the integrated scanner assembly (M427/M246) .....	811
Step 20: Install the right cover .....	816
Step 21: Install the left cover .....	818
Step 22: Install the cartridge door assembly .....	819
Step 23: Install Tray 2 .....	823
Removal and replacement: Connecting PCA .....	824
Introduction .....	824
Step 1: Remove Tray 2 .....	825
Step 2: Remove the cartridge door assembly .....	826
Step 3: Remove the left cover .....	828
Step 4: Remove the right cover .....	830
Step 5: Remove the integrated scanner assembly (M427/M246) .....	831
Step 6: Remove the control panel (M427/M246) .....	836
Step 7: Remove the top cover (M427/M426) .....	840
Step 8: Remove the top cover (M403/M402) .....	841
Step 9: Remove the paper delivery tray (output bin) .....	842
Step 10: Remove the sheet-metal formatter bracket and formatter PCA .....	843
Step 11: Remove the connecting PCA .....	845
Step 12: Unpack the replacement assembly .....	847
Step 13: Install the connecting PCA .....	847

Step 14: Install the sheet-metal formatter bracket and formatter PCA ...	849
Step 15: Install the paper delivery tray (output bin) .....	851
Step 16: Install the top cover (M403/M402) .....	852
Step 17: Install the top cover (M427/M426) .....	854
Step 18: Install the control panel (M427/M246) .....	856
Step 19: Install the integrated scanner assembly (M427/M246) .....	860
Step 20: Install the right cover .....	865
Step 21: Install the left cover .....	867
Step 22: Install the cartridge door assembly .....	868
Step 23: Install Tray 2 .....	872
Removal and replacement: Laser scanner FFC .....	873
Introduction .....	873
Step 1: Remove Tray 2 .....	874
Step 2: Remove the cartridge door assembly .....	875
Step 3: Remove the left cover .....	877
Step 4: Remove the right cover .....	879
Step 5: Remove the integrated scanner assembly (M427/M246) .....	880
Step 6: Remove the control panel (M427/M246) .....	885
Step 7: Remove the top cover (M427/M426) .....	889
Step 8: Remove the top cover (M403/M402) .....	890
Step 9: Remove the paper delivery tray (output bin) .....	891
Step 10: Remove the sheet-metal formatter bracket and formatter PCA .....	892
Step 11: Remove the tag-cable assembly .....	894
Step 12: Remove the laser scanner FFC .....	896
Step 13: Unpack the replacement assembly .....	898
Step 14: Install the laser scanner FFC .....	899
Step 15: Install the tag-cable assembly .....	901
Step 16: Install the sheet-metal formatter bracket and formatter PCA ...	903
Step 17: Install the paper delivery tray (output bin) .....	905
Step 18: Install the top cover (M403/M402) .....	906
Step 19: Install the top cover (M427/M426) .....	908
Step 20: Install the control panel (M427/M246) .....	910
Step 21: Install the integrated scanner assembly (M427/M246) .....	914
Step 22: Install the right cover .....	919
Step 23: Install the left cover .....	921
Step 24: Install the cartridge door assembly .....	922
Step 25: Install Tray 2 .....	926
Removal and replacement: High-voltage power supply .....	927
Introduction .....	927
Step 1: Remove Tray 2 .....	928

Step 2: Remove the cartridge door assembly .....	929
Step 3: Remove the left cover .....	931
Step 4: Remove the right cover .....	932
Step 5: Remove the integrated scanner assembly (M427/M246) .....	933
Step 6: Remove the control panel (M427/M246) .....	938
Step 7: Remove the top cover (M427/M426) .....	942
Step 8: Remove the top cover (M403/M402) .....	943
Step 9: Remove the paper delivery tray (output bin) .....	945
Step 10: Remove the sheet-metal formatter bracket and formatter PCA .....	946
Step 11: Remove the HVPS .....	948
Step 12: Unpack the replacement assembly .....	950
Step 13: Install the HVPS .....	951
Step 14: Install the sheet-metal formatter bracket and formatter PCA ...	953
Step 15: Install the paper delivery tray (output bin) .....	956
Step 16: Install the top cover (M403/M402) .....	956
Step 17: Install the top cover (M427/M426) .....	958
Step 18: Install the control panel (M427/M246) .....	960
Step 19: Install the integrated scanner assembly (M427/M246) .....	964
Step 20: Install the right cover .....	969
Step 21: Install the left cover .....	971
Step 22: Install the cartridge door assembly .....	972
Step 23: Install Tray 2 .....	976
Removal and replacement: Low-voltage power supply .....	977
Introduction .....	977
Step 1: Remove Tray 2 .....	978
Step 2: Remove the cartridge door assembly .....	979
Step 3: Remove the left cover .....	981
Step 4: Remove the right cover .....	983
Step 5: Remove the integrated scanner assembly (M427/M246) .....	984
Step 6: Remove the control panel (M427/M246) .....	989
Step 7: Remove the top cover (M427/M426) .....	993
Step 8: Remove the top cover (M403/M402) .....	994
Step 9: Remove the paper delivery tray (output bin) .....	995
Step 10: Remove the fan (FM1) .....	996
Step 11: Remove the sheet-metal formatter bracket and formatter PCA .....	997
Step 12: Remove the LVPS .....	999
Step 13: Unpack the replacement assembly .....	1003
Step 14: Install the LVPS .....	1004
Step 15: Install the sheet-metal formatter bracket and formatter PCA .	1008



Step 16: Install the fan (FM1) .....	1010
Step 17: Install the paper delivery tray (output bin) .....	1011
Step 18: Install the top cover (M403/M402) .....	1012
Step 19: Install the top cover (M427/M426) .....	1014
Step 20: Install the control panel (M427/M246) .....	1016
Step 21: Install the integrated scanner assembly (M427/M246) .....	1020
Step 23: Install the right cover .....	1025
Step 24: Install the left cover .....	519
Step 25: Install the cartridge door assembly .....	1028
Step 26: Install Tray 2 .....	1032
Removal and replacement: NFC cover (M427/M426) .....	1033
Introduction .....	1033
Step 1: Remove Tray 2 .....	1034
Step 2: Remove the cartridge door assembly .....	1034
Step 3: Remove the left cover .....	1037
Step 4: Remove the right cover .....	1038
Step 6: Remove the integrated scanner assembly (M427/M246) .....	1040
Step 5: Remove the control panel (M427/M426) .....	1044
Step 7: Remove the top cover (M427/M426) .....	1048
Step 8: Remove the NFC cover (M427/M426) .....	1049
Step 9: Unpack the replacement assembly .....	1050
Step 10: Install the NFC cover (M427/M426) .....	1050
Step 11: Install the top cover (M427/M426) .....	1051
Step 12: install the control panel (M427/M426) .....	1053
Step 12: Install the integrated scanner assembly (M427/M246) .....	1057
Step 13: Install the right cover .....	1062
Step 14: Install the left cover .....	1064
Step 15: Remove the cartridge door assembly .....	1065
Step 16: Install Tray 2 .....	1069
Removal and replacement: NFC PCA .....	1070
Introduction .....	1070
Step 1: Remove Tray 2 .....	1071
Step 2: Remove the cartridge door assembly .....	1072
Step 3: Remove the left cover .....	1074
Step 4: Remove the right cover .....	1075
Step 5: Remove the integrated scanner assembly (M427/M246) .....	1076
Step 6: Remove the control panel (M427/M426) .....	1081
Step 7: Remove the top cover (M427/M426) .....	1085
Step 8: Remove the NFC cover (M427/M426) .....	1086
Step 9: Remove the top cover (M403/M402) .....	1087
Step 10: Remove the NFC PCA .....	1088

Step 11: Unpack the replacement assembly .....	1089
Step 12: Install the NFC PCA .....	1090
Step 13: Install the top cover (M403/M402) .....	1091
Step 14: Install the NFC cover (M427/M426) .....	1093
Step 15: Install the top cover (M427/M426) .....	1094
Step 16: Install the control panel (M427/M426) .....	1096
Step 17: Install the integrated scanner assembly (M427/M246) .....	1100
Step 18: Install the right cover .....	1105
Step 19: Install the left cover .....	1107
Step 20: Remove the cartridge door assembly .....	1108
Step 21: Install Tray 2 .....	1112
Removal and replacement: Control-panel assembly (M403/M402) .....	1113
Introduction .....	1113
Step 1: Remove Tray 2 .....	1114
Step 2: Remove the cartridge door assembly .....	1114
Step 3: Remove the left cover .....	1117
Step 4: Remove the right cover .....	1118
Step 5: Remove the top cover (M403/M402) .....	1119
Step 6: Remove the paper delivery tray (output bin) .....	1121
Step 7: Remove the control-panel assembly (M403/M402) .....	1122
Step 8: Unpack the replacement assembly .....	1122
Step 9: Install the control-panel assembly (M403/M402) .....	1123
Step 10: Install the paper delivery tray (output bin) .....	1124
Step 11: Install the top cover (M403/M402) .....	1124
Step 12: Install the right cover .....	1126
Step 13: Install the left cover .....	1128
Step 14: Install the cartridge door assembly .....	1129
Step 15: Install Tray 2 .....	1133
Removal and replacement: Control panel (M427/M426) and control panel sub assemblies .....	1134
Introduction .....	1134
Step 1: Remove the control panel mount cover (M427/M426) .....	1135
Step 2: Remove the control panel (M427/M426) .....	1137
Step 3: Remove the control panel mount base (M427/M426) .....	1140
Step 4: Remove the control panel mount chassis assembly (M427/ M426) .....	1141
Step 5: Remove Tray 2 .....	1142
Step 6: Remove the cartridge door assembly .....	1143
Step 7: Remove the left cover .....	1145
Step 8: Remove the control panel 22-pin FFC (M427/M426) .....	1147
Step 9: Unpack the replacement assembly .....	1149

Step 10: Install the control panel 22-pin FFC (M427/M426) .....	1150
Step 11: Install the left cover .....	1152
Step 12: Install the cartridge door assembly .....	1153
Step 13: Install Tray 2 .....	1157
Step 14: Install the control panel mount chassis assembly (M427/ M426) .....	1157
Step 15: Install the control panel mount base (M427/M426) .....	1158
Step 16: Install the control panel (M427/M426) .....	1159
Step 17: Install the control panel mount cover (M427/M426) .....	1163
Removal and replacement: Trays .....	1165
Removal and replacement: Tray 2 .....	1165
RM2-5392-000CN 250-sheet paper input tray .....	1166
RM2-5452-000CN Tray 2 paper pickup roller assembly .....	1168
RM2-5397-000CN Tray 2 separation roller assembly .....	1175
Removal and replacement: Accessories .....	1180
550-sheet paper feeder .....	1180
C5F97-69001 optional 550-sheet paper feeder .....	1181
RM2-5413-000CN optional Tray 3 .....	1186
RM2-5741-000CN optional Tray 3 paper pickup roller assembly .....	1190
RM2-5745-000CN optional Tray 3 separation roller assembly .....	1197

## **2 Parts and diagrams ..... 1203**

For additional service and support .....	1204
Order parts, accessories, and supplies .....	1205
Ordering .....	1205
Orderable parts .....	1205
Supplies .....	1205
Accessories .....	1206
Customer self-repair parts .....	1206
How to use the parts lists and diagrams .....	1207
Document feeder and image scanner .....	1208
Main assemblies .....	1208
Covers, printer base .....	1210
Covers, M402 and M403 .....	1210
Covers, M426 and M427 .....	1212
Internal components, printer base .....	1214
Internal components, printer base (1 of 3) .....	1214
Internal components, printer base (2 of 3) .....	1216
Internal components, printer base (3 of 3) .....	1218
550-sheet paper feeder .....	1220
Covers, 550-sheet paper feeder .....	1220

Main body, 550-sheet paper feeder .....	1222
Alphabetical parts list .....	1224
Numerical parts list .....	1231

<b>Index .....</b>	<b>1239</b>
--------------------	-------------

---

## List of tables

Table 2-1	Supplies .....	1205
Table 2-2	Accessories .....	1206
Table 2-3	Main assemblies (document feeder and image scanner) .....	1209
Table 2-4	Covers, M402 and M403 .....	1211
Table 2-5	Covers, M426 and M427 .....	1213
Table 2-6	Internal components, printer base (1 of 3) .....	1215
Table 2-7	Internal components, printer base (2 of 3) .....	1217
Table 2-8	Internal components, printer base (3 of 3) .....	1219
Table 2-9	Covers, 550-sheet paper feeder .....	1221
Table 2-10	Main body, 550-sheet paper feeder .....	1223



---

# List of figures

Figure 1-1	Screwdrivers .....	5
Figure 1-2	Open the toner-cartridge door .....	9
Figure 1-3	Release two tabs .....	9
Figure 1-4	Remove the roller .....	10
Figure 1-5	Recycle and unpack .....	10
Figure 1-6	Install the roller .....	11
Figure 1-7	Engage two tabs .....	11
Figure 1-8	Close the toner-cartridge door .....	12
Figure 1-9	Remove the tray .....	14
Figure 1-10	Recycle and unpack .....	14
Figure 1-11	Install the tray .....	15
Figure 1-12	Pull the tray out of the printer .....	17
Figure 1-13	Release and remove the tray .....	17
Figure 1-14	Recycle and unpack .....	18
Figure 1-15	Install the tray .....	18
Figure 1-16	Close the tray .....	19
Figure 1-17	Remove the tray .....	21
Figure 1-18	Tilt the printer backward .....	21
Figure 1-19	Place the printer bottom-side face forward .....	22
Figure 1-20	Release one tab .....	22
Figure 1-21	Remove the roller holder .....	23
Figure 1-22	Recycle and unpack .....	23
Figure 1-23	Install the roller holder .....	24
Figure 1-24	Check the tab .....	24
Figure 1-25	Rotate the printer forward .....	25
Figure 1-26	Place the printer in the operational position .....	25
Figure 1-27	Install the tray .....	26
Figure 1-28	Pull the tray out of the printer .....	28
Figure 1-29	Release and remove the tray .....	28
Figure 1-30	Turn the accessory over .....	29
Figure 1-31	Release the assembly .....	29
Figure 1-32	Rotate the assembly up .....	30

Figure 1-33	Remove the assembly .....	30
Figure 1-34	Recycle and unpack .....	31
Figure 1-35	Install the roller assembly .....	31
Figure 1-36	Release the assembly .....	32
Figure 1-37	Check the installation .....	32
Figure 1-38	Install the tray .....	33
Figure 1-39	Close the tray .....	33
Figure 1-40	Remove the tray .....	35
Figure 1-41	Release the assembly .....	35
Figure 1-42	Remove the assembly .....	36
Figure 1-43	Recycle and unpack .....	36
Figure 1-44	Install the assembly .....	37
Figure 1-45	Release the assembly .....	37
Figure 1-46	Install the tray .....	38
Figure 1-47	Pull the tray out of the printer .....	40
Figure 1-48	Release and remove the tray .....	40
Figure 1-49	Release the assembly .....	41
Figure 1-50	Remove the assembly .....	41
Figure 1-51	Recycle and unpack .....	42
Figure 1-52	Install the assembly .....	42
Figure 1-53	Release the assembly .....	43
Figure 1-54	Install the tray .....	43
Figure 1-55	Close the tray .....	44
Figure 1-56	Remove the damper sheets .....	47
Figure 1-57	Recycle and unpack .....	47
Figure 1-58	Install the damper sheets .....	48
Figure 1-59	Pull the cover straight off .....	50
Figure 1-60	Remove the cover .....	50
Figure 1-61	Recycle and unpack .....	51
Figure 1-62	Align the tabs on the cover .....	51
Figure 1-63	Install the cover .....	52
Figure 1-64	Release the support shaft .....	54
Figure 1-65	Remove the support shaft .....	54
Figure 1-66	Recycle and unpack .....	55
Figure 1-67	Align the hinge .....	55
Figure 1-68	Install the support shaft .....	56
Figure 1-69	Release the support shaft .....	58
Figure 1-70	Remove the guide .....	58
Figure 1-71	Remove the link arm .....	59
Figure 1-72	Remove the door .....	59
Figure 1-73	Release the left-side retainer arm .....	60



Figure 1-74	Recycle and unpack .....	60
Figure 1-75	Engage the left-side retainer arm .....	61
Figure 1-76	Install the door .....	61
Figure 1-77	Install the pressure-release link .....	62
Figure 1-78	Install the guide .....	62
Figure 1-79	Align the hinge .....	63
Figure 1-80	Install the support shaft .....	63
Figure 1-81	Release the support shaft .....	65
Figure 1-82	Remove the guide .....	65
Figure 1-83	Remove the link arm .....	66
Figure 1-84	Remove the door .....	66
Figure 1-85	Release the left-side retainer arm .....	67
Figure 1-86	Release the pressure-release link .....	67
Figure 1-87	Remove the pressure-release link .....	68
Figure 1-88	Recycle and unpack .....	68
Figure 1-89	Align the keyed portion of the pin .....	69
Figure 1-90	Install the pressure-release link .....	69
Figure 1-91	Engage the left-side retainer arm .....	70
Figure 1-92	Install the door .....	70
Figure 1-93	Install the pressure-release link .....	71
Figure 1-94	Install the guide .....	71
Figure 1-95	Align the hinge .....	72
Figure 1-96	Install the support shaft .....	72
Figure 1-97	Pull the cover straight off .....	74
Figure 1-98	Remove the cover .....	75
Figure 1-99	Pull the cover straight off .....	75
Figure 1-100	Remove the tray .....	76
Figure 1-101	Release the support shaft .....	76
Figure 1-102	Remove the guide .....	77
Figure 1-103	Remove the link arm .....	77
Figure 1-104	Remove the door .....	78
Figure 1-105	Release the left-side retainer arm .....	78
Figure 1-106	Remove one screw .....	79
Figure 1-107	Release two bosses and three tabs .....	79
Figure 1-108	Remove the cover .....	80
Figure 1-109	Recycle and unpack .....	80
Figure 1-110	Install the cover .....	81
Figure 1-111	Engage three tabs and two bosses .....	81
Figure 1-112	Install one screw .....	81
Figure 1-113	Engage the left-side retainer arm .....	82
Figure 1-114	Install the door .....	82

Figure 1-115	Install the pressure-release link .....	83
Figure 1-116	Install the guide .....	83
Figure 1-117	Align the hinge .....	84
Figure 1-118	Install the support shaft .....	84
Figure 1-119	Install the tray .....	85
Figure 1-120	Install the cover .....	85
Figure 1-121	Align the tabs on the cover .....	86
Figure 1-122	Install the cover .....	86
Figure 1-123	Remove the tray .....	88
Figure 1-124	Release the support shaft .....	88
Figure 1-125	Remove the guide .....	89
Figure 1-126	Remove the link arm .....	89
Figure 1-127	Remove the door .....	90
Figure 1-128	Release the left-side retainer arm .....	90
Figure 1-129	Remove one screw .....	91
Figure 1-130	Release two bosses and three tabs .....	91
Figure 1-131	Remove the cover .....	91
Figure 1-132	Recycle and unpack .....	92
Figure 1-133	Install the cover .....	92
Figure 1-134	Engage two bosses and one tab .....	93
Figure 1-135	Check the power switch and cartridge door assembly button .....	93
Figure 1-136	Install one screw .....	93
Figure 1-137	Engage the left-side retainer arm .....	94
Figure 1-138	Install the door .....	94
Figure 1-139	Install the pressure-release link .....	95
Figure 1-140	Install the guide .....	95
Figure 1-141	Align the hinge .....	96
Figure 1-142	Install the support shaft .....	96
Figure 1-143	Install the tray .....	97
Figure 1-144	Remove the tray .....	99
Figure 1-145	Release the support shaft .....	100
Figure 1-146	Remove the guide .....	100
Figure 1-147	Remove the link arm .....	101
Figure 1-148	Remove the door .....	101
Figure 1-149	Release the left-side retainer arm .....	102
Figure 1-150	Remove one screw .....	102
Figure 1-151	Release two bosses and three tabs .....	103
Figure 1-152	Remove the cover .....	103
Figure 1-153	Remove one screw .....	104
Figure 1-154	Release two bosses and three tabs .....	104
Figure 1-155	Remove the cover .....	104

Figure 1-156	Duplex models, lower the duplex feed assembly .....	105
Figure 1-157	Remove two screws .....	105
Figure 1-158	Recycle and unpack .....	106
Figure 1-159	Install the rear cover .....	106
Figure 1-160	Install two screws .....	107
Figure 1-161	Install the cover .....	107
Figure 1-162	Engage two bosses and one tab .....	108
Figure 1-163	Check the power switch and cartridge door assembly button .....	108
Figure 1-164	Install one screw .....	108
Figure 1-165	Install the cover .....	109
Figure 1-166	Engage three tabs and two bosses .....	109
Figure 1-167	Install one screw .....	110
Figure 1-168	Engage the left-side retainer arm .....	110
Figure 1-169	Install the door .....	111
Figure 1-170	Install the pressure-release link .....	111
Figure 1-171	Install the guide .....	112
Figure 1-172	Align the hinge .....	112
Figure 1-173	Install the support shaft .....	113
Figure 1-174	Install the tray .....	113
Figure 1-175	Remove the tray .....	115
Figure 1-176	Release the support shaft .....	116
Figure 1-177	Remove the guide .....	116
Figure 1-178	Remove the link arm .....	117
Figure 1-179	Remove the door .....	117
Figure 1-180	Release the left-side retainer arm .....	118
Figure 1-181	Remove one screw .....	118
Figure 1-182	Release two bosses and three tabs .....	119
Figure 1-183	Remove the cover .....	119
Figure 1-184	Remove one screw .....	120
Figure 1-185	Release two bosses and three tabs .....	120
Figure 1-186	Remove the cover .....	120
Figure 1-187	Duplex models, lower the duplex feed assembly .....	121
Figure 1-188	Remove two screws .....	121
Figure 1-189	Locate the hinge retainer .....	122
Figure 1-190	Release the retainer and the hinge pin .....	122
Figure 1-191	Remove the cover .....	123
Figure 1-192	Recycle and unpack .....	123
Figure 1-193	Engage the right-side hinge and pin .....	124
Figure 1-194	Engage the left-side hinge and retainer .....	124
Figure 1-195	Install the rear cover .....	125
Figure 1-196	Install two screws .....	125

Figure 1-197	Install the cover .....	126
Figure 1-198	Engage two bosses and one tab .....	126
Figure 1-199	Check the power switch and cartridge door assembly button .....	126
Figure 1-200	Install one screw .....	127
Figure 1-201	Install the cover .....	127
Figure 1-202	Engage three tabs and two bosses .....	128
Figure 1-203	Install one screw .....	128
Figure 1-204	Engage the left-side retainer arm .....	129
Figure 1-205	Install the door .....	129
Figure 1-206	Install the pressure-release link .....	130
Figure 1-207	Install the guide .....	130
Figure 1-208	Align the hinge .....	131
Figure 1-209	Install the support shaft .....	131
Figure 1-210	Install the tray .....	132
Figure 1-211	Remove the tray .....	134
Figure 1-212	Release the support shaft .....	135
Figure 1-213	Remove the guide .....	135
Figure 1-214	Remove the link arm .....	136
Figure 1-215	Remove the door .....	136
Figure 1-216	Release the left-side retainer arm .....	137
Figure 1-217	Remove one screw .....	137
Figure 1-218	Release two bosses and three tabs .....	138
Figure 1-219	Remove the cover .....	138
Figure 1-220	Remove one screw .....	139
Figure 1-221	Release two bosses and three tabs .....	139
Figure 1-222	Remove the cover .....	139
Figure 1-223	Raise the ISA .....	140
Figure 1-224	Remove the ISA FFC cover .....	140
Figure 1-225	Disconnect three FFCs .....	141
Figure 1-226	Remove one screw .....	141
Figure 1-227	Pass the wire through the opening .....	142
Figure 1-228	Release one tab and rotate the slider pin .....	142
Figure 1-229	Remove the slider pin .....	143
Figure 1-230	Rotate the ISA towards the rear of the printer .....	143
Figure 1-231	Release the ISA .....	144
Figure 1-232	Remove the ISA .....	144
Figure 1-233	Disconnect one connector .....	145
Figure 1-234	Remove one screw .....	145
Figure 1-235	Release two tabs .....	146
Figure 1-236	Remove the cover .....	146
Figure 1-237	Remove one screw .....	147

Figure 1-238	Remove two screws .....	147
Figure 1-239	Lift up the control-panel assembly .....	148
Figure 1-240	Remove the control-panel assembly .....	148
Figure 1-241	Remove the USB cable .....	149
Figure 1-242	Remove the cover .....	149
Figure 1-243	Recycle and unpack .....	150
Figure 1-244	Release one tab .....	150
Figure 1-245	Release the guide .....	151
Figure 1-246	Remove the guide .....	151
Figure 1-247	Position the guide on the printer .....	152
Figure 1-248	Install the guide .....	152
Figure 1-249	Check the guide .....	153
Figure 1-250	Install the cover .....	153
Figure 1-251	Engage four bosses .....	154
Figure 1-252	Rotate the front edge of the cover down .....	154
Figure 1-253	Install the USB PCA .....	155
Figure 1-254	Install five screws .....	155
Figure 1-255	Install the control-panel FFC cover .....	156
Figure 1-256	Install the control-panel assembly .....	156
Figure 1-257	Install two screws .....	157
Figure 1-258	Remove one screw .....	157
Figure 1-259	Install the cover .....	158
Figure 1-260	Engage two tabs .....	158
Figure 1-261	Install one screw .....	159
Figure 1-262	Connect one connector .....	159
Figure 1-263	Position the ISA on the printer .....	160
Figure 1-264	Engage the hinge pins with the holders .....	160
Figure 1-265	Rotate the ISA towards the front of the printer .....	161
Figure 1-266	Pass the wire through the opening .....	161
Figure 1-267	Install one screw .....	162
Figure 1-268	Install the slider pin .....	162
Figure 1-269	Secure the slider pin .....	163
Figure 1-270	Connect three FFCs .....	163
Figure 1-271	Install the ISA FFC cover .....	164
Figure 1-272	Lower the ISA .....	164
Figure 1-273	Install the cover .....	165
Figure 1-274	Engage two bosses and one tab .....	165
Figure 1-275	Check the power switch and cartridge door assembly button .....	165
Figure 1-276	Install one screw .....	166
Figure 1-277	Install the cover .....	166
Figure 1-278	Engage three tabs and two bosses .....	167

Figure 1-279	Install one screw .....	167
Figure 1-280	Engage the left-side retainer arm .....	168
Figure 1-281	Install the door .....	168
Figure 1-282	Install the pressure-release link .....	169
Figure 1-283	Install the guide .....	169
Figure 1-284	Align the hinge .....	170
Figure 1-285	Install the support shaft .....	170
Figure 1-286	Install the tray .....	171
Figure 1-287	Remove the tray .....	173
Figure 1-288	Release the support shaft .....	174
Figure 1-289	Remove the guide .....	174
Figure 1-290	Remove the link arm .....	175
Figure 1-291	Remove the door .....	175
Figure 1-292	Release the left-side retainer arm .....	176
Figure 1-293	Remove one screw .....	176
Figure 1-294	Release two bosses and three tabs .....	177
Figure 1-295	Remove the cover .....	177
Figure 1-296	Remove one screw .....	178
Figure 1-297	Release two bosses and three tabs .....	178
Figure 1-298	Remove the cover .....	178
Figure 1-299	Disconnect one connector .....	179
Figure 1-300	Remove one screw .....	179
Figure 1-301	Release two tabs .....	180
Figure 1-302	Remove the cover .....	180
Figure 1-303	Remove one screw .....	181
Figure 1-304	Remove two screws .....	181
Figure 1-305	Lift up the control-panel assembly .....	182
Figure 1-306	Remove the control-panel assembly .....	182
Figure 1-307	Raise the ISA .....	183
Figure 1-308	Remove the ISA FFC cover .....	183
Figure 1-309	Disconnect three FFCs .....	184
Figure 1-310	Remove one screw .....	184
Figure 1-311	Pass the wire through the opening .....	185
Figure 1-312	Release one tab and rotate the slider pin .....	185
Figure 1-313	Remove the slider pin .....	186
Figure 1-314	Rotate the ISA towards the rear of the printer .....	186
Figure 1-315	Release the ISA .....	187
Figure 1-316	Remove the ISA .....	187
Figure 1-317	Remove the USB cable .....	188
Figure 1-318	Remove the cover .....	188
Figure 1-319	Release one tab .....	189

Figure 1-320	Release the guide .....	189
Figure 1-321	Remove the guide .....	190
Figure 1-322	Recycle and unpack .....	190
Figure 1-323	Position the guide on the printer .....	191
Figure 1-324	Install the guide .....	191
Figure 1-325	Check the guide .....	192
Figure 1-326	Install the cover .....	192
Figure 1-327	Engage four bosses .....	193
Figure 1-328	Rotate the front edge of the cover down .....	193
Figure 1-329	Install the USB PCA .....	194
Figure 1-330	Install five screws .....	194
Figure 1-331	Position the ISA on the printer .....	195
Figure 1-332	Engage the hinge pins with the holders .....	195
Figure 1-333	Rotate the ISA towards the front of the printer .....	196
Figure 1-334	Pass the wire through the opening .....	196
Figure 1-335	Install one screw .....	197
Figure 1-336	Install the slider pin .....	197
Figure 1-337	Secure the slider pin .....	198
Figure 1-338	Connect three FFCs .....	198
Figure 1-339	Install the ISA FFC cover .....	199
Figure 1-340	Lower the ISA .....	199
Figure 1-341	Install the control-panel FFC cover .....	200
Figure 1-342	Install the control-panel assembly .....	200
Figure 1-343	Install two screws .....	201
Figure 1-344	Remove one screw .....	201
Figure 1-345	Install the cover .....	202
Figure 1-346	Engage two tabs .....	202
Figure 1-347	Install one screw .....	203
Figure 1-348	Connect one connector .....	203
Figure 1-349	Install the cover .....	204
Figure 1-350	Engage two bosses and one tab .....	204
Figure 1-351	Check the power switch and cartridge door assembly button .....	204
Figure 1-352	Install one screw .....	205
Figure 1-353	Install the cover .....	205
Figure 1-354	Engage three tabs and two bosses .....	206
Figure 1-355	Install one screw .....	206
Figure 1-356	Engage the left-side retainer arm .....	207
Figure 1-357	Install the door .....	207
Figure 1-358	Install the pressure-release link .....	208
Figure 1-359	Install the guide .....	208
Figure 1-360	Align the hinge .....	209

Figure 1-361	Install the support shaft .....	209
Figure 1-362	Install the tray .....	210
Figure 1-363	Remove the tray .....	212
Figure 1-364	Release the support shaft .....	213
Figure 1-365	Remove the guide .....	213
Figure 1-366	Remove the link arm .....	214
Figure 1-367	Remove the door .....	214
Figure 1-368	Release the left-side retainer arm .....	215
Figure 1-369	Remove one screw .....	215
Figure 1-370	Release two bosses and three tabs .....	216
Figure 1-371	Remove the cover .....	216
Figure 1-372	Remove one screw .....	217
Figure 1-373	Release two bosses and three tabs .....	217
Figure 1-374	Remove the cover .....	217
Figure 1-375	Remove one screw .....	218
Figure 1-376	Release one boss and one tab .....	218
Figure 1-377	Remove the cover .....	219
Figure 1-378	Rotate the top edge of the operator cover .....	219
Figure 1-379	Remove the cover .....	220
Figure 1-380	Remove the cover .....	220
Figure 1-381	Recycle and unpack .....	221
Figure 1-382	Install the cover .....	221
Figure 1-383	Position the operator cover on the printer .....	222
Figure 1-384	Install the cover .....	222
Figure 1-385	Install the cover .....	223
Figure 1-386	Engage four bosses and tabs .....	223
Figure 1-387	Engage one boss and one tab .....	224
Figure 1-388	Install one screw .....	224
Figure 1-389	Install the cover .....	225
Figure 1-390	Engage two bosses and one tab .....	225
Figure 1-391	Check the power switch and cartridge door assembly button .....	225
Figure 1-392	Install one screw .....	226
Figure 1-393	Install the cover .....	226
Figure 1-394	Engage three tabs and two bosses .....	227
Figure 1-395	Install one screw .....	227
Figure 1-396	Engage the left-side retainer arm .....	228
Figure 1-397	Install the door .....	228
Figure 1-398	Install the pressure-release link .....	229
Figure 1-399	Install the guide .....	229
Figure 1-400	Align the hinge .....	230
Figure 1-401	Install the support shaft .....	230



Figure 1-402	Install the tray .....	231
Figure 1-403	Remove the tray .....	233
Figure 1-404	Release the support shaft .....	234
Figure 1-405	Remove the guide .....	234
Figure 1-406	Remove the link arm .....	235
Figure 1-407	Remove the door .....	235
Figure 1-408	Release the left-side retainer arm .....	236
Figure 1-409	Remove one screw .....	236
Figure 1-410	Release two bosses and three tabs .....	237
Figure 1-411	Remove the cover .....	237
Figure 1-412	Remove one screw .....	238
Figure 1-413	Release two bosses and three tabs .....	238
Figure 1-414	Remove the cover .....	238
Figure 1-415	Remove one screw .....	239
Figure 1-416	Release one boss and one tab .....	239
Figure 1-417	Remove the cover .....	240
Figure 1-418	Rotate the top edge of the operator cover .....	240
Figure 1-419	Remove the cover .....	241
Figure 1-420	Remove the cover .....	241
Figure 1-421	Recycle and unpack .....	242
Figure 1-422	Install the cover .....	242
Figure 1-423	Position the operator cover on the printer .....	243
Figure 1-424	Install the cover .....	243
Figure 1-425	Install the cover .....	244
Figure 1-426	Engage four bosses and tabs .....	244
Figure 1-427	Engage one boss and one tab .....	245
Figure 1-428	Install one screw .....	245
Figure 1-429	Install the cover .....	246
Figure 1-430	Engage two bosses and one tab .....	246
Figure 1-431	Check the power switch and cartridge door assembly button .....	246
Figure 1-432	Install one screw .....	247
Figure 1-433	Install the cover .....	247
Figure 1-434	Engage three tabs and two bosses .....	248
Figure 1-435	Install one screw .....	248
Figure 1-436	Engage the left-side retainer arm .....	249
Figure 1-437	Install the door .....	249
Figure 1-438	Install the pressure-release link .....	250
Figure 1-439	Install the guide .....	250
Figure 1-440	Align the hinge .....	251
Figure 1-441	Install the support shaft .....	251
Figure 1-442	Install the tray .....	252

Figure 1-443	Remove the tray .....	254
Figure 1-444	Release the support shaft .....	255
Figure 1-445	Remove the guide .....	255
Figure 1-446	Remove the link arm .....	256
Figure 1-447	Remove the door .....	256
Figure 1-448	Release the left-side retainer arm .....	257
Figure 1-449	Remove one screw .....	257
Figure 1-450	Release two bosses and three tabs .....	258
Figure 1-451	Remove the cover .....	258
Figure 1-452	Remove one screw .....	259
Figure 1-453	Release two bosses and three tabs .....	259
Figure 1-454	Remove the cover .....	259
Figure 1-455	Raise the ISA .....	260
Figure 1-456	Remove the ISA FFC cover .....	260
Figure 1-457	Disconnect three FFCs .....	261
Figure 1-458	Remove one screw .....	261
Figure 1-459	Pass the wire through the opening .....	262
Figure 1-460	Release one tab and rotate the slider pin .....	262
Figure 1-461	Remove the slider pin .....	263
Figure 1-462	Rotate the ISA towards the rear of the printer .....	263
Figure 1-463	Release the ISA .....	264
Figure 1-464	Remove the ISA .....	264
Figure 1-465	Disconnect one connector .....	265
Figure 1-466	Remove one screw .....	265
Figure 1-467	Release two tabs .....	266
Figure 1-468	Remove the cover .....	266
Figure 1-469	Remove one screw .....	267
Figure 1-470	Remove two screws .....	267
Figure 1-471	Lift up the control-panel assembly .....	268
Figure 1-472	Remove the control-panel assembly .....	268
Figure 1-473	Remove the USB cable .....	269
Figure 1-474	Remove the cover .....	269
Figure 1-475	Remove one screw .....	270
Figure 1-476	Release one boss and one tab .....	270
Figure 1-477	Remove the cover .....	271
Figure 1-478	Release two tabs .....	271
Figure 1-479	Recycle and unpack .....	272
Figure 1-480	Engage two tabs .....	273
Figure 1-481	Install the cover .....	273
Figure 1-482	Engage four bosses and tabs .....	274
Figure 1-483	Engage one boss and one tab .....	274

Figure 1-484	Install one screw .....	275
Figure 1-485	Install the cover .....	275
Figure 1-486	Engage four bosses .....	276
Figure 1-487	Rotate the front edge of the cover down .....	276
Figure 1-488	Install the USB PCA .....	277
Figure 1-489	Install five screws .....	277
Figure 1-490	Install the control-panel FFC cover .....	278
Figure 1-491	Install the control-panel assembly .....	278
Figure 1-492	Install two screws .....	279
Figure 1-493	Remove one screw .....	279
Figure 1-494	Install the cover .....	280
Figure 1-495	Engage two tabs .....	280
Figure 1-496	Install one screw .....	281
Figure 1-497	Connect one connector .....	281
Figure 1-498	Position the ISA on the printer .....	282
Figure 1-499	Engage the hinge pins with the holders .....	282
Figure 1-500	Rotate the ISA towards the front of the printer .....	283
Figure 1-501	Pass the wire through the opening .....	283
Figure 1-502	Install one screw .....	284
Figure 1-503	Install the slider pin .....	284
Figure 1-504	Secure the slider pin .....	285
Figure 1-505	Connect three FFCs .....	285
Figure 1-506	Install the ISA FFC cover .....	286
Figure 1-507	Lower the ISA .....	286
Figure 1-508	Install the cover .....	287
Figure 1-509	Engage two bosses and one tab .....	287
Figure 1-510	Check the power switch and cartridge door assembly button .....	287
Figure 1-511	Install one screw .....	288
Figure 1-512	Install the cover .....	288
Figure 1-513	Engage three tabs and two bosses .....	289
Figure 1-514	Install one screw .....	289
Figure 1-515	Engage the left-side retainer arm .....	290
Figure 1-516	Install the door .....	290
Figure 1-517	Install the pressure-release link .....	291
Figure 1-518	Install the guide .....	291
Figure 1-519	Align the hinge .....	292
Figure 1-520	Install the support shaft .....	292
Figure 1-521	Install the tray .....	293
Figure 1-522	Remove the tray .....	295
Figure 1-523	Release the support shaft .....	296
Figure 1-524	Remove the guide .....	296

Figure 1-525	Remove the link arm .....	297
Figure 1-526	Remove the door .....	297
Figure 1-527	Release the left-side retainer arm .....	298
Figure 1-528	Remove one screw .....	298
Figure 1-529	Release two bosses and three tabs .....	299
Figure 1-530	Remove the cover .....	299
Figure 1-531	Raise the ISA .....	300
Figure 1-532	Remove the ISA FFC cover .....	300
Figure 1-533	Disconnect three FFCs .....	301
Figure 1-534	Remove one screw .....	301
Figure 1-535	Pass the wire through the opening .....	302
Figure 1-536	Release one tab and rotate the slider pin .....	302
Figure 1-537	Remove the slider pin .....	303
Figure 1-538	Rotate the ISA towards the rear of the printer .....	303
Figure 1-539	Release the ISA .....	304
Figure 1-540	Remove the ISA .....	304
Figure 1-541	Recycle and unpack .....	305
Figure 1-542	Position the ISA on the printer .....	305
Figure 1-543	Engage the hinge pins with the holders .....	306
Figure 1-544	Rotate the ISA towards the front of the printer .....	306
Figure 1-545	Pass the wire through the opening .....	307
Figure 1-546	Install one screw .....	307
Figure 1-547	Install the slider pin .....	308
Figure 1-548	Secure the slider pin .....	308
Figure 1-549	Connect three FFCs .....	309
Figure 1-550	Install the ISA FFC cover .....	309
Figure 1-551	Lower the ISA .....	310
Figure 1-552	Install the cover .....	310
Figure 1-553	Engage three tabs and two bosses .....	311
Figure 1-554	Install one screw .....	311
Figure 1-555	Engage the left-side retainer arm .....	312
Figure 1-556	Install the door .....	312
Figure 1-557	Install the pressure-release link .....	313
Figure 1-558	Install the guide .....	313
Figure 1-559	Align the hinge .....	314
Figure 1-560	Install the support shaft .....	314
Figure 1-561	Install the tray .....	315
Figure 1-562	Release one tab and rotate the slider pin .....	317
Figure 1-563	Remove the slider pin .....	317
Figure 1-564	Lower the support arm .....	318
Figure 1-565	Before proceeding take note .....	318

Figure 1-566	Remove one screw .....	319
Figure 1-567	Remove the support arm .....	319
Figure 1-568	Recycle and unpack .....	320
Figure 1-569	Install the lift assembly .....	320
Figure 1-570	Lower the lift assembly .....	321
Figure 1-571	Before proceeding take note .....	321
Figure 1-572	Install one screw .....	322
Figure 1-573	Install the slider pin .....	322
Figure 1-574	Secure the slider pin .....	323
Figure 1-575	Remove the tray .....	326
Figure 1-576	Release the support shaft .....	327
Figure 1-577	Remove the guide .....	327
Figure 1-578	Remove the link arm .....	328
Figure 1-579	Remove the door .....	328
Figure 1-580	Release the left-side retainer arm .....	329
Figure 1-581	Remove one screw .....	329
Figure 1-582	Release two bosses and three tabs .....	330
Figure 1-583	Remove the cover .....	330
Figure 1-584	Remove one screw .....	331
Figure 1-585	Release two bosses and three tabs .....	331
Figure 1-586	Remove the cover .....	331
Figure 1-587	Duplex models, lower the duplex feed assembly .....	332
Figure 1-588	Remove two screws .....	332
Figure 1-589	Disconnect one connector .....	333
Figure 1-590	Remove the cover .....	333
Figure 1-591	Disconnect two connectors .....	334
Figure 1-592	Remove four screws .....	334
Figure 1-593	Release the pressure-release arm .....	335
Figure 1-594	Remove the fuser .....	335
Figure 1-595	Recycle and unpack .....	336
Figure 1-596	Install the fuser .....	336
Figure 1-597	Connect the pressure-release arm .....	337
Figure 1-598	Install four screws .....	337
Figure 1-599	Connect two connectors .....	338
Figure 1-600	Install the cover .....	338
Figure 1-601	Connect one connector .....	339
Figure 1-602	Install the rear cover .....	339
Figure 1-603	Install two screws .....	340
Figure 1-604	Install the cover .....	340
Figure 1-605	Engage two bosses and one tab .....	341
Figure 1-606	Check the power switch and cartridge door assembly button .....	341

Figure 1-607	Install one screw .....	341
Figure 1-608	Install the cover .....	342
Figure 1-609	Engage three tabs and two bosses .....	342
Figure 1-610	Install one screw .....	343
Figure 1-611	Engage the left-side retainer arm .....	343
Figure 1-612	Install the door .....	344
Figure 1-613	Install the pressure-release link .....	344
Figure 1-614	Install the guide .....	345
Figure 1-615	Align the hinge .....	345
Figure 1-616	Install the support shaft .....	346
Figure 1-617	Install the tray .....	346
Figure 1-618	Remove the tray .....	349
Figure 1-619	Release the support shaft .....	349
Figure 1-620	Remove the guide .....	350
Figure 1-621	Remove the link arm .....	350
Figure 1-622	Remove the door .....	351
Figure 1-623	Release the left-side retainer arm .....	351
Figure 1-624	Remove one screw .....	352
Figure 1-625	Release two bosses and three tabs .....	352
Figure 1-626	Remove the cover .....	353
Figure 1-627	Remove one screw .....	353
Figure 1-628	Release two bosses and three tabs .....	353
Figure 1-629	Remove the cover .....	354
Figure 1-630	Duplex models, lower the duplex feed assembly .....	354
Figure 1-631	Remove two screws .....	355
Figure 1-632	Raise the ISA .....	355
Figure 1-633	Remove the ISA FFC cover .....	356
Figure 1-634	Disconnect three FFCs .....	356
Figure 1-635	Remove one screw .....	357
Figure 1-636	Pass the wire through the opening .....	357
Figure 1-637	Release one tab and rotate the slider pin .....	358
Figure 1-638	Remove the slider pin .....	358
Figure 1-639	Rotate the ISA towards the rear of the printer .....	359
Figure 1-640	Release the ISA .....	359
Figure 1-641	Remove the ISA .....	360
Figure 1-642	Disconnect one connector .....	360
Figure 1-643	Remove one screw .....	361
Figure 1-644	Release two tabs .....	361
Figure 1-645	Remove the cover .....	362
Figure 1-646	Remove one screw .....	362
Figure 1-647	Remove two screws .....	363

Figure 1-648	Lift up the control-panel assembly .....	363
Figure 1-649	Remove the control-panel assembly .....	364
Figure 1-650	Remove the USB cable .....	364
Figure 1-651	Remove the cover .....	365
Figure 1-652	Remove one screw .....	365
Figure 1-653	Release one boss and one tab .....	366
Figure 1-654	Remove the cover .....	366
Figure 1-655	Release two tabs .....	367
Figure 1-656	Disconnect one connector .....	367
Figure 1-657	Remove the cover .....	368
Figure 1-658	Disconnect two connectors .....	368
Figure 1-659	Remove four screws .....	369
Figure 1-660	Release the pressure-release arm .....	369
Figure 1-661	Remove the fuser .....	370
Figure 1-662	Place the printer bottom-side face forward .....	370
Figure 1-663	Remove one screw and the guide .....	371
Figure 1-664	Move the link arm out of the way .....	371
Figure 1-665	Remove two screws .....	372
Figure 1-666	Move the pressure-release arm out of the way .....	372
Figure 1-667	Release the assembly .....	373
Figure 1-668	Remove the assembly .....	373
Figure 1-669	Recycle and unpack .....	374
Figure 1-670	Install the assembly .....	374
Figure 1-671	Install the pressure-release arm .....	375
Figure 1-672	Install two screws .....	375
Figure 1-673	Place the printer bottom-side face forward .....	376
Figure 1-674	Install the guide .....	376
Figure 1-675	Install the fuser .....	377
Figure 1-676	Connect the pressure-release arm .....	377
Figure 1-677	Install four screws .....	378
Figure 1-678	Connect two connectors .....	378
Figure 1-679	Install the cover .....	379
Figure 1-680	Connect one connector .....	379
Figure 1-681	Engage two tabs .....	380
Figure 1-682	Install the cover .....	380
Figure 1-683	Engage four bosses and tabs .....	381
Figure 1-684	Engage one boss and one tab .....	381
Figure 1-685	Install one screw .....	382
Figure 1-686	Install the cover .....	382
Figure 1-687	Engage four bosses .....	383
Figure 1-688	Rotate the front edge of the cover down .....	383

Figure 1-689	Install the USB PCA .....	384
Figure 1-690	Install five screws .....	384
Figure 1-691	Install the control-panel FFC cover .....	385
Figure 1-692	Install the control-panel assembly .....	385
Figure 1-693	Install two screws .....	386
Figure 1-694	Remove one screw .....	386
Figure 1-695	Install the cover .....	387
Figure 1-696	Engage two tabs .....	387
Figure 1-697	Install one screw .....	388
Figure 1-698	Connect one connector .....	388
Figure 1-699	Position the ISA on the printer .....	389
Figure 1-700	Engage the hinge pins with the holders .....	389
Figure 1-701	Rotate the ISA towards the front of the printer .....	390
Figure 1-702	Pass the wire through the opening .....	390
Figure 1-703	Install one screw .....	391
Figure 1-704	Install the slider pin .....	391
Figure 1-705	Secure the slider pin .....	392
Figure 1-706	Connect three FFCs .....	392
Figure 1-707	Install the ISA FFC cover .....	393
Figure 1-708	Lower the ISA .....	393
Figure 1-709	Install the rear cover .....	394
Figure 1-710	Install two screws .....	394
Figure 1-711	Install the cover .....	395
Figure 1-712	Engage two bosses and one tab .....	395
Figure 1-713	Check the power switch and cartridge door assembly button .....	395
Figure 1-714	Install one screw .....	396
Figure 1-715	Install the cover .....	396
Figure 1-716	Engage three tabs and two bosses .....	397
Figure 1-717	Install one screw .....	397
Figure 1-718	Engage the left-side retainer arm .....	398
Figure 1-719	Install the door .....	398
Figure 1-720	Install the pressure-release link .....	399
Figure 1-721	Install the guide .....	399
Figure 1-722	Align the hinge .....	400
Figure 1-723	Install the support shaft .....	400
Figure 1-724	Install the tray .....	401
Figure 1-725	Remove the tray .....	403
Figure 1-726	Release the support shaft .....	403
Figure 1-727	Remove the guide .....	404
Figure 1-728	Remove the link arm .....	404
Figure 1-729	Remove the door .....	405



Figure 1-730	Release the left-side retainer arm .....	405
Figure 1-731	Remove one screw .....	406
Figure 1-732	Release two bosses and three tabs .....	406
Figure 1-733	Remove the cover .....	406
Figure 1-734	Remove the motor .....	407
Figure 1-735	Recycle and unpack .....	407
Figure 1-736	Install the motor .....	408
Figure 1-737	Install the cover .....	408
Figure 1-738	Engage two bosses and one tab .....	409
Figure 1-739	Check the power switch and cartridge door assembly button .....	409
Figure 1-740	Install one screw .....	409
Figure 1-741	Engage the left-side retainer arm .....	410
Figure 1-742	Install the door .....	410
Figure 1-743	Install the pressure-release link .....	411
Figure 1-744	Install the guide .....	411
Figure 1-745	Align the hinge .....	412
Figure 1-746	Install the support shaft .....	412
Figure 1-747	Install the tray .....	413
Figure 1-748	Remove the tray .....	415
Figure 1-749	Release the support shaft .....	416
Figure 1-750	Remove the guide .....	416
Figure 1-751	Remove the link arm .....	417
Figure 1-752	Remove the door .....	417
Figure 1-753	Release the left-side retainer arm .....	418
Figure 1-754	Remove one screw .....	418
Figure 1-755	Release two bosses and three tabs .....	419
Figure 1-756	Remove the cover .....	419
Figure 1-757	Release one tab .....	420
Figure 1-758	Remove the switch lever .....	420
Figure 1-759	Disconnect one connector .....	421
Figure 1-760	Release one tab and remove the PCA .....	421
Figure 1-761	Recycle and unpack .....	422
Figure 1-762	Install the PCA .....	422
Figure 1-763	Connect one connector and install the wire harness in the guide .....	423
Figure 1-764	Install the switch lever .....	423
Figure 1-765	Install the cover .....	424
Figure 1-766	Engage two bosses and one tab .....	424
Figure 1-767	Check the power switch and cartridge door assembly button .....	424
Figure 1-768	Install one screw .....	425
Figure 1-769	Engage the left-side retainer arm .....	425
Figure 1-770	Install the door .....	426

Figure 1-771	Install the pressure-release link .....	426
Figure 1-772	Install the guide .....	427
Figure 1-773	Align the hinge .....	427
Figure 1-774	Install the support shaft .....	428
Figure 1-775	Install the tray .....	428
Figure 1-776	Remove the tray .....	430
Figure 1-777	Release the support shaft .....	431
Figure 1-778	Remove the guide .....	431
Figure 1-779	Remove the link arm .....	432
Figure 1-780	Remove the door .....	432
Figure 1-781	Release the left-side retainer arm .....	433
Figure 1-782	Remove one screw .....	433
Figure 1-783	Release two bosses and three tabs .....	434
Figure 1-784	Remove the cover .....	434
Figure 1-785	Remove four screws .....	435
Figure 1-786	Disconnect one connector and remove the PCA .....	435
Figure 1-787	Recycle and unpack .....	436
Figure 1-788	Connect one connector and install the PCA .....	436
Figure 1-789	Install four screws .....	437
Figure 1-790	Install the cover .....	437
Figure 1-791	Engage three tabs and two bosses .....	438
Figure 1-792	Install one screw .....	438
Figure 1-793	Engage the left-side retainer arm .....	439
Figure 1-794	Install the door .....	439
Figure 1-795	Install the pressure-release link .....	440
Figure 1-796	Install the guide .....	440
Figure 1-797	Align the hinge .....	441
Figure 1-798	Install the support shaft .....	441
Figure 1-799	Install the tray .....	442
Figure 1-800	Remove the tray .....	444
Figure 1-801	Release the support shaft .....	445
Figure 1-802	Remove the guide .....	445
Figure 1-803	Remove the link arm .....	446
Figure 1-804	Remove the door .....	446
Figure 1-805	Release the left-side retainer arm .....	447
Figure 1-806	Remove one screw .....	447
Figure 1-807	Release two bosses and three tabs .....	448
Figure 1-808	Remove the cover .....	448
Figure 1-809	Remove four screws .....	449
Figure 1-810	Disconnect one connector and remove the PCA .....	449
Figure 1-811	Disconnect one connector .....	450

Figure 1-812	Remove two screws .....	450
Figure 1-813	Remove the walkup USB PCA .....	451
Figure 1-814	Recycle and unpack .....	451
Figure 1-815	Install the walkup USB PCA .....	452
Figure 1-816	Install two screws .....	452
Figure 1-817	Connect one connector .....	453
Figure 1-818	Connect one connector and install the PCA .....	453
Figure 1-819	Install four screws .....	454
Figure 1-820	Install the cover .....	454
Figure 1-821	Engage three tabs and two bosses .....	455
Figure 1-822	Install one screw .....	455
Figure 1-823	Engage the left-side retainer arm .....	456
Figure 1-824	Install the door .....	456
Figure 1-825	Install the pressure-release link .....	457
Figure 1-826	Install the guide .....	457
Figure 1-827	Align the hinge .....	458
Figure 1-828	Install the support shaft .....	458
Figure 1-829	Install the tray .....	459
Figure 1-830	Remove the tray .....	461
Figure 1-831	Release the support shaft .....	462
Figure 1-832	Remove the guide .....	462
Figure 1-833	Remove the link arm .....	463
Figure 1-834	Remove the door .....	463
Figure 1-835	Release the left-side retainer arm .....	464
Figure 1-836	Remove one screw .....	464
Figure 1-837	Release two bosses and three tabs .....	465
Figure 1-838	Remove the cover .....	465
Figure 1-839	Remove one screw .....	466
Figure 1-840	Remove the wireless PCA .....	466
Figure 1-841	Recycle and unpack .....	467
Figure 1-842	Install the PCA .....	467
Figure 1-843	Install one screw .....	468
Figure 1-844	Install the cover .....	468
Figure 1-845	Engage three tabs and two bosses .....	469
Figure 1-846	Install one screw .....	469
Figure 1-847	Engage the left-side retainer arm .....	470
Figure 1-848	Install the door .....	470
Figure 1-849	Install the pressure-release link .....	471
Figure 1-850	Install the guide .....	471
Figure 1-851	Align the hinge .....	472
Figure 1-852	Install the support shaft .....	472

Figure 1-853	Install the tray .....	473
Figure 1-854	Remove the tray .....	475
Figure 1-855	Release the support shaft .....	476
Figure 1-856	Remove the guide .....	476
Figure 1-857	Remove the link arm .....	477
Figure 1-858	Remove the door .....	477
Figure 1-859	Release the left-side retainer arm .....	478
Figure 1-860	Remove one screw .....	478
Figure 1-861	Release two bosses and three tabs .....	479
Figure 1-862	Remove the cover .....	479
Figure 1-863	Remove four screws .....	480
Figure 1-864	Disconnect one connector and remove the PCA .....	480
Figure 1-865	Remove one screw .....	481
Figure 1-866	Remove the wireless PCA .....	481
Figure 1-867	Disconnect all of the connectors and FFCs .....	482
Figure 1-868	Remove the fax PCA support bracket .....	482
Figure 1-869	Remove the formatter PCA .....	483
Figure 1-870	Recycle and unpack .....	483
Figure 1-871	Install the formatter PCA .....	484
Figure 1-872	Remove the fax PCA support bracket .....	484
Figure 1-873	Connect all of the connectors and FFCs .....	485
Figure 1-874	Install the PCA .....	485
Figure 1-875	Install one screw .....	486
Figure 1-876	Connect one connector and install the PCA .....	486
Figure 1-877	Install four screws .....	487
Figure 1-878	Install the cover .....	487
Figure 1-879	Engage three tabs and two bosses .....	488
Figure 1-880	Install one screw .....	488
Figure 1-881	Engage the left-side retainer arm .....	489
Figure 1-882	Install the door .....	489
Figure 1-883	Install the pressure-release link .....	490
Figure 1-884	Install the guide .....	490
Figure 1-885	Align the hinge .....	491
Figure 1-886	Install the support shaft .....	491
Figure 1-887	Install the tray .....	492
Figure 1-888	Remove the tray .....	494
Figure 1-889	Release the support shaft .....	494
Figure 1-890	Remove the guide .....	495
Figure 1-891	Remove the link arm .....	495
Figure 1-892	Remove the door .....	496
Figure 1-893	Release the left-side retainer arm .....	496

Figure 1-894	Remove one screw .....	497
Figure 1-895	Release two bosses and three tabs .....	497
Figure 1-896	Remove the cover .....	498
Figure 1-897	Disconnect one connector .....	498
Figure 1-898	Release two tabs .....	499
Figure 1-899	Remove the fan .....	499
Figure 1-900	Recycle and unpack .....	500
Figure 1-901	Install the fan .....	500
Figure 1-902	Connect one connector .....	501
Figure 1-903	Install the cover .....	501
Figure 1-904	Engage three tabs and two bosses .....	502
Figure 1-905	Install one screw .....	502
Figure 1-906	Engage the left-side retainer arm .....	503
Figure 1-907	Install the door .....	503
Figure 1-908	Install the pressure-release link .....	504
Figure 1-909	Install the guide .....	504
Figure 1-910	Align the hinge .....	505
Figure 1-911	Install the support shaft .....	505
Figure 1-912	Install the tray .....	506
Figure 1-913	Remove the tray .....	508
Figure 1-914	Release the support shaft .....	509
Figure 1-915	Remove the guide .....	509
Figure 1-916	Remove the link arm .....	510
Figure 1-917	Remove the door .....	510
Figure 1-918	Release the left-side retainer arm .....	511
Figure 1-919	Remove one screw .....	511
Figure 1-920	Release two bosses and three tabs .....	512
Figure 1-921	Remove the cover .....	512
Figure 1-922	Disconnect one connector .....	513
Figure 1-923	Release two tabs .....	513
Figure 1-924	Remove the fan .....	514
Figure 1-925	Remove one screw .....	514
Figure 1-926	Release one tab .....	515
Figure 1-927	Release one tab .....	515
Figure 1-928	Remove the holder .....	516
Figure 1-929	Recycle and unpack .....	516
Figure 1-930	Install the holder .....	517
Figure 1-931	Engage one tab .....	517
Figure 1-932	Engage one tab .....	518
Figure 1-933	Install one screw .....	518
Figure 1-934	Install the fan .....	519

Figure 1-935	Connect one connector .....	519
Figure 1-936	Install the cover .....	520
Figure 1-937	Engage three tabs and two bosses .....	520
Figure 1-938	Install one screw .....	520
Figure 1-939	Engage the left-side retainer arm .....	521
Figure 1-940	Install the door .....	521
Figure 1-941	Install the pressure-release link .....	522
Figure 1-942	Install the guide .....	522
Figure 1-943	Align the hinge .....	523
Figure 1-944	Install the support shaft .....	523
Figure 1-945	Install the tray .....	524
Figure 1-946	Remove the tray .....	526
Figure 1-947	Release the support shaft .....	527
Figure 1-948	Remove the guide .....	527
Figure 1-949	Remove the link arm .....	528
Figure 1-950	Remove the door .....	528
Figure 1-951	Release the left-side retainer arm .....	529
Figure 1-952	Remove one screw .....	529
Figure 1-953	Release two bosses and three tabs .....	530
Figure 1-954	Remove the cover .....	530
Figure 1-955	Remove one screw .....	531
Figure 1-956	Release two bosses and three tabs .....	531
Figure 1-957	Remove the cover .....	531
Figure 1-958	Raise the ISA .....	532
Figure 1-959	Remove the ISA FFC cover .....	532
Figure 1-960	Disconnect three FFCs .....	533
Figure 1-961	Remove one screw .....	533
Figure 1-962	Pass the wire through the opening .....	534
Figure 1-963	Release one tab and rotate the slider pin .....	534
Figure 1-964	Remove the slider pin .....	535
Figure 1-965	Rotate the ISA towards the rear of the printer .....	535
Figure 1-966	Release the ISA .....	536
Figure 1-967	Remove the ISA .....	536
Figure 1-968	Disconnect one connector .....	537
Figure 1-969	Remove one screw .....	537
Figure 1-970	Release two tabs .....	538
Figure 1-971	Remove the cover .....	538
Figure 1-972	Remove one screw .....	539
Figure 1-973	Remove two screws .....	539
Figure 1-974	Lift up the control-panel assembly .....	540
Figure 1-975	Remove the control-panel assembly .....	540

Figure 1-976	Remove the USB cable .....	541
Figure 1-977	Remove the cover .....	541
Figure 1-978	Remove one screw .....	542
Figure 1-979	Release one boss and one tab .....	542
Figure 1-980	Remove the cover .....	543
Figure 1-981	Release two tabs .....	543
Figure 1-982	Disconnect one FFC and one connector .....	544
Figure 1-983	Remove the laser scanner .....	544
Figure 1-984	Recycle and unpack .....	545
Figure 1-985	Connect one FFC and one connector .....	545
Figure 1-986	Install the laser scanner .....	546
Figure 1-987	Engage two tabs .....	546
Figure 1-988	Install the cover .....	547
Figure 1-989	Engage four bosses and tabs .....	547
Figure 1-990	Engage one boss and one tab .....	548
Figure 1-991	Install one screw .....	548
Figure 1-992	Install the cover .....	549
Figure 1-993	Engage four bosses .....	549
Figure 1-994	Rotate the front edge of the cover down .....	550
Figure 1-995	Install the USB PCA .....	550
Figure 1-996	Install five screws .....	551
Figure 1-997	Install the control-panel FFC cover .....	551
Figure 1-998	Install the control-panel assembly .....	552
Figure 1-999	Install two screws .....	552
Figure 1-1000	Remove one screw .....	553
Figure 1-1001	Install the cover .....	553
Figure 1-1002	Engage two tabs .....	554
Figure 1-1003	Install one screw .....	554
Figure 1-1004	Connect one connector .....	555
Figure 1-1005	Position the ISA on the printer .....	555
Figure 1-1006	Engage the hinge pins with the holders .....	556
Figure 1-1007	Rotate the ISA towards the front of the printer .....	556
Figure 1-1008	Pass the wire through the opening .....	557
Figure 1-1009	Install one screw .....	557
Figure 1-1010	Install the slider pin .....	558
Figure 1-1011	Secure the slider pin .....	558
Figure 1-1012	Connect three FFCs .....	559
Figure 1-1013	Install the ISA FFC cover .....	559
Figure 1-1014	Lower the ISA .....	560
Figure 1-1015	Install the cover .....	560
Figure 1-1016	Engage two bosses and one tab .....	561

Figure 1-1017	Check the power switch and cartridge door assembly button .....	561
Figure 1-1018	Install one screw .....	561
Figure 1-1019	Install the cover .....	562
Figure 1-1020	Engage three tabs and two bosses .....	562
Figure 1-1021	Install one screw .....	563
Figure 1-1022	Engage the left-side retainer arm .....	563
Figure 1-1023	Install the door .....	564
Figure 1-1024	Install the pressure-release link .....	564
Figure 1-1025	Install the guide .....	565
Figure 1-1026	Align the hinge .....	565
Figure 1-1027	Install the support shaft .....	566
Figure 1-1028	Install the tray .....	566
Figure 1-1029	Remove the tray .....	568
Figure 1-1030	Release the support shaft .....	568
Figure 1-1031	Remove the guide .....	569
Figure 1-1032	Remove the link arm .....	569
Figure 1-1033	Remove the door .....	570
Figure 1-1034	Release the left-side retainer arm .....	570
Figure 1-1035	Remove one screw .....	571
Figure 1-1036	Release two bosses and three tabs .....	571
Figure 1-1037	Remove the cover .....	572
Figure 1-1038	Remove one screw .....	572
Figure 1-1039	Release two bosses and three tabs .....	572
Figure 1-1040	Remove the cover .....	573
Figure 1-1041	Raise the ISA .....	573
Figure 1-1042	Remove the ISA FFC cover .....	574
Figure 1-1043	Disconnect three FFCs .....	574
Figure 1-1044	Remove one screw .....	575
Figure 1-1045	Pass the wire through the opening .....	575
Figure 1-1046	Release one tab and rotate the slider pin .....	576
Figure 1-1047	Remove the slider pin .....	576
Figure 1-1048	Rotate the ISA towards the rear of the printer .....	577
Figure 1-1049	Release the ISA .....	577
Figure 1-1050	Remove the ISA .....	578
Figure 1-1051	Disconnect one connector .....	578
Figure 1-1052	Remove one screw .....	579
Figure 1-1053	Release two tabs .....	579
Figure 1-1054	Remove the cover .....	580
Figure 1-1055	Remove one screw .....	580
Figure 1-1056	Remove two screws .....	581
Figure 1-1057	Lift up the control-panel assembly .....	581



Figure 1-1058	Remove the control-panel assembly .....	582
Figure 1-1059	Remove the USB cable .....	582
Figure 1-1060	Remove the cover .....	583
Figure 1-1061	Remove one screw .....	583
Figure 1-1062	Release one boss and one tab .....	584
Figure 1-1063	Remove the cover .....	584
Figure 1-1064	Remove the guide .....	585
Figure 1-1065	Remove two screws .....	585
Figure 1-1066	Disconnect one connector .....	585
Figure 1-1067	Remove the guide .....	586
Figure 1-1068	Remove three screws .....	586
Figure 1-1069	Remove the bracket .....	586
Figure 1-1070	Install the bracket .....	587
Figure 1-1071	Install three screws .....	587
Figure 1-1072	Install the guide .....	587
Figure 1-1073	Connect one connector .....	588
Figure 1-1074	Install two screws .....	588
Figure 1-1075	Install the guide .....	588
Figure 1-1076	Install the cover .....	589
Figure 1-1077	Engage four bosses and tabs .....	589
Figure 1-1078	Engage one boss and one tab .....	590
Figure 1-1079	Install one screw .....	590
Figure 1-1080	Install the cover .....	591
Figure 1-1081	Engage four bosses .....	591
Figure 1-1082	Rotate the front edge of the cover down .....	592
Figure 1-1083	Install the USB PCA .....	592
Figure 1-1084	Install five screws .....	593
Figure 1-1085	Install the control-panel FFC cover .....	593
Figure 1-1086	Install the control-panel assembly .....	594
Figure 1-1087	Install two screws .....	594
Figure 1-1088	Remove one screw .....	595
Figure 1-1089	Install the cover .....	595
Figure 1-1090	Engage two tabs .....	596
Figure 1-1091	Install one screw .....	596
Figure 1-1092	Connect one connector .....	597
Figure 1-1093	Position the ISA on the printer .....	597
Figure 1-1094	Engage the hinge pins with the holders .....	598
Figure 1-1095	Rotate the ISA towards the front of the printer .....	598
Figure 1-1096	Pass the wire through the opening .....	599
Figure 1-1097	Install one screw .....	599
Figure 1-1098	Install the slider pin .....	600

Figure 1-1099	Secure the slider pin .....	600
Figure 1-1100	Connect three FFCs .....	601
Figure 1-1101	Install the ISA FFC cover .....	601
Figure 1-1102	Lower the ISA .....	602
Figure 1-1103	Install the cover .....	602
Figure 1-1104	Engage two bosses and one tab .....	603
Figure 1-1105	Check the power switch and cartridge door assembly button .....	603
Figure 1-1106	Install one screw .....	603
Figure 1-1107	Install the cover .....	604
Figure 1-1108	Engage three tabs and two bosses .....	604
Figure 1-1109	Install one screw .....	605
Figure 1-1110	Engage the left-side retainer arm .....	605
Figure 1-1111	Install the door .....	606
Figure 1-1112	Install the pressure-release link .....	606
Figure 1-1113	Install the guide .....	607
Figure 1-1114	Align the hinge .....	607
Figure 1-1115	Install the support shaft .....	608
Figure 1-1116	Install the tray .....	608
Figure 1-1117	Remove the tray .....	611
Figure 1-1118	Release the support shaft .....	611
Figure 1-1119	Remove the guide .....	612
Figure 1-1120	Remove the link arm .....	612
Figure 1-1121	Remove the door .....	613
Figure 1-1122	Release the left-side retainer arm .....	613
Figure 1-1123	Remove one screw .....	614
Figure 1-1124	Release two bosses and three tabs .....	614
Figure 1-1125	Remove the cover .....	615
Figure 1-1126	Remove one screw .....	615
Figure 1-1127	Release two bosses and three tabs .....	615
Figure 1-1128	Remove the cover .....	616
Figure 1-1129	Raise the ISA .....	616
Figure 1-1130	Remove the ISA FFC cover .....	617
Figure 1-1131	Disconnect three FFCs .....	617
Figure 1-1132	Remove one screw .....	618
Figure 1-1133	Pass the wire through the opening .....	618
Figure 1-1134	Release one tab and rotate the slider pin .....	619
Figure 1-1135	Remove the slider pin .....	619
Figure 1-1136	Rotate the ISA towards the rear of the printer .....	620
Figure 1-1137	Release the ISA .....	620
Figure 1-1138	Remove the ISA .....	621
Figure 1-1139	Disconnect one connector .....	621

Figure 1-1140	Remove one screw .....	622
Figure 1-1141	Release two tabs .....	622
Figure 1-1142	Remove the cover .....	623
Figure 1-1143	Remove one screw .....	623
Figure 1-1144	Remove two screws .....	624
Figure 1-1145	Lift up the control-panel assembly .....	624
Figure 1-1146	Remove the control-panel assembly .....	625
Figure 1-1147	Remove the USB cable .....	625
Figure 1-1148	Remove the cover .....	626
Figure 1-1149	Remove the cover .....	626
Figure 1-1150	Remove one screw .....	627
Figure 1-1151	Release one boss and one tab .....	627
Figure 1-1152	Remove the cover .....	628
Figure 1-1153	Release two tabs .....	628
Figure 1-1154	Remove one screw .....	629
Figure 1-1155	Remove the NFC PCA .....	629
Figure 1-1156	Release the FFC from the guide .....	630
Figure 1-1157	Release the FFC from the guide .....	630
Figure 1-1158	Disconnect and remove the FFC .....	631
Figure 1-1159	Recycle and unpack .....	631
Figure 1-1160	Connect the FFC .....	632
Figure 1-1161	Install the FFC in the guide .....	632
Figure 1-1162	Install the FFC in the guide .....	633
Figure 1-1163	Connect one FFC .....	633
Figure 1-1164	Install the NFC PCA .....	634
Figure 1-1165	Install one screw .....	634
Figure 1-1166	Engage two tabs .....	635
Figure 1-1167	Install the cover .....	635
Figure 1-1168	Engage four bosses and tabs .....	636
Figure 1-1169	Engage one boss and one tab .....	636
Figure 1-1170	Install one screw .....	637
Figure 1-1171	Remove the cover .....	637
Figure 1-1172	Install the cover .....	638
Figure 1-1173	Engage four bosses .....	638
Figure 1-1174	Rotate the front edge of the cover down .....	639
Figure 1-1175	Install the USB PCA .....	639
Figure 1-1176	Install five screws .....	640
Figure 1-1177	Install the control-panel FFC cover .....	640
Figure 1-1178	Install the control-panel assembly .....	641
Figure 1-1179	Install two screws .....	641
Figure 1-1180	Remove one screw .....	642

Figure 1-1181	Install the cover .....	642
Figure 1-1182	Engage two tabs .....	643
Figure 1-1183	Install one screw .....	643
Figure 1-1184	Connect one connector .....	644
Figure 1-1185	Position the ISA on the printer .....	644
Figure 1-1186	Engage the hinge pins with the holders .....	645
Figure 1-1187	Rotate the ISA towards the front of the printer .....	645
Figure 1-1188	Pass the wire through the opening .....	646
Figure 1-1189	Install one screw .....	646
Figure 1-1190	Install the slider pin .....	647
Figure 1-1191	Secure the slider pin .....	647
Figure 1-1192	Connect three FFCs .....	648
Figure 1-1193	Install the ISA FFC cover .....	648
Figure 1-1194	Lower the ISA .....	649
Figure 1-1195	Install the cover .....	649
Figure 1-1196	Engage two bosses and one tab .....	650
Figure 1-1197	Check the power switch and cartridge door assembly button .....	650
Figure 1-1198	Install one screw .....	650
Figure 1-1199	Install the cover .....	651
Figure 1-1200	Engage three tabs and two bosses .....	651
Figure 1-1201	Install one screw .....	652
Figure 1-1202	Engage the left-side retainer arm .....	652
Figure 1-1203	Install the door .....	653
Figure 1-1204	Install the pressure-release link .....	653
Figure 1-1205	Install the guide .....	654
Figure 1-1206	Align the hinge .....	654
Figure 1-1207	Install the support shaft .....	655
Figure 1-1208	Install the tray .....	655
Figure 1-1209	Remove the tray .....	657
Figure 1-1210	Release the support shaft .....	658
Figure 1-1211	Remove the guide .....	658
Figure 1-1212	Remove the link arm .....	659
Figure 1-1213	Remove the door .....	659
Figure 1-1214	Release the left-side retainer arm .....	660
Figure 1-1215	Remove one screw .....	660
Figure 1-1216	Release two bosses and three tabs .....	661
Figure 1-1217	Remove the cover .....	661
Figure 1-1218	Remove one screw .....	662
Figure 1-1219	Release two bosses and three tabs .....	662
Figure 1-1220	Remove the cover .....	662
Figure 1-1221	Remove one screw .....	663

Figure 1-1222	Release one boss and one tab .....	663
Figure 1-1223	Remove the cover .....	664
Figure 1-1224	Release two tabs .....	664
Figure 1-1225	Disconnect the FFC .....	665
Figure 1-1226	Release the FFC from the guide .....	665
Figure 1-1227	Disconnect and remove the FFC .....	666
Figure 1-1228	Recycle and unpack .....	666
Figure 1-1229	Connect the FFC .....	667
Figure 1-1230	Install the FFC in the guide .....	667
Figure 1-1231	Connect the FFC .....	668
Figure 1-1232	Engage two tabs .....	668
Figure 1-1233	Install the cover .....	669
Figure 1-1234	Engage four bosses and tabs .....	669
Figure 1-1235	Engage one boss and one tab .....	670
Figure 1-1236	Install one screw .....	670
Figure 1-1237	Install the cover .....	671
Figure 1-1238	Engage two bosses and one tab .....	671
Figure 1-1239	Check the power switch and cartridge door assembly button .....	671
Figure 1-1240	Install one screw .....	672
Figure 1-1241	Install the cover .....	672
Figure 1-1242	Engage three tabs and two bosses .....	673
Figure 1-1243	Install one screw .....	673
Figure 1-1244	Engage the left-side retainer arm .....	674
Figure 1-1245	Install the door .....	674
Figure 1-1246	Install the pressure-release link .....	675
Figure 1-1247	Install the guide .....	675
Figure 1-1248	Align the hinge .....	676
Figure 1-1249	Install the support shaft .....	676
Figure 1-1250	Install the tray .....	677
Figure 1-1251	Remove the tray .....	679
Figure 1-1252	Release the support shaft .....	680
Figure 1-1253	Remove the guide .....	680
Figure 1-1254	Remove the link arm .....	681
Figure 1-1255	Remove the door .....	681
Figure 1-1256	Release the left-side retainer arm .....	682
Figure 1-1257	Remove one screw .....	682
Figure 1-1258	Release two bosses and three tabs .....	683
Figure 1-1259	Remove the cover .....	683
Figure 1-1260	Remove one screw .....	684
Figure 1-1261	Release two bosses and three tabs .....	684
Figure 1-1262	Remove the cover .....	684

Figure 1-1263	Raise the ISA .....	685
Figure 1-1264	Remove the ISA FFC cover .....	685
Figure 1-1265	Disconnect three FFCs .....	686
Figure 1-1266	Remove one screw .....	686
Figure 1-1267	Pass the wire through the opening .....	687
Figure 1-1268	Release one tab and rotate the slider pin .....	687
Figure 1-1269	Remove the slider pin .....	688
Figure 1-1270	Rotate the ISA towards the rear of the printer .....	688
Figure 1-1271	Release the ISA .....	689
Figure 1-1272	Remove the ISA .....	689
Figure 1-1273	Disconnect one connector .....	690
Figure 1-1274	Remove one screw .....	690
Figure 1-1275	Release two tabs .....	691
Figure 1-1276	Remove the cover .....	691
Figure 1-1277	Remove one screw .....	692
Figure 1-1278	Remove two screws .....	692
Figure 1-1279	Lift up the control-panel assembly .....	693
Figure 1-1280	Remove the control-panel assembly .....	693
Figure 1-1281	Remove the USB cable .....	694
Figure 1-1282	Remove the cover .....	694
Figure 1-1283	Remove one screw .....	695
Figure 1-1284	Release one boss and one tab .....	695
Figure 1-1285	Remove the cover .....	696
Figure 1-1286	Remove the guide .....	696
Figure 1-1287	Remove two screws .....	697
Figure 1-1288	Disconnect one connector .....	697
Figure 1-1289	Remove the guide .....	697
Figure 1-1290	Remove three screws .....	698
Figure 1-1291	Remove the bracket .....	698
Figure 1-1292	Release the FFC .....	699
Figure 1-1293	Disconnect the FFC .....	699
Figure 1-1294	Recycle and unpack .....	700
Figure 1-1295	Connect one the FFC .....	700
Figure 1-1296	Adhere the FFC to the guide .....	701
Figure 1-1297	Install the bracket .....	701
Figure 1-1298	Install three screws .....	702
Figure 1-1299	Install the guide .....	702
Figure 1-1300	Connect one connector .....	702
Figure 1-1301	Install two screws .....	703
Figure 1-1302	Install the guide .....	703
Figure 1-1303	Install the cover .....	704

Figure 1-1304	Engage four bosses and tabs .....	704
Figure 1-1305	Engage one boss and one tab .....	705
Figure 1-1306	Install one screw .....	705
Figure 1-1307	Install the cover .....	706
Figure 1-1308	Engage four bosses .....	706
Figure 1-1309	Rotate the front edge of the cover down .....	707
Figure 1-1310	Install the USB PCA .....	707
Figure 1-1311	Install five screws .....	708
Figure 1-1312	Install the control-panel FFC cover .....	708
Figure 1-1313	Install the control-panel assembly .....	709
Figure 1-1314	Install two screws .....	709
Figure 1-1315	Remove one screw .....	710
Figure 1-1316	Install the cover .....	710
Figure 1-1317	Engage two tabs .....	711
Figure 1-1318	Install one screw .....	711
Figure 1-1319	Connect one connector .....	712
Figure 1-1320	Position the ISA on the printer .....	712
Figure 1-1321	Engage the hinge pins with the holders .....	713
Figure 1-1322	Rotate the ISA towards the front of the printer .....	713
Figure 1-1323	Pass the wire through the opening .....	714
Figure 1-1324	Install one screw .....	714
Figure 1-1325	Install the slider pin .....	715
Figure 1-1326	Secure the slider pin .....	715
Figure 1-1327	Connect three FFCs .....	716
Figure 1-1328	Install the ISA FFC cover .....	716
Figure 1-1329	Lower the ISA .....	717
Figure 1-1330	Install the cover .....	717
Figure 1-1331	Engage two bosses and one tab .....	718
Figure 1-1332	Check the power switch and cartridge door assembly button .....	718
Figure 1-1333	Install one screw .....	718
Figure 1-1334	Install the cover .....	719
Figure 1-1335	Engage three tabs and two bosses .....	719
Figure 1-1336	Install one screw .....	720
Figure 1-1337	Engage the left-side retainer arm .....	720
Figure 1-1338	Install the door .....	721
Figure 1-1339	Install the pressure-release link .....	721
Figure 1-1340	Install the guide .....	722
Figure 1-1341	Align the hinge .....	722
Figure 1-1342	Install the support shaft .....	723
Figure 1-1343	Install the tray .....	723
Figure 1-1344	Remove the tray .....	726

Figure 1-1345	Release the support shaft .....	726
Figure 1-1346	Remove the guide .....	727
Figure 1-1347	Remove the link arm .....	727
Figure 1-1348	Remove the door .....	728
Figure 1-1349	Release the left-side retainer arm .....	728
Figure 1-1350	Remove one screw .....	729
Figure 1-1351	Release two bosses and three tabs .....	729
Figure 1-1352	Remove the cover .....	730
Figure 1-1353	Remove one screw .....	730
Figure 1-1354	Release two bosses and three tabs .....	730
Figure 1-1355	Remove the cover .....	731
Figure 1-1356	Duplex models, lower the duplex feed assembly .....	731
Figure 1-1357	Remove two screws .....	732
Figure 1-1358	Raise the ISA .....	732
Figure 1-1359	Remove the ISA FFC cover .....	733
Figure 1-1360	Disconnect three FFCs .....	733
Figure 1-1361	Remove one screw .....	734
Figure 1-1362	Pass the wire through the opening .....	734
Figure 1-1363	Release one tab and rotate the slider pin .....	735
Figure 1-1364	Remove the slider pin .....	735
Figure 1-1365	Rotate the ISA towards the rear of the printer .....	736
Figure 1-1366	Release the ISA .....	736
Figure 1-1367	Remove the ISA .....	737
Figure 1-1368	Disconnect one connector .....	737
Figure 1-1369	Remove one screw .....	738
Figure 1-1370	Release two tabs .....	738
Figure 1-1371	Remove the cover .....	739
Figure 1-1372	Remove one screw .....	739
Figure 1-1373	Remove two screws .....	740
Figure 1-1374	Lift up the control-panel assembly .....	740
Figure 1-1375	Remove the control-panel assembly .....	741
Figure 1-1376	Remove the USB cable .....	741
Figure 1-1377	Remove the cover .....	742
Figure 1-1378	Remove one screw .....	742
Figure 1-1379	Release one boss and one tab .....	743
Figure 1-1380	Remove the cover .....	743
Figure 1-1381	Release two tabs .....	744
Figure 1-1382	Remove the guide .....	744
Figure 1-1383	Remove two screws .....	745
Figure 1-1384	Disconnect one connector .....	745
Figure 1-1385	Remove the guide .....	745



Figure 1-1386	Remove three screws .....	746
Figure 1-1387	Remove the bracket .....	746
Figure 1-1388	Disconnect three FFCs and six connectors .....	747
Figure 1-1389	Remove two screws .....	747
Figure 1-1390	Remove the DC controller .....	748
Figure 1-1391	Disconnect one the FFC .....	748
Figure 1-1392	Recycle and unpack .....	749
Figure 1-1393	Connect one the FFC .....	750
Figure 1-1394	Install the DC controller .....	750
Figure 1-1395	Connect three FFCs and six connectors .....	751
Figure 1-1396	Adhere the FFC to the guide .....	751
Figure 1-1397	Remove the guide .....	752
Figure 1-1398	Remove two screws .....	752
Figure 1-1399	Disconnect one connector .....	752
Figure 1-1400	Remove the guide .....	753
Figure 1-1401	Remove three screws .....	753
Figure 1-1402	Remove the bracket .....	753
Figure 1-1403	Engage two tabs .....	754
Figure 1-1404	Install the cover .....	754
Figure 1-1405	Engage four bosses and tabs .....	755
Figure 1-1406	Engage one boss and one tab .....	755
Figure 1-1407	Install one screw .....	756
Figure 1-1408	Install the cover .....	756
Figure 1-1409	Engage four bosses .....	757
Figure 1-1410	Rotate the front edge of the cover down .....	757
Figure 1-1411	Install the USB PCA .....	758
Figure 1-1412	Install five screws .....	758
Figure 1-1413	Install the control-panel FFC cover .....	759
Figure 1-1414	Install the control-panel assembly .....	759
Figure 1-1415	Install two screws .....	760
Figure 1-1416	Remove one screw .....	760
Figure 1-1417	Install the cover .....	761
Figure 1-1418	Engage two tabs .....	761
Figure 1-1419	Install one screw .....	762
Figure 1-1420	Connect one connector .....	762
Figure 1-1421	Position the ISA on the printer .....	763
Figure 1-1422	Engage the hinge pins with the holders .....	763
Figure 1-1423	Rotate the ISA towards the front of the printer .....	764
Figure 1-1424	Pass the wire through the opening .....	764
Figure 1-1425	Install one screw .....	765
Figure 1-1426	Install the slider pin .....	765

Figure 1-1427	Secure the slider pin .....	766
Figure 1-1428	Connect three FFCs .....	766
Figure 1-1429	Install the ISA FFC cover .....	767
Figure 1-1430	Lower the ISA .....	767
Figure 1-1431	Install the rear cover .....	768
Figure 1-1432	Install two screws .....	768
Figure 1-1433	Install the cover .....	769
Figure 1-1434	Engage two bosses and one tab .....	769
Figure 1-1435	Check the power switch and cartridge door assembly button .....	769
Figure 1-1436	Install one screw .....	770
Figure 1-1437	Install the cover .....	770
Figure 1-1438	Engage three tabs and two bosses .....	771
Figure 1-1439	Install one screw .....	771
Figure 1-1440	Engage the left-side retainer arm .....	772
Figure 1-1441	Install the door .....	772
Figure 1-1442	Install the pressure-release link .....	773
Figure 1-1443	Install the guide .....	773
Figure 1-1444	Align the hinge .....	774
Figure 1-1445	Install the support shaft .....	774
Figure 1-1446	Install the tray .....	775
Figure 1-1447	Remove the tray .....	777
Figure 1-1448	Release the support shaft .....	778
Figure 1-1449	Remove the guide .....	778
Figure 1-1450	Remove the link arm .....	779
Figure 1-1451	Remove the door .....	779
Figure 1-1452	Release the left-side retainer arm .....	780
Figure 1-1453	Remove one screw .....	780
Figure 1-1454	Release two bosses and three tabs .....	781
Figure 1-1455	Remove the cover .....	781
Figure 1-1456	Remove one screw .....	782
Figure 1-1457	Release two bosses and three tabs .....	782
Figure 1-1458	Remove the cover .....	782
Figure 1-1459	Raise the ISA .....	783
Figure 1-1460	Remove the ISA FFC cover .....	783
Figure 1-1461	Disconnect three FFCs .....	784
Figure 1-1462	Remove one screw .....	784
Figure 1-1463	Pass the wire through the opening .....	785
Figure 1-1464	Release one tab and rotate the slider pin .....	785
Figure 1-1465	Remove the slider pin .....	786
Figure 1-1466	Rotate the ISA towards the rear of the printer .....	786
Figure 1-1467	Release the ISA .....	787

Figure 1-1468	Remove the ISA .....	787
Figure 1-1469	Disconnect one connector .....	788
Figure 1-1470	Remove one screw .....	788
Figure 1-1471	Release two tabs .....	789
Figure 1-1472	Remove the cover .....	789
Figure 1-1473	Remove one screw .....	790
Figure 1-1474	Remove two screws .....	790
Figure 1-1475	Lift up the control-panel assembly .....	791
Figure 1-1476	Remove the control-panel assembly .....	791
Figure 1-1477	Remove the USB cable .....	792
Figure 1-1478	Remove the cover .....	792
Figure 1-1479	Remove one screw .....	793
Figure 1-1480	Release one boss and one tab .....	793
Figure 1-1481	Remove the cover .....	794
Figure 1-1482	Release two tabs .....	794
Figure 1-1483	Remove the guide .....	795
Figure 1-1484	Remove two screws .....	795
Figure 1-1485	Disconnect one connector .....	796
Figure 1-1486	Remove the guide .....	796
Figure 1-1487	Remove three screws .....	796
Figure 1-1488	Remove the bracket .....	797
Figure 1-1489	Disconnect one connector .....	797
Figure 1-1490	Remove one screw .....	798
Figure 1-1491	Remove the tag-cable assembly .....	798
Figure 1-1492	Recycle and unpack .....	799
Figure 1-1493	Install the assembly .....	799
Figure 1-1494	Install one screw .....	800
Figure 1-1495	Connect one connector .....	800
Figure 1-1496	Install the bracket .....	801
Figure 1-1497	Install three screws .....	801
Figure 1-1498	Install the guide .....	801
Figure 1-1499	Connect one connector .....	802
Figure 1-1500	Install two screws .....	802
Figure 1-1501	Install the guide .....	802
Figure 1-1502	Engage two tabs .....	803
Figure 1-1503	Install the cover .....	803
Figure 1-1504	Engage four bosses and tabs .....	804
Figure 1-1505	Engage one boss and one tab .....	804
Figure 1-1506	Install one screw .....	805
Figure 1-1507	Install the cover .....	805
Figure 1-1508	Engage four bosses .....	806

Figure 1-1509	Rotate the front edge of the cover down .....	806
Figure 1-1510	Install the USB PCA .....	807
Figure 1-1511	Install five screws .....	807
Figure 1-1512	Install the control-panel FFC cover .....	808
Figure 1-1513	Install the control-panel assembly .....	808
Figure 1-1514	Install two screws .....	809
Figure 1-1515	Remove one screw .....	809
Figure 1-1516	Install the cover .....	810
Figure 1-1517	Engage two tabs .....	810
Figure 1-1518	Install one screw .....	811
Figure 1-1519	Connect one connector .....	811
Figure 1-1520	Position the ISA on the printer .....	812
Figure 1-1521	Engage the hinge pins with the holders .....	812
Figure 1-1522	Rotate the ISA towards the front of the printer .....	813
Figure 1-1523	Pass the wire through the opening .....	813
Figure 1-1524	Install one screw .....	814
Figure 1-1525	Install the slider pin .....	814
Figure 1-1526	Secure the slider pin .....	815
Figure 1-1527	Connect three FFCs .....	815
Figure 1-1528	Install the ISA FFC cover .....	816
Figure 1-1529	Lower the ISA .....	816
Figure 1-1530	Install the cover .....	817
Figure 1-1531	Engage two bosses and one tab .....	817
Figure 1-1532	Check the power switch and cartridge door assembly button .....	817
Figure 1-1533	Install one screw .....	818
Figure 1-1534	Install the cover .....	818
Figure 1-1535	Engage three tabs and two bosses .....	819
Figure 1-1536	Install one screw .....	819
Figure 1-1537	Engage the left-side retainer arm .....	820
Figure 1-1538	Install the door .....	820
Figure 1-1539	Install the pressure-release link .....	821
Figure 1-1540	Install the guide .....	821
Figure 1-1541	Align the hinge .....	822
Figure 1-1542	Install the support shaft .....	822
Figure 1-1543	Install the tray .....	823
Figure 1-1544	Remove the tray .....	826
Figure 1-1545	Release the support shaft .....	826
Figure 1-1546	Remove the guide .....	827
Figure 1-1547	Remove the link arm .....	827
Figure 1-1548	Remove the door .....	828
Figure 1-1549	Release the left-side retainer arm .....	828

Figure 1-1550	Remove one screw .....	829
Figure 1-1551	Release two bosses and three tabs .....	829
Figure 1-1552	Remove the cover .....	830
Figure 1-1553	Remove one screw .....	830
Figure 1-1554	Release two bosses and three tabs .....	830
Figure 1-1555	Remove the cover .....	831
Figure 1-1556	Raise the ISA .....	831
Figure 1-1557	Remove the ISA FFC cover .....	832
Figure 1-1558	Disconnect three FFCs .....	832
Figure 1-1559	Remove one screw .....	833
Figure 1-1560	Pass the wire through the opening .....	833
Figure 1-1561	Release one tab and rotate the slider pin .....	834
Figure 1-1562	Remove the slider pin .....	834
Figure 1-1563	Rotate the ISA towards the rear of the printer .....	835
Figure 1-1564	Release the ISA .....	835
Figure 1-1565	Remove the ISA .....	836
Figure 1-1566	Disconnect one connector .....	836
Figure 1-1567	Remove one screw .....	837
Figure 1-1568	Release two tabs .....	837
Figure 1-1569	Remove the cover .....	838
Figure 1-1570	Remove one screw .....	838
Figure 1-1571	Remove two screws .....	839
Figure 1-1572	Lift up the control-panel assembly .....	839
Figure 1-1573	Remove the control-panel assembly .....	840
Figure 1-1574	Remove the USB cable .....	840
Figure 1-1575	Remove the cover .....	841
Figure 1-1576	Remove one screw .....	841
Figure 1-1577	Release one boss and one tab .....	842
Figure 1-1578	Remove the cover .....	842
Figure 1-1579	Release two tabs .....	843
Figure 1-1580	Remove the guide .....	843
Figure 1-1581	Remove two screws .....	844
Figure 1-1582	Disconnect one connector .....	844
Figure 1-1583	Remove the guide .....	844
Figure 1-1584	Remove three screws .....	845
Figure 1-1585	Remove the bracket .....	845
Figure 1-1586	Disconnect nine connectors .....	846
Figure 1-1587	Remove one screw .....	846
Figure 1-1588	Remove the connecting PCA .....	847
Figure 1-1589	Recycle and unpack .....	847
Figure 1-1590	Install the connecting PCA .....	848

Figure 1-1591	Install one screw .....	848
Figure 1-1592	Connect nine connectors .....	849
Figure 1-1593	Install the bracket .....	849
Figure 1-1594	Install three screws .....	850
Figure 1-1595	Install the guide .....	850
Figure 1-1596	Connect one connector .....	850
Figure 1-1597	Install two screws .....	851
Figure 1-1598	Install the guide .....	851
Figure 1-1599	Engage two tabs .....	852
Figure 1-1600	Install the cover .....	852
Figure 1-1601	Engage four bosses and tabs .....	853
Figure 1-1602	Engage one boss and one tab .....	853
Figure 1-1603	Install one screw .....	854
Figure 1-1604	Install the cover .....	854
Figure 1-1605	Engage four bosses .....	855
Figure 1-1606	Rotate the front edge of the cover down .....	855
Figure 1-1607	Install the USB PCA .....	856
Figure 1-1608	Install five screws .....	856
Figure 1-1609	Install the control-panel FFC cover .....	857
Figure 1-1610	Install the control-panel assembly .....	857
Figure 1-1611	Install two screws .....	858
Figure 1-1612	Remove one screw .....	858
Figure 1-1613	Install the cover .....	859
Figure 1-1614	Engage two tabs .....	859
Figure 1-1615	Install one screw .....	860
Figure 1-1616	Connect one connector .....	860
Figure 1-1617	Position the ISA on the printer .....	861
Figure 1-1618	Engage the hinge pins with the holders .....	861
Figure 1-1619	Rotate the ISA towards the front of the printer .....	862
Figure 1-1620	Pass the wire through the opening .....	862
Figure 1-1621	Install one screw .....	863
Figure 1-1622	Install the slider pin .....	863
Figure 1-1623	Secure the slider pin .....	864
Figure 1-1624	Connect three FFCs .....	864
Figure 1-1625	Install the ISA FFC cover .....	865
Figure 1-1626	Lower the ISA .....	865
Figure 1-1627	Install the cover .....	866
Figure 1-1628	Engage two bosses and one tab .....	866
Figure 1-1629	Check the power switch and cartridge door assembly button .....	866
Figure 1-1630	Install one screw .....	867
Figure 1-1631	Install the cover .....	867

Figure 1-1632	Engage three tabs and two bosses .....	868
Figure 1-1633	Install one screw .....	868
Figure 1-1634	Engage the left-side retainer arm .....	869
Figure 1-1635	Install the door .....	869
Figure 1-1636	Install the pressure-release link .....	870
Figure 1-1637	Install the guide .....	870
Figure 1-1638	Align the hinge .....	871
Figure 1-1639	Install the support shaft .....	871
Figure 1-1640	Install the tray .....	872
Figure 1-1641	Remove the tray .....	875
Figure 1-1642	Release the support shaft .....	875
Figure 1-1643	Remove the guide .....	876
Figure 1-1644	Remove the link arm .....	876
Figure 1-1645	Remove the door .....	877
Figure 1-1646	Release the left-side retainer arm .....	877
Figure 1-1647	Remove one screw .....	878
Figure 1-1648	Release two bosses and three tabs .....	878
Figure 1-1649	Remove the cover .....	879
Figure 1-1650	Remove one screw .....	879
Figure 1-1651	Release two bosses and three tabs .....	879
Figure 1-1652	Remove the cover .....	880
Figure 1-1653	Raise the ISA .....	880
Figure 1-1654	Remove the ISA FFC cover .....	881
Figure 1-1655	Disconnect three FFCs .....	881
Figure 1-1656	Remove one screw .....	882
Figure 1-1657	Pass the wire through the opening .....	882
Figure 1-1658	Release one tab and rotate the slider pin .....	883
Figure 1-1659	Remove the slider pin .....	883
Figure 1-1660	Rotate the ISA towards the rear of the printer .....	884
Figure 1-1661	Release the ISA .....	884
Figure 1-1662	Remove the ISA .....	885
Figure 1-1663	Disconnect one connector .....	885
Figure 1-1664	Remove one screw .....	886
Figure 1-1665	Release two tabs .....	886
Figure 1-1666	Remove the cover .....	887
Figure 1-1667	Remove one screw .....	887
Figure 1-1668	Remove two screws .....	888
Figure 1-1669	Lift up the control-panel assembly .....	888
Figure 1-1670	Remove the control-panel assembly .....	889
Figure 1-1671	Remove the USB cable .....	889
Figure 1-1672	Remove the cover .....	890

Figure 1-1673	Remove one screw .....	890
Figure 1-1674	Release one boss and one tab .....	891
Figure 1-1675	Remove the cover .....	891
Figure 1-1676	Release two tabs .....	892
Figure 1-1677	Remove the guide .....	892
Figure 1-1678	Remove two screws .....	893
Figure 1-1679	Disconnect one connector .....	893
Figure 1-1680	Remove the guide .....	893
Figure 1-1681	Remove three screws .....	894
Figure 1-1682	Remove the bracket .....	894
Figure 1-1683	Disconnect one connector .....	895
Figure 1-1684	Remove one screw .....	895
Figure 1-1685	Remove the tag-cable assembly .....	896
Figure 1-1686	Disconnect one FFC .....	896
Figure 1-1687	Remove one screw and the sheet-metal plate .....	897
Figure 1-1688	Disconnect one FFC .....	897
Figure 1-1689	Release the ferrite .....	898
Figure 1-1690	Remove the FFC .....	898
Figure 1-1691	Recycle and unpack .....	899
Figure 1-1692	Install the ferrite .....	899
Figure 1-1693	Install the FFC .....	900
Figure 1-1694	Connect one FFC .....	900
Figure 1-1695	Install the sheet-metal plate and install one screw .....	901
Figure 1-1696	Connect one FFC .....	901
Figure 1-1697	Install the assembly .....	902
Figure 1-1698	Install one screw .....	902
Figure 1-1699	Connect one connector .....	903
Figure 1-1700	Install the bracket .....	903
Figure 1-1701	Install three screws .....	904
Figure 1-1702	Install the guide .....	904
Figure 1-1703	Connect one connector .....	904
Figure 1-1704	Install two screws .....	905
Figure 1-1705	Install the guide .....	905
Figure 1-1706	Engage two tabs .....	906
Figure 1-1707	Install the cover .....	906
Figure 1-1708	Engage four bosses and tabs .....	907
Figure 1-1709	Engage one boss and one tab .....	907
Figure 1-1710	Install one screw .....	908
Figure 1-1711	Install the cover .....	908
Figure 1-1712	Engage four bosses .....	909
Figure 1-1713	Rotate the front edge of the cover down .....	909



Figure 1-1714	Install the USB PCA .....	910
Figure 1-1715	Install five screws .....	910
Figure 1-1716	Install the control-panel FFC cover .....	911
Figure 1-1717	Install the control-panel assembly .....	911
Figure 1-1718	Install two screws .....	912
Figure 1-1719	Remove one screw .....	912
Figure 1-1720	Install the cover .....	913
Figure 1-1721	Engage two tabs .....	913
Figure 1-1722	Install one screw .....	914
Figure 1-1723	Connect one connector .....	914
Figure 1-1724	Position the ISA on the printer .....	915
Figure 1-1725	Engage the hinge pins with the holders .....	915
Figure 1-1726	Rotate the ISA towards the front of the printer .....	916
Figure 1-1727	Pass the wire through the opening .....	916
Figure 1-1728	Install one screw .....	917
Figure 1-1729	Install the slider pin .....	917
Figure 1-1730	Secure the slider pin .....	918
Figure 1-1731	Connect three FFCs .....	918
Figure 1-1732	Install the ISA FFC cover .....	919
Figure 1-1733	Lower the ISA .....	919
Figure 1-1734	Install the cover .....	920
Figure 1-1735	Engage two bosses and one tab .....	920
Figure 1-1736	Check the power switch and cartridge door assembly button .....	920
Figure 1-1737	Install one screw .....	921
Figure 1-1738	Install the cover .....	921
Figure 1-1739	Engage three tabs and two bosses .....	922
Figure 1-1740	Install one screw .....	922
Figure 1-1741	Engage the left-side retainer arm .....	923
Figure 1-1742	Install the door .....	923
Figure 1-1743	Install the pressure-release link .....	924
Figure 1-1744	Install the guide .....	924
Figure 1-1745	Align the hinge .....	925
Figure 1-1746	Install the support shaft .....	925
Figure 1-1747	Install the tray .....	926
Figure 1-1748	Remove the tray .....	928
Figure 1-1749	Release the support shaft .....	929
Figure 1-1750	Remove the guide .....	929
Figure 1-1751	Remove the link arm .....	930
Figure 1-1752	Remove the door .....	930
Figure 1-1753	Release the left-side retainer arm .....	931
Figure 1-1754	Remove one screw .....	931

Figure 1-1755	Release two bosses and three tabs .....	932
Figure 1-1756	Remove the cover .....	932
Figure 1-1757	Remove one screw .....	933
Figure 1-1758	Release two bosses and three tabs .....	933
Figure 1-1759	Remove the cover .....	933
Figure 1-1760	Raise the ISA .....	934
Figure 1-1761	Remove the ISA FFC cover .....	934
Figure 1-1762	Disconnect three FFCs .....	935
Figure 1-1763	Remove one screw .....	935
Figure 1-1764	Pass the wire through the opening .....	936
Figure 1-1765	Release one tab and rotate the slider pin .....	936
Figure 1-1766	Remove the slider pin .....	937
Figure 1-1767	Rotate the ISA towards the rear of the printer .....	937
Figure 1-1768	Release the ISA .....	938
Figure 1-1769	Remove the ISA .....	938
Figure 1-1770	Disconnect one connector .....	939
Figure 1-1771	Remove one screw .....	939
Figure 1-1772	Release two tabs .....	940
Figure 1-1773	Remove the cover .....	940
Figure 1-1774	Remove one screw .....	941
Figure 1-1775	Remove two screws .....	941
Figure 1-1776	Lift up the control-panel assembly .....	942
Figure 1-1777	Remove the control-panel assembly .....	942
Figure 1-1778	Remove the USB cable .....	943
Figure 1-1779	Remove the cover .....	943
Figure 1-1780	Remove one screw .....	944
Figure 1-1781	Release one boss and one tab .....	944
Figure 1-1782	Remove the cover .....	945
Figure 1-1783	Release two tabs .....	945
Figure 1-1784	Remove the guide .....	946
Figure 1-1785	Remove two screws .....	946
Figure 1-1786	Disconnect one connector .....	947
Figure 1-1787	Remove the guide .....	947
Figure 1-1788	Remove three screws .....	947
Figure 1-1789	Remove the bracket .....	948
Figure 1-1790	Disconnect one FFC .....	948
Figure 1-1791	Disconnect one connector .....	949
Figure 1-1792	Remove two screws .....	949
Figure 1-1793	Release one tab .....	950
Figure 1-1794	Remove the HVPS .....	950
Figure 1-1795	Recycle and unpack .....	951

Figure 1-1796	Position the HVPS in the holder .....	951
Figure 1-1797	Engage one tab .....	952
Figure 1-1798	Install two screws .....	952
Figure 1-1799	Connect one connector .....	953
Figure 1-1800	Connect one FFC .....	953
Figure 1-1801	Install the bracket .....	954
Figure 1-1802	Install three screws .....	954
Figure 1-1803	Install the guide .....	954
Figure 1-1804	Connect one connector .....	955
Figure 1-1805	Install two screws .....	955
Figure 1-1806	Install the guide .....	955
Figure 1-1807	Engage two tabs .....	956
Figure 1-1808	Install the cover .....	956
Figure 1-1809	Engage four bosses and tabs .....	957
Figure 1-1810	Engage one boss and one tab .....	957
Figure 1-1811	Install one screw .....	958
Figure 1-1812	Install the cover .....	958
Figure 1-1813	Engage four bosses .....	959
Figure 1-1814	Rotate the front edge of the cover down .....	959
Figure 1-1815	Install the USB PCA .....	960
Figure 1-1816	Install five screws .....	960
Figure 1-1817	Install the control-panel FFC cover .....	961
Figure 1-1818	Install the control-panel assembly .....	961
Figure 1-1819	Install two screws .....	962
Figure 1-1820	Remove one screw .....	962
Figure 1-1821	Install the cover .....	963
Figure 1-1822	Engage two tabs .....	963
Figure 1-1823	Install one screw .....	964
Figure 1-1824	Connect one connector .....	964
Figure 1-1825	Position the ISA on the printer .....	965
Figure 1-1826	Engage the hinge pins with the holders .....	965
Figure 1-1827	Rotate the ISA towards the front of the printer .....	966
Figure 1-1828	Pass the wire through the opening .....	966
Figure 1-1829	Install one screw .....	967
Figure 1-1830	Install the slider pin .....	967
Figure 1-1831	Secure the slider pin .....	968
Figure 1-1832	Connect three FFCs .....	968
Figure 1-1833	Install the ISA FFC cover .....	969
Figure 1-1834	Lower the ISA .....	969
Figure 1-1835	Install the cover .....	970
Figure 1-1836	Engage two bosses and one tab .....	970

Figure 1-1837	Check the power switch and cartridge door assembly button .....	970
Figure 1-1838	Install one screw .....	971
Figure 1-1839	Install the cover .....	971
Figure 1-1840	Engage three tabs and two bosses .....	972
Figure 1-1841	Install one screw .....	972
Figure 1-1842	Engage the left-side retainer arm .....	973
Figure 1-1843	Install the door .....	973
Figure 1-1844	Install the pressure-release link .....	974
Figure 1-1845	Install the guide .....	974
Figure 1-1846	Align the hinge .....	975
Figure 1-1847	Install the support shaft .....	975
Figure 1-1848	Install the tray .....	976
Figure 1-1849	Remove the tray .....	979
Figure 1-1850	Release the support shaft .....	979
Figure 1-1851	Remove the guide .....	980
Figure 1-1852	Remove the link arm .....	980
Figure 1-1853	Remove the door .....	981
Figure 1-1854	Release the left-side retainer arm .....	981
Figure 1-1855	Remove one screw .....	982
Figure 1-1856	Release two bosses and three tabs .....	982
Figure 1-1857	Remove the cover .....	983
Figure 1-1858	Remove one screw .....	983
Figure 1-1859	Release two bosses and three tabs .....	983
Figure 1-1860	Remove the cover .....	984
Figure 1-1861	Raise the ISA .....	984
Figure 1-1862	Remove the ISA FFC cover .....	985
Figure 1-1863	Disconnect three FFCs .....	985
Figure 1-1864	Remove one screw .....	986
Figure 1-1865	Pass the wire through the opening .....	986
Figure 1-1866	Release one tab and rotate the slider pin .....	987
Figure 1-1867	Remove the slider pin .....	987
Figure 1-1868	Rotate the ISA towards the rear of the printer .....	988
Figure 1-1869	Release the ISA .....	988
Figure 1-1870	Remove the ISA .....	989
Figure 1-1871	Disconnect one connector .....	989
Figure 1-1872	Remove one screw .....	990
Figure 1-1873	Release two tabs .....	990
Figure 1-1874	Remove the cover .....	991
Figure 1-1875	Remove one screw .....	991
Figure 1-1876	Remove two screws .....	992
Figure 1-1877	Lift up the control-panel assembly .....	992

Figure 1-1878	Remove the control-panel assembly .....	993
Figure 1-1879	Remove the USB cable .....	993
Figure 1-1880	Remove the cover .....	994
Figure 1-1881	Remove one screw .....	994
Figure 1-1882	Release one boss and one tab .....	995
Figure 1-1883	Remove the cover .....	995
Figure 1-1884	Release two tabs .....	996
Figure 1-1885	Disconnect one connector .....	996
Figure 1-1886	Release two tabs .....	997
Figure 1-1887	Remove the fan .....	997
Figure 1-1888	Remove the guide .....	998
Figure 1-1889	Remove two screws .....	998
Figure 1-1890	Disconnect one connector .....	998
Figure 1-1891	Remove the guide .....	999
Figure 1-1892	Remove three screws .....	999
Figure 1-1893	Remove the bracket .....	999
Figure 1-1894	Disconnect two connectors .....	1000
Figure 1-1895	Remove one screw .....	1000
Figure 1-1896	Release one tab .....	1001
Figure 1-1897	Release one tab .....	1001
Figure 1-1898	Remove the holder .....	1002
Figure 1-1899	Remove two screws .....	1002
Figure 1-1900	Remove three screws .....	1003
Figure 1-1901	Remove the LVPS .....	1003
Figure 1-1902	Recycle and unpack .....	1004
Figure 1-1903	Install the LVPS .....	1004
Figure 1-1904	Install three screws .....	1005
Figure 1-1905	Install two screws .....	1005
Figure 1-1906	Install the holder .....	1006
Figure 1-1907	Engage one tab .....	1006
Figure 1-1908	Engage one tab .....	1007
Figure 1-1909	Install one screw .....	1007
Figure 1-1910	Connect two connectors .....	1008
Figure 1-1911	Install the bracket .....	1008
Figure 1-1912	Install three screws .....	1009
Figure 1-1913	Install the guide .....	1009
Figure 1-1914	Connect one connector .....	1009
Figure 1-1915	Install two screws .....	1010
Figure 1-1916	Install the guide .....	1010
Figure 1-1917	Install the fan .....	1011
Figure 1-1918	Connect one connector .....	1011

Figure 1-1919	Engage two tabs .....	1012
Figure 1-1920	Install the cover .....	1012
Figure 1-1921	Engage four bosses and tabs .....	1013
Figure 1-1922	Engage one boss and one tab .....	1013
Figure 1-1923	Install one screw .....	1014
Figure 1-1924	Install the cover .....	1014
Figure 1-1925	Engage four bosses .....	1015
Figure 1-1926	Rotate the front edge of the cover down .....	1015
Figure 1-1927	Install the USB PCA .....	1016
Figure 1-1928	Install five screws .....	1016
Figure 1-1929	Install the control-panel FFC cover .....	1017
Figure 1-1930	Install the control-panel assembly .....	1017
Figure 1-1931	Install two screws .....	1018
Figure 1-1932	Remove one screw .....	1018
Figure 1-1933	Install the cover .....	1019
Figure 1-1934	Engage two tabs .....	1019
Figure 1-1935	Install one screw .....	1020
Figure 1-1936	Connect one connector .....	1020
Figure 1-1937	Position the ISA on the printer .....	1021
Figure 1-1938	Engage the hinge pins with the holders .....	1021
Figure 1-1939	Rotate the ISA towards the front of the printer .....	1022
Figure 1-1940	Pass the wire through the opening .....	1022
Figure 1-1941	Install one screw .....	1023
Figure 1-1942	Install the slider pin .....	1023
Figure 1-1943	Secure the slider pin .....	1024
Figure 1-1944	Connect three FFCs .....	1024
Figure 1-1945	Install the ISA FFC cover .....	1025
Figure 1-1946	Lower the ISA .....	1025
Figure 1-1947	Install the cover .....	1026
Figure 1-1948	Engage two bosses and one tab .....	1026
Figure 1-1949	Check the power switch and cartridge door assembly button .....	1026
Figure 1-1950	Install one screw .....	1027
Figure 1-1951	Install the cover .....	1027
Figure 1-1952	Engage three tabs and two bosses .....	1028
Figure 1-1953	Install one screw .....	1028
Figure 1-1954	Engage the left-side retainer arm .....	1029
Figure 1-1955	Install the door .....	1029
Figure 1-1956	Install the pressure-release link .....	1030
Figure 1-1957	Install the guide .....	1030
Figure 1-1958	Align the hinge .....	1031
Figure 1-1959	Install the support shaft .....	1031

Figure 1-1960	Install the tray .....	1032
Figure 1-1961	Remove the tray .....	1034
Figure 1-1962	Release the support shaft .....	1035
Figure 1-1963	Remove the guide .....	1035
Figure 1-1964	Remove the link arm .....	1036
Figure 1-1965	Remove the door .....	1036
Figure 1-1966	Release the left-side retainer arm .....	1037
Figure 1-1967	Remove one screw .....	1037
Figure 1-1968	Release two bosses and three tabs .....	1038
Figure 1-1969	Remove the cover .....	1038
Figure 1-1970	Remove one screw .....	1039
Figure 1-1971	Release two bosses and three tabs .....	1039
Figure 1-1972	Remove the cover .....	1039
Figure 1-1973	Raise the ISA .....	1040
Figure 1-1974	Remove the ISA FFC cover .....	1040
Figure 1-1975	Disconnect three FFCs .....	1041
Figure 1-1976	Remove one screw .....	1041
Figure 1-1977	Pass the wire through the opening .....	1042
Figure 1-1978	Release one tab and rotate the slider pin .....	1042
Figure 1-1979	Remove the slider pin .....	1043
Figure 1-1980	Rotate the ISA towards the rear of the printer .....	1043
Figure 1-1981	Release the ISA .....	1044
Figure 1-1982	Remove the ISA .....	1044
Figure 1-1983	Disconnect one connector .....	1045
Figure 1-1984	Remove one screw .....	1045
Figure 1-1985	Release two tabs .....	1046
Figure 1-1986	Remove the cover .....	1046
Figure 1-1987	Remove one screw .....	1047
Figure 1-1988	Remove two screws .....	1047
Figure 1-1989	Lift up the control-panel assembly .....	1048
Figure 1-1990	Remove the control-panel assembly .....	1048
Figure 1-1991	Remove the USB cable .....	1049
Figure 1-1992	Remove the cover .....	1049
Figure 1-1993	Remove the cover .....	1050
Figure 1-1994	Recycle and unpack .....	1050
Figure 1-1995	Remove the cover .....	1051
Figure 1-1996	Install the cover .....	1051
Figure 1-1997	Engage four bosses .....	1052
Figure 1-1998	Rotate the front edge of the cover down .....	1052
Figure 1-1999	Install the USB PCA .....	1053
Figure 1-2000	Install five screws .....	1053

Figure 1-2001	Install the control-panel FFC cover .....	1054
Figure 1-2002	Install the control-panel assembly .....	1054
Figure 1-2003	Install two screws .....	1055
Figure 1-2004	Remove one screw .....	1055
Figure 1-2005	Install the cover .....	1056
Figure 1-2006	Engage two tabs .....	1056
Figure 1-2007	Install one screw .....	1057
Figure 1-2008	Connect one connector .....	1057
Figure 1-2009	Position the ISA on the printer .....	1058
Figure 1-2010	Engage the hinge pins with the holders .....	1058
Figure 1-2011	Rotate the ISA towards the front of the printer .....	1059
Figure 1-2012	Pass the wire through the opening .....	1059
Figure 1-2013	Install one screw .....	1060
Figure 1-2014	Install the slider pin .....	1060
Figure 1-2015	Secure the slider pin .....	1061
Figure 1-2016	Connect three FFCs .....	1061
Figure 1-2017	Install the ISA FFC cover .....	1062
Figure 1-2018	Lower the ISA .....	1062
Figure 1-2019	Install the cover .....	1063
Figure 1-2020	Engage two bosses and one tab .....	1063
Figure 1-2021	Check the power switch and cartridge door assembly button .....	1063
Figure 1-2022	Install one screw .....	1064
Figure 1-2023	Install the cover .....	1064
Figure 1-2024	Engage three tabs and two bosses .....	1065
Figure 1-2025	Install one screw .....	1065
Figure 1-2026	Engage the left-side retainer arm .....	1066
Figure 1-2027	Install the door .....	1066
Figure 1-2028	Install the pressure-release link .....	1067
Figure 1-2029	Install the guide .....	1067
Figure 1-2030	Align the hinge .....	1068
Figure 1-2031	Install the support shaft .....	1068
Figure 1-2032	Install the tray .....	1069
Figure 1-2033	Remove the tray .....	1071
Figure 1-2034	Release the support shaft .....	1072
Figure 1-2035	Remove the guide .....	1072
Figure 1-2036	Remove the link arm .....	1073
Figure 1-2037	Remove the door .....	1073
Figure 1-2038	Release the left-side retainer arm .....	1074
Figure 1-2039	Remove one screw .....	1074
Figure 1-2040	Release two bosses and three tabs .....	1075
Figure 1-2041	Remove the cover .....	1075



Figure 1-2042	Remove one screw .....	1076
Figure 1-2043	Release two bosses and three tabs .....	1076
Figure 1-2044	Remove the cover .....	1076
Figure 1-2045	Raise the ISA .....	1077
Figure 1-2046	Remove the ISA FFC cover .....	1077
Figure 1-2047	Disconnect three FFCs .....	1078
Figure 1-2048	Remove one screw .....	1078
Figure 1-2049	Pass the wire through the opening .....	1079
Figure 1-2050	Release one tab and rotate the slider pin .....	1079
Figure 1-2051	Remove the slider pin .....	1080
Figure 1-2052	Rotate the ISA towards the rear of the printer .....	1080
Figure 1-2053	Release the ISA .....	1081
Figure 1-2054	Remove the ISA .....	1081
Figure 1-2055	Disconnect one connector .....	1082
Figure 1-2056	Remove one screw .....	1082
Figure 1-2057	Release two tabs .....	1083
Figure 1-2058	Remove the cover .....	1083
Figure 1-2059	Remove one screw .....	1084
Figure 1-2060	Remove two screws .....	1084
Figure 1-2061	Lift up the control-panel assembly .....	1085
Figure 1-2062	Remove the control-panel assembly .....	1085
Figure 1-2063	Remove the USB cable .....	1086
Figure 1-2064	Remove the cover .....	1086
Figure 1-2065	Remove the cover .....	1087
Figure 1-2066	Remove one screw .....	1087
Figure 1-2067	Release one boss and one tab .....	1088
Figure 1-2068	Remove the cover .....	1088
Figure 1-2069	Remove one screw .....	1089
Figure 1-2070	Remove the NFC PCA .....	1089
Figure 1-2071	Recycle and unpack .....	1090
Figure 1-2072	Connect one FFC .....	1090
Figure 1-2073	Install the NFC PCA .....	1091
Figure 1-2074	Install one screw .....	1091
Figure 1-2075	Install the cover .....	1092
Figure 1-2076	Engage four bosses and tabs .....	1092
Figure 1-2077	Engage one boss and one tab .....	1093
Figure 1-2078	Install one screw .....	1093
Figure 1-2079	Remove the cover .....	1094
Figure 1-2080	Install the cover .....	1094
Figure 1-2081	Engage four bosses .....	1095
Figure 1-2082	Rotate the front edge of the cover down .....	1095

Figure 1-2083	Install the USB PCA .....	1096
Figure 1-2084	Install five screws .....	1096
Figure 1-2085	Install the control-panel FFC cover .....	1097
Figure 1-2086	Install the control-panel assembly .....	1097
Figure 1-2087	Install two screws .....	1098
Figure 1-2088	Remove one screw .....	1098
Figure 1-2089	Install the cover .....	1099
Figure 1-2090	Engage two tabs .....	1099
Figure 1-2091	Install one screw .....	1100
Figure 1-2092	Connect one connector .....	1100
Figure 1-2093	Position the ISA on the printer .....	1101
Figure 1-2094	Engage the hinge pins with the holders .....	1101
Figure 1-2095	Rotate the ISA towards the front of the printer .....	1102
Figure 1-2096	Pass the wire through the opening .....	1102
Figure 1-2097	Install one screw .....	1103
Figure 1-2098	Install the slider pin .....	1103
Figure 1-2099	Secure the slider pin .....	1104
Figure 1-2100	Connect three FFCs .....	1104
Figure 1-2101	Install the ISA FFC cover .....	1105
Figure 1-2102	Lower the ISA .....	1105
Figure 1-2103	Install the cover .....	1106
Figure 1-2104	Engage two bosses and one tab .....	1106
Figure 1-2105	Check the power switch and cartridge door assembly button .....	1106
Figure 1-2106	Install one screw .....	1107
Figure 1-2107	Install the cover .....	1107
Figure 1-2108	Engage three tabs and two bosses .....	1108
Figure 1-2109	Install one screw .....	1108
Figure 1-2110	Engage the left-side retainer arm .....	1109
Figure 1-2111	Install the door .....	1109
Figure 1-2112	Install the pressure-release link .....	1110
Figure 1-2113	Install the guide .....	1110
Figure 1-2114	Align the hinge .....	1111
Figure 1-2115	Install the support shaft .....	1111
Figure 1-2116	Install the tray .....	1112
Figure 1-2117	Remove the tray .....	1114
Figure 1-2118	Release the support shaft .....	1115
Figure 1-2119	Remove the guide .....	1115
Figure 1-2120	Remove the link arm .....	1116
Figure 1-2121	Remove the door .....	1116
Figure 1-2122	Release the left-side retainer arm .....	1117
Figure 1-2123	Remove one screw .....	1117

Figure 1-2124	Release two bosses and three tabs .....	1118
Figure 1-2125	Remove the cover .....	1118
Figure 1-2126	Remove one screw .....	1119
Figure 1-2127	Release two bosses and three tabs .....	1119
Figure 1-2128	Remove the cover .....	1119
Figure 1-2129	Remove one screw .....	1120
Figure 1-2130	Release one boss and one tab .....	1120
Figure 1-2131	Remove the cover .....	1121
Figure 1-2132	Release two tabs .....	1121
Figure 1-2133	Disconnect one FFC .....	1122
Figure 1-2134	Remove one screw and the control panel .....	1122
Figure 1-2135	Recycle and unpack .....	1123
Figure 1-2136	Install the control panel and one screw .....	1123
Figure 1-2137	Connect one FFC .....	1124
Figure 1-2138	Engage two tabs .....	1124
Figure 1-2139	Install the cover .....	1125
Figure 1-2140	Engage four bosses and tabs .....	1125
Figure 1-2141	Engage one boss and one tab .....	1126
Figure 1-2142	Install one screw .....	1126
Figure 1-2143	Install the cover .....	1127
Figure 1-2144	Engage two bosses and one tab .....	1127
Figure 1-2145	Check the power switch and cartridge door assembly button .....	1127
Figure 1-2146	Install one screw .....	1128
Figure 1-2147	Install the cover .....	1128
Figure 1-2148	Engage three tabs and two bosses .....	1129
Figure 1-2149	Install one screw .....	1129
Figure 1-2150	Engage the left-side retainer arm .....	1130
Figure 1-2151	Install the door .....	1130
Figure 1-2152	Install the pressure-release link .....	1131
Figure 1-2153	Install the guide .....	1131
Figure 1-2154	Align the hinge .....	1132
Figure 1-2155	Install the support shaft .....	1132
Figure 1-2156	Install the tray .....	1133
Figure 1-2157	Open the ISA .....	1136
Figure 1-2158	Remove one screw .....	1136
Figure 1-2159	Release two tabs .....	1137
Figure 1-2160	Remove the cover .....	1137
Figure 1-2161	Remove one screw .....	1138
Figure 1-2162	Tilt the control panel farther forward .....	1138
Figure 1-2163	Release the control panel .....	1139
Figure 1-2164	Separate the control panel from the printer .....	1139

Figure 1-2165	Release the FFC and remove the control panel .....	1140
Figure 1-2166	Remove two screws .....	1140
Figure 1-2167	Remove the FFC .....	1141
Figure 1-2168	Release the control panel mount base .....	1141
Figure 1-2169	Release the mount chassis assembly .....	1142
Figure 1-2170	Remove the mount chassis assembly .....	1142
Figure 1-2171	Remove the tray .....	1143
Figure 1-2172	Release the support shaft .....	1143
Figure 1-2173	Remove the guide .....	1144
Figure 1-2174	Remove the link arm .....	1144
Figure 1-2175	Remove the door .....	1145
Figure 1-2176	Release the left-side retainer arm .....	1145
Figure 1-2177	Remove one screw .....	1146
Figure 1-2178	Release two bosses and three tabs .....	1146
Figure 1-2179	Remove the cover .....	1147
Figure 1-2180	Remove the ISA FFC cover .....	1147
Figure 1-2181	Disconnect one FFC .....	1148
Figure 1-2182	Release the control-panel FFC cover .....	1148
Figure 1-2183	Remove the cover and FFC .....	1149
Figure 1-2184	Remove the FFC .....	1149
Figure 1-2185	Recycle and unpack .....	1150
Figure 1-2186	Install the FFC on the cover .....	1150
Figure 1-2187	Install the cover .....	1151
Figure 1-2188	Connect one FFC .....	1151
Figure 1-2189	Install the ISA FFC cover .....	1152
Figure 1-2190	Install the cover .....	1152
Figure 1-2191	Engage three tabs and two bosses .....	1153
Figure 1-2192	Install one screw .....	1153
Figure 1-2193	Engage the left-side retainer arm .....	1154
Figure 1-2194	Install the door .....	1154
Figure 1-2195	Install the pressure-release link .....	1155
Figure 1-2196	Install the guide .....	1155
Figure 1-2197	Align the hinge .....	1156
Figure 1-2198	Install the support shaft .....	1156
Figure 1-2199	Install the tray .....	1157
Figure 1-2200	Install the mount chassis assembly .....	1157
Figure 1-2201	Release the mount chassis assembly .....	1158
Figure 1-2202	Install the control panel mount base .....	1158
Figure 1-2203	Install two screws .....	1159
Figure 1-2204	Install the FFC .....	1159
Figure 1-2205	Connect the FFC .....	1160

Figure 1-2206	Align the control-panel hinge pins .....	1160
Figure 1-2207	Engage the control panel .....	1161
Figure 1-2208	Tilt the control-panel assembly backward .....	1162
Figure 1-2209	Install one screw .....	1162
Figure 1-2210	Install the control-panel cable cover .....	1163
Figure 1-2211	Check two tabs .....	1163
Figure 1-2212	Install one screw .....	1164
Figure 1-2213	Close the ISA .....	1164
Figure 1-2214	Remove the tray .....	1167
Figure 1-2215	Recycle and unpack .....	1167
Figure 1-2216	Install the tray .....	1168
Figure 1-2217	Remove the tray .....	1169
Figure 1-2218	Tilt the printer backward .....	1170
Figure 1-2219	Place the printer bottom-side face forward .....	1170
Figure 1-2220	Release one tab .....	1171
Figure 1-2221	Remove the roller holder .....	1171
Figure 1-2222	Recycle and unpack .....	1172
Figure 1-2223	Install the roller holder .....	1172
Figure 1-2224	Check the tab .....	1173
Figure 1-2225	Rotate the printer forward .....	1173
Figure 1-2226	Place the printer in the operational position .....	1174
Figure 1-2227	Install the tray .....	1174
Figure 1-2228	Remove the tray .....	1176
Figure 1-2229	Release the assembly .....	1176
Figure 1-2230	Remove the assembly .....	1177
Figure 1-2231	Recycle and unpack .....	1177
Figure 1-2232	Install the assembly .....	1178
Figure 1-2233	Release the assembly .....	1178
Figure 1-2234	Install the tray .....	1179
Figure 1-2235	Remove the printer .....	1182
Figure 1-2236	Recycle and unpack .....	1182
Figure 1-2237	Remove shipping tape .....	1183
Figure 1-2238	Install the printer .....	1183
Figure 1-2239	Remove Tray 3 .....	1184
Figure 1-2240	Adjust the paper guides .....	1184
Figure 1-2241	Load paper .....	1185
Figure 1-2242	Install .....	1185
Figure 1-2243	Pull the tray out of the printer .....	1187
Figure 1-2244	Release and remove the tray .....	1187
Figure 1-2245	Recycle and unpack .....	1188
Figure 1-2246	Install the tray .....	1188

Figure 1-2247	Close the tray .....	1189
Figure 1-2248	Pull the tray out of the printer .....	1191
Figure 1-2249	Release and remove the tray .....	1191
Figure 1-2250	Turn the accessory over .....	1192
Figure 1-2251	Release the assembly .....	1192
Figure 1-2252	Rotate the assembly up .....	1193
Figure 1-2253	Remove the assembly .....	1193
Figure 1-2254	Recycle and unpack .....	1194
Figure 1-2255	Install the roller assembly .....	31
Figure 1-2256	Release the assembly .....	1195
Figure 1-2257	Check the installation .....	1195
Figure 1-2258	Install the tray .....	1196
Figure 1-2259	Close the tray .....	1196
Figure 1-2260	Pull the tray out of the printer .....	1198
Figure 1-2261	Release and remove the tray .....	1198
Figure 1-2262	Release the assembly .....	1199
Figure 1-2263	Remove the assembly .....	1199
Figure 1-2264	Recycle and unpack .....	1200
Figure 1-2265	Install the assembly .....	1200
Figure 1-2266	Release the assembly .....	1201
Figure 1-2267	Install the tray .....	1201
Figure 1-2268	Close the tray .....	1202
Figure 2-1	Main assemblies (document feeder and image scanner) .....	1208
Figure 2-2	Covers, M402 and M403 .....	1210
Figure 2-3	Covers, M426 and M427 .....	1212
Figure 2-4	Internal components, printer base (1 of 5) .....	1214
Figure 2-5	Internal components, printer base (2 of 3) .....	1216
Figure 2-6	Internal components, printer base (3 of 3) .....	1218
Figure 2-7	Covers, 550-sheet paper feeder .....	1220
Figure 2-8	Main body, 550-sheet paper feeder .....	1222

---

# 1 Removal and replacement

- [For additional service and support](#)
- [Removal and replacement strategy](#)
- [Service approach](#)
- [Removal and replacement procedures](#)

## For additional service and support

HP service personnel, go to the Service Access Work Bench (SAW) at <http://h41302.www4.hp.com/km/saw/home.do>.

Channel partners, go to HP Channel Services Network (CSN) at <https://h30125.www3.hp.com/hpcsn>.

At these locations, find information on the following topics:

- Install and configure
- Printer specifications
- Up-to-date control panel message (CPMD) troubleshooting
- Solutions for printer issues and emerging issues
- Remove and replace part instructions and videos
- Service advisories
- Warranty and regulatory information

To access HP PartSurfer information from any mobile device, go to <http://partsurfermobile.hp.com/> or scan the Quick Response (QR) code below.





# Removal and replacement strategy

## Introduction

The printer uses a field repair strategy. Defective parts are diagnosed and replaced at the Field Replaceable Unit (FRU) assembly level. Repair normally begins by using the printer internal diagnostics and the following two-step process:

1. Isolate the problem to the major system (for example, the network, server, or printer).
2. Identify the cause of failures according to the printer troubleshooting service manual and follow the disassembly procedures to replace the defective parts or the consumable parts.

After locating a faulty part, the printer can usually be repaired at the assembly level by replacing FRUs. Some mechanical assemblies might need to be repaired at the subassembly level. HP does not support replacement of components on the printed circuit assemblies.

The user replaces toner cartridges as they are depleted. Additional instructions about other user-replaceable parts are provided in this section.

The printer tracks the amount of use on the customer-replaceable supplies by keeping a page count. The printer prompts the user to replace certain items when a supply is depleted or a specific number of pages has been printed.

Swapping toner cartridges between products might cause a misrepresentation of supply life values and is not recommended.

## Considerations during removal and replacement

This chapter describes the removal and replacement of FRUs only.

Replacing FRUs is generally the reverse of removal. Notes are included to provide directions for difficult or critical replacement procedures.

HP does not support repairing individual subassemblies or troubleshooting to the printed-circuit assembly (PCA) component level.


---

**⚠ WARNING!** Never operate or service the printer with the protective cover removed from the laser scanner assembly. The reflected beam, although invisible, can cause damage to the eyes.

The sheet-metal parts can have sharp edges. Be careful when handling sheet-metal parts.


Before attempting to remove or replace parts, turn the printer off and remove the power cable. Never operate the printer with the parts removed from the printer.

Turn the printer off, wait 5 seconds, and then remove the power cord before attempting to service the printer. *If this warning is not followed, severe injury can result as well as damage to the printer.* The power must be on for certain functional checks during troubleshooting. However, the power cord must be disconnected during parts removal. AC voltage is still present inside the printer when the power switch is in the off position. The power cord must be *disconnected* before servicing the printer.

 **CAUTION:** Incorrectly routed or loose wire harnesses might interfere with other internal components or assemblies and be damaged, pinched, or frayed. Make sure that wire harnesses are correctly routed and retained when installing assemblies.

Do not bend or fold the flat flexible cables (FFCs) during removal or installation. Do not straighten pre-folds in the FFCs.


Do not expose the toner cartridge, or cartridges, to strong light even for a short time.

 **IMPORTANT:** When an assembly is removed that includes a rating plate or tag (or a printer code label), make sure to transfer the plate or tag (or code label) to the replacement assembly.

Do not replace the formatter and DC controller simultaneously during a single printer servicing. Doing so might cause the printer to become unstable or inoperable.

During removal, replacement, or transportation of the printer, remove the cassettes.

Incorrectly routed or loose wire harnesses can interfere with other internal components and can become damaged or broken.


 **NOTE:** During assembly removal and replacement, or if the printer is moved, remove the toner cartridge.

Toner is a non-poisonous substance composed of plastic and a small number of colored components. If toner gets on the skin or clothing, wipe it off with dry tissue paper and wash in cold water. Hot water sets toner and it might be difficult, or impossible, to remove. Toner easily breaks down vinyl materials, so avoid letting toner contact vinyl.

Reassembling procedures are generally the reverse of removal unless otherwise specified. Occasionally, notes and tips are included to provide directions for difficult or critical replacement procedures.



Note the length, diameter, color, type, and location of each screw. Be sure to return each screw to its original location during reassembly.

To install a self-tapping screw, first turn it counterclockwise to align it with the existing thread pattern, and then carefully turn it clockwise to tighten. Do not overtighten. If a self-tapping screw hole becomes stripped, repair the screw-hole or replace the affected assembly.

 **TIP:** Some figures might show assemblies removed or installed that have not yet been removed or installed at that specific step. However, the procedures are correct for this printer and the target assembly. Always thoroughly read the instructions that accompany each figure.

---

## Electrostatic discharge

 **CAUTION:**  Some parts are sensitive to electrostatic discharge (ESD). Look for the ESD reminder when removing printer parts. Always perform service work at an ESD-protected workstation or mat. If an ESD workstation or mat is not available, touch the sheet-metal chassis to provide a static ground *before* touching an ESD-sensitive assembly.

Protect the ESD-sensitive assemblies by placing them in ESD pouches when they are out of the printer.

---

## Required tools

- #2 Phillips screwdriver with a magnetic tip and a 152 mm (6 in) shaft length
- Small, flat-blade screwdriver
- Socket screwdriver 5.5 mm (.216 in) shaft length

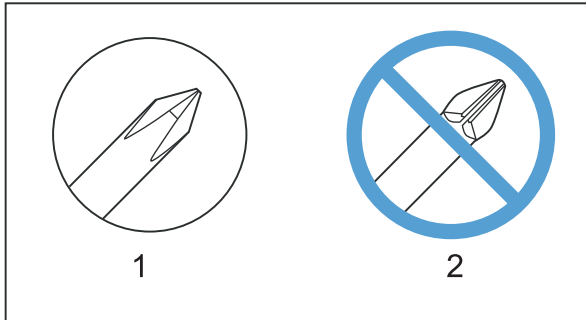
- Needle-nose pliers
- ESD strap (if one is available)
- Penlight

---

**⚠ CAUTION:** Always use a Phillips screwdriver (callout 1). Do not use a Pozidriv screwdriver (callout 2) or any motorized screwdriver. These can damage screws or screw threads.

---

**Figure 1-1** Screwdrivers



## Fasteners used in this printer

---

**⚠ WARNING!** Make sure that assemblies are replaced with the correct screw type. Using the incorrect screw (for example, substituting a long screw for the correct shorter screw) can cause damage to the printer or interfere with printer operation. Do not intermix screws that are removed from one assembly with the screws that are removed from another assembly.

**📝 NOTE:** To install a self-tapping screw, first turn it counterclockwise to align it with the existing thread pattern, and then carefully turn it clockwise to tighten. Do not overtighten. If a self-tapping screw hole becomes stripped, repair the screw hole or replace the affected assembly.

Always take note of the length, diameter, color, type, and location of each removed screw. Make sure that screws are installed in the original location they were removed from during reinstallation.

For a complete list of screw types and part numbers, see the Parts chapter.

---

# Service approach

## Before performing service

- Remove all paper from the product.
- Turn off the power using the power switch.
- Unplug the power cable and interface cable or cables.
- Place the product on an ESD workstation or mat, or use an ESD strap (if one is available). If an ESD workstation, mat, or strap is not available, ground yourself by touching the sheet-metal chassis *before* touching an ESD-sensitive part.
- Remove the toner cartridge.
- Remove the Tray 2 cassette.

## After performing service

1. Reinstall the toner cartridge or toner cartridges.
2. Reinstall the trays.
3. Return all paper to the trays.
4. Plug in the power cable and turn on the printer.
5. Perform print-quality tests by printing from a host computer.

## Post-service test

Perform the following test to verify that the repair or replacement was successful.

### Print-quality test

1. Verify that you have completed the necessary reassembly steps.
2. Make sure that the tray contains clean, unmarked paper.
3. Attach the power cord and interface cable or interface cables, and then turn on the product.
4. Verify that the expected startup sounds occur.
5. Print a configuration page, and then verify that the expected printing sounds occur.
6. Print a demo page, and then verify that the print quality is as expected.
7. Send a print job from the host computer, and then verify that the output meets expectations.
8. Clean the outside of the product with a damp cloth.

# Removal and replacement procedures

## Customer self-repair (CSR) A parts and assemblies

The CSR level indicates the expected difficulty the customer will experience when removing and replacing an assembly. The CSR A assemblies in this section are easy for the customer to remove and replace.

- [RL2-0656-000CN multipurpose tray roller](#)
- [RM2-5392-000CN 250-sheet paper input tray](#)
- [RM2-5413-000CN optional Tray 3](#)
- [RM2-5452-000CN Tray 2 paper pickup roller assembly](#)
- [RM2-5741-000CN optional Tray 3 paper pickup roller assembly](#)
- [RM2-5397-000CN Tray 2 separation roller assembly](#)
- [RM2-5745-000CN optional Tray 3 separation roller assembly](#)

## RL2-0656-000CN multipurpose tray roller

- [Introduction](#)
- [Step 1: Remove the roller](#)
- [Step 2: Unpack the replacement assembly](#)
- [Step 3: Install the roller](#)


### Introduction

This document provides the procedures to remove and replace the Multipurpose (MP) tray (Tray 1) roller.

### Before performing service

#### Turn the printer power off

- Disconnect the power cable.

 **WARNING!** To avoid damage to the printer, turn the printer off, wait 30 seconds, and then remove the power cable before attempting to service the printer.

Use the table below to identify the correct part number for your printer. To order the part, go to [www.hp.com/buy/parts](http://www.hp.com/buy/parts).

MP tray (Tray 1) roller part number	
RL2-0655-000CN	Roller, MP tray (Tray 1)

### Required tools

- No special tools are required to remove this part.

### After performing service

#### Turn the printer power on

- Connect the power cable.
- Use the power switch to turn the power on.

### Post service test

Make sure that the printer initializes to a **Ready** state.

Print a page from Tray 1 to make sure that the printer is functioning correctly.

### Step 1: Remove the roller

The M427/M426 printer is shown in this procedure. However, the instructions are valid for the M403/M402 printers.


1. Press the door-release button, and then open the toner-cartridge door.

**Figure 1-2** Open the toner-cartridge door



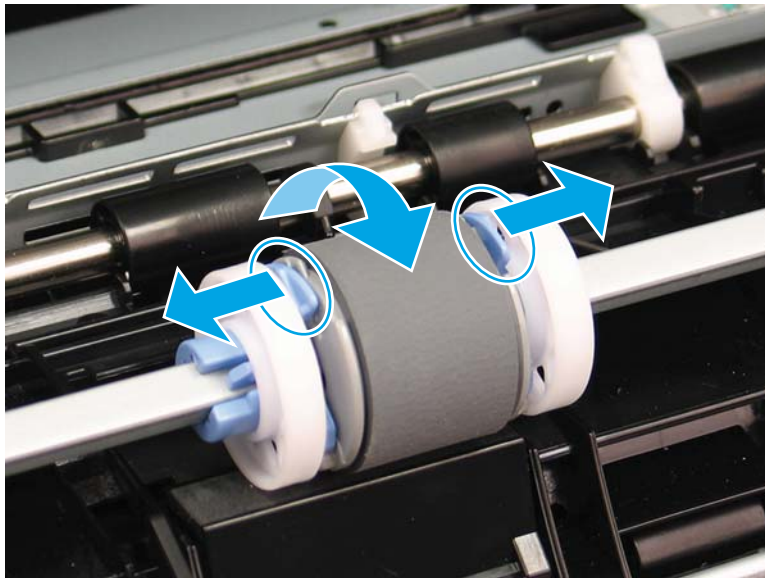
2. Release two tabs between the roller collar and roller, and then rotate the top of the roller out and away from the printer.

---

 **TIP:** Pushing down on the top of the roller might make it easier to release the tabs.

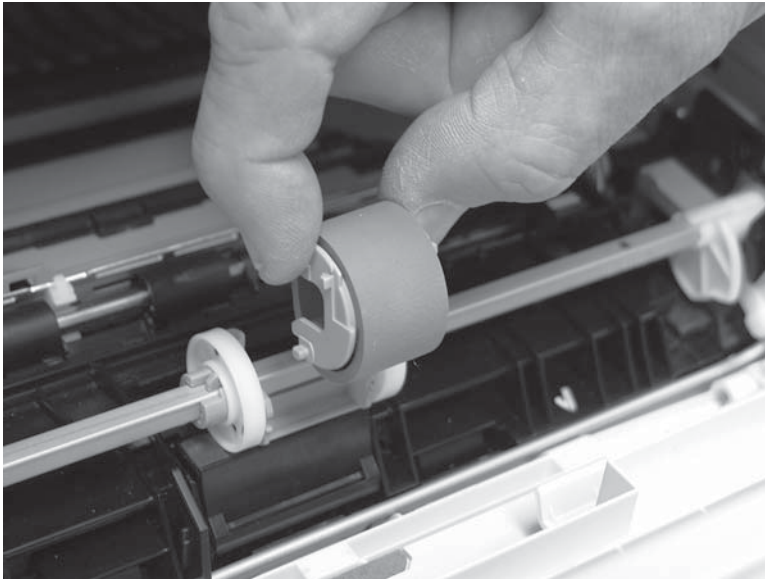
---

**Figure 1-3** Release two tabs



3. Remove the roller.

**Figure 1-4** Remove the roller



### Step 2: Unpack the replacement assembly

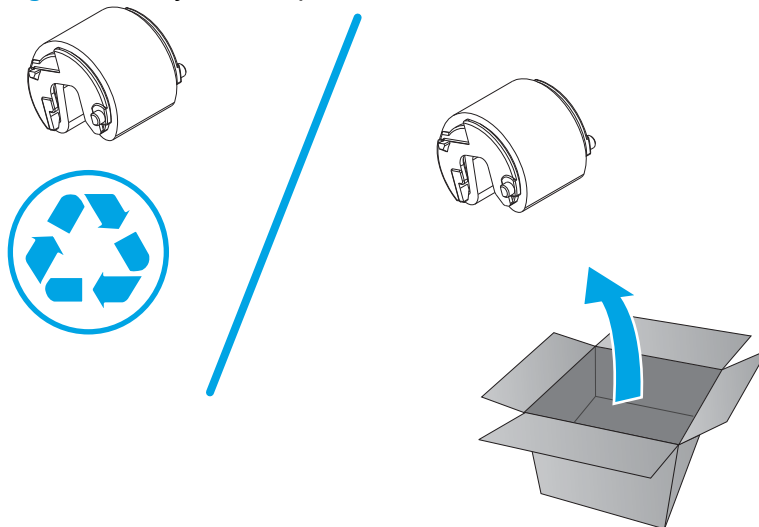
Unpack the replacement part from the packaging.

<http://www8.hp.com/us/en/hp-information/environment/product-recycling.html>

**CAUTION:** Do not touch the gray spongy portion of the replacement roller. Skin oils on the roller can cause paper handling problems.

**NOTE:** HP recommends responsible disposal of the defective part.

**Figure 1-5** Recycle and unpack





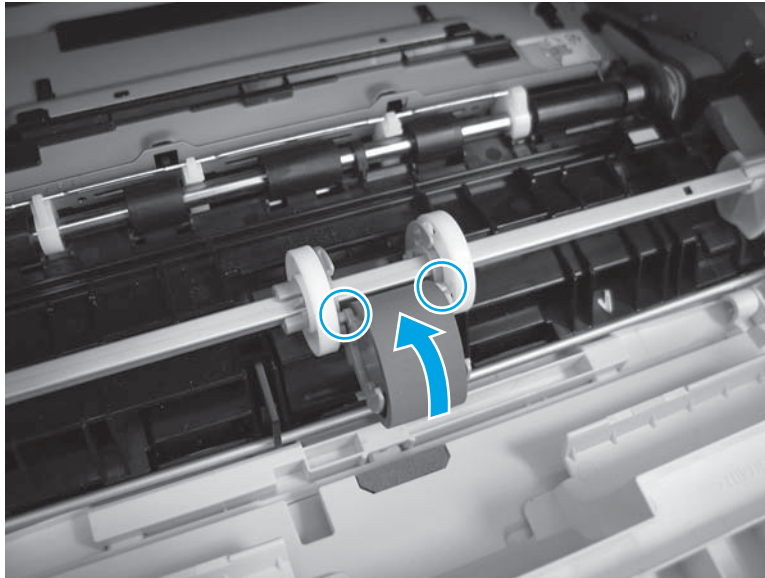
### Step 3: Install the roller

**CAUTION:** Do not touch the gray spongy portion of the replacement roller. Skin oils on the roller can cause paper handling problems.

The M427/M426 printer is shown in this procedure. However, the instructions are valid for the M403/M402 printers.

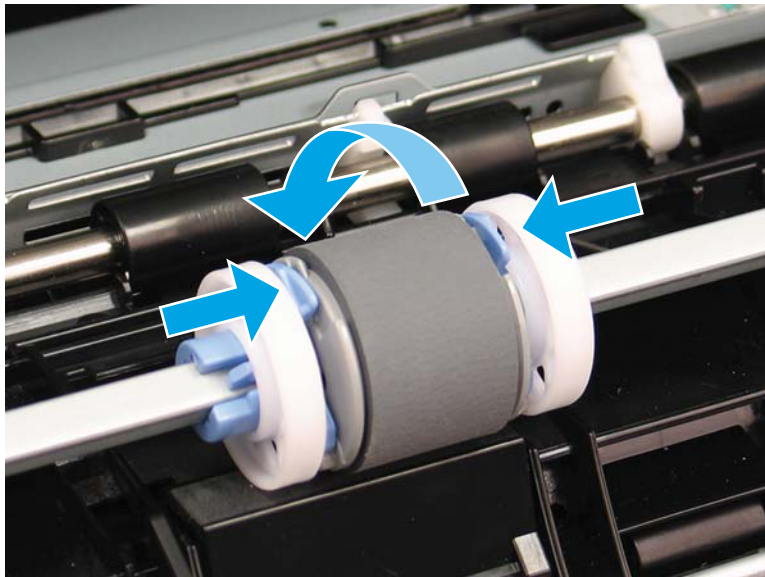
1. Position the replacement pickup roller with the pins in the provided slots on the holder, and then rotate the top of the roller up and toward the printer.

**Figure 1-6** Install the roller



2. Continue to rotate the top of the roller toward the printer (callout 1), until two tabs (callout 2) snap into place.

**Figure 1-7** Engage two tabs



3. Close the toner-cartridge door.

**Figure 1-8** Close the toner-cartridge door



## RM2-5392-000CN 250-sheet paper input tray

- [Introduction](#)
- [Step 1: Remove Tray 2](#)
- [Step 2: Unpack the replacement assembly](#)
- [Step 3: Install Tray 2](#)


### Introduction

This document provides the procedures to remove and replace Tray 2.

### Before performing service

#### Turn the printer power off

- Disconnect the power cable.

 **WARNING!** To avoid damage to the printer, turn the printer off, wait 30 seconds, and then remove the power cable before attempting to service the printer.

Use the table below to identify the correct part number for your printer. To order the part, go to [www.hp.com/buy/parts](http://www.hp.com/buy/parts).

Tray 2 part number	
RM2-5392-000CN	Cassette (Tray 2) assembly

### Required tools

- No special tools are required to remove this part.

### After performing service

#### Turn the printer power on

- Connect the power cable.
- Use the power switch to turn the power on.

### Post service test

Make sure that the printer initializes to a **Ready** state.

Print a configuration page (from Tray 2) to make sure that the printer is functioning correctly.

### Step 1: Remove Tray 2

- ▲ Pull the tray straight out of the printer to remove it.

**Figure 1-9** Remove the tray



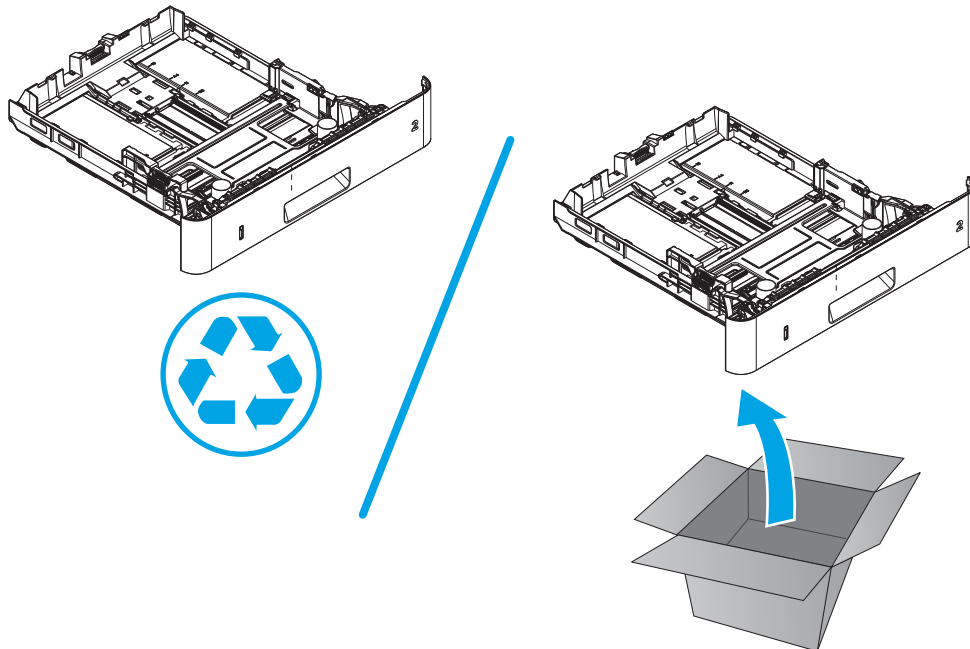
### Step 2: Unpack the replacement assembly

Unpack the replacement part from the packaging.

<http://www8.hp.com/us/en/hp-information/environment/product-recycling.html>

 **NOTE:** HP recommends responsible disposal of the defective part.

**Figure 1-10** Recycle and unpack



### Step 3: Install Tray 2

▲ Slide the tray straight into the printer to install it.

**Figure 1-11** Install the tray



## RM2-5413-000CN optional Tray 3

- [Introduction](#)
- [Step 1: Remove optional Tray 3](#)
- [Step 2: Unpack the replacement assembly](#)
- [Step 3: Install optional Tray 3](#)


### Introduction

This document provides the procedures to remove and replace the optional Tray 3.

### Before performing service

#### Turn the printer power off

- Disconnect the power cable.

 **WARNING!** To avoid damage to the printer, turn the printer off, wait 30 seconds, and then remove the power cable before attempting to service the printer.

Use the table below to identify the correct part number for your printer. To order the part, go to [www.hp.com/buy/parts](http://www.hp.com/buy/parts).

Tray 3 part number	
RM2-5413-000CN	550-sheet paper feeder cassette (optional Tray 3)

### Required tools

- No special tools are required to remove this part.

### After performing service

#### Turn the printer power on

- Connect the power cable.
- Use the power switch to turn the power on.

### Post service test

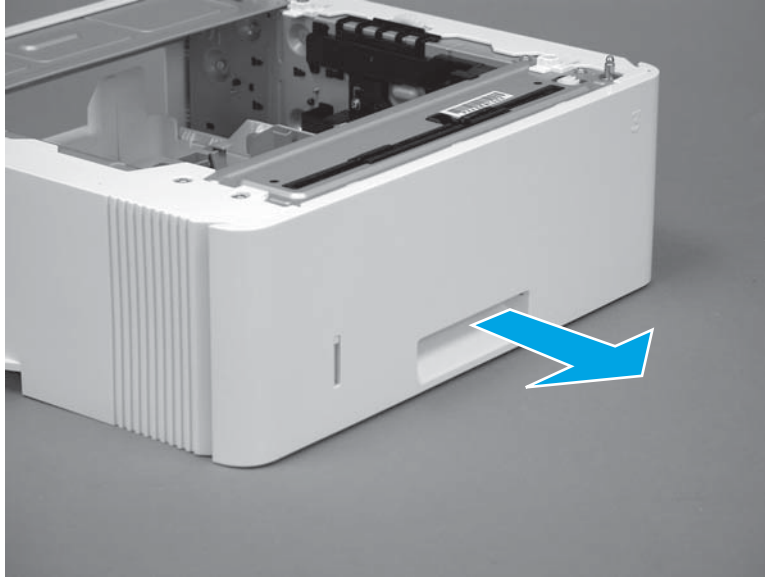
Make sure that the printer initializes to a **Ready** state.

Print a page from Tray 3 to make sure that the paper feeder is functioning correctly.

### Step 1: Remove optional Tray 3

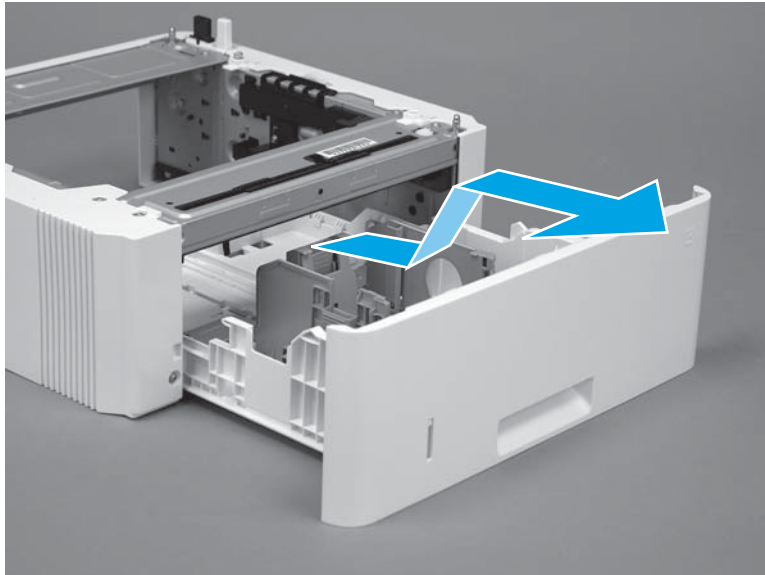
1. Pull the tray straight out of the printer until it stops.

**Figure 1-12** Pull the tray out of the printer



2. Slightly lift up on the front of the tray to release it, and then continue to pull the tray out of the accessory to remove it.

**Figure 1-13** Release and remove the tray



### Step 2: Unpack the replacement assembly

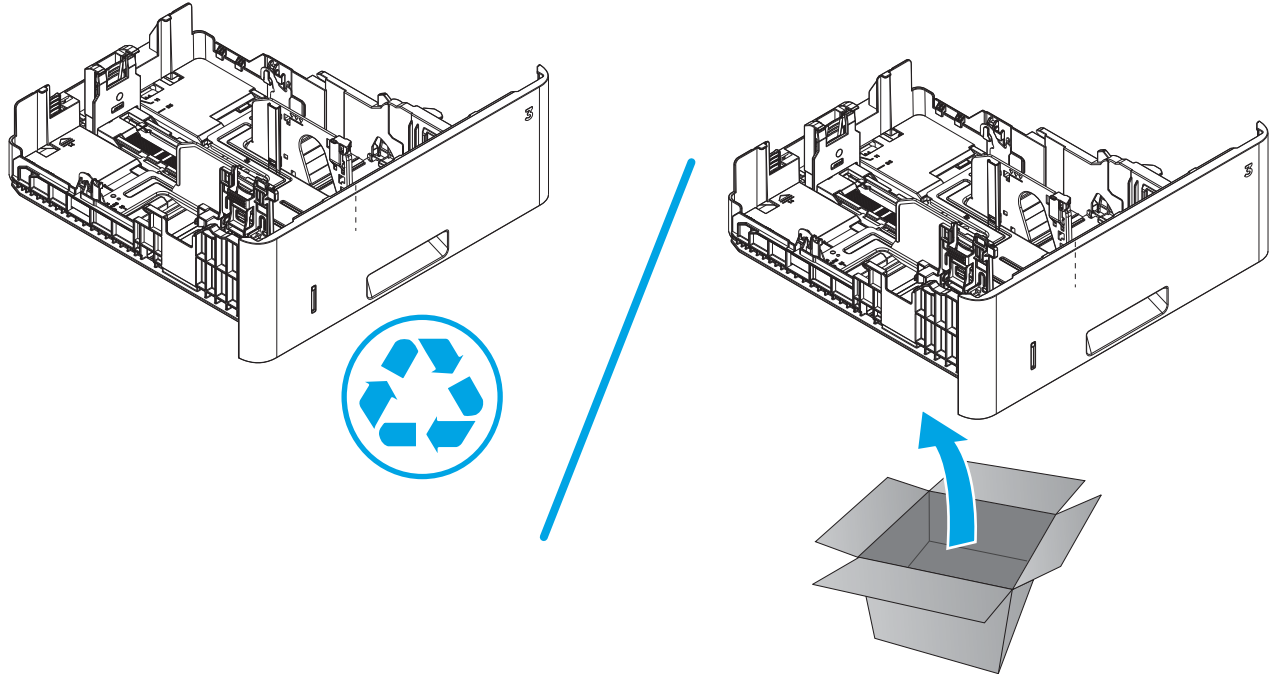
Unpack the replacement part from the packaging.

<http://www8.hp.com/us/en/hp-information/environment/product-recycling.html>



**NOTE:** HP recommends responsible disposal of the defective part.

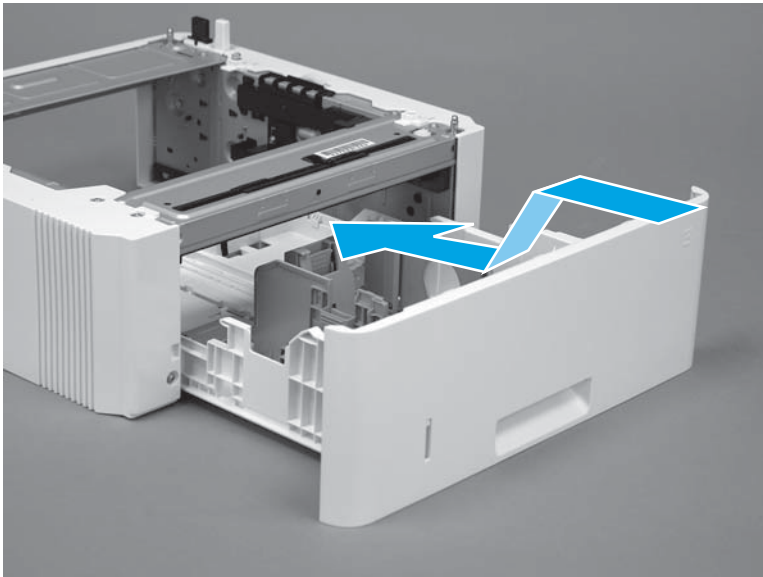
**Figure 1-14** Recycle and unpack



**Step 3: Install optional Tray 3**

1. With the tray at a slight angle, align the sides of the tray with the rails in the accessory, and then partially slide the tray into the accessory.

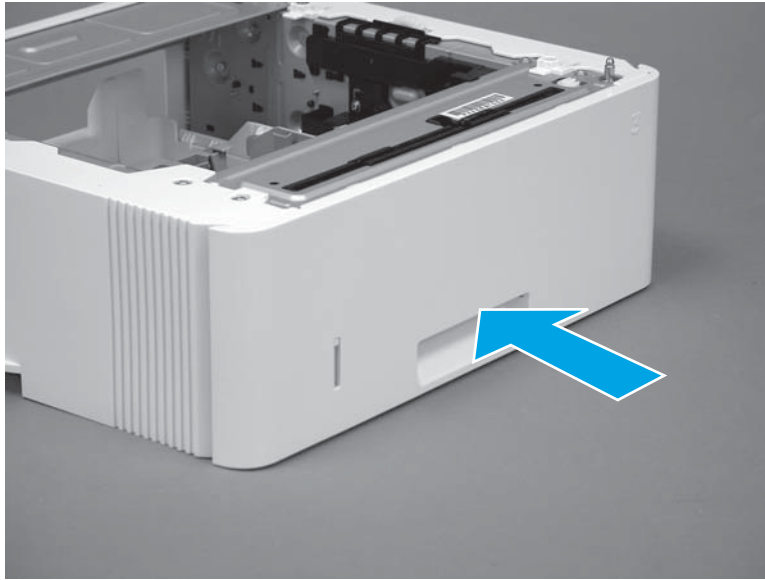
**Figure 1-15** Install the tray





2. Push the tray straight into the accessory to close it.

**Figure 1-16** Close the tray



## RM2-5452-000CN Tray 2 paper pickup roller assembly

- [Introduction](#)
- [Step 1: Remove Tray 2](#)
- [Step 2: Remove the pickup roller assembly \(Tray 2\)](#)
- [Step 3: Unpack the replacement assembly](#)
- [Step 4: Install the pickup roller assembly \(Tray 2\)](#)
- [Step 5: Install Tray 2](#)


### Introduction

This document provides the procedures to remove and replace the paper pickup roller assembly (Tray 2).

### Before performing service

#### Turn the printer power off

- Disconnect the power cable.

 **WARNING!** To avoid damage to the printer, turn the printer off, wait 30 seconds, and then remove the power cable before attempting to service the printer.

Use the table below to identify the correct part number for your printer. To order the part, go to [www.hp.com/buy/parts](http://www.hp.com/buy/parts).

---

Paper pickup roller assembly (Tray 2) part number	
---	--

---

RM2-5452-000CN	Paper pickup roller assembly (Tray 2)
----------------	---------------------------------------

---

### Required tools

- No special tools are required to remove this part.

### After performing service

#### Turn the printer power on

- Connect the power cable.
- Use the power switch to turn the power on.

### Post service test

Make sure that the printer initializes to a **Ready** state.

Print a page from Tray 2 to make sure that the printer is functioning correctly.

### Step 1: Remove Tray 2

- ▲ Pull the tray straight out of the printer to remove it.

**Figure 1-17** Remove the tray



**Step 2: Remove the pickup roller assembly (Tray 2)**

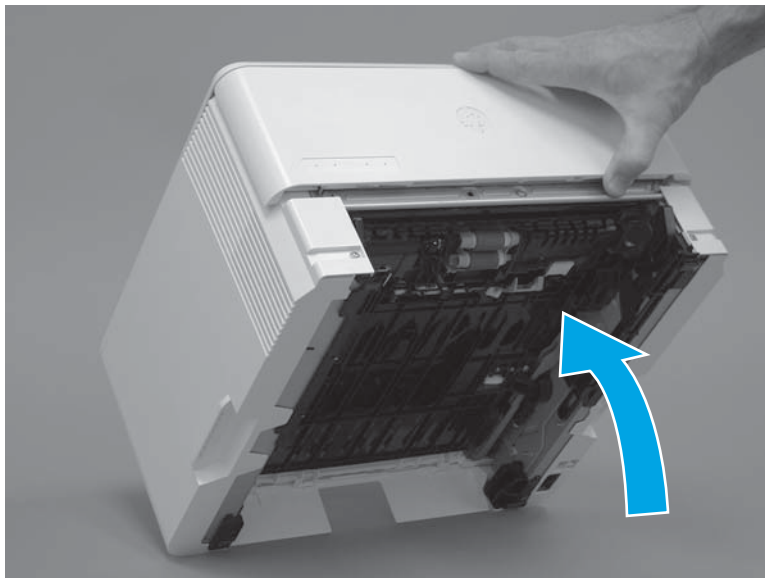
**CAUTION:** When handling the roller holder, do not touch the gray spongy portion of the rollers. Skin oils on the rollers can cause paper handling problems.

**NOTE:** The M403/M402 printer is shown in this procedure. However, the procedure is valid for the M427/M426 printers.

1. Carefully rotate the printer backward.

**CAUTION:** To avoid damage to the rear cassette cover, keep it in the closed position.

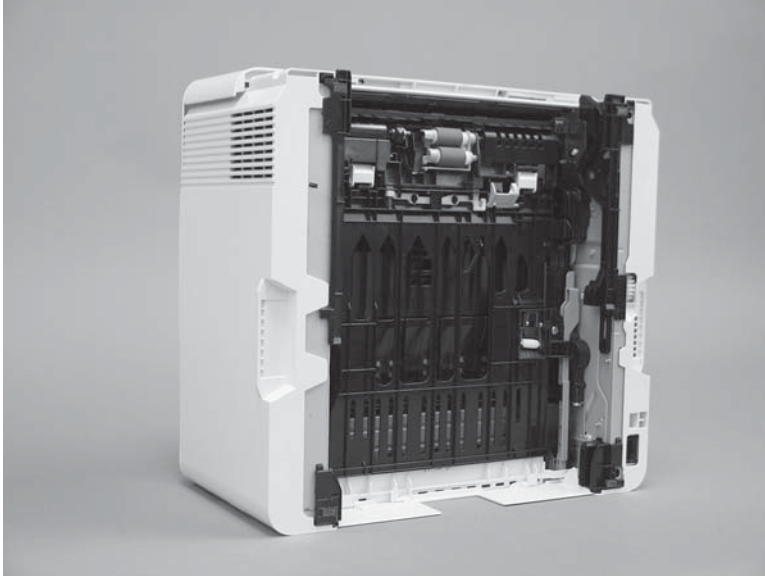
**Figure 1-18** Tilt the printer backward



2. Continue rotate the printer backward until it rests on the rear cover, bottom-side face forward.

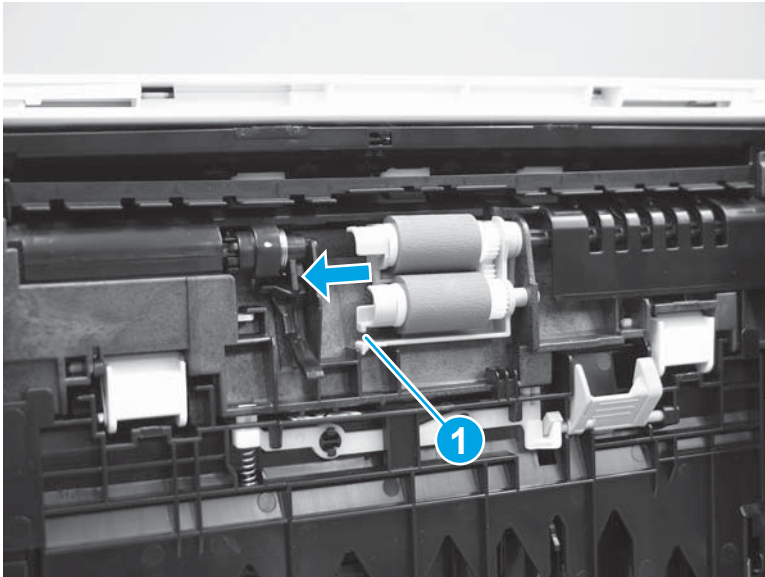
**⚠ CAUTION: M427/M426:** The integrated scanner assembly (ISA) is not captive, and can unexpectedly open when the printer is tilted back.

**Figure 1-19** Place the printer bottom-side face forward



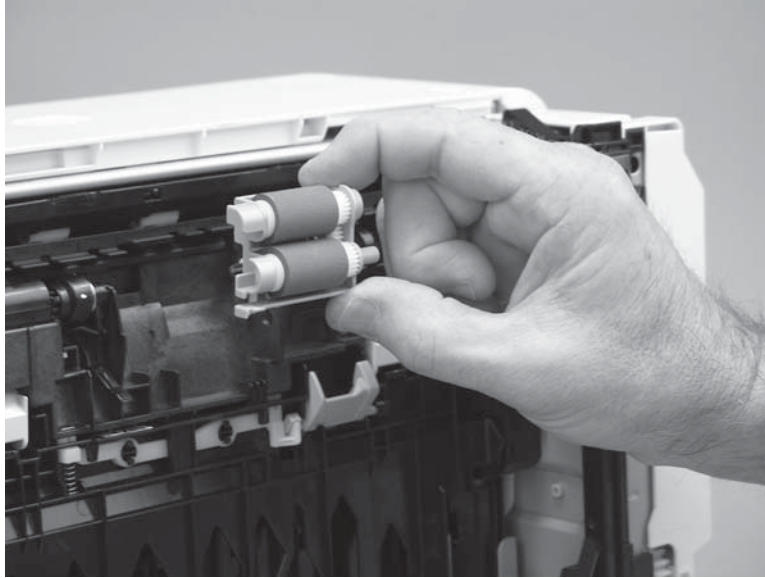
3. Release one tab (callout 1), and then slide the roller holder toward the left side of the printer to release it.

**Figure 1-20** Release one tab



4. Remove the roller holder.

**Figure 1-21** Remove the roller holder



### Step 3: Unpack the replacement assembly

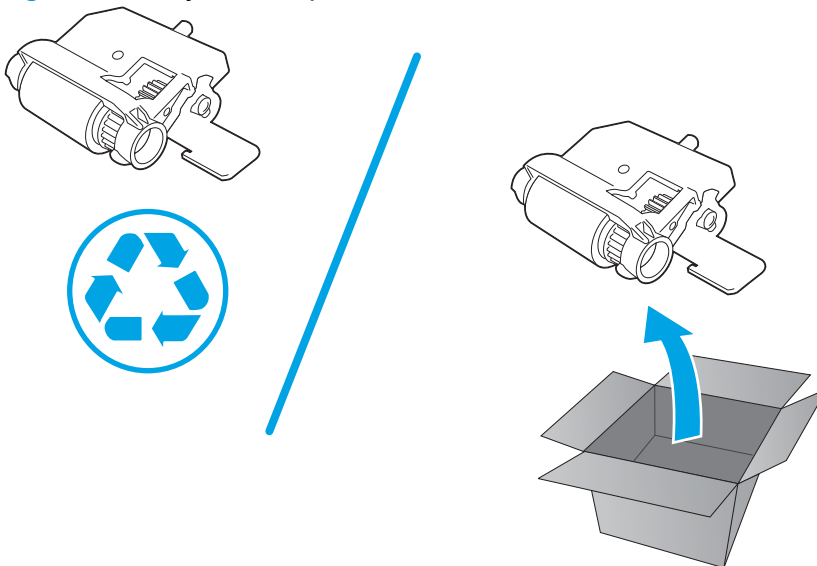
Unpack the replacement part from the packaging.

<http://www8.hp.com/us/en/hp-information/environment/product-recycling.html>

**CAUTION:** When handling the roller holder, do not touch the gray spongy portion of the rollers. Skin oils on the rollers can cause paper handling problems.

**NOTE:** HP recommends responsible disposal of the defective part.

**Figure 1-22** Recycle and unpack



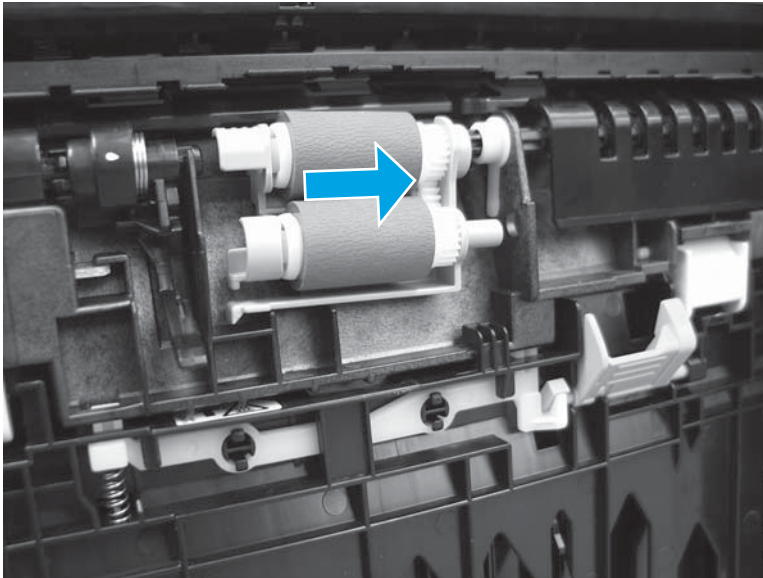
#### Step 4: Install the pickup roller assembly (Tray 2)

**CAUTION:** When handling the roller holder, do not touch the gray spongy portion of the rollers. Skin oils on the rollers can cause paper handling problems.

**NOTE:** The M403/M402 printer is shown in this procedure. However, the procedure is valid for the M427/M426 printers.

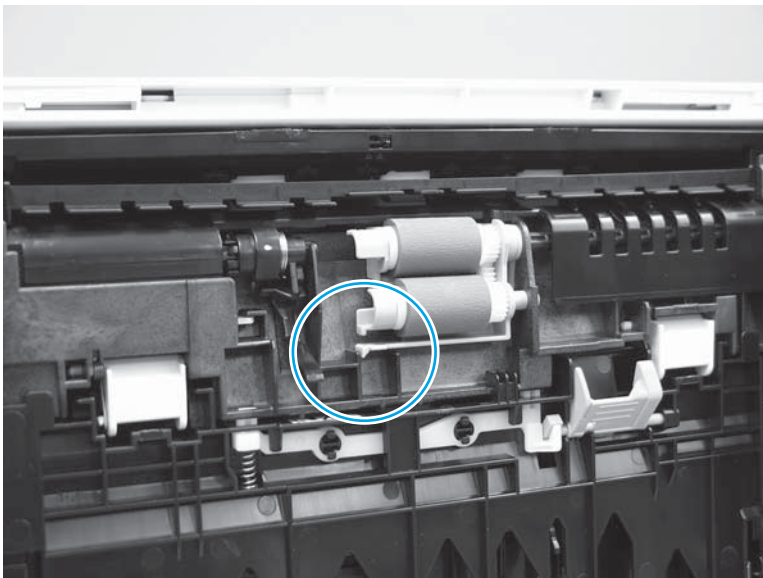
1. Position the roller holder assembly in the printer as shown, and then slide it toward the right side of the printer.

**Figure 1-23** Install the roller holder



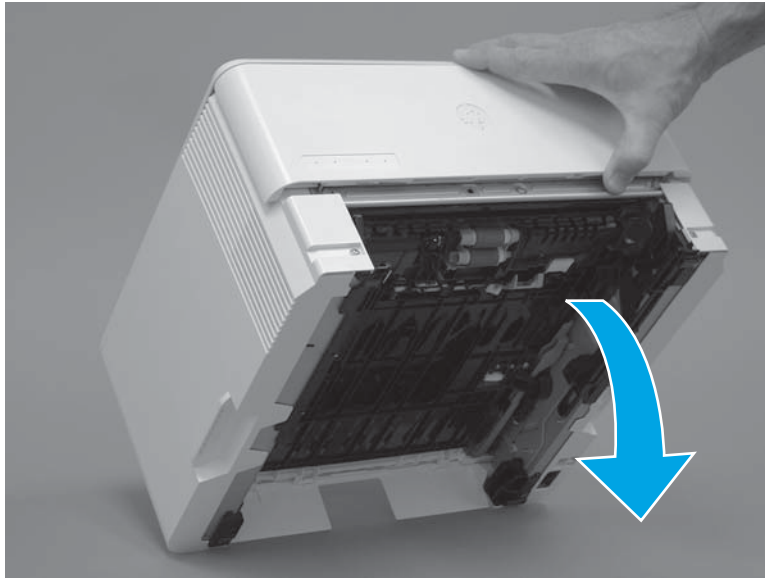
2. Make sure that the tab snaps into place.

**Figure 1-24** Check the tab



- Carefully rotate the printer forward.

**Figure 1-25** Rotate the printer forward



- Continue rotate the printer forward until it rests in the operational position.

**Figure 1-26** Place the printer in the operational position



### Step 5: Install Tray 2

- ▲ Slide the tray straight into the printer to install it.

**Figure 1-27** Install the tray





## RM2-5741-000CN optional Tray 3 paper pickup roller assembly

- [Introduction](#)
- [Step 1: Remove optional Tray 3](#)
- [Step 2: Remove the paper pickup roller assembly \(optional Tray 3\)](#)
- [Step 3: Unpack the replacement assembly](#)
- [Step 4: Install the paper pickup roller assembly \(optional Tray 3\)](#)
- [Step 5: Install optional Tray 3](#)


### Introduction

This document provides the procedures to remove and replace the paper pickup roller assembly (Tray 3).

### Before performing service

#### Turn the printer power off

- Disconnect the power cable.

 **WARNING!** To avoid damage to the printer, turn the printer off, wait 30 seconds, and then remove the power cable before attempting to service the printer.

Use the table below to identify the correct part number for your printer. To order the part, go to [www.hp.com/buy/parts](http://www.hp.com/buy/parts).

Paper pickup roller assembly (Tray 3) part number	
RM2-5741-000N	Paper pickup roller assembly (Tray 3)

### Required tools

- No special tools are required to remove this part.

### After performing service

#### Turn the printer power on

- Connect the power cable.
- Use the power switch to turn the power on.

### Post service test

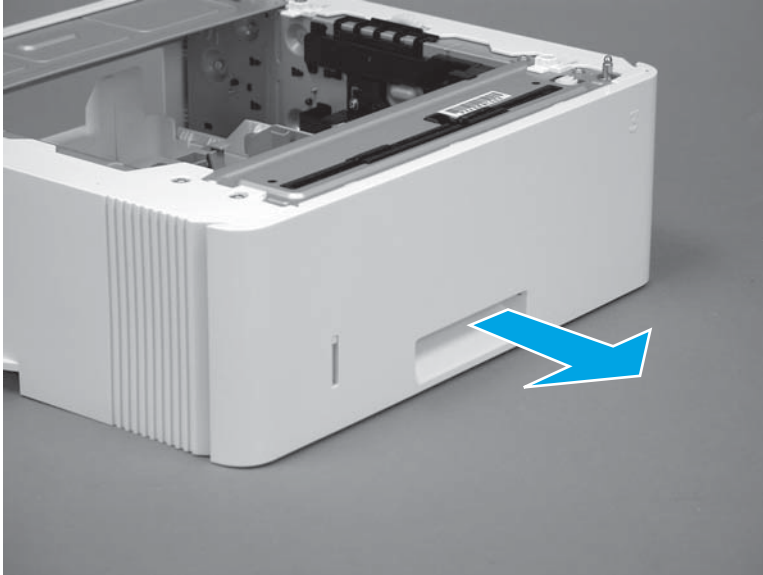
Make sure that the printer initializes to a **Ready** state.

Print a page from the accessory to make sure that the printer is functioning correctly.

### Step 1: Remove optional Tray 3

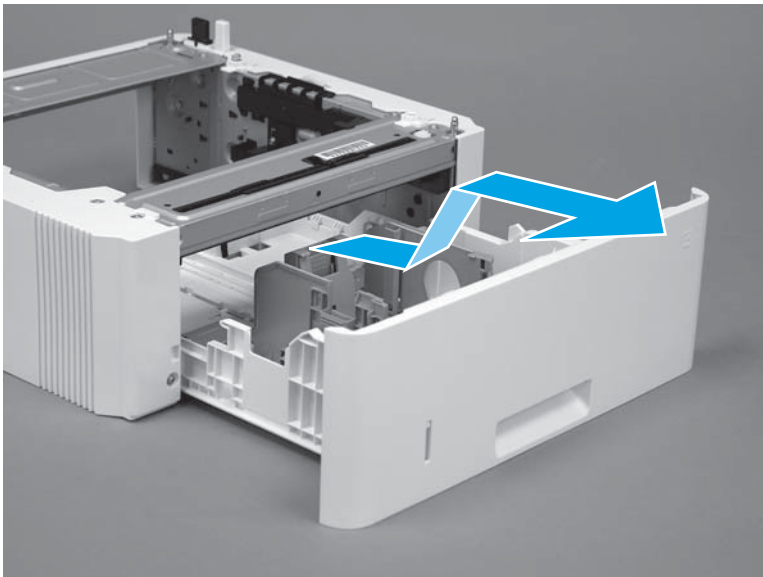
1. Pull the tray straight out of the printer until it stops.

**Figure 1-28** Pull the tray out of the printer



2. Slightly lift up on the front of the tray to release it, and then continue to pull the tray out of the accessory to remove it.

**Figure 1-29** Release and remove the tray



### Step 2: Remove the paper pickup roller assembly (optional Tray 3)

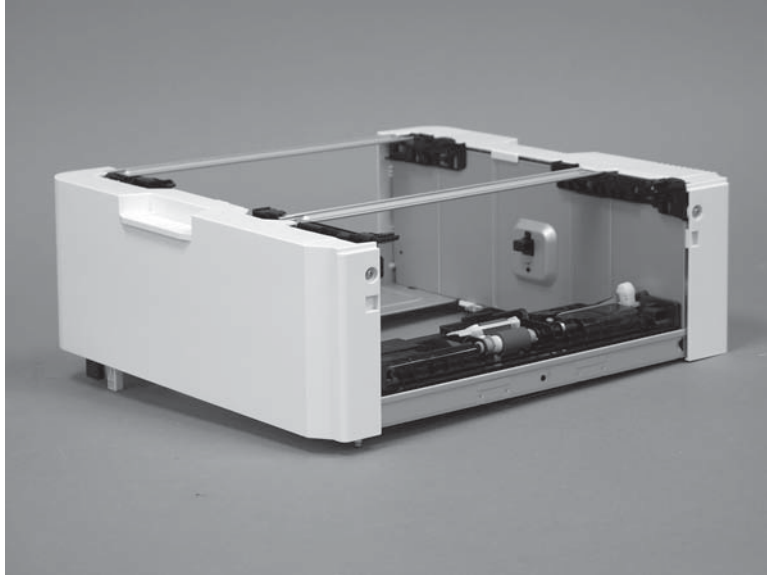
---

**CAUTION:** When handling the roller holder, do not touch the gray spongy portion of the rollers. Skin oils on the rollers can cause paper handling problems.

---

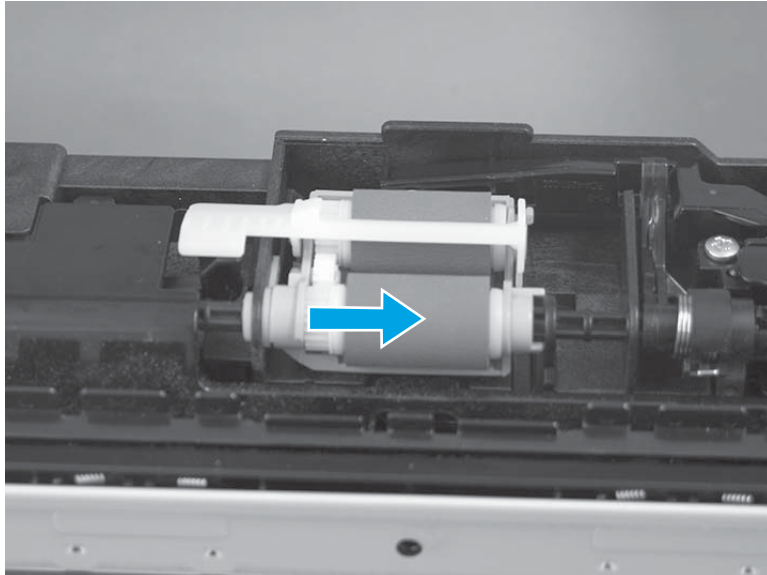
1. Carefully turn the accessory over to expose the roller assembly.

**Figure 1-30** Turn the accessory over



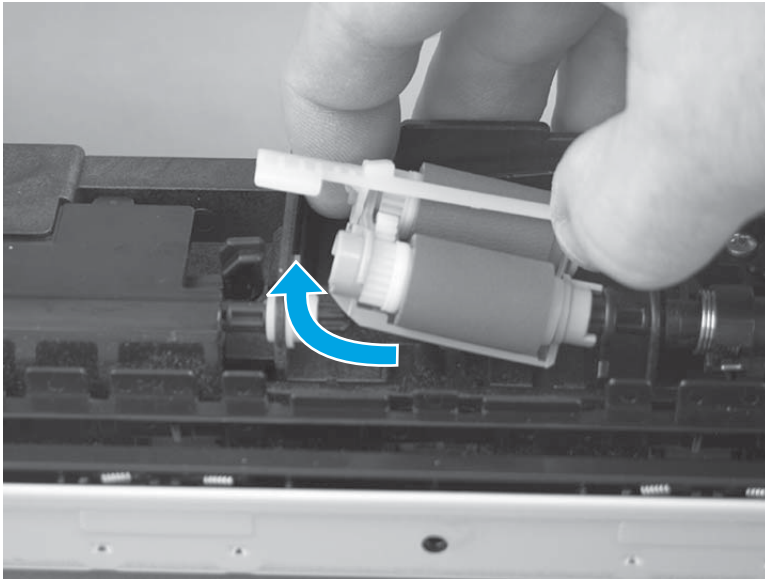
2. Slide the roller holder to the right to compress the spring-loaded shaft and release the assembly.

**Figure 1-31** Release the assembly



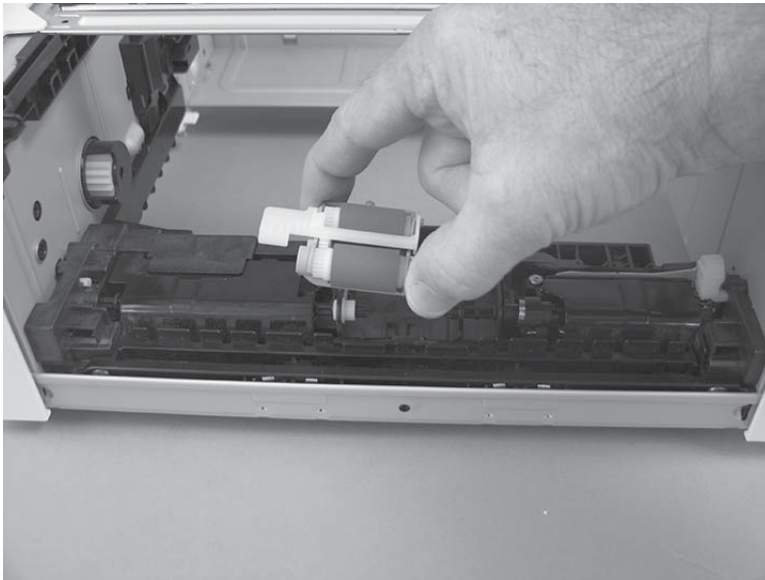
3. Rotate the end of the assembly up and away from the accessory.

**Figure 1-32** Rotate the assembly up



4. Remove the roller assembly.

**Figure 1-33** Remove the assembly



### Step 3: Unpack the replacement assembly

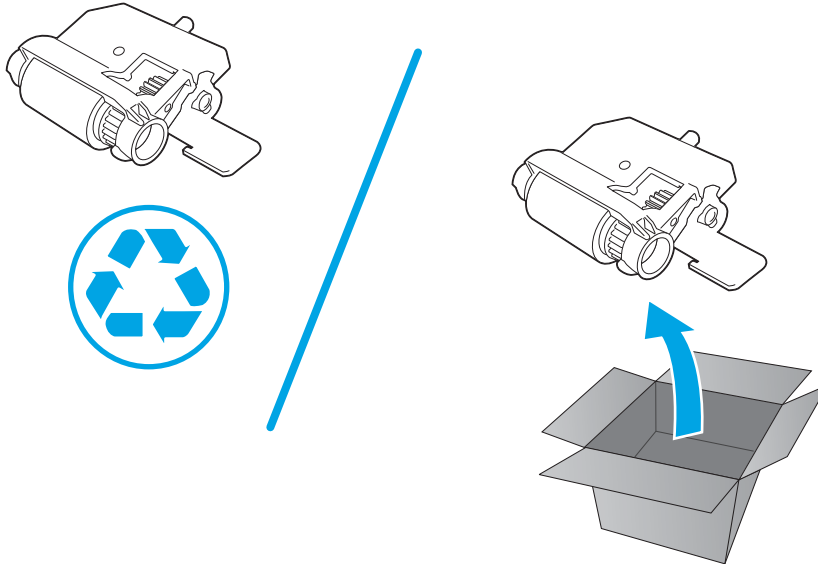
Unpack the replacement part from the packaging.

<http://www8.hp.com/us/en/hp-information/environment/product-recycling.html>

**CAUTION:** When handling the roller holder, do not touch the gray spongy portion of the rollers. Skin oils on the rollers can cause paper handling problems.

**NOTE:** HP recommends responsible disposal of the defective part.

**Figure 1-34** Recycle and unpack



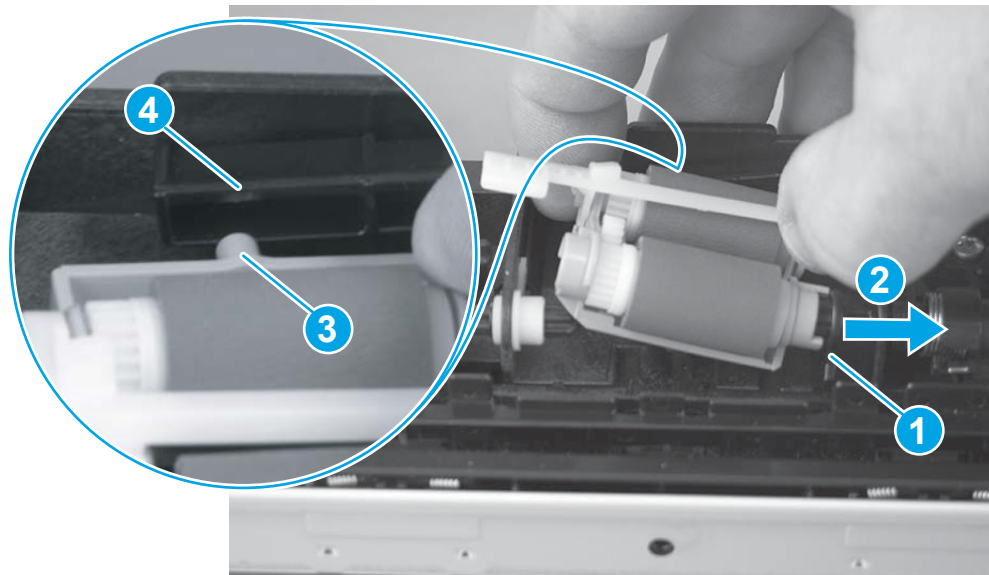
**Step 4: Install the paper pickup roller assembly (optional Tray 3)**

**CAUTION:** When handling the roller holder, do not touch the gray spongy portion of the rollers. Skin oils on the rollers can cause paper handling problems.

1. Install the right end of the assembly on the spring-loaded shaft (callout 1), and then slide it to the right to compress the shaft (callout 2).

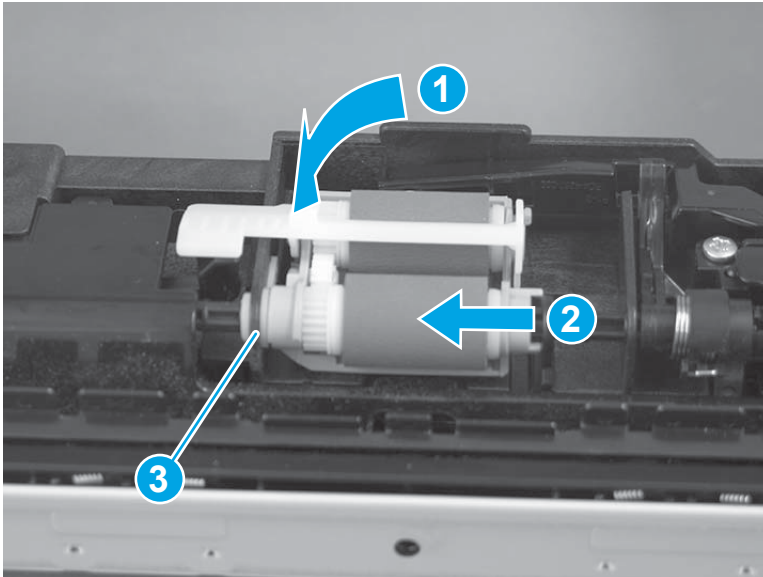
**IMPORTANT:** Make sure that the pin on the back of the holder (callout 3) is inserted in the slot (callout 4) in the lever arm. If the pin is not correctly installed, the accessory will not pick paper.

**Figure 1-35** Install the roller assembly



2. Rotate the left end of the assembly down and into place (callout 1), and then slide the assembly to the left (callout 2) to engage the drive end of the assembly with the drive shaft (callout 3).

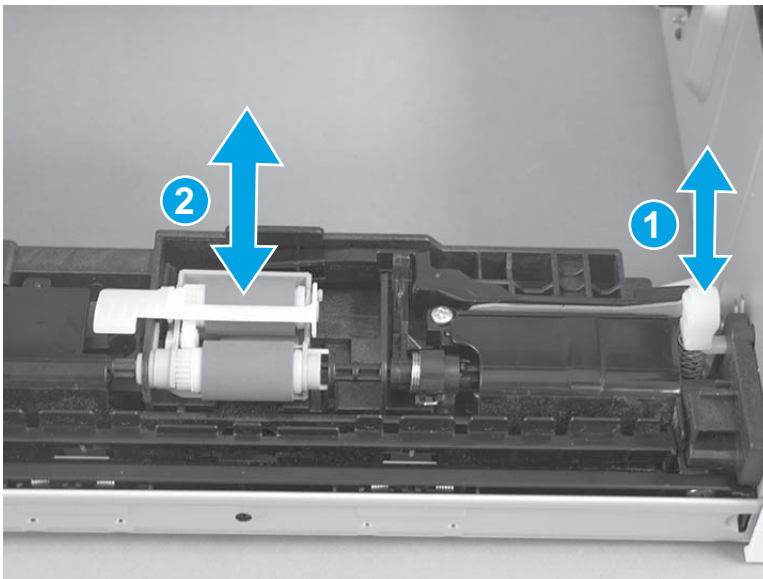
**Figure 1-36** Release the assembly



3. Push down and then release the tray-roller actuator (callout 1) and observe the roller assembly. It should move up and down (callout 2) in response to the actuator.

 **NOTE:** If it does not, remove the roller assembly and reinstall it making sure that the pin on the back of the assembly is in the lever arm. See [Figure 1-35 Install the roller assembly on page 31](#).

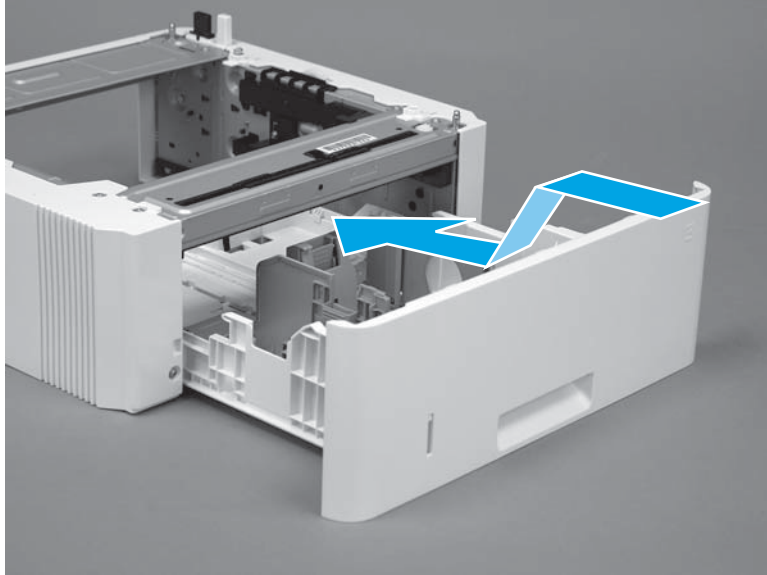
**Figure 1-37** Check the installation



### Step 5: Install optional Tray 3

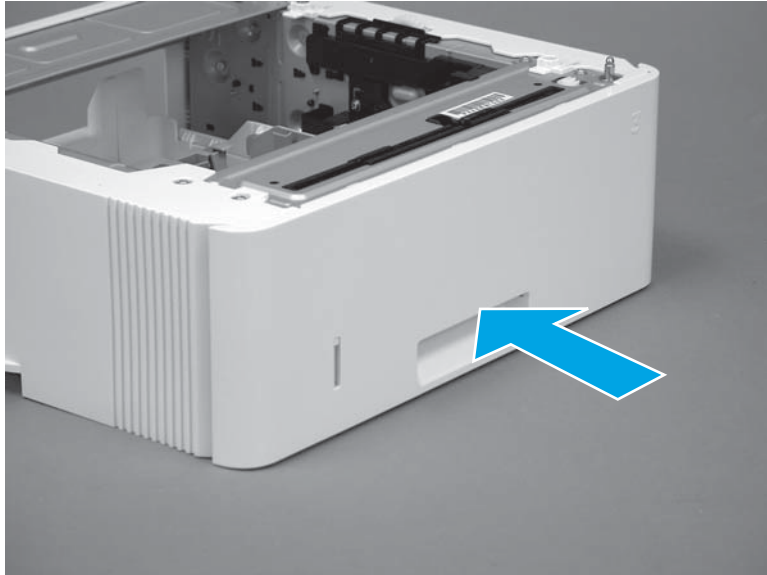
1. With the tray at a slight angle, align the sides of the tray with the rails in the accessory, and then partially slide the tray into the accessory.

**Figure 1-38** Install the tray



2. Push the tray straight into the accessory to close it.

**Figure 1-39** Close the tray



## RM2-5397-000CN Tray 2 separation roller assembly

- [Introduction](#)
- [Step 1: Remove Tray 2](#)
- [Step 2: Remove the separation pad roller assembly \(Tray 2\)](#)
- [Step 3: Unpack the replacement assembly](#)
- [Step 4: Install the separation pad roller assembly \(Tray 2\)](#)
- [Step 5: Install Tray 2](#)


### Introduction

This document provides the procedures to remove and replace the separation roller assembly (Tray 2).

### Before performing service

#### Turn the printer power off

- Disconnect the power cable.

 **WARNING!** To avoid damage to the printer, turn the printer off, wait 30 seconds, and then remove the power cable before attempting to service the printer.

Use the table below to identify the correct part number for your printer. To order the part, go to [www.hp.com/buy/parts](http://www.hp.com/buy/parts).

---

Separation roller assembly (Tray 2) part number	
---	--

---

RM2-5397-000CN
----------------

Separation roller assembly (Tray 2)
-------------------------------------

---

### Required tools

- No special tools are required to install this kit.

### After performing service

#### Turn the printer power on

- Connect the power cable.
- Use the power switch to turn the power on.

### Post service test

Make sure that the printer initializes to a **Ready** state.

Print a configuration page to make sure that the printer is functioning correctly.

### Step 1: Remove Tray 2

- ▲ Pull the tray straight out of the printer to remove it.



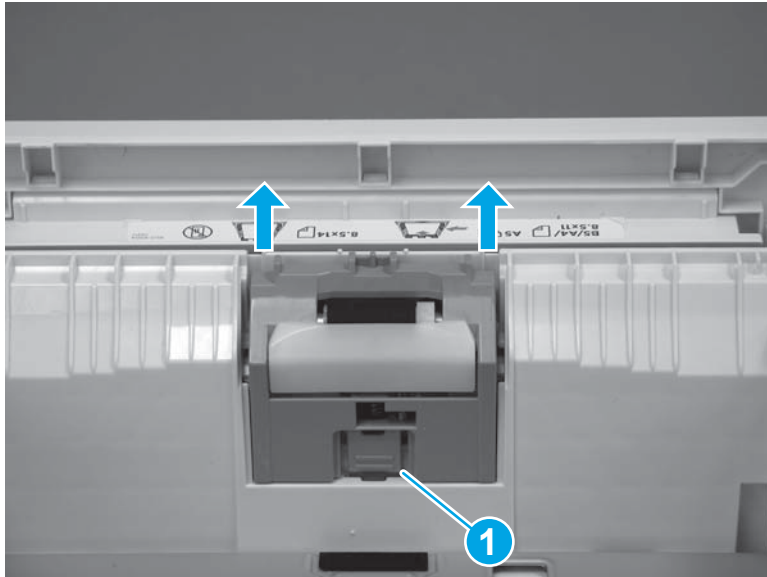
**Figure 1-40** Remove the tray



**Step 2: Remove the separation pad roller assembly (Tray 2)**

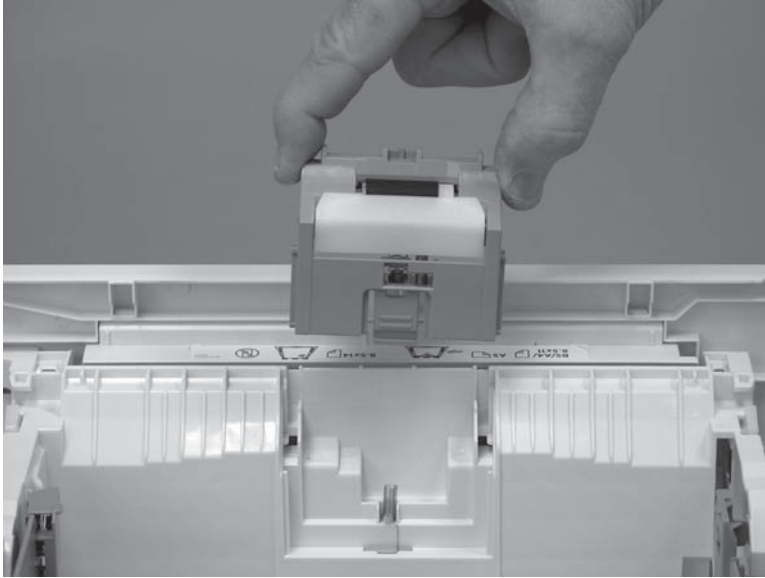
1. Press the locking lever (callout 1), and then pull the separation roller assembly straight up to release it.

**Figure 1-41** Release the assembly



2. Remove the assembly.

**Figure 1-42** Remove the assembly



### Step 3: Unpack the replacement assembly

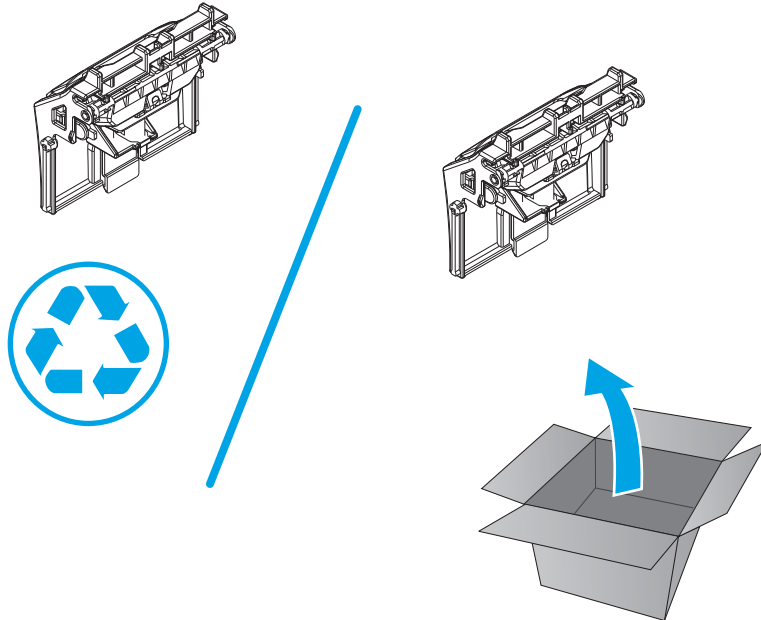
Unpack the replacement part from the packaging.

<http://www8.hp.com/us/en/hp-information/environment/product-recycling.html>



**NOTE:** HP recommends responsible disposal of the defective part.

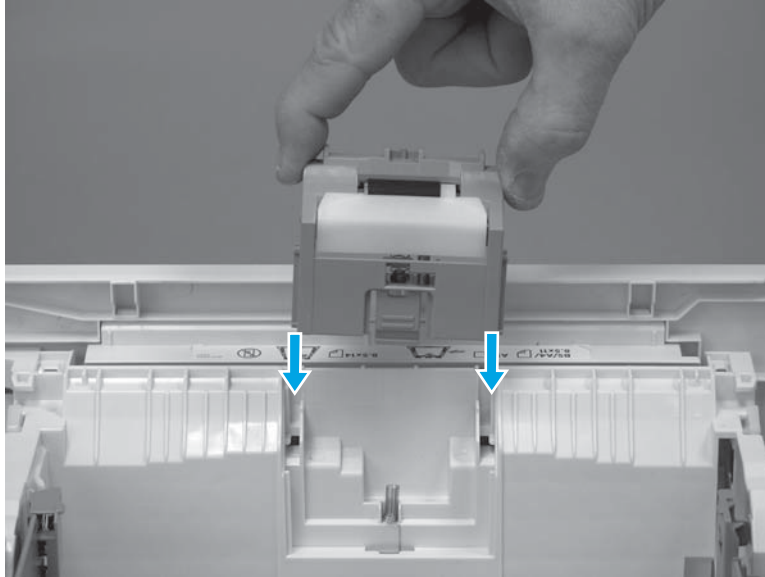
**Figure 1-43** Recycle and unpack



### Step 4: Install the separation pad roller assembly (Tray 2)

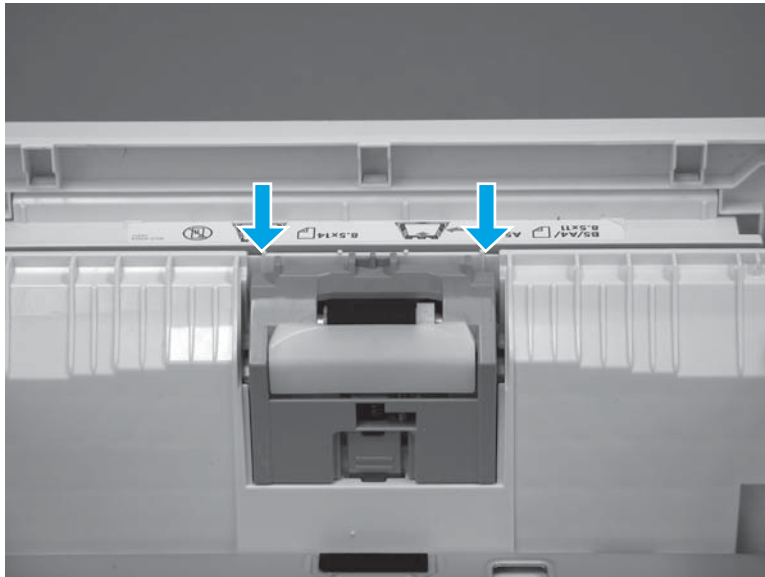
1. Install the assembly in the slots in the cassette.

**Figure 1-44** Install the assembly



2. Push the separation roller assembly straight down until it snaps into place.

**Figure 1-45** Release the assembly



### Step 5: Install Tray 2

- ▲ Slide the tray straight into the printer to install it.

**Figure 1-46** Install the tray



## RM2-5745-000CN optional Tray 3 separation roller assembly

- [Introduction](#)
- [Step 1: Remove Tray 3](#)
- [Step 2: Remove the separation roller assembly \(optional Tray 3\)](#)
- [Step 3: Unpack the replacement assembly](#)
- [Step 4: Install the separation roller assembly \(optional Tray 3\)](#)
- [Step 5: Install Tray 3](#)


### Introduction

This document provides the procedures to remove and replace the separation roller assembly (500-sheet feeder).

### Before performing service

#### Turn the printer power off

- Disconnect the power cable.

 **WARNING!** To avoid damage to the printer, turn the printer off, wait 30 seconds, and then remove the power cable before attempting to service the printer.

Use the table below to identify the correct part number for your printer. To order the part, go to [www.hp.com/buy/parts](http://www.hp.com/buy/parts).

Separation roller assembly (550-sheet feeder) part number	
RM2-5745-000CN	Separation roller assembly (550-sheet feeder)

### Required tools

- No special tools are required to install this kit.

### After performing service

#### Turn the printer power on

- Connect the power cable.
- Use the power switch to turn the power on.

### Post service test

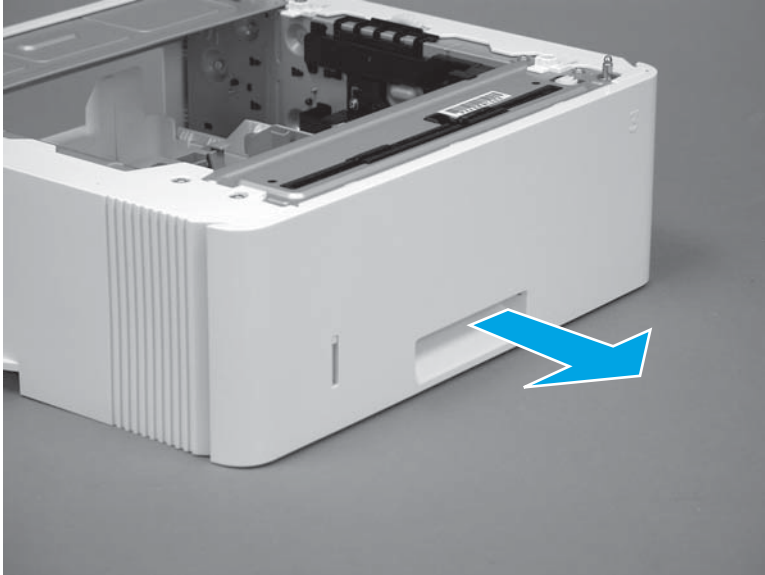
Make sure that the printer initializes to a **Ready** state.

Print a page from the accessory to make sure that the accessory is functioning correctly.

### Step 1: Remove Tray 3

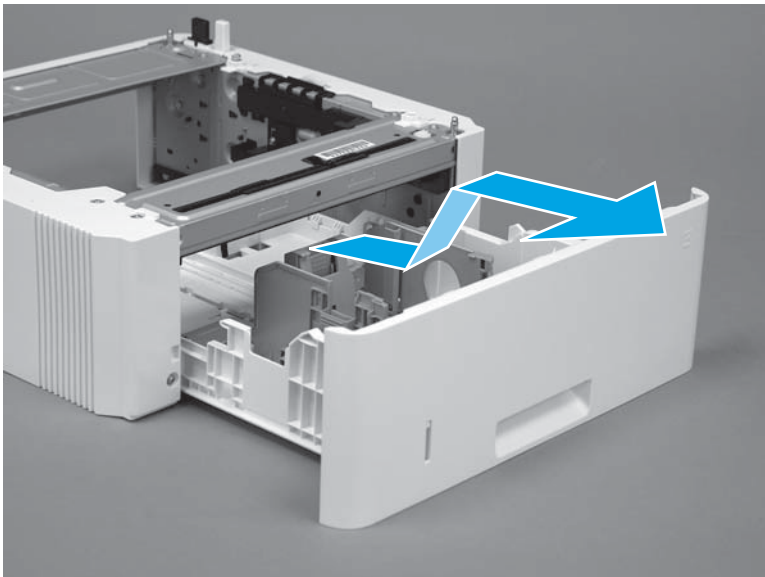
1. Pull the tray straight out of the printer until it stops.

**Figure 1-47** Pull the tray out of the printer



2. Slightly lift up on the front of the tray to release it, and then continue to pull the tray out of the accessory to remove it.

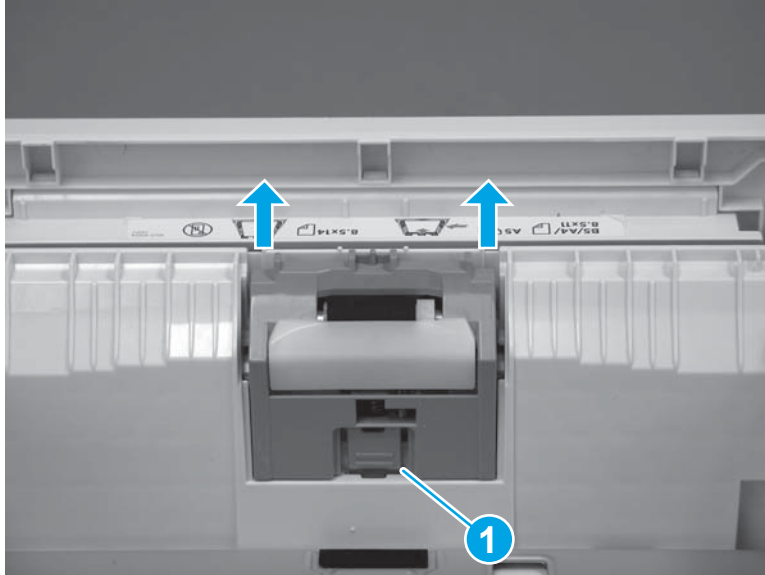
**Figure 1-48** Release and remove the tray



**Step 2: Remove the separation roller assembly (optional Tray 3)**

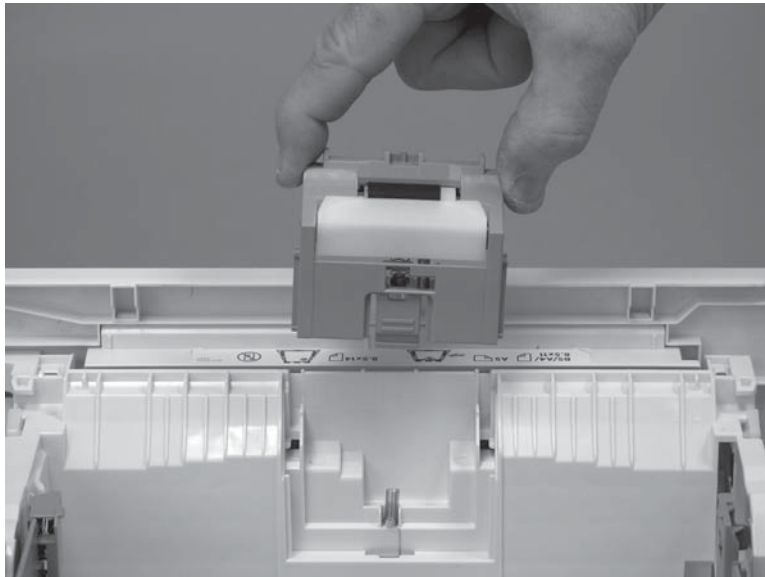
1. Press the locking lever (callout 1), and then pull the separation roller assembly straight up to release it.

**Figure 1-49** Release the assembly



2. Remove the assembly.

**Figure 1-50** Remove the assembly



### Step 3: Unpack the replacement assembly

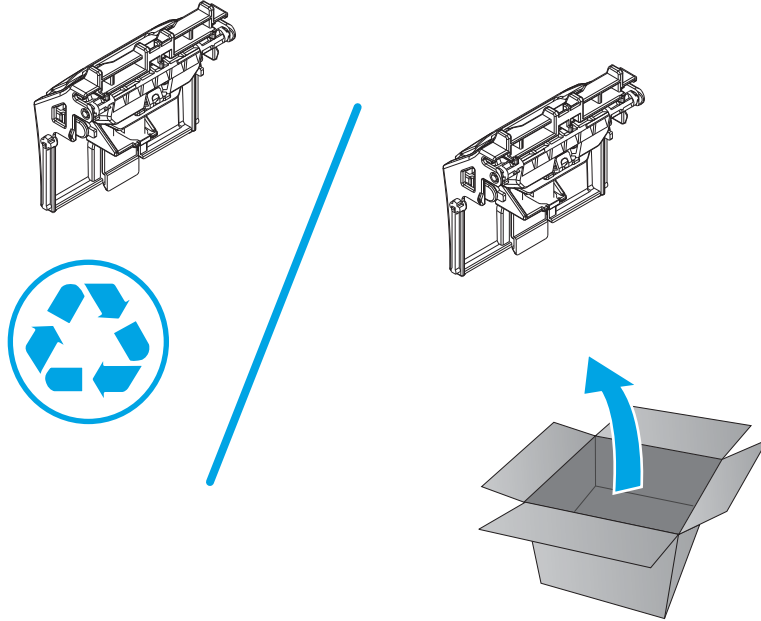
Unpack the replacement part from the packaging.

<http://www8.hp.com/us/en/hp-information/environment/product-recycling.html>



**NOTE:** HP recommends responsible disposal of the defective part.

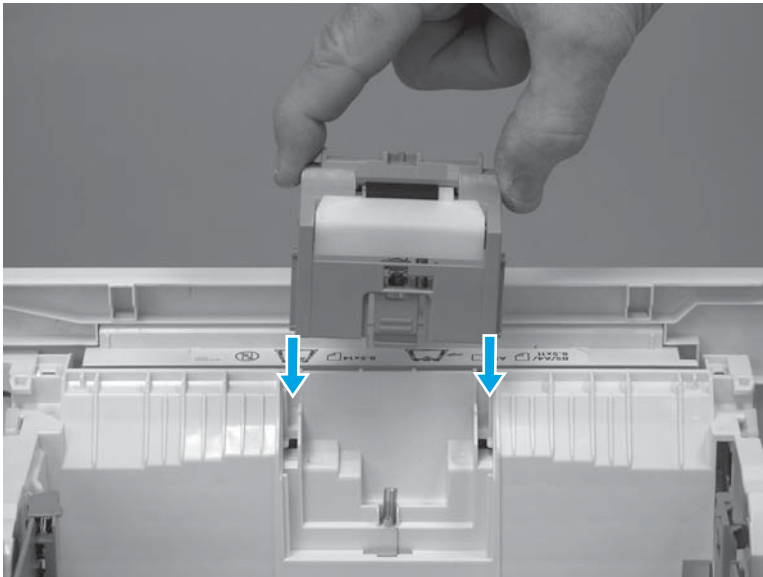
**Figure 1-51** Recycle and unpack



**Step 4: Install the separation roller assembly (optional Tray 3)**

1. Install the assembly in the slots in the cassette.

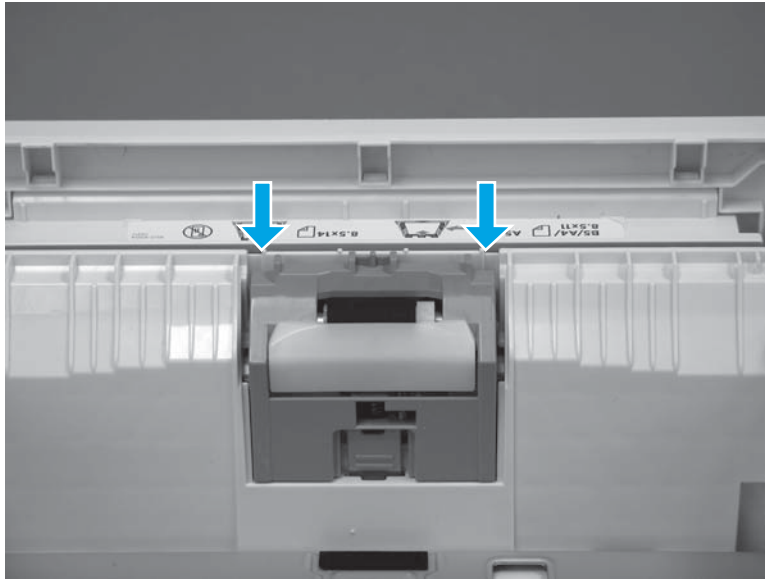
**Figure 1-52** Install the assembly





2. Push the separation roller assembly straight down until it snaps into place.

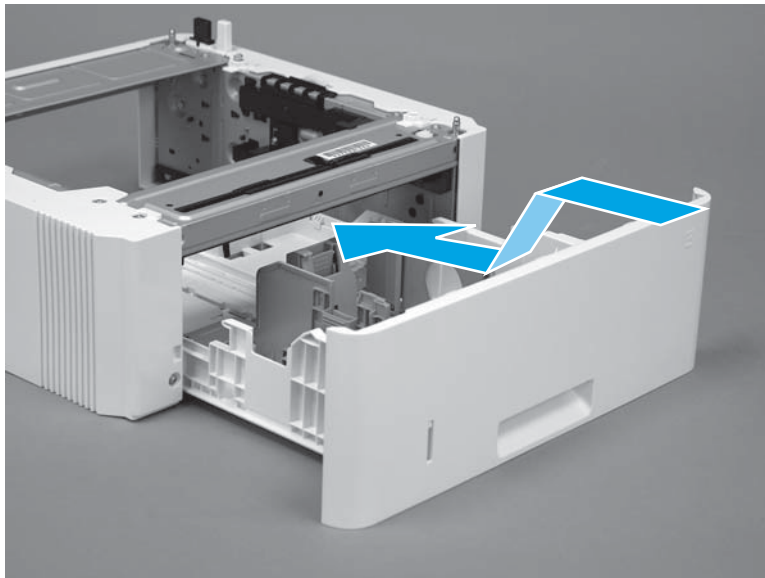
**Figure 1-53** Release the assembly



### Step 5: Install Tray 3

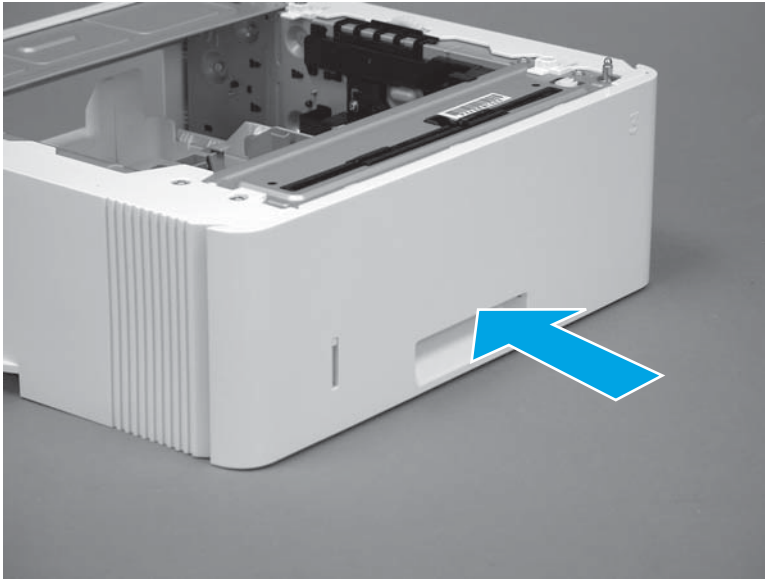
1. With the tray at a slight angle, align the sides of the tray with the rails in the accessory, and then partially slide the tray into the accessory.

**Figure 1-54** Install the tray



2. Push the tray straight into the accessory to close it.

**Figure 1-55** Close the tray



## Removal and replacement: External panels, covers, and doors

- [Removal and replacement: Damper sheets](#)
- [Removal and replacement: Rear USB cover](#)
- [Removal and replacement: Support shaft](#)
- [Removal and replacement: Cartridge door assembly](#)
- [Removal and replacement: Pressure-release link](#)
- [Removal and replacement: Left cover](#)
- [Removal and replacement: Right cover](#)
- [Removal and replacement: Rear door assembly](#)
- [Removal and replacement: Cassette rear cover](#)
- [Removal and replacement: Top cover \(M427/M426\)](#)
- [Removal and replacement: Cable guide \(M427/M426\)](#)
- [Removal and replacement: Top cover \(M403/M402\)](#)
- [Removal and replacement: 2-line LCD operator and indication covers \(M403/M402\)](#)
- [Removal and replacement: Paper delivery tray \(output bin\)](#)
- [Removal and replacement: Integrated scanner assembly \(M427/M426\)](#)
- [Removal and replacement: ISA lift assembly and slider pin \(M427/M426\)](#)

## Removal and replacement: Damper sheets

- [Introduction](#)
- [Step 1: Remove the damper sheets](#)
- [Step 2: Unpack the replacement assembly](#)
- [Step 3: Install the damper sheets](#)


### Introduction

This document provides the procedures to remove and replace the damper sheets.

### Before performing service

#### Turn the printer power off

- Disconnect the power cable.

 **WARNING!** To avoid damage to the printer, turn the printer off, wait 30 seconds, and then remove the power cord before attempting to service the printer.

Use the table below to identify the correct part number for your printer. To order the part, go to [www.hp.com/buy/parts](http://www.hp.com/buy/parts).

Damper sheets part number	
RC2-6075-000CN	Sheets, damper (2)

### Required tools

- No special tools are needed to remove or install this assembly.

### After performing service

#### Turn the printer power on


- Connect the power cable.
- Use the power switch to turn the power on.

### Post service test

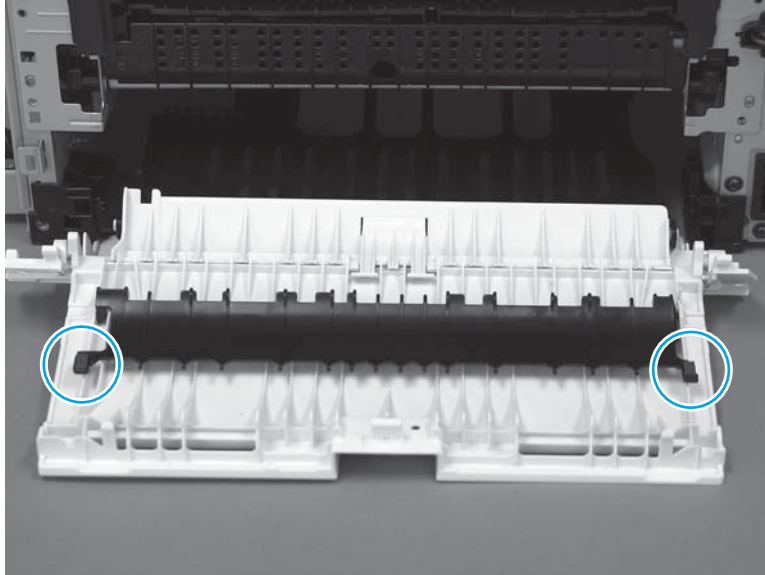
No post service test are available for this assembly.

### Step 1: Remove the damper sheets

- ▲ Remove the damper sheets from the rear cover.

 **Reinstallation tip:** Make sure that all of the residual adhesive is removed from the rear cover damper sheet area. Residual adhesive can cause the replacement sheets to not adhere properly to the door.

**Figure 1-56** Remove the damper sheets



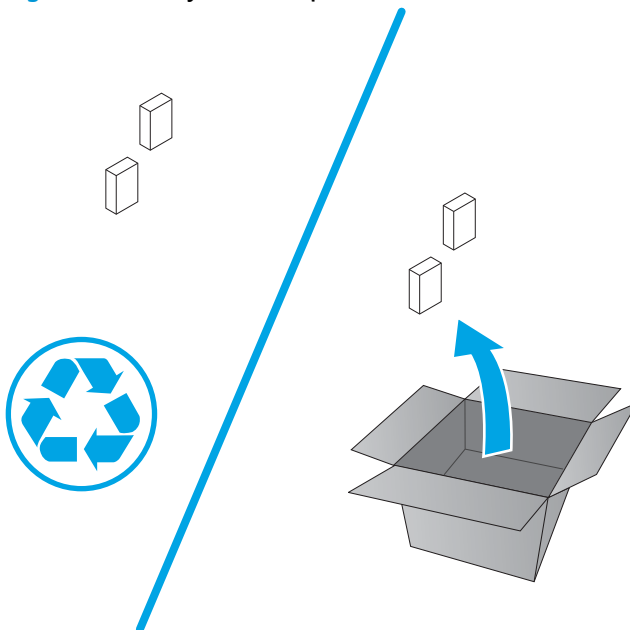
### Step 2: Unpack the replacement assembly

Unpack the replacement part from the packaging.

<http://www8.hp.com/us/en/hp-information/environment/product-recycling.html>

 **NOTE:** HP recommends responsible disposal of the defective part.

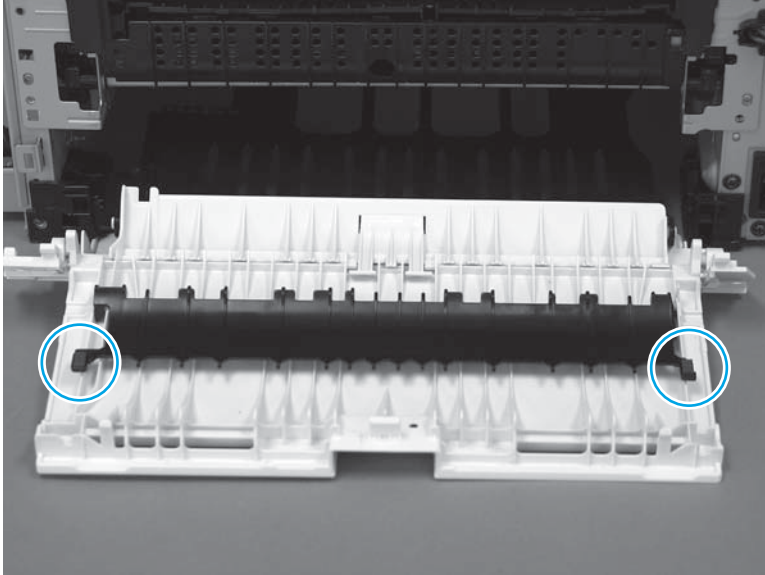
### Figure 1-57 Recycle and unpack



### Step 3: Install the damper sheets

- ▲ Remove the protective backing to expose the adhesive side of the damper sheets, and then install them on the rear cover.

**Figure 1-58** Install the damper sheets



## Removal and replacement: Rear USB cover

- [Introduction](#)
- [Step 1: Remove the rear USB cover](#)
- [Step 2: Unpack the replacement assembly](#)
- [Step 3: Install the rear USB cover](#)


### Introduction

This document provides the procedures to remove and replace the rear USB cover.

### Before performing service

#### Turn the printer power off

- Disconnect the power cable.

 **WARNING!** To avoid damage to the printer, turn the printer off, wait 30 seconds, and then remove the power cable before attempting to service the printer.

Use the table below to identify the correct part number for your printer. To order the part, go to [www.hp.com/buy/parts](http://www.hp.com/buy/parts).

Rear USB cover part number	
RC4-3298-000CN	Rear USB cover, small (M402/M403)
RC4-3299-000CN	Rear USB cover, small (M426/M427)

### Required tools

- No special tools are needed to remove or install this assembly.

### After performing service

#### Turn the printer power on

- Connect the power cable.
- Use the power switch to turn the power on.

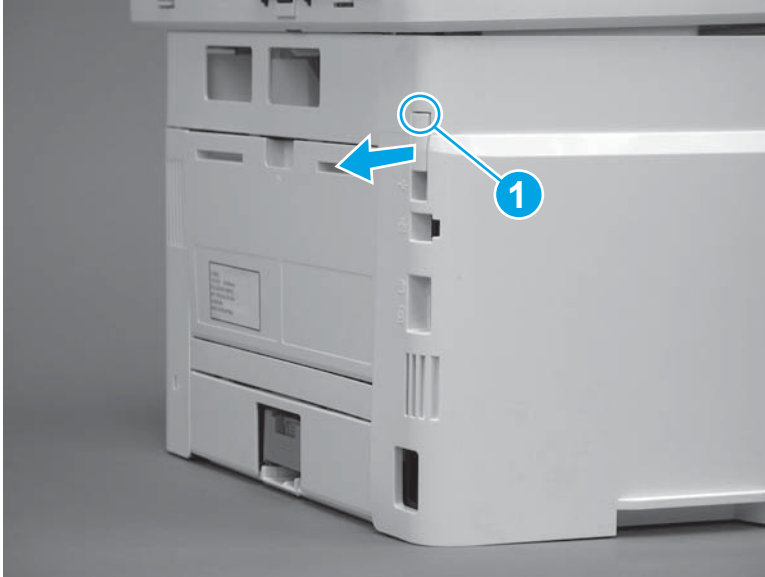
### Post service test

No post service test are available for this assembly.

### Step 1: Remove the rear USB cover

1. Use a finger to release two tabs (callout 1), and then pull the cover straight off of the printer.

**Figure 1-59** Pull the cover straight off



2. Remove the cover.



**NOTE:** For network models, also remove the network port cover (not shown; RC4-2907-000CN).

**Figure 1-60** Remove the cover



### Step 2: Unpack the replacement assembly

Unpack the replacement part from the packaging.

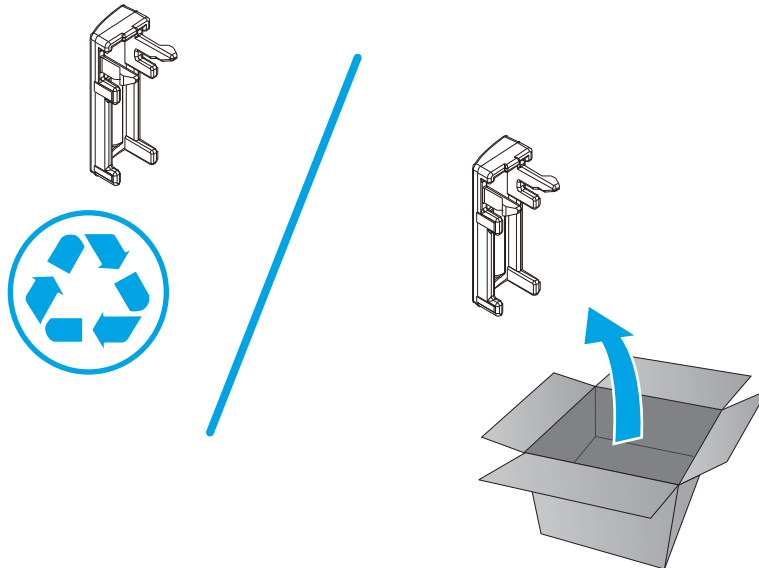
<http://www8.hp.com/us/en/hp-information/environment/product-recycling.html>



**NOTE:** HP recommends responsible disposal of the defective part.



**Figure 1-61** Recycle and unpack



**Step 3: Install the rear USB cover**

1. Align the tabs on the cover with the slots in the left cover.

**Figure 1-62** Align the tabs on the cover



2. Push the cover straight on to the printer to install it.

 **NOTE:** For network models, also install the network port cover (not shown; RC4-2907-000CN).

**Figure 1-63** Install the cover



## Removal and replacement: Support shaft

- [Introduction](#)
- [Step 1: Remove the support shaft](#)
- [Step 2: Unpack the replacement assembly](#)
- [Step 3: Install the support shaft](#)


### Introduction

This document provides the procedures to remove and replace the toner-cartridge door support shaft.

### Before performing service

#### Turn the printer power off

- Disconnect the power cable.

 **WARNING!** To avoid damage to the printer, turn the printer off, wait 30 seconds, and then remove the power cord before attempting to service the printer.

Use the table below to identify the correct part number for your printer. To order the part, go to [www.hp.com/buy/parts](http://www.hp.com/buy/parts).

Support shaft part number	
RC4-3002-000CN	Shaft, support

### Required tools

- Optional: Small flat-blade screwdriver.

### After performing service

#### Turn the printer power on

- Connect the power cable.
- Use the power switch to turn the power on.

### Post service test

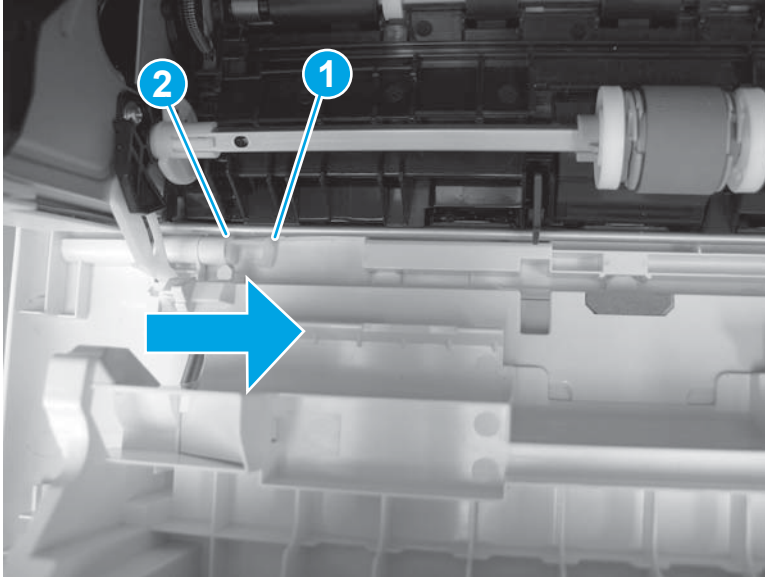
Make sure that toner toner-cartridge door correctly opens and closes.

### Step 1: Remove the support shaft

1. Release the support shaft (callout 1), and then slide it toward the center of the door (callout 2).

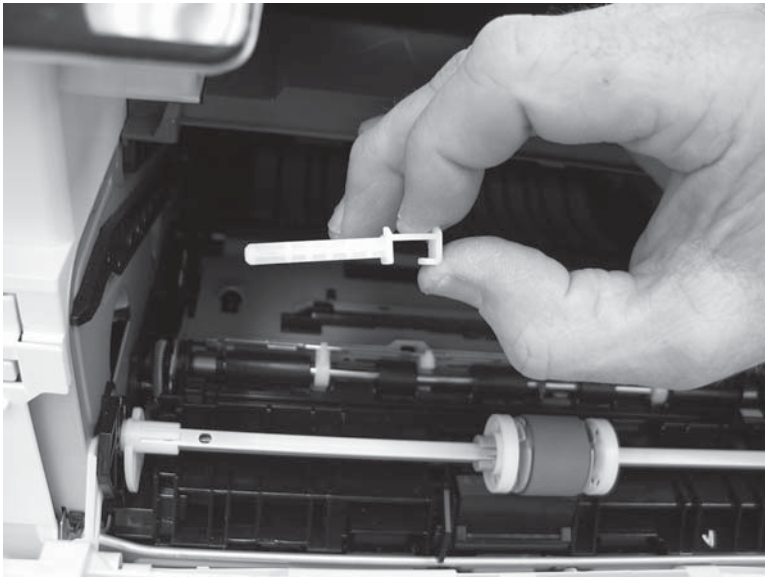
 **TIP:** It might be easier to release the support shaft by using a small flat-blade screwdriver.

**Figure 1-64** Release the support shaft



2. Remove the support shaft.

**Figure 1-65** Remove the support shaft



### Step 2: Unpack the replacement assembly

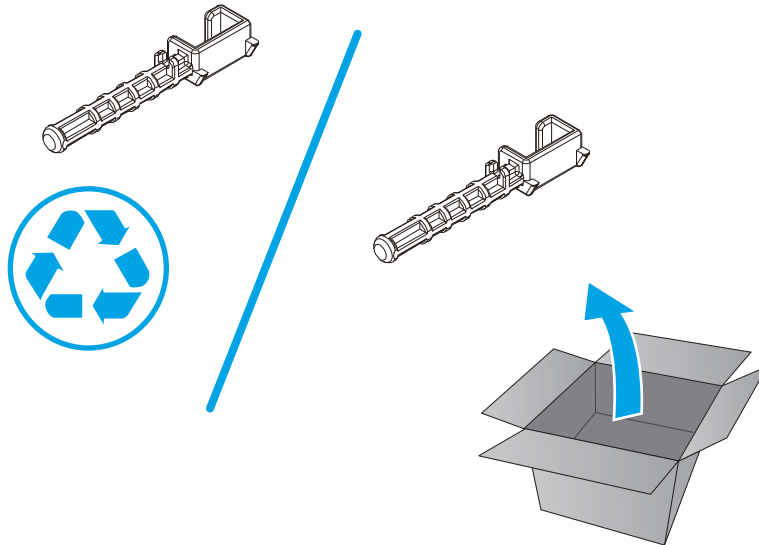
Unpack the replacement part from the packaging.

<http://www8.hp.com/us/en/hp-information/environment/product-recycling.html>



**NOTE:** HP recommends responsible disposal of the defective part.

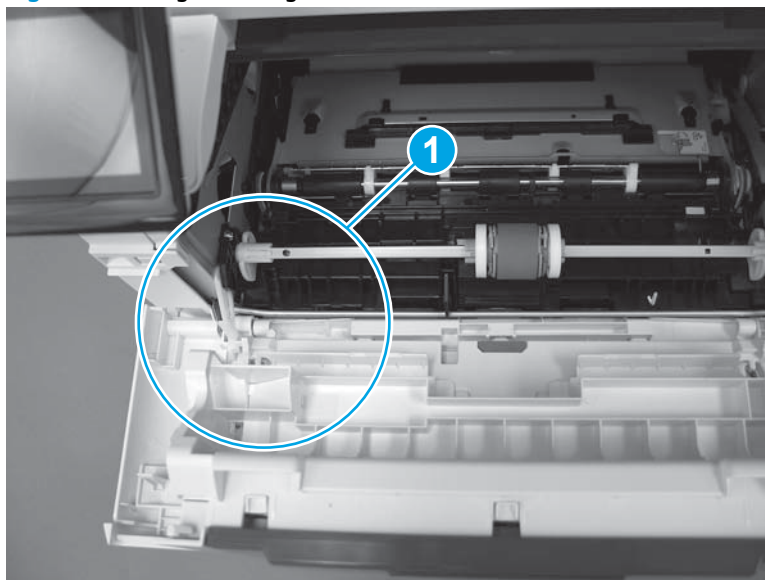
**Figure 1-66** Recycle and unpack




**Step 3: Install the support shaft**

1. Position the support shaft on the door, and then align the left-side hinge on the door with the hole in the chassis (callout 1).

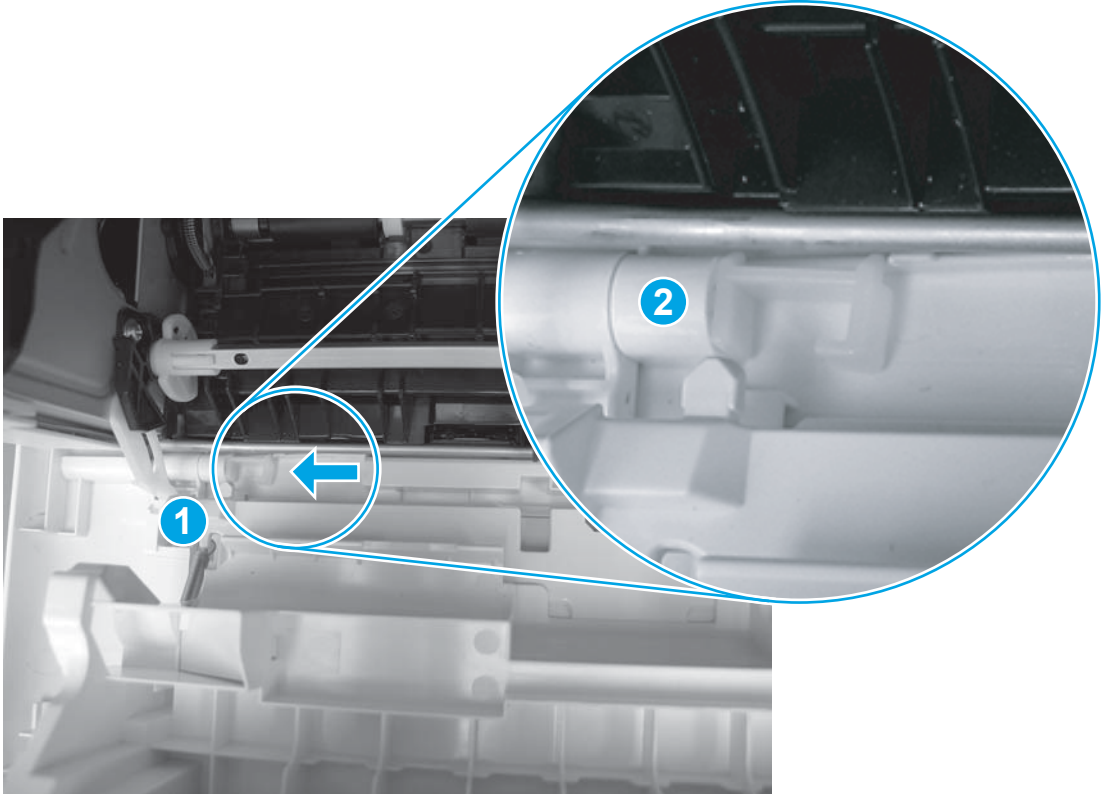
**Figure 1-67** Align the hinge



2. Push the shaft towards the left side of the printer to install it (callout 1).

 **Reinstallation tip:** Make sure that the support shaft is fully installed and correctly orientated (callout 2) so that it will not interfere with the door opening and closing.

**Figure 1-68** Install the support shaft



## Removal and replacement: Cartridge door assembly

- [Introduction](#)
- [Step 1: Remove the cartridge door assembly](#)
- [Step 2: Unpack the replacement assembly](#)
- [Step 3: Install the cartridge door assembly](#)


### Introduction

This document provides the procedures to remove and replace the cartridge door assembly.

### Before performing service

#### Turn the printer power off

- Disconnect the power cable.

 **WARNING!** To avoid damage to the printer, turn the printer off, wait 30 seconds, and then remove the power cable before attempting to service the printer.

Use the table below to identify the correct part number for your printer. To order the part, go to [www.hp.com/buy/parts](http://www.hp.com/buy/parts).

Cartridge door assembly part number	
RM2-5390-000CN	Cartridge door assembly (M403/M402 models)
RM2-5436-000CN	Cartridge door assembly (M403/M402 NFC models)
RM2-5408-000CN	Cartridge door assembly (M427/M426 models)
RM2-5435-000CN	Cartridge door assembly (M427/M426 NFC models)

### Required tools

- Small flat-blade screwdriver.

### After performing service


#### Turn the printer power on

- Connect the power cable.
- Use the power switch to turn the power on.

### Post service test

Make sure that the cartridge door assembly correctly opens and closes.

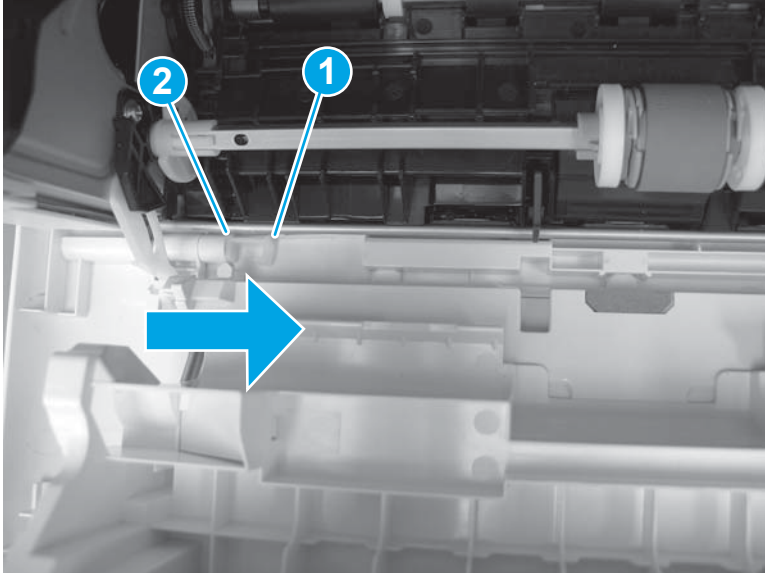
### Step 1: Remove the cartridge door assembly

 **NOTE:** If the toner cartridge was not removed prior to servicing the printer, remove it now.

1. Release one tab (callout 1), and then slide shaft (callout 2) in the direction the arrow indicates and remove it.

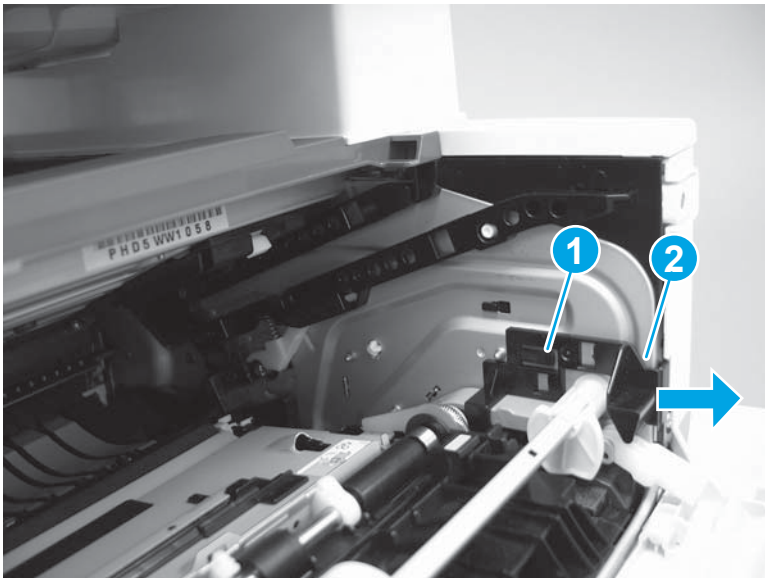
 **TIP:** It might be easier to release the support shaft by using a small flat-blade screwdriver.

**Figure 1-69** Release the support shaft



2. Release one tab (callout 1), and then slide the guide (callout 2) in the direction the arrow indicates and remove it.

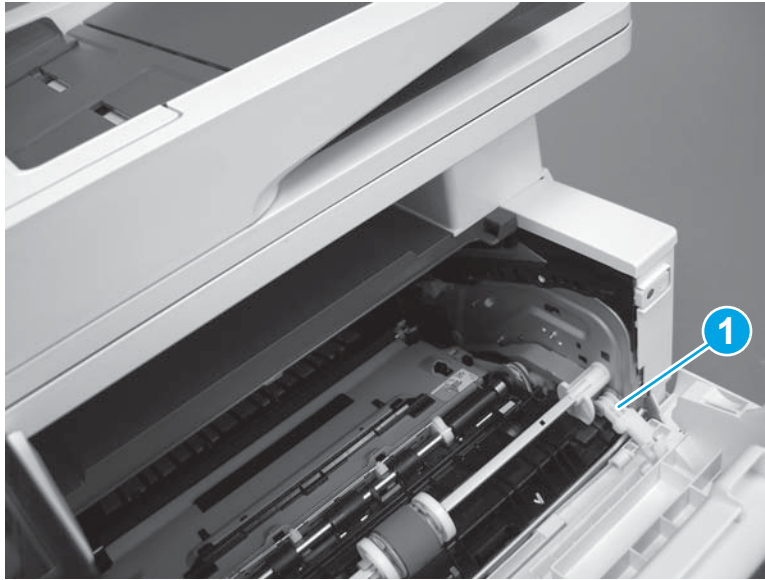
**Figure 1-70** Remove the guide





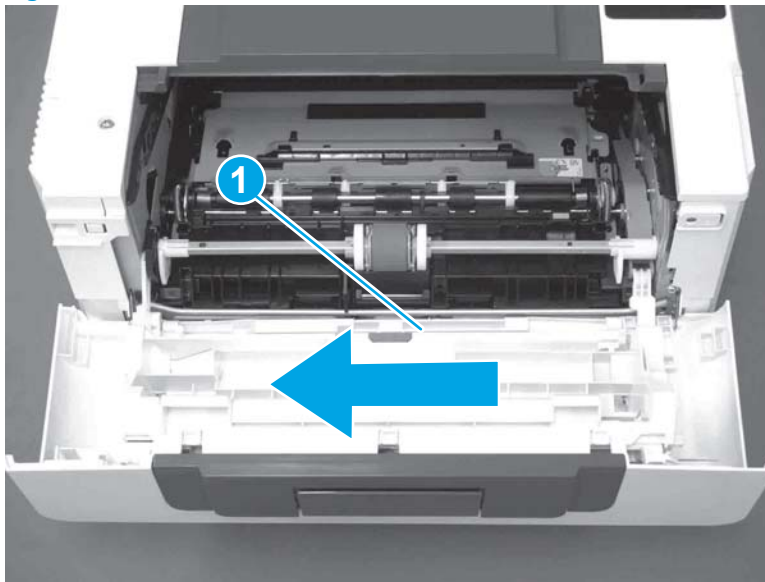
3. Remove the link arm (callout 1).

**Figure 1-71** Remove the link arm



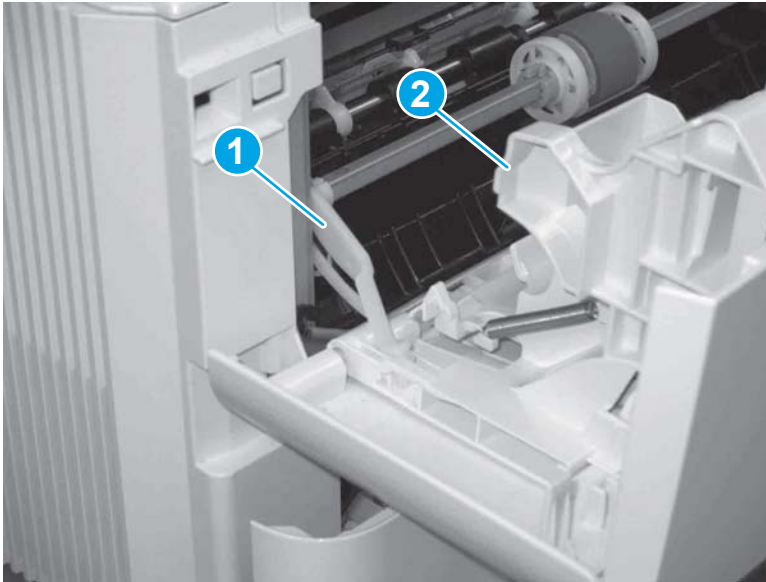
4. Slide the cartridge door assembly (callout 1) in the direction the arrow indicates and remove it.

**Figure 1-72** Remove the door



5. Remove the link (callout 1) from the cartridge door assembly (callout 2).

**Figure 1-73** Release the left-side retainer arm



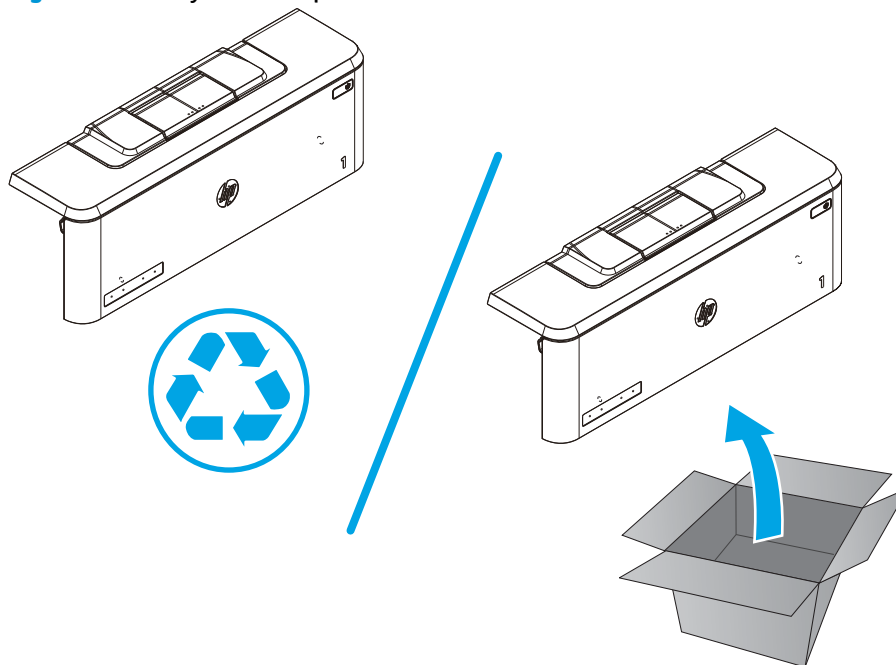
### Step 2: Unpack the replacement assembly

Unpack the replacement part from the packaging.


<http://www8.hp.com/us/en/hp-information/environment/product-recycling.html>

 **NOTE:** HP recommends responsible disposal of the defective part.

**Figure 1-74** Recycle and unpack

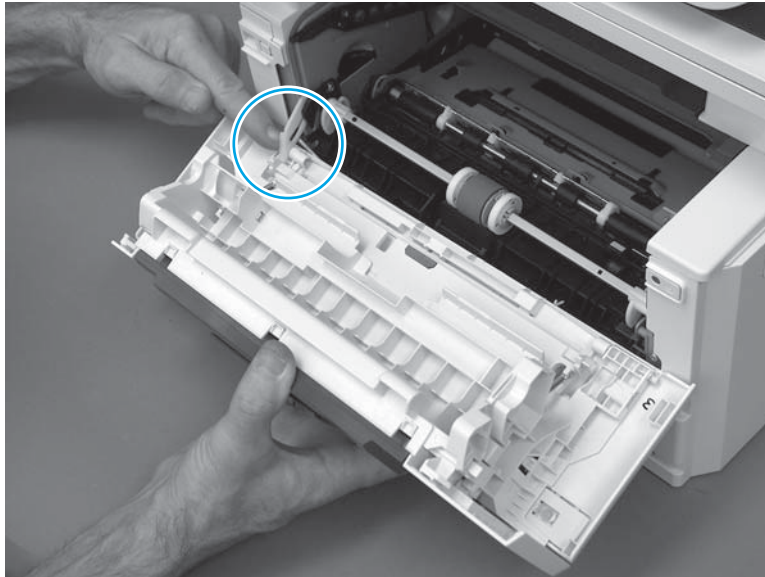


### Step 3: Install the cartridge door assembly

 **Reinstallation tip:** After a replacement door is installed, make sure to install the nameplate (supplied in the kit) corresponding to the printer name on the door.

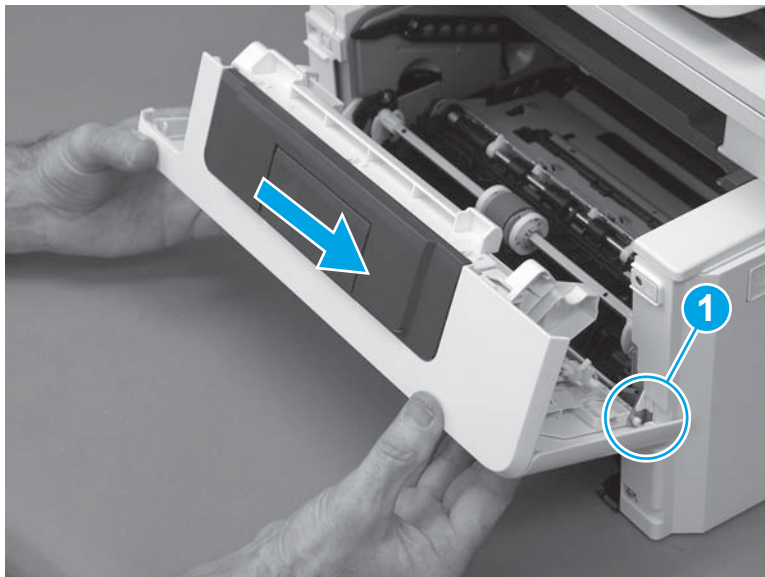
1. Position the door close to the printer, and then engage the keyed pin on the left-side retainer arm with the hole in the door.

**Figure 1-75** Engage the left-side retainer arm



2. Engage the right-side door hinge pin with the hole in the chassis (callout 1).

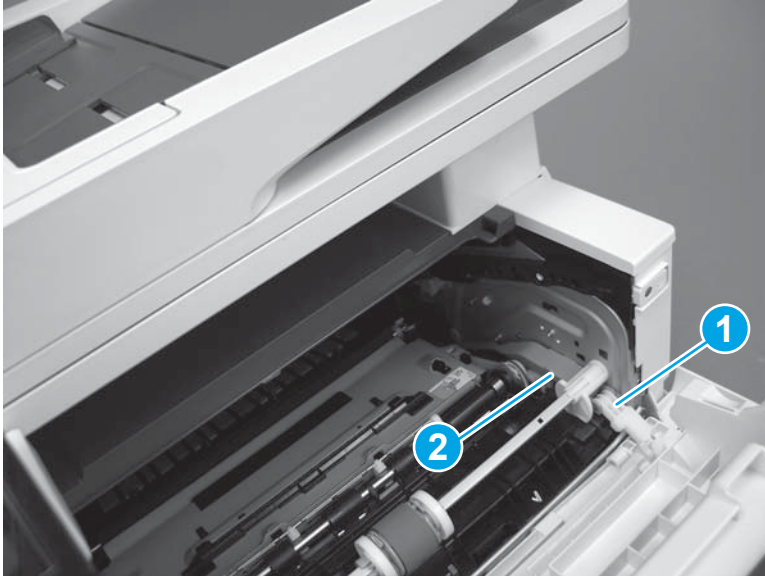
**Figure 1-76** Install the door



3. Install the link (callout 1).

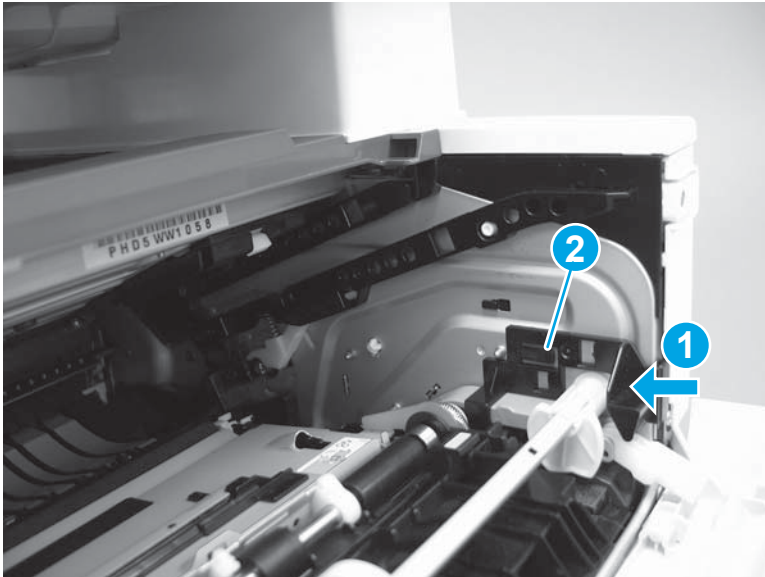
 **IMPORTANT:** Make sure that the link snaps into place on the arm (callout 2). The link actuates the fuser pressure-release mechanism.

**Figure 1-77** Install the pressure-release link



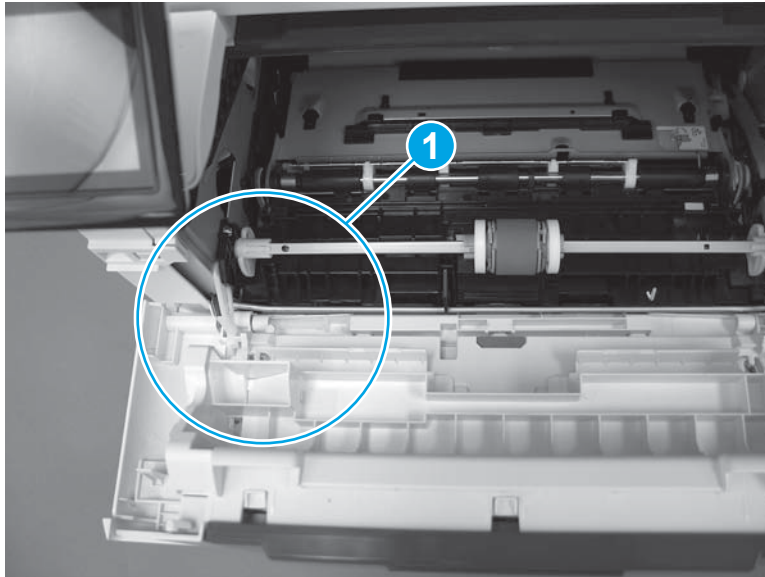
4. Slide the guide into the printer (callout 1), and then make sure that the tab (callout 2) snaps into place to secure the guide to the chassis.

**Figure 1-78** Install the guide




5. Position the shaft on the door, and then align the left-side hinge on the door with the hole in the chassis (callout 1).

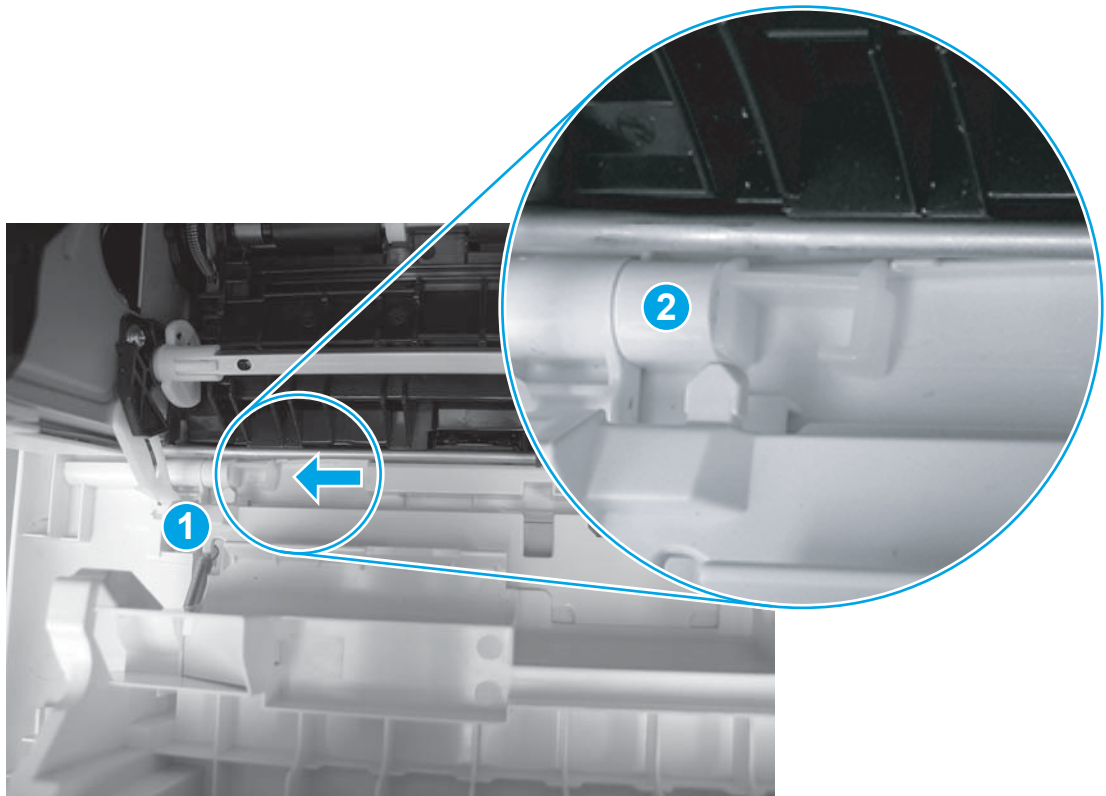
**Figure 1-79** Align the hinge



6. Push the shaft towards the left side of the printer to install it (callout 1).

 **Reinstallation tip:** Make sure that the support shaft is fully installed and correctly orientated (callout 2) so that it will not interfere with the door opening and closing.

**Figure 1-80** Install the support shaft



## Removal and replacement: Pressure-release link

- [Introduction](#)
- [Step 1: Remove the cartridge door assembly](#)
- [Step 2: Remove the pressure-release link](#)
- [Step 3: Unpack the replacement assembly](#)
- [Step 4: Install the pressure-release link](#)
- [Step 5: Install the cartridge door assembly](#)


### Introduction

This document provides the procedures to remove and replace the pressure-release link arm.

### Before performing service

#### Turn the printer power off

- Disconnect the power cable.

 **WARNING!** To avoid damage to the printer, turn the printer off, wait 30 seconds, and then remove the power cable before attempting to service the printer.

Use the table below to identify the correct part number for your printer. To order the part, go to [www.hp.com/buy/parts](http://www.hp.com/buy/parts).

Pressure-release link part number	
RC4-4479-000CN	Link, pressure-release link

### Required tools

- Small flat-blade screwdriver.

### After performing service

#### Turn the printer power on

- Connect the power cable.
- Use the power switch to turn the power on.

### Post service test

Make sure that the toner-cartridge door correctly opens and closes.

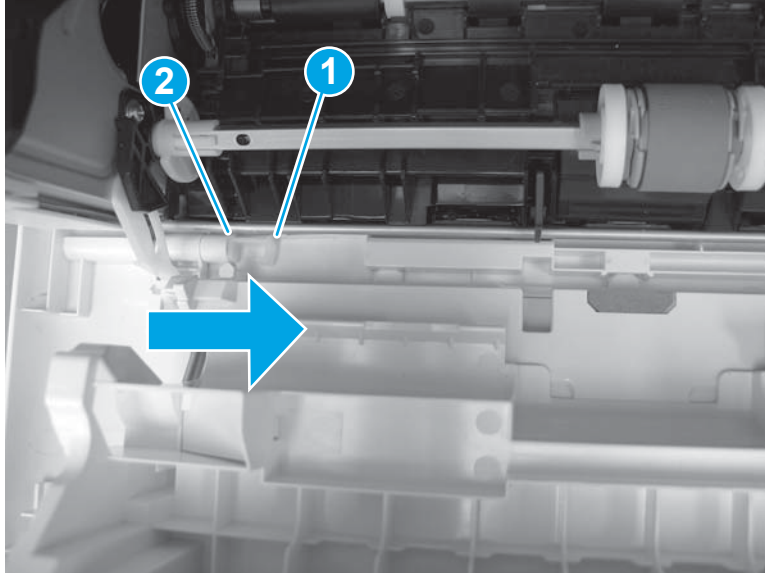
### Step 1: Remove the cartridge door assembly

 **NOTE:** If the toner cartridge was not removed prior to servicing the printer, remove it now.

1. Release one tab (callout 1), and then slide shaft (callout 2) in the direction the arrow indicates and remove it.

 **TIP:** It might be easier to release the support shaft by using a small flat-blade screwdriver.

**Figure 1-81** Release the support shaft



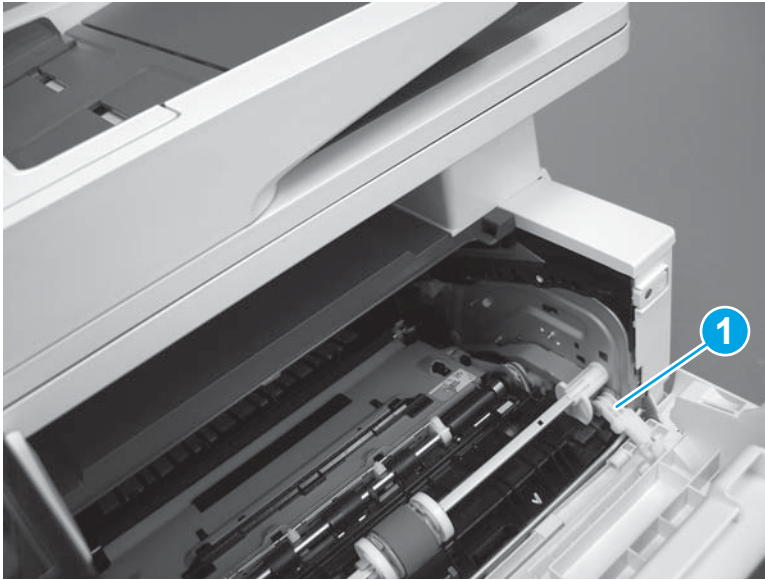
2. Release one tab (callout 1), and then slide the guide (callout 2) in the direction the arrow indicates and remove it.

**Figure 1-82** Remove the guide



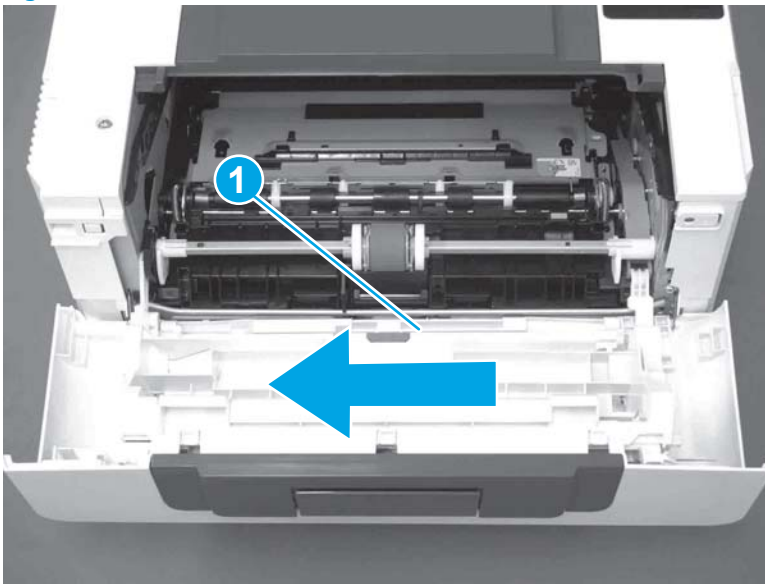
3. Remove the link arm (callout 1).

**Figure 1-83** Remove the link arm



4. Slide the cartridge door assembly (callout 1) in the direction the arrow indicates and remove it.

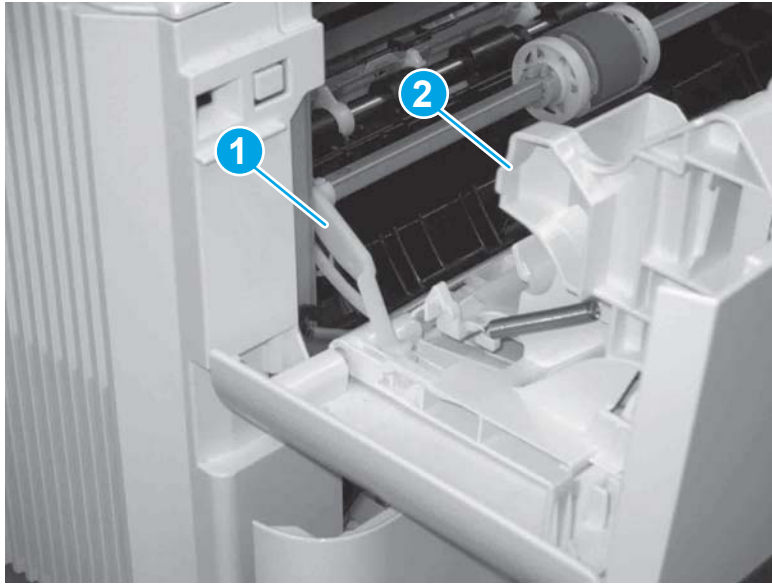
**Figure 1-84** Remove the door





5. Remove the link (callout 1) from the cartridge door assembly (callout 2).

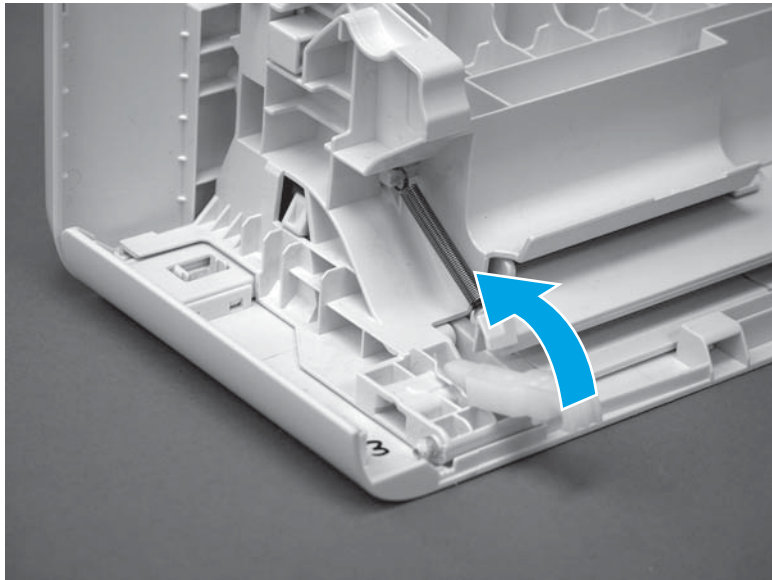
**Figure 1-85** Release the left-side retainer arm



**Step 2: Remove the pressure-release link**

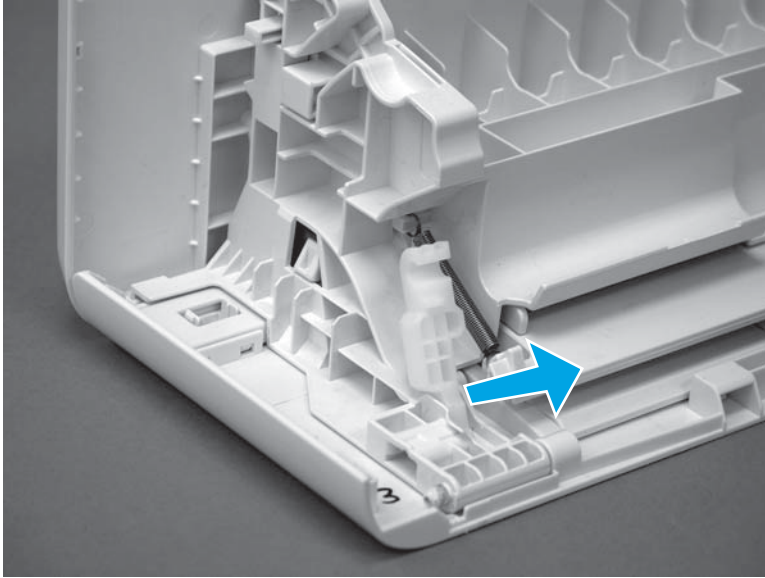
1. Rotate the pressure-release link until the keyed portion of the pin aligns with the slot in the holder.

**Figure 1-86** Release the pressure-release link



2. Remove the pressure-release link.

**Figure 1-87** Remove the pressure-release link



### Step 3: Unpack the replacement assembly

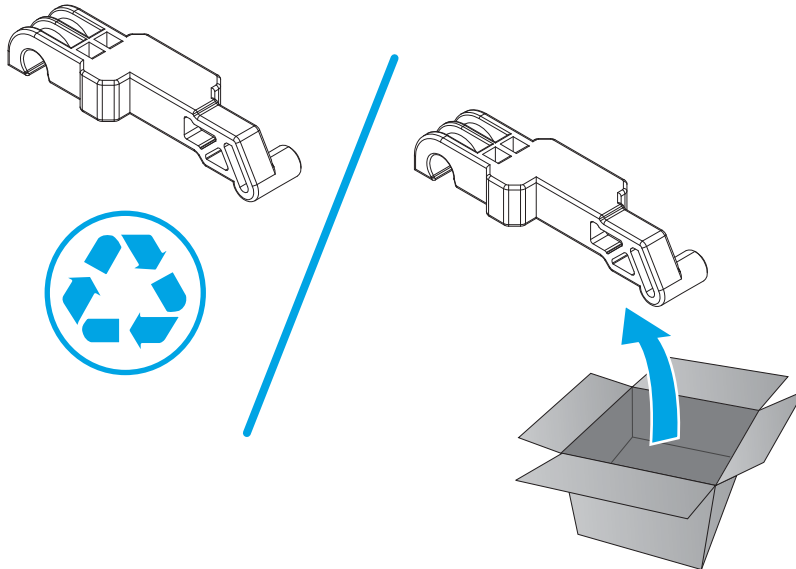
Unpack the replacement part from the packaging.

<http://www8.hp.com/us/en/hp-information/environment/product-recycling.html>



**NOTE:** HP recommends responsible disposal of the defective part.

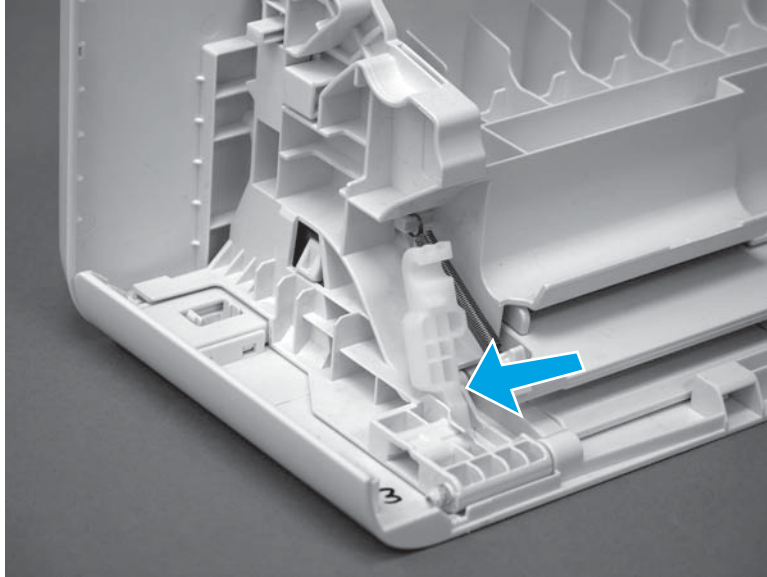
**Figure 1-88** Recycle and unpack



### Step 4: Install the pressure-release link

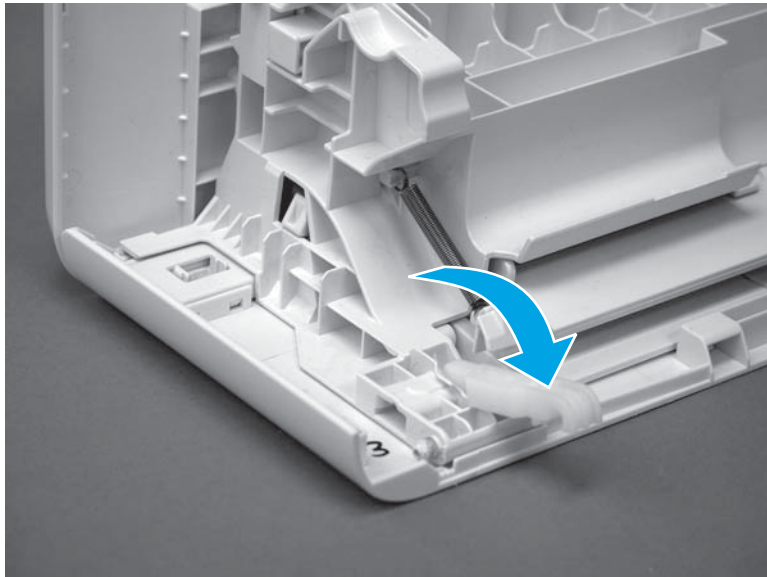
1. Align the keyed portion of the pin with the slot in the holder, and then install the link.

**Figure 1-89** Align the keyed portion of the pin




2. Rotate the pressure-release link to engage it with the door.

**Figure 1-90** Install the pressure-release link

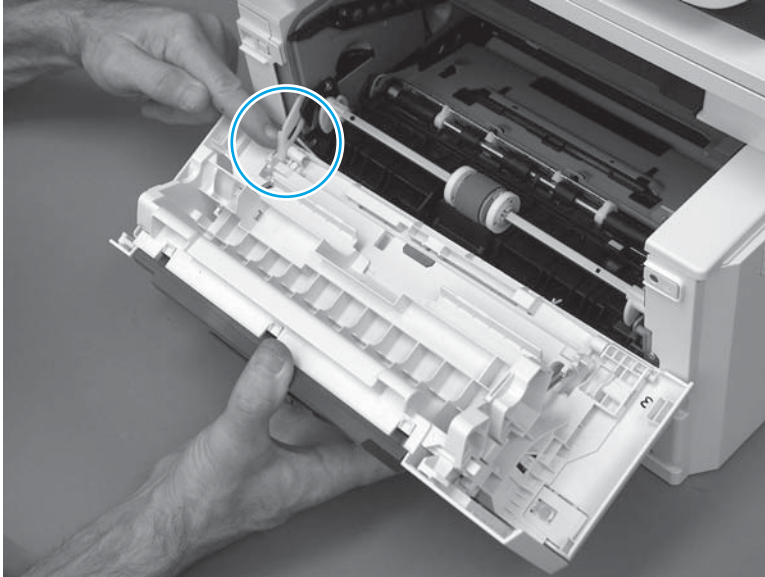


### Step 5: Install the cartridge door assembly

 **Reinstallation tip:** After a replacement door is installed, make sure to install the nameplate (supplied in the kit) corresponding to the printer name on the door.

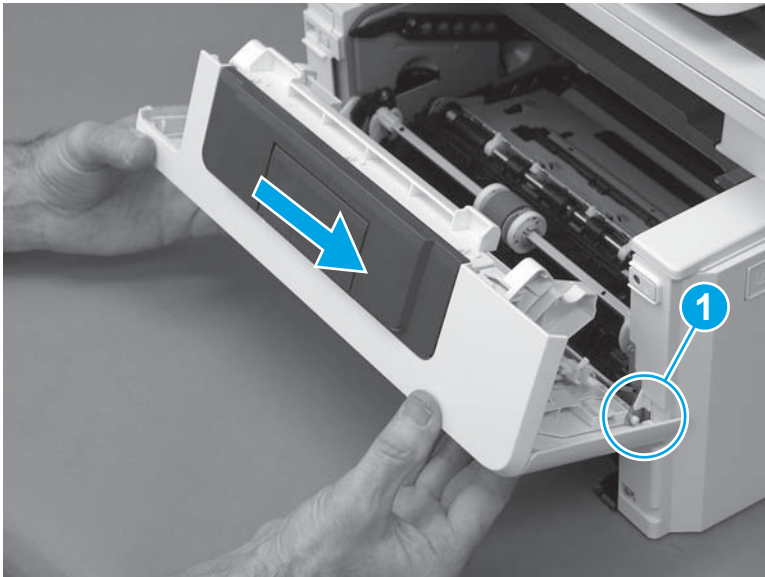
1. Position the door close to the printer, and then engage the keyed pin on the left-side retainer arm with the hole in the door.

**Figure 1-91** Engage the left-side retainer arm



2. Engage the right-side door hinge pin with the hole in the chassis (callout 1).

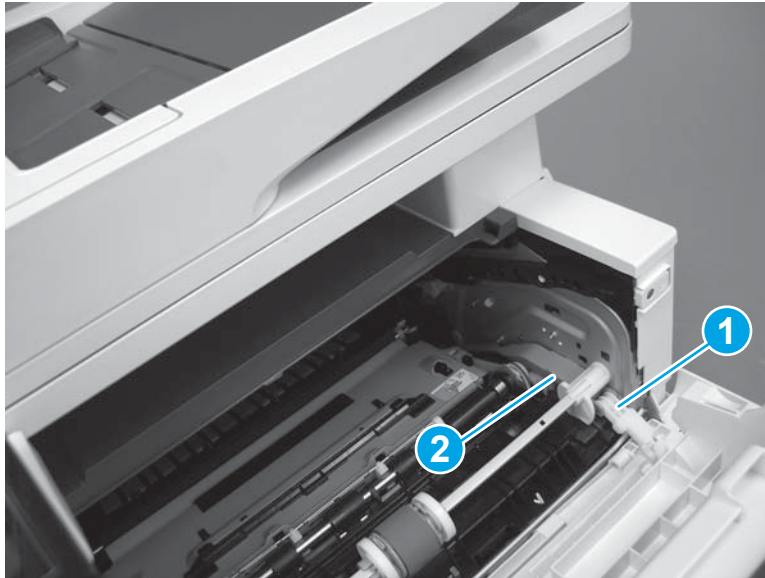
**Figure 1-92** Install the door



3. Install the link (callout 1).

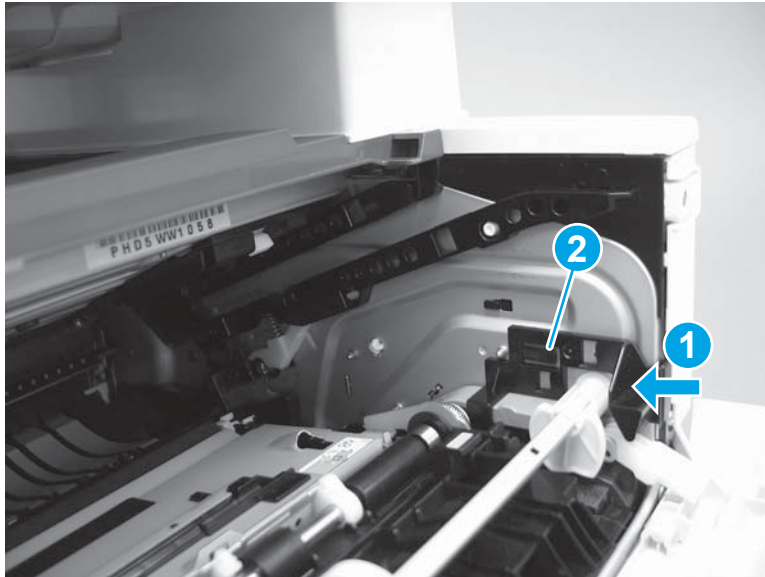
 **IMPORTANT:** Make sure that the link snaps into place on the arm (callout 2). The link actuates the fuser pressure-release mechanism.

**Figure 1-93** Install the pressure-release link



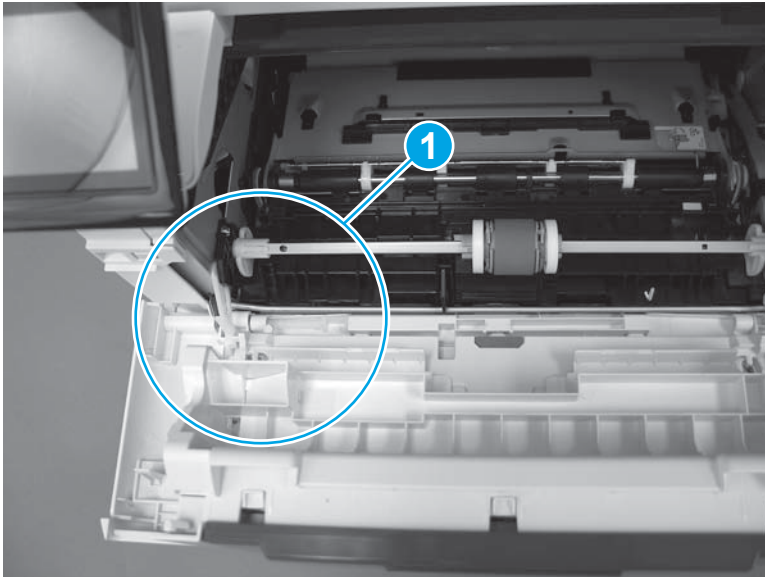
4. Slide the guide into the printer (callout 1), and then make sure that the tab (callout 2) snaps into place to secure the guide to the chassis.

**Figure 1-94** Install the guide




5. Position the shaft on the door, and then align the left-side hinge on the door with the hole in the chassis (callout 1).

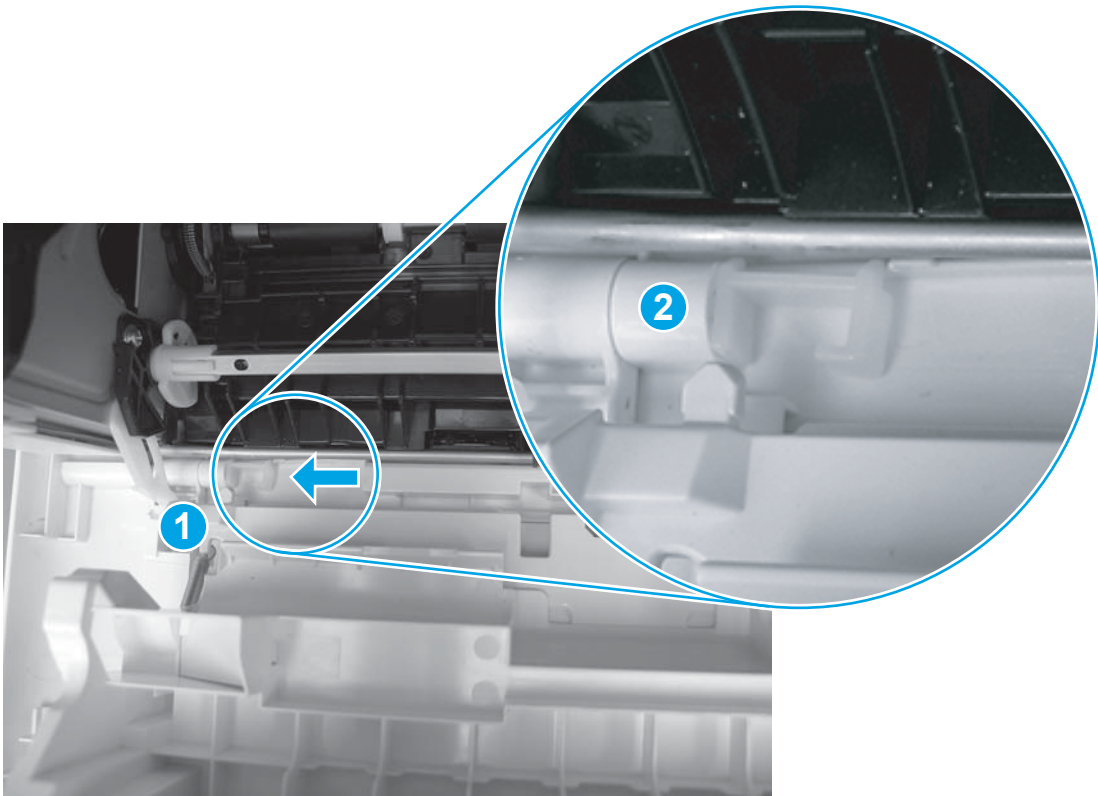
**Figure 1-95** Align the hinge



6. Push the shaft towards the left side of the printer to install it (callout 1).

 **Reinstallation tip:** Make sure that the support shaft is fully installed and correctly orientated (callout 2) so that it will not interfere with the door opening and closing.

**Figure 1-96** Install the support shaft



## Removal and replacement: Left cover

- [Introduction](#)
- [Step 1: Remove the rear USB cover](#)
- [Step 2: Remove the rear network cover \(M402d and M403d\)](#)
- [Step 3: Remove Tray 2](#)
- [Step 4: Remove the cartridge door assembly](#)
- [Step 5: Remove the left cover](#)
- [Step 6: Unpack the replacement assembly](#)
- [Step 7: Install the left cover](#)
- [Step 8: Install the cartridge door assembly](#)
- [Step 9: Install Tray 2](#)
- [Step 10: Install the rear network cover \(M402d and M403d\)](#)
- [Step 11: Install the rear USB cover](#)


### Introduction

This document provides the procedures to remove and replace the left cover.

### Before performing service

#### Turn the printer power off

- Disconnect the power cable.

 **WARNING!** To avoid damage to the printer, turn the printer off, wait 30 seconds, and then remove the power cable before attempting to service the printer.

Use the table below to identify the correct part number for your printer. To order the part, go to [www.hp.com/buy/parts](http://www.hp.com/buy/parts).

Left cover part number	
<b>RL2-0673-000CN</b>	Left cover (M403/M402 models)
<b>RL2-0674-000CN</b>	Left cover (M427/M426 models)

### Required tools

- #2 Phillips screwdriver with a magnetic tip.

## After performing service

### Turn the printer power on

- Connect the power cable.
- Use the power switch to turn the power on.

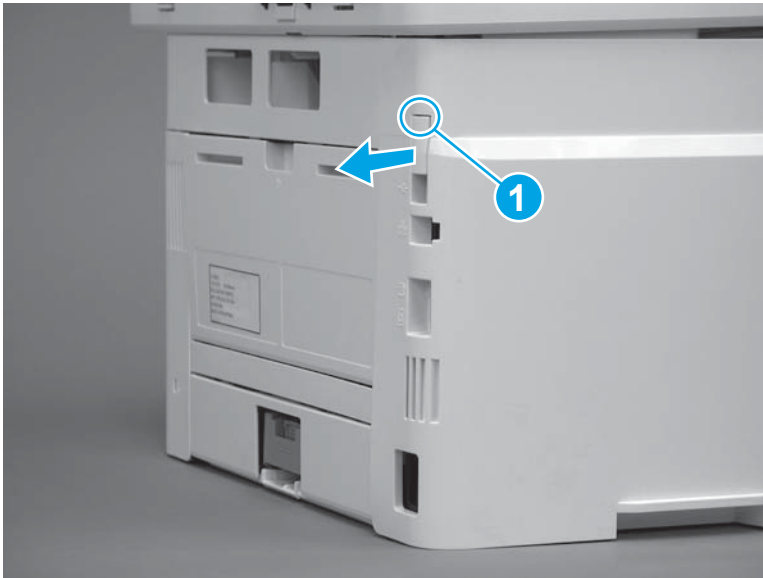
### Post service test

Make sure that the printer initializes to a **Ready** state.

### Step 1: Remove the rear USB cover

1. Use a finger to release two tabs (callout 1), and then pull the cover straight off of the printer.

**Figure 1-97** Pull the cover straight off





2. Remove the cover.

 **NOTE:** For network models, also remove the network port cover (not shown; RC4-2907-000CN).

**Figure 1-98** Remove the cover

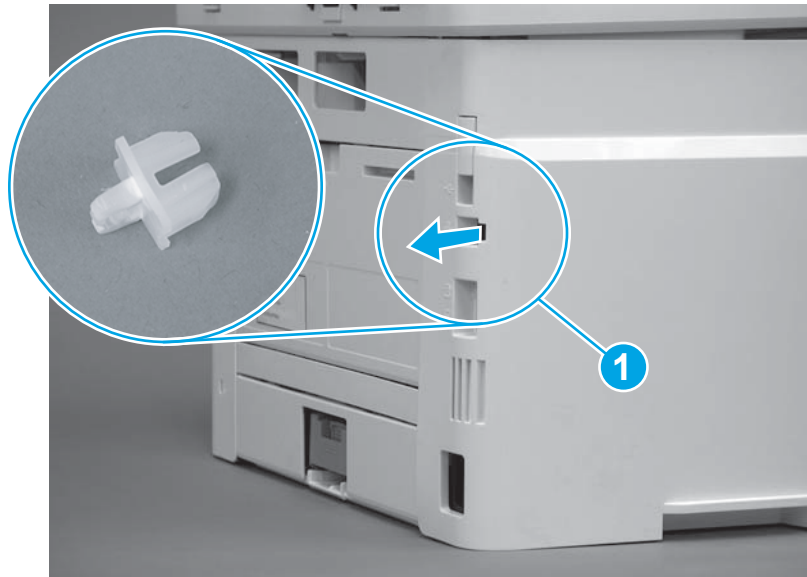


### Step 2: Remove the rear network cover (M402d and M403d)

M402d and M403d only.

- ▲ Grasp the network cover (callout 1) and pull the cover straight off of the printer.

**Figure 1-99** Pull the cover straight off



### Step 3: Remove Tray 2

- ▲ Pull the tray straight out of the printer to remove it.

**Figure 1-100** Remove the tray



**Step 4: Remove the cartridge door assembly**



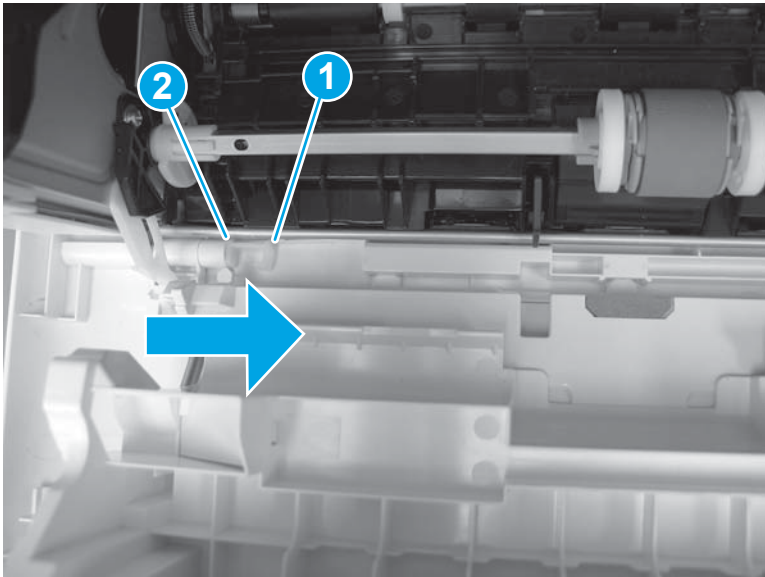
**NOTE:** If the toner cartridge was not removed prior to servicing the printer, remove it now.

1. Release one tab (callout 1), and then slide shaft (callout 2) in the direction the arrow indicates and remove it.



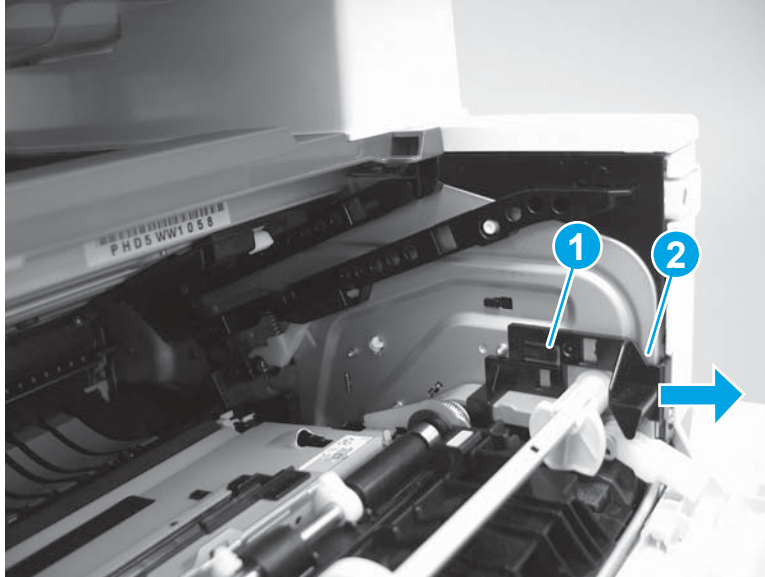
**TIP:** It might be easier to release the support shaft by using a small flat-blade screwdriver.

**Figure 1-101** Release the support shaft



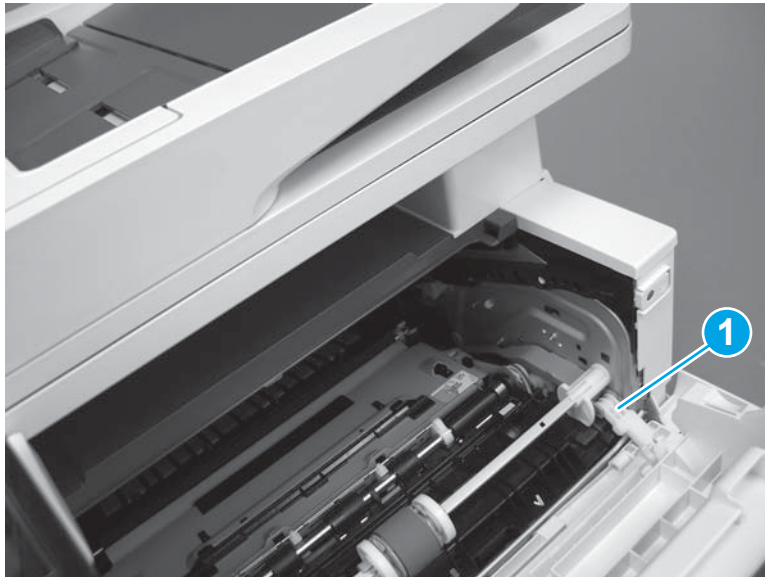
2. Release one tab (callout 1), and then slide the guide (callout 2) in the direction the arrow indicates and remove it.

**Figure 1-102** Remove the guide



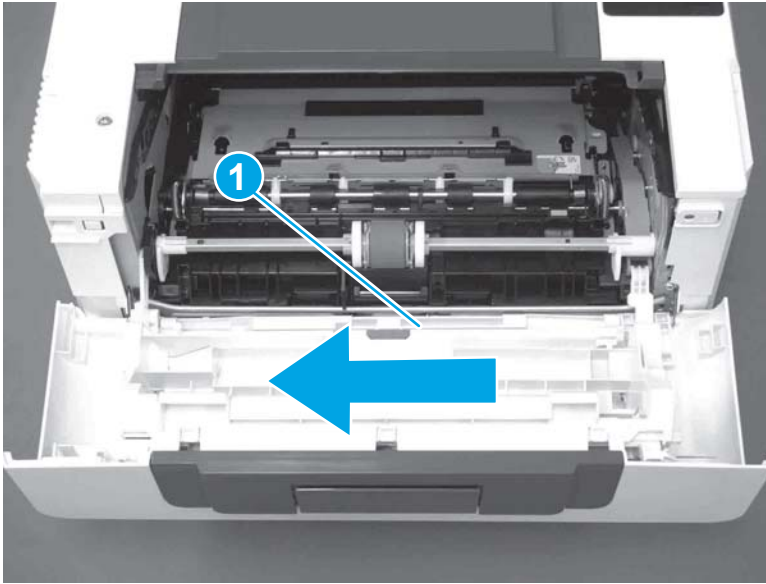
3. Remove the link arm (callout 1).

**Figure 1-103** Remove the link arm



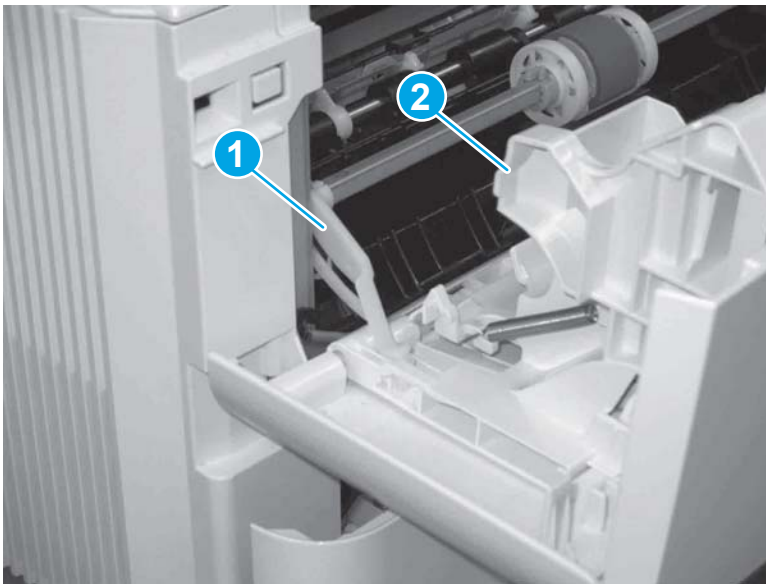
4. Slide the cartridge door assembly (callout 1) in the direction the arrow indicates and remove it.

**Figure 1-104** Remove the door



5. Remove the link (callout 1) from the cartridge door assembly (callout 2).

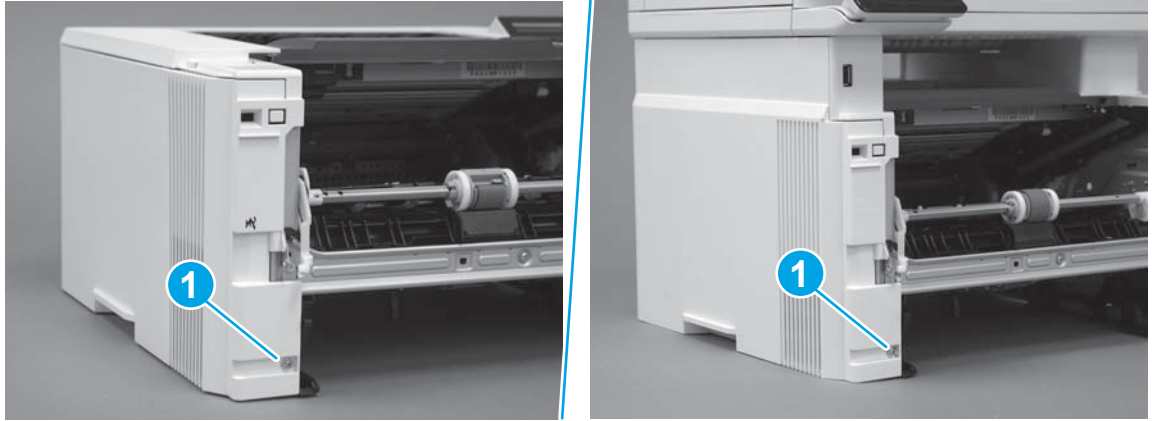
**Figure 1-105** Release the left-side retainer arm



### Step 5: Remove the left cover

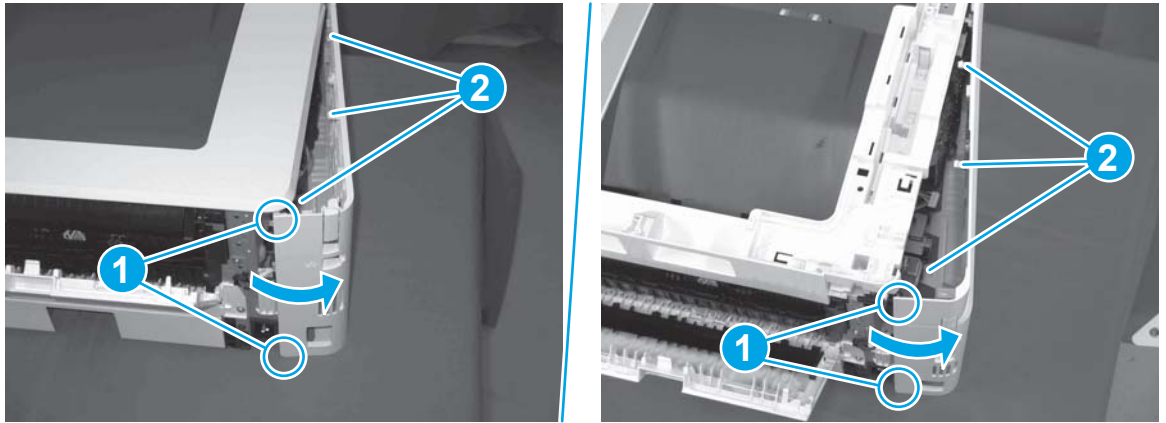
1. Remove one screw (callout 1).

**Figure 1-106** Remove one screw



2. Open the rear door, release two bosses (callout 1), and then release three tabs (callout 2).

**Figure 1-107** Release two bosses and three tabs

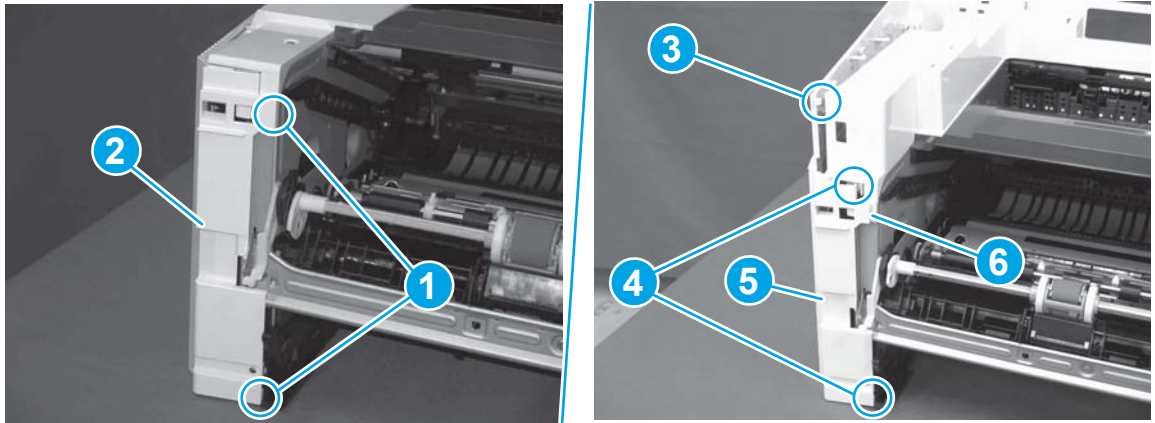


3. At the front of the printer, do one of the following:

- **M403/M402:** Release two bosses (callout 1), and then remove the cover (callout 2).
- **M427/M426:** Release one tab (callout 3), two bosses (callout 4), and then remove the cover (callout 5).

**CAUTION:** Be careful when releasing the upper bosses on the M427/M426 cover. One portion of the cover (callout 6) is fragile and is easily broken.

**Figure 1-108** Remove the cover



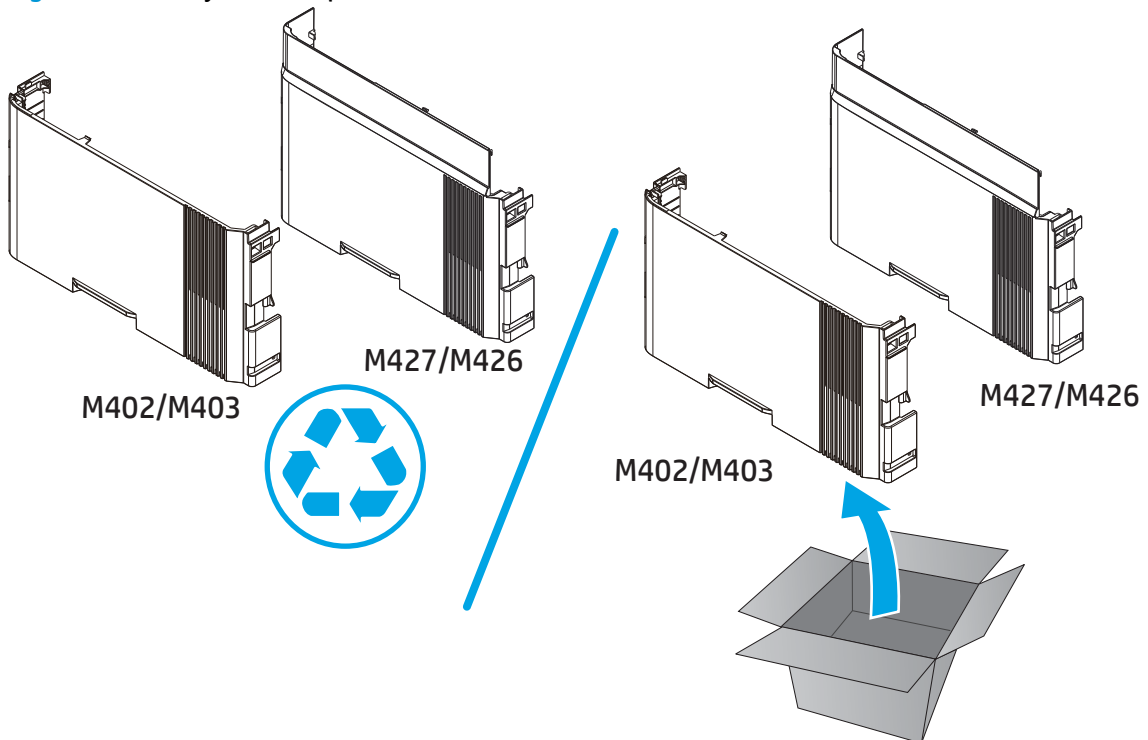
### Step 6: Unpack the replacement assembly

Unpack the replacement part from the packaging.

<http://www8.hp.com/us/en/hp-information/environment/product-recycling.html>

 **NOTE:** HP recommends responsible disposal of the defective part.

**Figure 1-109** Recycle and unpack

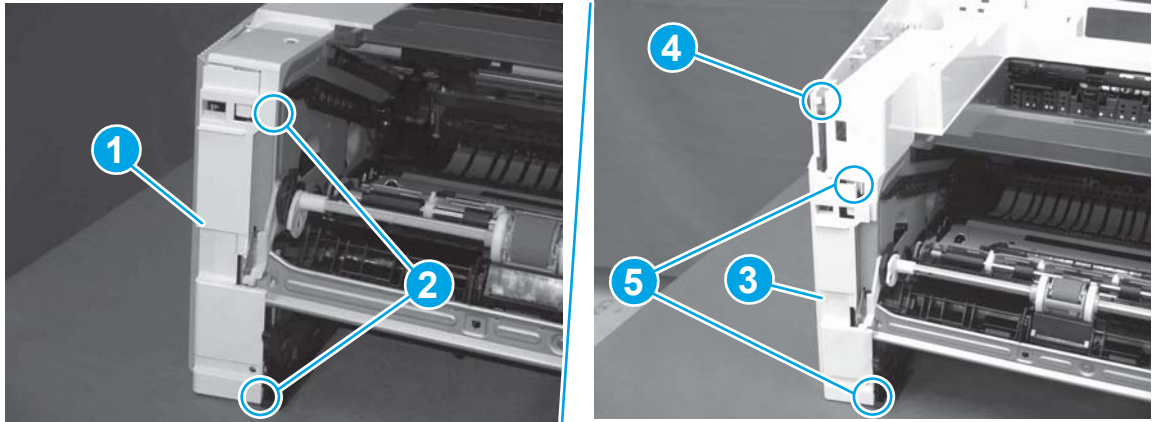


### Step 7: Install the left cover

1. At the front of the printer, do one of the following:

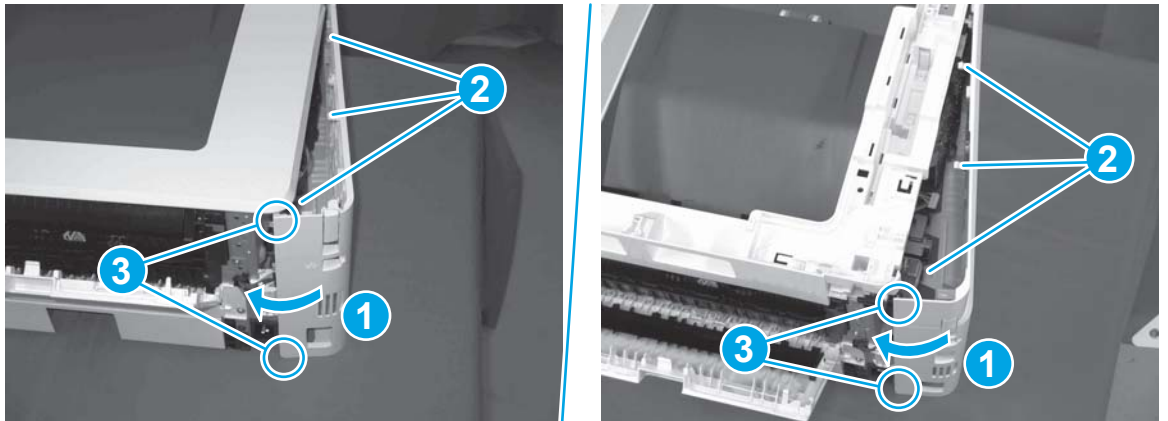
- **M403/M402:** Position the cover on the printer ( callout 1), and then engage two bosses (callout 2).
- **M427/M426:** Position the cover on the printer (callout 3), engage one tab (callout 4), and then engage two bosses (callout 4).

**Figure 1-110** Install the cover



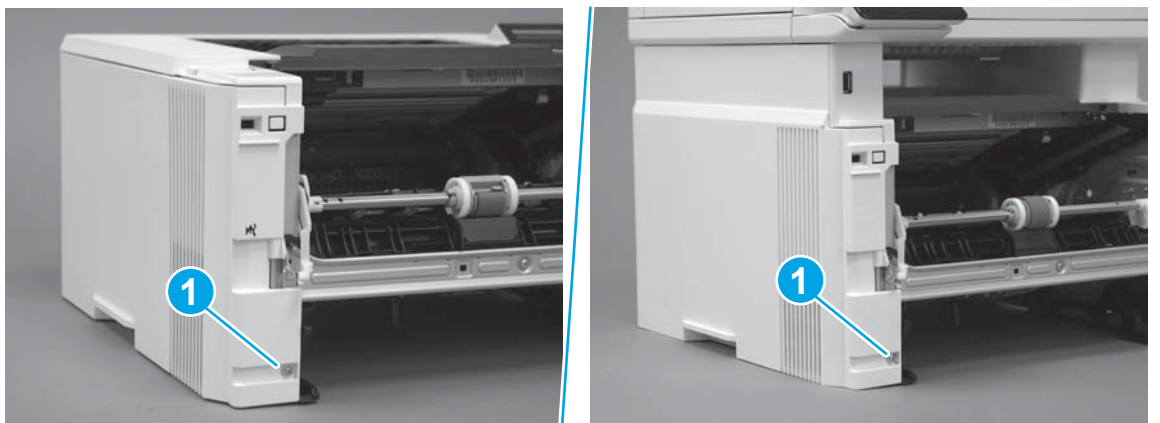
2. Carefully rotate the rear of the cover onto the printer (callout 1), engage three tabs (callout 2), and then engage two bosses (callout 3).

**Figure 1-111** Engage three tabs and two bosses




3. Install one screw (callout 1).

**Figure 1-112** Install one screw

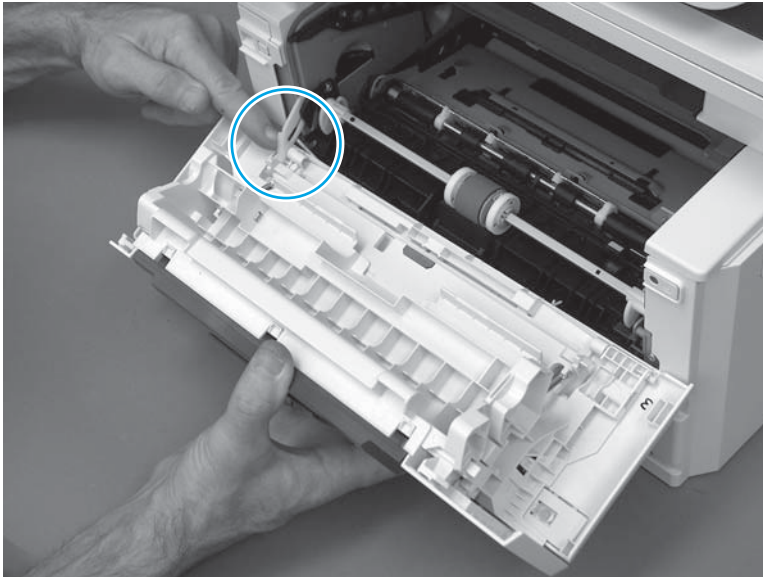


## Step 8: Install the cartridge door assembly

 **Reinstallation tip:** After a replacement door is installed, make sure to install the nameplate (supplied in the kit) corresponding to the printer name on the door.

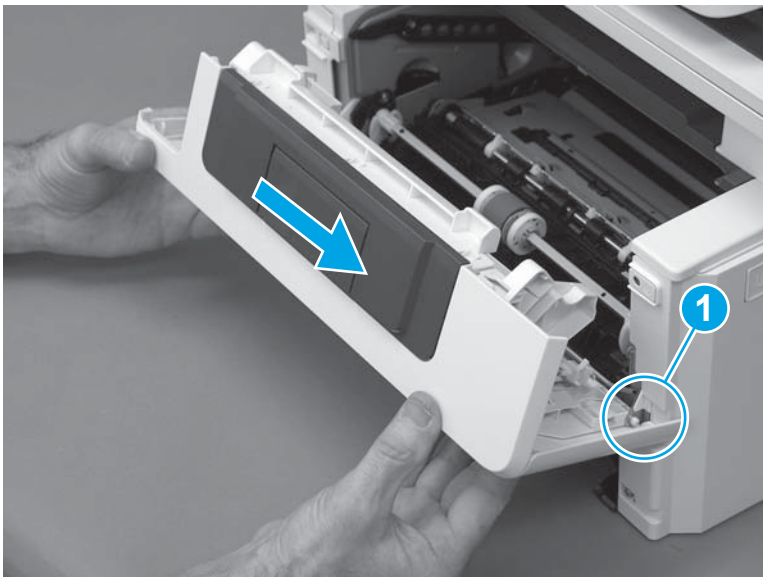
1. Position the door close to the printer, and then engage the keyed pin on the left-side retainer arm with the hole in the door.

**Figure 1-113** Engage the left-side retainer arm



2. Engage the right-side door hinge pin with the hole in the chassis (callout 1).

**Figure 1-114** Install the door

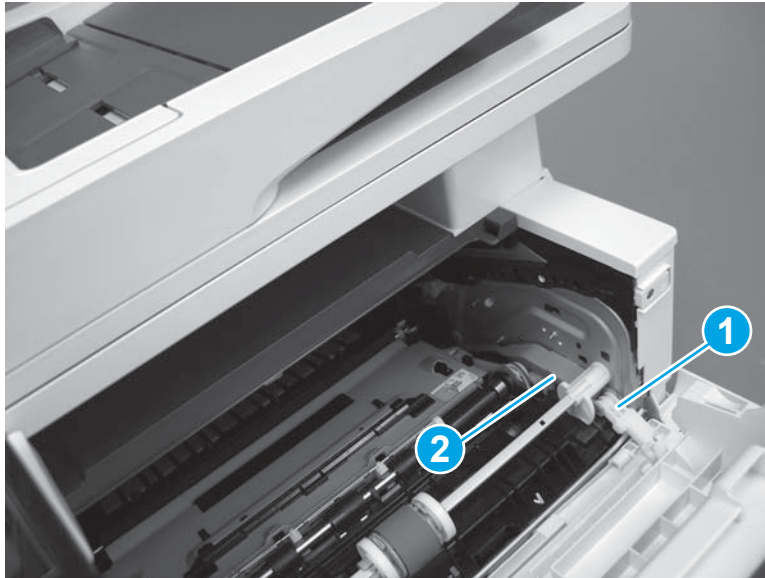




3. Install the link (callout 1).

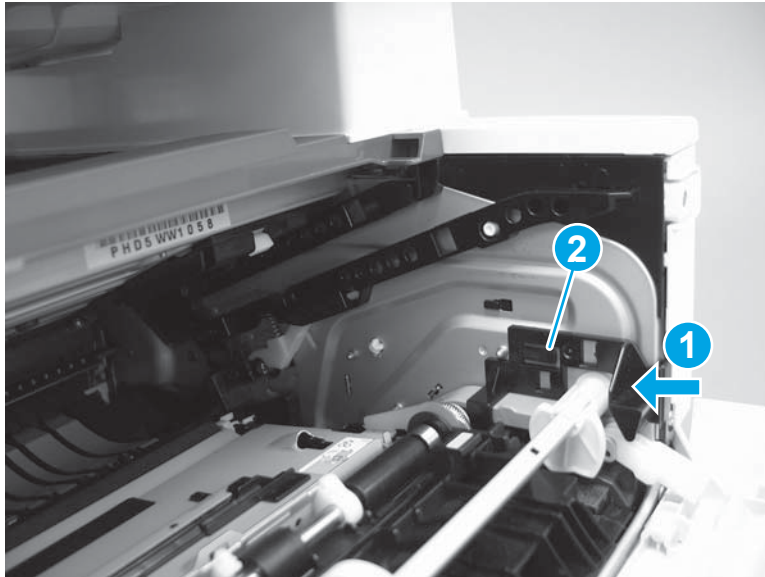
 **IMPORTANT:** Make sure that the link snaps into place on the arm (callout 2). The link actuates the fuser pressure-release mechanism.

**Figure 1-115** Install the pressure-release link



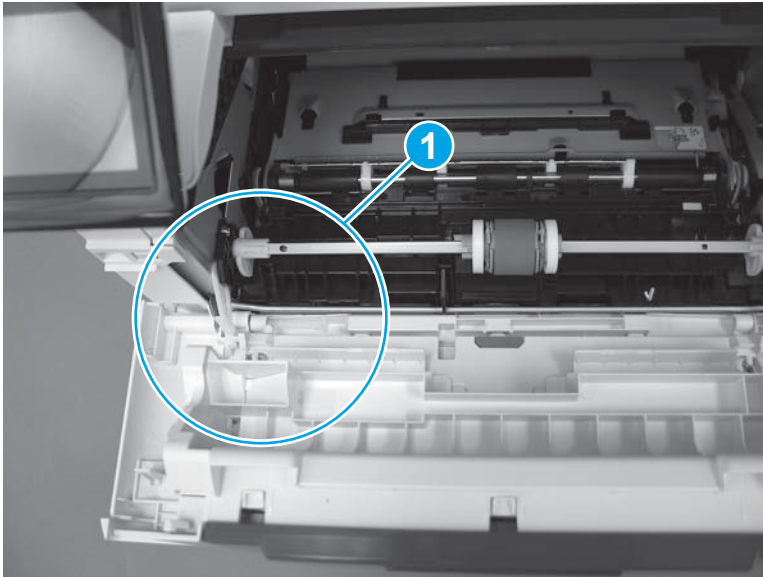
4. Slide the guide into the printer (callout 1), and then make sure that the tab (callout 2) snaps into place to secure the guide to the chassis.

**Figure 1-116** Install the guide




5. Position the shaft on the door, and then align the left-side hinge on the door with the hole in the chassis (callout 1).

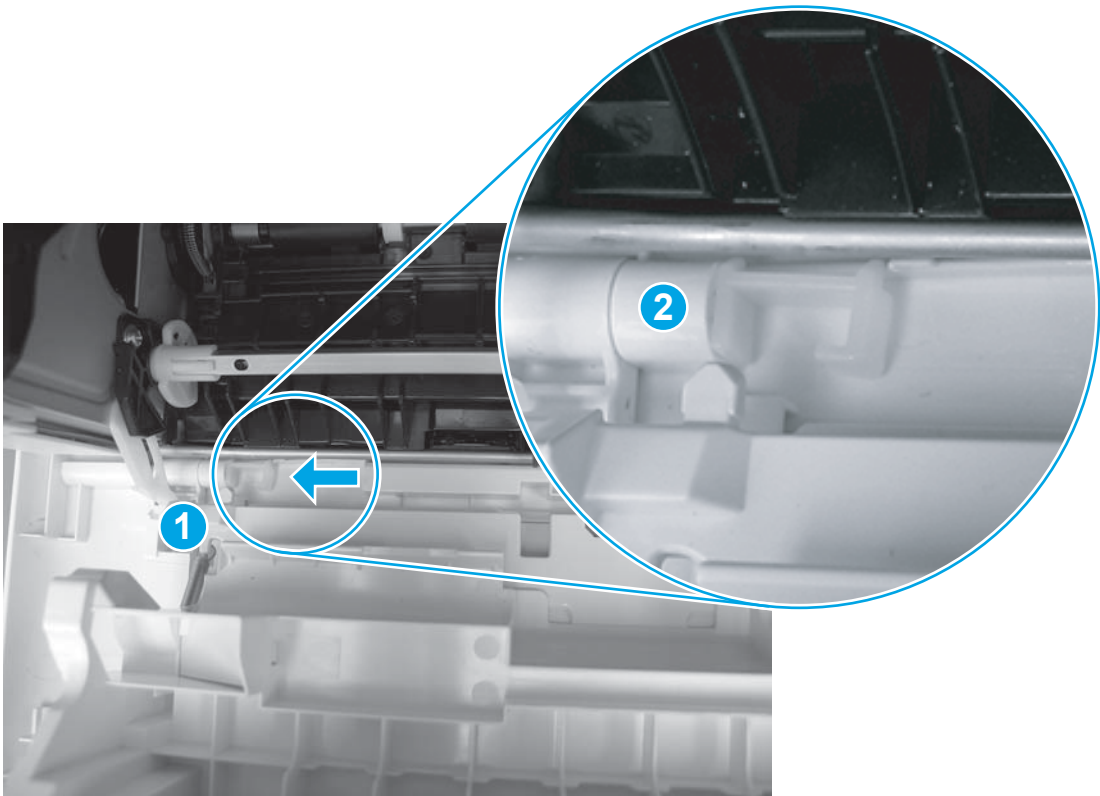
**Figure 1-117** Align the hinge



6. Push the shaft towards the left side of the printer to install it (callout 1).

 **Reinstallation tip:** Make sure that the support shaft is fully installed and correctly orientated (callout 2) so that it will not interfere with the door opening and closing.

**Figure 1-118** Install the support shaft



### Step 9: Install Tray 2

- ▲ Slide the tray straight into the printer to install it.

**Figure 1-119** Install the tray

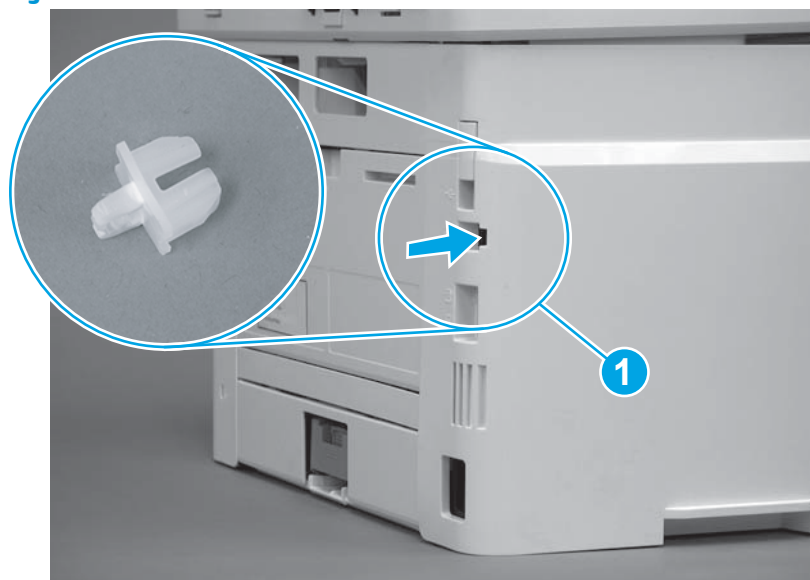


### Step 10: Install the rear network cover (M402d and M403d)

M402d and M403d only.

- ▲ Push the cover straight on to the printer to install it.

**Figure 1-120** Install the cover



### Step 11: Install the rear USB cover

1. Align the tabs on the cover with the slots in the left cover.

**Figure 1-121** Align the tabs on the cover

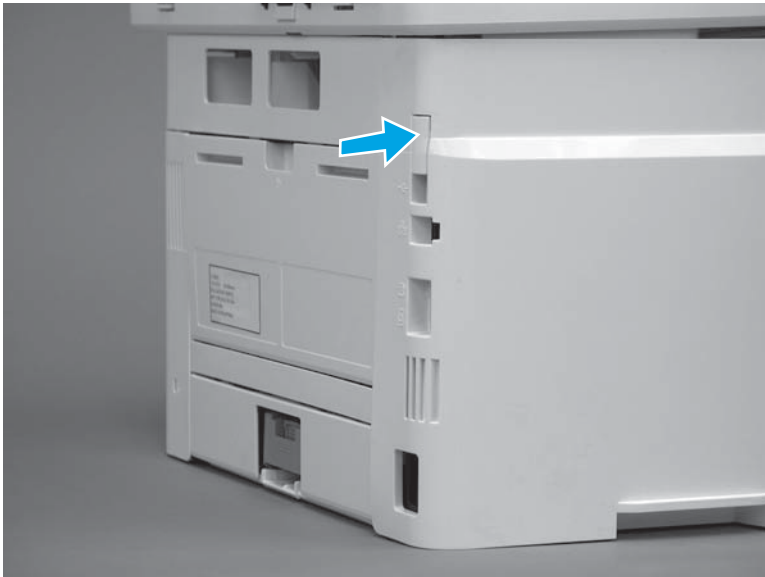


2. Push the cover straight on to the printer to install it.



**NOTE:** For network models, also install the network port cover (not shown; RC4-2907-000CN).

**Figure 1-122** Install the cover



## Removal and replacement: Right cover

- [Introduction](#)
- [Step 1: Remove Tray 2](#)
- [Step 2: Remove the cartridge door assembly](#)
- [Step 3: Remove the right cover](#)
- [Step 4: Unpack the replacement assembly](#)
- [Step 5: Install the right cover](#)
- [Step 6: Install the cartridge door assembly](#)
- [Step 7: Install Tray 2](#)


### Introduction

This document provides the procedures to remove and replace the right cover.

### Before performing service

#### Turn the printer power off

- Disconnect the power cable.

 **WARNING!** To avoid damage to the printer, turn the printer off, wait 30 seconds, and then remove the power cable before attempting to service the printer.

Use the table below to identify the correct part number for your printer. To order the part, go to [www.hp.com/buy/parts](http://www.hp.com/buy/parts).

Right cover part number	
RM2-5434-000CN	Right cover

### Required tools

- #2 Phillips screwdriver with a magnetic tip.

### After performing service

#### Turn the printer power on

- Connect the power cable.
- Use the power switch to turn the power on.

### Post service test

Make sure that the printer initializes to a **Ready** state.

### Step 1: Remove Tray 2

- ▲ Pull the tray straight out of the printer to remove it.

**Figure 1-123** Remove the tray



**Step 2: Remove the cartridge door assembly**



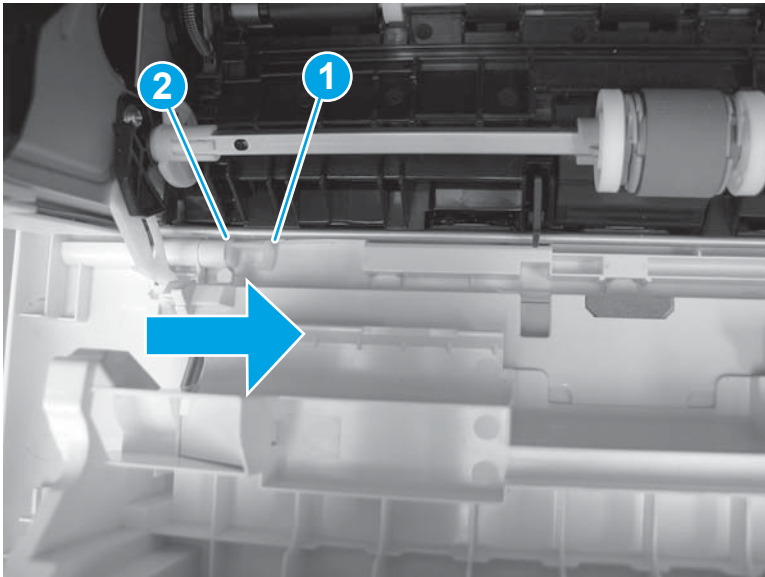
**NOTE:** If the toner cartridge was not removed prior to servicing the printer, remove it now.

1. Release one tab (callout 1), and then slide shaft (callout 2) in the direction the arrow indicates and remove it.



**TIP:** It might be easier to release the support shaft by using a small flat-blade screwdriver.

**Figure 1-124** Release the support shaft



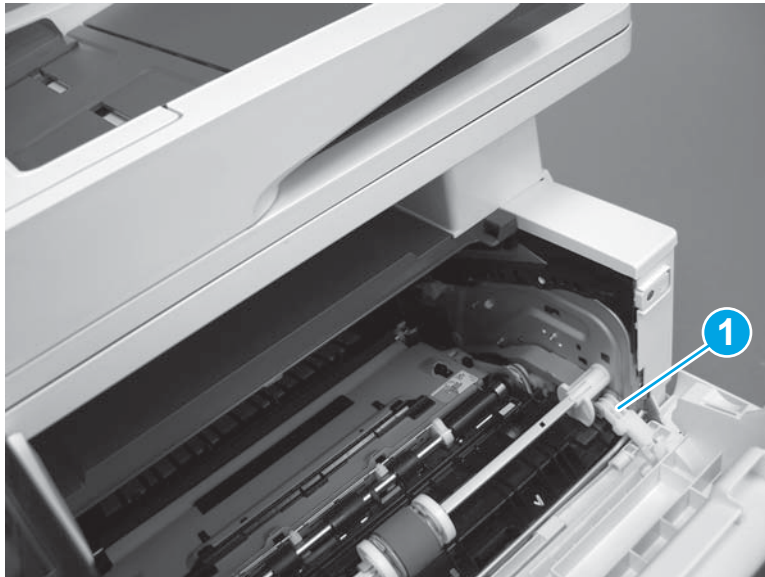
2. Release one tab (callout 1), and then slide the guide (callout 2) in the direction the arrow indicates and remove it.

**Figure 1-125** Remove the guide



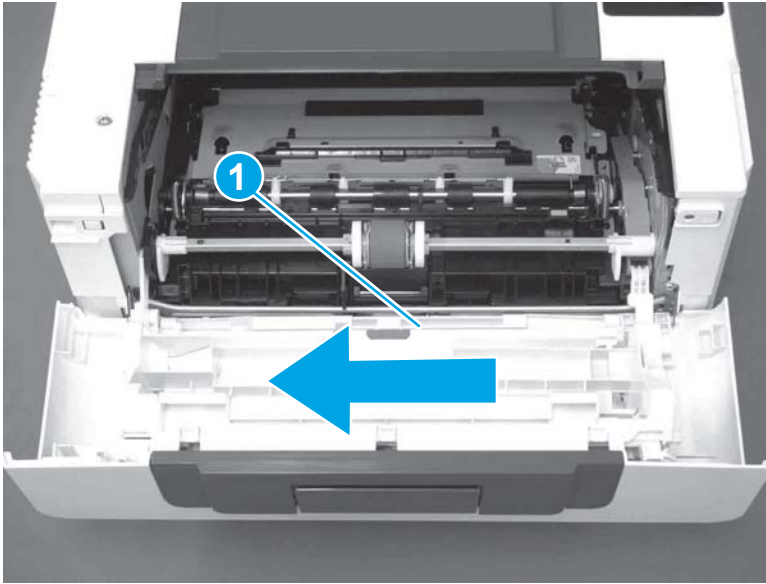
3. Remove the link arm (callout 1).

**Figure 1-126** Remove the link arm



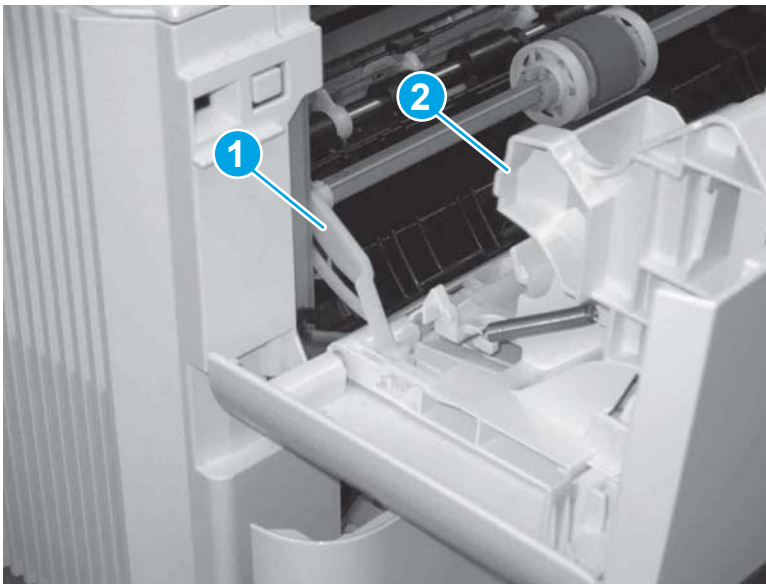
4. Slide the cartridge door assembly (callout 1) in the direction the arrow indicates and remove it.

**Figure 1-127** Remove the door



5. Remove the link (callout 1) from the cartridge door assembly (callout 2).

**Figure 1-128** Release the left-side retainer arm



### Step 3: Remove the right cover

1. Remove one screw (callout 1).

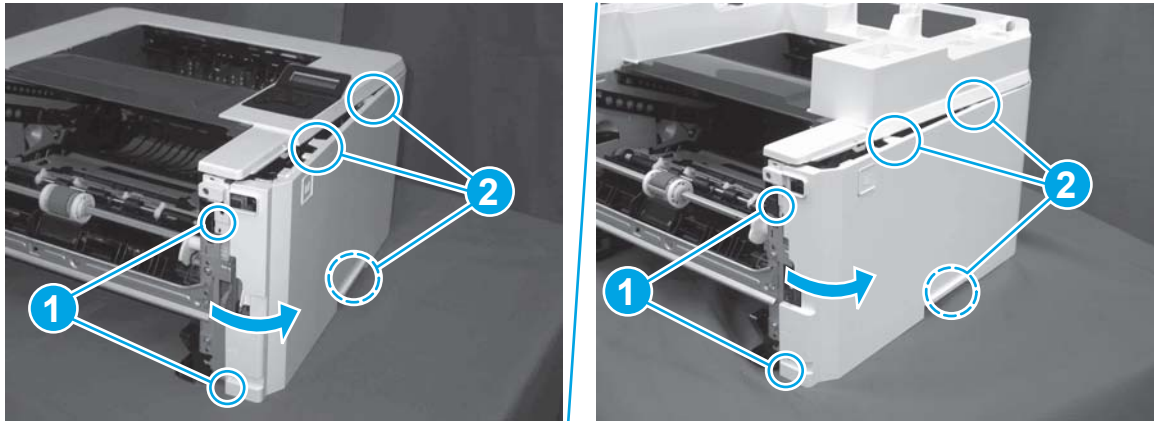


**Figure 1-129** Remove one screw



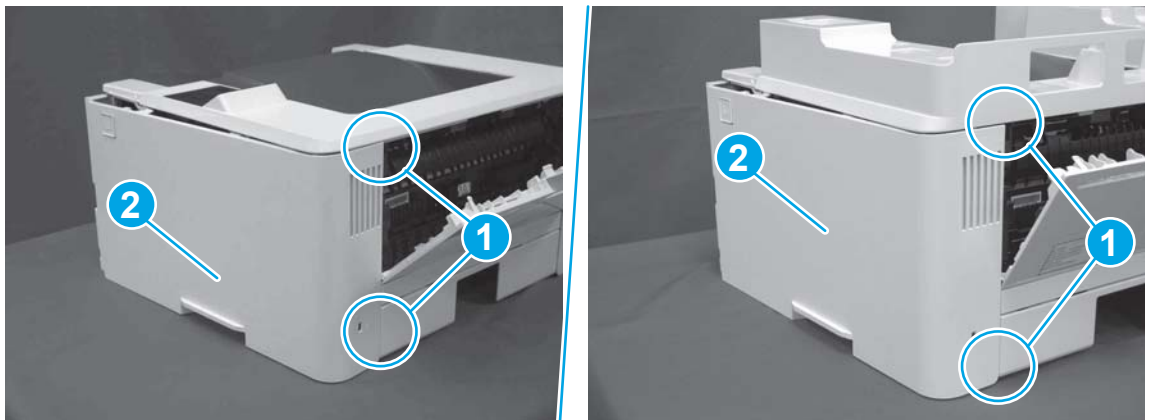
2. At the front of the printer, release two bosses (callout 1), and then release three tabs (callout 2).

**Figure 1-130** Release two bosses and three tabs



3. Open the rear door, release two bosses (callout 1), and then remove the cover (callout 2).

**Figure 1-131** Remove the cover



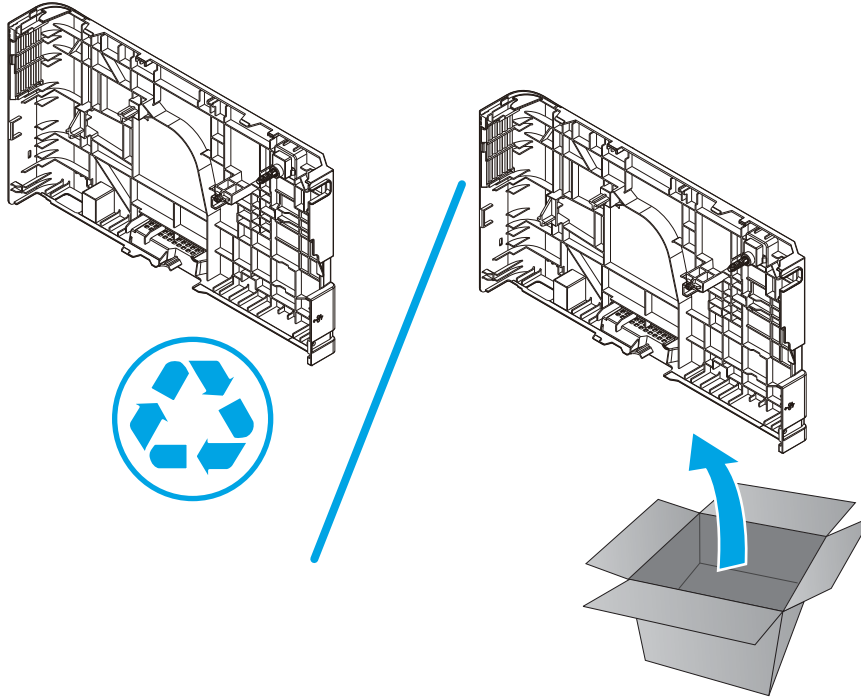
#### Step 4: Unpack the replacement assembly

Unpack the replacement part from the packaging.

<http://www8.hp.com/us/en/hp-information/environment/product-recycling.html>

 **NOTE:** HP recommends responsible disposal of the defective part.

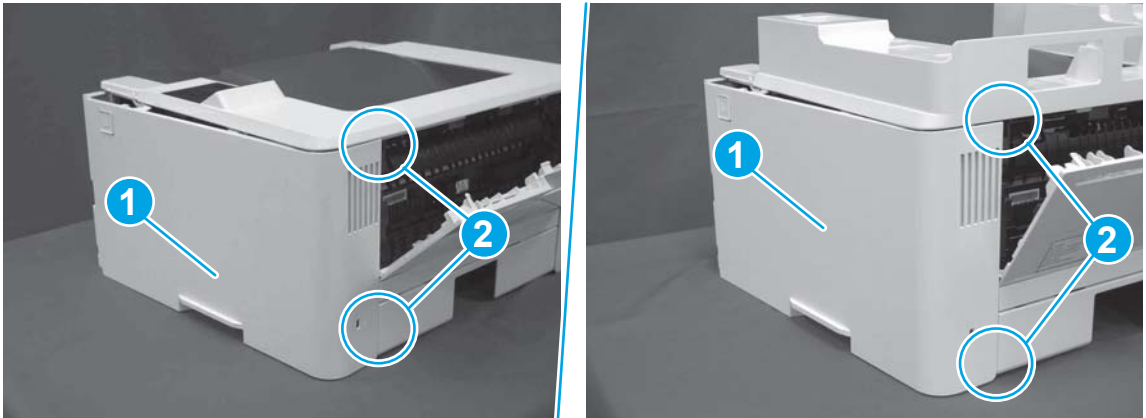
**Figure 1-132** Recycle and unpack



**Step 5: Install the right cover**

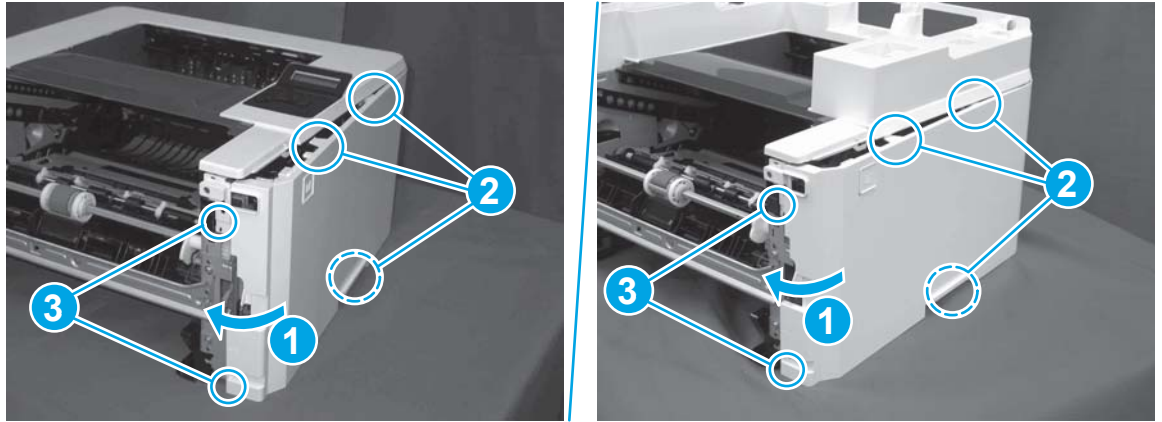
1. Position the cover (callout 1) on the printer, and then engage two bosses (callout 2).

**Figure 1-133** Install the cover




2. Rotate the front of the cover onto the printer (callout 1), engage three (callout 2) tabs, and then engage two bosses (callout 3).

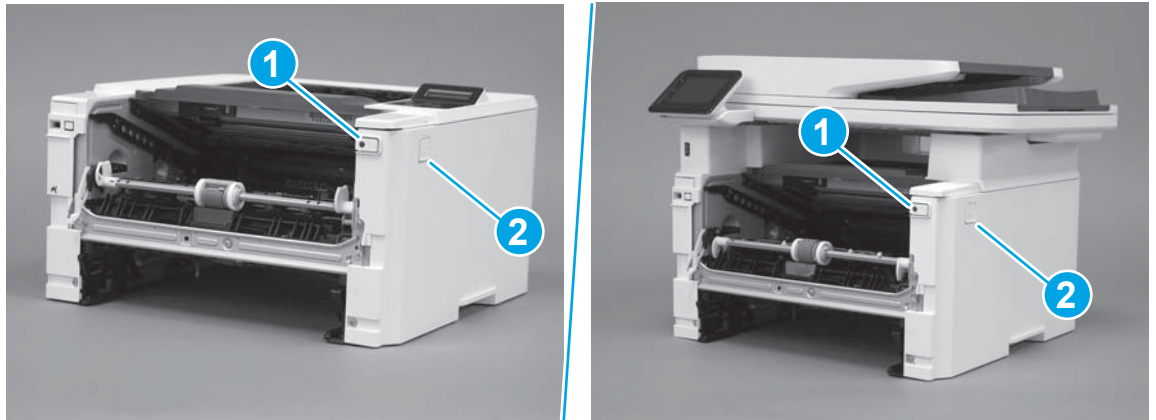
**Figure 1-134** Engage two bosses and one tab



3. Make sure that the power switch (callout 1) and cartridge door assembly button (callout 2) correctly function.

 **NOTE:** Remove, and then reinstall the cover if the switch or button does not correctly function.

**Figure 1-135** Check the power switch and cartridge door assembly button




4. Install one screw (callout 1).

**Figure 1-136** Install one screw

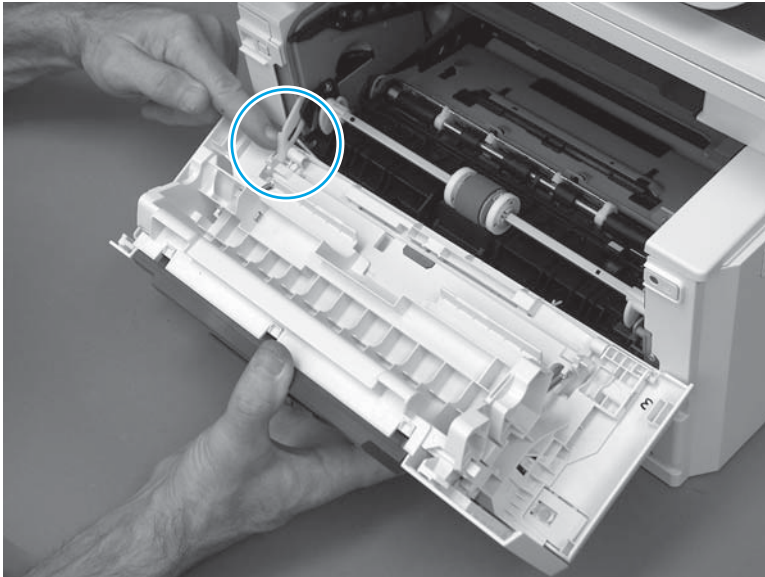


## Step 6: Install the cartridge door assembly

 **Reinstallation tip:** After a replacement door is installed, make sure to install the nameplate (supplied in the kit) corresponding to the printer name on the door.

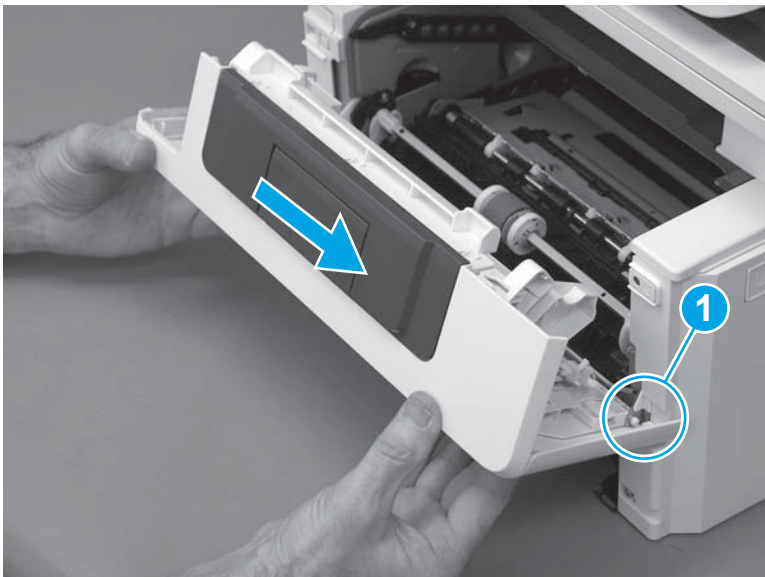
1. Position the door close to the printer, and then engage the keyed pin on the left-side retainer arm with the hole in the door.

**Figure 1-137** Engage the left-side retainer arm



2. Engage the right-side door hinge pin with the hole in the chassis (callout 1).

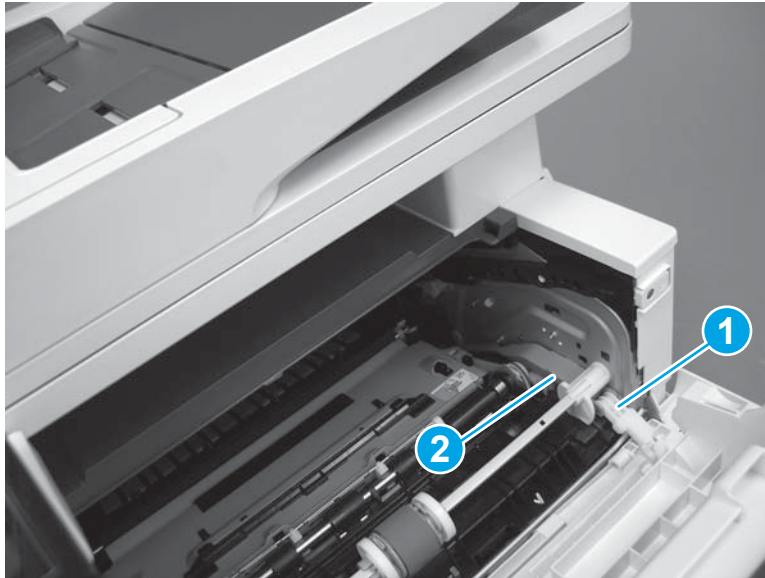
**Figure 1-138** Install the door



3. Install the link (callout 1).

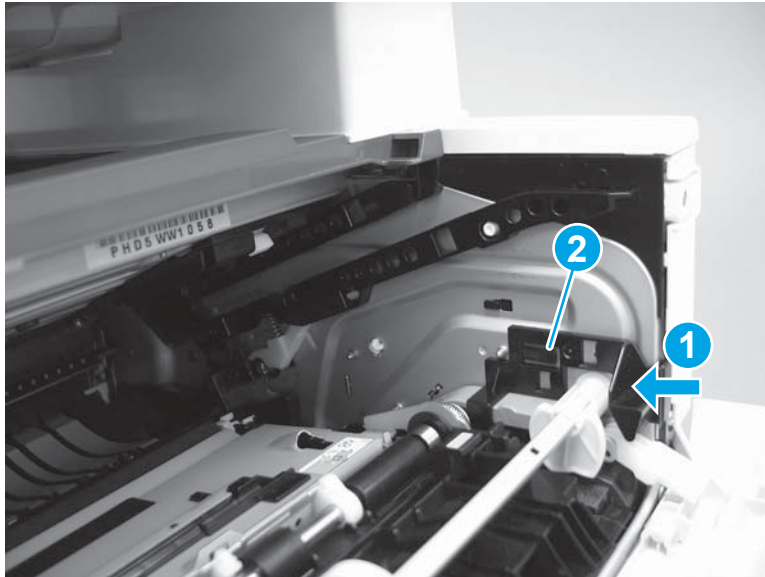
 **IMPORTANT:** Make sure that the link snaps into place on the arm (callout 2). The link actuates the fuser pressure-release mechanism.

**Figure 1-139** Install the pressure-release link



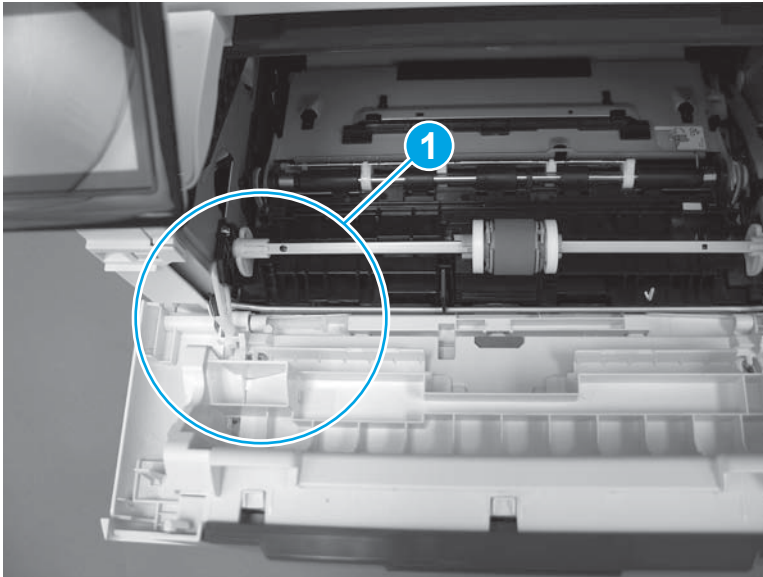
4. Slide the guide into the printer (callout 1), and then make sure that the tab (callout 2) snaps into place to secure the guide to the chassis.

**Figure 1-140** Install the guide




5. Position the shaft on the door, and then align the left-side hinge on the door with the hole in the chassis (callout 1).

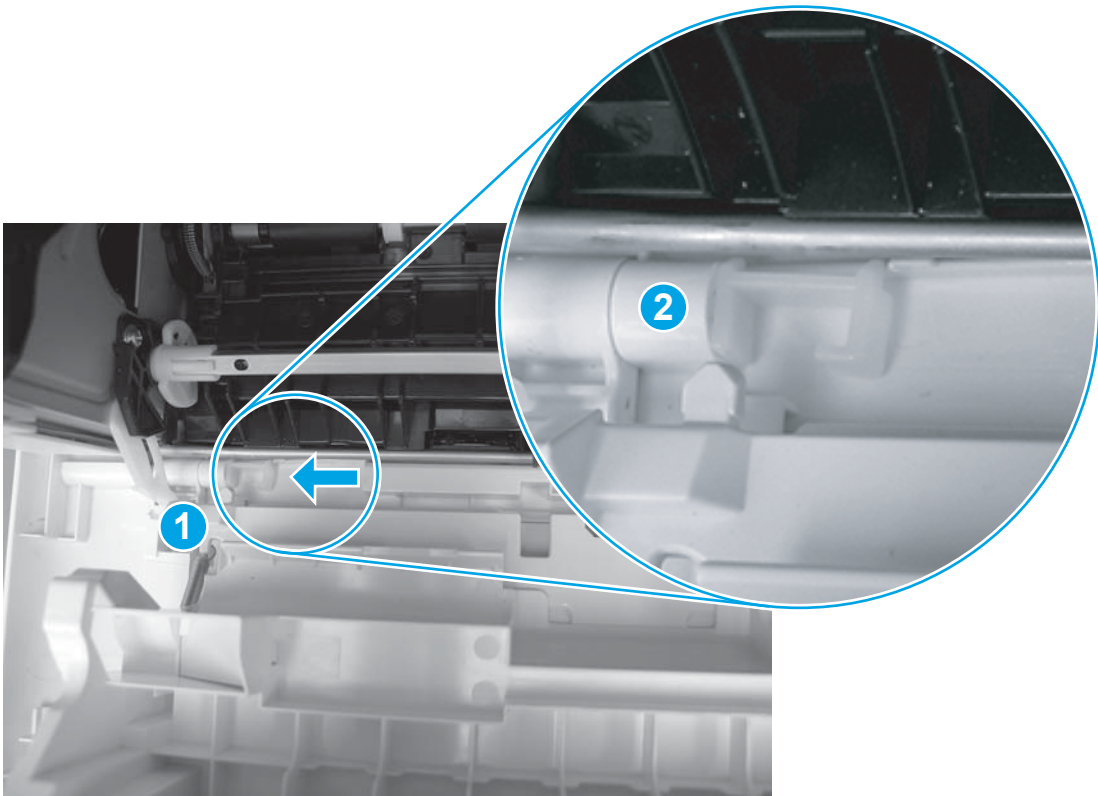
**Figure 1-141** Align the hinge



6. Push the shaft towards the left side of the printer to install it (callout 1).

 **Reinstallation tip:** Make sure that the support shaft is fully installed and correctly orientated (callout 2) so that it will not interfere with the door opening and closing.

**Figure 1-142** Install the support shaft



## Step 7: Install Tray 2

- ▲ Slide the tray straight into the printer to install it.

**Figure 1-143** Install the tray



## Removal and replacement: Rear door assembly



**NOTE:** Only duplex models have a duplex tray assembly installed.

- [Introduction](#)
- [Step 1: Remove Tray 2](#)
- [Step 2: Remove the cartridge door assembly](#)
- [Step 3: Remove the left cover](#)
- [Step 4: Remove the right cover](#)
- [Step 5: Remove the rear door assembly](#)
- [Step 6: Unpack the replacement assembly](#)
- [Step 7: Install the rear door assembly](#)
- [Step 8: Install the right cover](#)
- [Step 9: Install the left cover](#)
- [Step 10: Install the cartridge door assembly](#)
- [Step 11: Install Tray 2](#)

### Introduction

This document provides the procedures to remove and replace the rear door assembly.

### Before performing service

#### Turn the printer power off

- Disconnect the power cable.



**WARNING!** To avoid damage to the printer, turn the printer off, wait 30 seconds, and then remove the power cable before attempting to service the printer.

Use the table below to identify the correct part number for your printer. To order the part, go to [www.hp.com/buy/parts](http://www.hp.com/buy/parts).

Rear door assembly part number	
RM2-5430-000CN	Rear door assembly (simplex)
RM2-5405-000CN	Rear door assembly (duplex)

### Required tools

- #2 Phillips screwdriver with a magnetic tip.



## After performing service

### Turn the printer power on

- Connect the power cable.
- Use the power switch to turn the power on.

### Post service test

Make sure that the printer initializes to a **Ready** state.

Print a configuration page to make sure that the printer is functioning correctly.

### Step 1: Remove Tray 2

- ▲ Pull the tray straight out of the printer to remove it.

**Figure 1-144** Remove the tray



### Step 2: Remove the cartridge door assembly



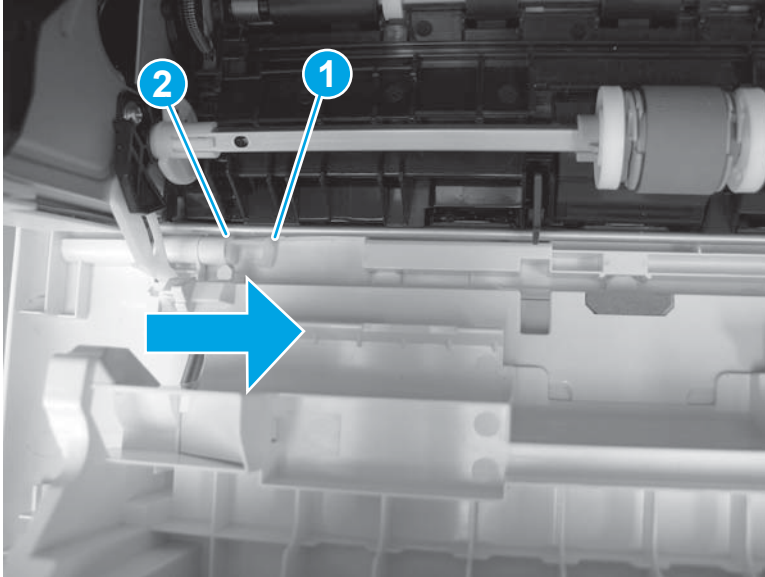
**NOTE:** If the toner cartridge was not removed prior to servicing the printer, remove it now.

1. Release one tab (callout 1), and then slide shaft (callout 2) in the direction the arrow indicates and remove it.



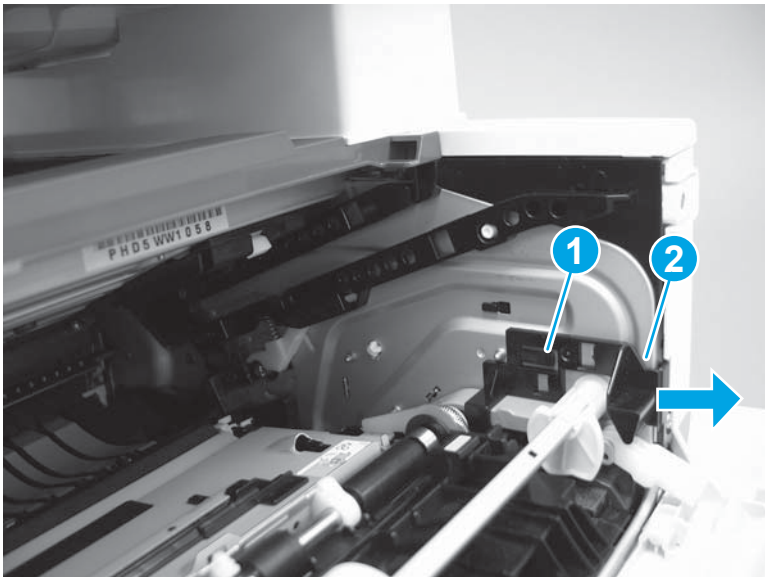
**TIP:** It might be easier to release the support shaft by using a small flat-blade screwdriver.

**Figure 1-145** Release the support shaft



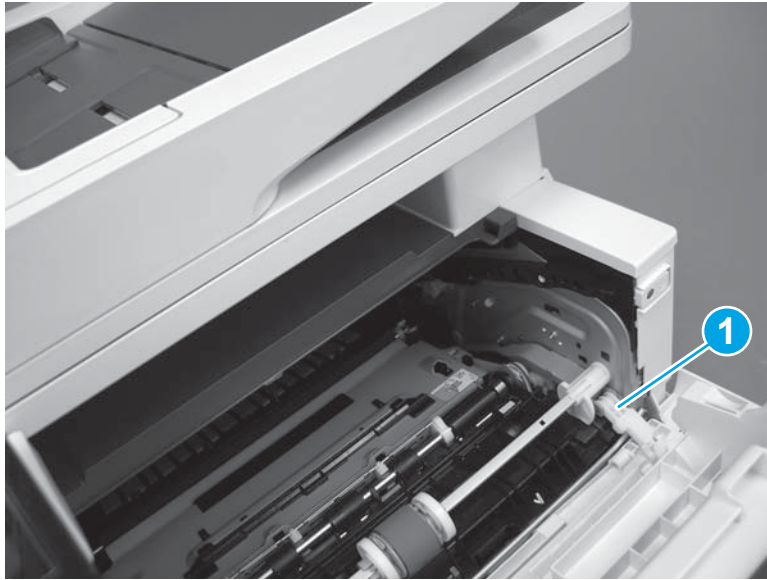
2. Release one tab (callout 1), and then slide the guide (callout 2) in the direction the arrow indicates and remove it.

**Figure 1-146** Remove the guide



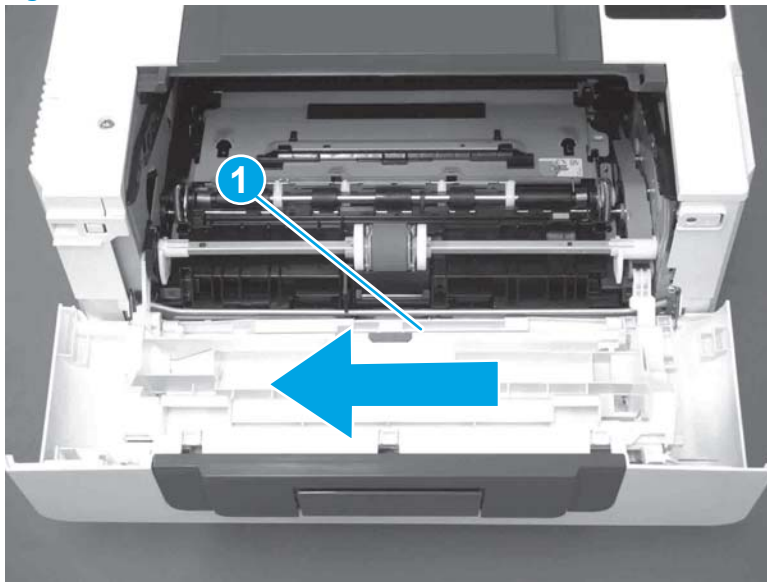
3. Remove the link arm (callout 1).

**Figure 1-147** Remove the link arm



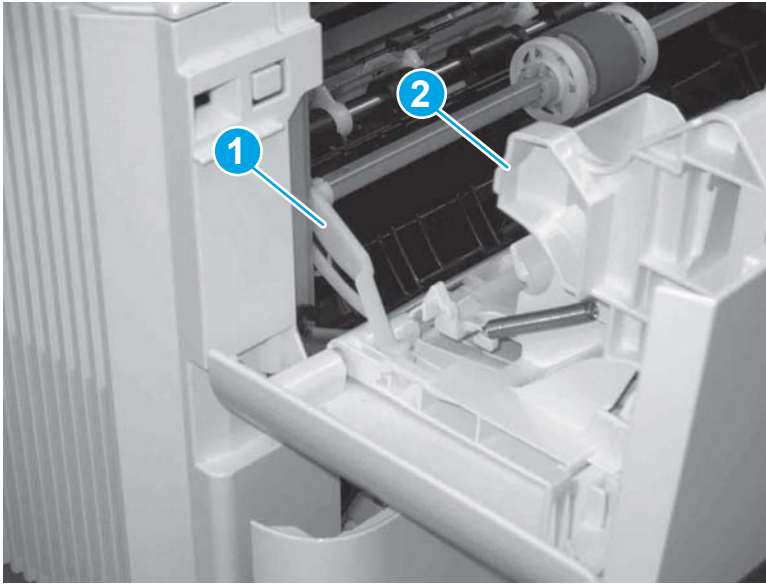
4. Slide the cartridge door assembly (callout 1) in the direction the arrow indicates and remove it.

**Figure 1-148** Remove the door



5. Remove the link (callout 1) from the cartridge door assembly (callout 2).

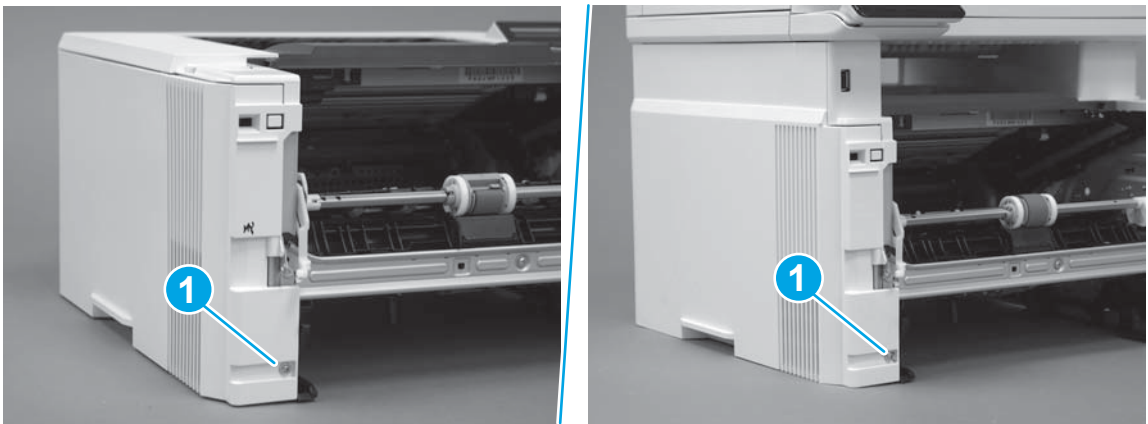
**Figure 1-149** Release the left-side retainer arm



### Step 3: Remove the left cover

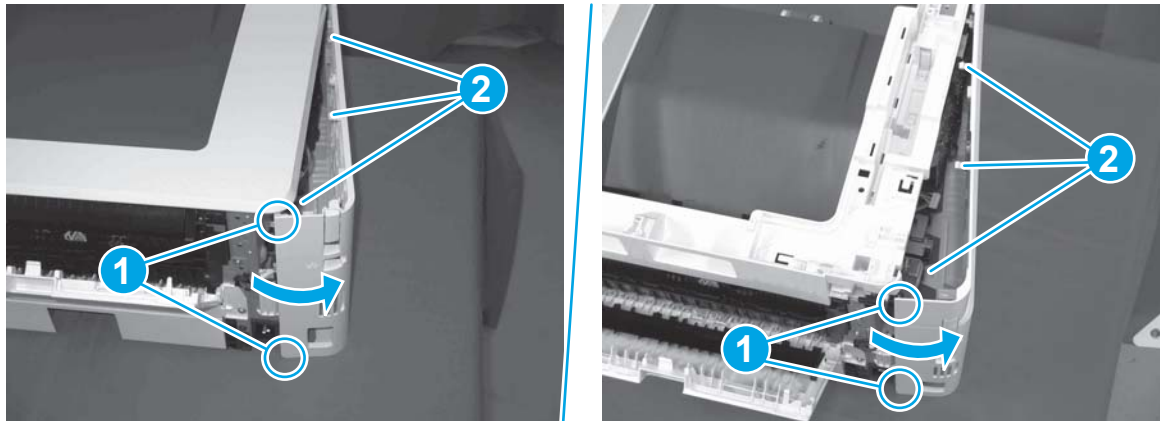
1. Remove one screw (callout 1).

**Figure 1-150** Remove one screw



2. Open the rear door, release two bosses (callout 1), and then release three tabs (callout 2).

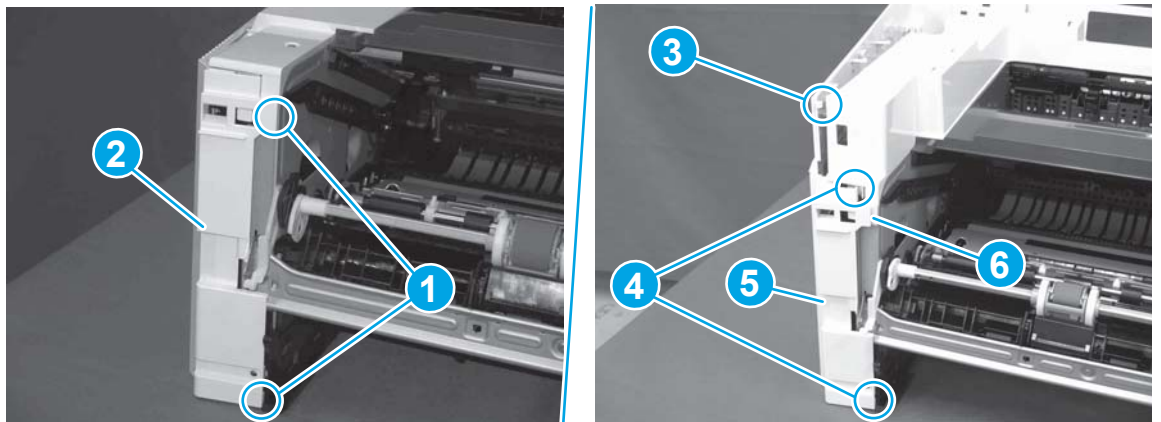
**Figure 1-151** Release two bosses and three tabs



3. At the front of the printer, do one of the following:
  - **M403/M402:** Release two bosses (callout 1), and then remove the cover (callout 2).
  - **M427/M426:** Release one tab (callout 3), two bosses (callout 4), and then remove the cover (callout 5).

**CAUTION:** Be careful when releasing the upper bosses on the M427/M426 cover. One portion of the cover (callout 6) is fragile and is easily broken.

**Figure 1-152** Remove the cover



#### Step 4: Remove the right cover

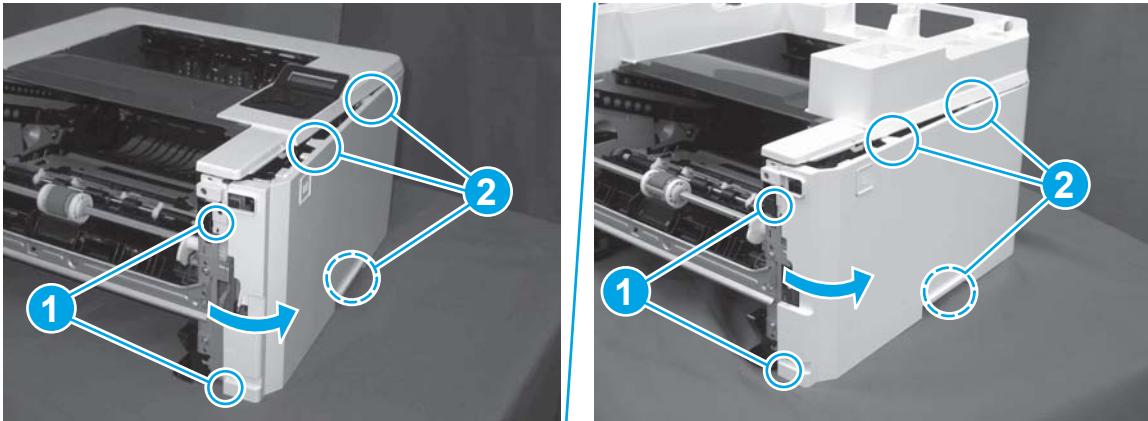
1. Remove one screw (callout 1).

**Figure 1-153** Remove one screw



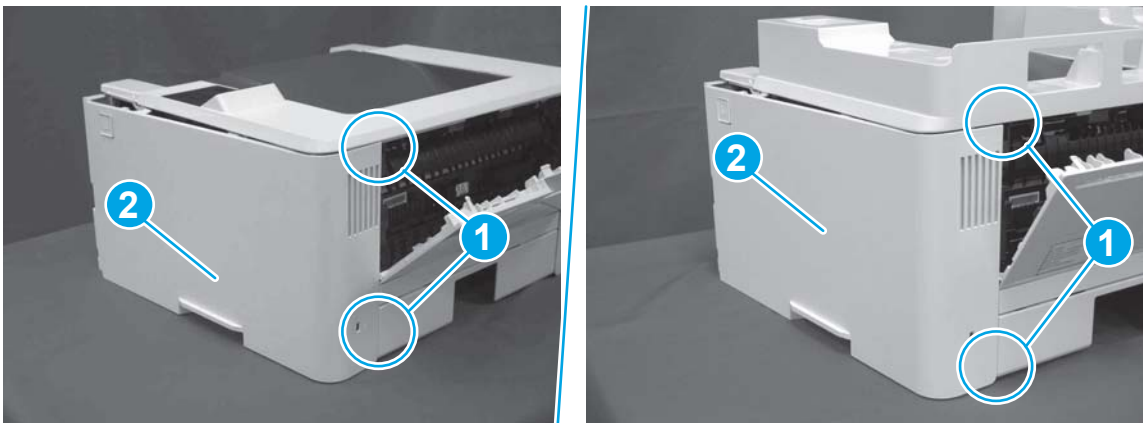
2. At the front of the printer, release two bosses (callout 1), and then release three tabs (callout 2).

**Figure 1-154** Release two bosses and three tabs



3. Open the rear door, release two bosses (callout 1), and then remove the cover (callout 2).

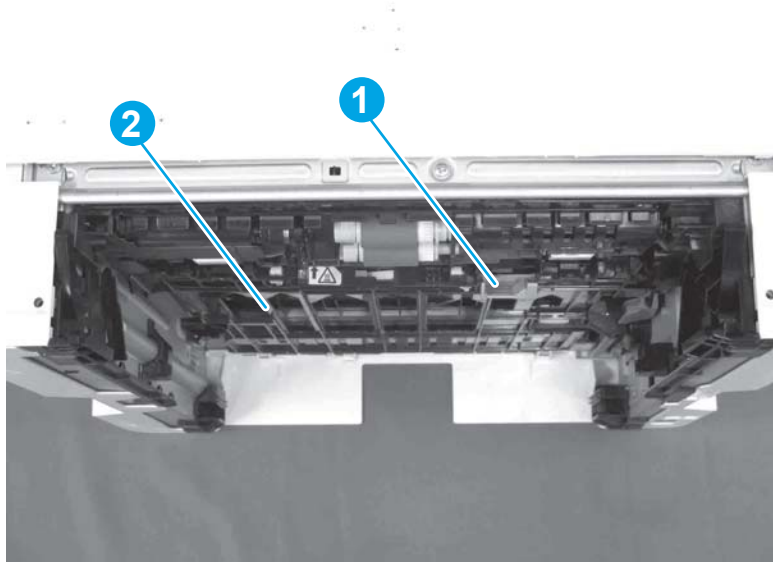
**Figure 1-155** Remove the cover



### Step 5: Remove the rear door assembly

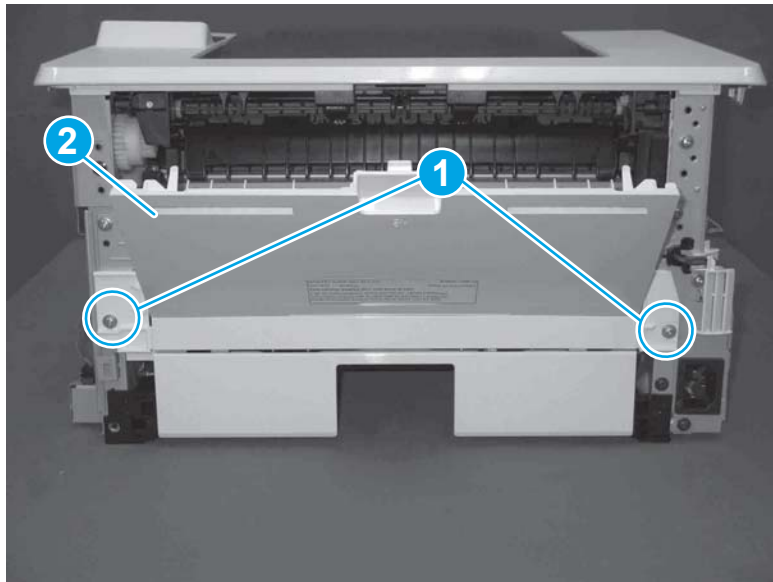
1. **Duplex models only:** Inside the Tray 2 cavity, press the green jam access lever (callout 1), and then lower the duplex feed assembly (callout 2).

**Figure 1-156** Duplex models, lower the duplex feed assembly



2. At the rear of the printer, remove two screws (callout 1), and then remove the rear door assembly (callout 2).

**Figure 1-157** Remove two screws



### Step 6: Unpack the replacement assembly

Unpack the replacement part from the packaging.

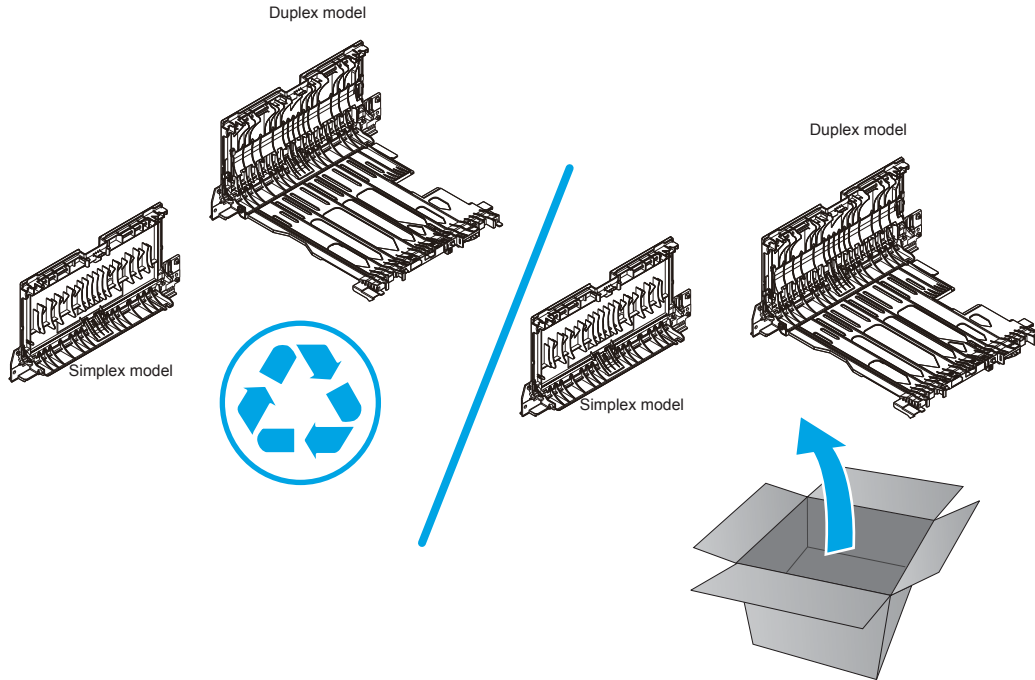
<http://www8.hp.com/us/en/hp-information/environment/product-recycling.html>

---

 **NOTE:** HP recommends responsible disposal of the defective part.


---

**Figure 1-158** Recycle and unpack

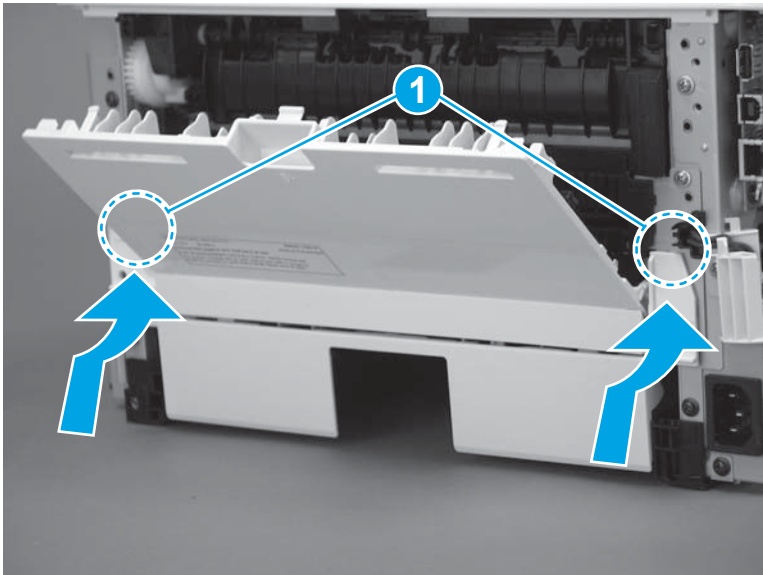


**Step 7: Install the rear door assembly**

1. At the rear of the printer, position the assembly so that the two tabs (callout 1) are installed in the slots (callout 2) in the chassis.


 **NOTE:** Duplex models only: Slide the duplex tray into the Tray 2 cavity.

**Figure 1-159** Install the rear cover





2. Install two screws.

 **NOTE: Duplex models only:** Reach in from the front of the Tray 2 cavity and raise the feed assembly to the up and locked position so that the rear cover will fit flat against the chassis.

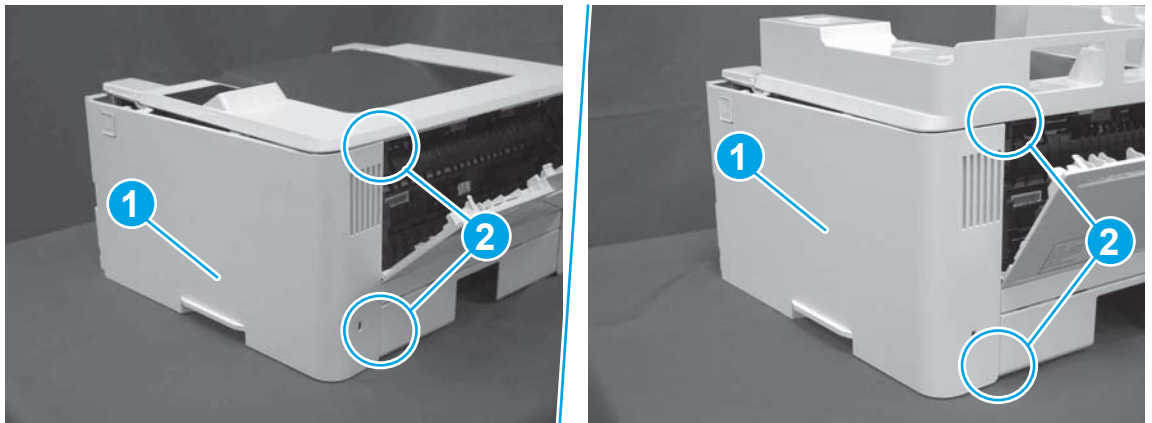
**Figure 1-160** Install two screws



### Step 8: Install the right cover

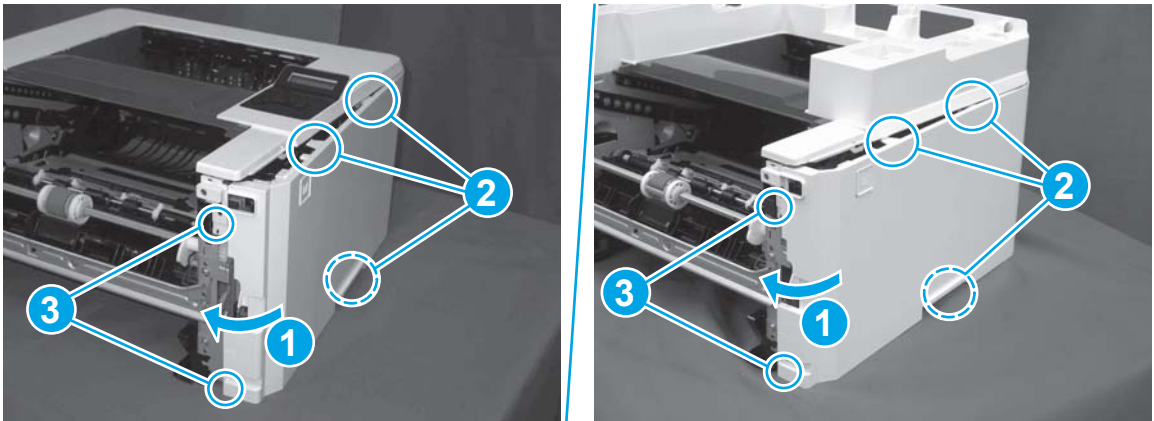
1. Position the cover (callout 1) on the printer, and then engage two bosses (callout 2).

**Figure 1-161** Install the cover



2. Rotate the front of the cover onto the printer (callout 1), engage three (callout 2) tabs, and then engage two bosses (callout 3).

**Figure 1-162** Engage two bosses and one tab

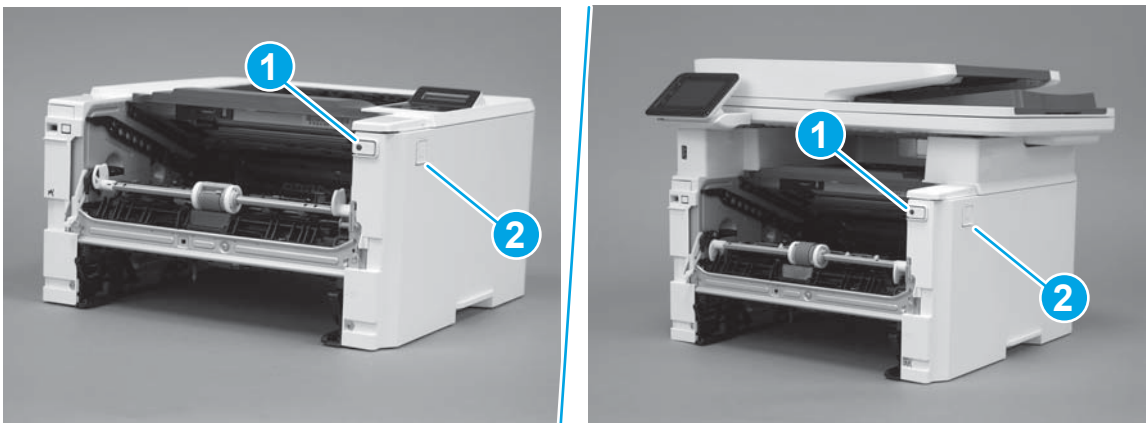


3. Make sure that the power switch (callout 1) and cartridge door assembly button (callout 2) correctly function.



**NOTE:** Remove, and then reinstall the cover if the switch or button does not correctly function.

**Figure 1-163** Check the power switch and cartridge door assembly button



4. Install one screw (callout 1).

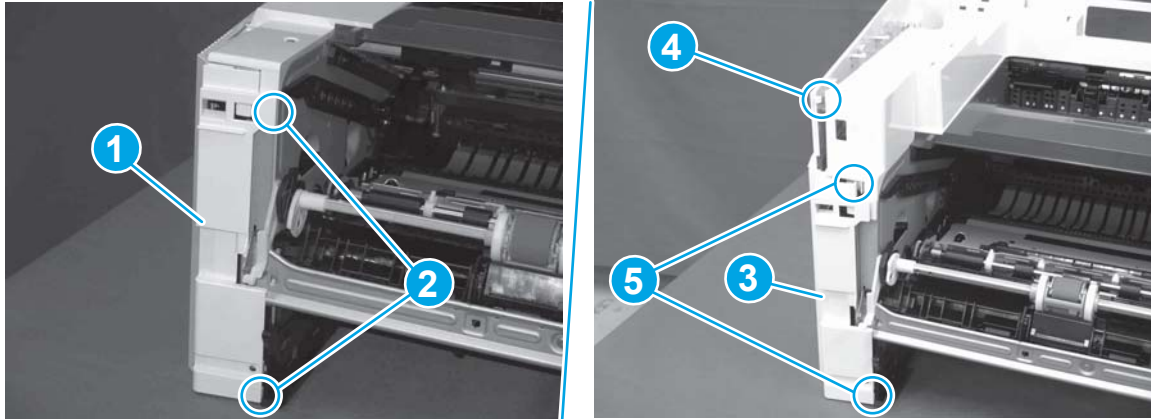
**Figure 1-164** Install one screw



## Step 9: Install the left cover

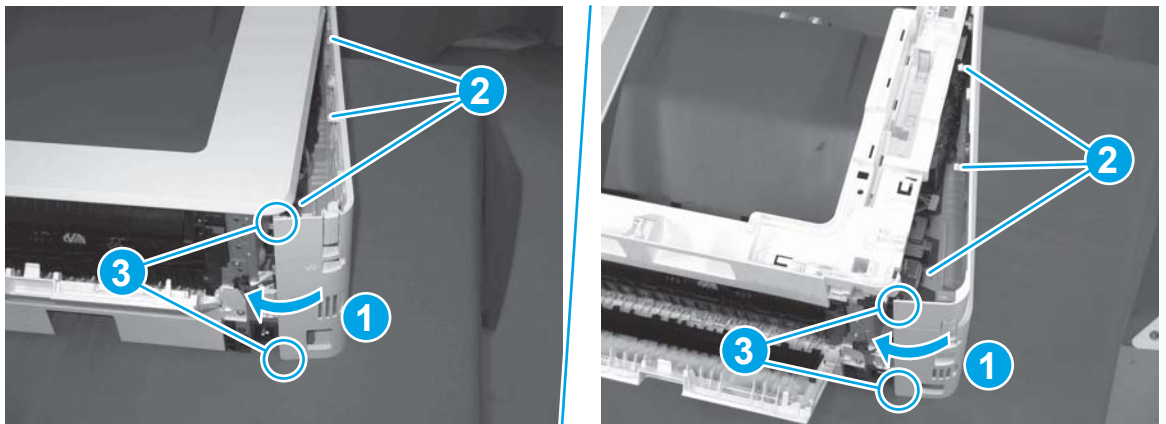
1. At the front of the printer, do one of the following:
  - **M403/M402:** Position the cover on the printer ( callout 1), and then engage two bosses (callout 2).
  - **M427/M426:** Position the cover on the printer (callout 3), engage one tab (callout 4), and then engage two bosses (callout 4).

**Figure 1-165** Install the cover



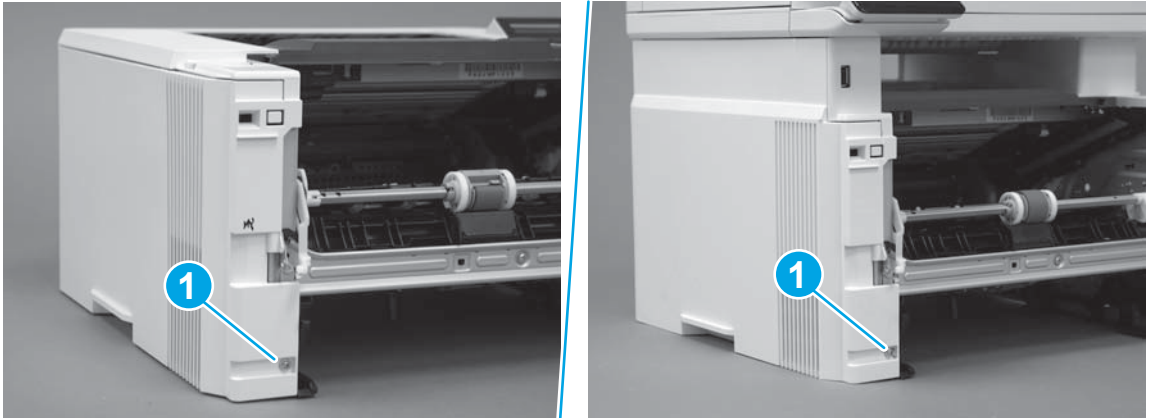
2. Carefully rotate the rear of the cover onto the printer (callout 1), engage three tabs (callout 2), and then engage two bosses (callout 3).

**Figure 1-166** Engage three tabs and two bosses




3. Install one screw (callout 1).

**Figure 1-167** Install one screw

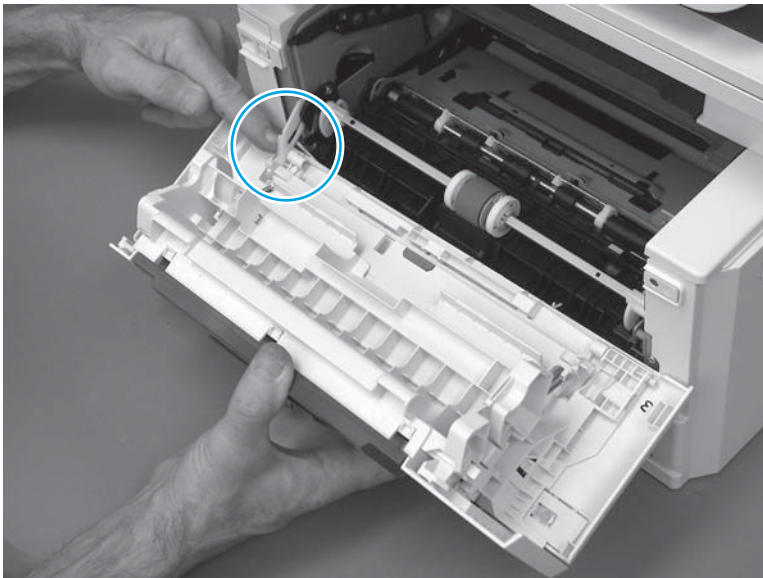


### Step 10: Install the cartridge door assembly

 **Reinstallation tip:** After a replacement door is installed, make sure to install the nameplate (supplied in the kit) corresponding to the printer name on the door.

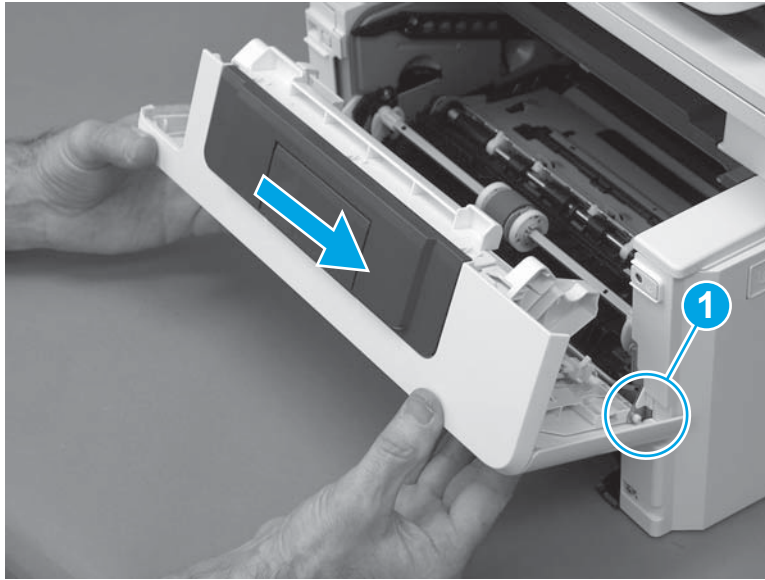
1. Position the door close to the printer, and then engage the keyed pin on the left-side retainer arm with the hole in the door.

**Figure 1-168** Engage the left-side retainer arm



2. Engage the right-side door hinge pin with the hole in the chassis (callout 1).

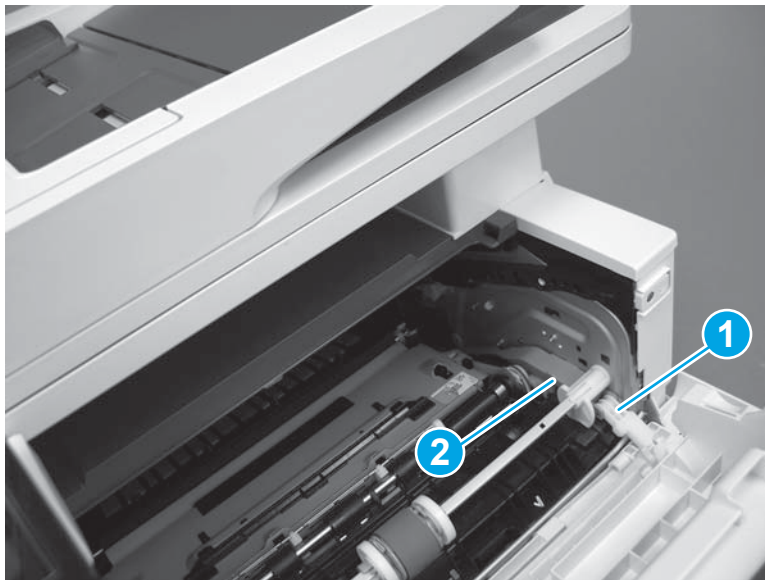
**Figure 1-169** Install the door



3. Install the link (callout 1).

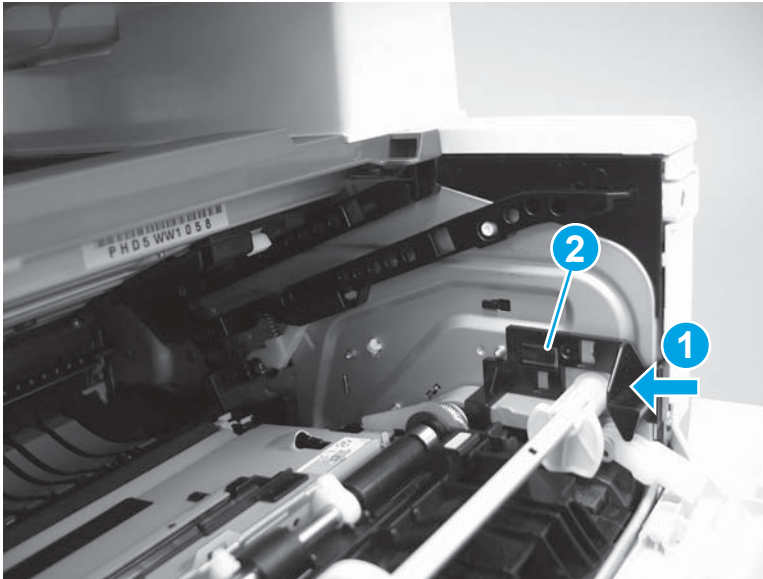
 **IMPORTANT:** Make sure that the link snaps into place on the arm (callout 2). The link actuates the fuser pressure-release mechanism.

**Figure 1-170** Install the pressure-release link



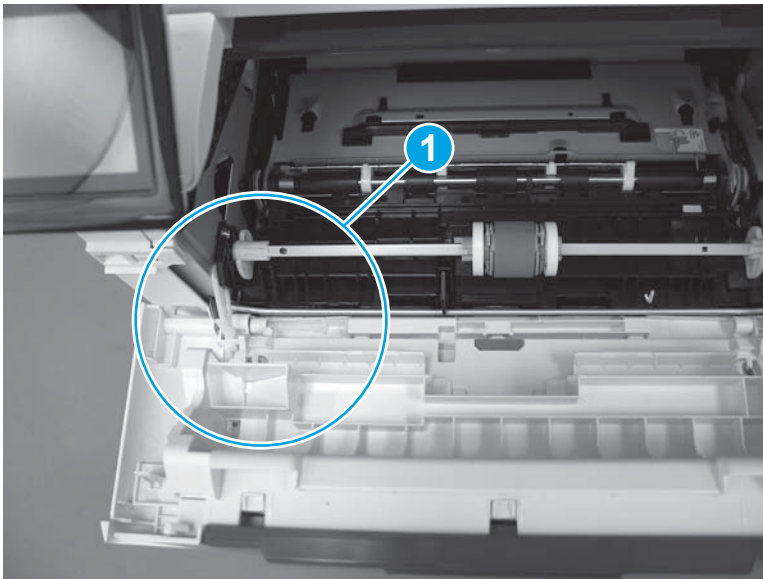
4. Slide the guide into the printer (callout 1), and then make sure that the tab (callout 2) snaps into place to secure the guide to the chassis.

**Figure 1-171** Install the guide




5. Position the shaft on the door, and then align the left-side hinge on the door with the hole in the chassis (callout 1).

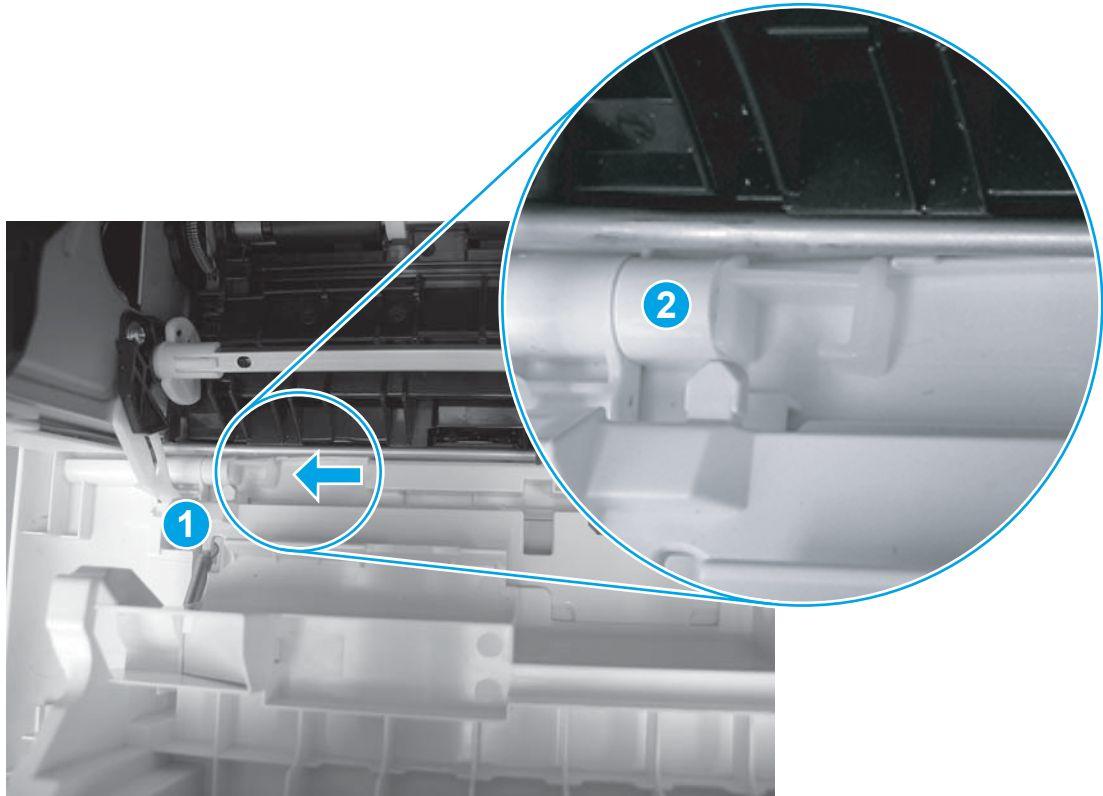
**Figure 1-172** Align the hinge



6. Push the shaft towards the left side of the printer to install it (callout 1).

 **Reinstallation tip:** Make sure that the support shaft is fully installed and correctly orientated (callout 2) so that it will not interfere with the door opening and closing.

**Figure 1-173** Install the support shaft



### Step 11: Install Tray 2

- ▲ Slide the tray straight into the printer to install it.

**Figure 1-174** Install the tray



## Removal and replacement: Cassette rear cover

- [Introduction](#)
- [Step 1: Remove Tray 2](#)
- [Step 2: Remove the cartridge door assembly](#)
- [Step 3: Remove the left cover](#)
- [Step 4: Remove the right cover](#)
- [Step 5: Remove the rear door assembly](#)
- [Step 6: Remove the cassette rear cover](#)
- [Step 7: Unpack the replacement assembly](#)
- [Step 8: Install the cassette rear door assembly](#)
- [Step 9: Install the rear door assembly](#)
- [Step 10: Install the right cover](#)
- [Step 11: Install the left cover](#)
- [Step 12: Install the cartridge door assembly](#)
- [Step 13: Install Tray 2](#)


### Introduction

This document provides the procedures to remove and replace the cassette rear cover.

### Before performing service

#### Turn the printer power off

- Disconnect the power cable.

 **WARNING!** To avoid damage to the printer, turn the printer off, wait 30 seconds, and then remove the power cable before attempting to service the printer.

Use the table below to identify the correct part number for your printer. To order the part, go to [www.hp.com/buy/parts](http://www.hp.com/buy/parts).

Cassette rear cover part number	
RC4-3082-000CN	Cassette rear cover

### Required tools

- #2 Phillips screwdriver with a magnetic tip.



## After performing service

### Turn the printer power on

- Connect the power cable.
- Use the power switch to turn the power on.

### Post service test

Make sure that the printer initializes to a **Ready** state.

Print a configuration page to make sure that the printer is functioning correctly.

### Step 1: Remove Tray 2

- ▲ Pull the tray straight out of the printer to remove it.

**Figure 1-175** Remove the tray



### Step 2: Remove the cartridge door assembly



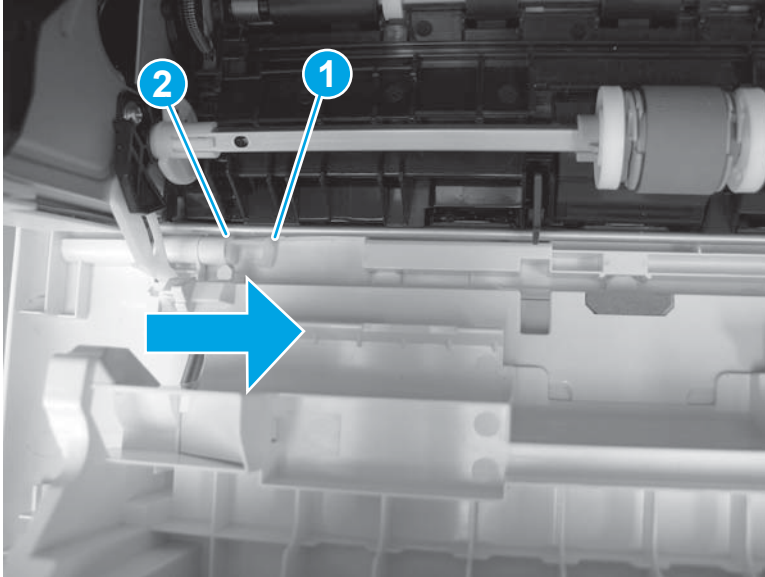
**NOTE:** If the toner cartridge was not removed prior to servicing the printer, remove it now.

1. Release one tab (callout 1), and then slide shaft (callout 2) in the direction the arrow indicates and remove it.



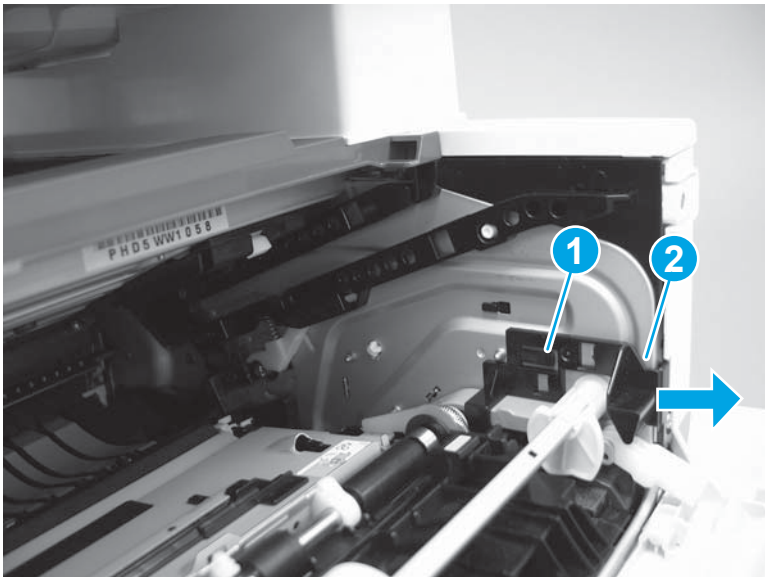
**TIP:** It might be easier to release the support shaft by using a small flat-blade screwdriver.

**Figure 1-176** Release the support shaft



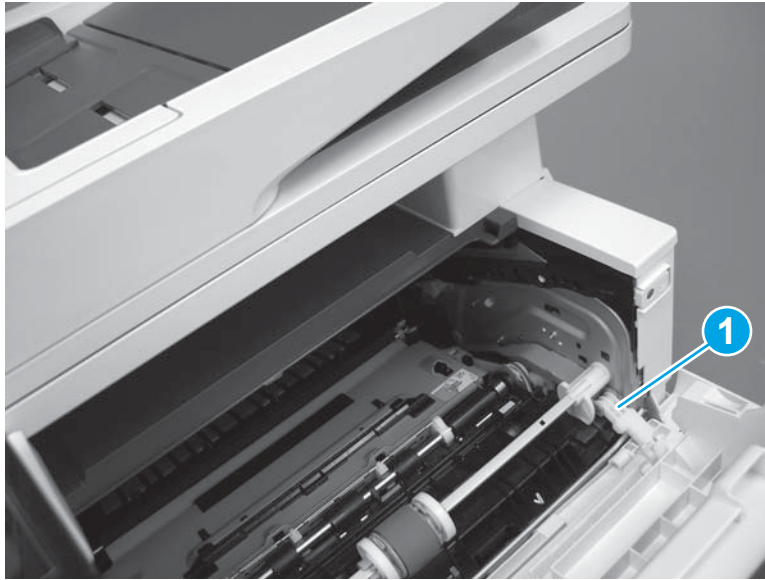
2. Release one tab (callout 1), and then slide the guide (callout 2) in the direction the arrow indicates and remove it.

**Figure 1-177** Remove the guide



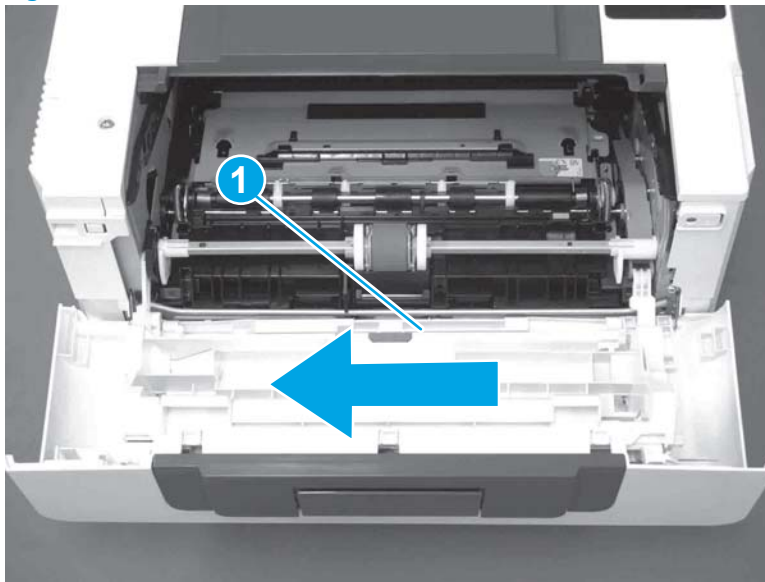
3. Remove the link arm (callout 1).

**Figure 1-178** Remove the link arm



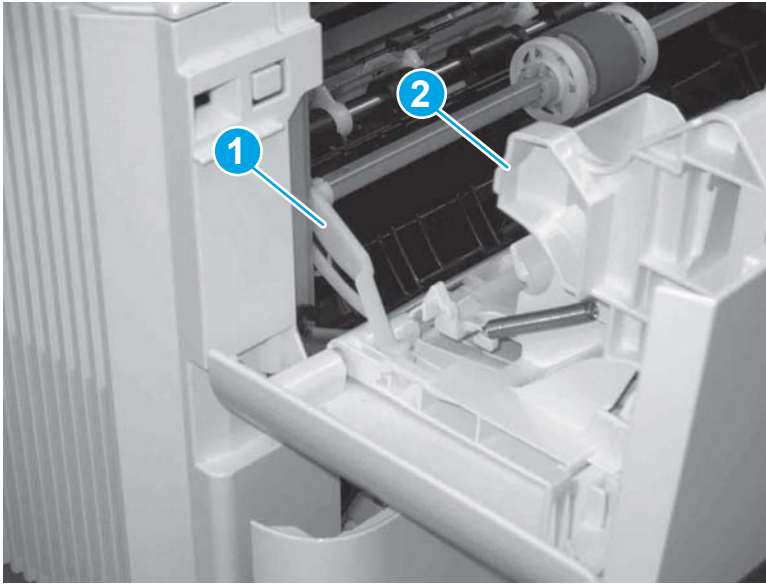
4. Slide the cartridge door assembly (callout 1) in the direction the arrow indicates and remove it.

**Figure 1-179** Remove the door



5. Remove the link (callout 1) from the cartridge door assembly (callout 2).

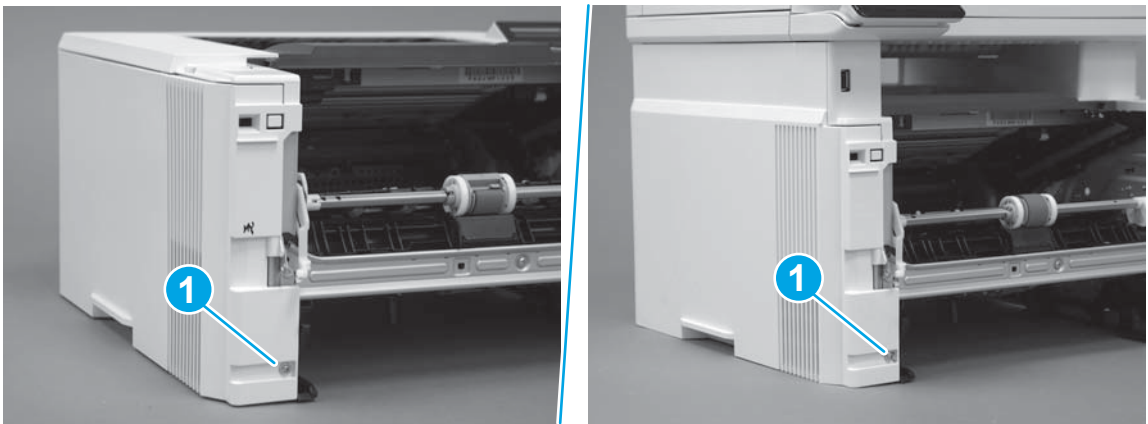
**Figure 1-180** Release the left-side retainer arm



### Step 3: Remove the left cover

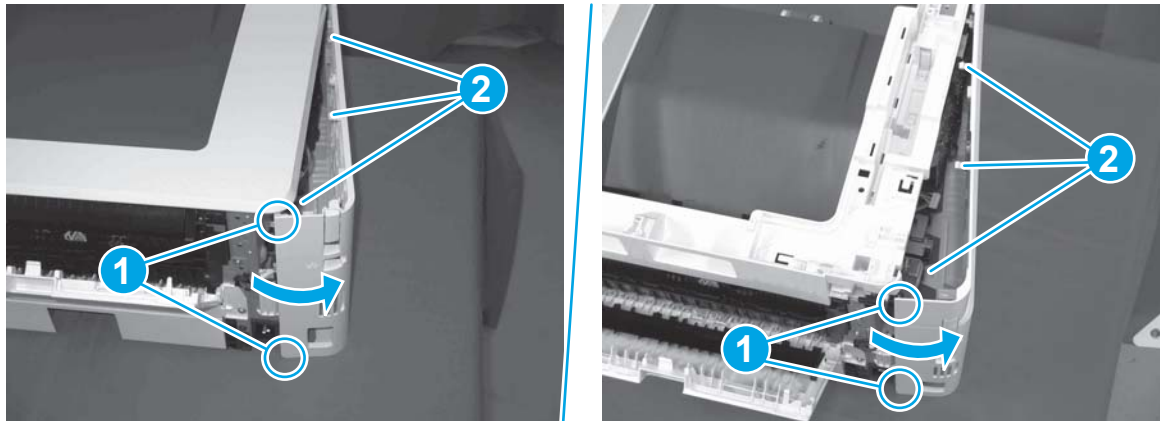
1. Remove one screw (callout 1).

**Figure 1-181** Remove one screw



2. Open the rear door, release two bosses (callout 1), and then release three tabs (callout 2).

**Figure 1-182** Release two bosses and three tabs

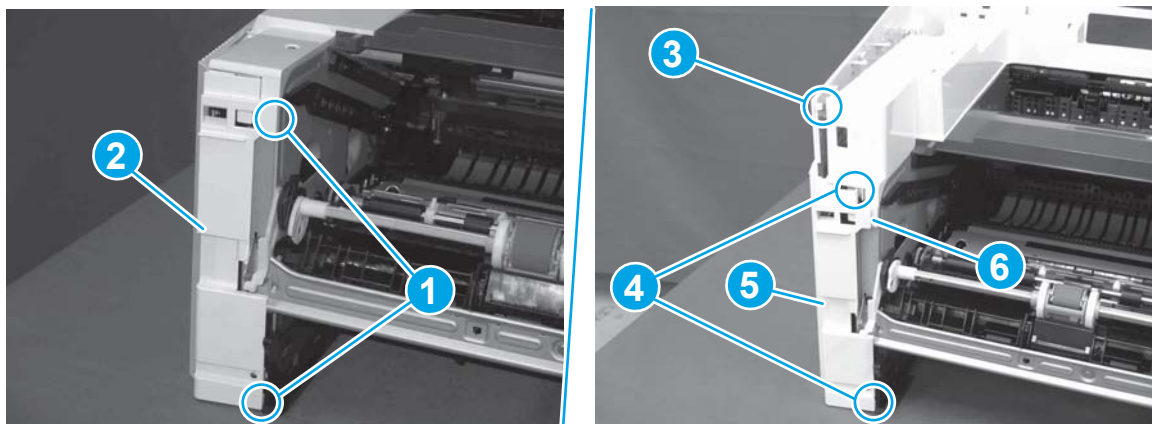


3. At the front of the printer, do one of the following:

- **M403/M402:** Release two bosses (callout 1), and then remove the cover (callout 2).
- **M427/M426:** Release one tab (callout 3), two bosses (callout 4), and then remove the cover (callout 5).

**CAUTION:** Be careful when releasing the upper bosses on the M427/M426 cover. One portion of the cover (callout 6) is fragile and is easily broken.

**Figure 1-183** Remove the cover



#### Step 4: Remove the right cover

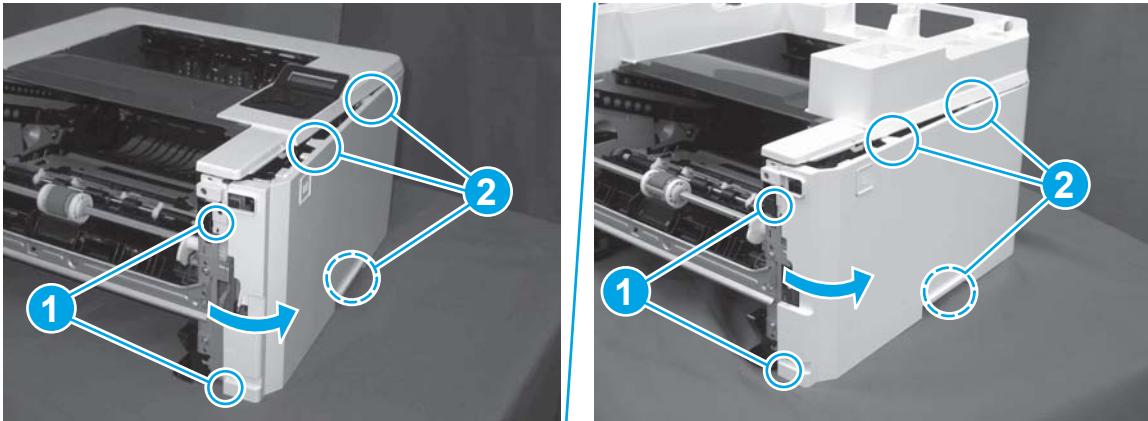
1. Remove one screw (callout 1).

**Figure 1-184** Remove one screw



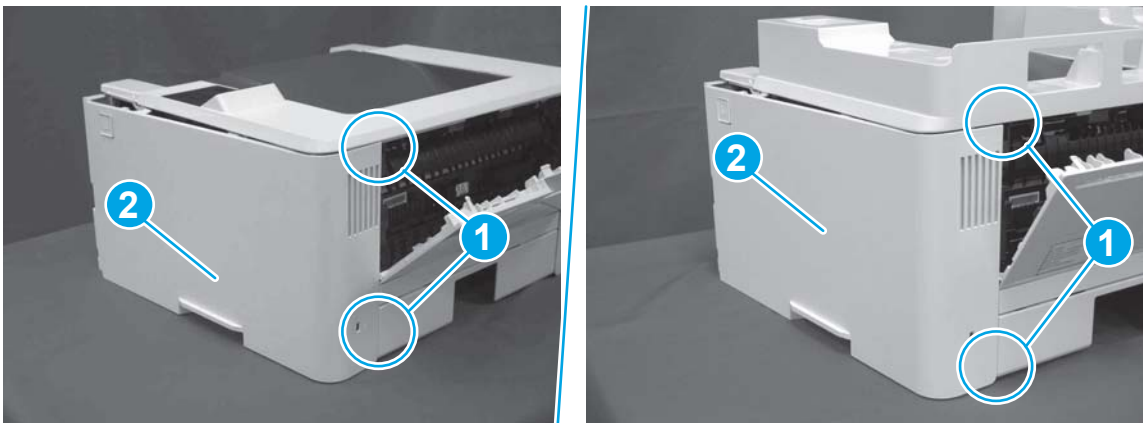
2. At the front of the printer, release two bosses (callout 1), and then release three tabs (callout 2).

**Figure 1-185** Release two bosses and three tabs



3. Open the rear door, release two bosses (callout 1), and then remove the cover (callout 2).

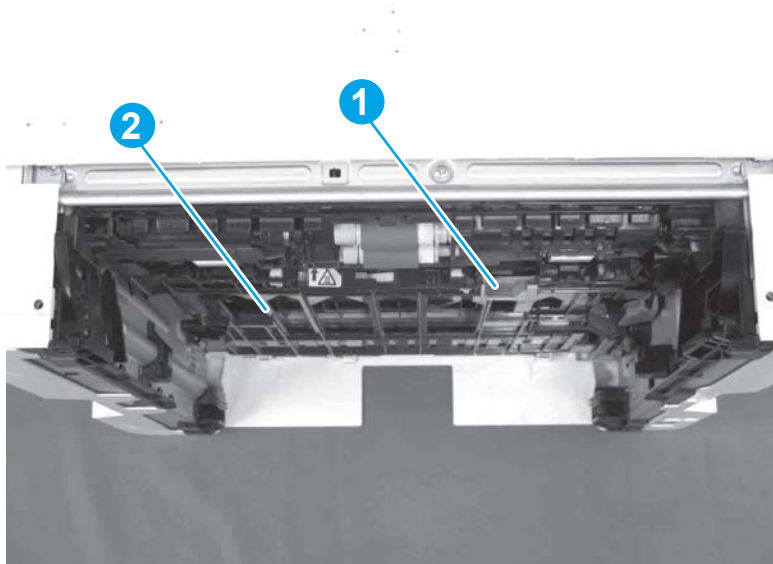
**Figure 1-186** Remove the cover



### Step 5: Remove the rear door assembly

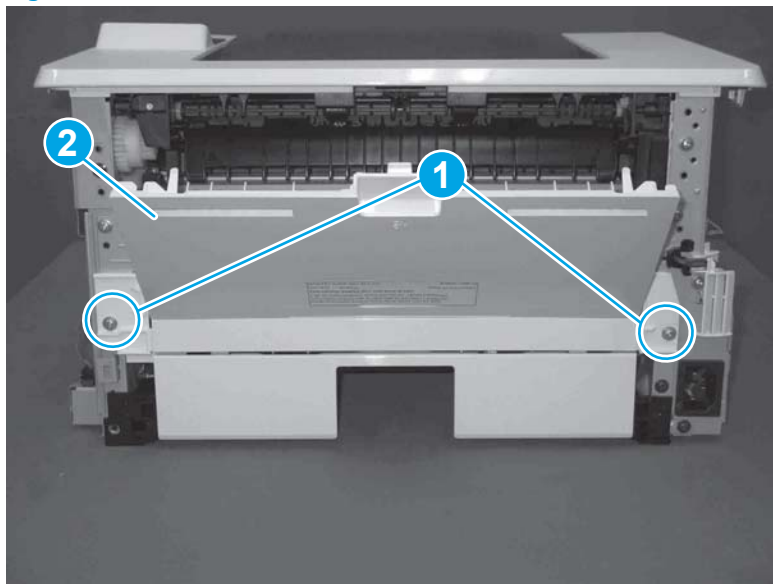
1. **Duplex models only:** Inside the Tray 2 cavity, press the green jam access lever (callout 1), and then lower the duplex feed assembly (callout 2).

**Figure 1-187** Duplex models, lower the duplex feed assembly



2. At the rear of the printer, remove two screws (callout 1), and then remove the rear door assembly (callout 2).

**Figure 1-188** Remove two screws

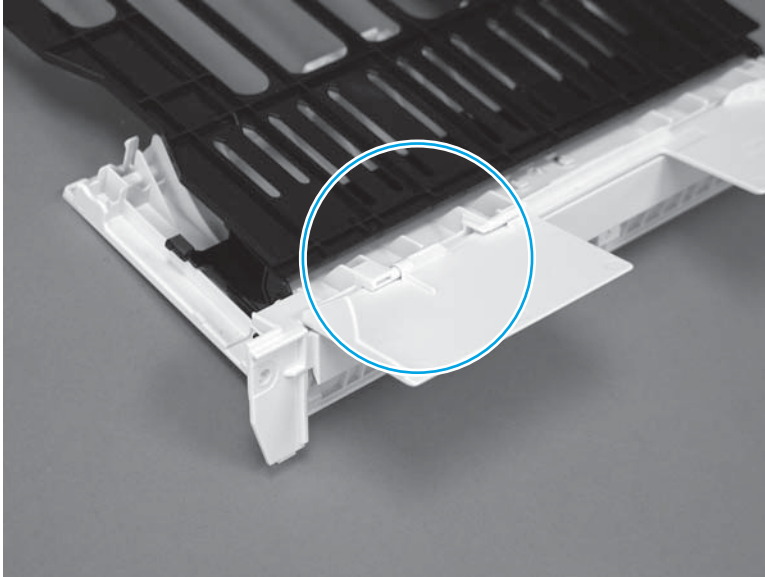


#### **Step 6: Remove the cassette rear cover**

The figures in this procedure show a duplex rear cover assembly. However, the procedure is valid for a simple rear cover.

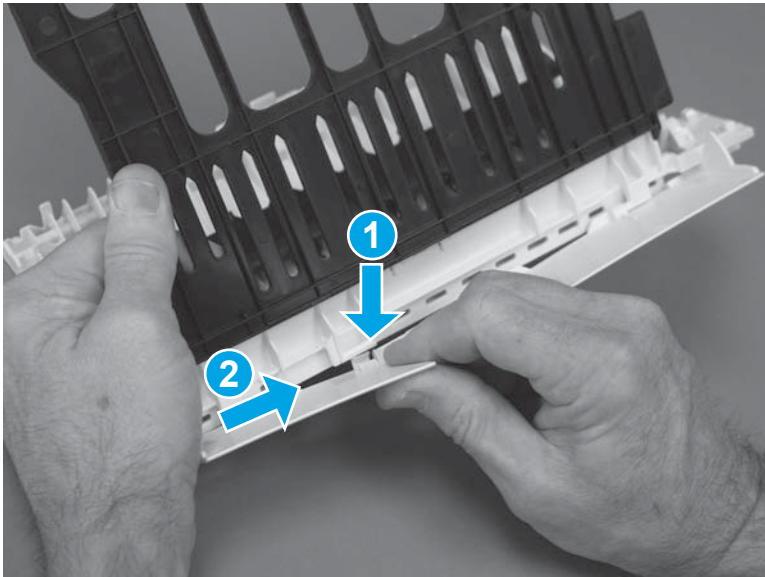
1. Locate the left-side hinge retainer (callout 1).

**Figure 1-189** Locate the hinge retainer



2. Carefully flex the cover to release the retainer (callout 1), and the left-side hinge pin (callout 2).

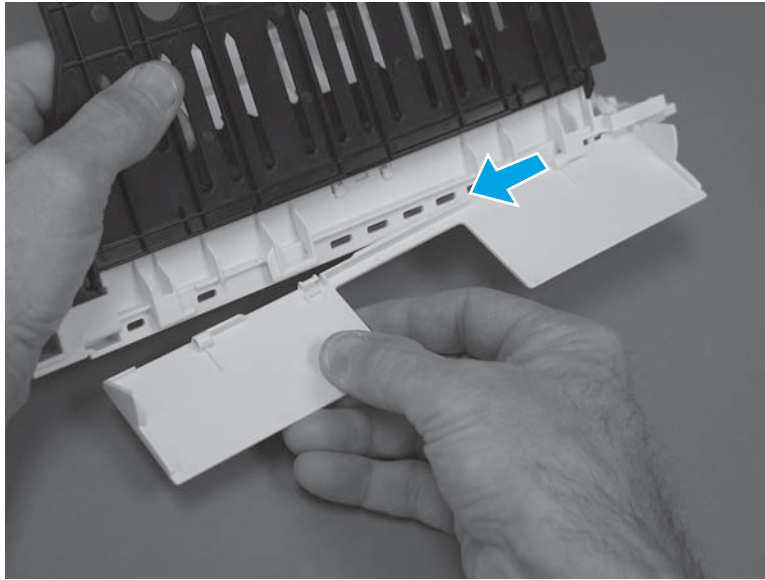
**Figure 1-190** Release the retainer and the hinge pin





3. Remove the cover.

**Figure 1-191** Remove the cover



### Step 7: Unpack the replacement assembly

Unpack the replacement part from the packaging.

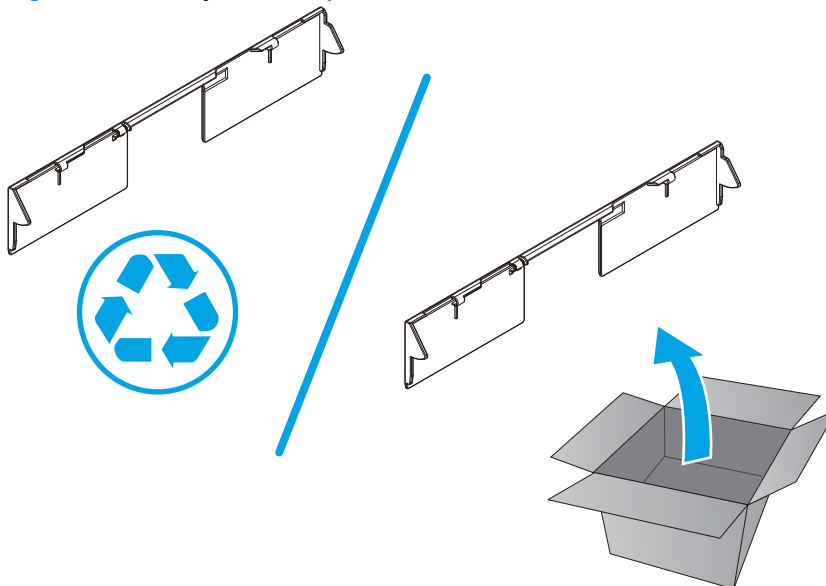
<http://www8.hp.com/us/en/hp-information/environment/product-recycling.html>

---

 **NOTE:** HP recommends responsible disposal of the defective part.

---

**Figure 1-192** Recycle and unpack

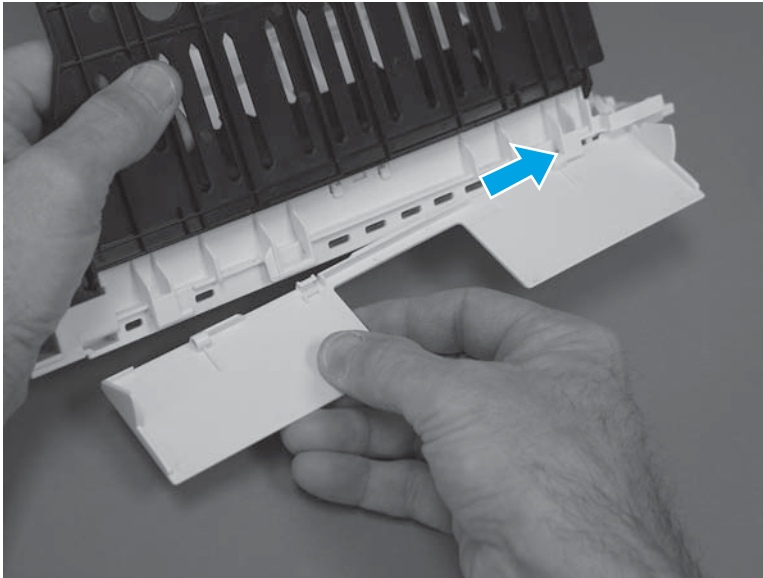


## Step 8: Install the cassette rear door assembly

The figures in this procedure show a duplex rear cover assembly. However, the procedure is valid for a simple rear cover.

1. Position the cover on the rear door with the right-side hinge holder on the cover engaged with the right-side hinge pin on the door.

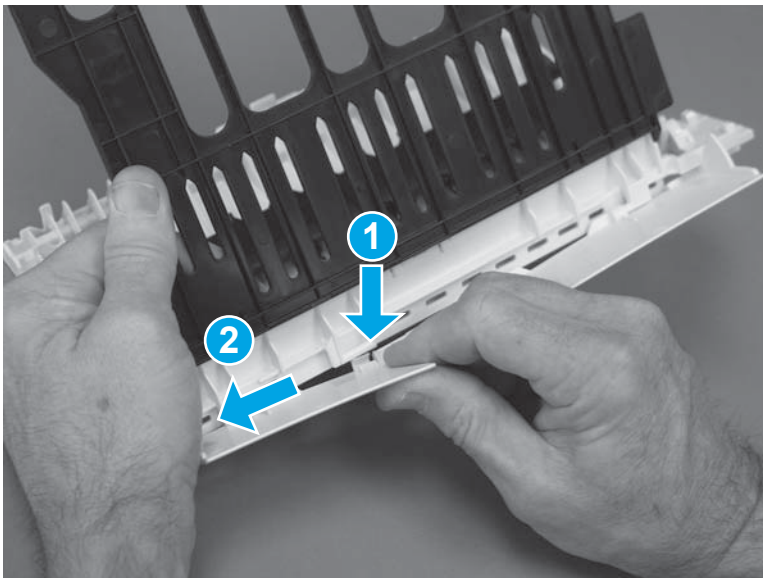
**Figure 1-193** Engage the right-side hinge and pin



2. Carefully flex the cover to engage the left-side hinge pin and holder (callout 1), and the retainer (callout 2).


 **NOTE:** When the cover is correctly installed, it moves freely on the hinge pins.

**Figure 1-194** Engage the left-side hinge and retainer

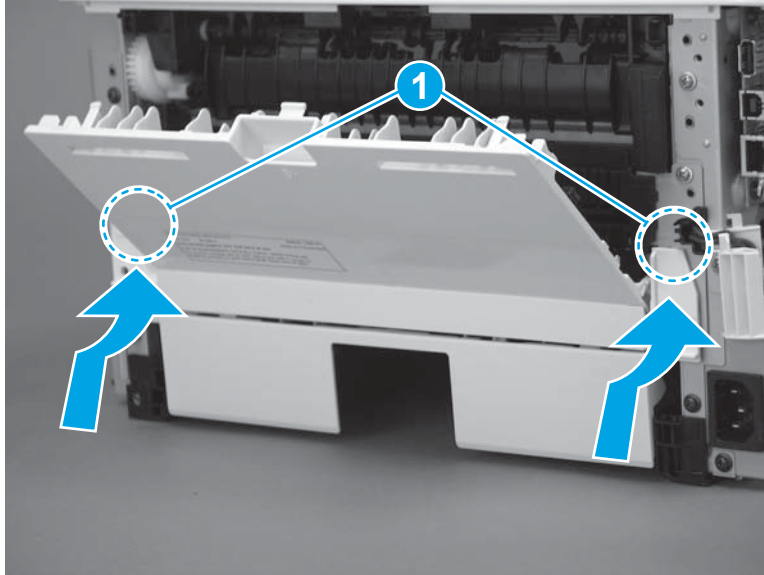


## Step 9: Install the rear door assembly

1. At the rear of the printer, position the assembly so that the two tabs (callout 1) are installed in the slots (callout 2) in the chassis.

 **NOTE:** **Duplex models only:** Slide the duplex tray into the Tray 2 cavity.

**Figure 1-195** Install the rear cover



2. Install two screws.

 **NOTE:** **Duplex models only:** Reach in from the front of the Tray 2 cavity and raise the feed assembly to the up and locked position so that the rear cover will fit flat against the chassis.

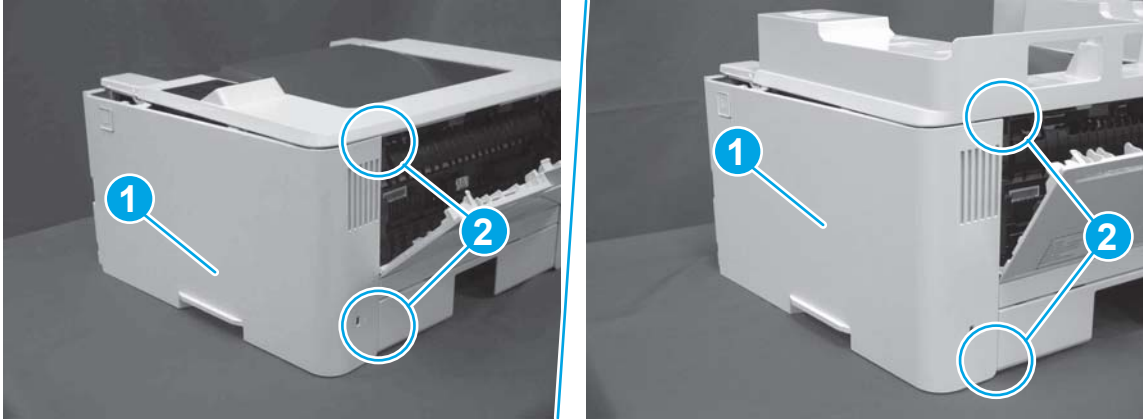
**Figure 1-196** Install two screws



## Step 10: Install the right cover

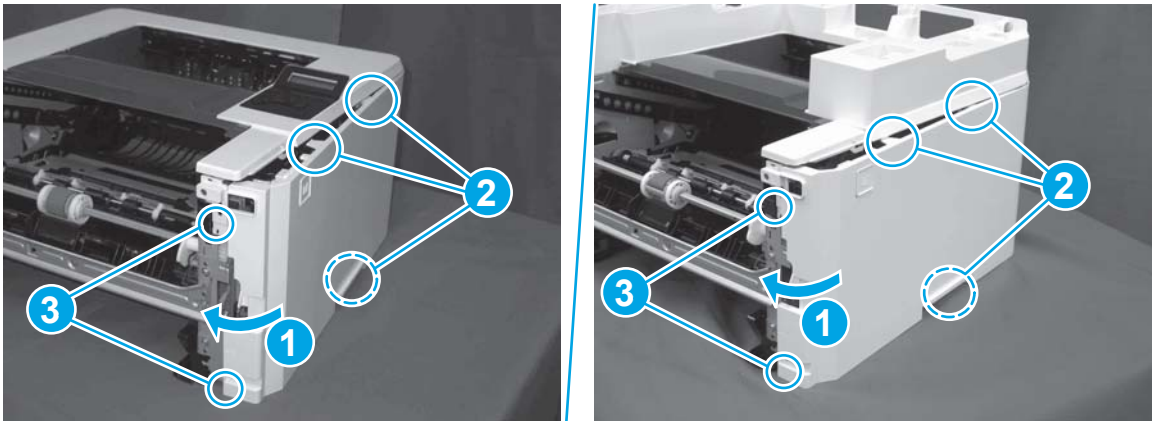
1. Position the cover (callout 1) on the printer, and then engage two bosses (callout 2).

**Figure 1-197** Install the cover




2. Rotate the front of the cover onto the printer (callout 1), engage three (callout 2) tabs, and then engage two bosses (callout 3).

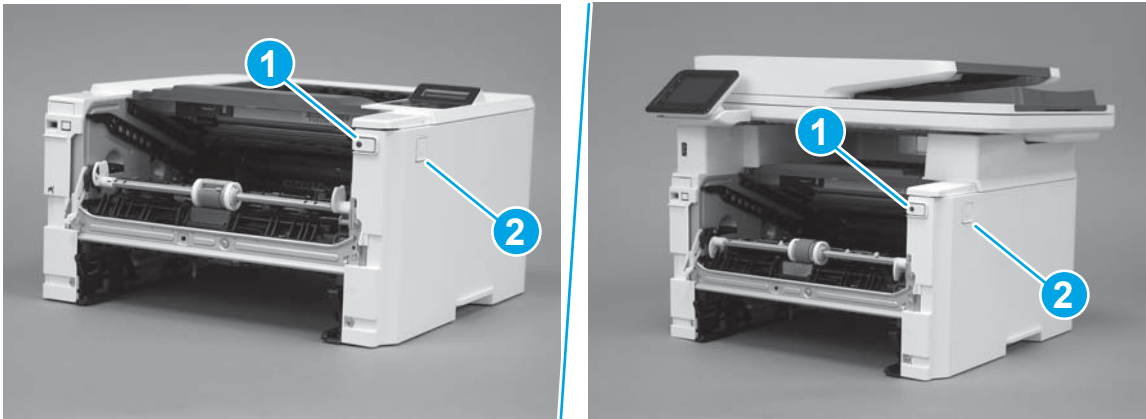
**Figure 1-198** Engage two bosses and one tab



3. Make sure that the power switch (callout 1) and cartridge door assembly button (callout 2) correctly function.

 **NOTE:** Remove, and then reinstall the cover if the switch or button does not correctly function.

**Figure 1-199** Check the power switch and cartridge door assembly button



4. Install one screw (callout 1).

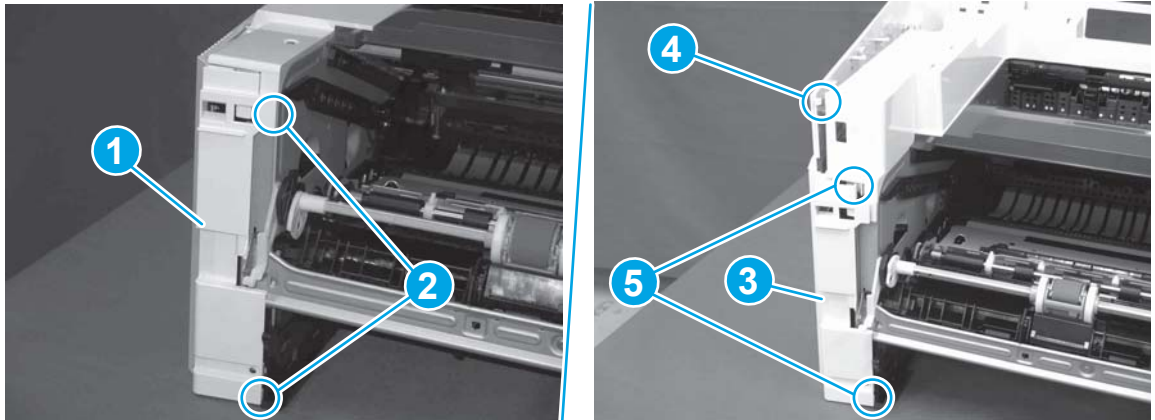
**Figure 1-200** Install one screw



### Step 11: Install the left cover

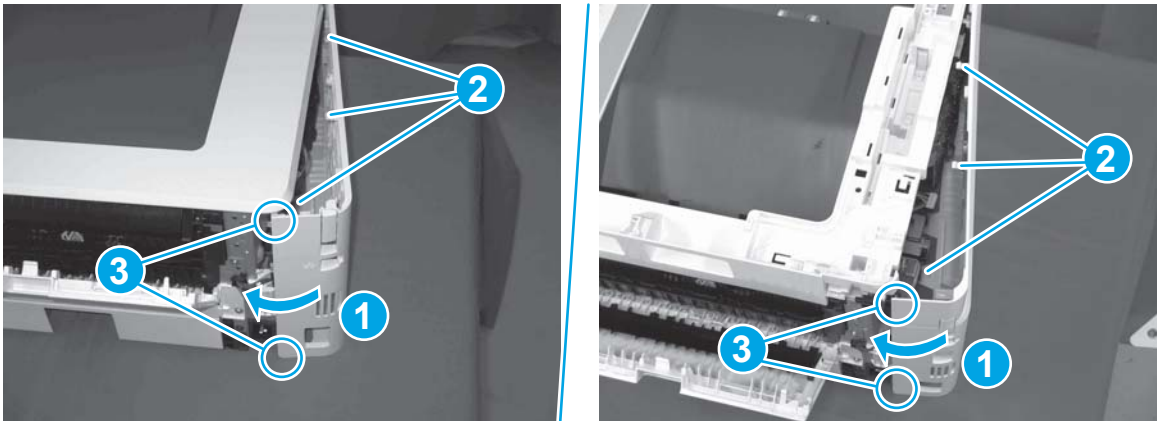
1. At the front of the printer, do one of the following:
  - **M403/M402:** Position the cover on the printer ( callout 1), and then engage two bosses (callout 2).
  - **M427/M426:** Position the cover on the printer (callout 3), engage one tab (callout 4), and then engage two bosses (callout 4).

**Figure 1-201** Install the cover



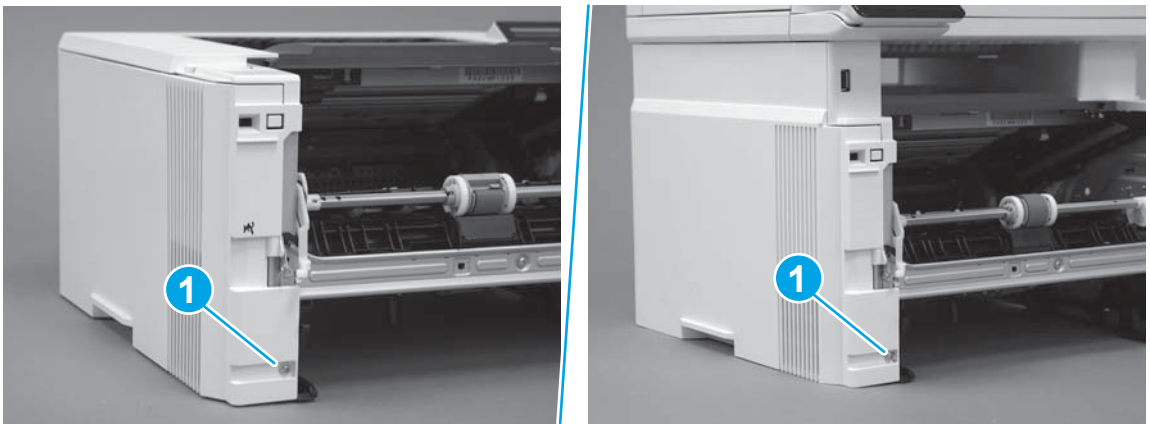
- Carefully rotate the rear of the cover onto the printer (callout 1), engage three tabs (callout 2), and then engage two bosses (callout 3).

**Figure 1-202** Engage three tabs and two bosses




- Install one screw (callout 1).

**Figure 1-203** Install one screw

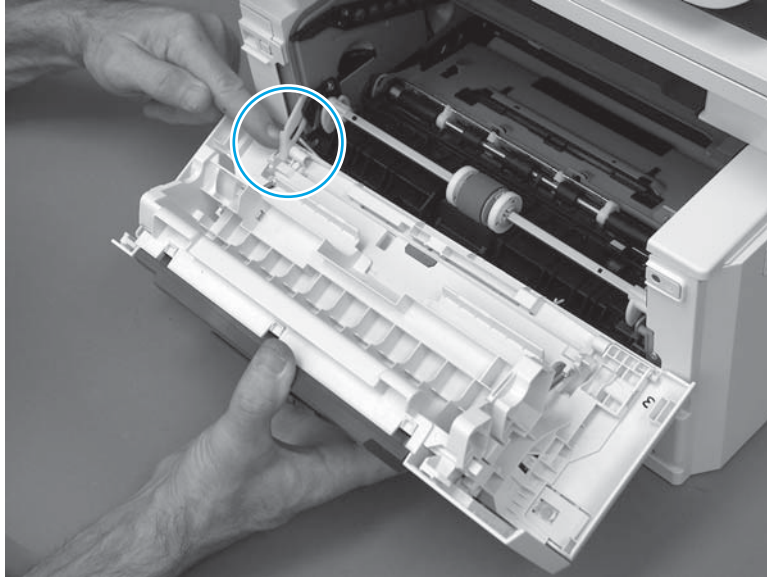


## Step 12: Install the cartridge door assembly

 **Reinstallation tip:** After a replacement door is installed, make sure to install the nameplate (supplied in the kit) corresponding to the printer name on the door.

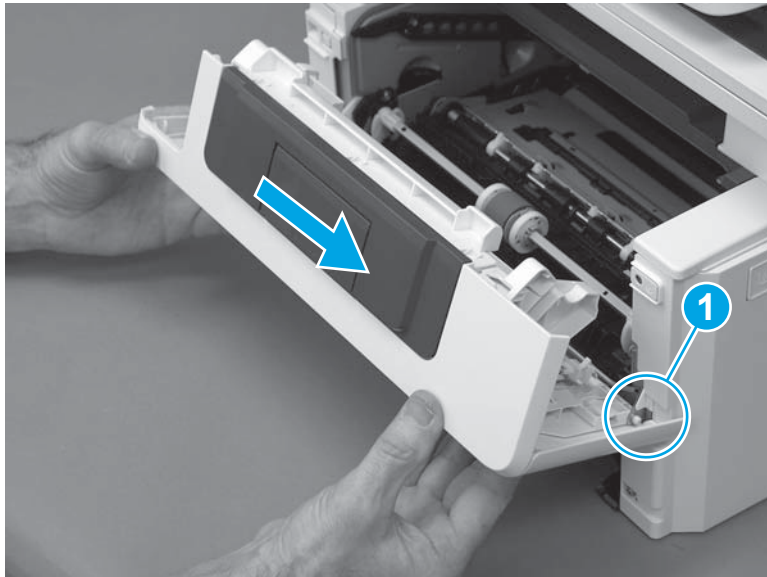
- Position the door close to the printer, and then engage the keyed pin on the left-side retainer arm with the hole in the door.

**Figure 1-204** Engage the left-side retainer arm



2. Engage the right-side door hinge pin with the hole in the chassis (callout 1).

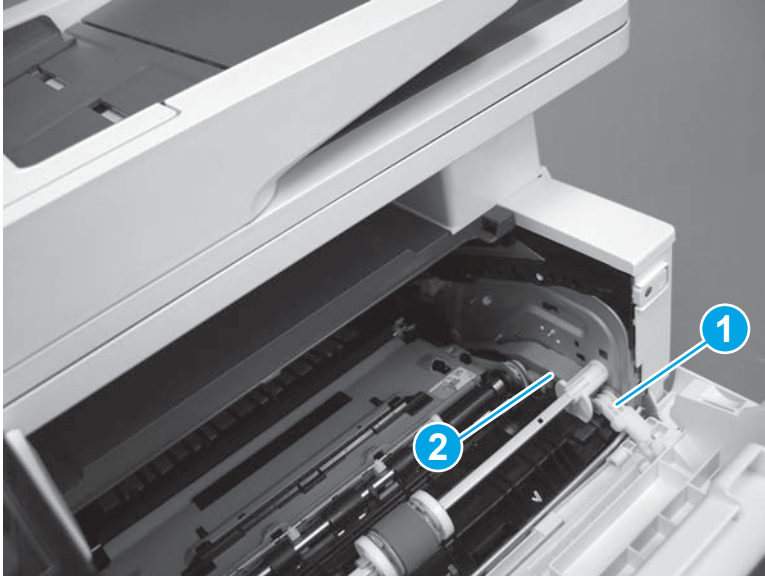
**Figure 1-205** Install the door



3. Install the link (callout 1).

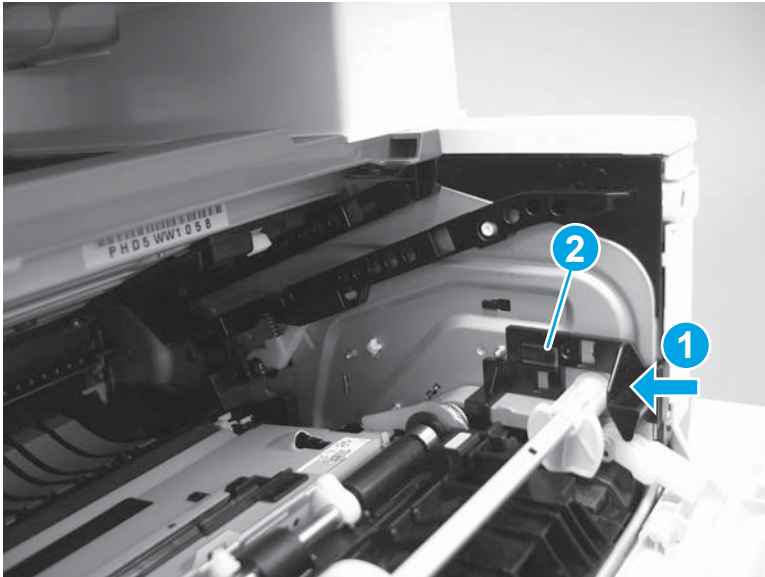
 **IMPORTANT:** Make sure that the link snaps into place on the arm (callout 2). The link actuates the fuser pressure-release mechanism.

**Figure 1-206** Install the pressure-release link



4. Slide the guide into the printer (callout 1), and then make sure that the tab (callout 2) snaps into place to secure the guide to the chassis.

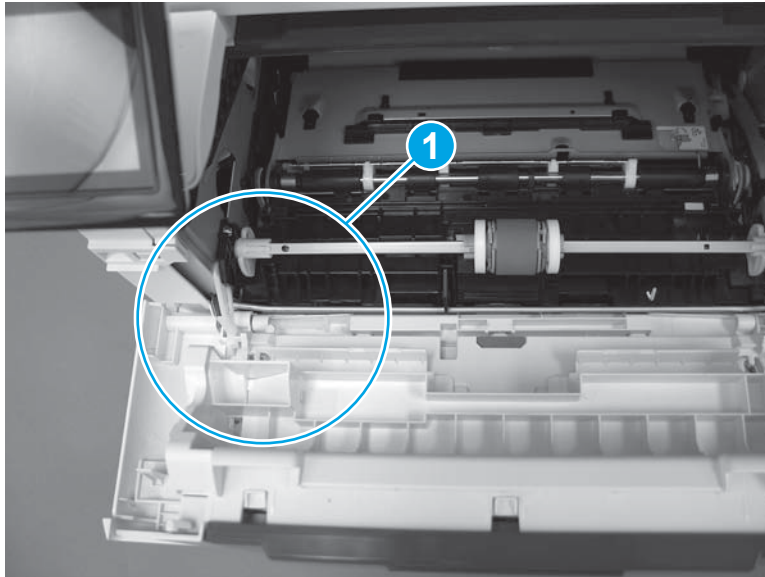
**Figure 1-207** Install the guide






5. Position the shaft on the door, and then align the left-side hinge on the door with the hole in the chassis (callout 1).

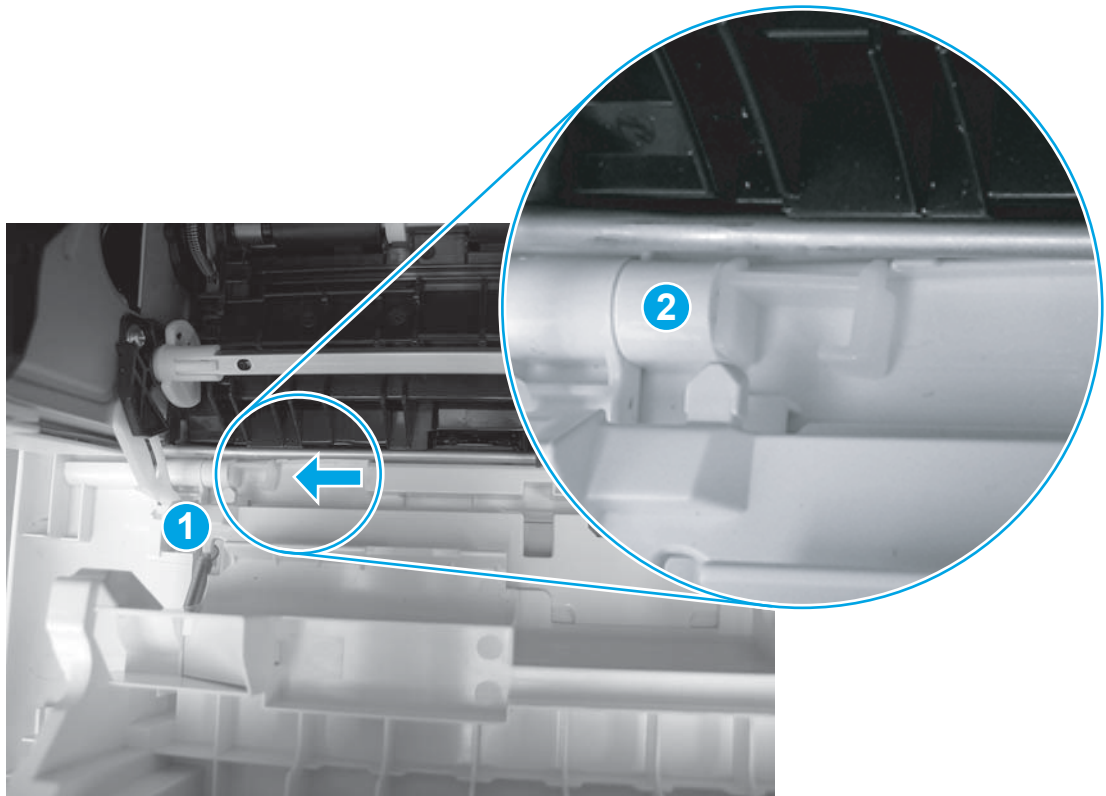
**Figure 1-208** Align the hinge



6. Push the shaft towards the left side of the printer to install it (callout 1).

 **Reinstallation tip:** Make sure that the support shaft is fully installed and correctly orientated (callout 2) so that it will not interfere with the door opening and closing.

**Figure 1-209** Install the support shaft



### Step 13: Install Tray 2

- ▲ Slide the tray straight into the printer to install it.

**Figure 1-210** Install the tray



## Removal and replacement: Top cover (M427/M426)

- [Introduction](#)
- [Step 1: Remove Tray 2](#)
- [Step 2: Remove the cartridge door assembly](#)
- [Step 3: Remove the left cover](#)
- [Step 4: Remove the right cover](#)
- [Step 5: Remove the integrated scanner assembly \(M427/M426\)](#)
- [Step 6: Remove the control panel \(M427/M426\)](#)
- [Step 7: Remove the top cover \(M427/M426\)](#)
- [Step 8: Unpack the replacement assembly](#)
- [Step 9: Remove the cable guide \(M427/M426\)](#)
- [Step 10: Install the cable guide \(M427/M426\)](#)
- [Step 11: Install the top cover \(M427/M426\)](#)
- [Step 12: Install the control panel \(M427/M426\)](#)
- [Step 13: Install the integrated scanner assembly \(M427/M246\)](#)
- [Step 14: Install the right cover](#)
- [Step 15: Install the left cover](#)
- [Step 16: Install the cartridge door assembly](#)
- [Step 17: Install Tray 2](#)


### Introduction

This document provides the procedures to remove and replace the top cover (M427/M426).

### Before performing service

#### Turn the printer power off

- Disconnect the power cable.

 **WARNING!** To avoid damage to the printer, turn the printer off, wait 30 seconds, and then remove the power cable before attempting to service the printer.

Use the table below to identify the correct part number for your printer. To order the part, go to [www.hp.com/buy/parts](http://www.hp.com/buy/parts).

Top cover (M427/M426) part number	
RC4-3207-000CN	Top cover (M427/M426)

## Required tools

- #2 Phillips screwdriver with a magnetic tip.
- Small flat-blade screw driver

## After performing service

### Turn the printer power on

- Connect the power cable.
- Use the power switch to turn the power on.

### Post service test

Make sure that the printer initializes to a **Ready** state.

Print a configuration page to make sure that the printer is functioning correctly.

### Step 1: Remove Tray 2

- ▲ Pull the tray straight out of the printer to remove it.

**Figure 1-211** Remove the tray



### Step 2: Remove the cartridge door assembly



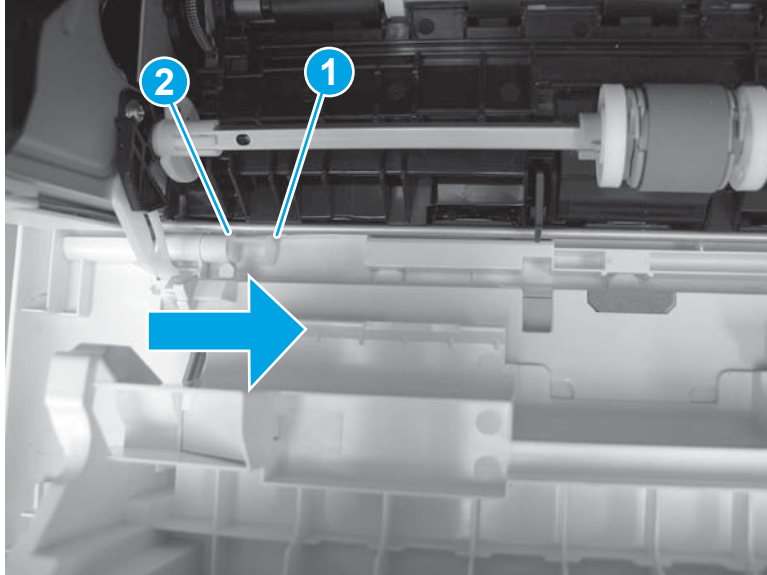
**NOTE:** If the toner cartridge was not removed prior to servicing the printer, remove it now.

1. Release one tab (callout 1), and then slide shaft (callout 2) in the direction the arrow indicates and remove it.



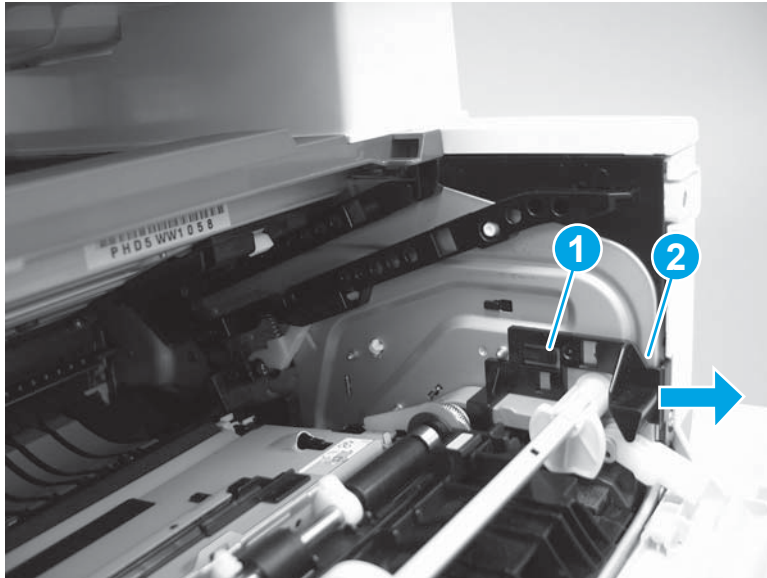
**TIP:** It might be easier to release the support shaft by using a small flat-blade screwdriver.

**Figure 1-212** Release the support shaft



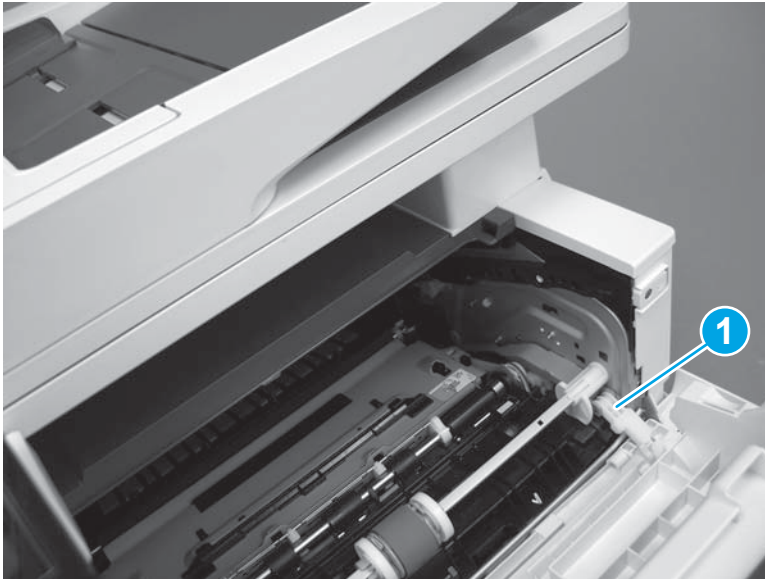
2. Release one tab (callout 1), and then slide the guide (callout 2) in the direction the arrow indicates and remove it.

**Figure 1-213** Remove the guide



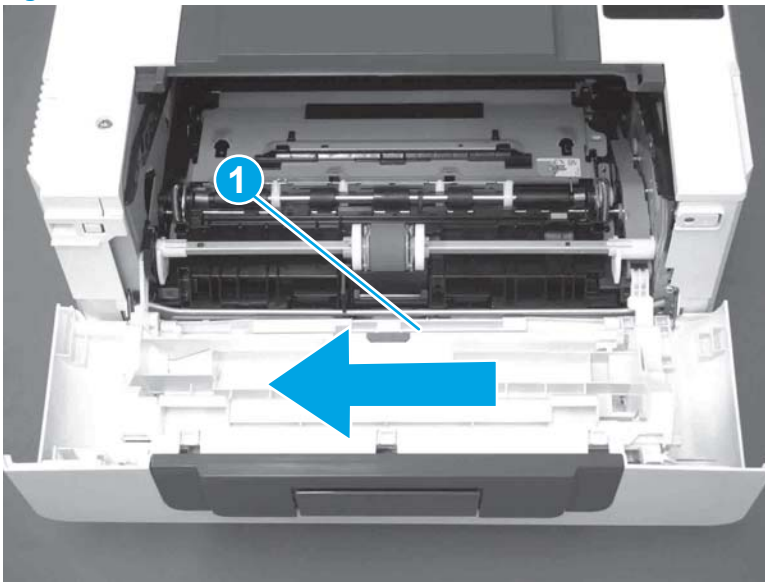
3. Remove the link arm (callout 1).

**Figure 1-214** Remove the link arm



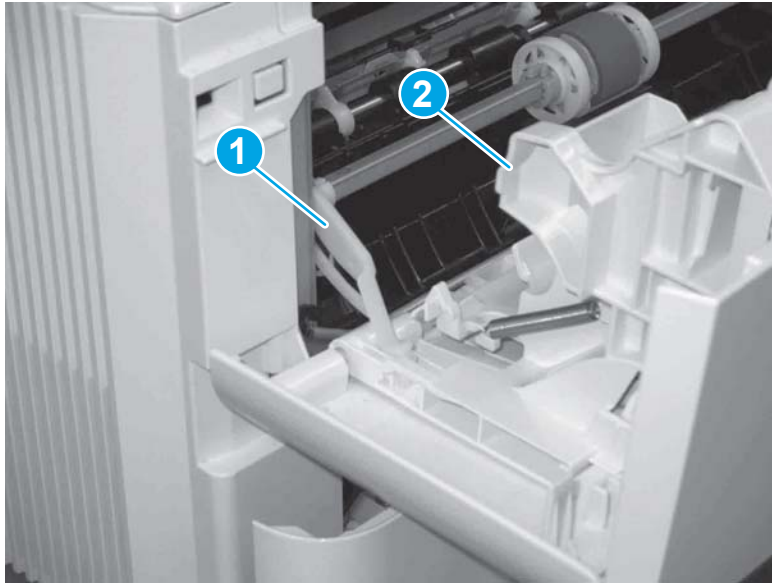
4. Slide the cartridge door assembly (callout 1) in the direction the arrow indicates and remove it.

**Figure 1-215** Remove the door



5. Remove the link (callout 1) from the cartridge door assembly (callout 2).

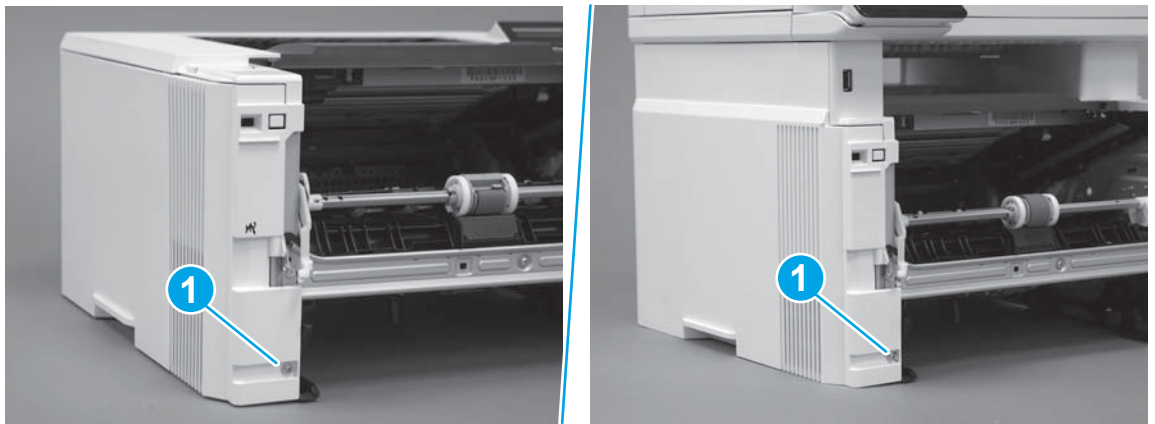
**Figure 1-216** Release the left-side retainer arm



### Step 3: Remove the left cover

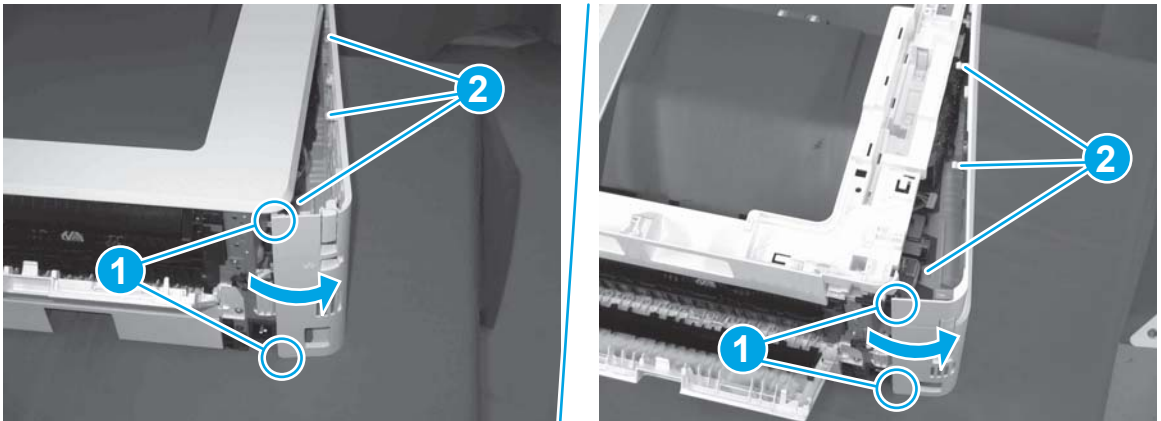
1. Remove one screw (callout 1).

**Figure 1-217** Remove one screw



2. Open the rear door, release two bosses (callout 1), and then release three tabs (callout 2).

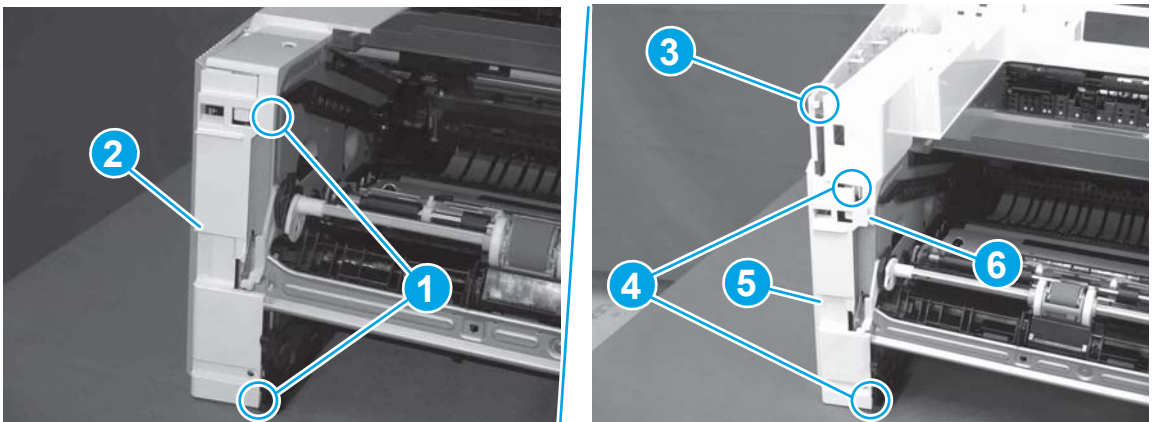
**Figure 1-218** Release two bosses and three tabs



3. At the front of the printer, do one of the following:
  - **M403/M402:** Release two bosses (callout 1), and then remove the cover (callout 2).
  - **M427/M426:** Release one tab (callout 3), two bosses (callout 4), and then remove the cover (callout 5).

**CAUTION:** Be careful when releasing the upper bosses on the M427/M426 cover. One portion of the cover (callout 6) is fragile and is easily broken.

**Figure 1-219** Remove the cover

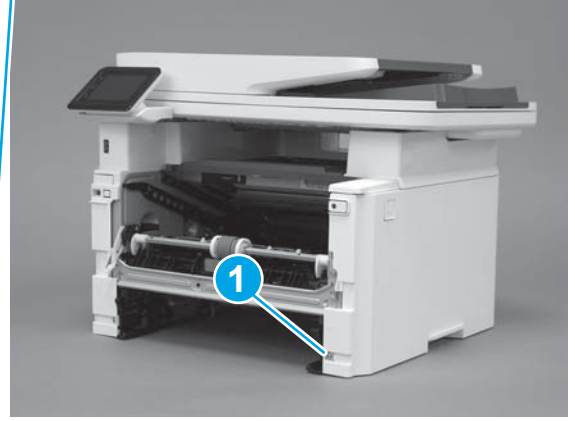
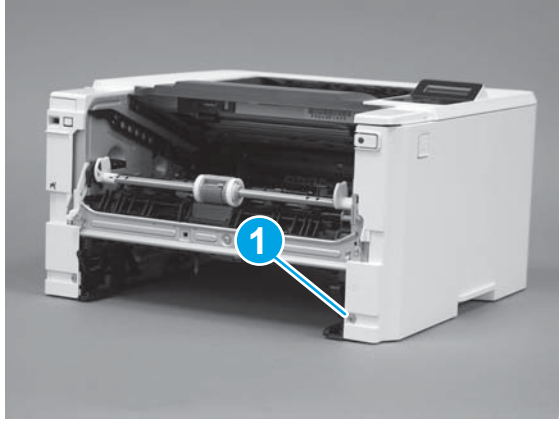


#### Step 4: Remove the right cover

1. Remove one screw (callout 1).

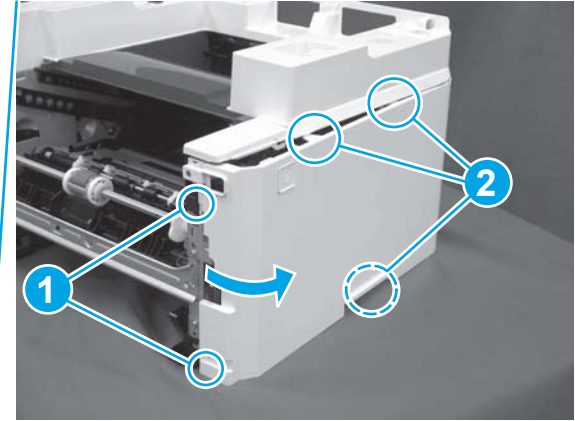
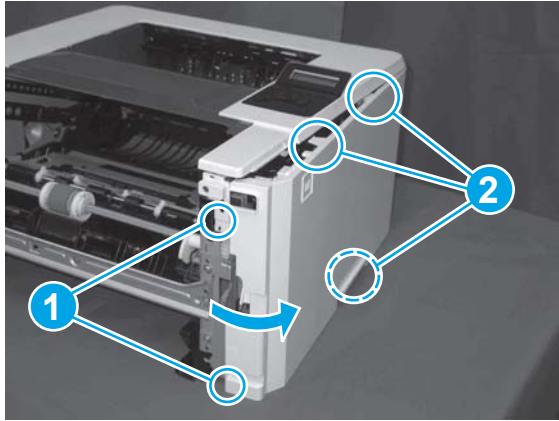


**Figure 1-220** Remove one screw



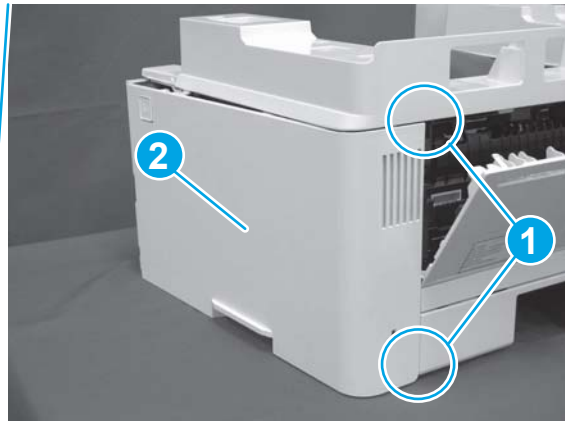
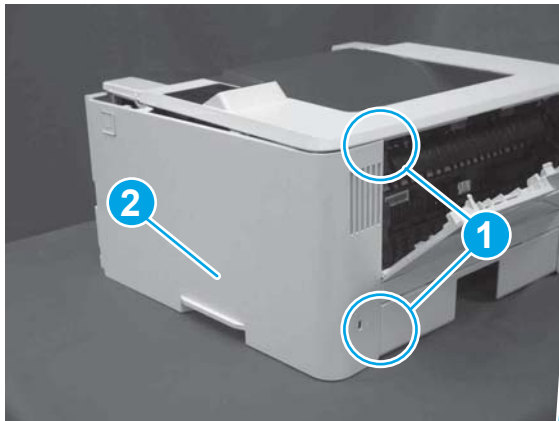
2. At the front of the printer, release two bosses (callout 1), and then release three tabs (callout 2).

**Figure 1-221** Release two bosses and three tabs




3. Open the rear door, release two bosses (callout 1), and then remove the cover (callout 2).

**Figure 1-222** Remove the cover

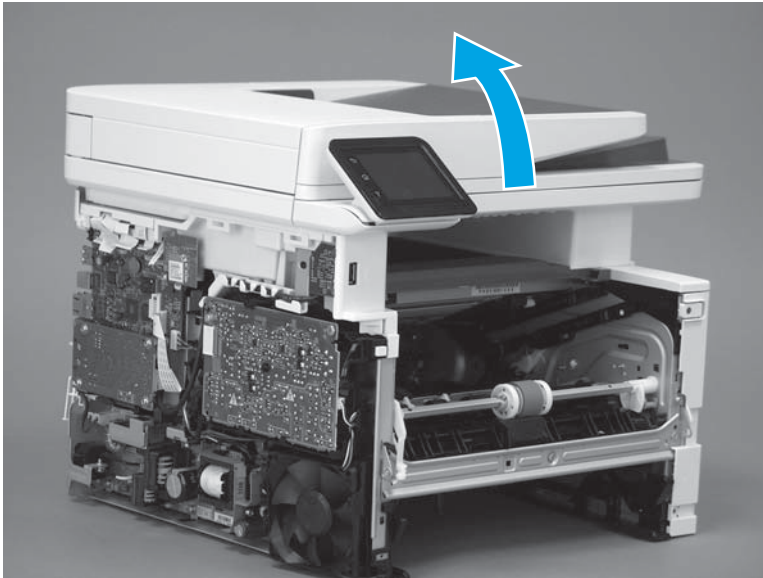


## Step 5: Remove the integrated scanner assembly (M427/M426)

 **NOTE:** M427/M426 models only. The integrated scanner assembly (ISA) includes the sub-scanner assembly (SSA) and the automatic document feeder (ADF).

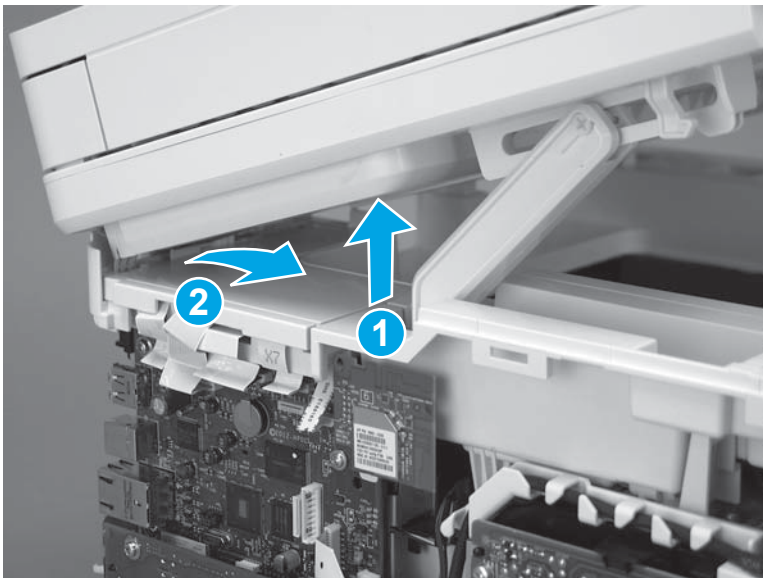
1. Raise the ISA.

**Figure 1-223** Raise the ISA



2. Release the ISA flat-flexible cable (FFC) cover (callout 1), and then remove it (callout 2).

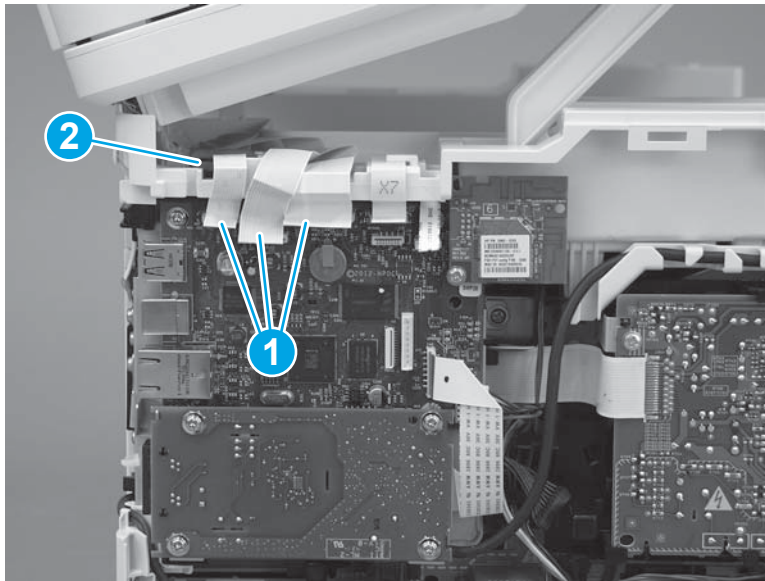
**Figure 1-224** Remove the ISA FFC cover



3. Disconnect three FFCs (callout 1), and then remove the ferrite (callout 2) from the holder.

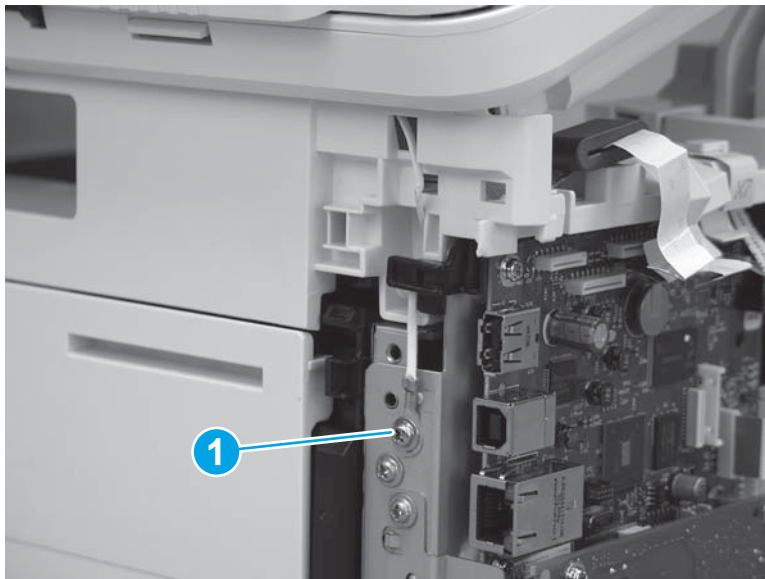
**CAUTION:** The ferrite is not captive on the FFC. Do not lose the ferrite while handling the ISA.

**Figure 1-225** Disconnect three FFCs



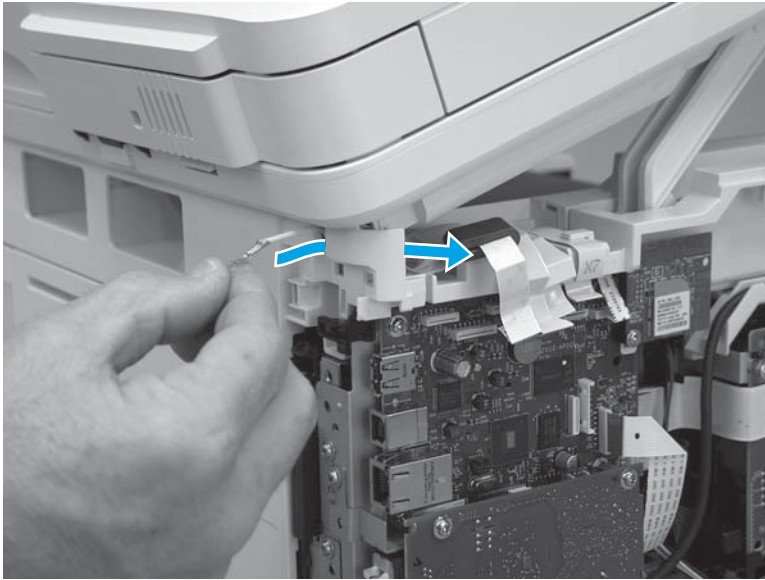
4. Remove one screw (callout 1).

**Figure 1-226** Remove one screw



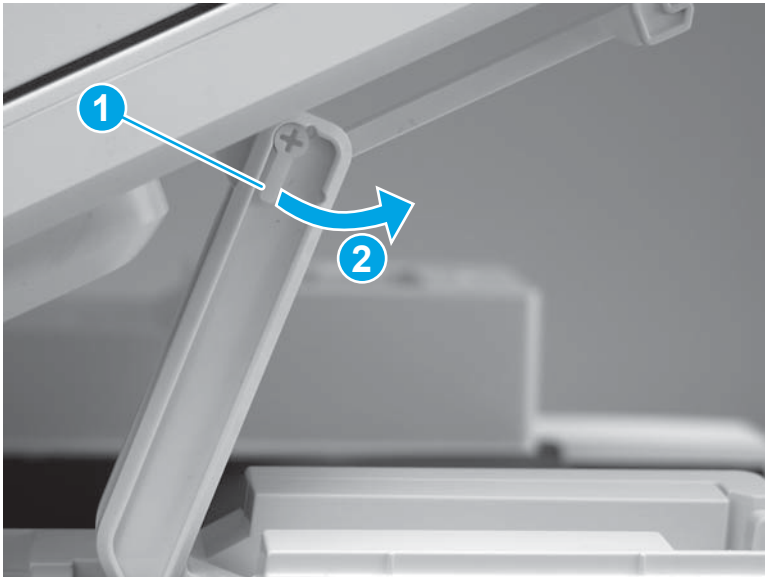
5. Pass the ground wire through the opening in the top cover.

**Figure 1-227** Pass the wire through the opening



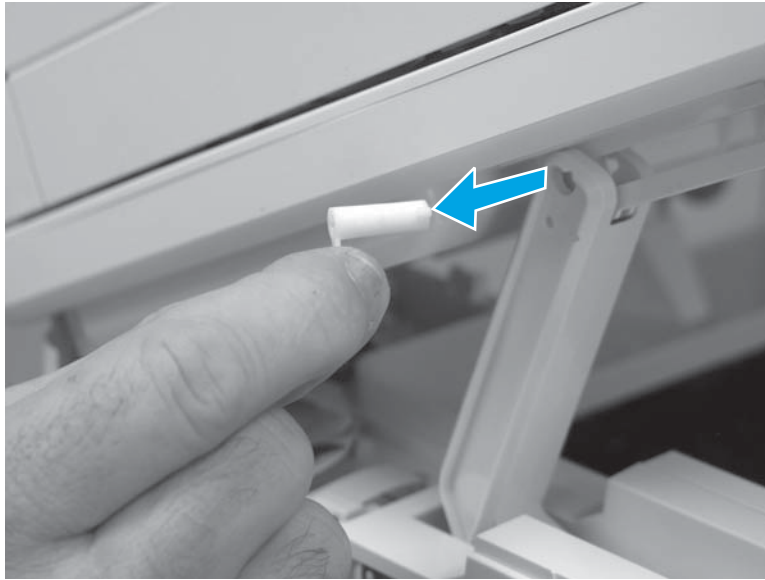
6. Release one tab (callout 1), and then rotate the ISA slider pin (callout 2) towards the front of the printer to release it.

**Figure 1-228** Release one tab and rotate the slider pin



7. Remove the slider pin.

**Figure 1-229** Remove the slider pin



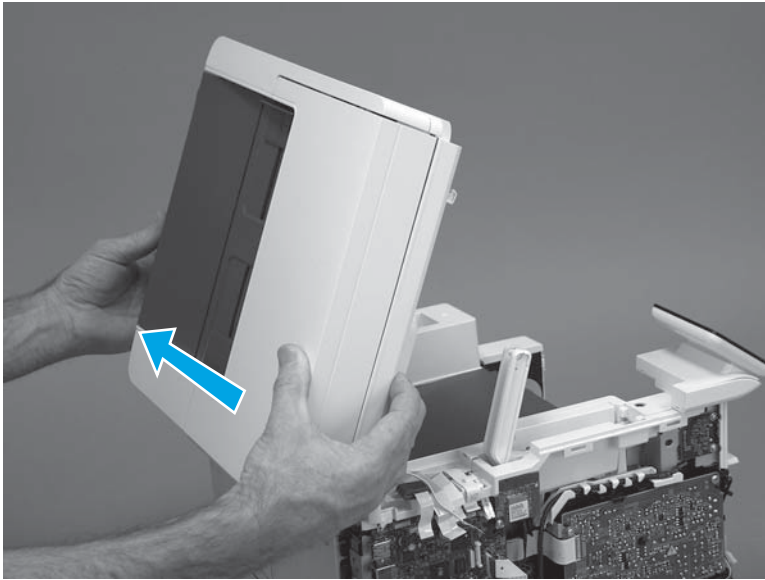
8. Rotate the ISA towards the rear of the printer until it stops.

**Figure 1-230** Rotate the ISA towards the rear of the printer



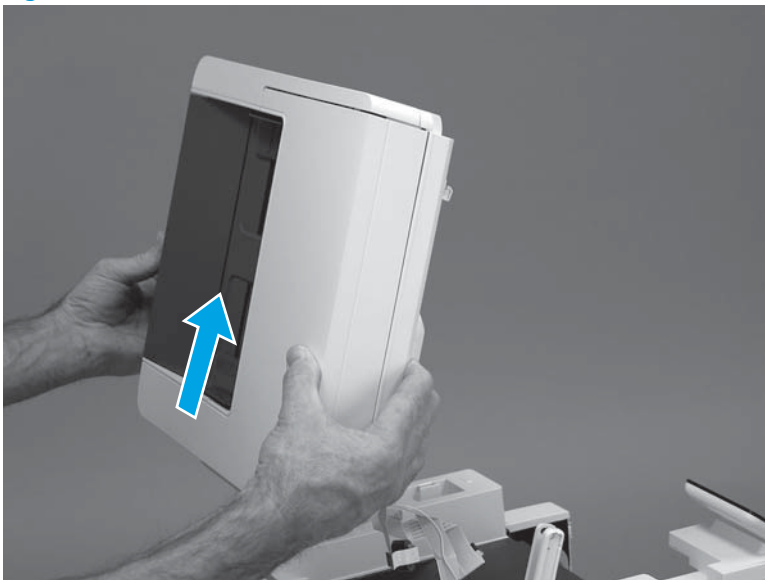
9. Slide the ISA as shown to release it.

**Figure 1-231** Release the ISA



10. Remove the ISA.

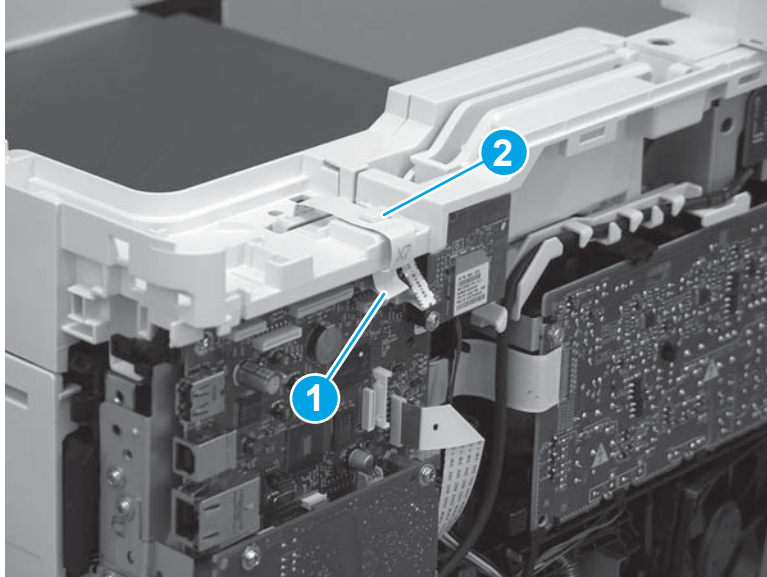
**Figure 1-232** Remove the ISA



### **Step 6: Remove the control panel (M427/M426)**

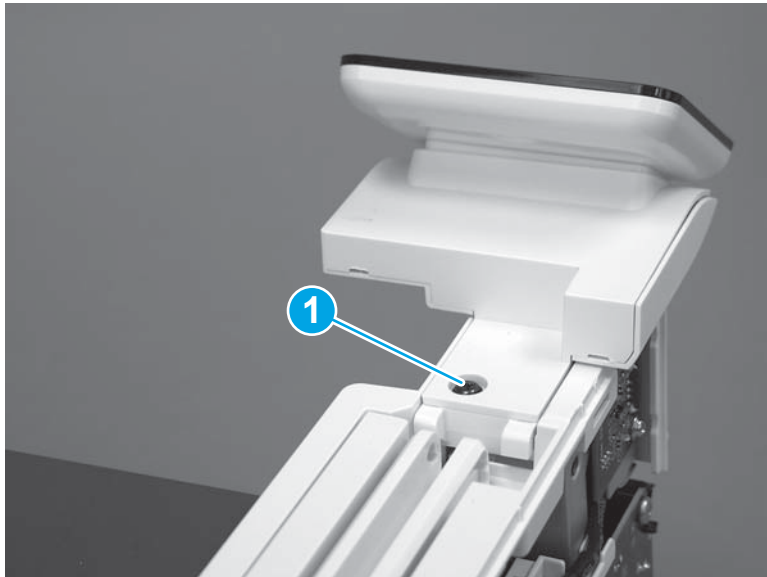
1. Disconnect one FFC (callout 1; J114), and then release the FFC from the retainer (callout 2).

**Figure 1-233** Disconnect one connector



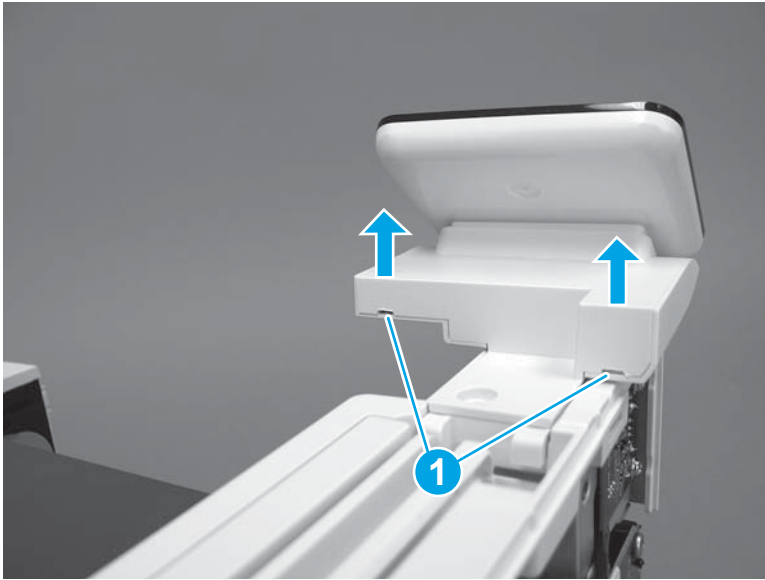
2. Remove one screw (callout 1).

**Figure 1-234** Remove one screw



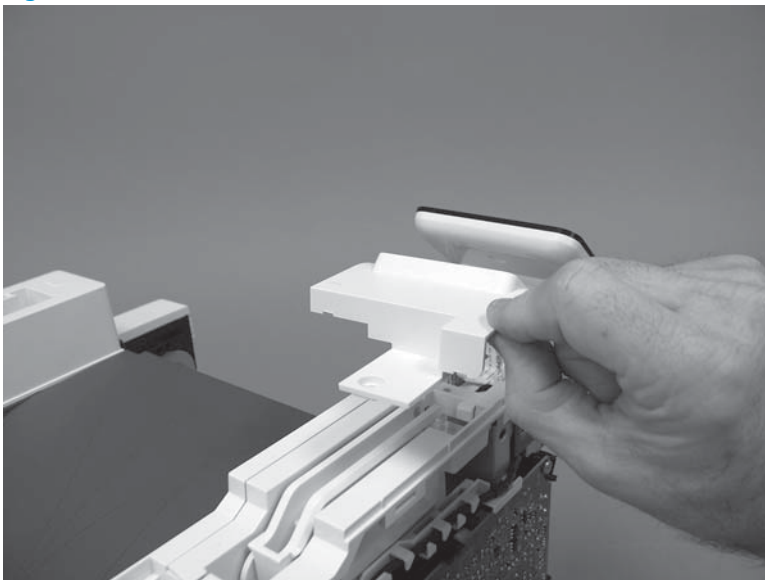
3. Use a small flat-blade screwdriver to release two tabs (callout 1) on the control-panel cable cover.

**Figure 1-235** Release two tabs



4. Remove the control-panel cable cover.

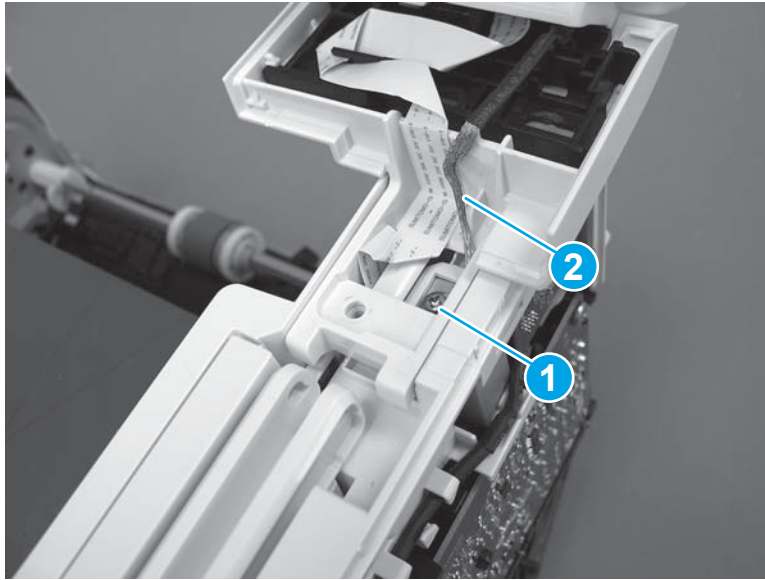
**Figure 1-236** Remove the cover





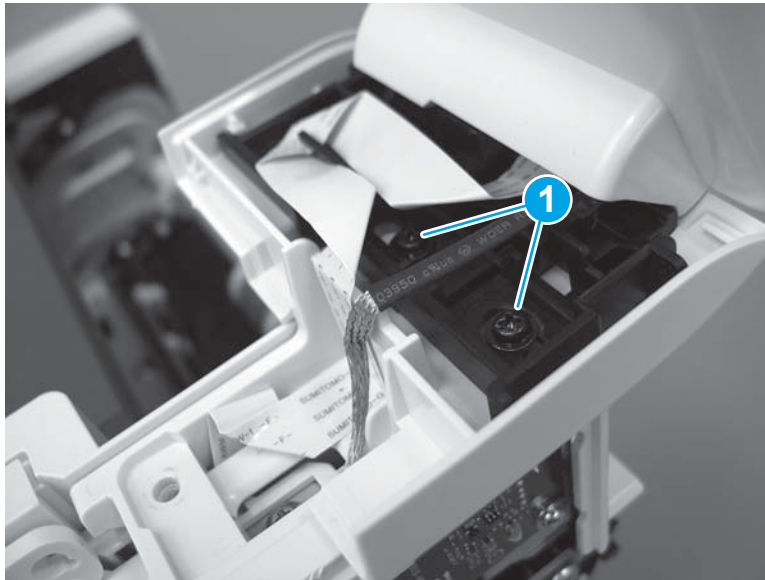
5. Remove one grounding screw (callout 1), and then move the ground cable (callout 2) out of the way.

**Figure 1-237** Remove one screw



6. Move the FFC out of the way, and then remove two screws (callout 1).

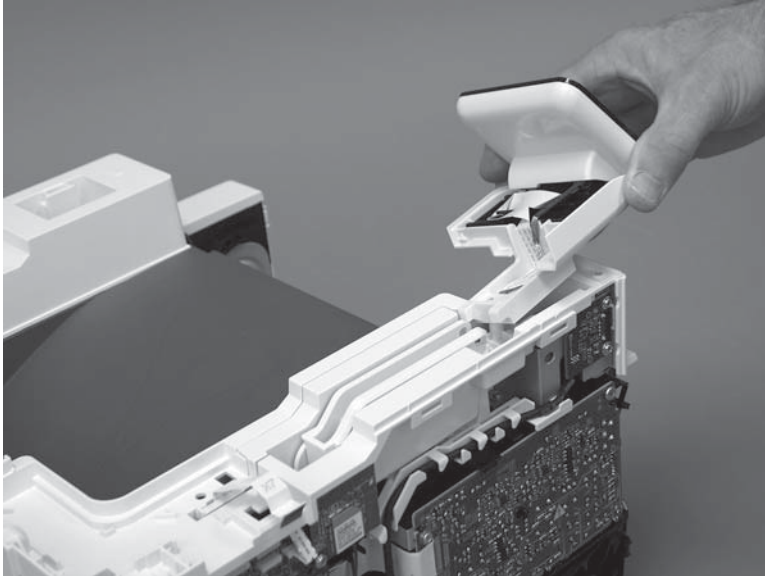
**Figure 1-238** Remove two screws



7. Slightly lift up the control-panel assembly to separate it from the top cover.

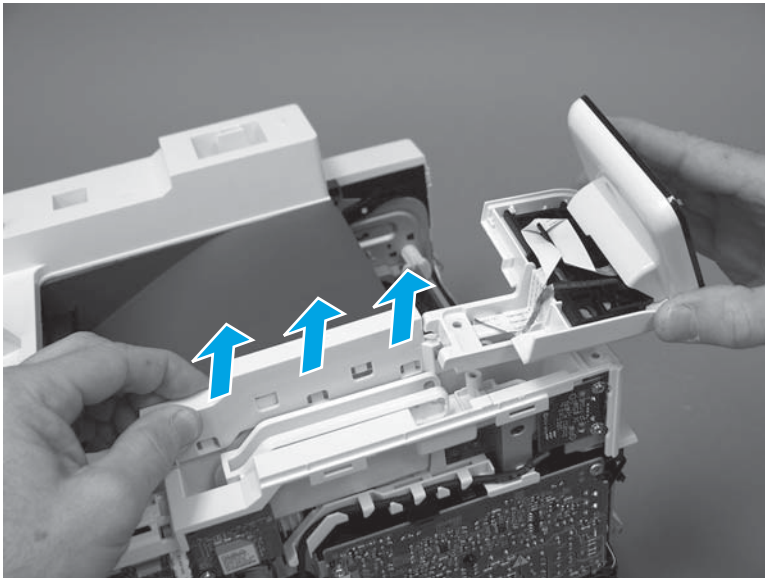
**⚠ CAUTION:** The control panel assembly is still connected to the printer by the FFC. Do not attempt to completely remove the assembly.

**Figure 1-239** Lift up the control-panel assembly



8. Lift up the control-panel FFC cover to remove the control-panel assembly.

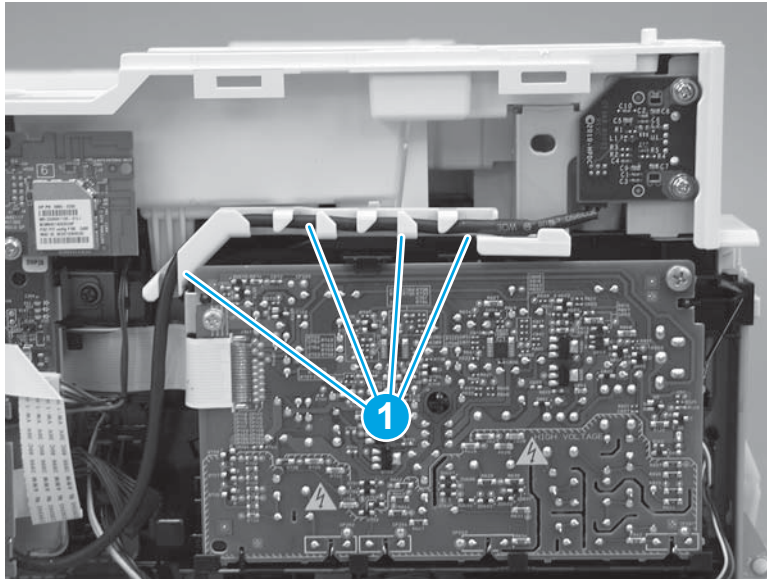
**Figure 1-240** Remove the control-panel assembly



### Step 7: Remove the top cover (M427/M426)

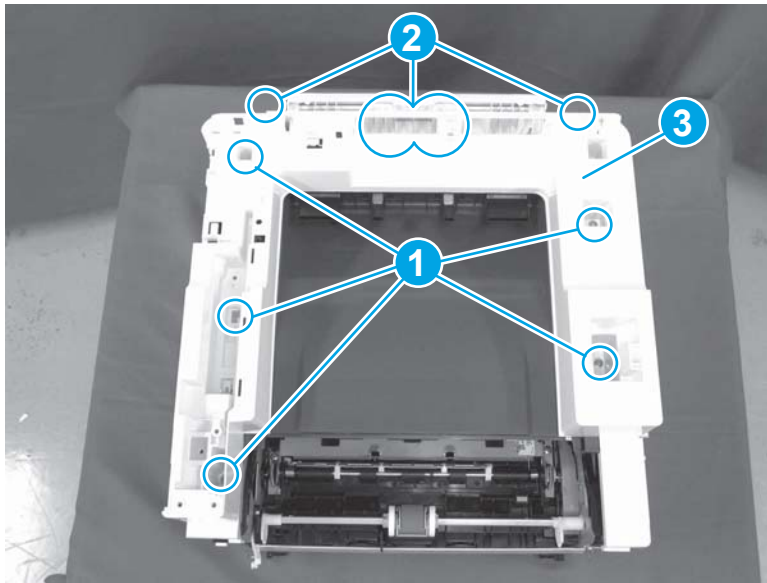
1. Release the USB cable (callout 1) from the cable guide.

**Figure 1-241** Remove the USB cable



2. Remove five screws (callout 1), release four bosses (callout 2), and then remove the top cover (callout 3).

**Figure 1-242** Remove the cover



### Step 8: Unpack the replacement assembly

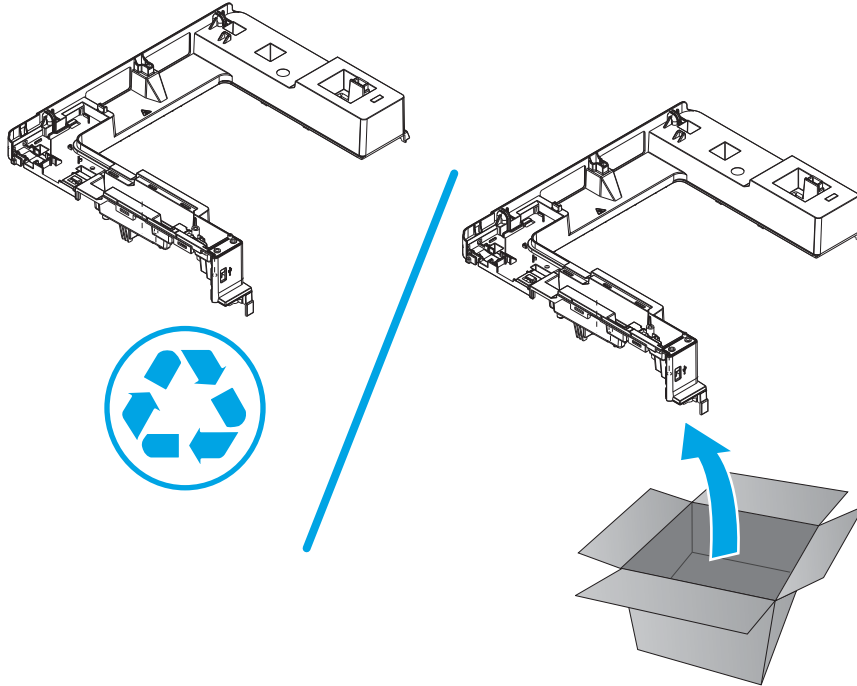
Unpack the replacement part from the packaging.

<http://www8.hp.com/us/en/hp-information/environment/product-recycling.html>



**NOTE:** HP recommends responsible disposal of the defective part.

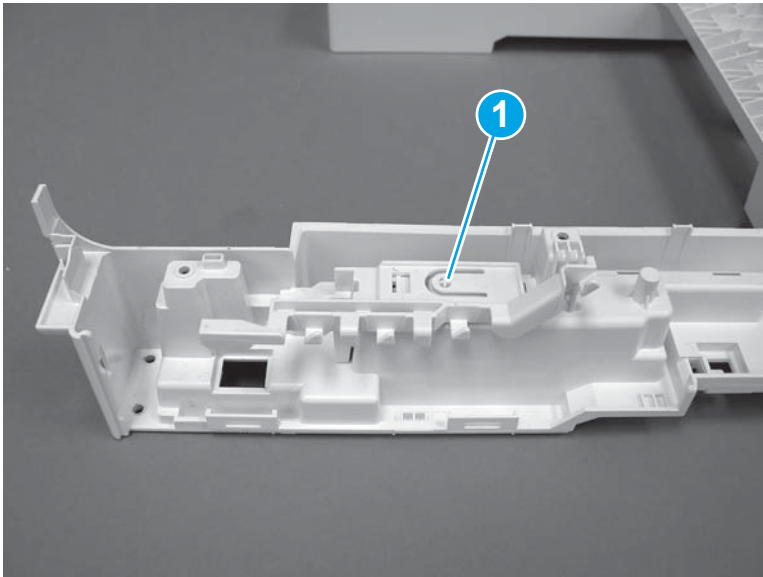
**Figure 1-243** Recycle and unpack



**Step 9: Remove the cable guide (M427/M426)**

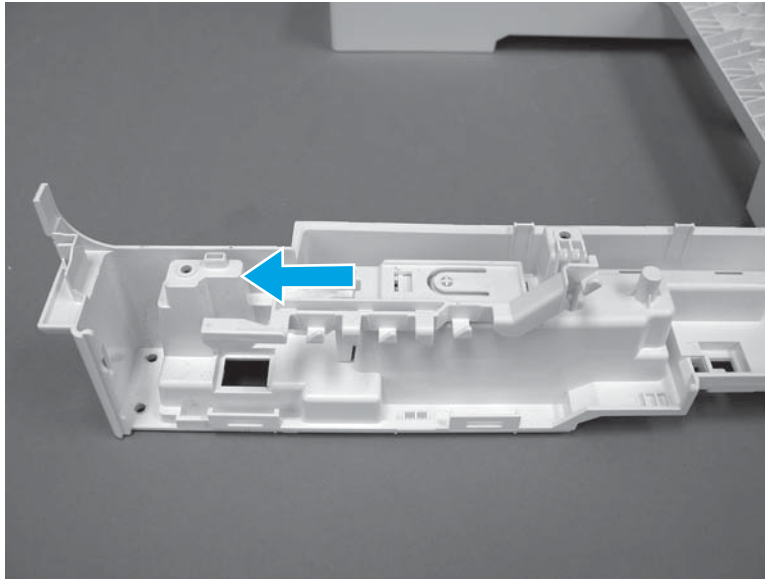
1. Turn the top cover over, and then release one tab (callout 1).

**Figure 1-244** Release one tab



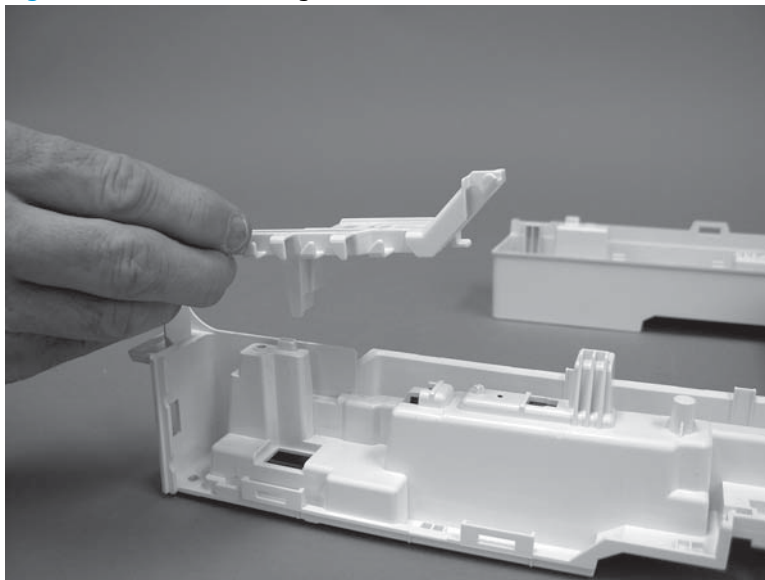
2. Slide the guide as shown to release it.

**Figure 1-245** Release the guide



3. Remove the guide.

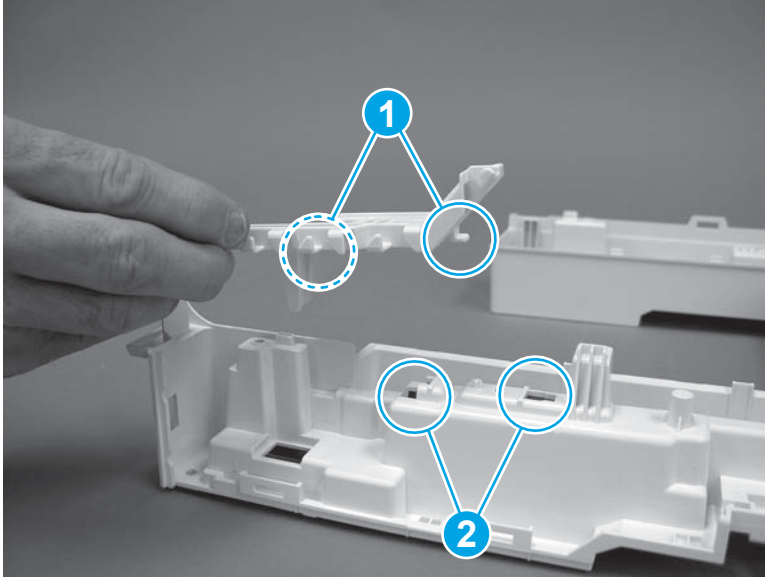
**Figure 1-246** Remove the guide



### **Step 10: Install the cable guide (M427/M426)**

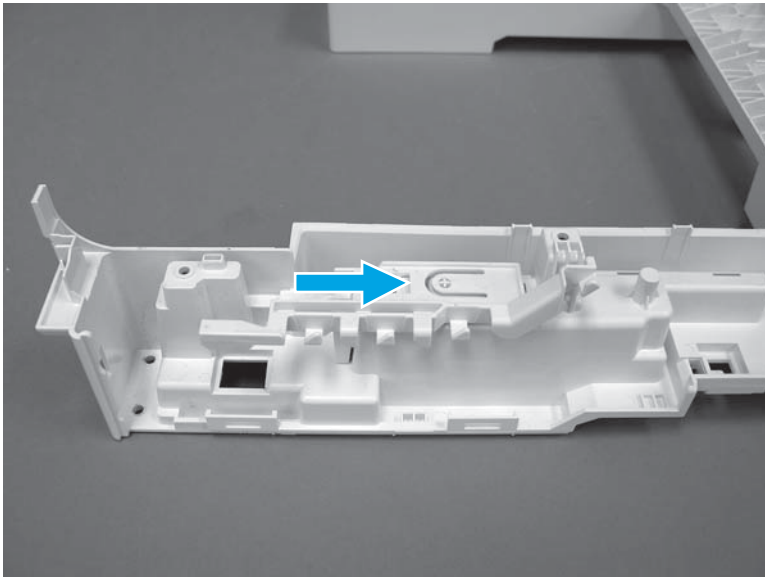
1. Position the guide on the printer with the two tabs (callout 1) in the slots (callout 2) in the chassis.

**Figure 1-247** Position the guide on the printer



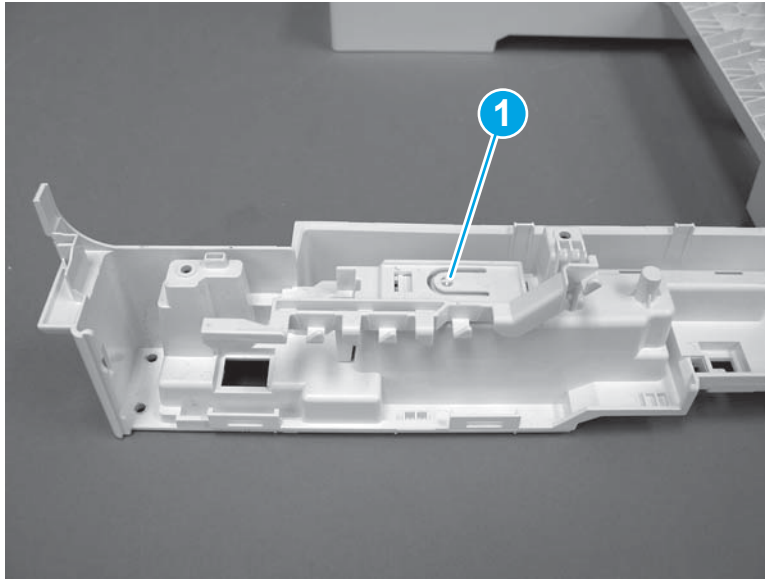
2. Slide the guide as shown (callout 1) to install it.

**Figure 1-248** Install the guide



3. Make sure that the tab (callout 1) snaps into place.

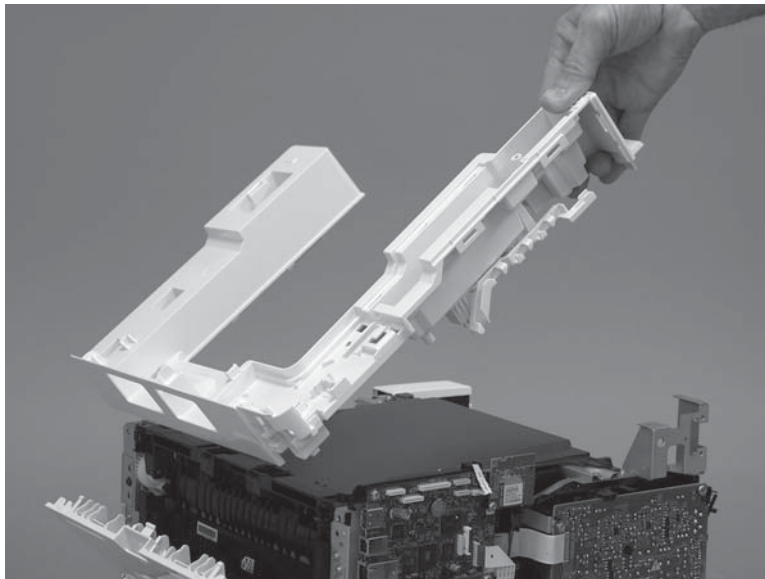
**Figure 1-249** Check the guide



### Step 11: Install the top cover (M427/M426)

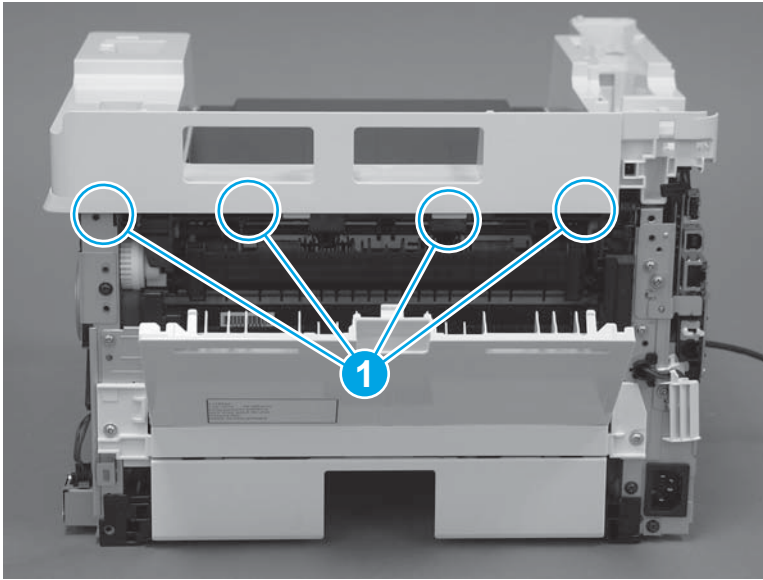
1. Position the rear edge of the top cover on the printer.

**Figure 1-250** Install the cover



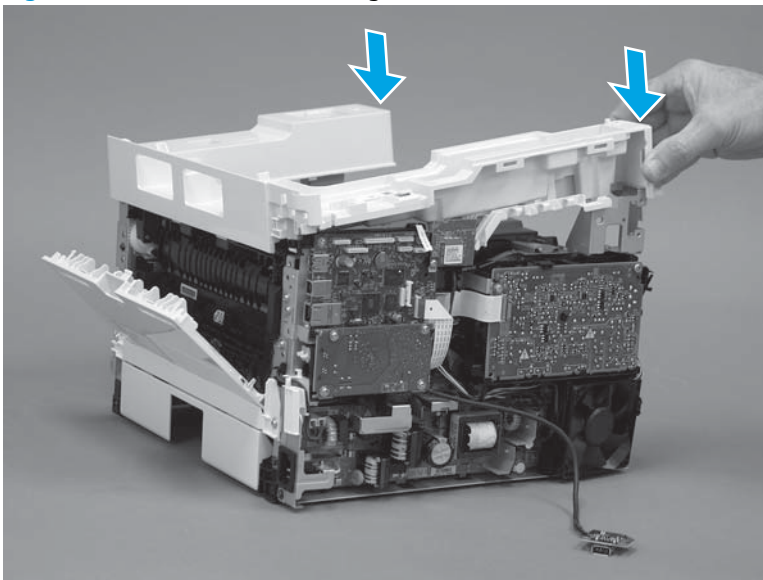
2. Engage four bosses (callout 1).

**Figure 1-251** Engage four bosses



3. Rotate the front edge of the cover down.

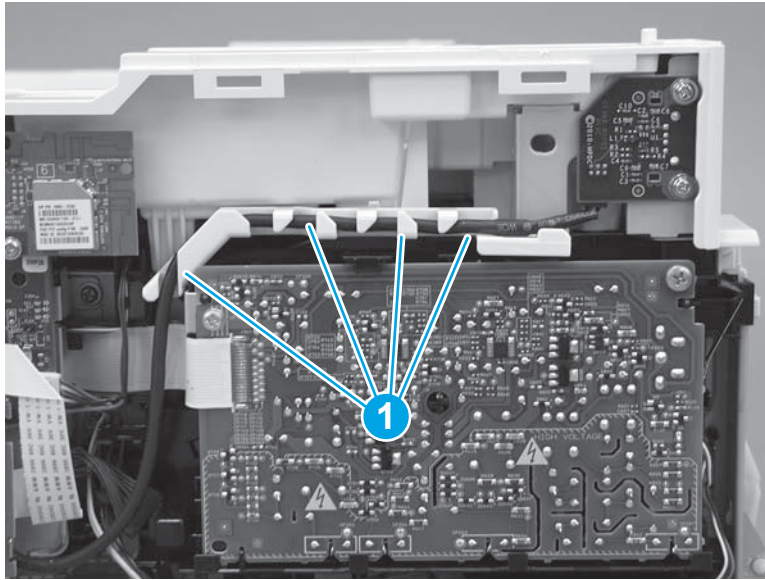
**Figure 1-252** Rotate the front edge of the cover down





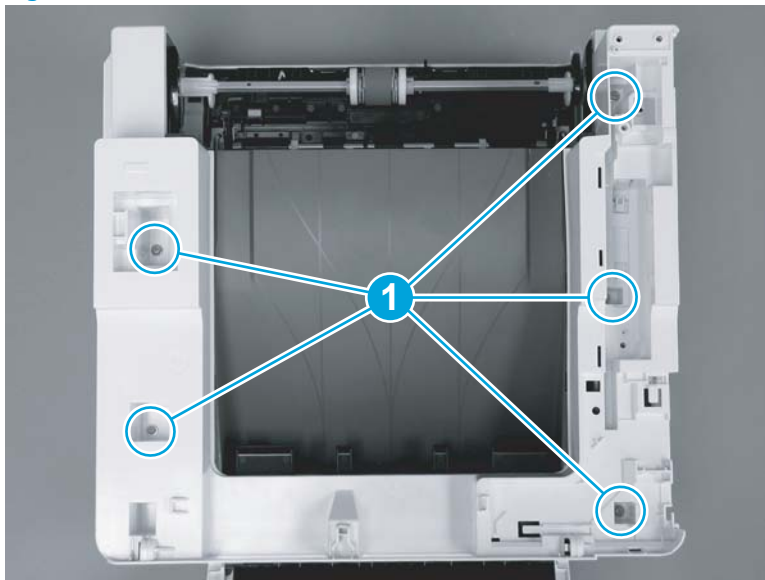
4. Install the USB cable (callout 1) in the guide.

**Figure 1-253** Install the USB PCA



5. Install five screws (callout 1).

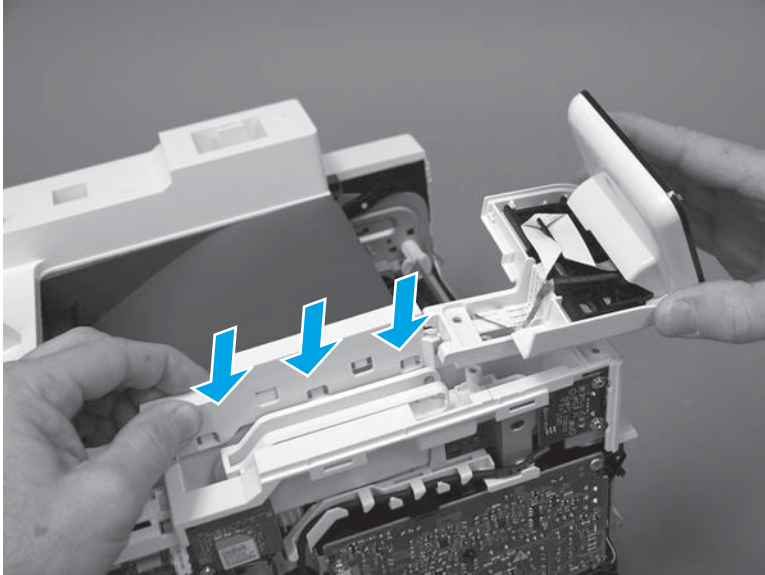
**Figure 1-254** Install five screws



### Step 12: Install the control panel (M427/M426)

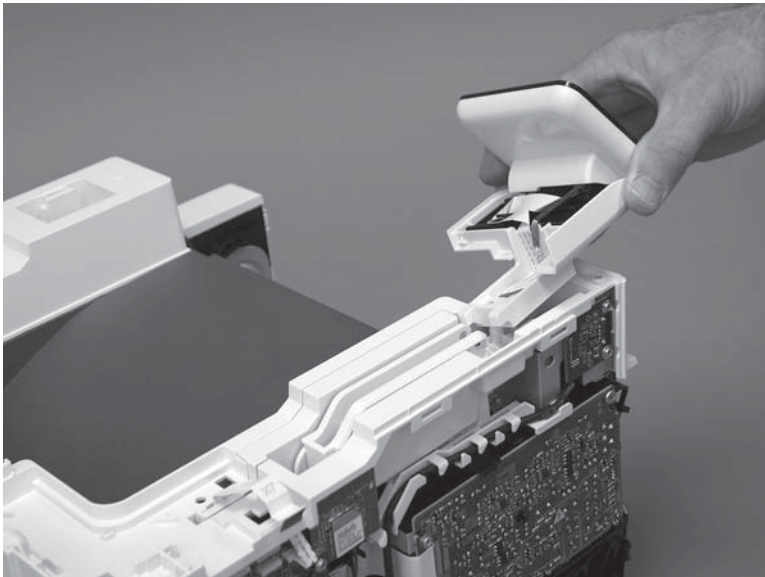
1. Slide the control-panel FFC cover into the slot in the top cover (next to the document feeder support arm) to install it.

**Figure 1-255** Install the control-panel FFC cover



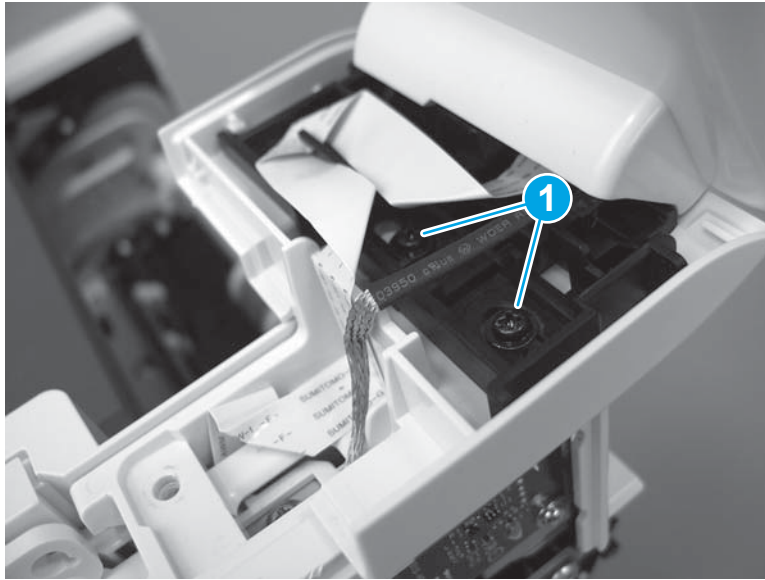
2. Install the control-panel assembly on the top cover.

**Figure 1-256** Install the control-panel assembly



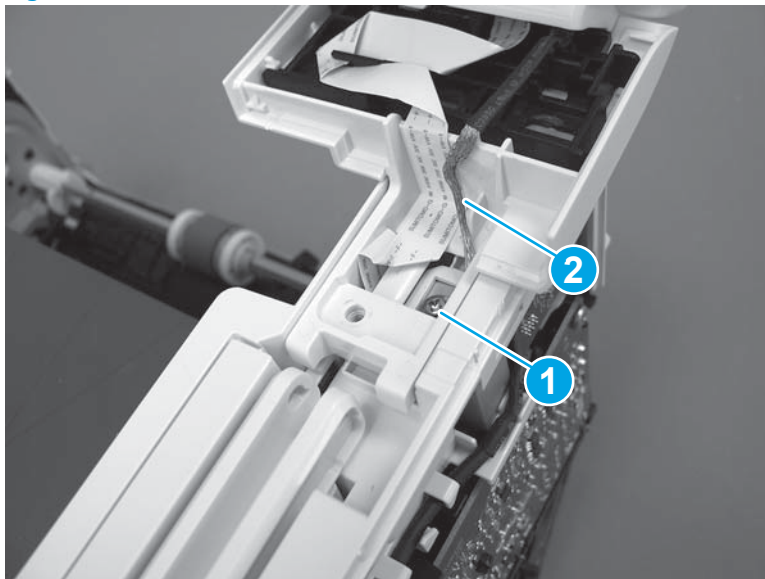
3. Move the FFC out of the way, and then install two screws (callout 1).

**Figure 1-257** Install two screws



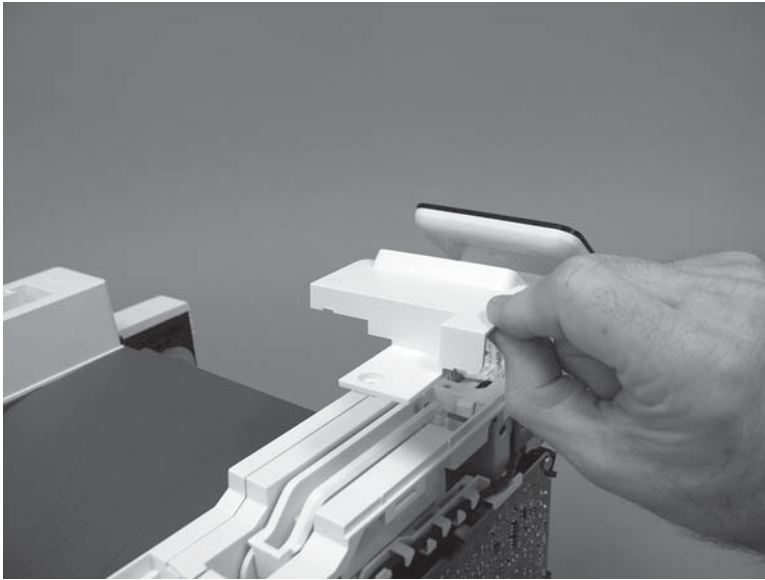
4. Install one grounding screw (callout 1), and then make sure that the ground cable (callout 2) is properly routed.

**Figure 1-258** Remove one screw



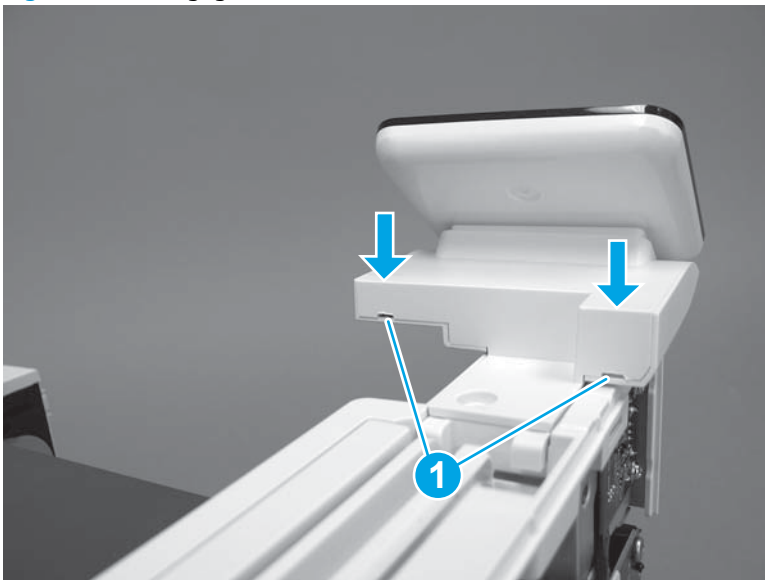
5. Install the control-panel cable cover.

**Figure 1-259** Install the cover



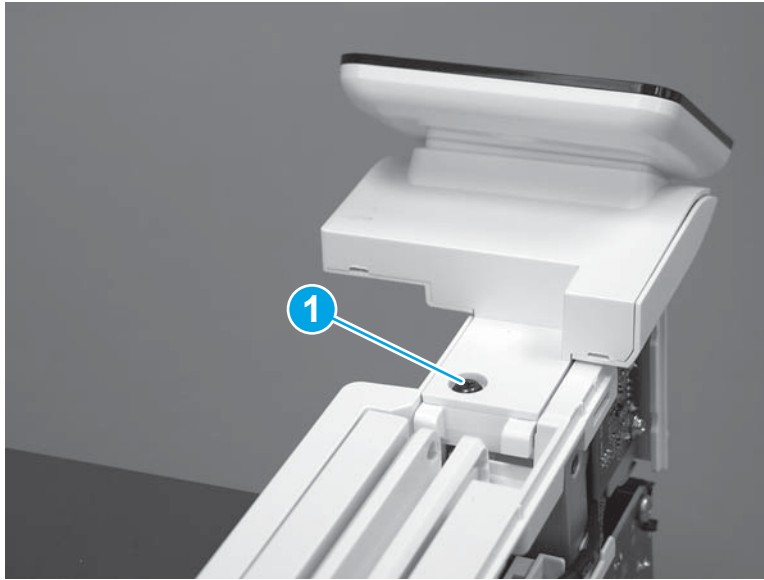
6. Make sure that the two tabs (callout 1) on the cover snap into place.

**Figure 1-260** Engage two tabs



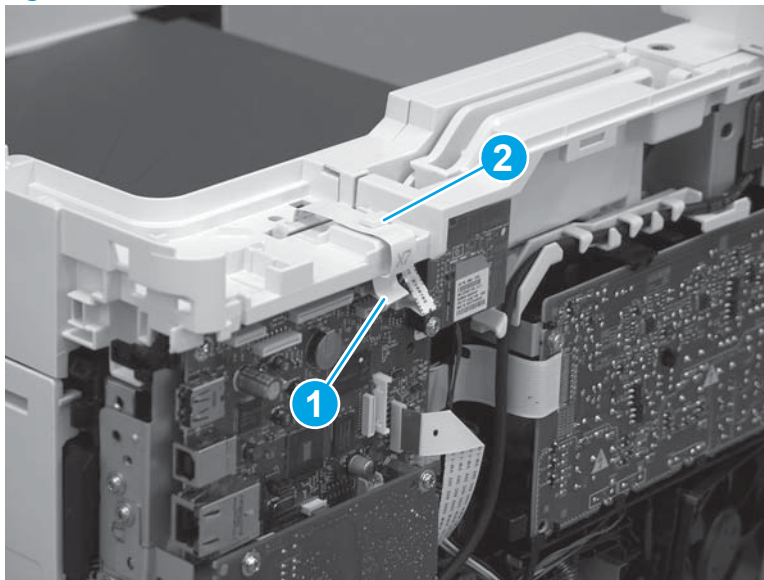
7. Install one screw (callout 1).

**Figure 1-261** Install one screw




8. Install the FFC in the retainer (callout 1), and then connect one FFC (callout 1; J114).

**Figure 1-262** Connect one connector



### Step 13: Install the integrated scanner assembly (M427/M246)

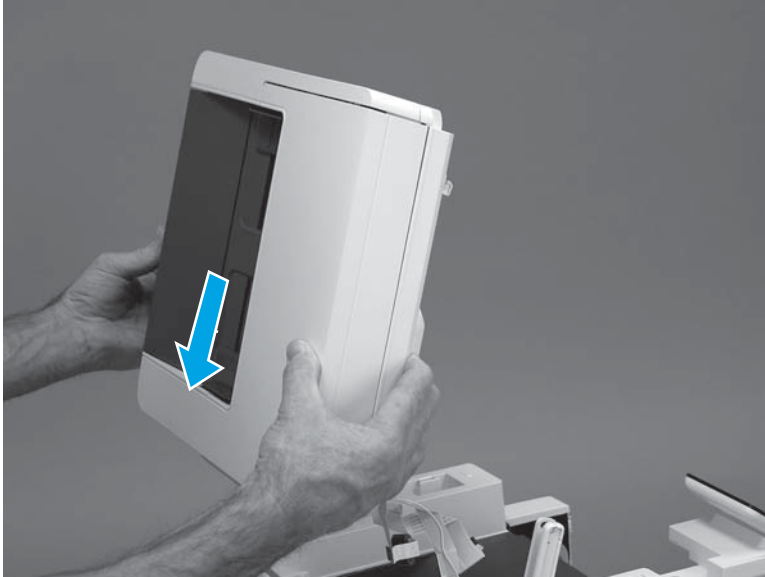
---

 **NOTE:** M427/M426 models only. The integrated scanner assembly (ISA) includes the sub-scanner assembly (SSA) and the automatic document feeder (ADF).

---

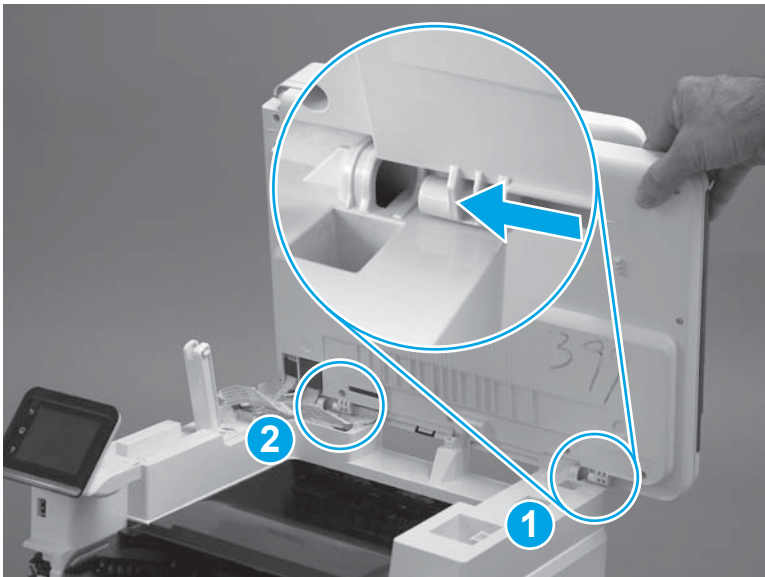
1. Position the ISA on the printer.

**Figure 1-263** Position the ISA on the printer



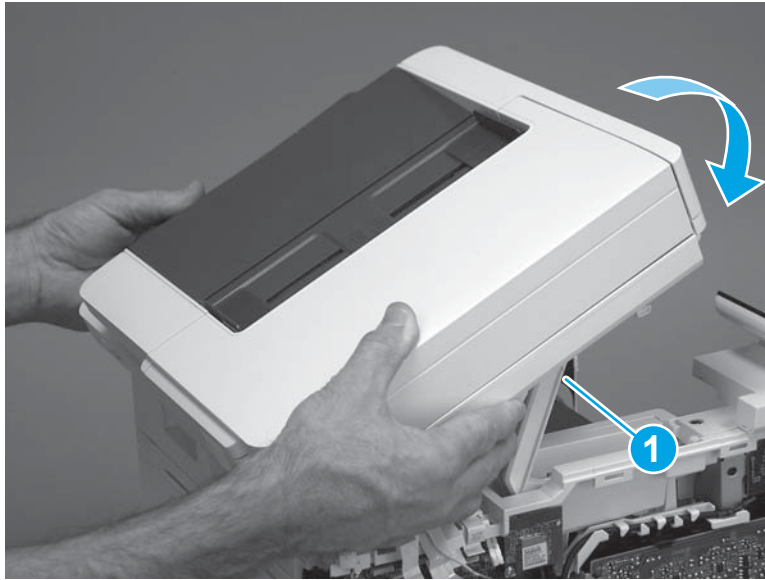
2. Engage the hinge pins on the ISA with the holders in the top cover (callouts 1/2), and then slide the ISA as shown to engage them

**Figure 1-264** Engage the hinge pins with the holders



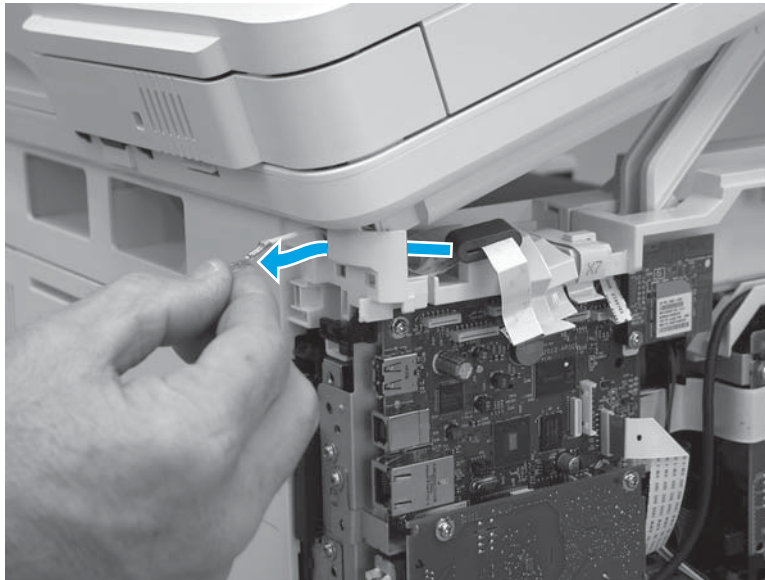
3. Rotate the ISA towards the front of the printer until it rests on the ISA lift assembly (callout 1).

**Figure 1-265** Rotate the ISA towards the front of the printer



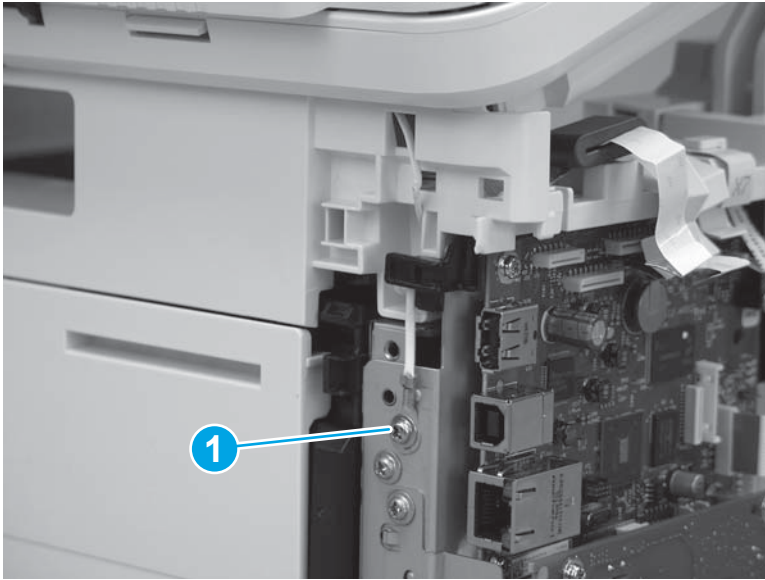
4. Pass the ground wire through the opening in the top cover.

**Figure 1-266** Pass the wire through the opening




5. Install one screw (callout 1).

**Figure 1-267** Install one screw



6. Install the ISA lift assembly slider pin.

 **Reinstallation tip:** Align the keyed portion of the locking pin with the slot and hole in the support arm.

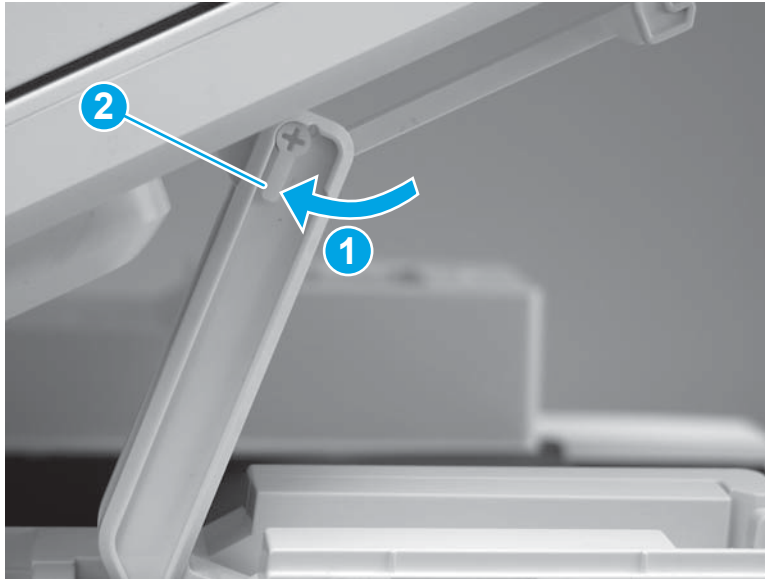
**Figure 1-268** Install the slider pin





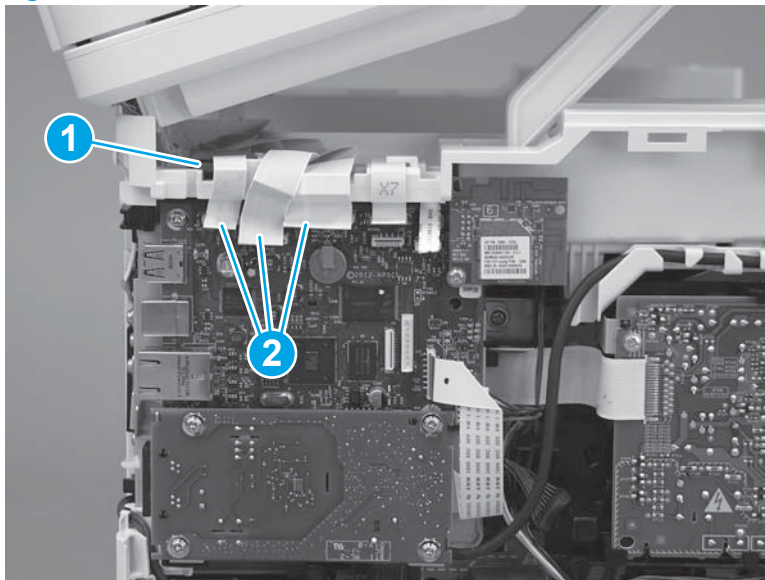
7. Rotate the slider pin (callout 1) towards the rear of the printer until the tab (callout 2) snap into place.

**Figure 1-269** Secure the slider pin



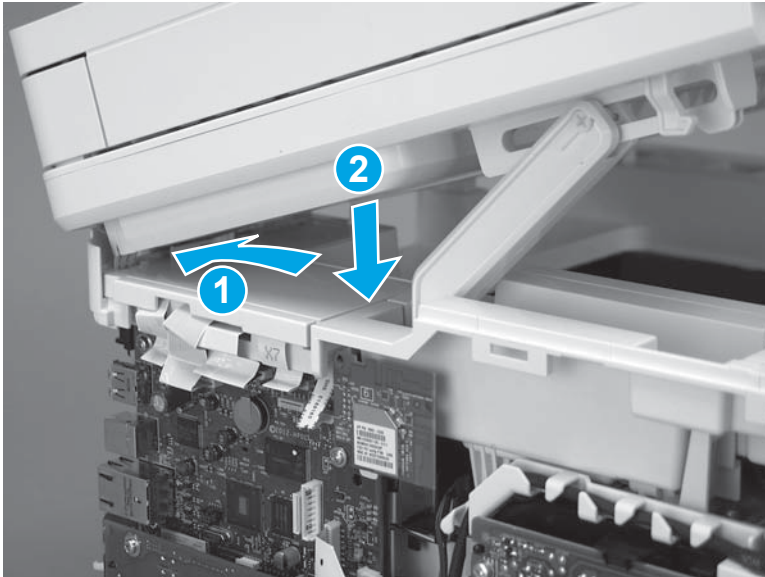
8. Install the ferrite (callout 1) in the holder, and then connect three FFCs (callout 2).

**Figure 1-270** Connect three FFCs



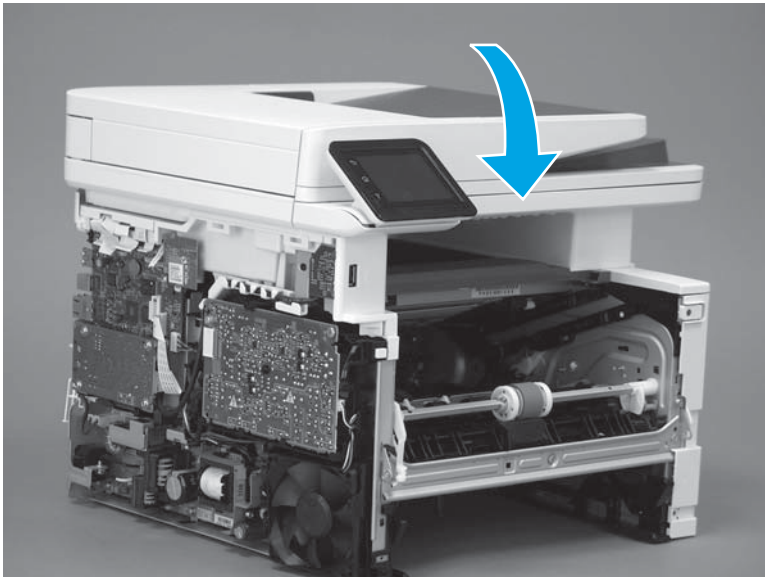
9. Position the rear edge of the ISA flat-flexible cable (FFC) cover on the printer (callout 1) , and then rotate it down (callout 2) until it snaps into place.

**Figure 1-271** Install the ISA FFC cover



10. Lower the ISA.

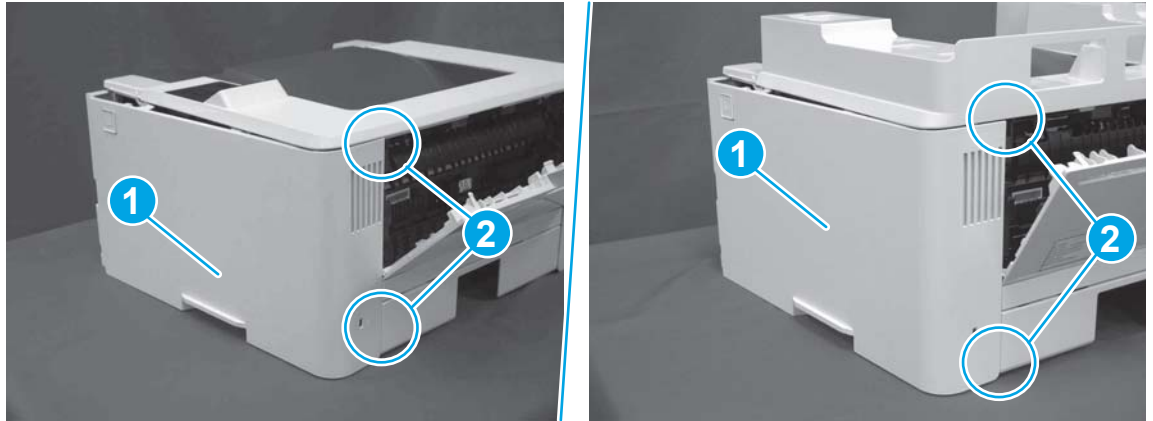
**Figure 1-272** Lower the ISA



#### **Step 14: Install the right cover**

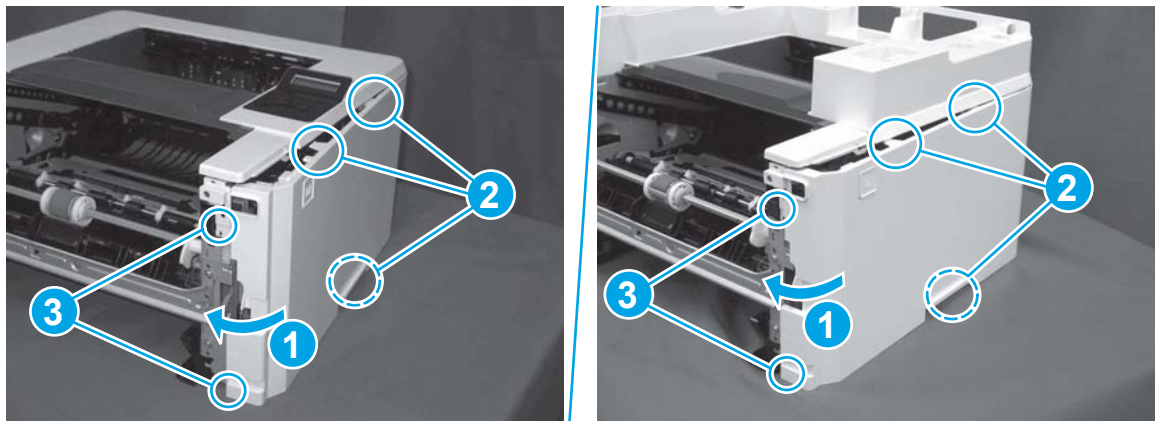
1. Position the cover (callout 1) on the printer, and then engage two bosses (callout 2).

**Figure 1-273** Install the cover



2. Rotate the front of the cover onto the printer (callout 1), engage three (callout 2) tabs, and then engage two bosses (callout 3).

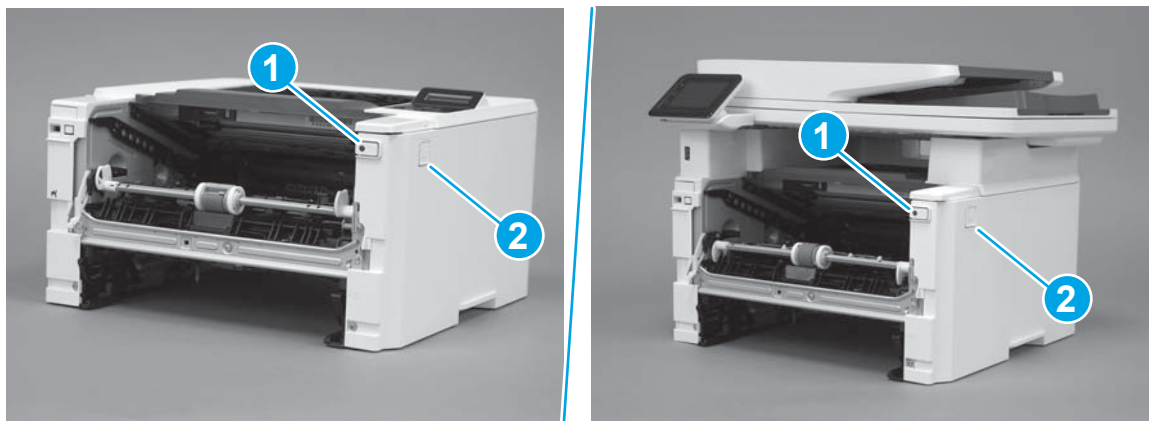
**Figure 1-274** Engage two bosses and one tab



3. Make sure that the power switch (callout 1) and cartridge door assembly button (callout 2) correctly function.

 **NOTE:** Remove, and then reinstall the cover if the switch or button does not correctly function.

**Figure 1-275** Check the power switch and cartridge door assembly button



4. Install one screw (callout 1).

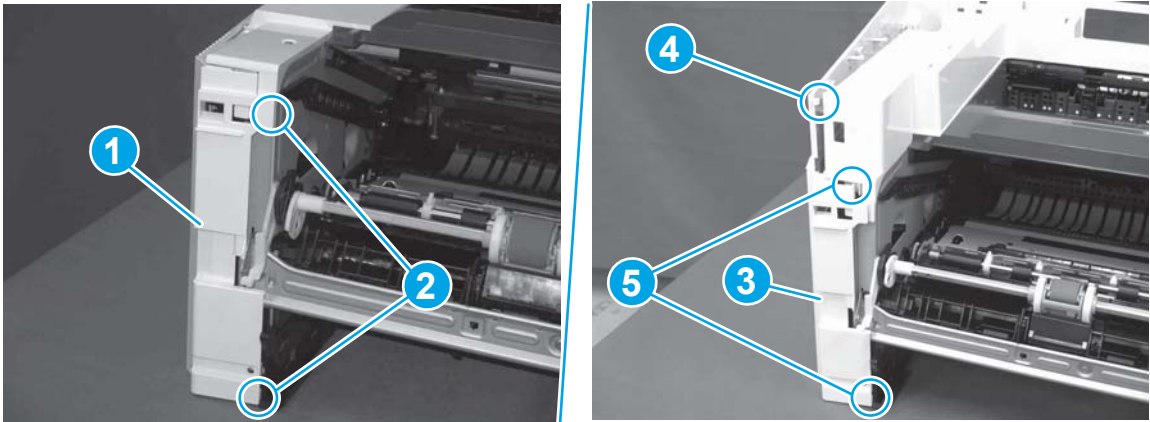
**Figure 1-276** Install one screw



### Step 15: Install the left cover

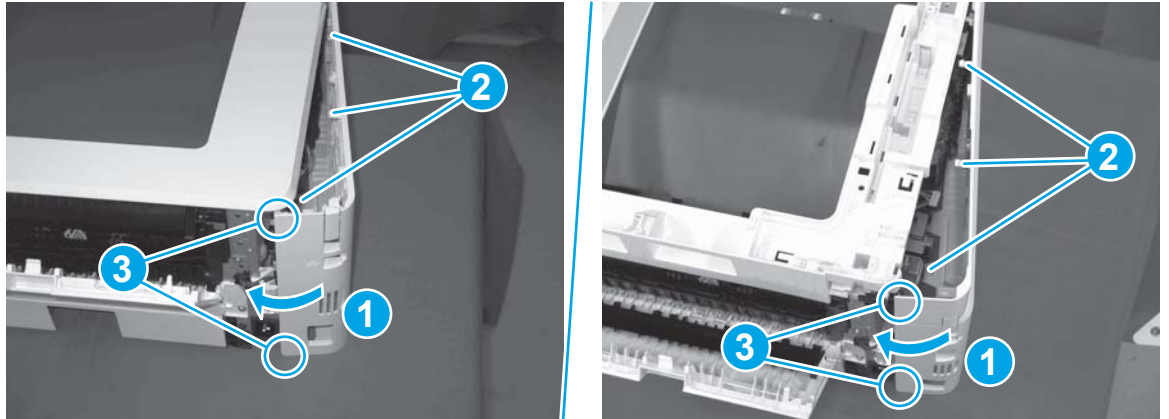
1. At the front of the printer, do one of the following:
  - **M403/M402:** Position the cover on the printer ( callout 1), and then engage two bosses (callout 2).
  - **M427/M426:** Position the cover on the printer (callout 3), engage one tab (callout 4), and then engage two bosses (callout 4).

**Figure 1-277** Install the cover



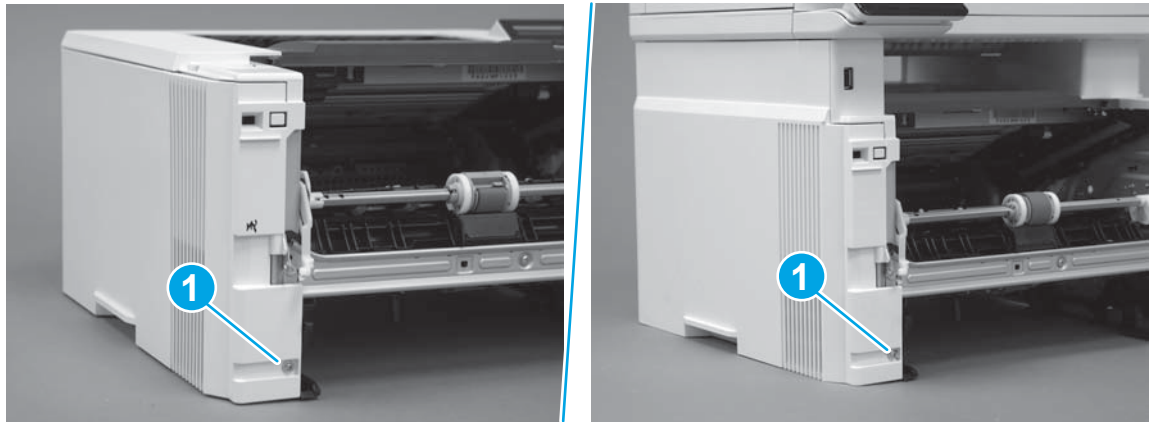
- Carefully rotate the rear of the cover onto the printer (callout 1), engage three tabs (callout 2), and then engage two bosses (callout 3).

**Figure 1-278** Engage three tabs and two bosses



- Install one screw (callout 1).

**Figure 1-279** Install one screw

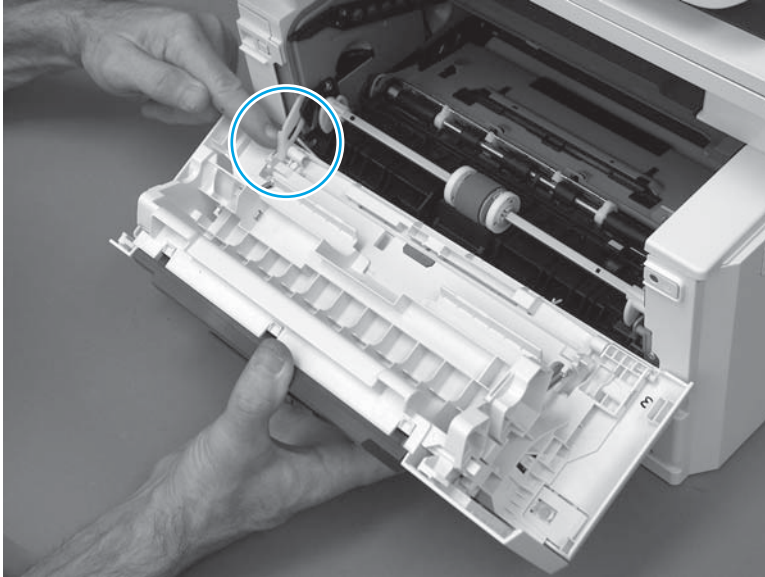


## Step 16: Install the cartridge door assembly

**Reinstallation tip:** After a replacement door is installed, make sure to install the nameplate (supplied in the kit) corresponding to the printer name on the door.

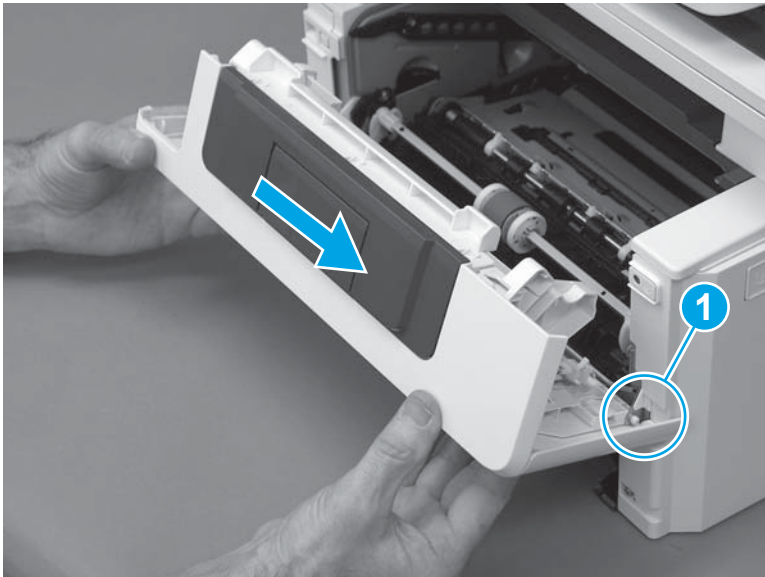
- Position the door close to the printer, and then engage the keyed pin on the left-side retainer arm with the hole in the door.

**Figure 1-280** Engage the left-side retainer arm



2. Engage the right-side door hinge pin with the hole in the chassis (callout 1).

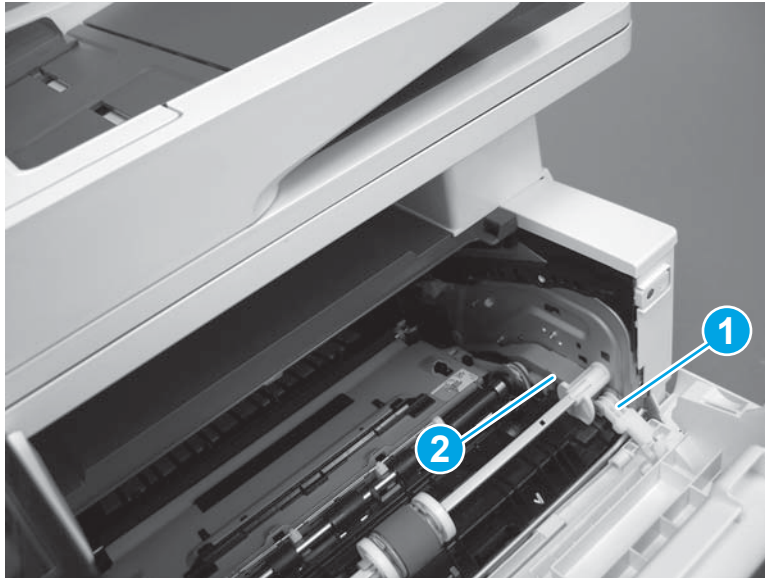
**Figure 1-281** Install the door



3. Install the link (callout 1).

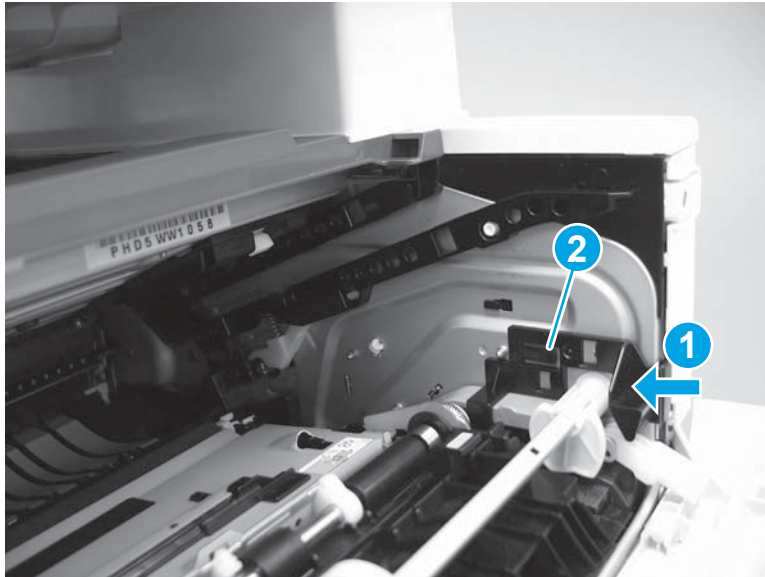
 **IMPORTANT:** Make sure that the link snaps into place on the arm (callout 2). The link actuates the fuser pressure-release mechanism.

**Figure 1-282** Install the pressure-release link



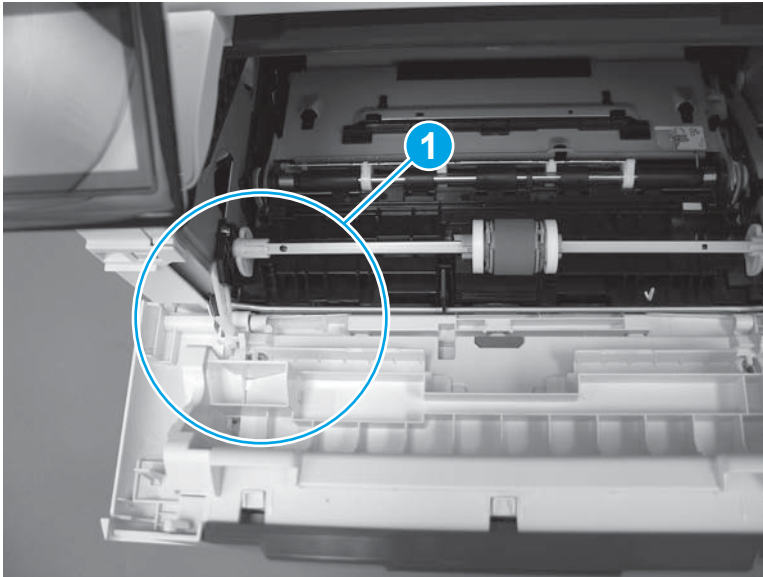
4. Slide the guide into the printer (callout 1), and then make sure that the tab (callout 2) snaps into place to secure the guide to the chassis.

**Figure 1-283** Install the guide




5. Position the shaft on the door, and then align the left-side hinge on the door with the hole in the chassis (callout 1).

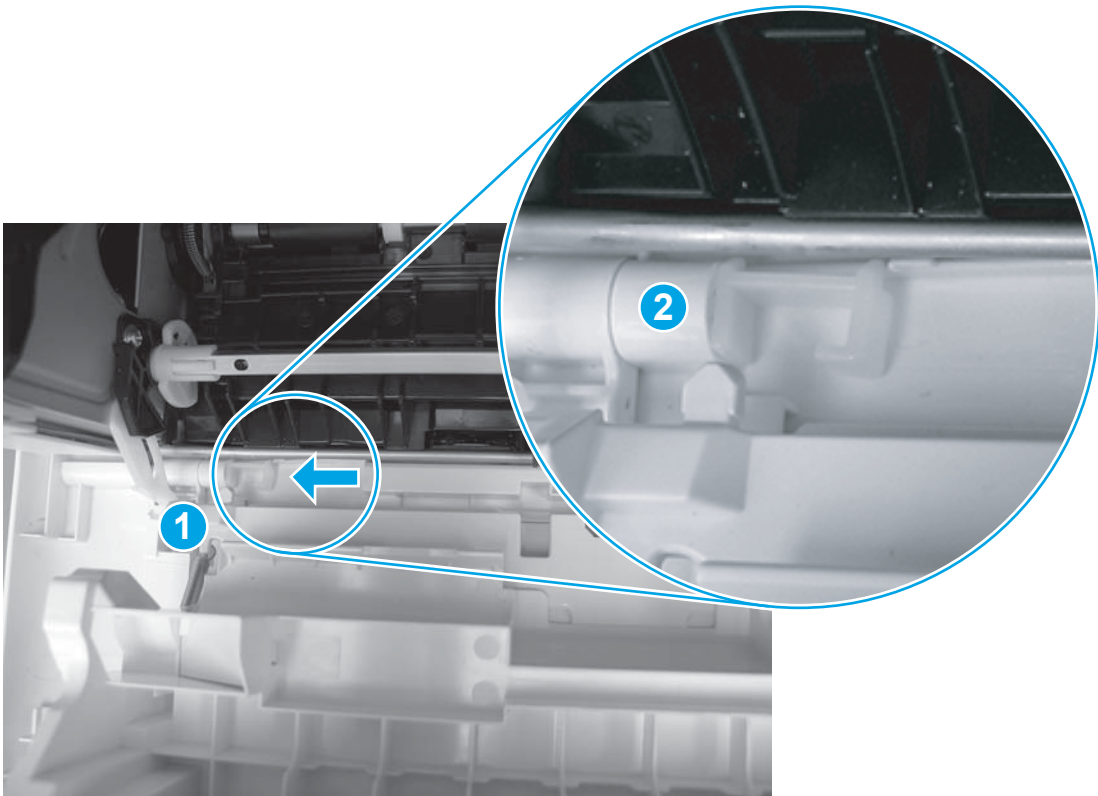
**Figure 1-284** Align the hinge



6. Push the shaft towards the left side of the printer to install it (callout 1).

 **Reinstallation tip:** Make sure that the support shaft is fully installed and correctly orientated (callout 2) so that it will not interfere with the door opening and closing.

**Figure 1-285** Install the support shaft





### Step 17: Install Tray 2

- ▲ Slide the tray straight into the printer to install it.

**Figure 1-286** Install the tray



## Removal and replacement: Cable guide (M427/M426)

- [Introduction](#)
- [Step 1: Remove Tray 2](#)
- [Step 2: Remove the cartridge door assembly](#)
- [Step 3: Remove the left cover](#)
- [Step 4: Remove the right cover](#)
- [Step 5: Remove the control panel \(M427/M426\)](#)
- [Step 6: Remove the integrated scanner assembly \(M427/M246\)](#)
- [Step 7: Remove the top cover \(M427/M426\)](#)
- [Step 8: Remove the cable guide \(M427/M426\)](#)
- [Step 9: Unpack the replacement assembly](#)
- [Step 10: Install the cable guide \(M427/M426\)](#)
- [Step 11: install the top cover \(M427/M426\)](#)
- [Step 12: Install the integrated scanner assembly \(M427/M246\)](#)
- [Step 13: Install the control panel \(M427/M426\)](#)
- [Step 14: Install the right cover](#)
- [Step 15: Install the left cover](#)
- [Step 16: Install the cartridge door assembly](#)
- [Step 17: Install Tray 2](#)


### Introduction

This document provides the procedures to remove and replace the cable guide (M427/M426).

### Before performing service

#### Turn the printer power off

- Disconnect the power cable.

 **WARNING!** To avoid damage to the printer, turn the printer off, wait 30 seconds, and then remove the power cable before attempting to service the printer.

Use the table below to identify the correct part number for your printer. To order the part, go to [www.hp.com/buy/parts](http://www.hp.com/buy/parts).

---

**Cable guide (M427/M426) part number**

---

RC4-3217-000CN

Cable guide (M427/M426)

---

## Required tools

- #2 Phillips screwdriver with a magnetic tip.
- Small flat-blade screw driver

## After performing service

### Turn the printer power on

- Connect the power cable.
- Use the power switch to turn the power on.

### Post service test

Make sure that the printer initializes to a **Ready** state.

Print a configuration page to make sure that the printer is functioning correctly.

### Step 1: Remove Tray 2

- ▲ Pull the tray straight out of the printer to remove it.

**Figure 1-287** Remove the tray



### Step 2: Remove the cartridge door assembly



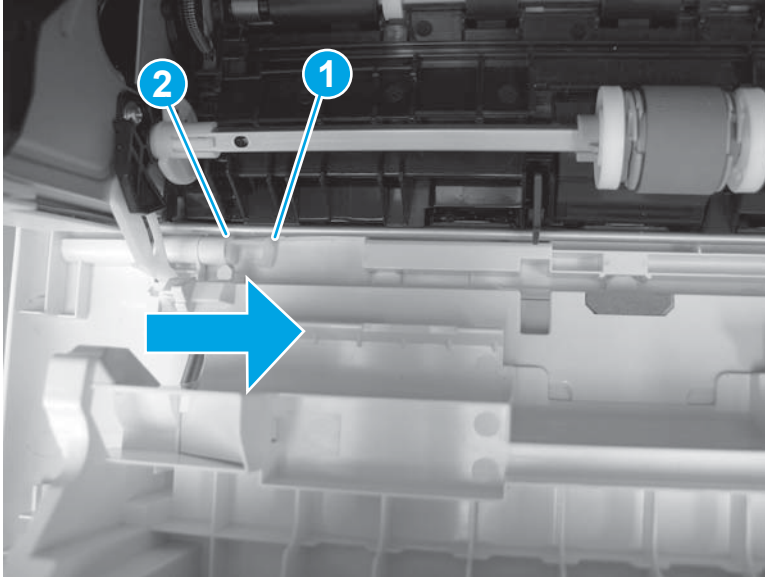
**NOTE:** If the toner cartridge was not removed prior to servicing the printer, remove it now.

1. Release one tab (callout 1), and then slide shaft (callout 2) in the direction the arrow indicates and remove it.



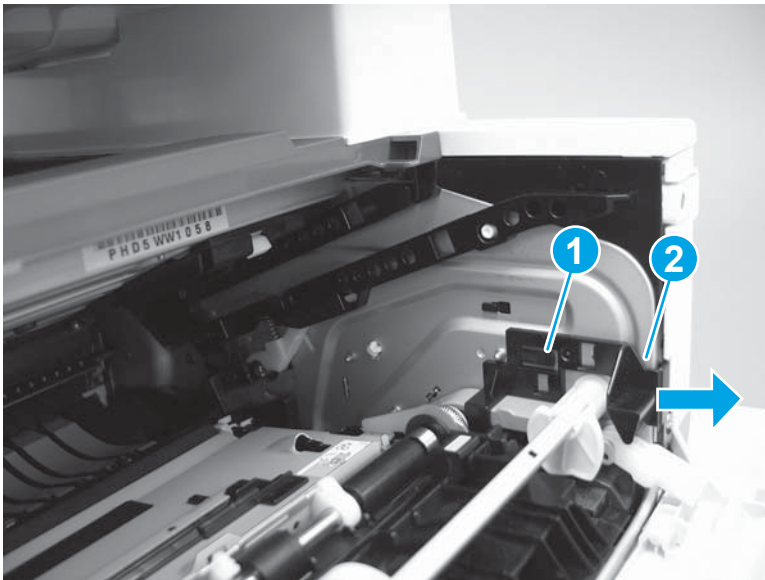
**TIP:** It might be easier to release the support shaft by using a small flat-blade screwdriver.

**Figure 1-288** Release the support shaft



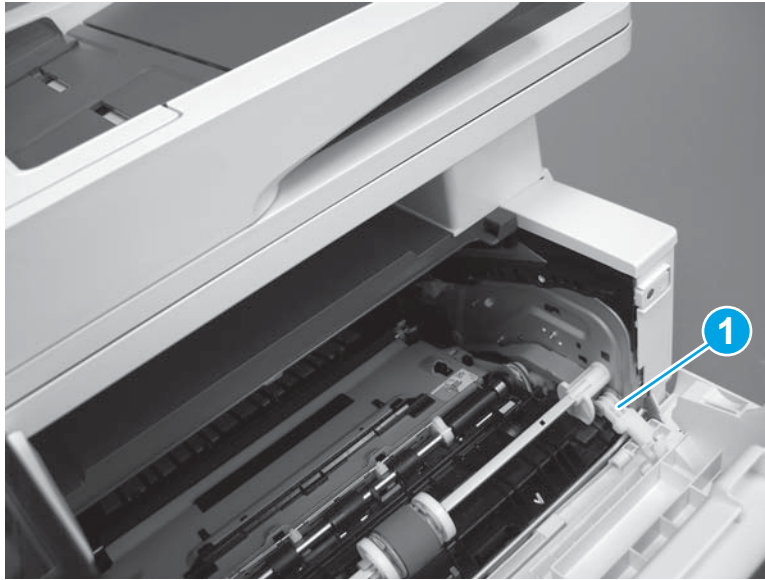
2. Release one tab (callout 1), and then slide the guide (callout 2) in the direction the arrow indicates and remove it.

**Figure 1-289** Remove the guide



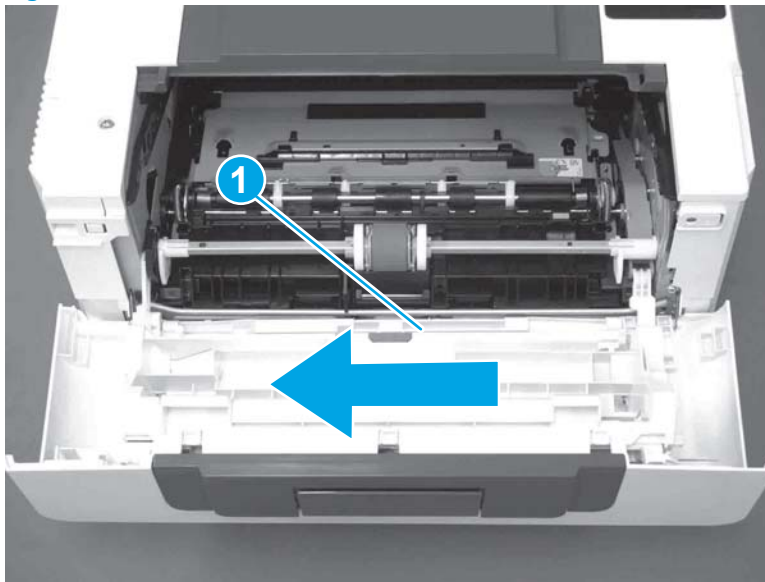
3. Remove the link arm (callout 1).

**Figure 1-290** Remove the link arm



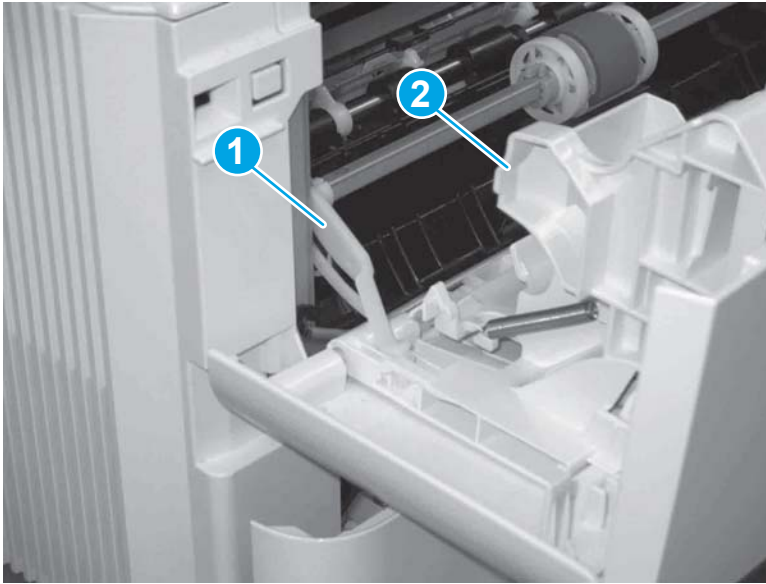
4. Slide the cartridge door assembly (callout 1) in the direction the arrow indicates and remove it.

**Figure 1-291** Remove the door



5. Remove the link (callout 1) from the cartridge door assembly (callout 2).

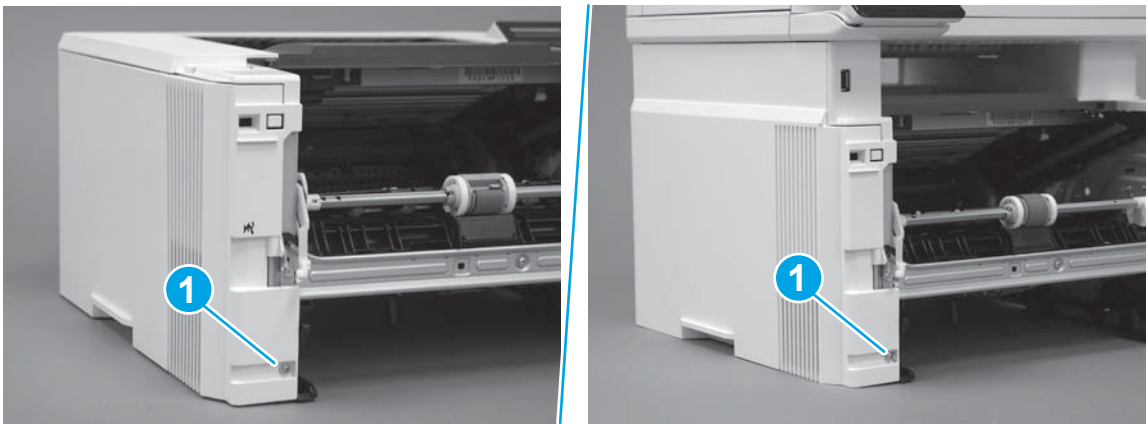
**Figure 1-292** Release the left-side retainer arm



### Step 3: Remove the left cover

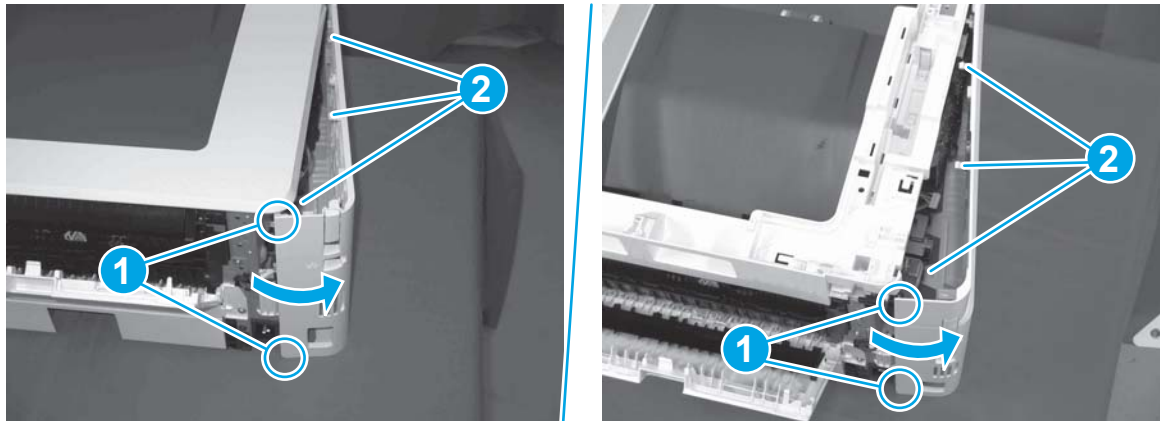
1. Remove one screw (callout 1).

**Figure 1-293** Remove one screw



2. Open the rear door, release two bosses (callout 1), and then release three tabs (callout 2).

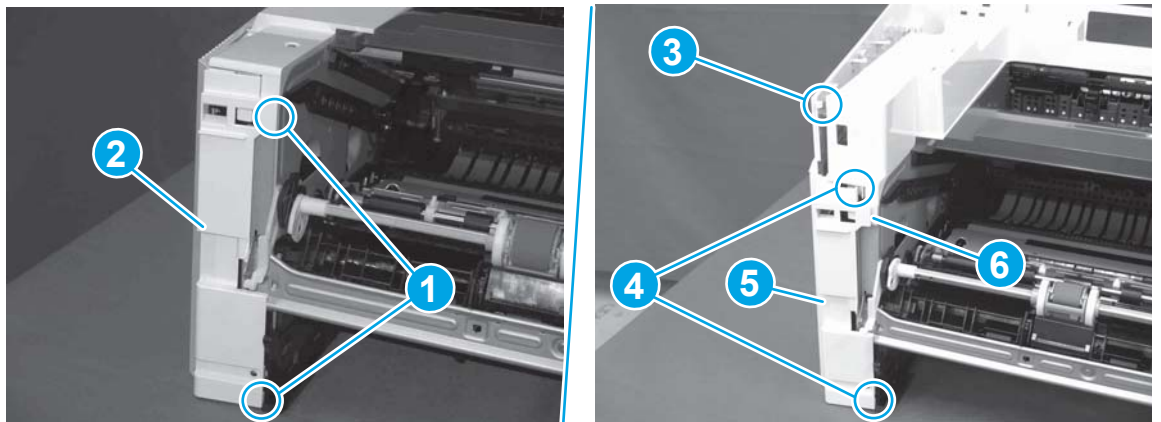
**Figure 1-294** Release two bosses and three tabs



3. At the front of the printer, do one of the following:
  - **M403/M402:** Release two bosses (callout 1), and then remove the cover (callout 2).
  - **M427/M426:** Release one tab (callout 3), two bosses (callout 4), and then remove the cover (callout 5).

**CAUTION:** Be careful when releasing the upper bosses on the M427/M426 cover. One portion of the cover (callout 6) is fragile and is easily broken.

**Figure 1-295** Remove the cover



#### Step 4: Remove the right cover

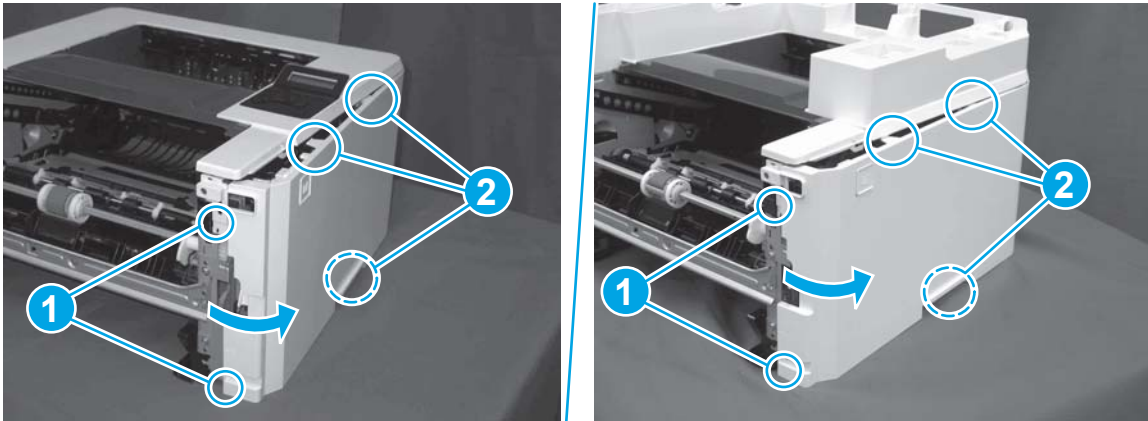
1. Remove one screw (callout 1).

**Figure 1-296** Remove one screw



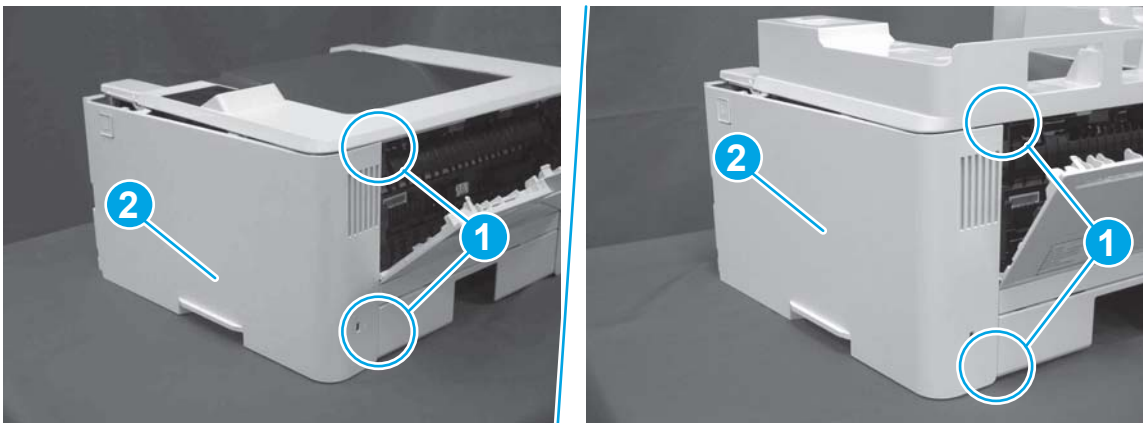
2. At the front of the printer, release two bosses (callout 1), and then release three tabs (callout 2).

**Figure 1-297** Release two bosses and three tabs



3. Open the rear door, release two bosses (callout 1), and then remove the cover (callout 2).

**Figure 1-298** Remove the cover

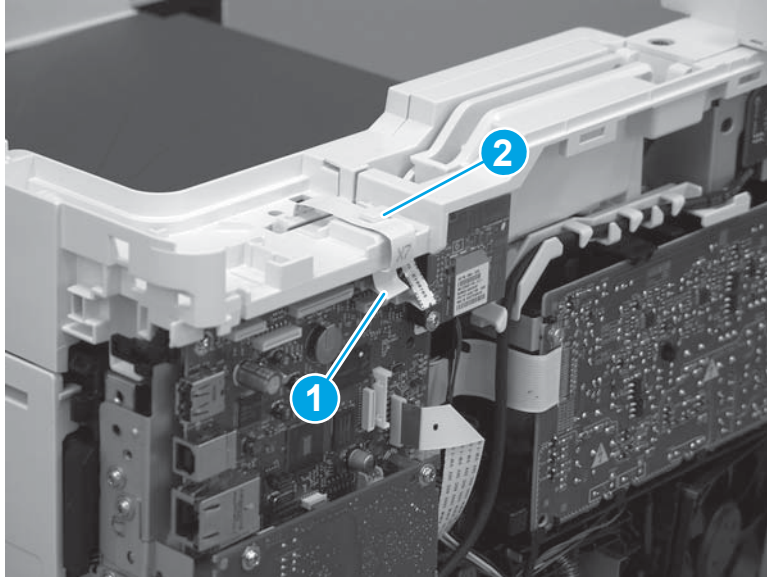


**Step 5: Remove the control panel (M427/M426)**

1. Disconnect one FFC (callout 1; J114), and then release the FFC from the retainer (callout 2).

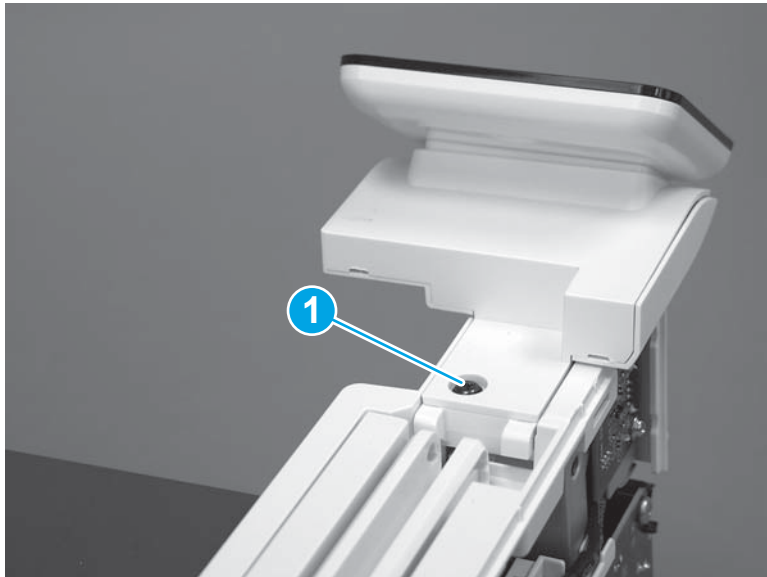


**Figure 1-299** Disconnect one connector



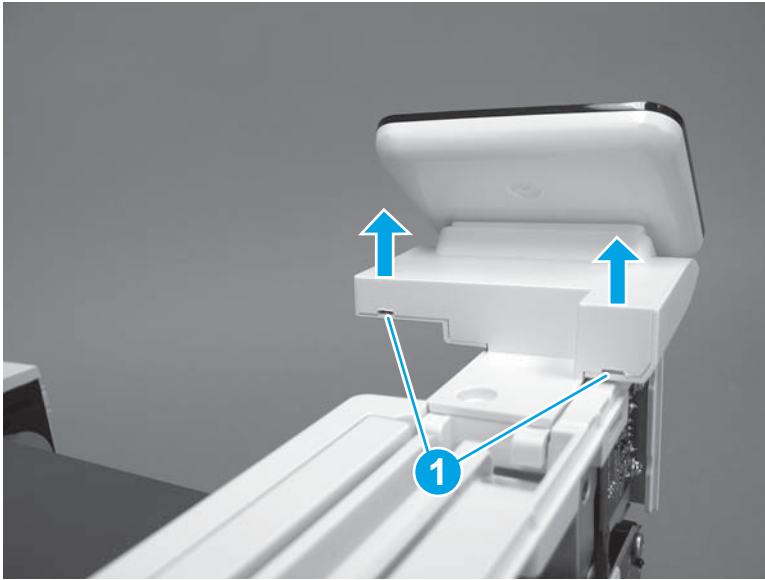
2. Remove one screw (callout 1).

**Figure 1-300** Remove one screw



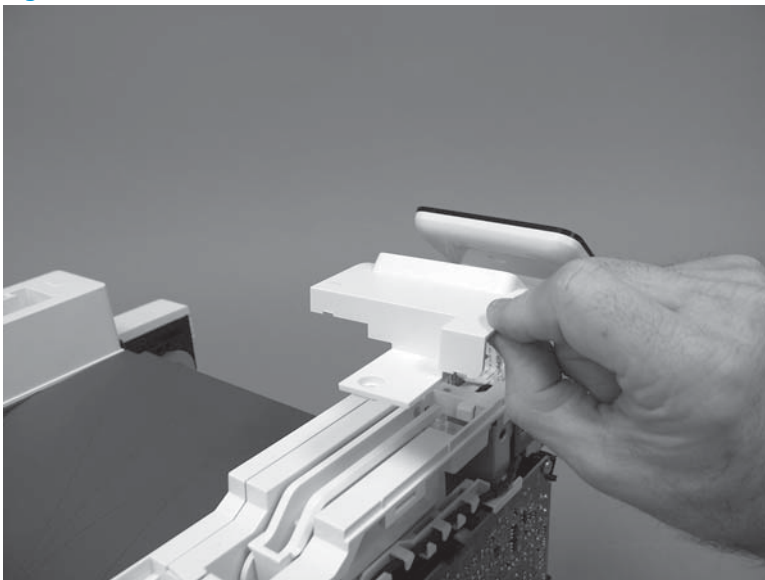
3. Use a small flat-blade screwdriver to release two tabs (callout 1) on the control-panel cable cover.

**Figure 1-301** Release two tabs



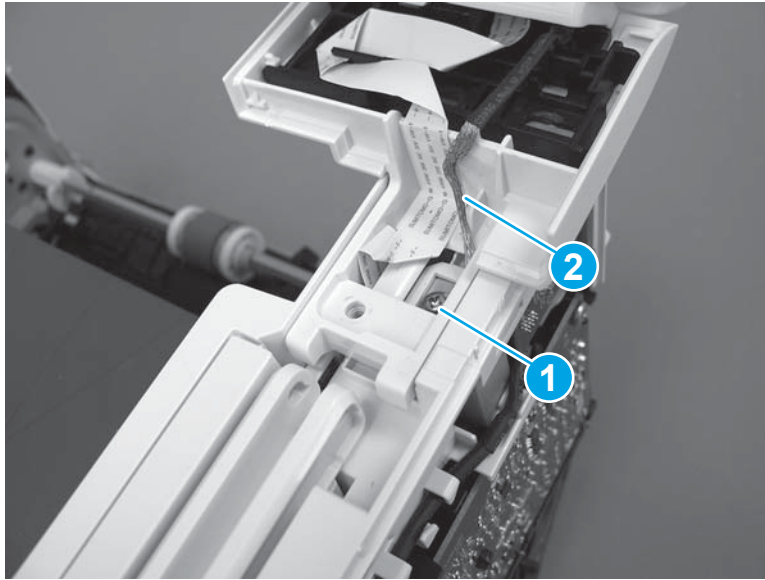
4. Remove the control-panel cable cover.

**Figure 1-302** Remove the cover



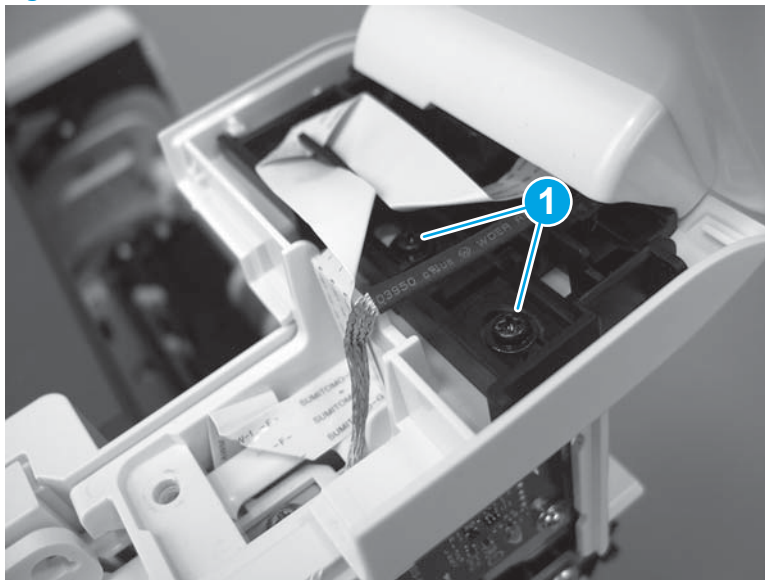
5. Remove one grounding screw (callout 1), and then move the ground cable (callout 2) out of the way.

**Figure 1-303** Remove one screw



6. Move the FFC out of the way, and then remove two screws (callout 1).

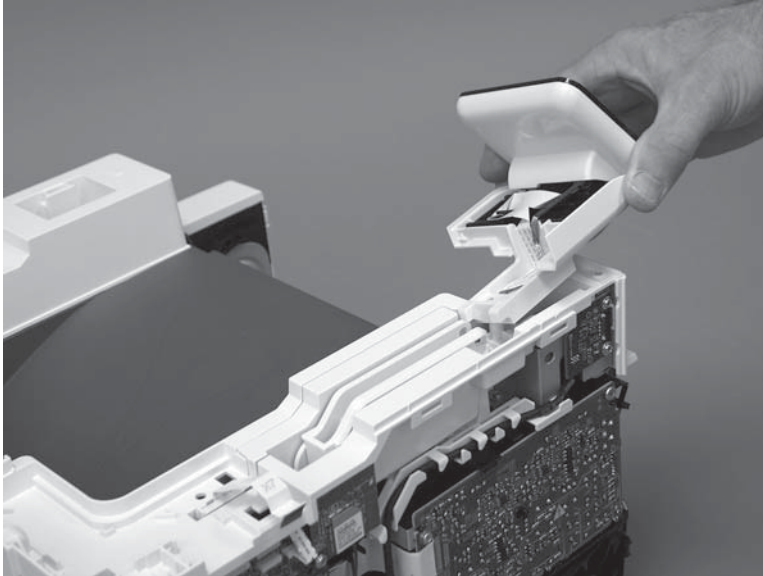
**Figure 1-304** Remove two screws



7. Slightly lift up the control-panel assembly to separate it from the top cover.

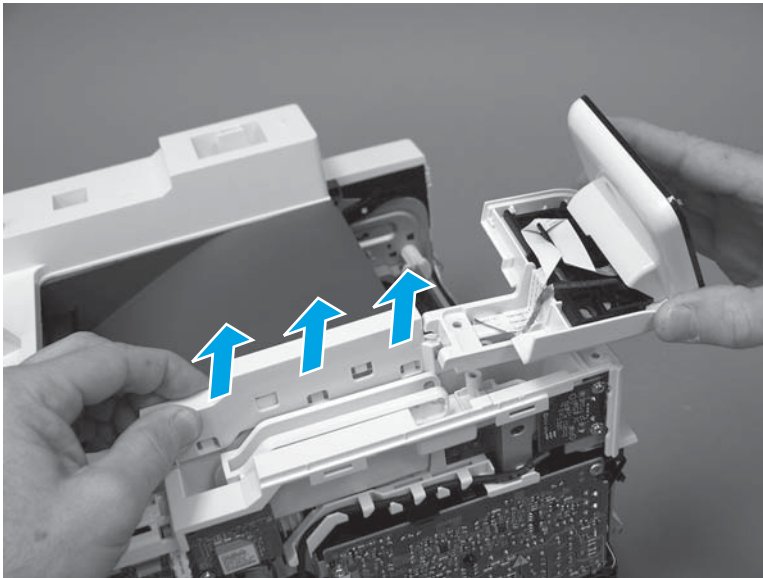
**⚠ CAUTION:** The control panel assembly is still connected to the printer by the FFC. Do not attempt to completely remove the assembly.

**Figure 1-305** Lift up the control-panel assembly



8. Lift up the control-panel FFC cover to remove the control-panel assembly.

**Figure 1-306** Remove the control-panel assembly

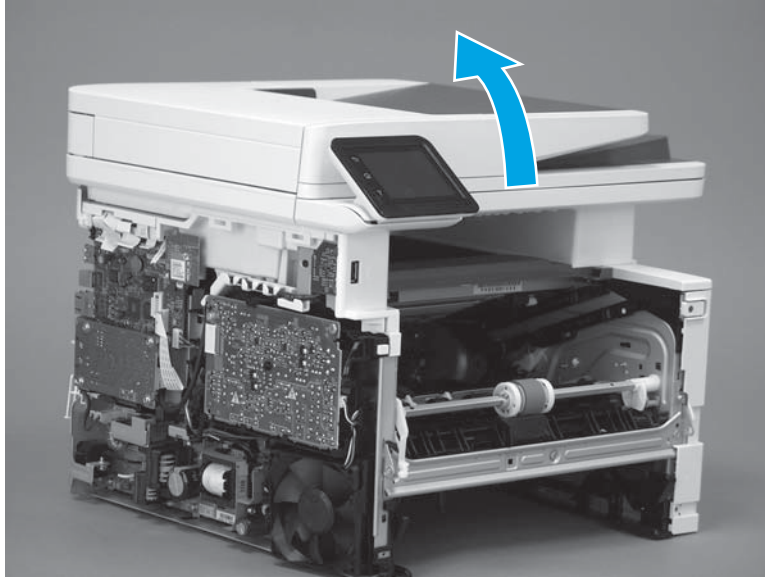


### Step 6: Remove the integrated scanner assembly (M427/M246)

**📄 NOTE:** M427/M426 models only. The integrated scanner assembly (ISA) includes the sub-scanner assembly (SSA) and the automatic document feeder (ADF).

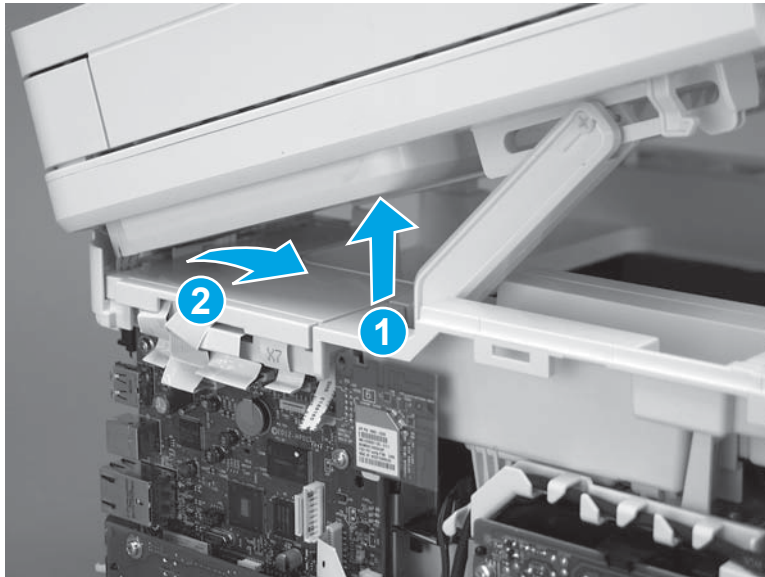
1. Raise the ISA.

**Figure 1-307** Raise the ISA



2. Release the ISA flat-flexible cable (FFC) cover (callout 1), and then remove it (callout 2).

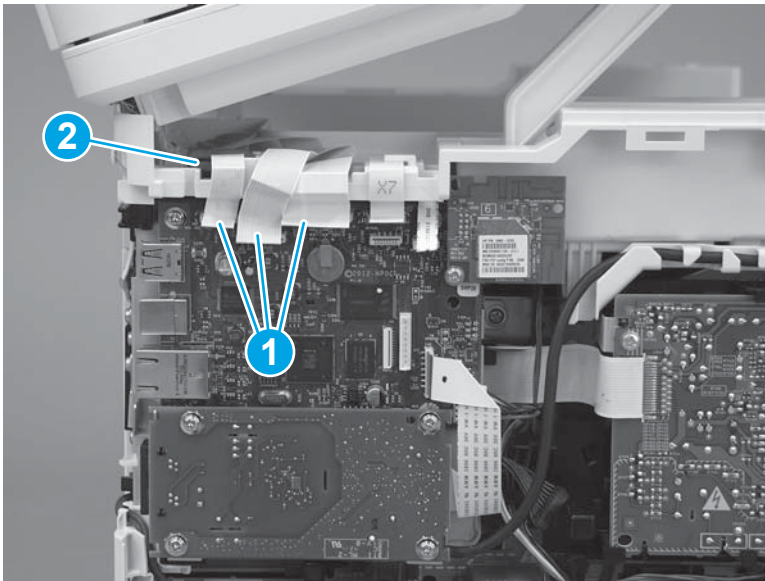
**Figure 1-308** Remove the ISA FFC cover



3. Disconnect three FFCs (callout 1), and then remove the ferrite (callout 2) from the holder.

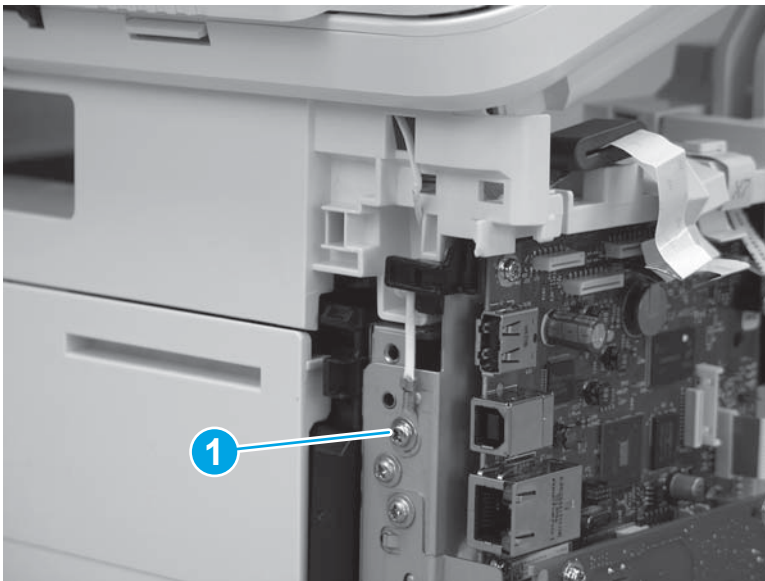
**⚠ CAUTION:** The ferrite is not captive on the FFC. Do not lose the ferrite while handling the ISA.

**Figure 1-309** Disconnect three FFCs



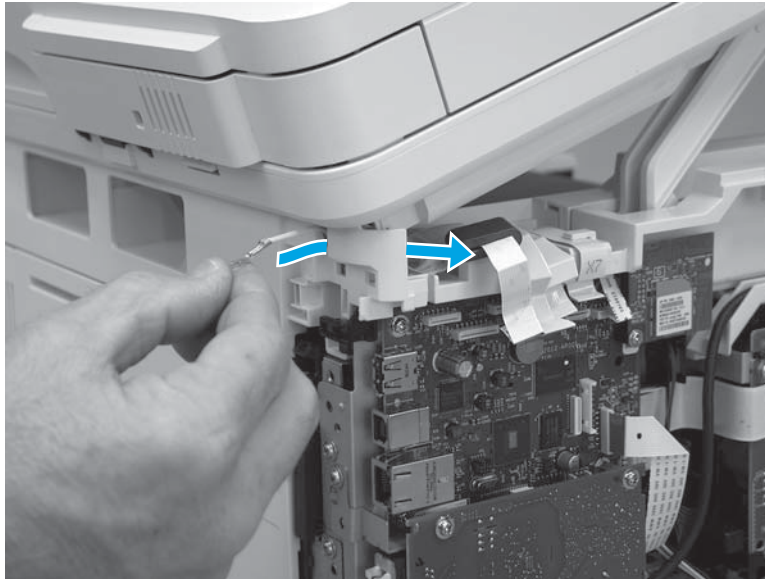
4. Remove one screw (callout 1).

**Figure 1-310** Remove one screw



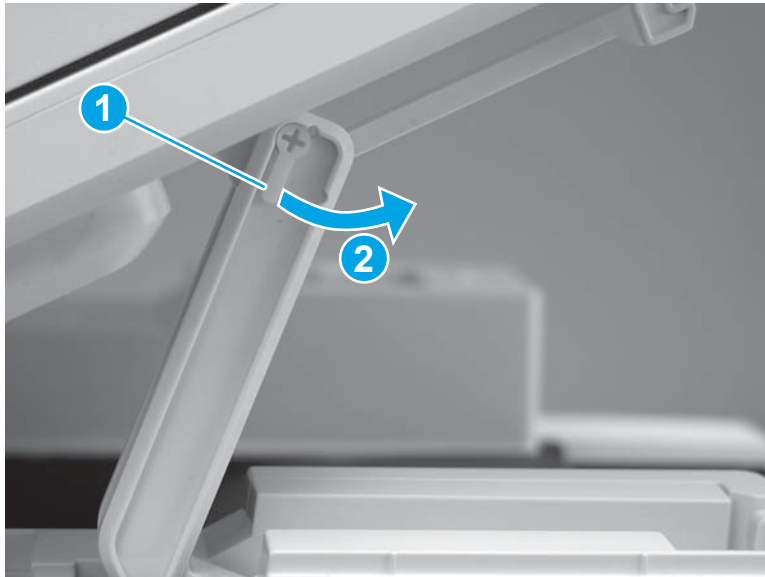
5. Pass the ground wire through the opening in the top cover.

**Figure 1-311** Pass the wire through the opening



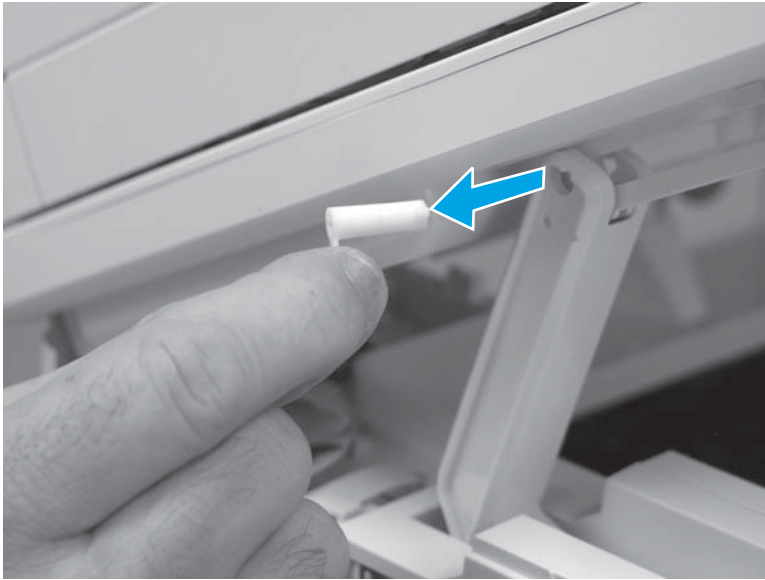
6. Release one tab (callout 1), and then rotate the ISA slider pin (callout 2) towards the front of the printer to release it.

**Figure 1-312** Release one tab and rotate the slider pin



7. Remove the slider pin.

**Figure 1-313** Remove the slider pin



8. Rotate the ISA towards the rear of the printer until it stops.

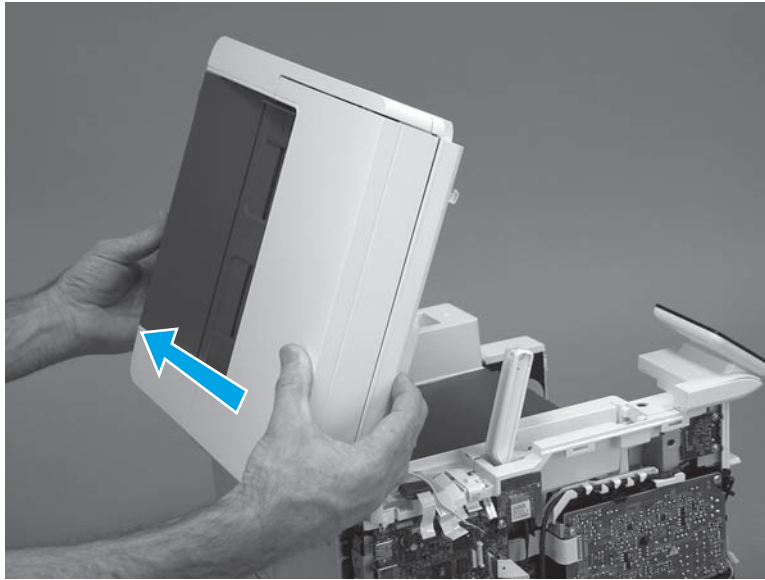
**Figure 1-314** Rotate the ISA towards the rear of the printer





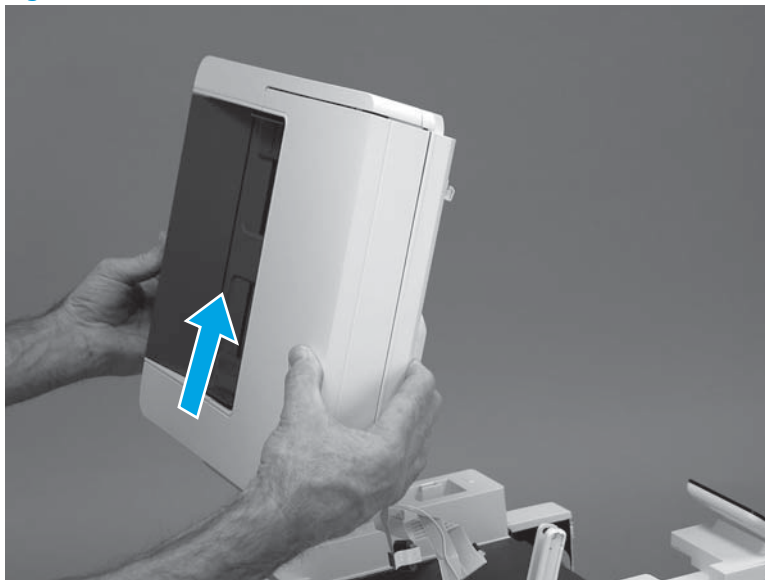
9. Slide the ISA as shown to release it.

**Figure 1-315** Release the ISA



10. Remove the ISA.

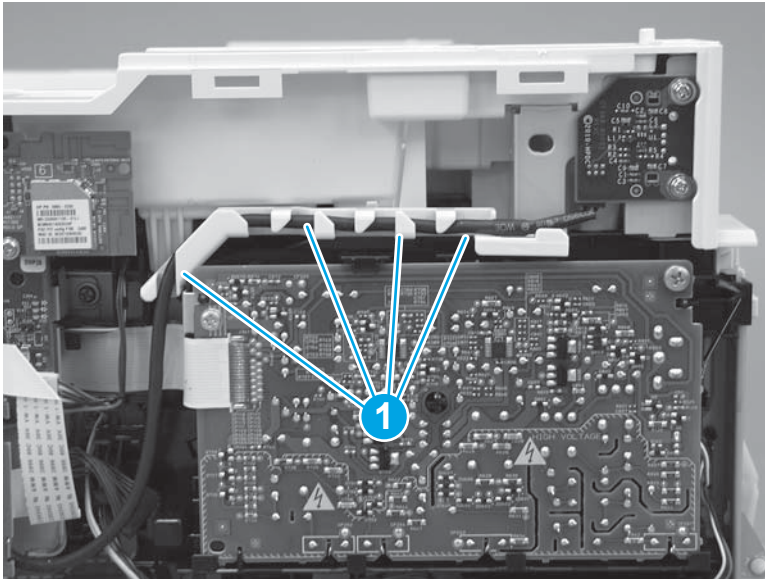
**Figure 1-316** Remove the ISA



#### **Step 7: Remove the top cover (M427/M426)**

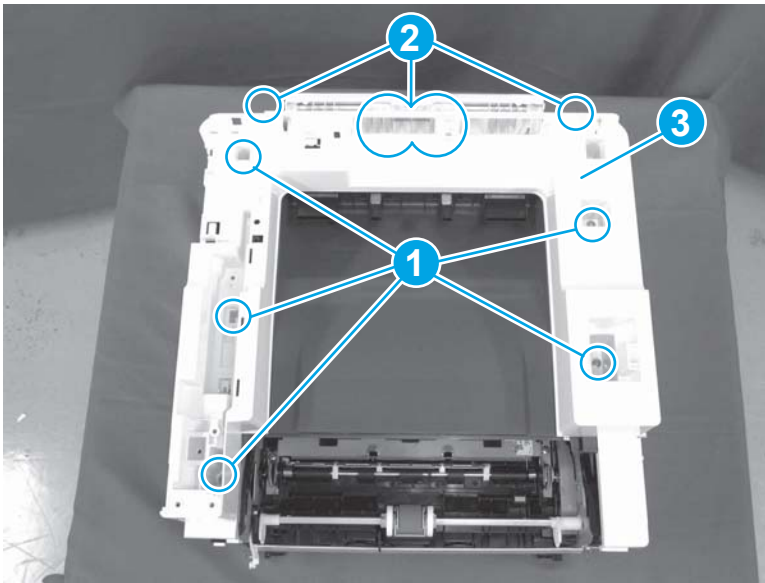
1. Release the USB cable (callout 1) from the cable guide.

**Figure 1-317** Remove the USB cable



2. Remove five screws (callout 1), release four bosses (callout 2), and then remove the top cover (callout 3).

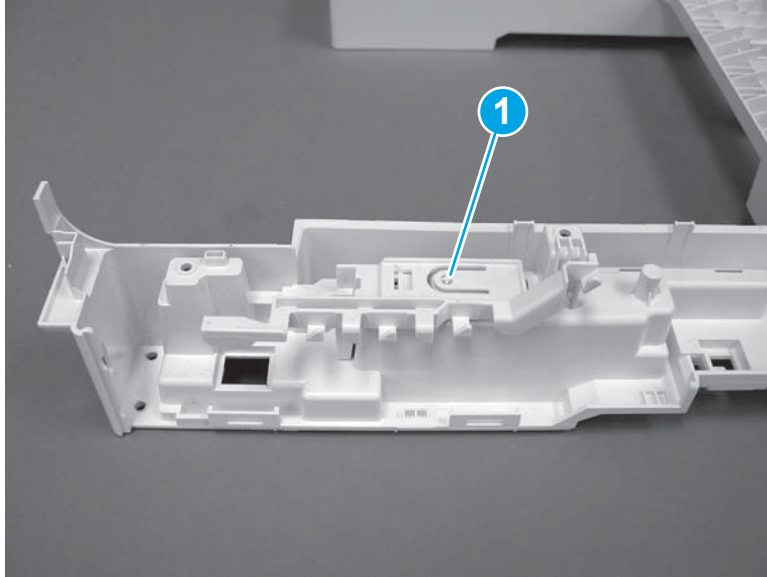
**Figure 1-318** Remove the cover



**Step 8: Remove the cable guide (M427/M426)**

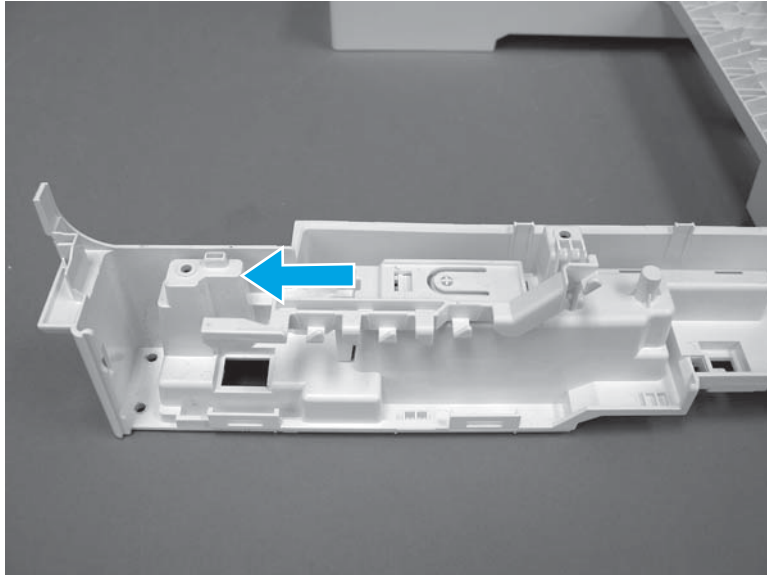
1. Turn the top cover over, and then release one tab (callout 1).

**Figure 1-319** Release one tab



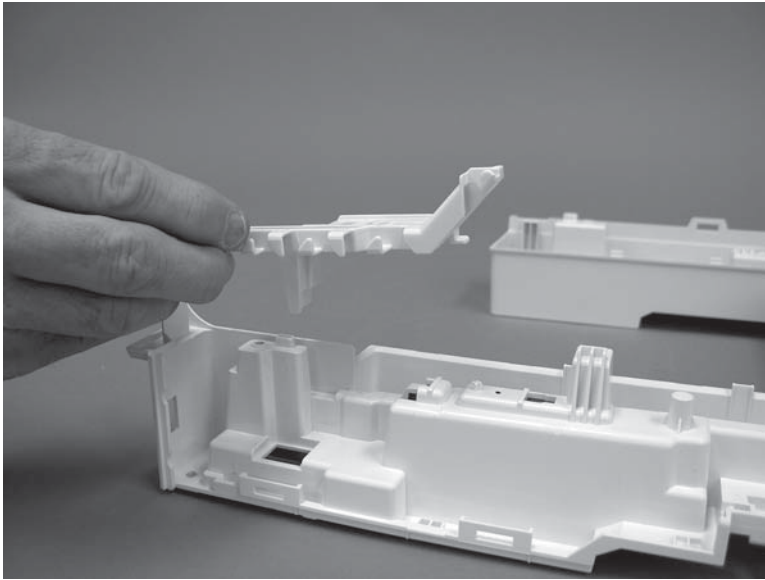
2. Slide the guide as shown to release it.

**Figure 1-320** Release the guide



3. Remove the guide.

**Figure 1-321** Remove the guide



### Step 9: Unpack the replacement assembly

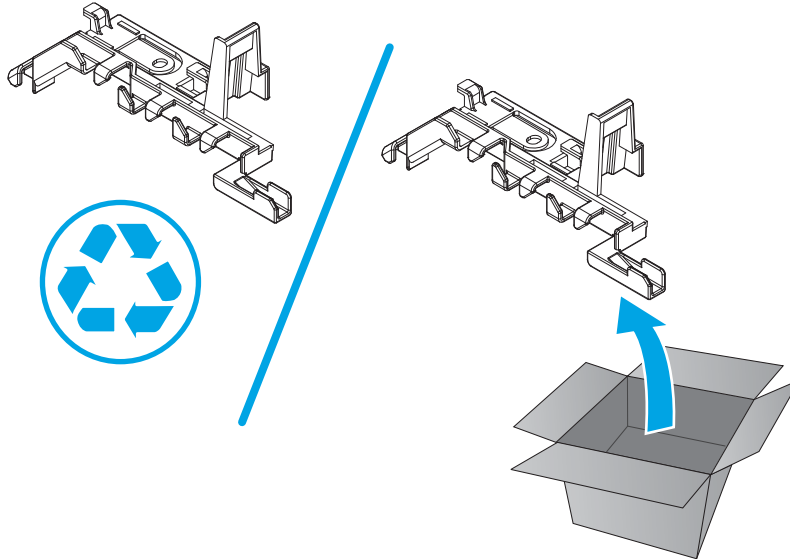
Unpack the replacement part from the packaging.

<http://www8.hp.com/us/en/hp-information/environment/product-recycling.html>



**NOTE:** HP recommends responsible disposal of the defective part.

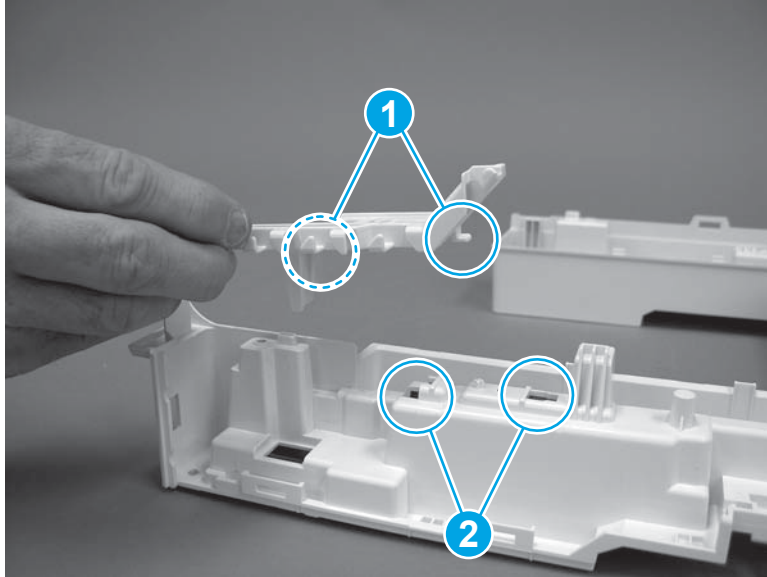
**Figure 1-322** Recycle and unpack



### Step 10: Install the cable guide (M427/M426)

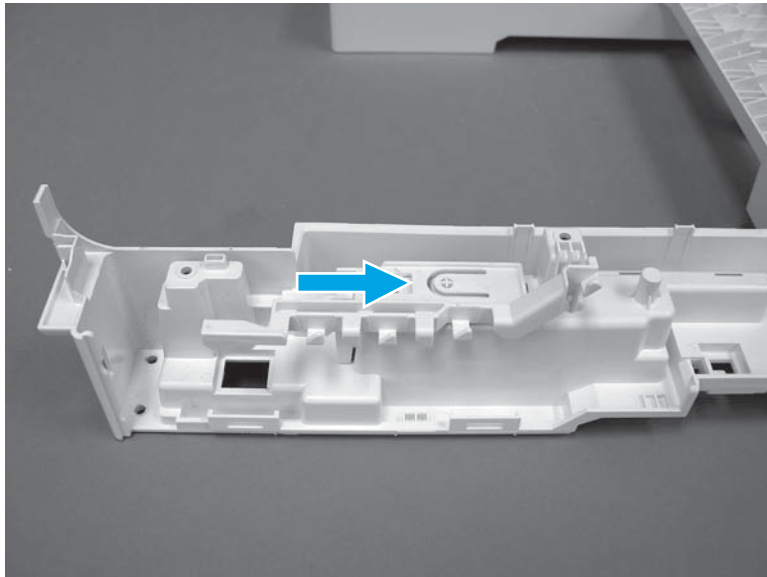
1. Position the guide on the printer with the two tabs (callout 1) in the slots (callout 2) in the chassis.

**Figure 1-323** Position the guide on the printer



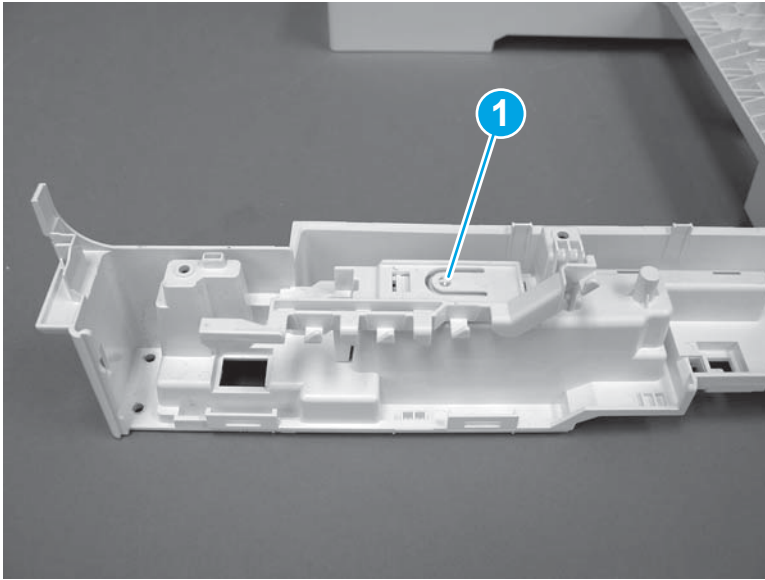
2. Slide the guide as shown (callout 1) to install it.

**Figure 1-324** Install the guide



3. Make sure that the tab (callout 1) snaps into place.

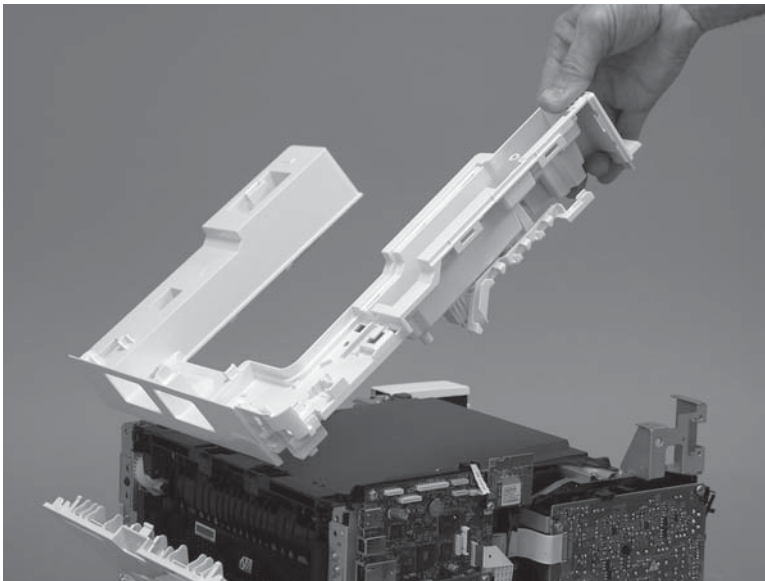
**Figure 1-325** Check the guide



**Step 11: install the top cover (M427/M426)**

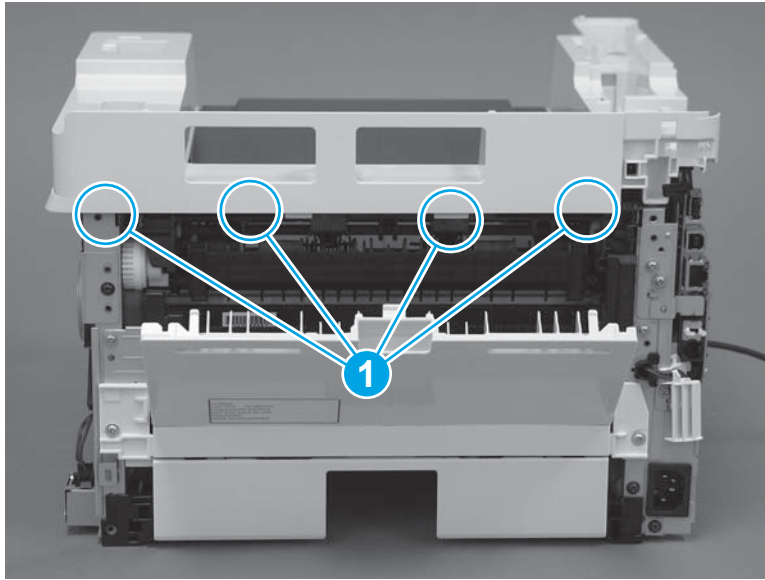
1. Position the rear edge of the top cover on the printer.

**Figure 1-326** Install the cover



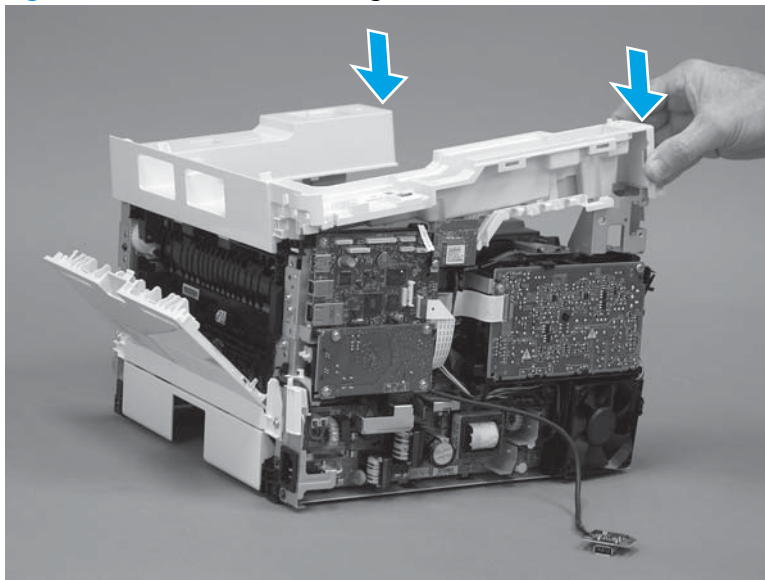
2. Engage four bosses (callout 1).

**Figure 1-327** Engage four bosses



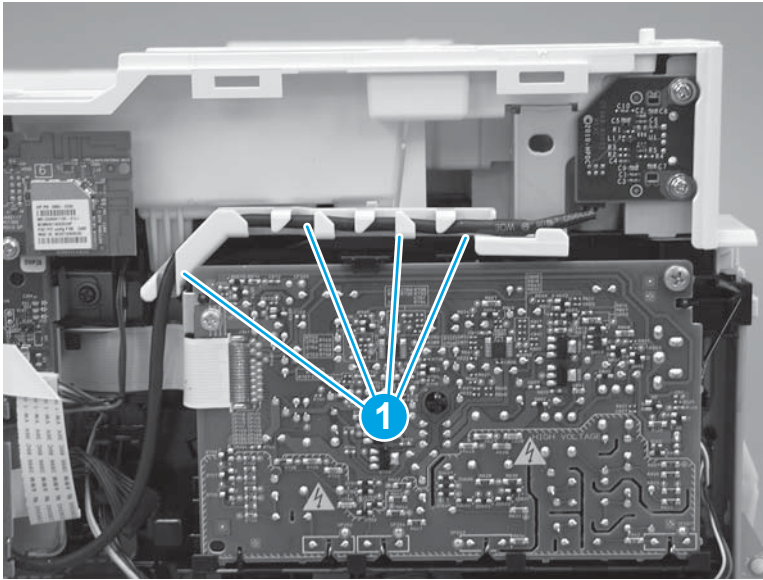
3. Rotate the front edge of the cover down.

**Figure 1-328** Rotate the front edge of the cover down



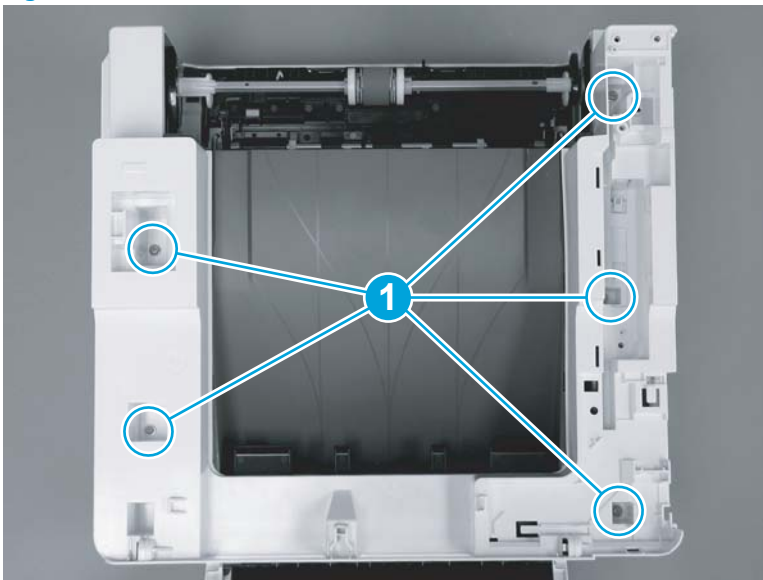
4. Install the USB cable (callout 1) in the guide.

**Figure 1-329** Install the USB PCA




5. Install five screws (callout 1).

**Figure 1-330** Install five screws



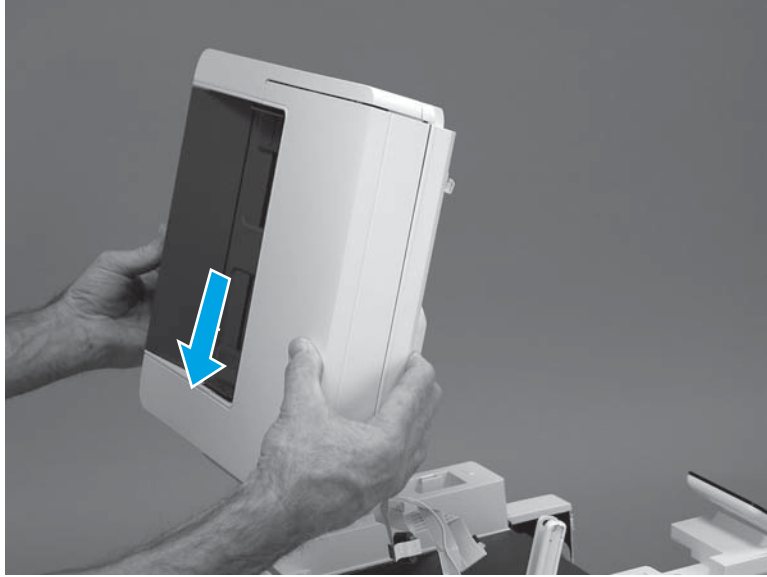
### Step 12: Install the integrated scanner assembly (M427/M246)

 **NOTE:** M427/M246 models only. The integrated scanner assembly (ISA) includes the sub-scanner assembly (SSA) and the automatic document feeder (ADF).

1. Position the ISA on the printer.

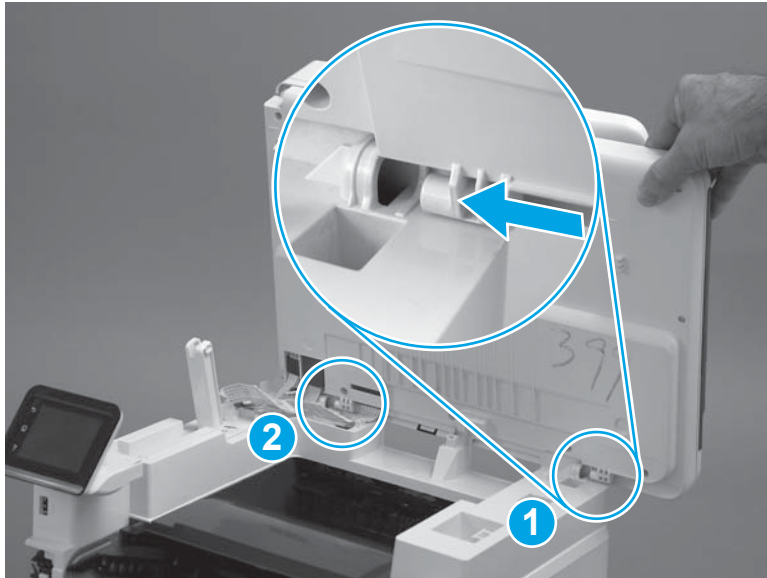


**Figure 1-331** Position the ISA on the printer



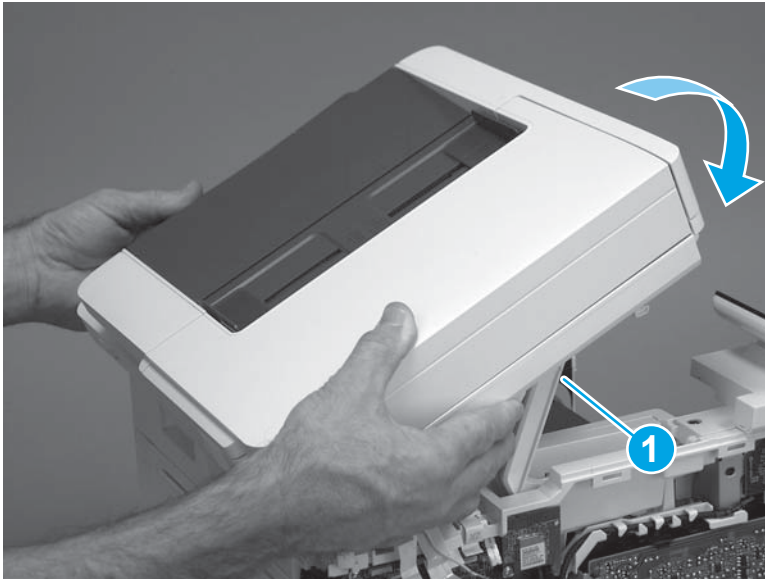
2. Engage the hinge pins on the ISA with the holders in the top cover (callouts 1/2), and then slide the ISA as shown to engage them

**Figure 1-332** Engage the hinge pins with the holders



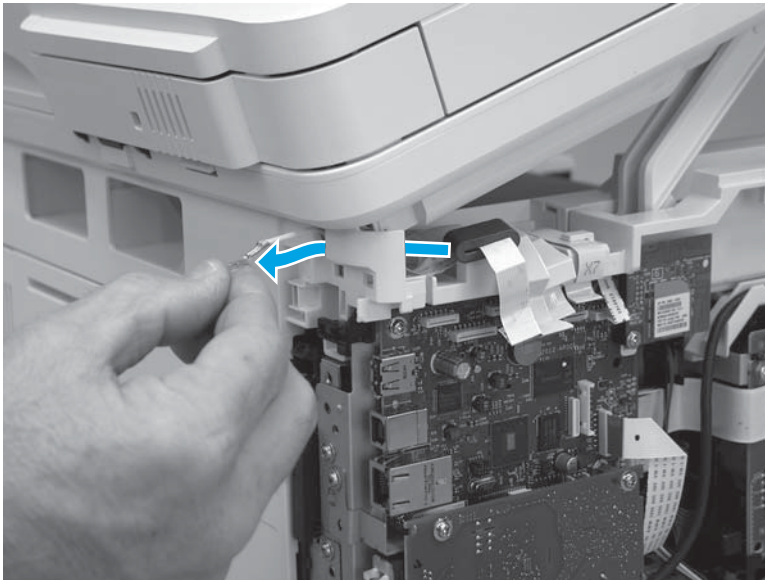
3. Rotate the ISA towards the front of the printer until it rests on the ISA lift assembly (callout 1).

**Figure 1-333** Rotate the ISA towards the front of the printer



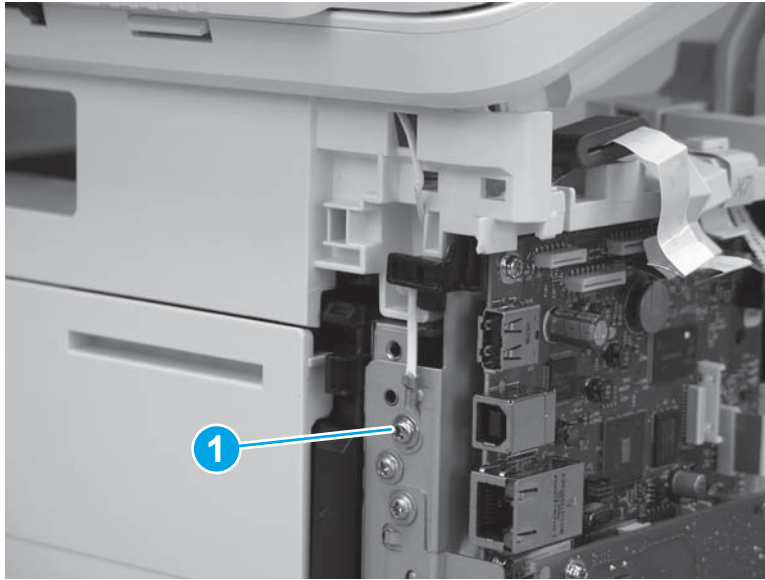
4. Pass the ground wire through the opening in the top cover.

**Figure 1-334** Pass the wire through the opening




5. Install one screw (callout 1).

**Figure 1-335** Install one screw



6. Install the ISA lift assembly slider pin.

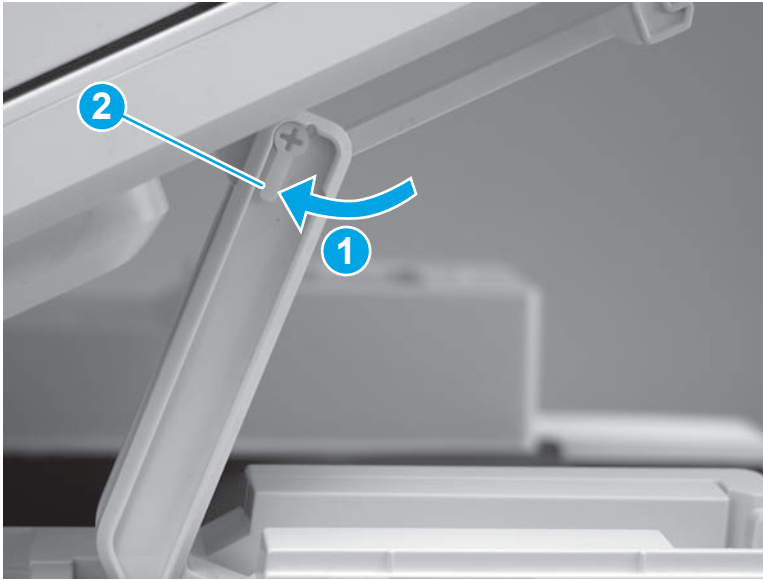
 **Reinstallation tip:** Align the keyed portion of the locking pin with the slot and hole in the support arm.

**Figure 1-336** Install the slider pin



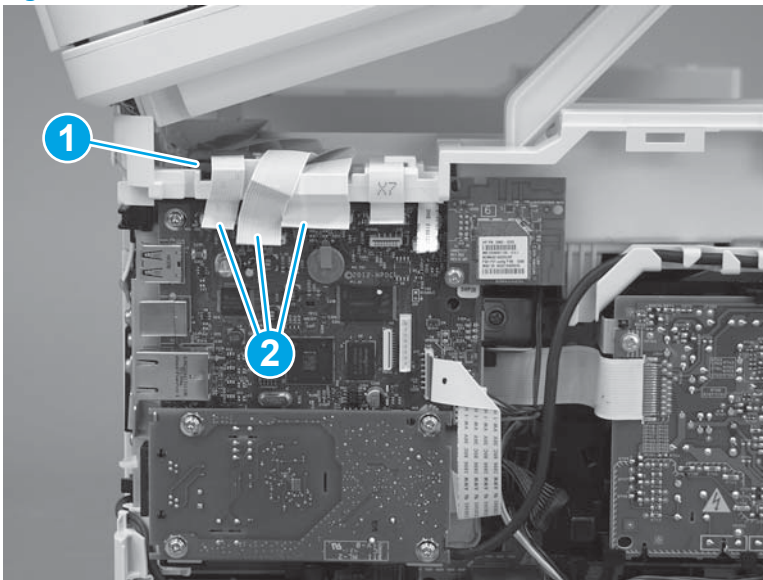
7. Rotate the slider pin (callout 1) towards the rear of the printer until the tab (callout 2) snap into place.

**Figure 1-337** Secure the slider pin



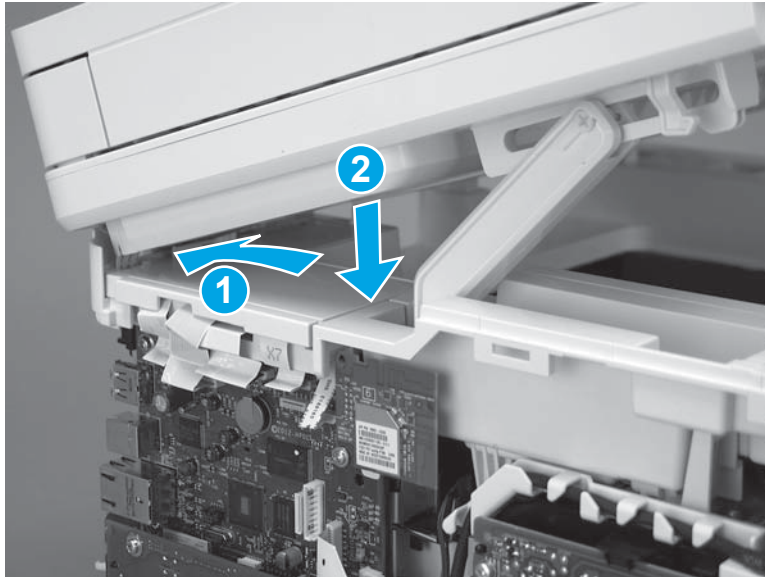
8. Install the ferrite (callout 1) in the holder, and then connect three FFCs (callout 2).

**Figure 1-338** Connect three FFCs



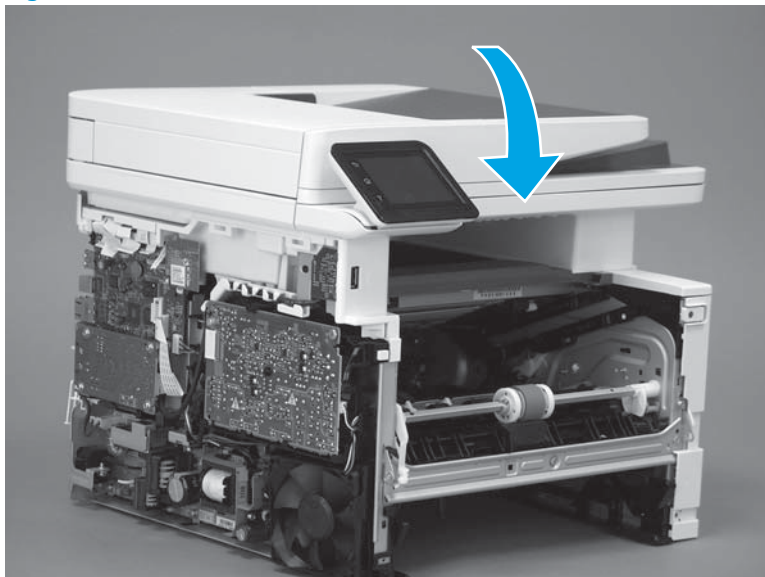
9. Position the rear edge of the ISA flat-flexible cable (FFC) cover on the printer (callout 1) , and then rotate it down (callout 2) until it snaps into place.

**Figure 1-339** Install the ISA FFC cover



10. Lower the ISA.

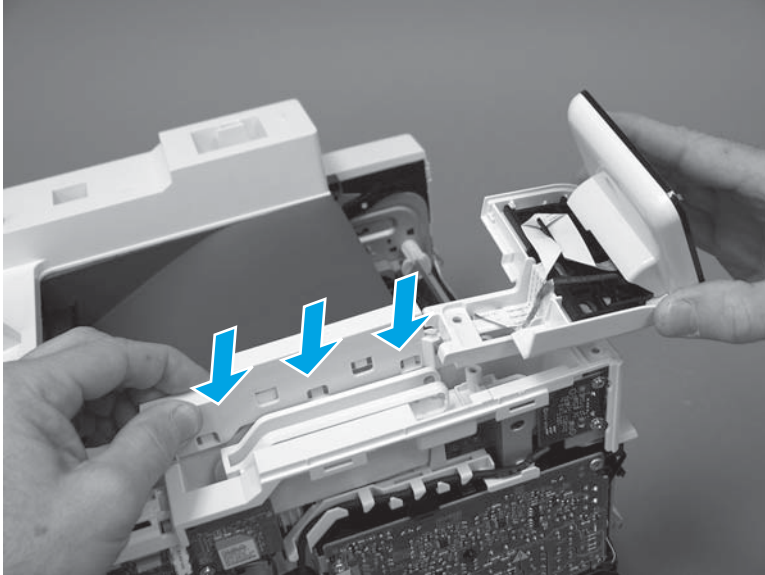
**Figure 1-340** Lower the ISA



### **Step 13: Install the control panel (M427/M426)**

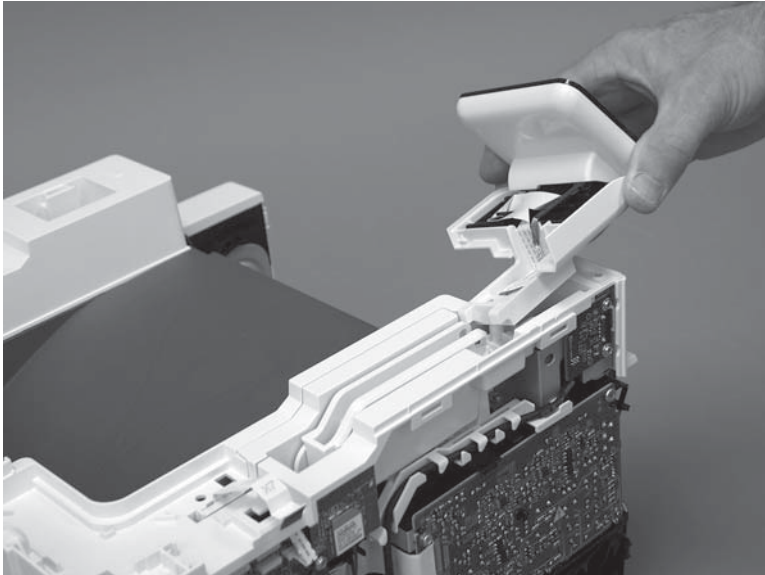
1. Slide the control-panel FFC cover into the slot in the top cover (next to the document feeder support arm) to install it.

**Figure 1-341** Install the control-panel FFC cover



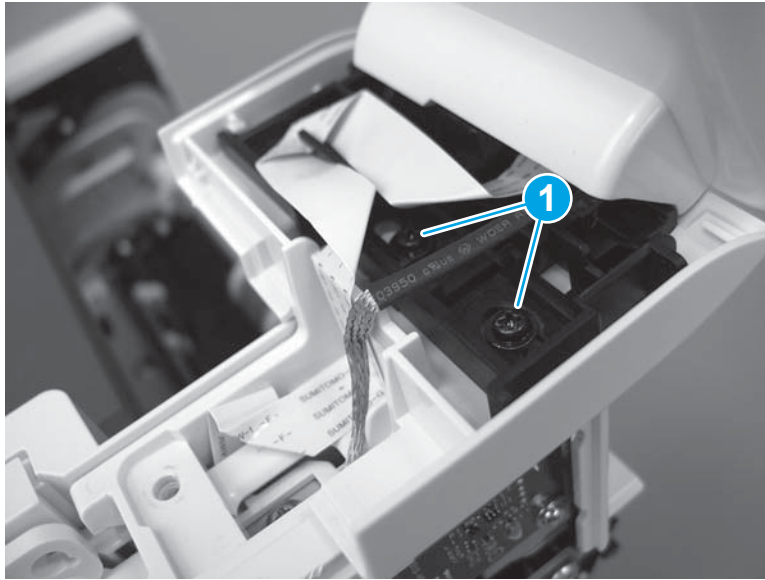
2. Install the control-panel assembly on the top cover.

**Figure 1-342** Install the control-panel assembly



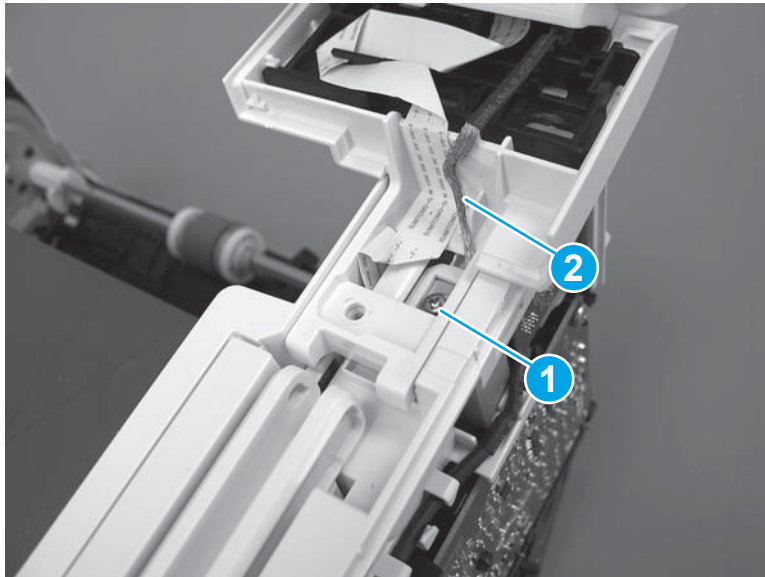
3. Move the FFC out of the way, and then install two screws (callout 1).

**Figure 1-343** Install two screws



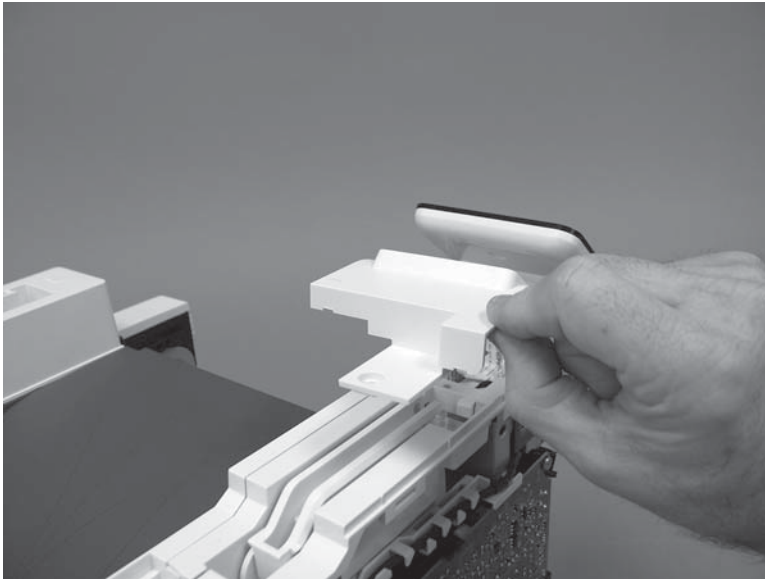
4. Install one grounding screw (callout 1), and then make sure that the ground cable (callout 2) is properly routed.

**Figure 1-344** Remove one screw



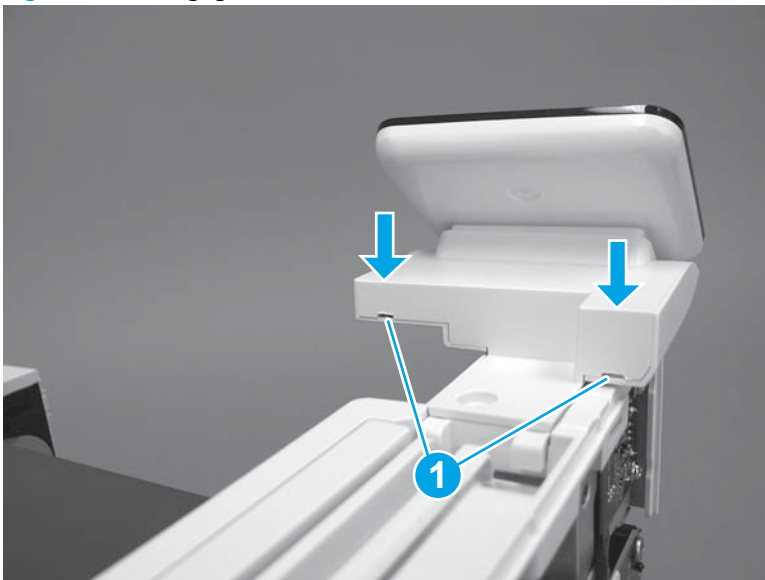
5. Install the control-panel cable cover.

**Figure 1-345** Install the cover



6. Make sure that the two tabs (callout 1) on the cover snap into place.

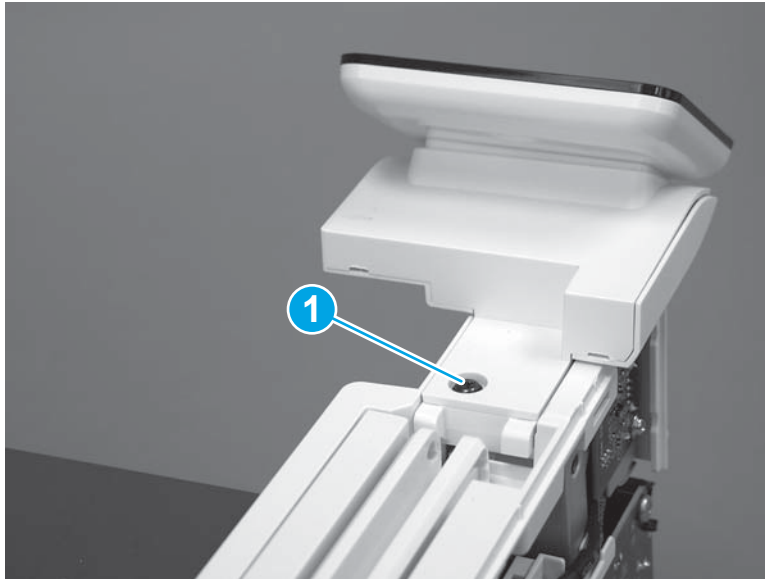
**Figure 1-346** Engage two tabs





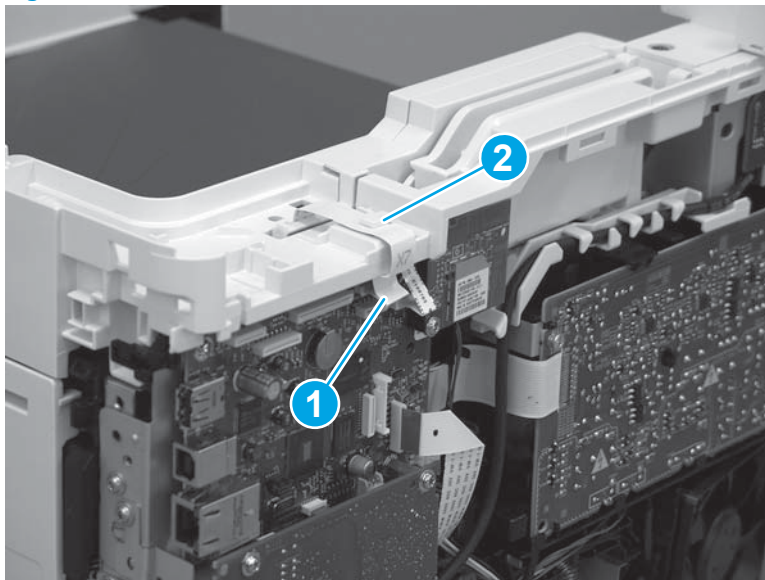
7. Install one screw (callout 1).

**Figure 1-347** Install one screw



8. Install the FFC in the retainer (callout 1), and then connect one FFC (callout 1; J114).

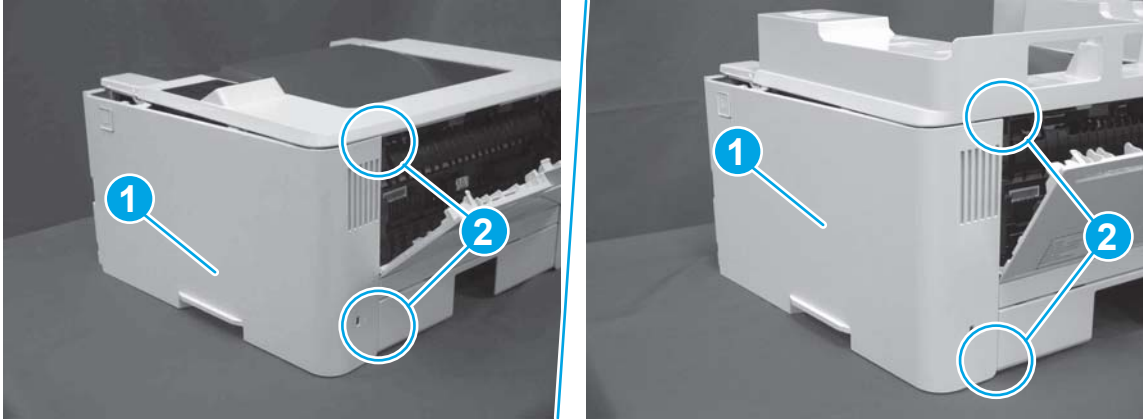
**Figure 1-348** Connect one connector



#### **Step 14: Install the right cover**

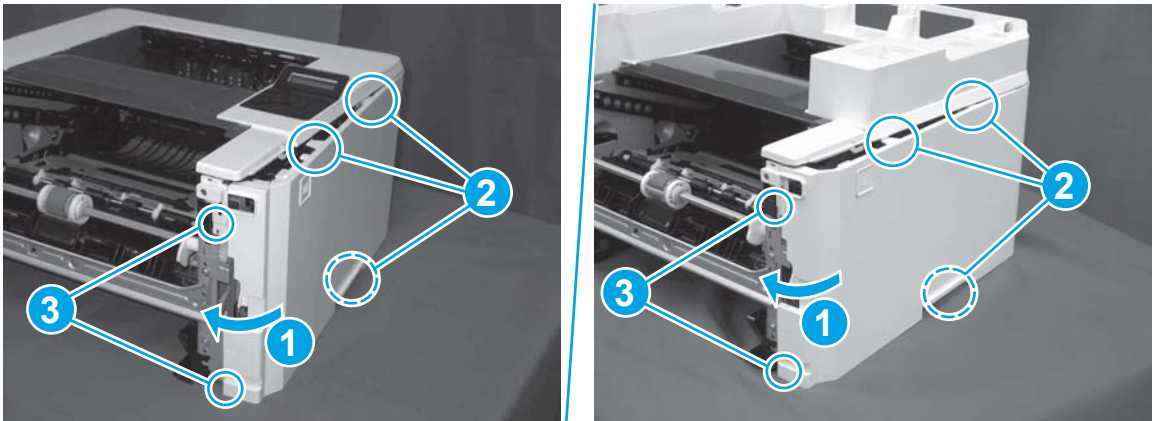
1. Position the cover (callout 1) on the printer, and then engage two bosses (callout 2).

**Figure 1-349** Install the cover




2. Rotate the front of the cover onto the printer (callout 1), engage three (callout 2) tabs, and then engage two bosses (callout 3).

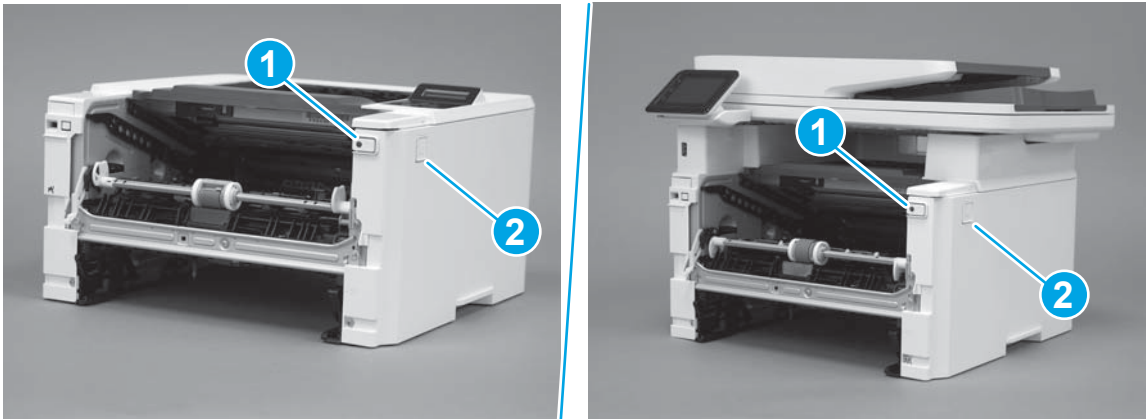
**Figure 1-350** Engage two bosses and one tab



3. Make sure that the power switch (callout 1) and cartridge door assembly button (callout 2) correctly function.

 **NOTE:** Remove, and then reinstall the cover if the switch or button does not correctly function.

**Figure 1-351** Check the power switch and cartridge door assembly button



4. Install one screw (callout 1).

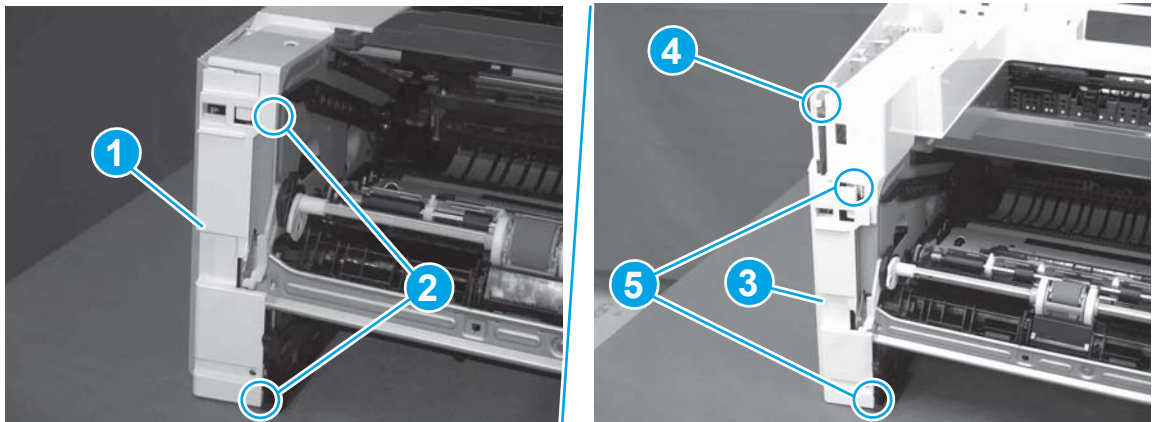
**Figure 1-352** Install one screw



### Step 15: Install the left cover

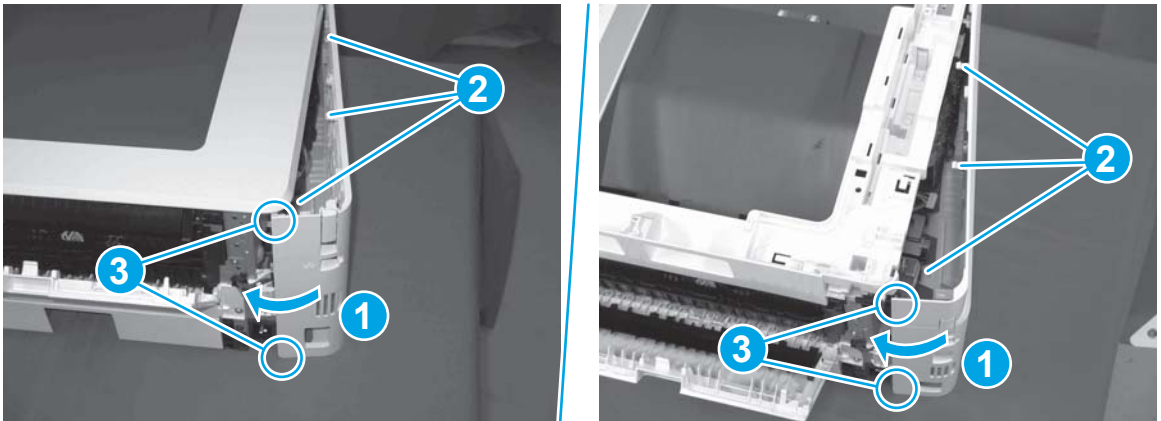
1. At the front of the printer, do one of the following:
  - **M403/M402:** Position the cover on the printer ( callout 1), and then engage two bosses (callout 2).
  - **M427/M426:** Position the cover on the printer (callout 3), engage one tab (callout 4), and then engage two bosses (callout 4).

**Figure 1-353** Install the cover



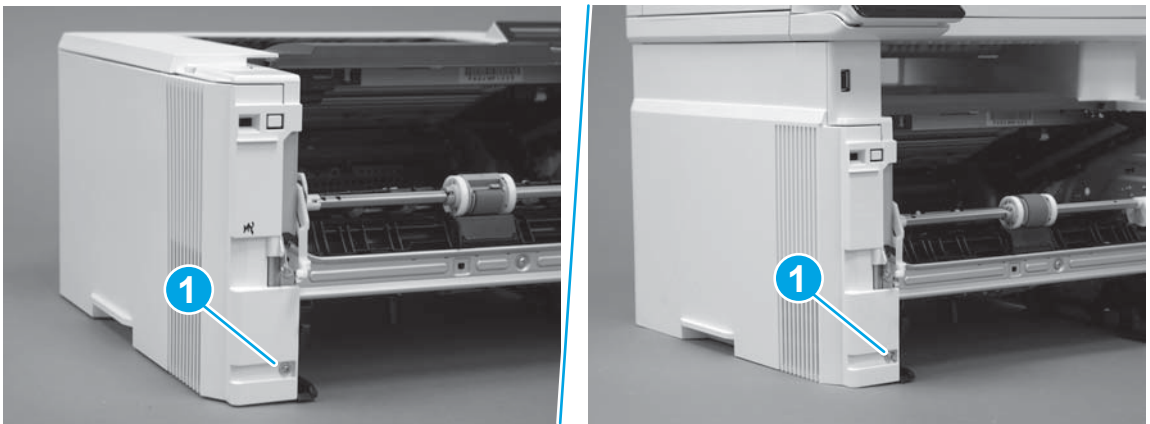
- Carefully rotate the rear of the cover onto the printer (callout 1), engage three tabs (callout 2), and then engage two bosses (callout 3).

**Figure 1-354** Engage three tabs and two bosses




- Install one screw (callout 1).

**Figure 1-355** Install one screw

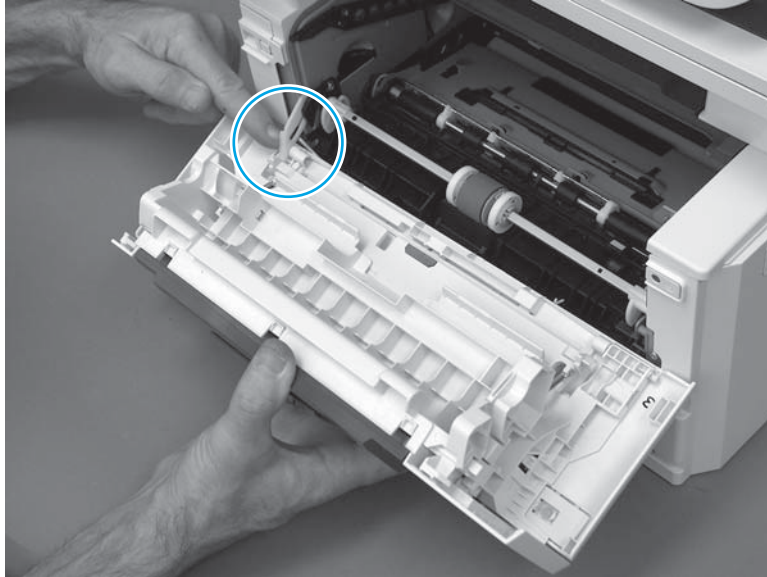


### Step 16: Install the cartridge door assembly

 **Reinstallation tip:** After a replacement door is installed, make sure to install the nameplate (supplied in the kit) corresponding to the printer name on the door.

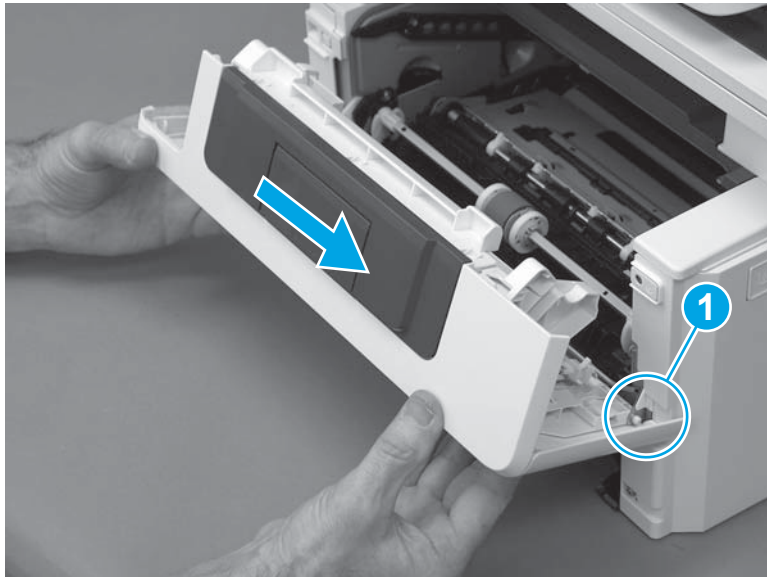
- Position the door close to the printer, and then engage the keyed pin on the left-side retainer arm with the hole in the door.

**Figure 1-356** Engage the left-side retainer arm



2. Engage the right-side door hinge pin with the hole in the chassis (callout 1).

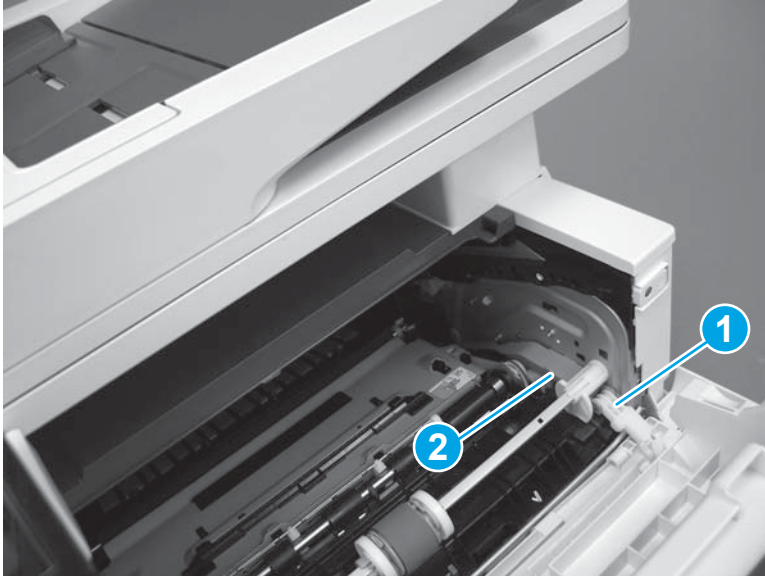
**Figure 1-357** Install the door



3. Install the link (callout 1).

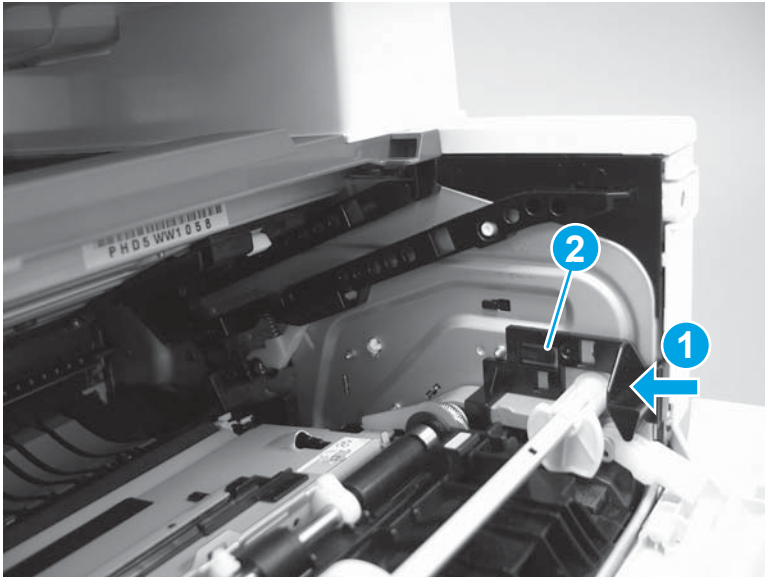
 **IMPORTANT:** Make sure that the link snaps into place on the arm (callout 2). The link actuates the fuser pressure-release mechanism.

**Figure 1-358** Install the pressure-release link



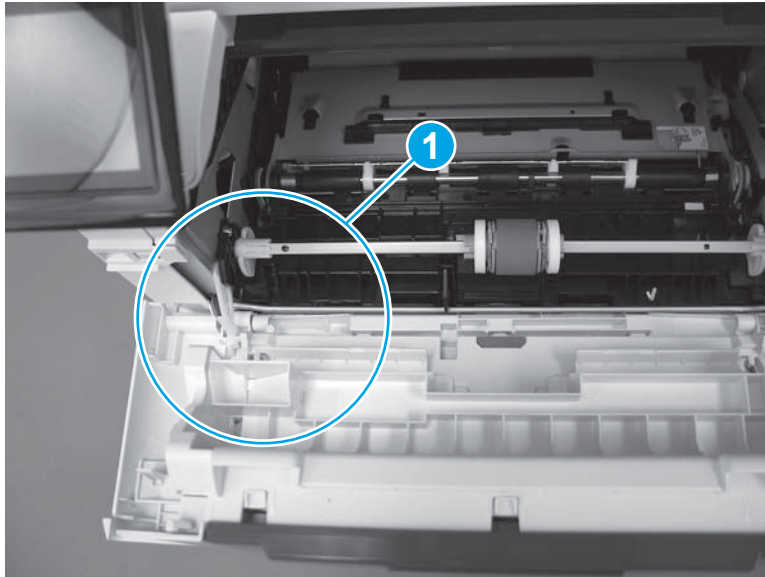
4. Slide the guide into the printer (callout 1), and then make sure that the tab (callout 2) snaps into place to secure the guide to the chassis.

**Figure 1-359** Install the guide




5. Position the shaft on the door, and then align the left-side hinge on the door with the hole in the chassis (callout 1).

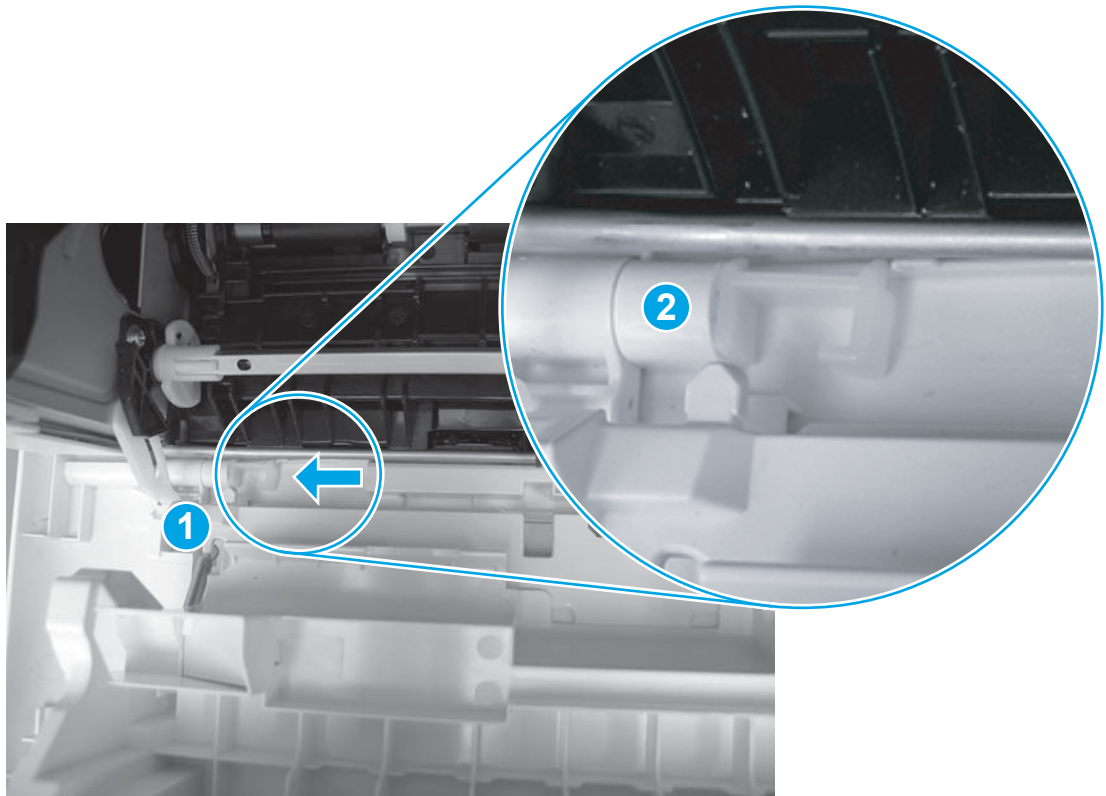
**Figure 1-360** Align the hinge



6. Push the shaft towards the left side of the printer to install it (callout 1).

 **Reinstallation tip:** Make sure that the support shaft is fully installed and correctly orientated (callout 2) so that it will not interfere with the door opening and closing.

**Figure 1-361** Install the support shaft



### Step 17: Install Tray 2

- ▲ Slide the tray straight into the printer to install it.

**Figure 1-362** Install the tray





## Removal and replacement: Top cover (M403/M402)

- [Introduction](#)
- [Step 1: Remove Tray 2](#)
- [Step 2: Remove the cartridge door assembly](#)
- [Step 3: Remove the left cover](#)
- [Step 4: Remove the right cover](#)
- [Step 5: Remove the top cover \(M403/M402\)](#)
- [Step 6: Remove the 2-line LCD operator and indication covers \(M403/M402\)](#)
- [Step 7: Unpack the replacement assembly](#)
- [Step 8: Install the 2-line LCD operator and indication covers \(M403/M402\)](#)
- [Step 9: Install the top cover \(M403/M402\)](#)
- [Step 10: Install the right cover](#)
- [Step 11: Install the left cover](#)
- [Step 12: Install the cartridge door assembly](#)
- [Step 13: Install Tray 2](#)


### Introduction

This document provides the procedures to remove and replace the top cover (M403/M402).

### Before performing service

#### Turn the printer power off

- Disconnect the power cable.

 **WARNING!** To avoid damage to the printer, turn the printer off, wait 30 seconds, and then remove the power cable before attempting to service the printer.

Use the table below to identify the correct part number for your printer. To order the part, go to [www.hp.com/buy/parts](http://www.hp.com/buy/parts).

Top cover (M403/M402) part number	
RC4-2956-000CN	Top cover (M403/M402)

### Required tools

- #2 Phillips screwdriver with a magnetic tip.

## After performing service

### Turn the printer power on

- Connect the power cable.
- Use the power switch to turn the power on.

### Post service test

Make sure that the printer initializes to a **Ready** state.

Print a configuration page to make sure that the printer is functioning correctly.

### Step 1: Remove Tray 2

- ▲ Pull the tray straight out of the printer to remove it.

**Figure 1-363** Remove the tray



### Step 2: Remove the cartridge door assembly

---

 **NOTE:** If the toner cartridge was not removed prior to servicing the printer, remove it now.

---

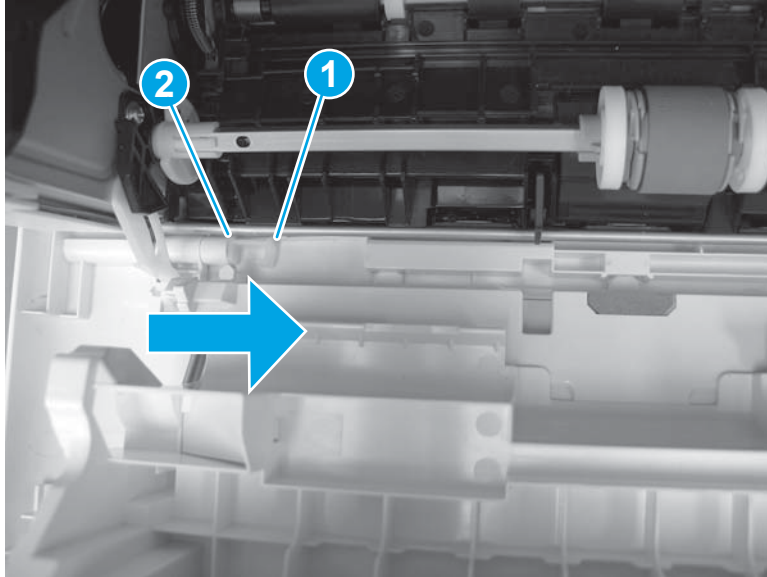
1. Release one tab (callout 1), and then slide shaft (callout 2) in the direction the arrow indicates and remove it.

---

 **TIP:** It might be easier to release the support shaft by using a small flat-blade screwdriver.

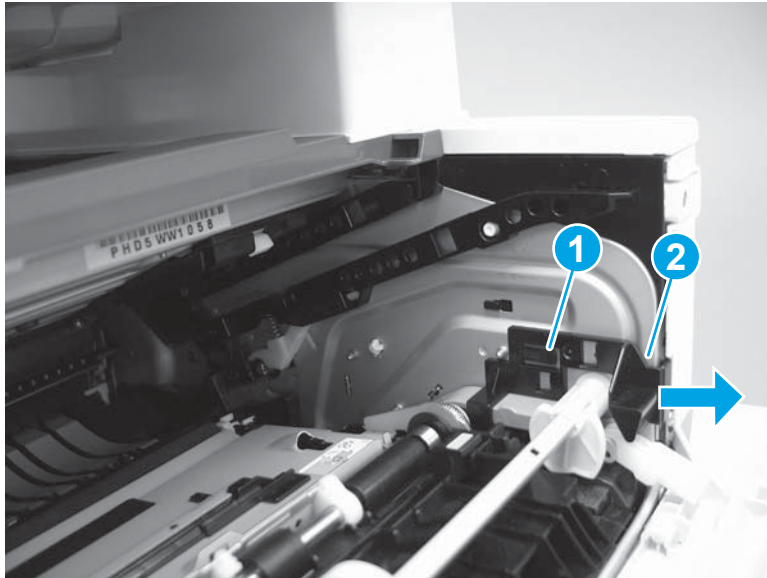
---

**Figure 1-364** Release the support shaft



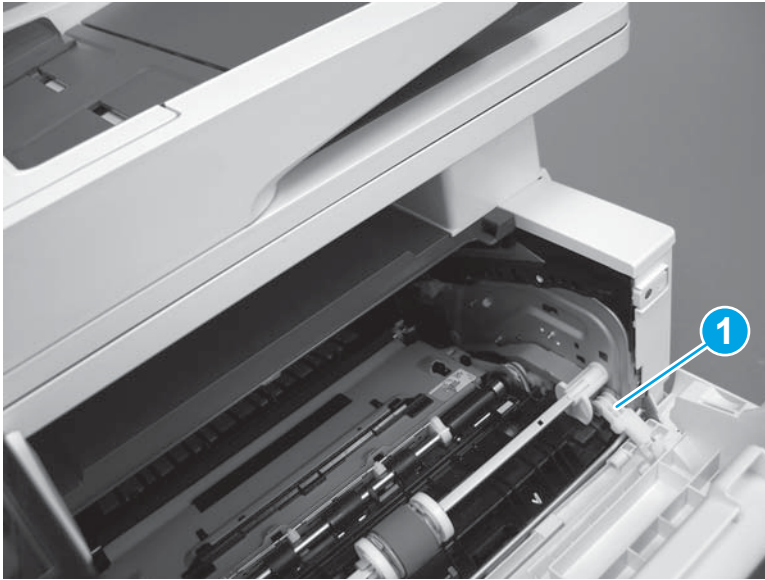
2. Release one tab (callout 1), and then slide the guide (callout 2) in the direction the arrow indicates and remove it.

**Figure 1-365** Remove the guide



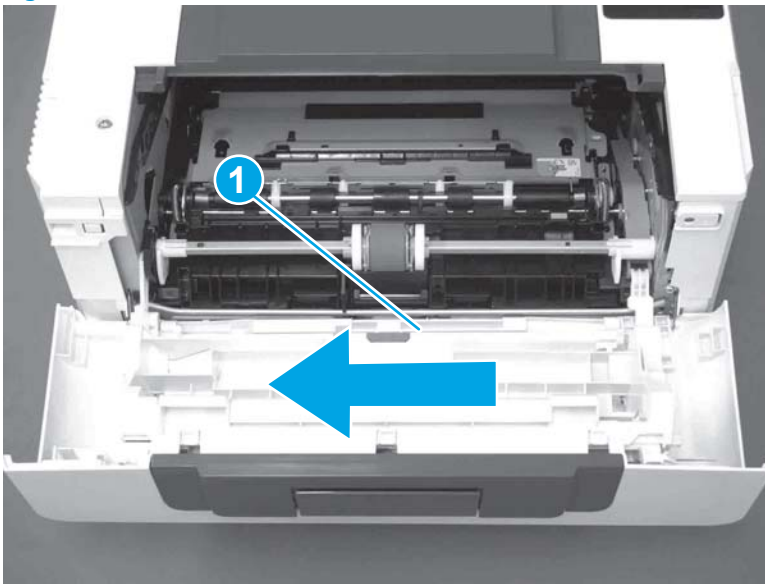
3. Remove the link arm (callout 1).

**Figure 1-366** Remove the link arm



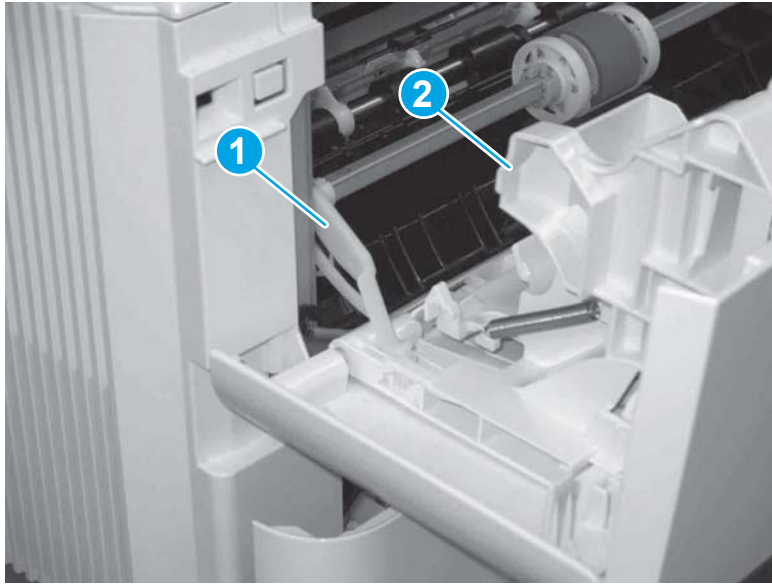
4. Slide the cartridge door assembly (callout 1) in the direction the arrow indicates and remove it.

**Figure 1-367** Remove the door



5. Remove the link (callout 1) from the cartridge door assembly (callout 2).

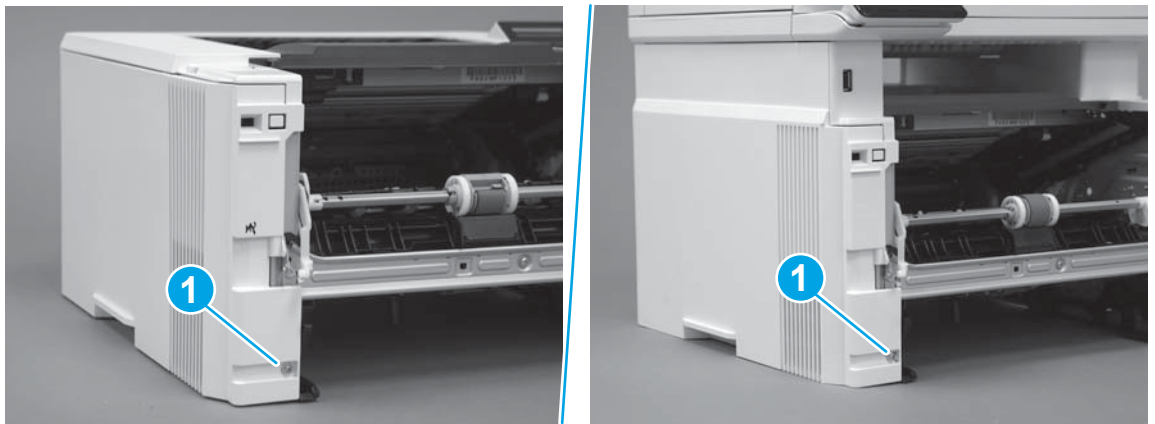
**Figure 1-368** Release the left-side retainer arm



### Step 3: Remove the left cover

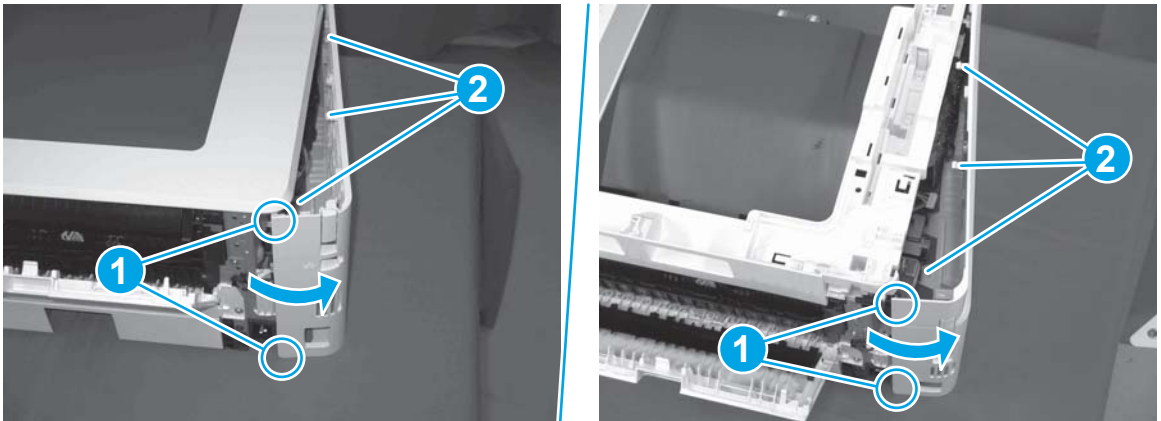
1. Remove one screw (callout 1).

**Figure 1-369** Remove one screw



2. Open the rear door, release two bosses (callout 1), and then release three tabs (callout 2).

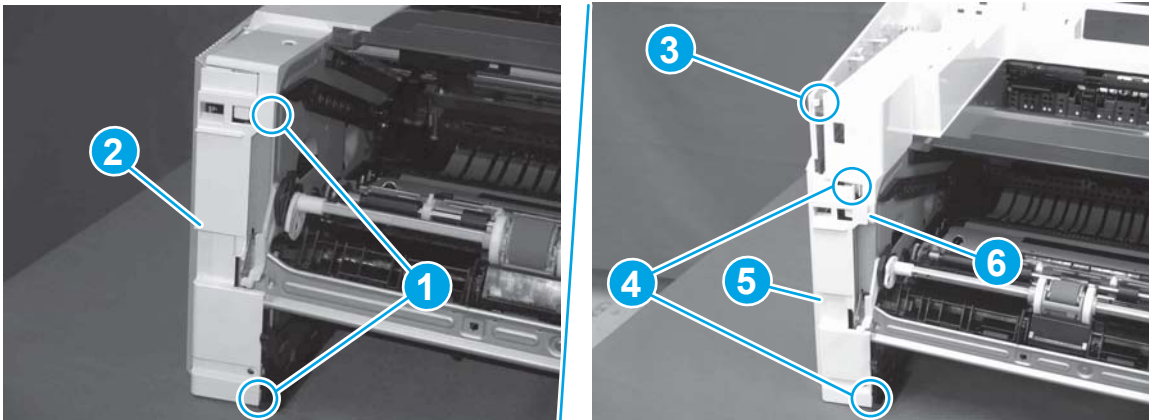
**Figure 1-370** Release two bosses and three tabs



3. At the front of the printer, do one of the following:
  - **M403/M402:** Release two bosses (callout 1), and then remove the cover (callout 2).
  - **M427/M426:** Release one tab (callout 3), two bosses (callout 4), and then remove the cover (callout 5).

**CAUTION:** Be careful when releasing the upper bosses on the M427/M426 cover. One portion of the cover (callout 6) is fragile and is easily broken.

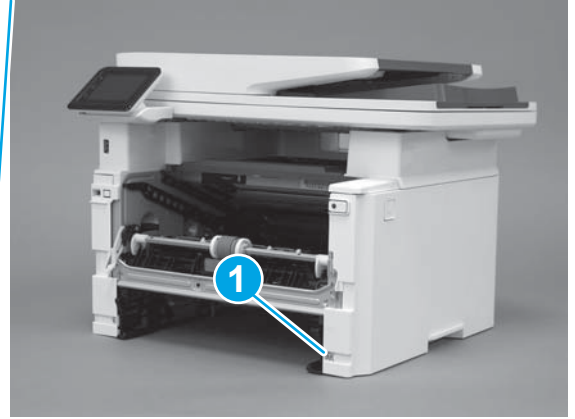
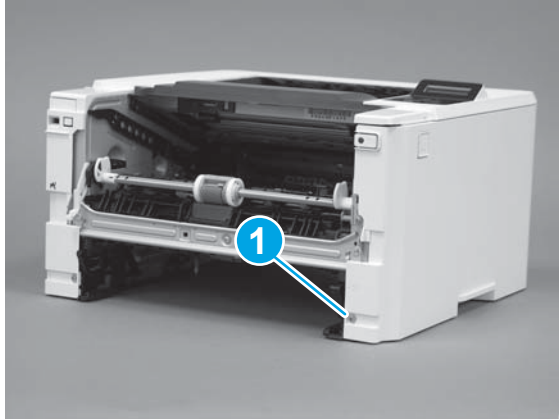
**Figure 1-371** Remove the cover



#### Step 4: Remove the right cover

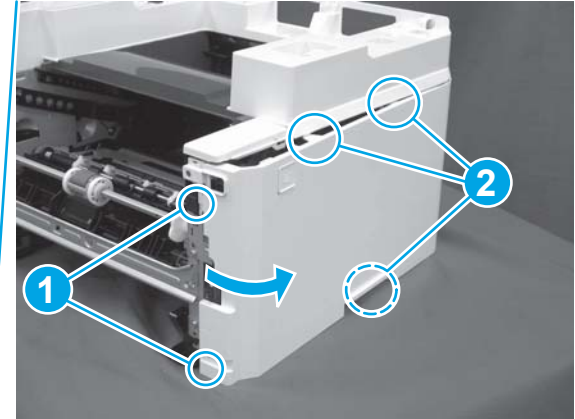
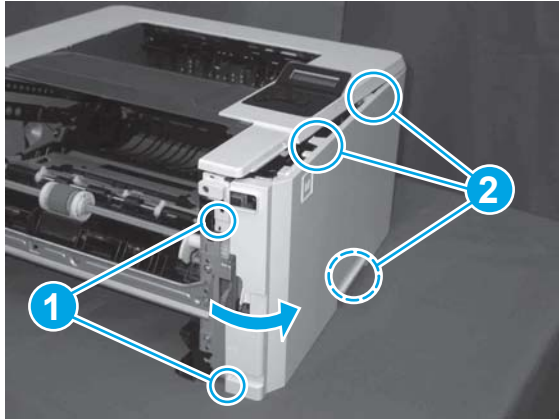
1. Remove one screw (callout 1).

**Figure 1-372** Remove one screw



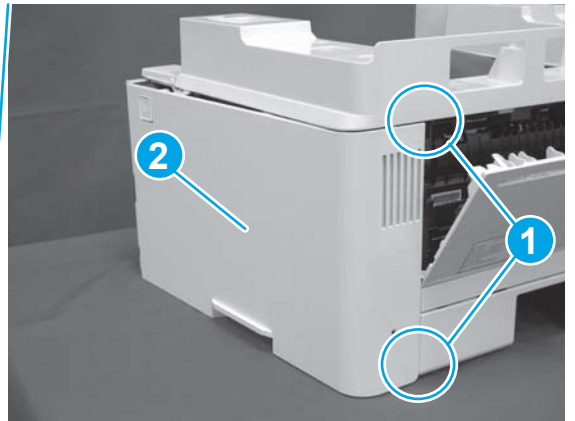
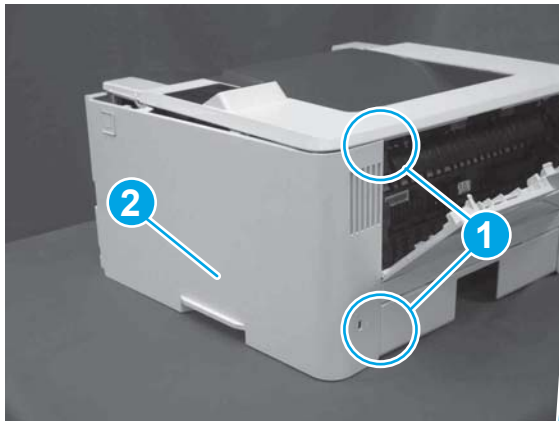
2. At the front of the printer, release two bosses (callout 1), and then release three tabs (callout 2).

**Figure 1-373** Release two bosses and three tabs



3. Open the rear door, release two bosses (callout 1), and then remove the cover (callout 2).

**Figure 1-374** Remove the cover



**Step 5: Remove the top cover (M403/M402)**

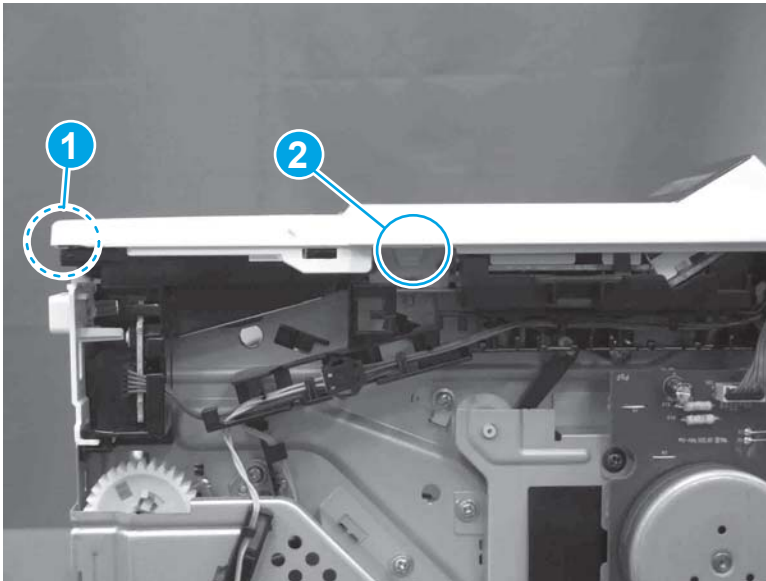
1. Remove one screw (callout 1).

**Figure 1-375** Remove one screw




2. At the right side of the printer, release the one boss (callout 1), and then release one tab (callout 2).

**Figure 1-376** Release one boss and one tab

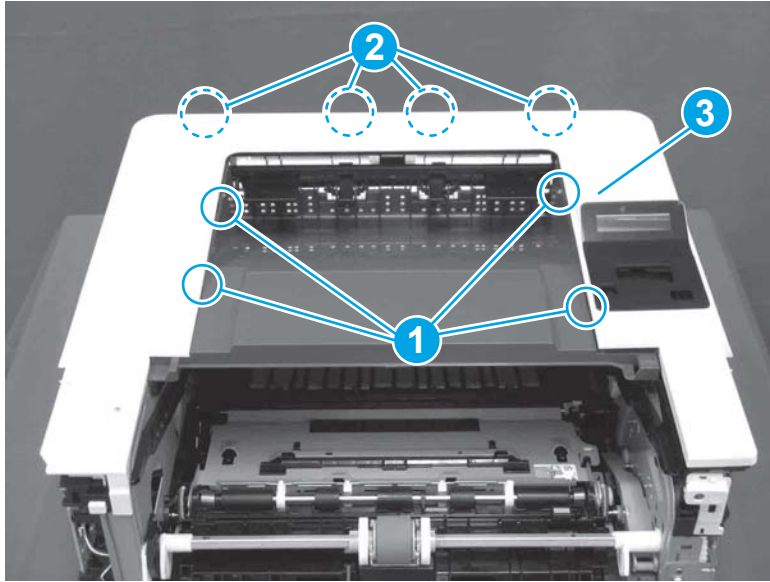




3. Release four tabs (callout 1), release four bosses (callout 2), and then remove the top cover (callout 3).

 **TIP:** Open the rear door to make releasing the bosses (callout 3) easier.

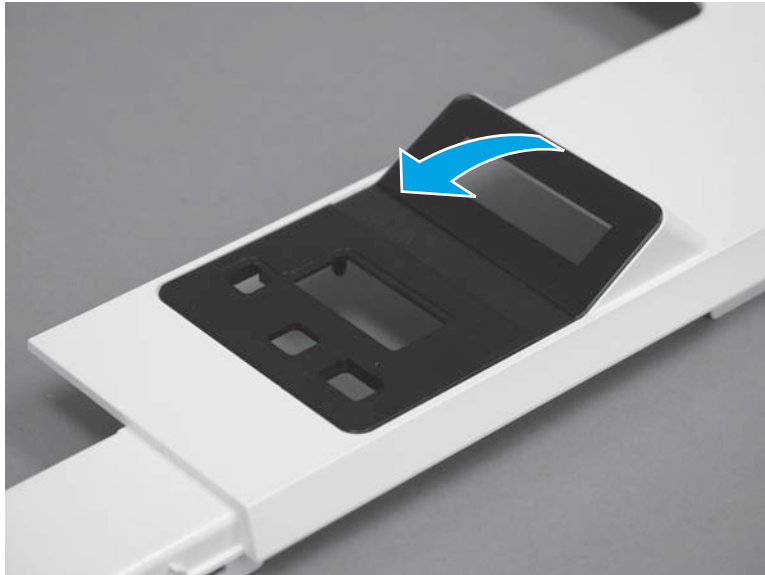
**Figure 1-377** Remove the cover



**Step 6: Remove the 2-line LCD operator and indication covers (M403/M402)**

1. Rotate the top edge of the operator cover away from the printer to release it.

**Figure 1-378** Rotate the top edge of the operator cover



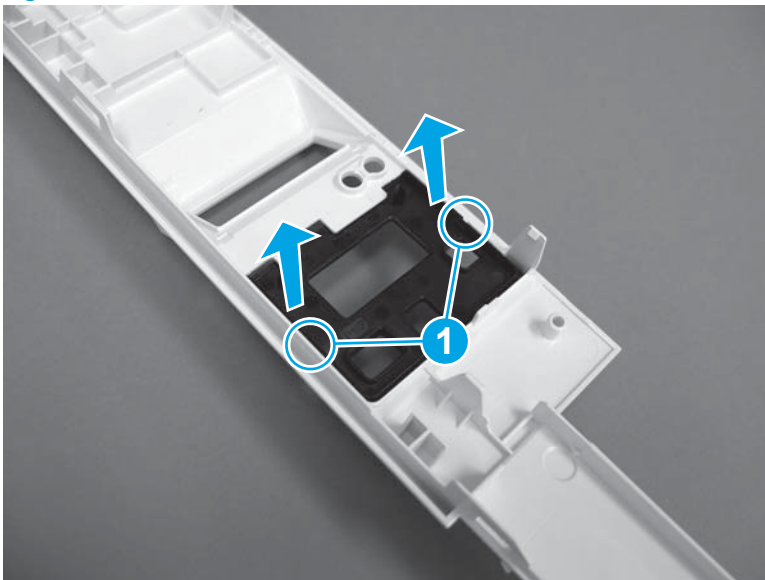
2. Remove the operator cover.

**Figure 1-379** Remove the cover



3. Turn the top cover over, release two tabs (callout 1), and then remove the indication cover.

**Figure 1-380** Remove the cover



### Step 7: Unpack the replacement assembly

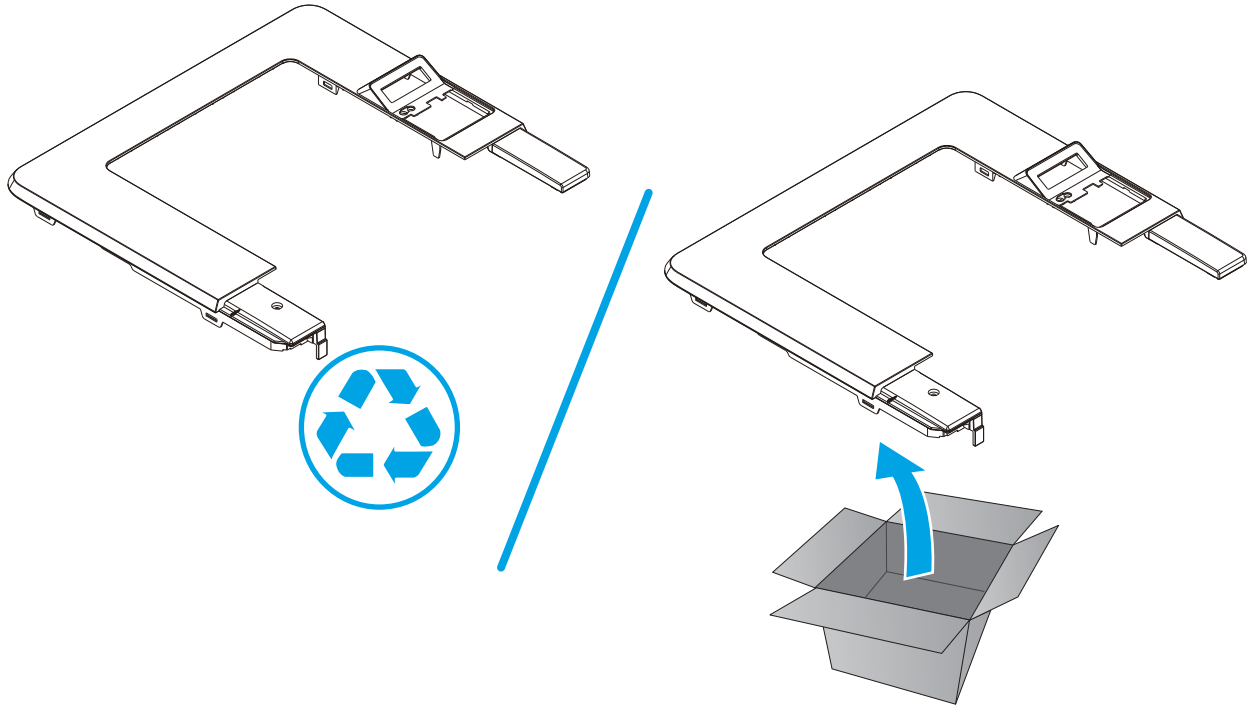
Unpack the replacement part from the packaging.

<http://www8.hp.com/us/en/hp-information/environment/product-recycling.html>



**NOTE:** HP recommends responsible disposal of the defective part.

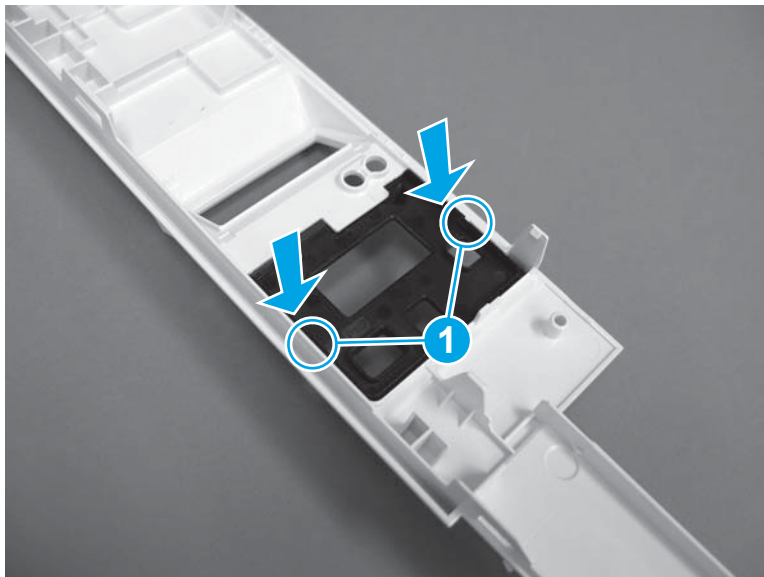
**Figure 1-381** Recycle and unpack



**Step 8: Install the 2-line LCD operator and indication covers (M403/M402)**

1. Position the indication cover on the top cover, and then make sure that the two tabs (callout 1) snap into place.

**Figure 1-382** Install the cover



2. Turn the top cover over, and then position the bottom edge of the operator cover with the tab (callout 1) under the indication cover (callout 2).

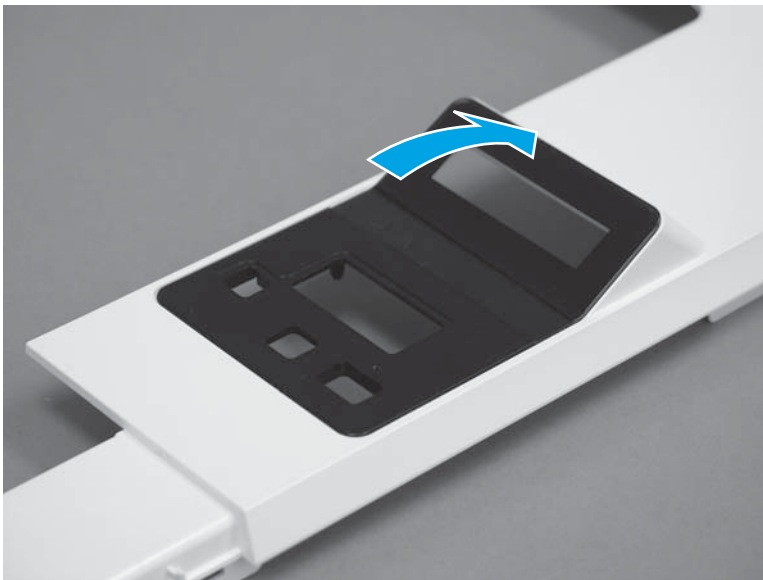
**Figure 1-383** Position the operator cover on the printer



3. Rotate the top edge of the cover towards from the printer to install it.

 **Reinstallation tip:** Use two-sided tape to secure the upper edge of the operator cover to the top cover.

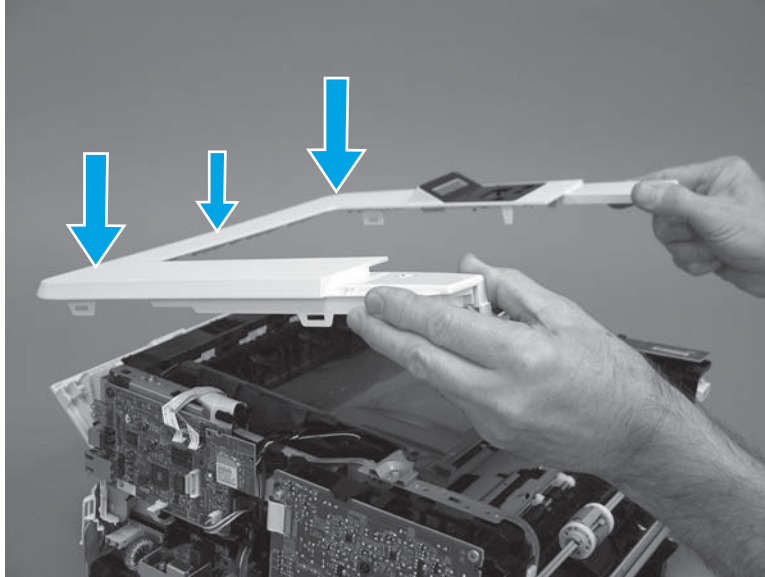
**Figure 1-384** Install the cover



### Step 9: Install the top cover (M403/M402)

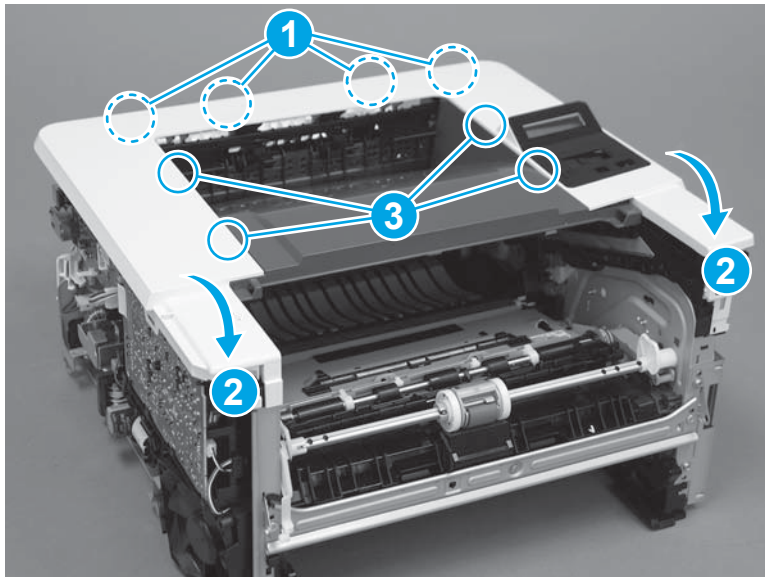
1. Position the rear edge of the cover on the printer.

**Figure 1-385** Install the cover



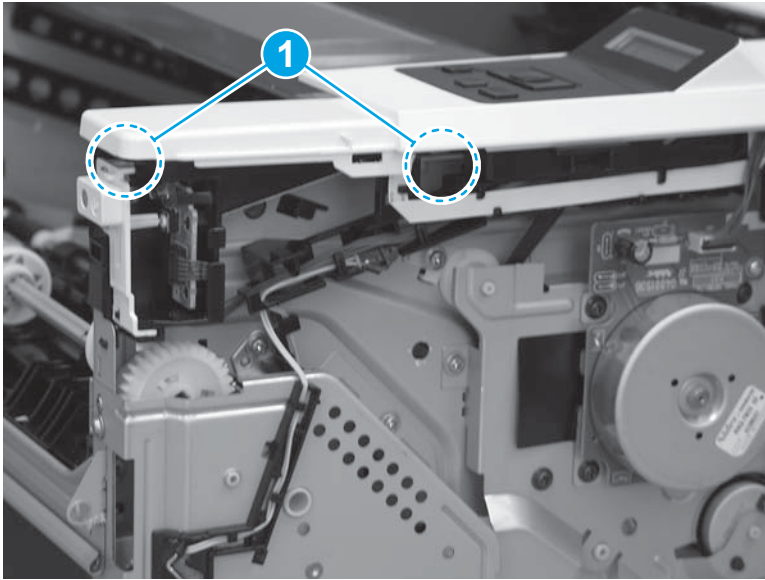
2. Engage four bosses (callout 1), rotate the front of the cover down (callout 2) and onto from the printer, and then engage four tabs (callout 3).

**Figure 1-386** Engage four bosses and tabs



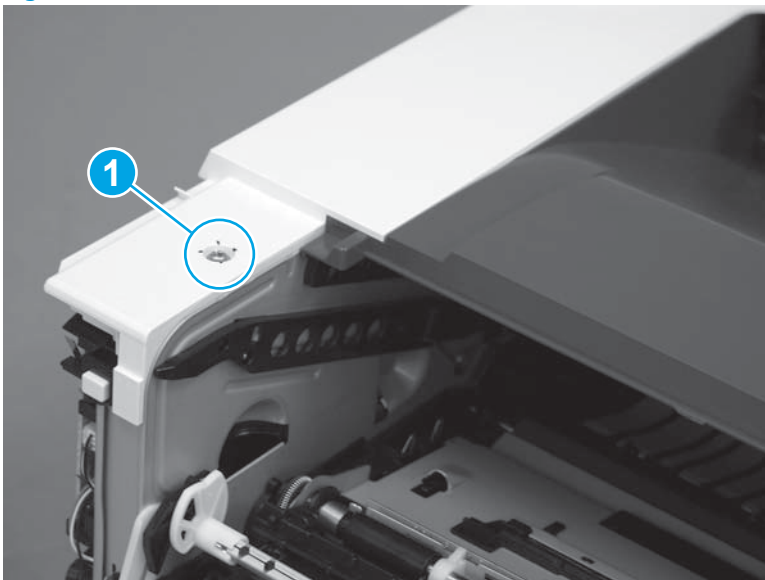
3. At the right side of the printer, engage the one boss and one tab (callout 1).

**Figure 1-387** Engage one boss and one tab



4. Install one screw (callout 1).

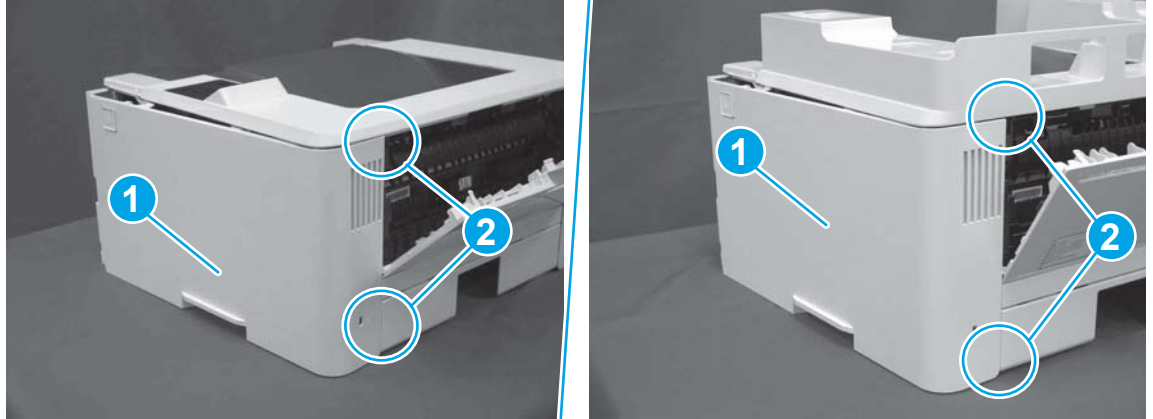
**Figure 1-388** Install one screw



### **Step 10: Install the right cover**

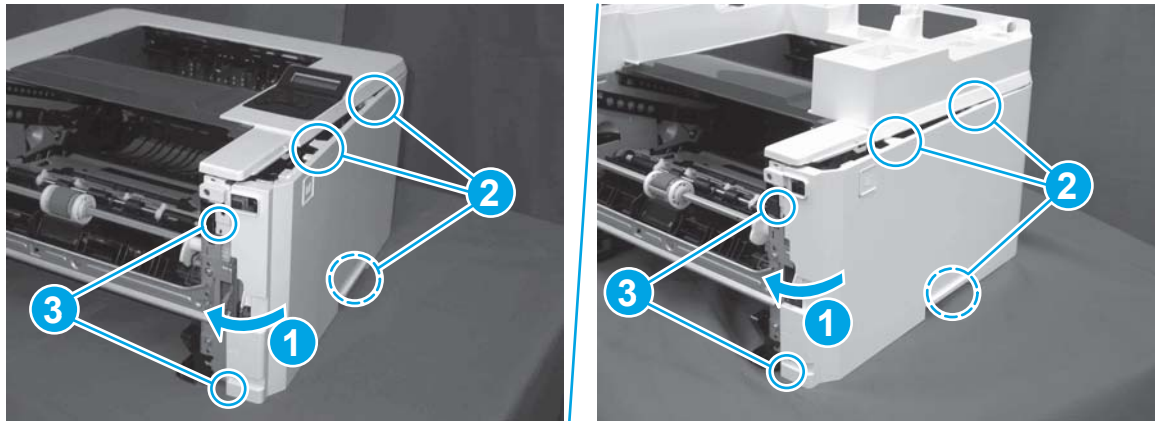
1. Position the cover (callout 1) on the printer, and then engage two bosses (callout 2).

**Figure 1-389** Install the cover



2. Rotate the front of the cover onto the printer (callout 1), engage three (callout 2) tabs, and then engage two bosses (callout 3).

**Figure 1-390** Engage two bosses and one tab

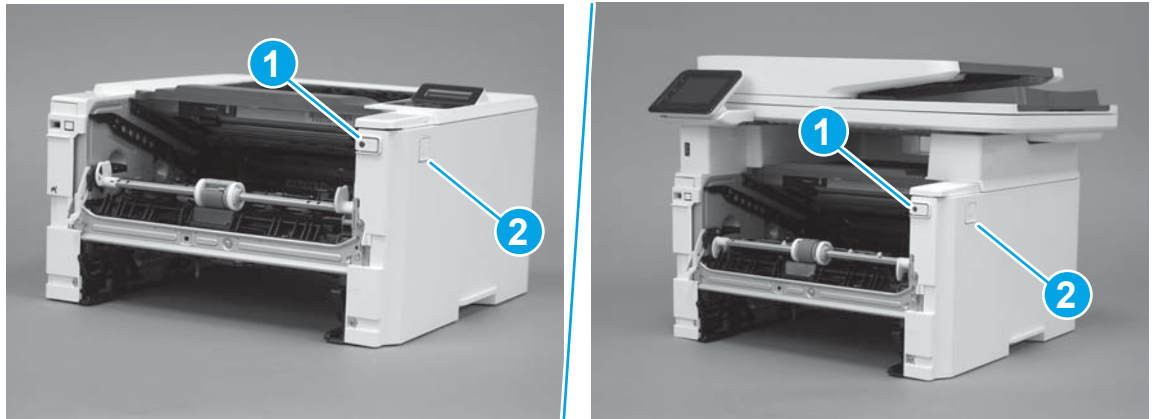


3. Make sure that the power switch (callout 1) and cartridge door assembly button (callout 2) correctly function.



**NOTE:** Remove, and then reinstall the cover if the switch or button does not correctly function.

**Figure 1-391** Check the power switch and cartridge door assembly button



4. Install one screw (callout 1).

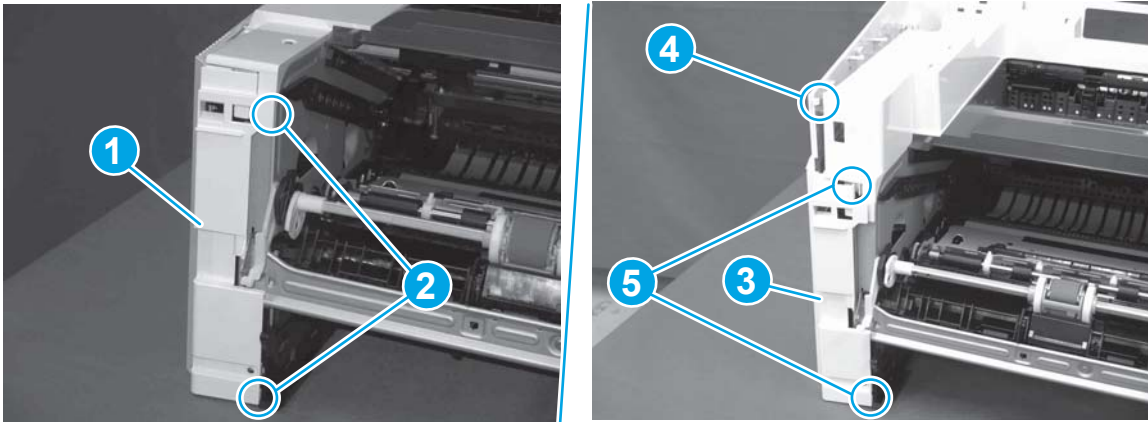
**Figure 1-392** Install one screw



### Step 11: Install the left cover

1. At the front of the printer, do one of the following:
  - **M403/M402:** Position the cover on the printer ( callout 1), and then engage two bosses (callout 2).
  - **M427/M426:** Position the cover on the printer (callout 3), engage one tab (callout 4), and then engage two bosses (callout 4).

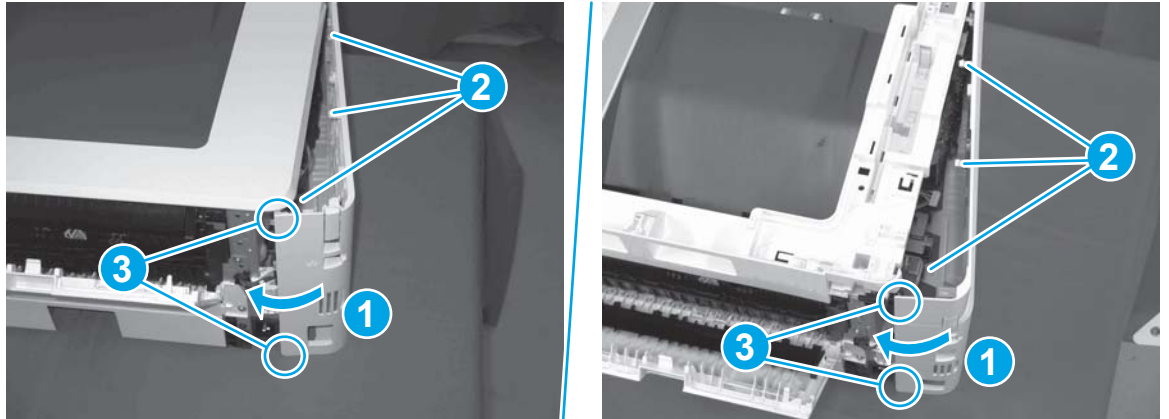
**Figure 1-393** Install the cover





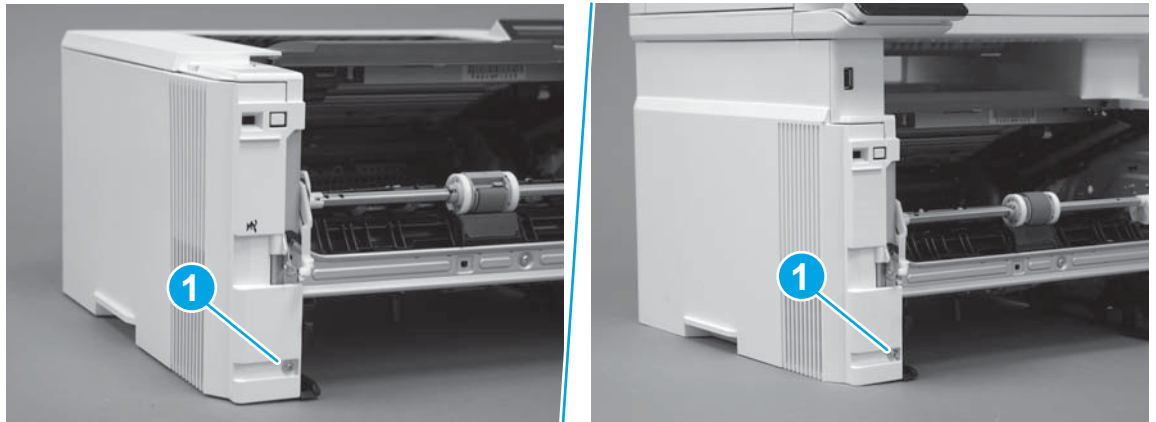
- Carefully rotate the rear of the cover onto the printer (callout 1), engage three tabs (callout 2), and then engage two bosses (callout 3).

**Figure 1-394** Engage three tabs and two bosses




- Install one screw (callout 1).

**Figure 1-395** Install one screw

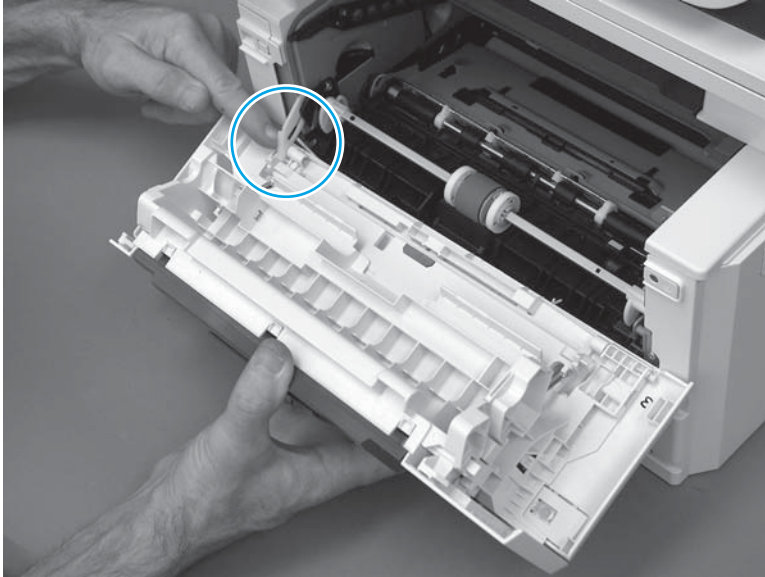


## Step 12: Install the cartridge door assembly

 **Reinstallation tip:** After a replacement door is installed, make sure to install the nameplate (supplied in the kit) corresponding to the printer name on the door.

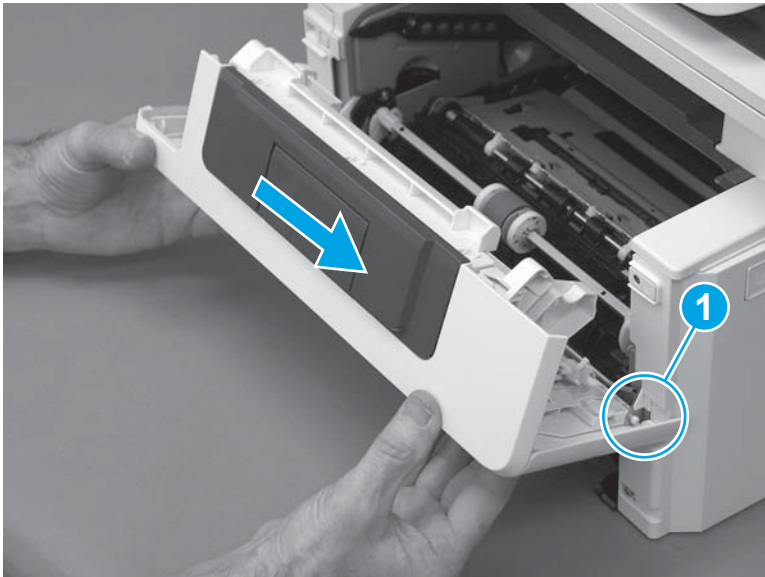
- Position the door close to the printer, and then engage the keyed pin on the left-side retainer arm with the hole in the door.

**Figure 1-396** Engage the left-side retainer arm



2. Engage the right-side door hinge pin with the hole in the chassis (callout 1).

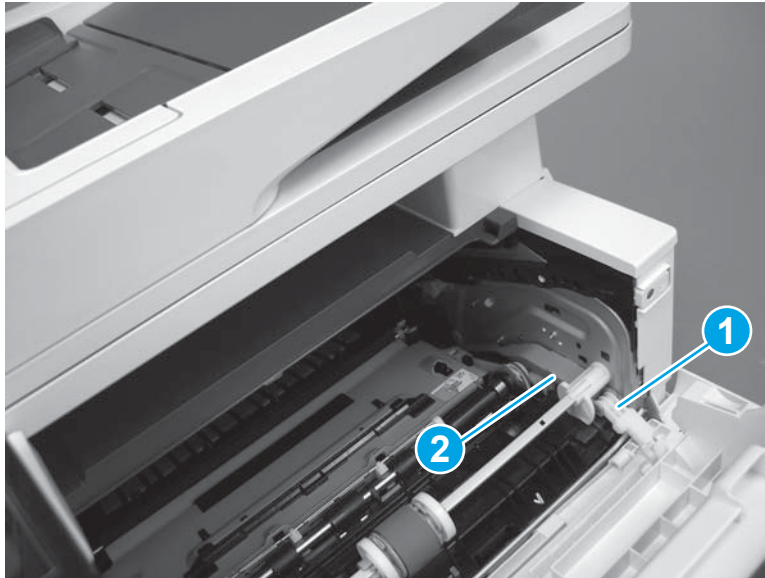
**Figure 1-397** Install the door



3. Install the link (callout 1).

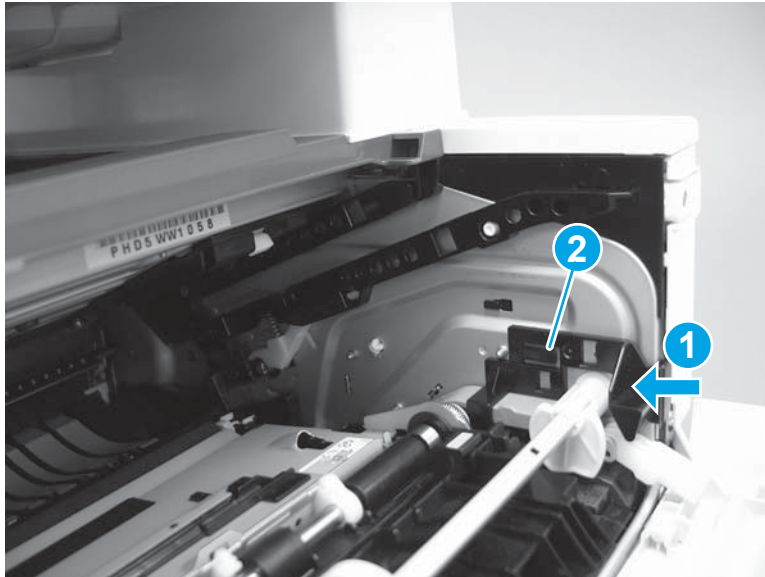
 **IMPORTANT:** Make sure that the link snaps into place on the arm (callout 2). The link actuates the fuser pressure-release mechanism.

**Figure 1-398** Install the pressure-release link



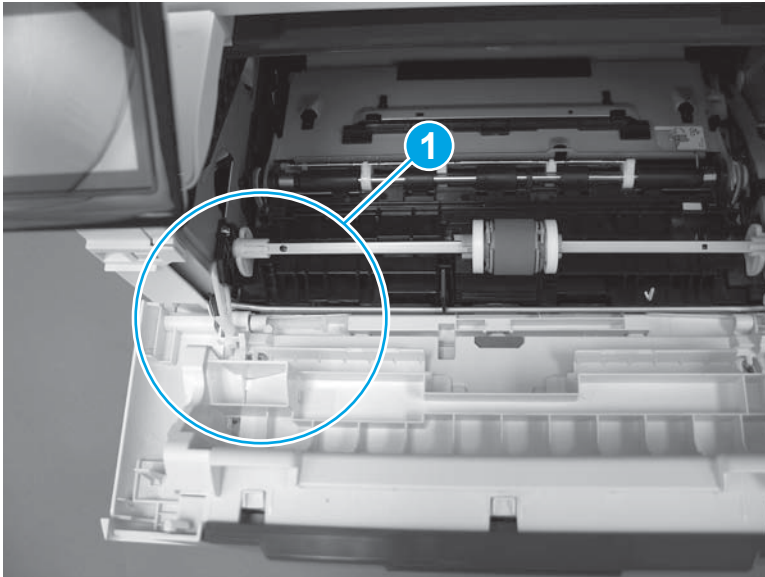
4. Slide the guide into the printer (callout 1), and then make sure that the tab (callout 2) snaps into place to secure the guide to the chassis.

**Figure 1-399** Install the guide




5. Position the shaft on the door, and then align the left-side hinge on the door with the hole in the chassis (callout 1).

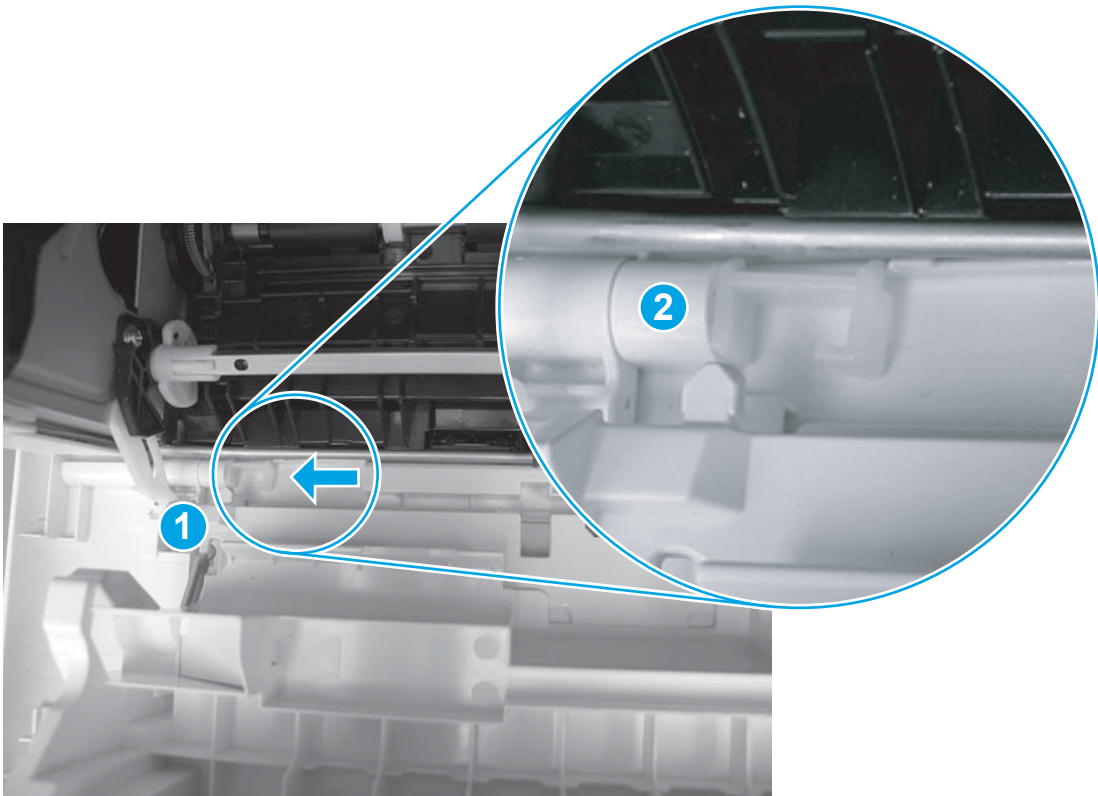
**Figure 1-400** Align the hinge



6. Push the shaft towards the left side of the printer to install it (callout 1).

 **Reinstallation tip:** Make sure that the support shaft is fully installed and correctly orientated (callout 2) so that it will not interfere with the door opening and closing.

**Figure 1-401** Install the support shaft



### Step 13: Install Tray 2

- ▲ Slide the tray straight into the printer to install it.

**Figure 1-402** Install the tray



## Removal and replacement: 2-line LCD operator and indication covers (M403/M402)

- [Introduction](#)
- [Step 1: Remove Tray 2](#)
- [Step 2: Remove the cartridge door assembly](#)
- [Step 3: Remove the left cover](#)
- [Step 4: Remove the right cover](#)
- [Step 5: Remove the top cover \(M403/M402\)](#)
- [Step 6: Remove the 2-line LCD operator and indication covers \(M403/M402\)](#)
- [Step 7: Unpack the replacement assembly](#)
- [Step 8: Install the 2-line LCD operator and indication covers \(M403/M402\)](#)
- [Step 9: Install the top cover \(M403/M402\)](#)
- [Step 10: Install the right cover](#)
- [Step 11: Install the left cover](#)
- [Step 12: Install the cartridge door assembly](#)
- [Step 13: Install Tray 2](#)


### Introduction

This document provides the procedures to remove and replace the 2-line LCD operator and indication covers.

### Before performing service

#### Turn the printer power off

- Disconnect the power cable.

 **WARNING!** To avoid damage to the printer, turn the printer off, wait 30 seconds, and then remove the power cable before attempting to service the printer.

Use the table below to identify the correct part number for your printer. To order the part, go to [www.hp.com/buy/parts](http://www.hp.com/buy/parts).

2-line LCD operator and indication covers (M403/M402) part number	
RC4-3312-000CN	2-line LCD operator cover (M403/M402; non-wireless models)
RC4-3322-000CN	2-line LCD operator cover (M402dw; wireless model)
RL2-0675-000CN	2-line LCD indication cover (M403/M402)

### Required tools

- #2 Phillips screwdriver with a magnetic tip.

## After performing service

### Turn the printer power on

- Connect the power cable.
- Use the power switch to turn the power on.

### Post service test

Make sure that the printer initializes to a **Ready** state.

Print a configuration page to make sure that the printer is functioning correctly.

### Step 1: Remove Tray 2

- ▲ Pull the tray straight out of the printer to remove it.

**Figure 1-403** Remove the tray



### Step 2: Remove the cartridge door assembly



---

**NOTE:** If the toner cartridge was not removed prior to servicing the printer, remove it now.

---

1. Release one tab (callout 1), and then slide shaft (callout 2) in the direction the arrow indicates and remove it.

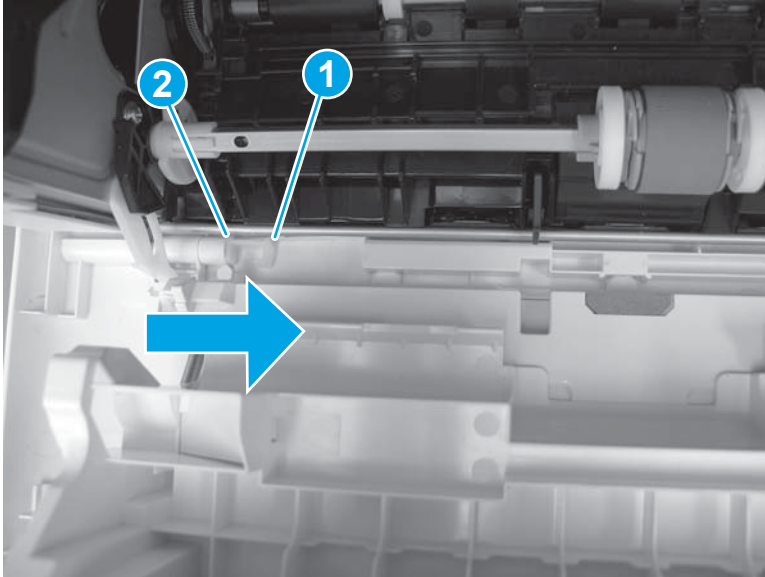


---

**TIP:** It might be easier to release the support shaft by using a small flat-blade screwdriver.

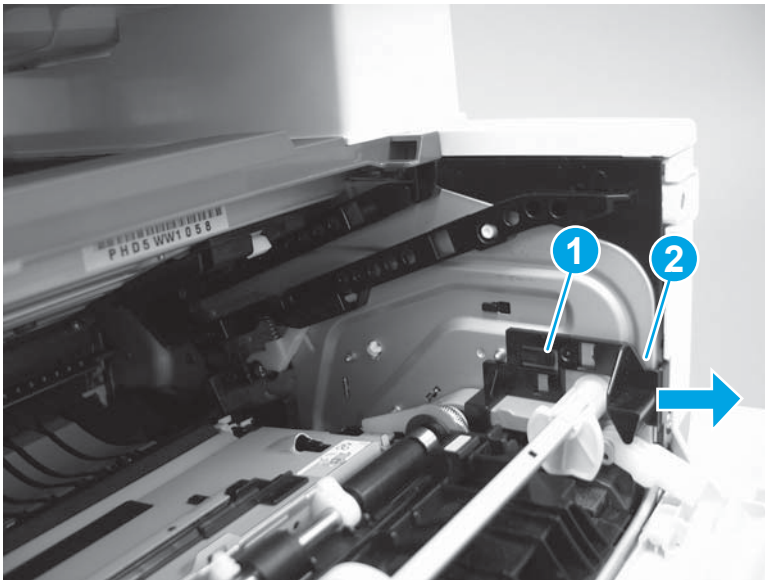
---

**Figure 1-404** Release the support shaft



2. Release one tab (callout 1), and then slide the guide (callout 2) in the direction the arrow indicates and remove it.

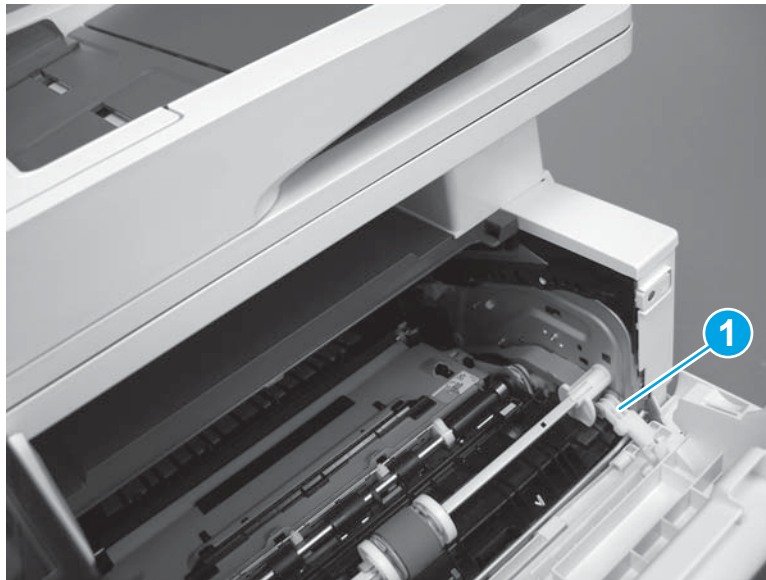
**Figure 1-405** Remove the guide





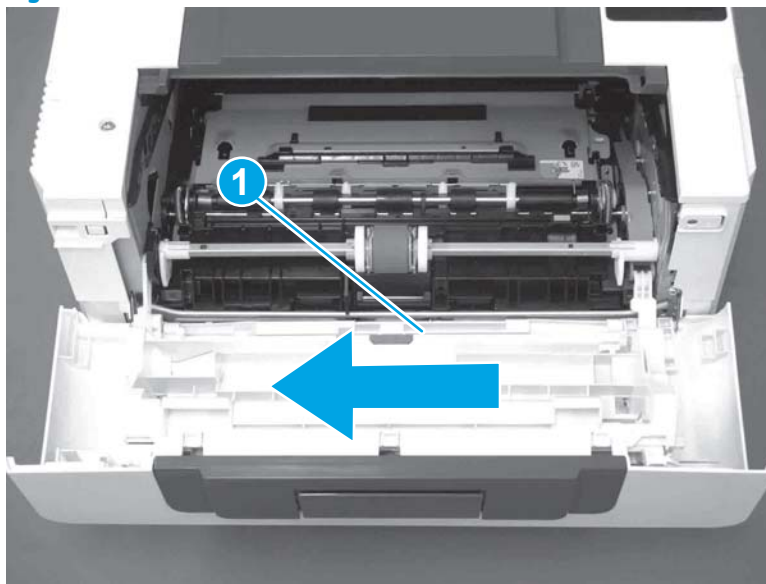
3. Remove the link arm (callout 1).

**Figure 1-406** Remove the link arm



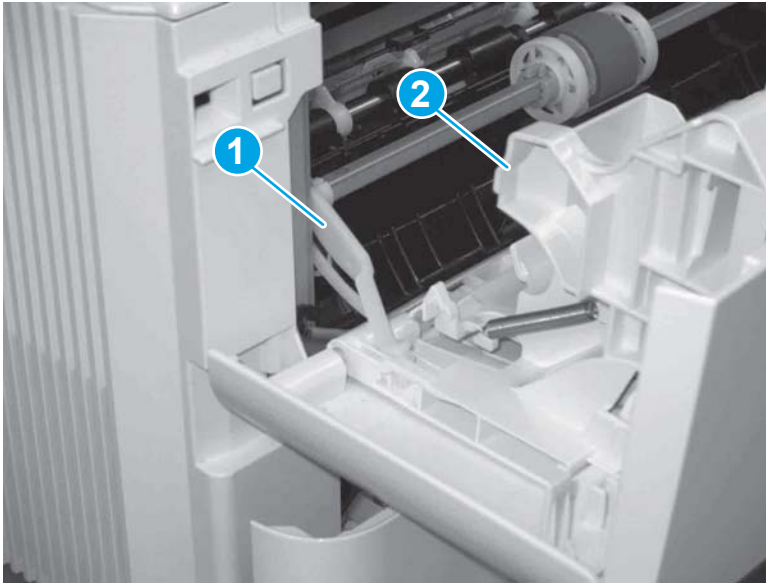
4. Slide the cartridge door assembly (callout 1) in the direction the arrow indicates and remove it.

**Figure 1-407** Remove the door



5. Remove the link (callout 1) from the cartridge door assembly (callout 2).

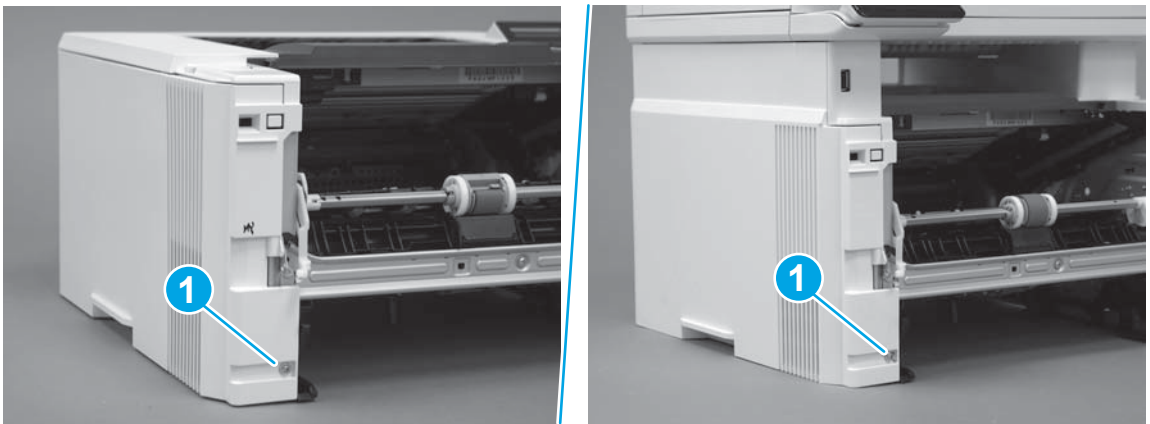
**Figure 1-408** Release the left-side retainer arm



### Step 3: Remove the left cover

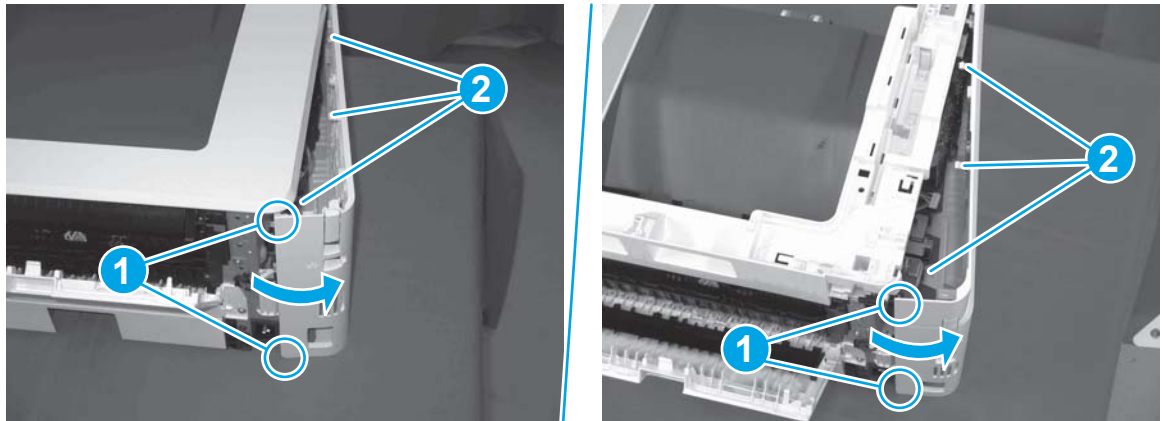
1. Remove one screw (callout 1).

**Figure 1-409** Remove one screw



2. Open the rear door, release two bosses (callout 1), and then release three tabs (callout 2).

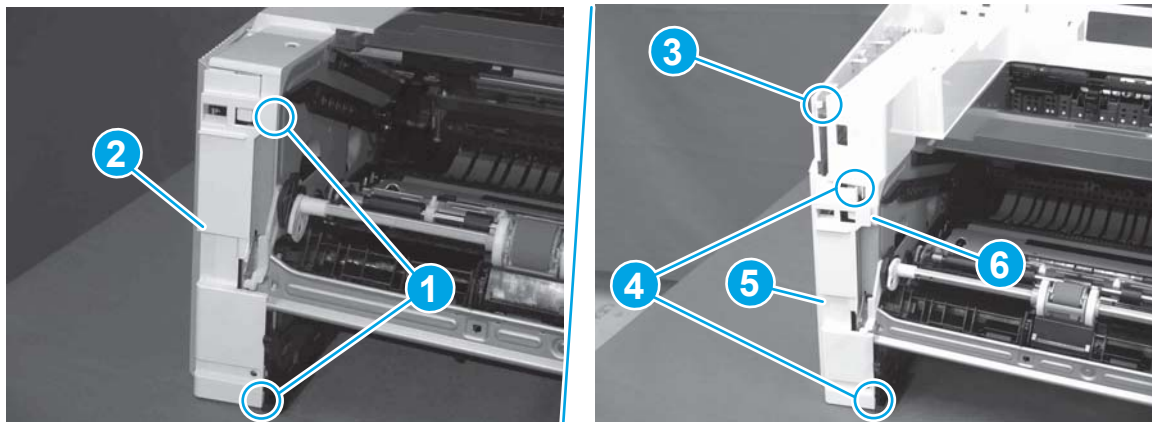
**Figure 1-410** Release two bosses and three tabs



3. At the front of the printer, do one of the following:
  - **M403/M402:** Release two bosses (callout 1), and then remove the cover (callout 2).
  - **M427/M426:** Release one tab (callout 3), two bosses (callout 4), and then remove the cover (callout 5).

**CAUTION:** Be careful when releasing the upper bosses on the M427/M426 cover. One portion of the cover (callout 6) is fragile and is easily broken.

**Figure 1-411** Remove the cover



#### Step 4: Remove the right cover

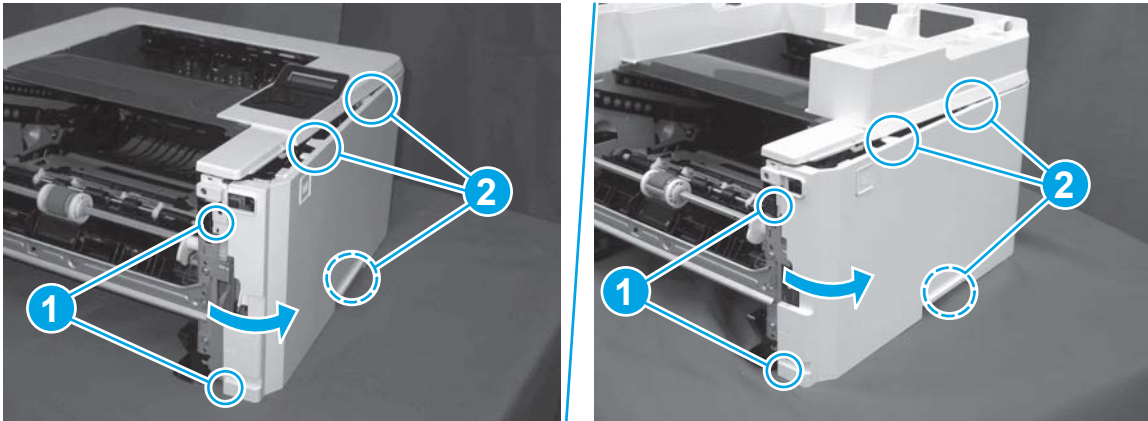
1. Remove one screw (callout 1).

**Figure 1-412** Remove one screw



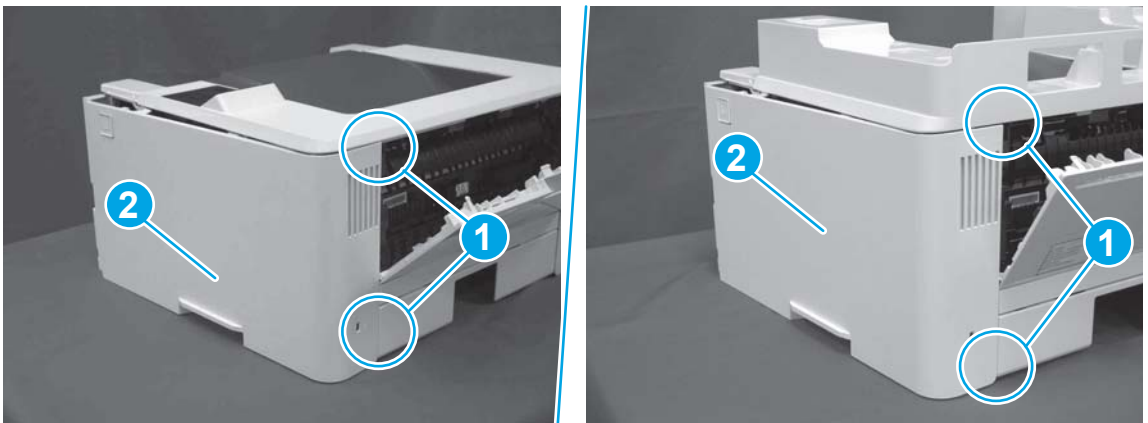
2. At the front of the printer, release two bosses (callout 1), and then release three tabs (callout 2).

**Figure 1-413** Release two bosses and three tabs



3. Open the rear door, release two bosses (callout 1), and then remove the cover (callout 2).

**Figure 1-414** Remove the cover



**Step 5: Remove the top cover (M403/M402)**

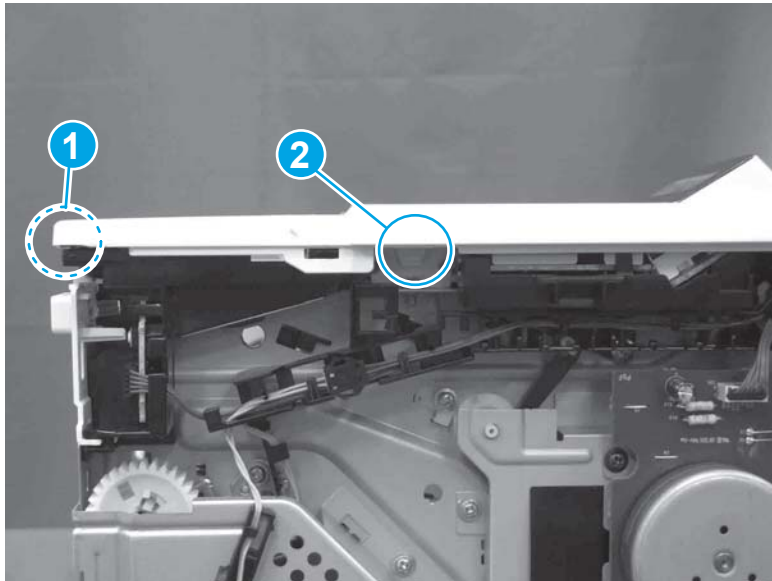
1. Remove one screw (callout 1).

**Figure 1-415** Remove one screw




2. At the right side of the printer, release the one boss (callout 1), and then release one tab (callout 2).

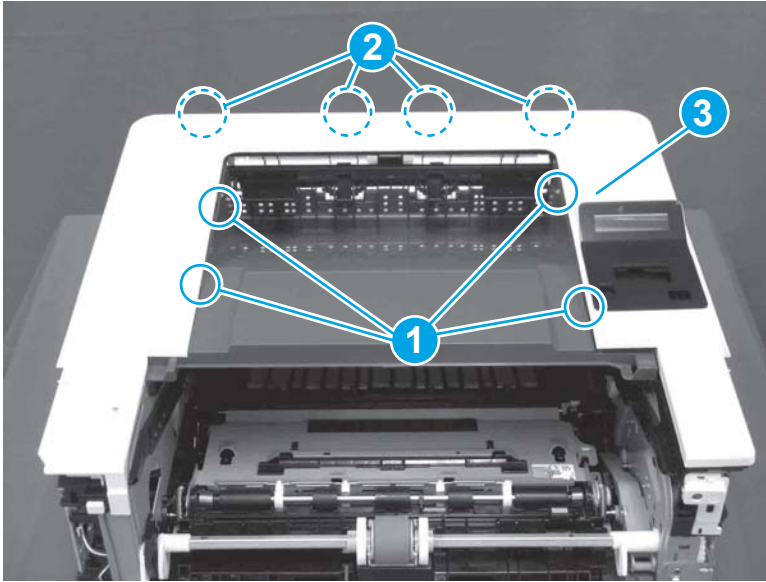
**Figure 1-416** Release one boss and one tab



3. Release four tabs (callout 1), release four bosses (callout 2), and then remove the top cover (callout 3).

 **TIP:** Open the rear door to make releasing the bosses (callout 3) easier.

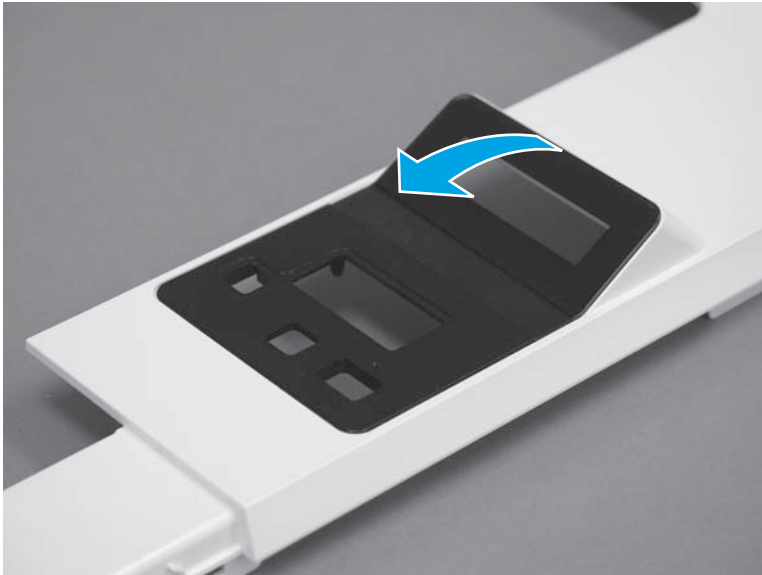
**Figure 1-417** Remove the cover



**Step 6: Remove the 2-line LCD operator and indication covers (M403/M402)**

1. Rotate the top edge of the operator cover away from the printer to release it.

**Figure 1-418** Rotate the top edge of the operator cover



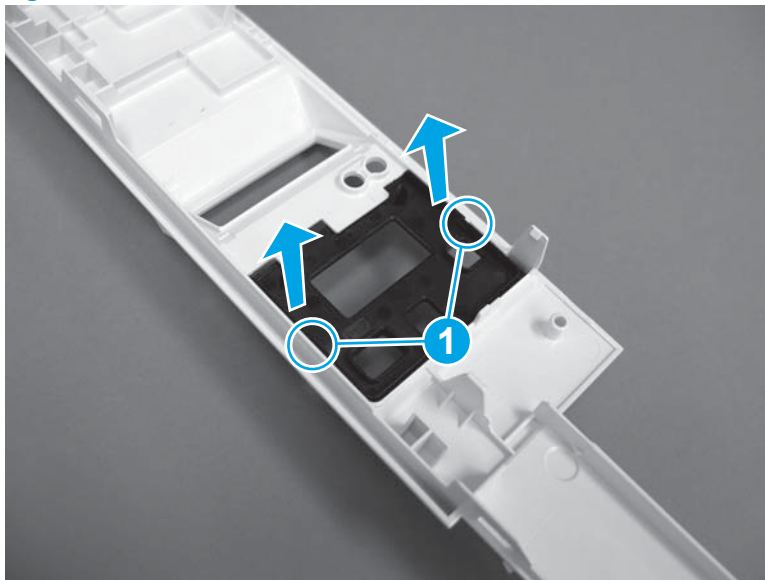
2. Remove the operator cover.

**Figure 1-419** Remove the cover



3. Turn the top cover over, release two tabs (callout 1), and then remove the indication cover.

**Figure 1-420** Remove the cover



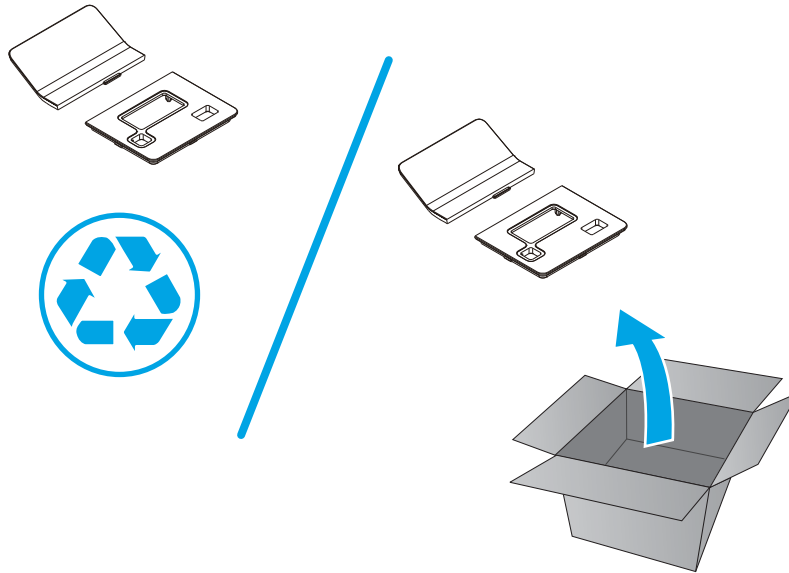
### Step 7: Unpack the replacement assembly

Unpack the replacement part from the packaging.

<http://www8.hp.com/us/en/hp-information/environment/product-recycling.html>

 **NOTE:** HP recommends responsible disposal of the defective part.

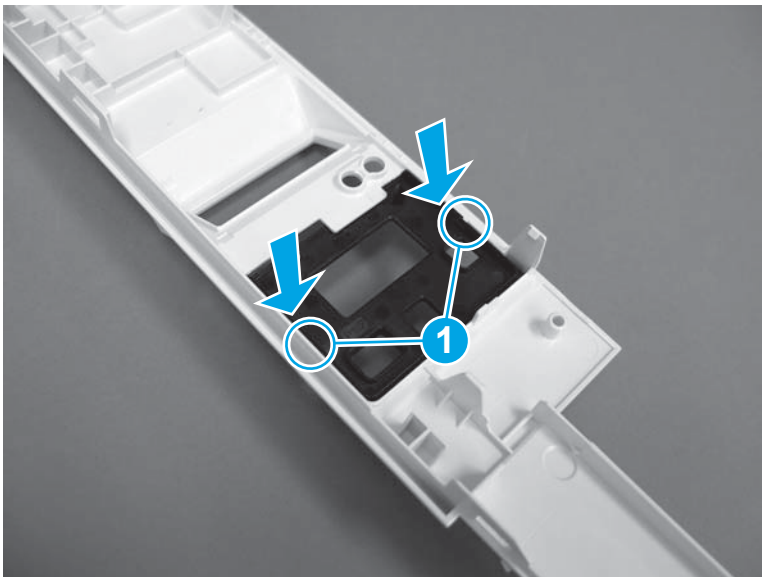
**Figure 1-421** Recycle and unpack



**Step 8: Install the 2-line LCD operator and indication covers (M403/M402)**

1. Position the indication cover on the top cover, and then make sure that the two tabs (callout 1) snap into place.

**Figure 1-422** Install the cover






2. Turn the top cover over, and then position the bottom edge of the operator cover with the tab (callout 1) under the indication cover (callout 2).

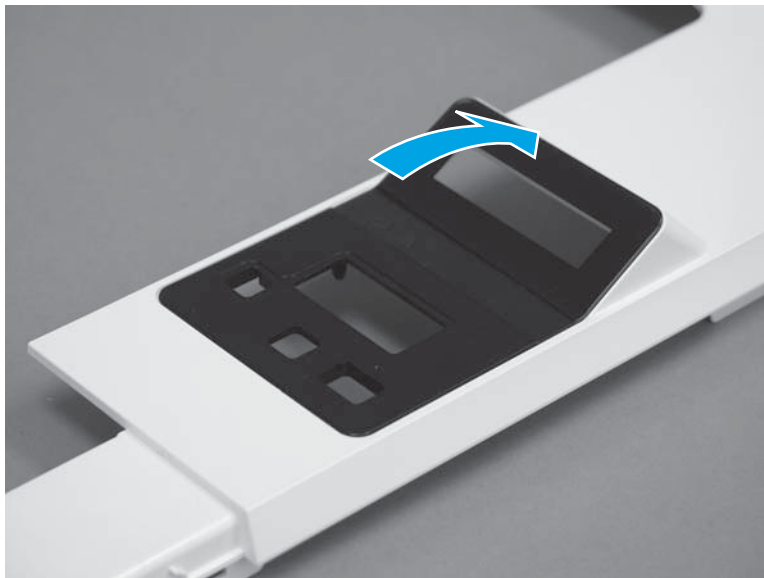
**Figure 1-423** Position the operator cover on the printer



3. Rotate the top edge of the cover towards from the printer to install it.

 **Reinstallation tip:** Use two-sided tape to secure the upper edge of the operator cover to the top cover.

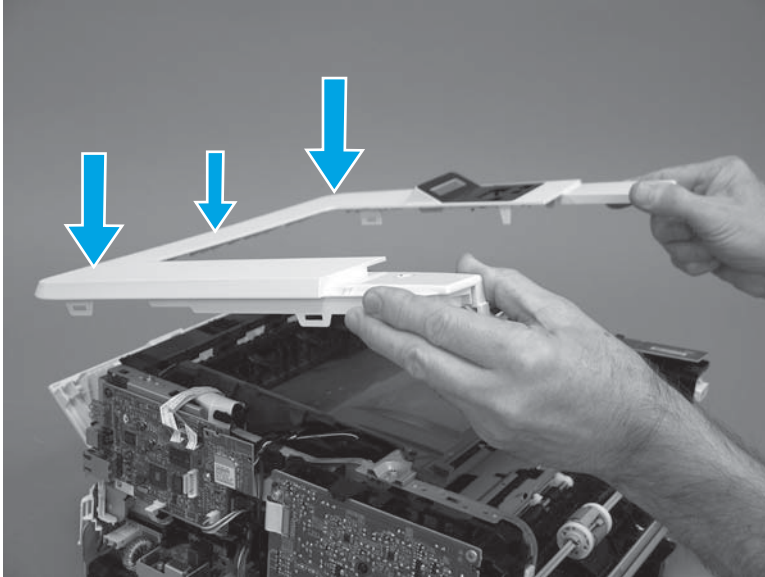
**Figure 1-424** Install the cover



### Step 9: Install the top cover (M403/M402)

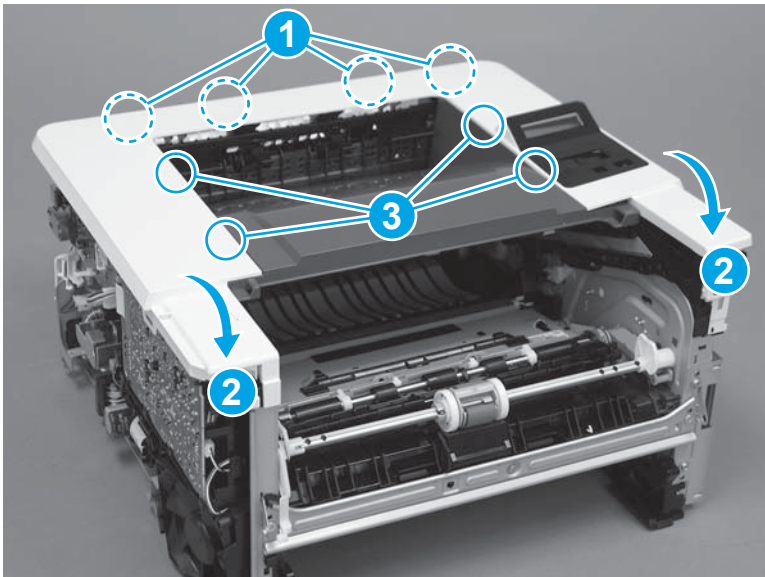
1. Position the rear edge of the cover on the printer.

**Figure 1-425** Install the cover



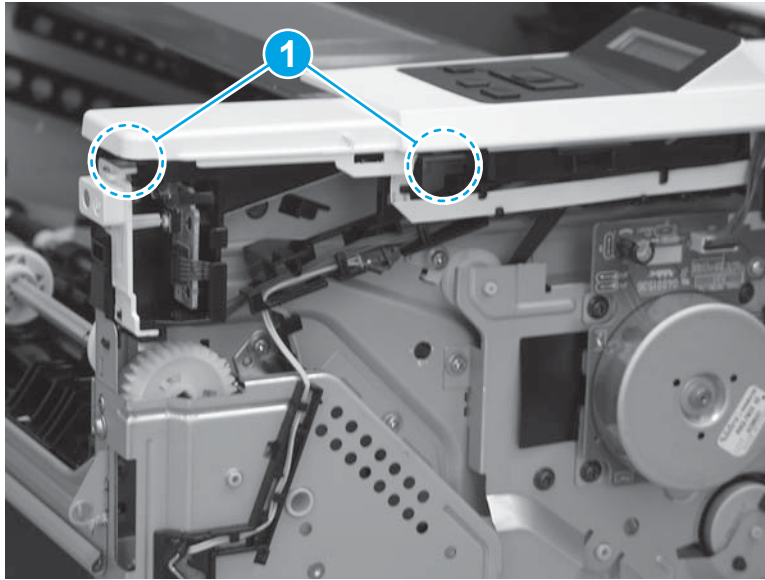
2. Engage four bosses (callout 1), rotate the front of the cover down (callout 2) and onto from the printer, and then engage four tabs (callout 3).

**Figure 1-426** Engage four bosses and tabs



3. At the right side of the printer, engage the one boss and one tab (callout 1).

**Figure 1-427** Engage one boss and one tab



4. Install one screw (callout 1).

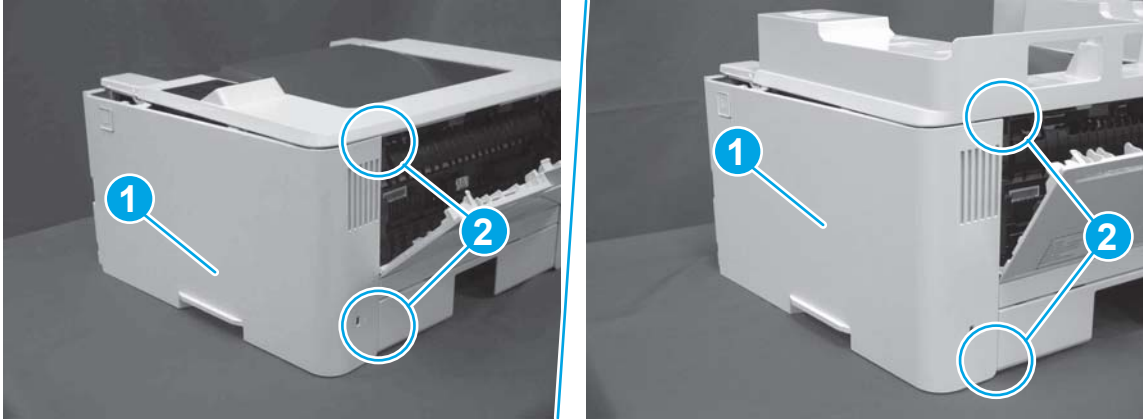
**Figure 1-428** Install one screw



### Step 10: Install the right cover

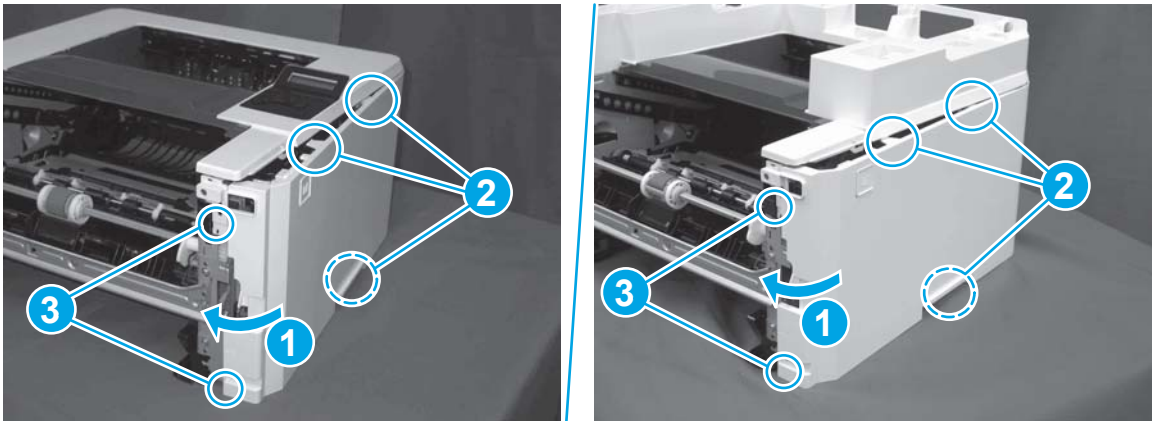
1. Position the cover (callout 1) on the printer, and then engage two bosses (callout 2).

**Figure 1-429** Install the cover




2. Rotate the front of the cover onto the printer (callout 1), engage three (callout 2) tabs, and then engage two bosses (callout 3).

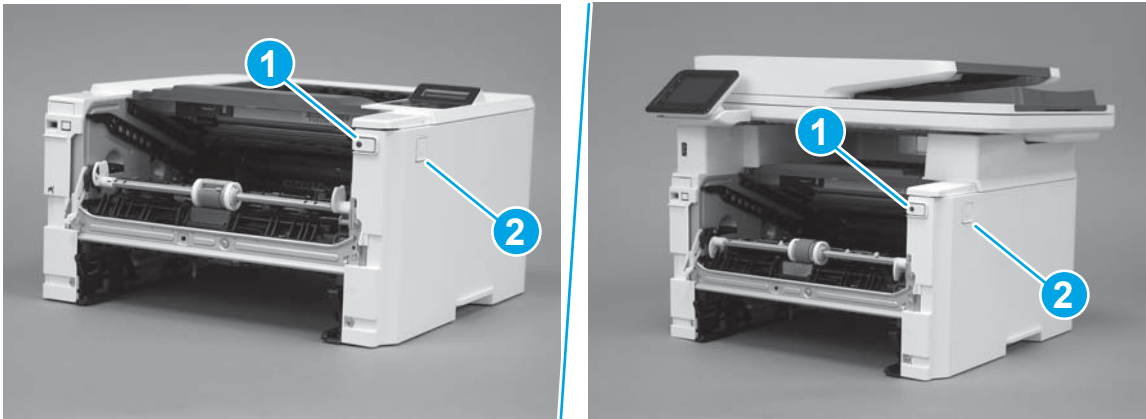
**Figure 1-430** Engage two bosses and one tab



3. Make sure that the power switch (callout 1) and cartridge door assembly button (callout 2) correctly function.

 **NOTE:** Remove, and then reinstall the cover if the switch or button does not correctly function.

**Figure 1-431** Check the power switch and cartridge door assembly button



4. Install one screw (callout 1).

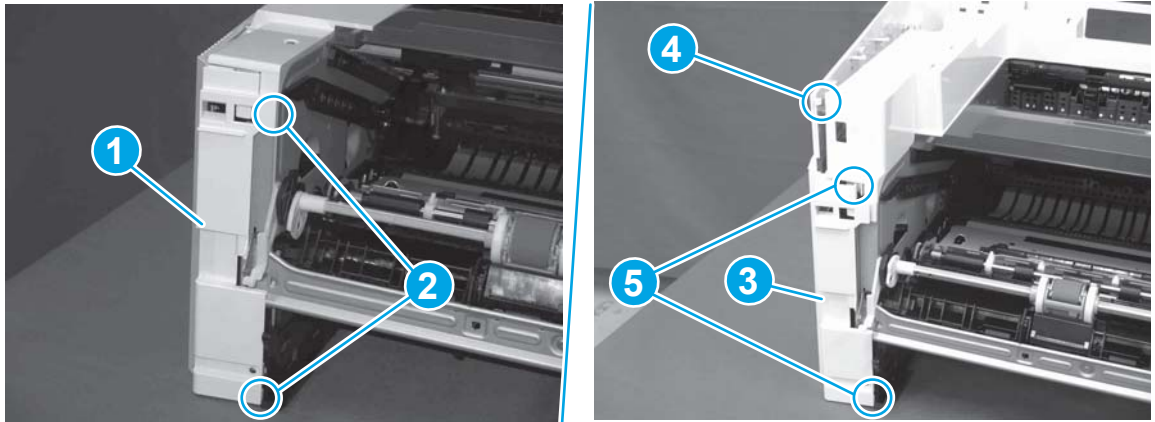
**Figure 1-432** Install one screw



### Step 11: Install the left cover

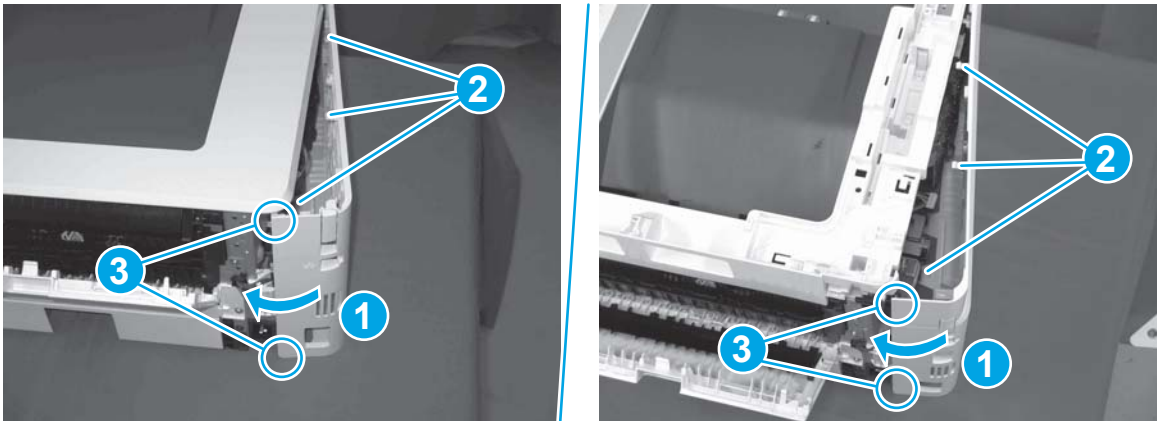
1. At the front of the printer, do one of the following:
  - **M403/M402:** Position the cover on the printer ( callout 1), and then engage two bosses (callout 2).
  - **M427/M426:** Position the cover on the printer (callout 3), engage one tab (callout 4), and then engage two bosses (callout 4).

**Figure 1-433** Install the cover



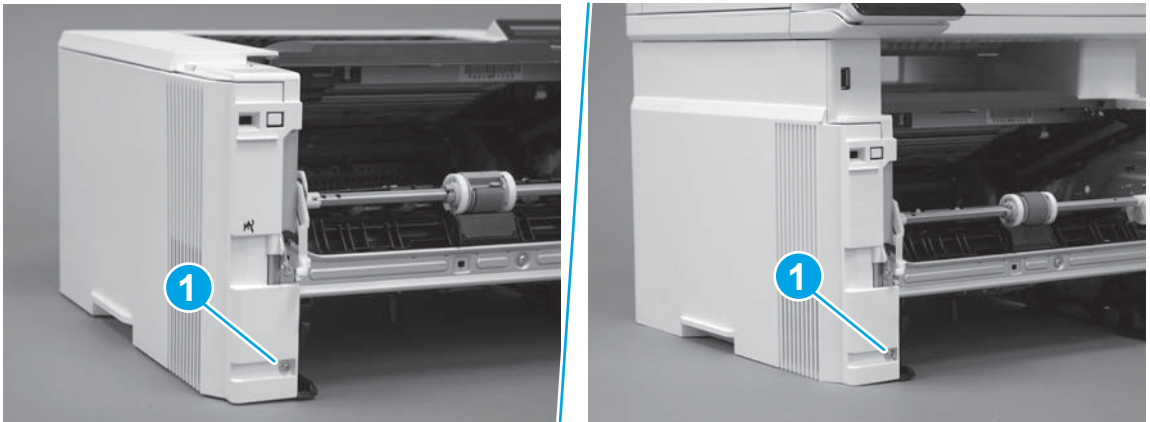
- Carefully rotate the rear of the cover onto the printer (callout 1), engage three tabs (callout 2), and then engage two bosses (callout 3).

**Figure 1-434** Engage three tabs and two bosses




- Install one screw (callout 1).

**Figure 1-435** Install one screw

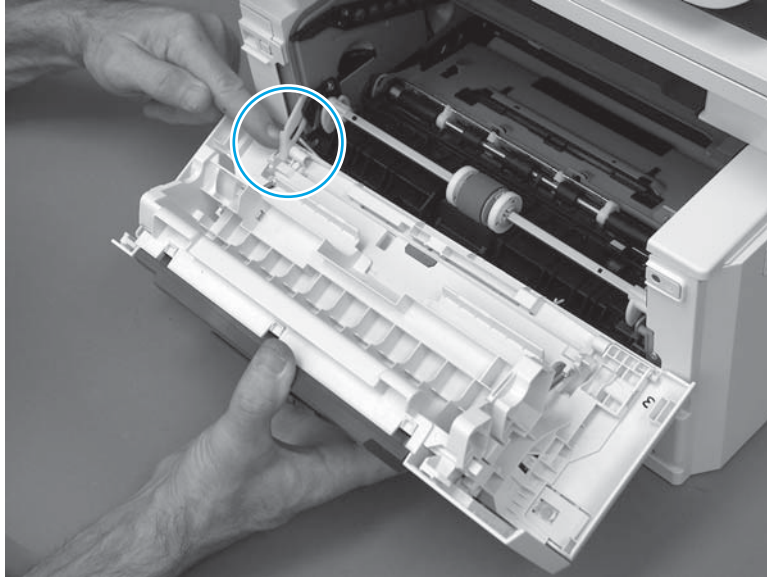


## Step 12: Install the cartridge door assembly

 **Reinstallation tip:** After a replacement door is installed, make sure to install the nameplate (supplied in the kit) corresponding to the printer name on the door.

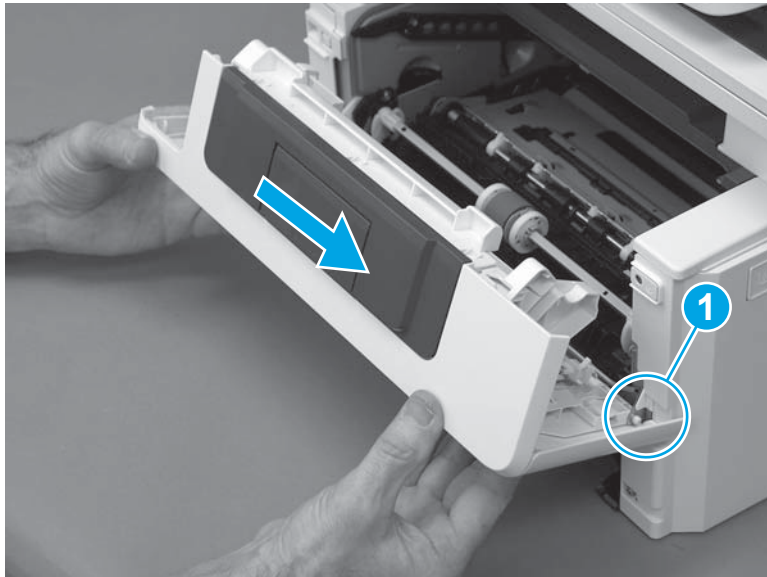
- Position the door close to the printer, and then engage the keyed pin on the left-side retainer arm with the hole in the door.

**Figure 1-436** Engage the left-side retainer arm



2. Engage the right-side door hinge pin with the hole in the chassis (callout 1).

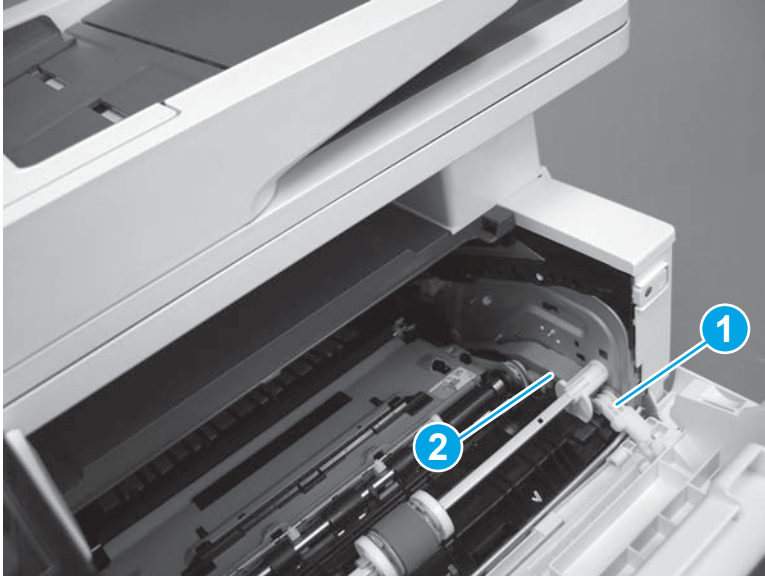
**Figure 1-437** Install the door



3. Install the link (callout 1).

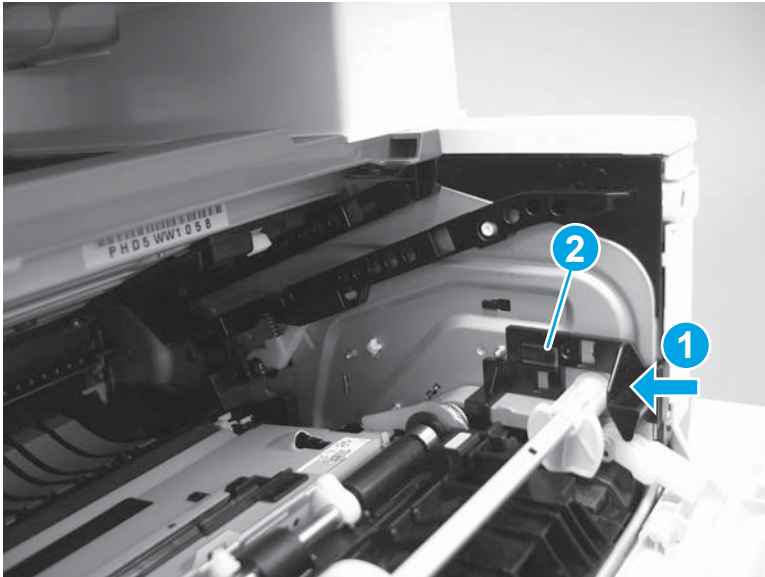
 **IMPORTANT:** Make sure that the link snaps into place on the arm (callout 2). The link actuates the fuser pressure-release mechanism.

**Figure 1-438** Install the pressure-release link



4. Slide the guide into the printer (callout 1), and then make sure that the tab (callout 2) snaps into place to secure the guide to the chassis.

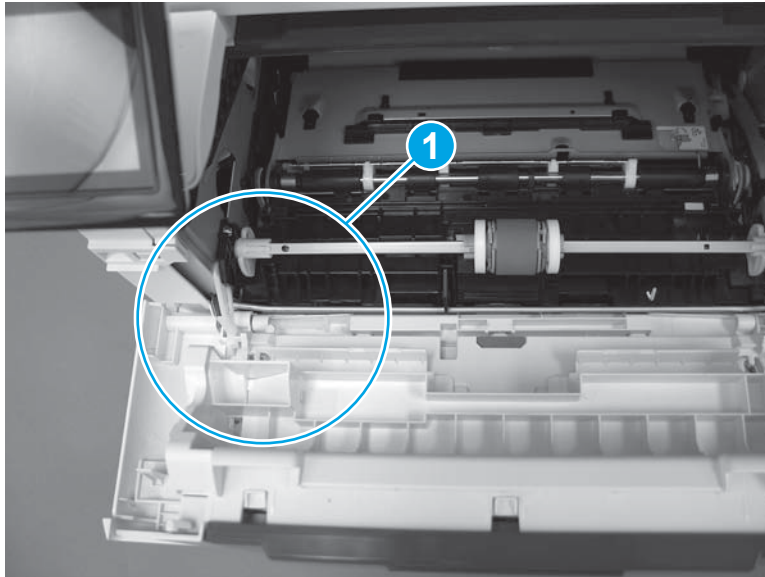
**Figure 1-439** Install the guide






5. Position the shaft on the door, and then align the left-side hinge on the door with the hole in the chassis (callout 1).

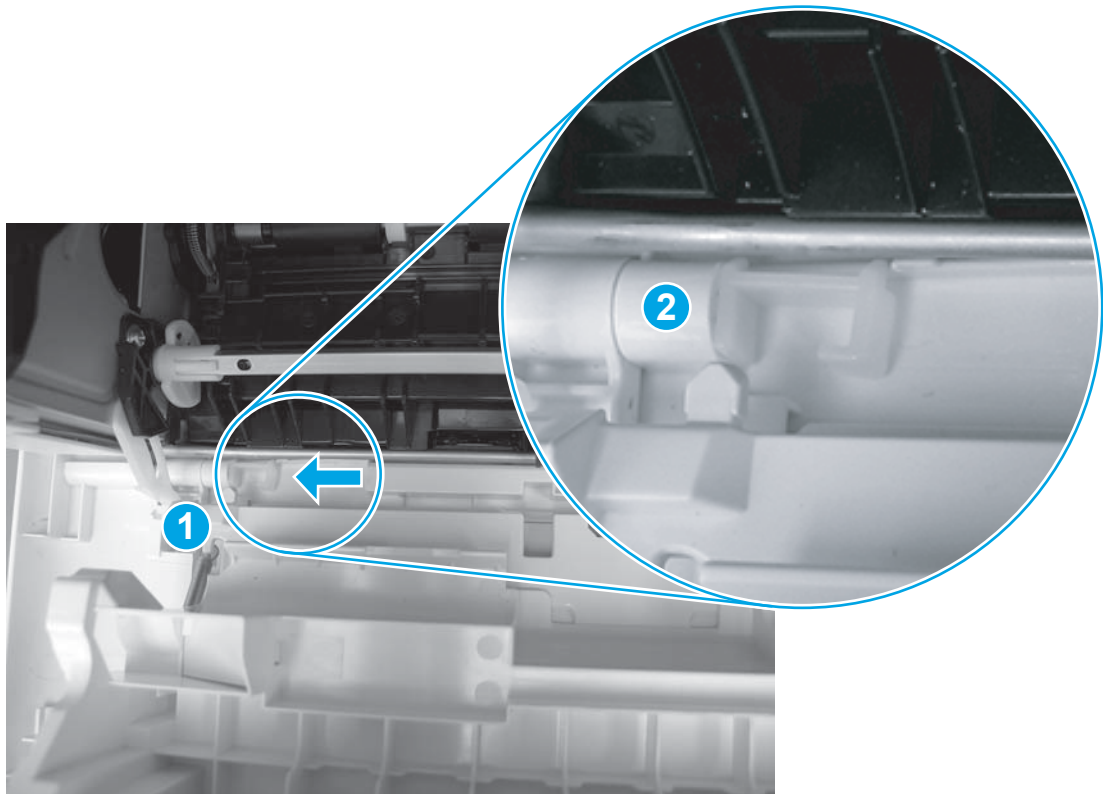
**Figure 1-440** Align the hinge



6. Push the shaft towards the left side of the printer to install it (callout 1).

 **Reinstallation tip:** Make sure that the support shaft is fully installed and correctly orientated (callout 2) so that it will not interfere with the door opening and closing.

**Figure 1-441** Install the support shaft



### Step 13: Install Tray 2

- ▲ Slide the tray straight into the printer to install it.

**Figure 1-442** Install the tray



## Removal and replacement: Paper delivery tray (output bin)

- [Introduction](#)
- [Step 1: Remove Tray 2](#)
- [Step 2: Remove the cartridge door assembly](#)
- [Step 3: Remove the left cover](#)
- [Step 4: Remove the right cover](#)
- [Step 5: Remove the integrated scanner assembly \(M427/M246\)](#)
- [Step 6: Remove the control panel \(M427/M246\)](#)
- [Step 7: Remove the top cover \(M427/M426\)](#)
- [Step 8: Remove the top cover \(M403/M402\)](#)
- [Step 9: Remove the paper delivery tray \(output bin\)](#)
- [Step 10: Unpack the replacement assembly](#)
- [Step 11: Install the paper delivery tray \(output bin\)](#)
- [Step 12: Install the top cover \(M403/M402\)](#)
- [Step 13: Install the top cover \(M427/M426\)](#)
- [Step 14: Install the control panel \(M427/M246\)](#)
- [Step 15: Install the integrated scanner assembly \(M427/M246\)](#)
- [Step 16: Install the right cover](#)
- [Step 17: Install the left cover](#)
- [Step 18: Install the cartridge door assembly](#)
- [Step 19: Install Tray 2](#)

### Introduction


This document provides the procedures to remove and replace the paper delivery tray (output bin).

### Before performing service

#### Turn the printer power off

- Disconnect the power cable.

---

 **WARNING!** To avoid damage to the printer, turn the printer off, wait 30 seconds, and then remove the power cable before attempting to service the printer.

---

Use the table below to identify the correct part number for your printer. To order the part, go to [www.hp.com/buy/parts](http://www.hp.com/buy/parts).

---

**Paper delivery tray (output bin) part number**

---

**RC4-3231-000CN**Paper delivery tray (output bin)

---

**Required tools**

- #2 Phillips screwdriver with a magnetic tip.
- Small flat-blade screwdriver (M427/M426 required; M403/M402 optional)

**After performing service****Turn the printer power on**

- Connect the power cable.
- Use the power switch to turn the power on.

**Post service test**

Make sure that the printer initializes to a **Ready** state.


Print a configuration page to make sure that the printer is functioning correctly.

**Step 1: Remove Tray 2**

- ▲ Pull the tray straight out of the printer to remove it.

**Figure 1-443** Remove the tray

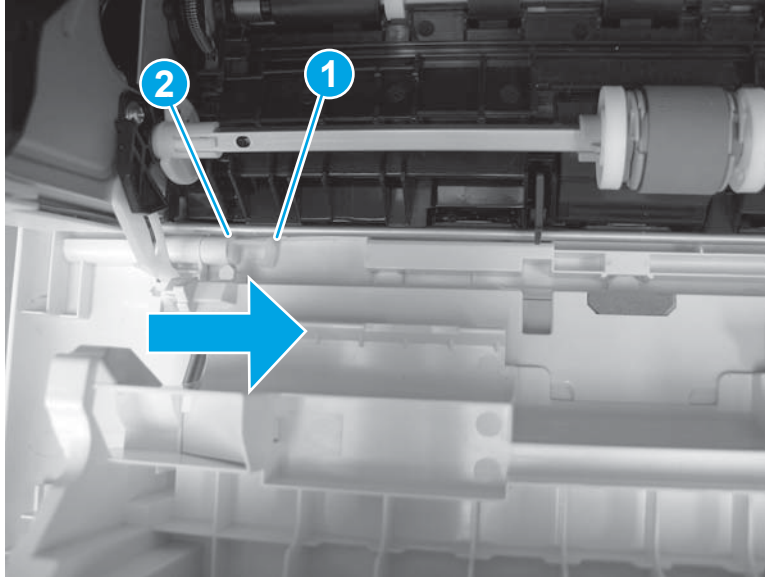
## Step 2: Remove the cartridge door assembly

 **NOTE:** If the toner cartridge was not removed prior to servicing the printer, remove it now.

1. Release one tab (callout 1), and then slide shaft (callout 2) in the direction the arrow indicates and remove it.

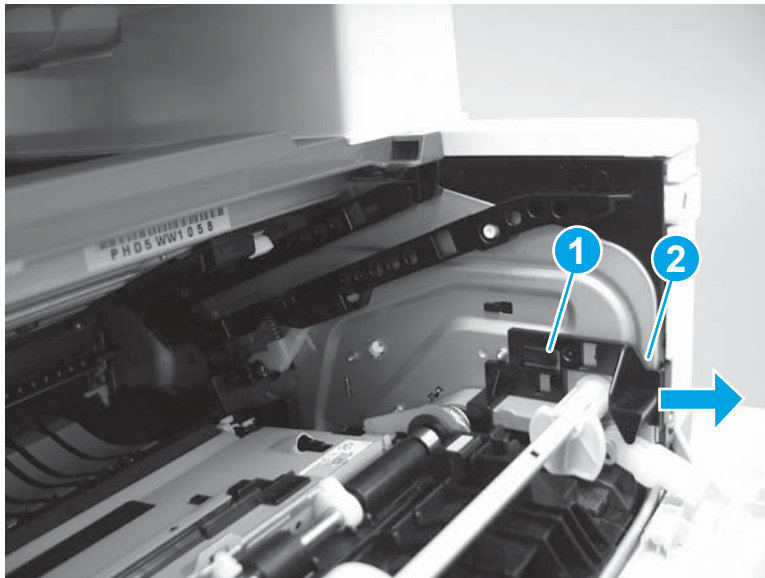
 **TIP:** It might be easier to release the support shaft by using a small flat-blade screwdriver.

**Figure 1-444** Release the support shaft



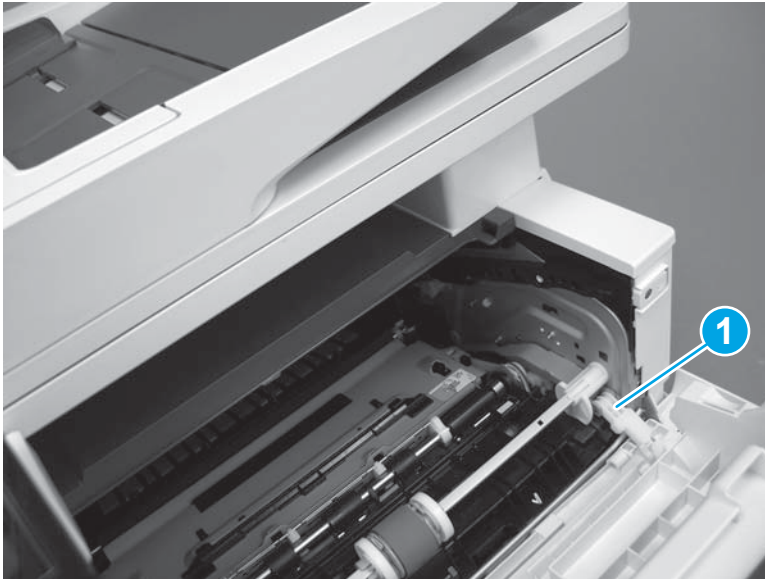
2. Release one tab (callout 1), and then slide the guide (callout 2) in the direction the arrow indicates and remove it.

**Figure 1-445** Remove the guide



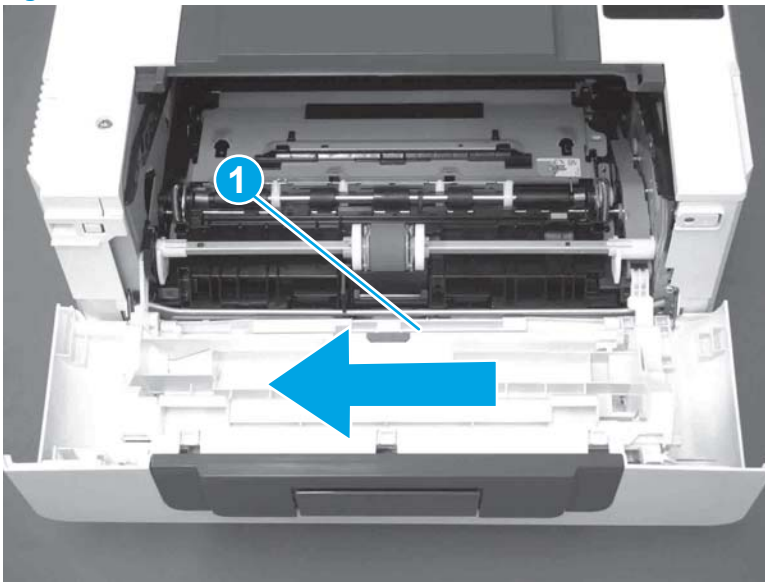
3. Remove the link arm (callout 1).

**Figure 1-446** Remove the link arm



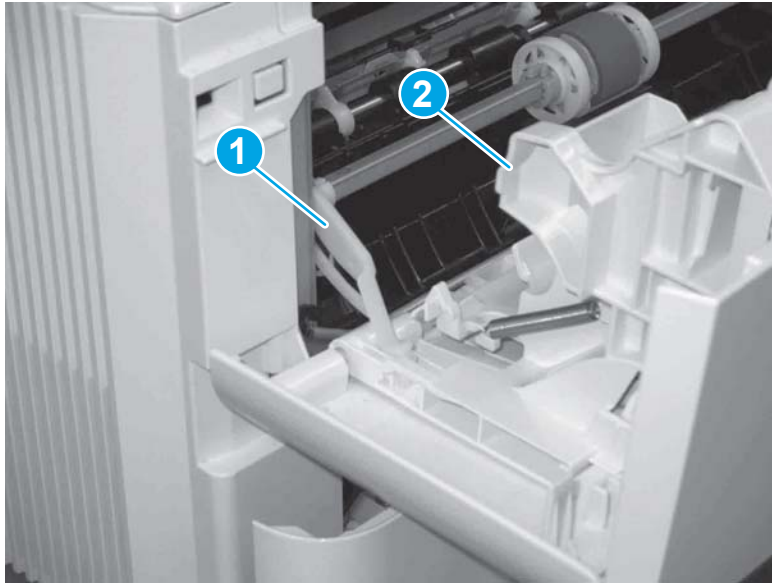
4. Slide the cartridge door assembly (callout 1) in the direction the arrow indicates and remove it.

**Figure 1-447** Remove the door



5. Remove the link (callout 1) from the cartridge door assembly (callout 2).

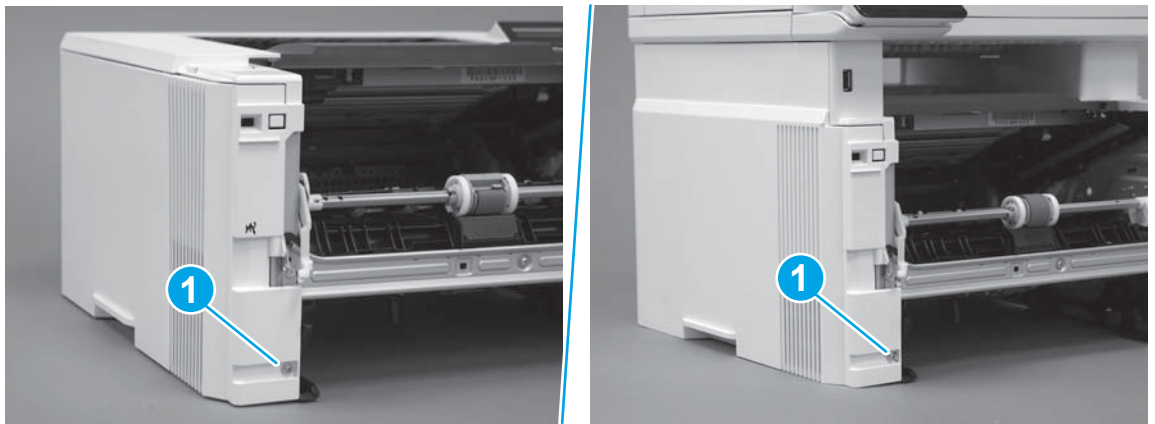
**Figure 1-448** Release the left-side retainer arm



### Step 3: Remove the left cover

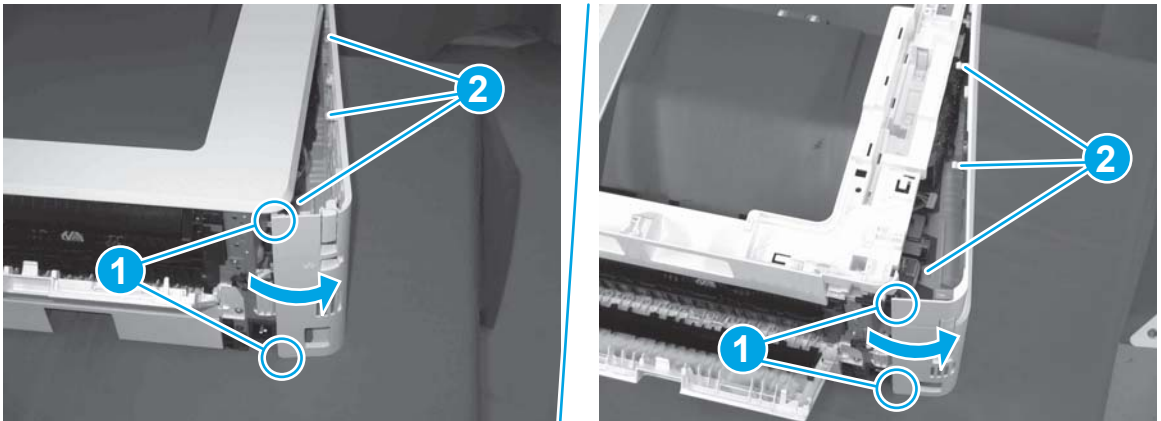
1. Remove one screw (callout 1).

**Figure 1-449** Remove one screw



2. Open the rear door, release two bosses (callout 1), and then release three tabs (callout 2).

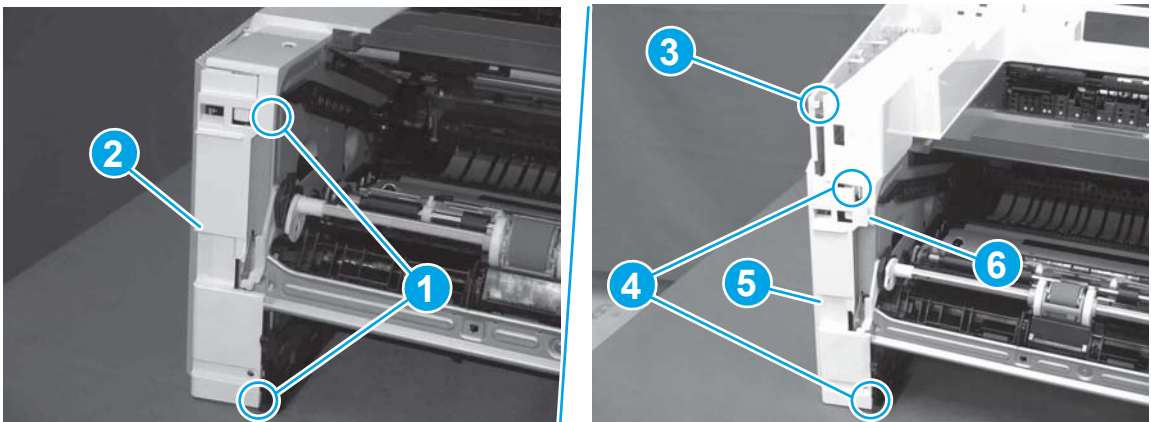
**Figure 1-450** Release two bosses and three tabs



3. At the front of the printer, do one of the following:
  - **M403/M402:** Release two bosses (callout 1), and then remove the cover (callout 2).
  - **M427/M426:** Release one tab (callout 3), two bosses (callout 4), and then remove the cover (callout 5).

**CAUTION:** Be careful when releasing the upper bosses on the M427/M426 cover. One portion of the cover (callout 6) is fragile and is easily broken.

**Figure 1-451** Remove the cover



#### Step 4: Remove the right cover

1. Remove one screw (callout 1).

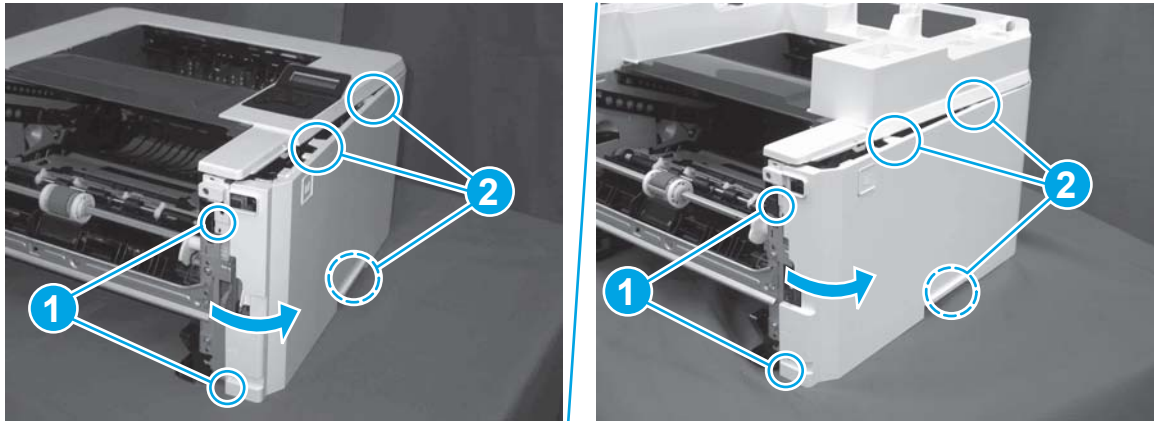


**Figure 1-452** Remove one screw



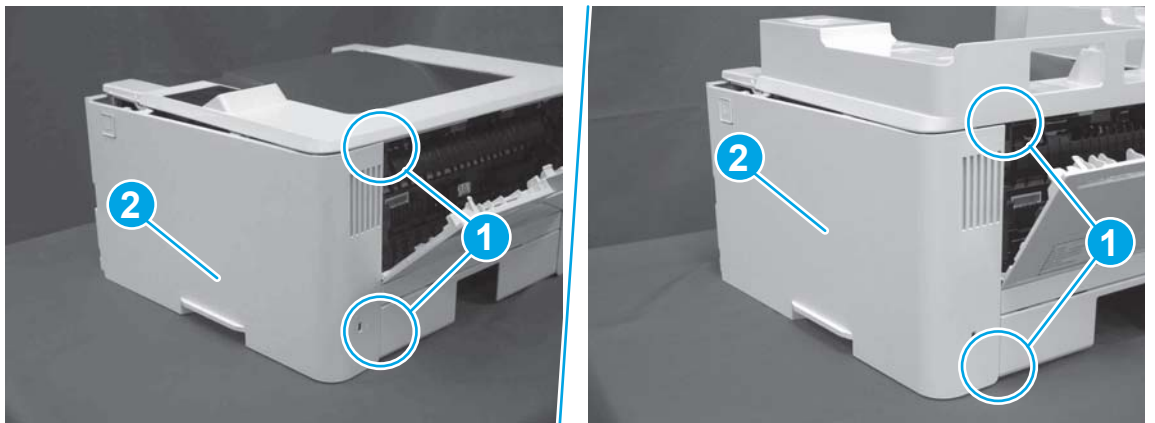
2. At the front of the printer, release two bosses (callout 1), and then release three tabs (callout 2).

**Figure 1-453** Release two bosses and three tabs





3. Open the rear door, release two bosses (callout 1), and then remove the cover (callout 2).

**Figure 1-454** Remove the cover



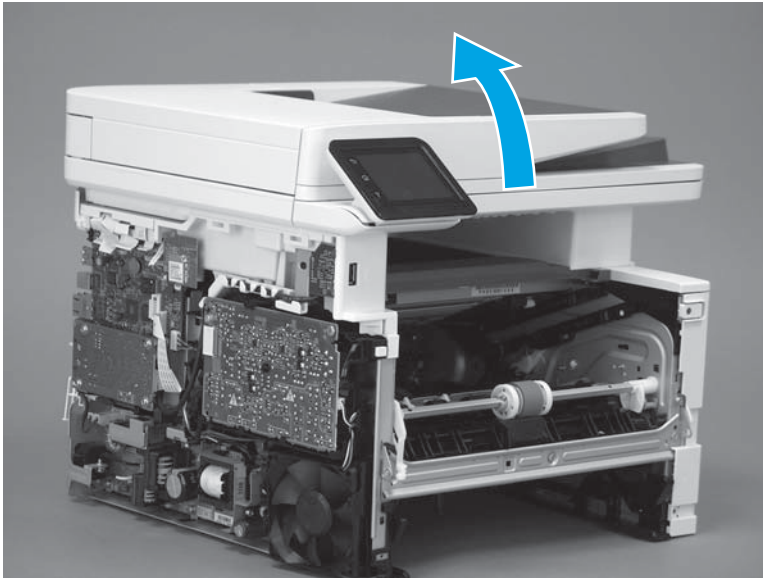
### Step 5: Remove the integrated scanner assembly (M427/M246)

 **NOTE:** The step is for the M427/M246 printer. For the M403/M402, skip this step and go to [Step 8: Remove the top cover \(M403/M402\)](#) on page 269.

 **NOTE:** M427/M426 models only. The integrated scanner assembly (ISA) includes the sub-scanner assembly (SSA) and the automatic document feeder (ADF).

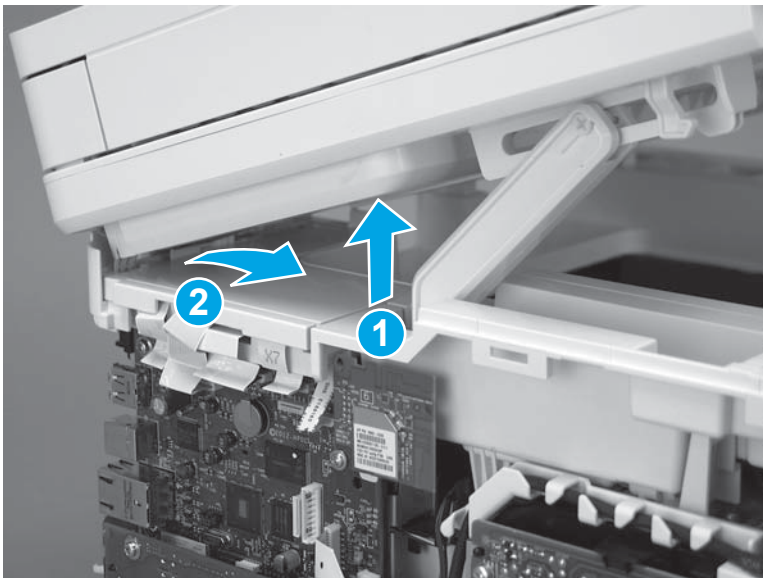
1. Raise the ISA.

**Figure 1-455** Raise the ISA



2. Release the ISA flat-flexible cable (FFC) cover (callout 1), and then remove it (callout 2).

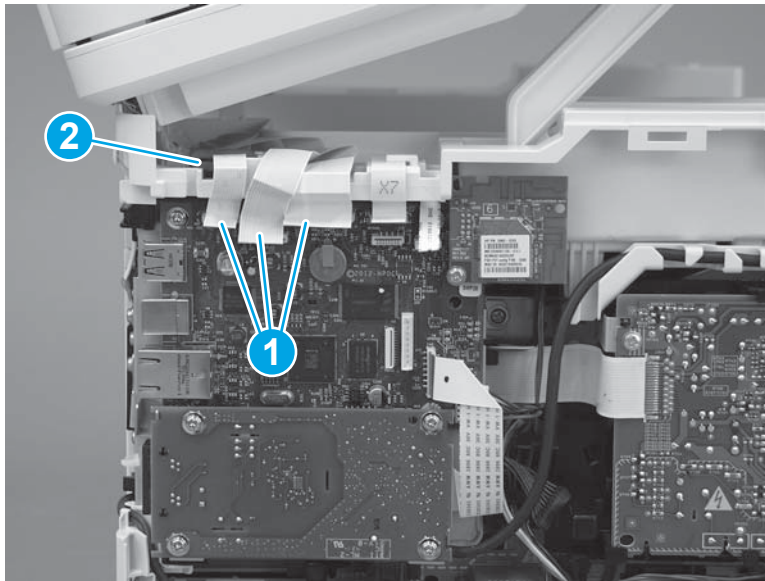
**Figure 1-456** Remove the ISA FFC cover



3. Disconnect three FFCs (callout 1), and then remove the ferrite (callout 2) from the holder.

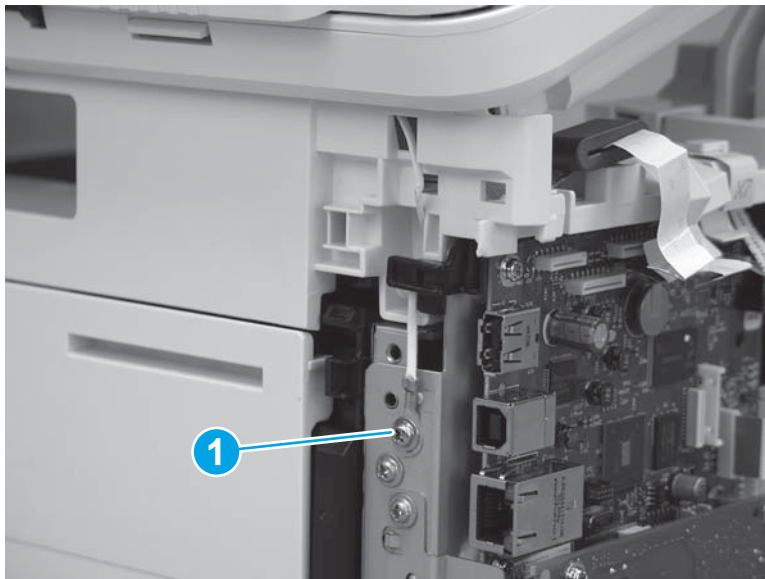
**CAUTION:** The ferrite is not captive on the FFC. Do not lose the ferrite while handling the ISA.

**Figure 1-457** Disconnect three FFCs



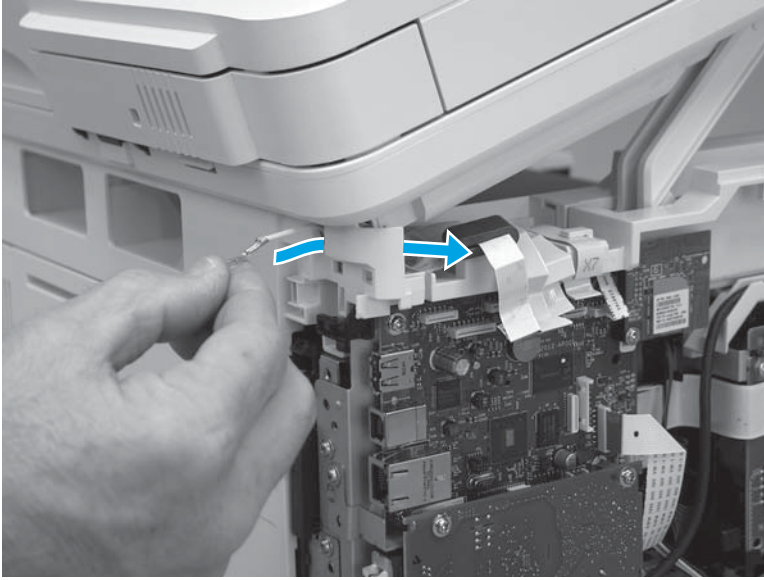
4. Remove one screw (callout 1).

**Figure 1-458** Remove one screw



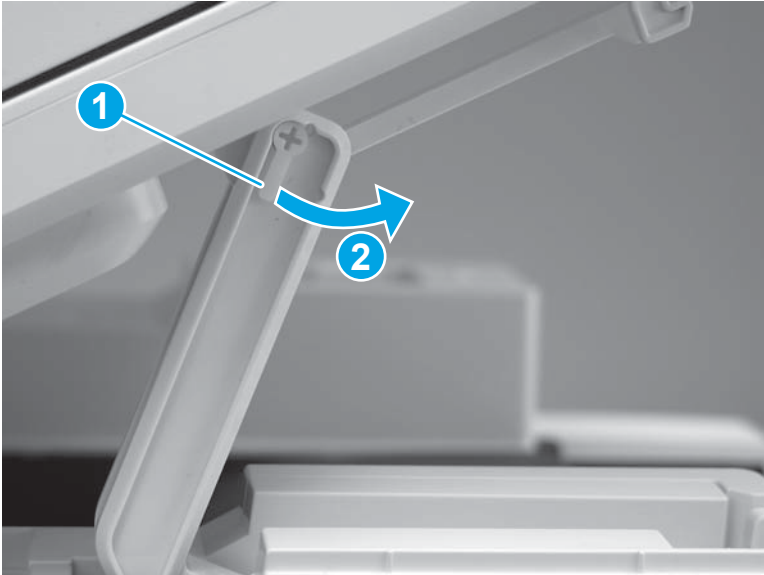
5. Pass the ground wire through the opening in the top cover.

**Figure 1-459** Pass the wire through the opening



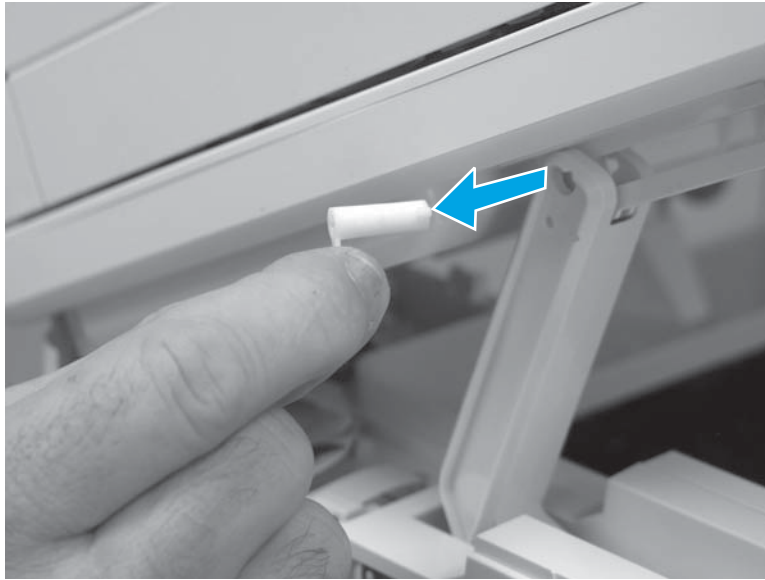
6. Release one tab (callout 1), and then rotate the ISA slider pin (callout 2) towards the front of the printer to release it.

**Figure 1-460** Release one tab and rotate the slider pin



7. Remove the slider pin.

**Figure 1-461** Remove the slider pin



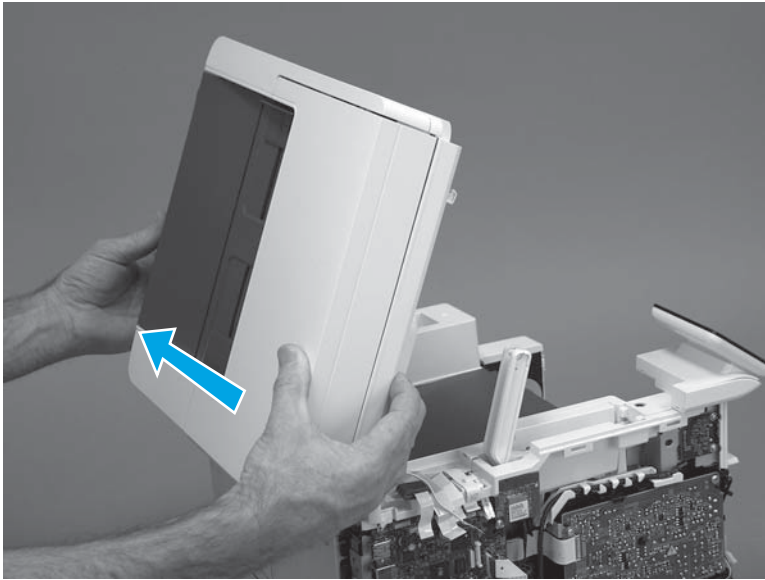
8. Rotate the ISA towards the rear of the printer until it stops.

**Figure 1-462** Rotate the ISA towards the rear of the printer



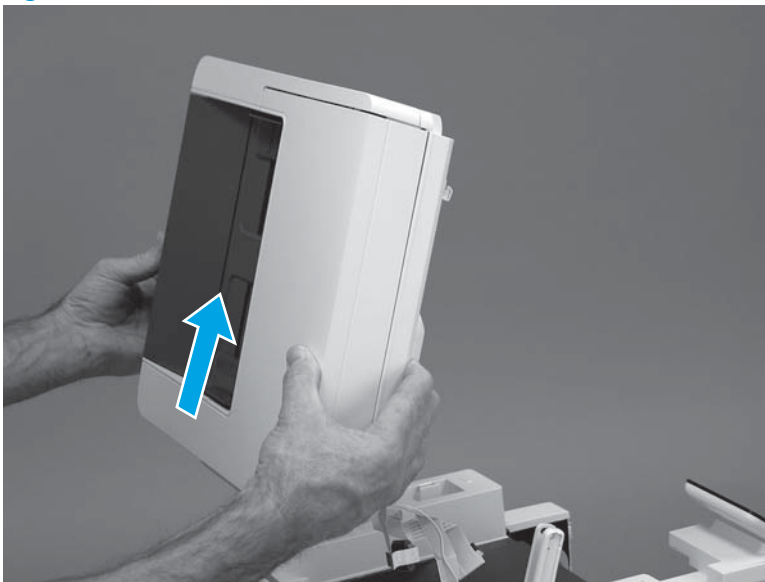
- Slide the ISA as shown to release it.

**Figure 1-463** Release the ISA



- Remove the ISA.

**Figure 1-464** Remove the ISA



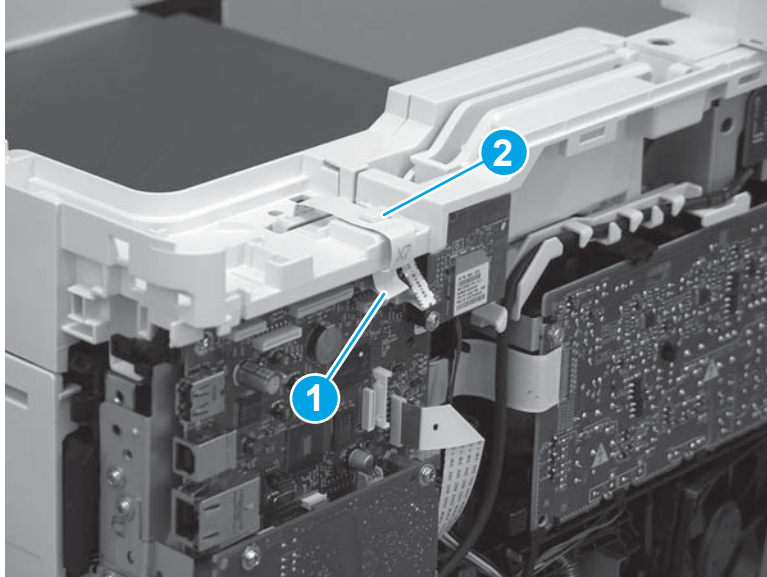
### Step 6: Remove the control panel (M427/M246)



**NOTE:** The step is for the M427/M426 printer. For the M403/M402, skip this step and go to [Step 8: Remove the top cover \(M403/M402\) on page 269](#).

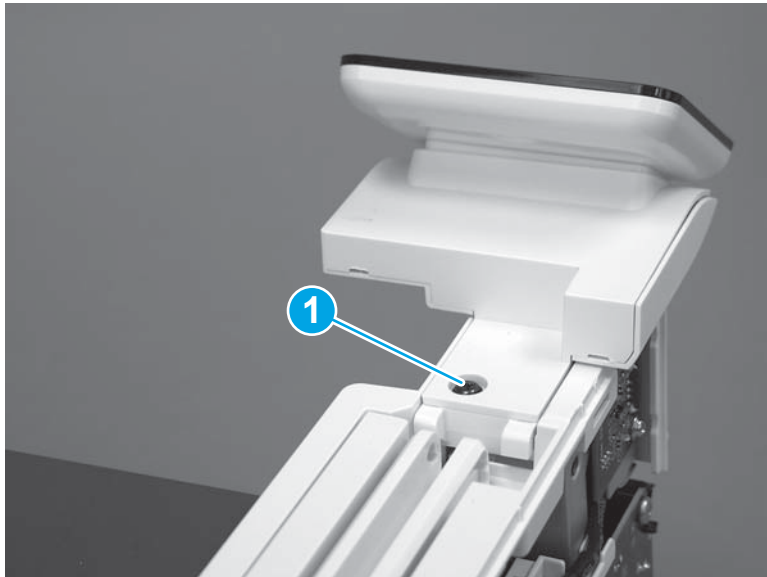
- Disconnect one FFC (callout 1; J114), and then release the FFC from the retainer (callout 2).

**Figure 1-465** Disconnect one connector



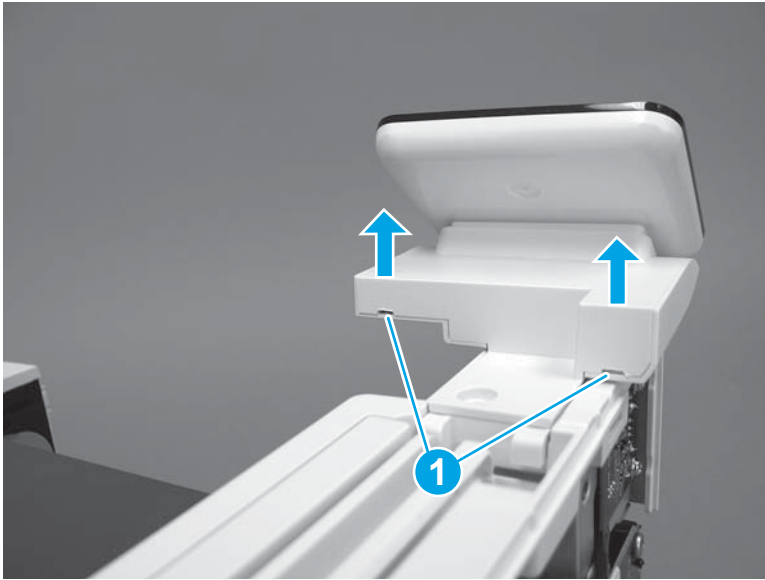
2. Remove one screw (callout 1).

**Figure 1-466** Remove one screw



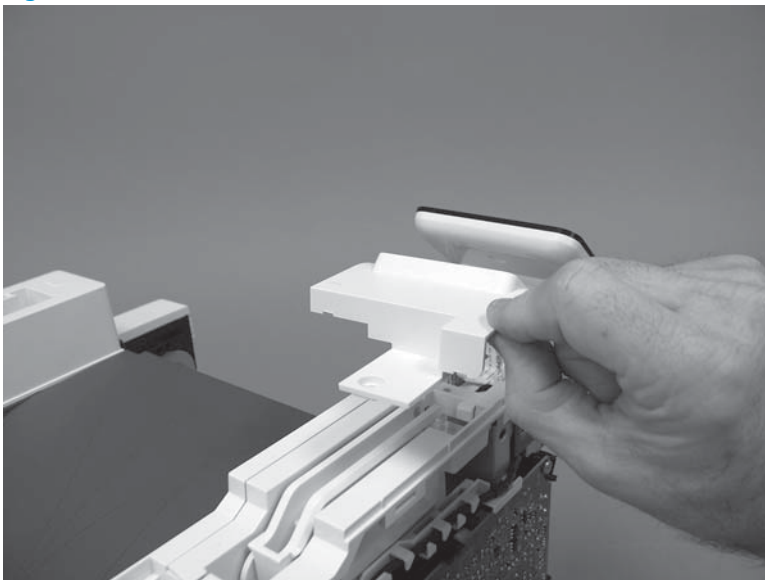
3. Use a small flat-blade screwdriver to release two tabs (callout 1) on the control-panel cable cover.

**Figure 1-467** Release two tabs



4. Remove the control-panel cable cover.

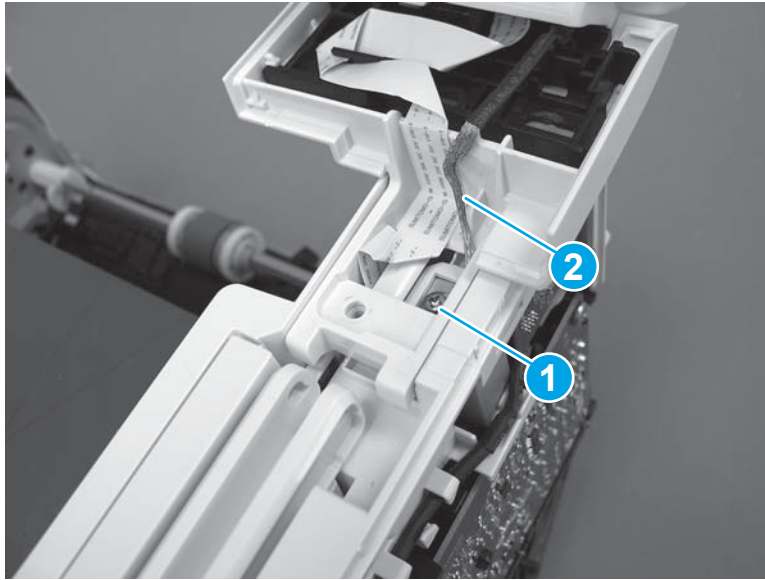
**Figure 1-468** Remove the cover





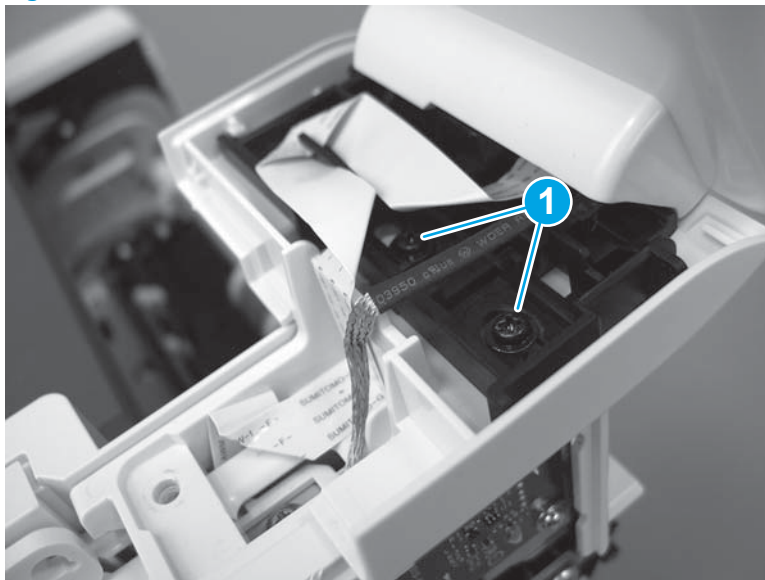
5. Remove one grounding screw (callout 1), and then move the ground cable (callout 2) out of the way.

**Figure 1-469** Remove one screw



6. Move the FFC out of the way, and then remove two screws (callout 1).

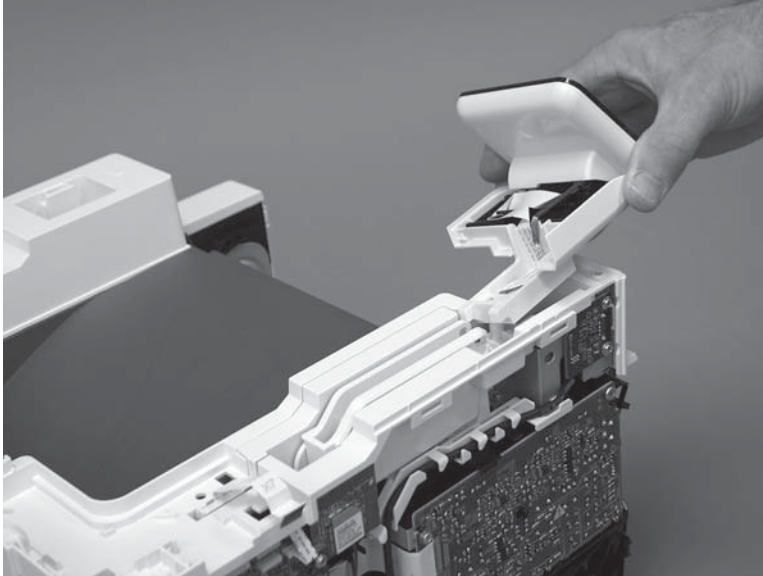
**Figure 1-470** Remove two screws



7. Slightly lift up the control-panel assembly to separate it from the top cover.

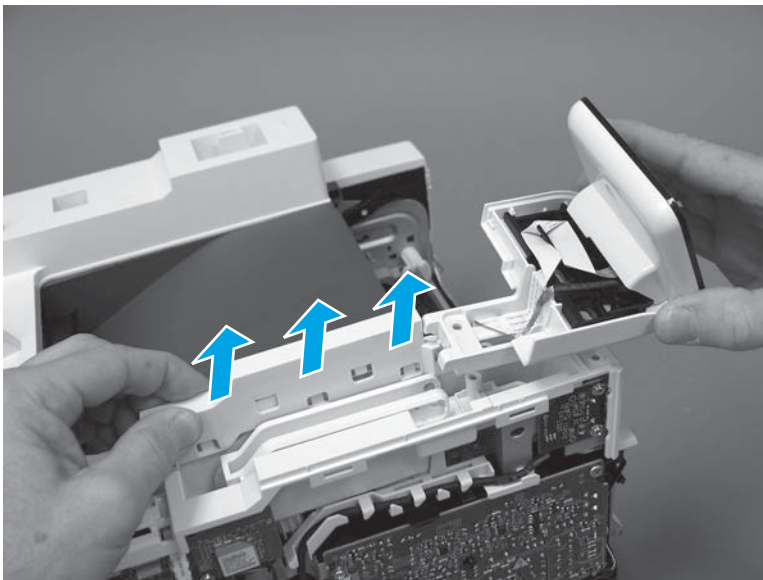
**⚠ CAUTION:** The control panel assembly is still connected to the printer by the FFC. Do not attempt to completely remove the assembly.

**Figure 1-471** Lift up the control-panel assembly



8. Lift up the control-panel FFC cover to remove the control-panel assembly.

**Figure 1-472** Remove the control-panel assembly

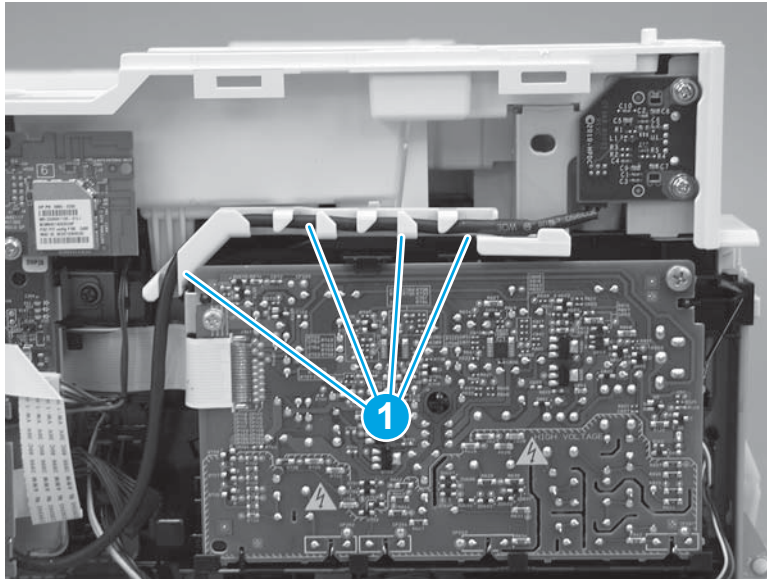


### Step 7: Remove the top cover (M427/M426)

**📝 NOTE:** The step is for the M427/M426 printer. For the M403/M402, skip this step and go to [Step 8: Remove the top cover \(M403/M402\) on page 269](#).

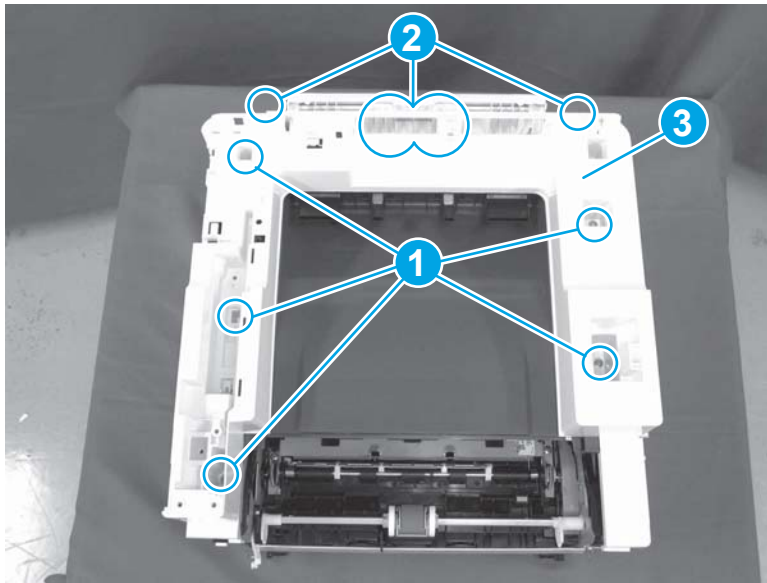
1. Release the USB cable (callout 1) from the cable guide.

**Figure 1-473** Remove the USB cable



2. Remove five screws (callout 1), release four bosses (callout 2), and then remove the top cover (callout 3).

**Figure 1-474** Remove the cover



### Step 8: Remove the top cover (M403/M402)

 **NOTE:** The step is for the M403/M402 printer. For the M427/M426, skip this step and go to [Step 9: Remove the paper delivery tray \(output bin\) on page 271.](#)

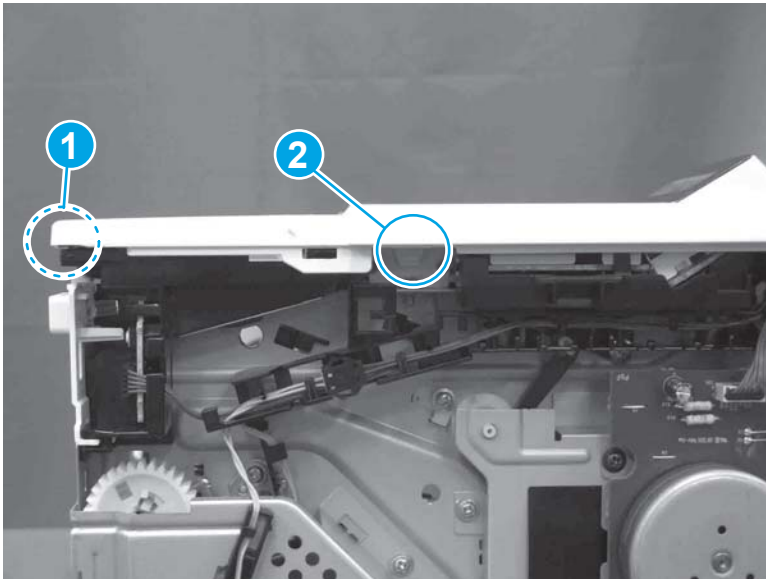
1. Remove one screw (callout 1).

**Figure 1-475** Remove one screw




2. At the right side of the printer, release the one boss (callout 1), and then release one tab (callout 2).

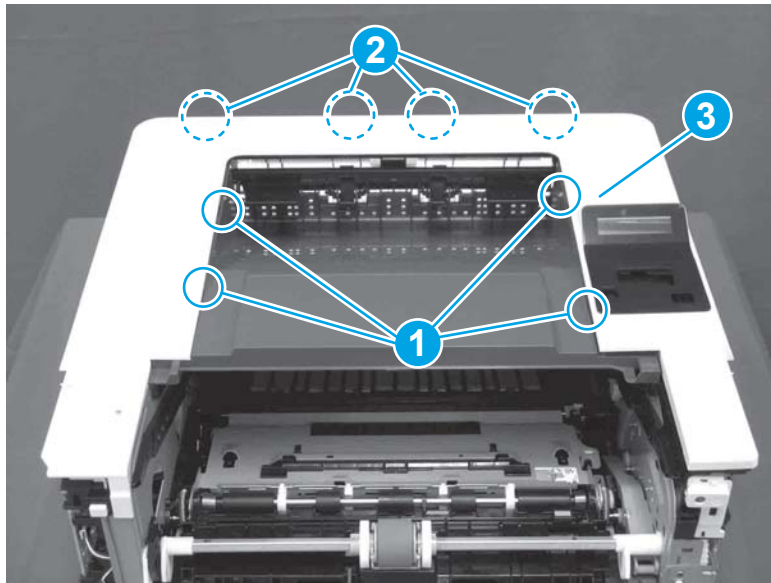
**Figure 1-476** Release one boss and one tab




3. Release four tabs (callout 1), release four bosses (callout 2), and then remove the top cover (callout 3).

 **TIP:** Open the rear door to make releasing the bosses (callout 3) easier.

**Figure 1-477** Remove the cover

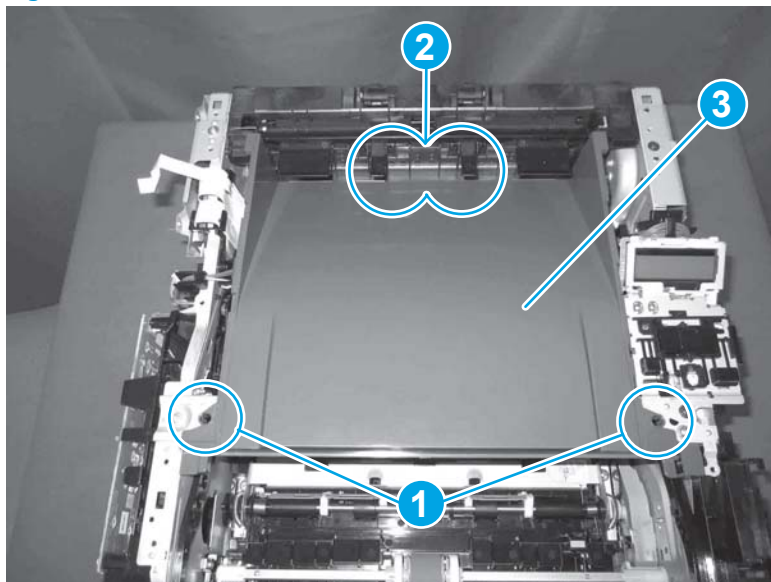


### Step 9: Remove the paper delivery tray (output bin)

 **NOTE:** This procedure shows the M403/M402 model, however, the paper delivery tray (output bin) removal is similar for the M427/M426 printer.

- ▲ Release two bosses (callout 1), release two tabs (callout 2), and then remove the paper delivery tray (output bin; callout 3).

**Figure 1-478** Release two tabs



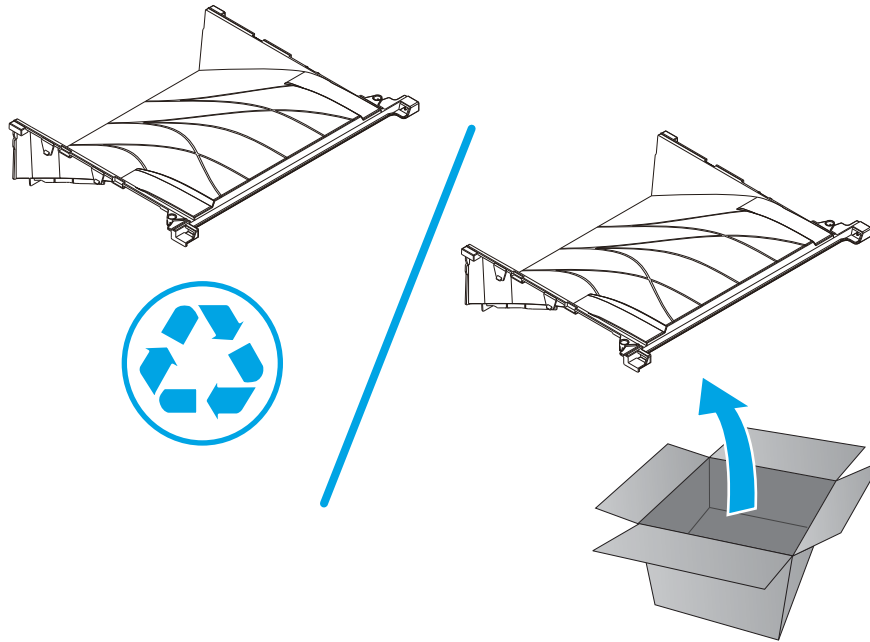
## Step 10: Unpack the replacement assembly

Unpack the replacement part from the packaging.


<http://www8.hp.com/us/en/hp-information/environment/product-recycling.html>

 **NOTE:** HP recommends responsible disposal of the defective part.

**Figure 1-479** Recycle and unpack

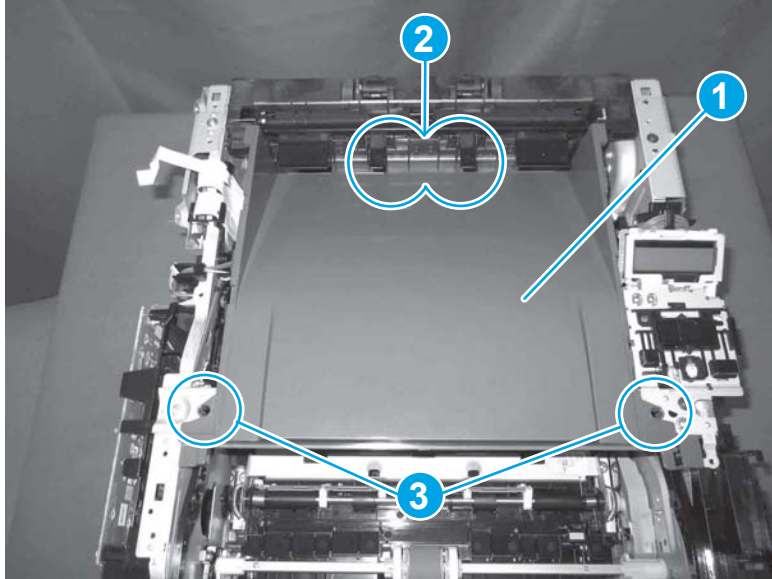


## Step 11: Install the paper delivery tray (output bin)


 **NOTE:** This procedure shows the M403/M402 model, however, the paper delivery tray (output bin) removal is similar for the M427/M426 printer.

- ▲ Position the remove the paper delivery tray (output bin; callout 1) on the printer, engage two tabs (callout 2), and then engage two bosses (callout 3).

**Figure 1-480** Engage two tabs

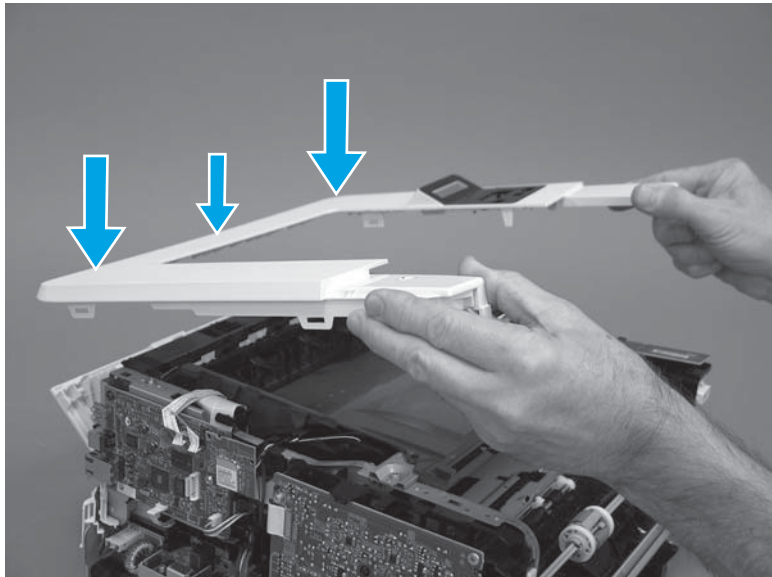


**Step 12: Install the top cover (M403/M402)**

 **NOTE:** The step is for the M403/M402 printer. For the M427/M426, skip this step and go to [Step 13: Install the top cover \(M427/M426\) on page 275](#).

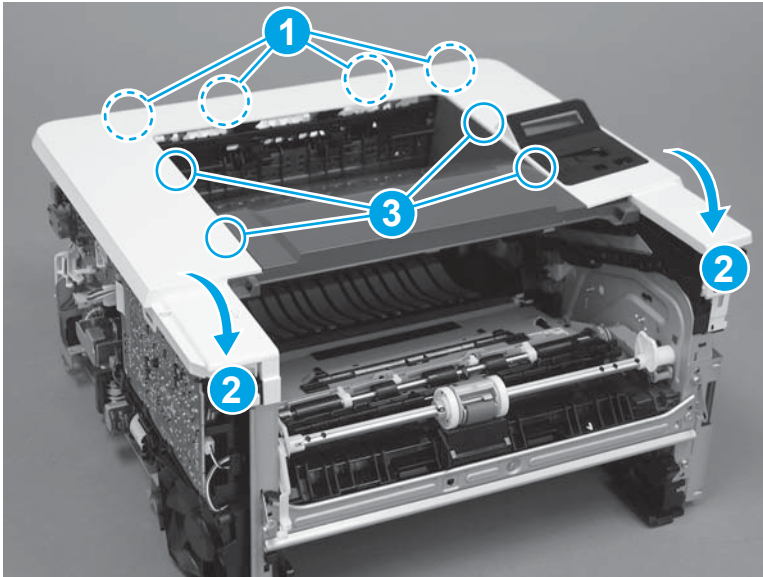
1. Position the rear edge of the cover on the printer.

**Figure 1-481** Install the cover



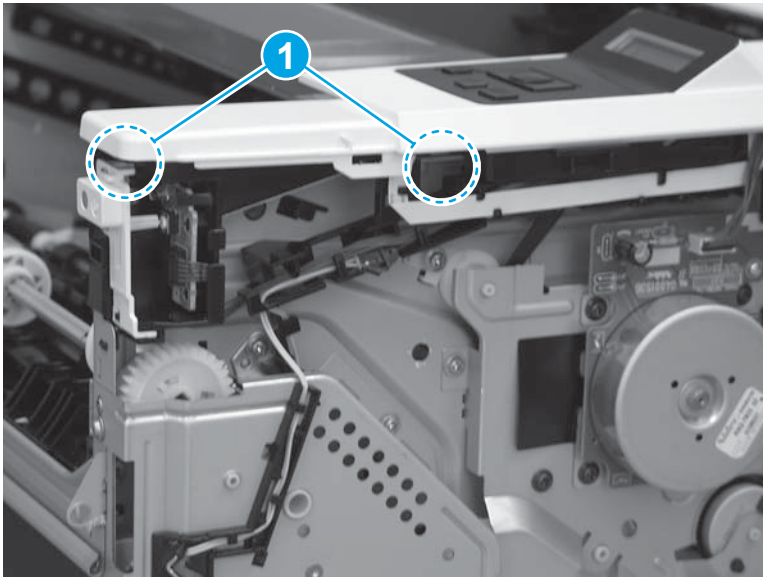
2. Engage four bosses (callout 1), rotate the front of the cover down (callout 2) and onto from the printer, and then engage four tabs (callout 3).

**Figure 1-482** Engage four bosses and tabs



3. At the right side of the printer, engage the one boss and one tab (callout 1).

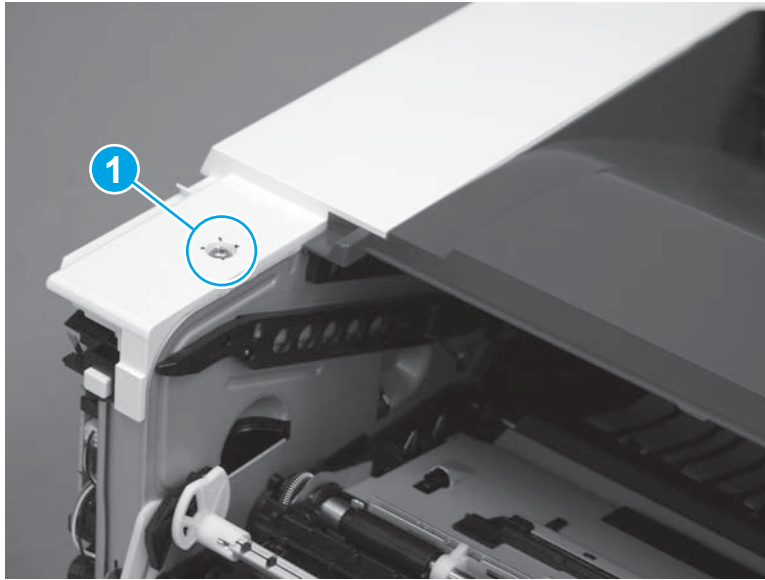
**Figure 1-483** Engage one boss and one tab






4. Install one screw (callout 1).

**Figure 1-484** Install one screw

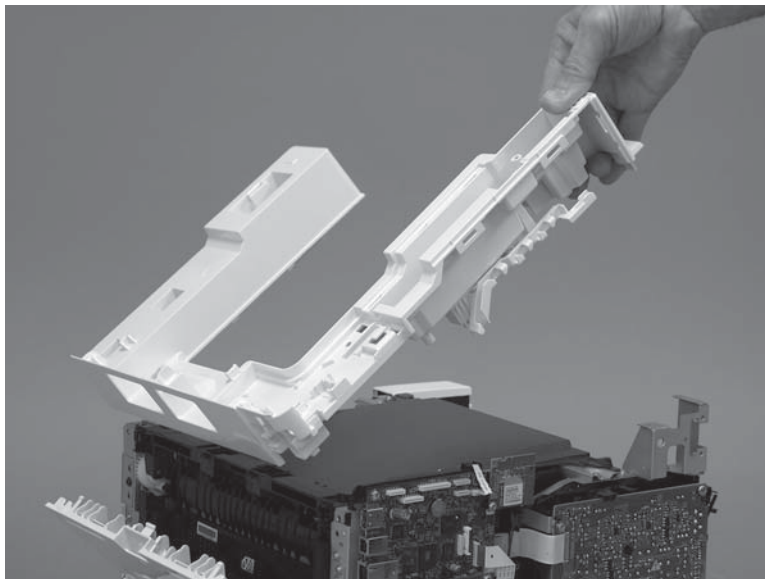


### Step 13: Install the top cover (M427/M426)

 **NOTE:** The step is for the M427/M426 printer. For the M403/M402, skip this step and go to [Step 16: Install the right cover on page 286](#).

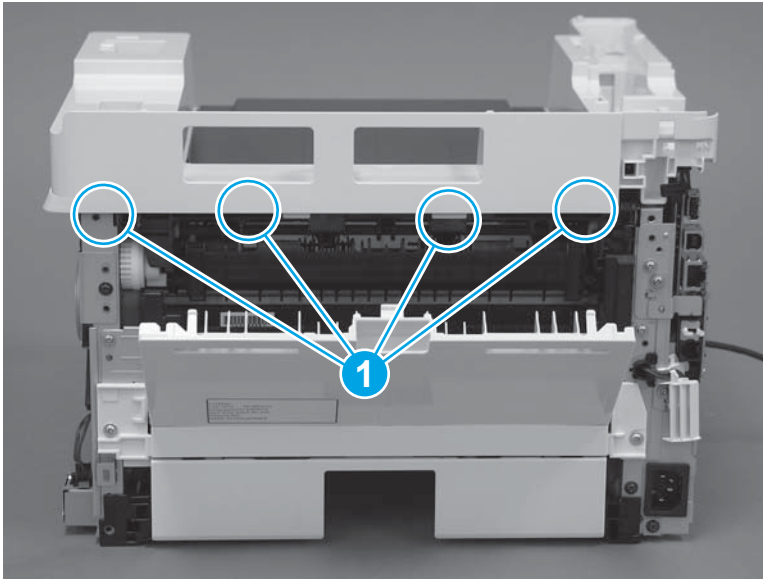
1. Position the rear edge of the top cover on the printer.

**Figure 1-485** Install the cover



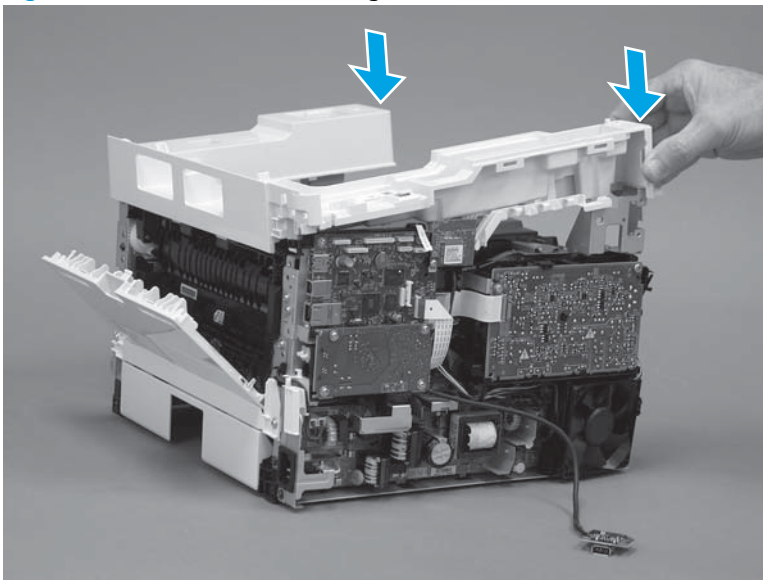
2. Engage four bosses (callout 1).

**Figure 1-486** Engage four bosses



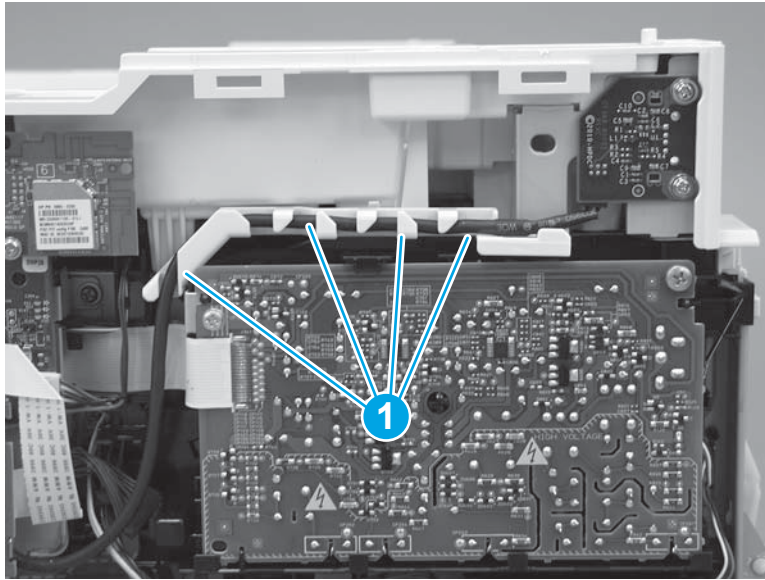
3. Rotate the front edge of the cover down.

**Figure 1-487** Rotate the front edge of the cover down



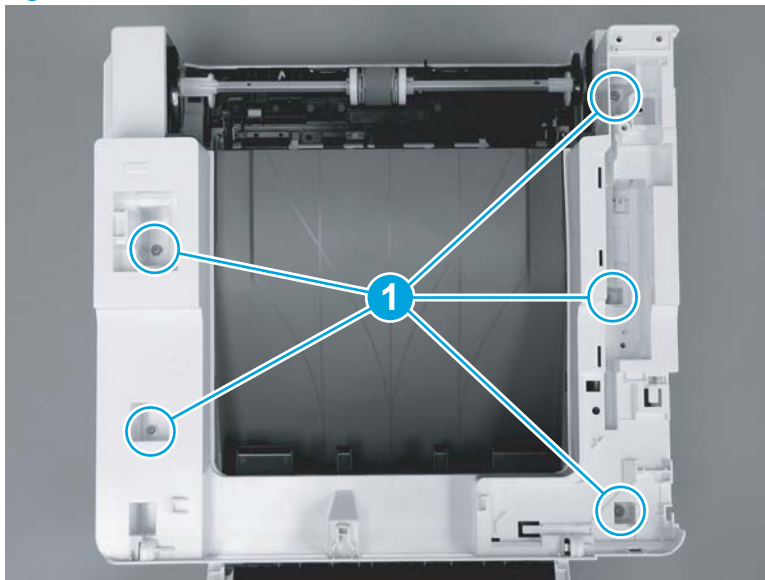
4. Install the USB cable (callout 1) in the guide.

**Figure 1-488** Install the USB PCA




5. Install five screws (callout 1).

**Figure 1-489** Install five screws

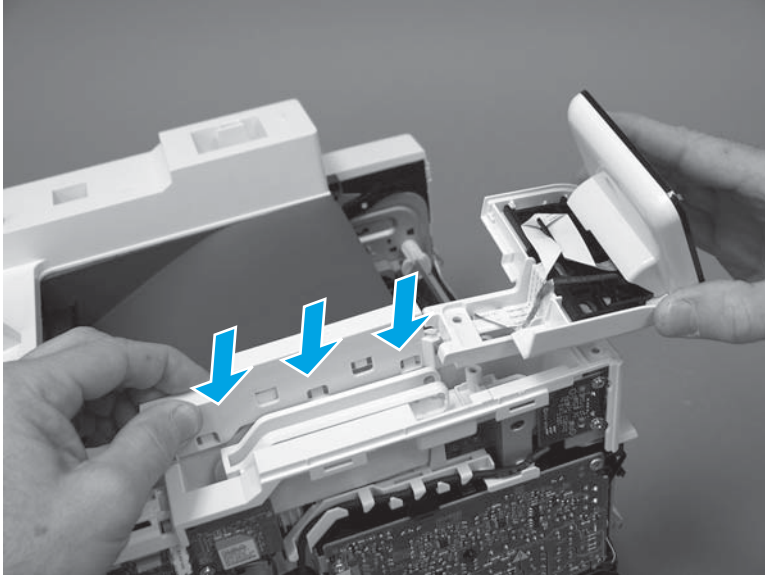


#### Step 14: Install the control panel (M427/M246)

 **NOTE:** The step is for the M427/M426 printer. For the M403/M402, skip this step and go to [Step 16: Install the right cover on page 286](#).

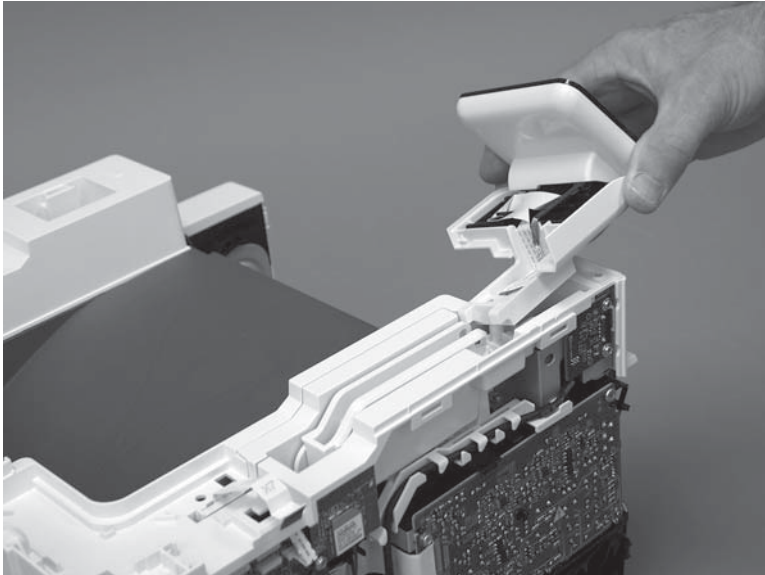
1. Slide the control-panel FFC cover into the slot in the top cover (next to the document feeder support arm) to install it.

**Figure 1-490** Install the control-panel FFC cover



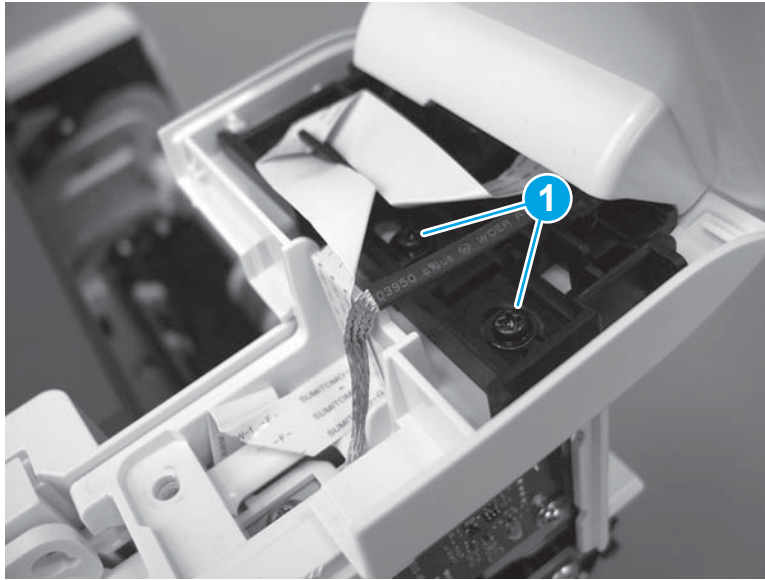
2. Install the control-panel assembly on the top cover.

**Figure 1-491** Install the control-panel assembly



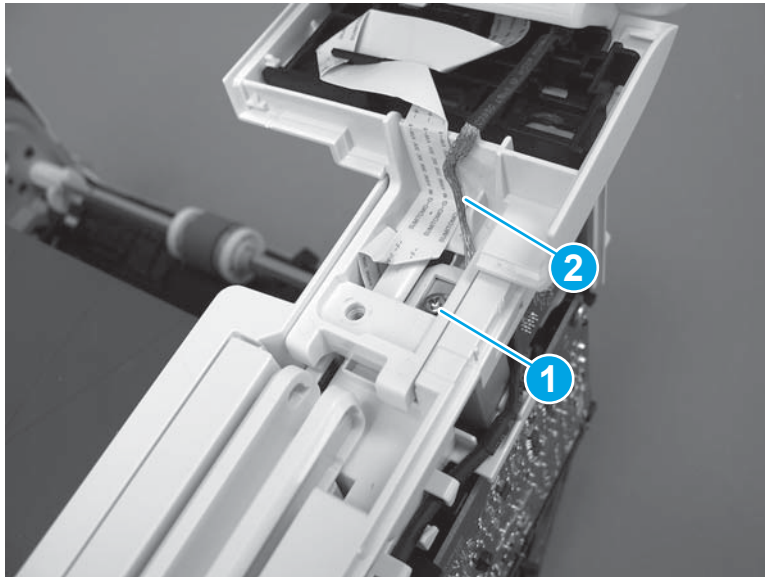
3. Move the FFC out of the way, and then install two screws (callout 1).

**Figure 1-492** Install two screws



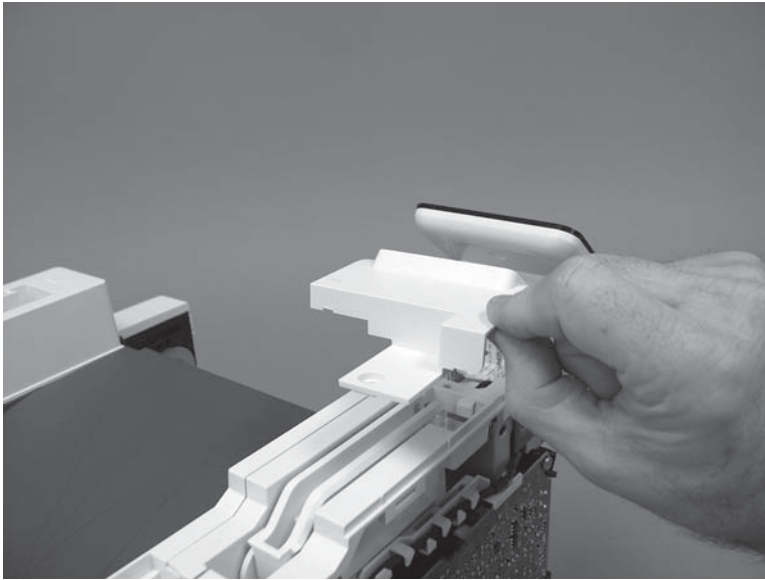
4. Install one grounding screw (callout 1), and then make sure that the ground cable (callout 2) is properly routed.

**Figure 1-493** Remove one screw



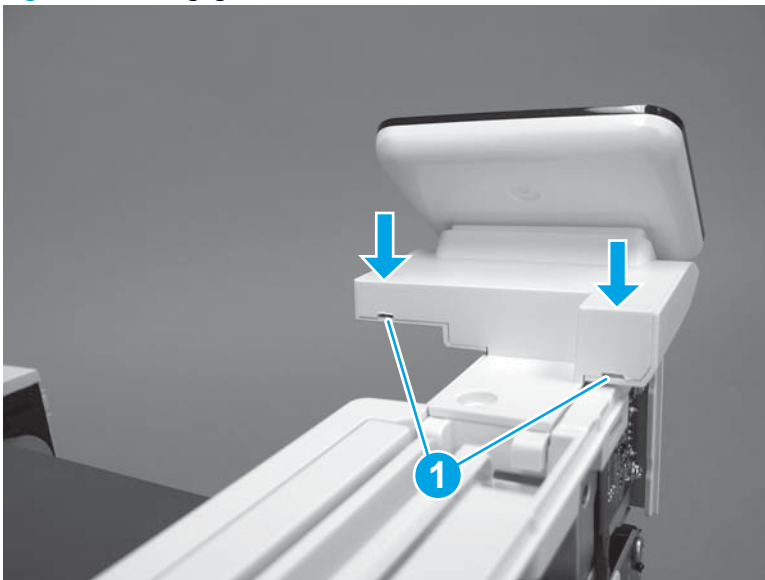
5. Install the control-panel cable cover.

**Figure 1-494** Install the cover



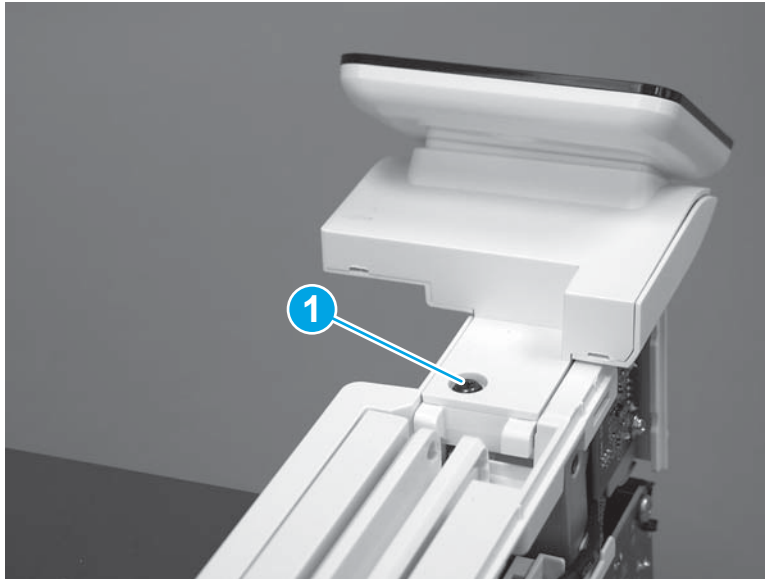
6. Make sure that the two tabs (callout 1) on the cover snap into place.

**Figure 1-495** Engage two tabs



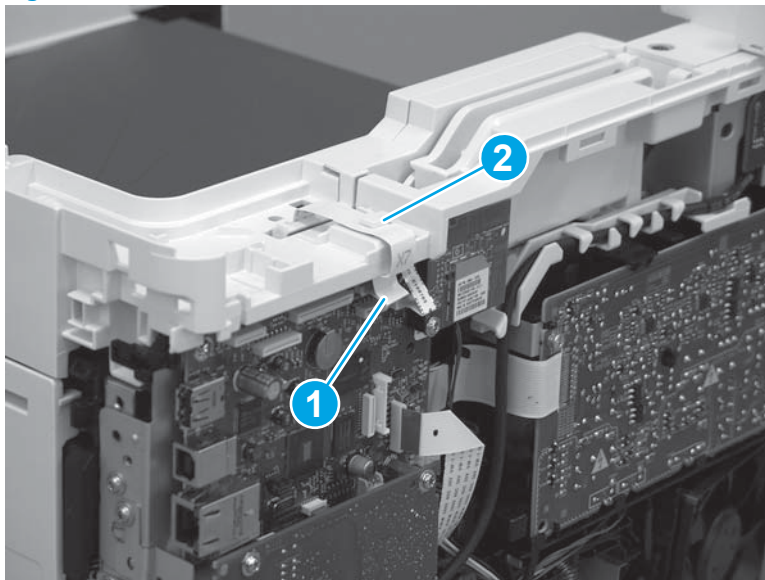
7. Install one screw (callout 1).

**Figure 1-496** Install one screw




8. Install the FFC in the retainer (callout 1), and then connect one FFC (callout 1; J114).

**Figure 1-497** Connect one connector




### Step 15: Install the integrated scanner assembly (M427/M246)

---

 **NOTE:** The step is for the M427/M426 printer. For the M403/M402, skip this step and go to [Step 16: Install the right cover on page 286](#).

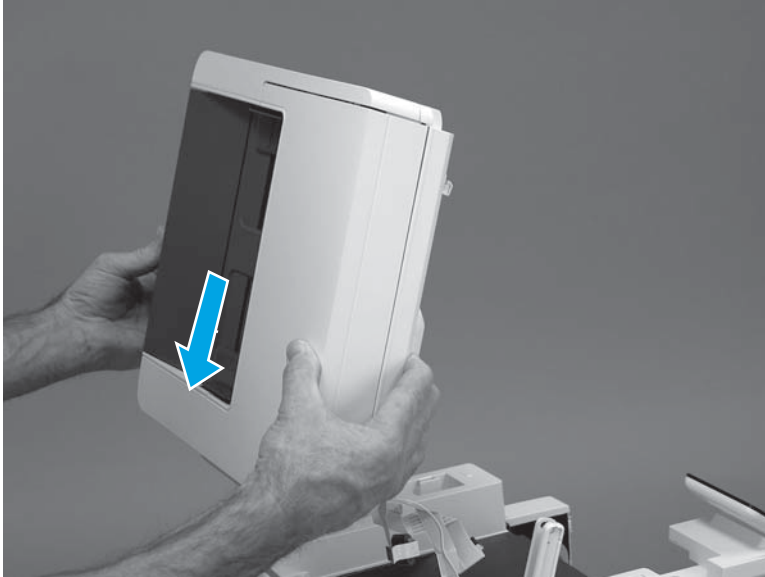
---

 **NOTE:** M427/M426 models only. The integrated scanner assembly (ISA) includes the sub-scanner assembly (SSA) and the automatic document feeder (ADF).

---

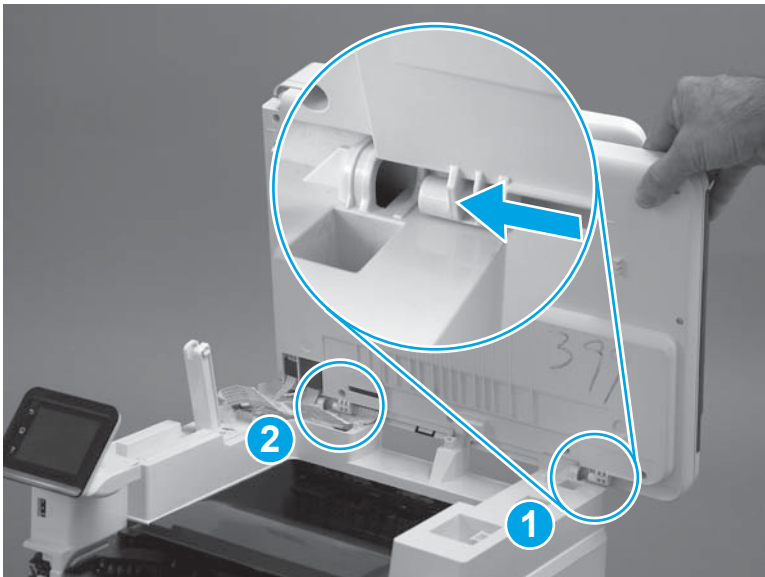
1. Position the ISA on the printer.

**Figure 1-498** Position the ISA on the printer



2. Engage the hinge pins on the ISA with the holders in the top cover (callouts 1/2), and then slide the ISA as shown to engage them

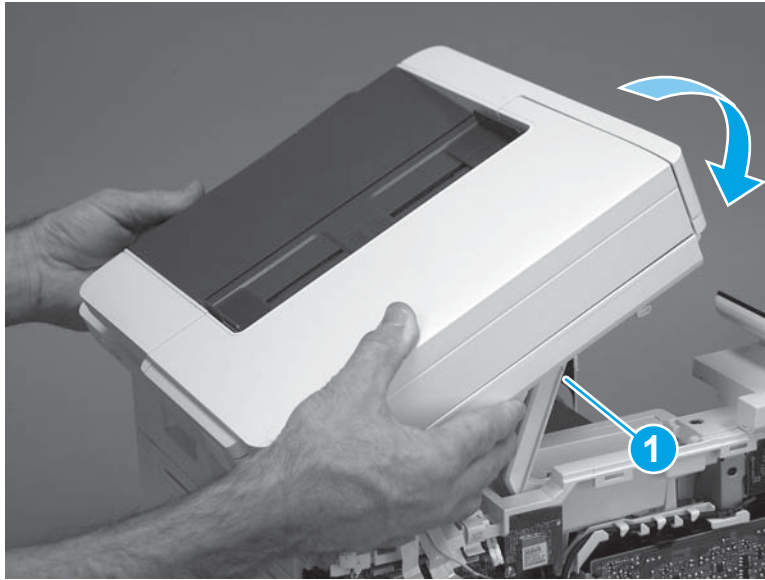
**Figure 1-499** Engage the hinge pins with the holders





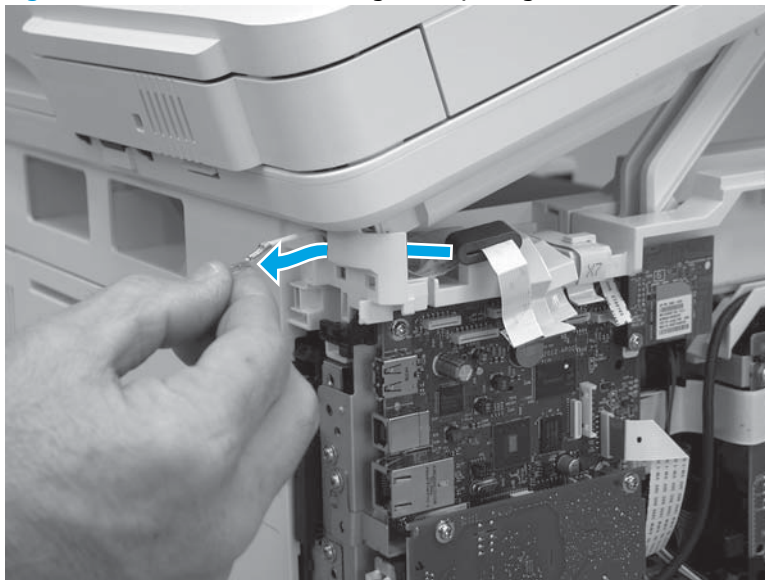
3. Rotate the ISA towards the front of the printer until it rests on the ISA lift assembly (callout 1).

**Figure 1-500** Rotate the ISA towards the front of the printer



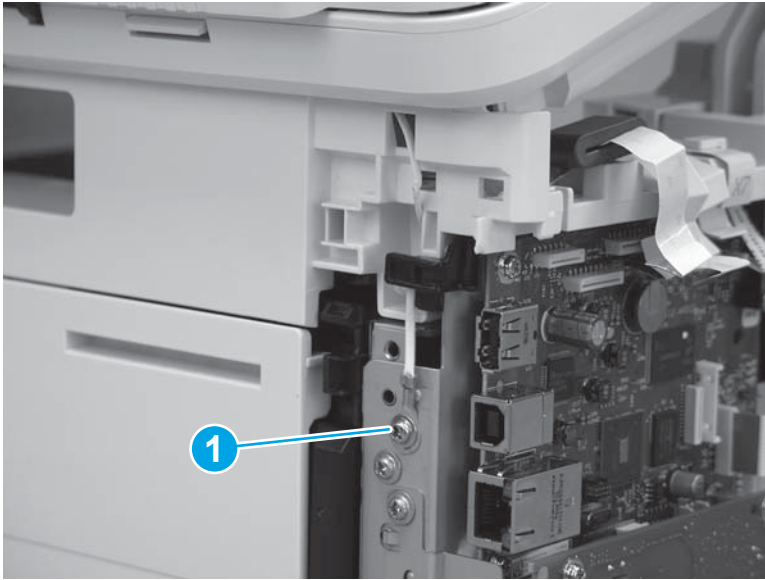
4. Pass the ground wire through the opening in the top cover.

**Figure 1-501** Pass the wire through the opening



5. Install one screw (callout 1).

**Figure 1-502** Install one screw



6. Install the ISA lift assembly slider pin.

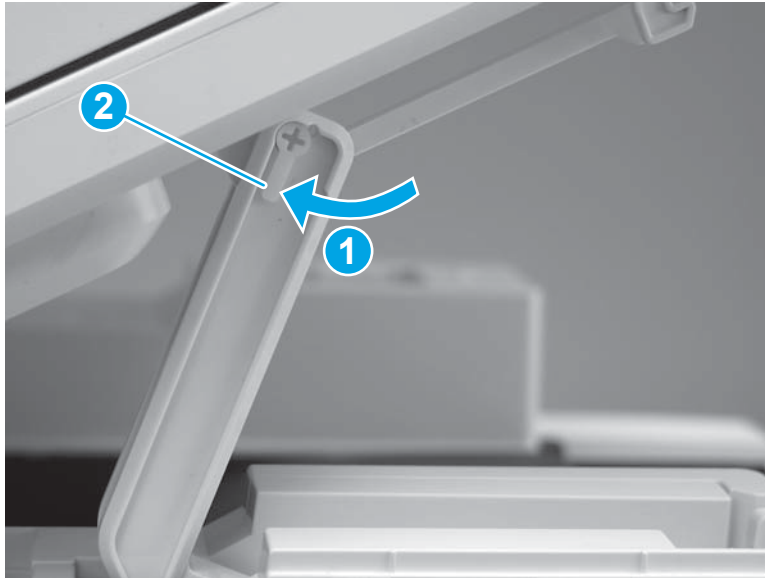
 **Reinstallation tip:** Align the keyed portion of the locking pin with the slot and hole in the support arm.

**Figure 1-503** Install the slider pin



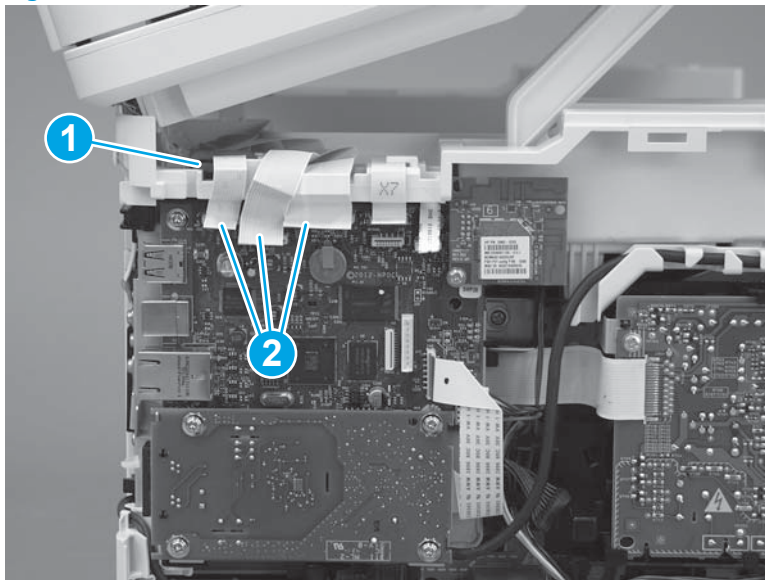
7. Rotate the slider pin (callout 1) towards the rear of the printer until the tab (callout 2) snap into place.

**Figure 1-504** Secure the slider pin



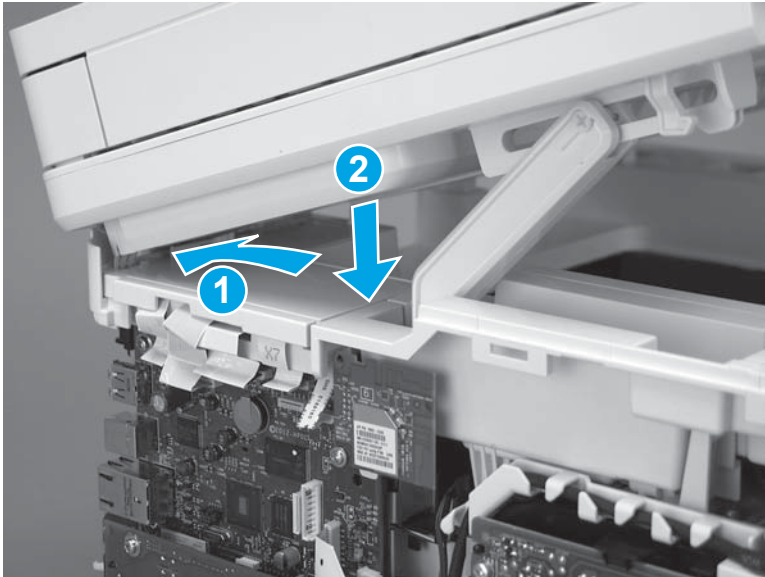
8. Install the ferrite (callout 1) in the holder, and then connect three FFCs (callout 2).

**Figure 1-505** Connect three FFCs



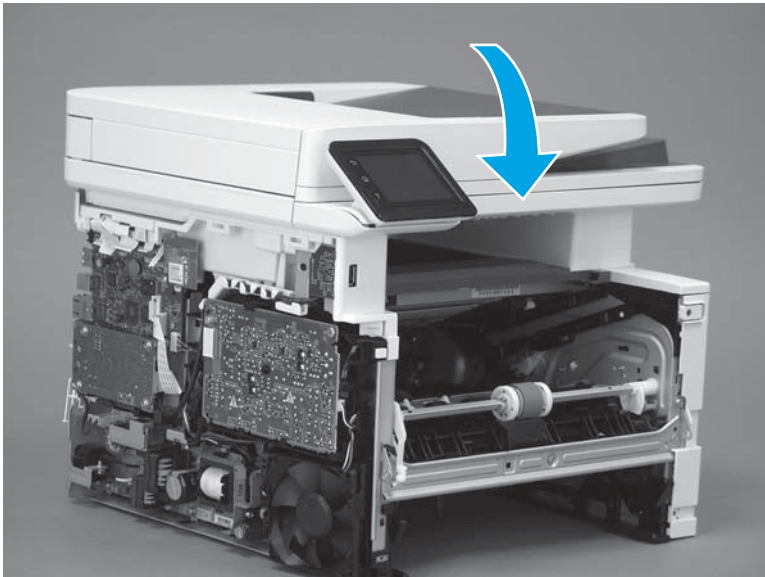
9. Position the rear edge of the ISA flat-flexible cable (FFC) cover on the printer (callout 1) , and then rotate it down (callout 2) until it snaps into place.

**Figure 1-506** Install the ISA FFC cover



10. Lower the ISA.

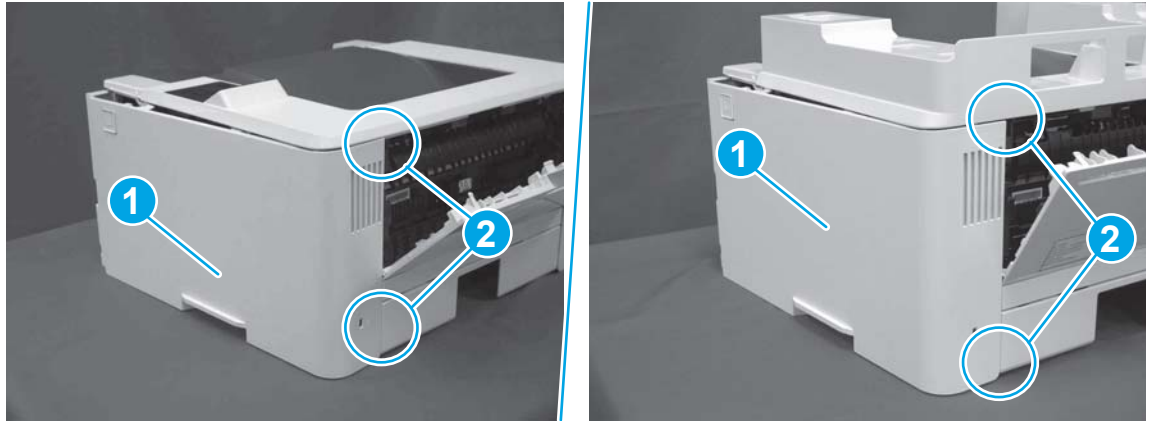
**Figure 1-507** Lower the ISA



### Step 16: Install the right cover

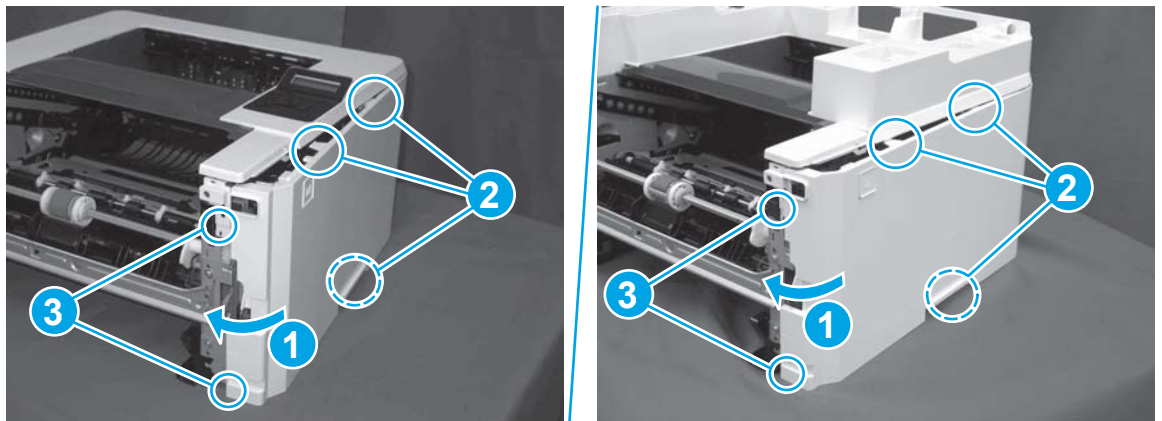
1. Position the cover (callout 1) on the printer, and then engage two bosses (callout 2).

**Figure 1-508** Install the cover



2. Rotate the front of the cover onto the printer (callout 1), engage three (callout 2) tabs, and then engage two bosses (callout 3).

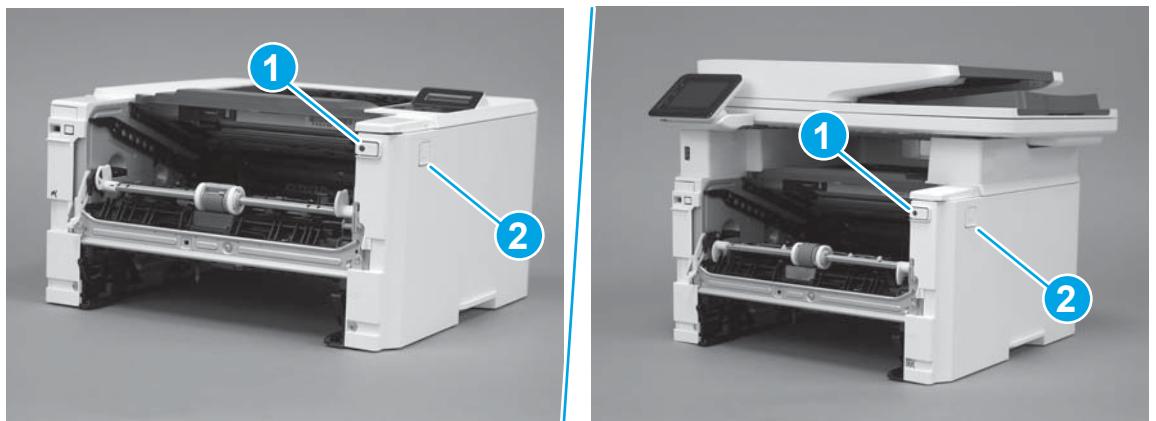
**Figure 1-509** Engage two bosses and one tab



3. Make sure that the power switch (callout 1) and cartridge door assembly button (callout 2) correctly function.

 **NOTE:** Remove, and then reinstall the cover if the switch or button does not correctly function.

**Figure 1-510** Check the power switch and cartridge door assembly button



4. Install one screw (callout 1).

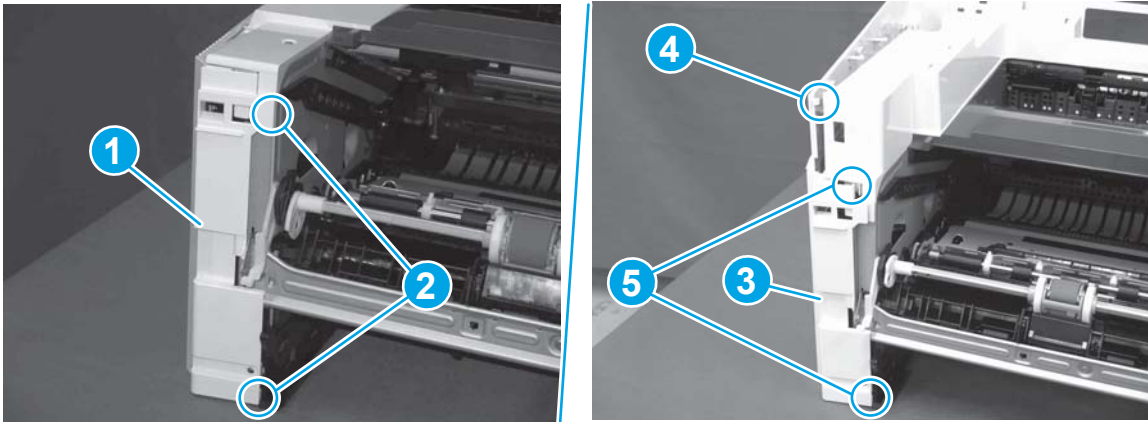
**Figure 1-511** Install one screw



### Step 17: Install the left cover

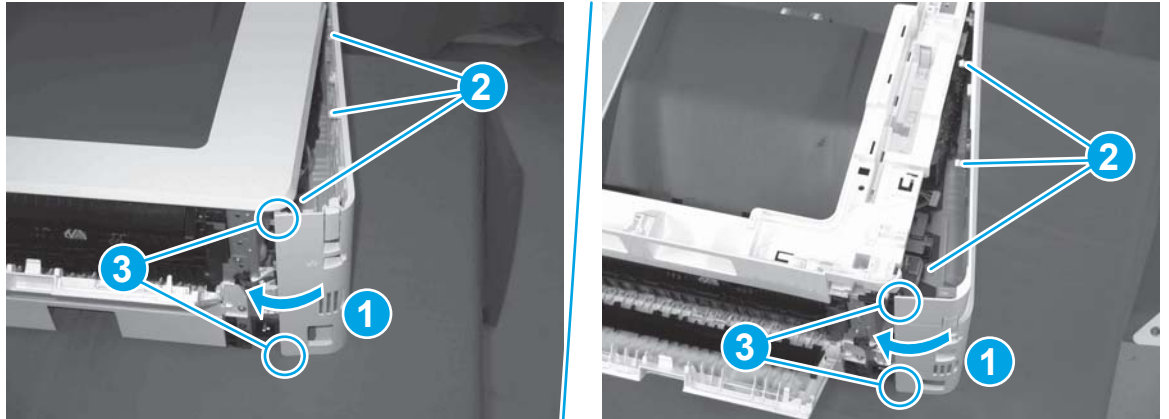
1. At the front of the printer, do one of the following:
  - **M403/M402:** Position the cover on the printer ( callout 1), and then engage two bosses (callout 2).
  - **M427/M426:** Position the cover on the printer (callout 3), engage one tab (callout 4), and then engage two bosses (callout 4).

**Figure 1-512** Install the cover



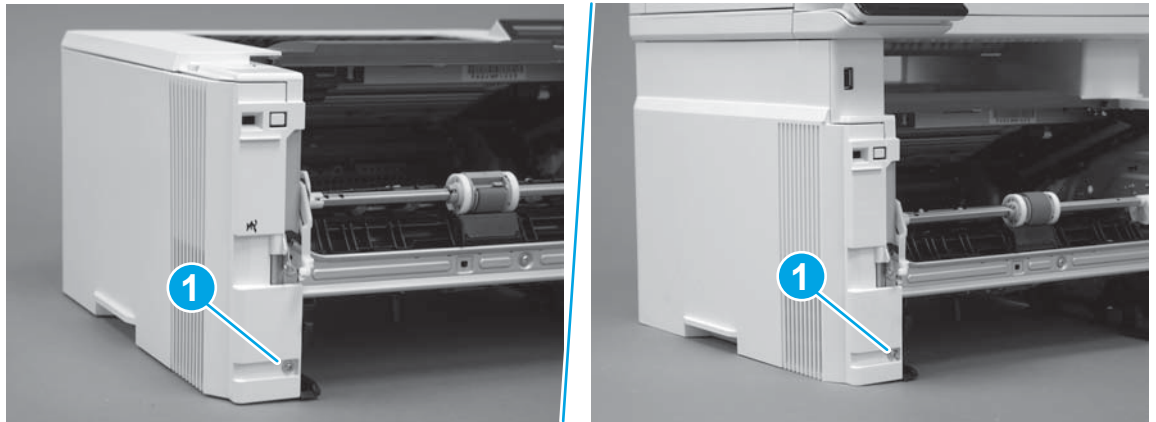
- Carefully rotate the rear of the cover onto the printer (callout 1), engage three tabs (callout 2), and then engage two bosses (callout 3).

**Figure 1-513** Engage three tabs and two bosses




- Install one screw (callout 1).

**Figure 1-514** Install one screw

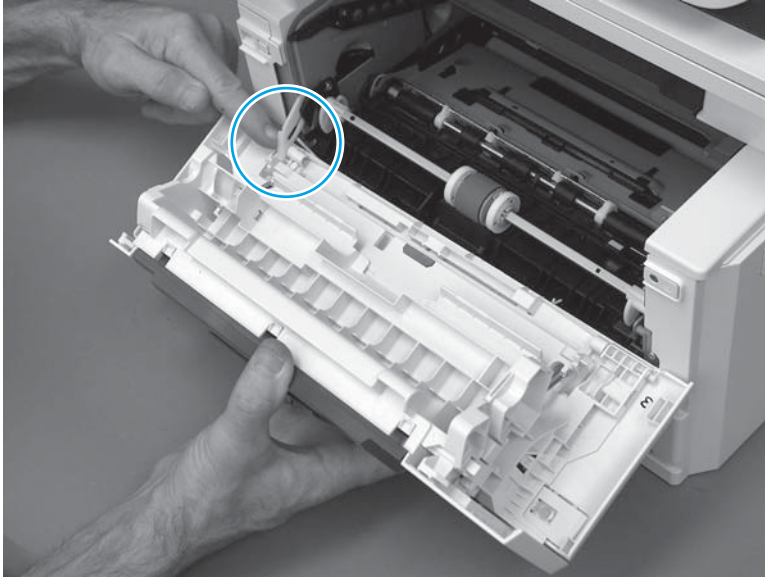


### Step 18: Install the cartridge door assembly

 **Reinstallation tip:** After a replacement door is installed, make sure to install the nameplate (supplied in the kit) corresponding to the printer name on the door.

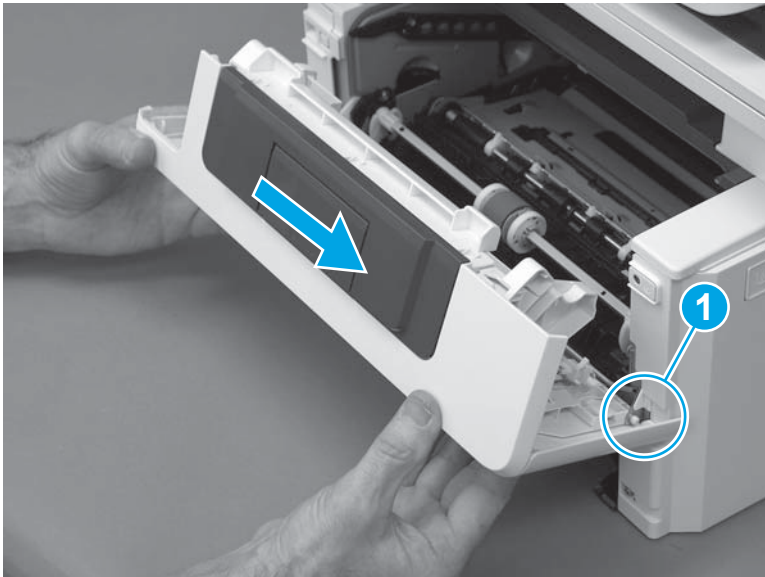
- Position the door close to the printer, and then engage the keyed pin on the left-side retainer arm with the hole in the door.

**Figure 1-515** Engage the left-side retainer arm



2. Engage the right-side door hinge pin with the hole in the chassis (callout 1).

**Figure 1-516** Install the door

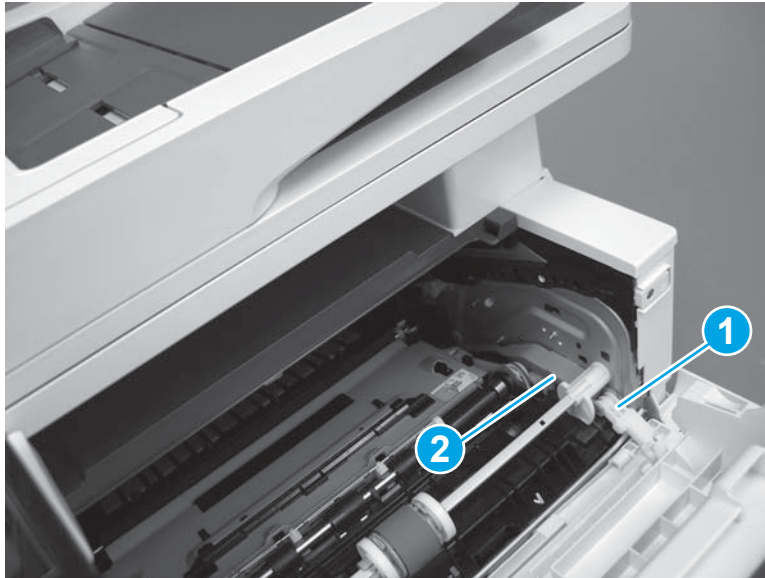




3. Install the link (callout 1).

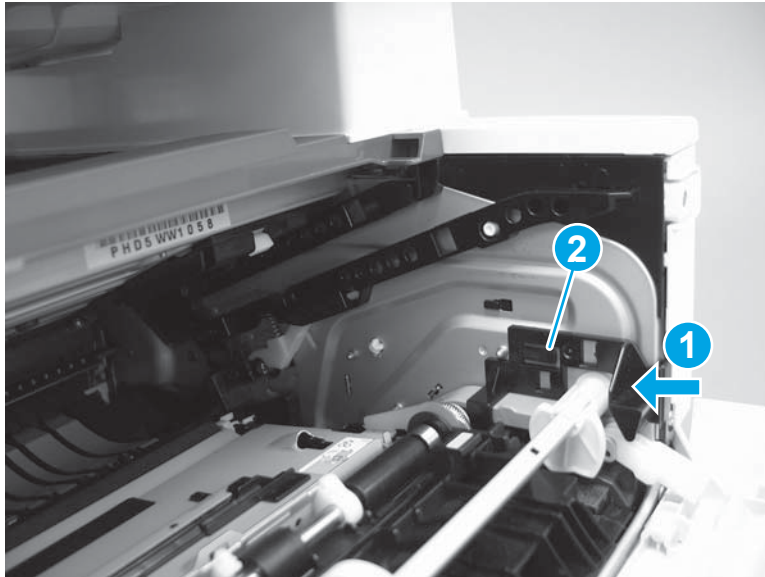
 **IMPORTANT:** Make sure that the link snaps into place on the arm (callout 2). The link actuates the fuser pressure-release mechanism.

**Figure 1-517** Install the pressure-release link



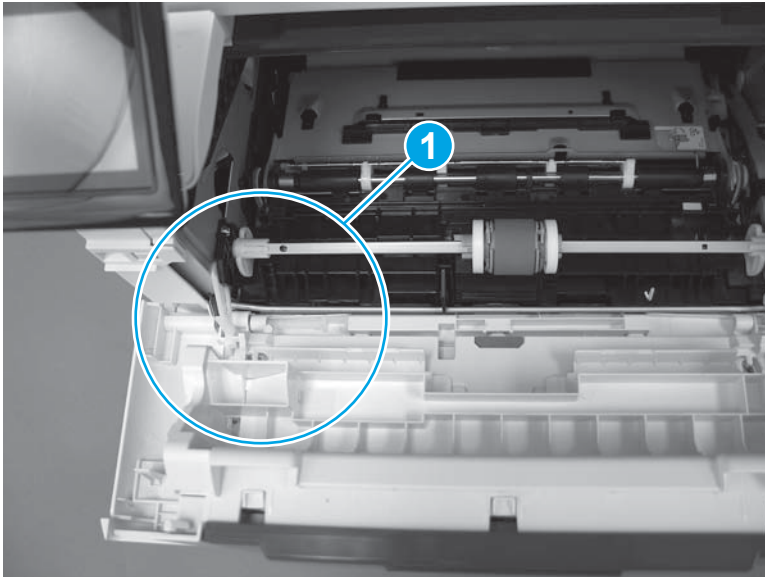
4. Slide the guide into the printer (callout 1), and then make sure that the tab (callout 2) snaps into place to secure the guide to the chassis.

**Figure 1-518** Install the guide




5. Position the shaft on the door, and then align the left-side hinge on the door with the hole in the chassis (callout 1).

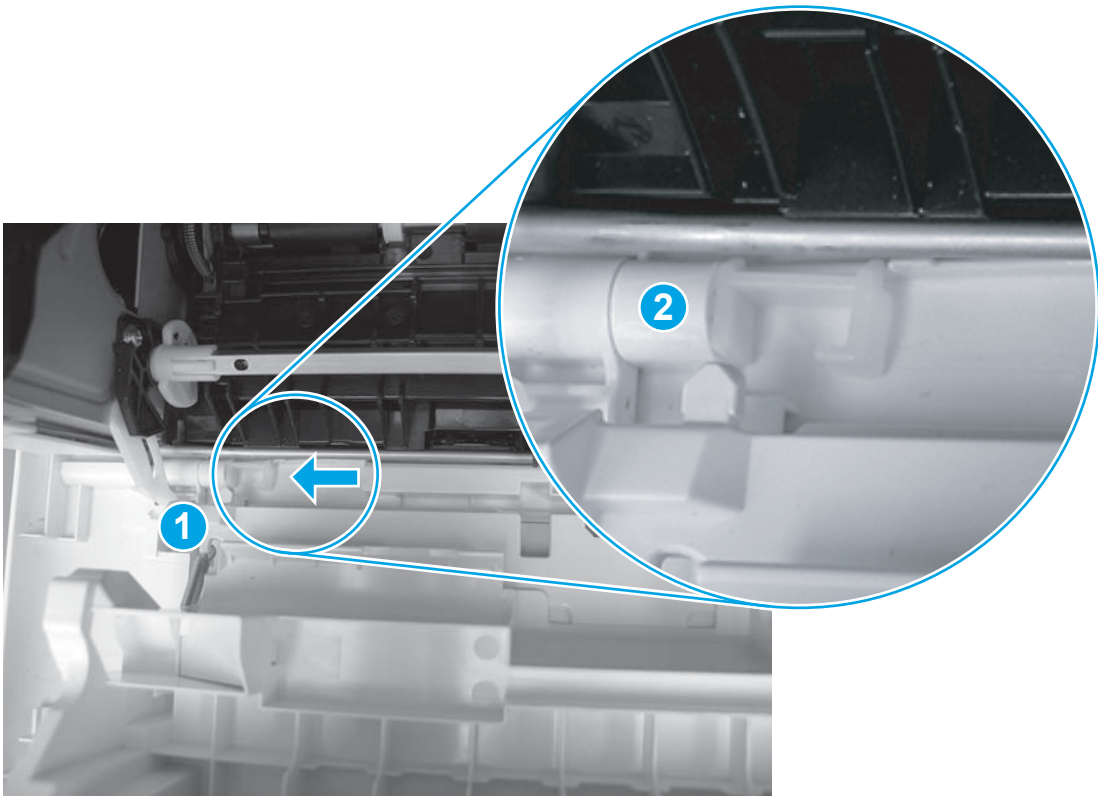
**Figure 1-519** Align the hinge



6. Push the shaft towards the left side of the printer to install it (callout 1).

 **Reinstallation tip:** Make sure that the support shaft is fully installed and correctly orientated (callout 2) so that it will not interfere with the door opening and closing.

**Figure 1-520** Install the support shaft



### Step 19: Install Tray 2

- ▲ Slide the tray straight into the printer to install it.

**Figure 1-521** Install the tray



## Removal and replacement: Integrated scanner assembly (M427/M426)



**NOTE:** M427/M426 models only. The integrated scanner assembly (ISA) includes the sub-scanner assembly (SSA) and the automatic document feeder (ADF).

- [Introduction](#)
- [Step 1: Remove Tray 2](#)
- [Step 2: Remove the cartridge door assembly](#)
- [Step 3: Remove the left cover](#)
- [Step 4: Remove the ISA \(M427/M426\)](#)
- [Step 5: Unpack the replacement assembly](#)
- [Step 6: Install the ISA \(M427/M426\)](#)
- [Step 7: Install the left cover](#)
- [Step 8: Install the cartridge door assembly](#)
- [Step 9: Install Tray 2](#)

### Introduction

This document provides the procedures to remove and replace the ISA.

### Before performing service

#### Turn the printer power off

- Disconnect the power cable.



**WARNING!** To avoid damage to the printer, turn the printer off, wait 30 seconds, and then remove the power cable before attempting to service the printer.

Use the table below to identify the correct part number for your printer. To order the part, go to [www.hp.com/buy/parts](http://www.hp.com/buy/parts).

ISA part number <sup>1</sup>	
<b>C5F98-60110</b>	ADF/scanner assembly, duplex ADF
<b>C5F98-60109</b>	ADF/scanner assembly, simplex ADF

<sup>1</sup> The ISA includes the SSA and the ADF.

### Required tools

- #2 Phillips screwdriver with a magnetic tip.

## After performing service

### Turn the printer power on

- Connect the power cable.
- Use the power switch to turn the power on.

### Post service test

Make sure that the printer initializes to a **Ready** state.

Print a configuration page, and then make a copy using the document feeder to make sure that it is properly functioning.

### Step 1: Remove Tray 2

- ▲ Pull the tray straight out of the printer to remove it.

**Figure 1-522** Remove the tray



### Step 2: Remove the cartridge door assembly



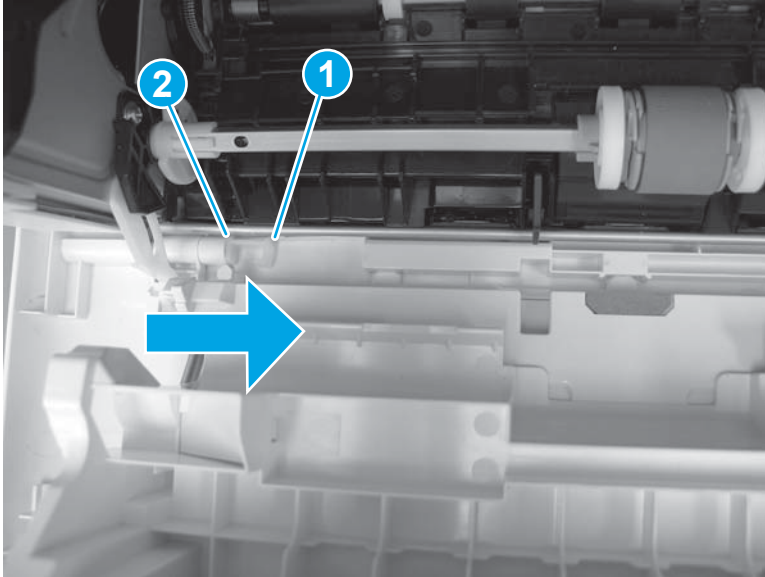
**NOTE:** If the toner cartridge was not removed prior to servicing the printer, remove it now.

1. Release one tab (callout 1), and then slide shaft (callout 2) in the direction the arrow indicates and remove it.



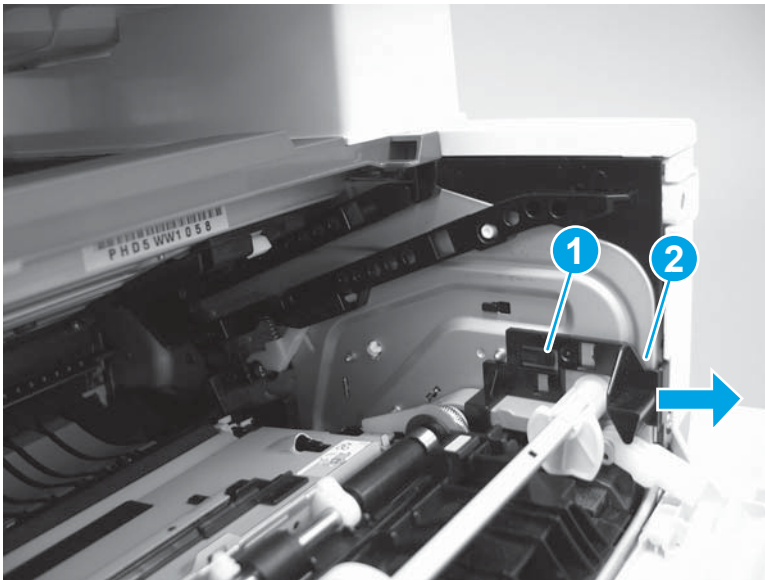
**TIP:** It might be easier to release the support shaft by using a small flat-blade screwdriver.

**Figure 1-523** Release the support shaft



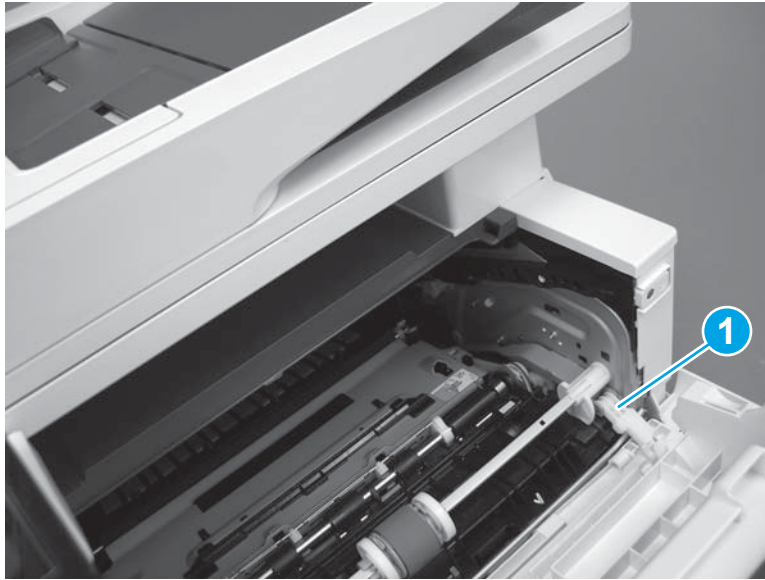
2. Release one tab (callout 1), and then slide the guide (callout 2) in the direction the arrow indicates and remove it.

**Figure 1-524** Remove the guide



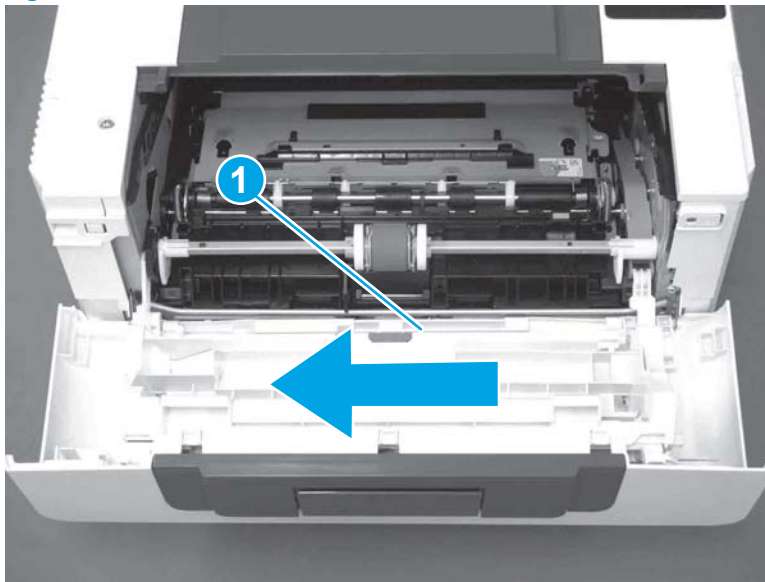
3. Remove the link arm (callout 1).

**Figure 1-525** Remove the link arm



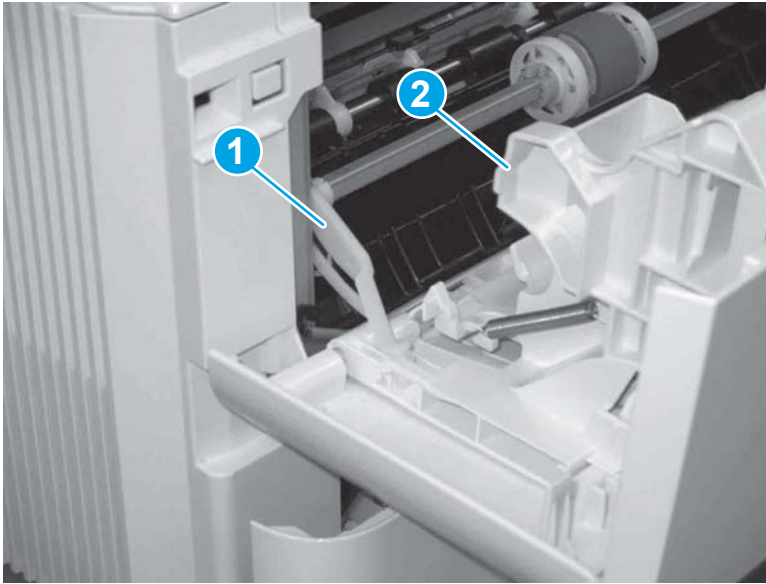
4. Slide the cartridge door assembly (callout 1) in the direction the arrow indicates and remove it.

**Figure 1-526** Remove the door



5. Remove the link (callout 1) from the cartridge door assembly (callout 2).

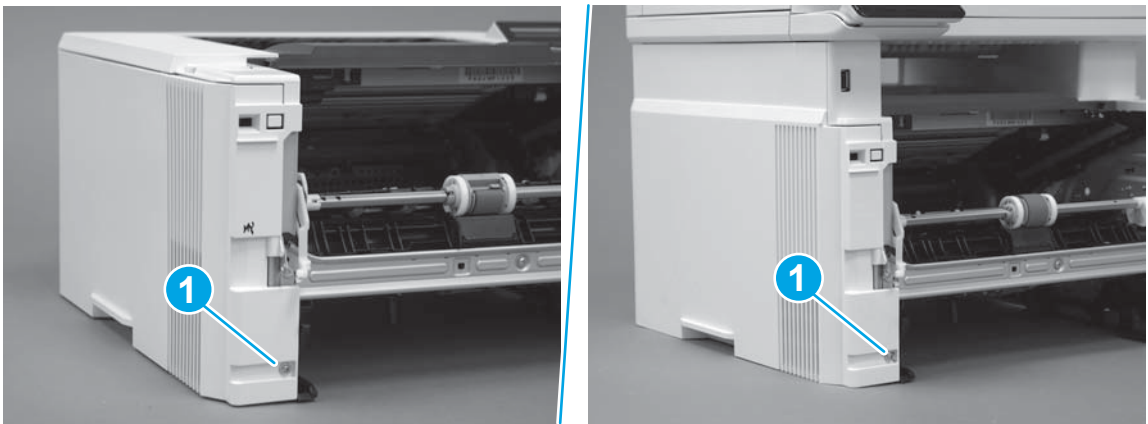
**Figure 1-527** Release the left-side retainer arm



### Step 3: Remove the left cover

1. Remove one screw (callout 1).

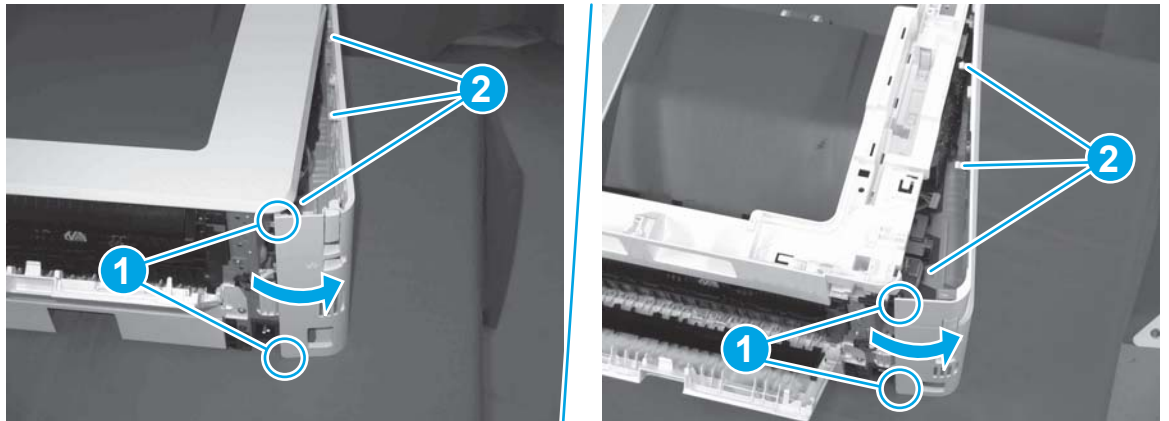
**Figure 1-528** Remove one screw





2. Open the rear door, release two bosses (callout 1), and then release three tabs (callout 2).

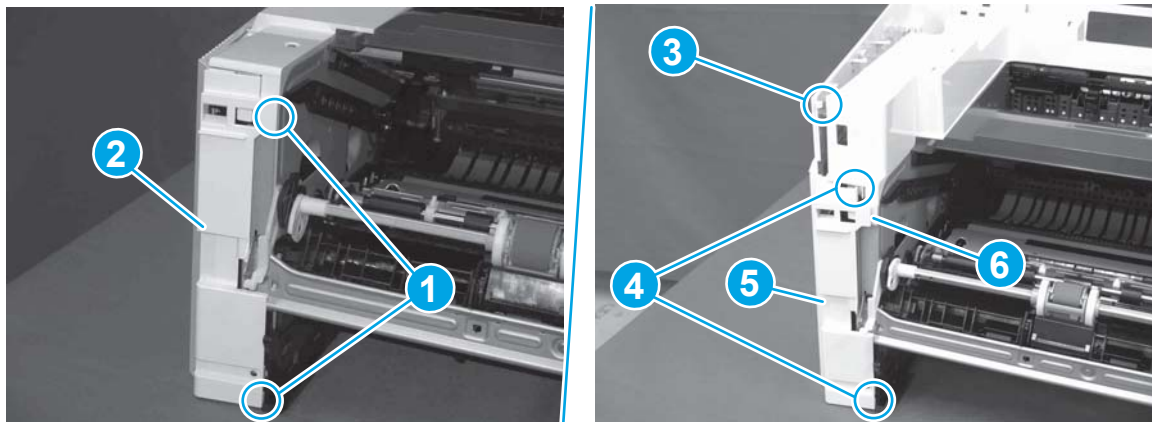
**Figure 1-529** Release two bosses and three tabs



3. At the front of the printer, do one of the following:
  - **M403/M402:** Release two bosses (callout 1), and then remove the cover (callout 2).
  - **M427/M426:** Release one tab (callout 3), two bosses (callout 4), and then remove the cover (callout 5).

**CAUTION:** Be careful when releasing the upper bosses on the M427/M426 cover. One portion of the cover (callout 6) is fragile and is easily broken.

**Figure 1-530** Remove the cover

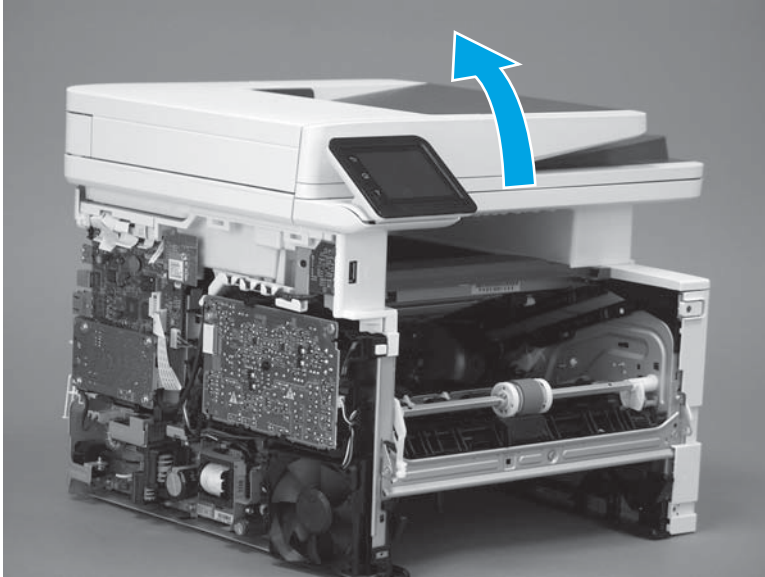


#### Step 4: Remove the ISA (M427/M426)

**NOTE:** M427/M426 models only. The integrated scanner assembly (ISA) includes the sub-scanner assembly (SSA) and the automatic document feeder (ADF).

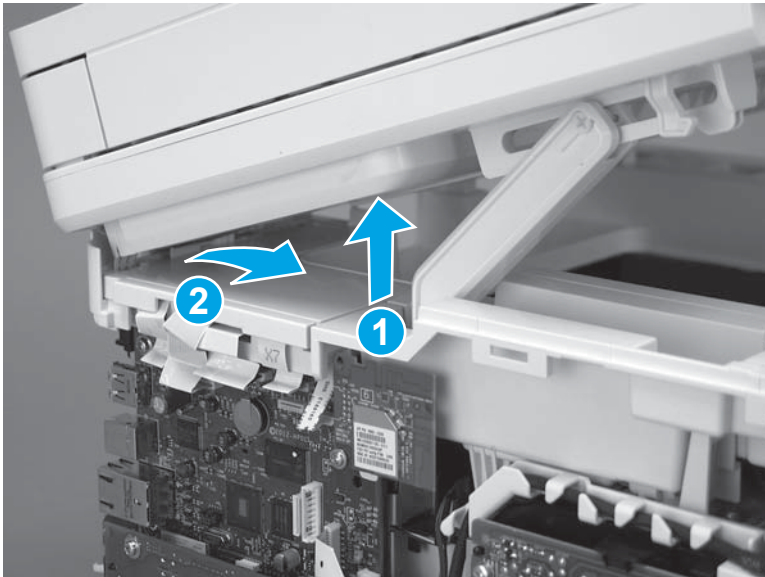
1. Raise the ISA.

**Figure 1-531** Raise the ISA



2. Release the ISA flat-flexible cable (FFC) cover (callout 1), and then remove it (callout 2).

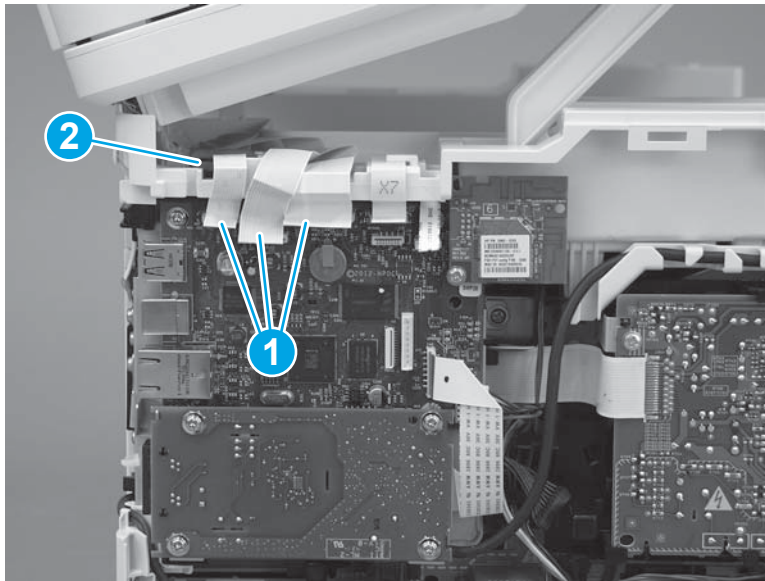
**Figure 1-532** Remove the ISA FFC cover



3. Disconnect three FFCs (callout 1), and then remove the ferrite (callout 2) from the holder.

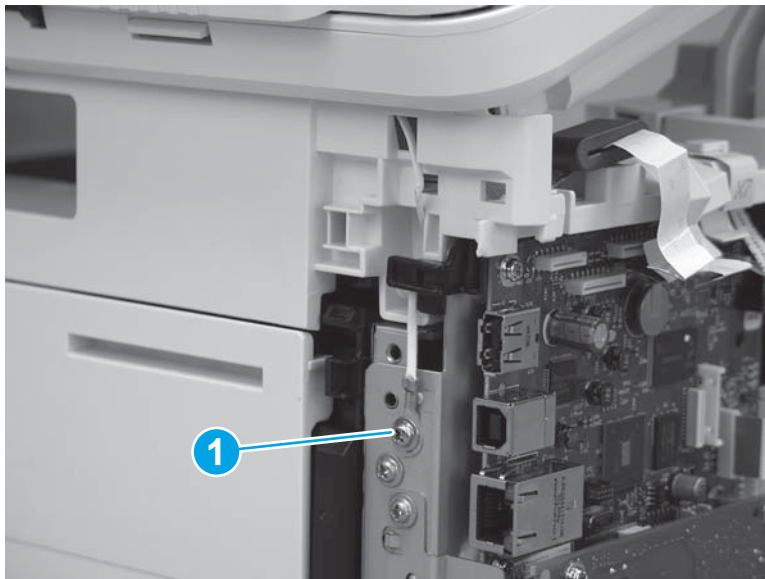
**CAUTION:** The ferrite is not captive on the FFC. Do not lose the ferrite while handling the ISA.

**Figure 1-533** Disconnect three FFCs



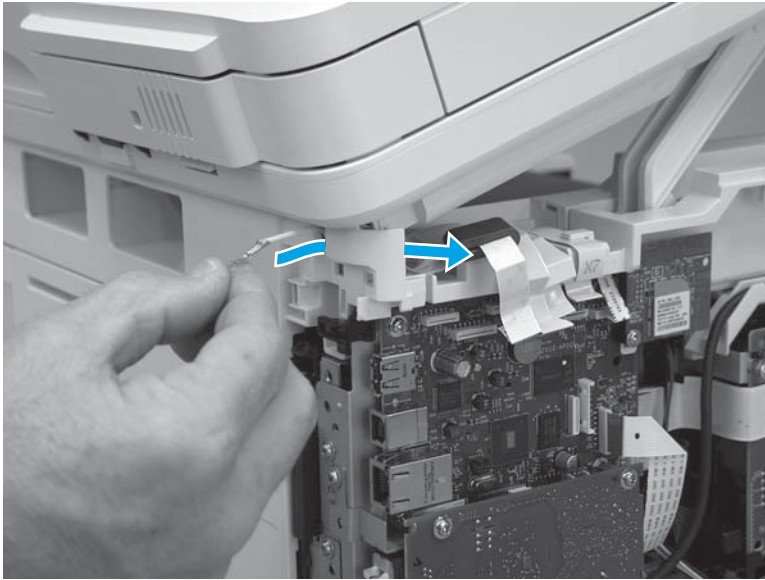
4. Remove one screw (callout 1).

**Figure 1-534** Remove one screw



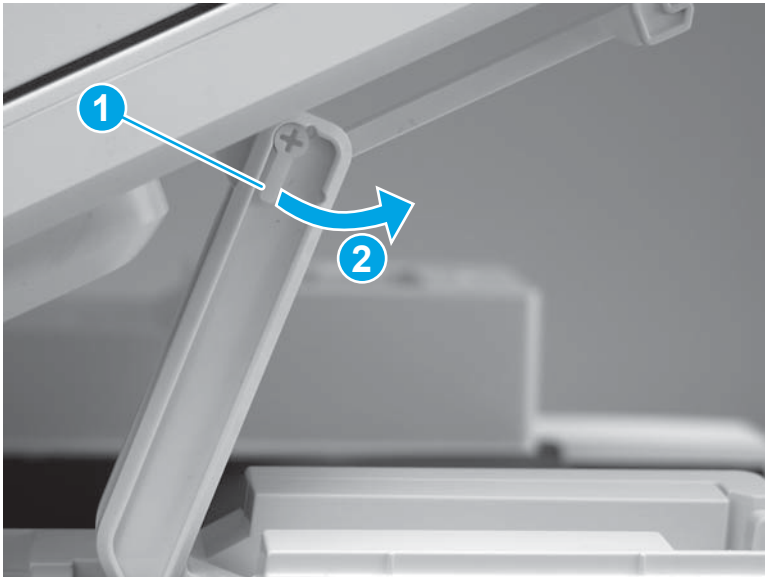
5. Pass the ground wire through the opening in the top cover.

**Figure 1-535** Pass the wire through the opening



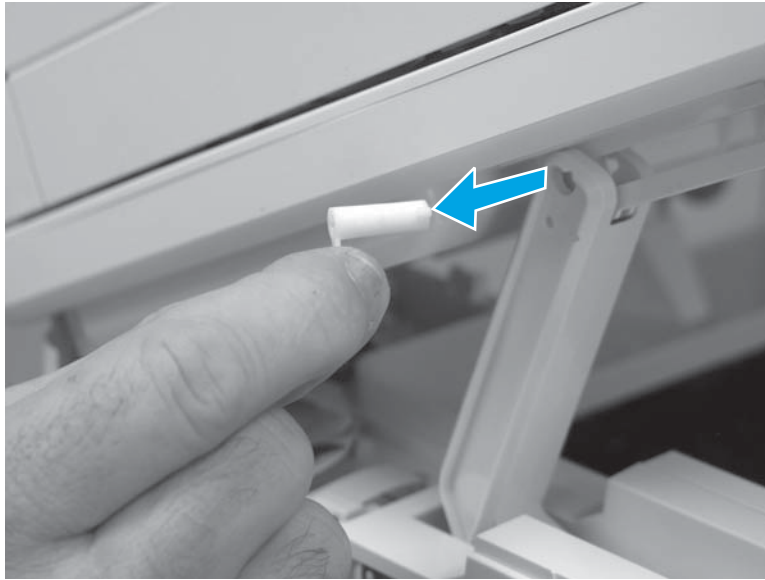
6. Release one tab (callout 1), and then rotate the ISA slider pin (callout 2) towards the front of the printer to release it.

**Figure 1-536** Release one tab and rotate the slider pin



7. Remove the slider pin.

**Figure 1-537** Remove the slider pin



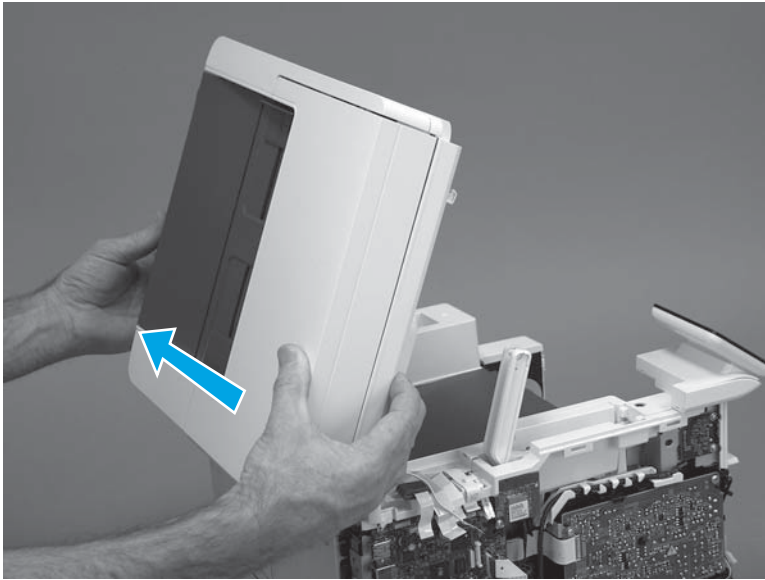
8. Rotate the ISA towards the rear of the printer until it stops.

**Figure 1-538** Rotate the ISA towards the rear of the printer



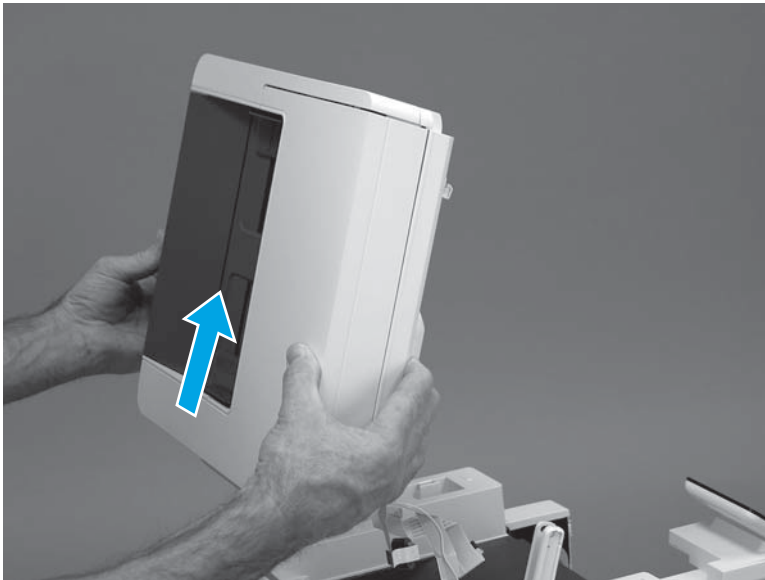
- Slide the ISA as shown to release it.

**Figure 1-539** Release the ISA



- Remove the ISA.

**Figure 1-540** Remove the ISA



### Step 5: Unpack the replacement assembly

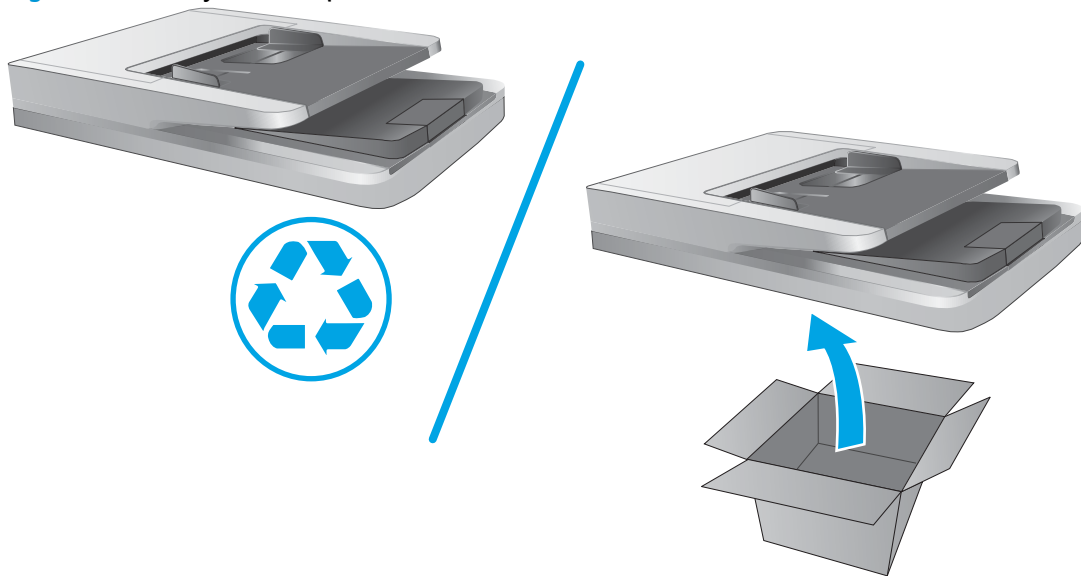
Unpack the replacement part from the packaging.

<http://www8.hp.com/us/en/hp-information/environment/product-recycling.html>




**NOTE:** HP recommends responsible disposal of the defective part.

**Figure 1-541** Recycle and unpack

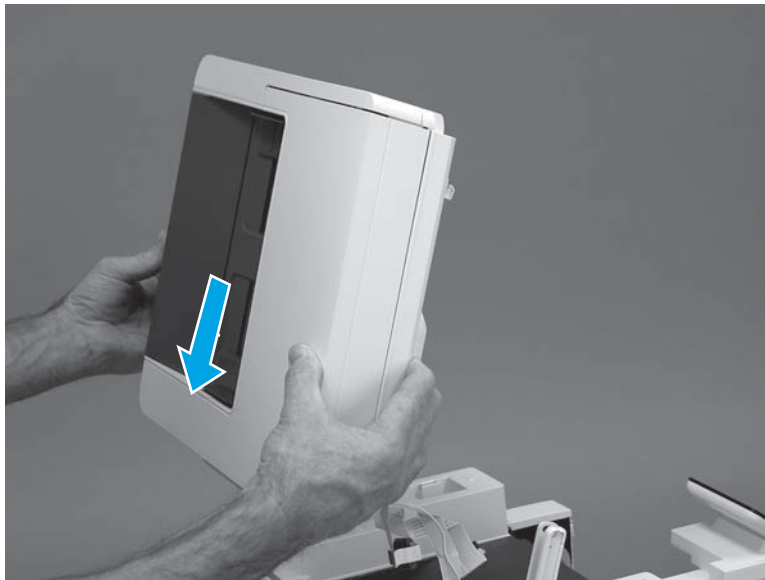


**Step 6: Install the ISA (M427/M426)**

 **NOTE:** M427/M426 models only. The integrated scanner assembly (ISA) includes the sub-scanner assembly (SSA) and the automatic document feeder (ADF).

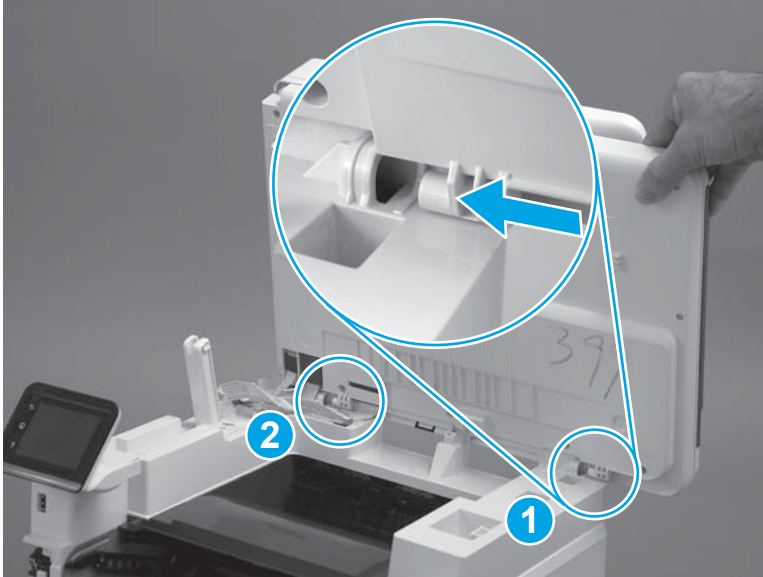
1. Position the ISA on the printer.

**Figure 1-542** Position the ISA on the printer



2. Engage the hinge pins on the ISA with the holders in the top cover (callouts 1/2), and then slide the ISA as shown to engage them

**Figure 1-543** Engage the hinge pins with the holders



3. Rotate the ISA towards the front of the printer until it rests on the ISA lift assembly (callout 1).

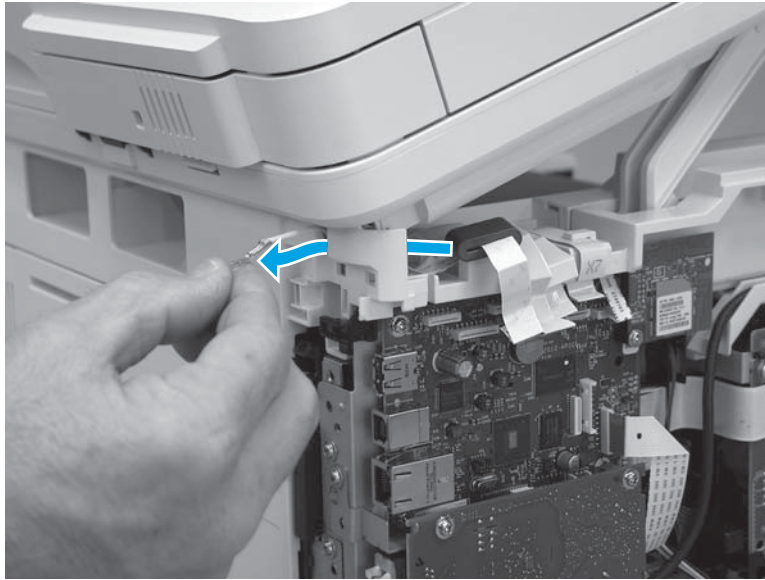
**Figure 1-544** Rotate the ISA towards the front of the printer





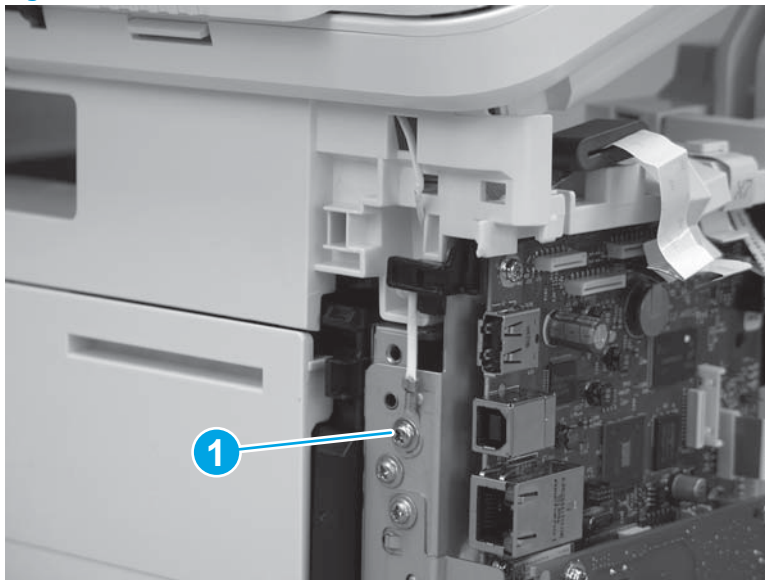
4. Pass the ground wire through the opening in the top cover.

**Figure 1-545** Pass the wire through the opening




5. Install one screw (callout 1).

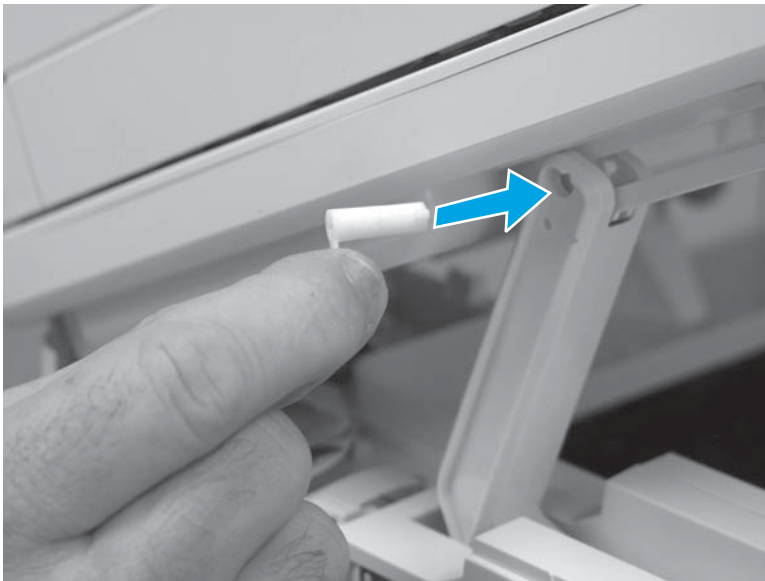
**Figure 1-546** Install one screw



6. Install the ISA lift assembly slider pin.

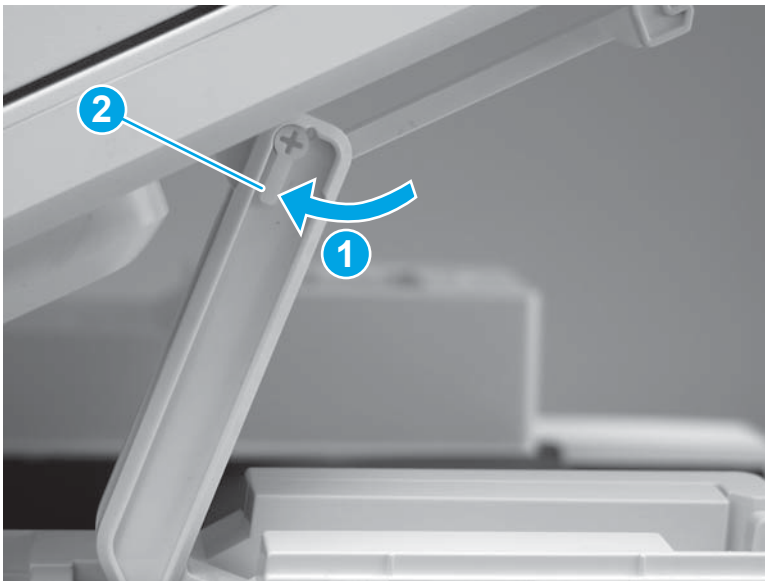
 **Reinstallation tip:** Align the keyed portion of the locking pin with the slot and hole in the support arm.

**Figure 1-547** Install the slider pin



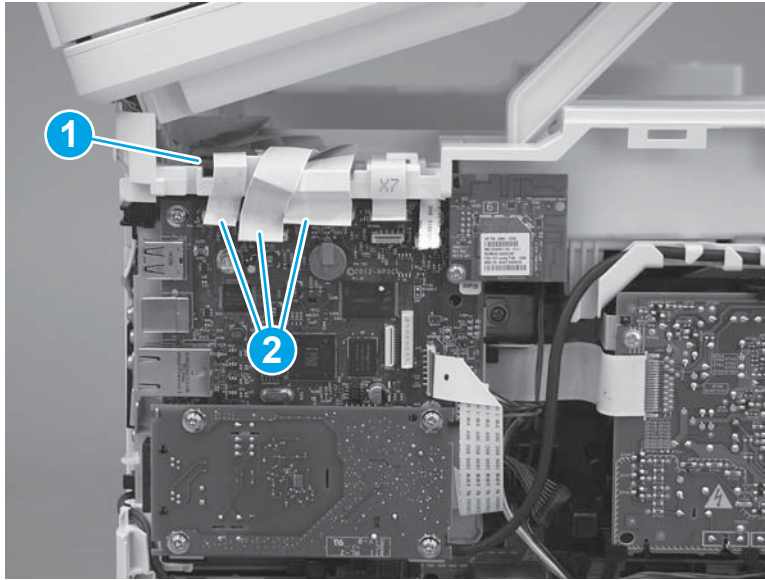
7. Rotate the slider pin (callout 1) towards the rear of the printer until the tab (callout 2) snap into place.

**Figure 1-548** Secure the slider pin



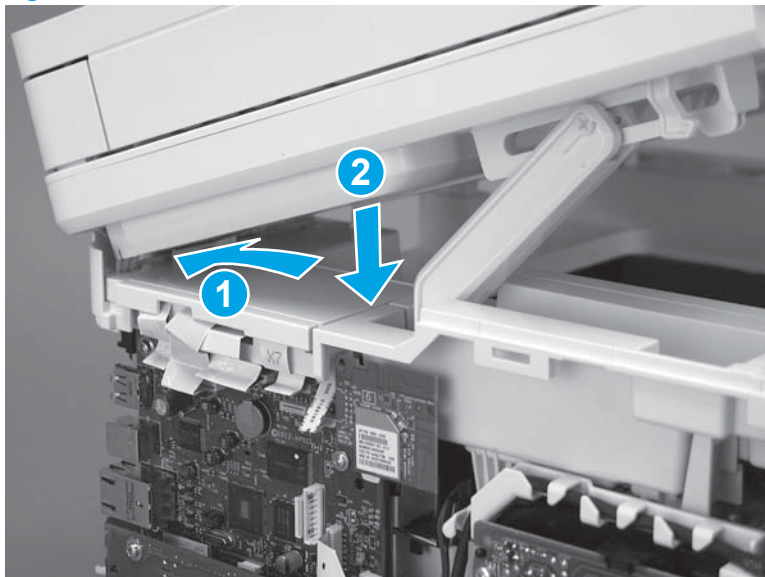
8. Install the ferrite (callout 1) in the holder, and then connect three FFCs (callout 2).

**Figure 1-549** Connect three FFCs



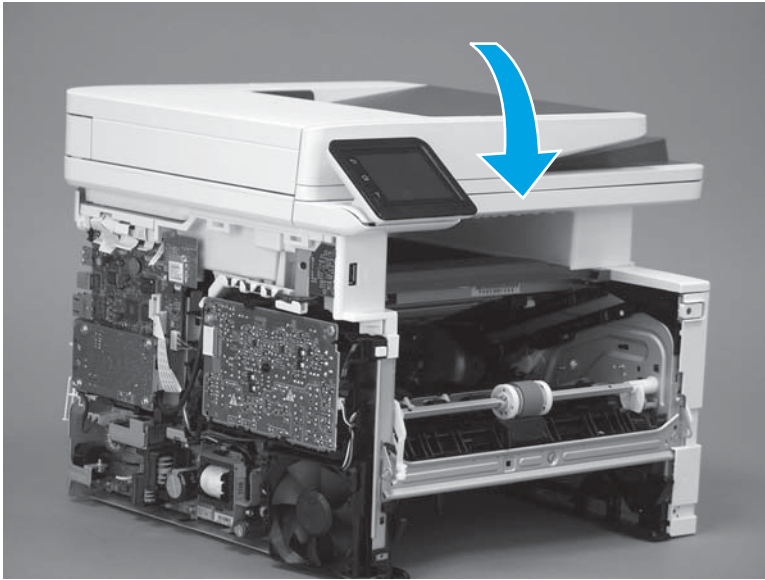
9. Position the rear edge of the ISA flat-flexible cable (FFC) cover on the printer (callout 1), and then rotate it down (callout 2) until it snaps into place.

**Figure 1-550** Install the ISA FFC cover



10. Lower the ISA.

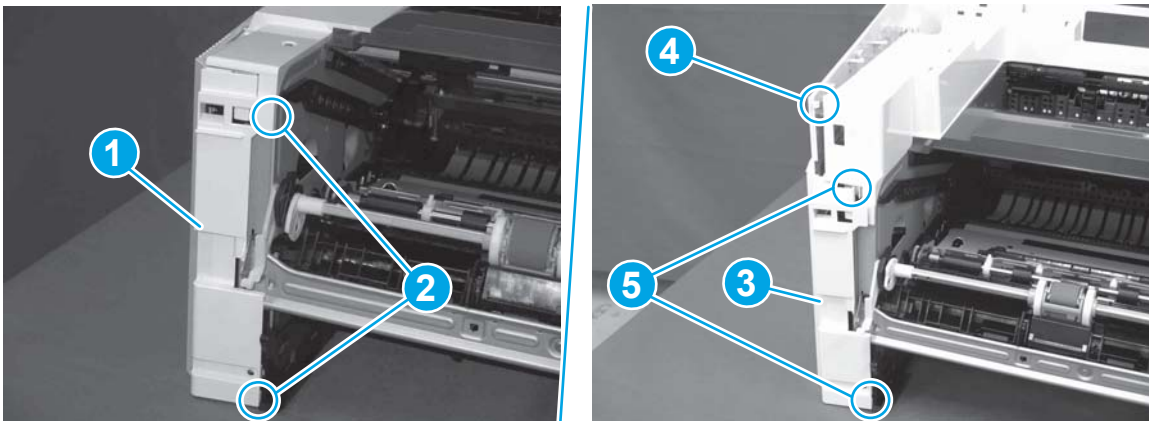
**Figure 1-551** Lower the ISA



### Step 7: Install the left cover

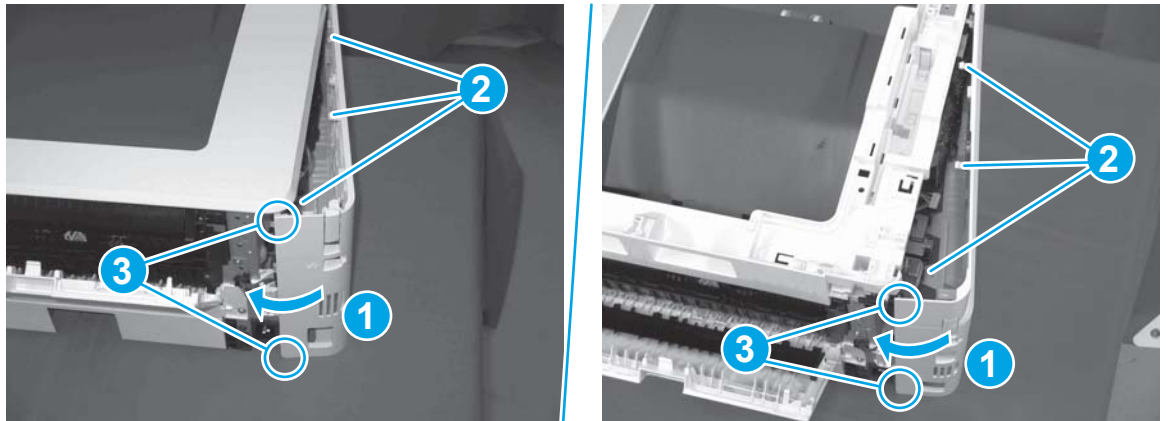
1. At the front of the printer, do one of the following:
  - **M403/M402:** Position the cover on the printer ( callout 1), and then engage two bosses (callout 2).
  - **M427/M426:** Position the cover on the printer (callout 3), engage one tab (callout 4), and then engage two bosses (callout 4).

**Figure 1-552** Install the cover



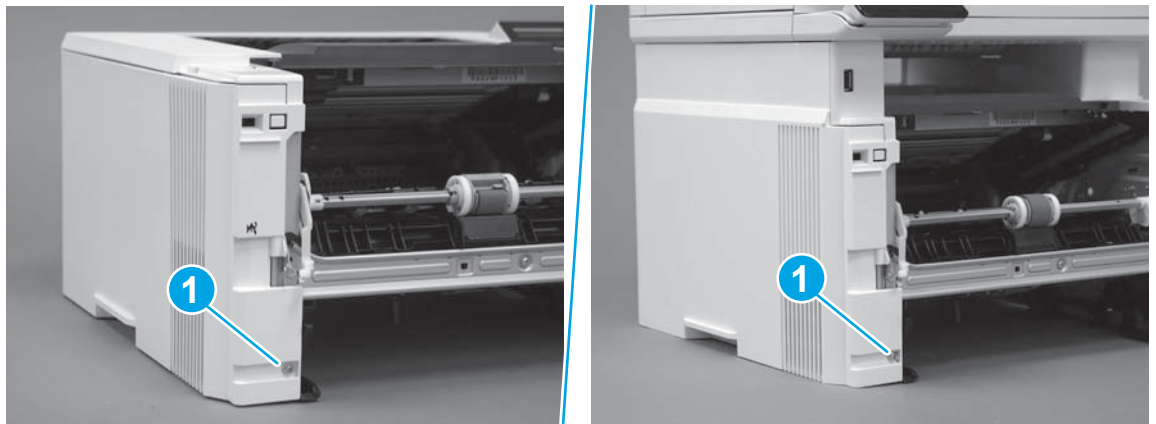
- Carefully rotate the rear of the cover onto the printer (callout 1), engage three tabs (callout 2), and then engage two bosses (callout 3).

**Figure 1-553** Engage three tabs and two bosses




- Install one screw (callout 1).

**Figure 1-554** Install one screw

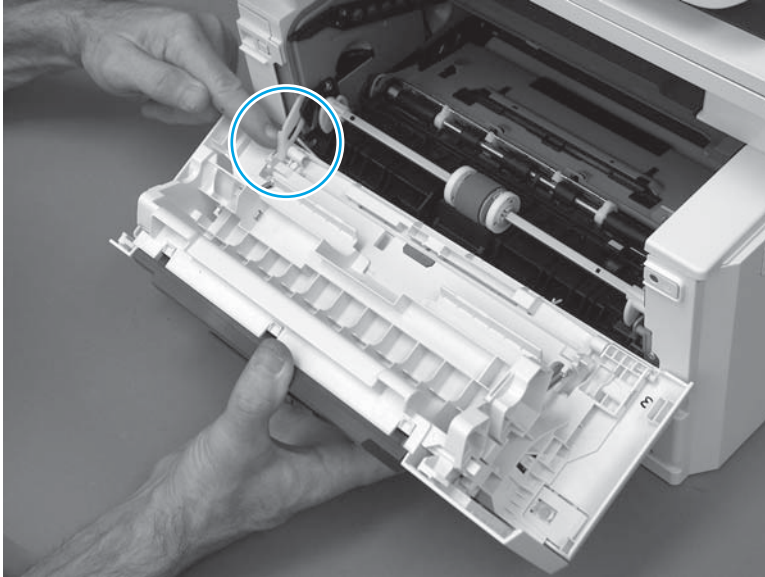


### Step 8: Install the cartridge door assembly

 **Reinstallation tip:** After a replacement door is installed, make sure to install the nameplate (supplied in the kit) corresponding to the printer name on the door.

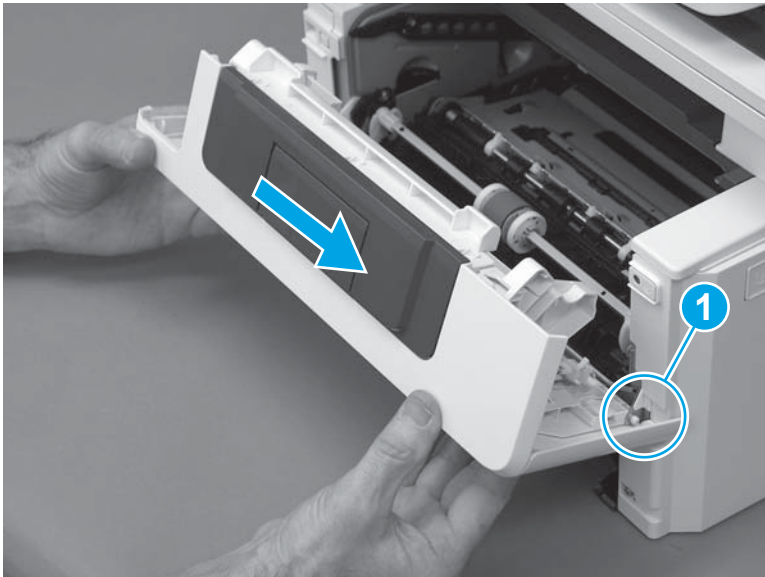
- Position the door close to the printer, and then engage the keyed pin on the left-side retainer arm with the hole in the door.

**Figure 1-555** Engage the left-side retainer arm



2. Engage the right-side door hinge pin with the hole in the chassis (callout 1).

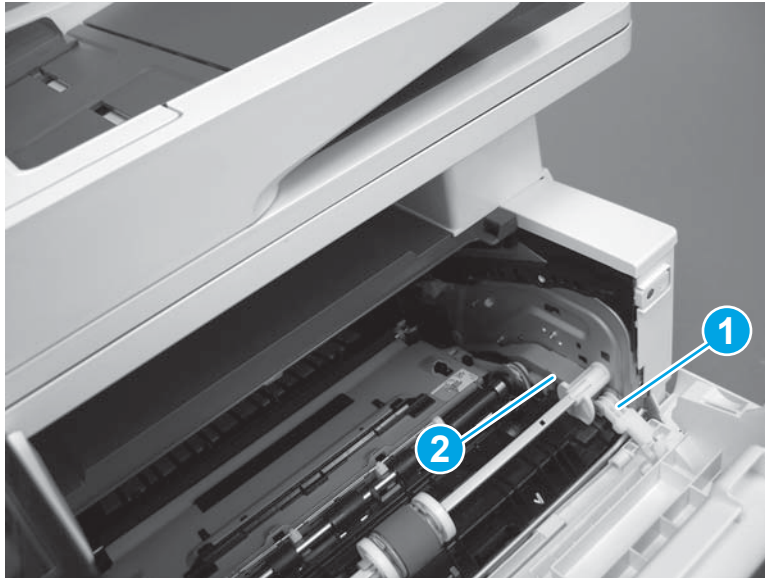
**Figure 1-556** Install the door



3. Install the link (callout 1).

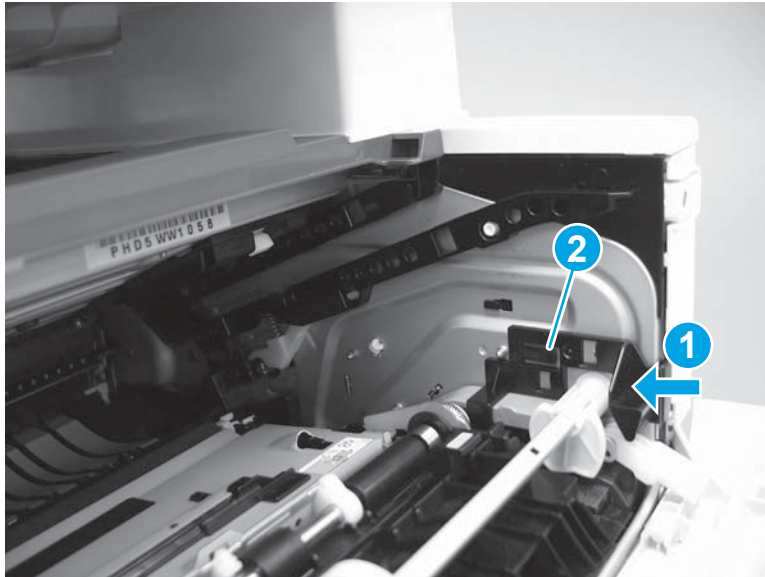
 **IMPORTANT:** Make sure that the link snaps into place on the arm (callout 2). The link actuates the fuser pressure-release mechanism.

**Figure 1-557** Install the pressure-release link



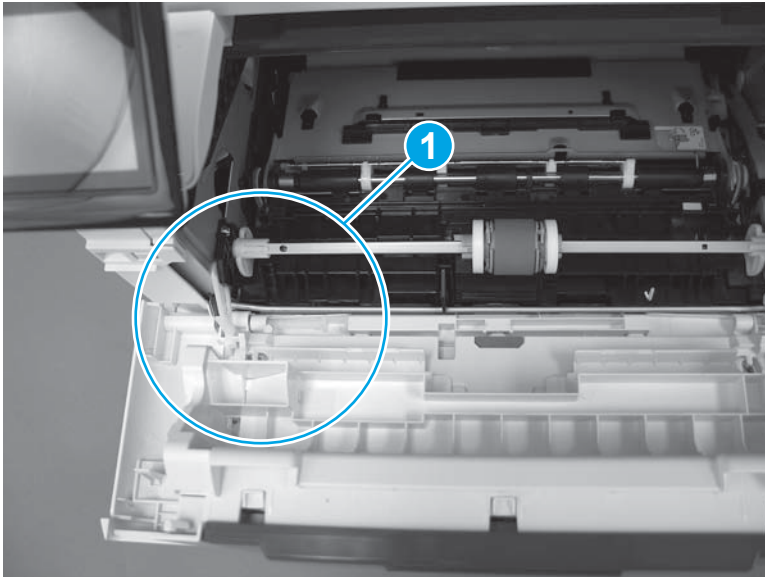
4. Slide the guide into the printer (callout 1), and then make sure that the tab (callout 2) snaps into place to secure the guide to the chassis.

**Figure 1-558** Install the guide




5. Position the shaft on the door, and then align the left-side hinge on the door with the hole in the chassis (callout 1).

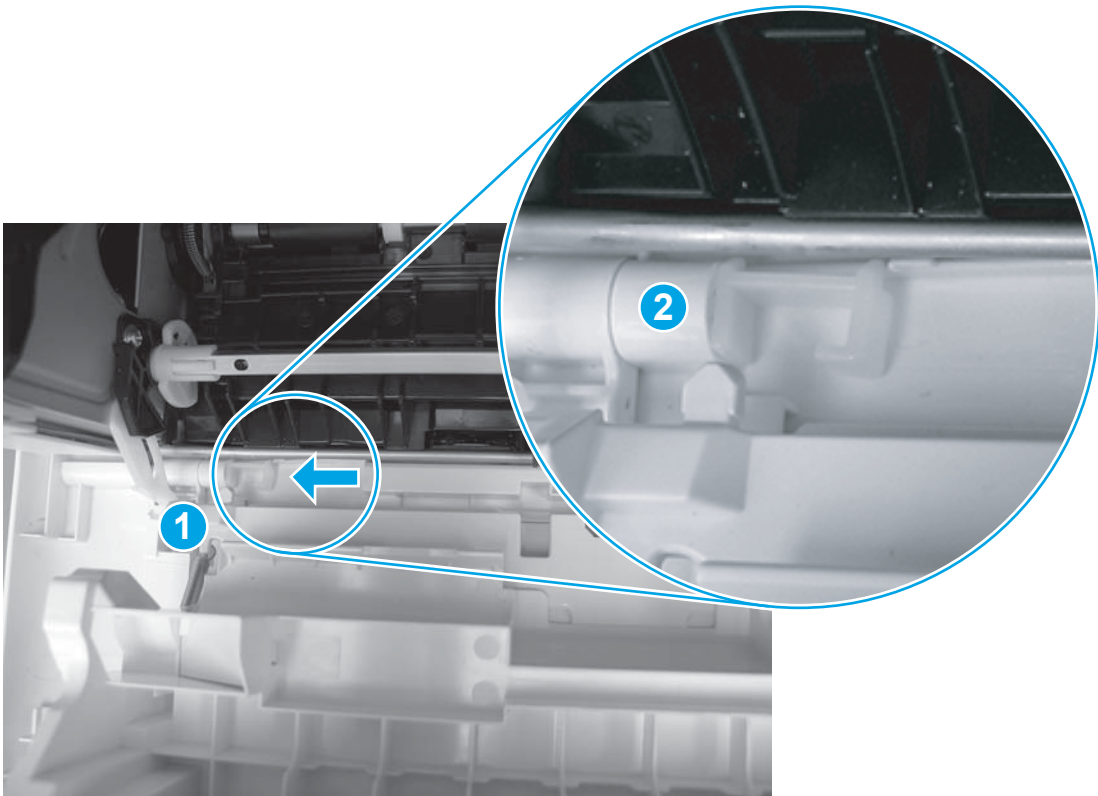
**Figure 1-559** Align the hinge



6. Push the shaft towards the left side of the printer to install it (callout 1).

 **Reinstallation tip:** Make sure that the support shaft is fully installed and correctly orientated (callout 2) so that it will not interfere with the door opening and closing.

**Figure 1-560** Install the support shaft





### Step 9: Install Tray 2

- ▲ Slide the tray straight into the printer to install it.

**Figure 1-561** Install the tray



## Removal and replacement: ISA lift assembly and slider pin (M427/M426)

 **NOTE:** M427/M426 models only.

- [Introduction](#)
- [Step 1: Remove the slider pin \(M427/M426\)](#)
- [Step 2: Remove the ISA lift assembly \(M427/M426\)](#)
- [Step 3: Unpack the replacement assembly](#)
- [Step 4: Install the ISA lift assembly \(M427/M426\)](#)
- [Step 5: Install the slider pin \(M427/M426\)](#)


### Introduction

This document provides the procedures to remove and replace the integrated scanner assembly (ISA) support arm.

### Before performing service

#### Turn the printer power off

- Disconnect the power cable.

 **WARNING!** To avoid damage to the printer, turn the printer off, wait 30 seconds, and then remove the power cable before attempting to service the printer.

Use the table below to identify the correct part number for your printer. To order the part, go to [www.hp.com/buy/parts](http://www.hp.com/buy/parts).

---

#### ISA lift assembly and slider pin

---

<b>83Q10-60128</b>	ISA lift assembly
<b>83Q10-40041</b>	Slider pin, ISA lift assembly

---

### Required tools

- #2 Phillips screwdriver with a magnetic tip.

### After performing service

#### Turn the printer power on

- Connect the power cable.
- Use the power switch to turn the power on.

### Post service test

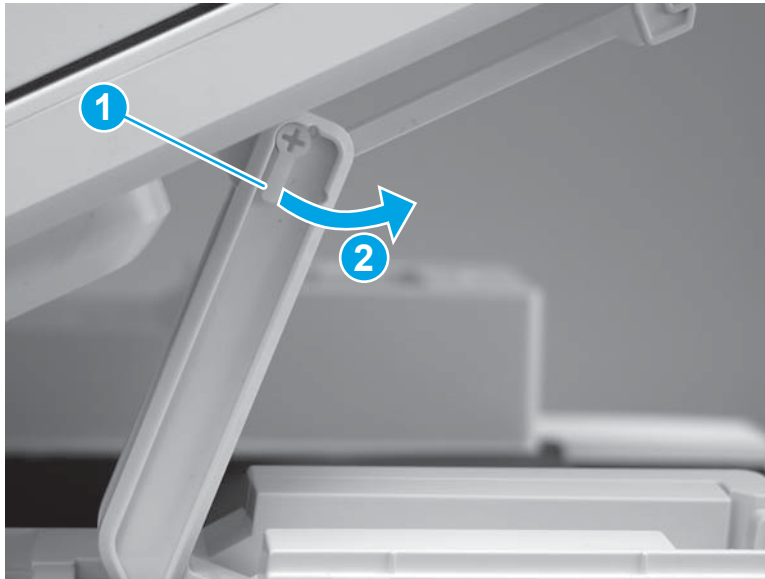
Make sure that the printer initializes to a **Ready** state.

Print a configuration page, and then make a copy using the document feeder to make sure that it is properly functioning.

### Step 1: Remove the slider pin (M427/M426)

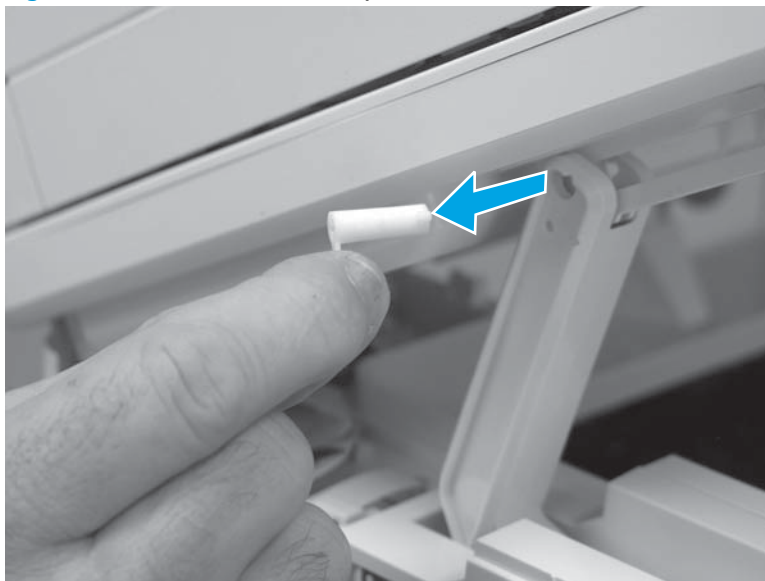
1. Open the ISA, release one tab (callout 1), and then rotate the ISA slider pin (callout 2) towards the front of the printer to release it.

**Figure 1-562** Release one tab and rotate the slider pin



2. Remove the slider pin.

**Figure 1-563** Remove the slider pin

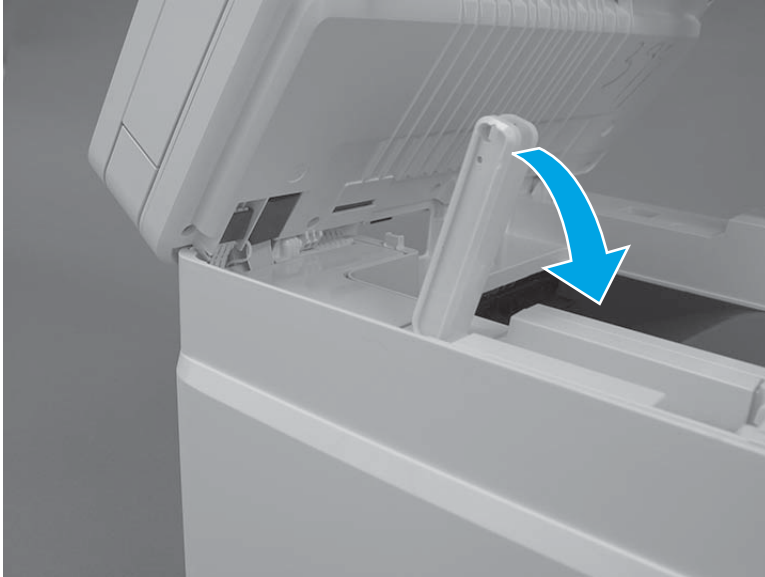


### Step 2: Remove the ISA lift assembly (M427/M426)

1. Move the ISA out of the way, and then lower the support arm to the closed position.

**CAUTION:** The ISA hinges are not captive in the top cover mounting bosses. Do not allow the ISA to slip off of the top cover.

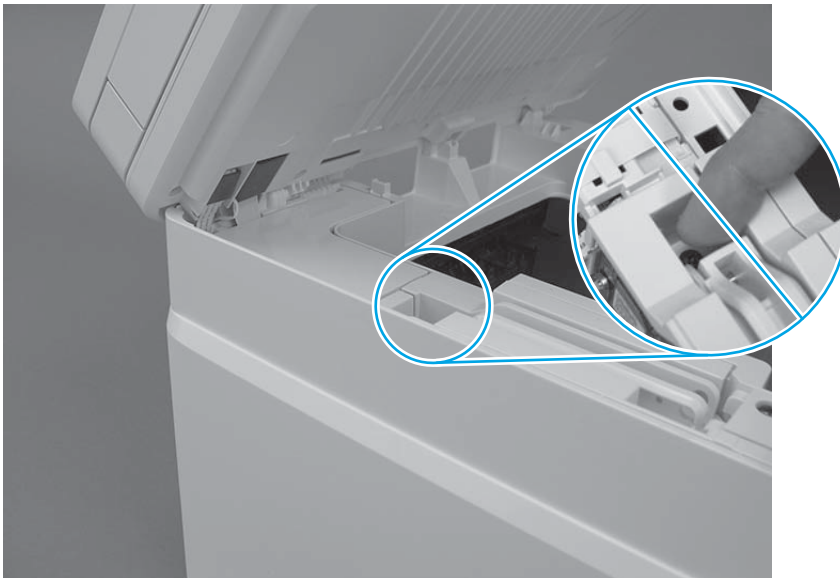
**Figure 1-564** Lower the support arm



2. Before proceeding take note of the following.

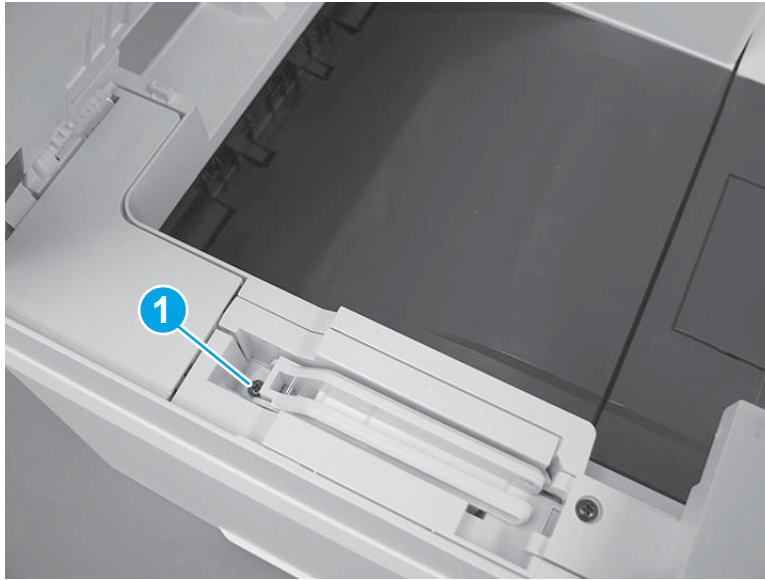
**⚠ CAUTION:** The support arm is spring loaded and can unexpectedly spring into the open position. To avoid injury, do not place a finger in the screw well when the support arm is in the closed position.

**Figure 1-565** Before proceeding take note



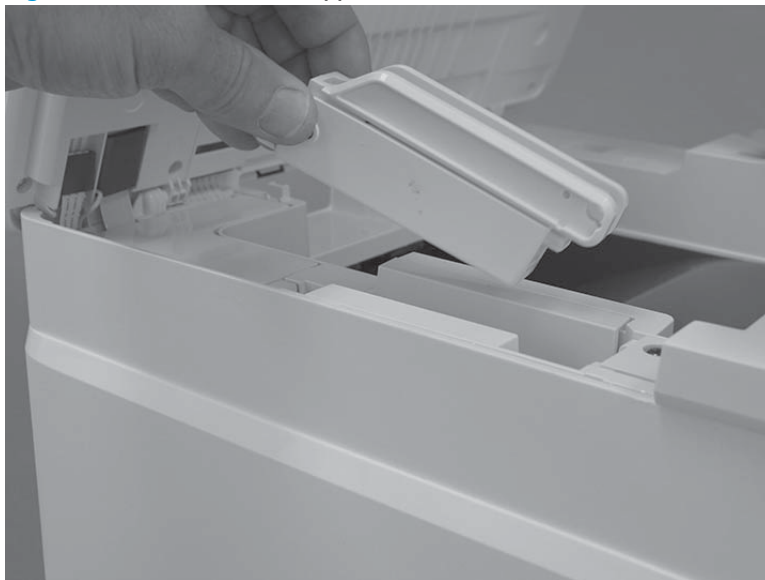
3. Remove one screw (callout 1).

**Figure 1-566** Remove one screw



4. Remove the support arm.

**Figure 1-567** Remove the support arm



### Step 3: Unpack the replacement assembly

Unpack the replacement part from the packaging.

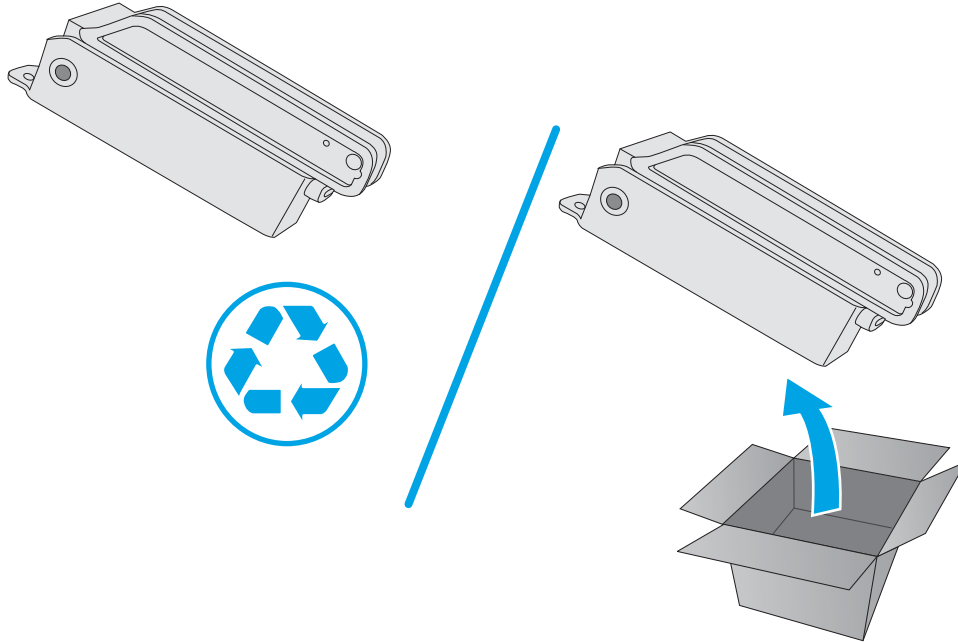
<http://www8.hp.com/us/en/hp-information/environment/product-recycling.html>

---

 **NOTE:** HP recommends responsible disposal of the defective part.

---

**Figure 1-568** Recycle and unpack



**Step 4: Install the ISA lift assembly (M427/M426)**

1. Support the ISA, align the tab (callout 1) on the lift assembly with the slot in the top cover (callout 2), and then install the lift assembly.

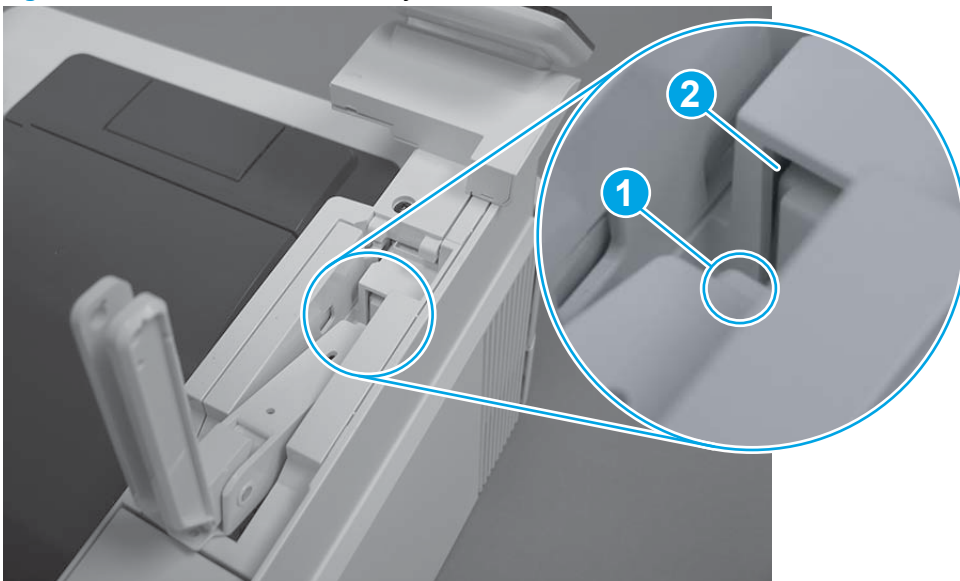
---

**CAUTION:** The ISA hinges are not captive in the top cover mounting bosses. Do not allow the ISA to slip off of the top cover.

**NOTE:** If the replacement lift assembly is in the closed position, place it in the open position.

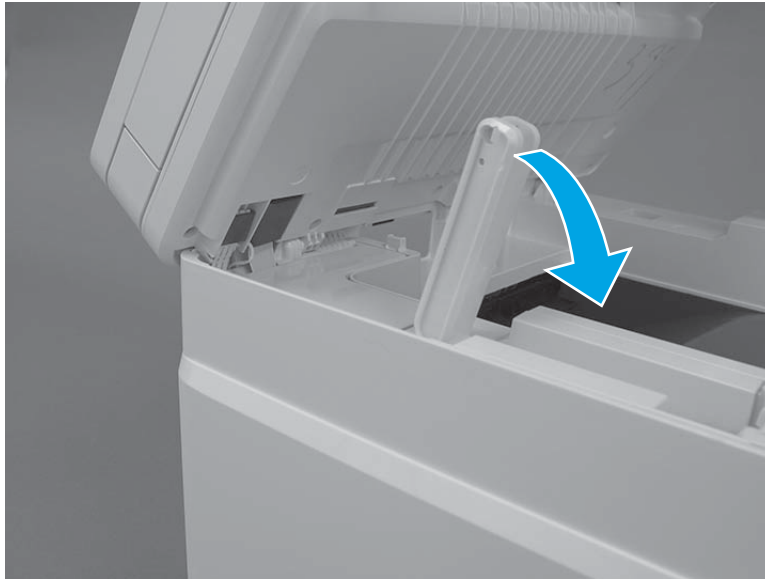
---

**Figure 1-569** Install the lift assembly



2. Lower the lift assembly to the closed position.

**Figure 1-570** Lower the lift assembly



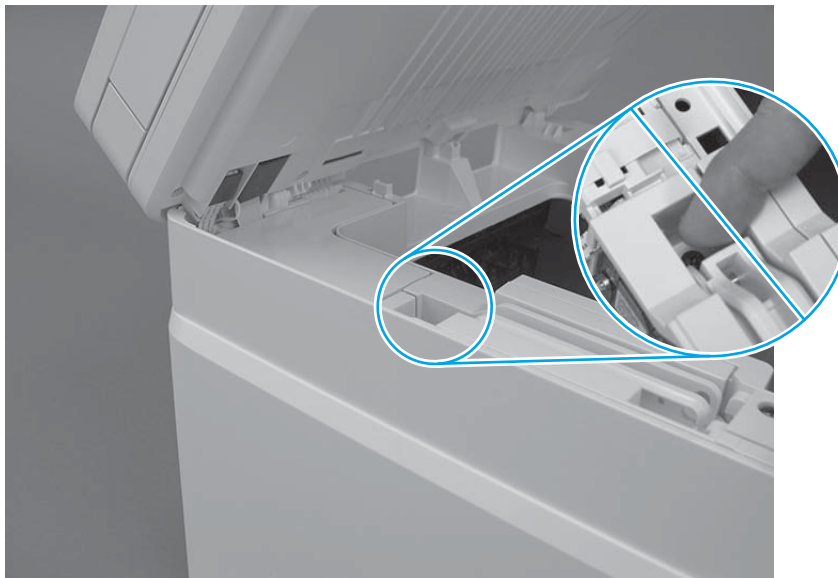
3. Before proceeding take note of the following.

---

**⚠ CAUTION:** The lift assembly is spring loaded and can unexpectedly spring into the open position. To avoid injury, do not place a finger in the screw well when the lift assembly is in the closed position.

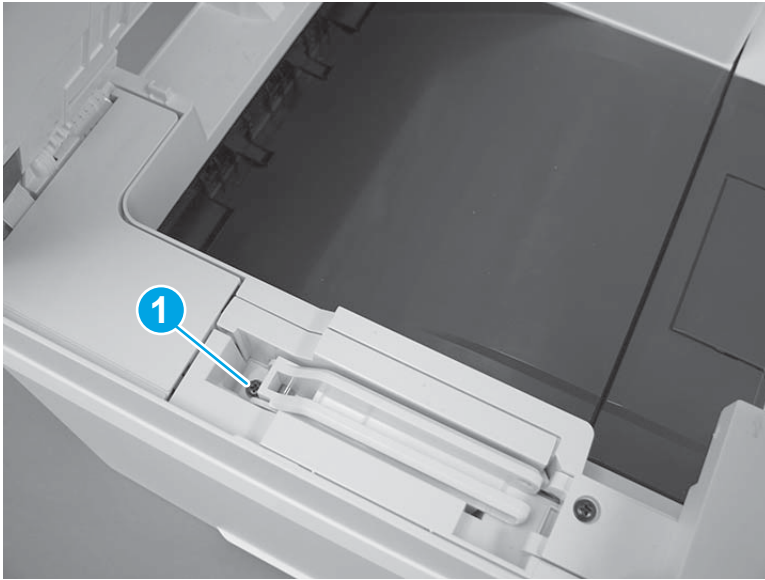
---

**Figure 1-571** Before proceeding take note




4. Install one screw (callout 1).

**Figure 1-572** Install one screw

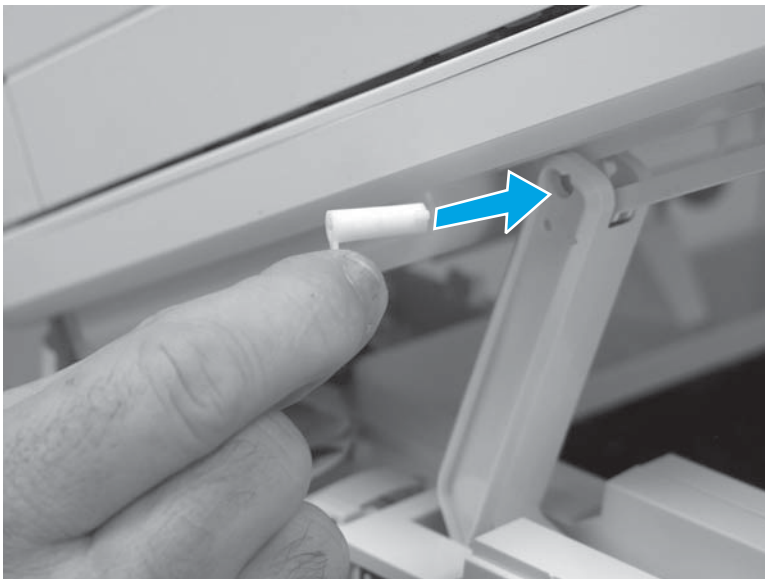


**Step 5: Install the slider pin (M427/M426)**

1. Raise the ISA lift assembly to the open position, engage the ISA with the lift assembly, and then install the slider pin.

 **Reinstallation tip:** Align the keyed portion of the slider pin with the slot and hole in the lift assembly.

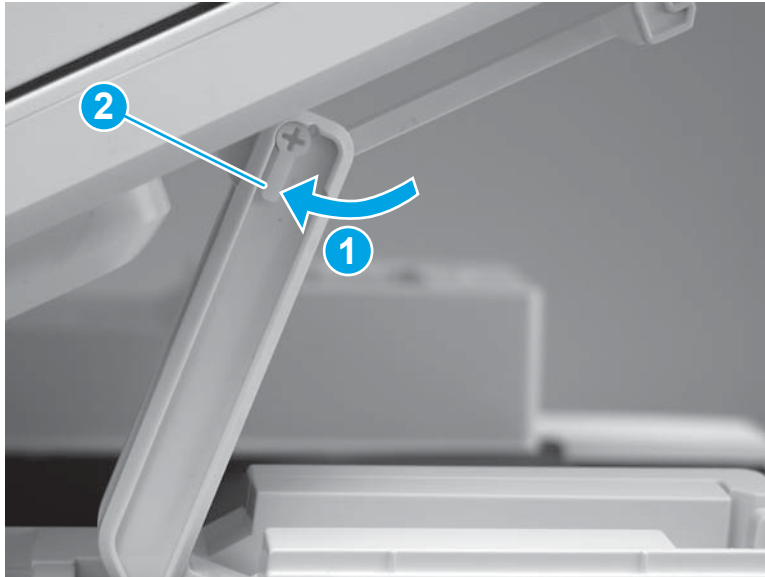
**Figure 1-573** Install the slider pin





2. Rotate the slider pin (callout 1) towards the rear of the printer until the tab (callout 2) snap into place. Close the ISA.

**Figure 1-574** Secure the slider pin



## Removal and replacement: Internal parts and assemblies

- [Removal and replacement: Fuser](#)
- [Removal and replacement: Registration assembly](#)
- [Removal and replacement: Main motor \(M1\)](#)
- [Removal and replacement: Power switch printed circuit assembly](#)
- [Removal and replacement: Fax PCA \(M427/M426\)](#)
- [Removal and replacement: Walkup USB PCA \(M427/M426\)](#)
- [Removal and replacement: Wireless PCA](#)
- [Removal and replacement: Formatter PCA](#)
- [Removal and replacement: Fan \(FM1\)](#)
- [Removal and replacement: Fan holder \(FM1\)](#)
- [Removal and replacement: Laser scanner assembly](#)
- [Removal and replacement: Sheet-metal formatter bracket and formatter PCA](#)
- [Removal and replacement: NFC FFC](#)
- [Removal and replacement: Control panel FFC, \(M403/M402\)](#)
- [Removal and replacement: Formatter FFC](#)
- [Removal and replacement: DC controller](#)
- [Removal and replacement: Tag-cable assembly \(toner-cartridge memory\)](#)
- [Removal and replacement: Connecting PCA](#)
- [Removal and replacement: Laser scanner FFC](#)
- [Removal and replacement: High-voltage power supply](#)
- [Removal and replacement: Low-voltage power supply](#)
- [Removal and replacement: NFC cover \(M427/M426\)](#)
- [Removal and replacement: NFC PCA](#)
- [Removal and replacement: Control-panel assembly \(M403/M402\)](#)
- [Removal and replacement: Control panel \(M427/M426\) and control panel sub assemblies](#)

## Removal and replacement: Fuser

- [Introduction](#)
- [Step 1: Remove Tray 2](#)
- [Step 2: Remove the cartridge door assembly](#)
- [Step 3: Remove the left cover](#)
- [Step 4: Remove the right cover](#)
- [Step 5: Remove the rear door assembly](#)
- [Step 6: Remove the fuser](#)
- [Step 7: Unpack the replacement assembly](#)
- [Step 8: Install the fuser](#)
- [Step 9: Install the rear door assembly](#)
- [Step 10: Install the right cover](#)
- [Step 11: Install the left cover](#)
- [Step 12: Install the cartridge door assembly](#)
- [Step 13: Install Tray 2](#)


### Introduction

This document provides the procedures to remove and replace the fuser.


### Before performing service

#### Turn the printer power off

- Disconnect the power cable.

 **WARNING!** To avoid damage to the printer, turn the printer off, wait 30 seconds, and then remove the power cable before attempting to service the printer.

Make sure the correct voltage fuser is installed in the printer.

 **CAUTION:** The fuser is hot. Wait at least 30 minutes after turning the printer off before removing the fuser.

Use the table below to identify the correct part number for your printer. To order the part, go to [www.hp.com/buy/parts](http://www.hp.com/buy/parts).

---

Fuser part number	
RM2-5399-000CN	Fuser (110V/127V)
RM2-5425-000CN	Fuser (220V/240V)

---

## Required tools

- #2 Phillips screwdriver with a magnetic tip.

## After performing service

### Turn the printer power on

- Connect the power cable.
- Use the power switch to turn the power on.

### Post service test

Make sure that the printer initializes to a **Ready** state.

Print a configuration page to make sure that the printer is functioning correctly.

### Step 1: Remove Tray 2

- ▲ Pull the tray straight out of the printer to remove it.

**Figure 1-575** Remove the tray



### Step 2: Remove the cartridge door assembly



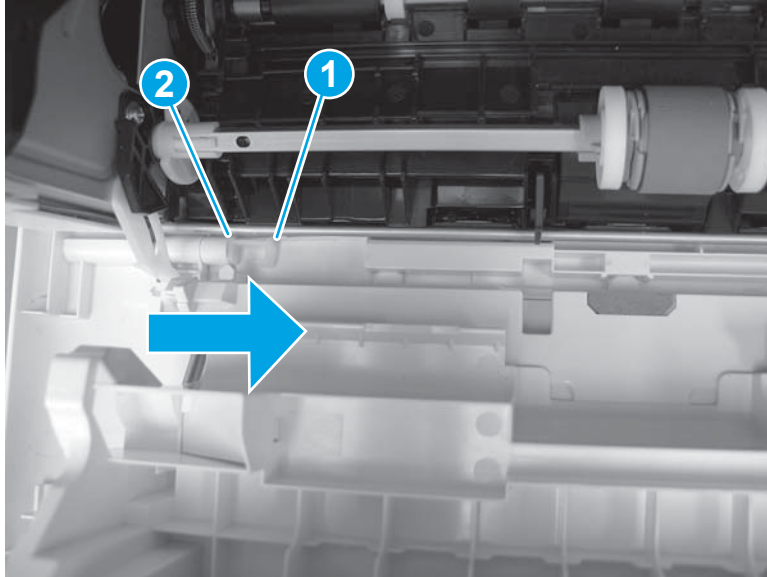
**NOTE:** If the toner cartridge was not removed prior to servicing the printer, remove it now.

1. Release one tab (callout 1), and then slide shaft (callout 2) in the direction the arrow indicates and remove it.



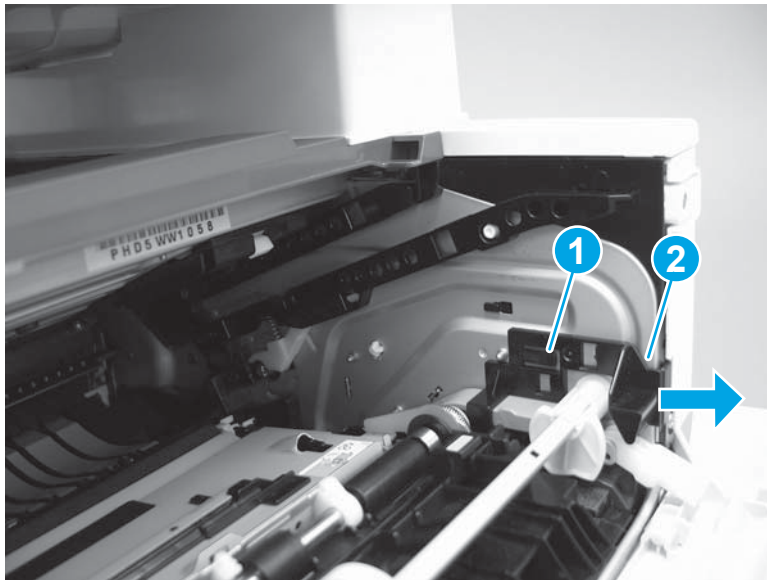
**TIP:** It might be easier to release the support shaft by using a small flat-blade screwdriver.

**Figure 1-576** Release the support shaft



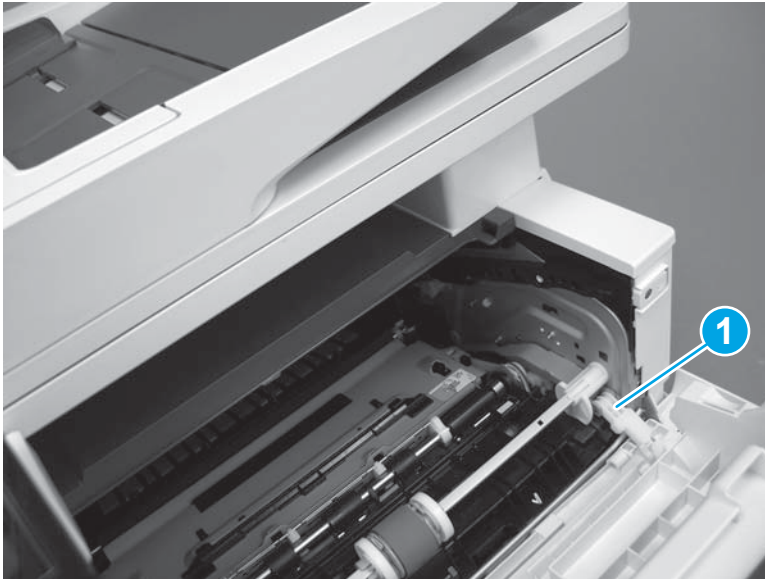
2. Release one tab (callout 1), and then slide the guide (callout 2) in the direction the arrow indicates and remove it.

**Figure 1-577** Remove the guide



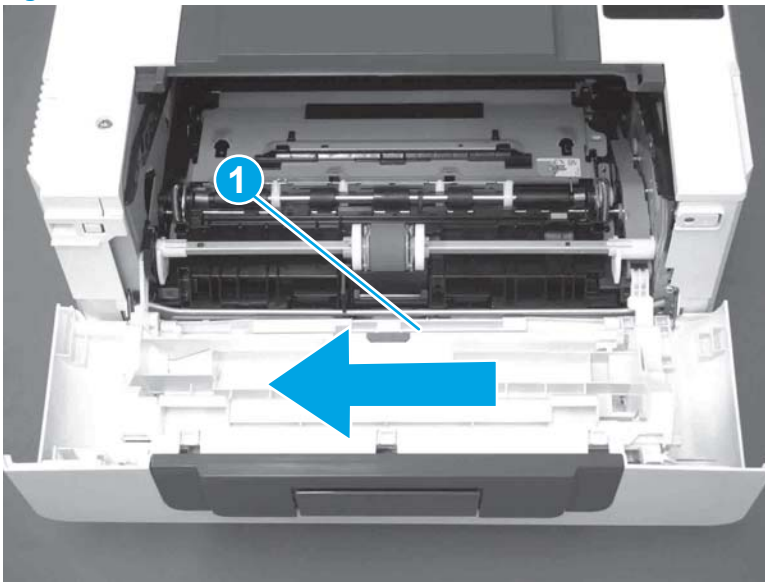
3. Remove the link arm (callout 1).

**Figure 1-578** Remove the link arm



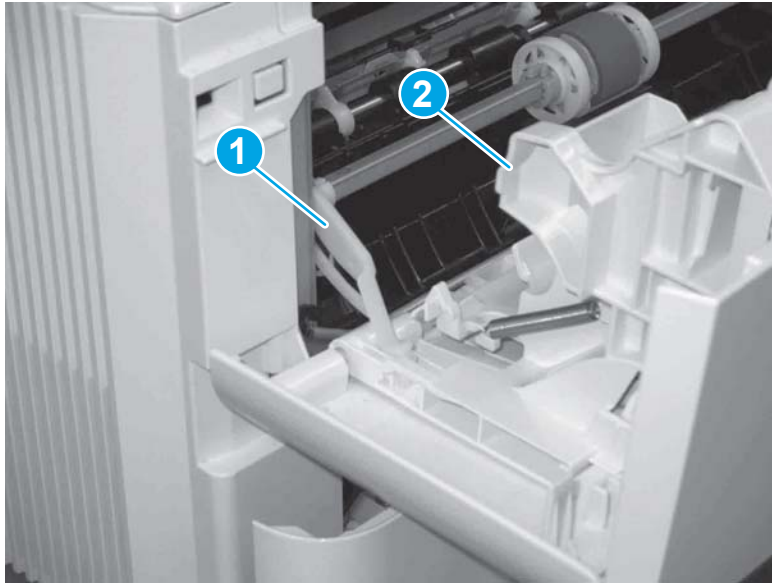
4. Slide the cartridge door assembly (callout 1) in the direction the arrow indicates and remove it.

**Figure 1-579** Remove the door



5. Remove the link (callout 1) from the cartridge door assembly (callout 2).

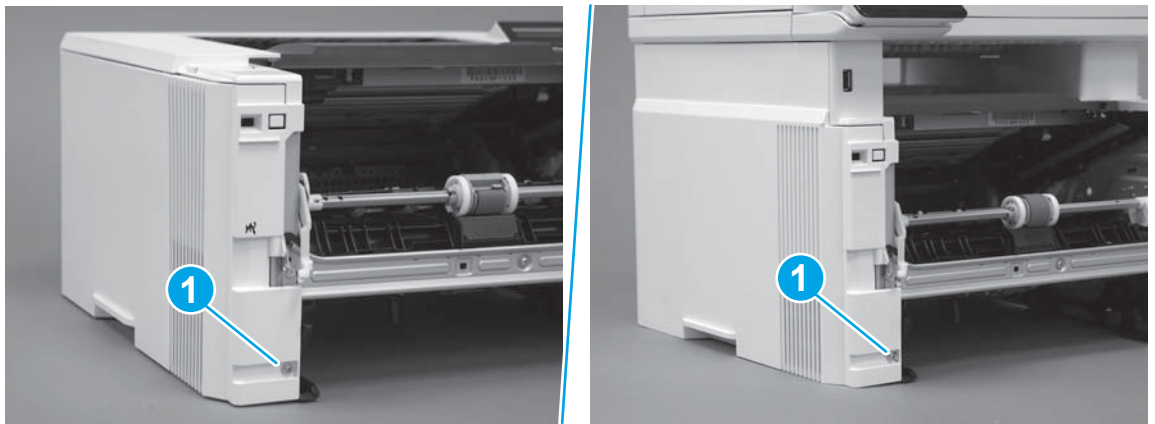
**Figure 1-580** Release the left-side retainer arm



### Step 3: Remove the left cover

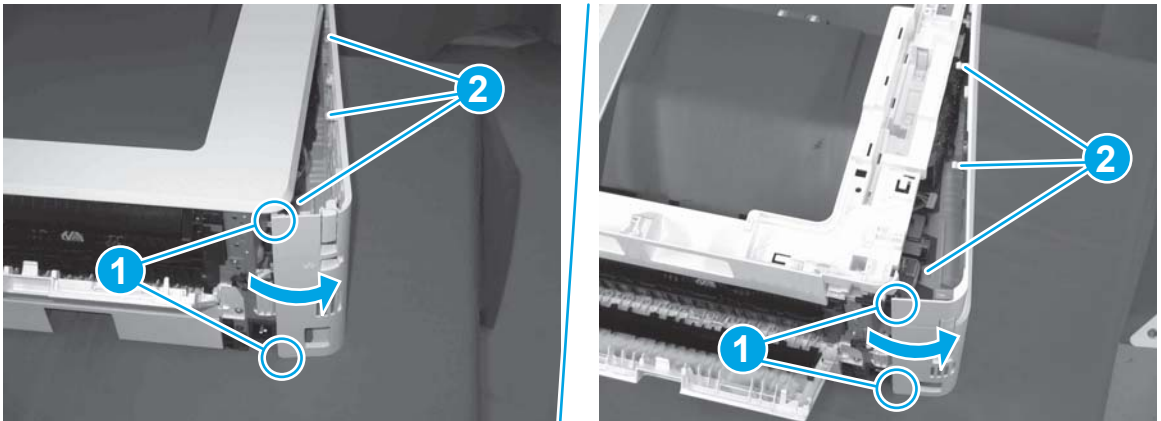
1. Remove one screw (callout 1).

**Figure 1-581** Remove one screw



2. Open the rear door, release two bosses (callout 1), and then release three tabs (callout 2).

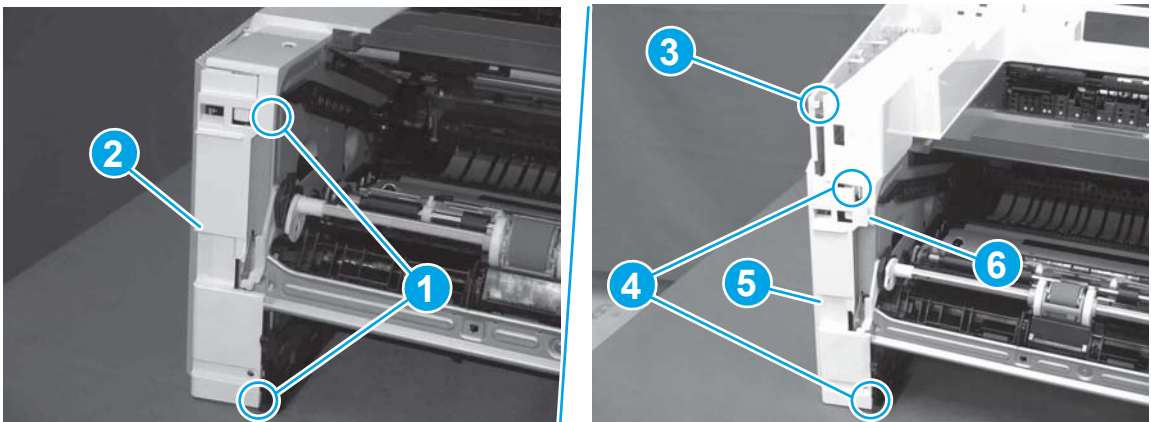
**Figure 1-582** Release two bosses and three tabs



3. At the front of the printer, do one of the following:
  - **M403/M402:** Release two bosses (callout 1), and then remove the cover (callout 2).
  - **M427/M426:** Release one tab (callout 3), two bosses (callout 4), and then remove the cover (callout 5).

**CAUTION:** Be careful when releasing the upper bosses on the M427/M426 cover. One portion of the cover (callout 6) is fragile and is easily broken.

**Figure 1-583** Remove the cover

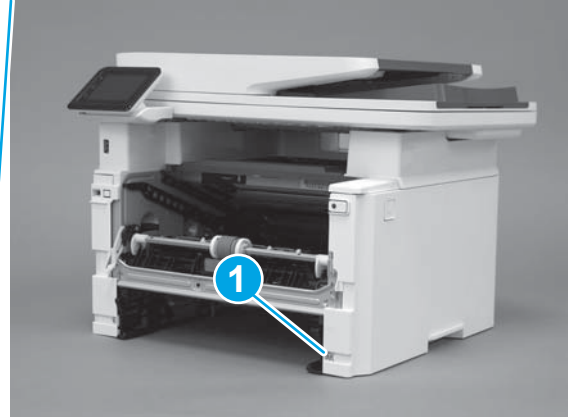
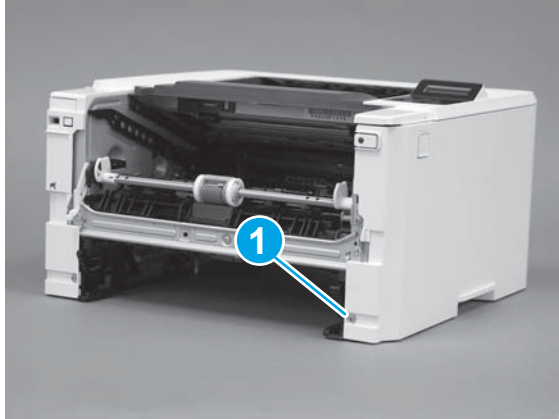


#### Step 4: Remove the right cover

1. Remove one screw (callout 1).

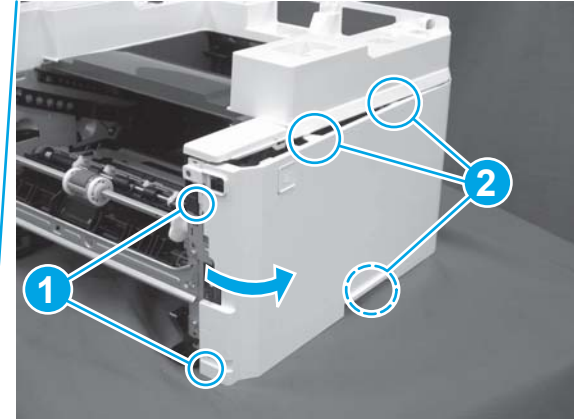
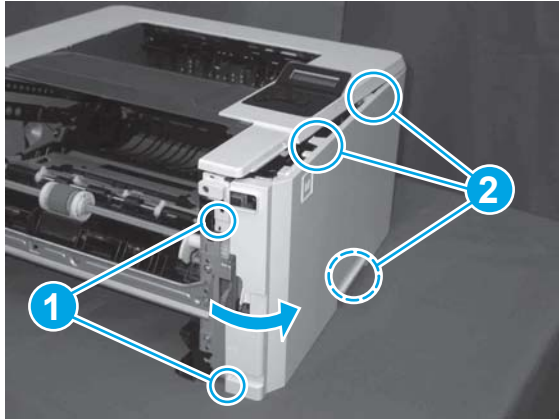


**Figure 1-584** Remove one screw



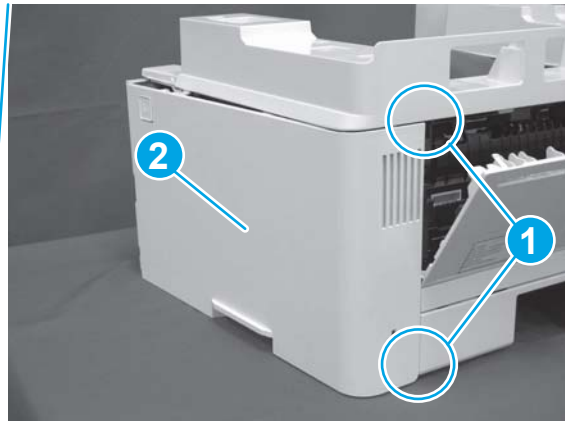
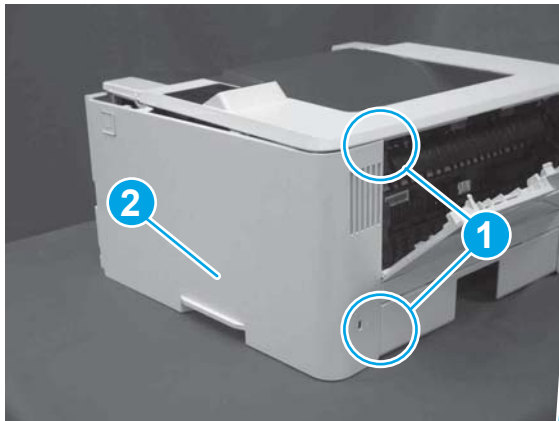
2. At the front of the printer, release two bosses (callout 1), and then release three tabs (callout 2).

**Figure 1-585** Release two bosses and three tabs



3. Open the rear door, release two bosses (callout 1), and then remove the cover (callout 2).

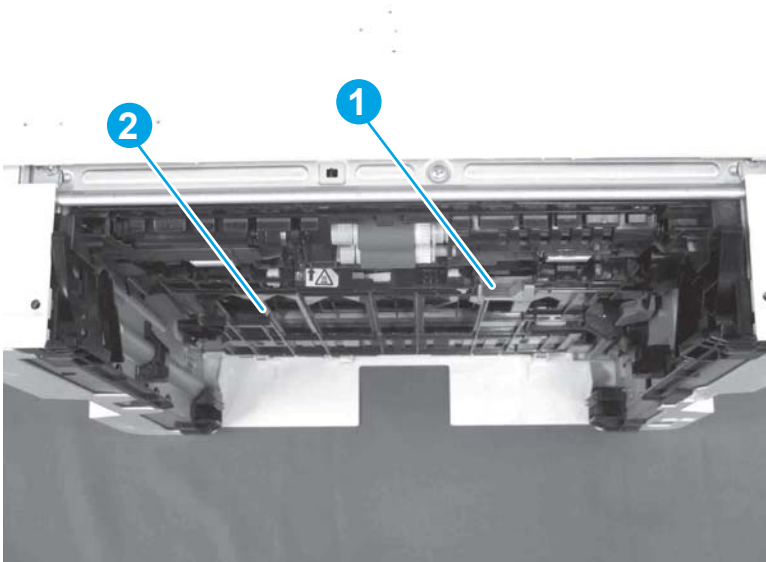
**Figure 1-586** Remove the cover



### Step 5: Remove the rear door assembly

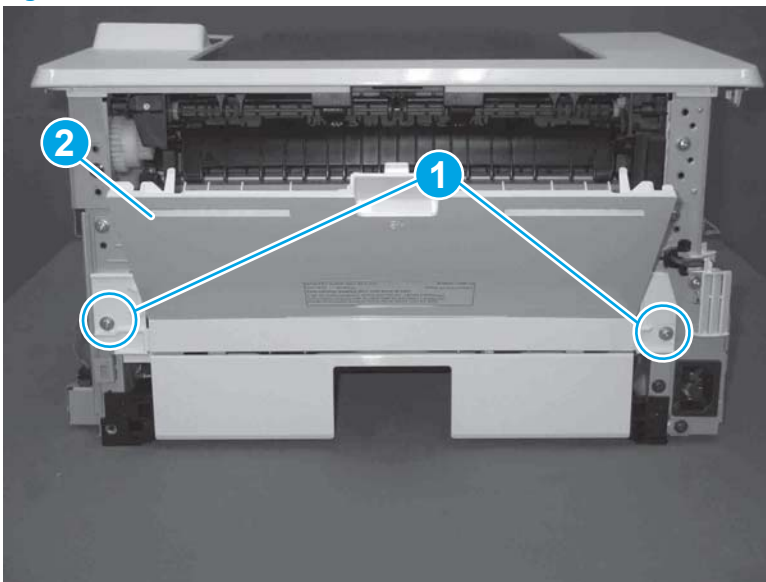
1. **Duplex models only:** Inside the Tray 2 cavity, press the green jam access lever (callout 1), and then lower the duplex feed assembly (callout 2).

**Figure 1-587** Duplex models, lower the duplex feed assembly



2. At the rear of the printer, remove two screws (callout 1), and then remove the rear door assembly (callout 2).

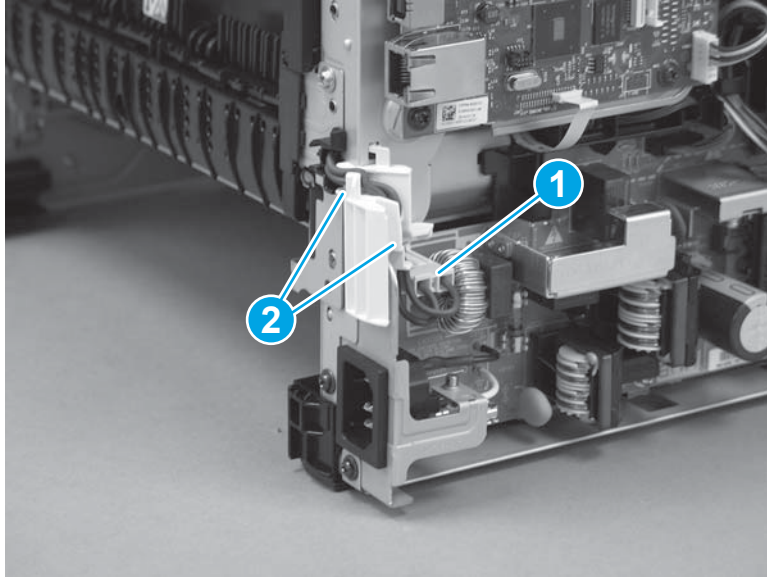
**Figure 1-588** Remove two screws



### Step 6: Remove the fuser

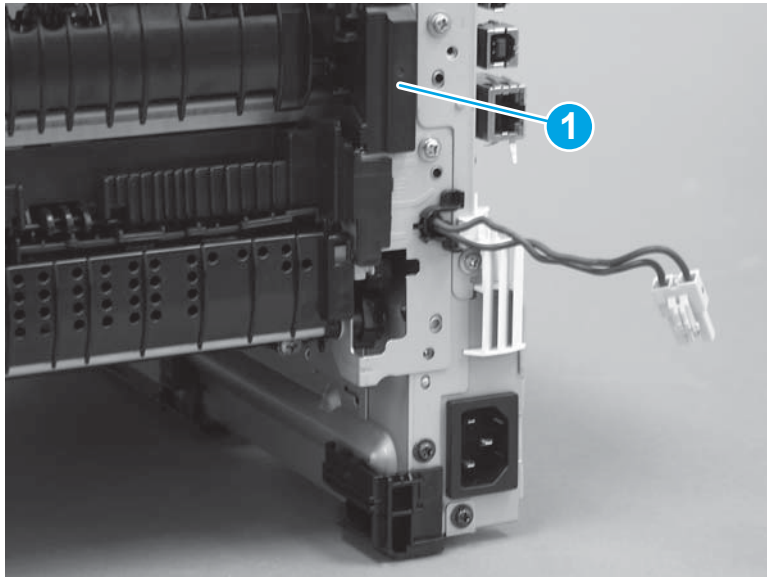
1. Disconnect one connector (callout 1), and then release the wire harness from the guide (callout 2).

**Figure 1-589** Disconnect one connector



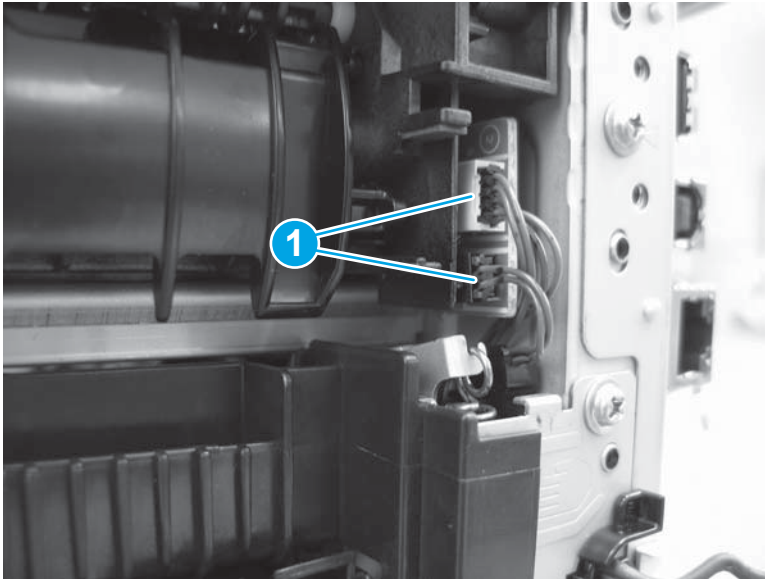
2. Pull the upper connector cover (callout 1) straight off of the printer to remove it.

**Figure 1-590** Remove the cover



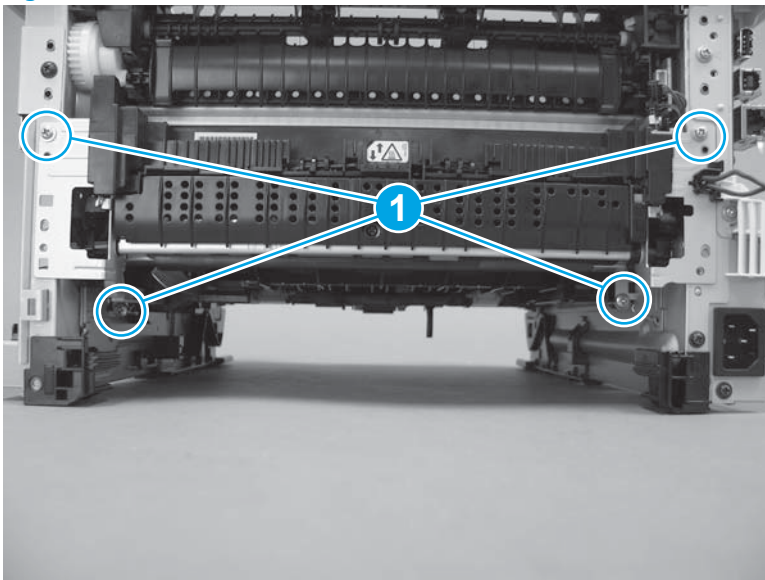
3. Disconnect two connectors (callout 1).

**Figure 1-591** Disconnect two connectors



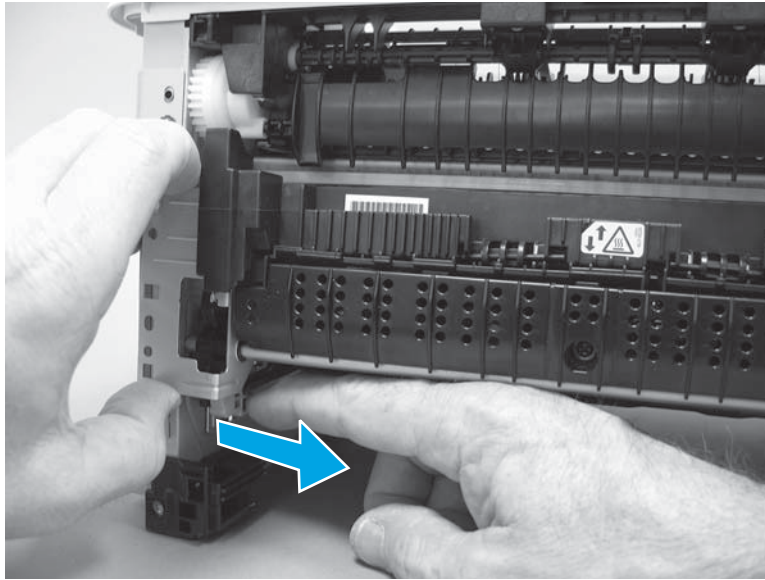
4. Remove four screws (callout 1).

**Figure 1-592** Remove four screws



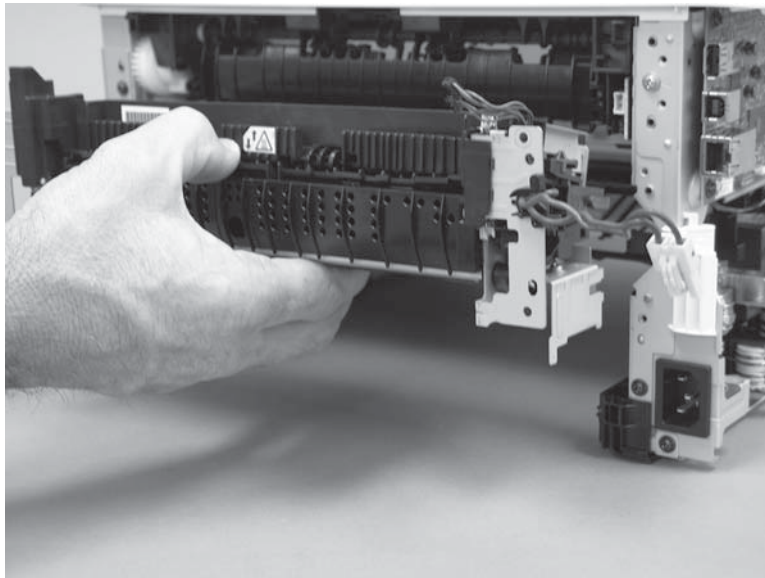
5. Pull the pressure-release link arm as shown to release it from the fuser.

**Figure 1-593** Release the pressure-release arm



6. Slide the fuser straight out of the printer.

**Figure 1-594** Remove the fuser



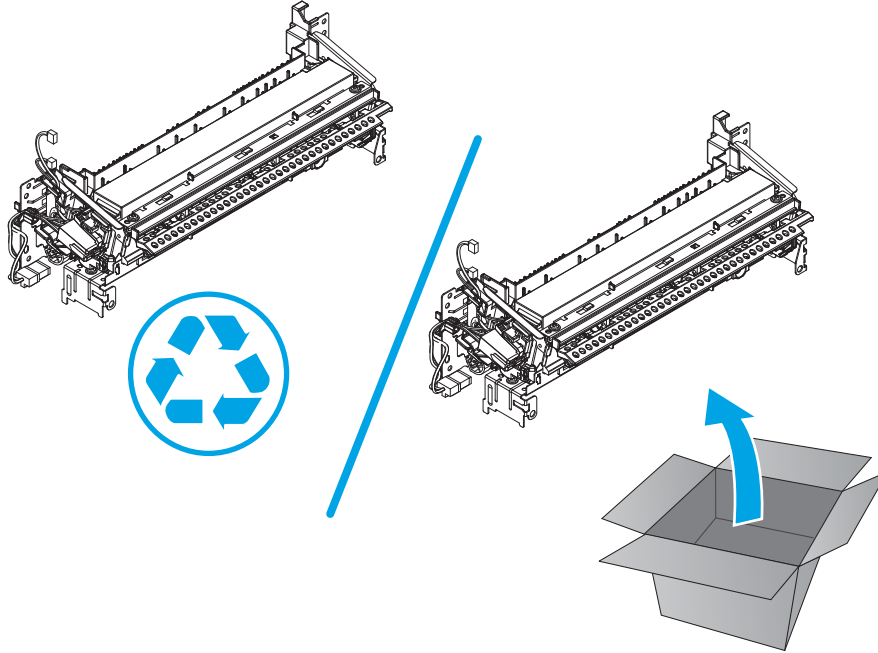
### Step 7: Unpack the replacement assembly

Unpack the replacement part from the packaging.

<http://www8.hp.com/us/en/hp-information/environment/product-recycling.html>

 **NOTE:** HP recommends responsible disposal of the defective part.

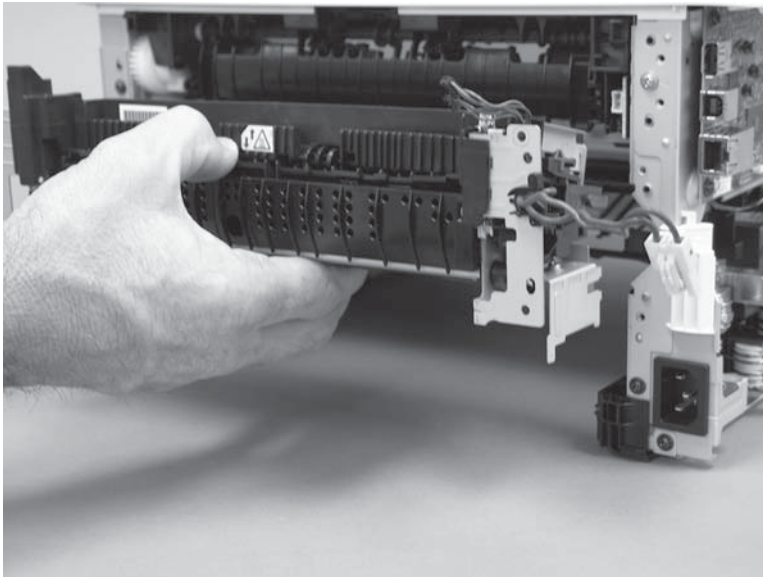
**Figure 1-595** Recycle and unpack



**Step 8: Install the fuser**

1. Slide the fuser straight into the printer.

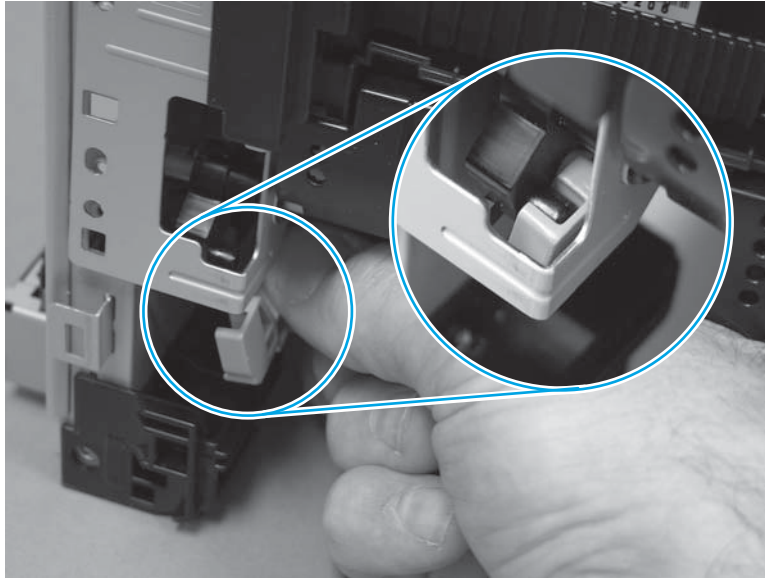
**Figure 1-596** Install the fuser



2. Connect the pressure-release link arm to the fuser.

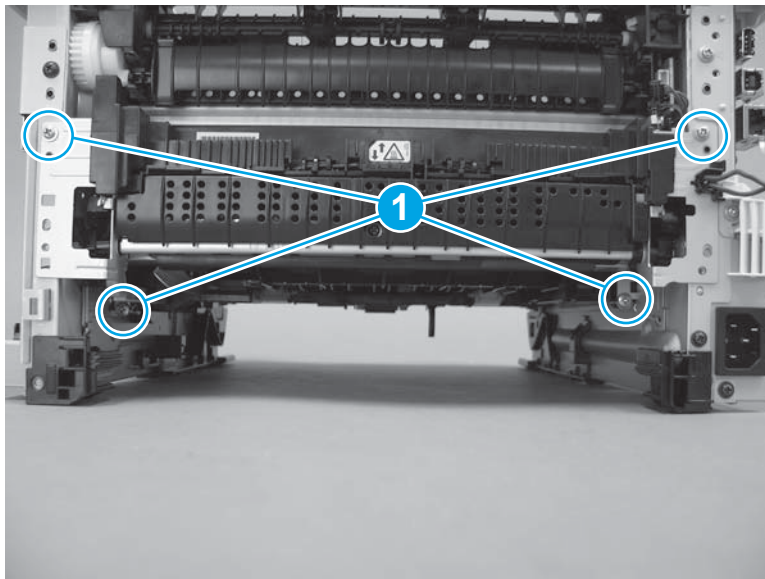
 **IMPORTANT:** Make sure that the pressure-release arm is correctly connected to the fuser.

**Figure 1-597** Connect the pressure-release arm



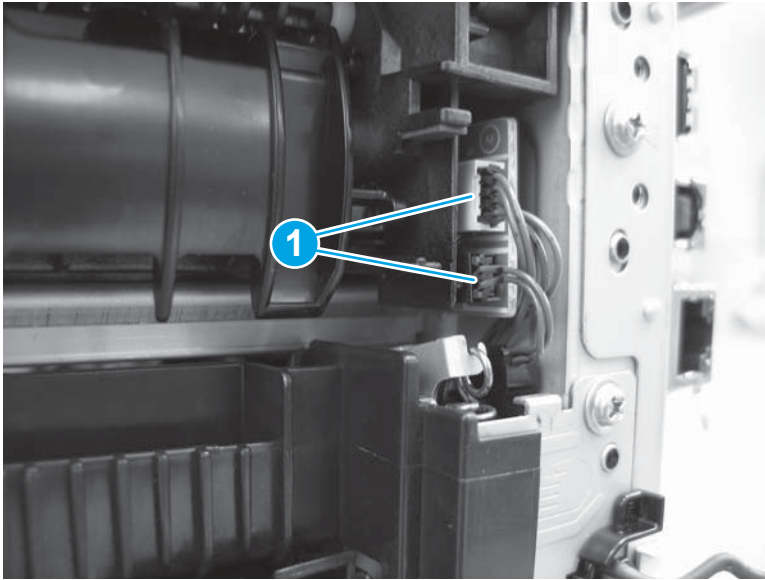
3. Install four screws (callout 1).

**Figure 1-598** Install four screws



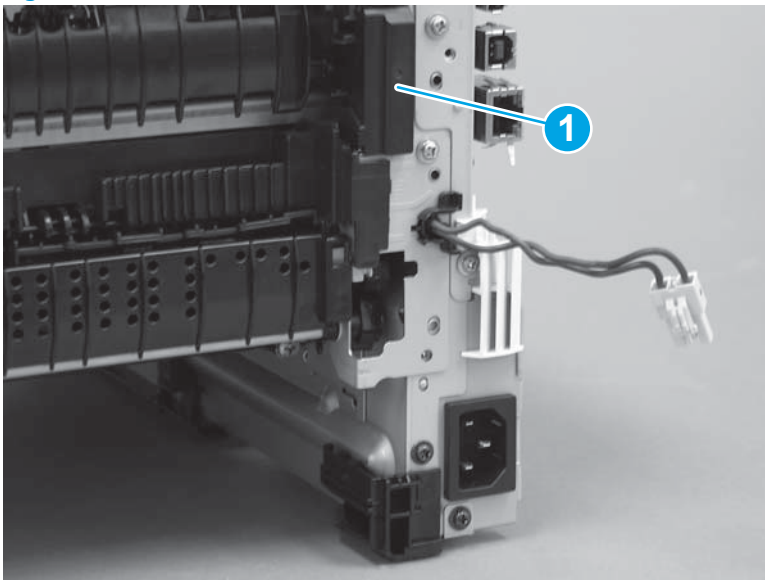
4. Connect two connectors (callout 1).

**Figure 1-599** Connect two connectors



5. Push the upper connector cover (callout 1) straight onto of the printer to install it.

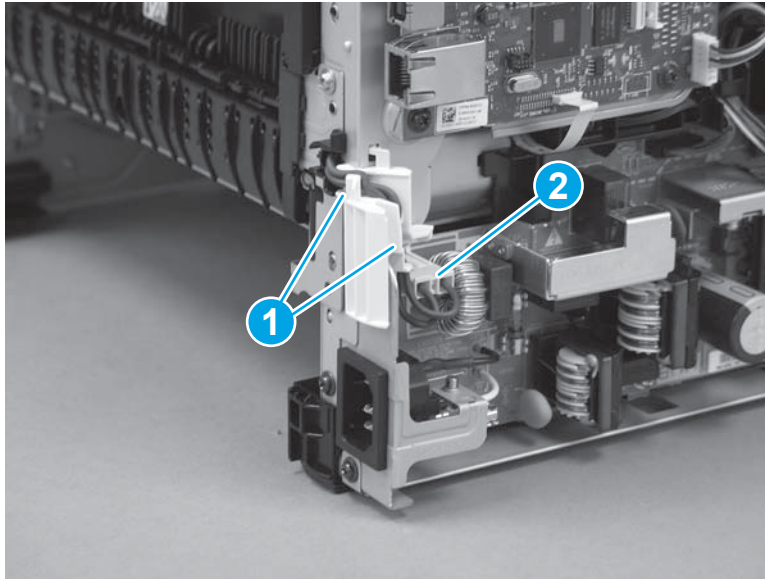
**Figure 1-600** Install the cover





6. Install the wire harness in the guide (callout 1), and then connect one connector (callout 2).

**Figure 1-601** Connect one connector



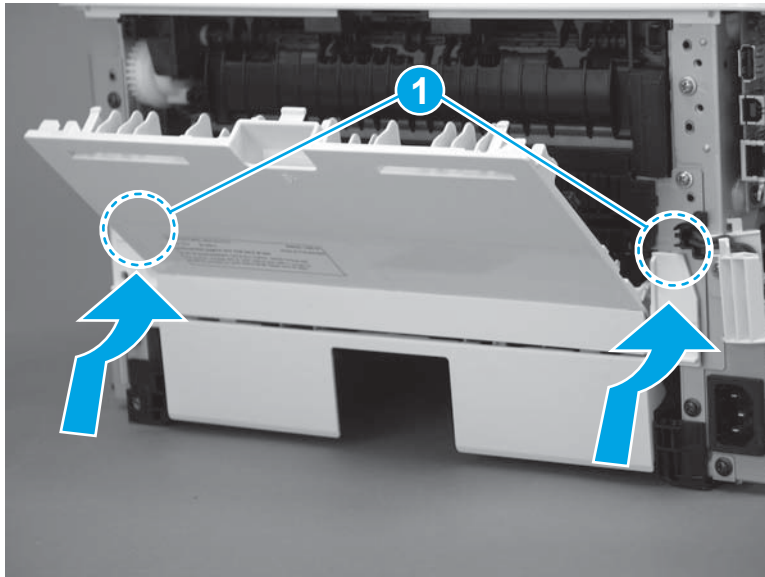
### Step 9: Install the rear door assembly

1. At the rear of the printer, position the assembly so that the two tabs (callout 1) are installed in the slots (callout 2) in the chassis.




**NOTE: Duplex models only:** Slide the duplex tray into the Tray 2 cavity.

**Figure 1-602** Install the rear cover



2. Install two screws.

 **NOTE: Duplex models only:** Reach in from the front of the Tray 2 cavity and raise the feed assembly to the up and locked position so that the rear cover will fit flat against the chassis.

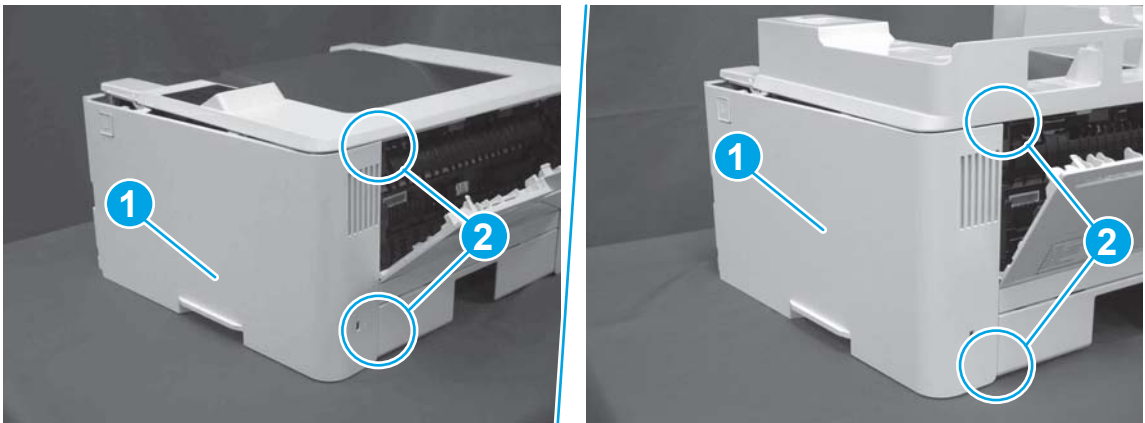
**Figure 1-603** Install two screws



### Step 10: Install the right cover

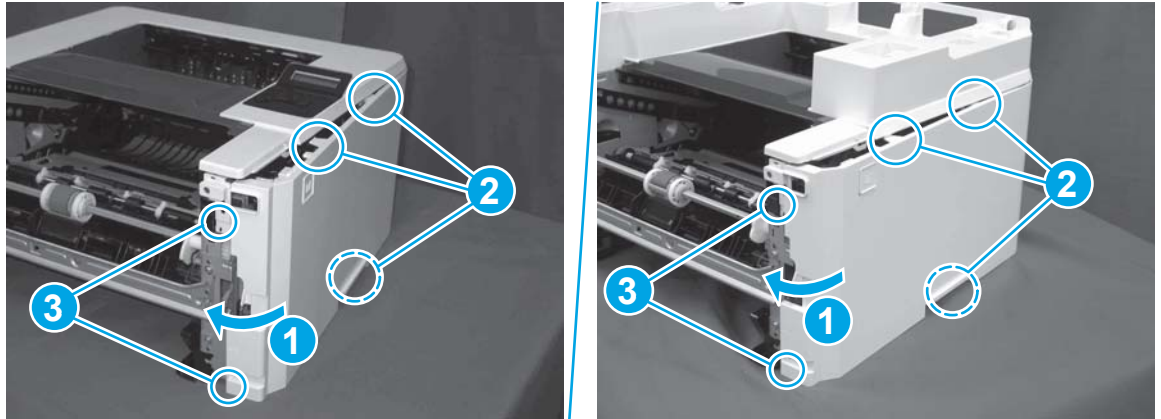
1. Position the cover (callout 1) on the printer, and then engage two bosses (callout 2).

**Figure 1-604** Install the cover



2. Rotate the front of the cover onto the printer (callout 1), engage three (callout 2) tabs, and then engage two bosses (callout 3).

**Figure 1-605** Engage two bosses and one tab

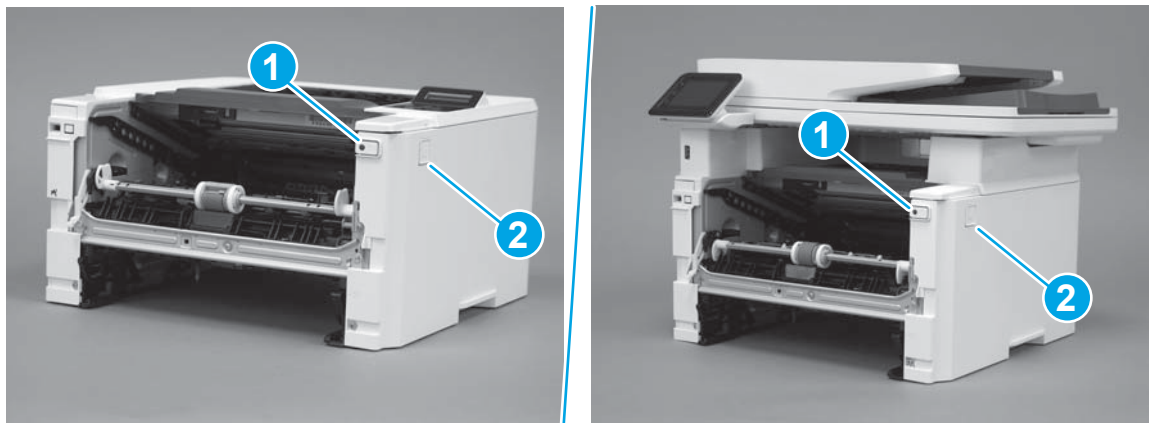


3. Make sure that the power switch (callout 1) and cartridge door assembly button (callout 2) correctly function.



**NOTE:** Remove, and then reinstall the cover if the switch or button does not correctly function.

**Figure 1-606** Check the power switch and cartridge door assembly button



4. Install one screw (callout 1).

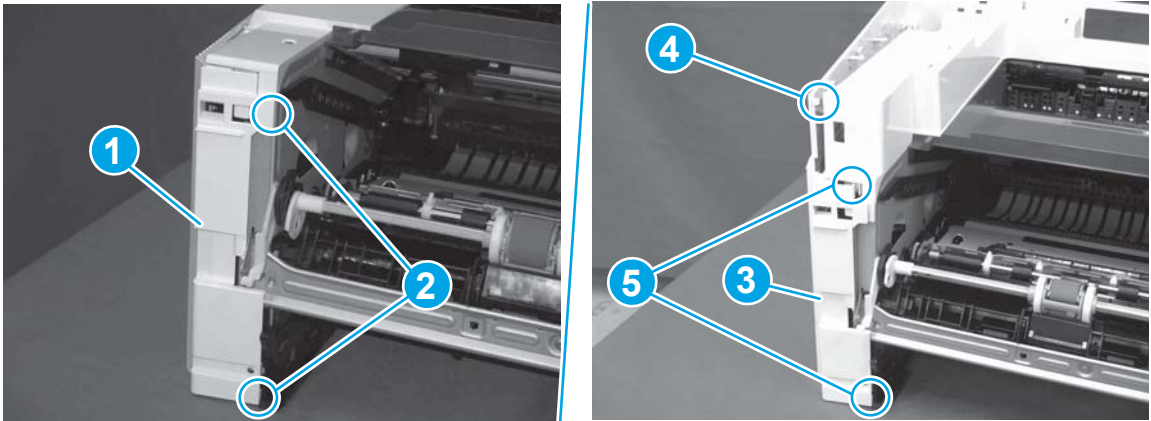
**Figure 1-607** Install one screw



## Step 11: Install the left cover

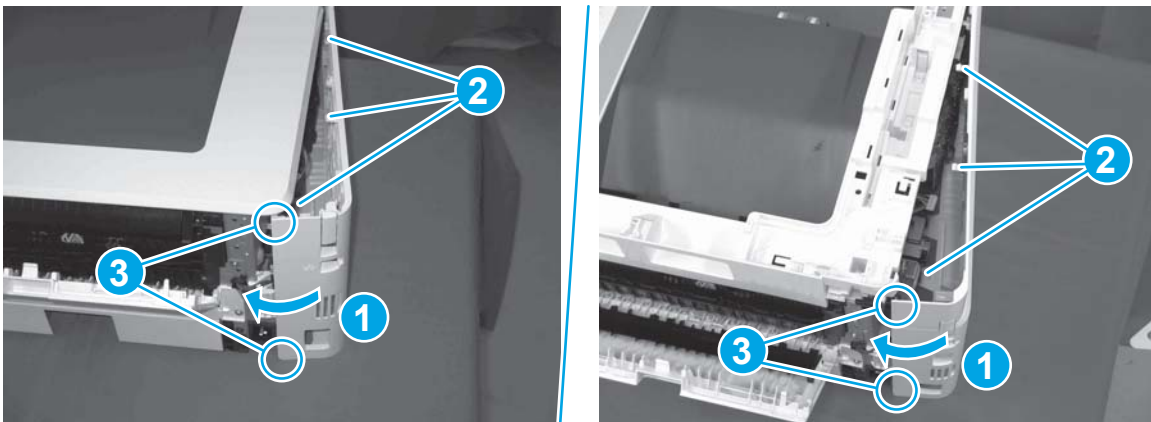
1. At the front of the printer, do one of the following:
  - **M403/M402:** Position the cover on the printer ( callout 1), and then engage two bosses (callout 2).
  - **M427/M426:** Position the cover on the printer (callout 3), engage one tab (callout 4), and then engage two bosses (callout 4).

**Figure 1-608** Install the cover



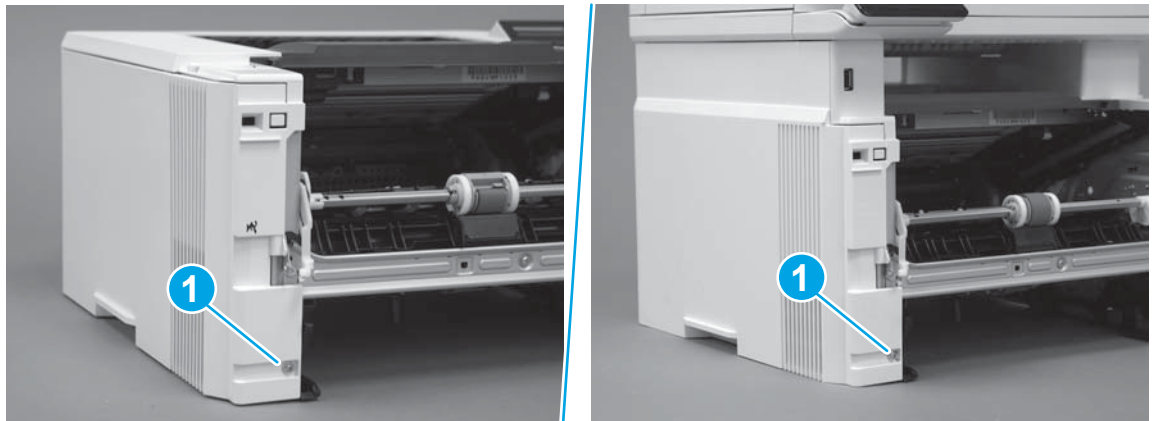
2. Carefully rotate the rear of the cover onto the printer (callout 1), engage three tabs (callout 2), and then engage two bosses (callout 3).

**Figure 1-609** Engage three tabs and two bosses




3. Install one screw (callout 1).

**Figure 1-610** Install one screw

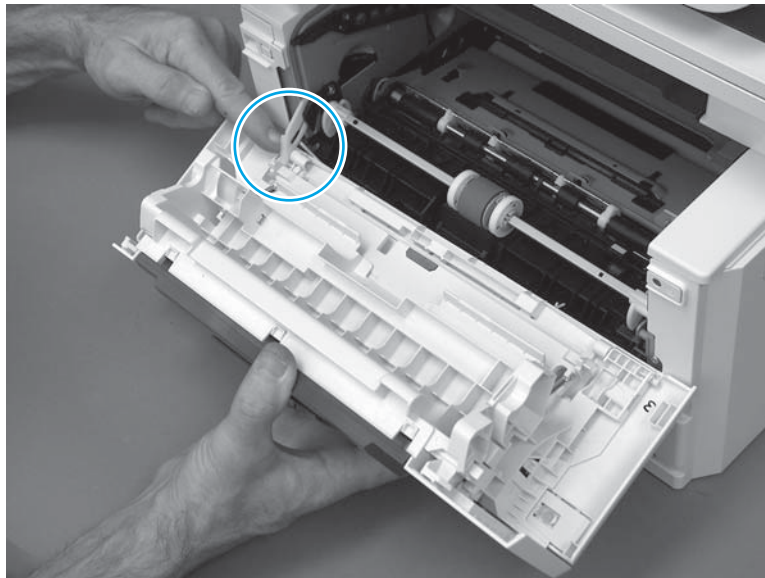


### Step 12: Install the cartridge door assembly

 **Reinstallation tip:** After a replacement door is installed, make sure to install the nameplate (supplied in the kit) corresponding to the printer name on the door.

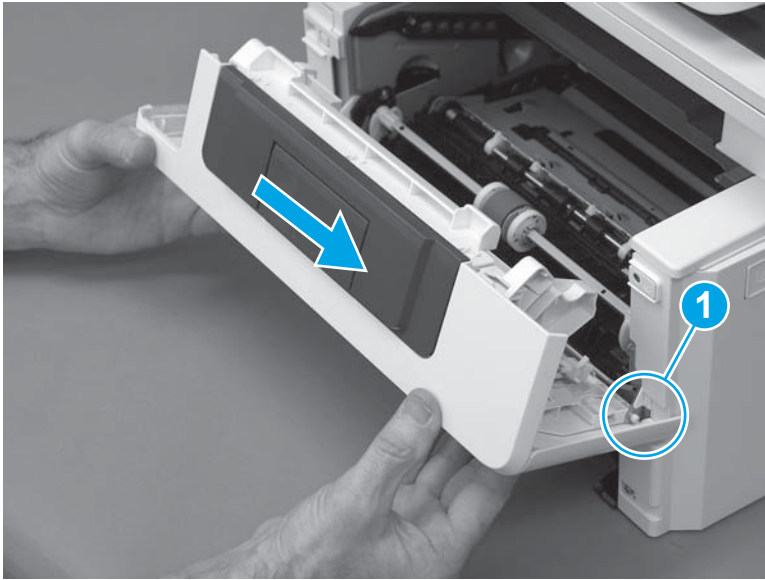
1. Position the door close to the printer, and then engage the keyed pin on the left-side retainer arm with the hole in the door.

**Figure 1-611** Engage the left-side retainer arm



2. Engage the right-side door hinge pin with the hole in the chassis (callout 1).

**Figure 1-612** Install the door



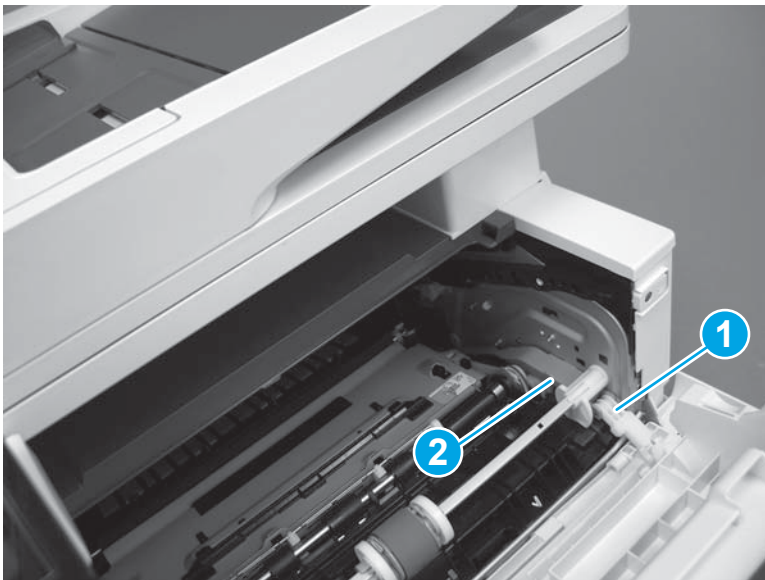
3. Install the link (callout 1).

---

 **IMPORTANT:** Make sure that the link snaps into place on the arm (callout 2). The link actuates the fuser pressure-release mechanism.

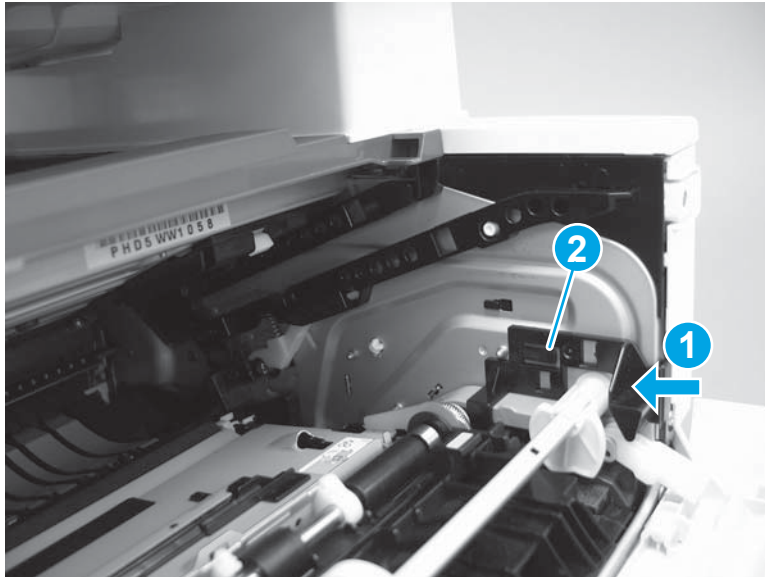
---

**Figure 1-613** Install the pressure-release link



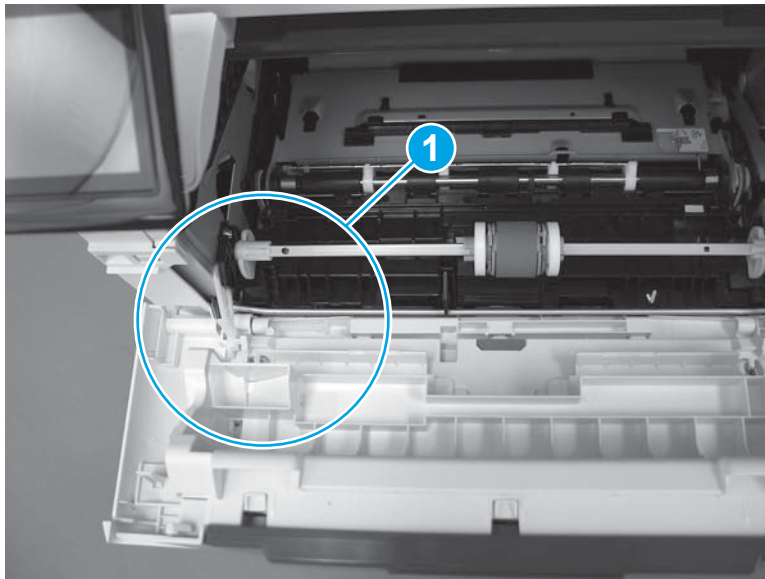
4. Slide the guide into the printer (callout 1), and then make sure that the tab (callout 2) snaps into place to secure the guide to the chassis.

**Figure 1-614** Install the guide




5. Position the shaft on the door, and then align the left-side hinge on the door with the hole in the chassis (callout 1).

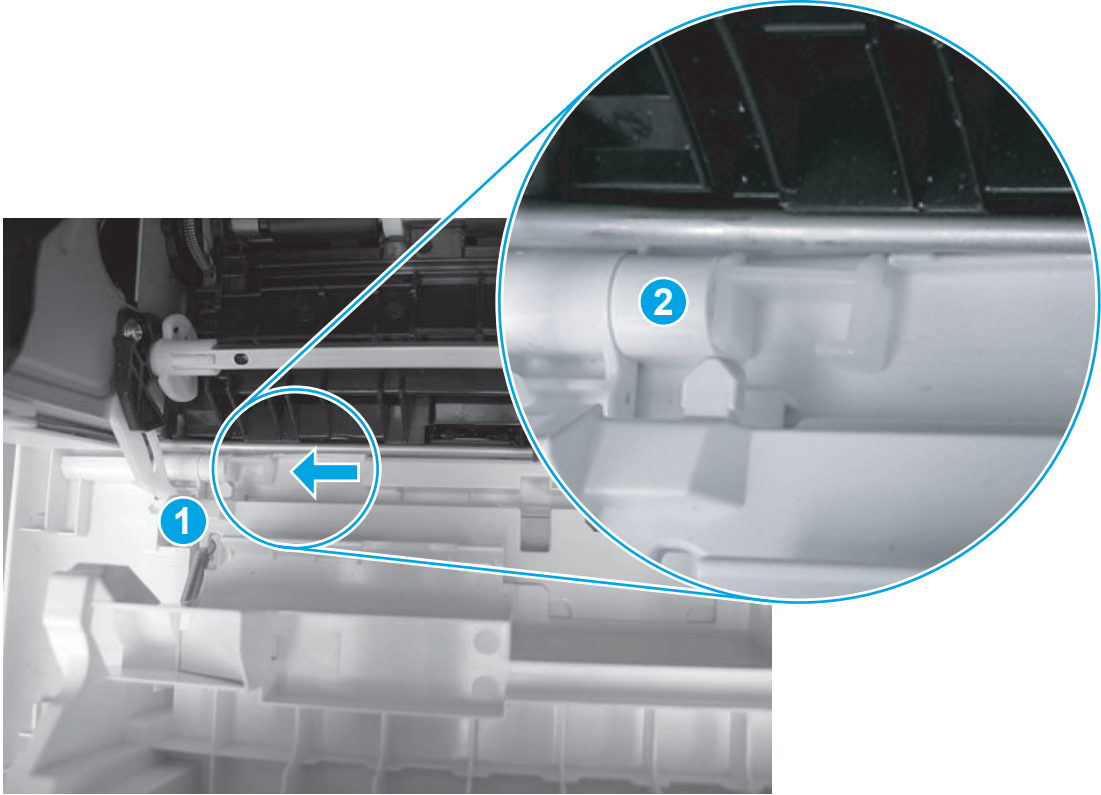
**Figure 1-615** Align the hinge



6. Push the shaft towards the left side of the printer to install it (callout 1).

 **Reinstallation tip:** Make sure that the support shaft is fully installed and correctly orientated (callout 2) so that it will not interfere with the door opening and closing.

**Figure 1-616** Install the support shaft



### Step 13: Install Tray 2

- ▲ Slide the tray straight into the printer to install it.

**Figure 1-617** Install the tray





## Removal and replacement: Registration assembly

- [Introduction](#)
- [Step 1: Remove Tray 2](#)
- [Step 2: Remove the cartridge door assembly](#)
- [Step 3: Remove the left cover](#)
- [Step 4: Remove the right cover](#)
- [Step 5: Remove the rear door assembly](#)
- [Step 6: Remove the integrated scanner assembly \(M427/M246\)](#)
- [Step 7: Remove the control panel \(M427/M426\)](#)
- [Step 8: Remove the top cover \(M427/M426\)](#)
- [Step 9: Remove the top cover \(M403/M402\)](#)
- [Step 10: Remove the paper delivery tray \(output bin\)](#)
- [Step 11: Remove the fuser](#)
- [Step 12: Remove the registration assembly](#)
- [Step 13: Unpack the replacement assembly](#)
- [Step 14: Install the registration assembly](#)
- [Step 15: Install the fuser](#)
- [Step 16: Install the paper delivery tray \(output bin\)](#)
- [Step 17: Install the top cover \(M403/M402\)](#)
- [Step 18: Install the top cover \(M427/M426\)](#)
- [Step 19: Install the control panel \(M427/M246\)](#)
- [Step 20: Install the integrated scanner assembly \(M427/M246\)](#)
- [Step 21: Install the rear door assembly](#)
- [Step 22: Install the right cover](#)
- [Step 23: Install the left cover](#)
- [Step 24: Install the cartridge door assembly](#)
- [Step 25: Install Install Tray 2](#)


### Introduction

This document provides the procedures to remove and replace the registration assembly.


## Before performing service

### Turn the printer power off

- Disconnect the power cable.

 **WARNING!** To avoid damage to the printer, turn the printer off, wait 30 seconds, and then remove the power cable before attempting to service the printer.

Make sure the correct voltage fuser is installed in the printer.

 **CAUTION:** The fuser is hot. Wait at least 30 minutes after turning the printer off before removing the fuser.

Use the table below to identify the correct part number for your printer. To order the part, go to [www.hp.com/buy/parts](http://www.hp.com/buy/parts).

---

Registration assembly part number	
-----------------------------------	--

RM2-5671-000CN	Registration assembly
----------------	-----------------------

---

### Required tools

- #2 Phillips screwdriver with a magnetic tip.

### After performing service

#### Turn the printer power on

- Connect the power cable.
- Use the power switch to turn the power on.

### Post service test

Make sure that the printer initializes to a **Ready** state.

Print a configuration page to make sure that the printer is functioning correctly.

#### Step 1: Remove Tray 2

- ▲ Pull the tray straight out of the printer to remove it.

**Figure 1-618** Remove the tray



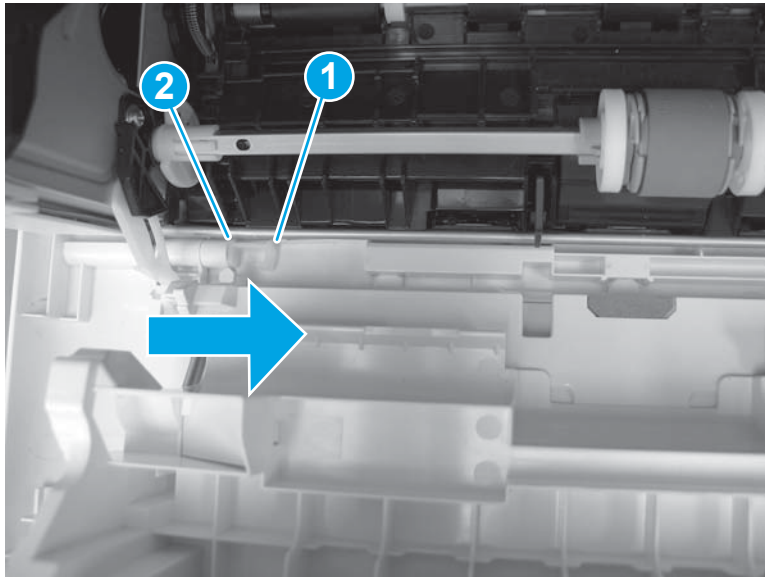
**Step 2: Remove the cartridge door assembly**

 **NOTE:** If the toner cartridge was not removed prior to servicing the printer, remove it now.

1. Release one tab (callout 1), and then slide shaft (callout 2) in the direction the arrow indicates and remove it.

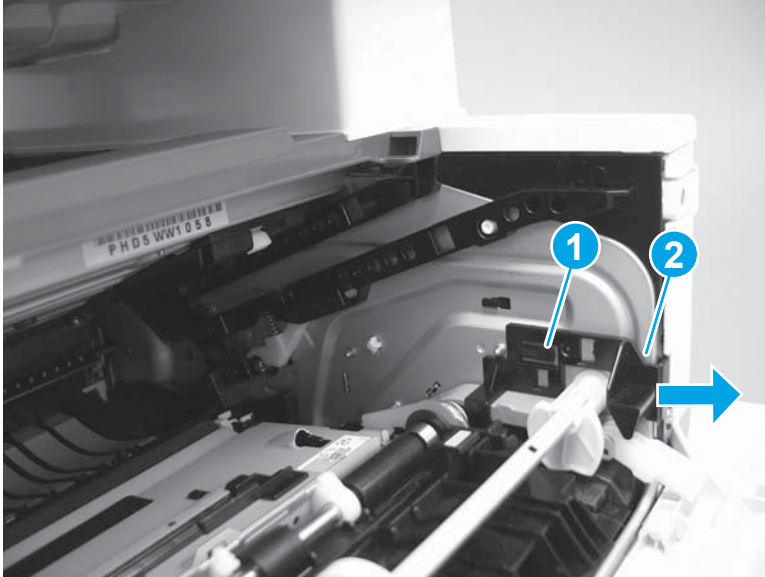
 **TIP:** It might be easier to release the support shaft by using a small flat-blade screwdriver.

**Figure 1-619** Release the support shaft



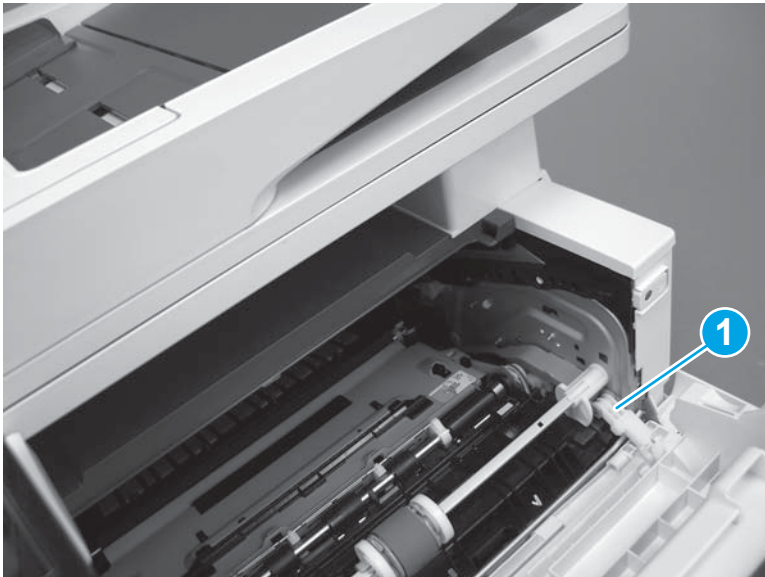
2. Release one tab (callout 1), and then slide the guide (callout 2) in the direction the arrow indicates and remove it.

**Figure 1-620** Remove the guide



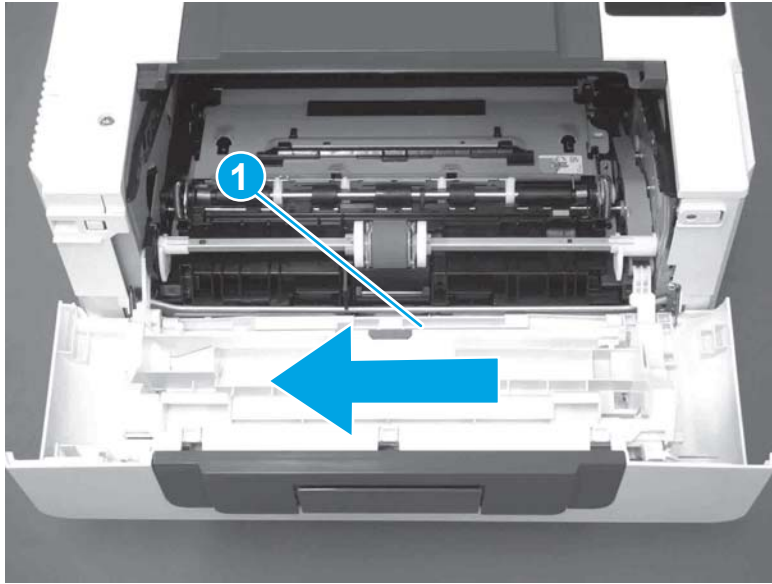
3. Remove the link arm (callout 1).

**Figure 1-621** Remove the link arm



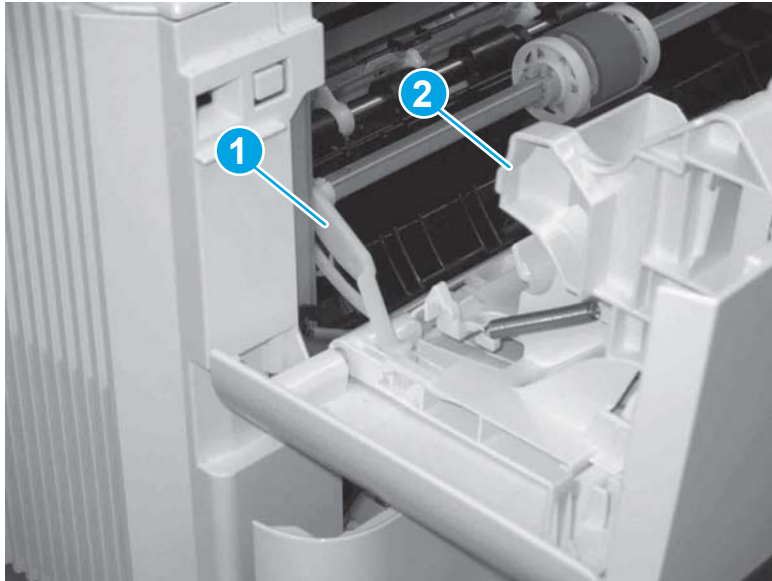
4. Slide the cartridge door assembly (callout 1) in the direction the arrow indicates and remove it.

**Figure 1-622** Remove the door



5. Remove the link (callout 1) from the cartridge door assembly (callout 2).

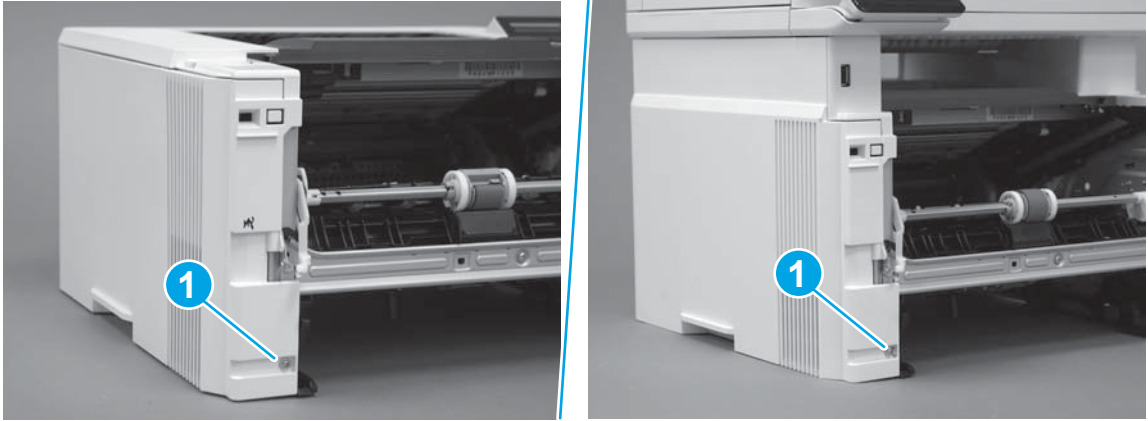
**Figure 1-623** Release the left-side retainer arm



### Step 3: Remove the left cover

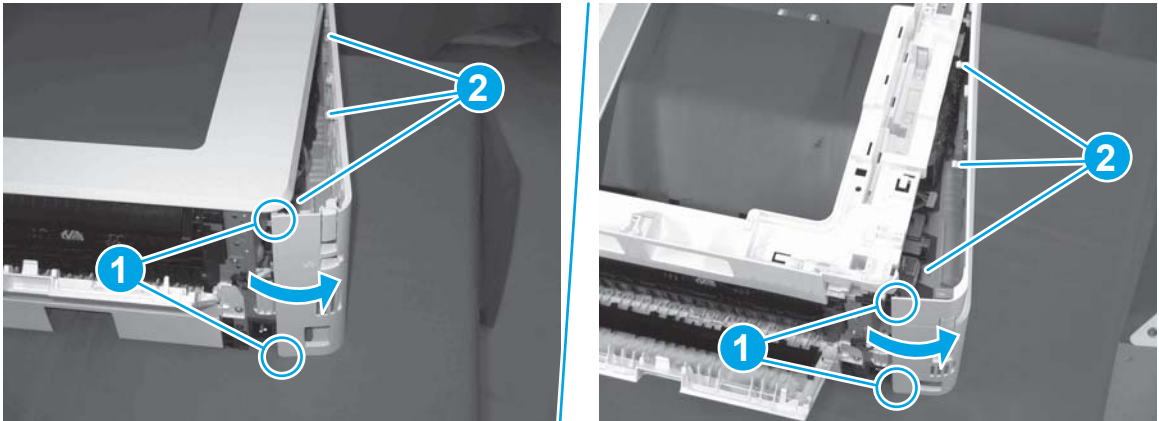
1. Remove one screw (callout 1).

**Figure 1-624** Remove one screw



2. Open the rear door, release two bosses (callout 1), and then release three tabs (callout 2).

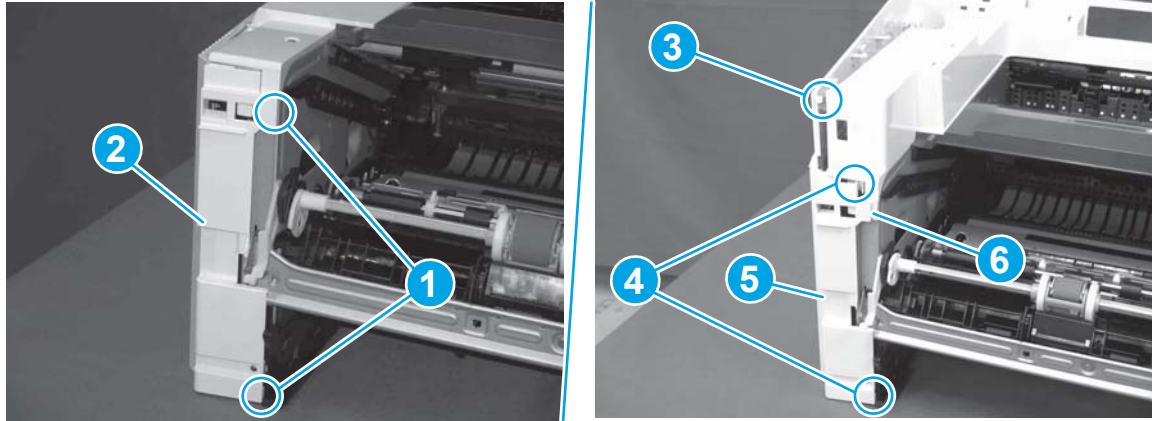
**Figure 1-625** Release two bosses and three tabs



3. At the front of the printer, do one of the following:
  - **M403/M402:** Release two bosses (callout 1), and then remove the cover (callout 2).
  - **M427/M426:** Release one tab (callout 3), two bosses (callout 4), and then remove the cover (callout 5).

**CAUTION:** Be careful when releasing the upper bosses on the M427/M426 cover. One portion of the cover (callout 6) is fragile and is easily broken.

**Figure 1-626** Remove the cover



**Step 4: Remove the right cover**

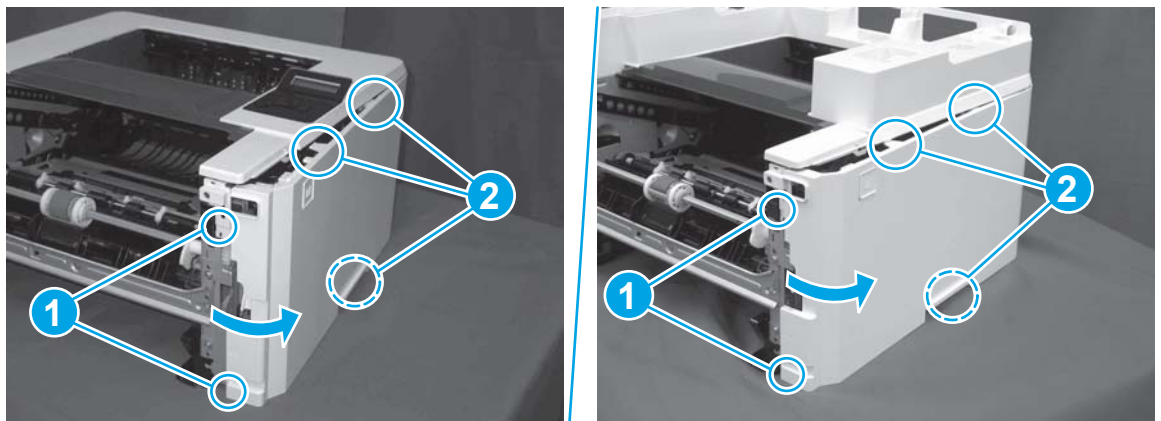
1. Remove one screw (callout 1).

**Figure 1-627** Remove one screw



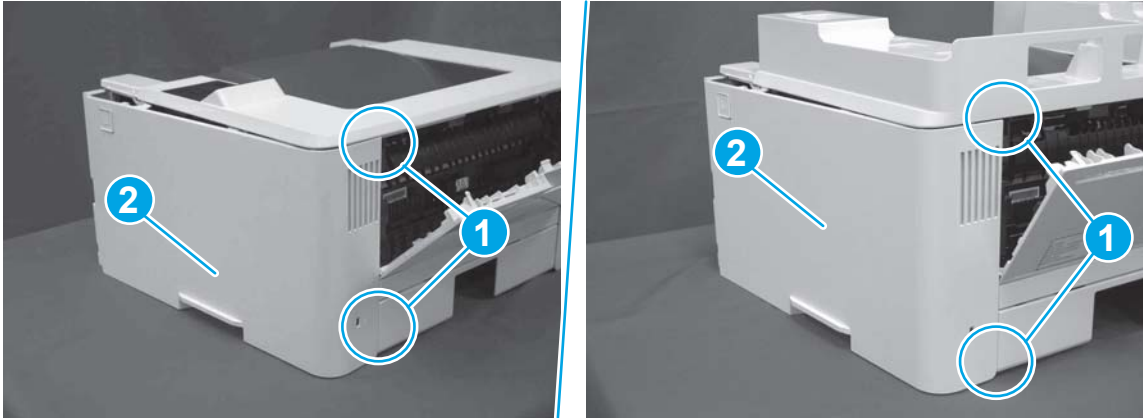
2. At the front of the printer, release two bosses (callout 1), and then release three tabs (callout 2).

**Figure 1-628** Release two bosses and three tabs



3. Open the rear door, release two bosses (callout 1), and then remove the cover (callout 2).

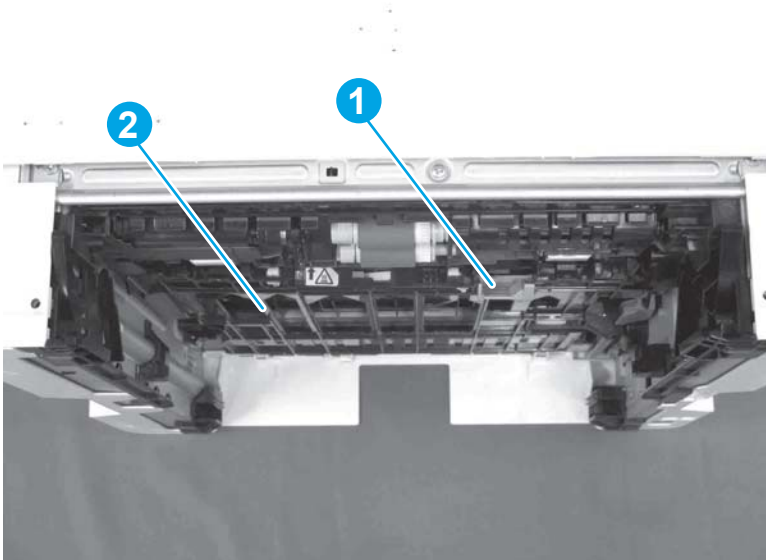
**Figure 1-629** Remove the cover



**Step 5: Remove the rear door assembly**

1. **Duplex models only:** Inside the Tray 2 cavity, press the green jam access lever (callout 1), and then lower the duplex feed assembly (callout 2).

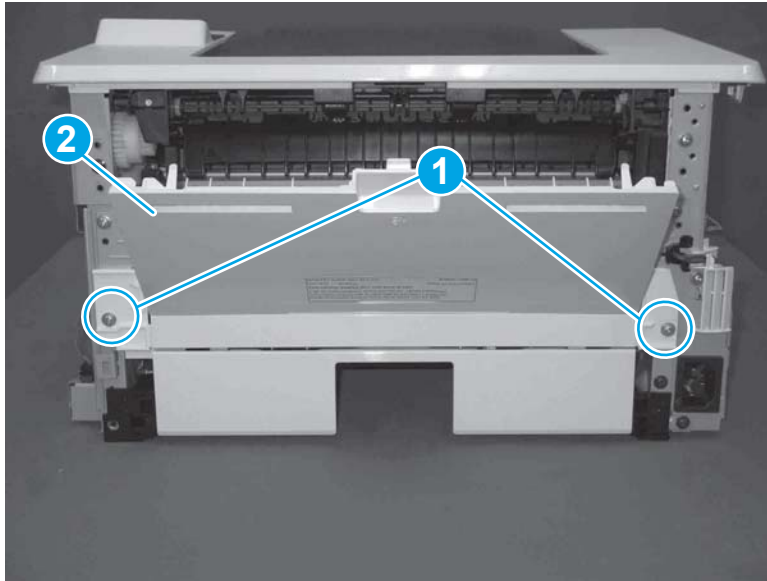
**Figure 1-630** Duplex models, lower the duplex feed assembly







2. At the rear of the printer, remove two screws (callout 1), and then remove the rear door assembly (callout 2).

**Figure 1-631** Remove two screws



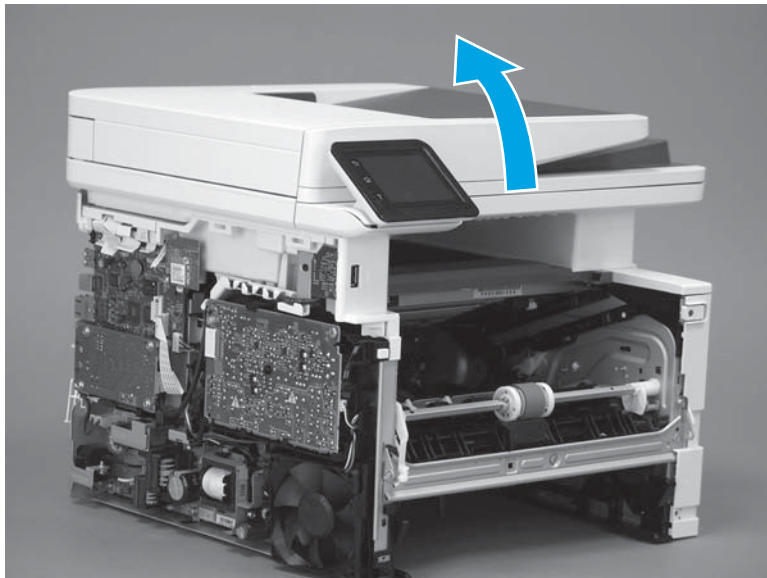
#### Step 6: Remove the integrated scanner assembly (M427/M246)

 **NOTE:** The step is for the M427/M426 printer. For the M403/M402, skip this step and go to [Step 9: Remove the top cover \(M403/M402\) on page 365](#).

 **NOTE:** M427/M426 models only. The integrated scanner assembly (ISA) includes the sub-scanner assembly (SSA) and the automatic document feeder (ADF).

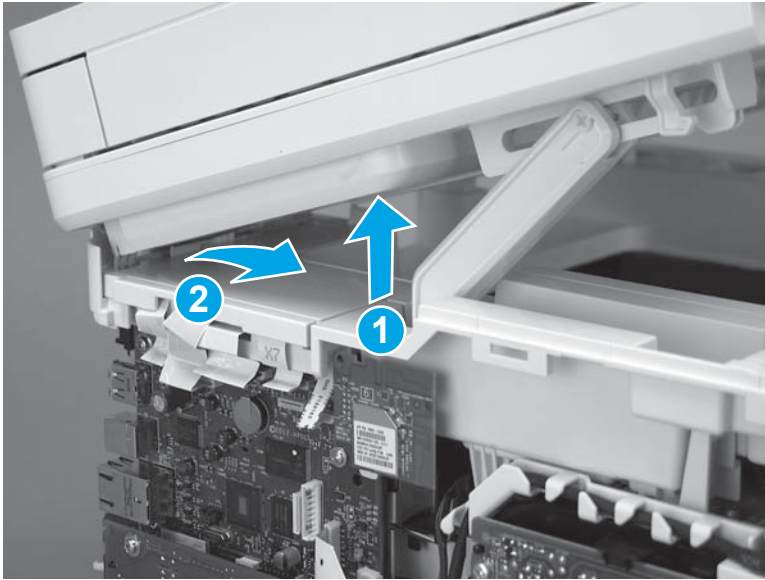
1. Raise the ISA.

**Figure 1-632** Raise the ISA



2. Release the ISA flat-flexible cable (FFC) cover (callout 1), and then remove it (callout 2).

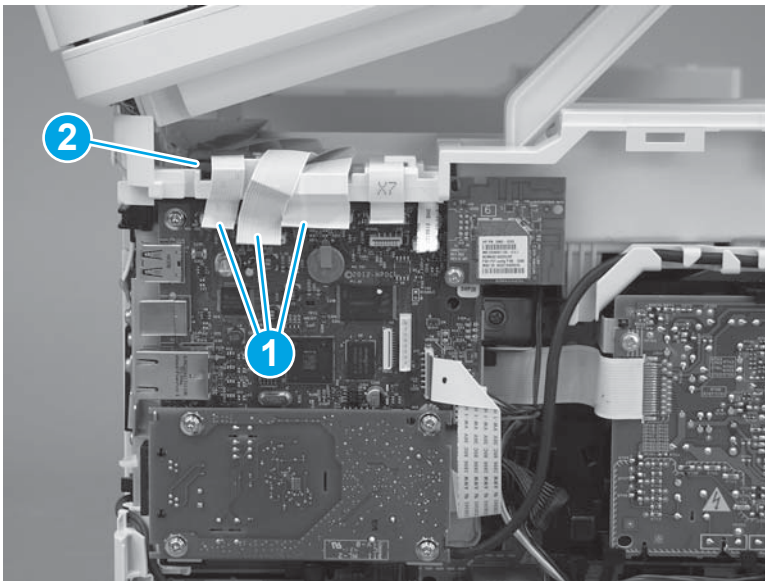
**Figure 1-633** Remove the ISA FFC cover



3. Disconnect three FFCs (callout 1), and then remove the ferrite (callout 2) from the holder.

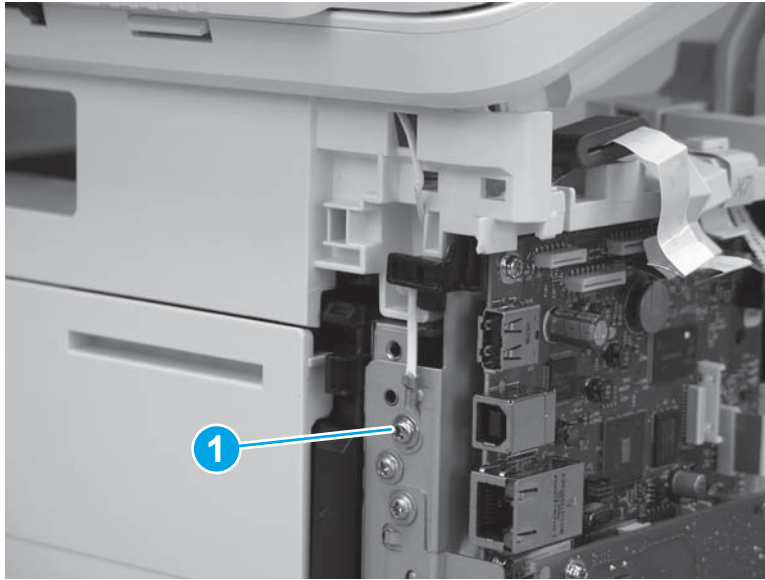
**CAUTION:** The ferrite is not captive on the FFC. Do not lose the ferrite while handling the ISA.

**Figure 1-634** Disconnect three FFCs



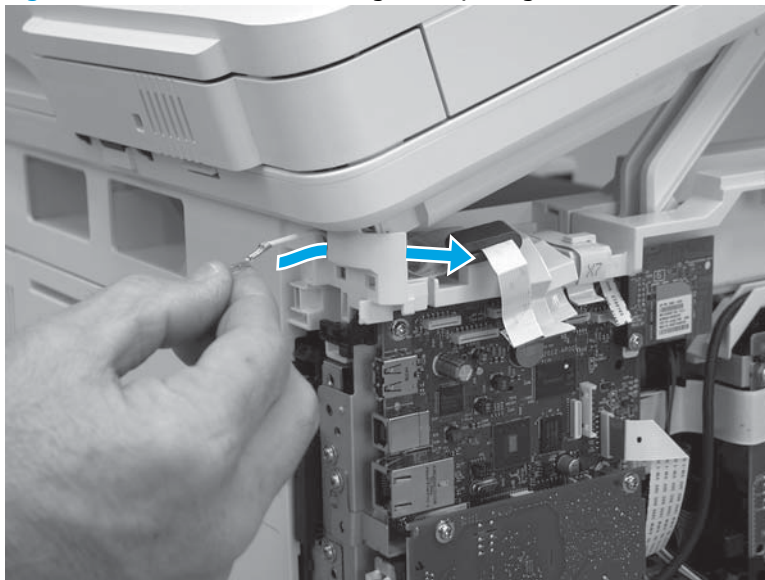
4. Remove one screw (callout 1).

**Figure 1-635** Remove one screw



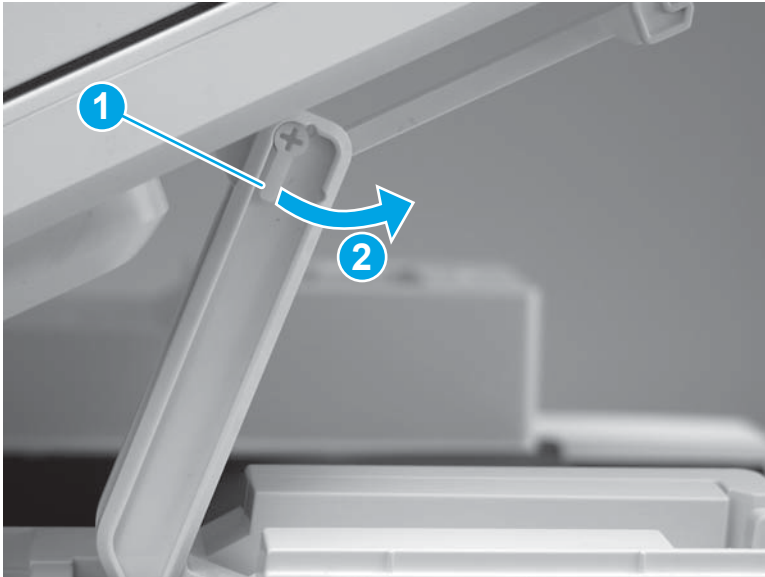
5. Pass the ground wire through the opening in the top cover.

**Figure 1-636** Pass the wire through the opening



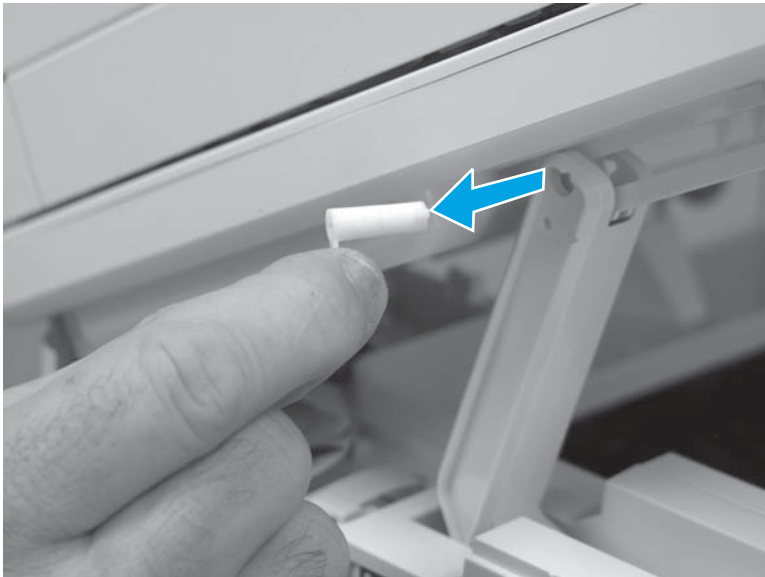
6. Release one tab (callout 1), and then rotate the ISA slider pin (callout 2) towards the front of the printer to release it.

**Figure 1-637** Release one tab and rotate the slider pin



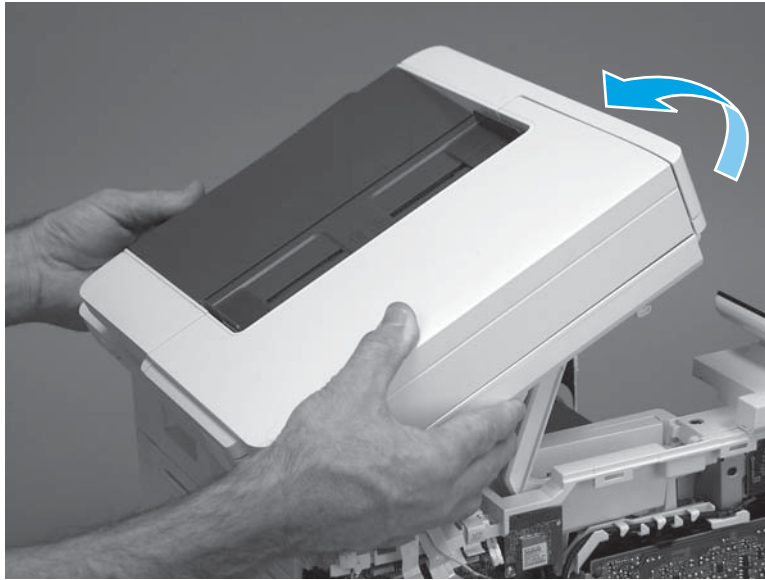
7. Remove the slider pin.

**Figure 1-638** Remove the slider pin



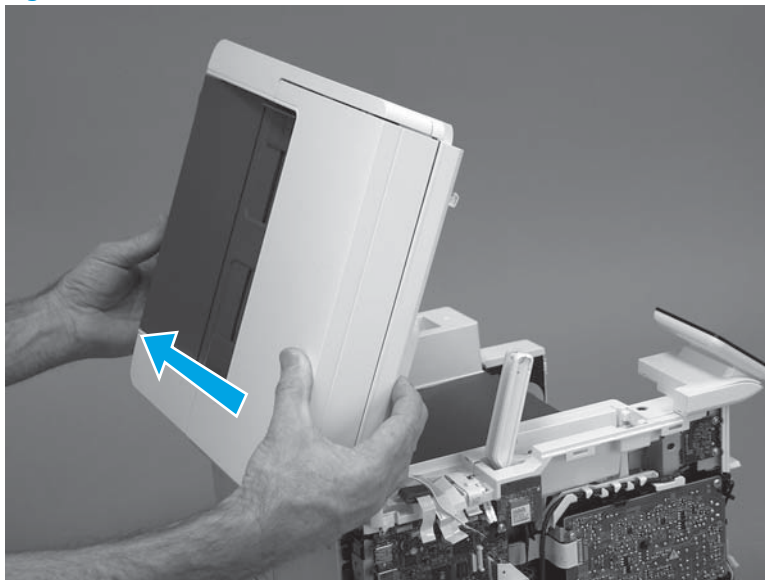
8. Rotate the ISA towards the rear of the printer until it stops.

**Figure 1-639** Rotate the ISA towards the rear of the printer



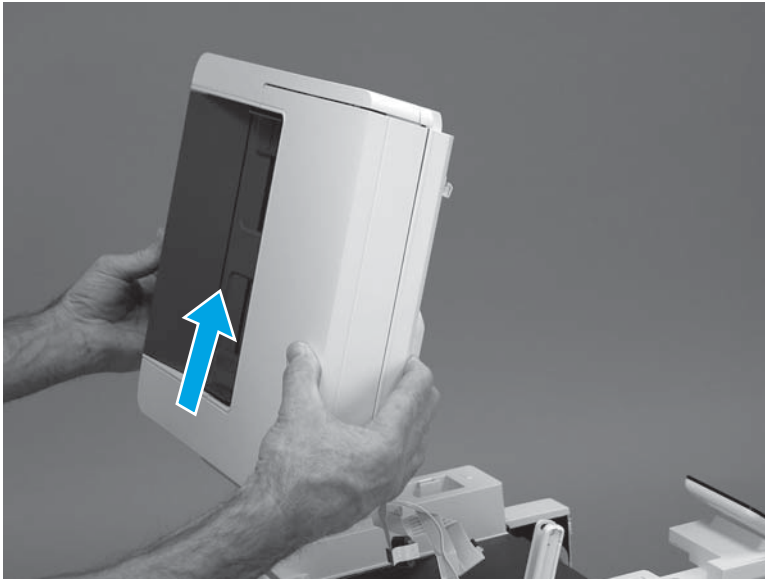
9. Slide the ISA as shown to release it.

**Figure 1-640** Release the ISA



10. Remove the ISA.

**Figure 1-641** Remove the ISA



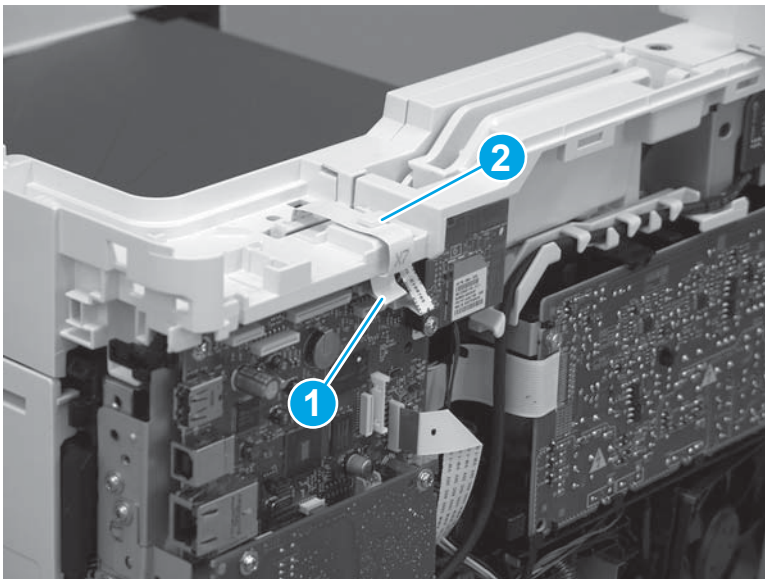
#### Step 7: Remove the control panel (M427/M426)



**NOTE:** The step is for the M427/M426 printer. For the M403/M402, skip this step and go to [Step 9: Remove the top cover \(M403/M402\) on page 365](#).

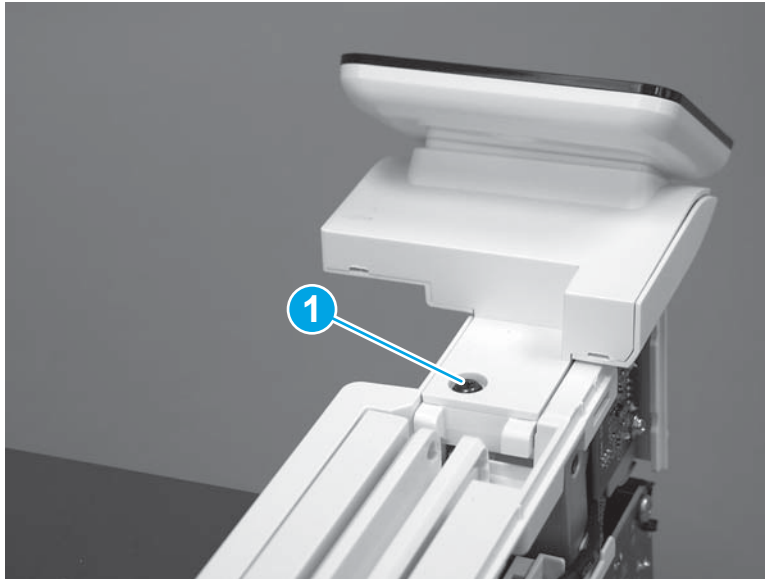
1. Disconnect one FFC (callout 1; J114), and then release the FFC from the retainer (callout 2).

**Figure 1-642** Disconnect one connector



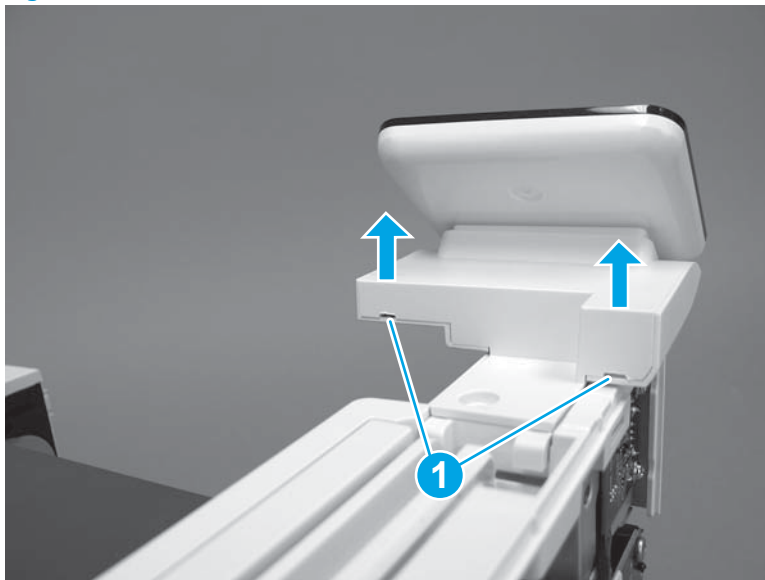
2. Remove one screw (callout 1).

**Figure 1-643** Remove one screw



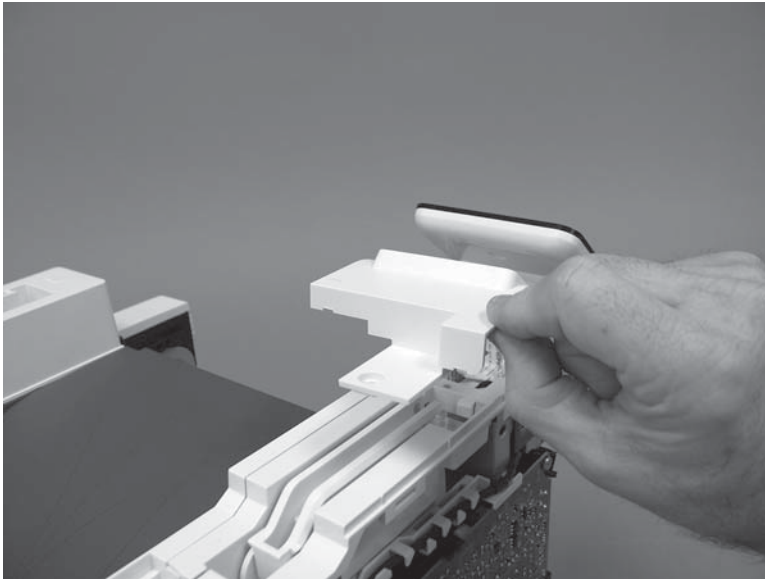
3. Use a small flat-blade screwdriver to release two tabs (callout 1) on the control-panel cable cover.

**Figure 1-644** Release two tabs



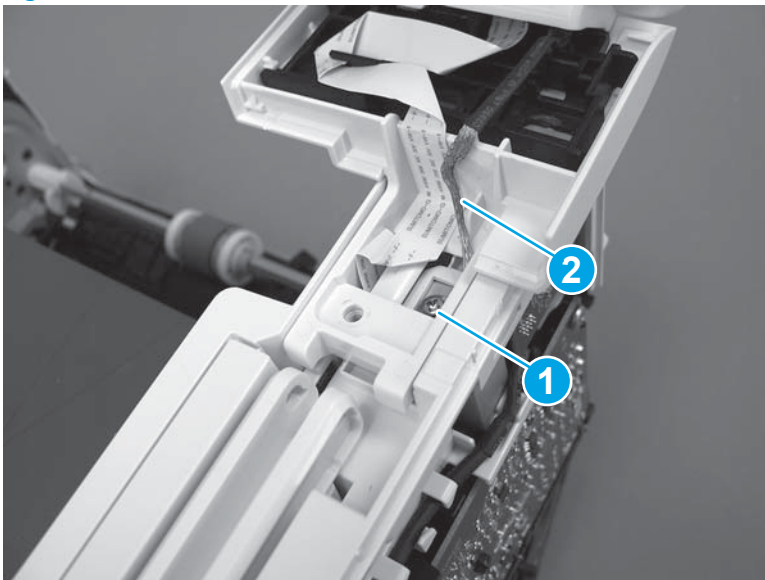
4. Remove the control-panel cable cover.

**Figure 1-645** Remove the cover



5. Remove one grounding screw (callout 1), and then move the ground cable (callout 2) out of the way.

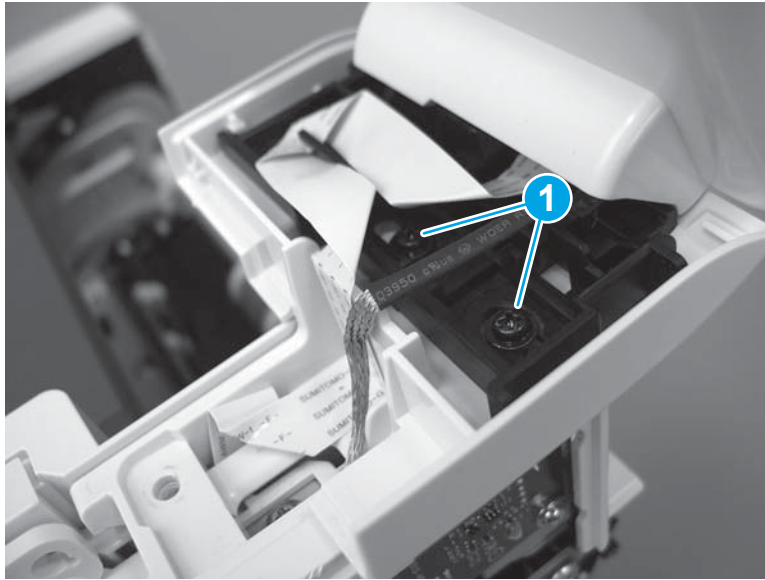
**Figure 1-646** Remove one screw





6. Move the FFC out of the way, and then remove two screws (callout 1).

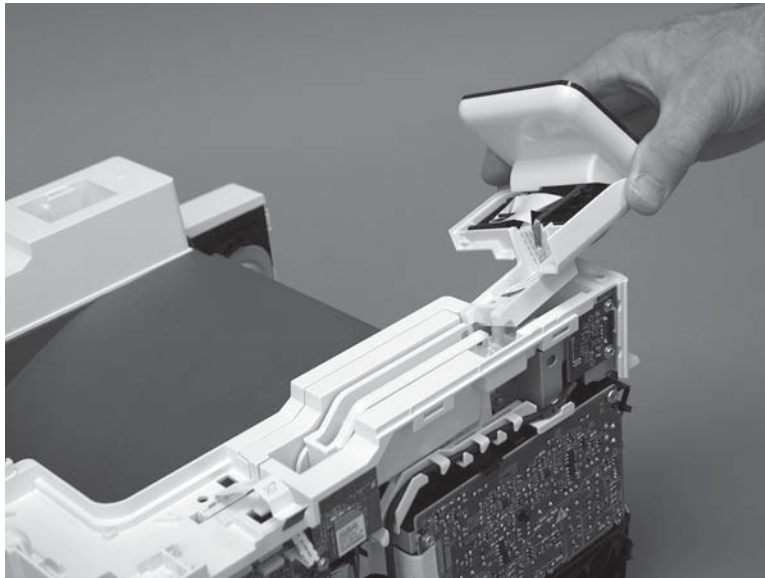
**Figure 1-647** Remove two screws



7. Slightly lift up the control-panel assembly to separate it from the top cover.

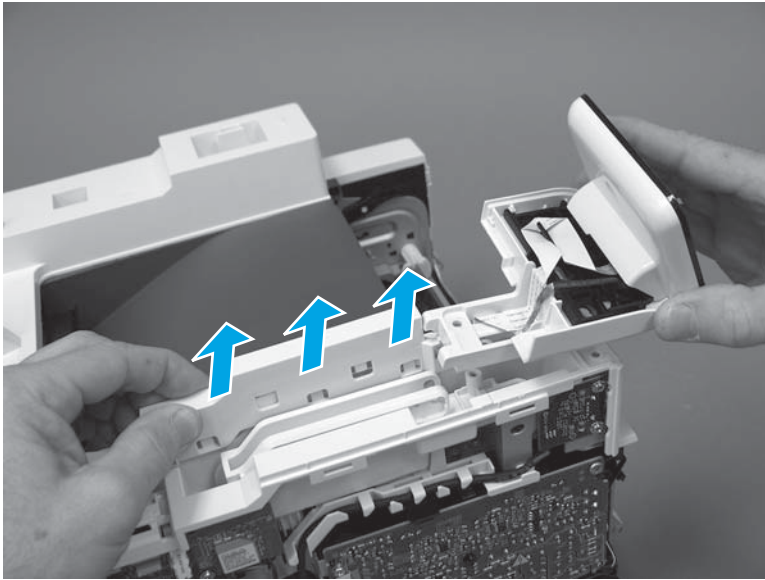
**⚠ CAUTION:** The control panel assembly is still connected to the printer by the FFC. Do not attempt to completely remove the assembly.

**Figure 1-648** Lift up the control-panel assembly



8. Lift up the control-panel FFC cover to remove the control-panel assembly.

**Figure 1-649** Remove the control-panel assembly



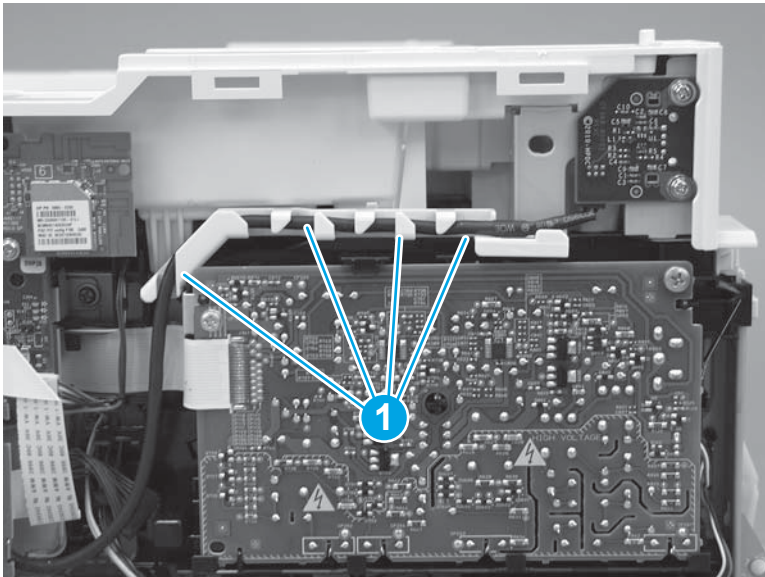
#### Step 8: Remove the top cover (M427/M426)



**NOTE:** The step is for the M427/M426 printer. For the M403/M402, skip this step and go to [Step 9: Remove the top cover \(M403/M402\) on page 365](#).

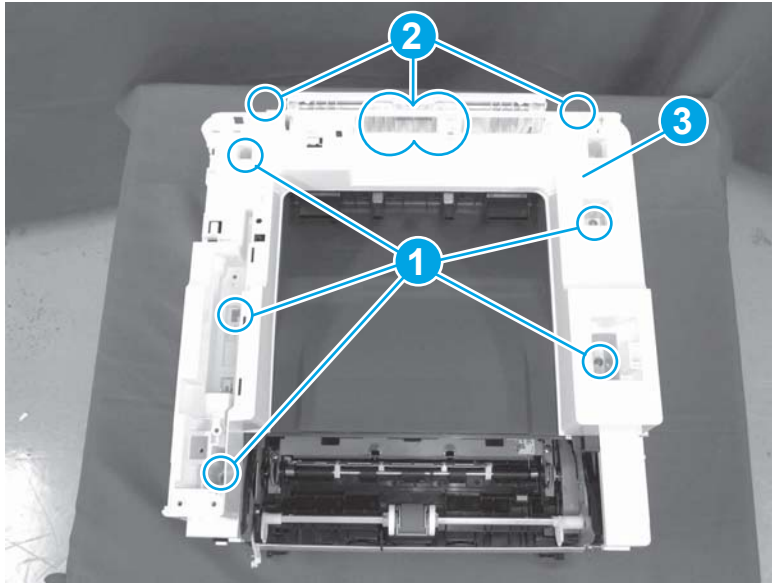
1. Release the USB cable (callout 1) from the cable guide.

**Figure 1-650** Remove the USB cable




2. Remove five screws (callout 1), release four bosses (callout 2), and then remove the top cover (callout 3).

**Figure 1-651** Remove the cover



### Step 9: Remove the top cover (M403/M402)

 **NOTE:** The step is for the M403/M402 printer. For the M427/M426, skip this step and go to [Step 10: Remove the paper delivery tray \(output bin\) on page 366](#).

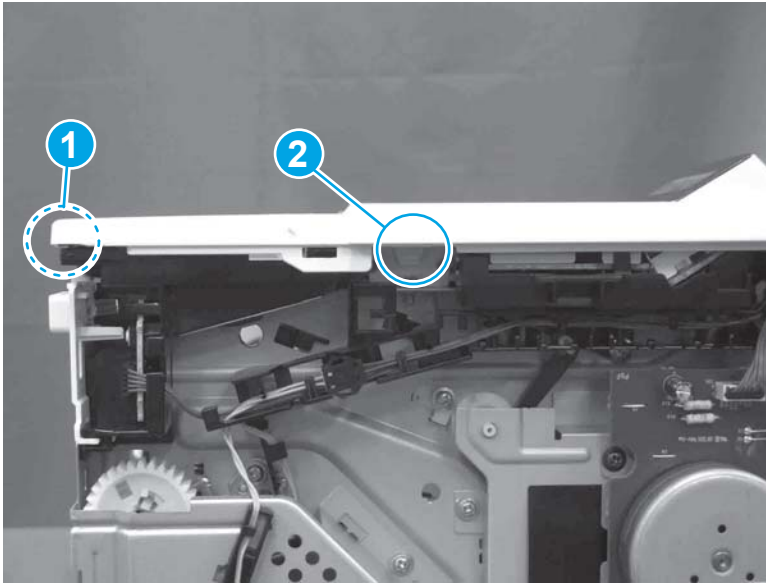
1. Remove one screw (callout 1).

**Figure 1-652** Remove one screw




2. At the right side of the printer, release the one boss (callout 1), and then release one tab (callout 2).

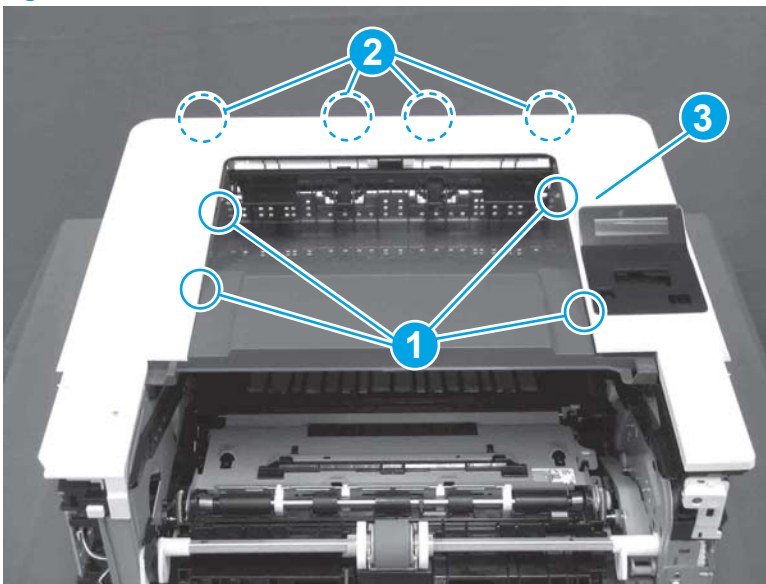
**Figure 1-653** Release one boss and one tab




3. Release four tabs (callout 1), release four bosses (callout 2), and then remove the top cover (callout 3).

 **TIP:** Open the rear door to make releasing the bosses (callout 3) easier.

**Figure 1-654** Remove the cover

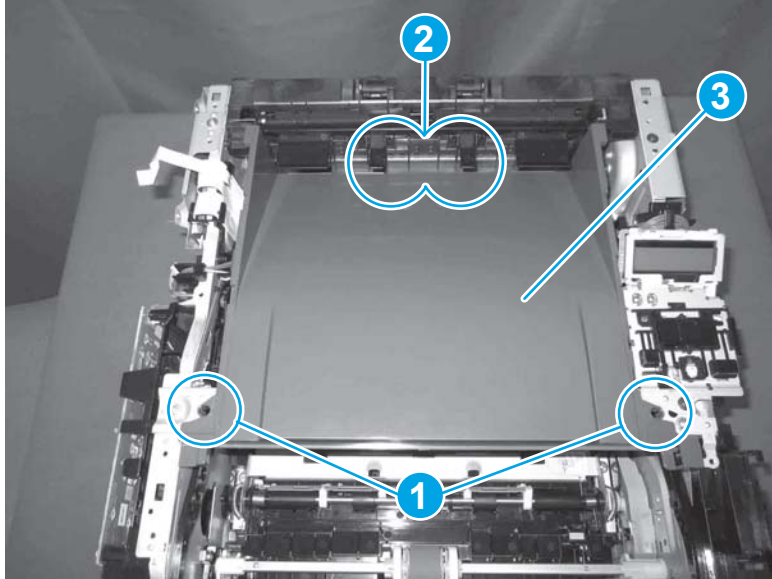


### Step 10: Remove the paper delivery tray (output bin)

 **NOTE:** This procedure shows the M403/M402 model, however, the paper delivery tray (output bin) removal is similar for the M427/M426 printer.

- ▲ Release two bosses (callout 1), release two tabs (callout 2), and then remove the paper delivery tray (output bin; callout 3).

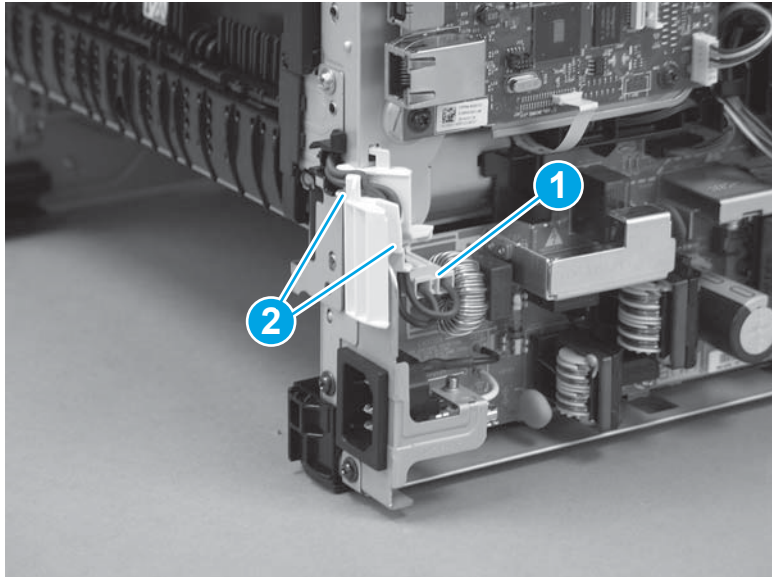
**Figure 1-655** Release two tabs



**Step 11: Remove the fuser**

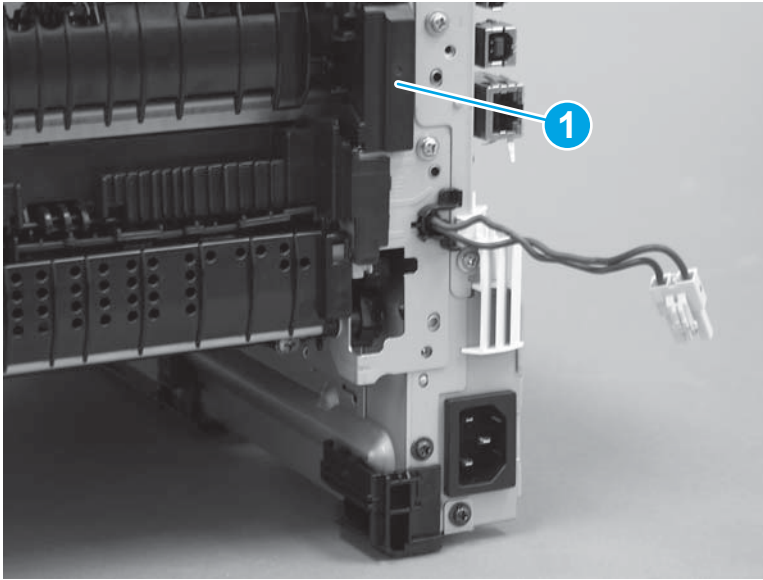
1. Disconnect one connector (callout 1), and then release the wire harness from the guide (callout 2).

**Figure 1-656** Disconnect one connector



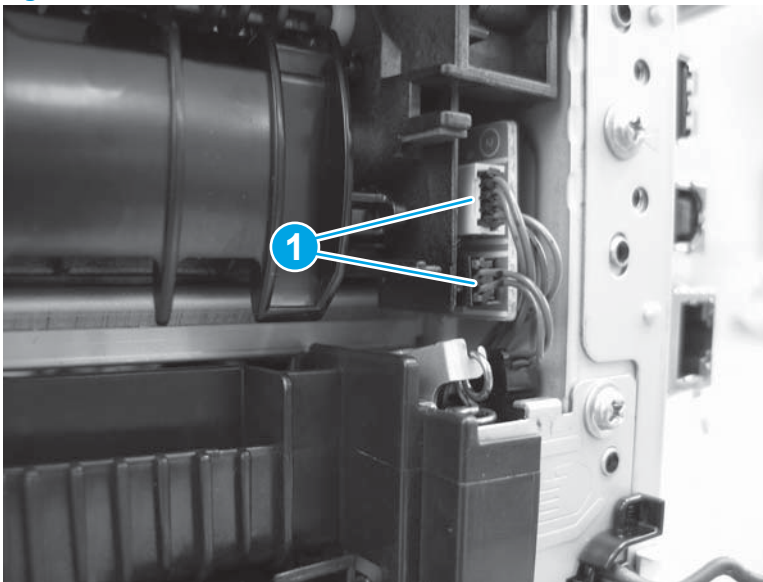
2. Pull the upper connector cover (callout 1) straight off of the printer to remove it.

**Figure 1-657** Remove the cover



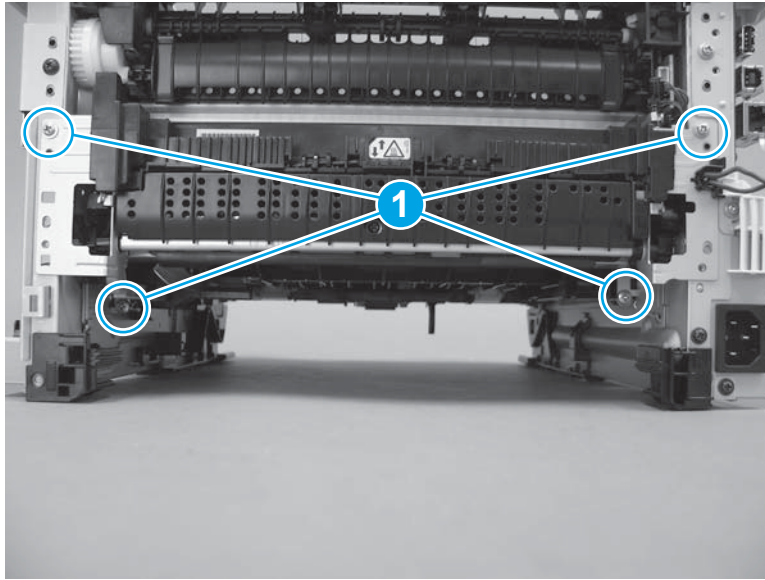
3. Disconnect two connectors (callout 1).

**Figure 1-658** Disconnect two connectors



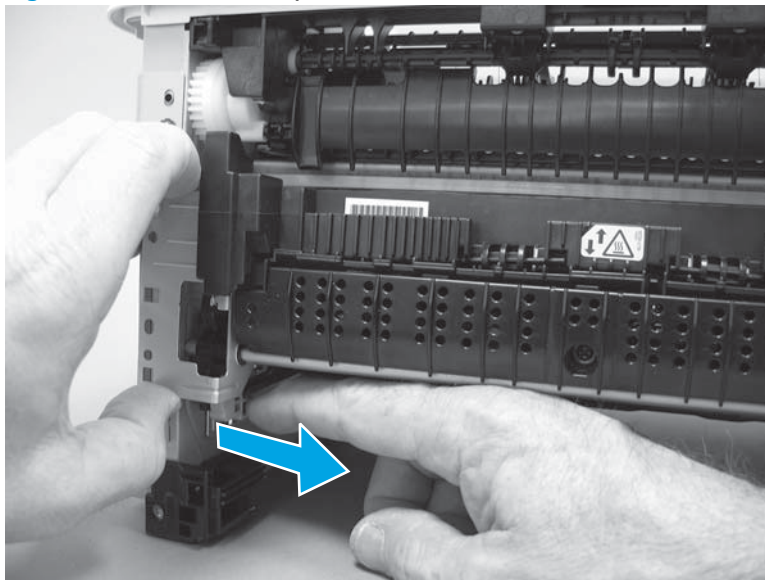
4. Remove four screws (callout 1).

**Figure 1-659** Remove four screws



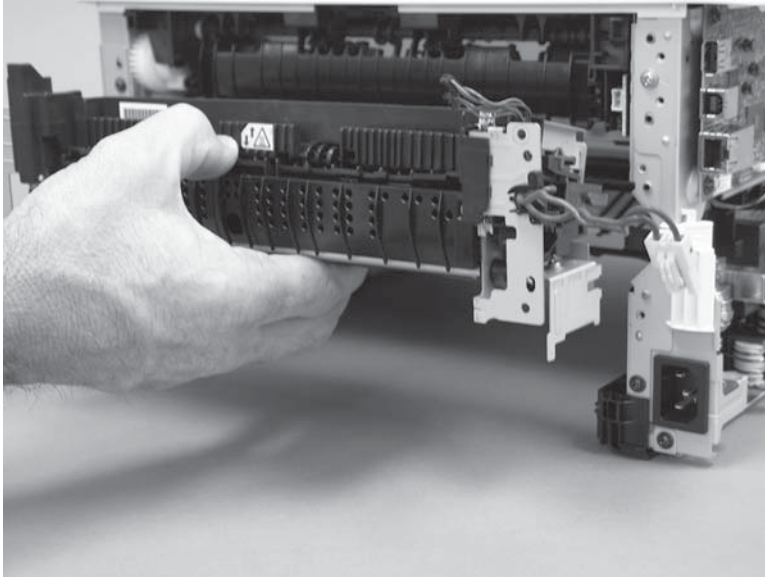
5. Pull the pressure-release link arm as shown to release it from the fuser.

**Figure 1-660** Release the pressure-release arm



6. Slide the fuser straight out of the printer.

**Figure 1-661** Remove the fuser

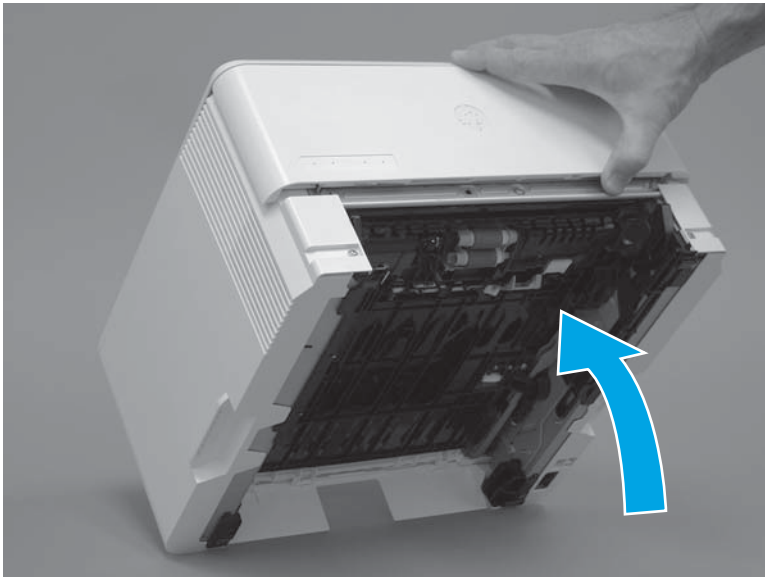


### Step 12: Remove the registration assembly

1. Carefully rotate the printer backward until it rests on the rear side, bottom-side face forward.

**CAUTION:** The integrated scanner assembly (ISA) on the M427/M426 is not captive and can suddenly open when the printer is tilted backward. Support the ISA when handling the M427/M426 printer.

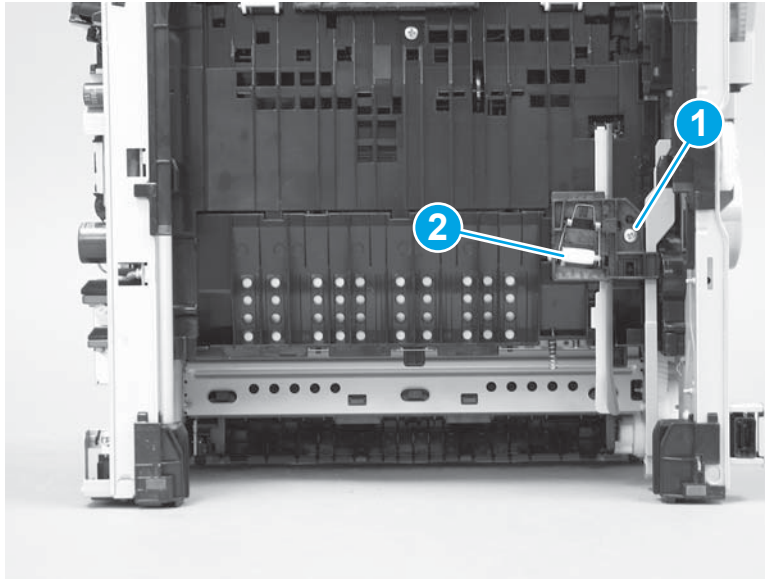
**Figure 1-662** Place the printer bottom-side face forward





2. Remove one screw (callout 1), and then remove the guide (callout 2).

**Figure 1-663** Remove one screw and the guide

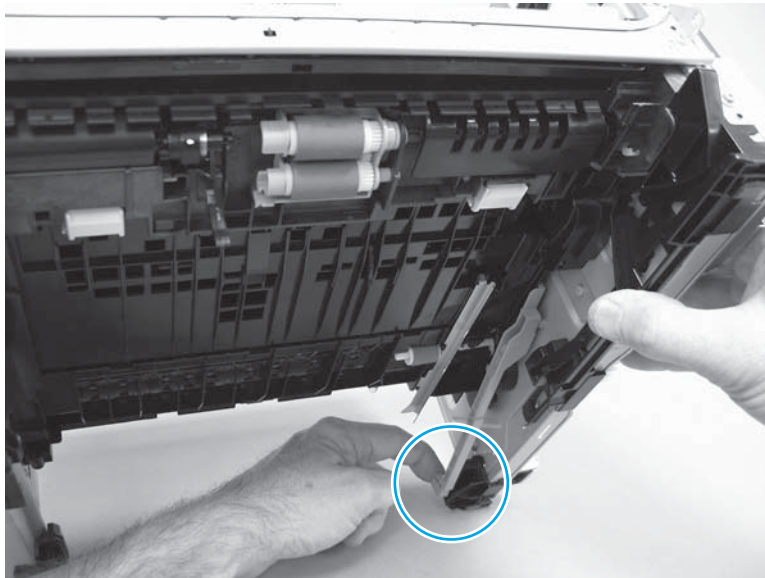


3. Move the end of pressure-release link arm out of the way.



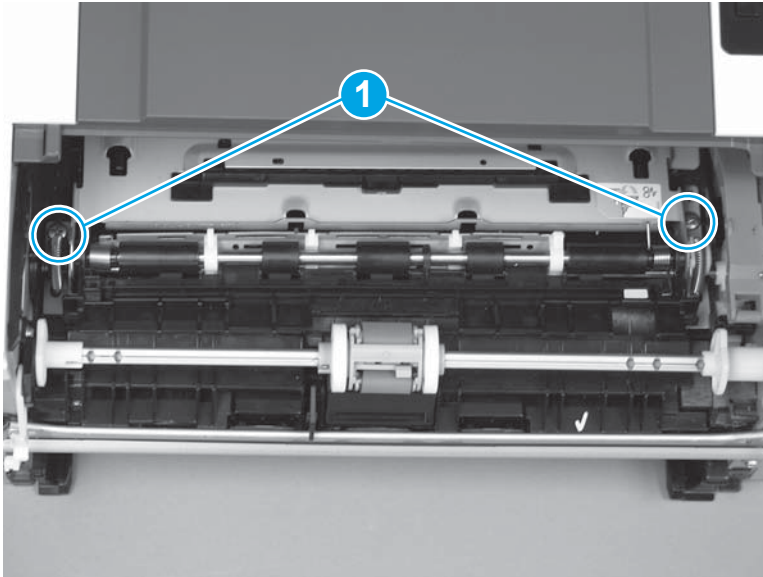
**NOTE:** Doing this makes the other end of the pressure-release arm easier to move out of the way of the later in this procedure.

**Figure 1-664** Move the link arm out of the way



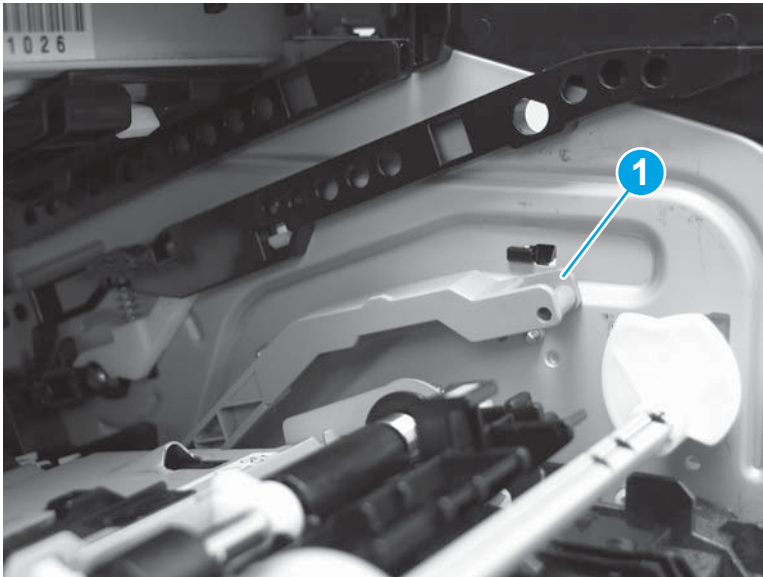
4. Place the printer with the bottom side down, look inside the toner-cartridge cavity, and then remove two screws (callout 1).

**Figure 1-665** Remove two screws



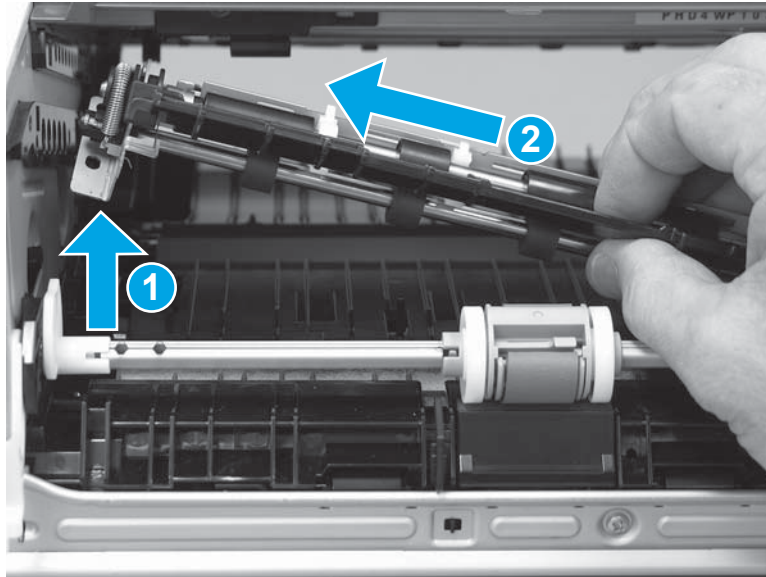
5. Move the end of pressure-release link arm (callout 1) out of the way.

**Figure 1-666** Move the pressure-release arm out of the way



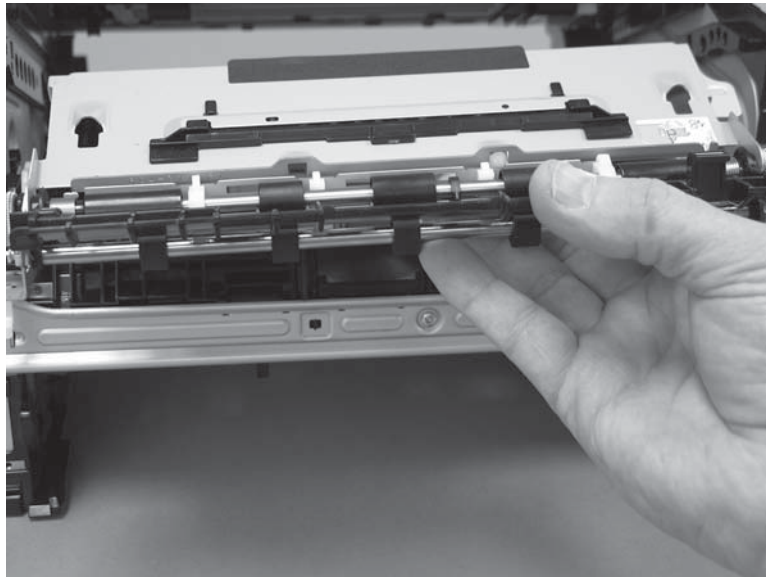
6. Rotate the left end of the registration up and out of the printer (callout 1), and then slide it to the left to release the gear end of the assembly (callout 2).

**Figure 1-667** Release the assembly



7. Remove the assembly.

**Figure 1-668** Remove the assembly



### Step 13: Unpack the replacement assembly

Unpack the replacement part from the packaging.

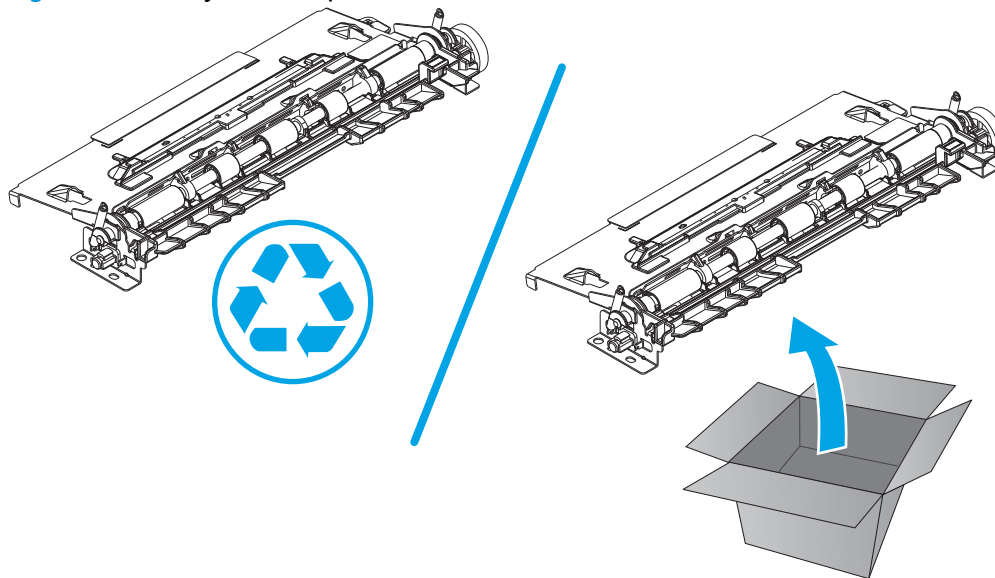
<http://www8.hp.com/us/en/hp-information/environment/product-recycling.html>

---

 **NOTE:** HP recommends responsible disposal of the defective part.

---

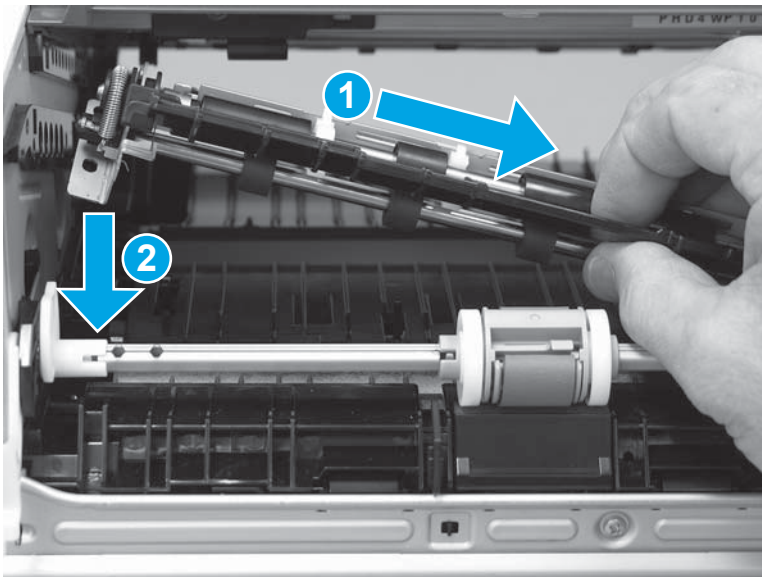
**Figure 1-669** Recycle and unpack



**Step 14: Install the registration assembly**

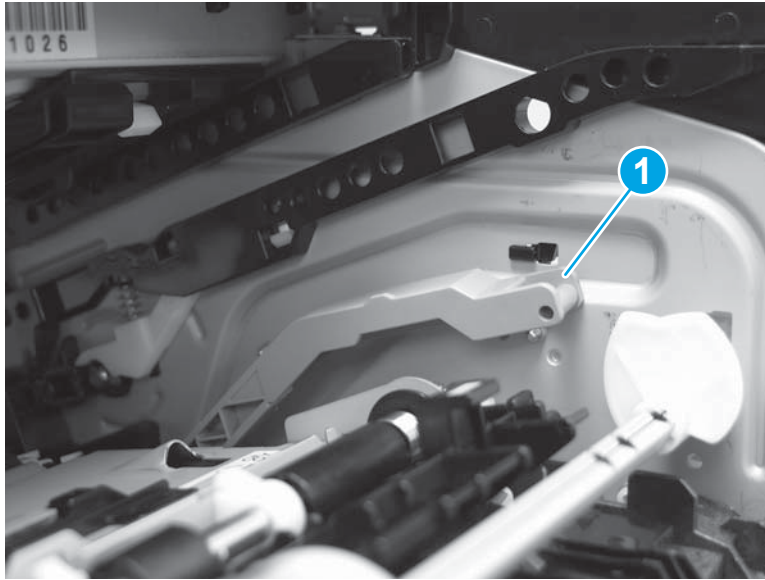
1. Position the gear end of the assembly in the printer (callout 1), and then rotate the left end of the registration down and into of the printer (callout 2).

**Figure 1-670** Install the assembly



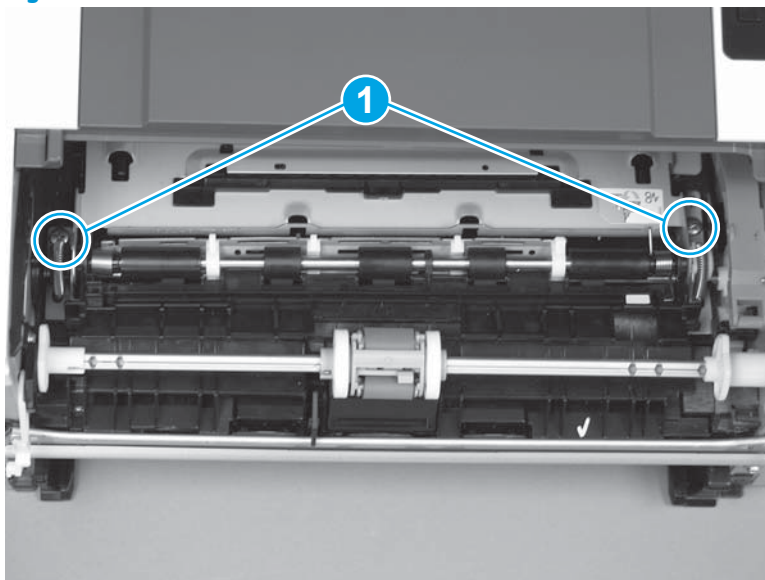
2. Install the end of pressure-release link arm (callout 1).

**Figure 1-671** Install the pressure-release arm



3. Install two screws (callout 1).

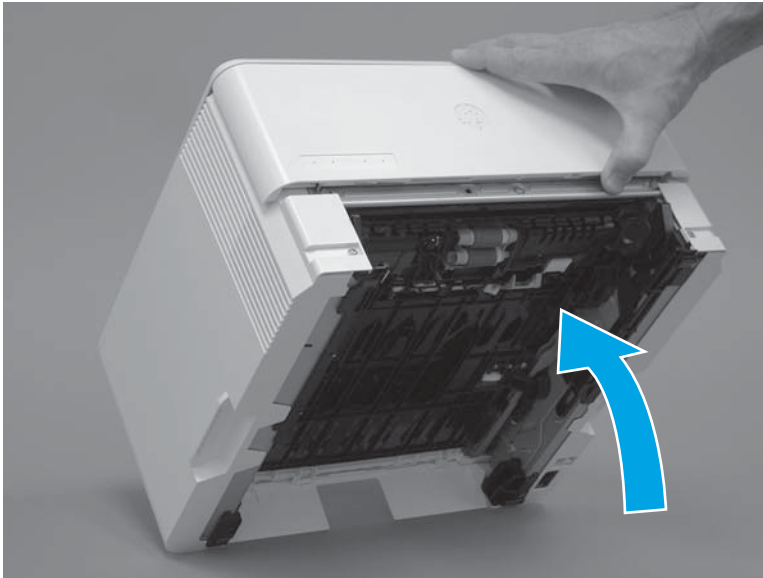
**Figure 1-672** Install two screws



- Carefully rotate the printer backward until it rests on the rear side, bottom-side face forward.

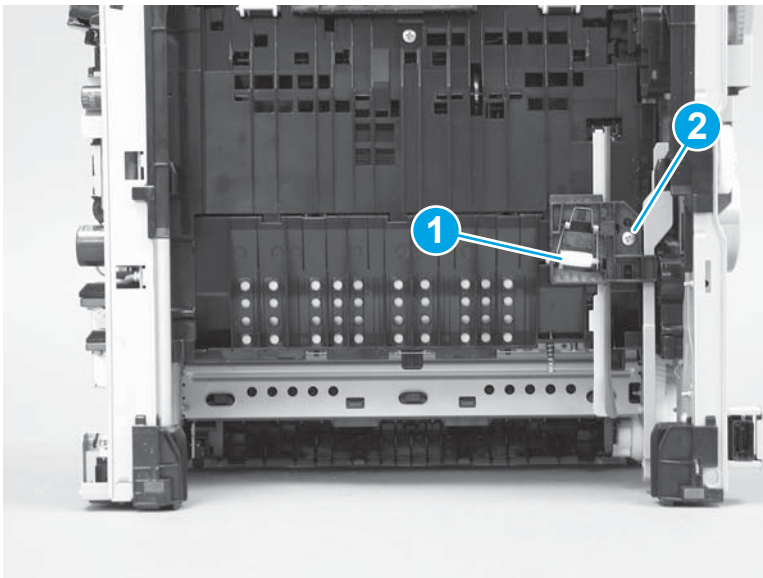
**⚠ CAUTION:** The integrated scanner assembly (ISA) on the M427/M426 is not captive and can suddenly open when the printer is tilted backward. Support the ISA when handling the M427/M426 printer.

**Figure 1-673** Place the printer bottom-side face forward



- Install the guide (callout 1), and then install one screw (callout 2).

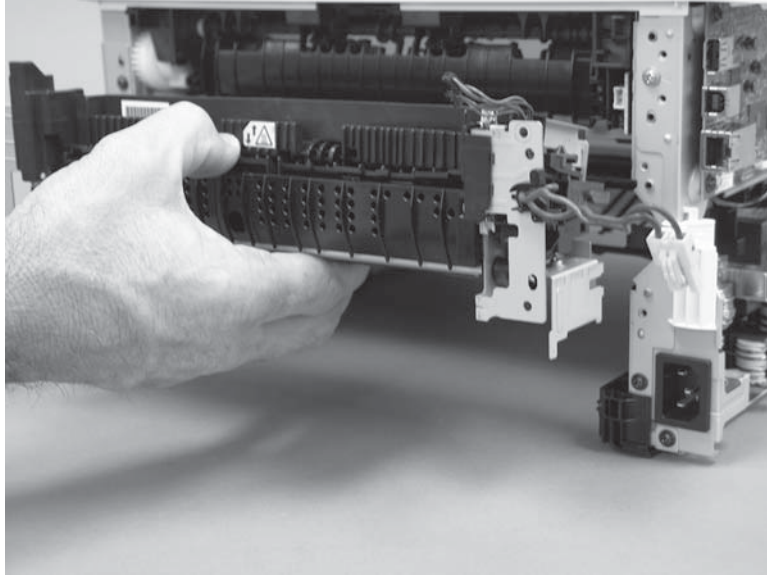
**Figure 1-674** Install the guide



### Step 15: Install the fuser

- Slide the fuser straight into the printer.

**Figure 1-675** Install the fuser

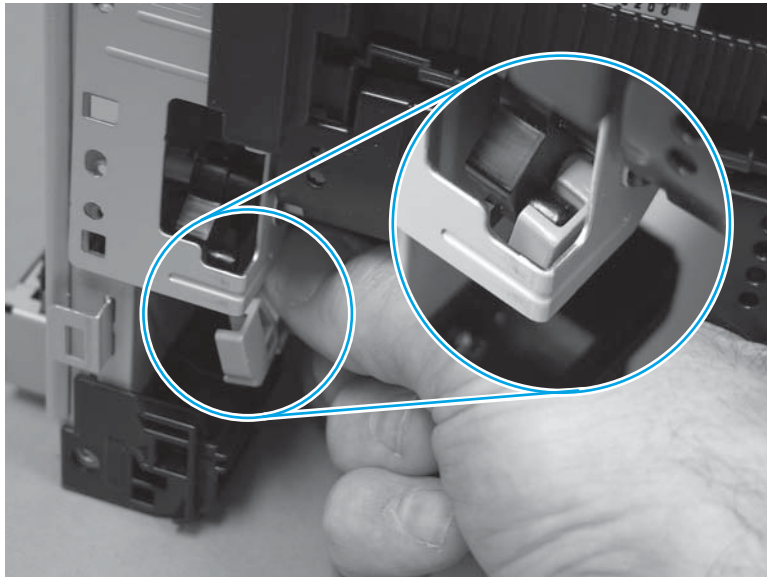


2. Connect the pressure-release link arm to the fuser.



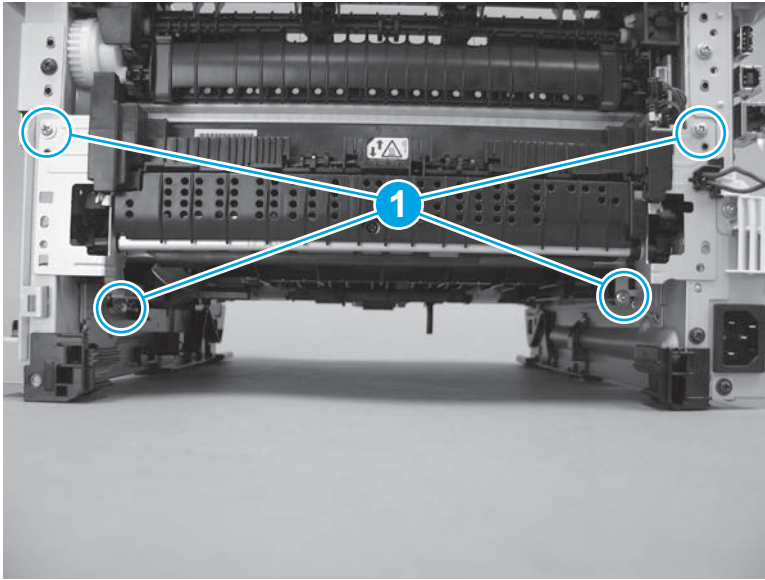
**IMPORTANT:** Make sure that the pressure-release arm is correctly connected to the fuser.

**Figure 1-676** Connect the pressure-release arm



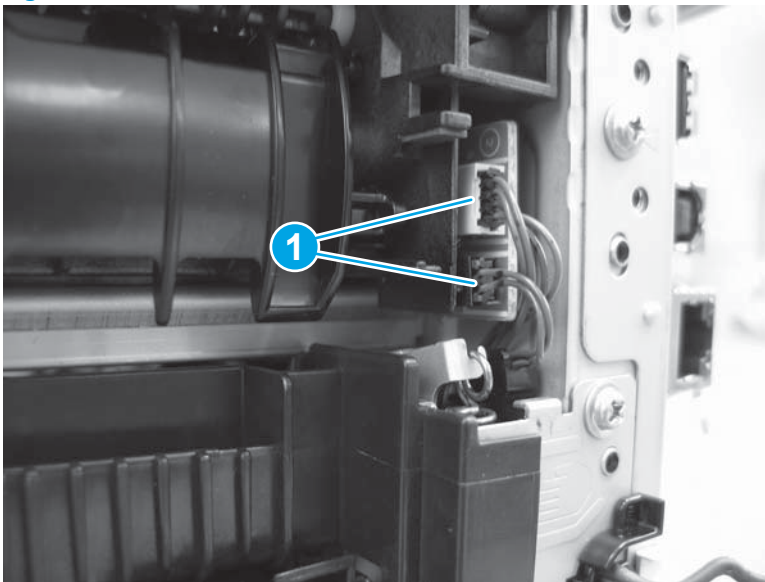
3. Install four screws (callout 1).

**Figure 1-677** Install four screws



4. Connect two connectors (callout 1).

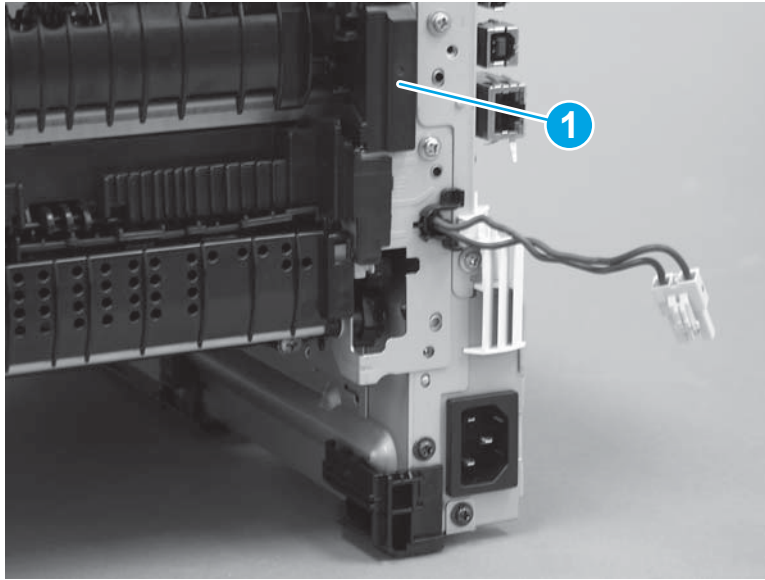
**Figure 1-678** Connect two connectors





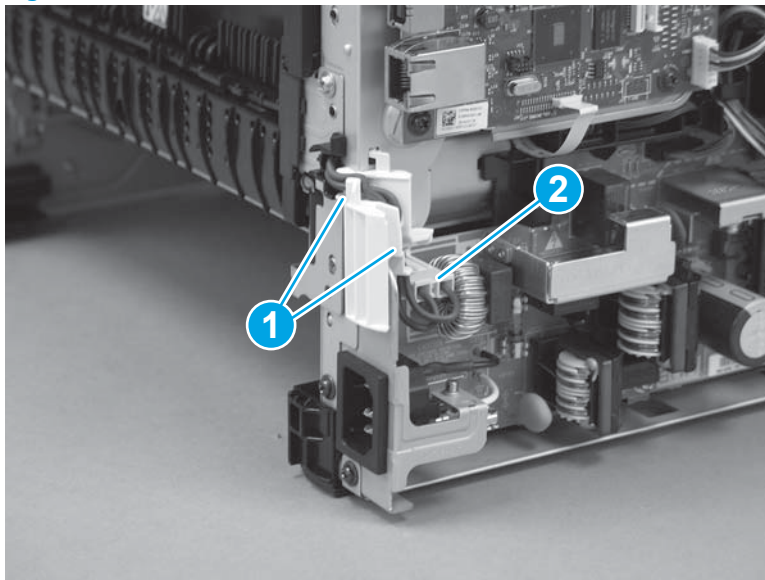
5. Push the upper connector cover (callout 1) straight onto of the printer to install it.

**Figure 1-679** Install the cover




6. Install the wire harness in the guide (callout 1), and then connect one connector (callout 2).

**Figure 1-680** Connect one connector

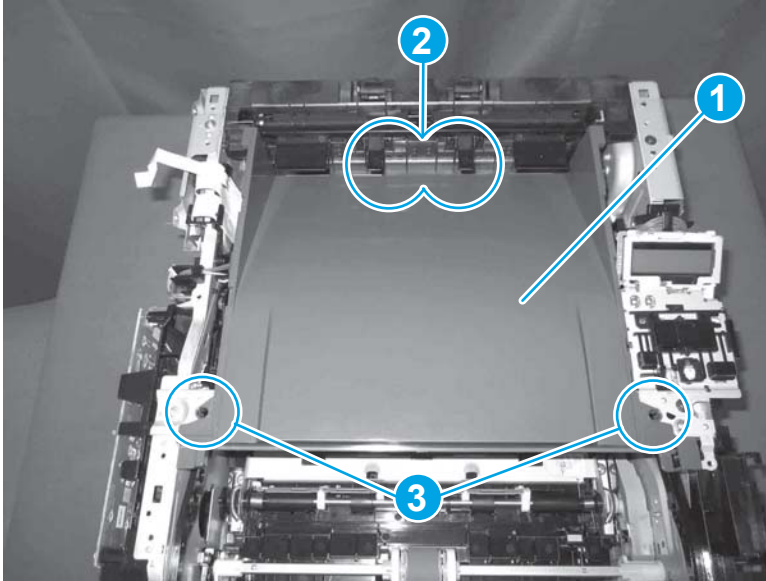


### Step 16: Install the paper delivery tray (output bin)


 **NOTE:** This procedure shows the M403/M402 model, however, the paper delivery tray (output bin) removal is similar for the M427/M426 printer.

- ▲ Position the remove the paper delivery tray (output bin; callout 1) on the printer, engage two tabs (callout 2), and then engage two bosses (callout 3).

**Figure 1-681** Engage two tabs

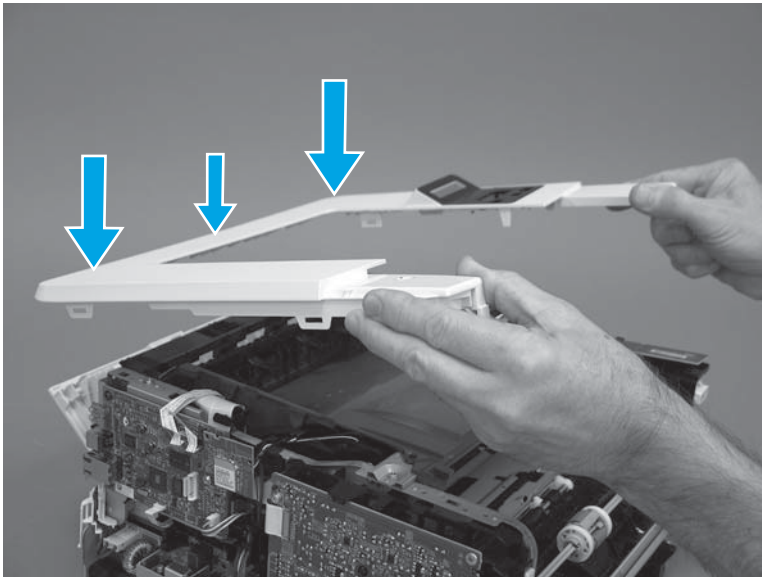


**Step 17: Install the top cover (M403/M402)**

 **NOTE:** The step is for the M403/M402 printer. For the M427/M426, skip this step and go to [Step 18: Install the top cover \(M427/M426\) on page 382](#).

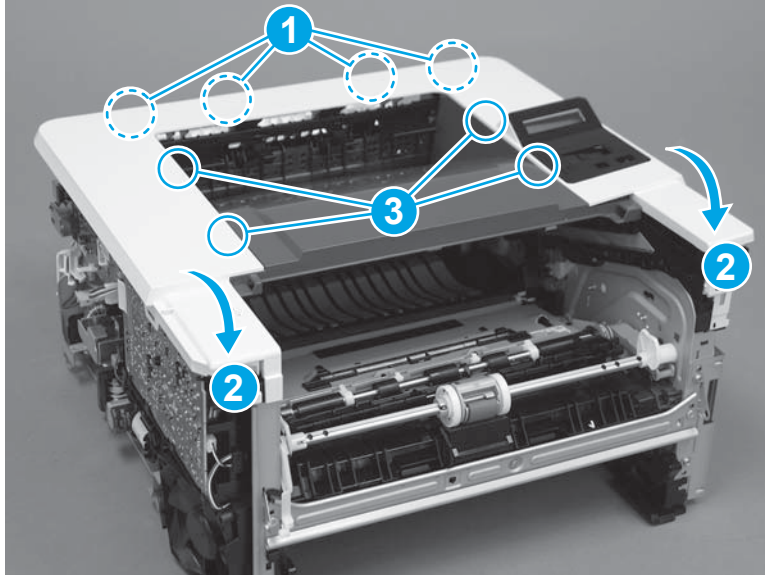
1. Position the rear edge of the cover on the printer.

**Figure 1-682** Install the cover



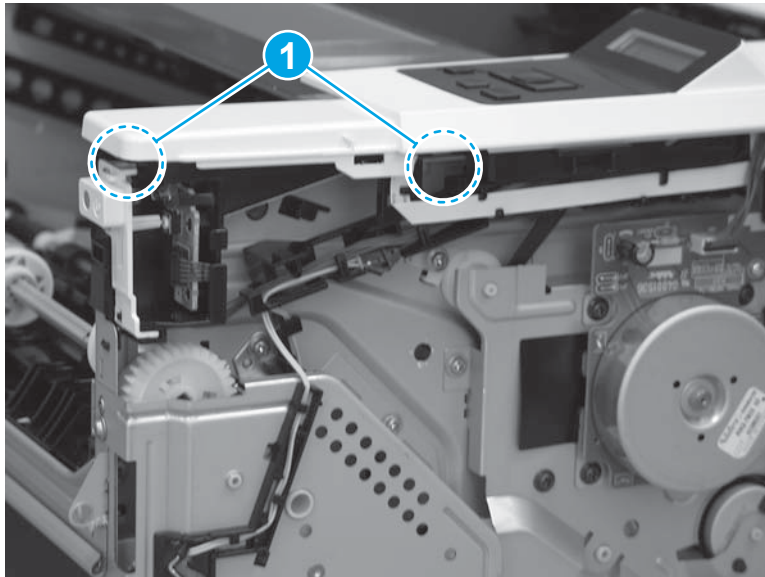
- Engage four bosses (callout 1), rotate the front of the cover down (callout 2) and onto from the printer, and then engage four tabs (callout 3).

**Figure 1-683** Engage four bosses and tabs



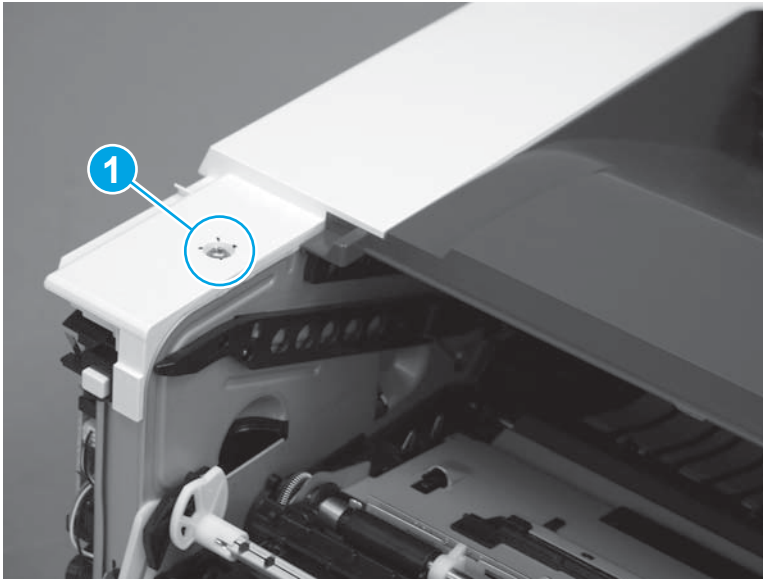
- At the right side of the printer, engage the one boss and one tab (callout 1).

**Figure 1-684** Engage one boss and one tab




4. Install one screw (callout 1).

**Figure 1-685** Install one screw

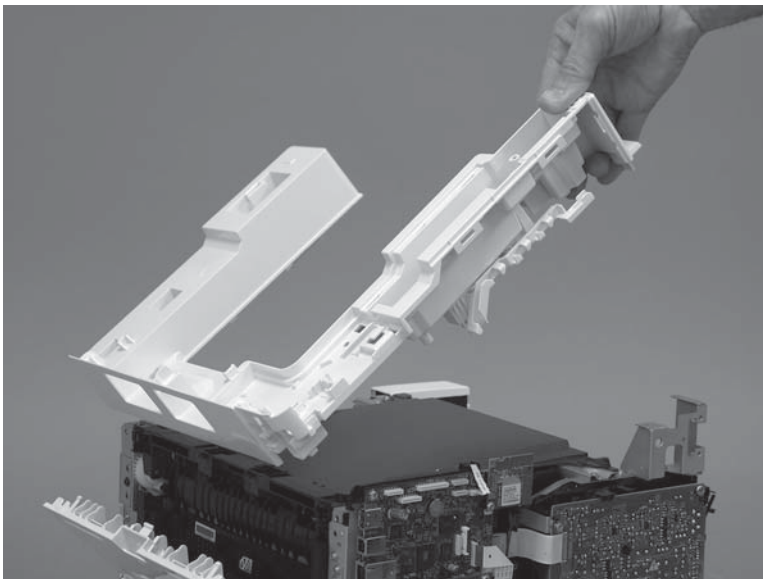


#### Step 18: Install the top cover (M427/M426)

 **NOTE:** The step is for the M427/M426 printer. For the M403/M402, skip this step and go to [Step 21: Install the rear door assembly on page 393](#).

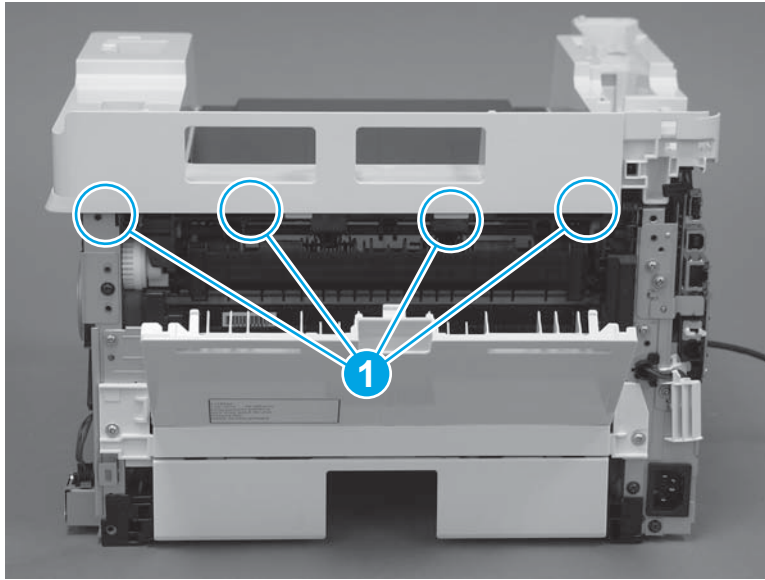
1. Position the rear edge of the top cover on the printer.

**Figure 1-686** Install the cover



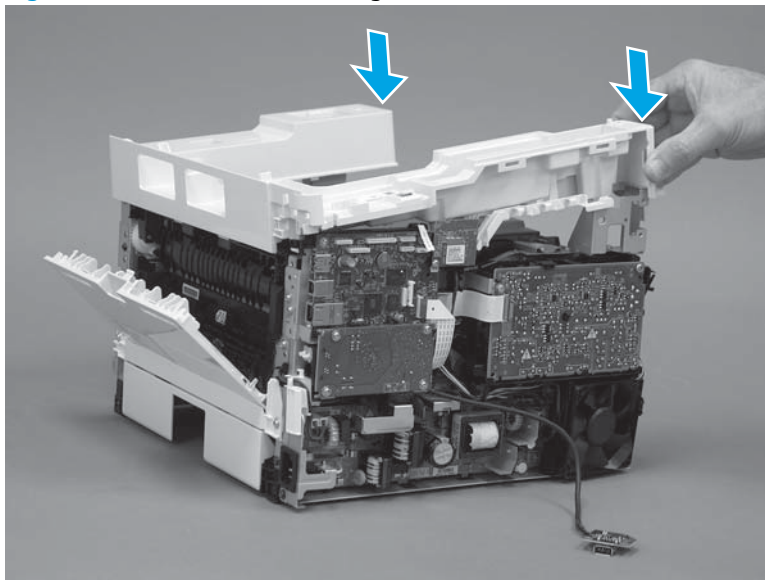
2. Engage four bosses (callout 1).

**Figure 1-687** Engage four bosses



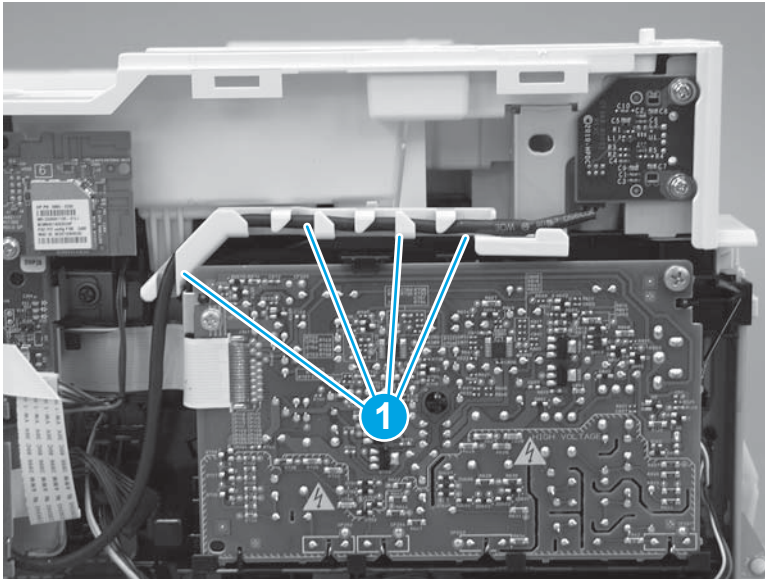
3. Rotate the front edge of the cover down.

**Figure 1-688** Rotate the front edge of the cover down



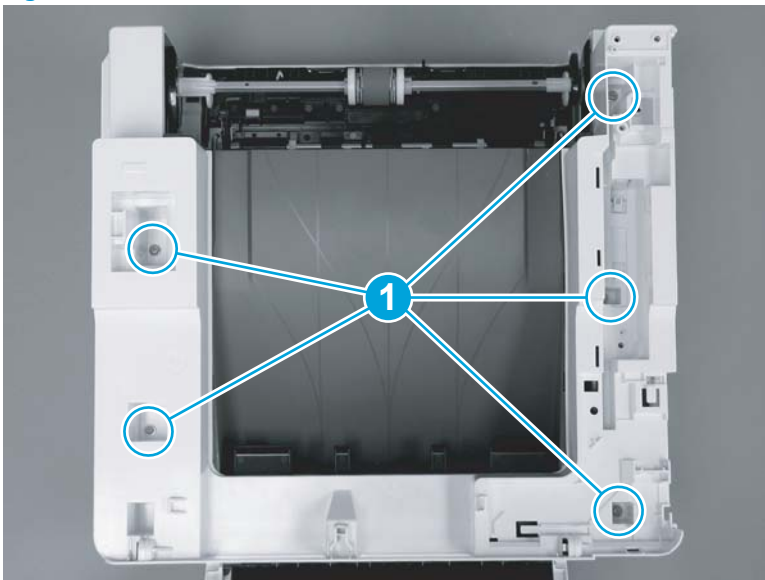
4. Install the USB cable (callout 1) in the guide.

**Figure 1-689** Install the USB PCA




5. Install five screws (callout 1).

**Figure 1-690** Install five screws

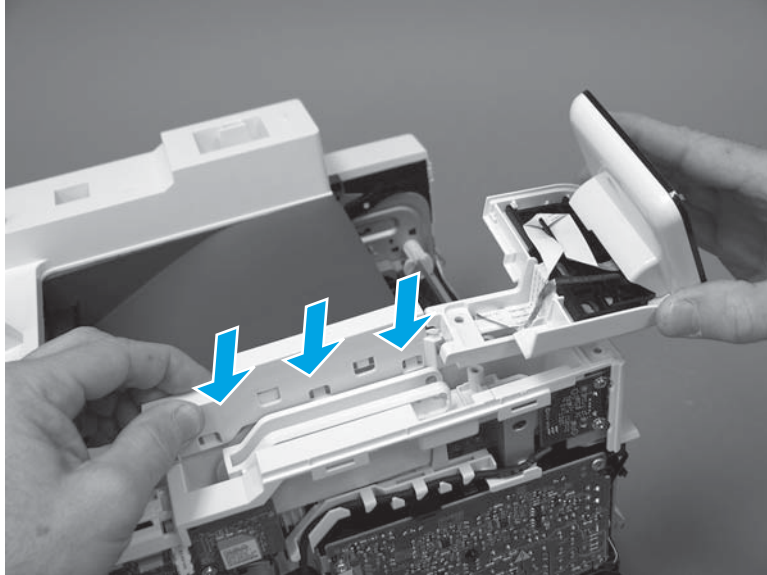


### Step 19: Install the control panel (M427/M246)

 **NOTE:** The step is for the M427/M426 printer. For the M403/M402, skip this step and go to [Step 21: Install the rear door assembly on page 393](#).

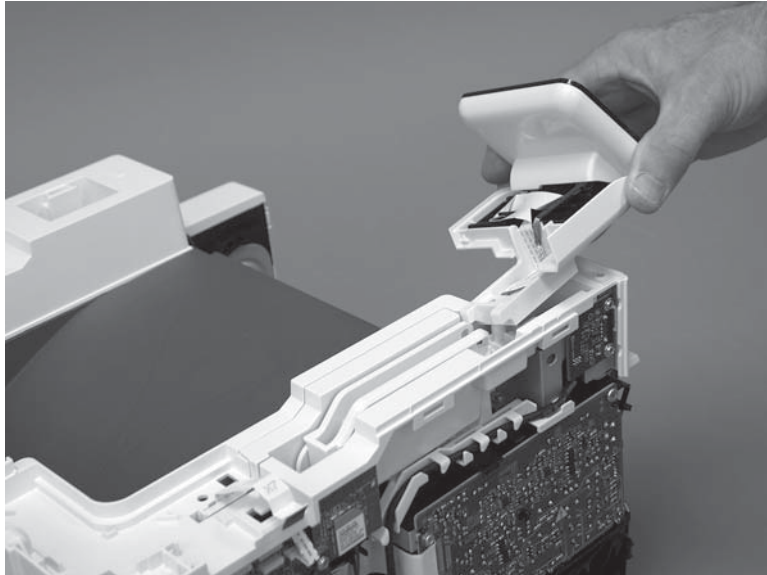
1. Slide the control-panel FFC cover into the slot in the top cover (next to the document feeder support arm) to install it.

**Figure 1-691** Install the control-panel FFC cover



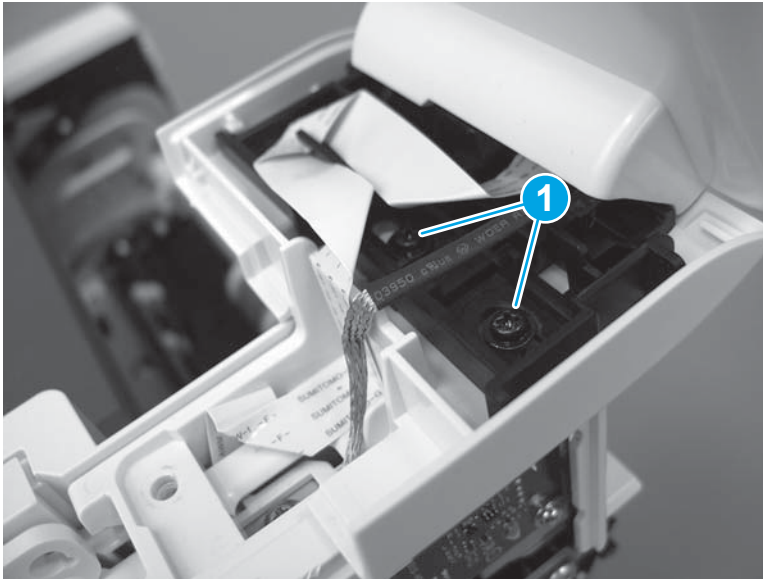
2. Install the control-panel assembly on the top cover.

**Figure 1-692** Install the control-panel assembly



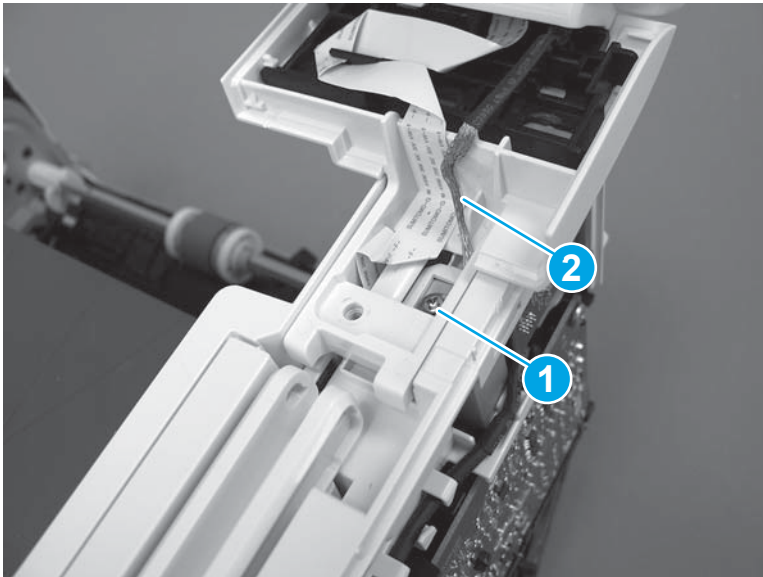
3. Move the FFC out of the way, and then install two screws (callout 1).

**Figure 1-693** Install two screws



4. Install one grounding screw (callout 1), and then make sure that the ground cable (callout 2) is properly routed.

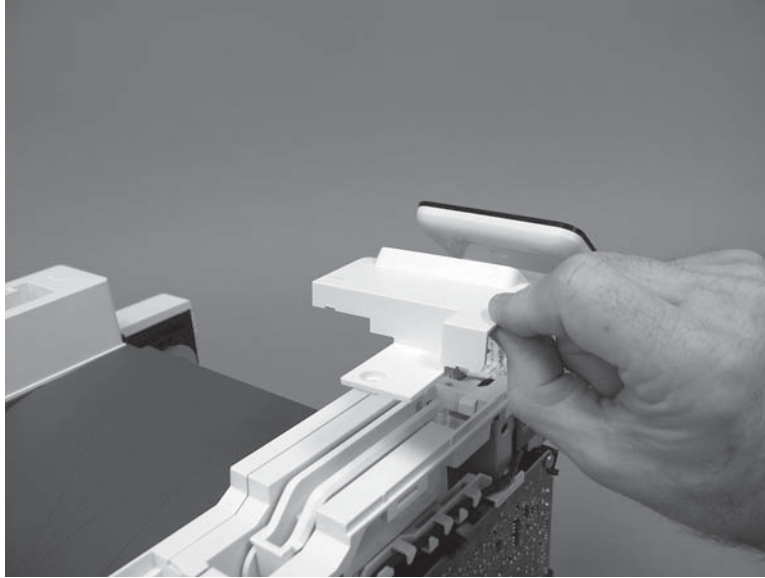
**Figure 1-694** Remove one screw





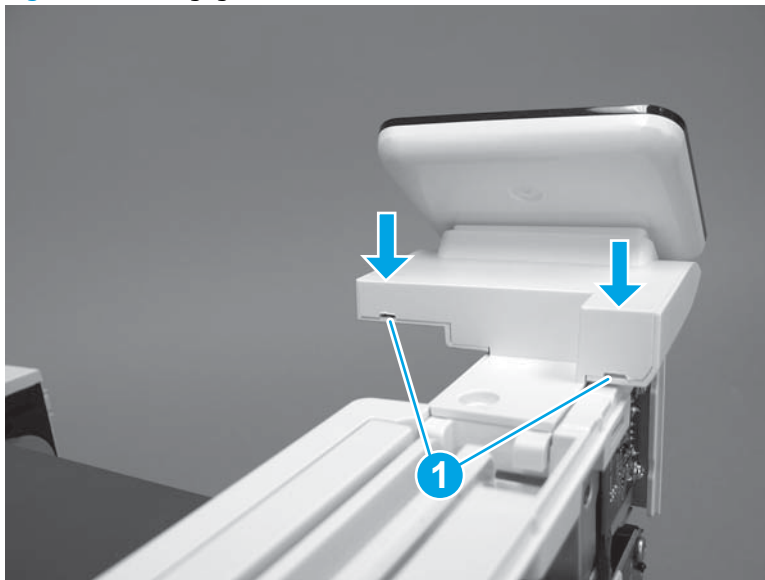
5. Install the control-panel cable cover.

**Figure 1-695** Install the cover



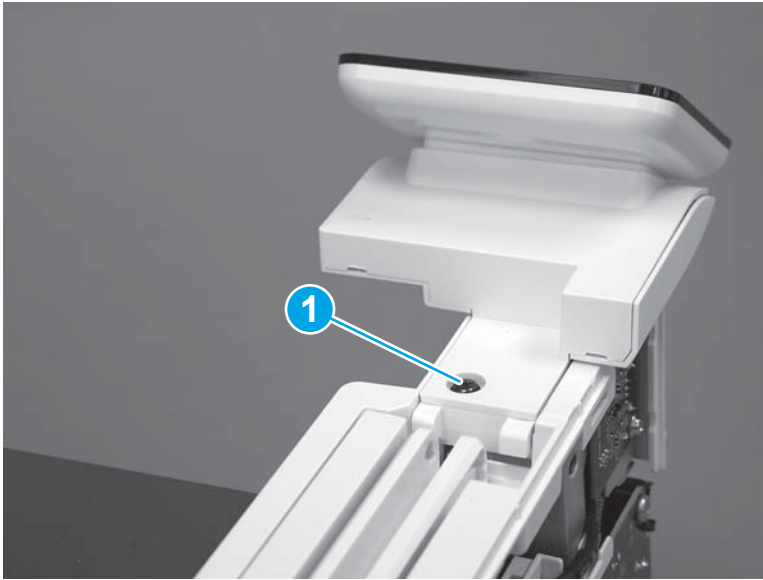
6. Make sure that the two tabs (callout 1) on the cover snap into place.

**Figure 1-696** Engage two tabs



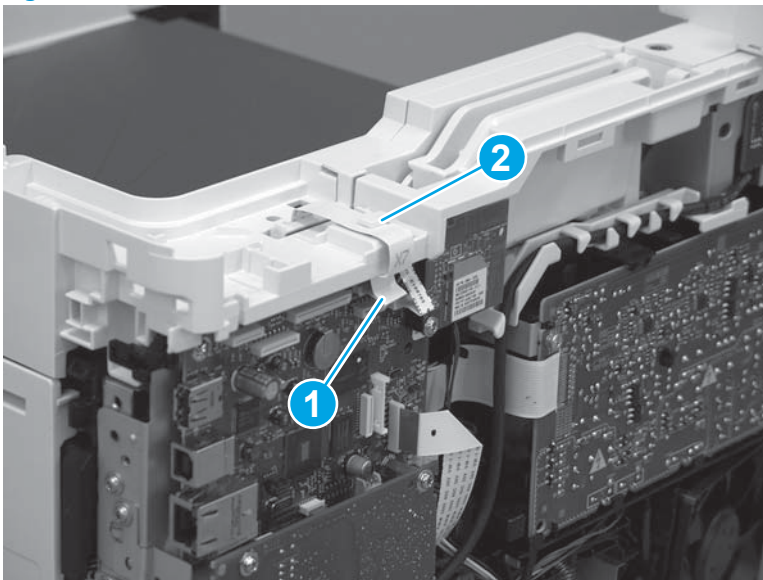
7. Install one screw (callout 1).

**Figure 1-697** Install one screw




8. Install the FFC in the retainer (callout 1), and then connect one FFC (callout 1; J114).

**Figure 1-698** Connect one connector




### Step 20: Install the integrated scanner assembly (M427/M246)

---

 **NOTE:** The step is for the M427/M426 printer. For the M403/M402, skip this step and go to [Step 21: Install the rear door assembly on page 393](#).

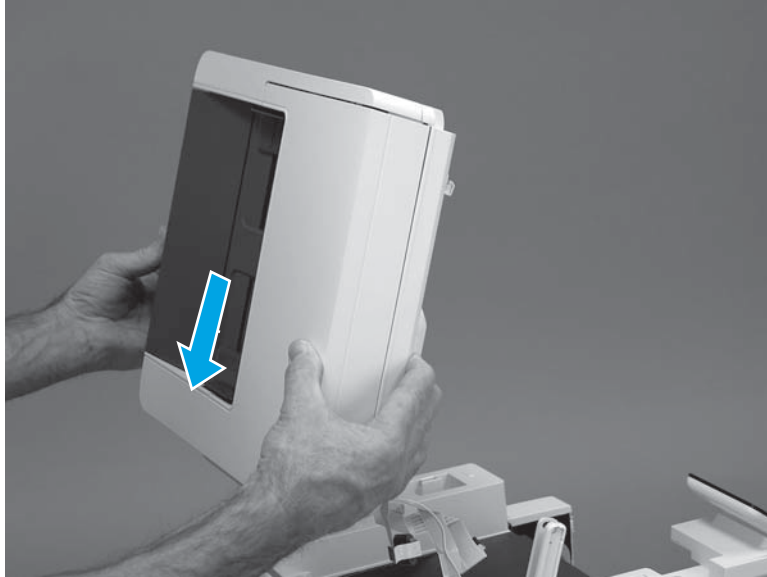
---

 **NOTE:** M427/M426 models only. The integrated scanner assembly (ISA) includes the sub-scanner assembly (SSA) and the automatic document feeder (ADF).

---

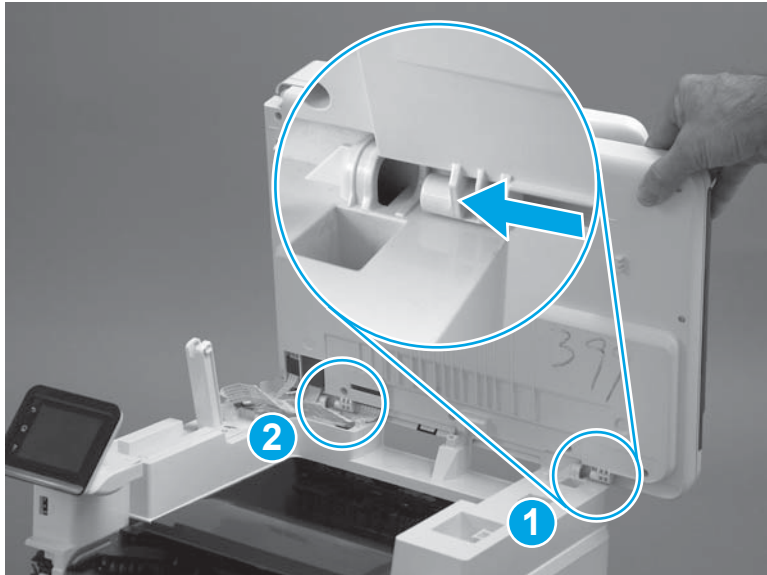
1. Position the ISA on the printer.

**Figure 1-699** Position the ISA on the printer



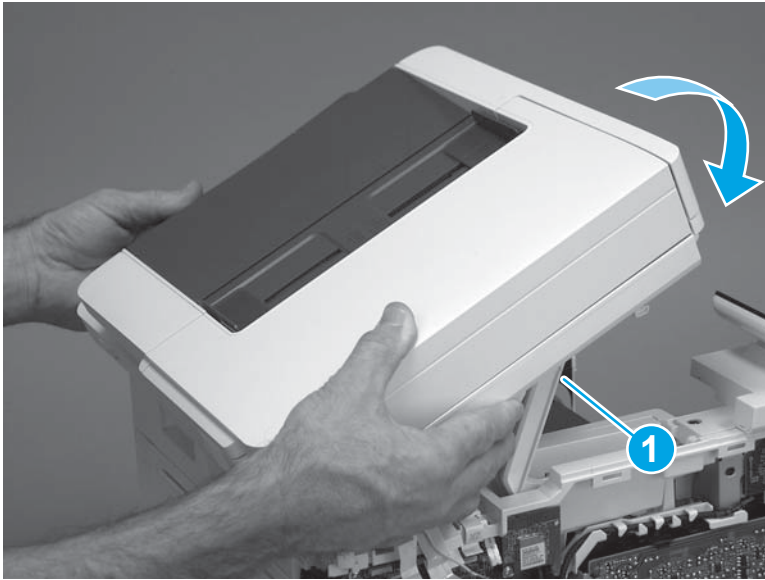
2. Engage the hinge pins on the ISA with the holders in the top cover (callouts 1/2), and then slide the ISA as shown to engage them

**Figure 1-700** Engage the hinge pins with the holders



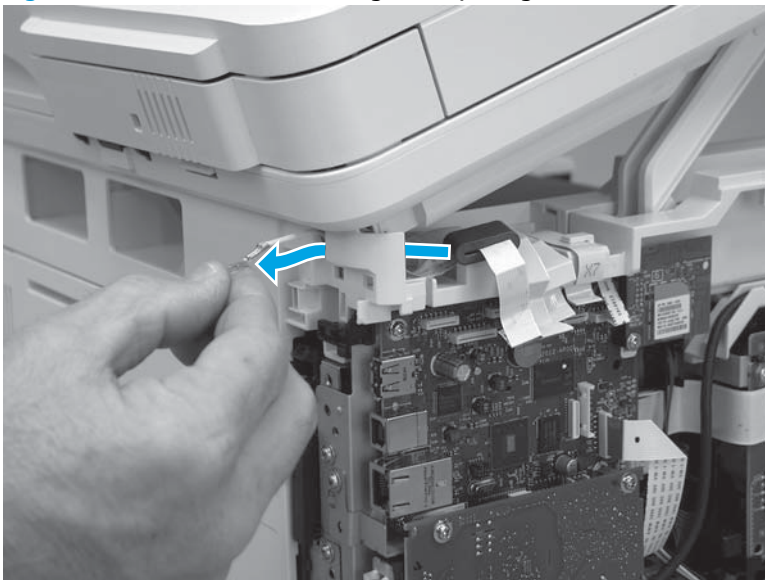
3. Rotate the ISA towards the front of the printer until it rests on the ISA lift assembly (callout 1).

**Figure 1-701** Rotate the ISA towards the front of the printer



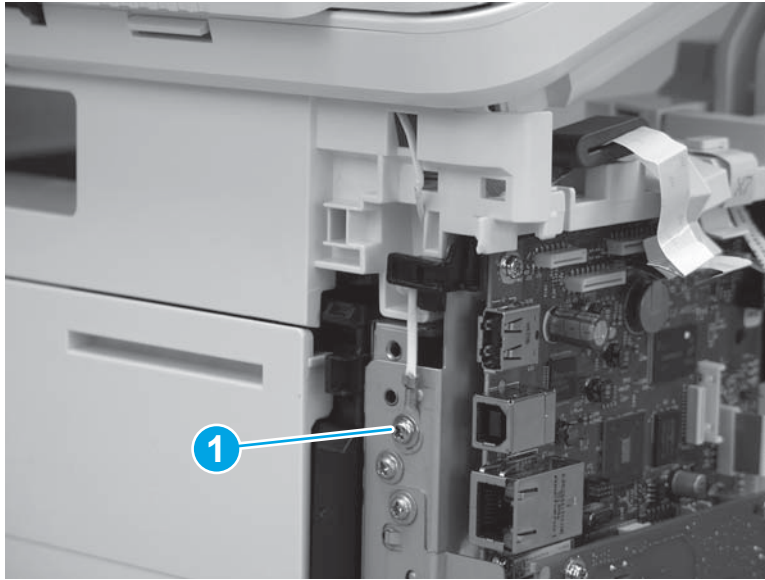
4. Pass the ground wire through the opening in the top cover.

**Figure 1-702** Pass the wire through the opening




5. Install one screw (callout 1).

**Figure 1-703** Install one screw



6. Install the ISA lift assembly slider pin.

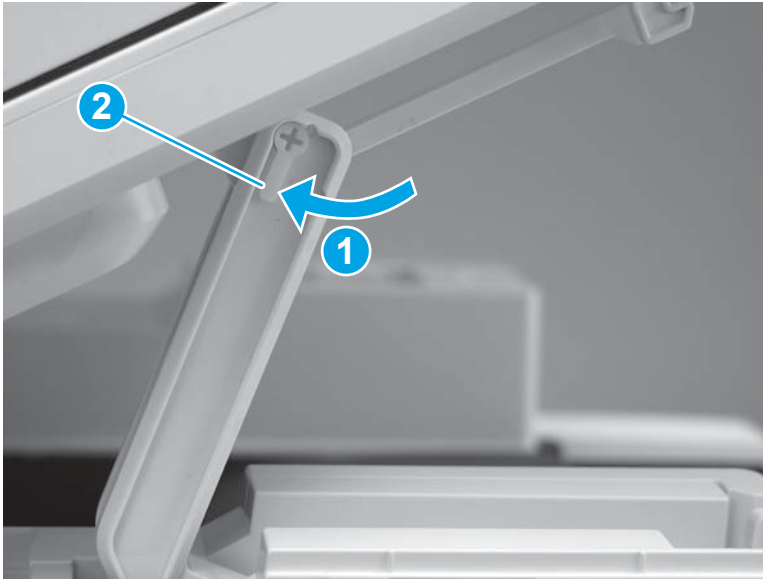
 **Reinstallation tip:** Align the keyed portion of the locking pin with the slot and hole in the support arm.

**Figure 1-704** Install the slider pin



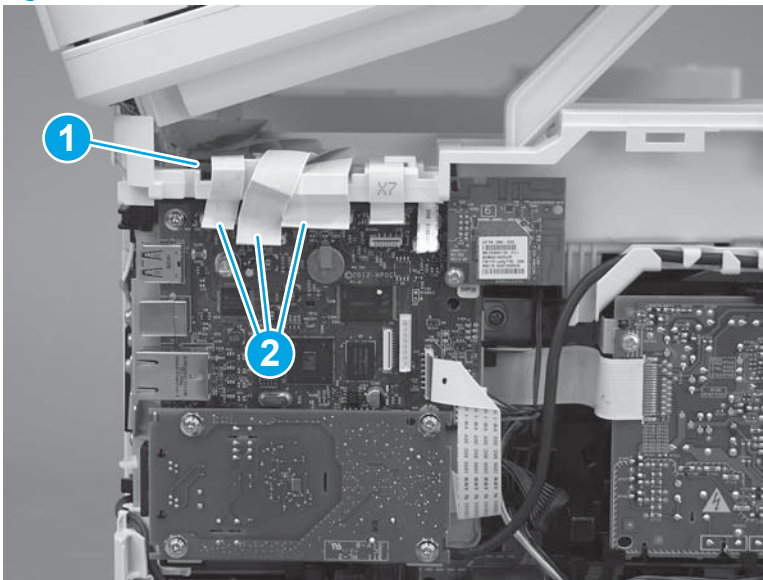
7. Rotate the slider pin (callout 1) towards the rear of the printer until the tab (callout 2) snap into place.

**Figure 1-705** Secure the slider pin



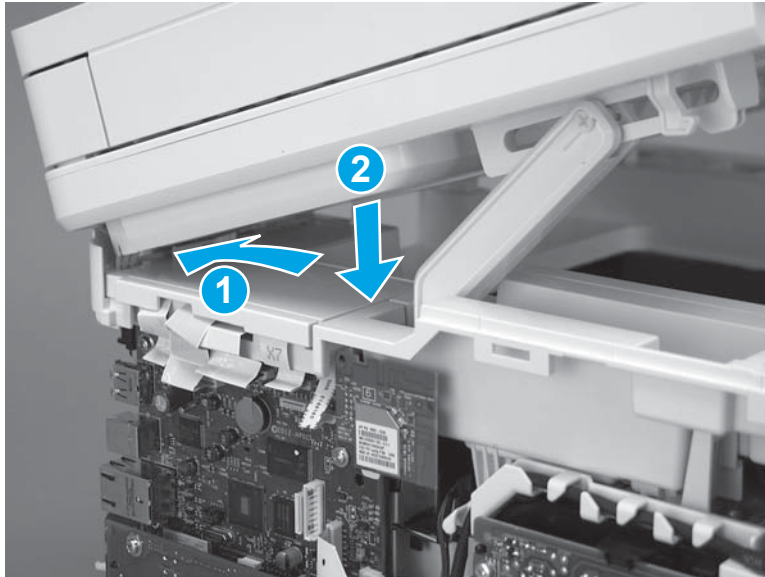
8. Install the ferrite (callout 1) in the holder, and then connect three FFCs (callout 2).

**Figure 1-706** Connect three FFCs



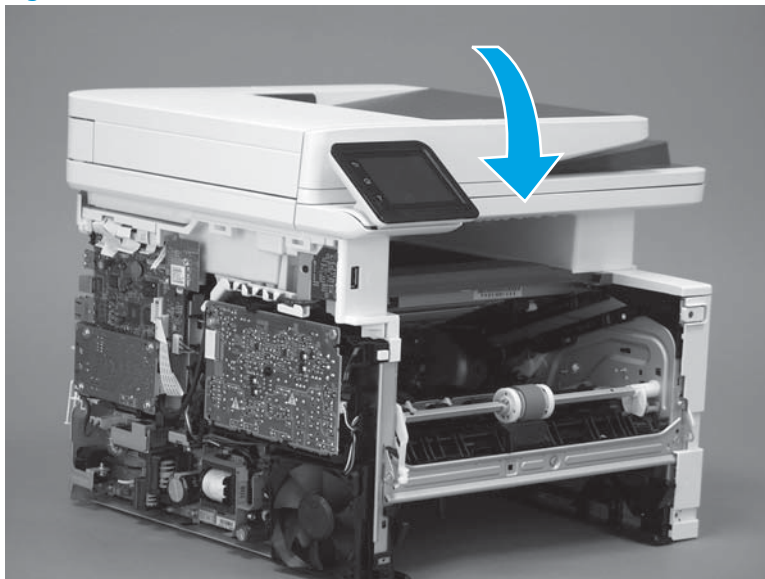
9. Position the rear edge of the ISA flat-flexible cable (FFC) cover on the printer (callout 1) , and then rotate it down (callout 2) until it snaps into place.

**Figure 1-707** Install the ISA FFC cover




10. Lower the ISA.

**Figure 1-708** Lower the ISA

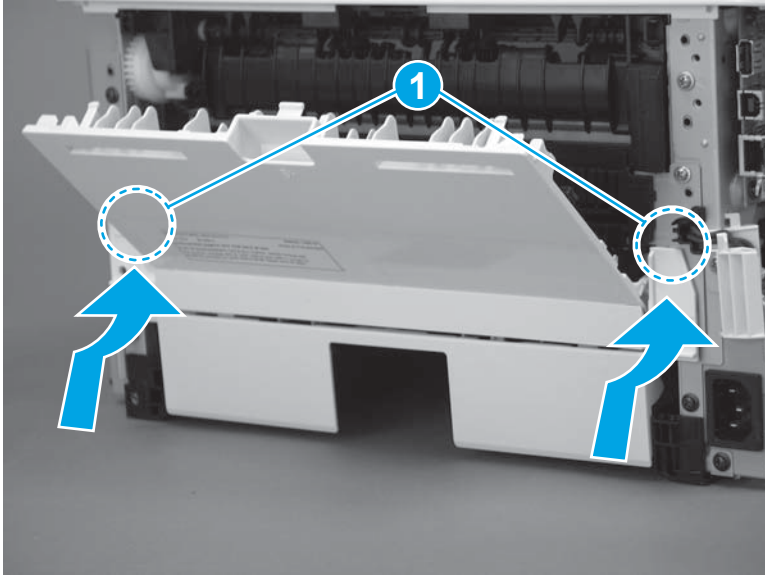


### Step 21: Install the rear door assembly

1. At the rear of the printer, position the assembly so that the two tabs (callout 1) are installed in the slots (callout 2) in the chassis.

 **NOTE:** **Duplex models only:** Slide the duplex tray into the Tray 2 cavity.

**Figure 1-709** Install the rear cover



2. Install two screws.



**NOTE: Duplex models only:** Reach in from the front of the Tray 2 cavity and raise the feed assembly to the up and locked position so that the rear cover will fit flat against the chassis.

**Figure 1-710** Install two screws

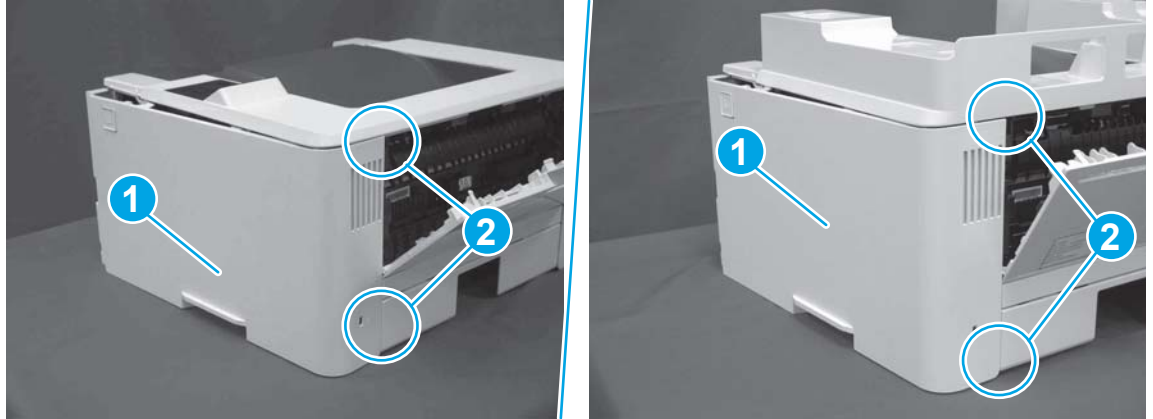


## Step 22: Install the right cover

1. Position the cover (callout 1) on the printer, and then engage two bosses (callout 2).

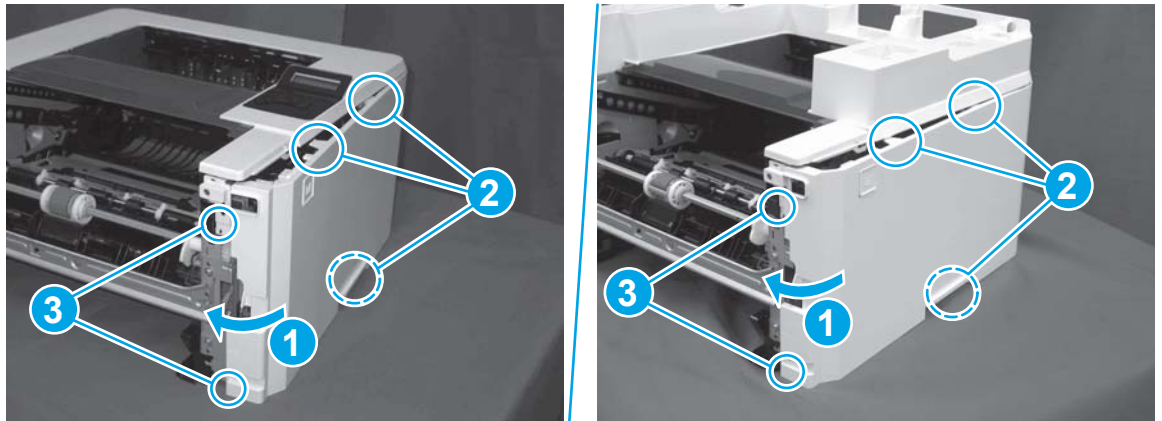


**Figure 1-711** Install the cover



2. Rotate the front of the cover onto the printer (callout 1), engage three (callout 2) tabs, and then engage two bosses (callout 3).

**Figure 1-712** Engage two bosses and one tab

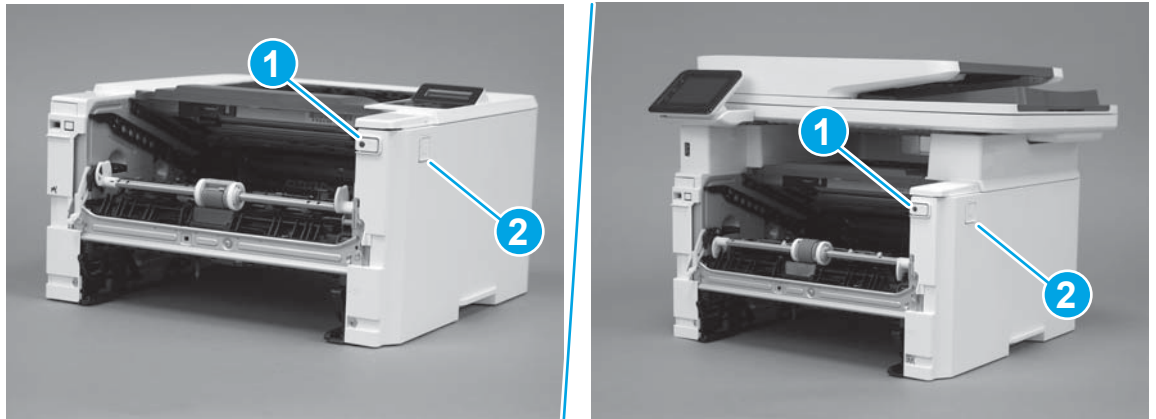


3. Make sure that the power switch (callout 1) and cartridge door assembly button (callout 2) correctly function.



**NOTE:** Remove, and then reinstall the cover if the switch or button does not correctly function.

**Figure 1-713** Check the power switch and cartridge door assembly button



4. Install one screw (callout 1).

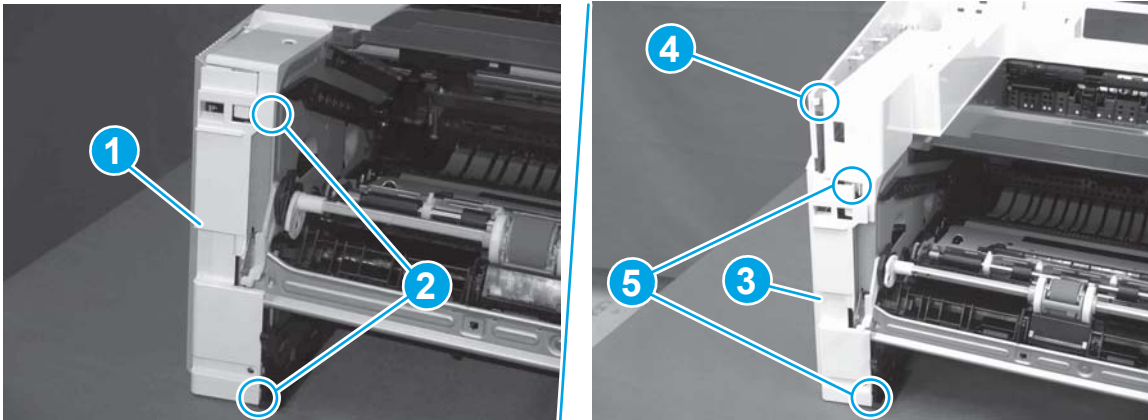
**Figure 1-714** Install one screw



### Step 23: Install the left cover

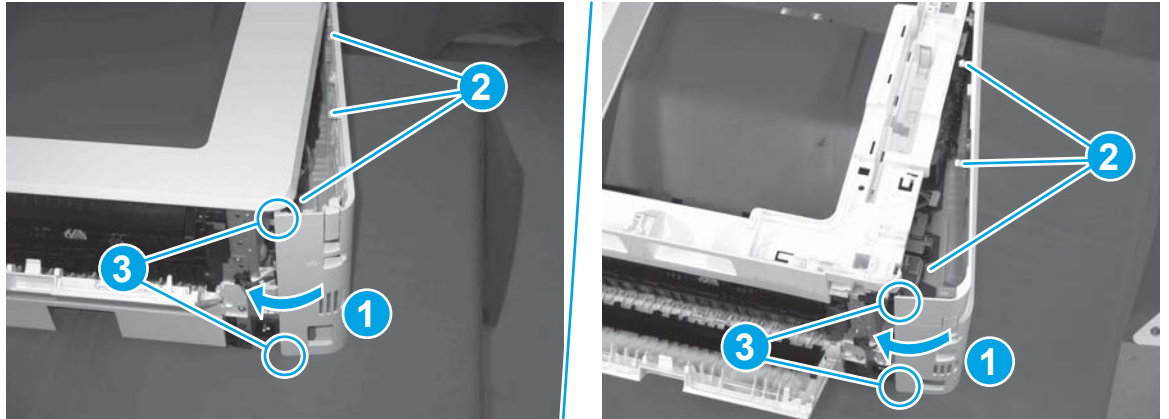
1. At the front of the printer, do one of the following:
  - **M403/M402:** Position the cover on the printer ( callout 1), and then engage two bosses (callout 2).
  - **M427/M426:** Position the cover on the printer (callout 3), engage one tab (callout 4), and then engage two bosses (callout 4).

**Figure 1-715** Install the cover



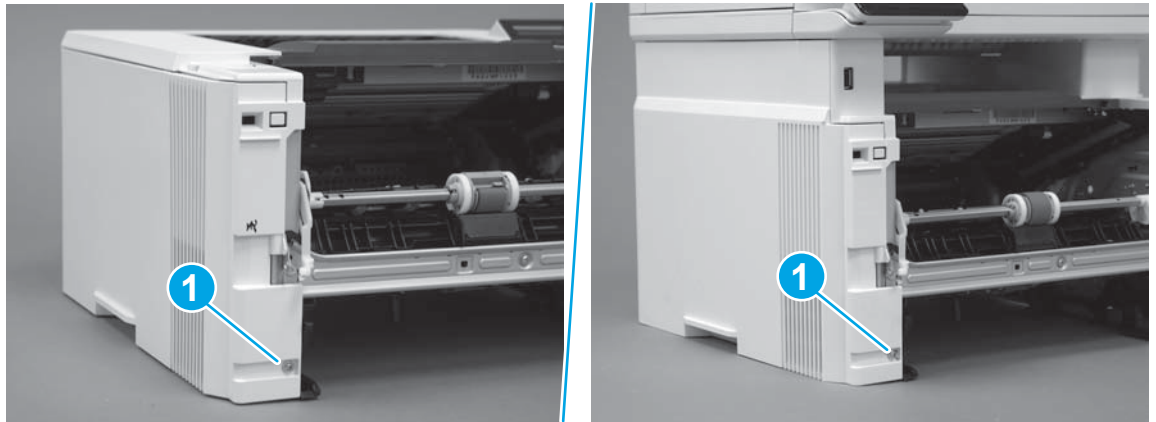
- Carefully rotate the rear of the cover onto the printer (callout 1), engage three tabs (callout 2), and then engage two bosses (callout 3).

**Figure 1-716** Engage three tabs and two bosses




- Install one screw (callout 1).

**Figure 1-717** Install one screw

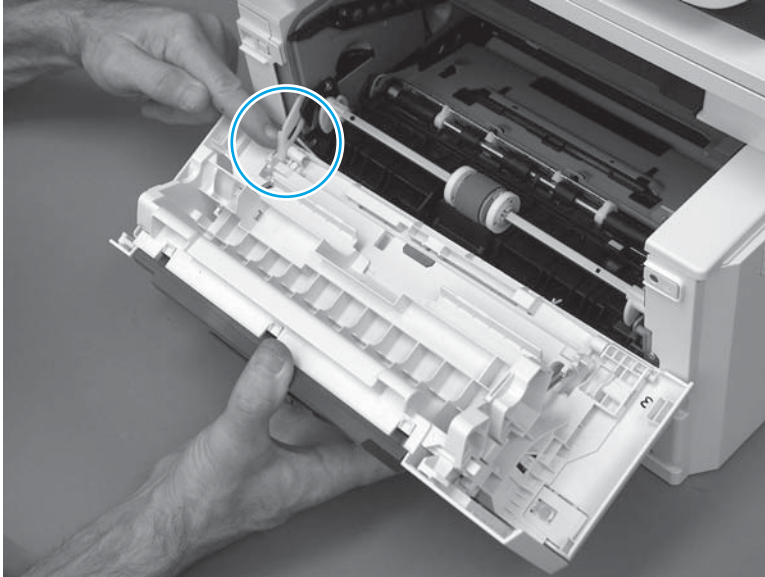


#### Step 24: Install the cartridge door assembly

 **Reinstallation tip:** After a replacement door is installed, make sure to install the nameplate (supplied in the kit) corresponding to the printer name on the door.

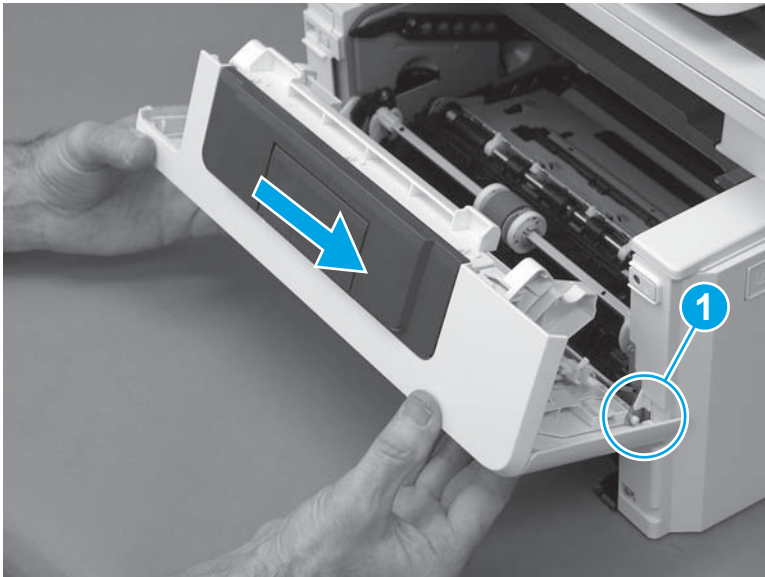
- Position the door close to the printer, and then engage the keyed pin on the left-side retainer arm with the hole in the door.

**Figure 1-718** Engage the left-side retainer arm



2. Engage the right-side door hinge pin with the hole in the chassis (callout 1).

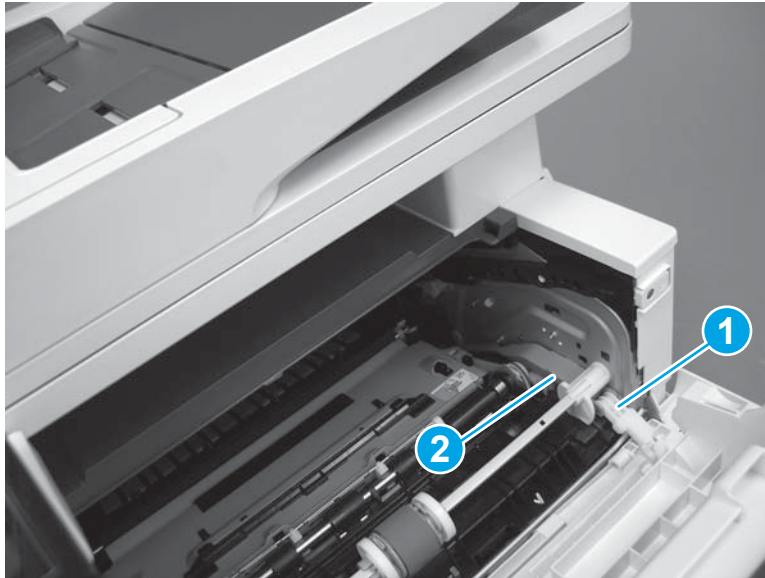
**Figure 1-719** Install the door



3. Install the link (callout 1).

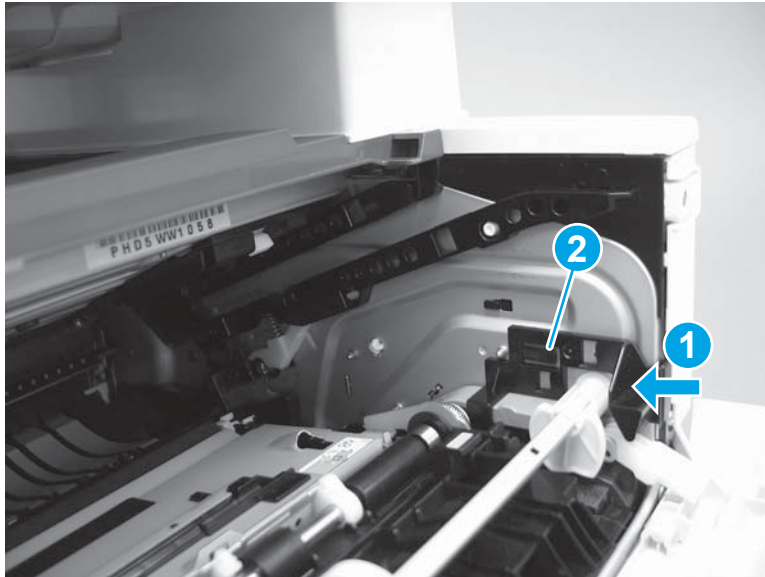
 **IMPORTANT:** Make sure that the link snaps into place on the arm (callout 2). The link actuates the fuser pressure-release mechanism.

**Figure 1-720** Install the pressure-release link



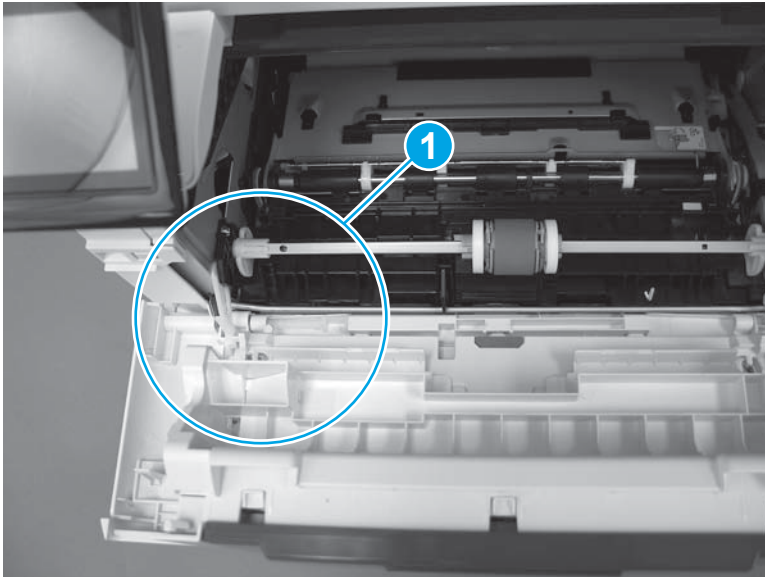
4. Slide the guide into the printer (callout 1), and then make sure that the tab (callout 2) snaps into place to secure the guide to the chassis.

**Figure 1-721** Install the guide




5. Position the shaft on the door, and then align the left-side hinge on the door with the hole in the chassis (callout 1).

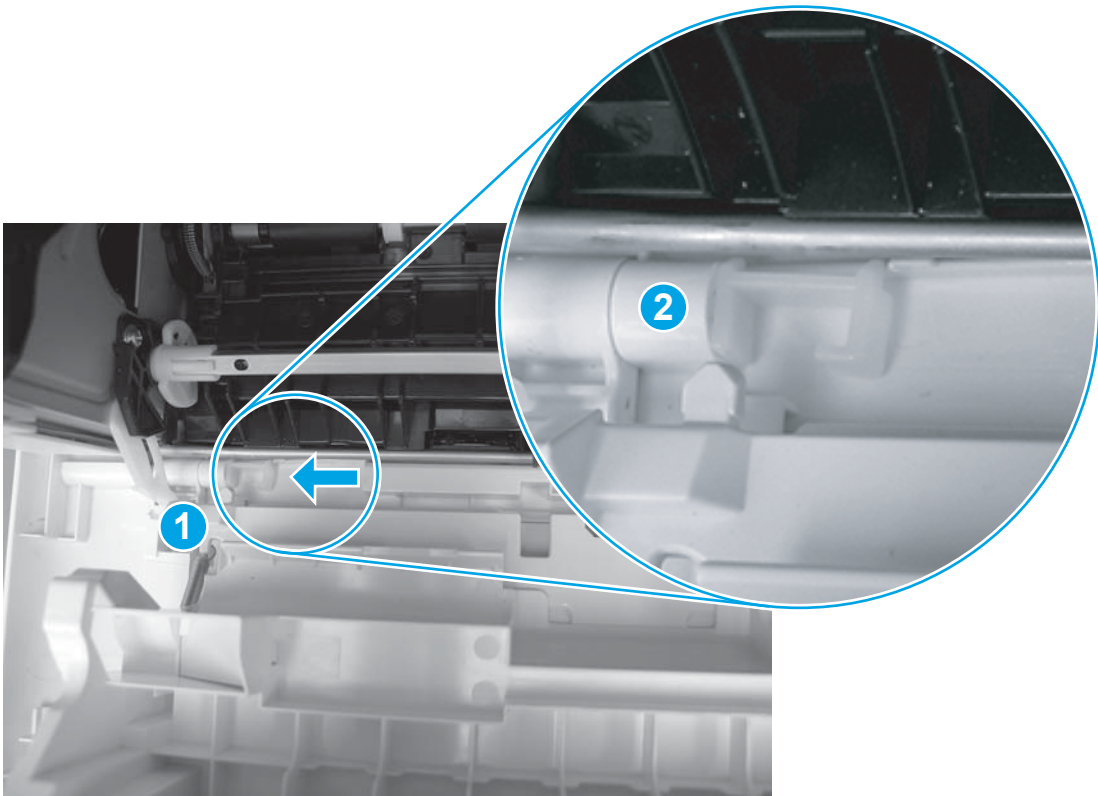
**Figure 1-722** Align the hinge



6. Push the shaft towards the left side of the printer to install it (callout 1).

 **Reinstallation tip:** Make sure that the support shaft is fully installed and correctly orientated (callout 2) so that it will not interfere with the door opening and closing.

**Figure 1-723** Install the support shaft



### Step 25: Install Install Tray 2

- ▲ Slide the tray straight into the printer to install it.

**Figure 1-724** Install the tray



## Removal and replacement: Main motor (M1)

- [Introduction](#)
- [Step 1: Remove Tray 2](#)
- [Step 2: Remove the cartridge door assembly](#)
- [Step 3: Remove the right cover](#)
- [Step 4: Remove the main motor \(M1\)](#)
- [Step 5: Unpack the replacement assembly](#)
- [Step 6: Install the main motor \(M1\)](#)
- [Step 7: Install the right cover](#)
- [Step 8: Install the cartridge door assembly](#)
- [Step 9: Install Tray 2](#)


### Introduction

This document provides the procedures to remove and replace the main motor (M1).

### Before performing service

#### Turn the printer power off

- Disconnect the power cable.

 **WARNING!** To avoid damage to the printer, turn the printer off, wait 30 seconds, and then remove the power cable before attempting to service the printer.

Use the table below to identify the correct part number for your printer. To order the part, go to [www.hp.com/buy/parts](http://www.hp.com/buy/parts).

Main motor (M1) part number	
RM2-8684-000CN	Main motor (M1)

### Required tools

- #2 Phillips screwdriver with a magnetic tip.

### After performing service

#### Turn the printer power on

- Connect the power cable.
- Use the power switch to turn the power on.

### Post service test

Make sure that the printer initializes to a **Ready** state.



Print a configuration page to make sure that the printer is functioning correctly.

### Step 1: Remove Tray 2

- ▲ Pull the tray straight out of the printer to remove it.

**Figure 1-725** Remove the tray



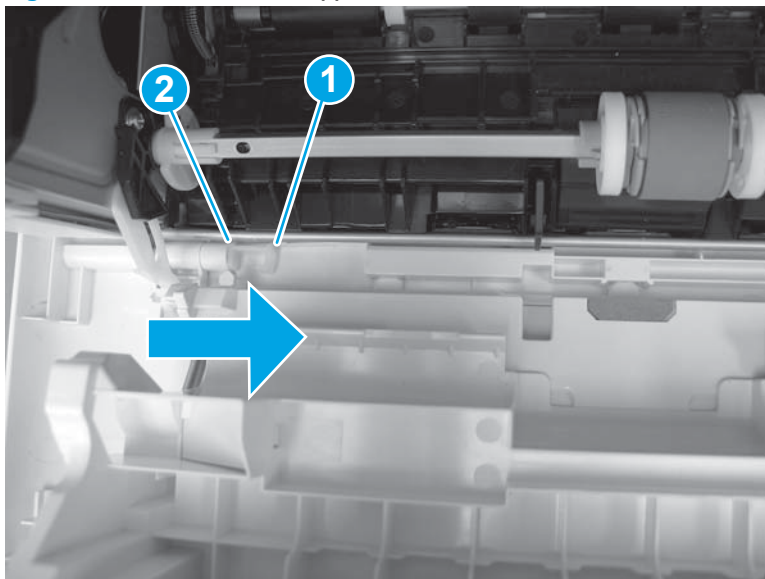
### Step 2: Remove the cartridge door assembly

 **NOTE:** If the toner cartridge was not removed prior to servicing the printer, remove it now.

1. Release one tab (callout 1), and then slide shaft (callout 2) in the direction the arrow indicates and remove it.

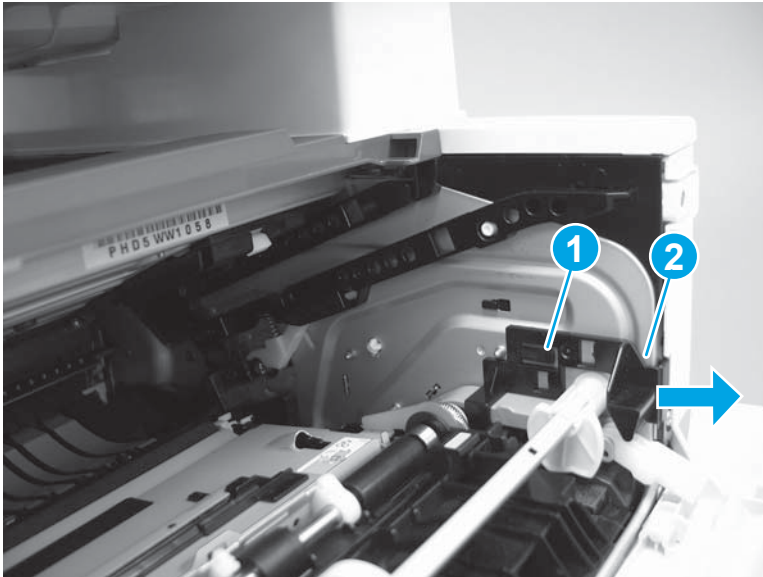
 **TIP:** It might be easier to release the support shaft by using a small flat-blade screwdriver.

**Figure 1-726** Release the support shaft



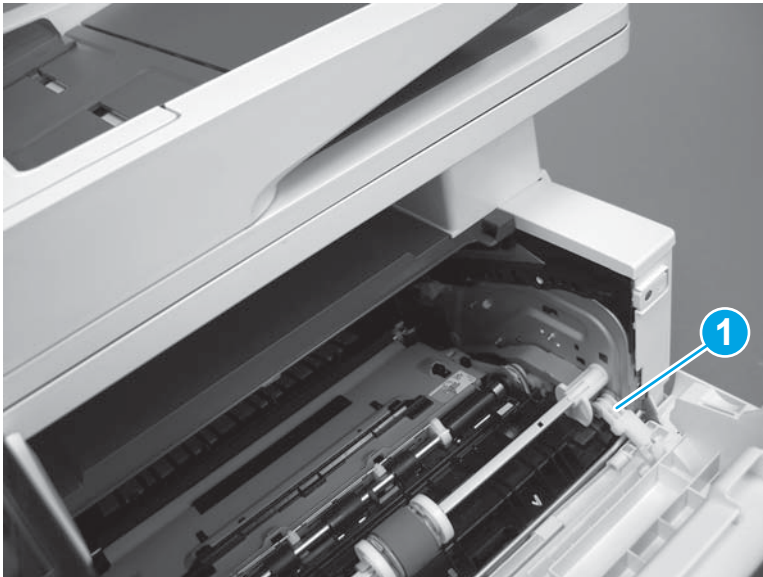
2. Release one tab (callout 1), and then slide the guide (callout 2) in the direction the arrow indicates and remove it.

**Figure 1-727** Remove the guide



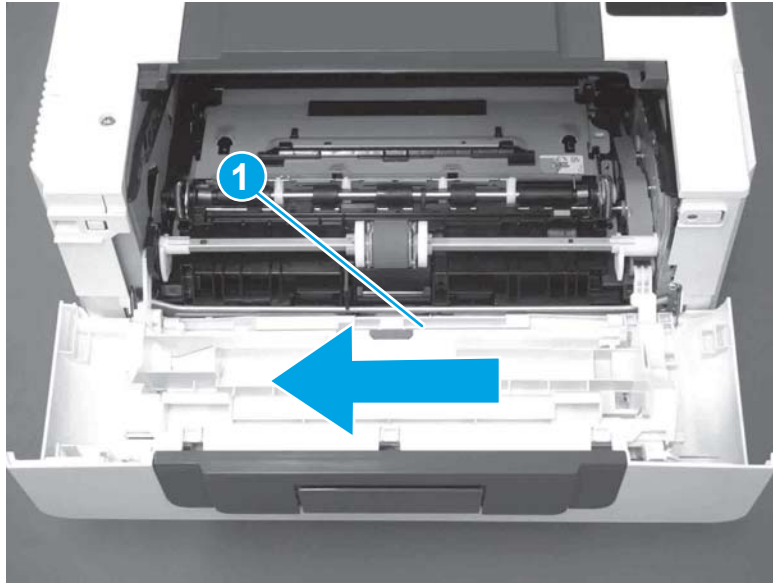
3. Remove the link arm (callout 1).

**Figure 1-728** Remove the link arm



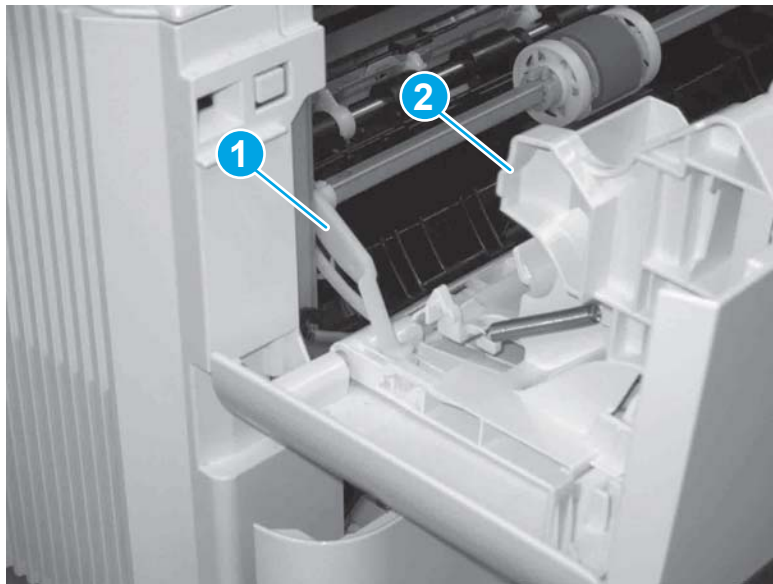
4. Slide the cartridge door assembly (callout 1) in the direction the arrow indicates and remove it.

**Figure 1-729** Remove the door



5. Remove the link (callout 1) from the cartridge door assembly (callout 2).

**Figure 1-730** Release the left-side retainer arm



### Step 3: Remove the right cover

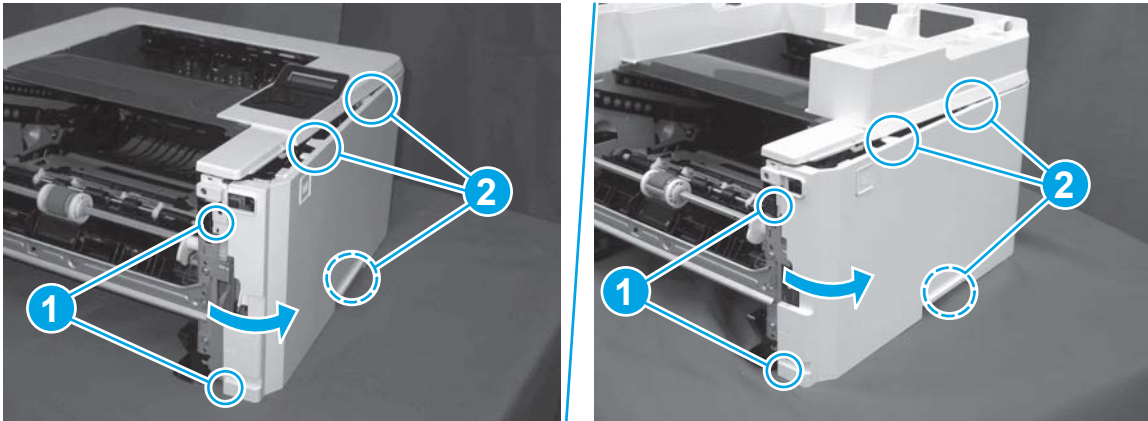
1. Remove one screw (callout 1).

**Figure 1-731** Remove one screw



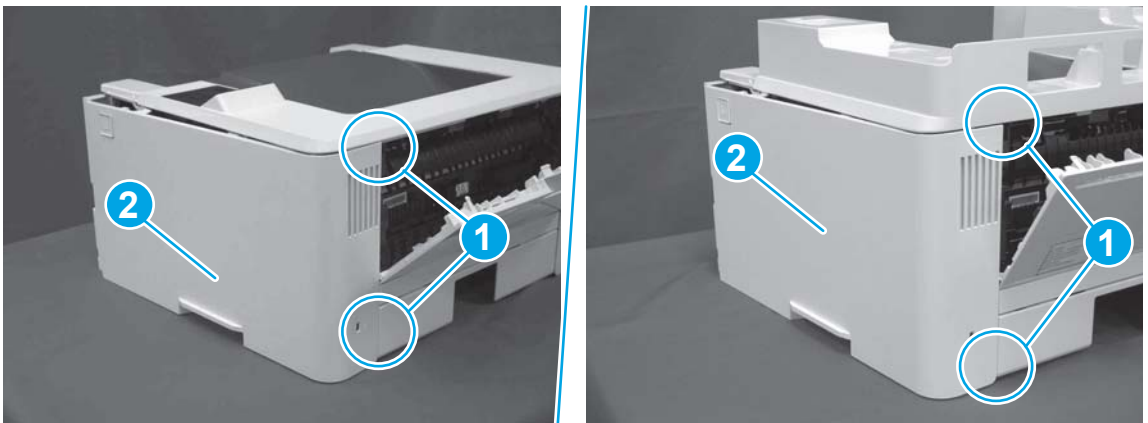
2. At the front of the printer, release two bosses (callout 1), and then release three tabs (callout 2).

**Figure 1-732** Release two bosses and three tabs



3. Open the rear door, release two bosses (callout 1), and then remove the cover (callout 2).

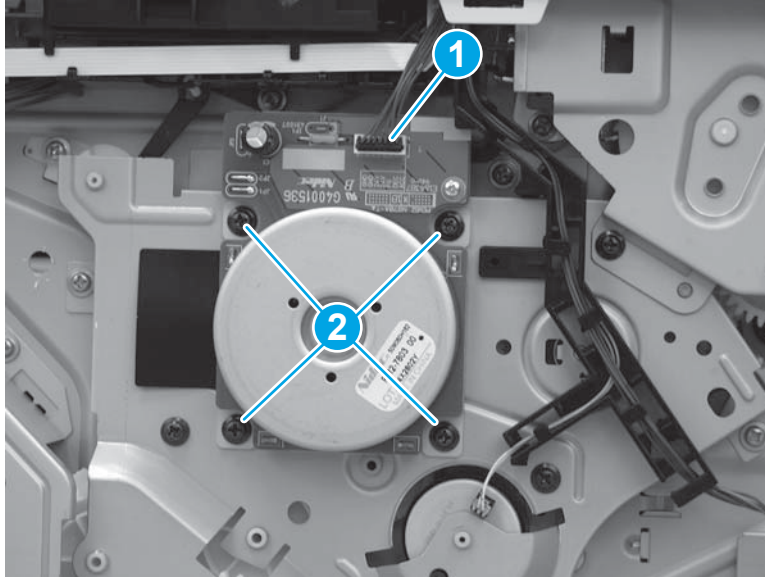
**Figure 1-733** Remove the cover



#### **Step 4: Remove the main motor (M1)**

- ▲ Disconnect one connector (callout 1), remove four screws (callout 2), and then remove the main motor (M1).

**Figure 1-734** Remove the motor



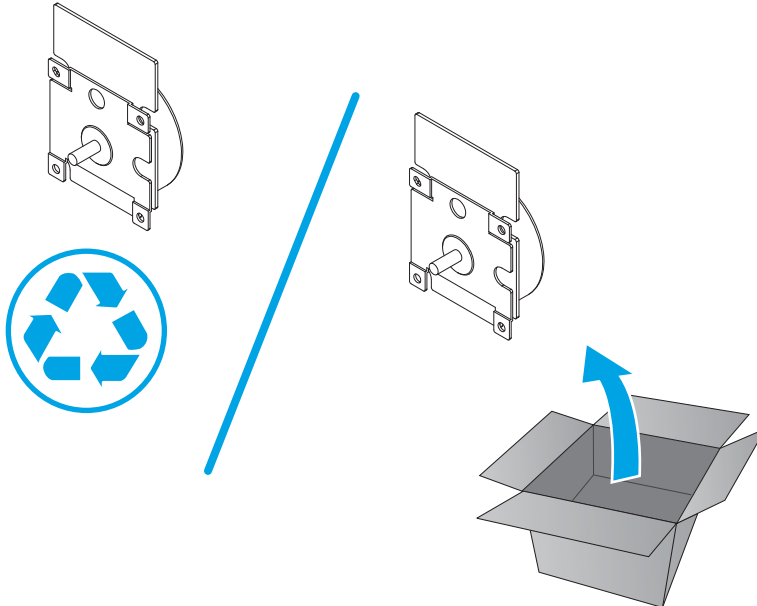
### Step 5: Unpack the replacement assembly

Unpack the replacement part from the packaging.

<http://www8.hp.com/us/en/hp-information/environment/product-recycling.html>

 **NOTE:** HP recommends responsible disposal of the defective part.

### Figure 1-735 Recycle and unpack

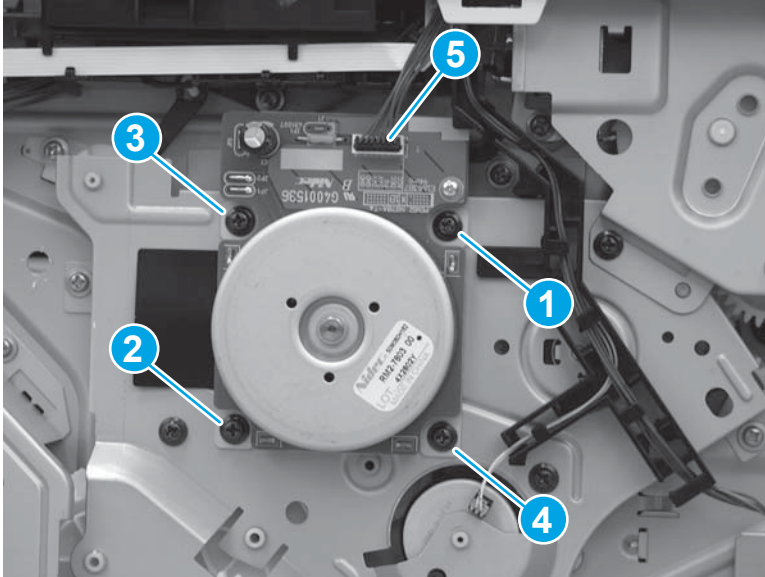


### Step 6: Install the main motor (M1)

- ▲ Position the motor on the chassis, install four screws in the order shown below (callout 1 to callout 4), and then connect one connector (callout 5).

 **CAUTION:** Make sure that the screws are installed in the order shown below.

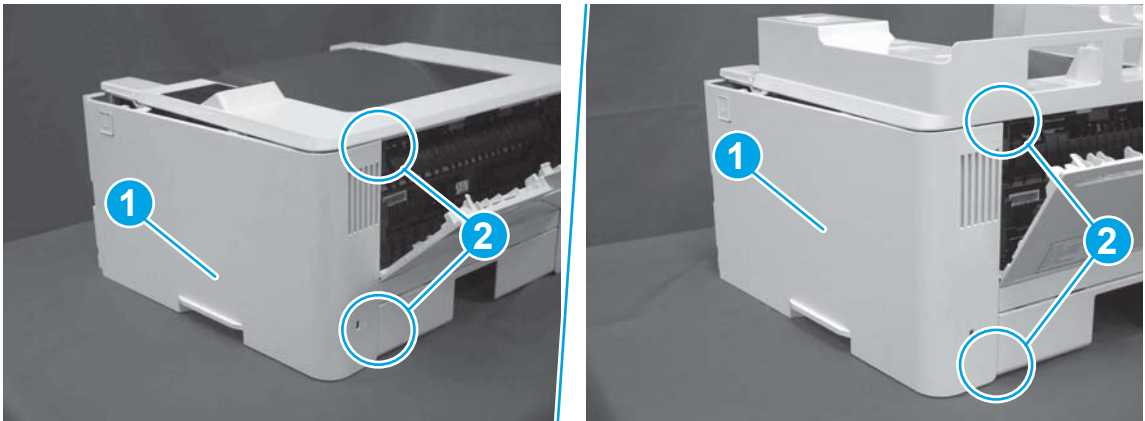
**Figure 1-736** Install the motor



**Step 7: Install the right cover**

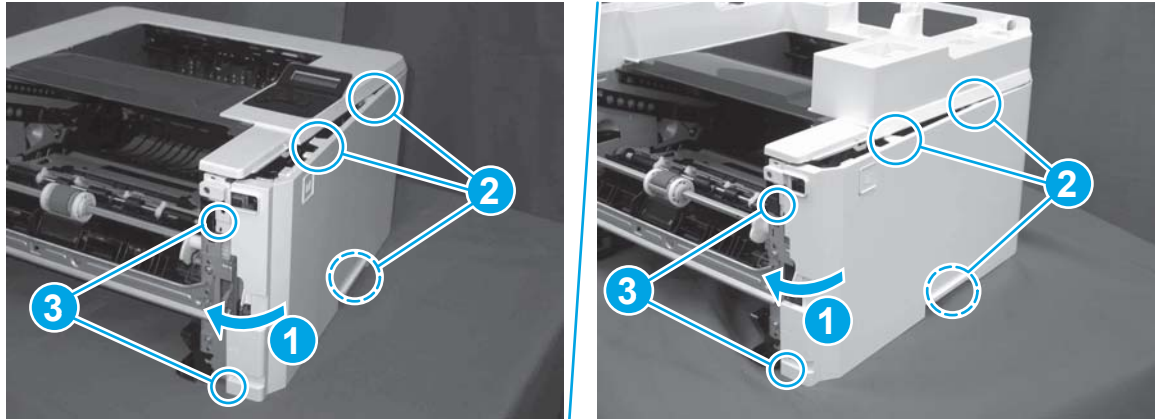
1. Position the cover (callout 1) on the printer, and then engage two bosses (callout 2).

**Figure 1-737** Install the cover



2. Rotate the front of the cover onto the printer (callout 1), engage three (callout 2) tabs, and then engage two bosses (callout 3).

**Figure 1-738** Engage two bosses and one tab

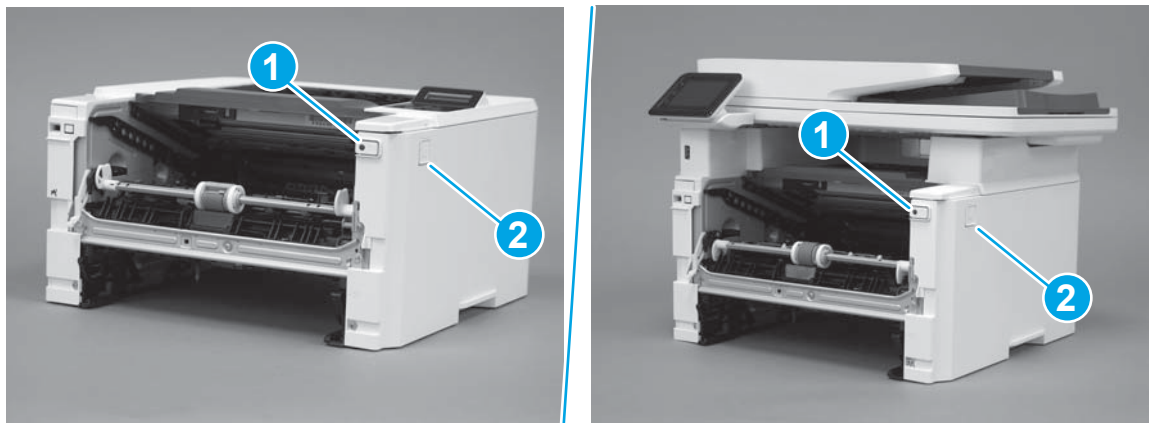


3. Make sure that the power switch (callout 1) and cartridge door assembly button (callout 2) correctly function.



**NOTE:** Remove, and then reinstall the cover if the switch or button does not correctly function.

**Figure 1-739** Check the power switch and cartridge door assembly button




4. Install one screw (callout 1).

**Figure 1-740** Install one screw

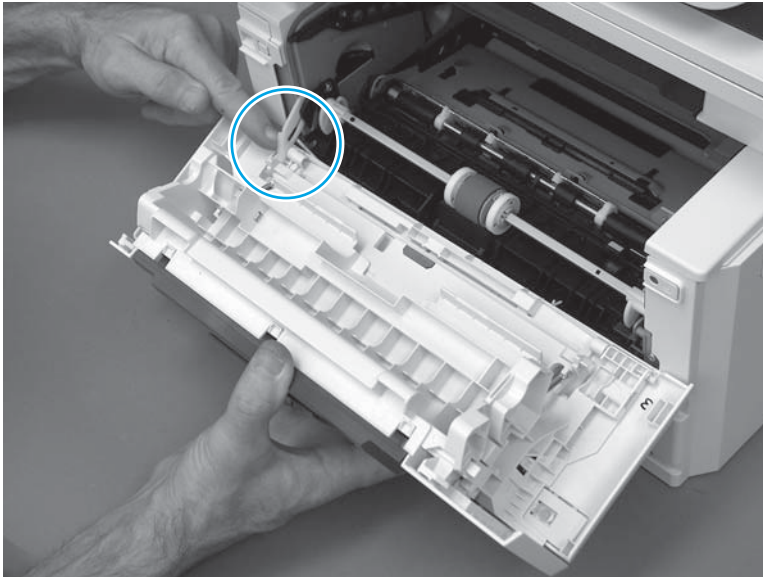


## Step 8: Install the cartridge door assembly

 **Reinstallation tip:** After a replacement door is installed, make sure to install the nameplate (supplied in the kit) corresponding to the printer name on the door.

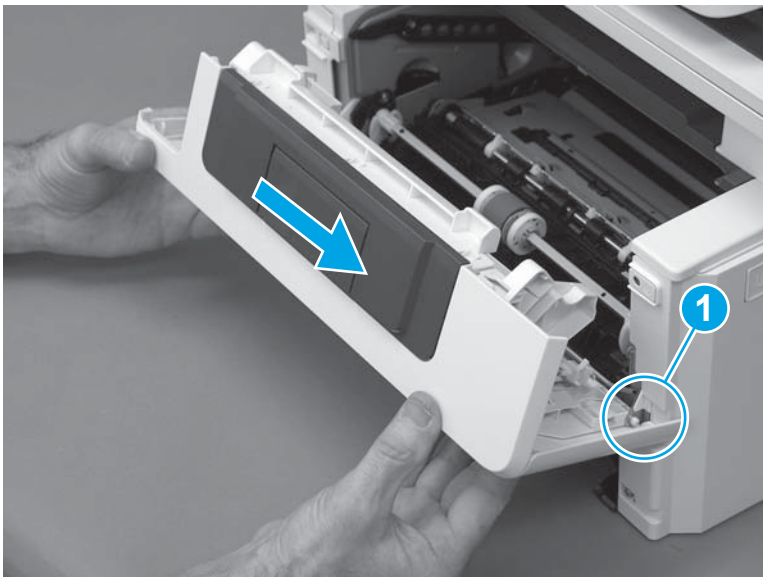
1. Position the door close to the printer, and then engage the keyed pin on the left-side retainer arm with the hole in the door.

**Figure 1-741** Engage the left-side retainer arm



2. Engage the right-side door hinge pin with the hole in the chassis (callout 1).

**Figure 1-742** Install the door

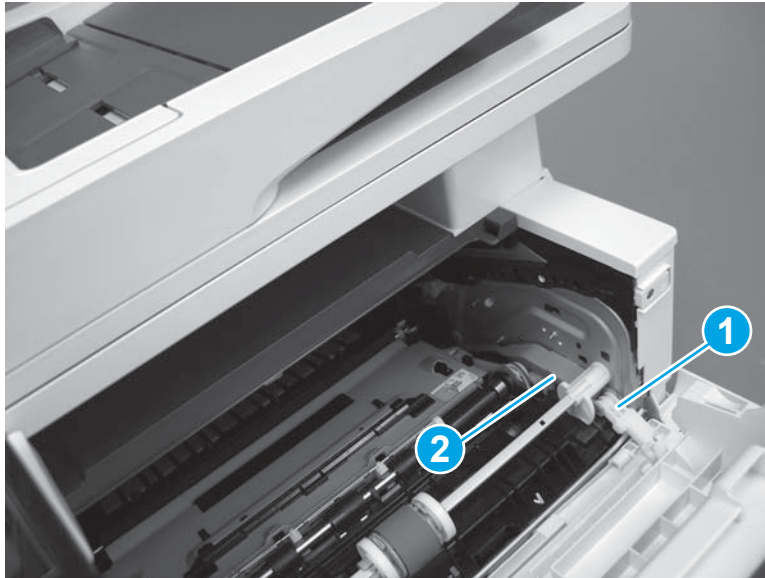




3. Install the link (callout 1).

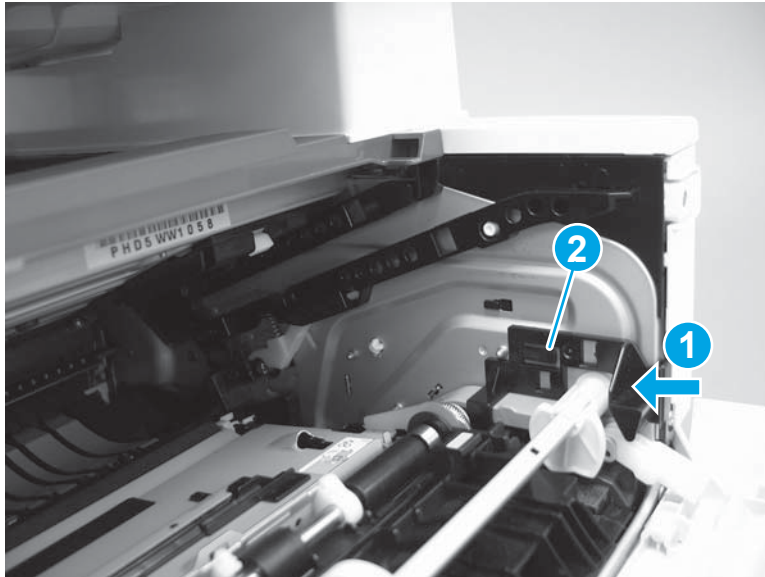
 **IMPORTANT:** Make sure that the link snaps into place on the arm (callout 2). The link actuates the fuser pressure-release mechanism.

**Figure 1-743** Install the pressure-release link



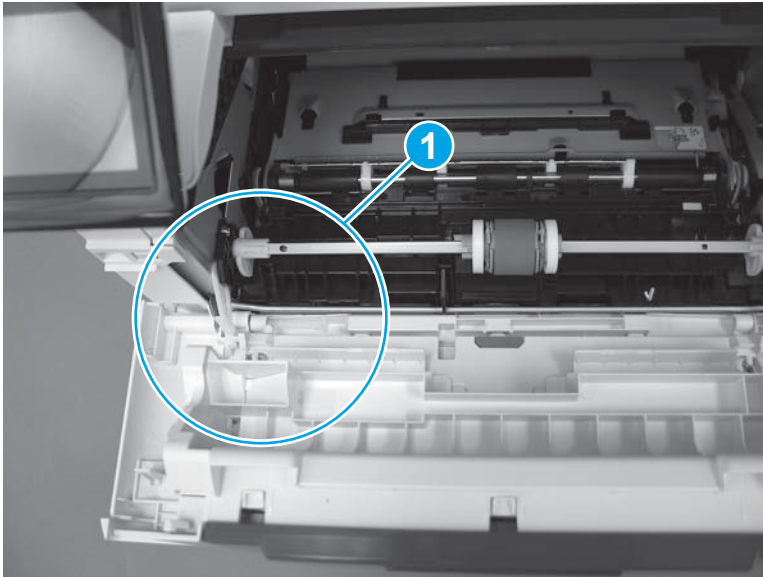
4. Slide the guide into the printer (callout 1), and then make sure that the tab (callout 2) snaps into place to secure the guide to the chassis.

**Figure 1-744** Install the guide




5. Position the shaft on the door, and then align the left-side hinge on the door with the hole in the chassis (callout 1).

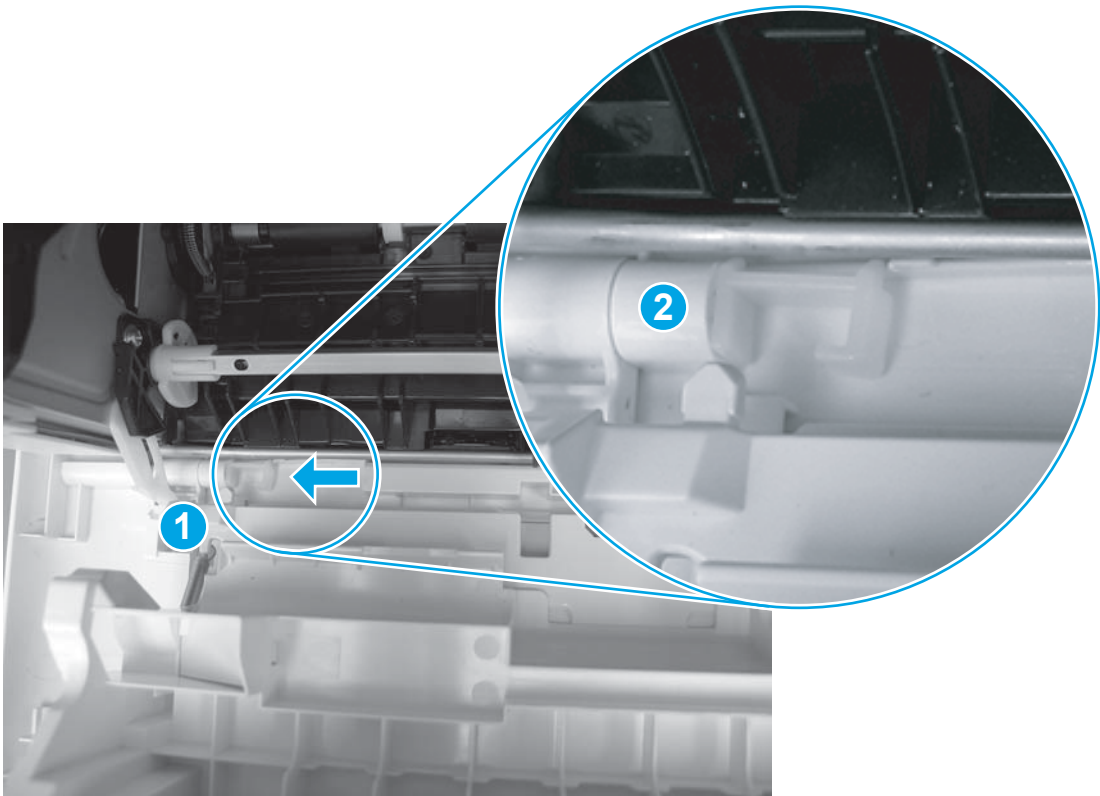
**Figure 1-745** Align the hinge



6. Push the shaft towards the left side of the printer to install it (callout 1).

 **Reinstallation tip:** Make sure that the support shaft is fully installed and correctly orientated (callout 2) so that it will not interfere with the door opening and closing.

**Figure 1-746** Install the support shaft



### Step 9: Install Tray 2

- ▲ Slide the tray straight into the printer to install it.

**Figure 1-747** Install the tray



## Removal and replacement: Power switch printed circuit assembly

- [Introduction](#)
- [Step 1: Remove Tray 2](#)
- [Step 2: Remove the cartridge door assembly](#)
- [Step 3: Remove the right cover](#)
- [Step 4: Remove the power switch PCA](#)
- [Step 5: Unpack the replacement assembly](#)
- [Step 6: Install the power switch PCA](#)
- [Step 7: Install the right cover](#)
- [Step 8: Install the cartridge door assembly](#)
- [Step 9: Install Tray 2](#)


### Introduction

This document provides the procedures to remove and replace the power switch printed circuit assembly (PCA).

### Before performing service

#### Turn the printer power off

- Disconnect the power cable.

 **WARNING!** To avoid damage to the printer, turn the printer off, wait 30 seconds, and then remove the power cable before attempting to service the printer.

Use the table below to identify the correct part number for your printer. To order the part, go to [www.hp.com/buy/parts](http://www.hp.com/buy/parts).

Power switch PCA part number	
RM2-8506-000CN	Power switch PCA

### Required tools

- #2 Phillips screwdriver with a magnetic tip.

### After performing service

#### Turn the printer power on

- Connect the power cable.
- Use the power switch to turn the power on.

## Post service test

Use the power switch to turn the printer on, and then off.

### Step 1: Remove Tray 2

- ▲ Pull the tray straight out of the printer to remove it.

**Figure 1-748** Remove the tray



### Step 2: Remove the cartridge door assembly

---

 **NOTE:** If the toner cartridge was not removed prior to servicing the printer, remove it now.

---

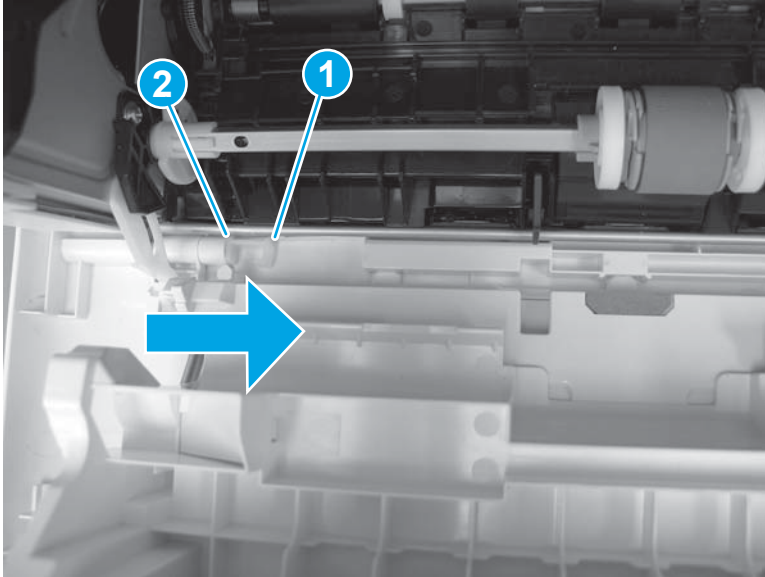
1. Release one tab (callout 1), and then slide shaft (callout 2) in the direction the arrow indicates and remove it.

---

 **TIP:** It might be easier to release the support shaft by using a small flat-blade screwdriver.

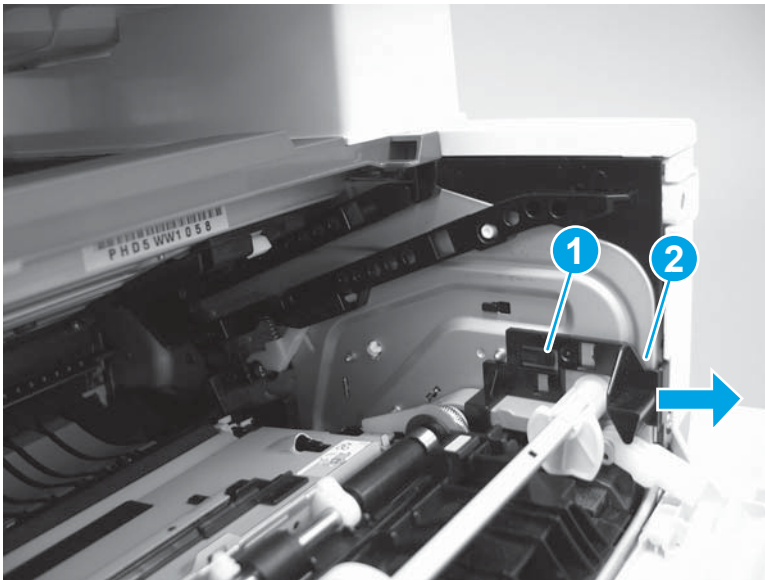
---

**Figure 1-749** Release the support shaft



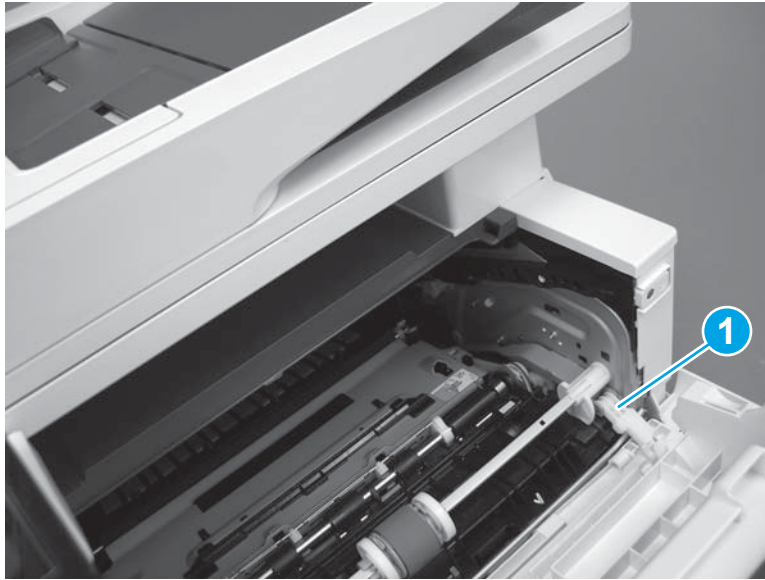
2. Release one tab (callout 1), and then slide the guide (callout 2) in the direction the arrow indicates and remove it.

**Figure 1-750** Remove the guide



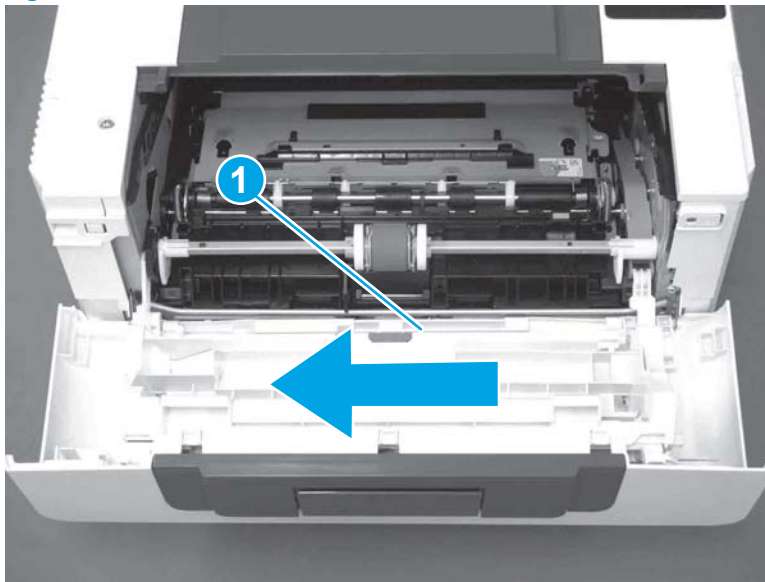
3. Remove the link arm (callout 1).

**Figure 1-751** Remove the link arm



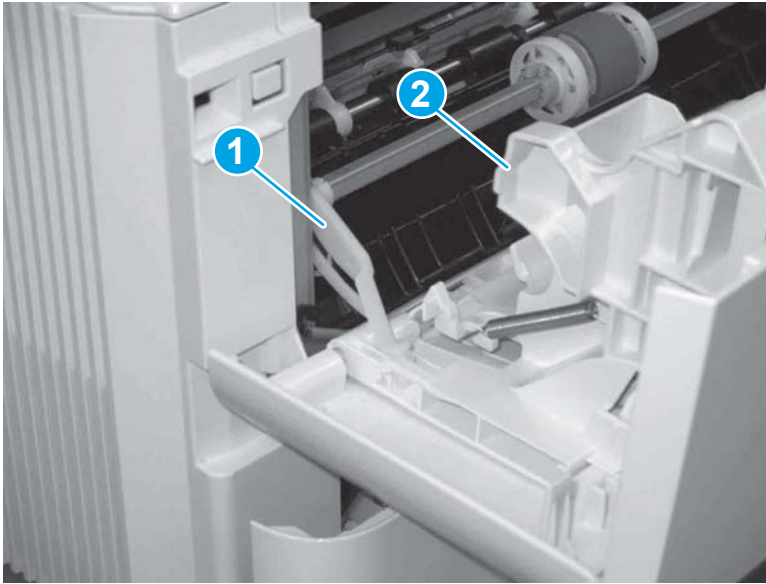
4. Slide the cartridge door assembly (callout 1) in the direction the arrow indicates and remove it.

**Figure 1-752** Remove the door



5. Remove the link (callout 1) from the cartridge door assembly (callout 2).

**Figure 1-753** Release the left-side retainer arm



### Step 3: Remove the right cover

1. Remove one screw (callout 1).

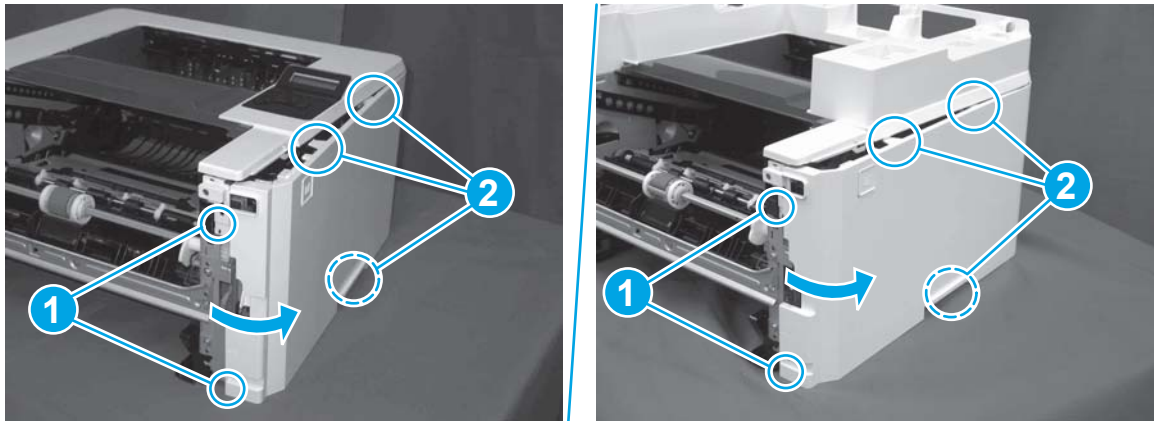
**Figure 1-754** Remove one screw





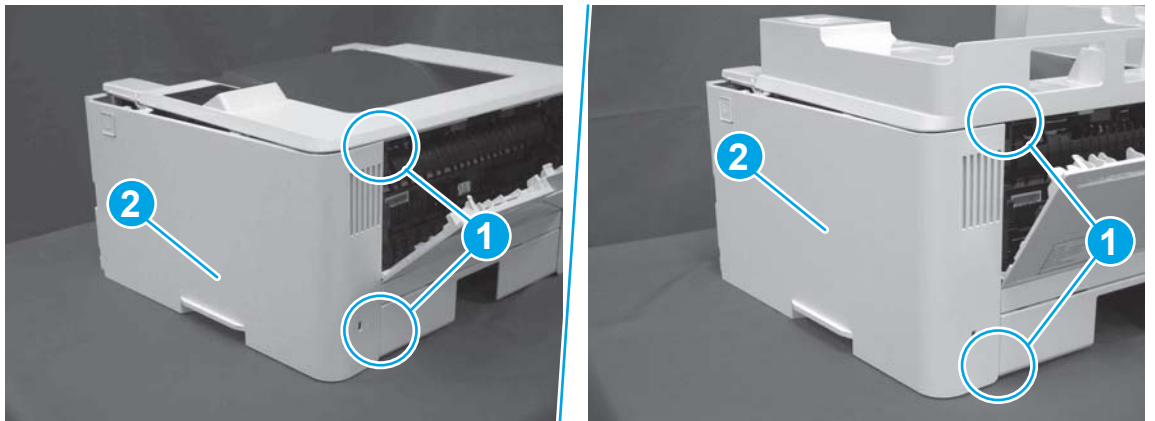
2. At the front of the printer, release two bosses (callout 1), and then release three tabs (callout 2).

**Figure 1-755** Release two bosses and three tabs



3. Open the rear door, release two bosses (callout 1), and then remove the cover (callout 2).

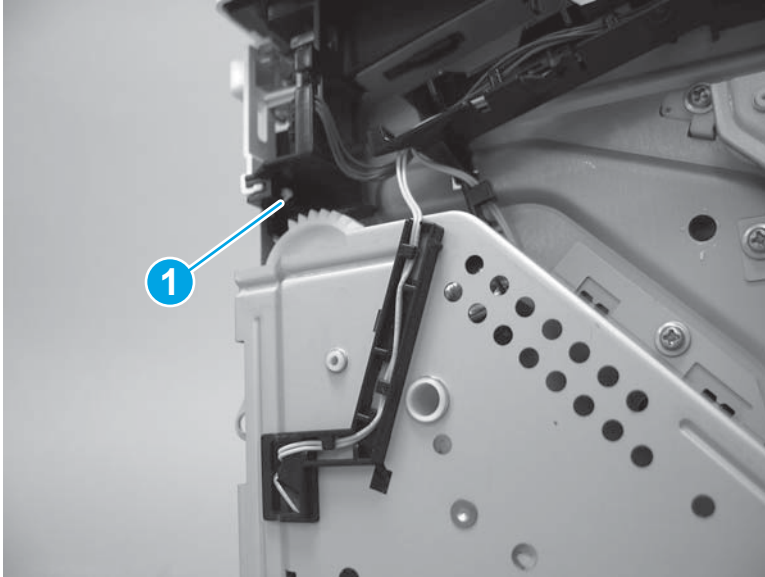
**Figure 1-756** Remove the cover



#### **Step 4: Remove the power switch PCA**

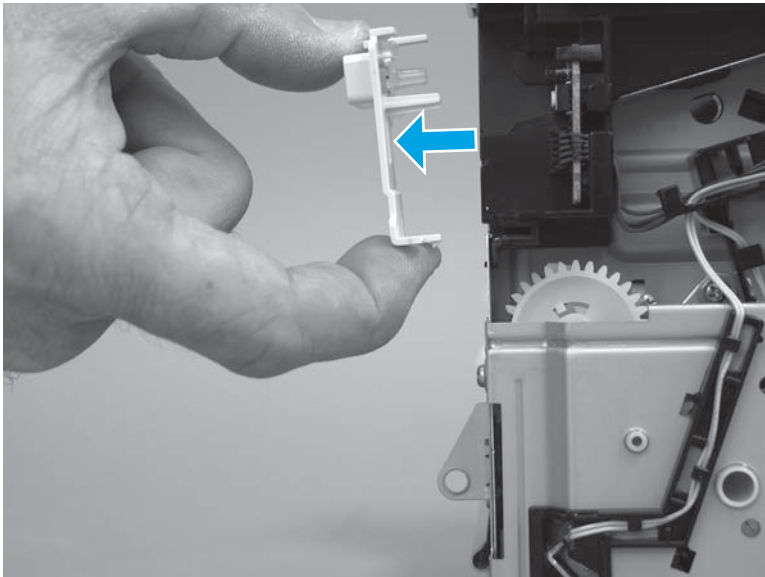
1. Release one tab (callout 1).

**Figure 1-757** Release one tab



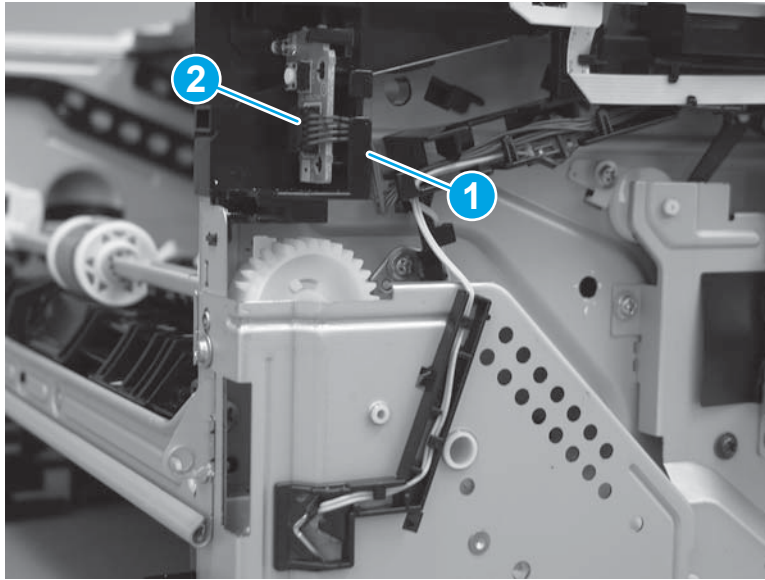
2. Remove the switch lever.

**Figure 1-758** Remove the switch lever



3. Release the wire harness from the guide (callout 1), and then disconnect one connector (callout 2).

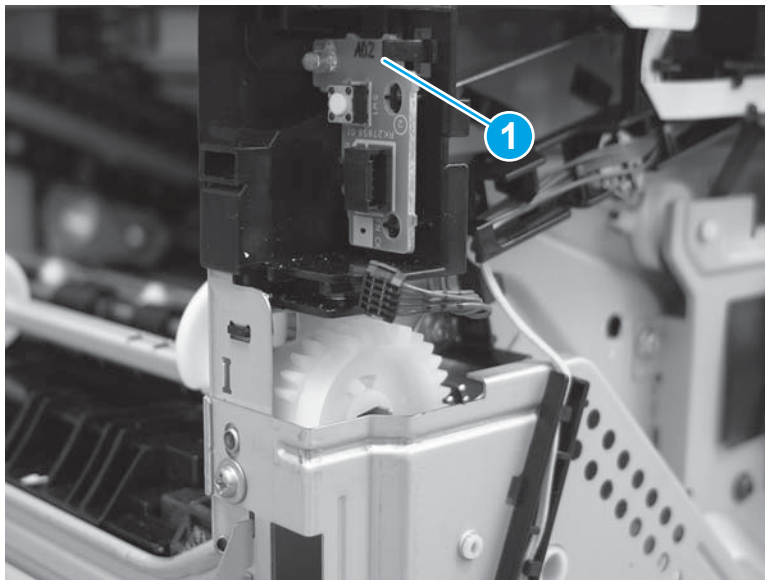
**Figure 1-759** Disconnect one connector



4. Release one tab (callout 1), and then remove the power switch PCA.

**⚠ CAUTION:** Do not damage the tab (callout 1) when releasing it. The tab must snap over the PCA when it is reinstalled.

**Figure 1-760** Release one tab and remove the PCA



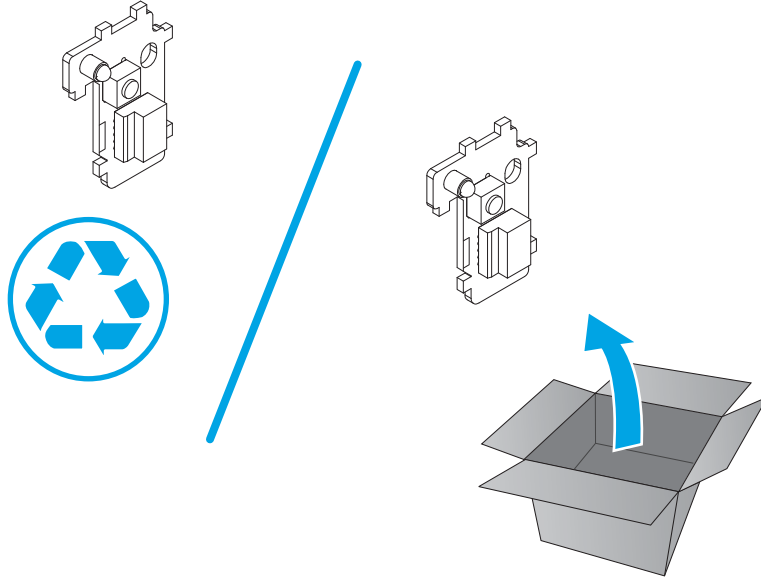
### Step 5: Unpack the replacement assembly

Unpack the replacement part from the packaging.

<http://www8.hp.com/us/en/hp-information/environment/product-recycling.html>


**📄 NOTE:** HP recommends responsible disposal of the defective part.

**Figure 1-761** Recycle and unpack



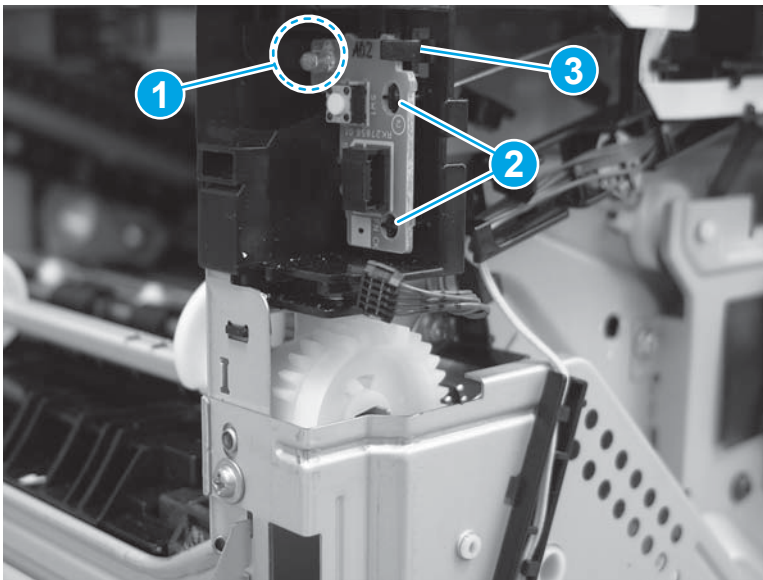
### Step 6: Install the power switch PCA

1. Position the PCA in the holder. The PCA must be securely installed in the holder.

 **IMPORTANT:** Make sure of the following:

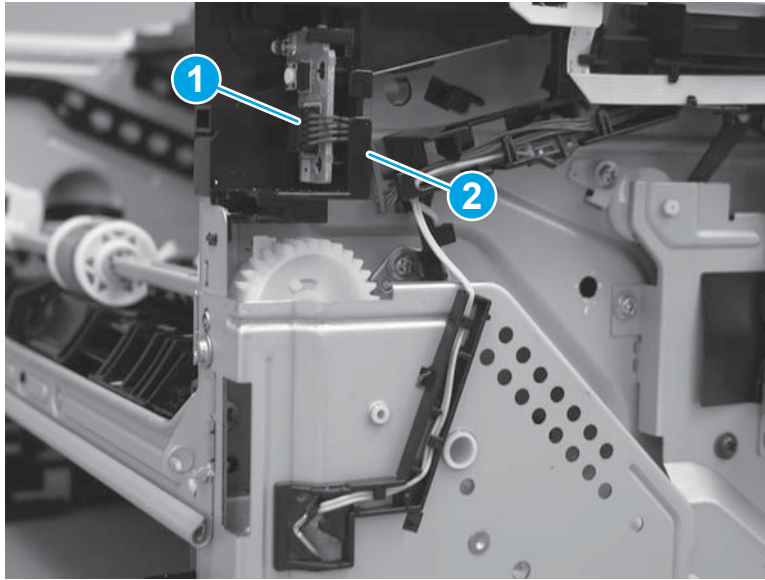
- The inside edge of the PCA is positioned behind the holder (callout 1).
- The two alignment pins are installed in the holes in the PCA (callout 2).
- The tab on the holder snaps in place over the edge of the PCA (callout 3).

**Figure 1-762** Install the PCA



2. Connect one connector (callout 1), and then install the wire harness in the guide (callout 2).

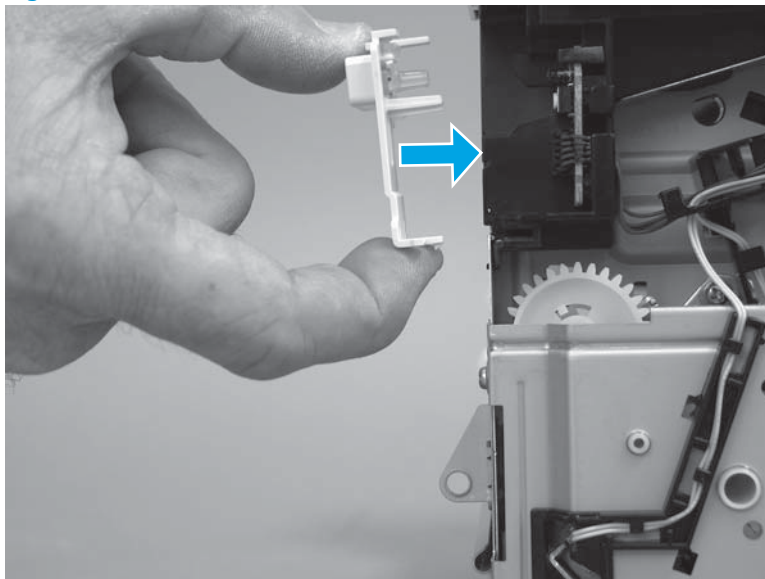
**Figure 1-763** Connect one connector and install the wire harness in the guide



3. Install the switch lever.

Make sure that the switch lever freely moves in and out when pushed, and that it makes proper contact with the monetary switch on the power switch PCA.

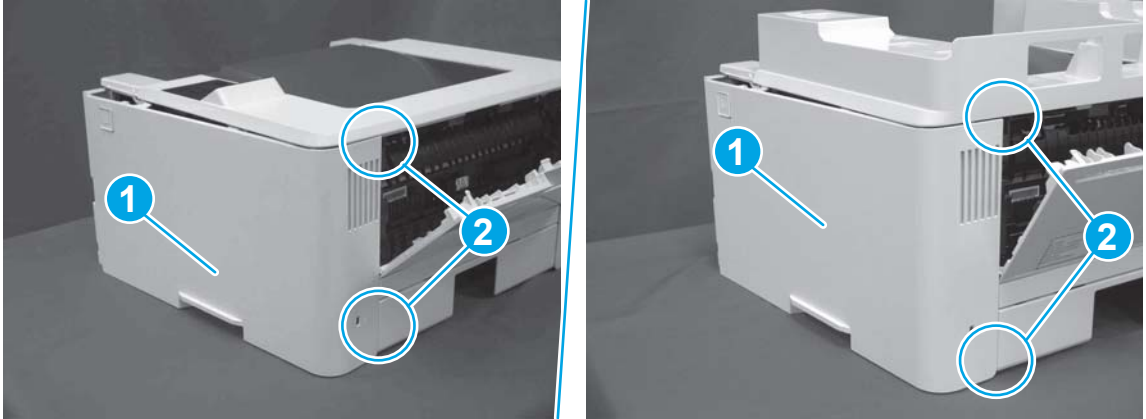
**Figure 1-764** Install the switch lever



### Step 7: Install the right cover

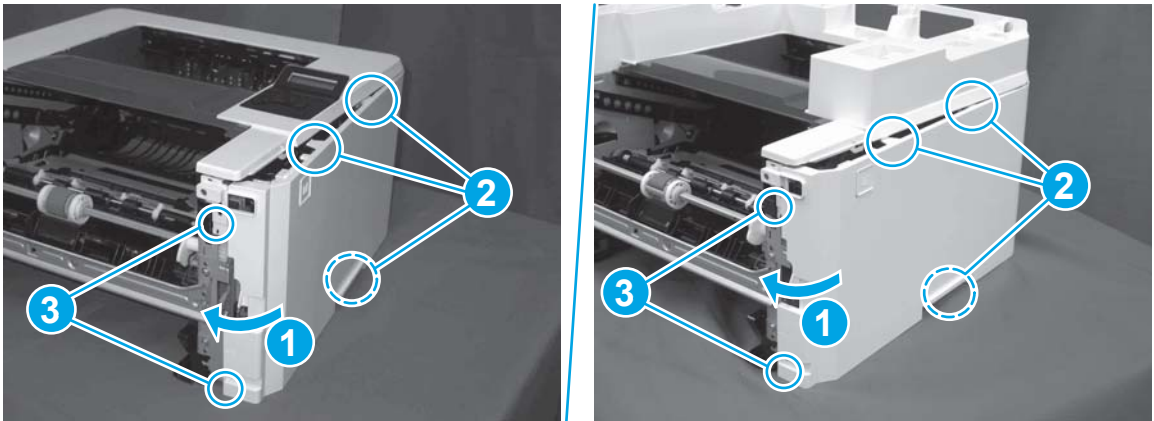
1. Position the cover (callout 1) on the printer, and then engage two bosses (callout 2).

**Figure 1-765** Install the cover




2. Rotate the front of the cover onto the printer (callout 1), engage three (callout 2) tabs, and then engage two bosses (callout 3).

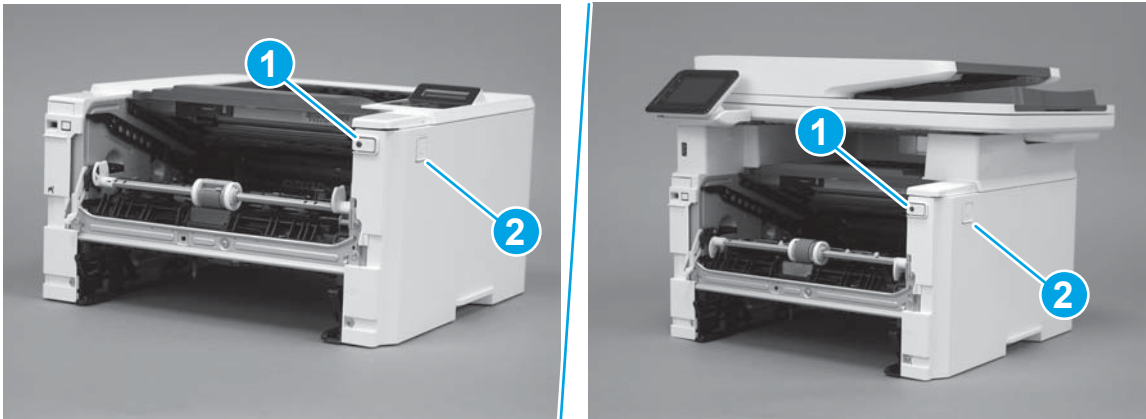
**Figure 1-766** Engage two bosses and one tab



3. Make sure that the power switch (callout 1) and cartridge door assembly button (callout 2) correctly function.

 **NOTE:** Remove, and then reinstall the cover if the switch or button does not correctly function.

**Figure 1-767** Check the power switch and cartridge door assembly button




4. Install one screw (callout 1).

**Figure 1-768** Install one screw

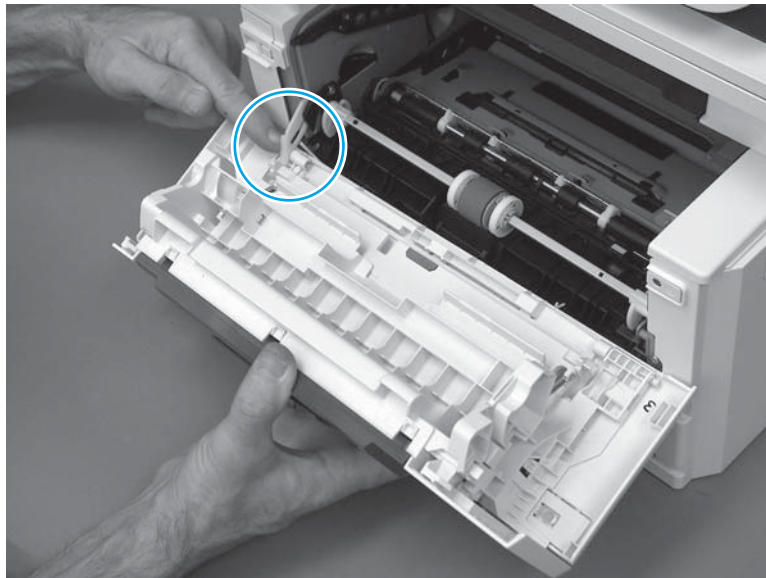


### Step 8: Install the cartridge door assembly

 **Reinstallation tip:** After a replacement door is installed, make sure to install the nameplate (supplied in the kit) corresponding to the printer name on the door.

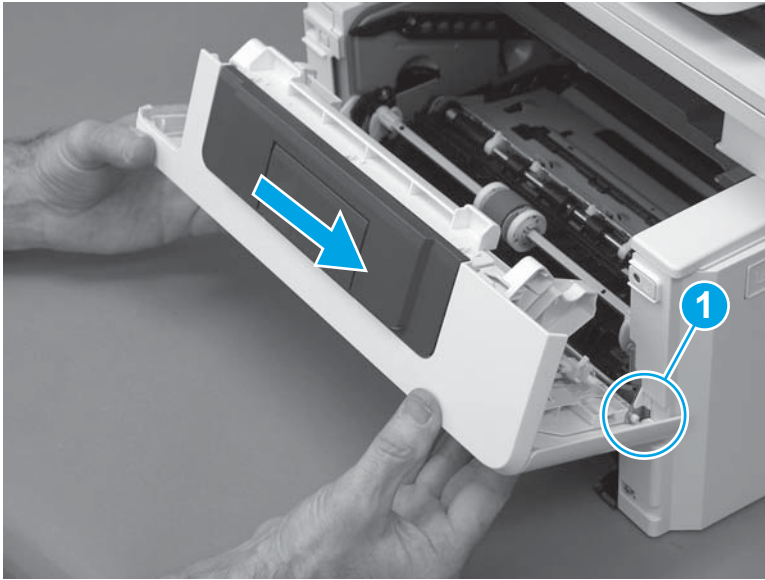
1. Position the door close to the printer, and then engage the keyed pin on the left-side retainer arm with the hole in the door.

**Figure 1-769** Engage the left-side retainer arm



2. Engage the right-side door hinge pin with the hole in the chassis (callout 1).

**Figure 1-770** Install the door



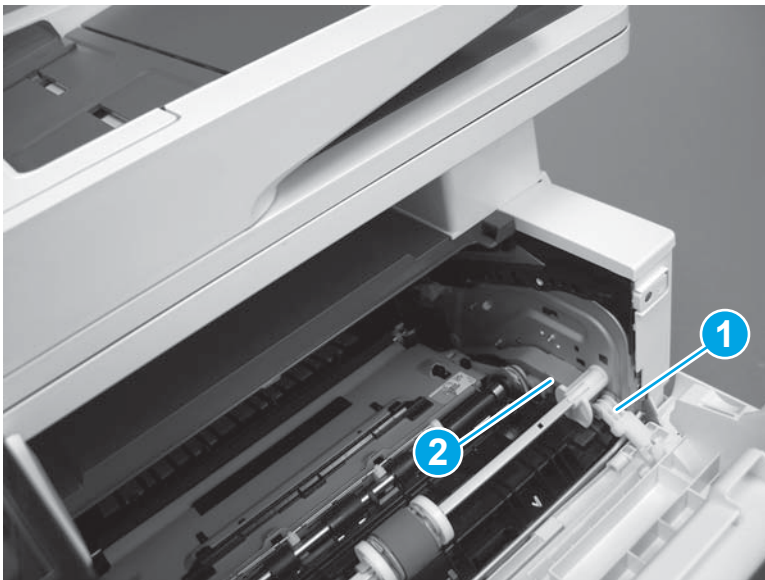
3. Install the link (callout 1).

---

 **IMPORTANT:** Make sure that the link snaps into place on the arm (callout 2). The link actuates the fuser pressure-release mechanism.

---

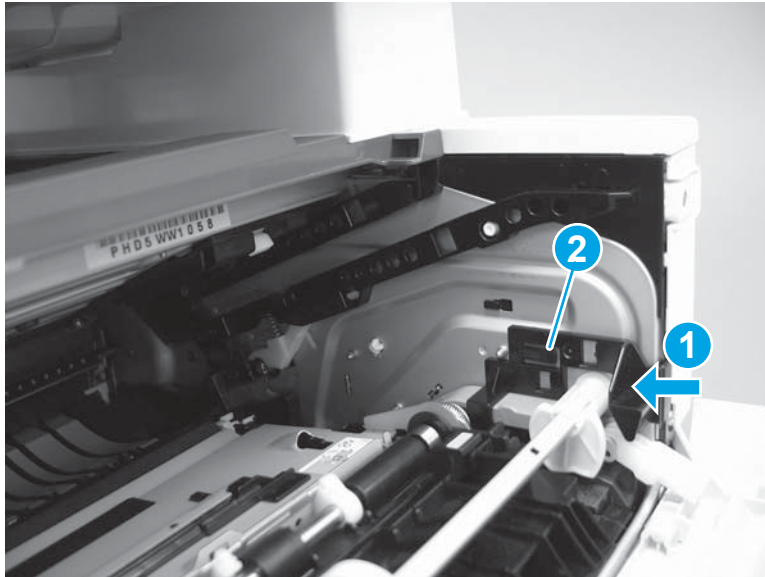
**Figure 1-771** Install the pressure-release link





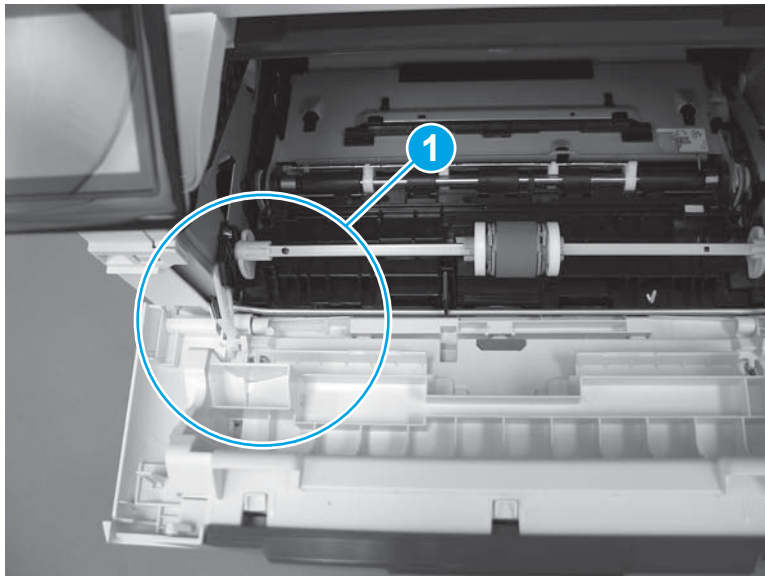
4. Slide the guide into the printer (callout 1), and then make sure that the tab (callout 2) snaps into place to secure the guide to the chassis.

**Figure 1-772** Install the guide




5. Position the shaft on the door, and then align the left-side hinge on the door with the hole in the chassis (callout 1).

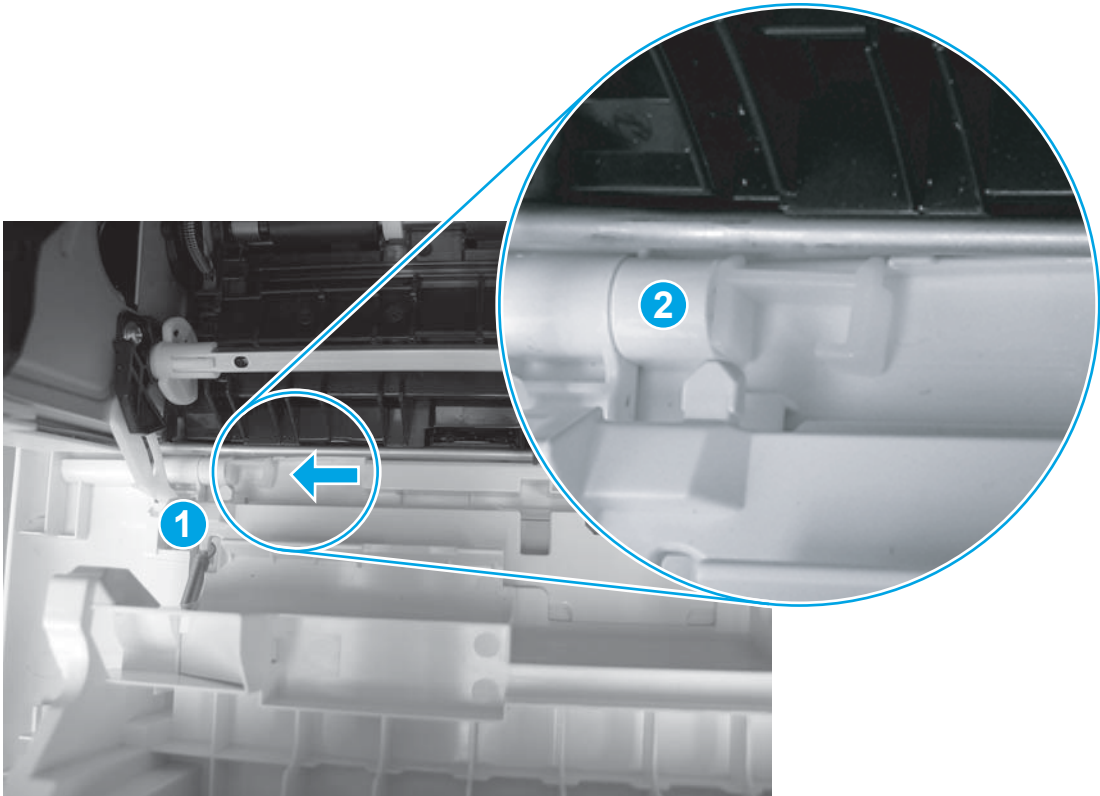
**Figure 1-773** Align the hinge



6. Push the shaft towards the left side of the printer to install it (callout 1).

 **Reinstallation tip:** Make sure that the support shaft is fully installed and correctly orientated (callout 2) so that it will not interfere with the door opening and closing.

**Figure 1-774** Install the support shaft



### Step 9: Install Tray 2

- ▲ Slide the tray straight into the printer to install it.

**Figure 1-775** Install the tray



## Removal and replacement: Fax PCA (M427/M426)



**NOTE:** Fax models only.

- [Introduction](#)
- [Step 1: Remove Tray 2](#)
- [Step 2: Remove the cartridge door assembly](#)
- [Step 3: Remove the left cover](#)
- [Step 4: Remove the fax PCA \(M427/M426\)](#)
- [Step 5: Unpack the replacement assembly](#)
- [Step 6: Install the fax PCA \(M427/M426\)](#)
- [Step 7: Install the left cover](#)
- [Step 8: Install the cartridge door assembly](#)
- [Step 9: Install Tray 2](#)

### Introduction

This document provides the procedures to remove and replace the fax printed circuit assembly (PCA).

### Before performing service

#### Turn the printer power off

- Disconnect the power cable.



**WARNING!** To avoid damage to the printer, turn the printer off, wait 30 seconds, and then remove the power cable before attempting to service the printer.

Use the table below to identify the correct part number for your printer. To order the part, go to [www.hp.com/buy/parts](http://www.hp.com/buy/parts).

Fax PCA part number	
<b>CF206-60001</b>	Fax PCA <sup>1</sup> US/AP
<b>CF207-60001</b>	Fax PCA <sup>1</sup> Euro
<b>CF208-60001</b>	Fax PCA <sup>1</sup> Brazil

<sup>1</sup> M427/M426 fax models only.

### Required tools

- #2 Phillips screwdriver with a magnetic tip.
- Small flat-blade screw driver

## After performing service

### Turn the printer power on

- Connect the power cable.
- Use the power switch to turn the power on.

### Post service test

Make sure that the printer initializes to a **Ready** state.

If possible, send a fax to the printer.

### Step 1: Remove Tray 2


- ▲ Pull the tray straight out of the printer to remove it.

**Figure 1-776** Remove the tray



### Step 2: Remove the cartridge door assembly

---

 **NOTE:** If the toner cartridge was not removed prior to servicing the printer, remove it now.

---

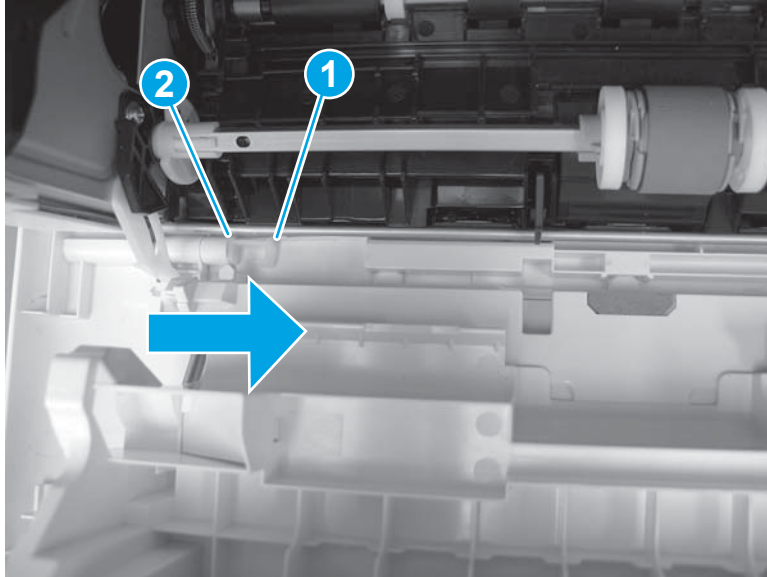
1. Release one tab (callout 1), and then slide shaft (callout 2) in the direction the arrow indicates and remove it.

---

 **TIP:** It might be easier to release the support shaft by using a small flat-blade screwdriver.

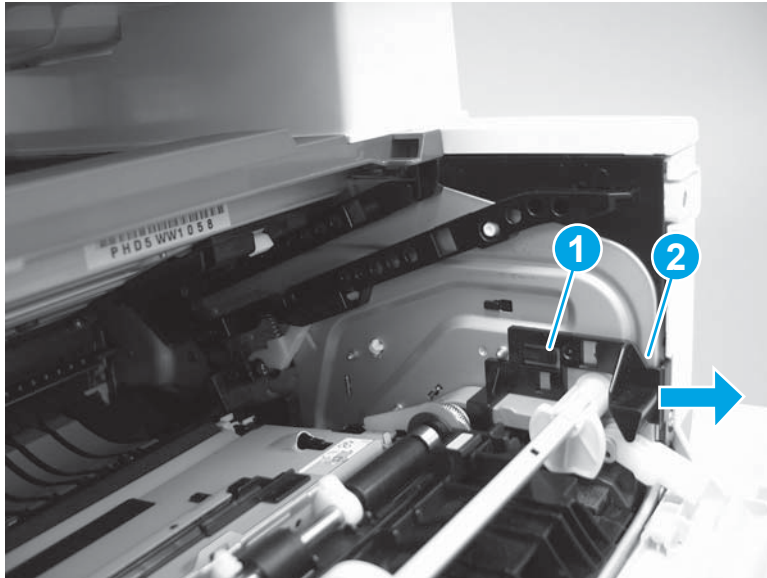
---

**Figure 1-777** Release the support shaft



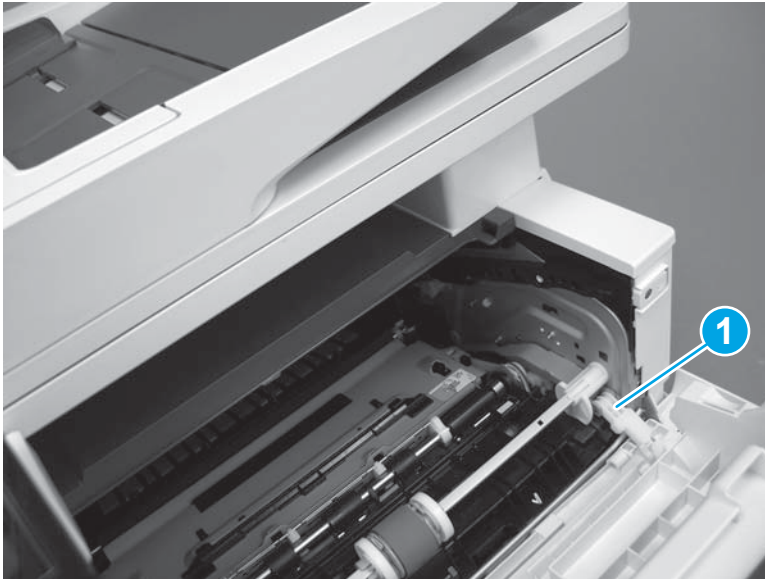
2. Release one tab (callout 1), and then slide the guide (callout 2) in the direction the arrow indicates and remove it.

**Figure 1-778** Remove the guide



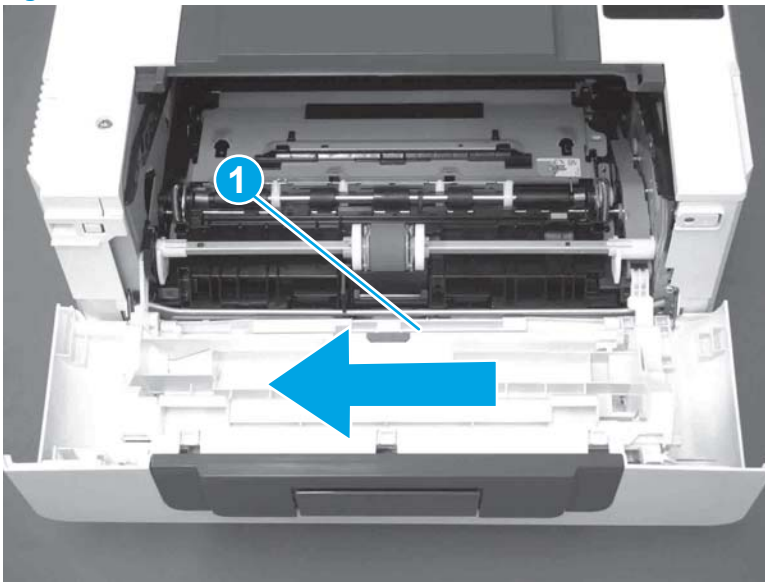
3. Remove the link arm (callout 1).

**Figure 1-779** Remove the link arm



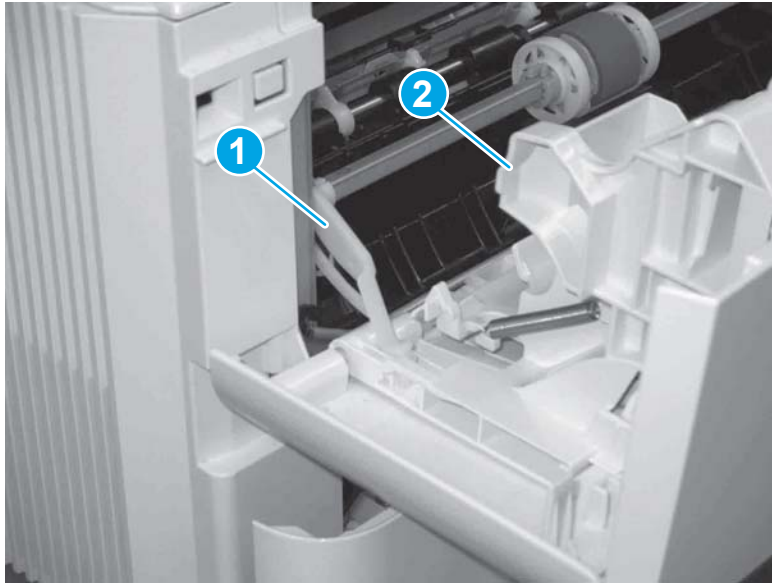
4. Slide the cartridge door assembly (callout 1) in the direction the arrow indicates and remove it.

**Figure 1-780** Remove the door



5. Remove the link (callout 1) from the cartridge door assembly (callout 2).

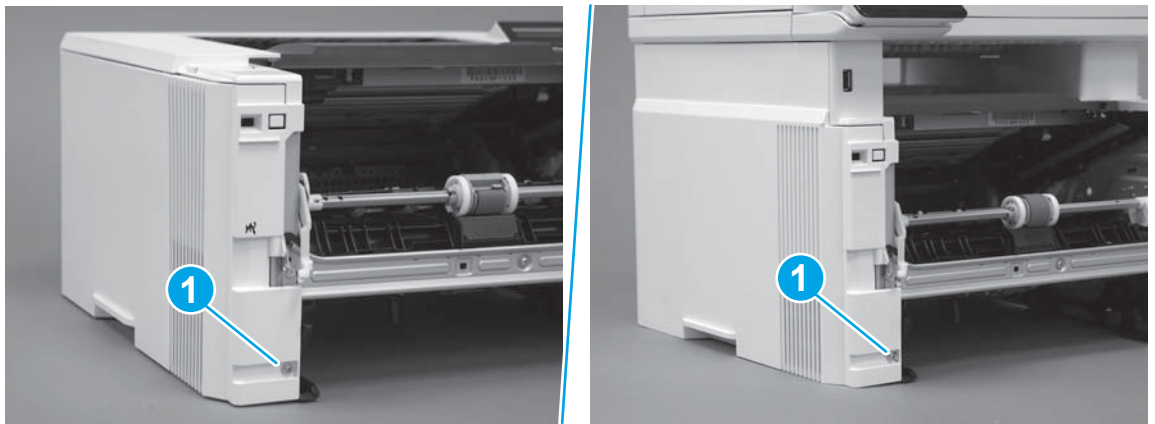
**Figure 1-781** Release the left-side retainer arm



### Step 3: Remove the left cover

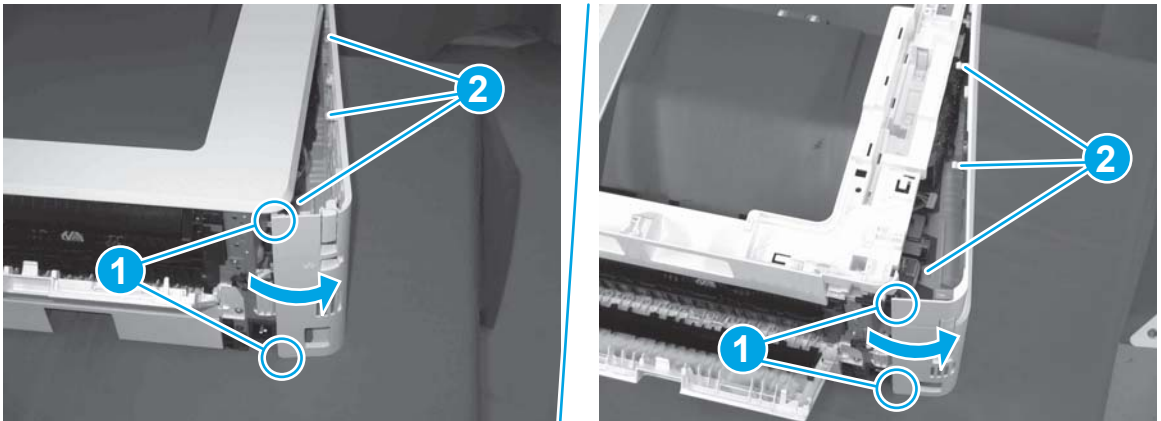
1. Remove one screw (callout 1).

**Figure 1-782** Remove one screw



2. Open the rear door, release two bosses (callout 1), and then release three tabs (callout 2).

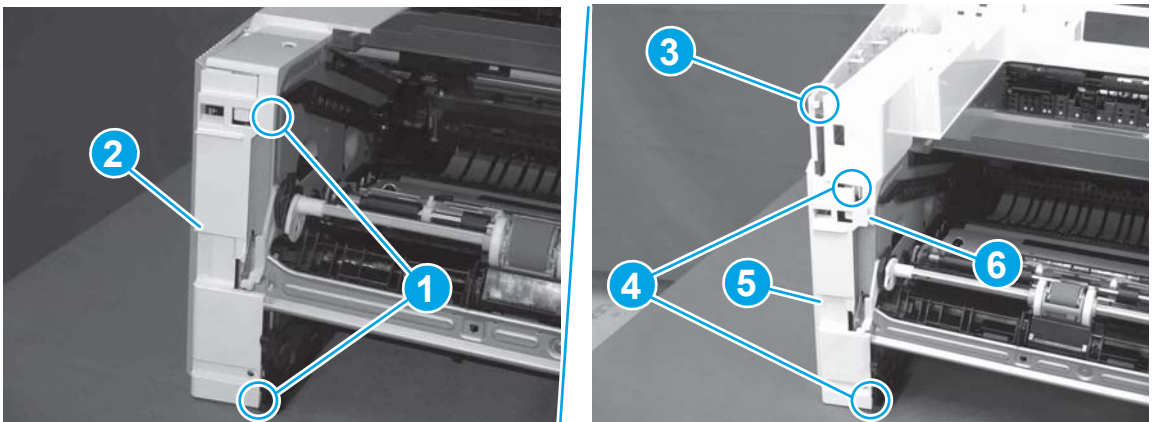
**Figure 1-783** Release two bosses and three tabs



3. At the front of the printer, do one of the following:
  - **M403/M402:** Release two bosses (callout 1), and then remove the cover (callout 2).
  - **M427/M426:** Release one tab (callout 3), two bosses (callout 4), and then remove the cover (callout 5).

**CAUTION:** Be careful when releasing the upper bosses on the M427/M426 cover. One portion of the cover (callout 6) is fragile and is easily broken.

**Figure 1-784** Remove the cover

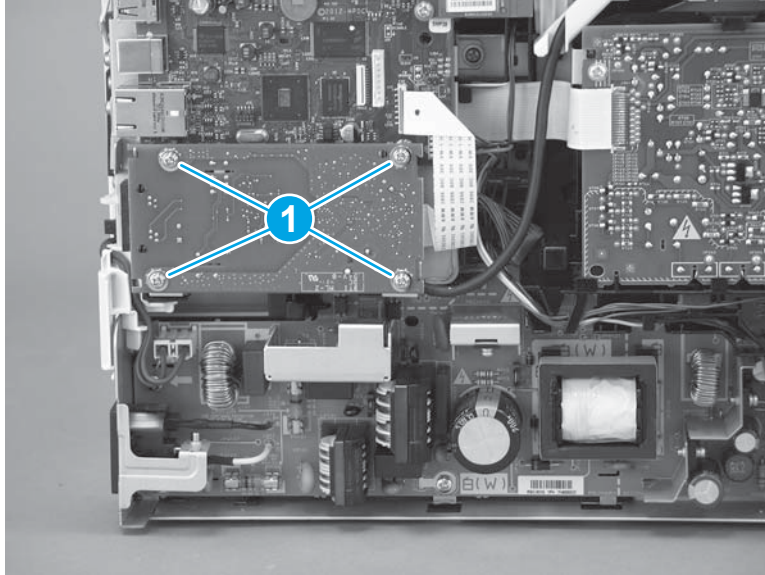


#### Step 4: Remove the fax PCA (M427/M426)

1. Remove four screws (callout 1).

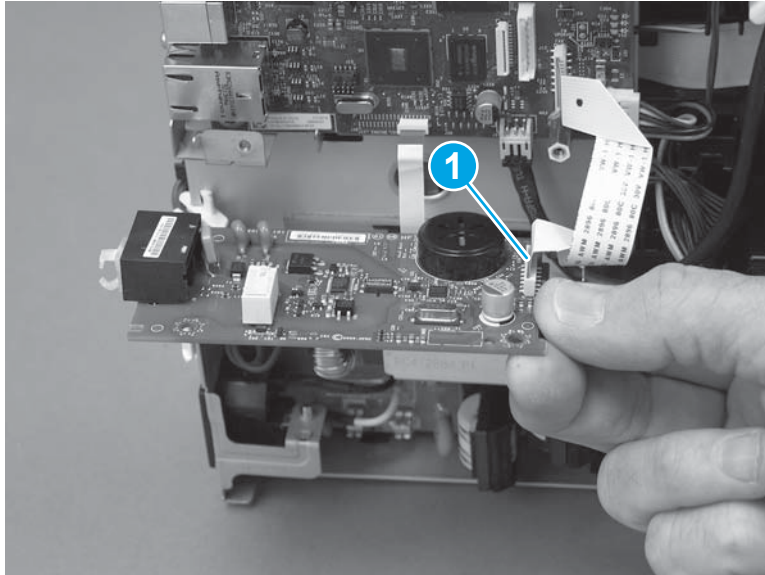


**Figure 1-785** Remove four screws



2. Disconnect one FFC (callout 1), and then remove the fax PCA.

**Figure 1-786** Disconnect one connector and remove the PCA



### Step 5: Unpack the replacement assembly

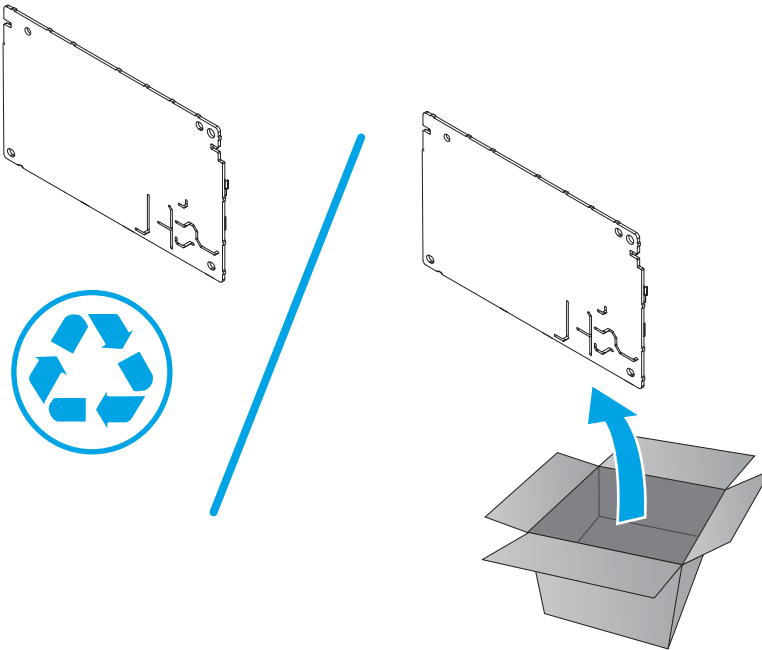
Unpack the replacement part from the packaging.

<http://www8.hp.com/us/en/hp-information/environment/product-recycling.html>



**NOTE:** HP recommends responsible disposal of the defective part.

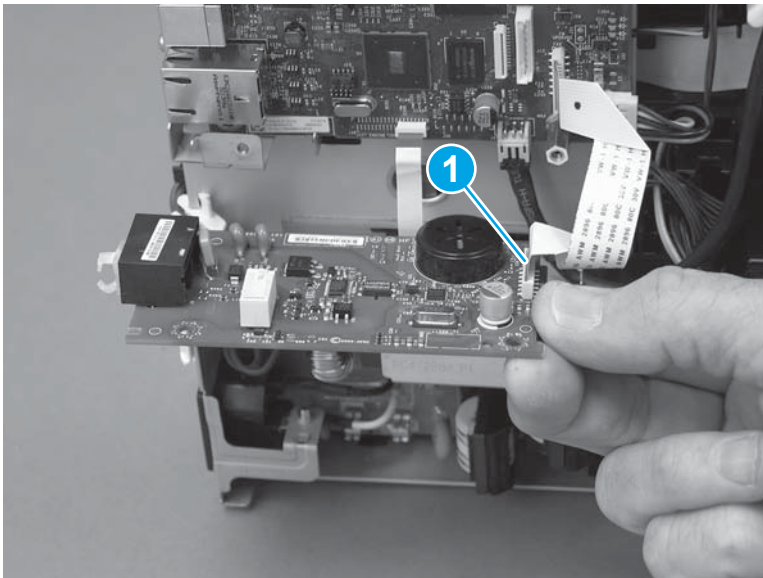
**Figure 1-787** Recycle and unpack



**Step 6: Install the fax PCA (M427/M426)**

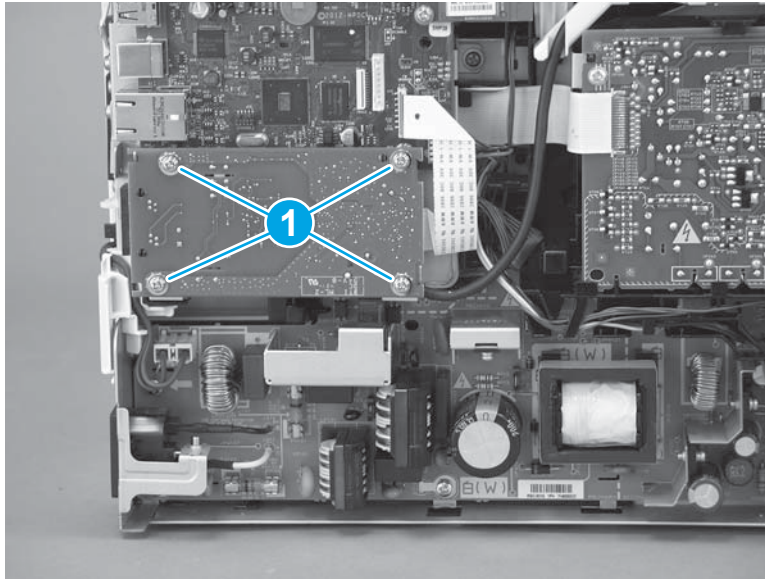
1. Connect one FFC cable (callout 1), and then position the fax PCA on the printer.

**Figure 1-788** Connect one connector and install the PCA



2. Install four screws (callout 1).

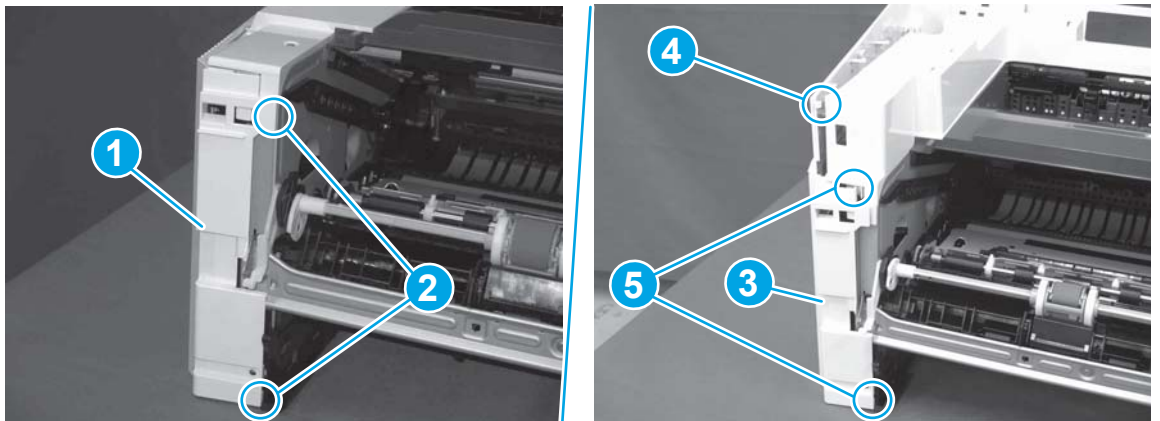
**Figure 1-789** Install four screws



### Step 7: Install the left cover

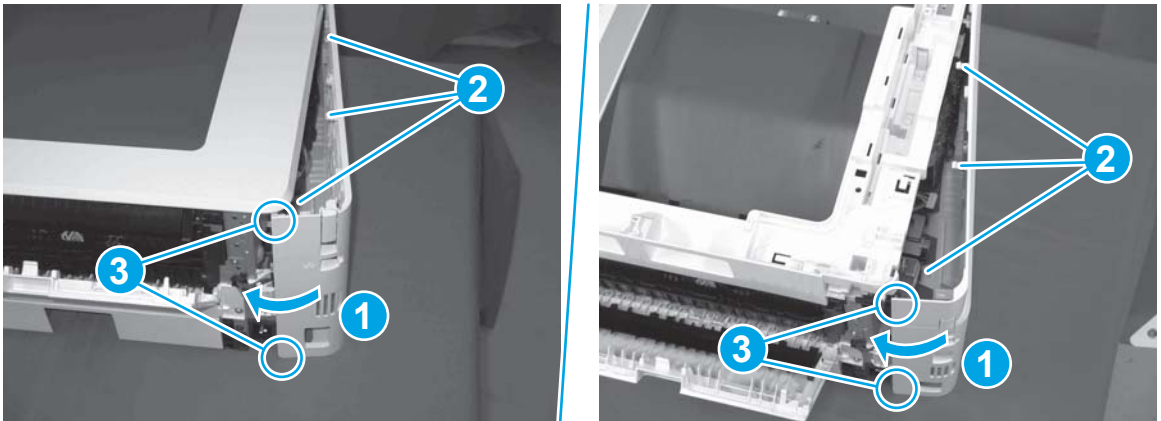
1. At the front of the printer, do one of the following:
  - **M403/M402:** Position the cover on the printer ( callout 1), and then engage two bosses (callout 2).
  - **M427/M426:** Position the cover on the printer (callout 3), engage one tab (callout 4), and then engage two bosses (callout 4).

**Figure 1-790** Install the cover



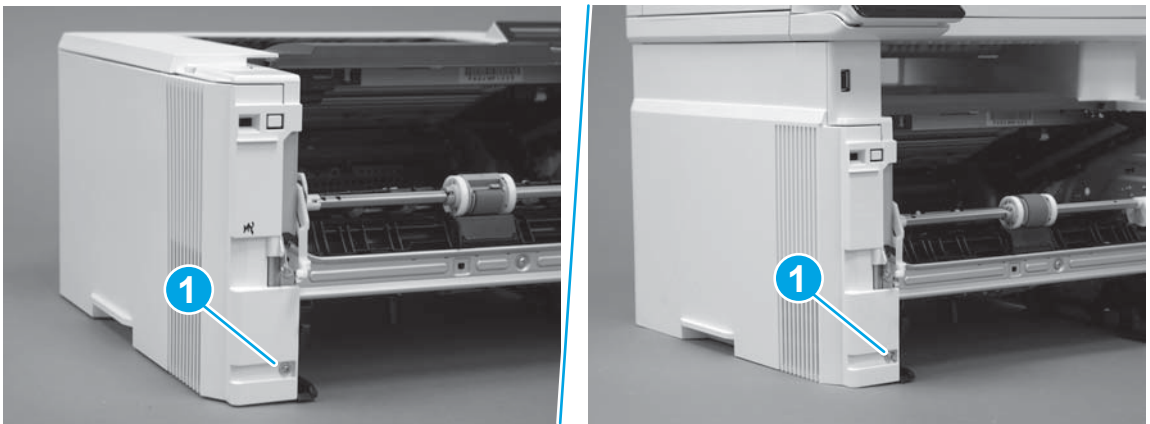
- Carefully rotate the rear of the cover onto the printer (callout 1), engage three tabs (callout 2), and then engage two bosses (callout 3).

**Figure 1-791** Engage three tabs and two bosses




- Install one screw (callout 1).

**Figure 1-792** Install one screw

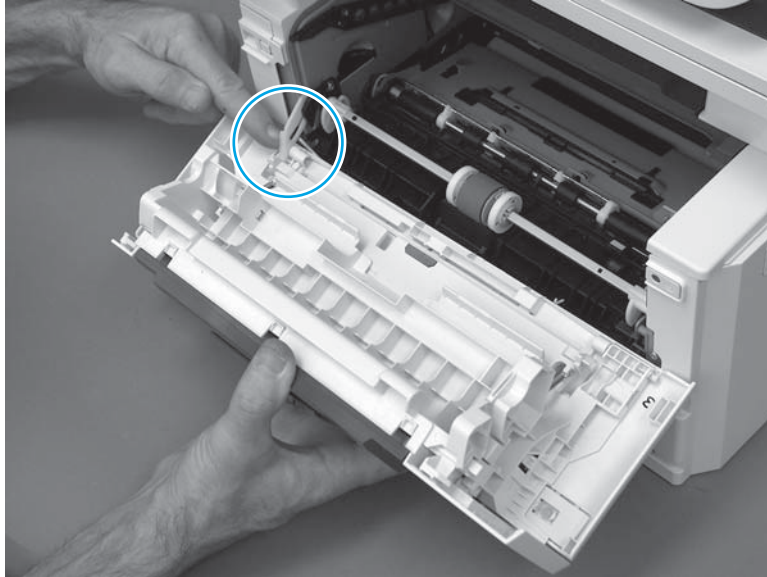


### Step 8: Install the cartridge door assembly

 **Reinstallation tip:** After a replacement door is installed, make sure to install the nameplate (supplied in the kit) corresponding to the printer name on the door.

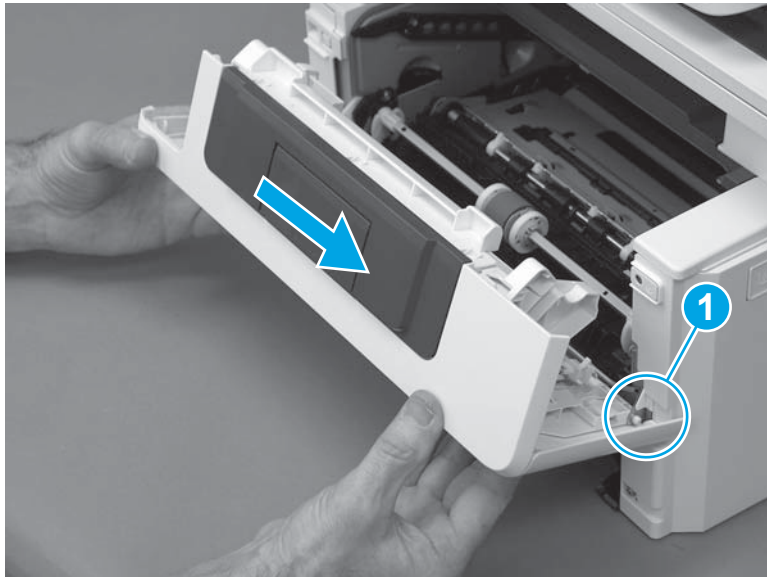
- Position the door close to the printer, and then engage the keyed pin on the left-side retainer arm with the hole in the door.

**Figure 1-793** Engage the left-side retainer arm



2. Engage the right-side door hinge pin with the hole in the chassis (callout 1).

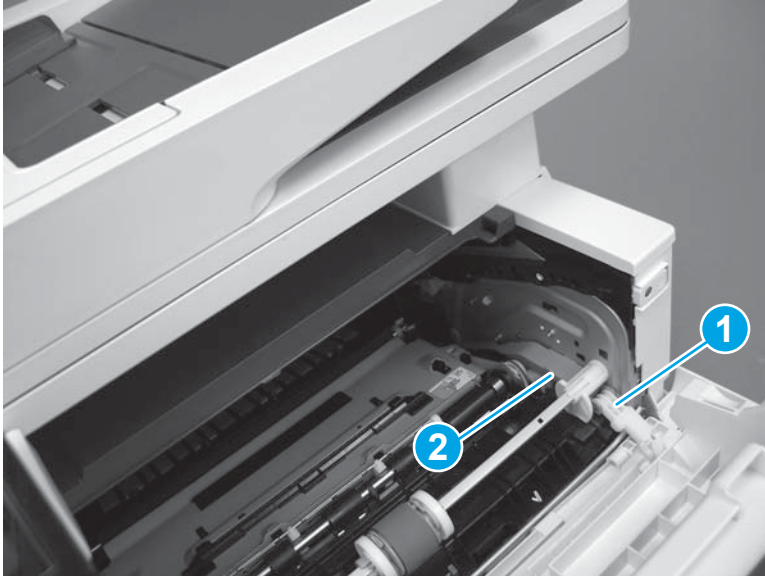
**Figure 1-794** Install the door



3. Install the link (callout 1).

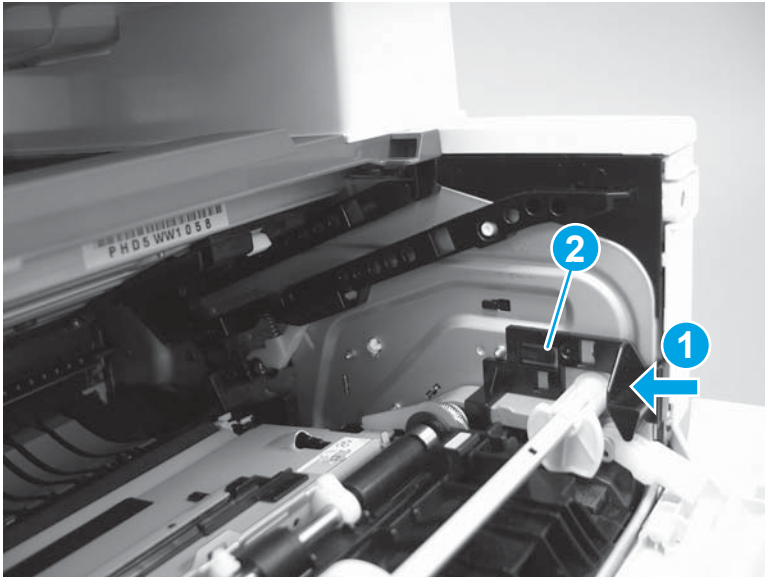
 **IMPORTANT:** Make sure that the link snaps into place on the arm (callout 2). The link actuates the fuser pressure-release mechanism.

**Figure 1-795** Install the pressure-release link



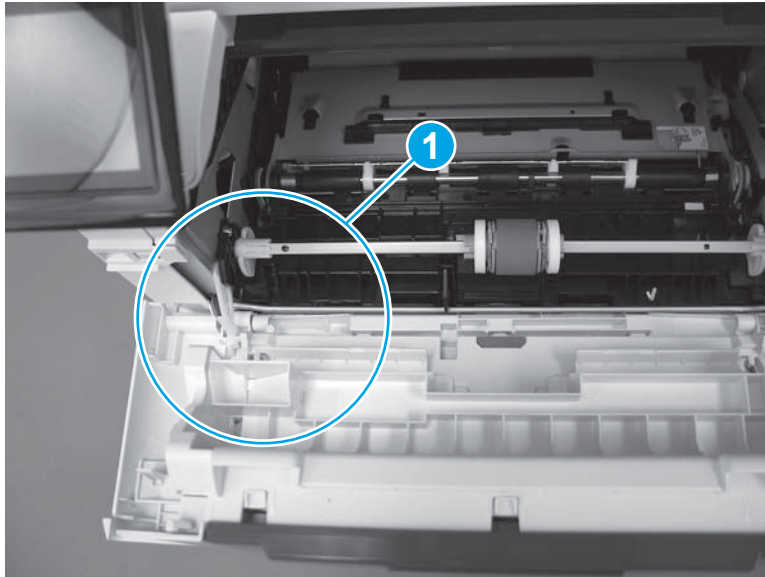
4. Slide the guide into the printer (callout 1), and then make sure that the tab (callout 2) snaps into place to secure the guide to the chassis.

**Figure 1-796** Install the guide




5. Position the shaft on the door, and then align the left-side hinge on the door with the hole in the chassis (callout 1).

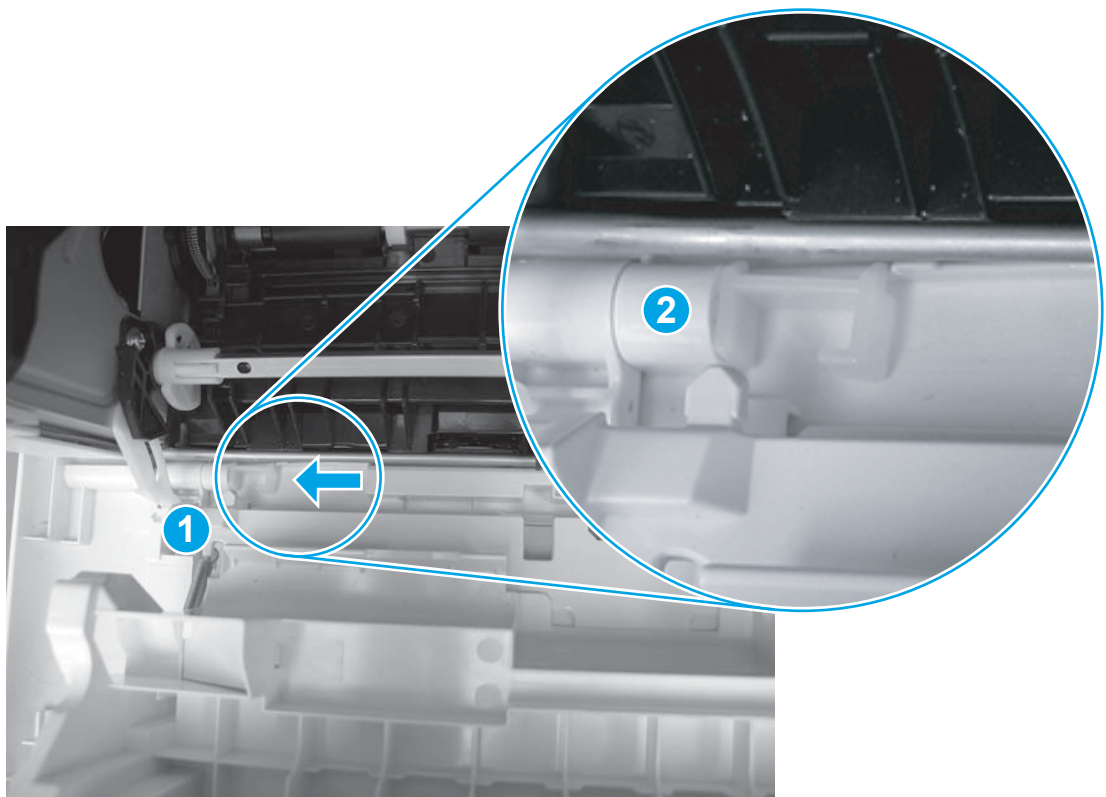
**Figure 1-797** Align the hinge



6. Push the shaft towards the left side of the printer to install it (callout 1).

 **Reinstallation tip:** Make sure that the support shaft is fully installed and correctly orientated (callout 2) so that it will not interfere with the door opening and closing.

**Figure 1-798** Install the support shaft



### Step 9: Install Tray 2

- ▲ Slide the tray straight into the printer to install it.

**Figure 1-799** Install the tray





## Removal and replacement: Walkup USB PCA (M427/M426)

- [Introduction](#)
- [Step 1: Remove Tray 2](#)
- [Step 2: Remove the cartridge door assembly](#)
- [Step 3: Remove the left cover](#)
- [Step 4: Remove the fax PCA](#)
- [Step 5: Remove the walkup USB PCA \(M427/M426\)](#)
- [Step 6: Unpack the replacement assembly](#)
- [Step 7: Install the walkup USB PCA \(M427/M426\)](#)
- [Step 8: Install the fax PCA](#)
- [Step 9: Install the left cover](#)
- [Step 10: Install the cartridge door assembly](#)
- [Step 9: Install Tray 2](#)


### Introduction

This document provides the procedures to remove and replace the walkup USB PCA.

### Before performing service

#### Turn the printer power off

- Disconnect the power cable.

 **WARNING!** To avoid damage to the printer, turn the printer off, wait 30 seconds, and then remove the power cable before attempting to service the printer.

Use the table below to identify the correct part number for your printer. To order the part, go to [www.hp.com/buy/parts](http://www.hp.com/buy/parts).

Walkup USB PCA part number	
CF368-60001	Walkup USB PCA <sup>1</sup>

<sup>1</sup> M427/M426 only.

### Required tools

- #2 Phillips screwdriver with a magnetic tip.

### After performing service

#### Turn the printer power on

- Connect the power cable.
- Use the power switch to turn the power on.

## Post service test

Make sure that the printer initializes to a **Ready** state.

Print a job from the walkup USB PCA.

## Step 1: Remove Tray 2

- ▲ Pull the tray straight out of the printer to remove it.

**Figure 1-800** Remove the tray



## Step 2: Remove the cartridge door assembly



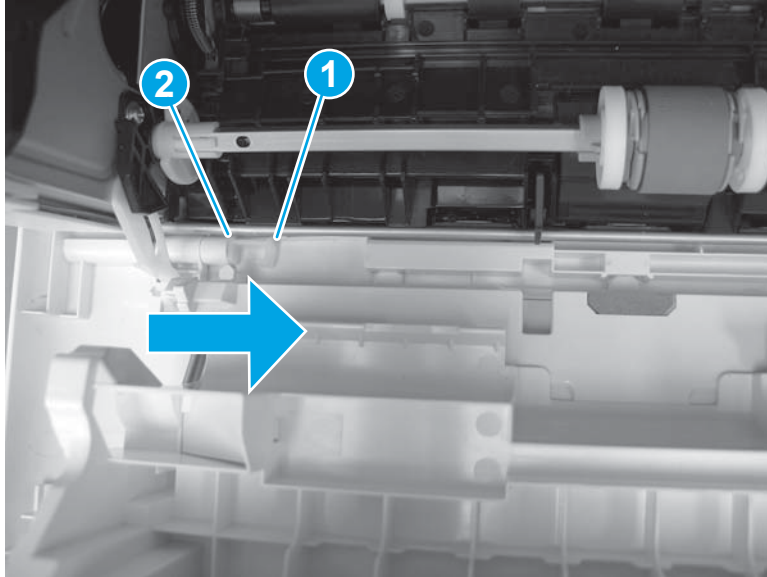
**NOTE:** If the toner cartridge was not removed prior to servicing the printer, remove it now.

1. Release one tab (callout 1), and then slide shaft (callout 2) in the direction the arrow indicates and remove it.



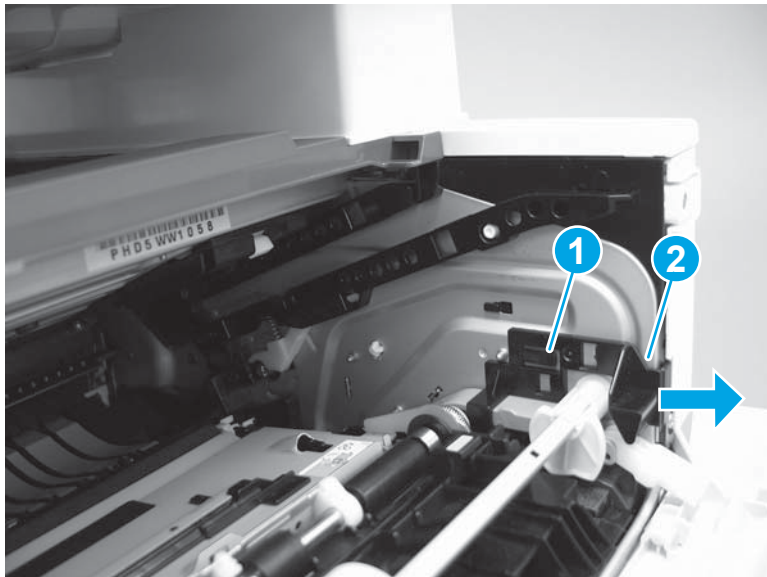
**TIP:** It might be easier to release the support shaft by using a small flat-blade screwdriver.

**Figure 1-801** Release the support shaft



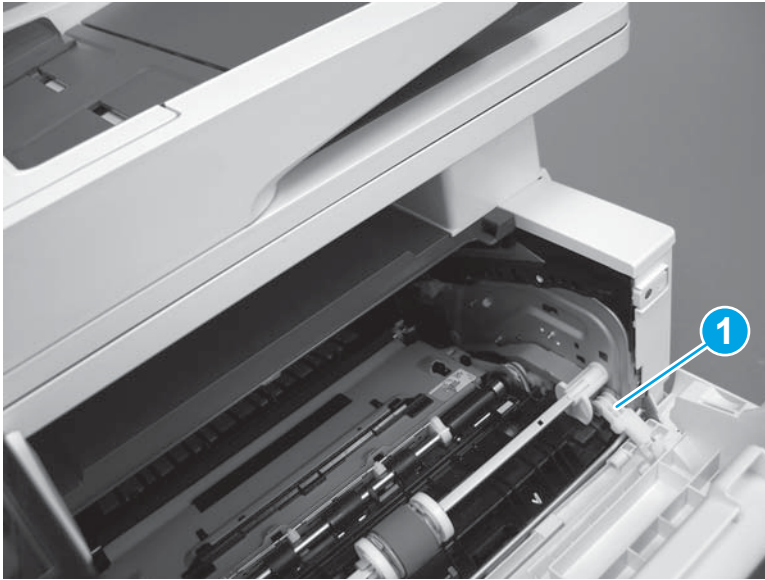
2. Release one tab (callout 1), and then slide the guide (callout 2) in the direction the arrow indicates and remove it.

**Figure 1-802** Remove the guide



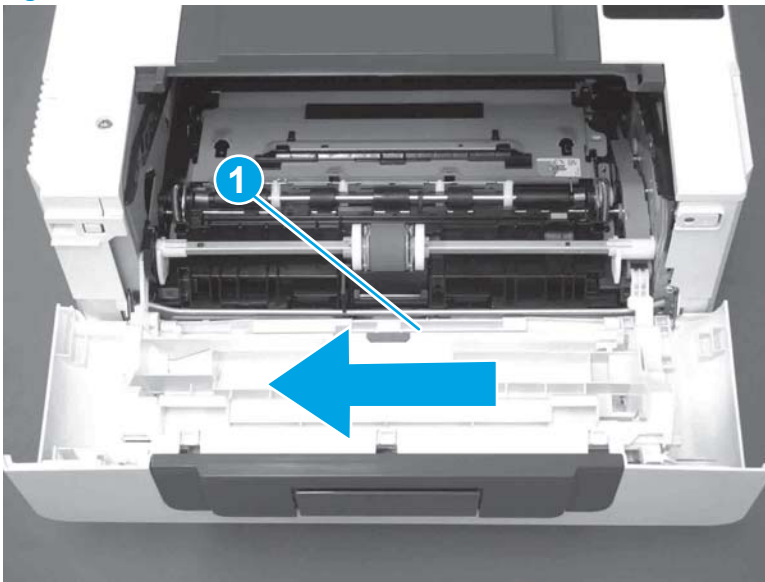
3. Remove the link arm (callout 1).

**Figure 1-803** Remove the link arm



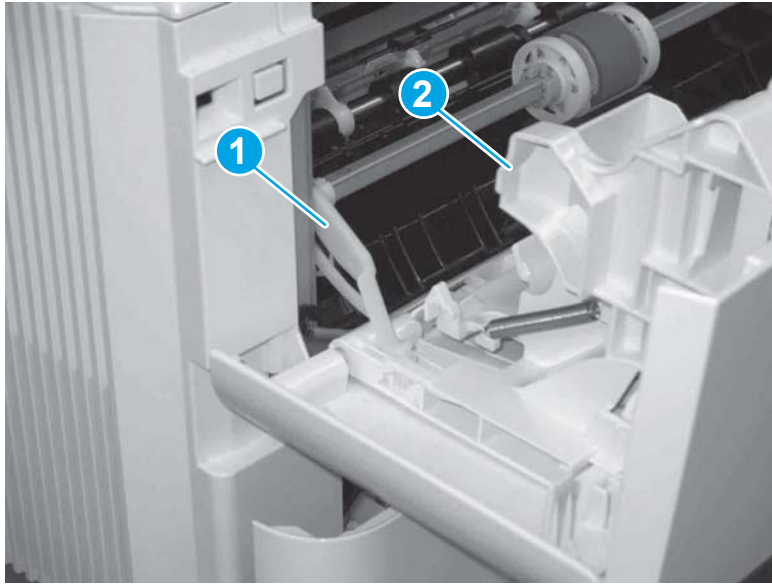
4. Slide the cartridge door assembly (callout 1) in the direction the arrow indicates and remove it.

**Figure 1-804** Remove the door



5. Remove the link (callout 1) from the cartridge door assembly (callout 2).

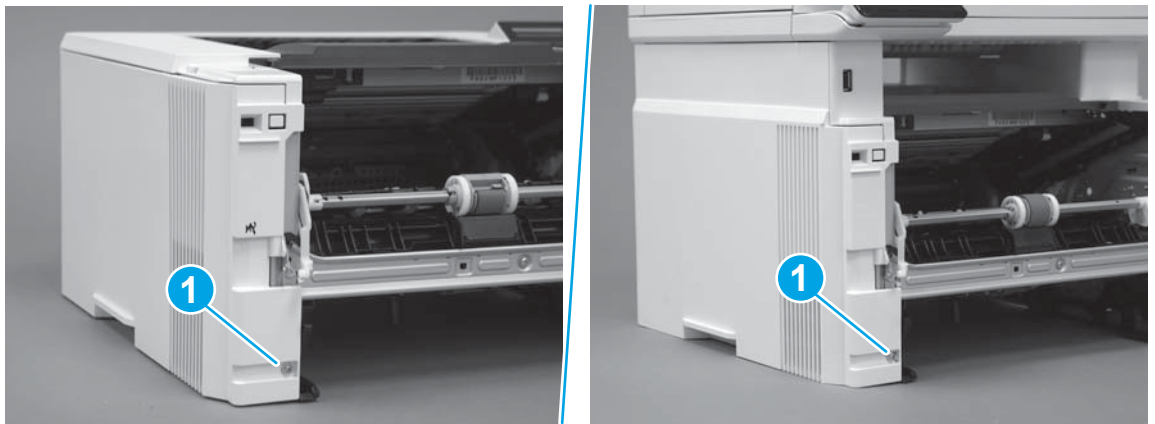
**Figure 1-805** Release the left-side retainer arm



### Step 3: Remove the left cover

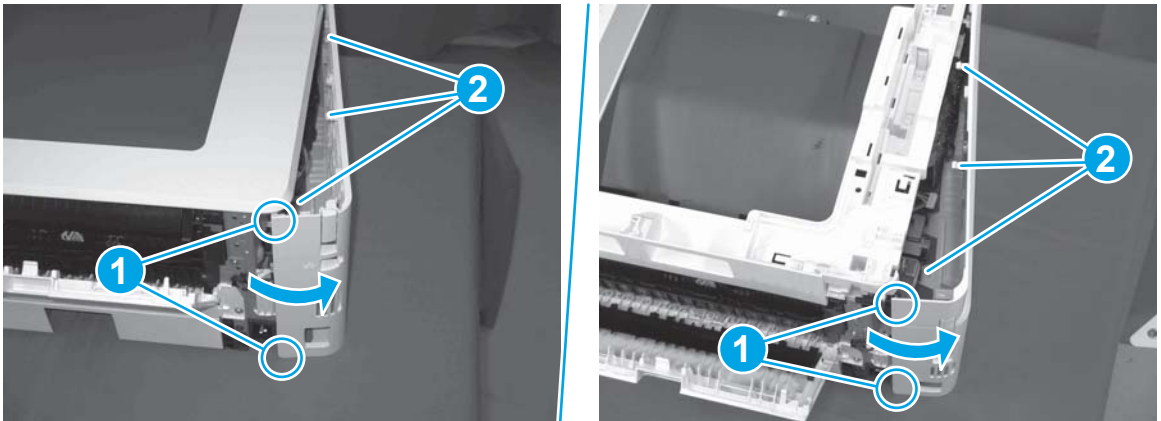
1. Remove one screw (callout 1).

**Figure 1-806** Remove one screw



2. Open the rear door, release two bosses (callout 1), and then release three tabs (callout 2).

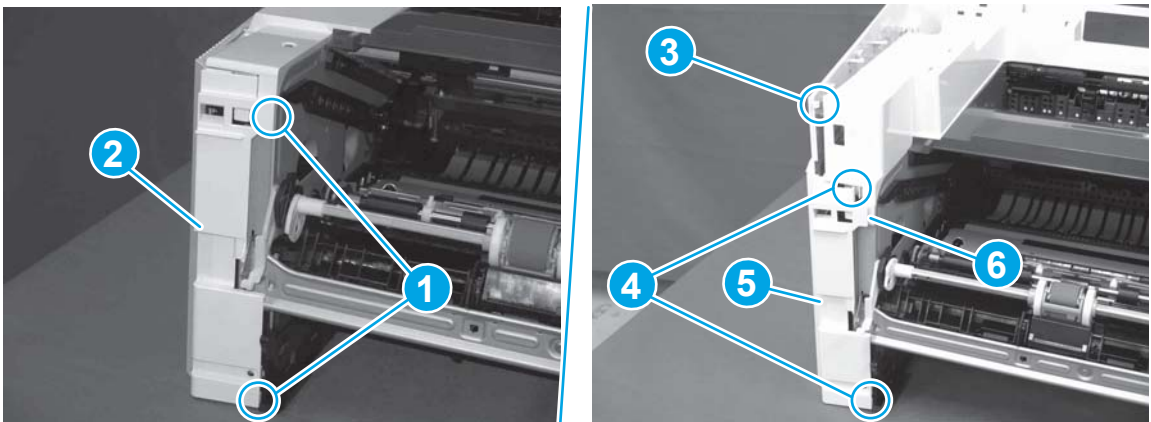
**Figure 1-807** Release two bosses and three tabs



3. At the front of the printer, do one of the following:
  - **M403/M402:** Release two bosses (callout 1), and then remove the cover (callout 2).
  - **M427/M426:** Release one tab (callout 3), two bosses (callout 4), and then remove the cover (callout 5).

**CAUTION:** Be careful when releasing the upper bosses on the M427/M426 cover. One portion of the cover (callout 6) is fragile and is easily broken.

**Figure 1-808** Remove the cover

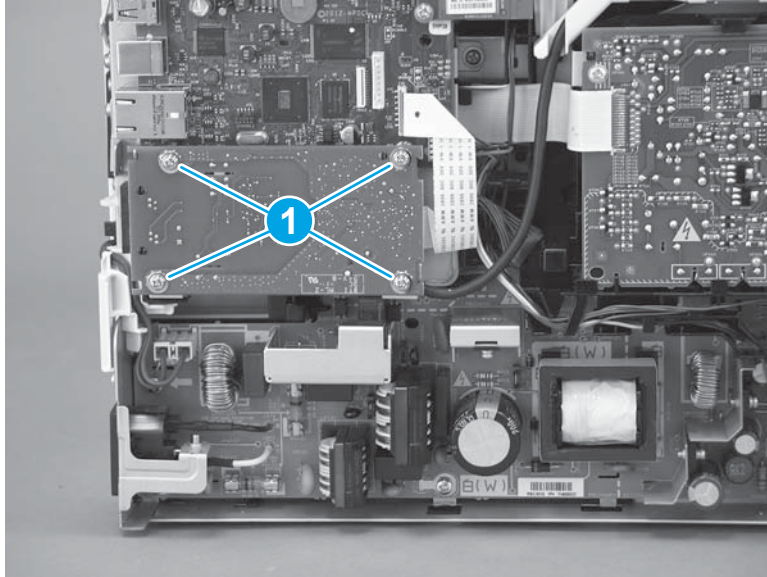


#### Step 4: Remove the fax PCA

**NOTE:** Fax models only. For all other models, skip this step and go to [Step 5: Remove the walkup USB PCA \(M427/M426\)](#) on page 449.

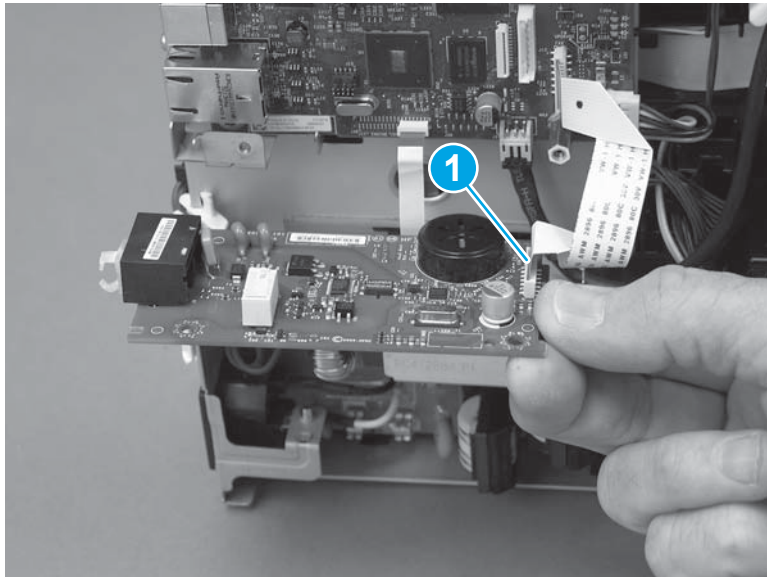
1. Remove four screws (callout 1).

**Figure 1-809** Remove four screws



2. Disconnect one FFC (callout 1), and then remove the fax PCA.

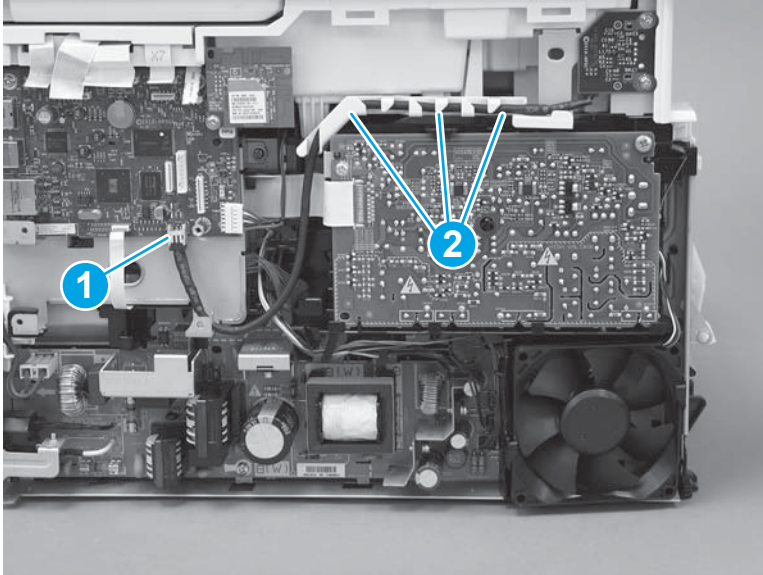
**Figure 1-810** Disconnect one connector and remove the PCA



**Step 5: Remove the walkup USB PCA (M427/M426)**

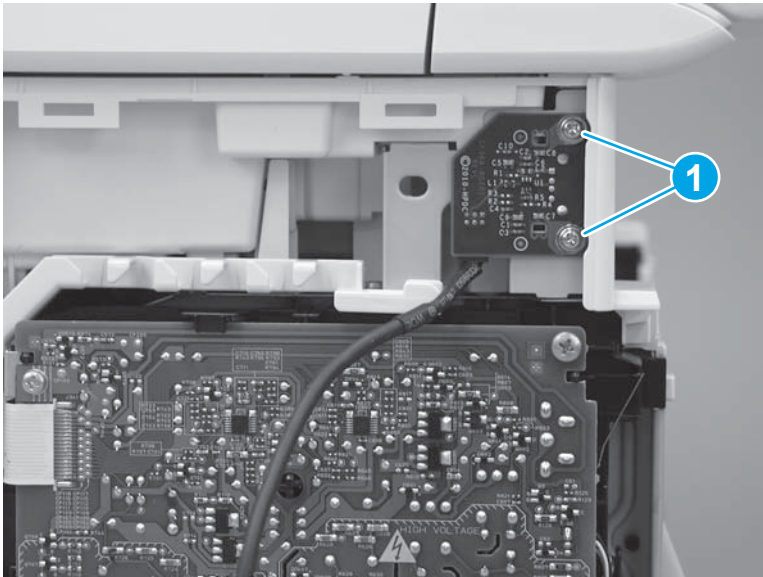
1. Disconnect one connector (callout 1), and then release the wire harness from the guide (callout 2).

**Figure 1-811** Disconnect one connector



2. Remove two screws (callout 1).

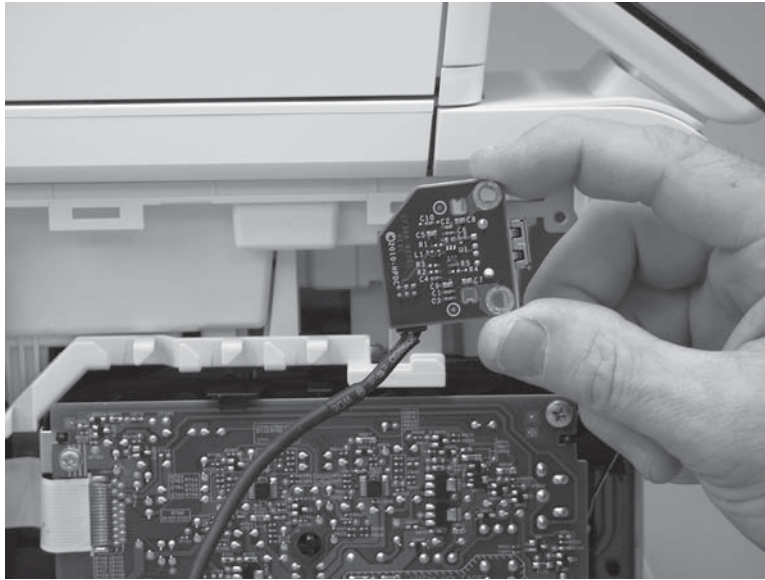
**Figure 1-812** Remove two screws





3. Remove the wakeup USB PCA.

**Figure 1-813** Remove the wakeup USB PCA



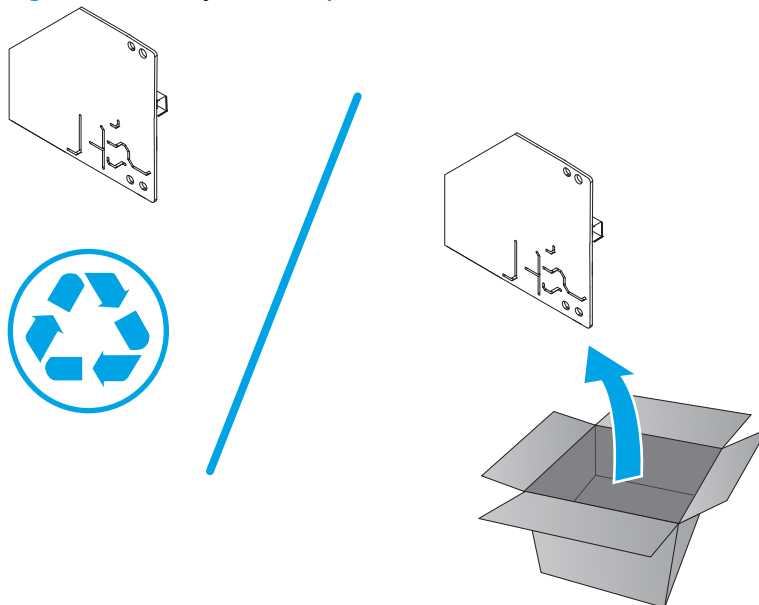
### Step 6: Unpack the replacement assembly

Unpack the replacement part from the packaging.

<http://www8.hp.com/us/en/hp-information/environment/product-recycling.html>

 **NOTE:** HP recommends responsible disposal of the defective part.

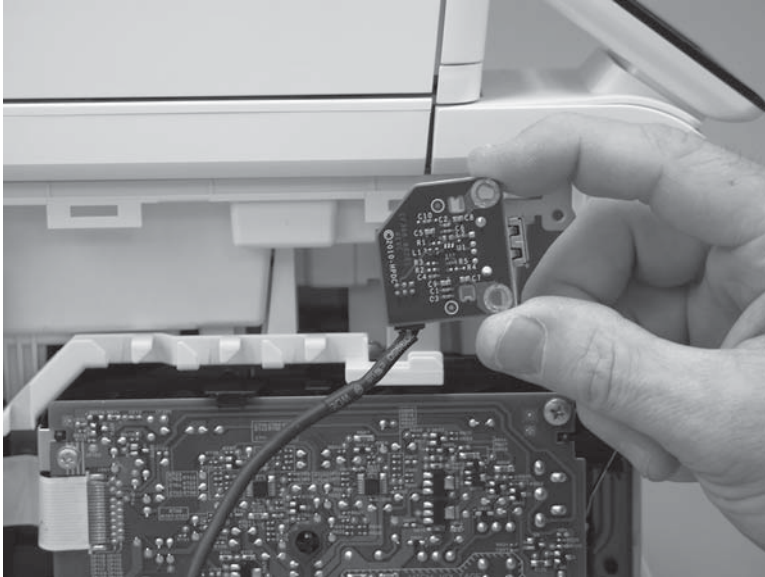
**Figure 1-814** Recycle and unpack



### Step 7: Install the wakeup USB PCA (M427/M426)

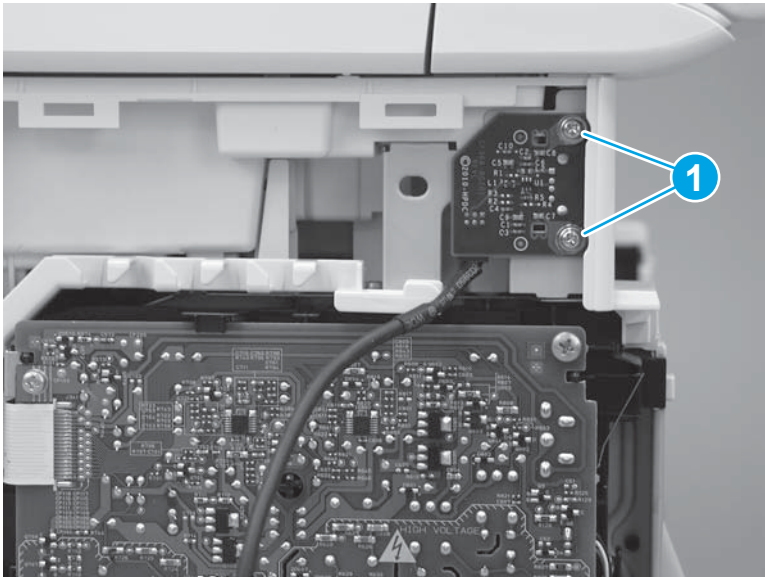
1. Position the wakeup USB PCA on the printer.

**Figure 1-815** Install the walkup USB PCA



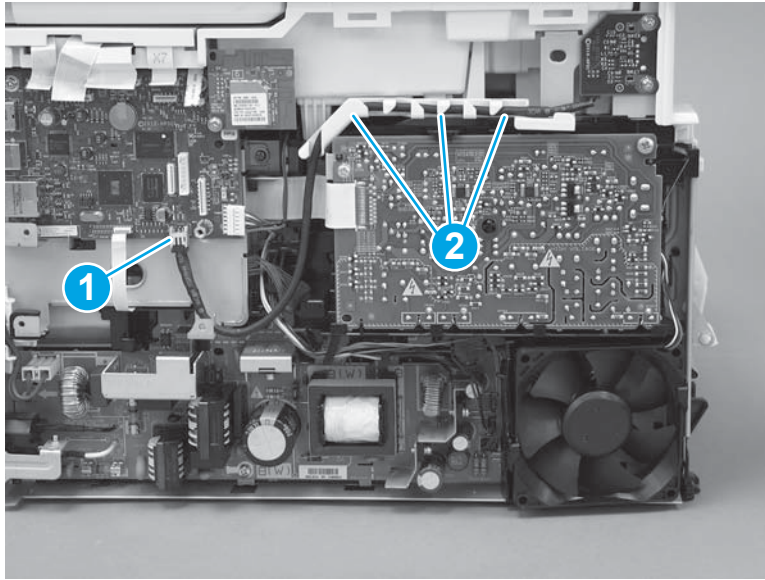
2. Install two screws (callout 1).

**Figure 1-816** Install two screws




3. Connect one connector (callout 1), and then install the wire harness in the guide (callout 2).

**Figure 1-817** Connect one connector

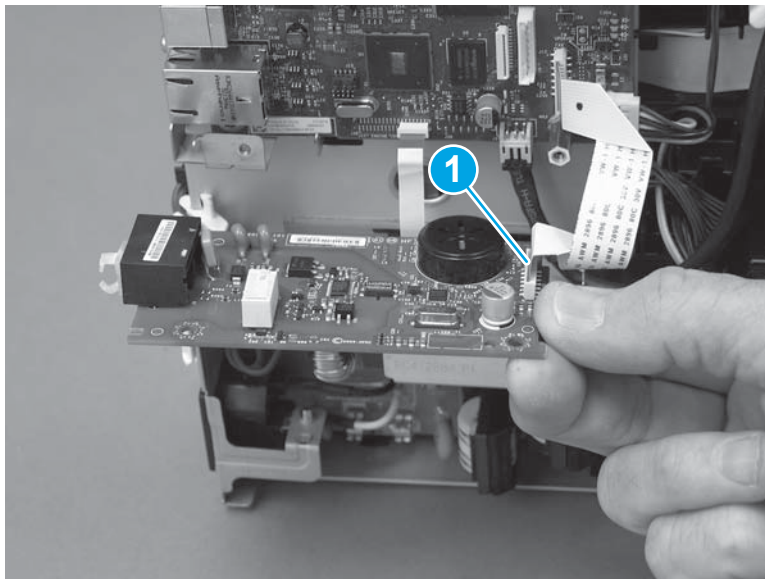


### Step 8: Install the fax PCA

 **NOTE:** Fax models only. For all other models, skip this step and go to [Step 9: Install the left cover on page 454](#).

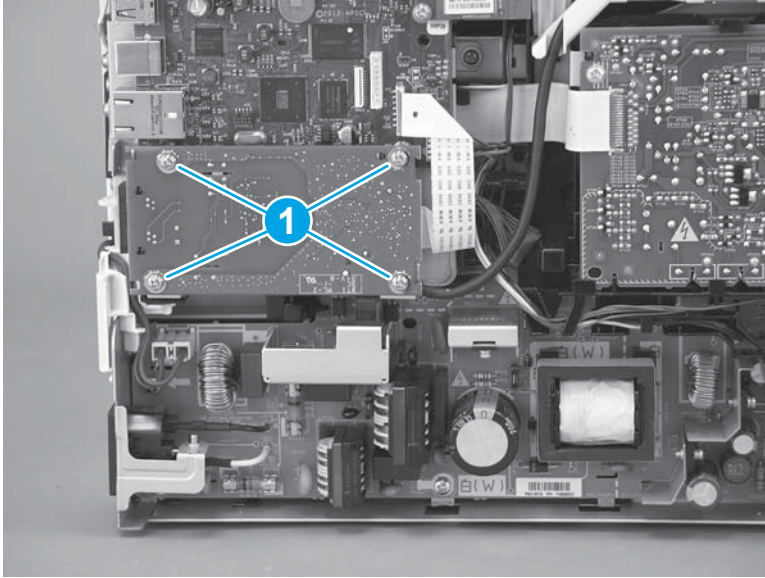
1. Connect one FFC cable (callout 1), and then position the fax PCA on the printer.

**Figure 1-818** Connect one connector and install the PCA



2. Install four screws (callout 1).

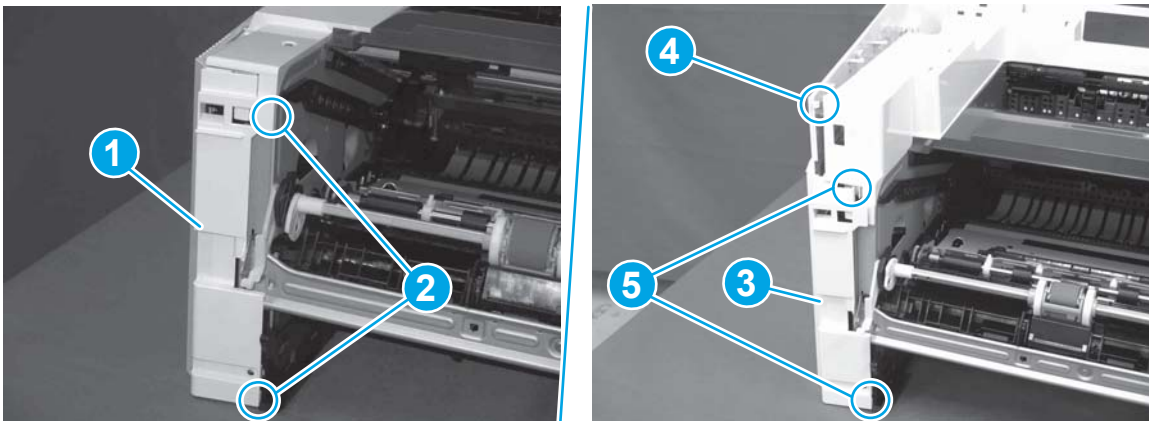
**Figure 1-819** Install four screws



### Step 9: Install the left cover

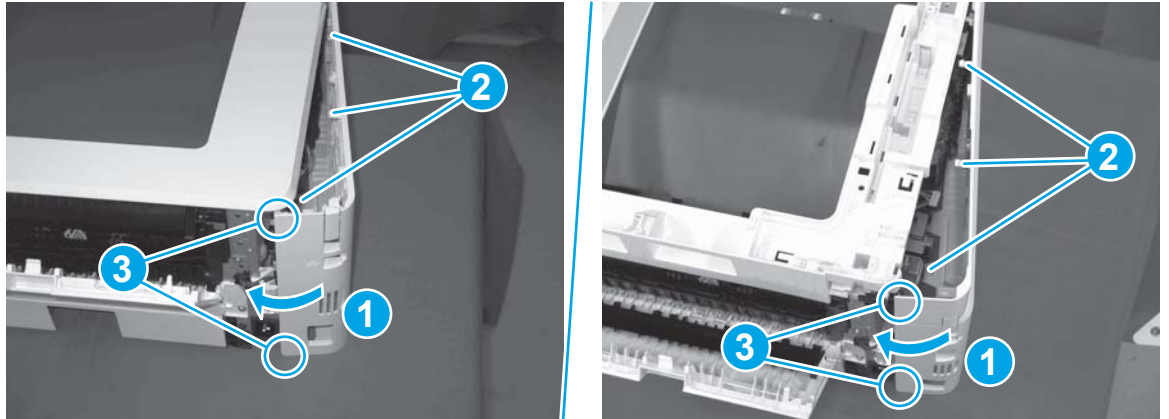
1. At the front of the printer, do one of the following:
  - **M403/M402:** Position the cover on the printer ( callout 1), and then engage two bosses (callout 2).
  - **M427/M426:** Position the cover on the printer (callout 3), engage one tab (callout 4), and then engage two bosses (callout 4).

**Figure 1-820** Install the cover



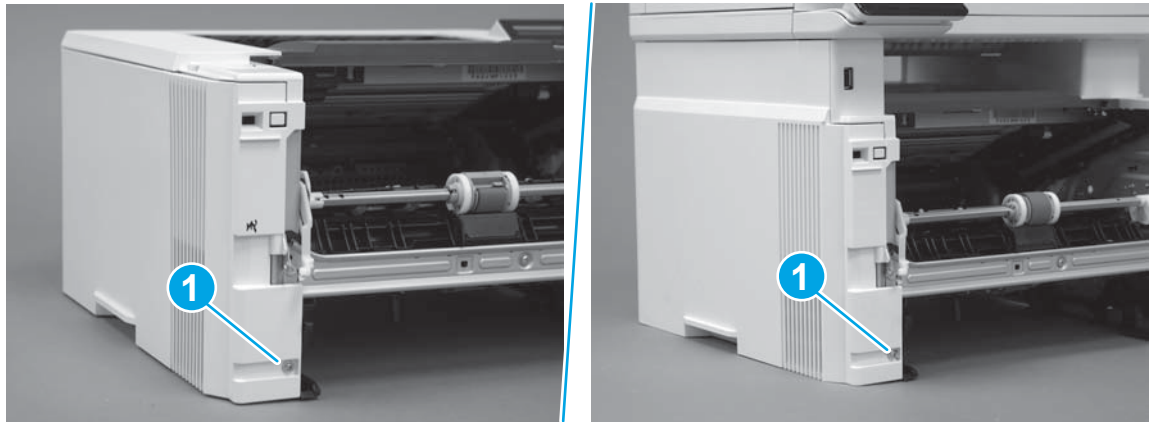
- Carefully rotate the rear of the cover onto the printer (callout 1), engage three tabs (callout 2), and then engage two bosses (callout 3).

**Figure 1-821** Engage three tabs and two bosses




- Install one screw (callout 1).

**Figure 1-822** Install one screw

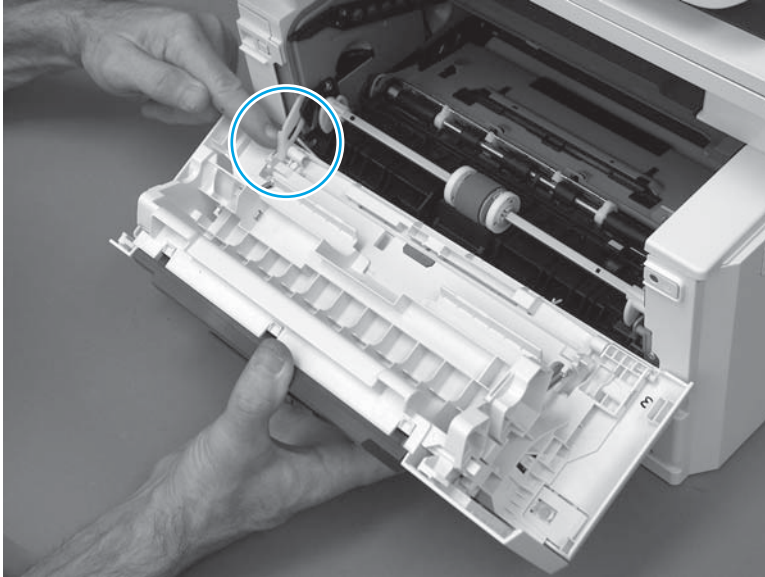


## Step 10: Install the cartridge door assembly

 **Reinstallation tip:** After a replacement door is installed, make sure to install the nameplate (supplied in the kit) corresponding to the printer name on the door.

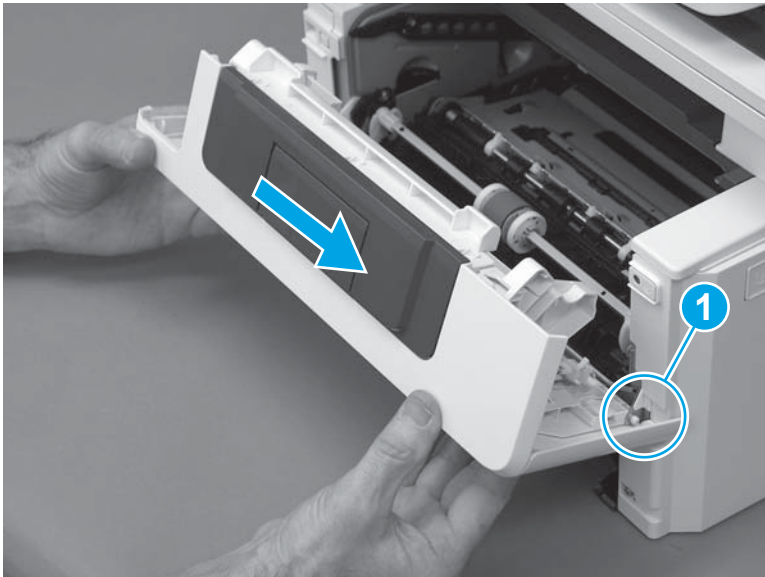
- Position the door close to the printer, and then engage the keyed pin on the left-side retainer arm with the hole in the door.

**Figure 1-823** Engage the left-side retainer arm



2. Engage the right-side door hinge pin with the hole in the chassis (callout 1).

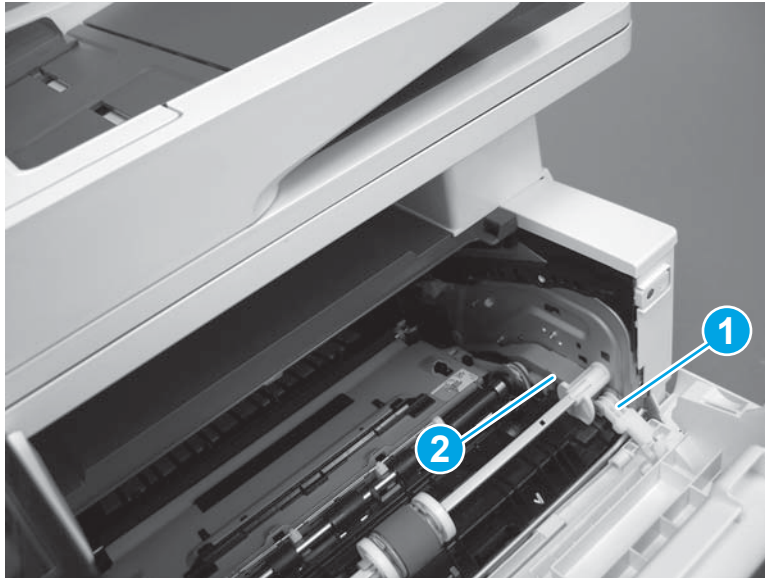
**Figure 1-824** Install the door



3. Install the link (callout 1).

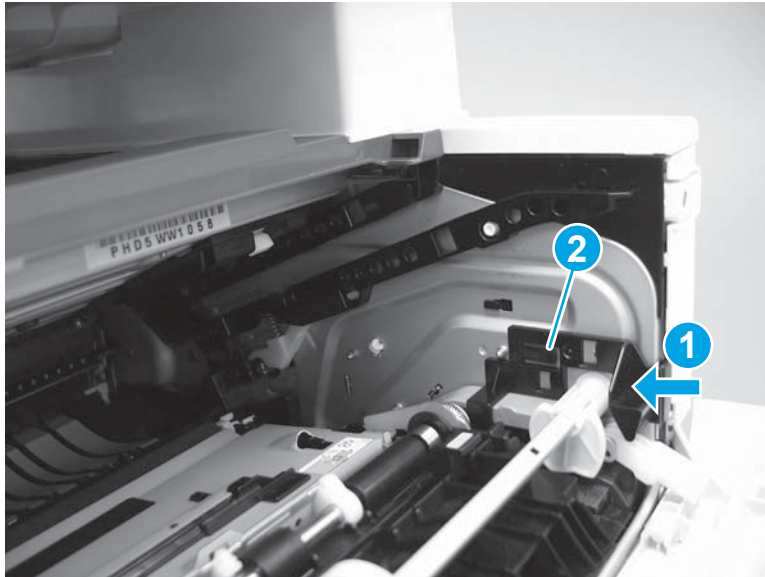
 **IMPORTANT:** Make sure that the link snaps into place on the arm (callout 2). The link actuates the fuser pressure-release mechanism.

**Figure 1-825** Install the pressure-release link



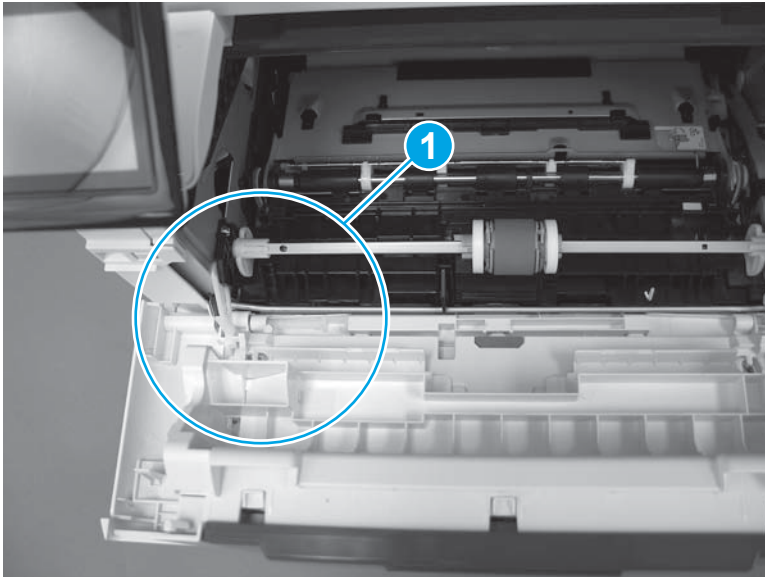
4. Slide the guide into the printer (callout 1), and then make sure that the tab (callout 2) snaps into place to secure the guide to the chassis.

**Figure 1-826** Install the guide




5. Position the shaft on the door, and then align the left-side hinge on the door with the hole in the chassis (callout 1).

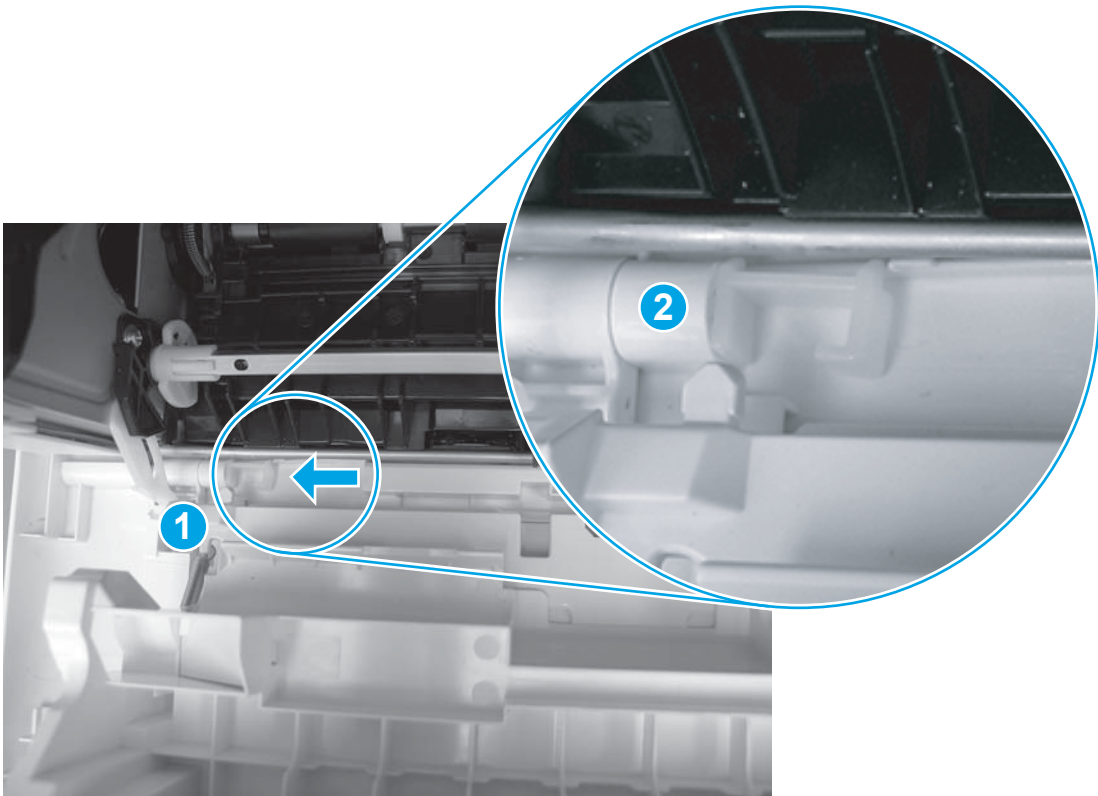
**Figure 1-827** Align the hinge



6. Push the shaft towards the left side of the printer to install it (callout 1).

 **Reinstallation tip:** Make sure that the support shaft is fully installed and correctly orientated (callout 2) so that it will not interfere with the door opening and closing.

**Figure 1-828** Install the support shaft





### Step 9: Install Tray 2

- ▲ Slide the tray straight into the printer to install it.

**Figure 1-829** Install the tray



## Removal and replacement: Wireless PCA



**NOTE:** Wireless models only.

- [Introduction](#)
- [Step 1: Remove Tray 2](#)
- [Step 2: Remove the cartridge door assembly](#)
- [Step 3: Remove the left cover](#)
- [Step 4: Remove the wireless PCA](#)
- [Step 5: Unpack the replacement assembly](#)
- [Step 6: Install the wireless PCA](#)
- [Step 7: Install the left cover](#)
- [Step 8: Install the cartridge door assembly](#)
- [Step 9: Install Tray 2](#)

### Introduction

This document provides the procedures to remove and replace the wireless printed circuit assembly (PCA).

### Before performing service

#### Turn the printer power off

- Disconnect the power cable.



**WARNING!** To avoid damage to the printer, turn the printer off, wait 30 seconds, and then remove the power cable before attempting to service the printer.

Use the table below to identify the correct part number for your printer. To order the part, go to [www.hp.com/buy/parts](http://www.hp.com/buy/parts).

Wireless PCA part number	
0960-3293	Wireless module <sup>1</sup>

<sup>1</sup> M427/M426 and M403/M402 wireless models only.

### Required tools

- #2 Phillips screwdriver with a magnetic tip.

### After performing service

#### Turn the printer power on

- Connect the power cable.
- Use the power switch to turn the power on.

## Post service test

Make sure that the printer initializes to a **Ready** state.

If possible, send a wireless print job to the printer.

## Step 1: Remove Tray 2

- ▲ Pull the tray straight out of the printer to remove it.

**Figure 1-830** Remove the tray



## Step 2: Remove the cartridge door assembly

---

 **NOTE:** If the toner cartridge was not removed prior to servicing the printer, remove it now.

---

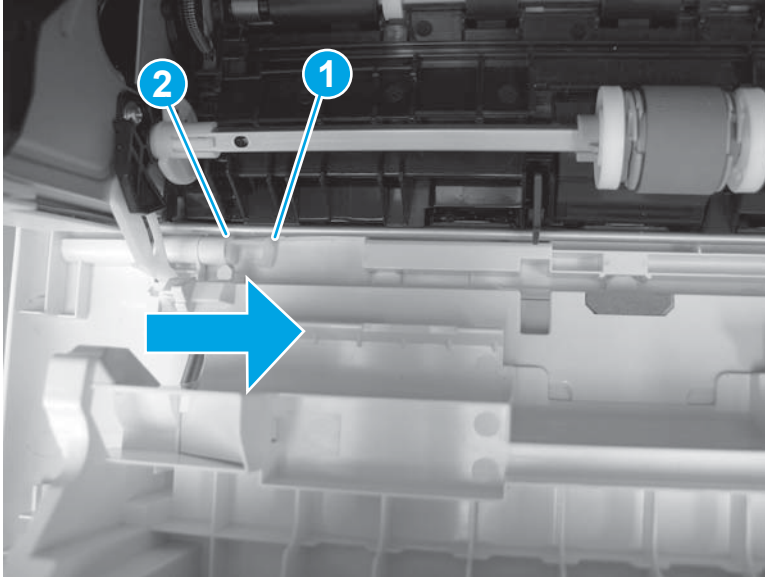
1. Release one tab (callout 1), and then slide shaft (callout 2) in the direction the arrow indicates and remove it.

---

 **TIP:** It might be easier to release the support shaft by using a small flat-blade screwdriver.

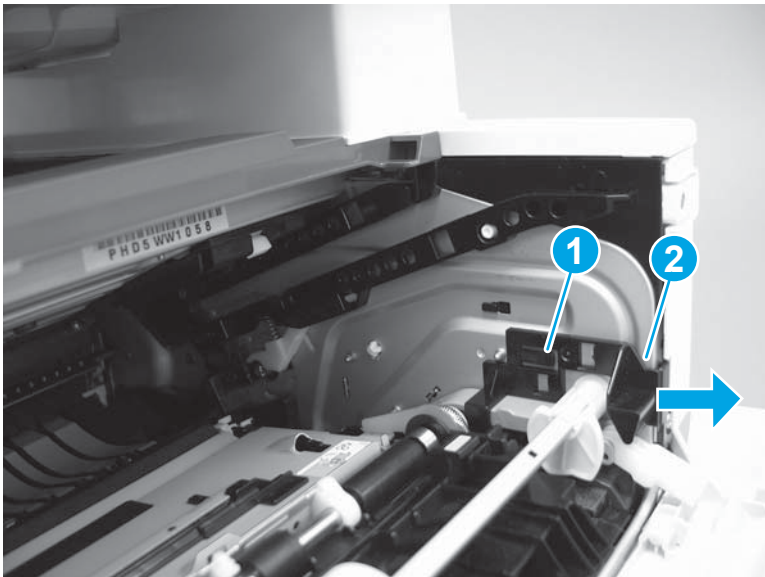
---

**Figure 1-831** Release the support shaft



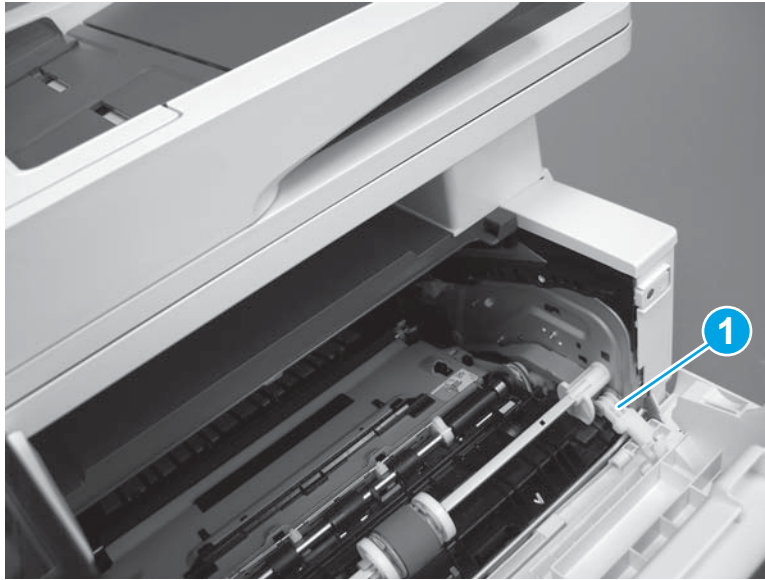
2. Release one tab (callout 1), and then slide the guide (callout 2) in the direction the arrow indicates and remove it.

**Figure 1-832** Remove the guide



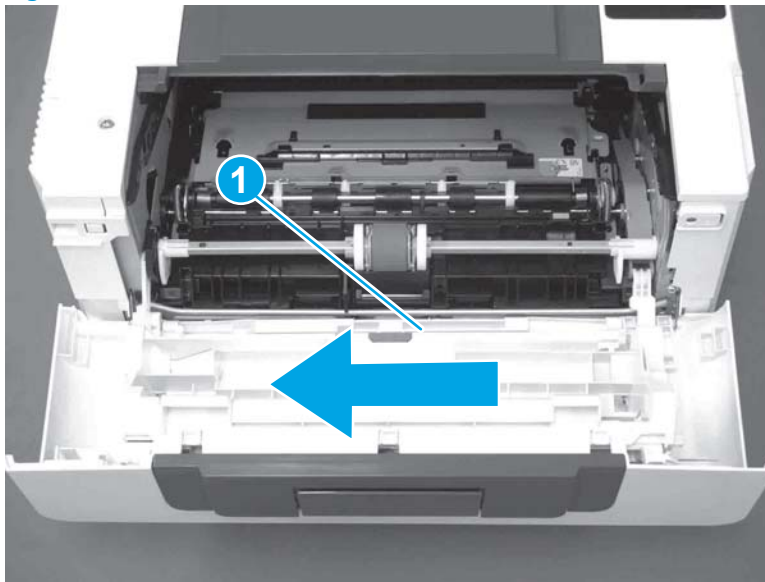
3. Remove the link arm (callout 1).

**Figure 1-833** Remove the link arm



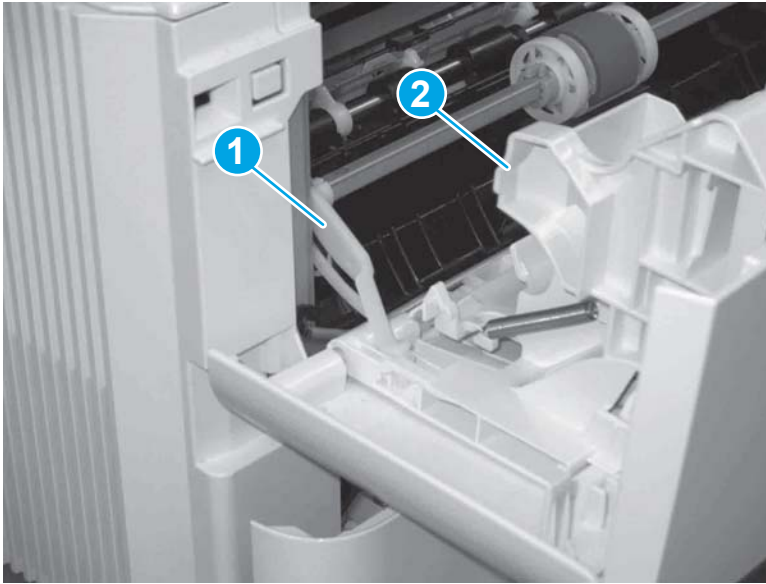
4. Slide the cartridge door assembly (callout 1) in the direction the arrow indicates and remove it.

**Figure 1-834** Remove the door



5. Remove the link (callout 1) from the cartridge door assembly (callout 2).

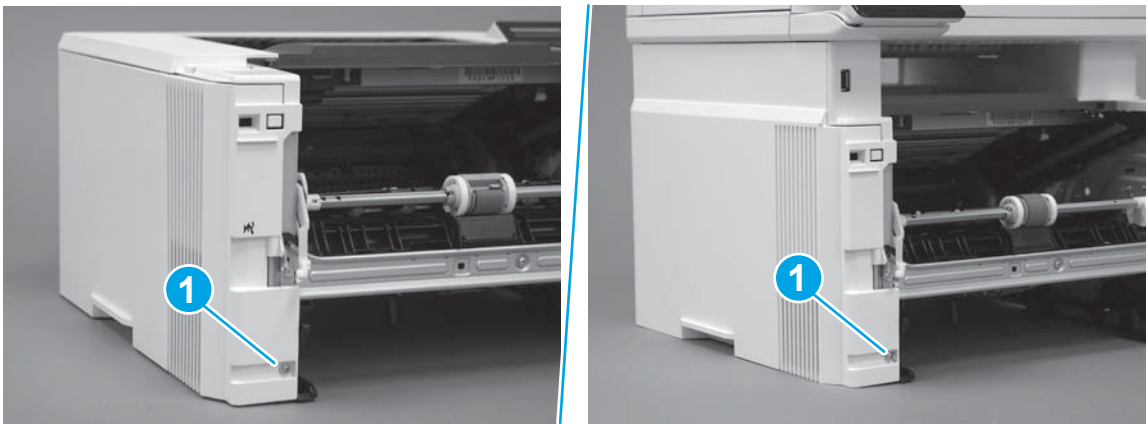
**Figure 1-835** Release the left-side retainer arm



### Step 3: Remove the left cover

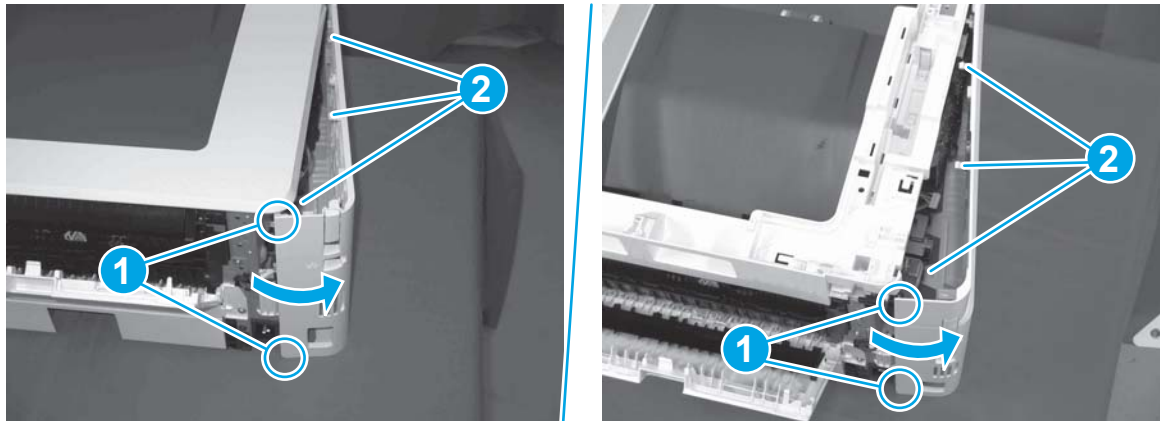
1. Remove one screw (callout 1).

**Figure 1-836** Remove one screw



2. Open the rear door, release two bosses (callout 1), and then release three tabs (callout 2).

**Figure 1-837** Release two bosses and three tabs

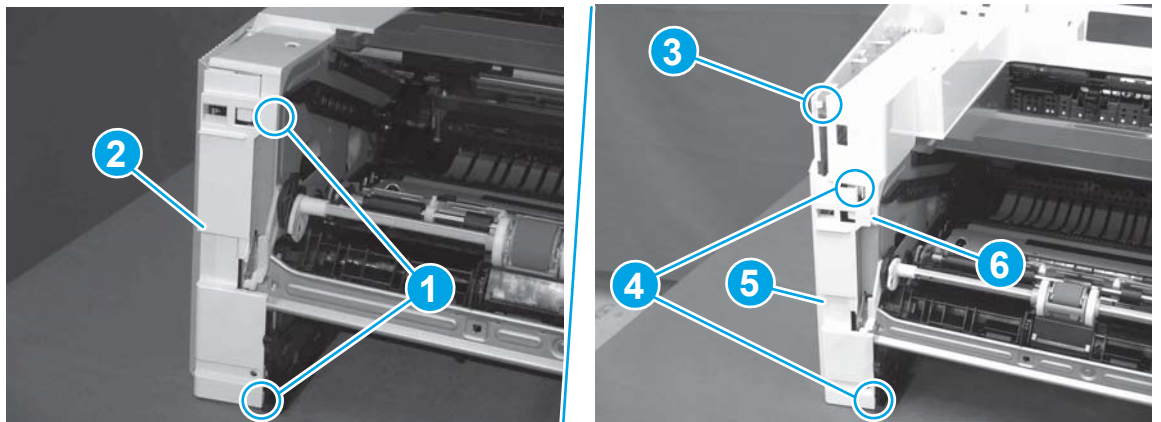


3. At the front of the printer, do one of the following:

- **M403/M402:** Release two bosses (callout 1), and then remove the cover (callout 2).
- **M427/M426:** Release one tab (callout 3), two bosses (callout 4), and then remove the cover (callout 5).

**CAUTION:** Be careful when releasing the upper bosses on the M427/M426 cover. One portion of the cover (callout 6) is fragile and is easily broken.

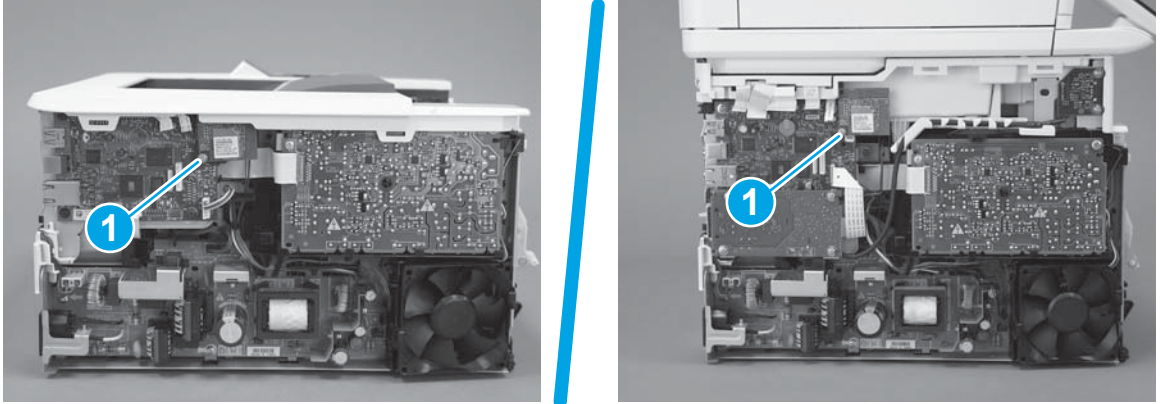
**Figure 1-838** Remove the cover



#### Step 4: Remove the wireless PCA

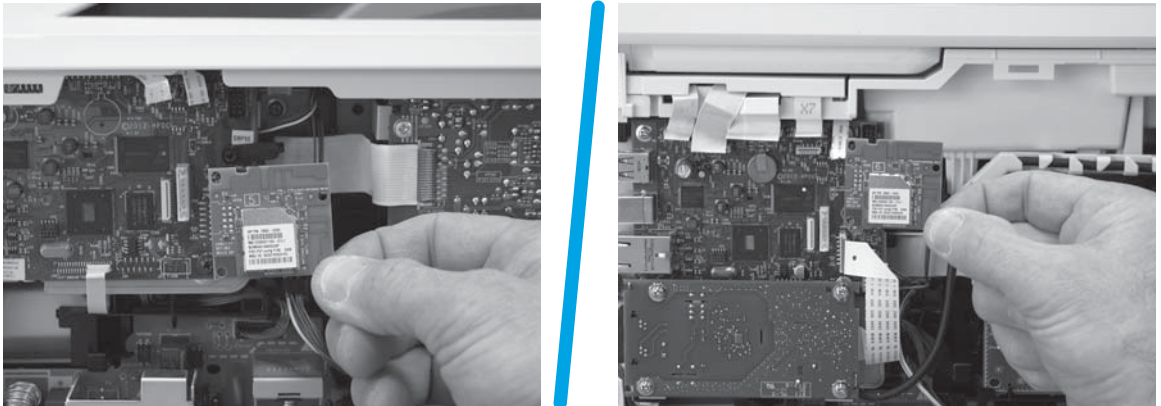
1. Remove one screw (callout 1).

**Figure 1-839** Remove one screw



2. Carefully pull the wireless PCA straight off of the formatter PCA to remove it.

**Figure 1-840** Remove the wireless PCA



### Step 5: Unpack the replacement assembly

Unpack the replacement part from the packaging.

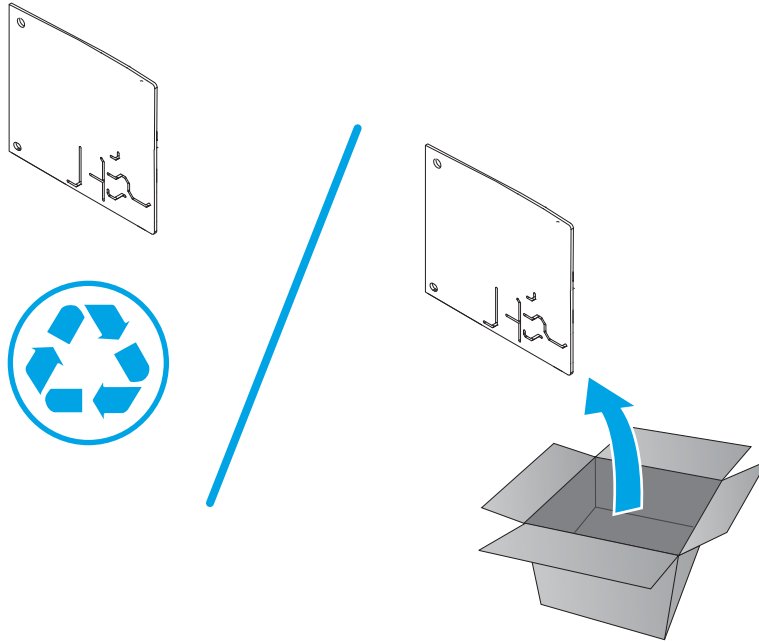
<http://www8.hp.com/us/en/hp-information/environment/product-recycling.html>



**NOTE:** HP recommends responsible disposal of the defective part.



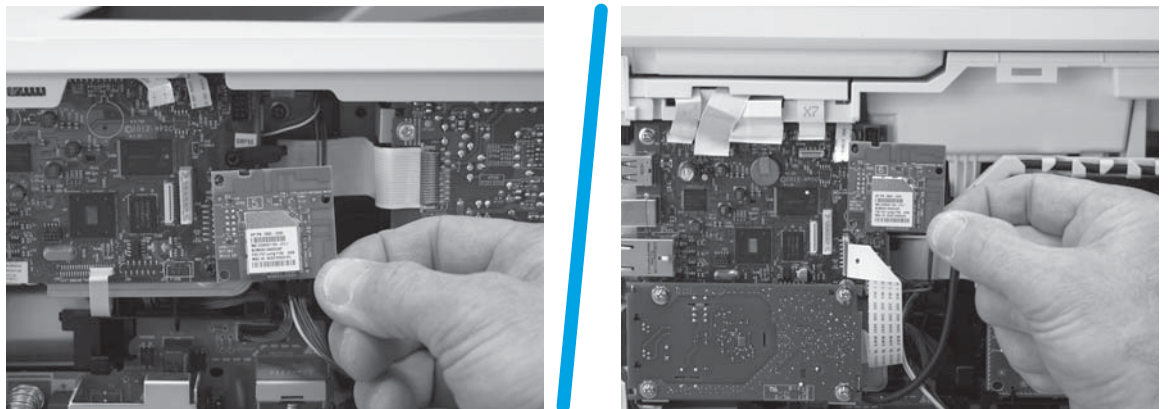
**Figure 1-841** Recycle and unpack



### Step 6: Install the wireless PCA

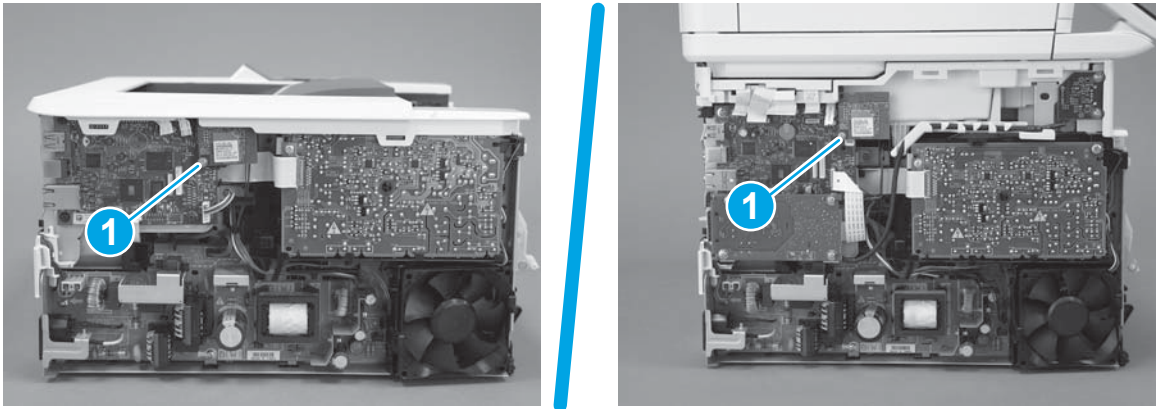
1. Carefully push the wireless PCA straight onto the formatter PCA to install it.

**Figure 1-842** Install the PCA



2. Install one screw (callout 1).

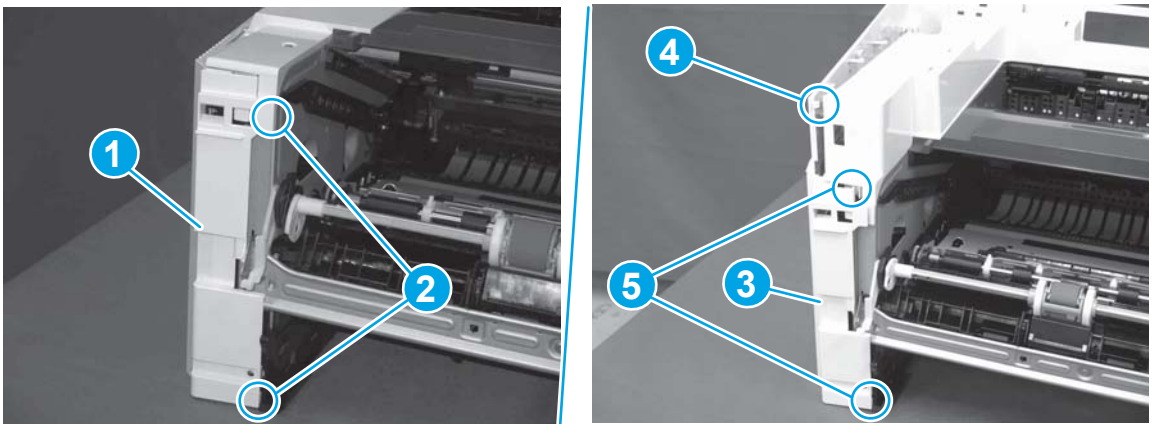
**Figure 1-843** Install one screw



### Step 7: Install the left cover

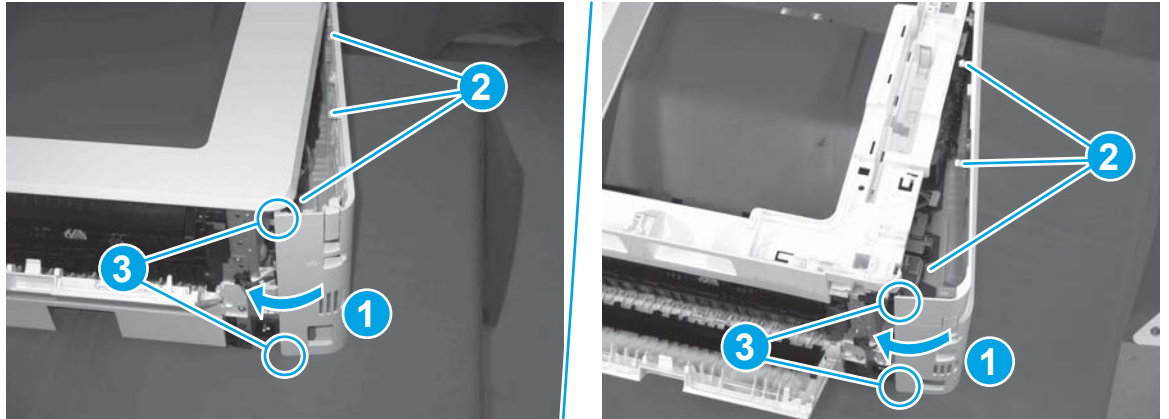
1. At the front of the printer, do one of the following:
  - **M403/M402:** Position the cover on the printer ( callout 1), and then engage two bosses (callout 2).
  - **M427/M426:** Position the cover on the printer (callout 3), engage one tab (callout 4), and then engage two bosses (callout 4).

**Figure 1-844** Install the cover



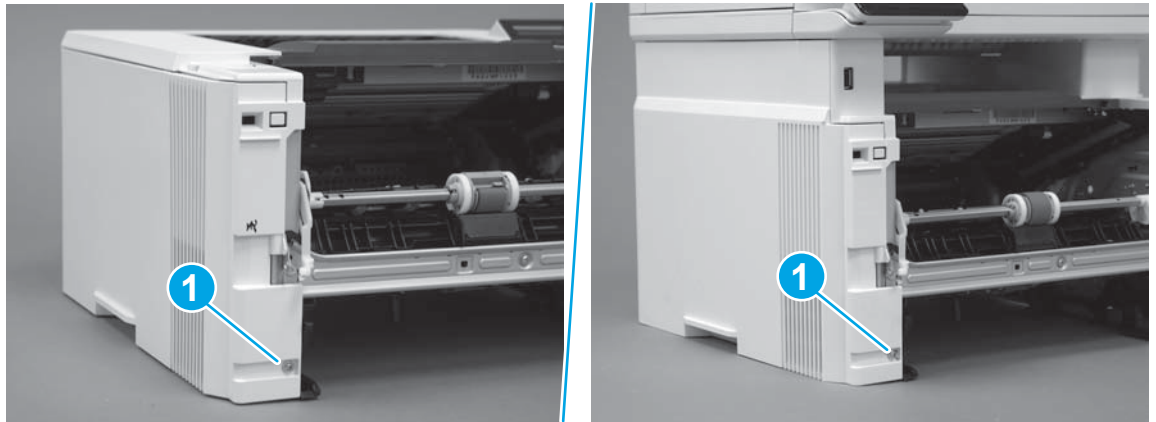
- Carefully rotate the rear of the cover onto the printer (callout 1), engage three tabs (callout 2), and then engage two bosses (callout 3).

**Figure 1-845** Engage three tabs and two bosses




- Install one screw (callout 1).

**Figure 1-846** Install one screw

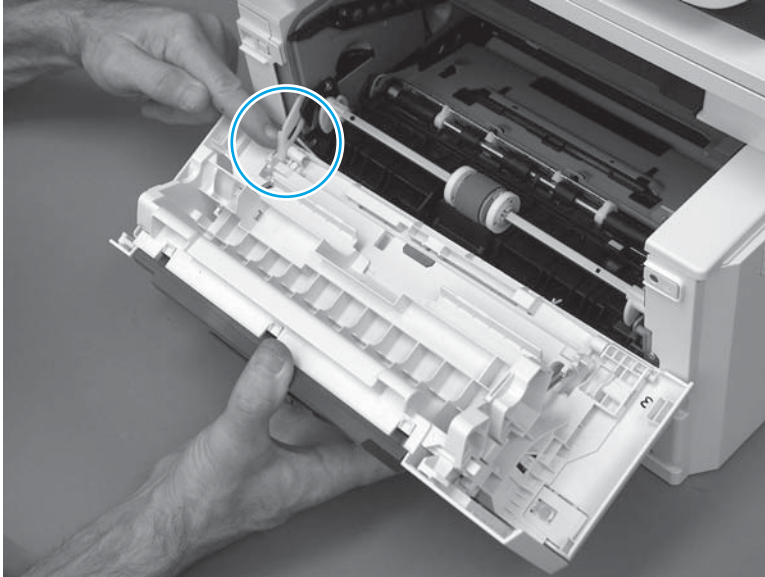


### Step 8: Install the cartridge door assembly

 **Reinstallation tip:** After a replacement door is installed, make sure to install the nameplate (supplied in the kit) corresponding to the printer name on the door.

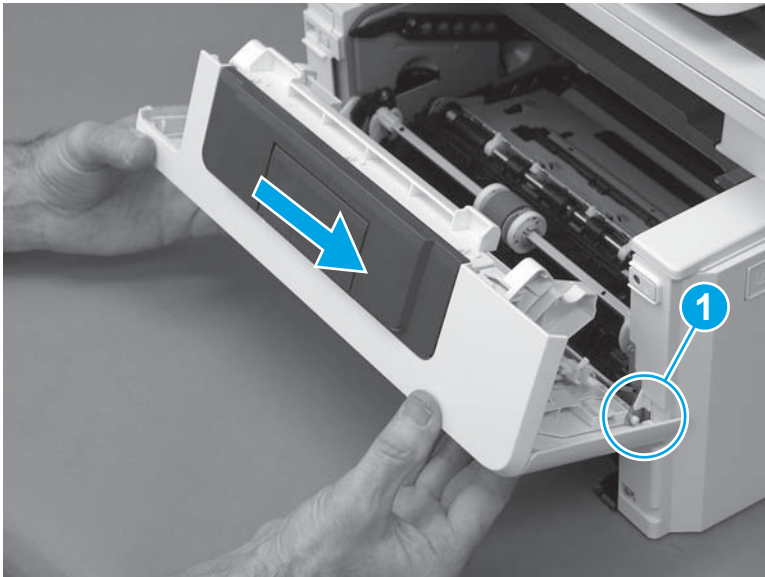
- Position the door close to the printer, and then engage the keyed pin on the left-side retainer arm with the hole in the door.

**Figure 1-847** Engage the left-side retainer arm



2. Engage the right-side door hinge pin with the hole in the chassis (callout 1).

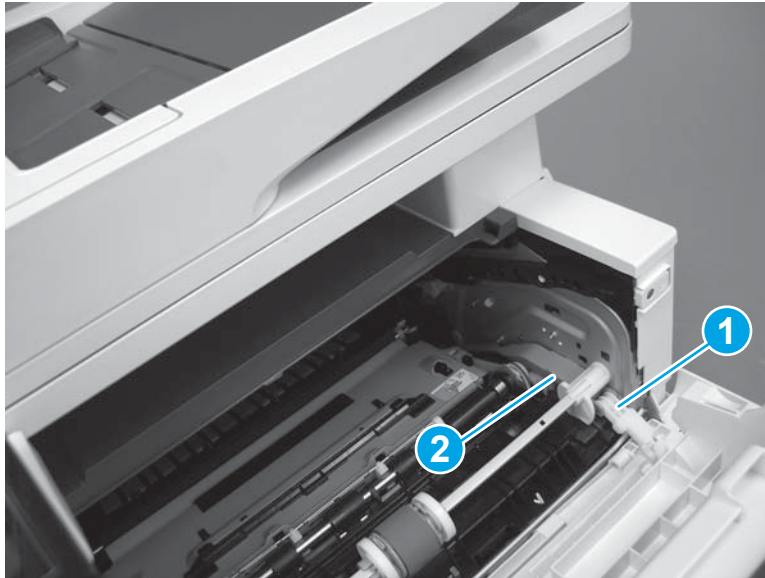
**Figure 1-848** Install the door



3. Install the link (callout 1).

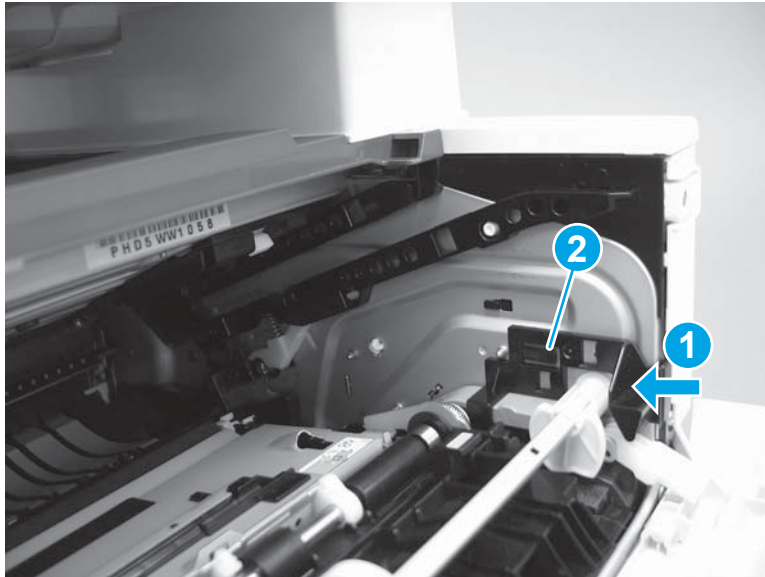
 **IMPORTANT:** Make sure that the link snaps into place on the arm (callout 2). The link actuates the fuser pressure-release mechanism.

**Figure 1-849** Install the pressure-release link



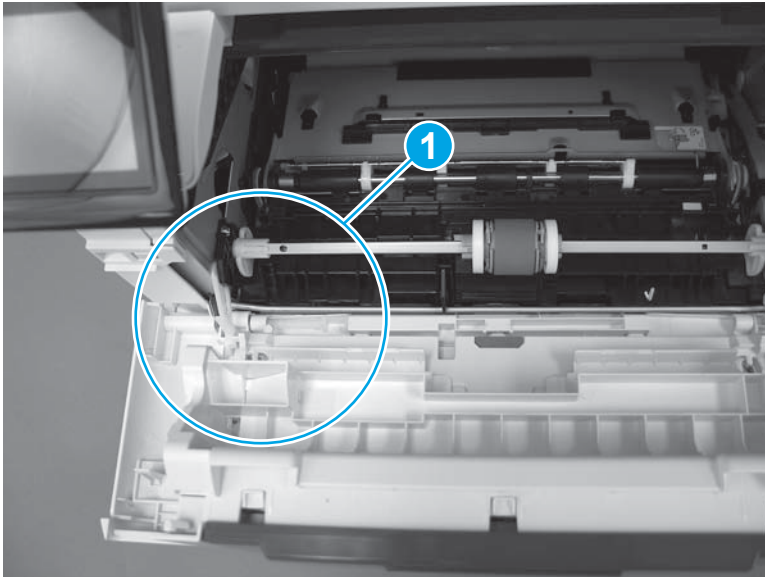
4. Slide the guide into the printer (callout 1), and then make sure that the tab (callout 2) snaps into place to secure the guide to the chassis.

**Figure 1-850** Install the guide




5. Position the shaft on the door, and then align the left-side hinge on the door with the hole in the chassis (callout 1).

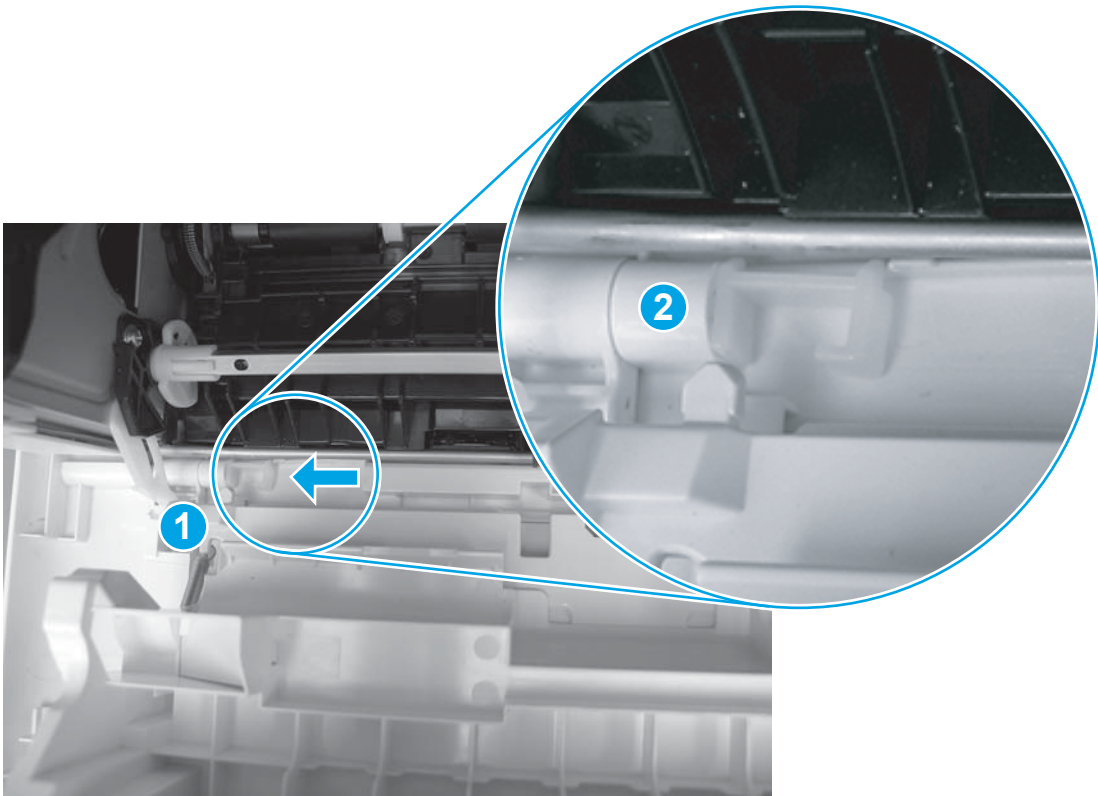
**Figure 1-851** Align the hinge



6. Push the shaft towards the left side of the printer to install it (callout 1).

 **Reinstallation tip:** Make sure that the support shaft is fully installed and correctly orientated (callout 2) so that it will not interfere with the door opening and closing.

**Figure 1-852** Install the support shaft



### Step 9: Install Tray 2

- ▲ Slide the tray straight into the printer to install it.

**Figure 1-853** Install the tray



## Removal and replacement: Formatter PCA

- [Introduction](#)
- [Step 1: Remove Tray 2](#)
- [Step 2: Remove the cartridge door assembly](#)
- [Step 3: Remove the left cover](#)
- [Step 4: Remove the fax PCA](#)
- [Step 5: Remove the wireless PCA](#)
- [Step 6: Remove the formatter PCA](#)
- [Step 7: Unpack the replacement assembly](#)
- [Step 8: Install the formatter PCA](#)
- [Step 9: Install the wireless PCA](#)
- [Step 10: Install the fax PCA](#)
- [Step 11: Install the left cover](#)
- [Step 12: Install the cartridge door assembly](#)
- [Step 13: Install Tray 2](#)


### Introduction

This document provides the procedures to remove and replace the formatter PCA.

### Before performing service

#### Turn the printer power off

- Disconnect the power cable.

 **WARNING!** To avoid damage to the printer, turn the printer off, wait 30 seconds, and then remove the power cable before attempting to service the printer.



**IMPORTANT:** Always replace the thermal transfer pad (5851-6550) when the formatter is replaced.

---

#### Formatter PCA part numbers

---

<b>C5F99-60001</b>	Formatter PCA (M426dw; M427dw)
<b>C5F98-60001</b>	Formatter PCA (M426fdn; M426fdw; M427fdn; M427fdw)
<b>C5F92-60001</b>	Formatter PCA (M402d; M403d)
<b>C5F93-60001</b>	Formatter PCA (M402n; M402dn; M403n; M403dn)
<b>C5F94-60001</b>	Formatter PCA (M402dw; M403dw)

---



## Required tools

- #2 Phillips screwdriver with a magnetic tip.
- 5.5 mm (0.22 inch) socket screwdriver.

## After performing service

### Turn the printer power on

- Connect the power cable.
- Use the power switch to turn the power on.

### Post service test

Make sure that the printer initializes to a **Ready** state.

Print a configuration page to make sure that the printer is functioning correctly.

### Step 1: Remove Tray 2

- ▲ Pull the tray straight out of the printer to remove it.

**Figure 1-854** Remove the tray



### Step 2: Remove the cartridge door assembly



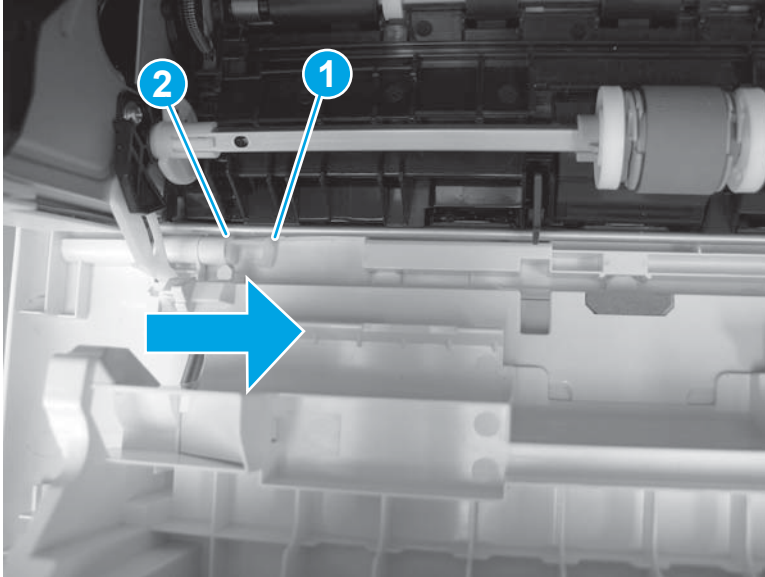
**NOTE:** If the toner cartridge was not removed prior to servicing the printer, remove it now.

1. Release one tab (callout 1), and then slide shaft (callout 2) in the direction the arrow indicates and remove it.



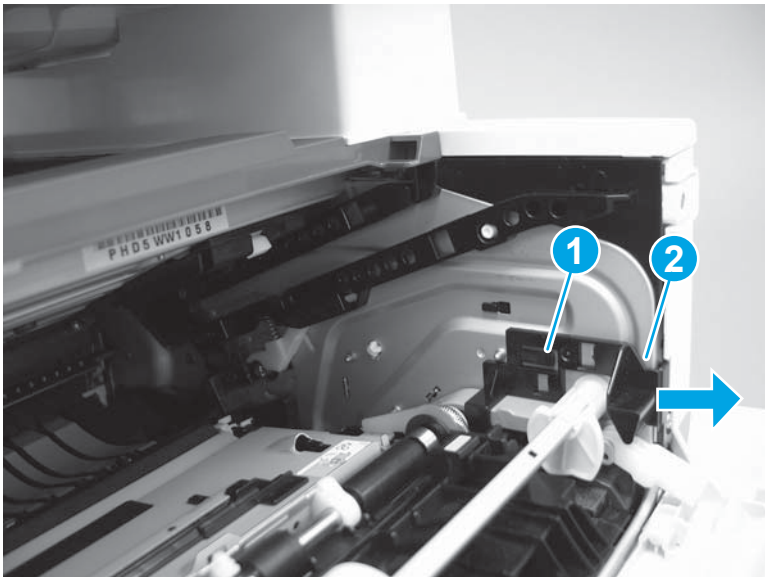
**TIP:** It might be easier to release the support shaft by using a small flat-blade screwdriver.

**Figure 1-855** Release the support shaft



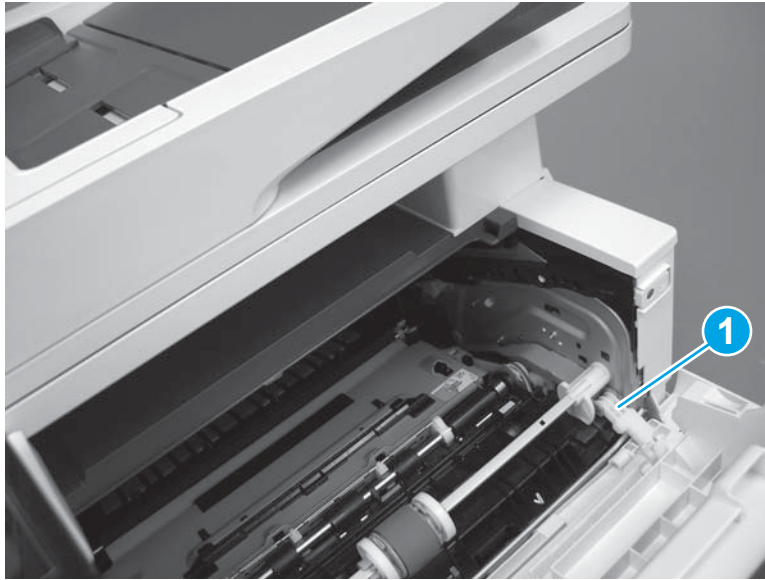
2. Release one tab (callout 1), and then slide the guide (callout 2) in the direction the arrow indicates and remove it.

**Figure 1-856** Remove the guide



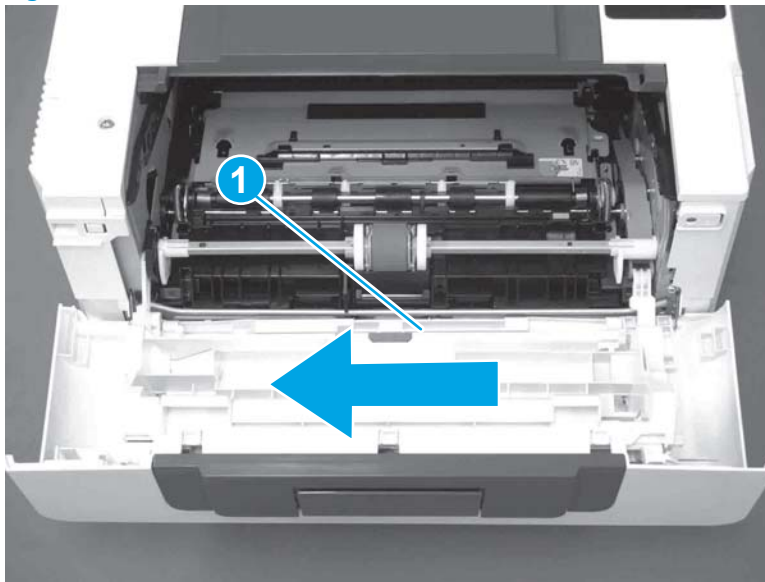
3. Remove the link arm (callout 1).

**Figure 1-857** Remove the link arm



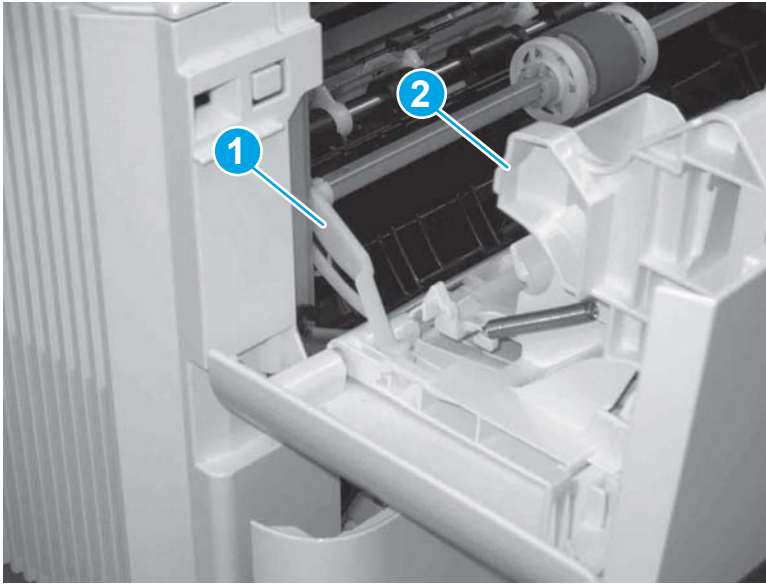
4. Slide the cartridge door assembly (callout 1) in the direction the arrow indicates and remove it.

**Figure 1-858** Remove the door



5. Remove the link (callout 1) from the cartridge door assembly (callout 2).

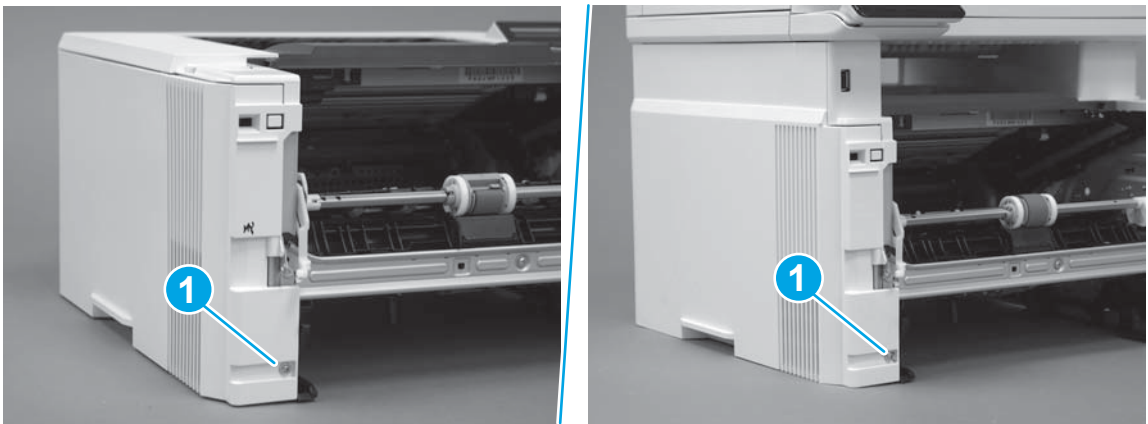
**Figure 1-859** Release the left-side retainer arm



### Step 3: Remove the left cover

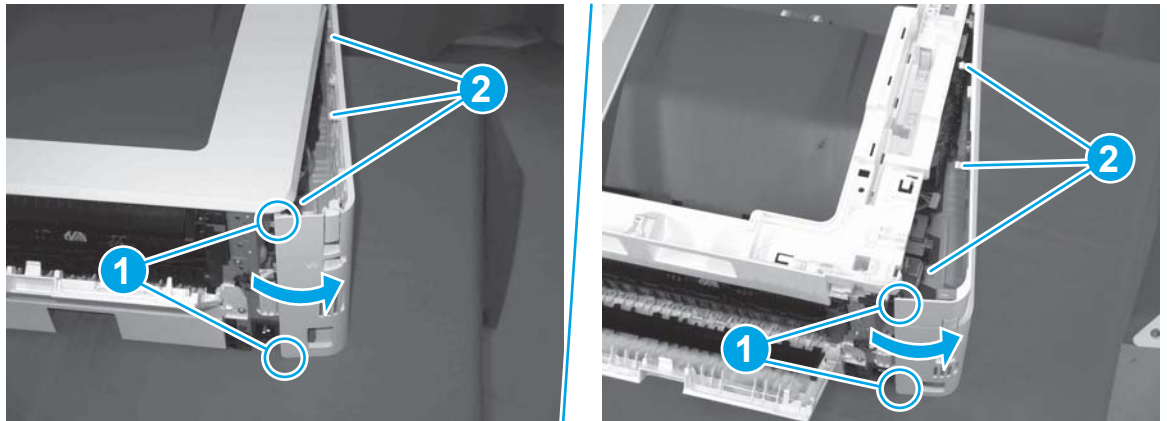
1. Remove one screw (callout 1).

**Figure 1-860** Remove one screw



2. Open the rear door, release two bosses (callout 1), and then release three tabs (callout 2).

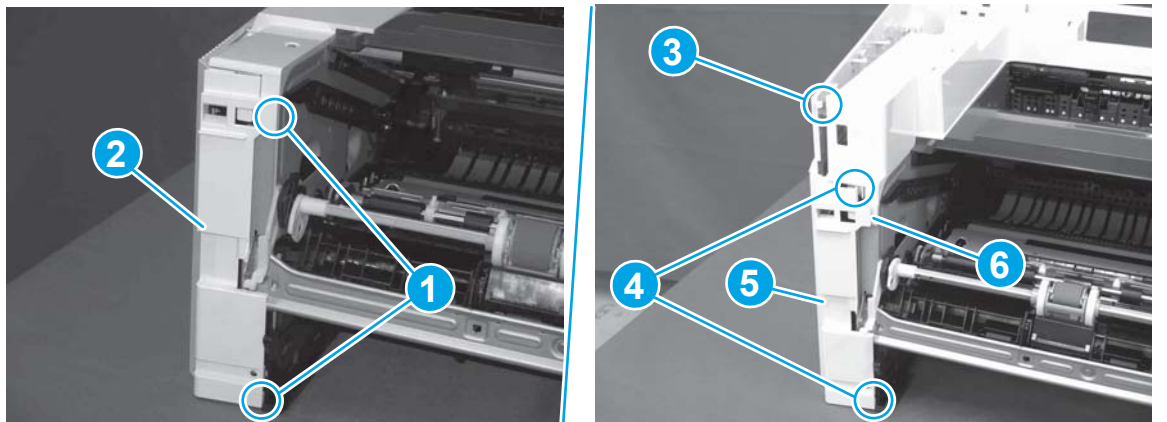
**Figure 1-861** Release two bosses and three tabs



3. At the front of the printer, do one of the following:
  - **M403/M402:** Release two bosses (callout 1), and then remove the cover (callout 2).
  - **M427/M426:** Release one tab (callout 3), two bosses (callout 4), and then remove the cover (callout 5).

**CAUTION:** Be careful when releasing the upper bosses on the M427/M426 cover. One portion of the cover (callout 6) is fragile and is easily broken.

**Figure 1-862** Remove the cover

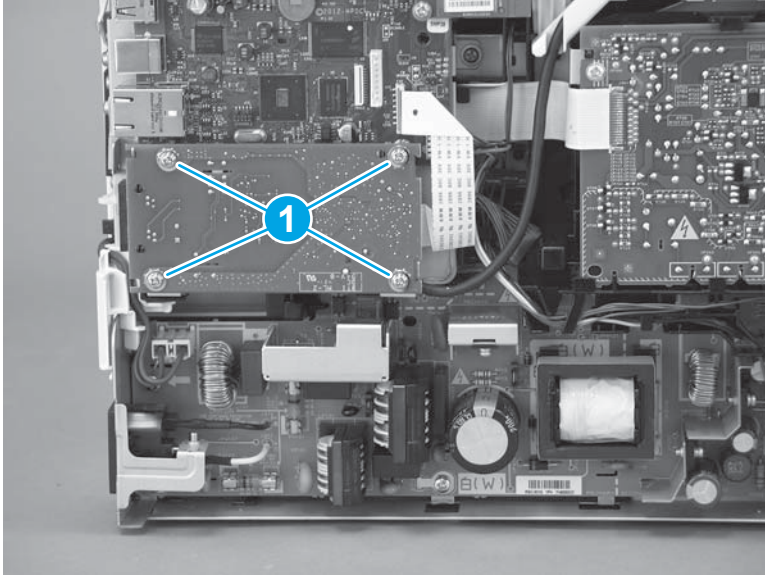


#### Step 4: Remove the fax PCA

**NOTE:** Fax models only. For all other models, skip this step and go to [Step 5: Remove the wireless PCA on page 480](#).

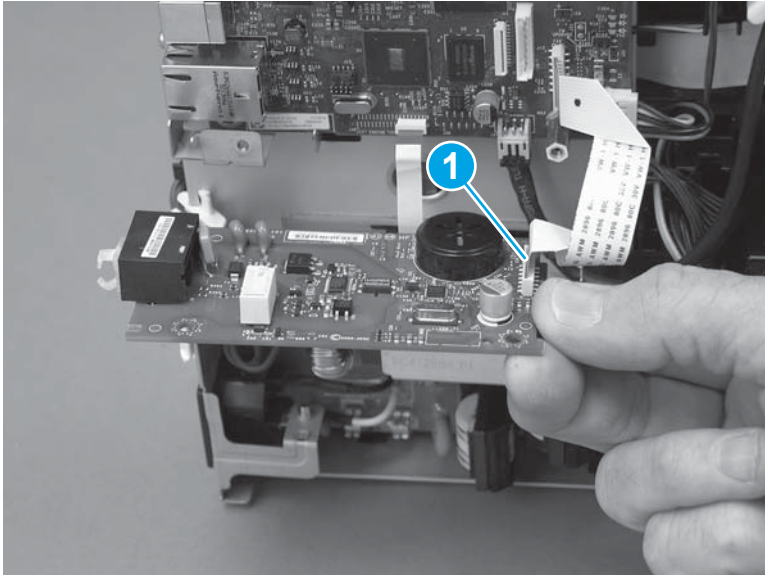
1. Remove four screws (callout 1).

**Figure 1-863** Remove four screws




2. Disconnect one FFC (callout 1), and then remove the fax PCA.

**Figure 1-864** Disconnect one connector and remove the PCA

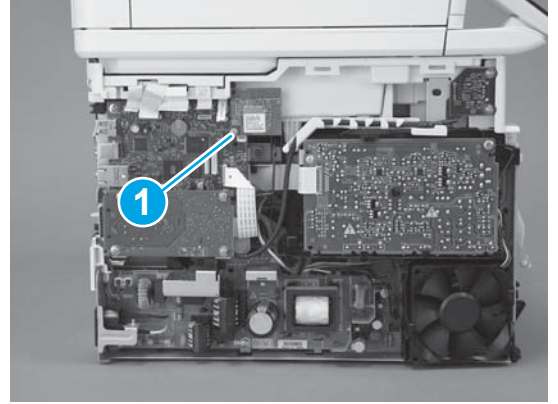
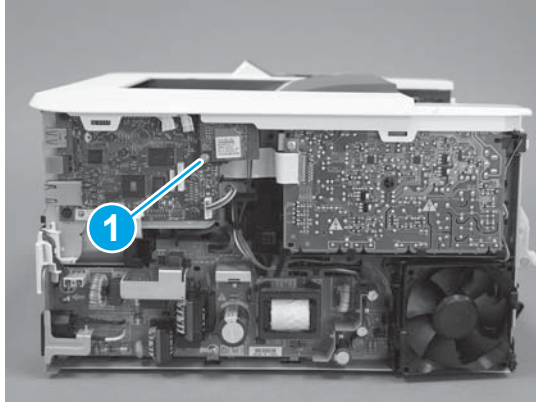


### Step 5: Remove the wireless PCA

 **NOTE:** Wireless models only. For all other models, skip this step and go to [Step 6: Remove the formatter PCA on page 481](#).

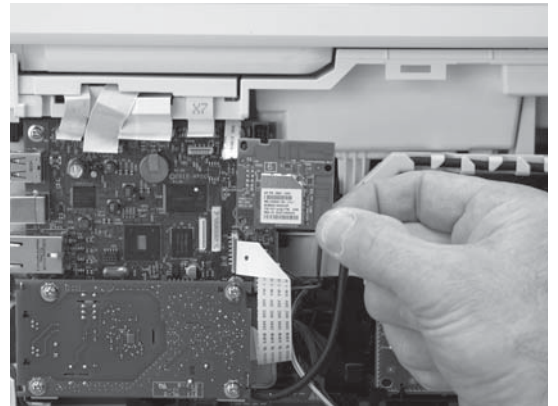
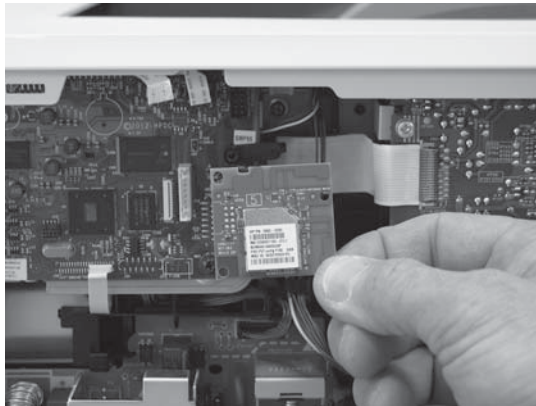
1. Remove one screw (callout 1).

**Figure 1-865** Remove one screw



2. Carefully pull the wireless PCA straight off of the formatter PCA to remove it.

**Figure 1-866** Remove the wireless PCA



## Step 6: Remove the formatter PCA

1. Disconnect all of the connectors and FFCs.

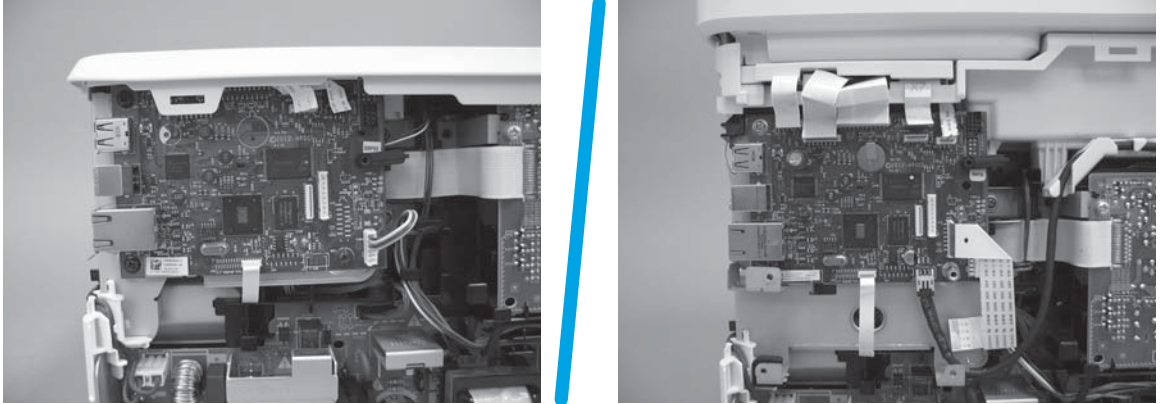
Depending on the M427/M426 model, the following connector locations are empty.

- J6; all models
- J7; all models
- J30; non-wireless models
- J12; non-fax models
- J15; all models
- J17; non-NFC models
- J28; all models

Depending on the M403/M402 model, the following connector locations are empty.

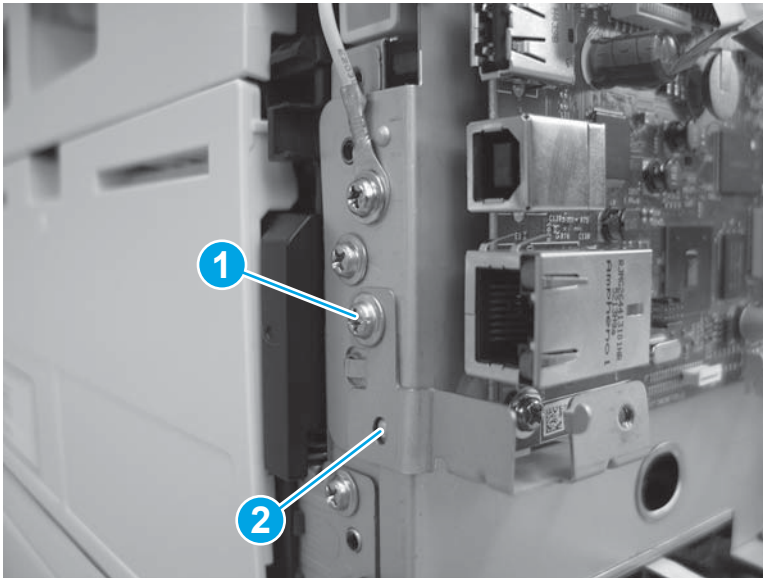
- J6; all models
- J7; all models
- J8; non-wireless models
- J15; all models
- J17; non-NFC models

**Figure 1-867** Disconnect all of the connectors and FFCs



- 2. M427/M426 fax models only:** Remove one screw (callout 1), and then remove the fax PCA support bracket (callout 2).


**Figure 1-868** Remove the fax PCA support bracket



- 3. Do one of the following:**

- **M426/M427:** Remove three screws (callout 1), remove one standoff (callout 2), and then remove the formatter PCA.


---

 **NOTE:** Use a 5.5 mm (0.22 inch) socket screwdriver to remove the standoff (callout 2).

---

- **M403/M402:** Remove four screws (callout 1), and then remove the formatter PCA.

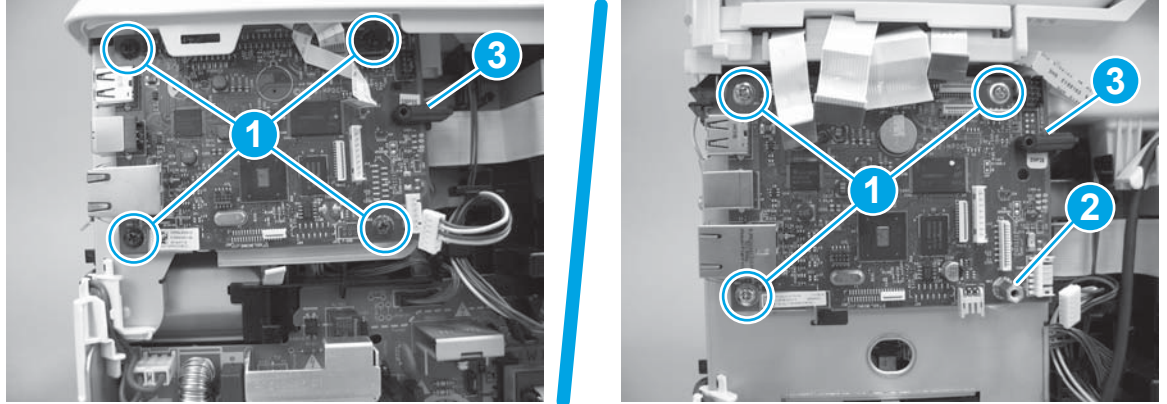
---

 **Reinstallation tip:** If a replacement formatter will be installed and the printer is a wireless model, make sure that the wireless PCA mounting holder (B3Q10-40054; callout 3) is transferred to the replacement formatter.

---



**Figure 1-869** Remove the formatter PCA



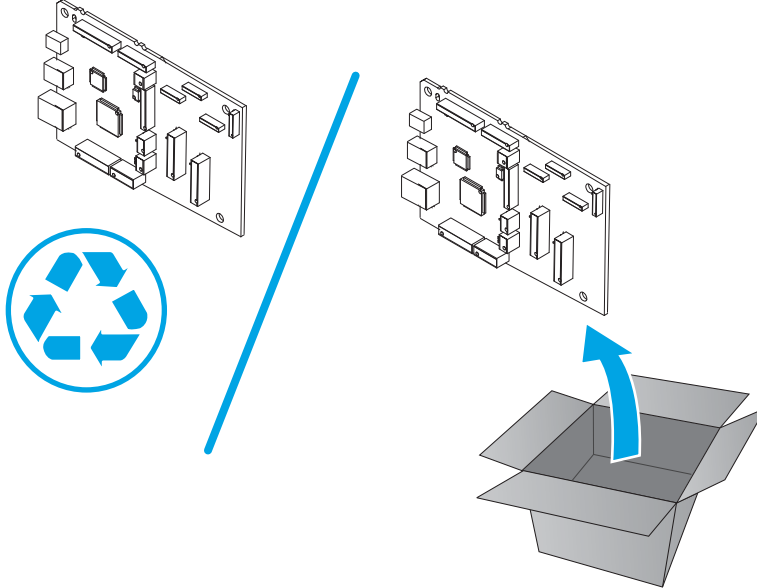
### Step 7: Unpack the replacement assembly

Unpack the replacement part from the packaging.


<http://www8.hp.com/us/en/hp-information/environment/product-recycling.html>

 **NOTE:** HP recommends responsible disposal of the defective part.

### Figure 1-870 Recycle and unpack




### Step 8: Install the formatter PCA

 **NOTE:** If the formatter PCA thermal pad on the back side of the PCA is broken or damaged, replace the pad (5851-6550).

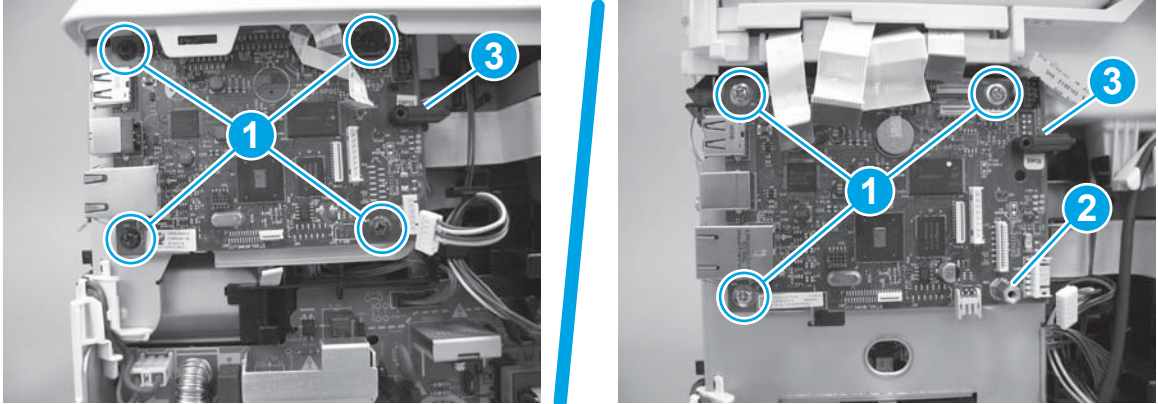
1. Adhere the pad to the sheet-metal bracket (a positioning line is embossed in the bracket).

Do one of the following:

- **M426/M427:** Position the formatter PCA on the printer, install three screws (callout 1), and then install one standoff (callout 2).
- **M403/M402:** Position the formatter PCA on the printer, and then install four screws (callout 1).

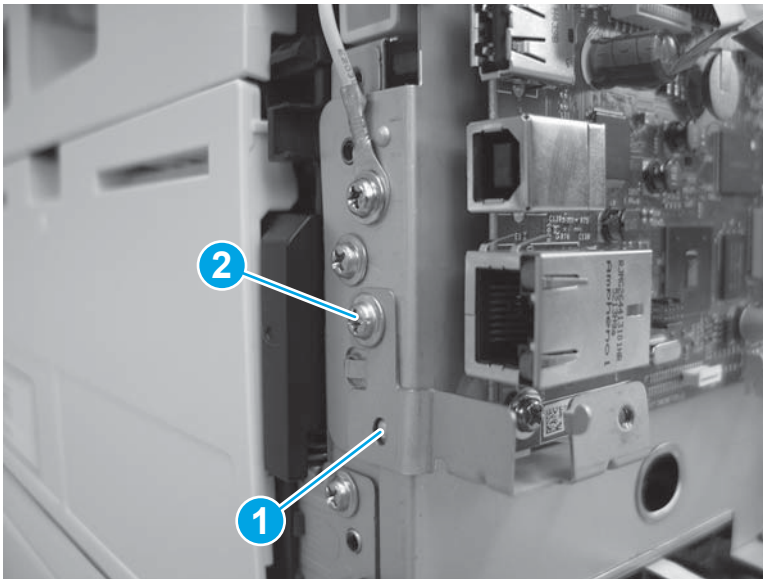
 **Reinstallation tip:** If a replacement formatter PCA will be installed and the printer is a wireless model, make sure that the wireless PCA mounting holder (callout 3) is transferred to the replacement formatter PCA.

**Figure 1-871** Install the formatter PCA



2. **M427/M426 fax models only:** Position the fax PCA support bracket (callout 1) on the printer, and then install one screw (callout 2).

**Figure 1-872** Remove the fax PCA support bracket



3. Connect all of the connectors and FFCs.

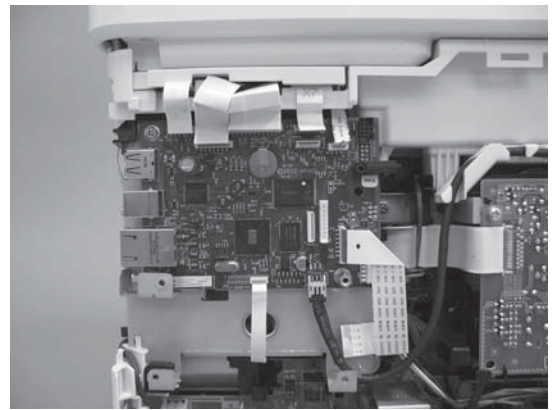
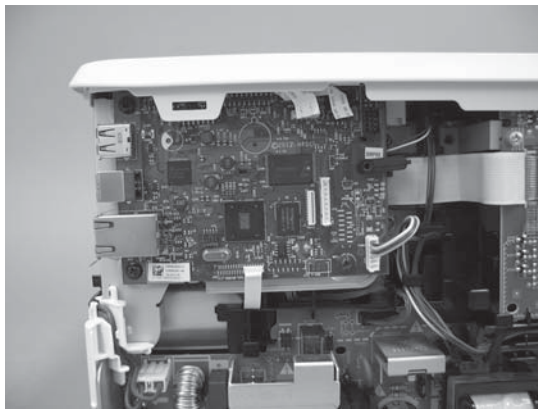
Depending on the M427/M426 model, the following connector locations are empty.

- J6; all models
- J7; all models
- J30; non-wireless models
- J12; non-fax models
- J15; all models
- J17; non-NFC models
- J28; all models


Depending on the M403/M402 model, the following connector locations are empty.

- J6; all models
- J7; all models
- J8; non-wireless models
- J15; all models
- J17; non-NFC models

**Figure 1-873** Connect all of the connectors and FFCs

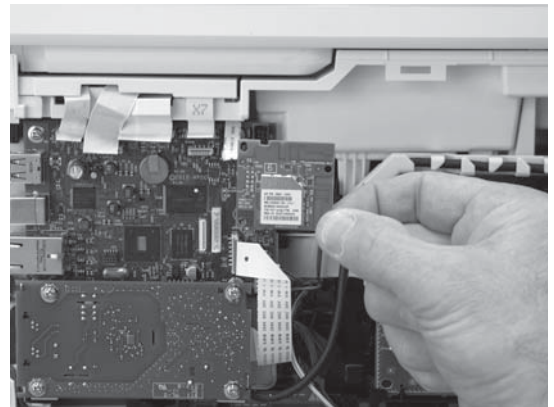
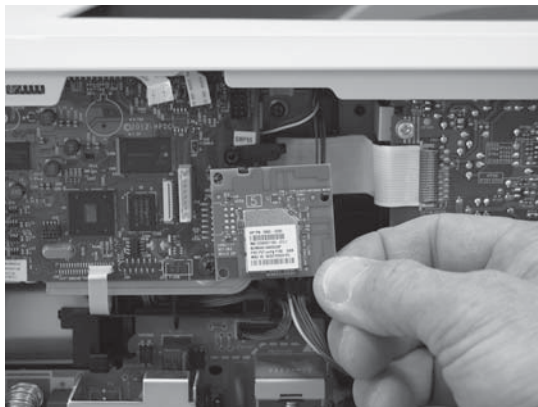


### Step 9: Install the wireless PCA

 **NOTE:** Wireless models only. For all other models, skip this step and go to [Step 10: Install the fax PCA on page 486](#).

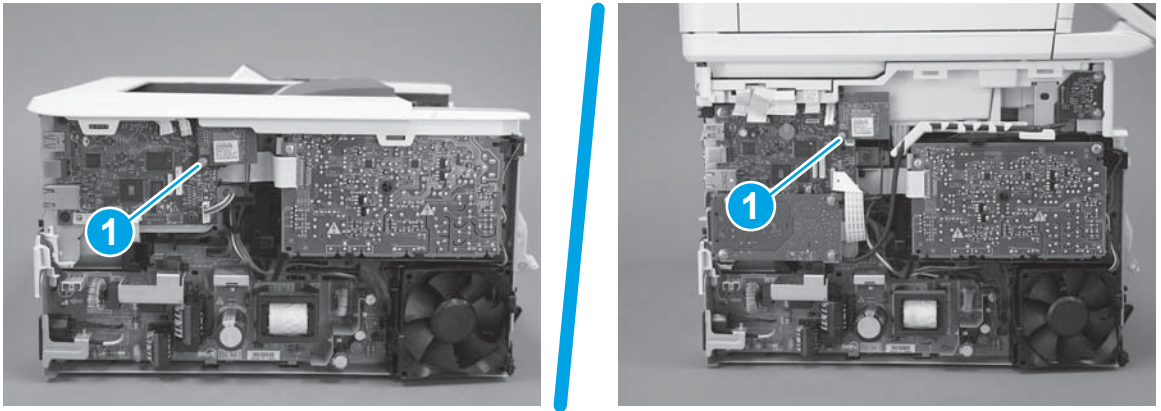
1. Carefully push the wireless PCA straight onto the formatter PCA to install it.

**Figure 1-874** Install the PCA



2. Install one screw (callout 1).

**Figure 1-875** Install one screw



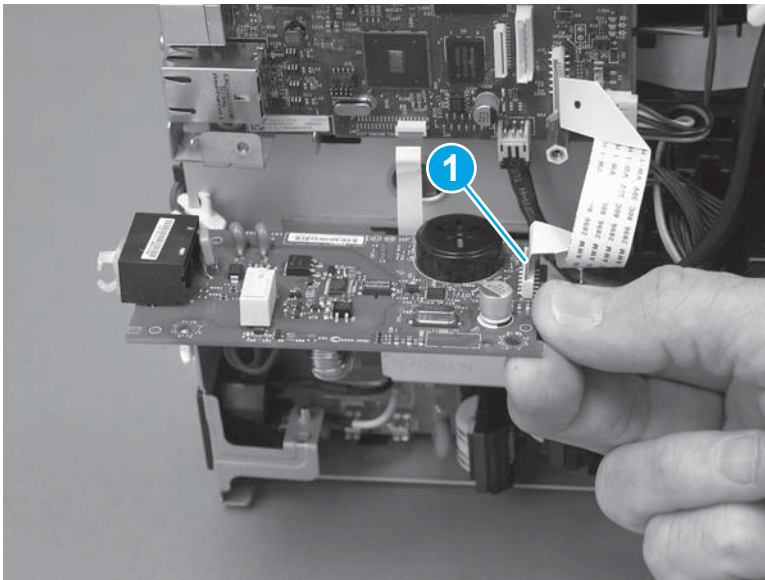
### Step 10: Install the fax PCA



**NOTE:** Fax models only. For all other models, skip this step and go to [Step 11: Install the left cover on page 487](#).

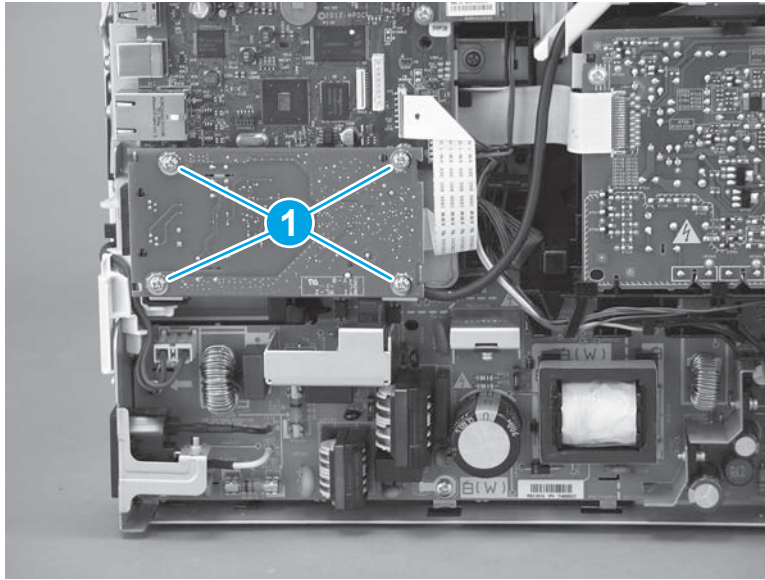
1. Connect one FFC cable (callout 1), and then position the fax PCA on the printer.

**Figure 1-876** Connect one connector and install the PCA



2. Install four screws (callout 1).

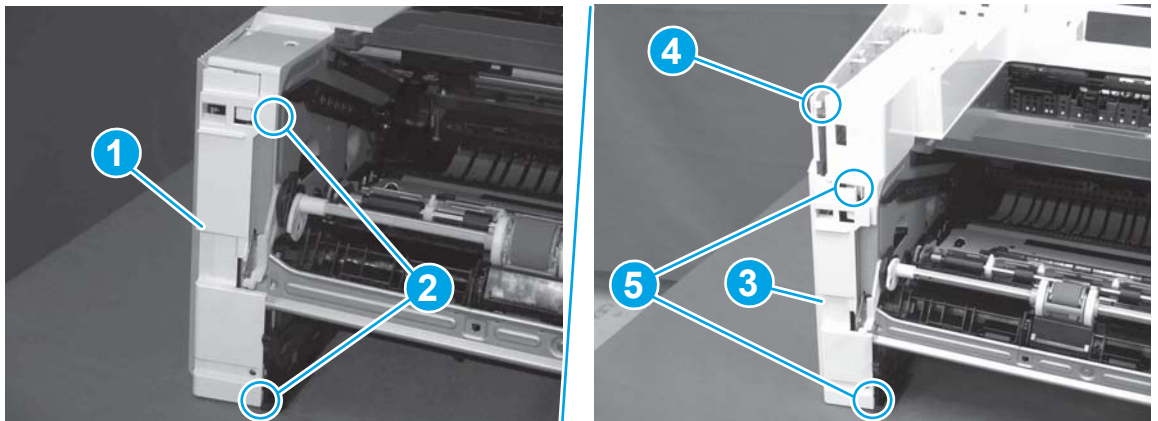
**Figure 1-877** Install four screws



### Step 11: Install the left cover

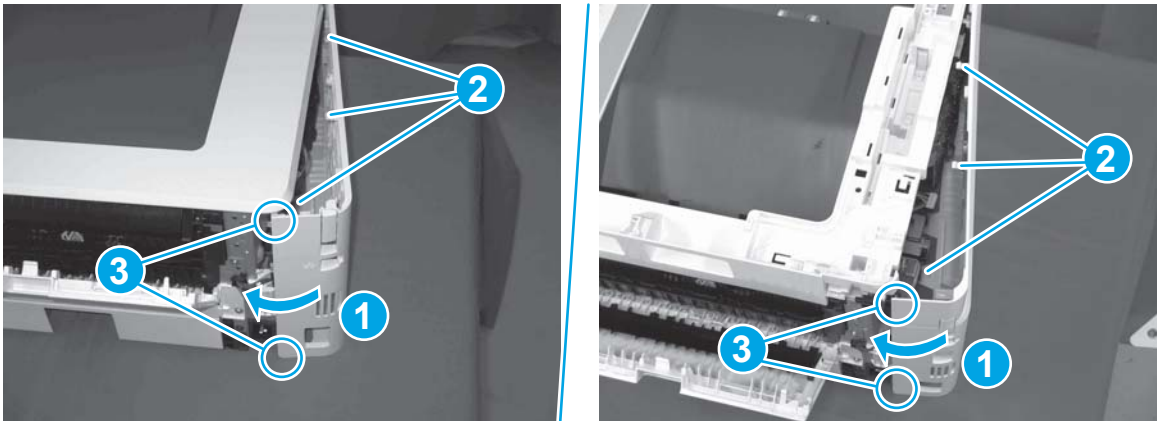
1. At the front of the printer, do one of the following:
  - **M403/M402:** Position the cover on the printer ( callout 1), and then engage two bosses (callout 2).
  - **M427/M426:** Position the cover on the printer (callout 3), engage one tab (callout 4), and then engage two bosses (callout 4).

**Figure 1-878** Install the cover



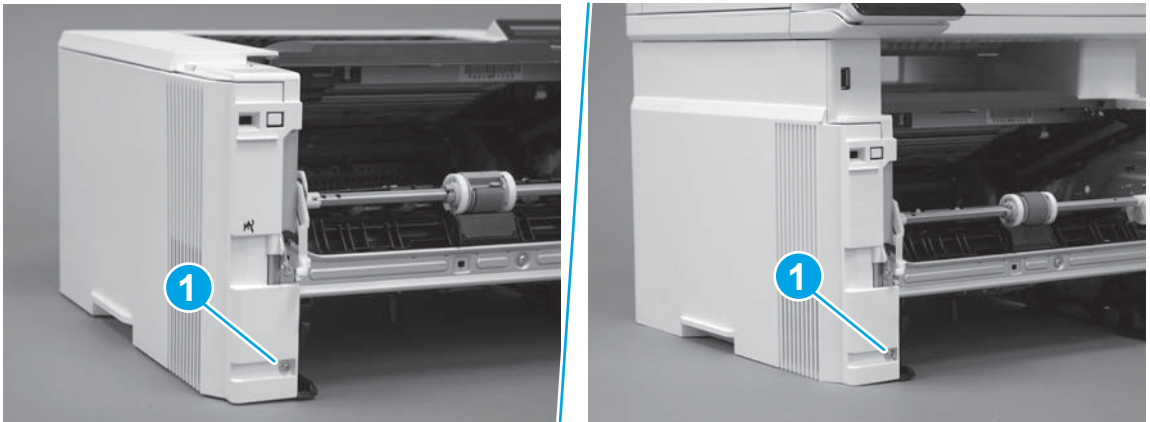
- Carefully rotate the rear of the cover onto the printer (callout 1), engage three tabs (callout 2), and then engage two bosses (callout 3).

**Figure 1-879** Engage three tabs and two bosses




- Install one screw (callout 1).

**Figure 1-880** Install one screw

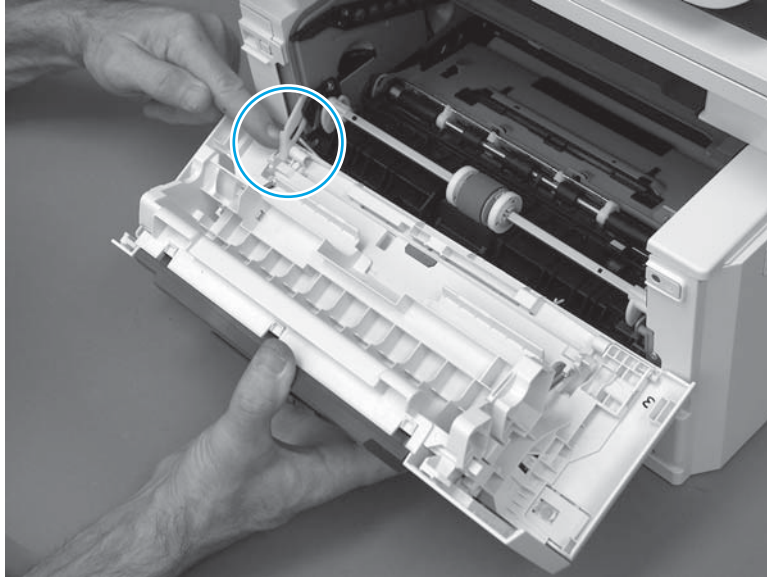


## Step 12: Install the cartridge door assembly

 **Reinstallation tip:** After a replacement door is installed, make sure to install the nameplate (supplied in the kit) corresponding to the printer name on the door.

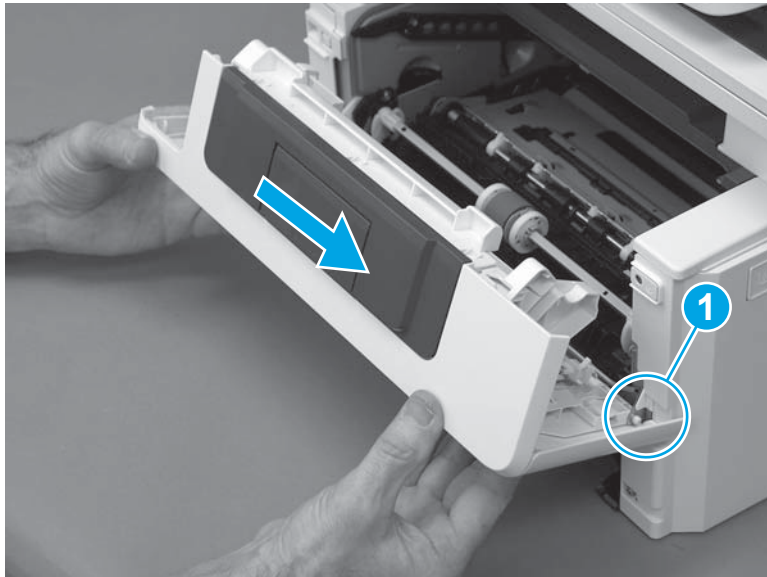
- Position the door close to the printer, and then engage the keyed pin on the left-side retainer arm with the hole in the door.

**Figure 1-881** Engage the left-side retainer arm



2. Engage the right-side door hinge pin with the hole in the chassis (callout 1).

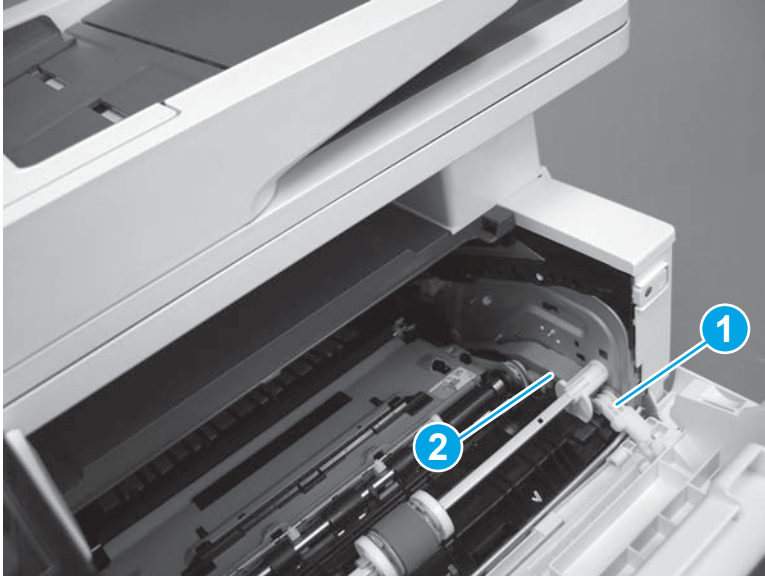
**Figure 1-882** Install the door



3. Install the link (callout 1).

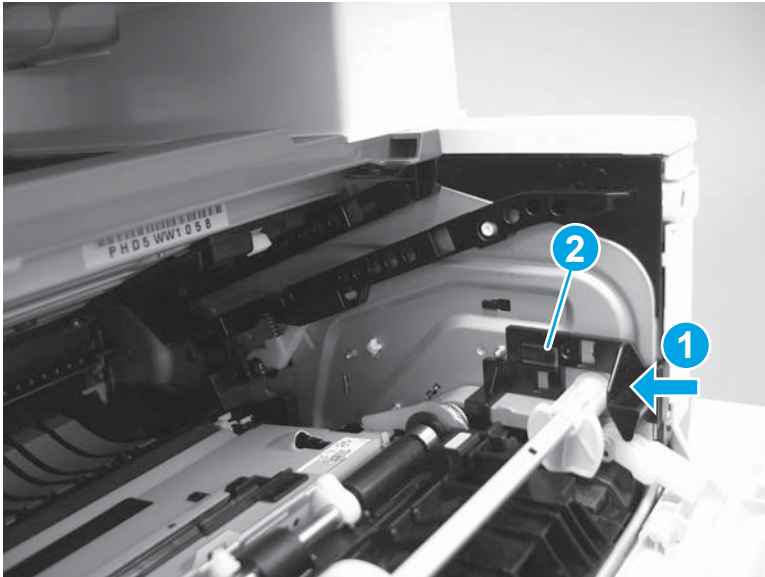
 **IMPORTANT:** Make sure that the link snaps into place on the arm (callout 2). The link actuates the fuser pressure-release mechanism.

**Figure 1-883** Install the pressure-release link



4. Slide the guide into the printer (callout 1), and then make sure that the tab (callout 2) snaps into place to secure the guide to the chassis.

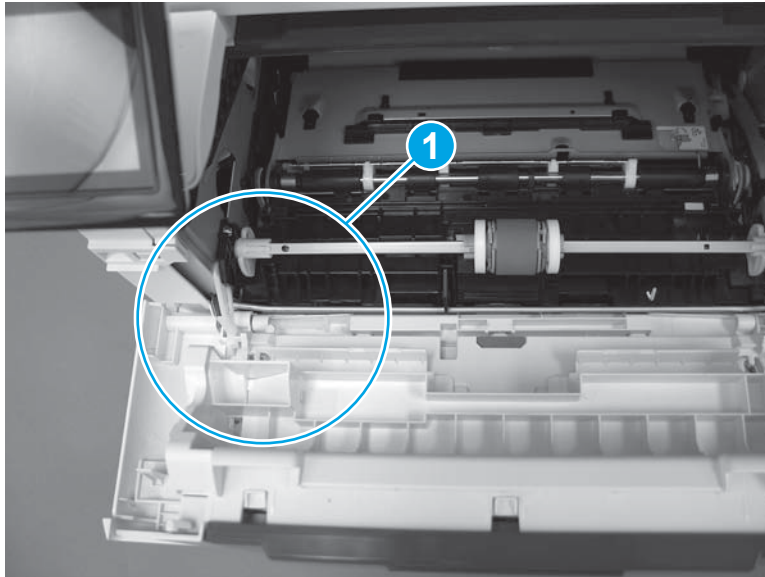
**Figure 1-884** Install the guide






5. Position the shaft on the door, and then align the left-side hinge on the door with the hole in the chassis (callout 1).

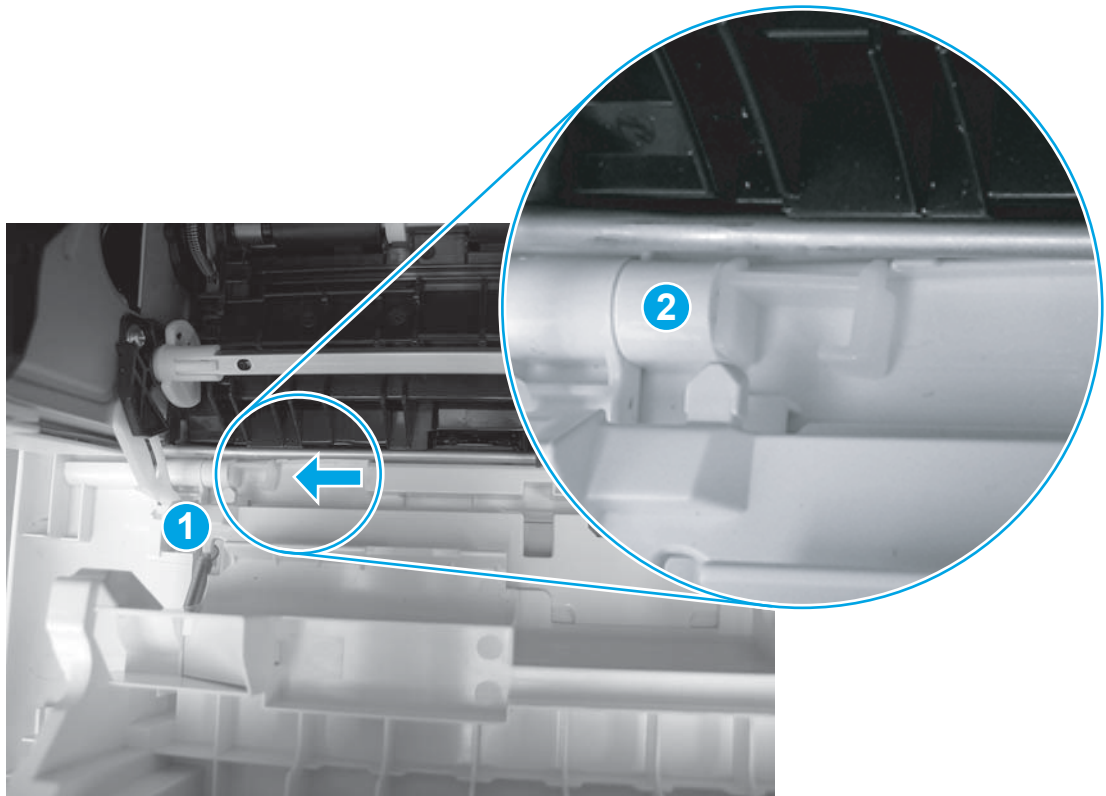
**Figure 1-885** Align the hinge



6. Push the shaft towards the left side of the printer to install it (callout 1).

 **Reinstallation tip:** Make sure that the support shaft is fully installed and correctly orientated (callout 2) so that it will not interfere with the door opening and closing.

**Figure 1-886** Install the support shaft



### Step 13: Install Tray 2

- ▲ Slide the tray straight into the printer to install it.

**Figure 1-887** Install the tray



## Removal and replacement: Fan (FM1)

- [Introduction](#)
- [Step 1: Remove Tray 2](#)
- [Step 2: Remove the cartridge door assembly](#)
- [Step 3: Remove the left cover](#)
- [Step 4: Remove the fan \(FM1\)](#)
- [Step 5: Unpack the replacement assembly](#)
- [Step 6: Install the fan \(FM1\)](#)
- [Step 7: Install the left cover](#)
- [Step 8: Install the cartridge door assembly](#)
- [Step 9: Install Tray 2](#)


### Introduction

This document provides the procedures to remove and replace the fan (FM1).

### Before performing service

#### Turn the printer power off

- Disconnect the power cable.

 **WARNING!** To avoid damage to the printer, turn the printer off, wait 30 seconds, and then remove the power cable before attempting to service the printer.

Use the table below to identify the correct part number for your printer. To order the part, go to [www.hp.com/buy/parts](http://www.hp.com/buy/parts).

Fan (FM1) part number	
RK2-8068-000CN	Fan (FM1)

### Required tools

- #2 Phillips screwdriver with a magnetic tip.

### After performing service

#### Turn the printer power on

- Connect the power cable.
- Use the power switch to turn the power on.

### Post service test

Listen for the fan to rotate when the printer power is turned on.


## Step 1: Remove Tray 2

- ▲ Pull the tray straight out of the printer to remove it.

**Figure 1-888** Remove the tray



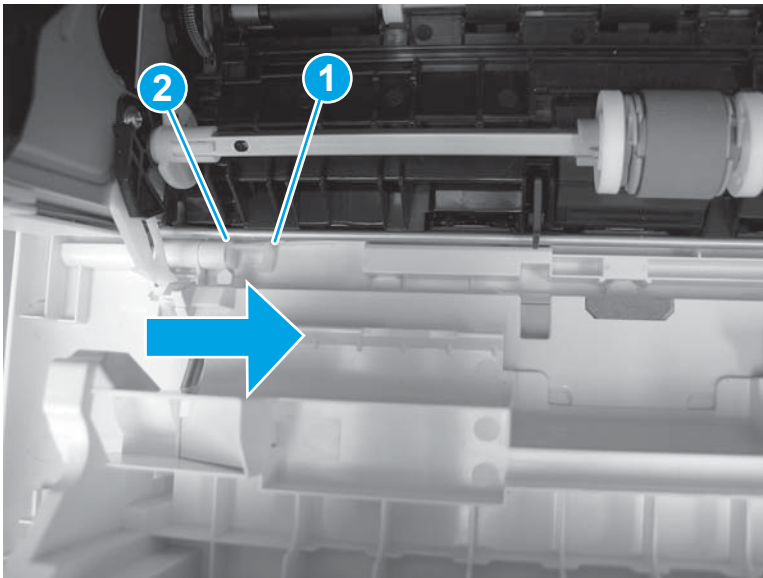
## Step 2: Remove the cartridge door assembly

 **NOTE:** If the toner cartridge was not removed prior to servicing the printer, remove it now.

1. Release one tab (callout 1), and then slide shaft (callout 2) in the direction the arrow indicates and remove it.

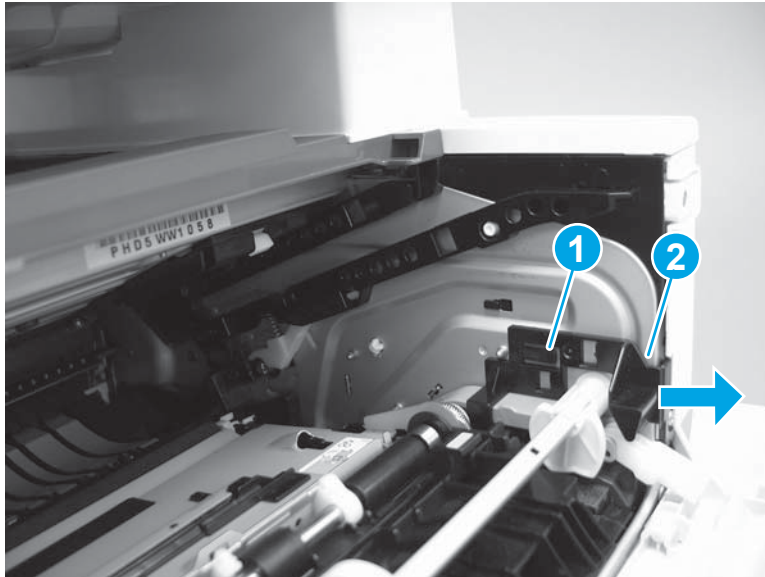
 **TIP:** It might be easier to release the support shaft by using a small flat-blade screwdriver.

**Figure 1-889** Release the support shaft



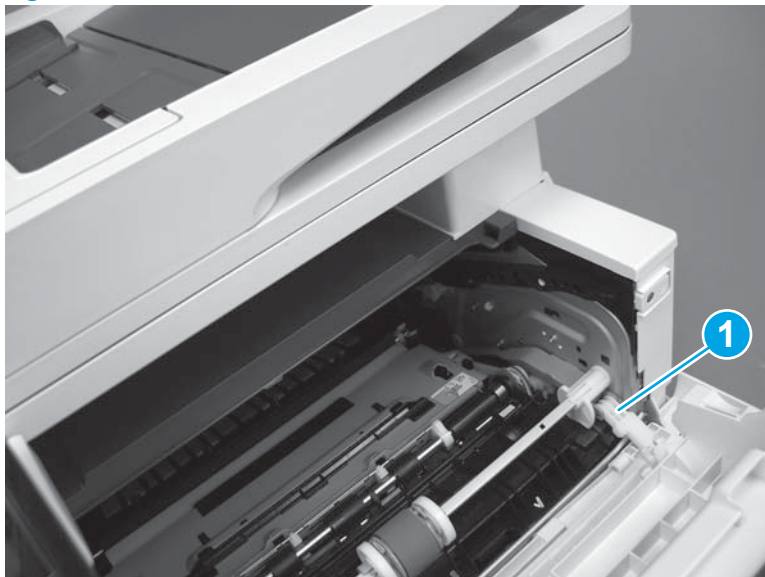
2. Release one tab (callout 1), and then slide the guide (callout 2) in the direction the arrow indicates and remove it.

**Figure 1-890** Remove the guide



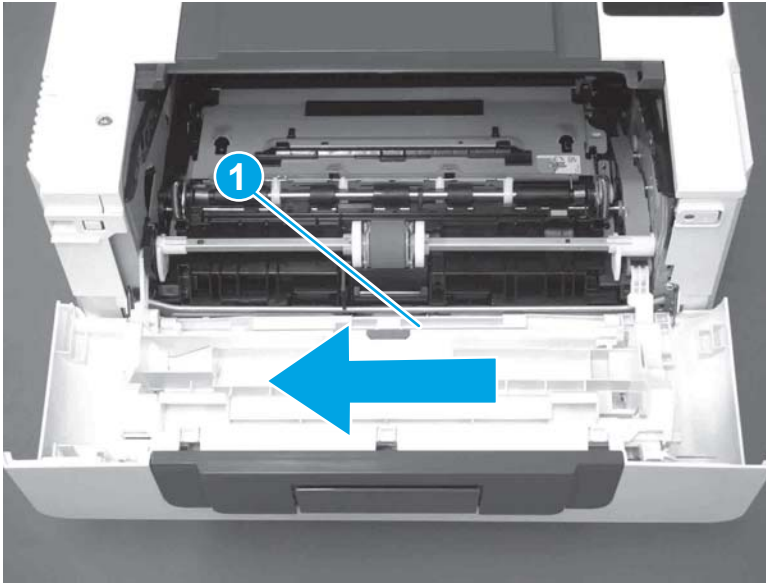
3. Remove the link arm (callout 1).

**Figure 1-891** Remove the link arm



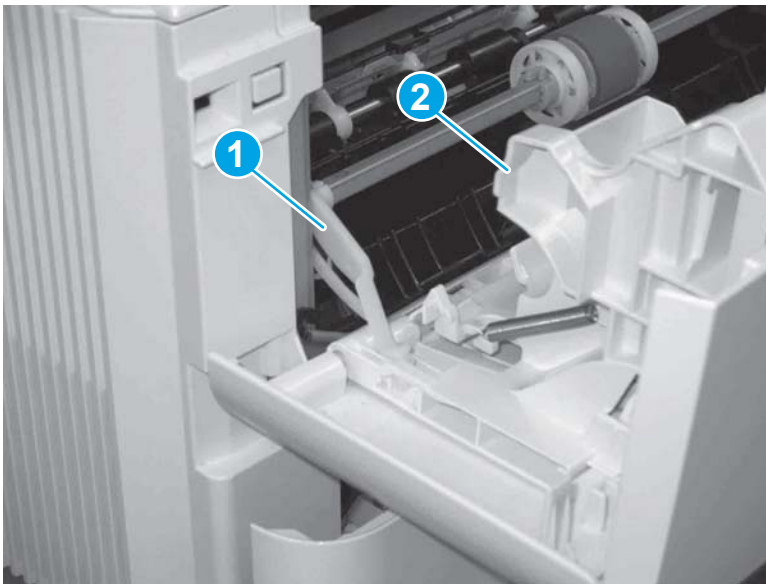
4. Slide the cartridge door assembly (callout 1) in the direction the arrow indicates and remove it.

**Figure 1-892** Remove the door



5. Remove the link (callout 1) from the cartridge door assembly (callout 2).

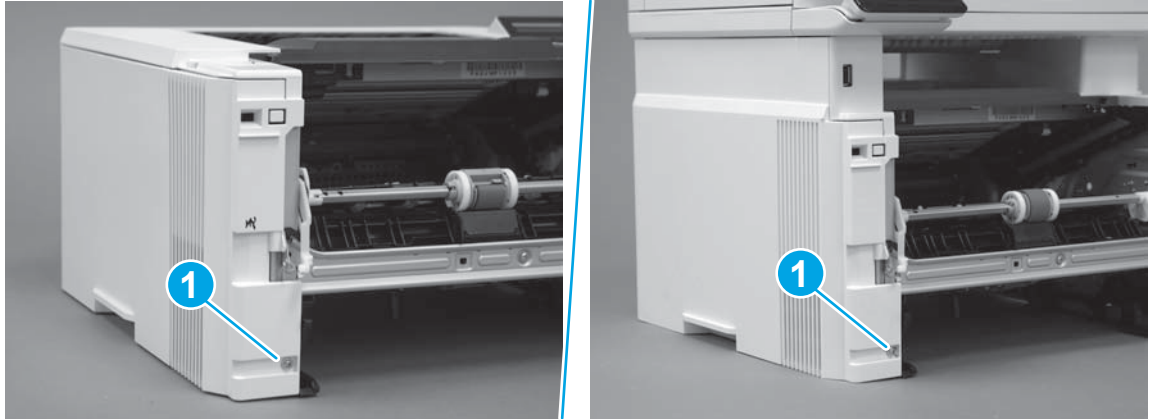
**Figure 1-893** Release the left-side retainer arm



### Step 3: Remove the left cover

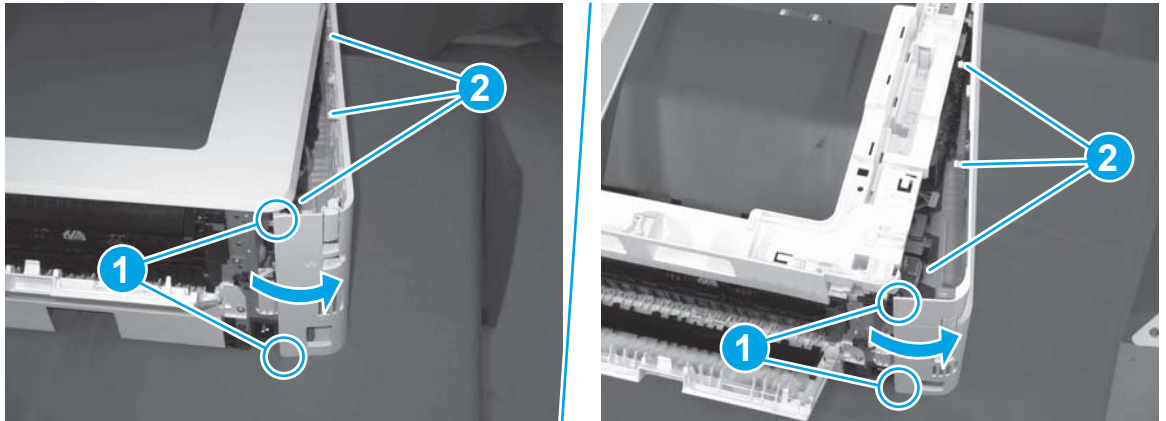
1. Remove one screw (callout 1).

**Figure 1-894** Remove one screw



2. Open the rear door, release two bosses (callout 1), and then release three tabs (callout 2).

**Figure 1-895** Release two bosses and three tabs



3. At the front of the printer, do one of the following:

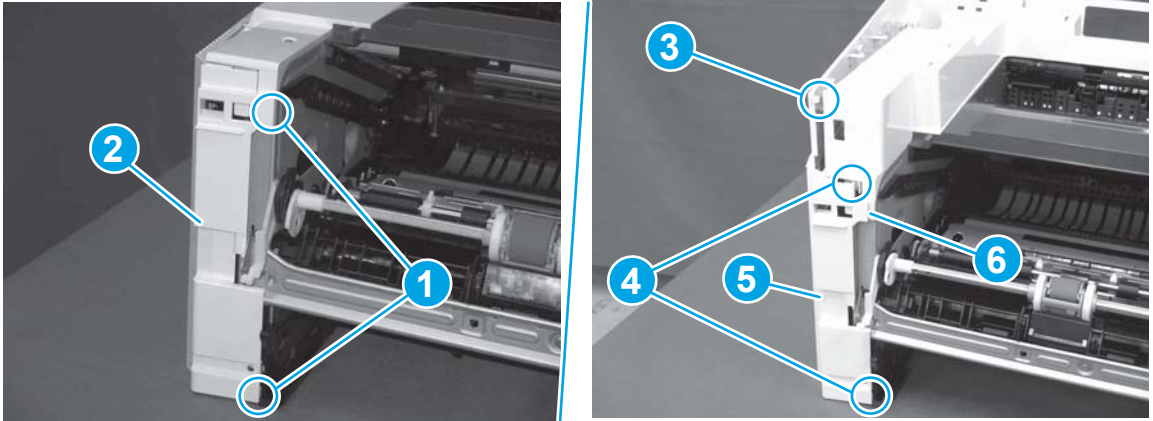
- **M403/M402:** Release two bosses (callout 1), and then remove the cover (callout 2).
- **M427/M426:** Release one tab (callout 3), two bosses (callout 4), and then remove the cover (callout 5).

---

**CAUTION:** Be careful when releasing the upper bosses on the M427/M426 cover. One portion of the cover (callout 6) is fragile and is easily broken.

---

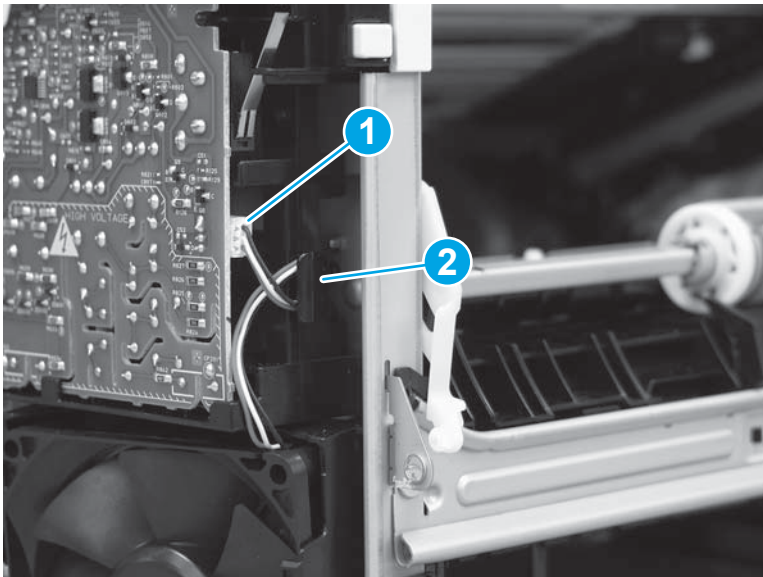
**Figure 1-896** Remove the cover



**Step 4: Remove the fan (FM1)**

1. Disconnect one connector (callout 1), and then release the wire harness from the retainer (callout 2).

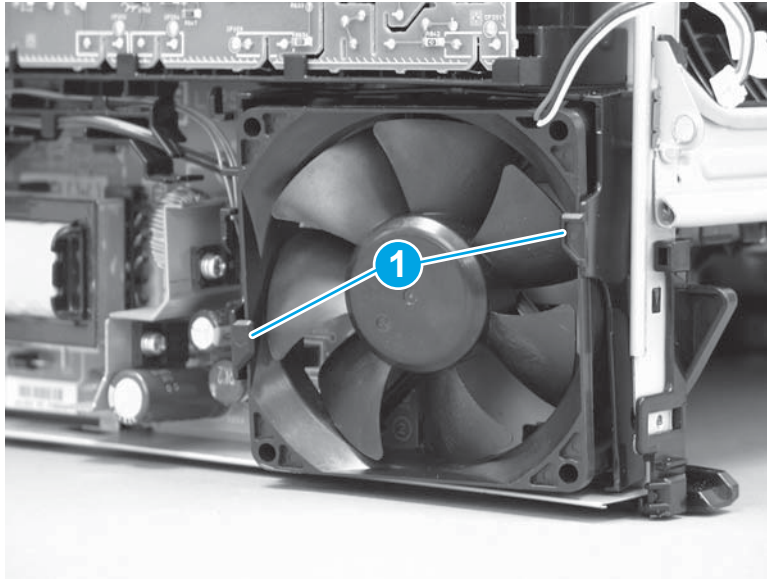
**Figure 1-897** Disconnect one connector





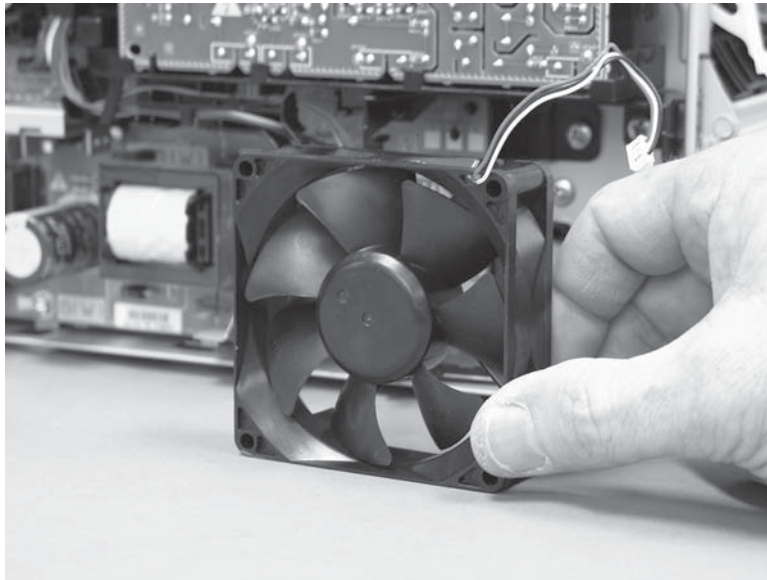
2. Release two tabs (callout 1).

**Figure 1-898** Release two tabs



3. Remove the fan.

**Figure 1-899** Remove the fan



### Step 5: Unpack the replacement assembly

Unpack the replacement part from the packaging.

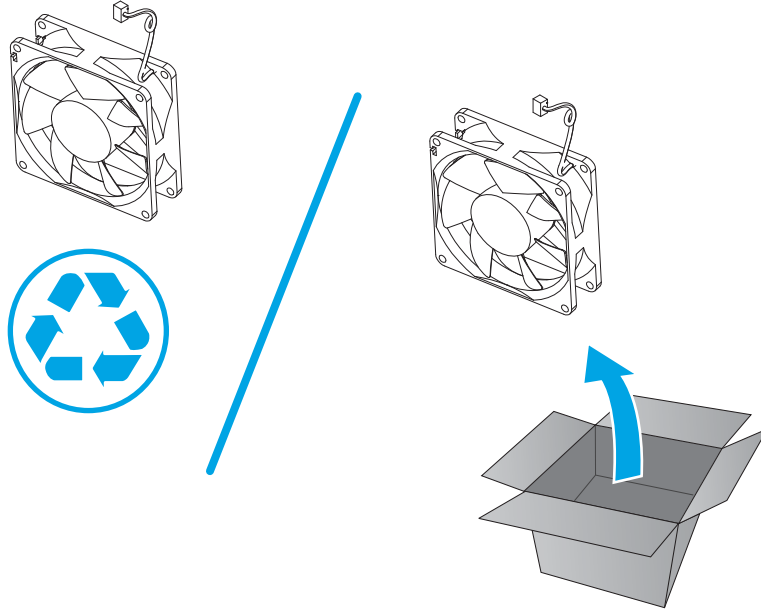
<http://www8.hp.com/us/en/hp-information/environment/product-recycling.html>

---

 **NOTE:** HP recommends responsible disposal of the defective part.

---

**Figure 1-900** Recycle and unpack

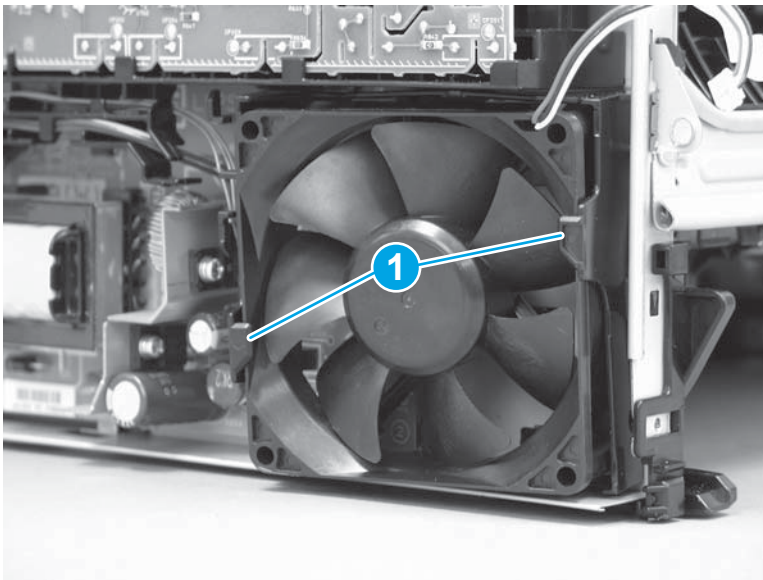


**Step 6: Install the fan (FM1)**

1. Position the fan in the holder. Make sure that the two tabs (callout 1) snap into place on the fan.

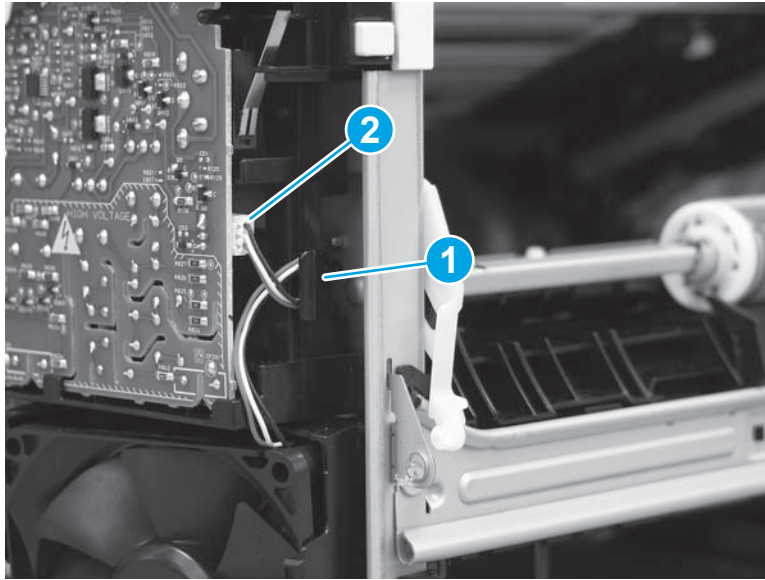
**⚠ CAUTION:** The fan must be correctly installed so that air is drawn into the printer. Make sure that the two arrows embossed on the right-side of the fan body—which indicate air flow direction—face upward and into the printer.

**Figure 1-901** Install the fan



2. Install the wire harness on the retainer (callout 2), and then connect one connector (callout 2).

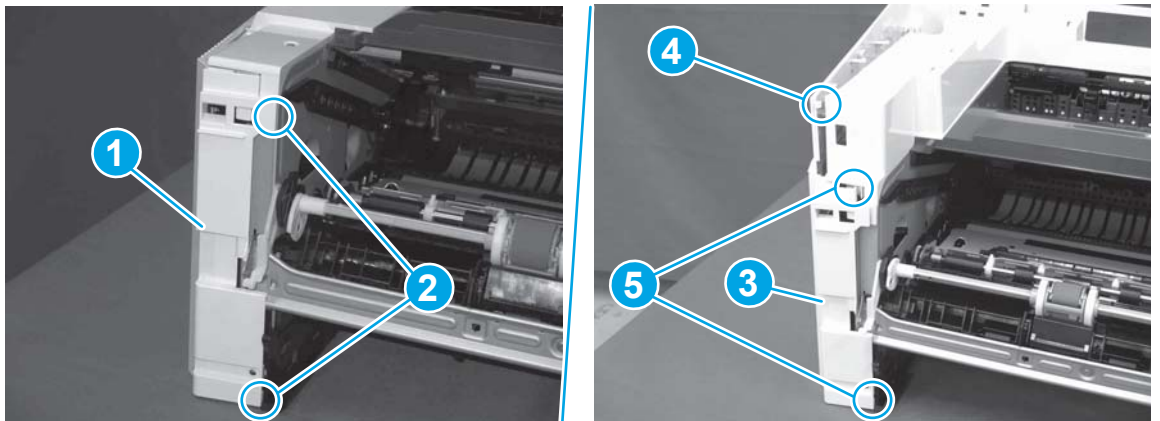
**Figure 1-902** Connect one connector



### Step 7: Install the left cover

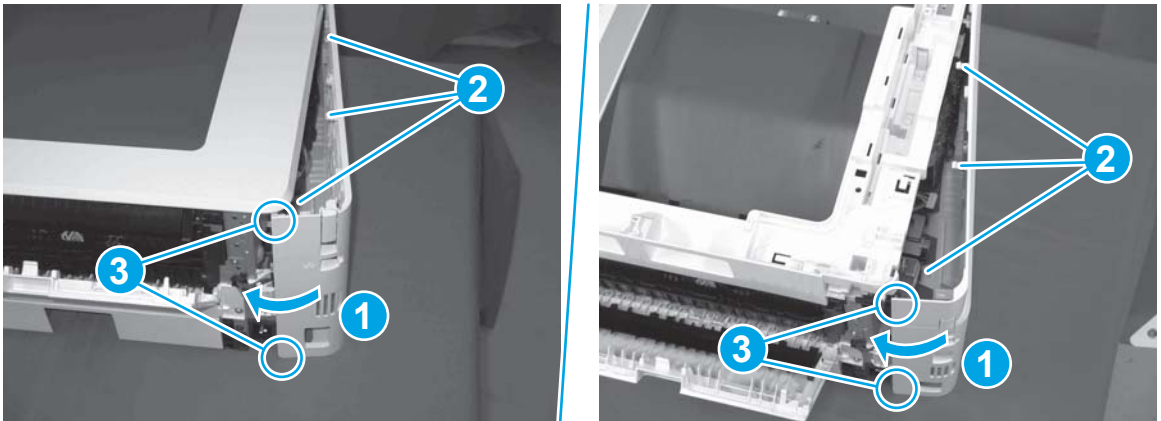
1. At the front of the printer, do one of the following:
  - **M403/M402:** Position the cover on the printer ( callout 1), and then engage two bosses (callout 2).
  - **M427/M426:** Position the cover on the printer (callout 3), engage one tab (callout 4), and then engage two bosses (callout 4).

**Figure 1-903** Install the cover



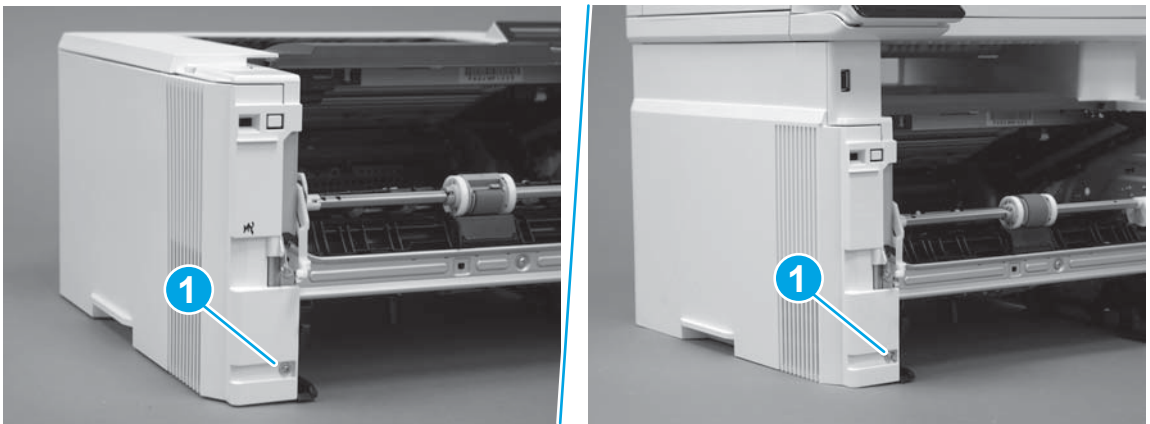
- Carefully rotate the rear of the cover onto the printer (callout 1), engage three tabs (callout 2), and then engage two bosses (callout 3).

**Figure 1-904** Engage three tabs and two bosses




- Install one screw (callout 1).

**Figure 1-905** Install one screw

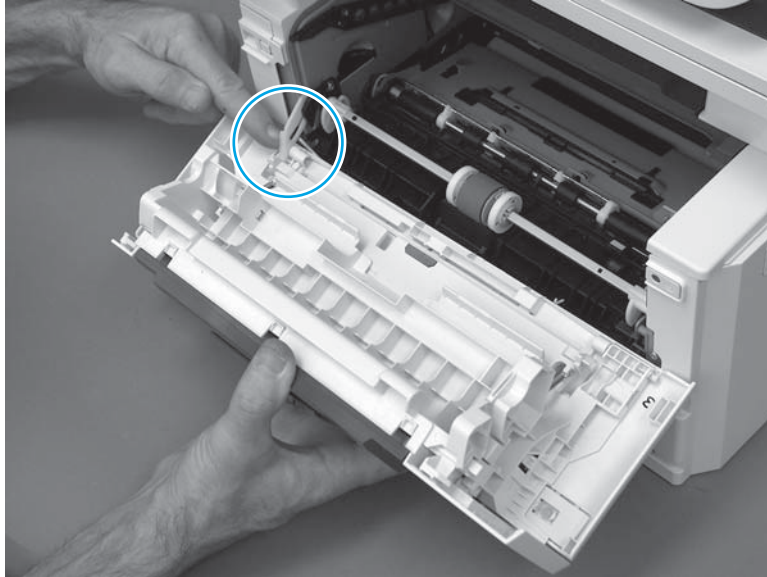


### Step 8: Install the cartridge door assembly

 **Reinstallation tip:** After a replacement door is installed, make sure to install the nameplate (supplied in the kit) corresponding to the printer name on the door.

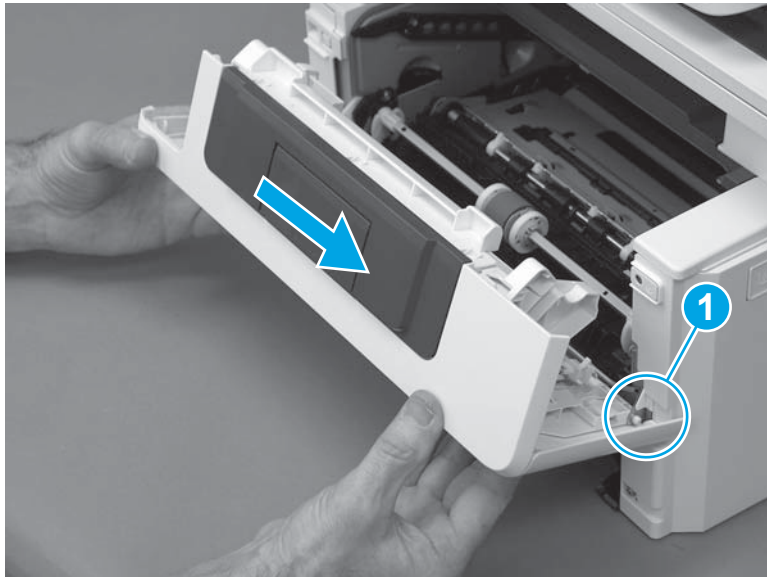
- Position the door close to the printer, and then engage the keyed pin on the left-side retainer arm with the hole in the door.

**Figure 1-906** Engage the left-side retainer arm



2. Engage the right-side door hinge pin with the hole in the chassis (callout 1).

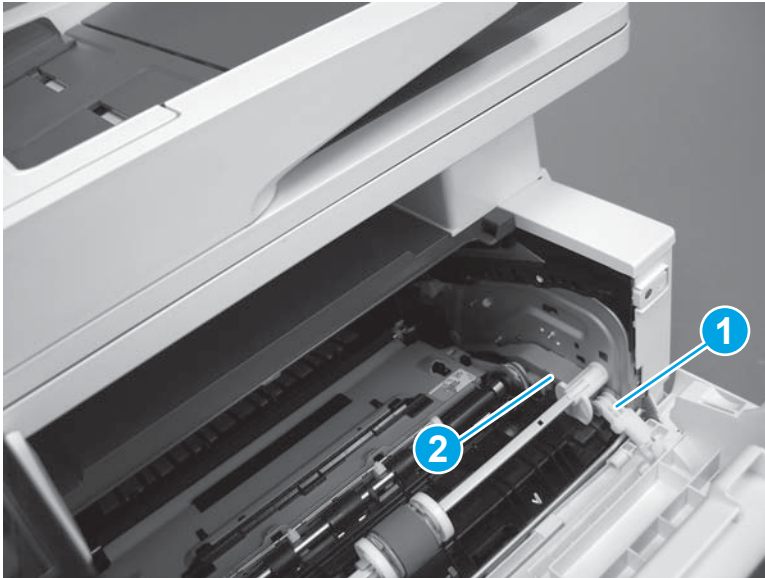
**Figure 1-907** Install the door



3. Install the link (callout 1).

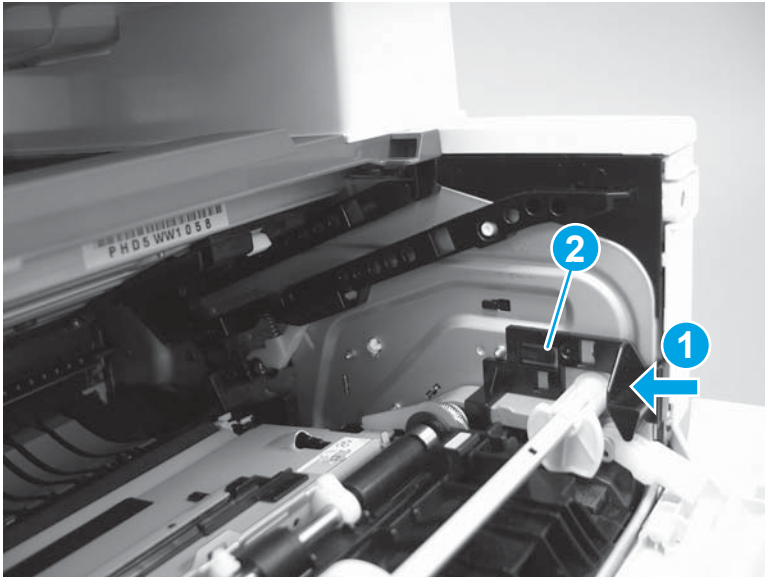
 **IMPORTANT:** Make sure that the link snaps into place on the arm (callout 2). The link actuates the fuser pressure-release mechanism.

**Figure 1-908** Install the pressure-release link



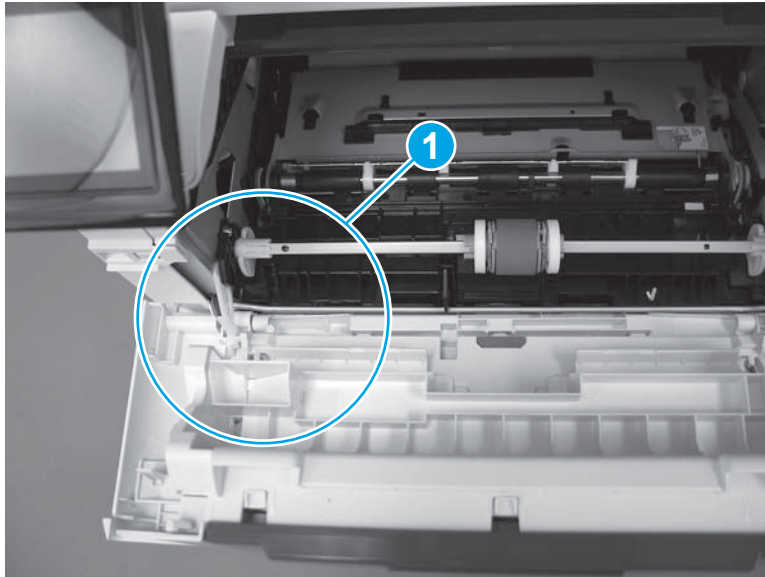
4. Slide the guide into the printer (callout 1), and then make sure that the tab (callout 2) snaps into place to secure the guide to the chassis.

**Figure 1-909** Install the guide




5. Position the shaft on the door, and then align the left-side hinge on the door with the hole in the chassis (callout 1).

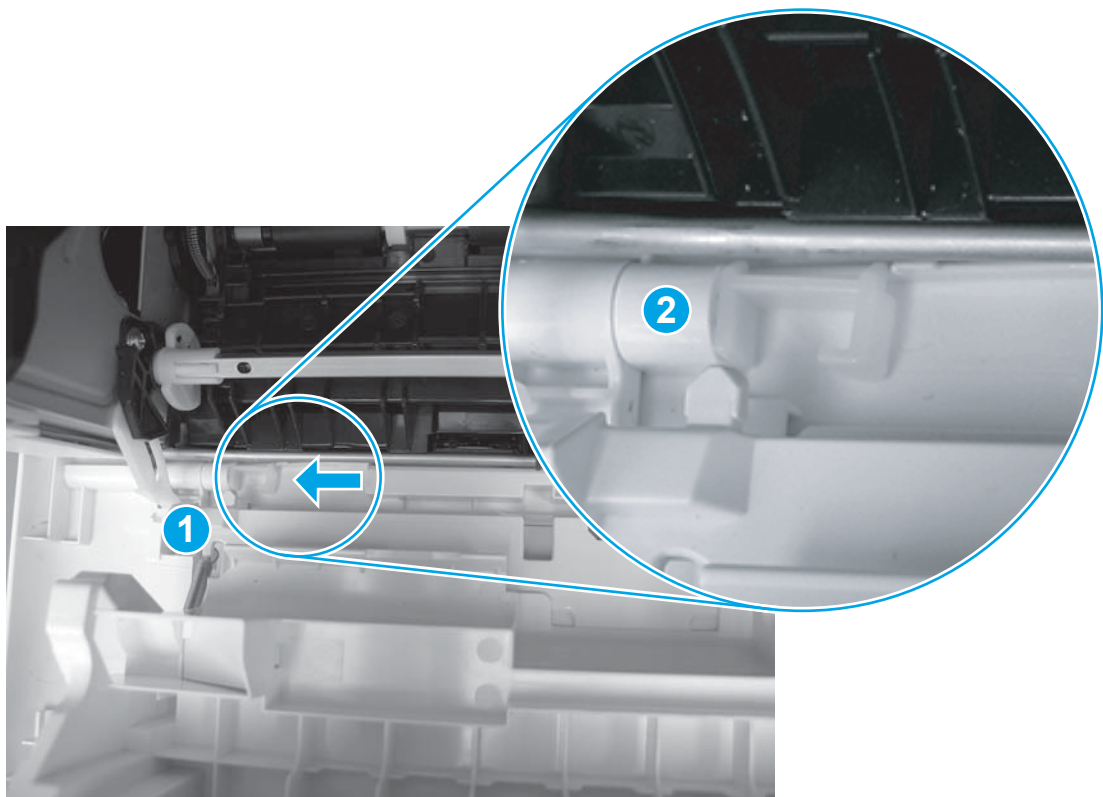
**Figure 1-910** Align the hinge



6. Push the shaft towards the left side of the printer to install it (callout 1).

 **Reinstallation tip:** Make sure that the support shaft is fully installed and correctly orientated (callout 2) so that it will not interfere with the door opening and closing.

**Figure 1-911** Install the support shaft



### Step 9: Install Tray 2

- ▲ Slide the tray straight into the printer to install it.

**Figure 1-912** Install the tray





## Removal and replacement: Fan holder (FM1)

- [Introduction](#)
- [Step 1: Remove Tray 2](#)
- [Step 2: Remove the cartridge door assembly](#)
- [Step 3: Remove the left cover](#)
- [Step 4: Remove the fan \(FM1\)](#)
- [Step 5: Remove the fan holder \(FM1\)](#)
- [Step 6: Unpack the replacement assembly](#)
- [Step 7: Install the fan holder \(FM1\)](#)
- [Step 8: Install the fan \(FM1\)](#)
- [Step 9: Install the left cover](#)
- [Step 10: Install the cartridge door assembly](#)
- [Step 11: Install Tray 2](#)


### Introduction

This document provides the procedures to remove and replace the fan holder (FM1).

### Before performing service

#### Turn the printer power off

- Disconnect the power cable.

 **WARNING!** To avoid damage to the printer, turn the printer off, wait 30 seconds, and then remove the power cable before attempting to service the printer.

Use the table below to identify the correct part number for your printer. To order the part, go to [www.hp.com/buy/parts](http://www.hp.com/buy/parts).

Fan holder (FM1) part number	
RC4-2891-000CN	Fan holder (FM1)

### Required tools

- #2 Phillips screwdriver with a magnetic tip.

### After performing service

#### Turn the printer power on

- Connect the power cable.
- Use the power switch to turn the power on.

## Post service test

Listen for the fan to rotate when the printer power is turned on.

### Step 1: Remove Tray 2

- ▲ Pull the tray straight out of the printer to remove it.

**Figure 1-913** Remove the tray



### Step 2: Remove the cartridge door assembly



---

**NOTE:** If the toner cartridge was not removed prior to servicing the printer, remove it now.

---

1. Release one tab (callout 1), and then slide shaft (callout 2) in the direction the arrow indicates and remove it.

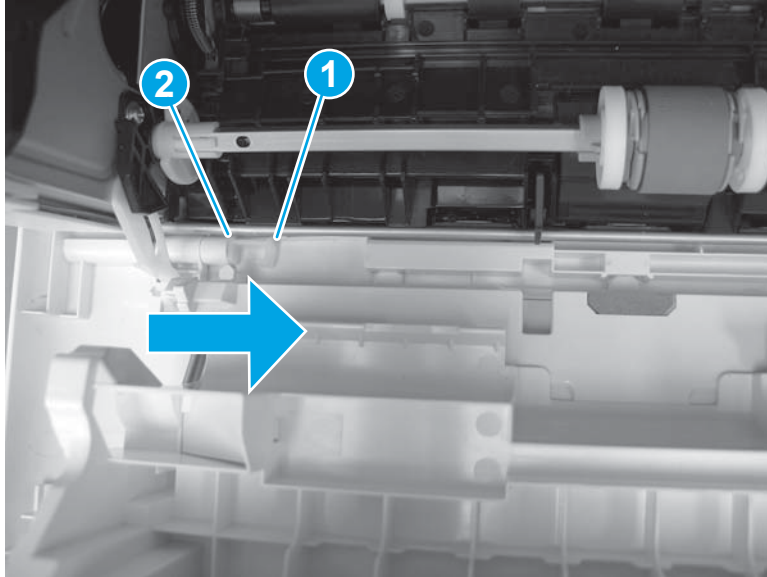


---

**TIP:** It might be easier to release the support shaft by using a small flat-blade screwdriver.

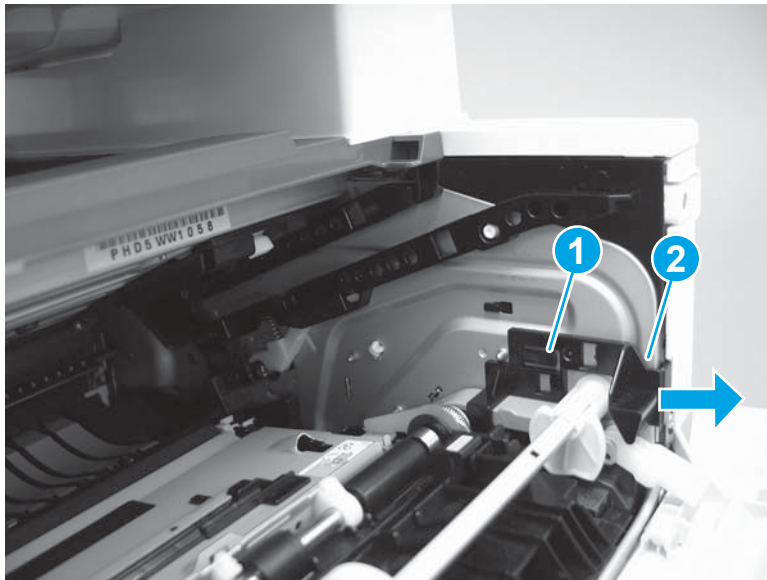
---

**Figure 1-914** Release the support shaft



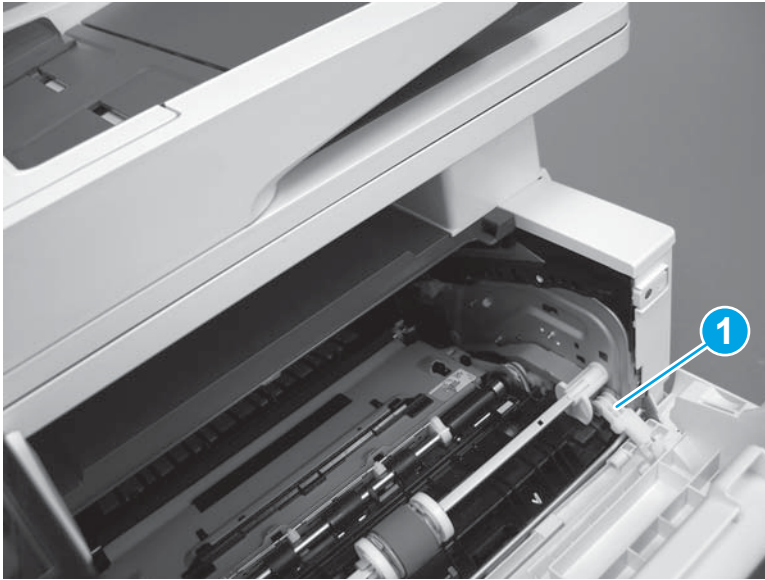
2. Release one tab (callout 1), and then slide the guide (callout 2) in the direction the arrow indicates and remove it.

**Figure 1-915** Remove the guide



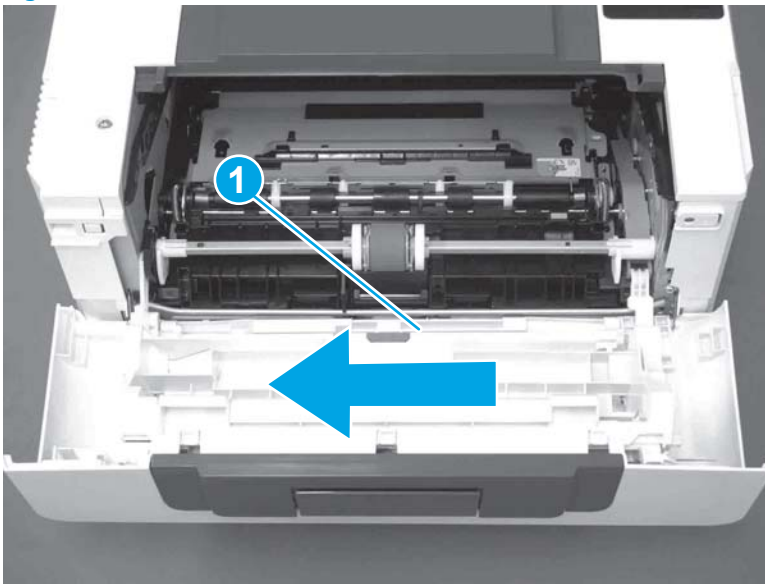
3. Remove the link arm (callout 1).

**Figure 1-916** Remove the link arm



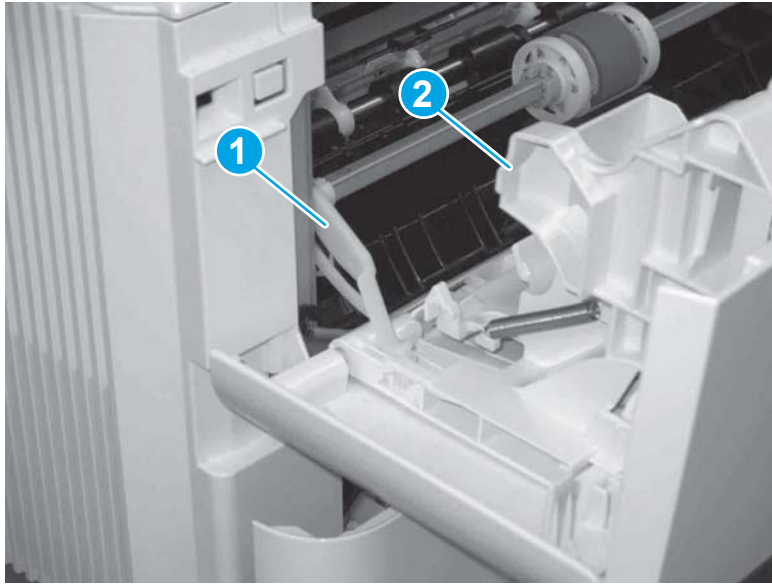
4. Slide the cartridge door assembly (callout 1) in the direction the arrow indicates and remove it.

**Figure 1-917** Remove the door



5. Remove the link (callout 1) from the cartridge door assembly (callout 2).

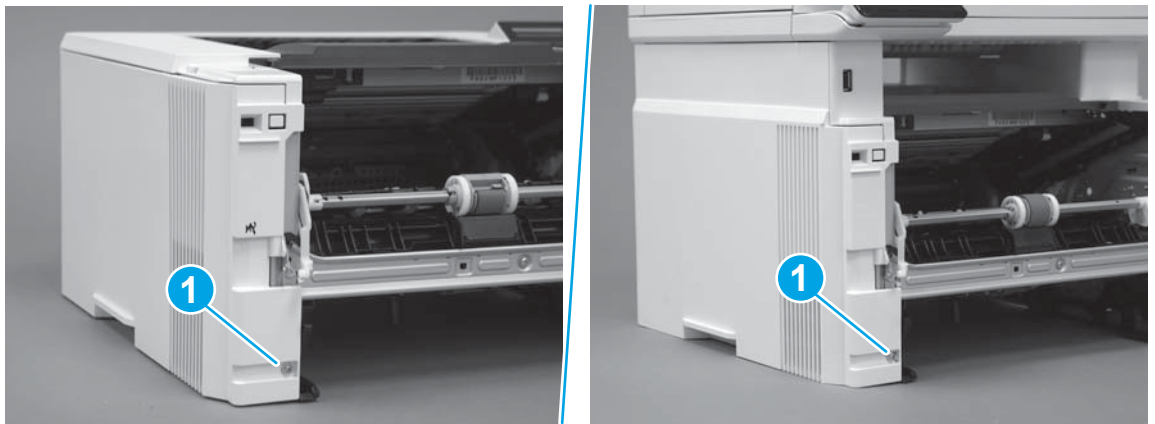
**Figure 1-918** Release the left-side retainer arm



**Step 3: Remove the left cover**

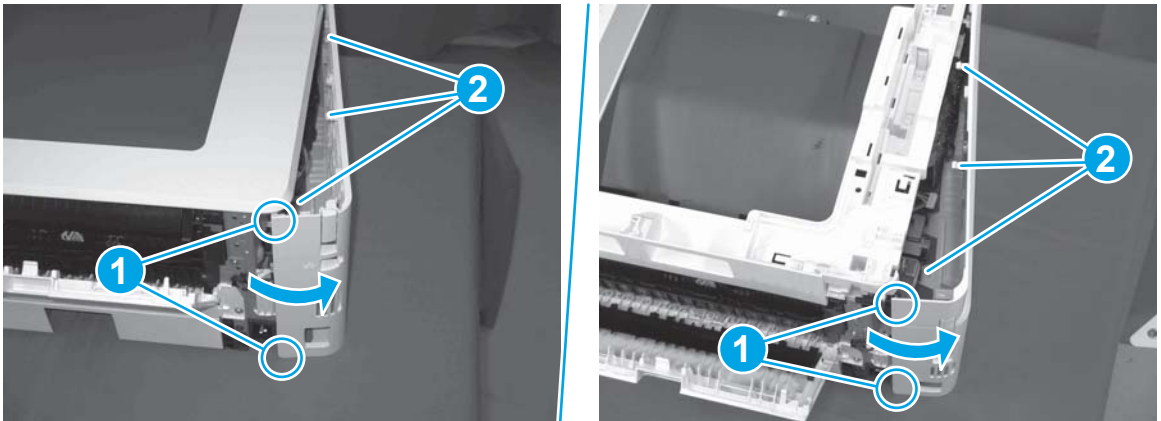
1. Remove one screw (callout 1).

**Figure 1-919** Remove one screw



2. Open the rear door, release two bosses (callout 1), and then release three tabs (callout 2).

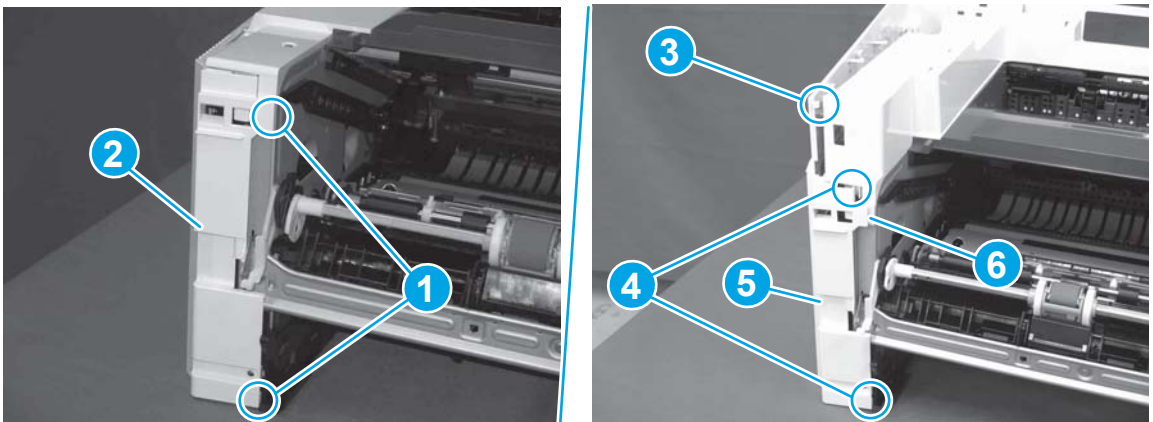
**Figure 1-920** Release two bosses and three tabs



3. At the front of the printer, do one of the following:
  - **M403/M402:** Release two bosses (callout 1), and then remove the cover (callout 2).
  - **M427/M426:** Release one tab (callout 3), two bosses (callout 4), and then remove the cover (callout 5).

**CAUTION:** Be careful when releasing the upper bosses on the M427/M426 cover. One portion of the cover (callout 6) is fragile and is easily broken.

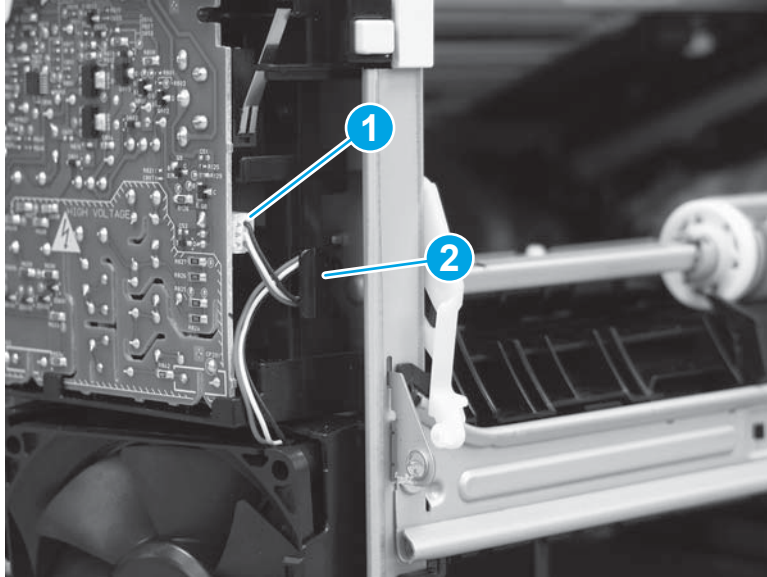
**Figure 1-921** Remove the cover



#### Step 4: Remove the fan (FM1)

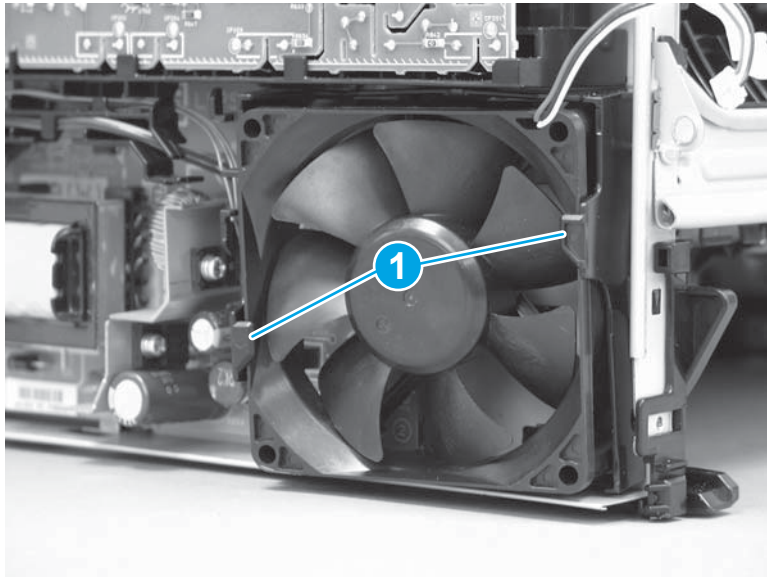
1. Disconnect one connector (callout 1), and then release the wire harness from the retainer (callout 2).

**Figure 1-922** Disconnect one connector



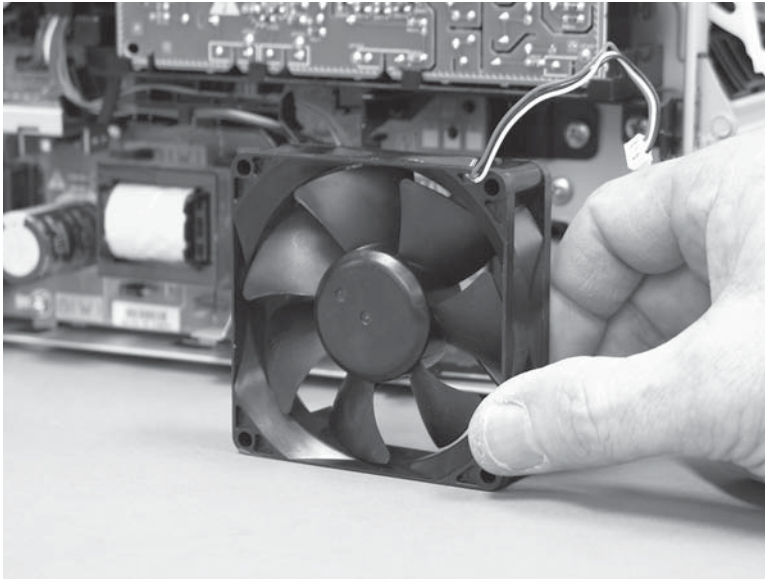
2. Release two tabs (callout 1).

**Figure 1-923** Release two tabs



3. Remove the fan.

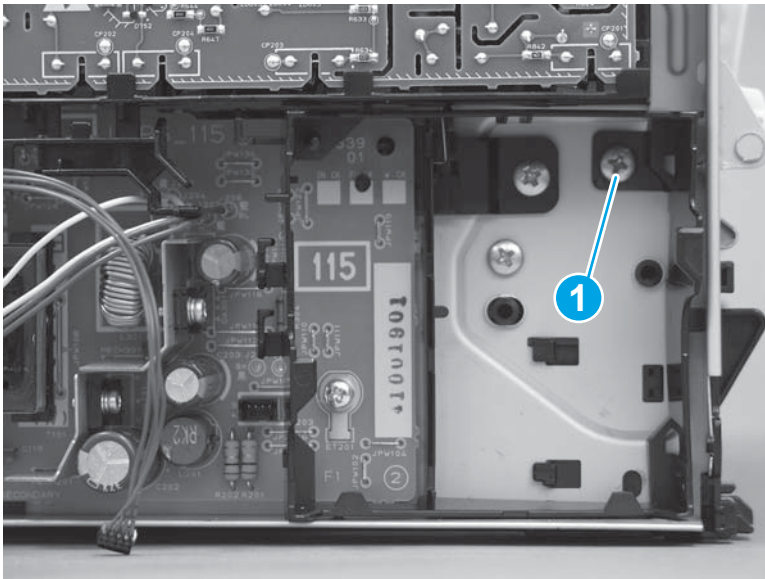
**Figure 1-924** Remove the fan



#### Step 5: Remove the fan holder (FM1)


1. Remove one screw (callout 1).

**Figure 1-925** Remove one screw

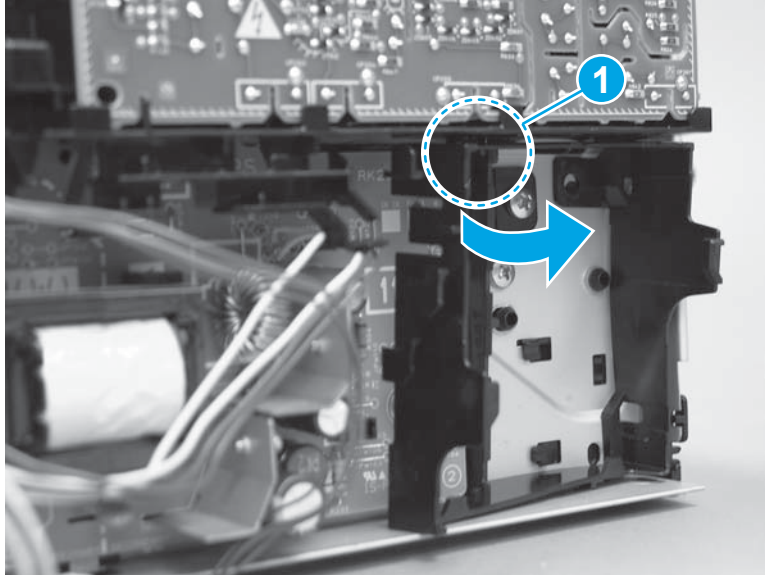




2. Release one tab at the top-left side of the fan holder (callout 1), and then rotate the top-left side corner of the holder away from the printer.

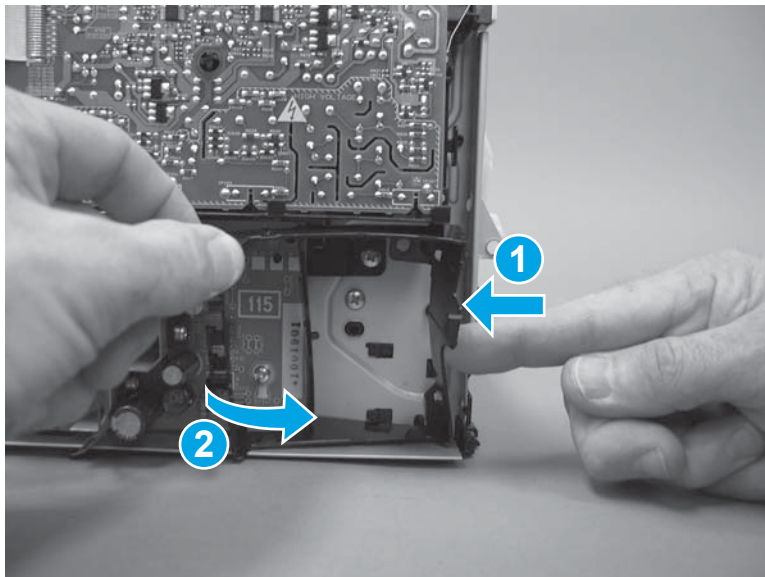
 **Reinstallation tip:** Use a flat-blade screwdriver to slightly flex the top of the holder down to make it easier to disengage this tab.

**Figure 1-926** Release one tab



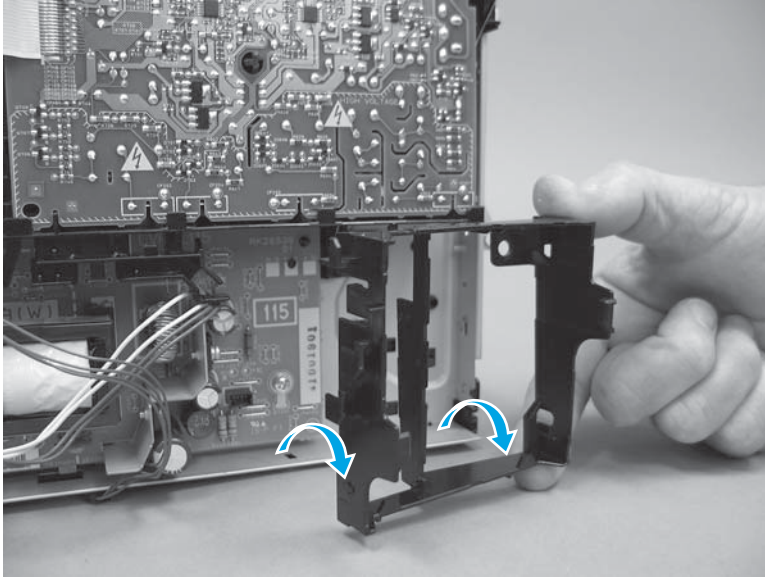
3. Slightly flex the right side of the holder to release one tab (callout 1), and then rotate the top of the holder away from the printer (callout 2).

**Figure 1-927** Release one tab



4. Lift the holder up to release two alignment tabs on the bottom of the holder, and then remove the holder.

**Figure 1-928** Remove the holder



### Step 6: Unpack the replacement assembly

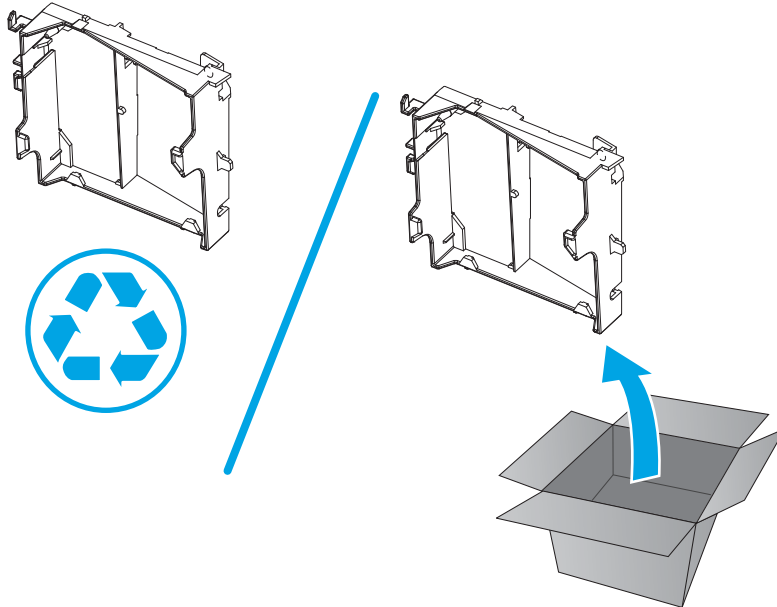
Unpack the replacement part from the packaging.

<http://www8.hp.com/us/en/hp-information/environment/product-recycling.html>



**NOTE:** HP recommends responsible disposal of the defective part.

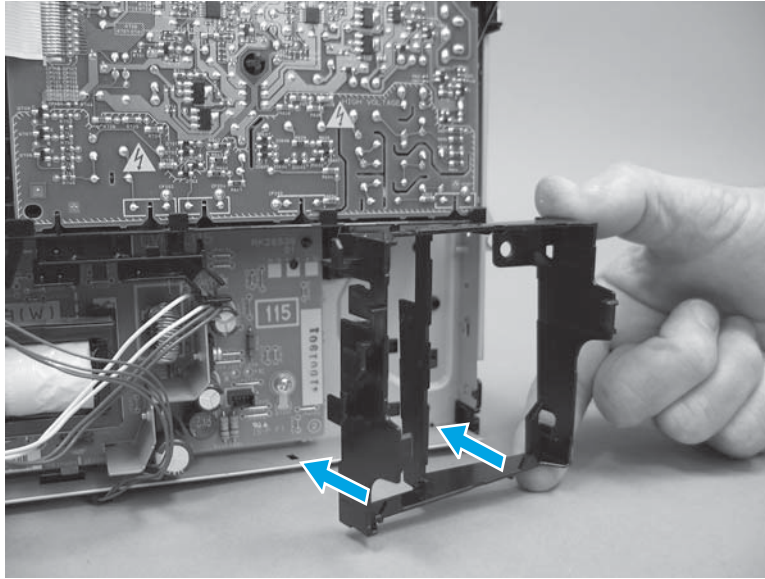
**Figure 1-929** Recycle and unpack



### Step 7: Install the fan holder (FM1)

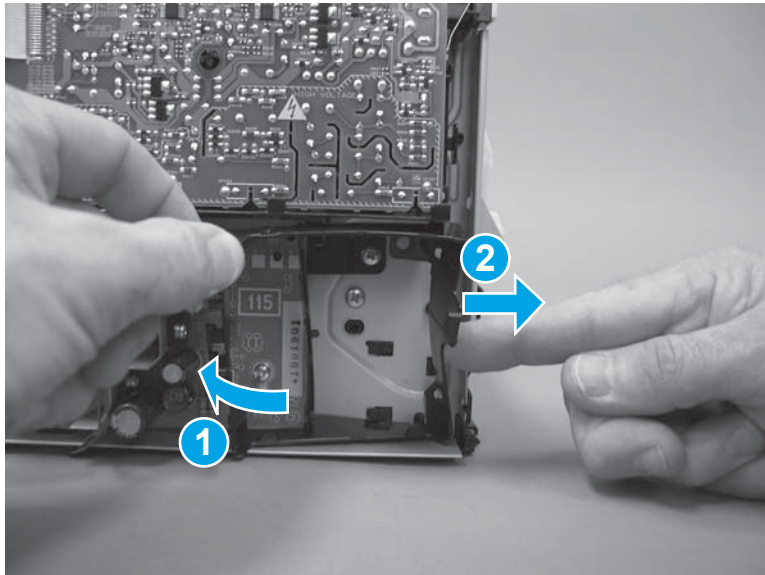
1. Position the bottom edge of the holder on the chassis—engage the two alignment tabs on the bottom of the holder with the slots in the chassis.

**Figure 1-930** Install the holder




2. Rotate the top of the holder toward the printer (callout 1), and then engage one tab on the right side of the holder (callout 2).

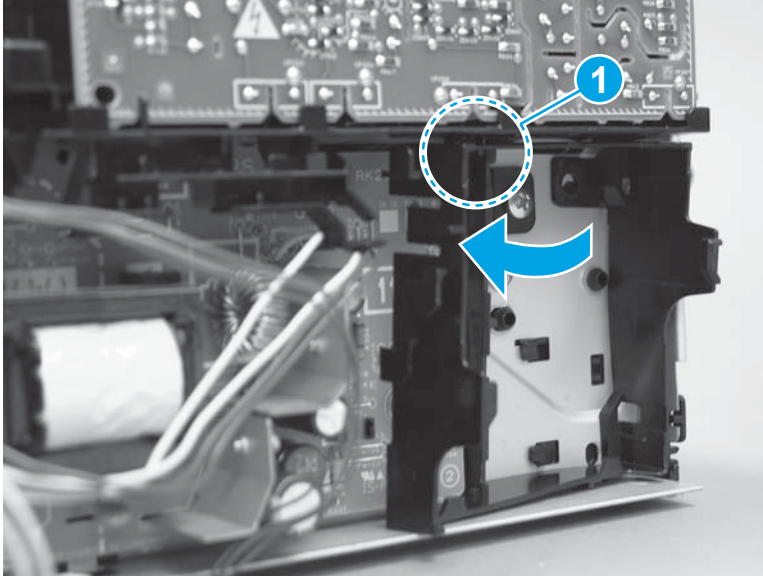
**Figure 1-931** Engage one tab



3. Rotate the top-left side corner of the holder toward the printer, and then engage one tab on the holder (callout 1).

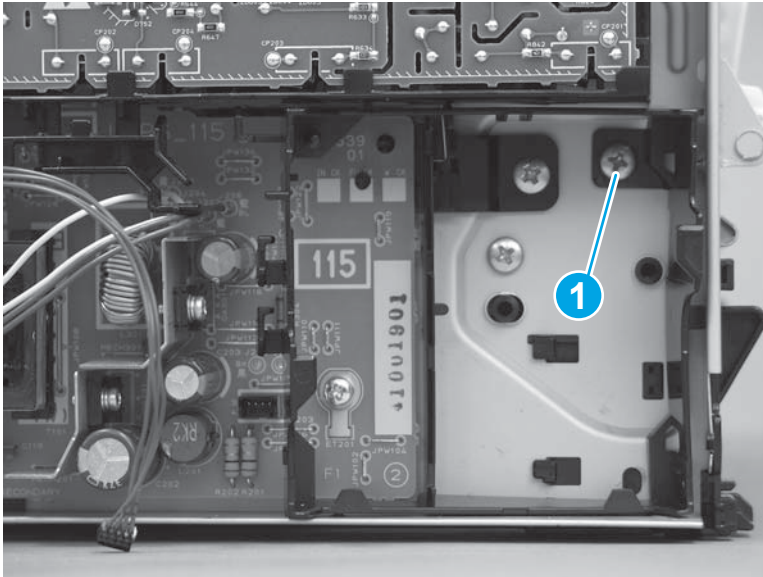
 **Reinstallation tip:** Use a flat-blade screwdriver to slightly flex the top of the holder down to make it easier to engage this tab.

**Figure 1-932** Engage one tab




4. Install one screw (callout 1).

**Figure 1-933** Install one screw

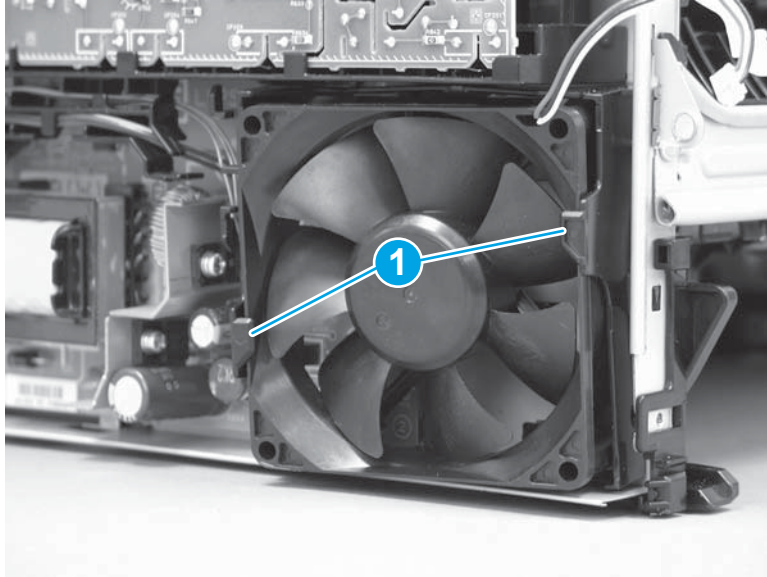


### Step 8: Install the fan (FM1)

1. Position the fan in the holder. Make sure that the two tabs (callout 1) snap into place on the fan.

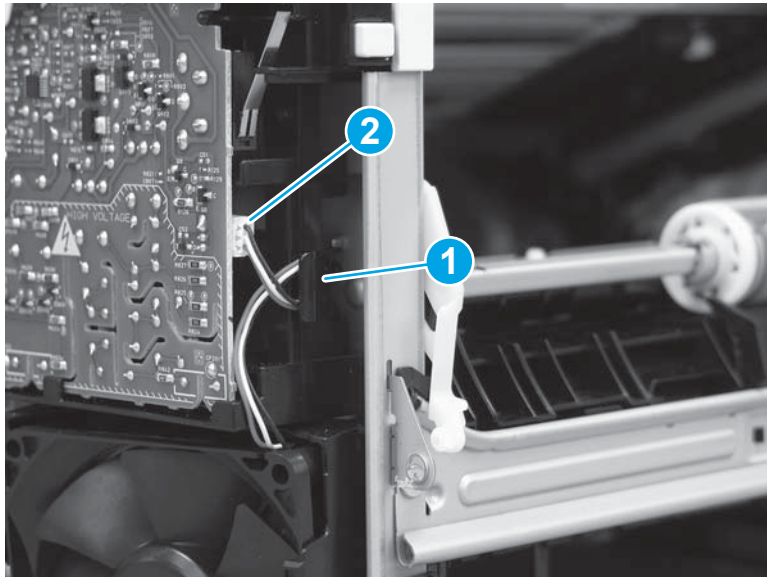
 **CAUTION:** The fan must be correctly installed so that air is drawn into the printer. Make sure that the two arrows embossed on the right-side of the fan body—which indicate air flow direction—face upward and into the printer.

**Figure 1-934** Install the fan



2. Install the wire harness on the retainer (callout 2), and then connect one connector (callout 2).

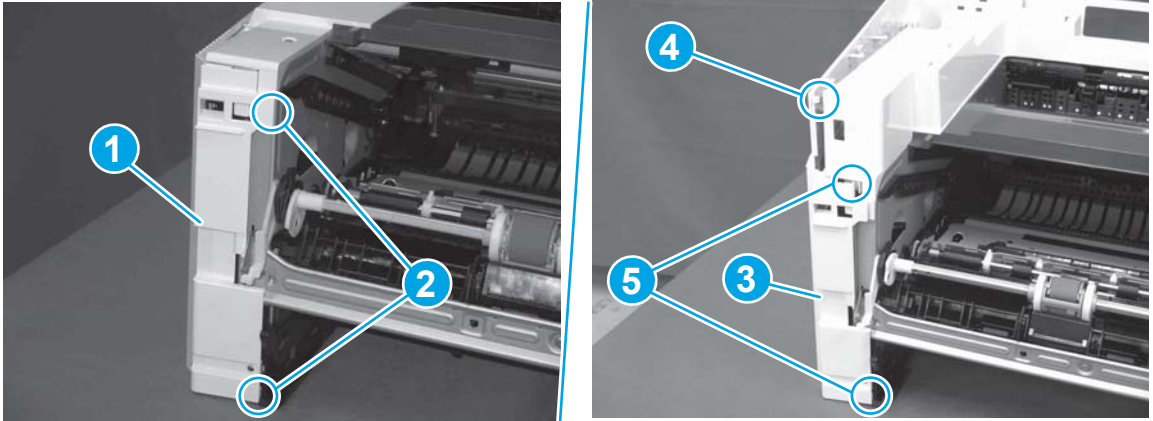
**Figure 1-935** Connect one connector



### Step 9: Install the left cover

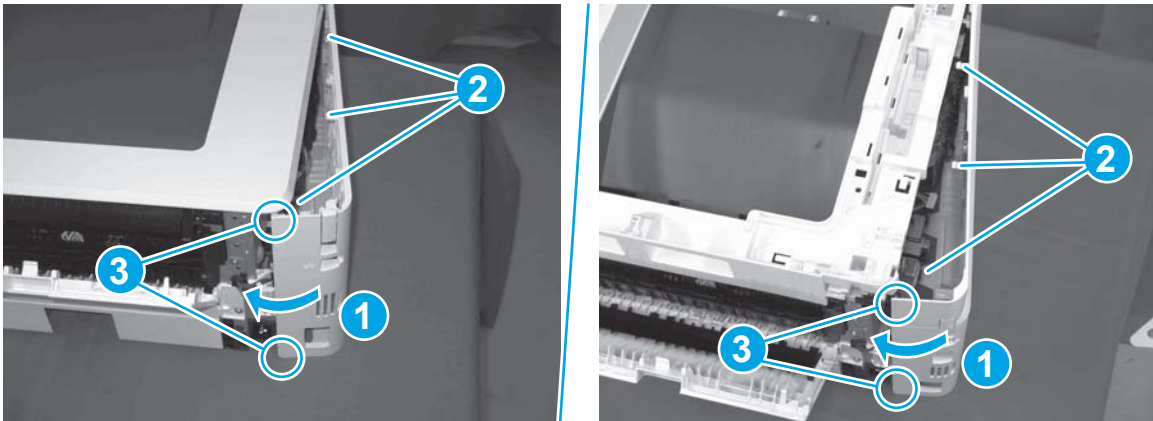
1. At the front of the printer, do one of the following:
  - **M403/M402:** Position the cover on the printer ( callout 1), and then engage two bosses (callout 2).
  - **M427/M426:** Position the cover on the printer (callout 3), engage one tab (callout 4), and then engage two bosses (callout 4).

**Figure 1-936** Install the cover



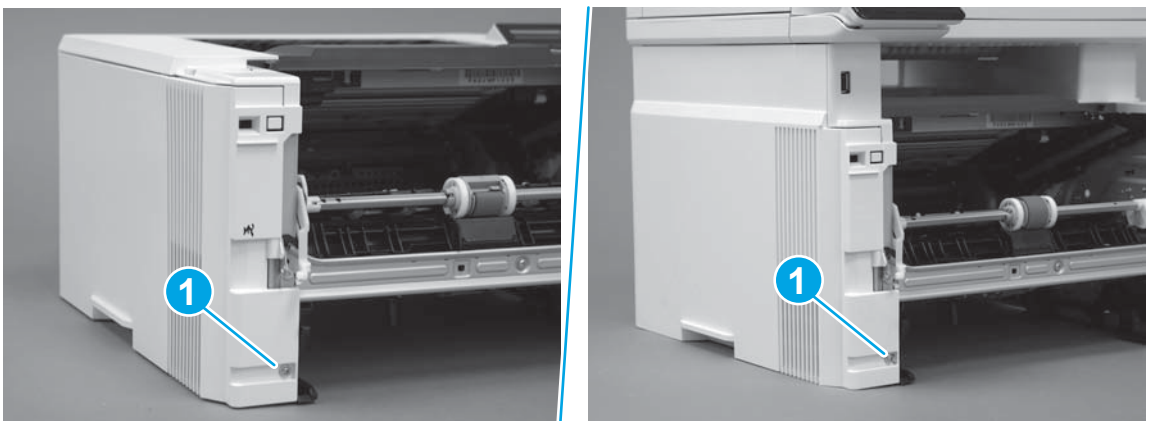
2. Carefully rotate the rear of the cover onto the printer (callout 1), engage three tabs (callout 2), and then engage two bosses (callout 3).

**Figure 1-937** Engage three tabs and two bosses




3. Install one screw (callout 1).

**Figure 1-938** Install one screw

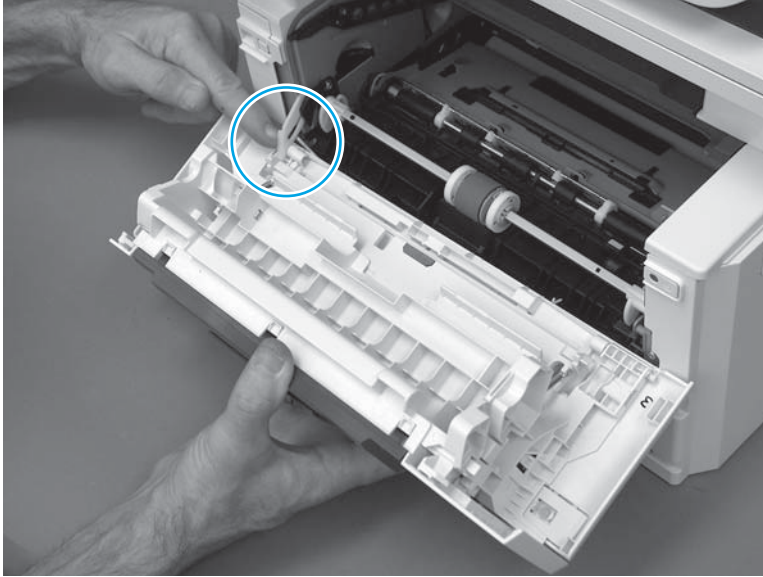


## Step 10: Install the cartridge door assembly

 **Reinstallation tip:** After a replacement door is installed, make sure to install the nameplate (supplied in the kit) corresponding to the printer name on the door.

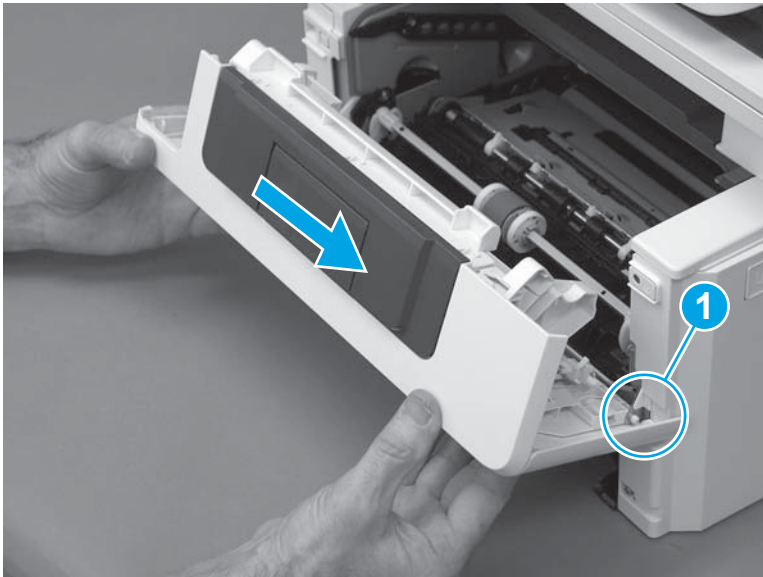
1. Position the door close to the printer, and then engage the keyed pin on the left-side retainer arm with the hole in the door.

**Figure 1-939** Engage the left-side retainer arm



2. Engage the right-side door hinge pin with the hole in the chassis (callout 1).

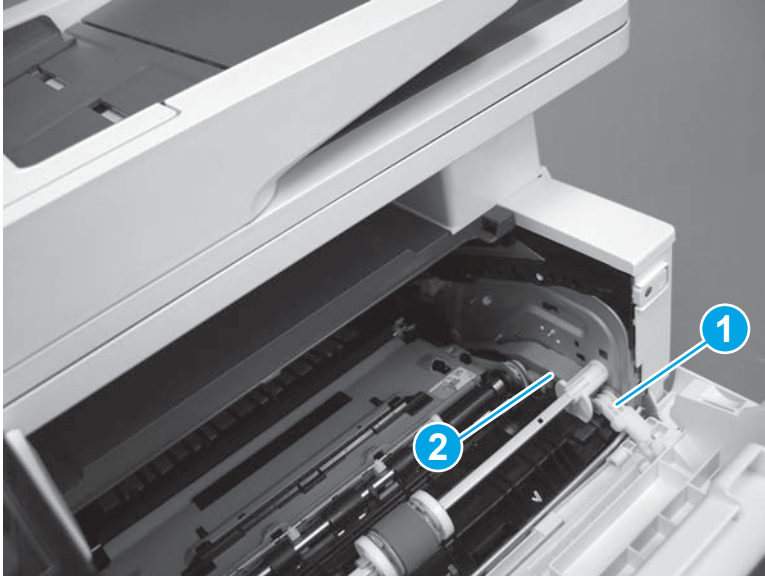
**Figure 1-940** Install the door



3. Install the link (callout 1).

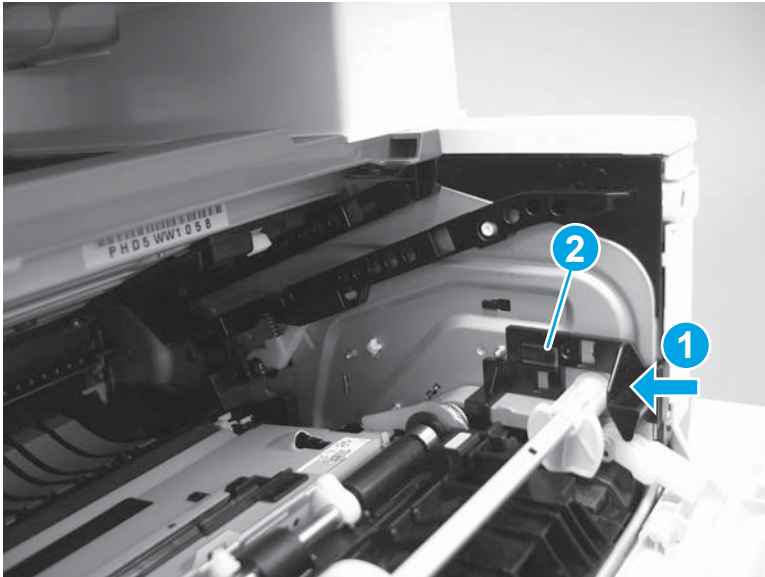
 **IMPORTANT:** Make sure that the link snaps into place on the arm (callout 2). The link actuates the fuser pressure-release mechanism.

**Figure 1-941** Install the pressure-release link



4. Slide the guide into the printer (callout 1), and then make sure that the tab (callout 2) snaps into place to secure the guide to the chassis.

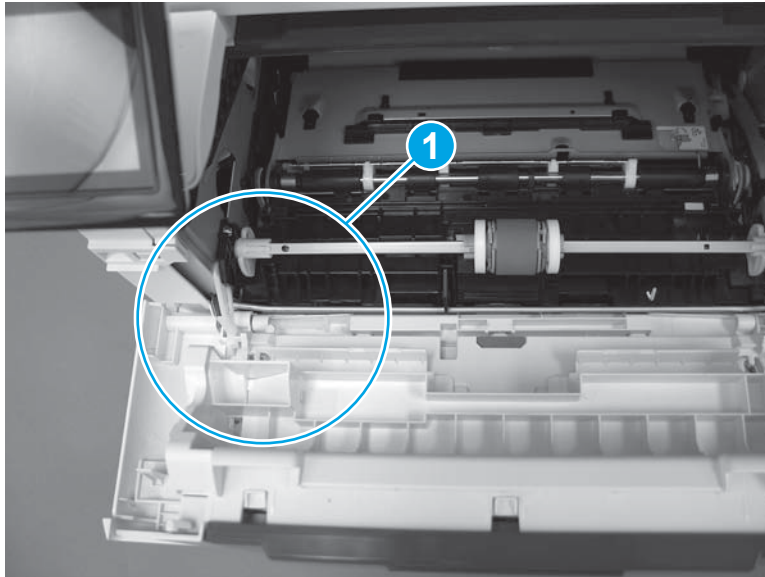
**Figure 1-942** Install the guide






5. Position the shaft on the door, and then align the left-side hinge on the door with the hole in the chassis (callout 1).

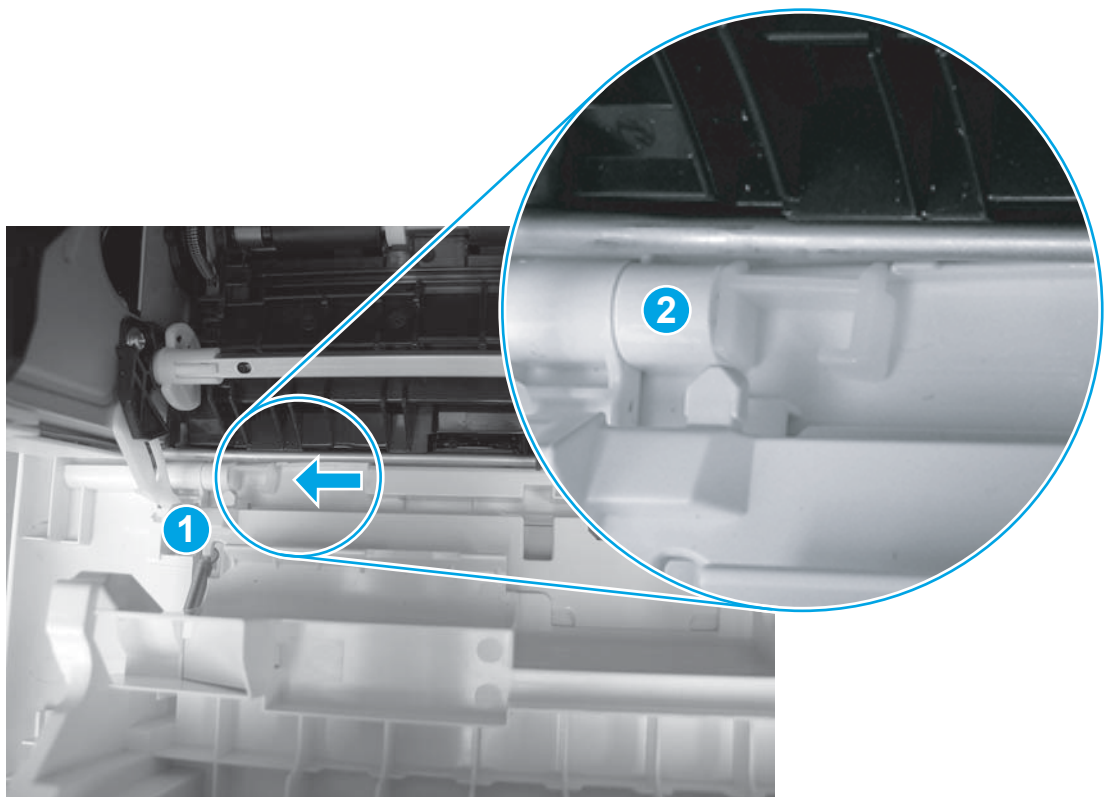
**Figure 1-943** Align the hinge



6. Push the shaft towards the left side of the printer to install it (callout 1).

 **Reinstallation tip:** Make sure that the support shaft is fully installed and correctly orientated (callout 2) so that it will not interfere with the door opening and closing.

**Figure 1-944** Install the support shaft



### Step 11: Install Tray 2

- ▲ Slide the tray straight into the printer to install it.

**Figure 1-945** Install the tray



## Removal and replacement: Laser scanner assembly

- [Introduction](#)
- [Step 1: Remove Tray 2](#)
- [Step 2: Remove the cartridge door assembly](#)
- [Step 3: Remove the left cover](#)
- [Step 4: Remove the right cover](#)
- [Step 5: Remove the integrated scanner assembly \(M427/M246\)](#)
- [Step 6: Remove the control panel \(M427/M246\)](#)
- [Step 7: Remove the top cover \(M427/M426\)](#)
- [Step 8: Remove the top cover \(M403/M402\)](#)
- [Step 9: Remove the paper delivery tray \(output bin\)](#)
- [Step 10: Remove the laser scanner assembly](#)
- [Step 11: Unpack the replacement assembly](#)
- [Step 12: Install the laser scanner assembly](#)
- [Step 13: Install the paper delivery tray \(output bin\)](#)
- [Step 14: Install the top cover \(M403/M402\)](#)
- [Step 15: Install the top cover \(M427/M426\)](#)
- [Step 16: Install the control panel \(M427/M246\)](#)
- [Step 17: Install the integrated scanner assembly \(M427/M246\)](#)
- [Step 18: Install the right cover](#)
- [Step 19: Install the left cover](#)
- [Step 20: Install the cartridge door assembly](#)
- [Step 21: Install Tray 2](#)

### Introduction


This document provides the procedures to remove and replace the laser scanner assembly.

### Before performing service

#### Turn the printer power off

- Disconnect the power cable.

---

 **WARNING!** To avoid damage to the printer, turn the printer off, wait 30 seconds, and then remove the power cable before attempting to service the printer.

---

Use the table below to identify the correct part number for your printer. To order the part, go to [www.hp.com/buy/parts](http://www.hp.com/buy/parts).

---

**Laser scanner assembly part number**

---

RM2-5528-000CN

Laser scanner assembly

---

**Required tools**

- #2 Phillips screwdriver with a magnetic tip.

**After performing service****Turn the printer power on**

- Connect the power cable.
- Use the power switch to turn the power on.

**Post service test**

Make sure that the printer initializes to a **Ready** state.

Print a configuration page to make sure that the printer is functioning correctly.

**Step 1: Remove Tray 2**

- ▲ Pull the tray straight out of the printer to remove it.

**Figure 1-946** Remove the tray**Step 2: Remove the cartridge door assembly**

---

**NOTE:** If the toner cartridge was not removed prior to servicing the printer, remove it now.

---

1. Release one tab (callout 1), and then slide shaft (callout 2) in the direction the arrow indicates and remove it.

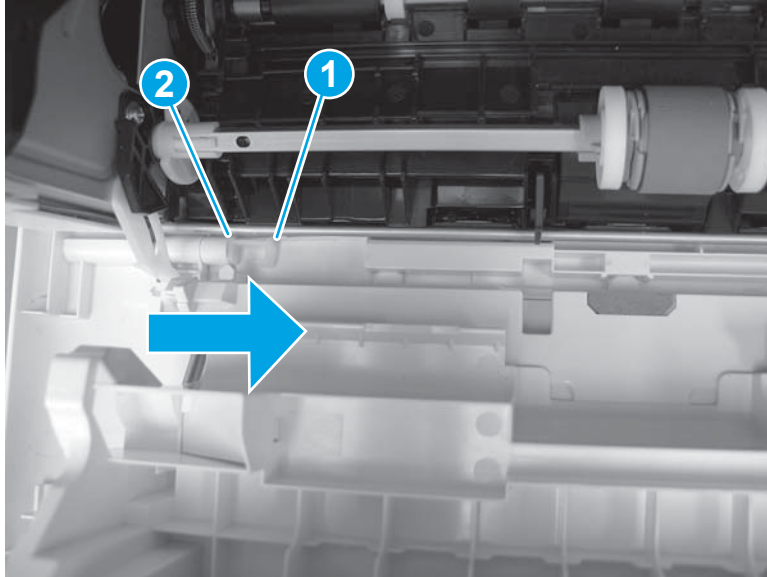


---

**TIP:** It might be easier to release the support shaft by using a small flat-blade screwdriver.

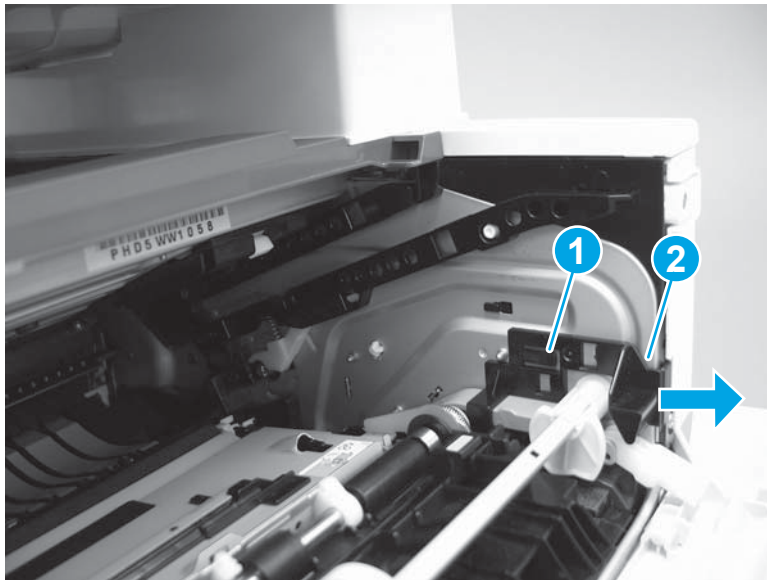
---

**Figure 1-947** Release the support shaft



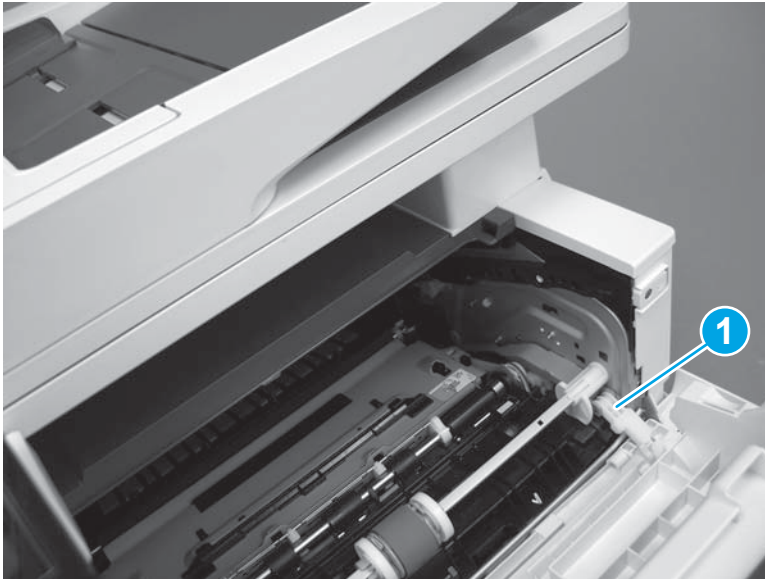
2. Release one tab (callout 1), and then slide the guide (callout 2) in the direction the arrow indicates and remove it.

**Figure 1-948** Remove the guide



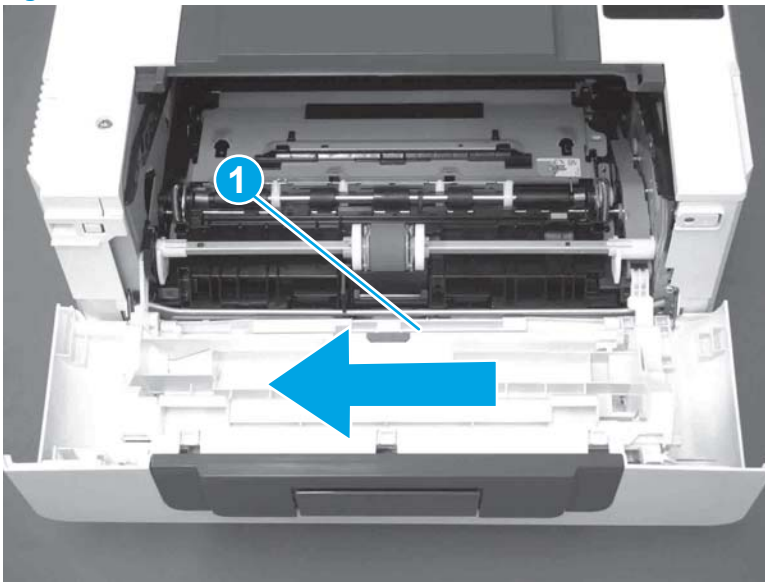
3. Remove the link arm (callout 1).

**Figure 1-949** Remove the link arm



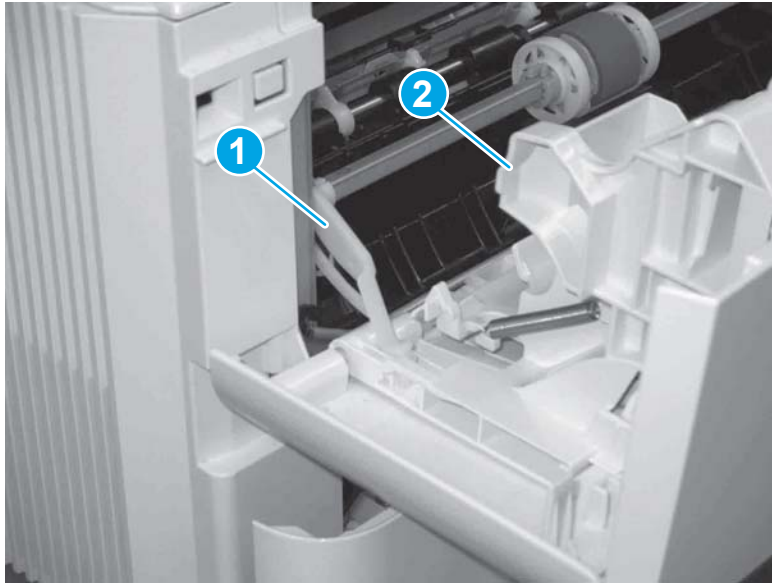
4. Slide the cartridge door assembly (callout 1) in the direction the arrow indicates and remove it.

**Figure 1-950** Remove the door



5. Remove the link (callout 1) from the cartridge door assembly (callout 2).

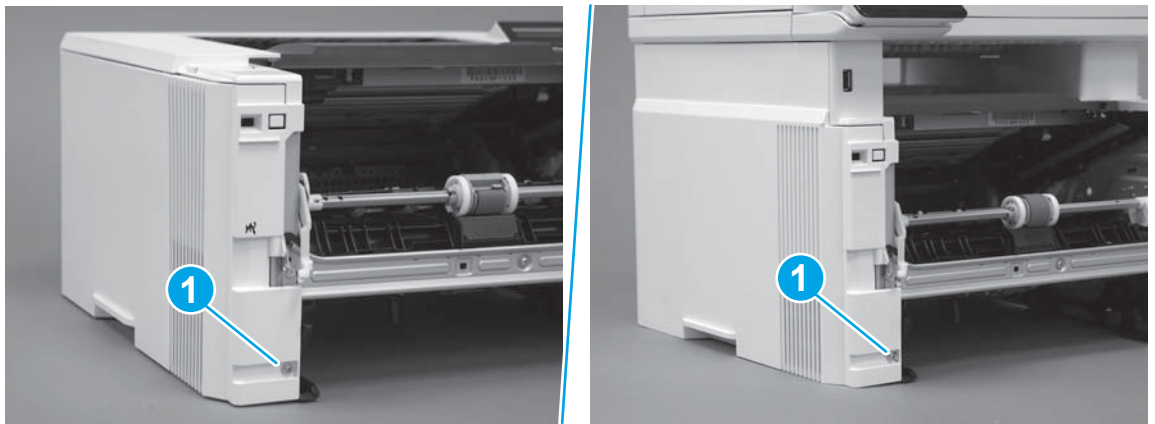
**Figure 1-951** Release the left-side retainer arm



### Step 3: Remove the left cover

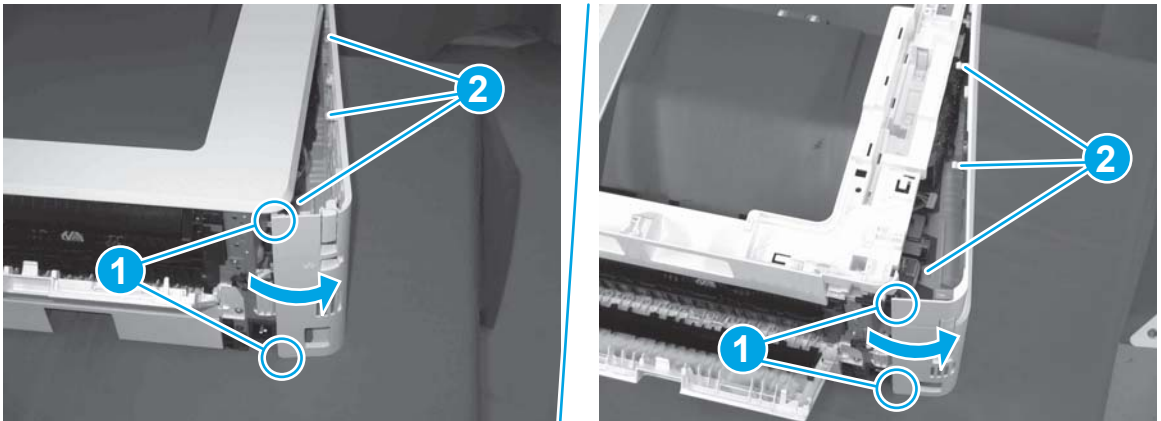
1. Remove one screw (callout 1).

**Figure 1-952** Remove one screw



2. Open the rear door, release two bosses (callout 1), and then release three tabs (callout 2).

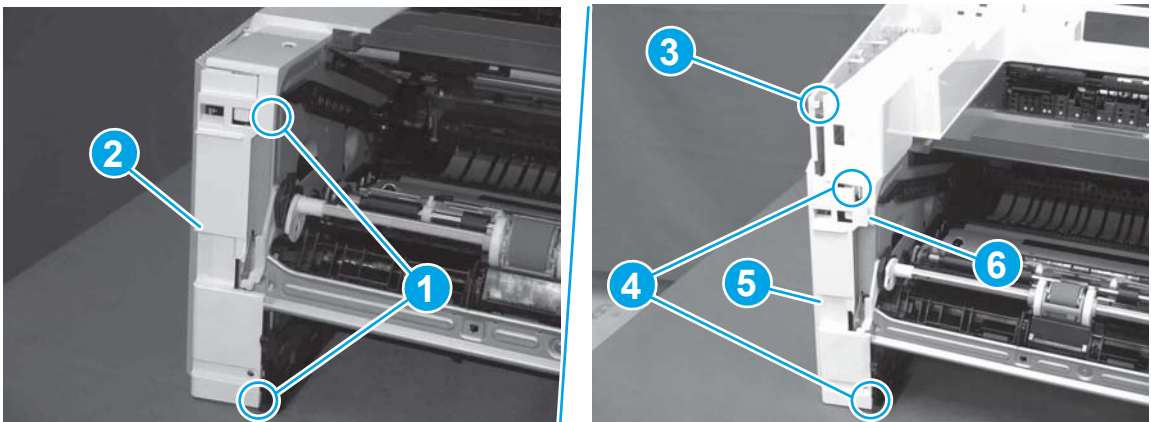
**Figure 1-953** Release two bosses and three tabs



3. At the front of the printer, do one of the following:
  - **M403/M402:** Release two bosses (callout 1), and then remove the cover (callout 2).
  - **M427/M426:** Release one tab (callout 3), two bosses (callout 4), and then remove the cover (callout 5).

**CAUTION:** Be careful when releasing the upper bosses on the M427/M426 cover. One portion of the cover (callout 6) is fragile and is easily broken.

**Figure 1-954** Remove the cover



#### Step 4: Remove the right cover

1. Remove one screw (callout 1).

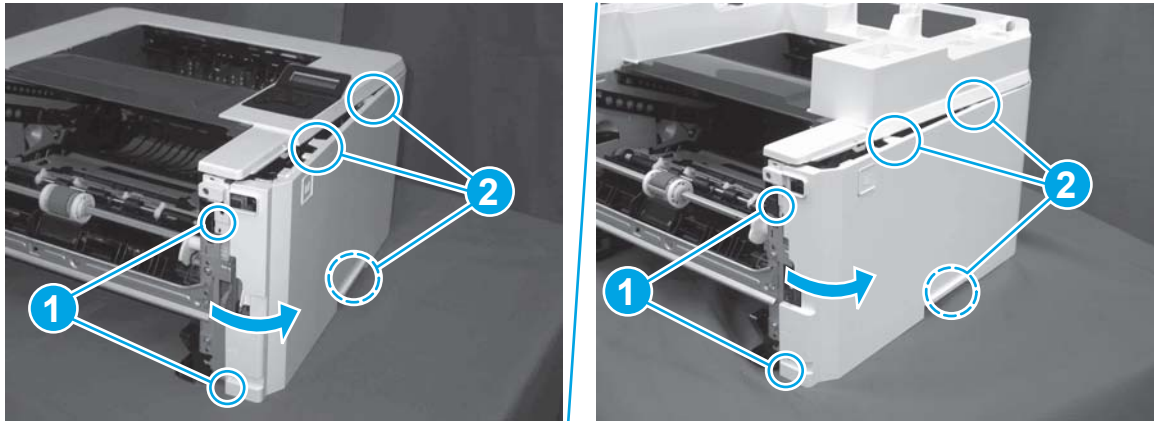


**Figure 1-955** Remove one screw



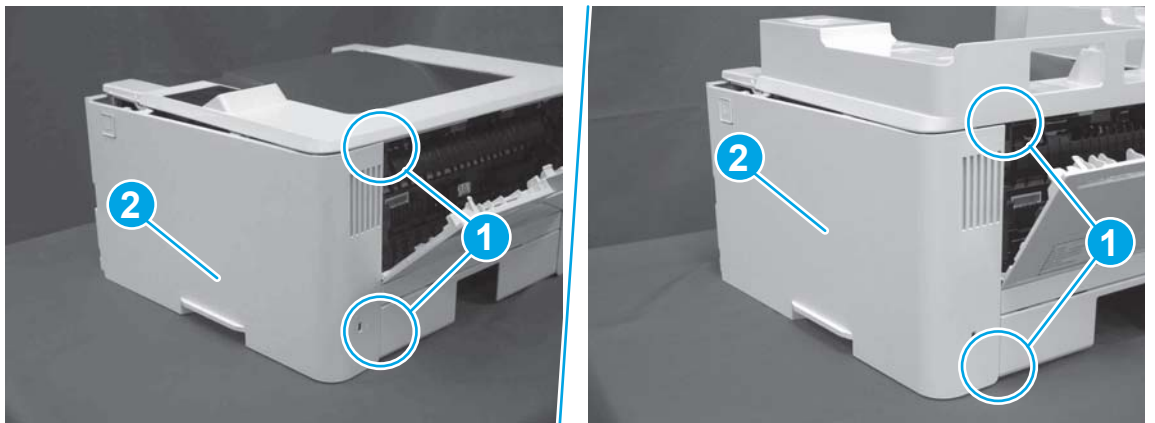
2. At the front of the printer, release two bosses (callout 1), and then release three tabs (callout 2).

**Figure 1-956** Release two bosses and three tabs





3. Open the rear door, release two bosses (callout 1), and then remove the cover (callout 2).

**Figure 1-957** Remove the cover



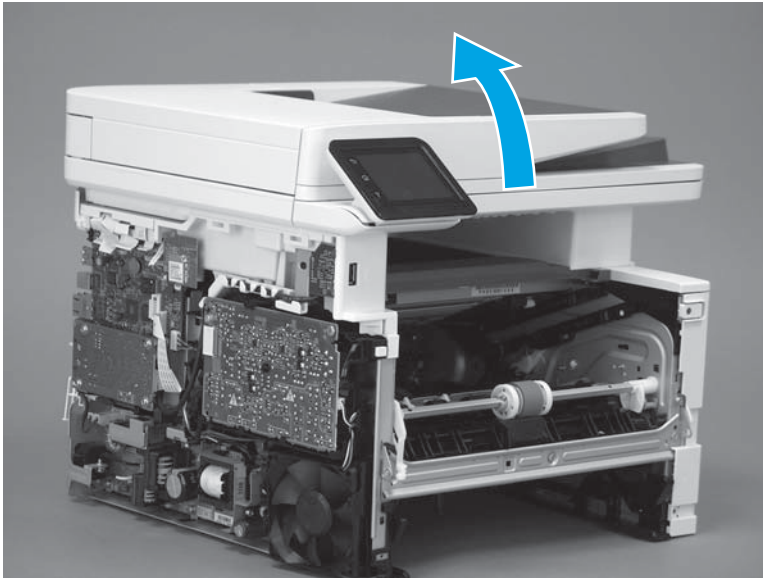
### Step 5: Remove the integrated scanner assembly (M427/M246)

 **NOTE:** The step is for the M427/M426 printer. For the M403/M402, skip this step and go to [Step 8: Remove the top cover \(M403/M402\)](#) on page 541.

 **NOTE:** M427/M426 models only. The integrated scanner assembly (ISA) includes the sub-scanner assembly (SSA) and the automatic document feeder (ADF).

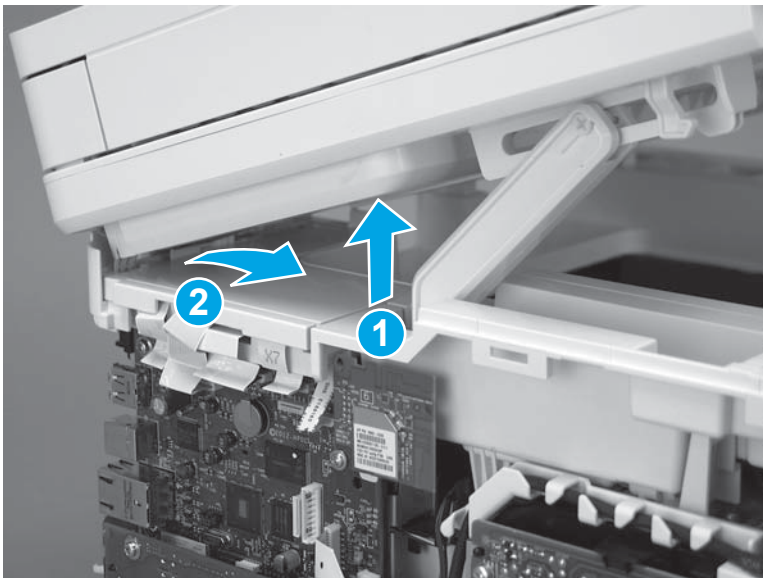
1. Raise the ISA.

**Figure 1-958** Raise the ISA



2. Release the ISA flat-flexible cable (FFC) cover (callout 1), and then remove it (callout 2).

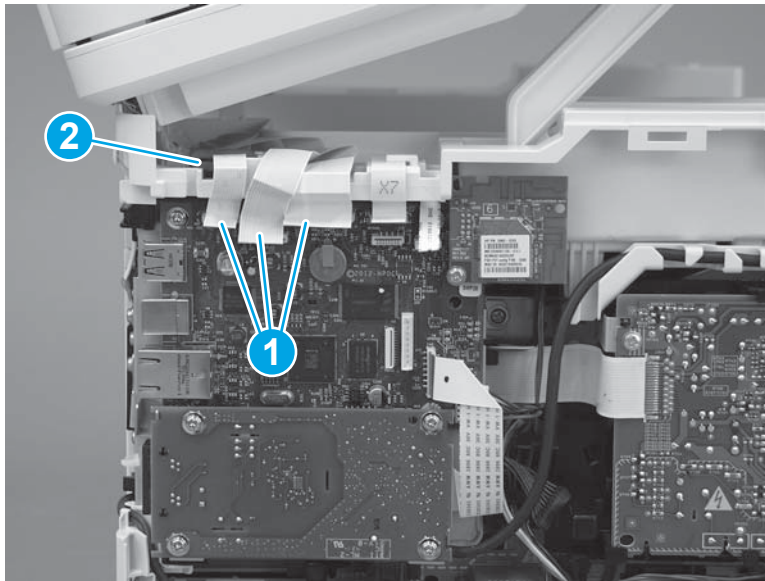
**Figure 1-959** Remove the ISA FFC cover



3. Disconnect three FFCs (callout 1), and then remove the ferrite (callout 2) from the holder.

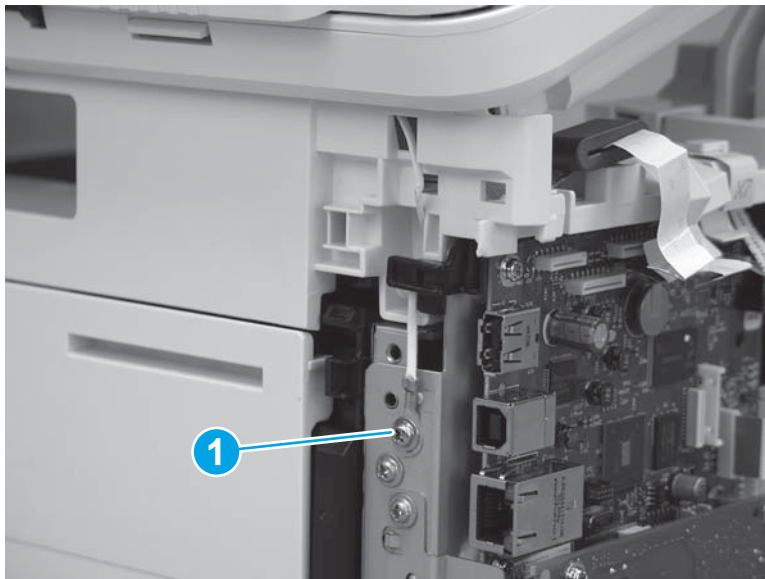
**CAUTION:** The ferrite is not captive on the FFC. Do not lose the ferrite while handling the ISA.

**Figure 1-960** Disconnect three FFCs



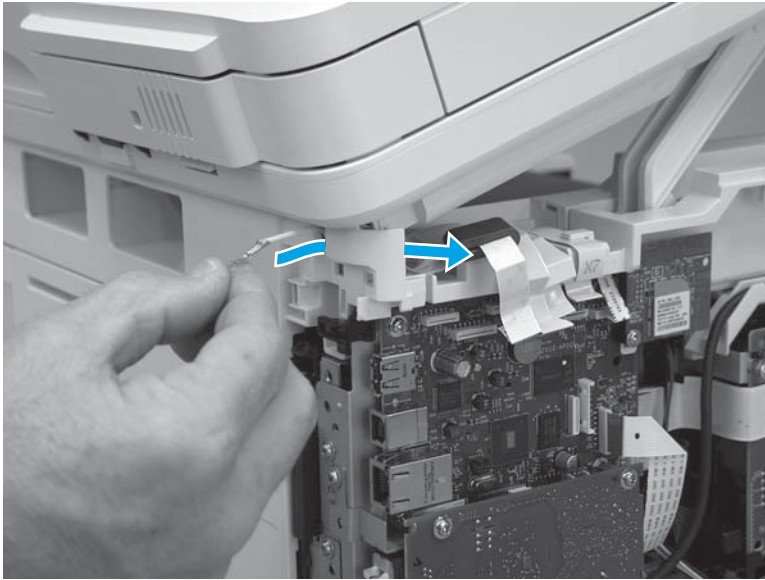
4. Remove one screw (callout 1).

**Figure 1-961** Remove one screw



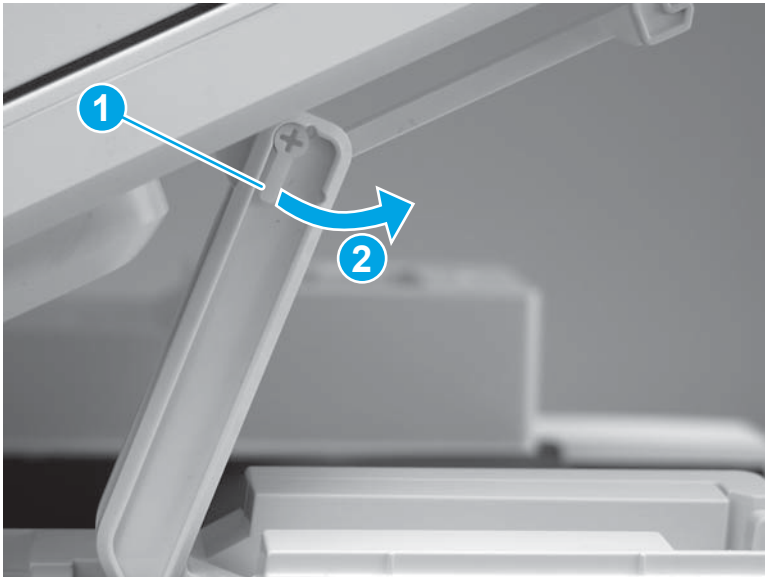
5. Pass the ground wire through the opening in the top cover.

**Figure 1-962** Pass the wire through the opening



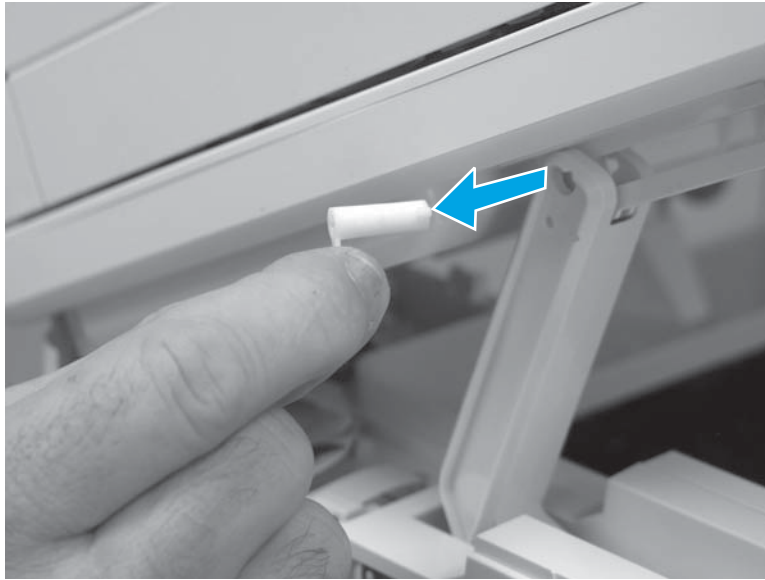
6. Release one tab (callout 1), and then rotate the ISA slider pin (callout 2) towards the front of the printer to release it.

**Figure 1-963** Release one tab and rotate the slider pin



7. Remove the slider pin.

**Figure 1-964** Remove the slider pin



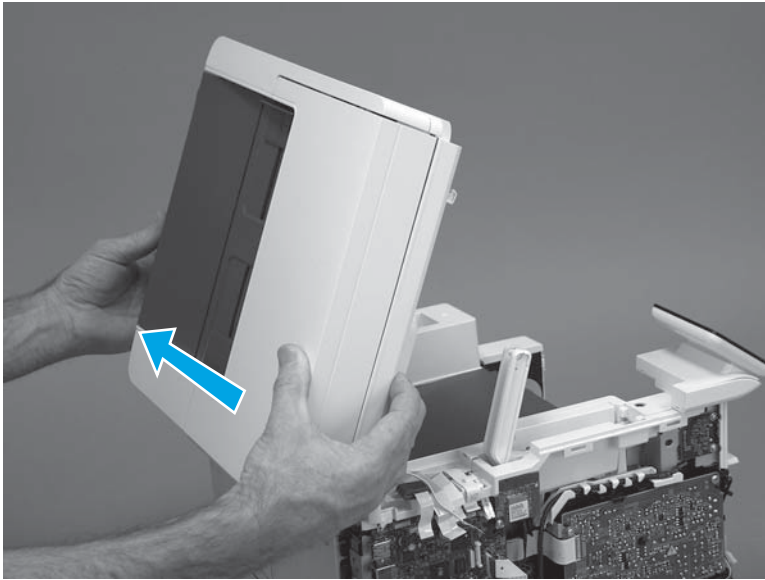
8. Rotate the ISA towards the rear of the printer until it stops.

**Figure 1-965** Rotate the ISA towards the rear of the printer



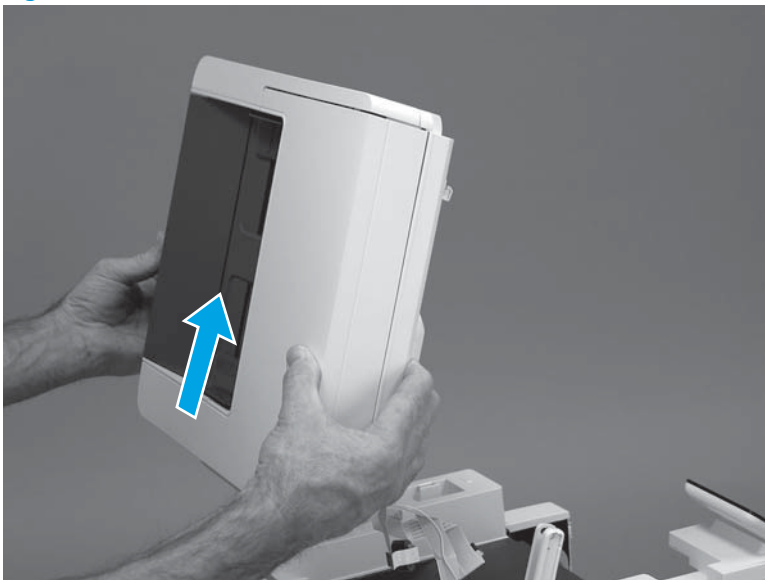
- Slide the ISA as shown to release it.

**Figure 1-966** Release the ISA



- Remove the ISA.

**Figure 1-967** Remove the ISA



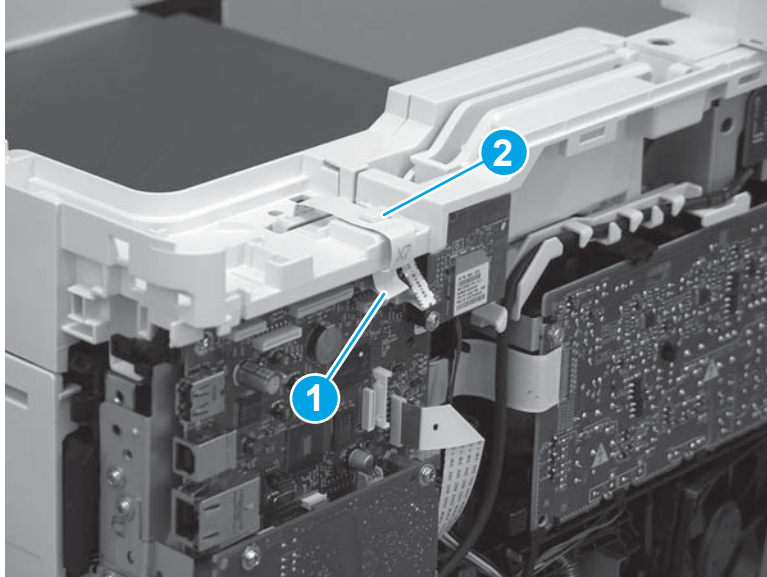
### Step 6: Remove the control panel (M427/M246)



**NOTE:** The step is for the M427/M426 printer. For the M403/M402, skip this step and go to [Step 8: Remove the top cover \(M403/M402\) on page 541](#).

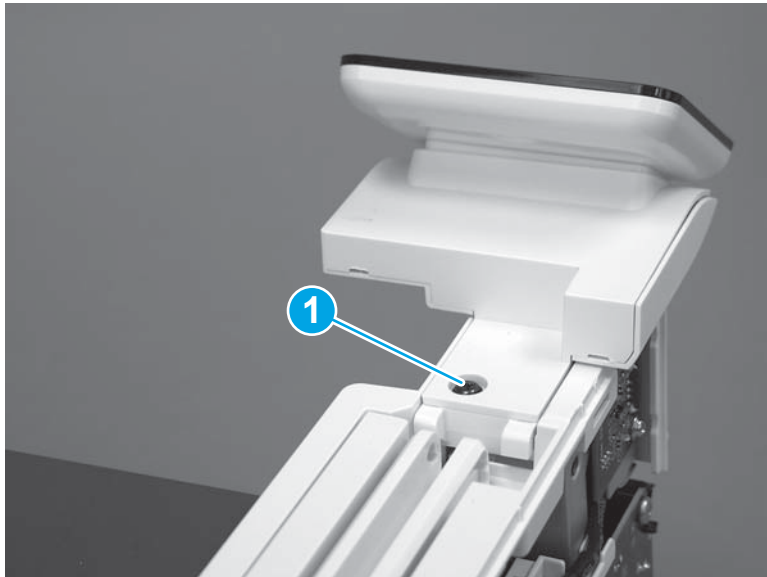
- Disconnect one FFC (callout 1; J114), and then release the FFC from the retainer (callout 2).

**Figure 1-968** Disconnect one connector



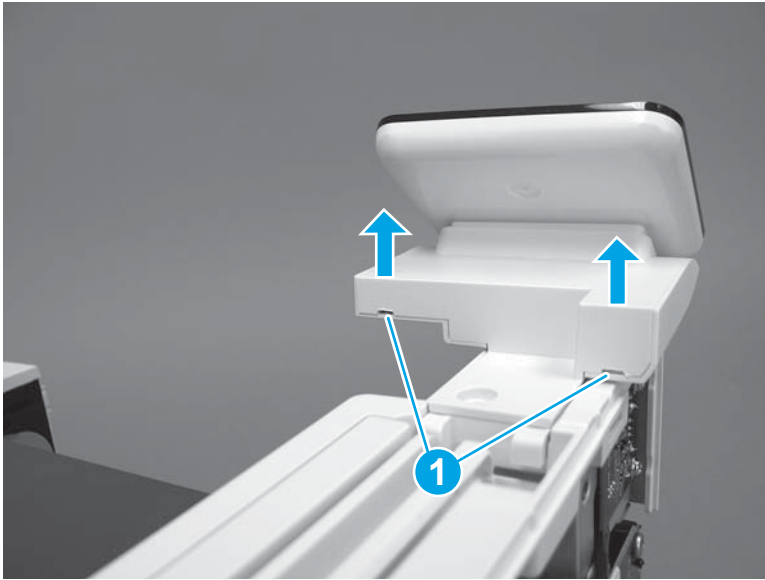
2. Remove one screw (callout 1).

**Figure 1-969** Remove one screw



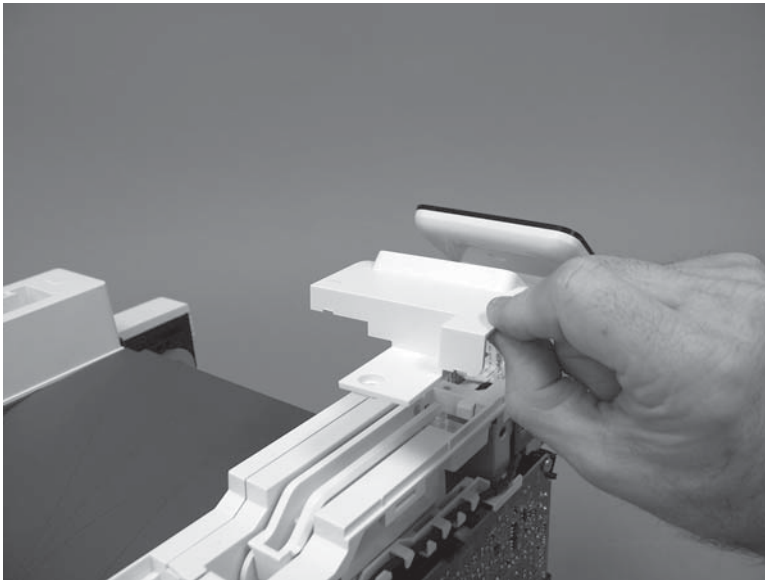
3. Use a small flat-blade screwdriver to release two tabs (callout 1) on the control-panel cable cover.

**Figure 1-970** Release two tabs



4. Remove the control-panel cable cover.

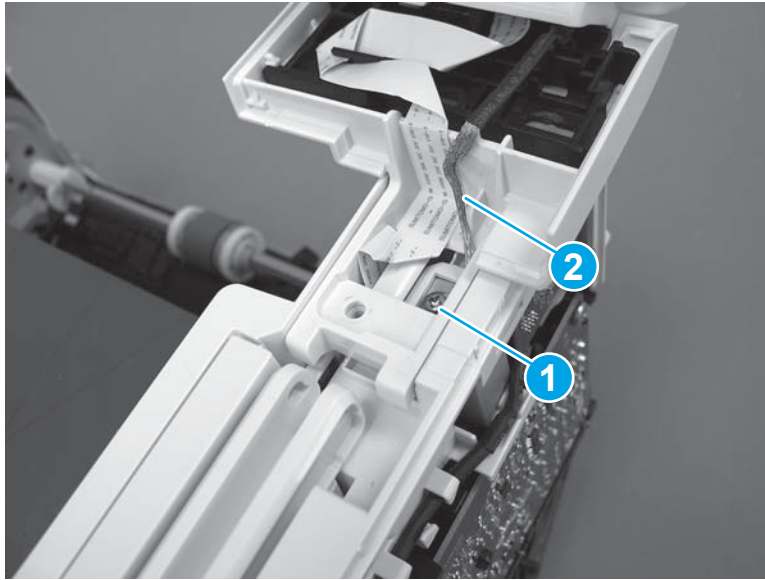
**Figure 1-971** Remove the cover





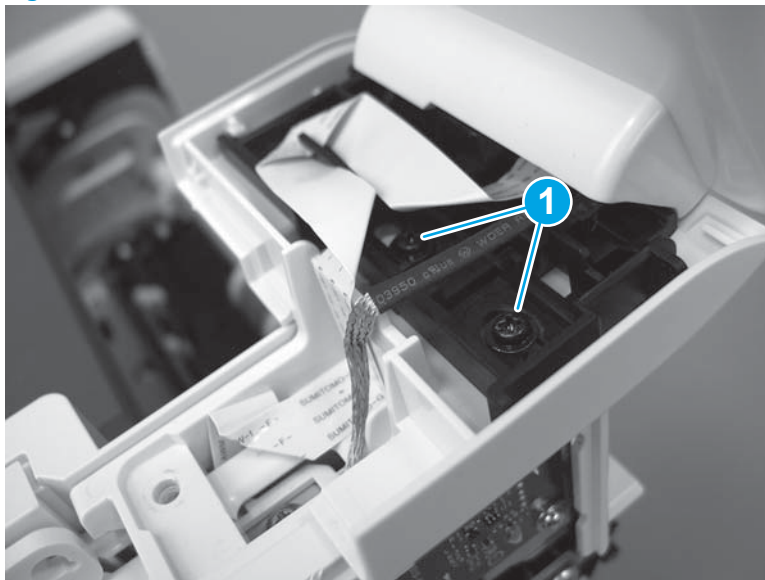
5. Remove one grounding screw (callout 1), and then move the ground cable (callout 2) out of the way.

**Figure 1-972** Remove one screw



6. Move the FFC out of the way, and then remove two screws (callout 1).

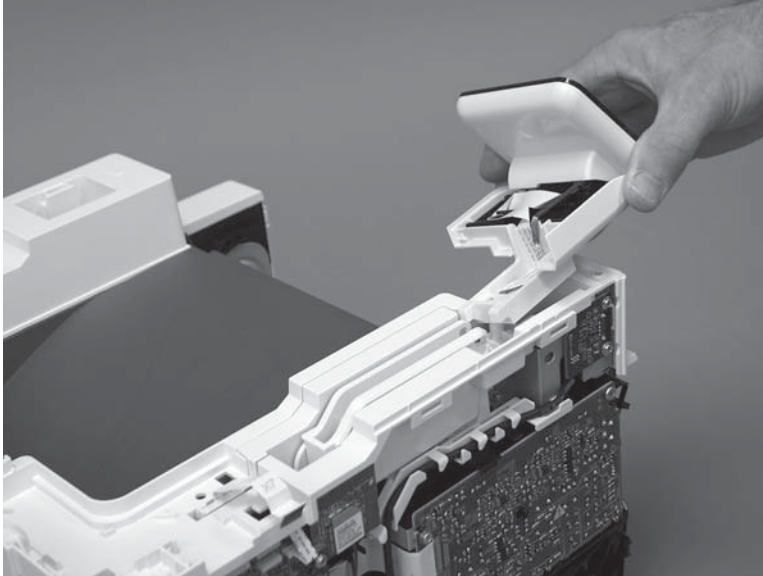
**Figure 1-973** Remove two screws



7. Slightly lift up the control-panel assembly to separate it from the top cover.

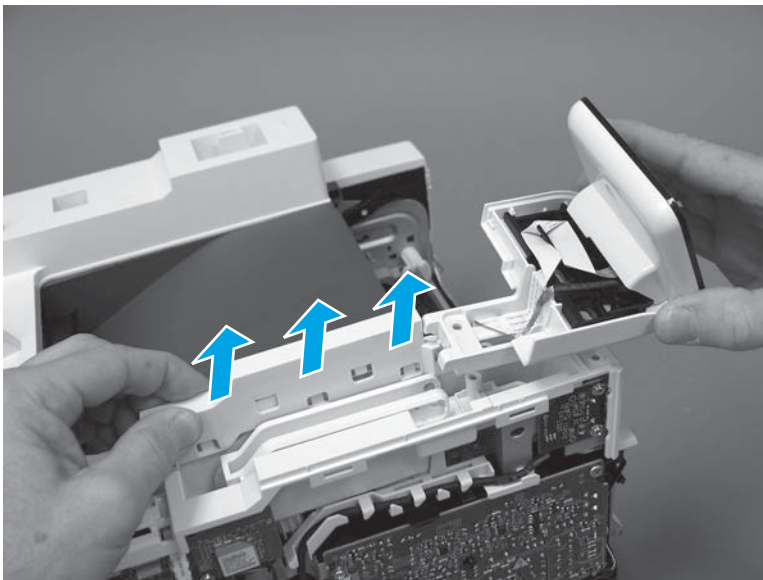
**⚠ CAUTION:** The control panel assembly is still connected to the printer by the FFC. Do not attempt to completely remove the assembly.

**Figure 1-974** Lift up the control-panel assembly



8. Lift up the control-panel FFC cover to remove the control-panel assembly.

**Figure 1-975** Remove the control-panel assembly

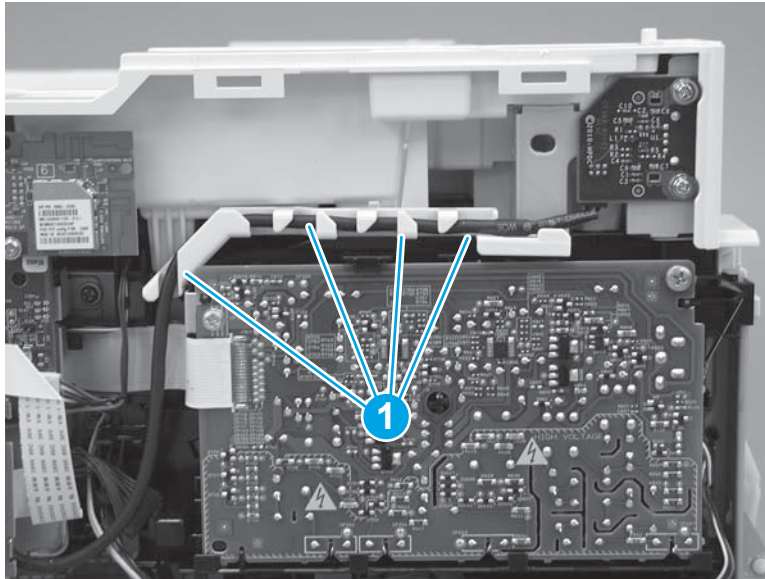


### Step 7: Remove the top cover (M427/M426)

**📝 NOTE:** The step is for the M427/M426 printer. For the M403/M402, skip this step and go to [Step 8: Remove the top cover \(M403/M402\) on page 541](#).

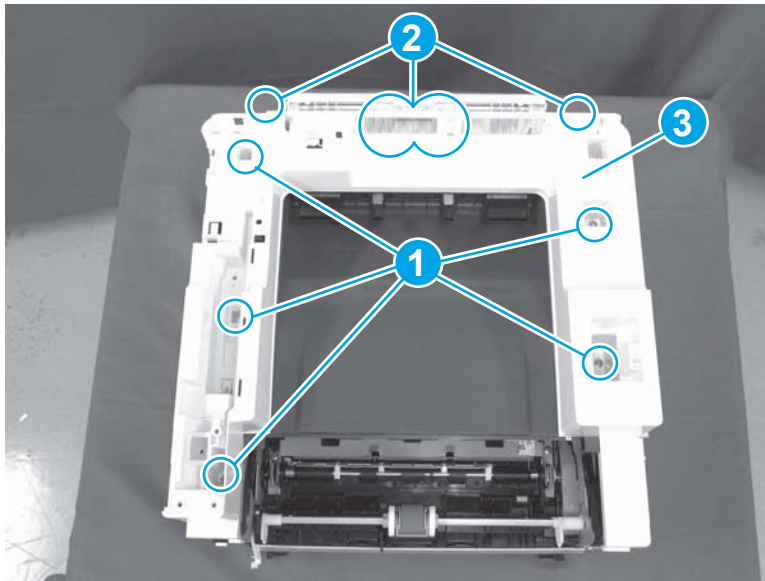
1. Release the USB cable (callout 1) from the cable guide.

**Figure 1-976** Remove the USB cable




2. Remove five screws (callout 1), release four bosses (callout 2), and then remove the top cover (callout 3).

**Figure 1-977** Remove the cover



### Step 8: Remove the top cover (M403/M402)

 **NOTE:** The step is for the M403/M402 printer. For the M427/M426, skip this step and go to [Step 9: Remove the paper delivery tray \(output bin\) on page 543.](#)

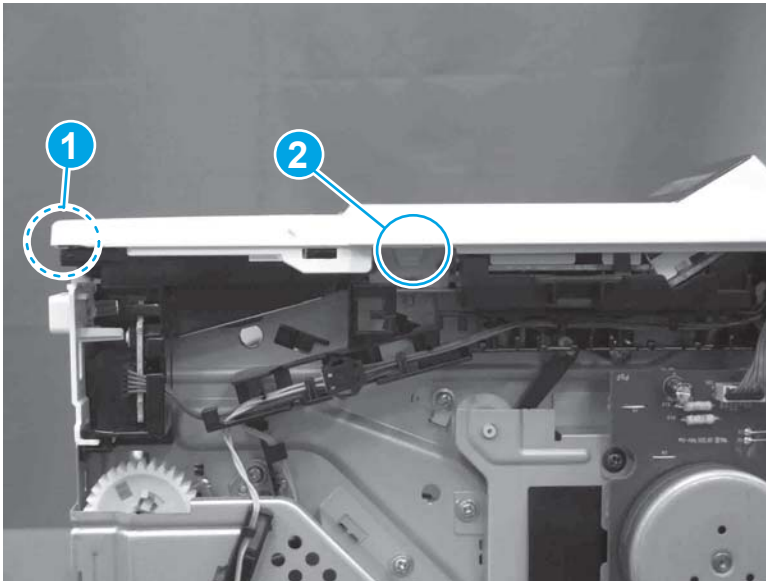
1. Remove one screw (callout 1).

**Figure 1-978** Remove one screw




2. At the right side of the printer, release the one boss (callout 1), and then release one tab (callout 2).

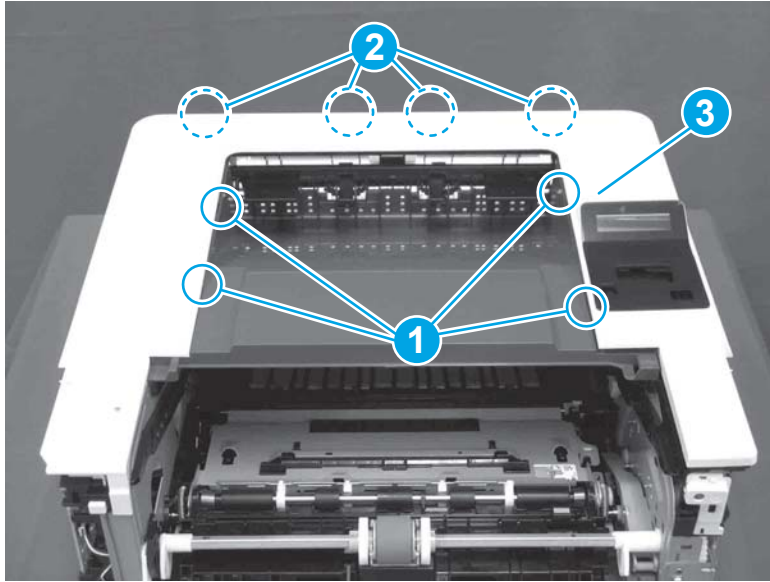
**Figure 1-979** Release one boss and one tab




3. Release four tabs (callout 1), release four bosses (callout 2), and then remove the top cover (callout 3).

 **TIP:** Open the rear door to make releasing the bosses (callout 3) easier.

**Figure 1-980** Remove the cover

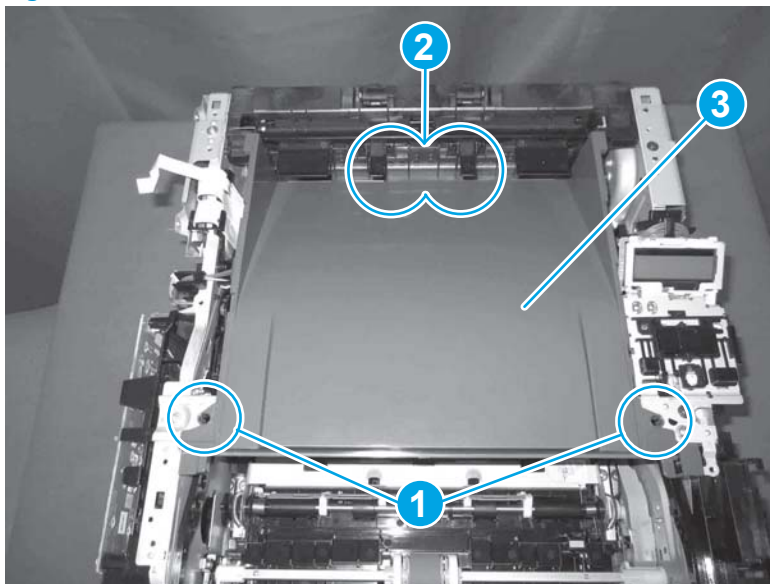


### Step 9: Remove the paper delivery tray (output bin)


 **NOTE:** This procedure shows the M403/M402 model, however, the paper delivery tray (output bin) removal is similar for the M427/M426 printer.

- ▲ Release two bosses (callout 1), release two tabs (callout 2), and then remove the paper delivery tray (output bin; callout 3).


**Figure 1-981** Release two tabs



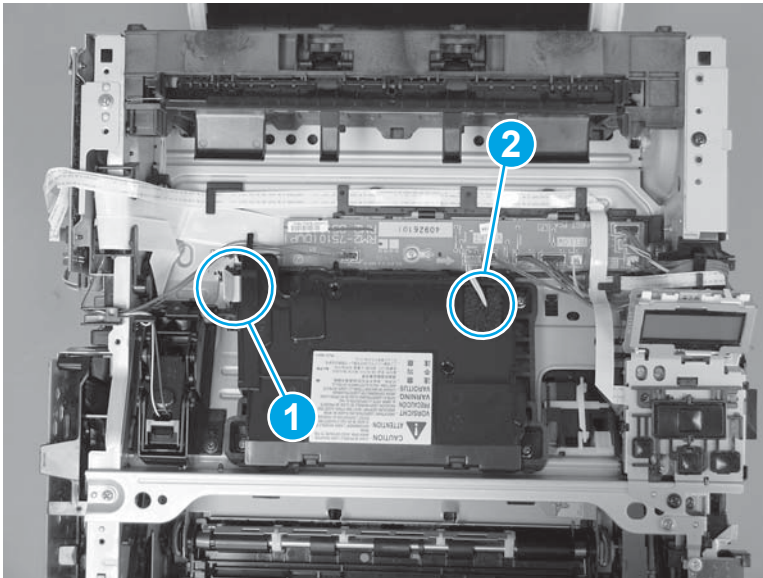
## Step 10: Remove the laser scanner assembly

 **NOTE:** The M403/M402 product is shown in this procedure. However, the procedure is valid for the M427/M426 laser scanner assembly.

1. Disconnect one flat-flexible cable (FFC) (callout 1), and one connector (callout 2).

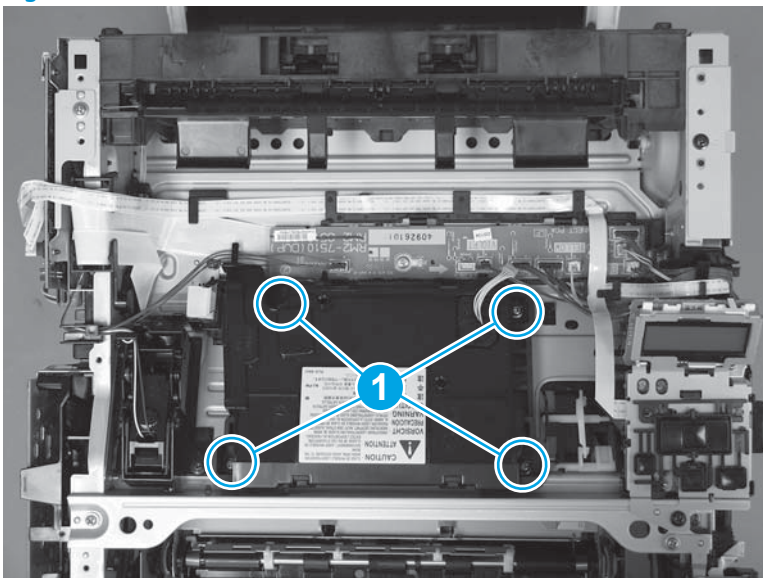
 **Reinstallation tip:** Transfer the antistatic foam pad (callout 2) from the discarded laser/scanner assembly to the replacement assembly.

**Figure 1-982** Disconnect one FFC and one connector



2. Remove four screws (callout 1), and then remove the laser scanner assembly.

**Figure 1-983** Remove the laser scanner

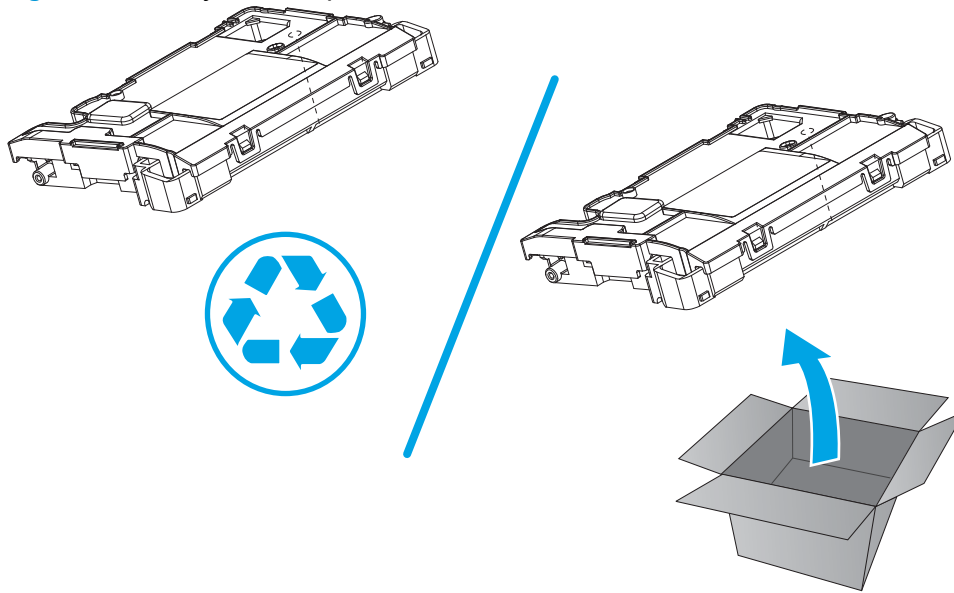


## Step 11: Unpack the replacement assembly


Unpack the replacement part from the packaging.

 **NOTE:** HP recommends responsible disposal of the defective part.


**Figure 1-984** Recycle and unpack



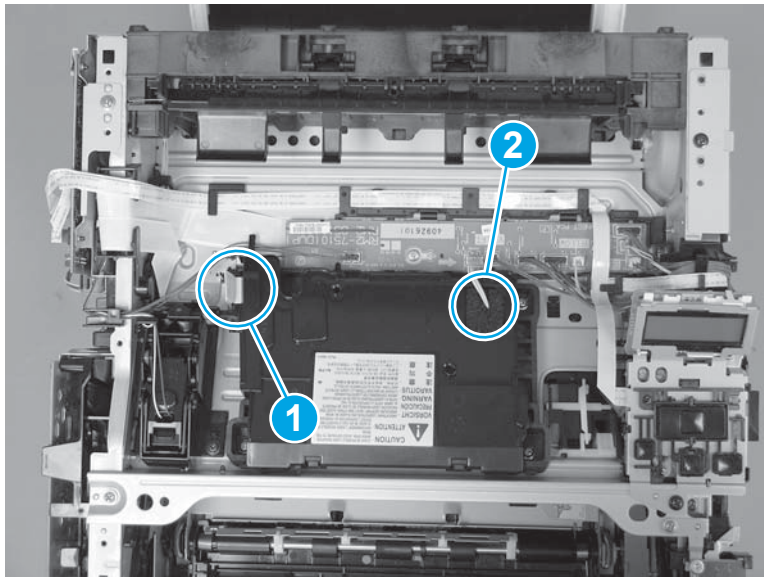
### Step 12: Install the laser scanner assembly

 **NOTE:** The M403/M402 product is shown in this procedure. However, the procedure is valid for the M427/M426 laser scanner assembly.

1. Position the laser scanner assembly in the printer, connect one FFC (callout 1) and one connector (callout 2).

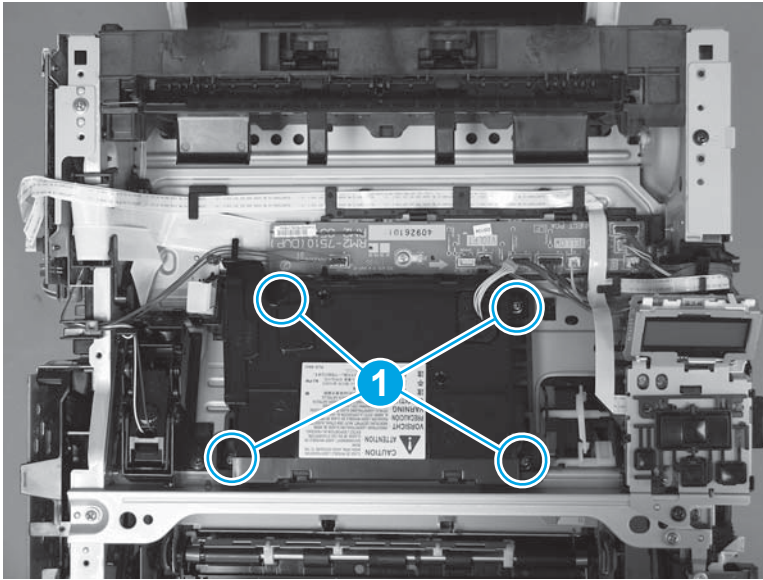
 **Reinstallation tip:** Transfer the antistatic foam pad (callout 2) from the discarded laser scanner assembly to the replacement assembly.

**Figure 1-985** Connect one FFC and one connector



2. Install four screws (callout 1).

**Figure 1-986** Install the laser scanner



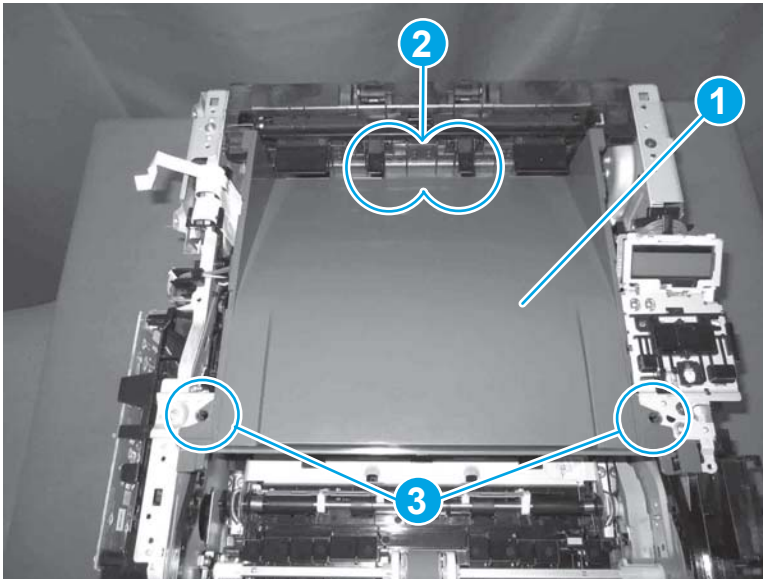
### Step 13: Install the paper delivery tray (output bin)



**NOTE:** This procedure shows the M403/M402 model, however, the paper delivery tray (output bin) removal is similar for the M427/M426 printer.

- ▲ Position the remove the paper delivery tray (output bin; callout 1) on the printer, engage two tabs (callout 2), and then engage two bosses (callout 3).

**Figure 1-987** Engage two tabs



### Step 14: Install the top cover (M403/M402)

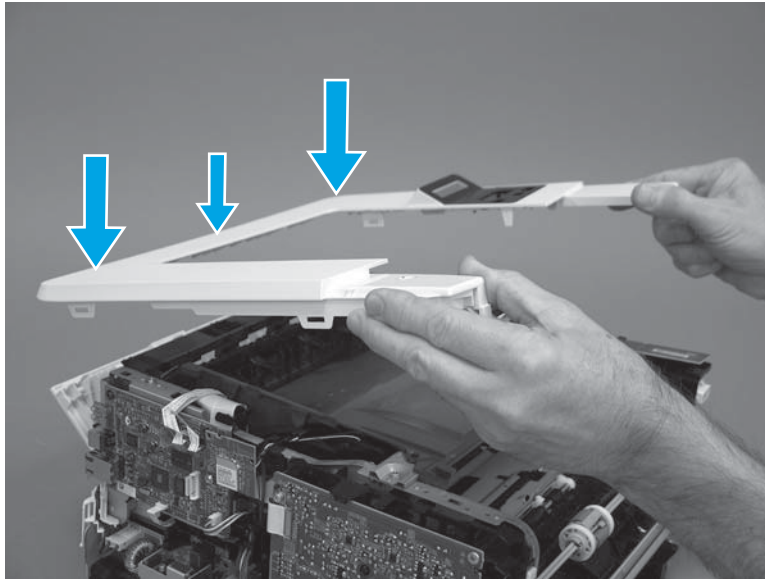


**NOTE:** The step is for the M403/M402 printer. For the M427/M426, skip this step and go to [Step 15: Install the top cover \(M427/M426\) on page 548](#).



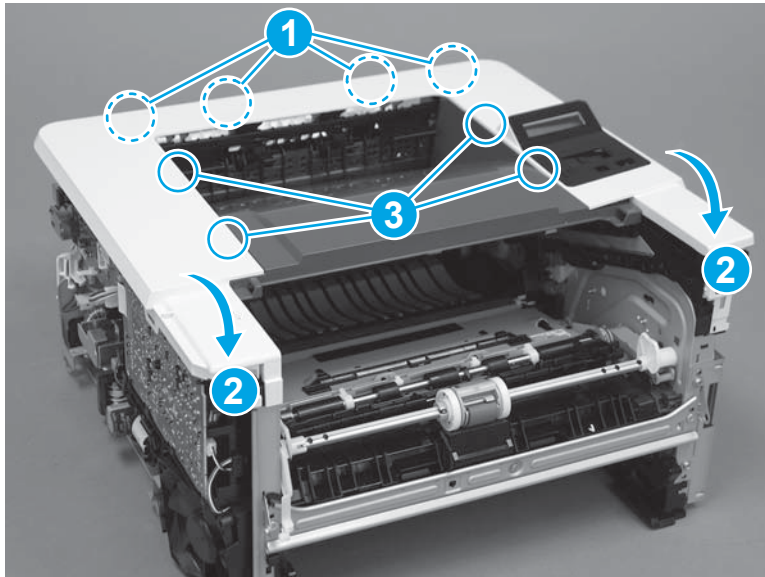
1. Position the rear edge of the cover on the printer.

**Figure 1-988** Install the cover



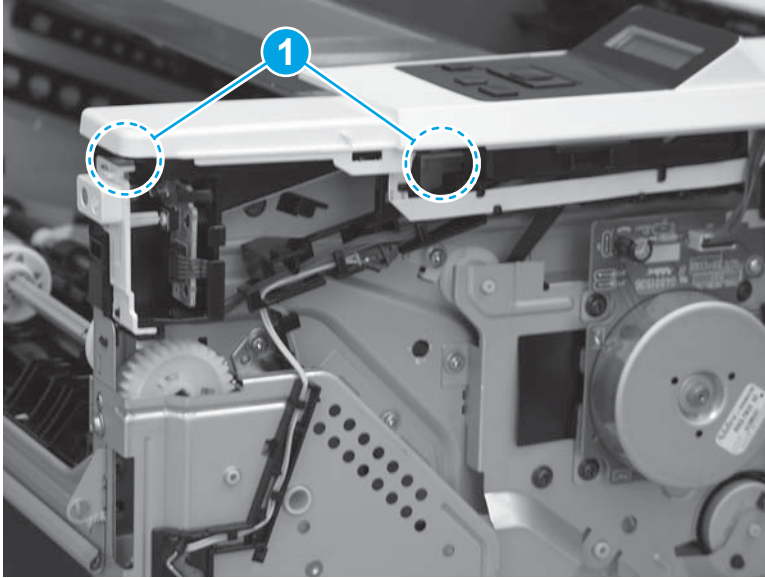
2. Engage four bosses (callout 1), rotate the front of the cover down (callout 2) and onto from the printer, and then engage four tabs (callout 3).

**Figure 1-989** Engage four bosses and tabs



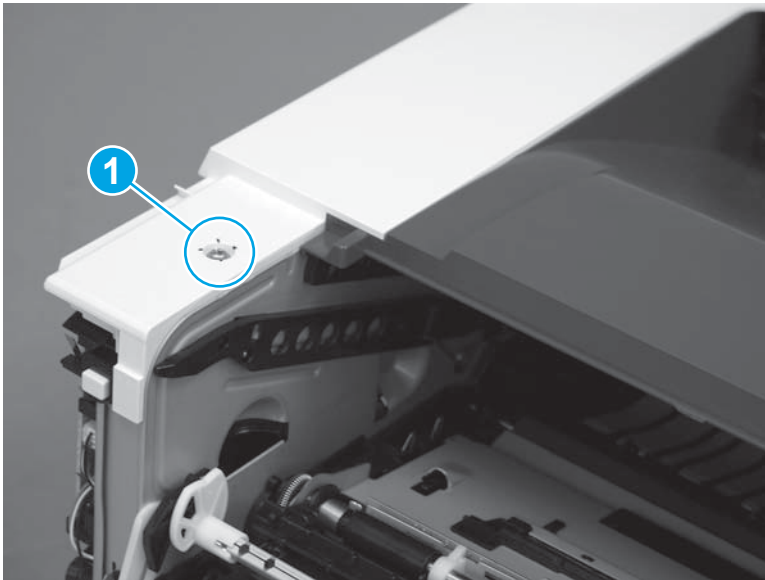
3. At the right side of the printer, engage the one boss and one tab (callout 1).

**Figure 1-990** Engage one boss and one tab




4. Install one screw (callout 1).

**Figure 1-991** Install one screw

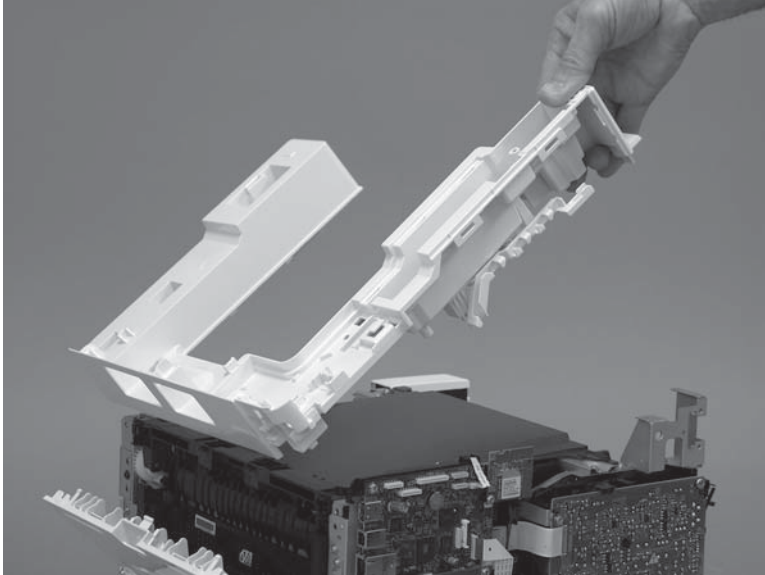


### Step 15: Install the top cover (M427/M426)

 **NOTE:** The step is for the M427/M426 printer. For the M403/M402, skip this step and go to [Step 18: Install the right cover on page 560](#).

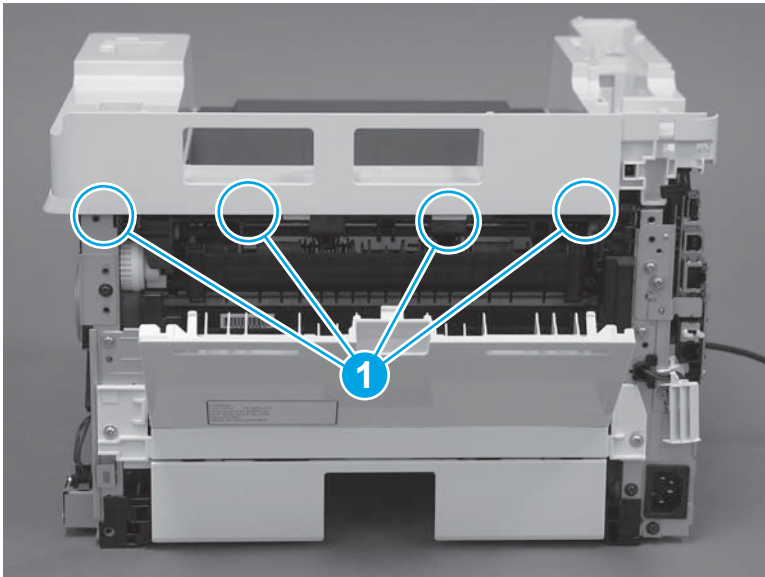
1. Position the rear edge of the top cover on the printer.

**Figure 1-992** Install the cover



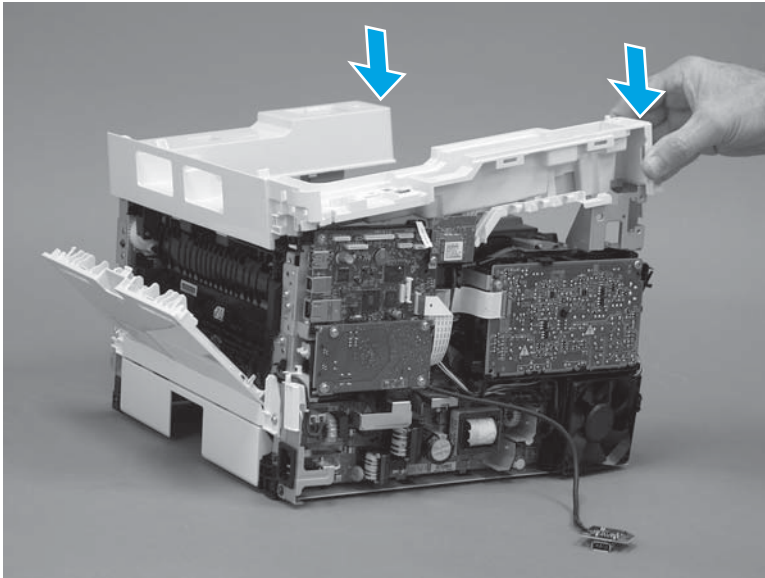
2. Engage four bosses (callout 1).

**Figure 1-993** Engage four bosses



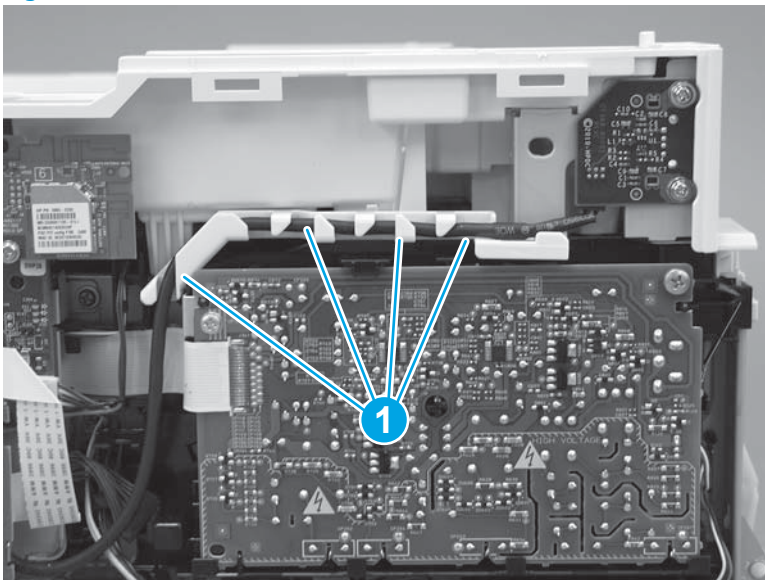
3. Rotate the front edge of the cover down.

**Figure 1-994** Rotate the front edge of the cover down



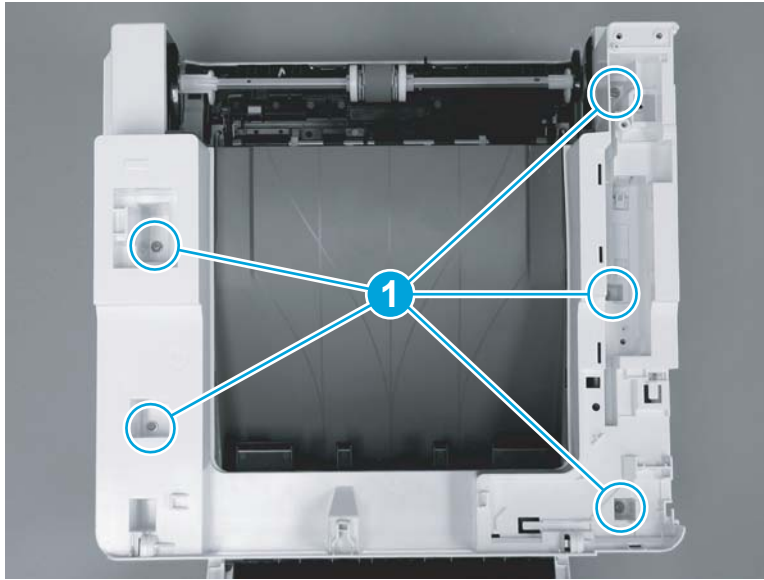
4. Install the USB cable (callout 1) in the guide.

**Figure 1-995** Install the USB PCA




5. Install five screws (callout 1).

**Figure 1-996** Install five screws

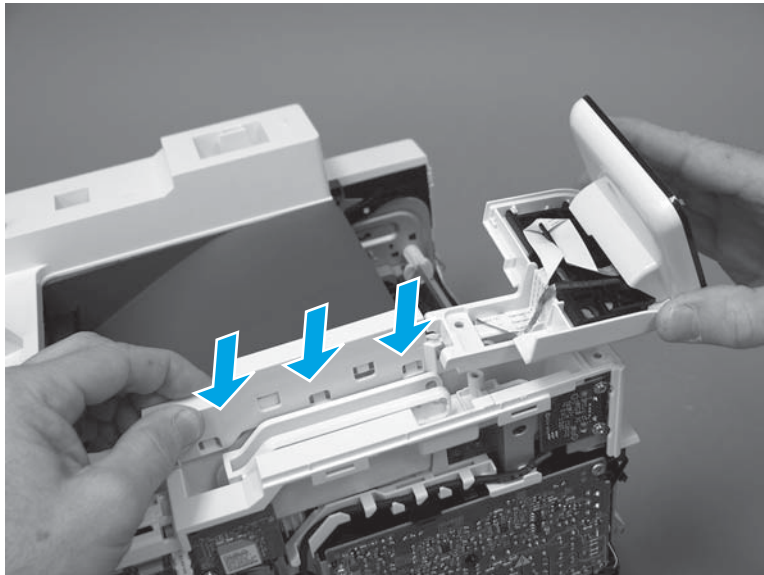


#### Step 16: Install the control panel (M427/M246)

 **NOTE:** The step is for the M427/M426 printer. For the M403/M402, skip this step and go to [Step 18: Install the right cover on page 560](#).

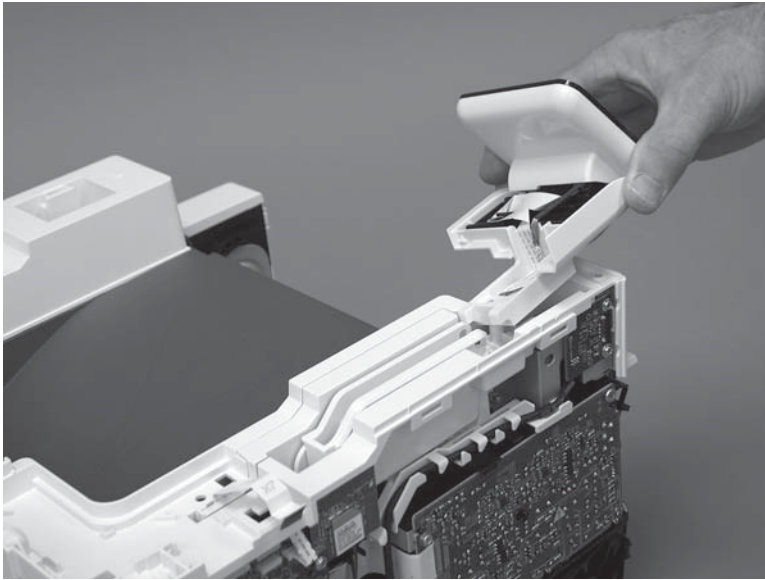
1. Slide the control-panel FFC cover into the slot in the top cover (next to the document feeder support arm) to install it.

**Figure 1-997** Install the control-panel FFC cover



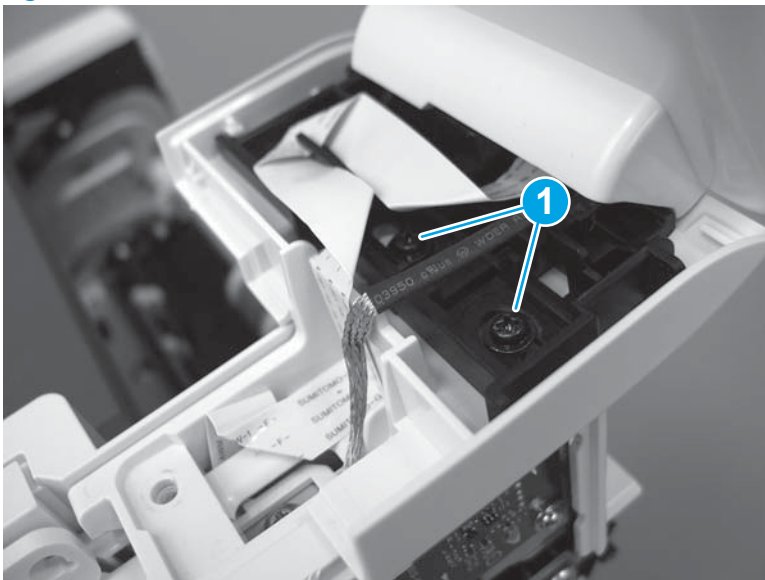
2. Install the control-panel assembly on the top cover.

**Figure 1-998** Install the control-panel assembly



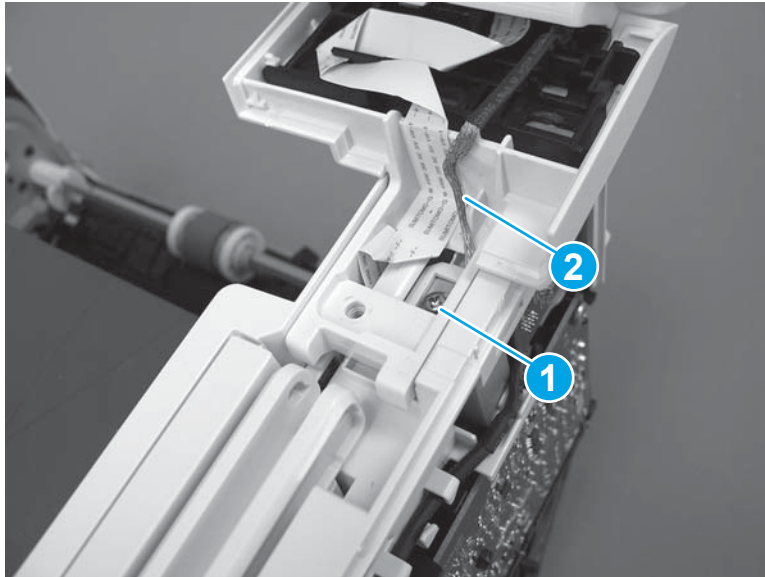
3. Move the FFC out of the way, and then install two screws (callout 1).

**Figure 1-999** Install two screws



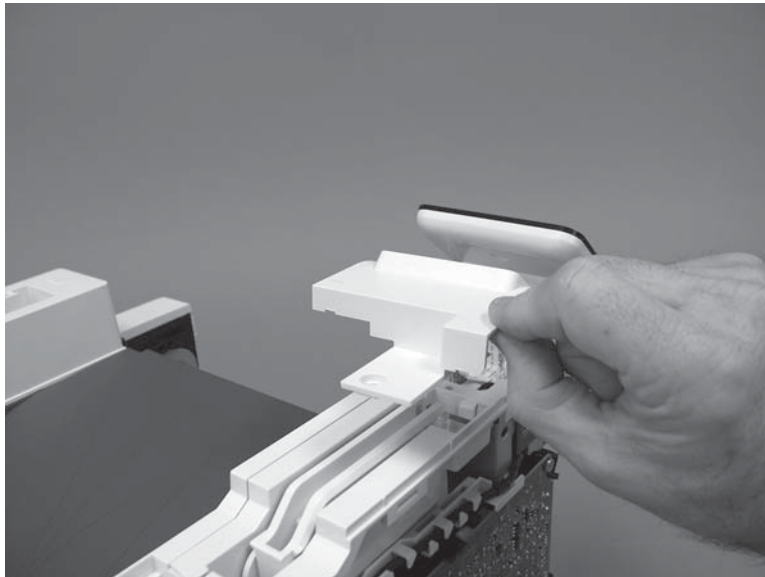
4. Install one grounding screw (callout 1), and then make sure that the ground cable (callout 2) is properly routed.

**Figure 1-1000** Remove one screw



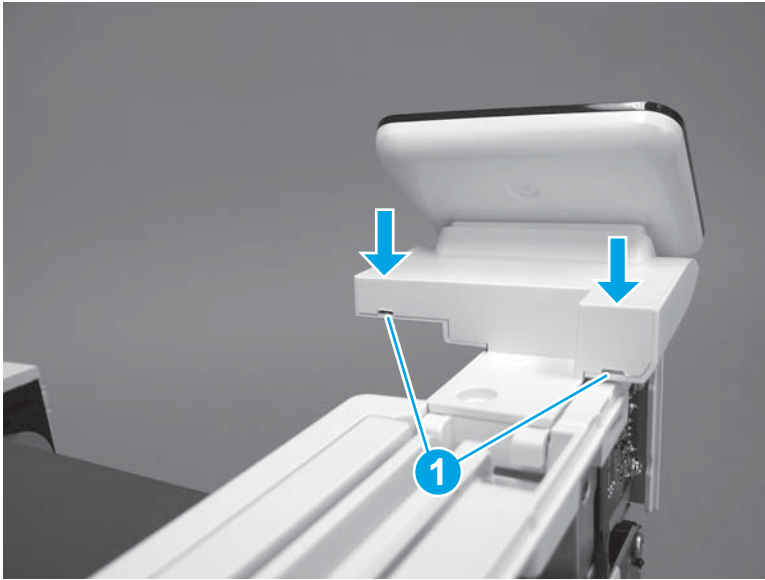
5. Install the control-panel cable cover.

**Figure 1-1001** Install the cover



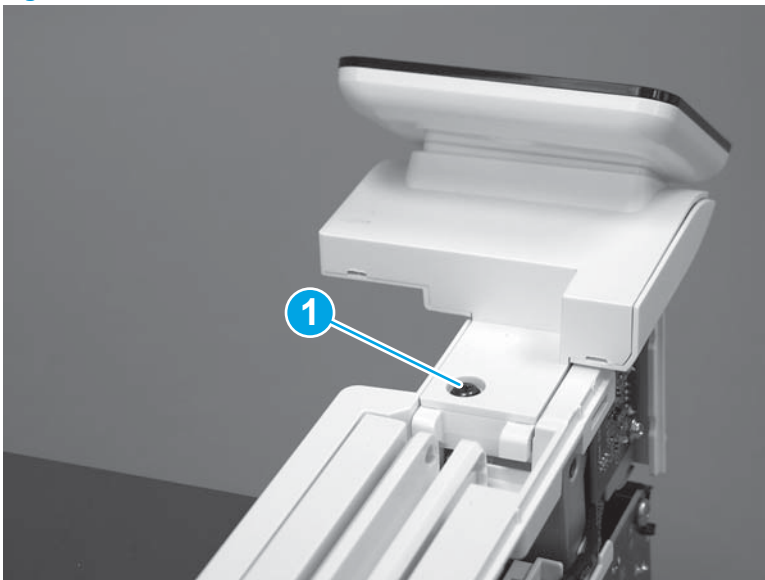
6. Make sure that the two tabs (callout 1) on the cover snap into place.

**Figure 1-1002** Engage two tabs



7. Install one screw (callout 1).

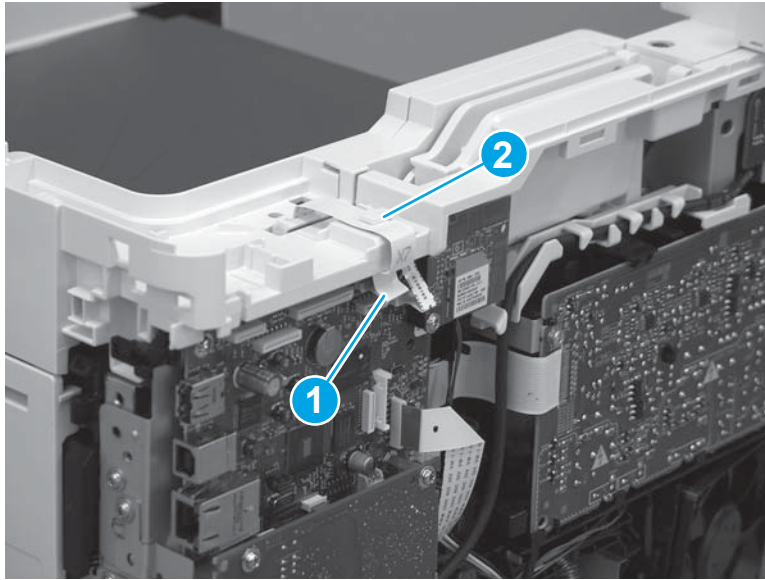
**Figure 1-1003** Install one screw







8. Install the FFC in the retainer (callout 1), and then connect one FFC (callout 2; J114).

**Figure 1-1004** Connect one connector



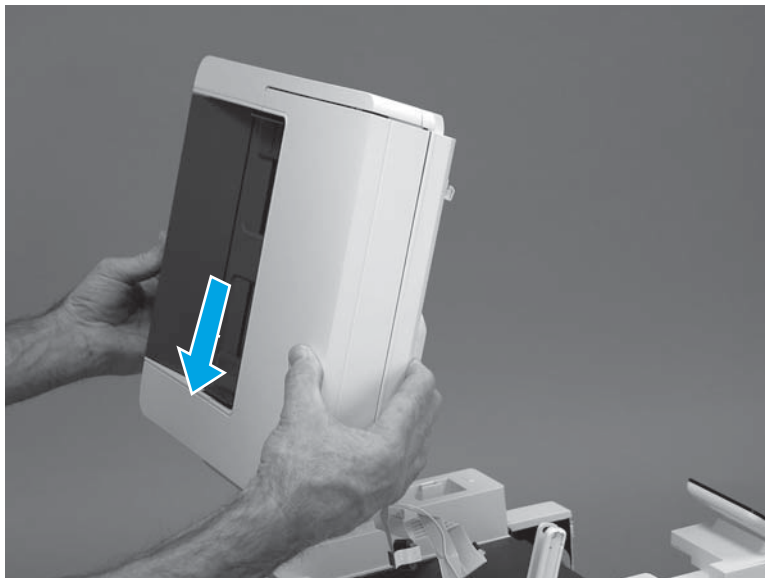
### Step 17: Install the integrated scanner assembly (M427/M246)

 **NOTE:** The step is for the M427/M426 printer. For the M403/M402, skip this step and go to [Step 18: Install the right cover on page 560](#).

 **NOTE:** M427/M426 models only. The integrated scanner assembly (ISA) includes the sub-scanner assembly (SSA) and the automatic document feeder (ADF).

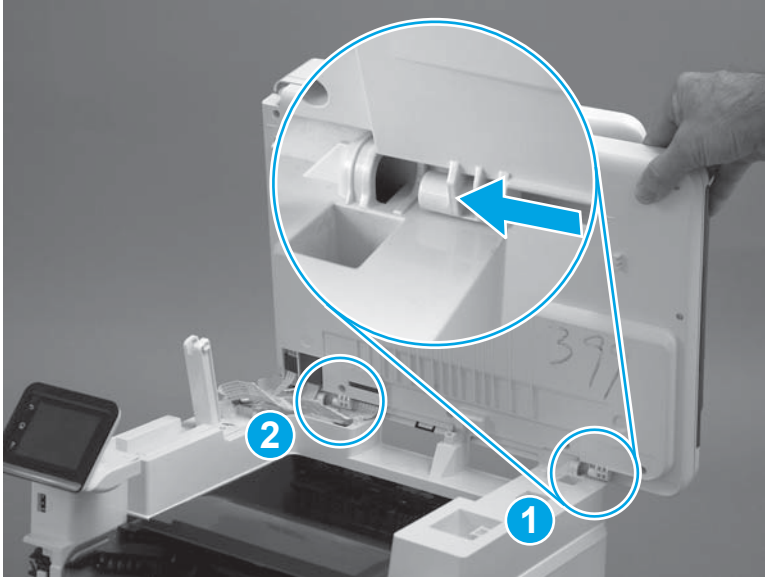
1. Position the ISA on the printer.

**Figure 1-1005** Position the ISA on the printer



2. Engage the hinge pins on the ISA with the holders in the top cover (callouts 1/2), and then slide the ISA as shown to engage them

**Figure 1-1006** Engage the hinge pins with the holders



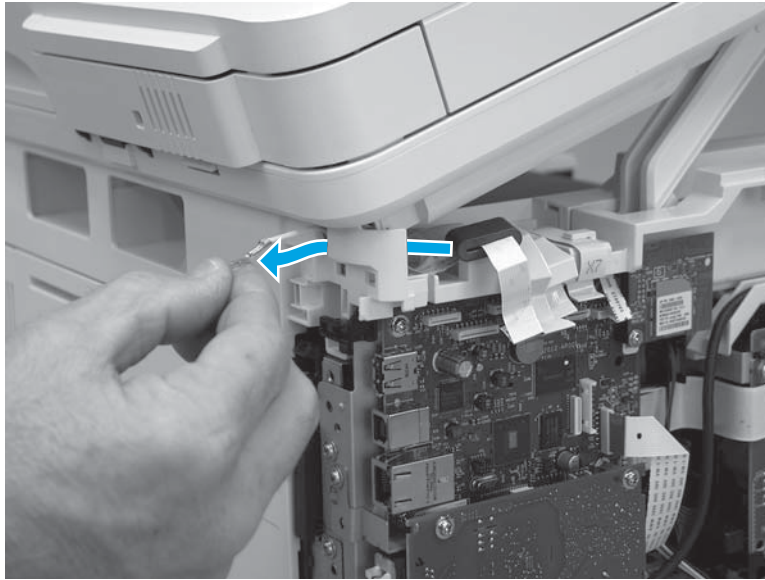
3. Rotate the ISA towards the front of the printer until it rests on the ISA lift assembly (callout 1).

**Figure 1-1007** Rotate the ISA towards the front of the printer



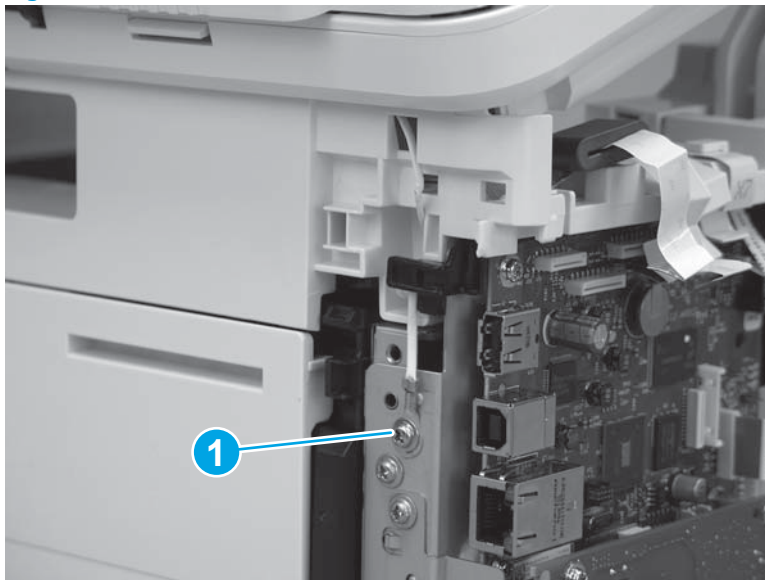
4. Pass the ground wire through the opening in the top cover.

**Figure 1-1008** Pass the wire through the opening




5. Install one screw (callout 1).

**Figure 1-1009** Install one screw



6. Install the ISA lift assembly slider pin.

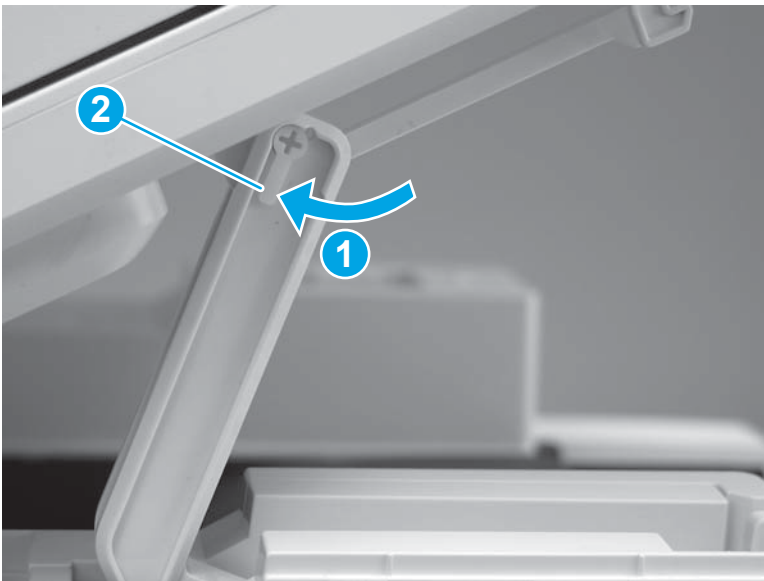
 **Reinstallation tip:** Align the keyed portion of the locking pin with the slot and hole in the support arm.

**Figure 1-1010** Install the slider pin



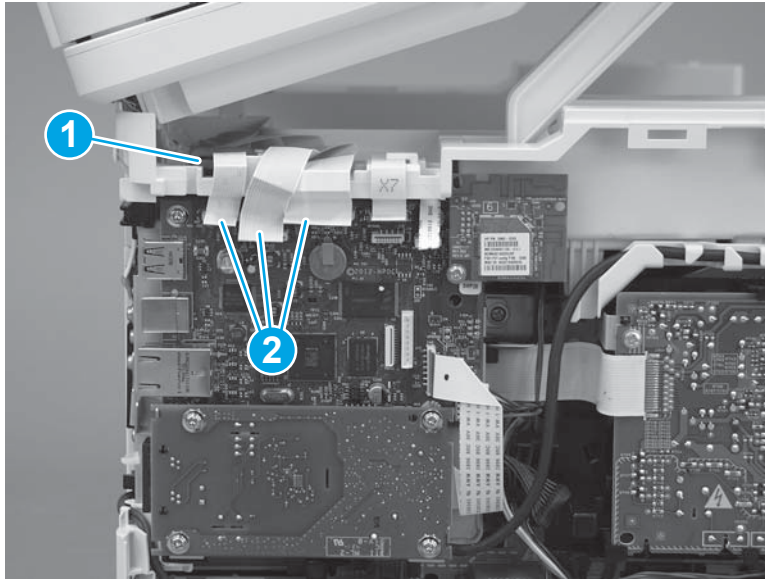
7. Rotate the slider pin (callout 1) towards the rear of the printer until the tab (callout 2) snap into place.

**Figure 1-1011** Secure the slider pin



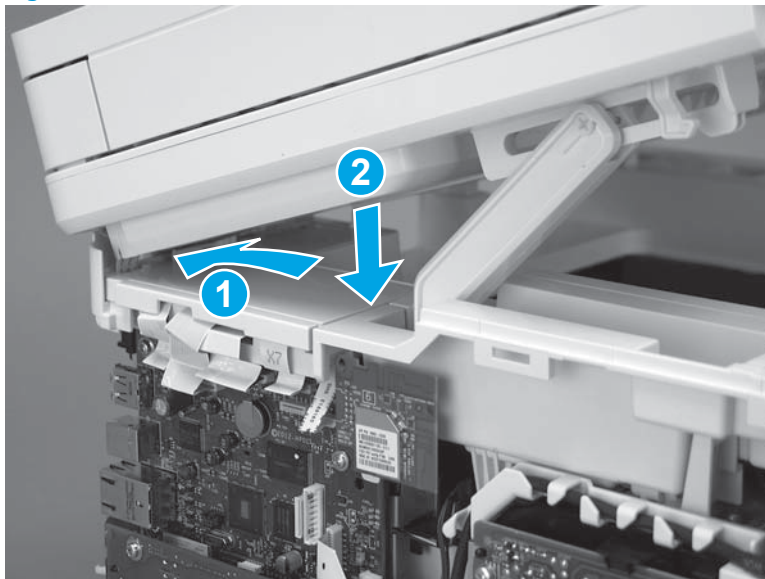
8. Install the ferrite (callout 1) in the holder, and then connect three FFCs (callout 2).

**Figure 1-1012** Connect three FFCs



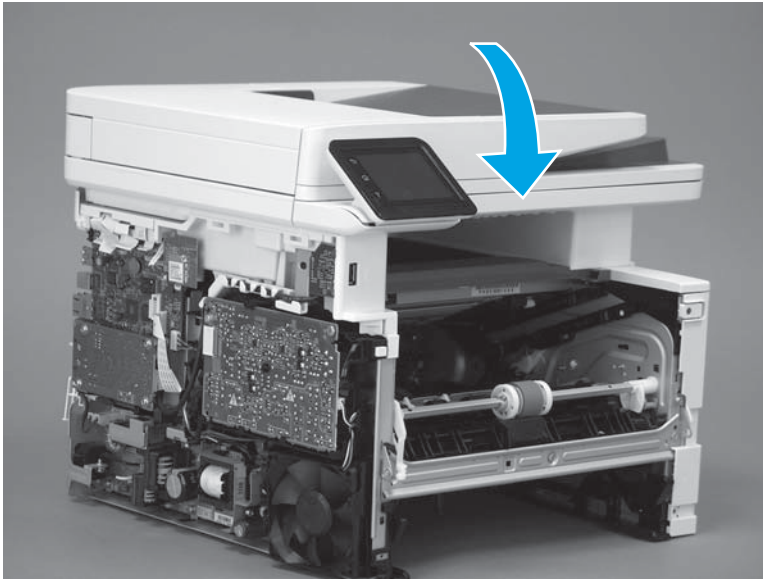
9. Position the rear edge of the ISA flat-flexible cable (FFC) cover on the printer (callout 1), and then rotate it down (callout 2) until it snaps into place.

**Figure 1-1013** Install the ISA FFC cover



10. Lower the ISA.

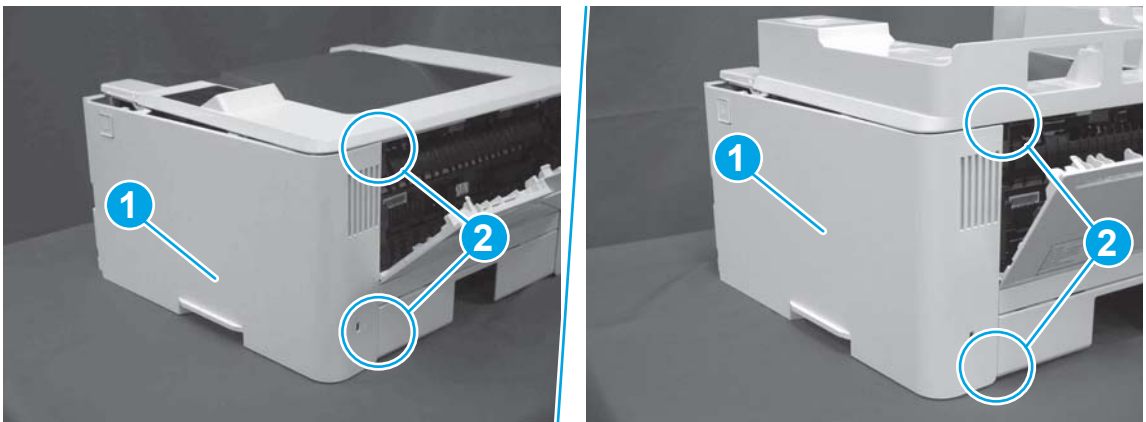
**Figure 1-1014** Lower the ISA



### Step 18: Install the right cover

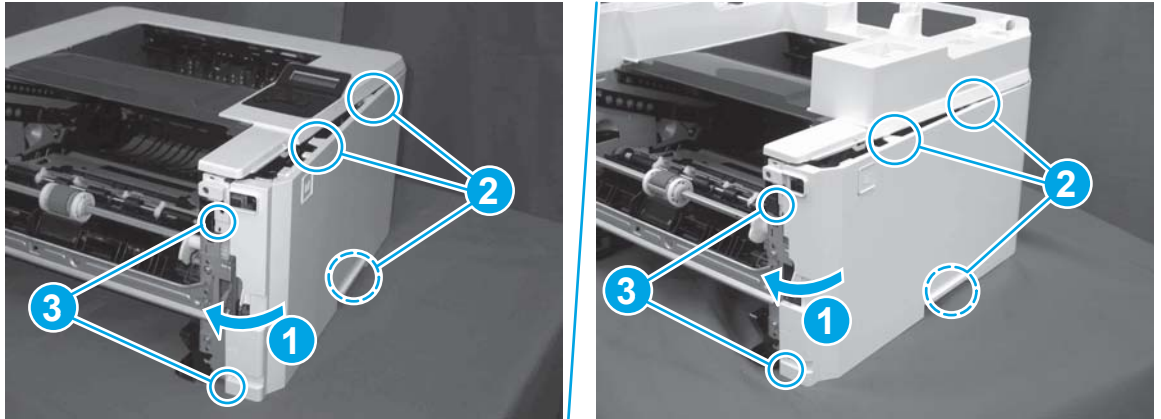
1. Position the cover (callout 1) on the printer, and then engage two bosses (callout 2).

**Figure 1-1015** Install the cover



2. Rotate the front of the cover onto the printer (callout 1), engage three (callout 2) tabs, and then engage two bosses (callout 3).

**Figure 1-1016** Engage two bosses and one tab

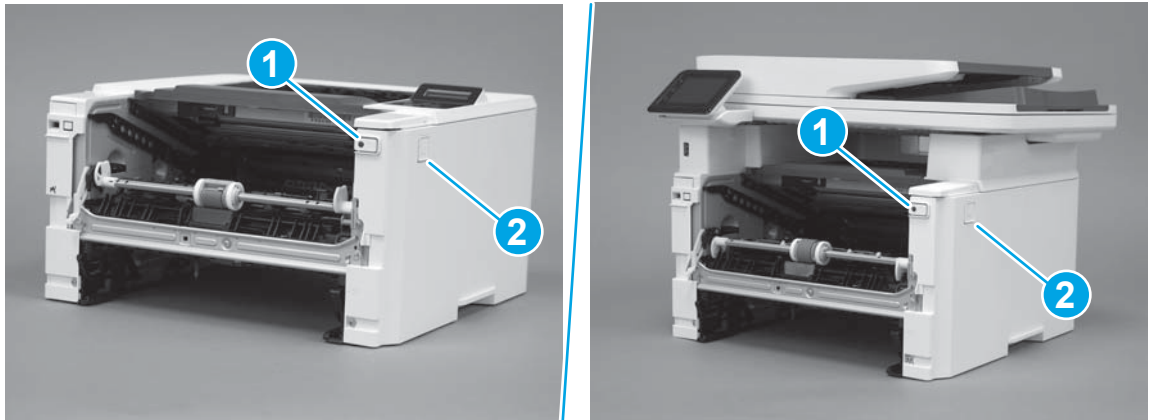


3. Make sure that the power switch (callout 1) and cartridge door assembly button (callout 2) correctly function.



**NOTE:** Remove, and then reinstall the cover if the switch or button does not correctly function.

**Figure 1-1017** Check the power switch and cartridge door assembly button



4. Install one screw (callout 1).

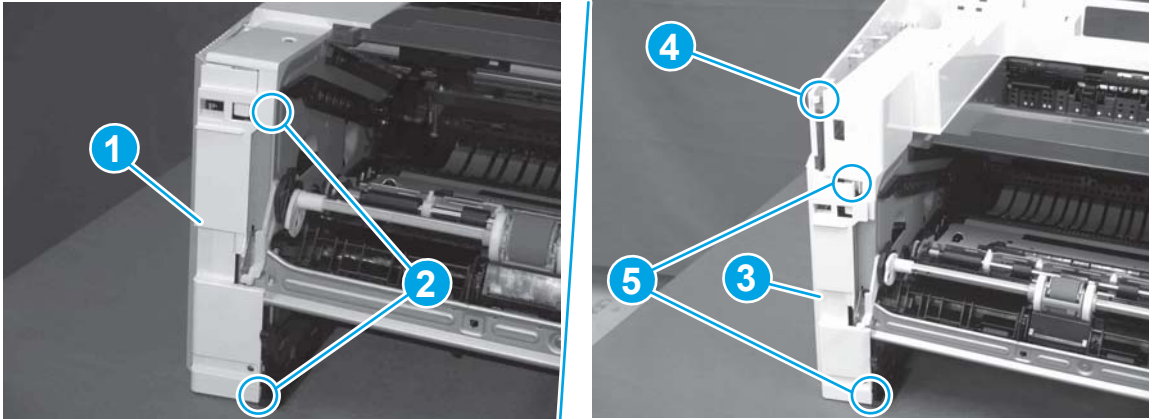
**Figure 1-1018** Install one screw



## Step 19: Install the left cover

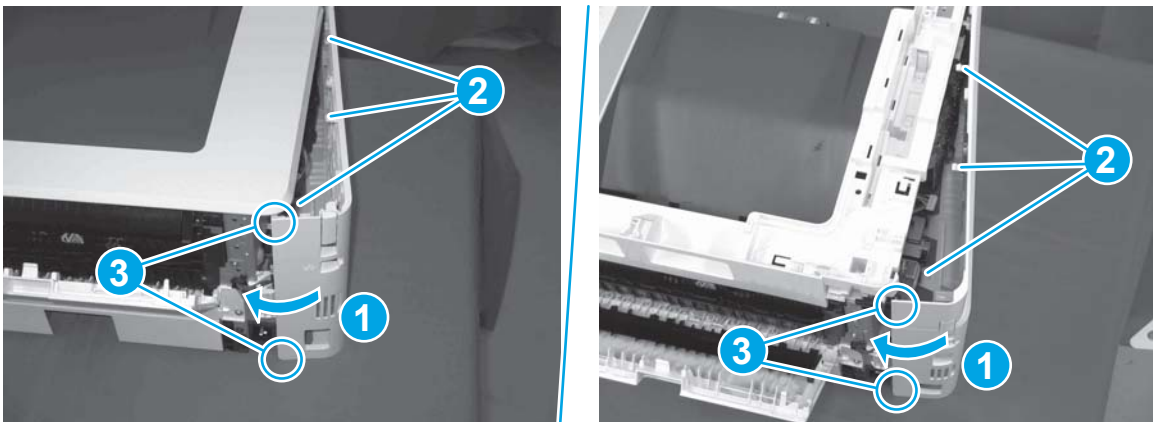
1. At the front of the printer, do one of the following:
  - **M403/M402:** Position the cover on the printer (callout 1), and then engage two bosses (callout 2).
  - **M427/M426:** Position the cover on the printer (callout 3), engage one tab (callout 4), and then engage two bosses (callout 4).

**Figure 1-1019** Install the cover



2. Carefully rotate the rear of the cover onto the printer (callout 1), engage three tabs (callout 2), and then engage two bosses (callout 3).

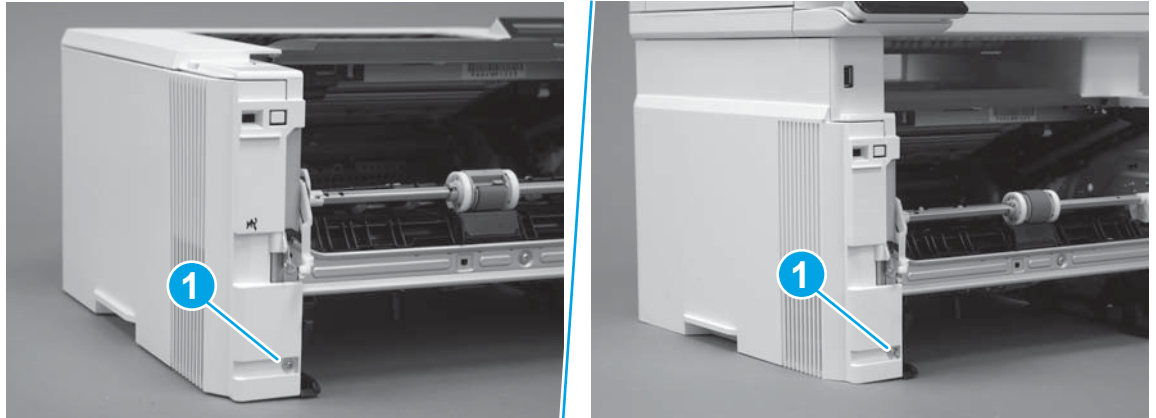
**Figure 1-1020** Engage three tabs and two bosses






3. Install one screw (callout 1).

**Figure 1-1021** Install one screw

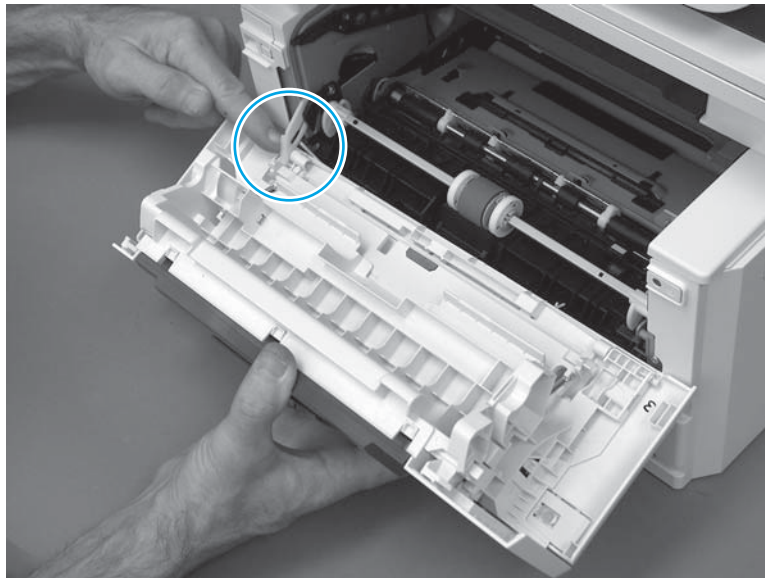


## Step 20: Install the cartridge door assembly

 **Reinstallation tip:** After a replacement door is installed, make sure to install the nameplate (supplied in the kit) corresponding to the printer name on the door.

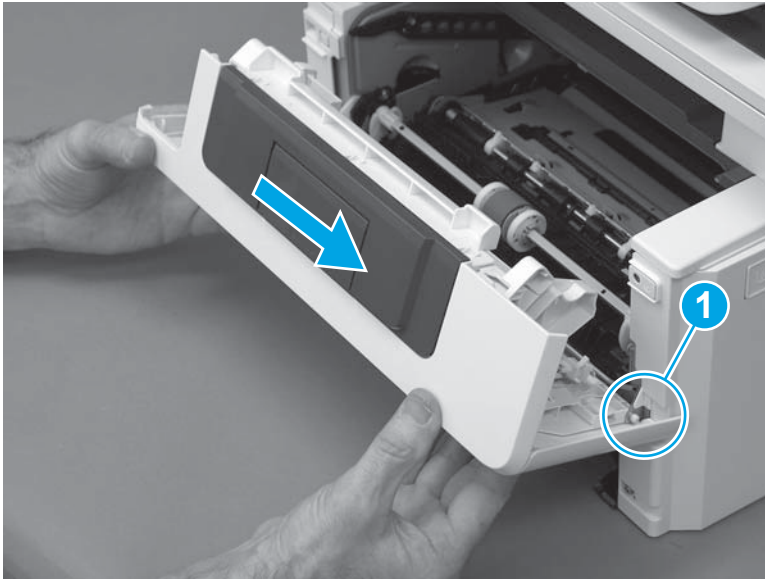
1. Position the door close to the printer, and then engage the keyed pin on the left-side retainer arm with the hole in the door.

**Figure 1-1022** Engage the left-side retainer arm



2. Engage the right-side door hinge pin with the hole in the chassis (callout 1).

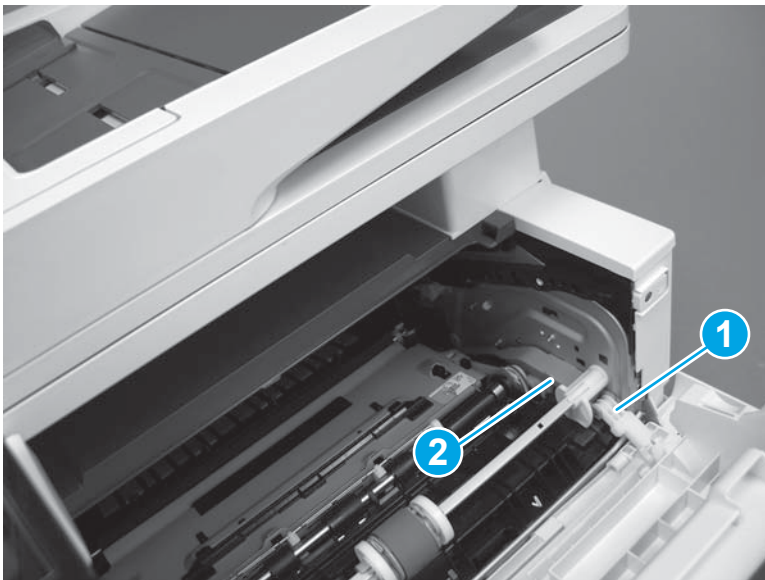
**Figure 1-1023** Install the door



3. Install the link (callout 1).

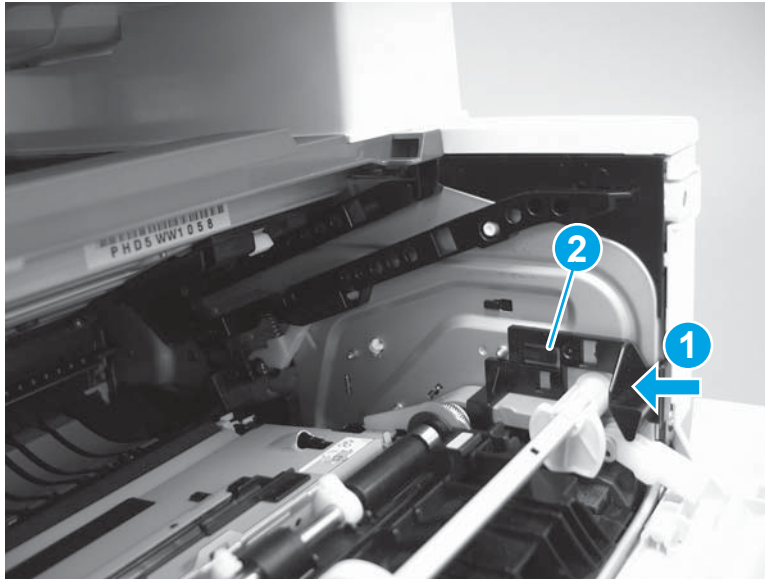
 **IMPORTANT:** Make sure that the link snaps into place on the arm (callout 2). The link actuates the fuser pressure-release mechanism.

**Figure 1-1024** Install the pressure-release link



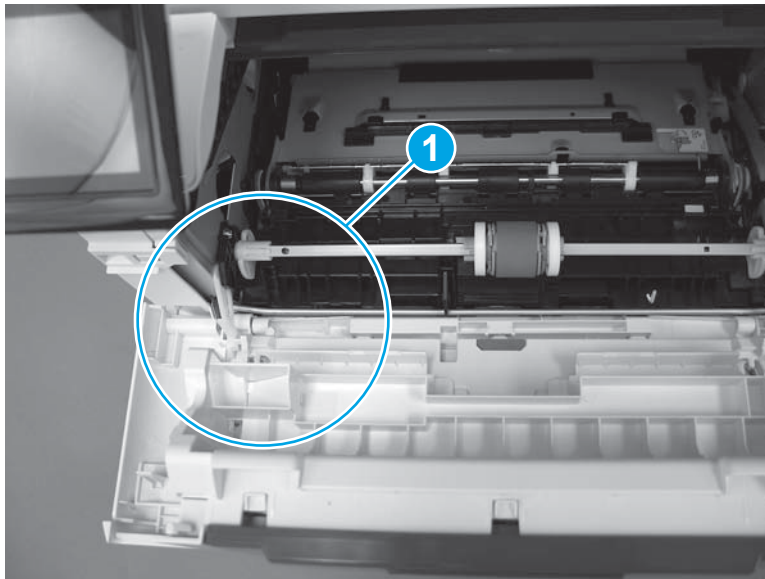
4. Slide the guide into the printer (callout 1), and then make sure that the tab (callout 2) snaps into place to secure the guide to the chassis.

**Figure 1-1025** Install the guide




5. Position the shaft on the door, and then align the left-side hinge on the door with the hole in the chassis (callout 1).

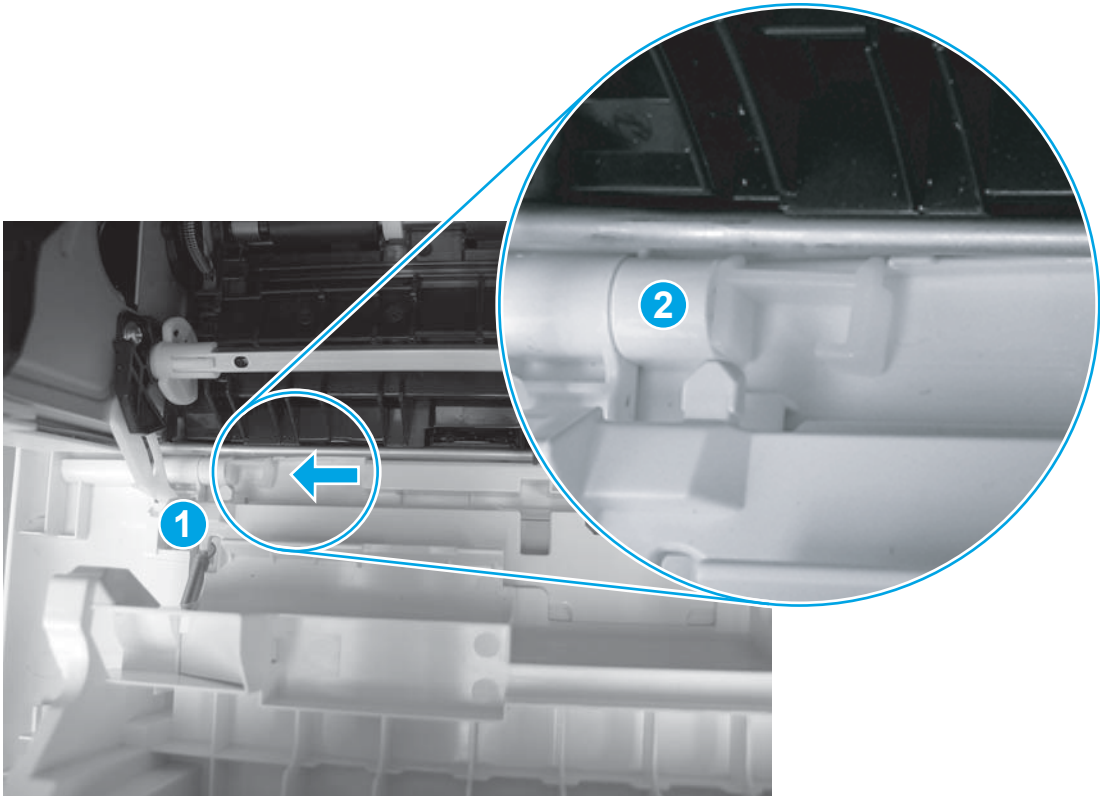
**Figure 1-1026** Align the hinge



6. Push the shaft towards the left side of the printer to install it (callout 1).

 **Reinstallation tip:** Make sure that the support shaft is fully installed and correctly orientated (callout 2) so that it will not interfere with the door opening and closing.

**Figure 1-1027** Install the support shaft



### Step 21: Install Tray 2

- ▲ Slide the tray straight into the printer to install it.

**Figure 1-1028** Install the tray



## Removal and replacement: Sheet-metal formatter bracket and formatter PCA

- [Step 1: Remove Tray 2](#)
- [Step 2: Remove the cartridge door assembly](#)
- [Step 3: Remove the left cover](#)
- [Step 4: Remove the right cover](#)
- [Step 5: Remove the integrated scanner assembly \(M427/M246\)](#)
- [Step 6: Remove the control panel \(M427/M246\)](#)
- [Step 7: Remove the top cover \(M427/M426\)](#)
- [Step 8: Remove the top cover \(M403/M402\)](#)
- [Step 9: Remove the sheet-metal formatter bracket and formatter PCA](#)
- [Step 10: Install the sheet-metal formatter bracket and formatter PCA](#)
- [Step 11: Install the top cover \(M403/M402\)](#)
- [Step 12: Install the top cover \(M427/M426\)](#)
- [Step 13: Install the control panel \(M427/M246\)](#)
- [Step 14: Install the integrated scanner assembly \(M427/M246\)](#)
- [Step 15: Install the right cover](#)
- [Step 16: Install the left cover](#)
- [Step 17: Install the cartridge door assembly](#)
- [Step 18: Install Tray 2](#)

### Step 1: Remove Tray 2

- ▲ Pull the tray straight out of the printer to remove it.

**Figure 1-1029** Remove the tray



**Step 2: Remove the cartridge door assembly**



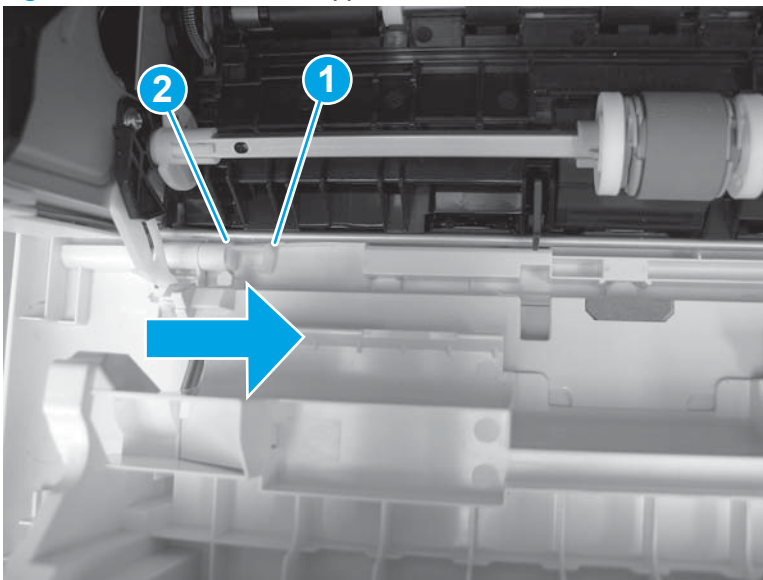
**NOTE:** If the toner cartridge was not removed prior to servicing the printer, remove it now.

1. Release one tab (callout 1), and then slide shaft (callout 2) in the direction the arrow indicates and remove it.



**TIP:** It might be easier to release the support shaft by using a small flat-blade screwdriver.

**Figure 1-1030** Release the support shaft



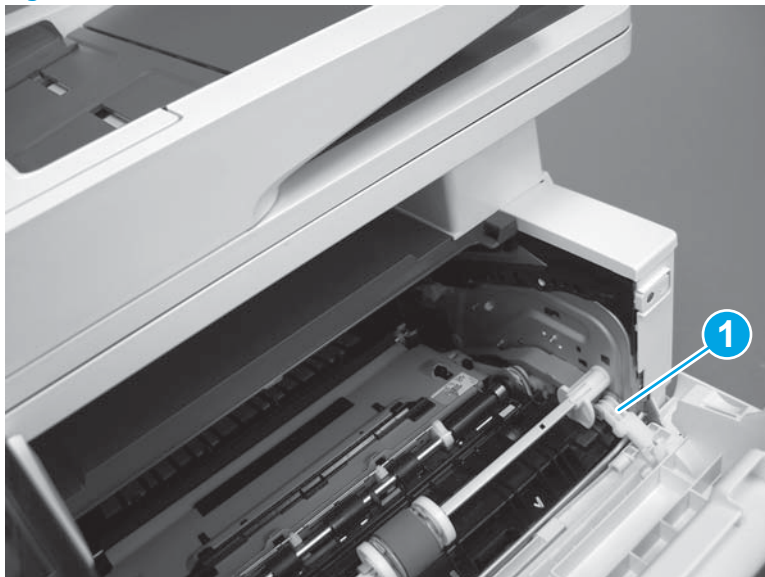
2. Release one tab (callout 1), and then slide the guide (callout 2) in the direction the arrow indicates and remove it.

**Figure 1-1031** Remove the guide



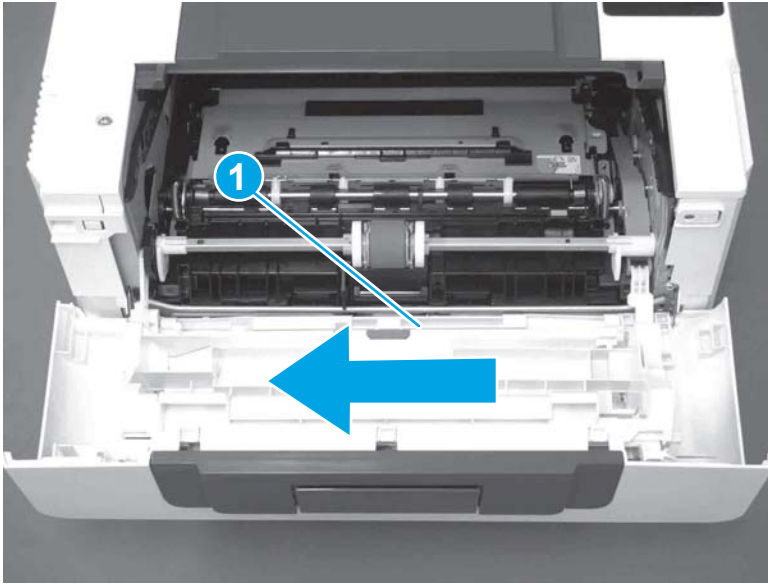
3. Remove the link arm (callout 1).

**Figure 1-1032** Remove the link arm



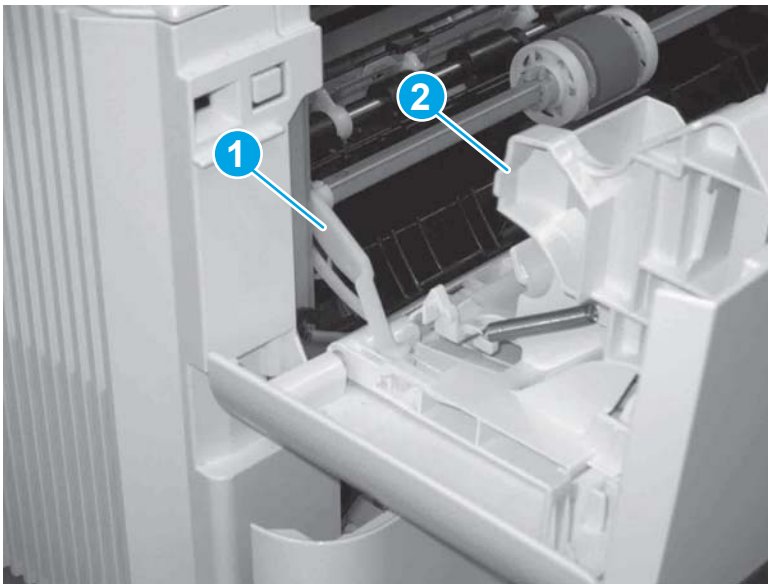
4. Slide the cartridge door assembly (callout 1) in the direction the arrow indicates and remove it.

**Figure 1-1033** Remove the door



5. Remove the link (callout 1) from the cartridge door assembly (callout 2).

**Figure 1-1034** Release the left-side retainer arm

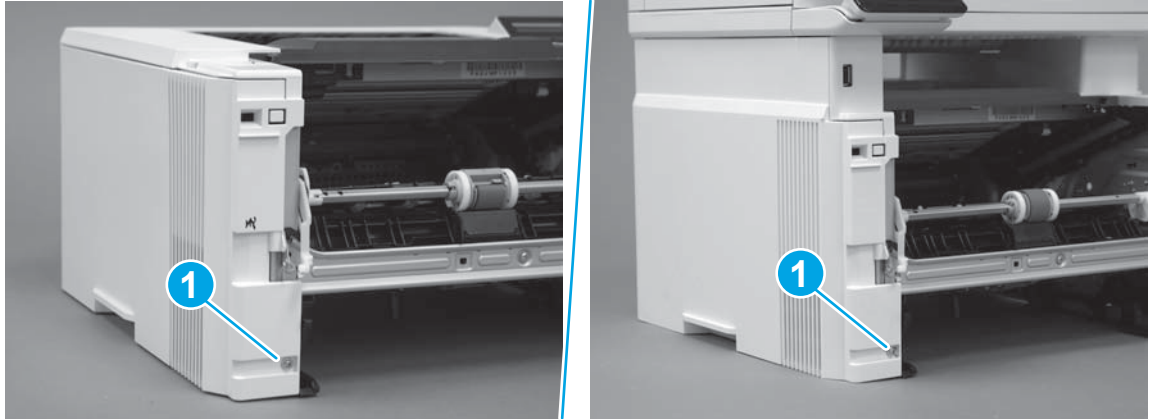


### Step 3: Remove the left cover

1. Remove one screw (callout 1).

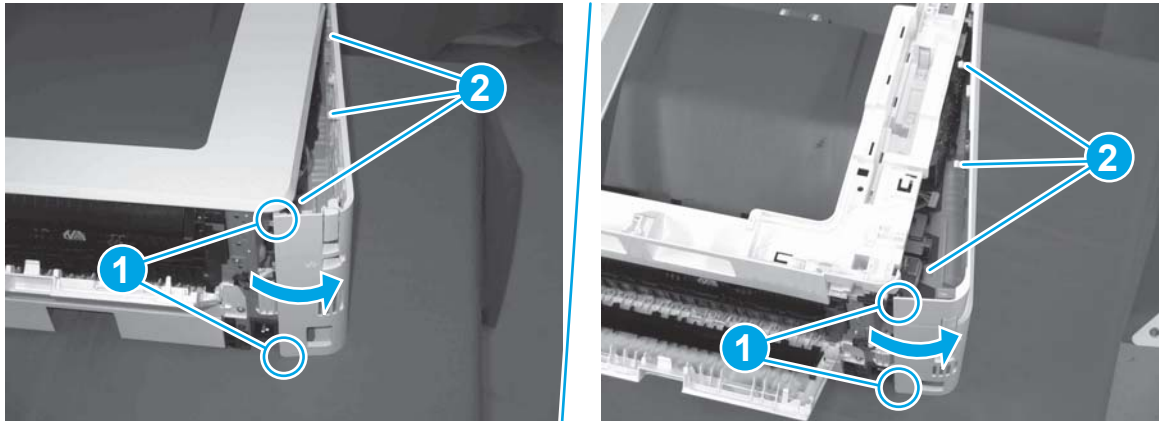


**Figure 1-1035** Remove one screw



2. Open the rear door, release two bosses (callout 1), and then release three tabs (callout 2).

**Figure 1-1036** Release two bosses and three tabs

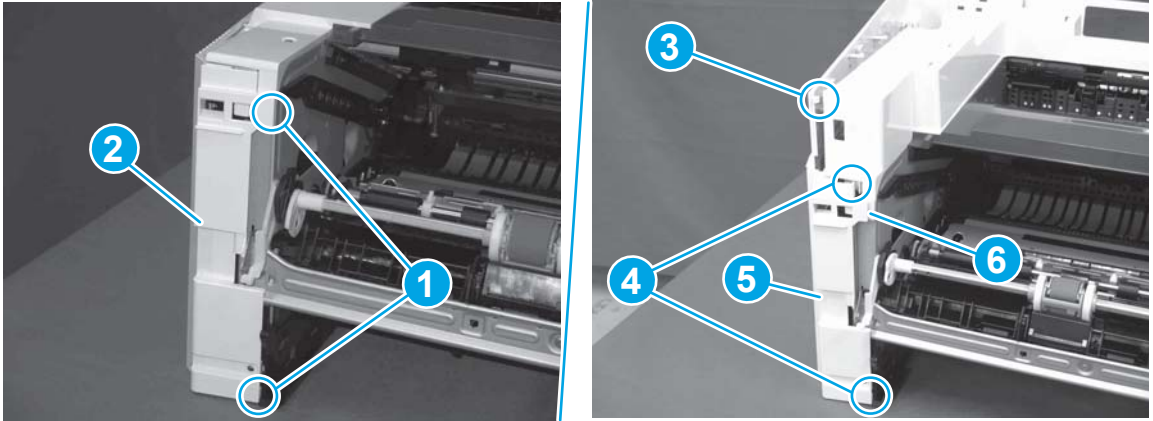


3. At the front of the printer, do one of the following:

- **M403/M402:** Release two bosses (callout 1), and then remove the cover (callout 2).
- **M427/M426:** Release one tab (callout 3), two bosses (callout 4), and then remove the cover (callout 5).

**CAUTION:** Be careful when releasing the upper bosses on the M427/M426 cover. One portion of the cover (callout 6) is fragile and is easily broken.

**Figure 1-1037** Remove the cover



**Step 4: Remove the right cover**

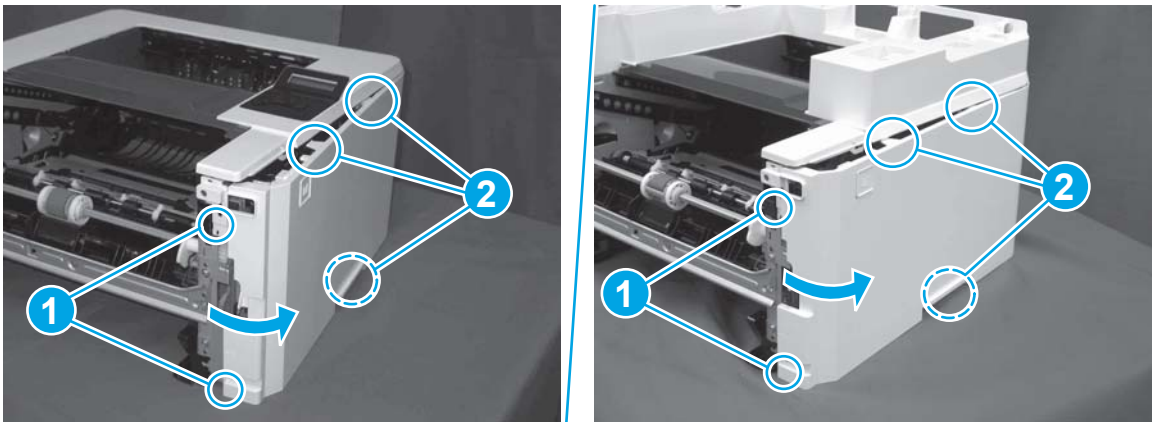
1. Remove one screw (callout 1).

**Figure 1-1038** Remove one screw



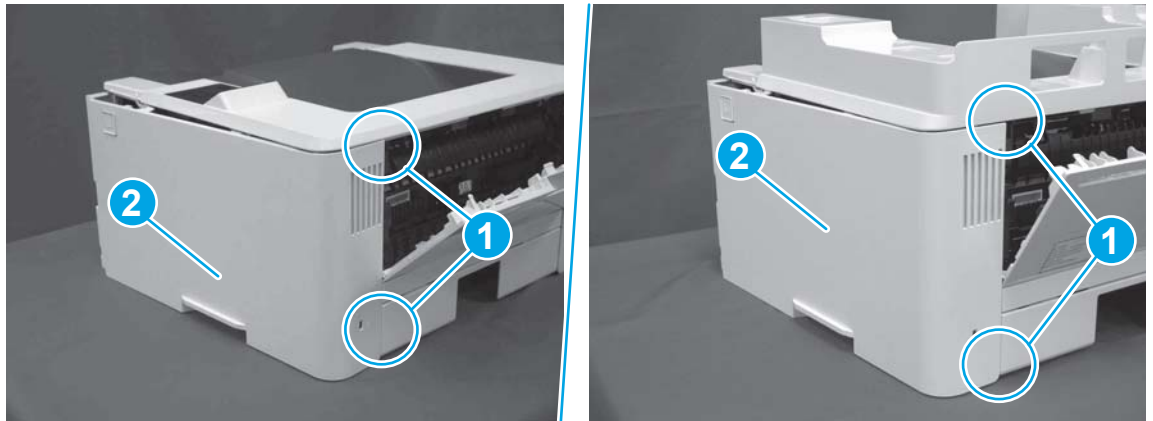
2. At the front of the printer, release two bosses (callout 1), and then release three tabs (callout 2).

**Figure 1-1039** Release two bosses and three tabs





3. Open the rear door, release two bosses (callout 1), and then remove the cover (callout 2).

**Figure 1-1040** Remove the cover



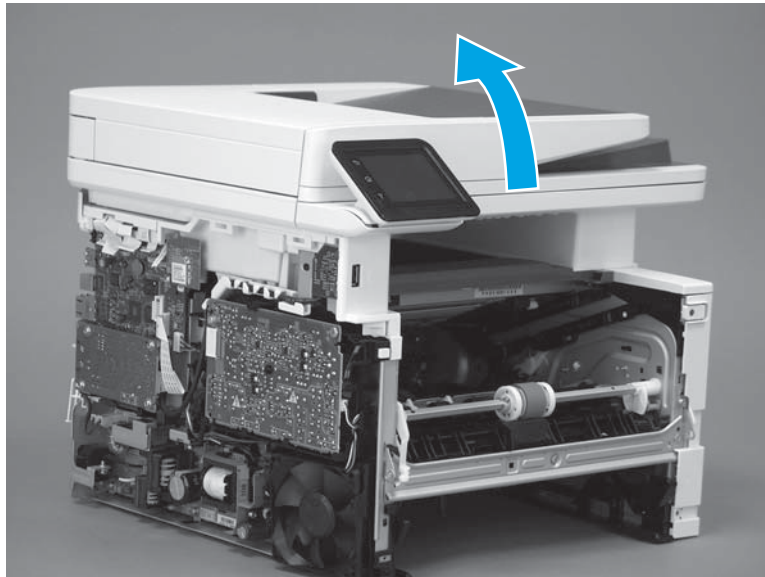
### Step 5: Remove the integrated scanner assembly (M427/M246)

 **NOTE:** The step is for the M427/M426 printer. For the M403/M402, skip this step and go to [Step 8: Remove the top cover \(M403/M402\) on page 583](#).

 **NOTE:** M427/M426 models only. The integrated scanner assembly (ISA) includes the sub-scanner assembly (SSA) and the automatic document feeder (ADF).

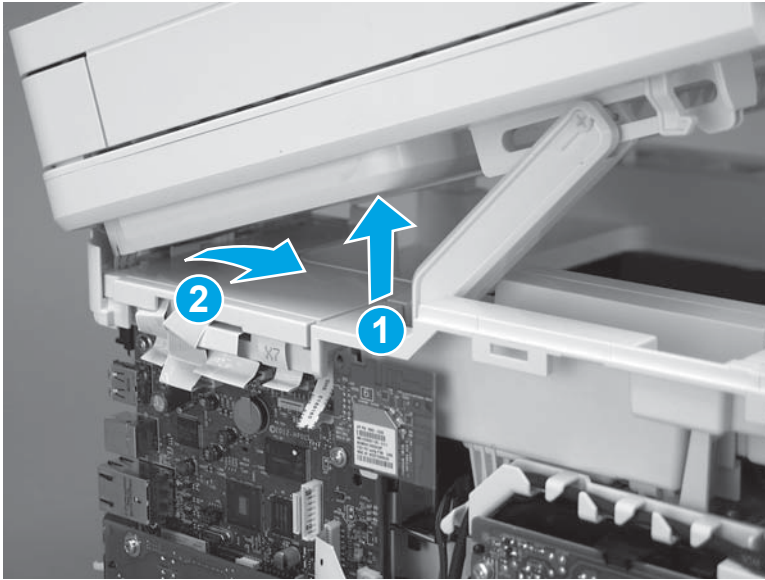
1. Raise the ISA.

**Figure 1-1041** Raise the ISA



2. Release the ISA flat-flexible cable (FFC) cover (callout 1), and then remove it (callout 2).

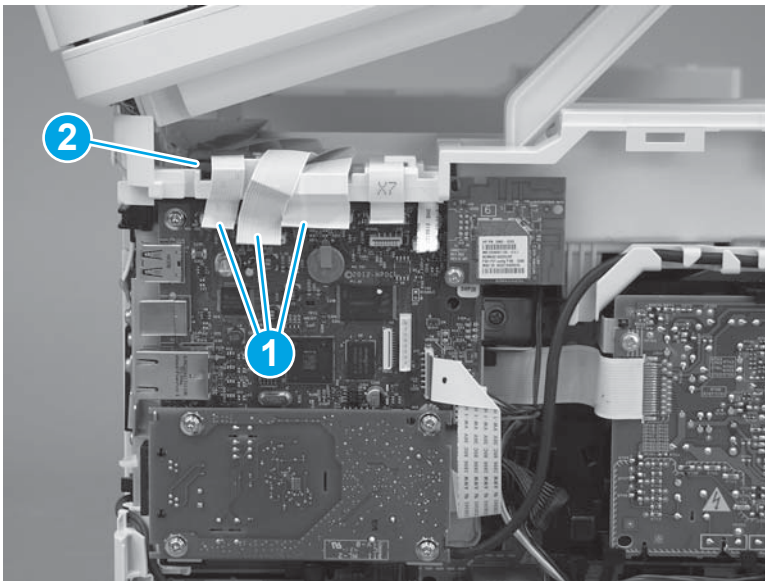
**Figure 1-1042** Remove the ISA FFC cover



3. Disconnect three FFCs (callout 1), and then remove the ferrite (callout 2) from the holder.

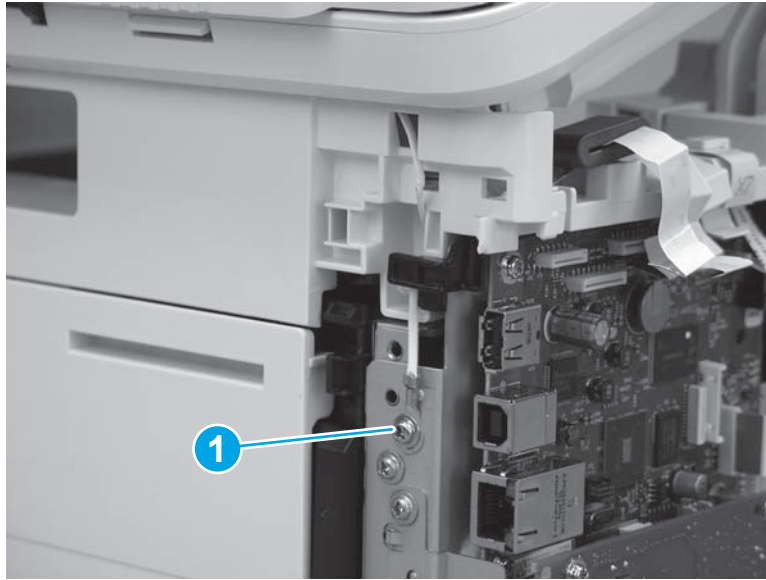
**CAUTION:** The ferrite is not captive on the FFC. Do not lose the ferrite while handling the ISA.

**Figure 1-1043** Disconnect three FFCs



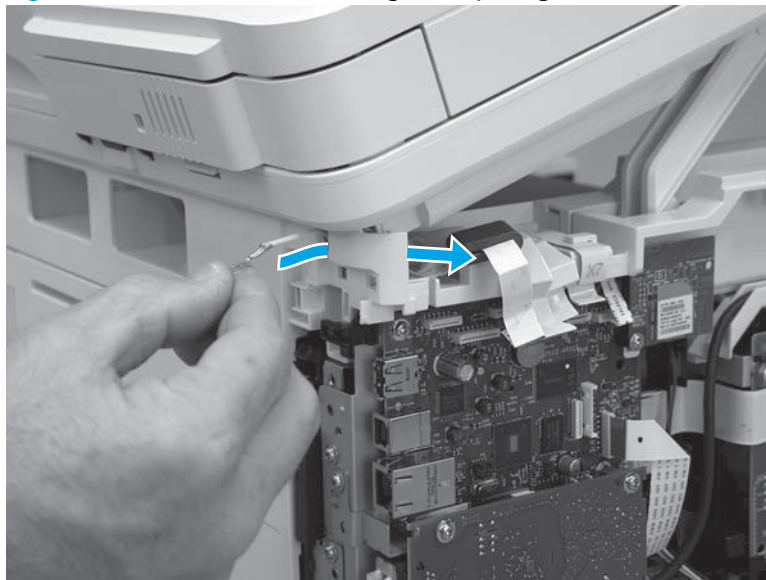
4. Remove one screw (callout 1).

**Figure 1-1044** Remove one screw



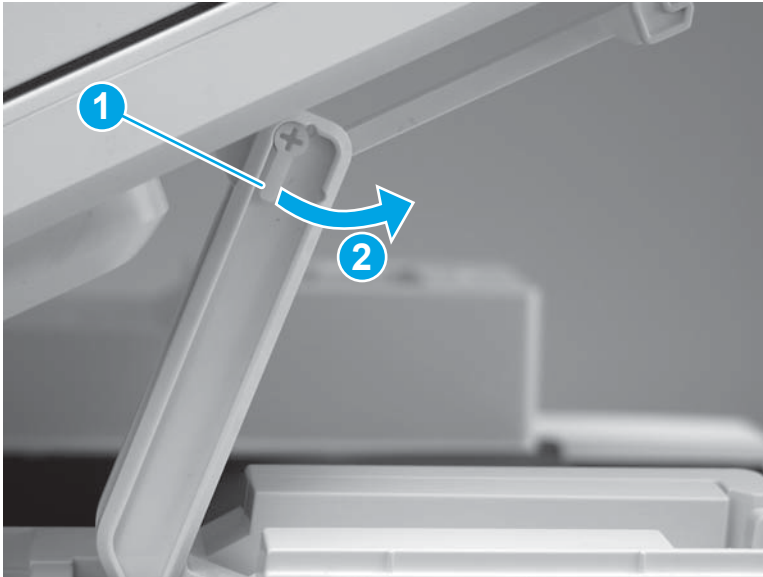
5. Pass the ground wire through the opening in the top cover.

**Figure 1-1045** Pass the wire through the opening



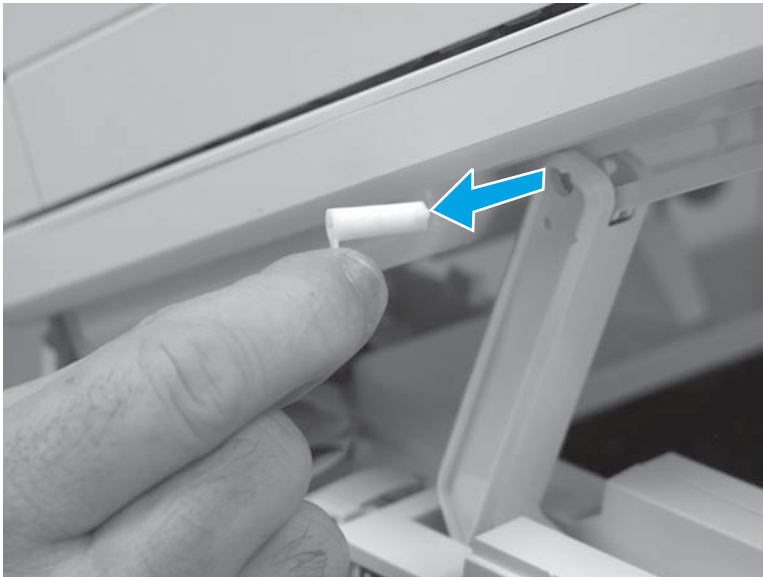
6. Release one tab (callout 1), and then rotate the ISA slider pin (callout 2) towards the front of the printer to release it.

**Figure 1-1046** Release one tab and rotate the slider pin



7. Remove the slider pin.

**Figure 1-1047** Remove the slider pin



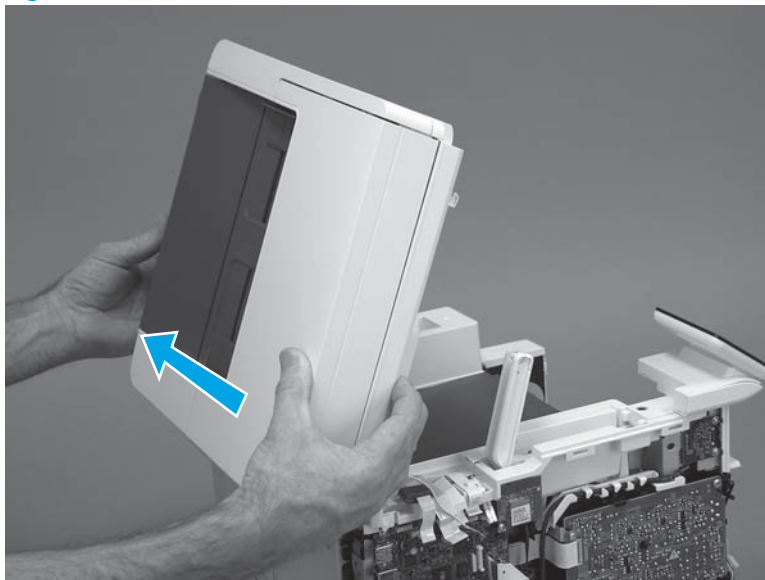
8. Rotate the ISA towards the rear of the printer until it stops.

**Figure 1-1048** Rotate the ISA towards the rear of the printer



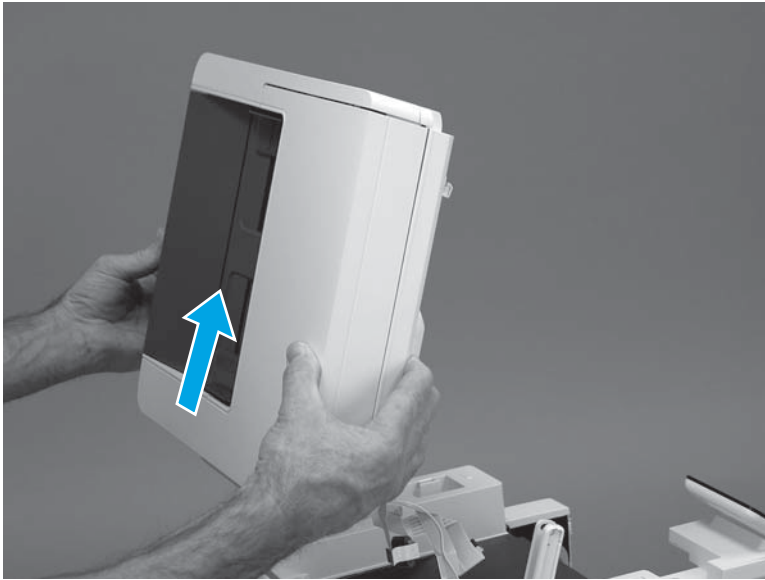
9. Slide the ISA as shown to release it.

**Figure 1-1049** Release the ISA



10. Remove the ISA.

**Figure 1-1050** Remove the ISA



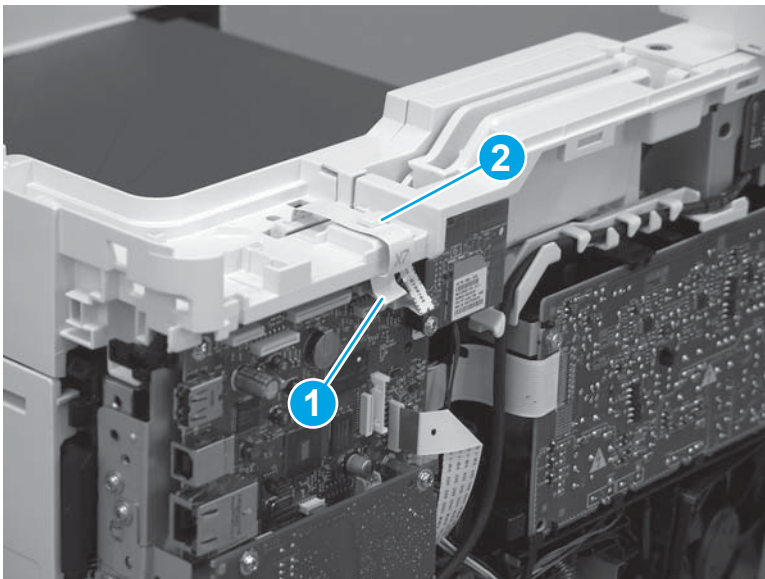
#### Step 6: Remove the control panel (M427/M246)



**NOTE:** The step is for the M427/M426 printer. For the M403/M402, skip this step and go to [Step 8: Remove the top cover \(M403/M402\) on page 583](#).

1. Disconnect one FFC (callout 1; J114), and then release the FFC from the retainer (callout 2).

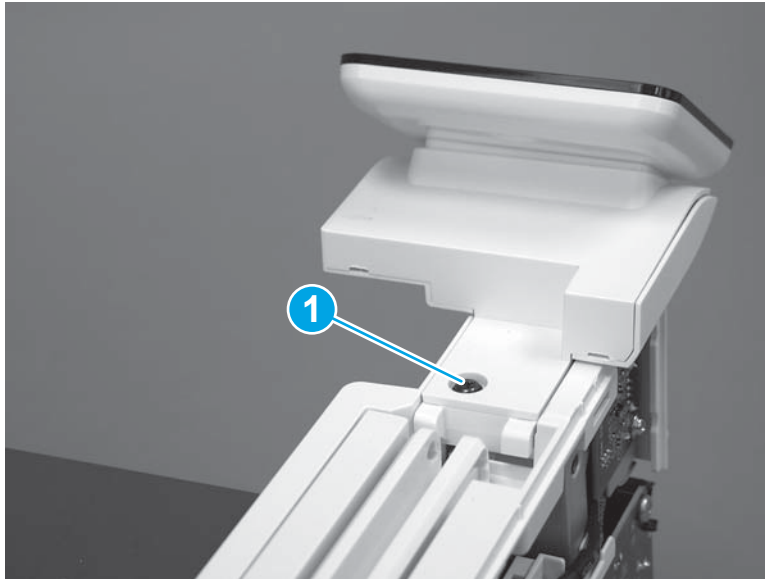
**Figure 1-1051** Disconnect one connector





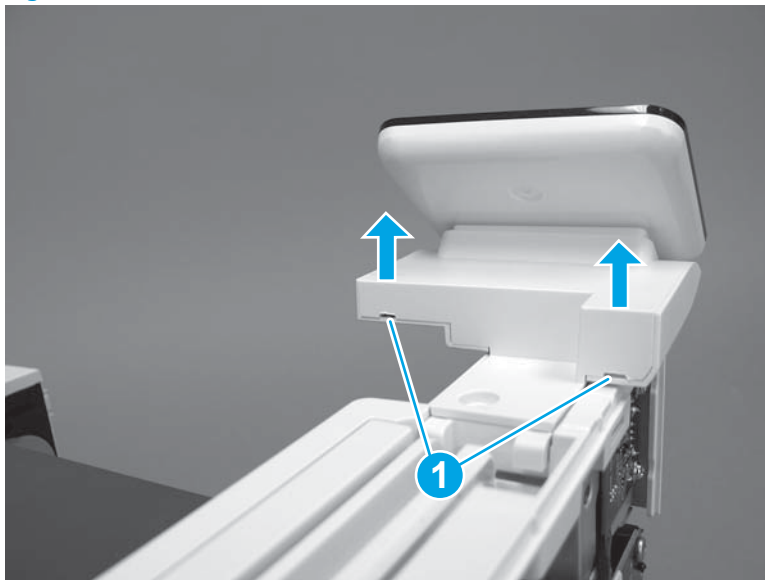
2. Remove one screw (callout 1).

**Figure 1-1052** Remove one screw



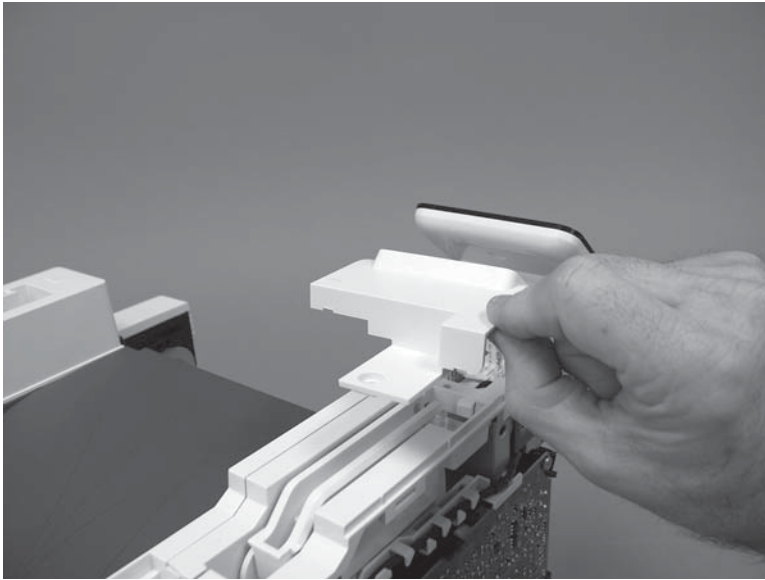
3. Use a small flat-blade screwdriver to release two tabs (callout 1) on the control-panel cable cover.

**Figure 1-1053** Release two tabs



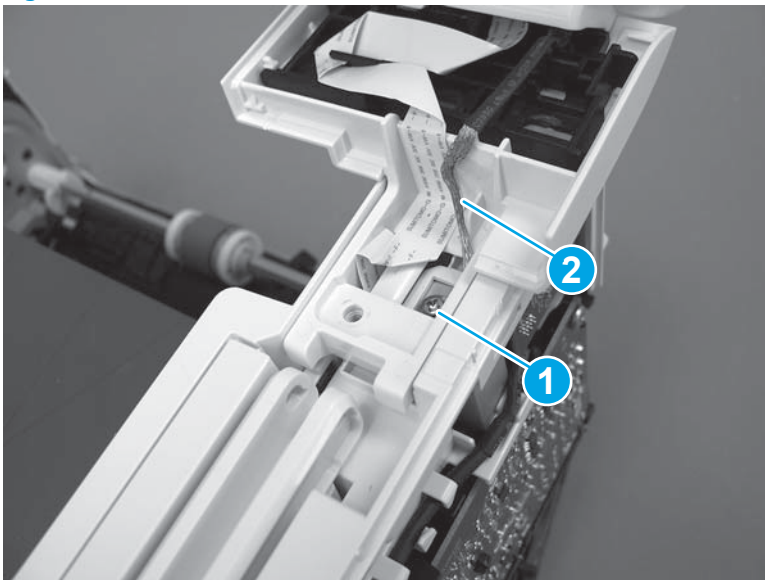
4. Remove the control-panel cable cover.

**Figure 1-1054** Remove the cover



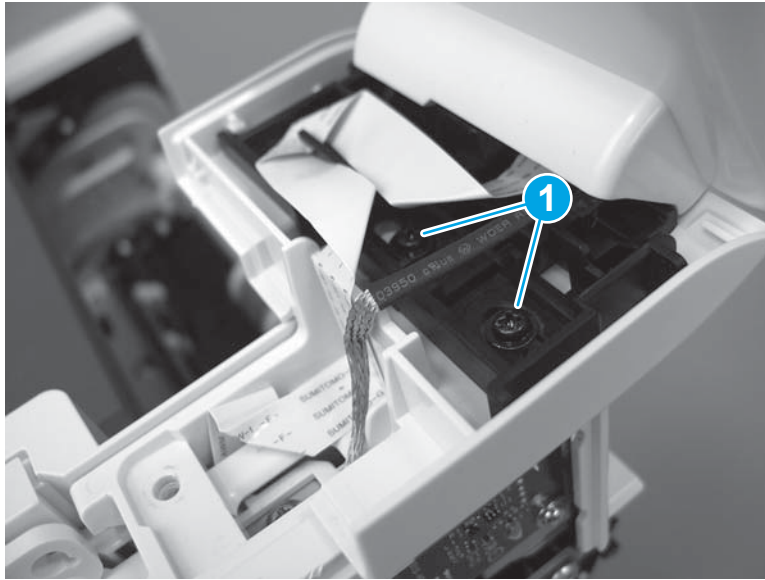
5. Remove one grounding screw (callout 1), and then move the ground cable (callout 2) out of the way.

**Figure 1-1055** Remove one screw



6. Move the FFC out of the way, and then remove two screws (callout 1).

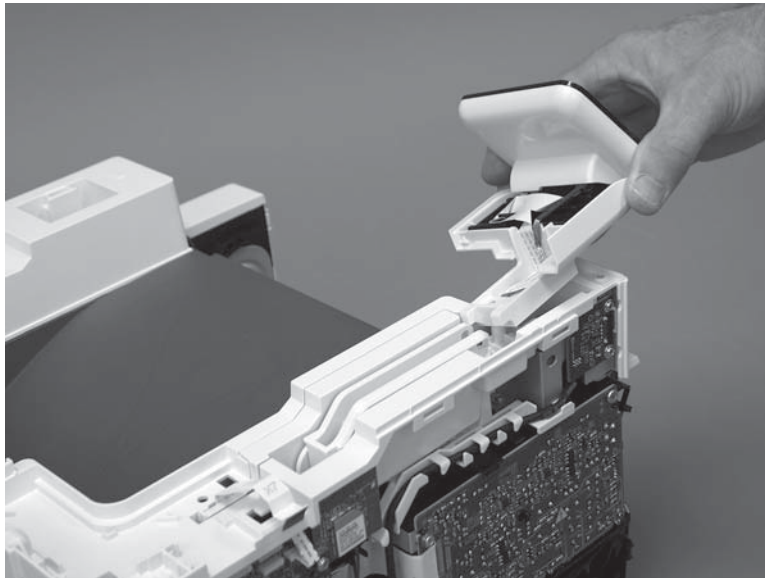
**Figure 1-1056** Remove two screws



7. Slightly lift up the control-panel assembly to separate it from the top cover.

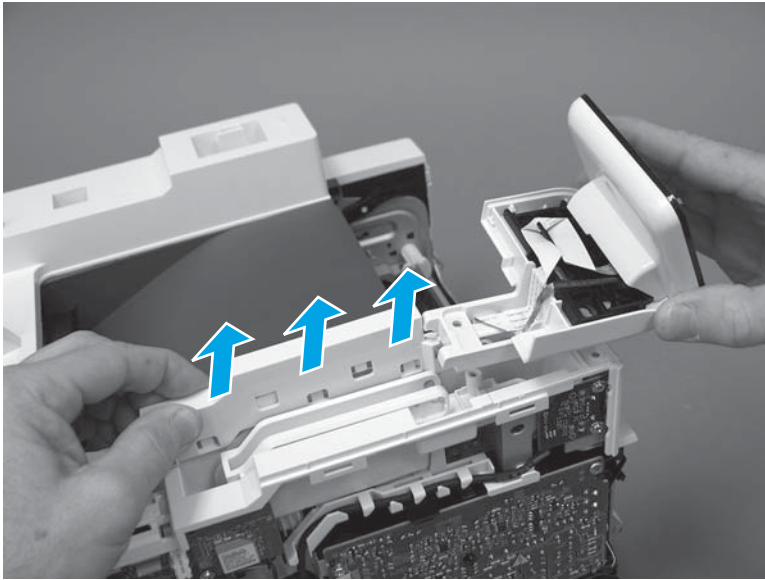
**⚠ CAUTION:** The control panel assembly is still connected to the printer by the FFC. Do not attempt to completely remove the assembly.

**Figure 1-1057** Lift up the control-panel assembly



8. Lift up the control-panel FFC cover to remove the control-panel assembly.

**Figure 1-1058** Remove the control-panel assembly



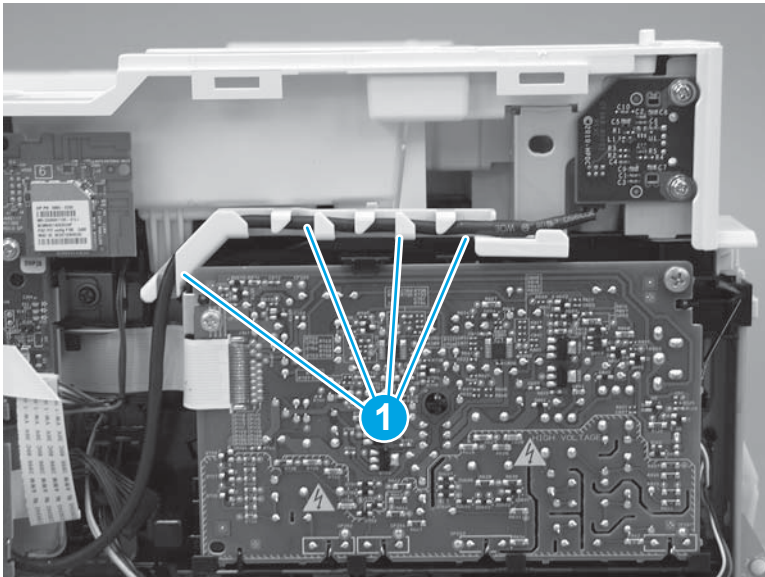
#### Step 7: Remove the top cover (M427/M426)



**NOTE:** The step is for the M427/M426 printer. For the M403/M402, skip this step and go to [Step 8: Remove the top cover \(M403/M402\) on page 583](#).

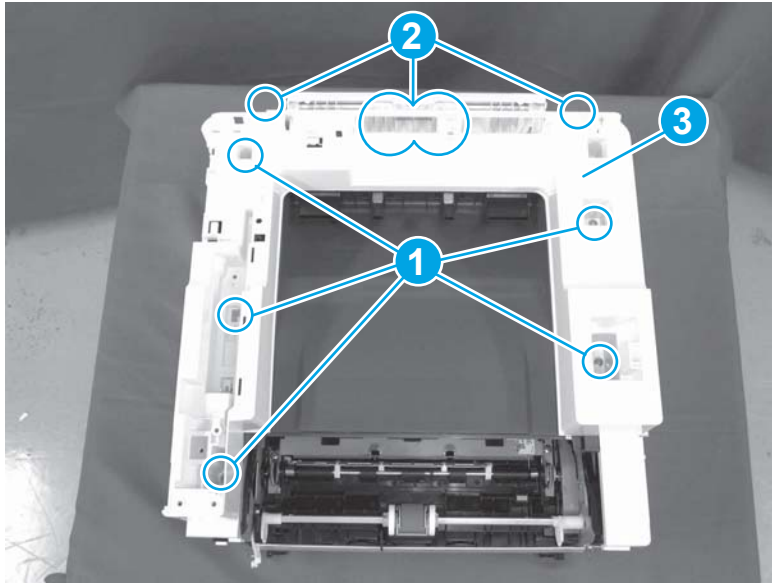
1. Release the USB cable (callout 1) from the cable guide.

**Figure 1-1059** Remove the USB cable



2. Remove five screws (callout 1), release four bosses (callout 2), and then remove the top cover (callout 3).

**Figure 1-1060** Remove the cover



### Step 8: Remove the top cover (M403/M402)

 **NOTE:** The step is for the M403/M402 printer. For the M427/M426, skip this step and go to [Step 9: Remove the sheet-metal formatter bracket and formatter PCA on page 584.](#)

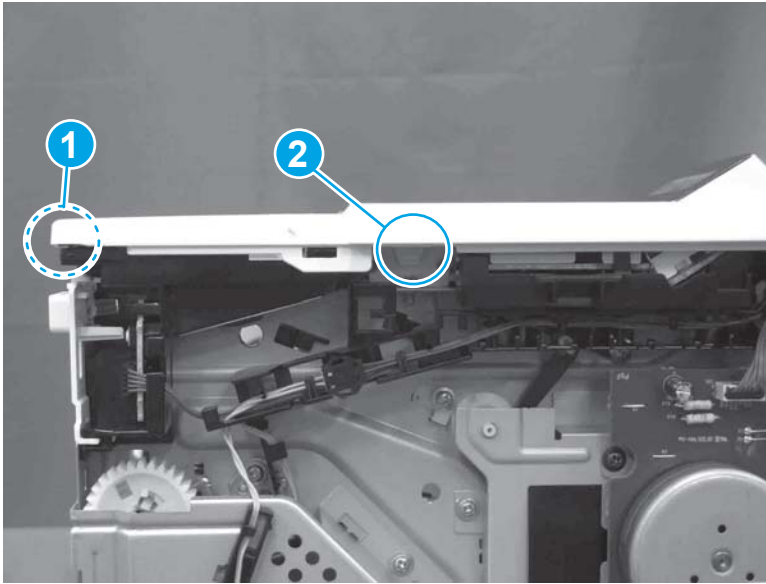
1. Remove one screw (callout 1).

**Figure 1-1061** Remove one screw




2. At the right side of the printer, release the one boss (callout 1), and then release one tab (callout 2).

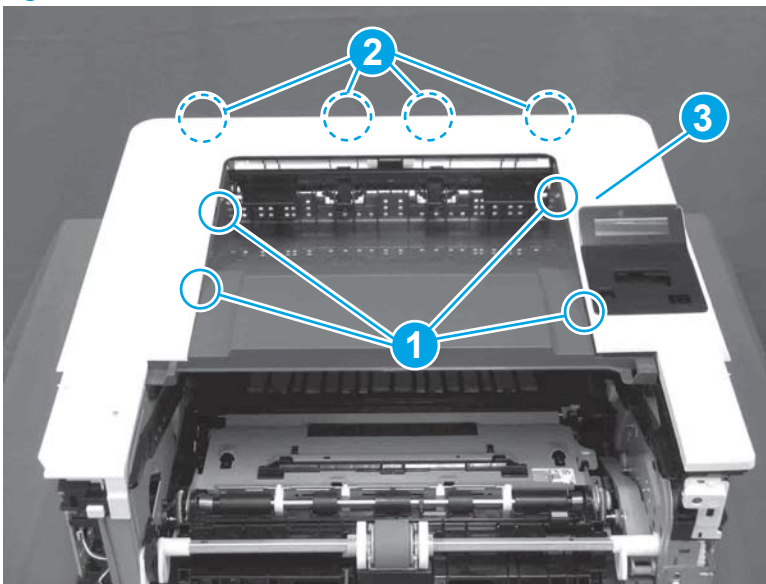
**Figure 1-1062** Release one boss and one tab



3. Release four tabs (callout 1), release four bosses (callout 2), and then remove the top cover (callout 3).

 **TIP:** Open the rear door to make releasing the bosses (callout 3) easier.

**Figure 1-1063** Remove the cover

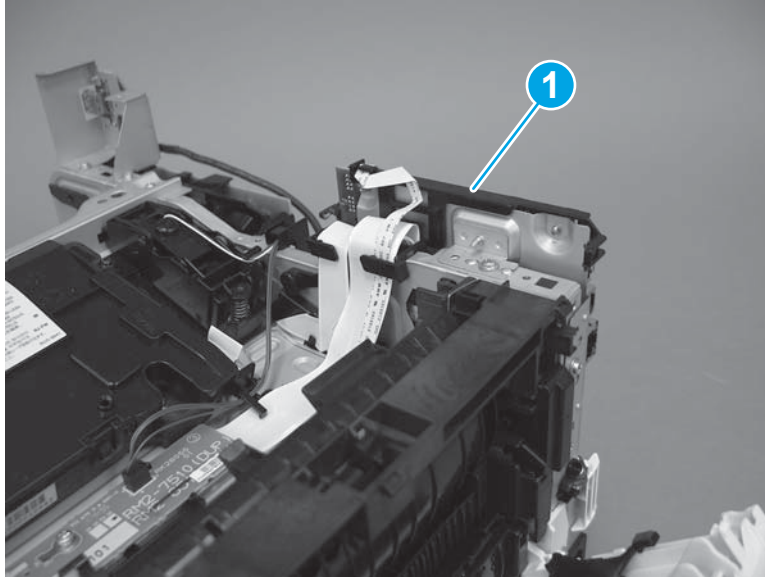


### Step 9: Remove the sheet-metal formatter bracket and formatter PCA

 **NOTE:** Disconnect any remaining formatter PCA FFCs or wire-harness connectors.

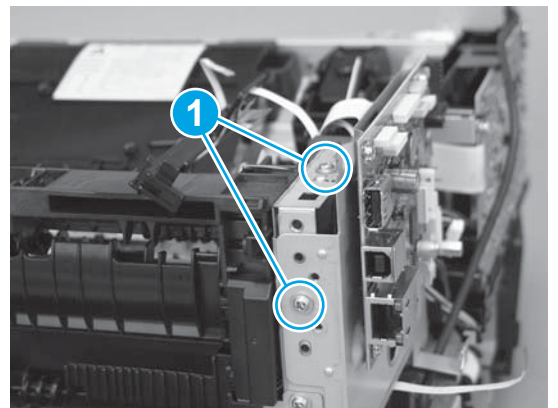
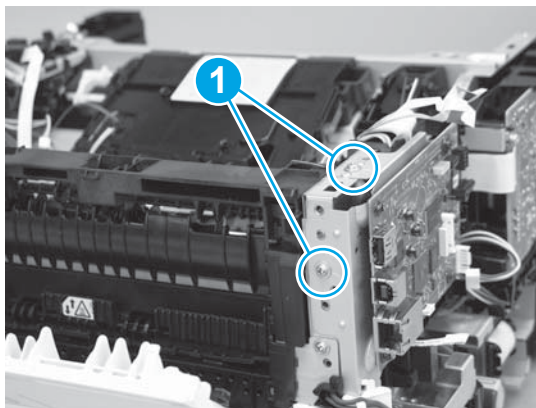
1. **M427/M426 only:** Remove the guide (callout 1).

**Figure 1-1064** Remove the guide



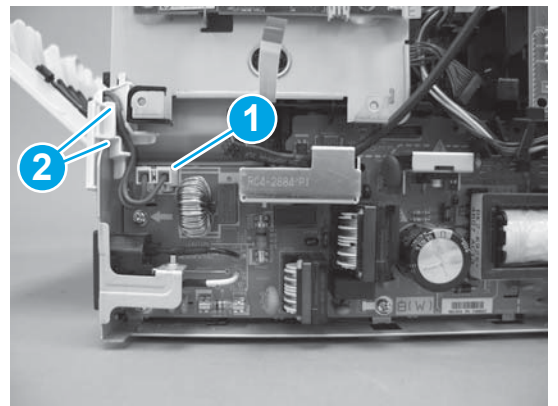
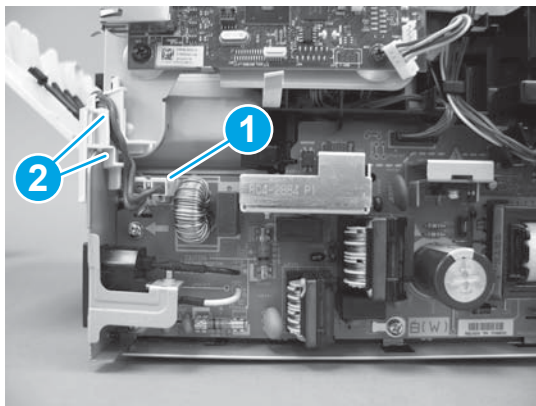
2. Remove two screws (callout 1).

**Figure 1-1065** Remove two screws



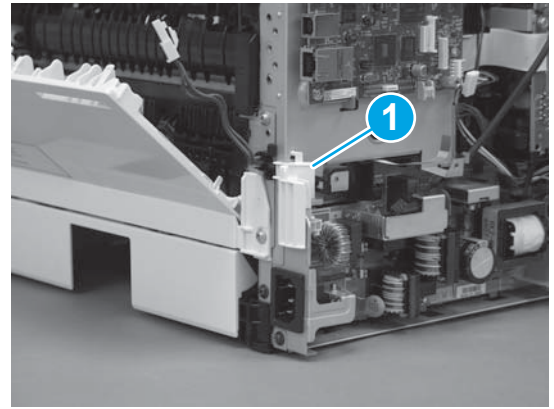
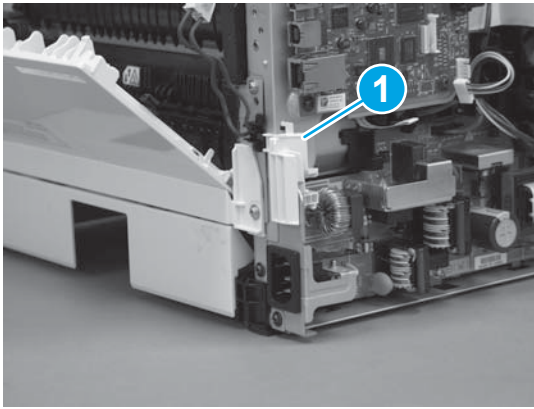
3. Disconnect one connector (callout 1), and then release the wire harness from the guide (callout 2).

**Figure 1-1066** Disconnect one connector



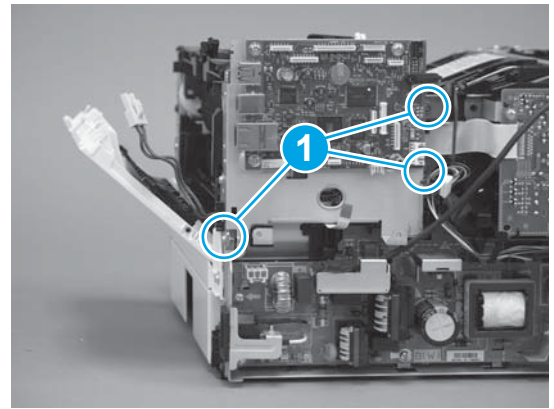
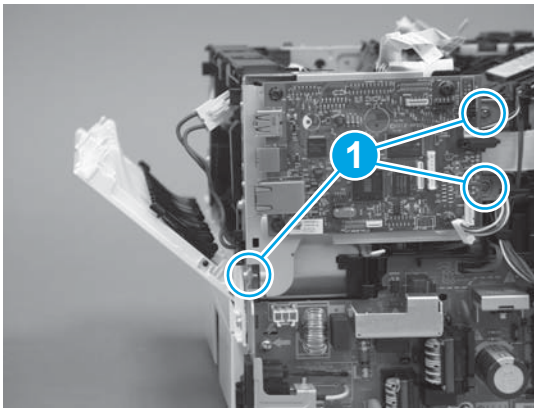
4. Remove the guide (callout 1).

**Figure 1-1067** Remove the guide



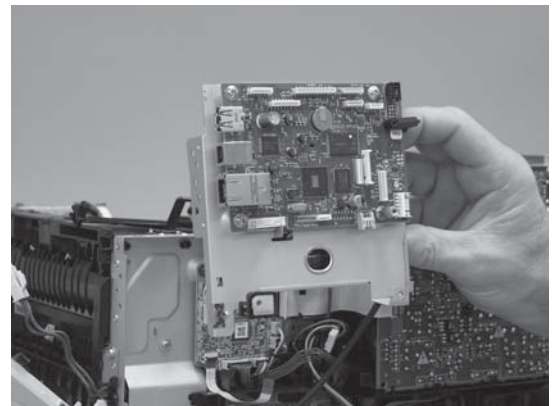
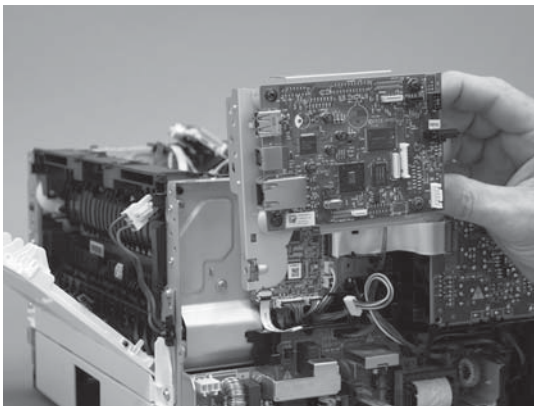
5. Remove three screws (callout 1).

**Figure 1-1068** Remove three screws




6. Remove the sheet-metal bracket and formatter PCA.

**Figure 1-1069** Remove the bracket



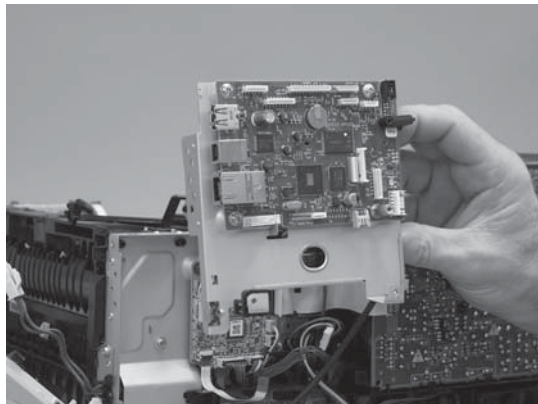
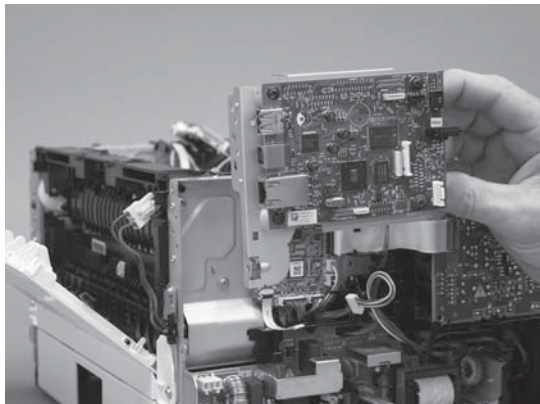


## Step 10: Install the sheet-metal formatter bracket and formatter PCA

 **NOTE:** Do not forget to connect any formatter PCA FFCs or wire-harness connectors that were disconnected when the bracket was removed.

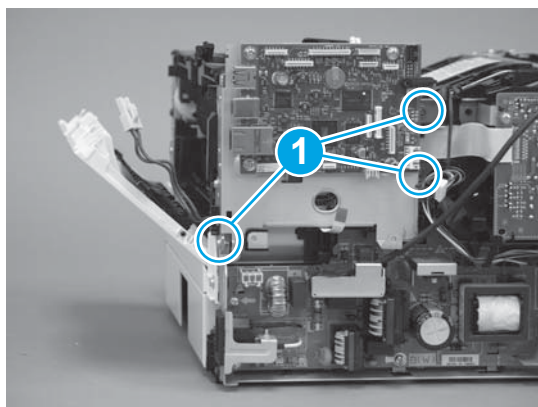
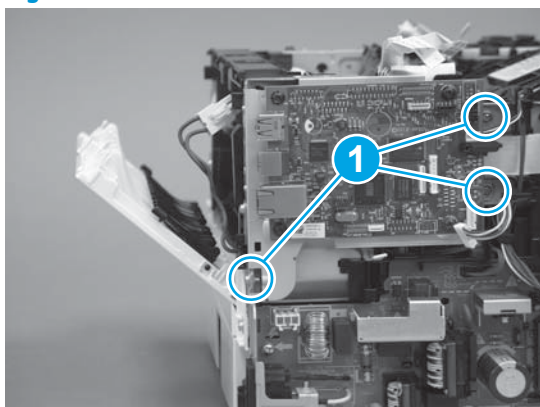
1. Position the sheet-metal bracket and formatter PCA on the printer.

**Figure 1-1070** Install the bracket



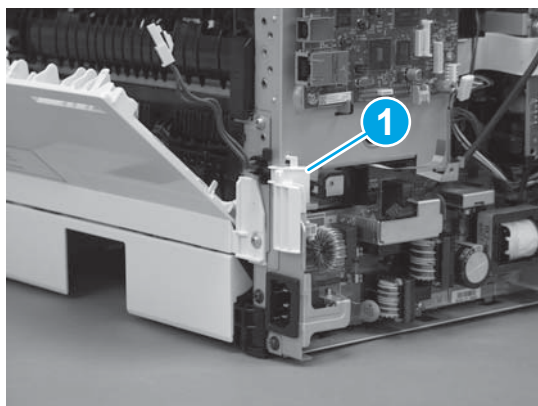
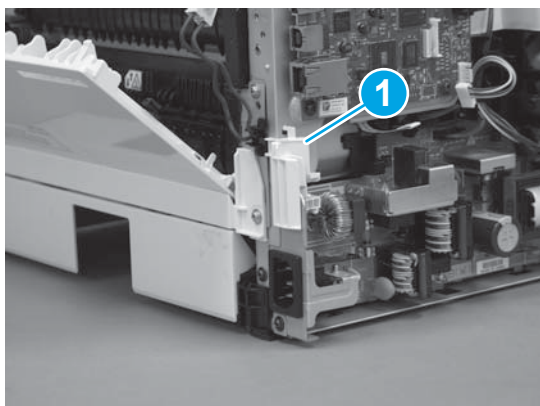
2. Install three screws (callout 1).

**Figure 1-1071** Install three screws



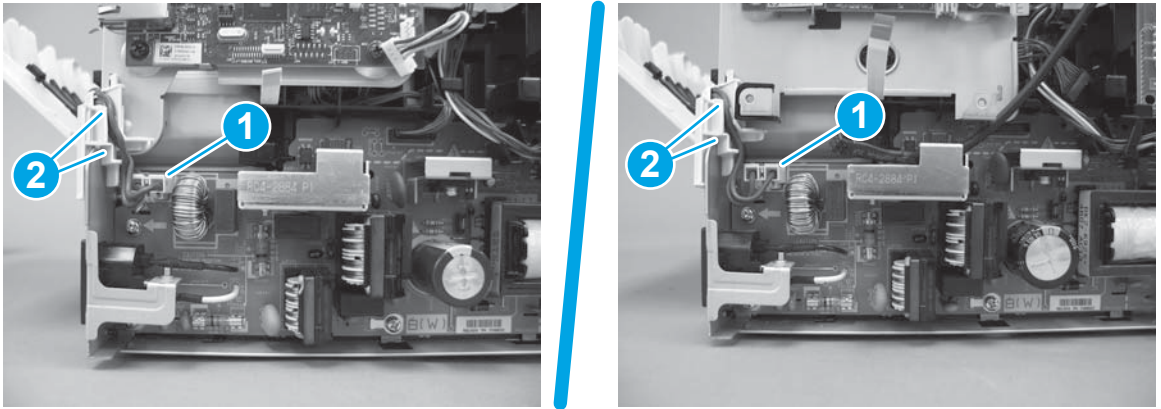
3. Install the guide (callout 1).

**Figure 1-1072** Install the guide



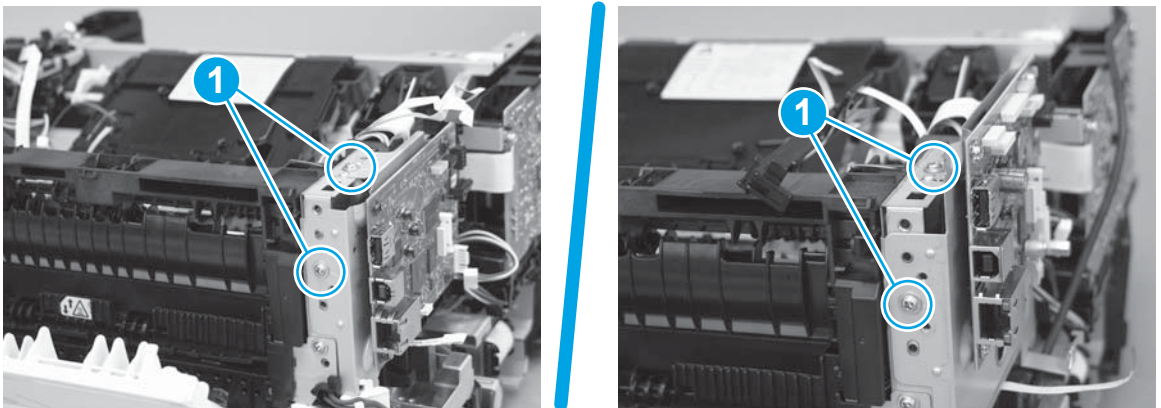
4. Connect one connector (callout 1), and then install the wire harness in the guide (callout 2).

**Figure 1-1073** Connect one connector



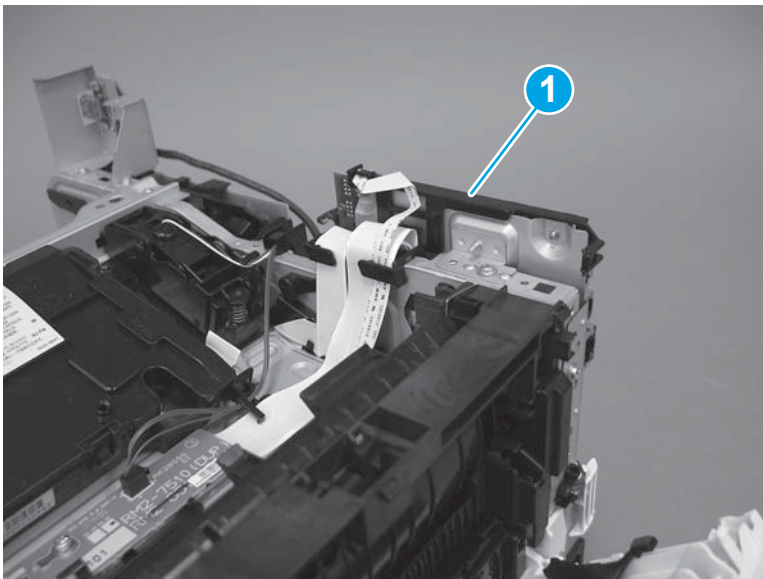
5. Install two screws (callout 1).

**Figure 1-1074** Install two screws




6. **M427/M426 only:** Install the guide (callout 1).

**Figure 1-1075** Install the guide

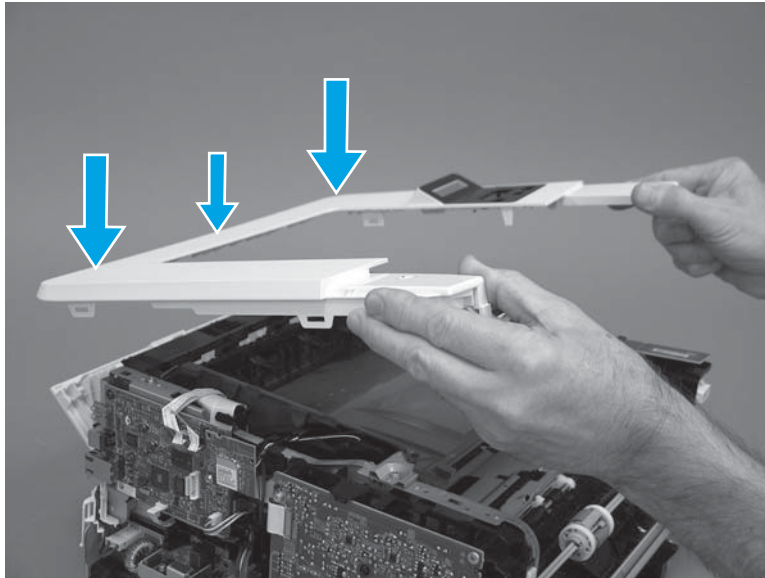


## Step 11: Install the top cover (M403/M402)

 **NOTE:** The step is for the M403/M402 printer. For the M427/M426, skip this step and go to [Step 12: Install the top cover \(M427/M426\) on page 590](#).

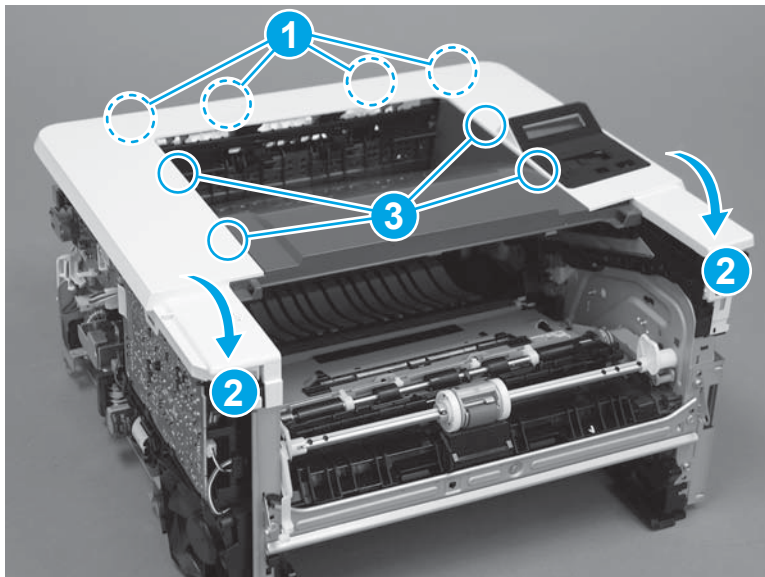
1. Position the rear edge of the cover on the printer.

**Figure 1-1076** Install the cover



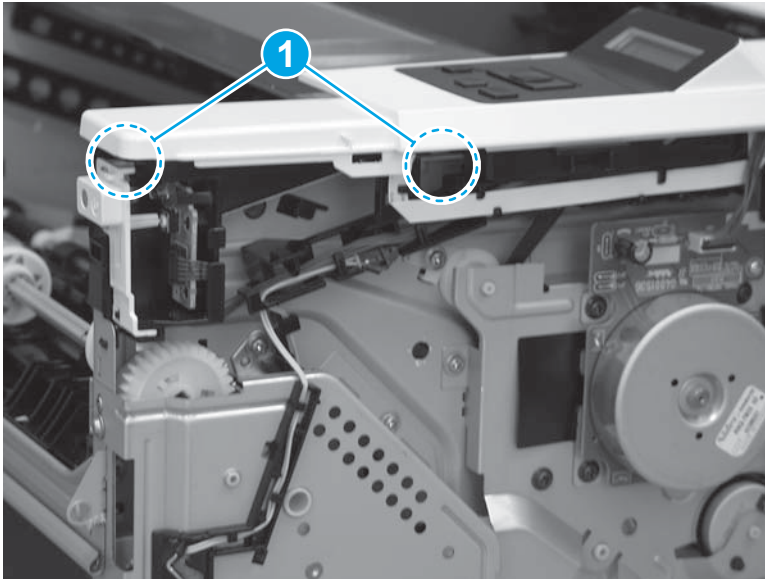
2. Engage four bosses (callout 1), rotate the front of the cover down (callout 2) and onto from the printer, and then engage four tabs (callout 3).

**Figure 1-1077** Engage four bosses and tabs



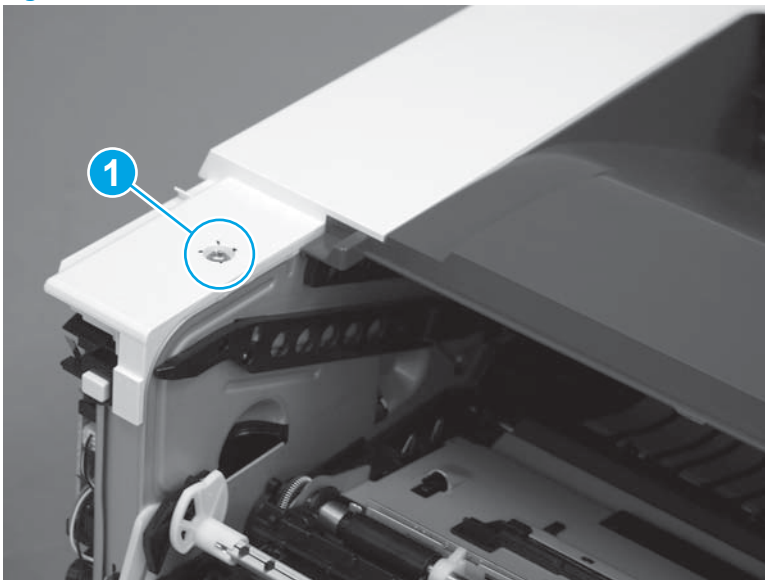
3. At the right side of the printer, engage the one boss and one tab (callout 1).

**Figure 1-1078** Engage one boss and one tab




4. Install one screw (callout 1).

**Figure 1-1079** Install one screw

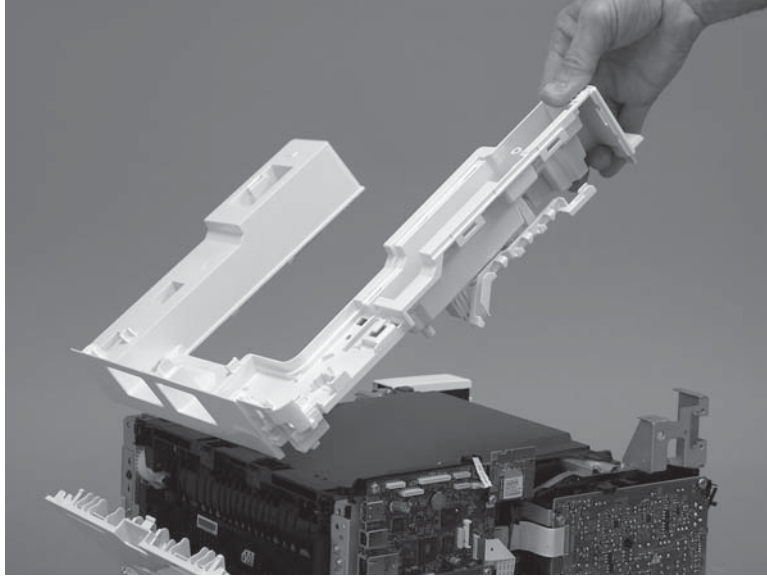


### Step 12: Install the top cover (M427/M426)

 **NOTE:** The step is for the M427/M426 printer. For the M403/M402, skip this step and go to [Step 15: Install the right cover on page 602](#).

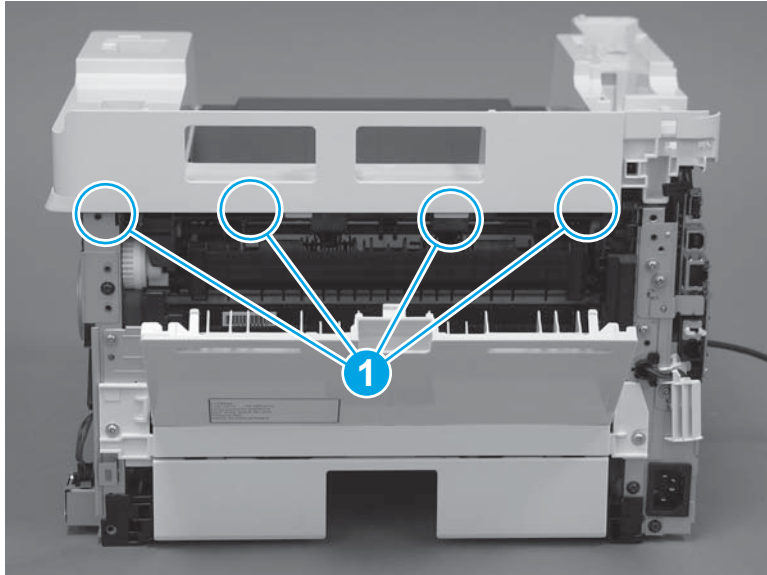
1. Position the rear edge of the top cover on the printer.

**Figure 1-1080** Install the cover



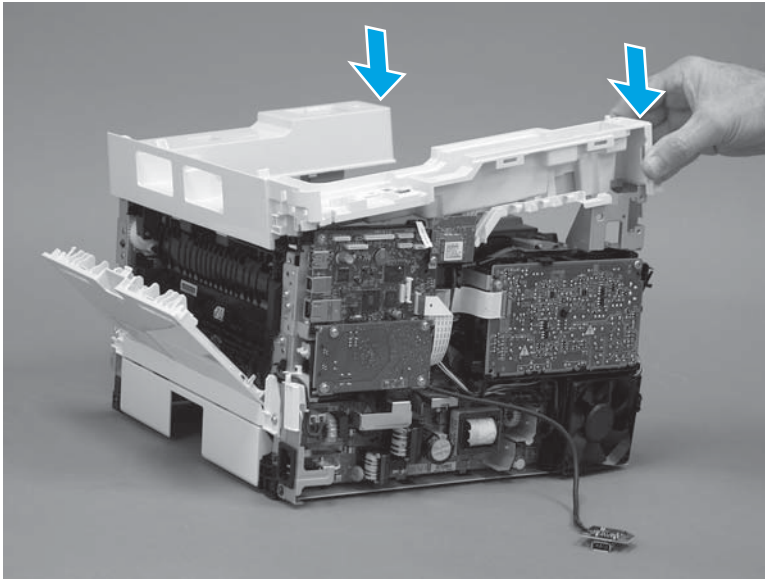
2. Engage four bosses (callout 1).

**Figure 1-1081** Engage four bosses



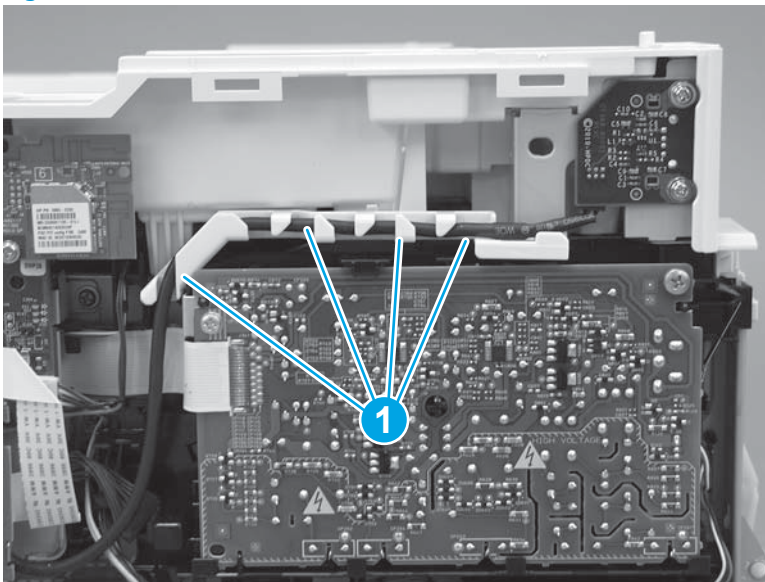
3. Rotate the front edge of the cover down.

**Figure 1-1082** Rotate the front edge of the cover down



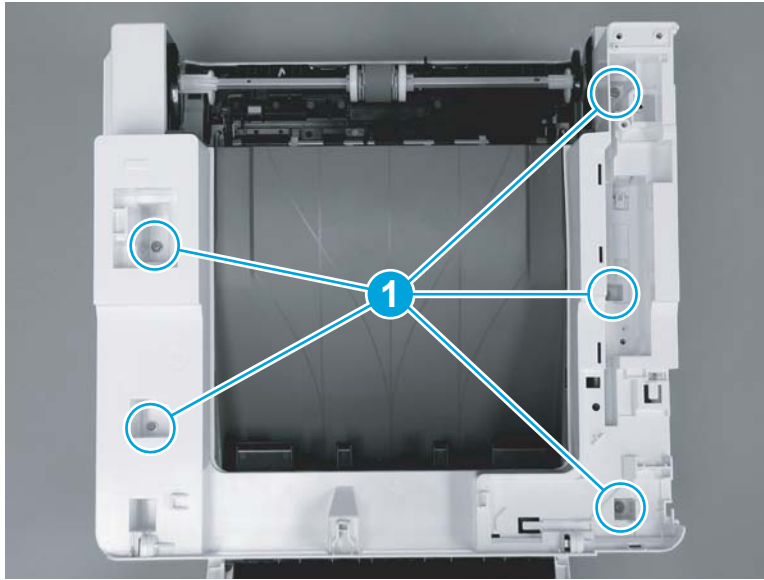
4. Install the USB cable (callout 1) in the guide.

**Figure 1-1083** Install the USB PCA




5. Install five screws (callout 1).

**Figure 1-1084** Install five screws

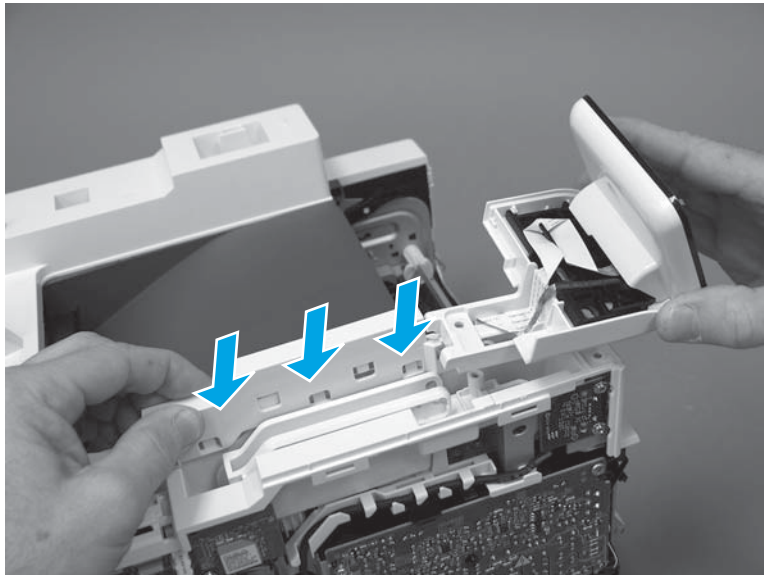


### Step 13: Install the control panel (M427/M246)

 **NOTE:** The step is for the M427/M426 printer. For the M403/M402, skip this step and go to [Step 15: Install the right cover on page 602](#).

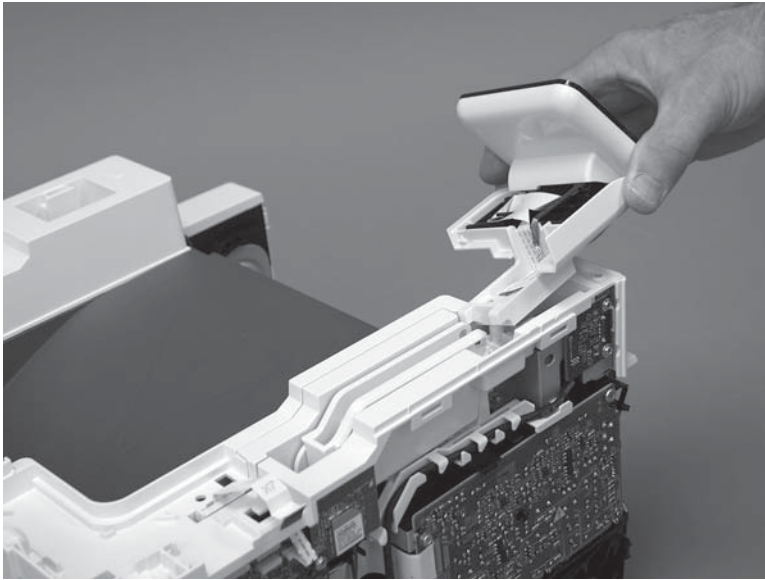
1. Slide the control-panel FFC cover into the slot in the top cover (next to the document feeder support arm) to install it.

**Figure 1-1085** Install the control-panel FFC cover



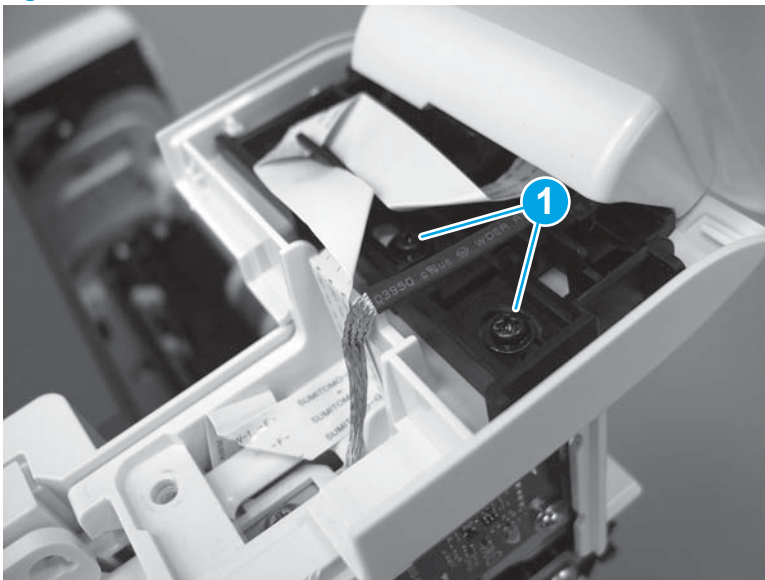
2. Install the control-panel assembly on the top cover.

**Figure 1-1086** Install the control-panel assembly



3. Move the FFC out of the way, and then install two screws (callout 1).

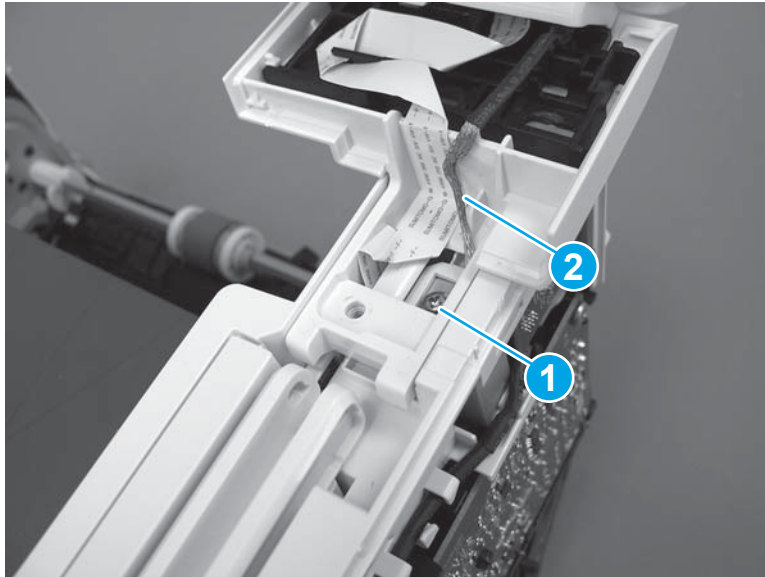
**Figure 1-1087** Install two screws





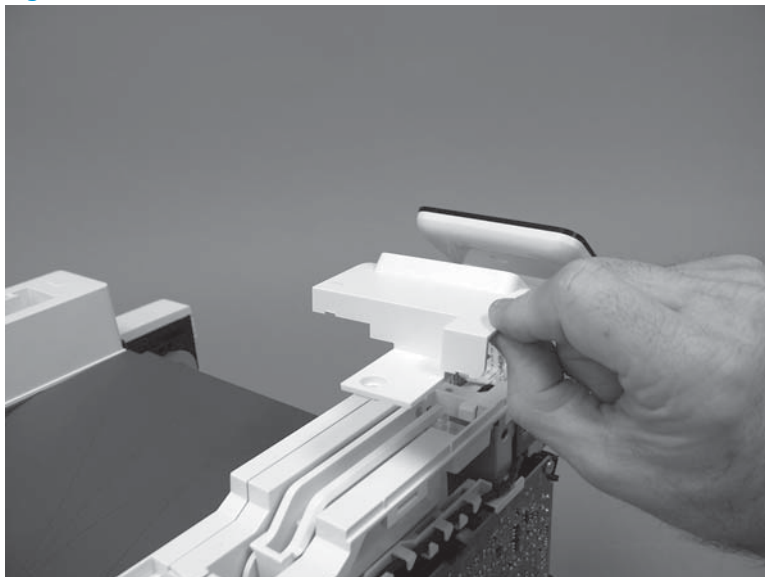
4. Install one grounding screw (callout 1), and then make sure that the ground cable (callout 2) is properly routed.

**Figure 1-1088** Remove one screw



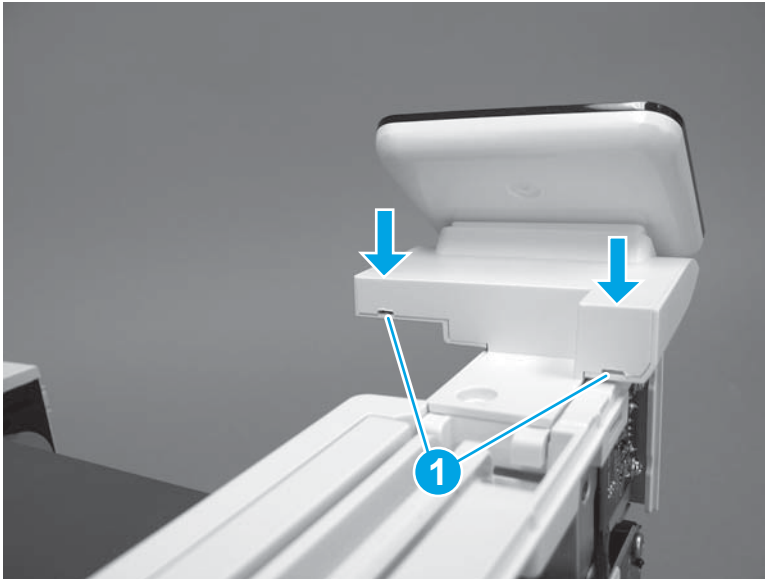
5. Install the control-panel cable cover.

**Figure 1-1089** Install the cover



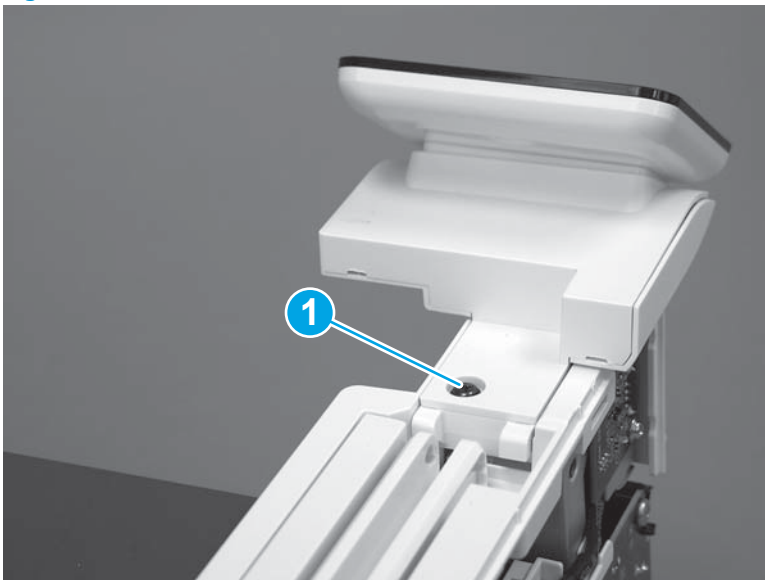
6. Make sure that the two tabs (callout 1) on the cover snap into place.

**Figure 1-1090** Engage two tabs



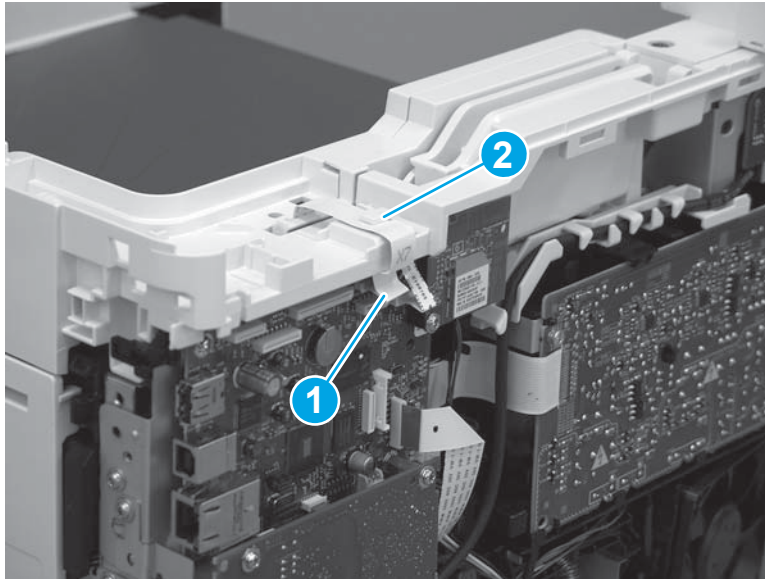
7. Install one screw (callout 1).

**Figure 1-1091** Install one screw





8. Install the FFC in the retainer (callout 1), and then connect one FFC (callout 2; J114).

**Figure 1-1092** Connect one connector



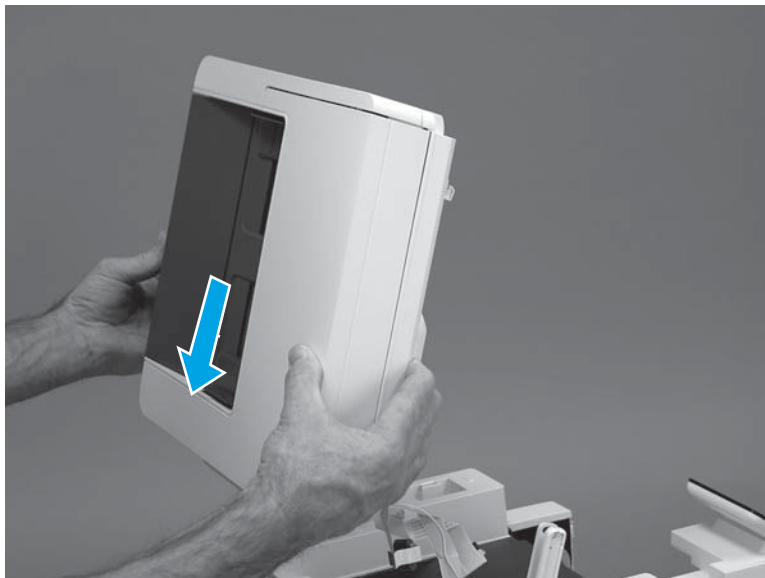
#### Step 14: Install the integrated scanner assembly (M427/M246)

 **NOTE:** The step is for the M427/M426 printer. For the M403/M402, skip this step and go to [Step 15: Install the right cover on page 602](#).

 **NOTE:** M427/M426 models only. The integrated scanner assembly (ISA) includes the sub-scanner assembly (SSA) and the automatic document feeder (ADF).

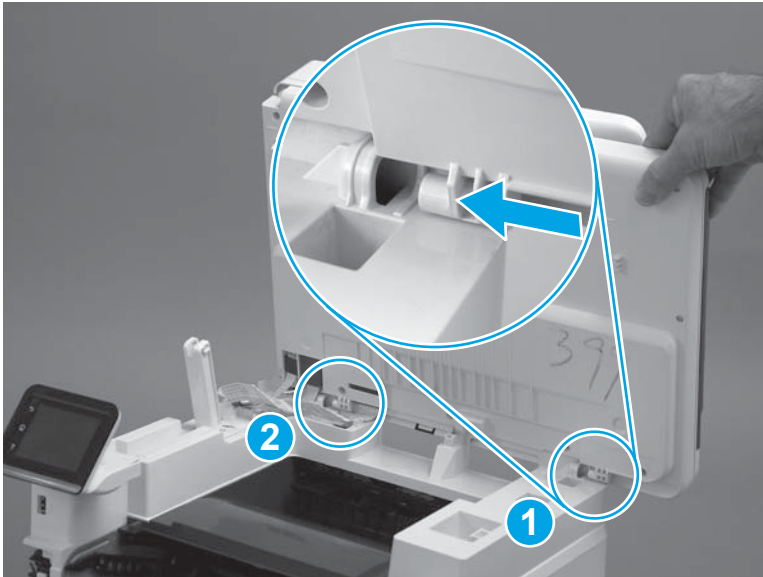
1. Position the ISA on the printer.

**Figure 1-1093** Position the ISA on the printer



2. Engage the hinge pins on the ISA with the holders in the top cover (callouts 1/2), and then slide the ISA as shown to engage them

**Figure 1-1094** Engage the hinge pins with the holders



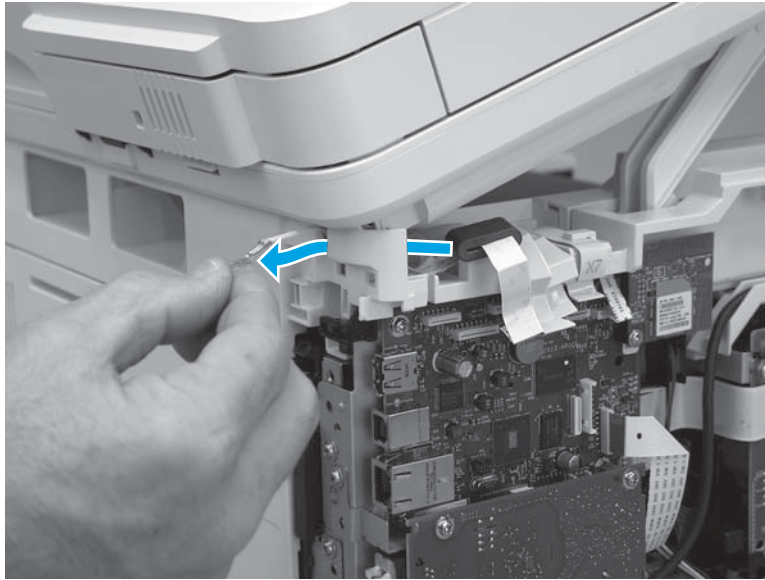
3. Rotate the ISA towards the front of the printer until it rests on the ISA lift assembly (callout 1).

**Figure 1-1095** Rotate the ISA towards the front of the printer



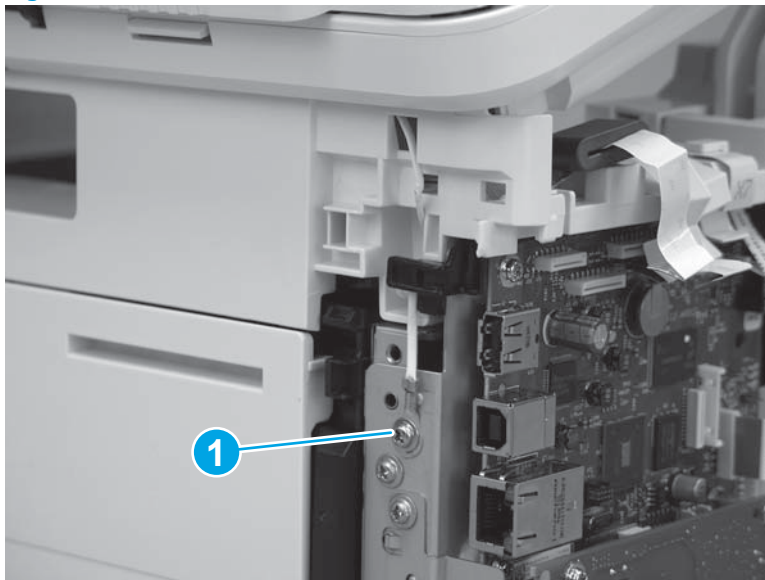
4. Pass the ground wire through the opening in the top cover.

**Figure 1-1096** Pass the wire through the opening




5. Install one screw (callout 1).

**Figure 1-1097** Install one screw



6. Install the ISA lift assembly slider pin.

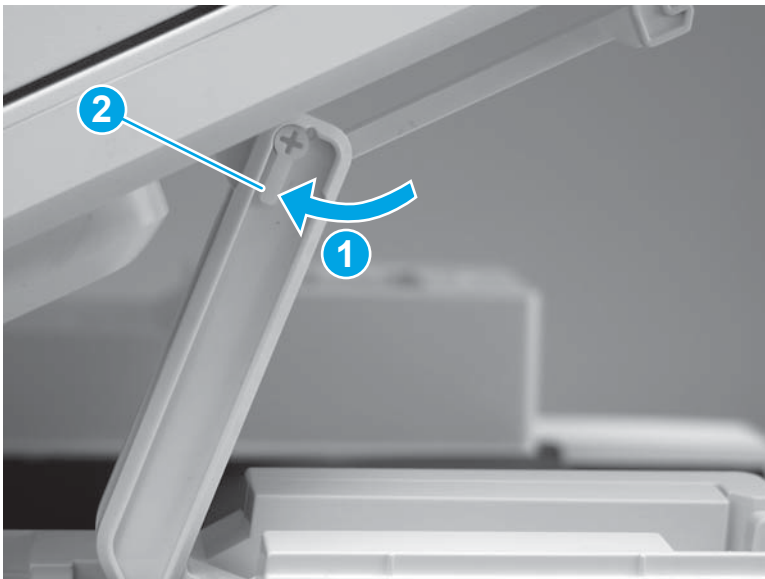
 **Reinstallation tip:** Align the keyed portion of the locking pin with the slot and hole in the support arm.

**Figure 1-1098** Install the slider pin



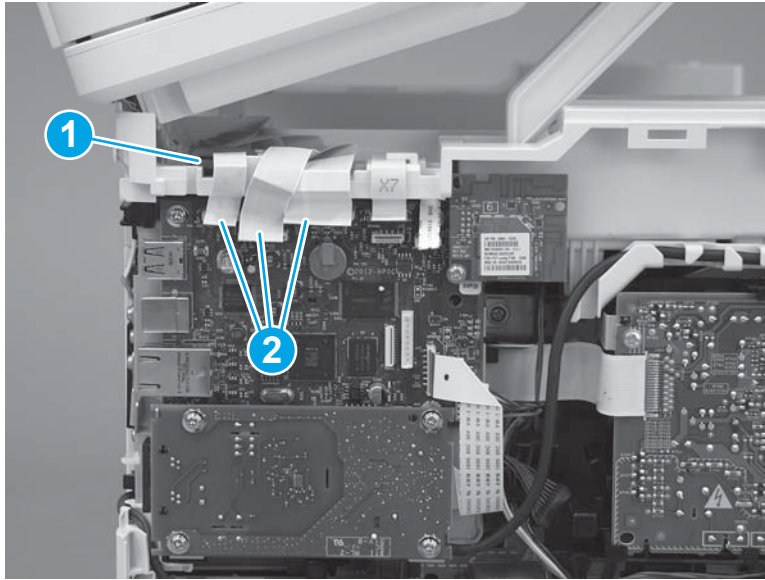
7. Rotate the slider pin (callout 1) towards the rear of the printer until the tab (callout 2) snap into place.

**Figure 1-1099** Secure the slider pin



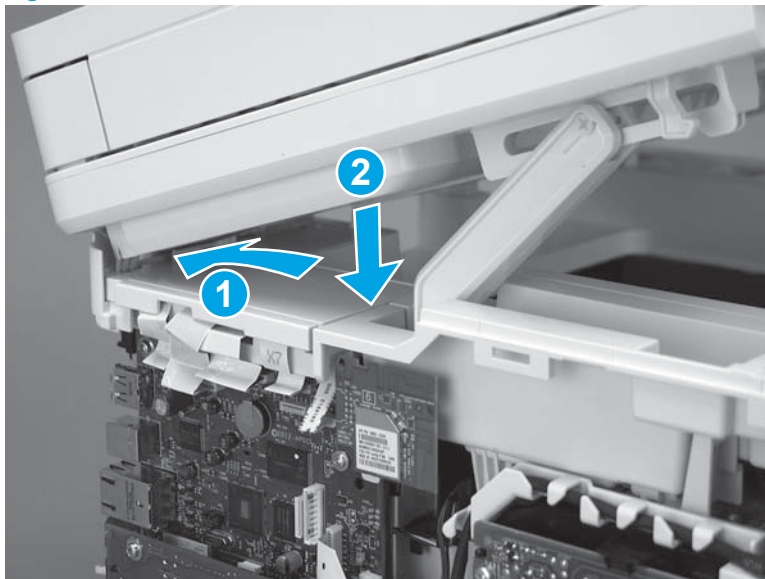
8. Install the ferrite (callout 1) in the holder, and then connect three FFCs (callout 2).

**Figure 1-1100** Connect three FFCs



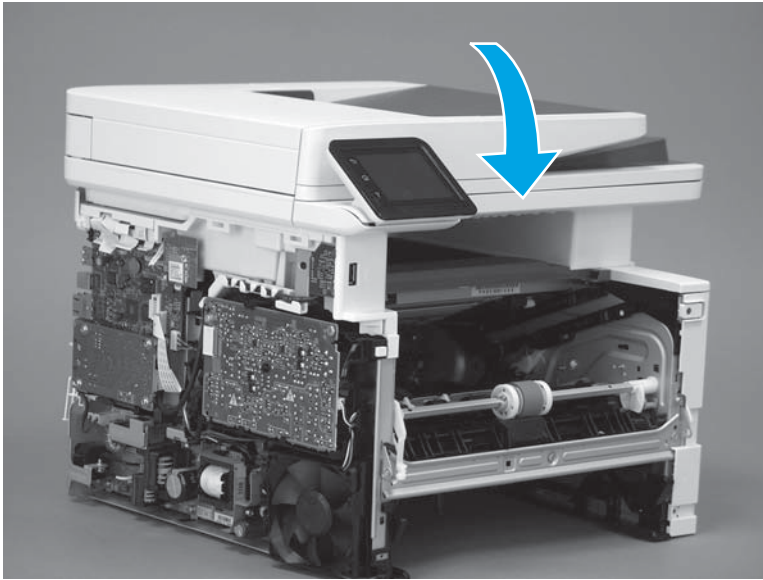
9. Position the rear edge of the ISA flat-flexible cable (FFC) cover on the printer (callout 1), and then rotate it down (callout 2) until it snaps into place.

**Figure 1-1101** Install the ISA FFC cover



10. Lower the ISA.

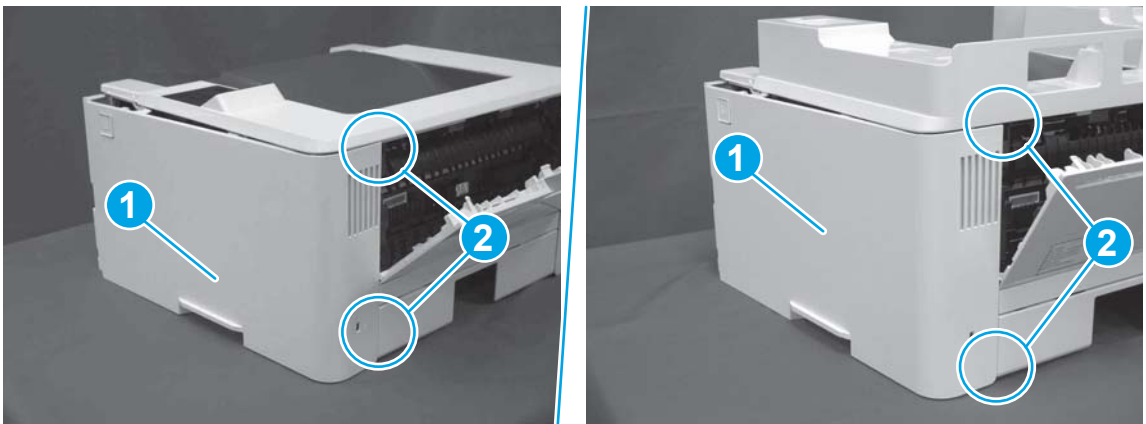
**Figure 1-1102** Lower the ISA



**Step 15: Install the right cover**

1. Position the cover (callout 1) on the printer, and then engage two bosses (callout 2).

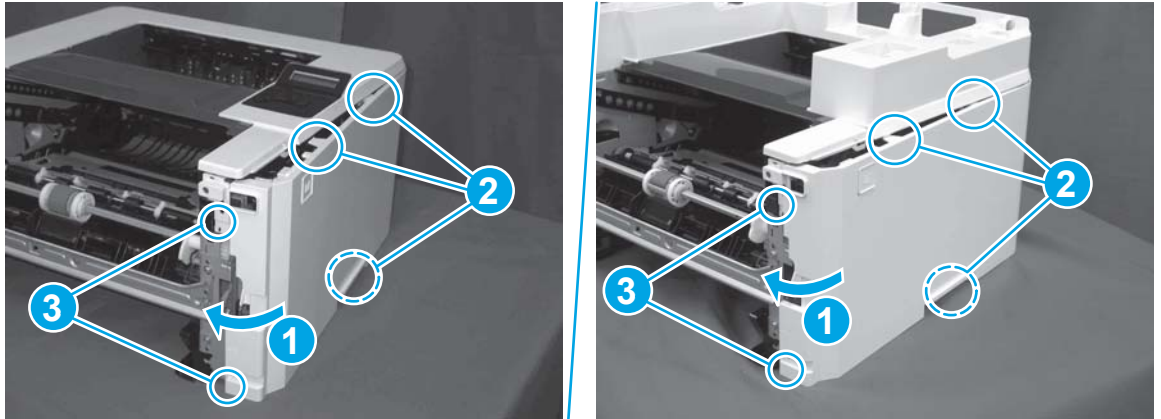
**Figure 1-1103** Install the cover





2. Rotate the front of the cover onto the printer (callout 1), engage three (callout 2) tabs, and then engage two bosses (callout 3).

**Figure 1-1104** Engage two bosses and one tab

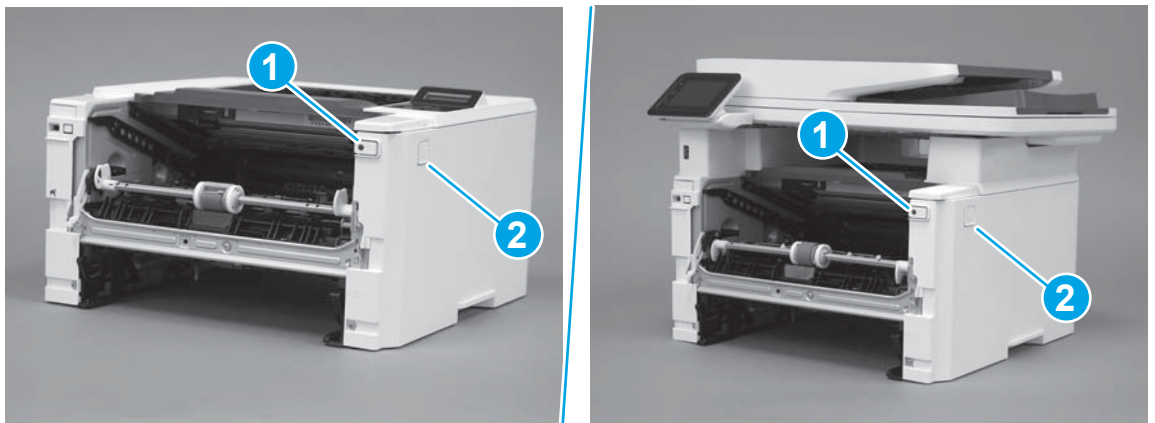


3. Make sure that the power switch (callout 1) and cartridge door assembly button (callout 2) correctly function.



**NOTE:** Remove, and then reinstall the cover if the switch or button does not correctly function.

**Figure 1-1105** Check the power switch and cartridge door assembly button



4. Install one screw (callout 1).

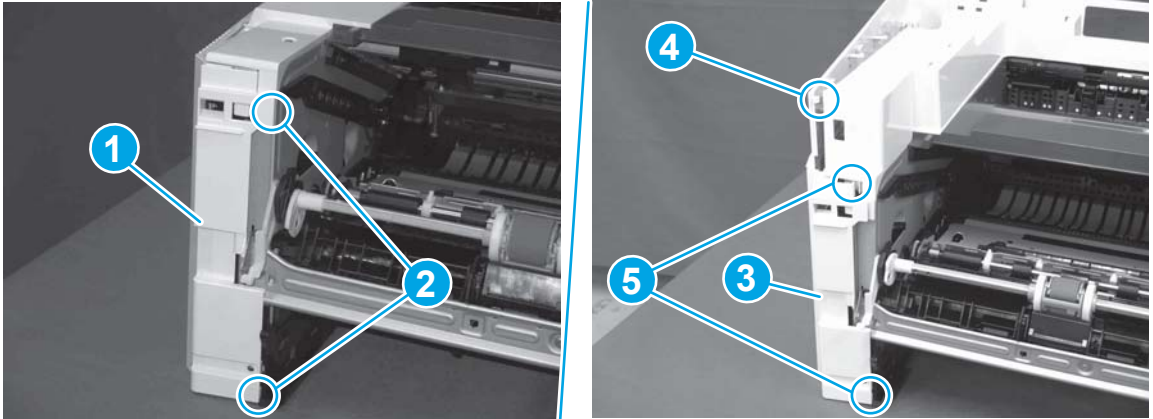
**Figure 1-1106** Install one screw



## Step 16: Install the left cover

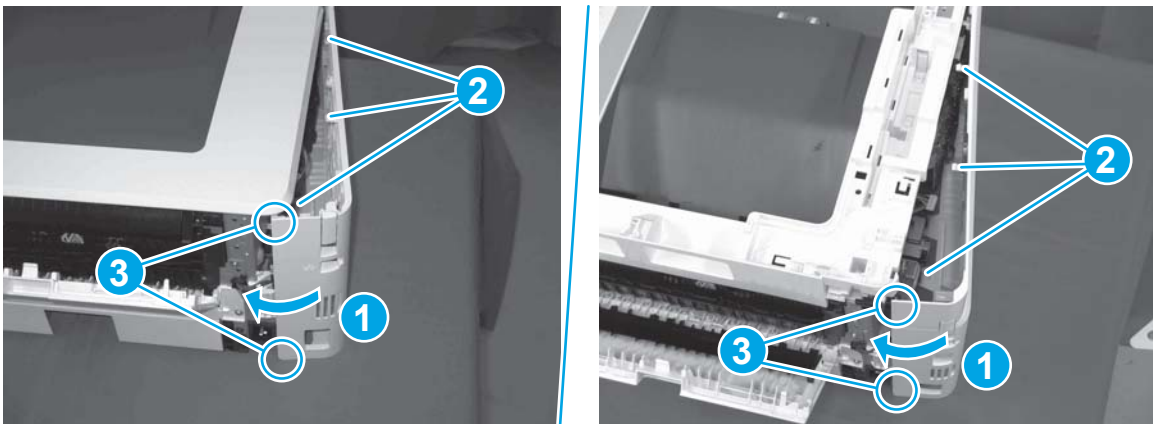
1. At the front of the printer, do one of the following:
  - **M403/M402:** Position the cover on the printer ( callout 1), and then engage two bosses (callout 2).
  - **M427/M426:** Position the cover on the printer (callout 3), engage one tab (callout 4), and then engage two bosses (callout 4).

**Figure 1-1107** Install the cover



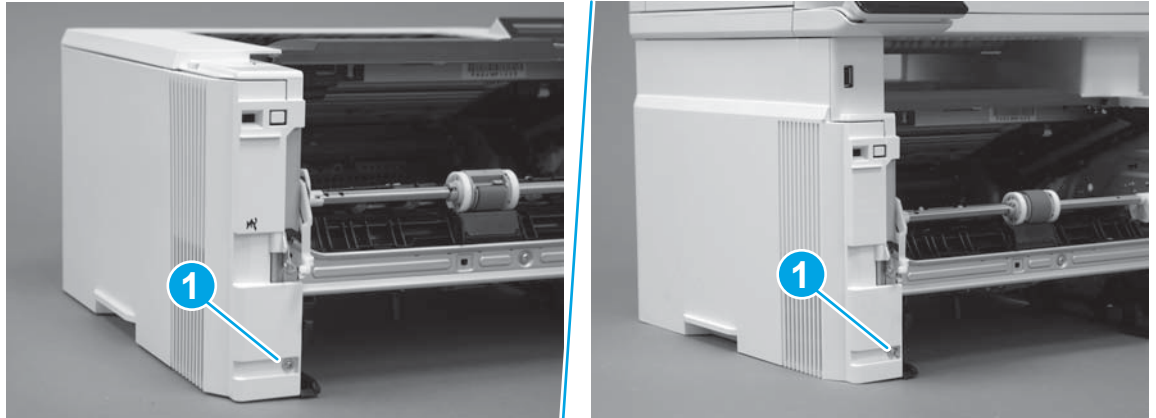
2. Carefully rotate the rear of the cover onto the printer (callout 1), engage three tabs (callout 2), and then engage two bosses (callout 3).

**Figure 1-1108** Engage three tabs and two bosses




3. Install one screw (callout 1).

**Figure 1-1109** Install one screw

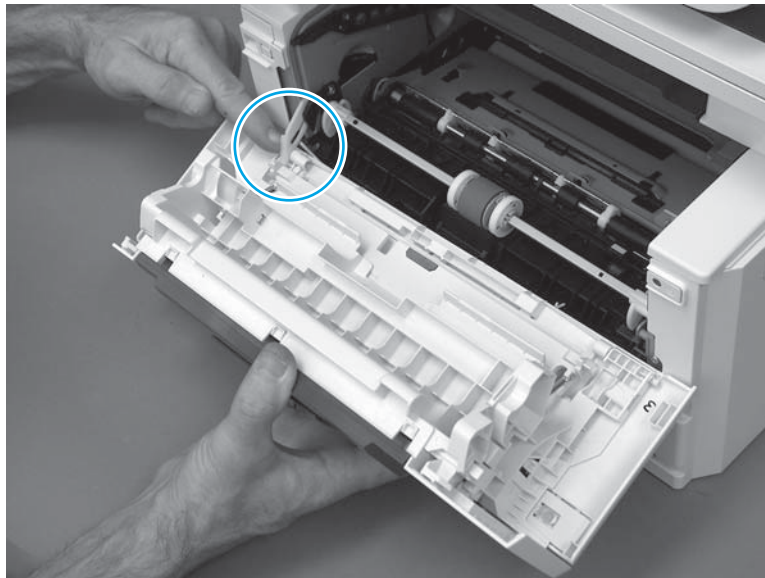


### Step 17: Install the cartridge door assembly

 **Reinstallation tip:** After a replacement door is installed, make sure to install the nameplate (supplied in the kit) corresponding to the printer name on the door.

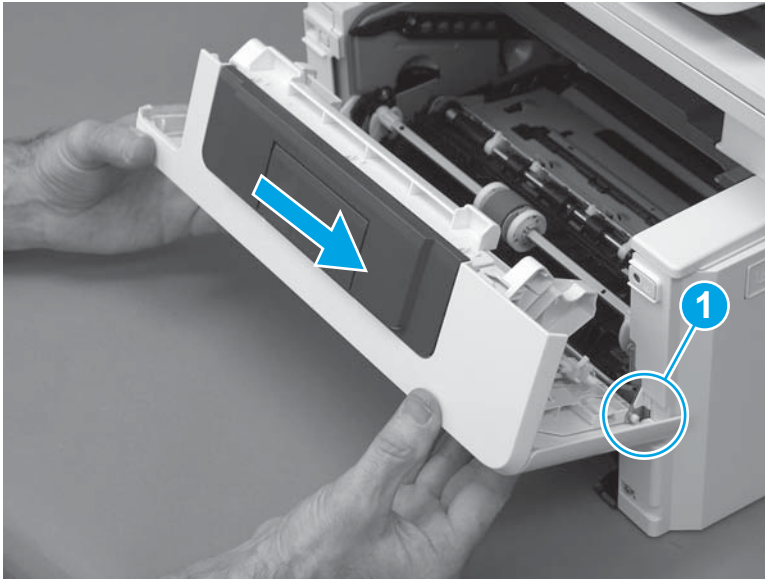
1. Position the door close to the printer, and then engage the keyed pin on the left-side retainer arm with the hole in the door.

**Figure 1-1110** Engage the left-side retainer arm



2. Engage the right-side door hinge pin with the hole in the chassis (callout 1).

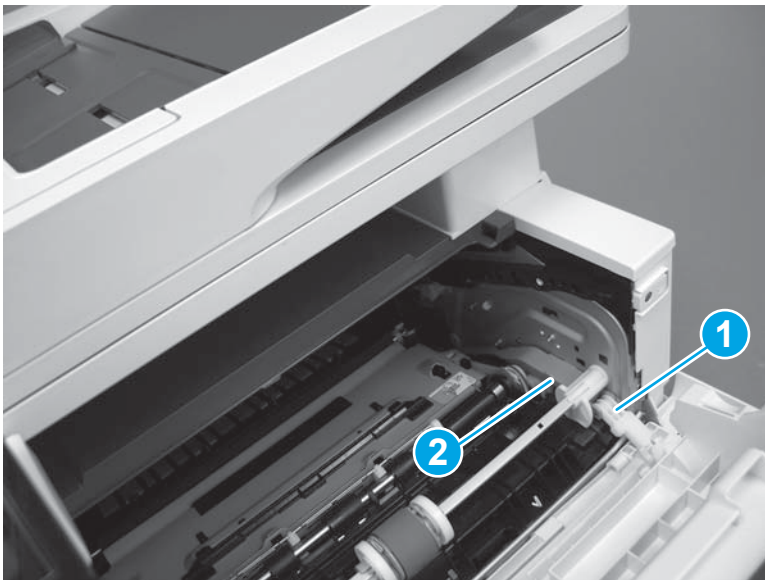
**Figure 1-1111** Install the door



3. Install the link (callout 1).

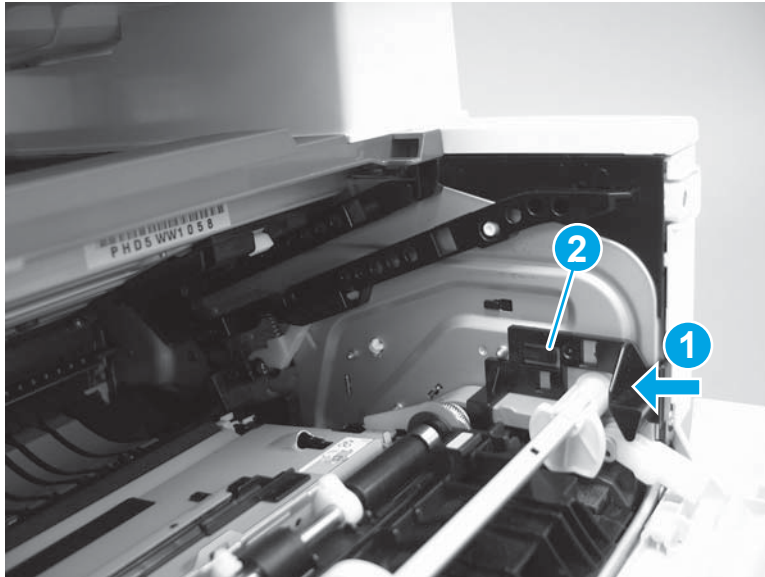
 **IMPORTANT:** Make sure that the link snaps into place on the arm (callout 2). The link actuates the fuser pressure-release mechanism.

**Figure 1-1112** Install the pressure-release link



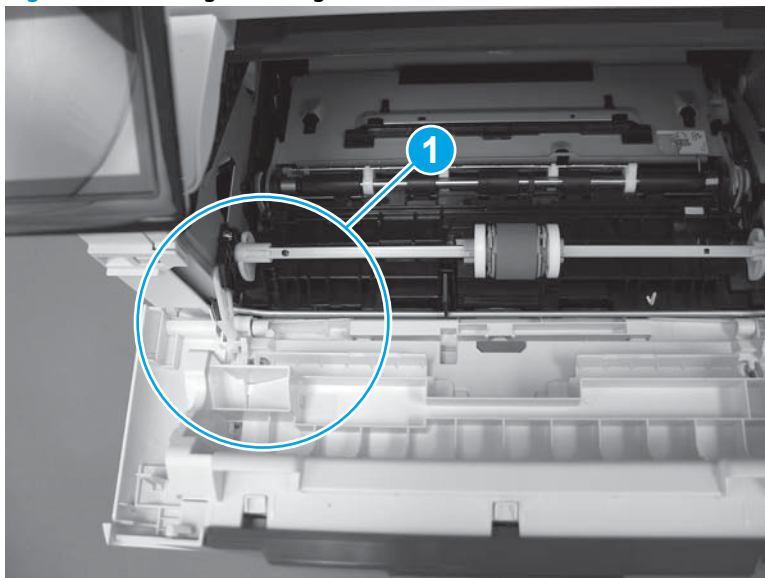
4. Slide the guide into the printer (callout 1), and then make sure that the tab (callout 2) snaps into place to secure the guide to the chassis.

**Figure 1-1113** Install the guide




5. Position the shaft on the door, and then align the left-side hinge on the door with the hole in the chassis (callout 1).

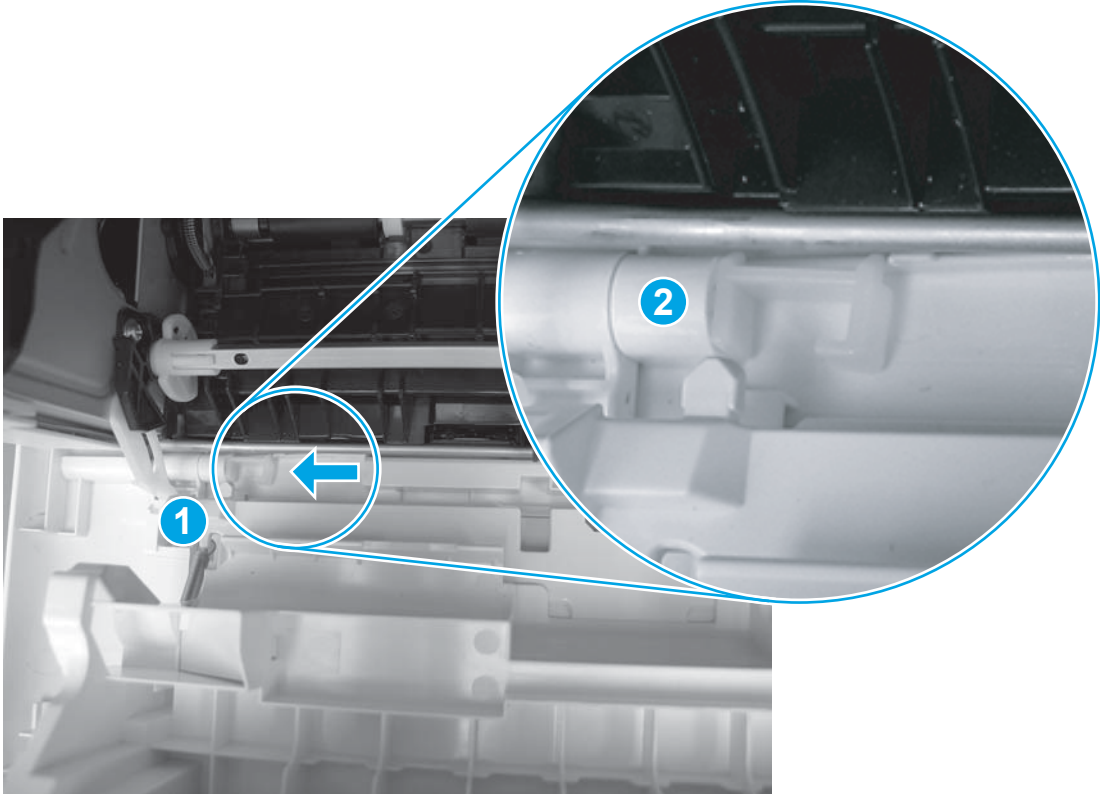
**Figure 1-1114** Align the hinge



6. Push the shaft towards the left side of the printer to install it (callout 1).

 **Reinstallation tip:** Make sure that the support shaft is fully installed and correctly orientated (callout 2) so that it will not interfere with the door opening and closing.

**Figure 1-1115** Install the support shaft



### Step 18: Install Tray 2

- ▲ Slide the tray straight into the printer to install it.

**Figure 1-1116** Install the tray



## Removal and replacement: NFC FFC

- [Introduction](#)
- [Step 1: Remove Tray 2](#)
- [Step 2: Remove the cartridge door assembly](#)
- [Step 3: Remove the left cover](#)
- [Step 4: Remove the right cover](#)
- [Step 5: Remove the integrated scanner assembly \(M427/M246\)](#)
- [Step 6: Remove the control panel \(M427/M246\)](#)
- [Step 7: Remove the top cover \(M427/M426\)](#)
- [Step 8: Remove the NFC PCA cover \(M427/M426\)](#)
- [Step 9: Remove the top cover \(M403/M402\)](#)
- [Step 10: Remove the paper delivery tray \(output bin\)](#)
- [Step 11: Remove the NFC PCA](#)
- [Step 12: Remove the NFC FFC](#)
- [Step 13: Unpack the replacement assembly](#)
- [Step 14: Install the NFC FFC](#)
- [Step 15: Install the NFC PCA](#)
- [Step 16: Install the paper delivery tray \(output bin\)](#)
- [Step 17: Install the top cover \(M403/M402\)](#)
- [Step 18: Install the NFC PCA cover \(M427/M426\)](#)
- [Step 19: Install the top cover \(M427/M426\)](#)
- [Step 20: Install the control panel \(M427/M246\)](#)
- [Step 21: Install the integrated scanner assembly \(M427/M246\)](#)
- [Step 22: Install the right cover](#)
- [Step 23: Install the left cover](#)
- [Step 24: Install the cartridge door assembly](#)
- [Step 25: Install Tray 2](#)


### Introduction

This document provides the procedures to remove and replace the near field communication (NFC) flat-flexible cable (FFC; M426fdw/M403dn models only).

## Before performing service

### Turn the printer power off

- Disconnect the power cable.

 **WARNING!** To avoid damage to the printer, turn the printer off, wait 30 seconds, and then remove the power cable before attempting to service the printer.

Use the table below to identify the correct part number for your printer. To order the part, go to [www.hp.com/buy/parts](http://www.hp.com/buy/parts).

NFC FFC part number	
<b>RK2-6949-000CN</b>	NFC FFC (M427/M426; wireless models)
<b>RK2-6947-000CN</b>	NFC FFC (M403/M402; wireless models)

### Required tools

- #2 Phillips screwdriver with a magnetic tip.

### After performing service

#### Turn the printer power on

- Connect the power cable.
- Use the power switch to turn the power on.

### Post service test

Make sure that the printer initializes to a **Ready** state.

Print a configuration page to make sure that the printer is functioning correctly.

#### Step 1: Remove Tray 2

- ▲ Pull the tray straight out of the printer to remove it.



**Figure 1-1117** Remove the tray



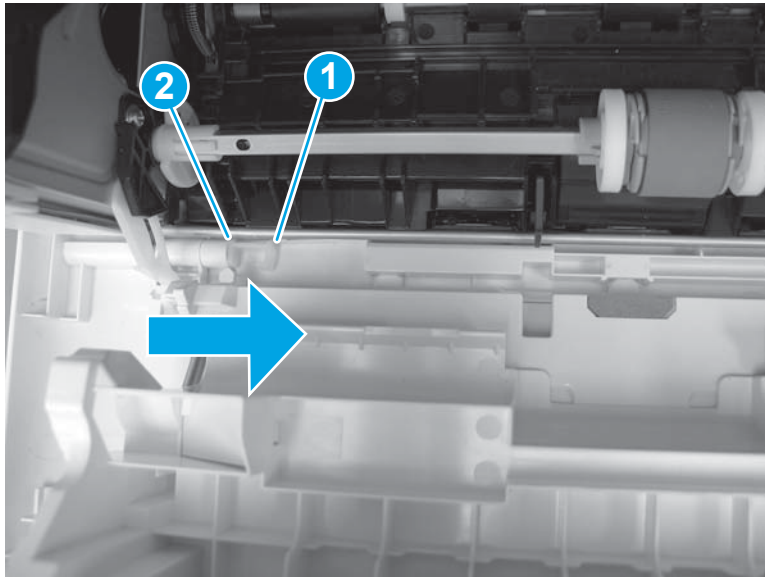
**Step 2: Remove the cartridge door assembly**

 **NOTE:** If the toner cartridge was not removed prior to servicing the printer, remove it now.

1. Release one tab (callout 1), and then slide shaft (callout 2) in the direction the arrow indicates and remove it.

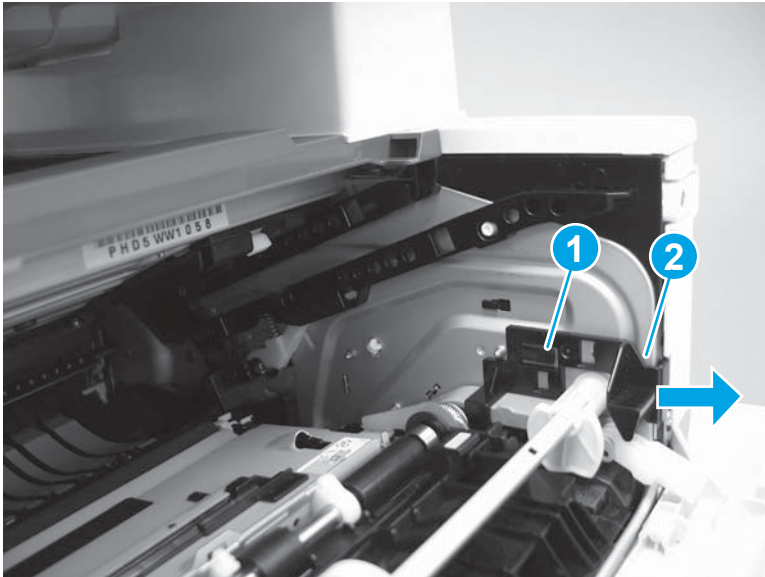
 **TIP:** It might be easier to release the support shaft by using a small flat-blade screwdriver.

**Figure 1-1118** Release the support shaft



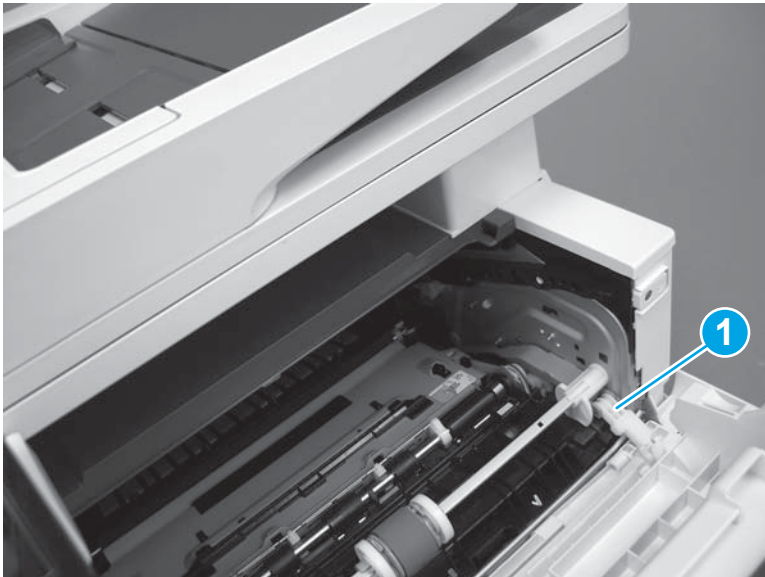
2. Release one tab (callout 1), and then slide the guide (callout 2) in the direction the arrow indicates and remove it.

**Figure 1-1119** Remove the guide



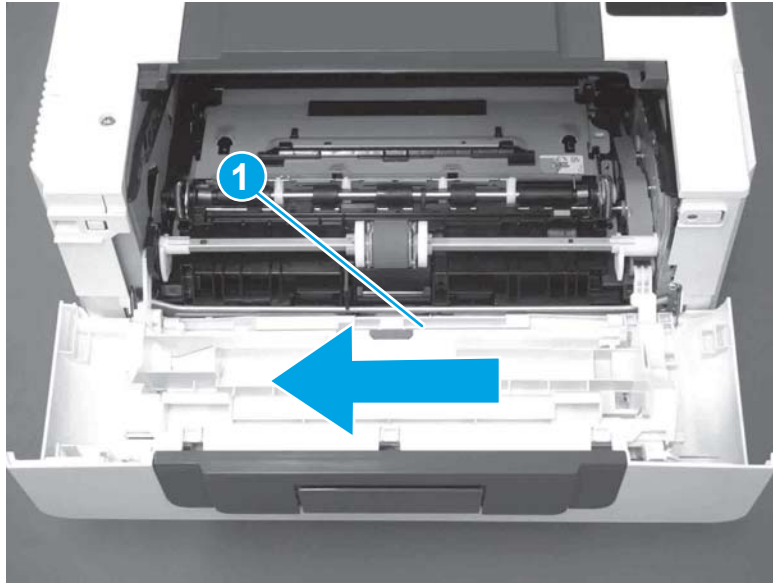
3. Remove the link arm (callout 1).

**Figure 1-1120** Remove the link arm



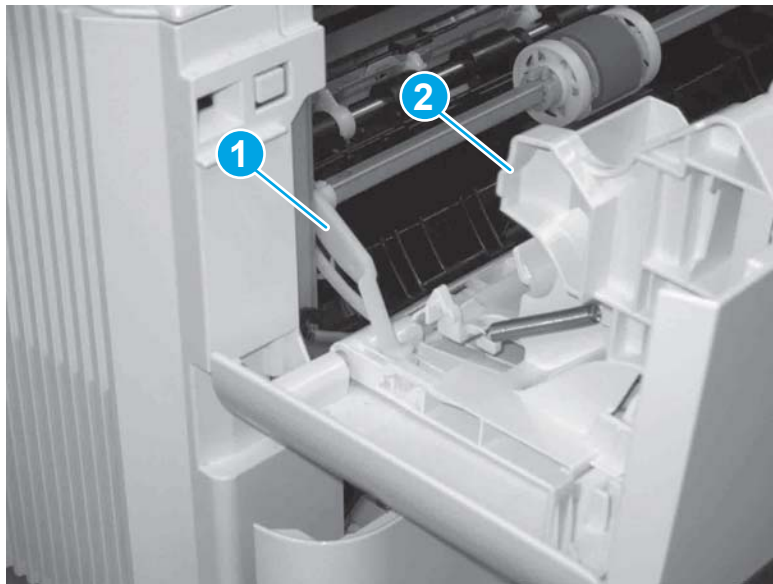
4. Slide the cartridge door assembly (callout 1) in the direction the arrow indicates and remove it.

**Figure 1-1121** Remove the door



5. Remove the link (callout 1) from the cartridge door assembly (callout 2).

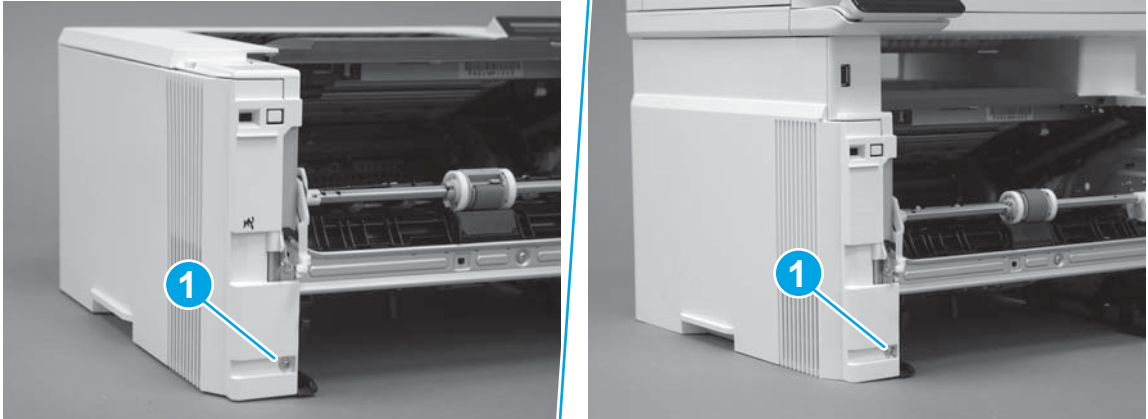
**Figure 1-1122** Release the left-side retainer arm



### Step 3: Remove the left cover

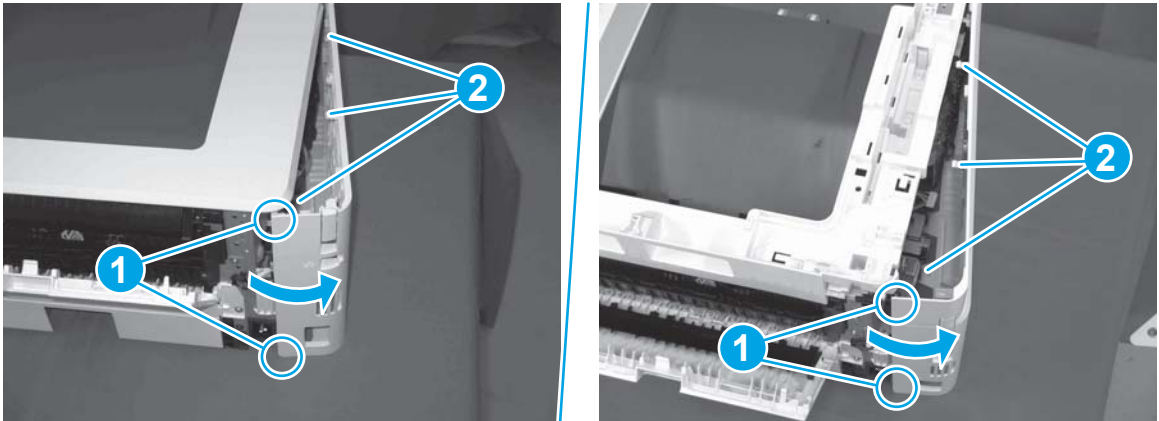
1. Remove one screw (callout 1).

**Figure 1-1123** Remove one screw



2. Open the rear door, release two bosses (callout 1), and then release three tabs (callout 2).

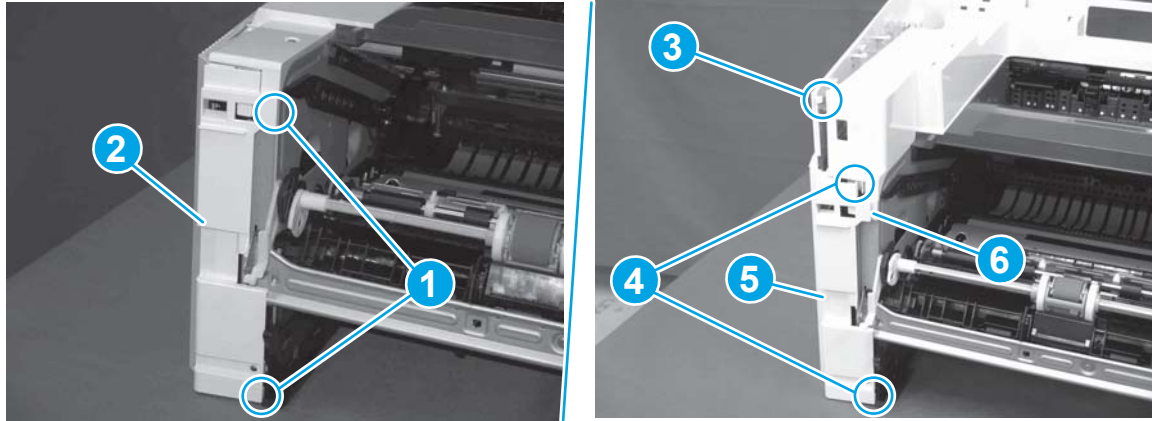
**Figure 1-1124** Release two bosses and three tabs



3. At the front of the printer, do one of the following:
  - **M403/M402:** Release two bosses (callout 1), and then remove the cover (callout 2).
  - **M427/M426:** Release one tab (callout 3), two bosses (callout 4), and then remove the cover (callout 5).

**CAUTION:** Be careful when releasing the upper bosses on the M427/M426 cover. One portion of the cover (callout 6) is fragile and is easily broken.

**Figure 1-1125** Remove the cover



**Step 4: Remove the right cover**

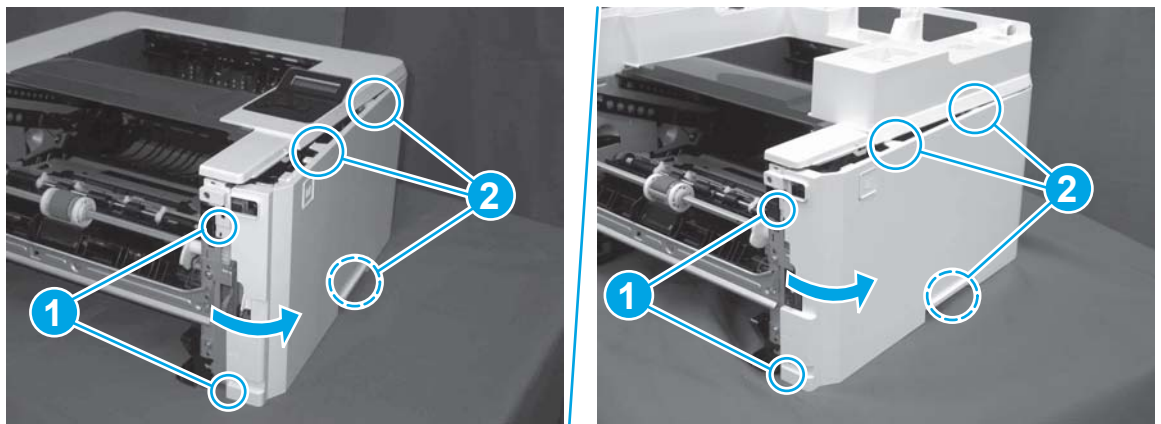
1. Remove one screw (callout 1).

**Figure 1-1126** Remove one screw



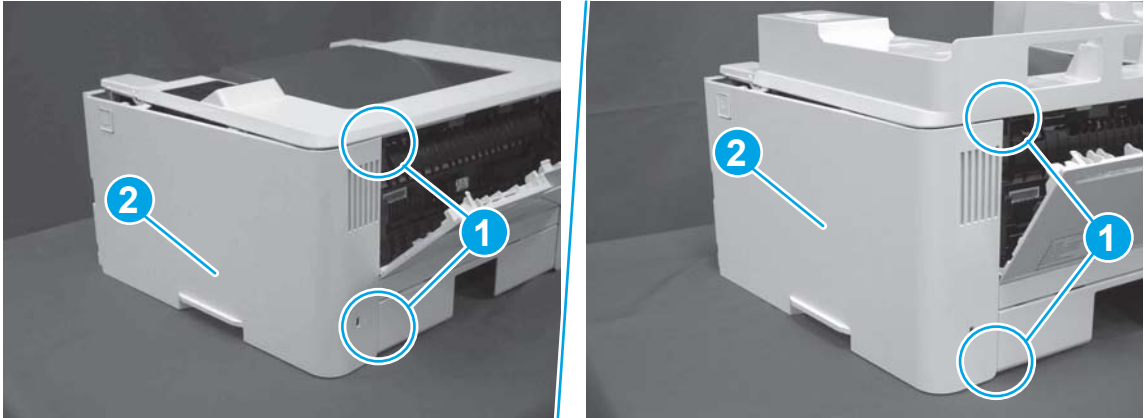
2. At the front of the printer, release two bosses (callout 1), and then release three tabs (callout 2).

**Figure 1-1127** Release two bosses and three tabs





3. Open the rear door, release two bosses (callout 1), and then remove the cover (callout 2).

**Figure 1-1128** Remove the cover



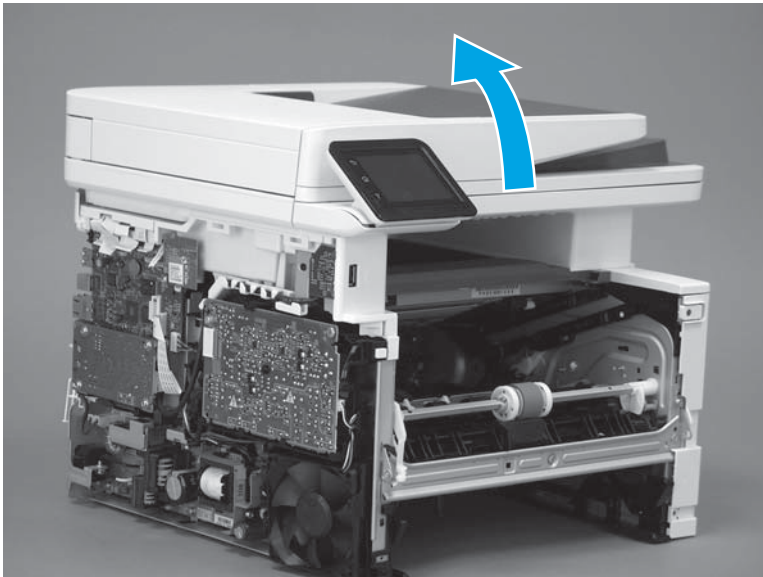
### Step 5: Remove the integrated scanner assembly (M427/M246)

 **NOTE:** The step is for the M427/M426 printer. For the M403/M402, skip this step and go to [Step 9: Remove the top cover \(M403/M402\) on page 627](#).

 **NOTE:** M427/M426 models only. The integrated scanner assembly (ISA) includes the sub-scanner assembly (SSA) and the automatic document feeder (ADF).

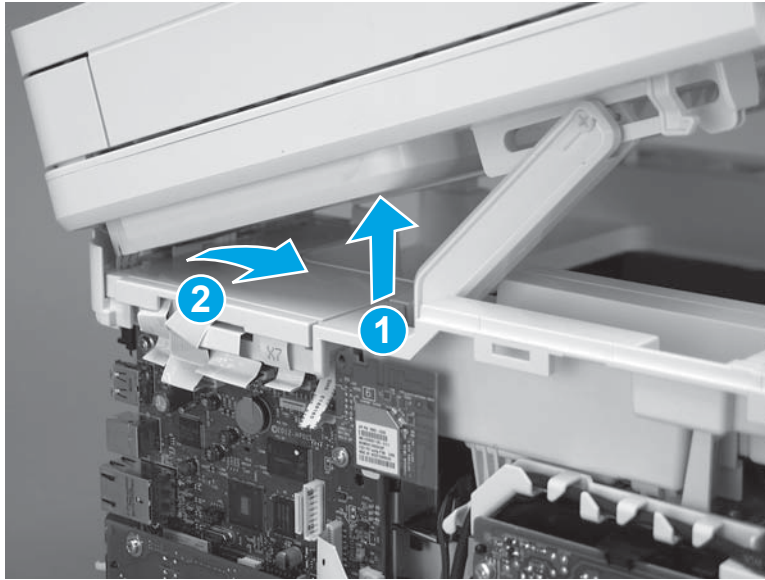
1. Raise the ISA.

**Figure 1-1129** Raise the ISA



2. Release the ISA flat-flexible cable (FFC) cover (callout 1), and then remove it (callout 2).

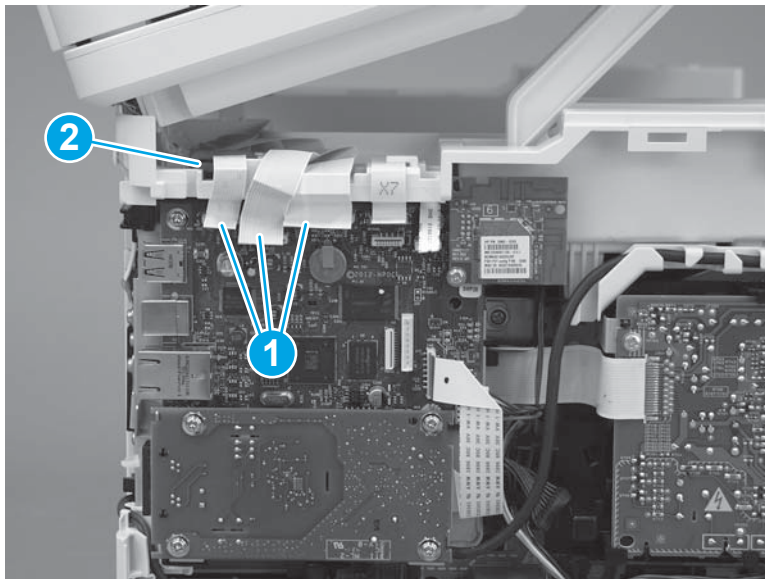
**Figure 1-1130** Remove the ISA FFC cover



3. Disconnect three FFCs (callout 1), and then remove the ferrite (callout 2) from the holder.

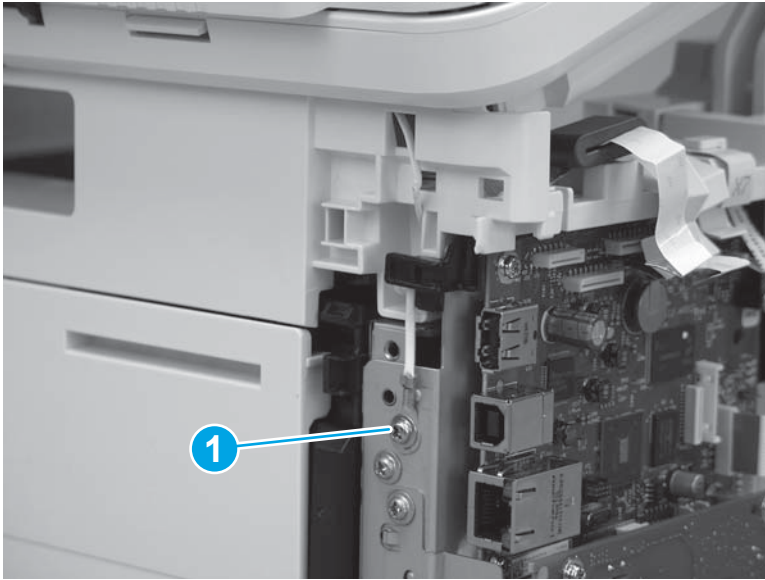
**CAUTION:** The ferrite is not captive on the FFC. Do not lose the ferrite while handling the ISA.

**Figure 1-1131** Disconnect three FFCs



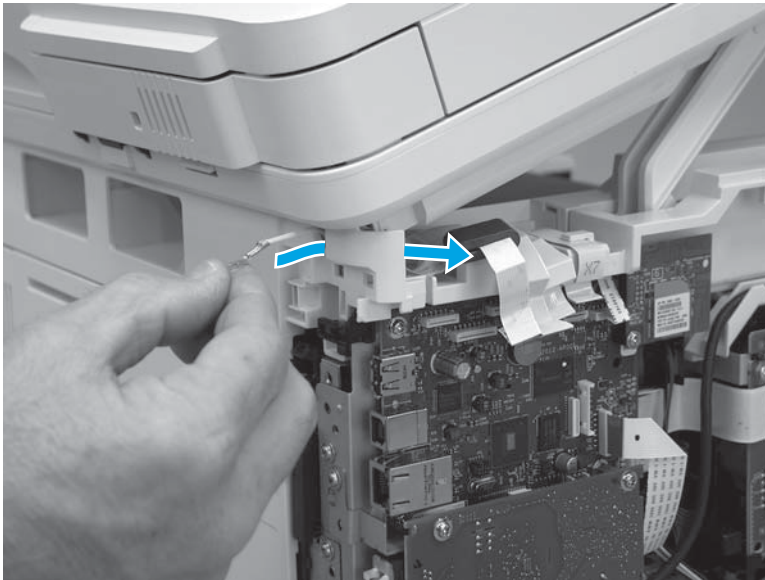
4. Remove one screw (callout 1).

**Figure 1-1132** Remove one screw



5. Pass the ground wire through the opening in the top cover.

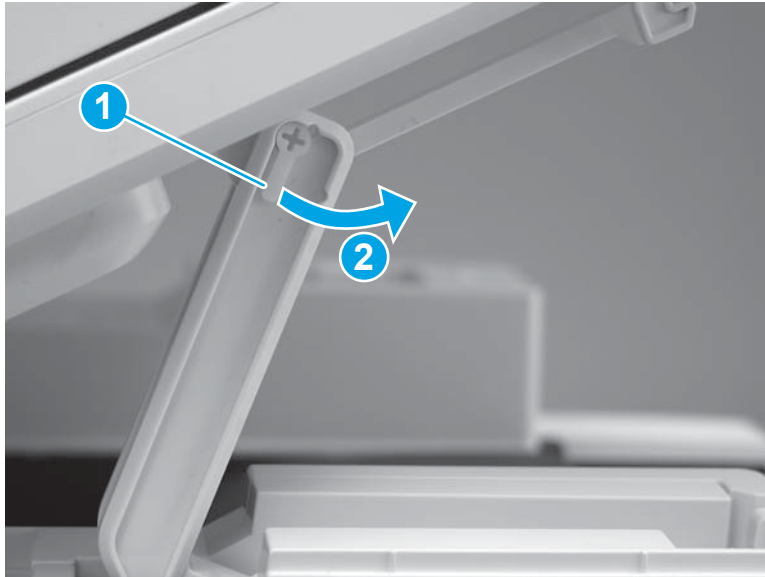
**Figure 1-1133** Pass the wire through the opening





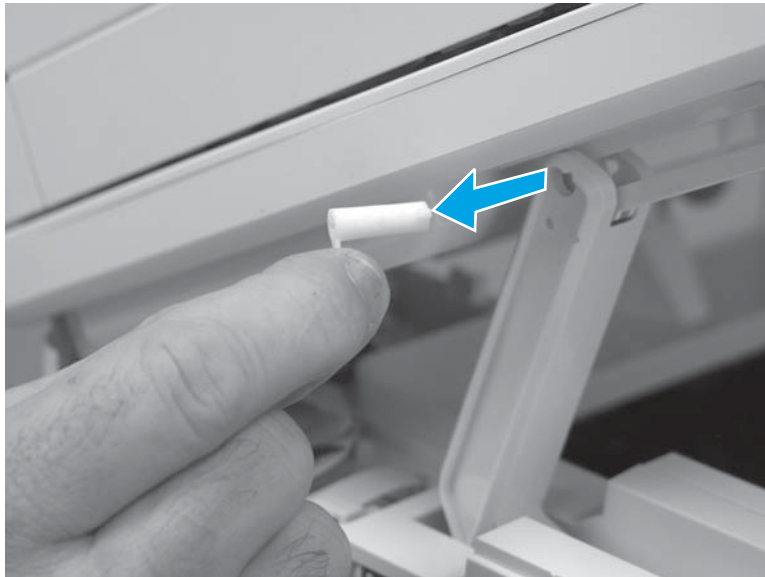
6. Release one tab (callout 1), and then rotate the ISA slider pin (callout 2) towards the front of the printer to release it.

**Figure 1-1134** Release one tab and rotate the slider pin



7. Remove the slider pin.

**Figure 1-1135** Remove the slider pin



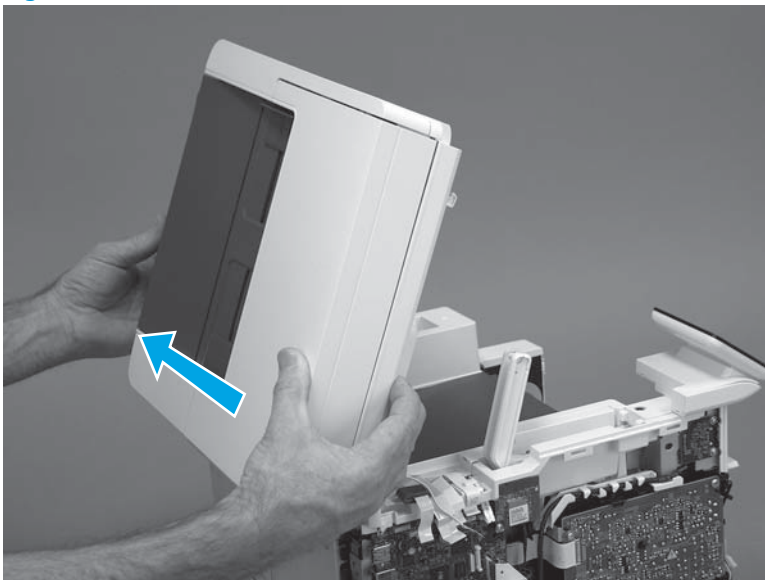
8. Rotate the ISA towards the rear of the printer until it stops.

**Figure 1-1136** Rotate the ISA towards the rear of the printer



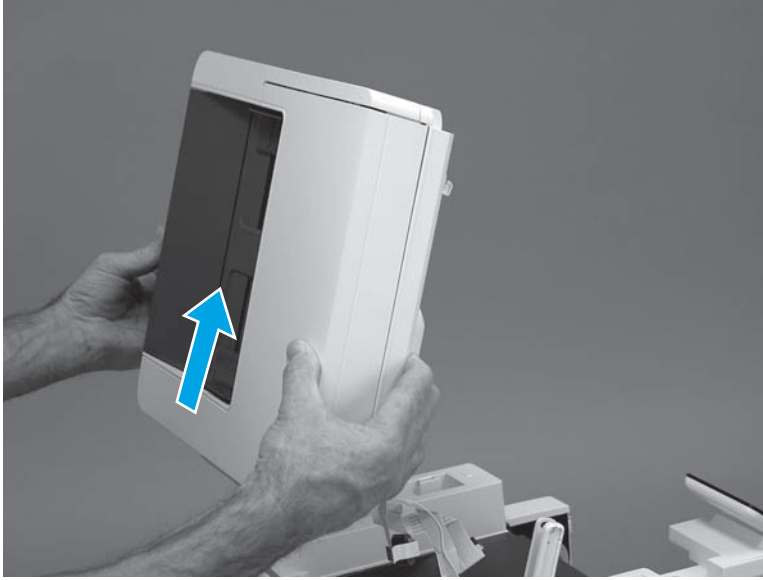
9. Slide the ISA as shown to release it.

**Figure 1-1137** Release the ISA




10. Remove the ISA.

**Figure 1-1138** Remove the ISA

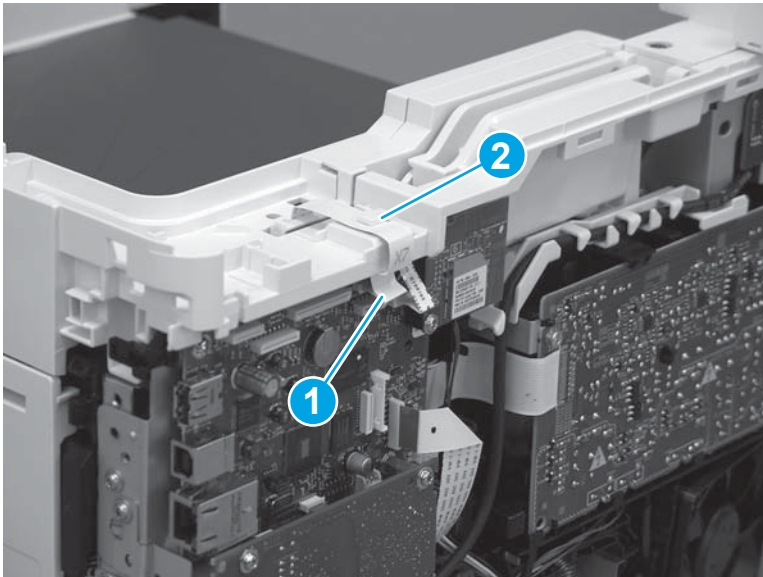


#### Step 6: Remove the control panel (M427/M246)

 **NOTE:** The step is for the M427/M426 printer. For the M403/M402, skip this step and go to [Step 9: Remove the top cover \(M403/M402\)](#) on page 627.

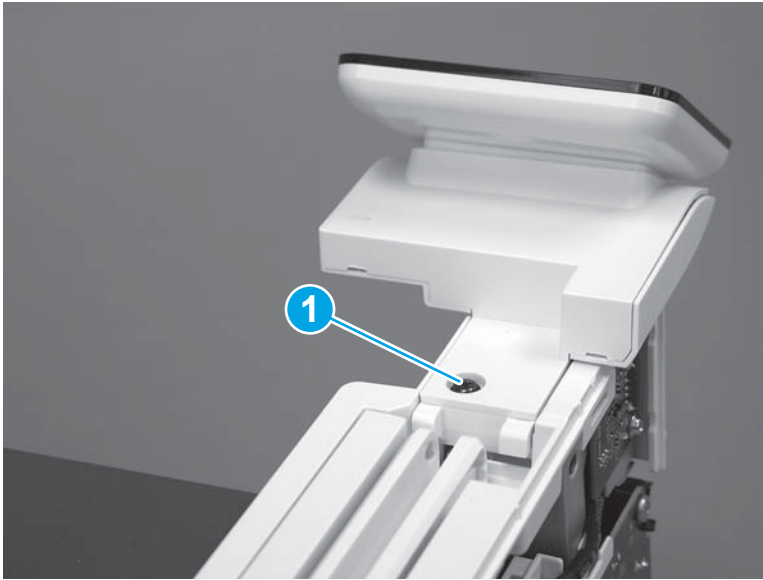
1. Disconnect one FFC (callout 1; J114), and then release the FFC from the retainer (callout 2).

**Figure 1-1139** Disconnect one connector



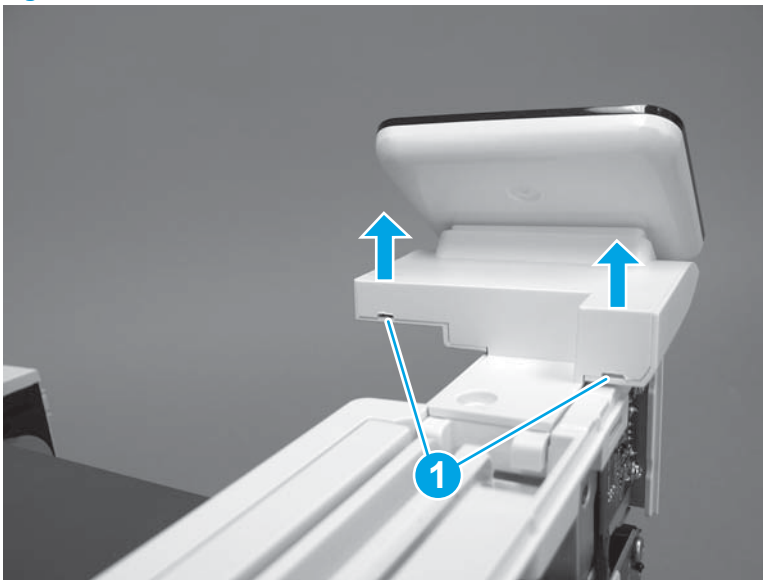
2. Remove one screw (callout 1).

**Figure 1-1140** Remove one screw



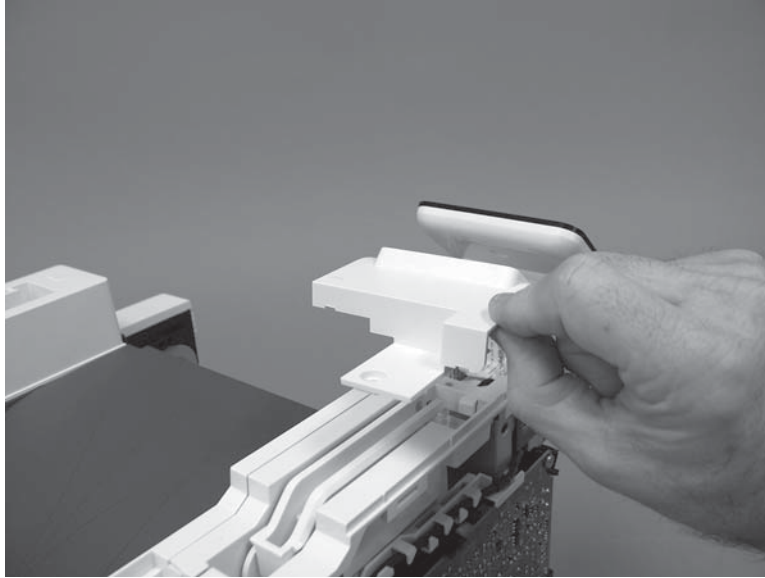
3. Use a small flat-blade screwdriver to release two tabs (callout 1) on the control-panel cable cover.

**Figure 1-1141** Release two tabs



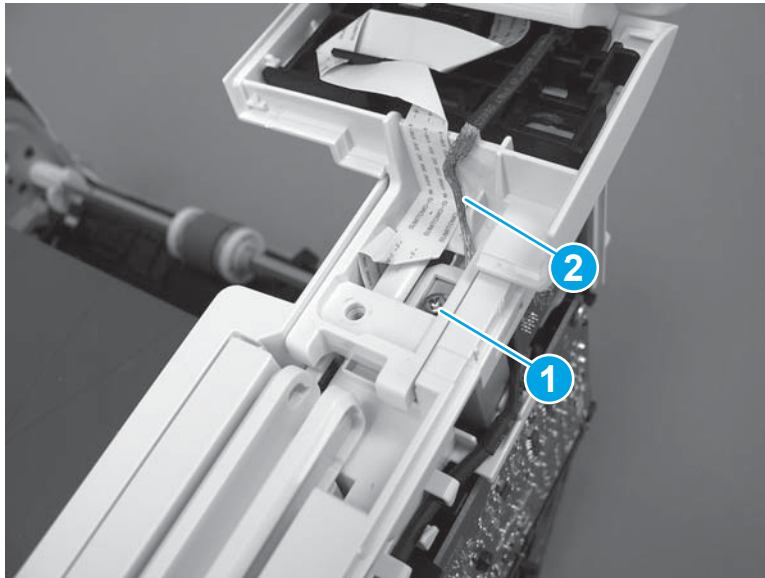
4. Remove the control-panel cable cover.

**Figure 1-1142** Remove the cover



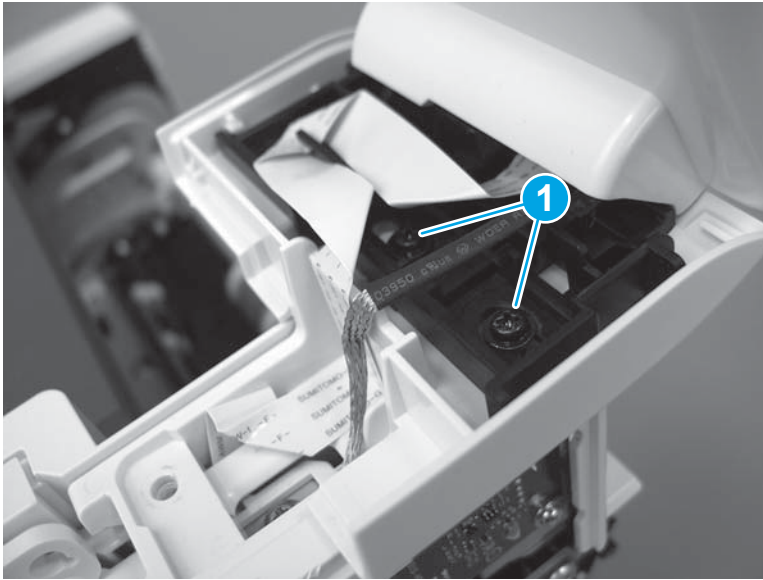
5. Remove one grounding screw (callout 1), and then move the ground cable (callout 2) out of the way.

**Figure 1-1143** Remove one screw



6. Move the FFC out of the way, and then remove two screws (callout 1).

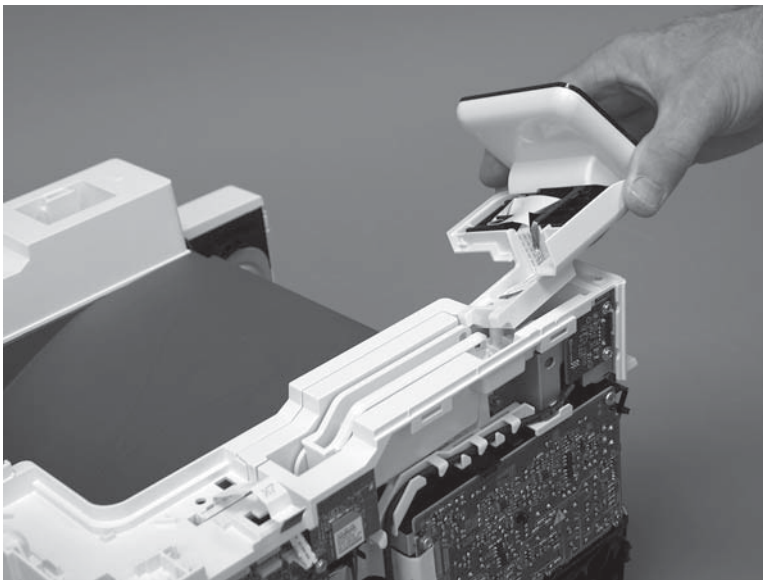
**Figure 1-1144** Remove two screws



7. Slightly lift up the control-panel assembly to separate it from the top cover.

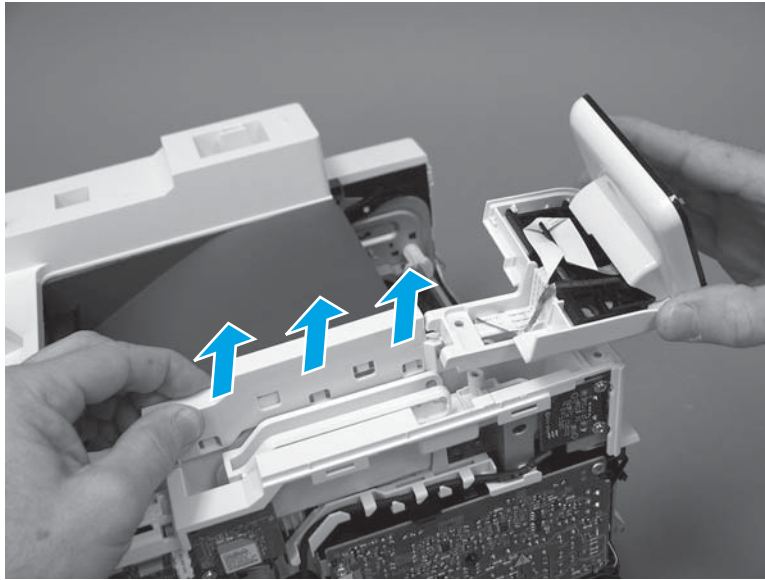
**CAUTION:** The control panel assembly is still connected to the printer by the FFC. Do not attempt to completely remove the assembly.

**Figure 1-1145** Lift up the control-panel assembly




8. Lift up the control-panel FFC cover to remove the control-panel assembly.

**Figure 1-1146** Remove the control-panel assembly

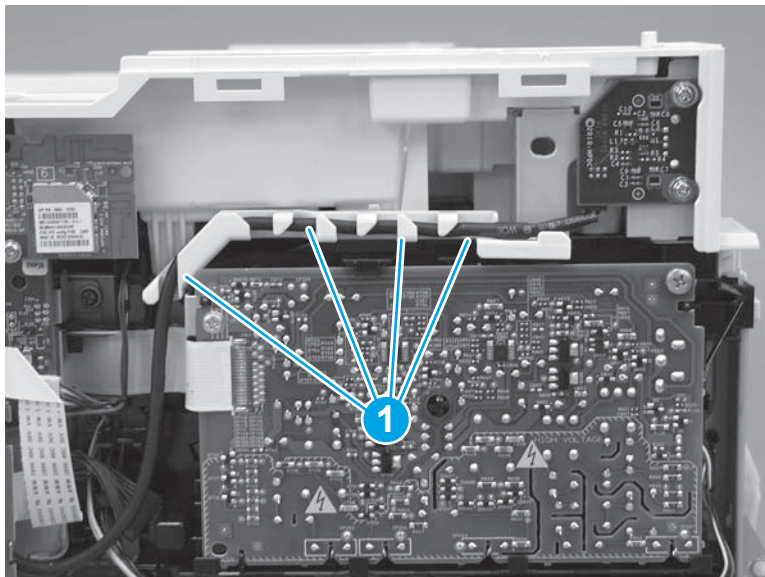


#### Step 7: Remove the top cover (M427/M426)

 **NOTE:** The step is for the M427/M426 printer. For the M403/M402, skip this step and go to [Step 9: Remove the top cover \(M403/M402\)](#) on page 627.

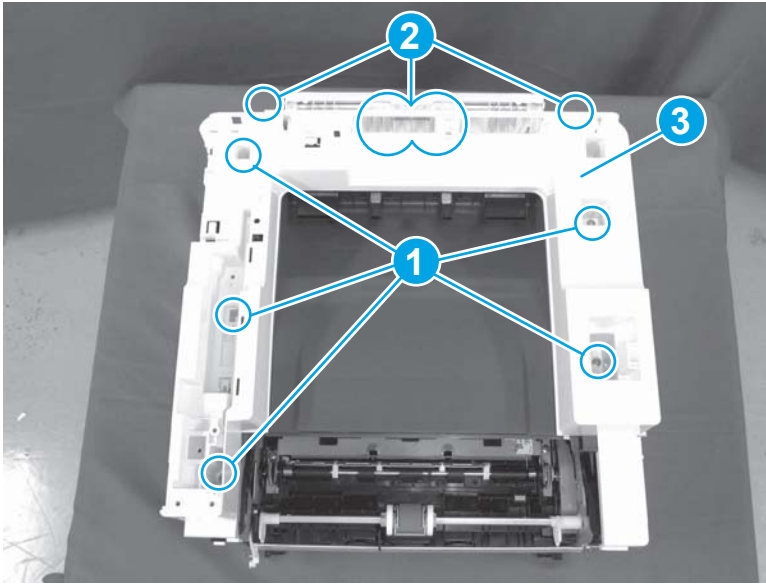
1. Release the USB cable (callout 1) from the cable guide.

**Figure 1-1147** Remove the USB cable




2. Remove five screws (callout 1), release four bosses (callout 2), and then remove the top cover (callout 3).

**Figure 1-1148** Remove the cover



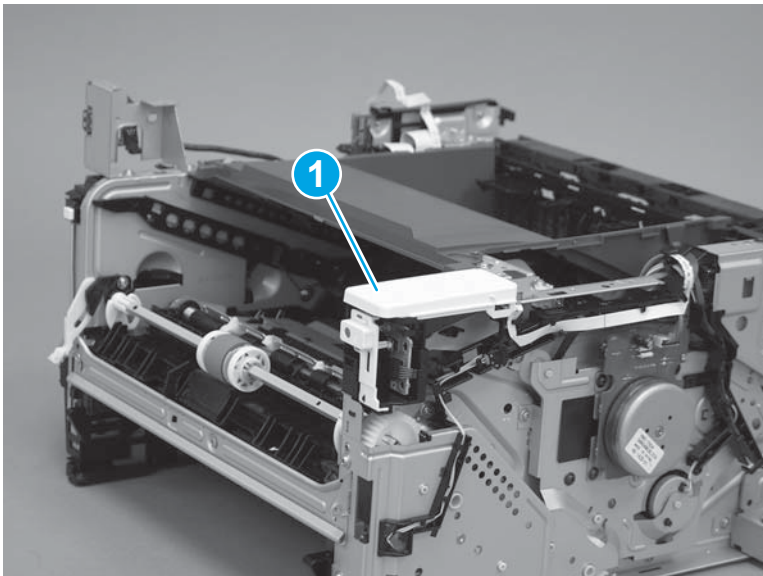
#### Step 8: Remove the NFC PCA cover (M427/M426)

 **NOTE:** The step is for the M427/M426 printer. For the M403/M402, skip this step and go to [Step 9: Remove the top cover \(M403/M402\) on page 627](#).

- ▲ Carefully pull up on the NFC cover (callout 1) to remove it.


 **CAUTION:** Do not damage the NFC PCA when removing the cover.

**Figure 1-1149** Remove the cover





## Step 9: Remove the top cover (M403/M402)

 **NOTE:** The step is for the M403/M402 printer. For the M427/M426, skip this step and go to [Step 10: Remove the paper delivery tray \(output bin\) on page 628](#).

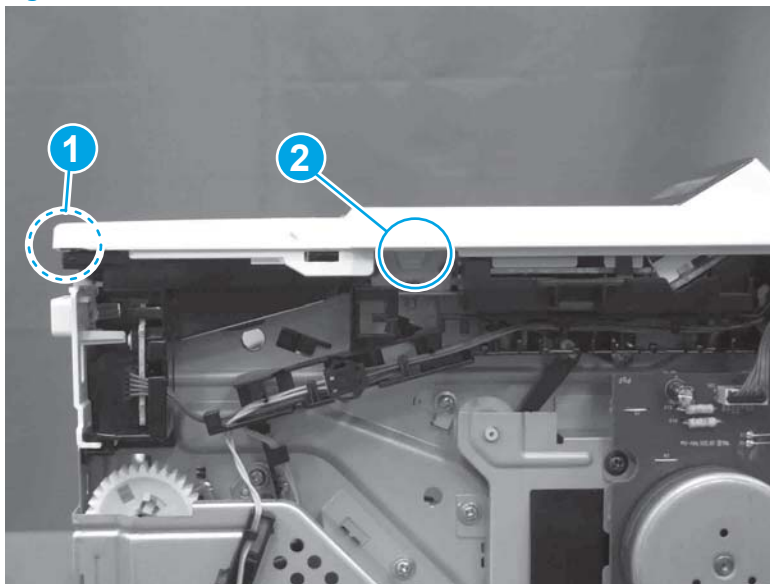
1. Remove one screw (callout 1).

**Figure 1-1150** Remove one screw




2. At the right side of the printer, release the one boss (callout 1), and then release one tab (callout 2).

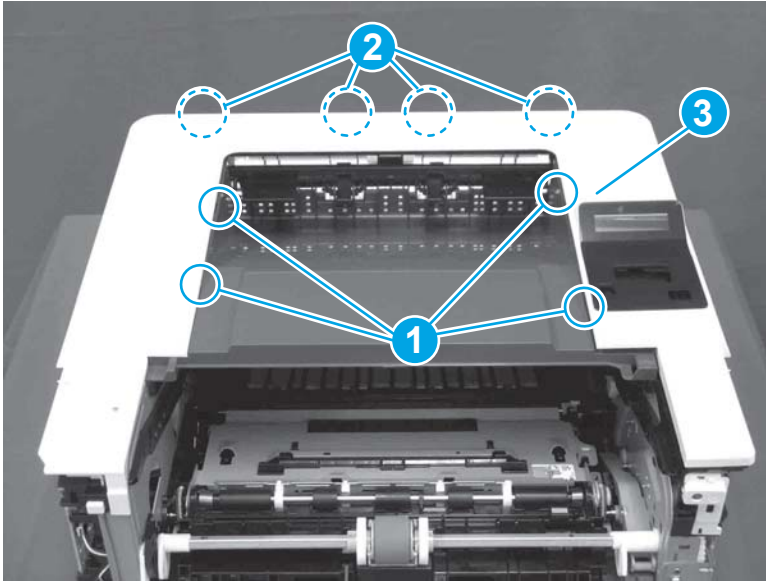
**Figure 1-1151** Release one boss and one tab




3. Release four tabs (callout 1), release four bosses (callout 2), and then remove the top cover (callout 3).

 **TIP:** Open the rear door to make releasing the bosses (callout 3) easier.

**Figure 1-1152** Remove the cover

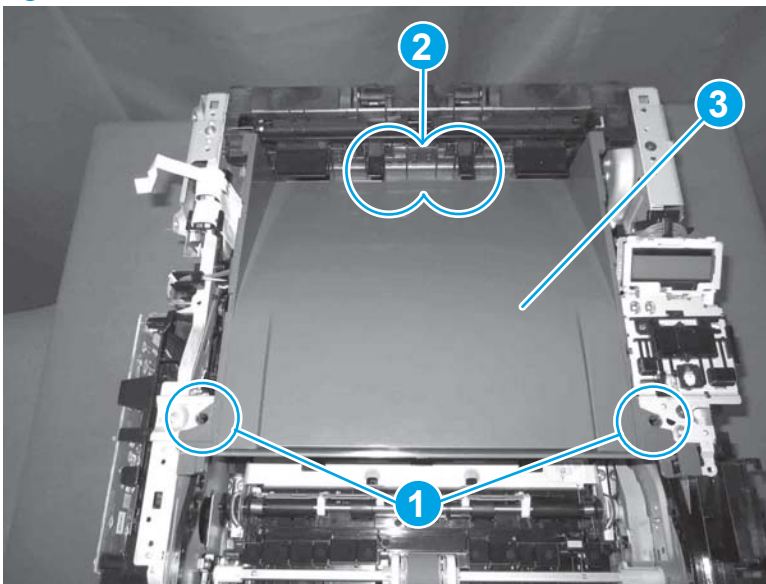


#### Step 10: Remove the paper delivery tray (output bin)

 **NOTE:** This procedure shows the M403/M402 model, however, the paper delivery tray (output bin) removal is similar for the M427/M426 printer.

- ▲ Release two bosses (callout 1), release two tabs (callout 2), and then remove the paper delivery tray (output bin; callout 3).

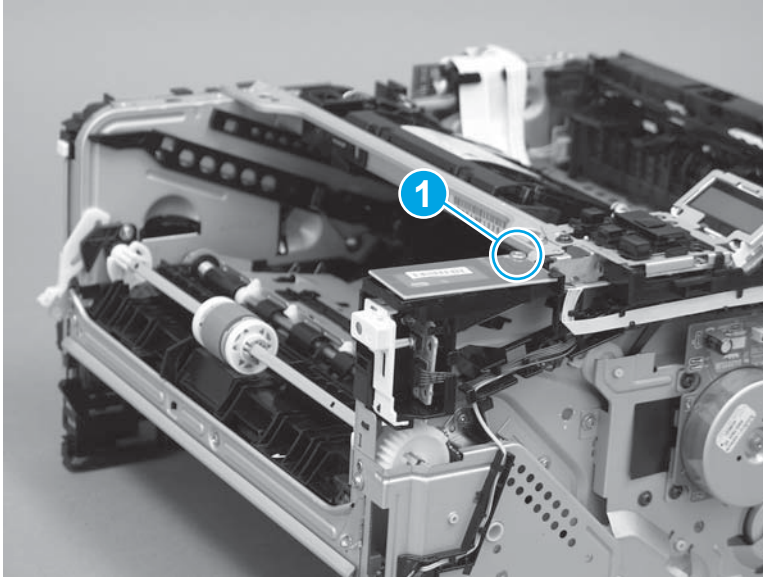
**Figure 1-1153** Release two tabs



### Step 11: Remove the NFC PCA

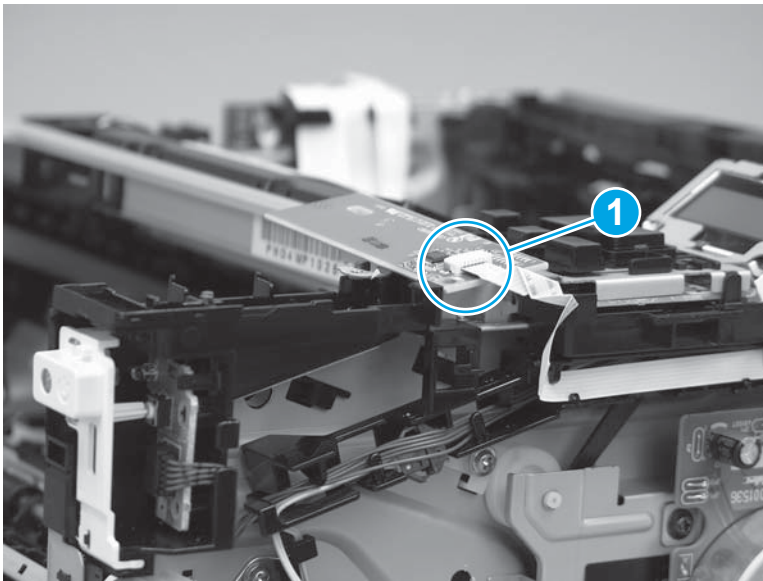
1. Remove one screw (callout 1).

**Figure 1-1154** Remove one screw




2. Turn the NFC PCA over to access the bottom side, disconnect one FFC (callout 1), and then remove the NFC PCA.

**Figure 1-1155** Remove the NFC PCA

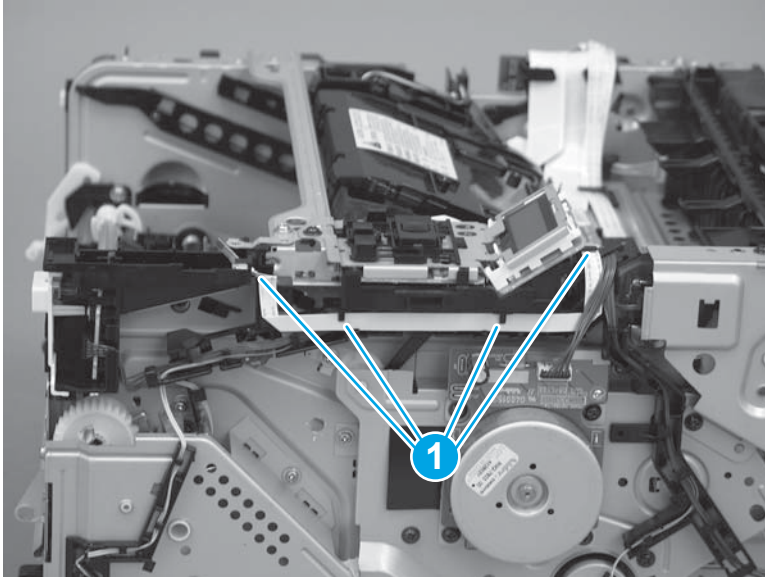


### Step 12: Remove the NFC FFC

 **NOTE:** The M403/M402 product is shown in this procedure. However, the procedure is valid for the M427/M426 connecting PCA.

1. Release the FFC from the guide (callout 1).

**Figure 1-1156** Release the FFC from the guide

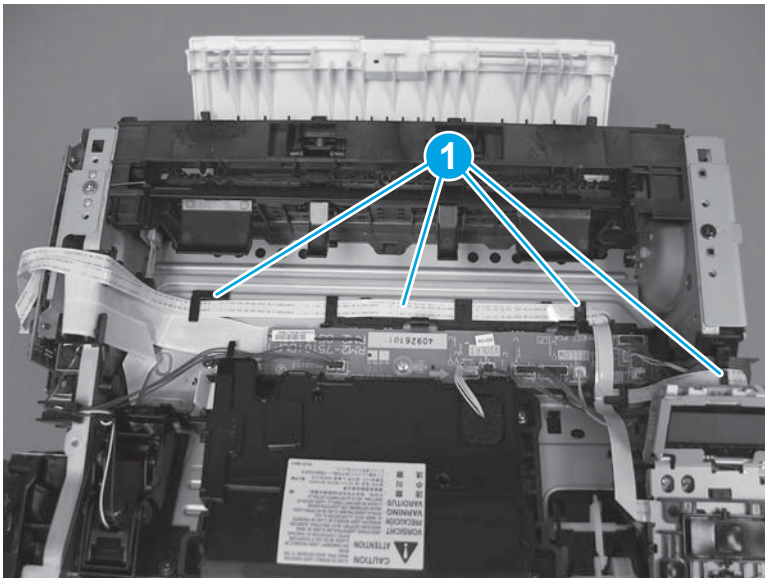


2. Release the FFC from the guide (callout 1).



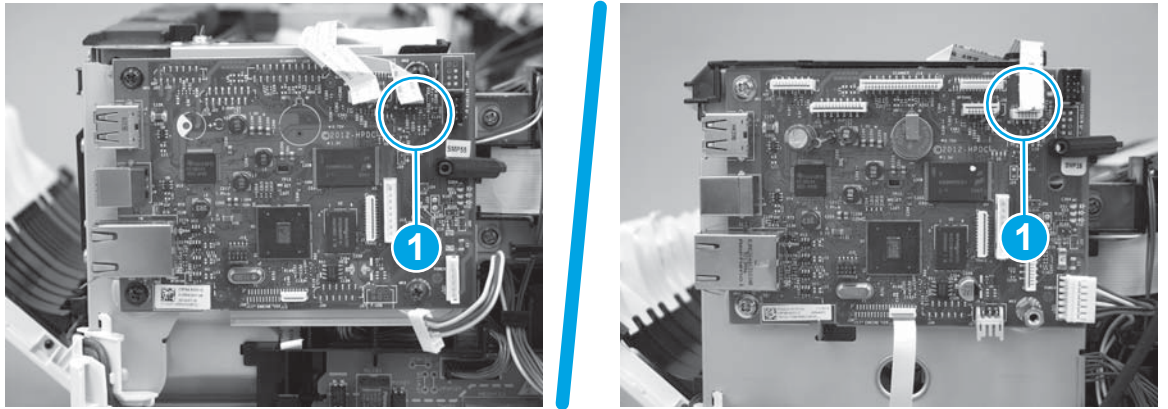
**NOTE: M403/M402 only:** The control-panel FFC might need to be moved out of the way to gain access to the NFC FFC.

**Figure 1-1157** Release the FFC from the guide



3. Disconnect one FFC (callout 1), and then remove the FFC.

**Figure 1-1158** Disconnect and remove the FFC



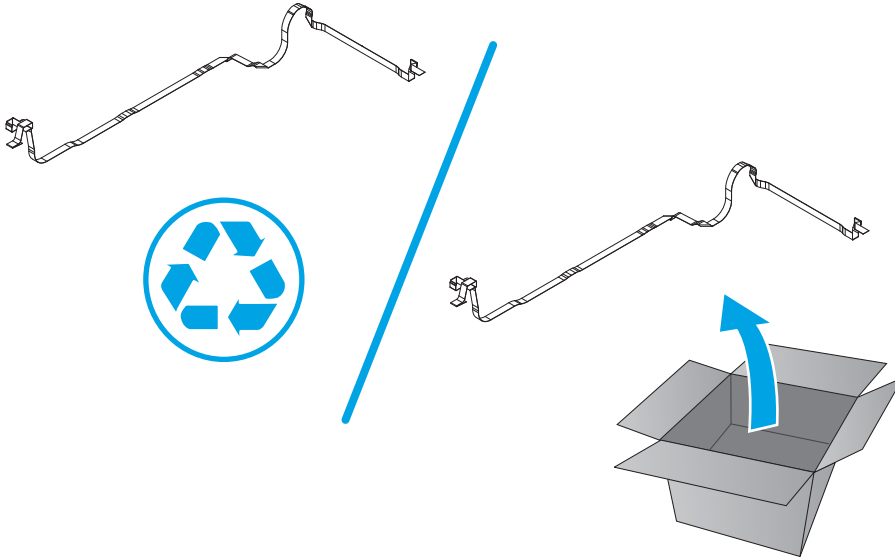
### Step 13: Unpack the replacement assembly

Unpack the replacement part from the packaging.


<http://www8.hp.com/us/en/hp-information/environment/product-recycling.html>

 **NOTE:** HP recommends responsible disposal of the defective part.

**Figure 1-1159** Recycle and unpack

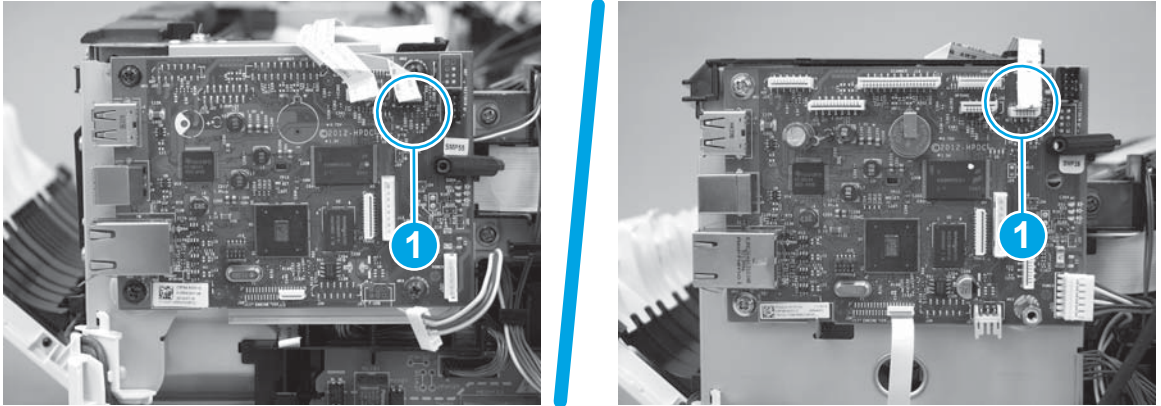


### Step 14: Install the NFC FFC

 **NOTE:** The M403/M402 product is shown in this procedure. However, the procedure is valid for the M427/M426 connecting PCA.

1. Connect one FFC (callout 1) to the formatter PCA.

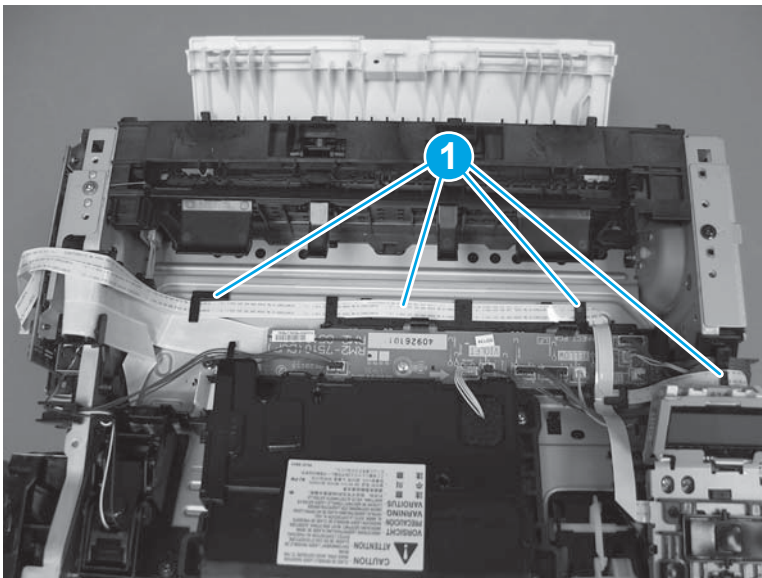
**Figure 1-1160** Connect the FFC



2. Install the NFC FFC in the guide (callout 1).

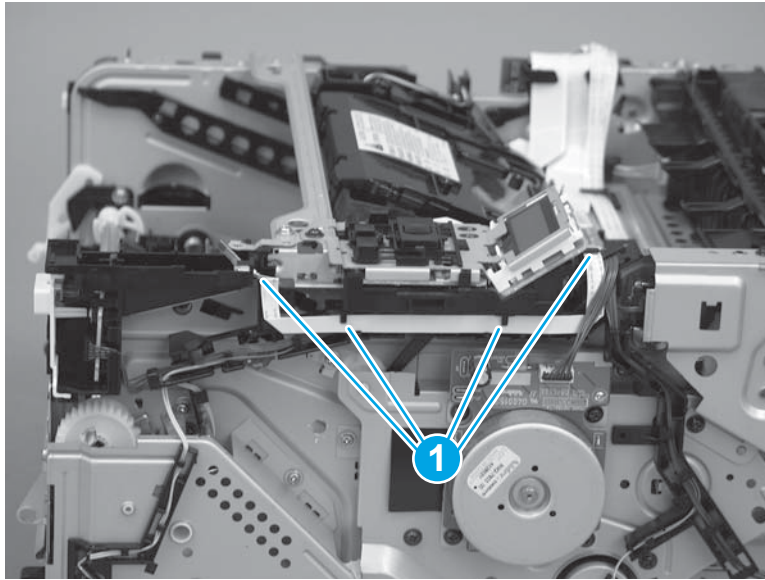
 **NOTE:** **M403/M402 only:** The control-panel FFC might need to be moved out of the way to gain access to the guide.

**Figure 1-1161** Install the FFC in the guide



3. Install the FFC in the guide (callout 1).

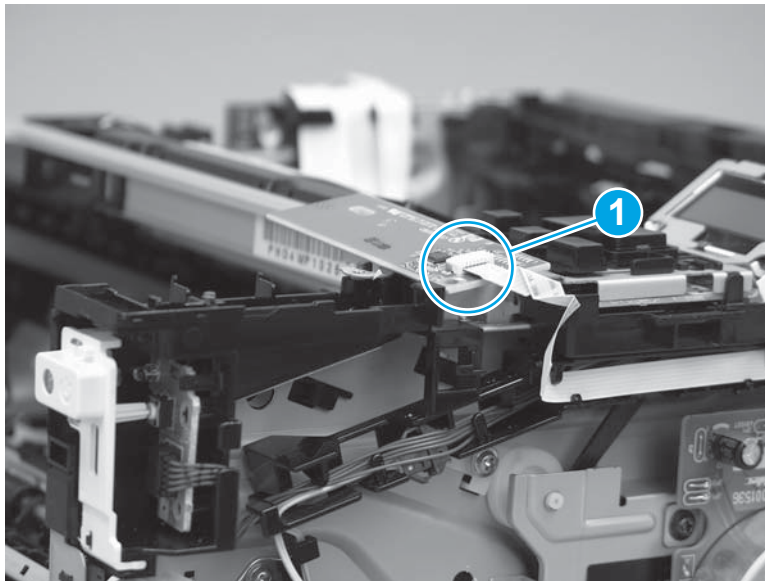
**Figure 1-1162** Install the FFC in the guide



#### Step 15: Install the NFC PCA

1. Connect one FFC (callout 1).

**Figure 1-1163** Connect one FFC

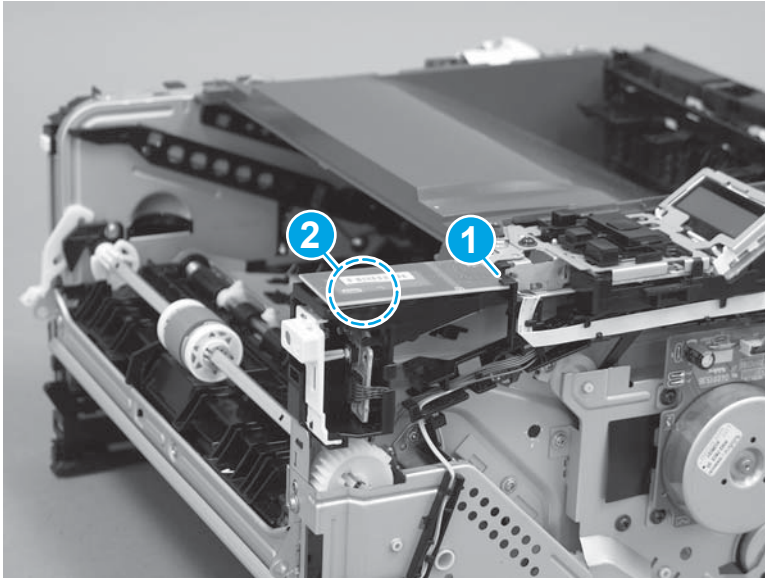


2. Position the NFC PCA on the holder.

**⚠ CAUTION:** Make sure that the NFC PCA is correctly positioned on the holder. One corner (callout 1) is under a tab on the holder, and the alignment pins on the holder fit in the hole and slot in the PCA (callout 2).

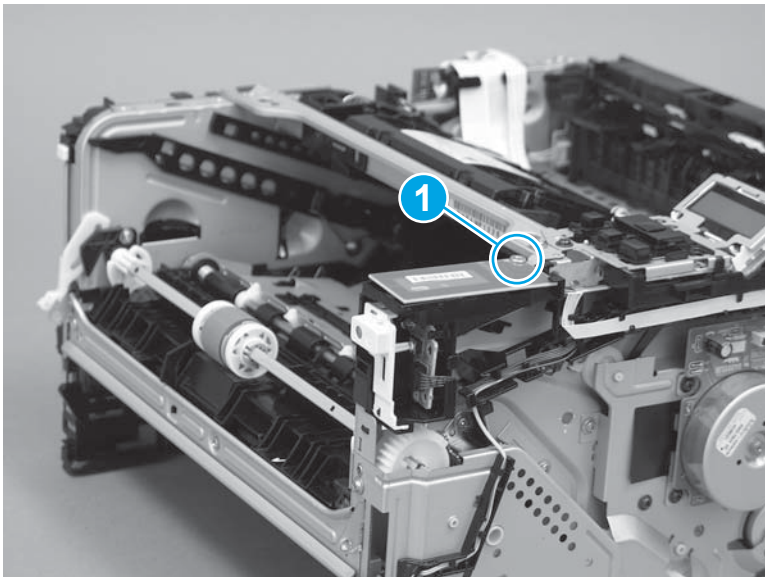
To avoid damage to the PCA, it must be installed flat on the holder **before** installing the mounting screw.

**Figure 1-1164** Install the NFC PCA




3. Install one screw (callout 1).

**Figure 1-1165** Install one screw



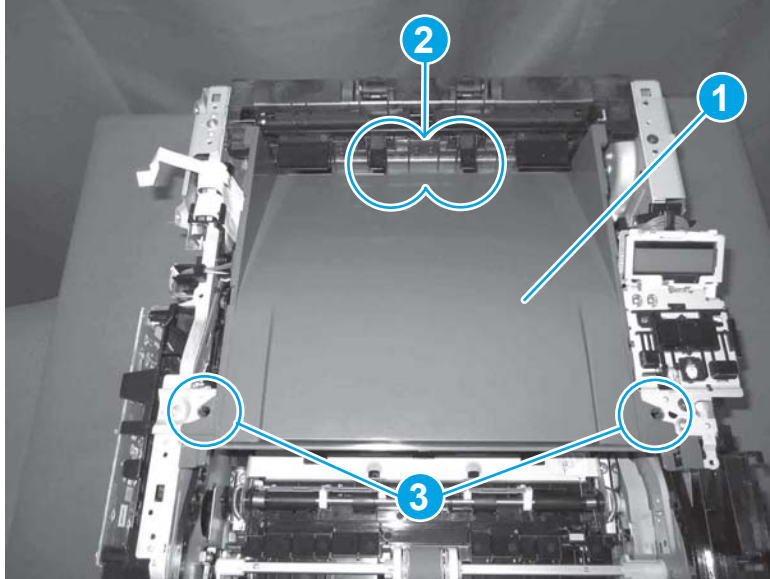


## Step 16: Install the paper delivery tray (output bin)


 **NOTE:** This procedure shows the M403/M402 model, however, the paper delivery tray (output bin) removal is similar for the M427/M426 printer.

- ▲ Position the remove the paper delivery tray (output bin; callout 1) on the printer, engage two tabs (callout 2), and then engage two bosses (callout 3).

**Figure 1-1166** Engage two tabs

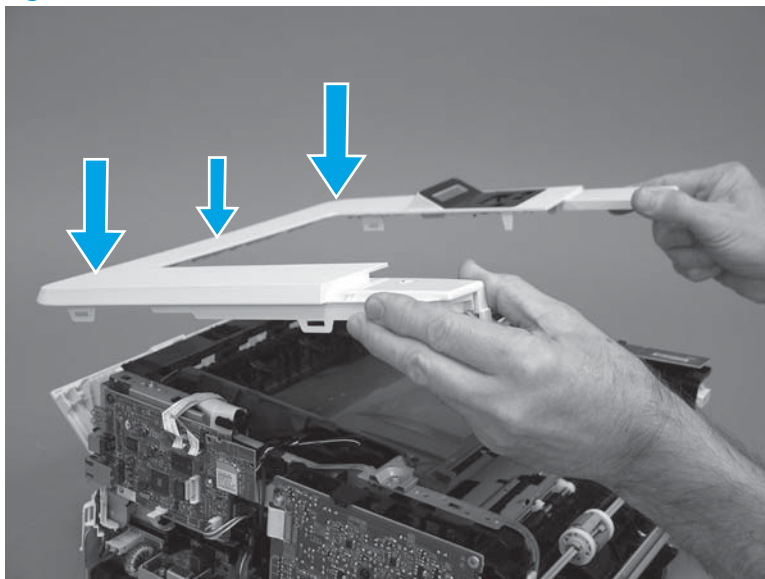


## Step 17: Install the top cover (M403/M402)

 **NOTE:** The step is for the M403/M402 printer. For the M427/M426, skip this step and go to [Step 18: Install the NFC PCA cover \(M427/M426\) on page 637](#).

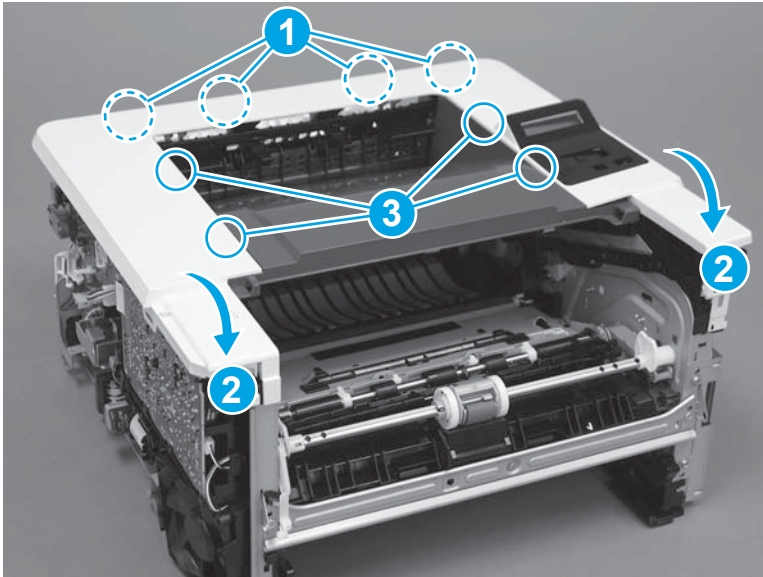
1. Position the rear edge of the cover on the printer.

**Figure 1-1167** Install the cover



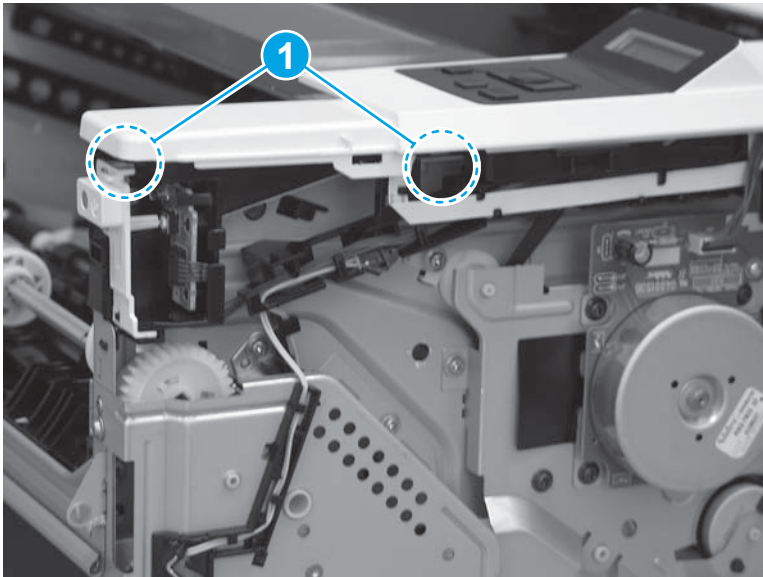
2. Engage four bosses (callout 1), rotate the front of the cover down (callout 2) and onto from the printer, and then engage four tabs (callout 3).

**Figure 1-1168** Engage four bosses and tabs



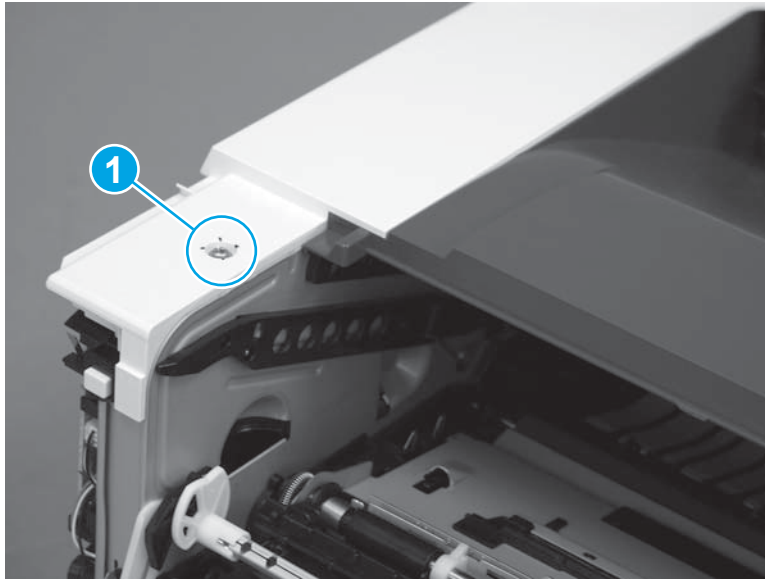
3. At the right side of the printer, engage the one boss and one tab (callout 1).

**Figure 1-1169** Engage one boss and one tab




4. Install one screw (callout 1).

**Figure 1-1170** Install one screw



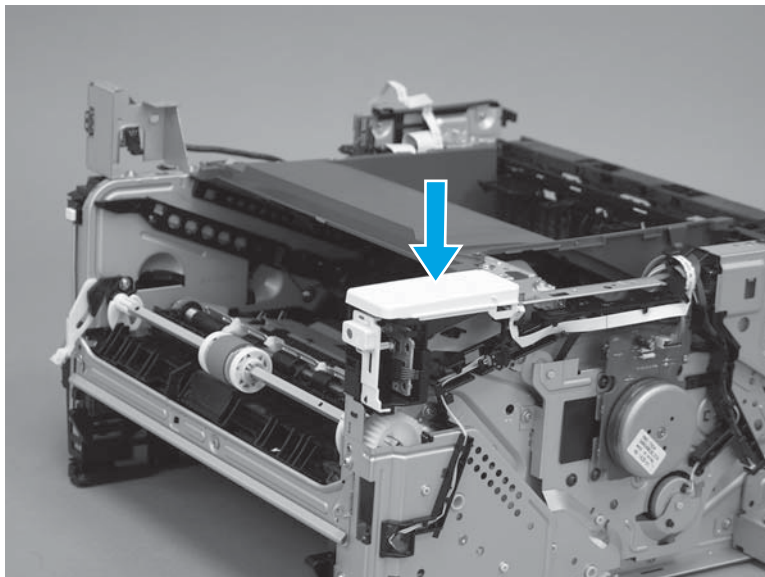
#### Step 18: Install the NFC PCA cover (M427/M426)

 **NOTE:** The step is for the (M427/M426) printer. For the M403/M402, skip this step and go to [Step 22: Install the right cover on page 649](#).


- ▲ Carefully install the NFC cover on the printer.

 **CAUTION:** Do not damage the NFC PCA when installing the cover.

**Figure 1-1171** Remove the cover

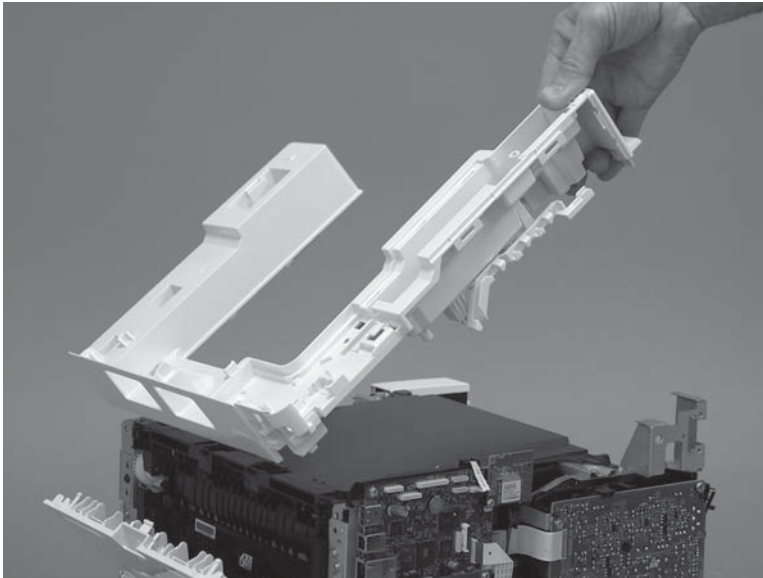


## Step 19: Install the top cover (M427/M426)

 **NOTE:** The step is for the M427/M426 printer. For the M403/M402, skip this step and go to [Step 22: Install the right cover on page 649](#).

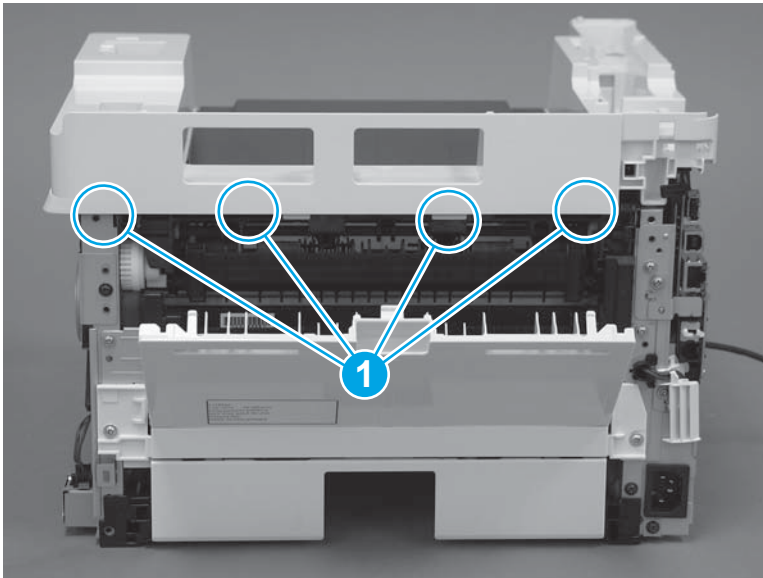
1. Position the rear edge of the top cover on the printer.

**Figure 1-1172** Install the cover



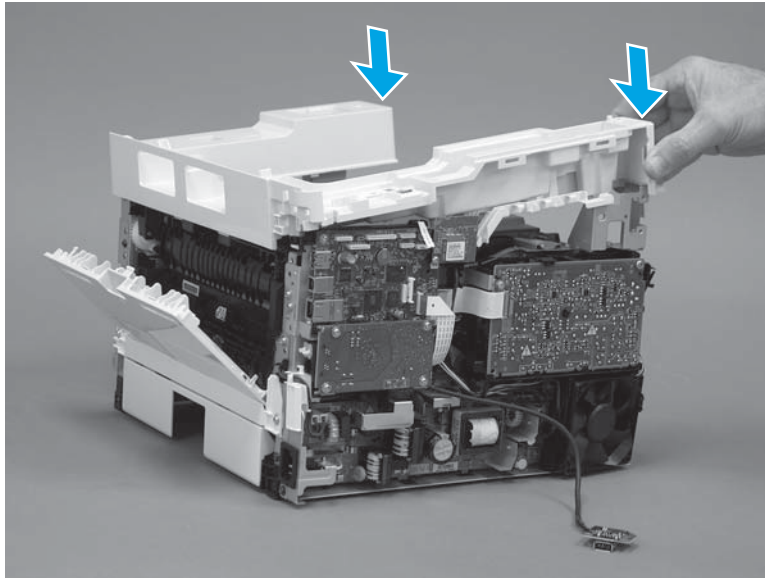
2. Engage four bosses (callout 1).

**Figure 1-1173** Engage four bosses



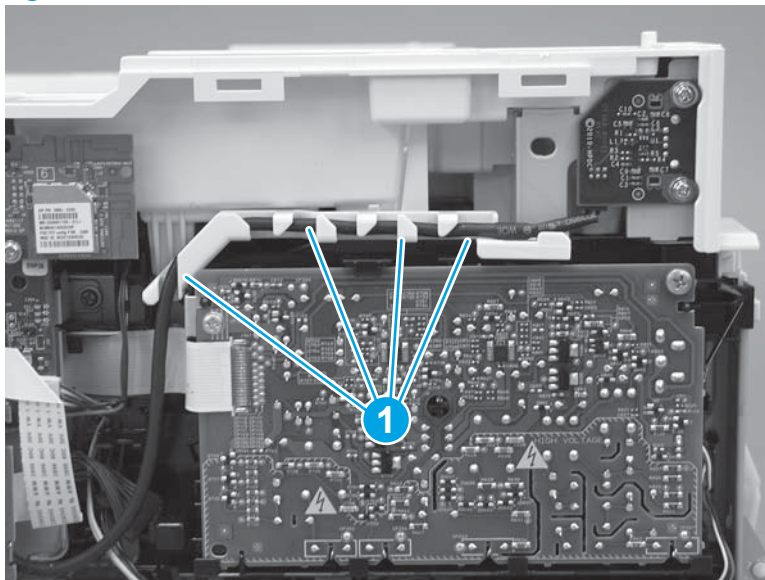
3. Rotate the front edge of the cover down.

**Figure 1-1174** Rotate the front edge of the cover down



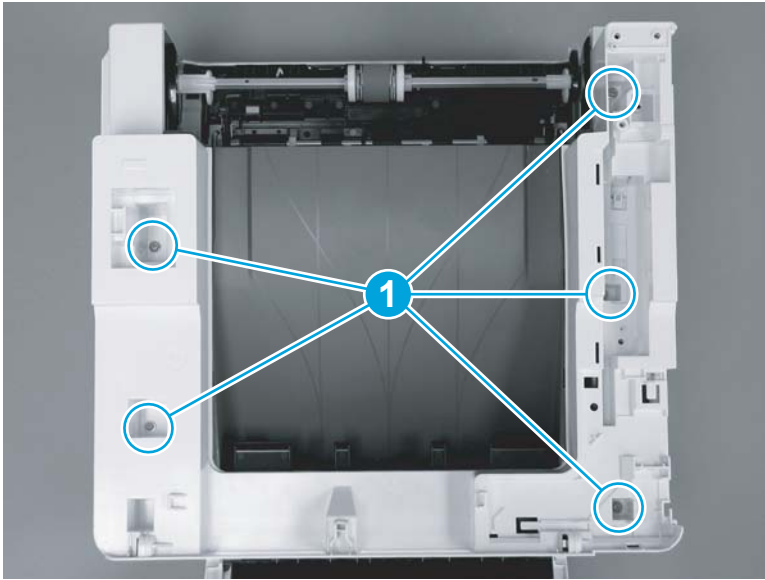
4. Install the USB cable (callout 1) in the guide.

**Figure 1-1175** Install the USB PCA




5. Install five screws (callout 1).

**Figure 1-1176** Install five screws

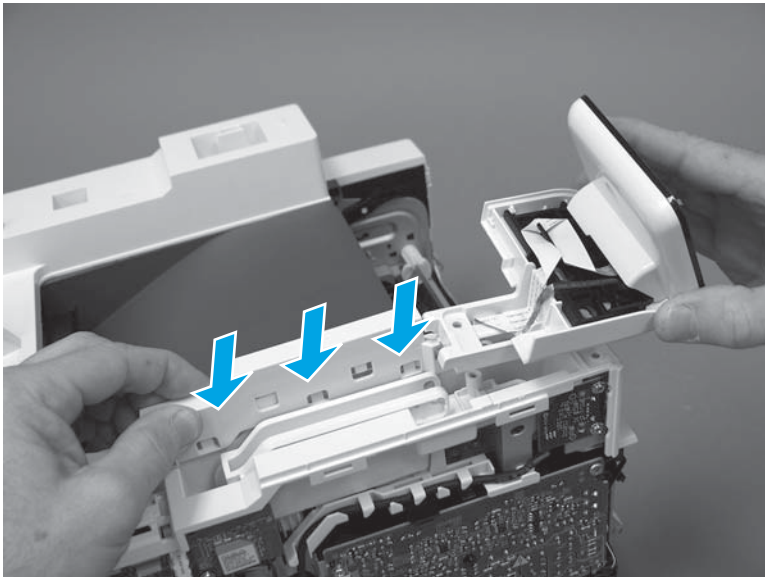


#### Step 20: Install the control panel (M427/M246)

 **NOTE:** The step is for the M427/M426 printer. For the M403/M402, skip this step and go to [Step 22: Install the right cover on page 649](#).

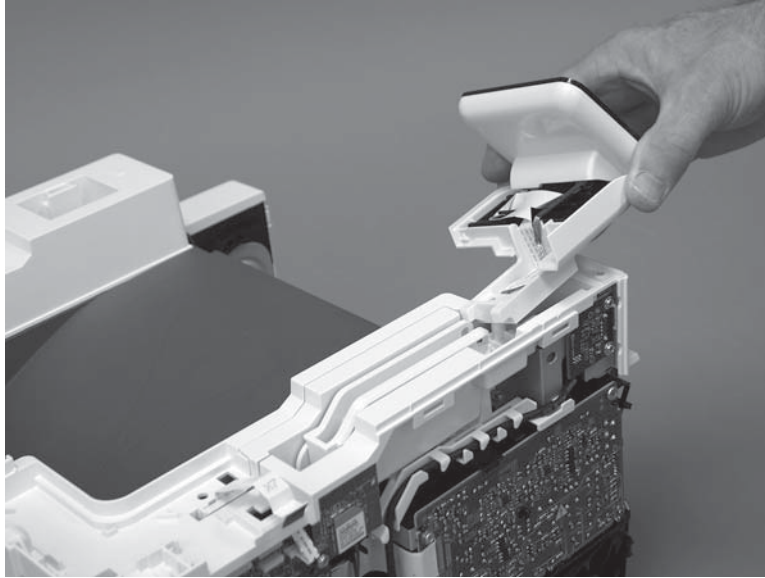
1. Slide the control-panel FFC cover into the slot in the top cover (next to the document feeder support arm) to install it.

**Figure 1-1177** Install the control-panel FFC cover



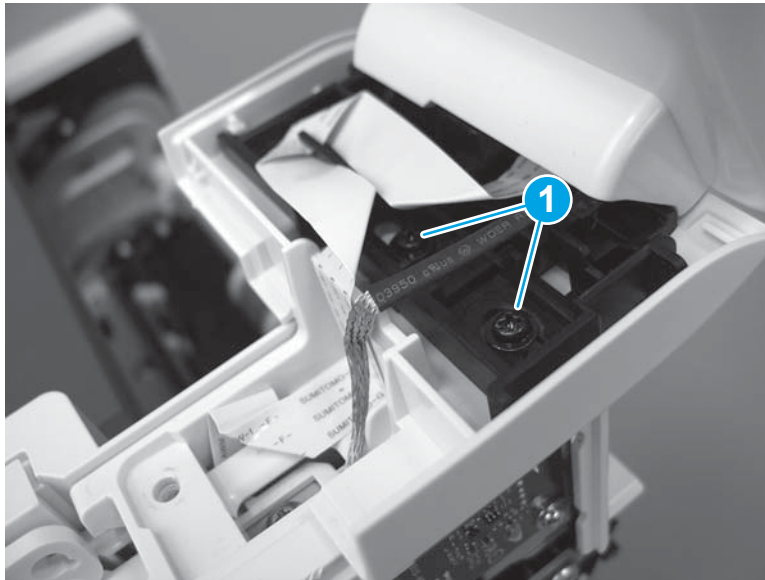
2. Install the control-panel assembly on the top cover.

**Figure 1-1178** Install the control-panel assembly



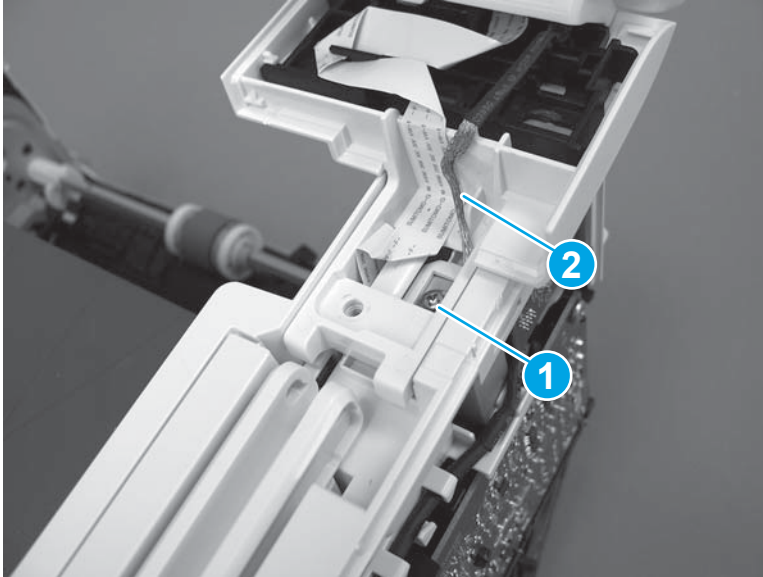
3. Move the FFC out of the way, and then install two screws (callout 1).

**Figure 1-1179** Install two screws



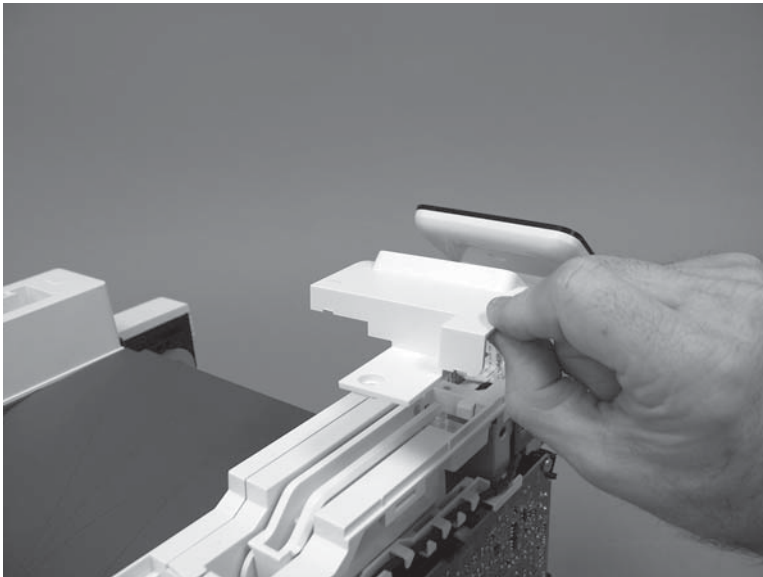
4. Install one grounding screw (callout 1), and then make sure that the ground cable (callout 2) is properly routed.

**Figure 1-1180** Remove one screw



5. Install the control-panel cable cover.

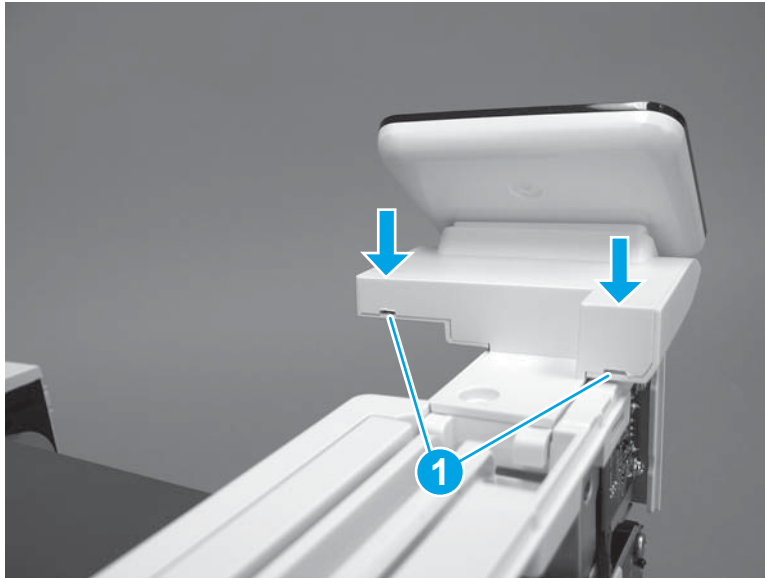
**Figure 1-1181** Install the cover





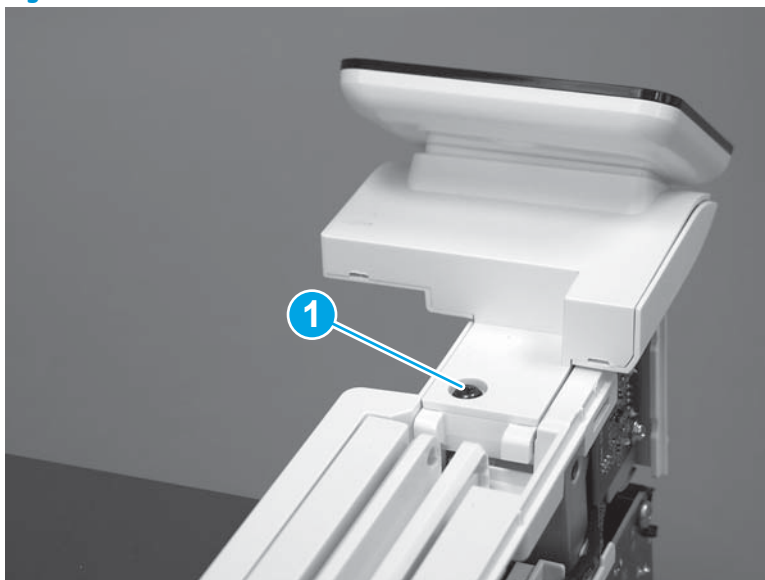
6. Make sure that the two tabs (callout 1) on the cover snap into place.

**Figure 1-1182** Engage two tabs



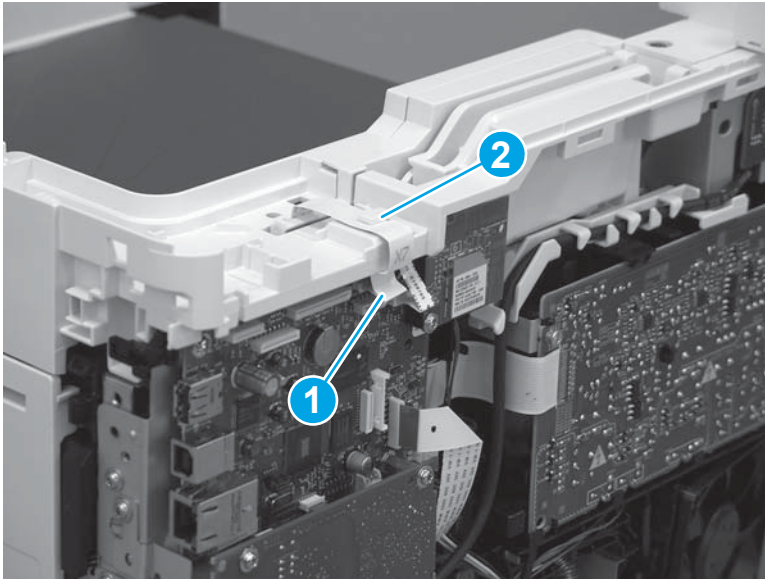
7. Install one screw (callout 1).

**Figure 1-1183** Install one screw





8. Install the FFC in the retainer (callout 1), and then connect one FFC (callout 1; J114).

**Figure 1-1184** Connect one connector



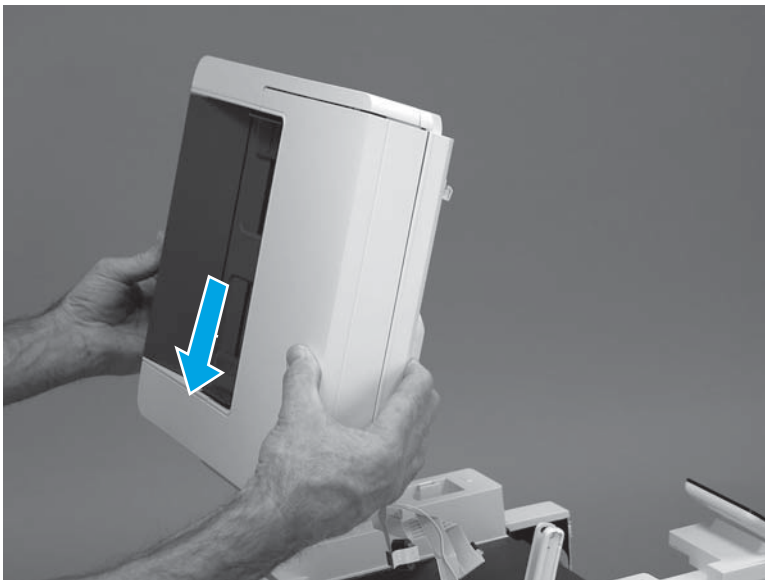
### Step 21: Install the integrated scanner assembly (M427/M246)

 **NOTE:** The step is for the M427/M426 printer. For the M403/M402, skip this step and go to [Step 22: Install the right cover on page 649](#).

 **NOTE:** M427/M426 models only. The integrated scanner assembly (ISA) includes the sub-scanner assembly (SSA) and the automatic document feeder (ADF).

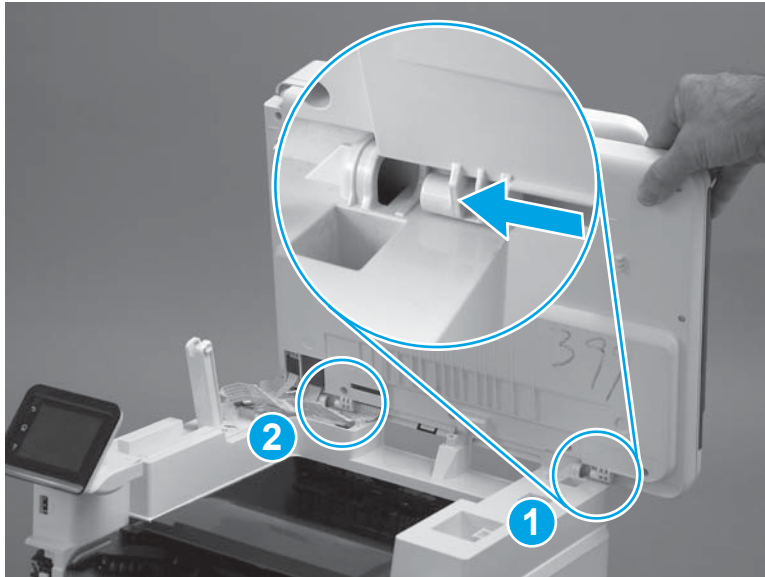
1. Position the ISA on the printer.

**Figure 1-1185** Position the ISA on the printer



2. Engage the hinge pins on the ISA with the holders in the top cover (callouts 1/2), and then slide the ISA as shown to engage them

**Figure 1-1186** Engage the hinge pins with the holders



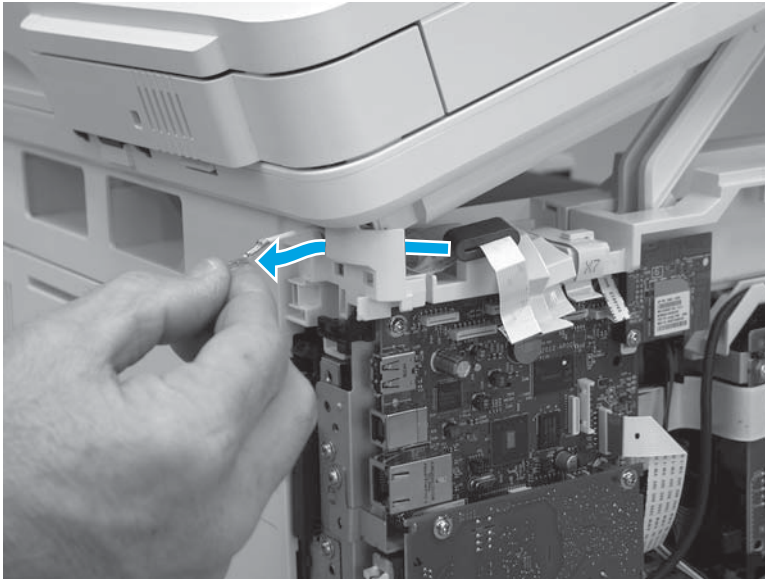
3. Rotate the ISA towards the front of the printer until it rests on the ISA lift assembly (callout 1).

**Figure 1-1187** Rotate the ISA towards the front of the printer



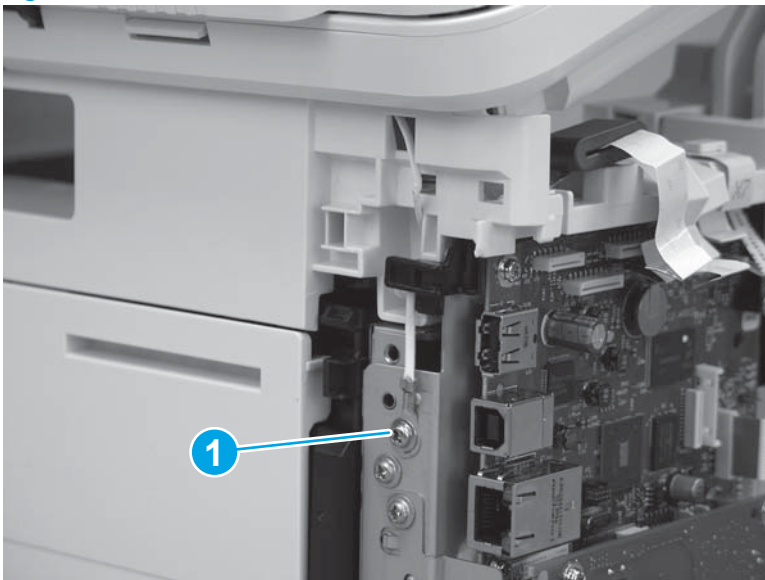
4. Pass the ground wire through the opening in the top cover.

**Figure 1-1188** Pass the wire through the opening




5. Install one screw (callout 1).

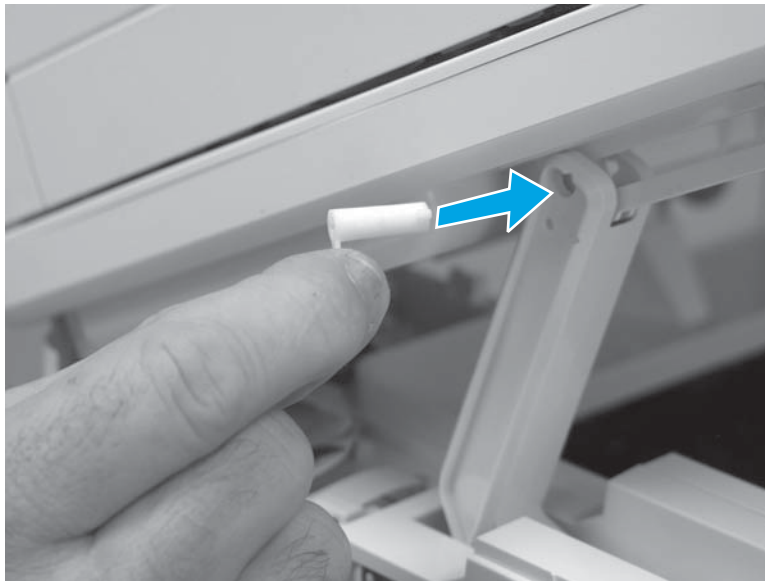
**Figure 1-1189** Install one screw



6. Install the ISA lift assembly slider pin.

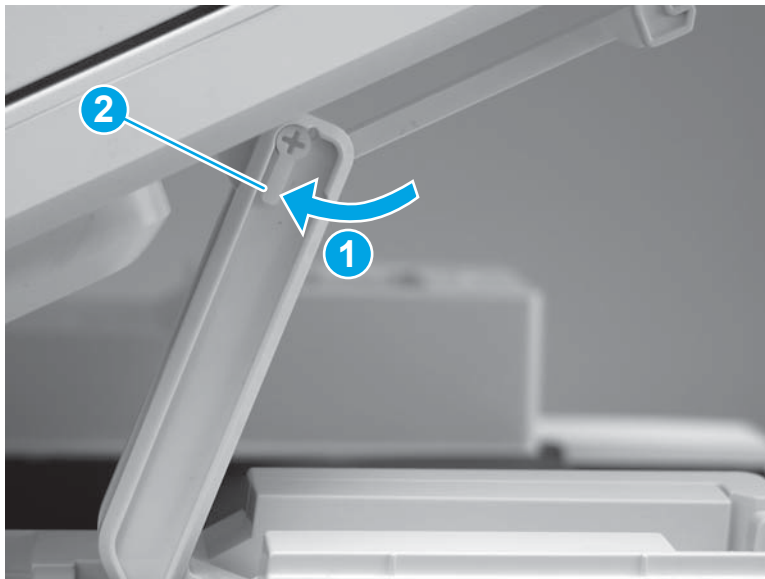
 **Reinstallation tip:** Align the keyed portion of the locking pin with the slot and hole in the support arm.

**Figure 1-1190** Install the slider pin



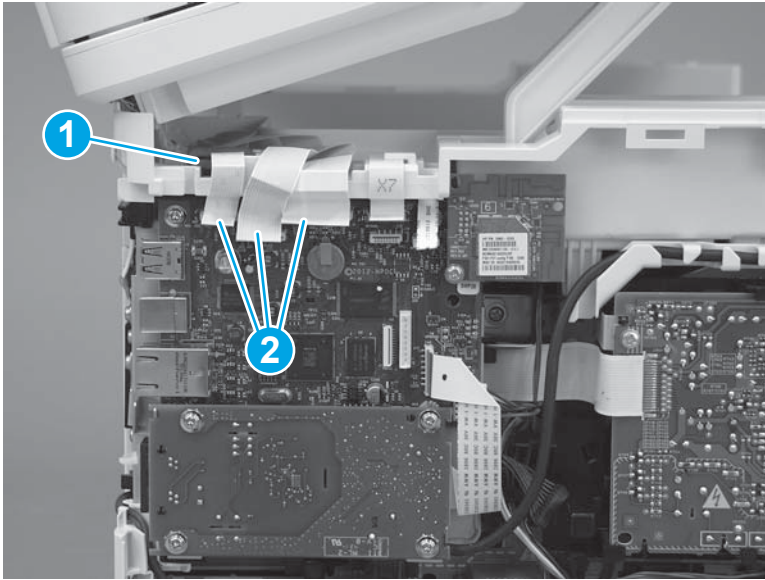
7. Rotate the slider pin (callout 1) towards the rear of the printer until the tab (callout 2) snap into place.

**Figure 1-1191** Secure the slider pin



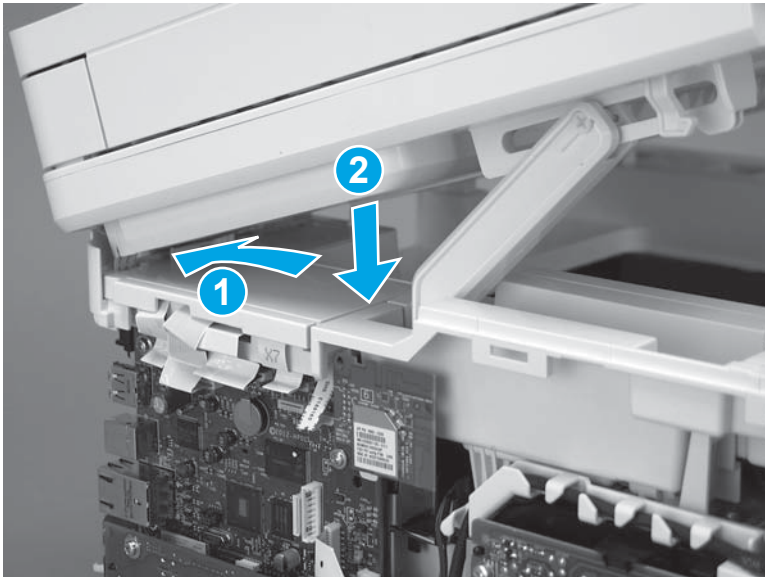
8. Install the ferrite (callout 1) in the holder, and then connect three FFCs (callout 2).

**Figure 1-1192** Connect three FFCs



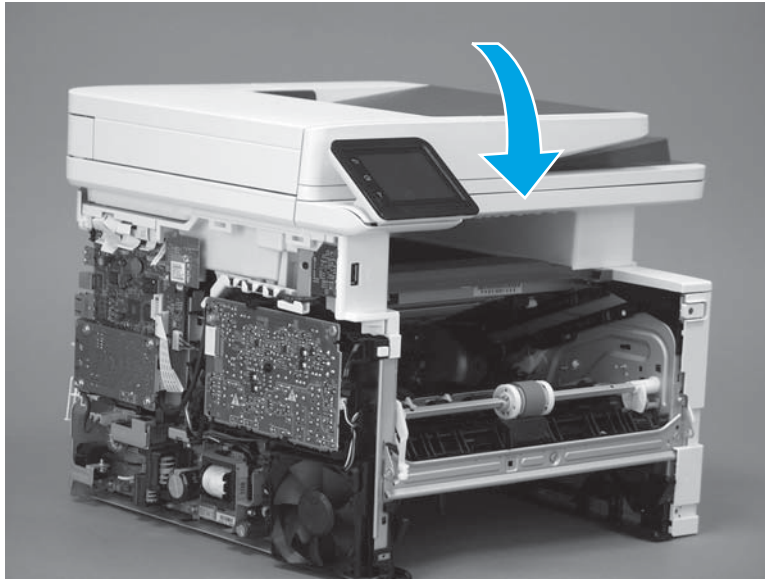
9. Position the rear edge of the ISA flat-flexible cable (FFC) cover on the printer (callout 1) , and then rotate it down (callout 2) until it snaps into place.

**Figure 1-1193** Install the ISA FFC cover



10. Lower the ISA.

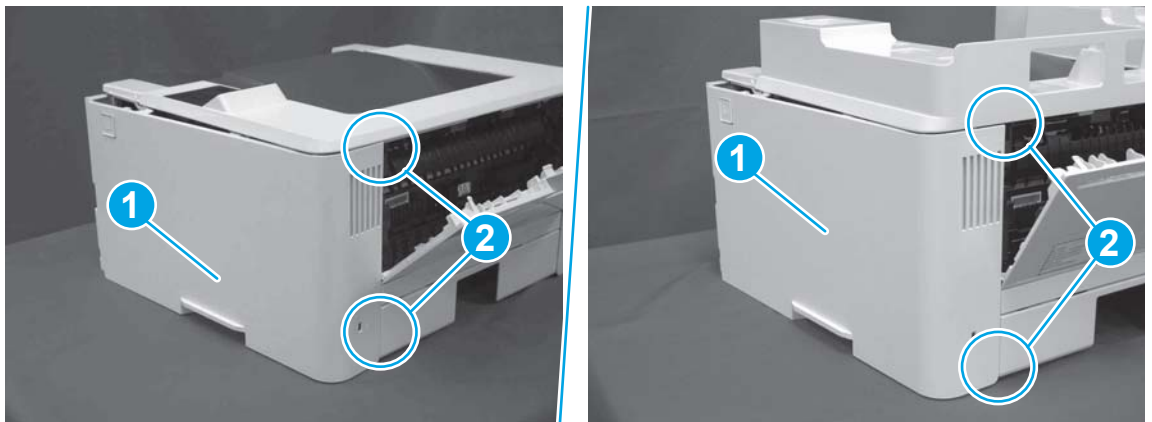
**Figure 1-1194** Lower the ISA



### Step 22: Install the right cover

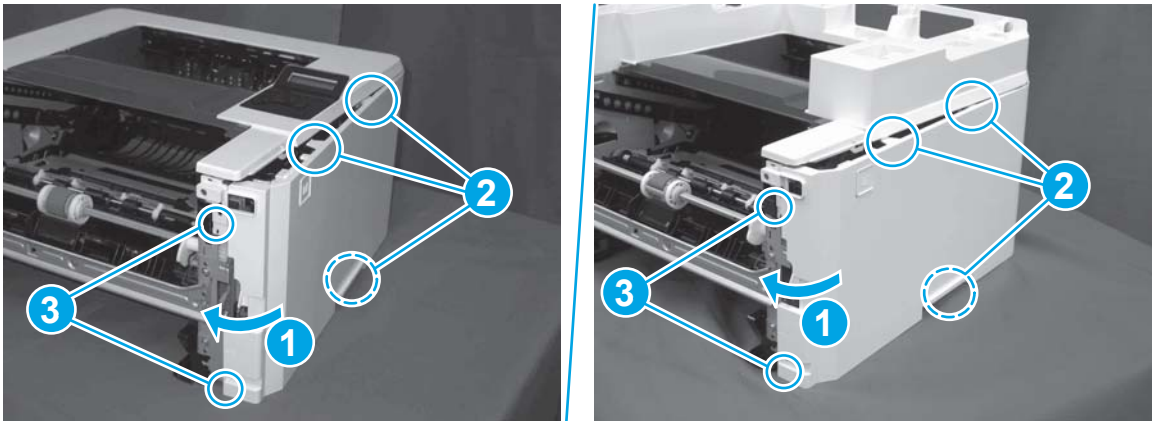
1. Position the cover (callout 1) on the printer, and then engage two bosses (callout 2).

**Figure 1-1195** Install the cover



2. Rotate the front of the cover onto the printer (callout 1), engage three (callout 2) tabs, and then engage two bosses (callout 3).

**Figure 1-1196** Engage two bosses and one tab

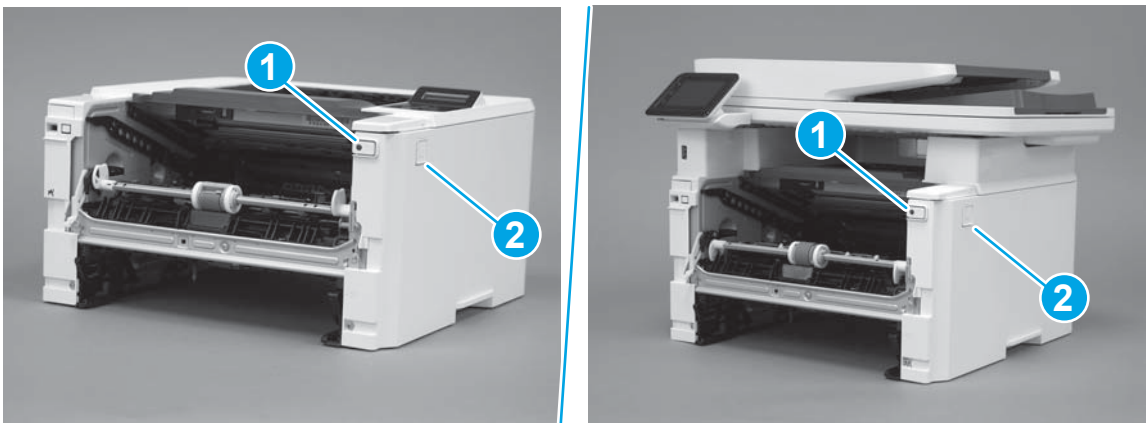


3. Make sure that the power switch (callout 1) and cartridge door assembly button (callout 2) correctly function.



**NOTE:** Remove, and then reinstall the cover if the switch or button does not correctly function.

**Figure 1-1197** Check the power switch and cartridge door assembly button



4. Install one screw (callout 1).

**Figure 1-1198** Install one screw

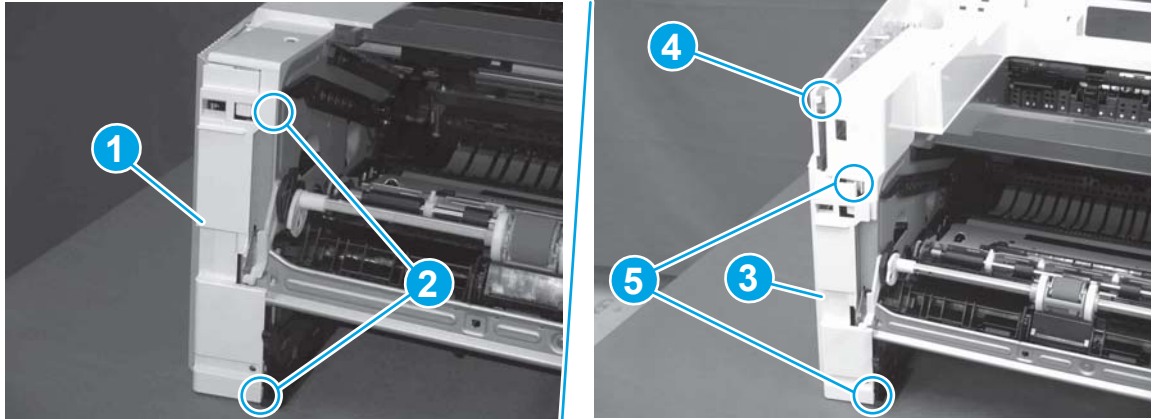




### Step 23: Install the left cover

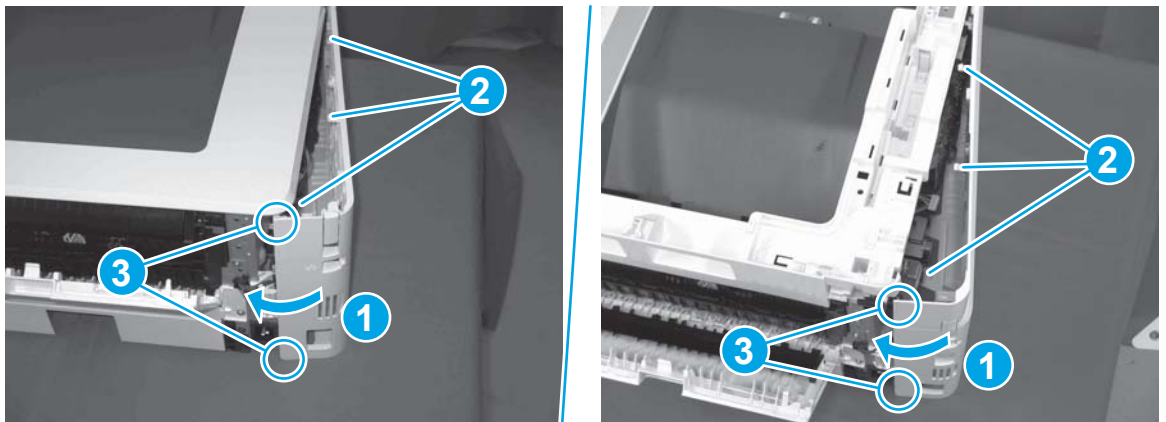
1. At the front of the printer, do one of the following:
  - **M403/M402:** Position the cover on the printer ( callout 1), and then engage two bosses (callout 2).
  - **M427/M426:** Position the cover on the printer (callout 3), engage one tab (callout 4), and then engage two bosses (callout 4).

**Figure 1-1199** Install the cover



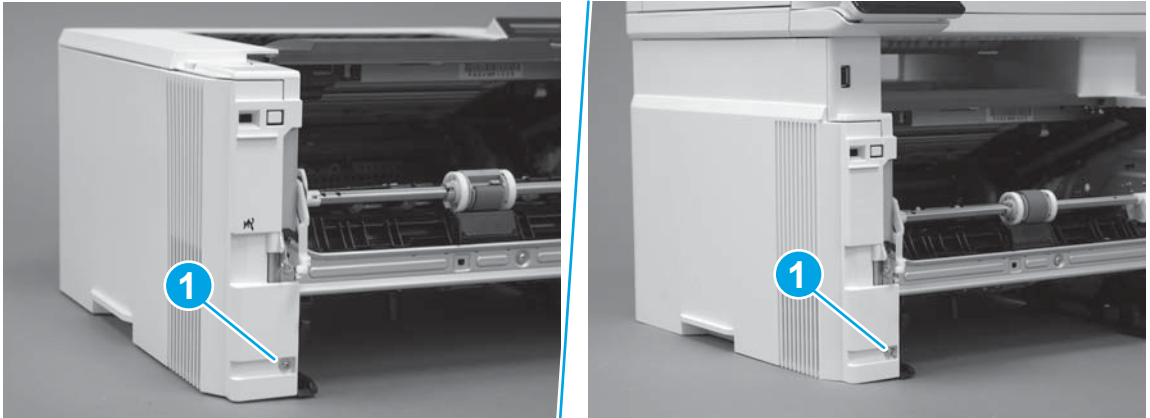
2. Carefully rotate the rear of the cover onto the printer (callout 1), engage three tabs (callout 2), and then engage two bosses (callout 3).

**Figure 1-1200** Engage three tabs and two bosses




3. Install one screw (callout 1).

**Figure 1-1201** Install one screw

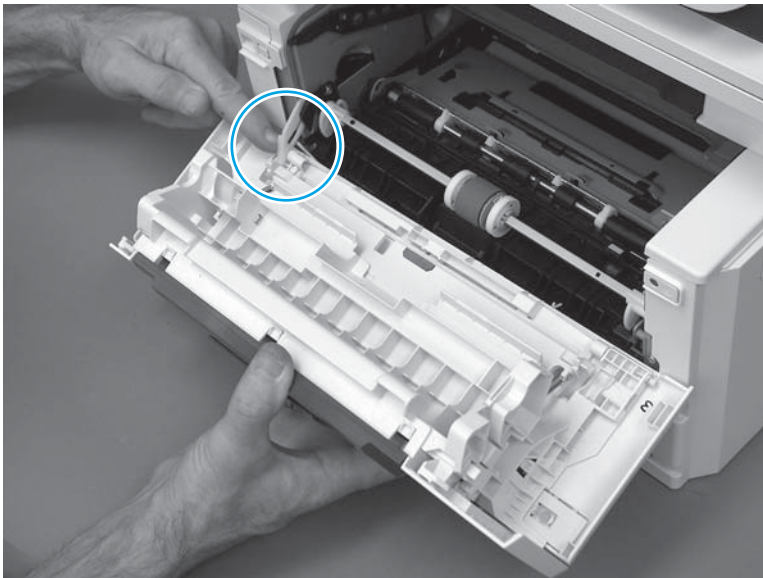


### Step 24: Install the cartridge door assembly

 **Reinstallation tip:** After a replacement door is installed, make sure to install the nameplate (supplied in the kit) corresponding to the printer name on the door.

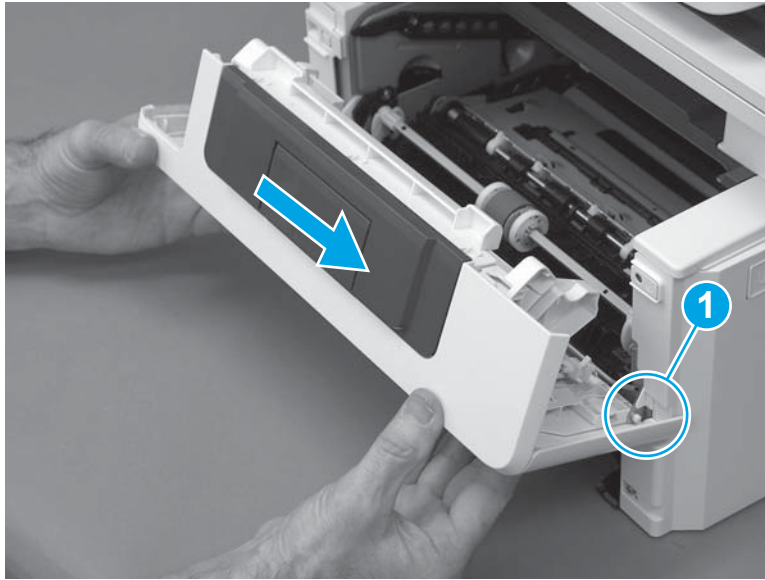
1. Position the door close to the printer, and then engage the keyed pin on the left-side retainer arm with the hole in the door.

**Figure 1-1202** Engage the left-side retainer arm



2. Engage the right-side door hinge pin with the hole in the chassis (callout 1).

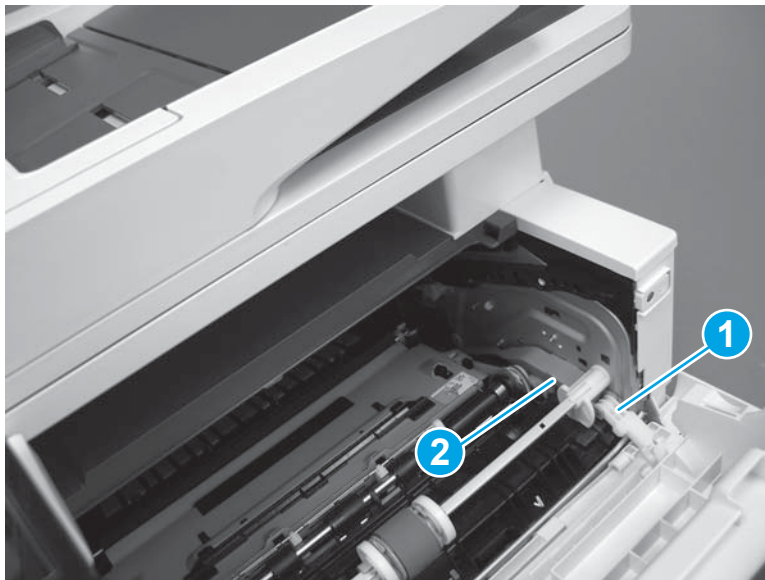
**Figure 1-1203** Install the door



3. Install the link (callout 1).

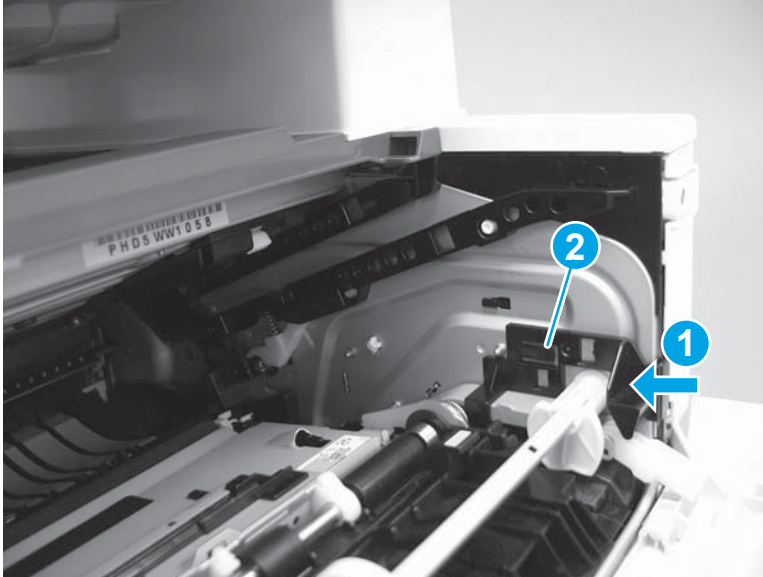
 **IMPORTANT:** Make sure that the link snaps into place on the arm (callout 2). The link actuates the fuser pressure-release mechanism.

**Figure 1-1204** Install the pressure-release link



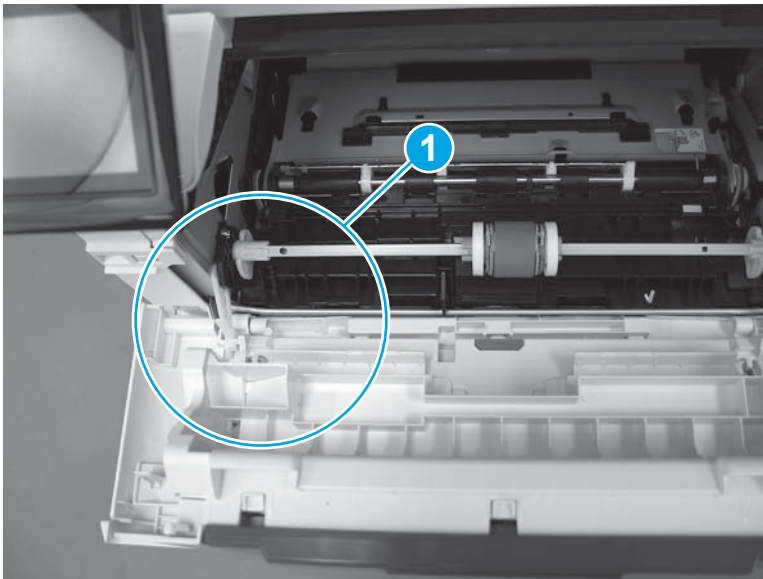
4. Slide the guide into the printer (callout 1), and then make sure that the tab (callout 2) snaps into place to secure the guide to the chassis.

**Figure 1-1205** Install the guide




5. Position the shaft on the door, and then align the left-side hinge on the door with the hole in the chassis (callout 1).

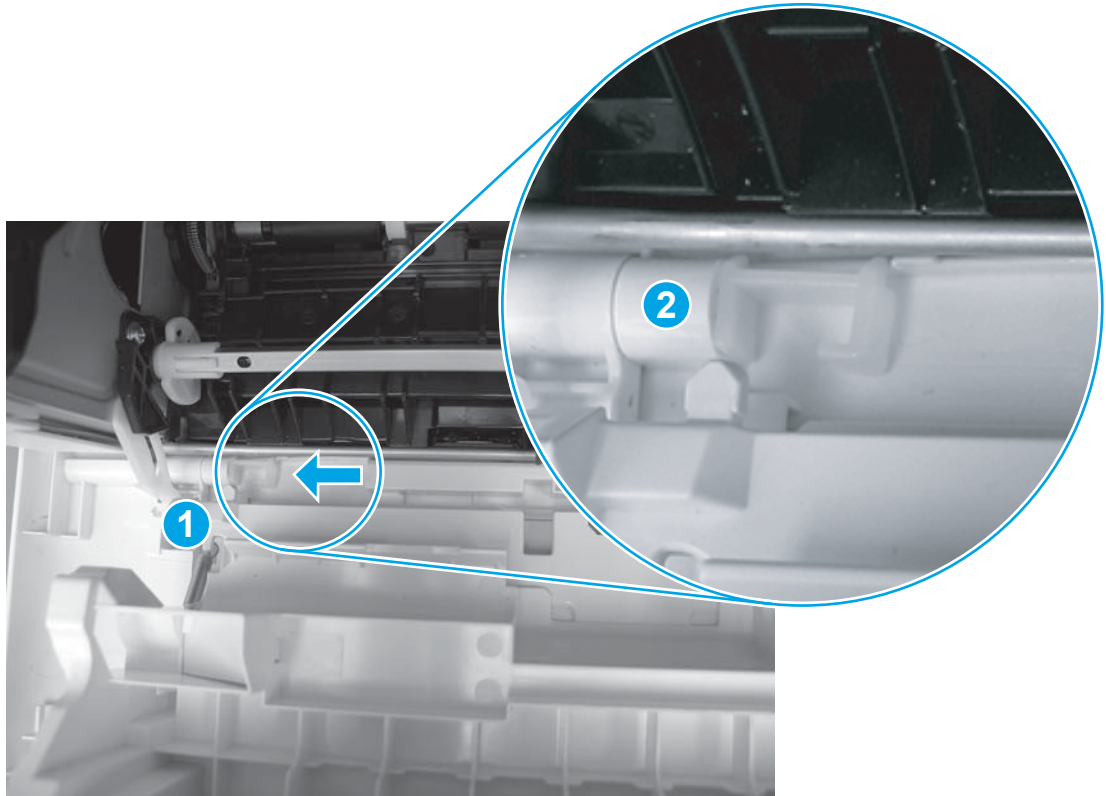
**Figure 1-1206** Align the hinge



6. Push the shaft towards the left side of the printer to install it (callout 1).

 **Reinstallation tip:** Make sure that the support shaft is fully installed and correctly orientated (callout 2) so that it will not interfere with the door opening and closing.

**Figure 1-1207** Install the support shaft



### Step 25: Install Tray 2

- ▲ Slide the tray straight into the printer to install it.

**Figure 1-1208** Install the tray



## Removal and replacement: Control panel FFC, (M403/M402)

- [Introduction](#)
- [Step 1: Remove Tray 2](#)
- [Step 2: Remove the cartridge door assembly](#)
- [Step 3: Remove the left cover](#)
- [Step 4: Remove the right cover](#)
- [Step 5: Remove the top cover \(M403/M402\)](#)
- [Step 6: Remove the paper delivery tray \(output bin\)](#)
- [Step 7: Remove the control panel FFC](#)
- [Step 8: Unpack the replacement assembly](#)
- [Step 9: Install the control panel FFC](#)
- [Step 10: Install the paper delivery tray \(output bin\)](#)
- [Step 11: Install the top cover \(M403/M402\)](#)
- [Step 12: Install the right cover](#)
- [Step 13: Install the left cover](#)
- [Step 14: Install the cartridge door assembly](#)
- [Step 15: Install Tray 2](#)


### Introduction

This document provides the procedures to remove and replace the control panel FFC (M403/M402 only).

### Before performing service

#### Turn the printer power off

- Disconnect the power cable.

 **WARNING!** To avoid damage to the printer, turn the printer off, wait 30 seconds, and then remove the power cable before attempting to service the printer.

Use the table below to identify the correct part number for your printer. To order the part, go to [www.hp.com/buy/parts](http://www.hp.com/buy/parts).

---

**Control panel FFC (M403/M402) part number**

---

**RK2-6943-000CN**Control panel FFC (M403/M402)

---

### Required tools

- #2 Phillips screwdriver with a magnetic tip.

## After performing service

### Turn the printer power on

- Connect the power cable.
- Use the power switch to turn the power on.

### Post service test

Make sure that the printer initializes to a **Ready** state.

Print a configuration page to make sure that the printer is functioning correctly.

### Step 1: Remove Tray 2

- ▲ Pull the tray straight out of the printer to remove it.

**Figure 1-1209** Remove the tray



### Step 2: Remove the cartridge door assembly



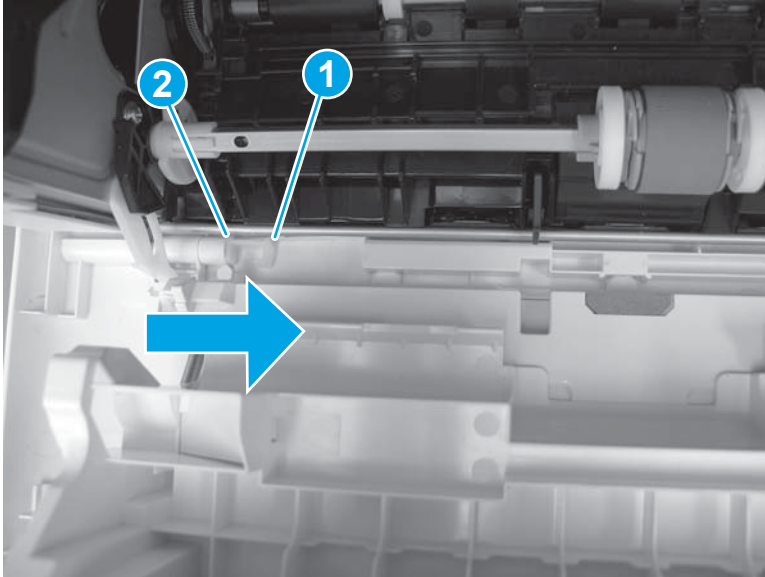
**NOTE:** If the toner cartridge was not removed prior to servicing the printer, remove it now.

1. Release one tab (callout 1), and then slide shaft (callout 2) in the direction the arrow indicates and remove it.



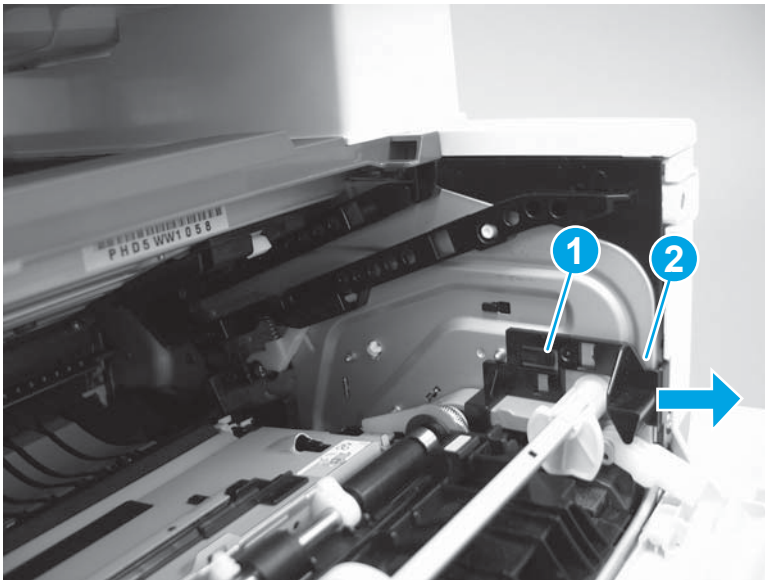
**TIP:** It might be easier to release the support shaft by using a small flat-blade screwdriver.

**Figure 1-1210** Release the support shaft



2. Release one tab (callout 1), and then slide the guide (callout 2) in the direction the arrow indicates and remove it.

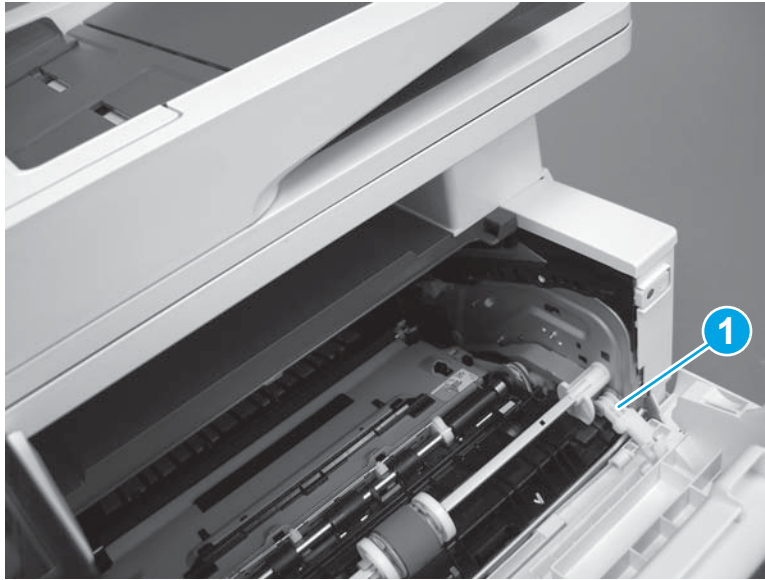
**Figure 1-1211** Remove the guide





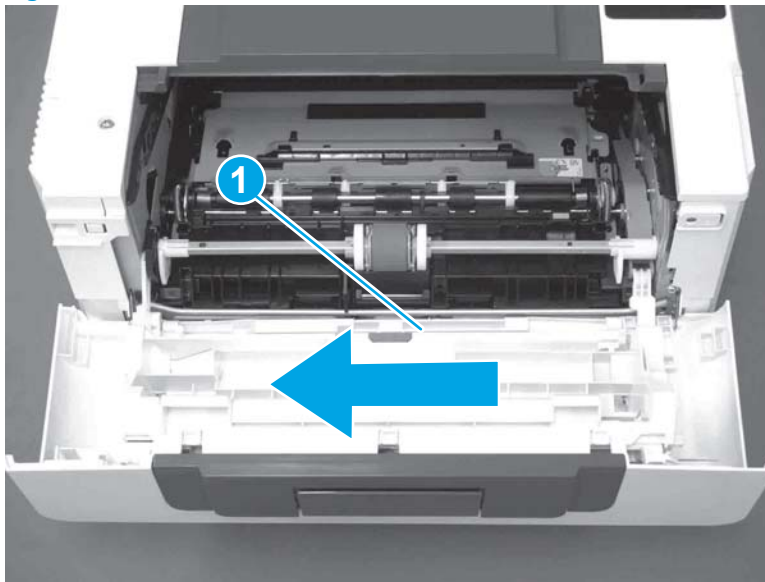
3. Remove the link arm (callout 1).

**Figure 1-1212** Remove the link arm



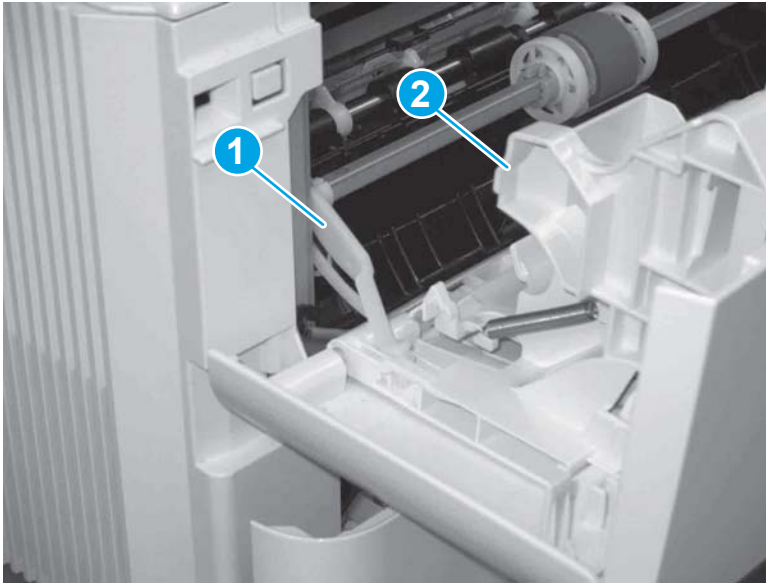
4. Slide the cartridge door assembly (callout 1) in the direction the arrow indicates and remove it.

**Figure 1-1213** Remove the door



5. Remove the link (callout 1) from the cartridge door assembly (callout 2).

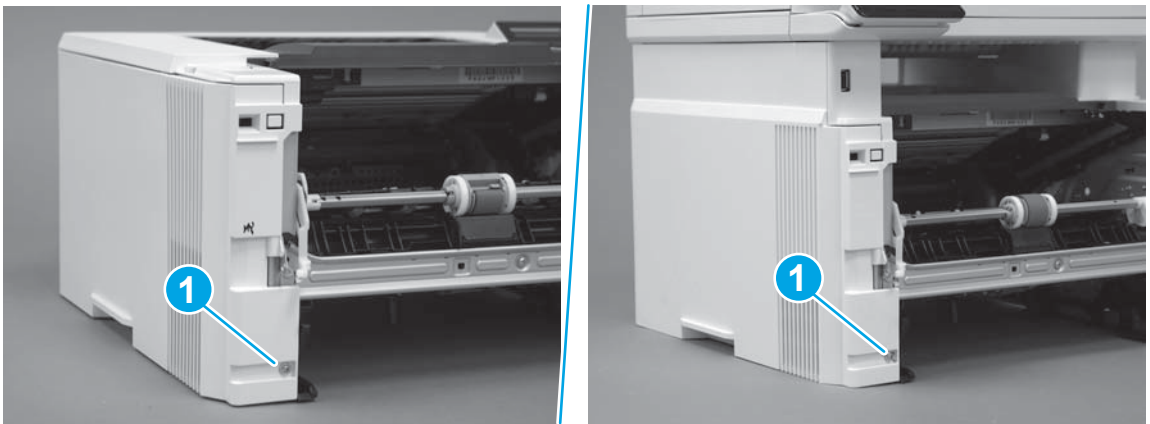
**Figure 1-1214** Release the left-side retainer arm



### Step 3: Remove the left cover

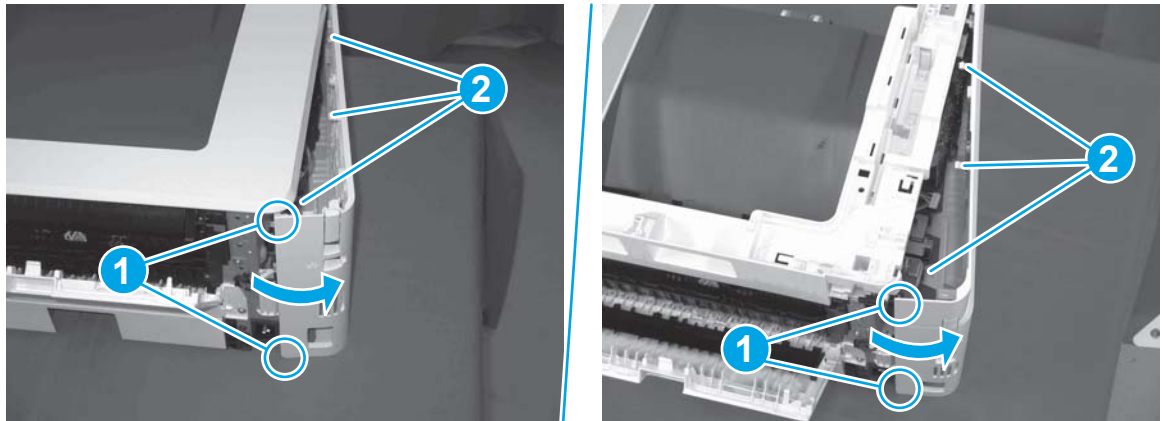
1. Remove one screw (callout 1).

**Figure 1-1215** Remove one screw



2. Open the rear door, release two bosses (callout 1), and then release three tabs (callout 2).

**Figure 1-1216** Release two bosses and three tabs

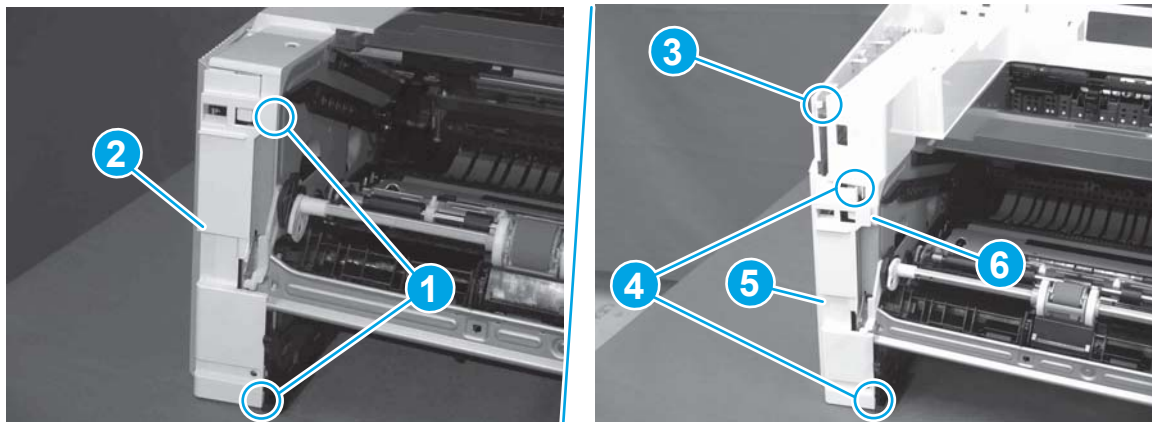


3. At the front of the printer, do one of the following:

- **M403/M402:** Release two bosses (callout 1), and then remove the cover (callout 2).
- **M427/M426:** Release one tab (callout 3), two bosses (callout 4), and then remove the cover (callout 5).

**CAUTION:** Be careful when releasing the upper bosses on the M427/M426 cover. One portion of the cover (callout 6) is fragile and is easily broken.

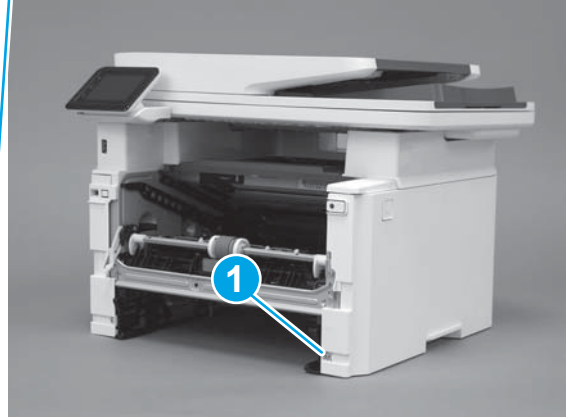
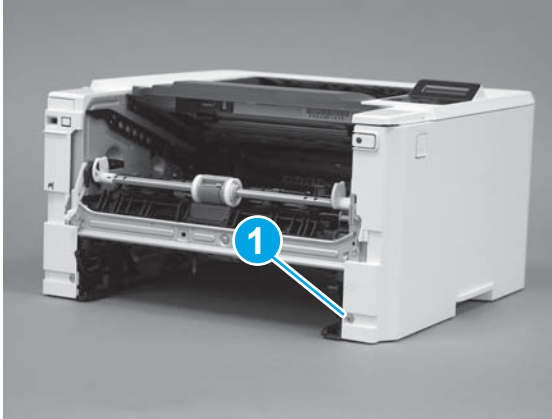
**Figure 1-1217** Remove the cover



#### Step 4: Remove the right cover

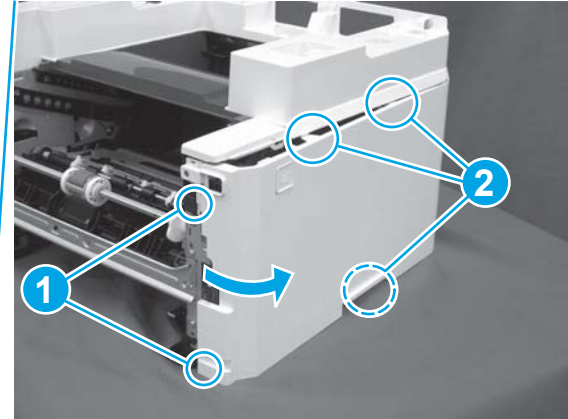
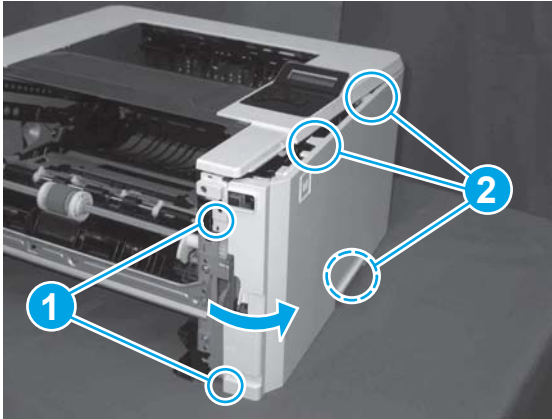
1. Remove one screw (callout 1).

**Figure 1-1218** Remove one screw



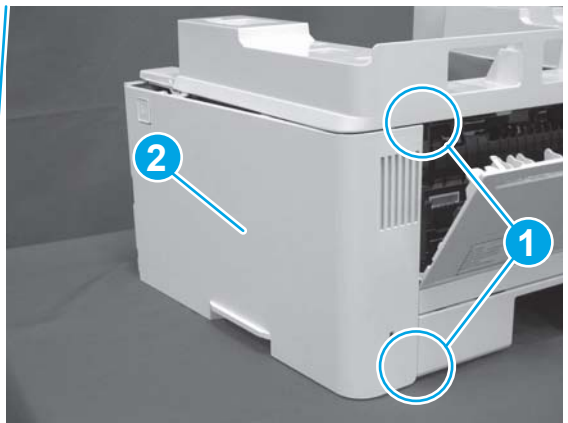
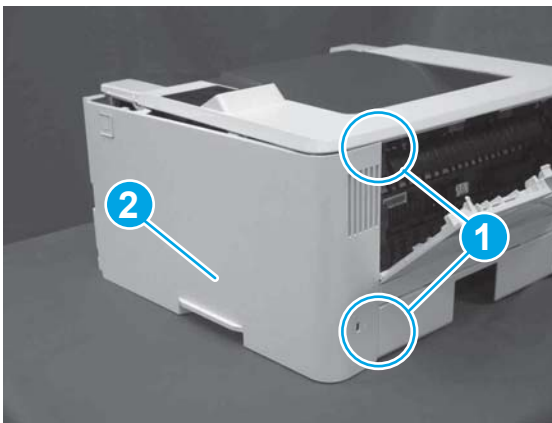
2. At the front of the printer, release two bosses (callout 1), and then release three tabs (callout 2).

**Figure 1-1219** Release two bosses and three tabs



3. Open the rear door, release two bosses (callout 1), and then remove the cover (callout 2).

**Figure 1-1220** Remove the cover



### Step 5: Remove the top cover (M403/M402)

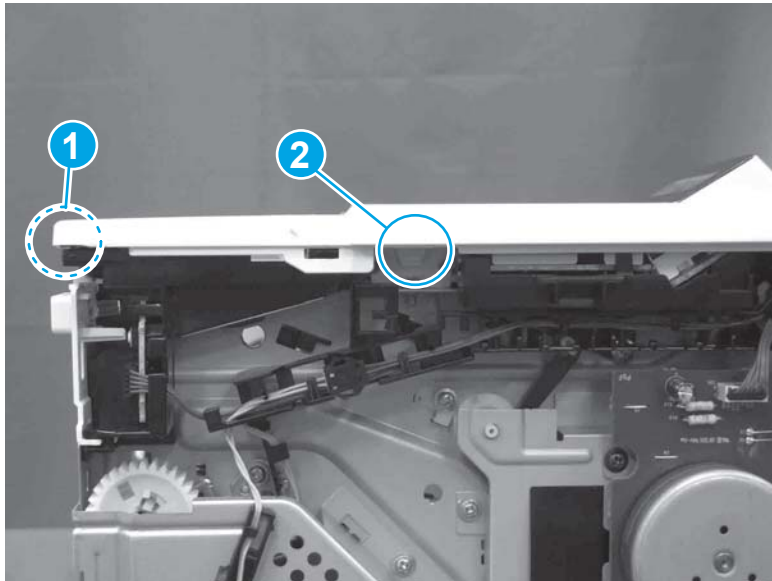
1. Remove one screw (callout 1).

**Figure 1-1221** Remove one screw




2. At the right side of the printer, release the one boss (callout 1), and then release one tab (callout 2).

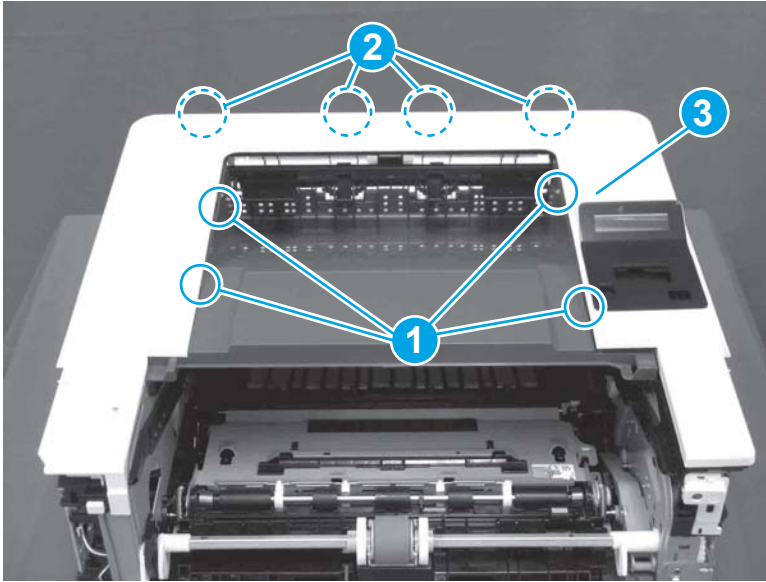
**Figure 1-1222** Release one boss and one tab




3. Release four tabs (callout 1), release four bosses (callout 2), and then remove the top cover (callout 3).

 **TIP:** Open the rear door to make releasing the bosses (callout 3) easier.

**Figure 1-1223** Remove the cover

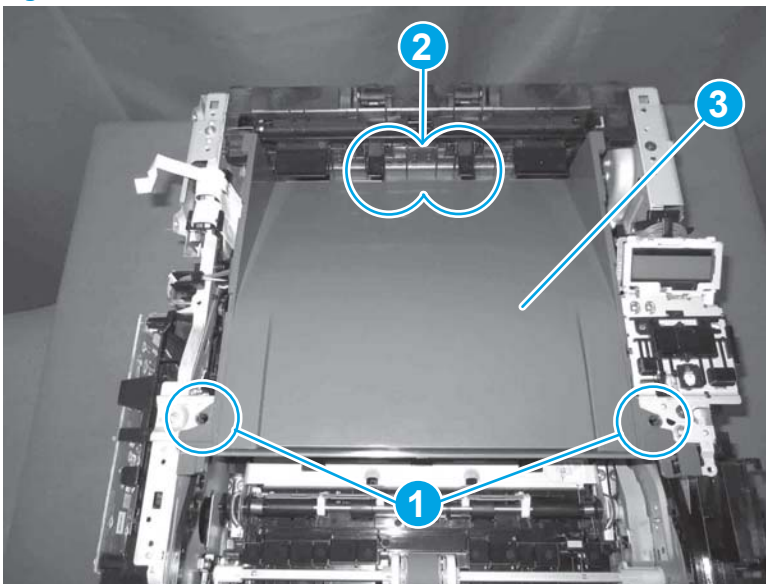


#### Step 6: Remove the paper delivery tray (output bin)

 **NOTE:** This procedure shows the M403/M402 model, however, the paper delivery tray (output bin) removal is similar for the M427/M426 printer.

- ▲ Release two bosses (callout 1), release two tabs (callout 2), and then remove the paper delivery tray (output bin; callout 3).

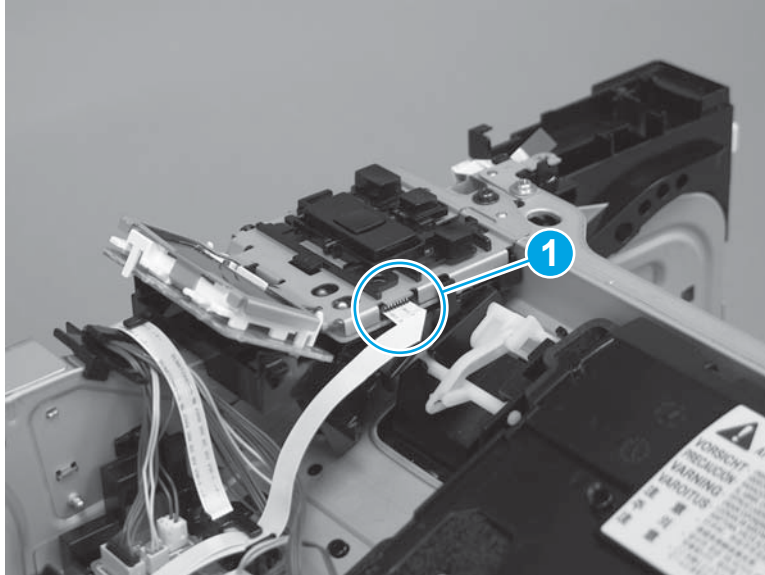
**Figure 1-1224** Release two tabs



## Step 7: Remove the control panel FFC

1. Disconnect the FFC from the control panel (callout 1).

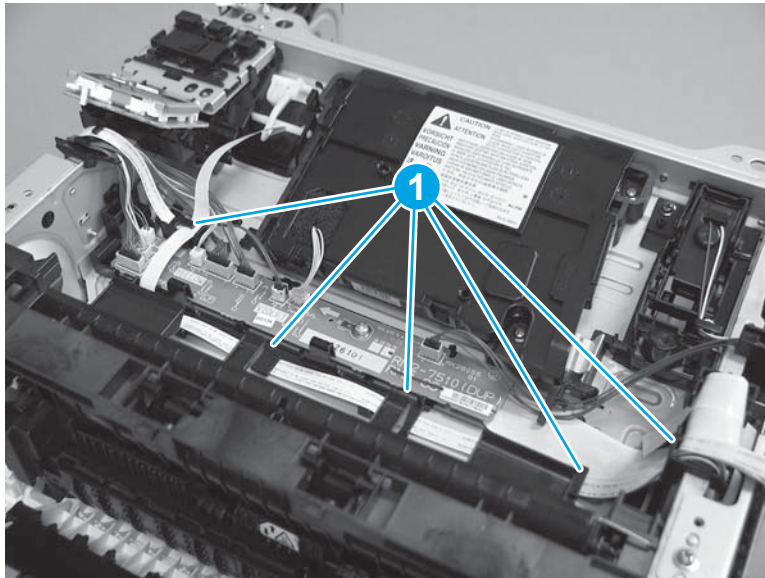
**Figure 1-1225** Disconnect the FFC



2. Release the FFC from the guide (callout 1).

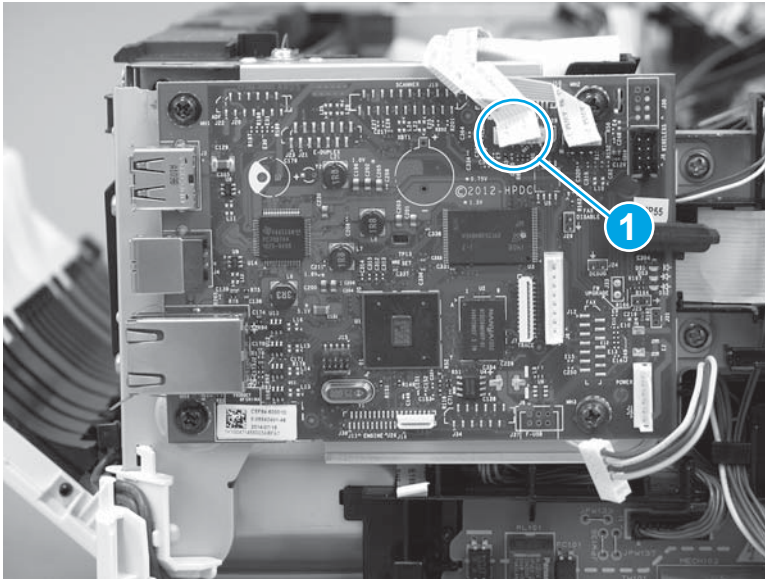
 **NOTE:** The near field communication (NFC) FFC might need to be moved out of the way to gain access to the control panel FFC.

**Figure 1-1226** Release the FFC from the guide



3. Disconnect one FFC (callout 1), and then remove the FFC.

**Figure 1-1227** Disconnect and remove the FFC



### Step 8: Unpack the replacement assembly

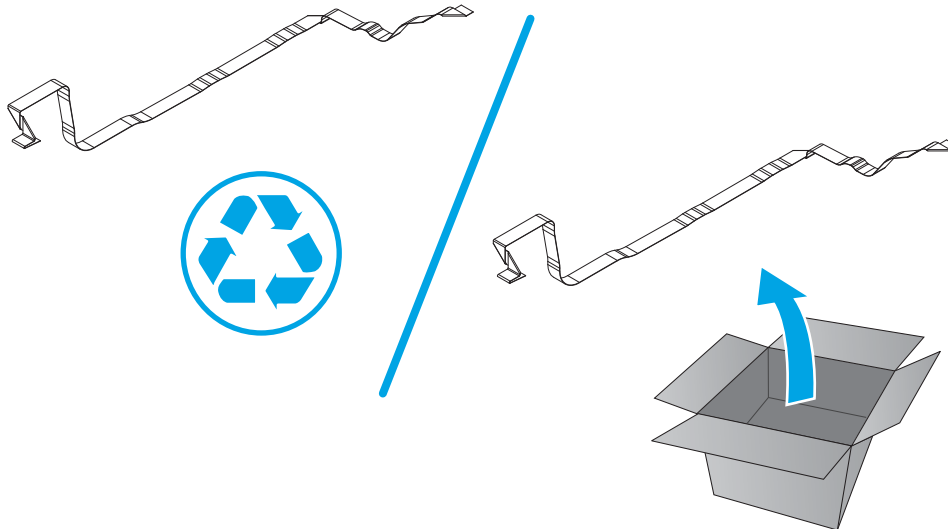
Unpack the replacement part from the packaging.

<http://www8.hp.com/us/en/hp-information/environment/product-recycling.html>



**NOTE:** HP recommends responsible disposal of the defective part.

**Figure 1-1228** Recycle and unpack

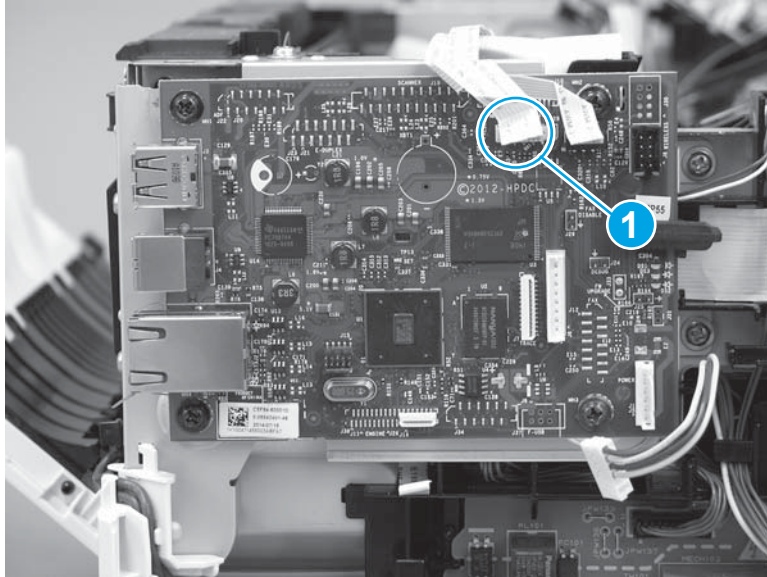


### Step 9: Install the control panel FFC


1. Connect the FFC (callout 1) to the formatter PCA.



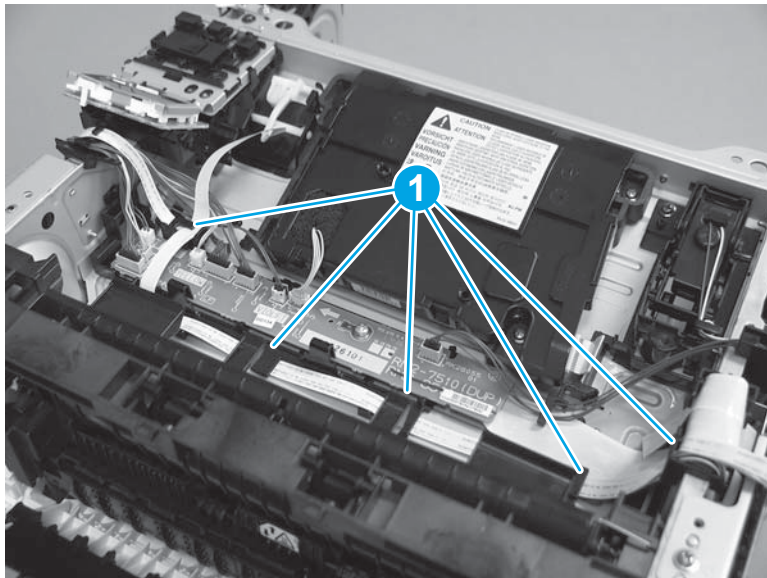
**Figure 1-1229** Connect the FFC



2. Install the FFC in the guide (callout 1).

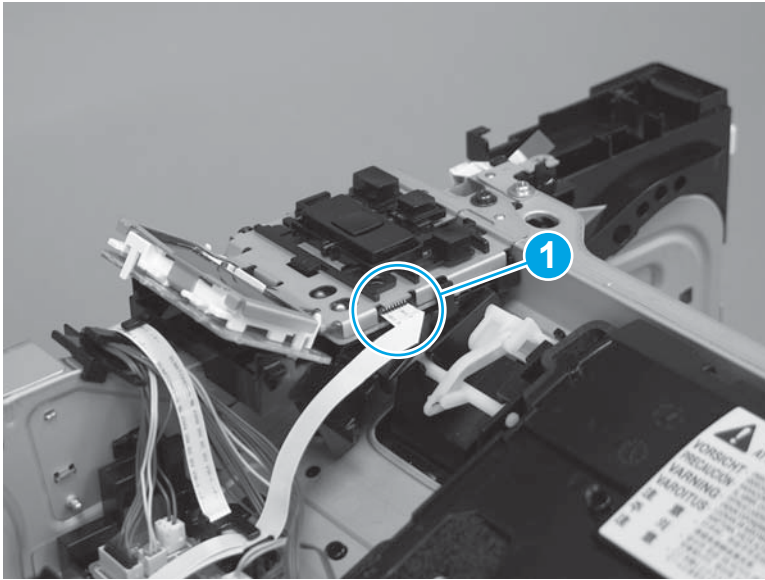
 **NOTE:** The near field communication (NFC) FFC might need to be moved out of the way to gain access to the control panel FFC.

**Figure 1-1230** Install the FFC in the guide



3. Connect the FFC to the control panel (callout 1).

**Figure 1-1231** Connect the FFC



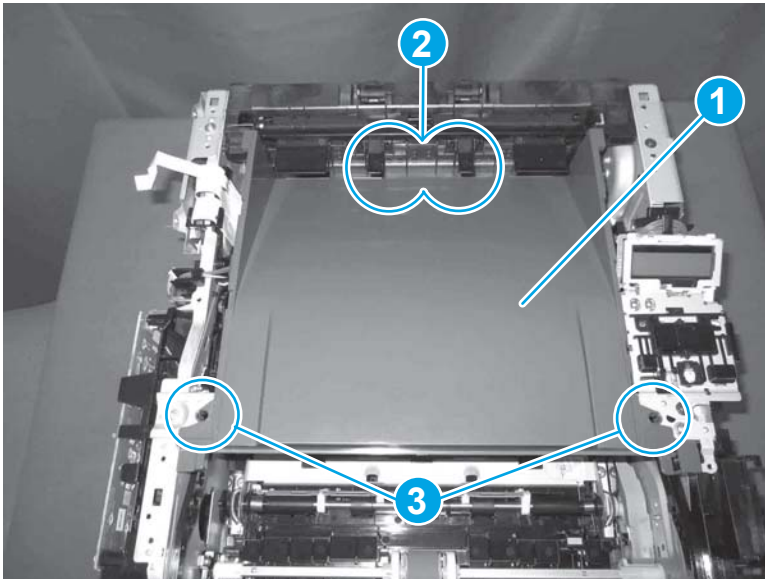
### Step 10: Install the paper delivery tray (output bin)



**NOTE:** This procedure shows the M403/M402 model, however, the paper delivery tray (output bin) removal is similar for the M427/M426 printer.

- ▲ Position the remove the paper delivery tray (output bin; callout 1) on the printer, engage two tabs (callout 2), and then engage two bosses (callout 3).

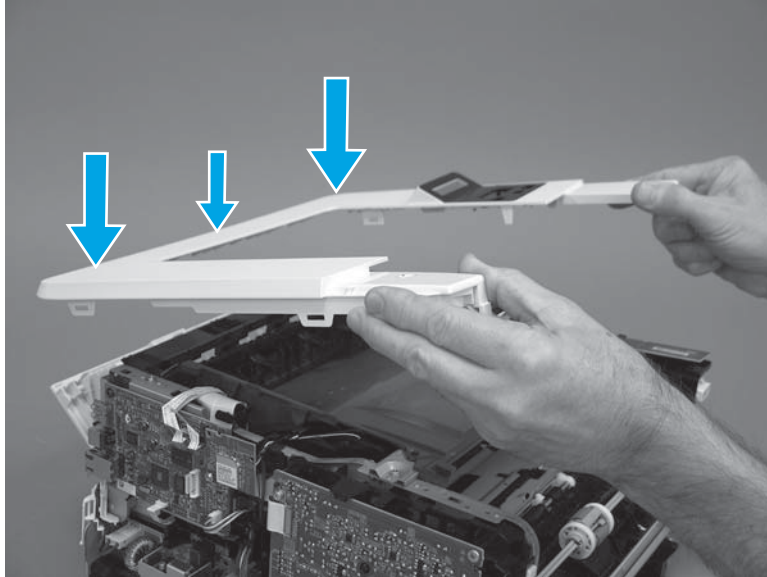
**Figure 1-1232** Engage two tabs



### Step 11: Install the top cover (M403/M402)

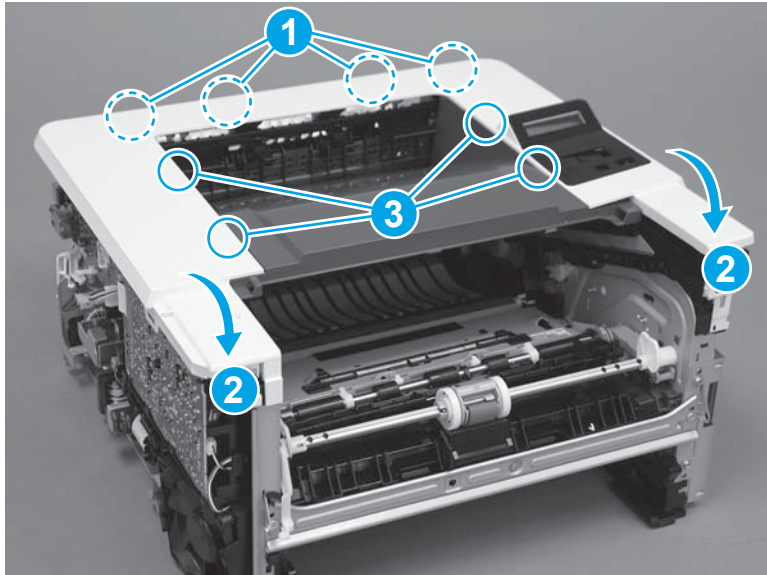
1. Position the rear edge of the cover on the printer.

**Figure 1-1233** Install the cover



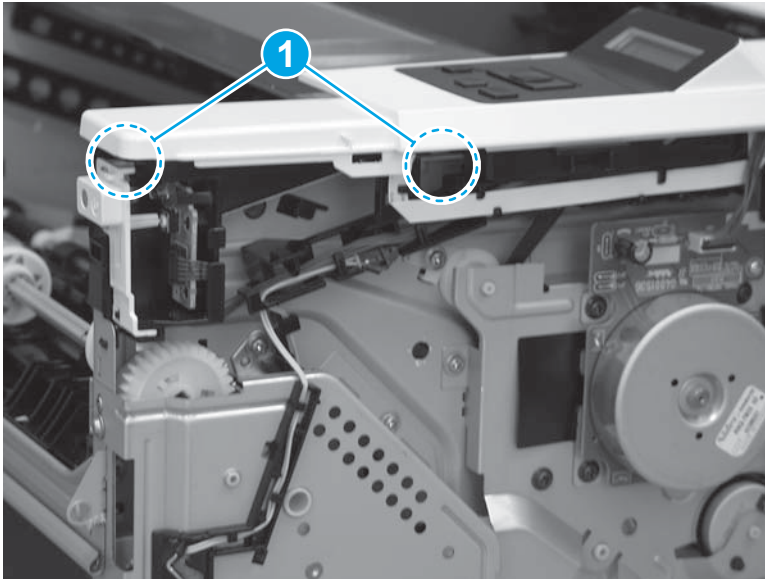
2. Engage four bosses (callout 1), rotate the front of the cover down (callout 2) and onto from the printer, and then engage four tabs (callout 3).

**Figure 1-1234** Engage four bosses and tabs



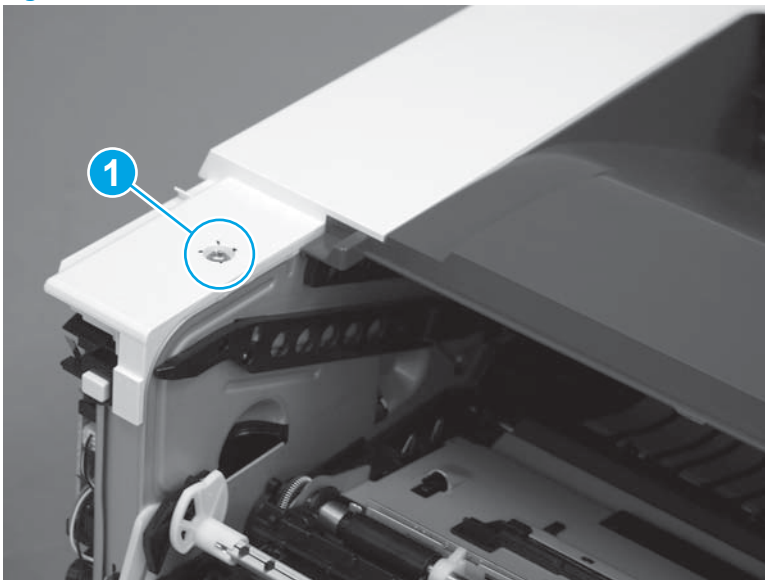
3. At the right side of the printer, engage the one boss and one tab (callout 1).

**Figure 1-1235** Engage one boss and one tab



4. Install one screw (callout 1).

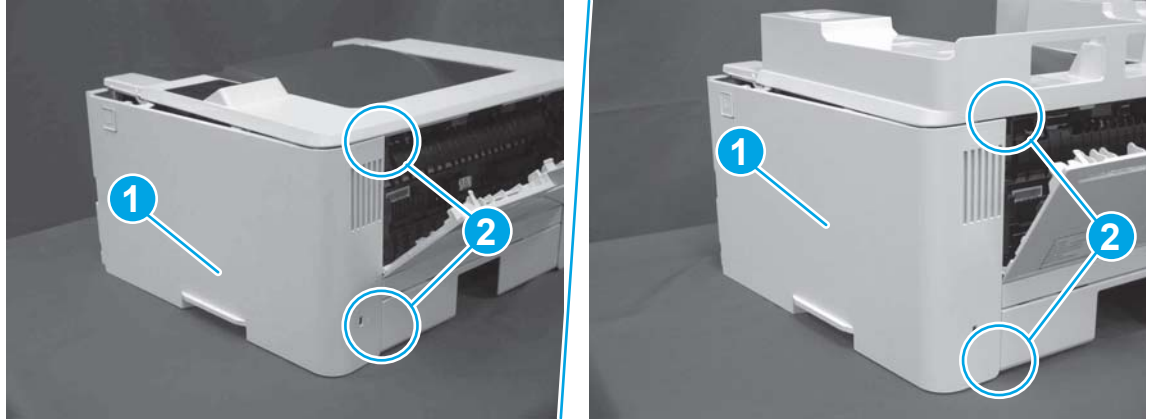
**Figure 1-1236** Install one screw



### **Step 12: Install the right cover**

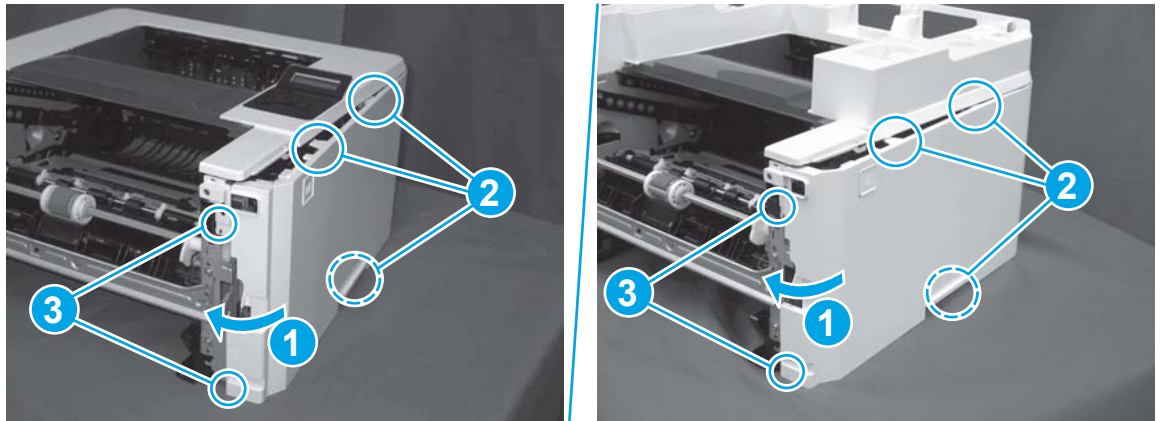
1. Position the cover (callout 1) on the printer, and then engage two bosses (callout 2).

**Figure 1-1237** Install the cover



2. Rotate the front of the cover onto the printer (callout 1), engage three (callout 2) tabs, and then engage two bosses (callout 3).

**Figure 1-1238** Engage two bosses and one tab

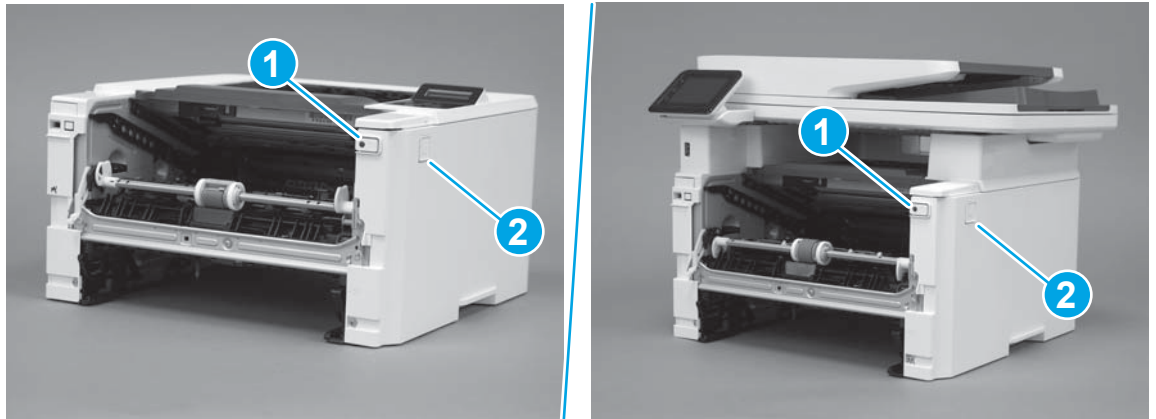


3. Make sure that the power switch (callout 1) and cartridge door assembly button (callout 2) correctly function.



**NOTE:** Remove, and then reinstall the cover if the switch or button does not correctly function.

**Figure 1-1239** Check the power switch and cartridge door assembly button



4. Install one screw (callout 1).

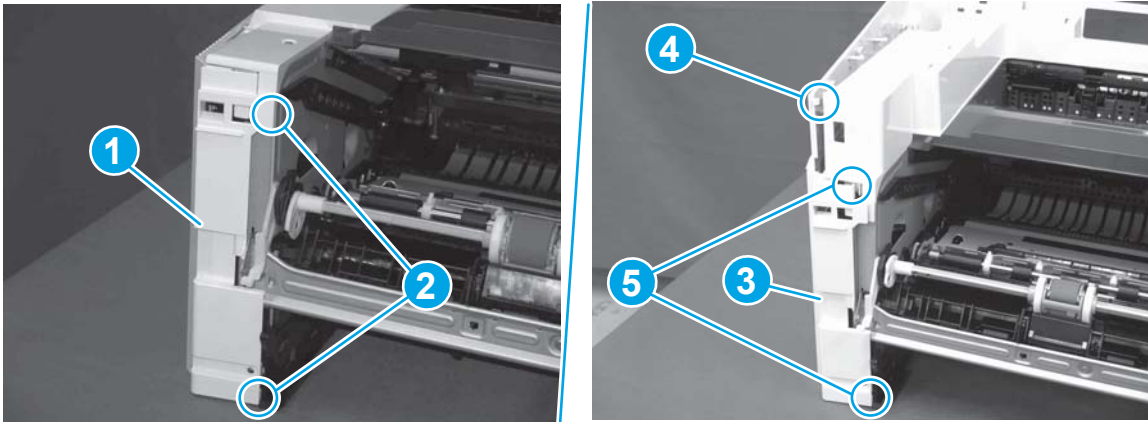
**Figure 1-1240** Install one screw



### Step 13: Install the left cover

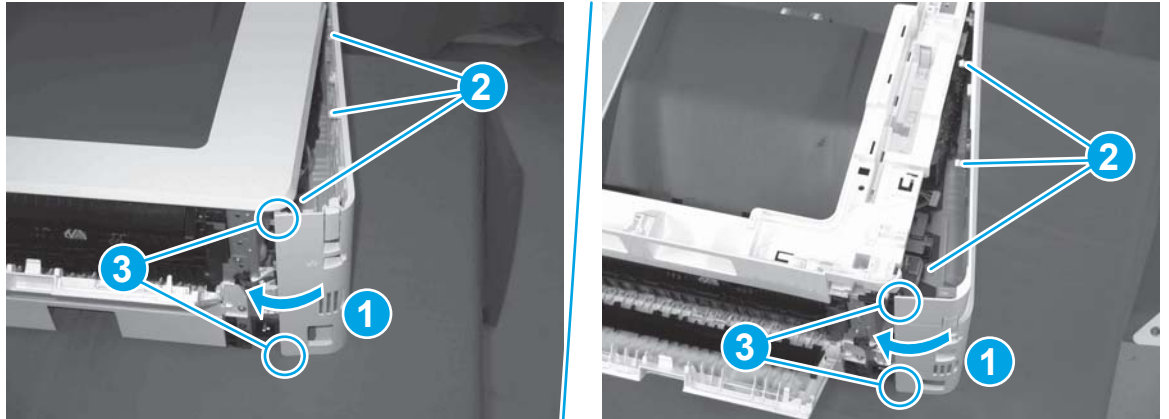
1. At the front of the printer, do one of the following:
  - **M403/M402:** Position the cover on the printer ( callout 1), and then engage two bosses (callout 2).
  - **M427/M426:** Position the cover on the printer (callout 3), engage one tab (callout 4), and then engage two bosses (callout 4).

**Figure 1-1241** Install the cover



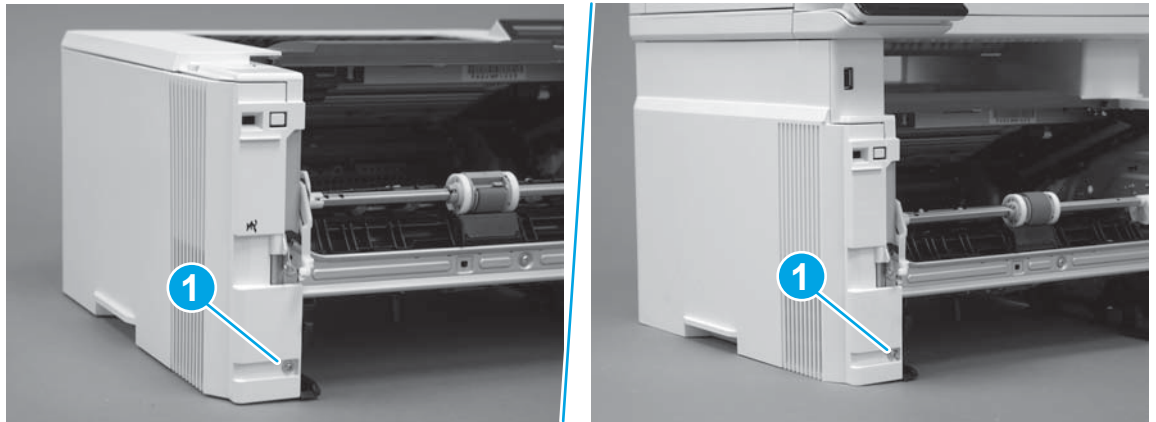
- Carefully rotate the rear of the cover onto the printer (callout 1), engage three tabs (callout 2), and then engage two bosses (callout 3).

**Figure 1-1242** Engage three tabs and two bosses




- Install one screw (callout 1).

**Figure 1-1243** Install one screw

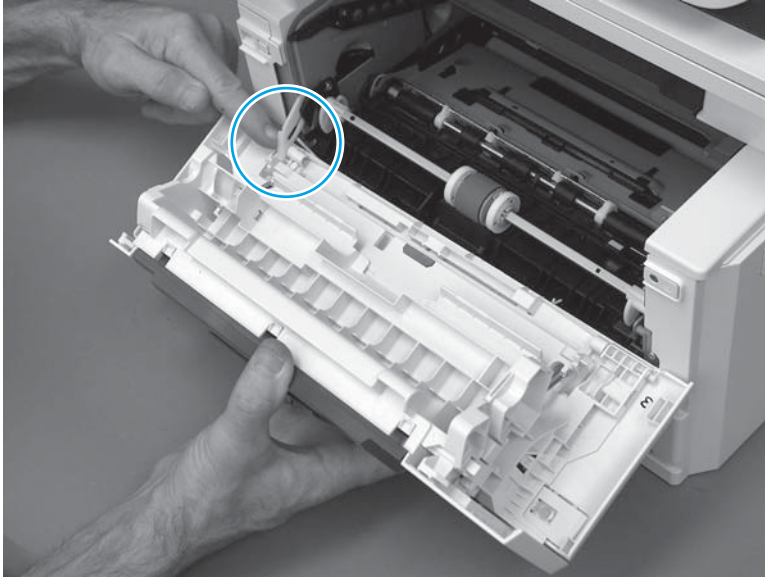


#### Step 14: Install the cartridge door assembly

 **Reinstallation tip:** After a replacement door is installed, make sure to install the nameplate (supplied in the kit) corresponding to the printer name on the door.

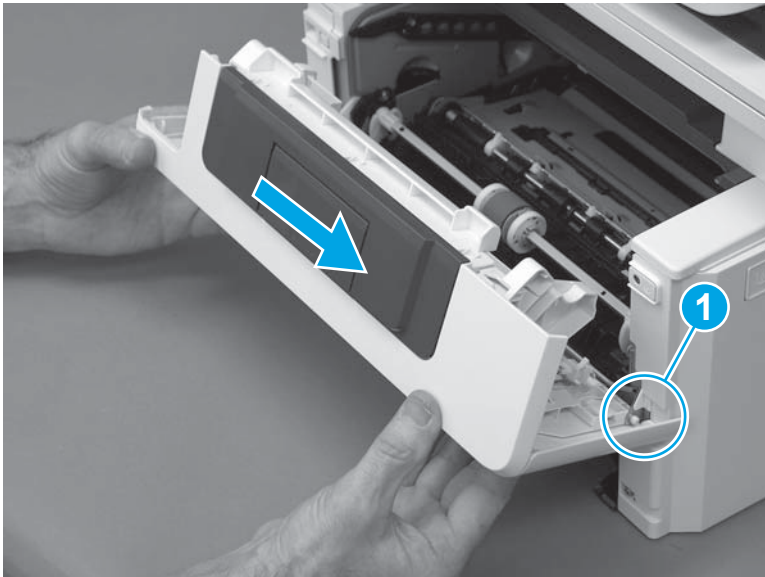
- Position the door close to the printer, and then engage the keyed pin on the left-side retainer arm with the hole in the door.

**Figure 1-1244** Engage the left-side retainer arm



2. Engage the right-side door hinge pin with the hole in the chassis (callout 1).

**Figure 1-1245** Install the door

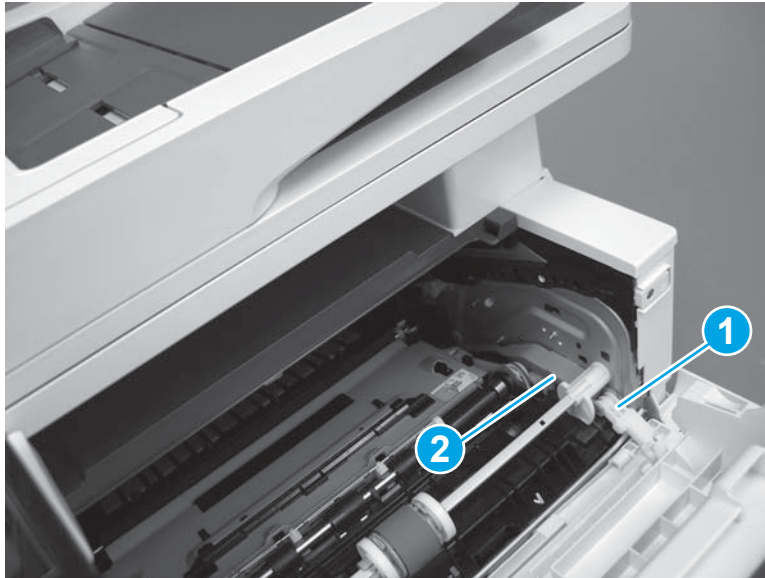




3. Install the link (callout 1).

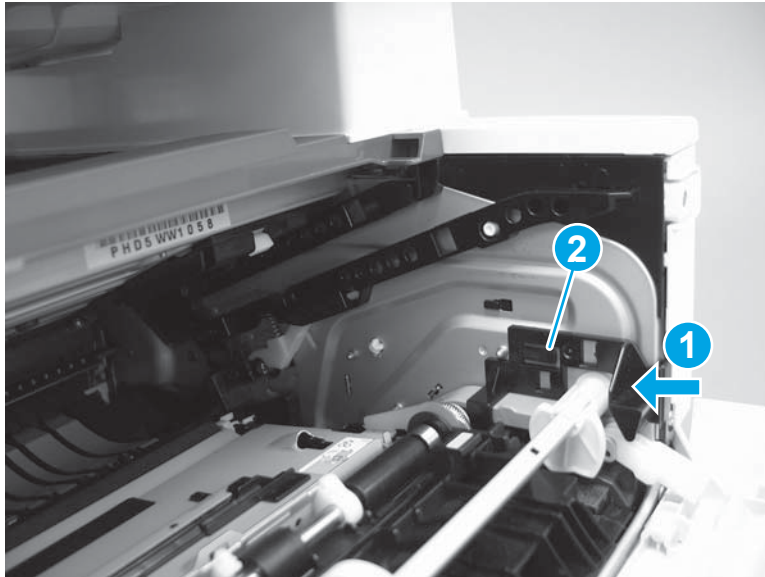
 **IMPORTANT:** Make sure that the link snaps into place on the arm (callout 2). The link actuates the fuser pressure-release mechanism.

**Figure 1-1246** Install the pressure-release link



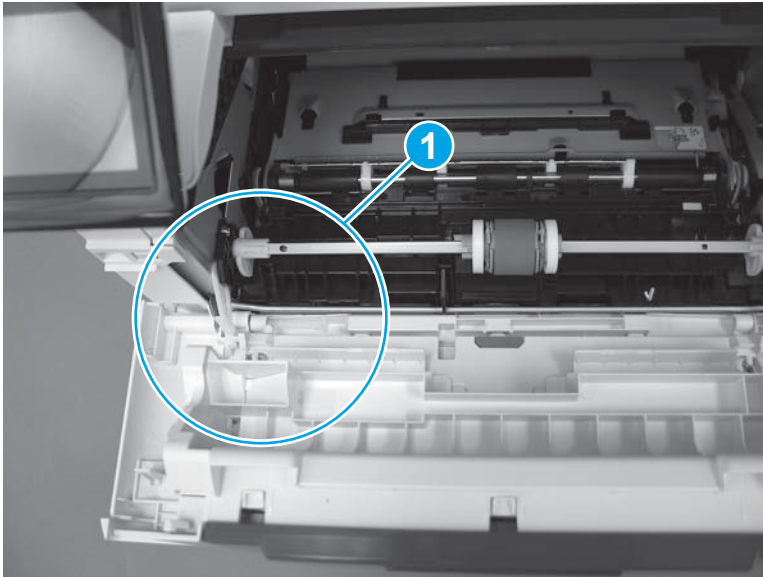
4. Slide the guide into the printer (callout 1), and then make sure that the tab (callout 2) snaps into place to secure the guide to the chassis.

**Figure 1-1247** Install the guide




5. Position the shaft on the door, and then align the left-side hinge on the door with the hole in the chassis (callout 1).

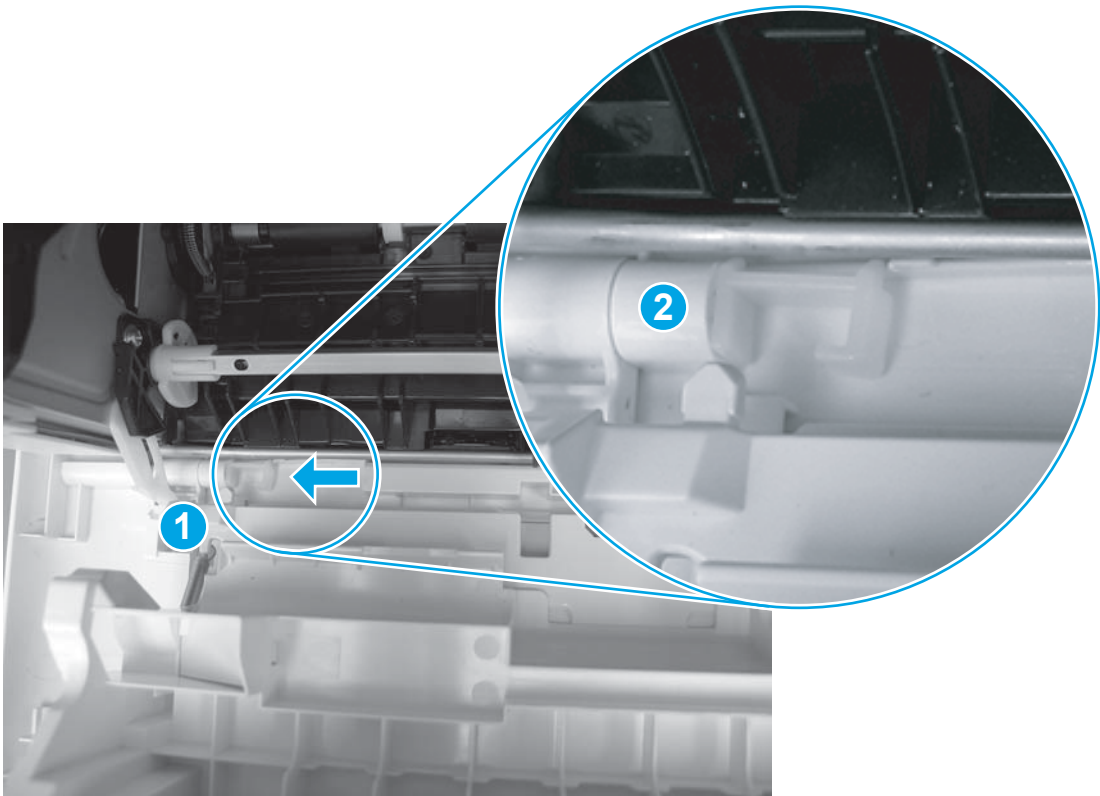
**Figure 1-1248** Align the hinge



6. Push the shaft towards the left side of the printer to install it (callout 1).

 **Reinstallation tip:** Make sure that the support shaft is fully installed and correctly orientated (callout 2) so that it will not interfere with the door opening and closing.

**Figure 1-1249** Install the support shaft



### Step 15: Install Tray 2

- ▲ Slide the tray straight into the printer to install it.

**Figure 1-1250** Install the tray



## Removal and replacement: Formatter FFC

- [Introduction](#)
- [Step 1: Remove Tray 2](#)
- [Step 2: Remove the cartridge door assembly](#)
- [Step 3: Remove the left cover](#)
- [Step 4: Remove the right cover](#)
- [Step 5: Remove the integrated scanner assembly \(M427/M246\)](#)
- [Step 6: Remove the control panel \(M427/M246\)](#)
- [Step 7: Remove the top cover \(M427/M426\)](#)
- [Step 8: Remove the top cover \(M403/M402\)](#)
- [Step 9: Remove the sheet-metal formatter bracket and formatter PCA](#)
- [Step 10: Remove the formatter FFC](#)
- [Step 11: Unpack the replacement assembly](#)
- [Step 12: Install the formatter FFC](#)
- [Step 13: Install the sheet-metal formatter bracket and formatter PCA](#)
- [Step 14: Install the top cover \(M403/M402\)](#)
- [Step 15: Install the top cover \(M427/M426\)](#)
- [Step 16: Install the control panel \(M427/M246\)](#)
- [Step 17: Install the integrated scanner assembly \(M427/M246\)](#)
- [Step 18: Install the right cover](#)
- [Step 19: Install the left cover](#)
- [Step 20: Install the cartridge door assembly](#)
- [Step 21: Install Tray 2](#)

### Introduction


This document provides the procedures to remove and replace the formatter flat-flexible cable (FFC).

### Before performing service

#### Turn the printer power off

- Disconnect the power cable.

---

 **WARNING!** To avoid damage to the printer, turn the printer off, wait 30 seconds, and then remove the power cable before attempting to service the printer.

---

Use the table below to identify the correct part number for your printer. To order the part, go to [www.hp.com/buy/parts](http://www.hp.com/buy/parts).

---

Formatter FFC part number	
RK2-6931-000CN	Formatter FFC (M427M426)
RK2-6920-000CN	Formatter FFC( M403/M402)

---

### Required tools

- #2 Phillips screwdriver with a magnetic tip.
- 5.5 mm (0.22 inch) socket screwdriver.

### After performing service

#### Turn the printer power on

- Connect the power cable.
- Use the power switch to turn the power on.

### Post service test

Make sure that the printer initializes to a **Ready** state.

Print a configuration page to make sure that the printer is functioning correctly.

### Step 1: Remove Tray 2

- ▲ Pull the tray straight out of the printer to remove it.

**Figure 1-1251** Remove the tray



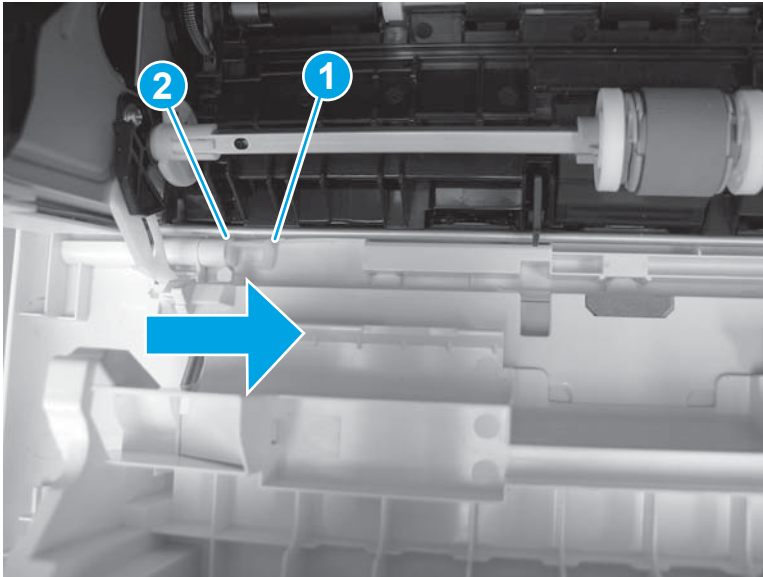
## Step 2: Remove the cartridge door assembly

 **NOTE:** If the toner cartridge was not removed prior to servicing the printer, remove it now.

1. Release one tab (callout 1), and then slide shaft (callout 2) in the direction the arrow indicates and remove it.

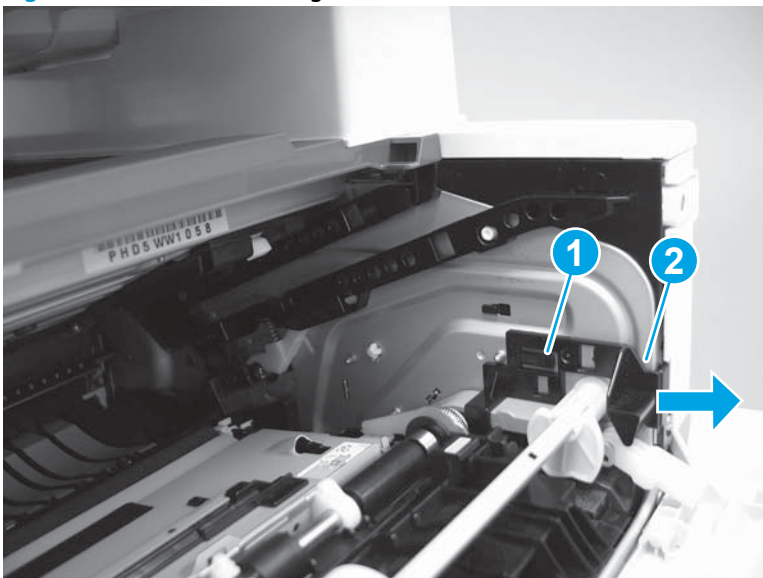
 **TIP:** It might be easier to release the support shaft by using a small flat-blade screwdriver.

**Figure 1-1252** Release the support shaft



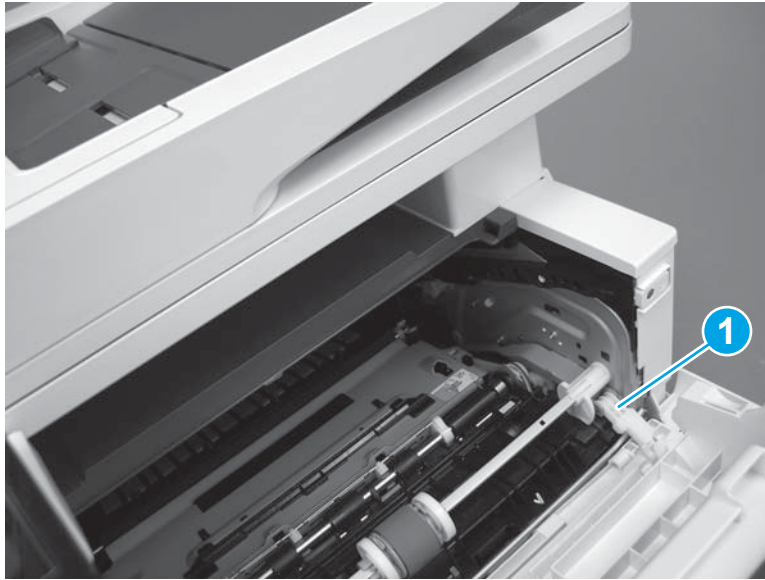
2. Release one tab (callout 1), and then slide the guide (callout 2) in the direction the arrow indicates and remove it.

**Figure 1-1253** Remove the guide



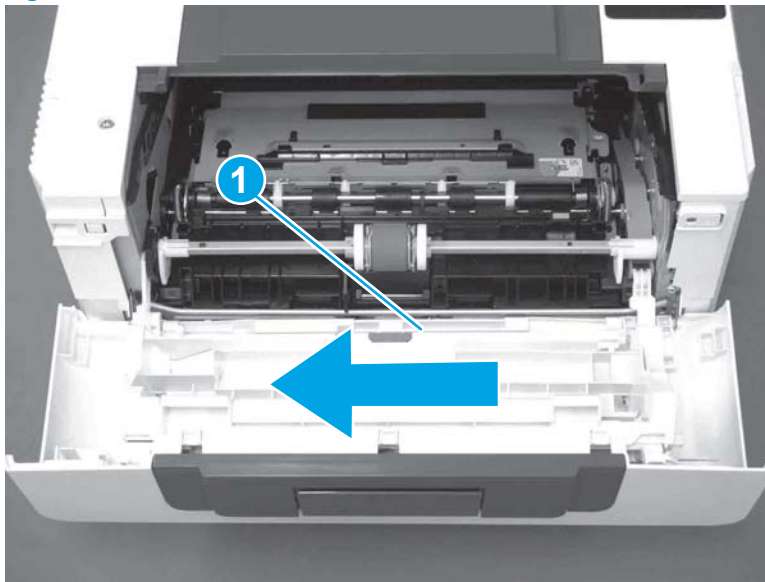
3. Remove the link arm (callout 1).

**Figure 1-1254** Remove the link arm



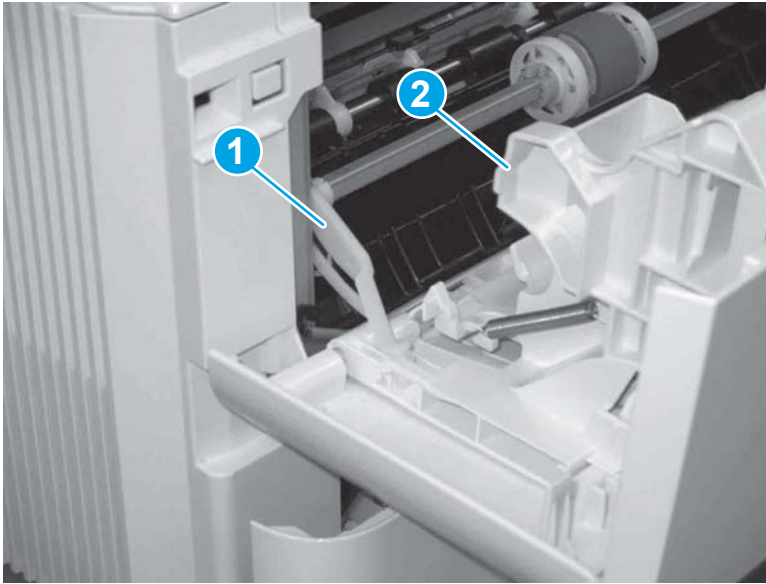
4. Slide the cartridge door assembly (callout 1) in the direction the arrow indicates and remove it.

**Figure 1-1255** Remove the door



5. Remove the link (callout 1) from the cartridge door assembly (callout 2).

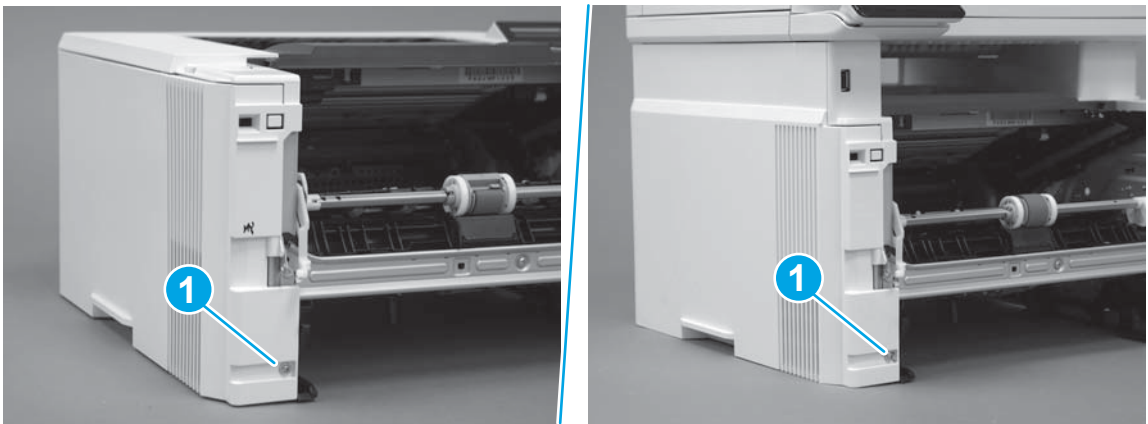
**Figure 1-1256** Release the left-side retainer arm



**Step 3: Remove the left cover**

1. Remove one screw (callout 1).

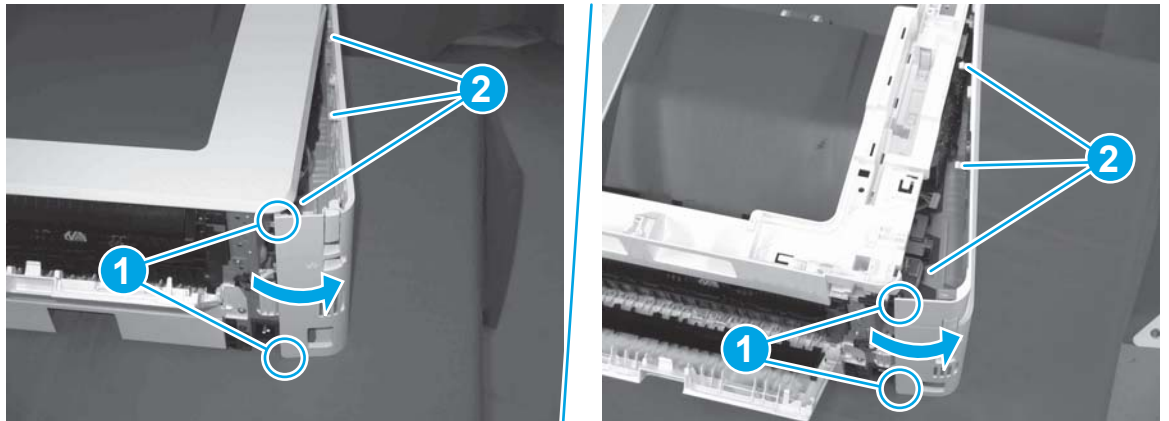
**Figure 1-1257** Remove one screw





2. Open the rear door, release two bosses (callout 1), and then release three tabs (callout 2).

**Figure 1-1258** Release two bosses and three tabs

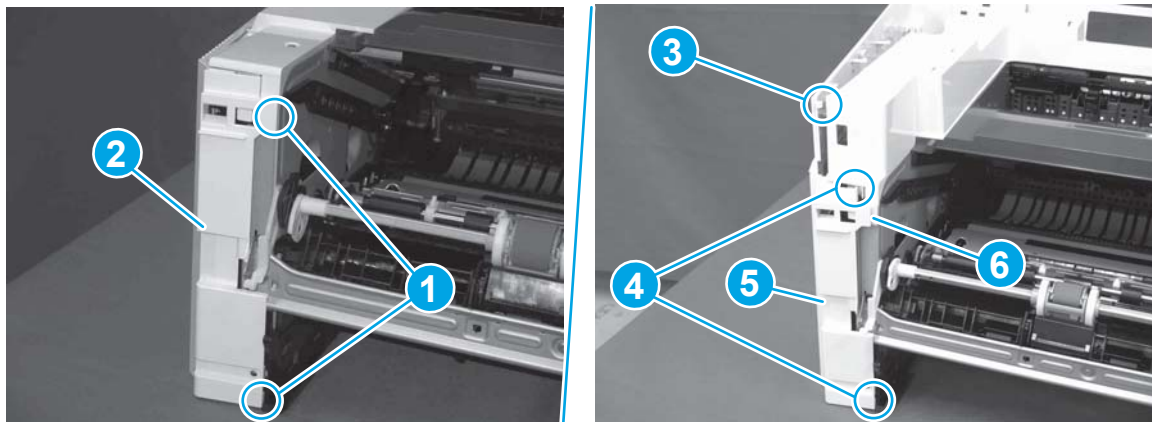


3. At the front of the printer, do one of the following:

- **M403/M402:** Release two bosses (callout 1), and then remove the cover (callout 2).
- **M427/M426:** Release one tab (callout 3), two bosses (callout 4), and then remove the cover (callout 5).

**CAUTION:** Be careful when releasing the upper bosses on the M427/M426 cover. One portion of the cover (callout 6) is fragile and is easily broken.

**Figure 1-1259** Remove the cover



#### Step 4: Remove the right cover

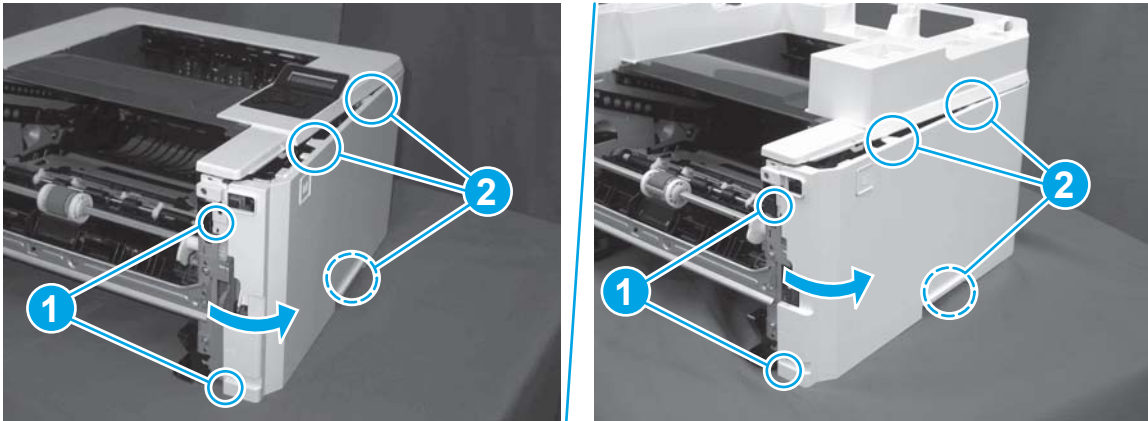
1. Remove one screw (callout 1).

**Figure 1-1260** Remove one screw



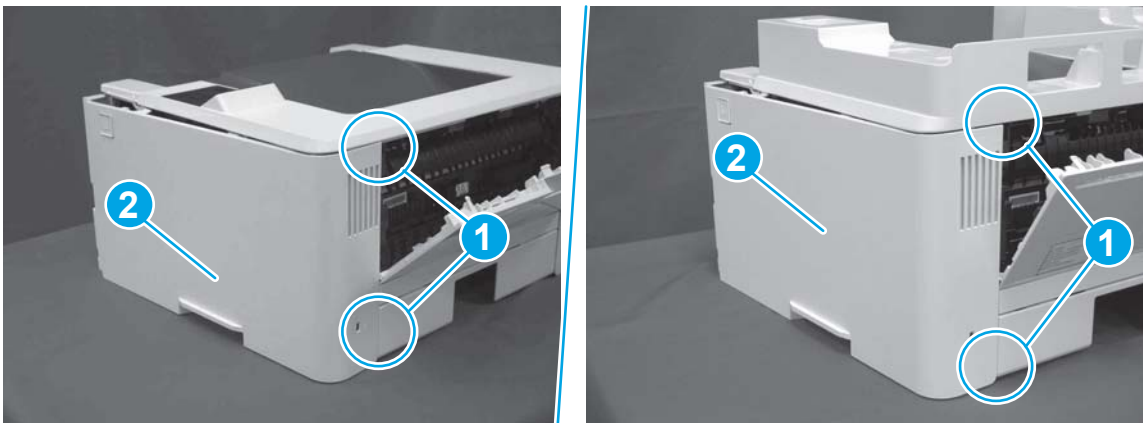
2. At the front of the printer, release two bosses (callout 1), and then release three tabs (callout 2).

**Figure 1-1261** Release two bosses and three tabs



3. Open the rear door, release two bosses (callout 1), and then remove the cover (callout 2).


**Figure 1-1262** Remove the cover



### Step 5: Remove the integrated scanner assembly (M427/M246)

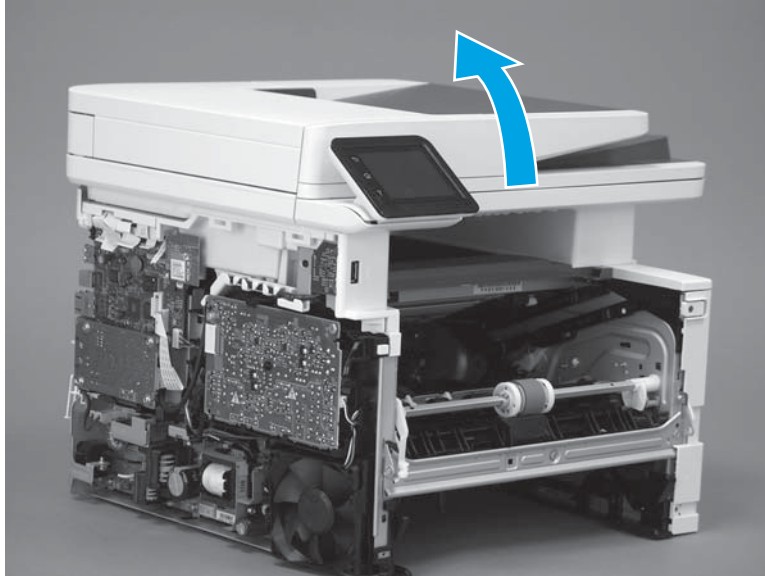


**NOTE:** The step is for the M427/M426 printer. For the M403/M402, skip this step and go to [Step 8: Remove the top cover \(M403/M402\)](#) on page 694.

 **NOTE:** M427/M426 models only. The integrated scanner assembly (ISA) includes the sub-scanner assembly (SSA) and the automatic document feeder (ADF).

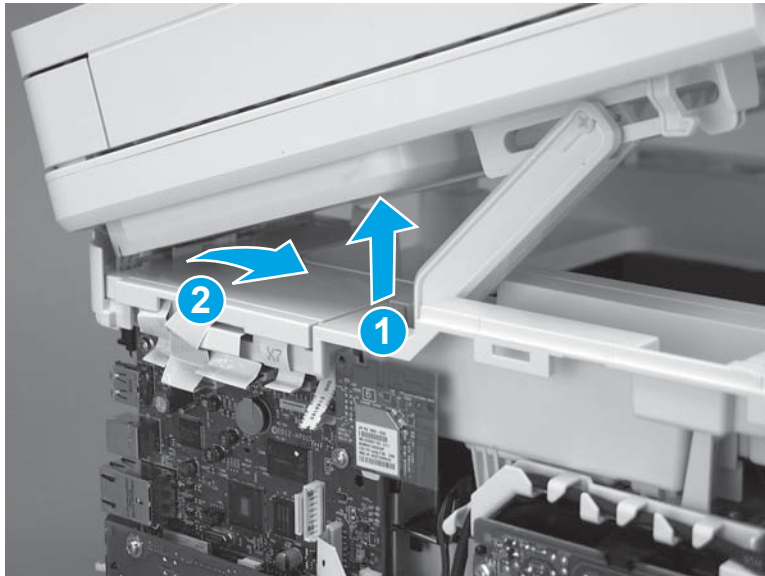
1. Raise the ISA.

**Figure 1-1263** Raise the ISA



2. Release the ISA flat-flexible cable (FFC) cover (callout 1), and then remove it (callout 2).

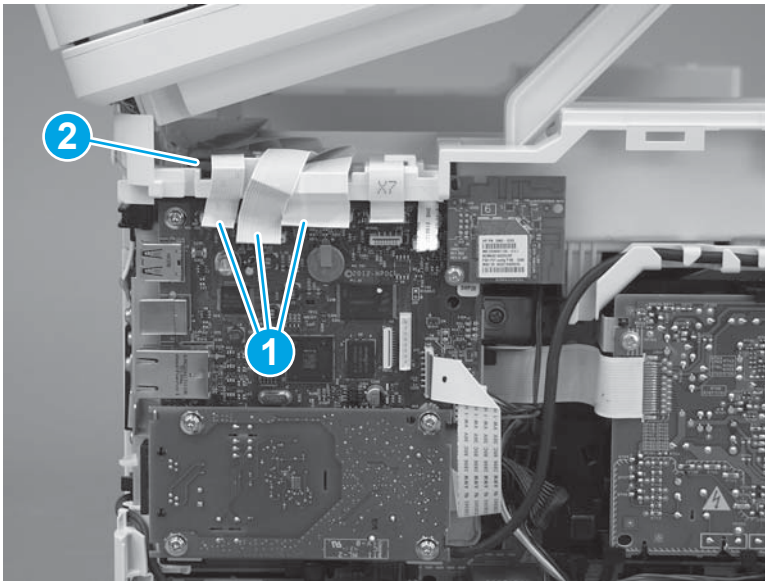
**Figure 1-1264** Remove the ISA FFC cover



3. Disconnect three FFCs (callout 1), and then remove the ferrite (callout 2) from the holder.

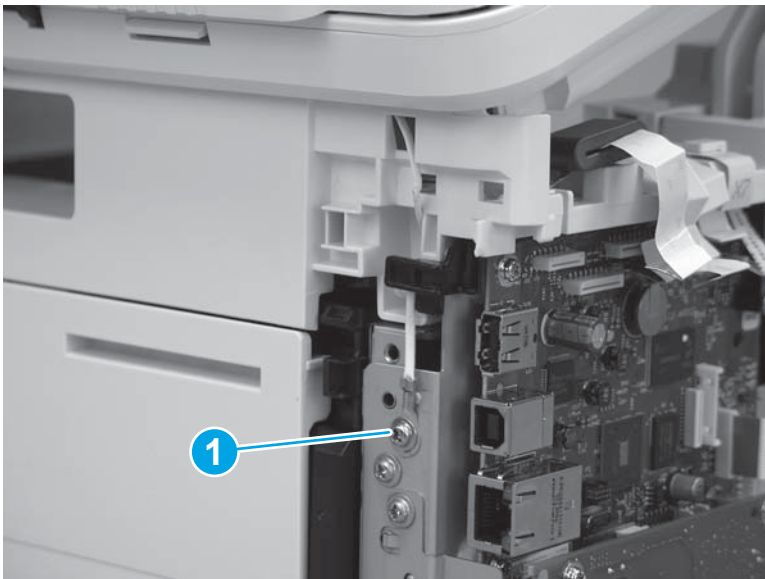
**⚠ CAUTION:** The ferrite is not captive on the FFC. Do not lose the ferrite while handling the ISA.

**Figure 1-1265** Disconnect three FFCs



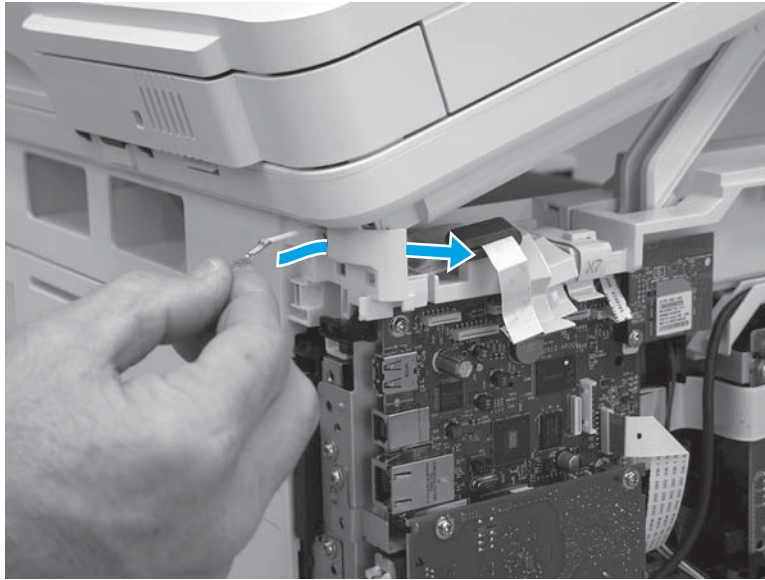
4. Remove one screw (callout 1).

**Figure 1-1266** Remove one screw



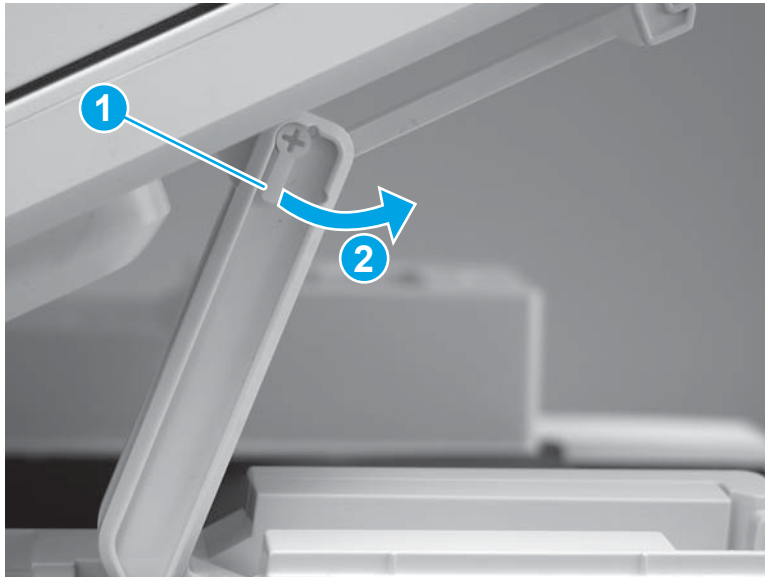
5. Pass the ground wire through the opening in the top cover.

**Figure 1-1267** Pass the wire through the opening



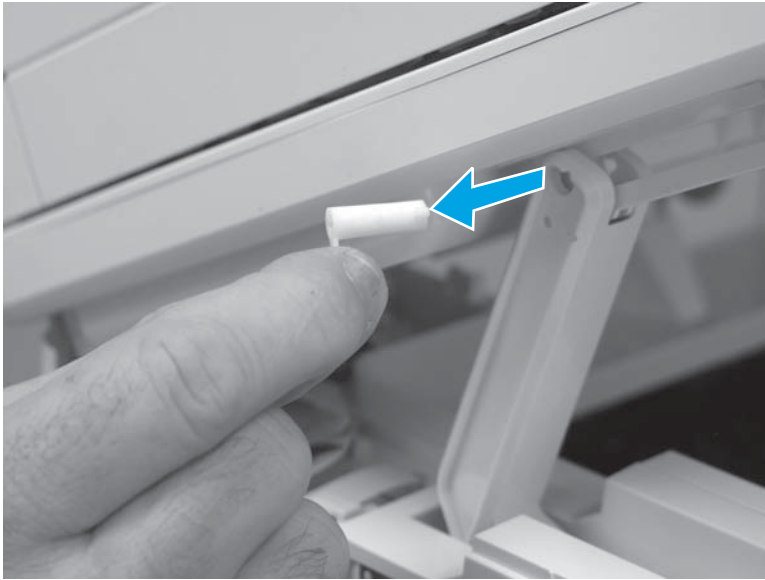
6. Release one tab (callout 1), and then rotate the ISA slider pin (callout 2) towards the front of the printer to release it.

**Figure 1-1268** Release one tab and rotate the slider pin



7. Remove the slider pin.

**Figure 1-1269** Remove the slider pin



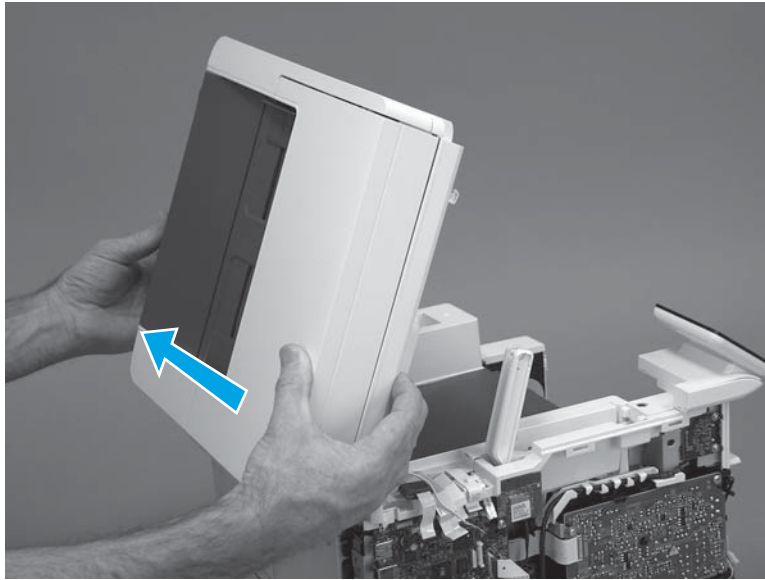
8. Rotate the ISA towards the rear of the printer until it stops.

**Figure 1-1270** Rotate the ISA towards the rear of the printer



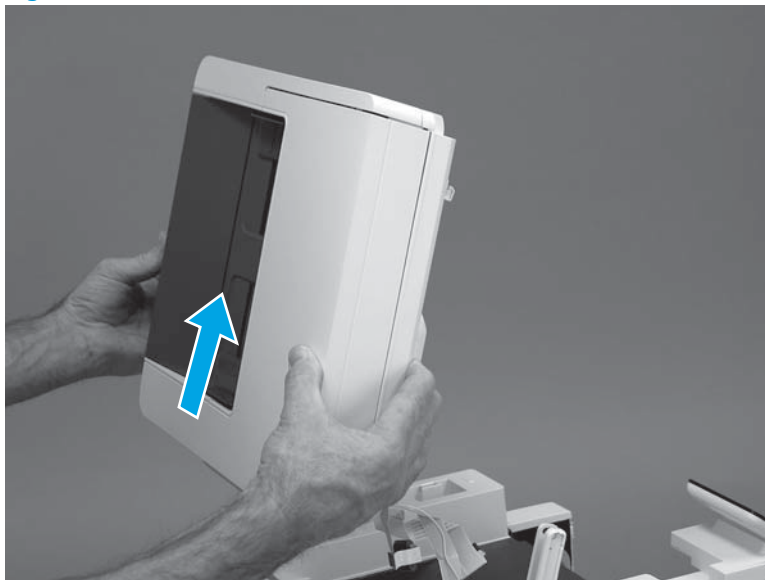
- Slide the ISA as shown to release it.

**Figure 1-1271** Release the ISA




- Remove the ISA.

**Figure 1-1272** Remove the ISA

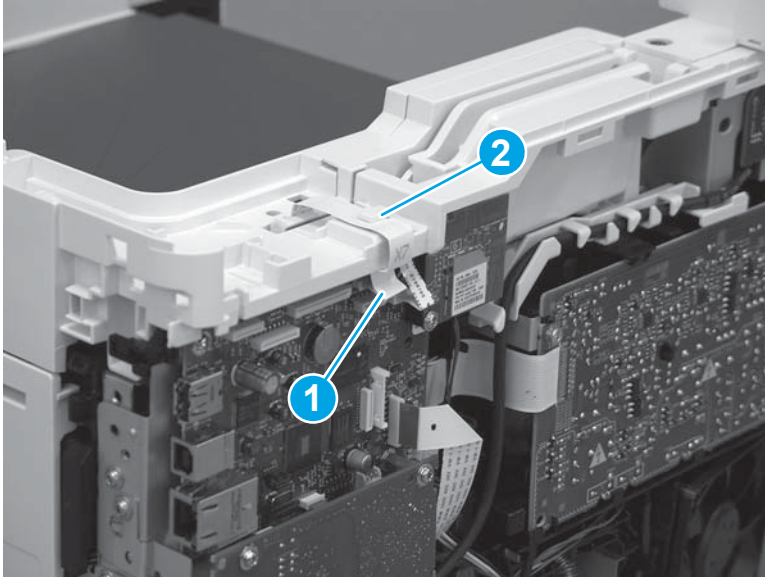


#### Step 6: Remove the control panel (M427/M246)

 **NOTE:** The step is for the M427/M426 printer. For the M403/M402, skip this step and go to [Step 8: Remove the top cover \(M403/M402\) on page 694](#).

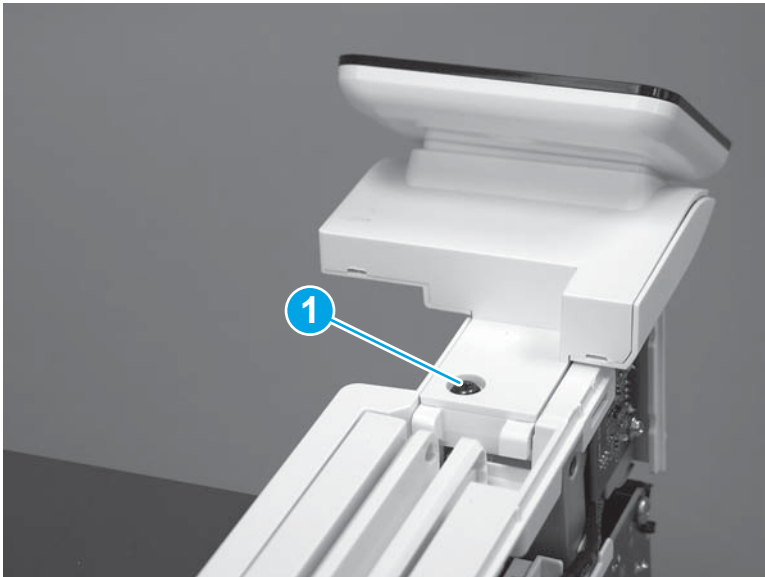
- Disconnect one FFC (callout 1; J114), and then release the FFC from the retainer (callout 2).

**Figure 1-1273** Disconnect one connector



2. Remove one screw (callout 1).

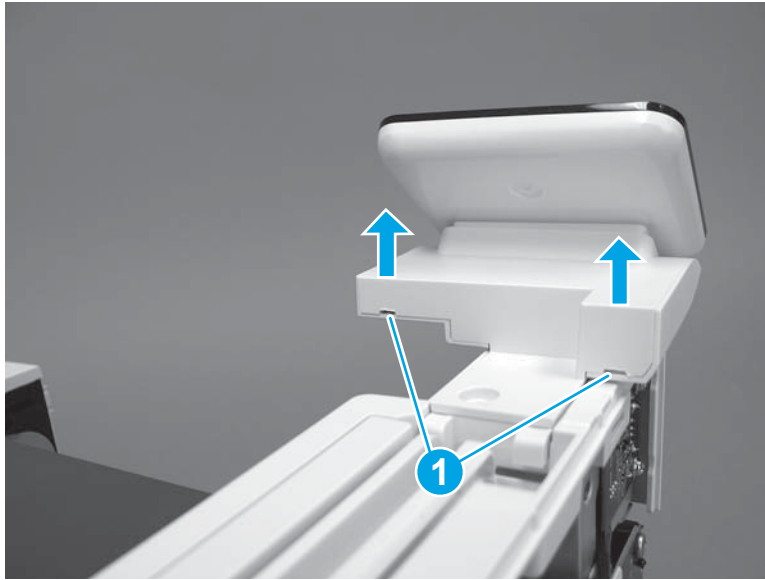
**Figure 1-1274** Remove one screw





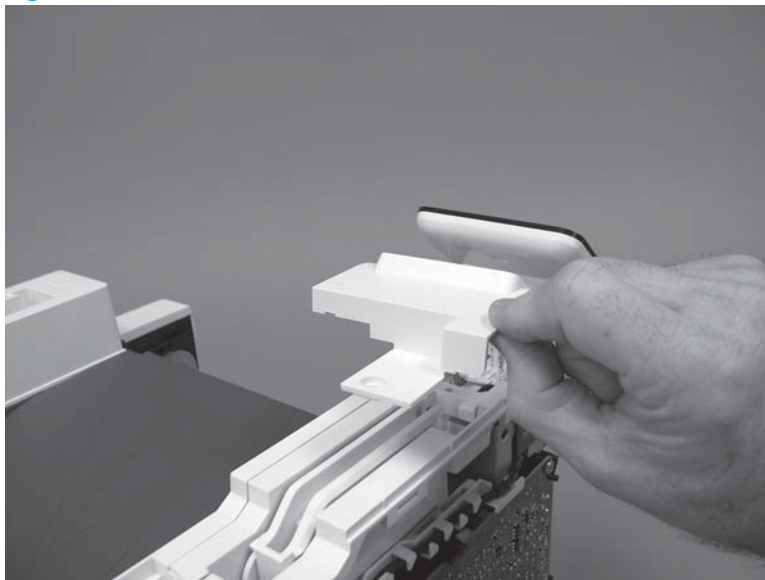
3. Use a small flat-blade screwdriver to release two tabs (callout 1) on the control-panel cable cover.

**Figure 1-1275** Release two tabs



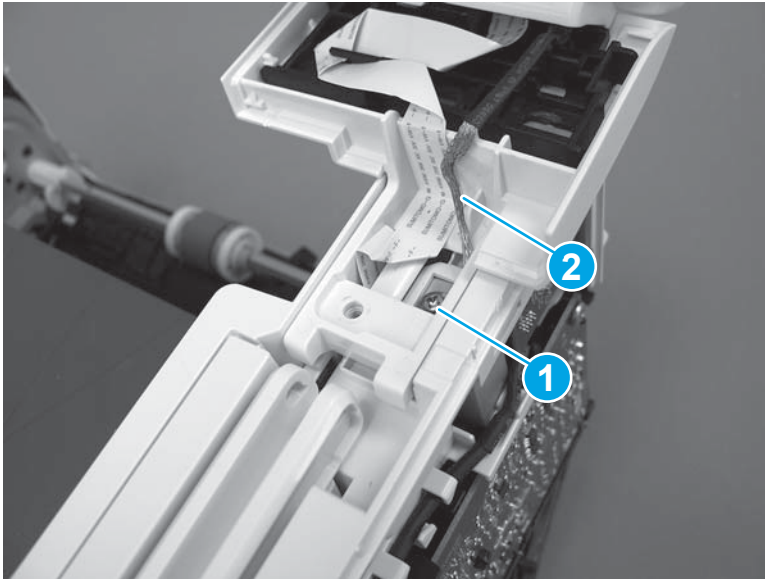
4. Remove the control-panel cable cover.

**Figure 1-1276** Remove the cover



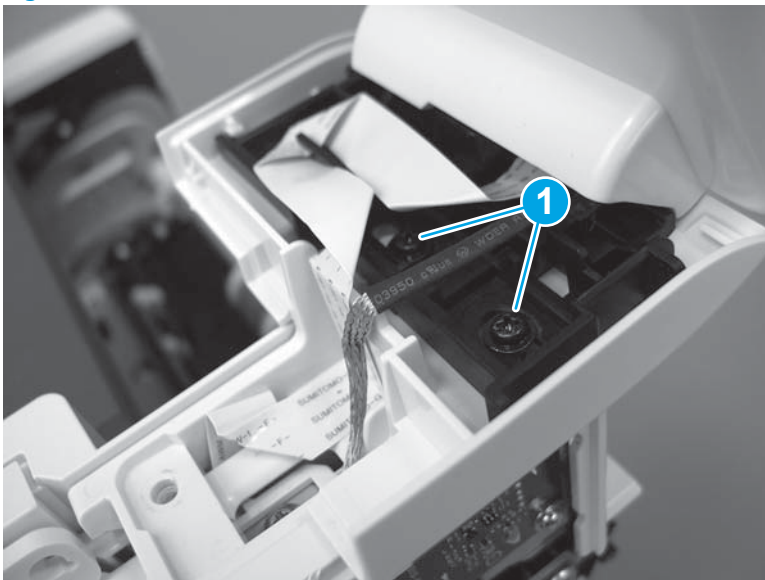
5. Remove one grounding screw (callout 1), and then move the ground cable (callout 2) out of the way.

**Figure 1-1277** Remove one screw



6. Move the FFC out of the way, and then remove two screws (callout 1).

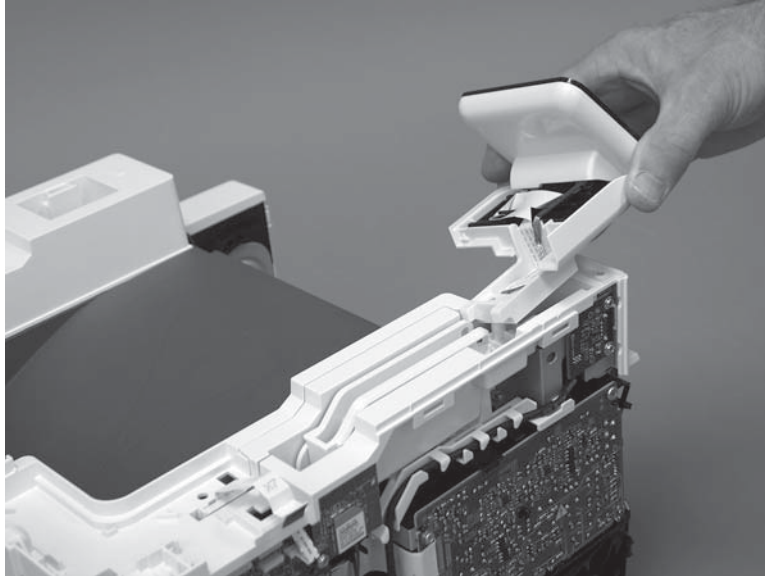
**Figure 1-1278** Remove two screws



7. Slightly lift up the control-panel assembly to separate it from the top cover.

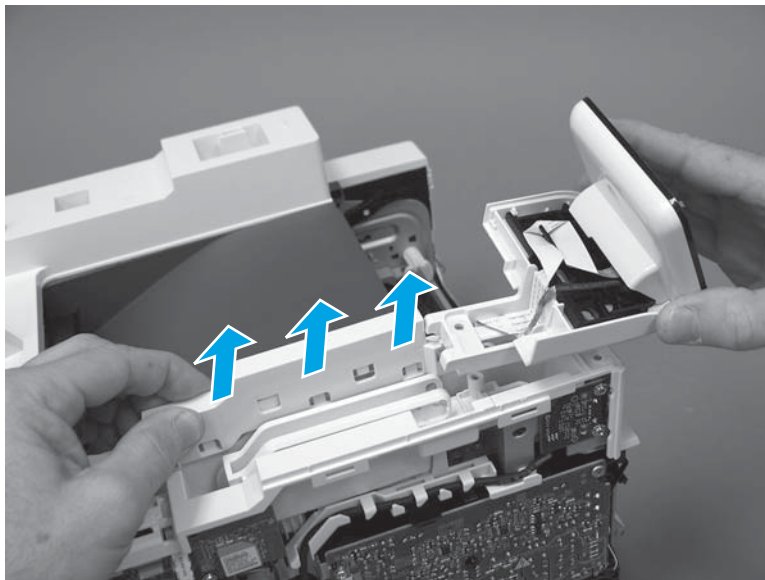
**CAUTION:** The control panel assembly is still connected to the printer by the FFC. Do not attempt to completely remove the assembly.

**Figure 1-1279** Lift up the control-panel assembly



8. Lift up the control-panel FFC cover to remove the control-panel assembly.

**Figure 1-1280** Remove the control-panel assembly

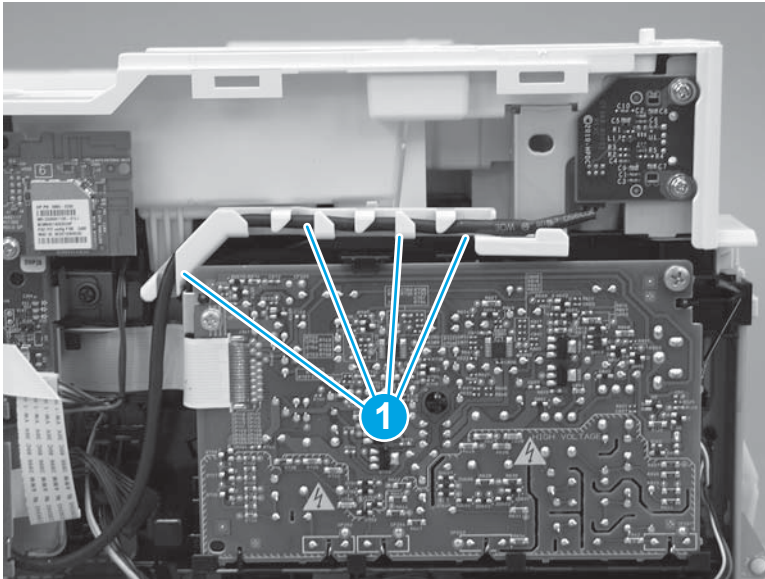


### Step 7: Remove the top cover (M427/M426)

**NOTE:** The step is for the M427/M426 printer. For the M403/M402, skip this step and go to [Step 8: Remove the top cover \(M403/M402\) on page 694](#).

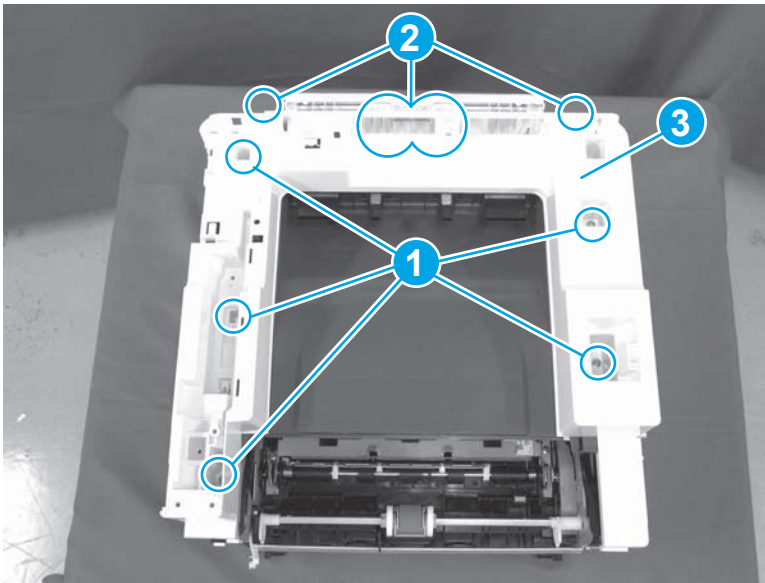
1. Release the USB cable (callout 1) from the cable guide.

**Figure 1-1281** Remove the USB cable



2. Remove five screws (callout 1), release four bosses (callout 2), and then remove the top cover (callout 3).

**Figure 1-1282** Remove the cover



### Step 8: Remove the top cover (M403/M402)

 **NOTE:** The step is for the M403/M402 printer. For the M427/M426, skip this step and go to [Step 9: Remove the sheet-metal formatter bracket and formatter PCA on page 696.](#)

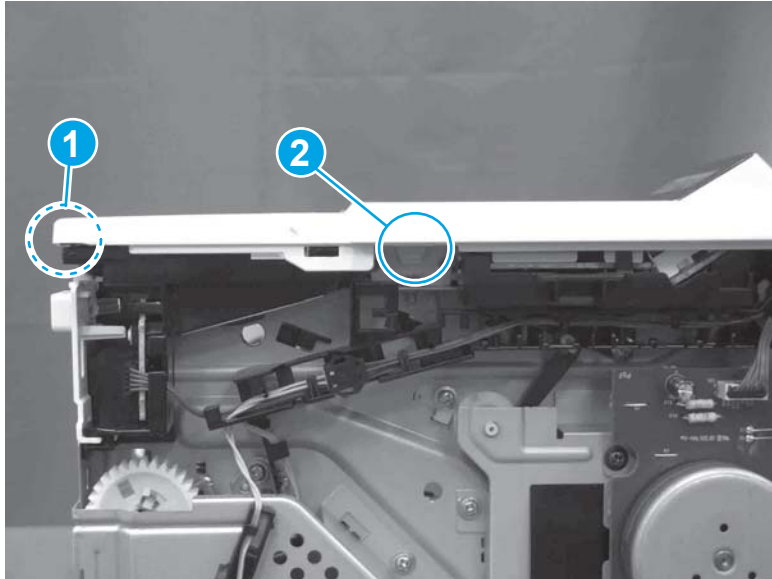
1. Remove one screw (callout 1).

**Figure 1-1283** Remove one screw




2. At the right side of the printer, release the one boss (callout 1), and then release one tab (callout 2).

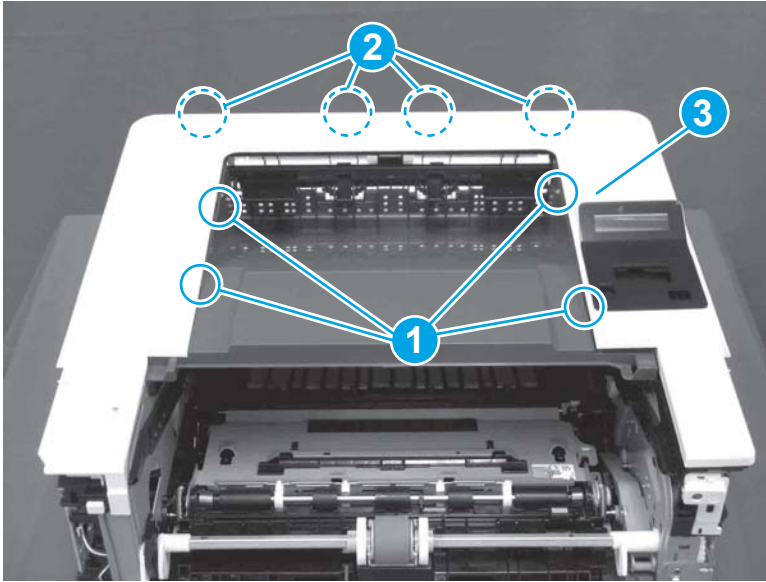
**Figure 1-1284** Release one boss and one tab



3. Release four tabs (callout 1), release four bosses (callout 2), and then remove the top cover (callout 3).

 **TIP:** Open the rear door to make releasing the bosses (callout 3) easier.

**Figure 1-1285** Remove the cover

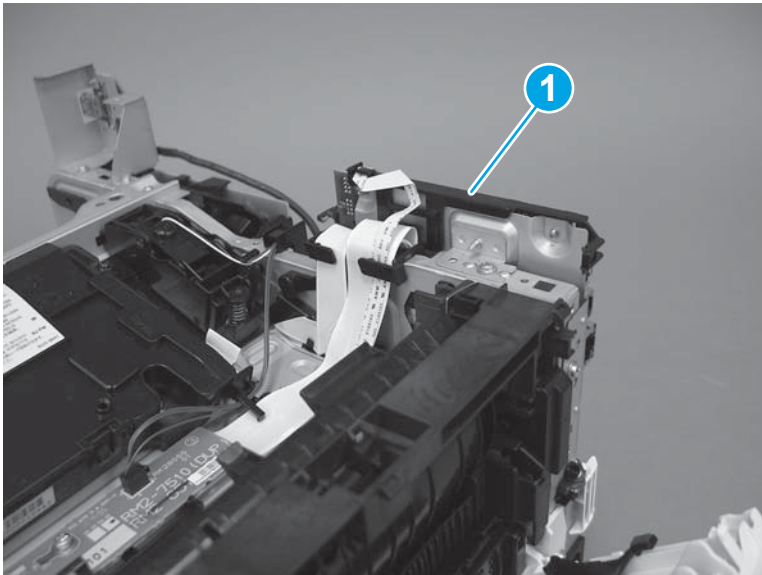


### Step 9: Remove the sheet-metal formatter bracket and formatter PCA

 **NOTE:** Disconnect any remaining formatter PCA FFCs or wire-harness connectors.

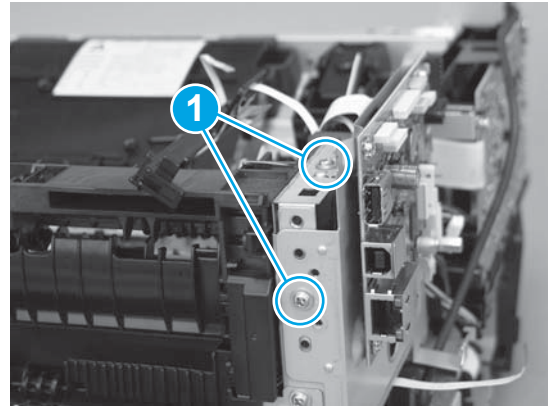
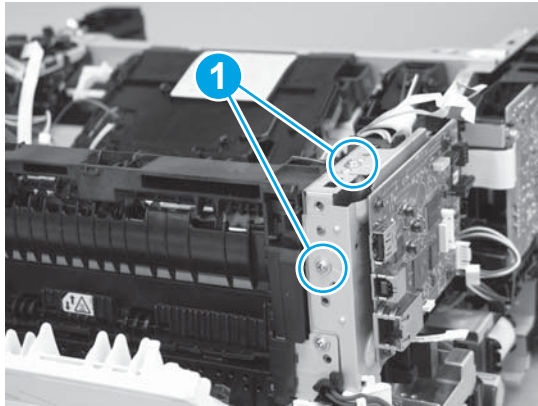
1. **M427/M426 only:** Remove the guide (callout 1).

**Figure 1-1286** Remove the guide



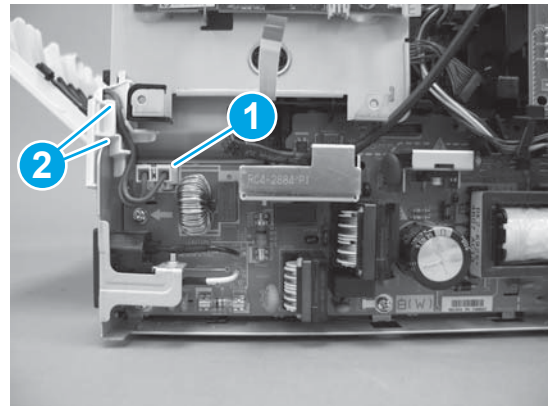
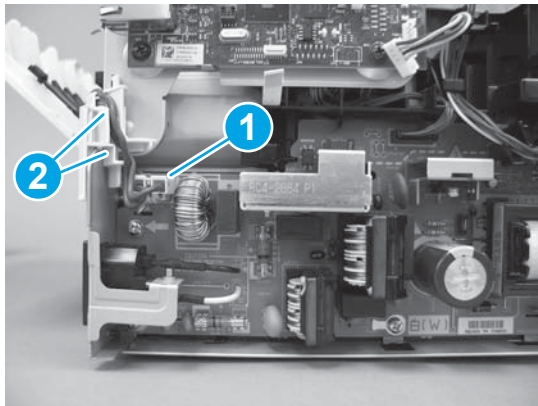
2. Remove two screws (callout 1).

**Figure 1-1287** Remove two screws



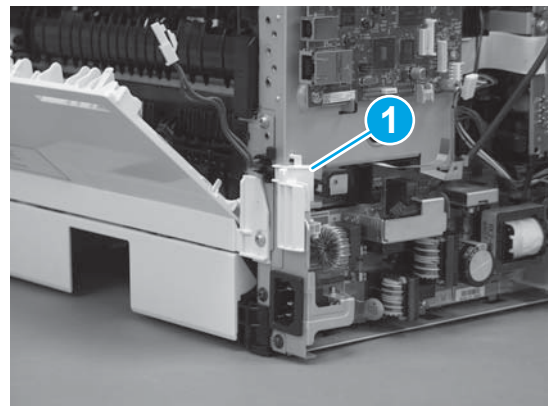
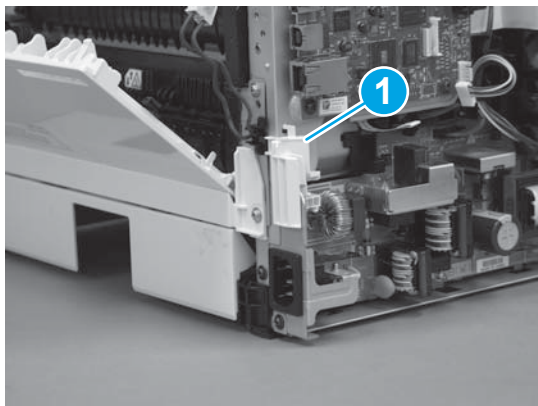
3. Disconnect one connector (callout 1), and then release the wire harness from the guide (callout 2).

**Figure 1-1288** Disconnect one connector



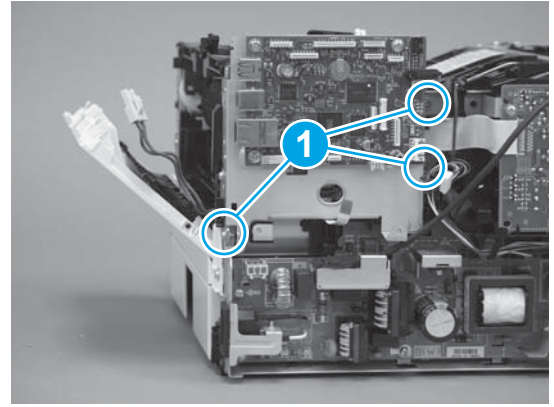
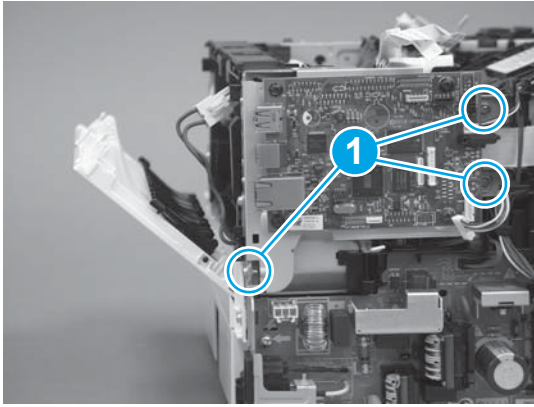
4. Remove the guide (callout 1).

**Figure 1-1289** Remove the guide



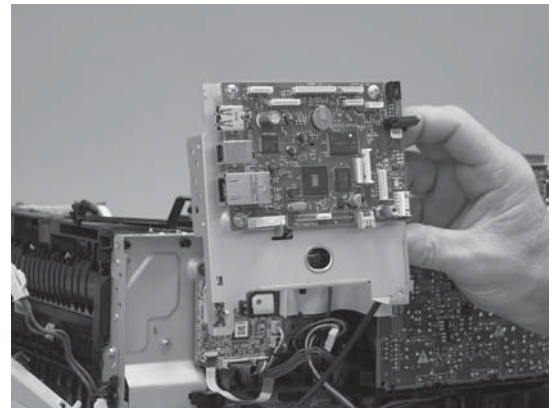
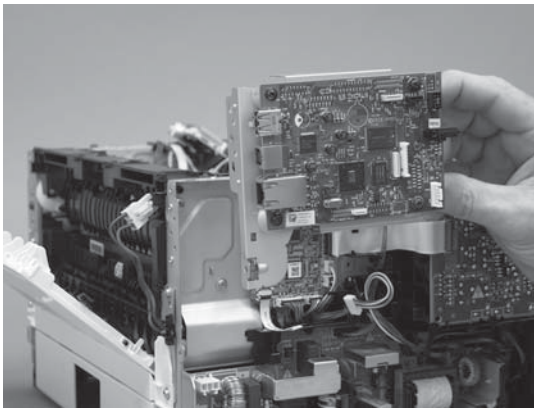
5. Remove three screws (callout 1).

**Figure 1-1290** Remove three screws



6. Remove the sheet-metal bracket and formatter PCA.

**Figure 1-1291** Remove the bracket



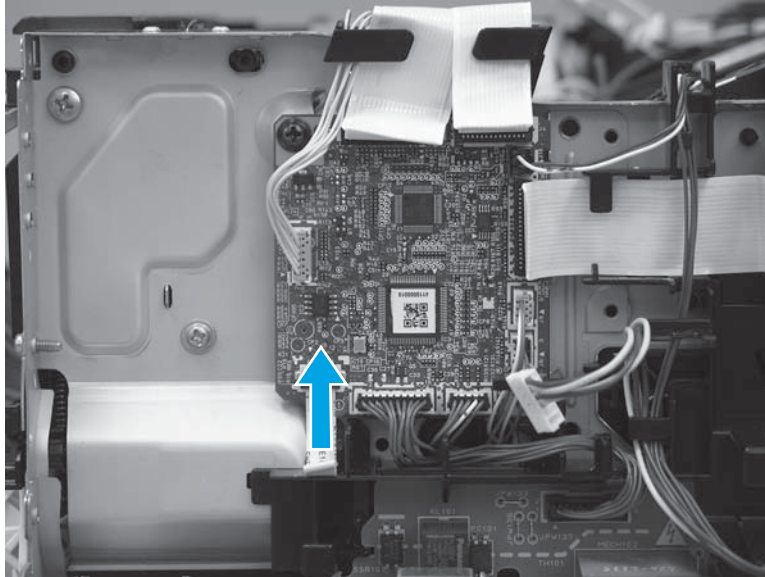
### Step 10: Remove the formatter FFC

1. Carefully pull up on the FFC (callout 1) to release it from the guide—the FFC is attached to the guide with two-sided tape.


**CAUTION:** The FFC is still attached to the DC controller. Do not attempt to completely remove the FFC.



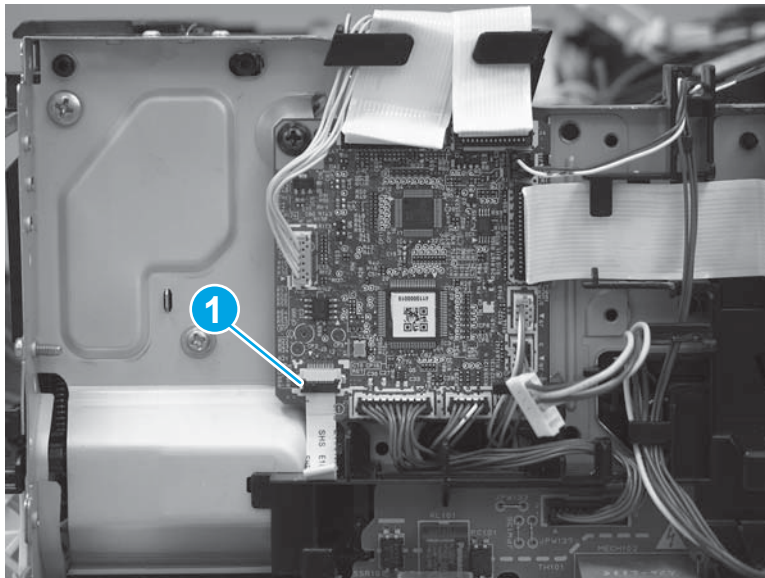
**Figure 1-1292** Release the FFC



2. Disconnect the formatter FFC (callout 1).

 **IMPORTANT:** The FFC connector (callout 2) is a Zero Insertion Force (ZIF) connector that uses a hinged retainer to secure the FFC. The hinged retainer must be opened to release the FFC.

**Figure 1-1293** Disconnect the FFC



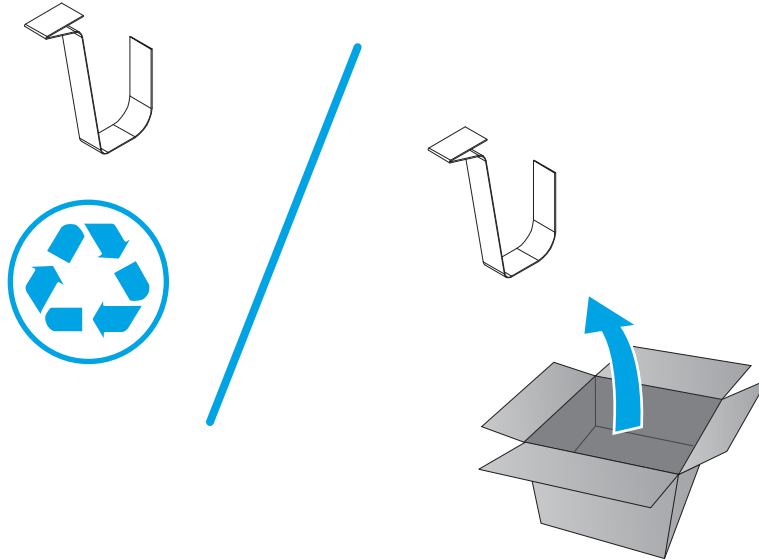
### Step 11: Unpack the replacement assembly

Unpack the replacement part from the packaging.

<http://www8.hp.com/us/en/hp-information/environment/product-recycling.html>

 **NOTE:** HP recommends responsible disposal of the defective part.

**Figure 1-1294** Recycle and unpack




### Step 12: Install the formatter FFC

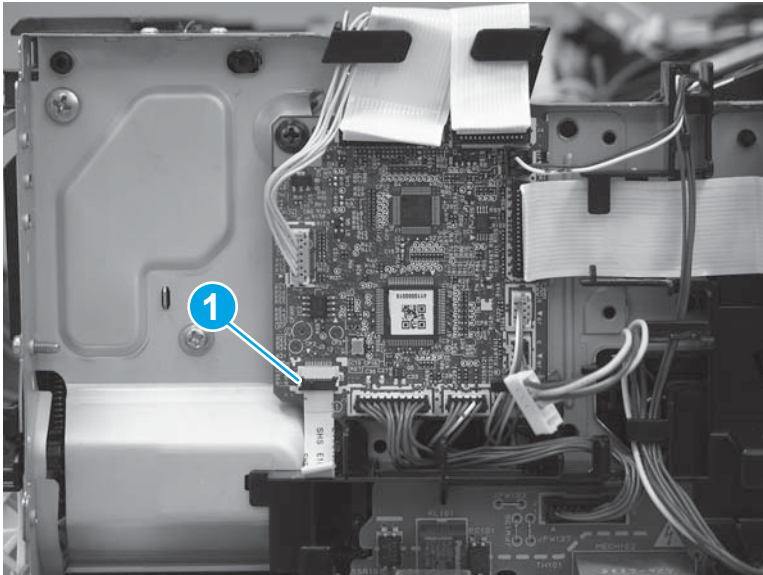
1. Connect the formatter FFC (callout 1) to the DC controller connector (callout 2).

Make sure that the FFC is fully inserted into the connector body, close the hinged retainer to lock the cable in place, and then slightly tug on the cable to make sure it is securely fastened.


 **IMPORTANT:** The ZIF connector hinged retainer must be in the open position to insert the FFC.

 **Reinstallation tip:** The pre-fold end of the FFC will connect to the formatter PCA.

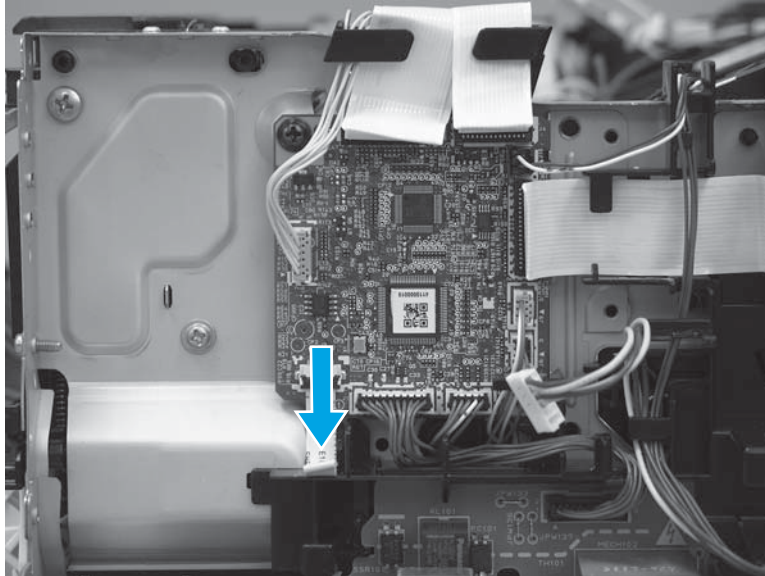
**Figure 1-1295** Connect one the FFC




- Carefully push on the FFC (callout 1) to adhere it to the guide.

 **Reinstallation tip:** Use the discarded FFC as a guide to apply a small section of two-sided tape to the replacement FFC.

**Figure 1-1296** Adhere the FFC to the guide

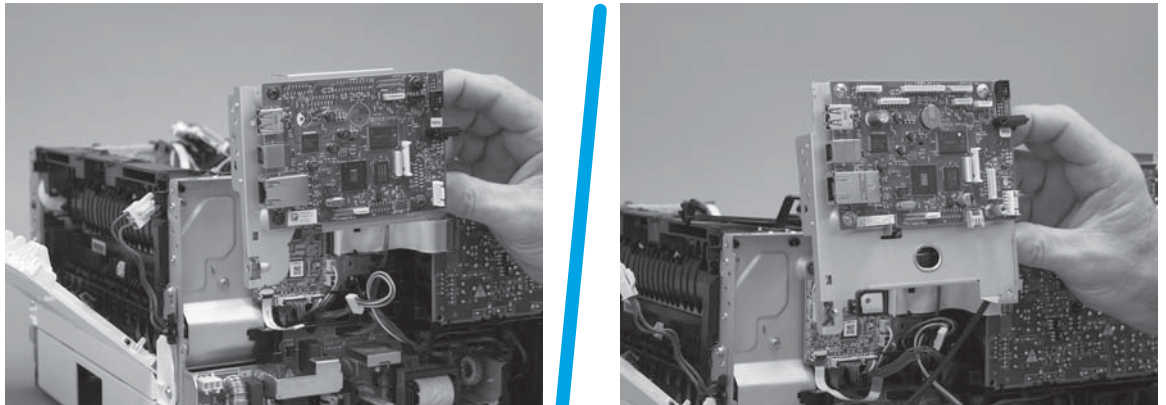


### Step 13: Install the sheet-metal formatter bracket and formatter PCA

 **NOTE:** Do not forget to connect any formatter PCA FFCs or wire-harness connectors that were disconnected when the bracket was removed.

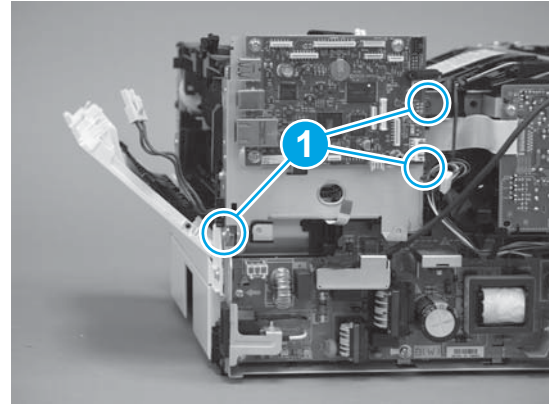
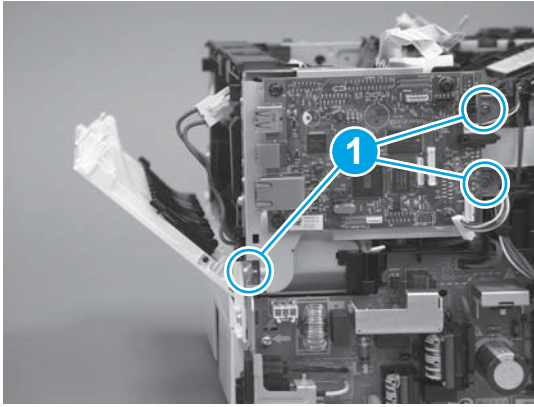
- Position the sheet-metal bracket and formatter PCA on the printer.

**Figure 1-1297** Install the bracket



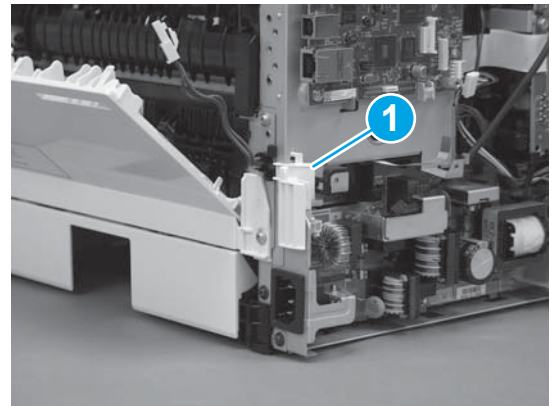
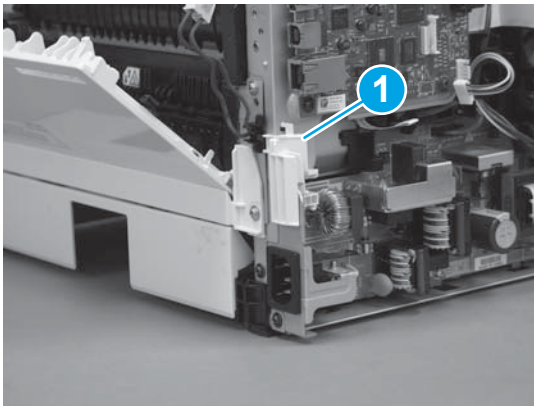
2. Install three screws (callout 1).

**Figure 1-1298** Install three screws



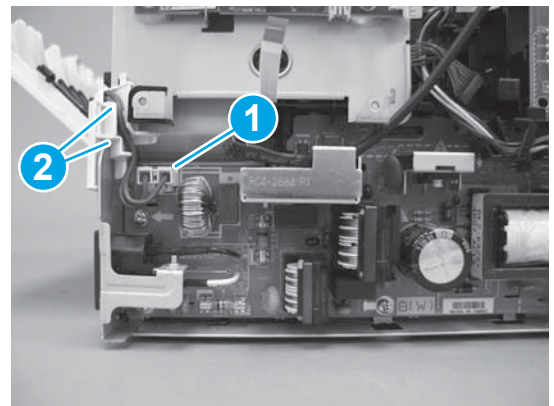
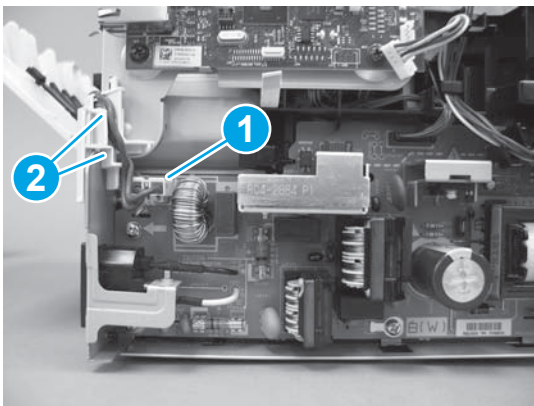
3. Install the guide (callout 1).

**Figure 1-1299** Install the guide



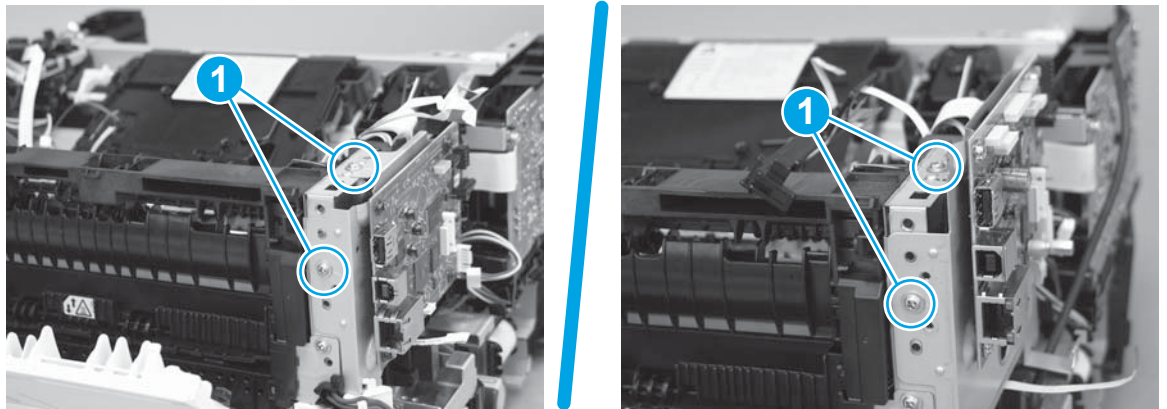
4. Connect one connector (callout 1), and then install the wire harness in the guide (callout 2).

**Figure 1-1300** Connect one connector



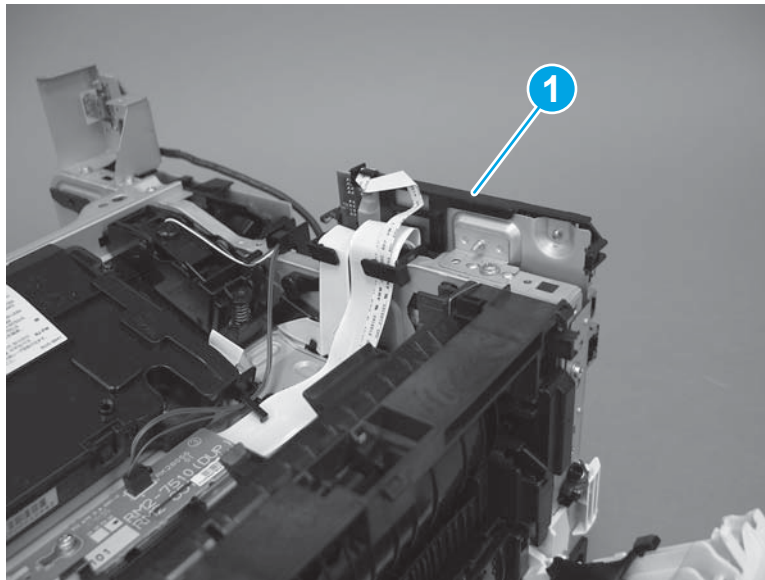
5. Install two screws (callout 1).

**Figure 1-1301** Install two screws




6. **M427/M426 only:** Install the guide (callout 1).

**Figure 1-1302** Install the guide

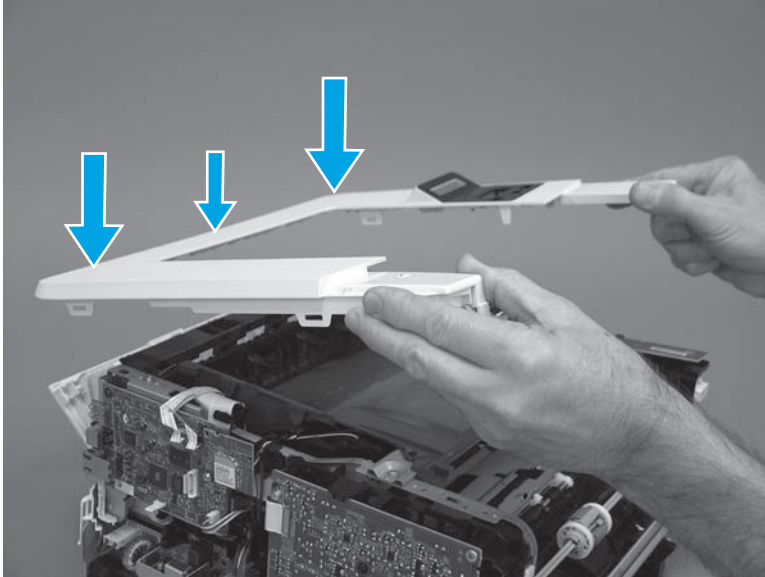


#### Step 14: Install the top cover (M403/M402)

 **NOTE:** The step is for the M403/M402 printer. For the M427/M426, skip this step and go to [Step 15: Install the top cover \(M427/M426\) on page 705](#).

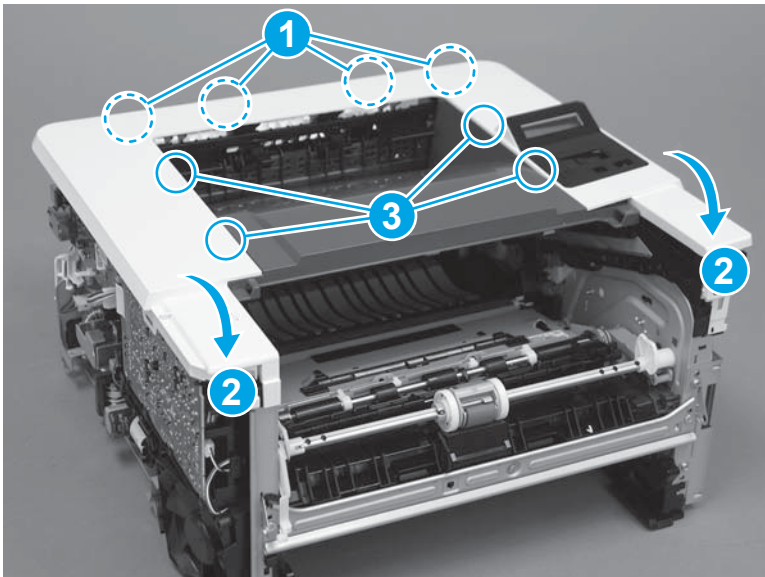
1. Position the rear edge of the cover on the printer.

**Figure 1-1303** Install the cover



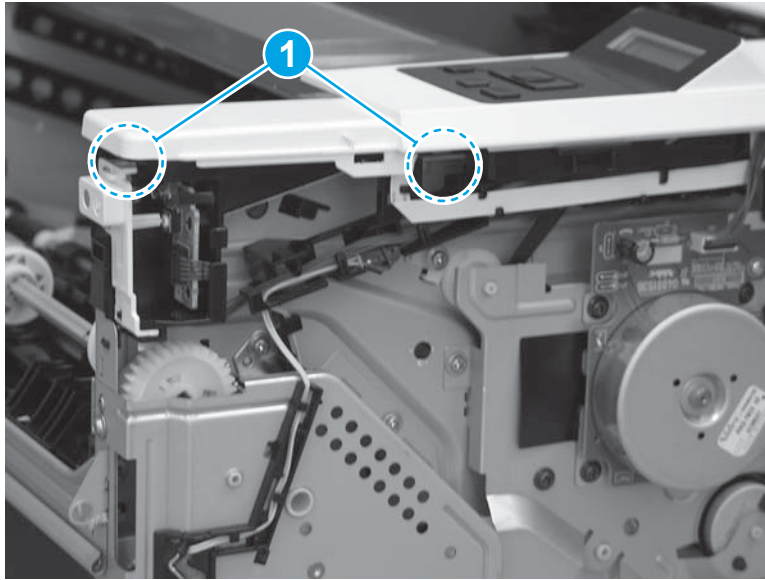
2. Engage four bosses (callout 1), rotate the front of the cover down (callout 2) and onto from the printer, and then engage four tabs (callout 3).

**Figure 1-1304** Engage four bosses and tabs



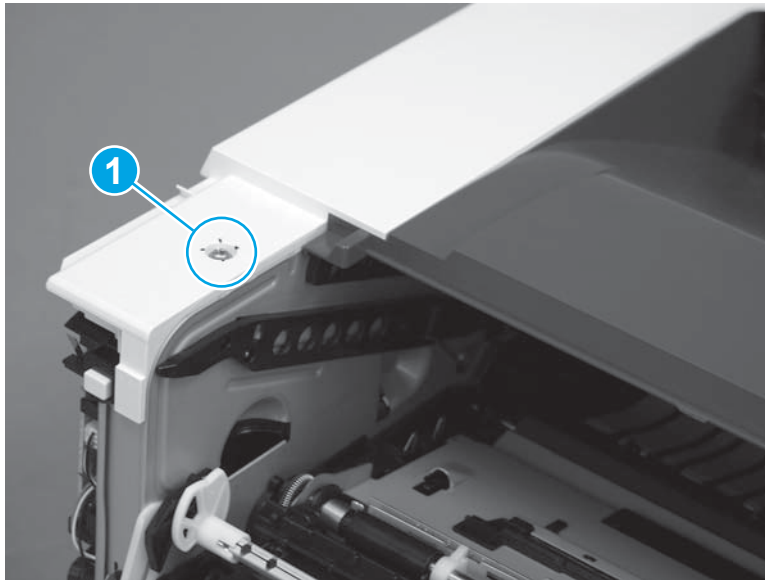
3. At the right side of the printer, engage the one boss and one tab (callout 1).

**Figure 1-1305** Engage one boss and one tab




4. Install one screw (callout 1).

**Figure 1-1306** Install one screw

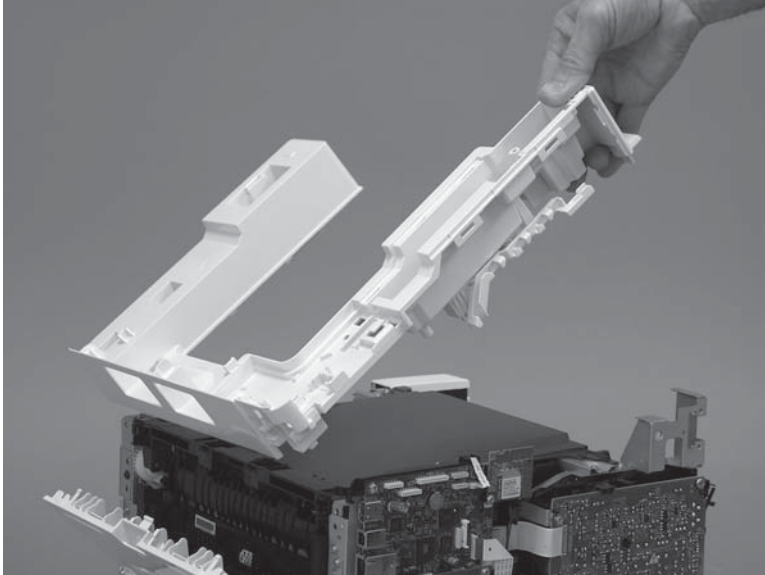


### Step 15: Install the top cover (M427/M426)

 **NOTE:** The step is for the M427/M426 printer. For the M403/M402, skip this step and go to [Step 18: Install the right cover on page 717](#).

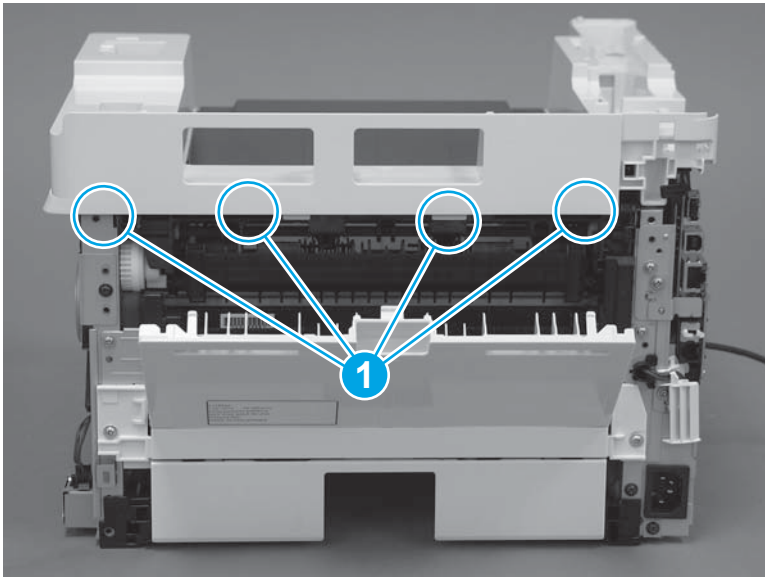
1. Position the rear edge of the top cover on the printer.

**Figure 1-1307** Install the cover



2. Engage four bosses (callout 1).

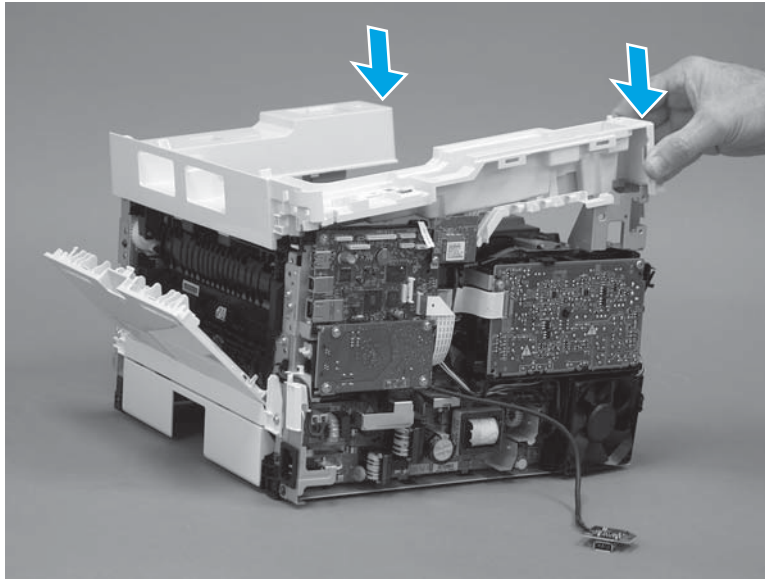
**Figure 1-1308** Engage four bosses





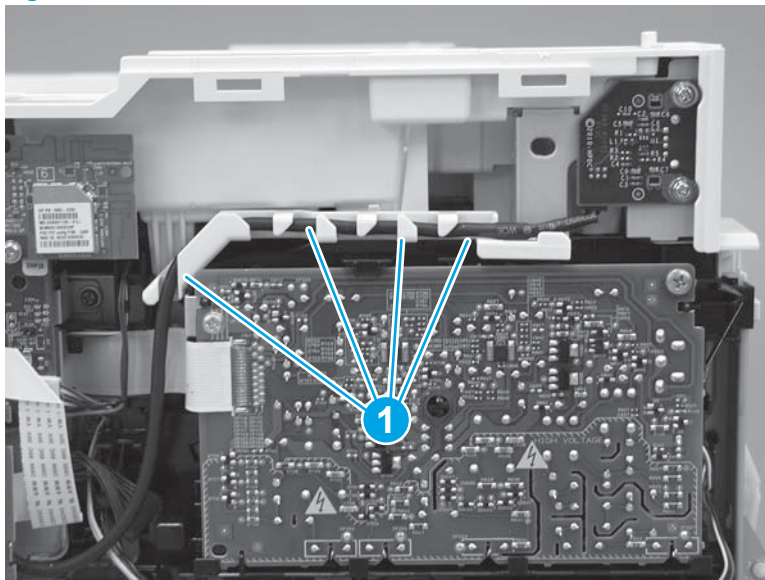
3. Rotate the front edge of the cover down.

**Figure 1-1309** Rotate the front edge of the cover down



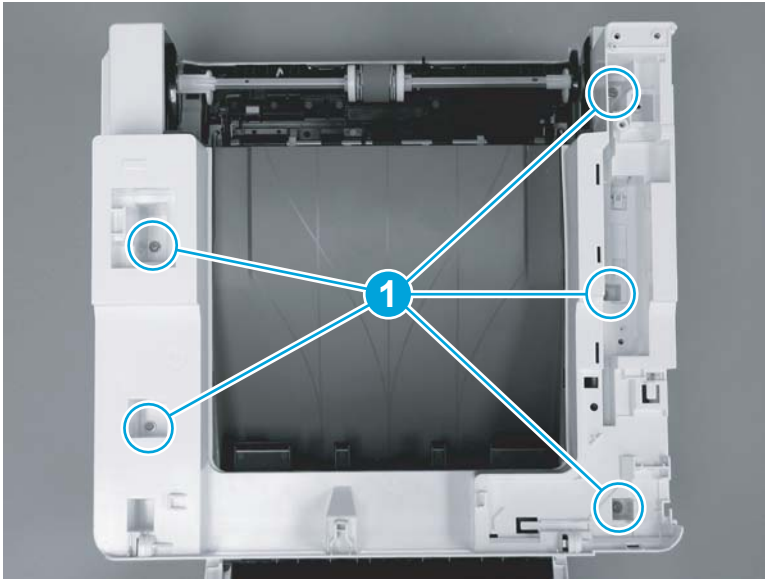
4. Install the USB cable (callout 1) in the guide.

**Figure 1-1310** Install the USB PCA




5. Install five screws (callout 1).

**Figure 1-1311** Install five screws

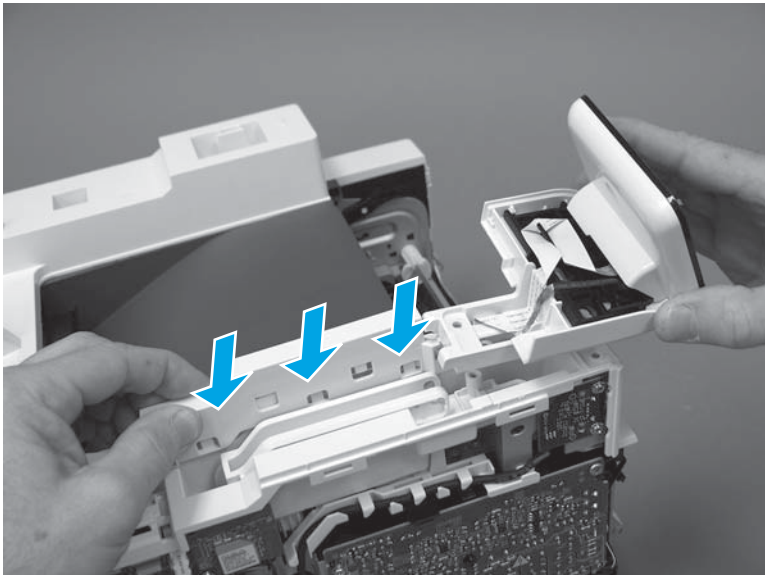


#### Step 16: Install the control panel (M427/M246)

 **NOTE:** The step is for the M427/M426 printer. For the M403/M402, skip this step and go to [Step 18: Install the right cover on page 717](#).

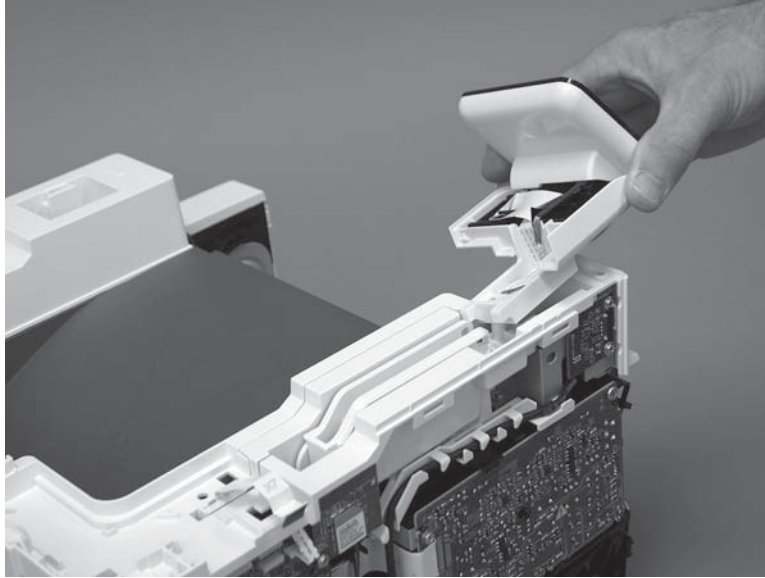
1. Slide the control-panel FFC cover into the slot in the top cover (next to the document feeder support arm) to install it.

**Figure 1-1312** Install the control-panel FFC cover



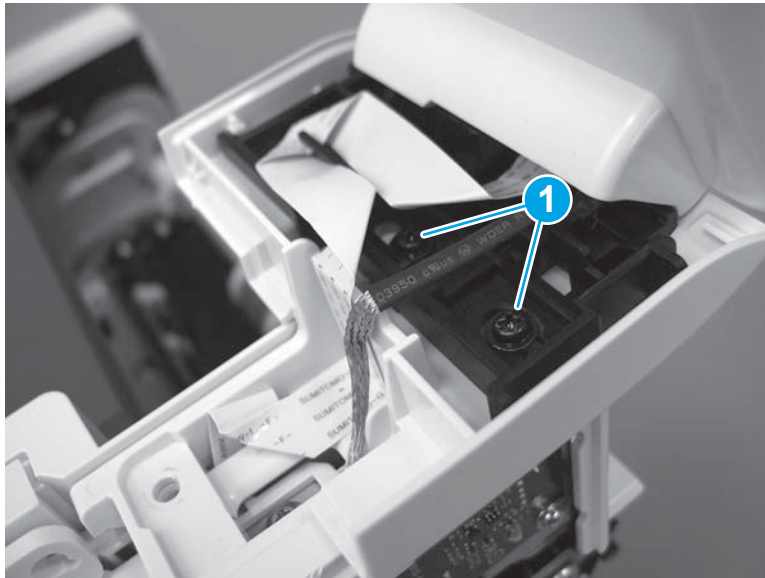
2. Install the control-panel assembly on the top cover.

**Figure 1-1313** Install the control-panel assembly



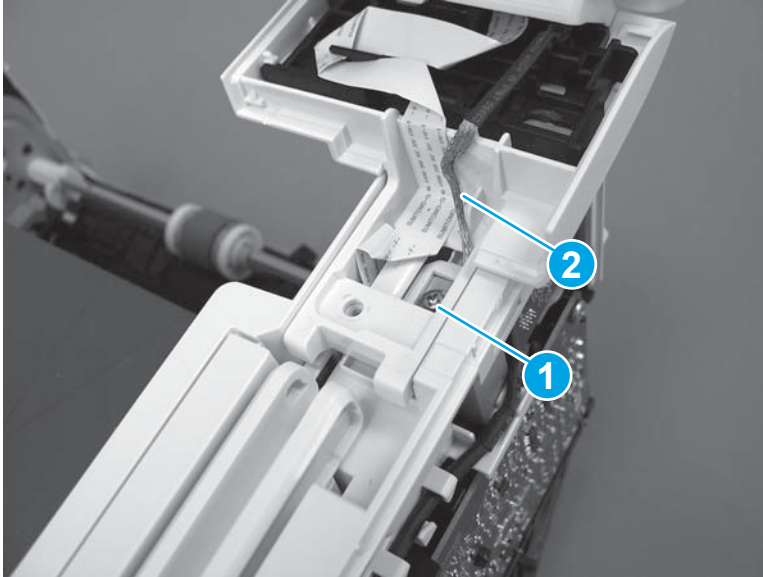
3. Move the FFC out of the way, and then install two screws (callout 1).

**Figure 1-1314** Install two screws



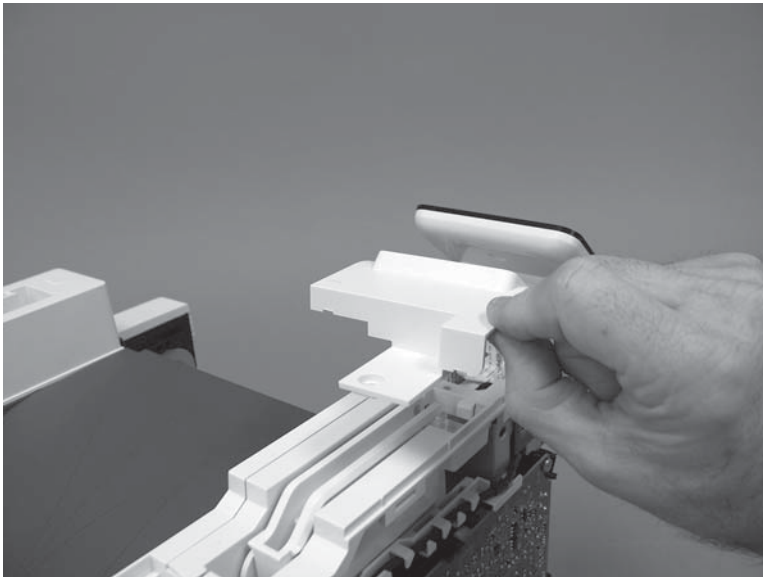
4. Install one grounding screw (callout 1), and then make sure that the ground cable (callout 2) is properly routed.

**Figure 1-1315** Remove one screw



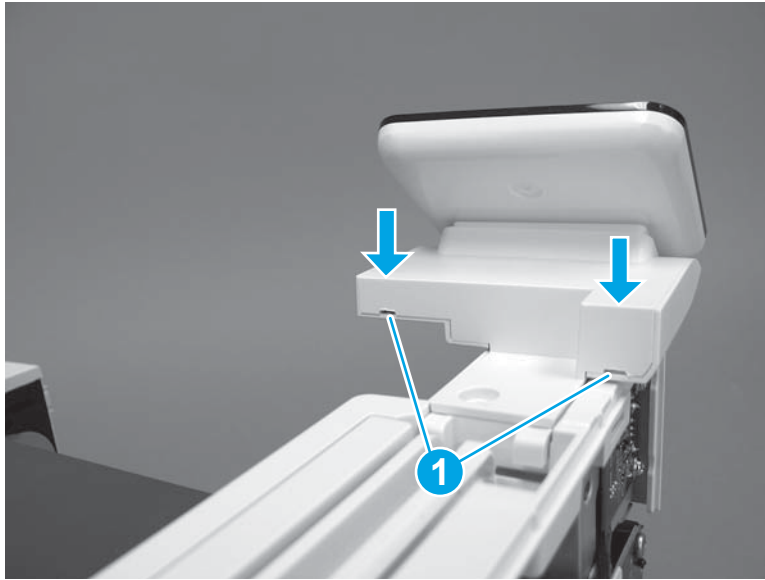
5. Install the control-panel cable cover.

**Figure 1-1316** Install the cover



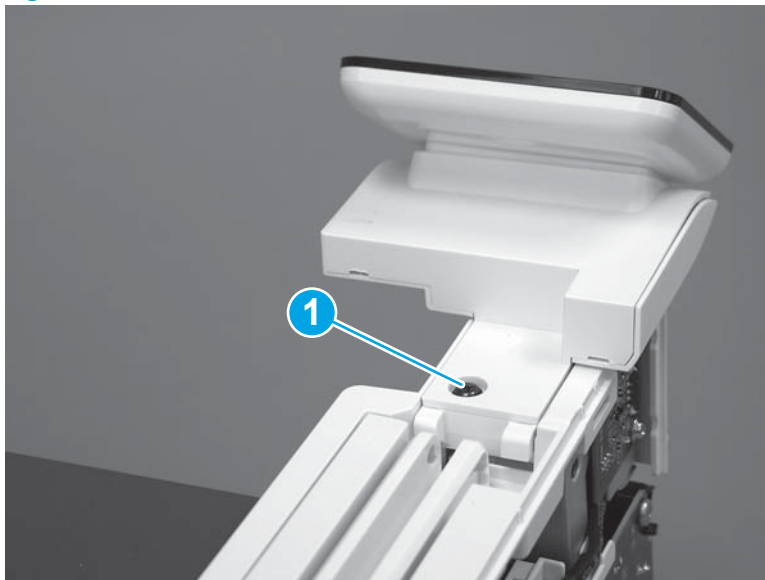
6. Make sure that the two tabs (callout 1) on the cover snap into place.

**Figure 1-1317** Engage two tabs



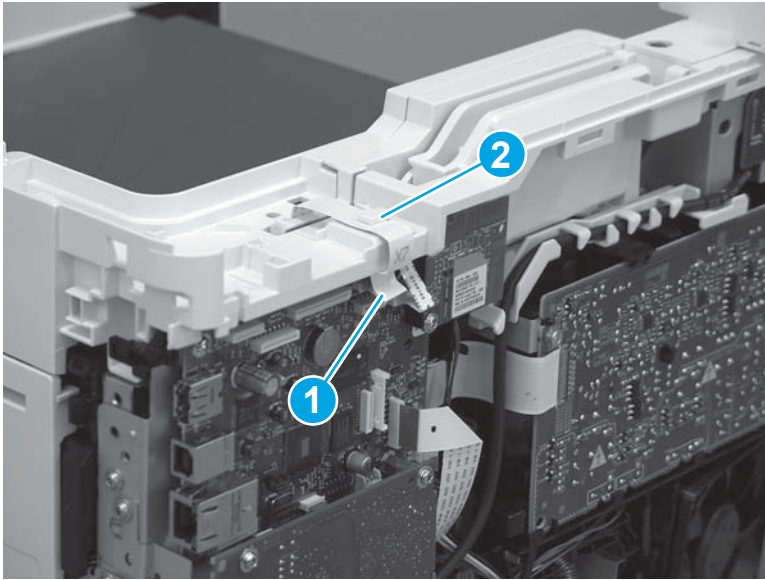
7. Install one screw (callout 1).

**Figure 1-1318** Install one screw





8. Install the FFC in the retainer (callout 1), and then connect one FFC (callout 1; J114).

**Figure 1-1319** Connect one connector



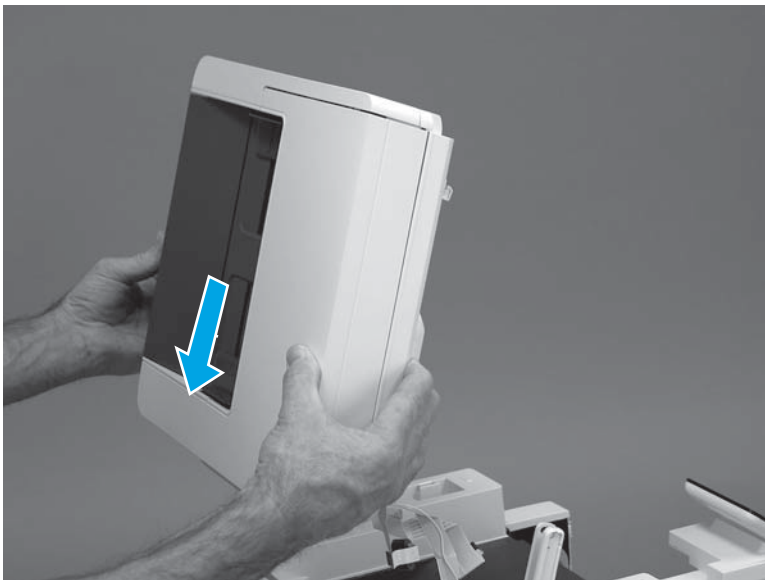
#### Step 17: Install the integrated scanner assembly (M427/M246)

 **NOTE:** The step is for the M427/M426 printer. For the M403/M402, skip this step and go to [Step 18: Install the right cover on page 717](#).

 **NOTE:** M427/M426 models only. The integrated scanner assembly (ISA) includes the sub-scanner assembly (SSA) and the automatic document feeder (ADF).

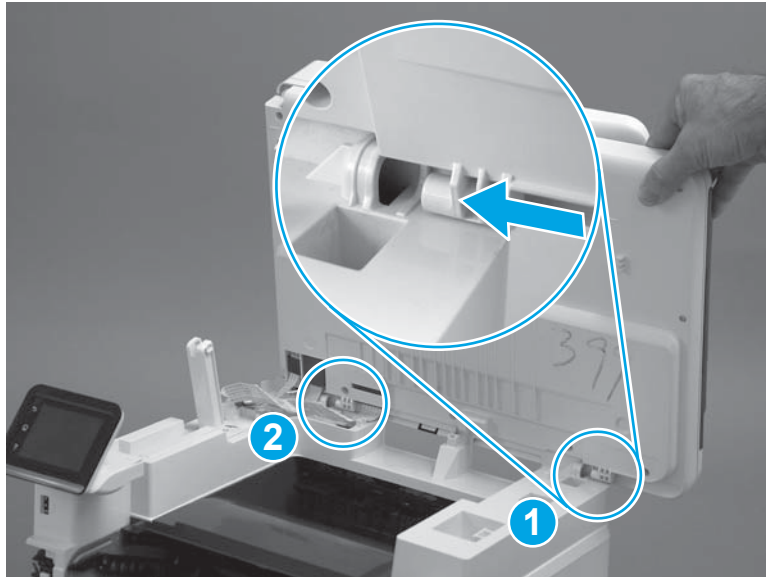
1. Position the ISA on the printer.

**Figure 1-1320** Position the ISA on the printer



2. Engage the hinge pins on the ISA with the holders in the top cover (callouts 1/2), and then slide the ISA as shown to engage them

**Figure 1-1321** Engage the hinge pins with the holders



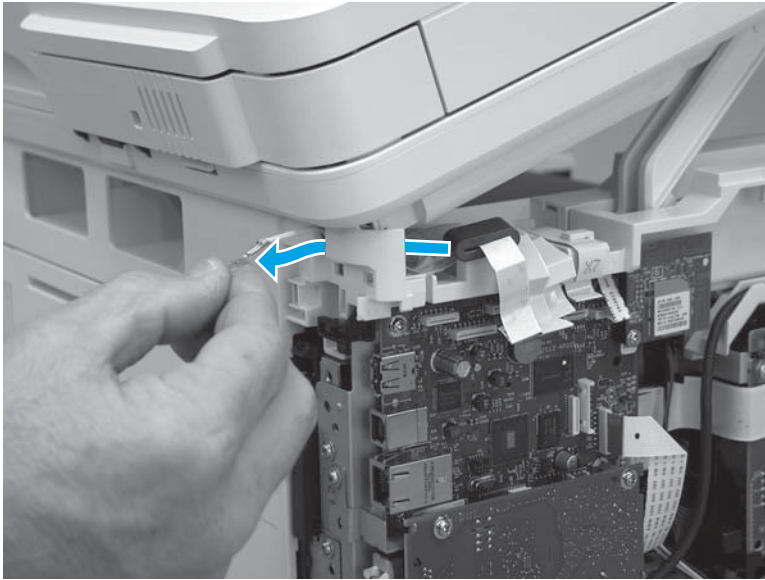
3. Rotate the ISA towards the front of the printer until it rests on the ISA lift assembly (callout 1).

**Figure 1-1322** Rotate the ISA towards the front of the printer



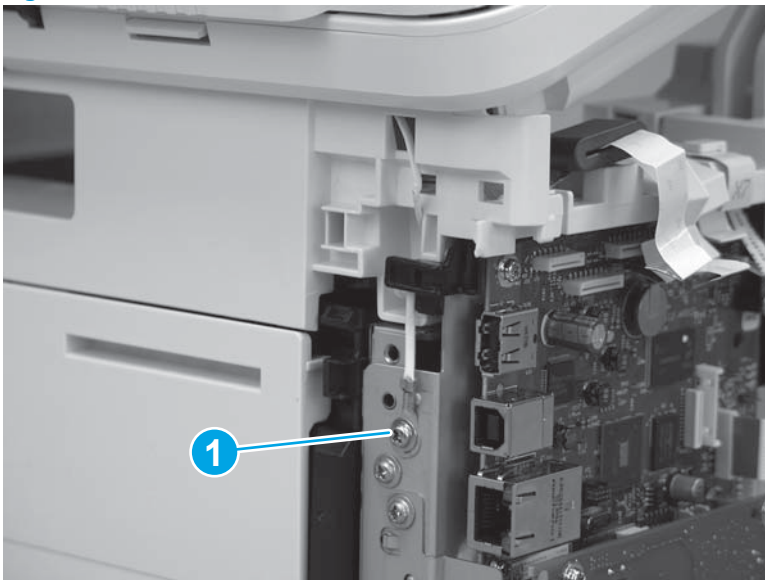
4. Pass the ground wire through the opening in the top cover.

**Figure 1-1323** Pass the wire through the opening




5. Install one screw (callout 1).

**Figure 1-1324** Install one screw

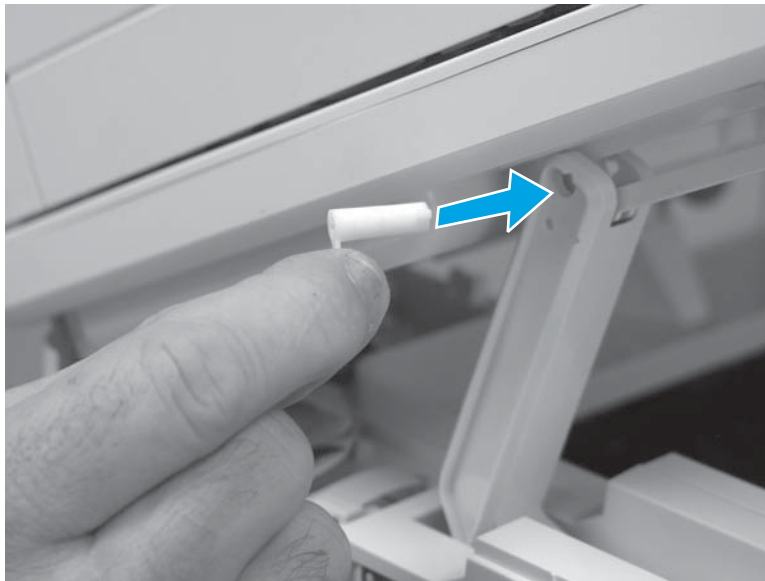




6. Install the ISA lift assembly slider pin.

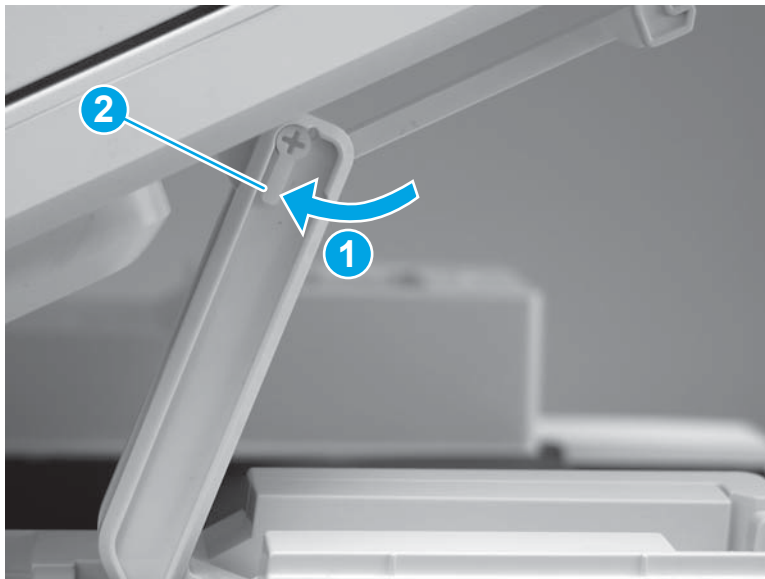
 **Reinstallation tip:** Align the keyed portion of the locking pin with the slot and hole in the support arm.

**Figure 1-1325** Install the slider pin



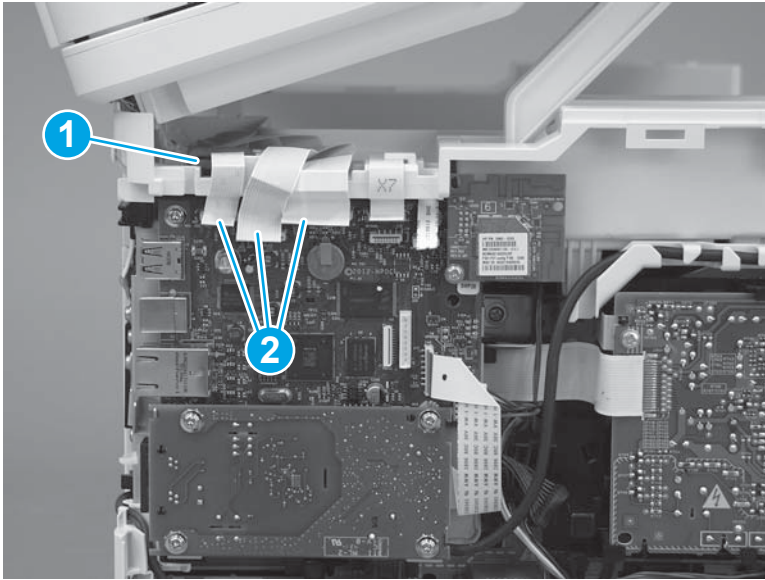
7. Rotate the slider pin (callout 1) towards the rear of the printer until the tab (callout 2) snap into place.

**Figure 1-1326** Secure the slider pin



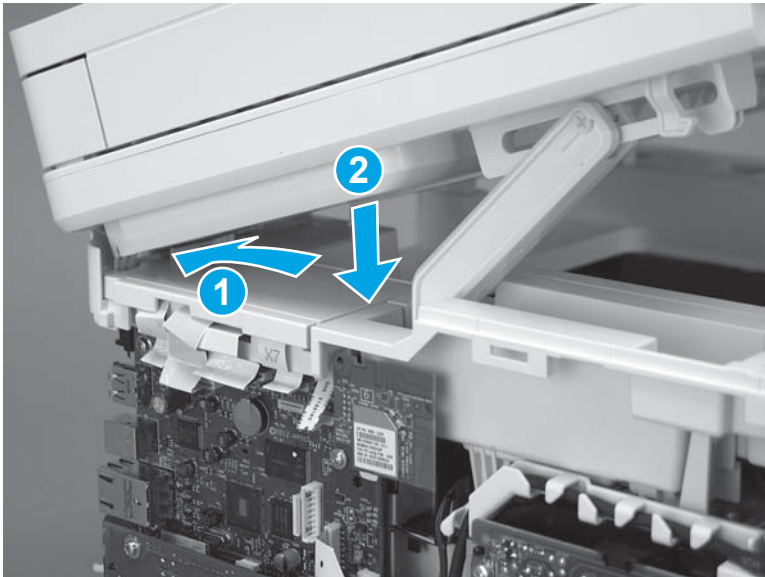
8. Install the ferrite (callout 1) in the holder, and then connect three FFCs (callout 2).

**Figure 1-1327** Connect three FFCs



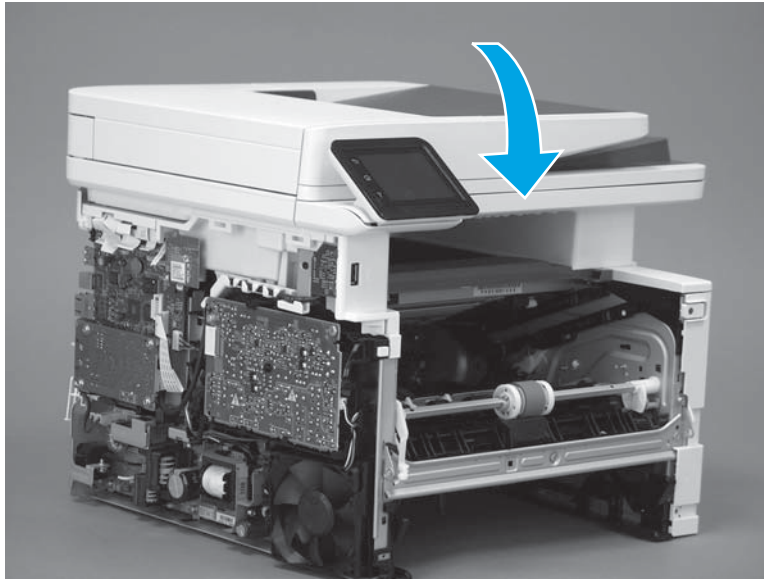
9. Position the rear edge of the ISA flat-flexible cable (FFC) cover on the printer (callout 1), and then rotate it down (callout 2) until it snaps into place.

**Figure 1-1328** Install the ISA FFC cover



10. Lower the ISA.

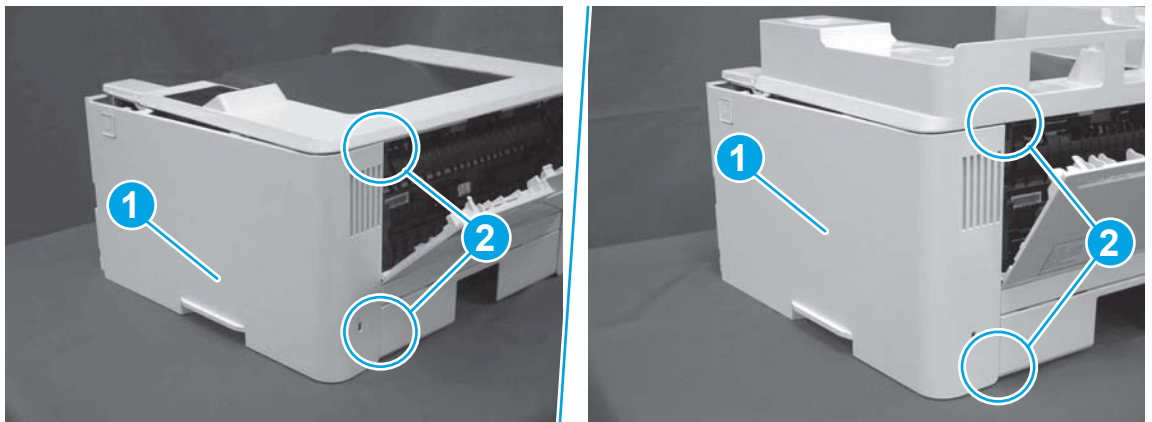
**Figure 1-1329** Lower the ISA



### Step 18: Install the right cover

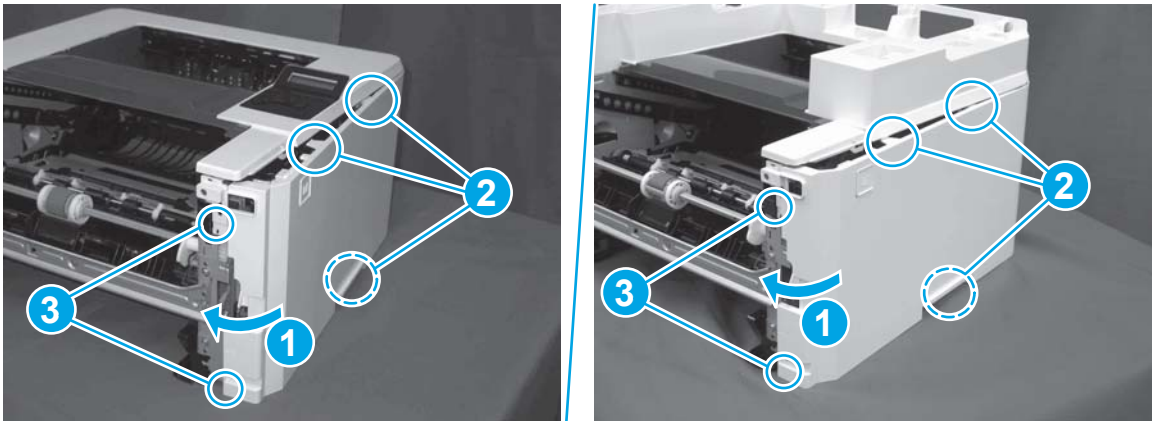
1. Position the cover (callout 1) on the printer, and then engage two bosses (callout 2).

**Figure 1-1330** Install the cover



2. Rotate the front of the cover onto the printer (callout 1), engage three (callout 2) tabs, and then engage two bosses (callout 3).

**Figure 1-1331** Engage two bosses and one tab

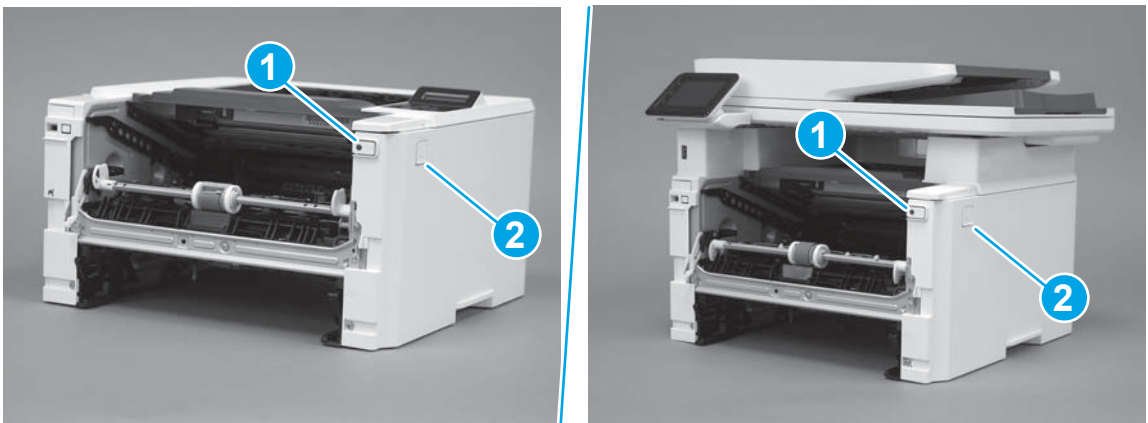


3. Make sure that the power switch (callout 1) and cartridge door assembly button (callout 2) correctly function.



**NOTE:** Remove, and then reinstall the cover if the switch or button does not correctly function.

**Figure 1-1332** Check the power switch and cartridge door assembly button



4. Install one screw (callout 1).

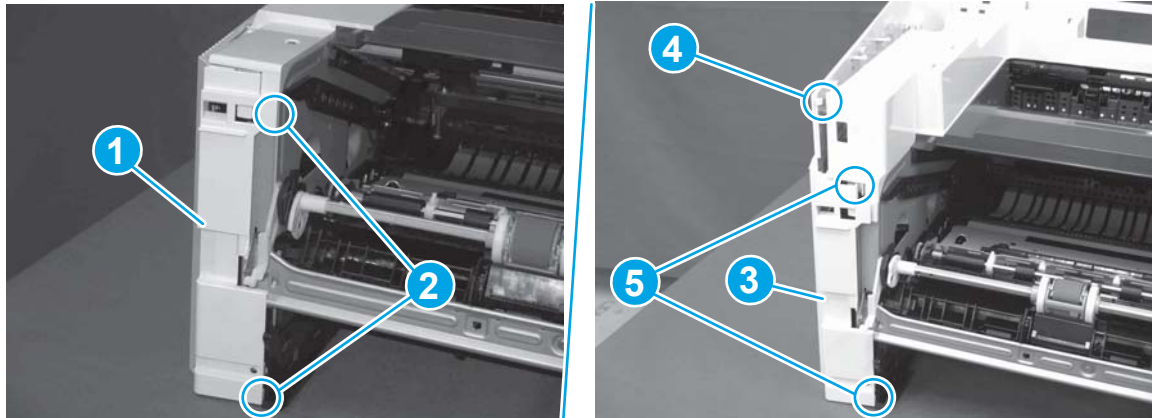
**Figure 1-1333** Install one screw



## Step 19: Install the left cover

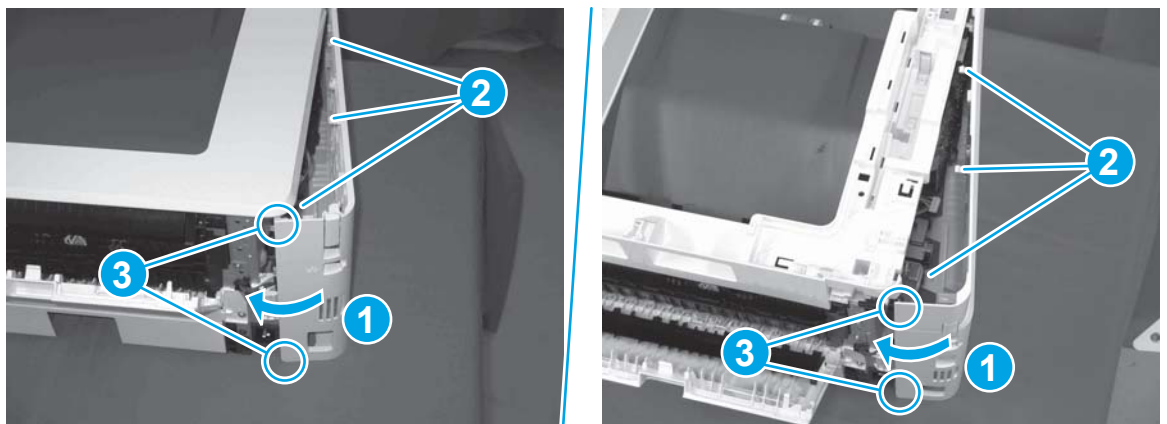
1. At the front of the printer, do one of the following:
  - **M403/M402:** Position the cover on the printer ( callout 1), and then engage two bosses (callout 2).
  - **M427/M426:** Position the cover on the printer (callout 3), engage one tab (callout 4), and then engage two bosses (callout 4).

**Figure 1-1334** Install the cover



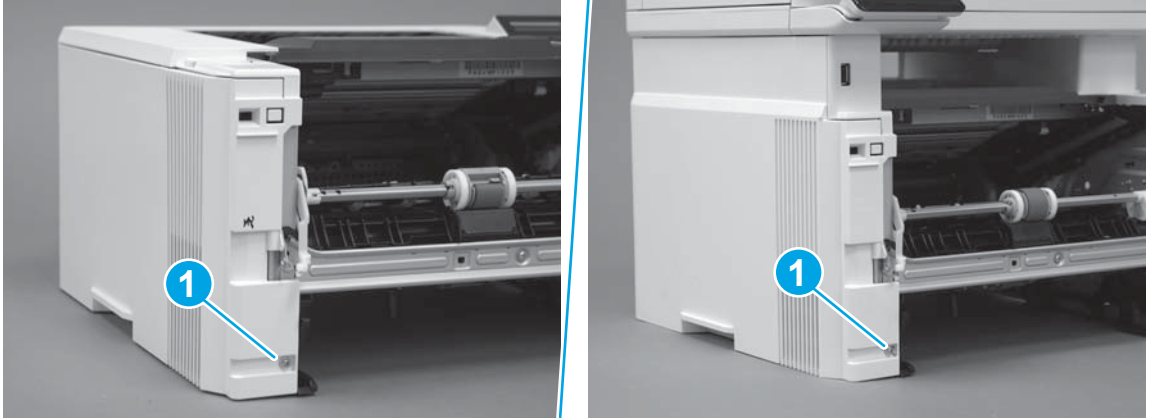
2. Carefully rotate the rear of the cover onto the printer (callout 1), engage three tabs (callout 2), and then engage two bosses (callout 3).

**Figure 1-1335** Engage three tabs and two bosses




3. Install one screw (callout 1).

**Figure 1-1336** Install one screw

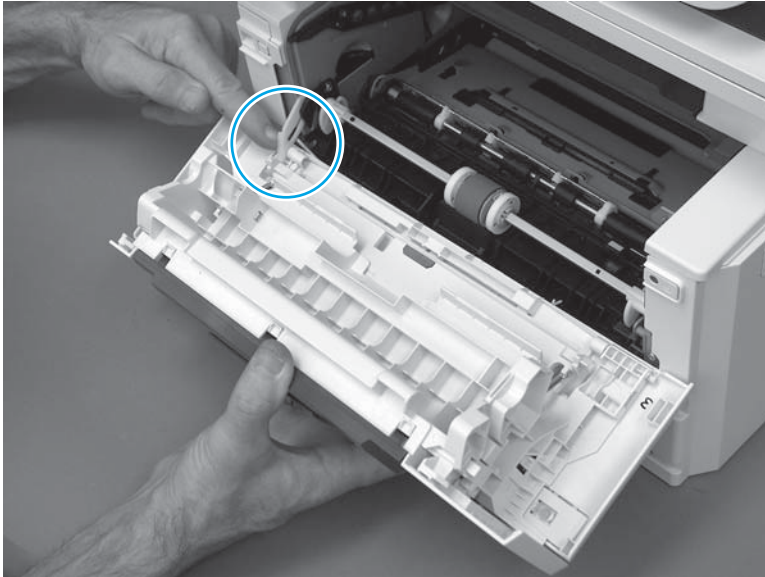


### Step 20: Install the cartridge door assembly

 **Reinstallation tip:** After a replacement door is installed, make sure to install the nameplate (supplied in the kit) corresponding to the printer name on the door.

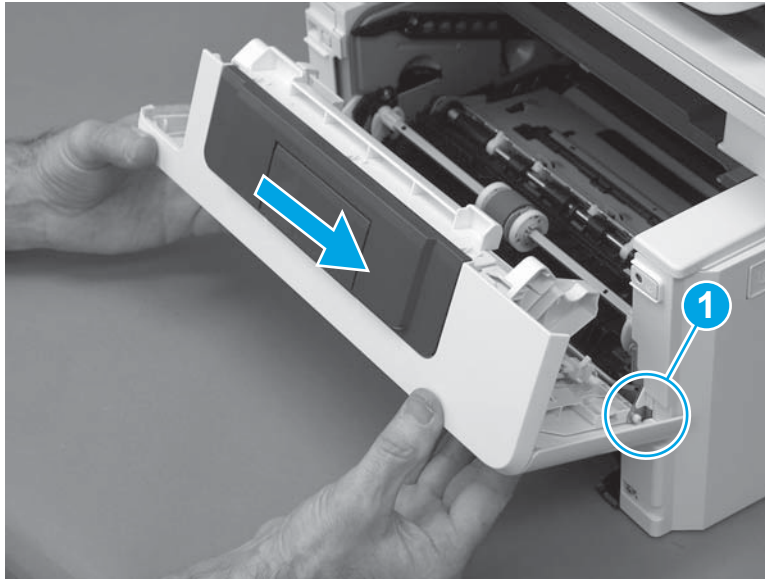
1. Position the door close to the printer, and then engage the keyed pin on the left-side retainer arm with the hole in the door.

**Figure 1-1337** Engage the left-side retainer arm



2. Engage the right-side door hinge pin with the hole in the chassis (callout 1).

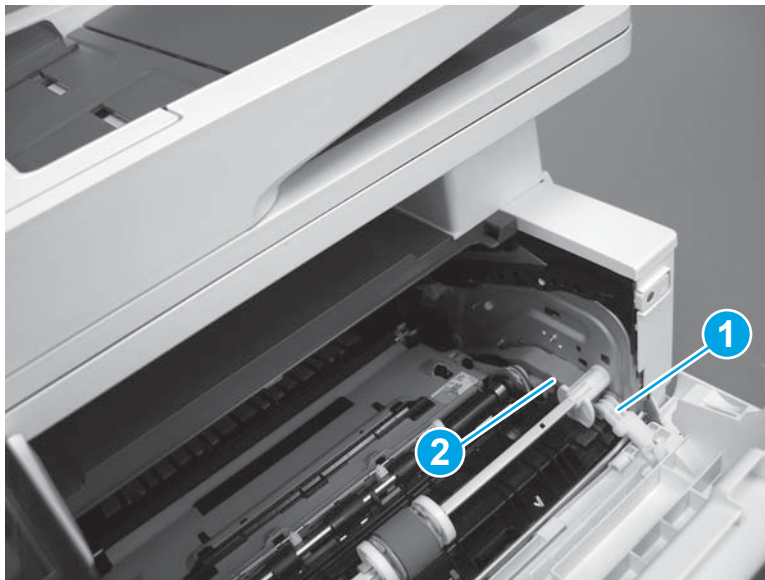
**Figure 1-1338** Install the door



3. Install the link (callout 1).

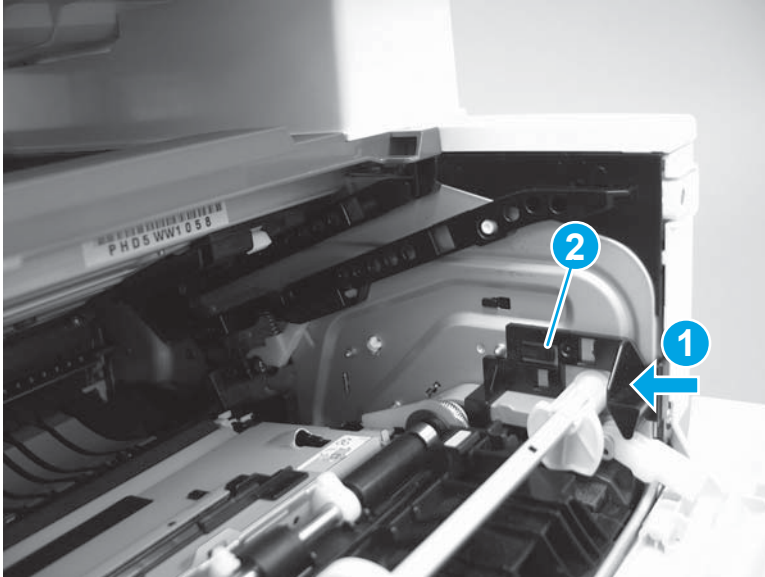
 **IMPORTANT:** Make sure that the link snaps into place on the arm (callout 2). The link actuates the fuser pressure-release mechanism.

**Figure 1-1339** Install the pressure-release link



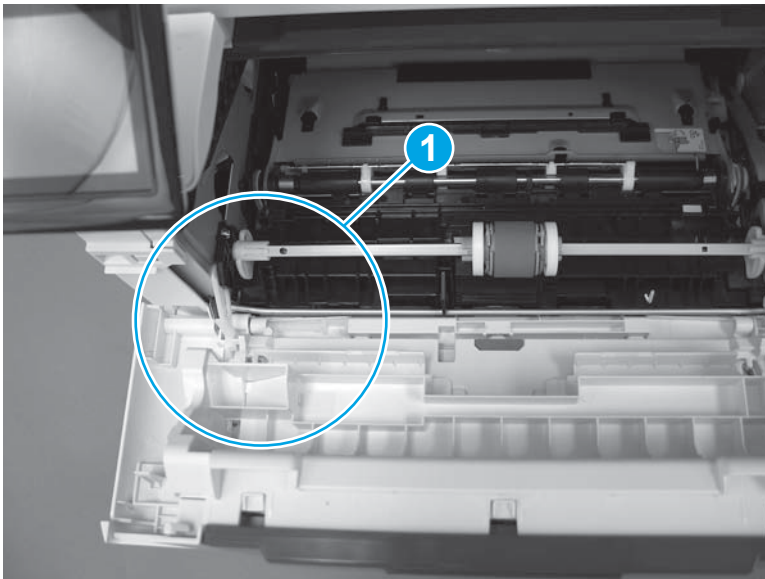
4. Slide the guide into the printer (callout 1), and then make sure that the tab (callout 2) snaps into place to secure the guide to the chassis.

**Figure 1-1340** Install the guide




5. Position the shaft on the door, and then align the left-side hinge on the door with the hole in the chassis (callout 1).

**Figure 1-1341** Align the hinge

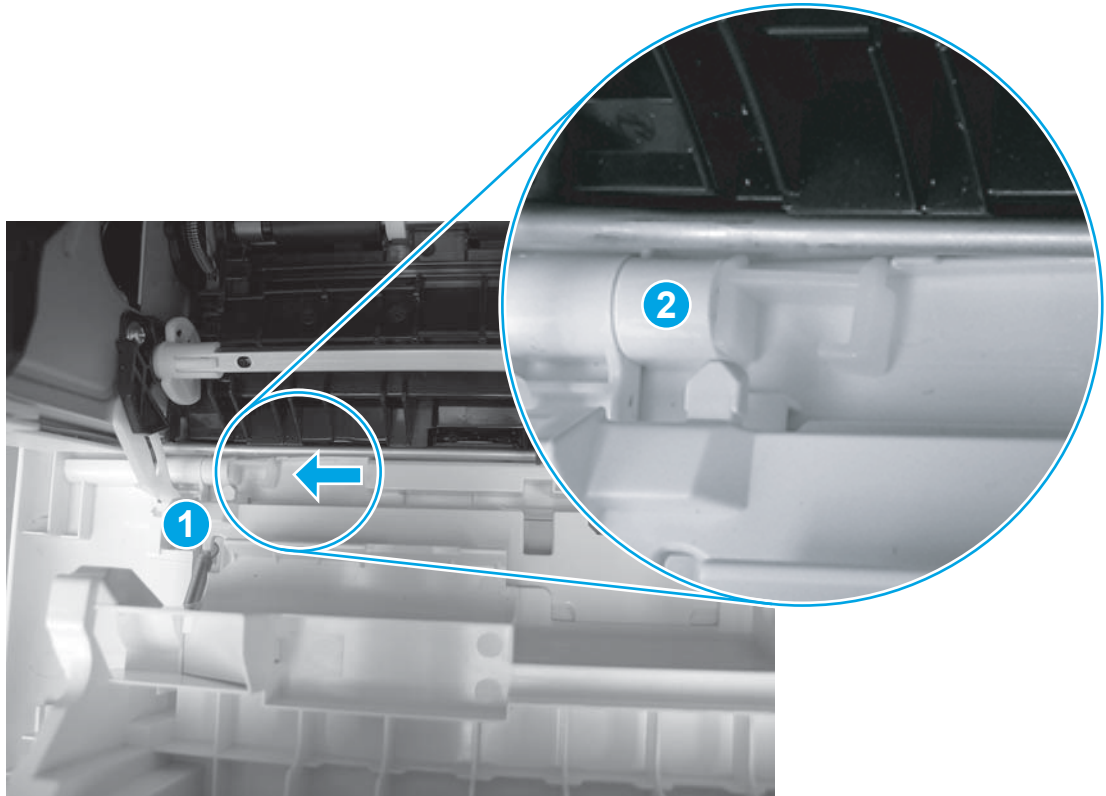




6. Push the shaft towards the left side of the printer to install it (callout 1).

 **Reinstallation tip:** Make sure that the support shaft is fully installed and correctly orientated (callout 2) so that it will not interfere with the door opening and closing.

**Figure 1-1342** Install the support shaft



### Step 21: Install Tray 2

- ▲ Slide the tray straight into the printer to install it.

**Figure 1-1343** Install the tray



## Removal and replacement: DC controller

- [Introduction](#)
- [Step 1: Remove Tray 2](#)
- [Step 2: Remove the cartridge door assembly](#)
- [Step 3: Remove the left cover](#)
- [Step 4: Remove the right cover](#)
- [Step 5: Remove the rear door assembly](#)
- [Step 6: Remove the integrated scanner assembly \(M427/M246\)](#)
- [Step 7: Remove the control panel \(M427/M246\)](#)
- [Step 8: Remove the top cover \(M427/M426\)](#)
- [Step 9: Remove the top cover \(M403/M402\)](#)
- [Step 10: Remove the paper delivery tray \(output bin\)](#)
- [Step 11: Remove the sheet-metal formatter bracket and formatter](#)
- [Step 12: Remove the DC controller](#)
- [Step 13: Unpack the replacement assembly](#)
- [Step 14: Install the DC controller](#)
- [Step 15: Install the sheet-metal formatter bracket and formatter](#)
- [Step 16: Install the paper delivery tray \(output bin\)](#)
- [Step 17: Install the top cover \(M403/M402\)](#)
- [Step 18: Install the top cover \(M427/M426\)](#)
- [Step 19: Install the control panel \(M427/M246\)](#)
- [Step 20: Install the integrated scanner assembly \(M427/M246\)](#)
- [Step 21: Install the rear door assembly](#)
- [Step 22: Install the right cover](#)
- [Step 23: Install the left cover](#)
- [Step 24: Install the cartridge door assembly](#)
- [Step 25: Install Tray 2](#)


### Introduction

This document provides the procedures to remove and replace the DC controller.

## Before performing service

### Turn the printer power off

- Disconnect the power cable.

 **WARNING!** To avoid damage to the printer, turn the printer off, wait 30 seconds, and then remove the power cable before attempting to service the printer.

Use the table below to identify the correct part number for your printer. To order the part, go to [www.hp.com/buy/parts](http://www.hp.com/buy/parts).

DC controller part number	
RM2-8680-000CN	DC controller

### Required tools

- #2 Phillips screwdriver with a magnetic tip.

### After performing service

#### Turn the printer power on

- Connect the power cable.
- Use the power switch to turn the power on.

### Post service test

Make sure that the printer initializes to a **Ready** state.

Print a configuration page to make sure that the printer is functioning correctly.

### Step 1: Remove Tray 2

- ▲ Pull the tray straight out of the printer to remove it.

**Figure 1-1344** Remove the tray



**Step 2: Remove the cartridge door assembly**



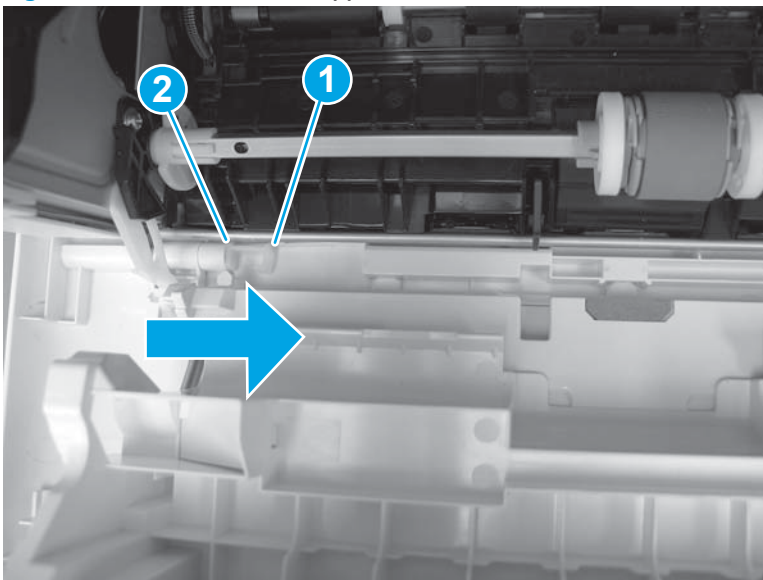
**NOTE:** If the toner cartridge was not removed prior to servicing the printer, remove it now.

1. Release one tab (callout 1), and then slide shaft (callout 2) in the direction the arrow indicates and remove it.



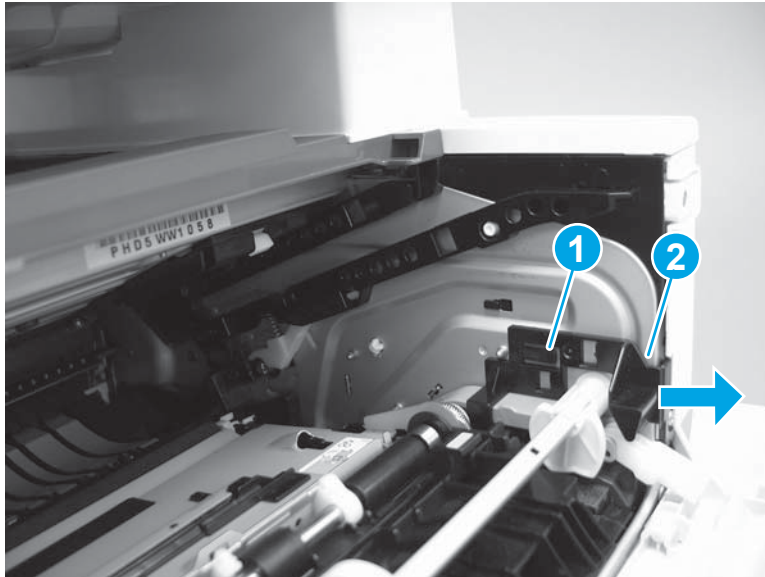
**TIP:** It might be easier to release the support shaft by using a small flat-blade screwdriver.

**Figure 1-1345** Release the support shaft



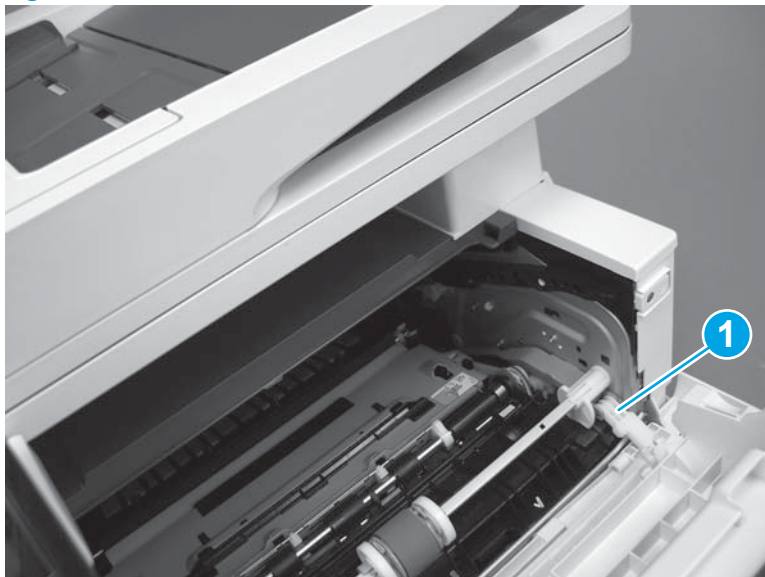
2. Release one tab (callout 1), and then slide the guide (callout 2) in the direction the arrow indicates and remove it.

**Figure 1-1346** Remove the guide



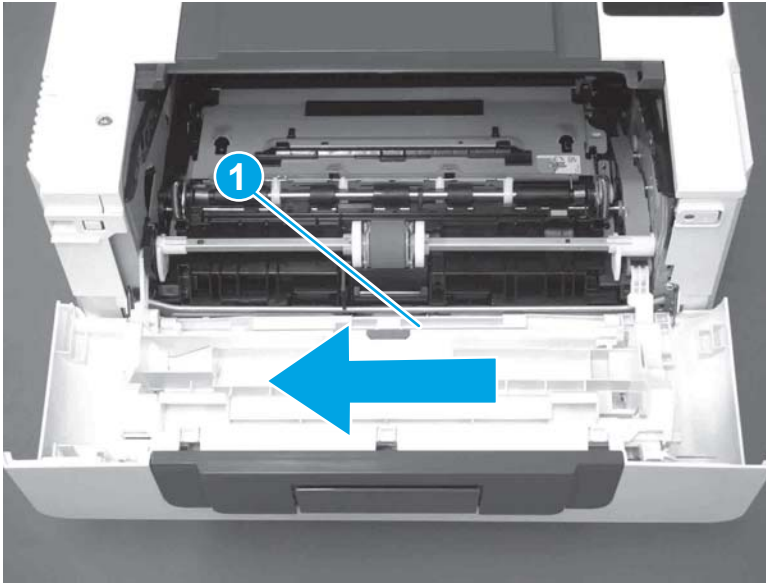
3. Remove the link arm (callout 1).

**Figure 1-1347** Remove the link arm



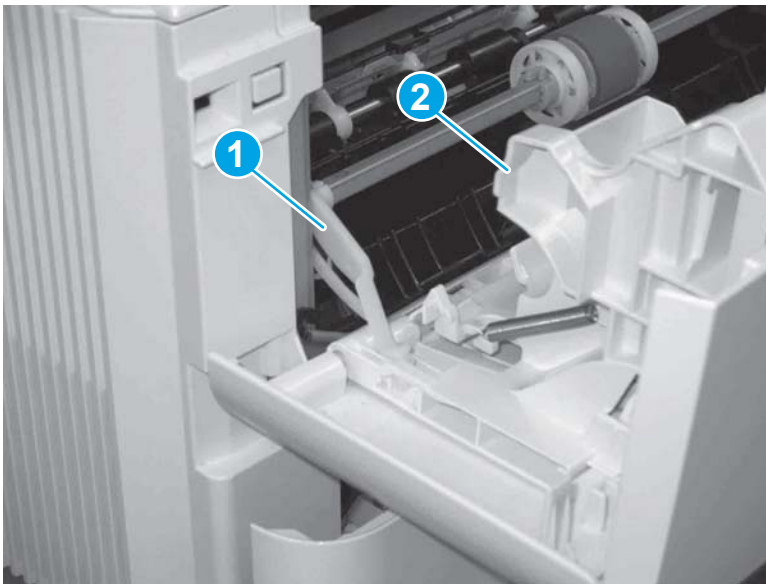
4. Slide the cartridge door assembly (callout 1) in the direction the arrow indicates and remove it.

**Figure 1-1348** Remove the door



5. Remove the link (callout 1) from the cartridge door assembly (callout 2).

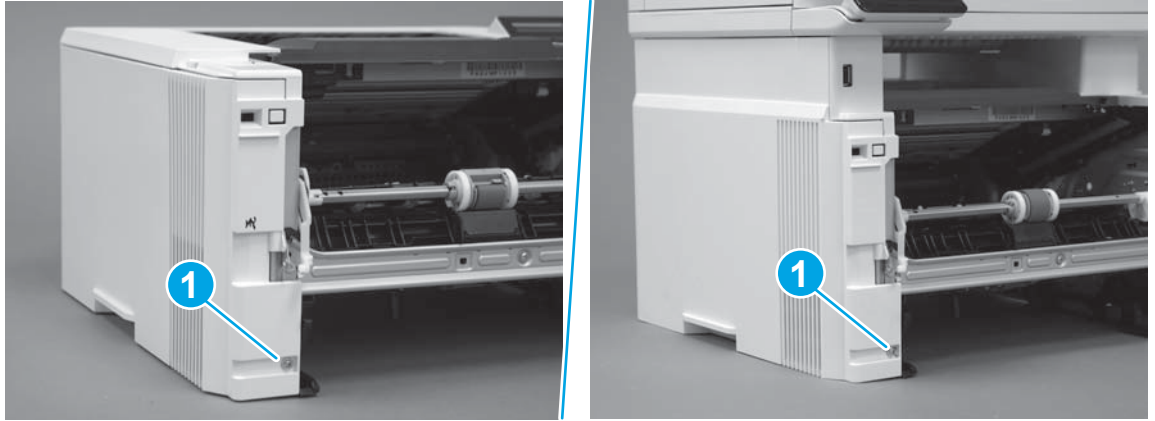
**Figure 1-1349** Release the left-side retainer arm



### Step 3: Remove the left cover

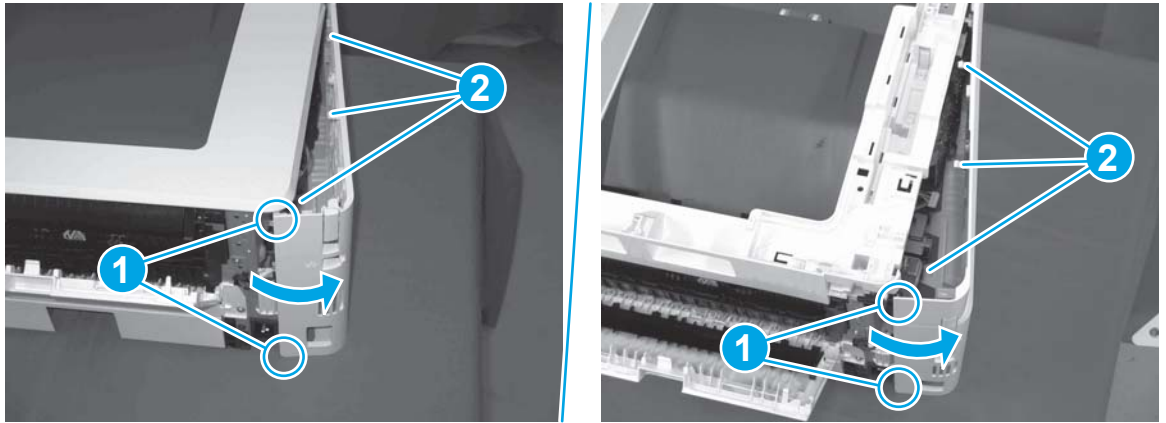
1. Remove one screw (callout 1).

**Figure 1-1350** Remove one screw



2. Open the rear door, release two bosses (callout 1), and then release three tabs (callout 2).

**Figure 1-1351** Release two bosses and three tabs

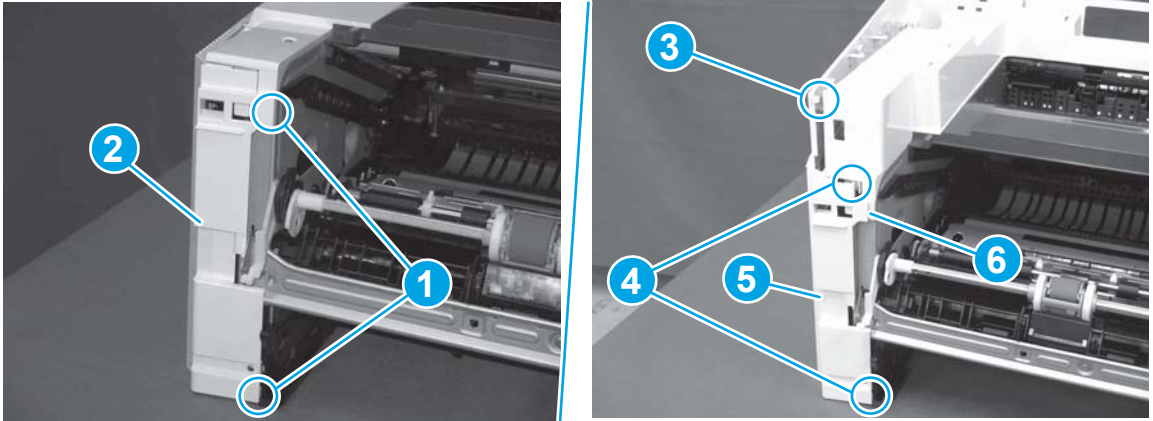


3. At the front of the printer, do one of the following:

- **M403/M402:** Release two bosses (callout 1), and then remove the cover (callout 2).
- **M427/M426:** Release one tab (callout 3), two bosses (callout 4), and then remove the cover (callout 5).

**CAUTION:** Be careful when releasing the upper bosses on the M427/M426 cover. One portion of the cover (callout 6) is fragile and is easily broken.

**Figure 1-1352** Remove the cover



**Step 4: Remove the right cover**

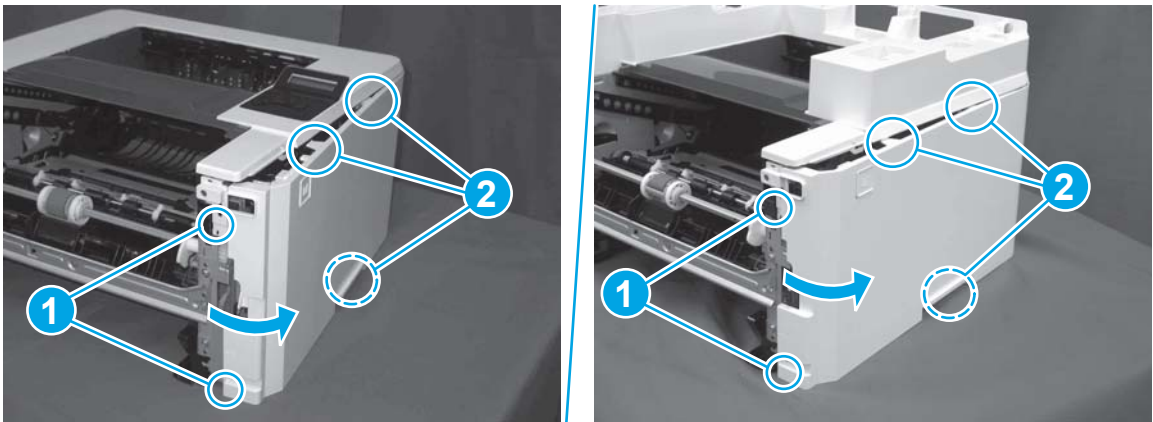
1. Remove one screw (callout 1).

**Figure 1-1353** Remove one screw



2. At the front of the printer, release two bosses (callout 1), and then release three tabs (callout 2).

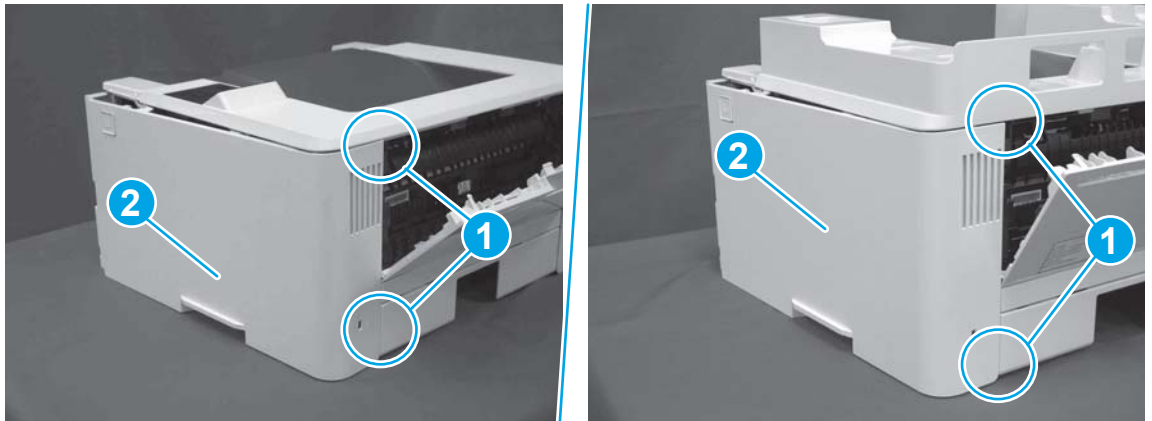
**Figure 1-1354** Release two bosses and three tabs





3. Open the rear door, release two bosses (callout 1), and then remove the cover (callout 2).

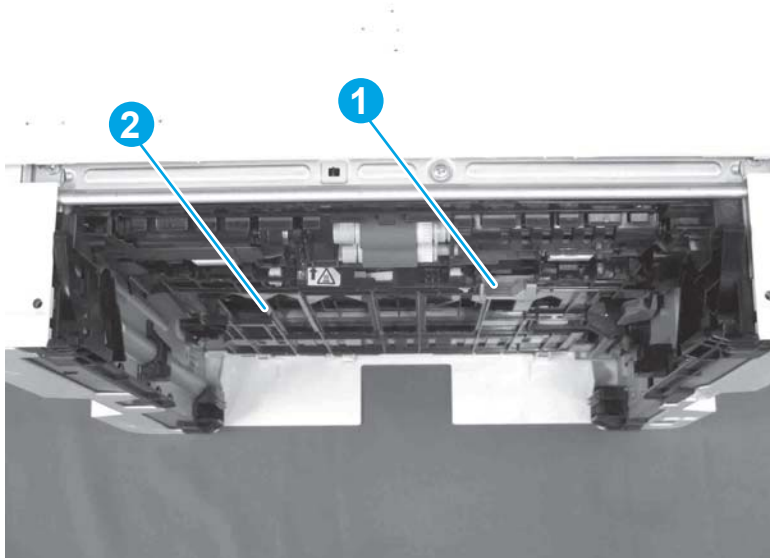
**Figure 1-1355** Remove the cover



**Step 5: Remove the rear door assembly**

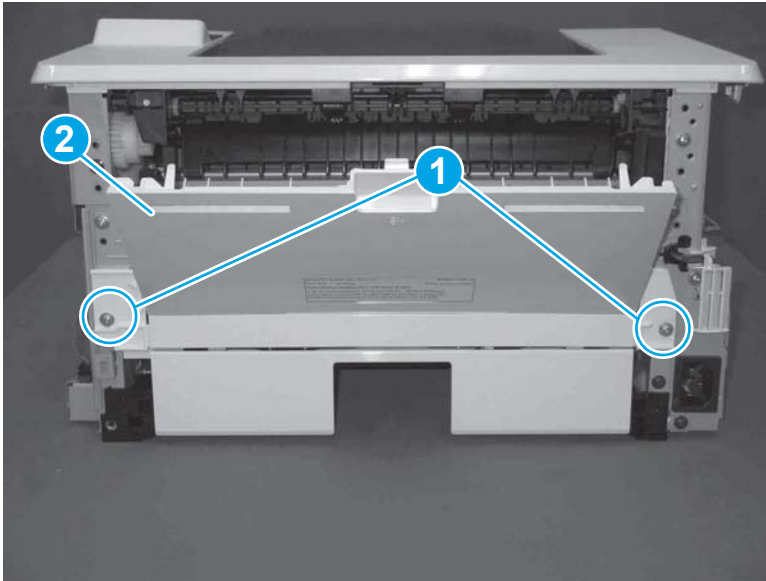
1. **Duplex models only:** Inside the Tray 2 cavity, press the green jam access lever (callout 1), and then lower the duplex feed assembly (callout 2).

**Figure 1-1356** Duplex models, lower the duplex feed assembly





2. At the rear of the printer, remove two screws (callout 1), and then remove the rear door assembly (callout 2).

**Figure 1-1357** Remove two screws



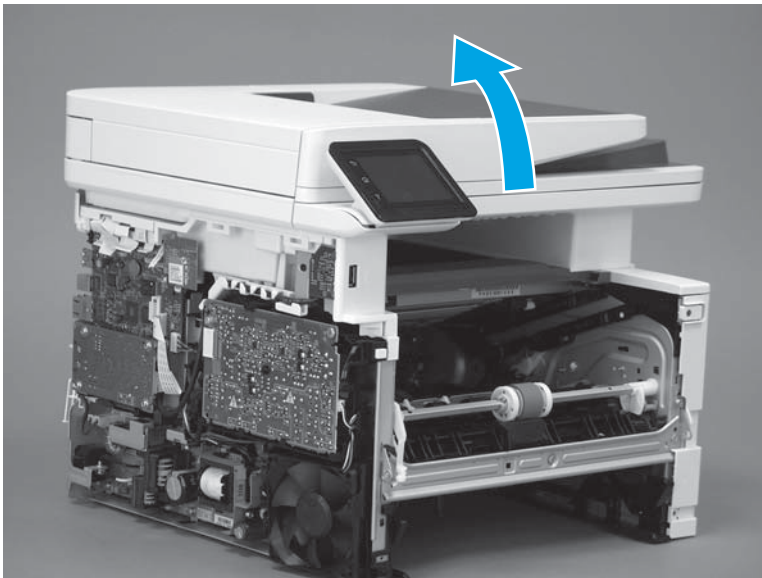
#### Step 6: Remove the integrated scanner assembly (M427/M246)

 **NOTE:** The step is for the M427/M426 printer. For the M403/M402, skip this step and go to [Step 9: Remove the top cover \(M403/M402\) on page 742](#).

 **NOTE:** M427/M426 models only. The integrated scanner assembly (ISA) includes the sub-scanner assembly (SSA) and the automatic document feeder (ADF).

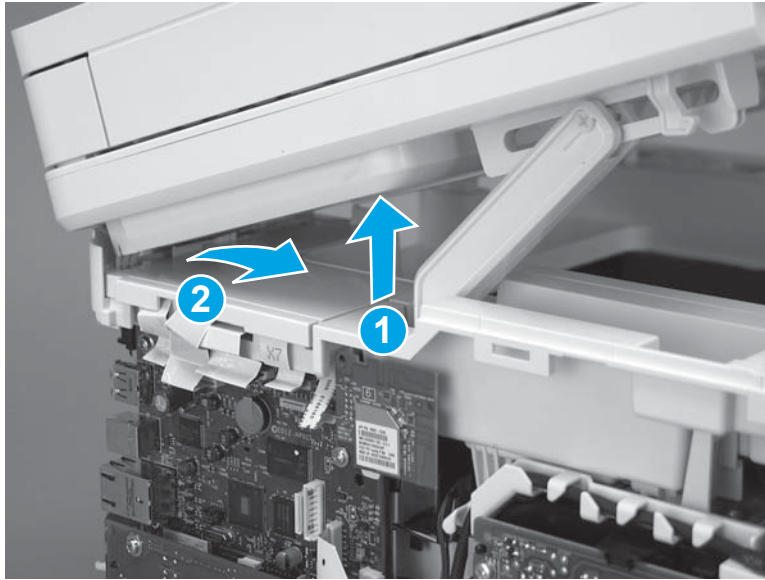
1. Raise the ISA.

**Figure 1-1358** Raise the ISA



2. Release the ISA flat-flexible cable (FFC) cover (callout 1), and then remove it (callout 2).

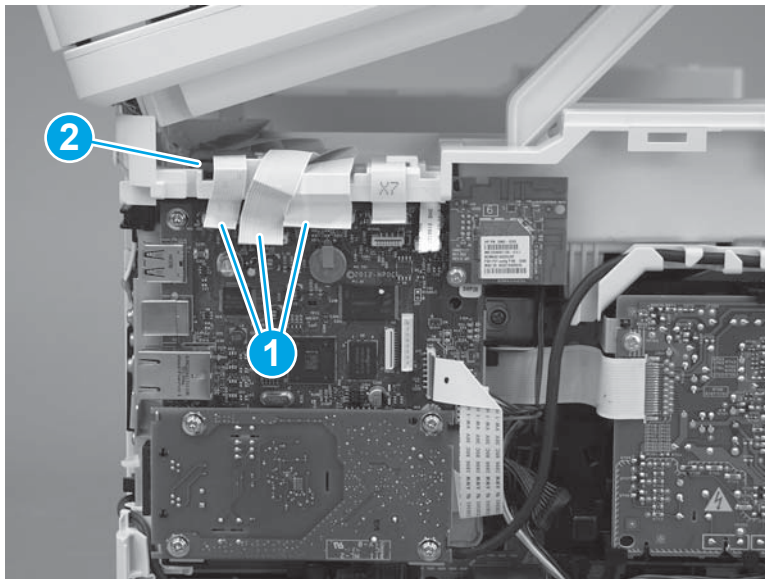
**Figure 1-1359** Remove the ISA FFC cover



3. Disconnect three FFCs (callout 1), and then remove the ferrite (callout 2) from the holder.

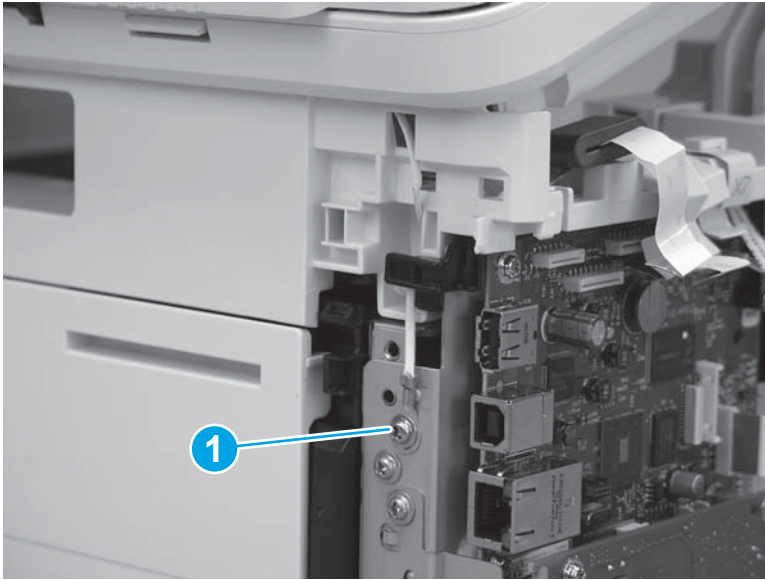
**CAUTION:** The ferrite is not captive on the FFC. Do not lose the ferrite while handling the ISA.

**Figure 1-1360** Disconnect three FFCs



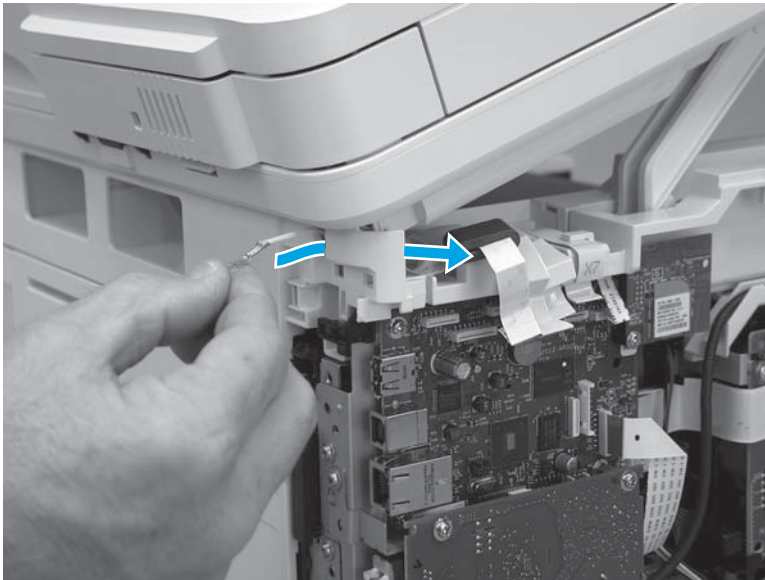
4. Remove one screw (callout 1).

**Figure 1-1361** Remove one screw



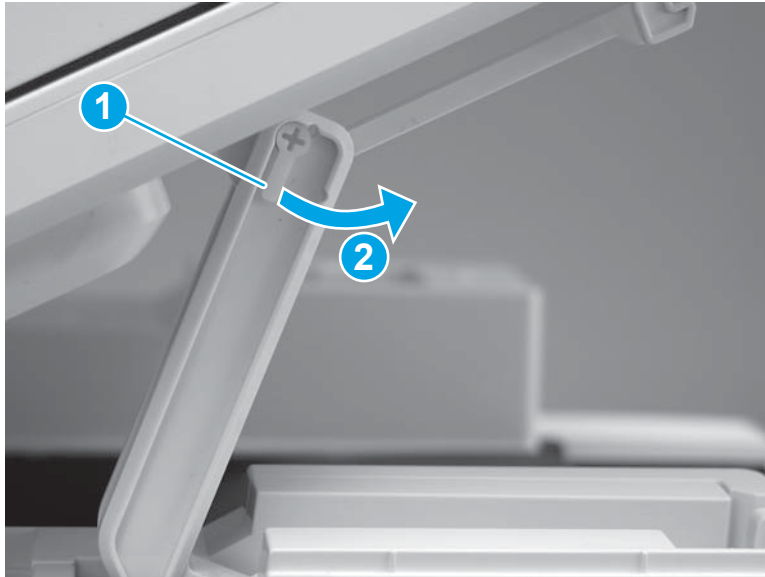
5. Pass the ground wire through the opening in the top cover.

**Figure 1-1362** Pass the wire through the opening



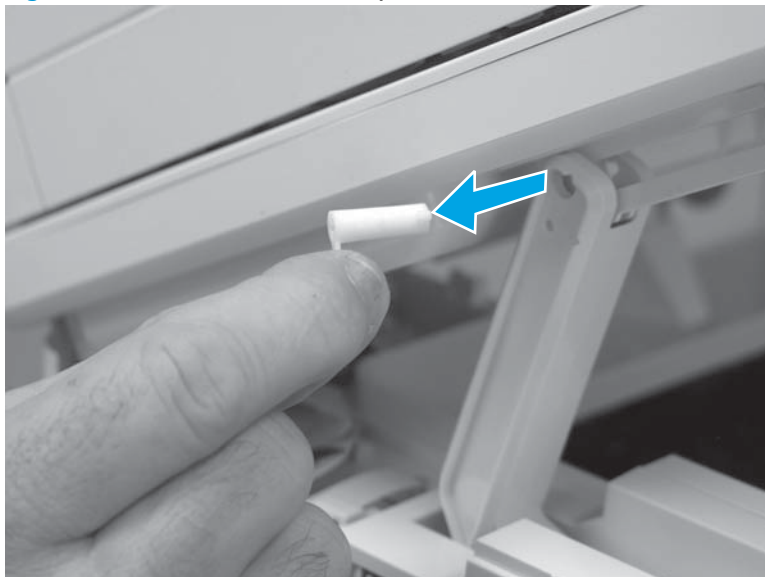
6. Release one tab (callout 1), and then rotate the ISA slider pin (callout 2) towards the front of the printer to release it.

**Figure 1-1363** Release one tab and rotate the slider pin



7. Remove the slider pin.

**Figure 1-1364** Remove the slider pin



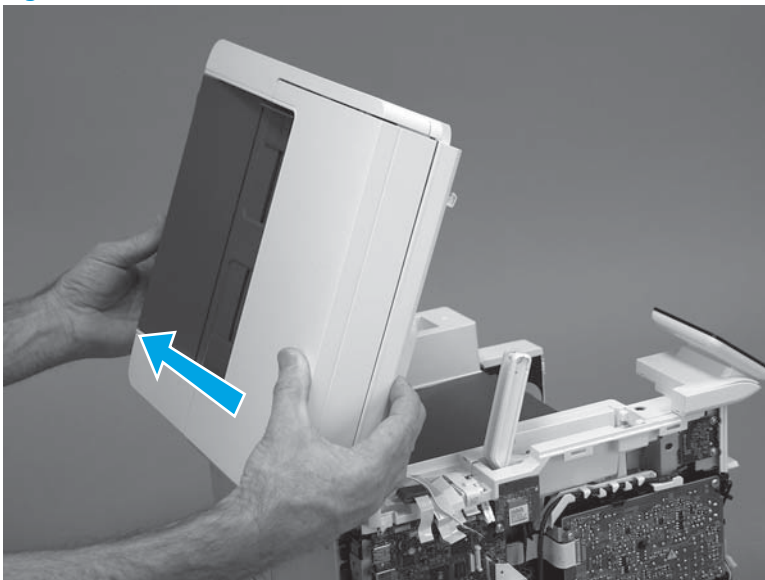
8. Rotate the ISA towards the rear of the printer until it stops.

**Figure 1-1365** Rotate the ISA towards the rear of the printer



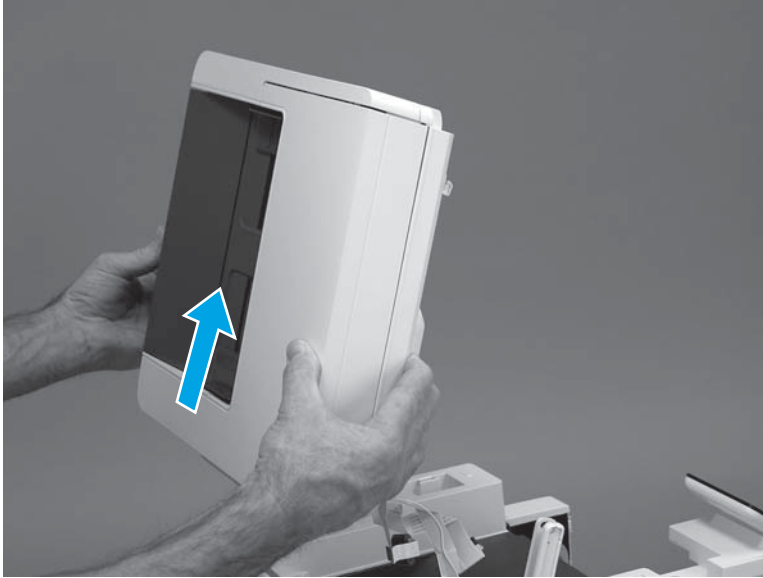
9. Slide the ISA as shown to release it.

**Figure 1-1366** Release the ISA




10. Remove the ISA.

**Figure 1-1367** Remove the ISA

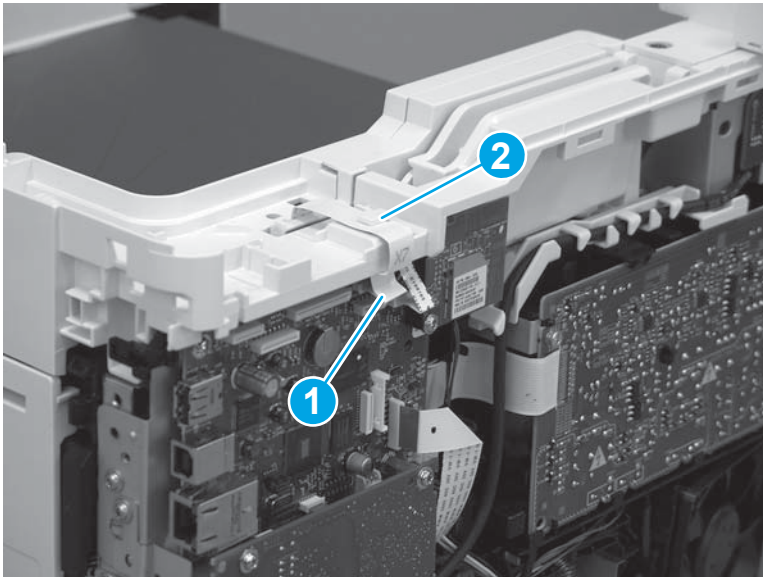


#### Step 7: Remove the control panel (M427/M246)

 **NOTE:** The step is for the M427/M426 printer. For the M403/M402, skip this step and go to [Step 9: Remove the top cover \(M403/M402\) on page 742](#).

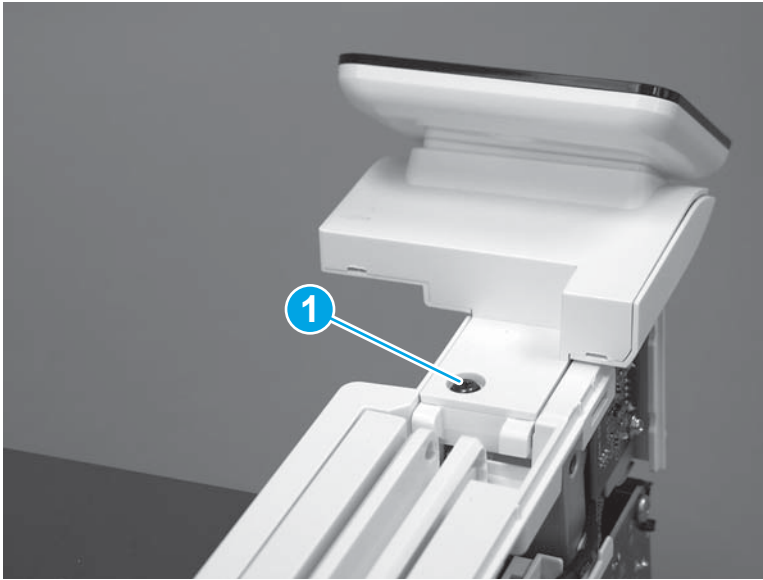
1. Disconnect one FFC (callout 1; J114), and then release the FFC from the retainer (callout 2).

**Figure 1-1368** Disconnect one connector



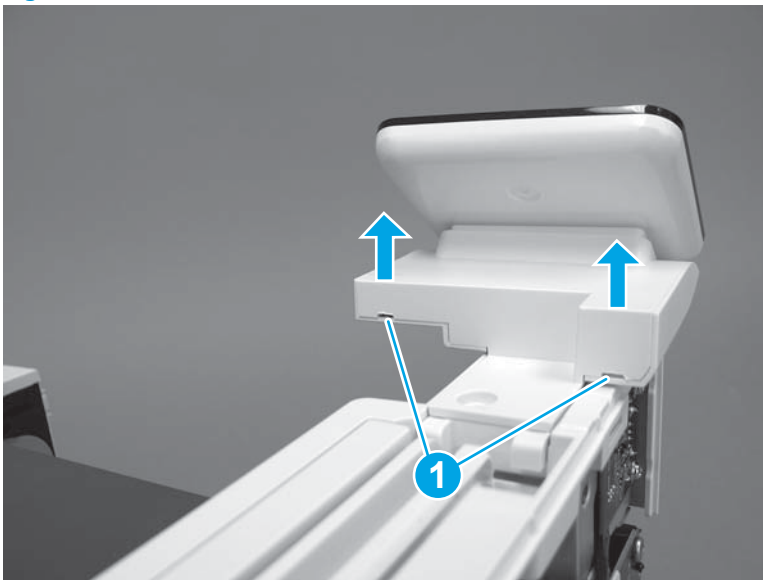
2. Remove one screw (callout 1).

**Figure 1-1369** Remove one screw



3. Use a small flat-blade screwdriver to release two tabs (callout 1) on the control-panel cable cover.

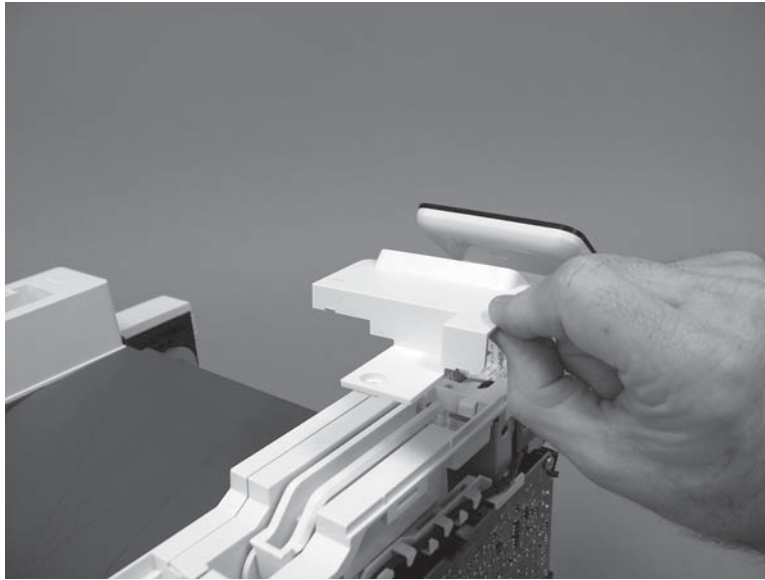
**Figure 1-1370** Release two tabs





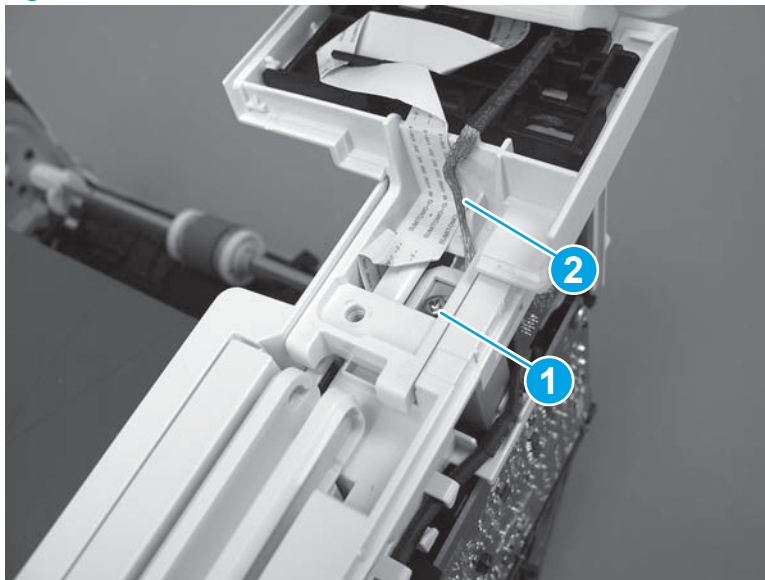
4. Remove the control-panel cable cover.

**Figure 1-1371** Remove the cover



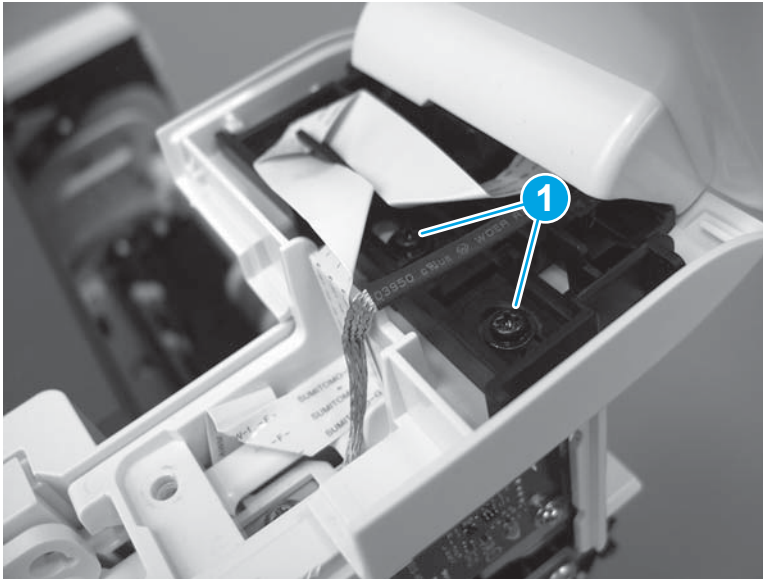
5. Remove one grounding screw (callout 1), and then move the ground cable (callout 2) out of the way.

**Figure 1-1372** Remove one screw



6. Move the FFC out of the way, and then remove two screws (callout 1).

**Figure 1-1373** Remove two screws



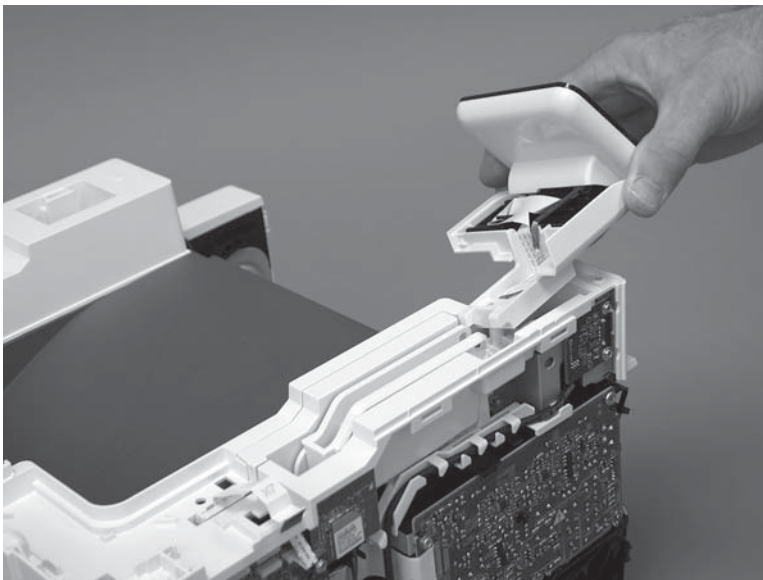
7. Slightly lift up the control-panel assembly to separate it from the top cover.

---

**CAUTION:** The control panel assembly is still connected to the printer by the FFC. Do not attempt to completely remove the assembly.

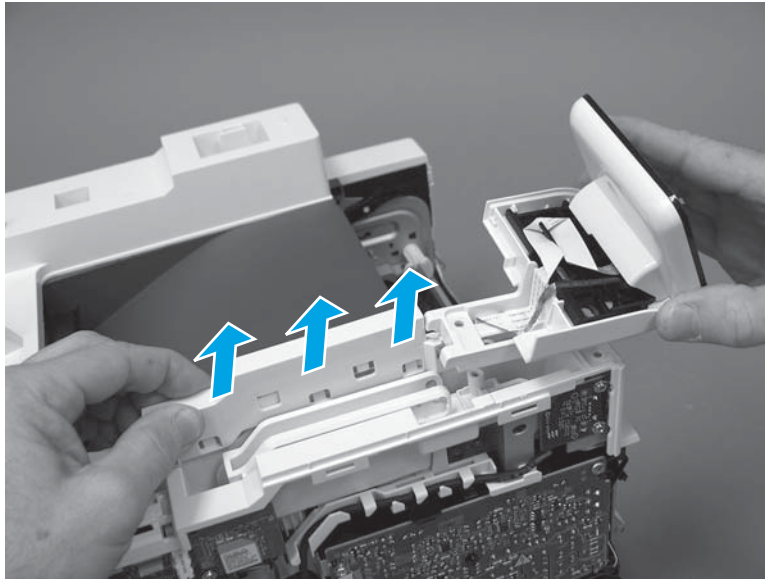
---

**Figure 1-1374** Lift up the control-panel assembly




8. Lift up the control-panel FFC cover to remove the control-panel assembly.

**Figure 1-1375** Remove the control-panel assembly

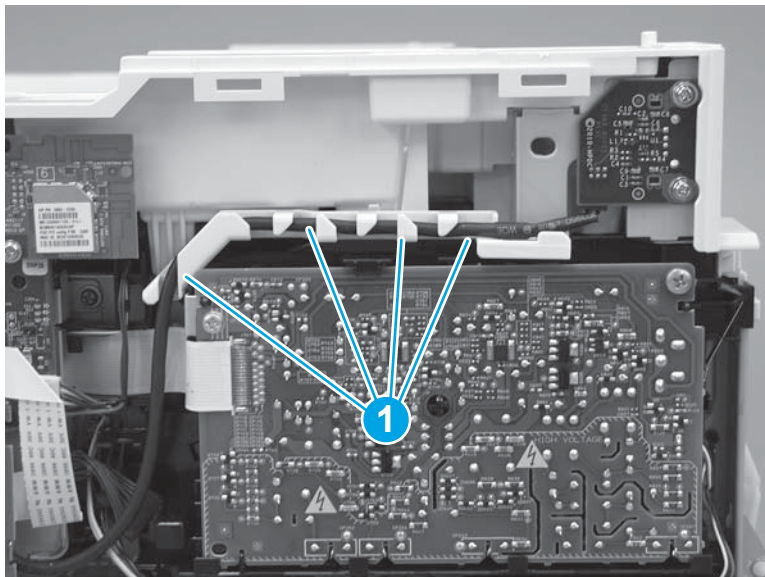


#### Step 8: Remove the top cover (M427/M426)

 **NOTE:** The step is for the M427/M426 printer. For the M403/M402, skip this step and go to [Step 9: Remove the top cover \(M403/M402\) on page 742](#).

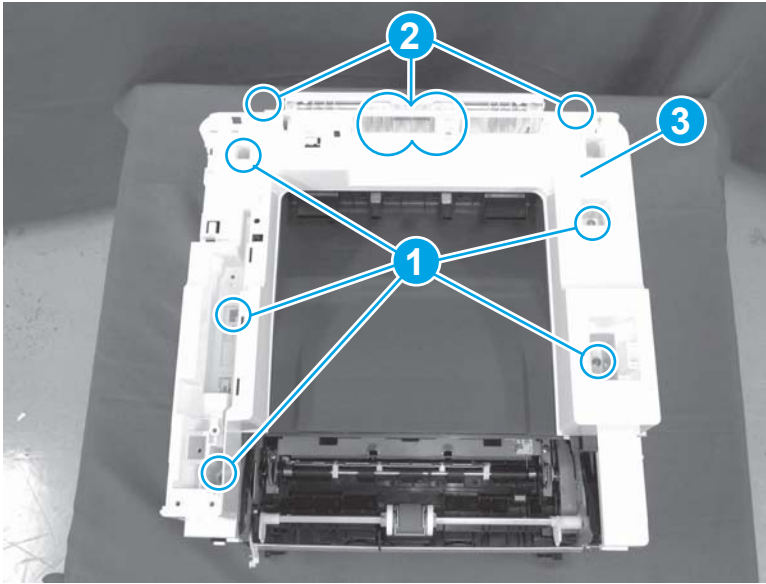
1. Release the USB cable (callout 1) from the cable guide.

**Figure 1-1376** Remove the USB cable




2. Remove five screws (callout 1), release four bosses (callout 2), and then remove the top cover (callout 3).

**Figure 1-1377** Remove the cover



### Step 9: Remove the top cover (M403/M402)

 **NOTE:** The step is for the M403/M402 printer. For the M427/M426, skip this step and go to [Step 10: Remove the paper delivery tray \(output bin\) on page 743](#).

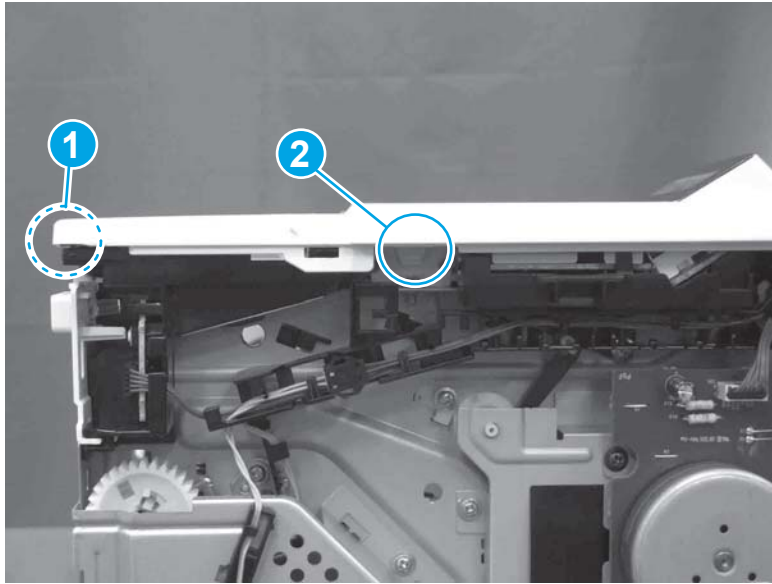
1. Remove one screw (callout 1).

**Figure 1-1378** Remove one screw




2. At the right side of the printer, release the one boss (callout 1), and then release one tab (callout 2).

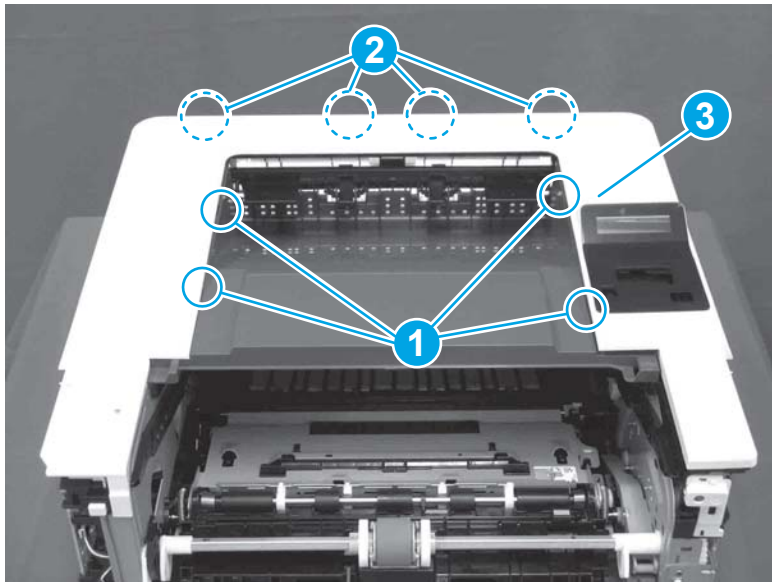
**Figure 1-1379** Release one boss and one tab




3. Release four tabs (callout 1), release four bosses (callout 2), and then remove the top cover (callout 3).

 **TIP:** Open the rear door to make releasing the bosses (callout 3) easier.

**Figure 1-1380** Remove the cover

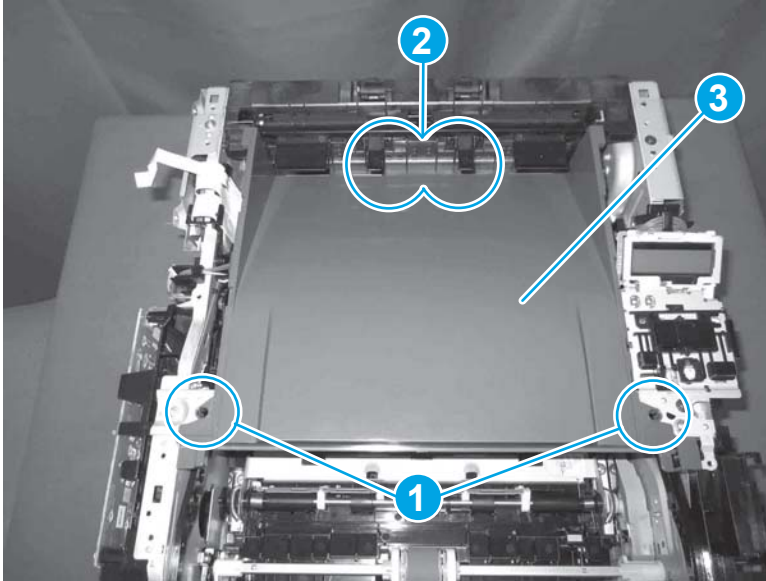


### Step 10: Remove the paper delivery tray (output bin)


 **NOTE:** This procedure shows the M403/M402 model, however, the paper delivery tray (output bin) removal is similar for the M427/M426 printer.

- ▲ Release two bosses (callout 1), release two tabs (callout 2), and then remove the paper delivery tray (output bin; callout 3).

**Figure 1-1381** Release two tabs

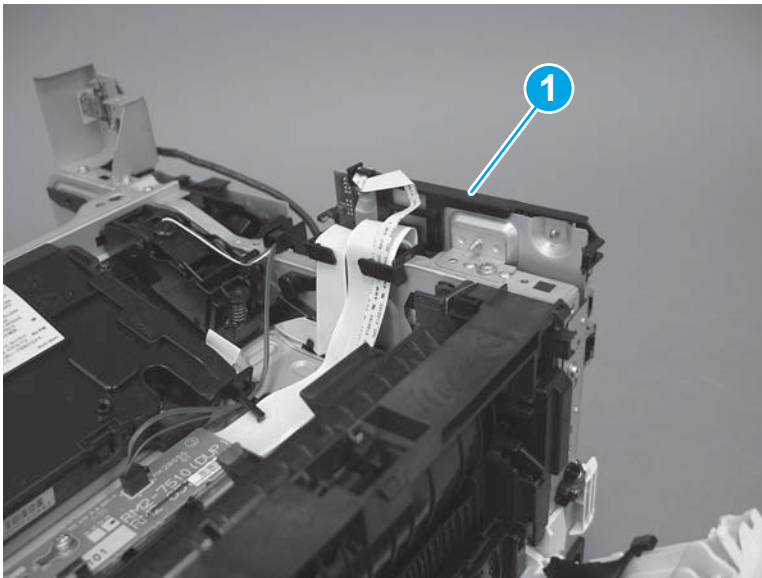


**Step 11: Remove the sheet-metal formatter bracket and formatter**

 **NOTE:** Disconnect any remaining formatter PCA FFCs or wire-harness connectors.

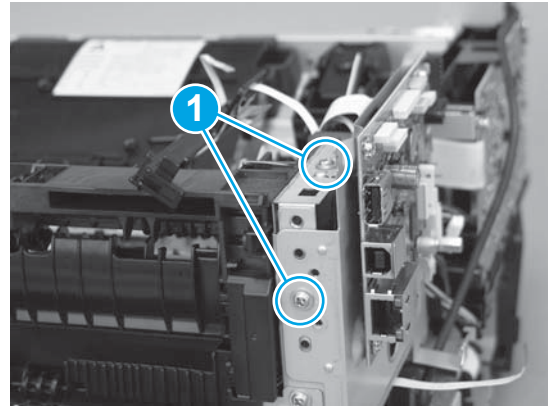
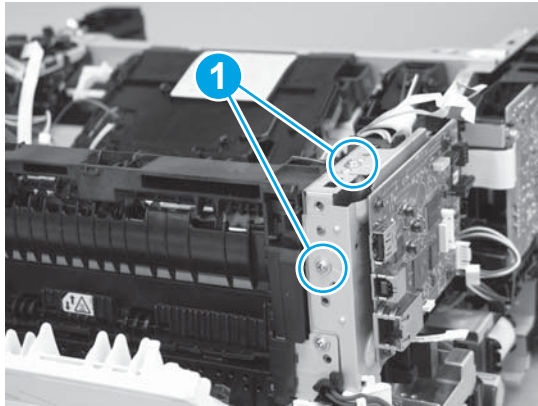
1. **M427/M426 only:** Remove the guide (callout 1).

**Figure 1-1382** Remove the guide



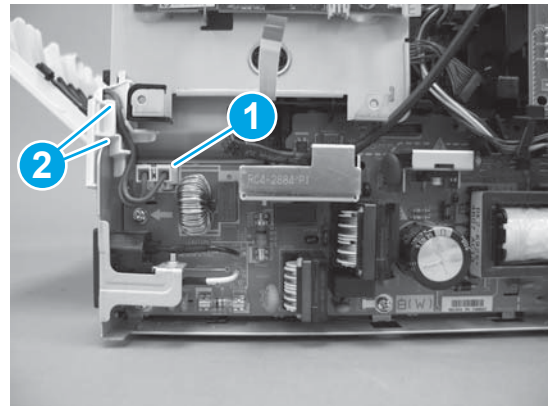
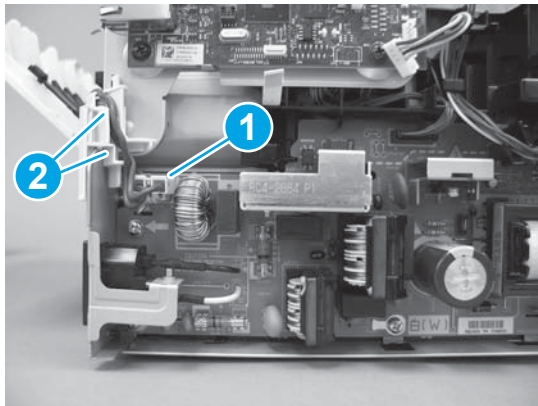
2. Remove two screws (callout 1).

**Figure 1-1383** Remove two screws



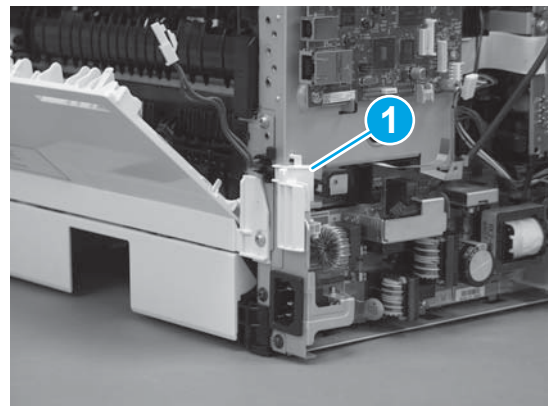
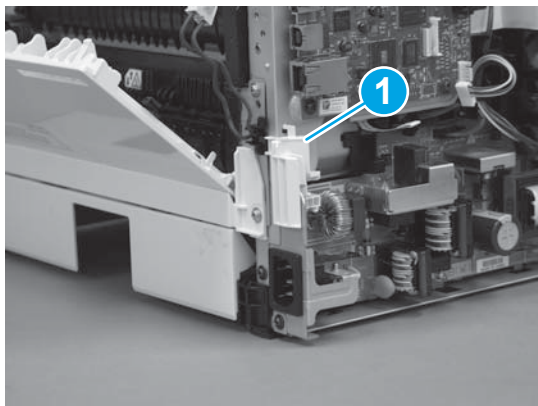
3. Disconnect one connector (callout 1), and then release the wire harness from the guide (callout 2).

**Figure 1-1384** Disconnect one connector



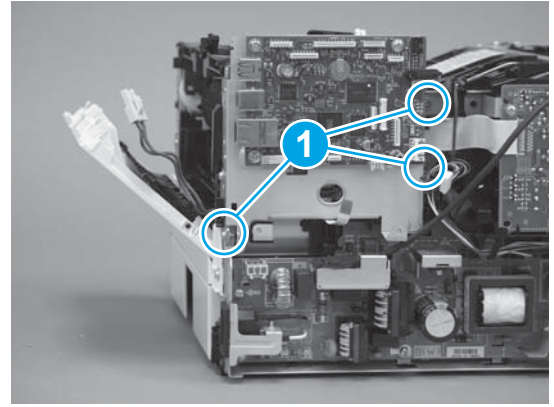
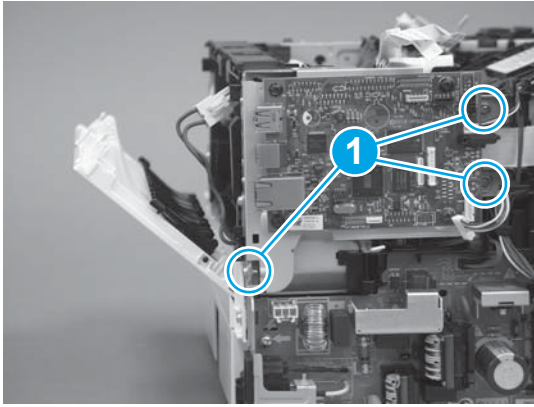
4. Remove the guide (callout 1).

**Figure 1-1385** Remove the guide



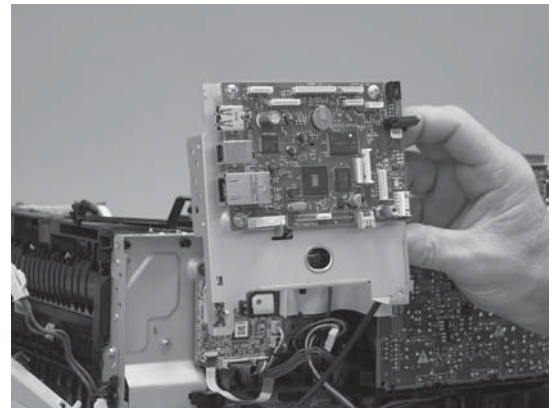
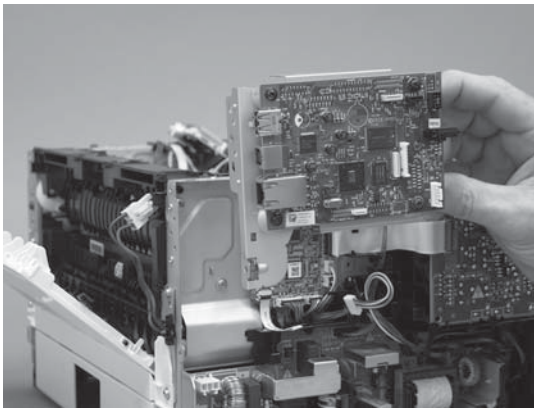
5. Remove three screws (callout 1).

**Figure 1-1386** Remove three screws




6. Remove the sheet-metal bracket and formatter PCA.

**Figure 1-1387** Remove the bracket



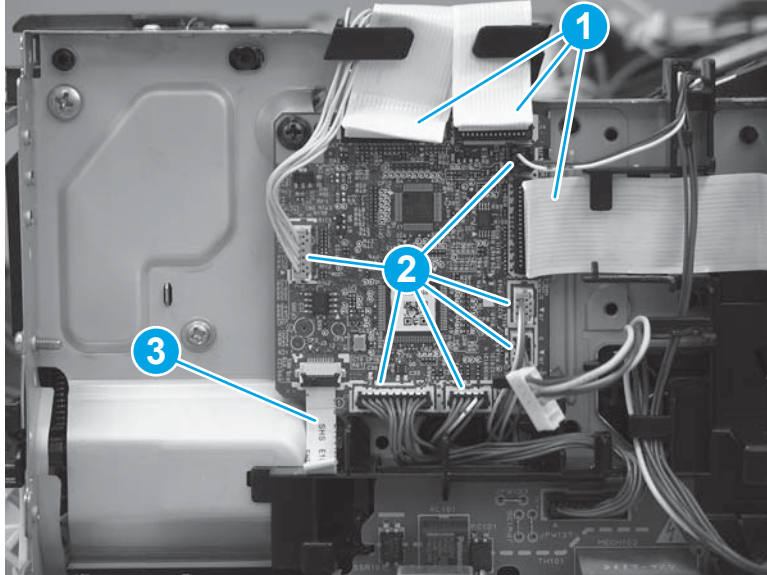
## Step 12: Remove the DC controller

1. Disconnect three FFCs (callout 1), and six connectors (callout 2).

 **IMPORTANT:** One FFC (callout 3) is fastened to the guide with two sided tape. This FFC will be removed later in the procedure.

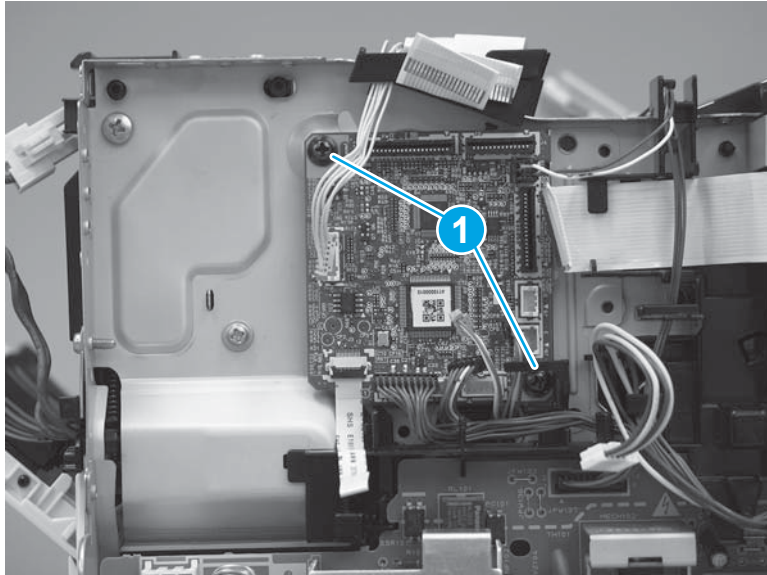


**Figure 1-1388** Disconnect three FFCs and six connectors



2. Remove two screws (callout 1).

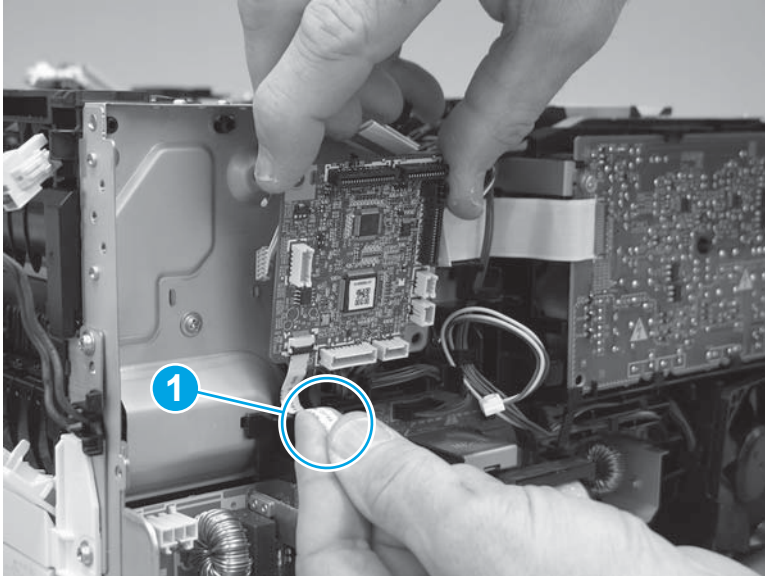
**Figure 1-1389** Remove two screws



3. Separate the DC controller from the printer.

**CAUTION:** Carefully pull up on the FFC (callout 1) to release it from the guide, and then remove the DC controller.

**Figure 1-1390** Remove the DC controller

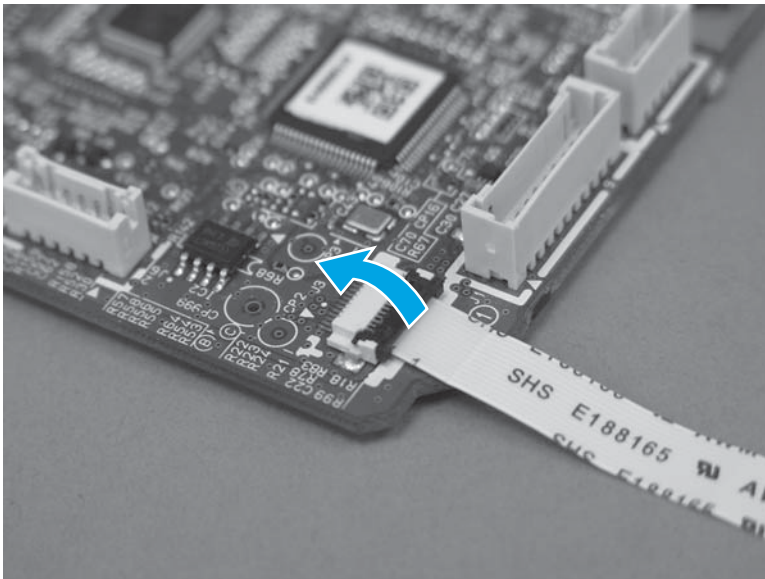


4. Disconnect one the FFC.

**IMPORTANT:** The FFC connector is a Zero Insertion Force (ZIF) connector that uses a hinged retainer to secure the FFC. The hinged retainer must be opened to release the FFC.

Do not discard this FFC. It must be installed on the replacement DC controller

**Figure 1-1391** Disconnect one the FFC

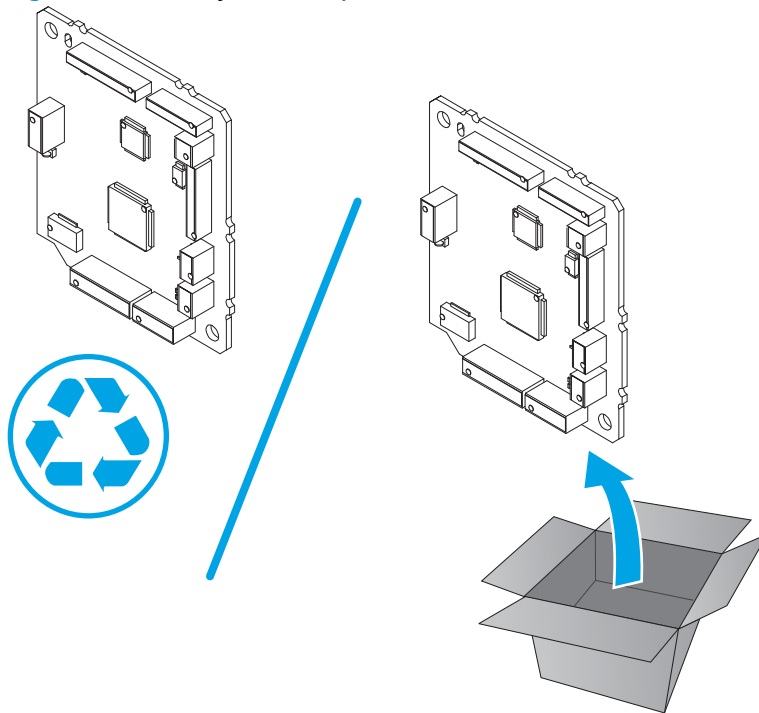


### Step 13: Unpack the replacement assembly

Unpack the replacement part from the packaging.

 **NOTE:** HP recommends responsible disposal of the defective part.


**Figure 1-1392** Recycle and unpack



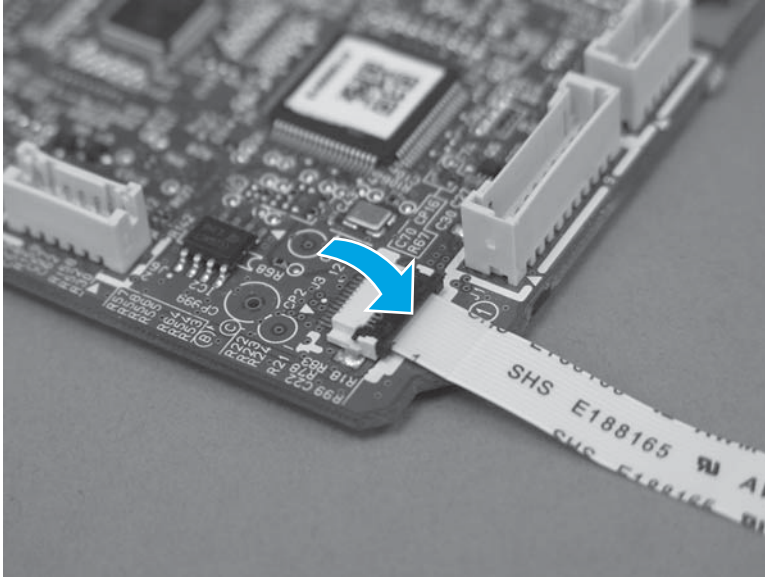
#### Step 14: Install the DC controller

1. Connect the formatter FFC to the replacement DC controller connector.

Make sure that the FFC is fully inserted into the connector body, close the hinged retainer to lock the cable in place, and then slightly tug on the cable to make sure it is securely fastened.

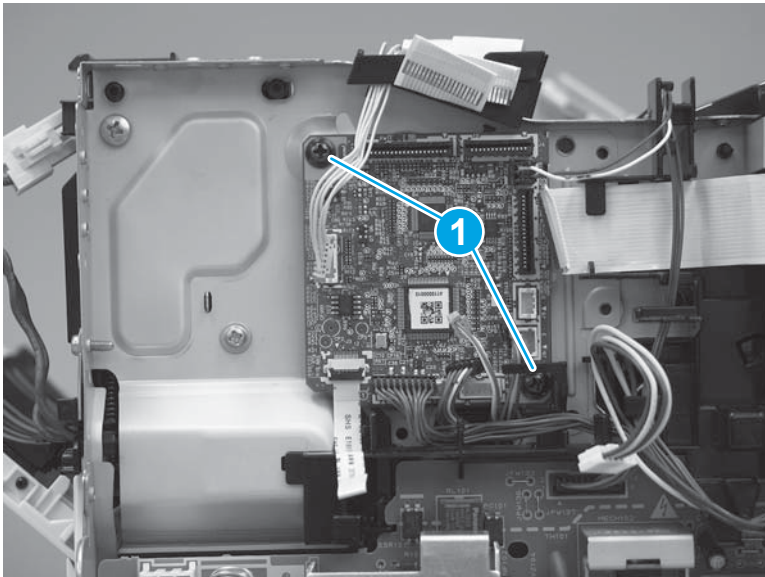
 **IMPORTANT:** The ZIF connector hinged retainer must be in the open position to insert the FFC.

**Figure 1-1393** Connect one the FFC



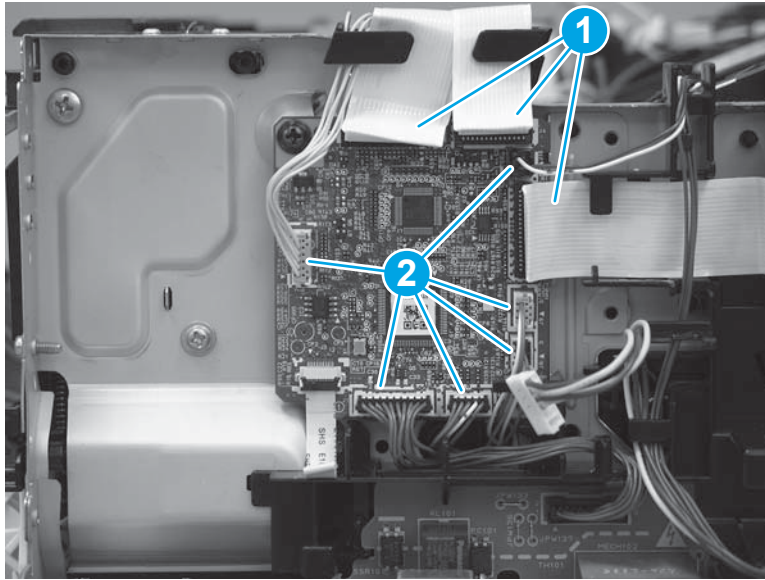
2. Position the DC controller on the printer, and then install two screws (callout 1).

**Figure 1-1394** Install the DC controller




3. Connect three FFCs (callout 1), and six connectors (callout 2).

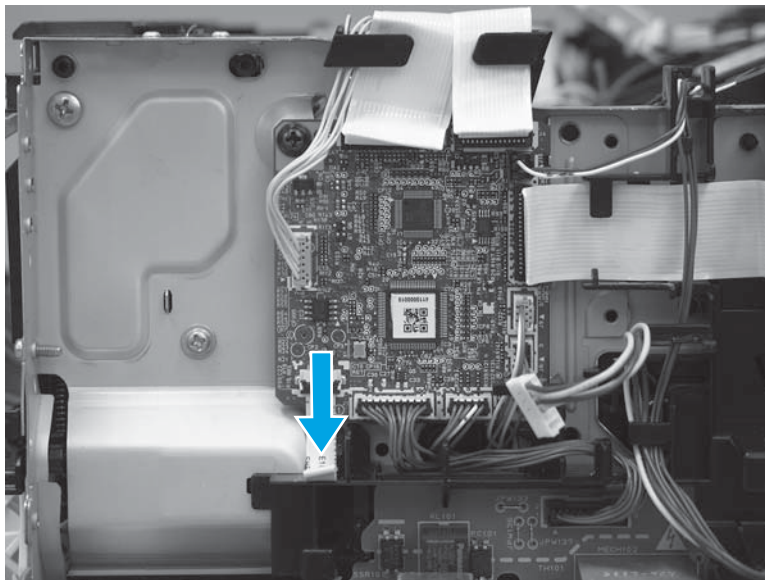
**Figure 1-1395** Connect three FFCs and six connectors



4. Carefully push on the FFC (callout 1) to adhere it to the guide.

 **Reinstallation tip:** The two sided tape on the back side of FFC might need to be replaced if it will not adhere to the guide.

**Figure 1-1396** Adhere the FFC to the guide

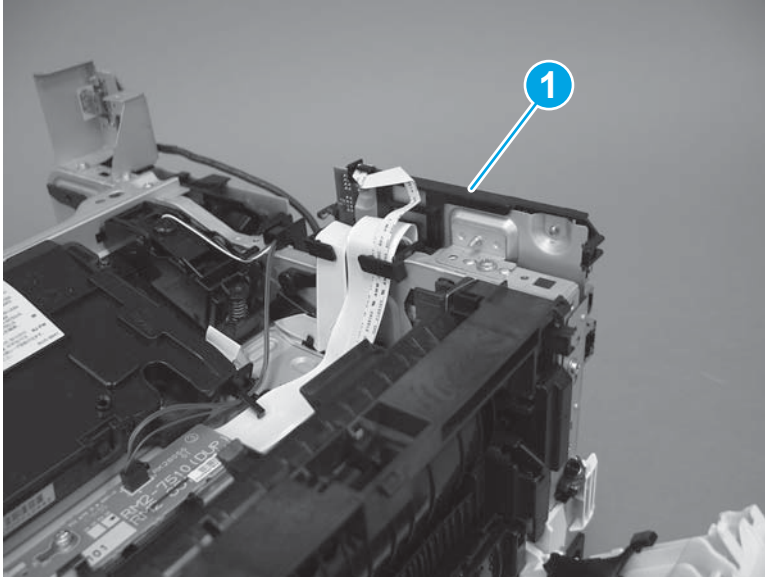


### Step 15: Install the sheet-metal formatter bracket and formatter

 **NOTE:** Disconnect any remaining formatter PCA FFCs or wire-harness connectors.

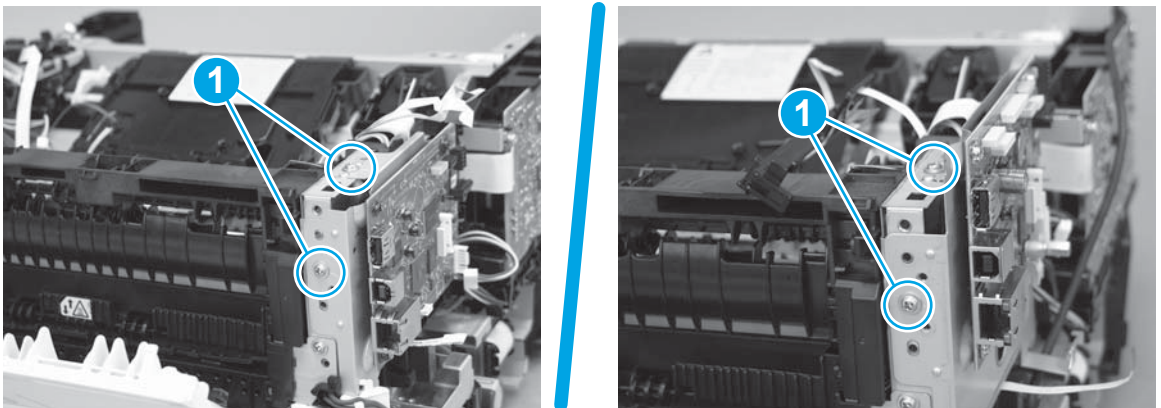
1. **M427/M426 only:** Remove the guide (callout 1).

**Figure 1-1397** Remove the guide



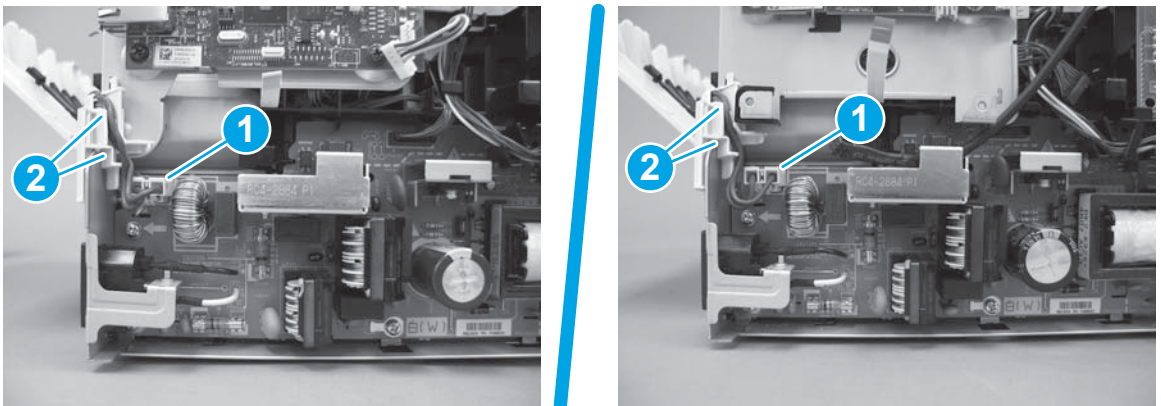
2. Remove two screws (callout 1).

**Figure 1-1398** Remove two screws



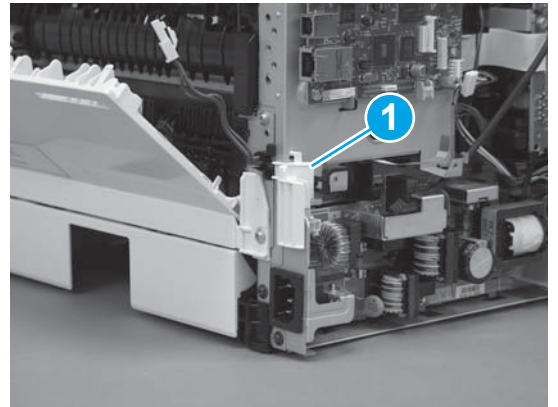
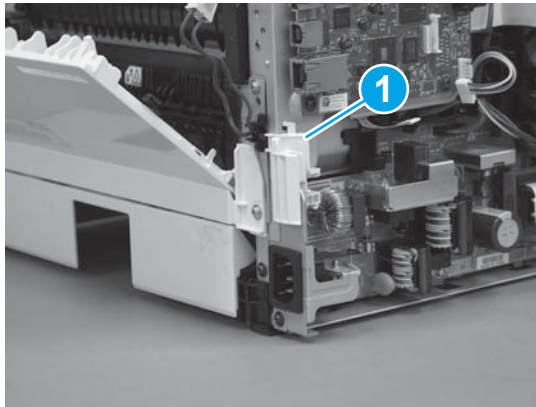
3. Disconnect one connector (callout 1), and then release the wire harness from the guide (callout 2).

**Figure 1-1399** Disconnect one connector



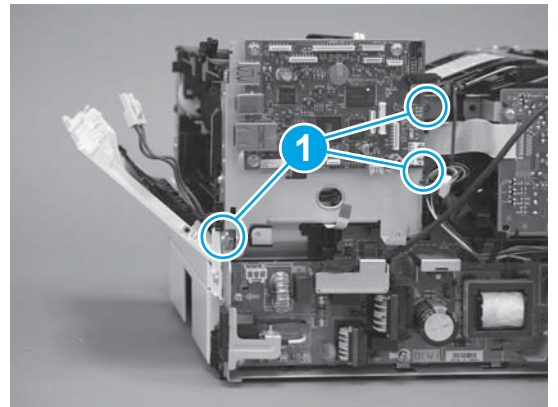
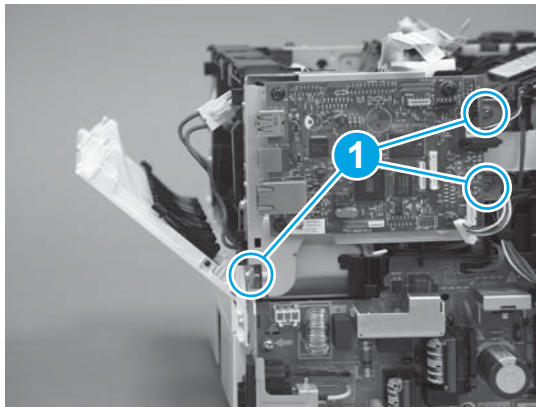
4. Remove the guide (callout 1).

**Figure 1-1400** Remove the guide



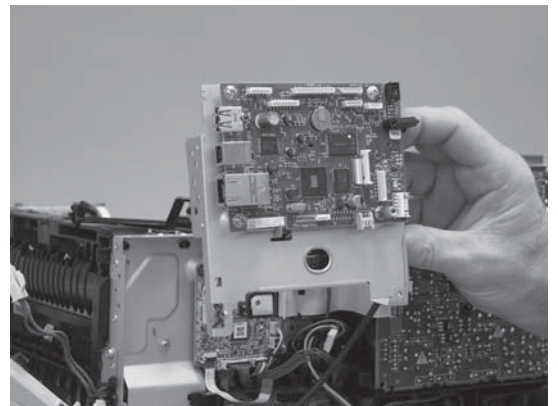
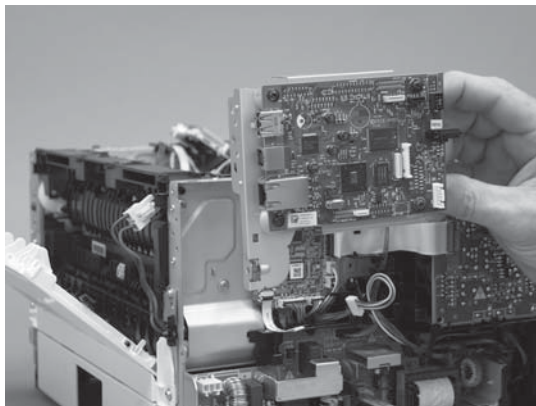
5. Remove three screws (callout 1).

**Figure 1-1401** Remove three screws




6. Remove the sheet-metal bracket and formatter PCA.

**Figure 1-1402** Remove the bracket

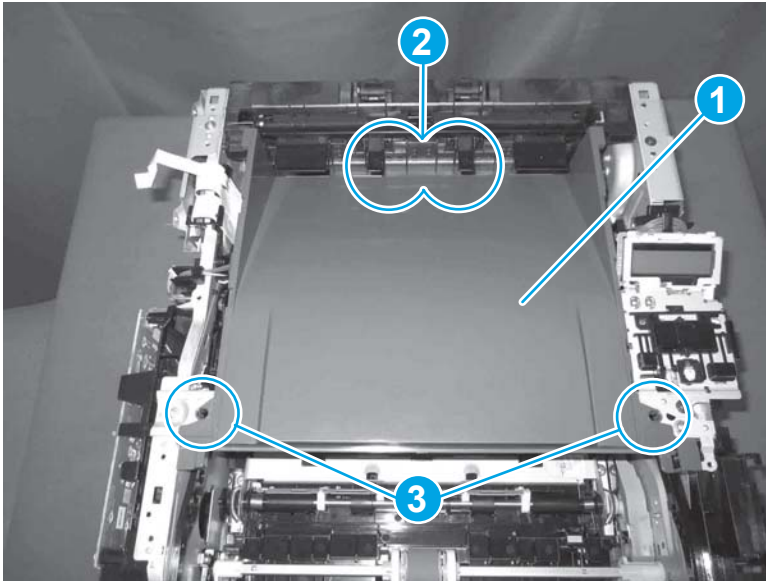


## Step 16: Install the paper delivery tray (output bin)


 **NOTE:** This procedure shows the M403/M402 model, however, the paper delivery tray (output bin) removal is similar for the M427/M426 printer.

- ▲ Position the remove the paper delivery tray (output bin; callout 1) on the printer, engage two tabs (callout 2), and then engage two bosses (callout 3).

**Figure 1-1403** Engage two tabs

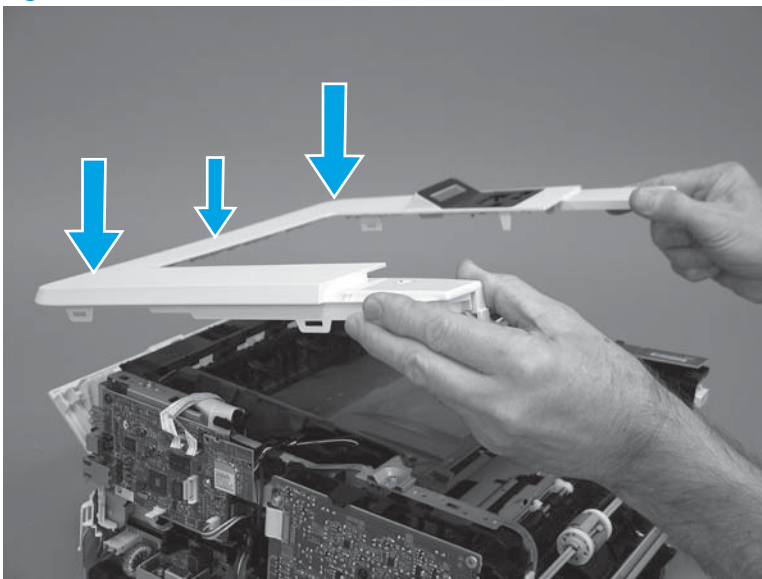


## Step 17: Install the top cover (M403/M402)

 **NOTE:** The step is for the M403/M402 printer. For the M427/M426, skip this step and go to [Step 18: Install the top cover \(M427/M426\) on page 756](#).

1. Position the rear edge of the cover on the printer.

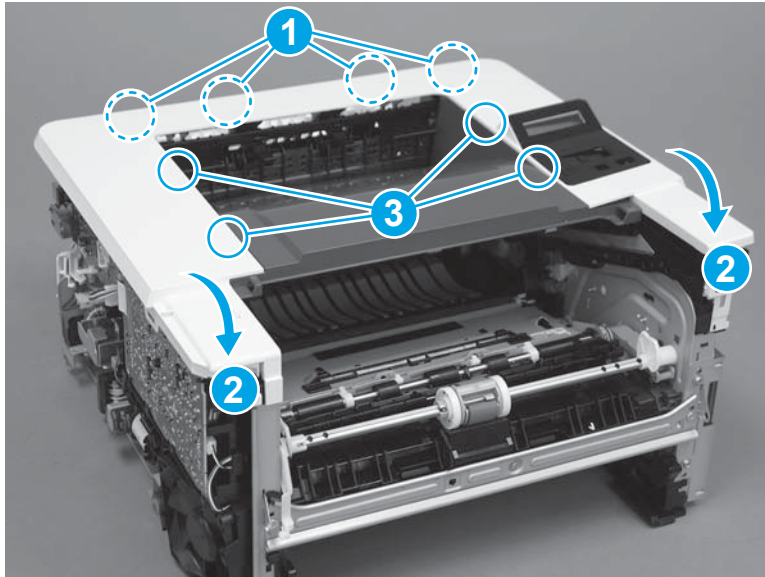
**Figure 1-1404** Install the cover





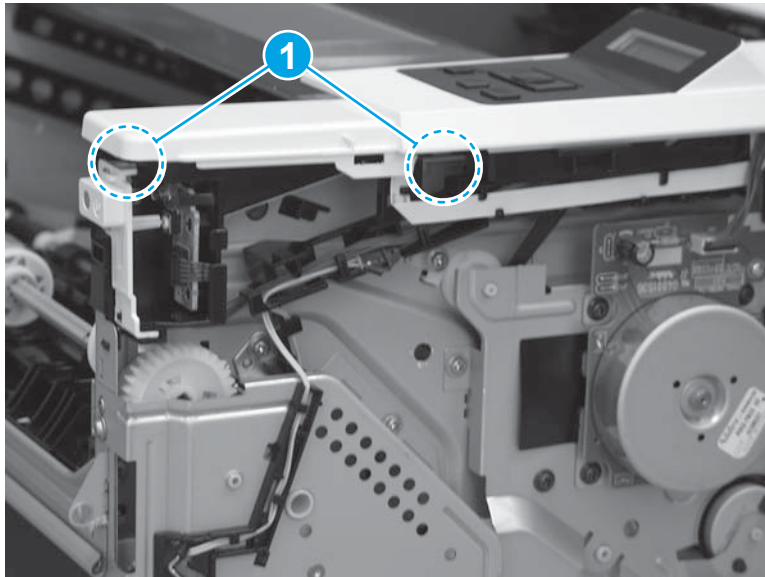
2. Engage four bosses (callout 1), rotate the front of the cover down (callout 2) and onto from the printer, and then engage four tabs (callout 3).

**Figure 1-1405** Engage four bosses and tabs



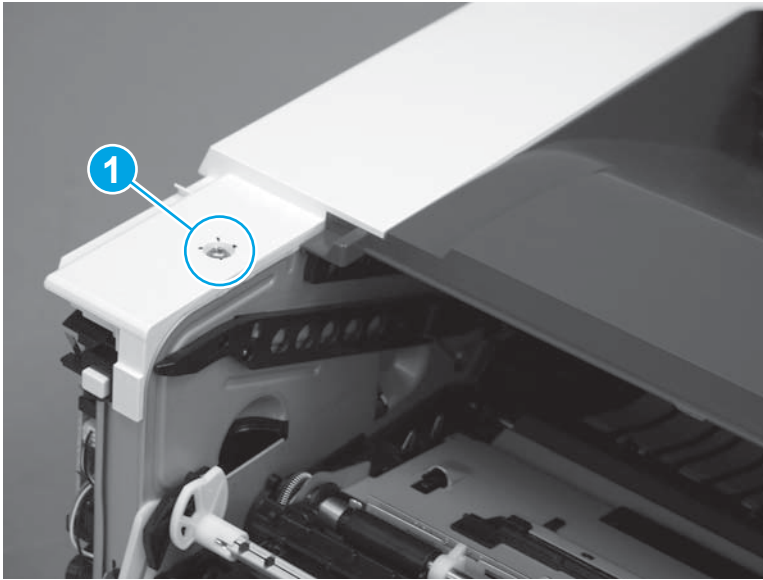
3. At the right side of the printer, engage the one boss and one tab (callout 1).

**Figure 1-1406** Engage one boss and one tab




4. Install one screw (callout 1).

**Figure 1-1407** Install one screw

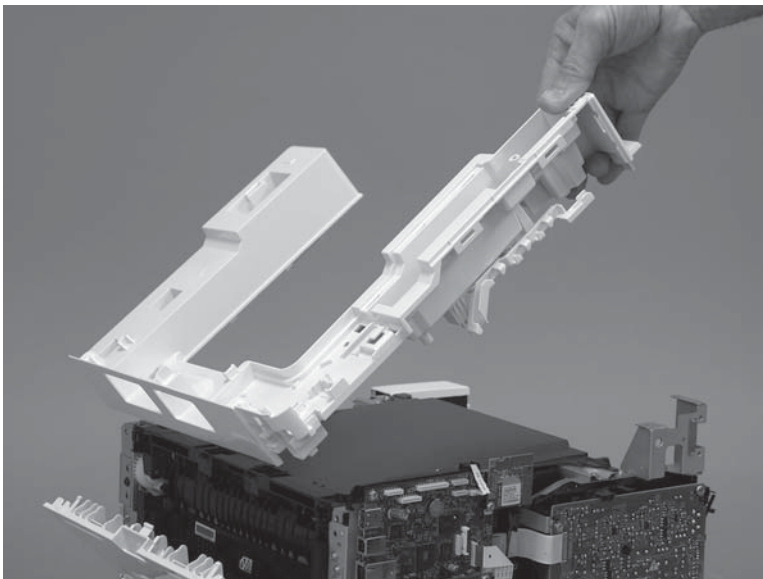


#### Step 18: Install the top cover (M427/M426)

 **NOTE:** The step is for the M427/M426 printer. For the M403/M402, skip this step and go to [Step 21: Install the rear door assembly on page 767](#).

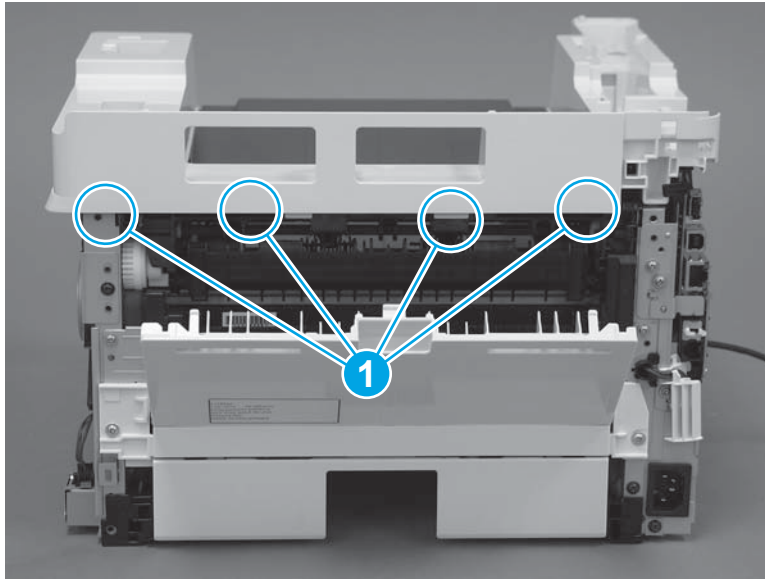
1. Position the rear edge of the top cover on the printer.

**Figure 1-1408** Install the cover



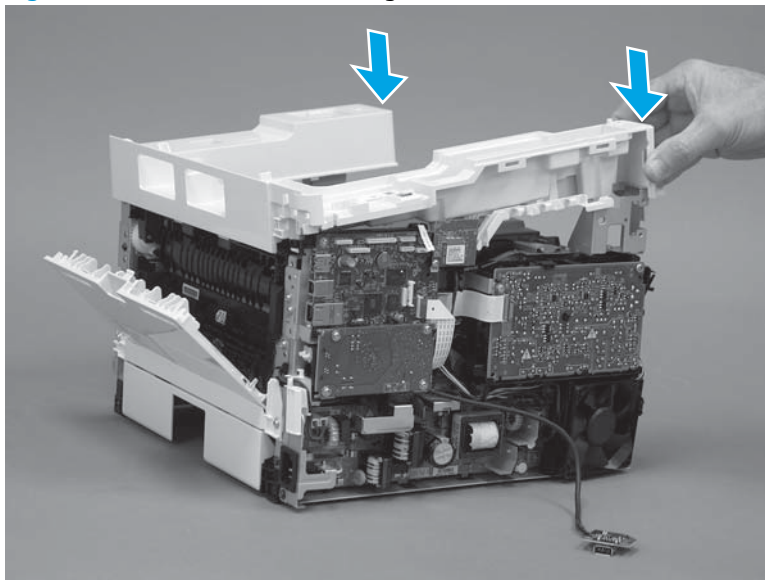
2. Engage four bosses (callout 1).

**Figure 1-1409** Engage four bosses



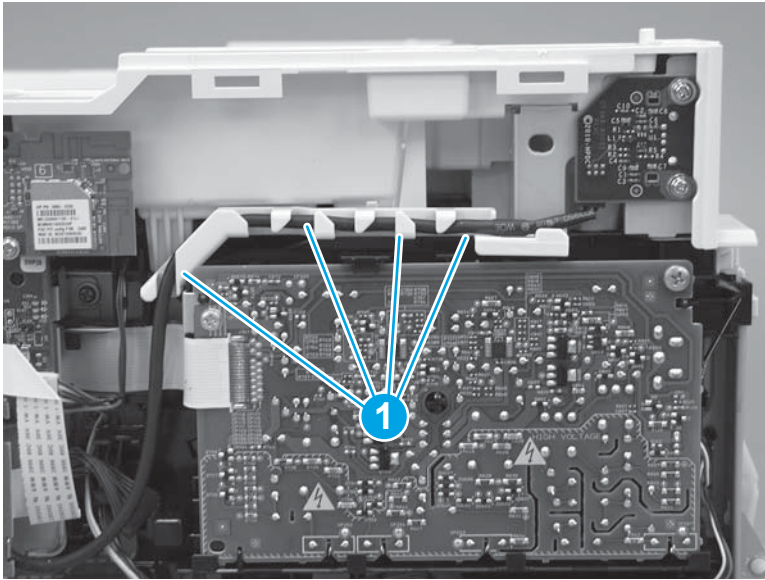
3. Rotate the front edge of the cover down.

**Figure 1-1410** Rotate the front edge of the cover down



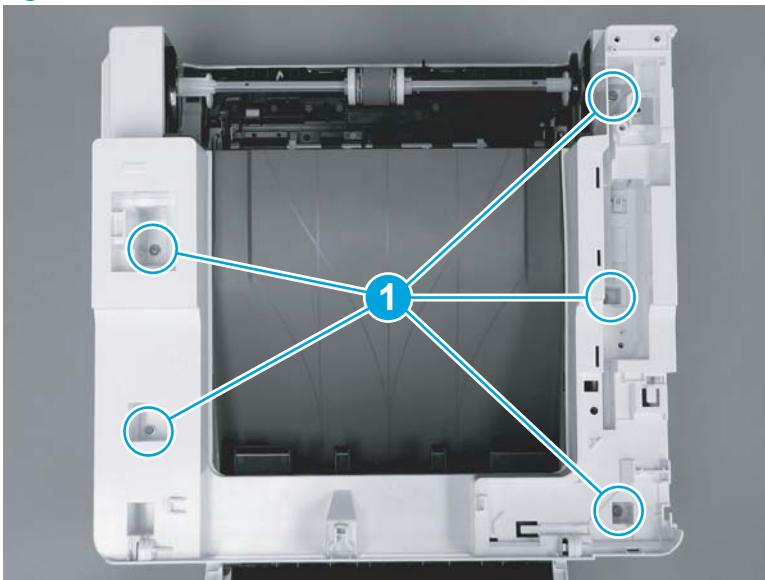
4. Install the USB cable (callout 1) in the guide.

**Figure 1-1411** Install the USB PCA




5. Install five screws (callout 1).

**Figure 1-1412** Install five screws

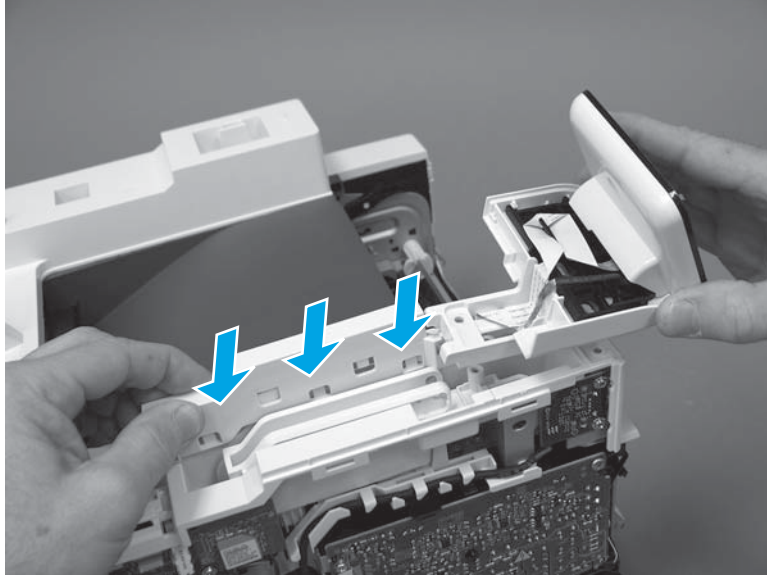


### Step 19: Install the control panel (M427/M246)

 **NOTE:** The step is for the M427/M426 printer. For the M403/M402, skip this step and go to [Step 21: Install the rear door assembly on page 767](#).

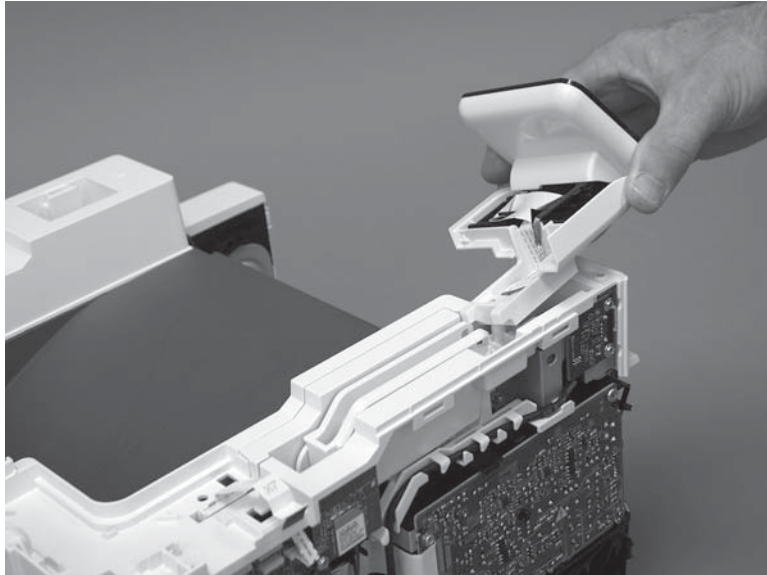
1. Slide the control-panel FFC cover into the slot in the top cover (next to the document feeder support arm) to install it.

**Figure 1-1413** Install the control-panel FFC cover



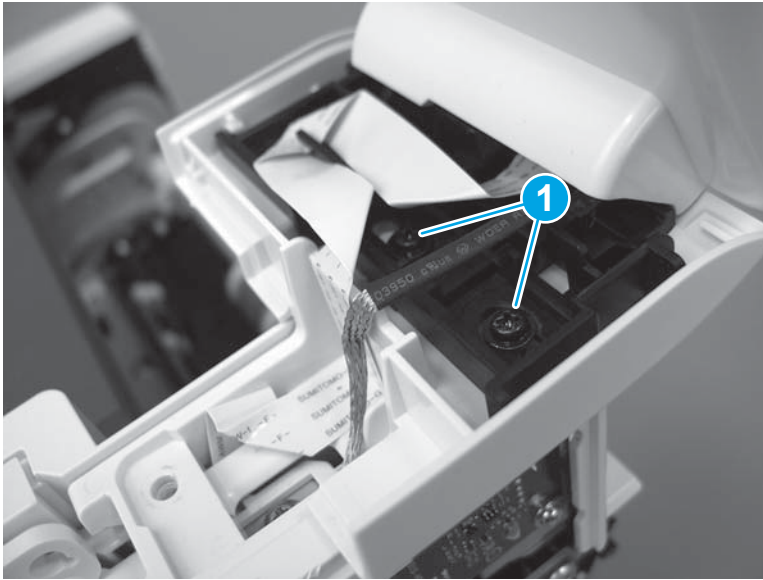
2. Install the control-panel assembly on the top cover.

**Figure 1-1414** Install the control-panel assembly



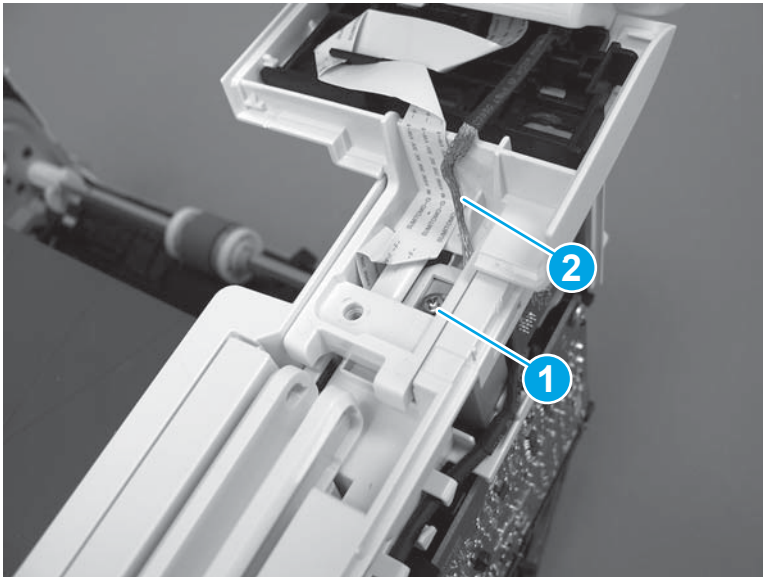
3. Move the FFC out of the way, and then install two screws (callout 1).

**Figure 1-1415** Install two screws



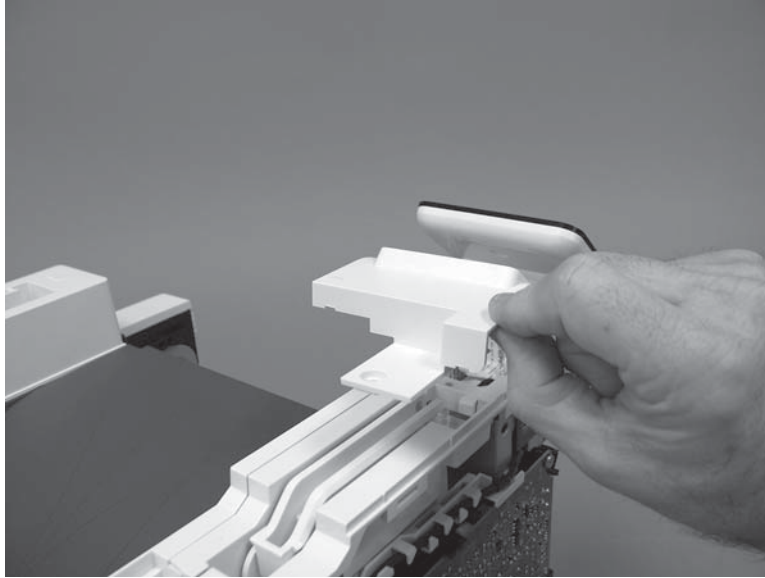
4. Install one grounding screw (callout 1), and then make sure that the ground cable (callout 2) is properly routed.

**Figure 1-1416** Remove one screw



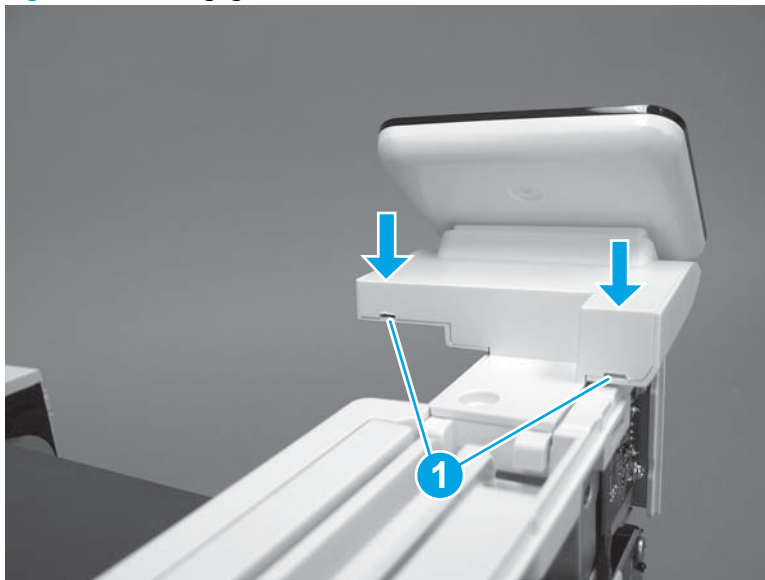
5. Install the control-panel cable cover.

**Figure 1-1417** Install the cover



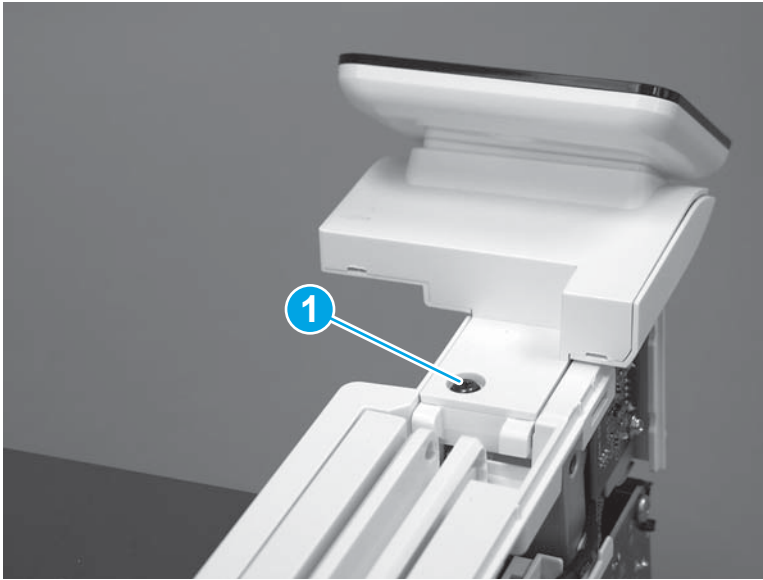
6. Make sure that the two tabs (callout 1) on the cover snap into place.

**Figure 1-1418** Engage two tabs



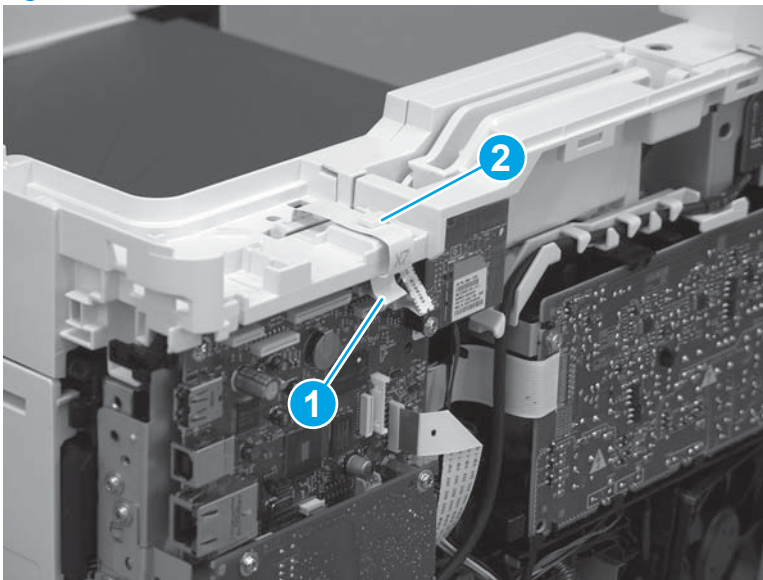
7. Install one screw (callout 1).

**Figure 1-1419** Install one screw





8. Install the FFC in the retainer (callout 1), and then connect one FFC (callout 1; J114).

**Figure 1-1420** Connect one connector



### Step 20: Install the integrated scanner assembly (M427/M246)

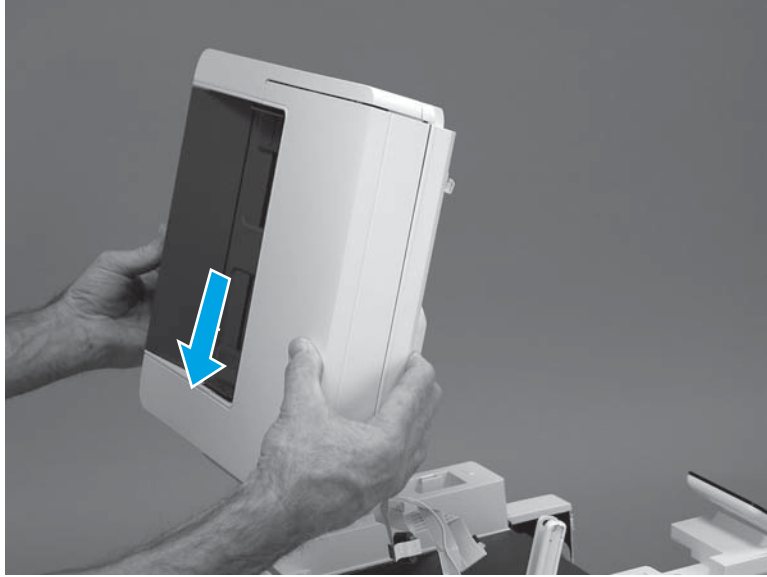
 **NOTE:** The step is for the M427/M426 printer. For the M403/M402, skip this step and go to [Step 21: Install the rear door assembly on page 767](#).

 **NOTE:** M427/M426 models only. The integrated scanner assembly (ISA) includes the sub-scanner assembly (SSA) and the automatic document feeder (ADF).

1. Position the ISA on the printer.

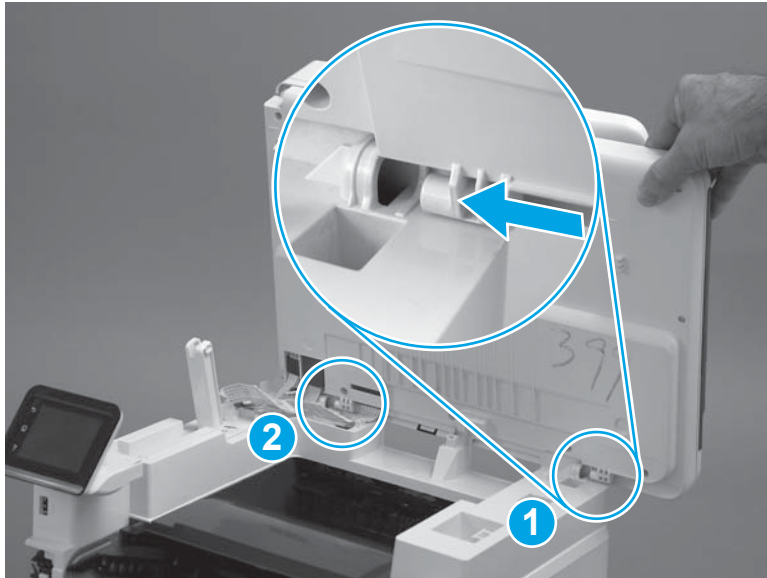


**Figure 1-1421** Position the ISA on the printer



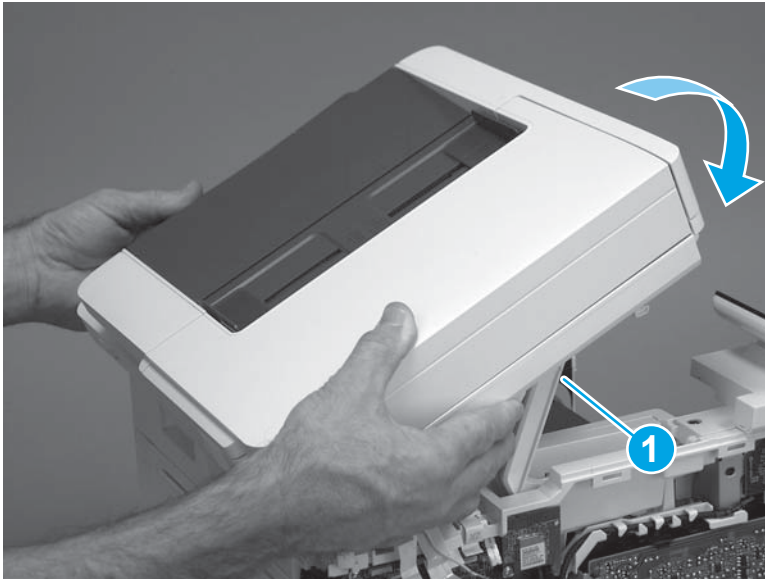
2. Engage the hinge pins on the ISA with the holders in the top cover (callouts 1/2), and then slide the ISA as shown to engage them

**Figure 1-1422** Engage the hinge pins with the holders



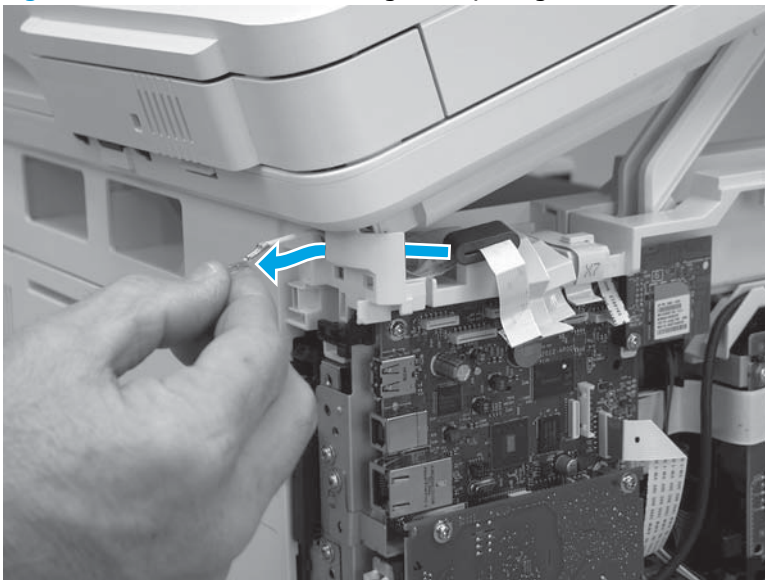
3. Rotate the ISA towards the front of the printer until it rests on the ISA lift assembly (callout 1).

**Figure 1-1423** Rotate the ISA towards the front of the printer



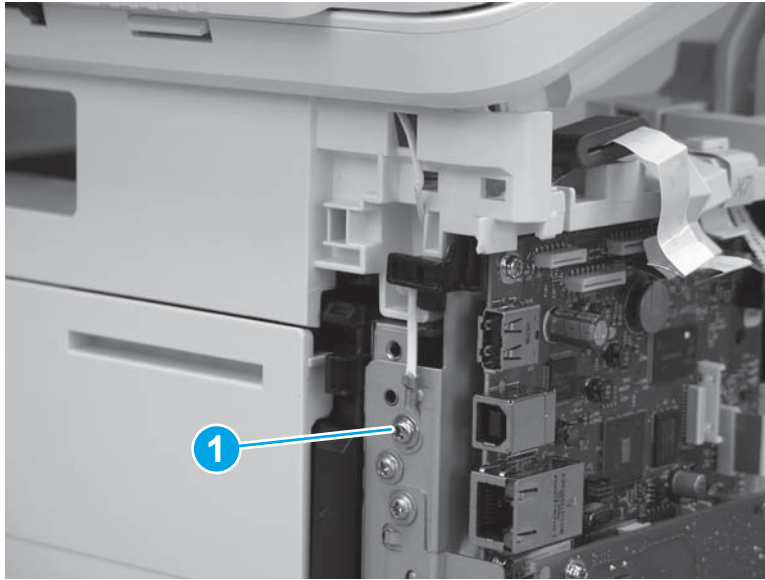
4. Pass the ground wire through the opening in the top cover.

**Figure 1-1424** Pass the wire through the opening




5. Install one screw (callout 1).

**Figure 1-1425** Install one screw



6. Install the ISA lift assembly slider pin.

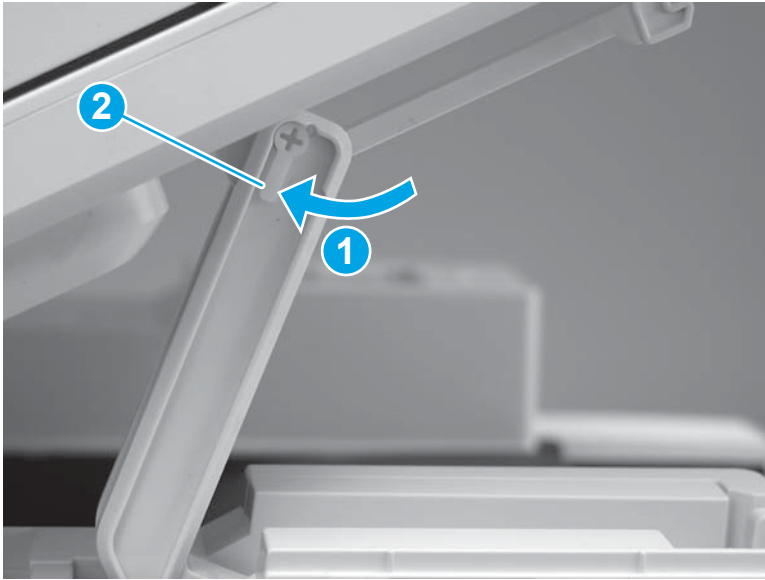
 **Reinstallation tip:** Align the keyed portion of the locking pin with the slot and hole in the support arm.

**Figure 1-1426** Install the slider pin



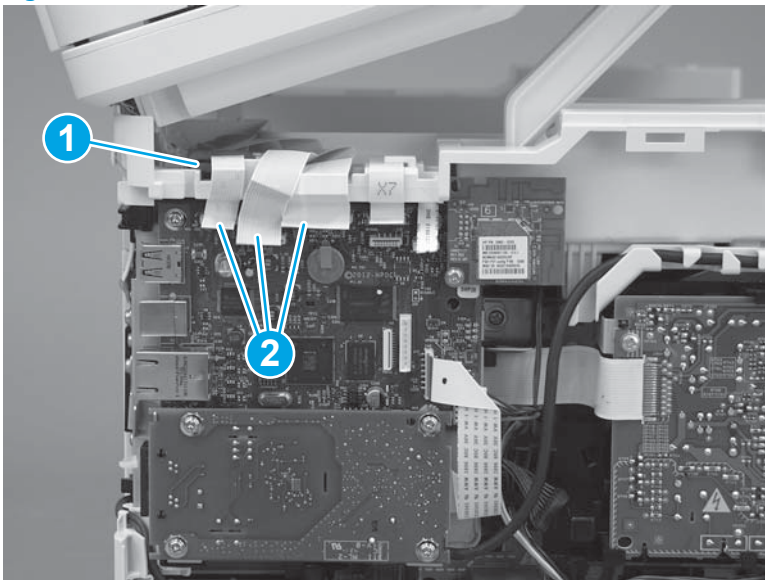
7. Rotate the slider pin (callout 1) towards the rear of the printer until the tab (callout 2) snap into place.

**Figure 1-1427** Secure the slider pin



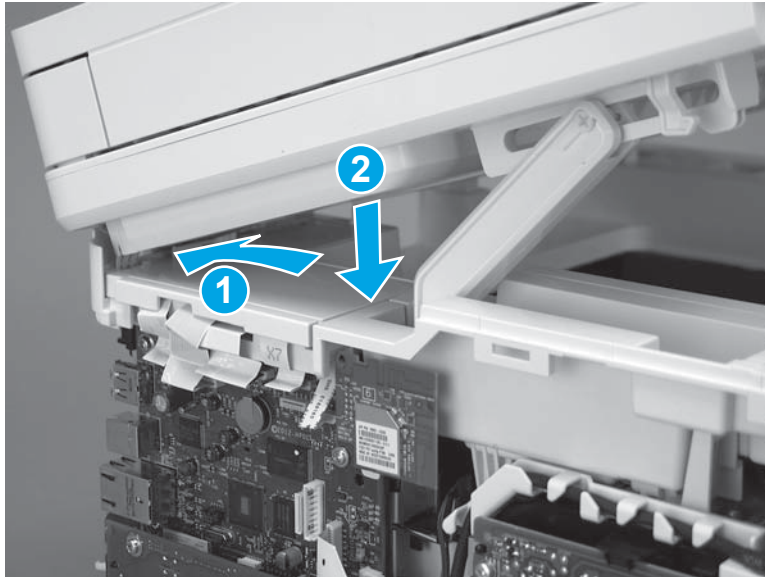
8. Install the ferrite (callout 1) in the holder, and then connect three FFCs (callout 2).

**Figure 1-1428** Connect three FFCs



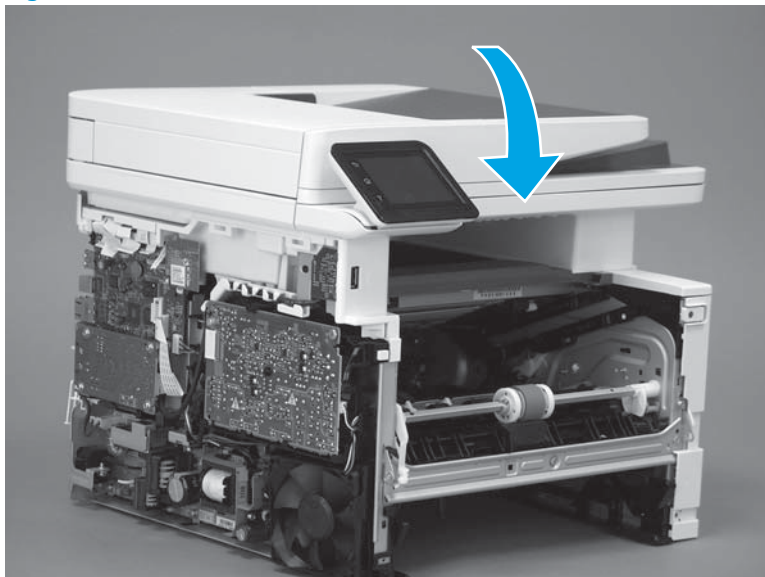
9. Position the rear edge of the ISA flat-flexible cable (FFC) cover on the printer (callout 1) , and then rotate it down (callout 2) until it snaps into place.

**Figure 1-1429** Install the ISA FFC cover




10. Lower the ISA.

**Figure 1-1430** Lower the ISA

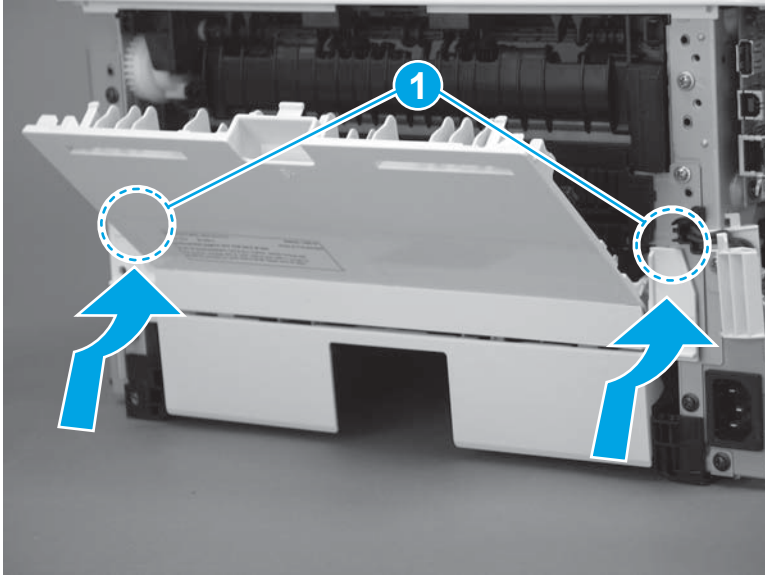


### Step 21: Install the rear door assembly

1. At the rear of the printer, position the assembly so that the two tabs (callout 1) are installed in the slots (callout 2) in the chassis.

 **NOTE:** Duplex models only: Slide the duplex tray into the Tray 2 cavity.

**Figure 1-1431** Install the rear cover



2. Install two screws.



**NOTE: Duplex models only:** Reach in from the front of the Tray 2 cavity and raise the feed assembly to the up and locked position so that the rear cover will fit flat against the chassis.

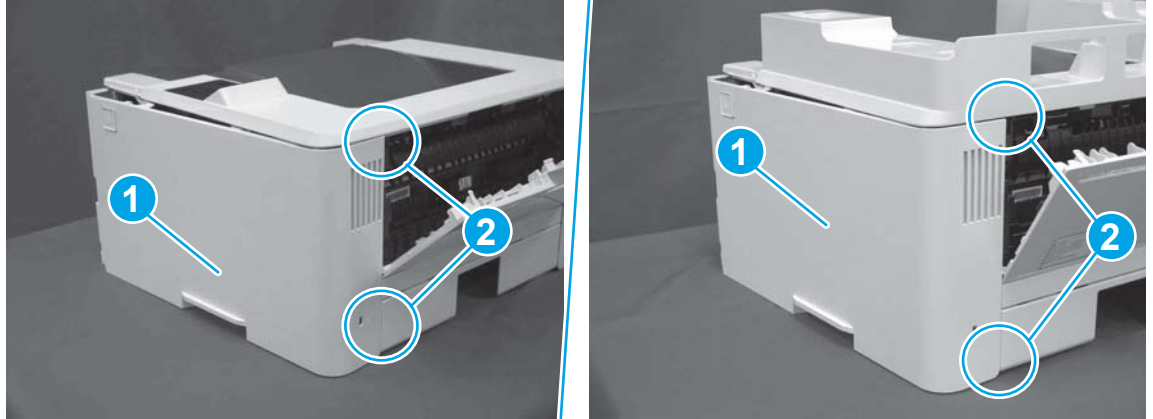
**Figure 1-1432** Install two screws



## Step 22: Install the right cover

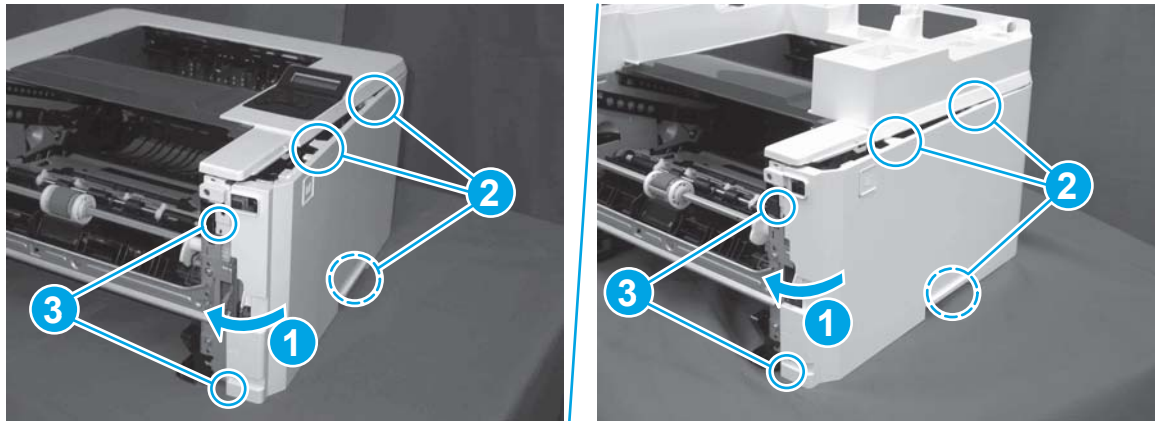
1. Position the cover (callout 1) on the printer, and then engage two bosses (callout 2).

**Figure 1-1433** Install the cover



2. Rotate the front of the cover onto the printer (callout 1), engage three (callout 2) tabs, and then engage two bosses (callout 3).

**Figure 1-1434** Engage two bosses and one tab

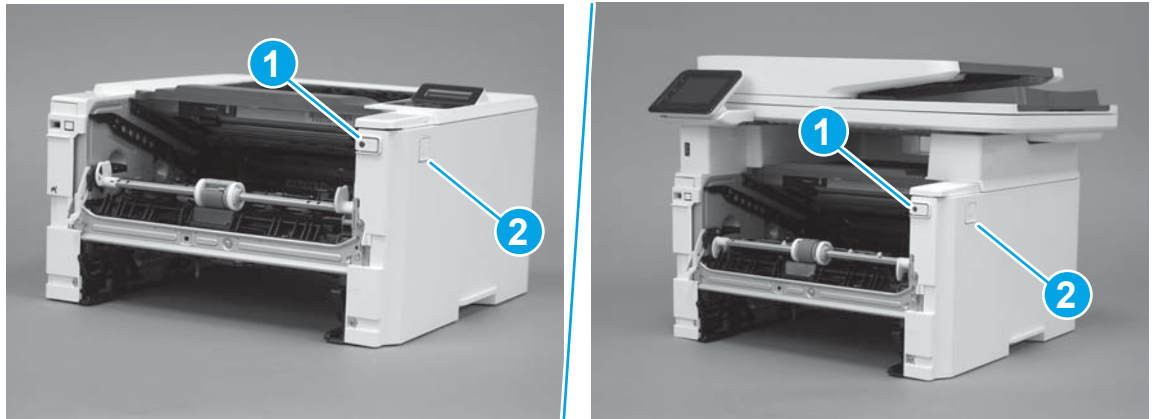


3. Make sure that the power switch (callout 1) and cartridge door assembly button (callout 2) correctly function.



**NOTE:** Remove, and then reinstall the cover if the switch or button does not correctly function.

**Figure 1-1435** Check the power switch and cartridge door assembly button



4. Install one screw (callout 1).

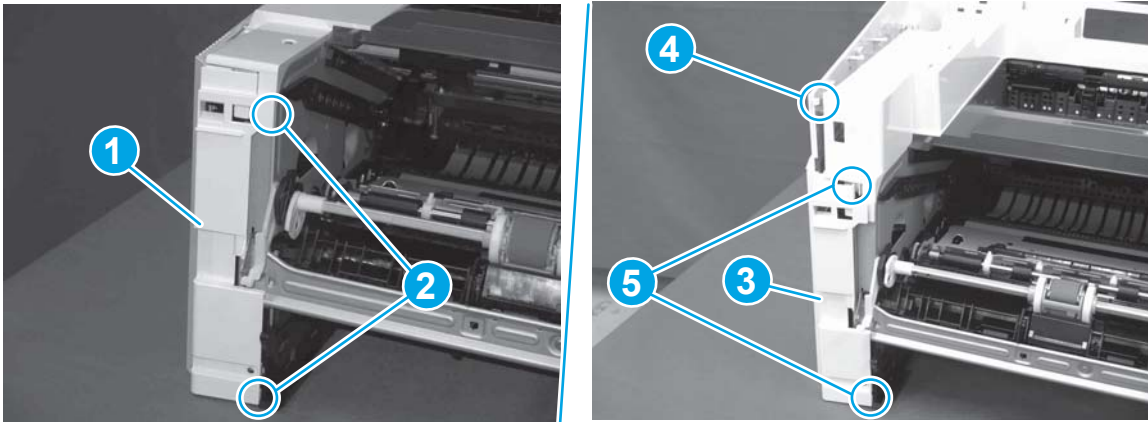
**Figure 1-1436** Install one screw



**Step 23: Install the left cover**

1. At the front of the printer, do one of the following:
  - **M403/M402:** Position the cover on the printer ( callout 1), and then engage two bosses (callout 2).
  - **M427/M426:** Position the cover on the printer (callout 3), engage one tab (callout 4), and then engage two bosses (callout 4).

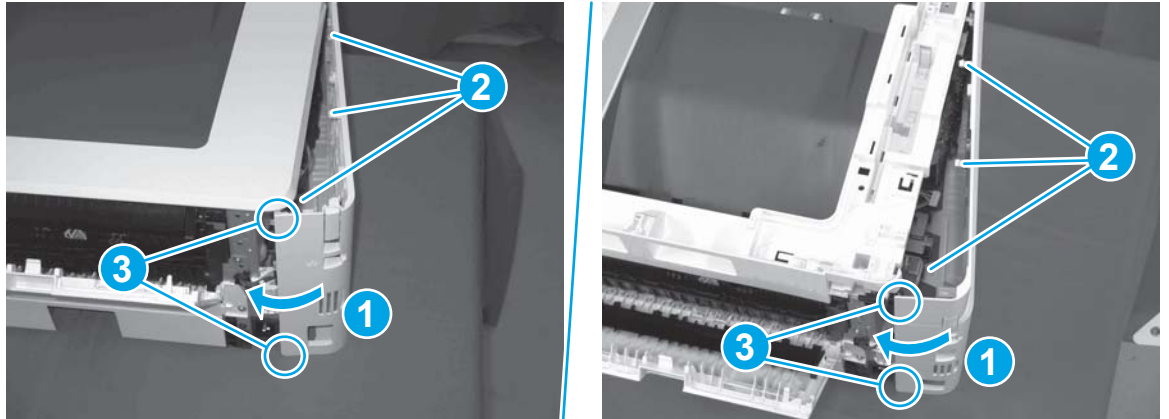
**Figure 1-1437** Install the cover





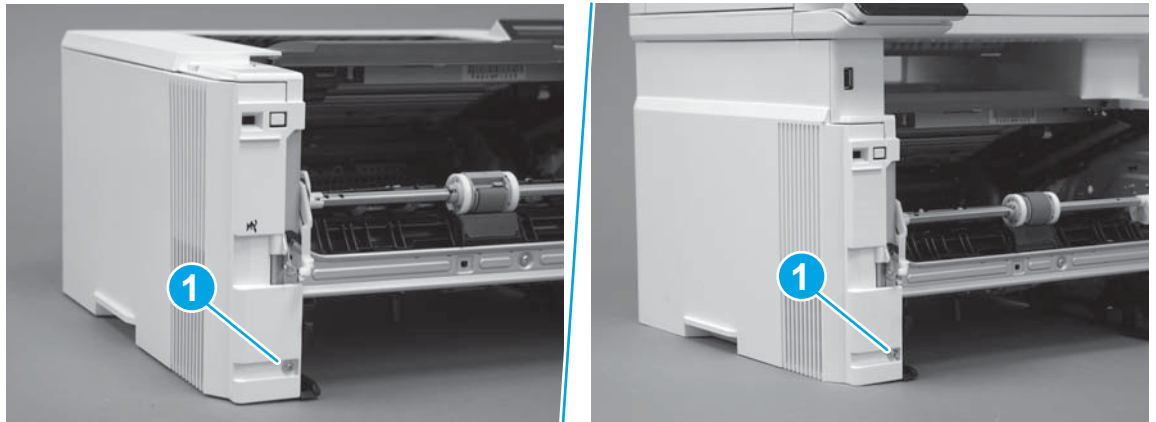
- Carefully rotate the rear of the cover onto the printer (callout 1), engage three tabs (callout 2), and then engage two bosses (callout 3).

**Figure 1-1438** Engage three tabs and two bosses



- Install one screw (callout 1).

**Figure 1-1439** Install one screw

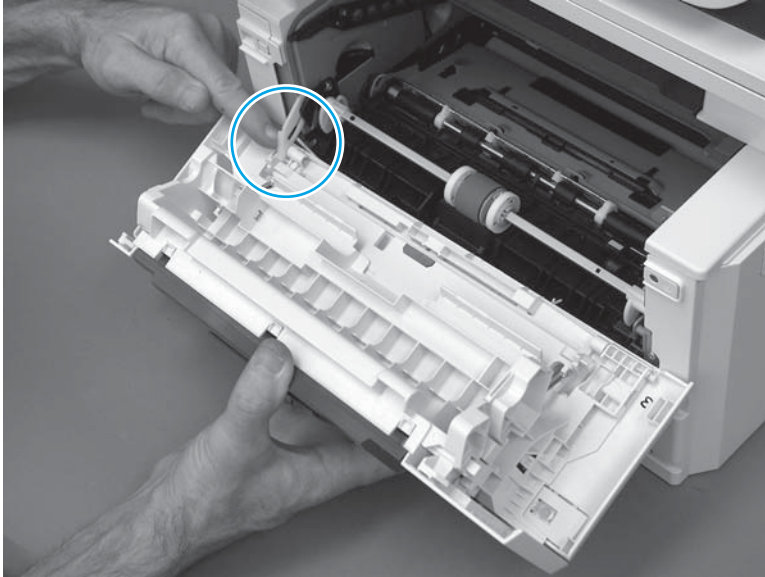


#### Step 24: Install the cartridge door assembly

**Reinstallation tip:** After a replacement door is installed, make sure to install the nameplate (supplied in the kit) corresponding to the printer name on the door.

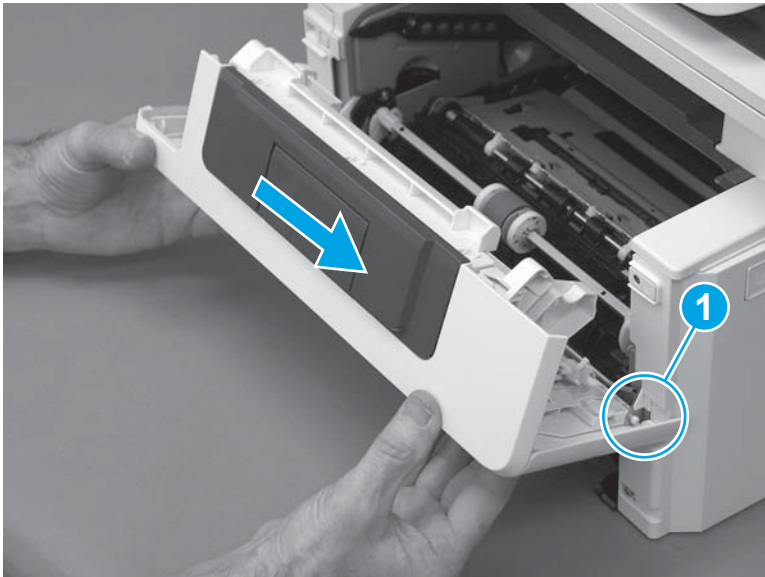
- Position the door close to the printer, and then engage the keyed pin on the left-side retainer arm with the hole in the door.

**Figure 1-1440** Engage the left-side retainer arm



2. Engage the right-side door hinge pin with the hole in the chassis (callout 1).

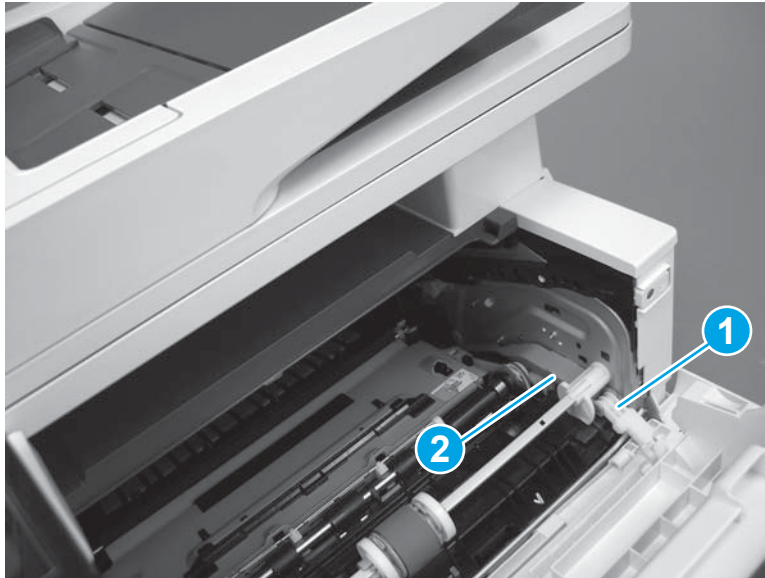
**Figure 1-1441** Install the door



3. Install the link (callout 1).

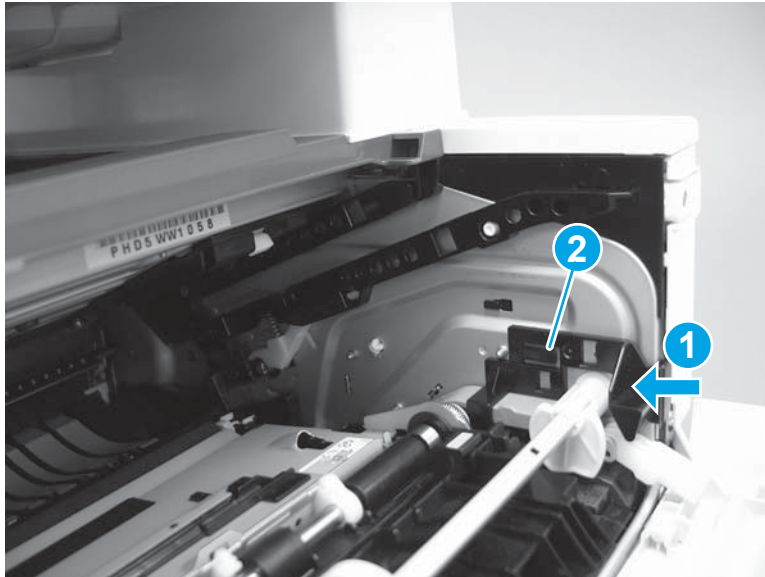
 **IMPORTANT:** Make sure that the link snaps into place on the arm (callout 2). The link actuates the fuser pressure-release mechanism.

**Figure 1-1442** Install the pressure-release link



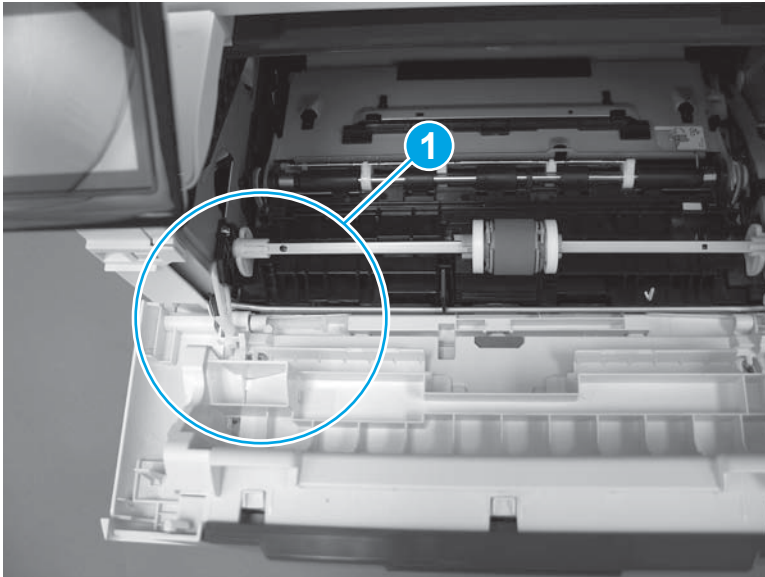
4. Slide the guide into the printer (callout 1), and then make sure that the tab (callout 2) snaps into place to secure the guide to the chassis.

**Figure 1-1443** Install the guide




5. Position the shaft on the door, and then align the left-side hinge on the door with the hole in the chassis (callout 1).

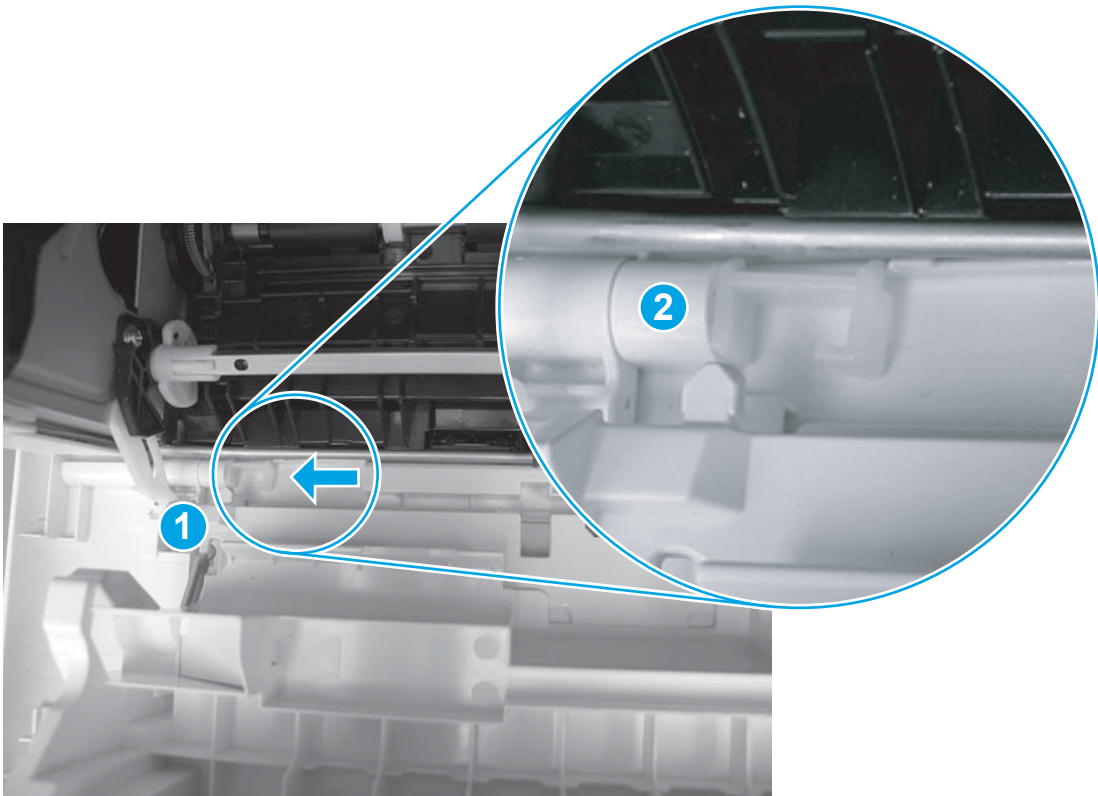
**Figure 1-1444** Align the hinge



6. Push the shaft towards the left side of the printer to install it (callout 1).

 **Reinstallation tip:** Make sure that the support shaft is fully installed and correctly orientated (callout 2) so that it will not interfere with the door opening and closing.

**Figure 1-1445** Install the support shaft



## Step 25: Install Tray 2

- ▲ Slide the tray straight into the printer to install it.

**Figure 1-1446** Install the tray



## Removal and replacement: Tag-cable assembly (toner-cartridge memory)

- [Introduction](#)
- [Step 1: Remove Tray 2](#)
- [Step 2: Remove the cartridge door assembly](#)
- [Step 3: Remove the left cover](#)
- [Step 4: Remove the right cover](#)
- [Step 5: Remove the integrated scanner assembly \(M427/M246\)](#)
- [Step 6: Remove the control panel \(M427/M246\)](#)
- [Step 7: Remove the top cover \(M427/M426\)](#)
- [Step 8: Remove the top cover \(M403/M402\)](#)
- [Step 9: Remove the paper delivery tray \(output bin\)](#)
- [Step 10: Remove the sheet-metal formatter bracket and formatter PCA](#)
- [Step 11: Remove the tag-cable assembly \(toner-cartridge memory\)](#)
- [Step 12: Unpack the replacement assembly](#)
- [Step 13: Install the tag-cable assembly \(toner-cartridge memory\)](#)
- [Step 14: Install the sheet-metal formatter bracket and formatter PCA](#)
- [Step 15: Install the paper delivery tray \(output bin\)](#)
- [Step 16: Install the top cover \(M403/M402\)](#)
- [Step 17: Install the top cover \(M427/M426\)](#)
- [Step 18: Install the control panel \(M427/M246\)](#)
- [Step 19: Install the integrated scanner assembly \(M427/M246\)](#)
- [Step 20: Install the right cover](#)
- [Step 21: Install the left cover](#)
- [Step 22: Install the cartridge door assembly](#)
- [Step 23: Install Tray 2](#)

### Introduction

This document provides the procedures to remove and replace the tag-cable assembly (toner-cartridge memory).

### Before performing service

#### Turn the printer power off

- Disconnect the power cable.

**⚠ WARNING!** To avoid damage to the printer, turn the printer off, wait 30 seconds, and then remove the power cable before attempting to service the printer.

Use the table below to identify the correct part number for your printer. To order the part, go to [www.hp.com/buy/parts](http://www.hp.com/buy/parts).

Tag-cable assembly (toner-cartridge memory) part number	
RM2-5426-000CN	Tag-cable assembly (toner-cartridge memory)

### Required tools

- #2 Phillips screwdriver with a magnetic tip.
- 5.5 mm (0.22 inch) socket screwdriver.

### After performing service

#### Turn the printer power on

- Connect the power cable.
- Use the power switch to turn the power on.

### Post service test

Make sure that the printer initializes to a **Ready** state.

Print a configuration page to make sure that the printer is functioning correctly.

### Step 1: Remove Tray 2

- ▲ Pull the tray straight out of the printer to remove it.

**Figure 1-1447** Remove the tray



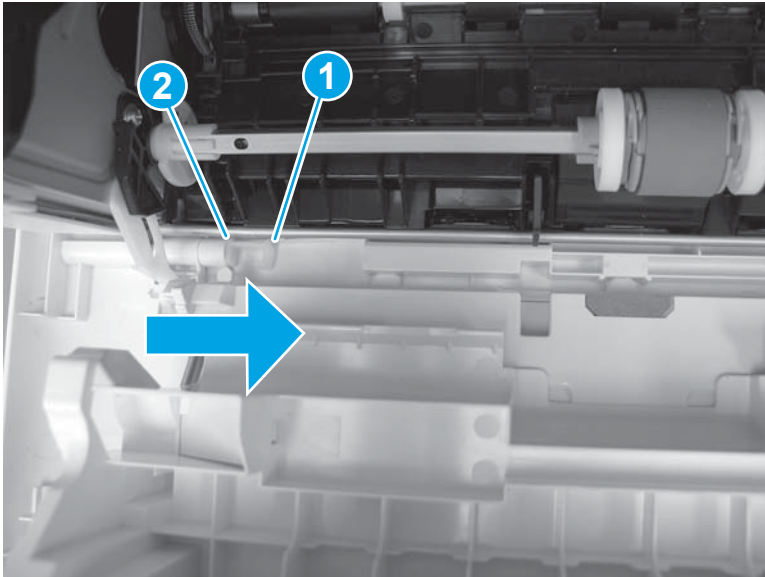
## Step 2: Remove the cartridge door assembly

 **NOTE:** If the toner cartridge was not removed prior to servicing the printer, remove it now.

1. Release one tab (callout 1), and then slide shaft (callout 2) in the direction the arrow indicates and remove it.

 **TIP:** It might be easier to release the support shaft by using a small flat-blade screwdriver.

**Figure 1-1448** Release the support shaft



2. Release one tab (callout 1), and then slide the guide (callout 2) in the direction the arrow indicates and remove it.

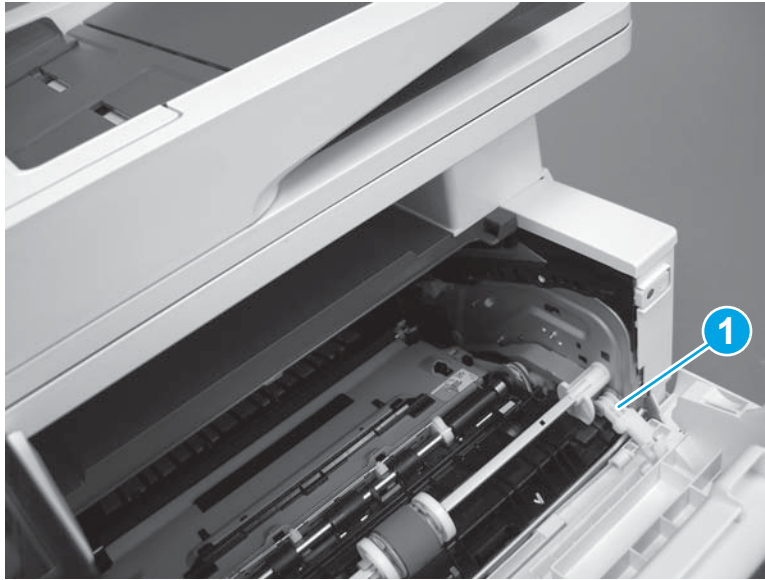
**Figure 1-1449** Remove the guide





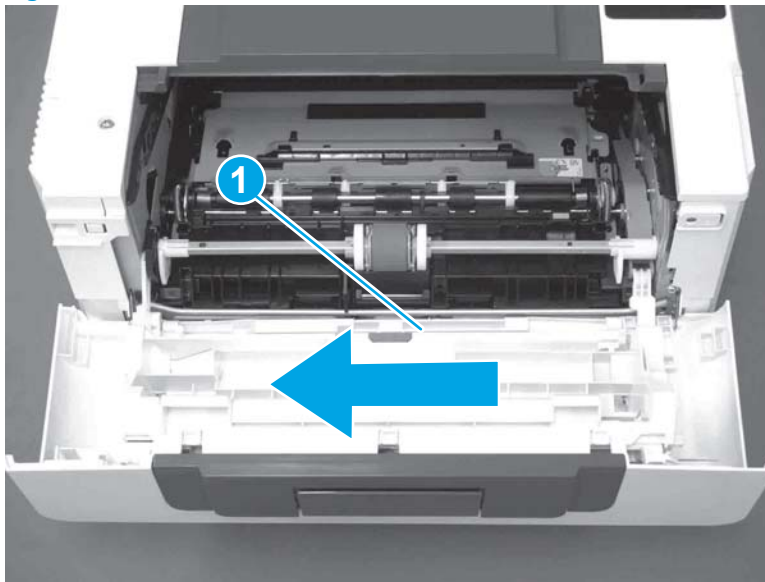
3. Remove the link arm (callout 1).

**Figure 1-1450** Remove the link arm



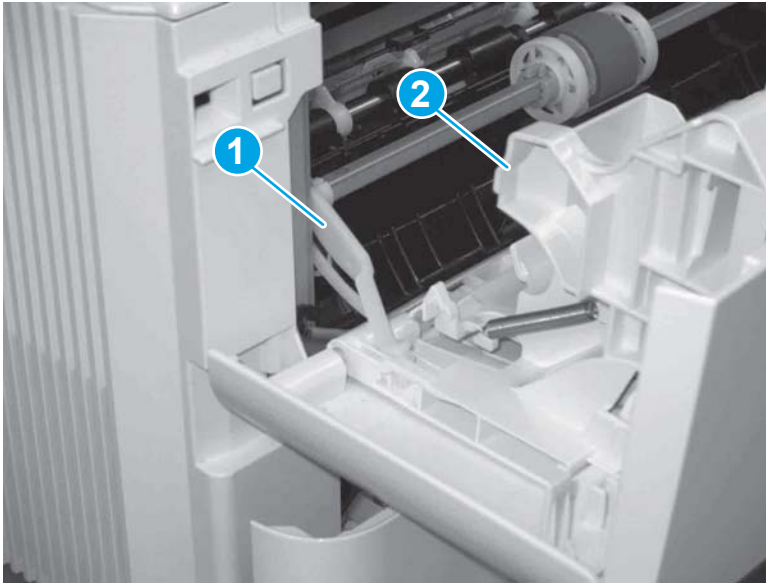
4. Slide the cartridge door assembly (callout 1) in the direction the arrow indicates and remove it.

**Figure 1-1451** Remove the door



5. Remove the link (callout 1) from the cartridge door assembly (callout 2).

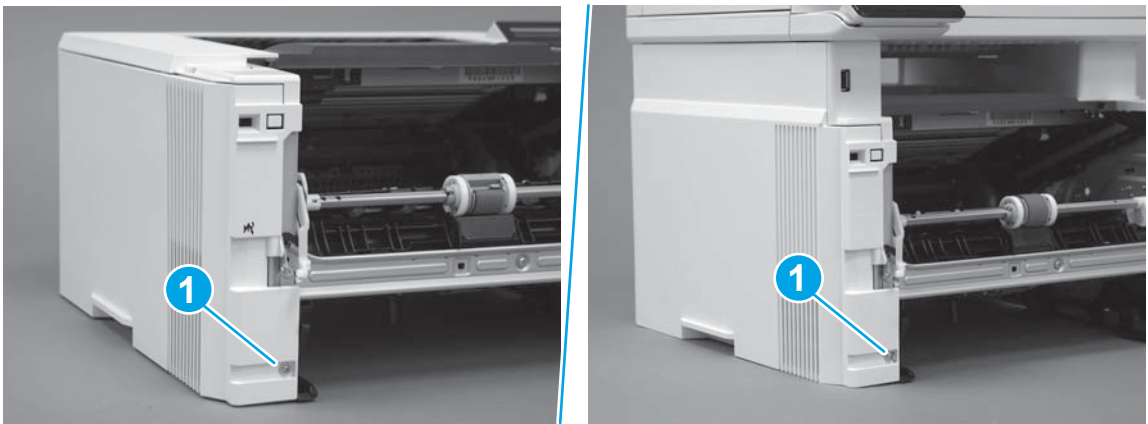
**Figure 1-1452** Release the left-side retainer arm



### Step 3: Remove the left cover

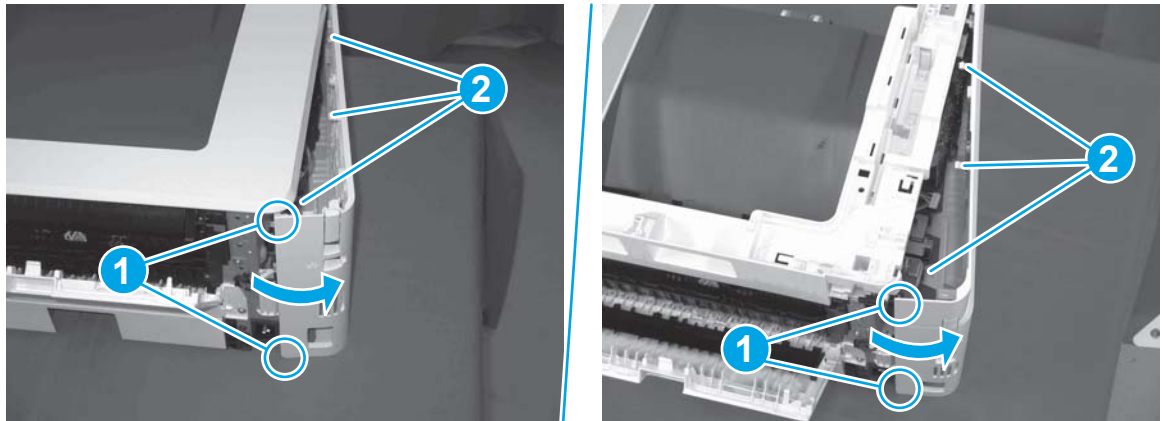
1. Remove one screw (callout 1).

**Figure 1-1453** Remove one screw



2. Open the rear door, release two bosses (callout 1), and then release three tabs (callout 2).

**Figure 1-1454** Release two bosses and three tabs

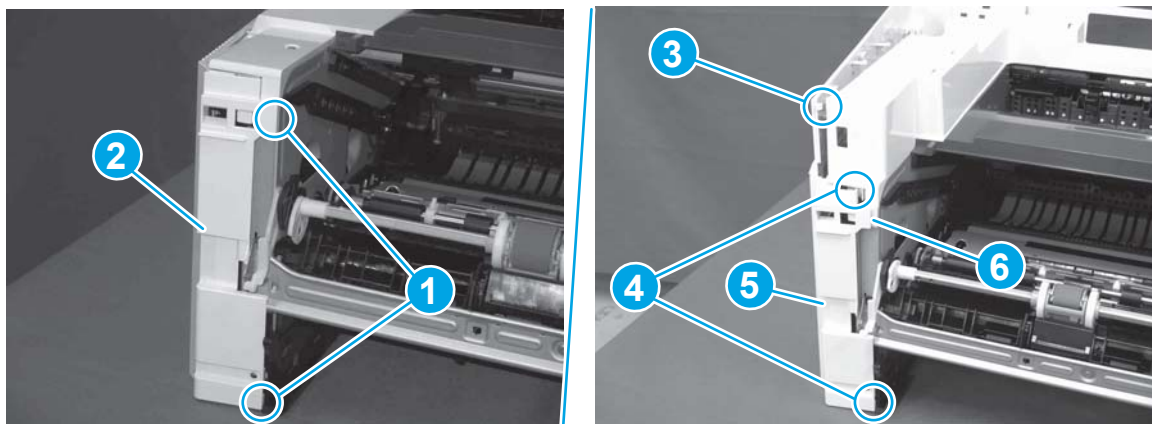


3. At the front of the printer, do one of the following:

- **M403/M402:** Release two bosses (callout 1), and then remove the cover (callout 2).
- **M427/M426:** Release one tab (callout 3), two bosses (callout 4), and then remove the cover (callout 5).

**CAUTION:** Be careful when releasing the upper bosses on the M427/M426 cover. One portion of the cover (callout 6) is fragile and is easily broken.

**Figure 1-1455** Remove the cover



#### Step 4: Remove the right cover

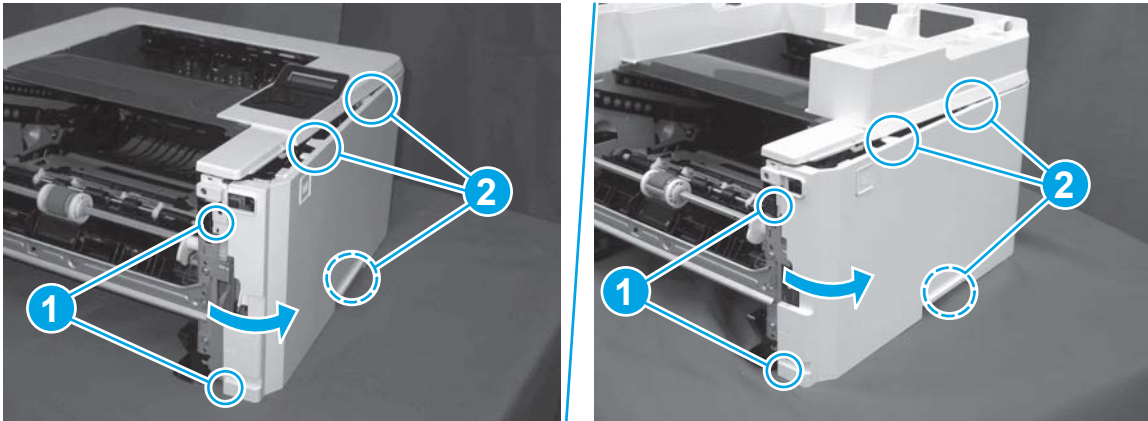
1. Remove one screw (callout 1).

**Figure 1-1456** Remove one screw



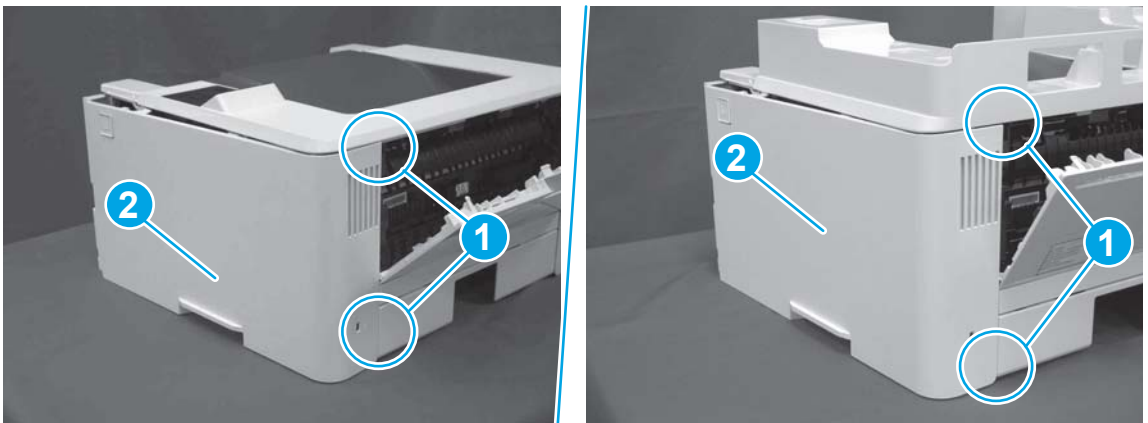
2. At the front of the printer, release two bosses (callout 1), and then release three tabs (callout 2).

**Figure 1-1457** Release two bosses and three tabs



3. Open the rear door, release two bosses (callout 1), and then remove the cover (callout 2).


**Figure 1-1458** Remove the cover



### Step 5: Remove the integrated scanner assembly (M427/M246)

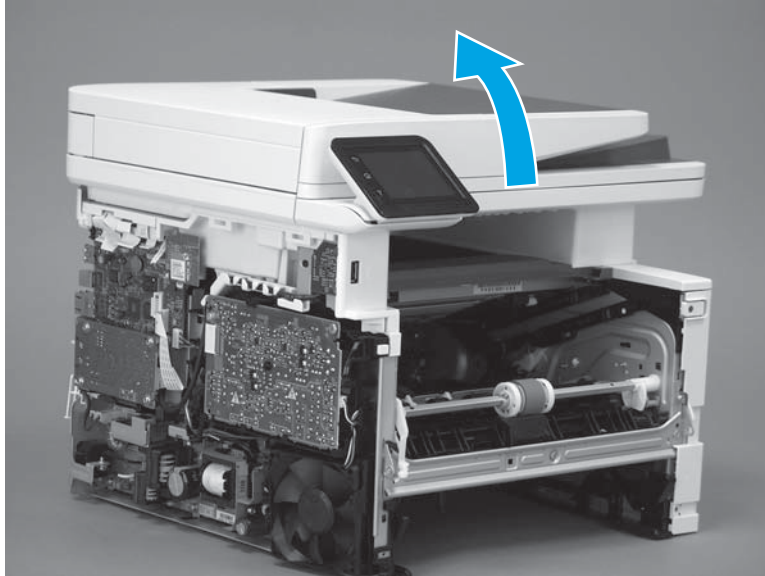


**NOTE:** The step is for the M427/M426 printer. For the M403/M402, skip this step and go to [Step 8: Remove the top cover \(M403/M402\)](#) on page 792.

 **NOTE:** M427/M426 models only. The integrated scanner assembly (ISA) includes the sub-scanner assembly (SSA) and the automatic document feeder (ADF).

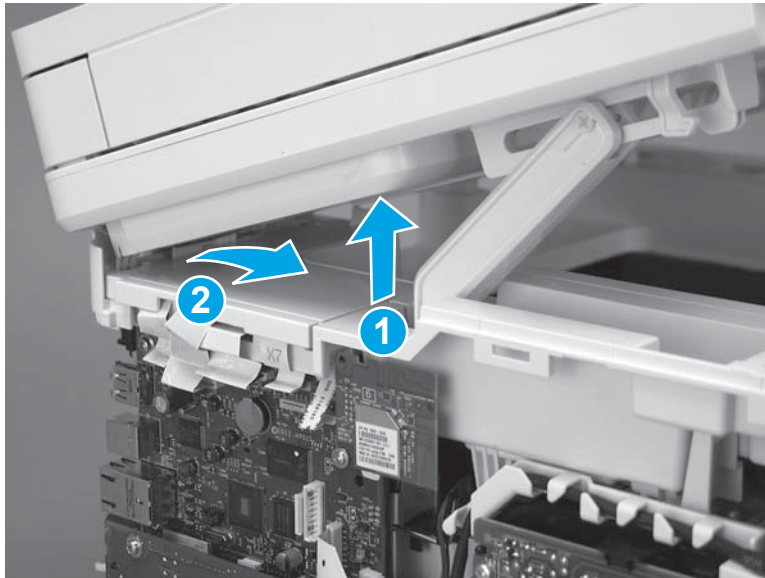
1. Raise the ISA.

**Figure 1-1459** Raise the ISA



2. Release the ISA flat-flexible cable (FFC) cover (callout 1), and then remove it (callout 2).

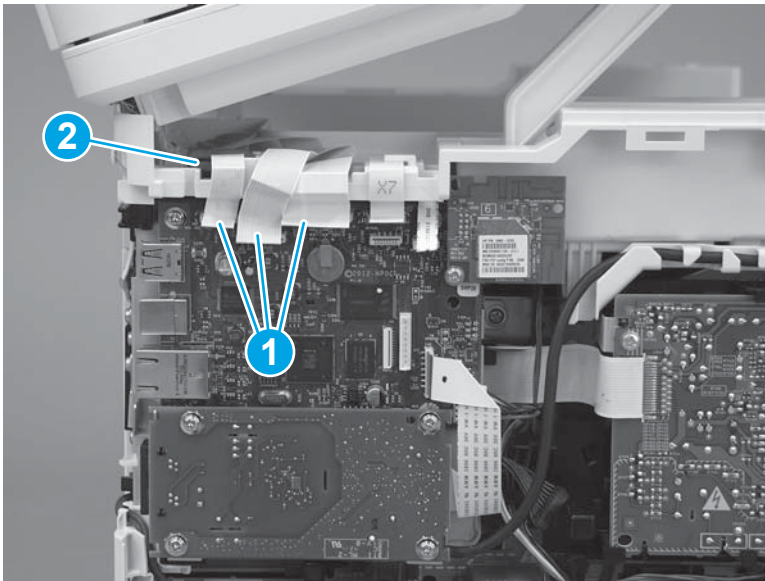
**Figure 1-1460** Remove the ISA FFC cover



3. Disconnect three FFCs (callout 1), and then remove the ferrite (callout 2) from the holder.

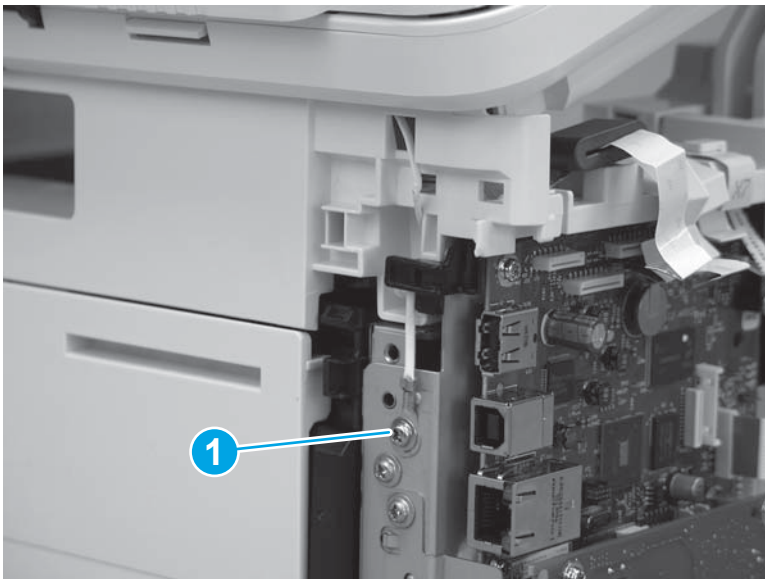
**⚠ CAUTION:** The ferrite is not captive on the FFC. Do not lose the ferrite while handling the ISA.

**Figure 1-1461** Disconnect three FFCs



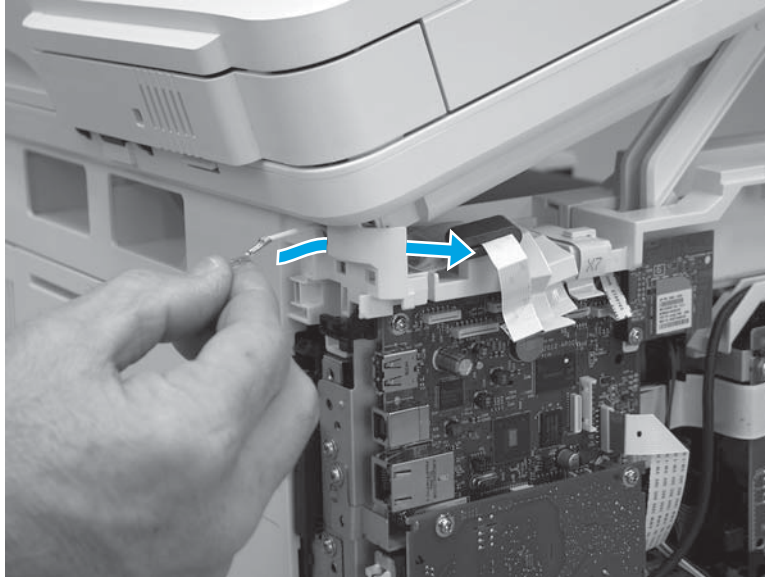
4. Remove one screw (callout 1).

**Figure 1-1462** Remove one screw



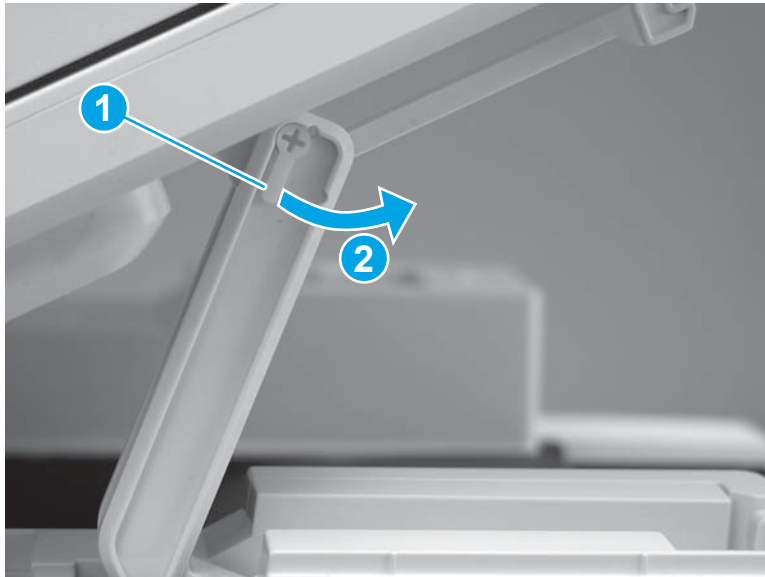
5. Pass the ground wire through the opening in the top cover.

**Figure 1-1463** Pass the wire through the opening



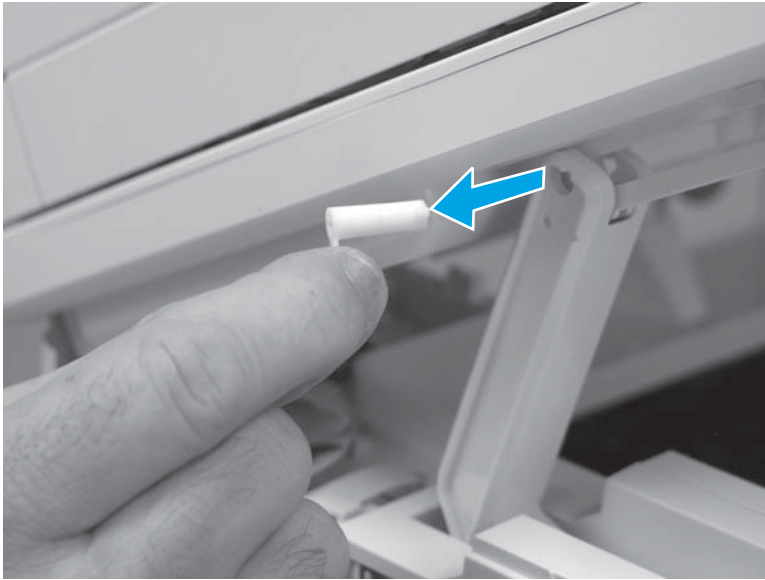
6. Release one tab (callout 1), and then rotate the ISA slider pin (callout 2) towards the front of the printer to release it.

**Figure 1-1464** Release one tab and rotate the slider pin



7. Remove the slider pin.

**Figure 1-1465** Remove the slider pin



8. Rotate the ISA towards the rear of the printer until it stops.

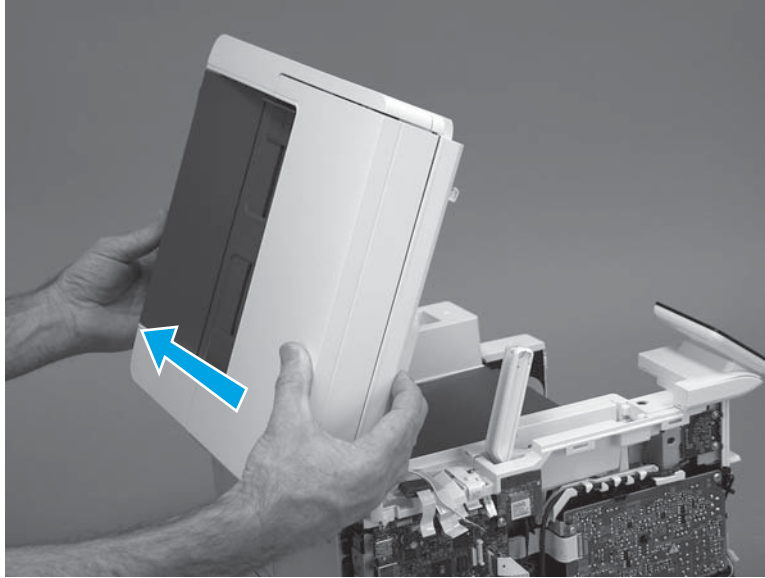
**Figure 1-1466** Rotate the ISA towards the rear of the printer





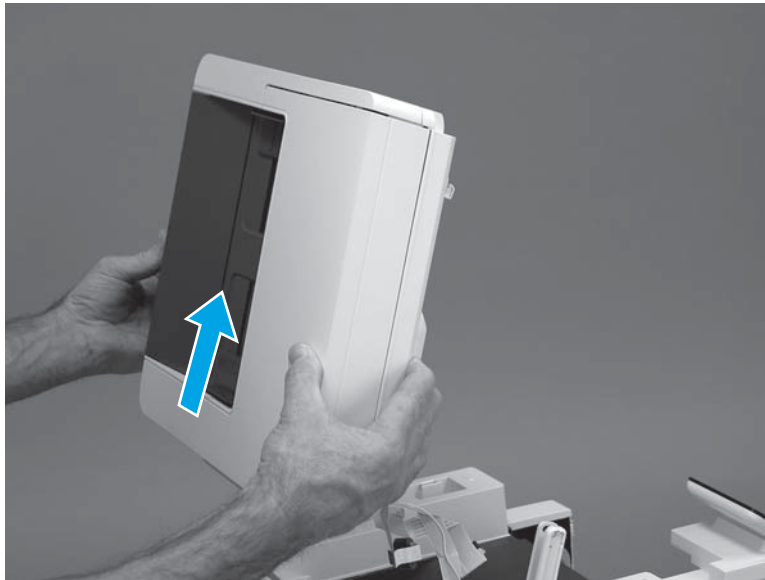
- Slide the ISA as shown to release it.

**Figure 1-1467** Release the ISA




- Remove the ISA.

**Figure 1-1468** Remove the ISA

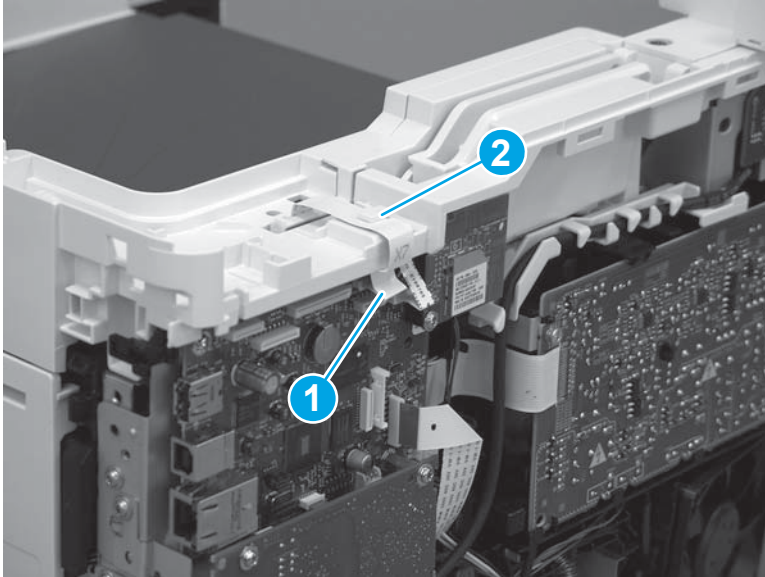


#### Step 6: Remove the control panel (M427/M246)

 **NOTE:** The step is for the M427/M426 printer. For the M403/M402, skip this step and go to [Step 8: Remove the top cover \(M403/M402\) on page 792](#).

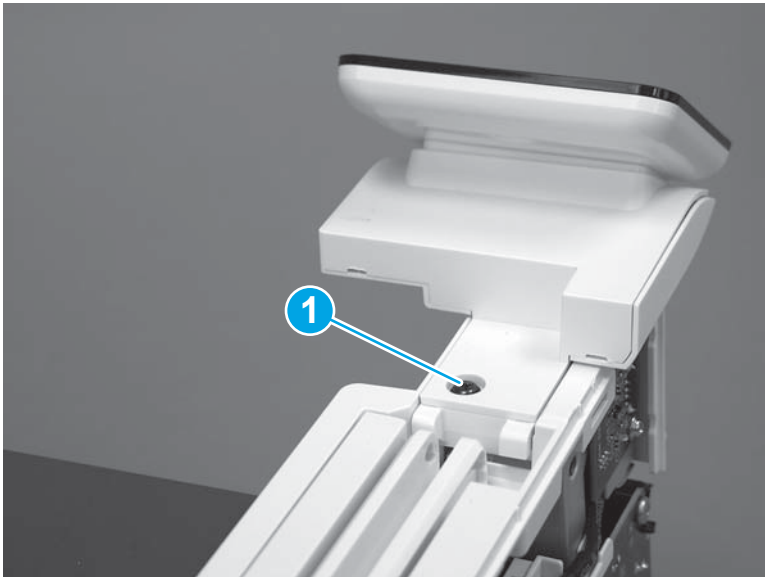
- Disconnect one FFC (callout 1; J114), and then release the FFC from the retainer (callout 2).

**Figure 1-1469** Disconnect one connector



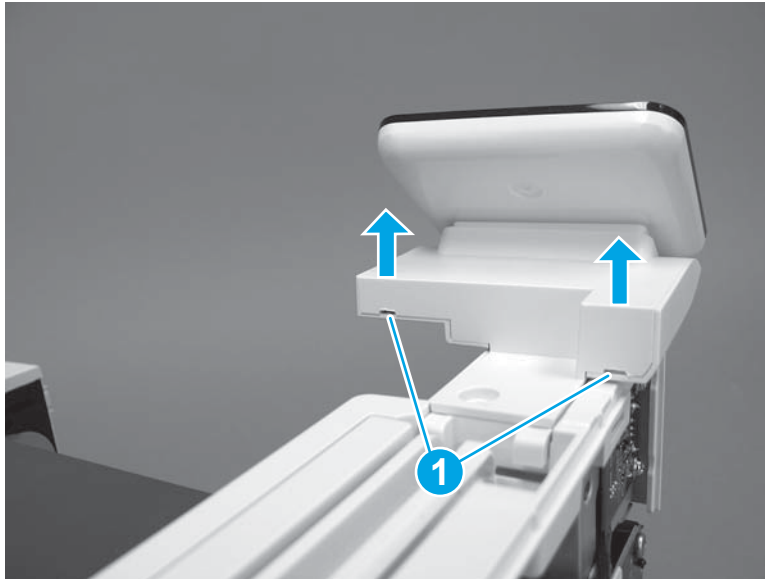
2. Remove one screw (callout 1).

**Figure 1-1470** Remove one screw



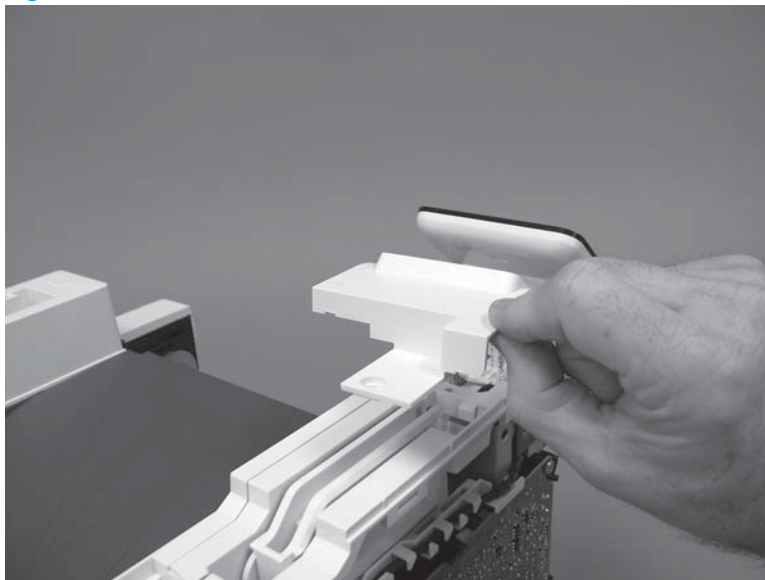
3. Use a small flat-blade screwdriver to release two tabs (callout 1) on the control-panel cable cover.

**Figure 1-1471** Release two tabs



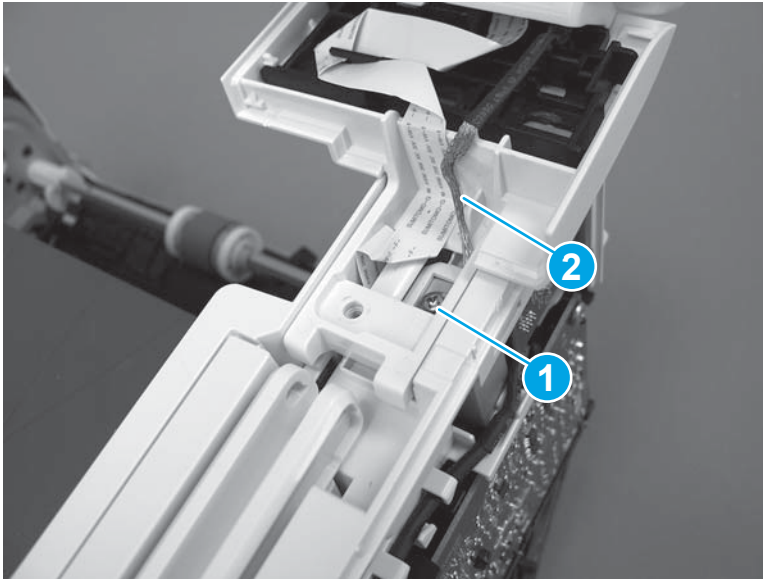
4. Remove the control-panel cable cover.

**Figure 1-1472** Remove the cover



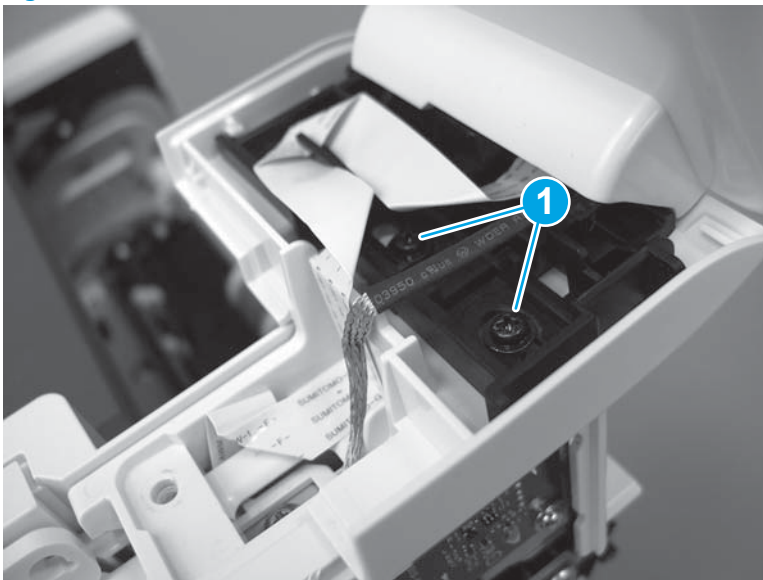
5. Remove one grounding screw (callout 1), and then move the ground cable (callout 2) out of the way.

**Figure 1-1473** Remove one screw



6. Move the FFC out of the way, and then remove two screws (callout 1).

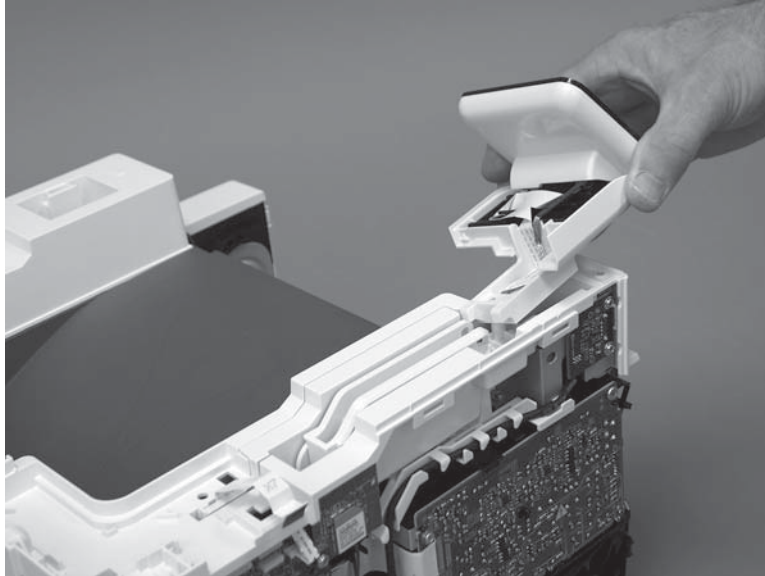
**Figure 1-1474** Remove two screws



7. Slightly lift up the control-panel assembly to separate it from the top cover.

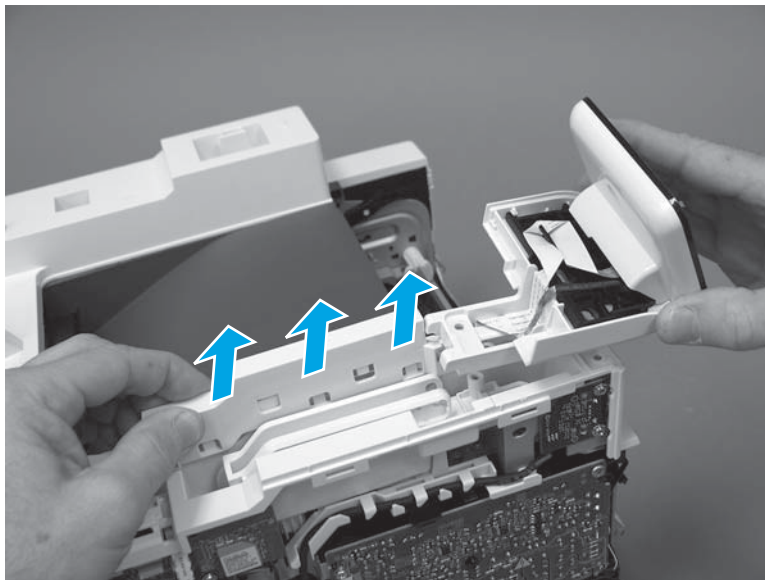
**CAUTION:** The control panel assembly is still connected to the printer by the FFC. Do not attempt to completely remove the assembly.

**Figure 1-1475** Lift up the control-panel assembly



8. Lift up the control-panel FFC cover to remove the control-panel assembly.

**Figure 1-1476** Remove the control-panel assembly

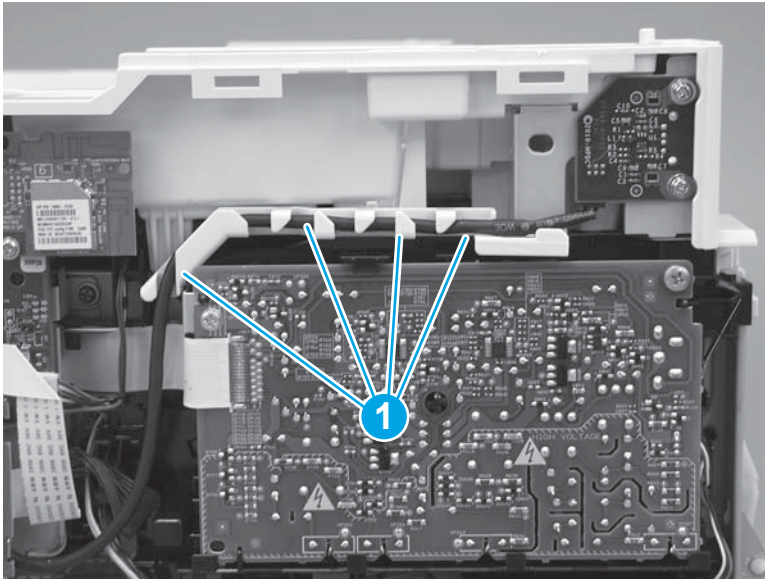


### Step 7: Remove the top cover (M427/M426)

**NOTE:** The step is for the M427/M426 printer. For the M403/M402, skip this step and go to [Step 8: Remove the top cover \(M403/M402\) on page 792](#).

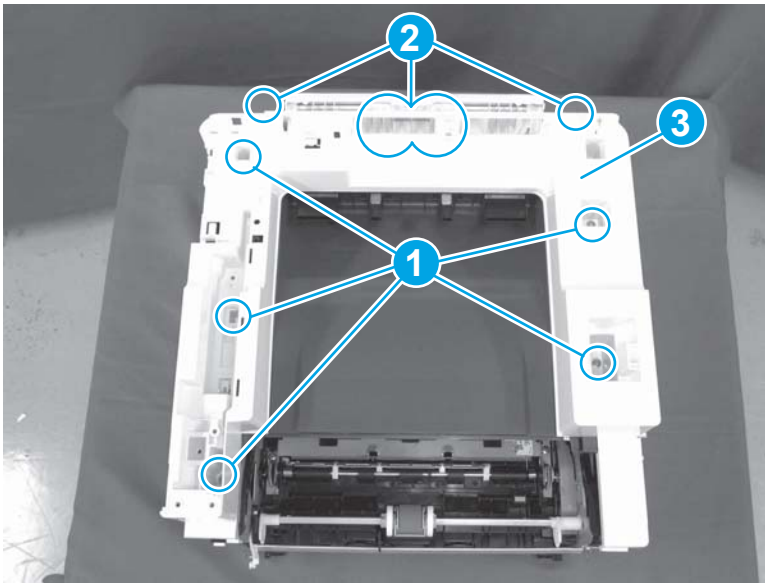
1. Release the USB cable (callout 1) from the cable guide.

**Figure 1-1477** Remove the USB cable




2. Remove five screws (callout 1), release four bosses (callout 2), and then remove the top cover (callout 3).

**Figure 1-1478** Remove the cover



### Step 8: Remove the top cover (M403/M402)

 **NOTE:** The step is for the M403/M402 printer. For the M427/M426, skip this step and go to [Step 9: Remove the paper delivery tray \(output bin\) on page 794.](#)

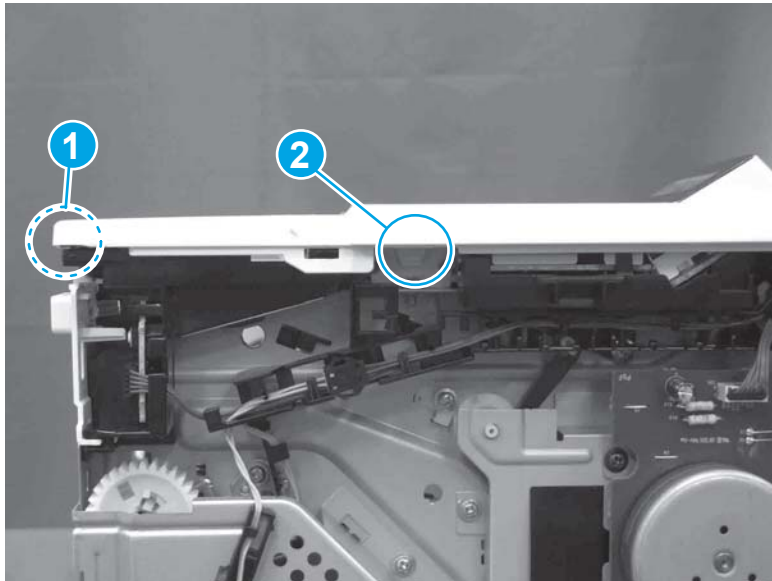
1. Remove one screw (callout 1).

**Figure 1-1479** Remove one screw




2. At the right side of the printer, release the one boss (callout 1), and then release one tab (callout 2).

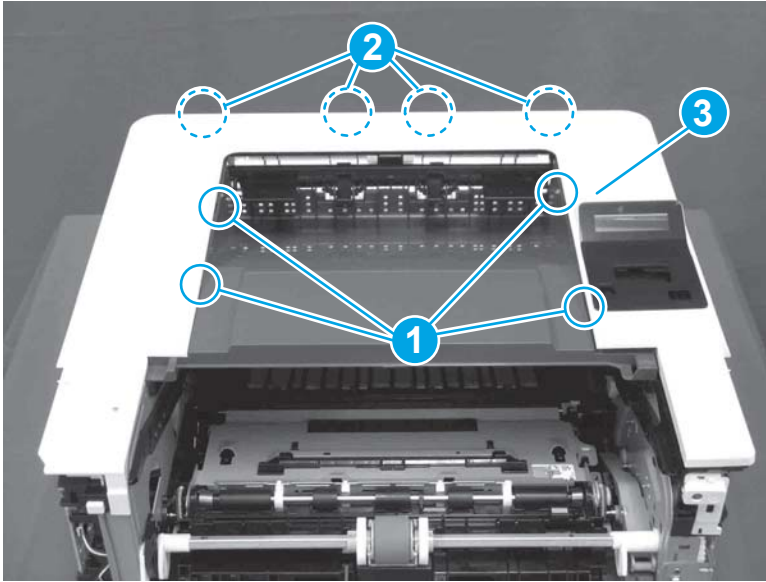
**Figure 1-1480** Release one boss and one tab




3. Release four tabs (callout 1), release four bosses (callout 2), and then remove the top cover (callout 3).

 **TIP:** Open the rear door to make releasing the bosses (callout 3) easier.

**Figure 1-1481** Remove the cover

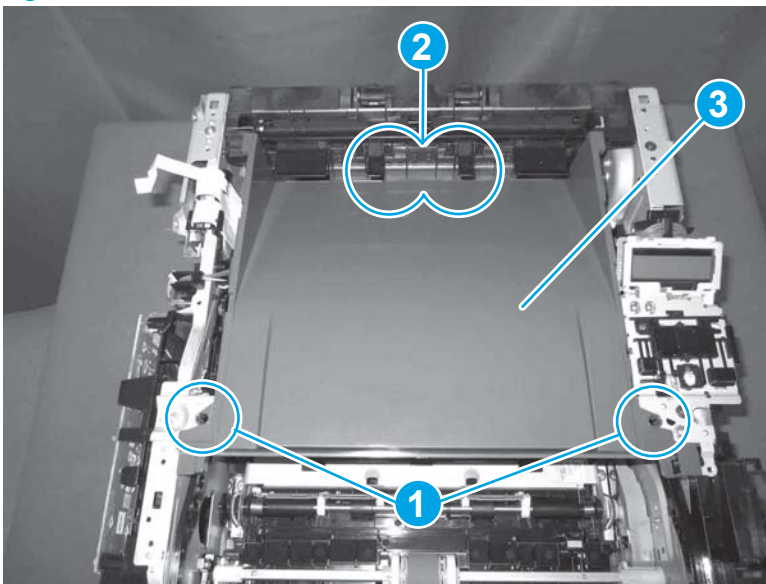


### Step 9: Remove the paper delivery tray (output bin)

 **NOTE:** This procedure shows the M403/M402 model, however, the paper delivery tray (output bin) removal is similar for the M427/M426 printer.


- ▲ Release two bosses (callout 1), release two tabs (callout 2), and then remove the paper delivery tray (output bin; callout 3).

**Figure 1-1482** Release two tabs



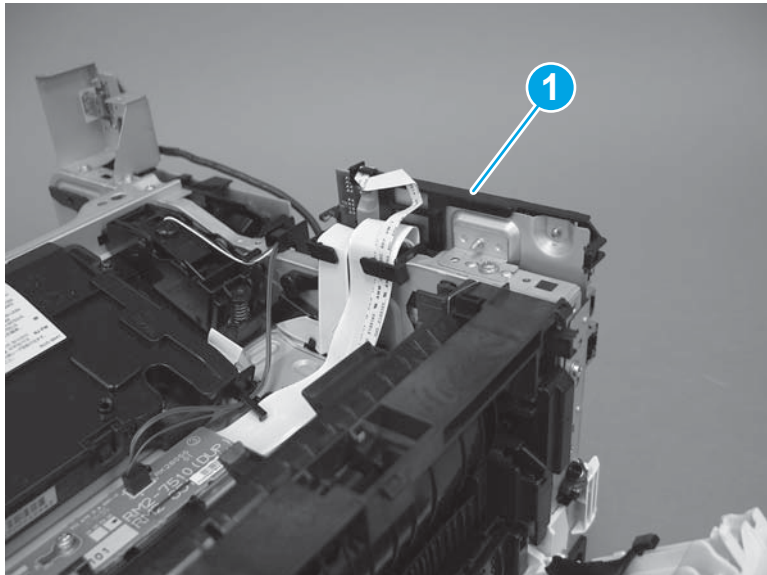


## Step 10: Remove the sheet-metal formatter bracket and formatter PCA

 **NOTE:** Disconnect any remaining formatter PCA FFCs or wire-harness connectors.

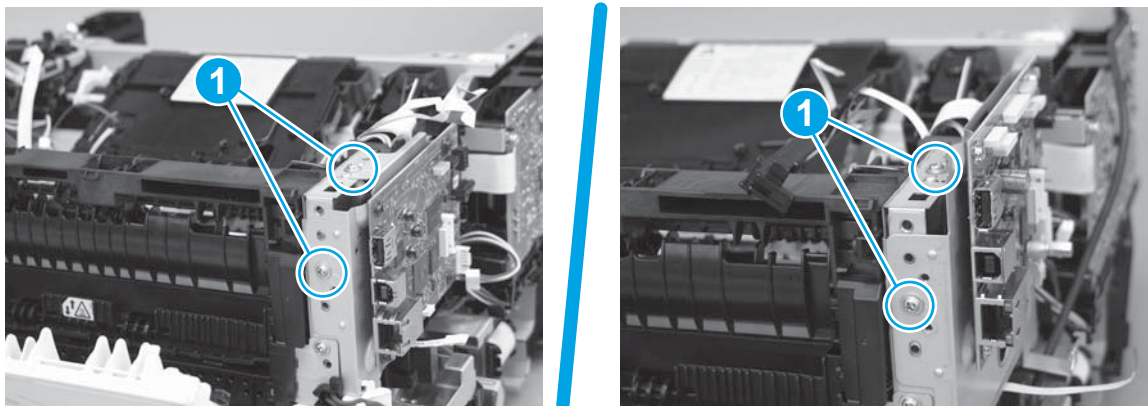
1. **M427/M426 only:** Remove the guide (callout 1).

**Figure 1-1483** Remove the guide



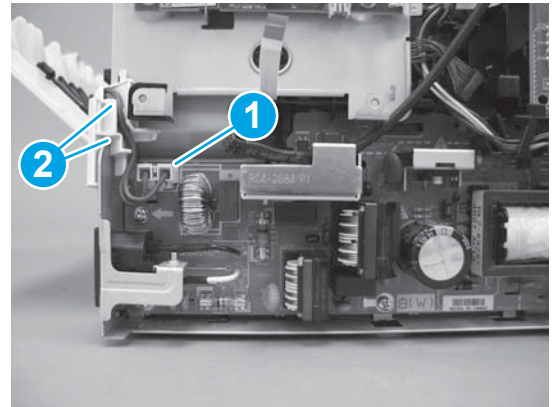
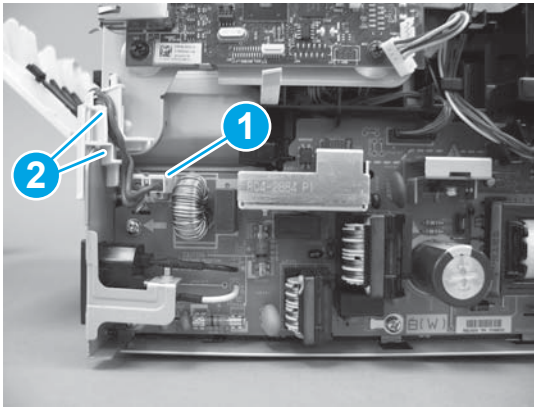
2. Remove two screws (callout 1).

**Figure 1-1484** Remove two screws



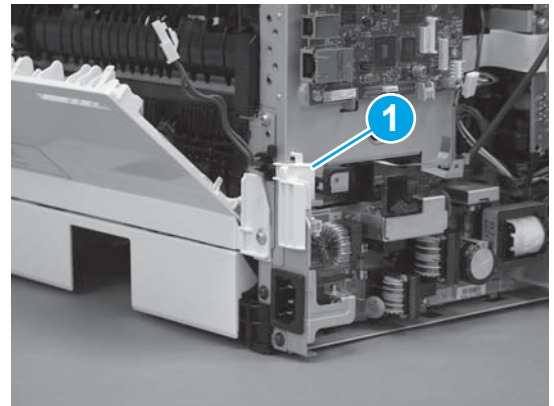
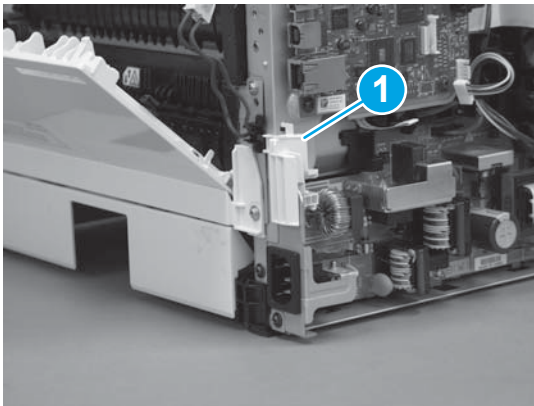
3. Disconnect one connector (callout 1), and then release the wire harness from the guide (callout 2).

**Figure 1-1485** Disconnect one connector



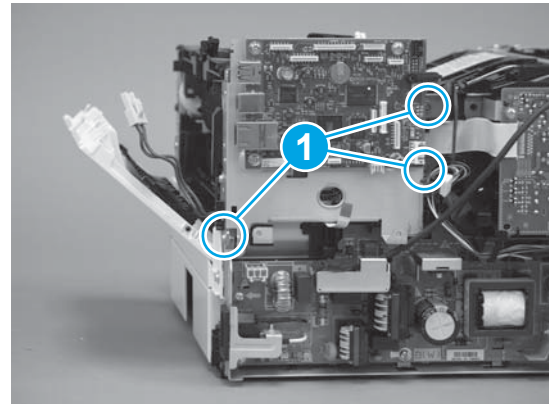
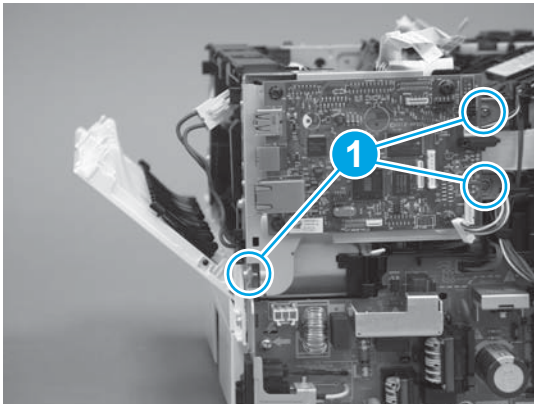
4. Remove the guide (callout 1).

**Figure 1-1486** Remove the guide



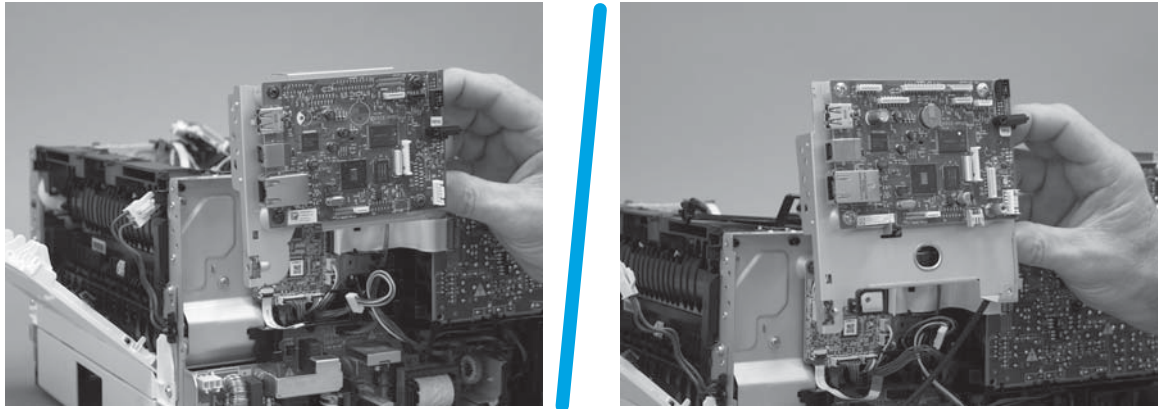
5. Remove three screws (callout 1).

**Figure 1-1487** Remove three screws



6. Remove the sheet-metal bracket and formatter PCA.

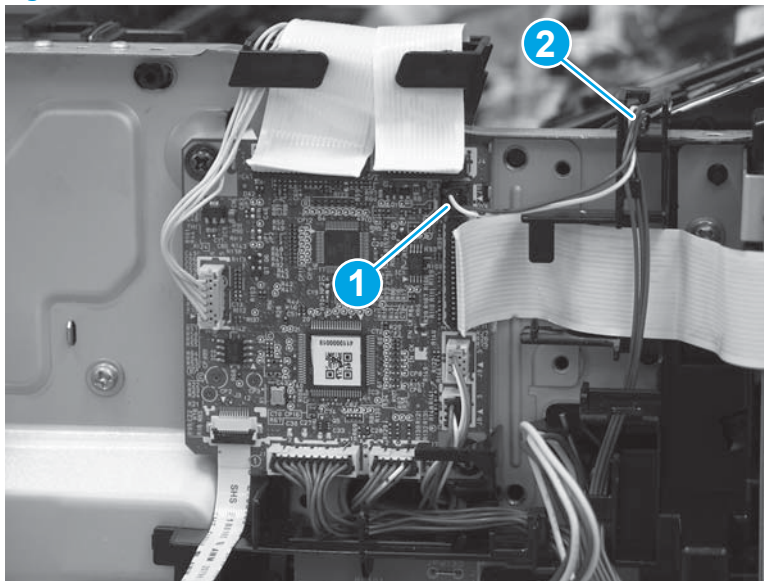
**Figure 1-1488** Remove the bracket



**Step 11: Remove the tag-cable assembly (toner-cartridge memory)**

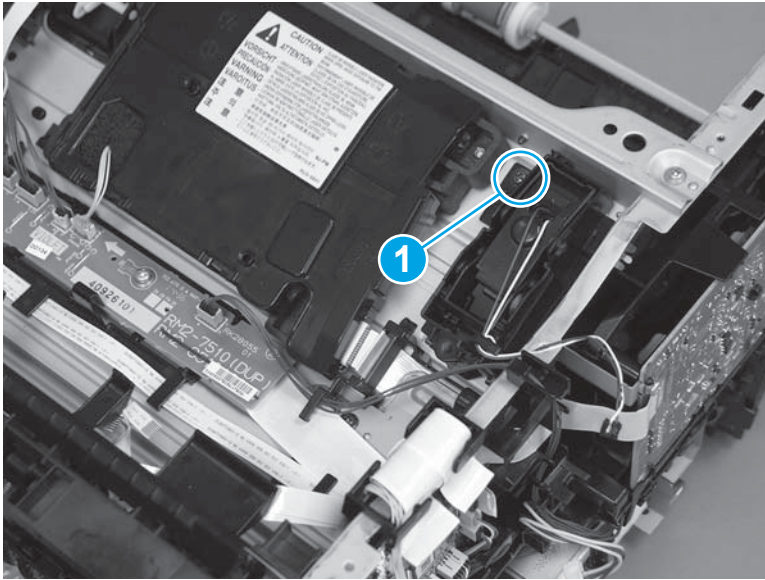
1. Disconnect one connector (callout 1), and then release the wire harness from the guide (callout 2).

**Figure 1-1489** Disconnect one connector



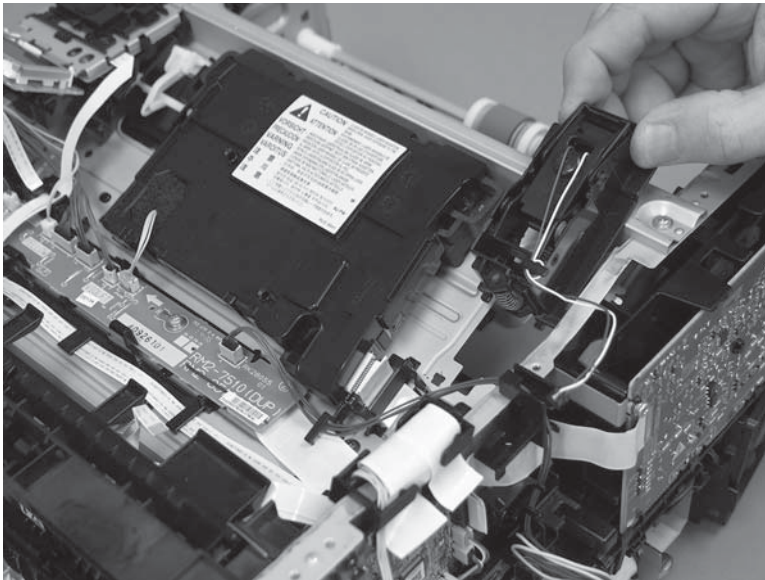
2. Remove one screw (callout 1).

**Figure 1-1490** Remove one screw



3. Remove the tag-cable assembly.

**Figure 1-1491** Remove the tag-cable assembly



### Step 12: Unpack the replacement assembly

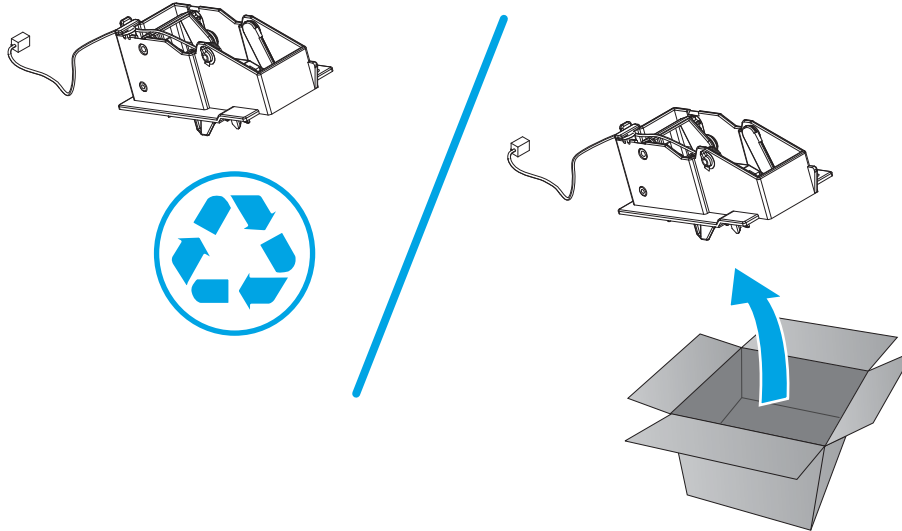
Unpack the replacement part from the packaging.

<http://www8.hp.com/us/en/hp-information/environment/product-recycling.html>




**NOTE:** HP recommends responsible disposal of the defective part.

**Figure 1-1492** Recycle and unpack

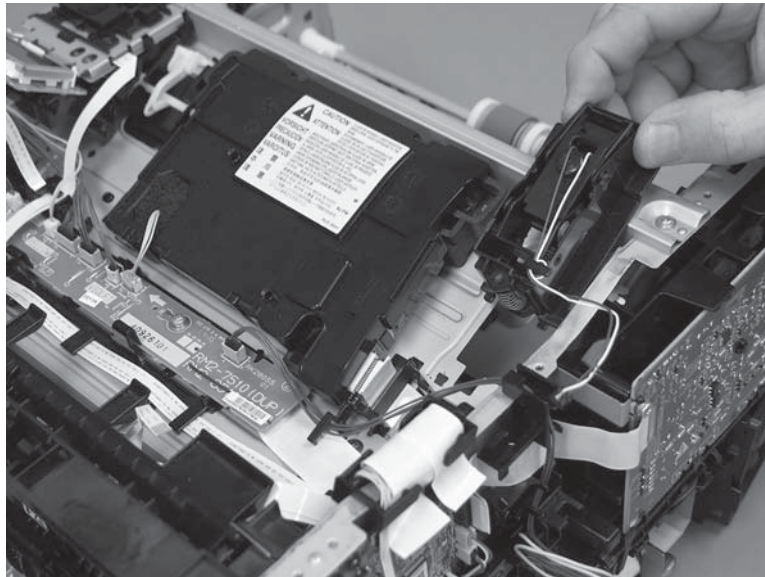


**Step 13: Install the tag-cable assembly (toner-cartridge memory)**

1. Position the assembly on the printer.

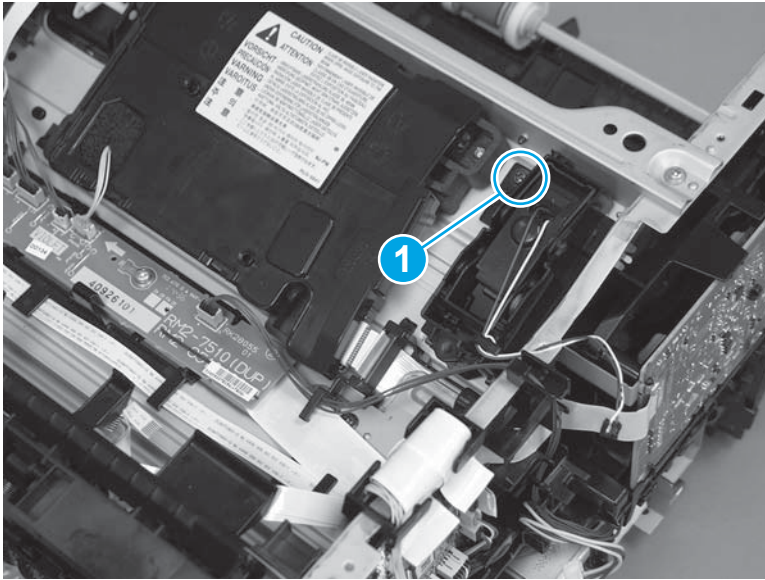
 **IMPORTANT:** Make sure that the assembly is flat against the chassis. If the assembly is not correctly installed, it might not make proper contact with the toner cartridge.

**Figure 1-1493** Install the assembly



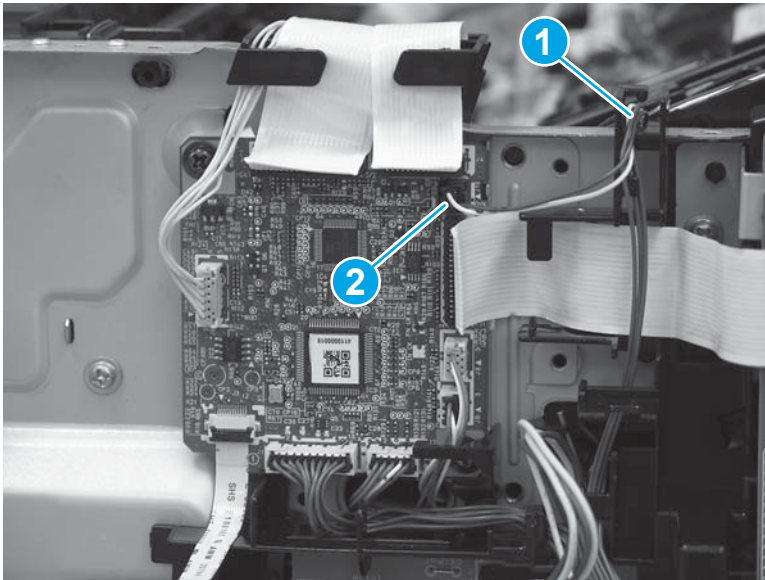
2. Install one screw (callout 1).

**Figure 1-1494** Install one screw




3. Install the wire harness in the guide (callout 1), and then connect one connector (callout 2).

**Figure 1-1495** Connect one connector

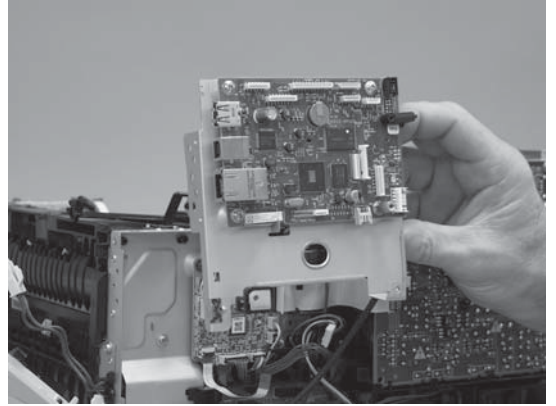
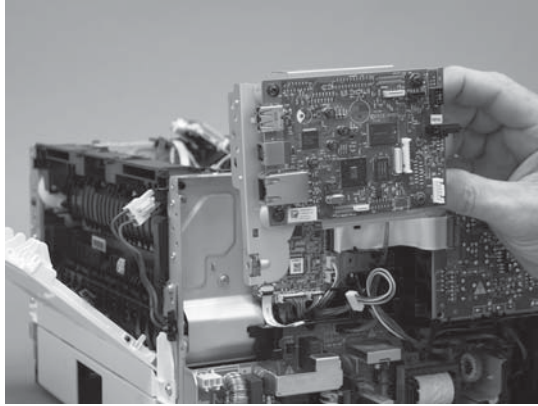


#### Step 14: Install the sheet-metal formatter bracket and formatter PCA

 **NOTE:** Do not forget to connect any formatter PCA FFCs or wire-harness connectors that were disconnected when the bracket was removed.

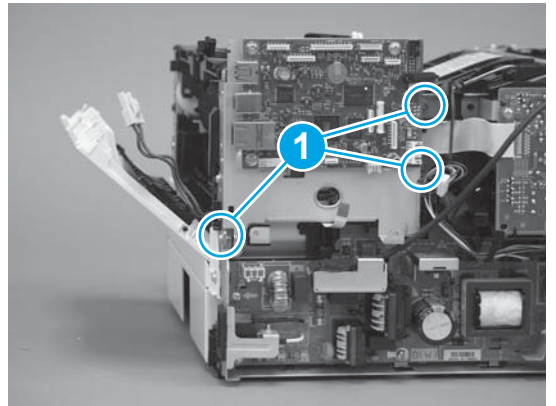
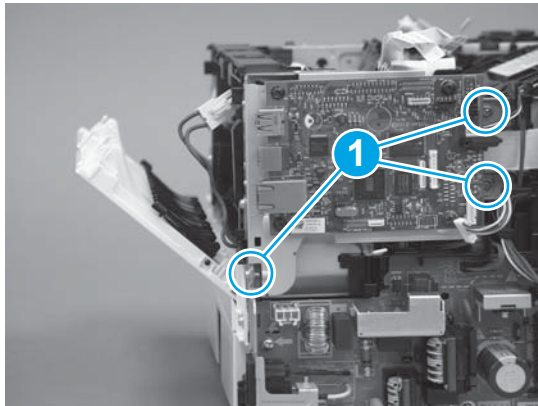
1. Position the sheet-metal bracket and formatter PCA on the printer.

**Figure 1-1496** Install the bracket



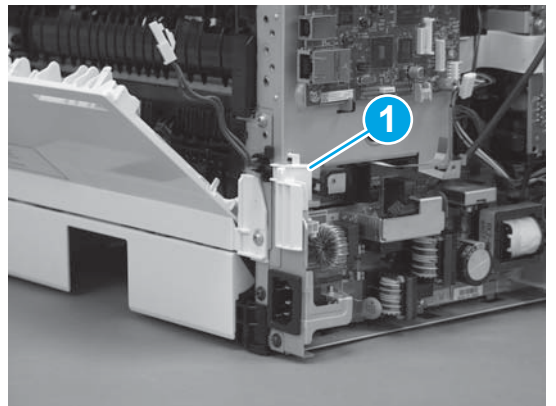
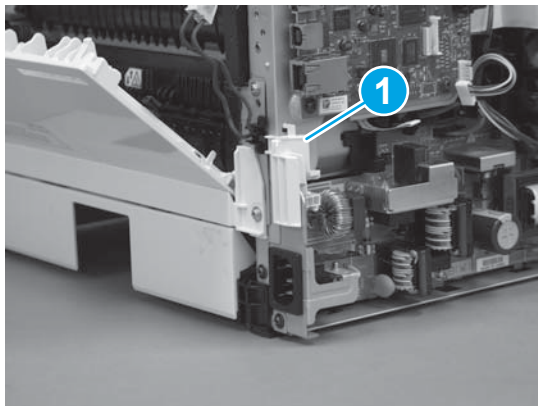
2. Install three screws (callout 1).

**Figure 1-1497** Install three screws



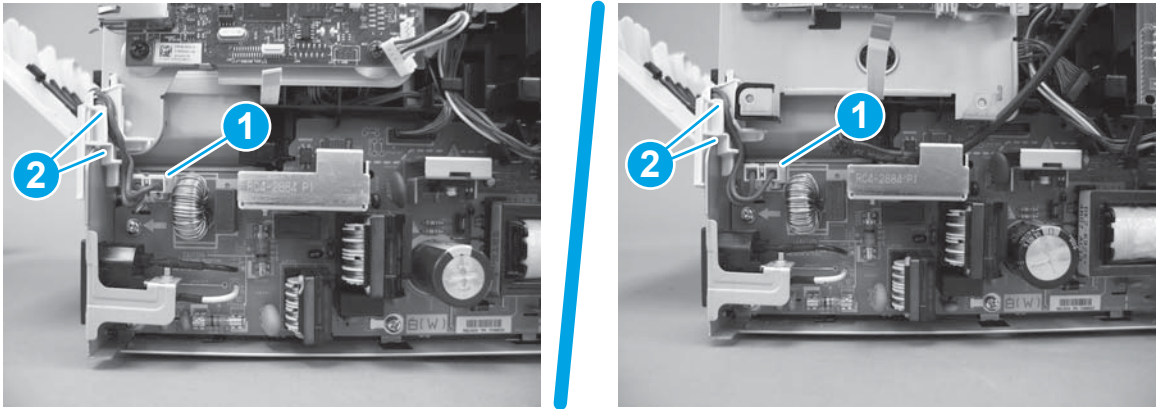
3. Install the guide (callout 1).

**Figure 1-1498** Install the guide



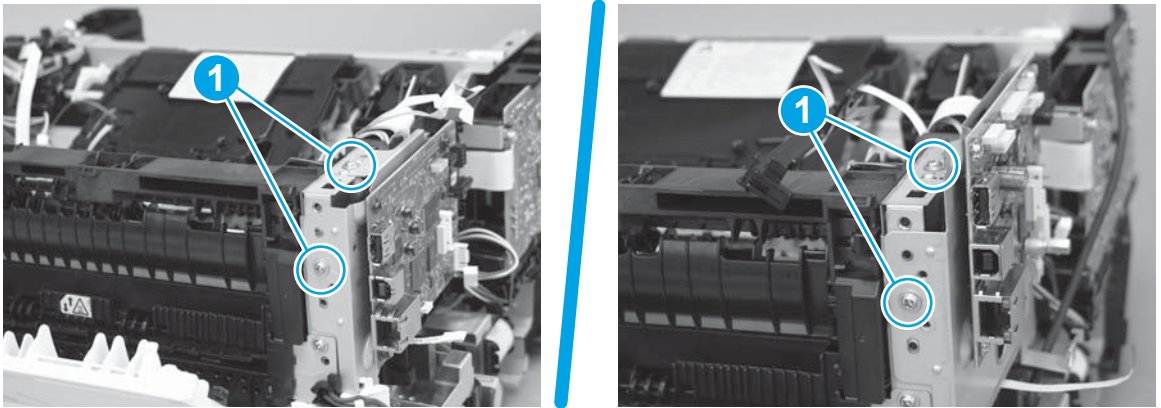
4. Connect one connector (callout 1), and then install the wire harness in the guide (callout 2).

**Figure 1-1499** Connect one connector



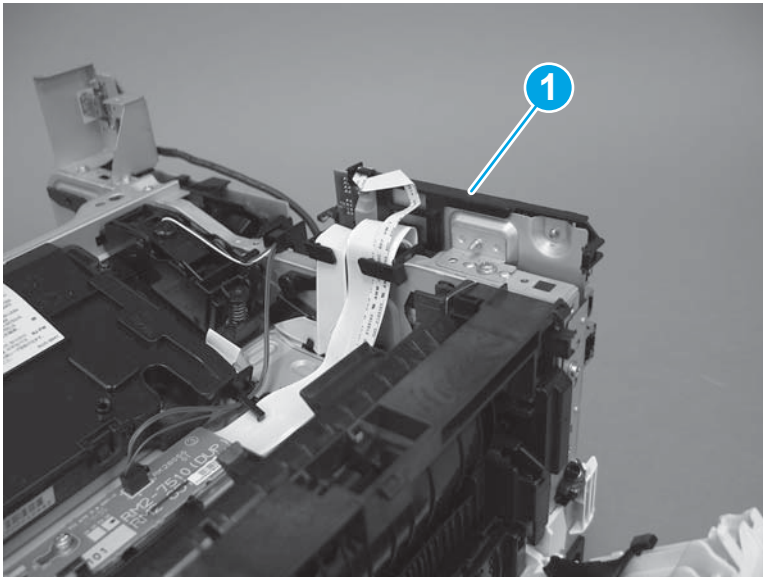
5. Install two screws (callout 1).

**Figure 1-1500** Install two screws




6. **M427/M426 only:** Install the guide (callout 1).

**Figure 1-1501** Install the guide



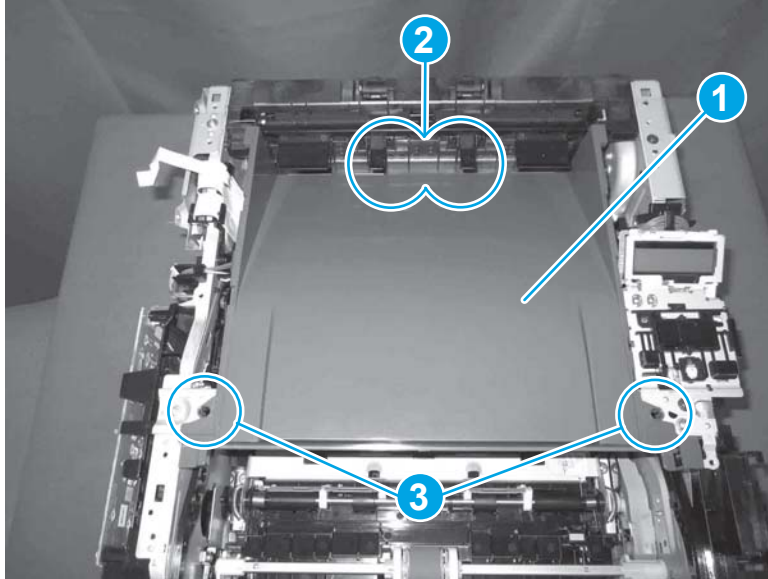


### Step 15: Install the paper delivery tray (output bin)


 **NOTE:** This procedure shows the M403/M402 model, however, the paper delivery tray (output bin) removal is similar for the M427/M426 printer.

- ▲ Position the remove the paper delivery tray (output bin; callout 1) on the printer, engage two tabs (callout 2), and then engage two bosses (callout 3).

**Figure 1-1502** Engage two tabs

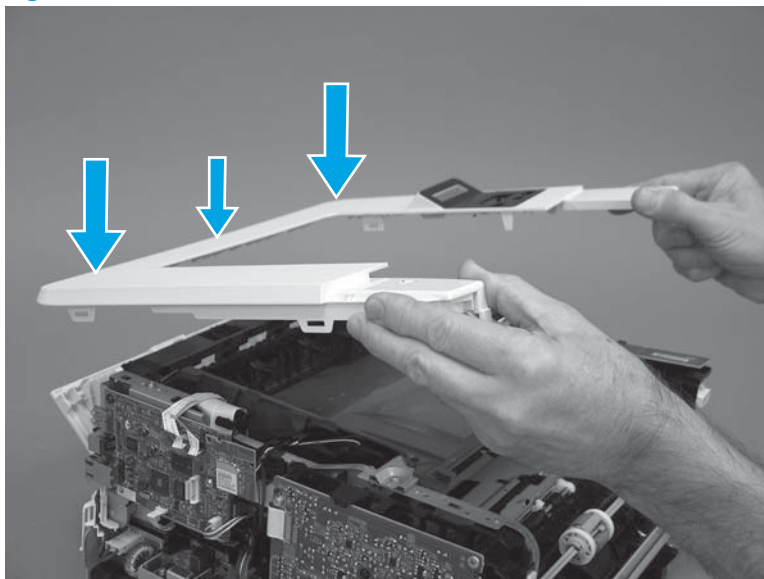


### Step 16: Install the top cover (M403/M402)

 **NOTE:** The step is for the M403/M402 printer. For the M427/M426, skip this step and go to [Step 17: Install the top cover \(M427/M426\) on page 805](#).

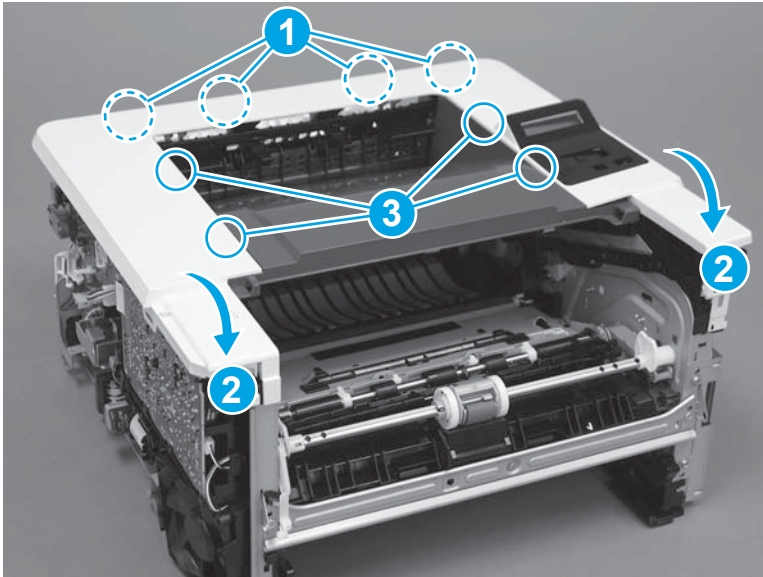
1. Position the rear edge of the cover on the printer.

**Figure 1-1503** Install the cover



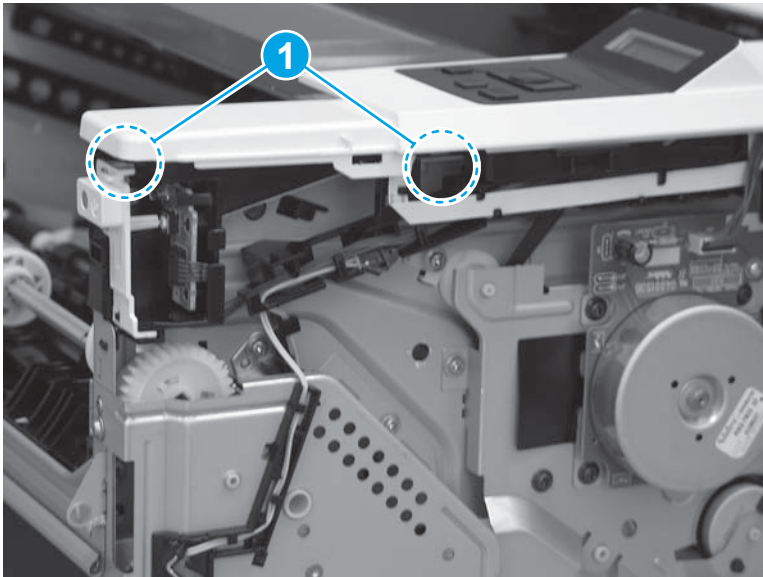
2. Engage four bosses (callout 1), rotate the front of the cover down (callout 2) and onto from the printer, and then engage four tabs (callout 3).

**Figure 1-1504** Engage four bosses and tabs



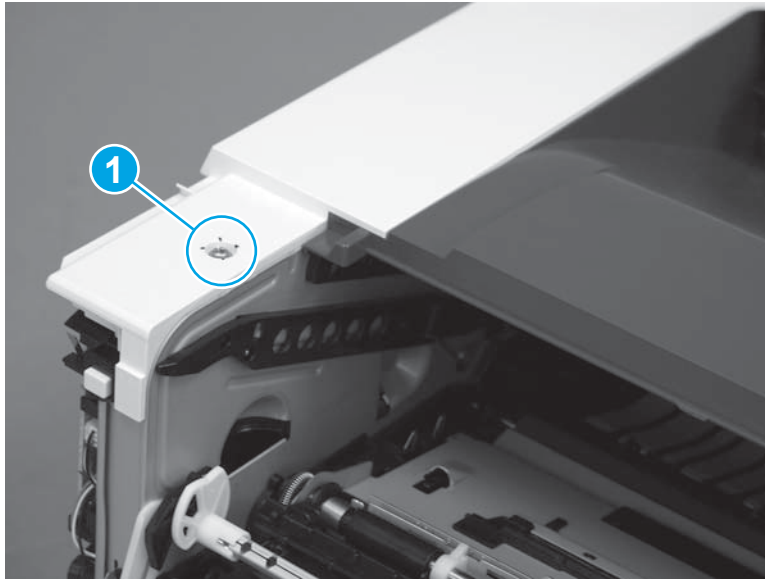
3. At the right side of the printer, engage the one boss and one tab (callout 1).

**Figure 1-1505** Engage one boss and one tab




4. Install one screw (callout 1).

**Figure 1-1506** Install one screw

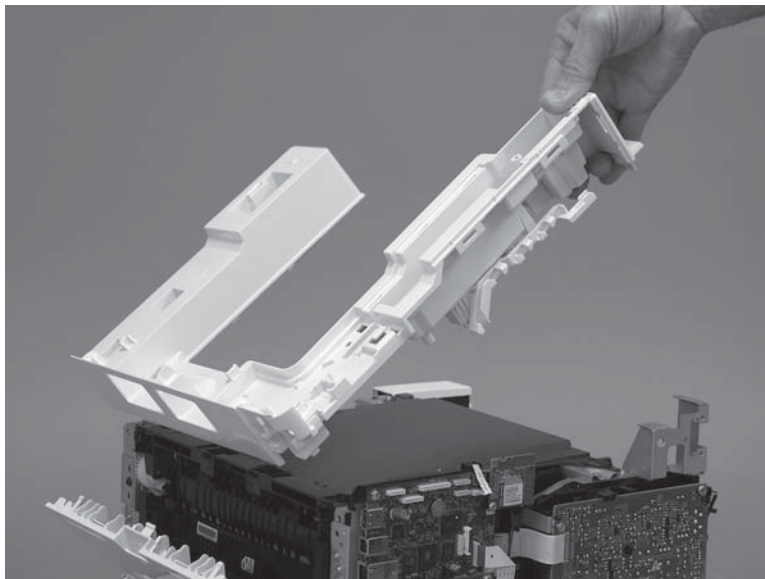


#### Step 17: Install the top cover (M427/M426)

 **NOTE:** The step is for the M427/M426 printer. For the M403/M402, skip this step and go to [Step 20: Install the right cover on page 816](#).

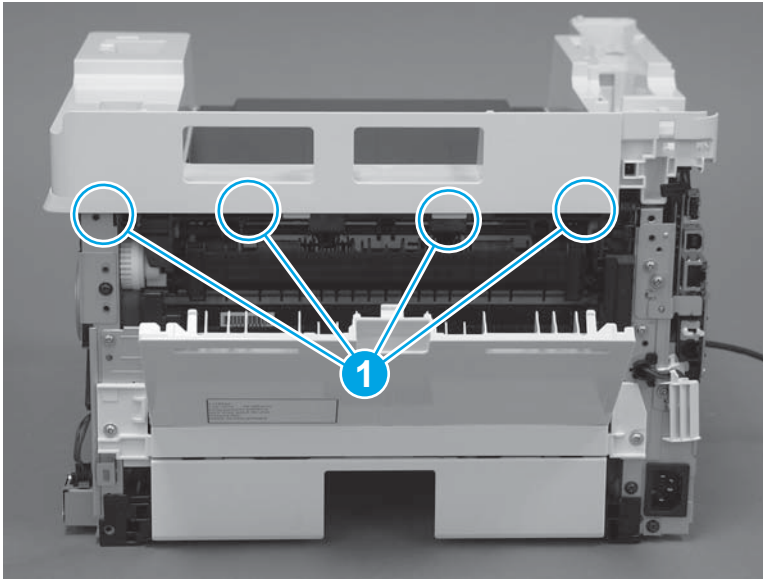
1. Position the rear edge of the top cover on the printer.

**Figure 1-1507** Install the cover



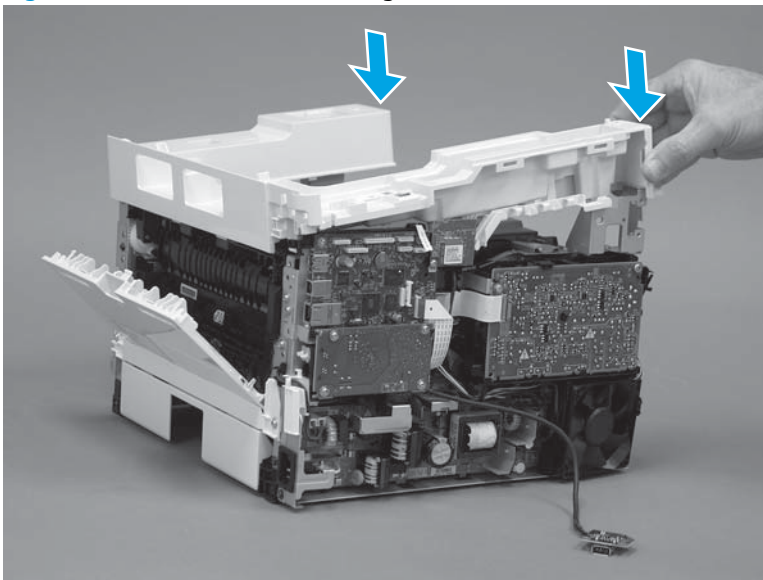
2. Engage four bosses (callout 1).

**Figure 1-1508** Engage four bosses



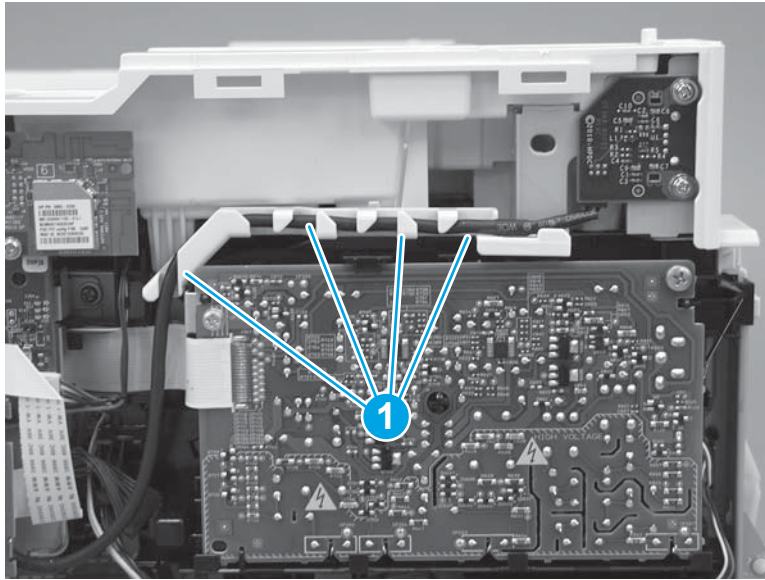
3. Rotate the front edge of the cover down.

**Figure 1-1509** Rotate the front edge of the cover down



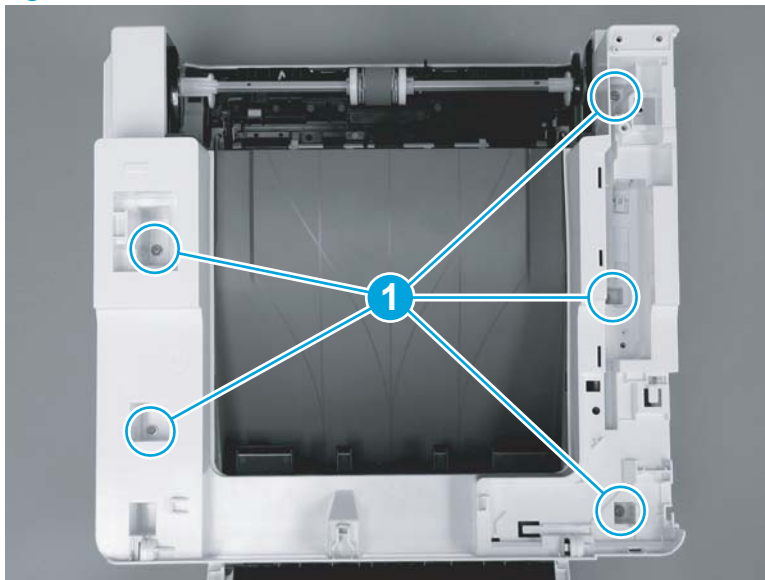
4. Install the USB cable (callout 1) in the guide.

**Figure 1-1510** Install the USB PCA




5. Install five screws (callout 1).

**Figure 1-1511** Install five screws

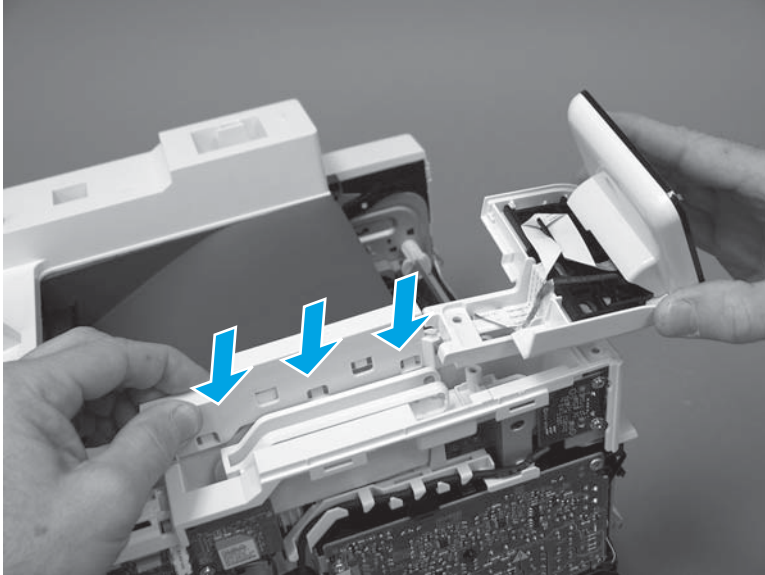


### Step 18: Install the control panel (M427/M246)

 **NOTE:** The step is for the M427/M426 printer. For the M403/M402, skip this step and go to [Step 20: Install the right cover on page 816](#).

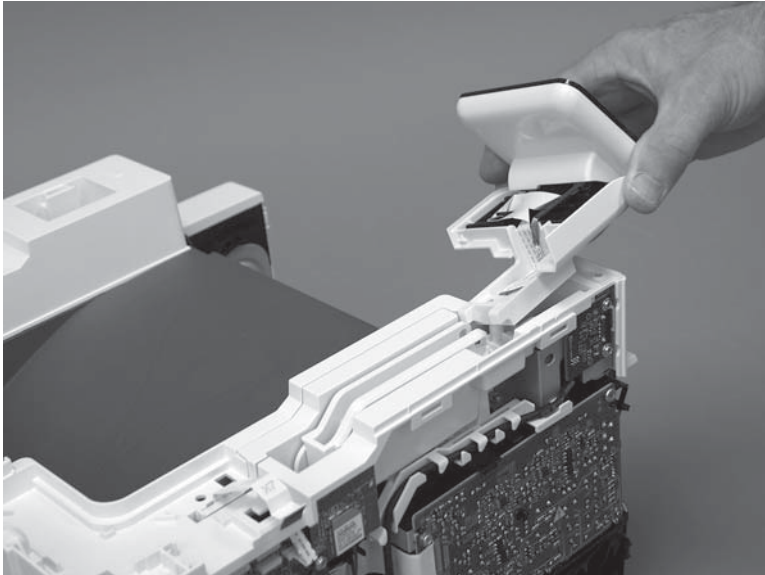
1. Slide the control-panel FFC cover into the slot in the top cover (next to the document feeder support arm) to install it.

**Figure 1-1512** Install the control-panel FFC cover



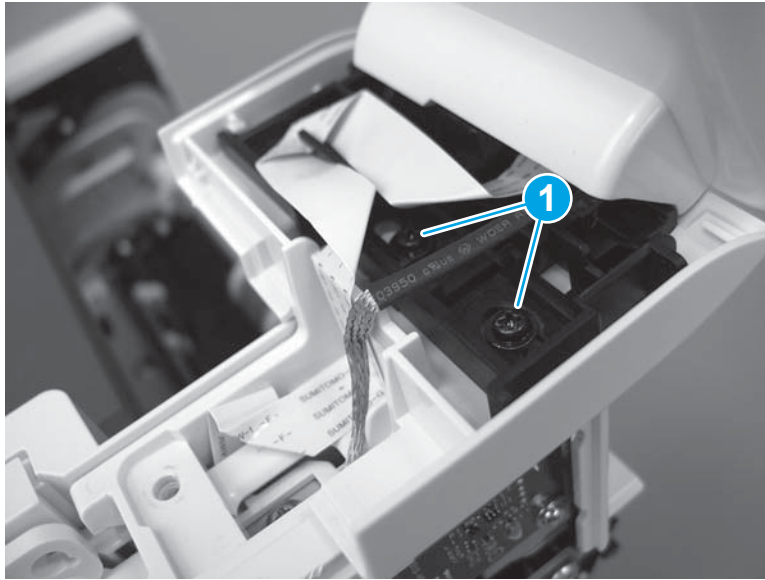
2. Install the control-panel assembly on the top cover.

**Figure 1-1513** Install the control-panel assembly



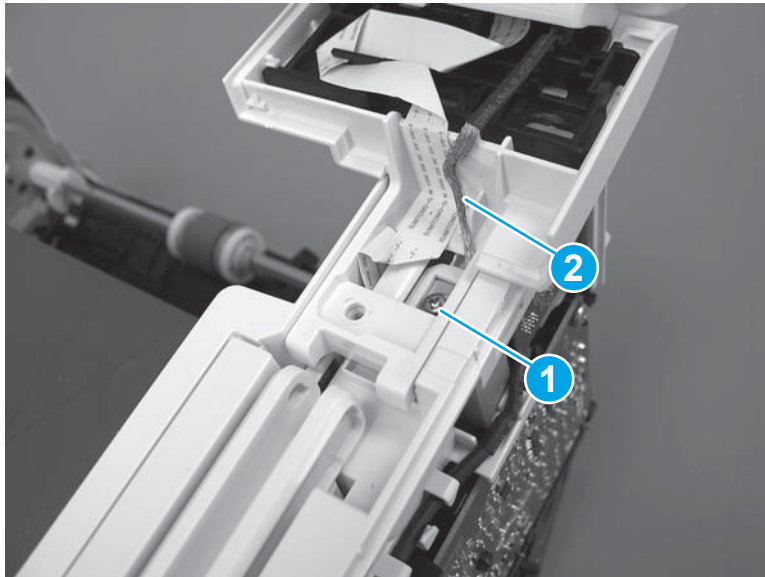
3. Move the FFC out of the way, and then install two screws (callout 1).

**Figure 1-1514** Install two screws



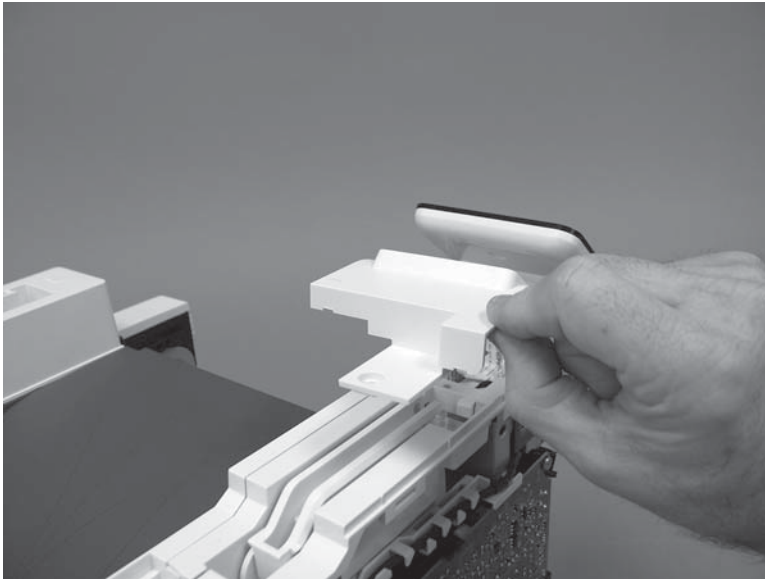
4. Install one grounding screw (callout 1), and then make sure that the ground cable (callout 2) is properly routed.

**Figure 1-1515** Remove one screw



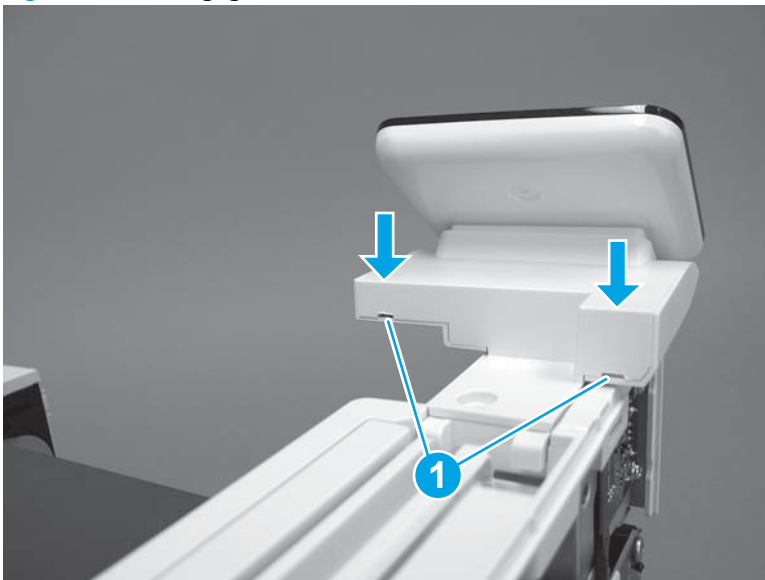
5. Install the control-panel cable cover.

**Figure 1-1516** Install the cover



6. Make sure that the two tabs (callout 1) on the cover snap into place.

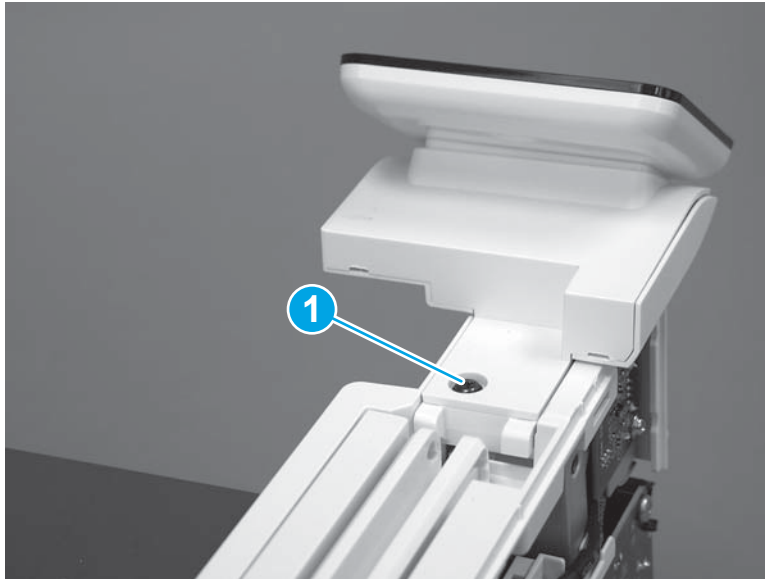
**Figure 1-1517** Engage two tabs





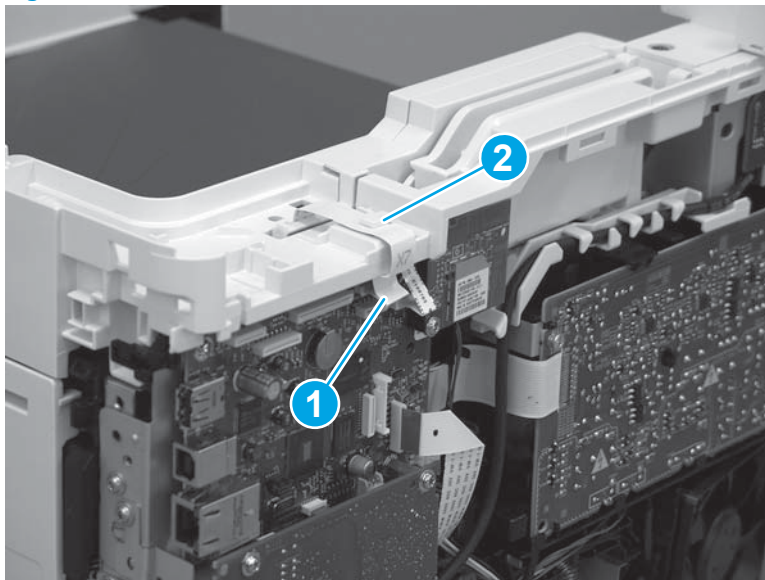
7. Install one screw (callout 1).

**Figure 1-1518** Install one screw





8. Install the FFC in the retainer (callout 1), and then connect one FFC (callout 1; J114).

**Figure 1-1519** Connect one connector



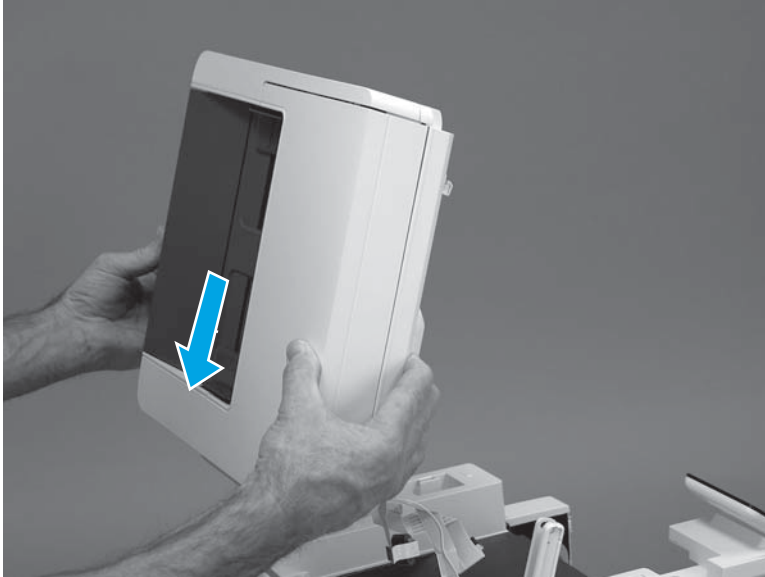
### Step 19: Install the integrated scanner assembly (M427/M246)

 **NOTE:** The step is for the M427/M426 printer. For the M403/M402, skip this step and go to [Step 20: Install the right cover on page 816](#).

 **NOTE:** M427/M426 models only. The integrated scanner assembly (ISA) includes the sub-scanner assembly (SSA) and the automatic document feeder (ADF).

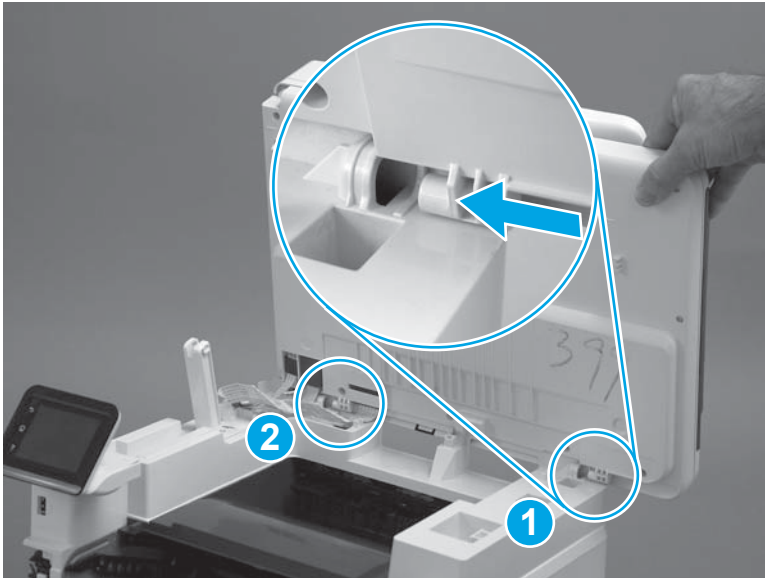
1. Position the ISA on the printer.

**Figure 1-1520** Position the ISA on the printer



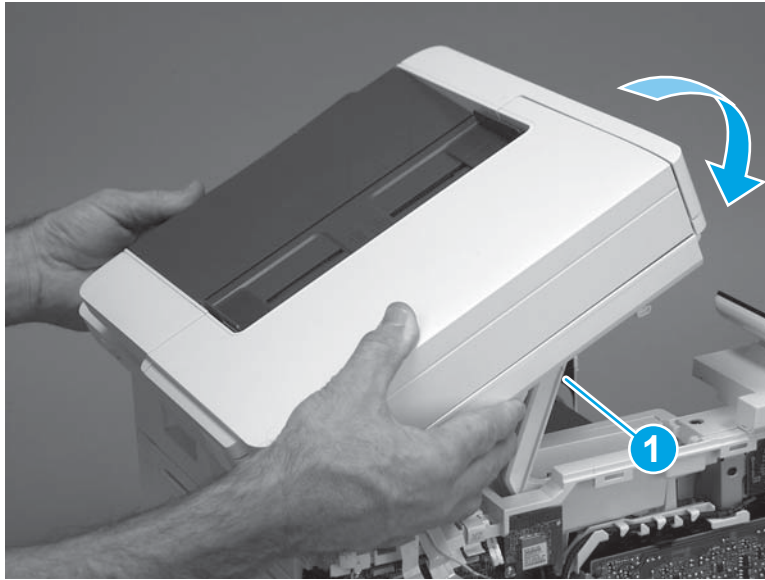
2. Engage the hinge pins on the ISA with the holders in the top cover (callouts 1/2), and then slide the ISA as shown to engage them

**Figure 1-1521** Engage the hinge pins with the holders



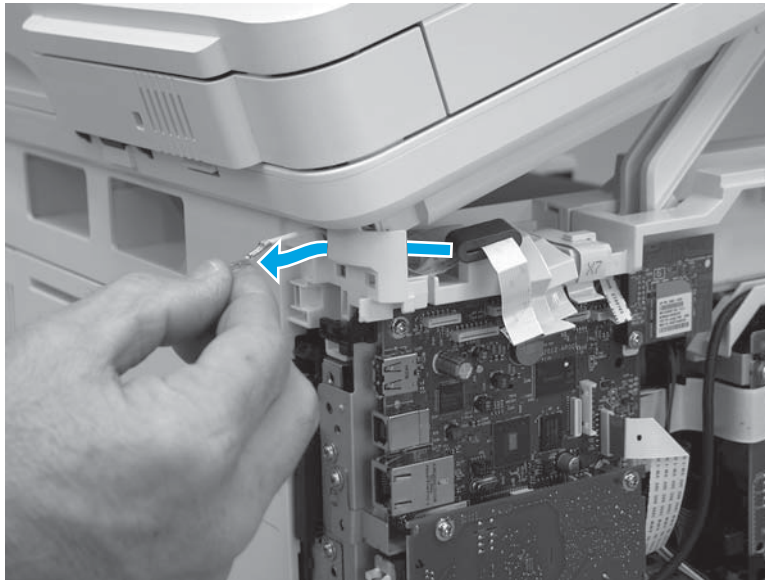
3. Rotate the ISA towards the front of the printer until it rests on the ISA lift assembly (callout 1).

**Figure 1-1522** Rotate the ISA towards the front of the printer



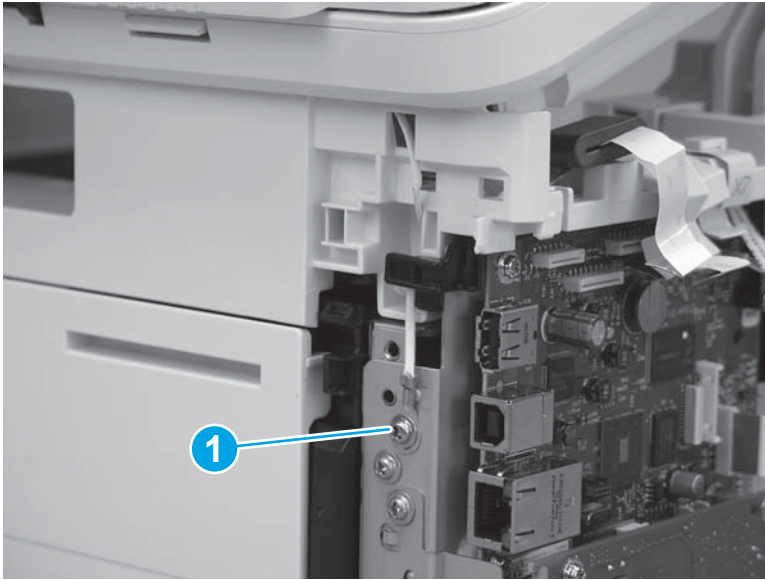
4. Pass the ground wire through the opening in the top cover.

**Figure 1-1523** Pass the wire through the opening




5. Install one screw (callout 1).

**Figure 1-1524** Install one screw



6. Install the ISA lift assembly slider pin.

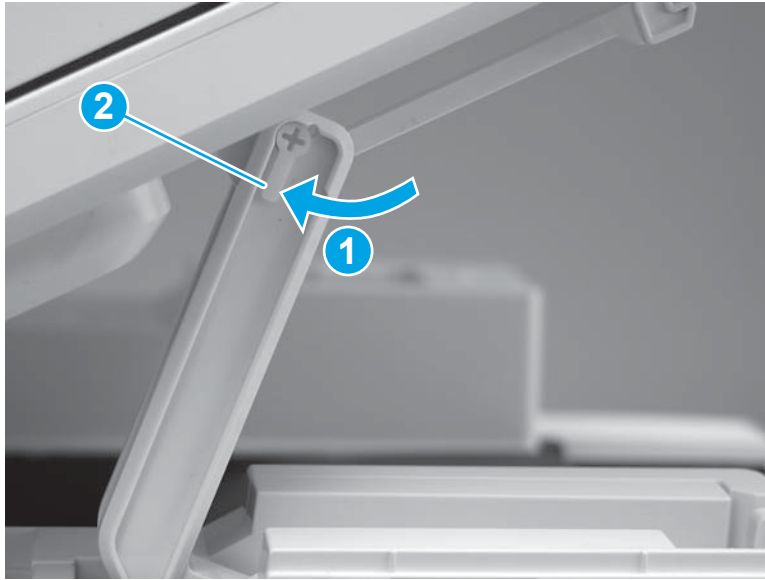
 **Reinstallation tip:** Align the keyed portion of the locking pin with the slot and hole in the support arm.

**Figure 1-1525** Install the slider pin



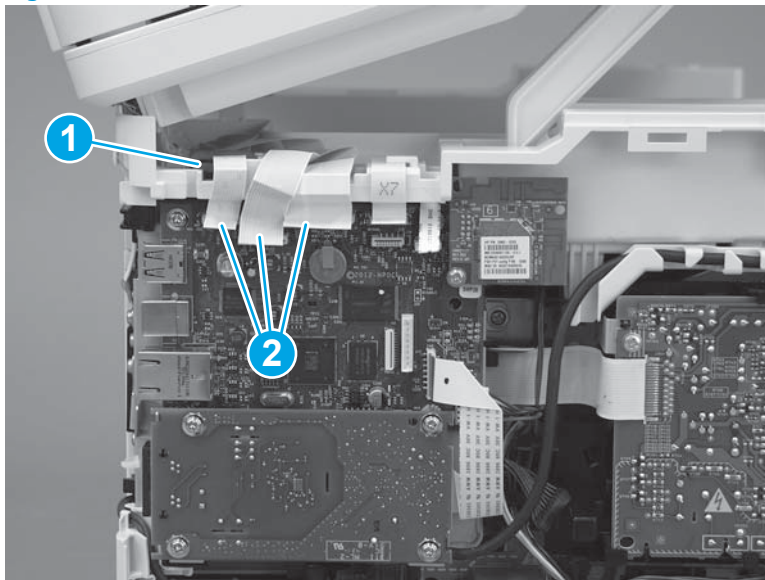
7. Rotate the slider pin (callout 1) towards the rear of the printer until the tab (callout 2) snap into place.

**Figure 1-1526** Secure the slider pin



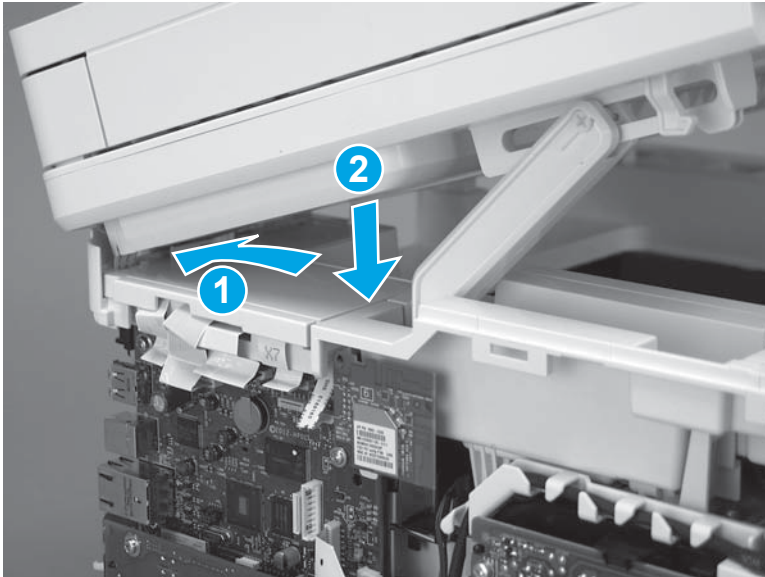
8. Install the ferrite (callout 1) in the holder, and then connect three FFCs (callout 2).

**Figure 1-1527** Connect three FFCs



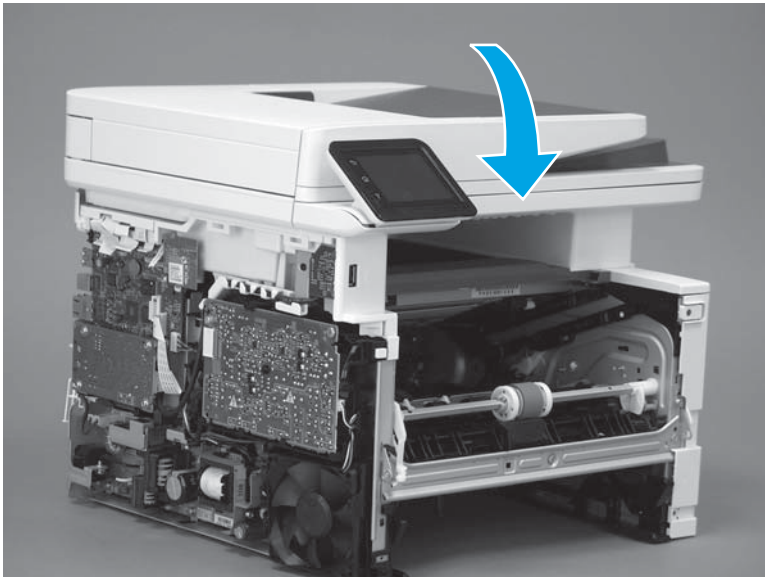
9. Position the rear edge of the ISA flat-flexible cable (FFC) cover on the printer (callout 1) , and then rotate it down (callout 2) until it snaps into place.

**Figure 1-1528** Install the ISA FFC cover



10. Lower the ISA.

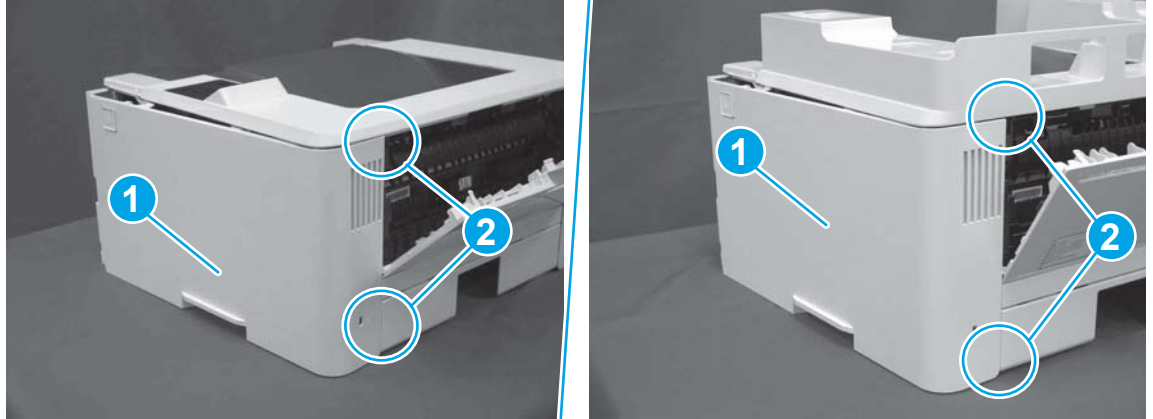
**Figure 1-1529** Lower the ISA



### Step 20: Install the right cover

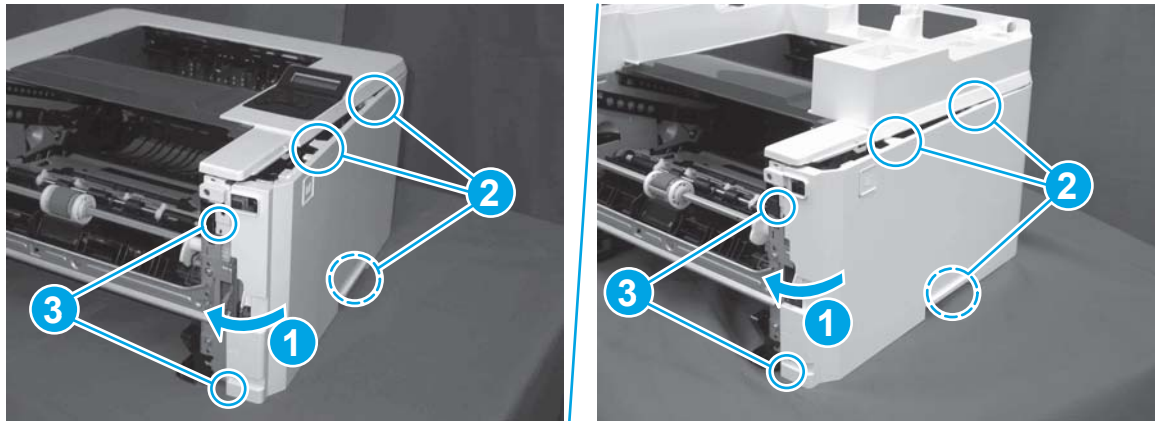
1. Position the cover (callout 1) on the printer, and then engage two bosses (callout 2).

**Figure 1-1530** Install the cover



2. Rotate the front of the cover onto the printer (callout 1), engage three (callout 2) tabs, and then engage two bosses (callout 3).

**Figure 1-1531** Engage two bosses and one tab

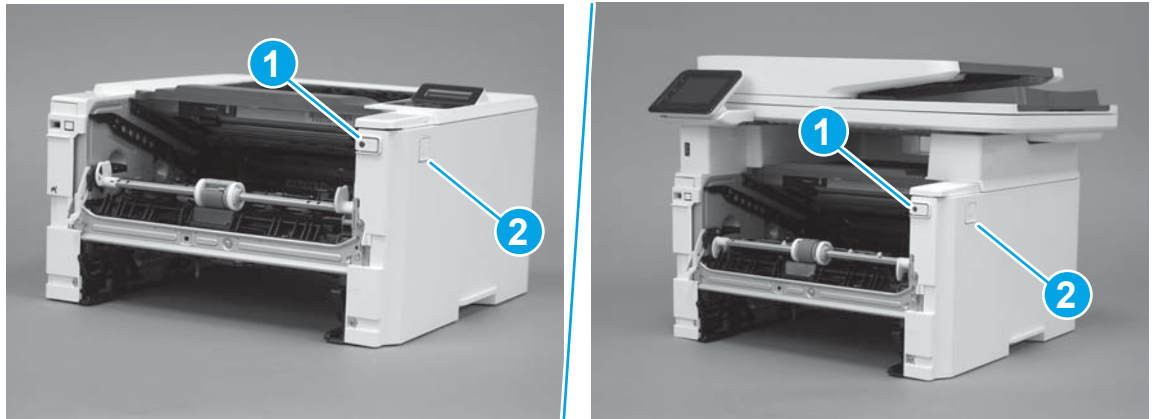


3. Make sure that the power switch (callout 1) and cartridge door assembly button (callout 2) correctly function.



**NOTE:** Remove, and then reinstall the cover if the switch or button does not correctly function.

**Figure 1-1532** Check the power switch and cartridge door assembly button



4. Install one screw (callout 1).

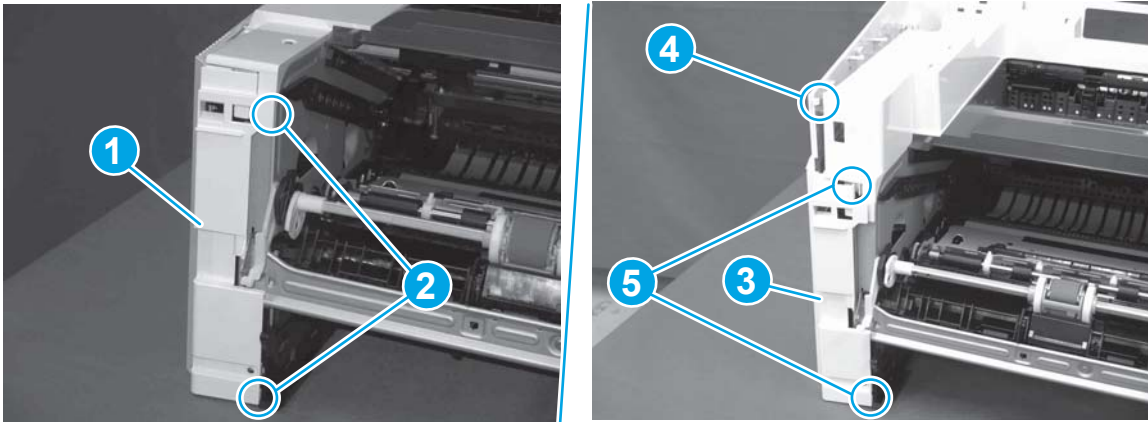
**Figure 1-1533** Install one screw



### Step 21: Install the left cover

1. At the front of the printer, do one of the following:
  - **M403/M402:** Position the cover on the printer ( callout 1), and then engage two bosses (callout 2).
  - **M427/M426:** Position the cover on the printer (callout 3), engage one tab (callout 4), and then engage two bosses (callout 4).

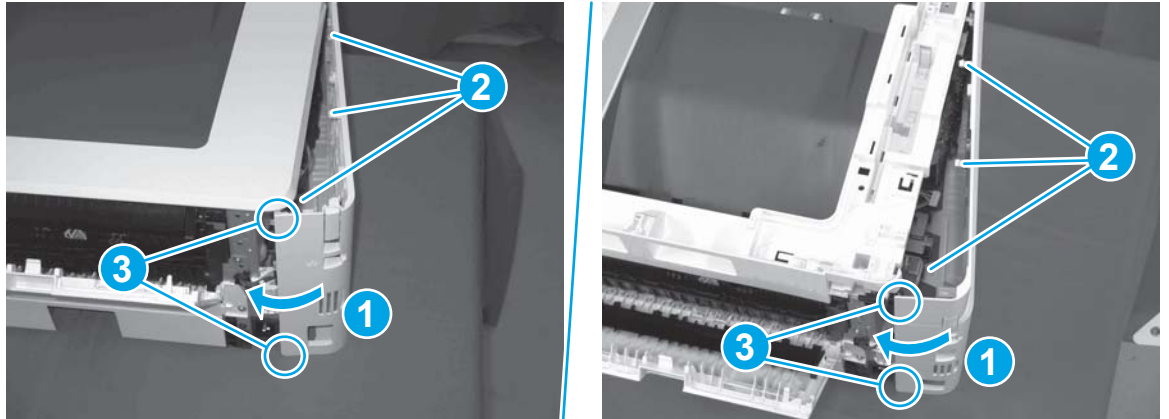
**Figure 1-1534** Install the cover





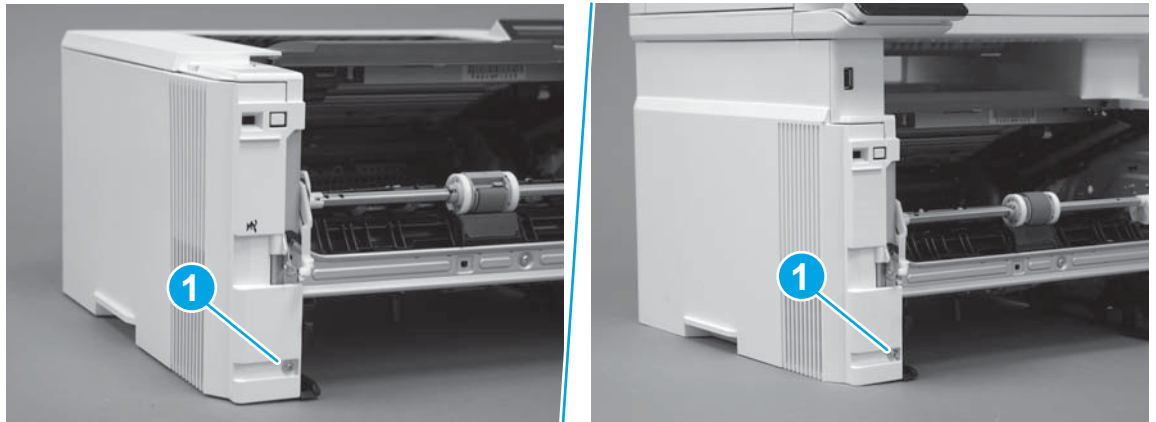
- Carefully rotate the rear of the cover onto the printer (callout 1), engage three tabs (callout 2), and then engage two bosses (callout 3).

**Figure 1-1535** Engage three tabs and two bosses




- Install one screw (callout 1).

**Figure 1-1536** Install one screw

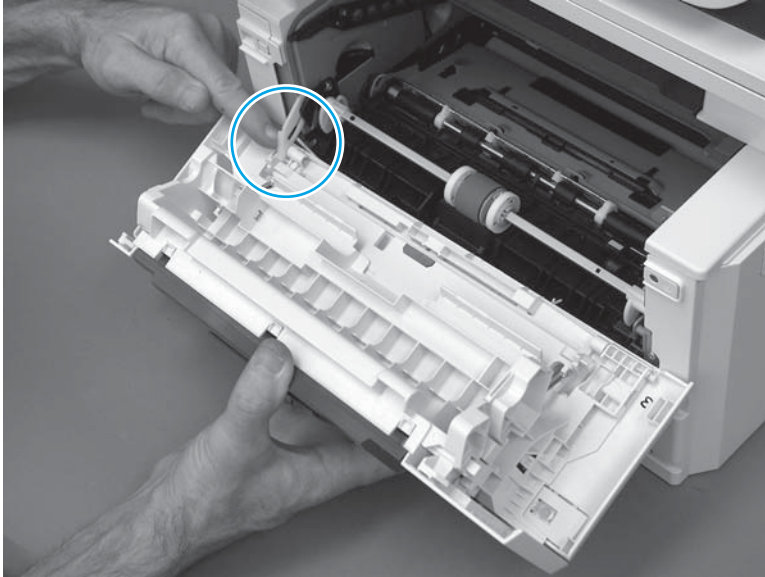


## Step 22: Install the cartridge door assembly

 **Reinstallation tip:** After a replacement door is installed, make sure to install the nameplate (supplied in the kit) corresponding to the printer name on the door.

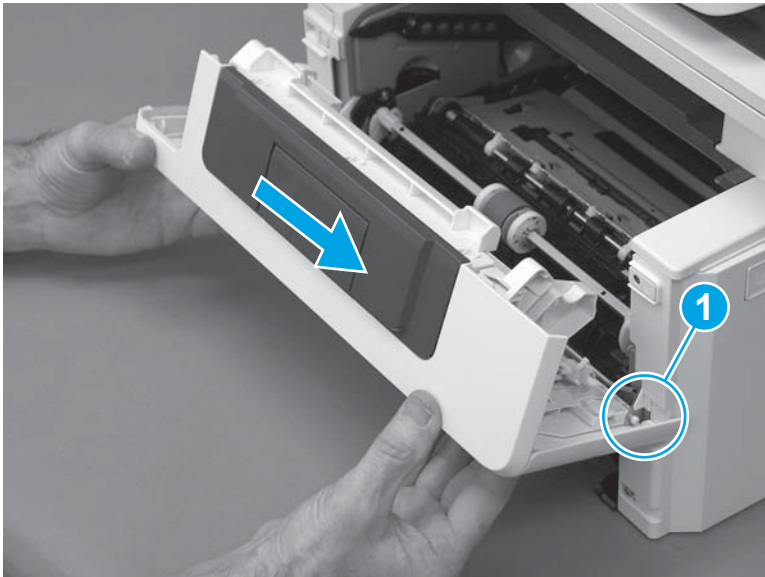
- Position the door close to the printer, and then engage the keyed pin on the left-side retainer arm with the hole in the door.

**Figure 1-1537** Engage the left-side retainer arm



2. Engage the right-side door hinge pin with the hole in the chassis (callout 1).

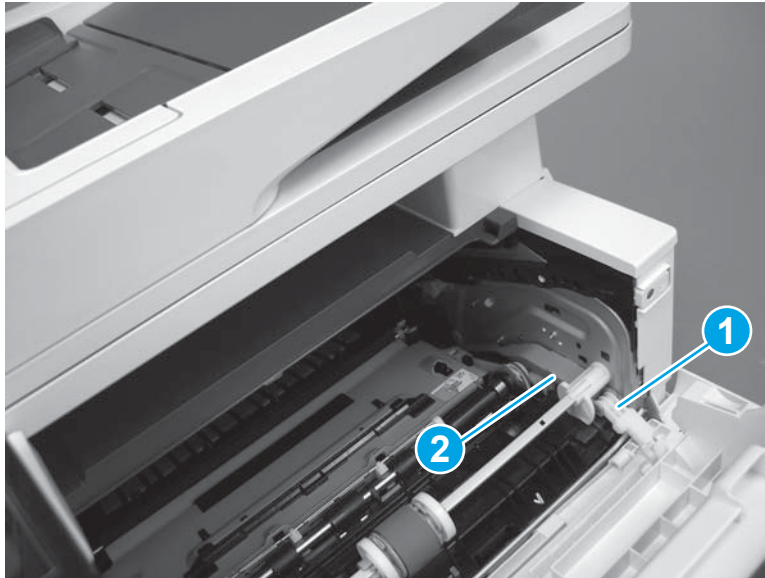
**Figure 1-1538** Install the door



3. Install the link (callout 1).

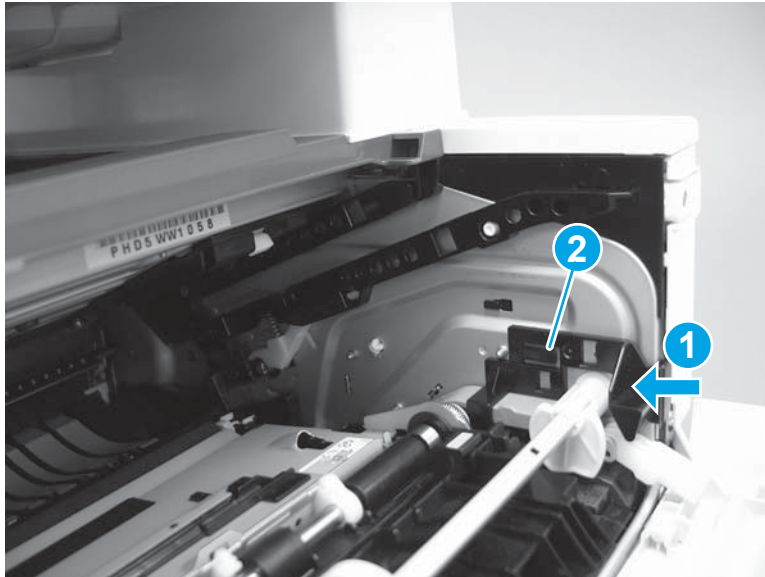
 **IMPORTANT:** Make sure that the link snaps into place on the arm (callout 2). The link actuates the fuser pressure-release mechanism.

**Figure 1-1539** Install the pressure-release link



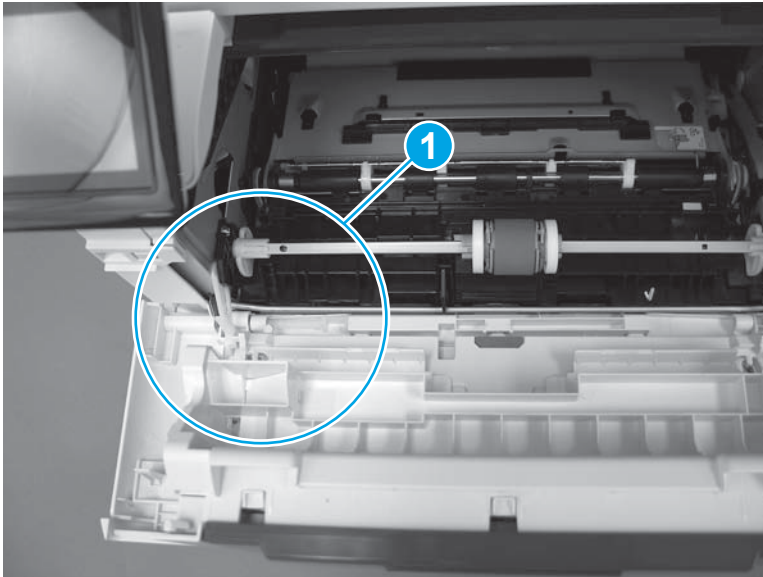
4. Slide the guide into the printer (callout 1), and then make sure that the tab (callout 2) snaps into place to secure the guide to the chassis.

**Figure 1-1540** Install the guide




5. Position the shaft on the door, and then align the left-side hinge on the door with the hole in the chassis (callout 1).

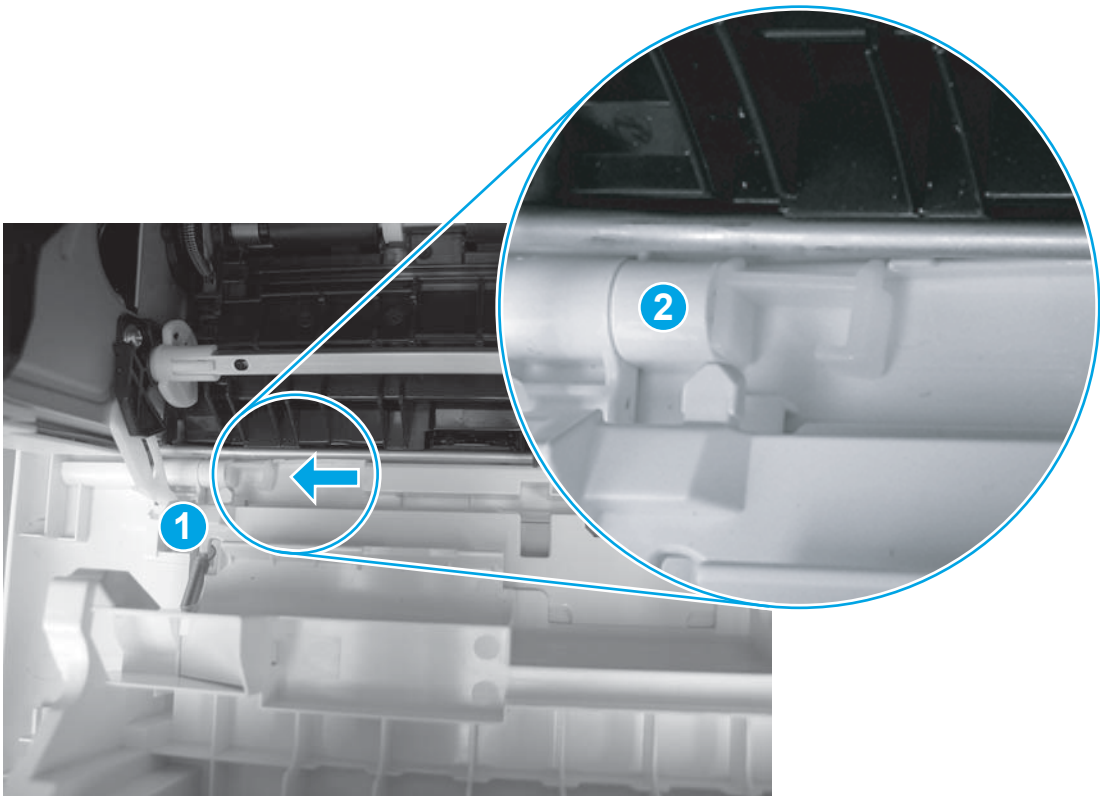
**Figure 1-1541** Align the hinge



6. Push the shaft towards the left side of the printer to install it (callout 1).

 **Reinstallation tip:** Make sure that the support shaft is fully installed and correctly orientated (callout 2) so that it will not interfere with the door opening and closing.

**Figure 1-1542** Install the support shaft



### Step 23: Install Tray 2

- ▲ Slide the tray straight into the printer to install it.

**Figure 1-1543** Install the tray



## Removal and replacement: Connecting PCA

- [Introduction](#)
- [Step 1: Remove Tray 2](#)
- [Step 2: Remove the cartridge door assembly](#)
- [Step 3: Remove the left cover](#)
- [Step 4: Remove the right cover](#)
- [Step 5: Remove the integrated scanner assembly \(M427/M246\)](#)
- [Step 6: Remove the control panel \(M427/M246\)](#)
- [Step 7: Remove the top cover \(M427/M426\)](#)
- [Step 8: Remove the top cover \(M403/M402\)](#)
- [Step 9: Remove the paper delivery tray \(output bin\)](#)
- [Step 10: Remove the sheet-metal formatter bracket and formatter PCA](#)
- [Step 11: Remove the connecting PCA](#)
- [Step 12: Unpack the replacement assembly](#)
- [Step 13: Install the connecting PCA](#)
- [Step 14: Install the sheet-metal formatter bracket and formatter PCA](#)
- [Step 15: Install the paper delivery tray \(output bin\)](#)
- [Step 16: Install the top cover \(M403/M402\)](#)
- [Step 17: Install the top cover \(M427/M426\)](#)
- [Step 18: Install the control panel \(M427/M246\)](#)
- [Step 19: Install the integrated scanner assembly \(M427/M246\)](#)
- [Step 20: Install the right cover](#)
- [Step 21: Install the left cover](#)
- [Step 22: Install the cartridge door assembly](#)
- [Step 23: Install Tray 2](#)

### Introduction


This document provides the procedures to remove and replace the connecting printed circuit assembly (PCA).

### Before performing service

#### Turn the printer power off

- Disconnect the power cable.

---

 **WARNING!** To avoid damage to the printer, turn the printer off, wait 30 seconds, and then remove the power cable before attempting to service the printer.

---

Use the table below to identify the correct part number for your printer. To order the part, go to [www.hp.com/buy/parts](http://www.hp.com/buy/parts).

---

Connecting printed circuit assembly (PCA) part number	
<b>RM2-7510-000CN</b>	Connecting PCA (duplex models <sup>1</sup> )
<b>RM2-8510-000CN</b>	Connecting PCA (simplex models)

---

<sup>1</sup> All M426/M427 printers are duplex models and use the RM2-7510-000CN connecting PCA.

### Required tools

- #2 Phillips screwdriver with a magnetic tip.
- 5.5 mm (0.22 inch) socket screwdriver.

### After performing service

#### Turn the printer power on

- Connect the power cable.
- Use the power switch to turn the power on.

### Post service test

Make sure that the printer initializes to a **Ready** state.

Print a configuration page to make sure that the printer is functioning correctly.

### Step 1: Remove Tray 2

- ▲ Pull the tray straight out of the printer to remove it.

**Figure 1-1544** Remove the tray



**Step 2: Remove the cartridge door assembly**



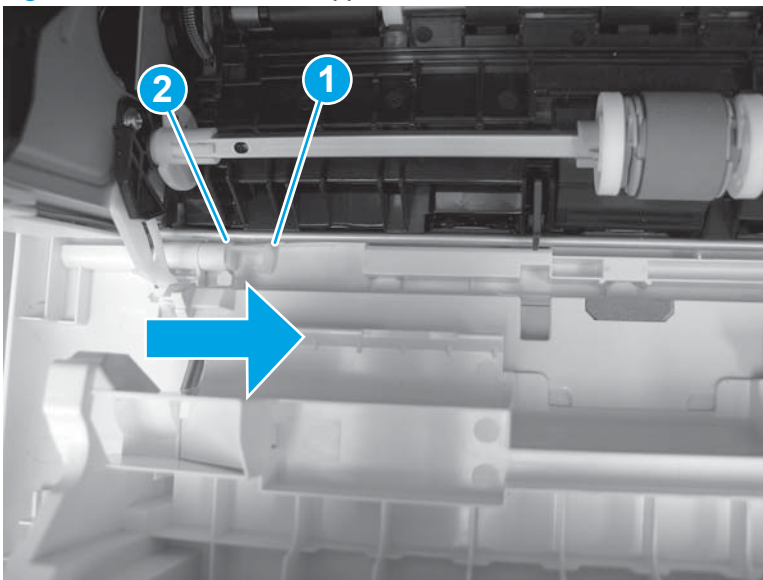
**NOTE:** If the toner cartridge was not removed prior to servicing the printer, remove it now.

1. Release one tab (callout 1), and then slide shaft (callout 2) in the direction the arrow indicates and remove it.



**TIP:** It might be easier to release the support shaft by using a small flat-blade screwdriver.

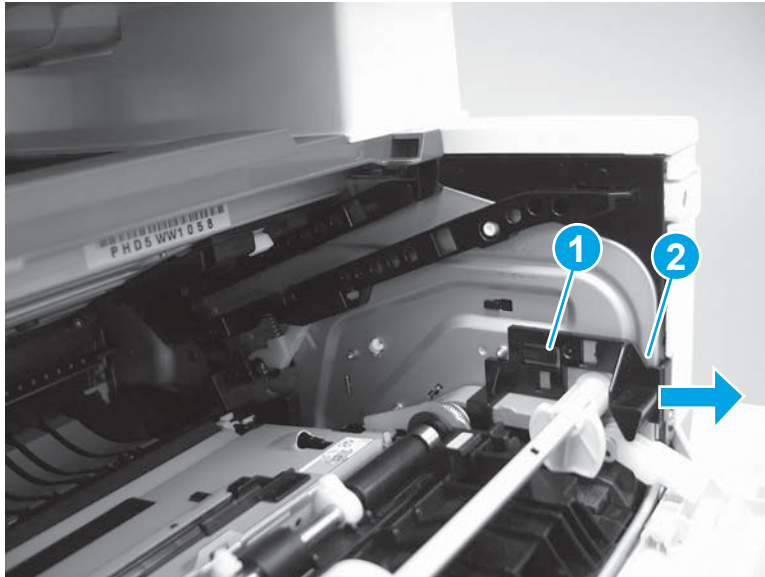
**Figure 1-1545** Release the support shaft





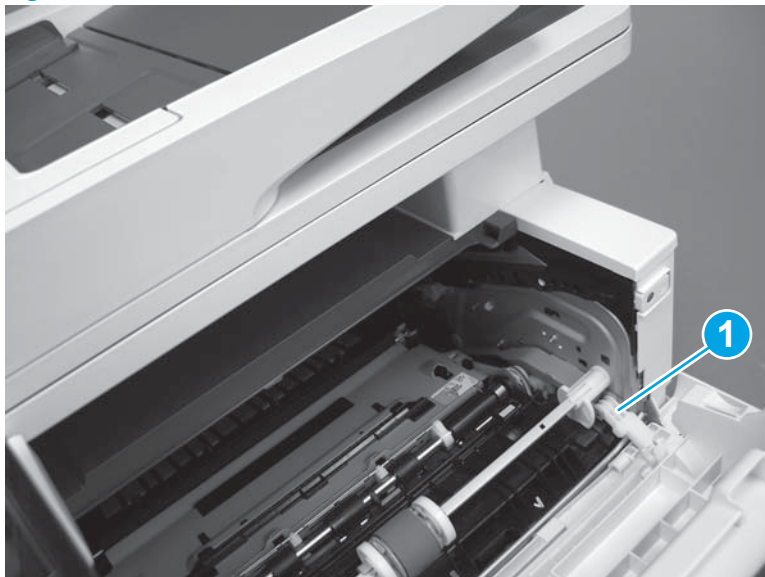
2. Release one tab (callout 1), and then slide the guide (callout 2) in the direction the arrow indicates and remove it.

**Figure 1-1546** Remove the guide



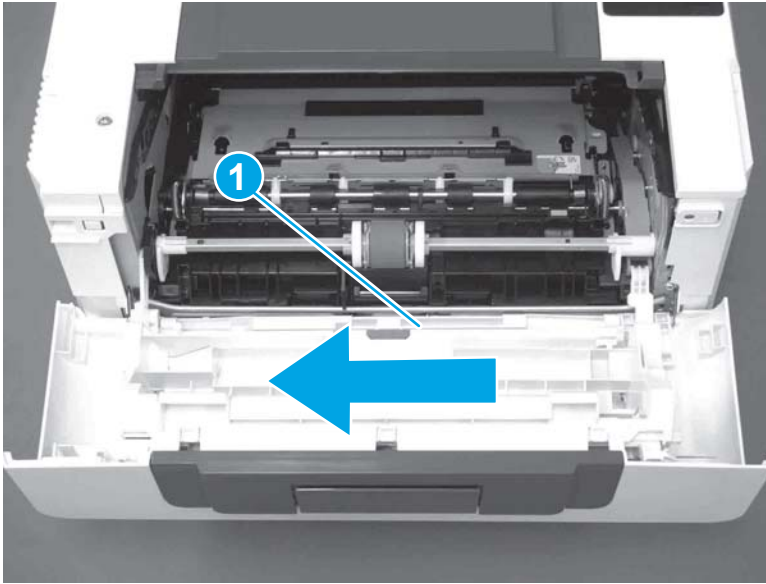
3. Remove the link arm (callout 1).

**Figure 1-1547** Remove the link arm



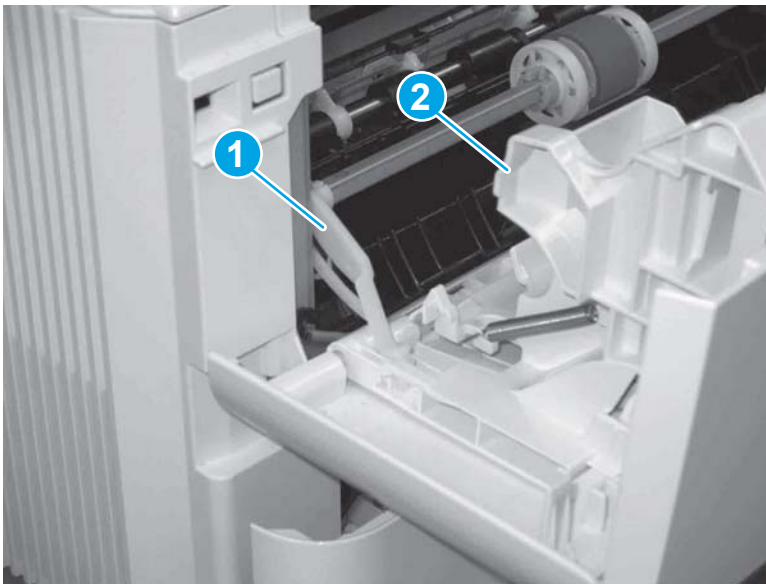
4. Slide the cartridge door assembly (callout 1) in the direction the arrow indicates and remove it.

**Figure 1-1548** Remove the door



5. Remove the link (callout 1) from the cartridge door assembly (callout 2).

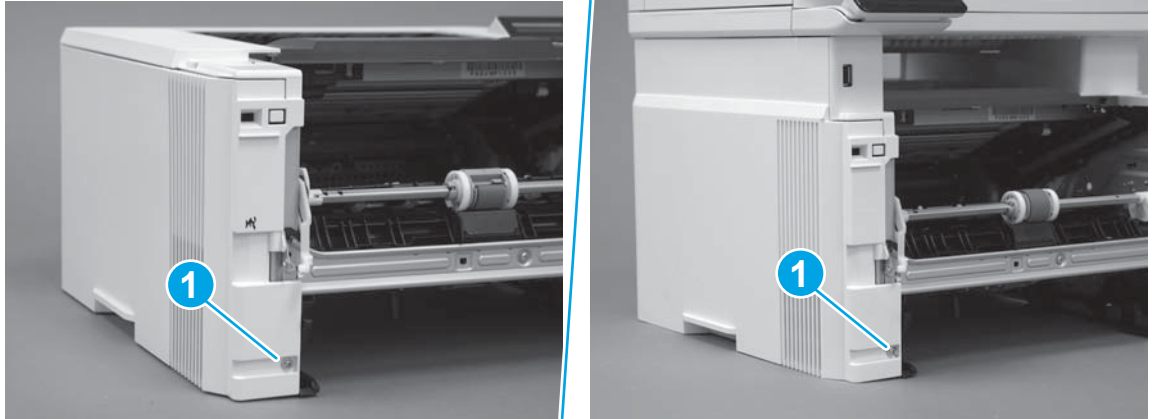
**Figure 1-1549** Release the left-side retainer arm



### Step 3: Remove the left cover

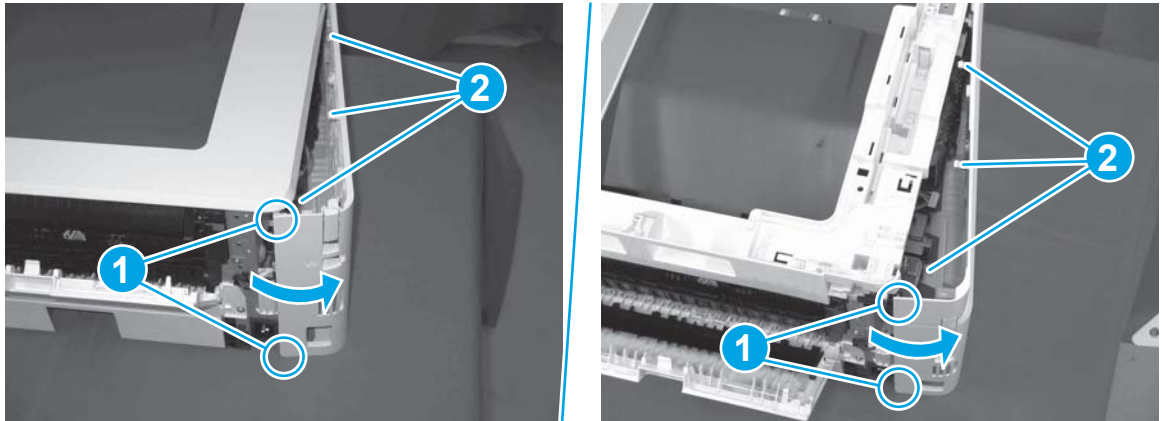
1. Remove one screw (callout 1).

**Figure 1-1550** Remove one screw



2. Open the rear door, release two bosses (callout 1), and then release three tabs (callout 2).

**Figure 1-1551** Release two bosses and three tabs

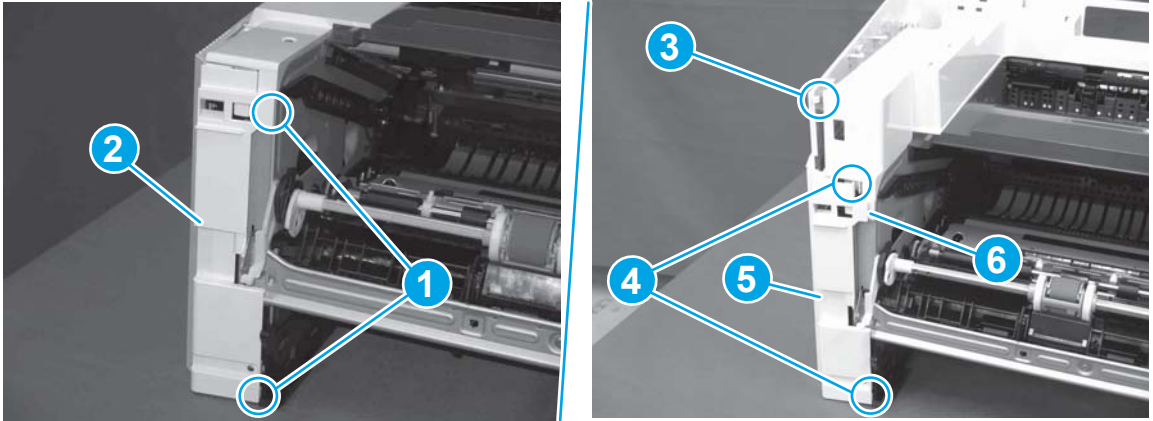


3. At the front of the printer, do one of the following:

- **M403/M402:** Release two bosses (callout 1), and then remove the cover (callout 2).
- **M427/M426:** Release one tab (callout 3), two bosses (callout 4), and then remove the cover (callout 5).

**CAUTION:** Be careful when releasing the upper bosses on the M427/M426 cover. One portion of the cover (callout 6) is fragile and is easily broken.

**Figure 1-1552** Remove the cover



**Step 4: Remove the right cover**

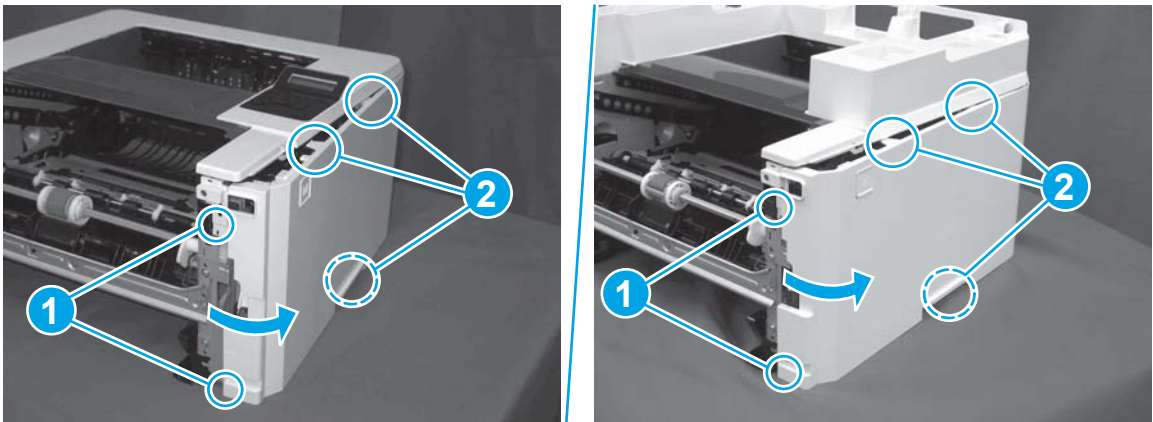
1. Remove one screw (callout 1).

**Figure 1-1553** Remove one screw



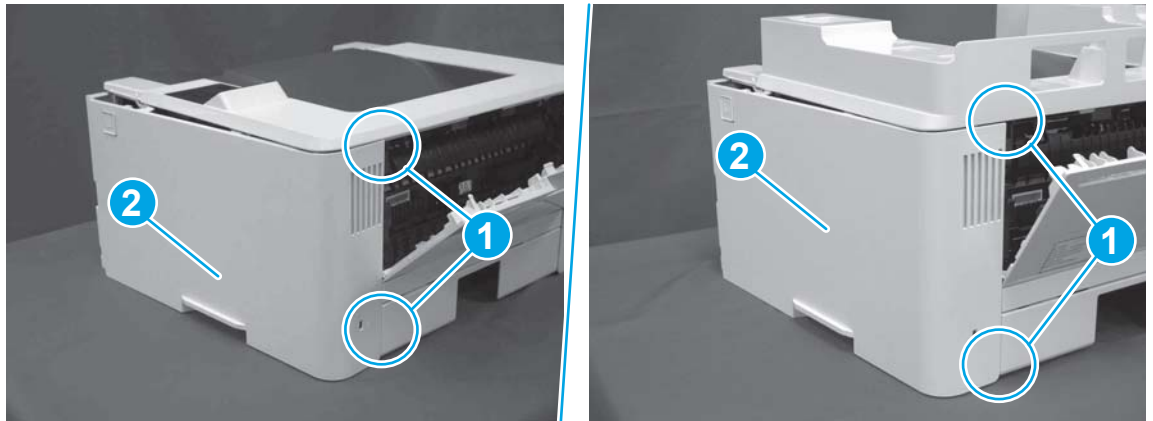
2. At the front of the printer, release two bosses (callout 1), and then release three tabs (callout 2).

**Figure 1-1554** Release two bosses and three tabs





3. Open the rear door, release two bosses (callout 1), and then remove the cover (callout 2).

**Figure 1-1555** Remove the cover



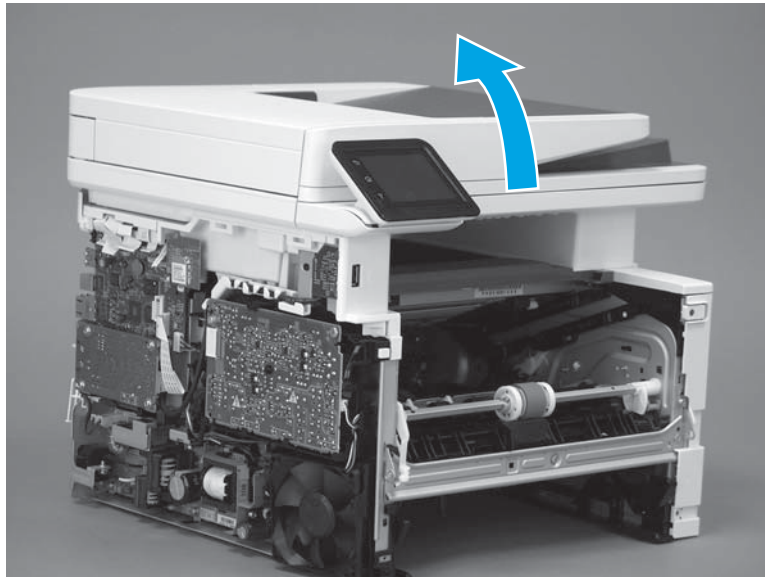
### Step 5: Remove the integrated scanner assembly (M427/M246)

 **NOTE:** The step is for the M427/M426 printer. For the M403/M402, skip this step and go to [Step 8: Remove the top cover \(M403/M402\)](#) on page 841.

 **NOTE:** M427/M426 models only. The integrated scanner assembly (ISA) includes the sub-scanner assembly (SSA) and the automatic document feeder (ADF).

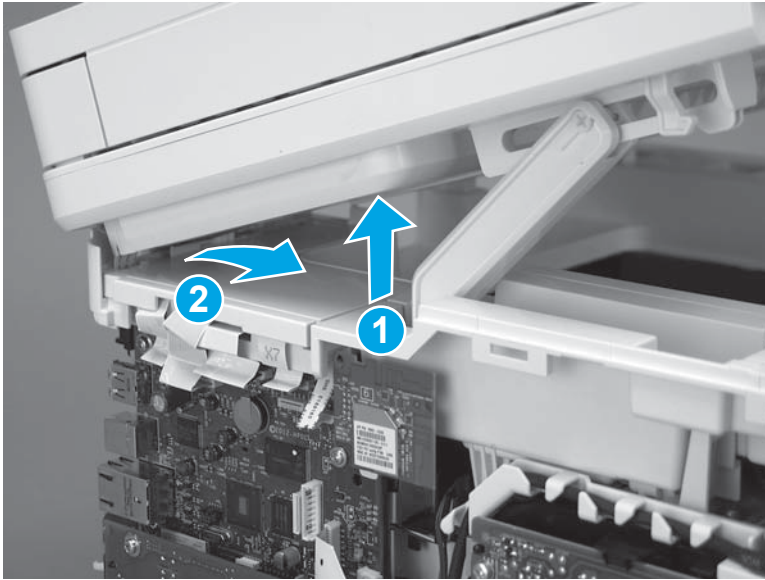
1. Raise the ISA.

**Figure 1-1556** Raise the ISA



2. Release the ISA flat-flexible cable (FFC) cover (callout 1), and then remove it (callout 2).

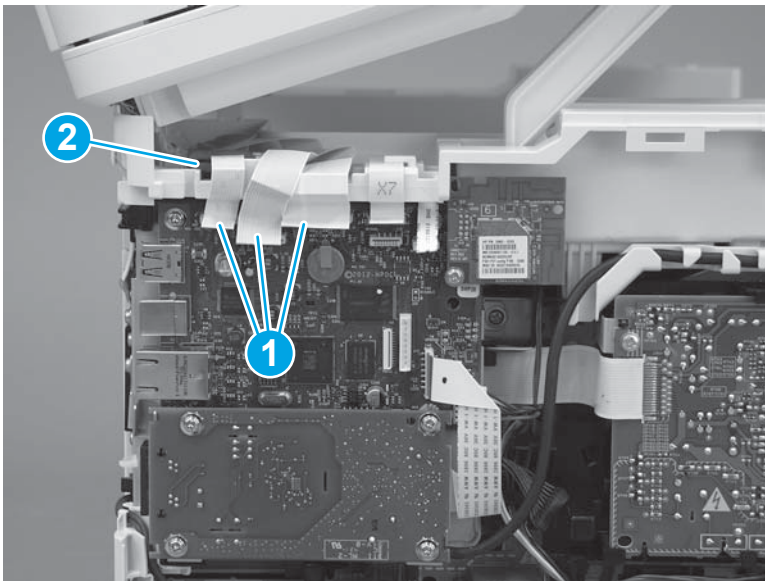
**Figure 1-1557** Remove the ISA FFC cover



3. Disconnect three FFCs (callout 1), and then remove the ferrite (callout 2) from the holder.

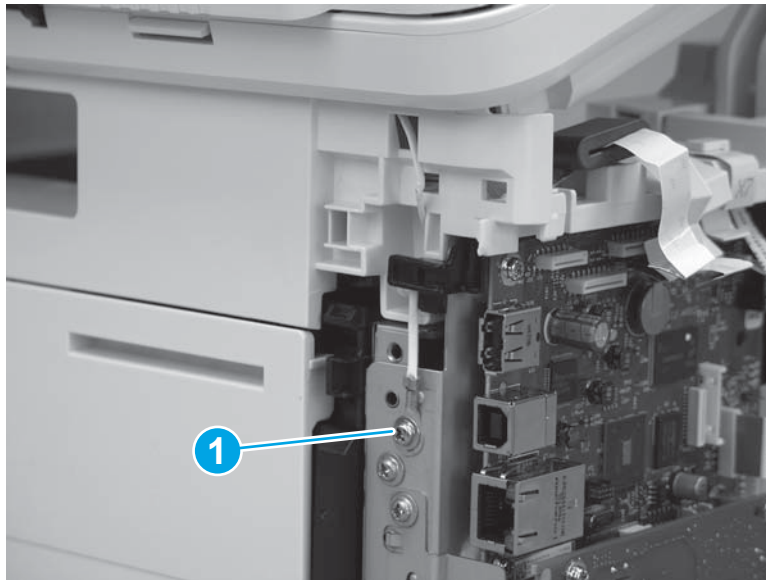
**CAUTION:** The ferrite is not captive on the FFC. Do not lose the ferrite while handling the ISA.

**Figure 1-1558** Disconnect three FFCs



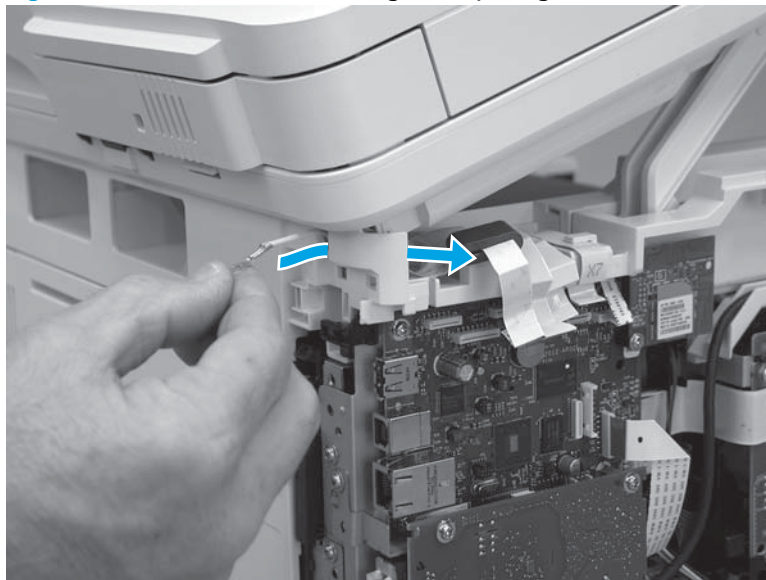
4. Remove one screw (callout 1).

**Figure 1-1559** Remove one screw



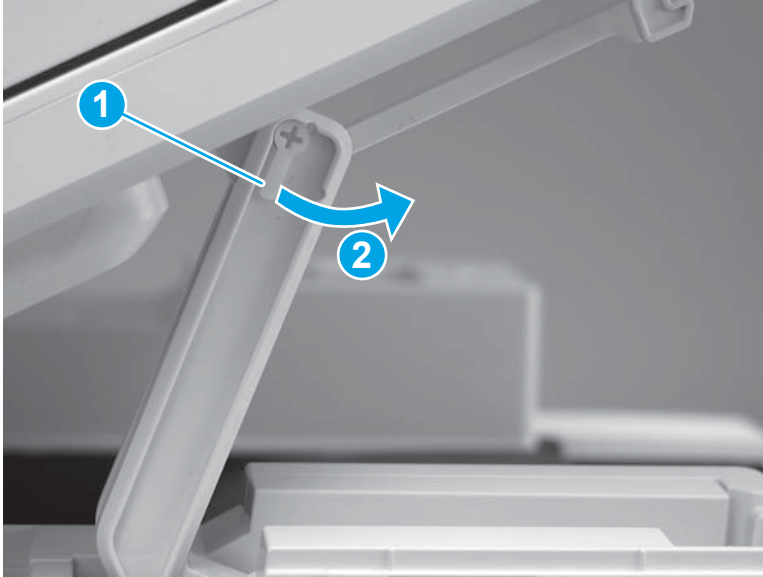
5. Pass the ground wire through the opening in the top cover.

**Figure 1-1560** Pass the wire through the opening



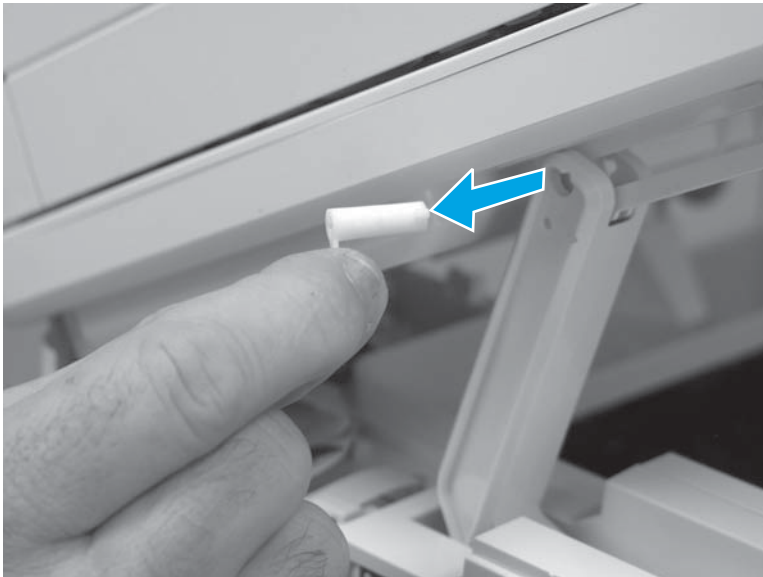
6. Release one tab (callout 1), and then rotate the ISA slider pin (callout 2) towards the front of the printer to release it.

**Figure 1-1561** Release one tab and rotate the slider pin



7. Remove the slider pin.

**Figure 1-1562** Remove the slider pin





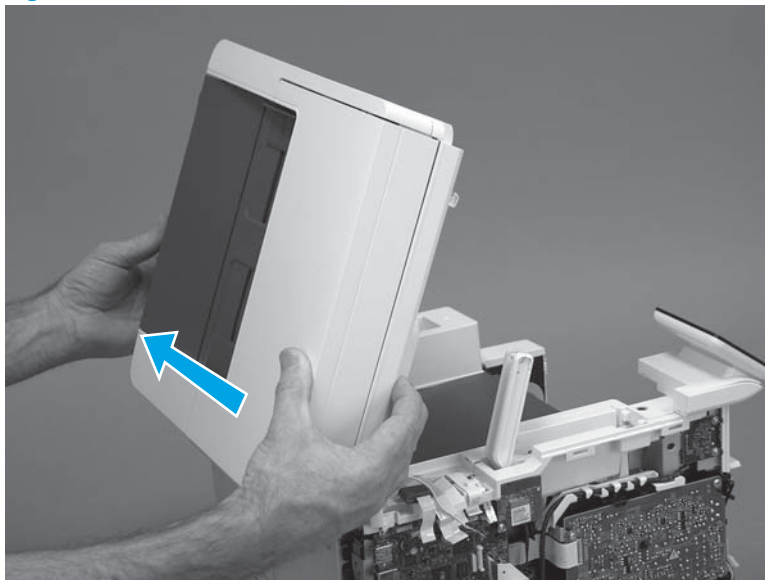
8. Rotate the ISA towards the rear of the printer until it stops.

**Figure 1-1563** Rotate the ISA towards the rear of the printer



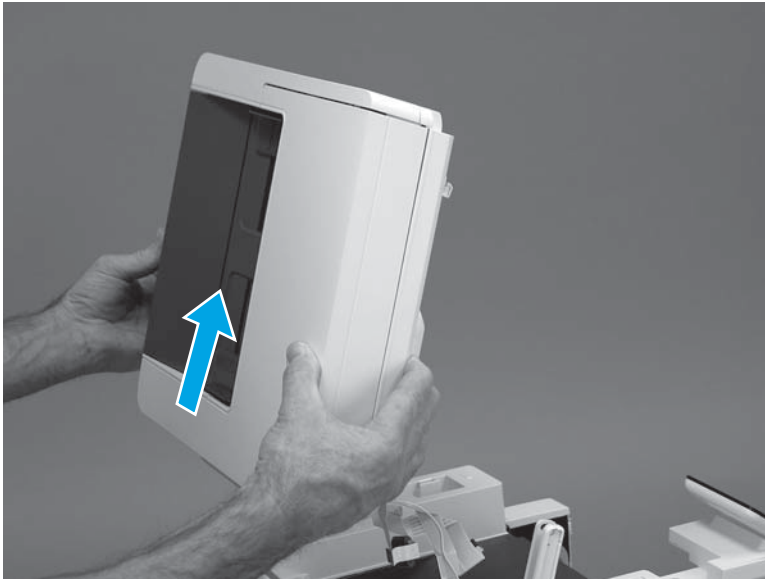
9. Slide the ISA as shown to release it.

**Figure 1-1564** Release the ISA



10. Remove the ISA.

**Figure 1-1565** Remove the ISA



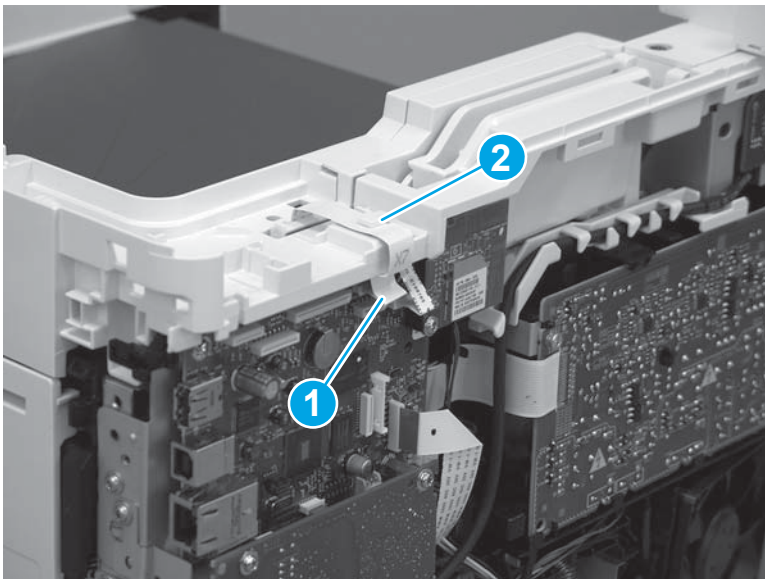
#### Step 6: Remove the control panel (M427/M246)



**NOTE:** The step is for the M427/M426 printer. For the M403/M402, skip this step and go to [Step 8: Remove the top cover \(M403/M402\)](#) on page 841.

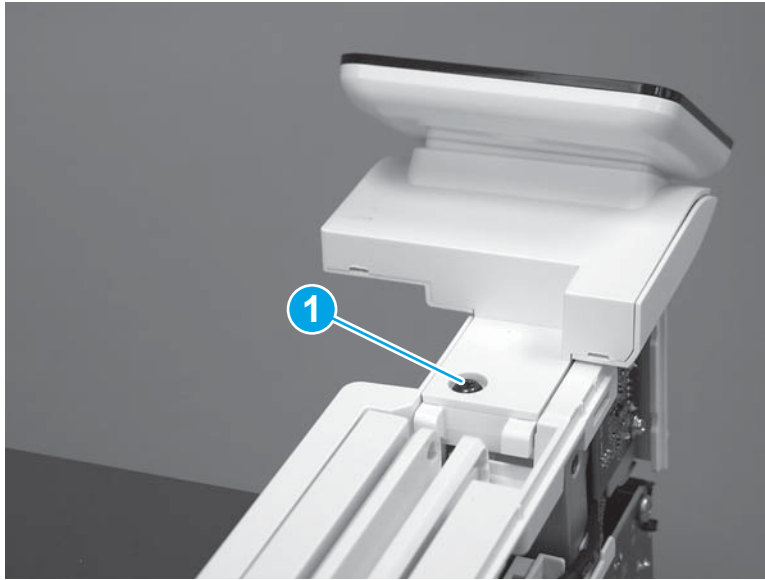
1. Disconnect one FFC (callout 1; J114), and then release the FFC from the retainer (callout 2).

**Figure 1-1566** Disconnect one connector



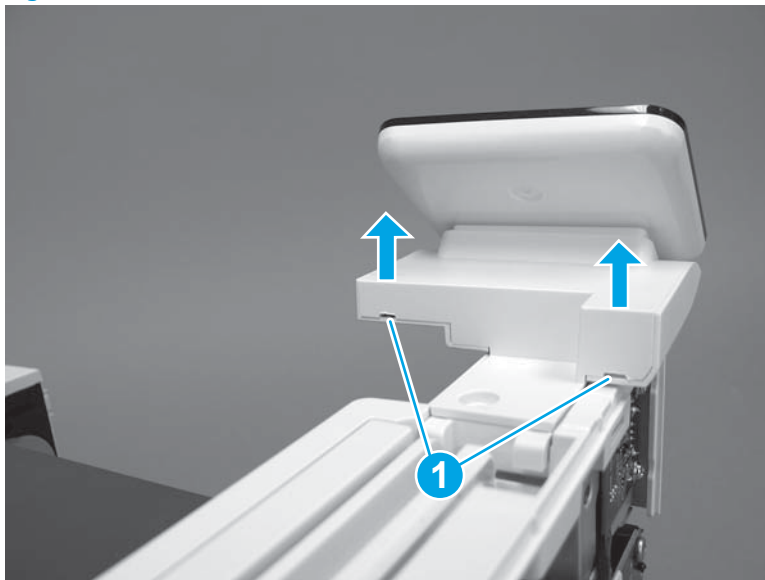
2. Remove one screw (callout 1).

**Figure 1-1567** Remove one screw



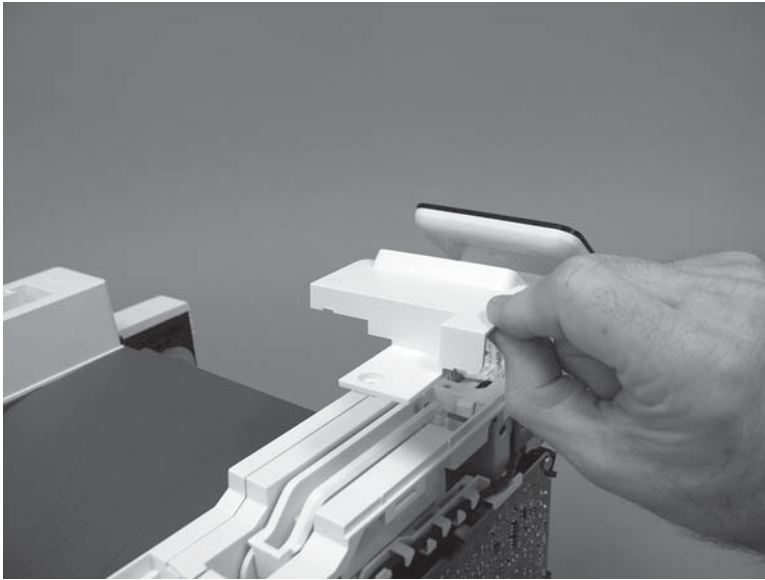
3. Use a small flat-blade screwdriver to release two tabs (callout 1) on the control-panel cable cover.

**Figure 1-1568** Release two tabs



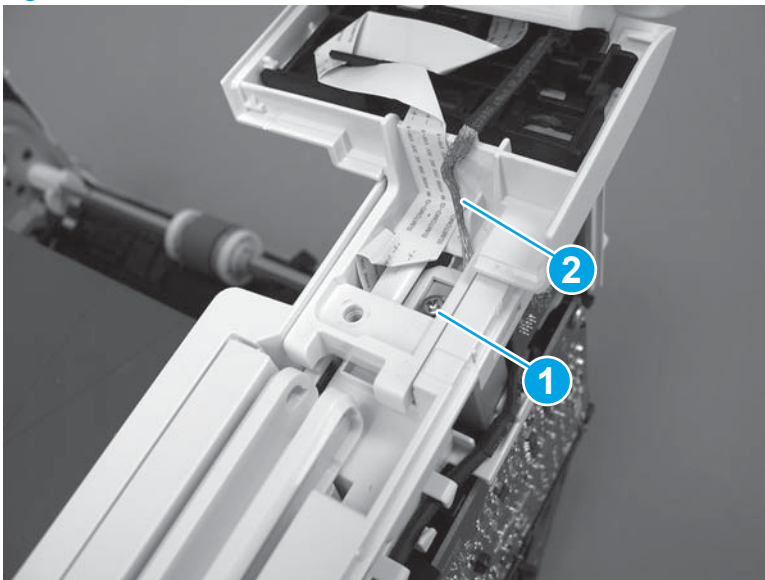
4. Remove the control-panel cable cover.

**Figure 1-1569** Remove the cover



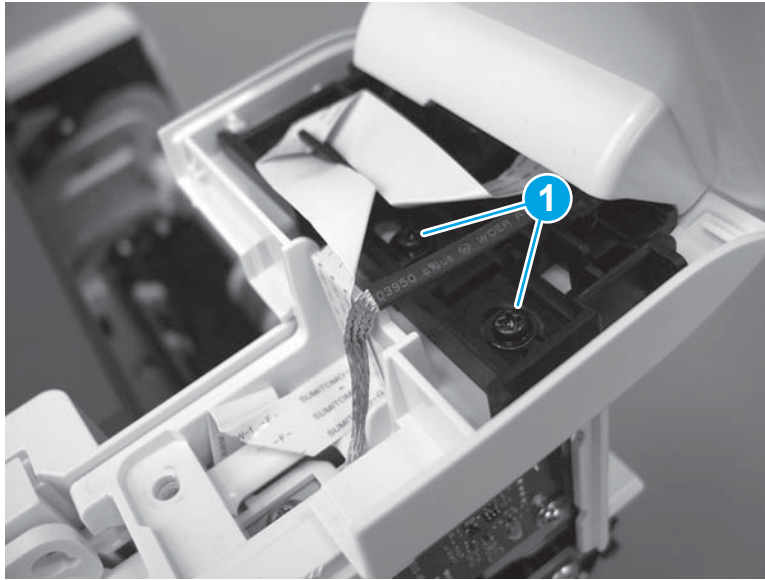
5. Remove one grounding screw (callout 1), and then move the ground cable (callout 2) out of the way.

**Figure 1-1570** Remove one screw



6. Move the FFC out of the way, and then remove two screws (callout 1).

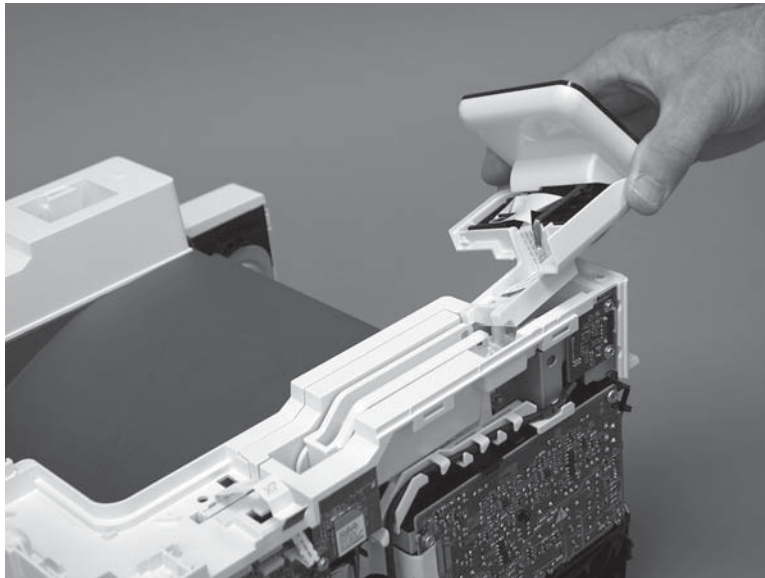
**Figure 1-1571** Remove two screws



7. Slightly lift up the control-panel assembly to separate it from the top cover.

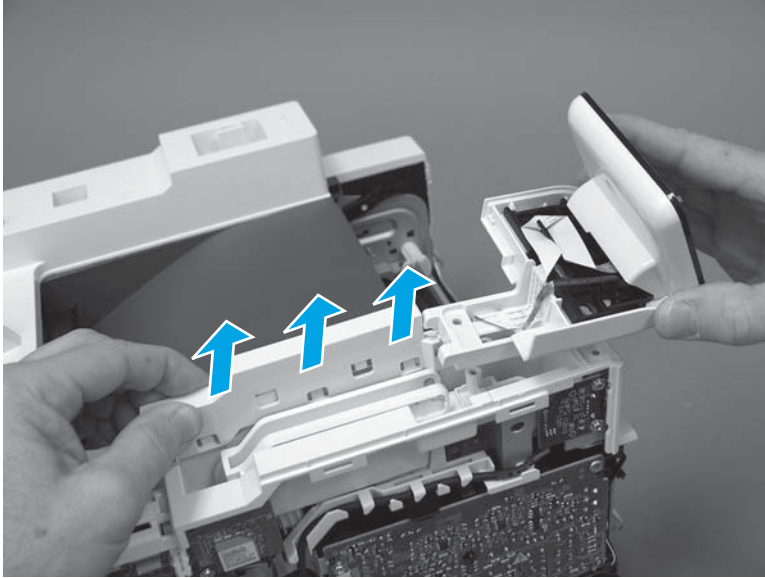
**⚠ CAUTION:** The control panel assembly is still connected to the printer by the FFC. Do not attempt to completely remove the assembly.

**Figure 1-1572** Lift up the control-panel assembly



8. Lift up the control-panel FFC cover to remove the control-panel assembly.

**Figure 1-1573** Remove the control-panel assembly



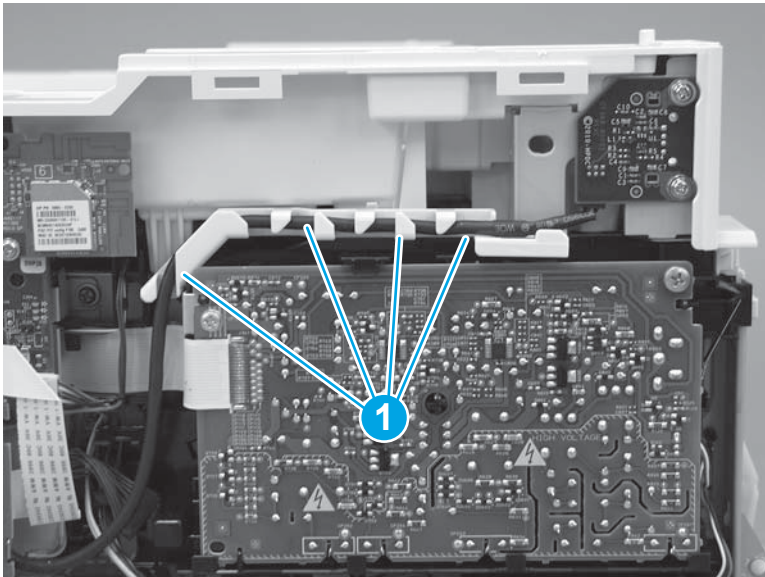
#### Step 7: Remove the top cover (M427/M426)



**NOTE:** The step is for the M427/M426 printer. For the M403/M402, skip this step and go to [Step 8: Remove the top cover \(M403/M402\) on page 841](#).

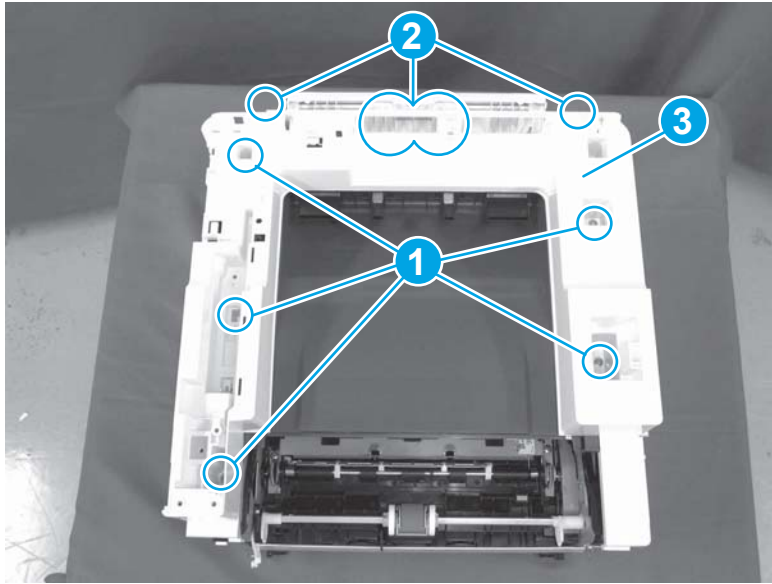
1. Release the USB cable (callout 1) from the cable guide.

**Figure 1-1574** Remove the USB cable




2. Remove five screws (callout 1), release four bosses (callout 2), and then remove the top cover (callout 3).

**Figure 1-1575** Remove the cover



### Step 8: Remove the top cover (M403/M402)

 **NOTE:** The step is for the M403/M402 printer. For the M427/M426, skip this step and go to [Step 9: Remove the paper delivery tray \(output bin\) on page 842.](#)

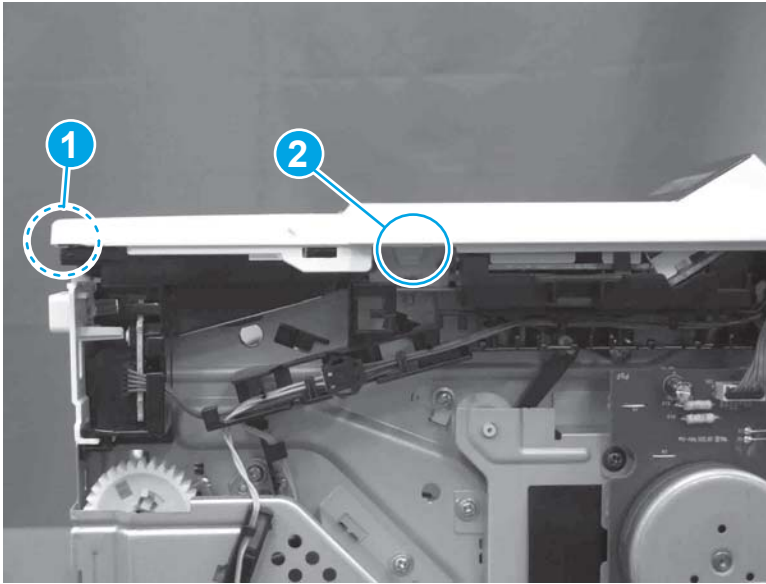
1. Remove one screw (callout 1).

**Figure 1-1576** Remove one screw




2. At the right side of the printer, release the one boss (callout 1), and then release one tab (callout 2).

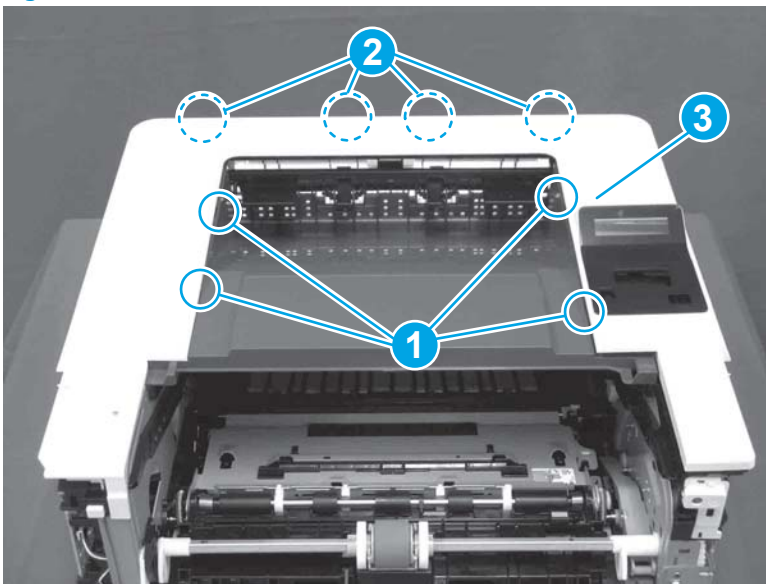
**Figure 1-1577** Release one boss and one tab




3. Release four tabs (callout 1), release four bosses (callout 2), and then remove the top cover (callout 3).

 **TIP:** Open the rear door to make releasing the bosses (callout 3) easier.

**Figure 1-1578** Remove the cover



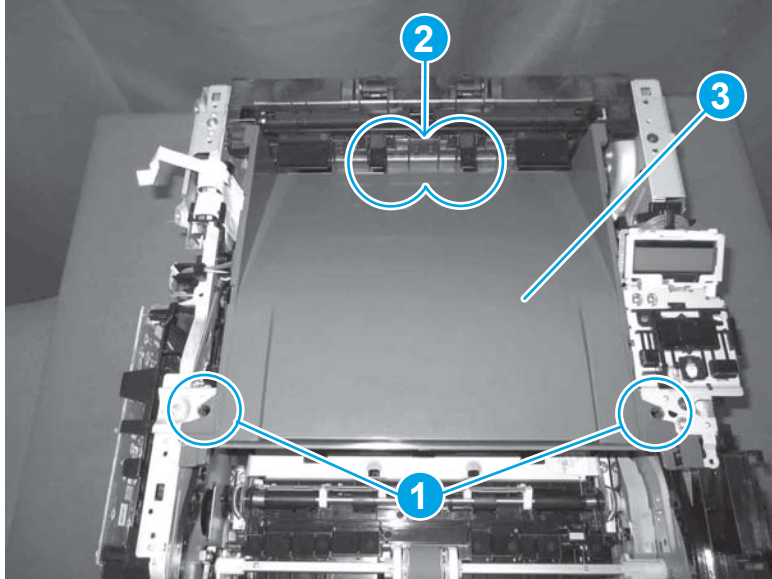
### Step 9: Remove the paper delivery tray (output bin)

 **NOTE:** This procedure shows the M403/M402 model, however, the paper delivery tray (output bin) removal is similar for the M427/M426 printer.

- ▲ Release two bosses (callout 1), release two tabs (callout 2), and then remove the paper delivery tray (output bin; callout 3).



**Figure 1-1579** Release two tabs

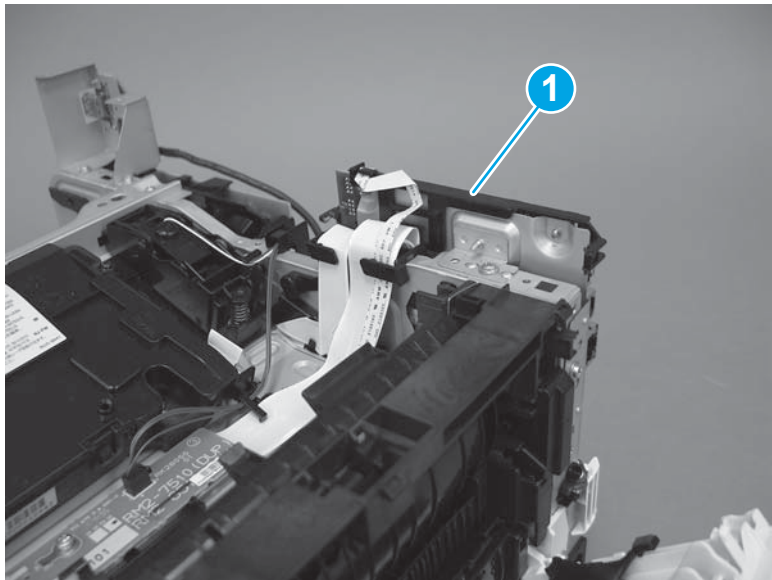


**Step 10: Remove the sheet-metal formatter bracket and formatter PCA**

 **NOTE:** Disconnect any remaining formatter PCA FFCs or wire-harness connectors.

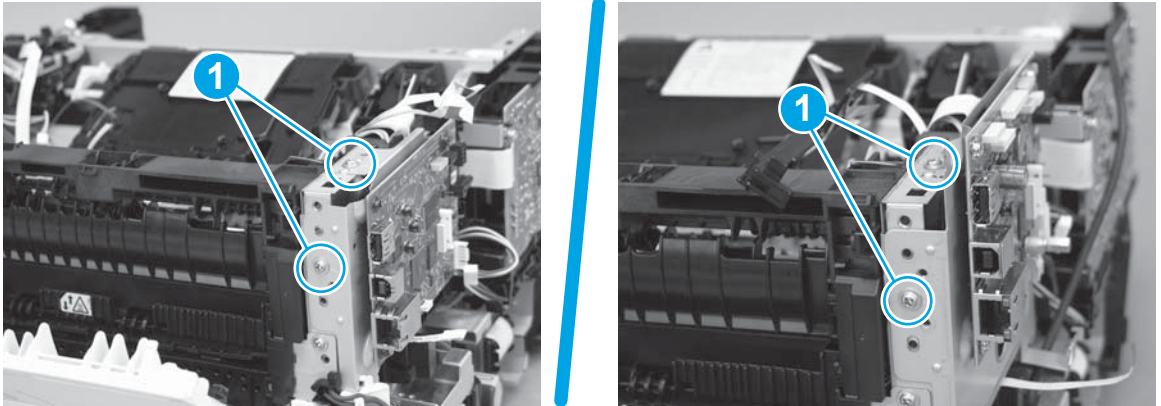
1. **M427/M426 only:** Remove the guide (callout 1).

**Figure 1-1580** Remove the guide



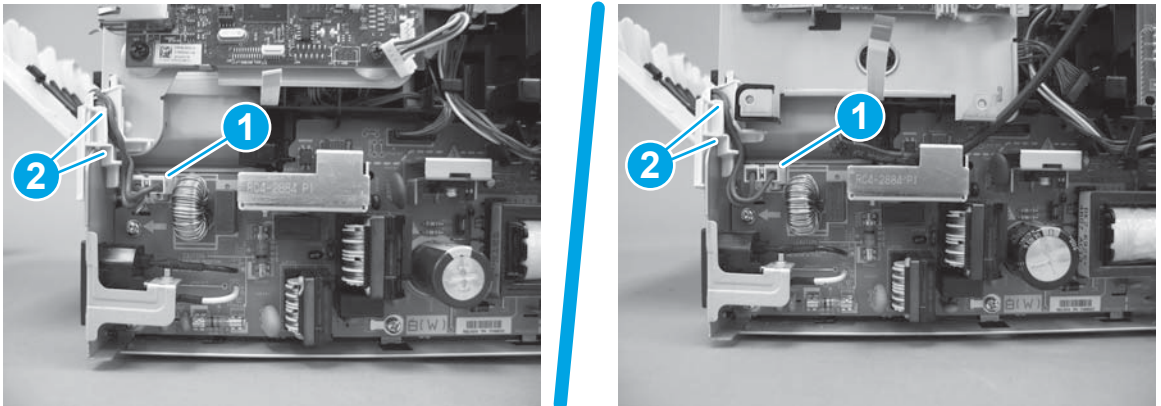
2. Remove two screws (callout 1).

**Figure 1-1581** Remove two screws



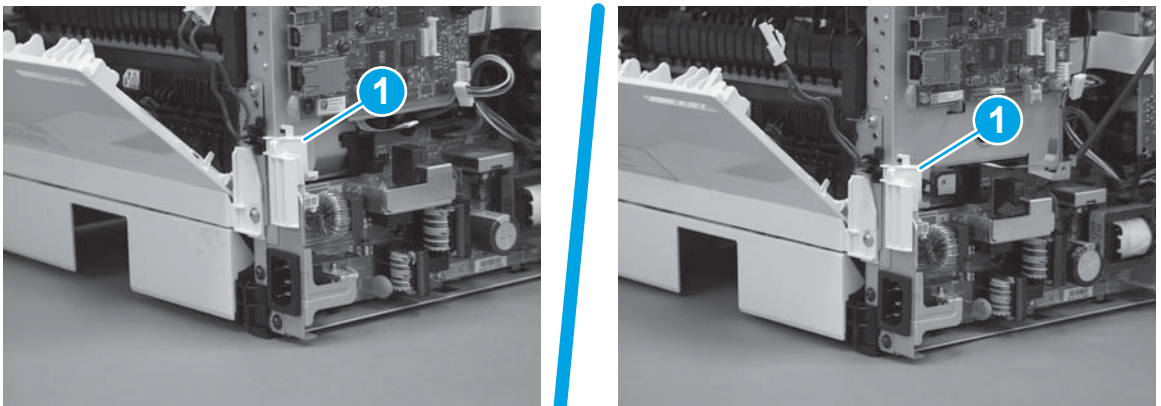
3. Disconnect one connector (callout 1), and then release the wire harness from the guide (callout 2).

**Figure 1-1582** Disconnect one connector



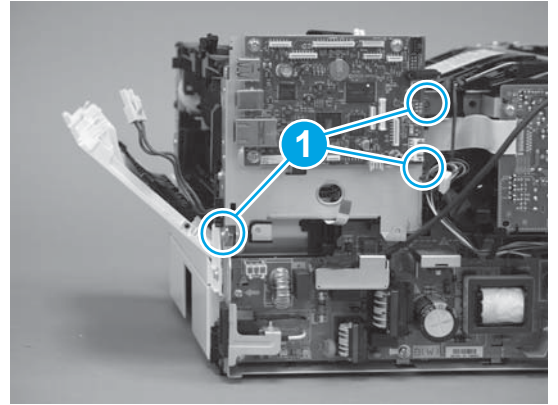
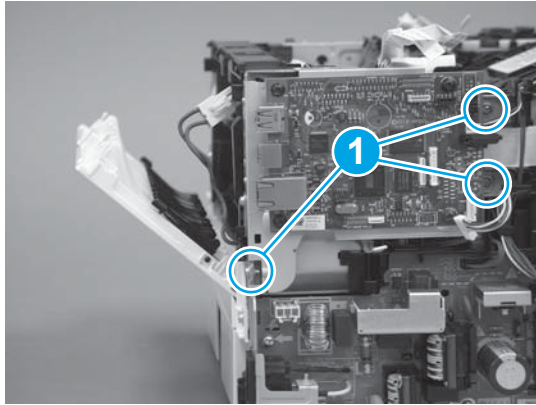
4. Remove the guide (callout 1).

**Figure 1-1583** Remove the guide



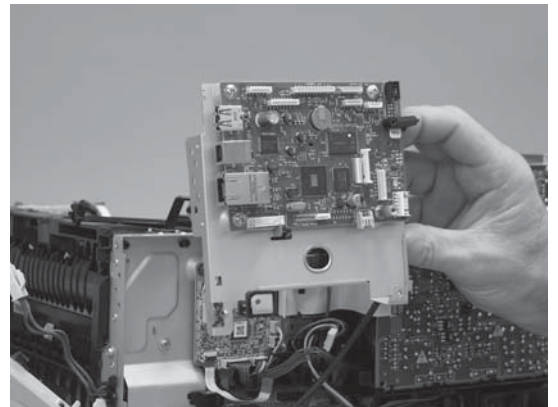
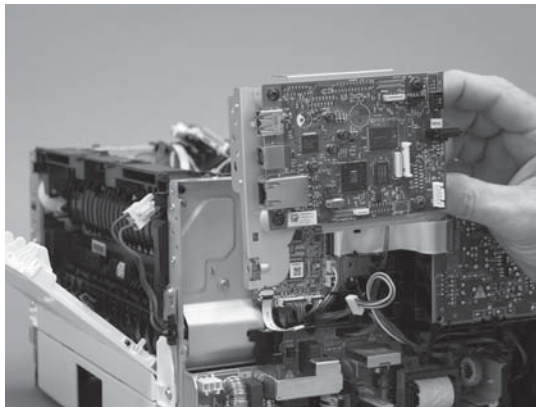
5. Remove three screws (callout 1).

**Figure 1-1584** Remove three screws



6. Remove the sheet-metal bracket and formatter PCA.

**Figure 1-1585** Remove the bracket

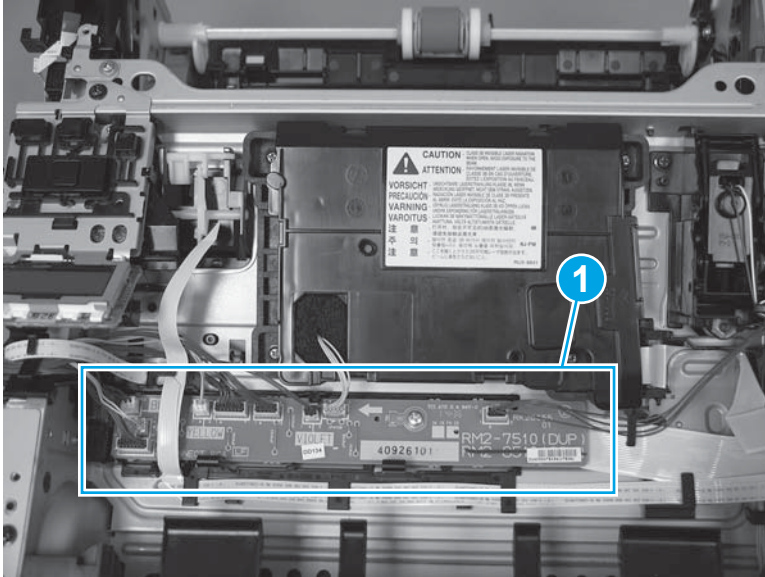


### Step 11: Remove the connecting PCA

1. Disconnect nine connectors (callout 1).

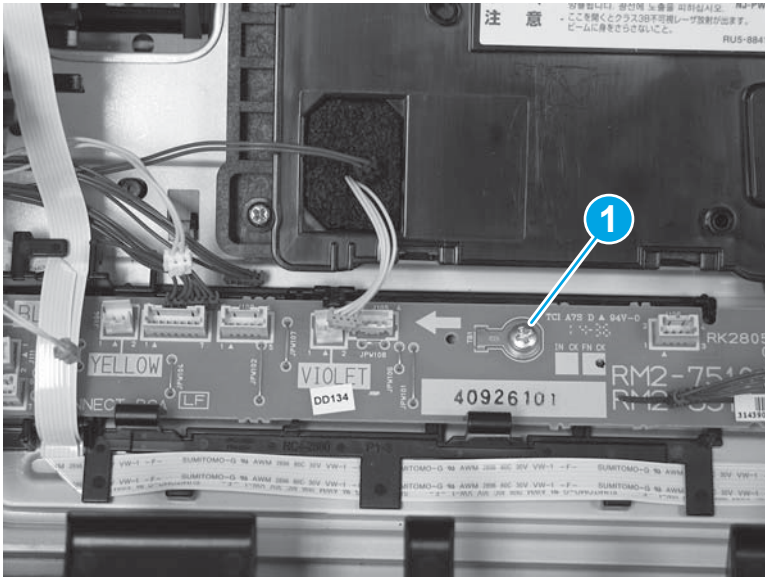
 **TIP:** Some of these connectors might be easier to disconnect if the wire harnesses are removed from the guides.

**Figure 1-1586** Disconnect nine connectors



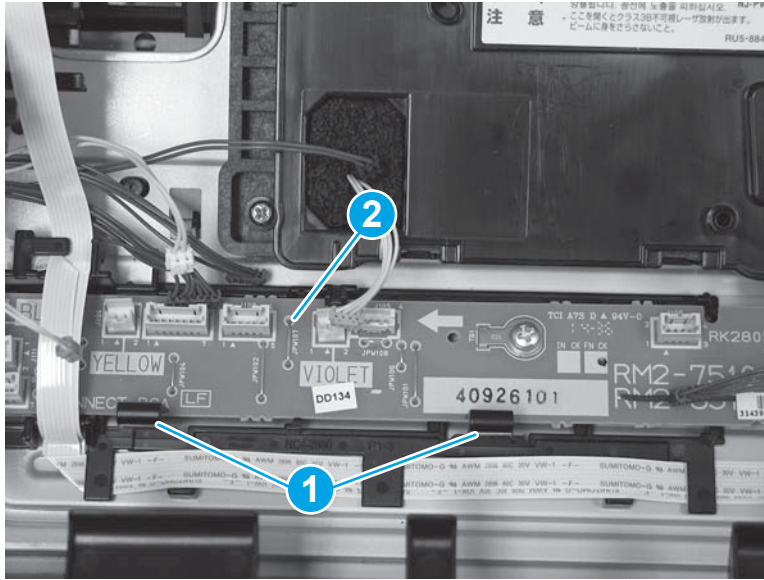
2. Remove one screw (callout 1).

**Figure 1-1587** Remove one screw



3. Release two holders (callout 1), and then remove the connecting PCA (callout 2).

**Figure 1-1588** Remove the connecting PCA



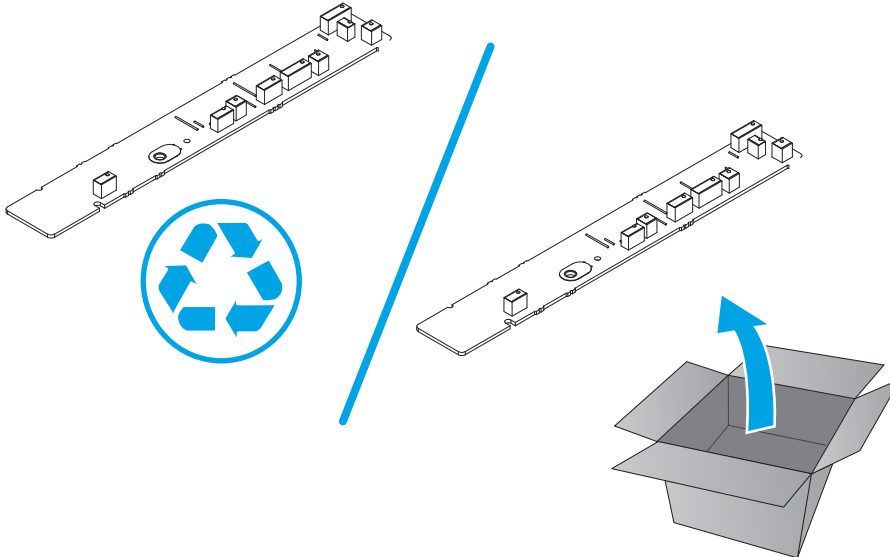
### Step 12: Unpack the replacement assembly

Unpack the replacement part from the packaging.

<http://www8.hp.com/us/en/hp-information/environment/product-recycling.html>

 **NOTE:** HP recommends responsible disposal of the defective part.

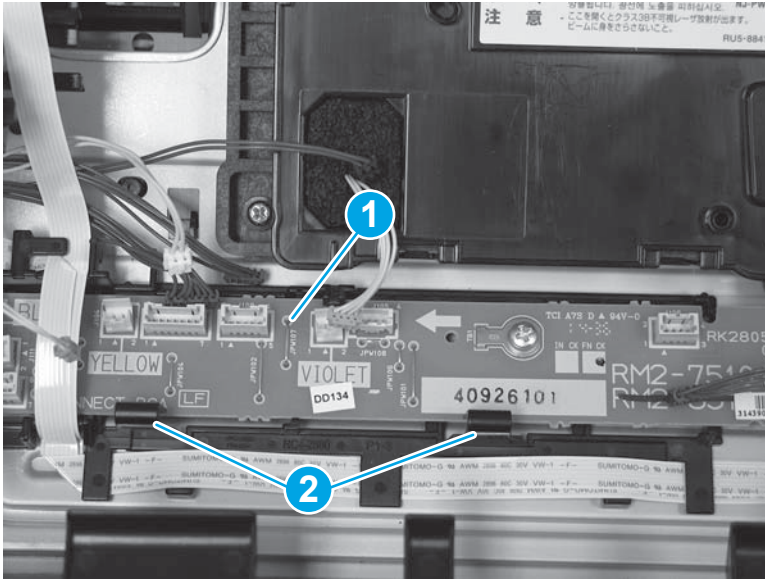
**Figure 1-1589** Recycle and unpack



### Step 13: Install the connecting PCA

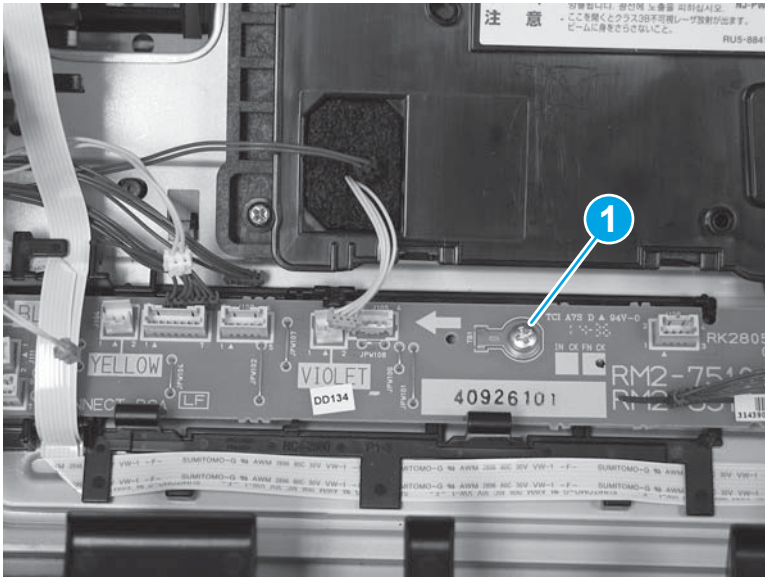
1. Position the connecting PCA (callout 1) under the two holders (callout 2).

**Figure 1-1590** Install the connecting PCA




2. Install one screw (callout 1).

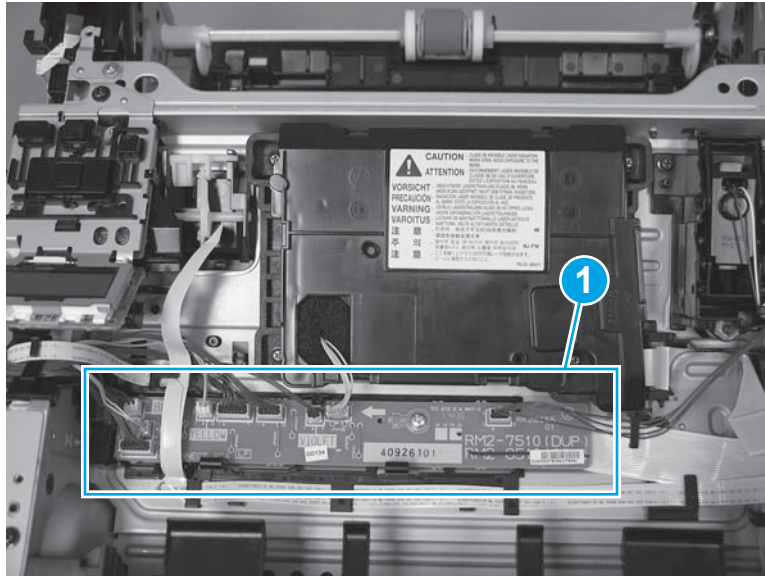
**Figure 1-1591** Install one screw




3. Connect nine connectors (callout 1).

 **Reinstallation tip:** If any of the connectors were removed from the guides, make sure that they are reinstalled now.

**Figure 1-1592** Connect nine connectors

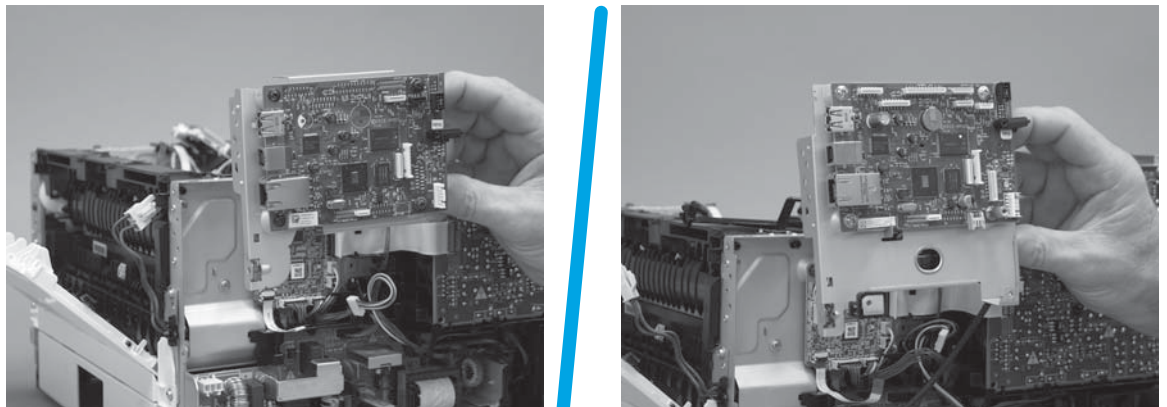


#### Step 14: Install the sheet-metal formatter bracket and formatter PCA

 **NOTE:** Do not forget to connect any formatter PCA FFCs or wire-harness connectors that were disconnected when the bracket was removed.

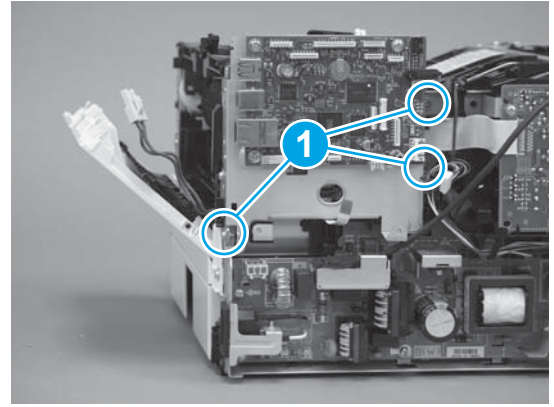
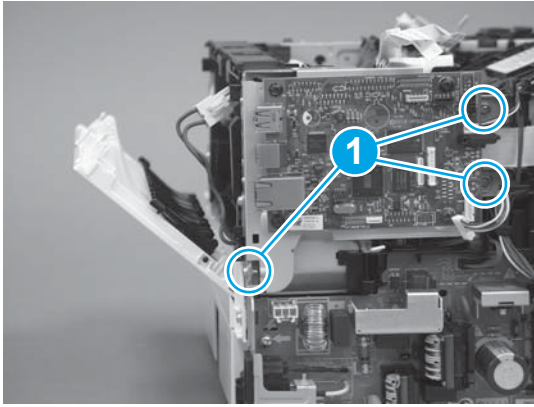
1. Position the sheet-metal bracket and formatter PCA on the printer.

**Figure 1-1593** Install the bracket



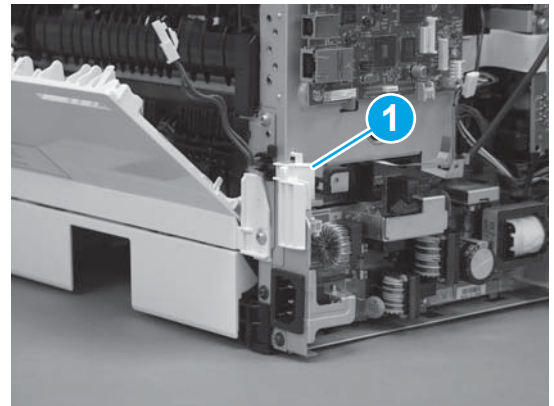
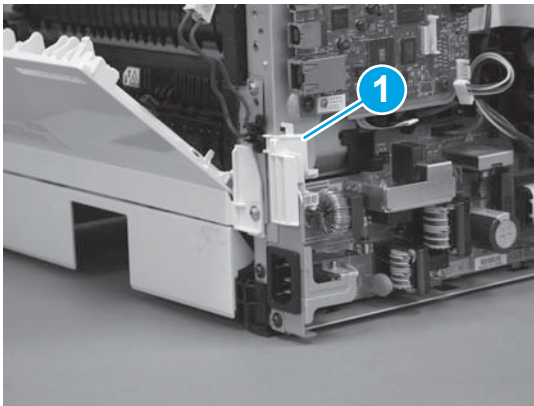
2. Install three screws (callout 1).

**Figure 1-1594** Install three screws



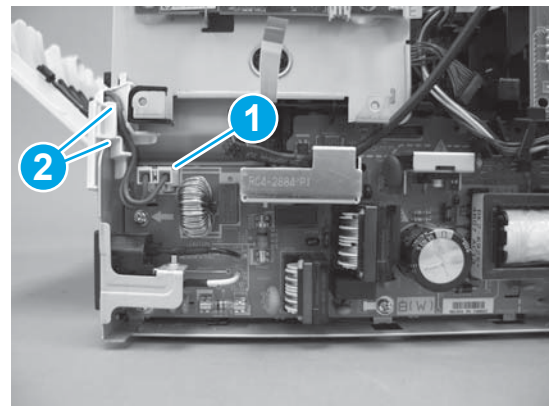
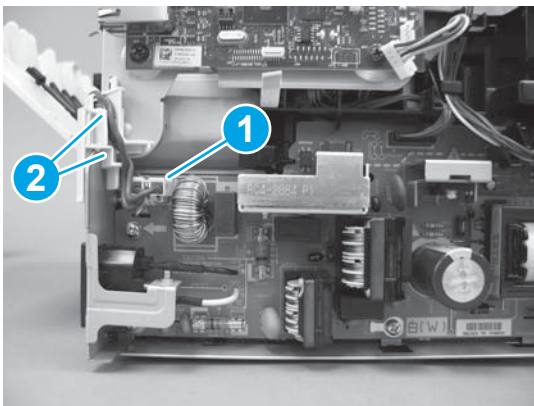
3. Install the guide (callout 1).

**Figure 1-1595** Install the guide



4. Connect one connector (callout 1), and then install the wire harness in the guide (callout 2).

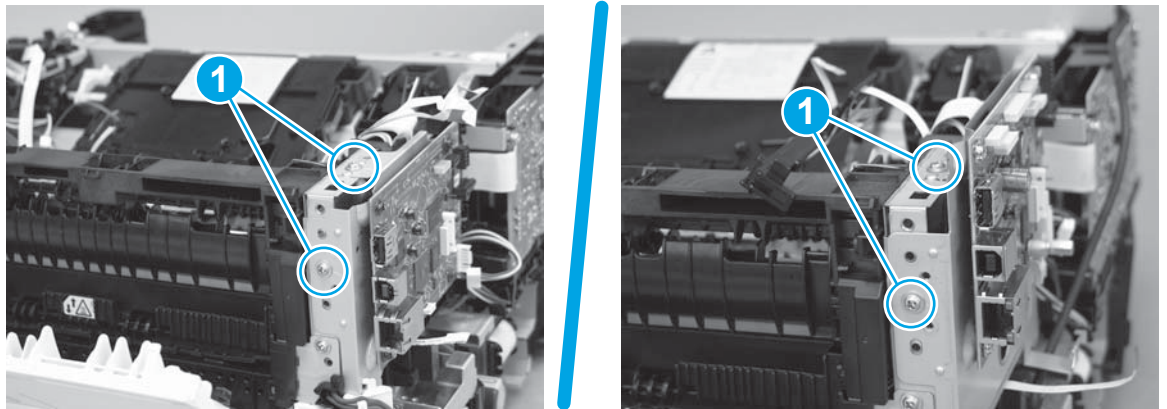
**Figure 1-1596** Connect one connector





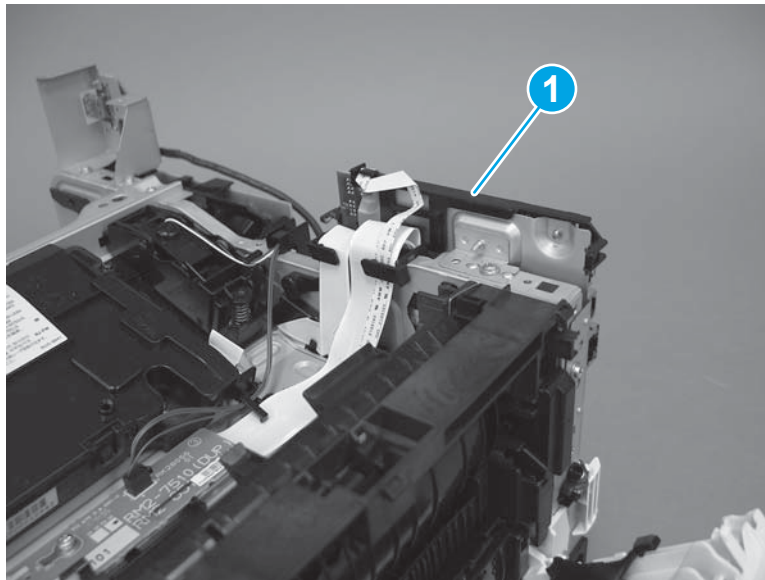
5. Install two screws (callout 1).

**Figure 1-1597** Install two screws




6. **M427/M426 only:** Install the guide (callout 1).

**Figure 1-1598** Install the guide

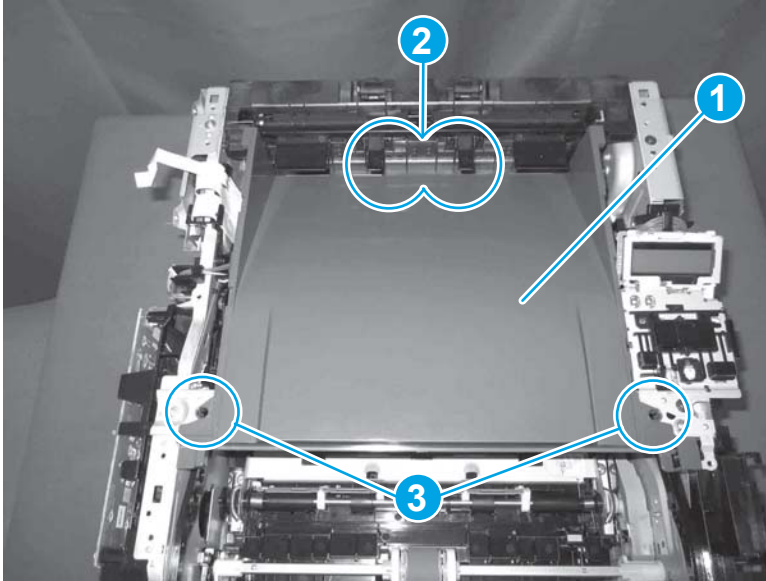


### Step 15: Install the paper delivery tray (output bin)


 **NOTE:** This procedure shows the M403/M402 model, however, the paper delivery tray (output bin) removal is similar for the M427/M426 printer.

- ▲ Position the remove the paper delivery tray (output bin; callout 1) on the printer, engage two tabs (callout 2), and then engage two bosses (callout 3).

**Figure 1-1599** Engage two tabs

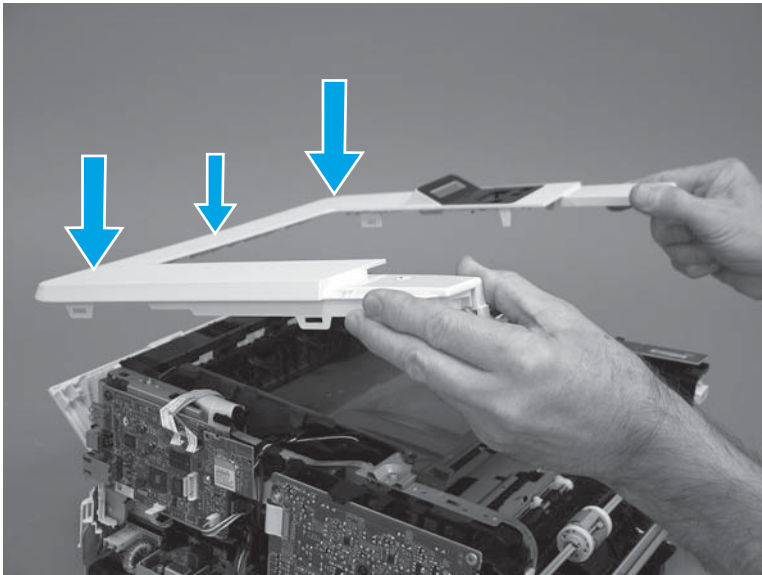


**Step 16: Install the top cover (M403/M402)**

 **NOTE:** The step is for the M403/M402 printer. For the M427/M426, skip this step and go to [Step 17: Install the top cover \(M427/M426\) on page 854](#).

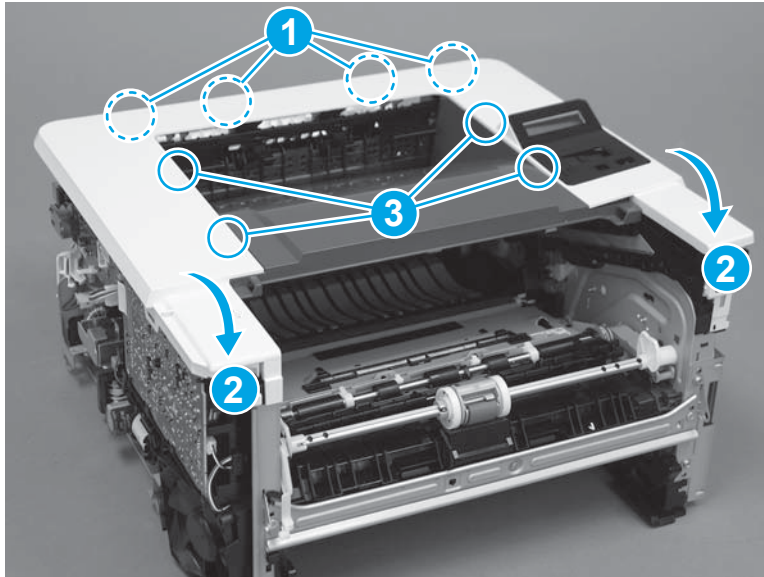
1. Position the rear edge of the cover on the printer.

**Figure 1-1600** Install the cover



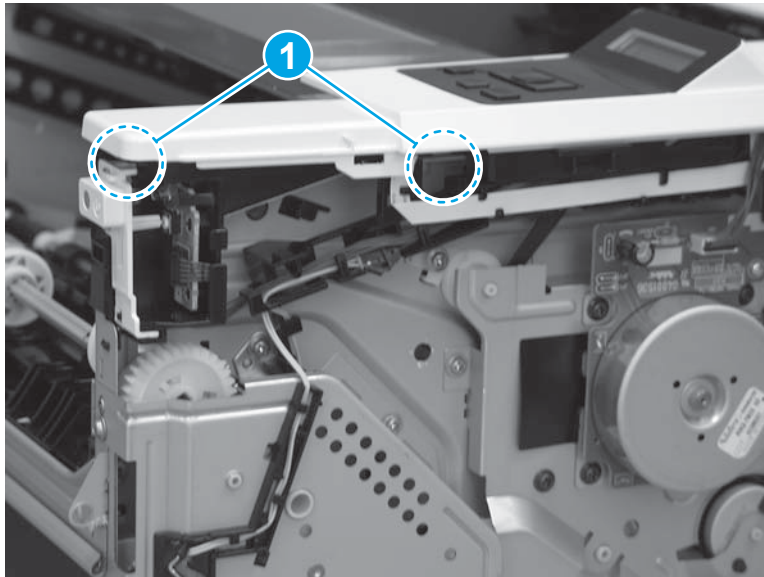
- Engage four bosses (callout 1), rotate the front of the cover down (callout 2) and onto from the printer, and then engage four tabs (callout 3).

**Figure 1-1601** Engage four bosses and tabs



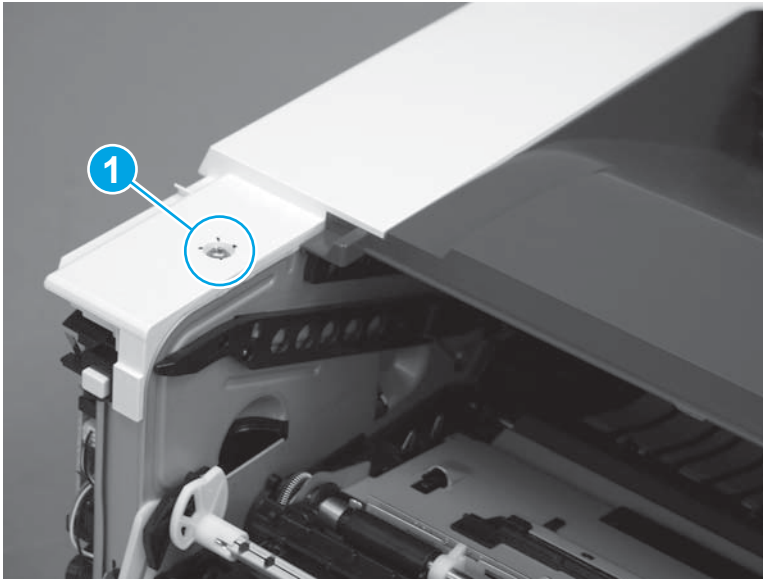
- At the right side of the printer, engage the one boss and one tab (callout 1).

**Figure 1-1602** Engage one boss and one tab




4. Install one screw (callout 1).

**Figure 1-1603** Install one screw

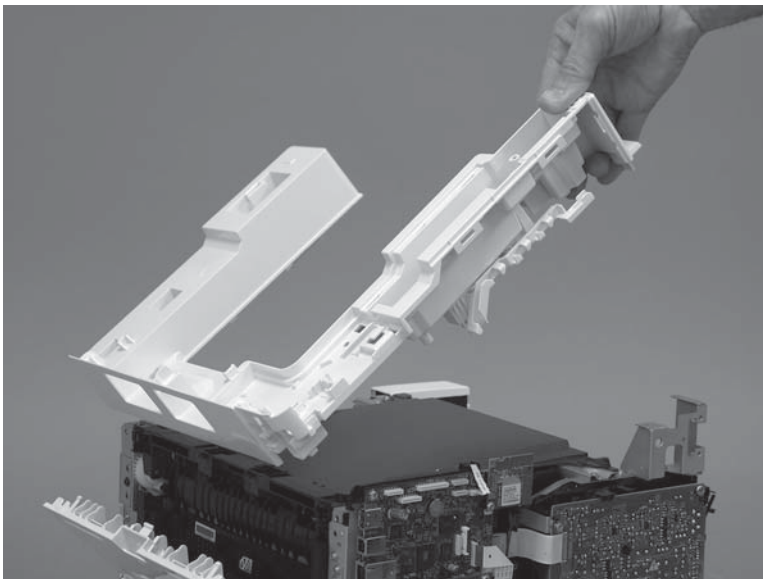


#### Step 17: Install the top cover (M427/M426)

 **NOTE:** The step is for the M427/M426 printer. For the M403/M402, skip this step and go to [Step 20: Install the right cover on page 865](#).

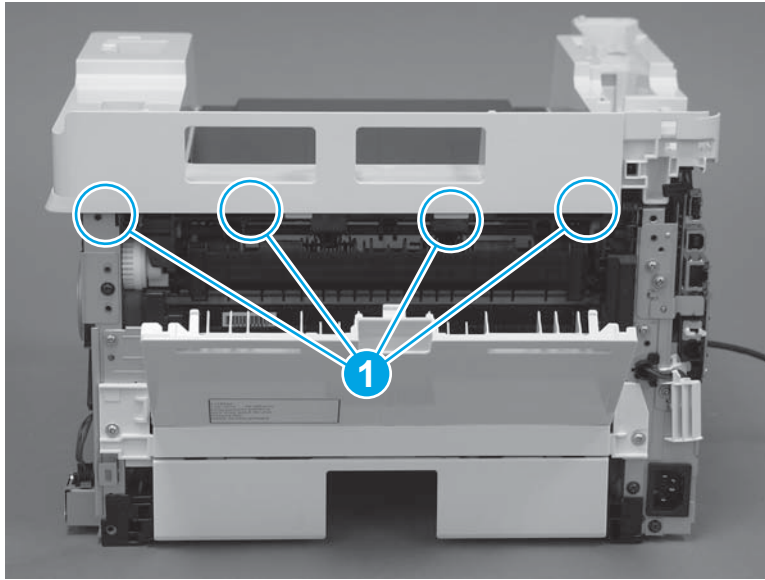
1. Position the rear edge of the top cover on the printer.

**Figure 1-1604** Install the cover



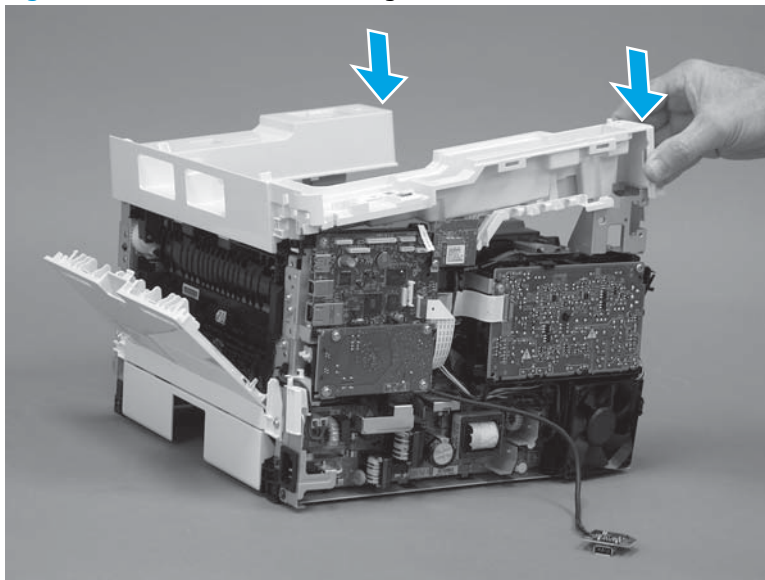
2. Engage four bosses (callout 1).

**Figure 1-1605** Engage four bosses



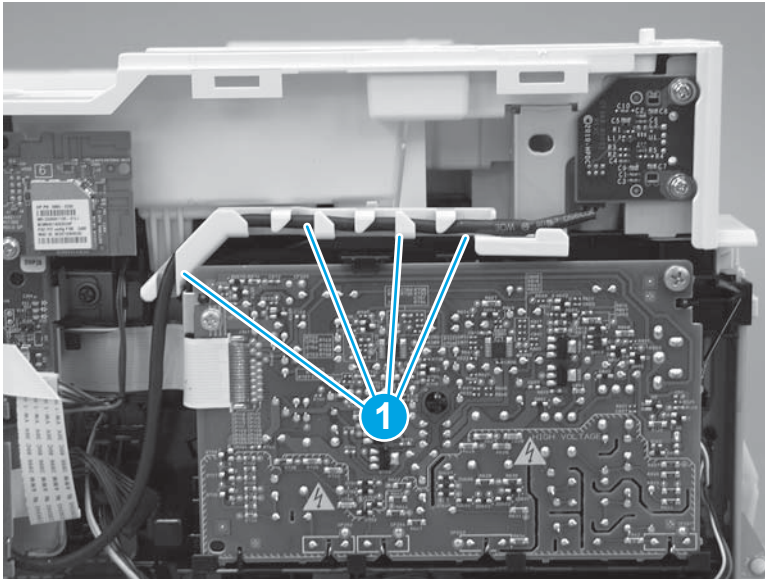
3. Rotate the front edge of the cover down.

**Figure 1-1606** Rotate the front edge of the cover down



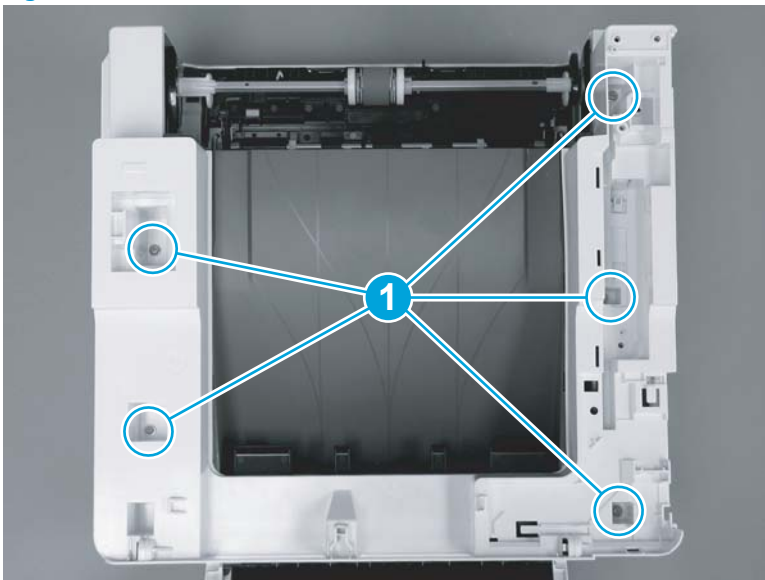
4. Install the USB cable (callout 1) in the guide.

**Figure 1-1607** Install the USB PCA




5. Install five screws (callout 1).

**Figure 1-1608** Install five screws

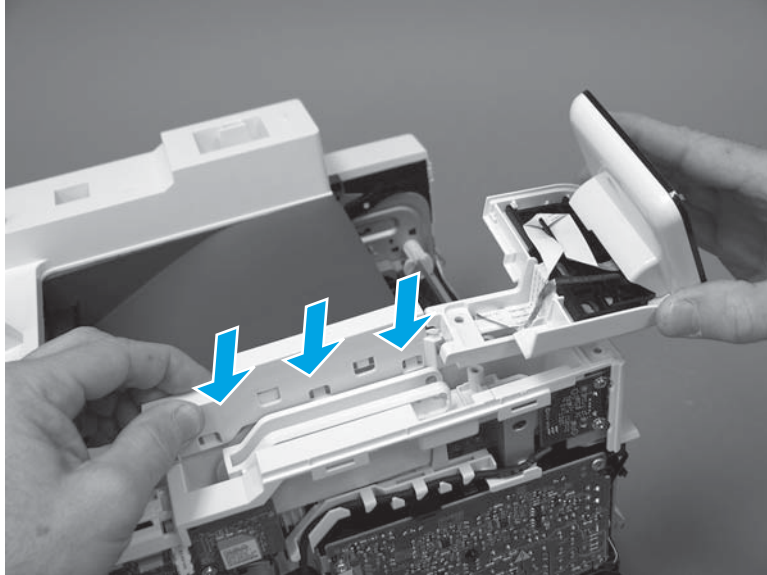


### Step 18: Install the control panel (M427/M246)

 **NOTE:** The step is for the M427/M426 printer. For the M403/M402, skip this step and go to [Step 20: Install the right cover on page 865](#).

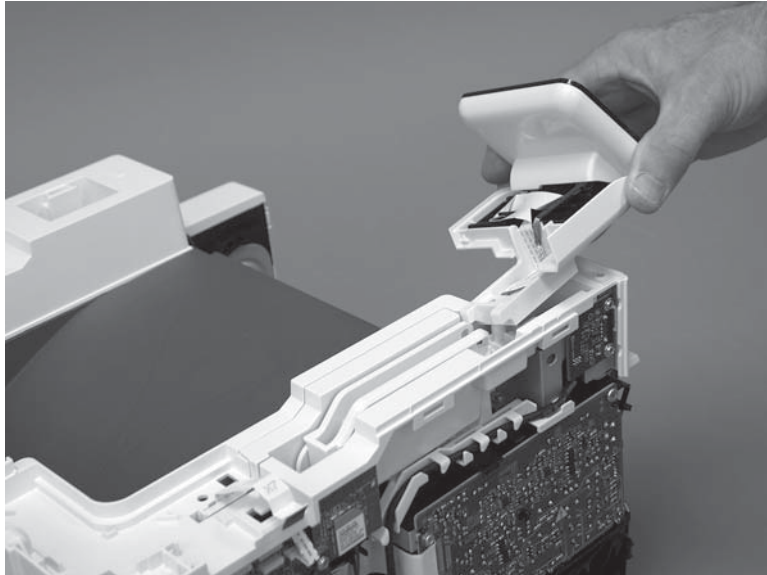
1. Slide the control-panel FFC cover into the slot in the top cover (next to the document feeder support arm) to install it.

**Figure 1-1609** Install the control-panel FFC cover



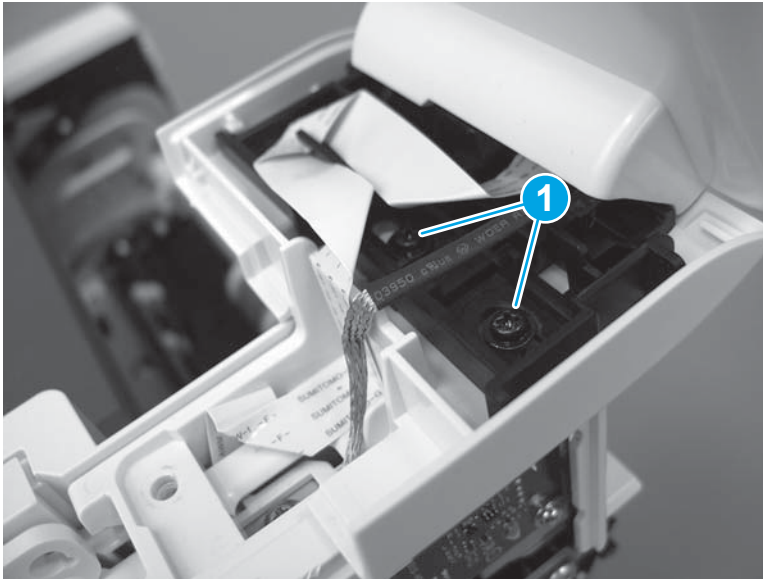
2. Install the control-panel assembly on the top cover.

**Figure 1-1610** Install the control-panel assembly



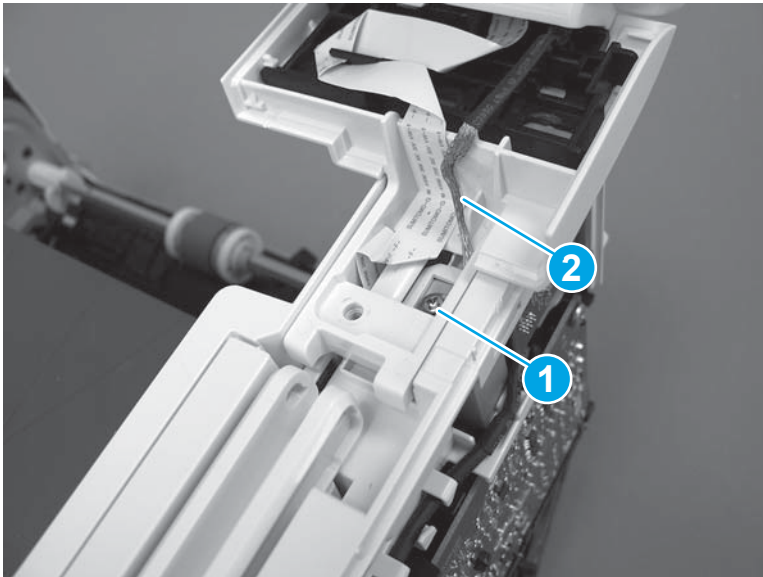
3. Move the FFC out of the way, and then install two screws (callout 1).

**Figure 1-1611** Install two screws



4. Install one grounding screw (callout 1), and then make sure that the ground cable (callout 2) is properly routed.

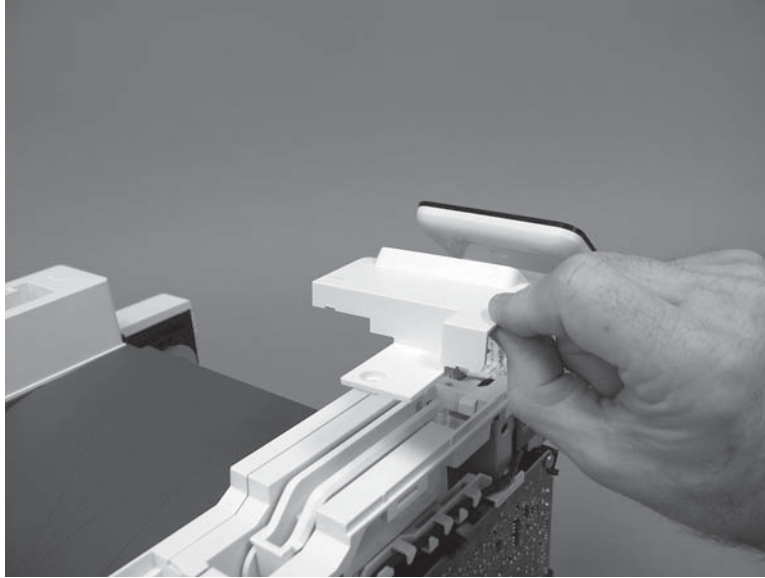
**Figure 1-1612** Remove one screw





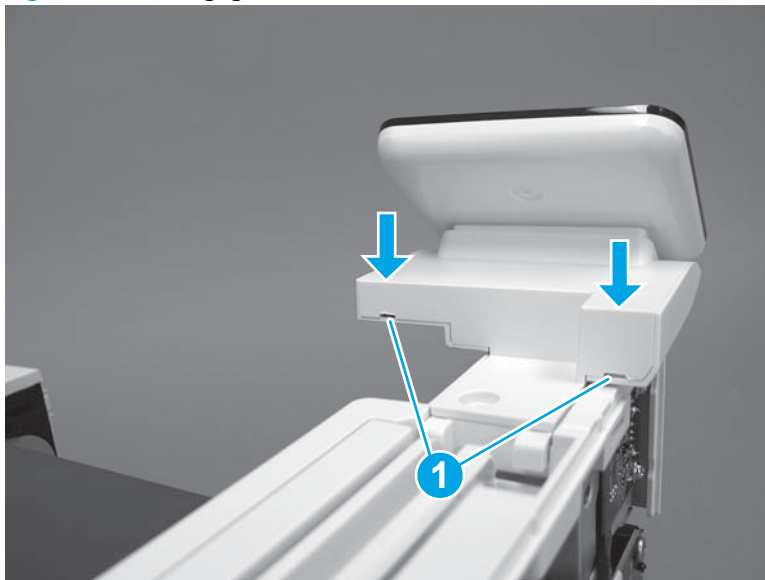
5. Install the control-panel cable cover.

**Figure 1-1613** Install the cover



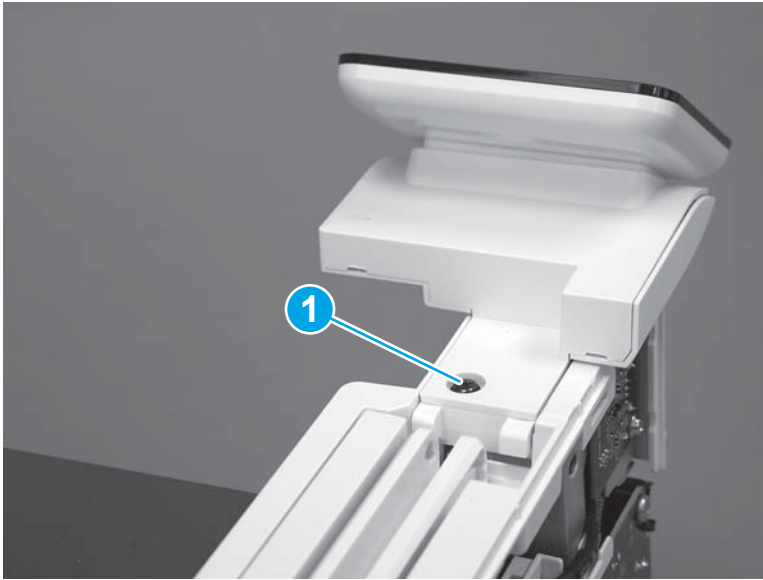
6. Make sure that the two tabs (callout 1) on the cover snap into place.

**Figure 1-1614** Engage two tabs



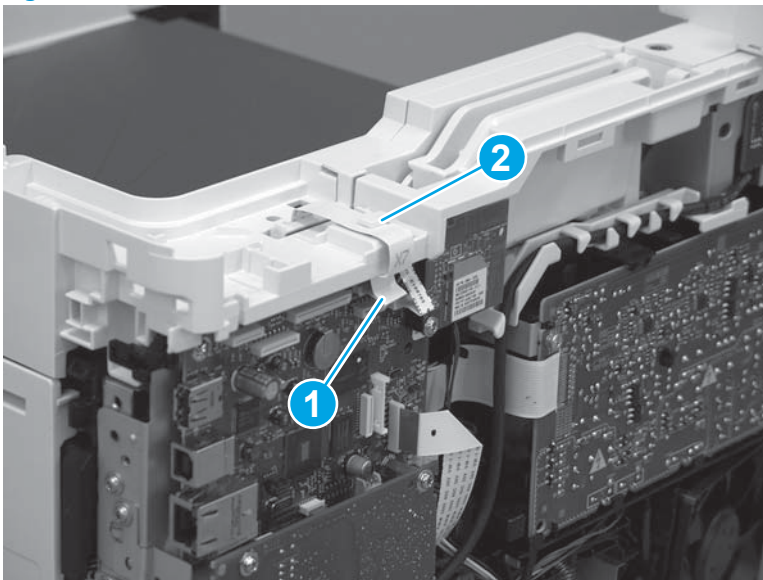
7. Install one screw (callout 1).

**Figure 1-1615** Install one screw





8. Install the FFC in the retainer (callout 1), and then connect one FFC (callout 1; J114).

**Figure 1-1616** Connect one connector



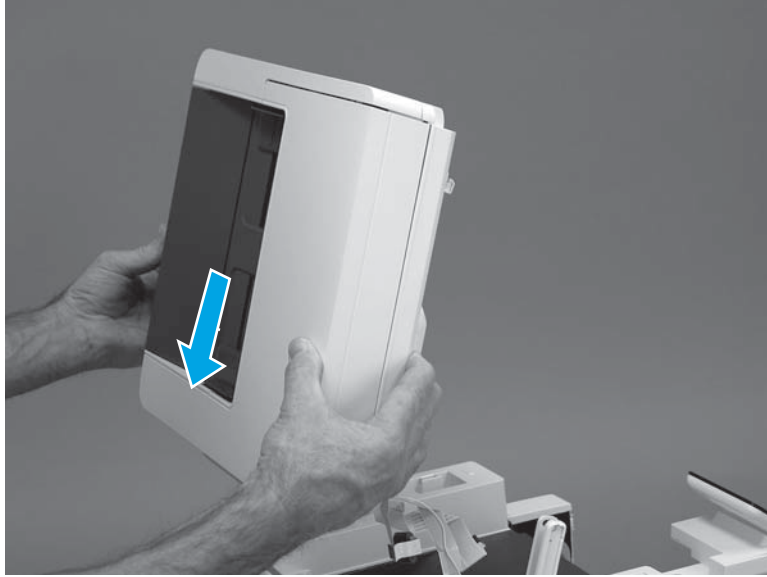
### Step 19: Install the integrated scanner assembly (M427/M246)

 **NOTE:** The step is for the M427/M426 printer. For the M403/M402, skip this step and go to [Step 20: Install the right cover on page 865](#).

 **NOTE:** M427/M426 models only. The integrated scanner assembly (ISA) includes the sub-scanner assembly (SSA) and the automatic document feeder (ADF).

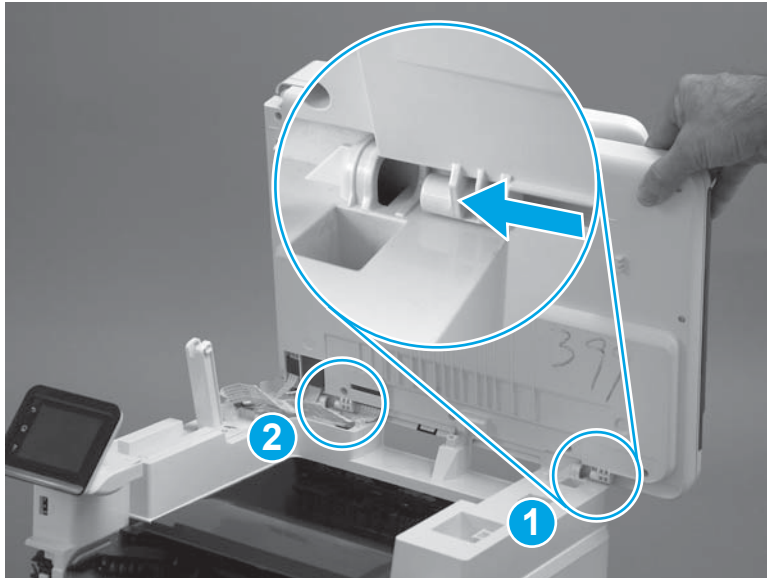
1. Position the ISA on the printer.

**Figure 1-1617** Position the ISA on the printer



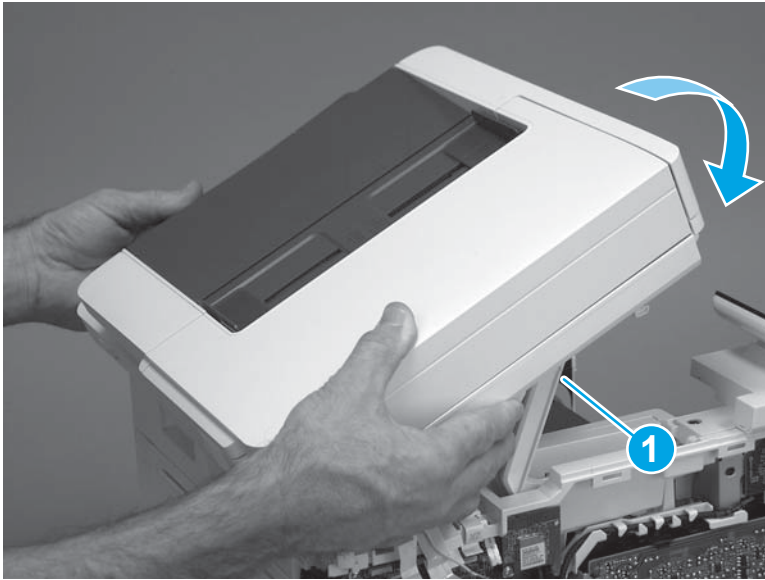
2. Engage the hinge pins on the ISA with the holders in the top cover (callouts 1/2), and then slide the ISA as shown to engage them

**Figure 1-1618** Engage the hinge pins with the holders



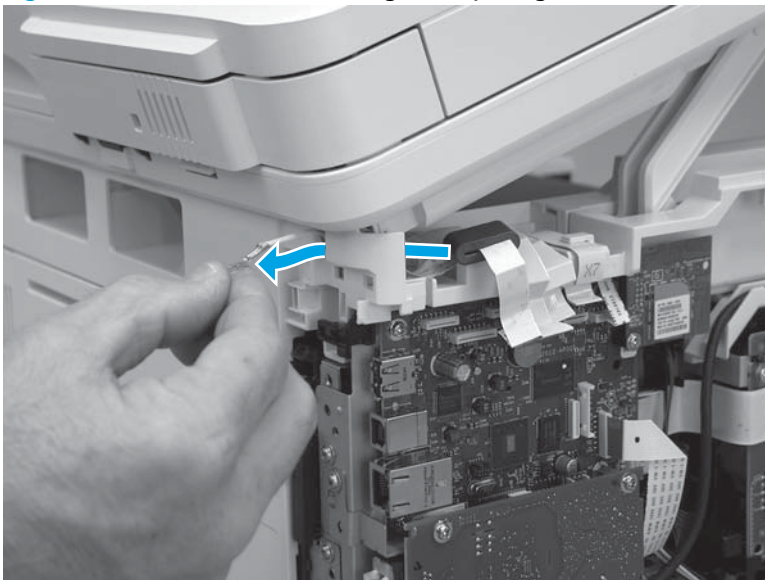
3. Rotate the ISA towards the front of the printer until it rests on the ISA lift assembly (callout 1).

**Figure 1-1619** Rotate the ISA towards the front of the printer



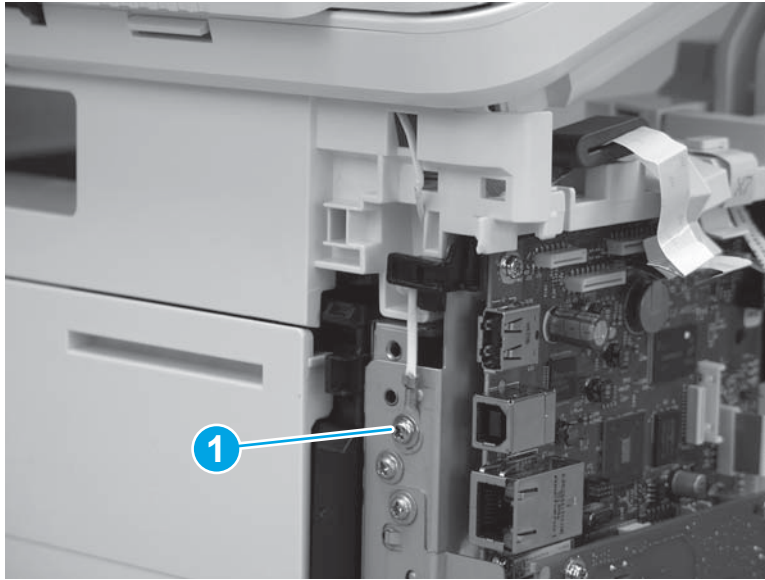
4. Pass the ground wire through the opening in the top cover.

**Figure 1-1620** Pass the wire through the opening




5. Install one screw (callout 1).

**Figure 1-1621** Install one screw



6. Install the ISA lift assembly slider pin.

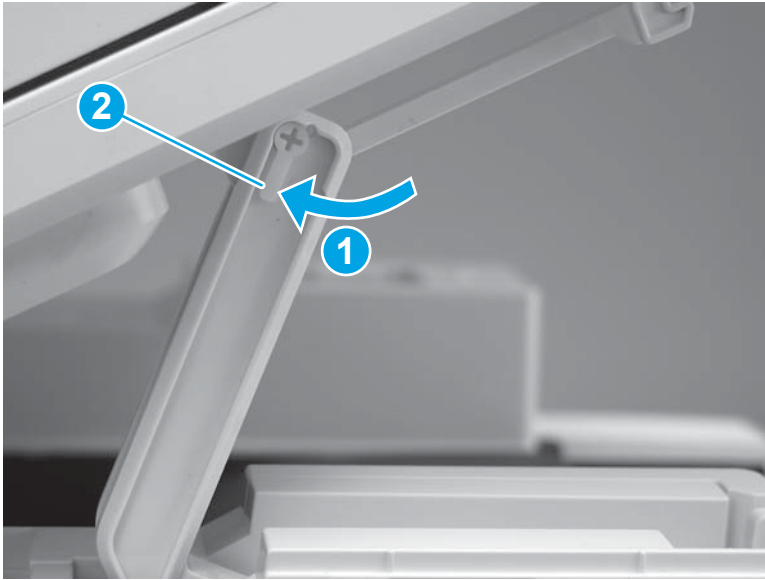
 **Reinstallation tip:** Align the keyed portion of the locking pin with the slot and hole in the support arm.

**Figure 1-1622** Install the slider pin



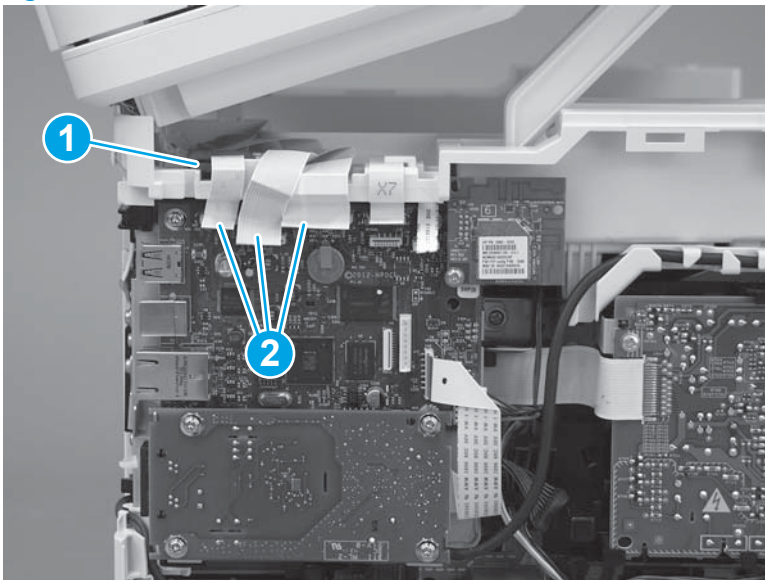
7. Rotate the slider pin (callout 1) towards the rear of the printer until the tab (callout 2) snap into place.

**Figure 1-1623** Secure the slider pin



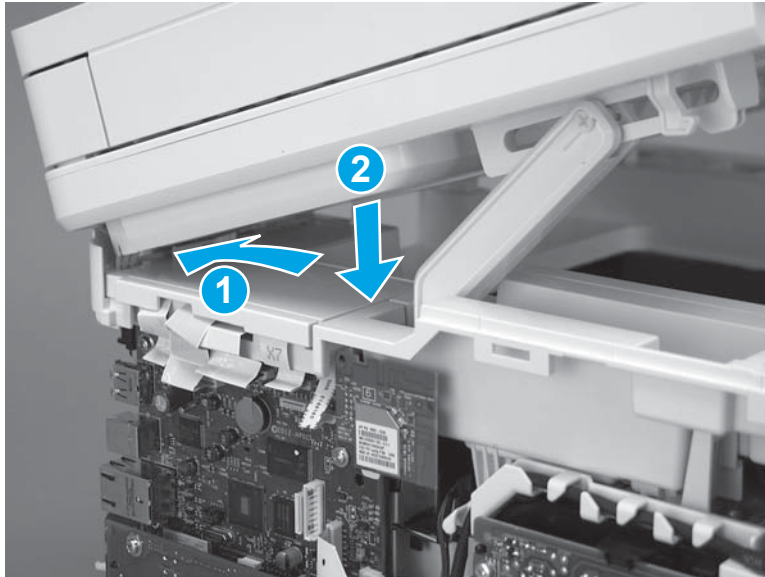
8. Install the ferrite (callout 1) in the holder, and then connect three FFCs (callout 2).

**Figure 1-1624** Connect three FFCs



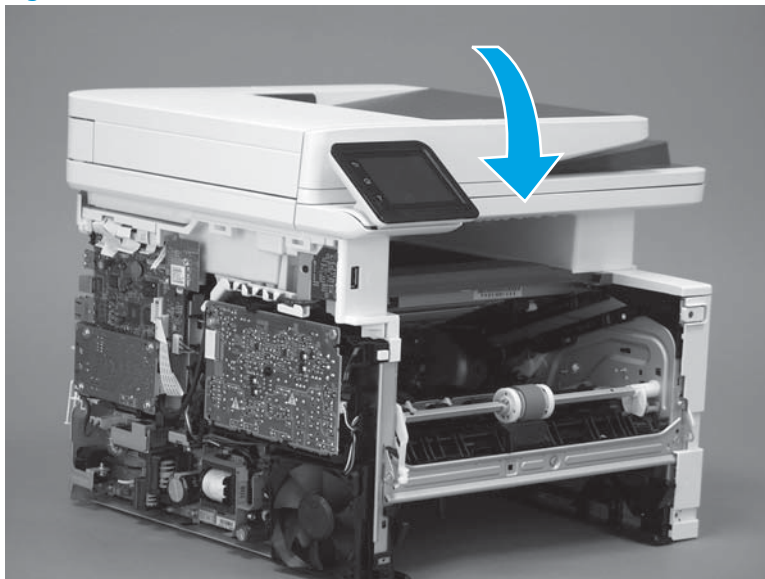
9. Position the rear edge of the ISA flat-flexible cable (FFC) cover on the printer (callout 1) , and then rotate it down (callout 2) until it snaps into place.

**Figure 1-1625** Install the ISA FFC cover



10. Lower the ISA.

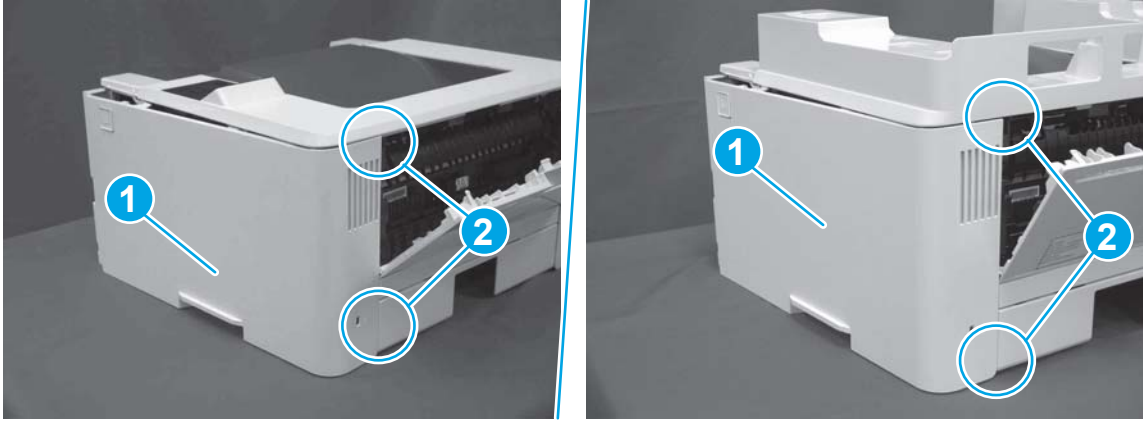
**Figure 1-1626** Lower the ISA



### Step 20: Install the right cover

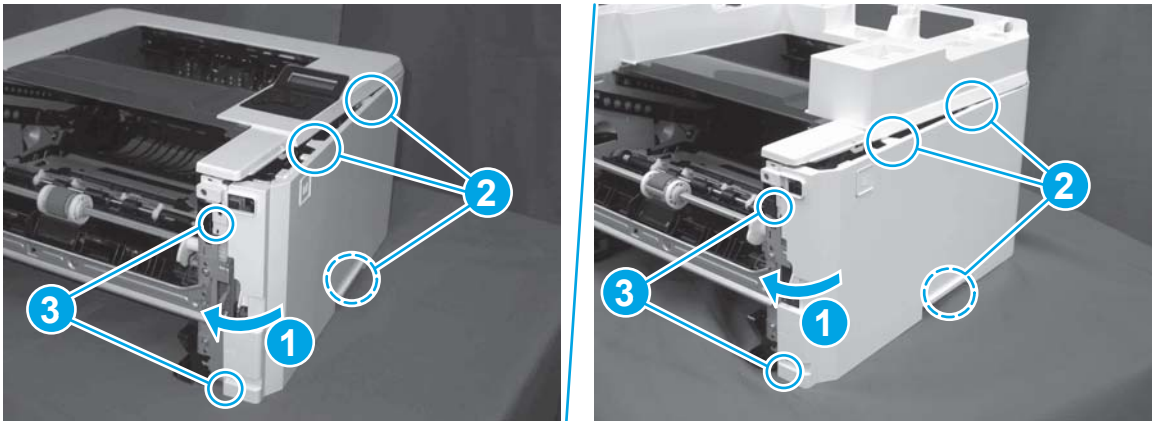
1. Position the cover (callout 1) on the printer, and then engage two bosses (callout 2).

**Figure 1-1627** Install the cover




2. Rotate the front of the cover onto the printer (callout 1), engage three (callout 2) tabs, and then engage two bosses (callout 3).

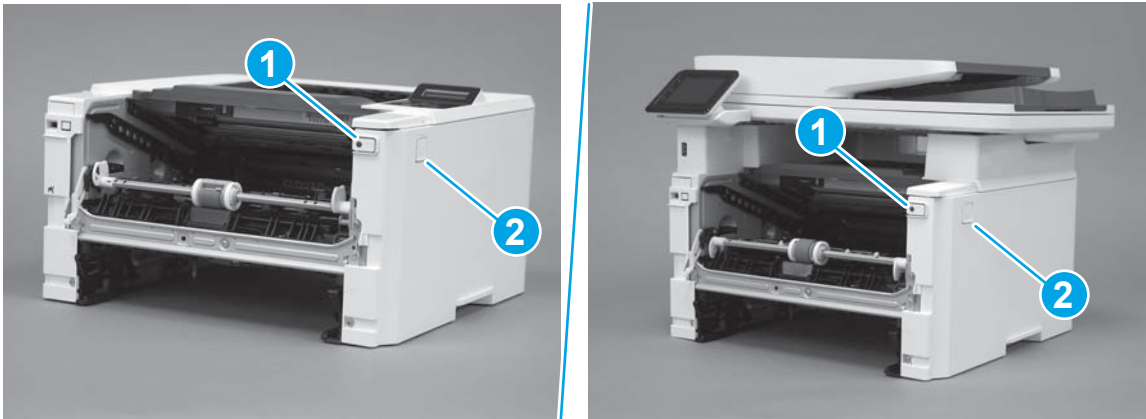
**Figure 1-1628** Engage two bosses and one tab



3. Make sure that the power switch (callout 1) and cartridge door assembly button (callout 2) correctly function.

 **NOTE:** Remove, and then reinstall the cover if the switch or button does not correctly function.

**Figure 1-1629** Check the power switch and cartridge door assembly button





4. Install one screw (callout 1).

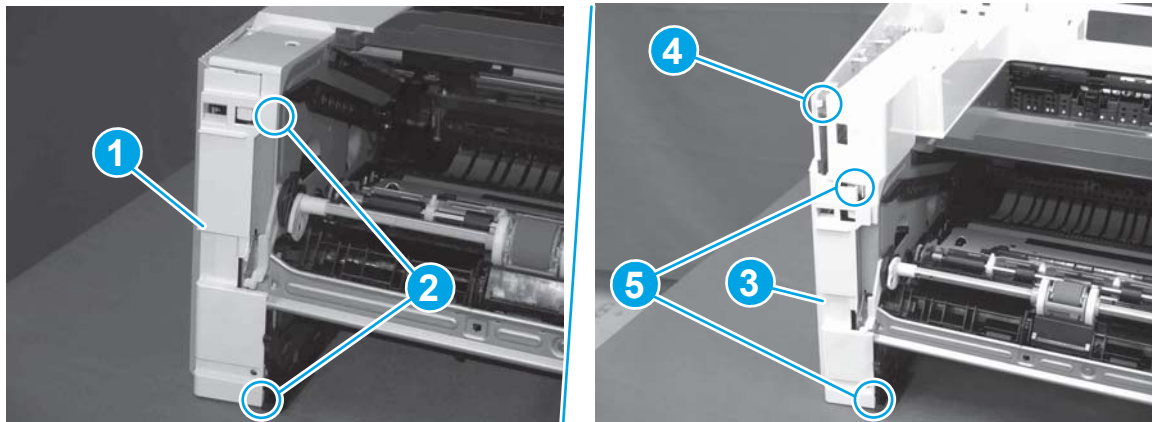
**Figure 1-1630** Install one screw



### Step 21: Install the left cover

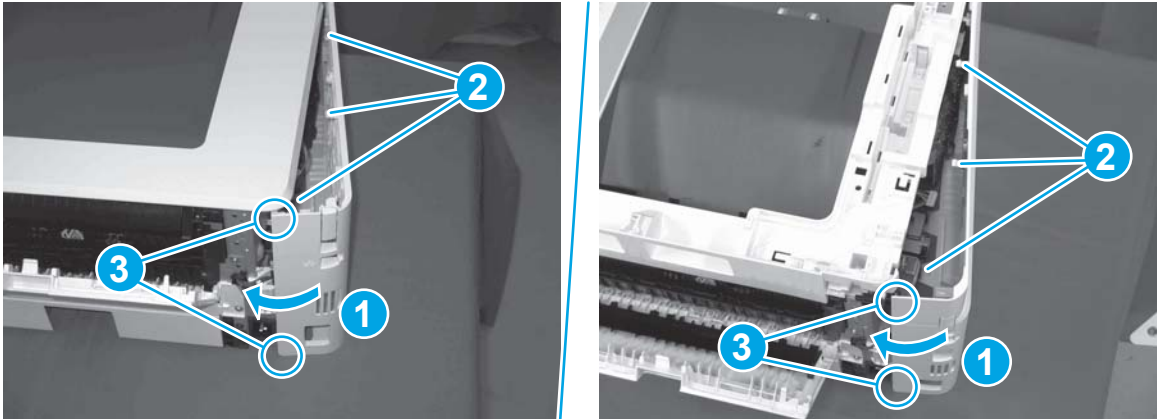
1. At the front of the printer, do one of the following:
  - **M403/M402:** Position the cover on the printer ( callout 1), and then engage two bosses (callout 2).
  - **M427/M426:** Position the cover on the printer (callout 3), engage one tab (callout 4), and then engage two bosses (callout 4).

**Figure 1-1631** Install the cover



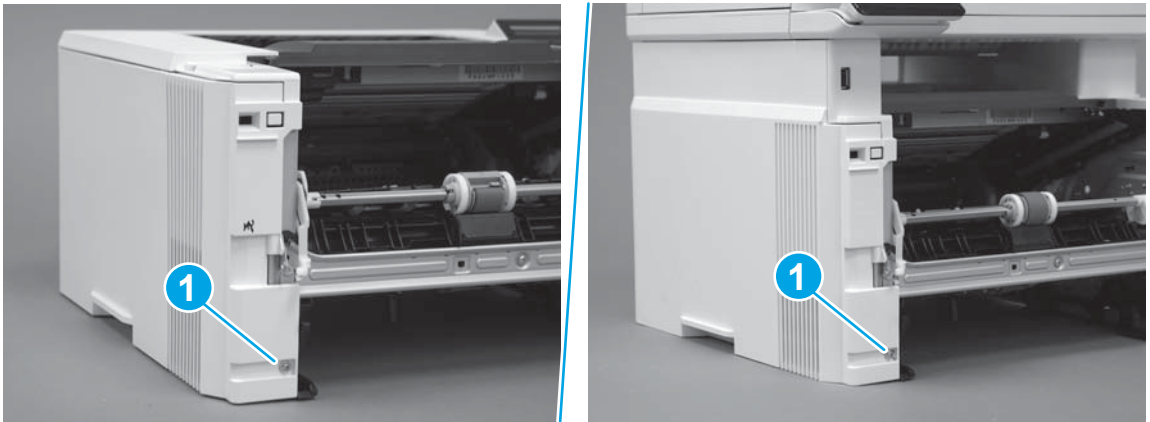
- Carefully rotate the rear of the cover onto the printer (callout 1), engage three tabs (callout 2), and then engage two bosses (callout 3).

**Figure 1-1632** Engage three tabs and two bosses




- Install one screw (callout 1).

**Figure 1-1633** Install one screw

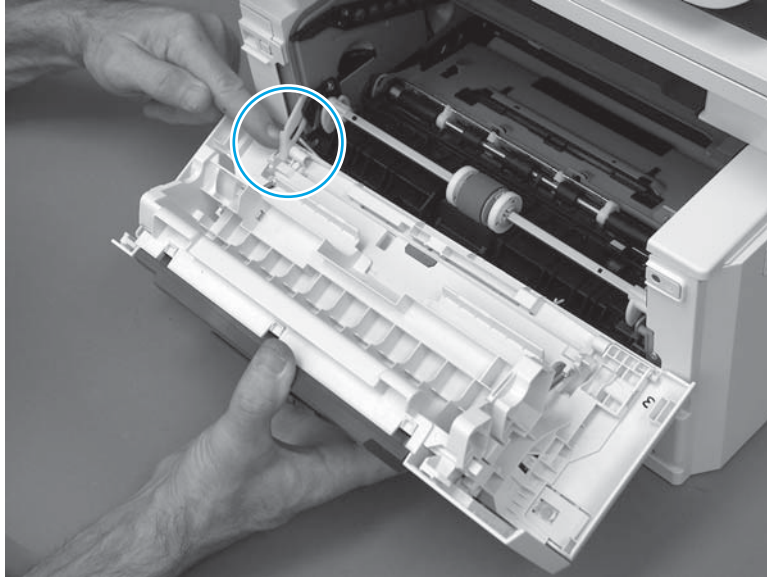


## Step 22: Install the cartridge door assembly

 **Reinstallation tip:** After a replacement door is installed, make sure to install the nameplate (supplied in the kit) corresponding to the printer name on the door.

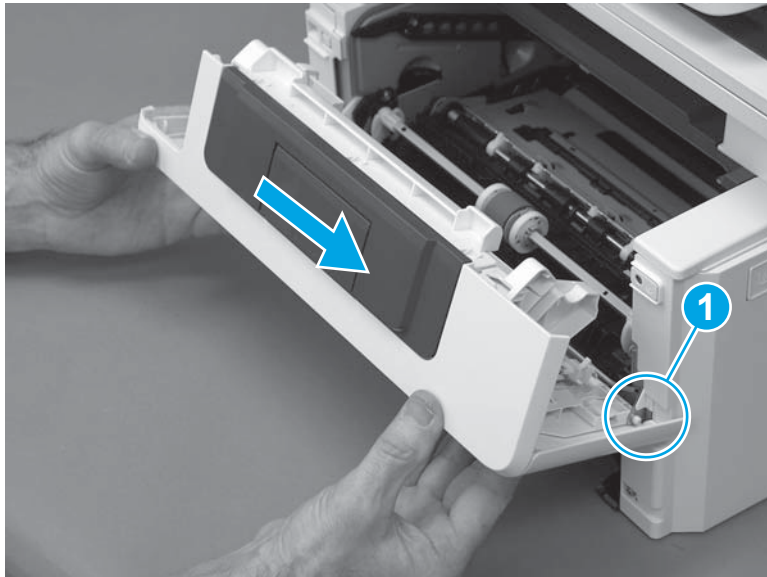
- Position the door close to the printer, and then engage the keyed pin on the left-side retainer arm with the hole in the door.

**Figure 1-1634** Engage the left-side retainer arm



2. Engage the right-side door hinge pin with the hole in the chassis (callout 1).

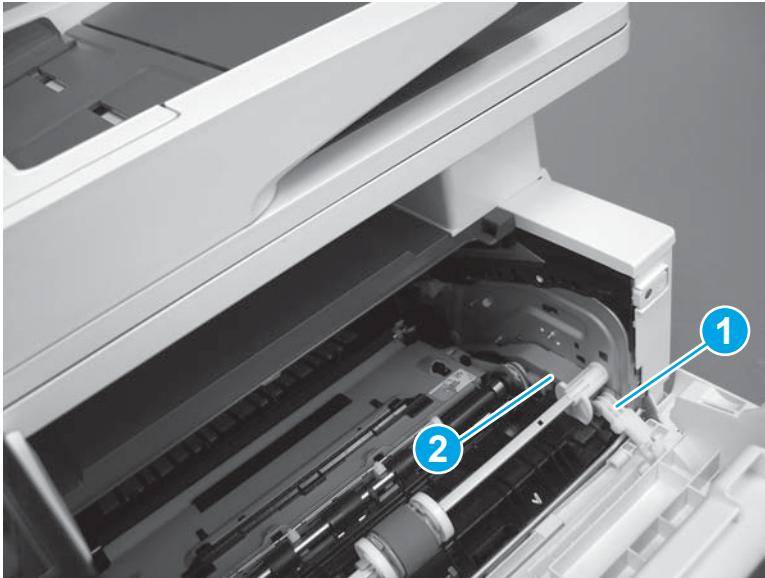
**Figure 1-1635** Install the door



3. Install the link (callout 1).

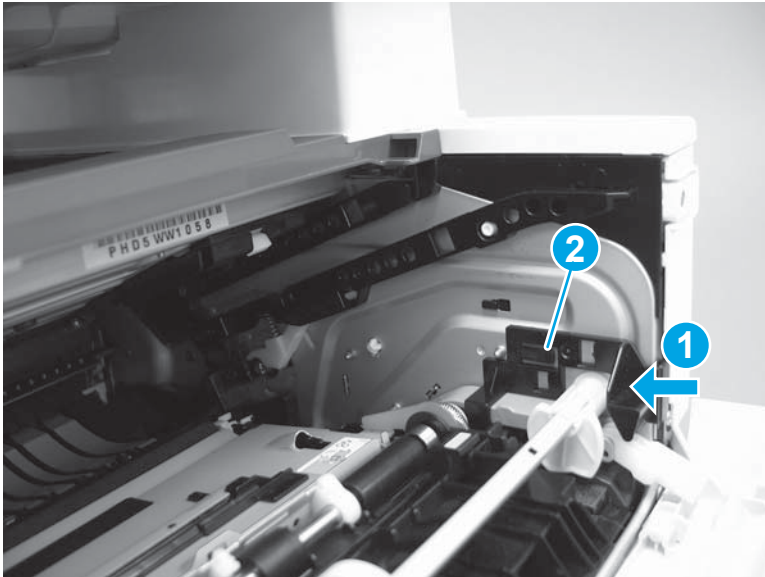
 **IMPORTANT:** Make sure that the link snaps into place on the arm (callout 2). The link actuates the fuser pressure-release mechanism.

**Figure 1-1636** Install the pressure-release link



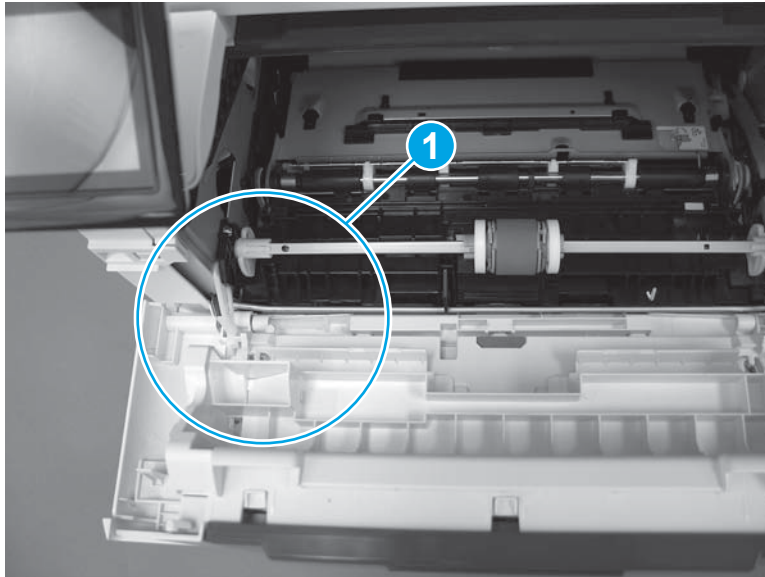
4. Slide the guide into the printer (callout 1), and then make sure that the tab (callout 2) snaps into place to secure the guide to the chassis.

**Figure 1-1637** Install the guide




5. Position the shaft on the door, and then align the left-side hinge on the door with the hole in the chassis (callout 1).

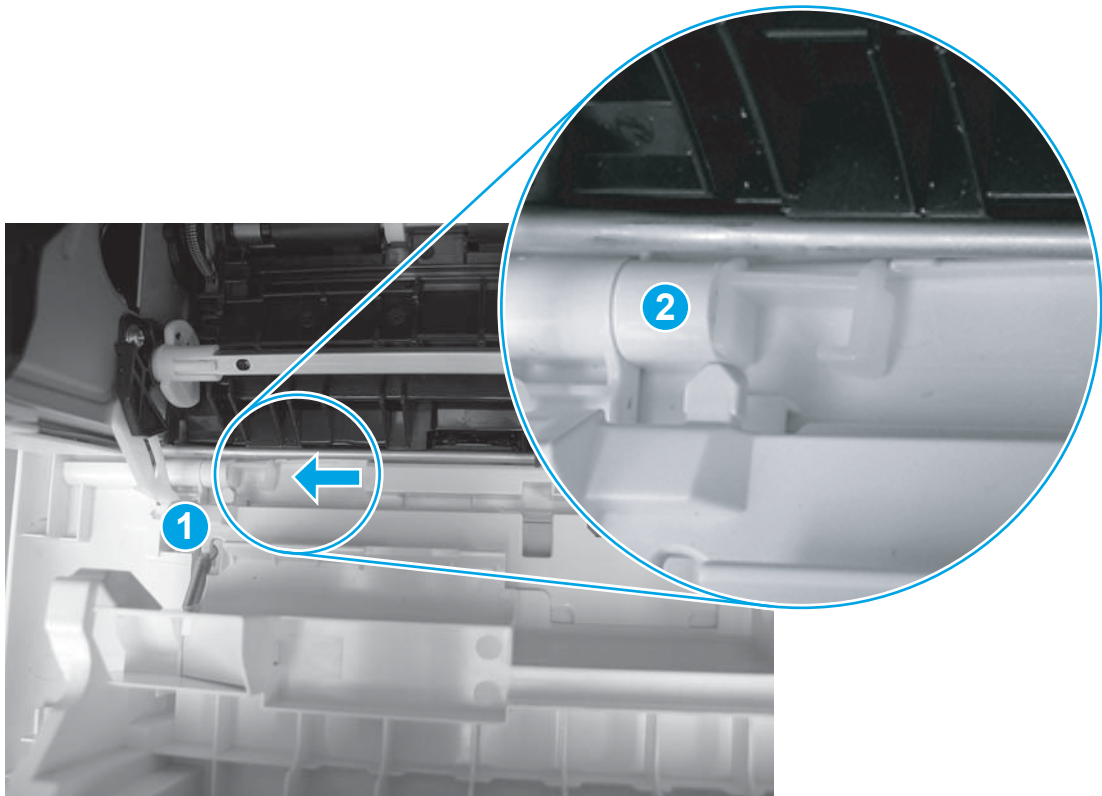
**Figure 1-1638** Align the hinge



6. Push the shaft towards the left side of the printer to install it (callout 1).

 **Reinstallation tip:** Make sure that the support shaft is fully installed and correctly orientated (callout 2) so that it will not interfere with the door opening and closing.

**Figure 1-1639** Install the support shaft



### Step 23: Install Tray 2

- ▲ Slide the tray straight into the printer to install it.

**Figure 1-1640** Install the tray



## Removal and replacement: Laser scanner FFC

- [Introduction](#)
- [Step 1: Remove Tray 2](#)
- [Step 2: Remove the cartridge door assembly](#)
- [Step 3: Remove the left cover](#)
- [Step 4: Remove the right cover](#)
- [Step 5: Remove the integrated scanner assembly \(M427/M246\)](#)
- [Step 6: Remove the control panel \(M427/M246\)](#)
- [Step 7: Remove the top cover \(M427/M426\)](#)
- [Step 8: Remove the top cover \(M403/M402\)](#)
- [Step 9: Remove the paper delivery tray \(output bin\)](#)
- [Step 10: Remove the sheet-metal formatter bracket and formatter PCA](#)
- [Step 11: Remove the tag-cable assembly](#)
- [Step 12: Remove the laser scanner FFC](#)
- [Step 13: Unpack the replacement assembly](#)
- [Step 14: Install the laser scanner FFC](#)
- [Step 15: Install the tag-cable assembly](#)
- [Step 16: Install the sheet-metal formatter bracket and formatter PCA](#)
- [Step 17: Install the paper delivery tray \(output bin\)](#)
- [Step 18: Install the top cover \(M403/M402\)](#)
- [Step 19: Install the top cover \(M427/M426\)](#)
- [Step 20: Install the control panel \(M427/M246\)](#)
- [Step 21: Install the integrated scanner assembly \(M427/M246\)](#)
- [Step 22: Install the right cover](#)
- [Step 23: Install the left cover](#)
- [Step 24: Install the cartridge door assembly](#)
- [Step 25: Install Tray 2](#)


### Introduction

This document provides the procedures to remove and replace the laser scanner flat-flexible cable (FFC).

## Before performing service

### Turn the printer power off

- Disconnect the power cable.

 **WARNING!** To avoid damage to the printer, turn the printer off, wait 30 seconds, and then remove the power cable before attempting to service the printer.

Use the table below to identify the correct part number for your printer. To order the part, go to [www.hp.com/buy/parts](http://www.hp.com/buy/parts).

Laser scanner FFC part number	
RK2-6919-000CN	Laser scanner FFC

### Required tools

- #2 Phillips screwdriver with a magnetic tip.
- 5.5 mm (0.22 inch) socket screwdriver.

### After performing service

#### Turn the printer power on

- Connect the power cable.
- Use the power switch to turn the power on.

### Post service test

Make sure that the printer initializes to a **Ready** state.

Print a configuration page to make sure that the printer is functioning correctly.

#### Step 1: Remove Tray 2

- ▲ Pull the tray straight out of the printer to remove it.



**Figure 1-1641** Remove the tray



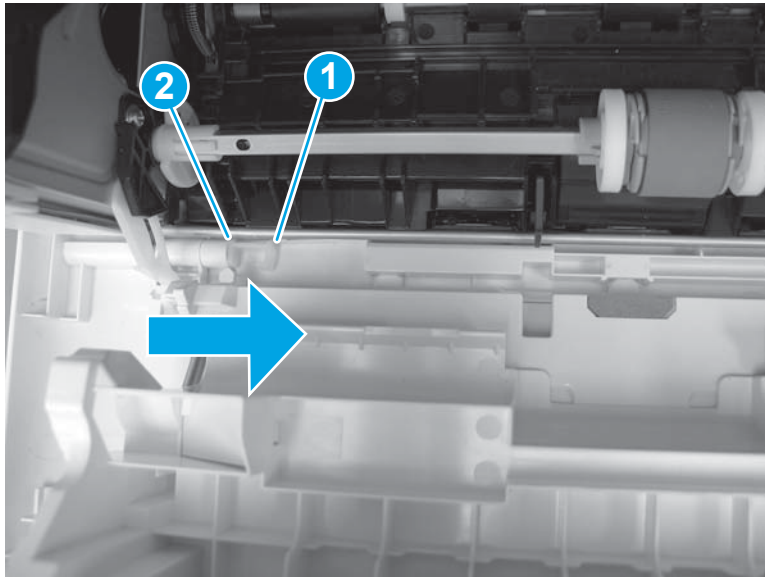
**Step 2: Remove the cartridge door assembly**

 **NOTE:** If the toner cartridge was not removed prior to servicing the printer, remove it now.

1. Release one tab (callout 1), and then slide shaft (callout 2) in the direction the arrow indicates and remove it.

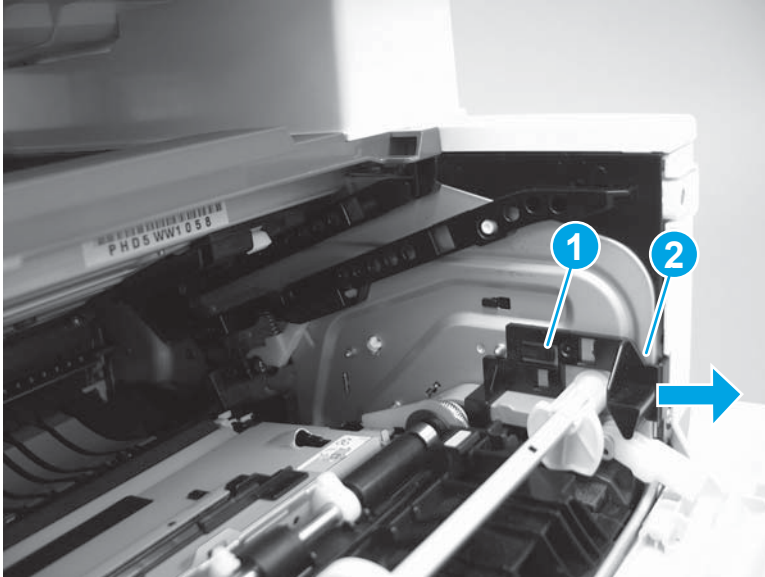
 **TIP:** It might be easier to release the support shaft by using a small flat-blade screwdriver.

**Figure 1-1642** Release the support shaft



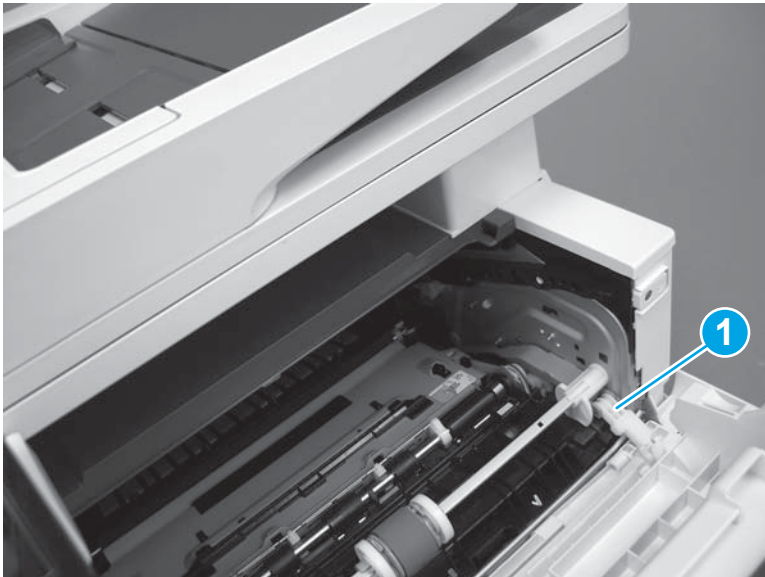
2. Release one tab (callout 1), and then slide the guide (callout 2) in the direction the arrow indicates and remove it.

**Figure 1-1643** Remove the guide



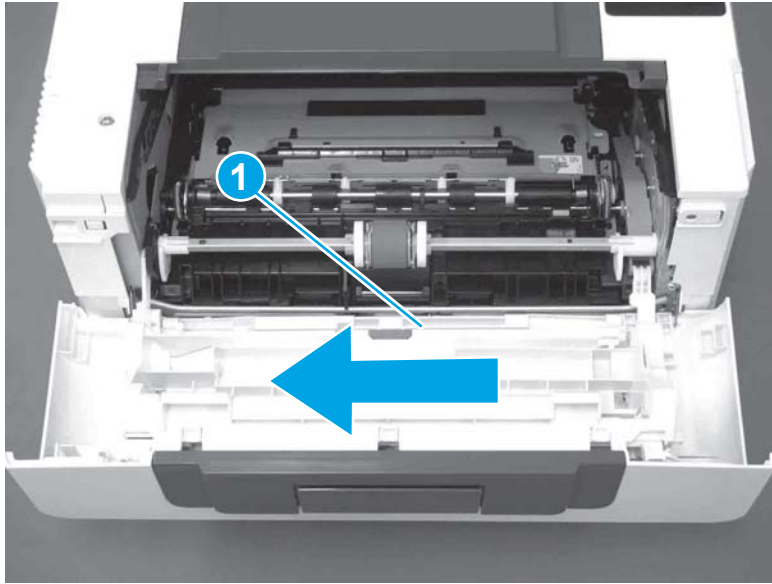
3. Remove the link arm (callout 1).

**Figure 1-1644** Remove the link arm



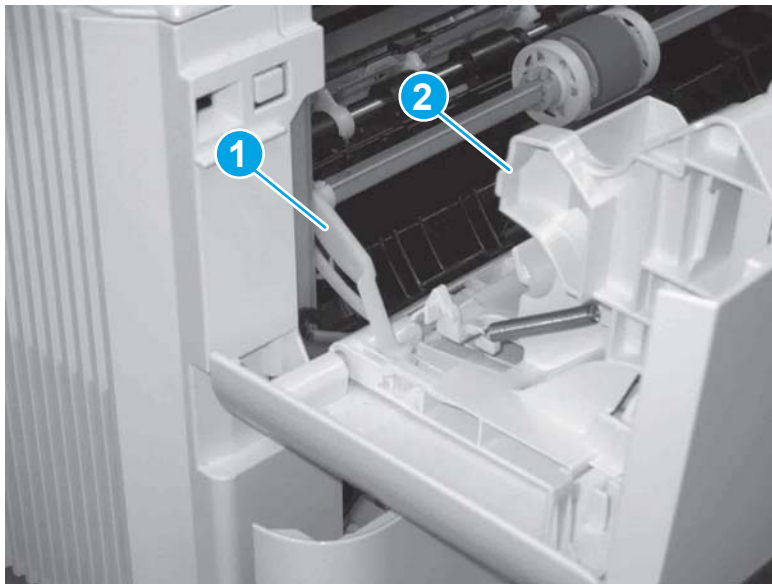
4. Slide the cartridge door assembly (callout 1) in the direction the arrow indicates and remove it.

**Figure 1-1645** Remove the door



5. Remove the link (callout 1) from the cartridge door assembly (callout 2).

**Figure 1-1646** Release the left-side retainer arm



### Step 3: Remove the left cover

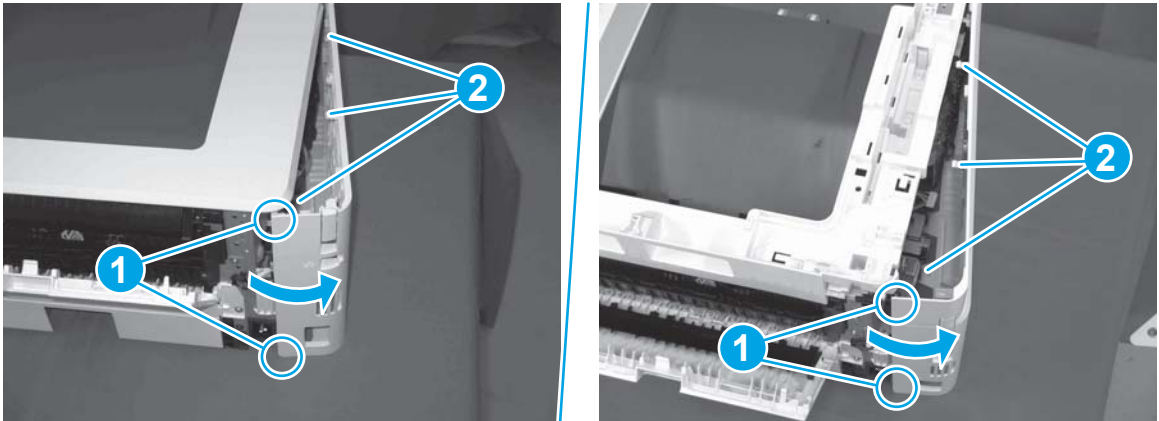
1. Remove one screw (callout 1).

**Figure 1-1647** Remove one screw



2. Open the rear door, release two bosses (callout 1), and then release three tabs (callout 2).

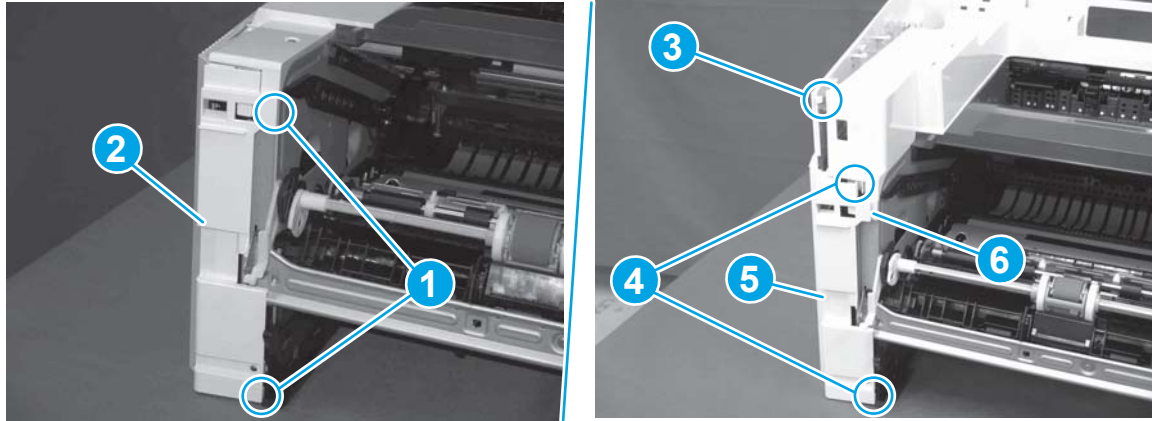
**Figure 1-1648** Release two bosses and three tabs



3. At the front of the printer, do one of the following:
  - **M403/M402:** Release two bosses (callout 1), and then remove the cover (callout 2).
  - **M427/M426:** Release one tab (callout 3), two bosses (callout 4), and then remove the cover (callout 5).

**CAUTION:** Be careful when releasing the upper bosses on the M427/M426 cover. One portion of the cover (callout 6) is fragile and is easily broken.

**Figure 1-1649** Remove the cover



**Step 4: Remove the right cover**

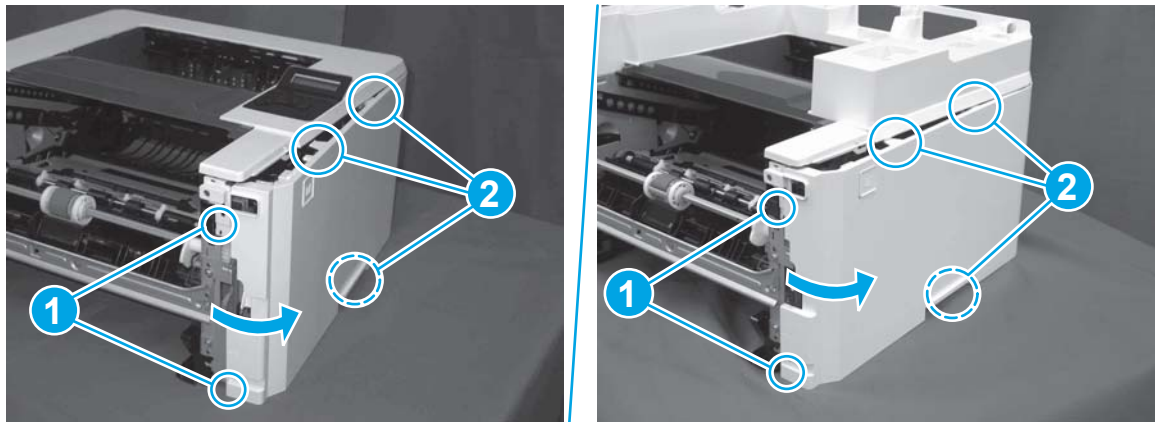
1. Remove one screw (callout 1).

**Figure 1-1650** Remove one screw



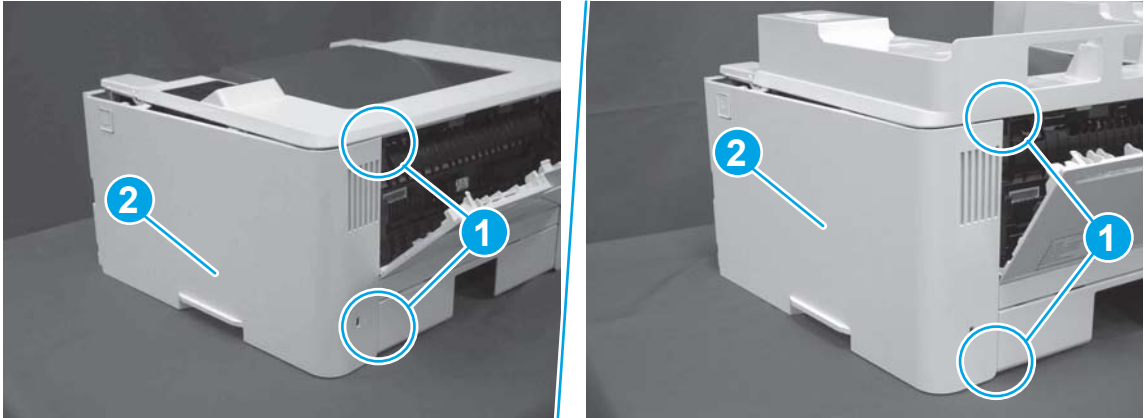
2. At the front of the printer, release two bosses (callout 1), and then release three tabs (callout 2).

**Figure 1-1651** Release two bosses and three tabs





3. Open the rear door, release two bosses (callout 1), and then remove the cover (callout 2).

**Figure 1-1652** Remove the cover



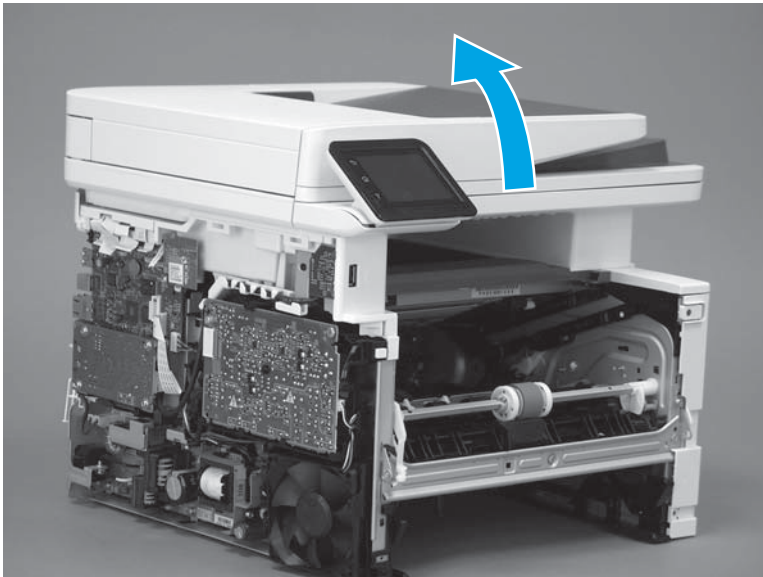
### Step 5: Remove the integrated scanner assembly (M427/M246)

 **NOTE:** The step is for the M427/M426 printer. For the M403/M402, skip this step and go to [Step 8: Remove the top cover \(M403/M402\)](#) on page 890.

 **NOTE:** M427/M426 models only. The integrated scanner assembly (ISA) includes the sub-scanner assembly (SSA) and the automatic document feeder (ADF).

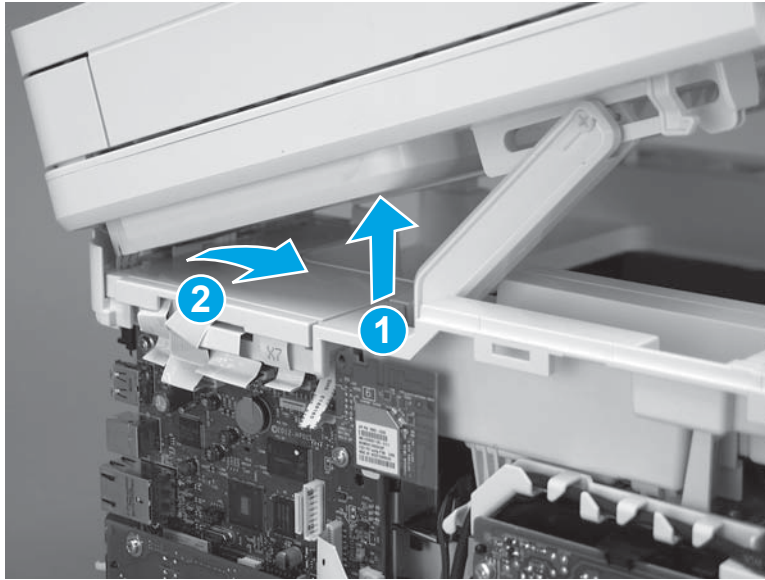
1. Raise the ISA.

**Figure 1-1653** Raise the ISA



2. Release the ISA flat-flexible cable (FFC) cover (callout 1), and then remove it (callout 2).

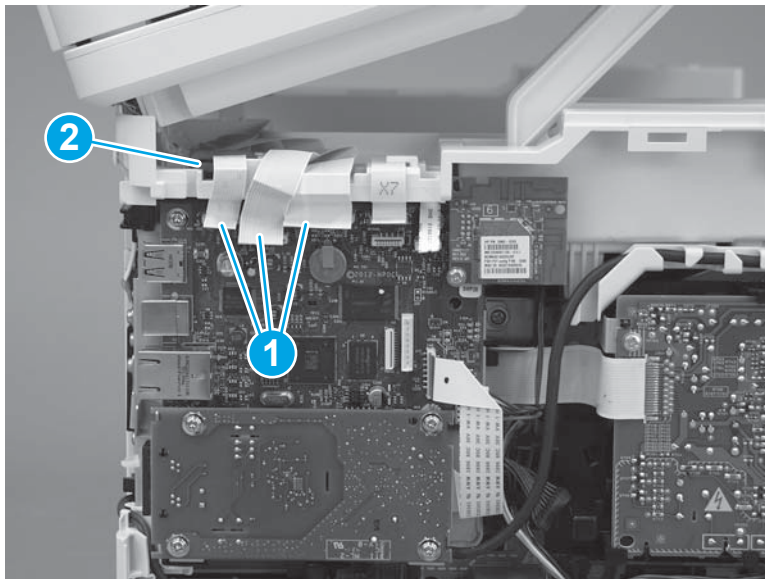
**Figure 1-1654** Remove the ISA FFC cover



3. Disconnect three FFCs (callout 1), and then remove the ferrite (callout 2) from the holder.

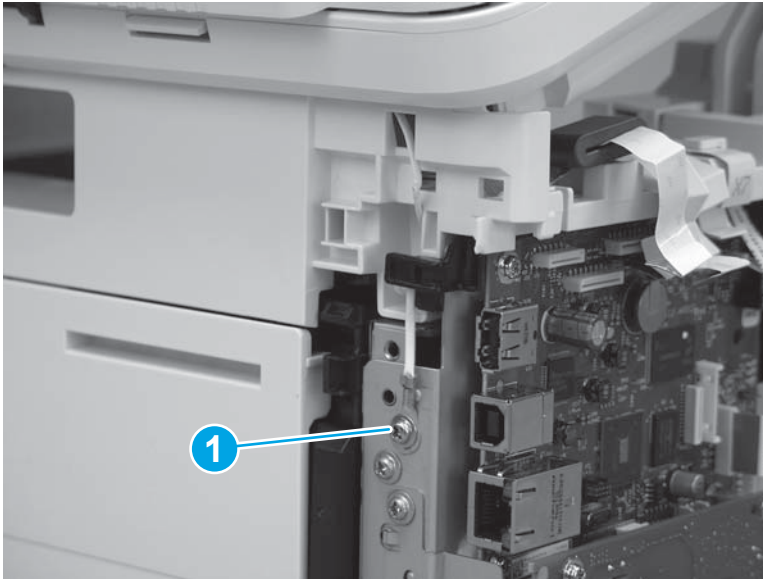
**CAUTION:** The ferrite is not captive on the FFC. Do not lose the ferrite while handling the ISA.

**Figure 1-1655** Disconnect three FFCs



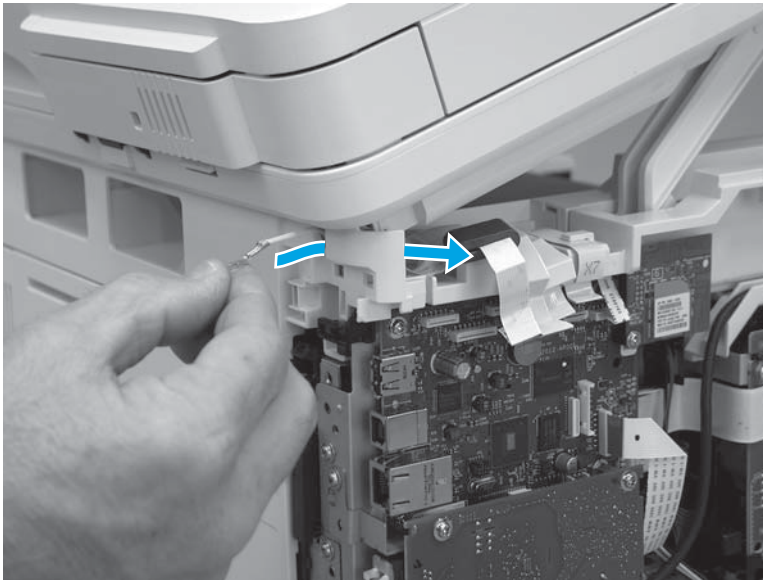
4. Remove one screw (callout 1).

**Figure 1-1656** Remove one screw



5. Pass the ground wire through the opening in the top cover.

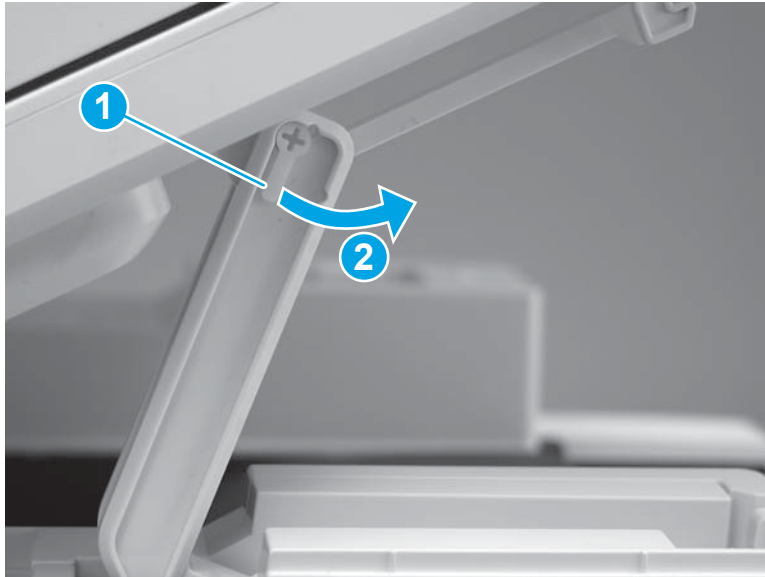
**Figure 1-1657** Pass the wire through the opening





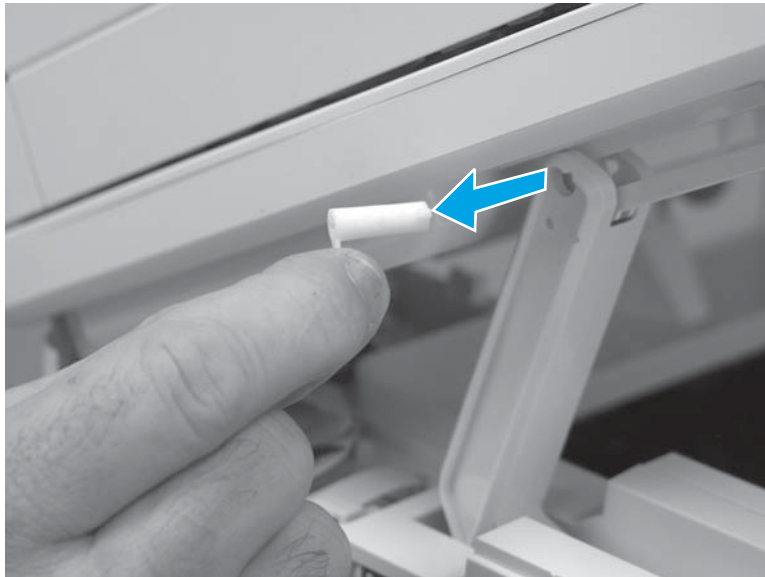
6. Release one tab (callout 1), and then rotate the ISA slider pin (callout 2) towards the front of the printer to release it.

**Figure 1-1658** Release one tab and rotate the slider pin



7. Remove the slider pin.

**Figure 1-1659** Remove the slider pin



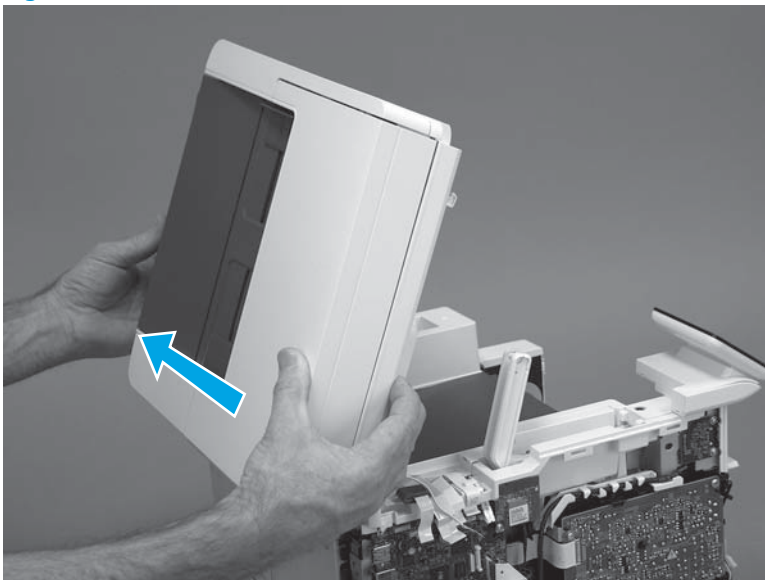
8. Rotate the ISA towards the rear of the printer until it stops.

**Figure 1-1660** Rotate the ISA towards the rear of the printer



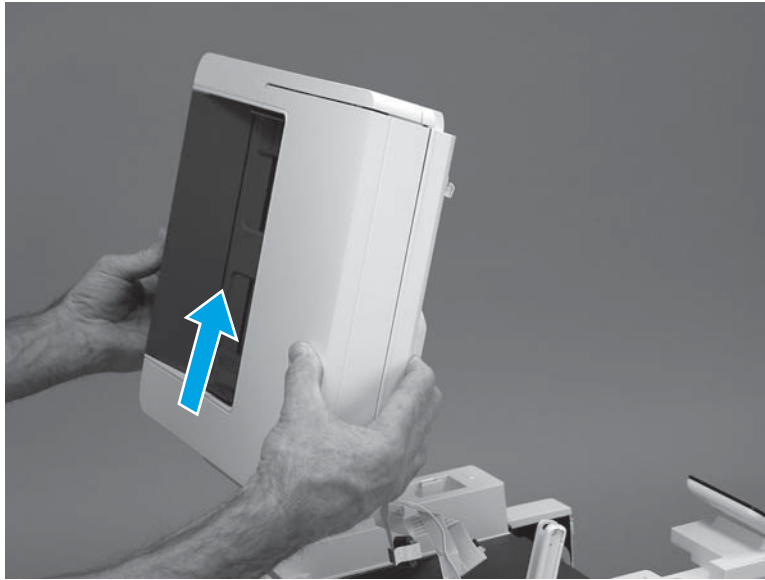
9. Slide the ISA as shown to release it.

**Figure 1-1661** Release the ISA




10. Remove the ISA.

**Figure 1-1662** Remove the ISA

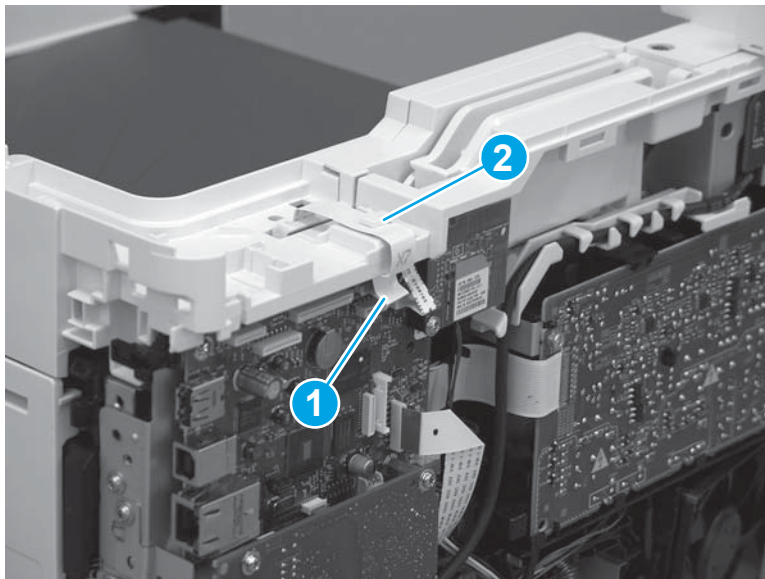


#### Step 6: Remove the control panel (M427/M246)

 **NOTE:** The step is for the M427/M426 printer. For the M403/M402, skip this step and go to [Step 8: Remove the top cover \(M403/M402\) on page 890](#).

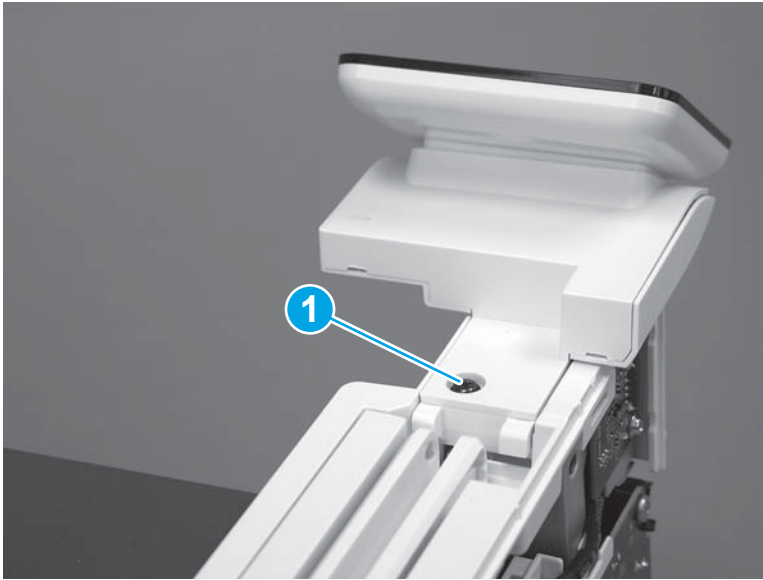
1. Disconnect one FFC (callout 1; J114), and then release the FFC from the retainer (callout 2).

**Figure 1-1663** Disconnect one connector



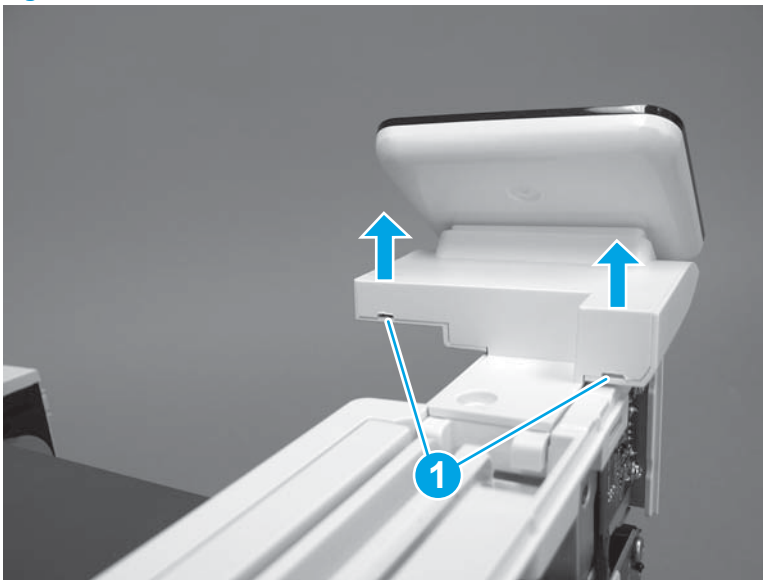
2. Remove one screw (callout 1).

**Figure 1-1664** Remove one screw



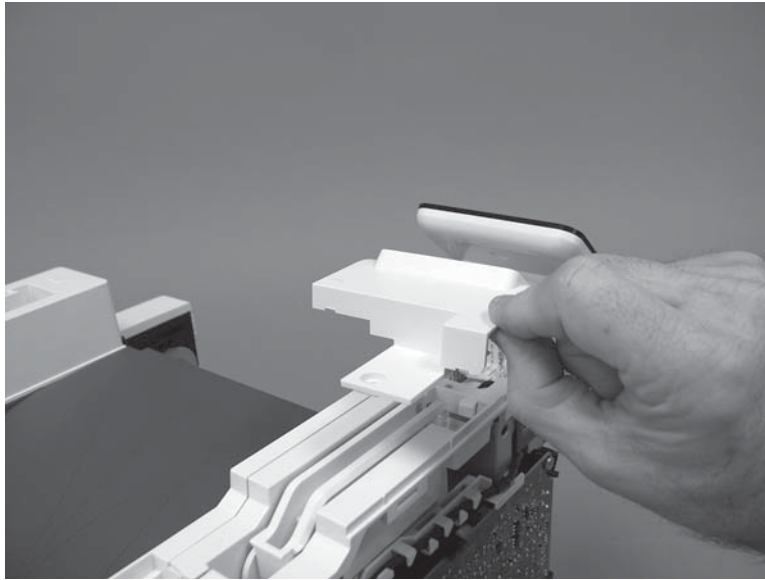
3. Use a small flat-blade screwdriver to release two tabs (callout 1) on the control-panel cable cover.

**Figure 1-1665** Release two tabs



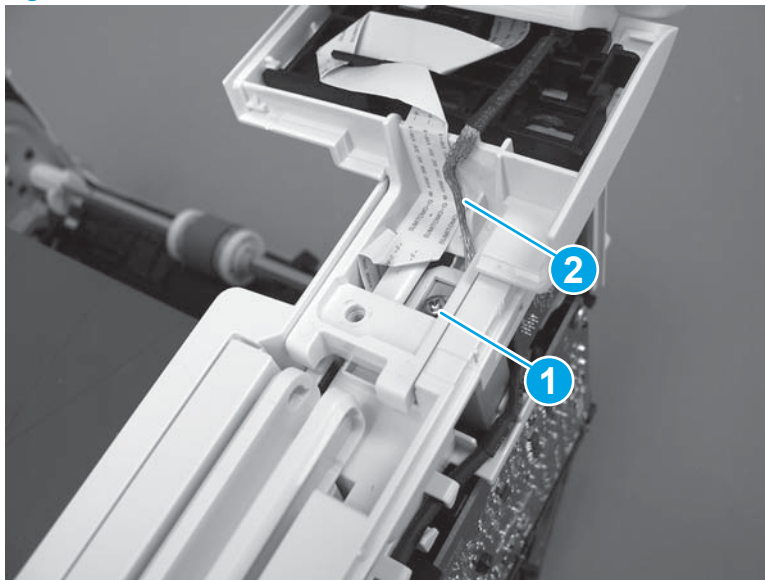
4. Remove the control-panel cable cover.

**Figure 1-1666** Remove the cover



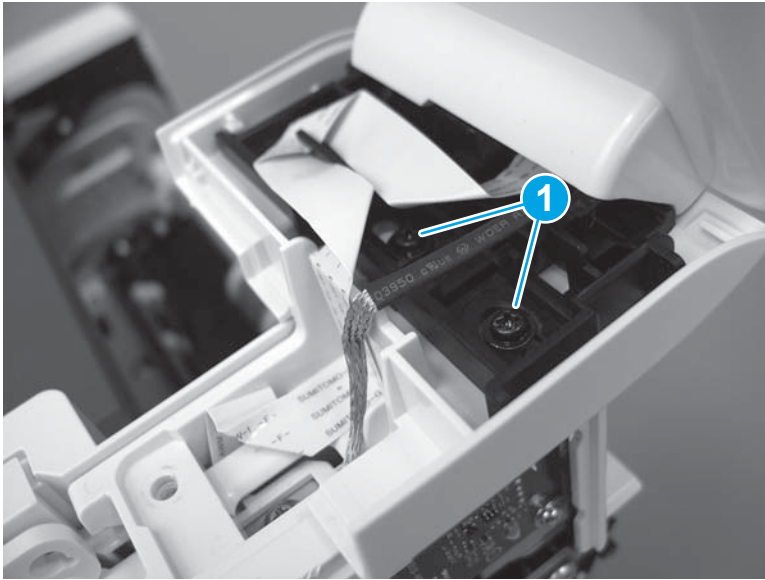
5. Remove one grounding screw (callout 1), and then move the ground cable (callout 2) out of the way.

**Figure 1-1667** Remove one screw



6. Move the FFC out of the way, and then remove two screws (callout 1).

**Figure 1-1668** Remove two screws



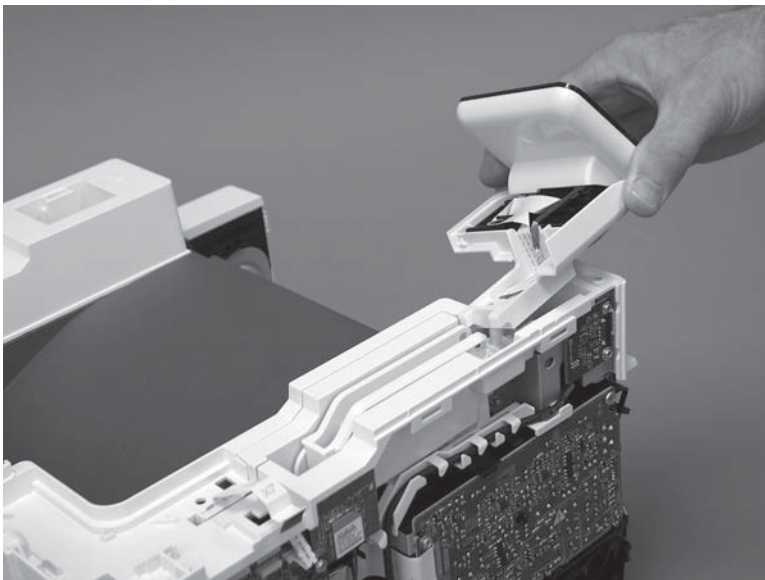
7. Slightly lift up the control-panel assembly to separate it from the top cover.

---

**CAUTION:** The control panel assembly is still connected to the printer by the FFC. Do not attempt to completely remove the assembly.

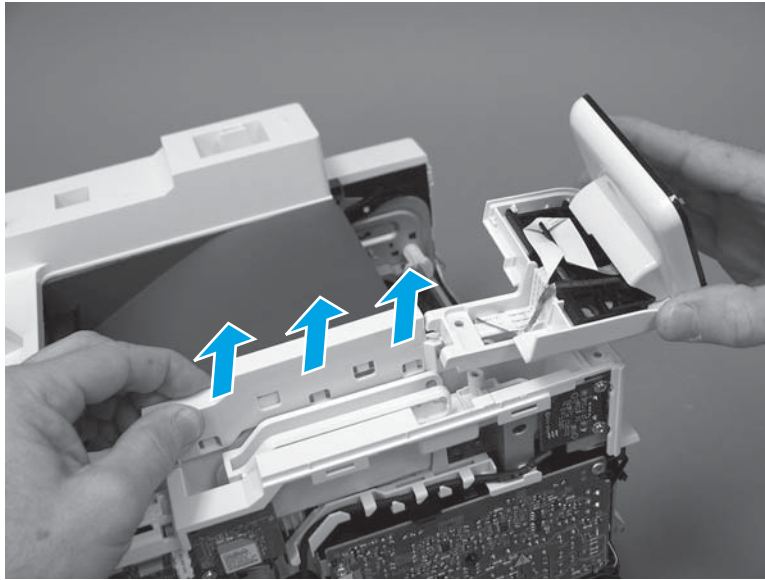
---

**Figure 1-1669** Lift up the control-panel assembly




8. Lift up the control-panel FFC cover to remove the control-panel assembly.

**Figure 1-1670** Remove the control-panel assembly

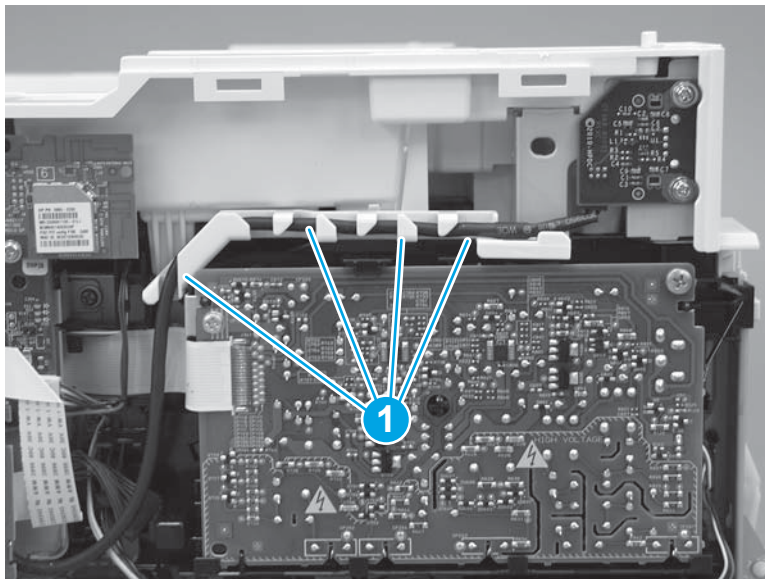


### Step 7: Remove the top cover (M427/M426)

 **NOTE:** The step is for the M427/M426 printer. For the M403/M402, skip this step and go to [Step 8: Remove the top cover \(M403/M402\) on page 890](#).

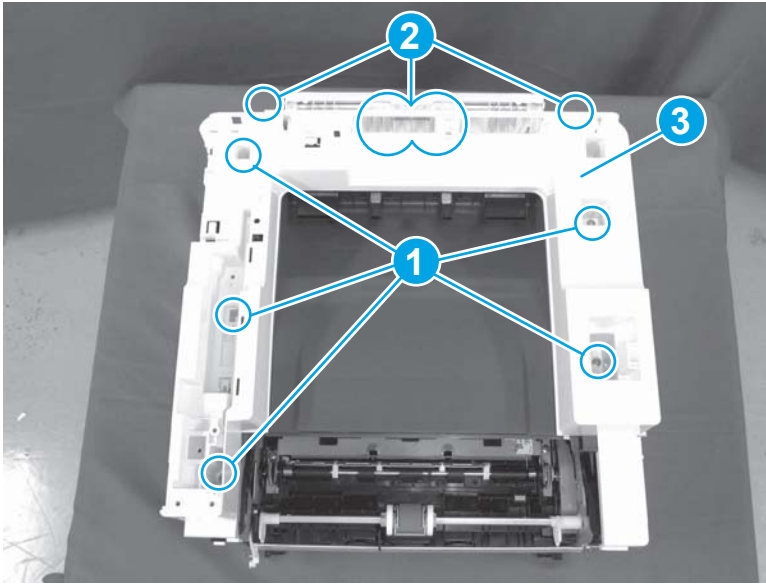
1. Release the USB cable (callout 1) from the cable guide.

**Figure 1-1671** Remove the USB cable



2. Remove five screws (callout 1), release four bosses (callout 2), and then remove the top cover (callout 3).

**Figure 1-1672** Remove the cover



### Step 8: Remove the top cover (M403/M402)



**NOTE:** The step is for the M403/M402 printer. For the M427/M426, skip this step and go to [Step 9: Remove the paper delivery tray \(output bin\) on page 891](#).

1. Remove one screw (callout 1).

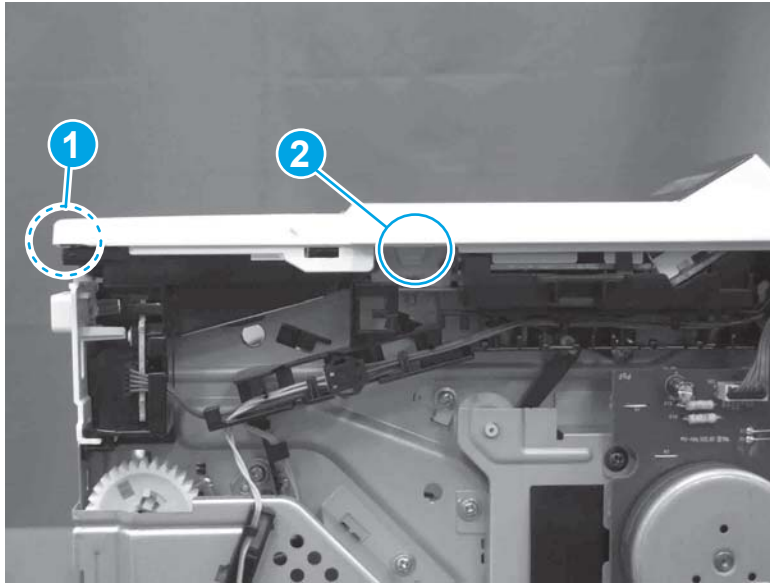
**Figure 1-1673** Remove one screw






2. At the right side of the printer, release the one boss (callout 1), and then release one tab (callout 2).

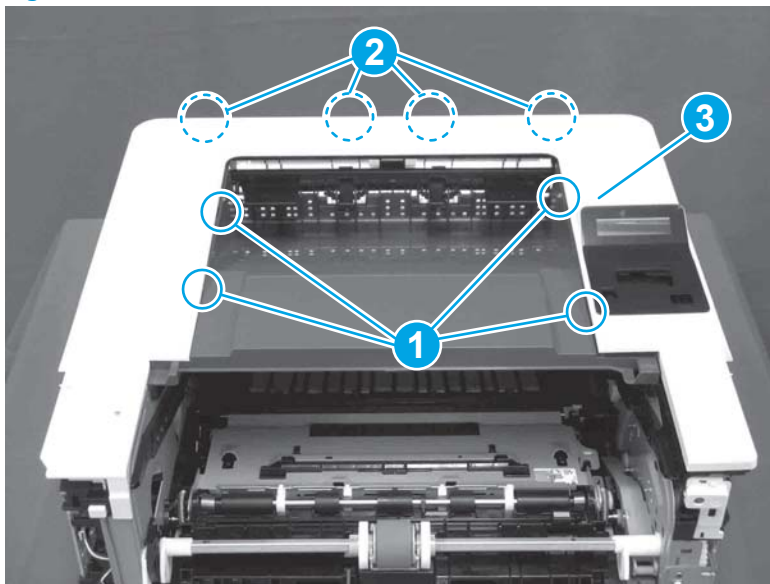
**Figure 1-1674** Release one boss and one tab




3. Release four tabs (callout 1), release four bosses (callout 2), and then remove the top cover (callout 3).

 **TIP:** Open the rear door to make releasing the bosses (callout 3) easier.

**Figure 1-1675** Remove the cover

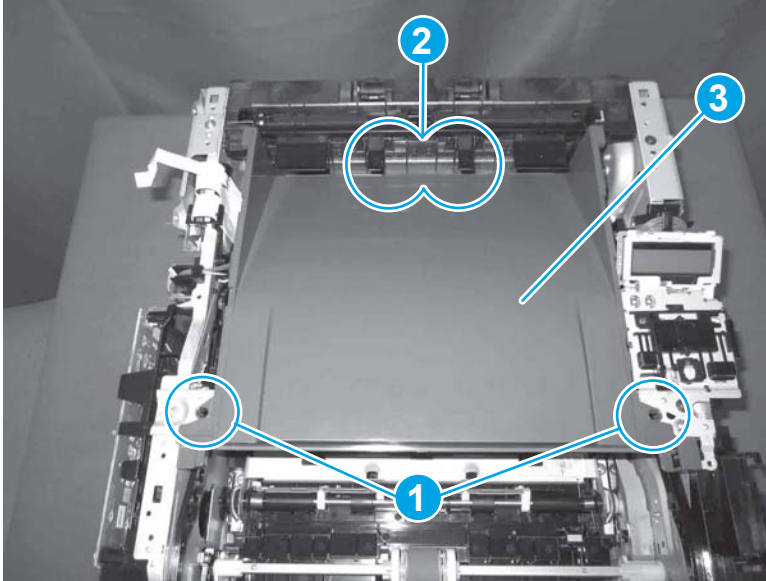


### Step 9: Remove the paper delivery tray (output bin)


 **NOTE:** This procedure shows the M403/M402 model, however, the paper delivery tray (output bin) removal is similar for the M427/M426 printer.

- ▲ Release two bosses (callout 1), release two tabs (callout 2), and then remove the paper delivery tray (output bin; callout 3).

**Figure 1-1676** Release two tabs

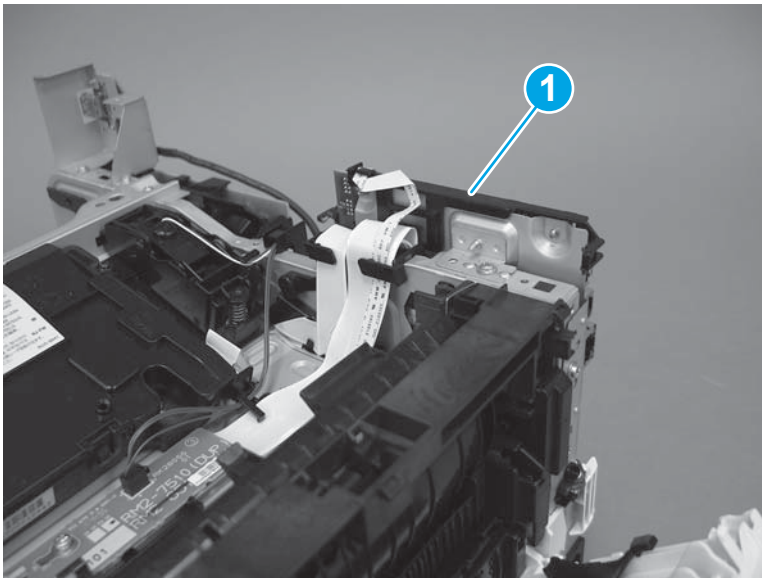


**Step 10: Remove the sheet-metal formatter bracket and formatter PCA**

 **NOTE:** Disconnect any remaining formatter PCA FFCs or wire-harness connectors.

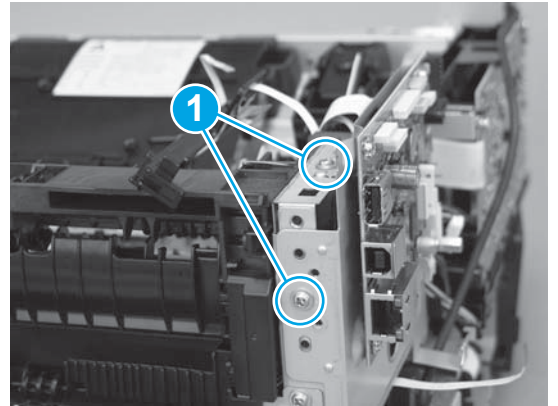
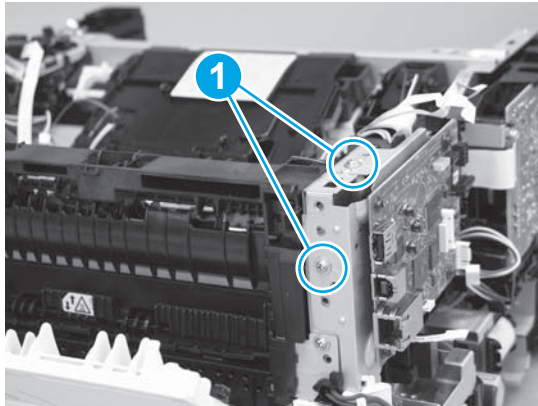
1. **M427/M426 only:** Remove the guide (callout 1).

**Figure 1-1677** Remove the guide



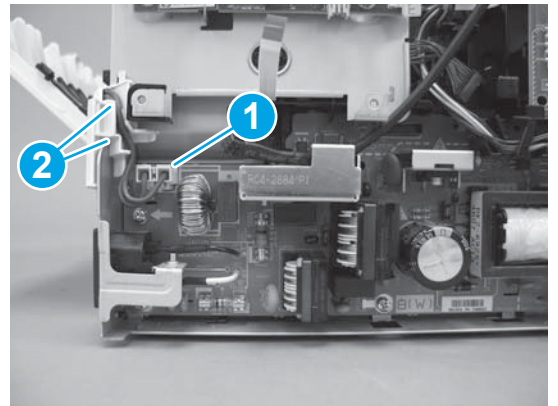
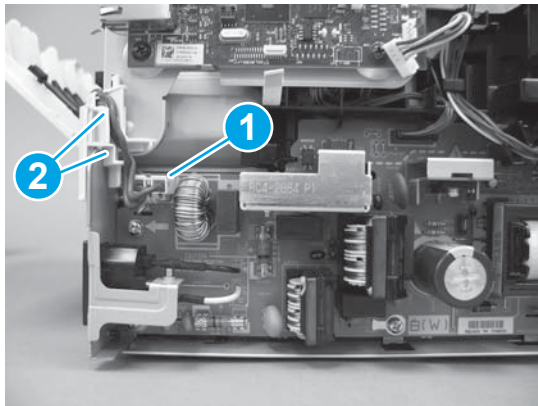
2. Remove two screws (callout 1).

**Figure 1-1678** Remove two screws



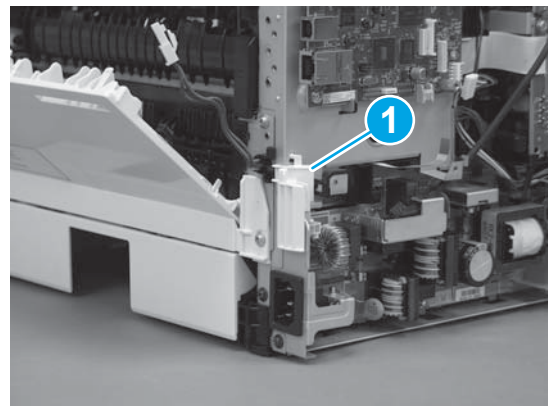
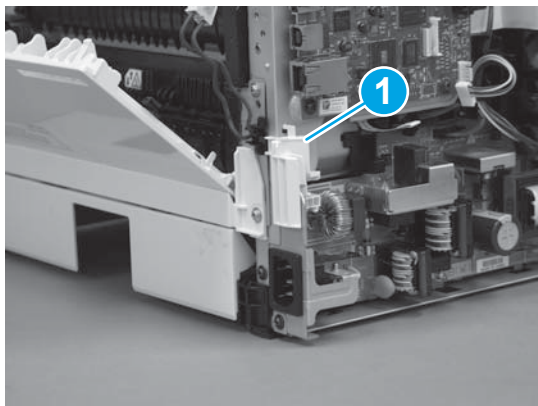
3. Disconnect one connector (callout 1), and then release the wire harness from the guide (callout 2).

**Figure 1-1679** Disconnect one connector



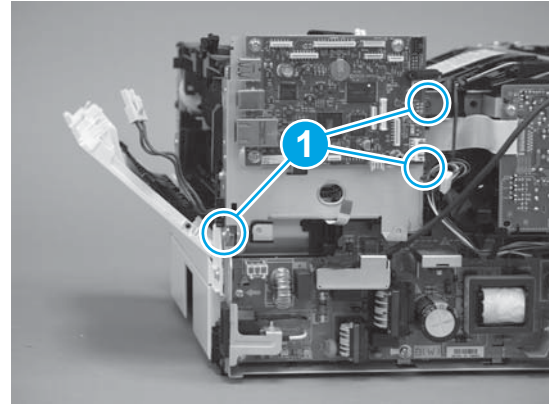
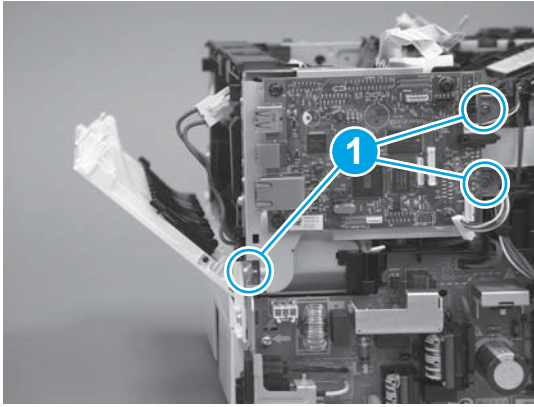
4. Remove the guide (callout 1).

**Figure 1-1680** Remove the guide



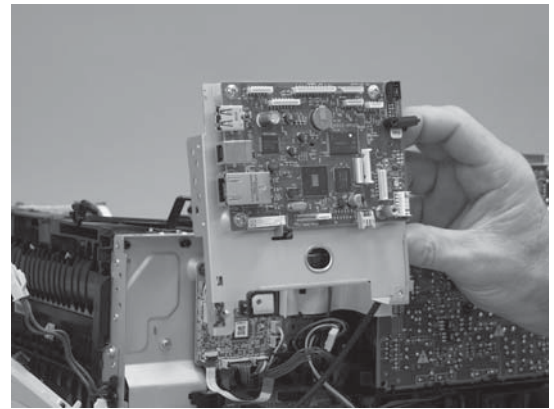
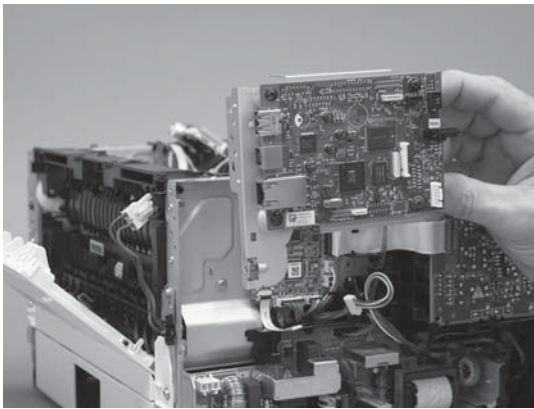
5. Remove three screws (callout 1).

**Figure 1-1681** Remove three screws



6. Remove the sheet-metal bracket and formatter PCA.

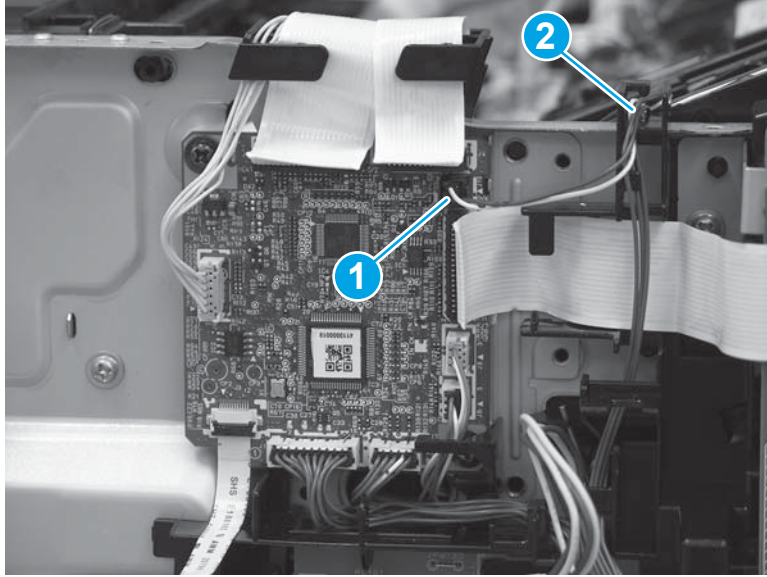
**Figure 1-1682** Remove the bracket



### Step 11: Remove the tag-cable assembly

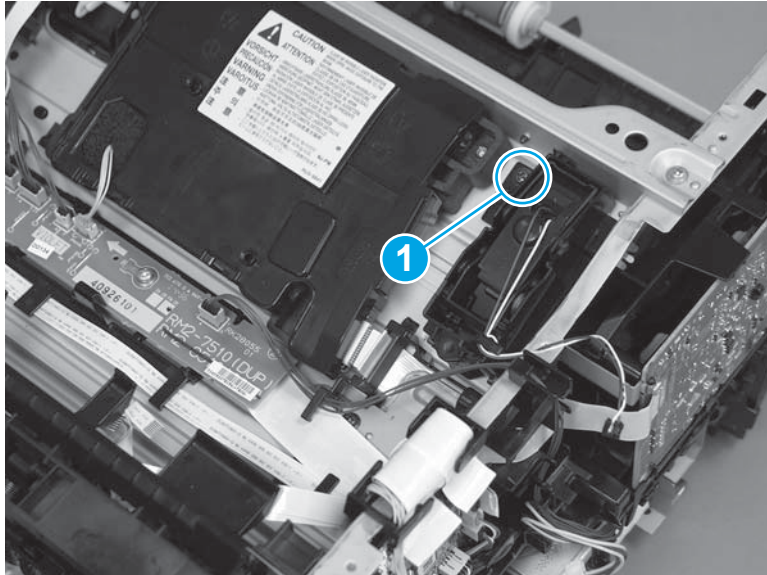
1. Disconnect one connector (callout 1), and then release the wire harness from the guide (callout 2).

**Figure 1-1683** Disconnect one connector



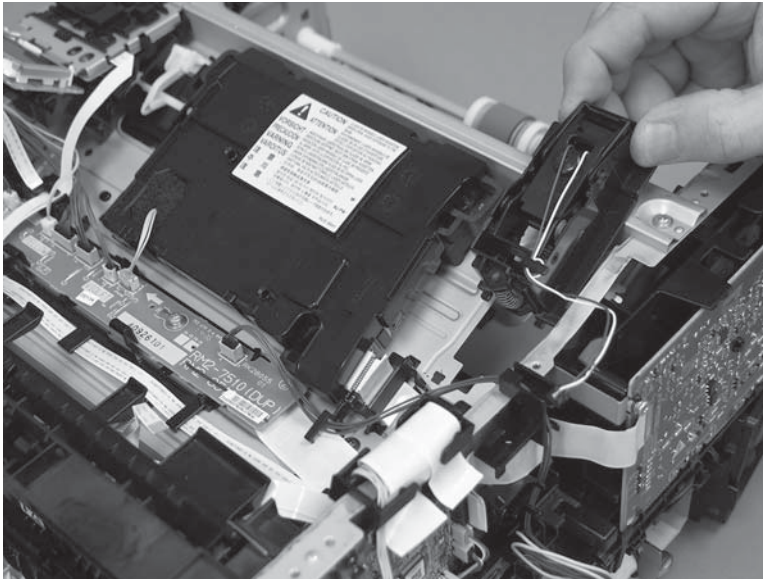
2. Remove one screw (callout 1).

**Figure 1-1684** Remove one screw



3. Remove the tag-cable assembly.

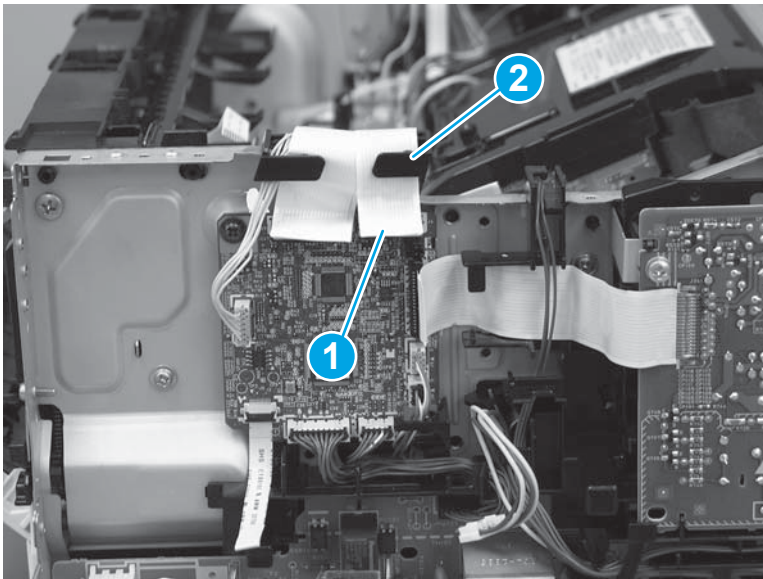
**Figure 1-1685** Remove the tag-cable assembly



#### Step 12: Remove the laser scanner FFC

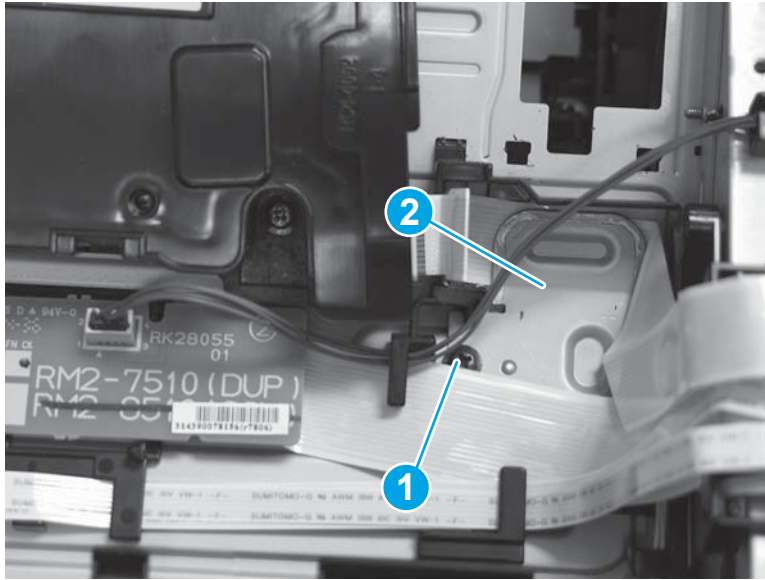
1. Disconnect one FFC (callout 1), and then release it from the guide (callout 2).

**Figure 1-1686** Disconnect one FFC



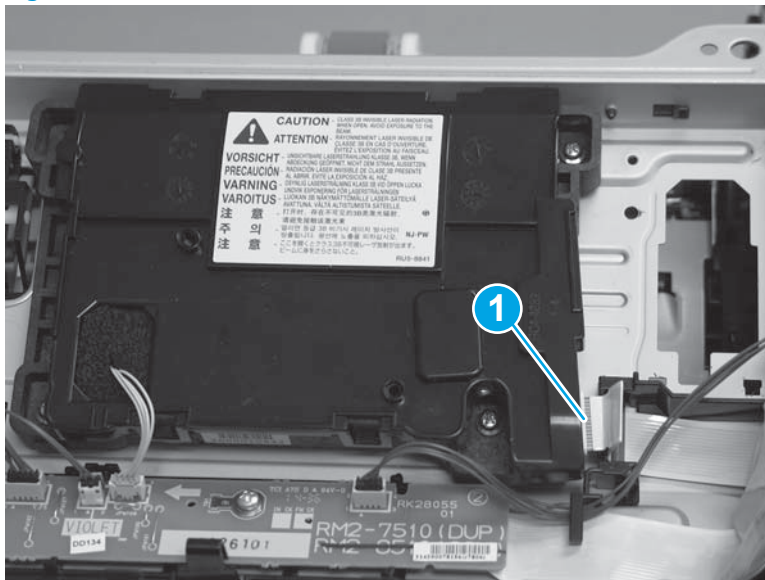
2. Remove one screw (callout 1), and then remove the sheet-metal plate (callout 2).

**Figure 1-1687** Remove one screw and the sheet-metal plate



3. Disconnect one FFC (callout 1).

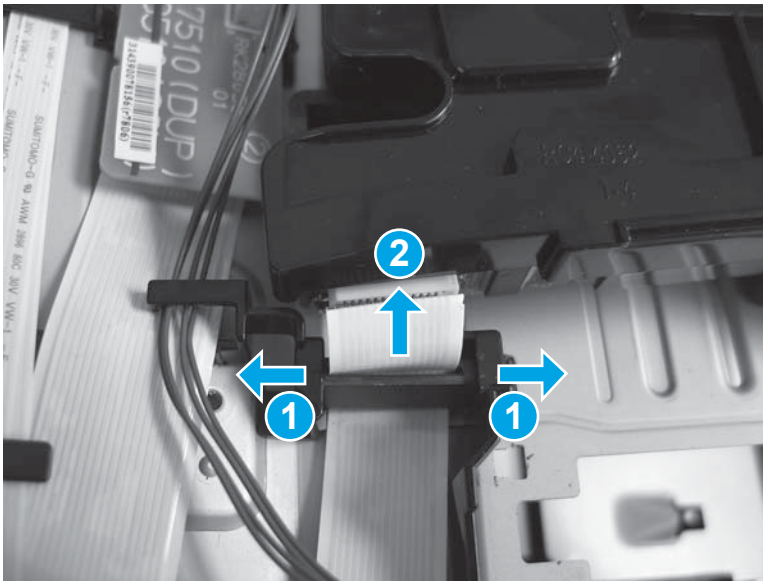
**Figure 1-1688** Disconnect one FFC



4. Slightly flex the holder (callout 1), and then release the FFC ferrite (callout 2).

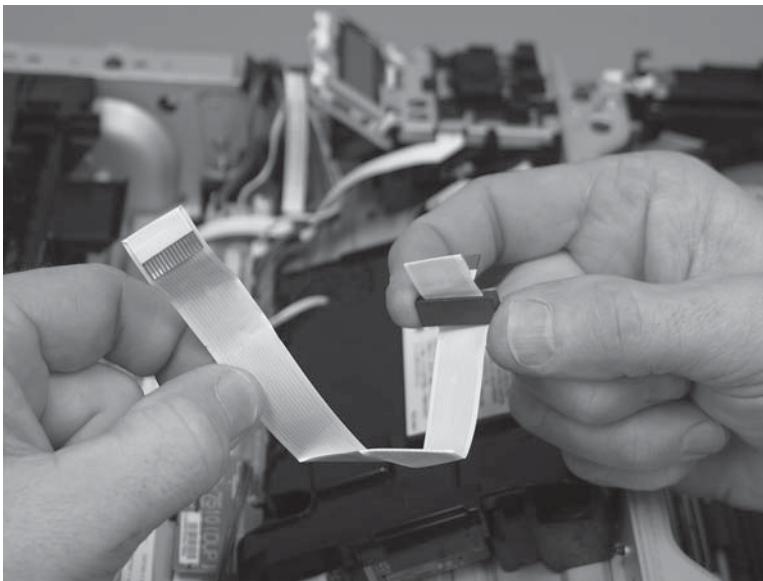
 **Reinstallation tip:** Do not discard the ferrite. It will be installed on the replacement FFC.

**Figure 1-1689** Release the ferrite



5. Remove the FFC.

**Figure 1-1690** Remove the FFC



### Step 13: Unpack the replacement assembly

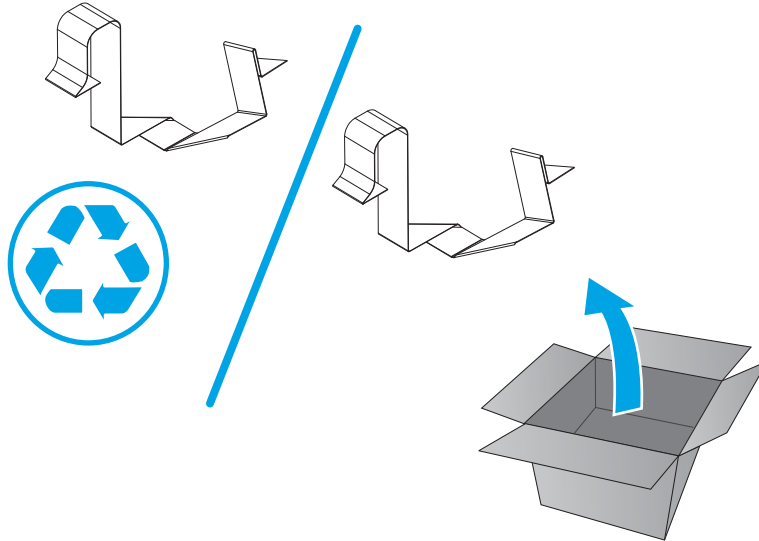
Unpack the replacement part from the packaging.

<http://www8.hp.com/us/en/hp-information/environment/product-recycling.html>

 **NOTE:** HP recommends responsible disposal of the defective part.



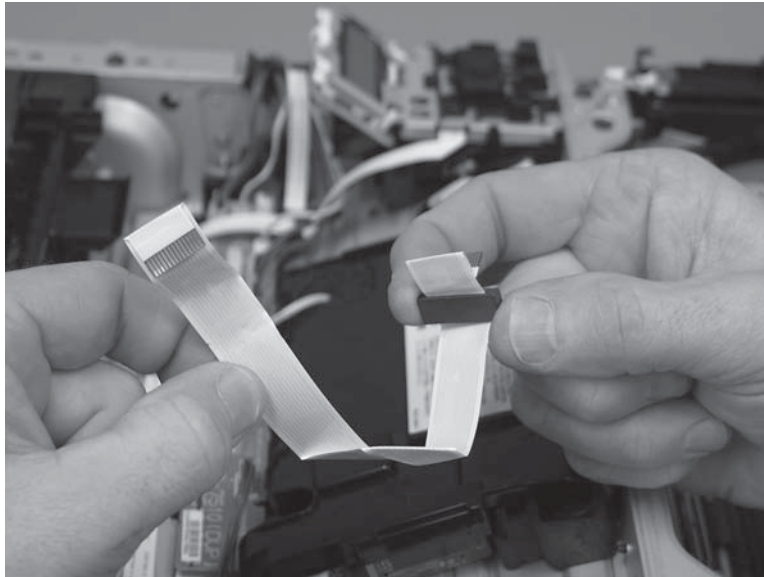
**Figure 1-1691** Recycle and unpack



**Step 14: Install the laser scanner FFC**

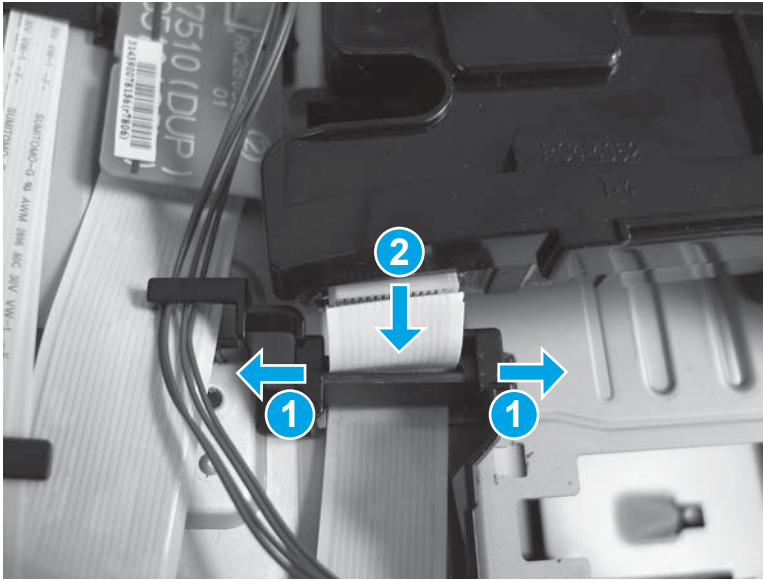
1. Install the ferrite on the replacement FFC.

**Figure 1-1692** Install the ferrite



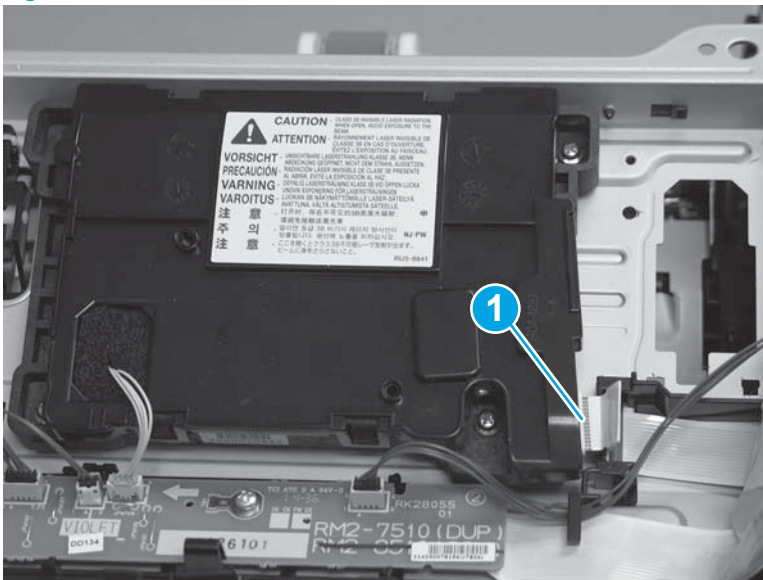
2. Slightly flex the holder (callout 1), and then install the FFC ferrite (callout 2) in the holder.

**Figure 1-1693** Install the FFC



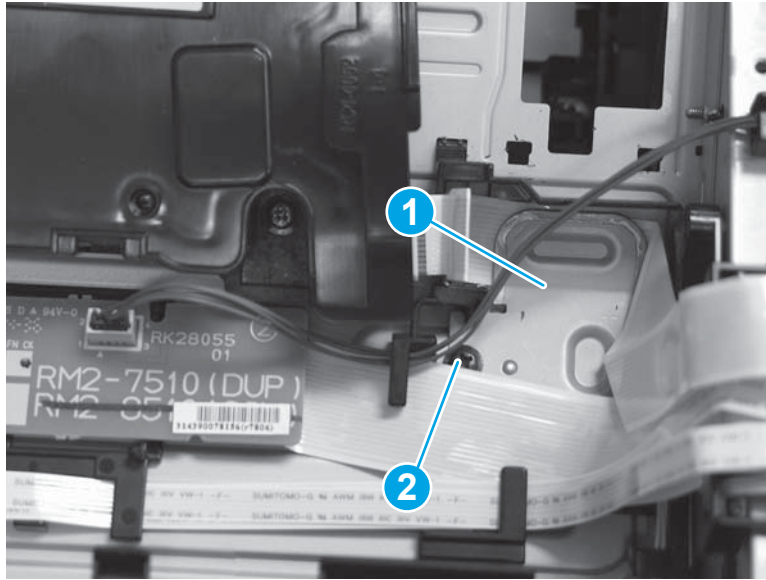
3. Connect one FFC (callout 1).

**Figure 1-1694** Connect one FFC



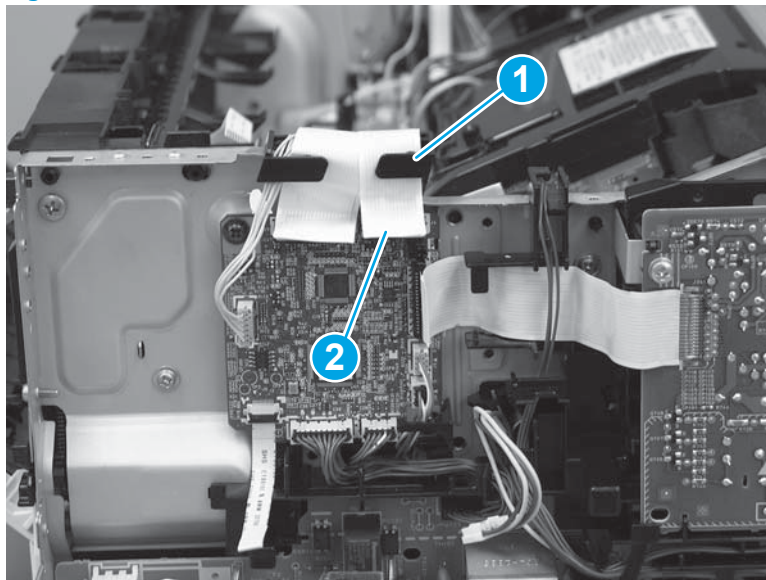
4. Install the sheet-metal plate (callout 1), and then install one screw (callout 2).

**Figure 1-1695** Install the sheet-metal plate and install one screw




5. Install the FFC in the guide (callout 1), and then connect the FFC (callout 1) to the DC controller.

**Figure 1-1696** Connect one FFC

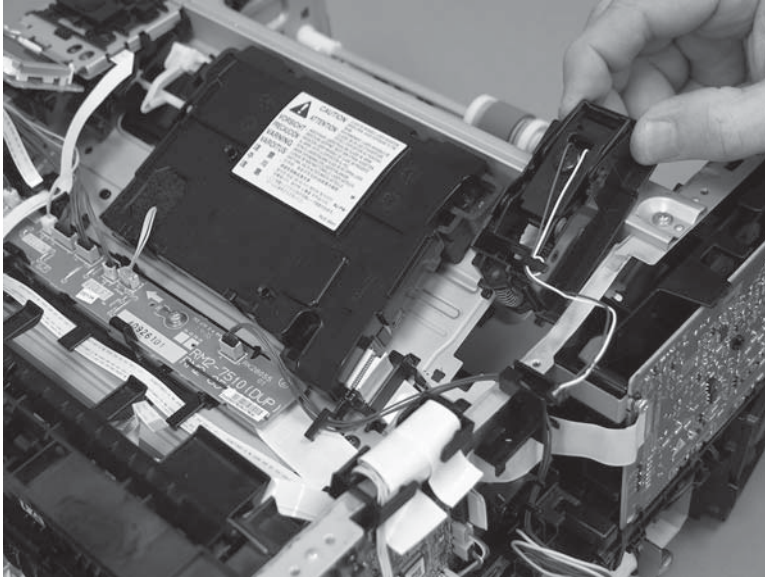


### Step 15: Install the tag-cable assembly

1. Position the assembly on the printer.

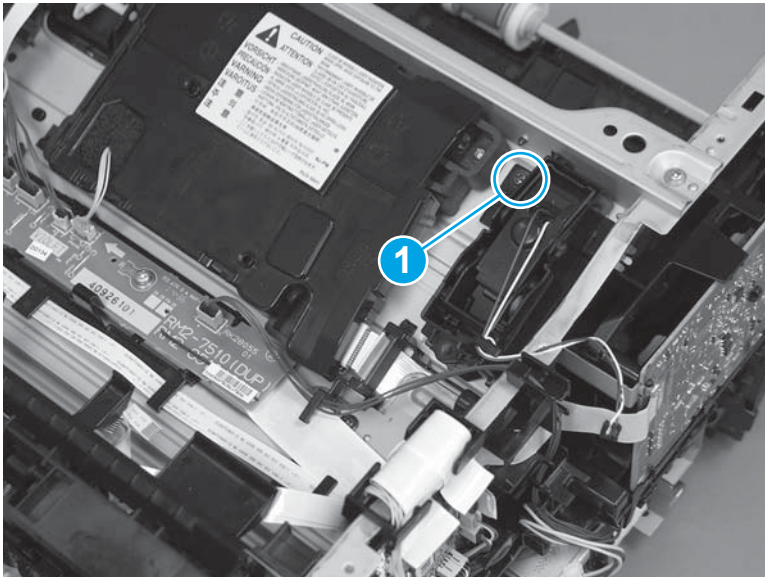
 **IMPORTANT:** Make sure that the assembly is flat against the chassis. If the assembly is not correctly installed, it might not make proper contact with the toner cartridge.

**Figure 1-1697** Install the assembly



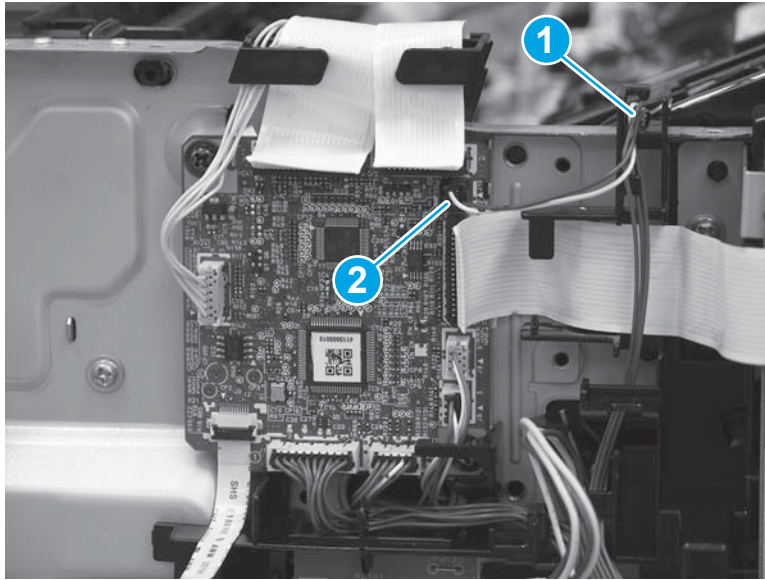
2. Install one screw (callout 1).

**Figure 1-1698** Install one screw



3. Install the wire harness in the guide (callout 1), and then connect one connector (callout 2).

**Figure 1-1699** Connect one connector

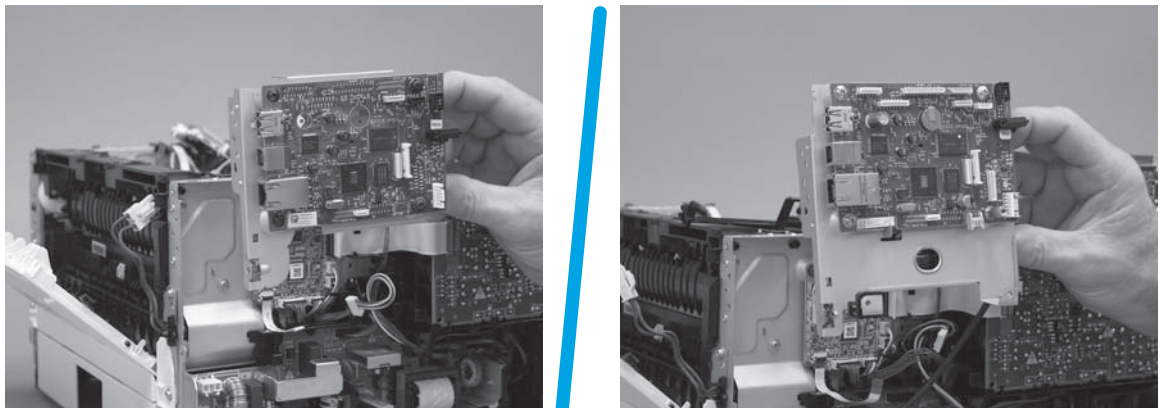


#### Step 16: Install the sheet-metal formatter bracket and formatter PCA

 **NOTE:** Do not forget to connect any formatter PCA FFCs or wire-harness connectors that were disconnected when the bracket was removed.

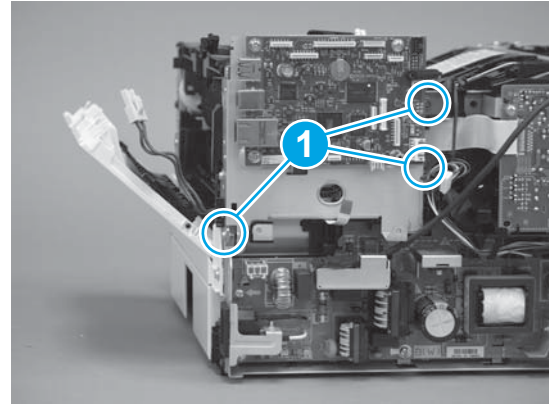
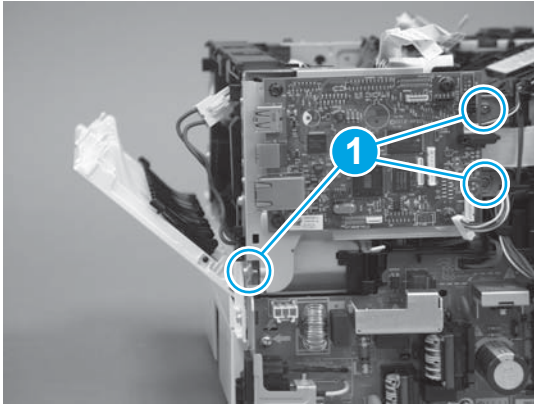
1. Position the sheet-metal bracket and formatter PCA on the printer.

**Figure 1-1700** Install the bracket



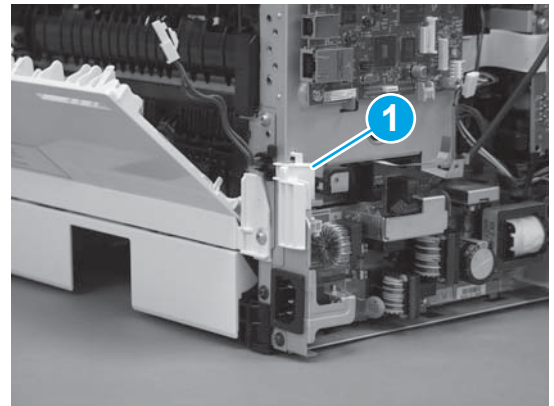
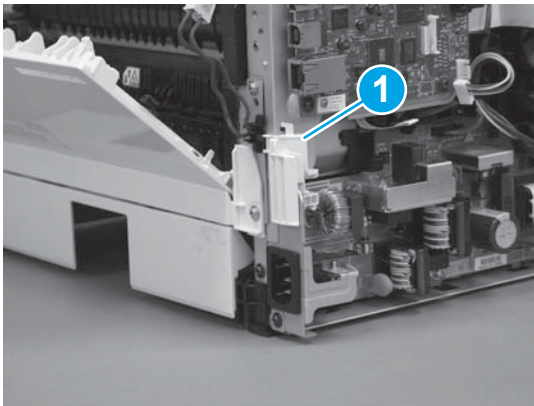
2. Install three screws (callout 1).

**Figure 1-1701** Install three screws



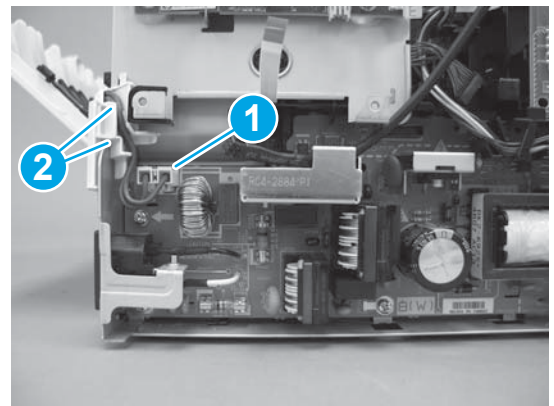
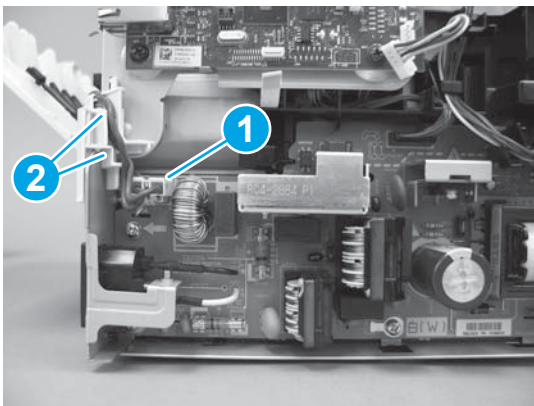
3. Install the guide (callout 1).

**Figure 1-1702** Install the guide



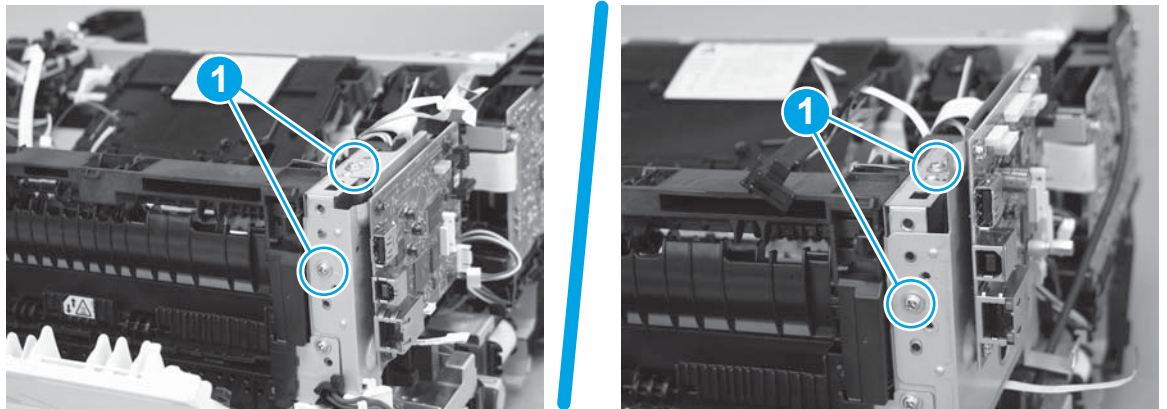
4. Connect one connector (callout 1), and then install the wire harness in the guide (callout 2).

**Figure 1-1703** Connect one connector



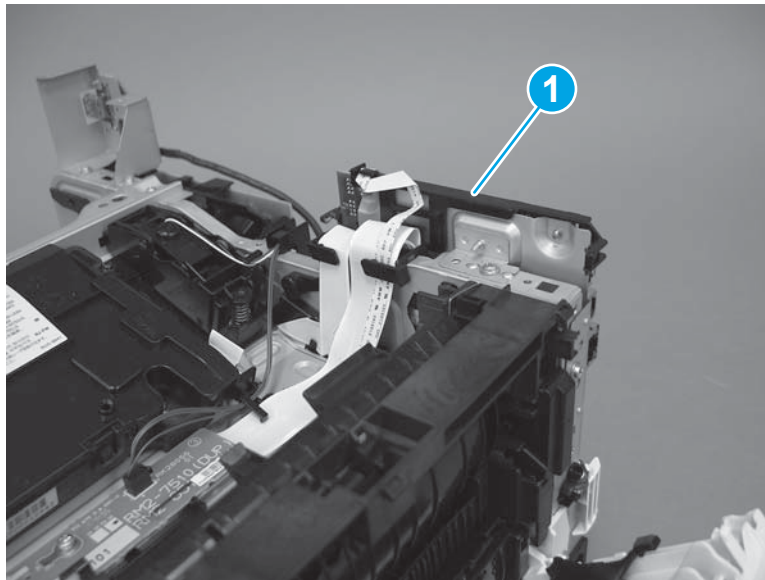
5. Install two screws (callout 1).

**Figure 1-1704** Install two screws




6. **M427/M426 only:** Install the guide (callout 1).

**Figure 1-1705** Install the guide

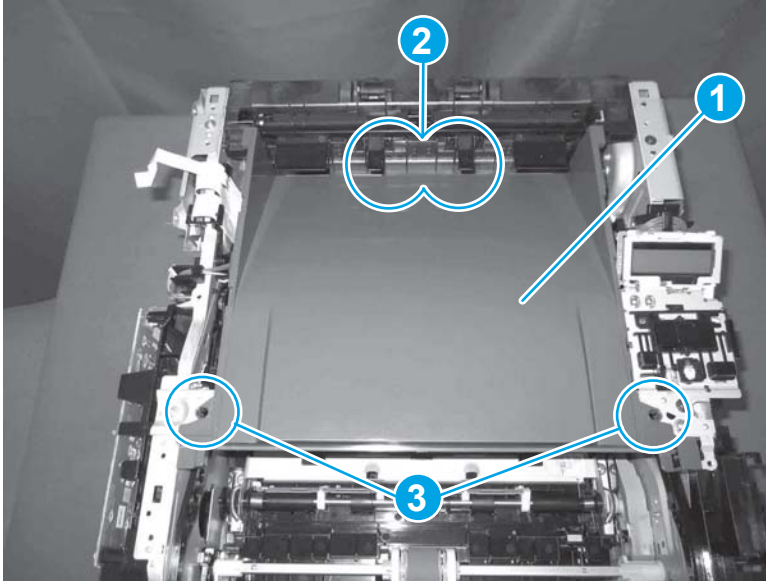


### Step 17: Install the paper delivery tray (output bin)


 **NOTE:** This procedure shows the M403/M402 model, however, the paper delivery tray (output bin) removal is similar for the M427/M426 printer.

- ▲ Position the remove the paper delivery tray (output bin; callout 1) on the printer, engage two tabs (callout 2), and then engage two bosses (callout 3).

**Figure 1-1706** Engage two tabs

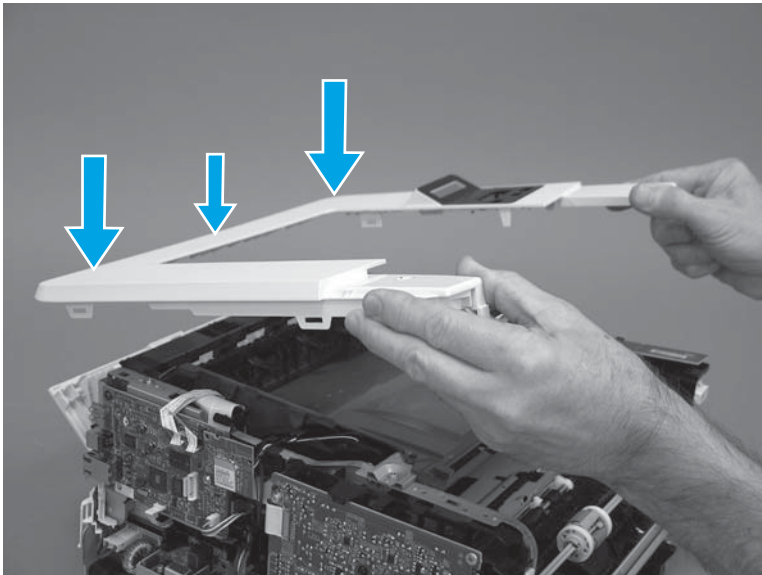


**Step 18: Install the top cover (M403/M402)**

 **NOTE:** The step is for the M403/M402 printer. For the M427/M426, skip this step and go to [Step 19: Install the top cover \(M427/M426\) on page 908](#).

1. Position the rear edge of the cover on the printer.

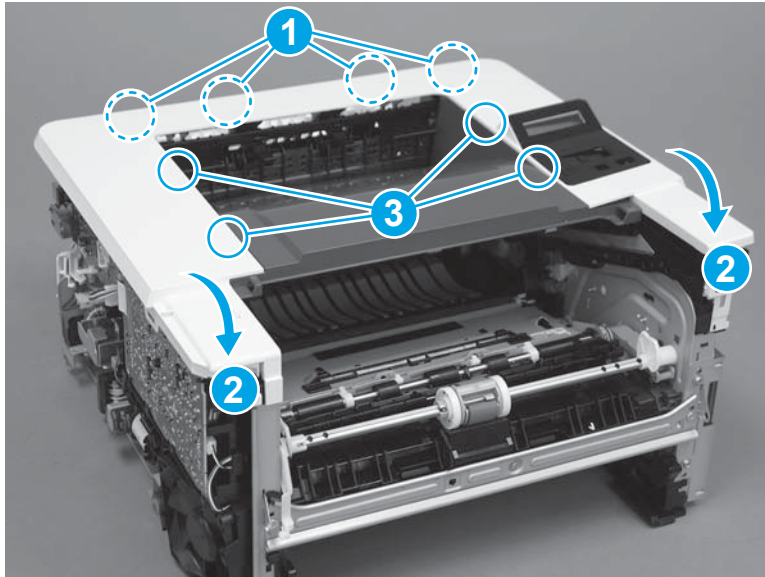
**Figure 1-1707** Install the cover





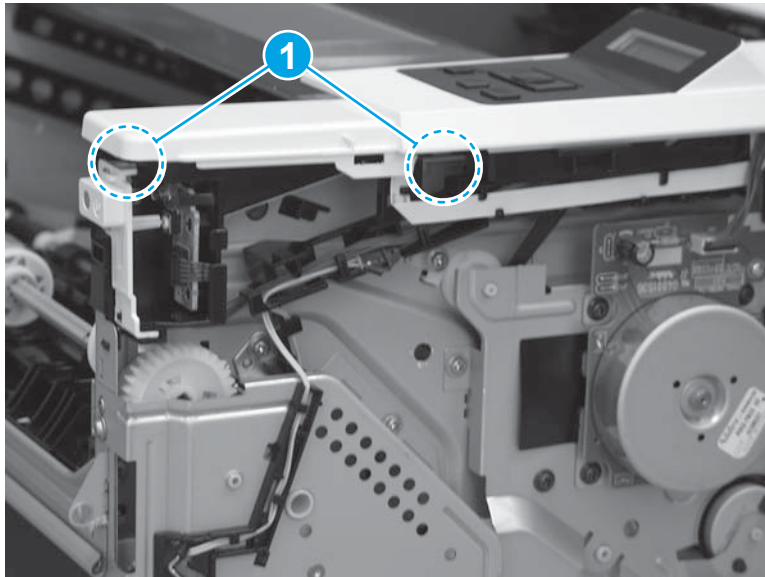
- Engage four bosses (callout 1), rotate the front of the cover down (callout 2) and onto from the printer, and then engage four tabs (callout 3).

**Figure 1-1708** Engage four bosses and tabs



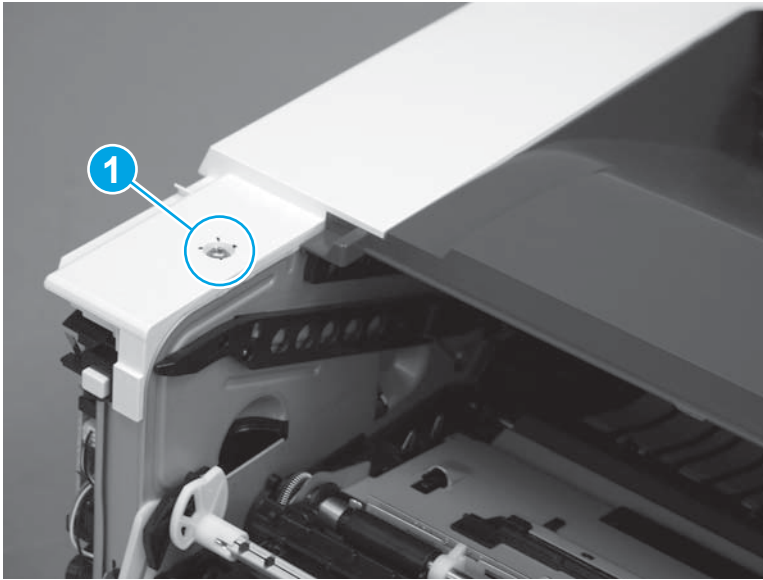
- At the right side of the printer, engage the one boss and one tab (callout 1).

**Figure 1-1709** Engage one boss and one tab




4. Install one screw (callout 1).

**Figure 1-1710** Install one screw

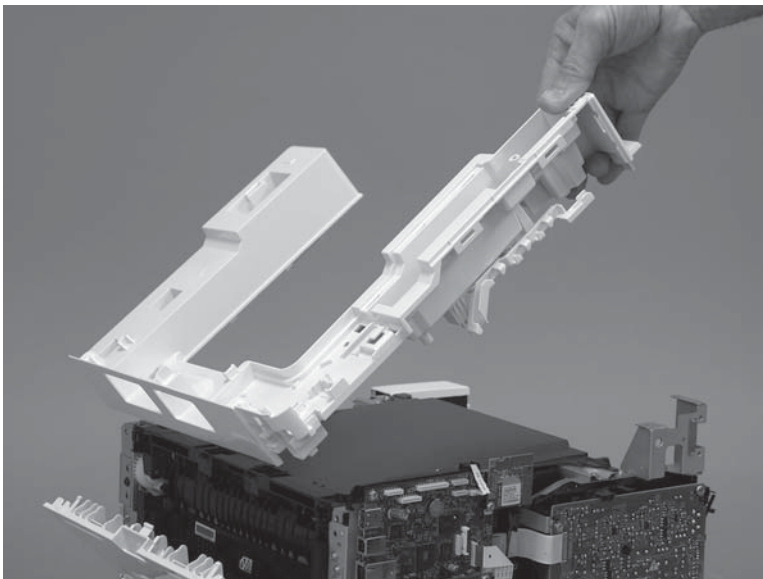


#### Step 19: Install the top cover (M427/M426)

 **NOTE:** The step is for the M427/M426 printer. For the M403/M402, skip this step and go to [Step 22: Install the right cover on page 919](#).

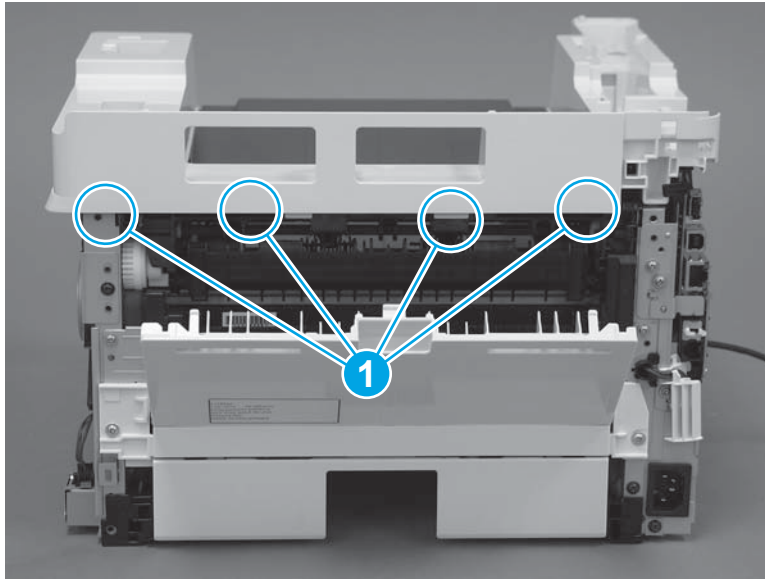
1. Position the rear edge of the top cover on the printer.

**Figure 1-1711** Install the cover



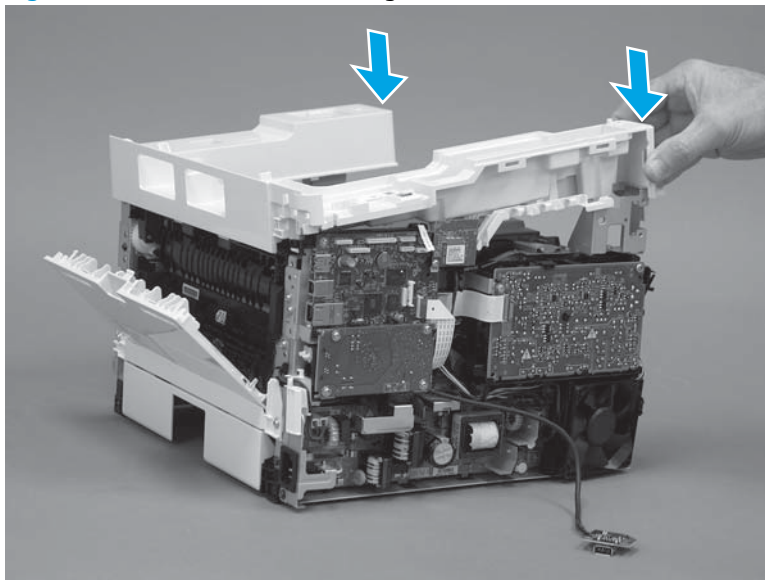
2. Engage four bosses (callout 1).

**Figure 1-1712** Engage four bosses



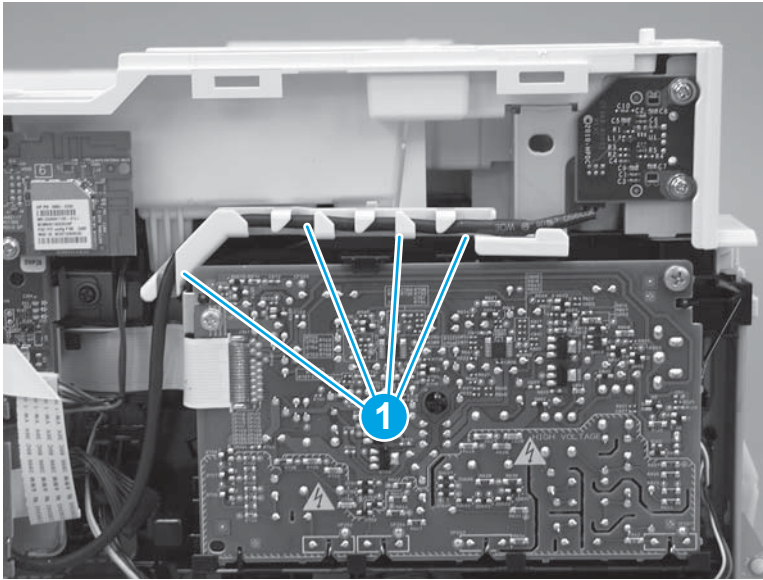
3. Rotate the front edge of the cover down.

**Figure 1-1713** Rotate the front edge of the cover down



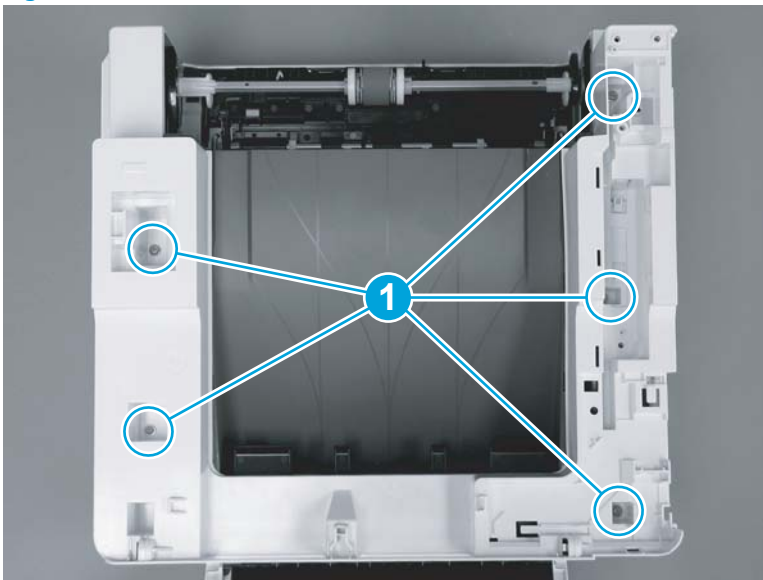
4. Install the USB cable (callout 1) in the guide.

**Figure 1-1714** Install the USB PCA




5. Install five screws (callout 1).

**Figure 1-1715** Install five screws

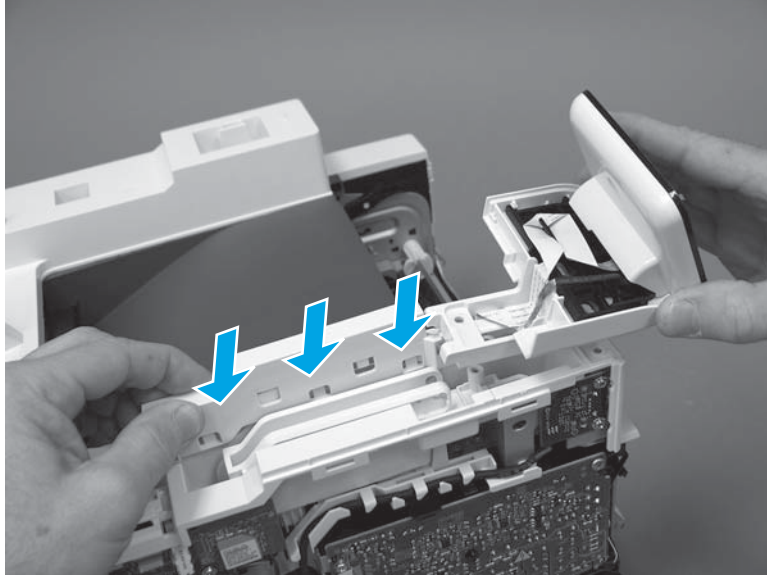


### Step 20: Install the control panel (M427/M246)

 **NOTE:** The step is for the M427/M426 printer. For the M403/M402, skip this step and go to [Step 22: Install the right cover on page 919](#).

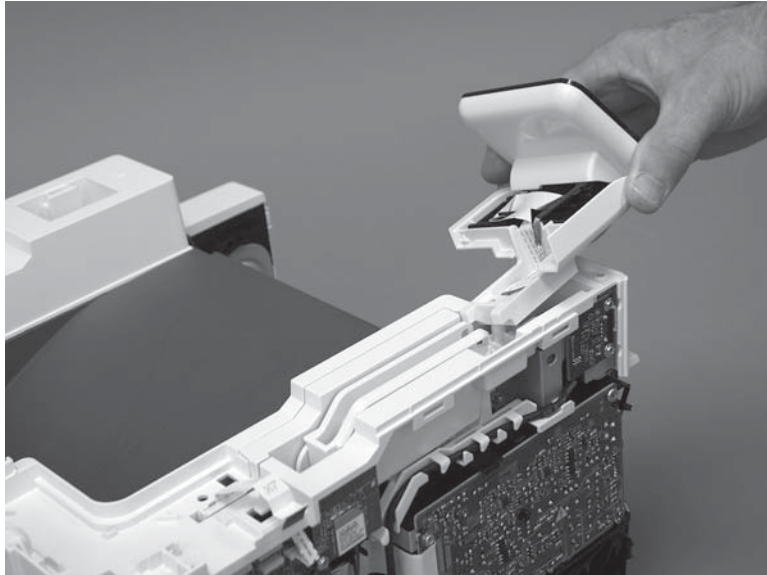
1. Slide the control-panel FFC cover into the slot in the top cover (next to the document feeder support arm) to install it.

**Figure 1-1716** Install the control-panel FFC cover



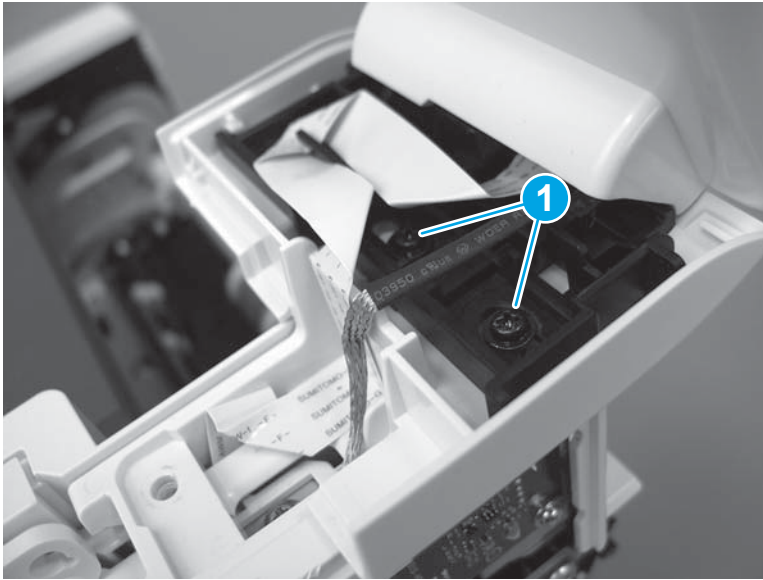
2. Install the control-panel assembly on the top cover.

**Figure 1-1717** Install the control-panel assembly



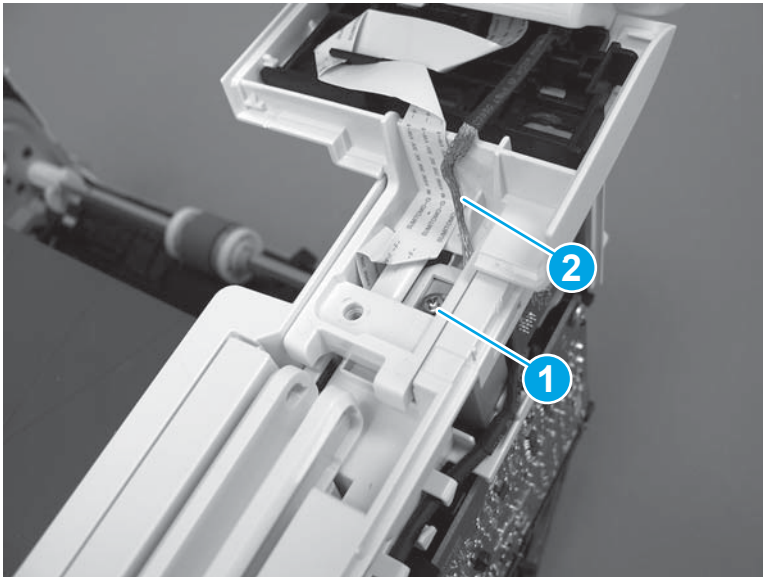
3. Move the FFC out of the way, and then install two screws (callout 1).

**Figure 1-1718** Install two screws



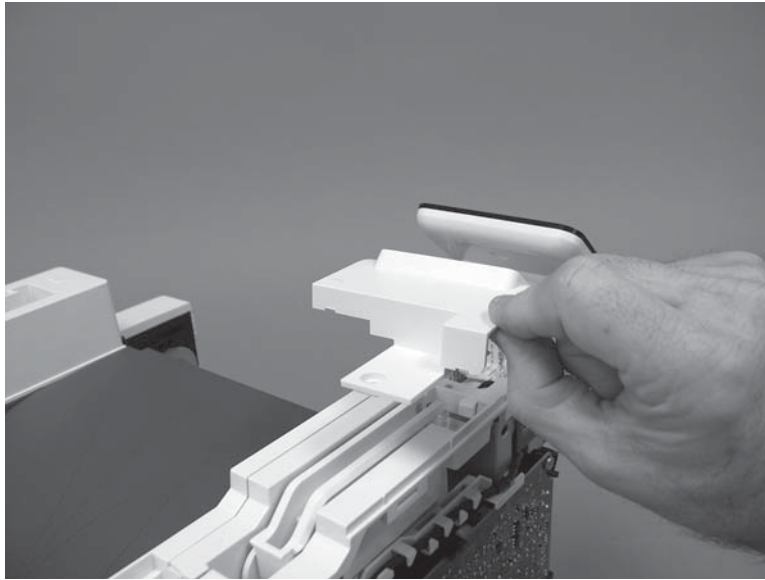
4. Install one grounding screw (callout 1), and then make sure that the ground cable (callout 2) is properly routed.

**Figure 1-1719** Remove one screw



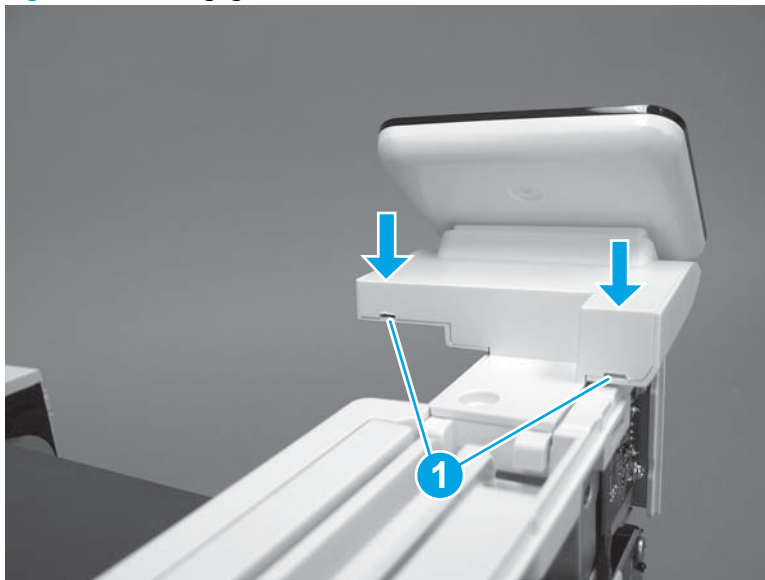
5. Install the control-panel cable cover.

**Figure 1-1720** Install the cover



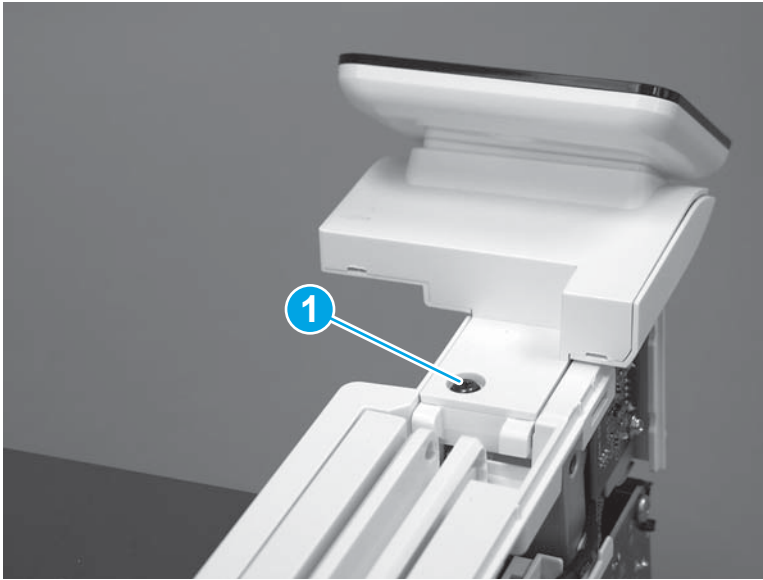
6. Make sure that the two tabs (callout 1) on the cover snap into place.

**Figure 1-1721** Engage two tabs



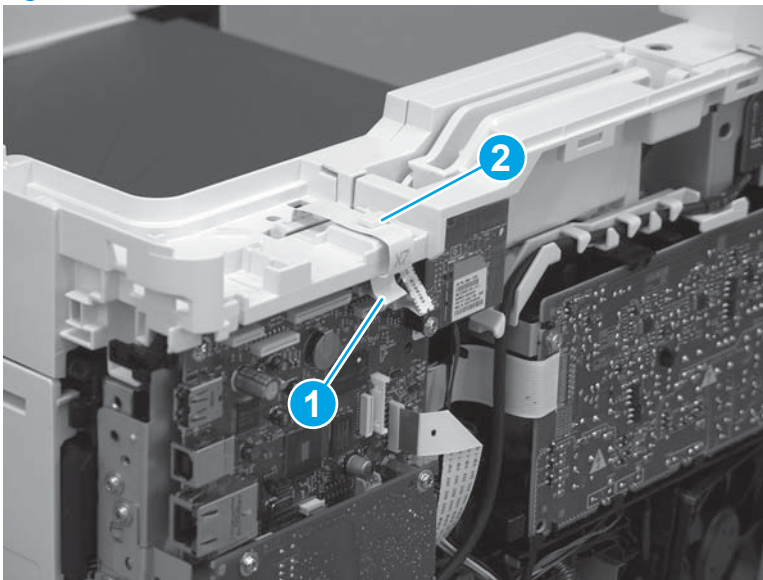
7. Install one screw (callout 1).

**Figure 1-1722** Install one screw




8. Install the FFC in the retainer (callout 1), and then connect one FFC (callout 1; J114).

**Figure 1-1723** Connect one connector




### Step 21: Install the integrated scanner assembly (M427/M246)

---

 **NOTE:** The step is for the M427/M426 printer. For the M403/M402, skip this step and go to [Step 22: Install the right cover on page 919](#).

---

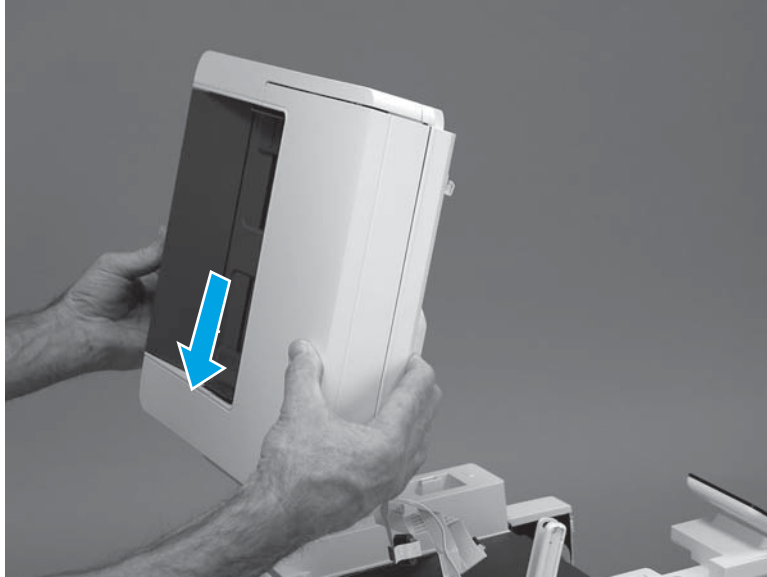
 **NOTE:** M427/M426 models only. The integrated scanner assembly (ISA) includes the sub-scanner assembly (SSA) and the automatic document feeder (ADF).

---

1. Position the ISA on the printer.

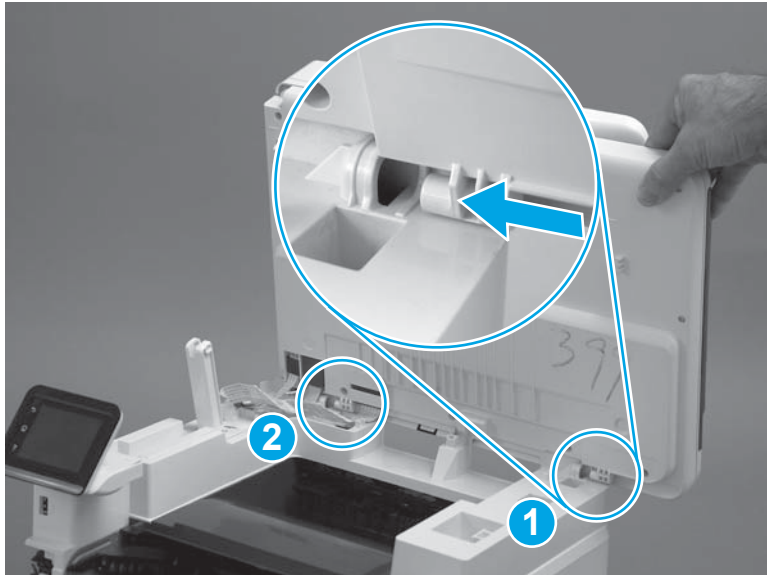


**Figure 1-1724** Position the ISA on the printer



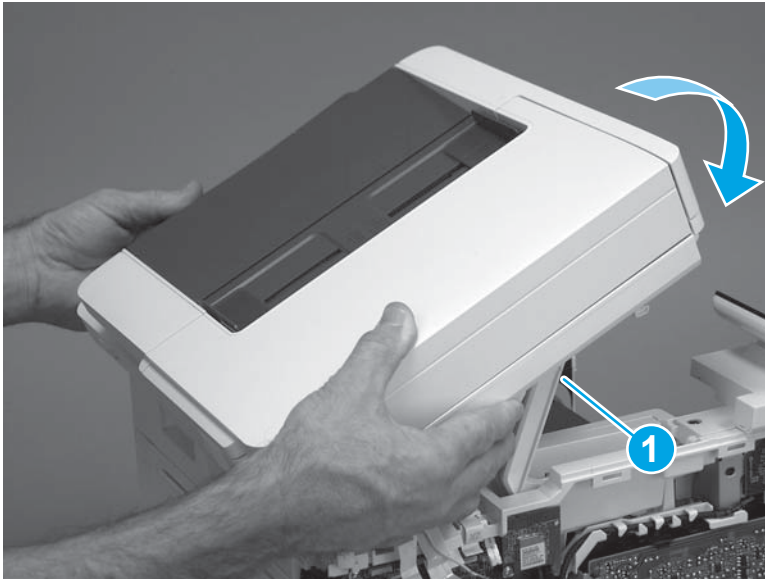
2. Engage the hinge pins on the ISA with the holders in the top cover (callouts 1/2), and then slide the ISA as shown to engage them

**Figure 1-1725** Engage the hinge pins with the holders



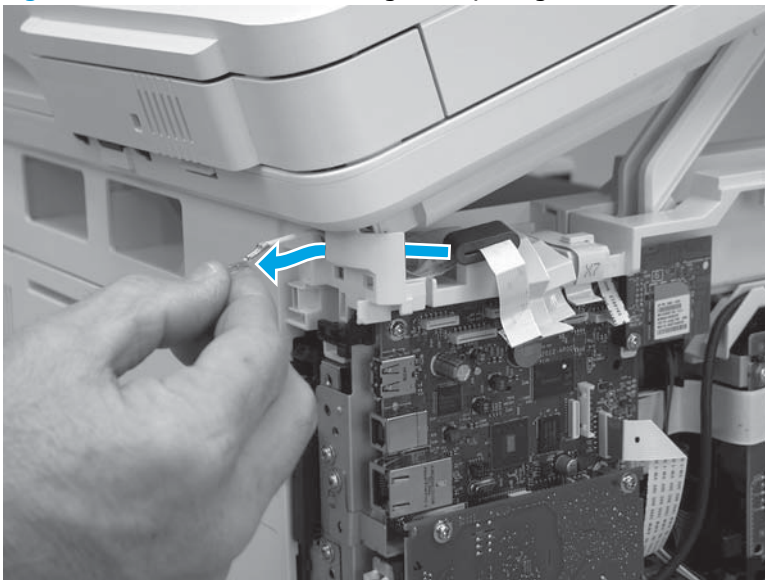
3. Rotate the ISA towards the front of the printer until it rests on the ISA lift assembly (callout 1).

**Figure 1-1726** Rotate the ISA towards the front of the printer



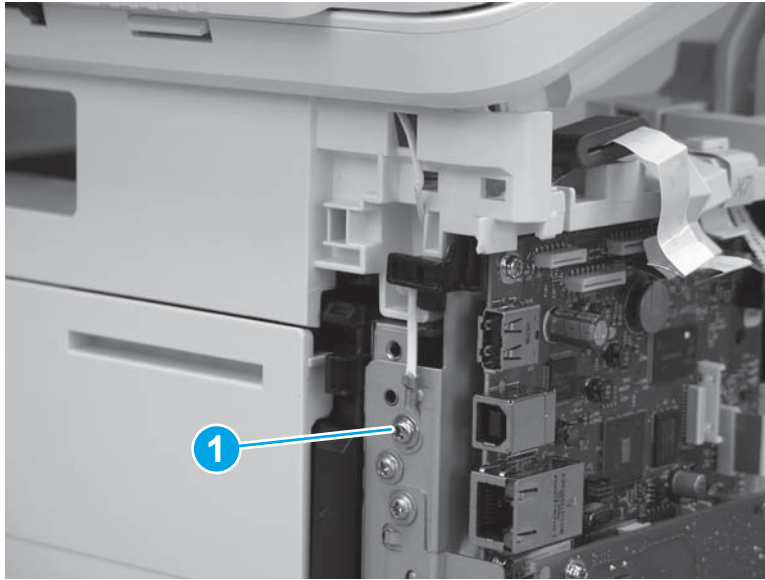
4. Pass the ground wire through the opening in the top cover.

**Figure 1-1727** Pass the wire through the opening




5. Install one screw (callout 1).

**Figure 1-1728** Install one screw



6. Install the ISA lift assembly slider pin.

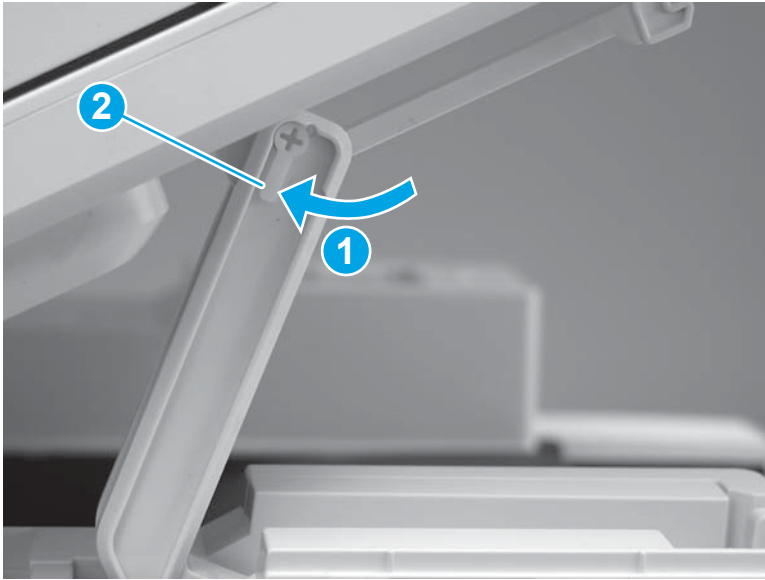
 **Reinstallation tip:** Align the keyed portion of the locking pin with the slot and hole in the support arm.

**Figure 1-1729** Install the slider pin



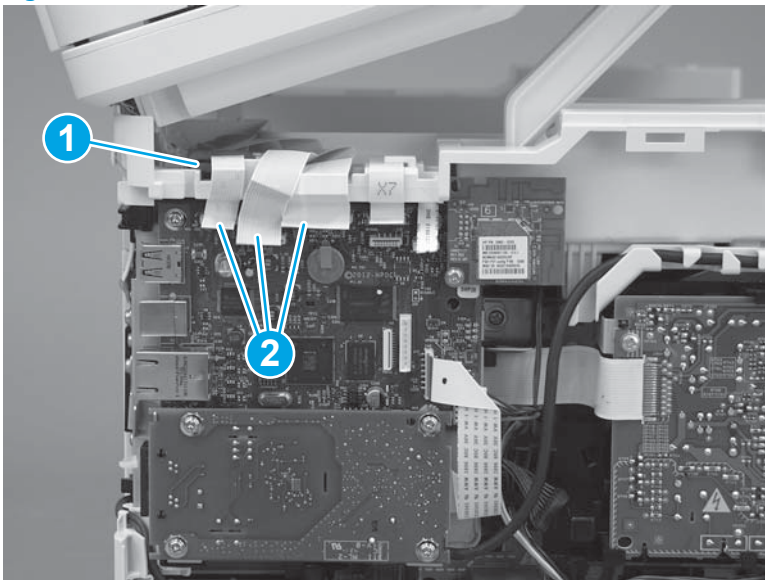
7. Rotate the slider pin (callout 1) towards the rear of the printer until the tab (callout 2) snap into place.

**Figure 1-1730** Secure the slider pin



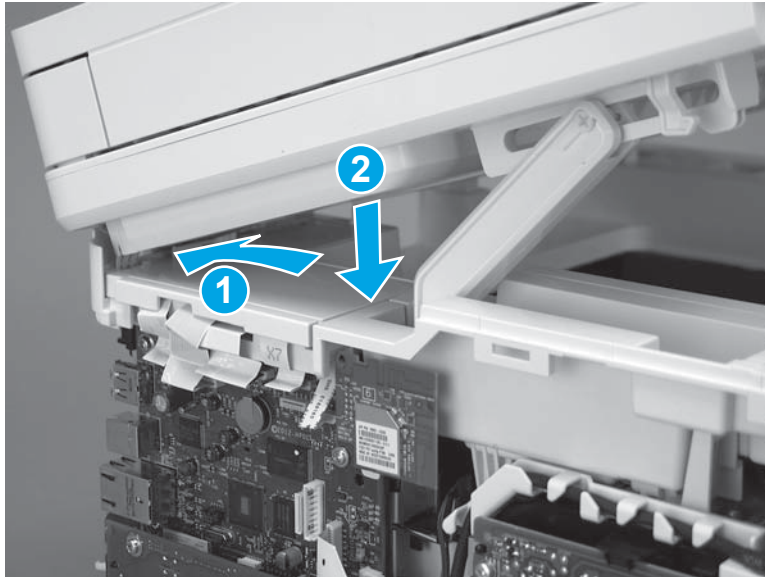
8. Install the ferrite (callout 1) in the holder, and then connect three FFCs (callout 2).

**Figure 1-1731** Connect three FFCs



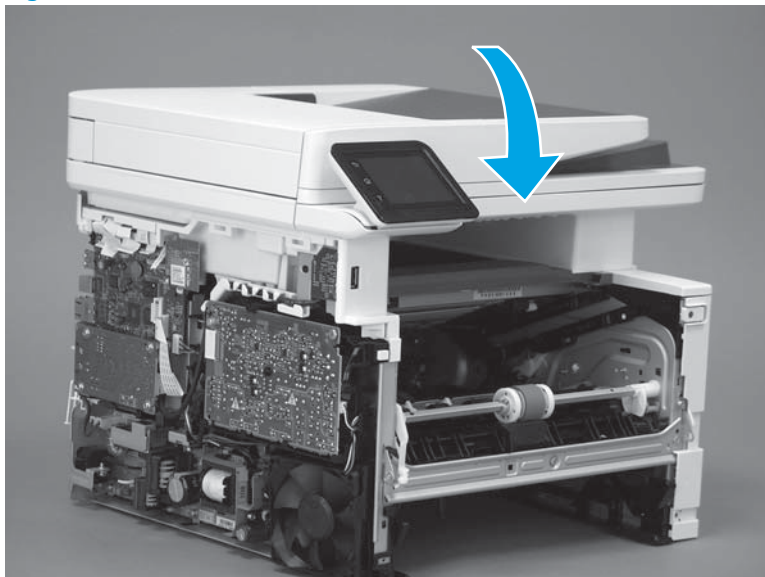
9. Position the rear edge of the ISA flat-flexible cable (FFC) cover on the printer (callout 1) , and then rotate it down (callout 2) until it snaps into place.

**Figure 1-1732** Install the ISA FFC cover



10. Lower the ISA.

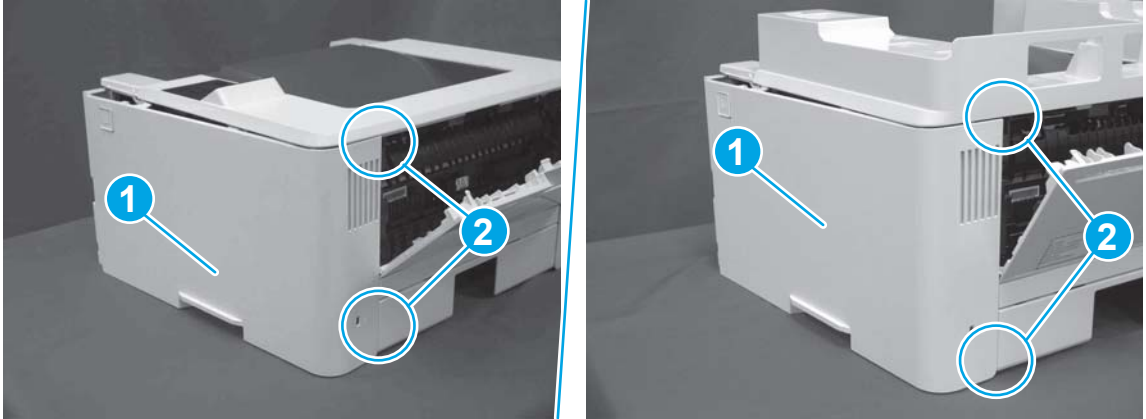
**Figure 1-1733** Lower the ISA



## Step 22: Install the right cover

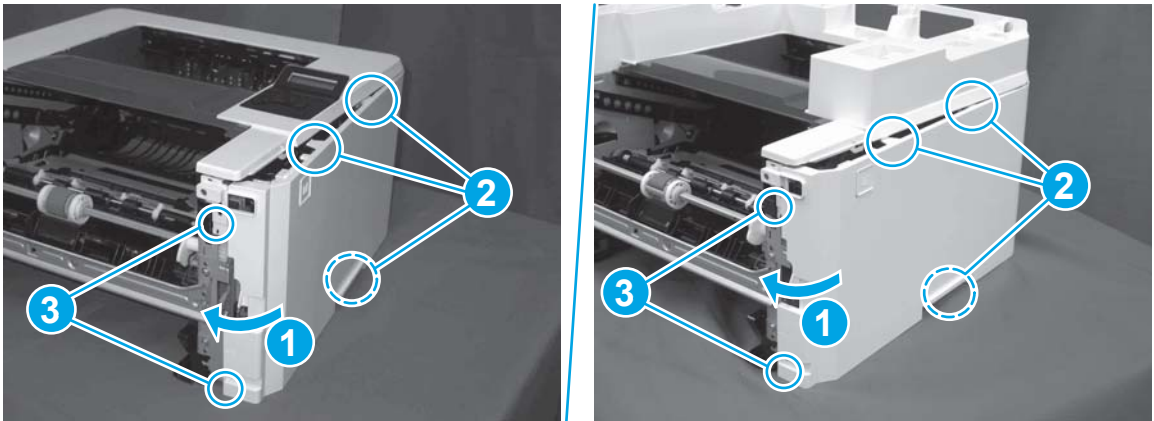
1. Position the cover (callout 1) on the printer, and then engage two bosses (callout 2).

**Figure 1-1734** Install the cover




2. Rotate the front of the cover onto the printer (callout 1), engage three (callout 2) tabs, and then engage two bosses (callout 3).

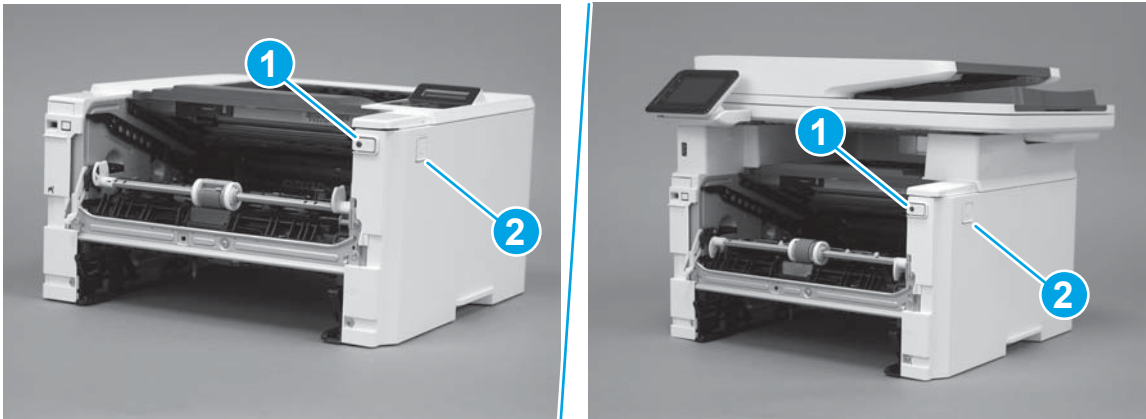
**Figure 1-1735** Engage two bosses and one tab



3. Make sure that the power switch (callout 1) and cartridge door assembly button (callout 2) correctly function.

 **NOTE:** Remove, and then reinstall the cover if the switch or button does not correctly function.

**Figure 1-1736** Check the power switch and cartridge door assembly button



4. Install one screw (callout 1).

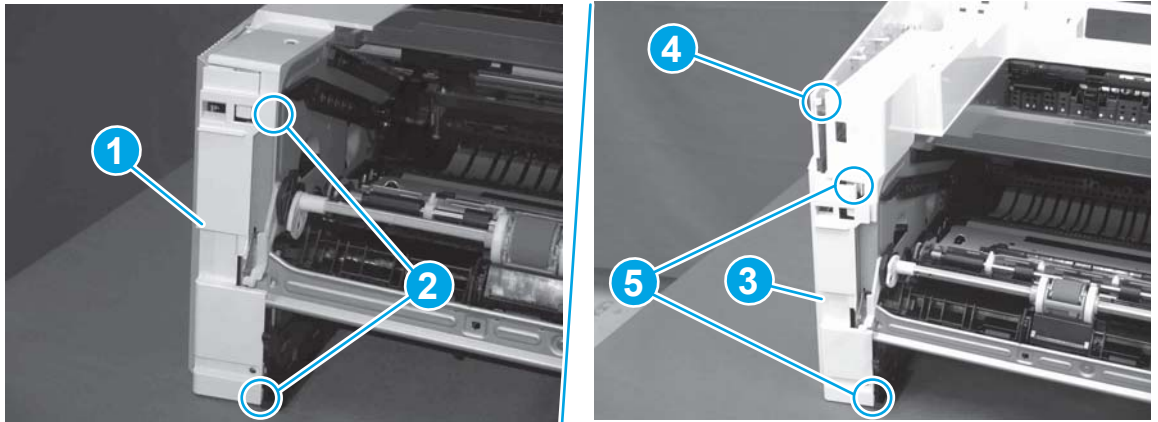
**Figure 1-1737** Install one screw



### Step 23: Install the left cover

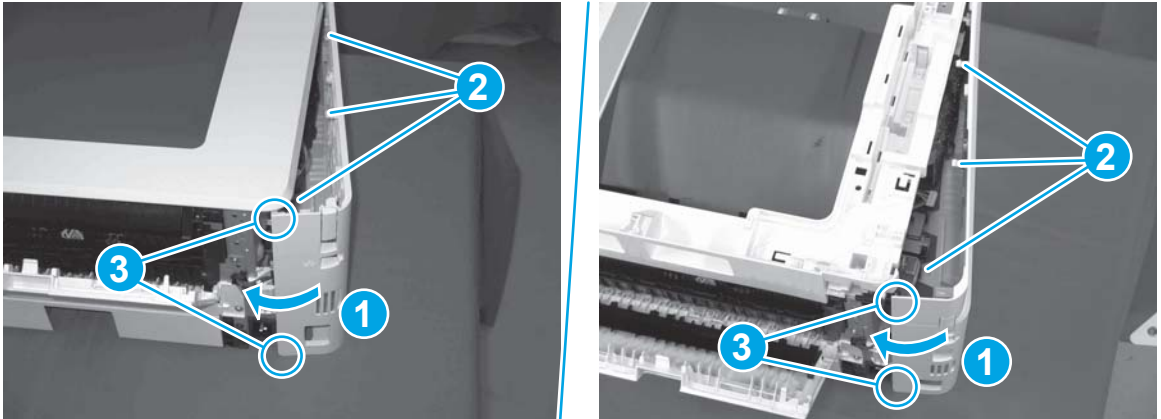
1. At the front of the printer, do one of the following:
  - **M403/M402:** Position the cover on the printer ( callout 1), and then engage two bosses (callout 2).
  - **M427/M426:** Position the cover on the printer (callout 3), engage one tab (callout 4), and then engage two bosses (callout 4).

**Figure 1-1738** Install the cover



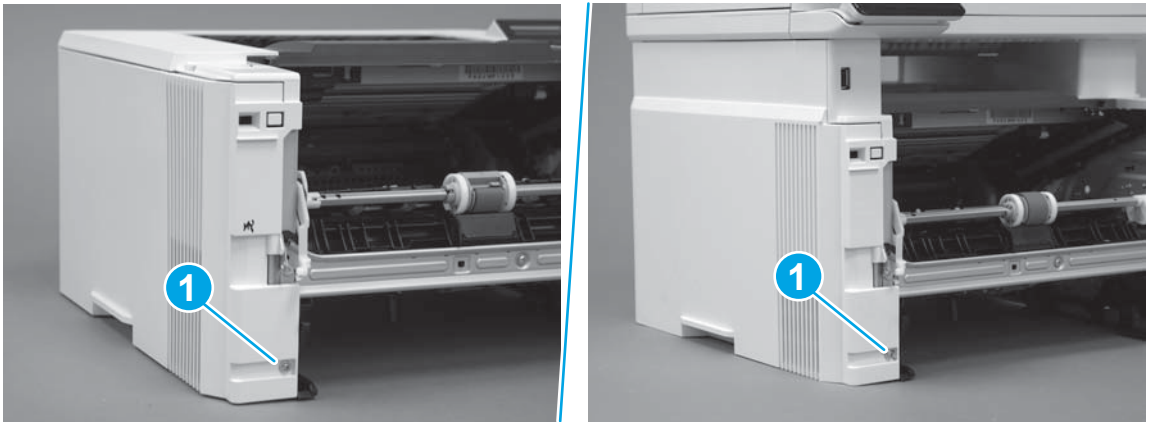
- Carefully rotate the rear of the cover onto the printer (callout 1), engage three tabs (callout 2), and then engage two bosses (callout 3).

**Figure 1-1739** Engage three tabs and two bosses




- Install one screw (callout 1).

**Figure 1-1740** Install one screw



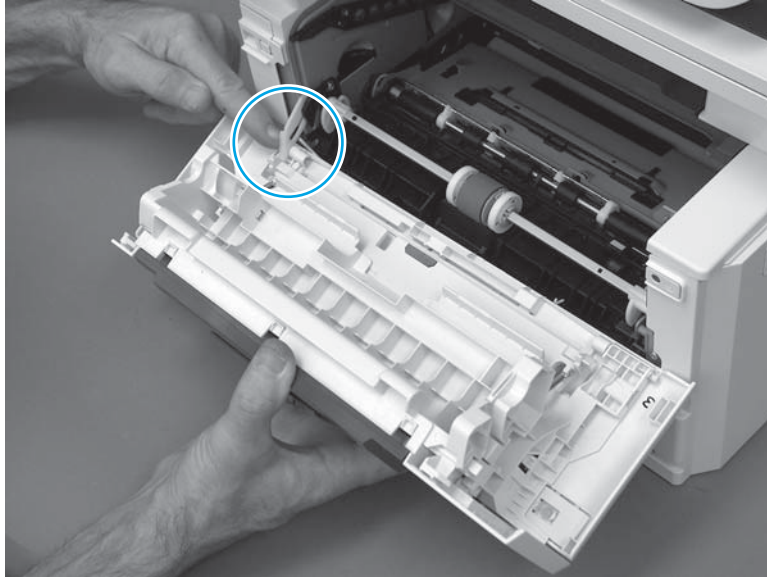
### Step 24: Install the cartridge door assembly

 **Reinstallation tip:** After a replacement door is installed, make sure to install the nameplate (supplied in the kit) corresponding to the printer name on the door.

- Position the door close to the printer, and then engage the keyed pin on the left-side retainer arm with the hole in the door.

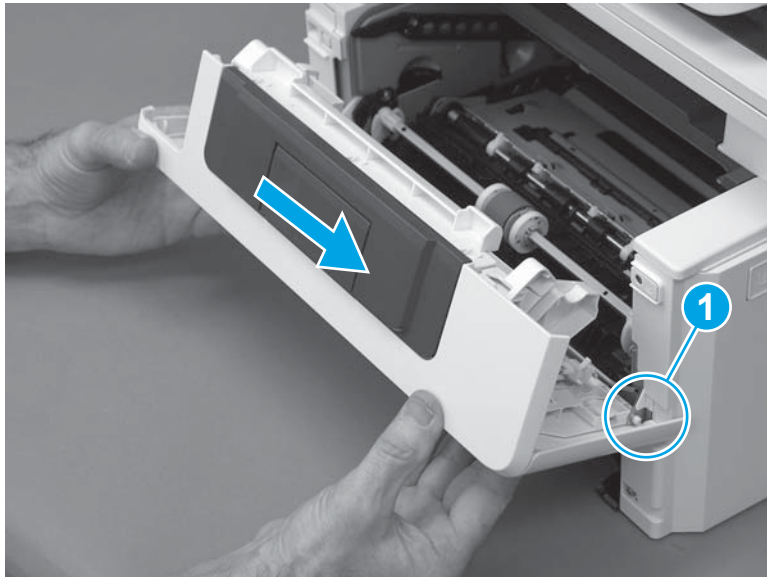


**Figure 1-1741** Engage the left-side retainer arm



2. Engage the right-side door hinge pin with the hole in the chassis (callout 1).

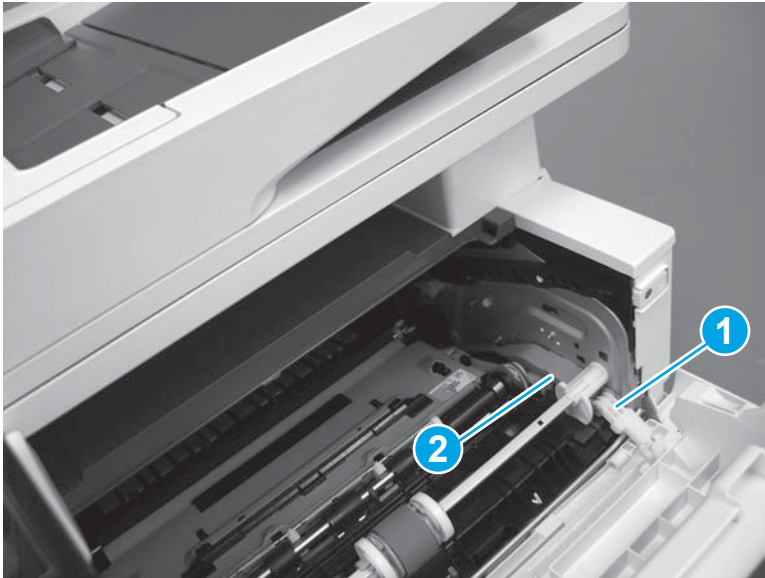
**Figure 1-1742** Install the door



3. Install the link (callout 1).

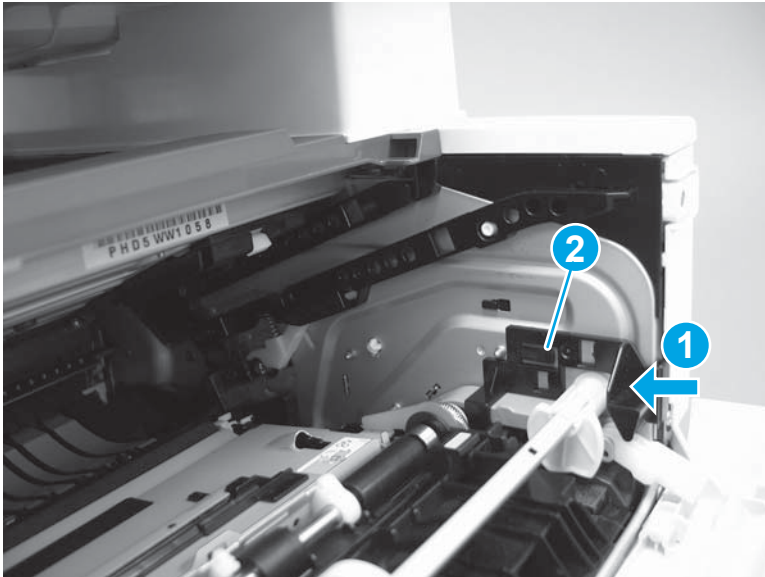
 **IMPORTANT:** Make sure that the link snaps into place on the arm (callout 2). The link actuates the fuser pressure-release mechanism.

**Figure 1-1743** Install the pressure-release link



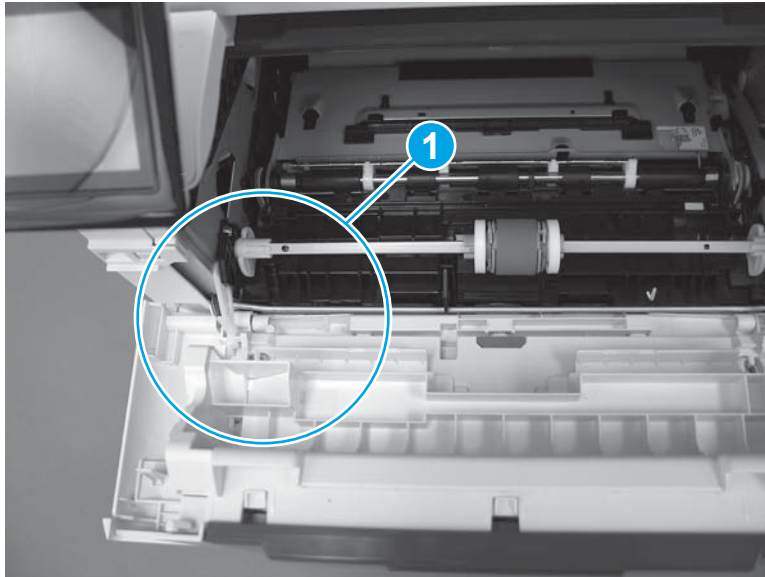
4. Slide the guide into the printer (callout 1), and then make sure that the tab (callout 2) snaps into place to secure the guide to the chassis.

**Figure 1-1744** Install the guide




5. Position the shaft on the door, and then align the left-side hinge on the door with the hole in the chassis (callout 1).

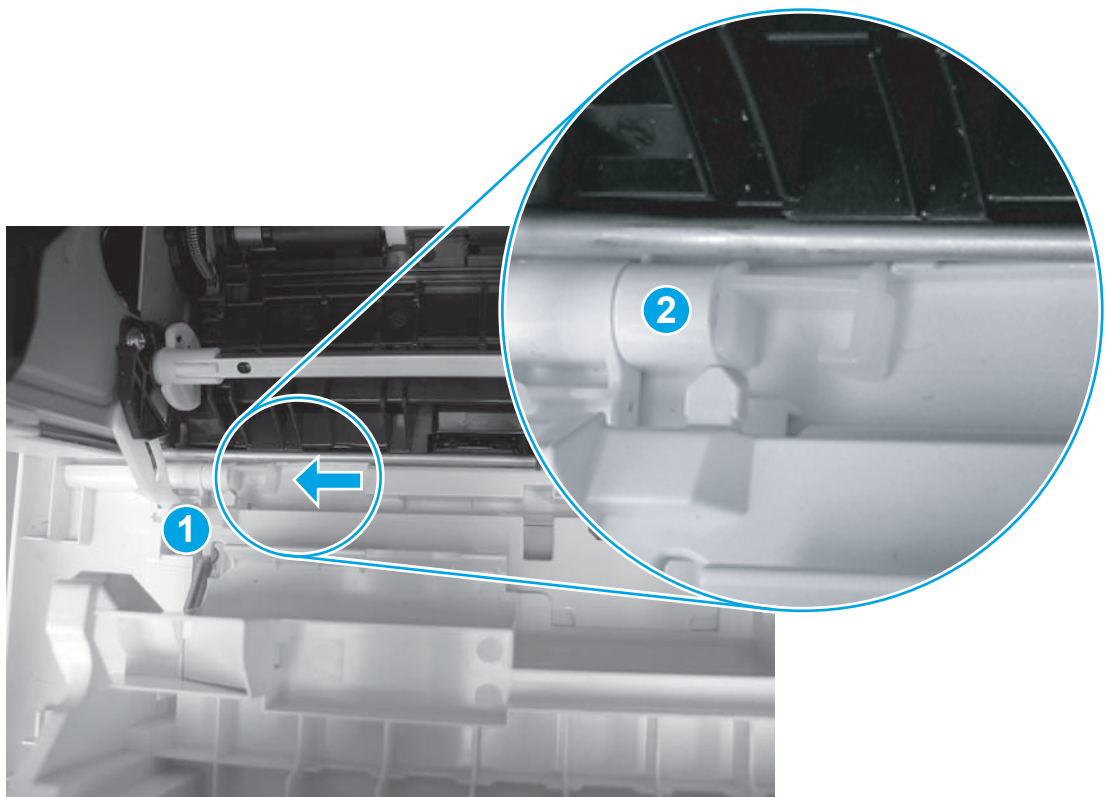
**Figure 1-1745** Align the hinge



6. Push the shaft towards the left side of the printer to install it (callout 1).

 **Reinstallation tip:** Make sure that the support shaft is fully installed and correctly orientated (callout 2) so that it will not interfere with the door opening and closing.

**Figure 1-1746** Install the support shaft



## Step 25: Install Tray 2

- ▲ Slide the tray straight into the printer to install it.

**Figure 1-1747** Install the tray



## Removal and replacement: High-voltage power supply

- [Introduction](#)
- [Step 1: Remove Tray 2](#)
- [Step 2: Remove the cartridge door assembly](#)
- [Step 3: Remove the left cover](#)
- [Step 4: Remove the right cover](#)
- [Step 5: Remove the integrated scanner assembly \(M427/M246\)](#)
- [Step 6: Remove the control panel \(M427/M246\)](#)
- [Step 7: Remove the top cover \(M427/M426\)](#)
- [Step 8: Remove the top cover \(M403/M402\)](#)
- [Step 9: Remove the paper delivery tray \(output bin\)](#)
- [Step 10: Remove the sheet-metal formatter bracket and formatter PCA](#)
- [Step 11: Remove the HVPS](#)
- [Step 12: Unpack the replacement assembly](#)
- [Step 13: Install the HVPS](#)
- [Step 14: Install the sheet-metal formatter bracket and formatter PCA](#)
- [Step 15: Install the paper delivery tray \(output bin\)](#)
- [Step 16: Install the top cover \(M403/M402\)](#)
- [Step 17: Install the top cover \(M427/M426\)](#)
- [Step 18: Install the control panel \(M427/M246\)](#)
- [Step 19: Install the integrated scanner assembly \(M427/M246\)](#)
- [Step 20: Install the right cover](#)
- [Step 21: Install the left cover](#)
- [Step 22: Install the cartridge door assembly](#)
- [Step 23: Install Tray 2](#)

### Introduction

This document provides the procedures to remove and replace the high-voltage power supply (HVPS).

### Before performing service

#### Turn the printer power off

- Disconnect the power cable.

**⚠ WARNING!** To avoid damage to the printer, turn the printer off, wait 30 seconds, and then remove the power cable before attempting to service the printer.

Use the table below to identify the correct part number for your printer. To order the part, go to [www.hp.com/buy/parts](http://www.hp.com/buy/parts).

High-voltage power supply (HVPS) part number	
RM2-7508-000CN	High-voltage power supply (HVPS)

### Required tools

- #2 Phillips screwdriver with a magnetic tip.

### After performing service

#### Turn the printer power on

- Connect the power cable.
- Use the power switch to turn the power on.

### Post service test

Make sure that the printer initializes to a **Ready** state.

Print a configuration page to make sure that the printer is functioning correctly.

### Step 1: Remove Tray 2

- ▲ Pull the tray straight out of the printer to remove it.

**Figure 1-1748** Remove the tray



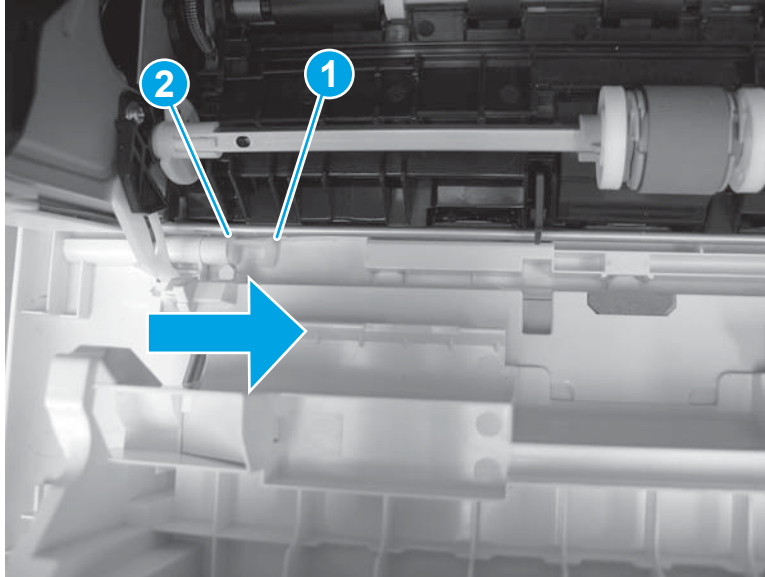
## Step 2: Remove the cartridge door assembly

 **NOTE:** If the toner cartridge was not removed prior to servicing the printer, remove it now.

1. Release one tab (callout 1), and then slide shaft (callout 2) in the direction the arrow indicates and remove it.

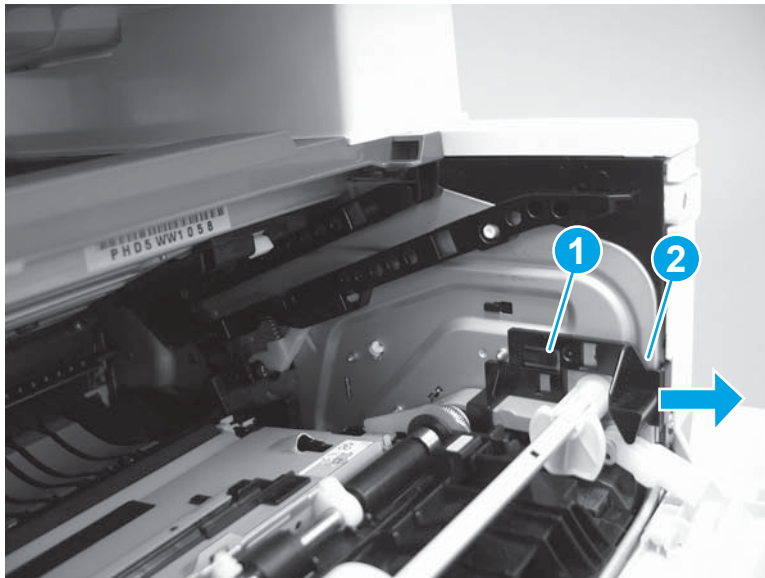
 **TIP:** It might be easier to release the support shaft by using a small flat-blade screwdriver.

**Figure 1-1749** Release the support shaft



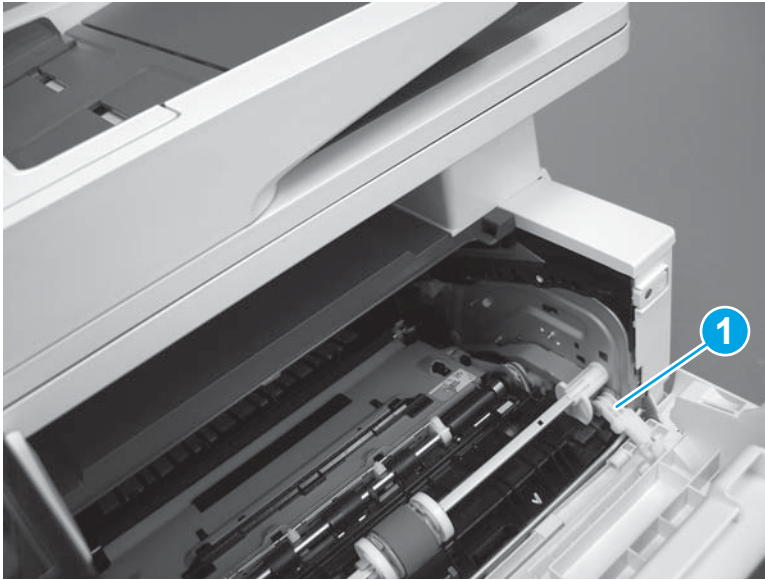
2. Release one tab (callout 1), and then slide the guide (callout 2) in the direction the arrow indicates and remove it.

**Figure 1-1750** Remove the guide



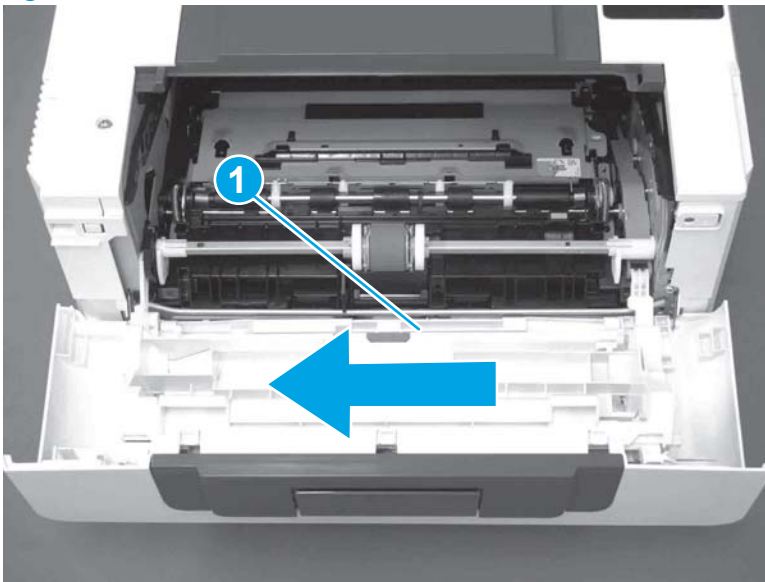
3. Remove the link arm (callout 1).

**Figure 1-1751** Remove the link arm



4. Slide the cartridge door assembly (callout 1) in the direction the arrow indicates and remove it.

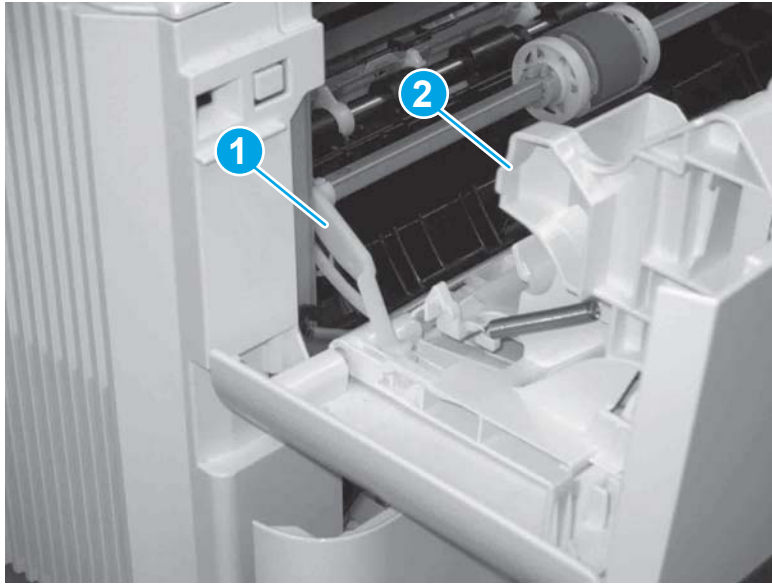
**Figure 1-1752** Remove the door





5. Remove the link (callout 1) from the cartridge door assembly (callout 2).

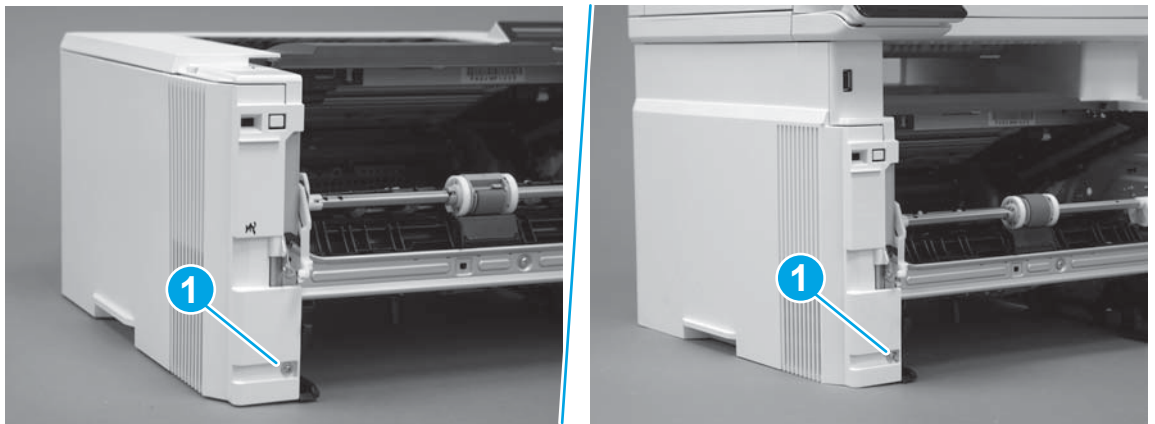
**Figure 1-1753** Release the left-side retainer arm



### Step 3: Remove the left cover

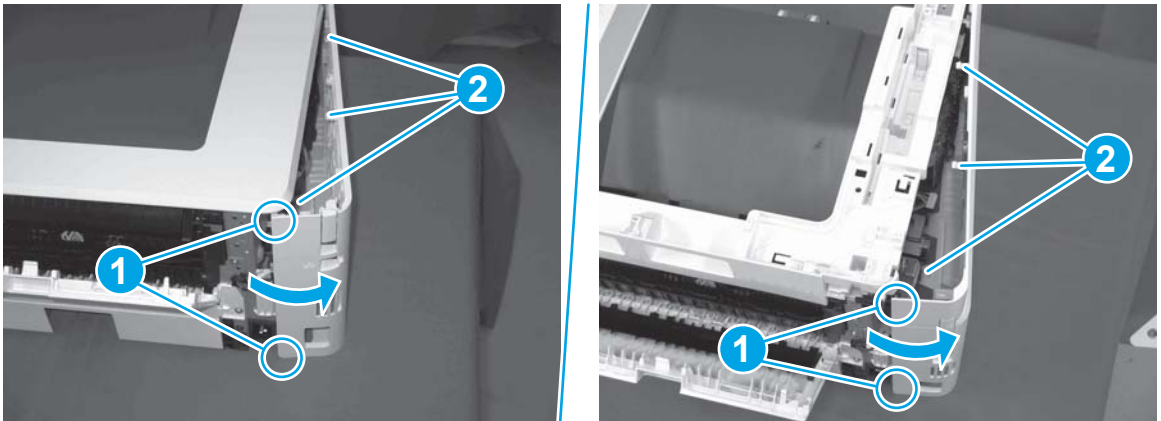
1. Remove one screw (callout 1).

**Figure 1-1754** Remove one screw



2. Open the rear door, release two bosses (callout 1), and then release three tabs (callout 2).

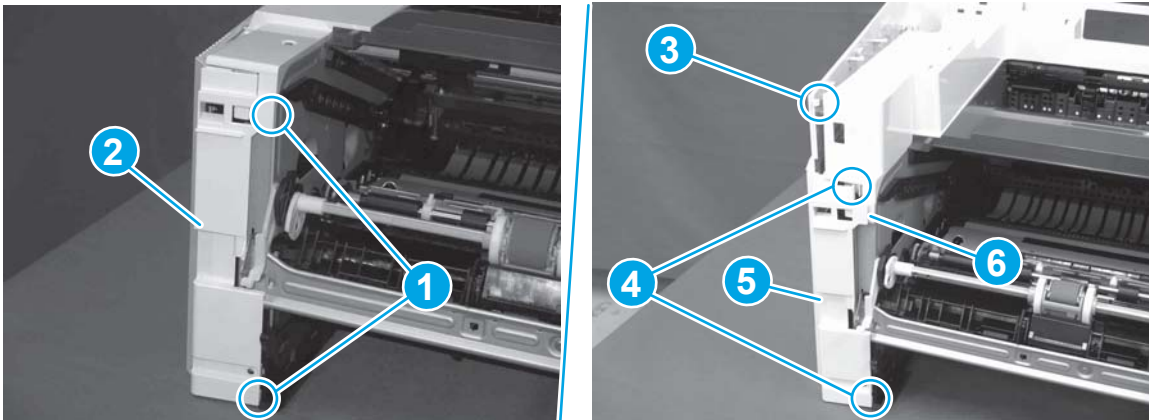
**Figure 1-1755** Release two bosses and three tabs



3. At the front of the printer, do one of the following:
  - **M403/M402:** Release two bosses (callout 1), and then remove the cover (callout 2).
  - **M427/M426:** Release one tab (callout 3), two bosses (callout 4), and then remove the cover (callout 5).

**CAUTION:** Be careful when releasing the upper bosses on the M427/M426 cover. One portion of the cover (callout 6) is fragile and is easily broken.

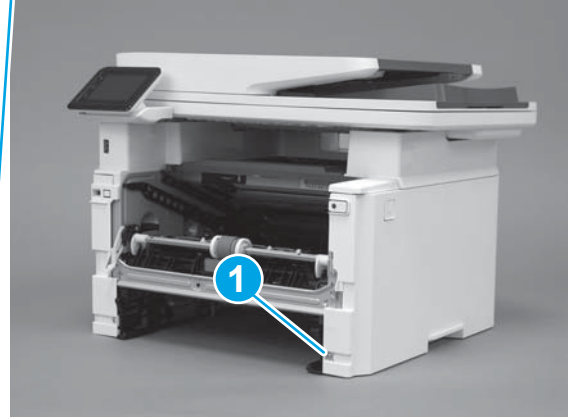
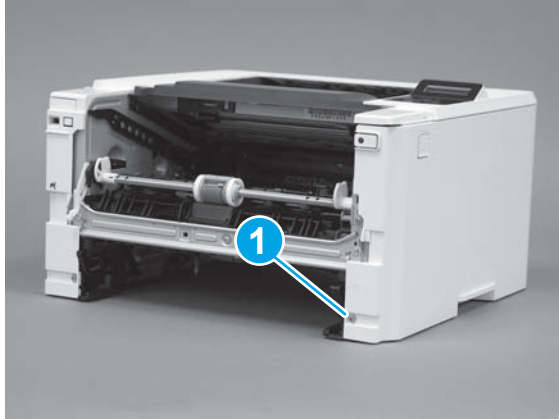
**Figure 1-1756** Remove the cover



#### Step 4: Remove the right cover

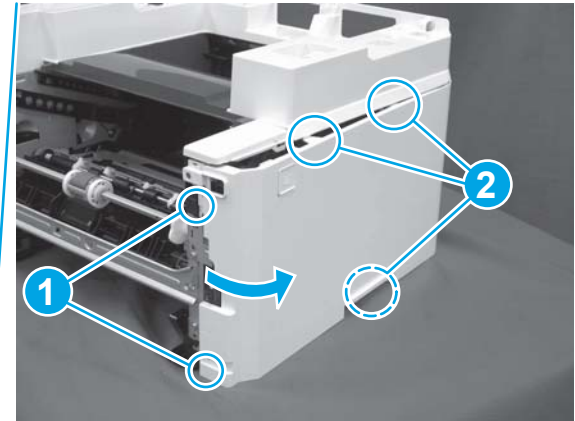
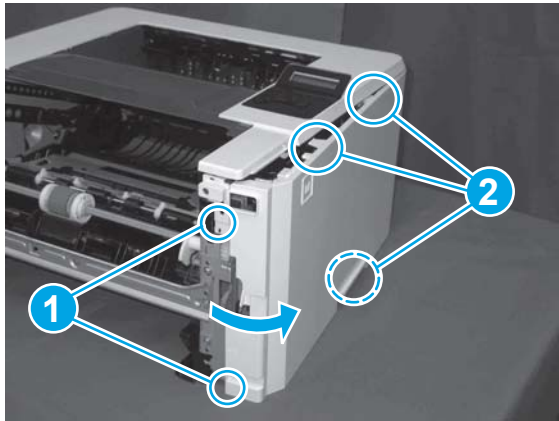
1. Remove one screw (callout 1).

**Figure 1-1757** Remove one screw



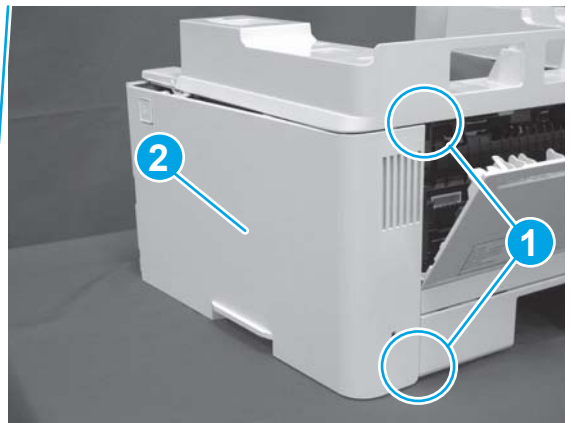
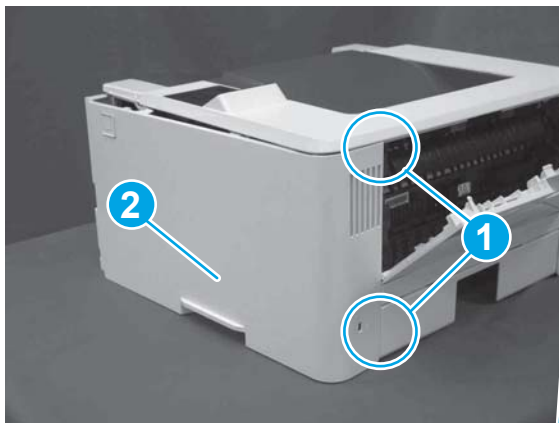
2. At the front of the printer, release two bosses (callout 1), and then release three tabs (callout 2).

**Figure 1-1758** Release two bosses and three tabs





3. Open the rear door, release two bosses (callout 1), and then remove the cover (callout 2).

**Figure 1-1759** Remove the cover



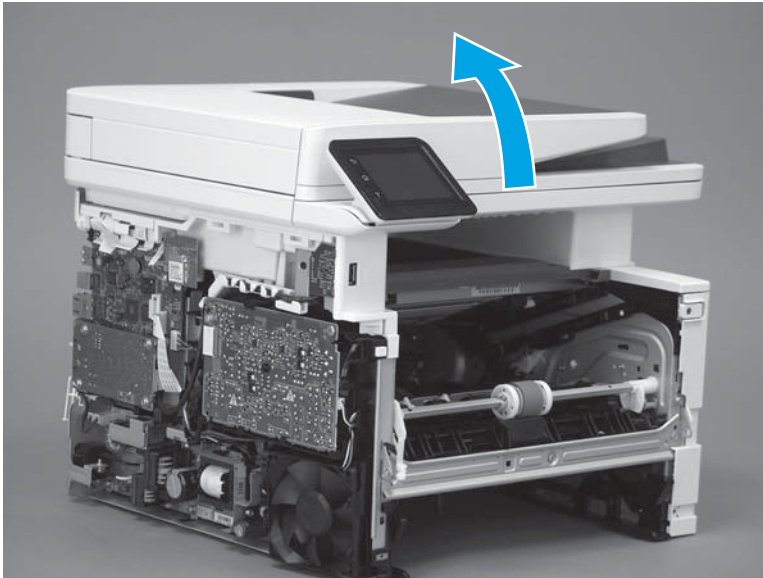
### Step 5: Remove the integrated scanner assembly (M427/M246)

 **NOTE:** The step is for the M427/M426 printer. For the M403/M402, skip this step and go to [Step 8: Remove the top cover \(M403/M402\)](#) on page 943.

 **NOTE:** M427/M426 models only. The integrated scanner assembly (ISA) includes the sub-scanner assembly (SSA) and the automatic document feeder (ADF).

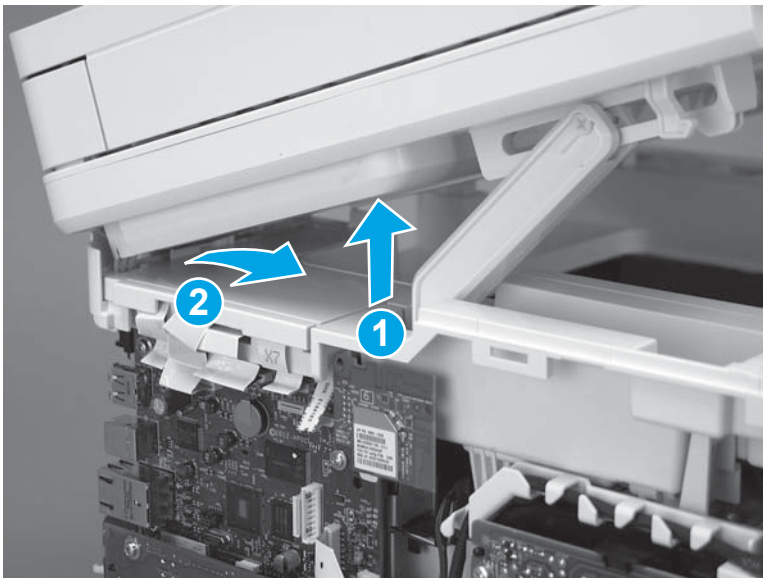
1. Raise the ISA.

**Figure 1-1760** Raise the ISA



2. Release the ISA flat-flexible cable (FFC) cover (callout 1), and then remove it (callout 2).

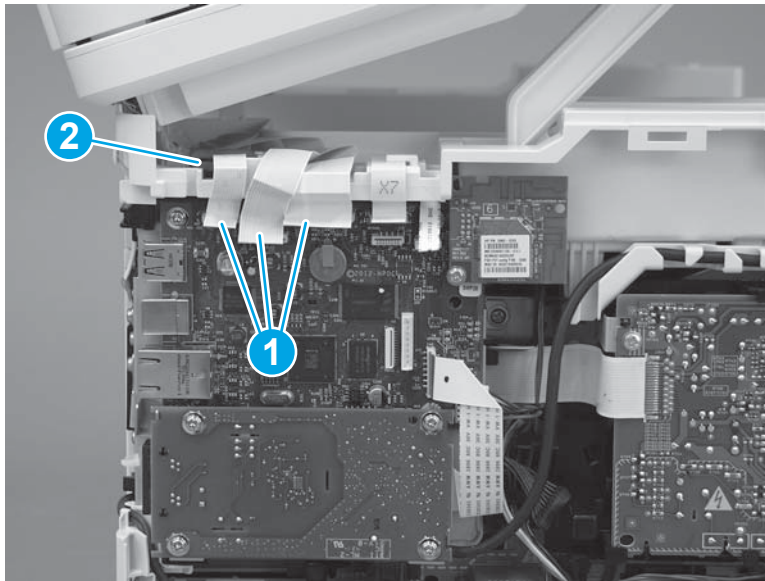
**Figure 1-1761** Remove the ISA FFC cover



3. Disconnect three FFCs (callout 1), and then remove the ferrite (callout 2) from the holder.

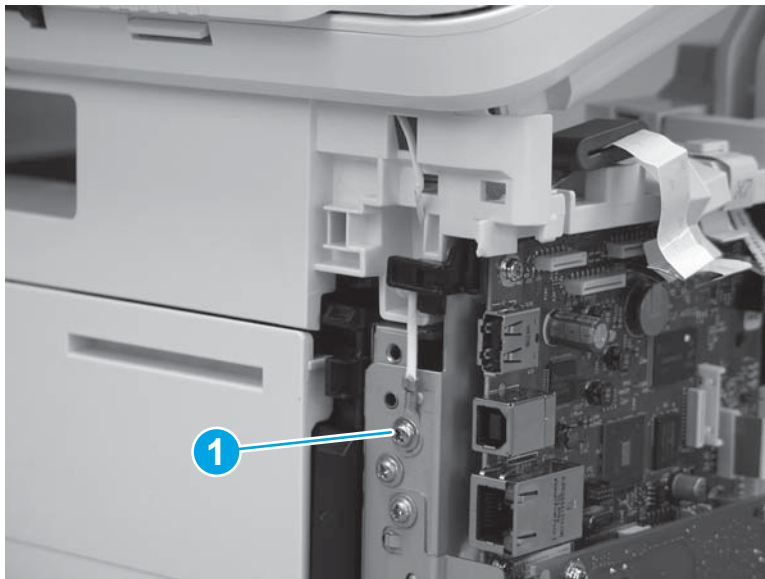
**CAUTION:** The ferrite is not captive on the FFC. Do not lose the ferrite while handling the ISA.

**Figure 1-1762** Disconnect three FFCs



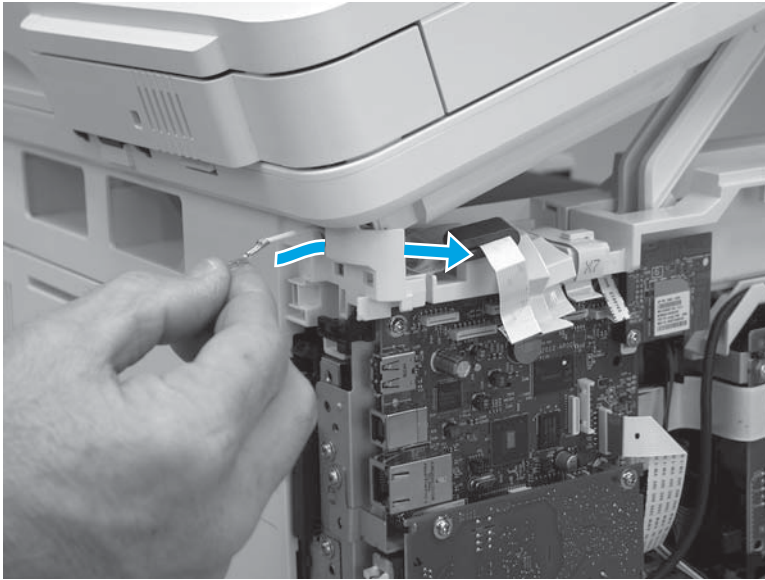
4. Remove one screw (callout 1).

**Figure 1-1763** Remove one screw



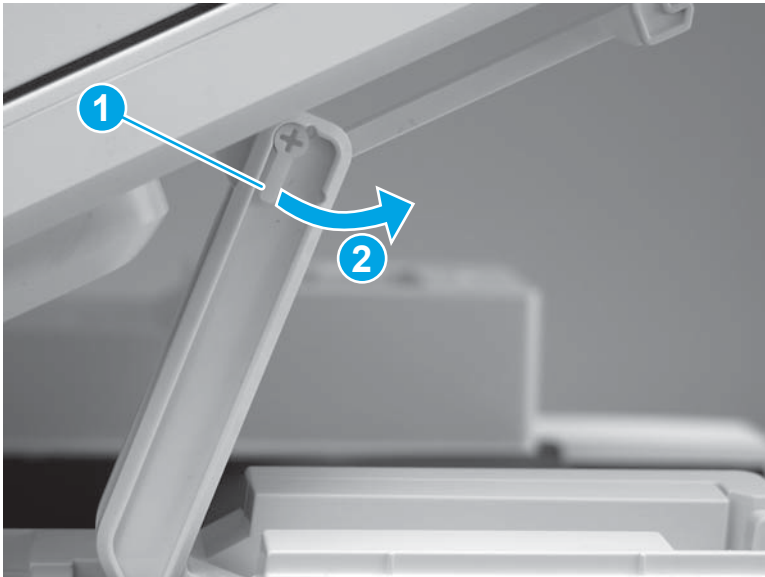
5. Pass the ground wire through the opening in the top cover.

**Figure 1-1764** Pass the wire through the opening



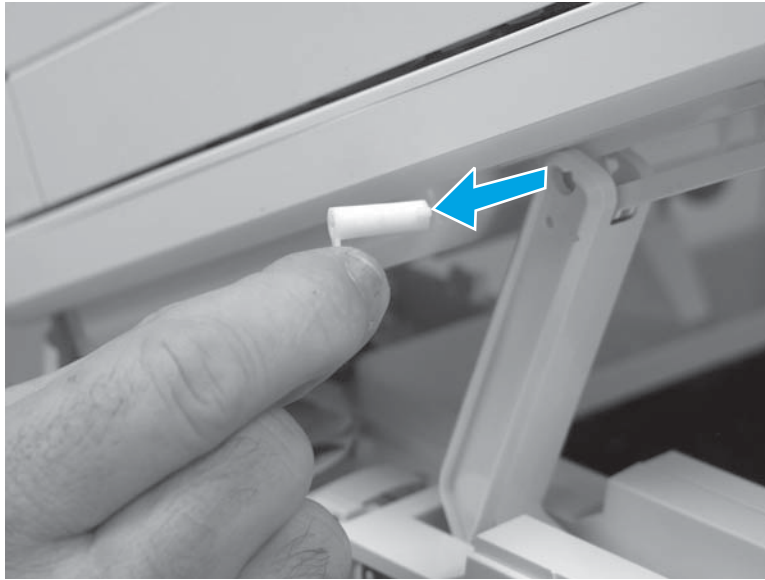
6. Release one tab (callout 1), and then rotate the ISA slider pin (callout 2) towards the front of the printer to release it.

**Figure 1-1765** Release one tab and rotate the slider pin



7. Remove the slider pin.

**Figure 1-1766** Remove the slider pin



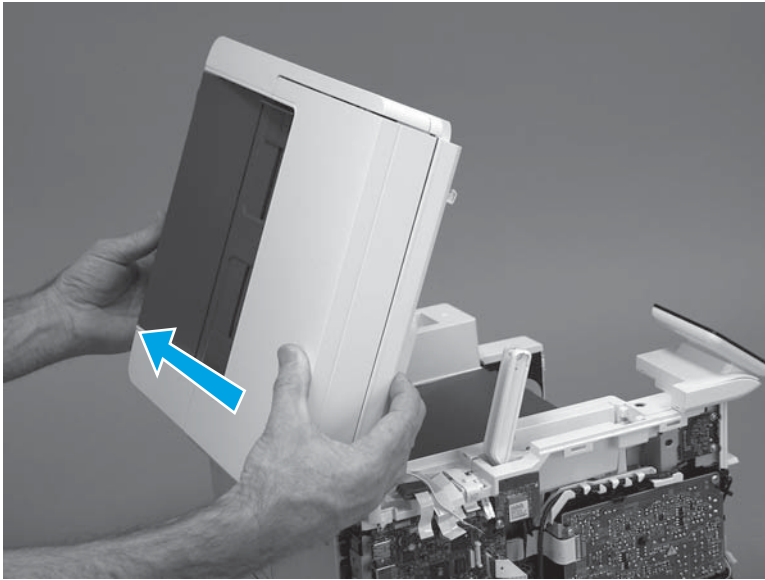
8. Rotate the ISA towards the rear of the printer until it stops.

**Figure 1-1767** Rotate the ISA towards the rear of the printer



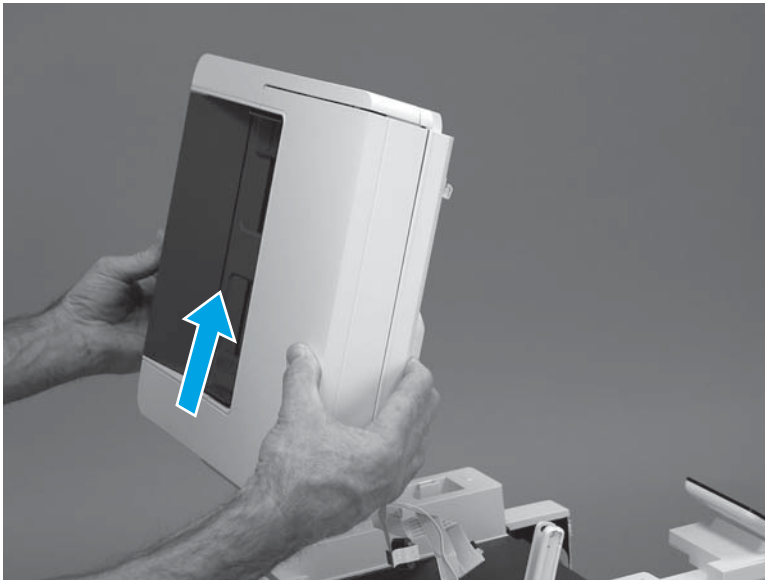
9. Slide the ISA as shown to release it.

**Figure 1-1768** Release the ISA



10. Remove the ISA.

**Figure 1-1769** Remove the ISA



### Step 6: Remove the control panel (M427/M246)

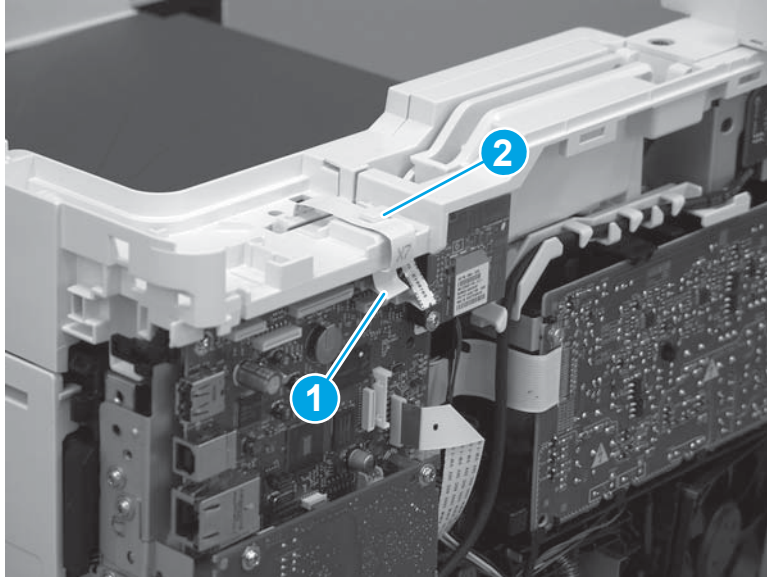


**NOTE:** The step is for the M427/M426 printer. For the M403/M402, skip this step and go to [Step 8: Remove the top cover \(M403/M402\) on page 943](#).

1. Disconnect one FFC (callout 1; J114), and then release the FFC from the retainer (callout 2).

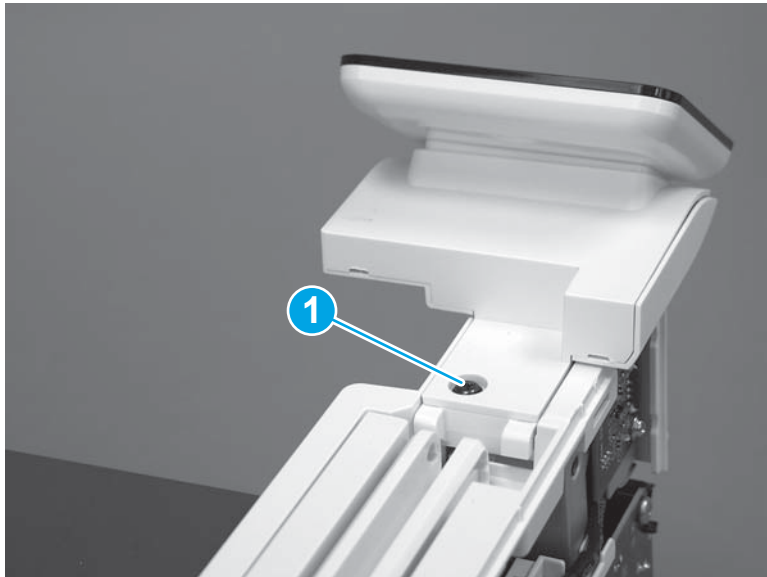


**Figure 1-1770** Disconnect one connector



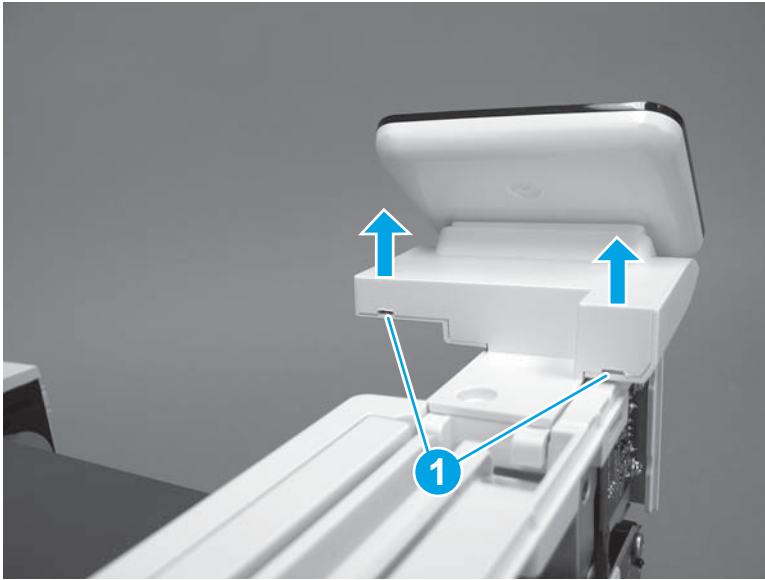
2. Remove one screw (callout 1).

**Figure 1-1771** Remove one screw



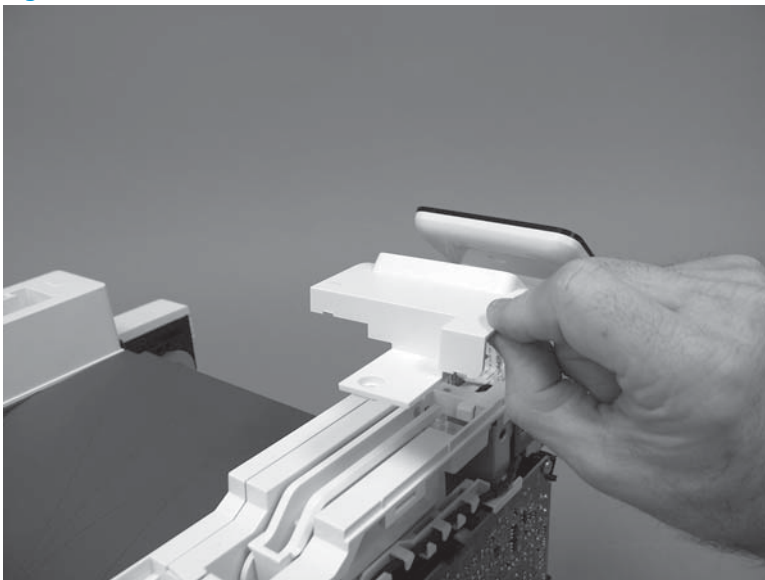
3. Use a small flat-blade screwdriver to release two tabs (callout 1) on the control-panel cable cover.

**Figure 1-1772** Release two tabs



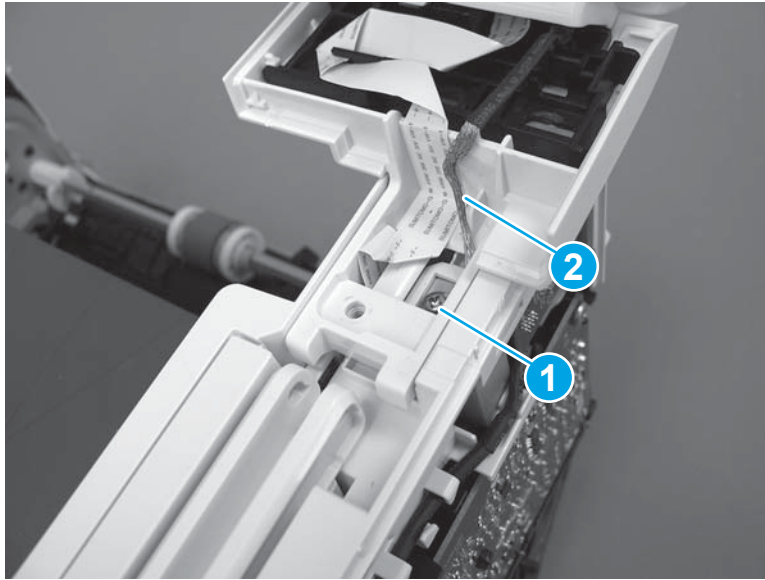
4. Remove the control-panel cable cover.

**Figure 1-1773** Remove the cover



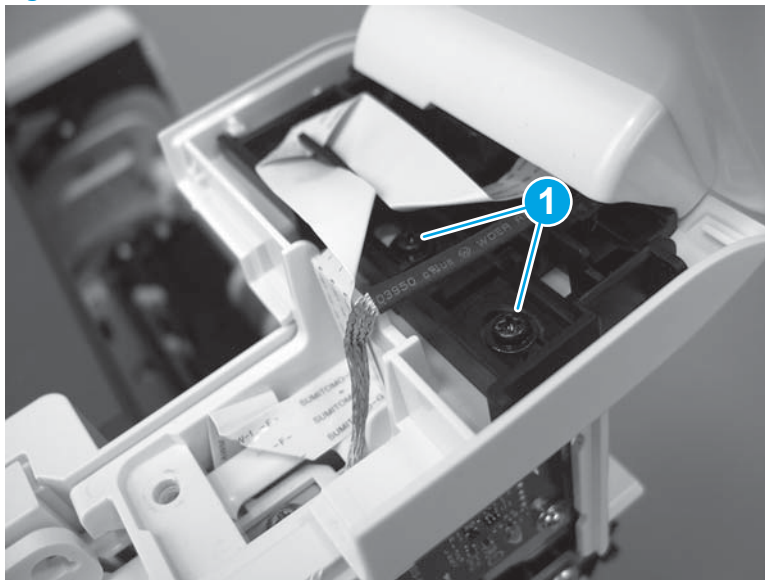
5. Remove one grounding screw (callout 1), and then move the ground cable (callout 2) out of the way.

**Figure 1-1774** Remove one screw



6. Move the FFC out of the way, and then remove two screws (callout 1).

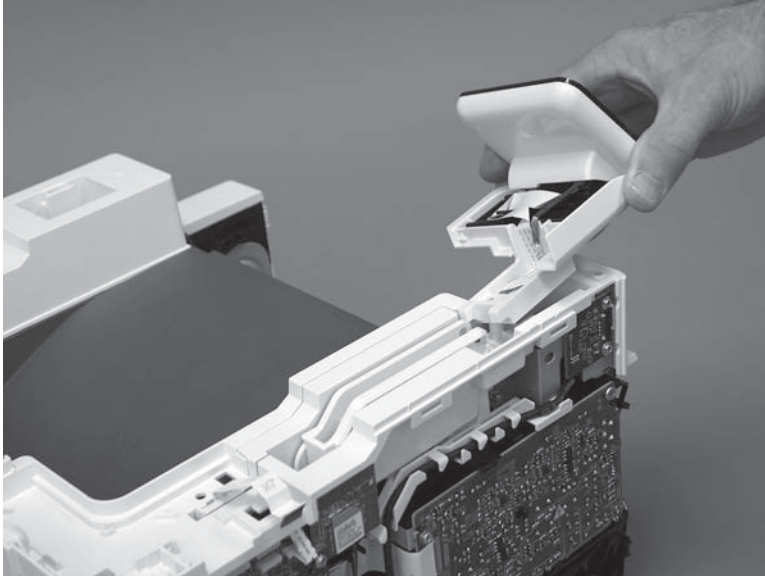
**Figure 1-1775** Remove two screws



7. Slightly lift up the control-panel assembly to separate it from the top cover.

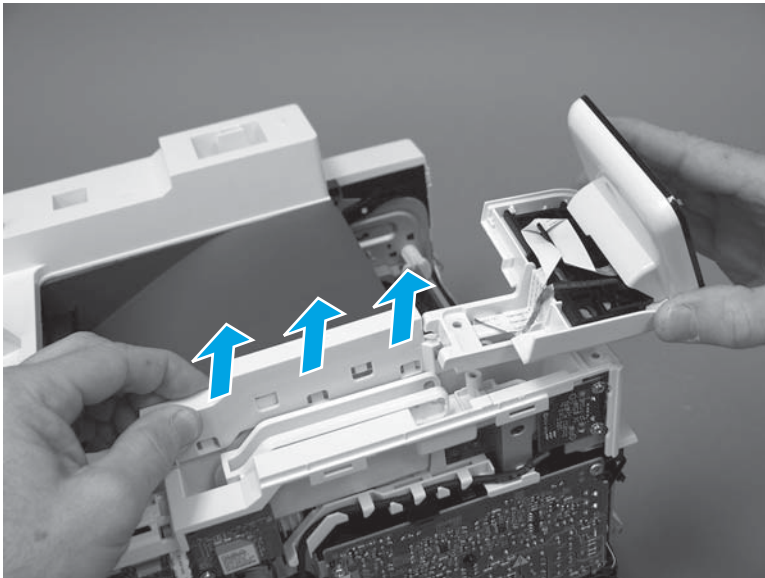
**⚠ CAUTION:** The control panel assembly is still connected to the printer by the FFC. Do not attempt to completely remove the assembly.

**Figure 1-1776** Lift up the control-panel assembly



8. Lift up the control-panel FFC cover to remove the control-panel assembly.

**Figure 1-1777** Remove the control-panel assembly

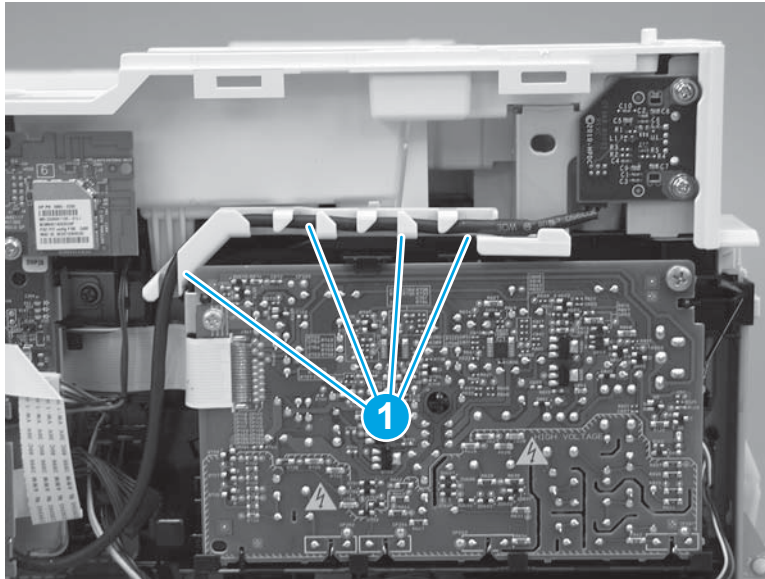


### Step 7: Remove the top cover (M427/M426)

**📝 NOTE:** The step is for the M427/M426 printer. For the M403/M402, skip this step and go to [Step 8: Remove the top cover \(M403/M402\) on page 943](#).

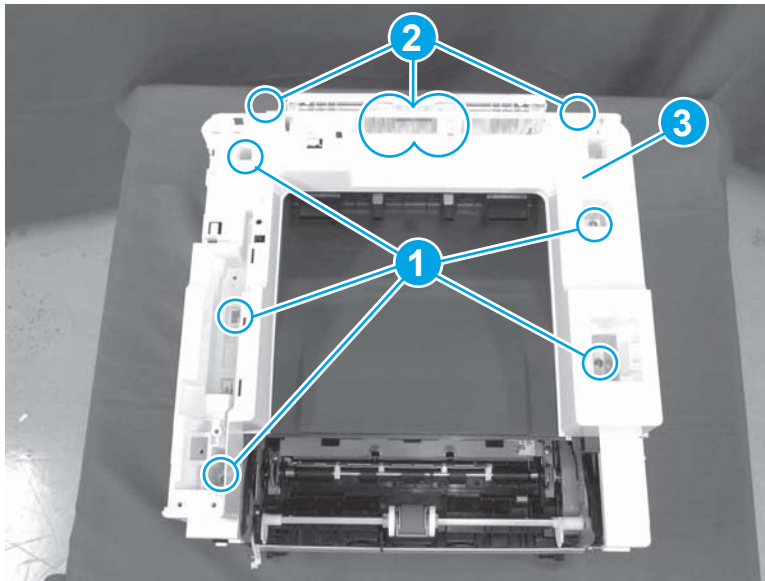
1. Release the USB cable (callout 1) from the cable guide.

**Figure 1-1778** Remove the USB cable




2. Remove five screws (callout 1), release four bosses (callout 2), and then remove the top cover (callout 3).

**Figure 1-1779** Remove the cover



### Step 8: Remove the top cover (M403/M402)

 **NOTE:** The step is for the M403/M402 printer. For the M427/M426, skip this step and go to [Step 9: Remove the paper delivery tray \(output bin\) on page 945.](#)

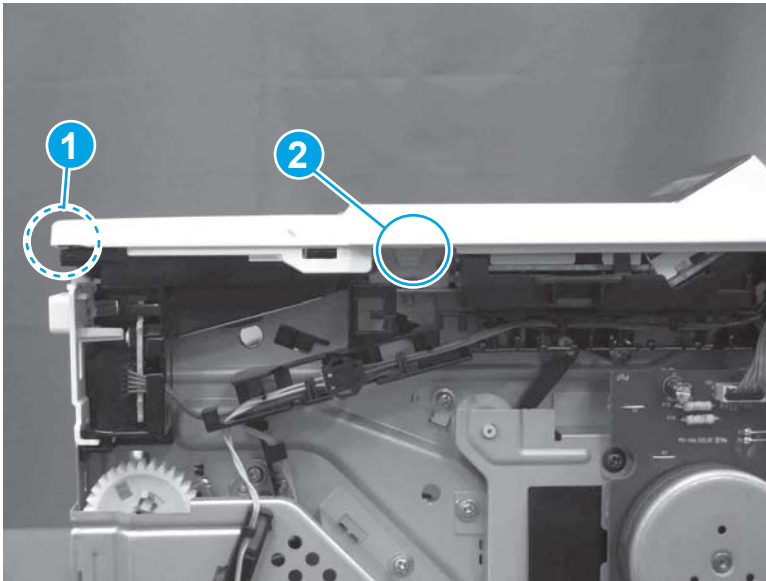
1. Remove one screw (callout 1).

**Figure 1-1780** Remove one screw




2. At the right side of the printer, release the one boss (callout 1), and then release one tab (callout 2).

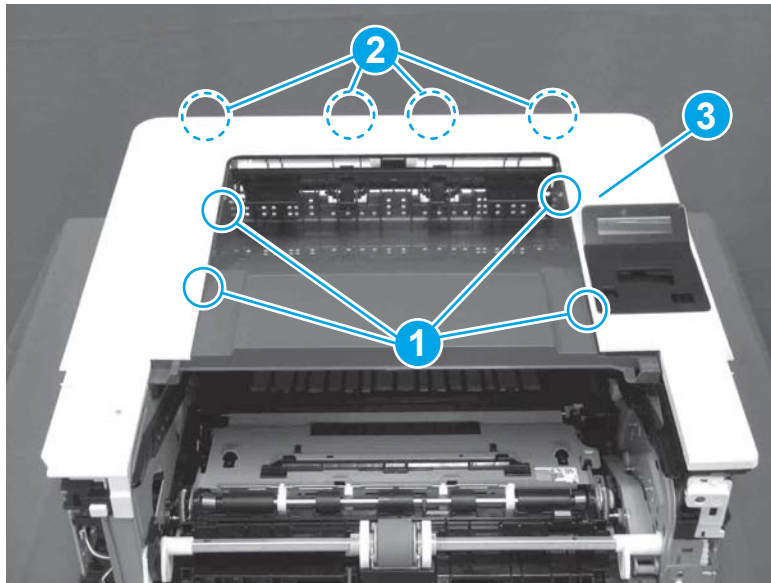
**Figure 1-1781** Release one boss and one tab




3. Release four tabs (callout 1), release four bosses (callout 2), and then remove the top cover (callout 3).

 **TIP:** Open the rear door to make releasing the bosses (callout 3) easier.

**Figure 1-1782** Remove the cover

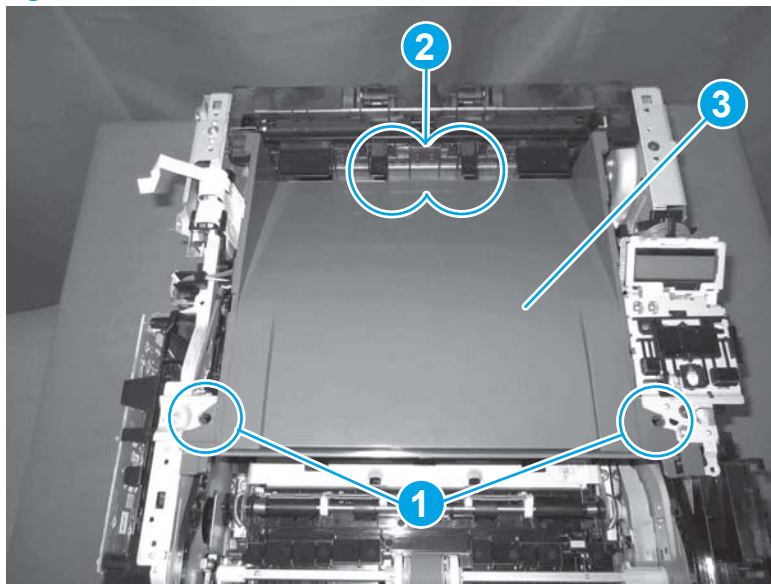


### Step 9: Remove the paper delivery tray (output bin)

 **NOTE:** This procedure shows the M403/M402 model, however, the paper delivery tray (output bin) removal is similar for the M427/M426 printer.

- ▲ Release two bosses (callout 1), release two tabs (callout 2), and then remove the paper delivery tray (output bin; callout 3).

**Figure 1-1783** Release two tabs

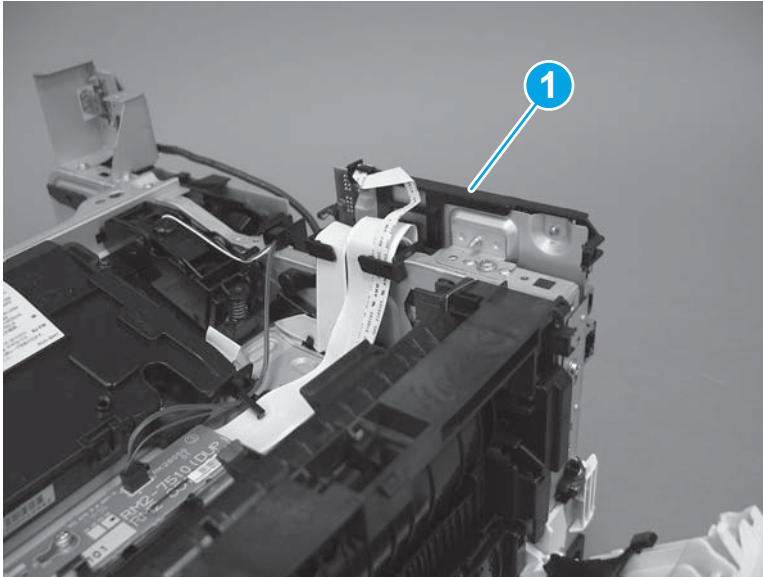


## Step 10: Remove the sheet-metal formatter bracket and formatter PCA

 **NOTE:** Disconnect any remaining formatter PCA FFCs or wire-harness connectors.

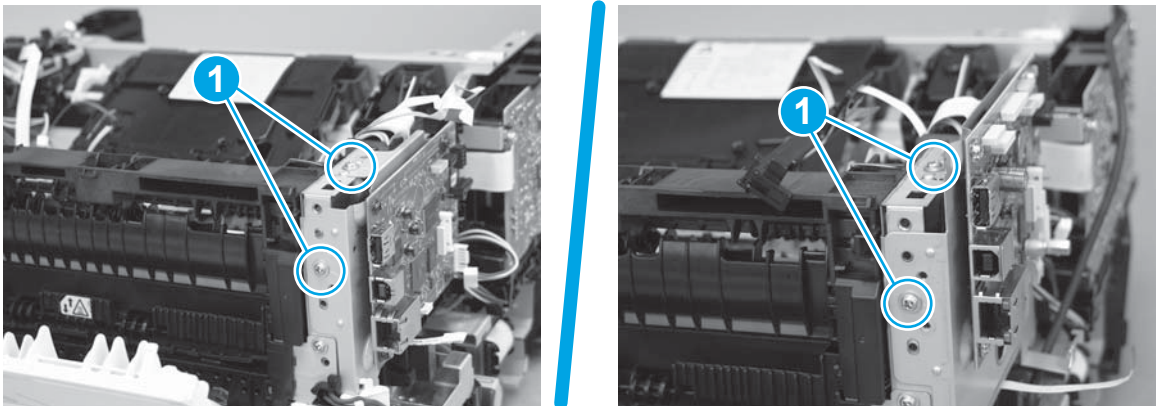
1. **M427/M426 only:** Remove the guide (callout 1).

**Figure 1-1784** Remove the guide



2. Remove two screws (callout 1).

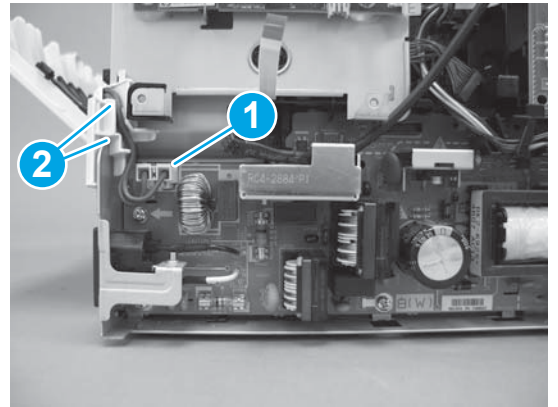
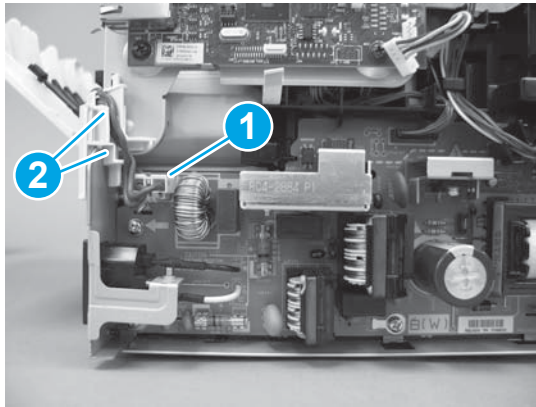
**Figure 1-1785** Remove two screws





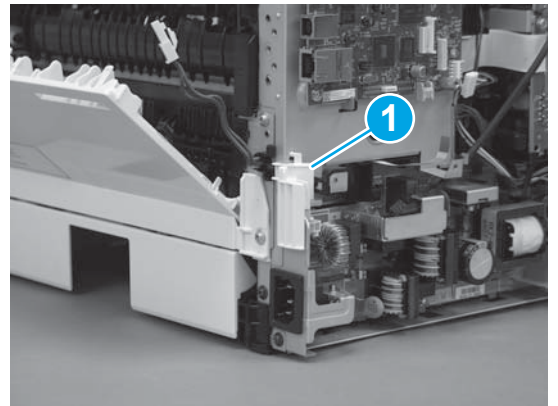
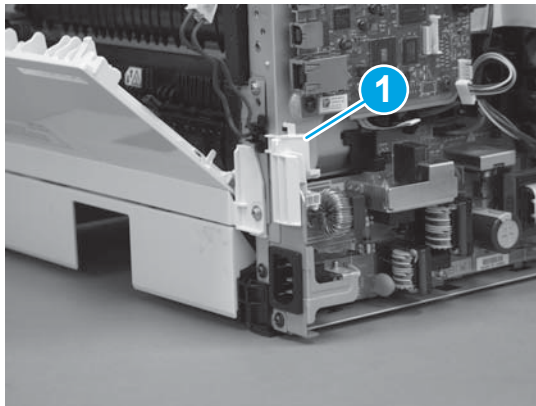
3. Disconnect one connector (callout 1), and then release the wire harness from the guide (callout 2).

**Figure 1-1786** Disconnect one connector



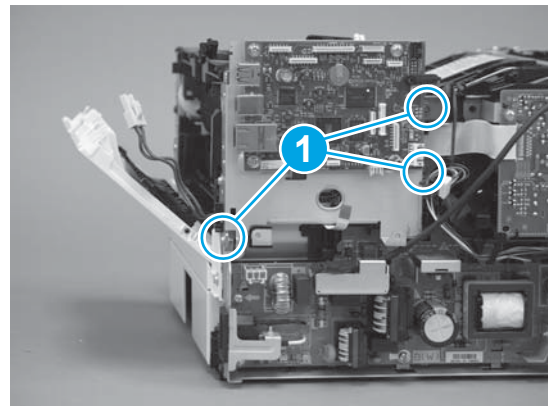
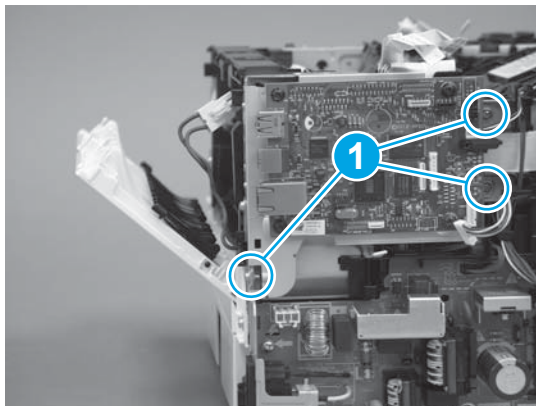
4. Remove the guide (callout 1).

**Figure 1-1787** Remove the guide



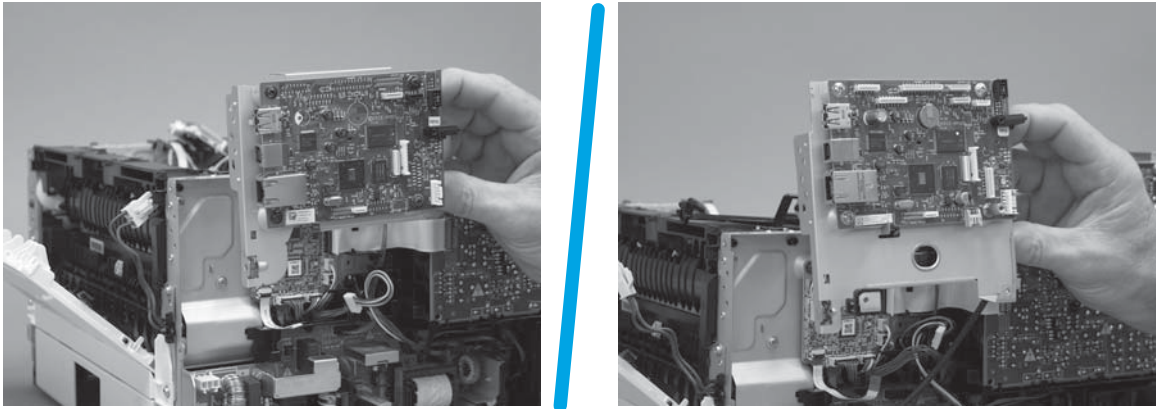
5. Remove three screws (callout 1).

**Figure 1-1788** Remove three screws



6. Remove the sheet-metal bracket and formatter PCA.

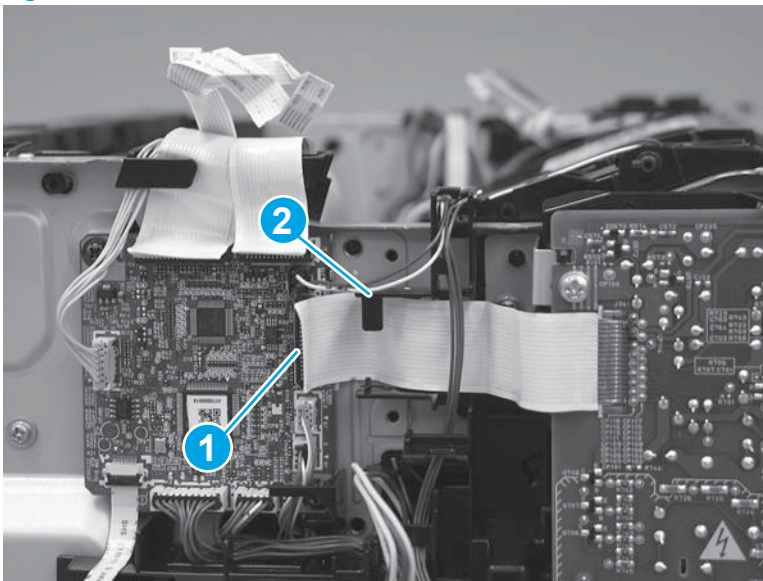
**Figure 1-1789** Remove the bracket



### Step 11: Remove the HVPS

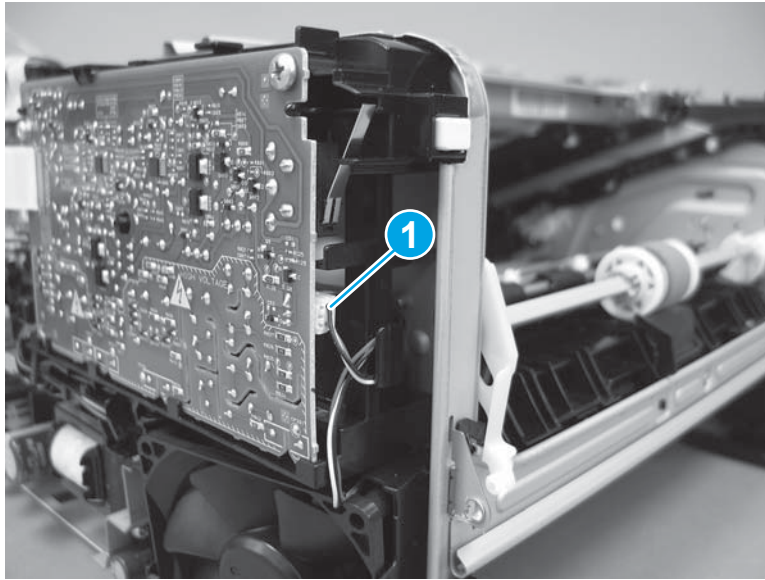
1. Disconnect one FFC (callout 1) on the DC controller, and then release it from the guide (callout 2).

**Figure 1-1790** Disconnect one FFC



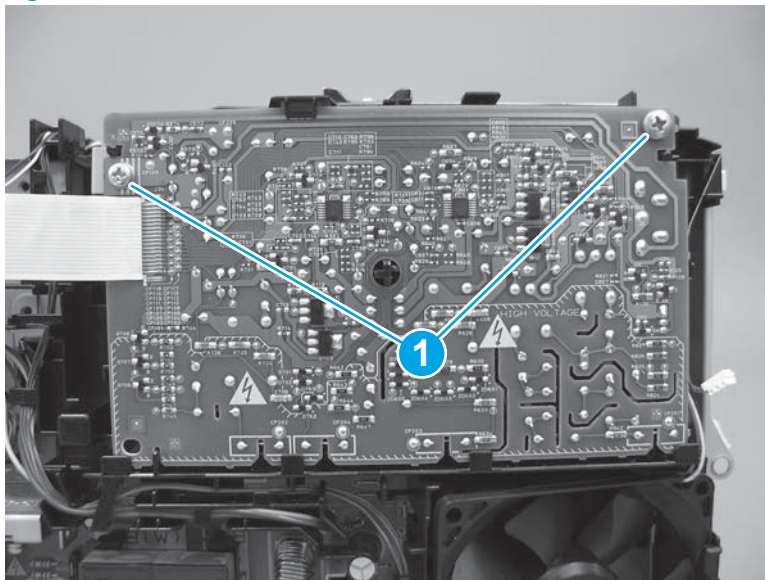
2. Disconnect one connector (callout 1).

**Figure 1-1791** Disconnect one connector



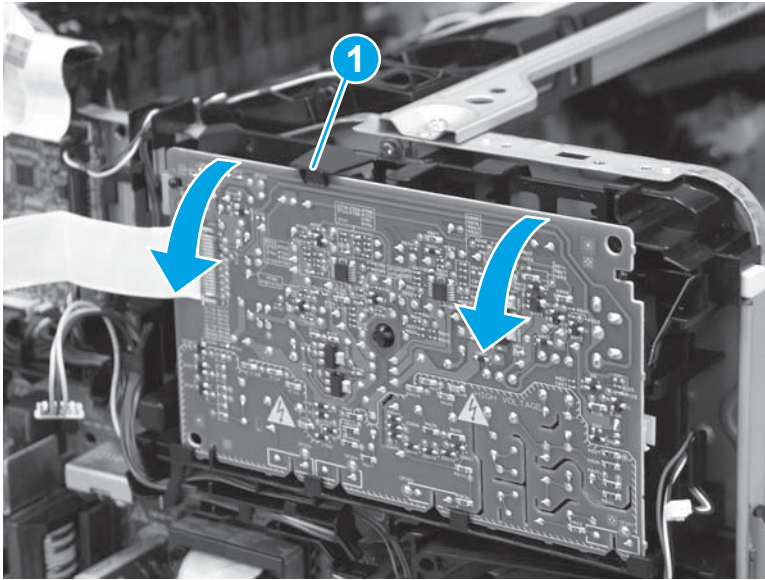
3. Remove two screws (callout 1).

**Figure 1-1792** Remove two screws



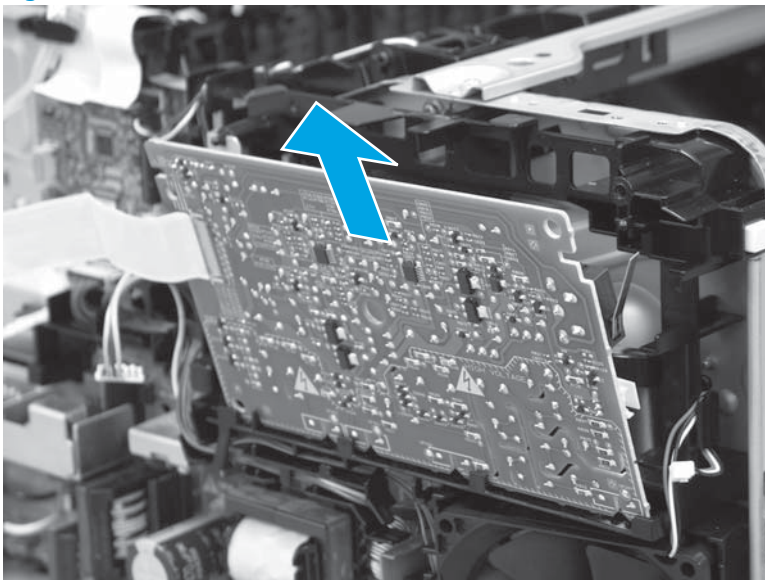
4. Release one tab (callout 1), and then rotate the top of the HVPS away from the printer.

**Figure 1-1793** Release one tab



5. Slide the HVPS up and away from the holder to remove it.

**Figure 1-1794** Remove the HVPS



### Step 12: Unpack the replacement assembly

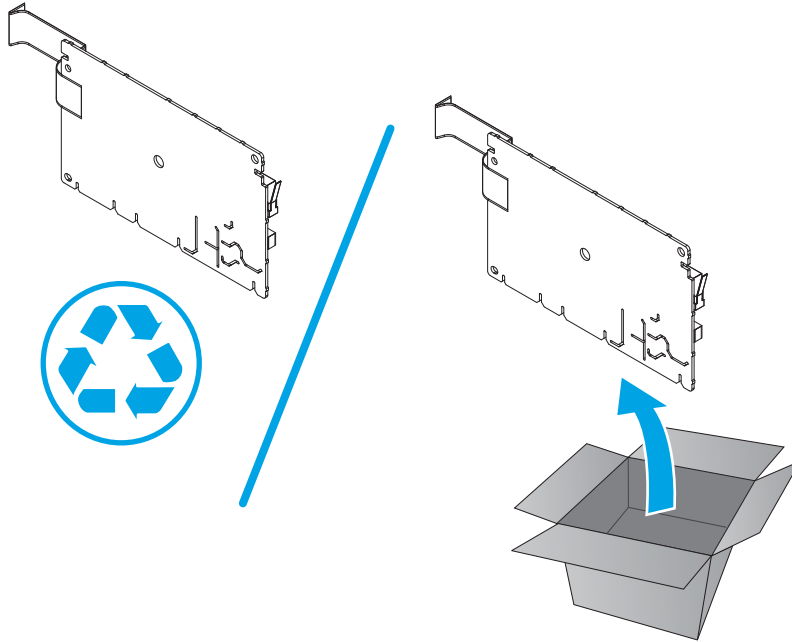
Unpack the replacement part from the packaging.

<http://www8.hp.com/us/en/hp-information/environment/product-recycling.html>



**NOTE:** HP recommends responsible disposal of the defective part.

**Figure 1-1795** Recycle and unpack



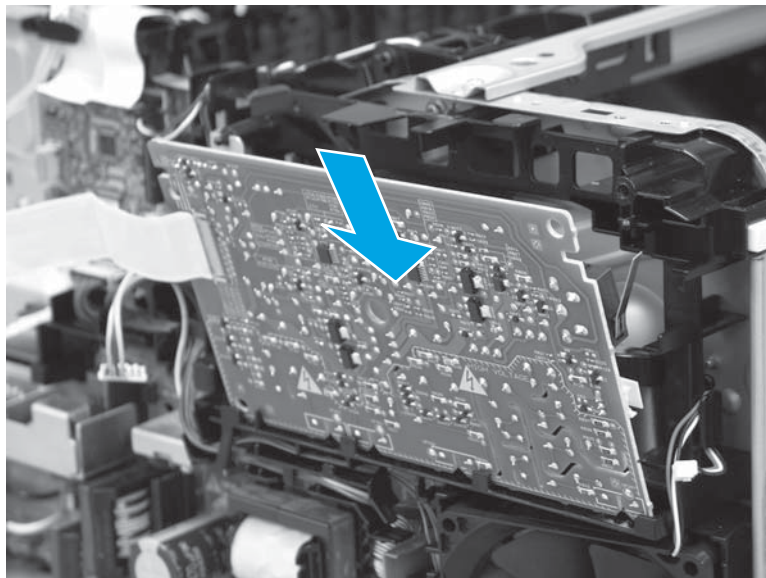
### Step 13: Install the HVPS

1. Position the HVPS in the holder with the bottom edge behind the taps on the holder (callout 1).



**NOTE:** If the HVPS is not correctly installed, the high-voltage springs will not touch the HVPS contacts and the printer will not properly function.

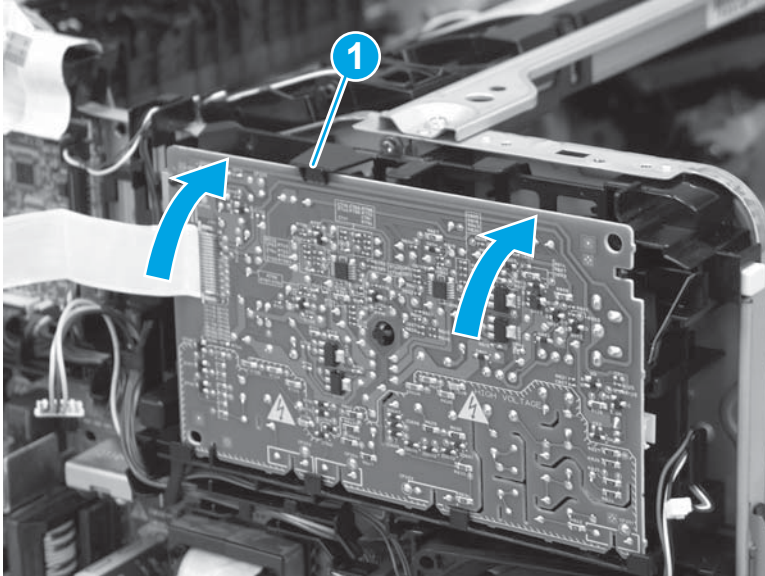
**Figure 1-1796** Position the HVPS in the holder



2. Rotate the top of the HVPS toward the printer (callout 1) until the tab (callout 2) snaps into place.

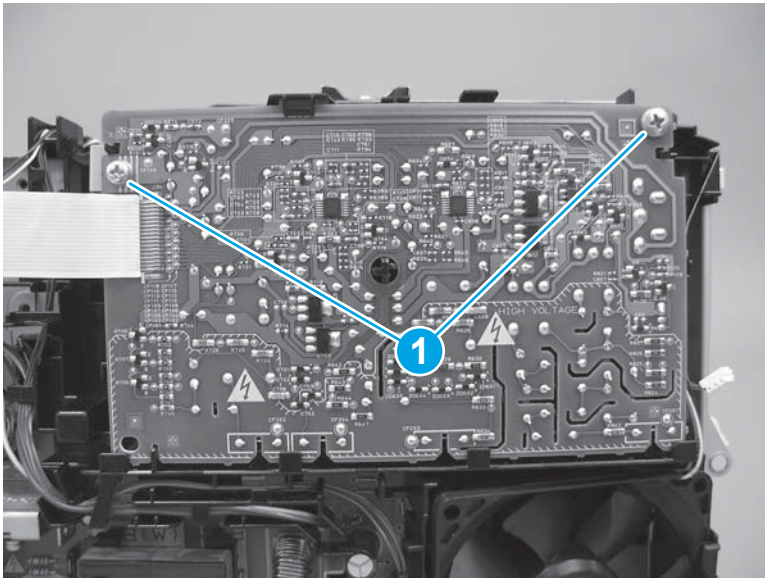
**⚠ CAUTION:** Do not damage the toner-cartridge detection switch lever (callout 3) when installing the HVPS

**Figure 1-1797** Engage one tab



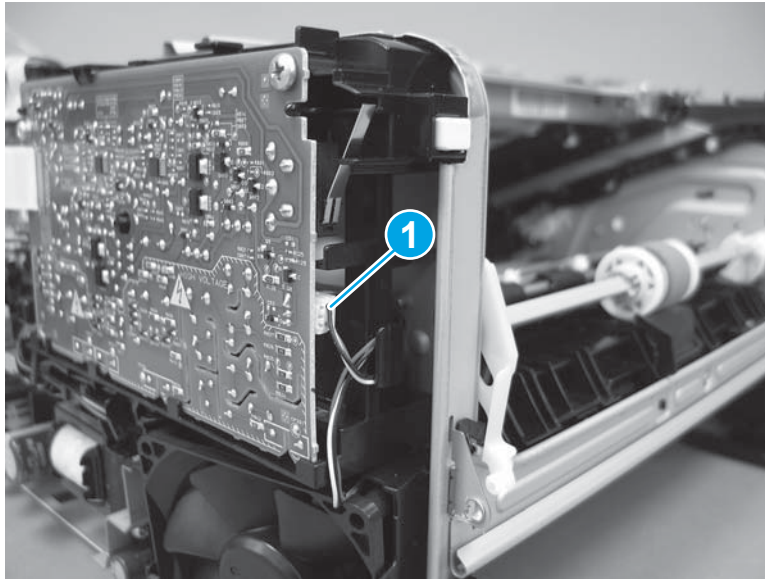
3. Install two screws (callout 1).

**Figure 1-1798** Install two screws



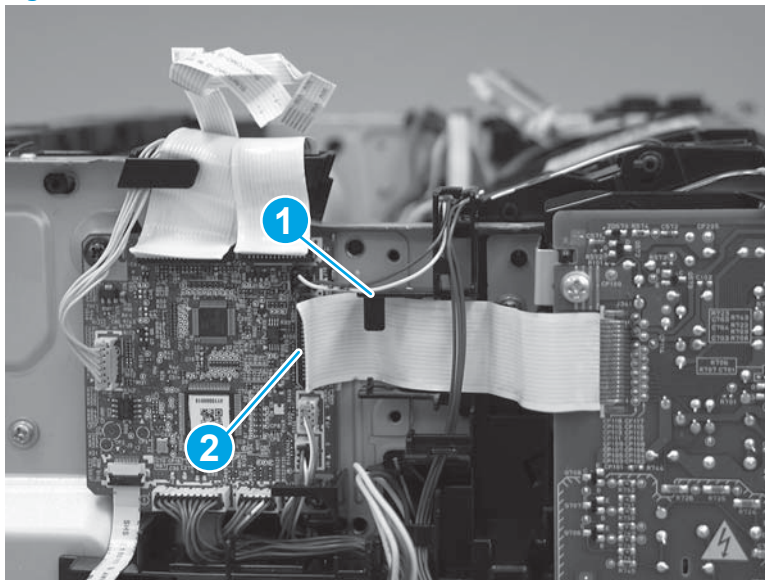
4. Connect one connector (callout 1).

**Figure 1-1799** Connect one connector



5. Install the FFC in the guide (callout 1), and then connect the FFC to the DC controller (callout 2).

**Figure 1-1800** Connect one FFC

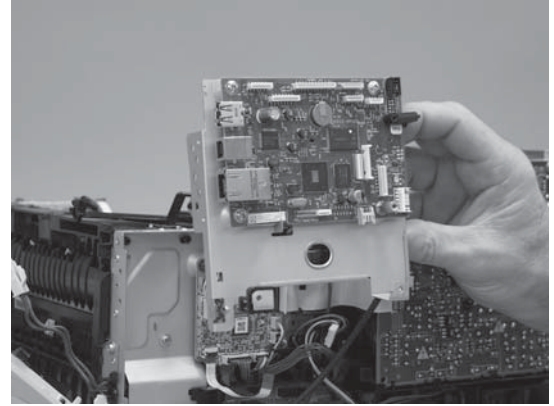
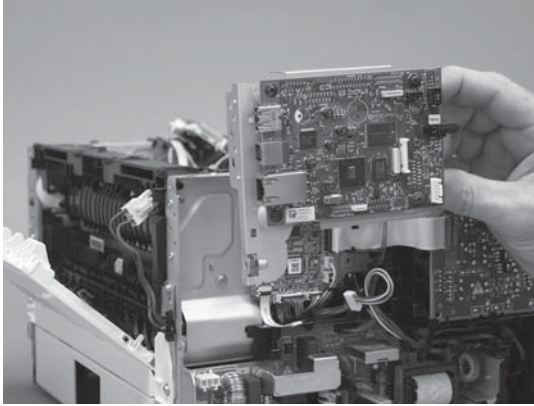


#### Step 14: Install the sheet-metal formatter bracket and formatter PCA

 **NOTE:** Do not forget to connect any formatter PCA FFCs or wire-harness connectors that were disconnected when the bracket was removed.

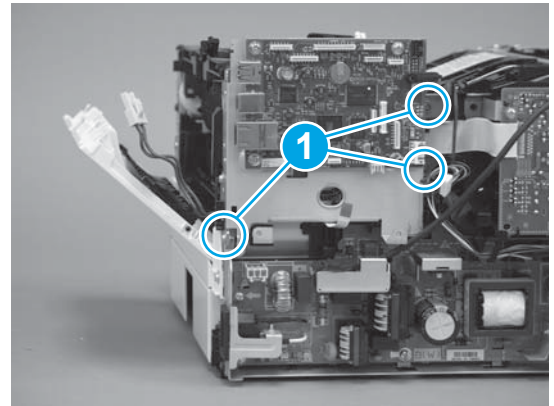
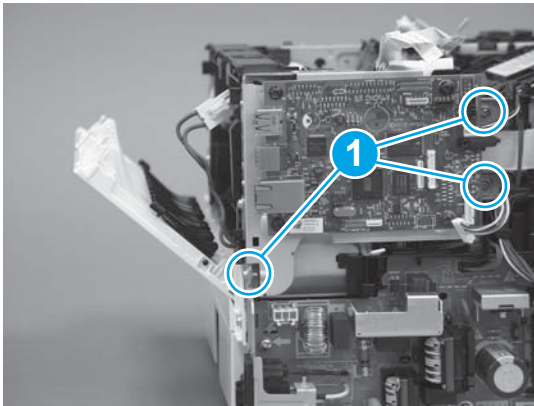
1. Position the sheet-metal bracket and formatter PCA on the printer.

**Figure 1-1801** Install the bracket



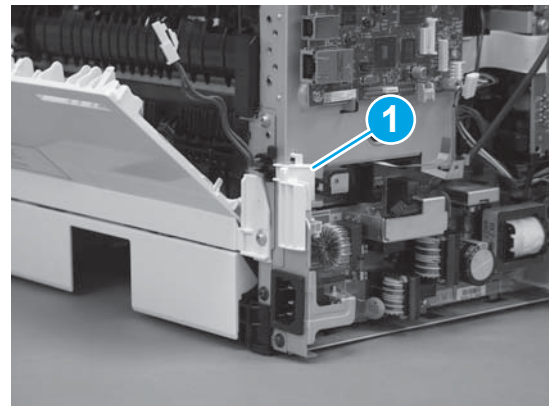
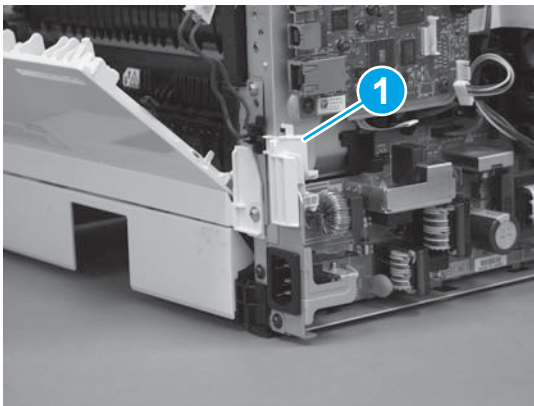
2. Install three screws (callout 1).

**Figure 1-1802** Install three screws



3. Install the guide (callout 1).

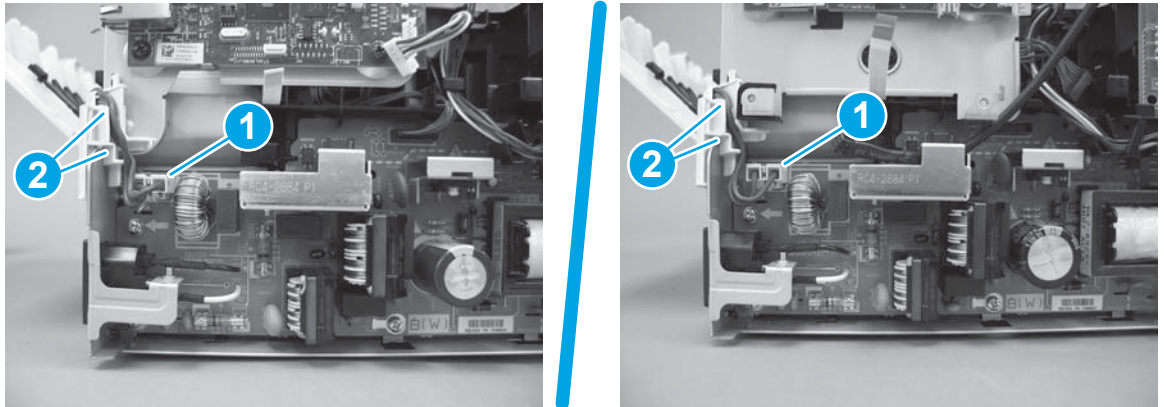
**Figure 1-1803** Install the guide





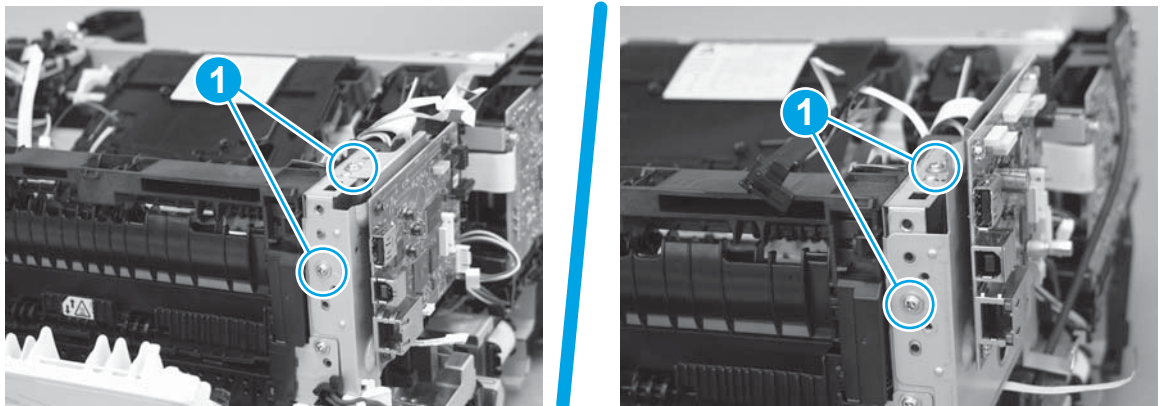
4. Connect one connector (callout 1), and then install the wire harness in the guide (callout 2).

**Figure 1-1804** Connect one connector



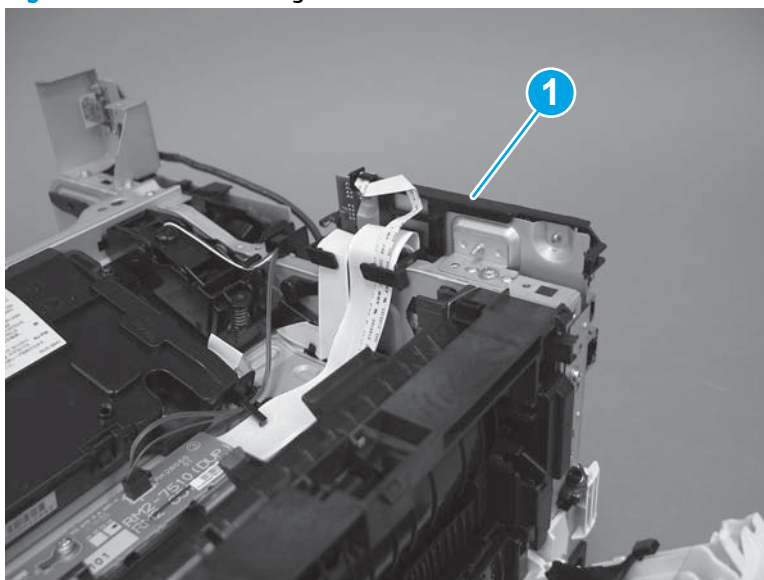
5. Install two screws (callout 1).

**Figure 1-1805** Install two screws




6. **M427/M426 only:** Install the guide (callout 1).

**Figure 1-1806** Install the guide

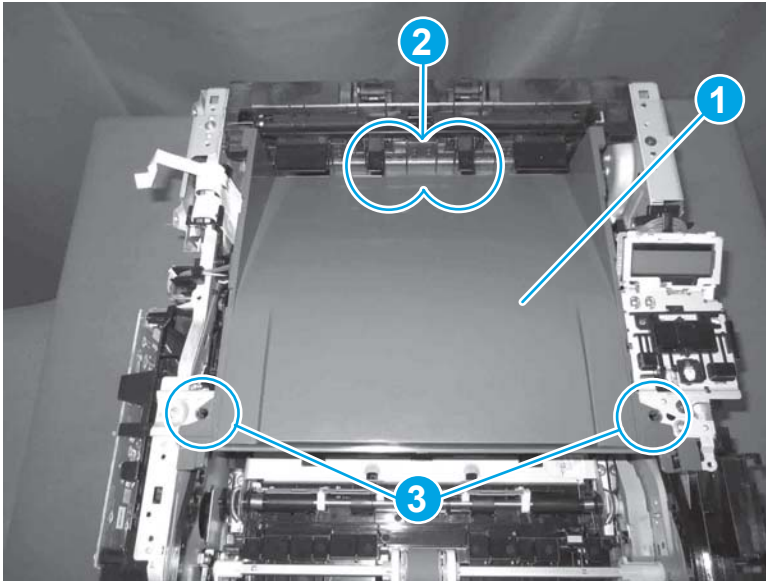


### Step 15: Install the paper delivery tray (output bin)


 **NOTE:** This procedure shows the M403/M402 model, however, the paper delivery tray (output bin) removal is similar for the M427/M426 printer.

- ▲ Position the remove the paper delivery tray (output bin; callout 1) on the printer, engage two tabs (callout 2), and then engage two bosses (callout 3).

**Figure 1-1807** Engage two tabs

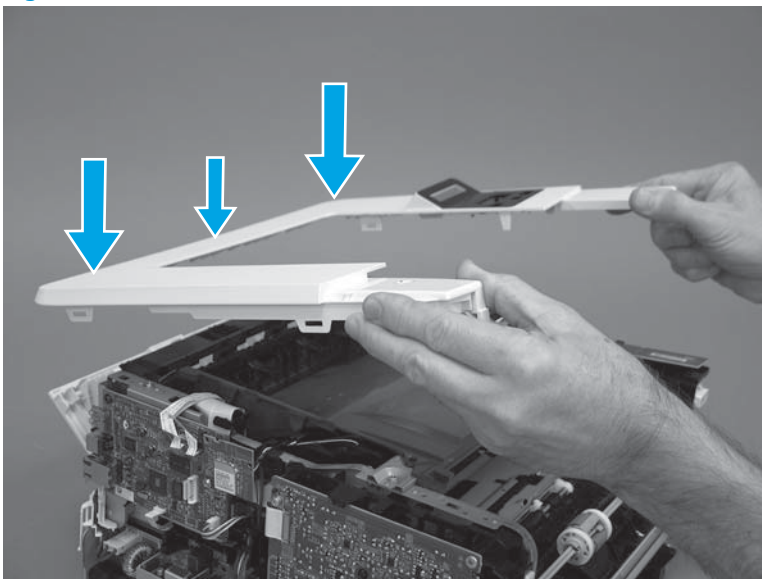


### Step 16: Install the top cover (M403/M402)

 **NOTE:** The step is for the M403/M402 printer. For the M427/M426, skip this step and go to [Step 17: Install the top cover \(M427/M426\) on page 958](#).

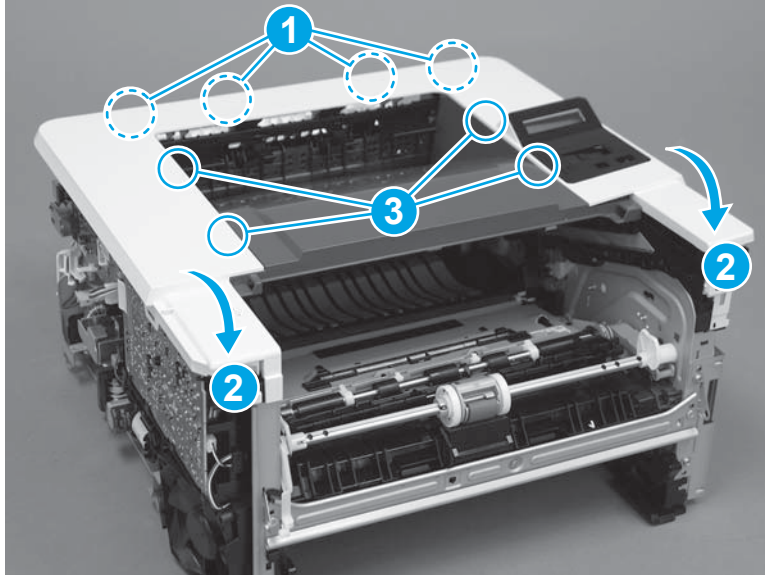
1. Position the rear edge of the cover on the printer.

**Figure 1-1808** Install the cover



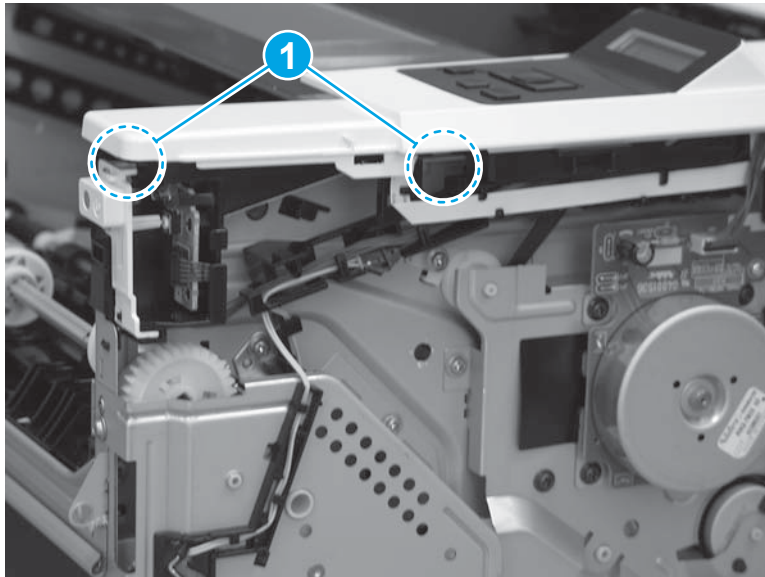
- Engage four bosses (callout 1), rotate the front of the cover down (callout 2) and onto from the printer, and then engage four tabs (callout 3).

**Figure 1-1809** Engage four bosses and tabs



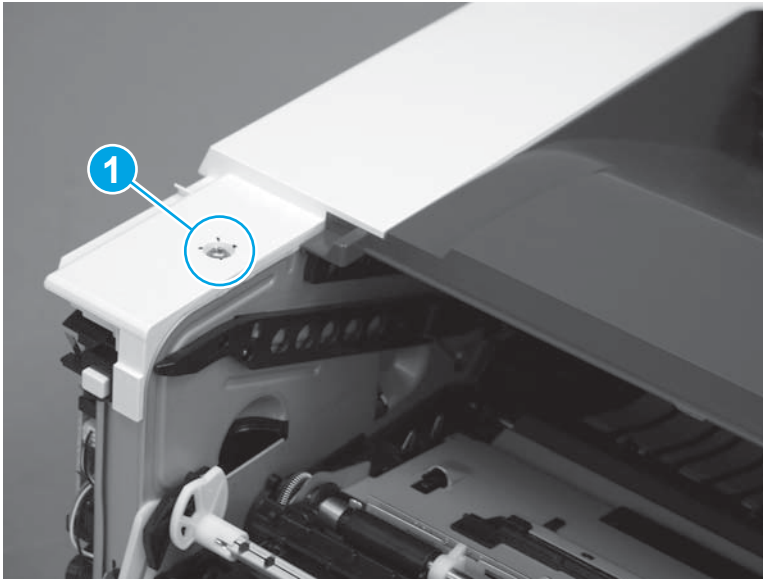
- At the right side of the printer, engage the one boss and one tab (callout 1).

**Figure 1-1810** Engage one boss and one tab




4. Install one screw (callout 1).

**Figure 1-1811** Install one screw

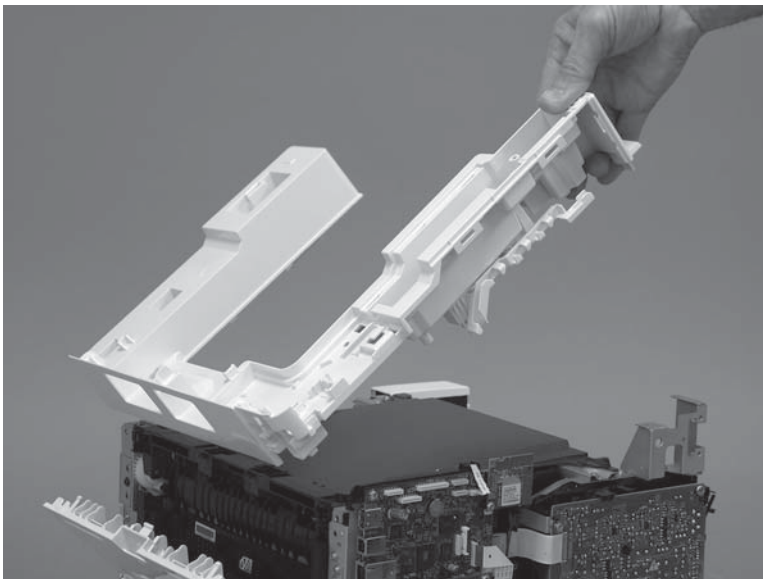


#### Step 17: Install the top cover (M427/M426)

 **NOTE:** The step is for the M427/M426 printer. For the M403/M402, skip this step and go to [Step 20: Install the right cover on page 969](#).

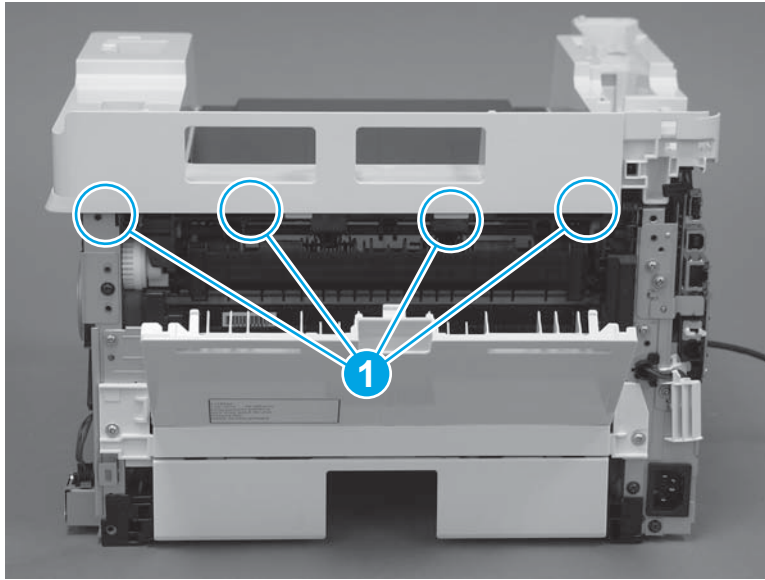
1. Position the rear edge of the top cover on the printer.

**Figure 1-1812** Install the cover



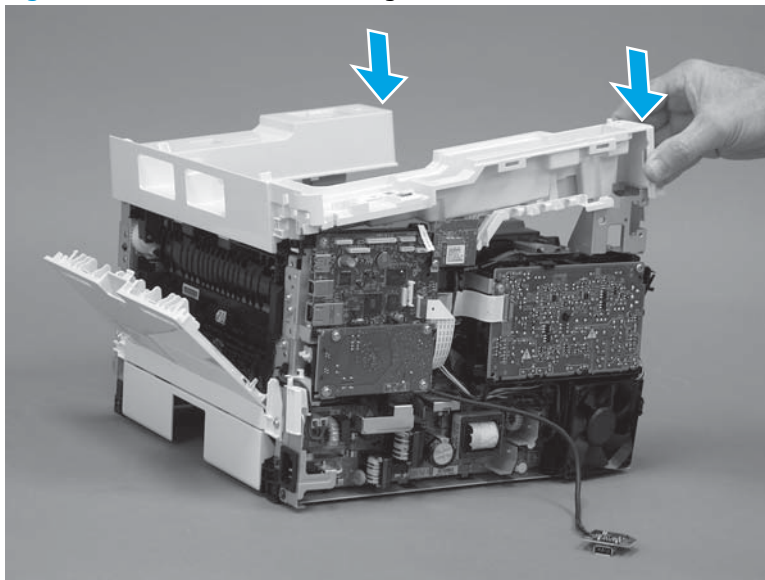
2. Engage four bosses (callout 1).

**Figure 1-1813** Engage four bosses



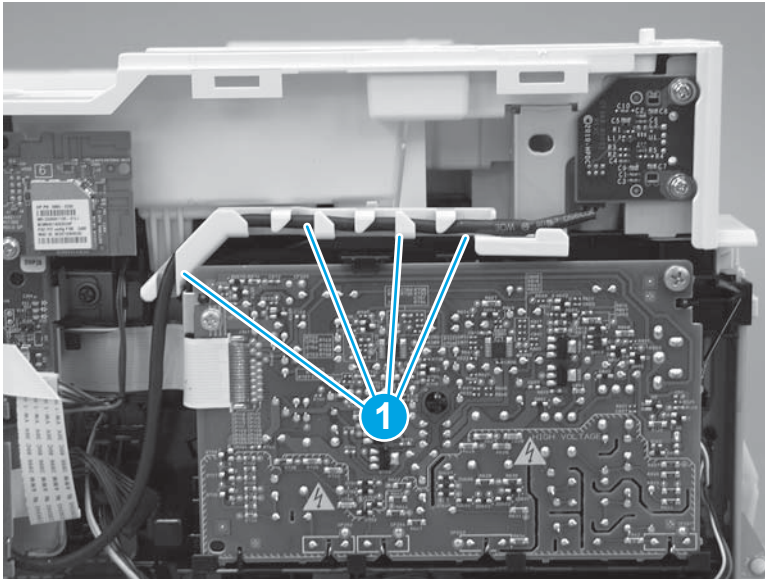
3. Rotate the front edge of the cover down.

**Figure 1-1814** Rotate the front edge of the cover down



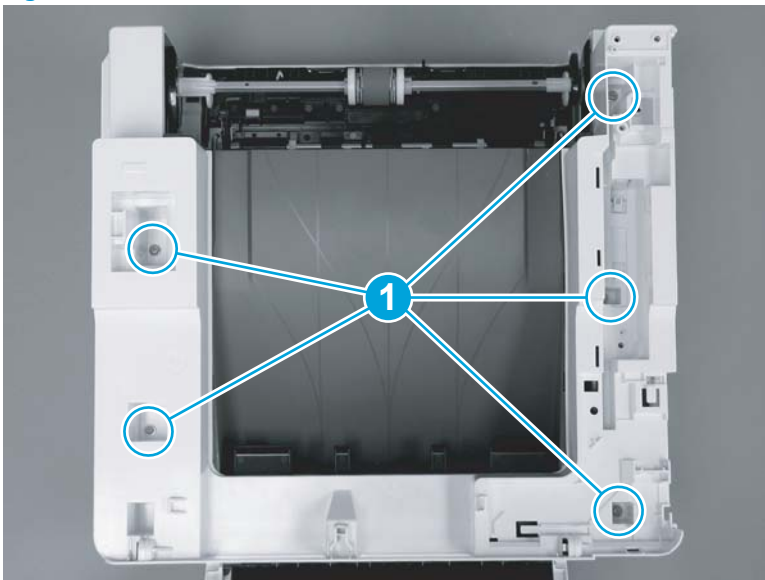
4. Install the USB cable (callout 1) in the guide.

**Figure 1-1815** Install the USB PCA




5. Install five screws (callout 1).

**Figure 1-1816** Install five screws

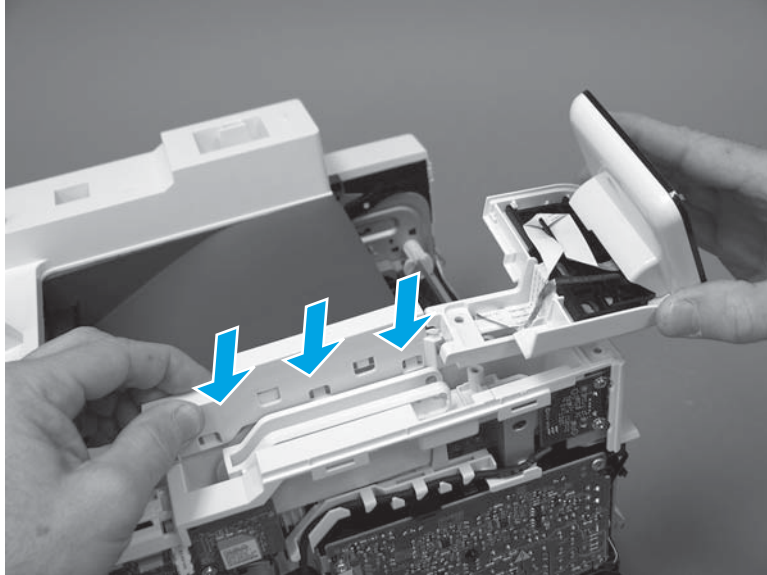


### Step 18: Install the control panel (M427/M246)

 **NOTE:** The step is for the M427/M426 printer. For the M403/M402, skip this step and go to [Step 20: Install the right cover on page 969](#).

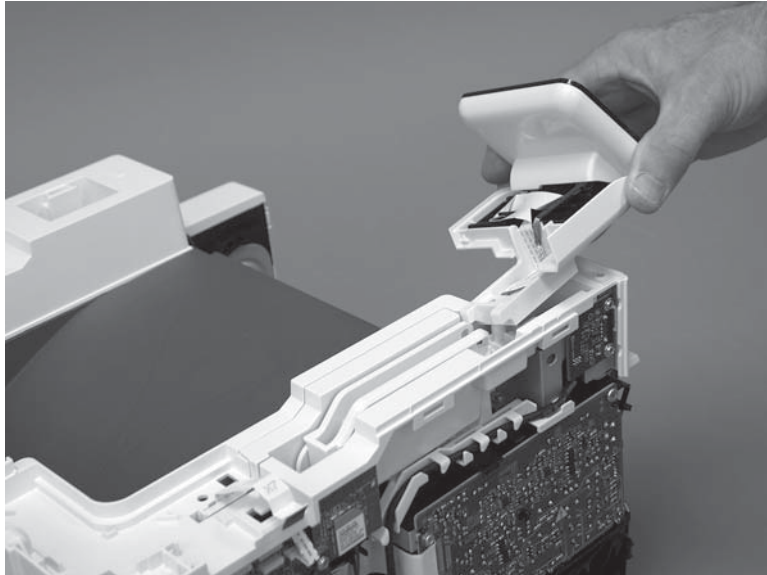
1. Slide the control-panel FFC cover into the slot in the top cover (next to the document feeder support arm) to install it.

**Figure 1-1817** Install the control-panel FFC cover



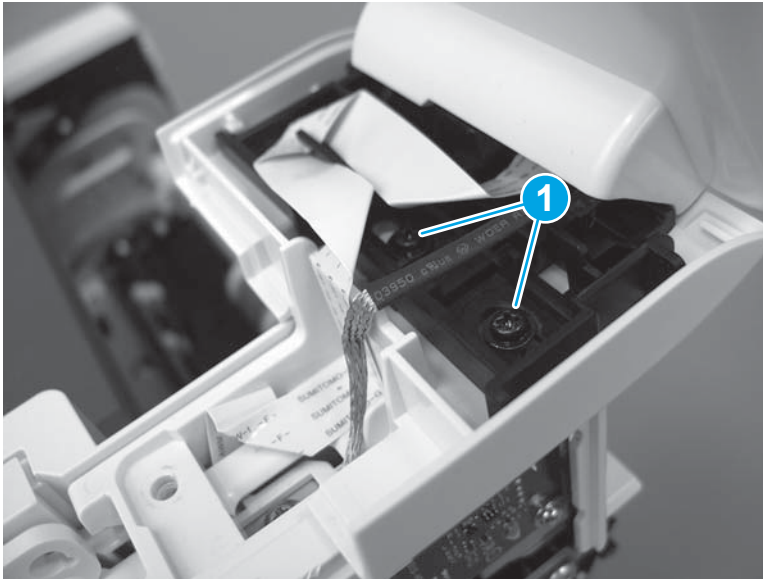
2. Install the control-panel assembly on the top cover.

**Figure 1-1818** Install the control-panel assembly



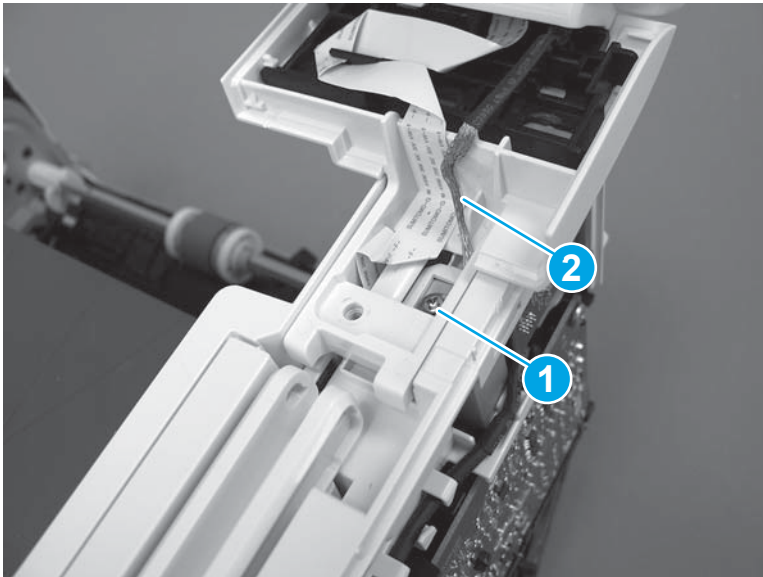
3. Move the FFC out of the way, and then install two screws (callout 1).

**Figure 1-1819** Install two screws



4. Install one grounding screw (callout 1), and then make sure that the ground cable (callout 2) is properly routed.

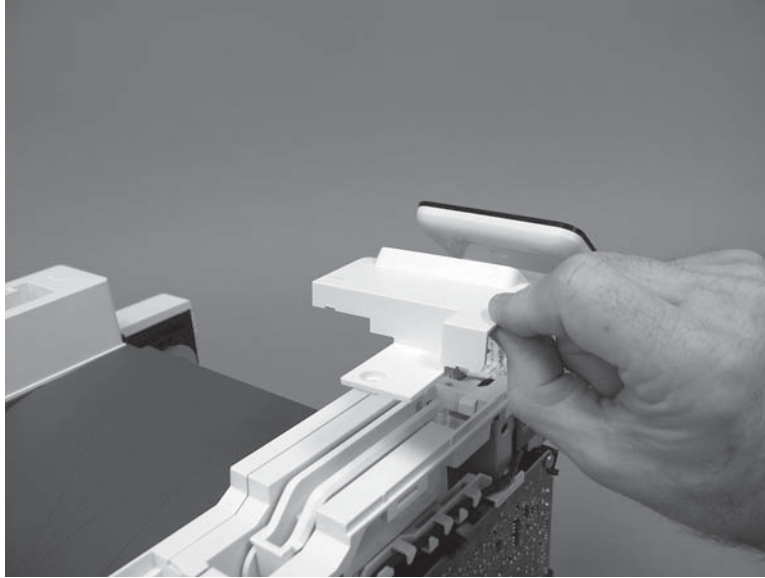
**Figure 1-1820** Remove one screw





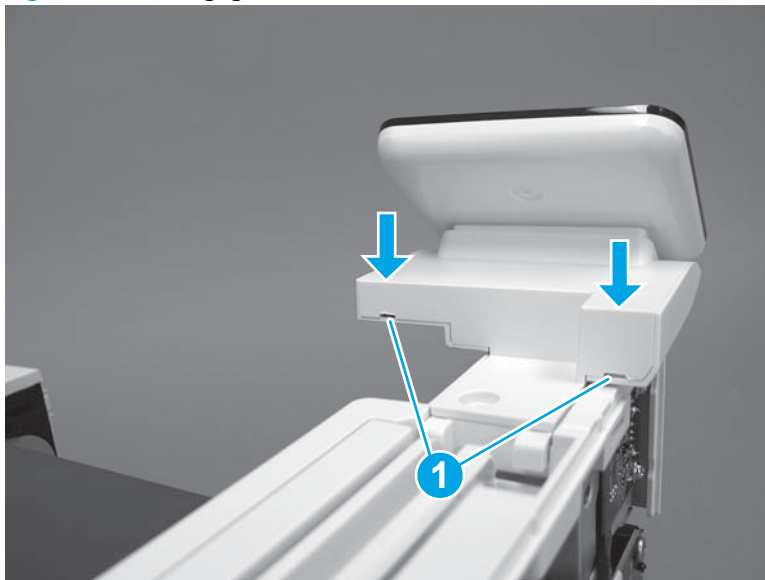
5. Install the control-panel cable cover.

**Figure 1-1821** Install the cover



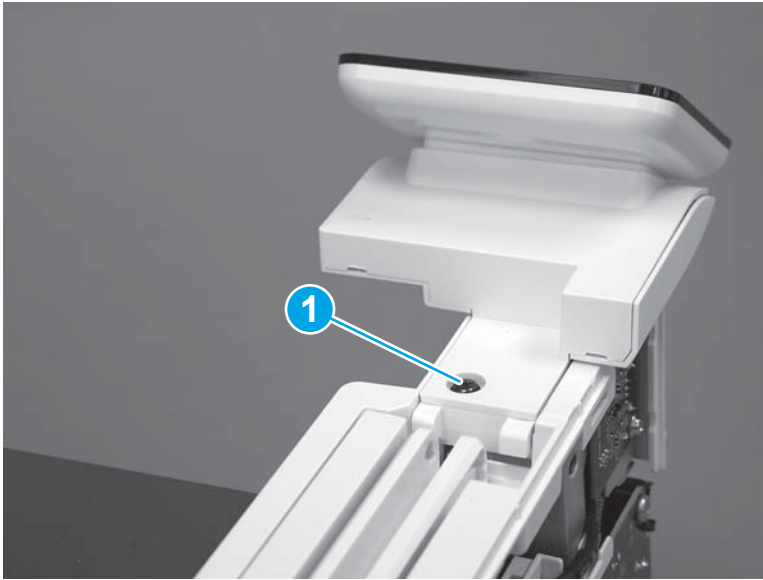
6. Make sure that the two tabs (callout 1) on the cover snap into place.

**Figure 1-1822** Engage two tabs



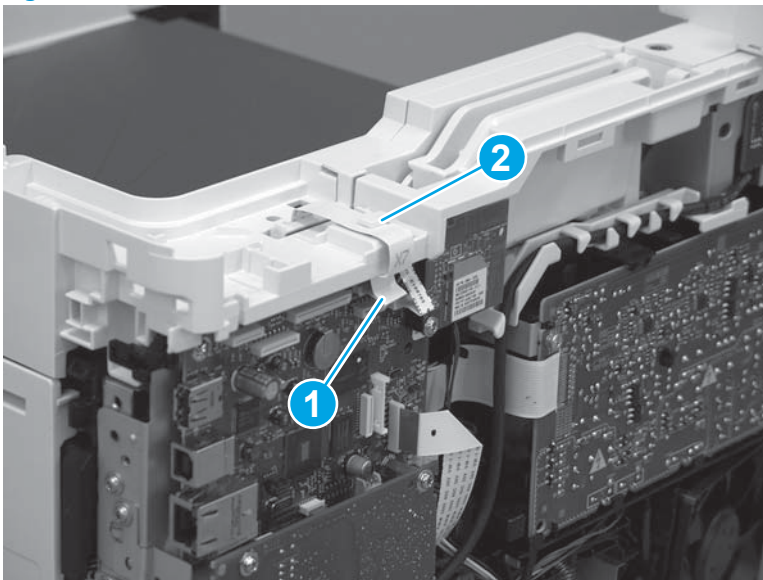
7. Install one screw (callout 1).

**Figure 1-1823** Install one screw





8. Install the FFC in the retainer (callout 1), and then connect one FFC (callout 1; J114).

**Figure 1-1824** Connect one connector



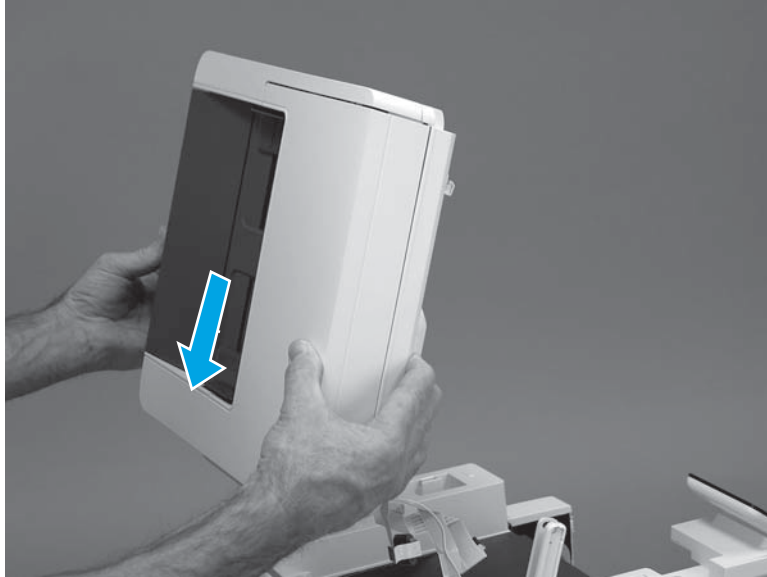
### Step 19: Install the integrated scanner assembly (M427/M246)

 **NOTE:** The step is for the M427/M426 printer. For the M403/M402, skip this step and go to [Step 20: Install the right cover on page 969](#).

 **NOTE:** M427/M426 models only. The integrated scanner assembly (ISA) includes the sub-scanner assembly (SSA) and the automatic document feeder (ADF).

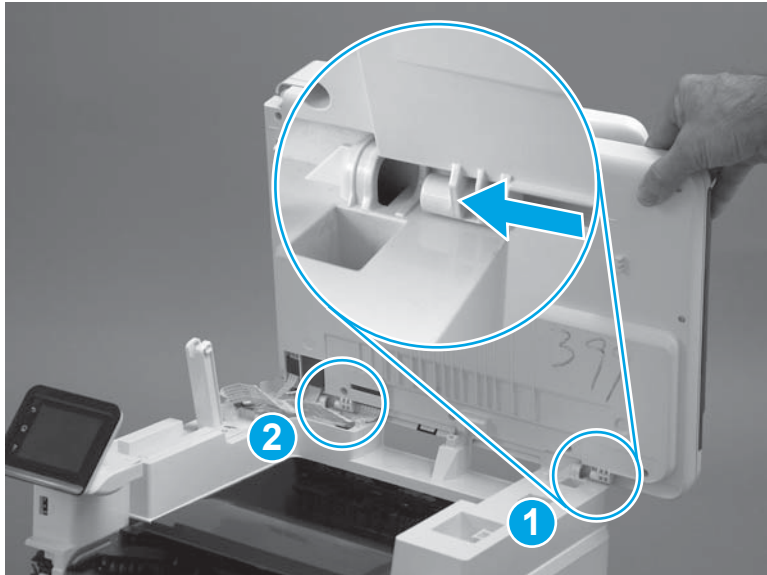
1. Position the ISA on the printer.

**Figure 1-1825** Position the ISA on the printer



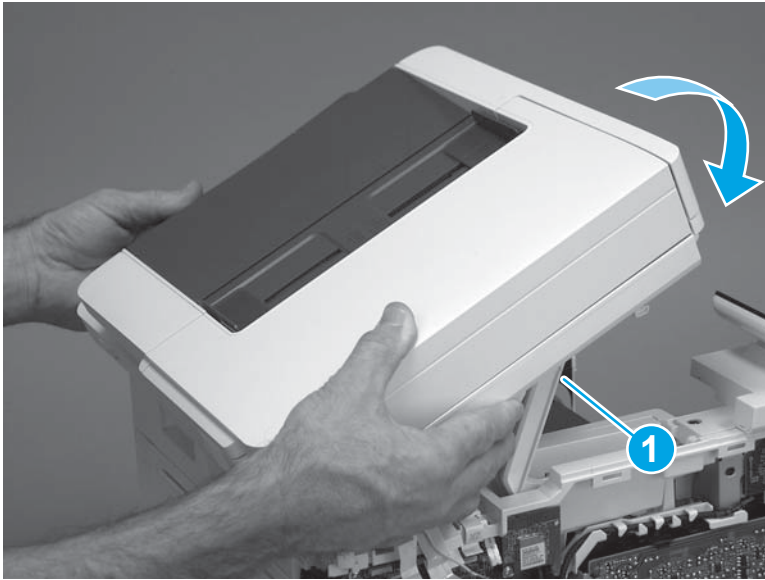
2. Engage the hinge pins on the ISA with the holders in the top cover (callouts 1/2), and then slide the ISA as shown to engage them

**Figure 1-1826** Engage the hinge pins with the holders



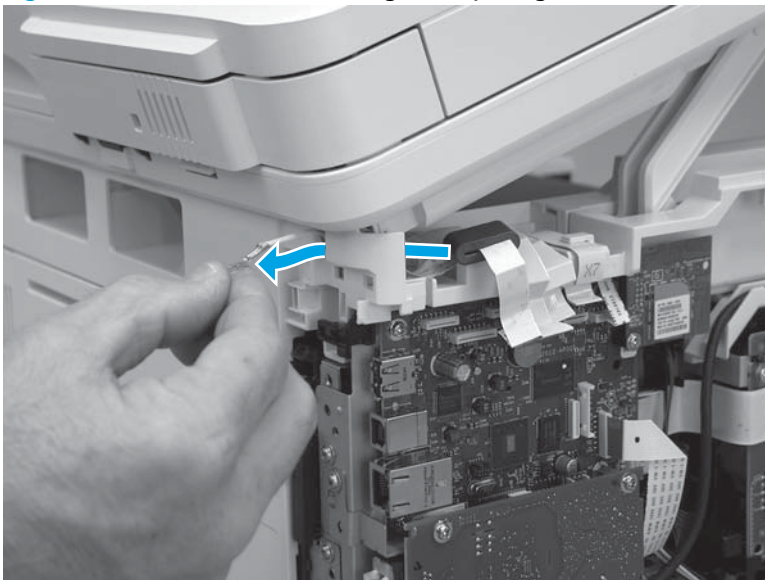
3. Rotate the ISA towards the front of the printer until it rests on the ISA lift assembly (callout 1).

**Figure 1-1827** Rotate the ISA towards the front of the printer



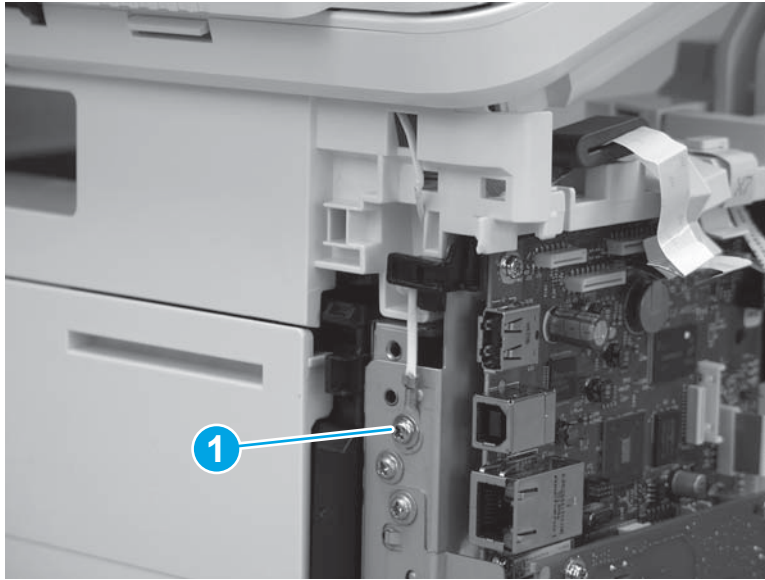
4. Pass the ground wire through the opening in the top cover.

**Figure 1-1828** Pass the wire through the opening




5. Install one screw (callout 1).

**Figure 1-1829** Install one screw



6. Install the ISA lift assembly slider pin.

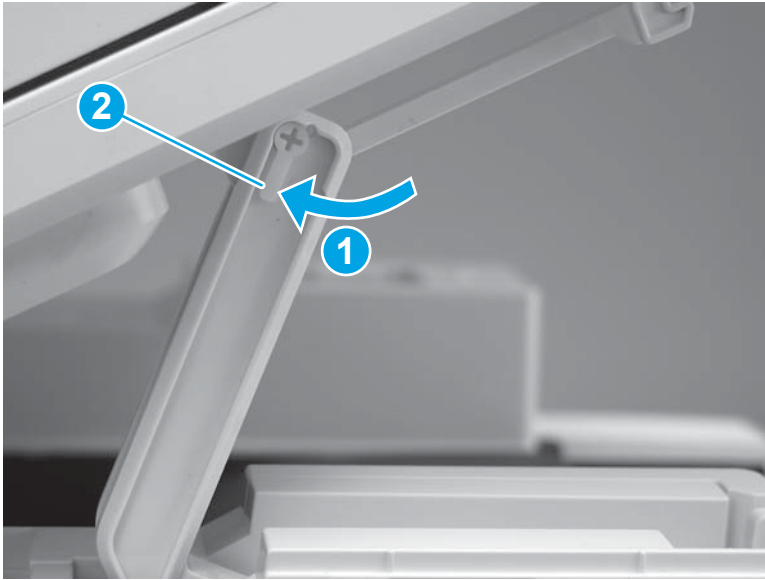
 **Reinstallation tip:** Align the keyed portion of the locking pin with the slot and hole in the support arm.

**Figure 1-1830** Install the slider pin



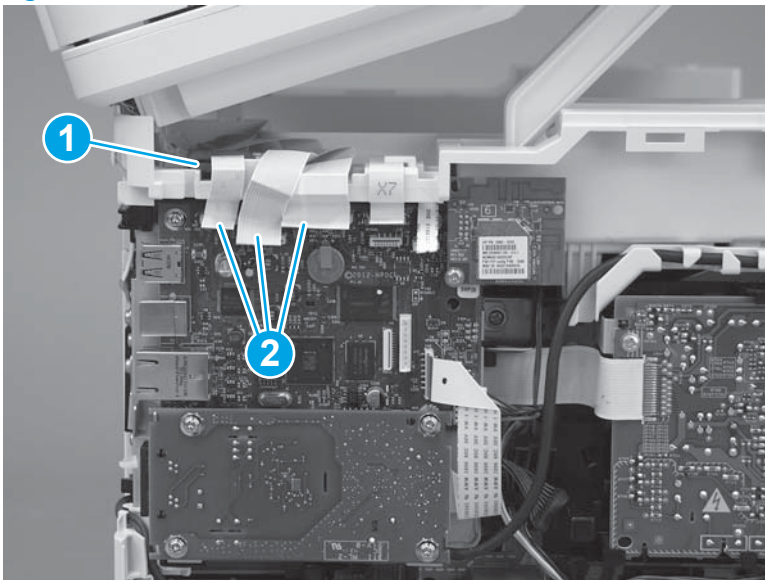
7. Rotate the slider pin (callout 1) towards the rear of the printer until the tab (callout 2) snap into place.

**Figure 1-1831** Secure the slider pin



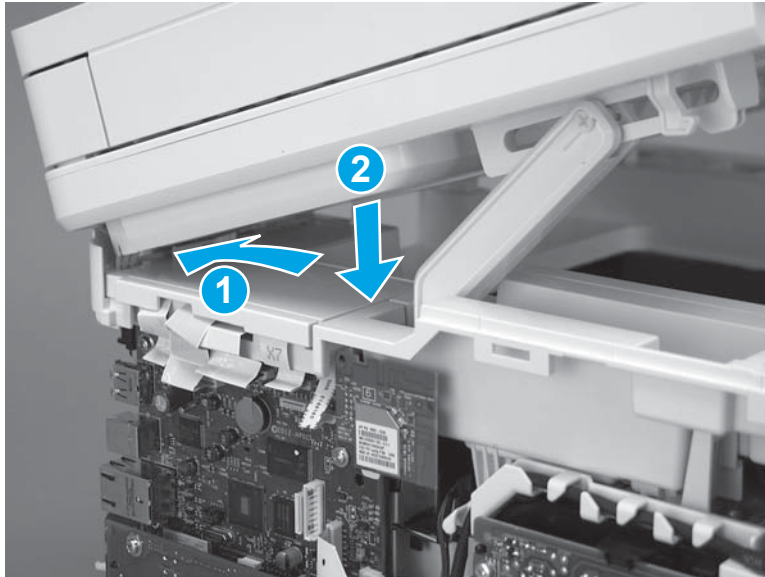
8. Install the ferrite (callout 1) in the holder, and then connect three FFCs (callout 2).

**Figure 1-1832** Connect three FFCs



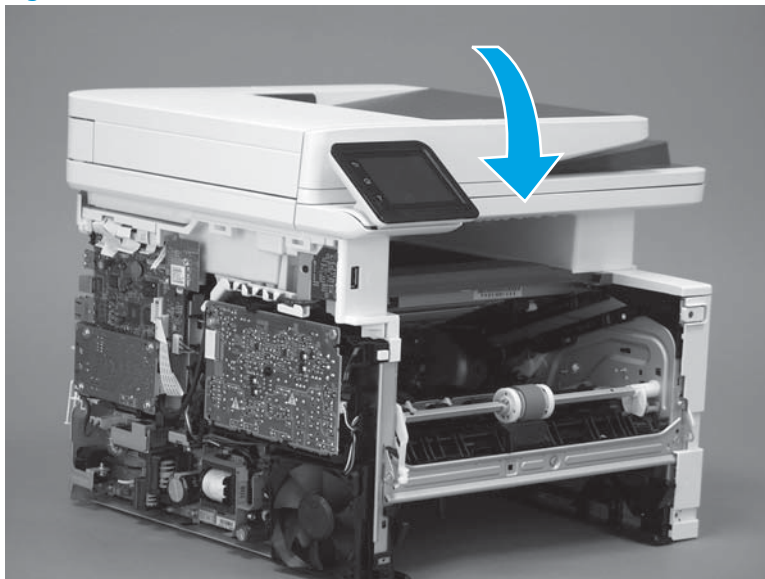
9. Position the rear edge of the ISA flat-flexible cable (FFC) cover on the printer (callout 1) , and then rotate it down (callout 2) until it snaps into place.

**Figure 1-1833** Install the ISA FFC cover



10. Lower the ISA.

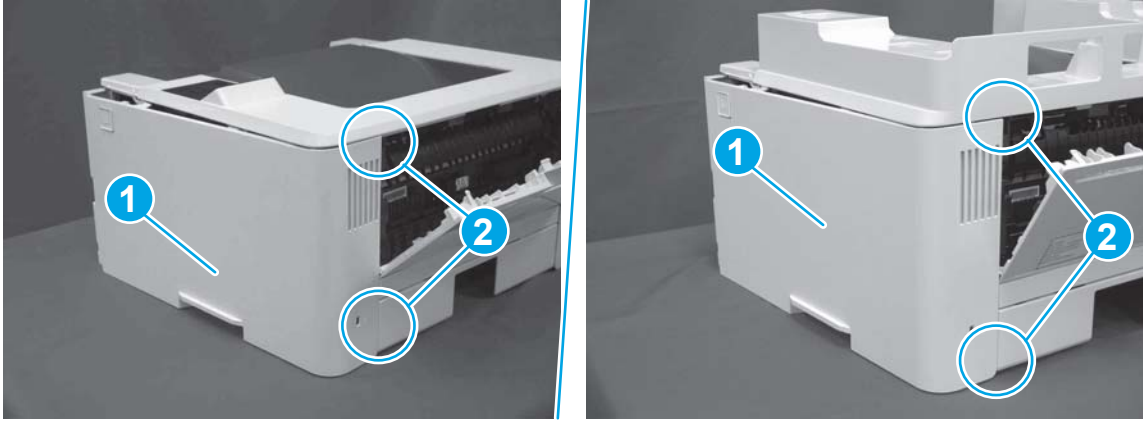
**Figure 1-1834** Lower the ISA



### Step 20: Install the right cover

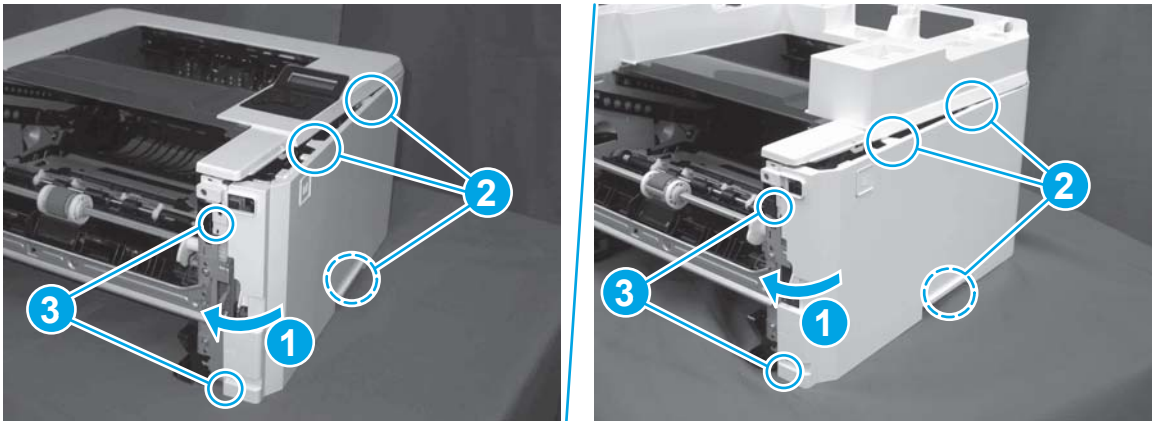
1. Position the cover (callout 1) on the printer, and then engage two bosses (callout 2).

**Figure 1-1835** Install the cover




2. Rotate the front of the cover onto the printer (callout 1), engage three (callout 2) tabs, and then engage two bosses (callout 3).

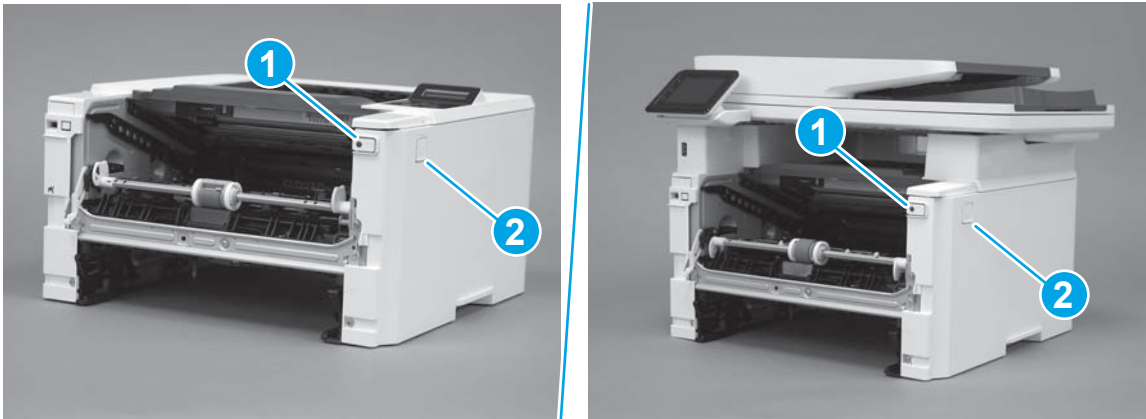
**Figure 1-1836** Engage two bosses and one tab



3. Make sure that the power switch (callout 1) and cartridge door assembly button (callout 2) correctly function.

 **NOTE:** Remove, and then reinstall the cover if the switch or button does not correctly function.

**Figure 1-1837** Check the power switch and cartridge door assembly button





4. Install one screw (callout 1).

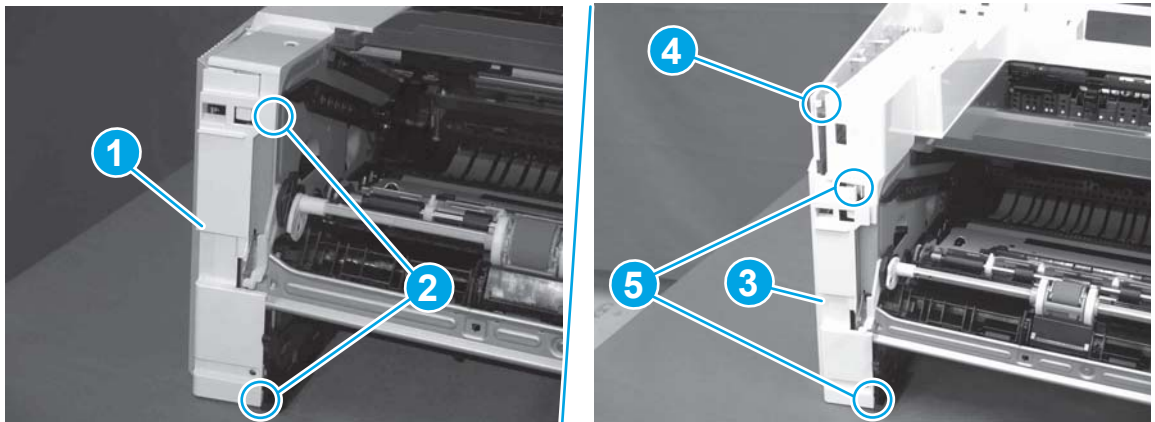
**Figure 1-1838** Install one screw



### Step 21: Install the left cover

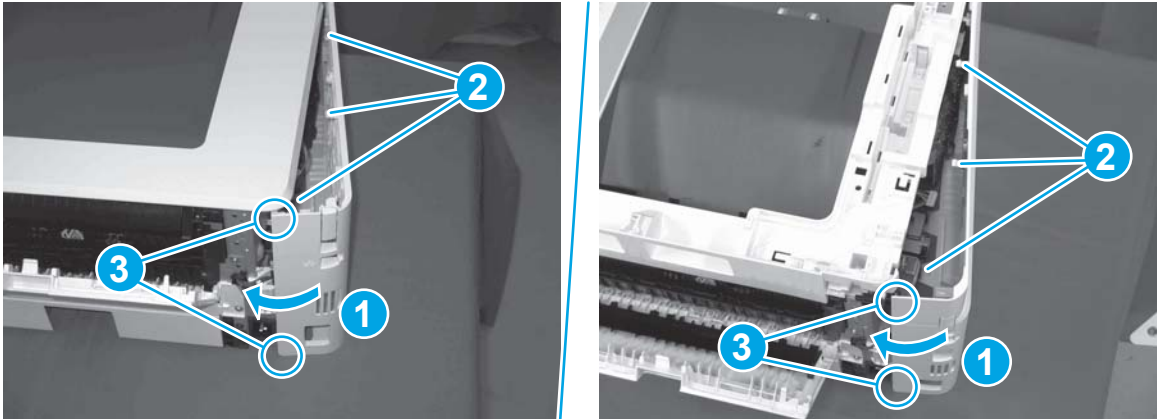
1. At the front of the printer, do one of the following:
  - **M403/M402:** Position the cover on the printer ( callout 1), and then engage two bosses (callout 2).
  - **M427/M426:** Position the cover on the printer (callout 3), engage one tab (callout 4), and then engage two bosses (callout 4).

**Figure 1-1839** Install the cover



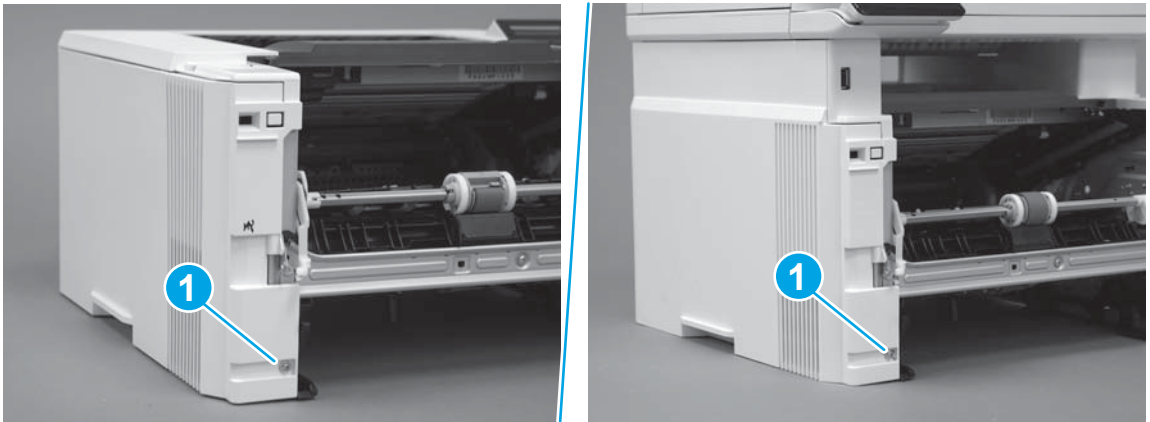
- Carefully rotate the rear of the cover onto the printer (callout 1), engage three tabs (callout 2), and then engage two bosses (callout 3).

**Figure 1-1840** Engage three tabs and two bosses




- Install one screw (callout 1).

**Figure 1-1841** Install one screw

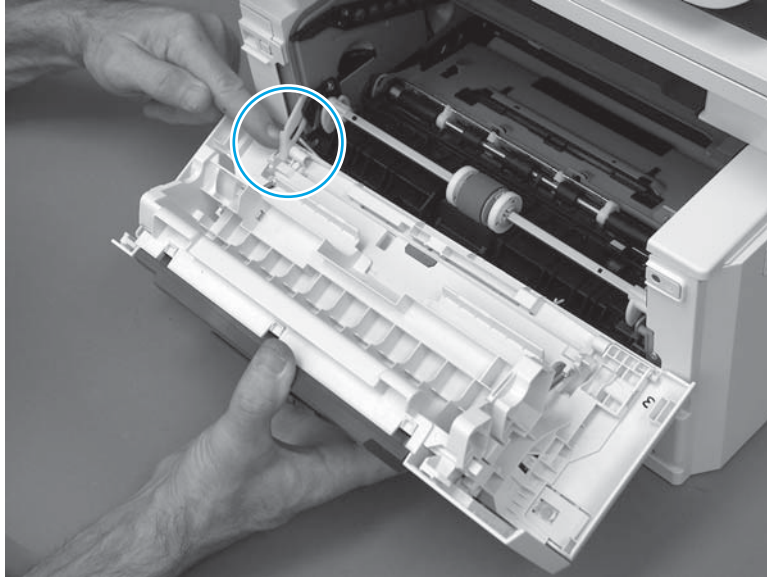


## Step 22: Install the cartridge door assembly

 **Reinstallation tip:** After a replacement door is installed, make sure to install the nameplate (supplied in the kit) corresponding to the printer name on the door.

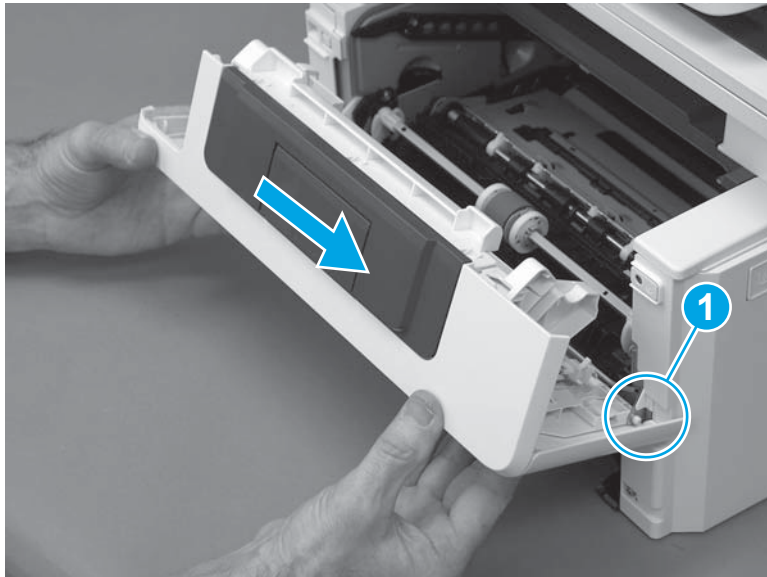
- Position the door close to the printer, and then engage the keyed pin on the left-side retainer arm with the hole in the door.

**Figure 1-1842** Engage the left-side retainer arm



2. Engage the right-side door hinge pin with the hole in the chassis (callout 1).

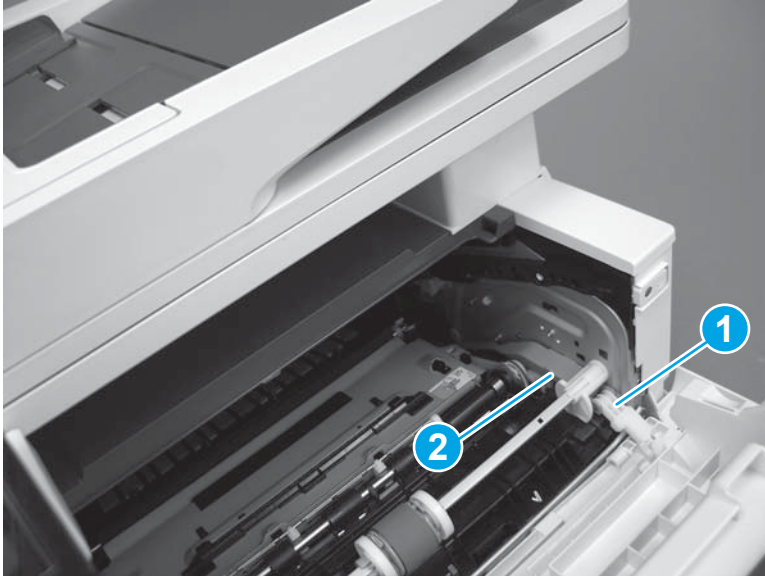
**Figure 1-1843** Install the door



3. Install the link (callout 1).

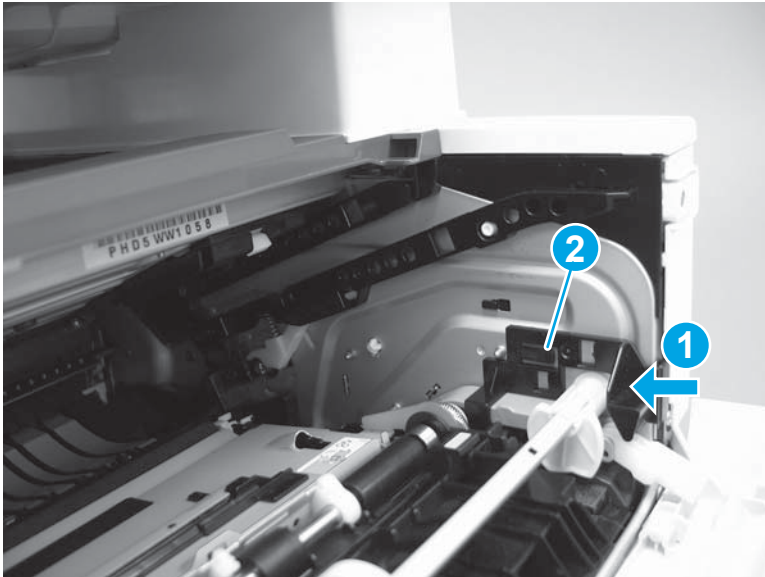
 **IMPORTANT:** Make sure that the link snaps into place on the arm (callout 2). The link actuates the fuser pressure-release mechanism.

**Figure 1-1844** Install the pressure-release link



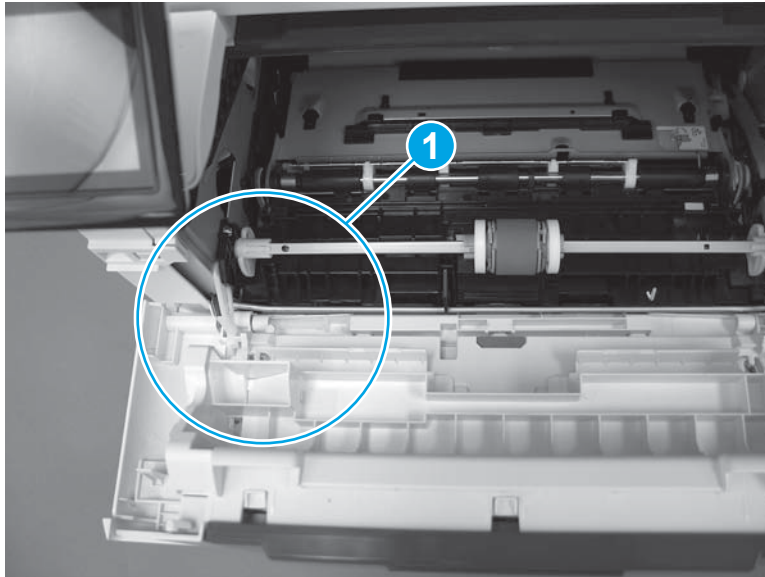
4. Slide the guide into the printer (callout 1), and then make sure that the tab (callout 2) snaps into place to secure the guide to the chassis.

**Figure 1-1845** Install the guide




5. Position the shaft on the door, and then align the left-side hinge on the door with the hole in the chassis (callout 1).

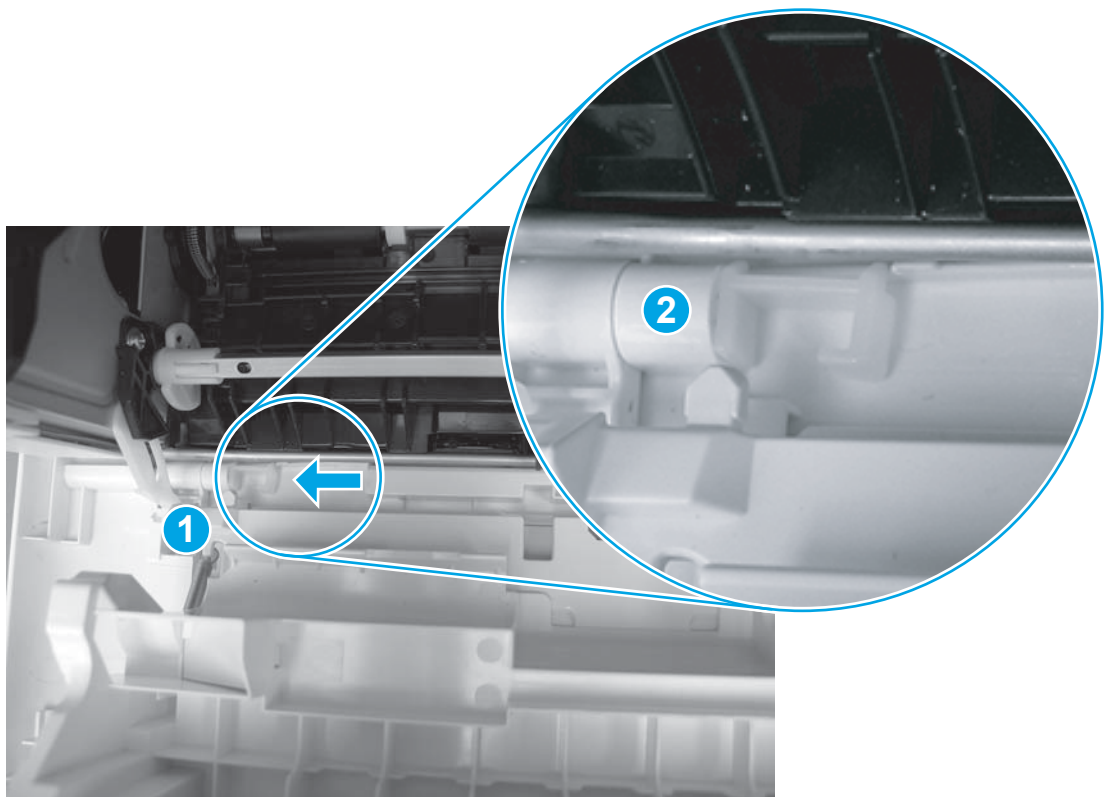
**Figure 1-1846** Align the hinge



6. Push the shaft towards the left side of the printer to install it (callout 1).

 **Reinstallation tip:** Make sure that the support shaft is fully installed and correctly orientated (callout 2) so that it will not interfere with the door opening and closing.

**Figure 1-1847** Install the support shaft



### Step 23: Install Tray 2

- ▲ Slide the tray straight into the printer to install it.

**Figure 1-1848** Install the tray



## Removal and replacement: Low-voltage power supply

- [Introduction](#)
- [Step 1: Remove Tray 2](#)
- [Step 2: Remove the cartridge door assembly](#)
- [Step 3: Remove the left cover](#)
- [Step 4: Remove the right cover](#)
- [Step 5: Remove the integrated scanner assembly \(M427/M246\)](#)
- [Step 6: Remove the control panel \(M427/M246\)](#)
- [Step 7: Remove the top cover \(M427/M426\)](#)
- [Step 8: Remove the top cover \(M403/M402\)](#)
- [Step 9: Remove the paper delivery tray \(output bin\)](#)
- [Step 10: Remove the fan \(FM1\)](#)
- [Step 11: Remove the sheet-metal formatter bracket and formatter PCA](#)
- [Step 12: Remove the LVPS](#)
- [Step 13: Unpack the replacement assembly](#)
- [Step 14: Install the LVPS](#)
- [Step 15: Install the sheet-metal formatter bracket and formatter PCA](#)
- [Step 16: Install the fan \(FM1\)](#)
- [Step 17: Install the paper delivery tray \(output bin\)](#)
- [Step 18: Install the top cover \(M403/M402\)](#)
- [Step 19: Install the top cover \(M427/M426\)](#)
- [Step 20: Install the control panel \(M427/M246\)](#)
- [Step 21: Install the integrated scanner assembly \(M427/M246\)](#)
- [Step 23: Install the right cover](#)
- [Step 24: Install the left cover](#)
- [Step 25: Install the cartridge door assembly](#)
- [Step 26: Install Tray 2](#)


### Introduction

This document provides the procedures to remove and replace the low-voltage power supply (LVPS).

## Before performing service

### Turn the printer power off

- Disconnect the power cable.

 **WARNING!** To avoid damage to the printer, turn the printer off, wait 30 seconds, and then remove the power cable before attempting to service the printer.

Use the table below to identify the correct part number for your printer. To order the part, go to [www.hp.com/buy/parts](http://www.hp.com/buy/parts).

Low-voltage power supply (LVPS) part number	
RM2-8518-000CN	Low-voltage power supply (M427/M426; 110V-127V)
RM2-8519-000CN	Low-voltage power supply (M427/M426; 220V-240V)
RM2-8516-000CN	Low-voltage power supply (M403/M402; 110V-127V)
RM2-8517-000CN	Low-voltage power supply (M403/M402; 220V-240V)

### Required tools

- #2 Phillips screwdriver with a magnetic tip.

### After performing service

#### Turn the printer power on

- Connect the power cable.
- Use the power switch to turn the power on.

### Post service test

Make sure that the printer initializes to a **Ready** state.

Print a configuration page to make sure that the printer is functioning correctly.

### Step 1: Remove Tray 2

- ▲ Pull the tray straight out of the printer to remove it.



**Figure 1-1849** Remove the tray



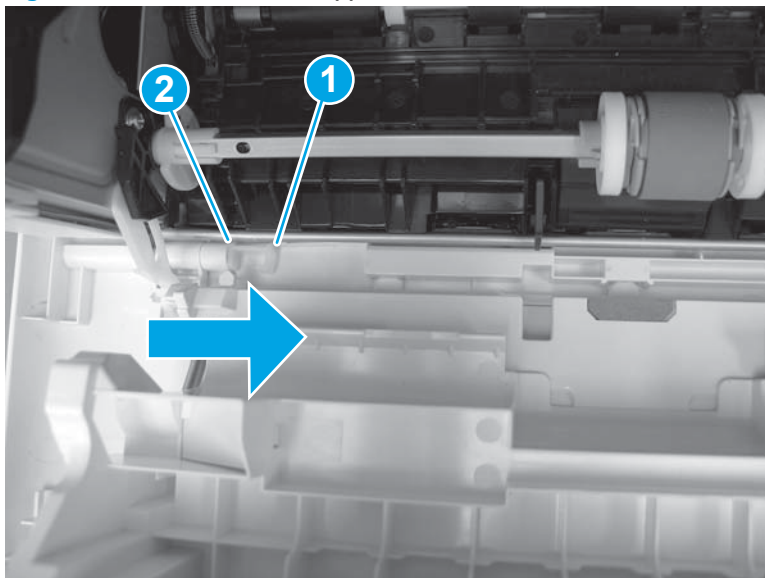
**Step 2: Remove the cartridge door assembly**

 **NOTE:** If the toner cartridge was not removed prior to servicing the printer, remove it now.

1. Release one tab (callout 1), and then slide shaft (callout 2) in the direction the arrow indicates and remove it.

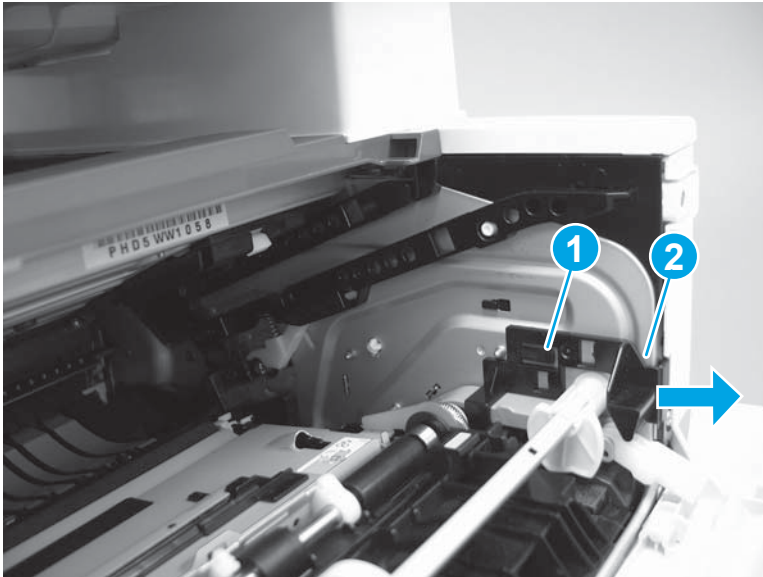
 **TIP:** It might be easier to release the support shaft by using a small flat-blade screwdriver.

**Figure 1-1850** Release the support shaft



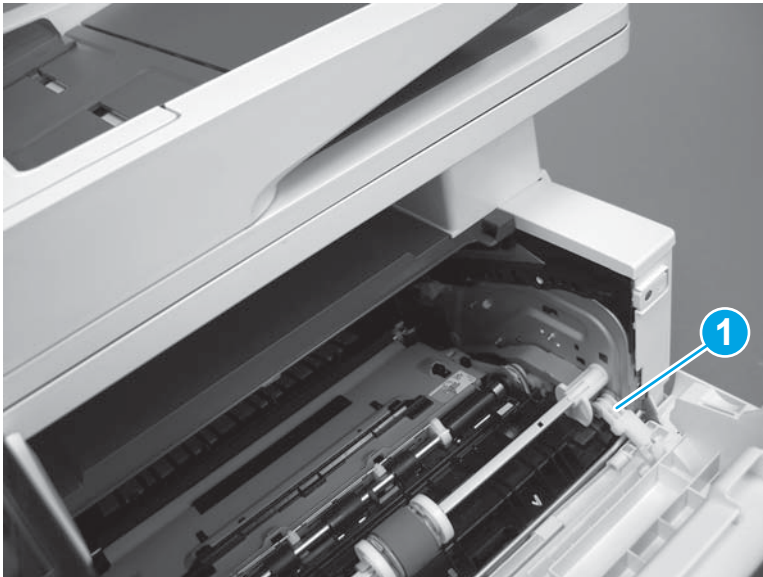
2. Release one tab (callout 1), and then slide the guide (callout 2) in the direction the arrow indicates and remove it.

**Figure 1-1851** Remove the guide



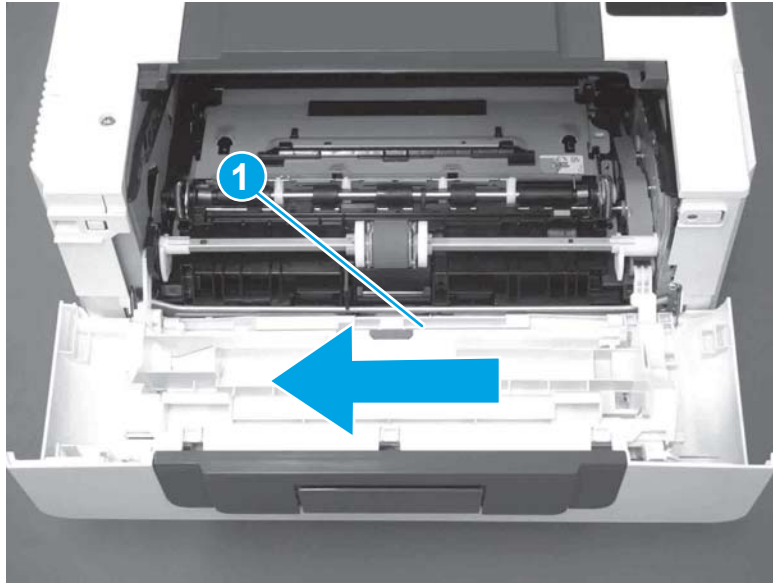
3. Remove the link arm (callout 1).

**Figure 1-1852** Remove the link arm



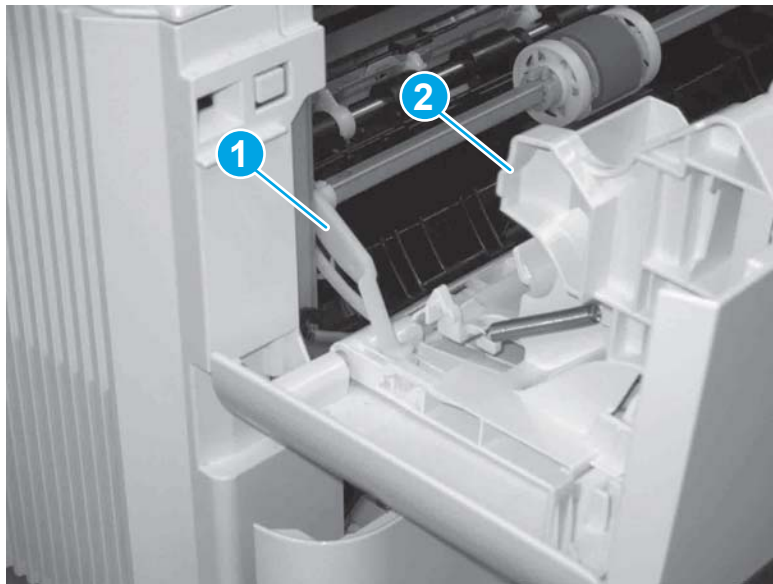
4. Slide the cartridge door assembly (callout 1) in the direction the arrow indicates and remove it.

**Figure 1-1853** Remove the door



5. Remove the link (callout 1) from the cartridge door assembly (callout 2).

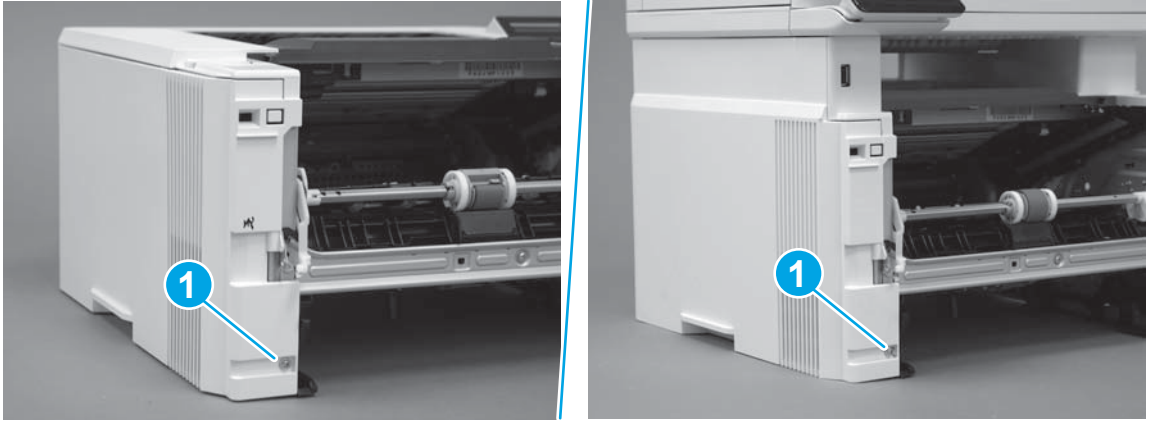
**Figure 1-1854** Release the left-side retainer arm



### Step 3: Remove the left cover

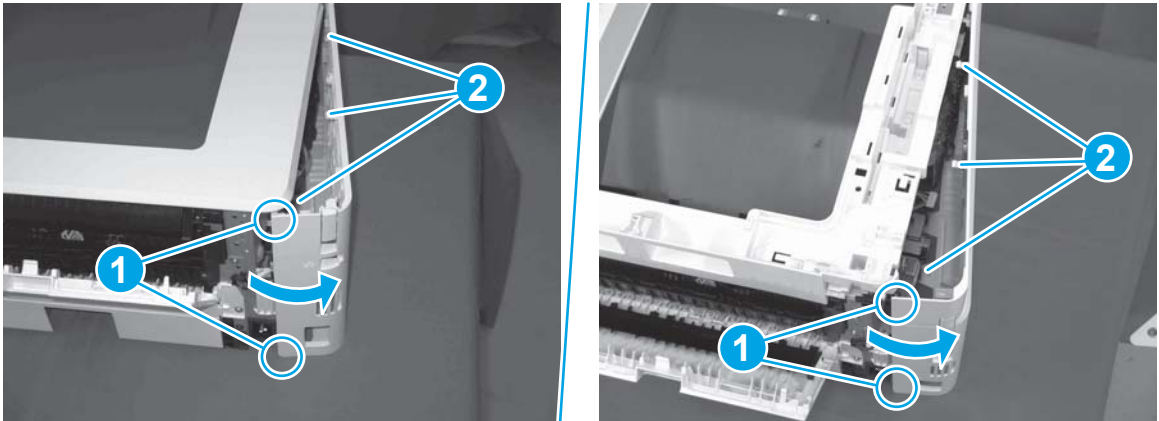
1. Remove one screw (callout 1).

**Figure 1-1855** Remove one screw



2. Open the rear door, release two bosses (callout 1), and then release three tabs (callout 2).

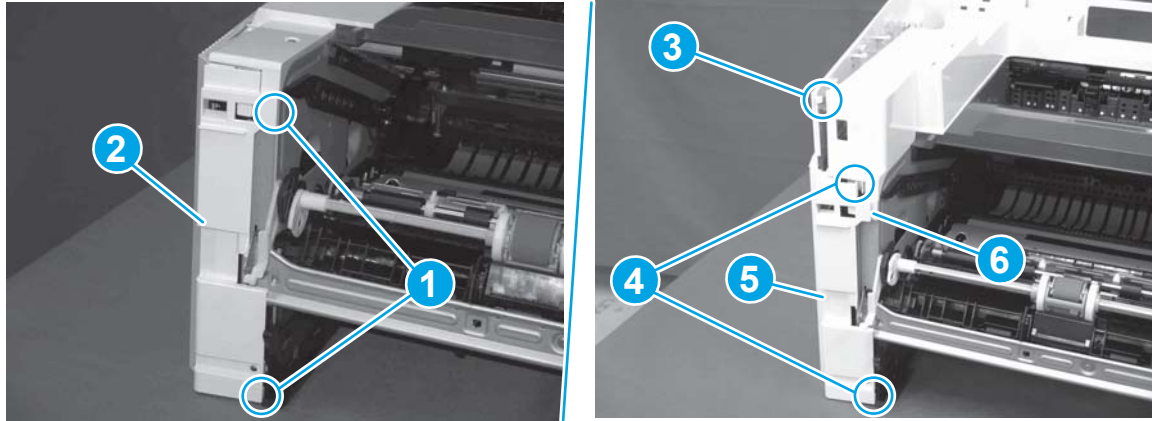
**Figure 1-1856** Release two bosses and three tabs



3. At the front of the printer, do one of the following:
  - **M403/M402:** Release two bosses (callout 1), and then remove the cover (callout 2).
  - **M427/M426:** Release one tab (callout 3), two bosses (callout 4), and then remove the cover (callout 5).

**CAUTION:** Be careful when releasing the upper bosses on the M427/M426 cover. One portion of the cover (callout 6) is fragile and is easily broken.

**Figure 1-1857** Remove the cover



**Step 4: Remove the right cover**

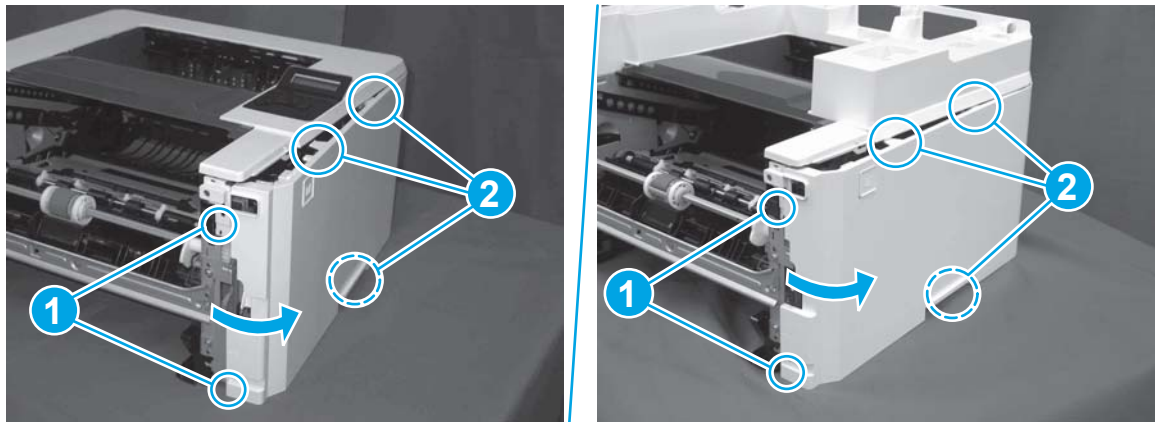
1. Remove one screw (callout 1).

**Figure 1-1858** Remove one screw



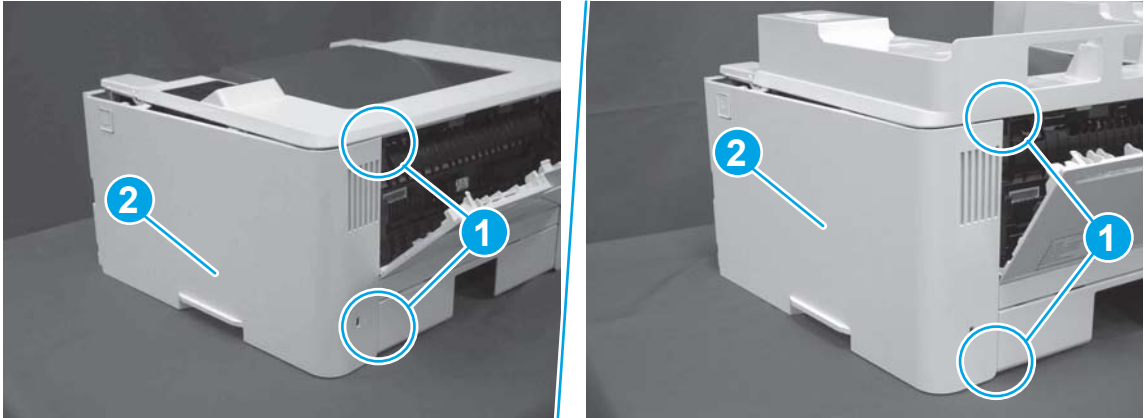
2. At the front of the printer, release two bosses (callout 1), and then release three tabs (callout 2).

**Figure 1-1859** Release two bosses and three tabs





3. Open the rear door, release two bosses (callout 1), and then remove the cover (callout 2).

**Figure 1-1860** Remove the cover



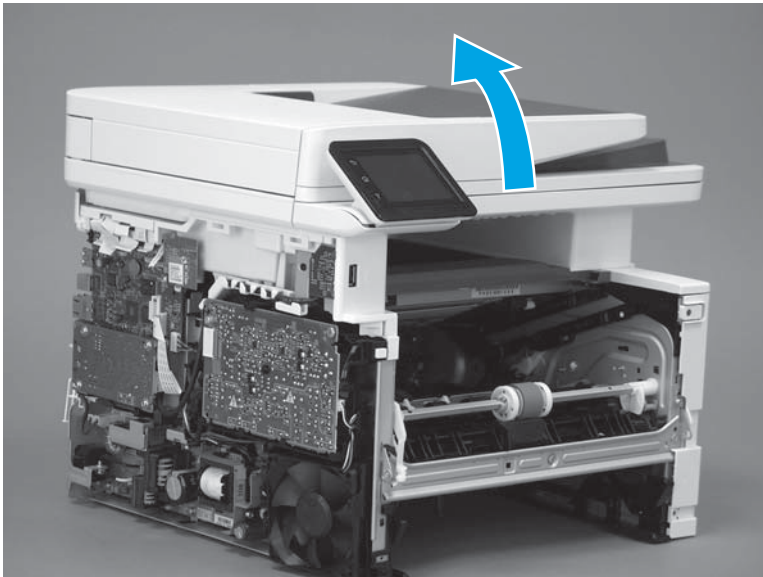
### Step 5: Remove the integrated scanner assembly (M427/M246)

 **NOTE:** The step is for the M427/M426 printer. For the M403/M402, skip this step and go to [Step 8: Remove the top cover \(M403/M402\) on page 994](#).

 **NOTE:** M427/M426 models only. The integrated scanner assembly (ISA) includes the sub-scanner assembly (SSA) and the automatic document feeder (ADF).

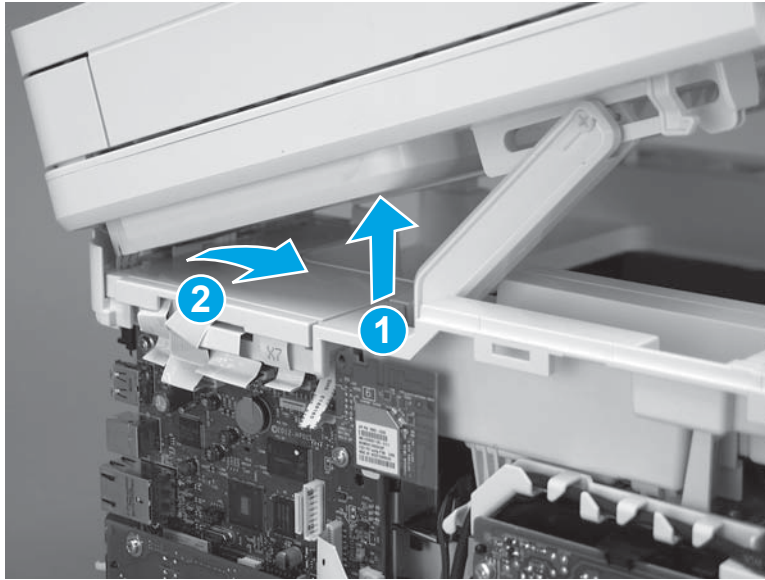
1. Raise the ISA.

**Figure 1-1861** Raise the ISA



2. Release the ISA flat-flexible cable (FFC) cover (callout 1), and then remove it (callout 2).

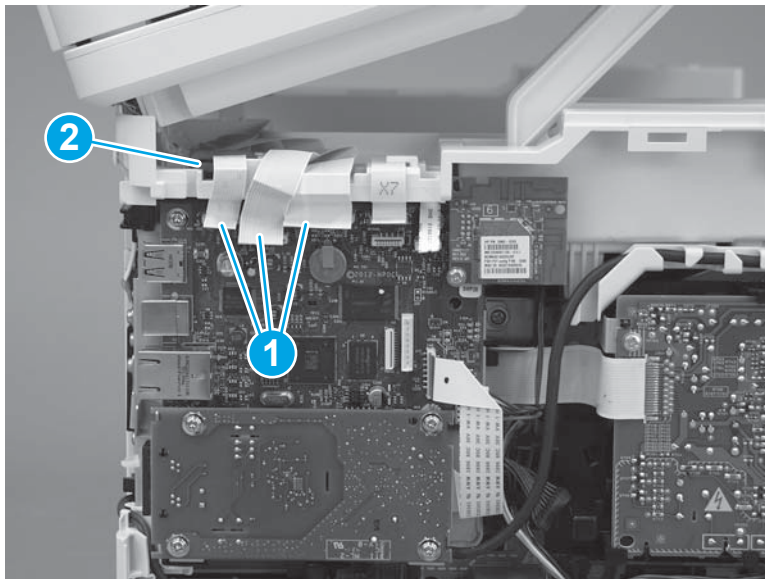
**Figure 1-1862** Remove the ISA FFC cover



3. Disconnect three FFCs (callout 1), and then remove the ferrite (callout 2) from the holder.

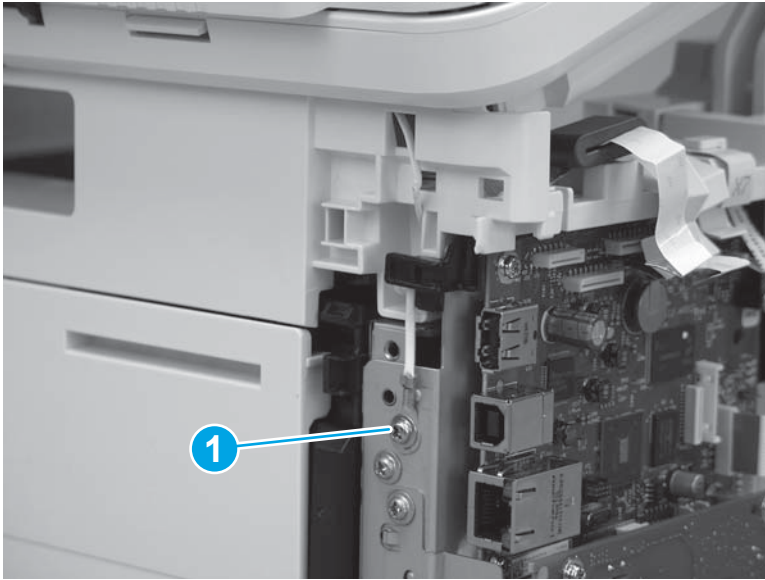
**CAUTION:** The ferrite is not captive on the FFC. Do not lose the ferrite while handling the ISA.

**Figure 1-1863** Disconnect three FFCs



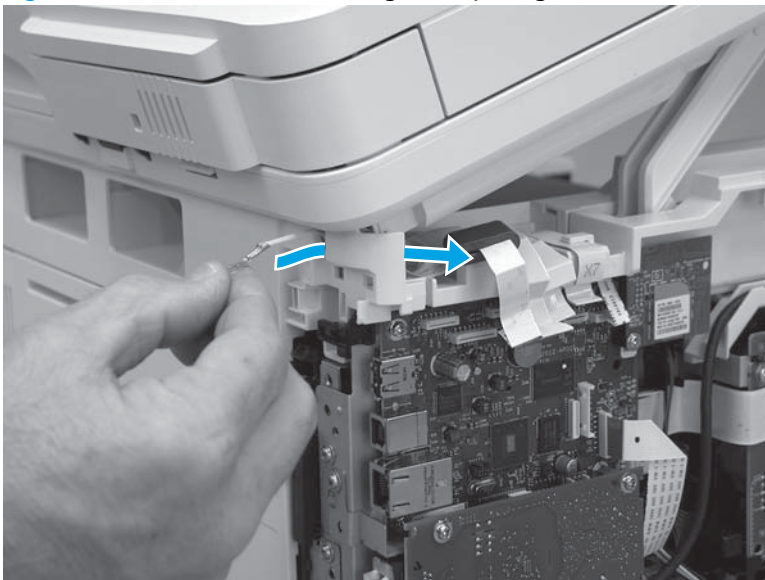
4. Remove one screw (callout 1).

**Figure 1-1864** Remove one screw



5. Pass the ground wire through the opening in the top cover.

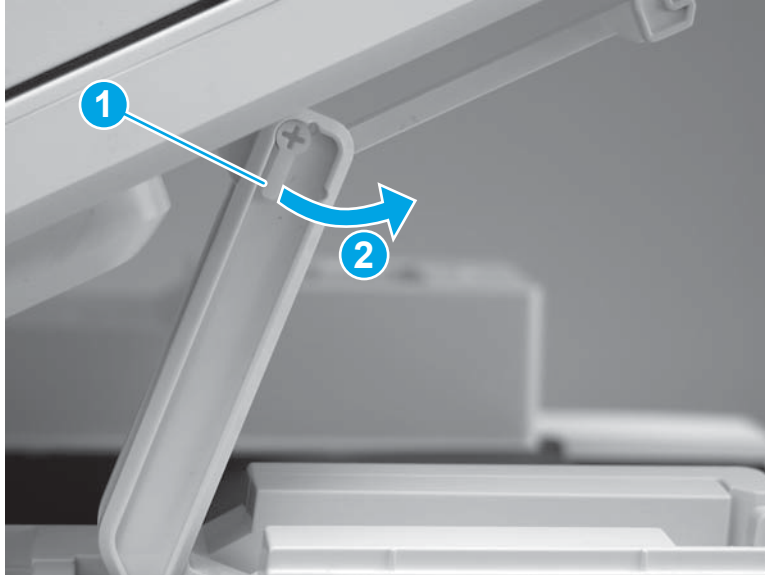
**Figure 1-1865** Pass the wire through the opening





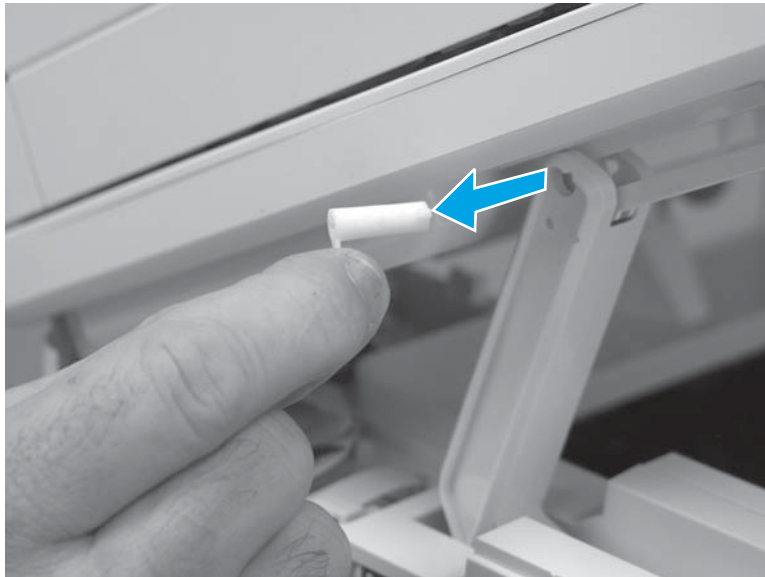
6. Release one tab (callout 1), and then rotate the ISA slider pin (callout 2) towards the front of the printer to release it.

**Figure 1-1866** Release one tab and rotate the slider pin



7. Remove the slider pin.

**Figure 1-1867** Remove the slider pin



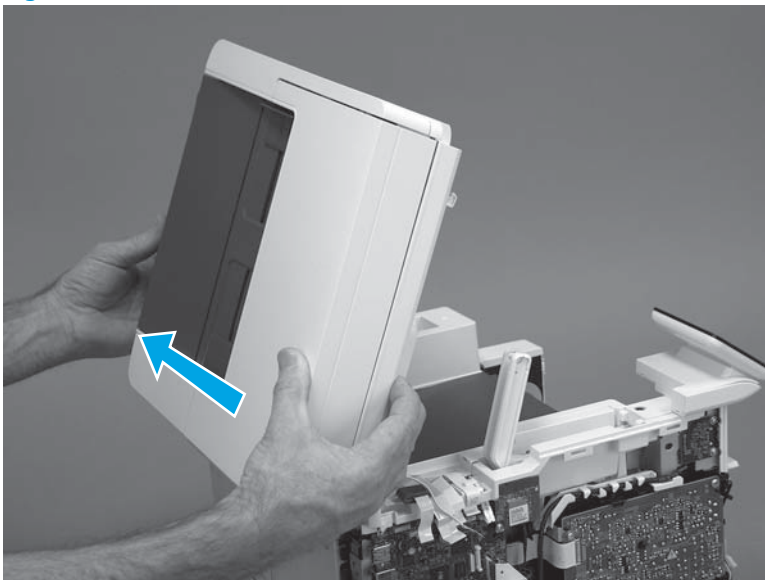
8. Rotate the ISA towards the rear of the printer until it stops.

**Figure 1-1868** Rotate the ISA towards the rear of the printer



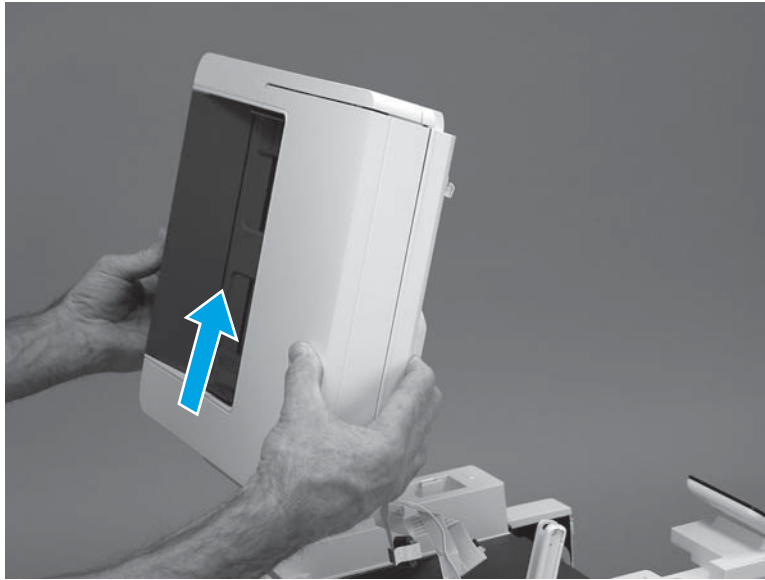
9. Slide the ISA as shown to release it.

**Figure 1-1869** Release the ISA




10. Remove the ISA.

**Figure 1-1870** Remove the ISA

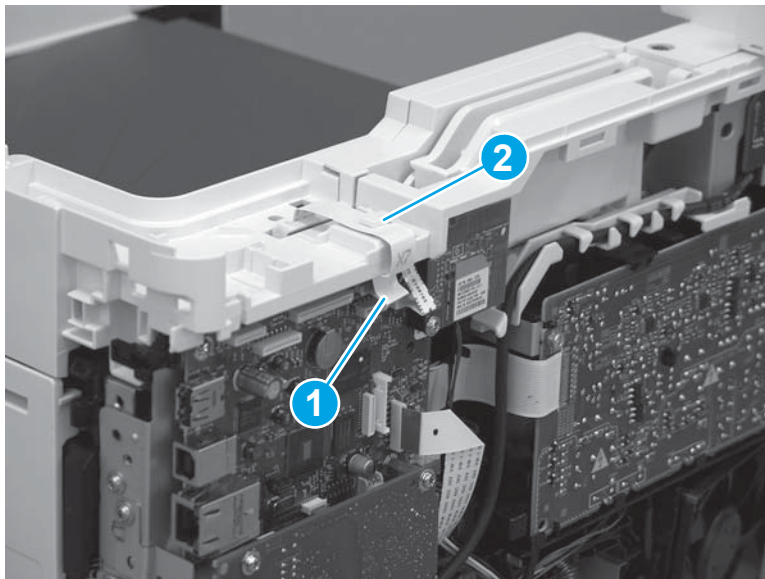


#### Step 6: Remove the control panel (M427/M246)

 **NOTE:** The step is for the M427/M426 printer. For the M403/M402, skip this step and go to [Step 8: Remove the top cover \(M403/M402\) on page 994](#).

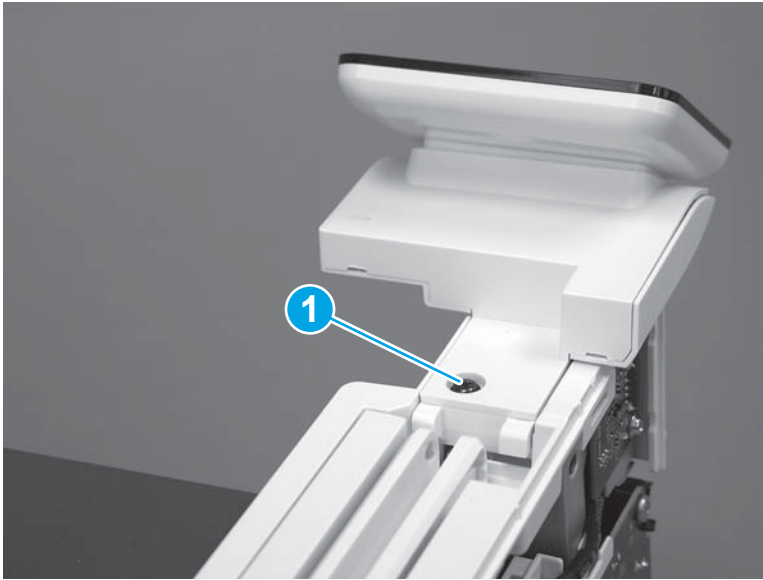
1. Disconnect one FFC (callout 1; J114), and then release the FFC from the retainer (callout 2).

**Figure 1-1871** Disconnect one connector



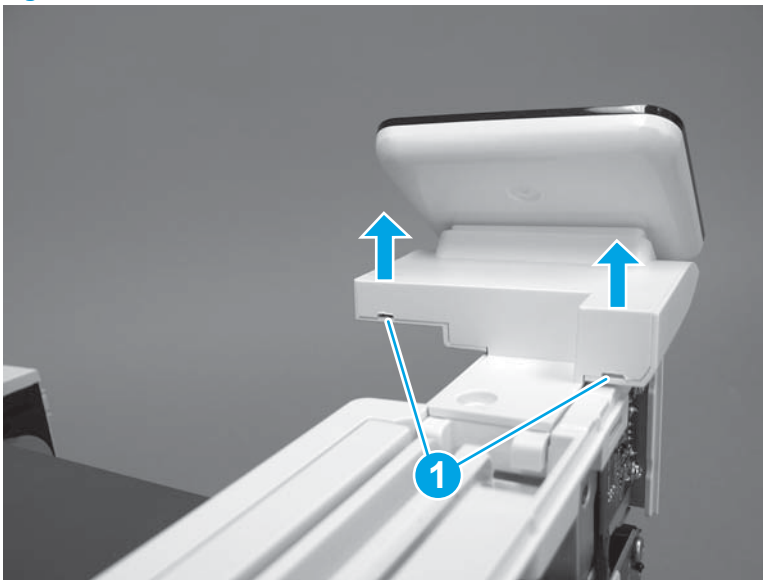
2. Remove one screw (callout 1).

**Figure 1-1872** Remove one screw



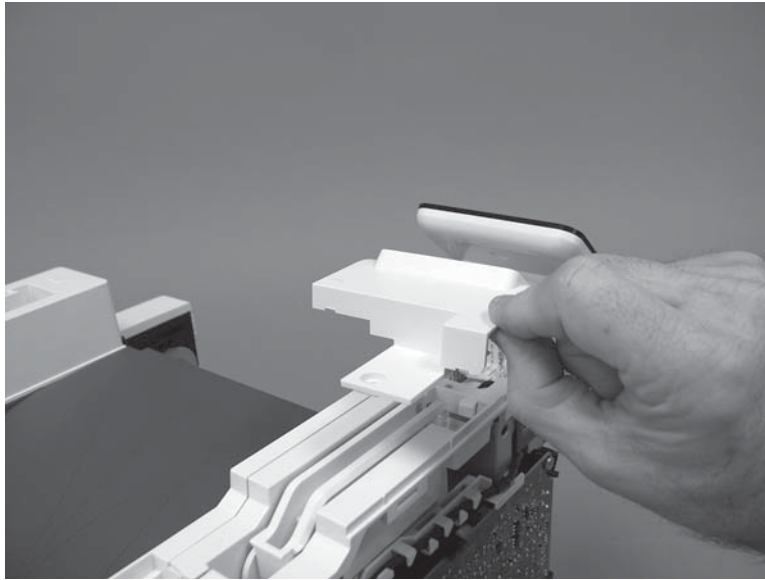
3. Use a small flat-blade screwdriver to release two tabs (callout 1) on the control-panel cable cover.

**Figure 1-1873** Release two tabs



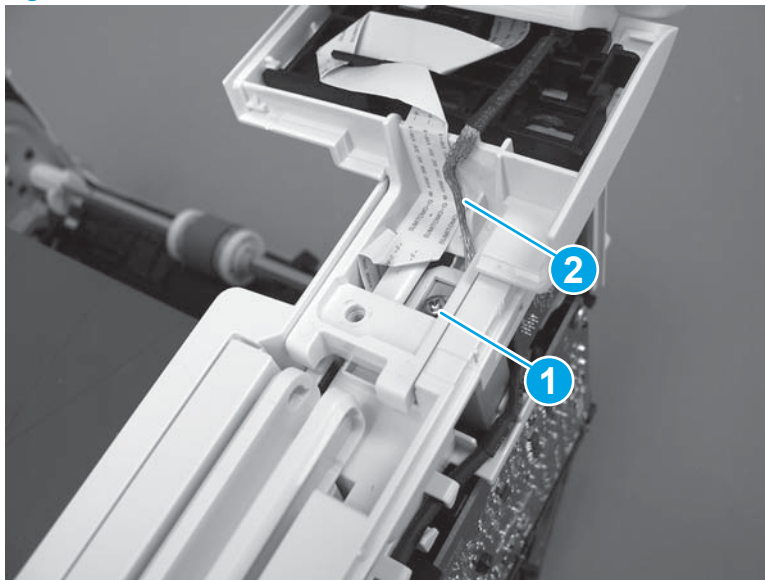
4. Remove the control-panel cable cover.

**Figure 1-1874** Remove the cover



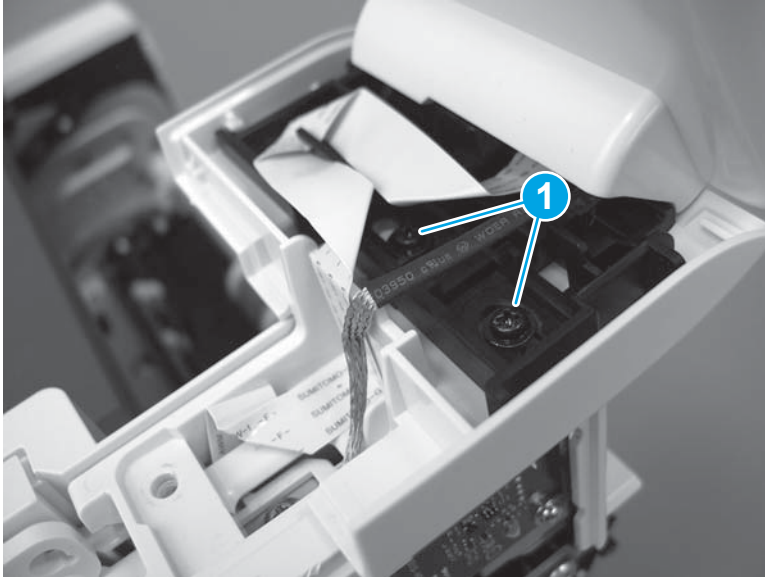
5. Remove one grounding screw (callout 1), and then move the ground cable (callout 2) out of the way.

**Figure 1-1875** Remove one screw



6. Move the FFC out of the way, and then remove two screws (callout 1).

**Figure 1-1876** Remove two screws



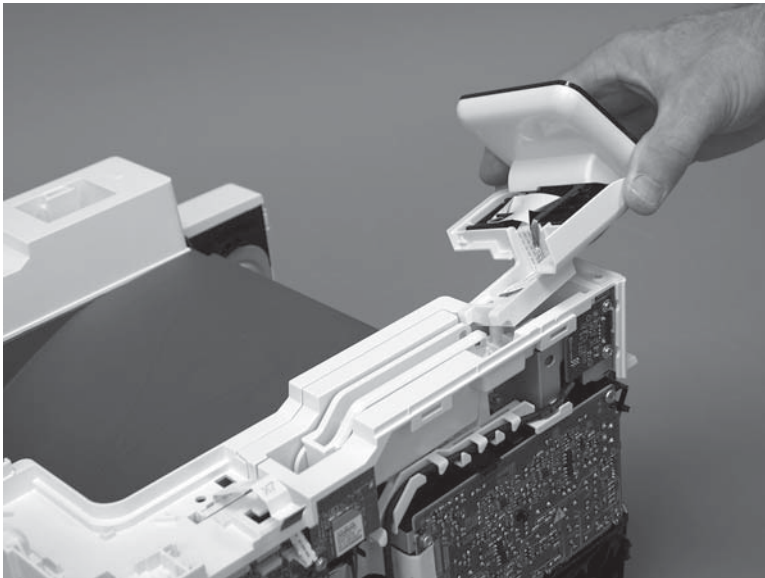
7. Slightly lift up the control-panel assembly to separate it from the top cover.

---

**CAUTION:** The control panel assembly is still connected to the printer by the FFC. Do not attempt to completely remove the assembly.

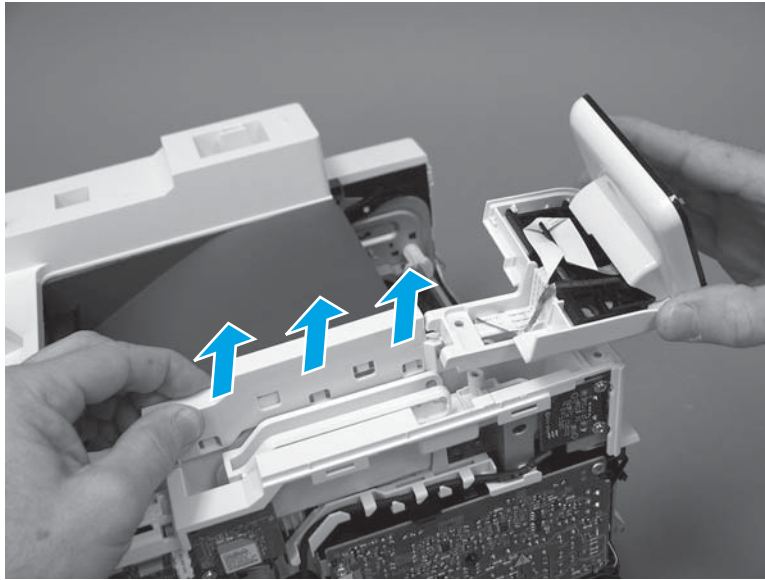
---

**Figure 1-1877** Lift up the control-panel assembly




8. Lift up the control-panel FFC cover to remove the control-panel assembly.

**Figure 1-1878** Remove the control-panel assembly

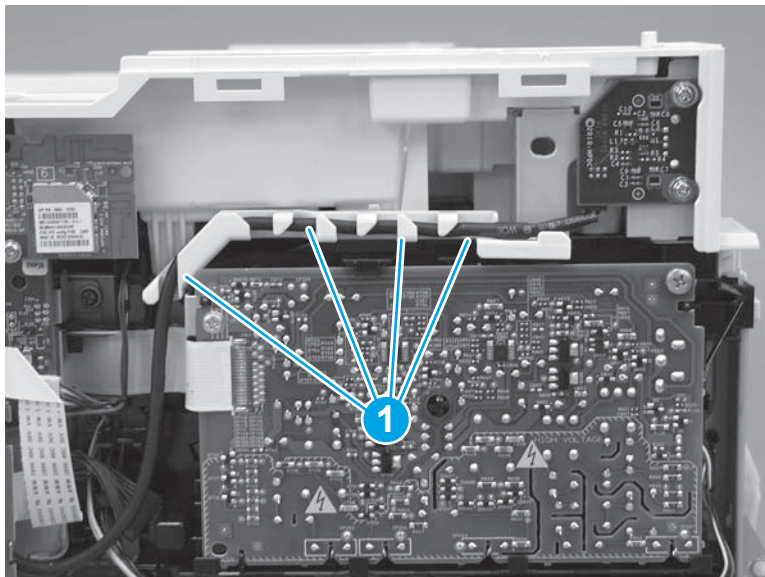


#### Step 7: Remove the top cover (M427/M426)

 **NOTE:** The step is for the M427/M426 printer. For the M403/M402, skip this step and go to [Step 8: Remove the top cover \(M403/M402\) on page 994](#).

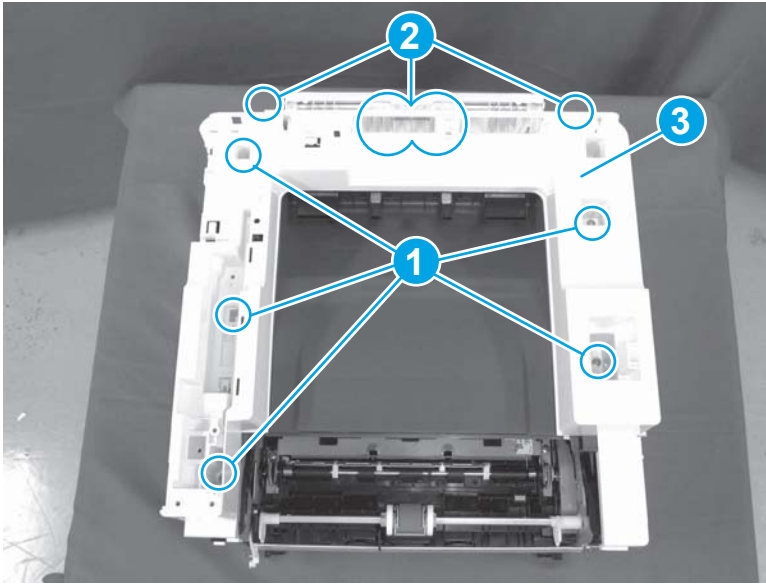
1. Release the USB cable (callout 1) from the cable guide.

**Figure 1-1879** Remove the USB cable



2. Remove five screws (callout 1), release four bosses (callout 2), and then remove the top cover (callout 3).

**Figure 1-1880** Remove the cover



### Step 8: Remove the top cover (M403/M402)



**NOTE:** The step is for the M403/M402 printer. For the M427/M426, skip this step and go to [Step 9: Remove the paper delivery tray \(output bin\) on page 995](#).

1. Remove one screw (callout 1).

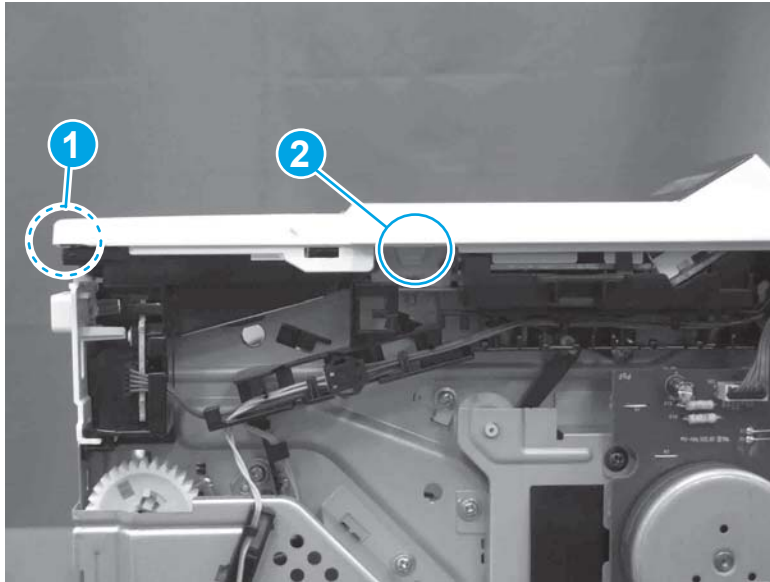
**Figure 1-1881** Remove one screw






2. At the right side of the printer, release the one boss (callout 1), and then release one tab (callout 2).

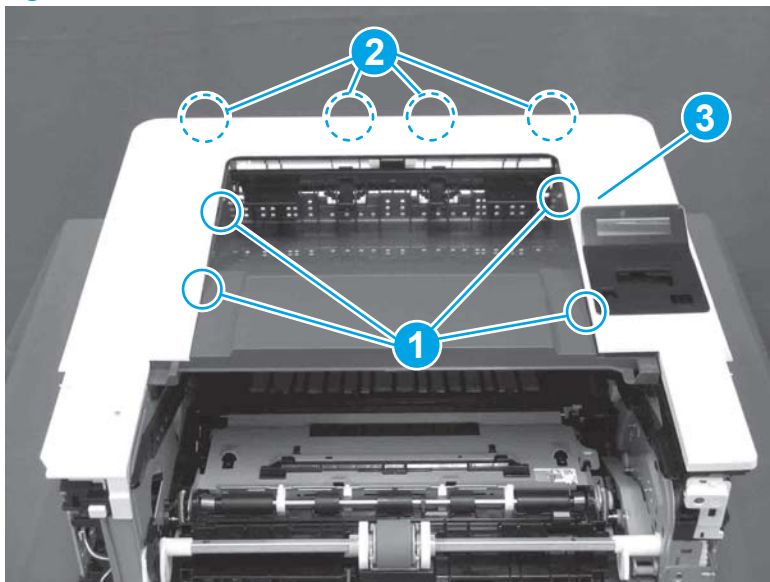
**Figure 1-1882** Release one boss and one tab




3. Release four tabs (callout 1), release four bosses (callout 2), and then remove the top cover (callout 3).

 **TIP:** Open the rear door to make releasing the bosses (callout 3) easier.

**Figure 1-1883** Remove the cover

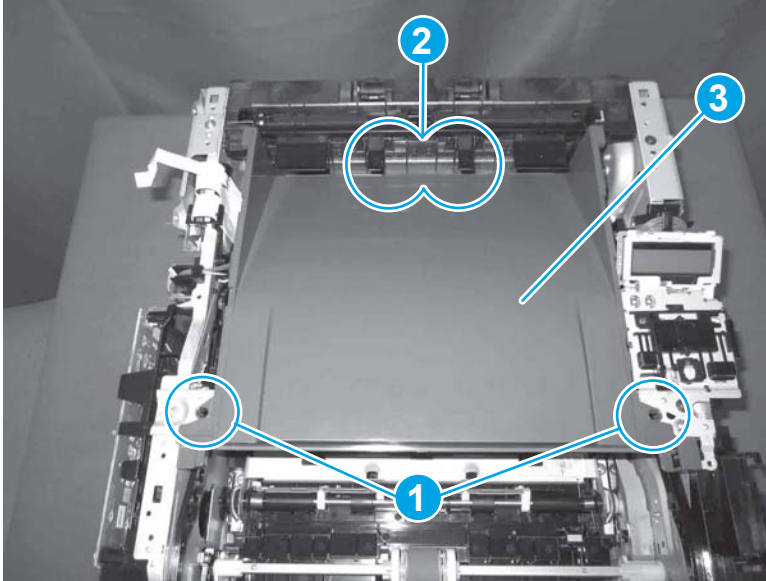


### Step 9: Remove the paper delivery tray (output bin)

 **NOTE:** This procedure shows the M403/M402 model, however, the paper delivery tray (output bin) removal is similar for the M427/M426 printer.

- ▲ Release two bosses (callout 1), release two tabs (callout 2), and then remove the paper delivery tray (output bin; callout 3).

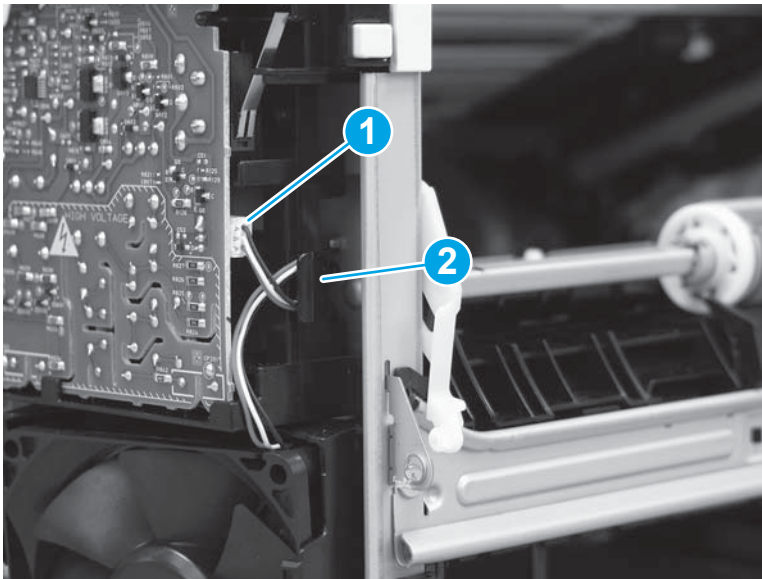
**Figure 1-1884** Release two tabs



**Step 10: Remove the fan (FM1)**

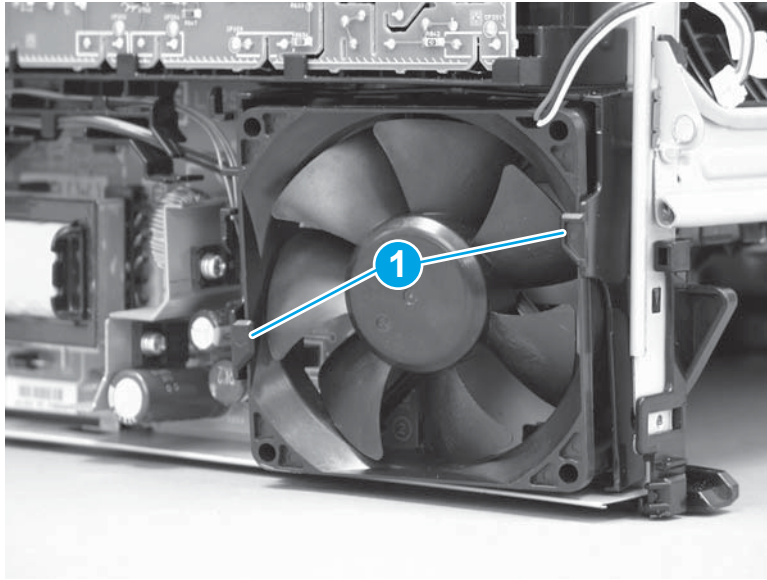
1. Disconnect one connector (callout 1), and then release the wire harness from the retainer (callout 2).

**Figure 1-1885** Disconnect one connector



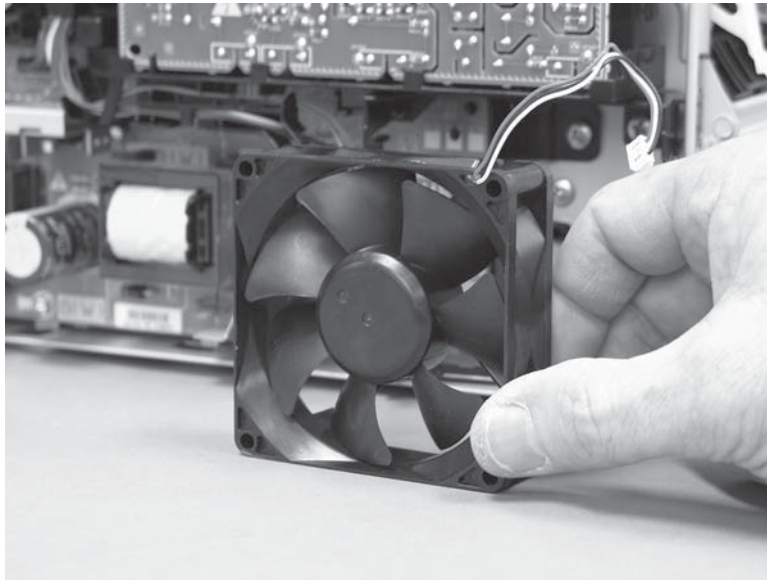
2. Release two tabs (callout 1).

**Figure 1-1886** Release two tabs



3. Remove the fan.

**Figure 1-1887** Remove the fan



### Step 11: Remove the sheet-metal formatter bracket and formatter PCA

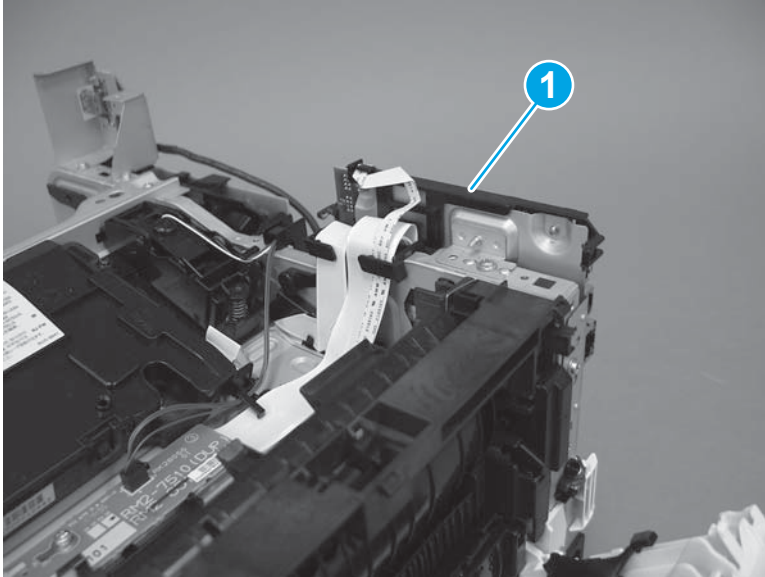
---

 **NOTE:** Disconnect any remaining formatter PCA FFCs or wire-harness connectors.

---

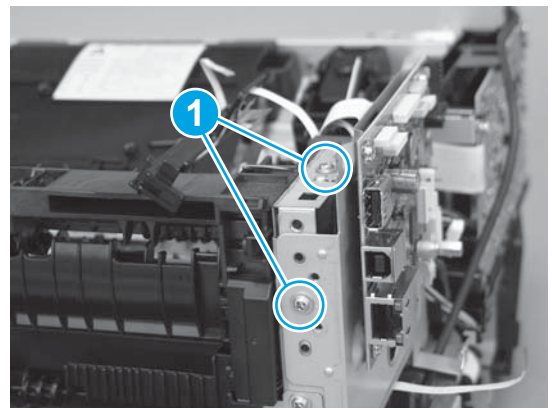
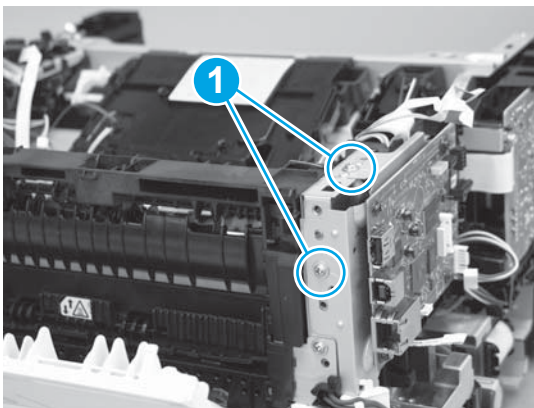
1. **M427/M426 only:** Remove the guide (callout 1).

**Figure 1-1888** Remove the guide



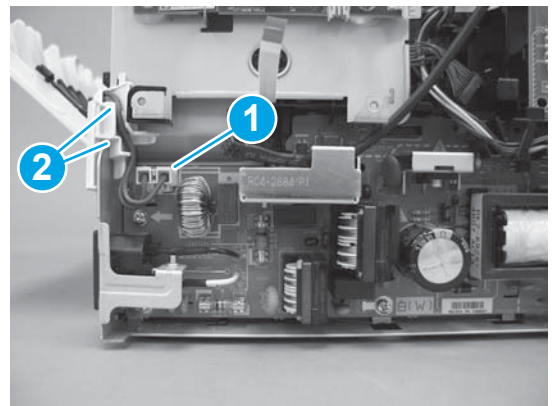
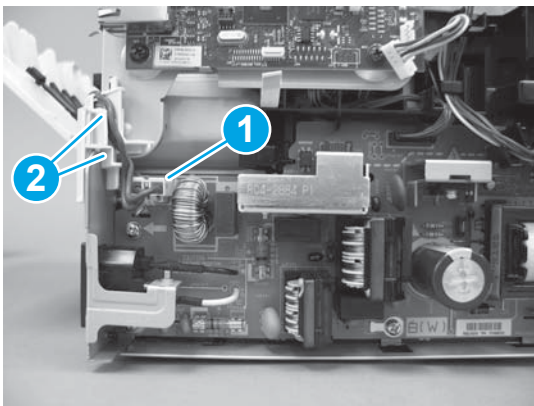
2. Remove two screws (callout 1).

**Figure 1-1889** Remove two screws



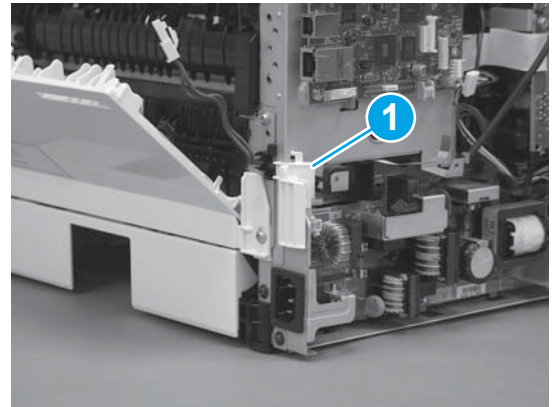
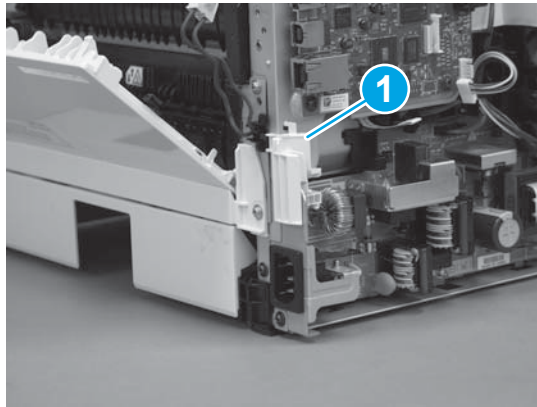
3. Disconnect one connector (callout 1), and then release the wire harness from the guide (callout 2).

**Figure 1-1890** Disconnect one connector



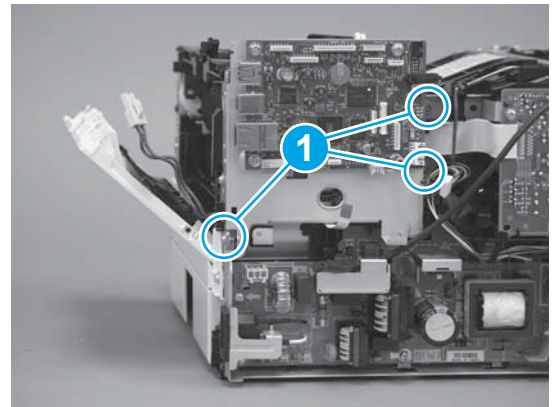
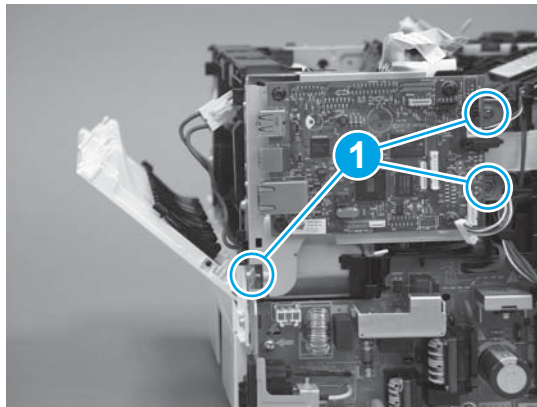
4. Remove the guide (callout 1).

**Figure 1-1891** Remove the guide



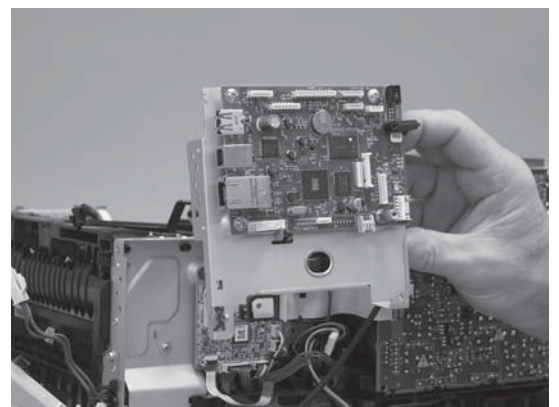
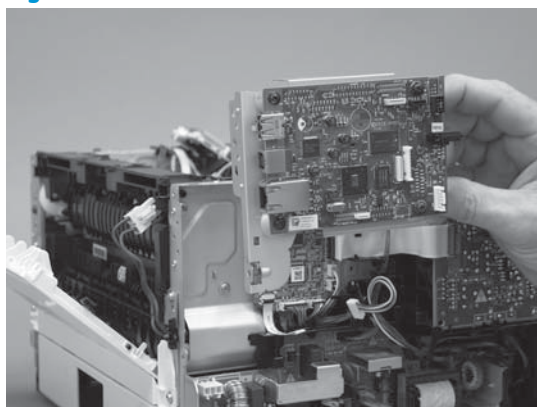
5. Remove three screws (callout 1).

**Figure 1-1892** Remove three screws



6. Remove the sheet-metal bracket and formatter PCA.

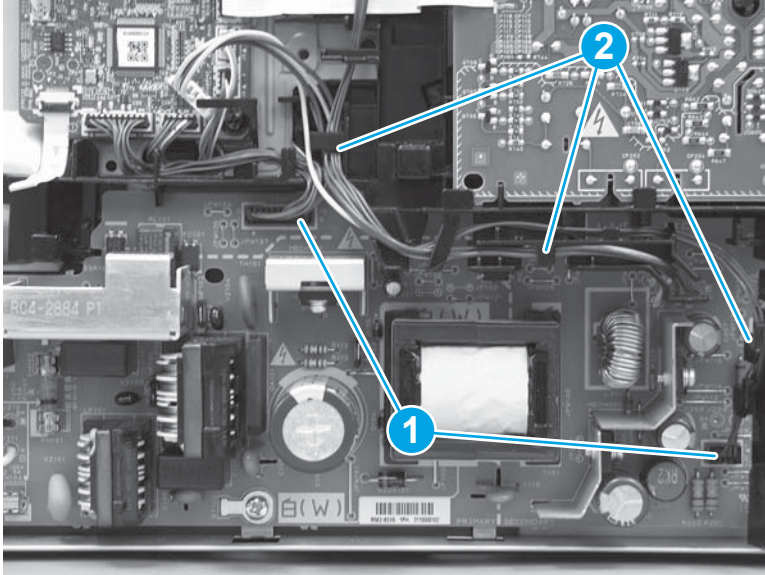
**Figure 1-1893** Remove the bracket



## Step 12: Remove the LVPS

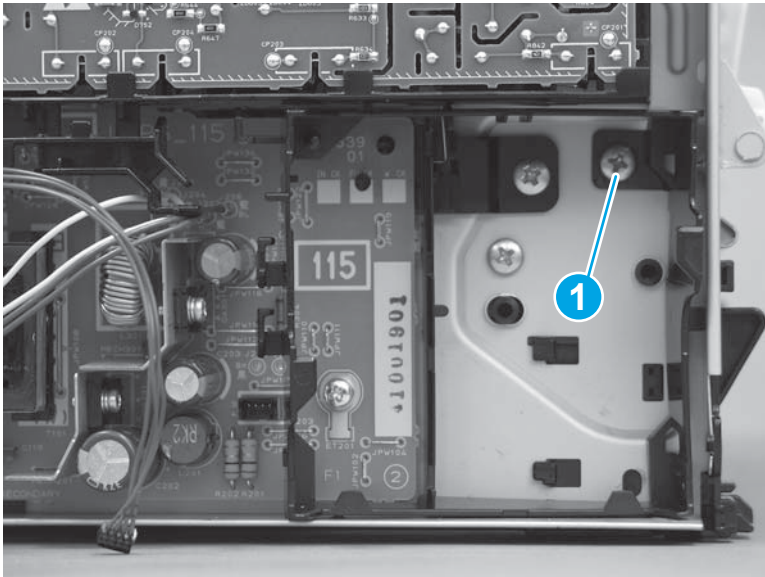
1. Disconnect two connectors (callout 1) on the LVPS, and then release the wire harnesses from the guides (callout 2).

**Figure 1-1894** Disconnect two connectors




2. Remove one screw (callout 1).

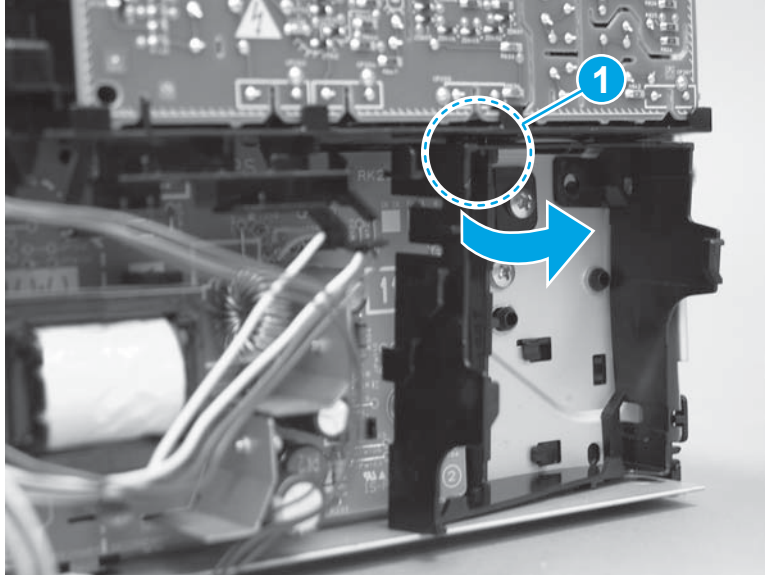
**Figure 1-1895** Remove one screw



3. Release one tab at the top-left side of the fan holder (callout 1), and then rotate the top-left side corner of the holder away from the printer.

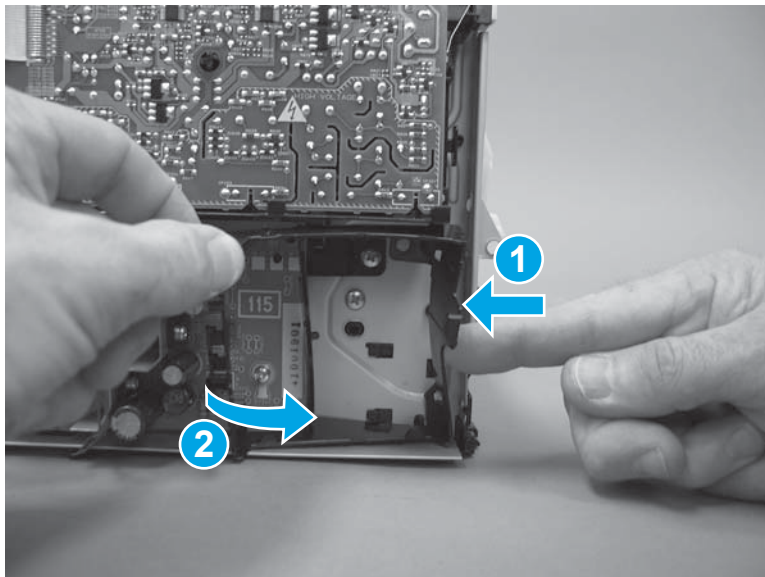
 **Reinstallation tip:** Use a flat-blade screwdriver to slightly flex the top of the holder down to make it easier to disengage this tab.

**Figure 1-1896** Release one tab



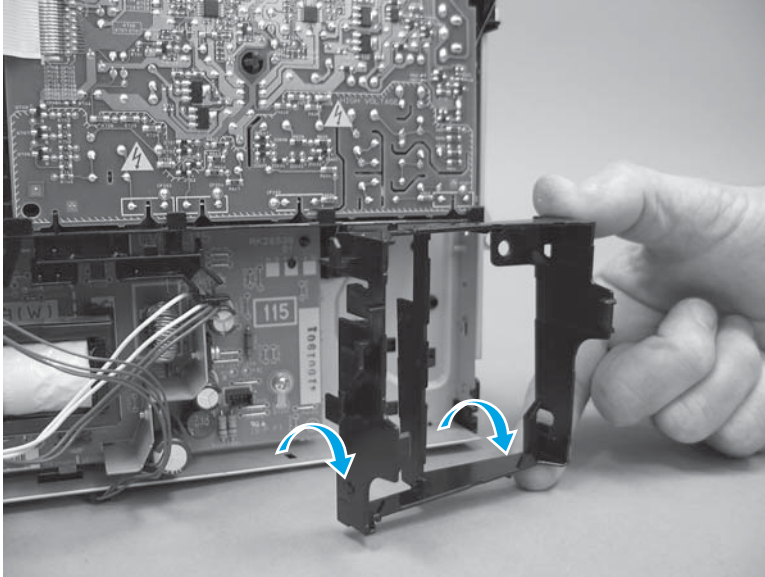
4. Slightly flex the right side of the holder to release one tab (callout 1), and then rotate the top of the holder away from the printer (callout 2).

**Figure 1-1897** Release one tab



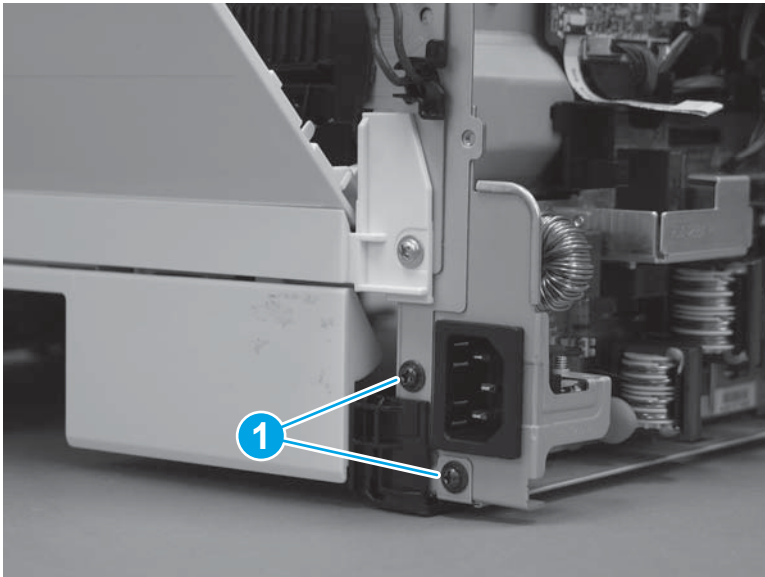
5. Lift the holder up to release two alignment tabs on the bottom of the holder, and then remove the holder.

**Figure 1-1898** Remove the holder



6. Remove two screws (callout 1).

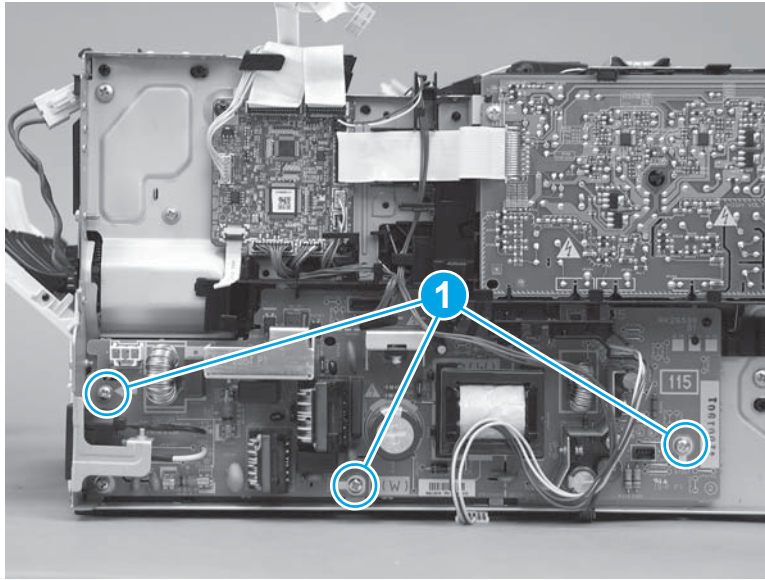
**Figure 1-1899** Remove two screws





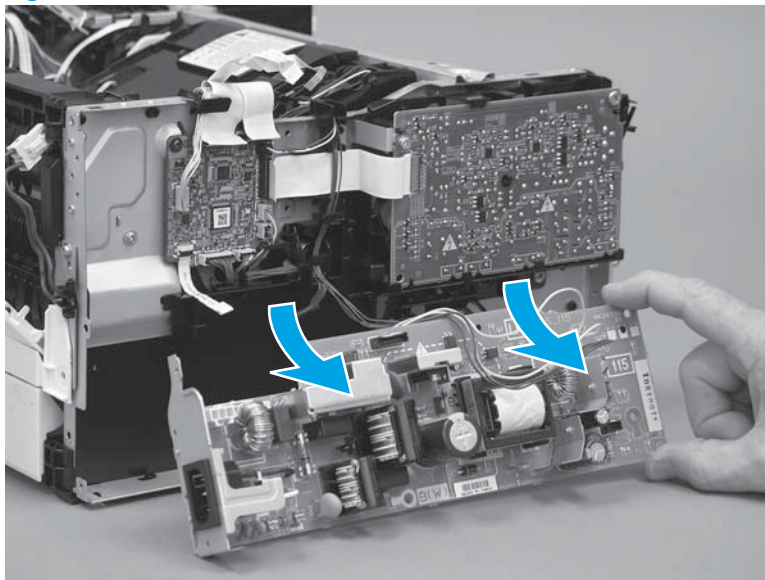
7. Remove three screws (callout 1).

**Figure 1-1900** Remove three screws



8. Rotate the bottom of the LVPS away from the printer, and then remove the LVPS.

**Figure 1-1901** Remove the LVPS



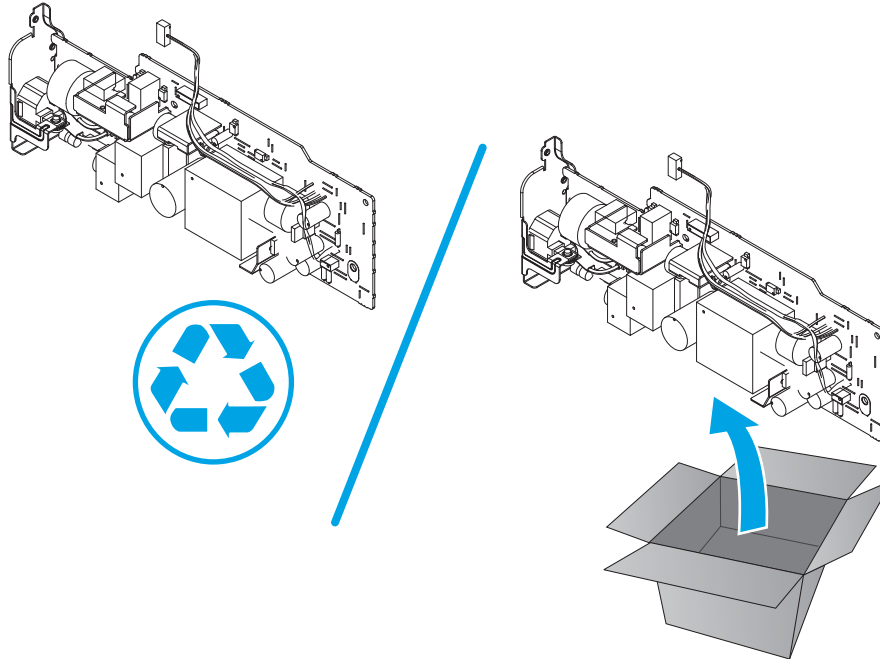
### Step 13: Unpack the replacement assembly

Unpack the replacement part from the packaging.

<http://www8.hp.com/us/en/hp-information/environment/product-recycling.html>

 **NOTE:** HP recommends responsible disposal of the defective part.

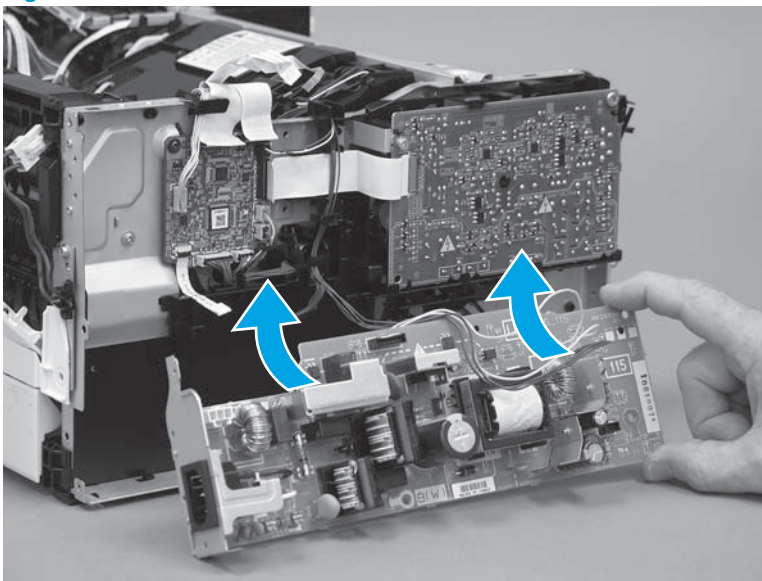
**Figure 1-1902** Recycle and unpack



**Step 14: Install the LVPS**

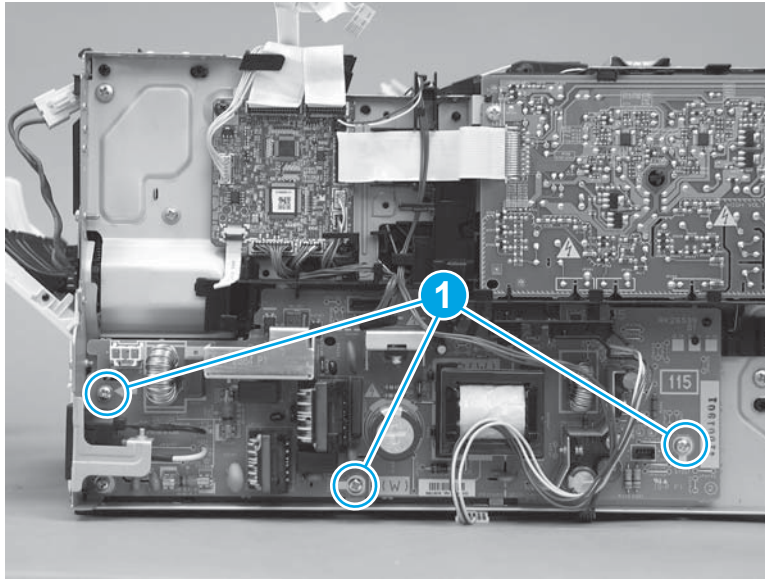
1. Position the top of LVPS in the printer, and then rotate the bottom toward the printer to install the LVPS.

**Figure 1-1903** Install the LVPS



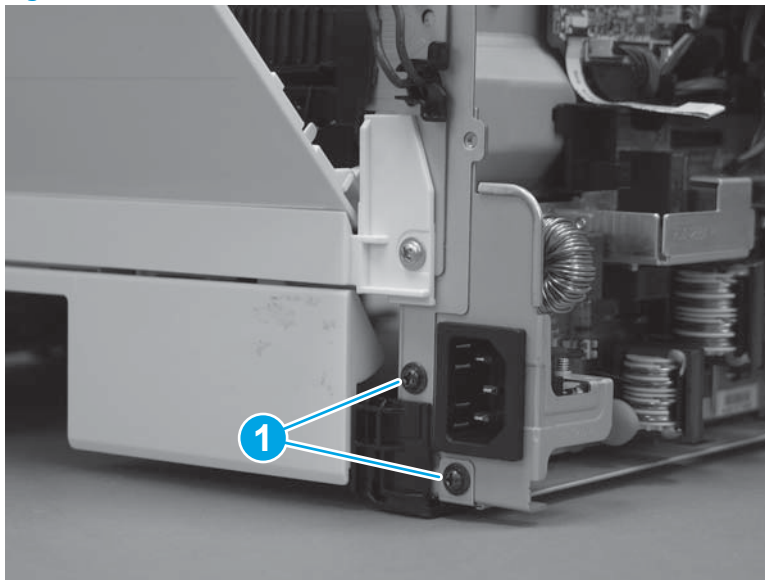
2. Install three screws (callout 1).

**Figure 1-1904** Install three screws



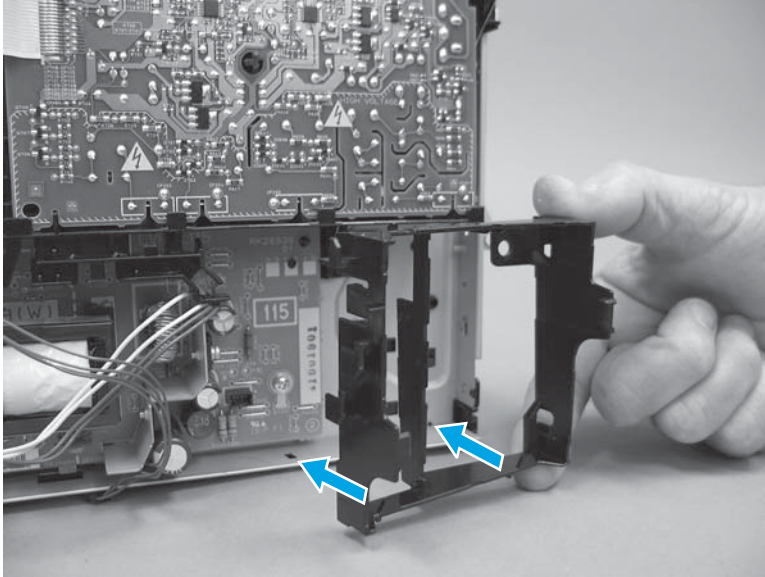
3. Install two screws (callout 1).

**Figure 1-1905** Install two screws



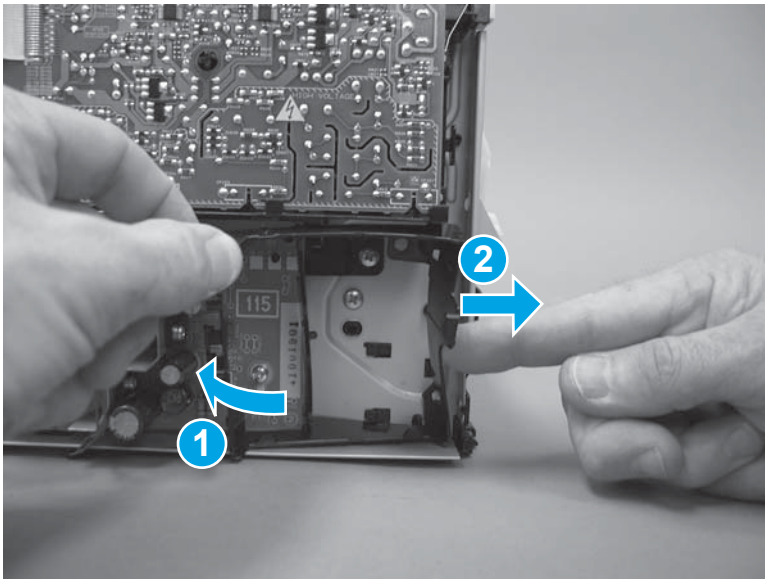
4. Position the bottom edge of the holder on the chassis—engage the two alignment tabs on the bottom of the holder with the slots in the chassis.

**Figure 1-1906** Install the holder




5. Rotate the top of the holder toward the printer (callout 1), and then engage one tab on the right side of the holder (callout 2).

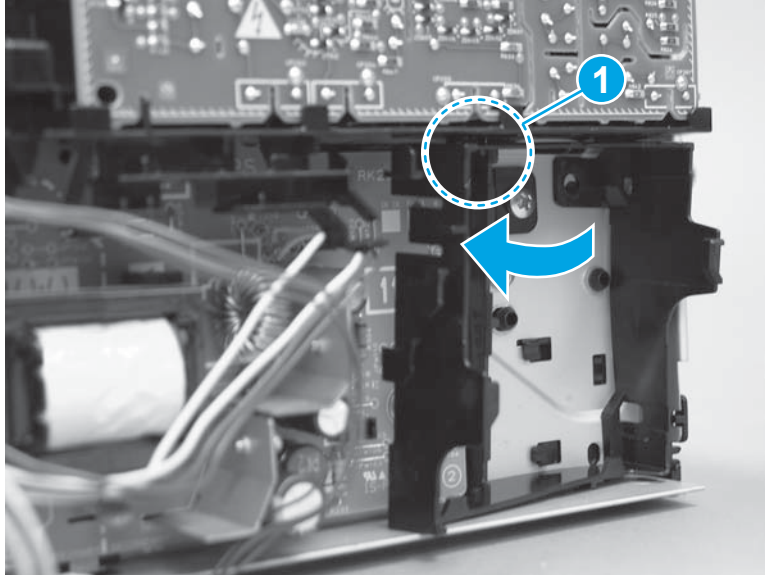
**Figure 1-1907** Engage one tab



6. Rotate the top-left side corner of the holder toward the printer, and then engage one tab on the holder (callout 1).

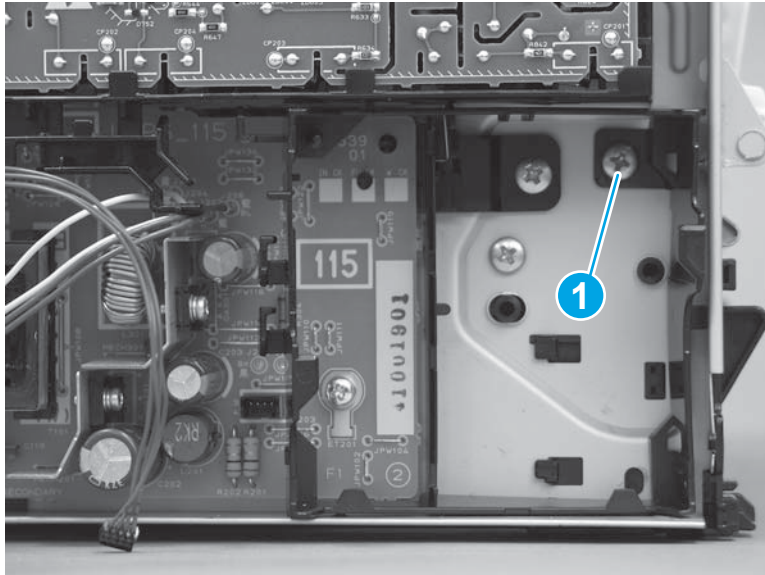
 **Reinstallation tip:** Use a flat-blade screwdriver to slightly flex the top of the holder down to make it easier to engage this tab.

**Figure 1-1908** Engage one tab



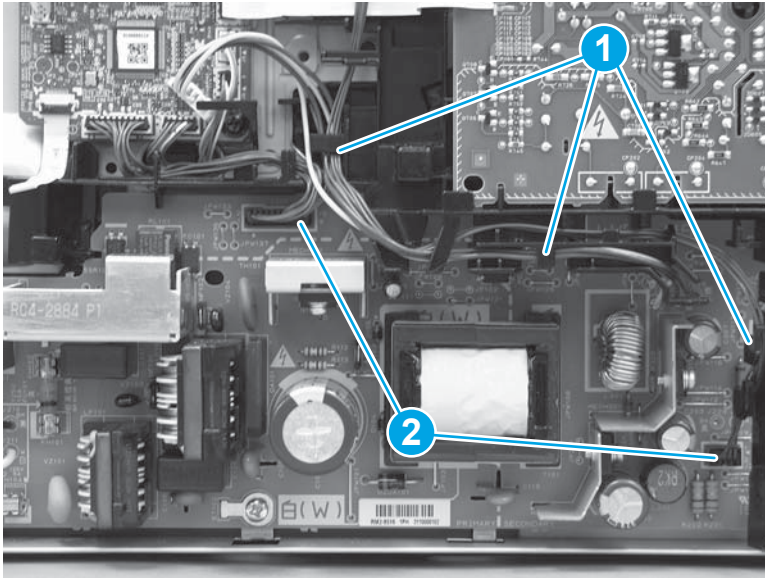
7. Install one screw (callout 1).

**Figure 1-1909** Install one screw



8. Install the wire harnesses in the guides (callout 1), and then connect two connectors (callout 2).

**Figure 1-1910** Connect two connectors



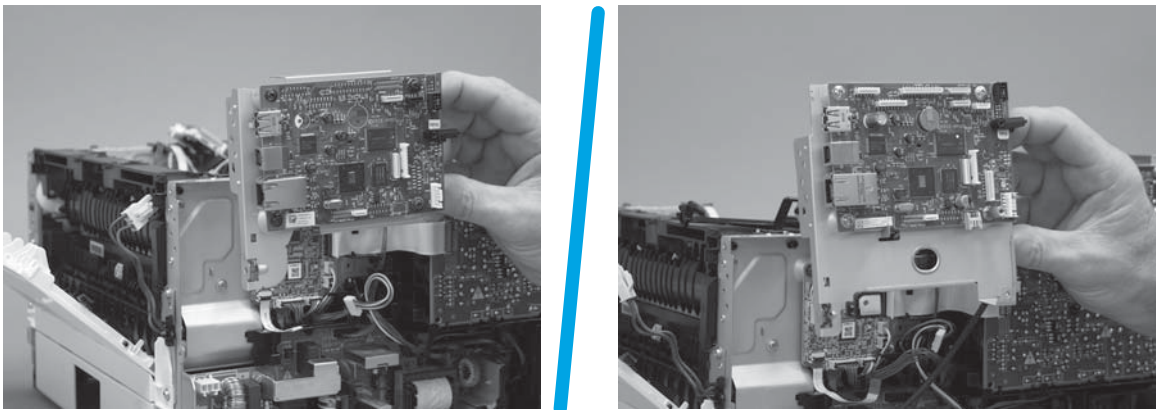
#### Step 15: Install the sheet-metal formatter bracket and formatter PCA



**NOTE:** Do not forget to connect any formatter PCA FFCs or wire-harness connectors that were disconnected when the bracket was removed.

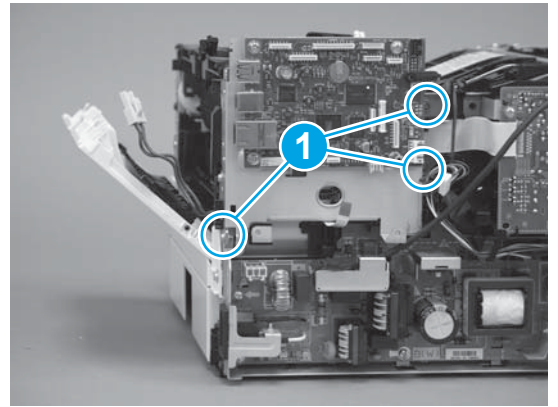
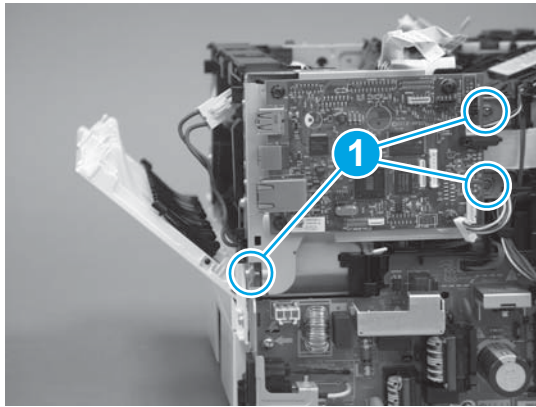
1. Position the sheet-metal bracket and formatter PCA on the printer.

**Figure 1-1911** Install the bracket



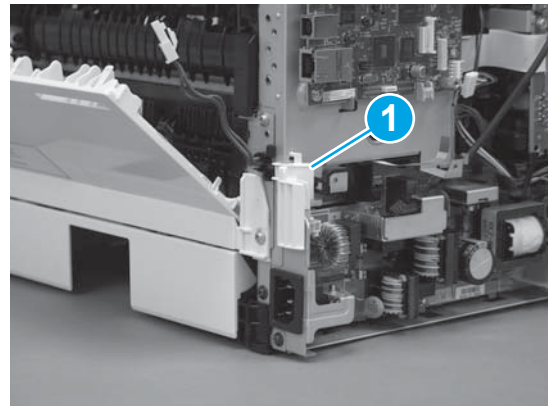
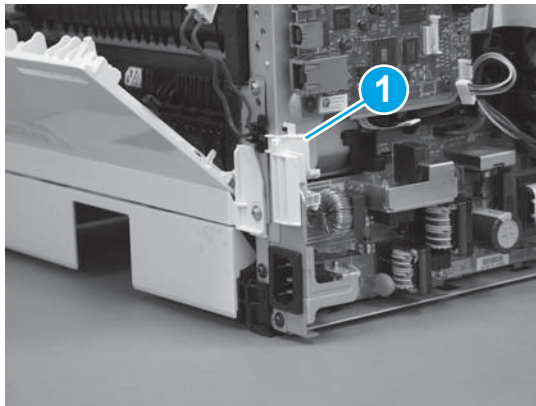
2. Install three screws (callout 1).

**Figure 1-1912** Install three screws



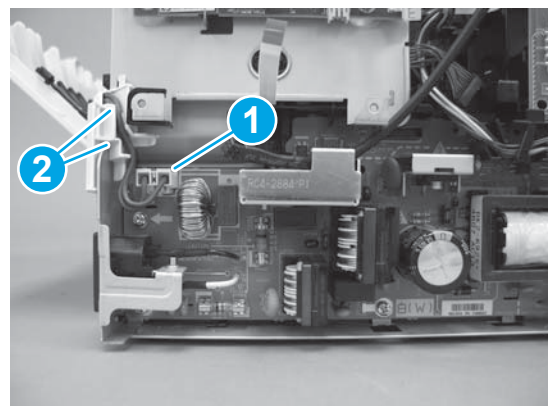
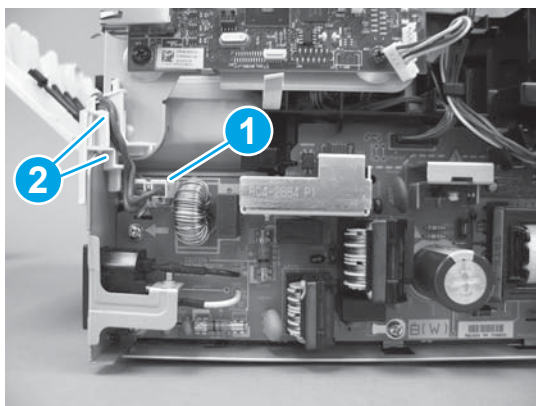
3. Install the guide (callout 1).

**Figure 1-1913** Install the guide



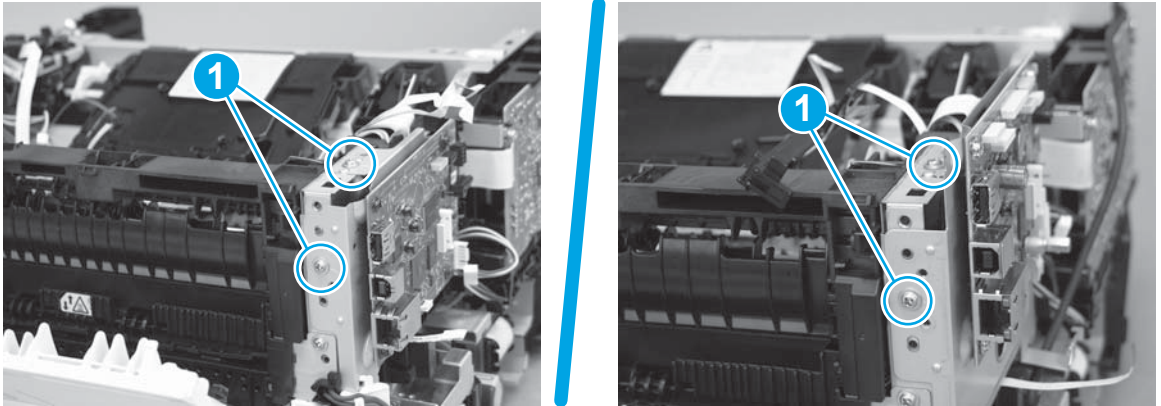
4. Connect one connector (callout 1), and then install the wire harness in the guide (callout 2).

**Figure 1-1914** Connect one connector



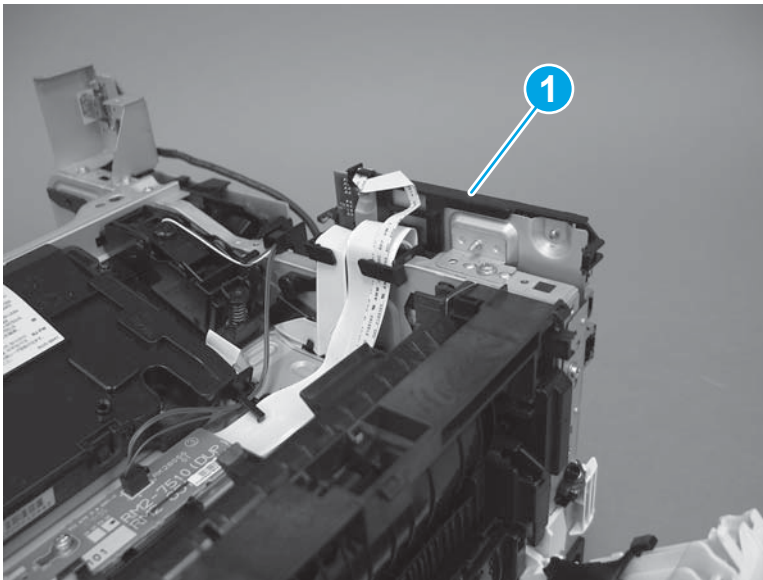
5. Install two screws (callout 1).

**Figure 1-1915** Install two screws



6. **M427/M426 only:** Install the guide (callout 1).

**Figure 1-1916** Install the guide



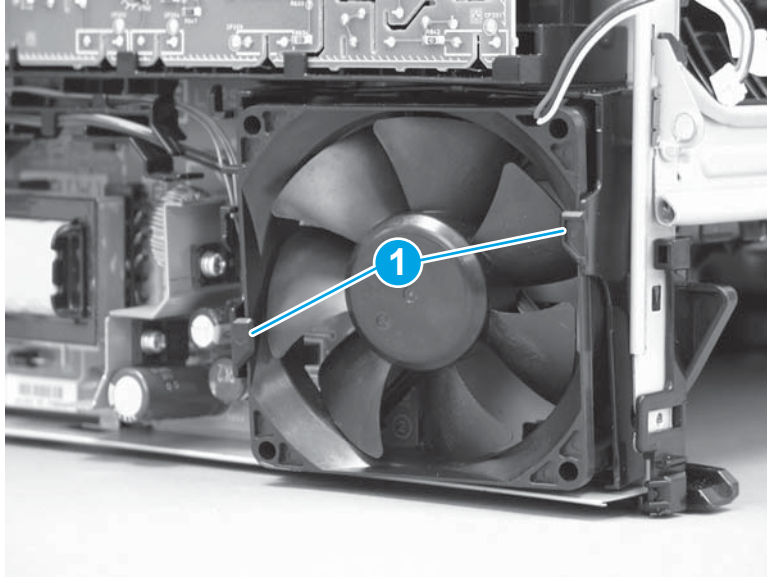
### Step 16: Install the fan (FM1)

1. Position the fan in the holder. Make sure that the two tabs (callout 1) snap into place on the fan.

**CAUTION:** The fan must be correctly installed so that air is drawn into the printer. Make sure that the two arrows embossed on the right-side of the fan body—which indicate air flow direction—face upward and into the printer.

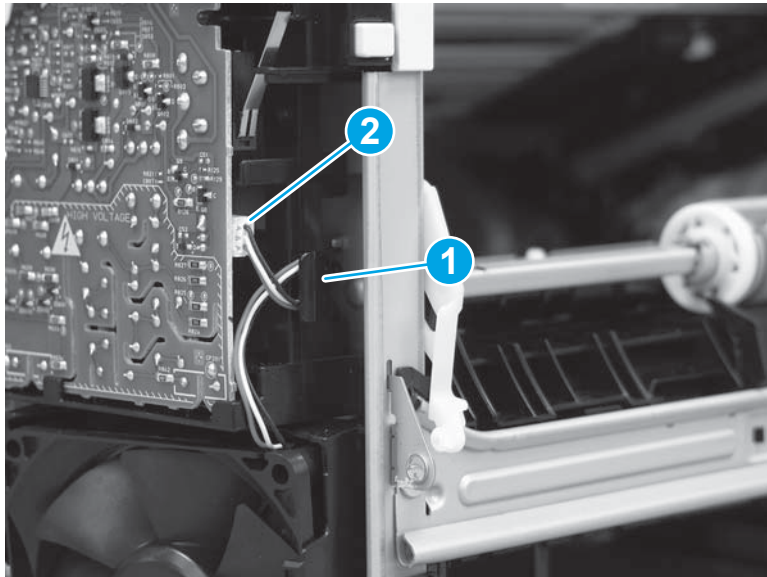


**Figure 1-1917** Install the fan




2. Install the wire harness on the retainer (callout 2), and then connect one connector (callout 2).

**Figure 1-1918** Connect one connector

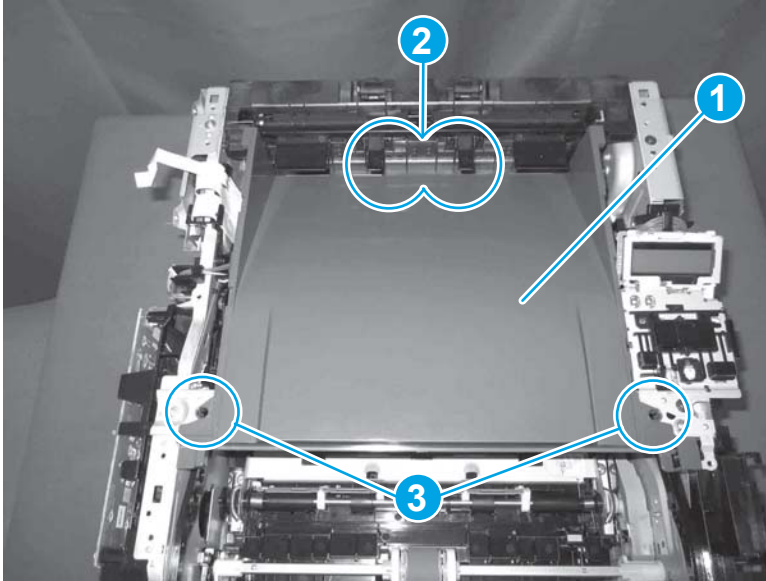


### Step 17: Install the paper delivery tray (output bin)


 **NOTE:** This procedure shows the M403/M402 model, however, the paper delivery tray (output bin) removal is similar for the M427/M426 printer.

- ▲ Position the remove the paper delivery tray (output bin; callout 1) on the printer, engage two tabs (callout 2), and then engage two bosses (callout 3).

**Figure 1-1919** Engage two tabs

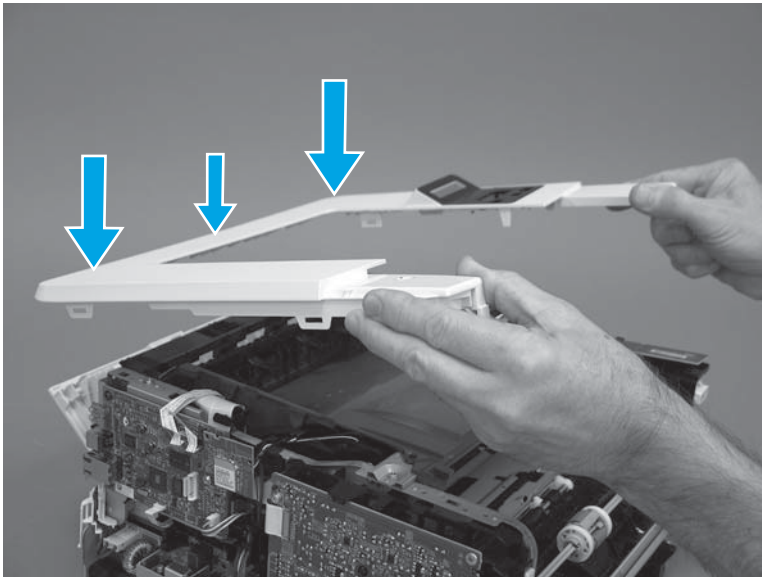


**Step 18: Install the top cover (M403/M402)**

 **NOTE:** The step is for the M403/M402 printer. For the M427/M426, skip this step and go to [Step 19: Install the top cover \(M427/M426\) on page 1014](#).

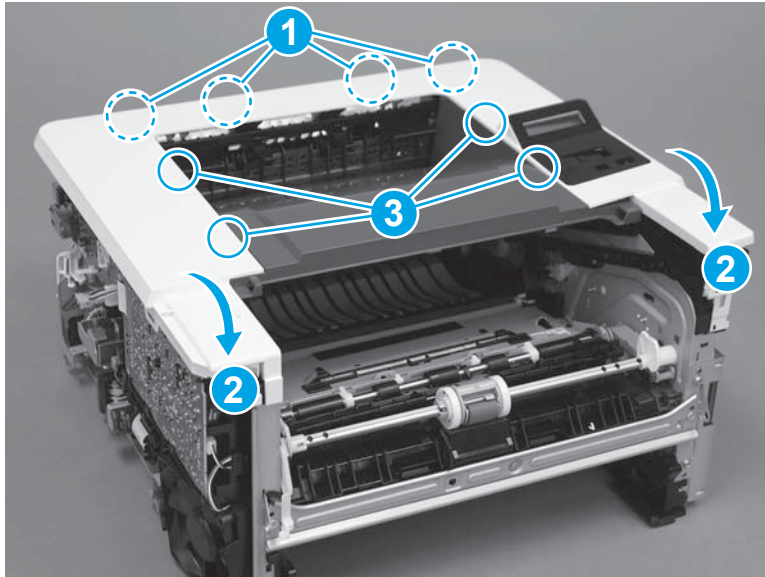
1. Position the rear edge of the cover on the printer.

**Figure 1-1920** Install the cover



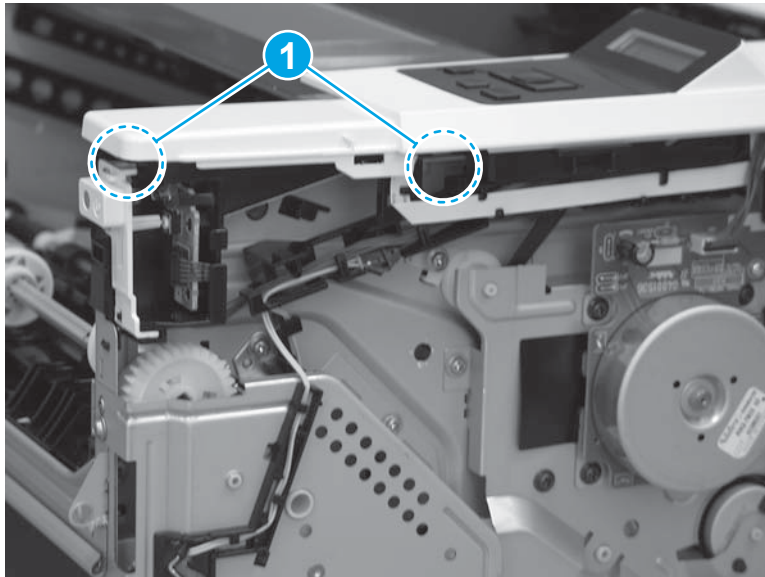
- Engage four bosses (callout 1), rotate the front of the cover down (callout 2) and onto from the printer, and then engage four tabs (callout 3).

**Figure 1-1921** Engage four bosses and tabs



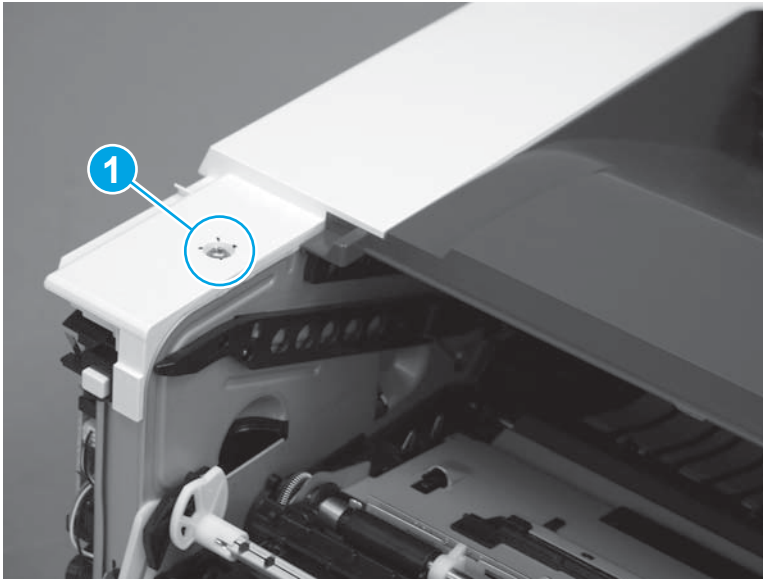
- At the right side of the printer, engage the one boss and one tab (callout 1).

**Figure 1-1922** Engage one boss and one tab




4. Install one screw (callout 1).

**Figure 1-1923** Install one screw

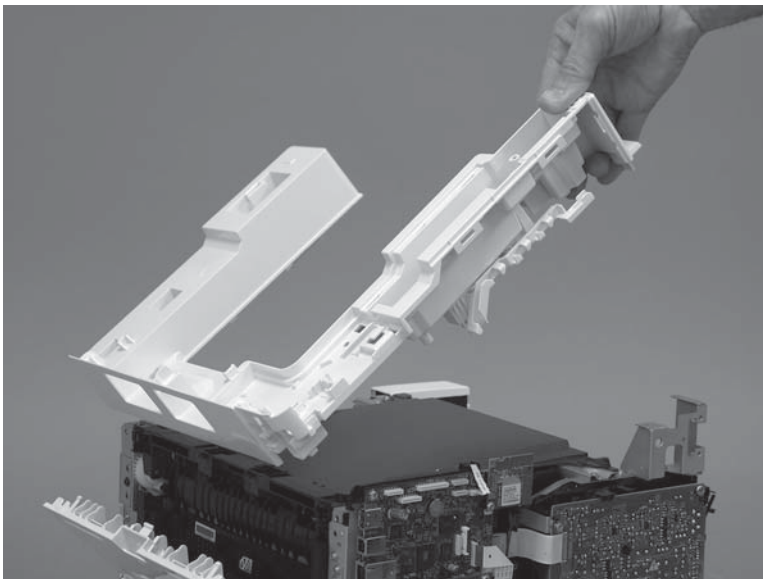


#### Step 19: Install the top cover (M427/M426)

 **NOTE:** The step is for the M427/M426 printer. For the M403/M402, skip this step and go to [Step 23: Install the right cover on page 1025](#).

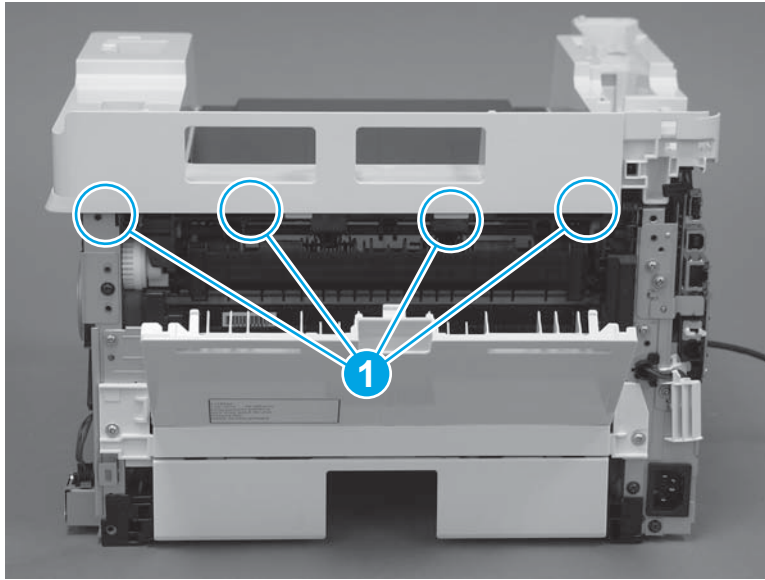
1. Position the rear edge of the top cover on the printer.

**Figure 1-1924** Install the cover



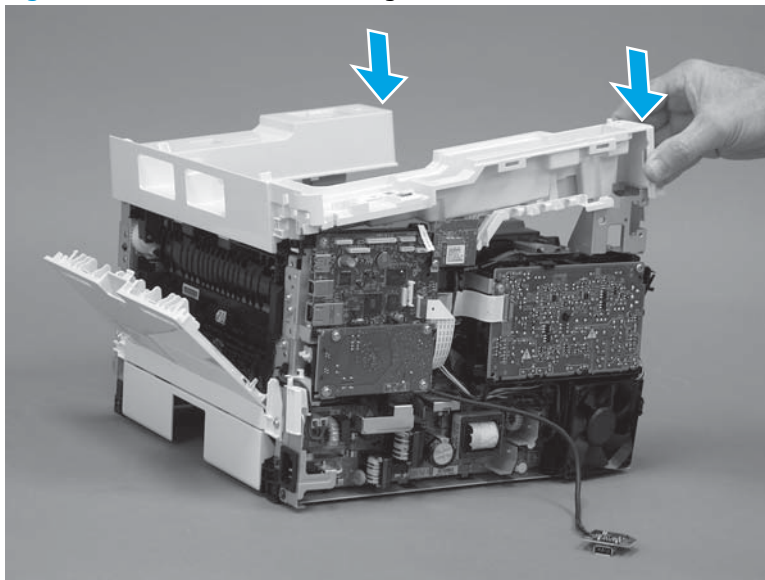
2. Engage four bosses (callout 1).

**Figure 1-1925** Engage four bosses



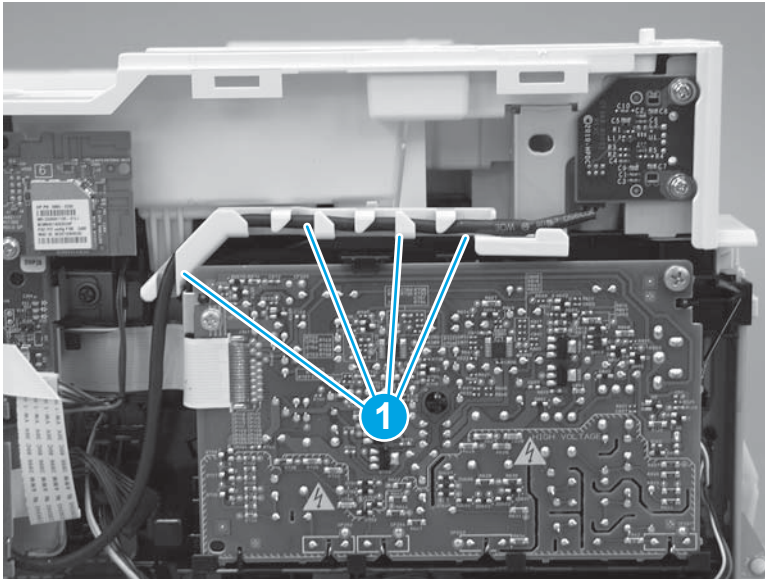
3. Rotate the front edge of the cover down.

**Figure 1-1926** Rotate the front edge of the cover down



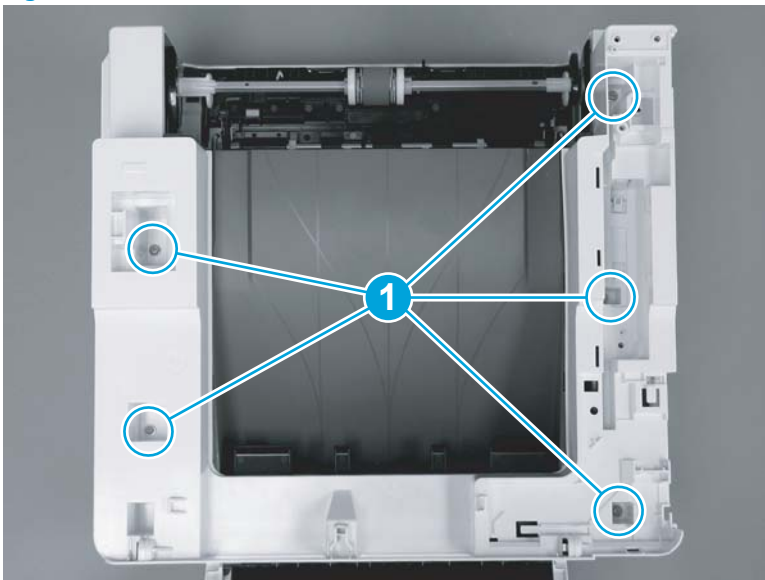
4. Install the USB cable (callout 1) in the guide.

**Figure 1-1927** Install the USB PCA




5. Install five screws (callout 1).

**Figure 1-1928** Install five screws

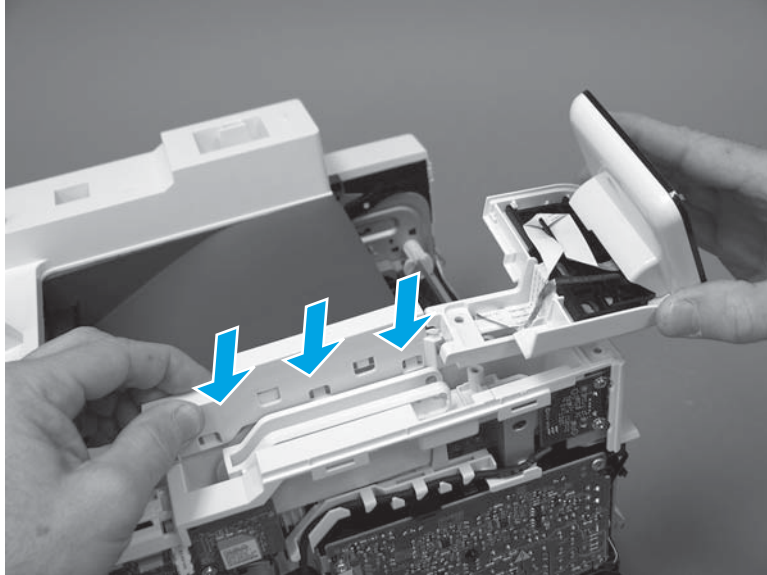


### Step 20: Install the control panel (M427/M246)

 **NOTE:** The step is for the M427/M426 printer. For the M403/M402, skip this step and go to [Step 23: Install the right cover on page 1025](#).

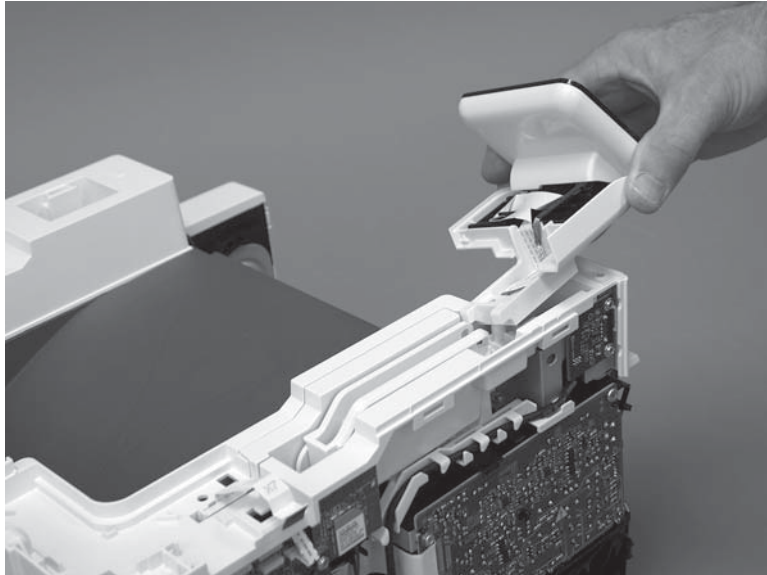
1. Slide the control-panel FFC cover into the slot in the top cover (next to the document feeder support arm) to install it.

**Figure 1-1929** Install the control-panel FFC cover



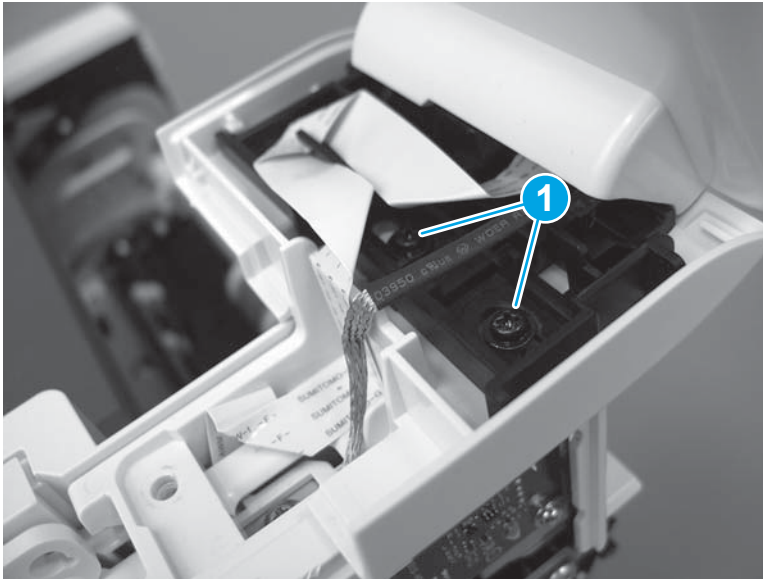
2. Install the control-panel assembly on the top cover.

**Figure 1-1930** Install the control-panel assembly



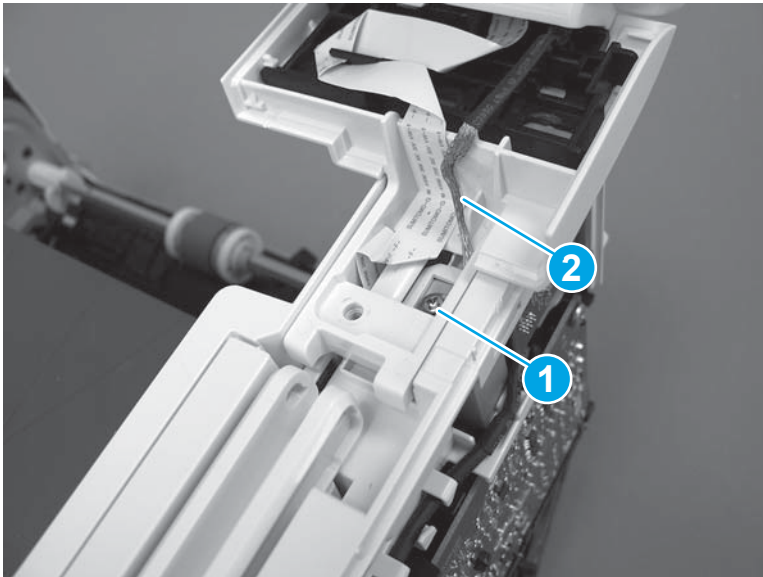
3. Move the FFC out of the way, and then install two screws (callout 1).

**Figure 1-1931** Install two screws



4. Install one grounding screw (callout 1), and then make sure that the ground cable (callout 2) is properly routed.

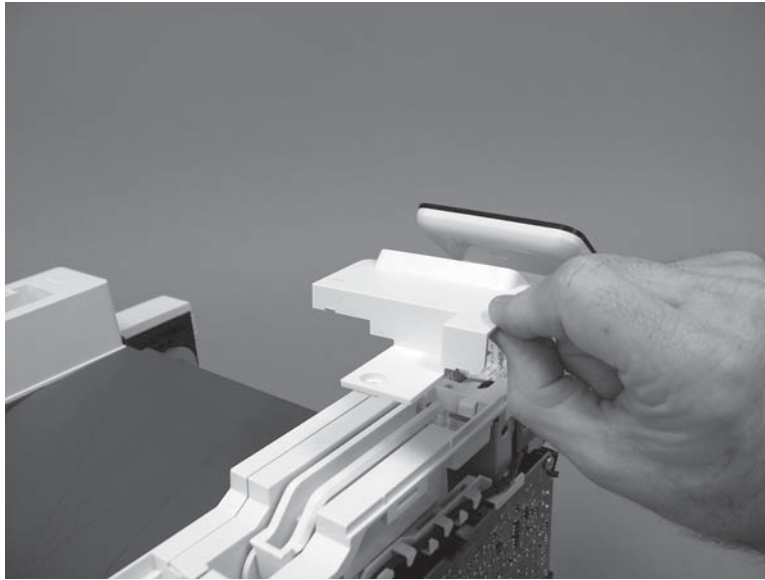
**Figure 1-1932** Remove one screw





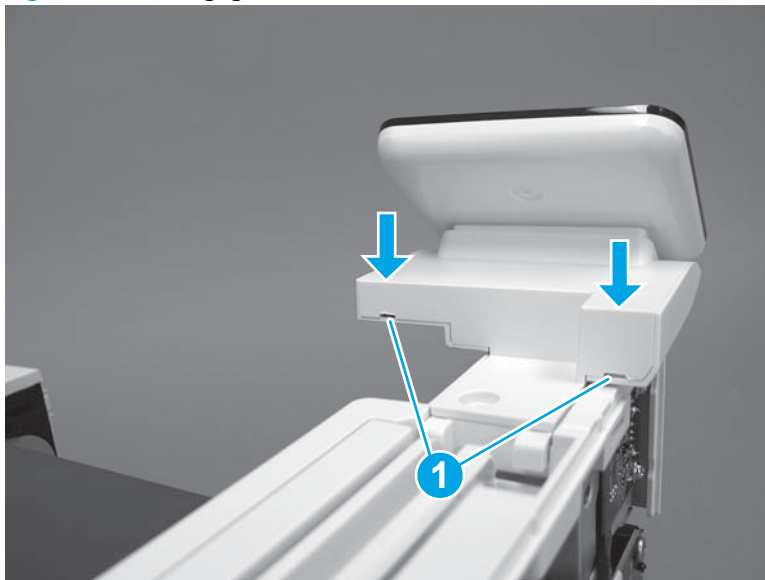
5. Install the control-panel cable cover.

**Figure 1-1933** Install the cover



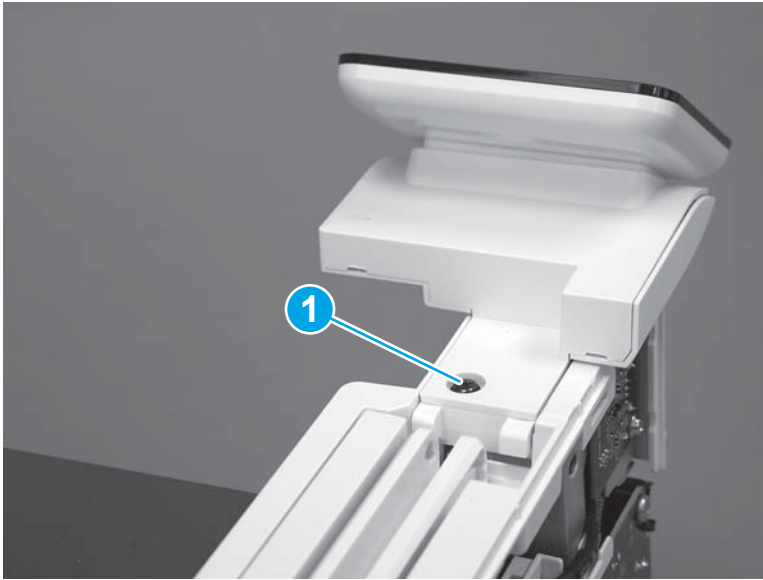
6. Make sure that the two tabs (callout 1) on the cover snap into place.

**Figure 1-1934** Engage two tabs



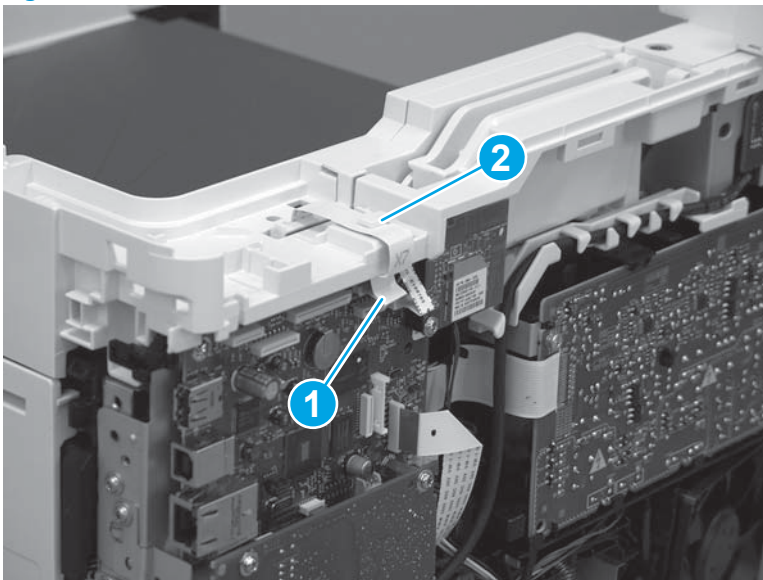
7. Install one screw (callout 1).

**Figure 1-1935** Install one screw




8. Install the FFC in the retainer (callout 1), and then connect one FFC (callout 1; J114).

**Figure 1-1936** Connect one connector




### Step 21: Install the integrated scanner assembly (M427/M246)

---

 **NOTE:** The step is for the M427/M426 printer. For the M403/M402, skip this step and go to [Step 23: Install the right cover on page 1025](#).

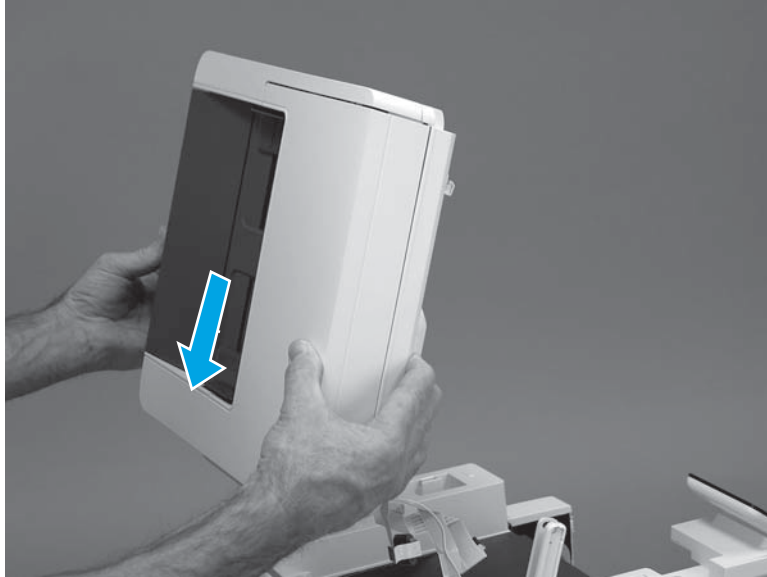
---

 **NOTE:** M427/M426 models only. The integrated scanner assembly (ISA) includes the sub-scanner assembly (SSA) and the automatic document feeder (ADF).

---

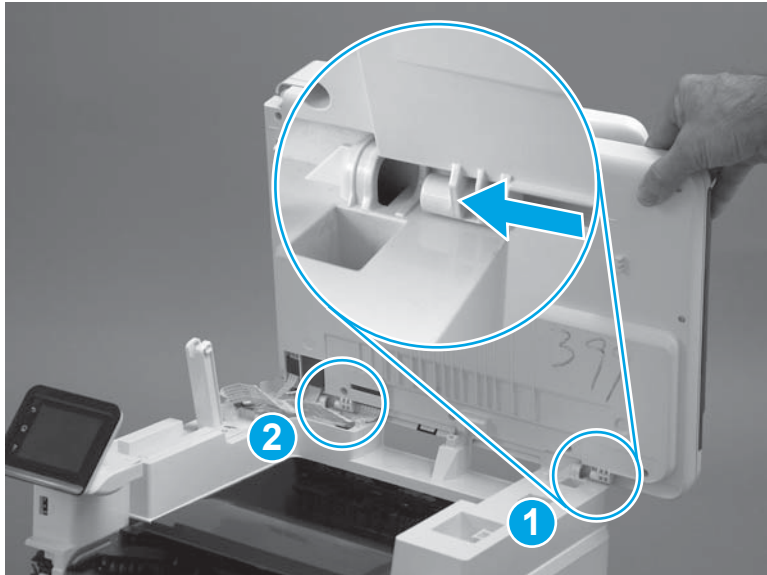
1. Position the ISA on the printer.

**Figure 1-1937** Position the ISA on the printer



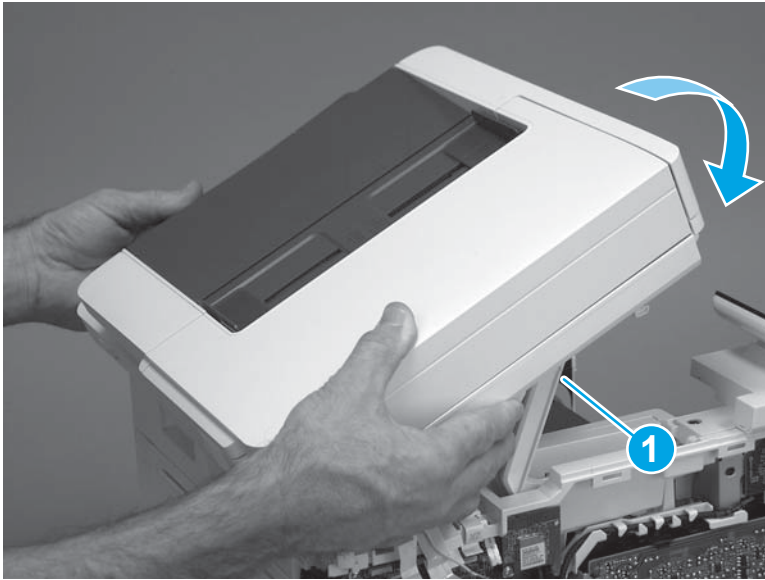
2. Engage the hinge pins on the ISA with the holders in the top cover (callouts 1/2), and then slide the ISA as shown to engage them

**Figure 1-1938** Engage the hinge pins with the holders



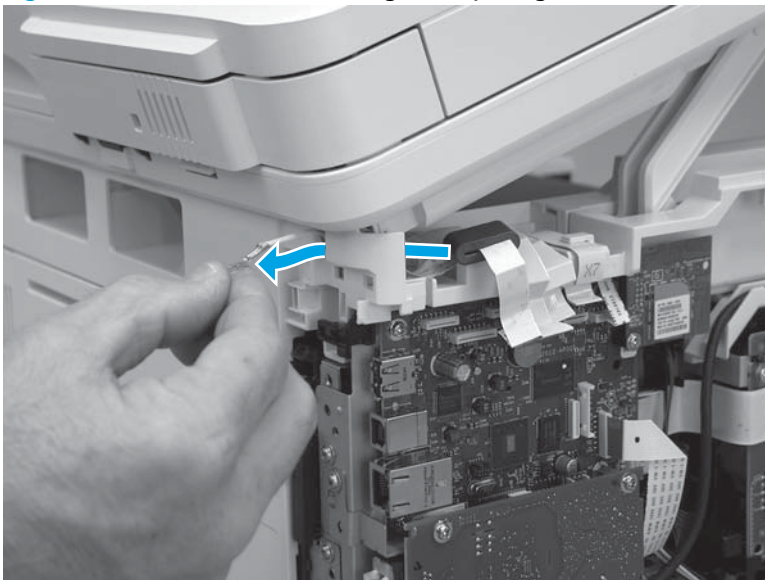
3. Rotate the ISA towards the front of the printer until it rests on the ISA lift assembly (callout 1).

**Figure 1-1939** Rotate the ISA towards the front of the printer



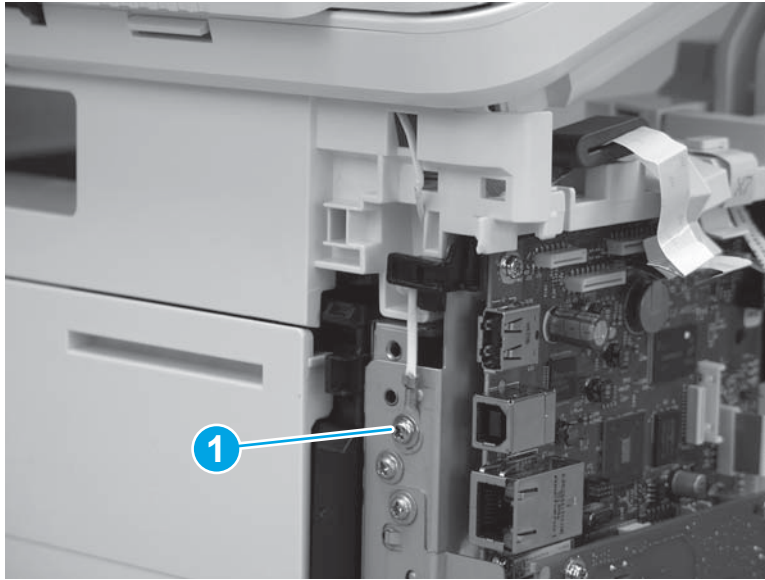
4. Pass the ground wire through the opening in the top cover.

**Figure 1-1940** Pass the wire through the opening




5. Install one screw (callout 1).

**Figure 1-1941** Install one screw



6. Install the ISA lift assembly slider pin.

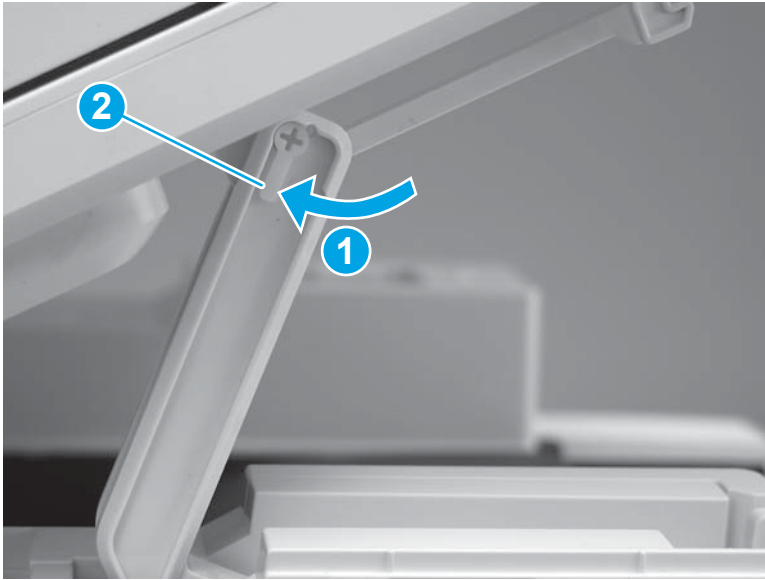
 **Reinstallation tip:** Align the keyed portion of the locking pin with the slot and hole in the support arm.

**Figure 1-1942** Install the slider pin



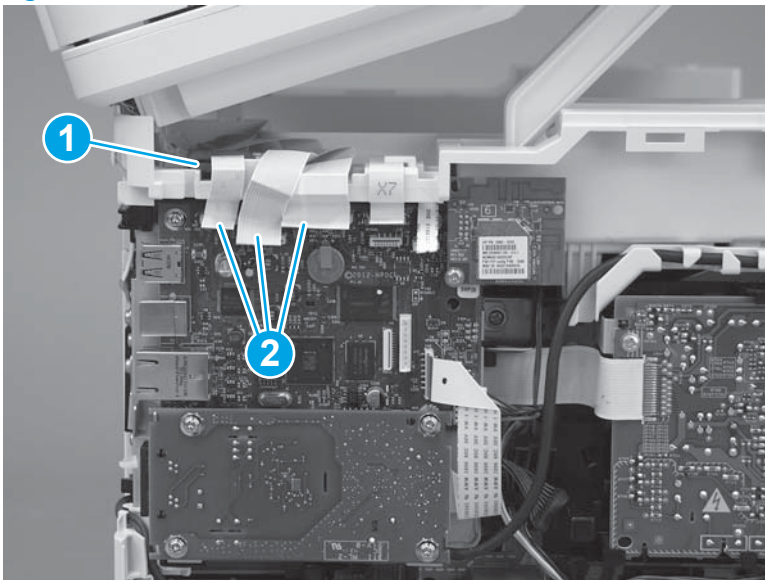
7. Rotate the slider pin (callout 1) towards the rear of the printer until the tab (callout 2) snap into place.

**Figure 1-1943** Secure the slider pin



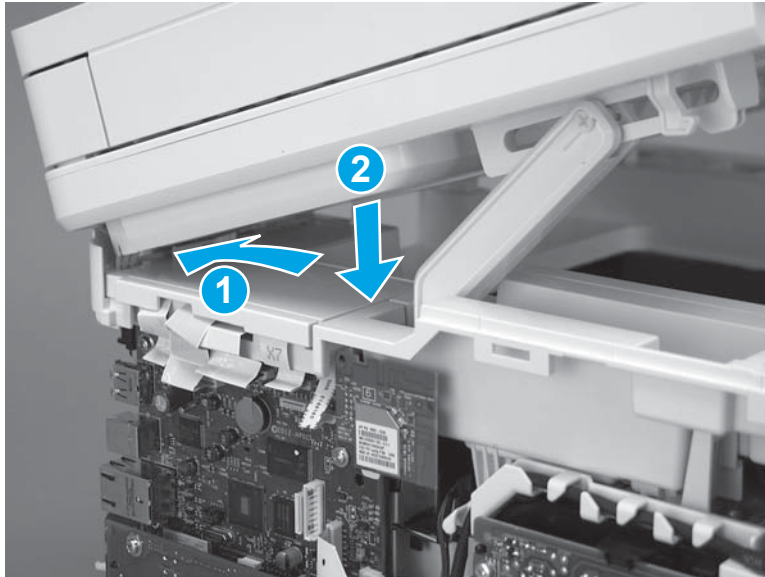
8. Install the ferrite (callout 1) in the holder, and then connect three FFCs (callout 2).

**Figure 1-1944** Connect three FFCs



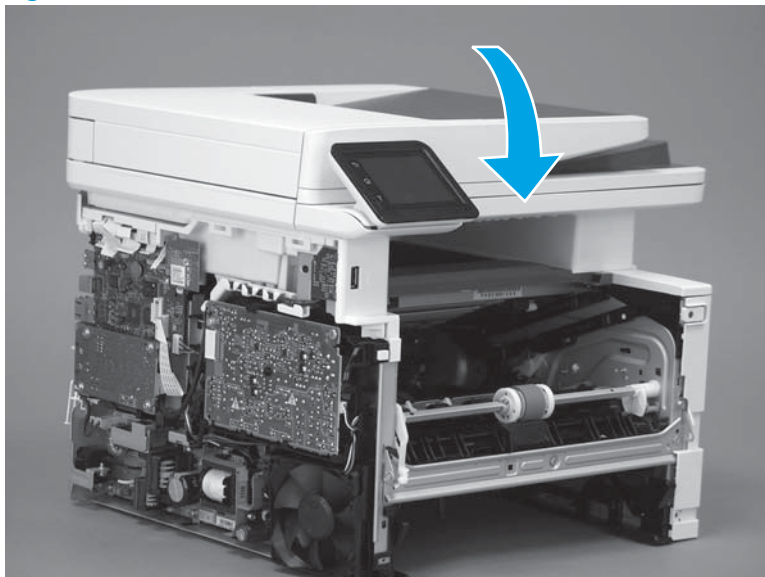
9. Position the rear edge of the ISA flat-flexible cable (FFC) cover on the printer (callout 1) , and then rotate it down (callout 2) until it snaps into place.

**Figure 1-1945** Install the ISA FFC cover



10. Lower the ISA.

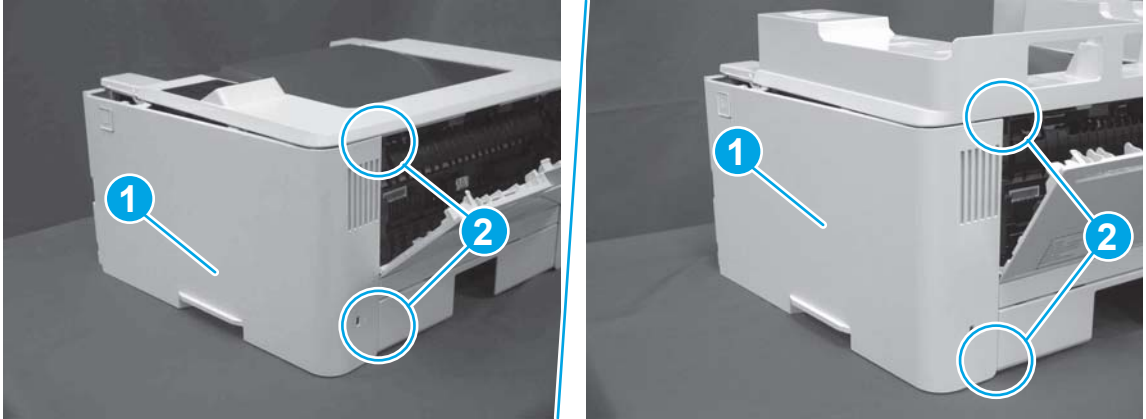
**Figure 1-1946** Lower the ISA



### Step 23: Install the right cover

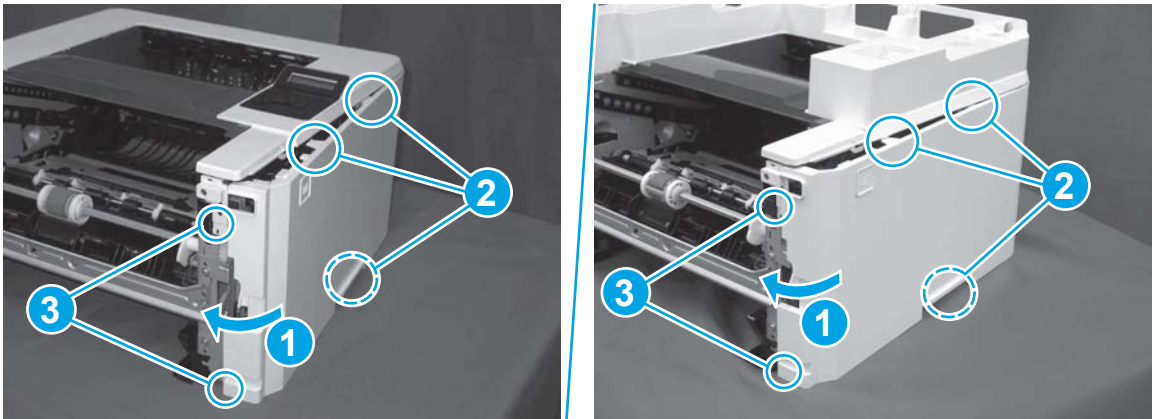
1. Position the cover (callout 1) on the printer, and then engage two bosses (callout 2).

**Figure 1-1947** Install the cover




2. Rotate the front of the cover onto the printer (callout 1), engage three (callout 2) tabs, and then engage two bosses (callout 3).

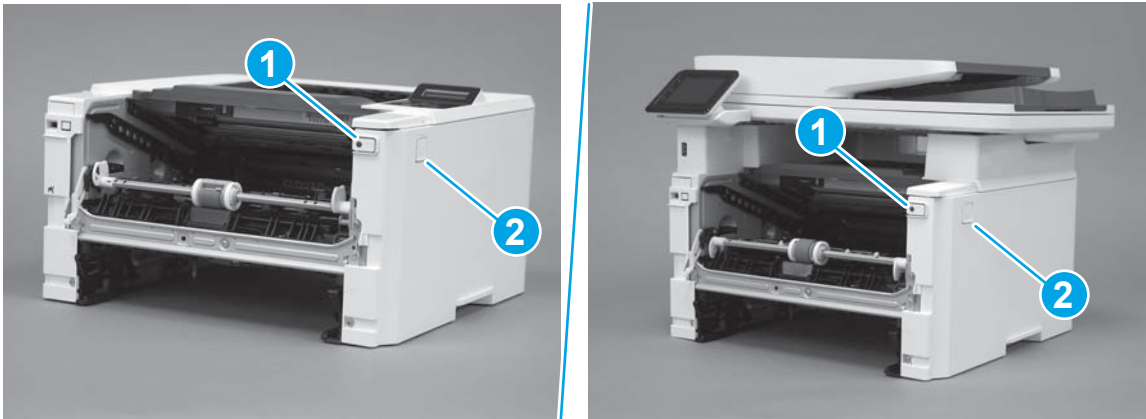
**Figure 1-1948** Engage two bosses and one tab



3. Make sure that the power switch (callout 1) and cartridge door assembly button (callout 2) correctly function.

 **NOTE:** Remove, and then reinstall the cover if the switch or button does not correctly function.

**Figure 1-1949** Check the power switch and cartridge door assembly button





4. Install one screw (callout 1).

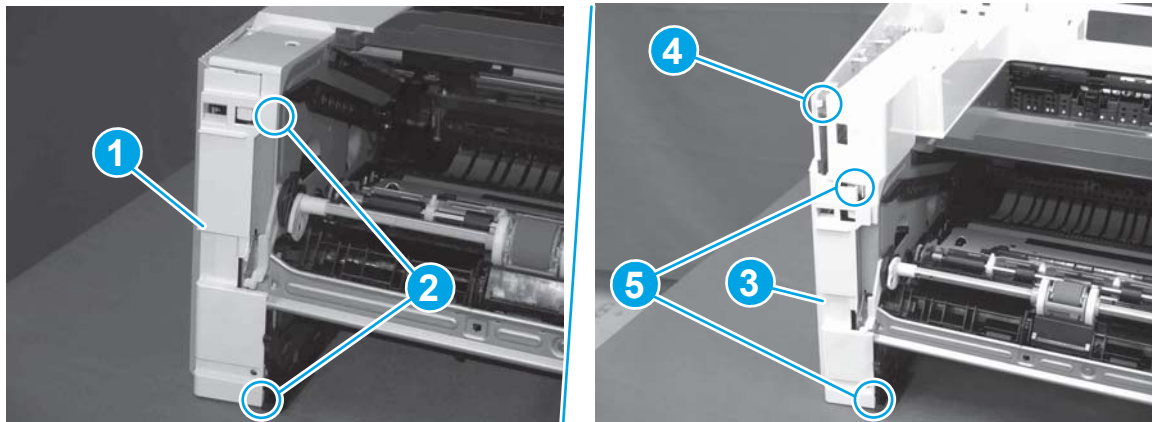
**Figure 1-1950** Install one screw



#### Step 24: Install the left cover

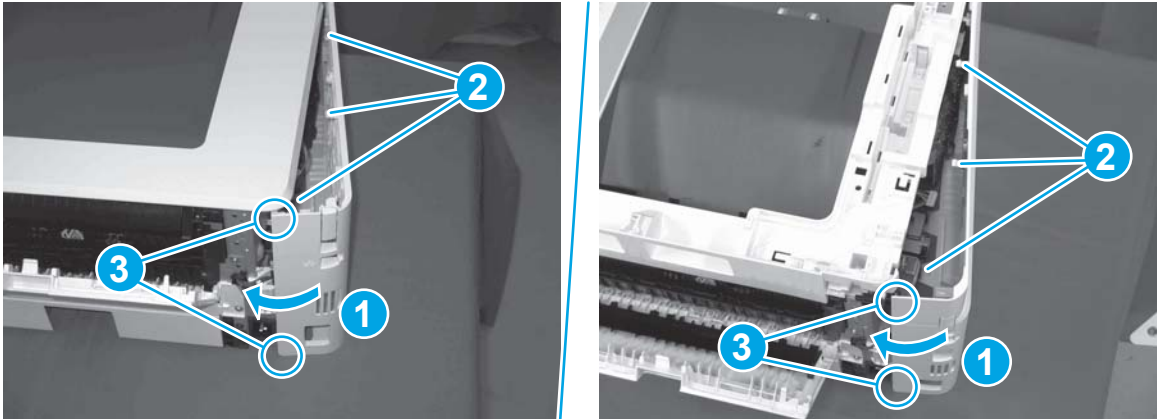
1. At the front of the printer, do one of the following:
  - **M403/M402:** Position the cover on the printer ( callout 1), and then engage two bosses (callout 2).
  - **M427/M426:** Position the cover on the printer (callout 3), engage one tab (callout 4), and then engage two bosses (callout 4).

**Figure 1-1951** Install the cover



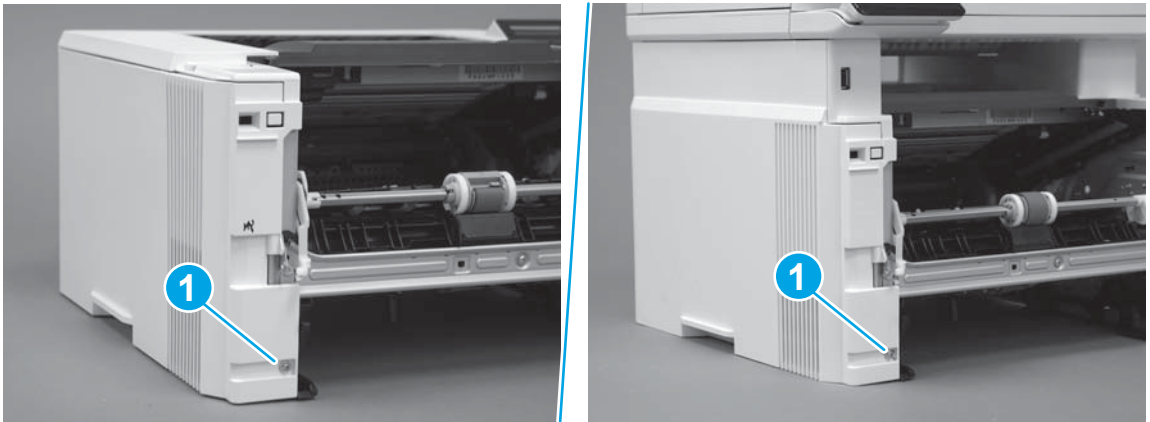
- Carefully rotate the rear of the cover onto the printer (callout 1), engage three tabs (callout 2), and then engage two bosses (callout 3).

**Figure 1-1952** Engage three tabs and two bosses




- Install one screw (callout 1).

**Figure 1-1953** Install one screw

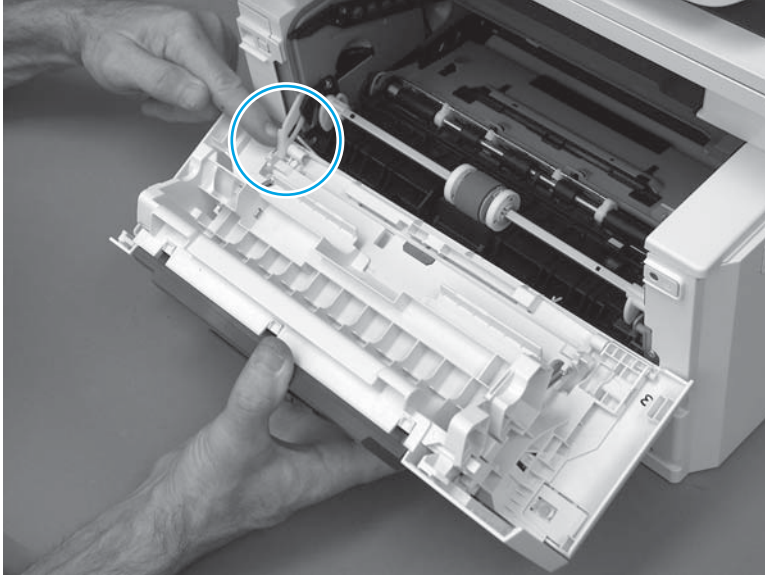


### Step 25: Install the cartridge door assembly

 **Reinstallation tip:** After a replacement door is installed, make sure to install the nameplate (supplied in the kit) corresponding to the printer name on the door.

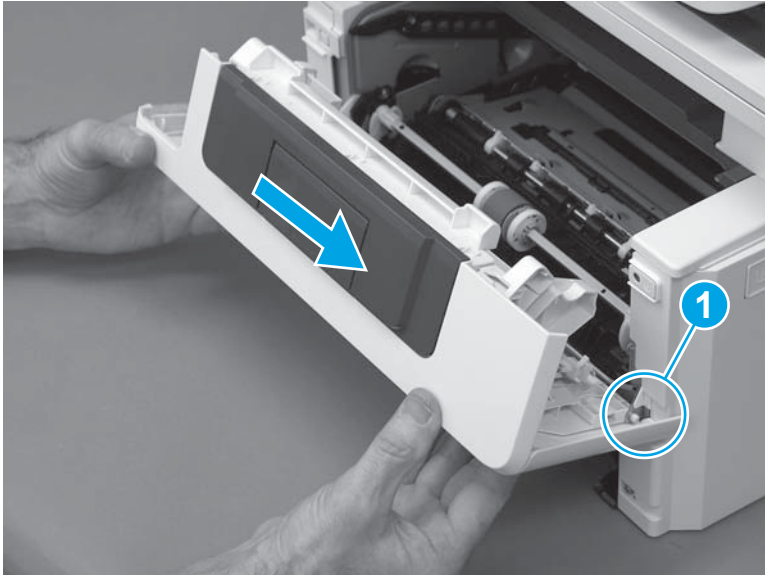
- Position the door close to the printer, and then engage the keyed pin on the left-side retainer arm with the hole in the door.

**Figure 1-1954** Engage the left-side retainer arm



2. Engage the right-side door hinge pin with the hole in the chassis (callout 1).

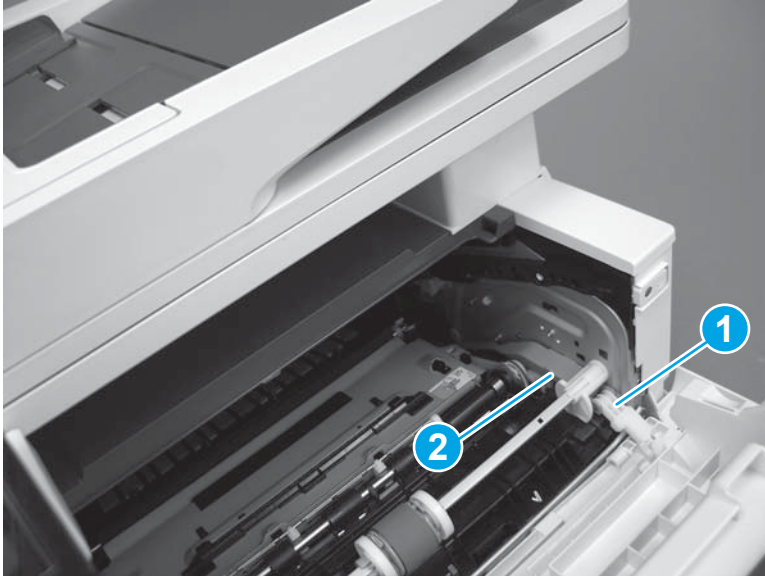
**Figure 1-1955** Install the door



3. Install the link (callout 1).

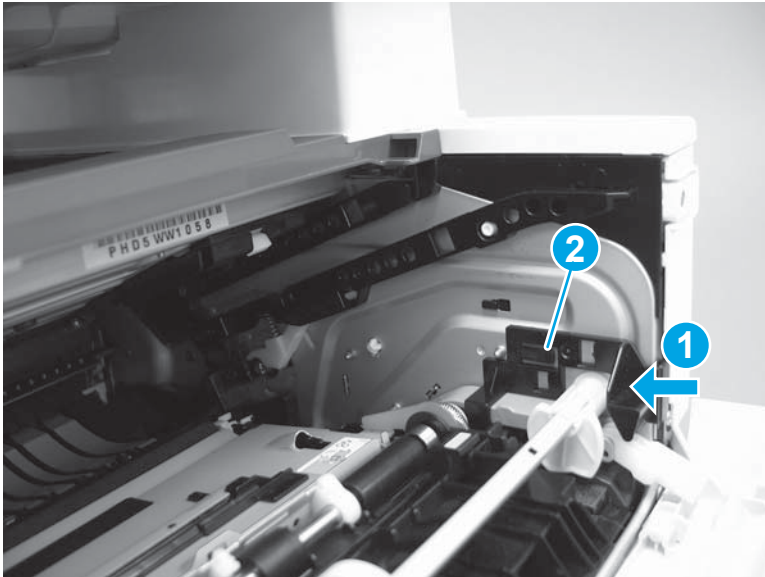
 **IMPORTANT:** Make sure that the link snaps into place on the arm (callout 2). The link actuates the fuser pressure-release mechanism.

**Figure 1-1956** Install the pressure-release link



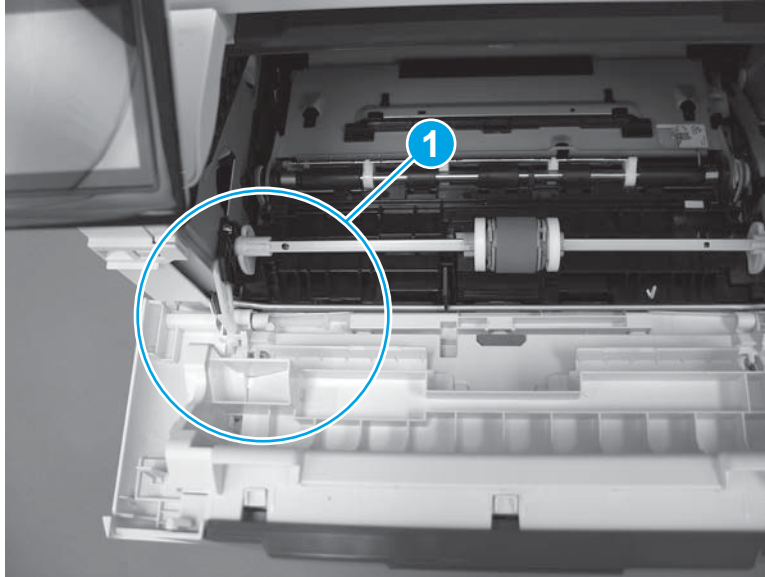
4. Slide the guide into the printer (callout 1), and then make sure that the tab (callout 2) snaps into place to secure the guide to the chassis.

**Figure 1-1957** Install the guide




5. Position the shaft on the door, and then align the left-side hinge on the door with the hole in the chassis (callout 1).

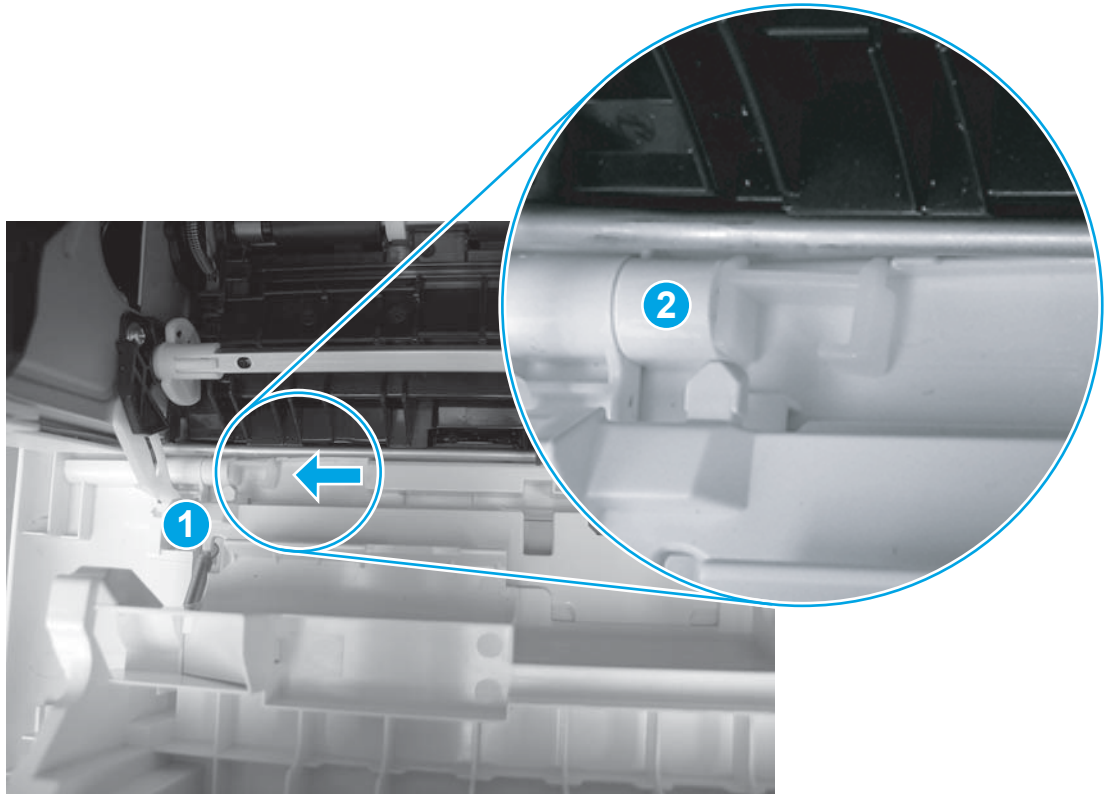
**Figure 1-1958** Align the hinge



6. Push the shaft towards the left side of the printer to install it (callout 1).

 **Reinstallation tip:** Make sure that the support shaft is fully installed and correctly orientated (callout 2) so that it will not interfere with the door opening and closing.

**Figure 1-1959** Install the support shaft



## Step 26: Install Tray 2

- ▲ Slide the tray straight into the printer to install it.

**Figure 1-1960** Install the tray



## Removal and replacement: NFC cover (M427/M426)



**NOTE:** M427/M426 models only.

- [Introduction](#)
- [Step 1: Remove Tray 2](#)
- [Step 2: Remove the cartridge door assembly](#)
- [Step 3: Remove the left cover](#)
- [Step 4: Remove the right cover](#)
- [Step 6: Remove the integrated scanner assembly \(M427/M246\)](#)
- [Step 5: Remove the control panel \(M427/M426\)](#)
- [Step 7: Remove the top cover \(M427/M426\)](#)
- [Step 8: Remove the NFC cover \(M427/M426\)](#)
- [Step 9: Unpack the replacement assembly](#)
- [Step 10: Install the NFC cover \(M427/M426\)](#)
- [Step 11: Install the top cover \(M427/M426\)](#)
- [Step 12: install the control panel \(M427/M426\)](#)
- [Step 12: Install the integrated scanner assembly \(M427/M246\)](#)
- [Step 13: Install the right cover](#)
- [Step 14: Install the left cover](#)
- [Step 15: Remove the cartridge door assembly](#)
- [Step 16: Install Tray 2](#)

### Introduction

This document provides the procedures to remove and replace the near field communication (NFC) cover.

### Before performing service

#### Turn the printer power off

- Disconnect the power cable.



**WARNING!** To avoid damage to the printer, turn the printer off, wait 30 seconds, and then remove the power cable before attempting to service the printer.

Use the table below to identify the correct part number for your printer. To order the part, go to [www.hp.com/buy/parts](http://www.hp.com/buy/parts).

NFC cover part number	
RC4-2961-000CN	NFC cover

## Required tools

- #2 Phillips screwdriver with a magnetic tip.

## After performing service

### Turn the printer power on

- Connect the power cable.
- Use the power switch to turn the power on.

### Post service test

Make sure that the printer initializes to a **Ready** state.

Use a NFC enabled device to print a job from the printer.

### Step 1: Remove Tray 2

- ▲ Pull the tray straight out of the printer to remove it.

**Figure 1-1961** Remove the tray



### Step 2: Remove the cartridge door assembly

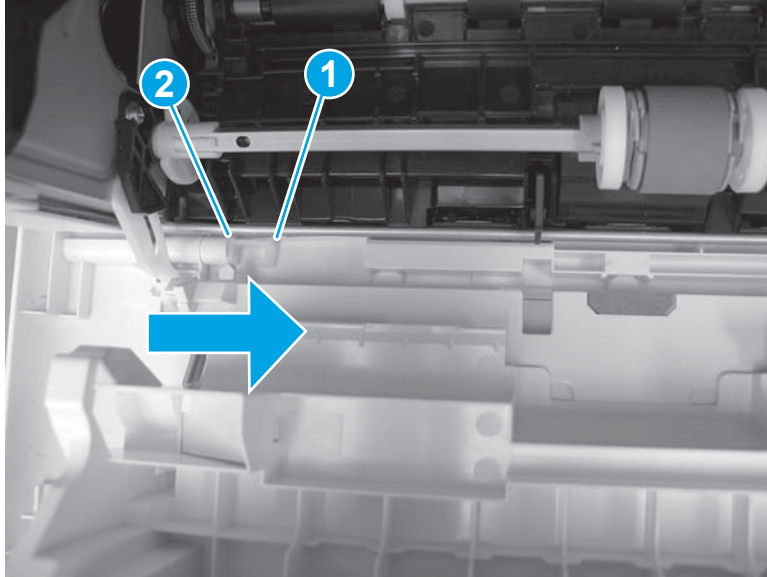
 **NOTE:** If the toner cartridge was not removed prior to servicing the printer, remove it now.

1. Release one tab (callout 1), and then slide shaft (callout 2) in the direction the arrow indicates and remove it.

 **TIP:** It might be easier to release the support shaft by using a small flat-blade screwdriver.

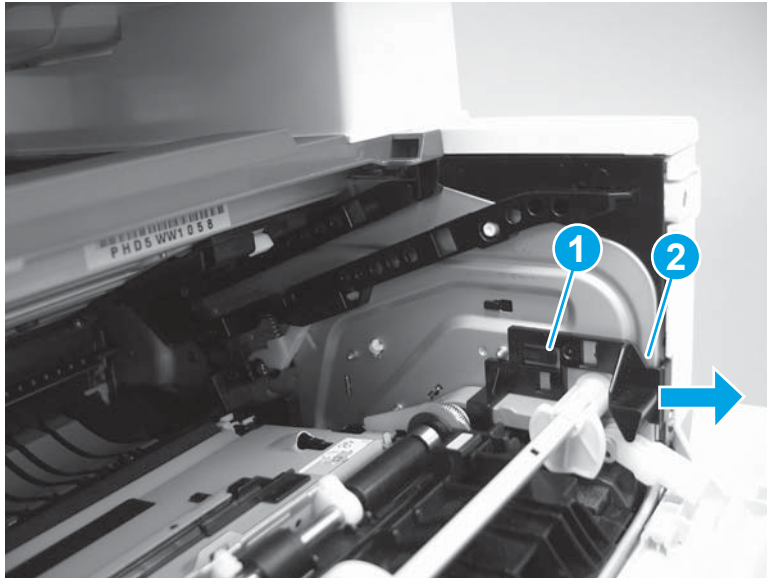


**Figure 1-1962** Release the support shaft



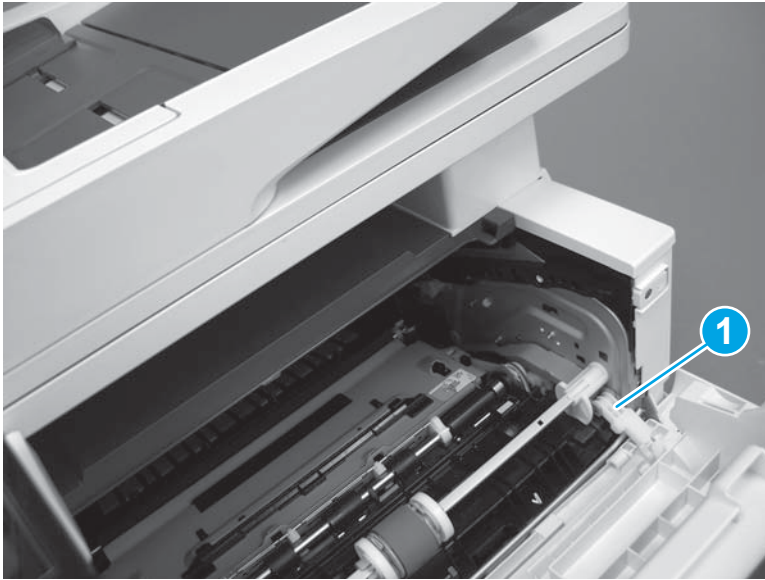
2. Release one tab (callout 1), and then slide the guide (callout 2) in the direction the arrow indicates and remove it.

**Figure 1-1963** Remove the guide



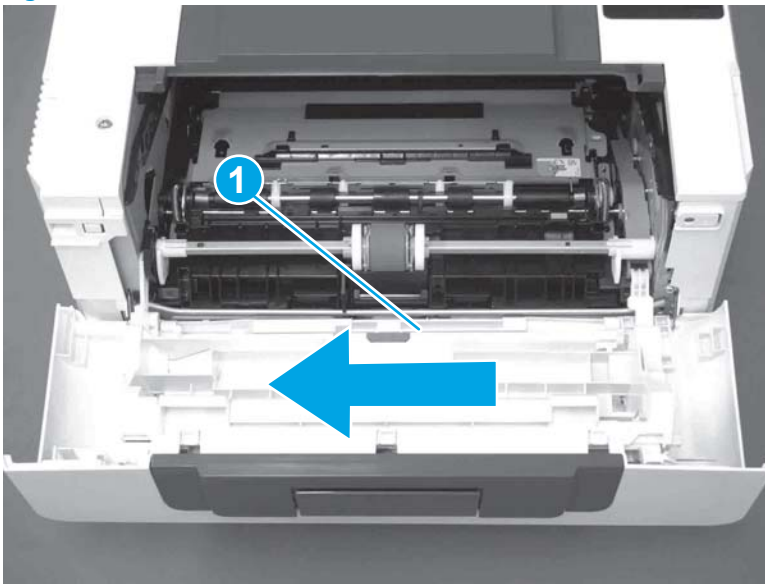
3. Remove the link arm (callout 1).

**Figure 1-1964** Remove the link arm



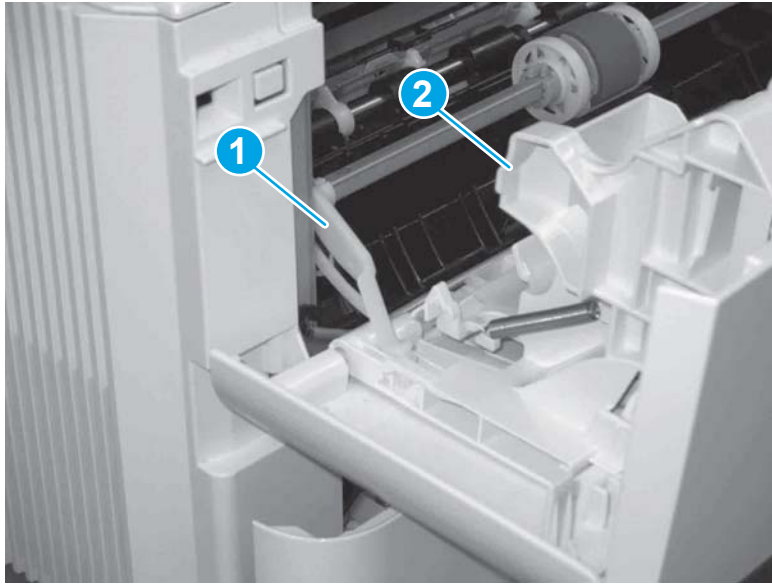
4. Slide the cartridge door assembly (callout 1) in the direction the arrow indicates and remove it.

**Figure 1-1965** Remove the door



5. Remove the link (callout 1) from the cartridge door assembly (callout 2).

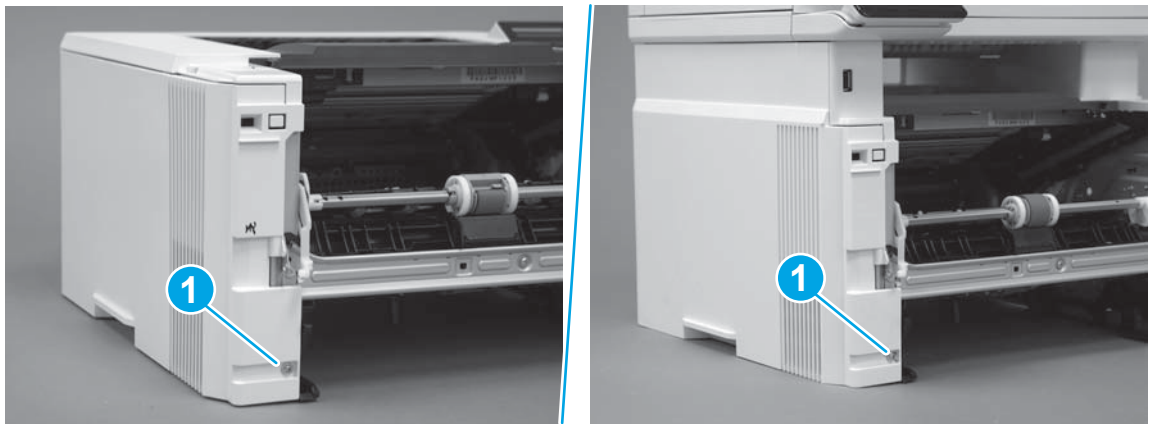
**Figure 1-1966** Release the left-side retainer arm



### Step 3: Remove the left cover

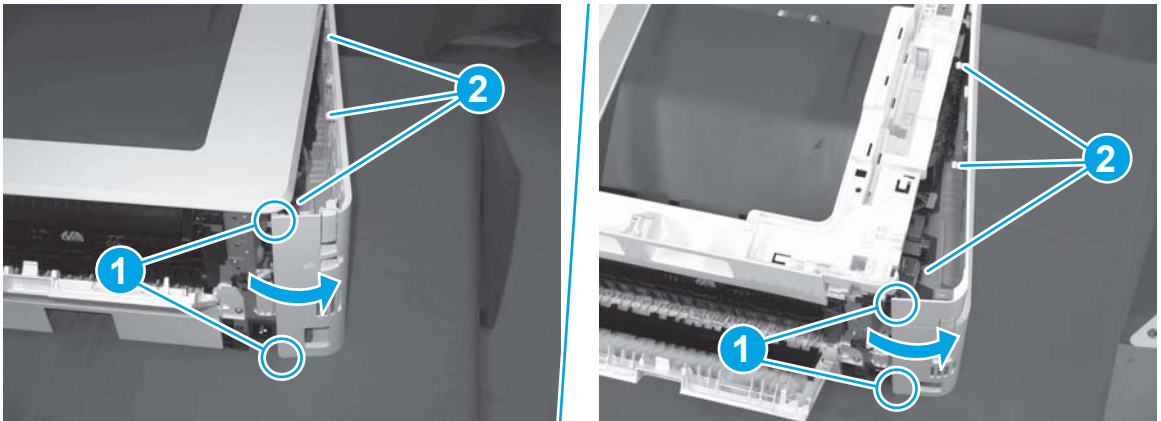
1. Remove one screw (callout 1).

**Figure 1-1967** Remove one screw



2. Open the rear door, release two bosses (callout 1), and then release three tabs (callout 2).

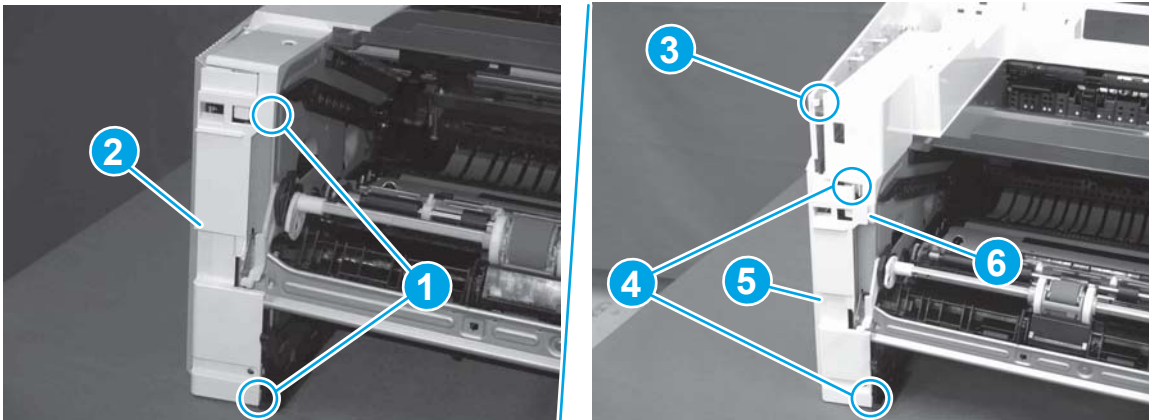
**Figure 1-1968** Release two bosses and three tabs



3. At the front of the printer, do one of the following:
  - **M403/M402:** Release two bosses (callout 1), and then remove the cover (callout 2).
  - **M427/M426:** Release one tab (callout 3), two bosses (callout 4), and then remove the cover (callout 5).

**CAUTION:** Be careful when releasing the upper bosses on the M427/M426 cover. One portion of the cover (callout 6) is fragile and is easily broken.

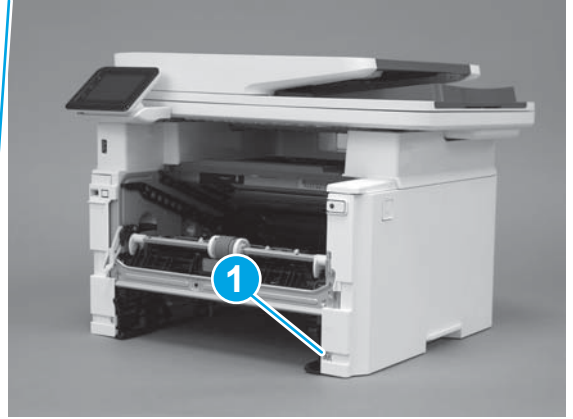
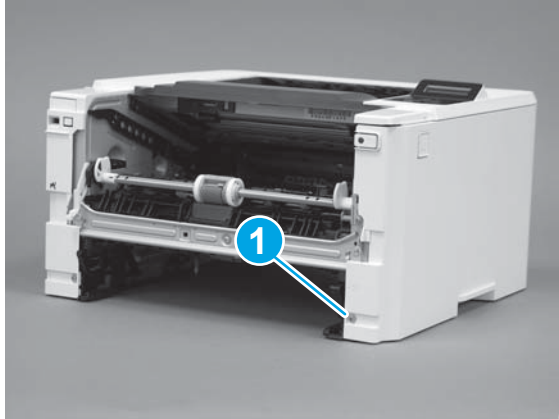
**Figure 1-1969** Remove the cover



#### Step 4: Remove the right cover

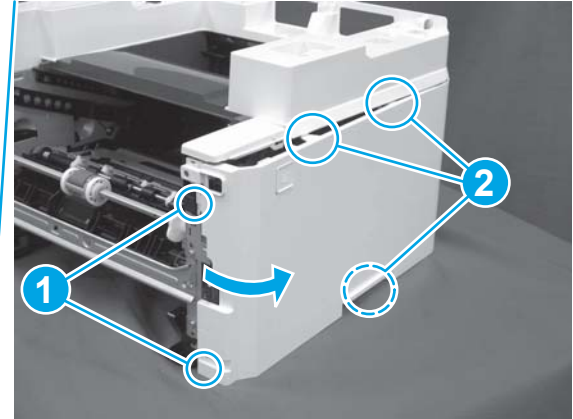
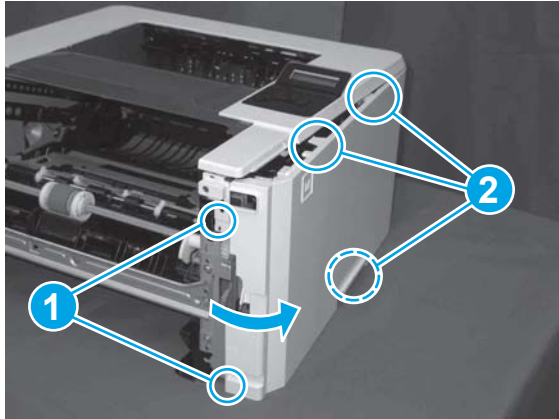
1. Remove one screw (callout 1).

**Figure 1-1970** Remove one screw



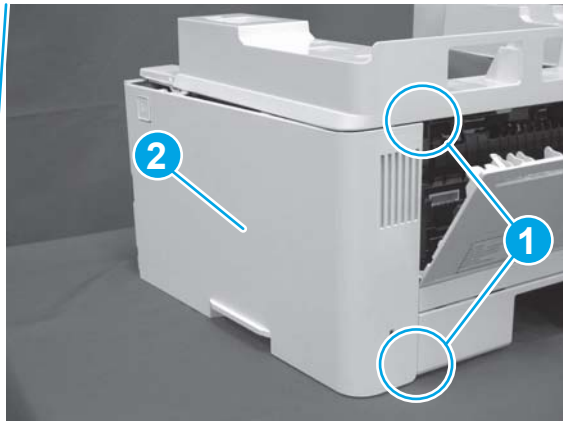
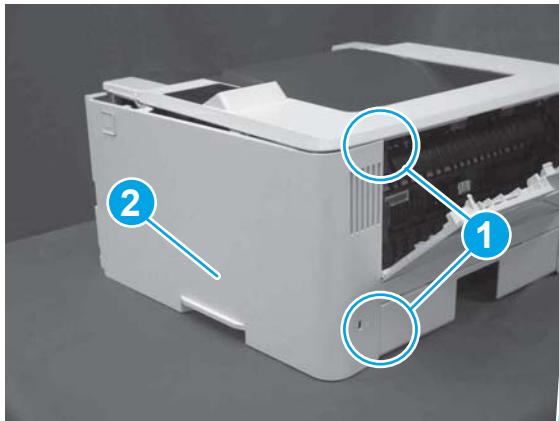
2. At the front of the printer, release two bosses (callout 1), and then release three tabs (callout 2).

**Figure 1-1971** Release two bosses and three tabs




3. Open the rear door, release two bosses (callout 1), and then remove the cover (callout 2).

**Figure 1-1972** Remove the cover

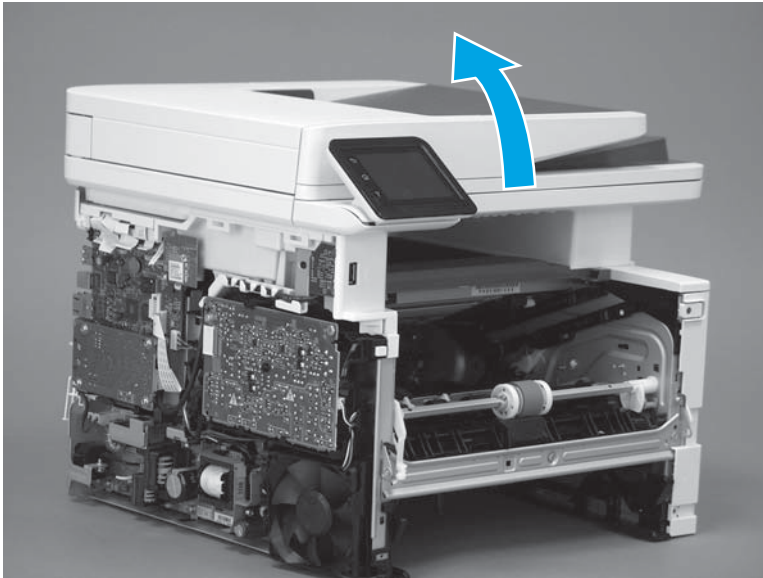


## Step 6: Remove the integrated scanner assembly (M427/M246)

 **NOTE:** M427/M426 models only. The integrated scanner assembly (ISA) includes the sub-scanner assembly (SSA) and the automatic document feeder (ADF).

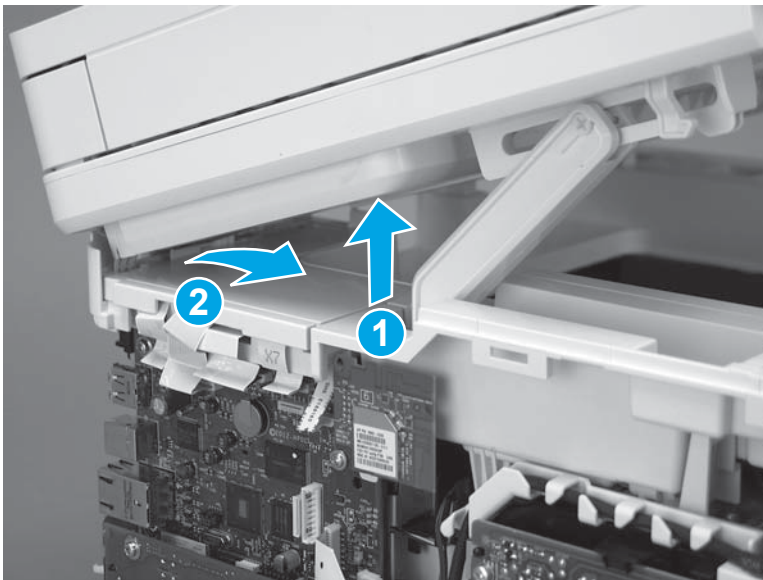
1. Raise the ISA.

**Figure 1-1973** Raise the ISA



2. Release the ISA flat-flexible cable (FFC) cover (callout 1), and then remove it (callout 2).

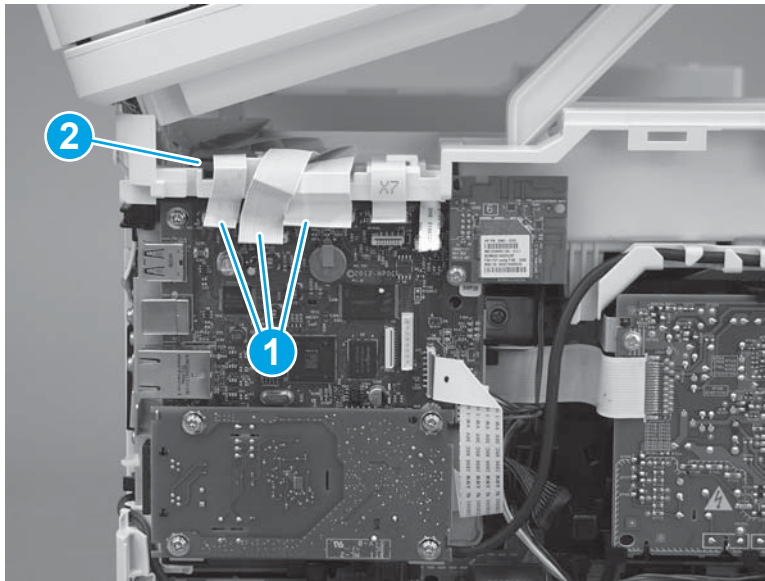
**Figure 1-1974** Remove the ISA FFC cover



3. Disconnect three FFCs (callout 1), and then remove the ferrite (callout 2) from the holder.

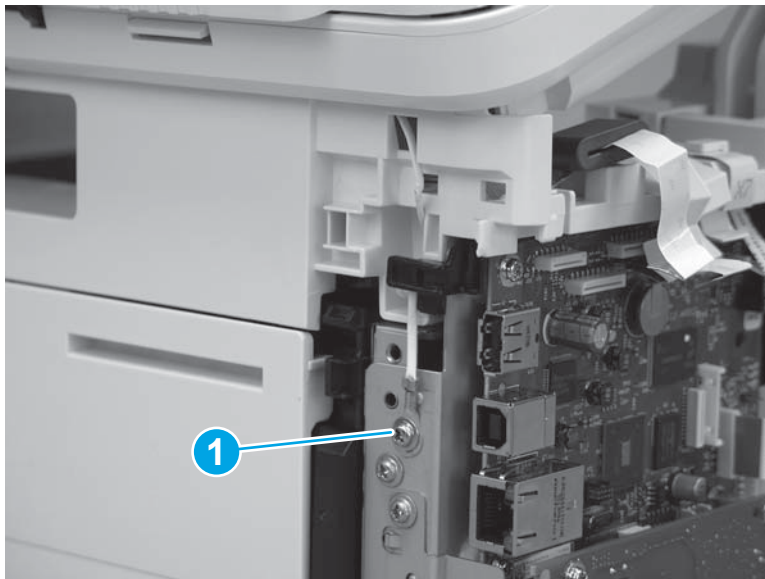
**CAUTION:** The ferrite is not captive on the FFC. Do not lose the ferrite while handling the ISA.

**Figure 1-1975** Disconnect three FFCs



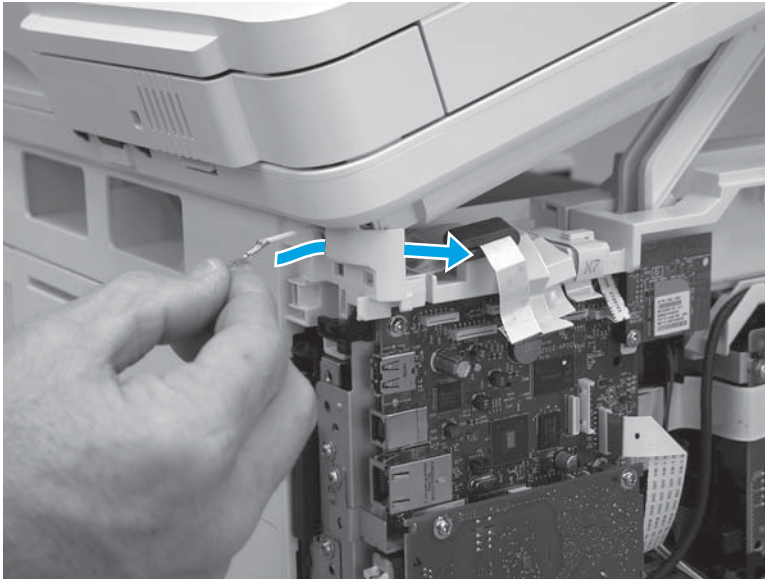
4. Remove one screw (callout 1).

**Figure 1-1976** Remove one screw



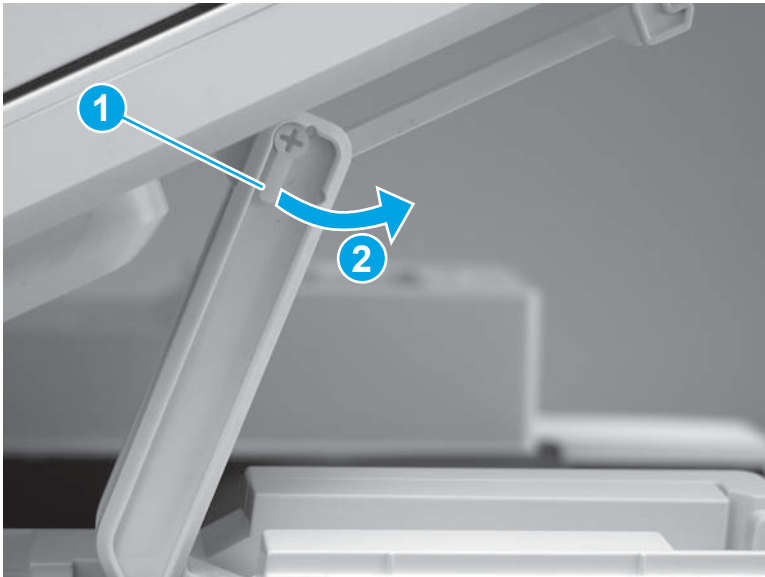
5. Pass the ground wire through the opening in the top cover.

**Figure 1-1977** Pass the wire through the opening



6. Release one tab (callout 1), and then rotate the ISA slider pin (callout 2) towards the front of the printer to release it.

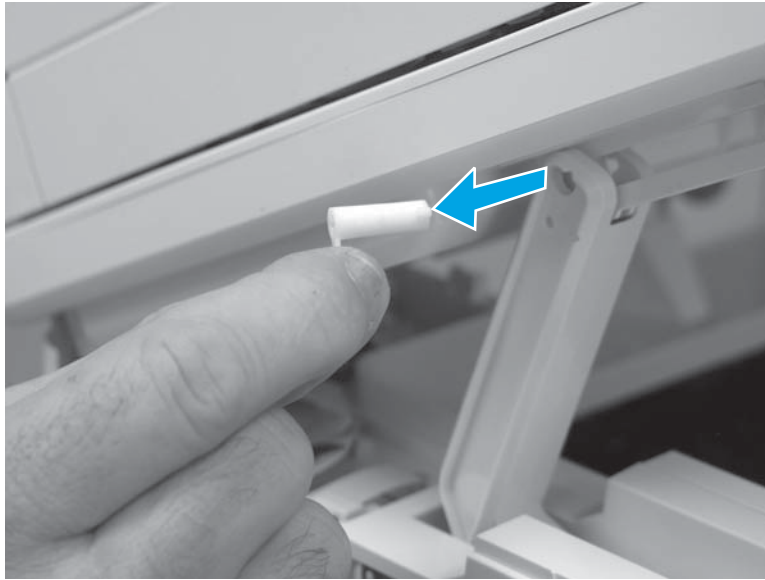
**Figure 1-1978** Release one tab and rotate the slider pin





7. Remove the slider pin.

**Figure 1-1979** Remove the slider pin



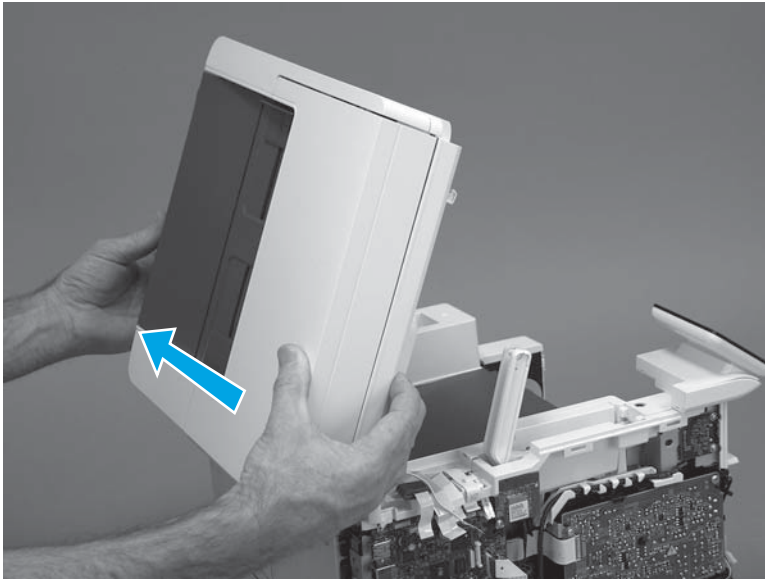
8. Rotate the ISA towards the rear of the printer until it stops.

**Figure 1-1980** Rotate the ISA towards the rear of the printer



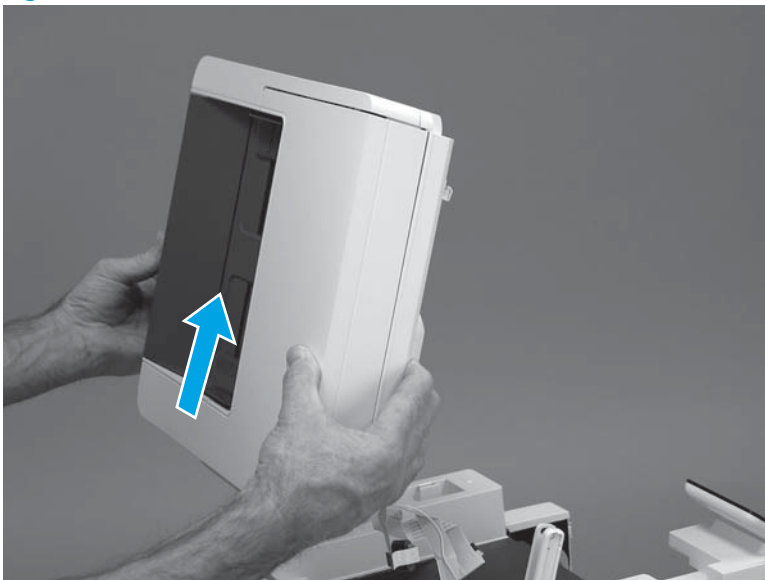
9. Slide the ISA as shown to release it.

**Figure 1-1981** Release the ISA



10. Remove the ISA.

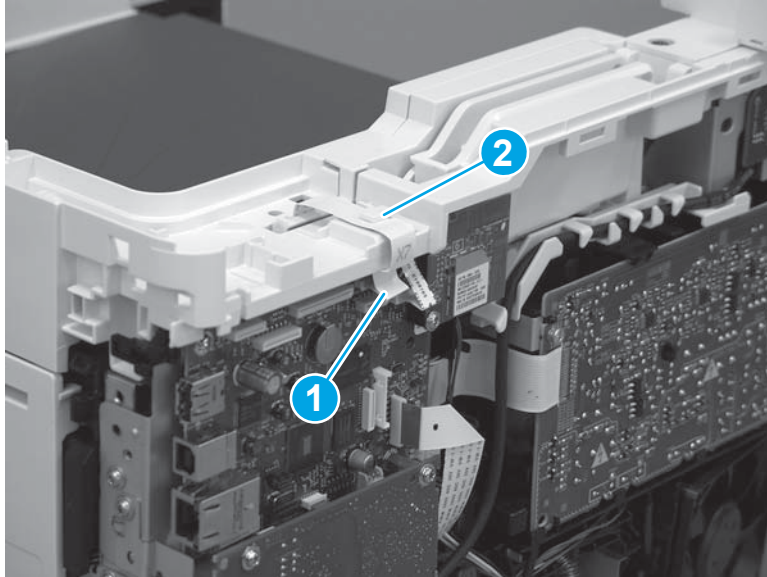
**Figure 1-1982** Remove the ISA



#### **Step 5: Remove the control panel (M427/M426)**

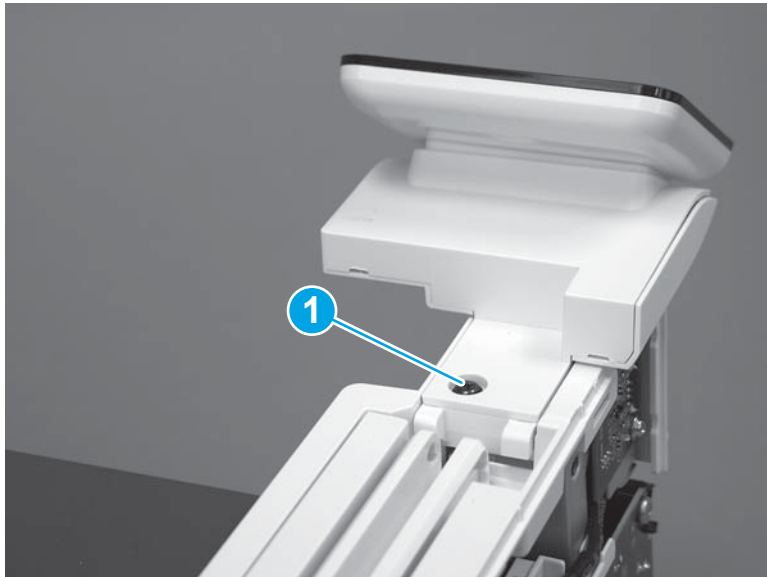
1. Disconnect one FFC (callout 1; J114), and then release the FFC from the retainer (callout 2).

**Figure 1-1983** Disconnect one connector



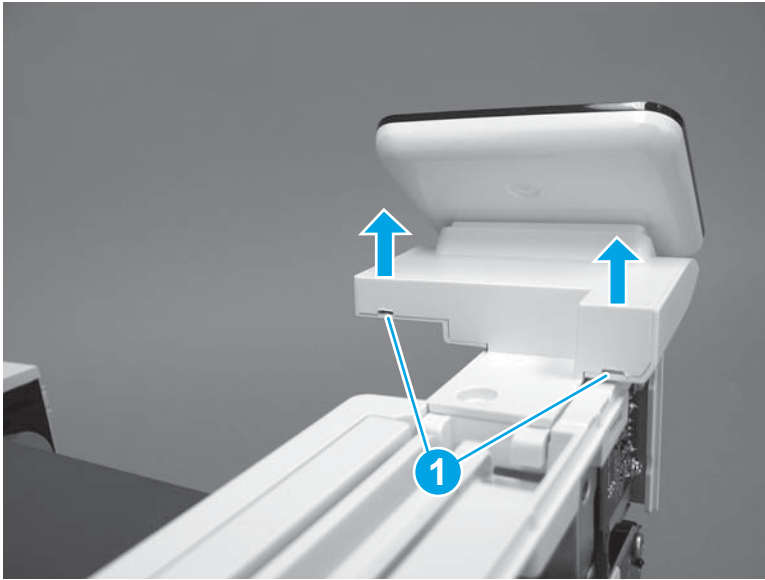
2. Remove one screw (callout 1).

**Figure 1-1984** Remove one screw



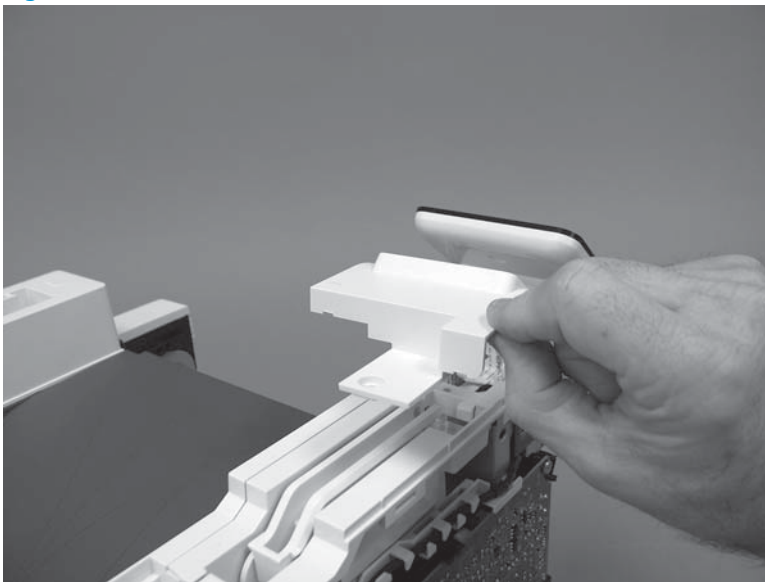
3. Use a small flat-blade screwdriver to release two tabs (callout 1) on the control-panel cable cover.

**Figure 1-1985** Release two tabs



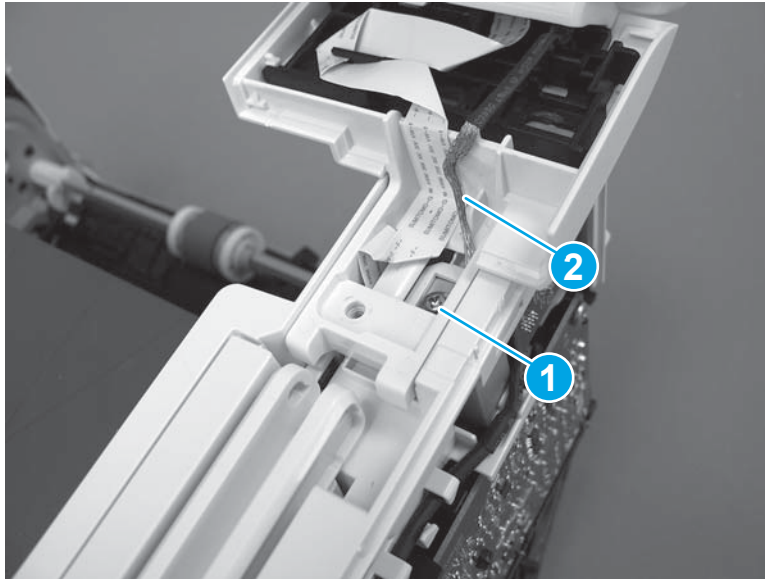
4. Remove the control-panel cable cover.

**Figure 1-1986** Remove the cover



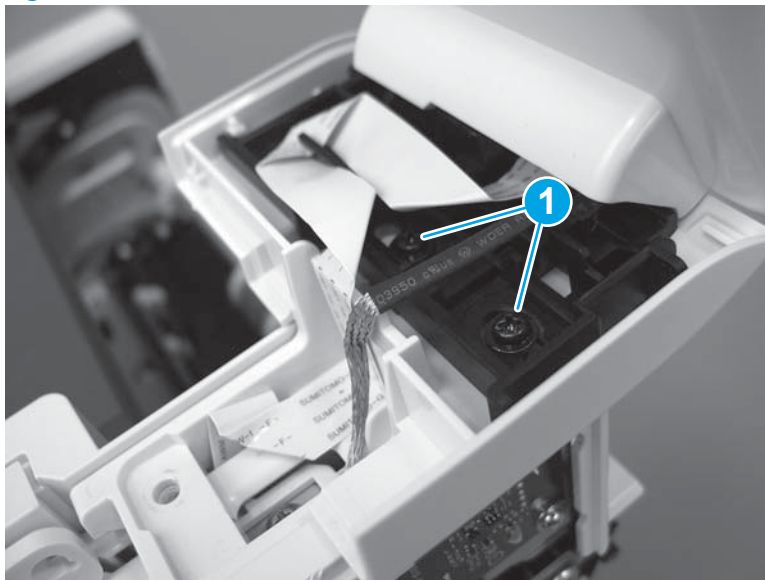
5. Remove one grounding screw (callout 1), and then move the ground cable (callout 2) out of the way.

**Figure 1-1987** Remove one screw



6. Move the FFC out of the way, and then remove two screws (callout 1).

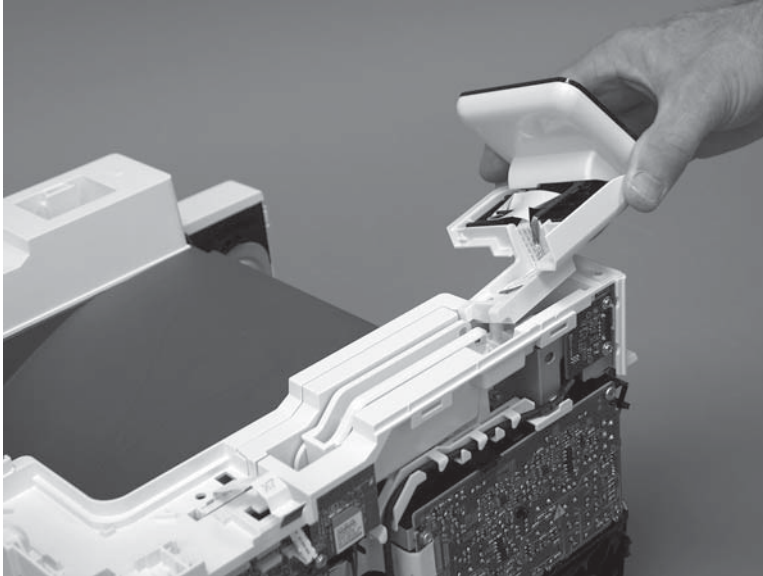
**Figure 1-1988** Remove two screws



7. Slightly lift up the control-panel assembly to separate it from the top cover.

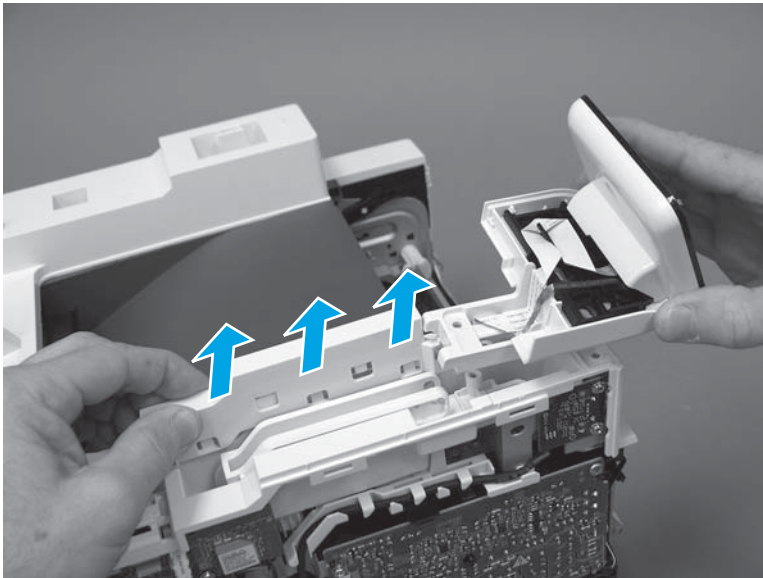
**⚠ CAUTION:** The control panel assembly is still connected to the printer by the FFC. Do not attempt to completely remove the assembly.

**Figure 1-1989** Lift up the control-panel assembly



8. Lift up the control-panel FFC cover to remove the control-panel assembly.

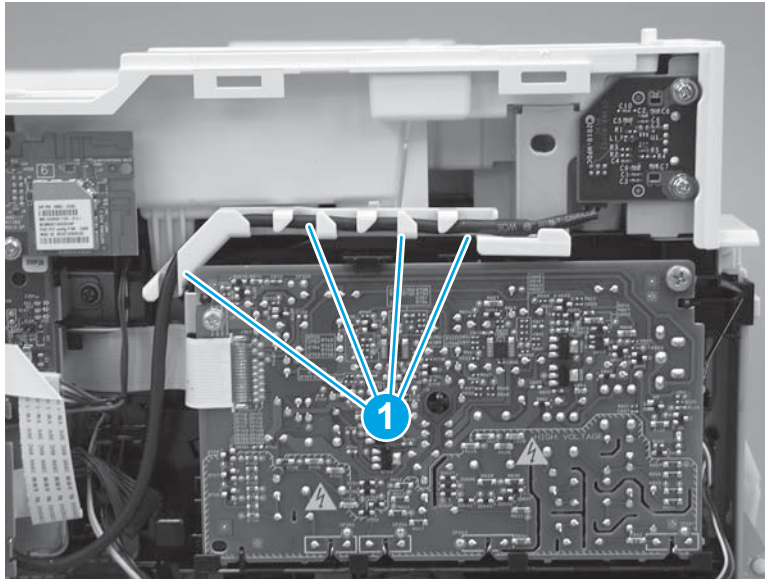
**Figure 1-1990** Remove the control-panel assembly



### Step 7: Remove the top cover (M427/M426)

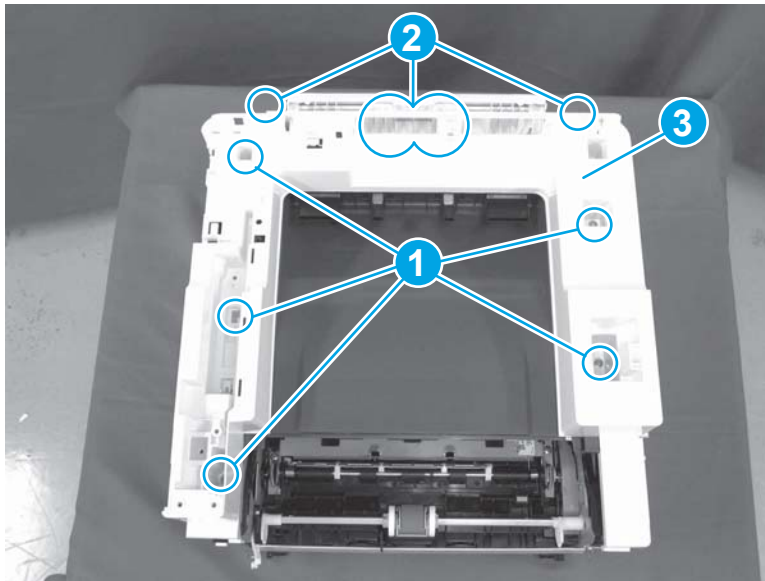
1. Release the USB cable (callout 1) from the cable guide.

**Figure 1-1991** Remove the USB cable



2. Remove five screws (callout 1), release four bosses (callout 2), and then remove the top cover (callout 3).

**Figure 1-1992** Remove the cover

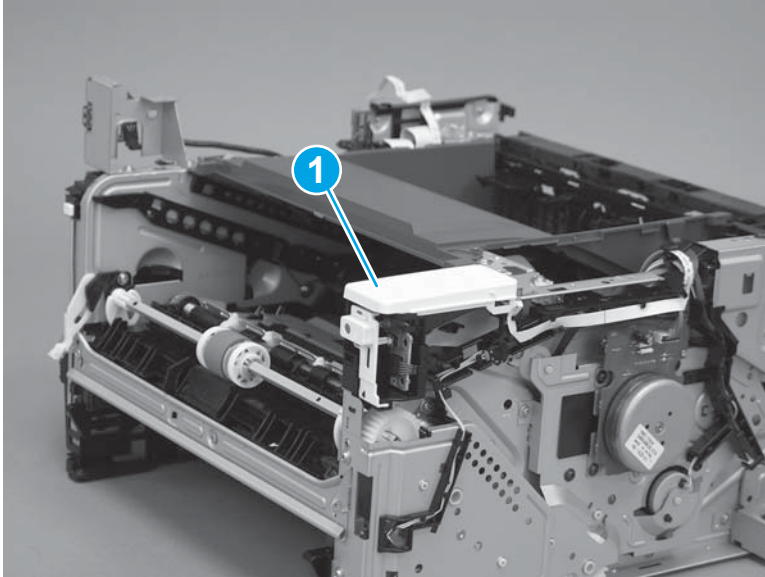


**Step 8: Remove the NFC cover (M427/M426)**

- ▲ Carefully pull up on the NFC cover (callout 1) to remove it.

**⚠ CAUTION:** Do not damage the NFC PCA when removing the cover.

**Figure 1-1993** Remove the cover



**Step 9: Unpack the replacement assembly**

Unpack the replacement part from the packaging.

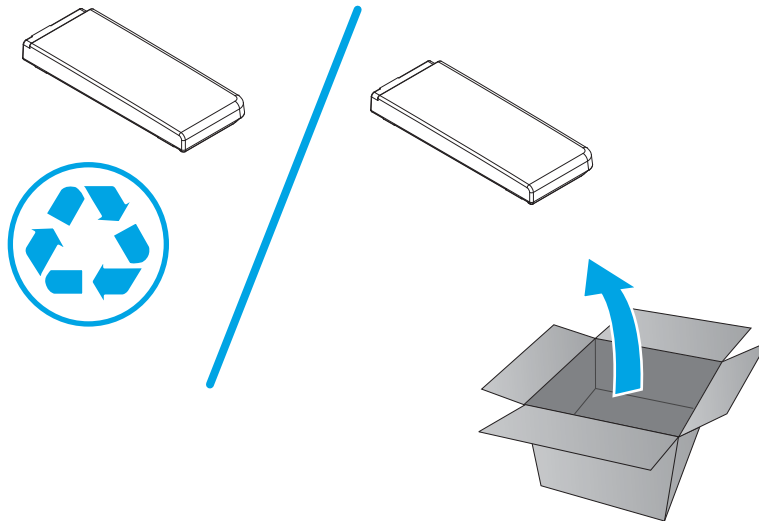
<http://www8.hp.com/us/en/hp-information/environment/product-recycling.html>

---

 **NOTE:** HP recommends responsible disposal of the defective part.

---

**Figure 1-1994** Recycle and unpack



**Step 10: Install the NFC cover (M427/M426)**

▲ Carefully install the NFC cover on the printer.

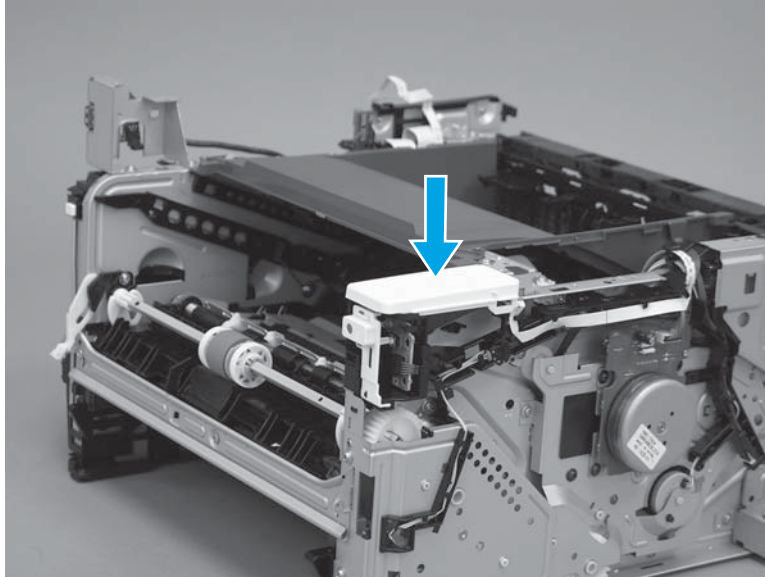
---

 **CAUTION:** Do not damage the NFC PCA when installing the cover.

---



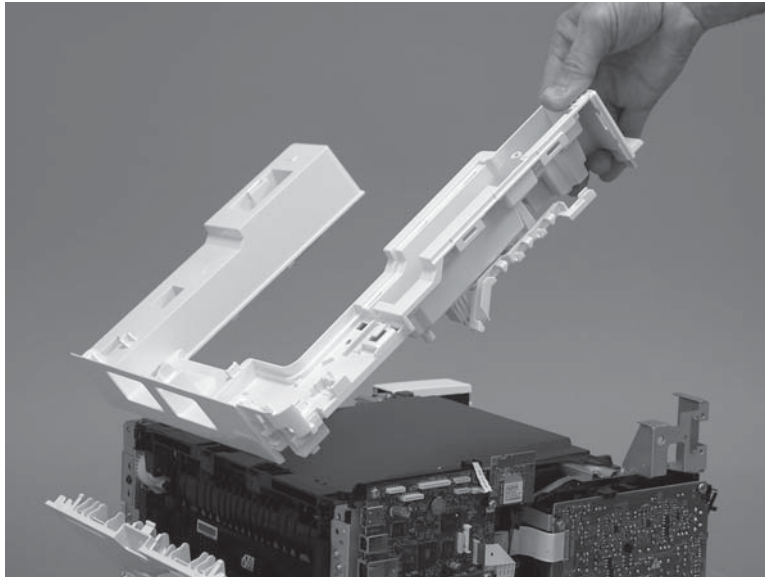
**Figure 1-1995** Remove the cover



**Step 11: Install the top cover (M427/M426)**

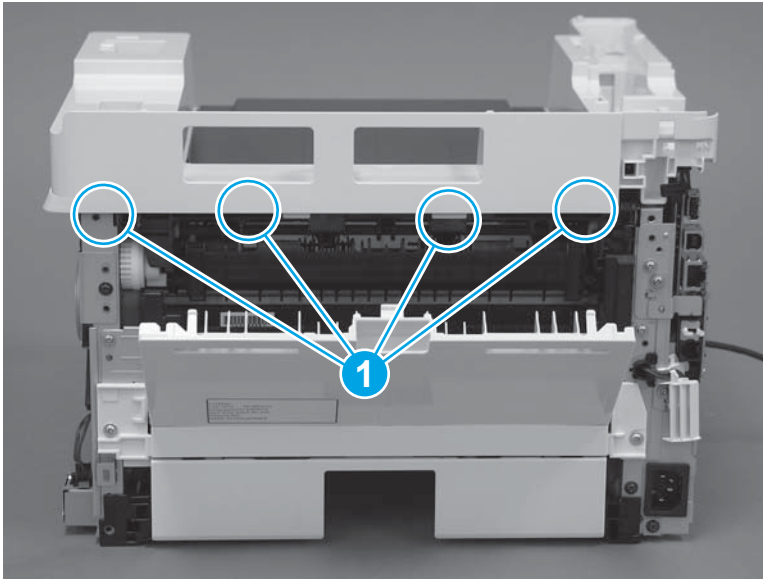
1. Position the rear edge of the top cover on the printer.

**Figure 1-1996** Install the cover



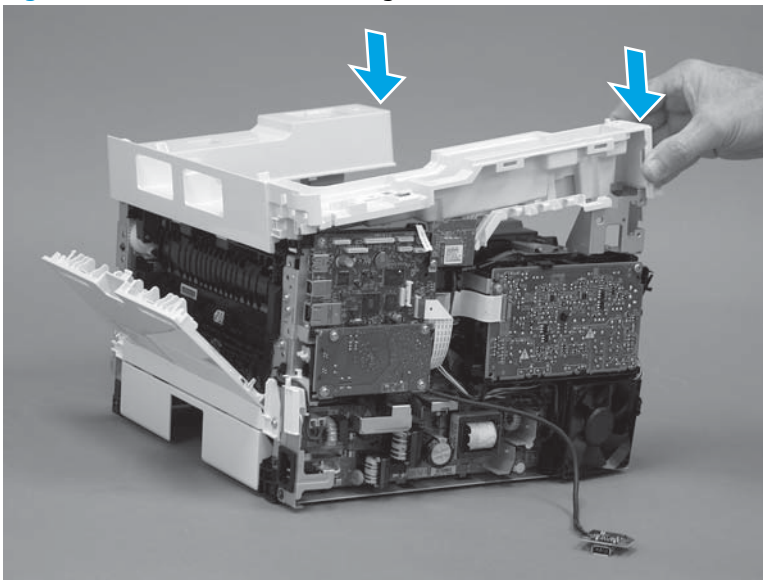
2. Engage four bosses (callout 1).

**Figure 1-1997** Engage four bosses



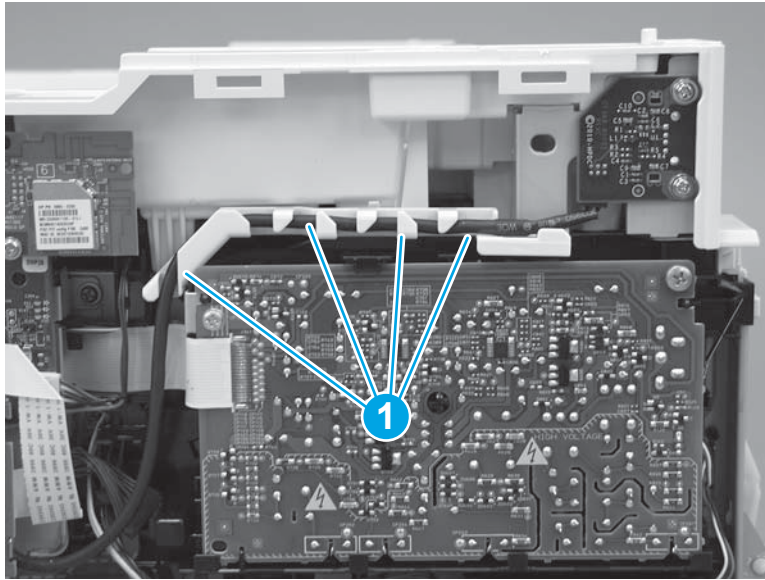
3. Rotate the front edge of the cover down.

**Figure 1-1998** Rotate the front edge of the cover down



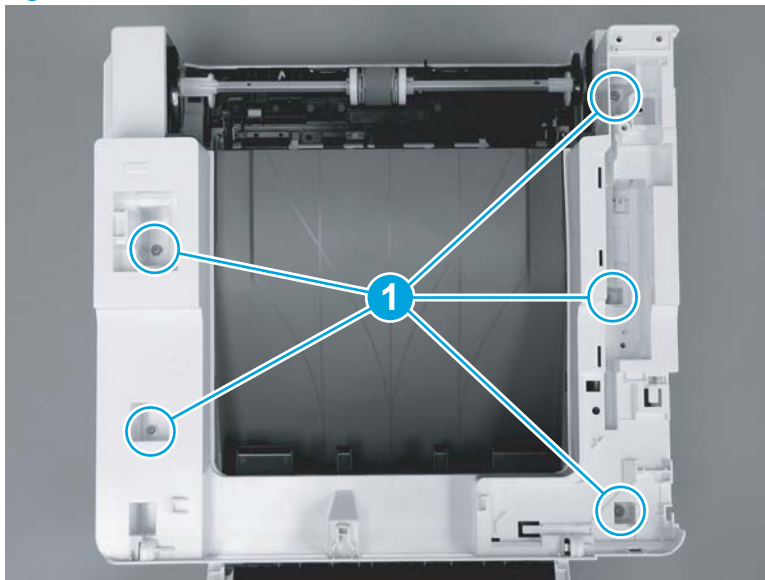
4. Install the USB cable (callout 1) in the guide.

**Figure 1-1999** Install the USB PCA



5. Install five screws (callout 1).

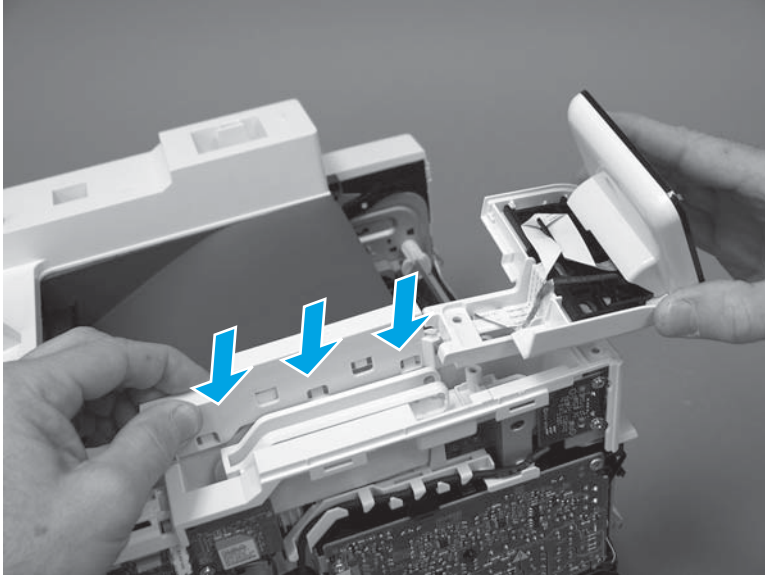
**Figure 1-2000** Install five screws



### Step 12: install the control panel (M427/M426)

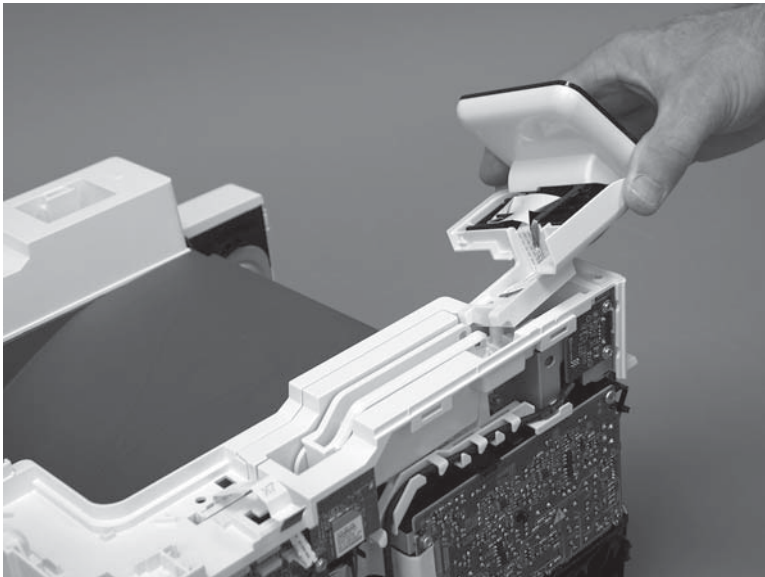
1. Slide the control-panel FFC cover into the slot in the top cover (next to the document feeder support arm) to install it.

**Figure 1-2001** Install the control-panel FFC cover



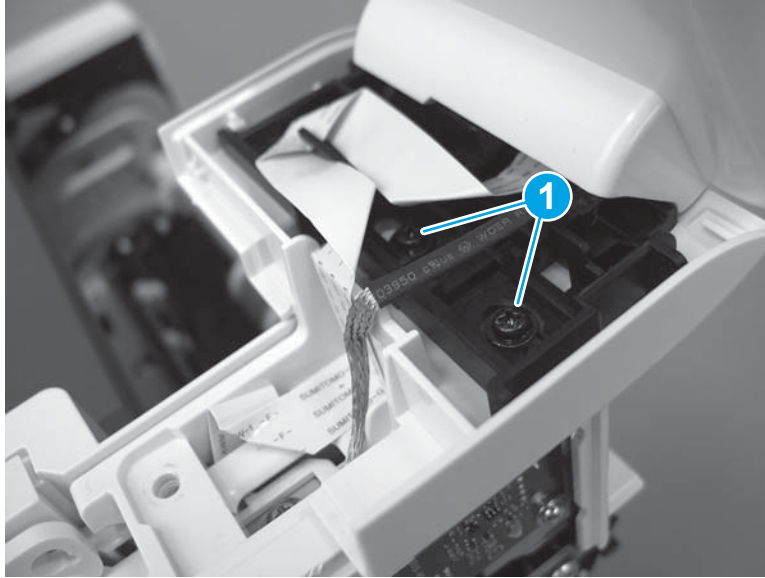
2. Install the control-panel assembly on the top cover.

**Figure 1-2002** Install the control-panel assembly



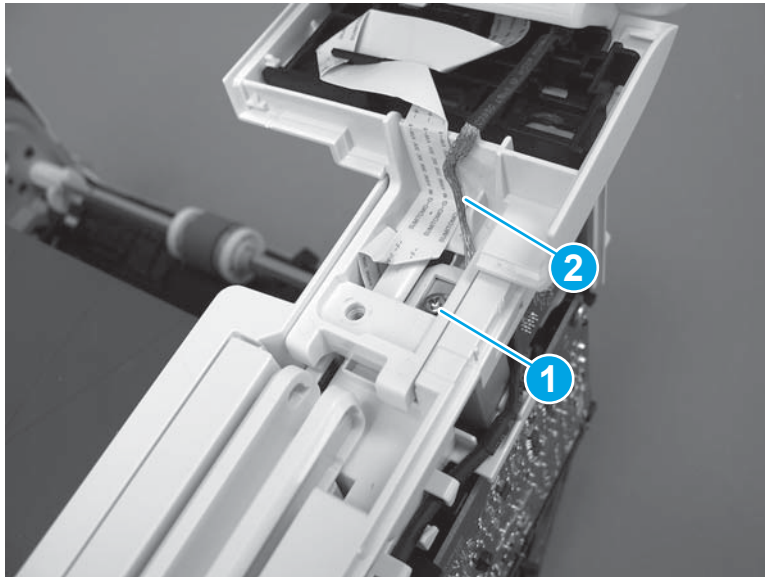
3. Move the FFC out of the way, and then install two screws (callout 1).

**Figure 1-2003** Install two screws



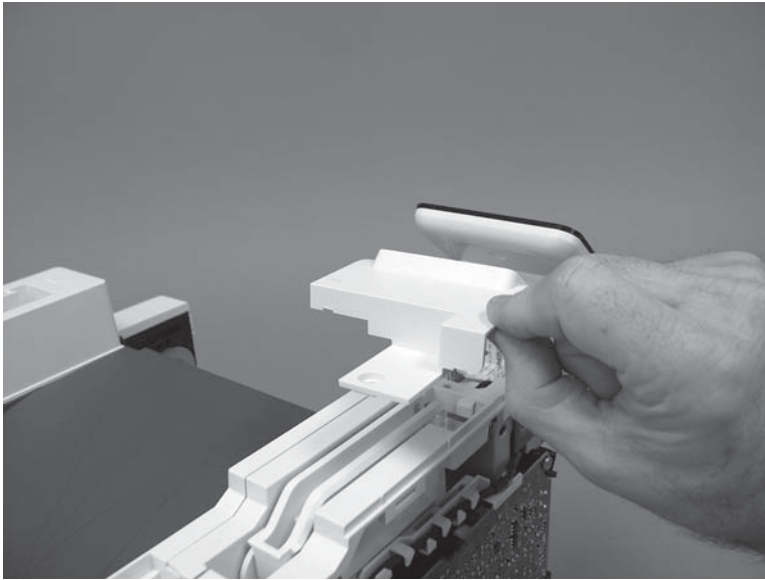
4. Install one grounding screw (callout 1), and then make sure that the ground cable (callout 2) is properly routed.

**Figure 1-2004** Remove one screw



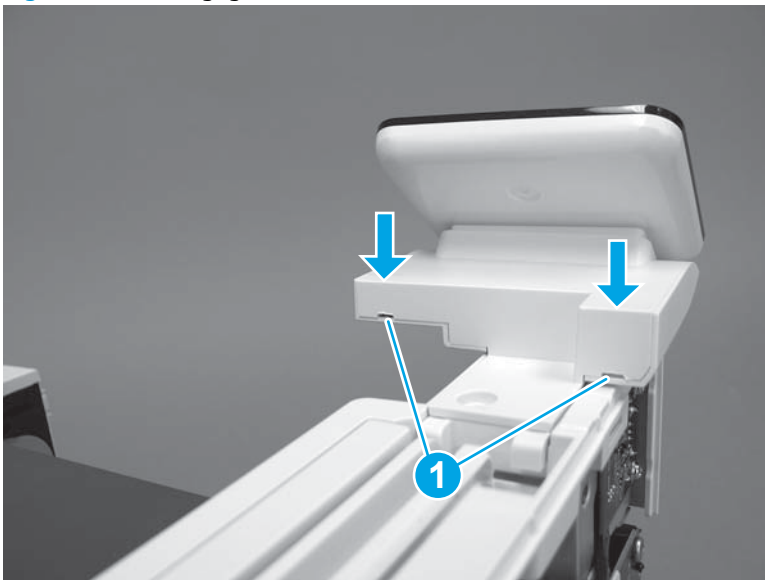
5. Install the control-panel cable cover.

**Figure 1-2005** Install the cover



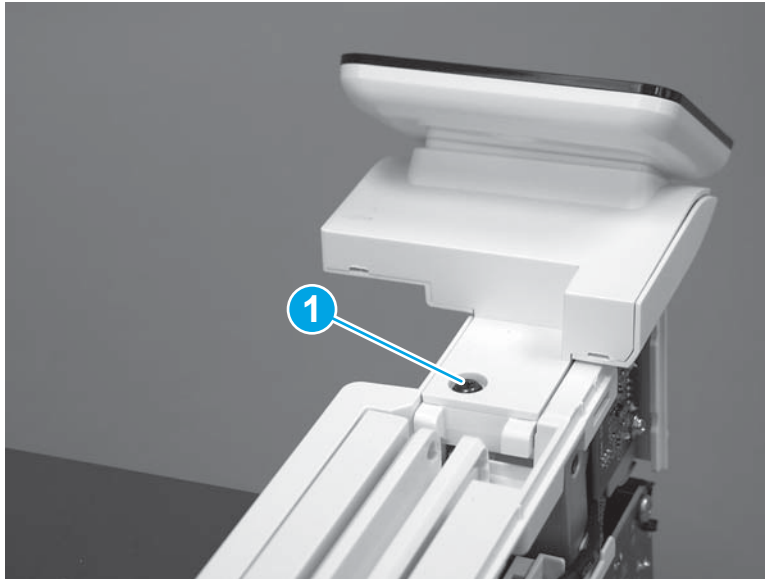
6. Make sure that the two tabs (callout 1) on the cover snap into place.

**Figure 1-2006** Engage two tabs



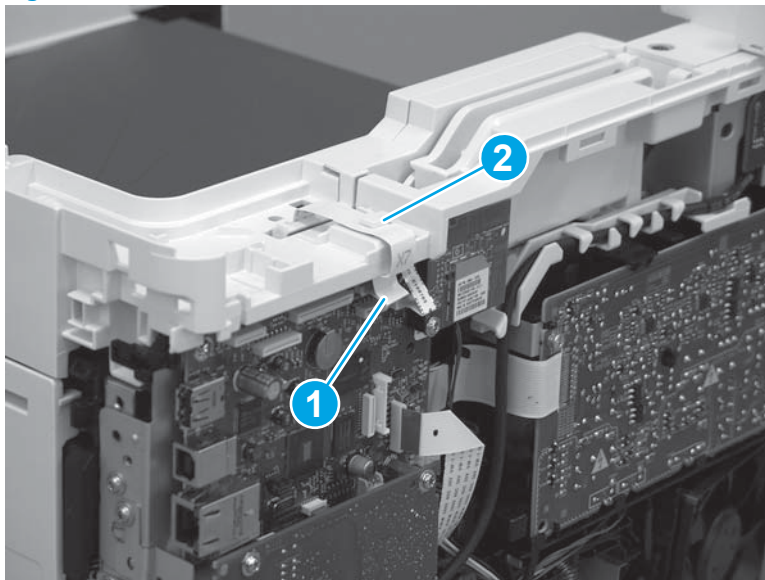
7. Install one screw (callout 1).

**Figure 1-2007** Install one screw




8. Install the FFC in the retainer (callout 1), and then connect one FFC (callout 1; J114).

**Figure 1-2008** Connect one connector



### Step 12: Install the integrated scanner assembly (M427/M246)

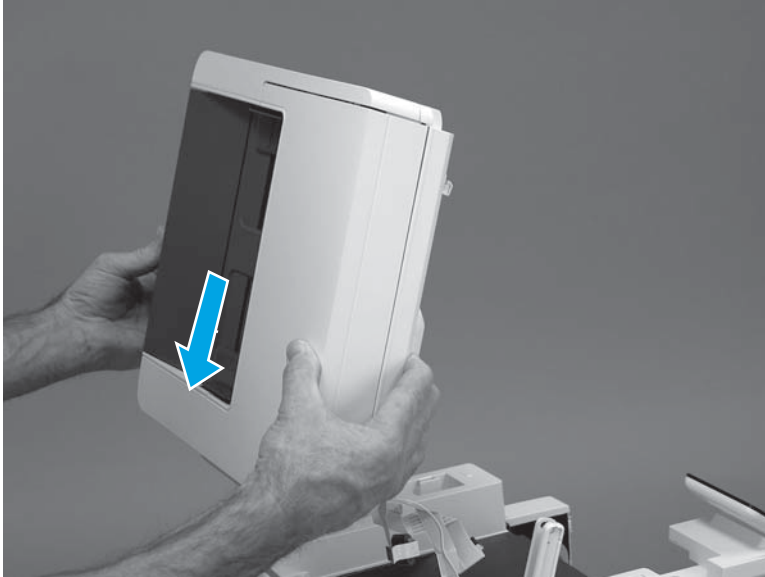
---

 **NOTE:** M427/M426 models only. The integrated scanner assembly (ISA) includes the sub-scanner assembly (SSA) and the automatic document feeder (ADF).

---

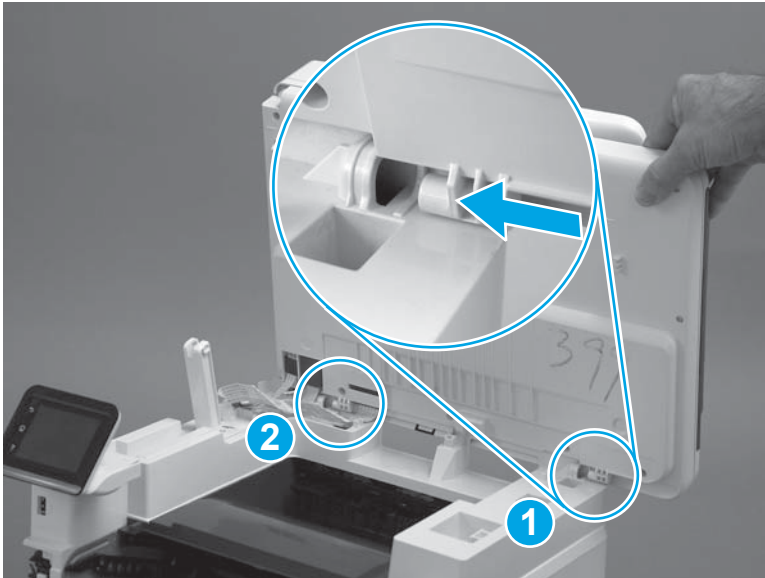
1. Position the ISA on the printer.

**Figure 1-2009** Position the ISA on the printer



2. Engage the hinge pins on the ISA with the holders in the top cover (callouts 1/2), and then slide the ISA as shown to engage them

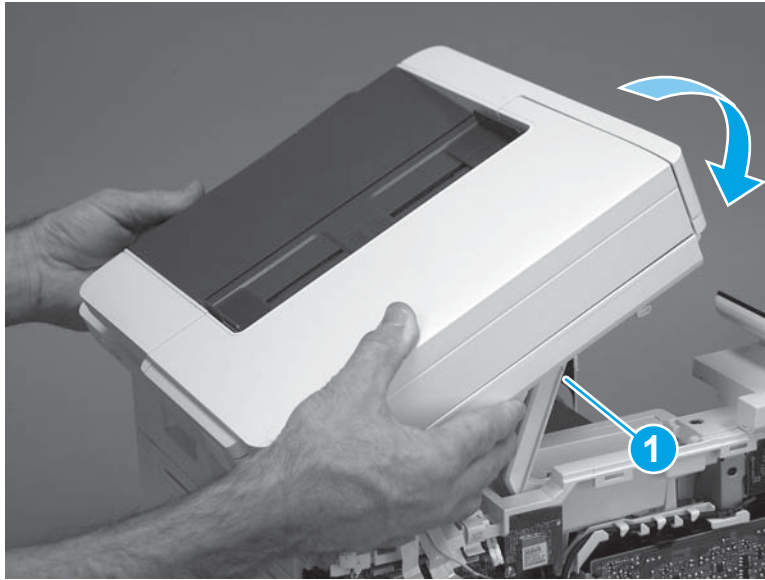
**Figure 1-2010** Engage the hinge pins with the holders





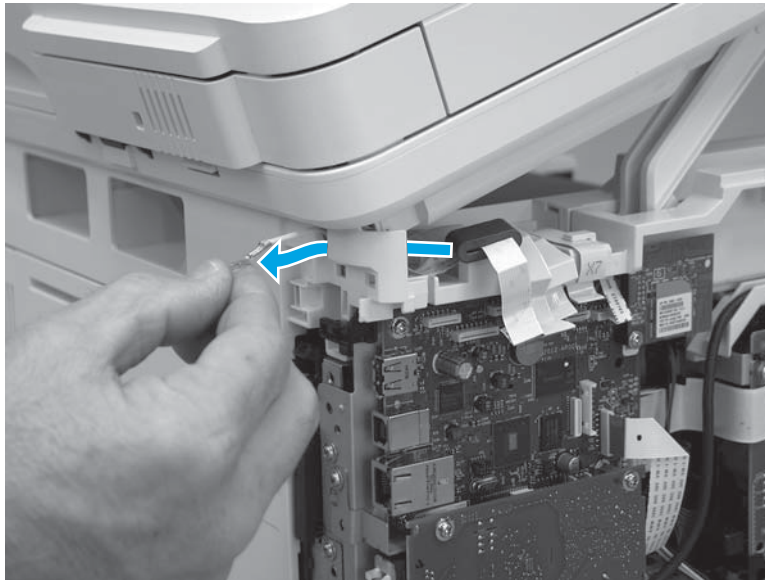
3. Rotate the ISA towards the front of the printer until it rests on the ISA lift assembly (callout 1).

**Figure 1-2011** Rotate the ISA towards the front of the printer



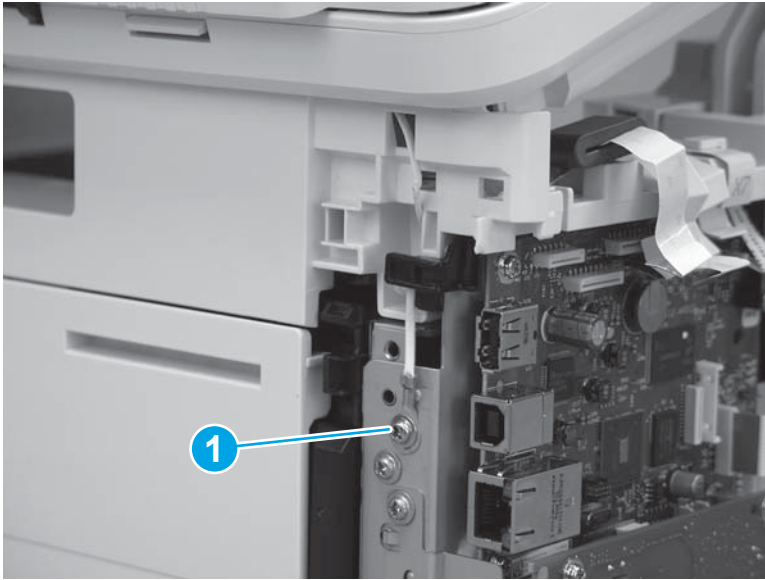
4. Pass the ground wire through the opening in the top cover.

**Figure 1-2012** Pass the wire through the opening




5. Install one screw (callout 1).

**Figure 1-2013** Install one screw



6. Install the ISA lift assembly slider pin.

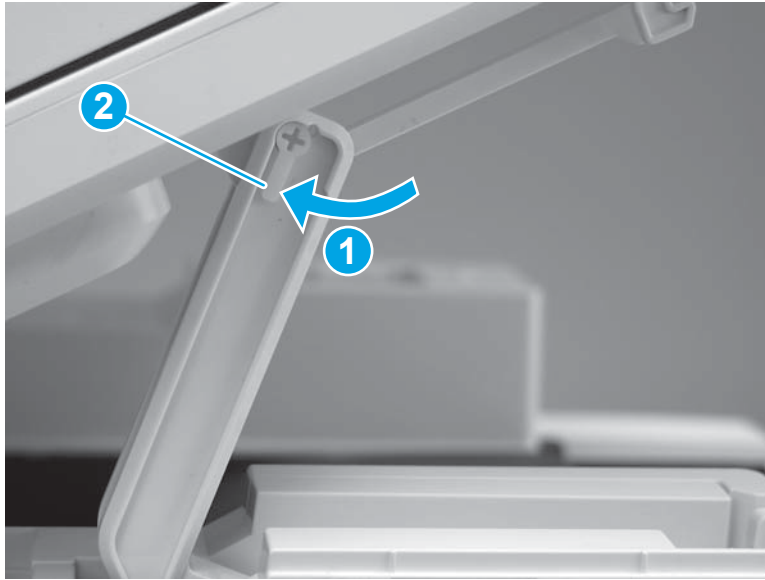
 **Reinstallation tip:** Align the keyed portion of the locking pin with the slot and hole in the support arm.

**Figure 1-2014** Install the slider pin



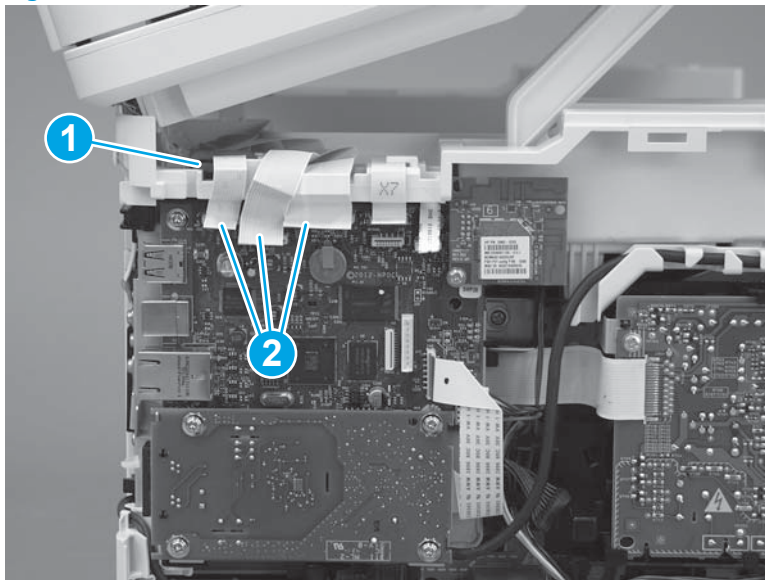
7. Rotate the slider pin (callout 1) towards the rear of the printer until the tab (callout 2) snap into place.

**Figure 1-2015** Secure the slider pin



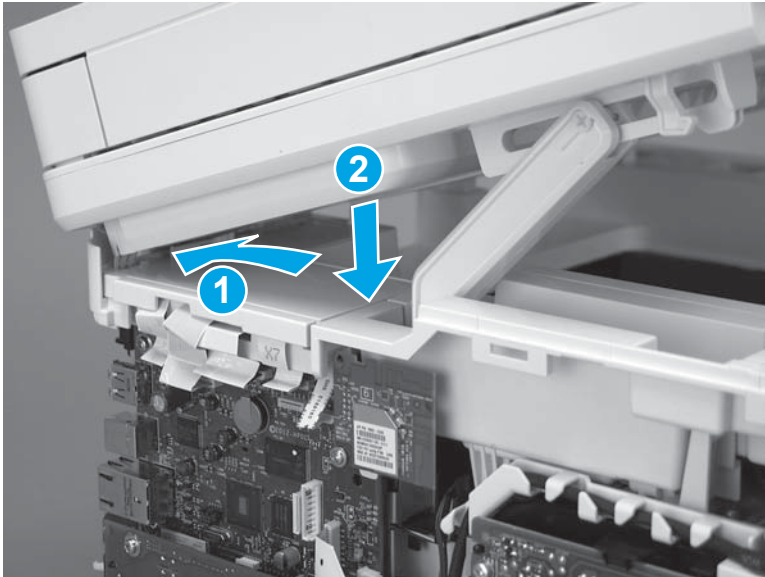
8. Install the ferrite (callout 1) in the holder, and then connect three FFCs (callout 2).

**Figure 1-2016** Connect three FFCs



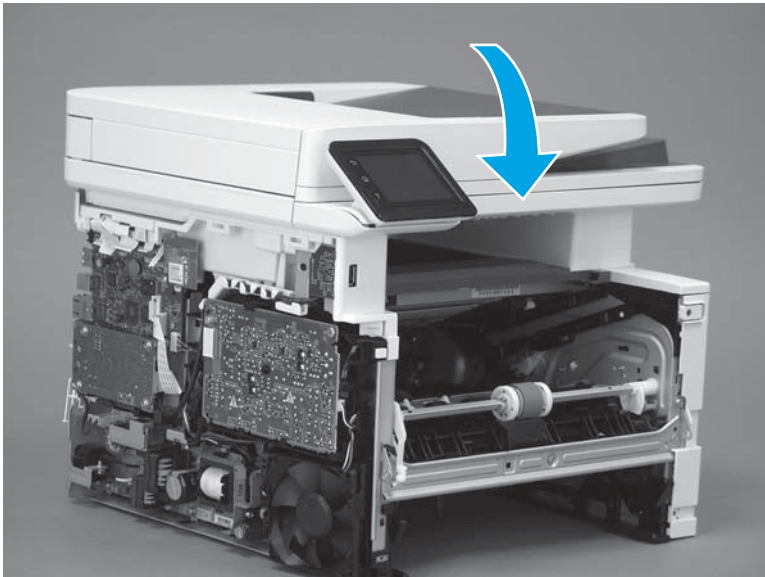
9. Position the rear edge of the ISA flat-flexible cable (FFC) cover on the printer (callout 1) , and then rotate it down (callout 2) until it snaps into place.

**Figure 1-2017** Install the ISA FFC cover



10. Lower the ISA.

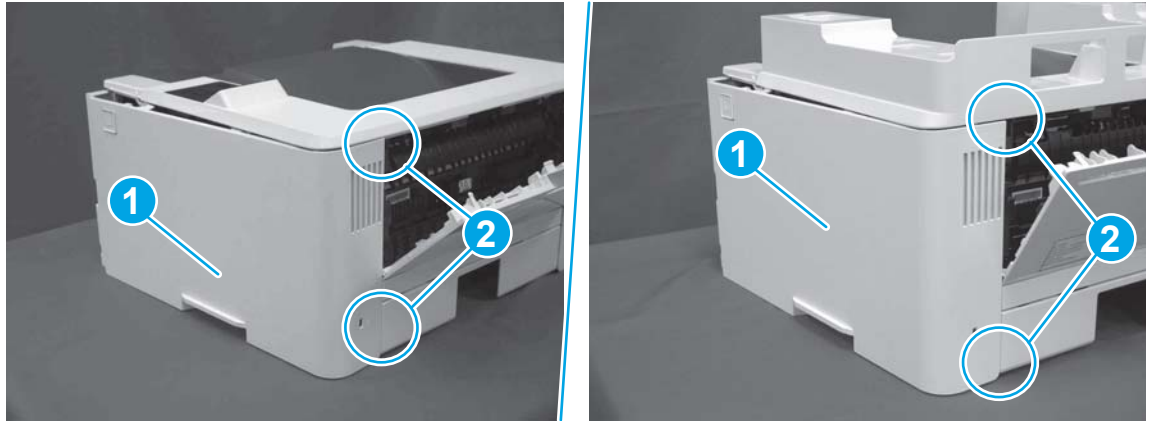
**Figure 1-2018** Lower the ISA



### Step 13: Install the right cover

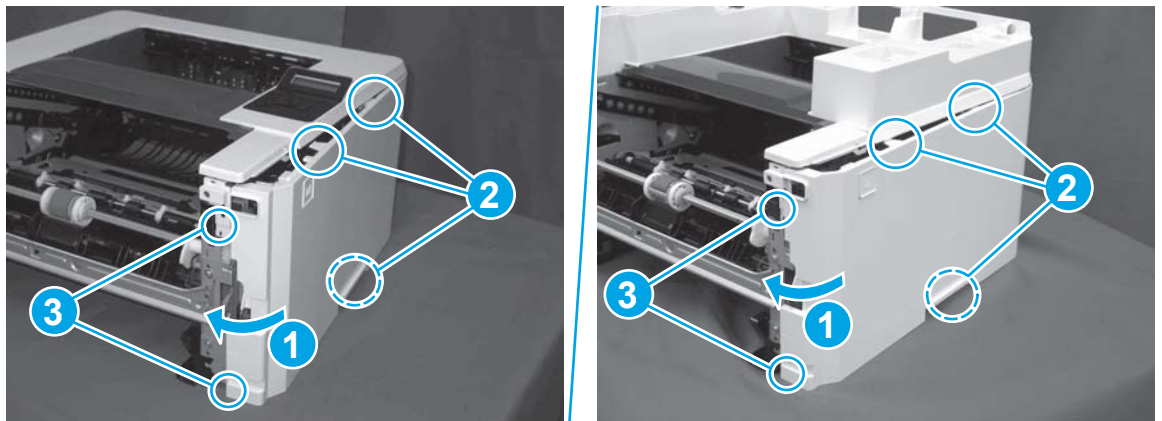
1. Position the cover (callout 1) on the printer, and then engage two bosses (callout 2).

**Figure 1-2019** Install the cover



2. Rotate the front of the cover onto the printer (callout 1), engage three (callout 2) tabs, and then engage two bosses (callout 3).

**Figure 1-2020** Engage two bosses and one tab

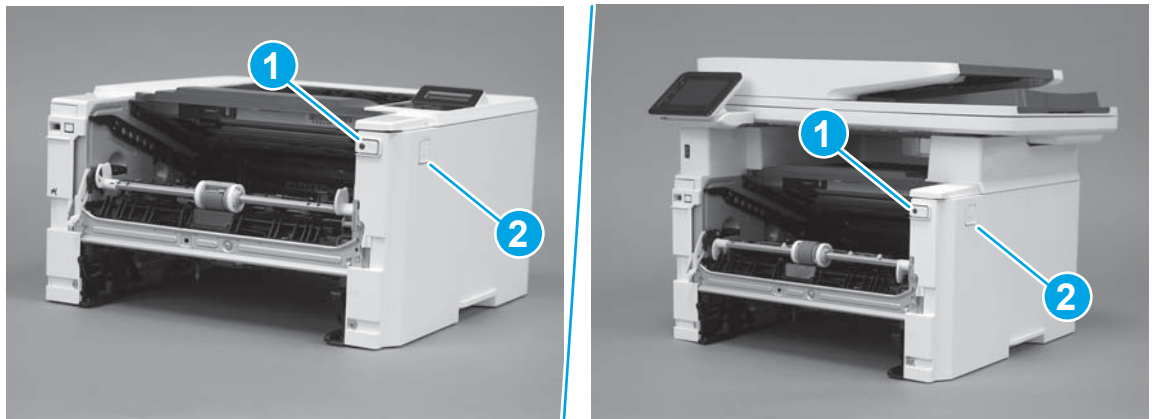


3. Make sure that the power switch (callout 1) and cartridge door assembly button (callout 2) correctly function.



**NOTE:** Remove, and then reinstall the cover if the switch or button does not correctly function.

**Figure 1-2021** Check the power switch and cartridge door assembly button



4. Install one screw (callout 1).

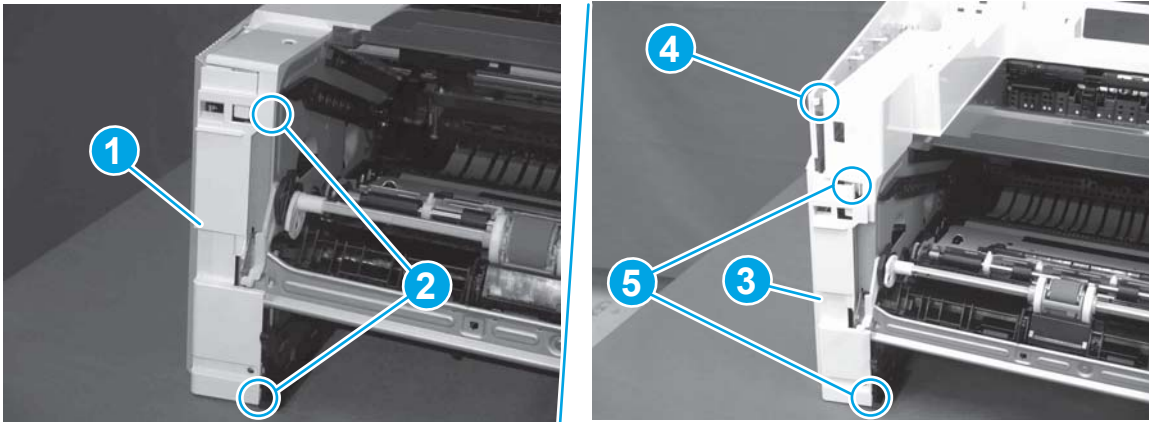
**Figure 1-2022** Install one screw



#### Step 14: Install the left cover

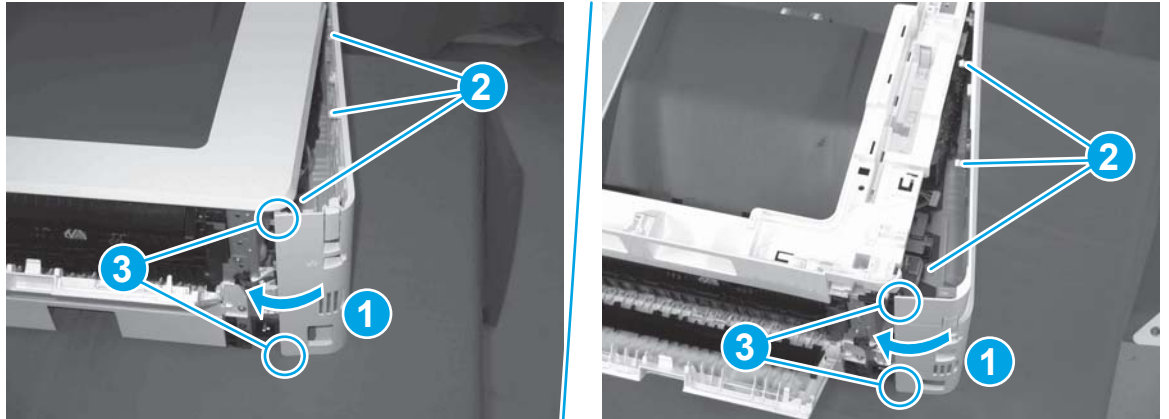
1. At the front of the printer, do one of the following:
  - **M403/M402:** Position the cover on the printer ( callout 1), and then engage two bosses (callout 2).
  - **M427/M426:** Position the cover on the printer (callout 3), engage one tab (callout 4), and then engage two bosses (callout 4).

**Figure 1-2023** Install the cover



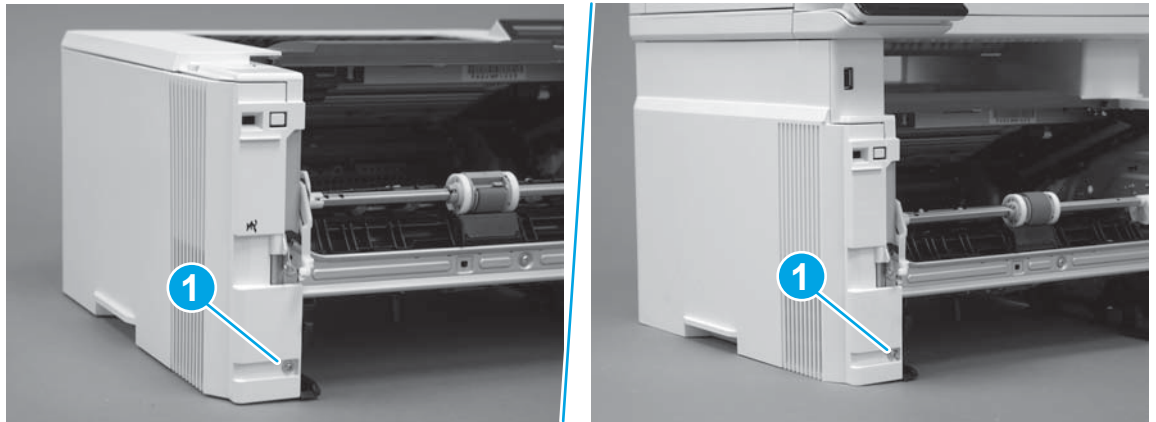
- Carefully rotate the rear of the cover onto the printer (callout 1), engage three tabs (callout 2), and then engage two bosses (callout 3).

**Figure 1-2024** Engage three tabs and two bosses




- Install one screw (callout 1).

**Figure 1-2025** Install one screw

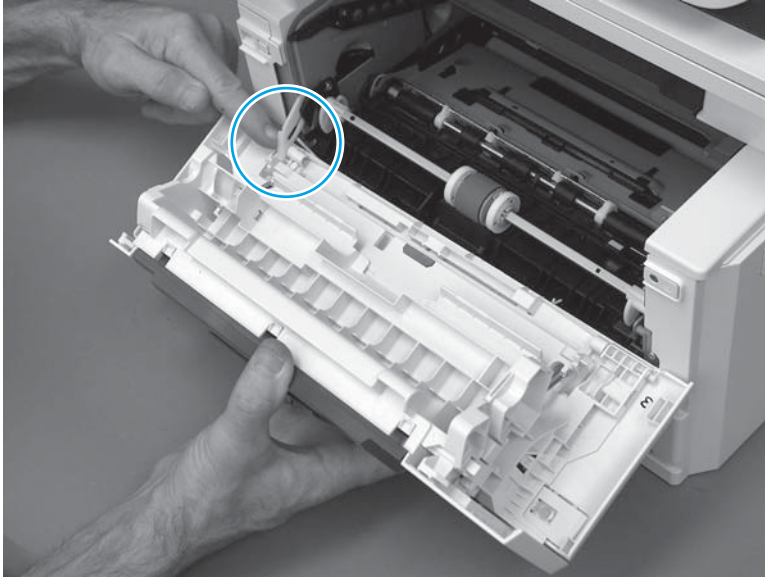


### Step 15: Remove the cartridge door assembly

 **Reinstallation tip:** After a replacement door is installed, make sure to install the nameplate (supplied in the kit) corresponding to the printer name on the door.

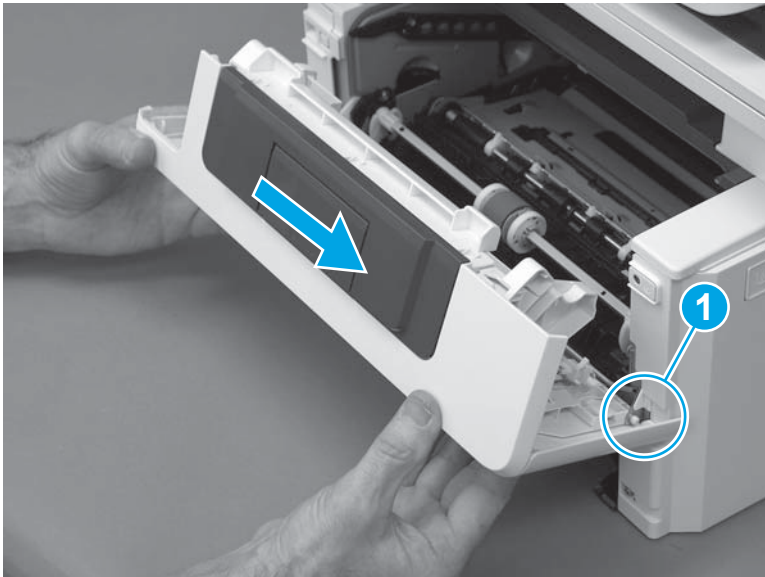
- Position the door close to the printer, and then engage the keyed pin on the left-side retainer arm with the hole in the door.

**Figure 1-2026** Engage the left-side retainer arm



2. Engage the right-side door hinge pin with the hole in the chassis (callout 1).

**Figure 1-2027** Install the door

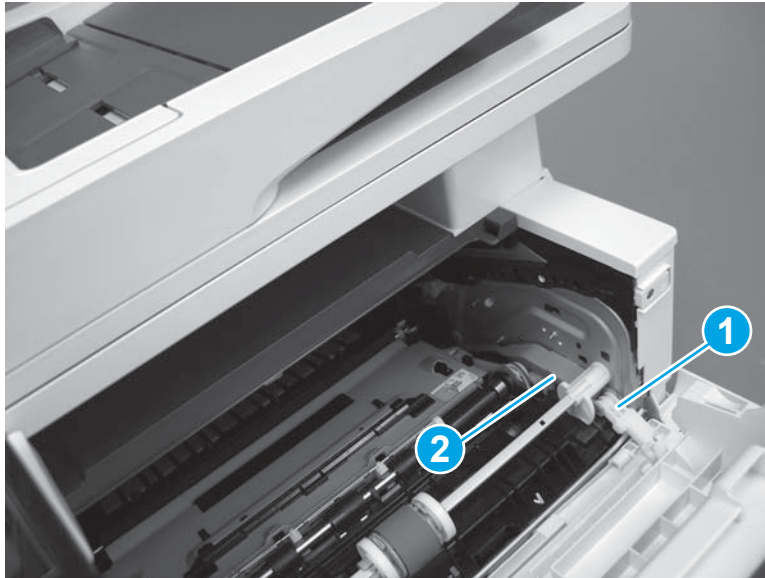




3. Install the link (callout 1).

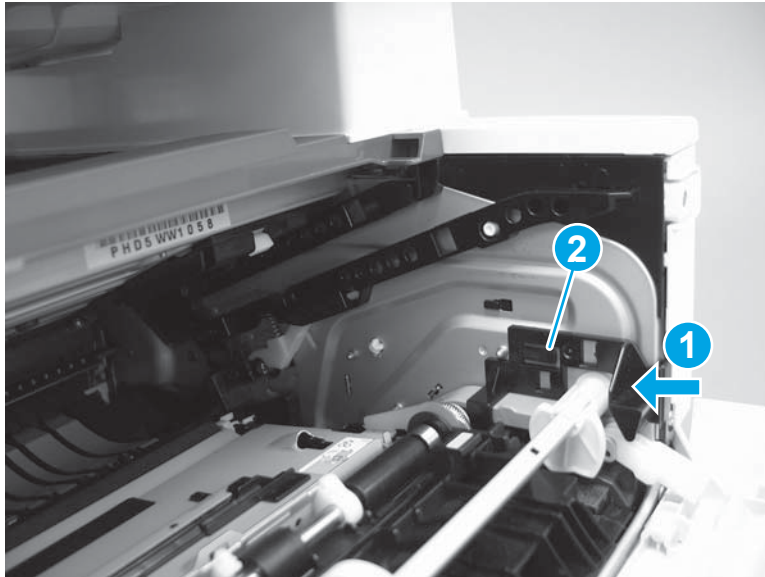
 **IMPORTANT:** Make sure that the link snaps into place on the arm (callout 2). The link actuates the fuser pressure-release mechanism.

**Figure 1-2028** Install the pressure-release link



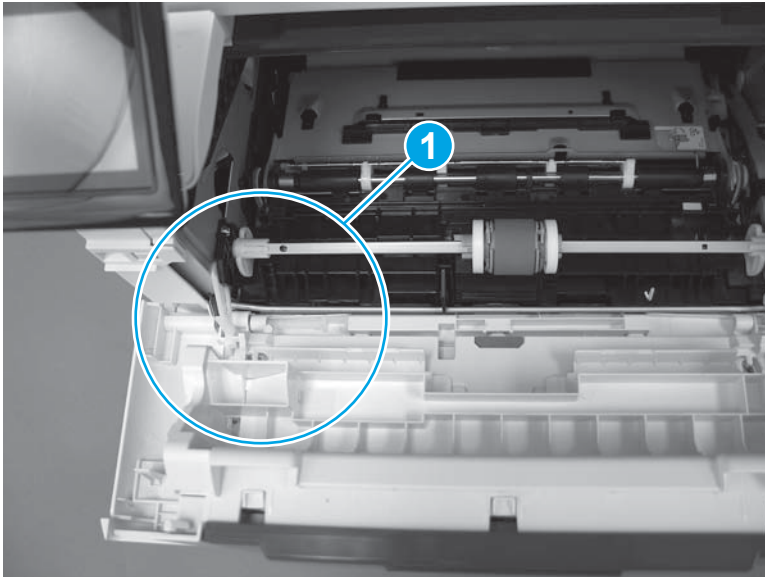
4. Slide the guide into the printer (callout 1), and then make sure that the tab (callout 2) snaps into place to secure the guide to the chassis.

**Figure 1-2029** Install the guide




5. Position the shaft on the door, and then align the left-side hinge on the door with the hole in the chassis (callout 1).

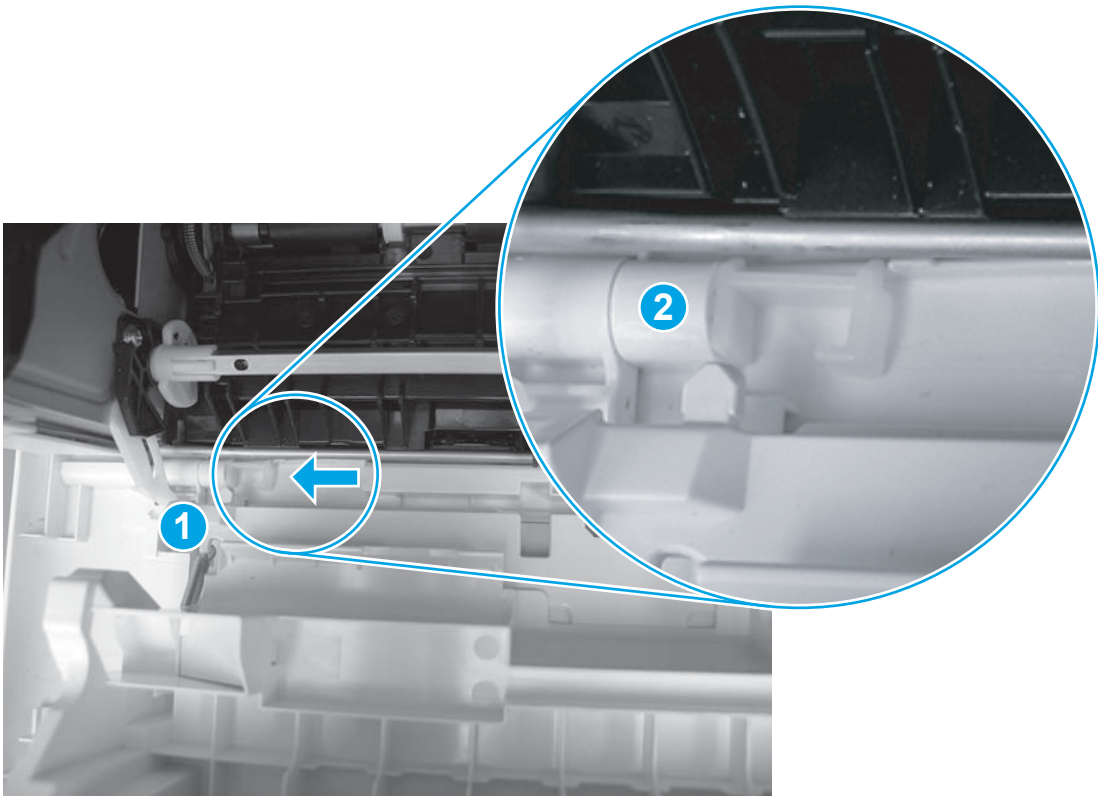
**Figure 1-2030** Align the hinge



6. Push the shaft towards the left side of the printer to install it (callout 1).

 **Reinstallation tip:** Make sure that the support shaft is fully installed and correctly orientated (callout 2) so that it will not interfere with the door opening and closing.

**Figure 1-2031** Install the support shaft



## Step 16: Install Tray 2

- ▲ Slide the tray straight into the printer to install it.

**Figure 1-2032** Install the tray



## Removal and replacement: NFC PCA



**NOTE:** M427fdw/M426fdw/M402dw/M403dw models only.

---

- [Introduction](#)
- [Step 1: Remove Tray 2](#)
- [Step 2: Remove the cartridge door assembly](#)
- [Step 3: Remove the left cover](#)
- [Step 4: Remove the right cover](#)
- [Step 5: Remove the integrated scanner assembly \(M427/M246\)](#)
- [Step 6: Remove the control panel \(M427/M426\)](#)
- [Step 7: Remove the top cover \(M427/M426\)](#)
- [Step 8: Remove the NFC cover \(M427/M426\)](#)
- [Step 9: Remove the top cover \(M403/M402\)](#)
- [Step 10: Remove the NFC PCA](#)
- [Step 11: Unpack the replacement assembly](#)
- [Step 12: Install the NFC PCA](#)
- [Step 13: Install the top cover \(M403/M402\)](#)
- [Step 14: Install the NFC cover \(M427/M426\)](#)
- [Step 15: Install the top cover \(M427/M426\)](#)
- [Step 16: Install the control panel \(M427/M426\)](#)
- [Step 17: Install the integrated scanner assembly \(M427/M246\)](#)
- [Step 18: Install the right cover](#)
- [Step 19: Install the left cover](#)
- [Step 20: Remove the cartridge door assembly](#)
- [Step 21: Install Tray 2](#)

### Introduction

This document provides the procedures to remove and replace the near field communication (NFC) printed circuit assembly (PCA; M426fdw/M403dn models only).

### Before performing service

#### Turn the printer power off

- Disconnect the power cable.

**⚠ WARNING!** To avoid damage to the printer, turn the printer off, wait 30 seconds, and then remove the power cable before attempting to service the printer.

Use the table below to identify the correct part number for your printer. To order the part, go to [www.hp.com/buy/parts](http://www.hp.com/buy/parts).

NFC PCA part number	
<b>B4K93-60001</b>	NFC PCA <sup>1</sup>

<sup>1</sup> M427fdw/M426fdw/M402dw/M403dw models only.

### Required tools

- #2 Phillips screwdriver with a magnetic tip.

### After performing service

#### Turn the printer power on

- Connect the power cable.
- Use the power switch to turn the power on.

### Post service test

Make sure that the printer initializes to a **Ready** state.

Use a NFC enabled device to print a job from the printer.


### Step 1: Remove Tray 2

- ▲ Pull the tray straight out of the printer to remove it.

**Figure 1-2033** Remove the tray



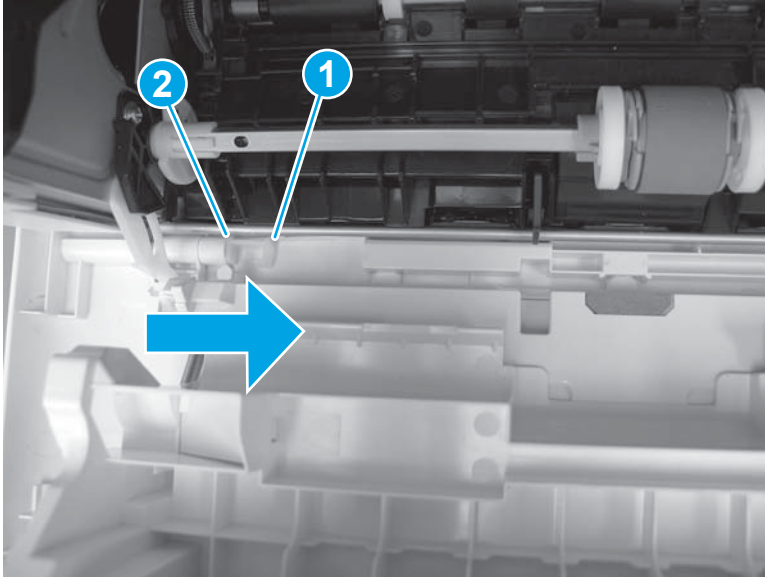
## Step 2: Remove the cartridge door assembly

 **NOTE:** If the toner cartridge was not removed prior to servicing the printer, remove it now.

1. Release one tab (callout 1), and then slide shaft (callout 2) in the direction the arrow indicates and remove it.

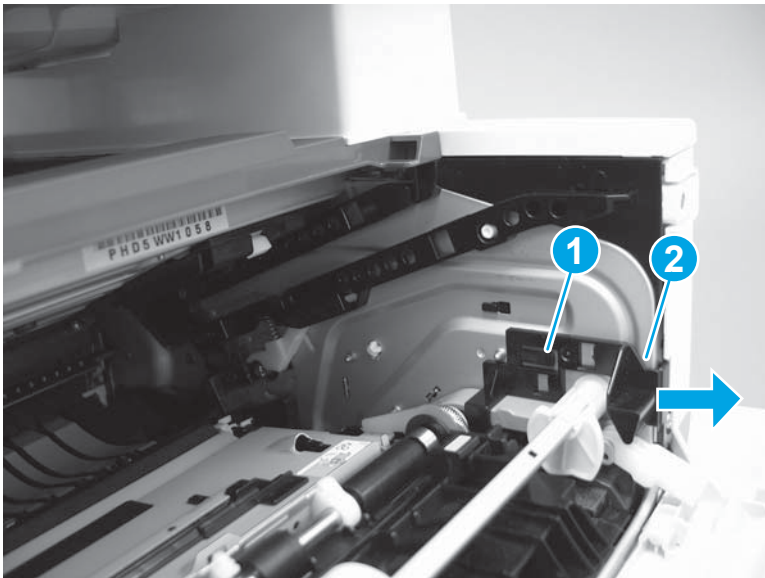
 **TIP:** It might be easier to release the support shaft by using a small flat-blade screwdriver.

**Figure 1-2034** Release the support shaft



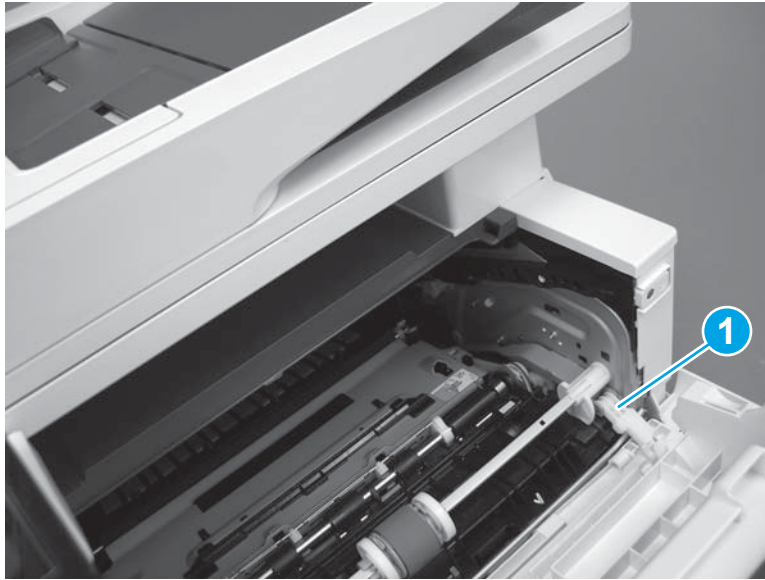
2. Release one tab (callout 1), and then slide the guide (callout 2) in the direction the arrow indicates and remove it.

**Figure 1-2035** Remove the guide



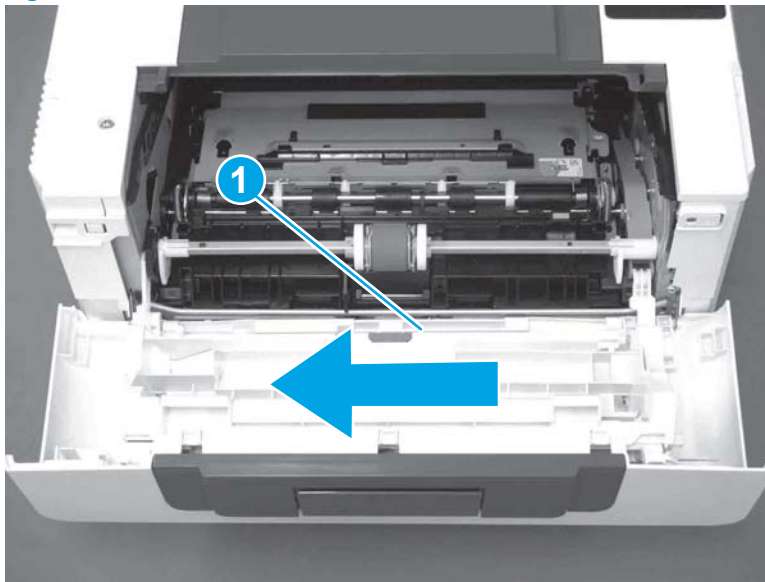
3. Remove the link arm (callout 1).

**Figure 1-2036** Remove the link arm



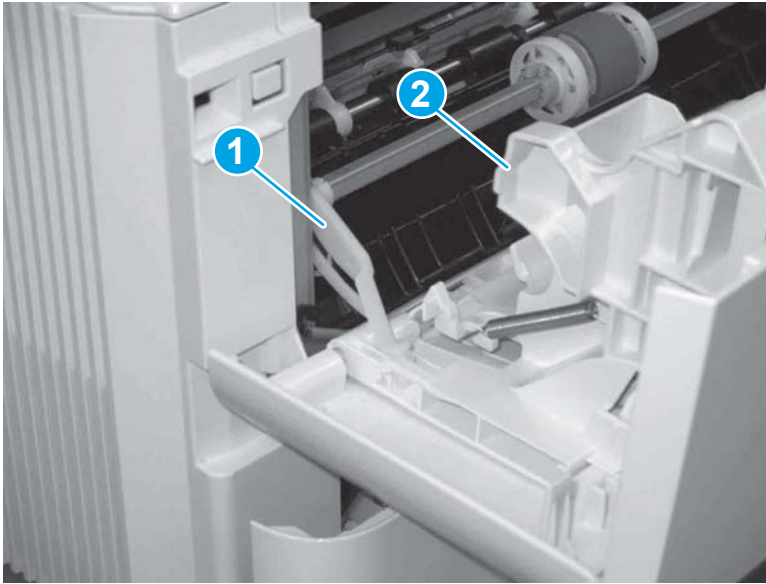
4. Slide the cartridge door assembly (callout 1) in the direction the arrow indicates and remove it.

**Figure 1-2037** Remove the door



5. Remove the link (callout 1) from the cartridge door assembly (callout 2).

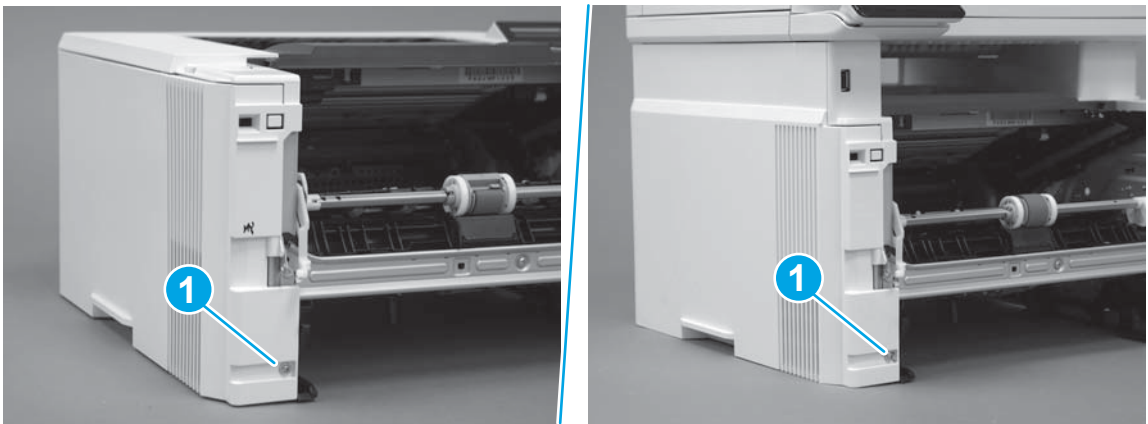
**Figure 1-2038** Release the left-side retainer arm



### Step 3: Remove the left cover

1. Remove one screw (callout 1).

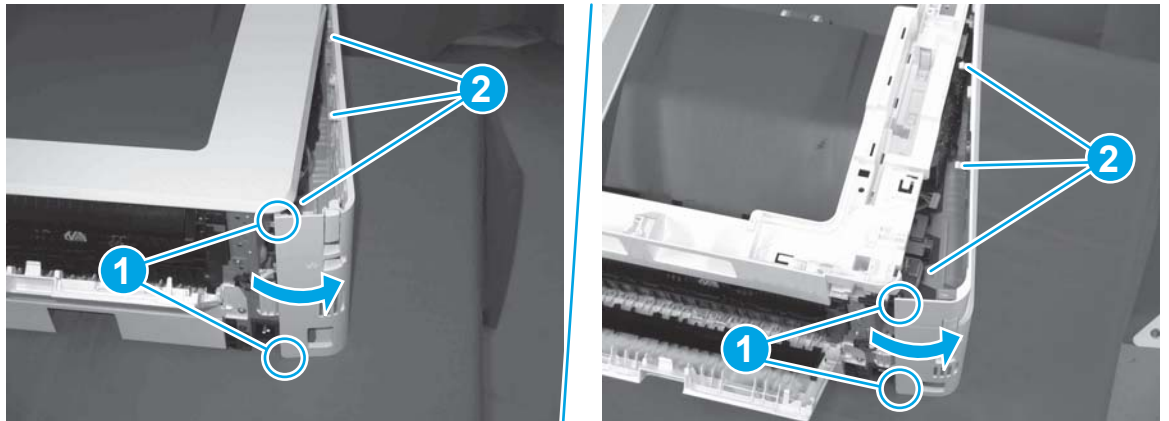
**Figure 1-2039** Remove one screw





2. Open the rear door, release two bosses (callout 1), and then release three tabs (callout 2).

**Figure 1-2040** Release two bosses and three tabs

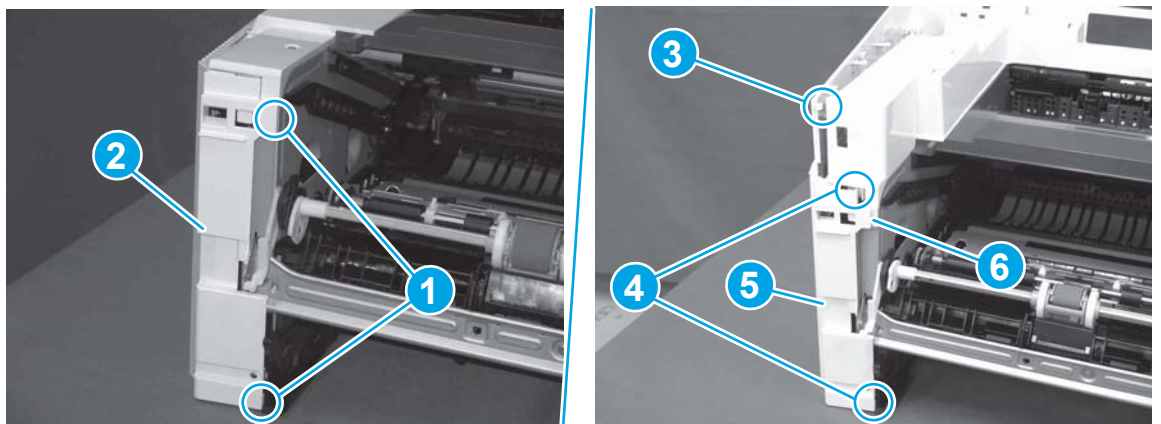


3. At the front of the printer, do one of the following:

- **M403/M402:** Release two bosses (callout 1), and then remove the cover (callout 2).
- **M427/M426:** Release one tab (callout 3), two bosses (callout 4), and then remove the cover (callout 5).

**CAUTION:** Be careful when releasing the upper bosses on the M427/M426 cover. One portion of the cover (callout 6) is fragile and is easily broken.

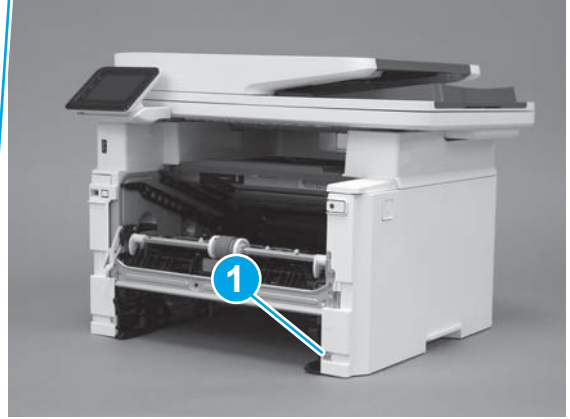
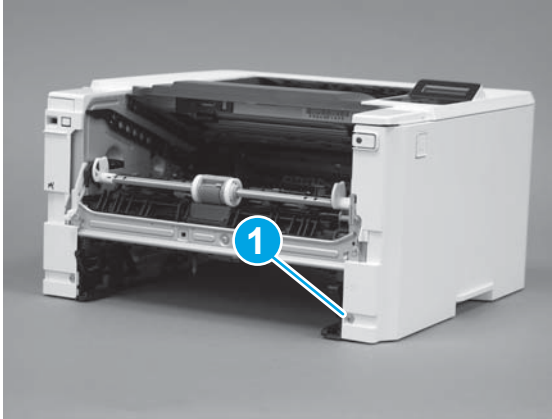
**Figure 1-2041** Remove the cover



#### Step 4: Remove the right cover

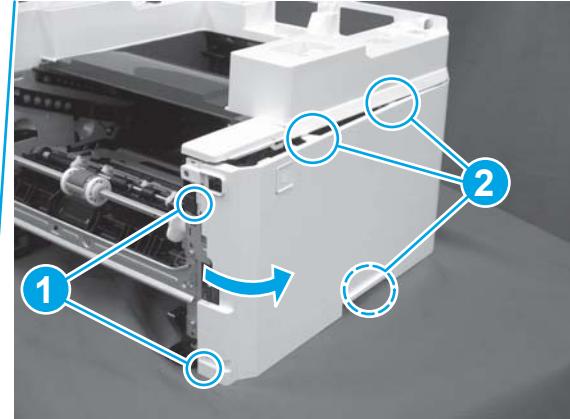
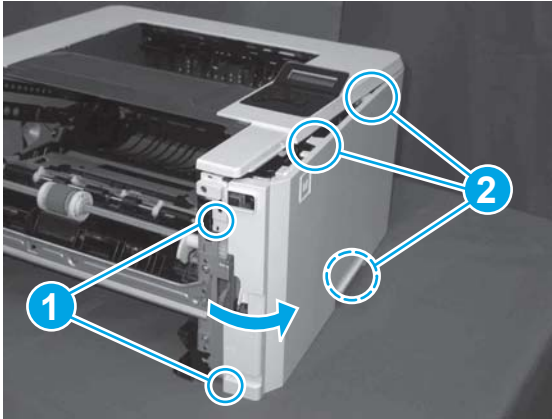
1. Remove one screw (callout 1).

**Figure 1-2042** Remove one screw



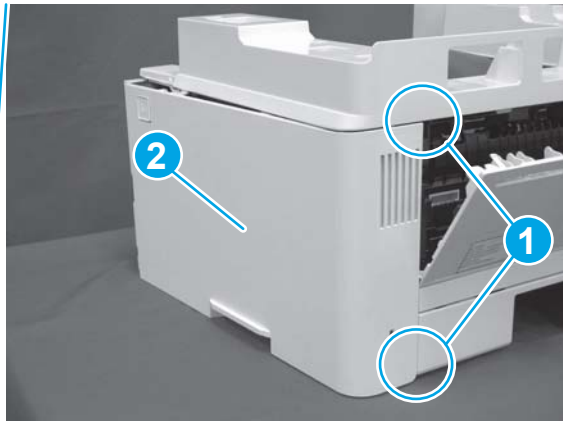
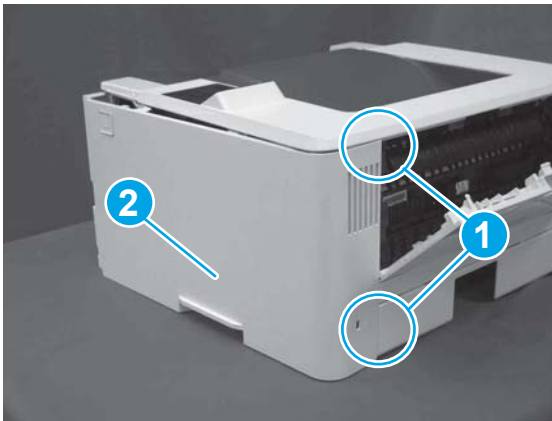
2. At the front of the printer, release two bosses (callout 1), and then release three tabs (callout 2).

**Figure 1-2043** Release two bosses and three tabs



3. Open the rear door, release two bosses (callout 1), and then remove the cover (callout 2).


**Figure 1-2044** Remove the cover



### Step 5: Remove the integrated scanner assembly (M427/M246)

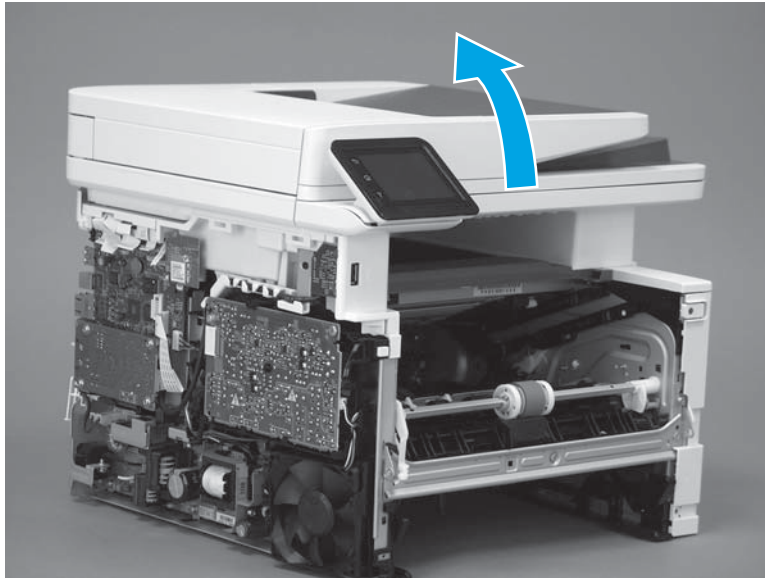


**NOTE:** The step is for the M427/M426 printer. For the M403/M402, skip this step and go to [Step 9: Remove the top cover \(M403/M402\) on page 1087](#).

 **NOTE:** M427/M426 models only. The integrated scanner assembly (ISA) includes the sub-scanner assembly (SSA) and the automatic document feeder (ADF).

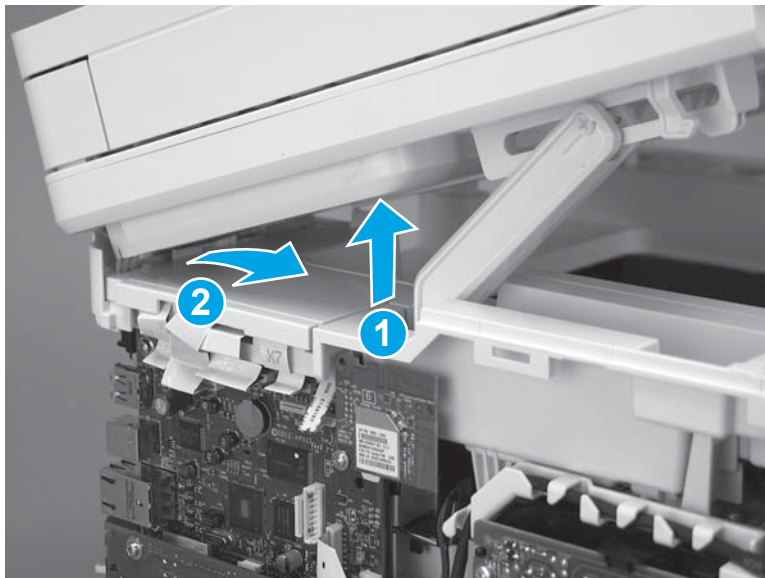
1. Raise the ISA.

**Figure 1-2045** Raise the ISA



2. Release the ISA flat-flexible cable (FFC) cover (callout 1), and then remove it (callout 2).

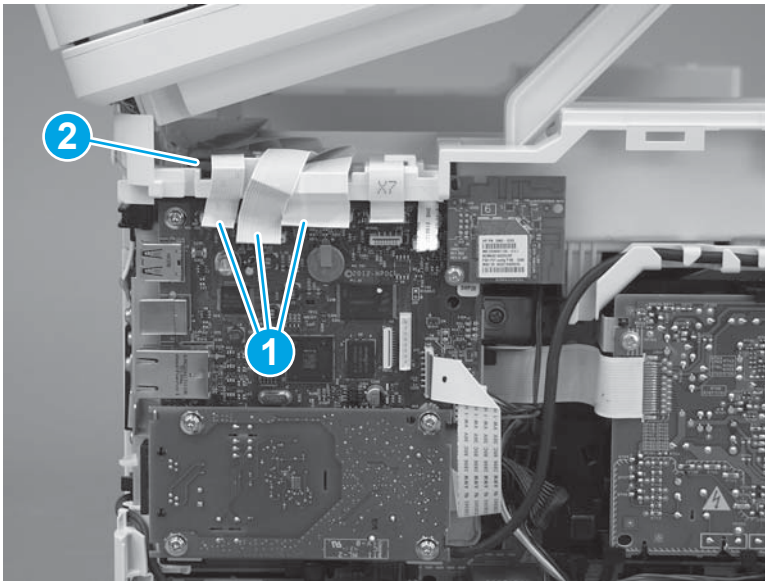
**Figure 1-2046** Remove the ISA FFC cover



3. Disconnect three FFCs (callout 1), and then remove the ferrite (callout 2) from the holder.

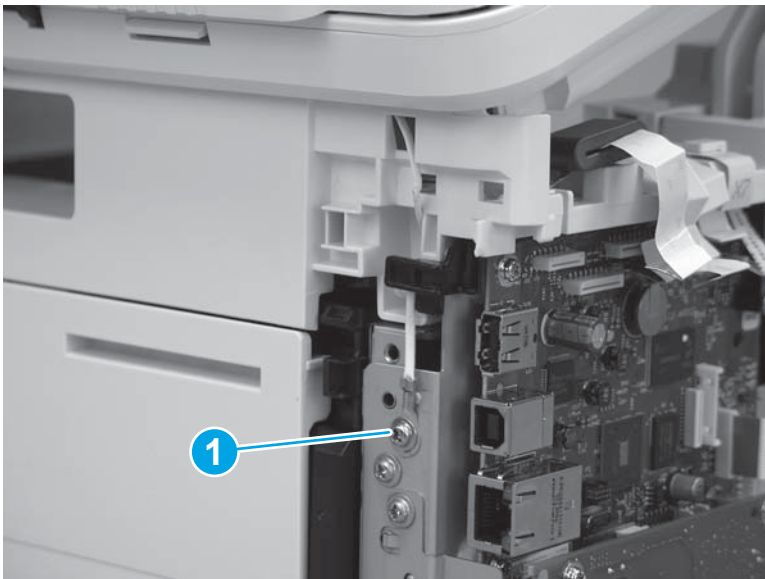
**⚠ CAUTION:** The ferrite is not captive on the FFC. Do not lose the ferrite while handling the ISA.

**Figure 1-2047** Disconnect three FFCs



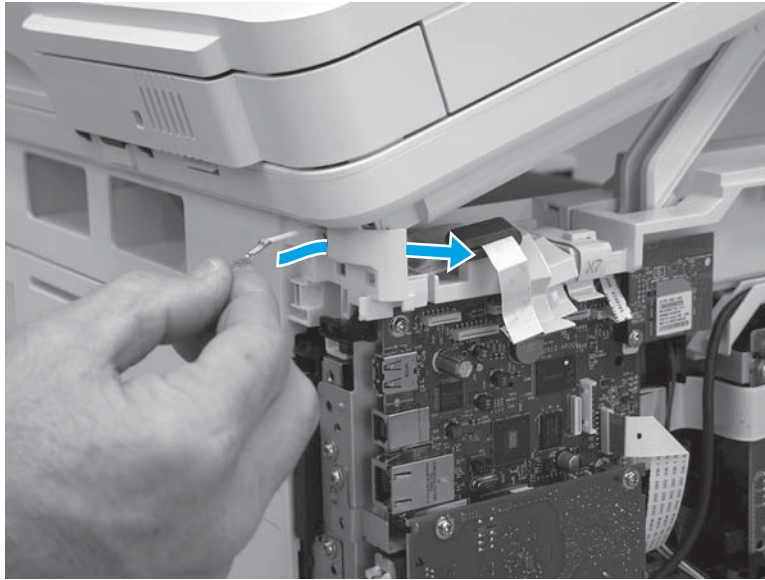
4. Remove one screw (callout 1).

**Figure 1-2048** Remove one screw



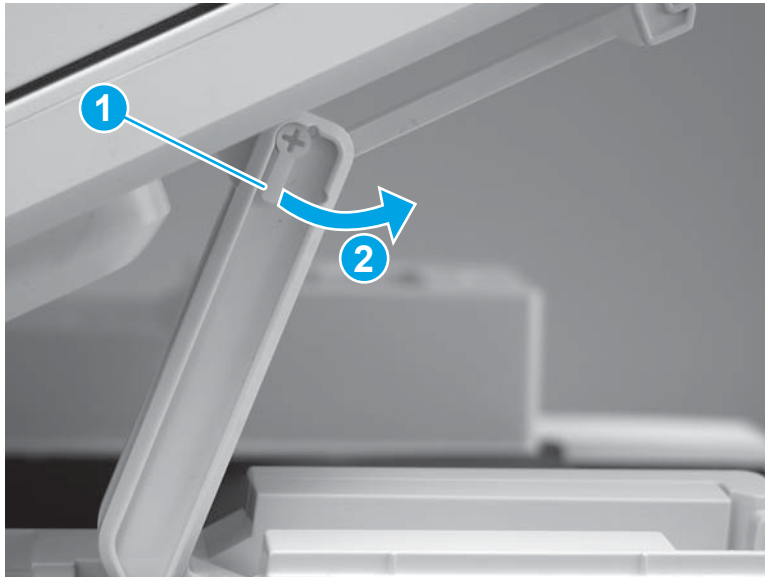
5. Pass the ground wire through the opening in the top cover.

**Figure 1-2049** Pass the wire through the opening



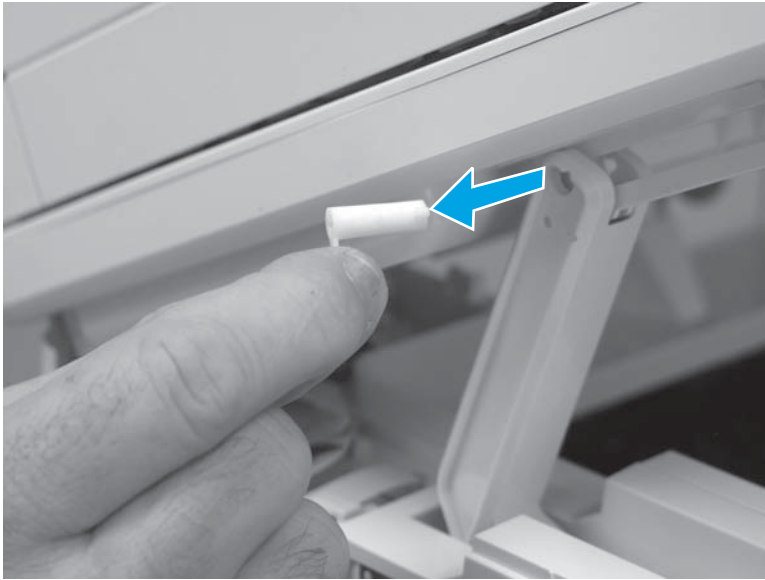
6. Release one tab (callout 1), and then rotate the ISA slider pin (callout 2) towards the front of the printer to release it.

**Figure 1-2050** Release one tab and rotate the slider pin



7. Remove the slider pin.

**Figure 1-2051** Remove the slider pin



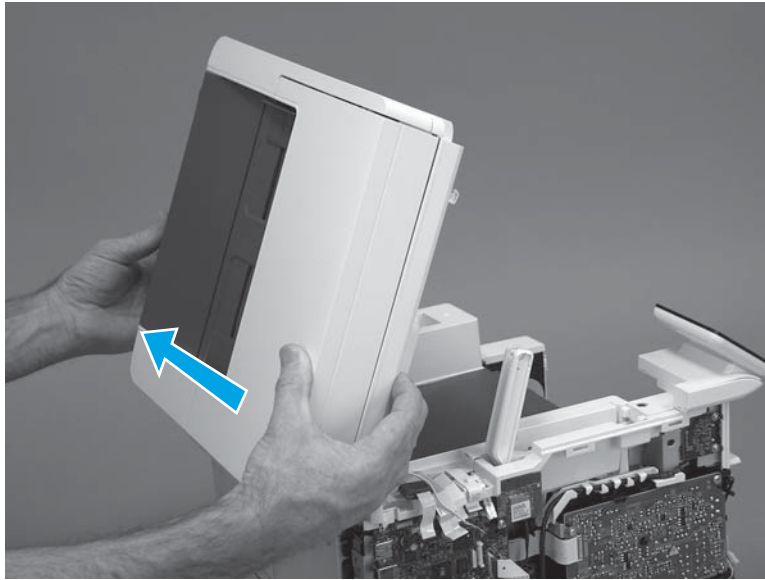
8. Rotate the ISA towards the rear of the printer until it stops.

**Figure 1-2052** Rotate the ISA towards the rear of the printer



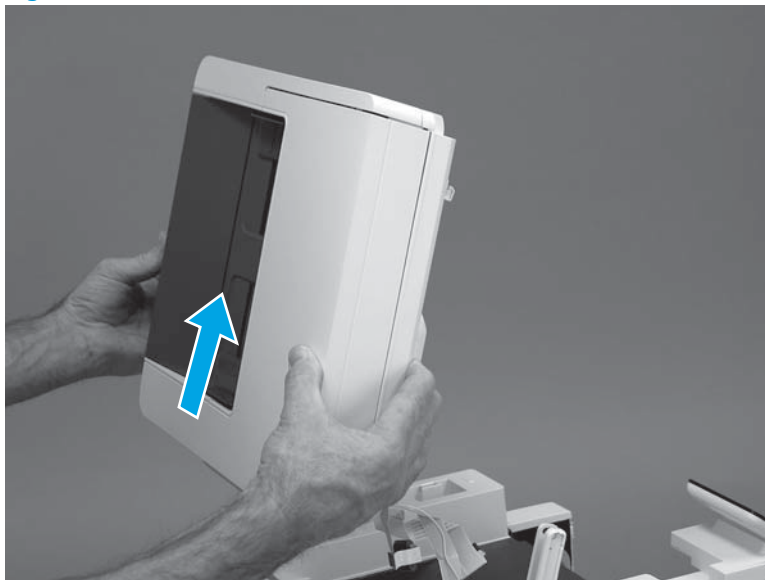
9. Slide the ISA as shown to release it.

**Figure 1-2053** Release the ISA




10. Remove the ISA.

**Figure 1-2054** Remove the ISA

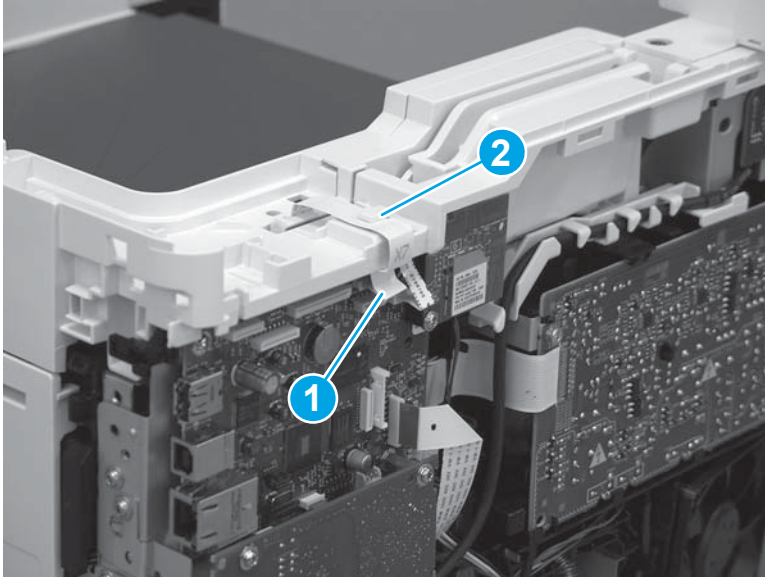


#### **Step 6: Remove the control panel (M427/M426)**

 **NOTE:** The step is for the M427/M426 printer. For the M403/M402, skip this step and go to [Step 9: Remove the top cover \(M403/M402\) on page 1087](#).

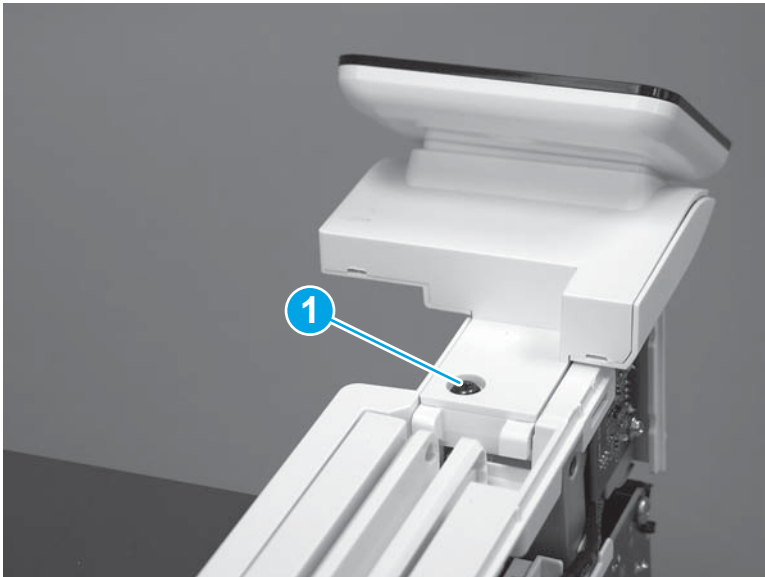
1. Disconnect one FFC (callout 1; J114), and then release the FFC from the retainer (callout 2).

**Figure 1-2055** Disconnect one connector



2. Remove one screw (callout 1).

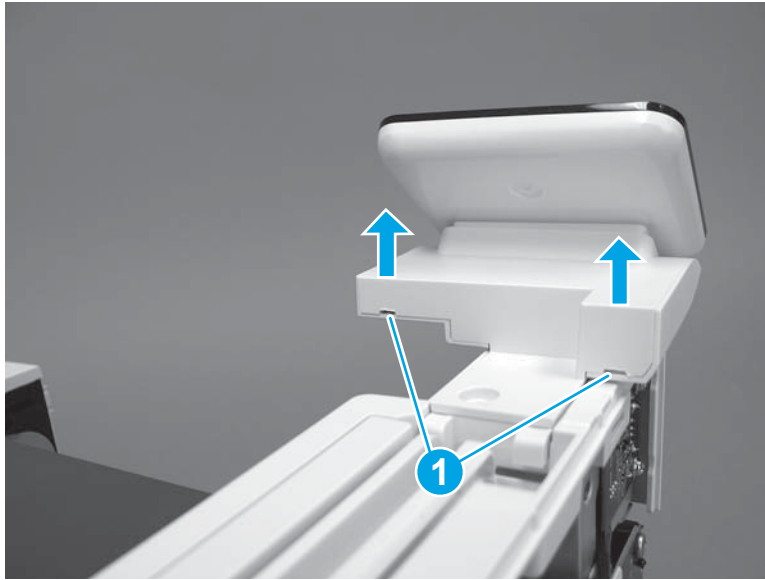
**Figure 1-2056** Remove one screw





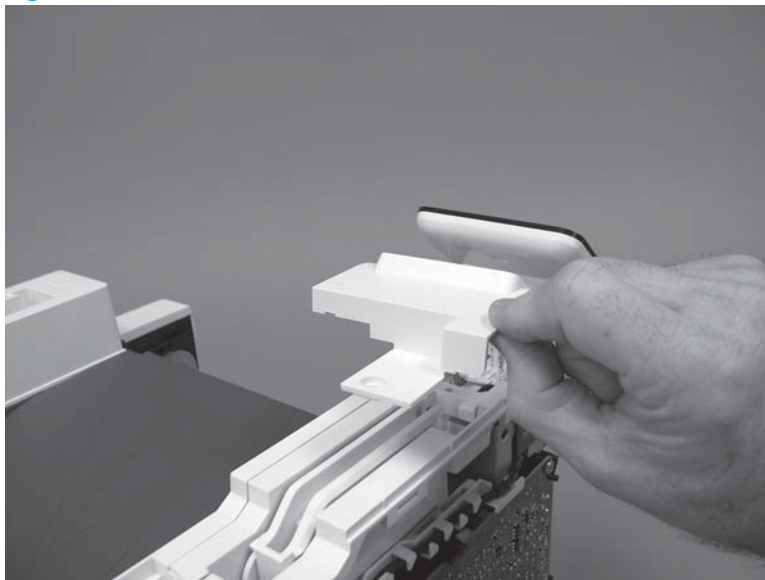
3. Use a small flat-blade screwdriver to release two tabs (callout 1) on the control-panel cable cover.

**Figure 1-2057** Release two tabs



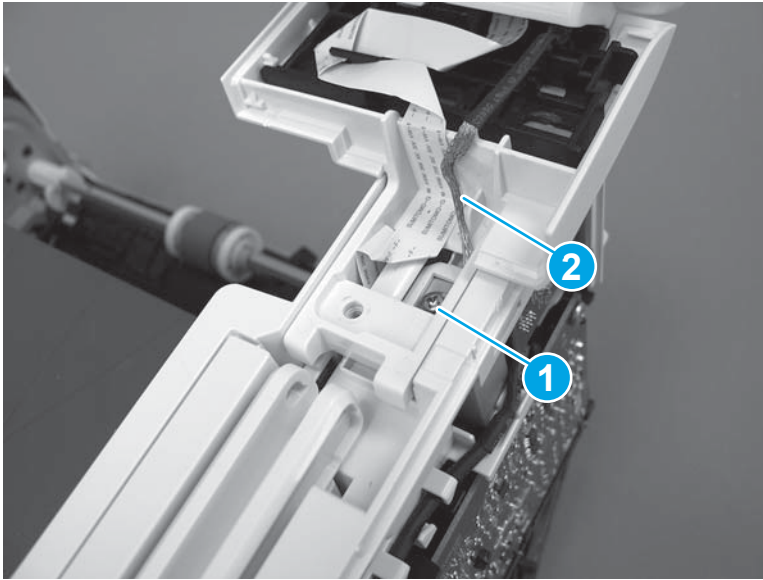
4. Remove the control-panel cable cover.

**Figure 1-2058** Remove the cover



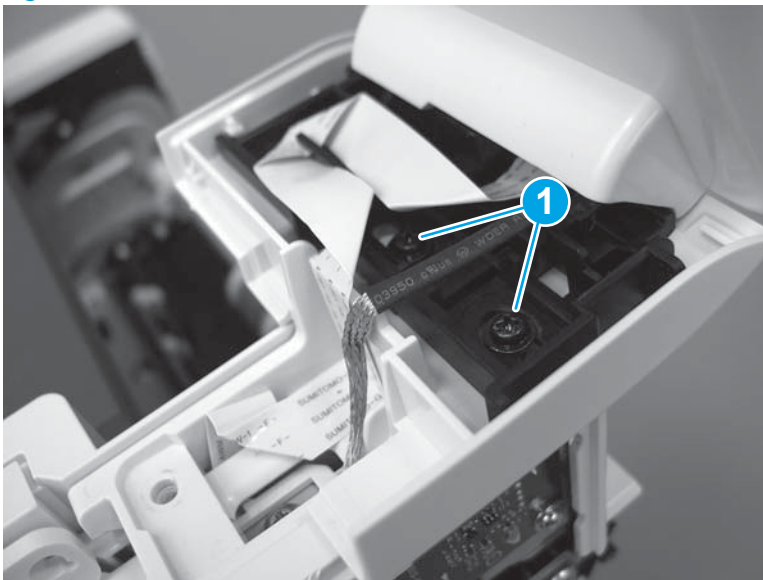
5. Remove one grounding screw (callout 1), and then move the ground cable (callout 2) out of the way.

**Figure 1-2059** Remove one screw



6. Move the FFC out of the way, and then remove two screws (callout 1).

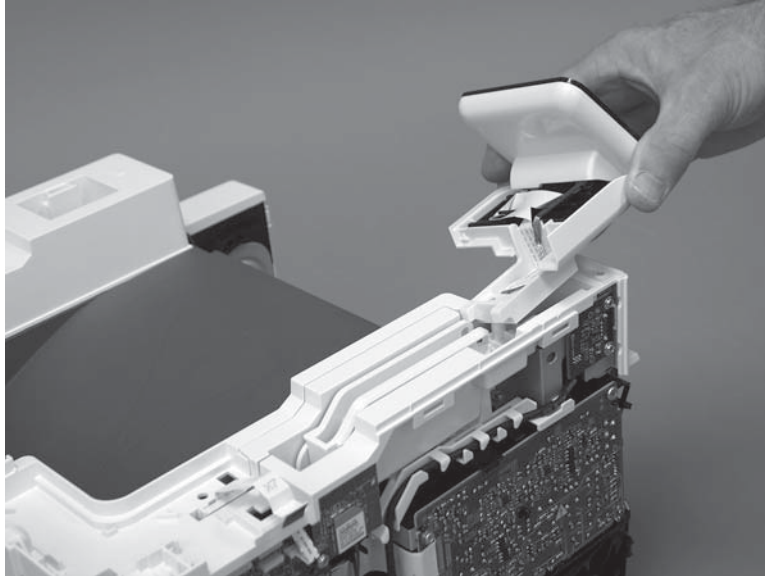
**Figure 1-2060** Remove two screws



7. Slightly lift up the control-panel assembly to separate it from the top cover.

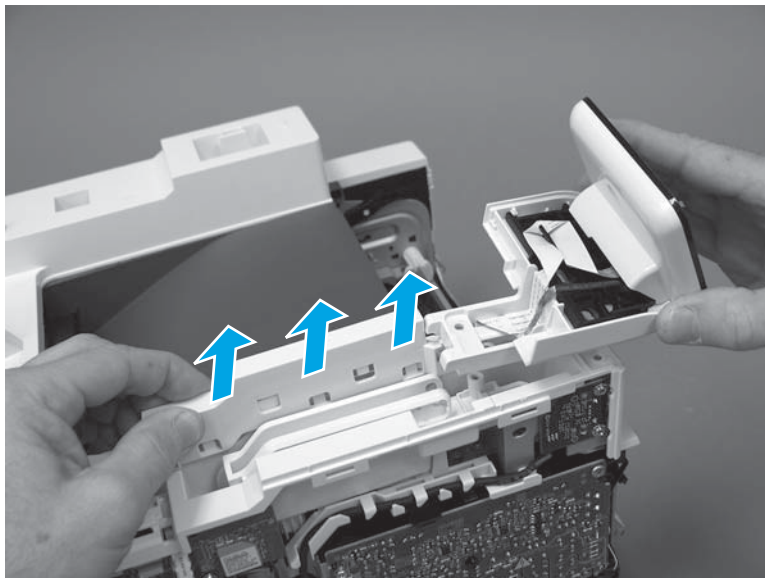
**CAUTION:** The control panel assembly is still connected to the printer by the FFC. Do not attempt to completely remove the assembly.

**Figure 1-2061** Lift up the control-panel assembly



8. Lift up the control-panel FFC cover to remove the control-panel assembly.

**Figure 1-2062** Remove the control-panel assembly

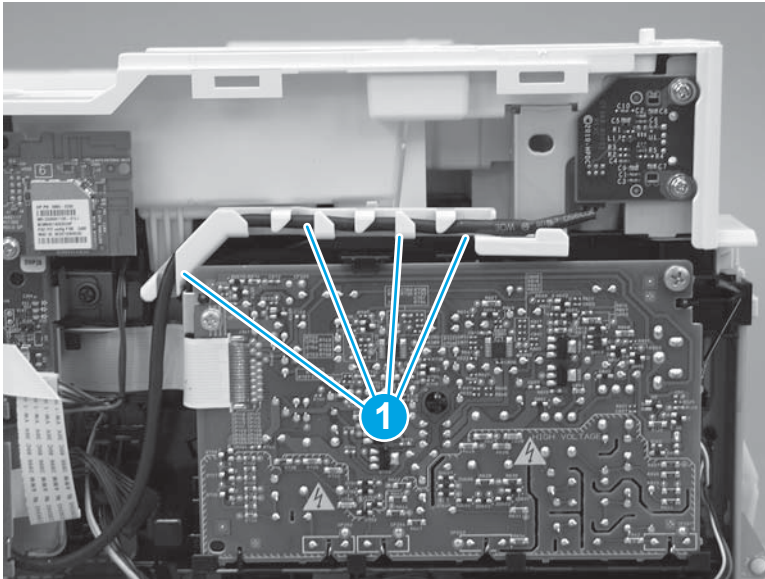


### Step 7: Remove the top cover (M427/M426)

**NOTE:** The step is for the M427/M426 printer. For the M403/M402, skip this step and go to [Step 9: Remove the top cover \(M403/M402\) on page 1087](#).

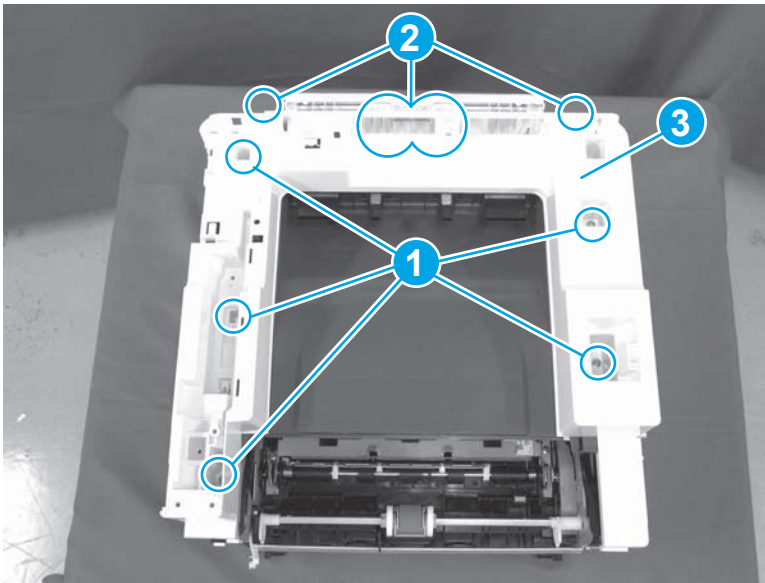
1. Release the USB cable (callout 1) from the cable guide.

**Figure 1-2063** Remove the USB cable



2. Remove five screws (callout 1), release four bosses (callout 2), and then remove the top cover (callout 3).

**Figure 1-2064** Remove the cover



### Step 8: Remove the NFC cover (M427/M426)



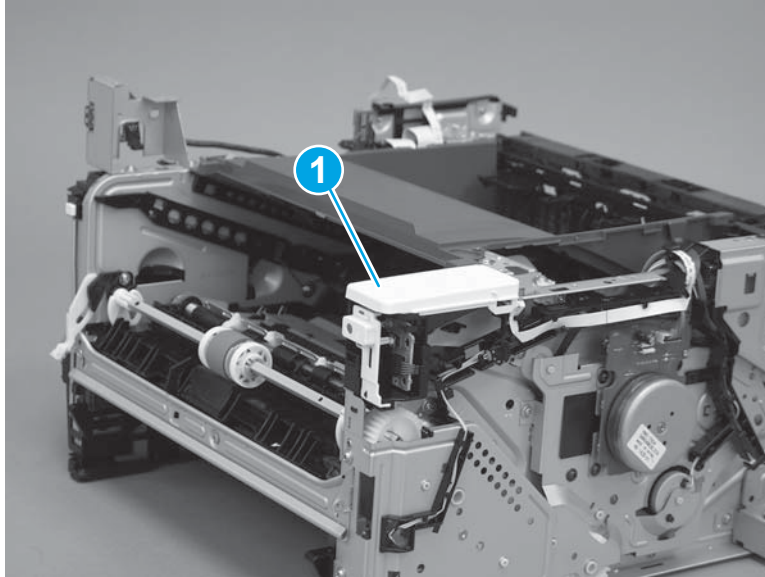
**NOTE:** The step is for the M427/M426 printer. For the M403/M402, skip this step and go to [Step 9: Remove the top cover \(M403/M402\) on page 1087](#).

- ▲ Carefully pull up on the NFC cover (callout 1) to remove it.




**CAUTION:** Do not damage the NFC PCA when removing the cover.

**Figure 1-2065** Remove the cover



**Step 9: Remove the top cover (M403/M402)**

 **NOTE:** The step is for the M403/M402 printer. For the M427/M426, skip this step and go to [Step 10: Remove the NFC PCA on page 1088](#).

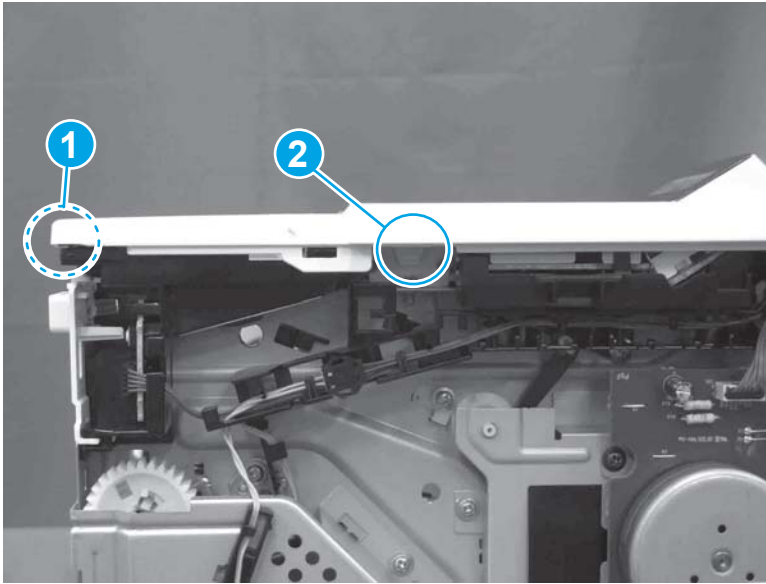
1. Remove one screw (callout 1).

**Figure 1-2066** Remove one screw




2. At the right side of the printer, release the one boss (callout 1), and then release one tab (callout 2).

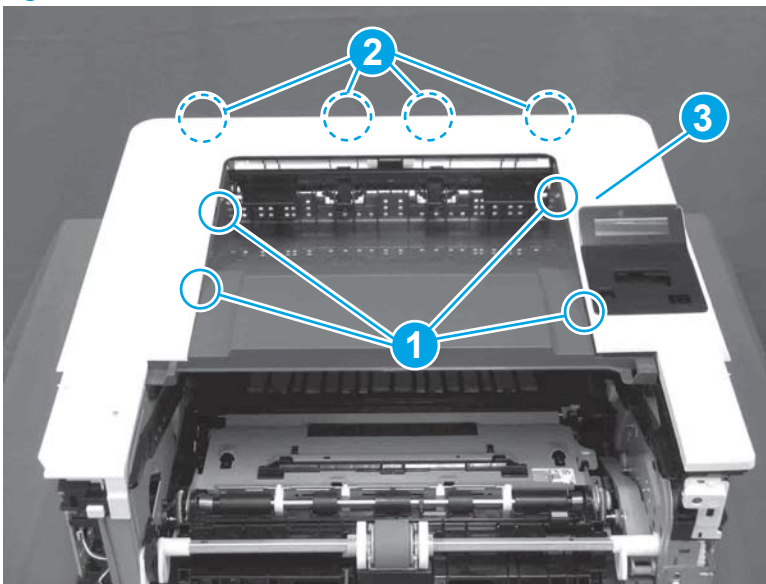
**Figure 1-2067** Release one boss and one tab



3. Release four tabs (callout 1), release four bosses (callout 2), and then remove the top cover (callout 3).

 **TIP:** Open the rear door to make releasing the bosses (callout 3) easier.

**Figure 1-2068** Remove the cover



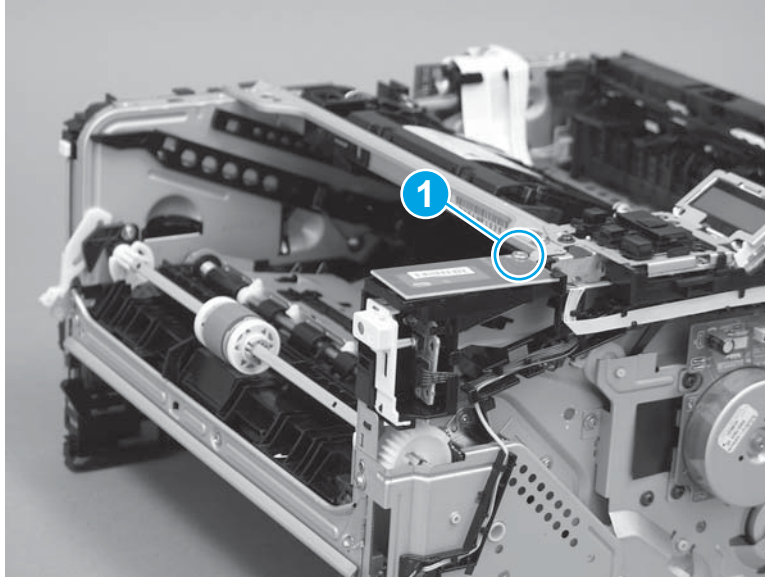
### Step 10: Remove the NFC PCA

 **NOTE:** M427fdw/M426fdw/M402dw/M403dw models only.

The M403 printer is shown in this procedure. However, the procedure is valid for the M427/M426/M402 printers.

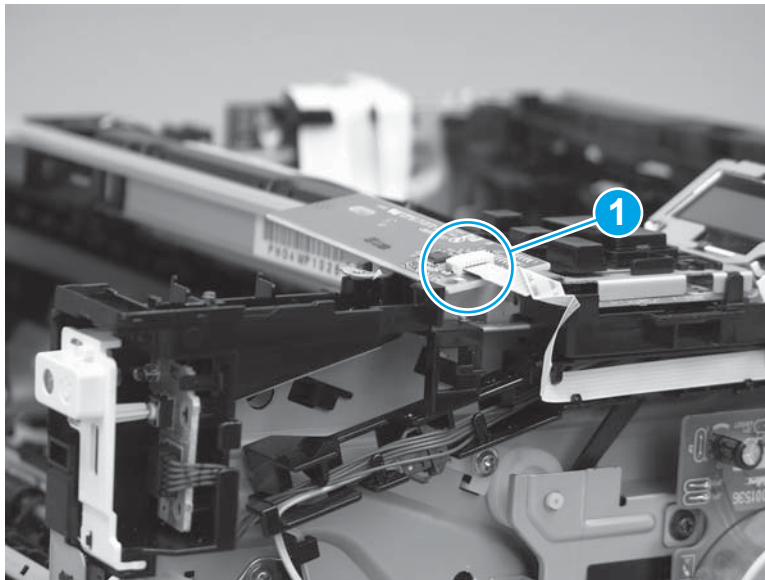
1. Remove one screw (callout 1).

**Figure 1-2069** Remove one screw



2. Turn the NFC PCA over to access the bottom side, disconnect one FFC (callout 1), and then remove the NFC PCA.

**Figure 1-2070** Remove the NFC PCA



### Step 11: Unpack the replacement assembly

Unpack the replacement part from the packaging.

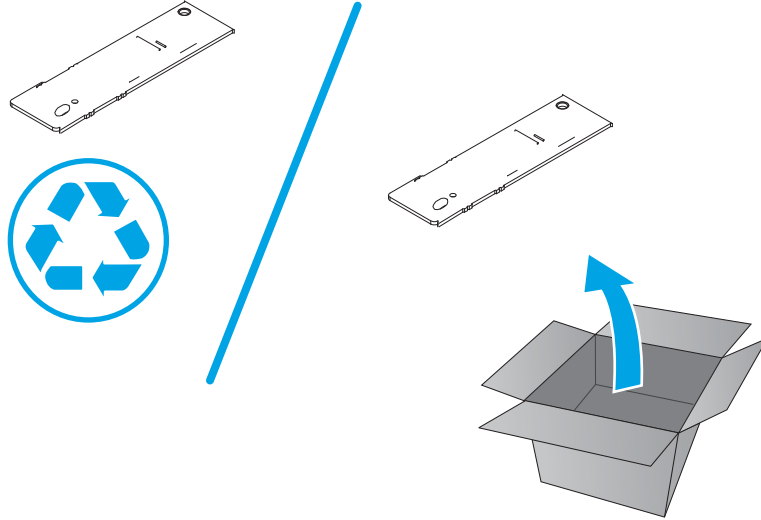
<http://www8.hp.com/us/en/hp-information/environment/product-recycling.html>

---

 **NOTE:** HP recommends responsible disposal of the defective part.

---

**Figure 1-2071** Recycle and unpack



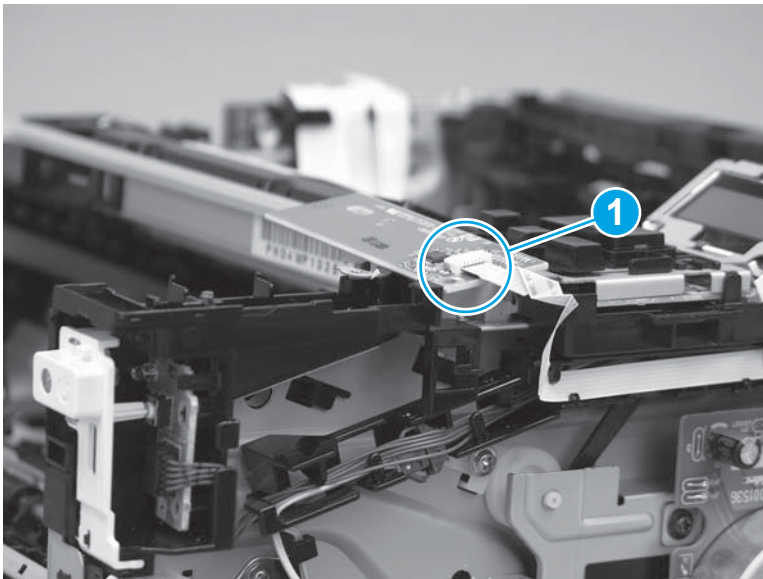
## Step 12: Install the NFC PCA

 **NOTE:** M427fdw/M426fdw/M402dw/M403dw models only.

The M403dw printer is shown in this procedure. However, the procedure is valid for the M427/M426/M402 printers.

1. Connect one FFC (callout 1).

**Figure 1-2072** Connect one FFC



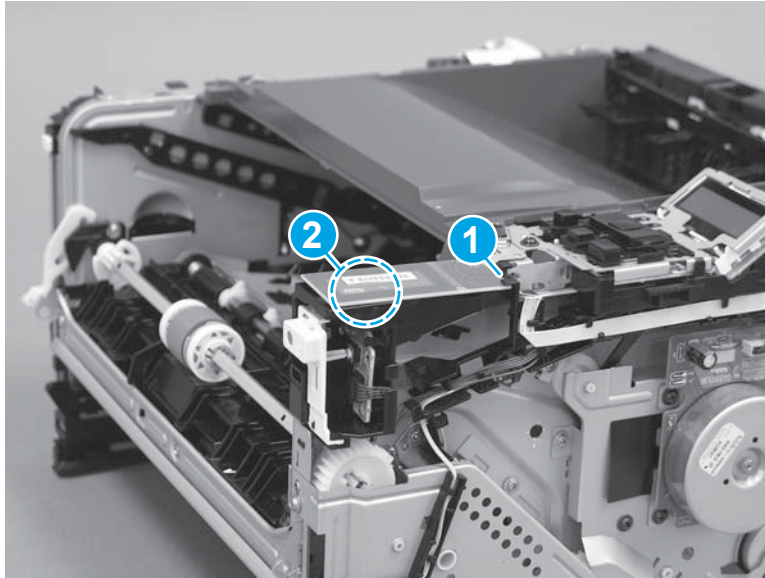


2. Position the NFC PCA on the holder.

**CAUTION:** Make sure that the NFC PCA is correctly positioned on the holder. One corner (callout 1) is under a tab on the holder, and the alignment pins on the holder fit in the hole and slot in the PCA (callout 2).

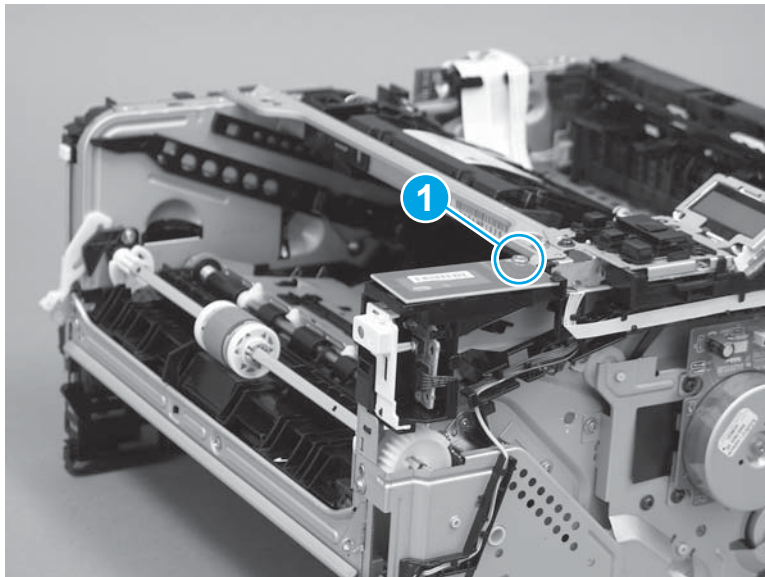
To avoid damage to the PCA, it must be installed flat on the holder **before** installing the mounting screw.

**Figure 1-2073** Install the NFC PCA



3. Install one screw (callout 1).

**Figure 1-2074** Install one screw

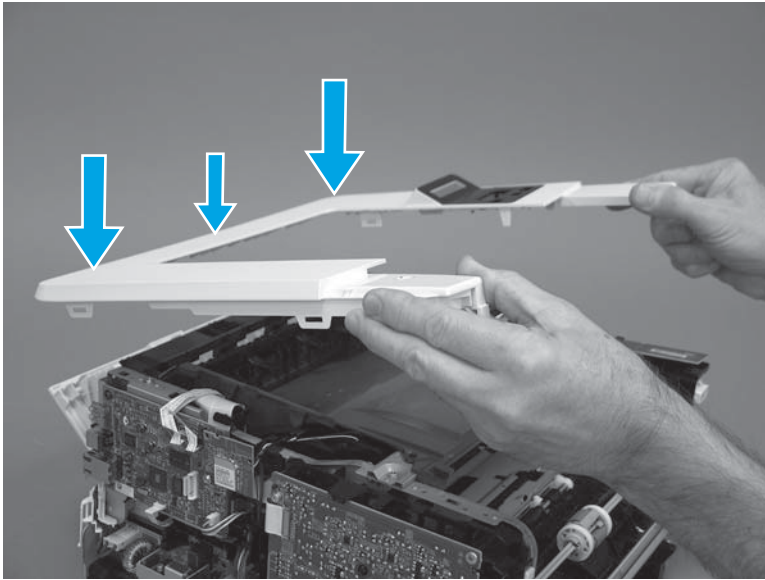


### Step 13: Install the top cover (M403/M402)

**NOTE:** The step is for the M403/M402 printer. For the M427/M426, skip this step and go to [Step 18: Install the right cover on page 1105](#).

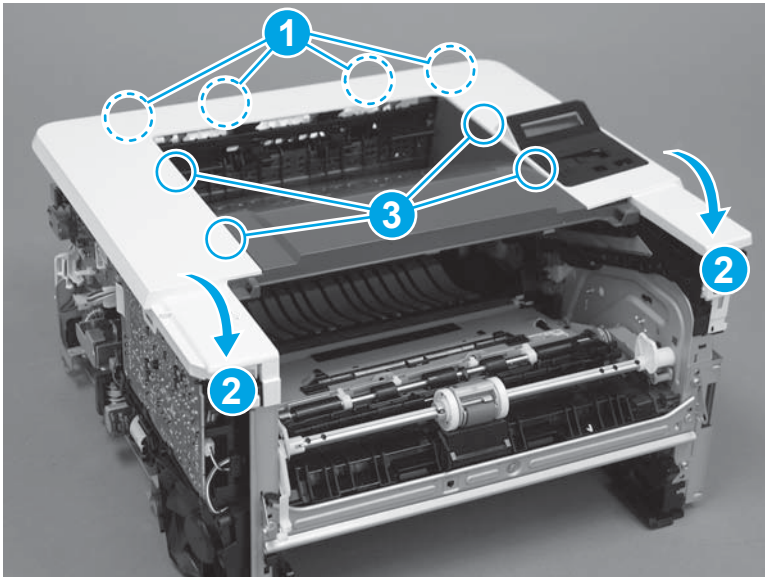
1. Position the rear edge of the cover on the printer.

**Figure 1-2075** Install the cover



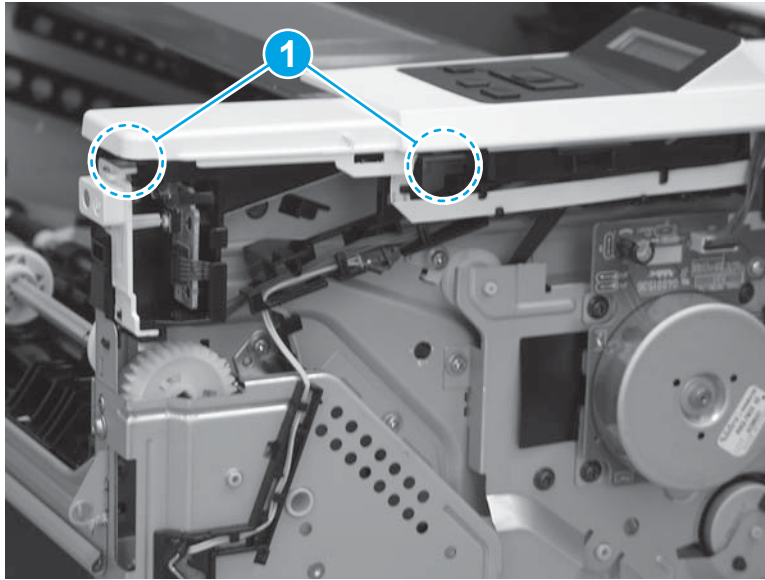
2. Engage four bosses (callout 1), rotate the front of the cover down (callout 2) and onto from the printer, and then engage four tabs (callout 3).

**Figure 1-2076** Engage four bosses and tabs



3. At the right side of the printer, engage the one boss and one tab (callout 1).

**Figure 1-2077** Engage one boss and one tab




4. Install one screw (callout 1).

**Figure 1-2078** Install one screw



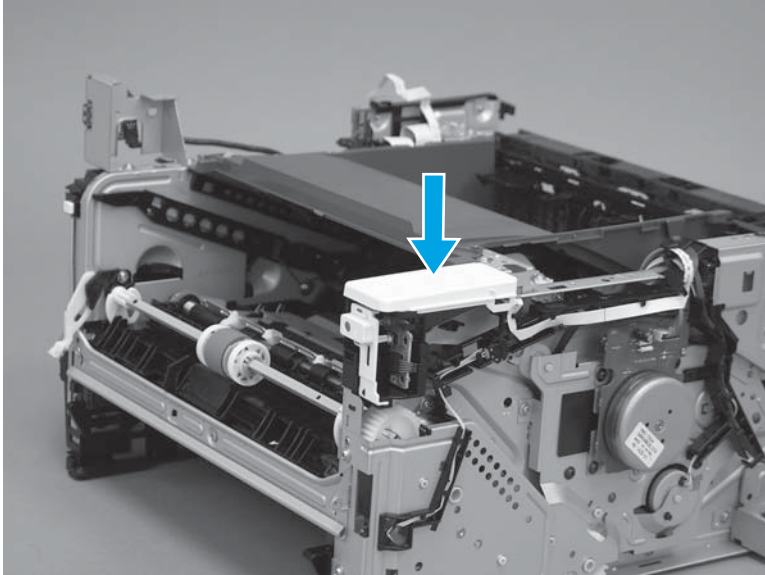
#### Step 14: Install the NFC cover (M427/M426)

 **NOTE:** The step is for the (M427/M426) printer. For the M403/M402, skip this step and go to [Step 18: Install the right cover on page 1105](#).


- ▲ Carefully install the NFC cover on the printer.

 **CAUTION:** Do not damage the NFC PCA when installing the cover.

**Figure 1-2079** Remove the cover

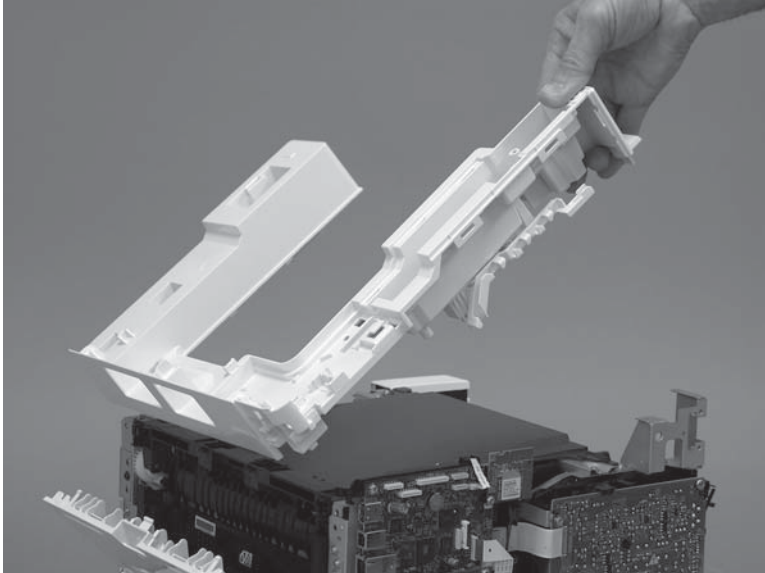


**Step 15: Install the top cover (M427/M426)**

 **NOTE:** The step is for the M427/M426 printer. For the M403/M402, skip this step and go to [Step 18: Install the right cover on page 1105](#).

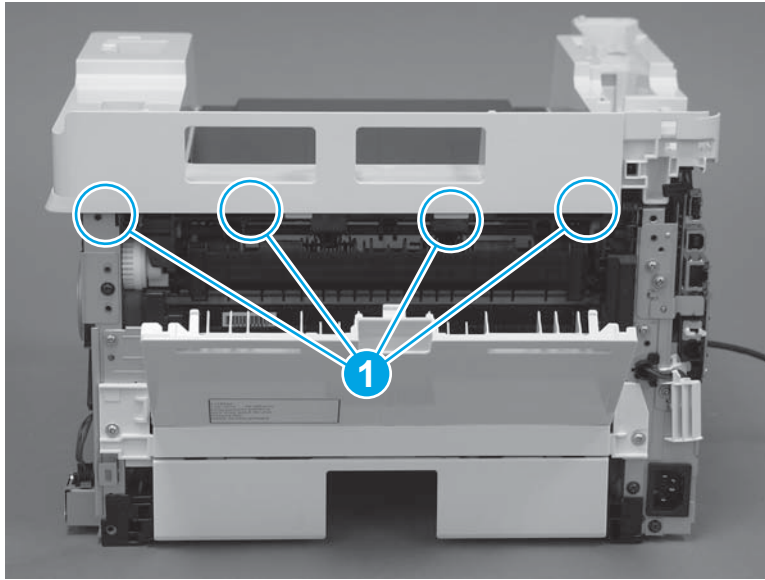
1. Position the rear edge of the top cover on the printer.

**Figure 1-2080** Install the cover



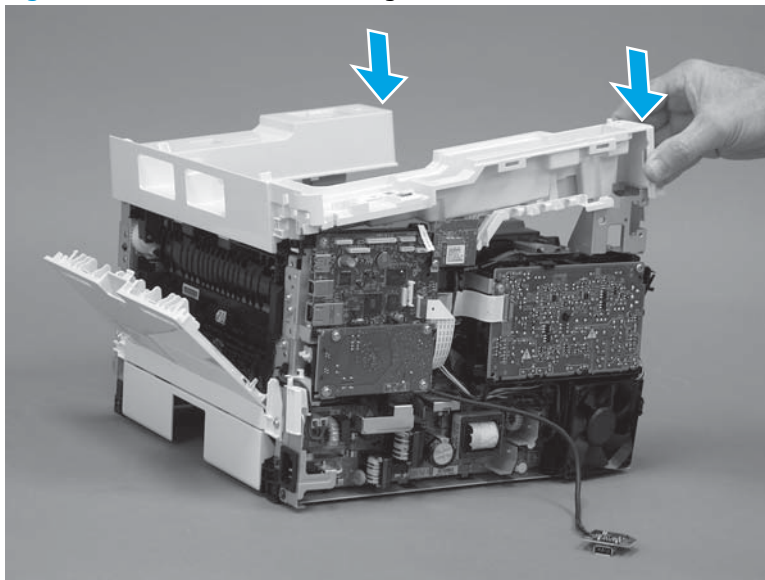
2. Engage four bosses (callout 1).

**Figure 1-2081** Engage four bosses



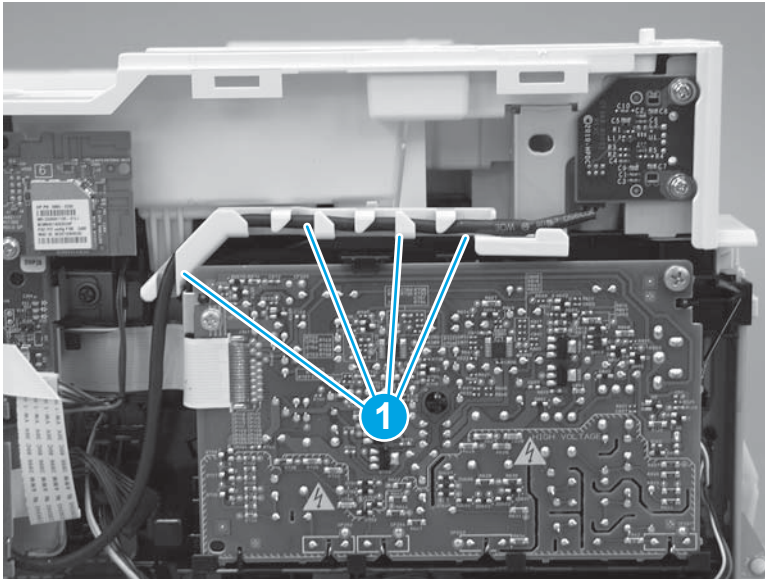
3. Rotate the front edge of the cover down.

**Figure 1-2082** Rotate the front edge of the cover down



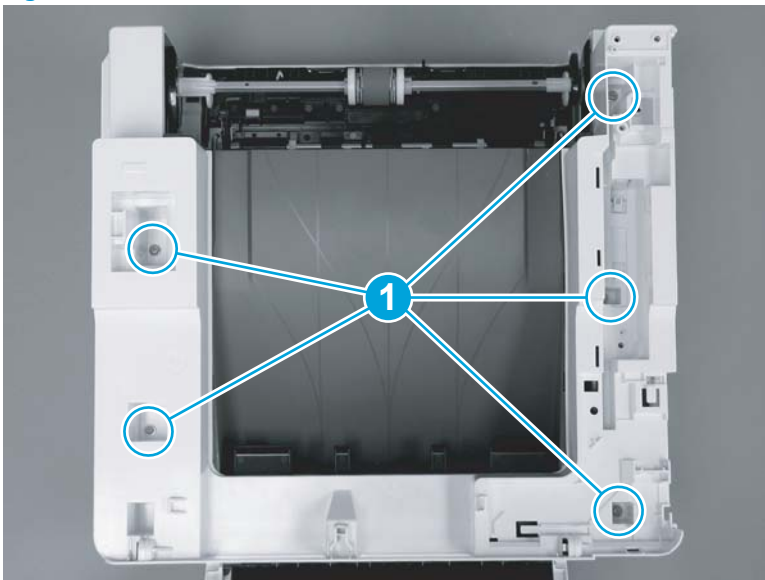
4. Install the USB cable (callout 1) in the guide.

**Figure 1-2083** Install the USB PCA




5. Install five screws (callout 1).

**Figure 1-2084** Install five screws

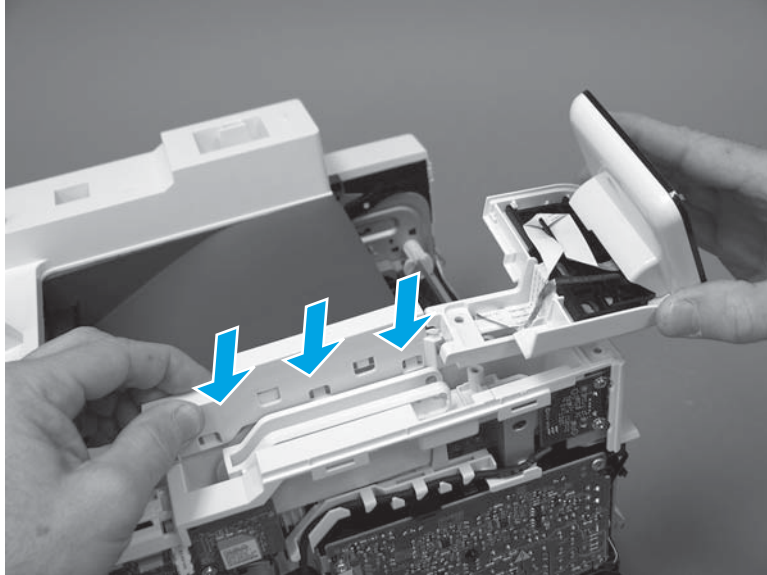


### Step 16: Install the control panel (M427/M426)

 **NOTE:** The step is for the M427/M426 printer. For the M403/M402, skip this step and go to [Step 18: Install the right cover on page 1105](#).

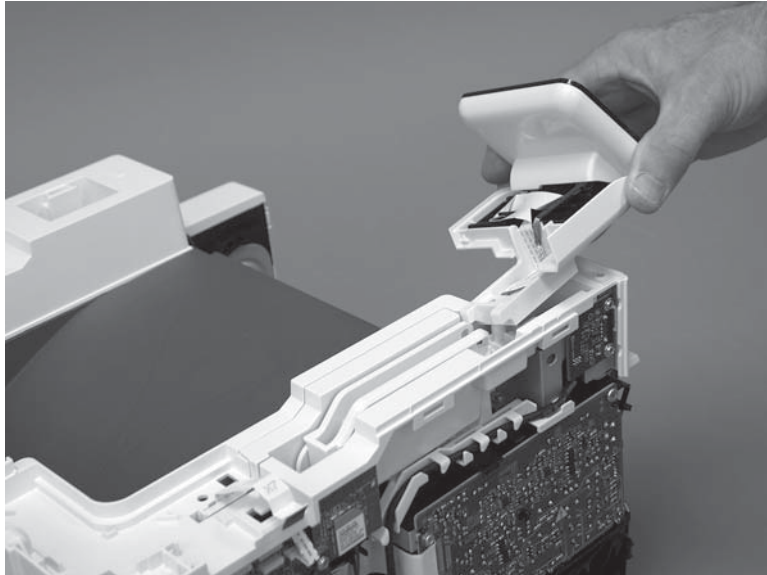
1. Slide the control-panel FFC cover into the slot in the top cover (next to the document feeder support arm) to install it.

**Figure 1-2085** Install the control-panel FFC cover



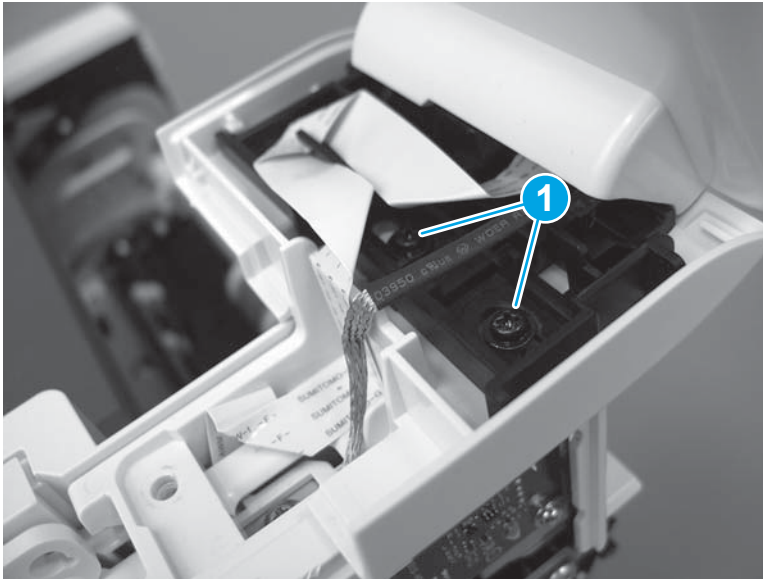
2. Install the control-panel assembly on the top cover.

**Figure 1-2086** Install the control-panel assembly



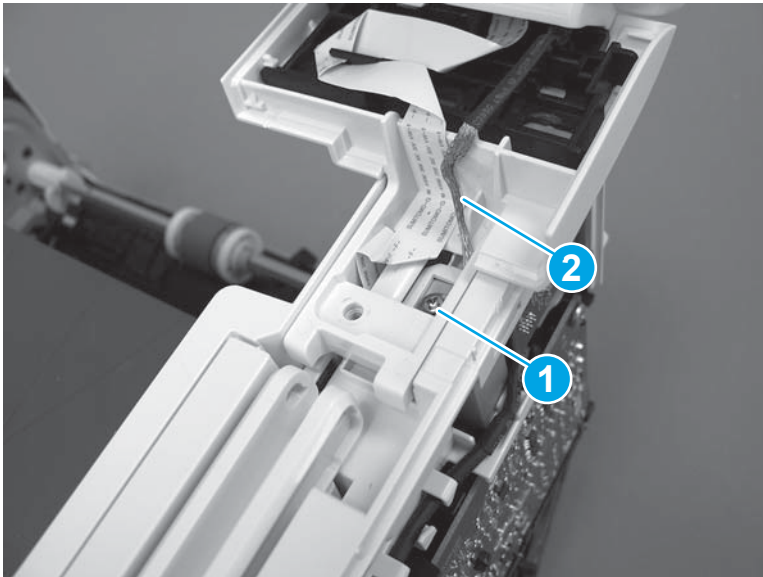
3. Move the FFC out of the way, and then install two screws (callout 1).

**Figure 1-2087** Install two screws



4. Install one grounding screw (callout 1), and then make sure that the ground cable (callout 2) is properly routed.

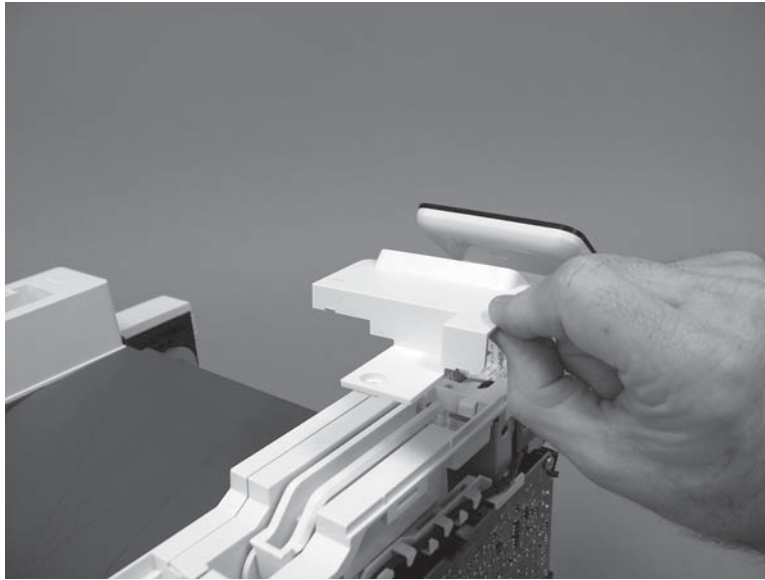
**Figure 1-2088** Remove one screw





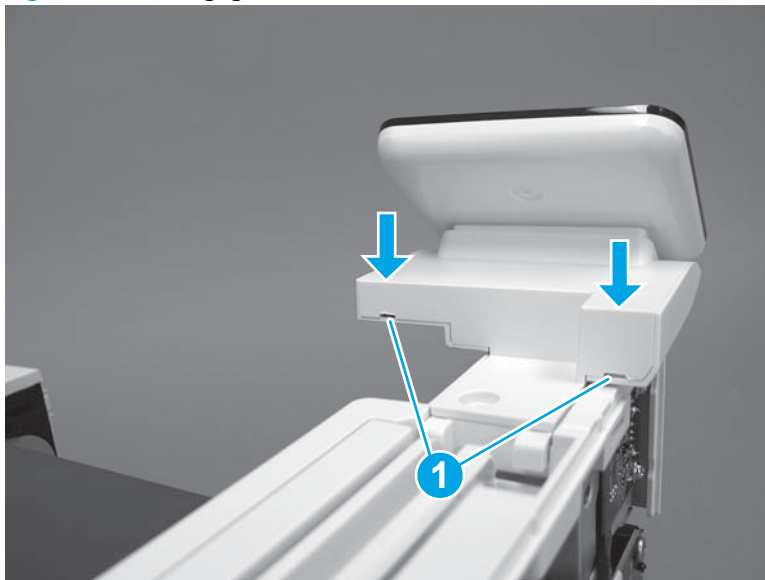
5. Install the control-panel cable cover.

**Figure 1-2089** Install the cover



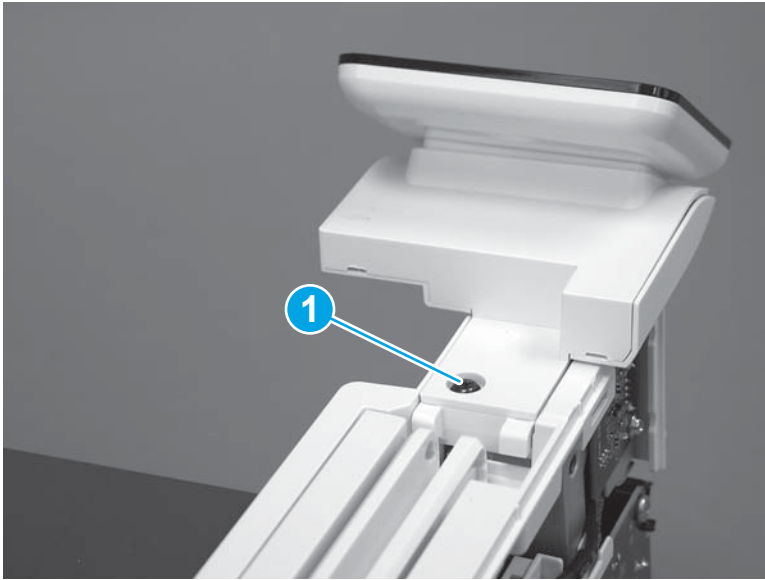
6. Make sure that the two tabs (callout 1) on the cover snap into place.

**Figure 1-2090** Engage two tabs



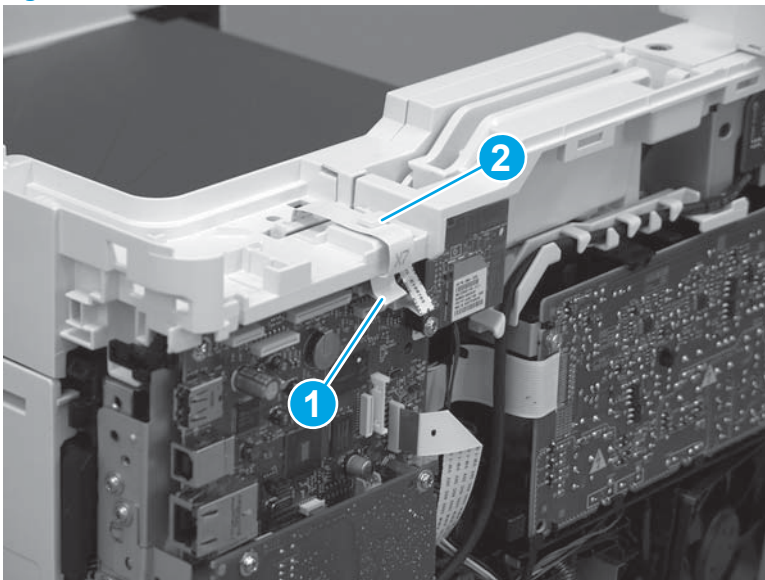
7. Install one screw (callout 1).

**Figure 1-2091** Install one screw





8. Install the FFC in the retainer (callout 1), and then connect one FFC (callout 1; J114).

**Figure 1-2092** Connect one connector



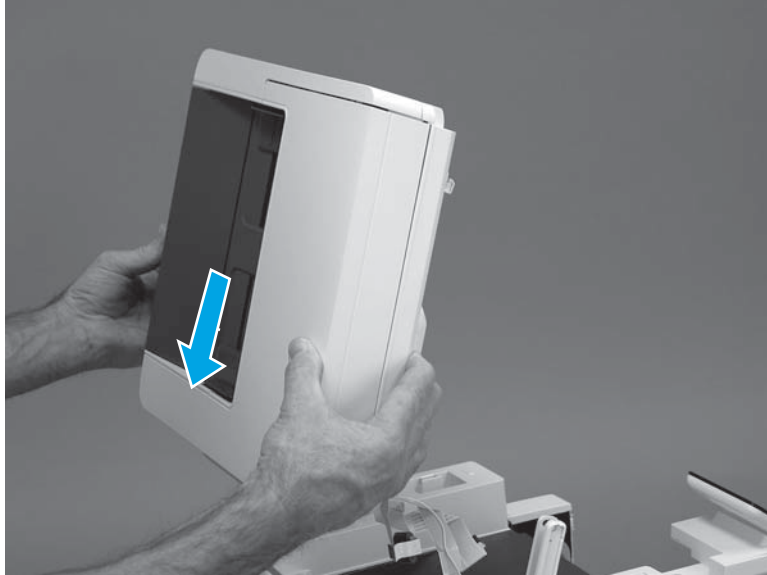
### Step 17: Install the integrated scanner assembly (M427/M246)

 **NOTE:** The step is for the M427/M426 printer. For the M403/M402, skip this step and go to [Step 18: Install the right cover on page 1105](#).

 **NOTE:** M427/M426 models only. The integrated scanner assembly (ISA) includes the sub-scanner assembly (SSA) and the automatic document feeder (ADF).

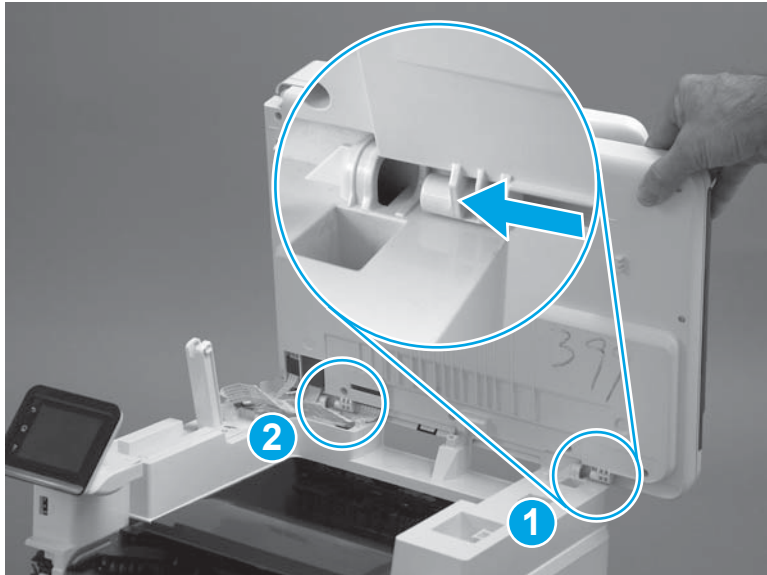
1. Position the ISA on the printer.

**Figure 1-2093** Position the ISA on the printer



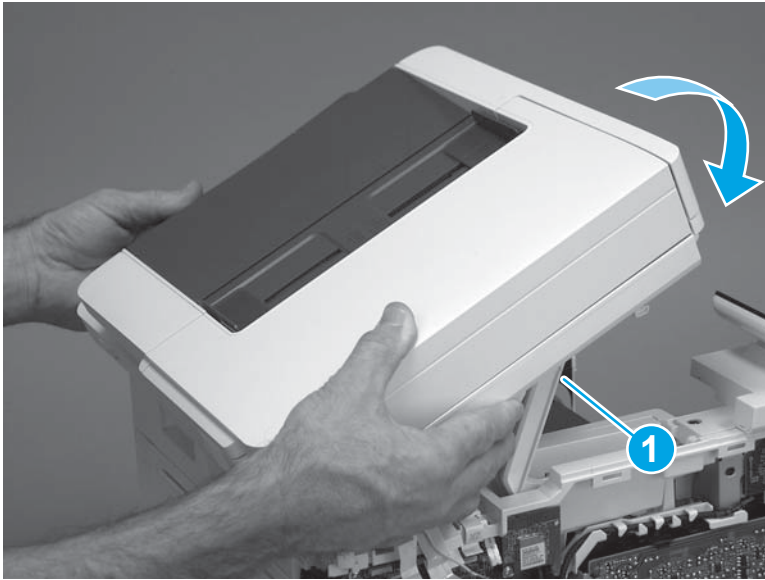
2. Engage the hinge pins on the ISA with the holders in the top cover (callouts 1/2), and then slide the ISA as shown to engage them

**Figure 1-2094** Engage the hinge pins with the holders



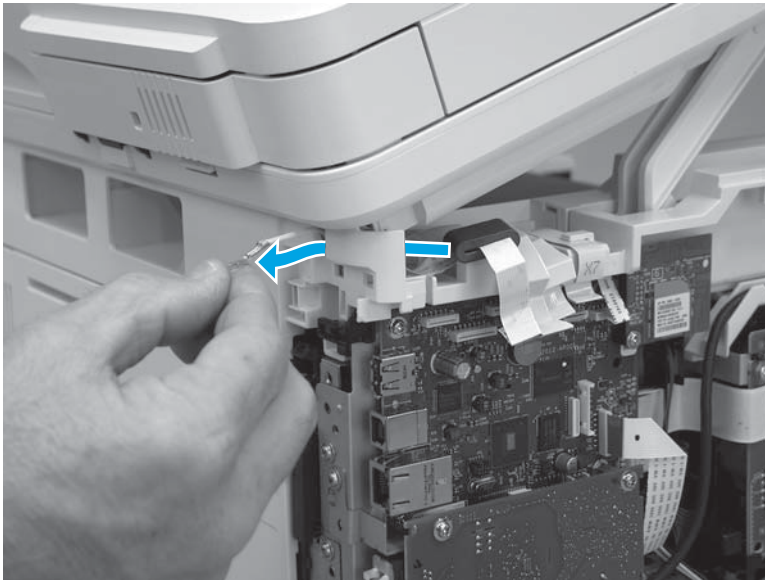
3. Rotate the ISA towards the front of the printer until it rests on the ISA lift assembly (callout 1).

**Figure 1-2095** Rotate the ISA towards the front of the printer



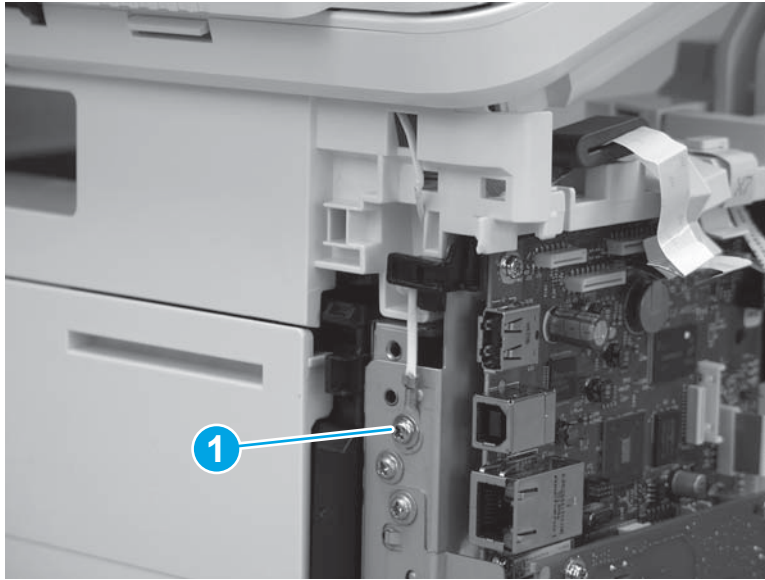
4. Pass the ground wire through the opening in the top cover.

**Figure 1-2096** Pass the wire through the opening




5. Install one screw (callout 1).

**Figure 1-2097** Install one screw



6. Install the ISA lift assembly slider pin.

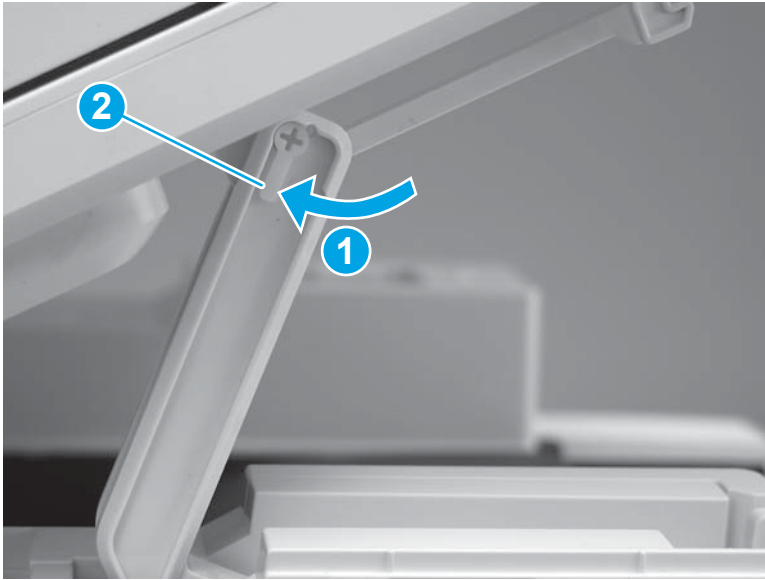
 **Reinstallation tip:** Align the keyed portion of the locking pin with the slot and hole in the support arm.

**Figure 1-2098** Install the slider pin



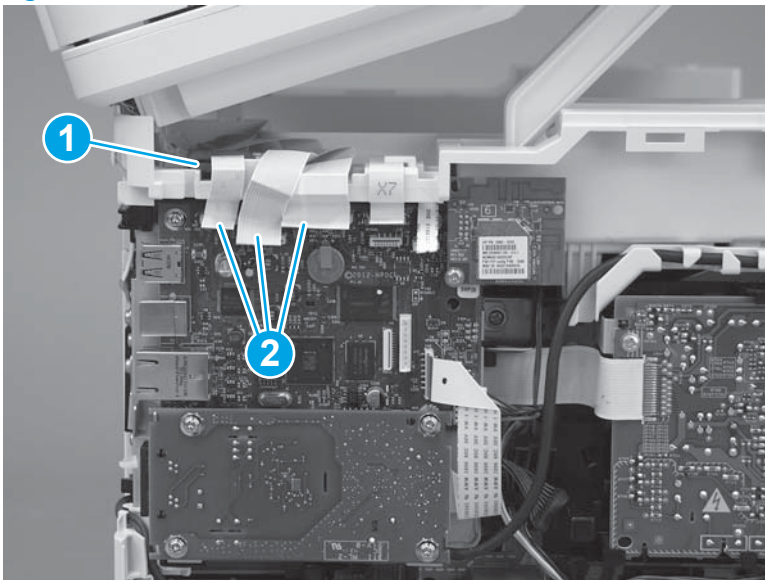
7. Rotate the slider pin (callout 1) towards the rear of the printer until the tab (callout 2) snap into place.

**Figure 1-2099** Secure the slider pin



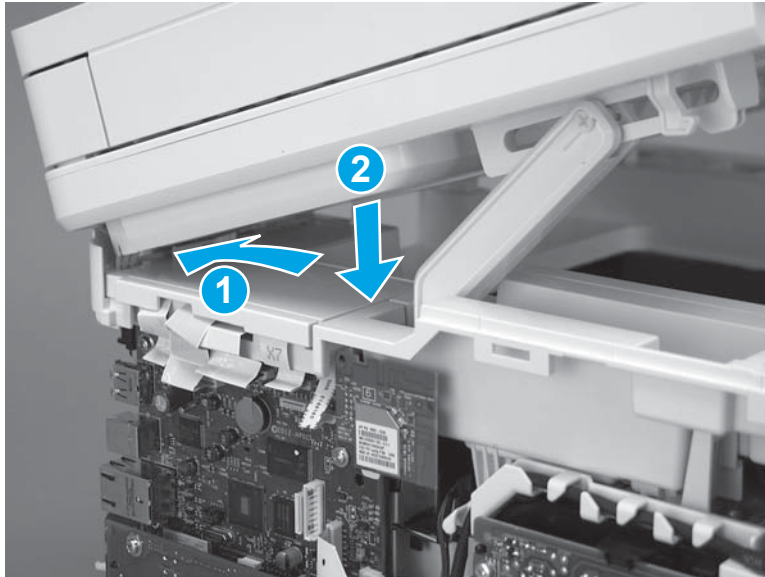
8. Install the ferrite (callout 1) in the holder, and then connect three FFCs (callout 2).

**Figure 1-2100** Connect three FFCs



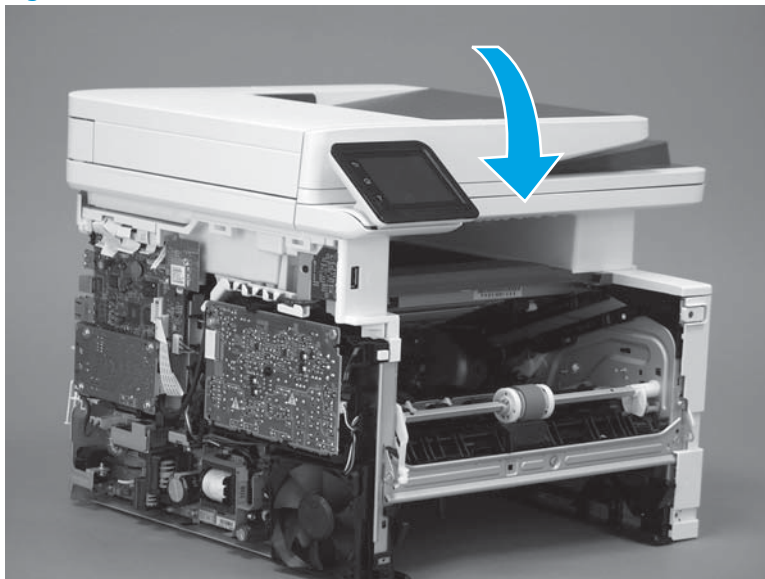
9. Position the rear edge of the ISA flat-flexible cable (FFC) cover on the printer (callout 1) , and then rotate it down (callout 2) until it snaps into place.

**Figure 1-2101** Install the ISA FFC cover



10. Lower the ISA.

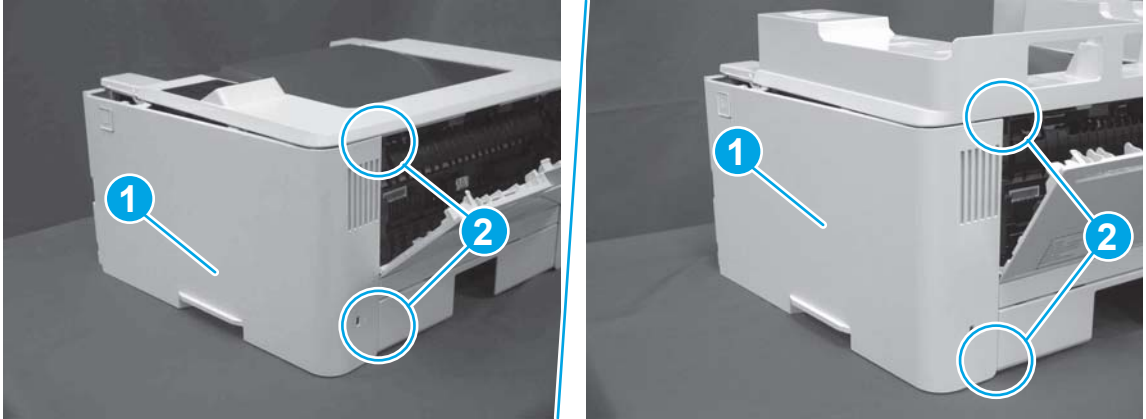
**Figure 1-2102** Lower the ISA



### Step 18: Install the right cover

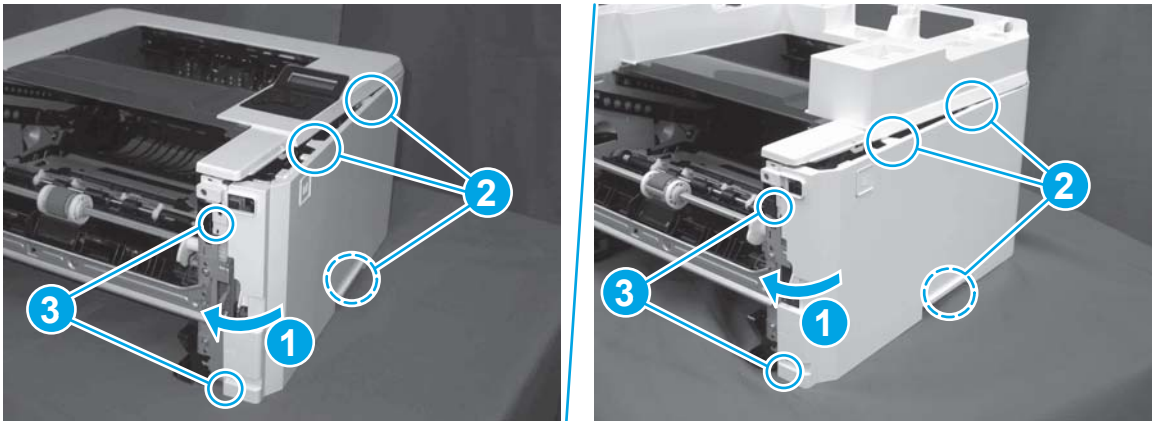
1. Position the cover (callout 1) on the printer, and then engage two bosses (callout 2).

**Figure 1-2103** Install the cover




2. Rotate the front of the cover onto the printer (callout 1), engage three (callout 2) tabs, and then engage two bosses (callout 3).

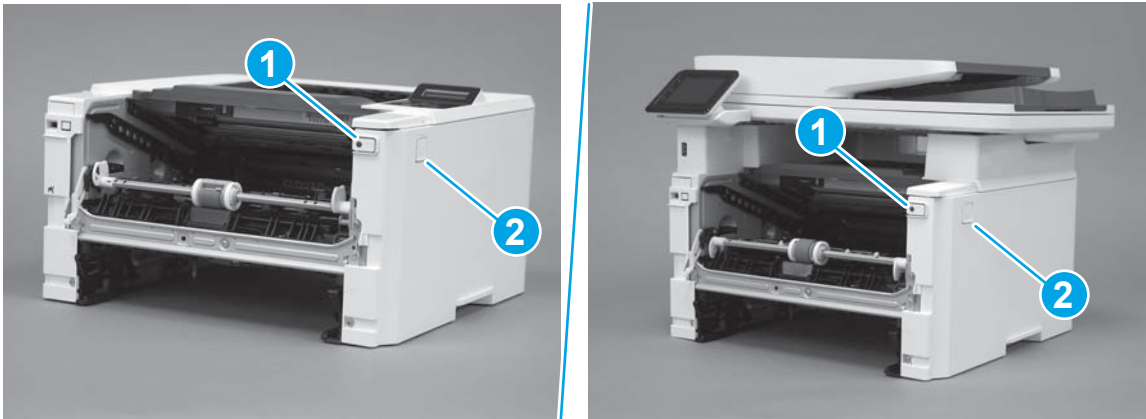
**Figure 1-2104** Engage two bosses and one tab



3. Make sure that the power switch (callout 1) and cartridge door assembly button (callout 2) correctly function.

 **NOTE:** Remove, and then reinstall the cover if the switch or button does not correctly function.

**Figure 1-2105** Check the power switch and cartridge door assembly button





4. Install one screw (callout 1).

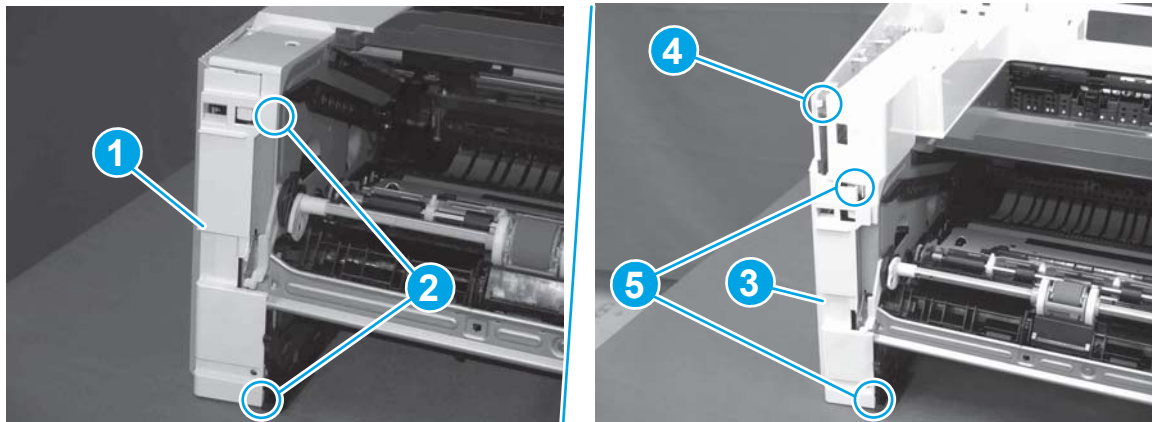
**Figure 1-2106** Install one screw



### Step 19: Install the left cover

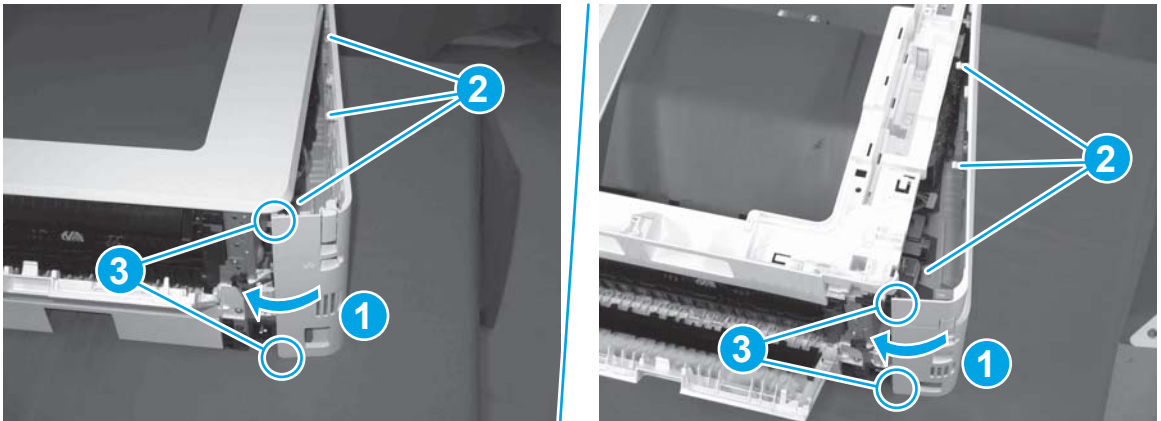
1. At the front of the printer, do one of the following:
  - **M403/M402:** Position the cover on the printer ( callout 1), and then engage two bosses (callout 2).
  - **M427/M426:** Position the cover on the printer (callout 3), engage one tab (callout 4), and then engage two bosses (callout 4).

**Figure 1-2107** Install the cover



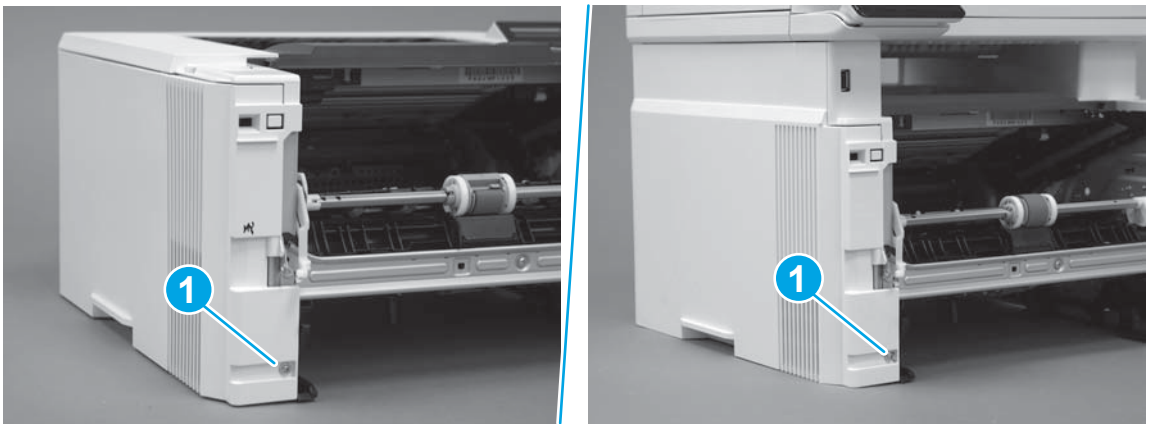
- Carefully rotate the rear of the cover onto the printer (callout 1), engage three tabs (callout 2), and then engage two bosses (callout 3).

**Figure 1-2108** Engage three tabs and two bosses




- Install one screw (callout 1).

**Figure 1-2109** Install one screw

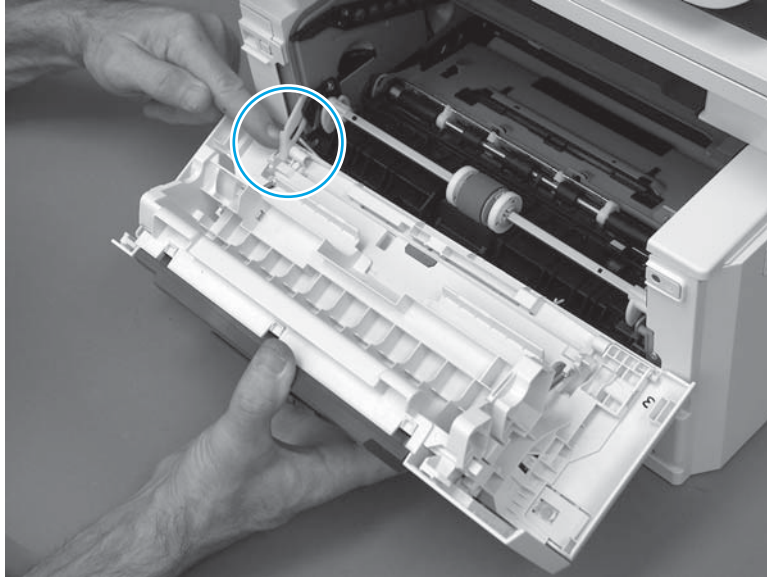


## Step 20: Remove the cartridge door assembly

 **Reinstallation tip:** After a replacement door is installed, make sure to install the nameplate (supplied in the kit) corresponding to the printer name on the door.

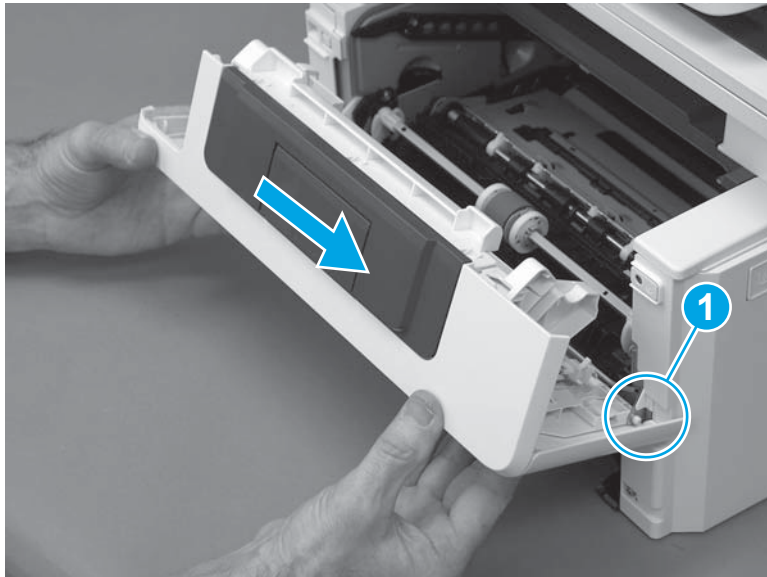
- Position the door close to the printer, and then engage the keyed pin on the left-side retainer arm with the hole in the door.

**Figure 1-2110** Engage the left-side retainer arm



2. Engage the right-side door hinge pin with the hole in the chassis (callout 1).

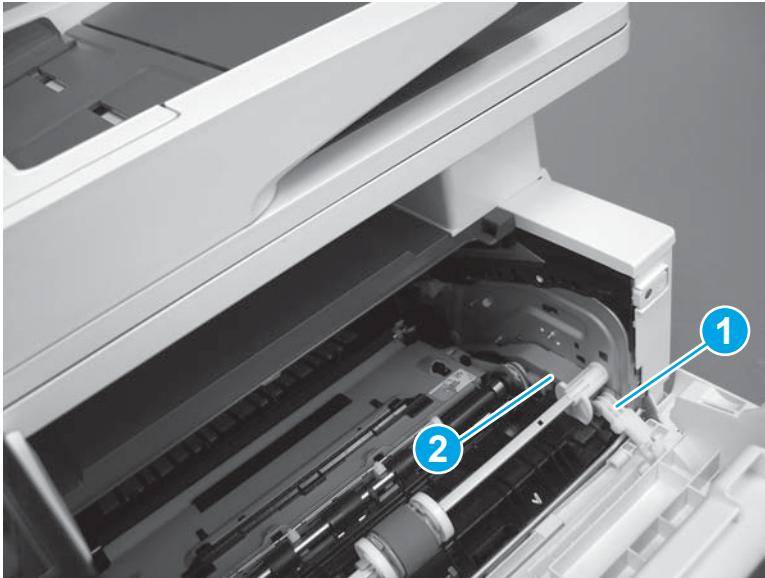
**Figure 1-2111** Install the door



3. Install the link (callout 1).

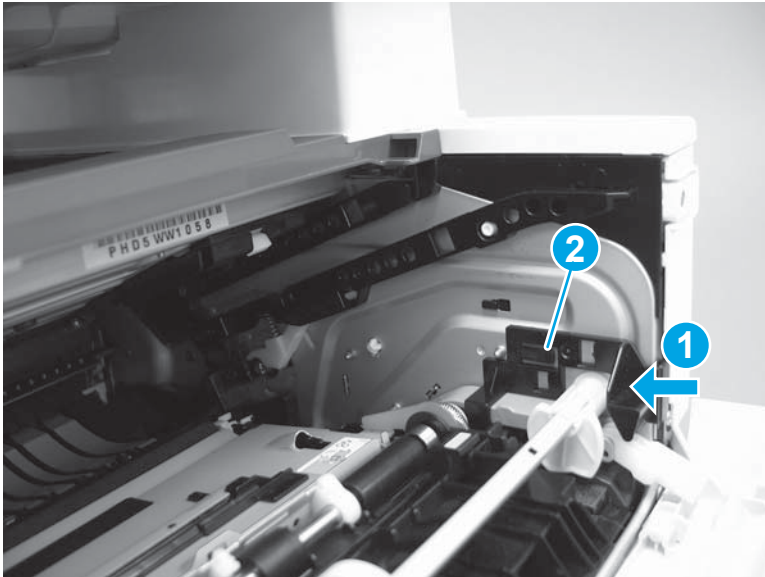
 **IMPORTANT:** Make sure that the link snaps into place on the arm (callout 2). The link actuates the fuser pressure-release mechanism.

**Figure 1-2112** Install the pressure-release link



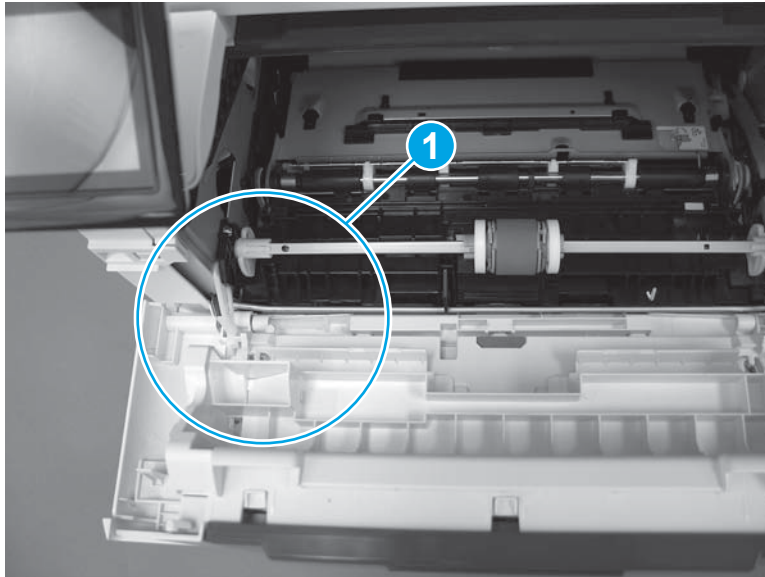
4. Slide the guide into the printer (callout 1), and then make sure that the tab (callout 2) snaps into place to secure the guide to the chassis.

**Figure 1-2113** Install the guide




5. Position the shaft on the door, and then align the left-side hinge on the door with the hole in the chassis (callout 1).

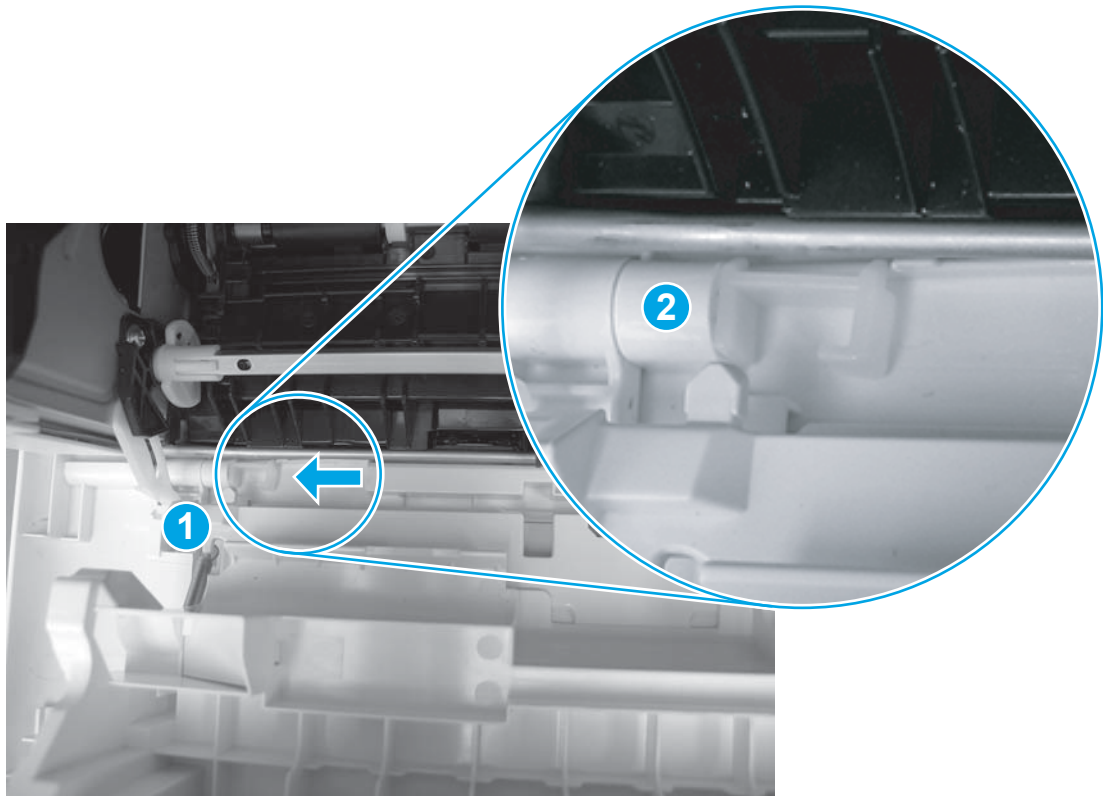
**Figure 1-2114** Align the hinge



6. Push the shaft towards the left side of the printer to install it (callout 1).

 **Reinstallation tip:** Make sure that the support shaft is fully installed and correctly orientated (callout 2) so that it will not interfere with the door opening and closing.

**Figure 1-2115** Install the support shaft



## Step 21: Install Tray 2

- ▲ Slide the tray straight into the printer to install it.

**Figure 1-2116** Install the tray



## Removal and replacement: Control-panel assembly (M403/M402)

- [Introduction](#)
- [Step 1: Remove Tray 2](#)
- [Step 2: Remove the cartridge door assembly](#)
- [Step 3: Remove the left cover](#)
- [Step 4: Remove the right cover](#)
- [Step 5: Remove the top cover \(M403/M402\)](#)
- [Step 6: Remove the paper delivery tray \(output bin\)](#)
- [Step 7: Remove the control-panel assembly \(M403/M402\)](#)
- [Step 8: Unpack the replacement assembly](#)
- [Step 9: Install the control-panel assembly \(M403/M402\)](#)
- [Step 10: Install the paper delivery tray \(output bin\)](#)
- [Step 11: Install the top cover \(M403/M402\)](#)
- [Step 12: Install the right cover](#)
- [Step 13: Install the left cover](#)
- [Step 14: Install the cartridge door assembly](#)
- [Step 15: Install Tray 2](#)


### Introduction

This document provides the procedures to remove and replace the control-panel assembly (M403/M402).

### Before performing service

#### Turn the printer power off

- Disconnect the power cable.

 **WARNING!** To avoid damage to the printer, turn the printer off, wait 30 seconds, and then remove the power cable before attempting to service the printer.

Use the table below to identify the correct part number for your printer. To order the part, go to [www.hp.com/buy/parts](http://www.hp.com/buy/parts).

Control-panel assembly (M403/M402) part number	
RM2-5391-000CN	Control-panel assembly (M403/M402)
RM2-5424-000CN	Control-panel assembly (M403/M402; wireless model)

### Required tools

- #2 Phillips screwdriver with a magnetic tip.

## After performing service

### Turn the printer power on

- Connect the power cable.
- Use the power switch to turn the power on.

### Post service test

Make sure that the printer initializes to a **Ready** state.

Print a configuration page to make sure that the printer is functioning correctly.

### Step 1: Remove Tray 2


- ▲ Pull the tray straight out of the printer to remove it.

**Figure 1-2117** Remove the tray



### Step 2: Remove the cartridge door assembly

---

 **NOTE:** If the toner cartridge was not removed prior to servicing the printer, remove it now.

---

1. Release one tab (callout 1), and then slide shaft (callout 2) in the direction the arrow indicates and remove it.

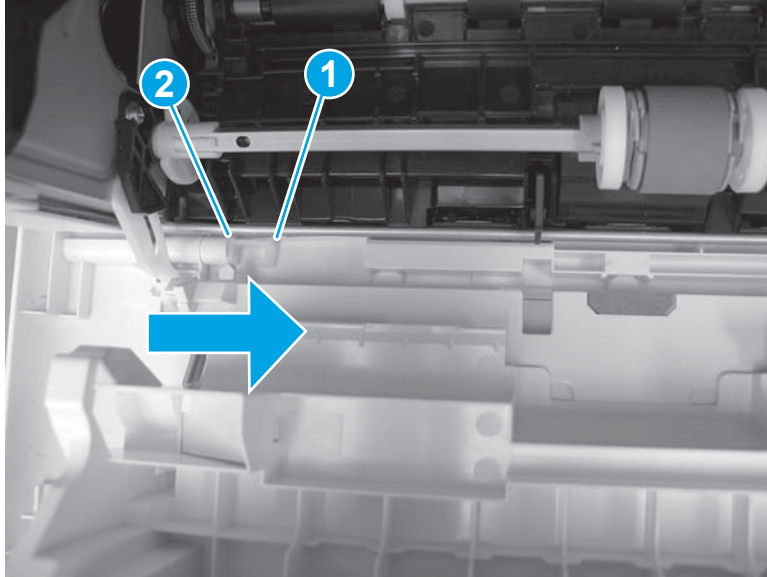
---

 **TIP:** It might be easier to release the support shaft by using a small flat-blade screwdriver.

---

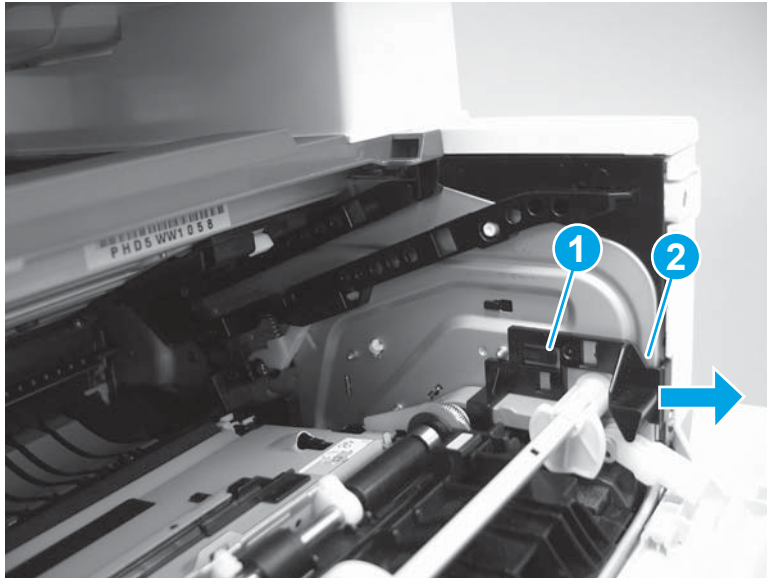


**Figure 1-2118** Release the support shaft



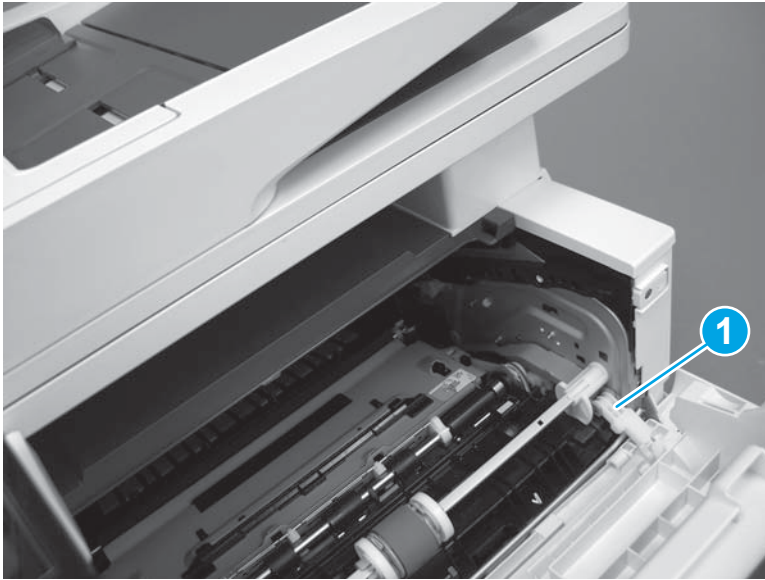
2. Release one tab (callout 1), and then slide the guide (callout 2) in the direction the arrow indicates and remove it.

**Figure 1-2119** Remove the guide



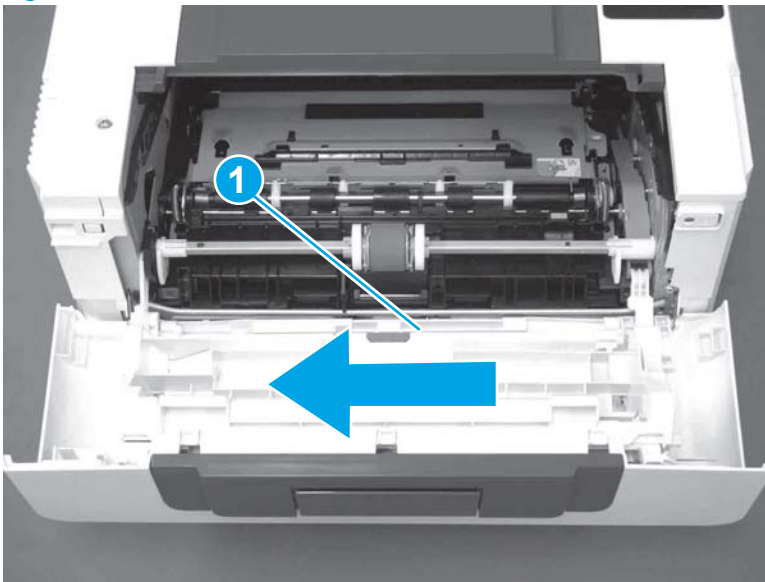
3. Remove the link arm (callout 1).

**Figure 1-2120** Remove the link arm



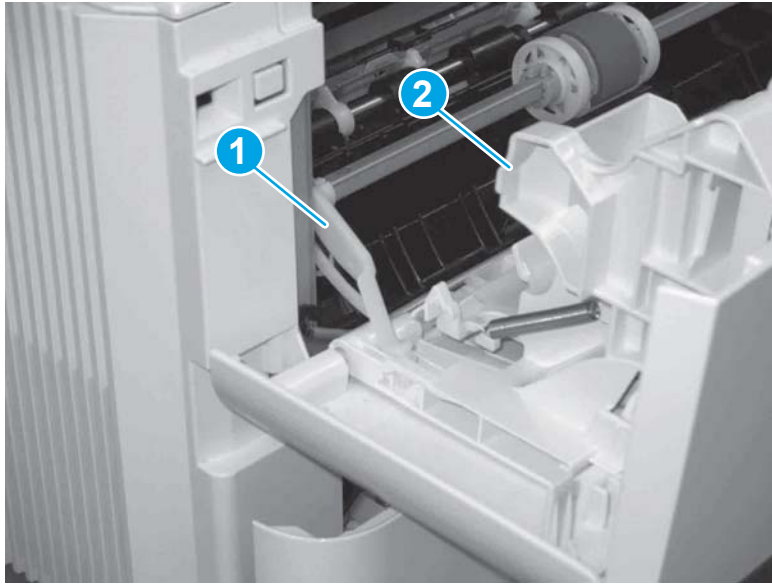
4. Slide the cartridge door assembly (callout 1) in the direction the arrow indicates and remove it.

**Figure 1-2121** Remove the door



5. Remove the link (callout 1) from the cartridge door assembly (callout 2).

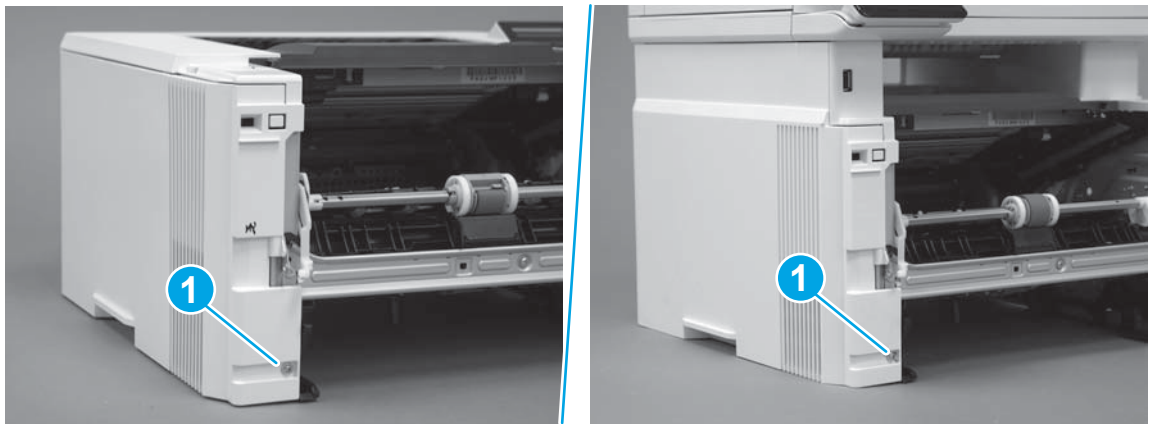
**Figure 1-2122** Release the left-side retainer arm



### Step 3: Remove the left cover

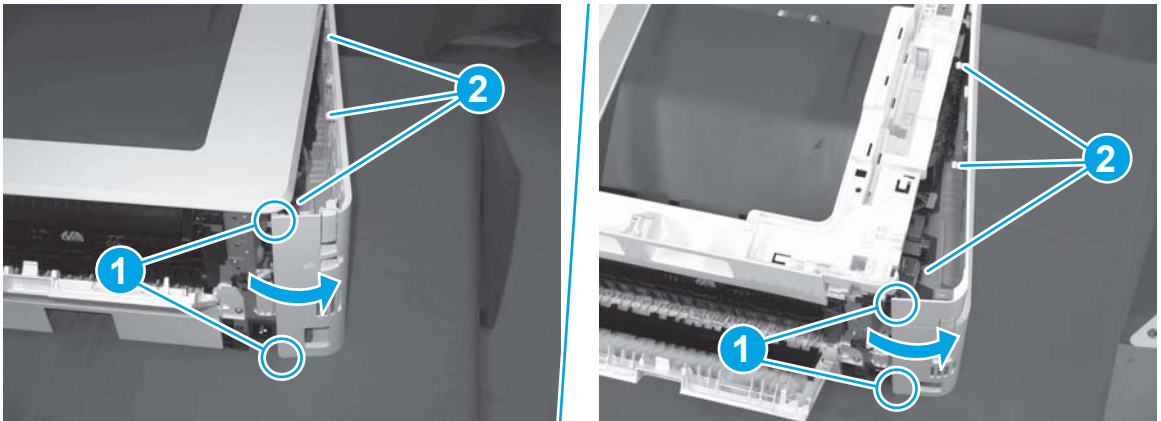
1. Remove one screw (callout 1).

**Figure 1-2123** Remove one screw



2. Open the rear door, release two bosses (callout 1), and then release three tabs (callout 2).

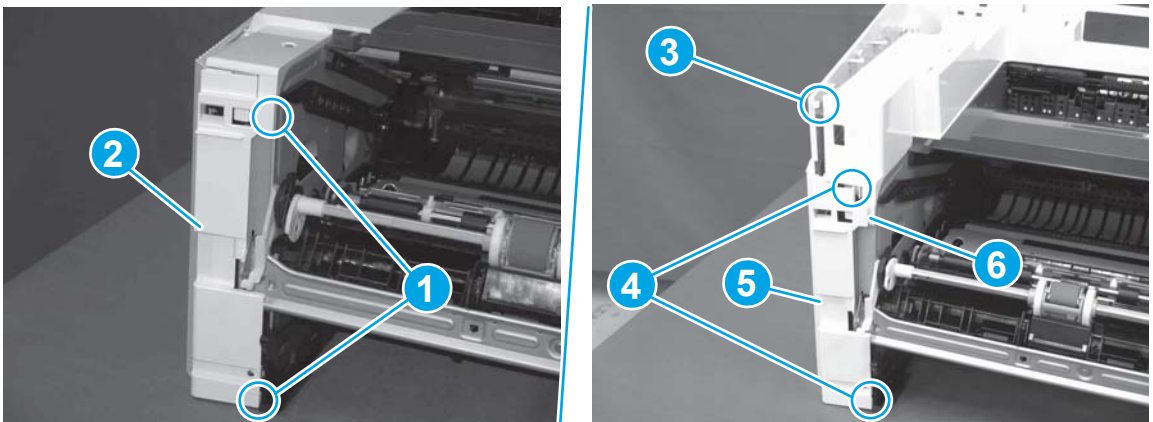
**Figure 1-2124** Release two bosses and three tabs



3. At the front of the printer, do one of the following:
  - **M403/M402:** Release two bosses (callout 1), and then remove the cover (callout 2).
  - **M427/M426:** Release one tab (callout 3), two bosses (callout 4), and then remove the cover (callout 5).

**CAUTION:** Be careful when releasing the upper bosses on the M427/M426 cover. One portion of the cover (callout 6) is fragile and is easily broken.

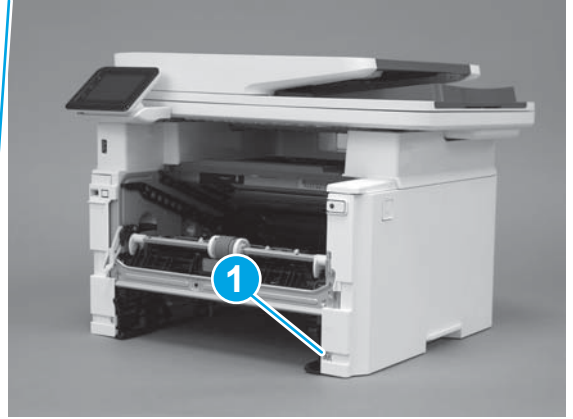
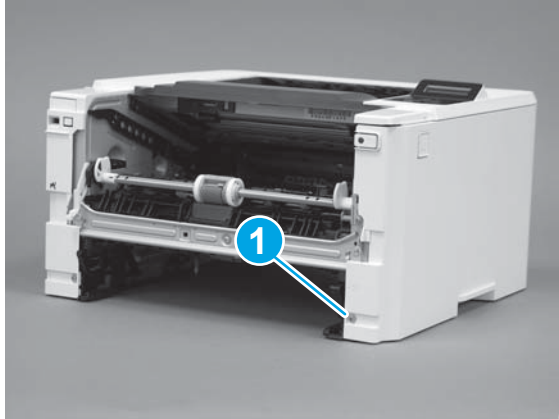
**Figure 1-2125** Remove the cover



#### Step 4: Remove the right cover

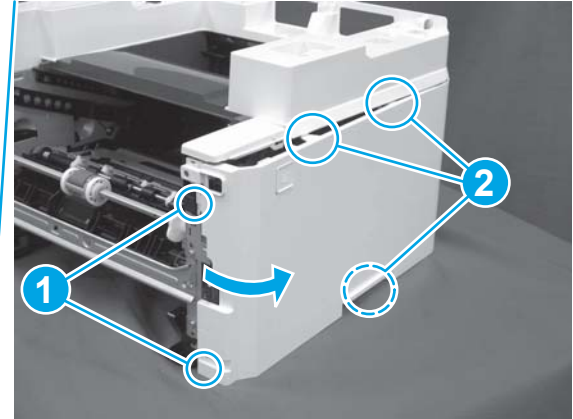
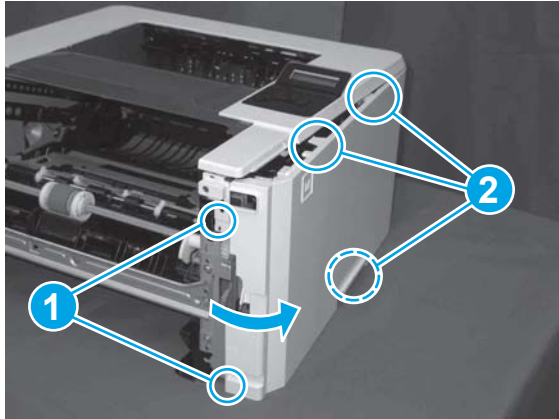
1. Remove one screw (callout 1).

**Figure 1-2126** Remove one screw



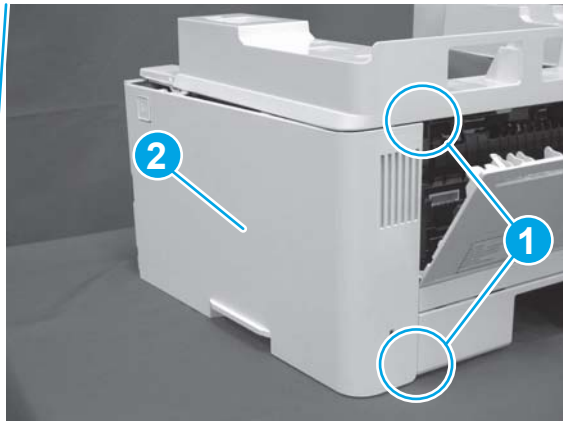
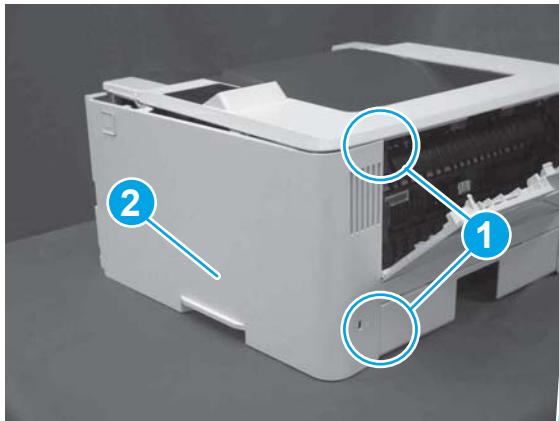
2. At the front of the printer, release two bosses (callout 1), and then release three tabs (callout 2).

**Figure 1-2127** Release two bosses and three tabs



3. Open the rear door, release two bosses (callout 1), and then remove the cover (callout 2).

**Figure 1-2128** Remove the cover



### Step 5: Remove the top cover (M403/M402)

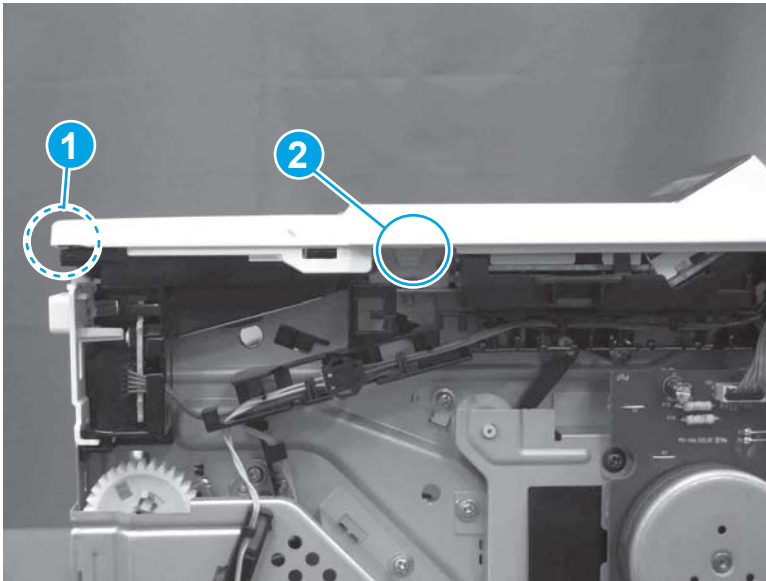
1. Remove one screw (callout 1).

**Figure 1-2129** Remove one screw




2. At the right side of the printer, release the one boss (callout 1), and then release one tab (callout 2).

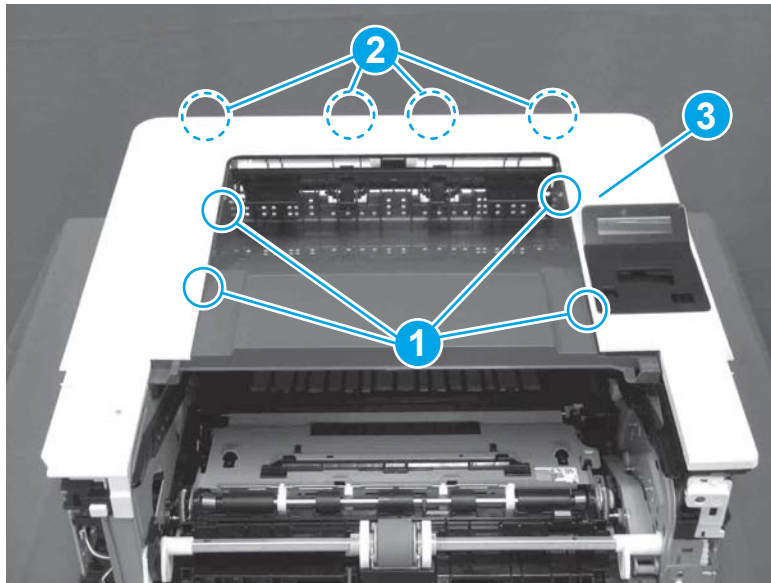
**Figure 1-2130** Release one boss and one tab




3. Release four tabs (callout 1), release four bosses (callout 2), and then remove the top cover (callout 3).

 **TIP:** Open the rear door to make releasing the bosses (callout 3) easier.

**Figure 1-2131** Remove the cover

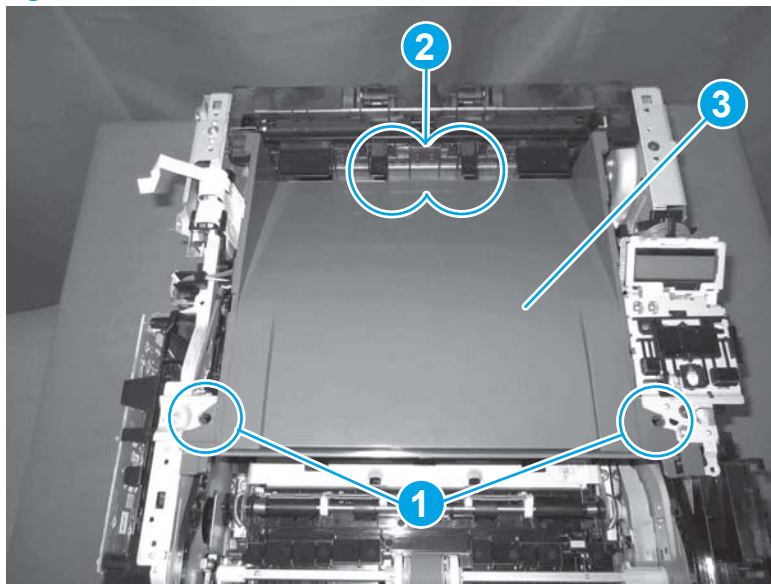


#### Step 6: Remove the paper delivery tray (output bin)

 **NOTE:** This procedure shows the M403/M402 model, however, the paper delivery tray (output bin) removal is similar for the M427/M426 printer.

- ▲ Release two bosses (callout 1), release two tabs (callout 2), and then remove the paper delivery tray (output bin; callout 3).

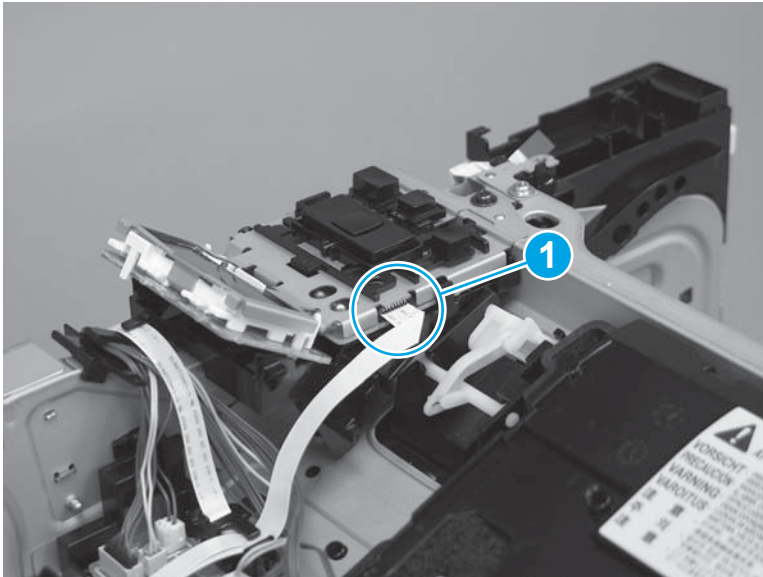
**Figure 1-2132** Release two tabs



### Step 7: Remove the control-panel assembly (M403/M402)

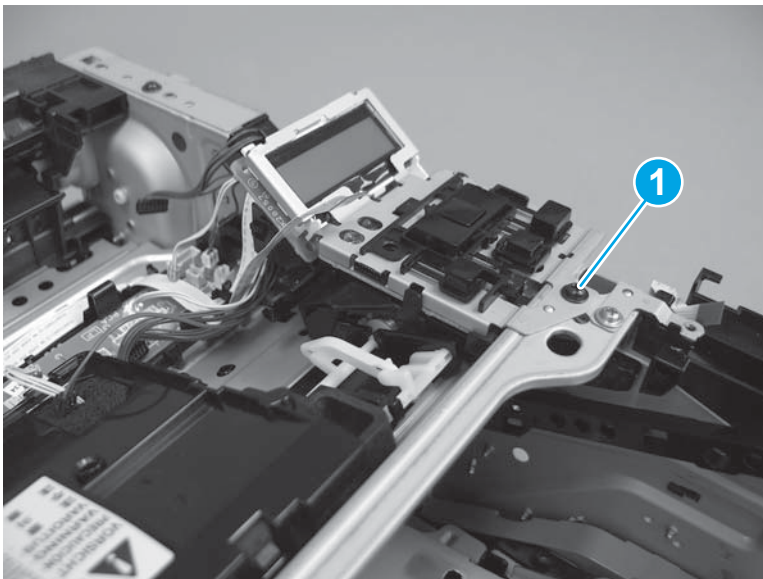
1. Disconnect one FFC (callout 1).

**Figure 1-2133** Disconnect one FFC



2. Remove one screw (callout 1), and then remove the control panel.

**Figure 1-2134** Remove one screw and the control panel



### Step 8: Unpack the replacement assembly

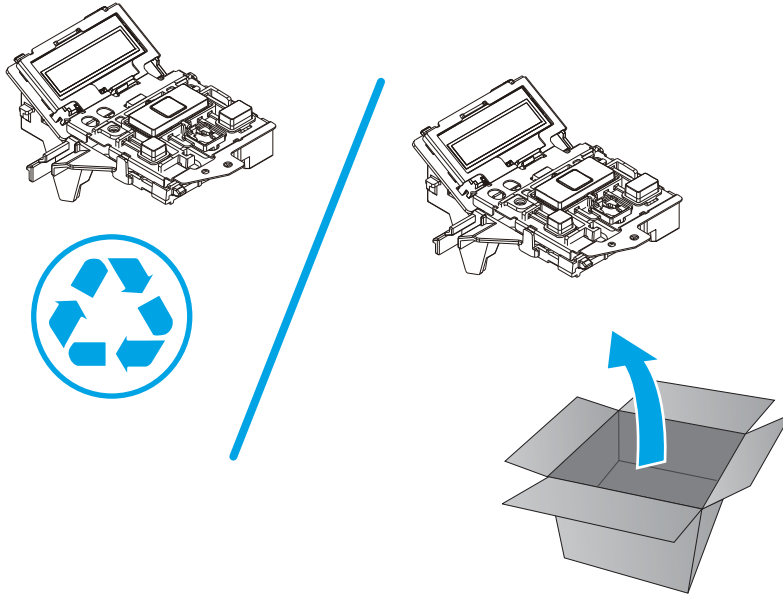
Unpack the replacement part from the packaging.

<http://www8.hp.com/us/en/hp-information/environment/product-recycling.html>

 **NOTE:** HP recommends responsible disposal of the defective part.



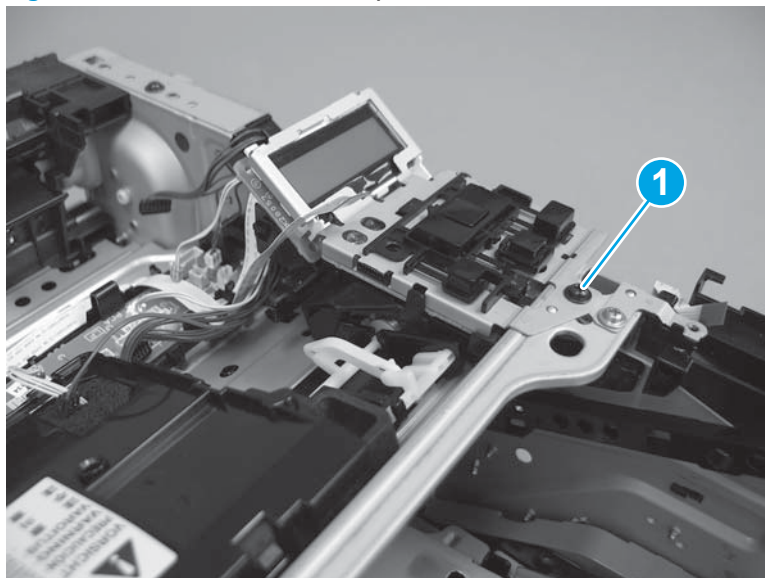
**Figure 1-2135** Recycle and unpack



**Step 9: Install the control-panel assembly (M403/M402)**

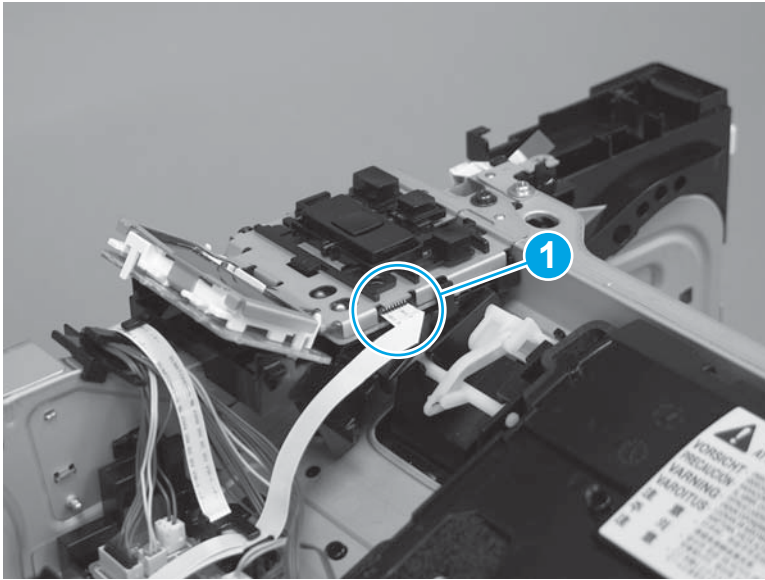
1. Position the control panel on the chassis, and then install one screw (callout 1).

**Figure 1-2136** Install the control panel and one screw



2. Connect one FFC (callout 1).

**Figure 1-2137** Connect one FFC



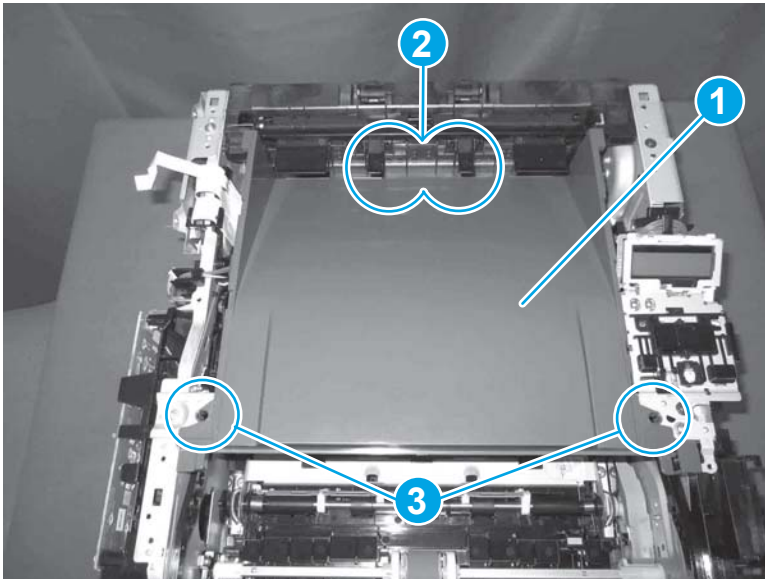
### Step 10: Install the paper delivery tray (output bin)



**NOTE:** This procedure shows the M403/M402 model, however, the paper delivery tray (output bin) removal is similar for the M427/M426 printer.

- ▲ Position the remove the paper delivery tray (output bin; callout 1) on the printer, engage two tabs (callout 2), and then engage two bosses (callout 3).

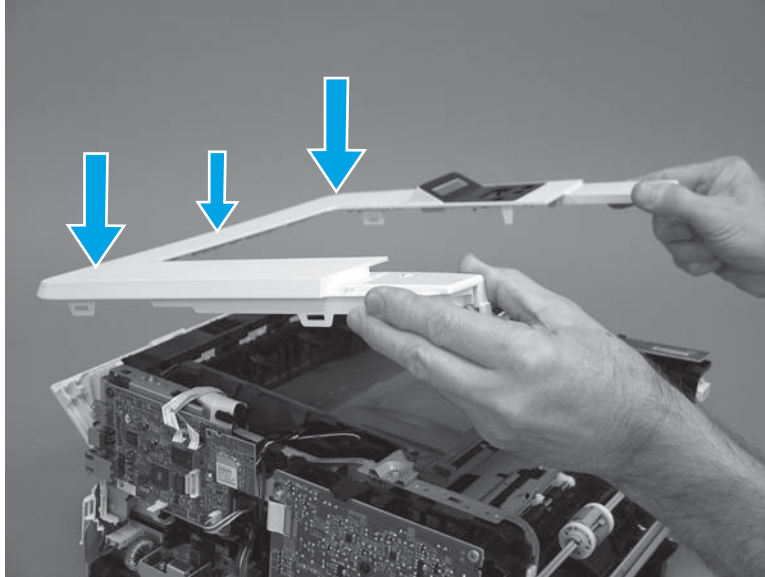
**Figure 1-2138** Engage two tabs



### Step 11: Install the top cover (M403/M402)

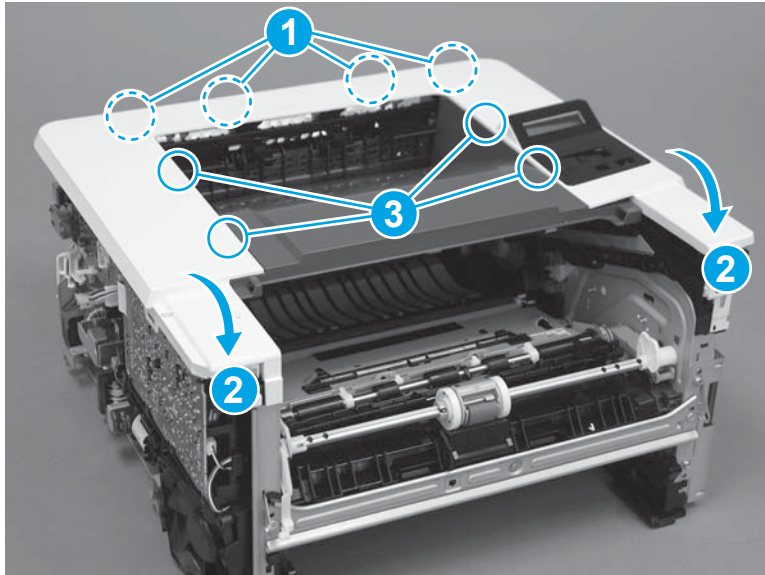
1. Position the rear edge of the cover on the printer.

**Figure 1-2139** Install the cover



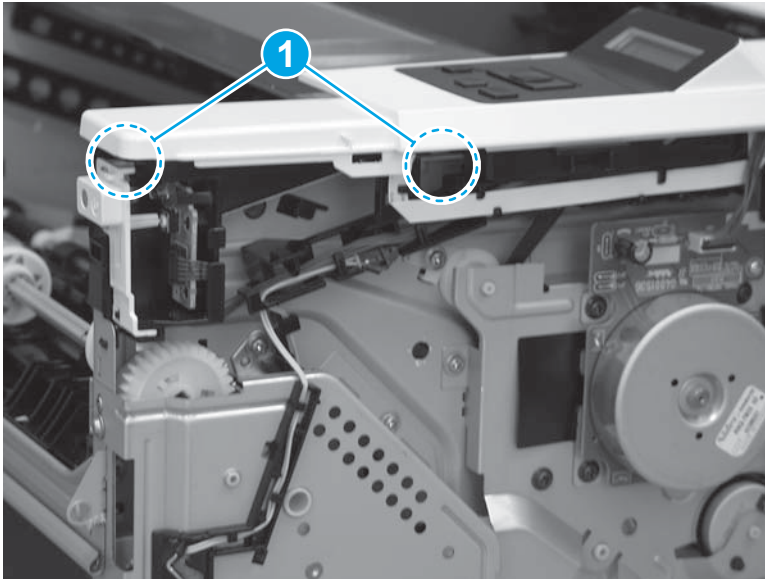
2. Engage four bosses (callout 1), rotate the front of the cover down (callout 2) and onto from the printer, and then engage four tabs (callout 3).

**Figure 1-2140** Engage four bosses and tabs



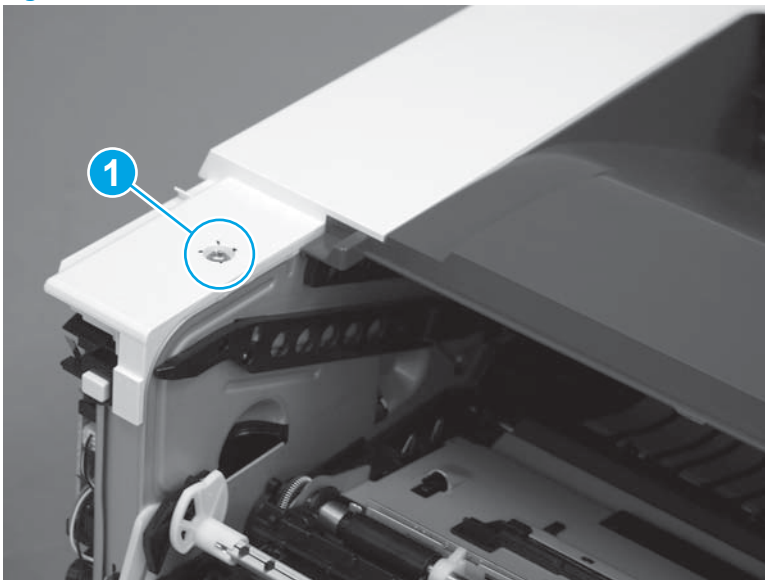
3. At the right side of the printer, engage the one boss and one tab (callout 1).

**Figure 1-2141** Engage one boss and one tab



4. Install one screw (callout 1).

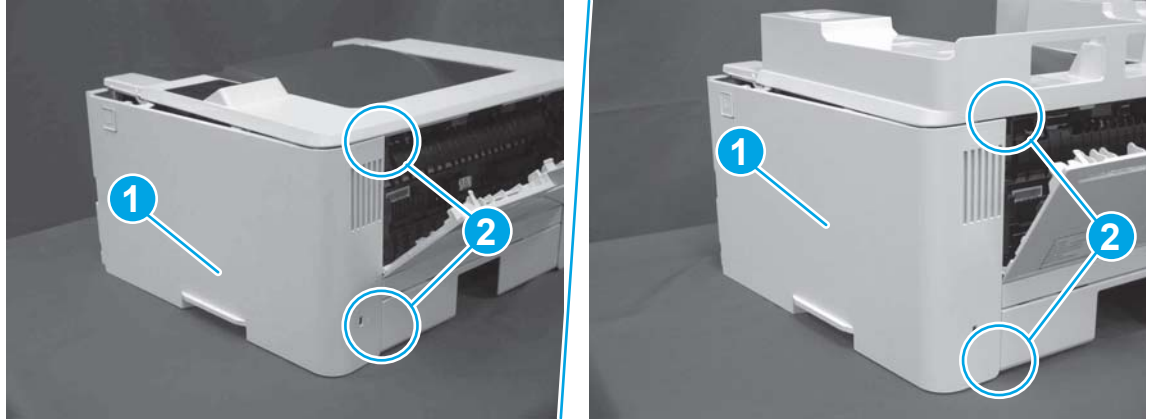
**Figure 1-2142** Install one screw



### **Step 12: Install the right cover**

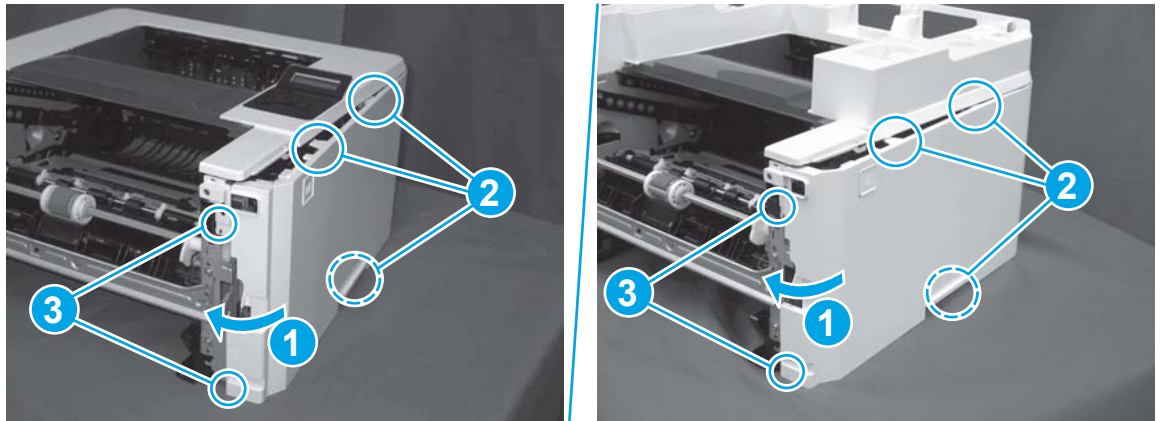
1. Position the cover (callout 1) on the printer, and then engage two bosses (callout 2).

**Figure 1-2143** Install the cover



2. Rotate the front of the cover onto the printer (callout 1), engage three (callout 2) tabs, and then engage two bosses (callout 3).

**Figure 1-2144** Engage two bosses and one tab

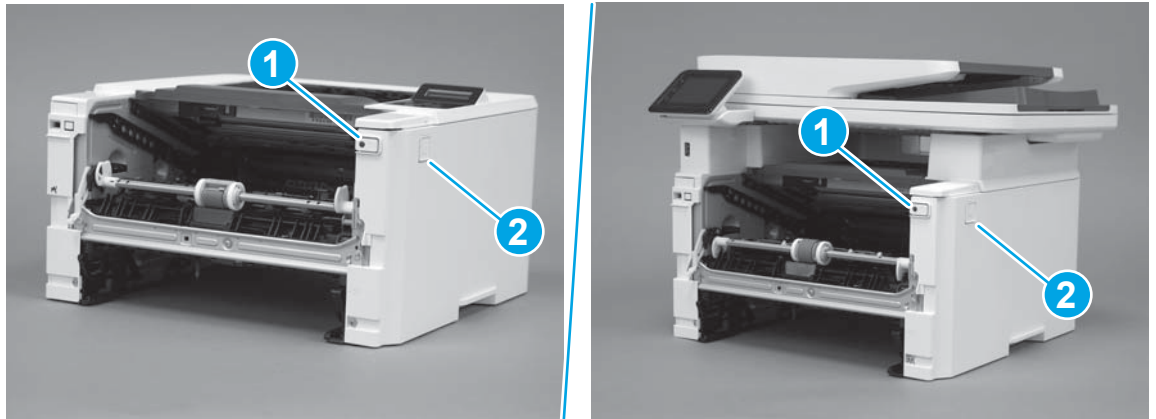


3. Make sure that the power switch (callout 1) and cartridge door assembly button (callout 2) correctly function.



**NOTE:** Remove, and then reinstall the cover if the switch or button does not correctly function.

**Figure 1-2145** Check the power switch and cartridge door assembly button



4. Install one screw (callout 1).

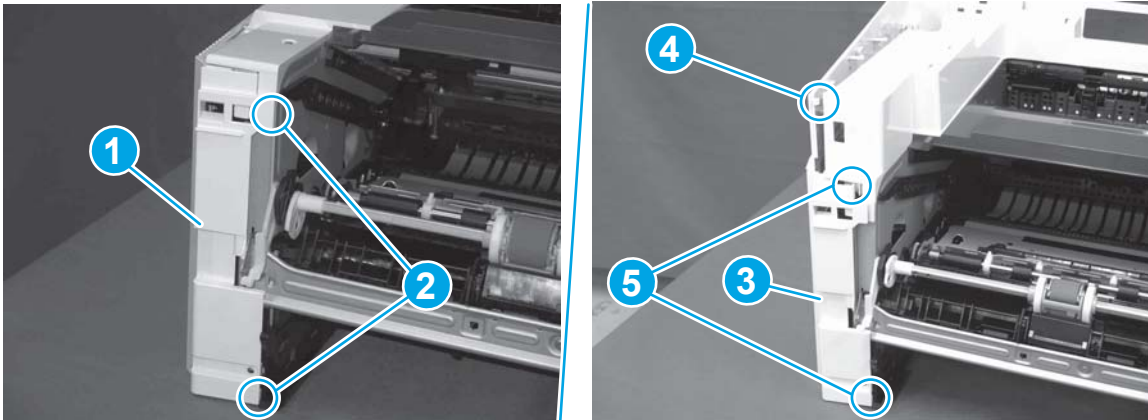
**Figure 1-2146** Install one screw



### Step 13: Install the left cover

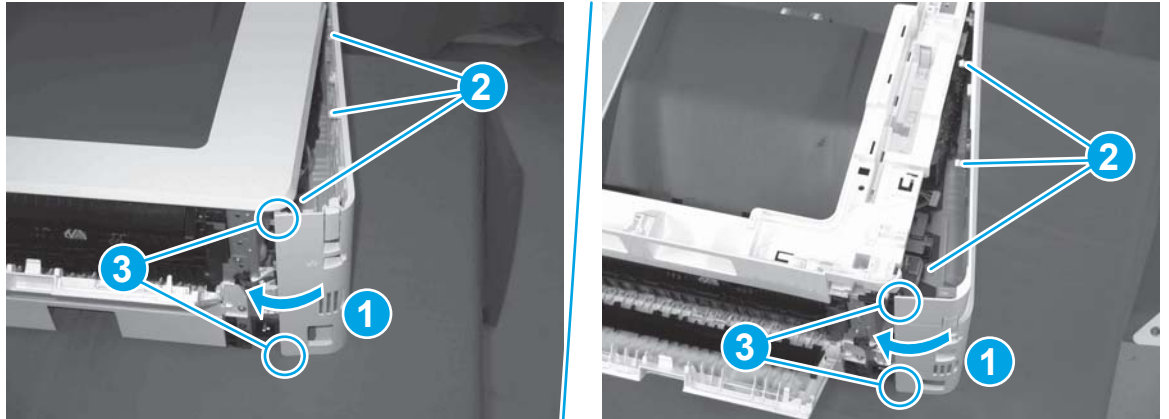
1. At the front of the printer, do one of the following:
  - **M403/M402:** Position the cover on the printer ( callout 1), and then engage two bosses (callout 2).
  - **M427/M426:** Position the cover on the printer (callout 3), engage one tab (callout 4), and then engage two bosses (callout 4).

**Figure 1-2147** Install the cover



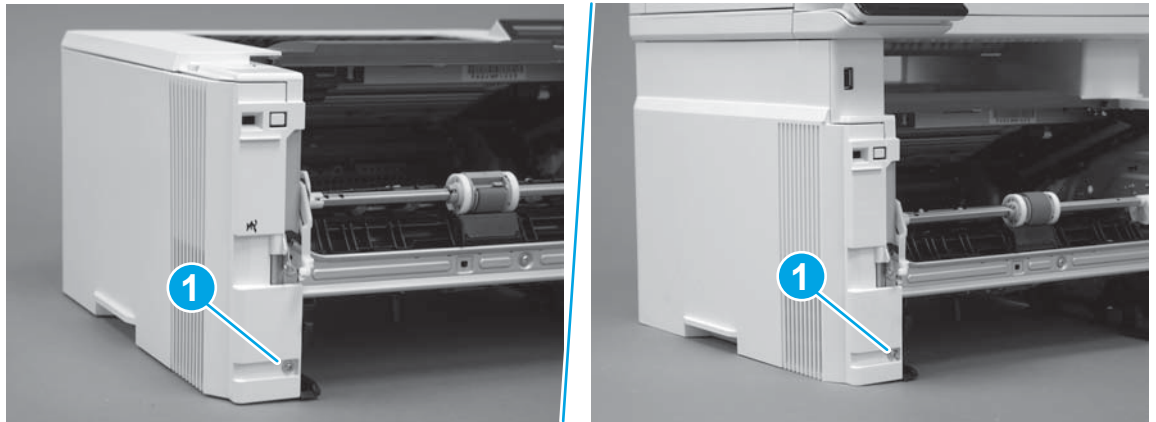
- Carefully rotate the rear of the cover onto the printer (callout 1), engage three tabs (callout 2), and then engage two bosses (callout 3).

**Figure 1-2148** Engage three tabs and two bosses




- Install one screw (callout 1).

**Figure 1-2149** Install one screw

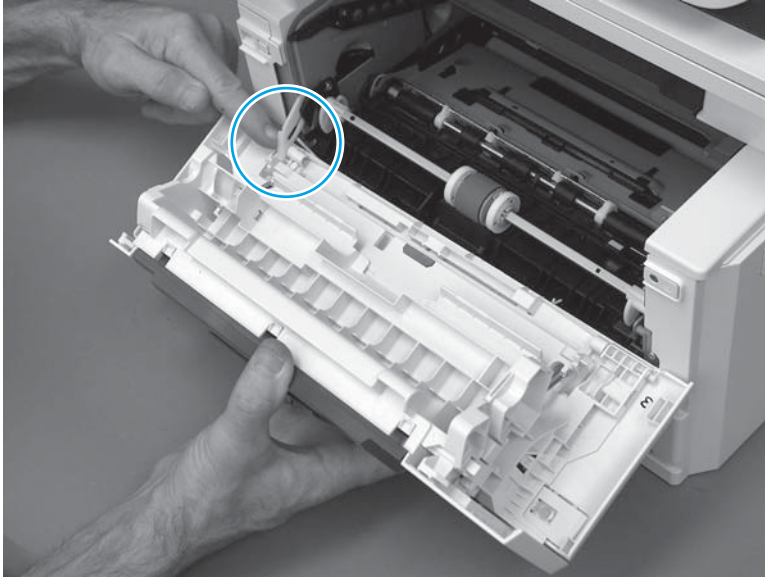


#### Step 14: Install the cartridge door assembly

 **Reinstallation tip:** After a replacement door is installed, make sure to install the nameplate (supplied in the kit) corresponding to the printer name on the door.

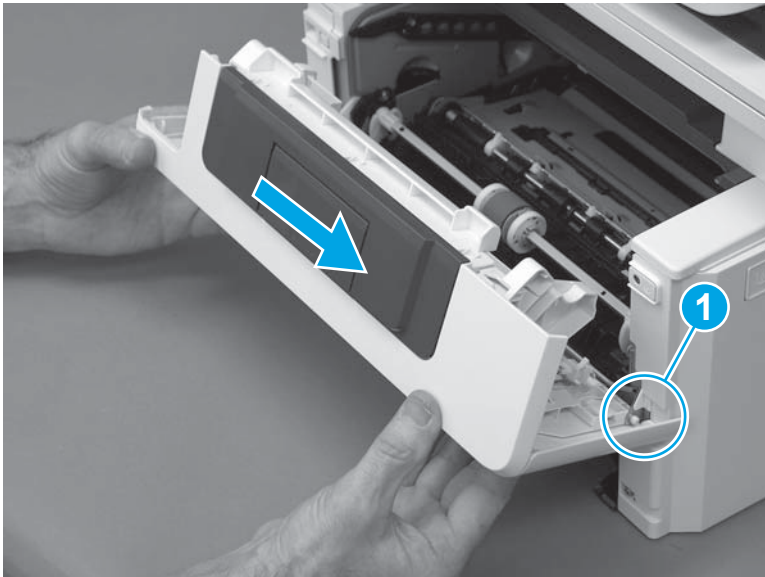
- Position the door close to the printer, and then engage the keyed pin on the left-side retainer arm with the hole in the door.

**Figure 1-2150** Engage the left-side retainer arm



2. Engage the right-side door hinge pin with the hole in the chassis (callout 1).

**Figure 1-2151** Install the door

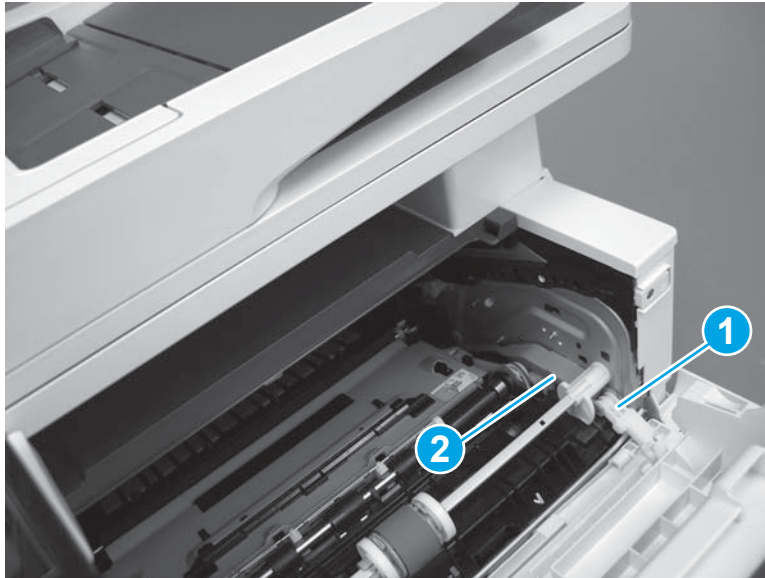




3. Install the link (callout 1).

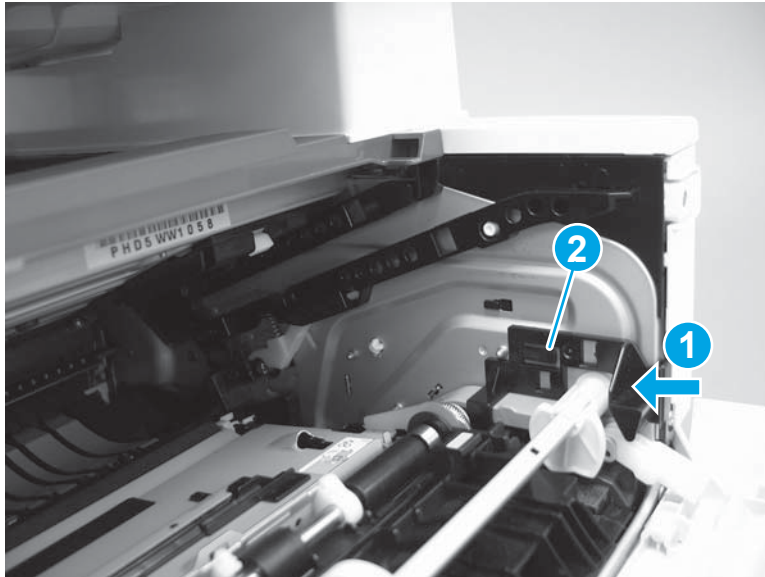
 **IMPORTANT:** Make sure that the link snaps into place on the arm (callout 2). The link actuates the fuser pressure-release mechanism.

**Figure 1-2152** Install the pressure-release link



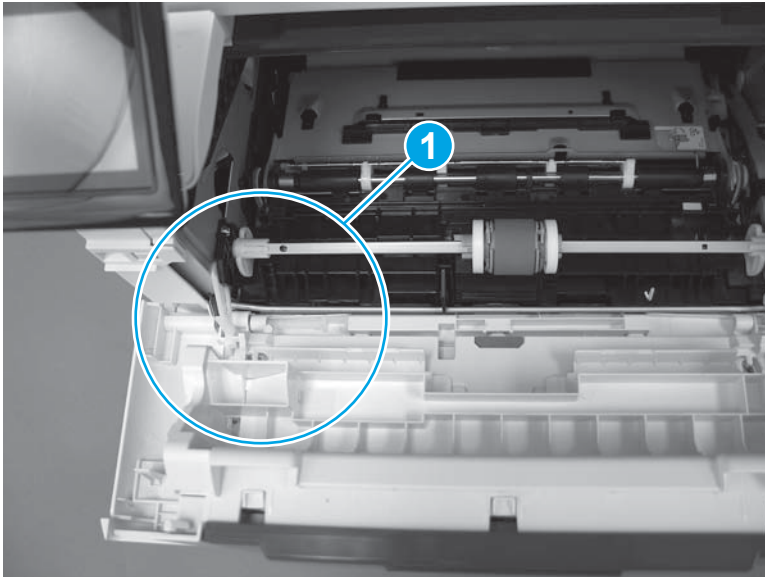
4. Slide the guide into the printer (callout 1), and then make sure that the tab (callout 2) snaps into place to secure the guide to the chassis.

**Figure 1-2153** Install the guide




5. Position the shaft on the door, and then align the left-side hinge on the door with the hole in the chassis (callout 1).

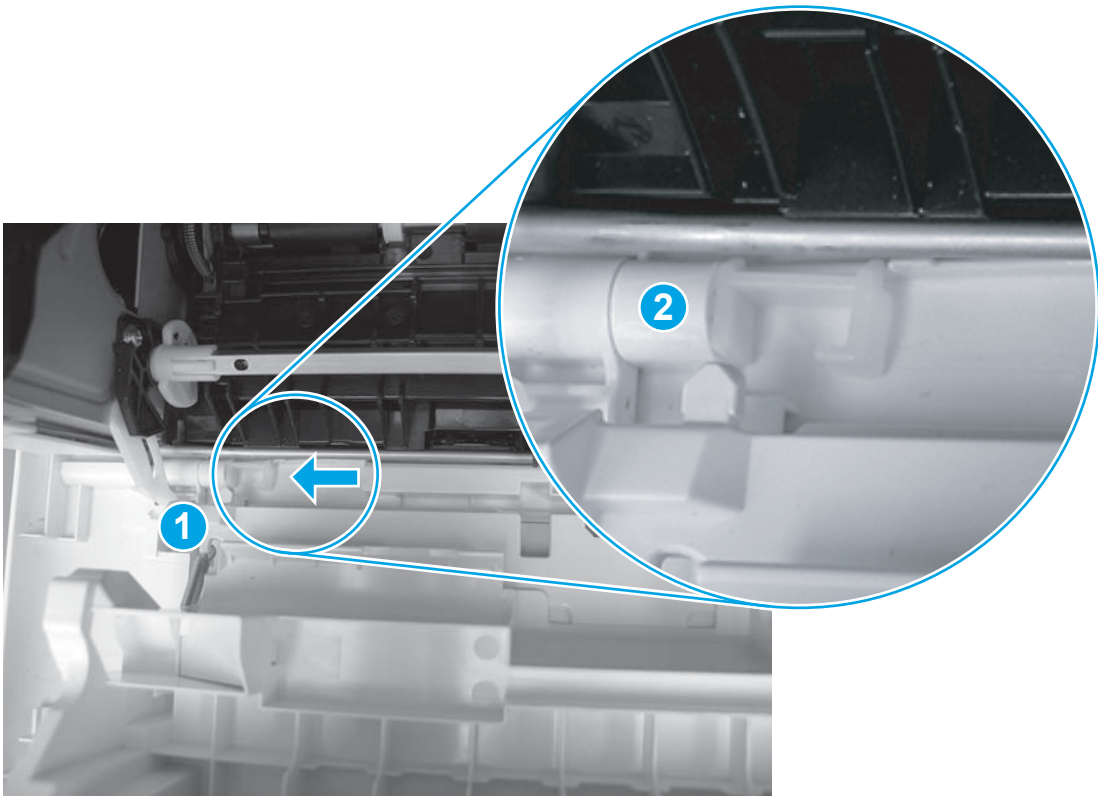
**Figure 1-2154** Align the hinge



6. Push the shaft towards the left side of the printer to install it (callout 1).

 **Reinstallation tip:** Make sure that the support shaft is fully installed and correctly orientated (callout 2) so that it will not interfere with the door opening and closing.

**Figure 1-2155** Install the support shaft



### Step 15: Install Tray 2

- ▲ Slide the tray straight into the printer to install it.

**Figure 1-2156** Install the tray



## Removal and replacement: Control panel (M427/M426) and control panel sub assemblies

- [Introduction](#)
- [Step 1: Remove the control panel mount cover \(M427/M426\)](#)
- [Step 2: Remove the control panel \(M427/M426\)](#)
- [Step 3: Remove the control panel mount base \(M427/M426\)](#)
- [Step 4: Remove the control panel mount chassis assembly \(M427/M426\)](#)
- [Step 5: Remove Tray 2](#)
- [Step 6: Remove the cartridge door assembly](#)
- [Step 7: Remove the left cover](#)
- [Step 8: Remove the control panel 22-pin FFC \(M427/M426\)](#)
- [Step 9: Unpack the replacement assembly](#)
- [Step 10: Install the control panel 22-pin FFC \(M427/M426\)](#)
- [Step 11: Install the left cover](#)
- [Step 12: Install the cartridge door assembly](#)
- [Step 13: Install Tray 2](#)
- [Step 14: Install the control panel mount chassis assembly \(M427/M426\)](#)
- [Step 15: Install the control panel mount base \(M427/M426\)](#)
- [Step 16: Install the control panel \(M427/M426\)](#)
- [Step 17: Install the control panel mount cover \(M427/M426\)](#)

### Introduction


This document provides the procedures to remove and replace the M427/M426 control panel, control panel mount cover, control panel base, control panel mount chassis assembly, and the control panel 22-pin flat flexible cable (FFC).

### Before performing service

#### Turn the printer power off

- Disconnect the power cable.

---

 **WARNING!** To avoid damage to the printer, turn the printer off, wait 30 seconds, and then remove the power cable before attempting to service the printer.

---

Use the table below to identify the correct part number for your printer. To order the part, go to [www.hp.com/buy/parts](http://www.hp.com/buy/parts).

---

#### Control panel (M427/M426) part numbers

---

<b>B3Q10-60139</b>	Control panel (M427/M426; 76.2 mm (3.0 in))
<b>B3Q10-40056</b>	Cover, back control panel (M427/M426)
<b>B3Q11-40002</b>	Control panel mount cover (M427/M426)
<b>B3Q11-40001</b>	Control panel mount base (M427/M426)
<b>B3Q10-60145</b>	Control panel mount chassis (M427/M426)
<b>C5F98-60104</b>	Control panel 22-pin FFC (M427/M426)

**NOTE:** If the control panel is damaged, order the following parts and assemble them together.

- B3Q10-60139
  - B3Q10-40056
- 

#### Required tools

- #2 Phillips screwdriver with a magnetic tip.

#### After performing service

##### Turn the printer power on


- Connect the power cable.
- Use the power switch to turn the power on.

#### Post service test

Make sure that the printer initializes to a **Ready** state.

Navigate the control-panel menus to make sure that the control panel is correctly functioning.

---

 **TIP:** If the control panel is not functioning, check the FFC connections at the formatter and control panel. See [Step 10: Install the control panel 22-pin FFC \(M427/M426\) on page 1150](#) and [Step 16: Install the control panel \(M427/M426\) on page 1159](#).

---

#### Step 1: Remove the control panel mount cover (M427/M426)

1. Open the integrated scanner assembly (ISA).

---

 **NOTE:** If the control panel is not fully tilted forward, tilt it forward now until it stops.

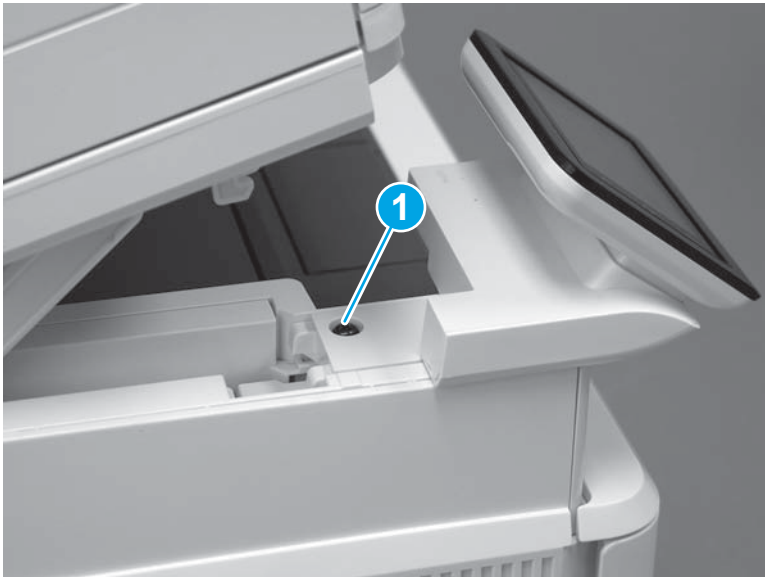
---

**Figure 1-2157** Open the ISA



2. Remove one screw (callout 1).

**Figure 1-2158** Remove one screw



3. Use a small flat-blade screwdriver to release two tabs (callout 1) on the control-panel cable cover.

**Figure 1-2159** Release two tabs



4. Rotate the control-panel cable cover up towards the control panel to release it, and then remove the cover.

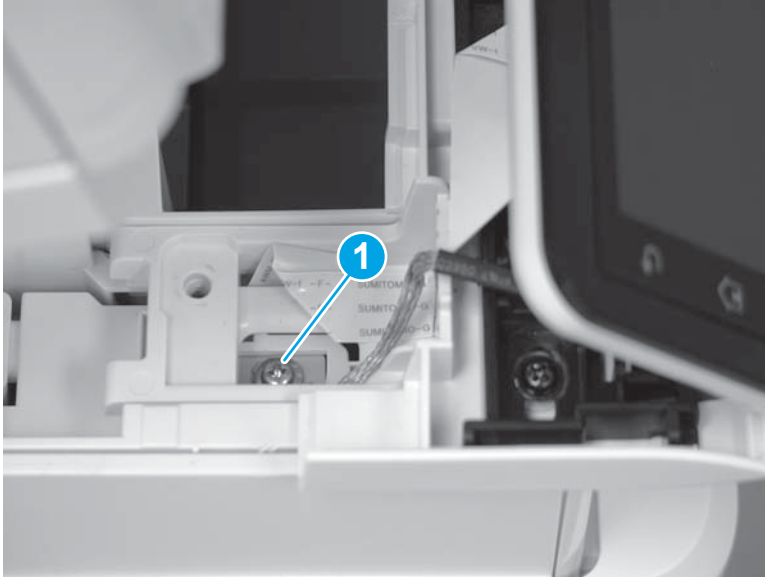
**Figure 1-2160** Remove the cover



### **Step 2: Remove the control panel (M427/M426)**

1. Remove one ground screw (callout 1).

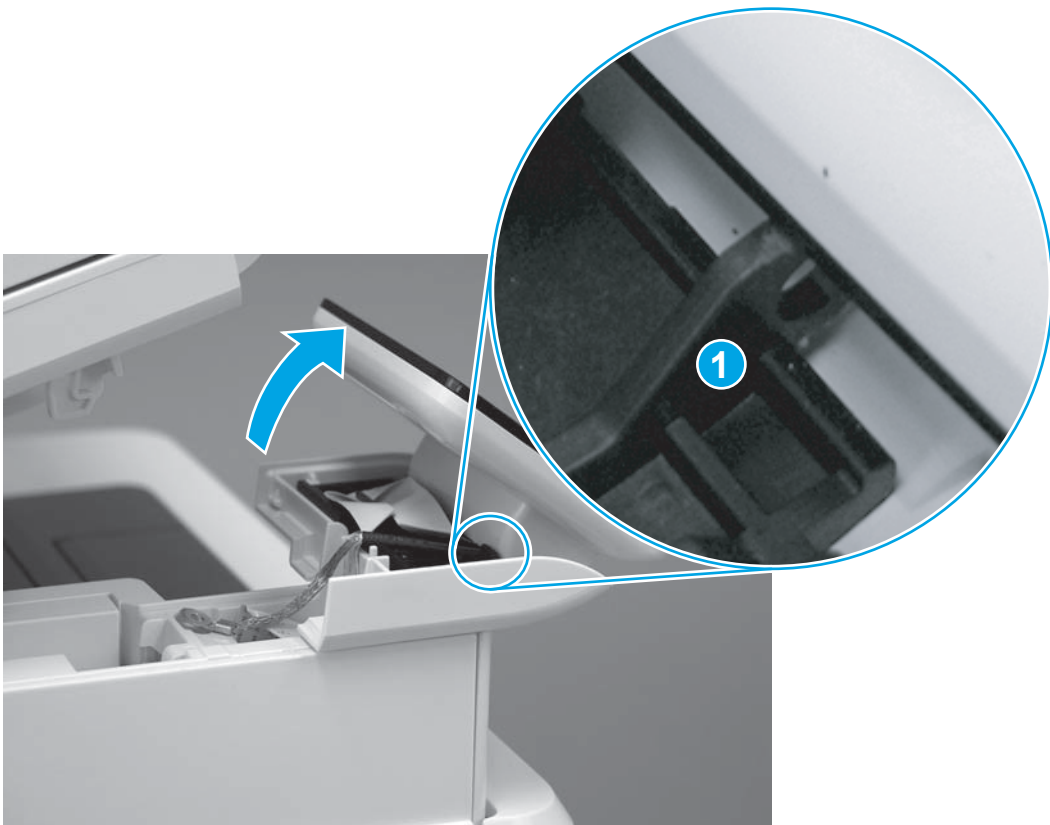
**Figure 1-2161** Remove one screw



2. Gently tilt the control panel farther forward about 3.18 mm (.125 in).

**⚠ CAUTION:** Do not use excessive force. The black-plastic mounting retainer (callout 1) for the control-panel hinge pin is easily broken

**Figure 1-2162** Tilt the control panel farther forward

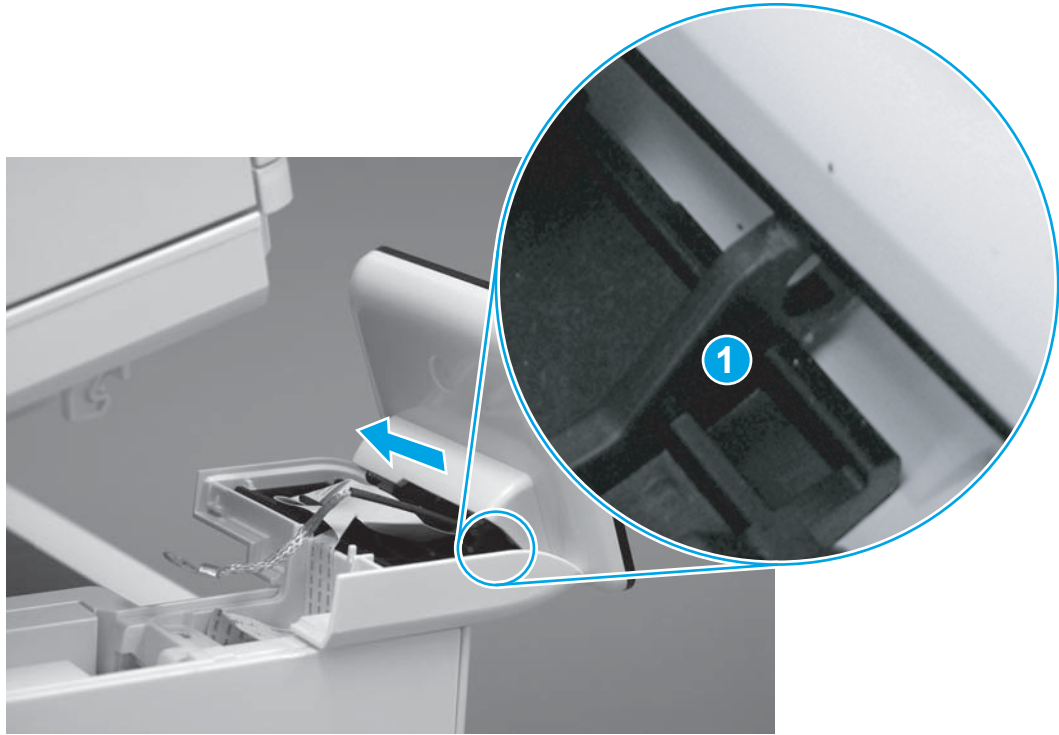




3. Slightly shift the control panel in the direction of the arrow about 6.35 mm (.25 in) to remove it.

**CAUTION:** Do not twist the control panel. The black-plastic mounting retainer (callout 1) for the control-panel hinge pin is easily broken

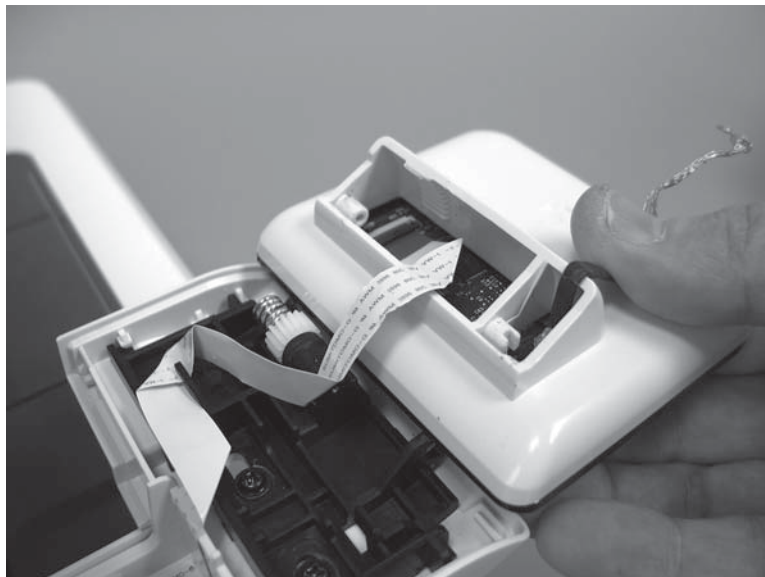
**Figure 1-2163** Release the control panel



4. Separate the control panel from the printer.

**CAUTION:** The control panel is still connected to the mounting printer by a FFC. Do not attempt to completely remove the control panel.

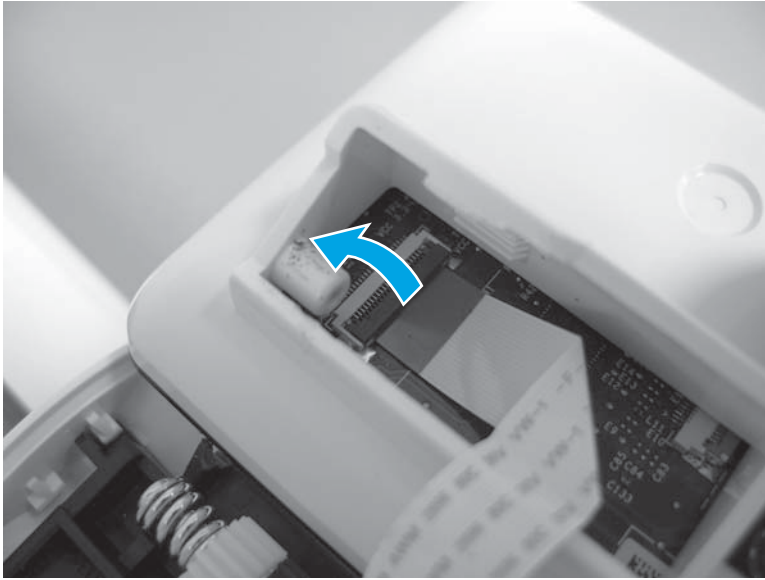
**Figure 1-2164** Separate the control panel from the printer



5. Open the hinged latch to release the FFC, and then remove the control panel.

**⚠ CAUTION:** Be careful. Do not dislodge the latch from the connector.

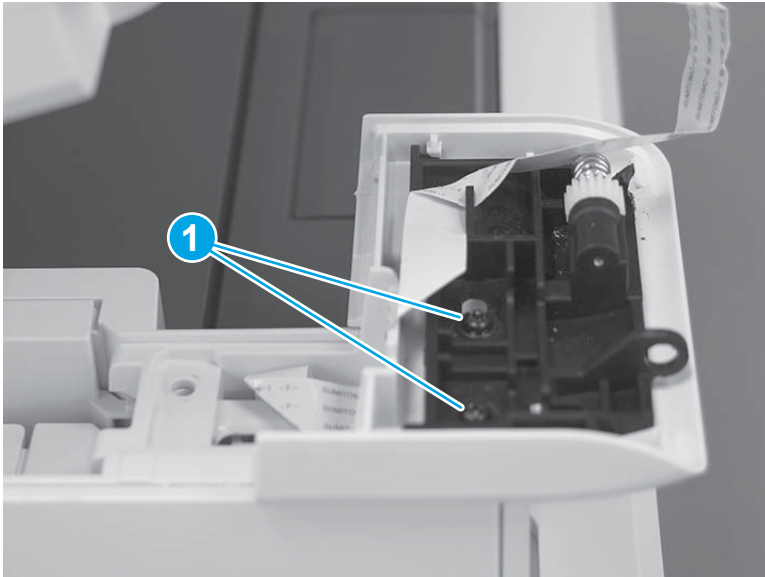
**Figure 1-2165** Release the FFC and remove the control panel



**Step 3: Remove the control panel mount base (M427/M426)**

1. Remove two screws (callout 1).

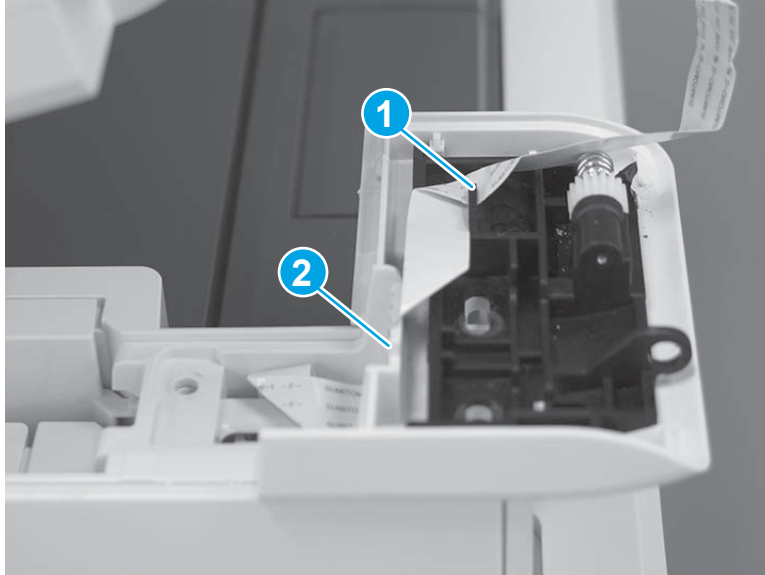
**Figure 1-2166** Remove two screws



2. Release the FFC from the retainer (callout 1), and then gently remove the FFC from mount base (callout 2).

**CAUTION:** The FFC is adhered to the mount base with two-sided tape (callout 2). Do not damage the FFC when removing it from the mount base.

**Figure 1-2167** Remove the FFC



3. Remove the control panel mount base.

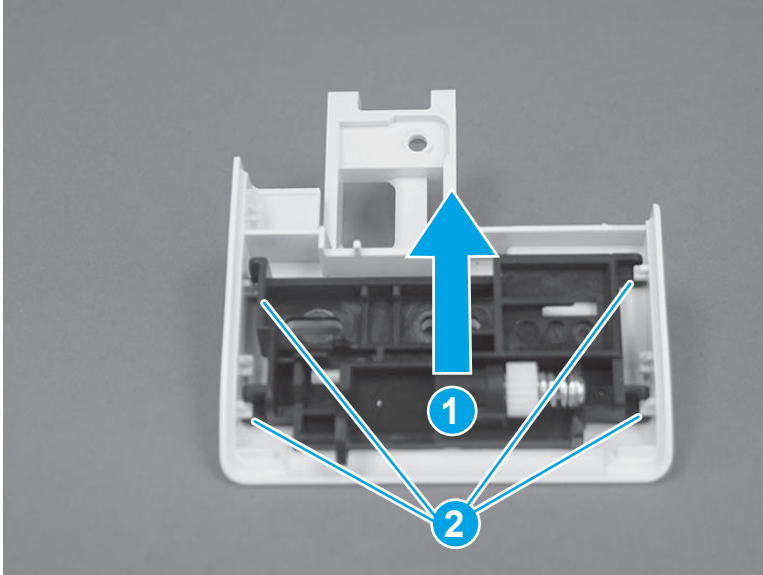
**Figure 1-2168** Release the control panel mount base



#### **Step 4: Remove the control panel mount chassis assembly (M427/M426)**

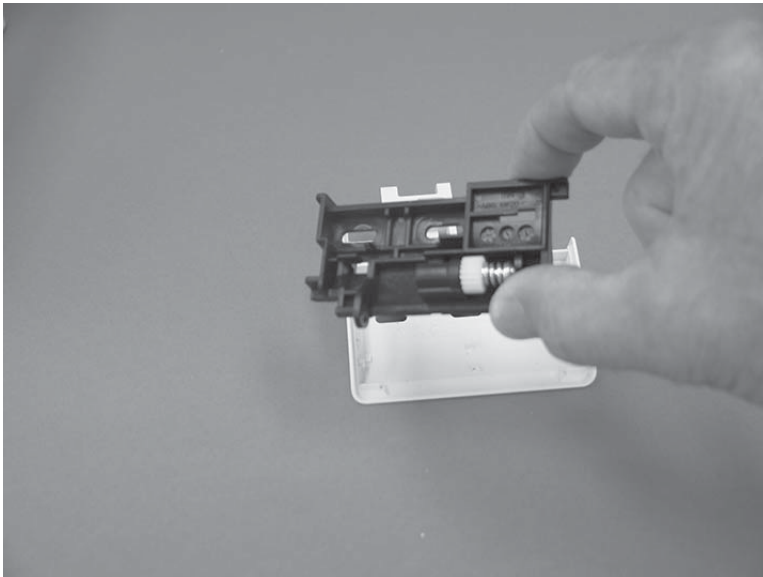
1. Slide the mount chassis assembly as shown (callout 1) to release it from four bosses (callout 2).

**Figure 1-2169** Release the mount chassis assembly



2. Separate the mount chassis assembly from the mount base.

**Figure 1-2170** Remove the mount chassis assembly



### Step 5: Remove Tray 2



**NOTE:** If the 22-pin control panel FFC does not need to be removed and replaced, skip this step and go to [Step 9: Unpack the replacement assembly on page 1149](#).

- ▲ Pull the tray straight out of the printer to remove it.

**Figure 1-2171** Remove the tray




**Step 6: Remove the cartridge door assembly**

---

 **NOTE:** If the 22-pin control panel FFC does not need to be removed and replaced, skip this step and go to [Step 9: Unpack the replacement assembly on page 1149](#).

---

 **NOTE:** If the toner cartridge was not removed prior to servicing the printer, remove it now.

---

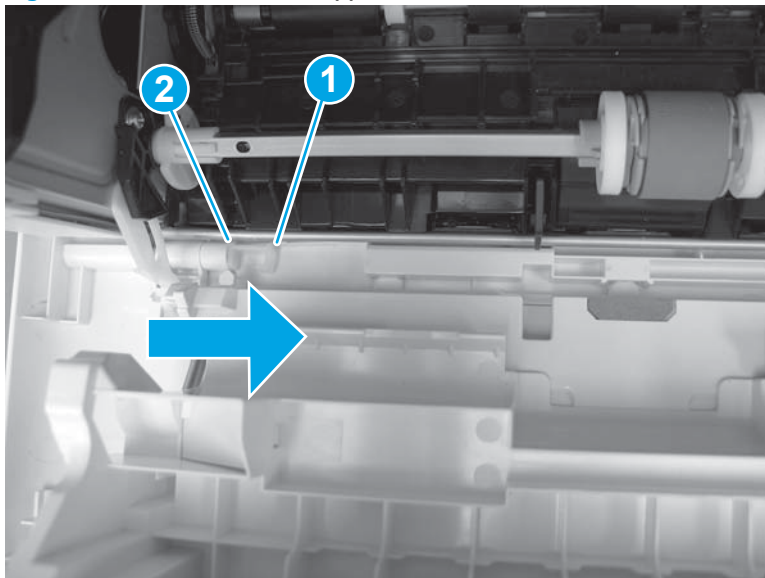
1. Release one tab (callout 1), and then slide shaft (callout 2) in the direction the arrow indicates and remove it.

---

 **TIP:** It might be easier to release the support shaft by using a small flat-blade screwdriver.

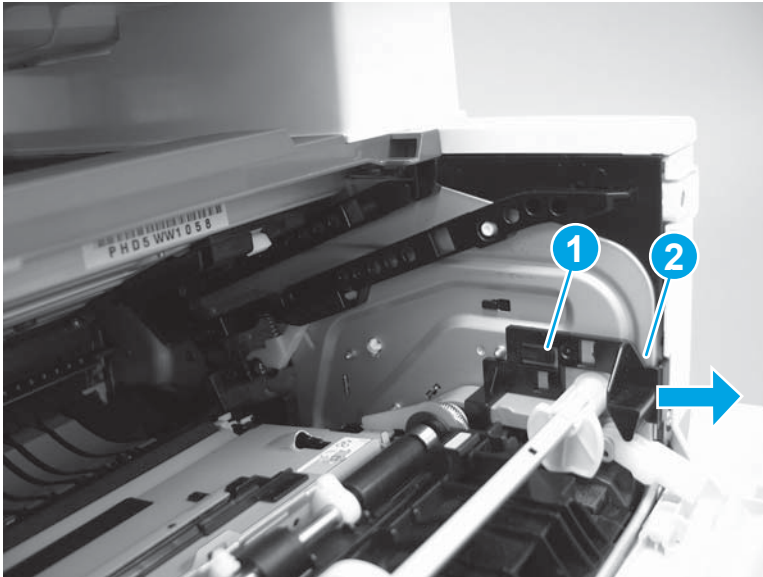
---

**Figure 1-2172** Release the support shaft



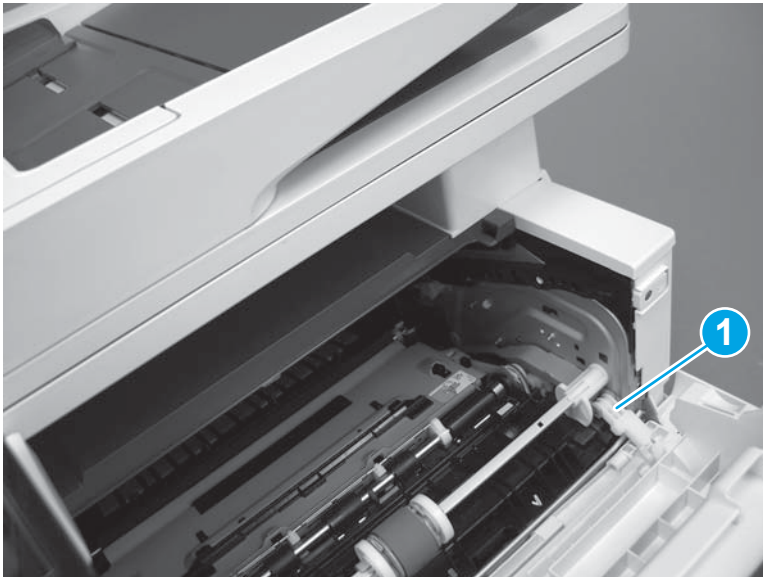
2. Release one tab (callout 1), and then slide the guide (callout 2) in the direction the arrow indicates and remove it.

**Figure 1-2173** Remove the guide



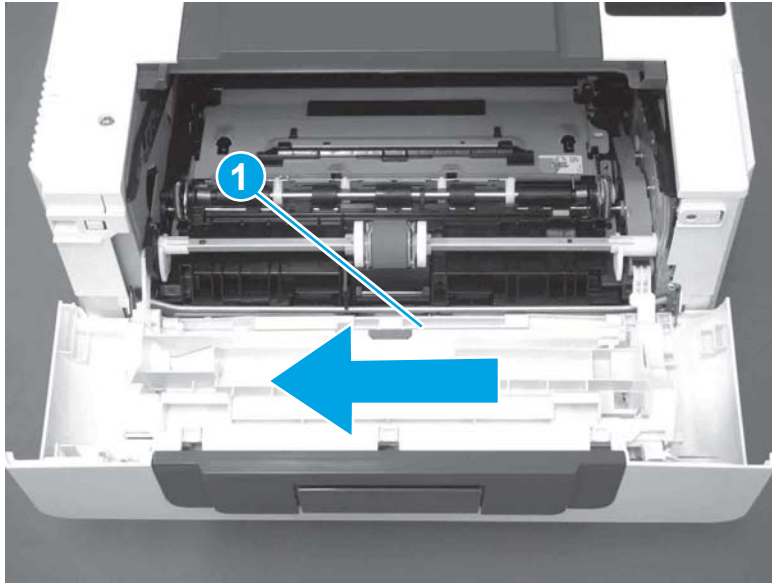
3. Remove the link arm (callout 1).

**Figure 1-2174** Remove the link arm



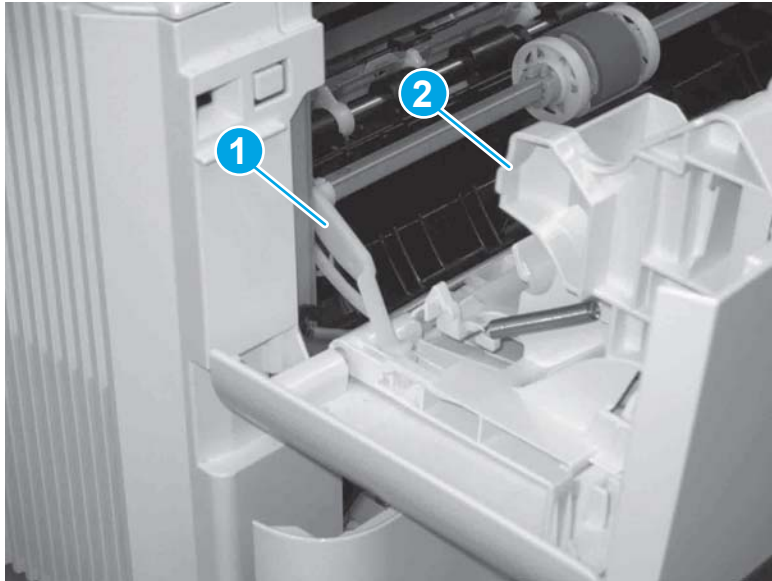
4. Slide the cartridge door assembly (callout 1) in the direction the arrow indicates and remove it.

**Figure 1-2175** Remove the door




5. Remove the link (callout 1) from the cartridge door assembly (callout 2).

**Figure 1-2176** Release the left-side retainer arm

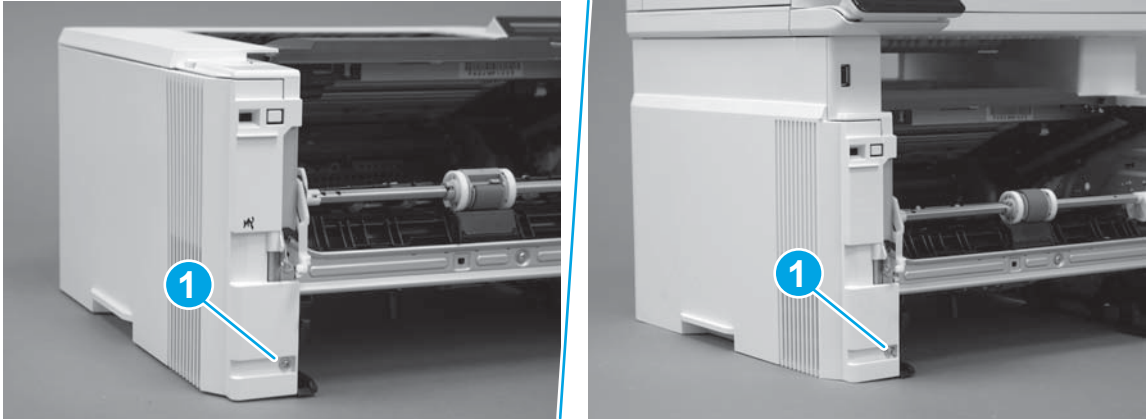


### Step 7: Remove the left cover

 **NOTE:** If the 22-pin control panel FFC does not need to be removed and replaced, skip this step and go to [Step 9: Unpack the replacement assembly on page 1149.](#)

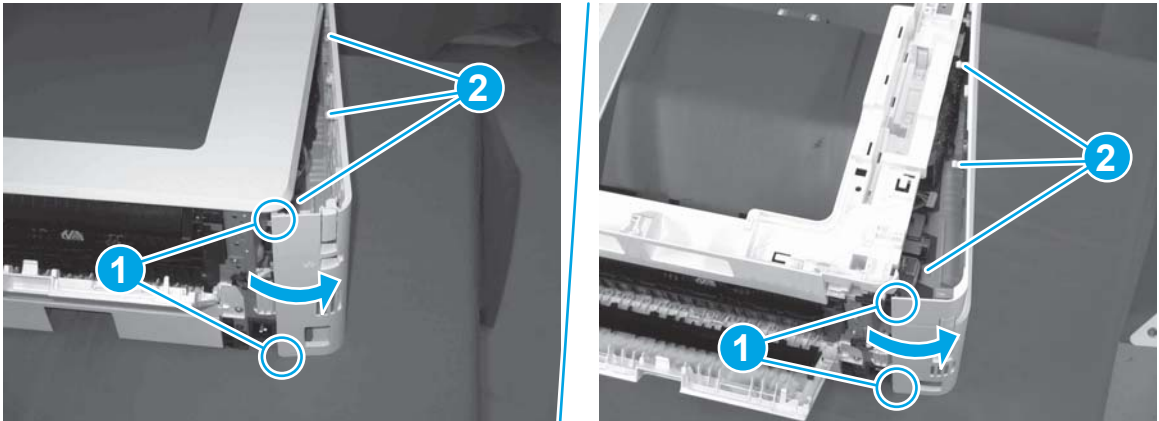
1. Remove one screw (callout 1).

**Figure 1-2177** Remove one screw



2. Open the rear door, release two bosses (callout 1), and then release three tabs (callout 2).

**Figure 1-2178** Release two bosses and three tabs

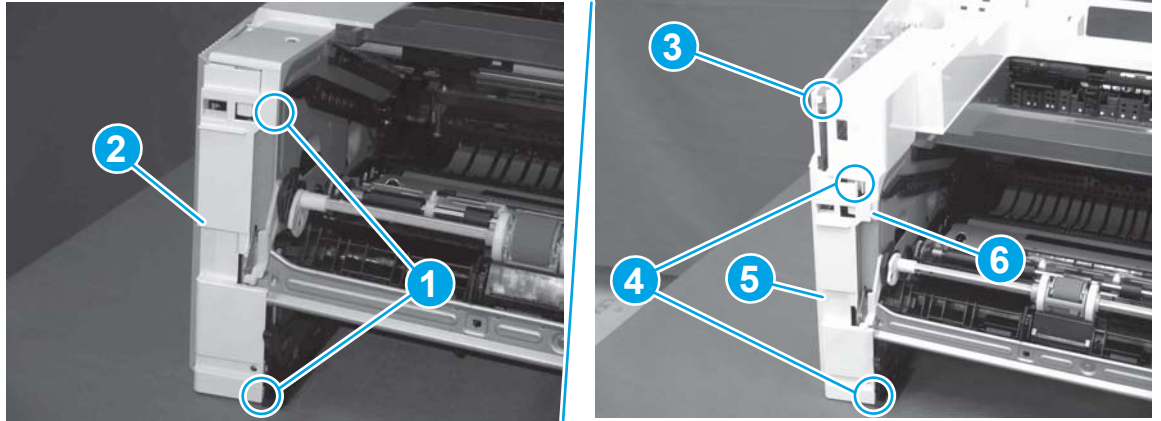


3. At the front of the printer, do one of the following:
  - **M403/M402:** Release two bosses (callout 1), and then remove the cover (callout 2).
  - **M427/M426:** Release one tab (callout 3), two bosses (callout 4), and then remove the cover (callout 5).


**CAUTION:** Be careful when releasing the upper bosses on the M427/M426 cover. One portion of the cover (callout 6) is fragile and is easily broken.



**Figure 1-2179** Remove the cover

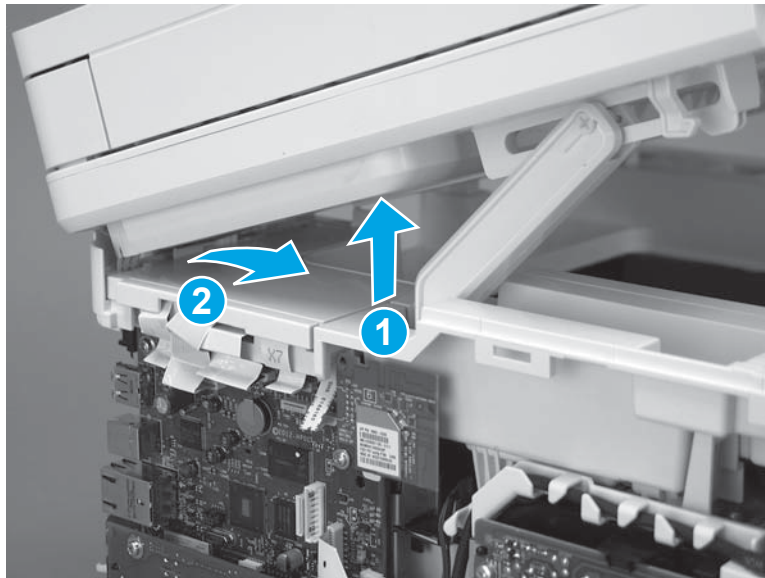


**Step 8: Remove the control panel 22-pin FFC (M427/M426)**

 **NOTE:** If the 22-pin control panel FFC does not need to be removed and replaced, skip this step and go to [Step 9: Unpack the replacement assembly on page 1149](#).

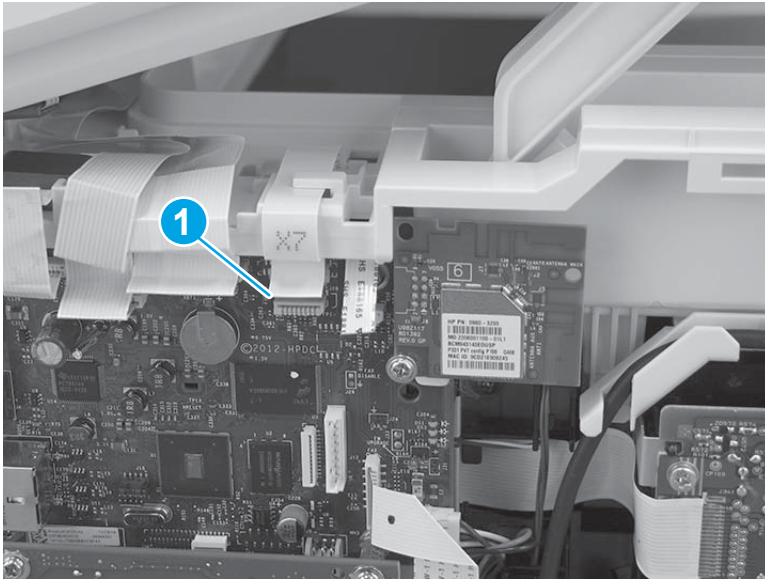
1. Release the ISA flat-flexible cable (FFC) cover (callout 1), and then remove it (callout 2).

**Figure 1-2180** Remove the ISA FFC cover



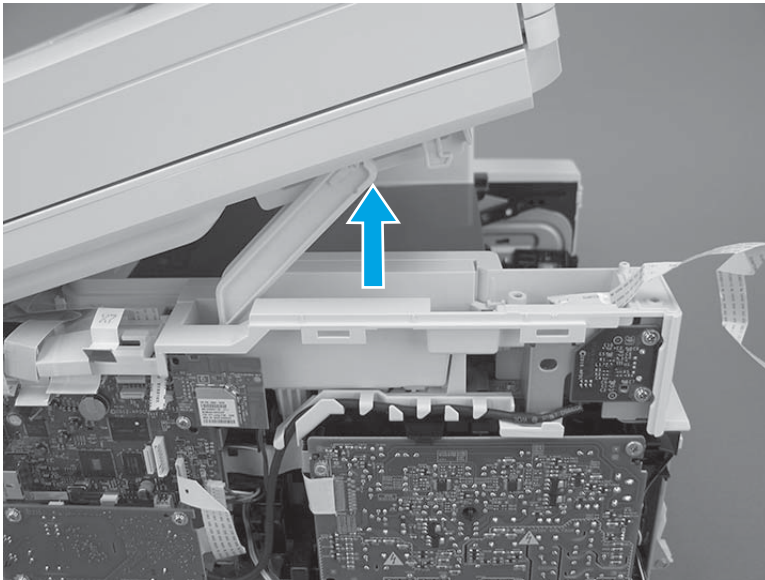
2. Disconnect one FFC (callout 1).

**Figure 1-2181** Disconnect one FFC



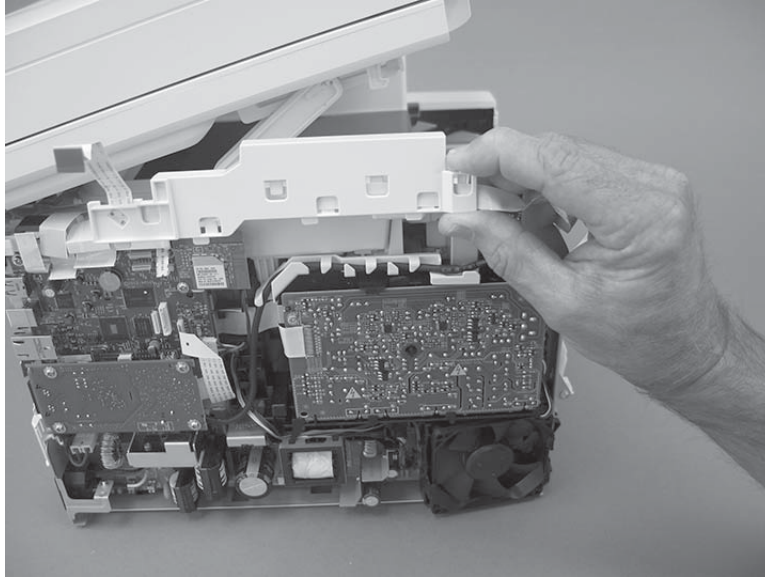
3. Lift up the control-panel FFC cover to release it.

**Figure 1-2182** Release the control-panel FFC cover




4. Remove the cover and FFC.

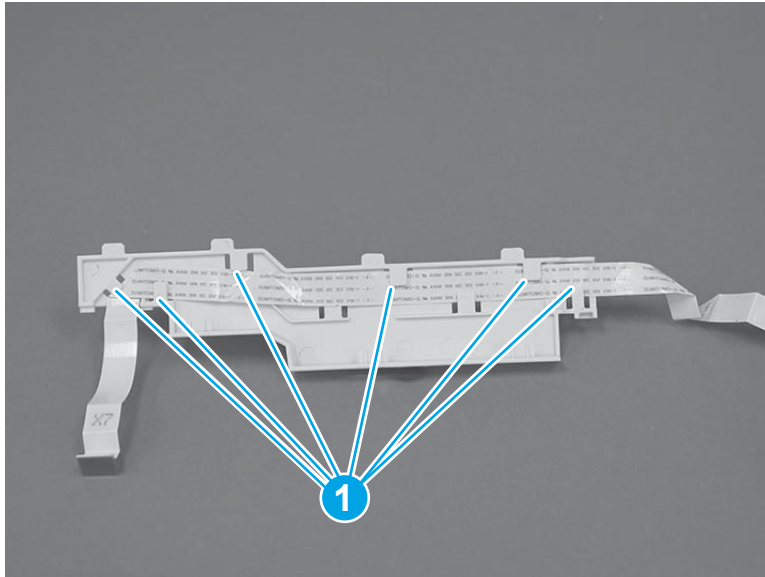
**Figure 1-2183** Remove the cover and FFC



5. Release the FFC from the retainers (callout 1) on the cover to remove it.

 **Reinstallation tip:** Take note of how the FFC is installed on the cover. Make sure that the replacement FFC is installed with the pre-folds in the FFC correctly positioned to reach the formatter and the control panel.

**Figure 1-2184** Remove the FFC



### Step 9: Unpack the replacement assembly

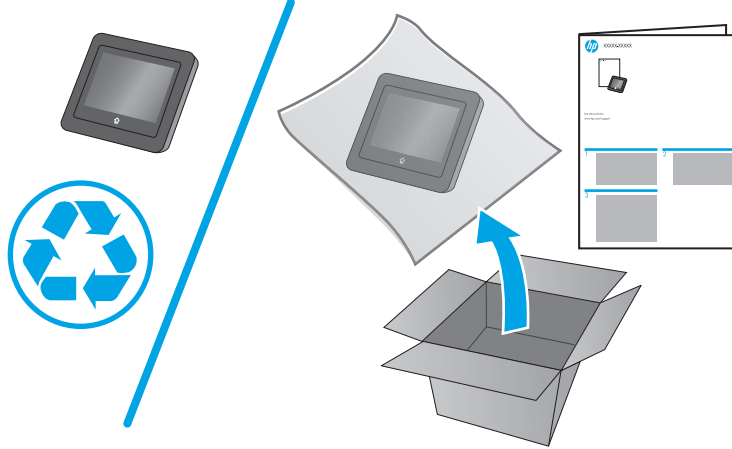
Unpack the replacement part from the packaging.

 **NOTE:** Unpack the appropriate assembly that is being replaced. The control panel is shown below.

<http://www8.hp.com/us/en/hp-information/environment/product-recycling.html>

 **NOTE:** HP recommends responsible disposal of the defective part.


**Figure 1-2185** Recycle and unpack



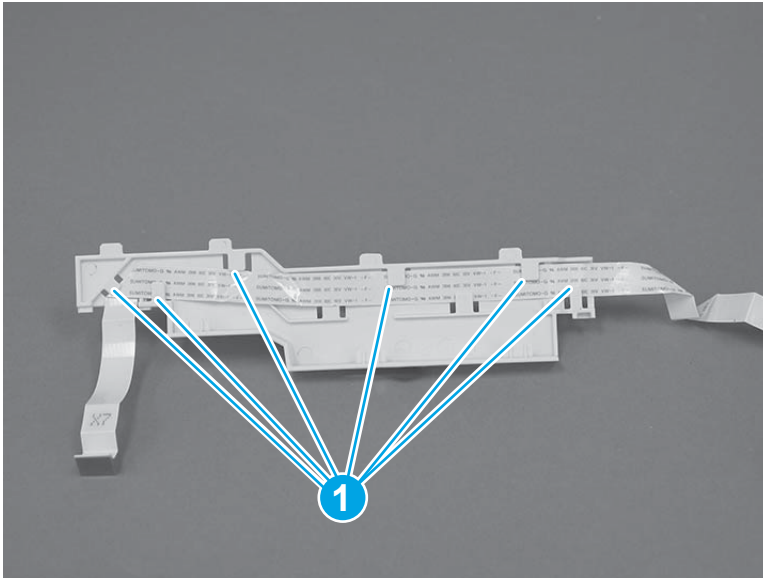
### Step 10: Install the control panel 22-pin FFC (M427/M426)

 **NOTE:** If the 22-pin control panel FFC does not need to be removed and replaced, skip this step and go to [Step 14: Install the control panel mount chassis assembly \(M427/M426\) on page 1157.](#)

1. Install the FFC in the retainers (callout 1) on the control-panel FFC.

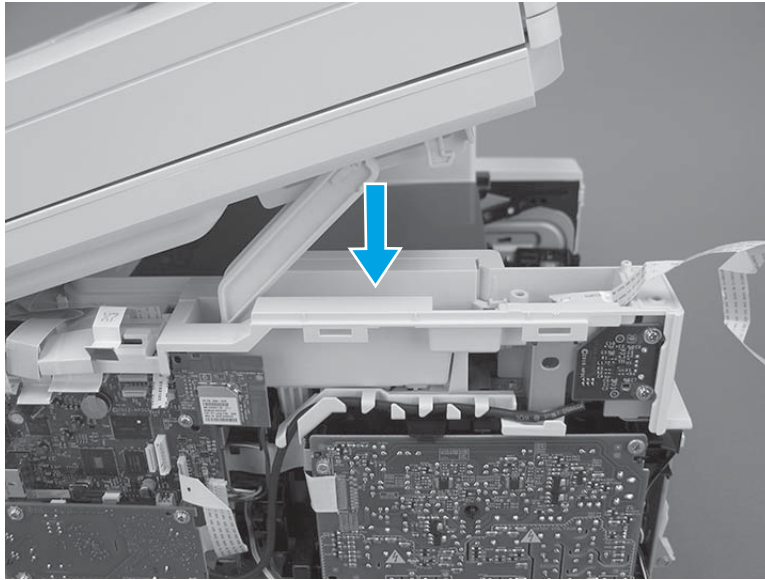
 **Reinstallation tip:** Make sure that the replacement FFC is installed with the pre-folds in the FFC correctly positioned to reach the formatter and the control panel.

**Figure 1-2186** Install the FFC on the cover



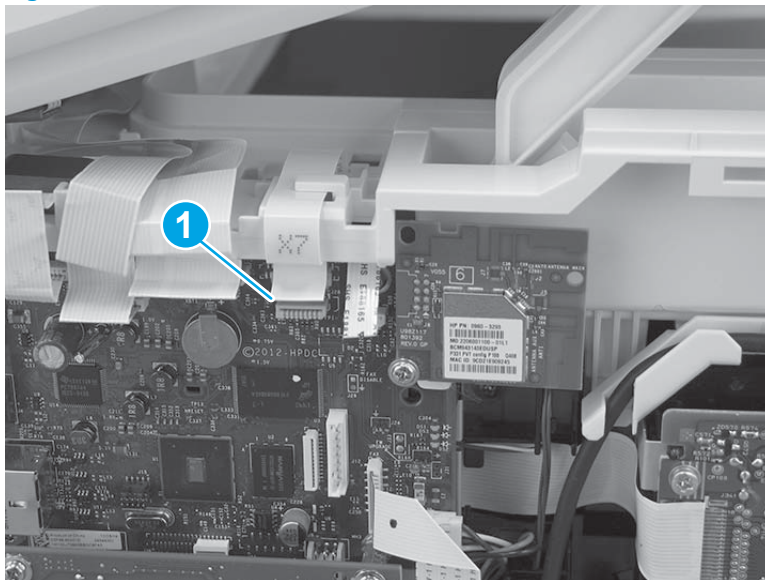
2. Position the cover on the printer, and then push down to install it.

**Figure 1-2187** Install the cover



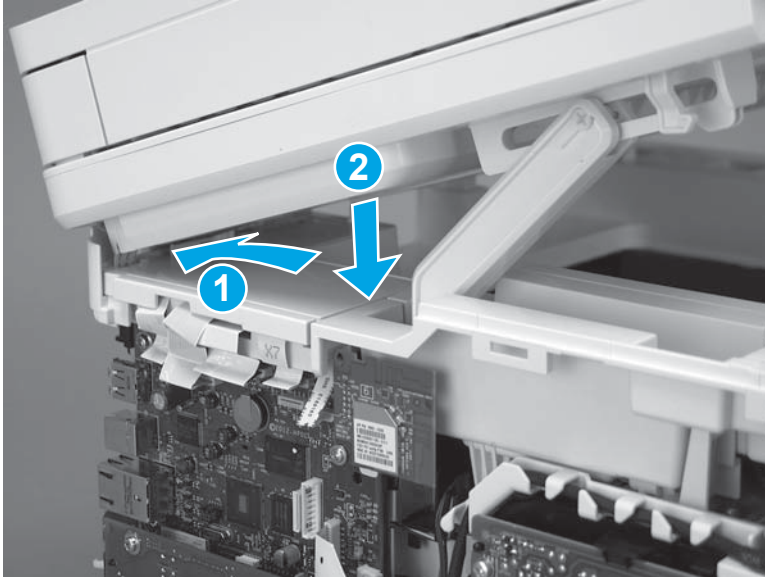
3. Connect one FFC (callout 1).

**Figure 1-2188** Connect one FFC



4. Position the rear edge of the ISA flat-flexible cable (FFC) cover on the printer (callout 1), and then rotate it down (callout 2) until it snaps into place.

**Figure 1-2189** Install the ISA FFC cover

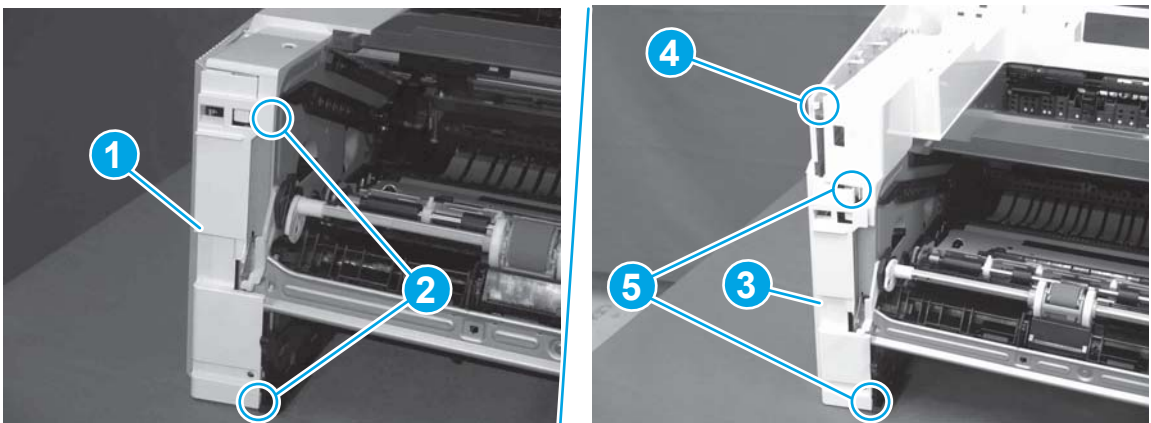


### Step 11: Install the left cover

 **NOTE:** If the 22-pin control panel FFC was not replaced, skip this step and go to [Step 14: Install the control panel mount chassis assembly \(M427/M426\) on page 1157](#).

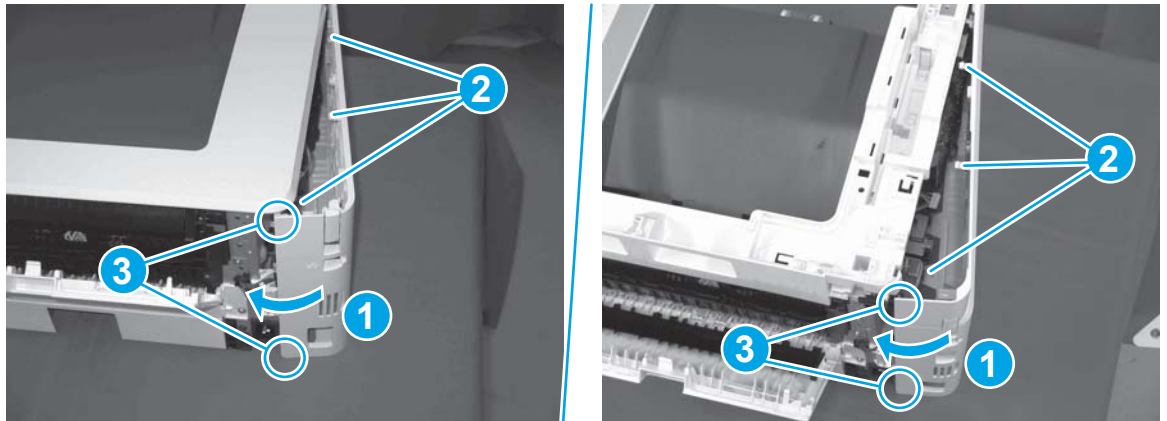
1. At the front of the printer, do one of the following:
  - **M403/M402:** Position the cover on the printer (callout 1), and then engage two bosses (callout 2).
  - **M427/M426:** Position the cover on the printer (callout 3), engage one tab (callout 4), and then engage two bosses (callout 5).

**Figure 1-2190** Install the cover



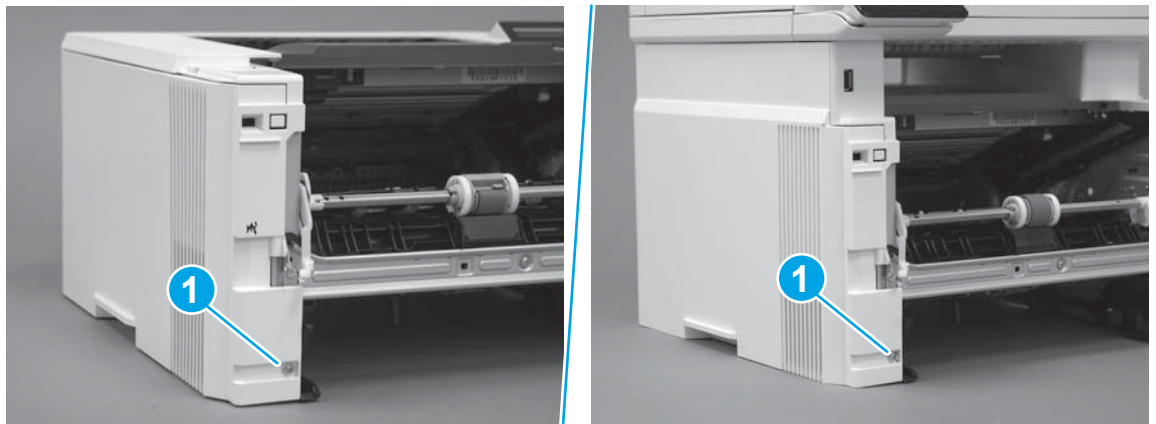
- Carefully rotate the rear of the cover onto the printer (callout 1), engage three tabs (callout 2), and then engage two bosses (callout 3).

**Figure 1-2191** Engage three tabs and two bosses




- Install one screw (callout 1).

**Figure 1-2192** Install one screw



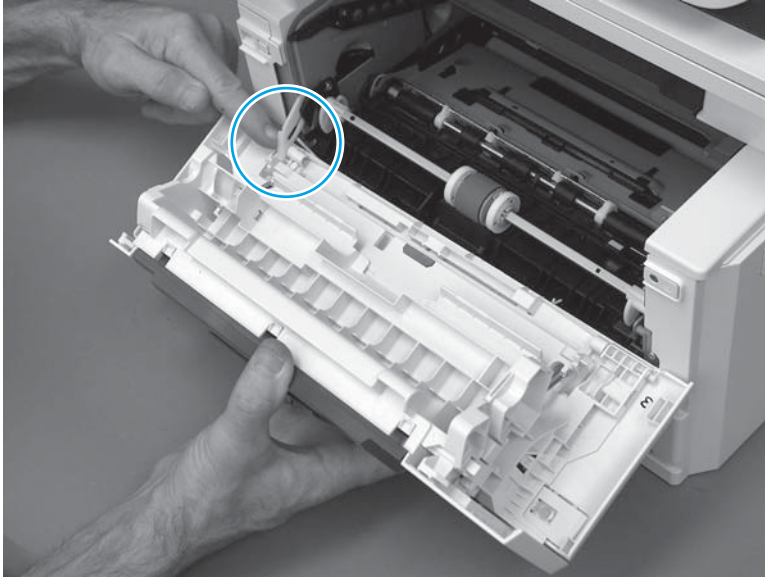
## Step 12: Install the cartridge door assembly

 **NOTE:** If the 22-pin control panel FFC was not replaced, skip this step and go to [Step 14: Install the control panel mount chassis assembly \(M427/M426\)](#) on page 1157.

 **Reinstallation tip:** After a replacement door is installed, make sure to install the nameplate (supplied in the kit) corresponding to the printer name on the door.

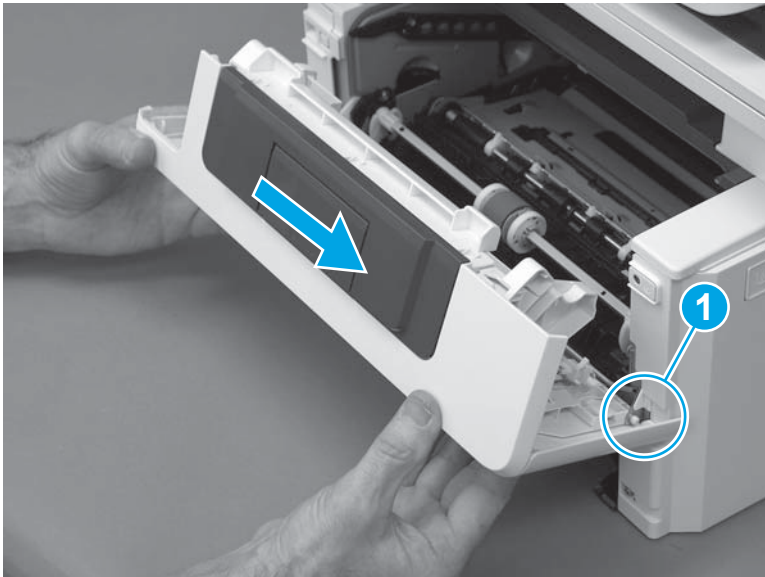
- Position the door close to the printer, and then engage the keyed pin on the left-side retainer arm with the hole in the door.

**Figure 1-2193** Engage the left-side retainer arm



2. Engage the right-side door hinge pin with the hole in the chassis (callout 1).

**Figure 1-2194** Install the door

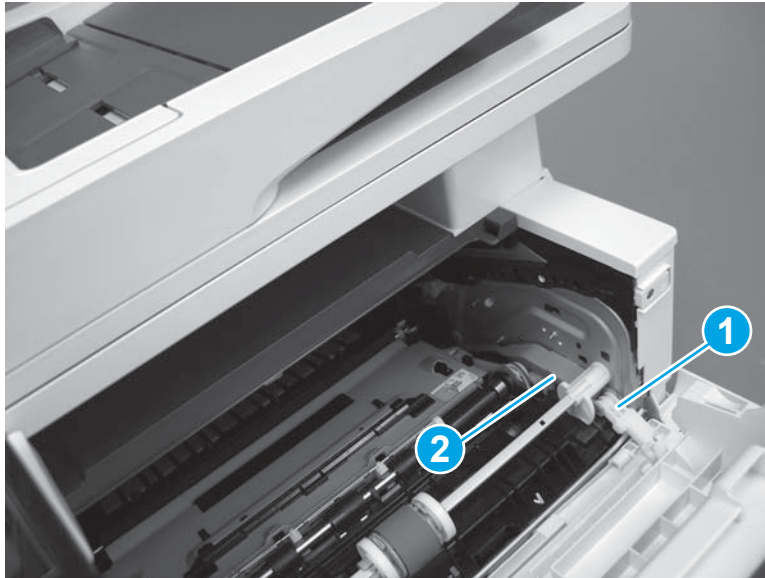




3. Install the link (callout 1).

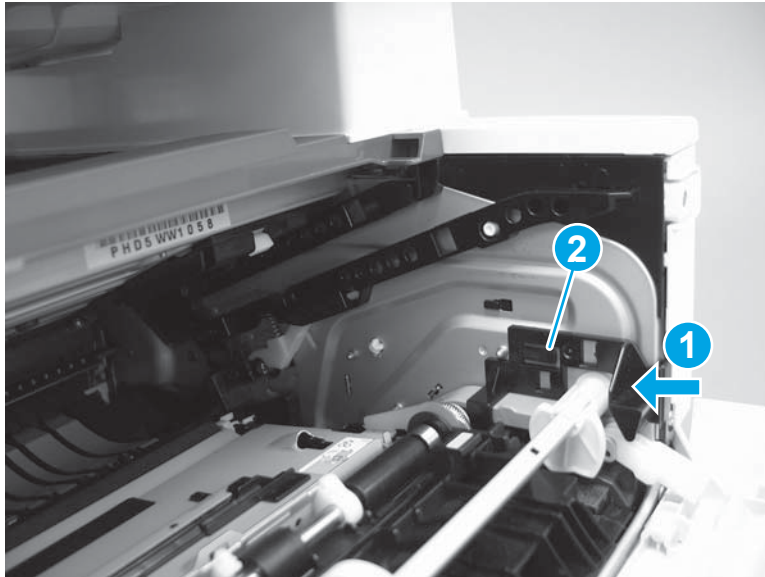
 **IMPORTANT:** Make sure that the link snaps into place on the arm (callout 2). The link actuates the fuser pressure-release mechanism.

**Figure 1-2195** Install the pressure-release link



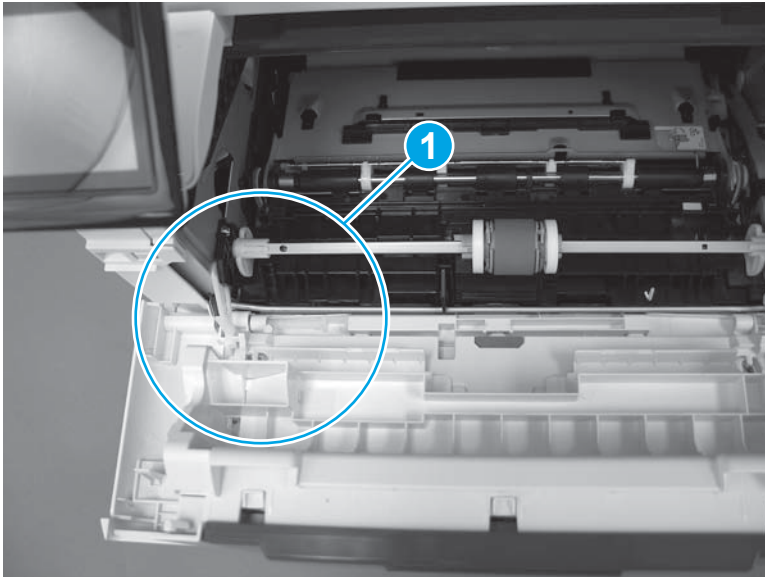
4. Slide the guide into the printer (callout 1), and then make sure that the tab (callout 2) snaps into place to secure the guide to the chassis.

**Figure 1-2196** Install the guide




5. Position the shaft on the door, and then align the left-side hinge on the door with the hole in the chassis (callout 1).

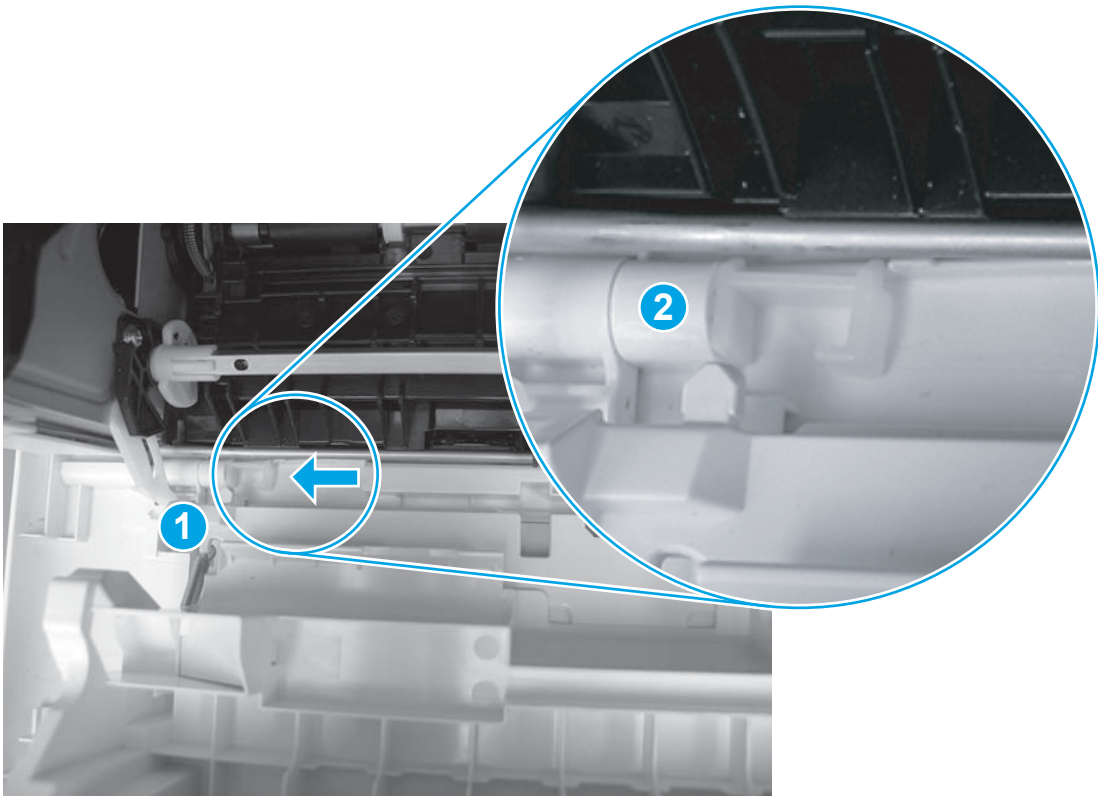
**Figure 1-2197** Align the hinge



6. Push the shaft towards the left side of the printer to install it (callout 1).

 **Reinstallation tip:** Make sure that the support shaft is fully installed and correctly orientated (callout 2) so that it will not interfere with the door opening and closing.

**Figure 1-2198** Install the support shaft



### Step 13: Install Tray 2

 **NOTE:** If the 22-pin control panel FFC was not replaced, skip this step and go to [Step 14: Install the control panel mount chassis assembly \(M427/M426\) on page 1157](#).

- ▲ Slide the tray straight into the printer to install it.

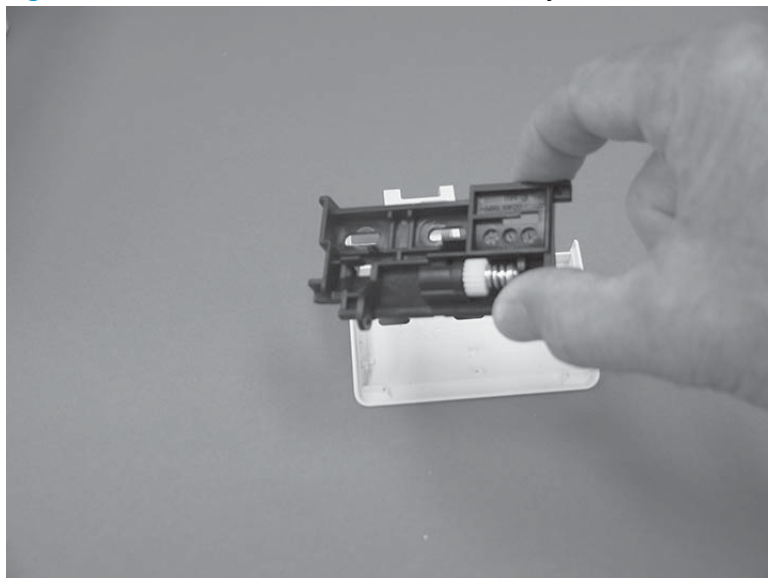
**Figure 1-2199** Install the tray



### Step 14: Install the control panel mount chassis assembly (M427/M426)

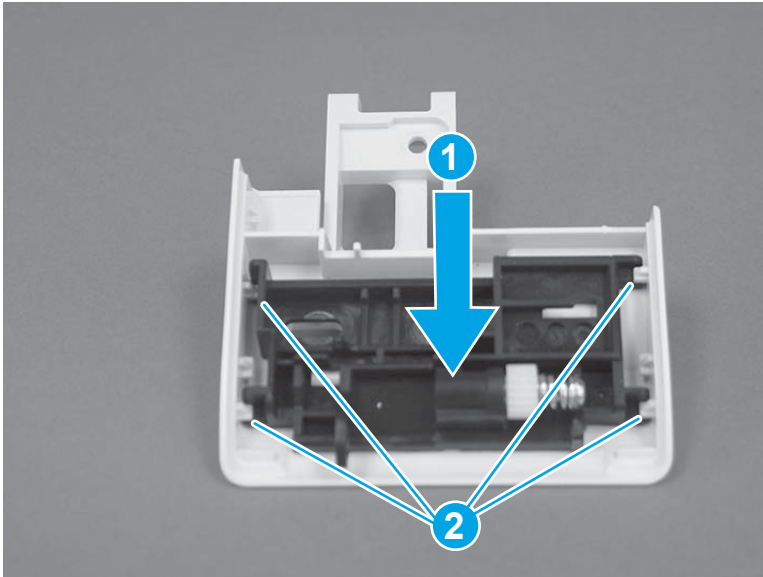
1. Position the mount chassis assembly on the mount base.

**Figure 1-2200** Install the mount chassis assembly



2. Slide the mount chassis assembly as shown (callout 1) to engage it with four bosses (callout 2) on the mount base.

**Figure 1-2201** Release the mount chassis assembly



**Step 15: Install the control panel mount base (M427/M426)**

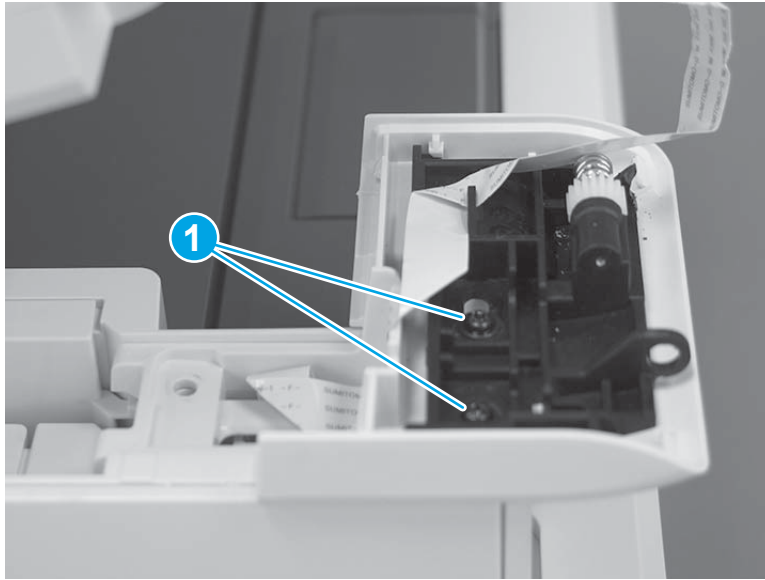
1. Install the control panel mount base on the printer.

**Figure 1-2202** Install the control panel mount base




2. Install two screws (callout 1).

**Figure 1-2203** Install two screws

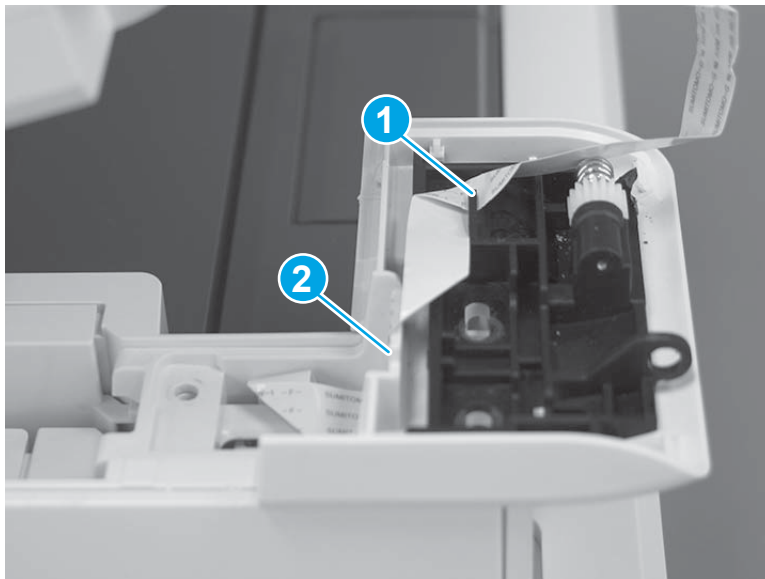


3. Install the FFC in the retainer (callout 1).

 **NOTE:** Remove the protective film from the two-sided tape on the replacement FFC to expose the sticky side of the tape.

Make sure to press the FFC against the mount base (callout 2) to adhere it to the mount base.


**Figure 1-2204** Install the FFC



### Step 16: Install the control panel (M427/M426)

1. Insert the FFC in the connector (the contact portion of the FFC must face towards the PCA), and then close the latch to secure it.

 **CAUTION:** Be careful. Do not dislodge the latch from the connector.

 **Reinstallation tip:** Gently pull on the FFC to make sure it is fully seated and secured by the latch on the connector. Do not forcibly pull on the FFC, a gentle tug is all that is required.

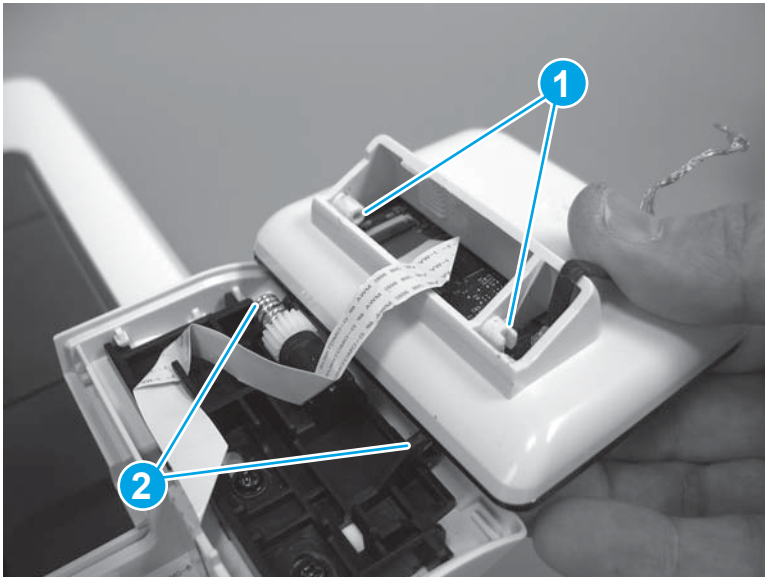
---

**Figure 1-2205** Connect the FFC



2. Align the control-panel hinge pins (callout 1) with the mounting retainers (callout 2) on the printer.

**Figure 1-2206** Align the control-panel hinge pins



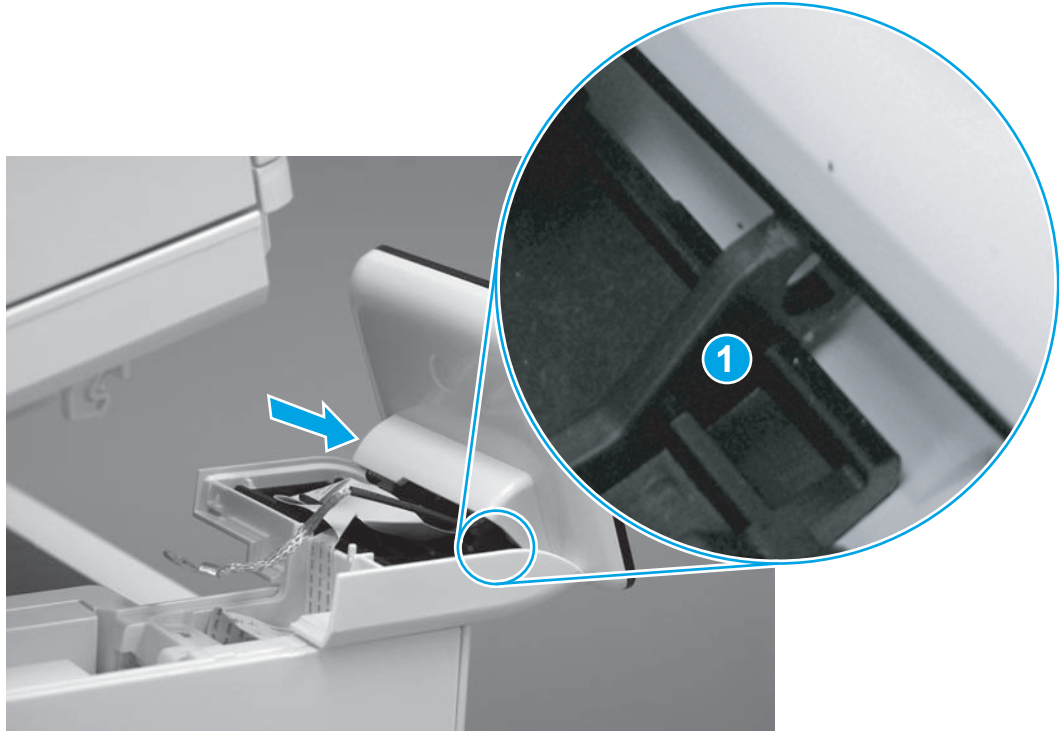
3. Slightly shift the control panel in the direction of the arrow about 6.35 mm (.25 in) to engage the hinge pins.

---

**⚠ CAUTION:** Do not twist the control panel. The black-plastic mounting retainer (callout 1) for the control-panel hinge pin is easily broken

---

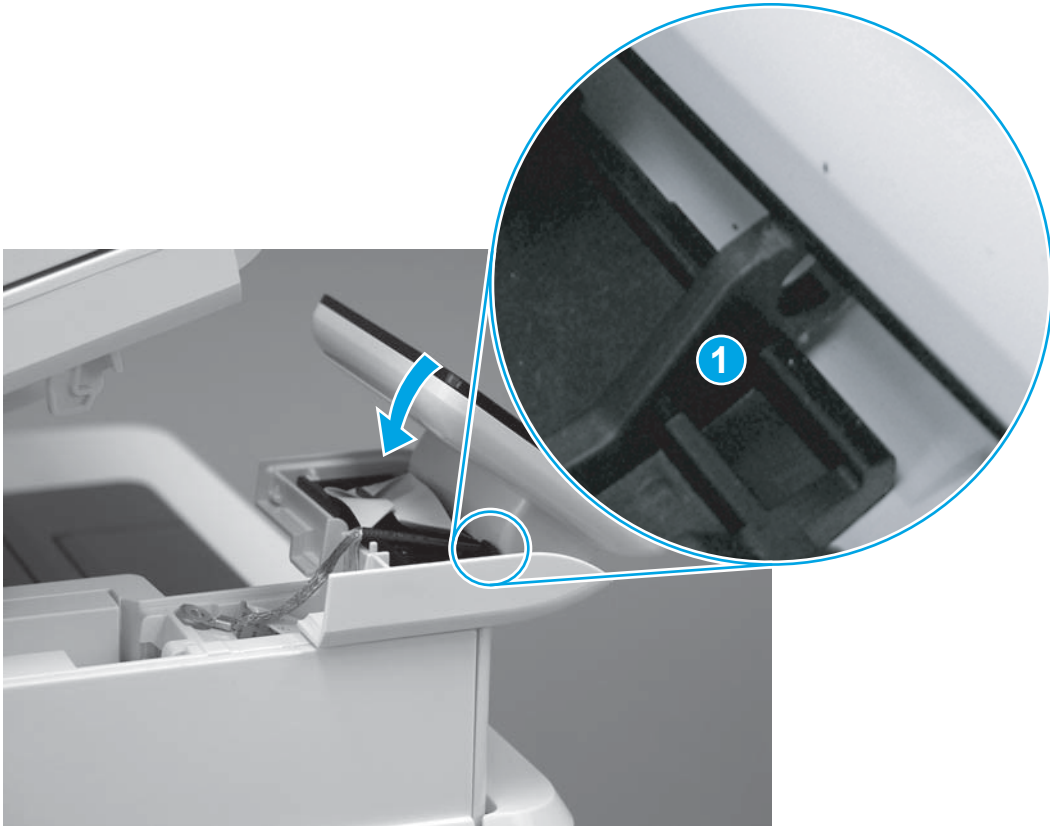
**Figure 1-2207** Engage the control panel



4. With the hinge pins engaged, gently tilt the control panel backward about 3.18 mm (.125 in).

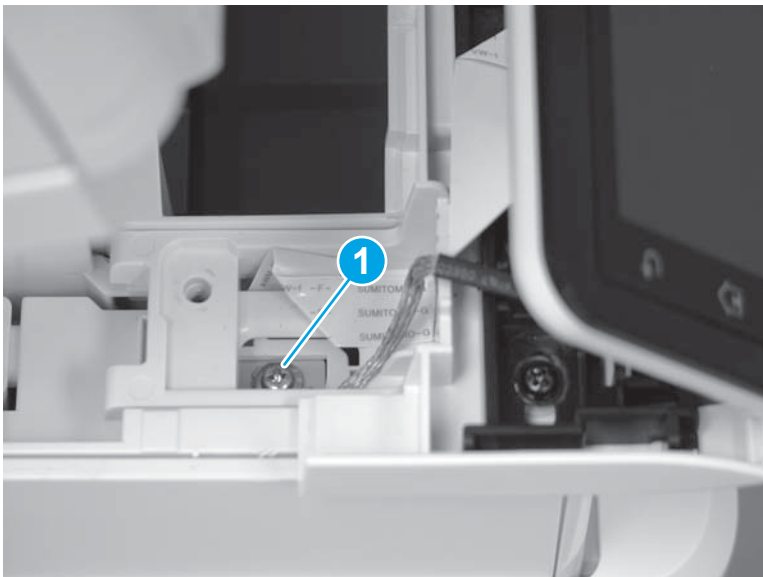
**⚠ CAUTION:** Do not use excessive force. The black-plastic mounting retainer (callout 1) for the control-panel hinge pin is easily broken

**Figure 1-2208** Tilt the control-panel assembly backward



5. Install one ground screw (callout 1).

**Figure 1-2209** Install one screw





### Step 17: Install the control panel mount cover (M427/M426)

1. Position the front edge of the control-panel cable cover at the base of the control panel (callout 1), and then rotate it down to install it (callout 2).

**Figure 1-2210** Install the control-panel cable cover



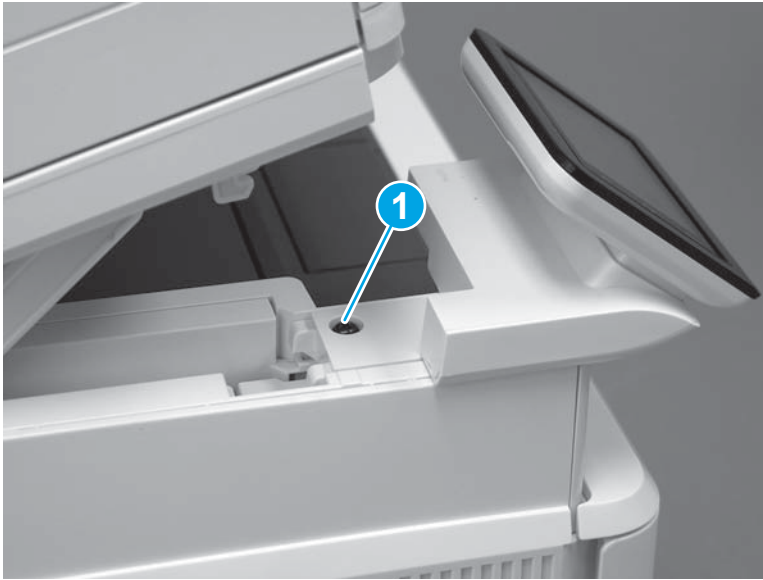
2. Make sure that the two tabs (callout 1) on the cover snap into place.

**Figure 1-2211** Check two tabs



3. Install one screw (callout 1).

**Figure 1-2212** Install one screw



4. Close the ISA.

**Figure 1-2213** Close the ISA



## Removal and replacement: Trays

- [Removal and replacement: Tray 2](#)

### Removal and replacement: Tray 2

- [RM2-5392-000CN 250-sheet paper input tray](#)
- [RM2-5452-000CN Tray 2 paper pickup roller assembly](#)
- [RM2-5397-000CN Tray 2 separation roller assembly](#)

## RM2-5392-000CN 250-sheet paper input tray

- [Introduction](#)
- [Step 1: Remove Tray 2](#)
- [Step 2: Unpack the replacement assembly](#)
- [Step 3: Install Tray 2](#)

### Introduction


This document provides the procedures to remove and replace Tray 2.

### Before performing service

#### Turn the printer power off

- Disconnect the power cable.

---

 **WARNING!** To avoid damage to the printer, turn the printer off, wait 30 seconds, and then remove the power cable before attempting to service the printer.

---

Use the table below to identify the correct part number for your printer. To order the part, go to [www.hp.com/buy/parts](http://www.hp.com/buy/parts).

---

Tray 2 part number	
RM2-5392-000CN	Cassette (Tray 2) assembly

---

### Required tools

- No special tools are required to remove this part.

### After performing service

#### Turn the printer power on

- Connect the power cable.
- Use the power switch to turn the power on.

### Post service test

Make sure that the printer initializes to a **Ready** state.

Print a configuration page (from Tray 2) to make sure that the printer is functioning correctly.

### Step 1: Remove Tray 2

- ▲ Pull the tray straight out of the printer to remove it.

**Figure 1-2214** Remove the tray



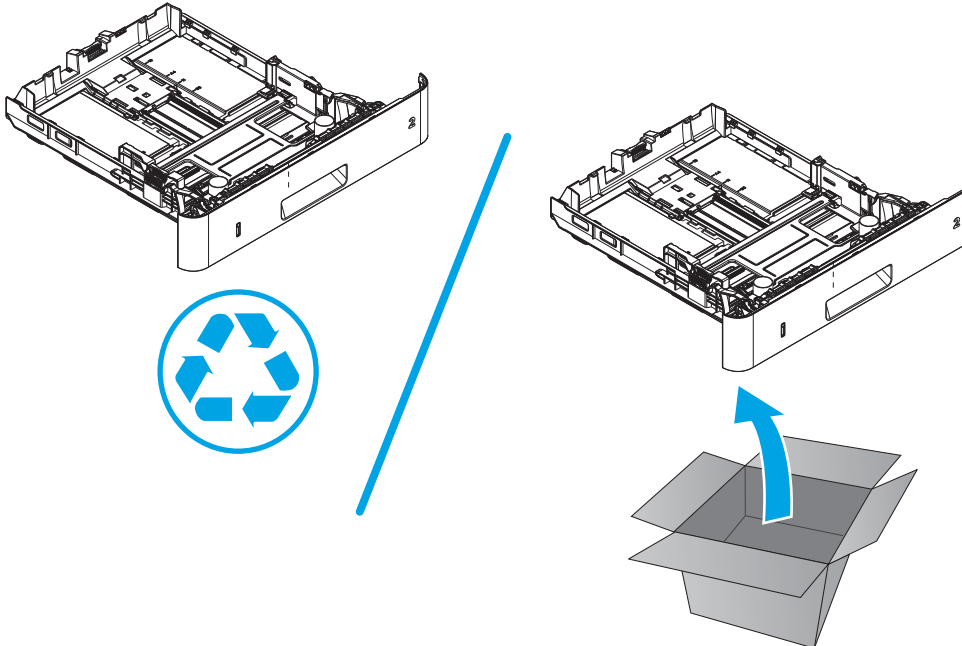
**Step 2: Unpack the replacement assembly**

Unpack the replacement part from the packaging.

<http://www8.hp.com/us/en/hp-information/environment/product-recycling.html>

 **NOTE:** HP recommends responsible disposal of the defective part.

**Figure 1-2215** Recycle and unpack



**Step 3: Install Tray 2**

- ▲ Slide the tray straight into the printer to install it.

**Figure 1-2216** Install the tray



### RM2-5452-000CN Tray 2 paper pickup roller assembly

- [Introduction](#)
- [Step 1: Remove Tray 2](#)
- [Step 2: Remove the pickup roller assembly \(Tray 2\)](#)
- [Step 3: Unpack the replacement assembly](#)
- [Step 4: Install the pickup roller assembly \(Tray 2\)](#)
- [Step 5: Install Tray 2](#)

### Introduction

This document provides the procedures to remove and replace the paper pickup roller assembly (Tray 2).

### Before performing service

#### Turn the printer power off

- Disconnect the power cable.

**⚠ WARNING!** To avoid damage to the printer, turn the printer off, wait 30 seconds, and then remove the power cable before attempting to service the printer.

Use the table below to identify the correct part number for your printer. To order the part, go to [www.hp.com/buy/parts](http://www.hp.com/buy/parts).

Paper pickup roller assembly (Tray 2) part number	
RM2-5452-000CN	Paper pickup roller assembly (Tray 2)

## Required tools

- No special tools are required to remove this part.

## After performing service

### Turn the printer power on

- Connect the power cable.
- Use the power switch to turn the power on.

### Post service test

Make sure that the printer initializes to a **Ready** state.

Print a page from Tray 2 to make sure that the printer is functioning correctly.

### Step 1: Remove Tray 2

- ▲ Pull the tray straight out of the printer to remove it.

**Figure 1-2217** Remove the tray



### Step 2: Remove the pickup roller assembly (Tray 2)

---

**CAUTION:** When handling the roller holder, do not touch the gray spongy portion of the rollers. Skin oils on the rollers can cause paper handling problems.

**NOTE:** The M403/M402 printer is shown in this procedure. However, the procedure is valid for the M427/M426 printers.

---

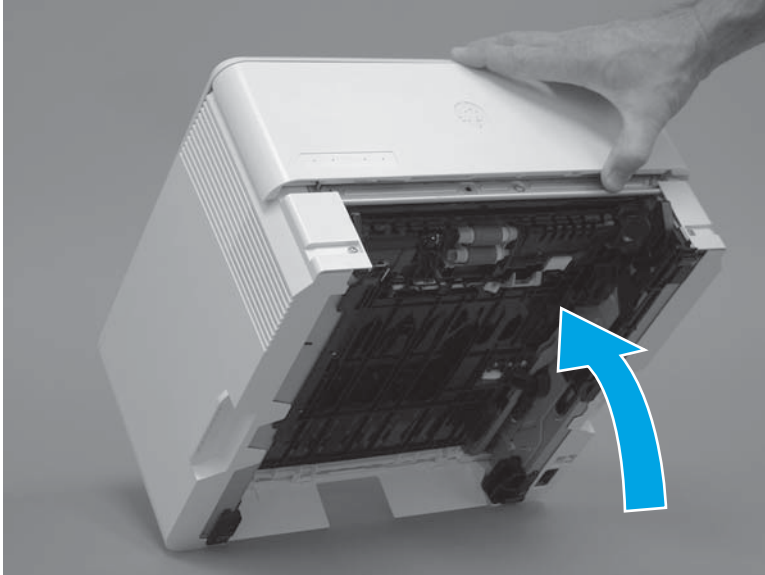
1. Carefully rotate the printer backward.

---

**CAUTION:** To avoid damage to the rear cassette cover, keep it in the closed position.

---

**Figure 1-2218** Tilt the printer backward



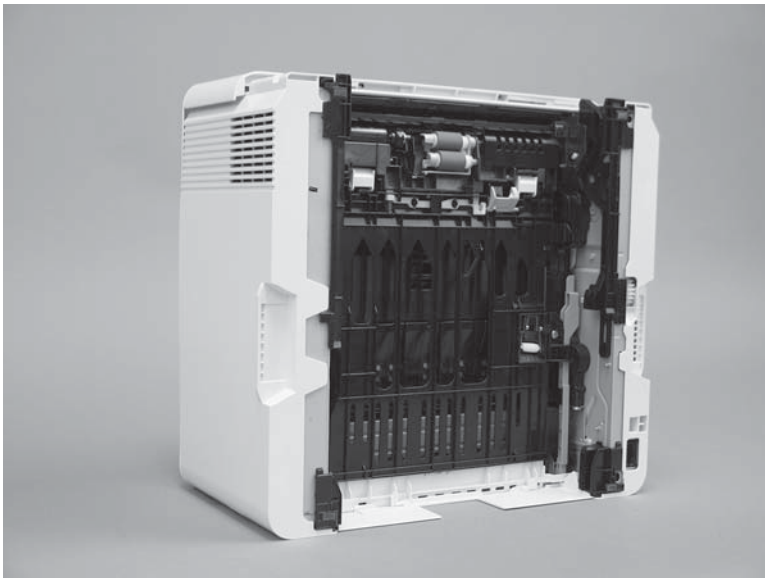
2. Continue rotate the printer backward until it rests on the rear cover, bottom-side face forward.

---

**⚠ CAUTION:** **M427/M426:** The integrated scanner assembly (ISA) is not captive, and can unexpectedly open when the printer is tilted back.

---

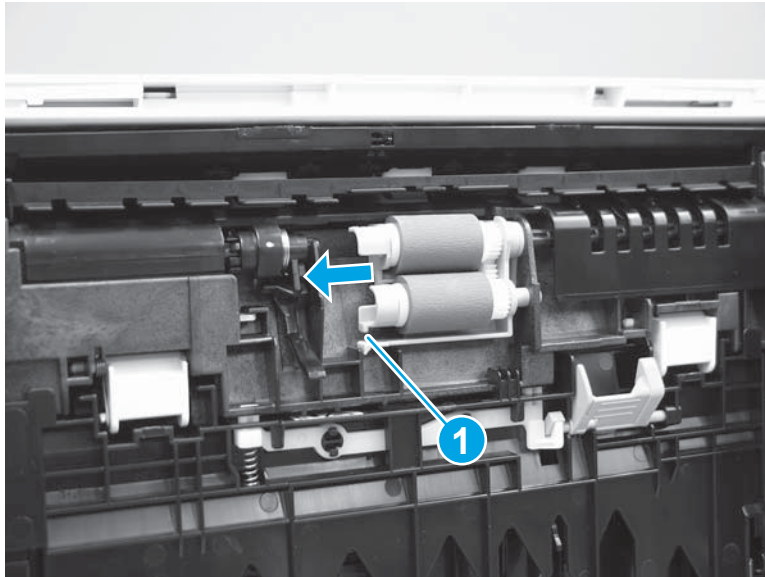
**Figure 1-2219** Place the printer bottom-side face forward





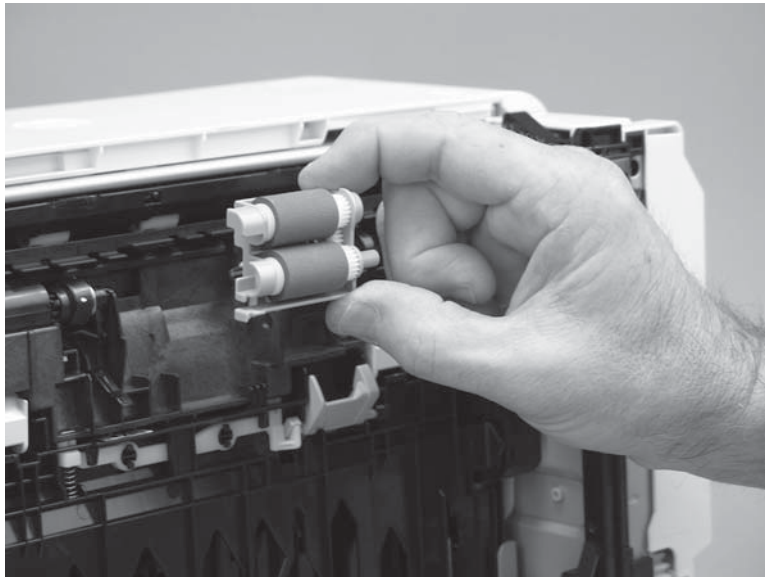
3. Release one tab (callout 1), and then slide the roller holder toward the left side of the printer to release it.

**Figure 1-2220** Release one tab



4. Remove the roller holder.

**Figure 1-2221** Remove the roller holder



### Step 3: Unpack the replacement assembly

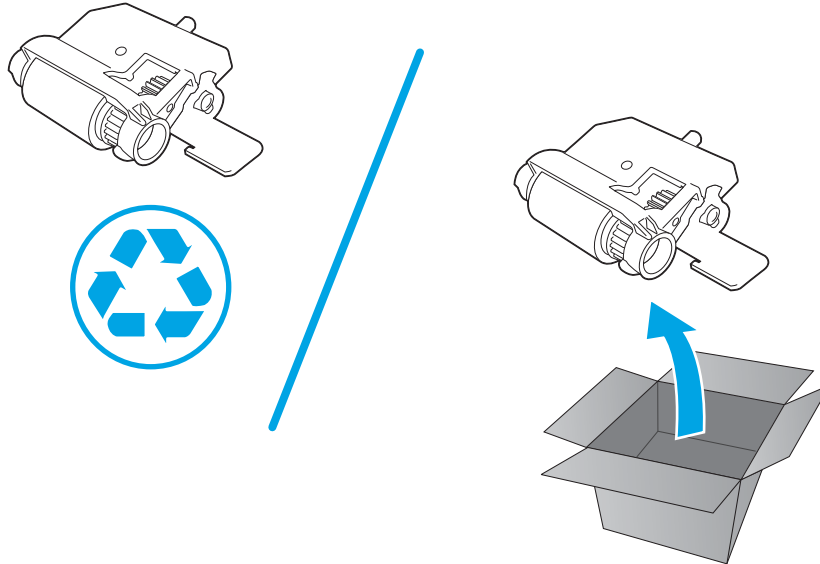
Unpack the replacement part from the packaging.

<http://www8.hp.com/us/en/hp-information/environment/product-recycling.html>

**CAUTION:** When handling the roller holder, do not touch the gray spongy portion of the rollers. Skin oils on the rollers can cause paper handling problems.

**NOTE:** HP recommends responsible disposal of the defective part.

**Figure 1-2222** Recycle and unpack



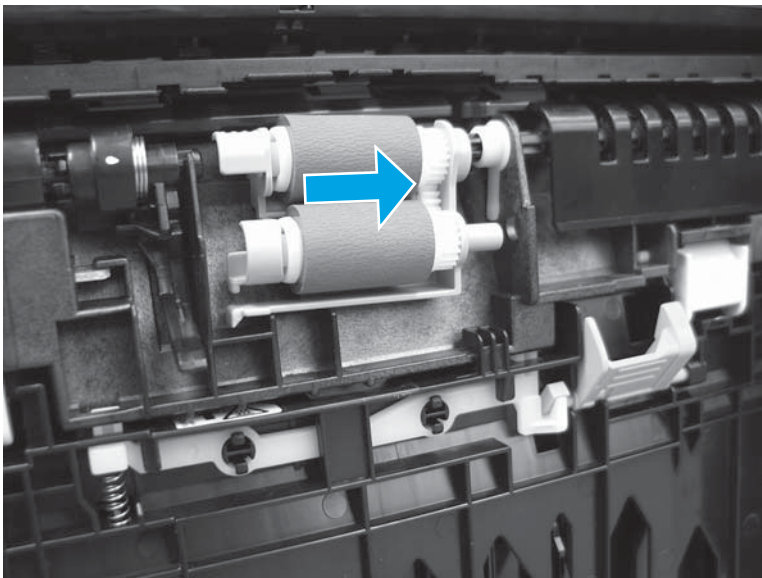
**Step 4: Install the pickup roller assembly (Tray 2)**

**CAUTION:** When handling the roller holder, do not touch the gray spongy portion of the rollers. Skin oils on the rollers can cause paper handling problems.

**NOTE:** The M403/M402 printer is shown in this procedure. However, the procedure is valid for the M427/M426 printers.

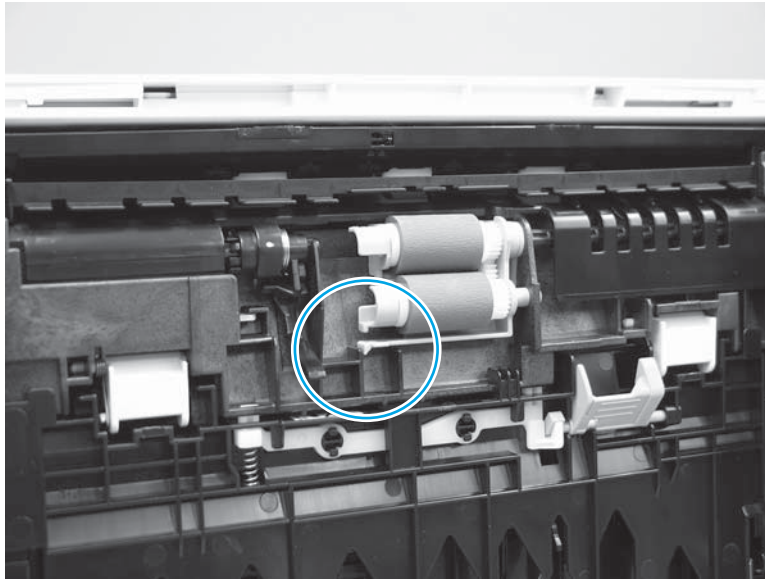
1. Position the roller holder assembly in the printer as shown, and then slide it toward the right side of the printer.

**Figure 1-2223** Install the roller holder



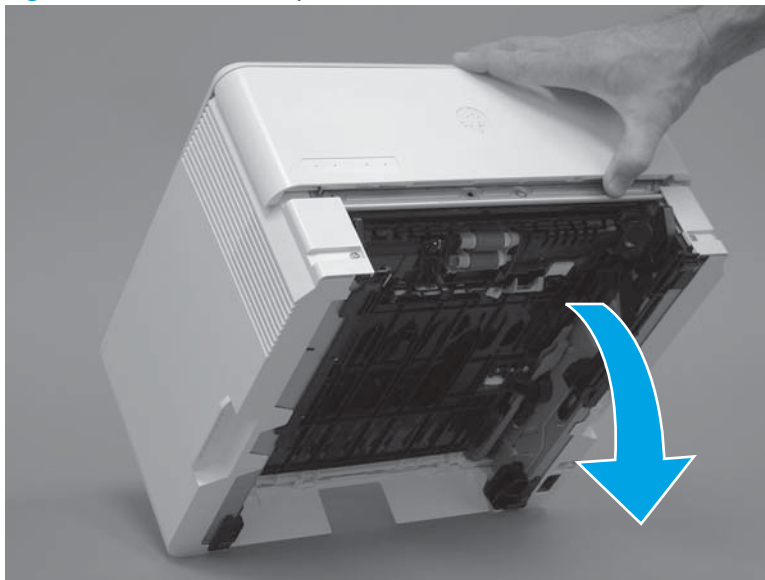
2. Make sure that the tab snaps into place.

**Figure 1-2224** Check the tab



3. Carefully rotate the printer forward.

**Figure 1-2225** Rotate the printer forward



4. Continue rotate the printer forward until it rests in the operational position.

**Figure 1-2226** Place the printer in the operational position



#### Step 5: Install Tray 2

- ▲ Slide the tray straight into the printer to install it.

**Figure 1-2227** Install the tray



## RM2-5397-000CN Tray 2 separation roller assembly

- [Introduction](#)
- [Step 1: Remove Tray 2](#)
- [Step 2: Remove the separation pad roller assembly \(Tray 2\)](#)
- [Step 3: Unpack the replacement assembly](#)
- [Step 4: Install the separation pad roller assembly \(Tray 2\)](#)
- [Step 5: Install Tray 2](#)


### Introduction

This document provides the procedures to remove and replace the separation roller assembly (Tray 2).

### Before performing service

#### Turn the printer power off

- Disconnect the power cable.

 **WARNING!** To avoid damage to the printer, turn the printer off, wait 30 seconds, and then remove the power cable before attempting to service the printer.

Use the table below to identify the correct part number for your printer. To order the part, go to [www.hp.com/buy/parts](http://www.hp.com/buy/parts).

Separation roller assembly (Tray 2) part number	
RM2-5397-000CN	Separation roller assembly (Tray 2)

### Required tools

- No special tools are required to install this kit.

### After performing service

#### Turn the printer power on

- Connect the power cable.
- Use the power switch to turn the power on.

### Post service test

Make sure that the printer initializes to a **Ready** state.

Print a configuration page to make sure that the printer is functioning correctly.

### Step 1: Remove Tray 2

- ▲ Pull the tray straight out of the printer to remove it.

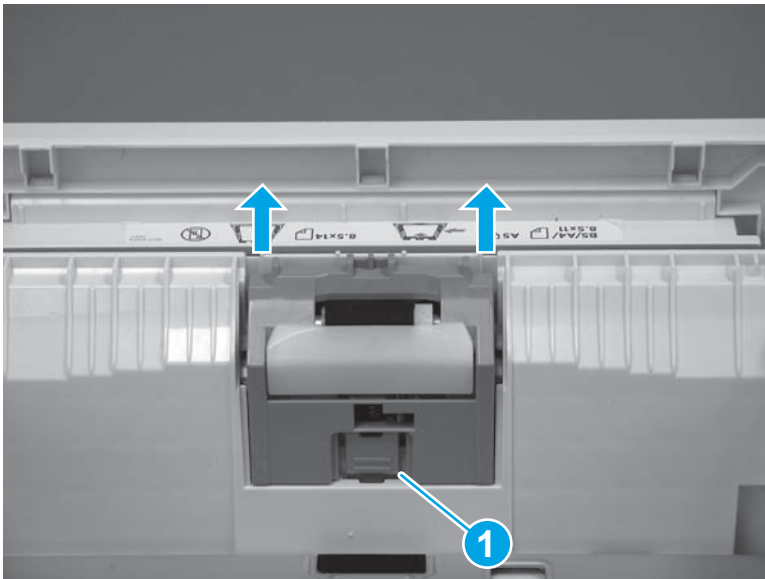
**Figure 1-2228** Remove the tray



**Step 2: Remove the separation pad roller assembly (Tray 2)**

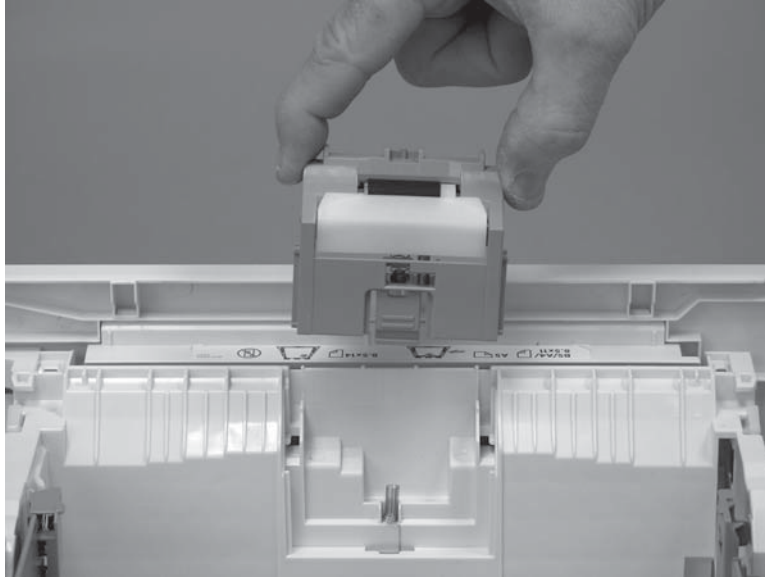
1. Pull the separation pad assembly straight up to release it.

**Figure 1-2229** Release the assembly



2. Remove the assembly.

**Figure 1-2230** Remove the assembly



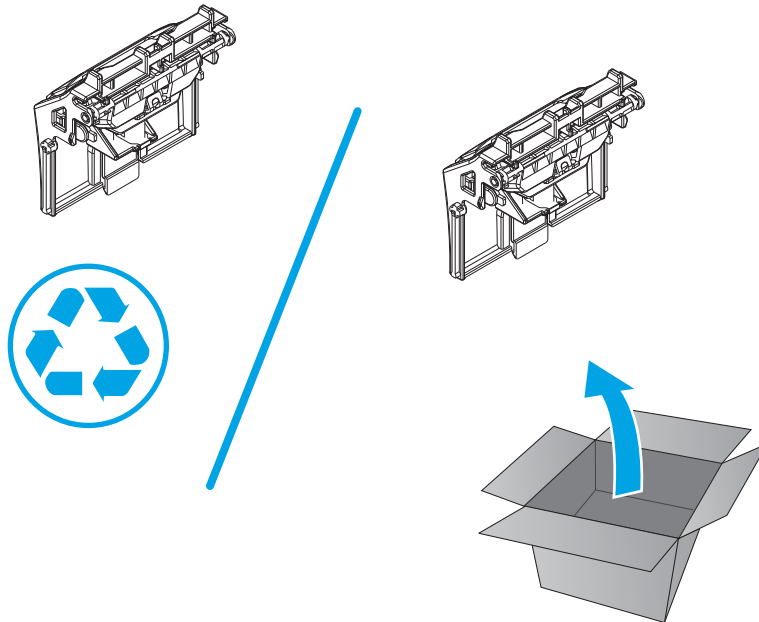
### Step 3: Unpack the replacement assembly

Unpack the replacement part from the packaging.

<http://www8.hp.com/us/en/hp-information/environment/product-recycling.html>

 **NOTE:** HP recommends responsible disposal of the defective part.

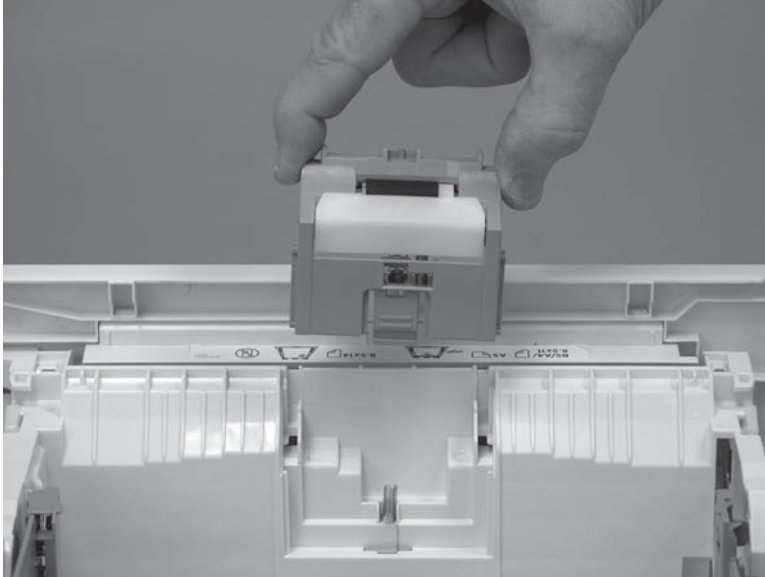
**Figure 1-2231** Recycle and unpack



### Step 4: Install the separation pad roller assembly (Tray 2)

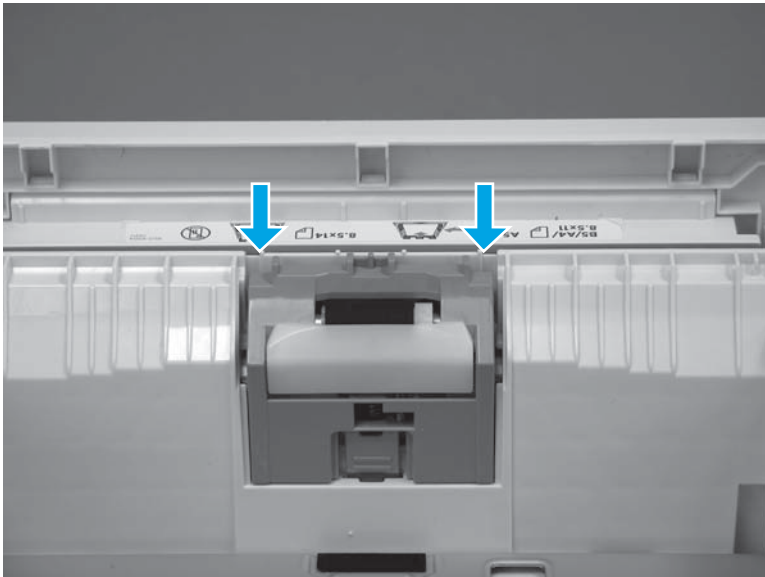
1. Install the assembly in the slot in the cassette.

**Figure 1-2232** Install the assembly



2. Push the separation pad assembly straight down until it snaps into place.

**Figure 1-2233** Release the assembly



### Step 5: Install Tray 2

- ▲ Slide the tray straight into the printer to install it.



**Figure 1-2234** Install the tray



## Removal and replacement: Accessories

- [550-sheet paper feeder](#)

### 550-sheet paper feeder



---

**NOTE:** HP recommends removing the accessory from the product before servicing them.

---

- [C5F97-69001 optional 550-sheet paper feeder](#)
- [RM2-5413-000CN optional Tray 3](#)
- [RM2-5741-000CN optional Tray 3 paper pickup roller assembly](#)
- [RM2-5745-000CN optional Tray 3 separation roller assembly](#)

## C5F97-69001 optional 550-sheet paper feeder

- [Introduction](#)
- [Step 1: Remove the optional 550-sheet feeder Tray 3](#)
- [Step 2: Unpack the replacement optional paper feeder](#)
- [Step 3: Install the optional 550-sheet feeder Tray 3](#)


### Introduction

This document provides the procedures to remove and replace the optional 550-sheet paper feeder.

### Before performing service

#### Turn the printer power off

- Disconnect the power cable.

 **WARNING!** To avoid damage to the printer, turn the printer off, wait 30 seconds, and then remove the power cable before attempting to service the printer.

Use the table below to identify the correct part number for your printer. To order the part, go to [www.hp.com/buy/parts](http://www.hp.com/buy/parts).

Optional 550-sheet paper feeder part number	
C5F697-69001	Optional 550-sheet paper feeder (optional Tray 3)

### Required tools

- No special tools are required to remove this part.

### After performing service

#### Turn the printer power on

- Connect the power cable.
- Use the power switch to turn the power on.

### Post service test

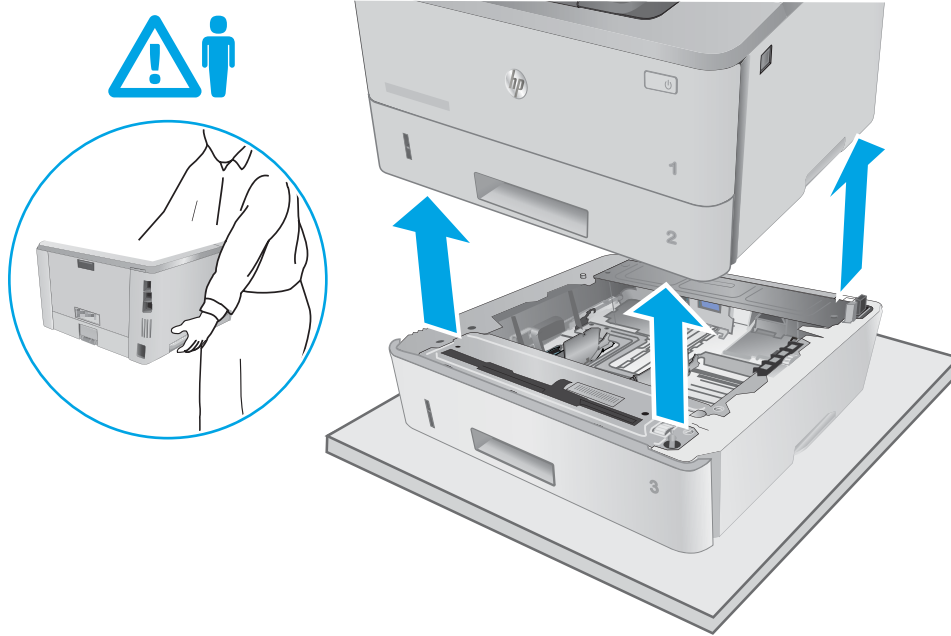
Make sure that the printer initializes to a **Ready** state.

Print a page from the optional Tray 3 to make sure that the paper feeder is functioning correctly.

### Step 1: Remove the optional 550-sheet feeder Tray 3

- ▲ Carefully lift the printer off of the paper feeder assembly.


**Figure 1-2235** Remove the printer



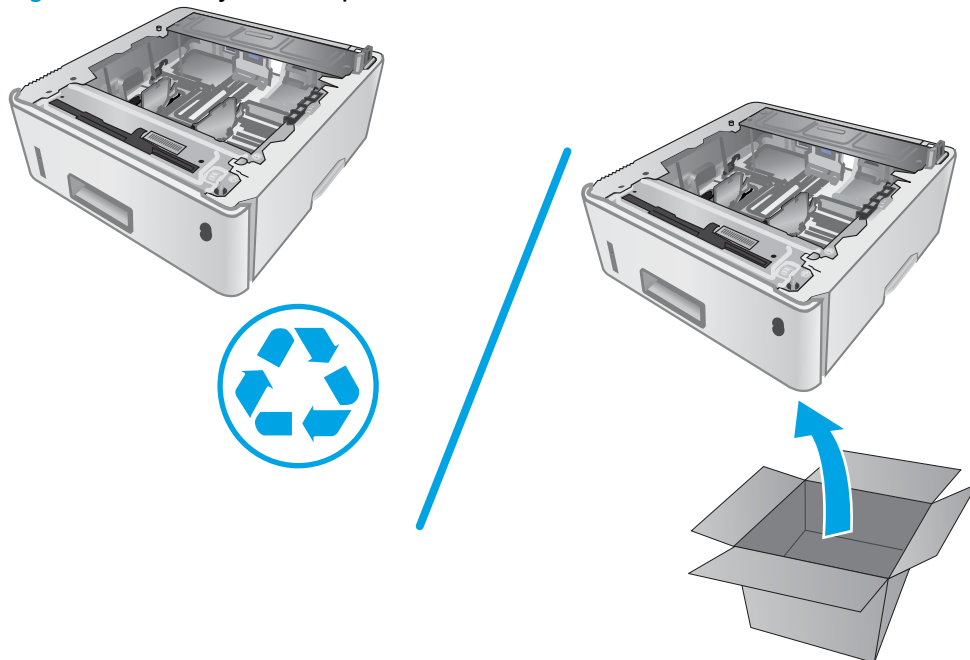
**Step 2: Unpack the replacement optional paper feeder**

Unpack the replacement part from the packaging.

<http://www8.hp.com/us/en/hp-information/environment/product-recycling.html>

 **NOTE:** HP recommends responsible disposal of the defective part.

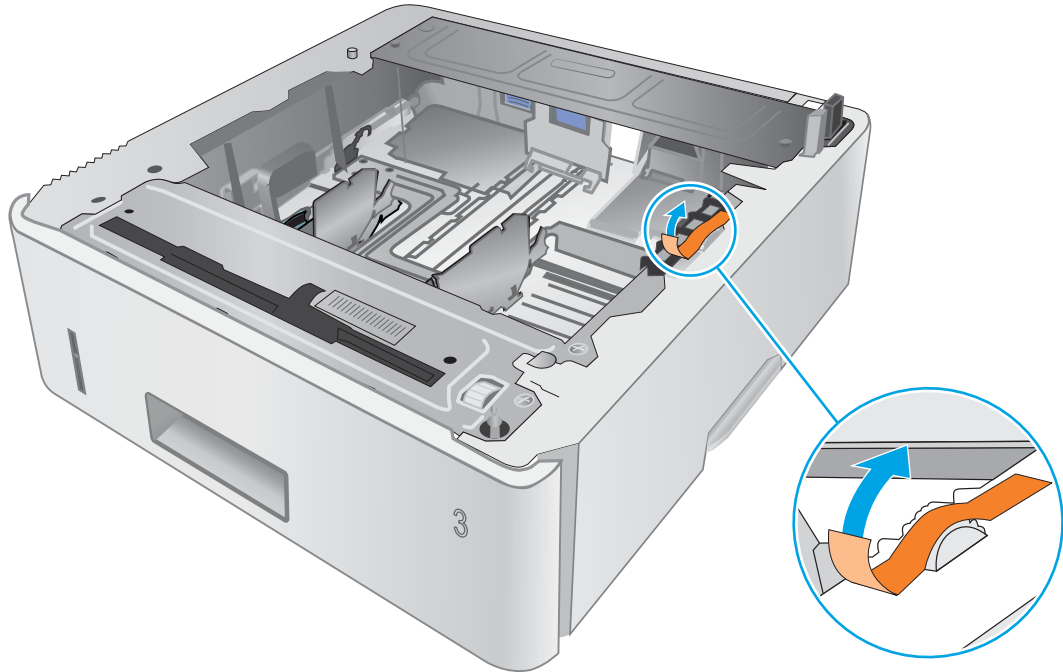
**Figure 1-2236** Recycle and unpack



### Step 3: Install the optional 550-sheet feeder Tray 3

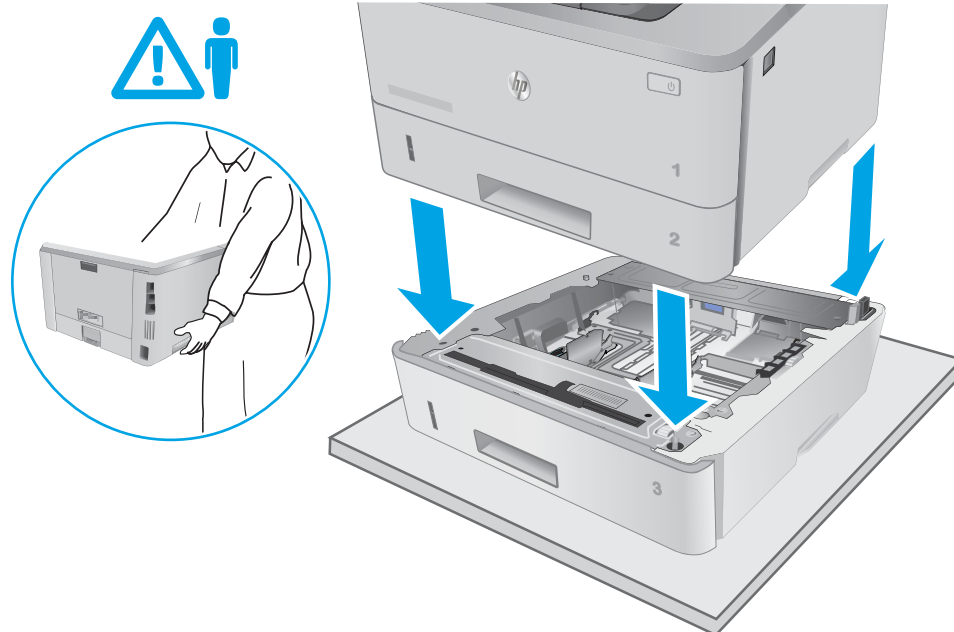
1. Remove the orange shipping tape.

**Figure 1-2237** Remove shipping tape



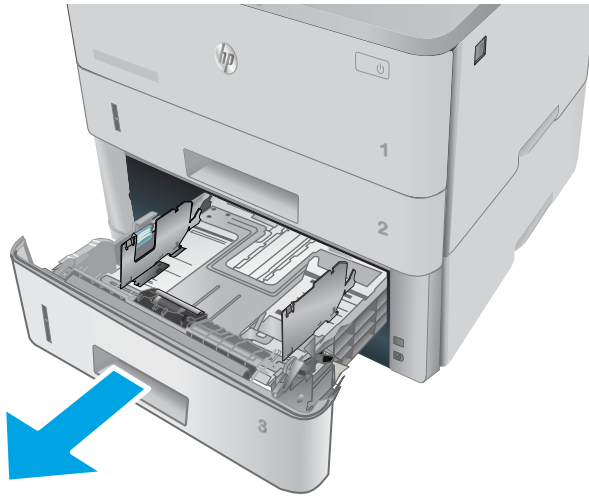
2. Carefully place the printer on the paper feeder assembly.

**Figure 1-2238** Install the printer



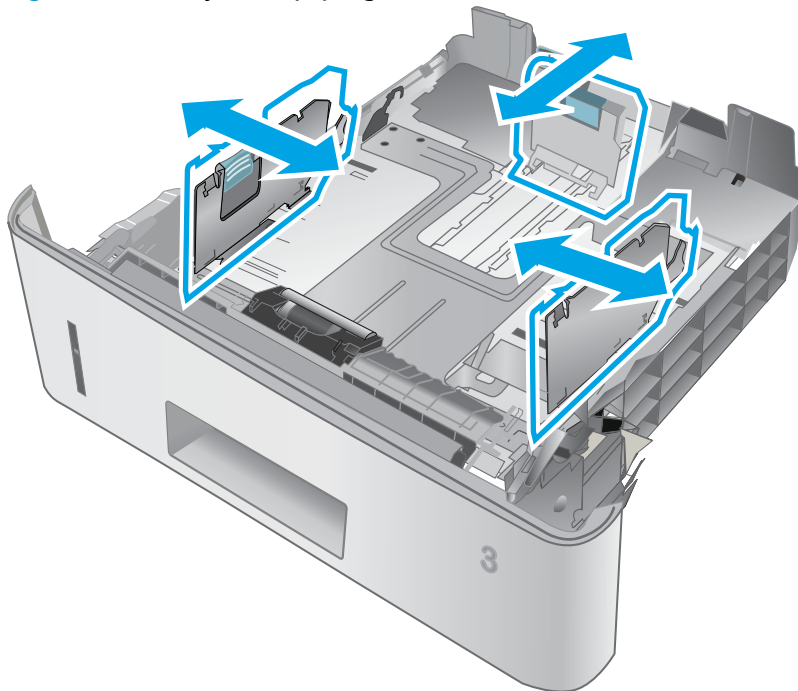
3. Pull Tray 3 out of the paper feeder assembly to remove it.

**Figure 1-2239** Remove Tray 3



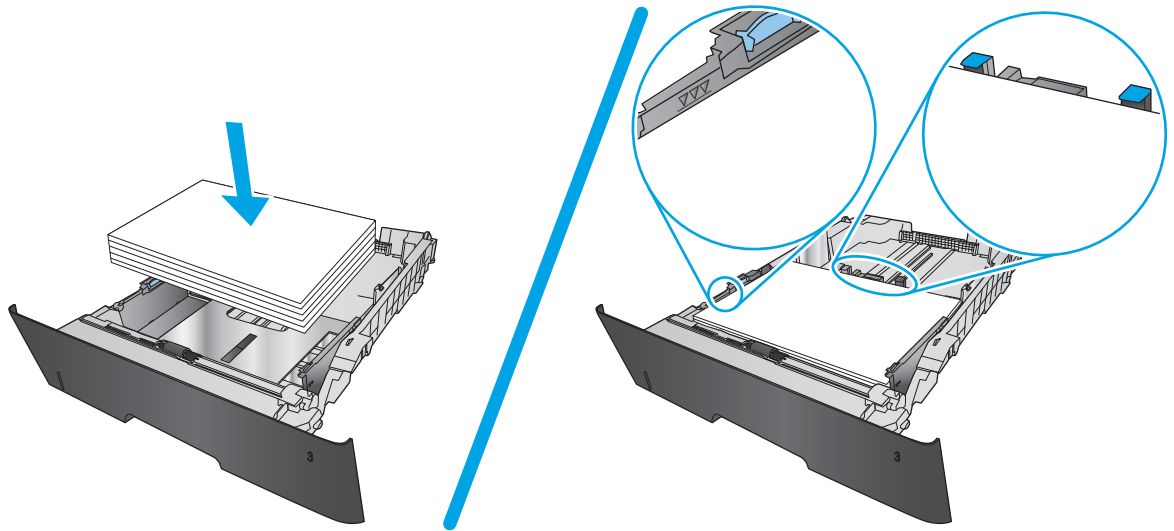
4. Adjust the Tray 3 sliding paper guides.

**Figure 1-2240** Adjust the paper guides



5. Load paper in Tray 3.

**Figure 1-2241** Load paper



6. Slide Tray 3 into the paper feeder assembly to install it.

**Figure 1-2242** Install



## RM2-5413-000CN optional Tray 3

- [Introduction](#)
- [Step 1: Remove optional Tray 3](#)
- [Step 2: Unpack the replacement assembly](#)
- [Step 3: Install optional Tray 3](#)

### Introduction


This document provides the procedures to remove and replace the optional Tray 3.

### Before performing service

#### Turn the printer power off

- Disconnect the power cable.

---

 **WARNING!** To avoid damage to the printer, turn the printer off, wait 30 seconds, and then remove the power cable before attempting to service the printer.

---

Use the table below to identify the correct part number for your printer. To order the part, go to [www.hp.com/buy/parts](http://www.hp.com/buy/parts).

---

Tray 3 part number	
RM2-5413-000CN	550-sheet paper feeder cassette (optional Tray 3)

---

### Required tools

- No special tools are required to remove this part.

### After performing service

#### Turn the printer power on

- Connect the power cable.
- Use the power switch to turn the power on.

### Post service test

Make sure that the printer initializes to a **Ready** state.

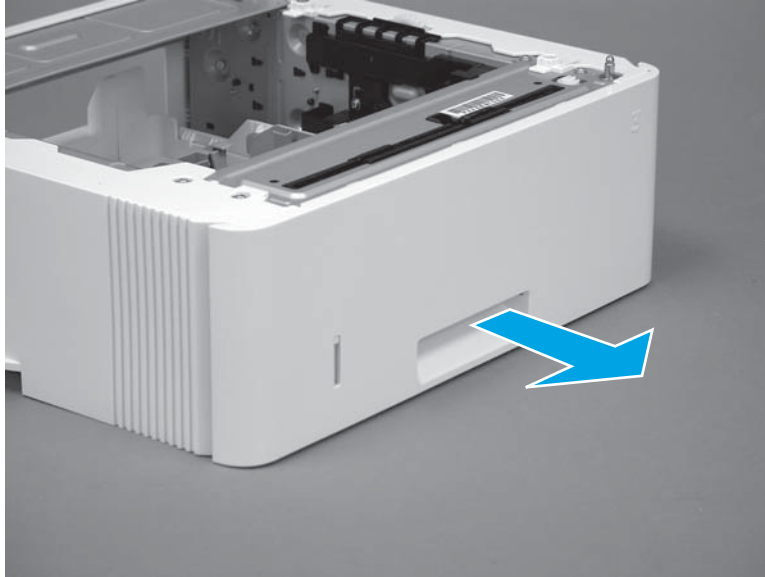
Print a page from Tray 3 to make sure that the paper feeder is functioning correctly.

### Step 1: Remove optional Tray 3

1. Pull the tray straight out of the printer until it stops.

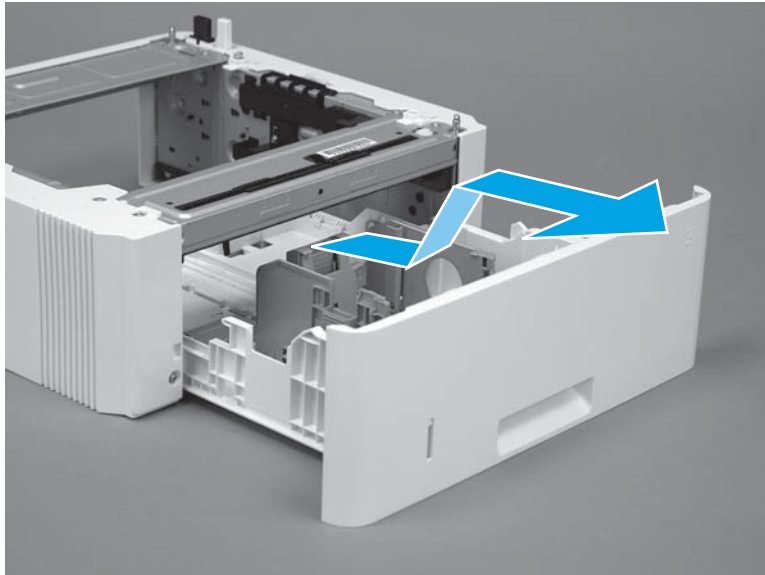


**Figure 1-2243** Pull the tray out of the printer



2. Slightly lift up on the front of the tray to release it, and then continue to pull the tray out of the accessory to remove it.

**Figure 1-2244** Release and remove the tray



### Step 2: Unpack the replacement assembly

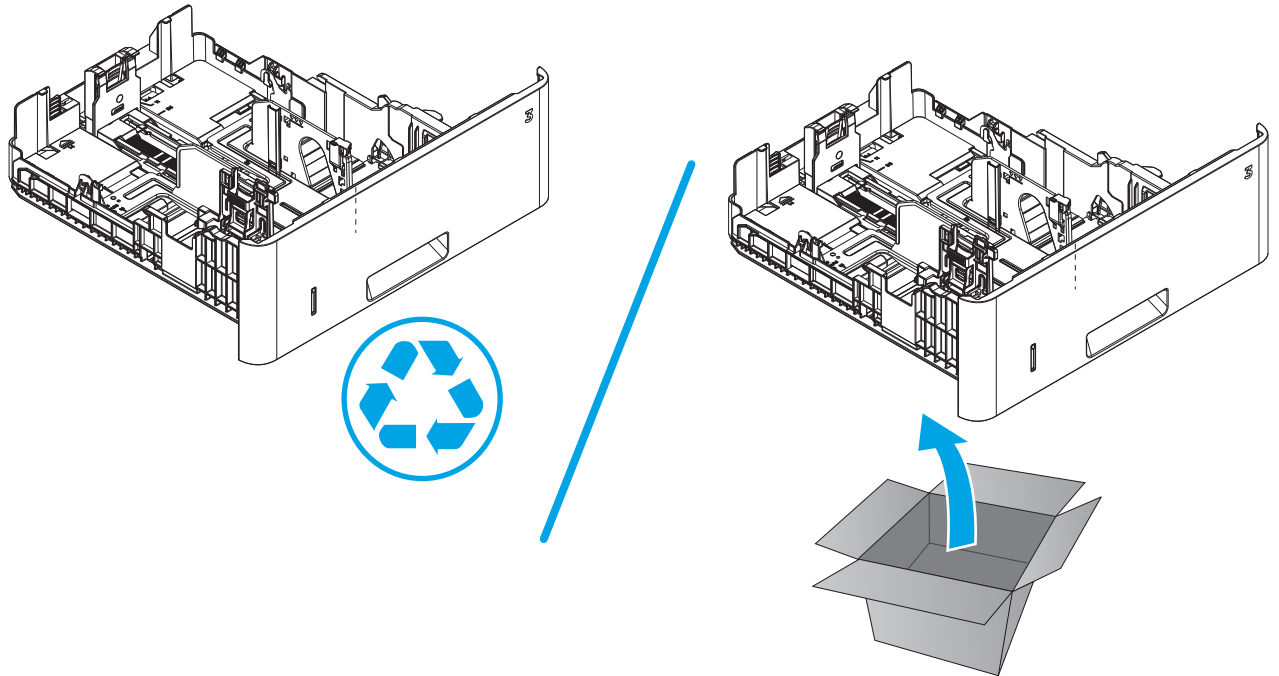
Unpack the replacement part from the packaging.

<http://www8.hp.com/us/en/hp-information/environment/product-recycling.html>



**NOTE:** HP recommends responsible disposal of the defective part.

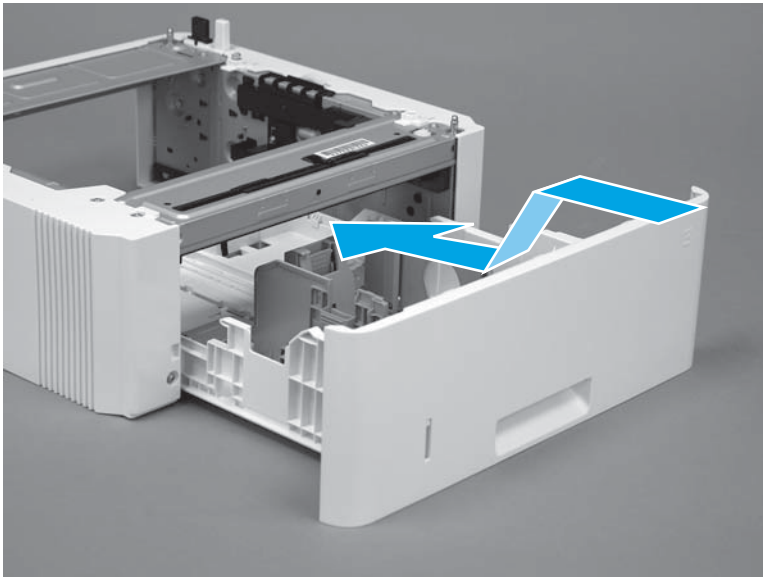
**Figure 1-2245** Recycle and unpack



**Step 3: Install optional Tray 3**

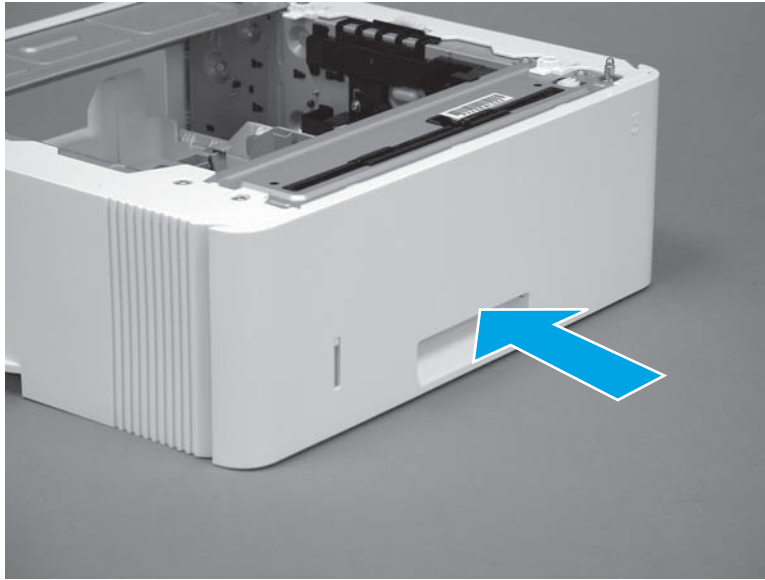
1. With the tray at a slight angle, align the sides of the tray with the rails in the accessory, and then partially slide the tray into the accessory.

**Figure 1-2246** Install the tray



2. Push the tray straight into the accessory to close it.

**Figure 1-2247** Close the tray



## RM2-5741-000CN optional Tray 3 paper pickup roller assembly

- [Introduction](#)
- [Step 1: Remove optional Tray 3](#)
- [Step 2: Remove the paper pickup roller assembly \(Tray 3\)](#)
- [Step 3: Unpack the replacement assembly](#)
- [Step 4: Install the paper pickup roller assembly \(Tray 3\)](#)
- [Step 5: Install optional Tray 3](#)


### Introduction

This document provides the procedures to remove and replace the paper pickup roller assembly (Tray 3).

### Before performing service

#### Turn the printer power off

- Disconnect the power cable.

 **WARNING!** To avoid damage to the printer, turn the printer off, wait 30 seconds, and then remove the power cable before attempting to service the printer.

Use the table below to identify the correct part number for your printer. To order the part, go to [www.hp.com/buy/parts](http://www.hp.com/buy/parts).

---

Paper pickup roller assembly (Tray 3) part number	
---	--

---

RM2-5741-000N	Paper pickup roller assembly (Tray 3)
---------------	---------------------------------------

---

### Required tools

- No special tools are required to remove this part.

### After performing service

#### Turn the printer power on

- Connect the power cable.
- Use the power switch to turn the power on.

### Post service test

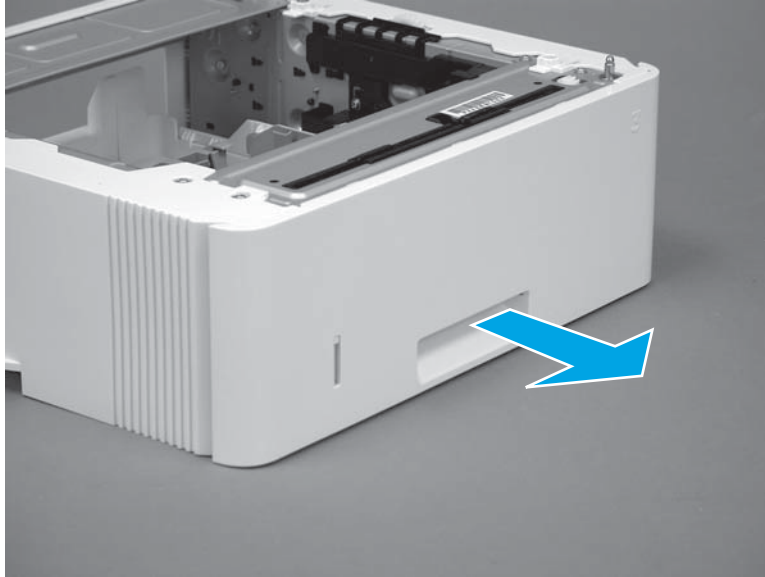
Make sure that the printer initializes to a **Ready** state.

Print a page from the accessory to make sure that the printer is functioning correctly.

### Step 1: Remove optional Tray 3

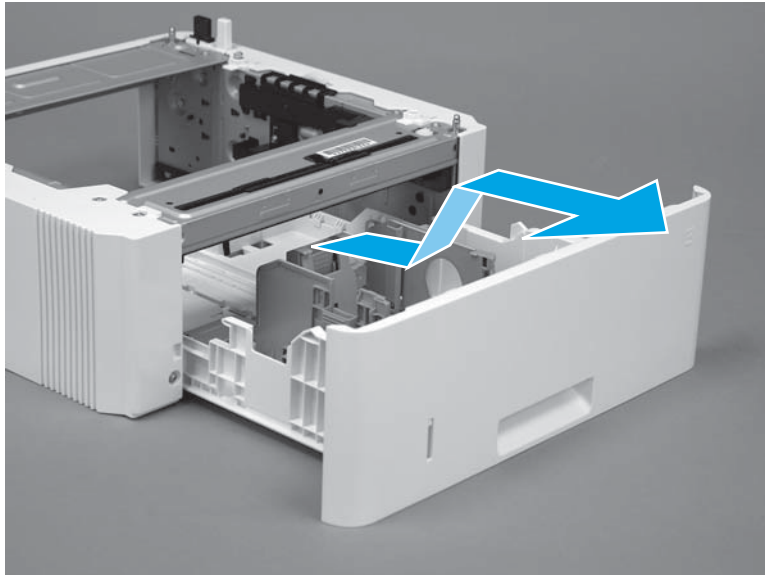
1. Pull the tray straight out of the printer until it stops.

**Figure 1-2248** Pull the tray out of the printer



2. Slightly lift up on the front of the tray to release it, and then continue to pull the tray out of the accessory to remove it.

**Figure 1-2249** Release and remove the tray



### Step 2: Remove the paper pickup roller assembly (Tray 3)

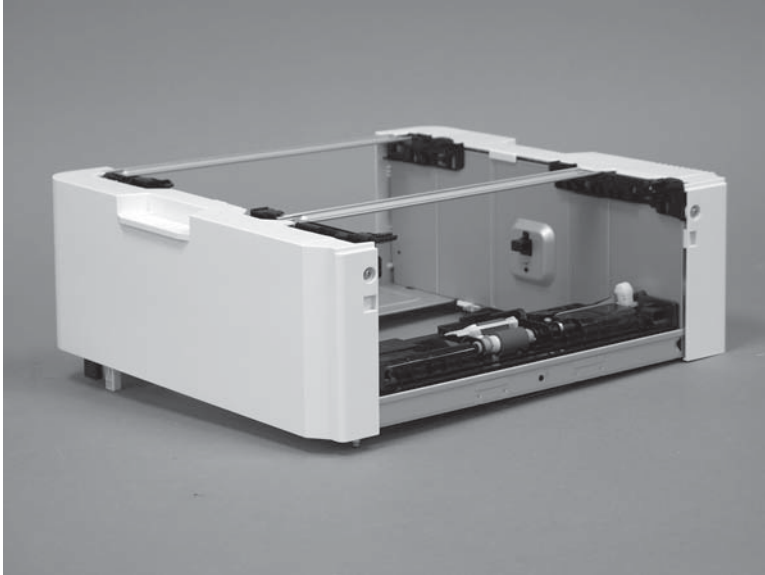
---

**CAUTION:** When handling the roller holder, do not touch the gray spongy portion of the rollers. Skin oils on the rollers can cause paper handling problems.

---

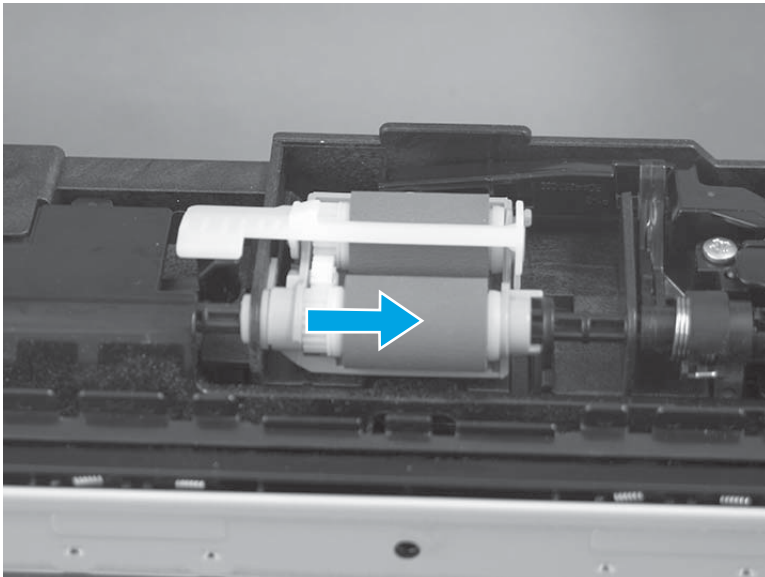
1. Carefully turn the accessory over to expose the roller assembly.

**Figure 1-2250** Turn the accessory over



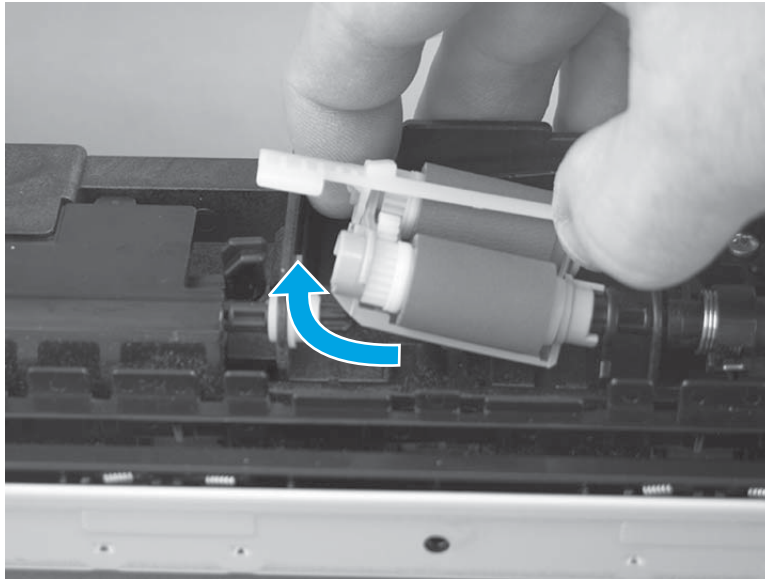
2. Slide the roller holder to the right to compress the spring-loaded shaft and release the assembly.

**Figure 1-2251** Release the assembly



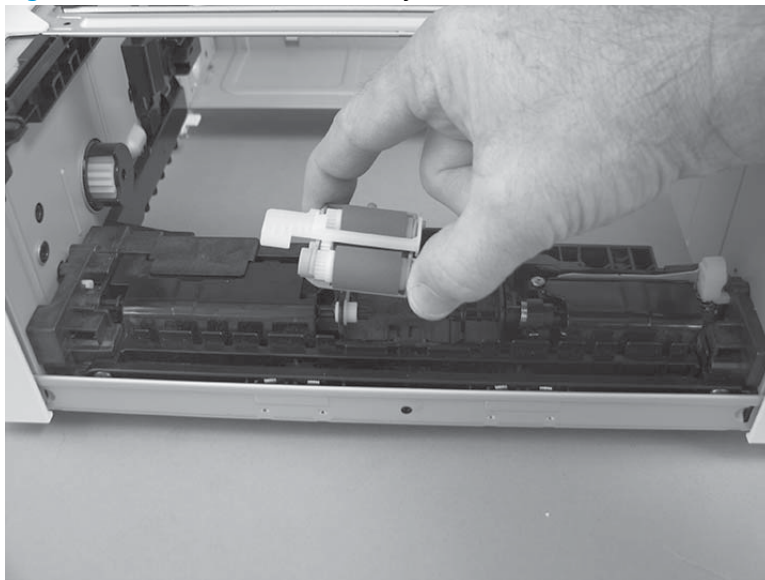
3. Rotate the end of the assembly up and away from the accessory.

**Figure 1-2252** Rotate the assembly up



4. Remove the roller assembly.

**Figure 1-2253** Remove the assembly



### Step 3: Unpack the replacement assembly

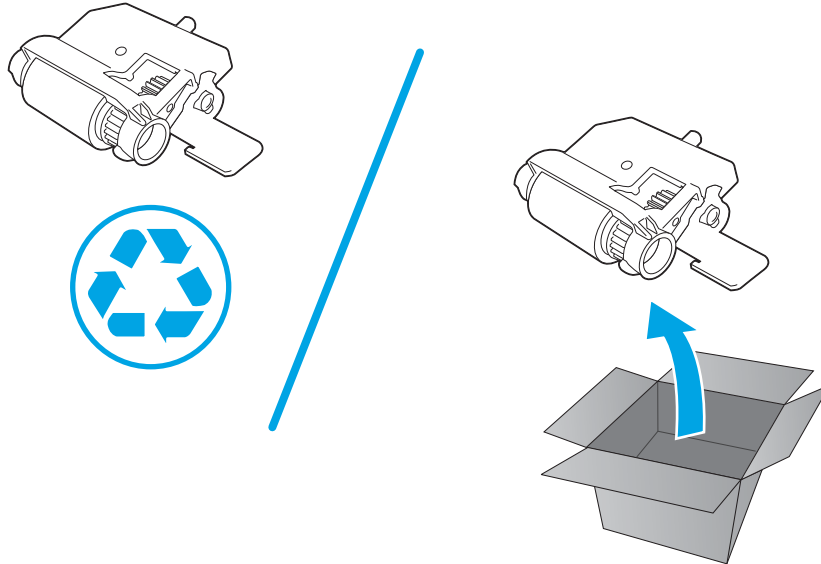
Unpack the replacement part from the packaging.

<http://www8.hp.com/us/en/hp-information/environment/product-recycling.html>

**CAUTION:** When handling the roller holder, do not touch the gray spongy portion of the rollers. Skin oils on the rollers can cause paper handling problems.

**NOTE:** HP recommends responsible disposal of the defective part.

**Figure 1-2254** Recycle and unpack



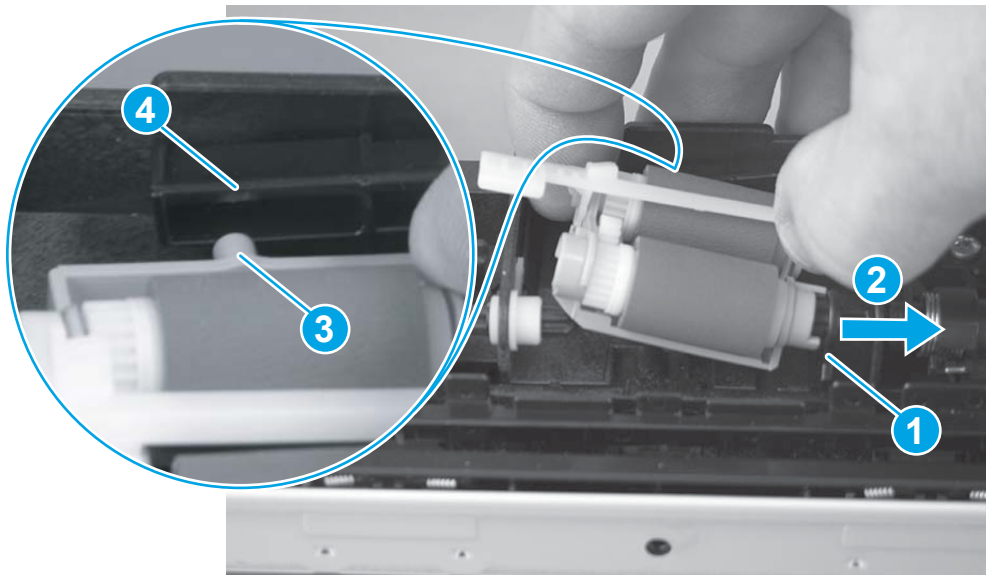
**Step 4: Install the paper pickup roller assembly (Tray 3)**

**CAUTION:** When handling the roller holder, do not touch the gray spongy portion of the rollers. Skin oils on the rollers can cause paper handling problems.

1. Install the right end of the assembly on the spring-loaded shaft (callout 1), and then slide it to the right to compress the shaft (callout 2).

**IMPORTANT:** Make sure that the pin on the back of the holder (callout 3) is inserted in the slot (callout 4) in the lever arm. If the pin is not correctly installed, the accessory will not pick paper.

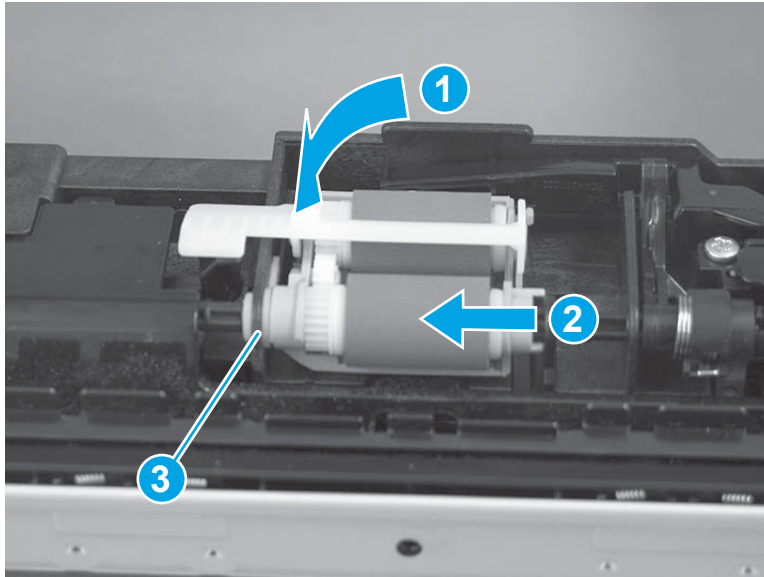
**Figure 1-2255** Install the roller assembly






2. Rotate the left end of the assembly down and into place (callout 1), and then slide the assembly to the left (callout 2) to engage the drive end of the assembly with the drive shaft (callout 3).

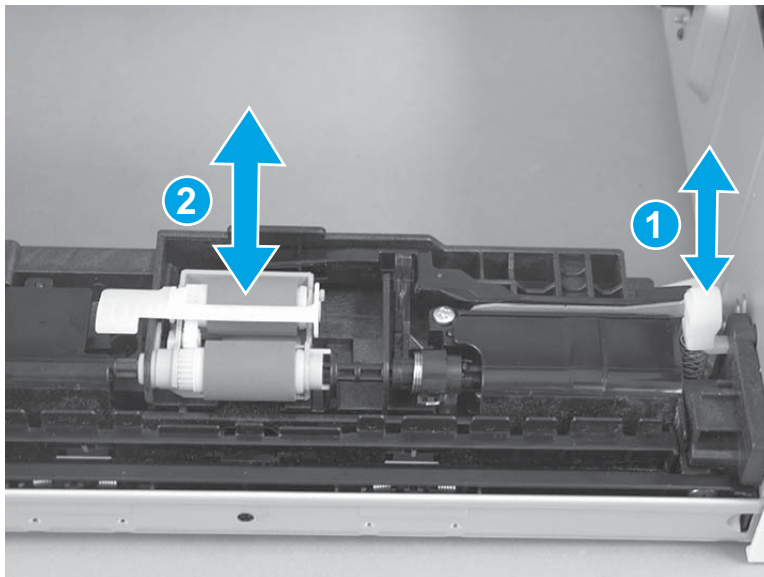
**Figure 1-2256** Release the assembly



3. Push down and then release the tray-roller actuator (callout 1) and observe the roller assembly. It should move up and down (callout 2) in response to the actuator.

 **NOTE:** If it does not, remove the roller assembly and reinstall it making sure that the pin on the back of the assembly is in the lever arm. See [Figure 1-35 Install the roller assembly on page 31](#).

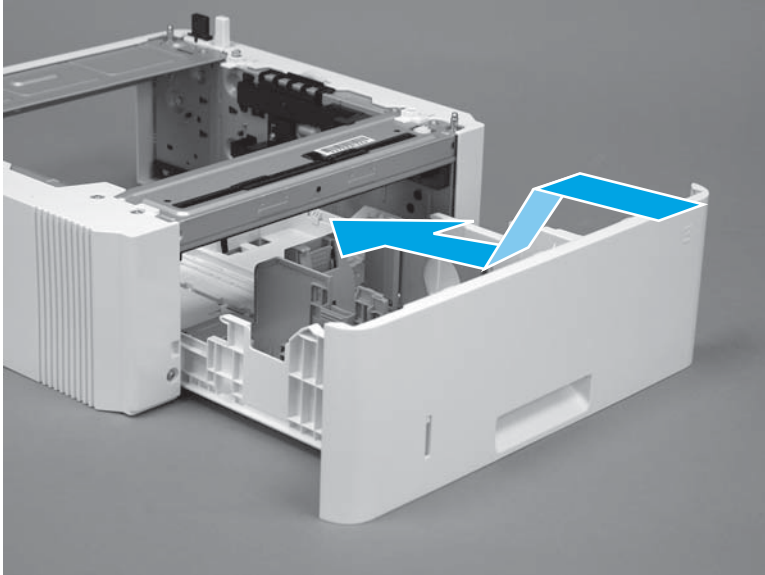
**Figure 1-2257** Check the installation



### Step 5: Install optional Tray 3

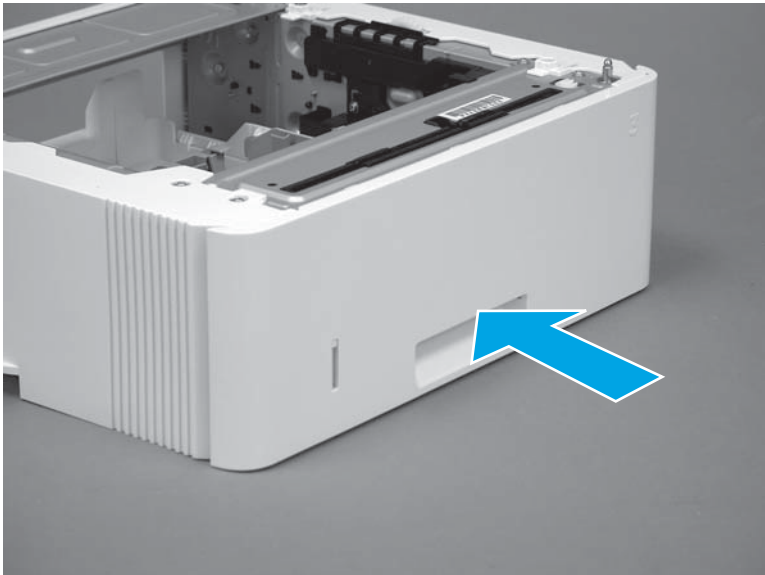
1. With the tray at a slight angle, align the sides of the tray with the rails in the accessory, and then partially slide the tray into the accessory.

**Figure 1-2258** Install the tray



2. Push the tray straight into the accessory to close it.

**Figure 1-2259** Close the tray



## RM2-5745-000CN optional Tray 3 separation roller assembly

- [Introduction](#)
- [Step 1: Remove optional Tray 3](#)
- [Step 2: Remove the separation pad assembly \(550-sheet feeder\)](#)
- [Step 3: Unpack the replacement assembly](#)
- [Step 4: Install the separation pad assembly \(550-sheet feeder\)](#)
- [Step 5: Install optional Tray 3](#)


### Introduction

This document provides the procedures to remove and replace the separation roller assembly (500-sheet feeder).

### Before performing service

#### Turn the printer power off

- Disconnect the power cable.

 **WARNING!** To avoid damage to the printer, turn the printer off, wait 30 seconds, and then remove the power cable before attempting to service the printer.

Use the table below to identify the correct part number for your printer. To order the part, go to [www.hp.com/buy/parts](http://www.hp.com/buy/parts).

Separation roller assembly (550-sheet feeder) part number	
RM2-5745-000CN	Separation roller assembly (550-sheet feeder)

### Required tools

- No special tools are required to install this kit.

### After performing service

#### Turn the printer power on

- Connect the power cable.
- Use the power switch to turn the power on.

### Post service test

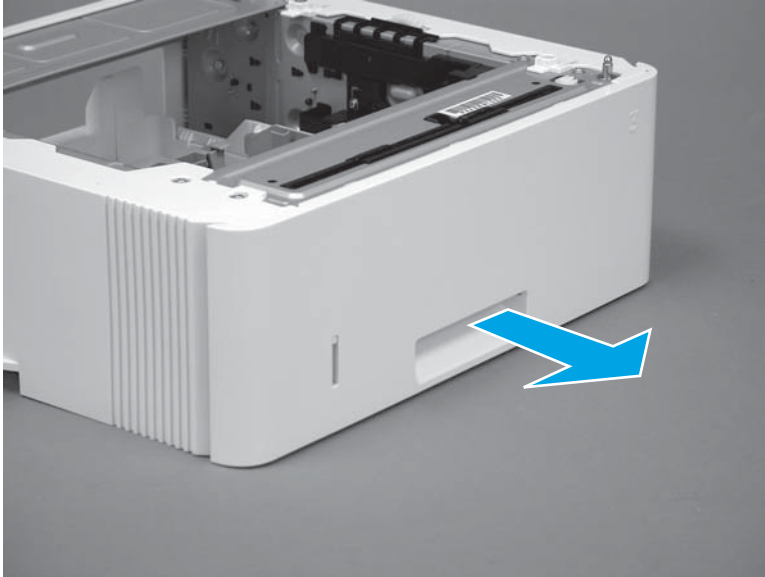
Make sure that the printer initializes to a **Ready** state.

Print a page from the accessory to make sure that the accessory is functioning correctly.

### Step 1: Remove optional Tray 3

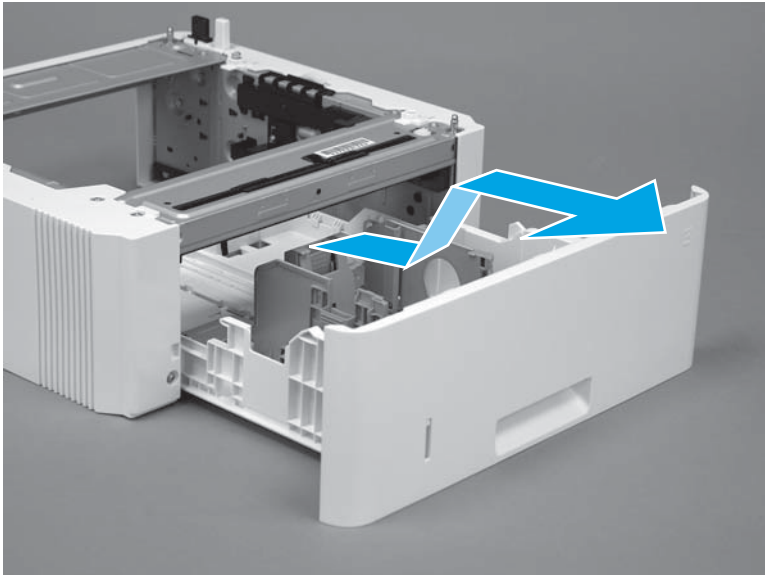
1. Pull the tray straight out of the printer until it stops.

**Figure 1-2260** Pull the tray out of the printer



2. Slightly lift up on the front of the tray to release it, and then continue to pull the tray out of the accessory to remove it.

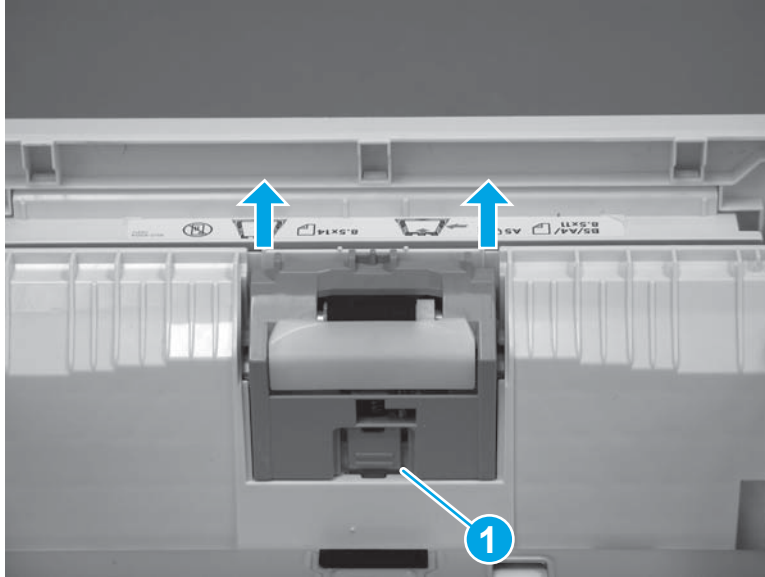
**Figure 1-2261** Release and remove the tray



### **Step 2: Remove the separation pad assembly (550-sheet feeder)**

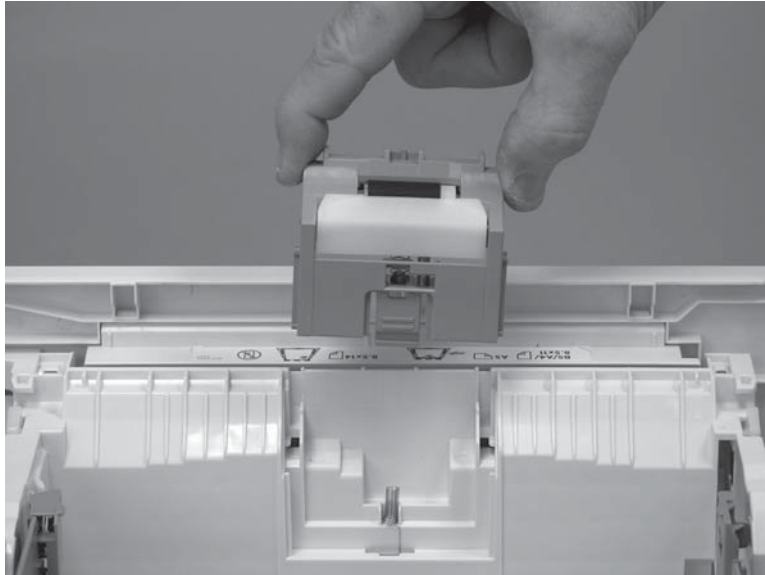
1. Press the locking lever (callout 1), and then pull the separation roller assembly straight up to release it.

**Figure 1-2262** Release the assembly



2. Remove the assembly.

**Figure 1-2263** Remove the assembly



### Step 3: Unpack the replacement assembly

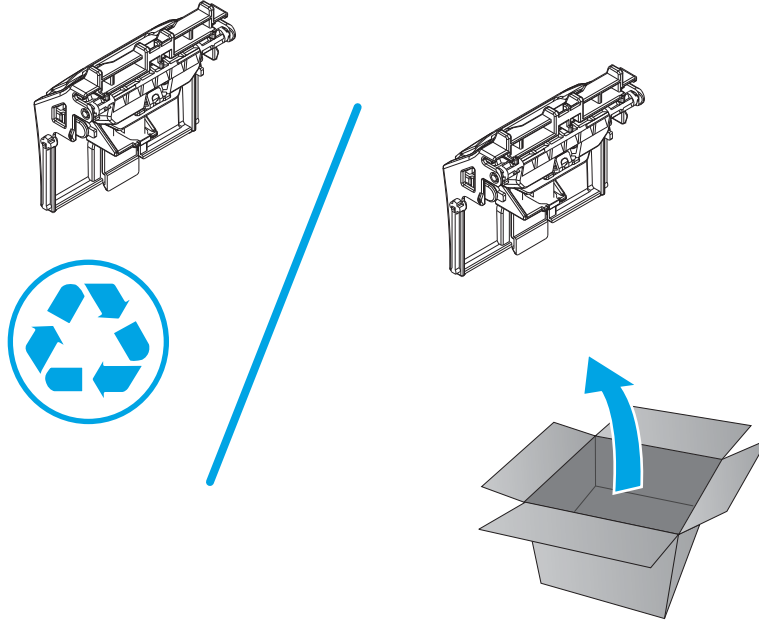
Unpack the replacement part from the packaging.

<http://www8.hp.com/us/en/hp-information/environment/product-recycling.html>



**NOTE:** HP recommends responsible disposal of the defective part.

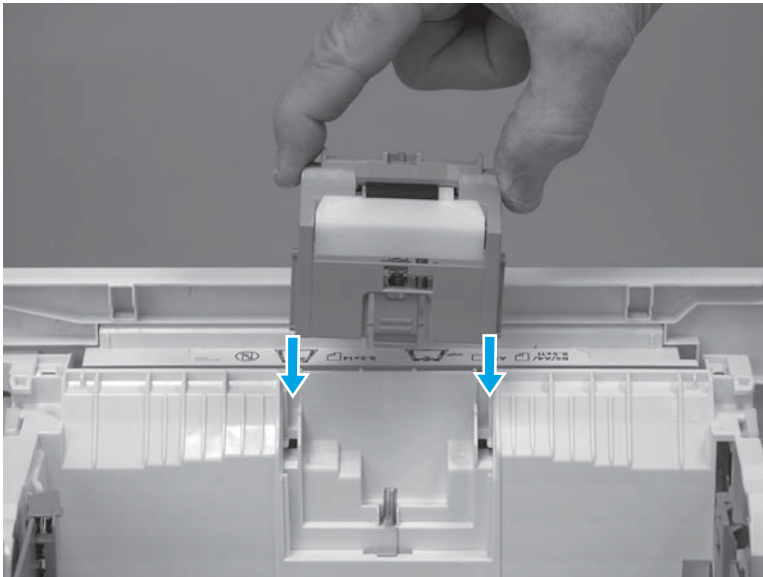
**Figure 1-2264** Recycle and unpack



**Step 4: Install the separation pad assembly (550-sheet feeder)**

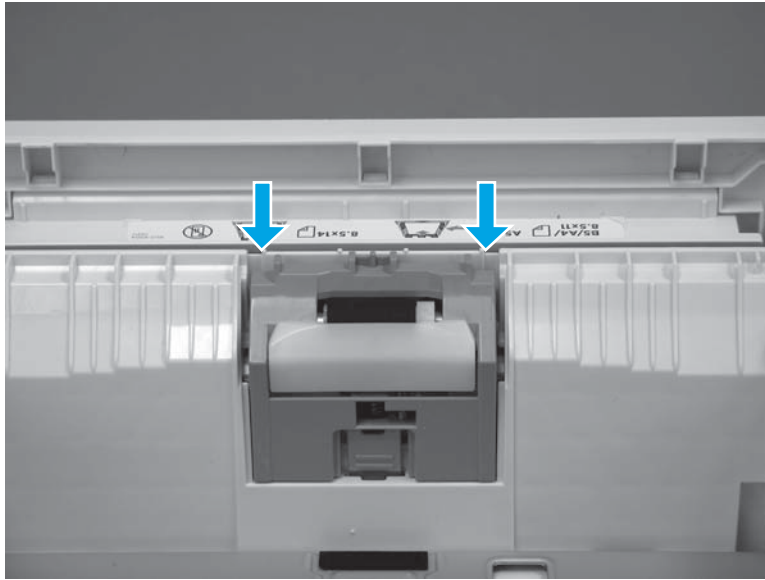
1. Install the assembly in the slots in the cassette.

**Figure 1-2265** Install the assembly



2. Push the separation roller assembly straight down until it snaps into place.

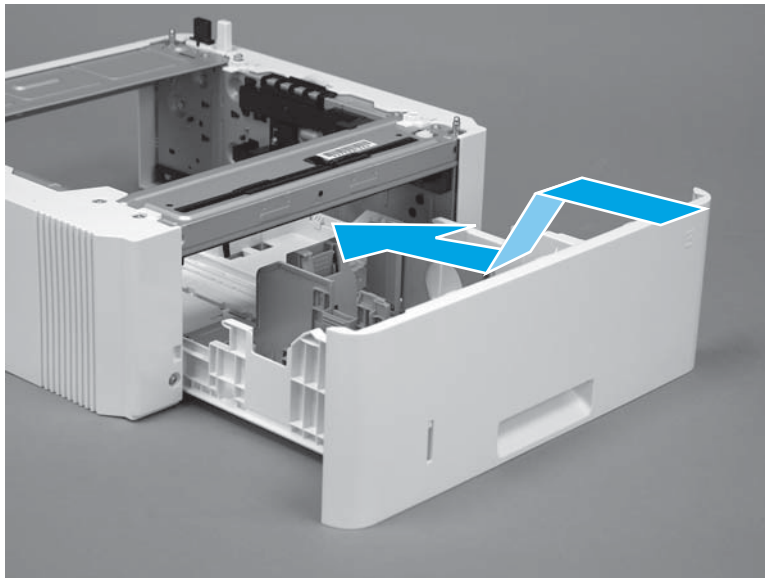
**Figure 1-2266** Release the assembly



#### Step 5: Install optional Tray 3

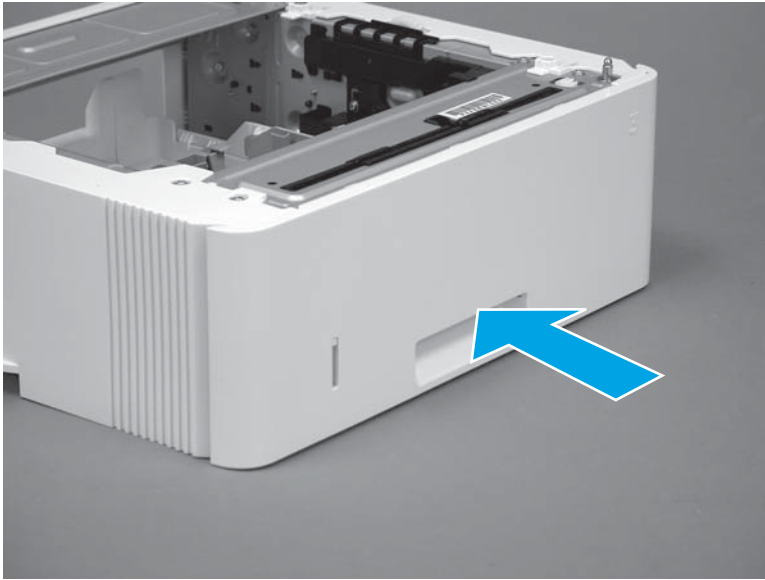
1. With the tray at a slight angle, align the sides of the tray with the rails in the accessory, and then partially slide the tray into the accessory.

**Figure 1-2267** Install the tray



2. Push the tray straight into the accessory to close it.

**Figure 1-2268** Close the tray





---

## 2 Parts and diagrams

- [For additional service and support](#)
- [Order parts, accessories, and supplies](#)
- [How to use the parts lists and diagrams](#)
- [Document feeder and image scanner](#)
- [Covers, printer base](#)
- [Internal components, printer base](#)
- [550-sheet paper feeder](#)
- [Alphabetical parts list](#)
- [Numerical parts list](#)

## For additional service and support

HP service personnel, go to the Service Access Work Bench (SAW) at <http://h41302.www4.hp.com/km/saw/home.do>.

Channel partners, go to HP Channel Services Network (CSN) at <https://h30125.www3.hp.com/hpcsn>.

- To access HP PartSurfer information from any mobile device, go to <http://partsurfermobile.hp.com/> or scan the Quick Response (QR) code below.



- Install and configure
- Printer specifications
- Up-to-date control panel message (CPMD) troubleshooting
- Solutions for printer issues and emerging issues
- Remove and replace part instructions and videos
- Service advisories
- Warranty and regulatory information

# Order parts, accessories, and supplies

## Ordering

Order supplies and paper	<a href="http://www.hp.com/go/suresupply">www.hp.com/go/suresupply</a>
Order genuine HP parts or accessories	<a href="http://www.hp.com/buy/parts">www.hp.com/buy/parts</a>
	or
	<a href="http://partsurfer.hp.com">partsurfer.hp.com</a>
Order through service or support providers	Contact an HP-authorized service or support provider.
Order using the HP Embedded Web Server (EWS)	To access, in a supported Web browser on your computer, enter the printer IP address or host name in the address/URL field. The EWS contains a link to the HP SureSupply Web site, which provides options for purchasing Original HP supplies.

## Orderable parts

Not all of the parts shown in the diagrams in this chapter can be ordered. Refer to the table following the diagram or the parts lists at the end of this chapter to determine if a part is orderable.

## Supplies

Following are the part numbers for the supplies available for the printers.

**Table 2-1 Supplies**

Item	Description	Cartridge number	Part number
<b>Supplies</b>			
HP 26A Black Original LaserJet Toner Cartridge	Standard-capacity replacement black toner cartridge	26A	CF226A
<b>NOTE:</b> M402 and M426 models only			
HP 28A Black Original LaserJet Toner Cartridge	Standard-capacity replacement black toner cartridge	28A	CF228A
<b>NOTE:</b> M403 and M427 models only			
HP 26X High Yield Black Original LaserJet Toner Cartridge	High-capacity replacement black toner cartridge	26X	CF226X
<b>NOTE:</b> M402 and M426 models only			
HP 28X High Yield Black Original LaserJet Toner Cartridge)	High-capacity replacement black toner cartridge	28X	CF228X
<b>NOTE:</b> M403 and M427 models only			

## Accessories

Following are the part numbers for the accessories available for the printer.

**Table 2-2 Accessories**

Item	Part number
550-sheet paper feeder (optional Tray 3)	C5F97-69001

## Customer self-repair parts

Customer Self-Repair (CSR) parts are available for many HP LaserJet printers to reduce repair time. More information about the CSR program and benefits can be found at [www.hp.com/go/csr-support](http://www.hp.com/go/csr-support) and [www.hp.com/go/csr-faq](http://www.hp.com/go/csr-faq).

Genuine HP replacement parts can be ordered at [www.hp.com/buy/parts](http://www.hp.com/buy/parts) or by contacting an HP-authorized service or support provider. When ordering, one of the following will be needed: part number, serial number (found on back of printer), printer number, or printer name.


- Parts listed as **Mandatory** self-replacement are to be installed by customers, unless you are willing to pay HP service personnel to perform the repair. For these parts, on-site or return-to-depot support is not provided under the HP printer warranty.
- Parts listed as **Optional** self-replacement can be installed by HP service personnel at your request for no additional charge during the printer warranty period.


Item	Description	Self-replacement options	Part number
250-sheet paper input tray	Replacement cassette for Tray 2	Mandatory	RM2-5392-000CN
Optional 550-sheet accessory tray	Replacement cassette for Tray 3	Mandatory	RM2-5413-000CN
Tray 2 separation roller assembly	Tray 2 separation roller	Mandatory	RM2-5397-000CN
Optional Tray 3 separation roller assembly	Optional Tray 3 separation roller	Mandatory	RM2-5745-000CN
Multipurpose roller	Multipurpose roller	Mandatory	RL2-0656-000CN
Tray 2 paper pickup roller assembly	Tray 2 pickup roller	Mandatory	RM2-5452-000CN
Optional Tray 3 paper pickup roller assembly	Optional Tray 3 pickup roller	Mandatory	RM2-5741-000CN

## How to use the parts lists and diagrams

The figures in this chapter show the major subassemblies in the printer and their component parts. A parts list table follows each exploded view assembly diagram. Each table lists the item number, the associated part number, and the description of each part. If a part is not listed in the table, then it is not a field replacement unit (FRU).


---

 **CAUTION:** Be sure to order the correct part. When looking for part numbers for electrical components, pay careful attention to the voltage that is listed in the description column. Doing so will ensure that the part number selected is for the correct model.

 **NOTE:** In this manual, the abbreviation “PCA” stands for “printed circuit-board assembly.” Components described as a PCA might consist of a single circuit board or a circuit board plus other parts, such as cables and sensors.

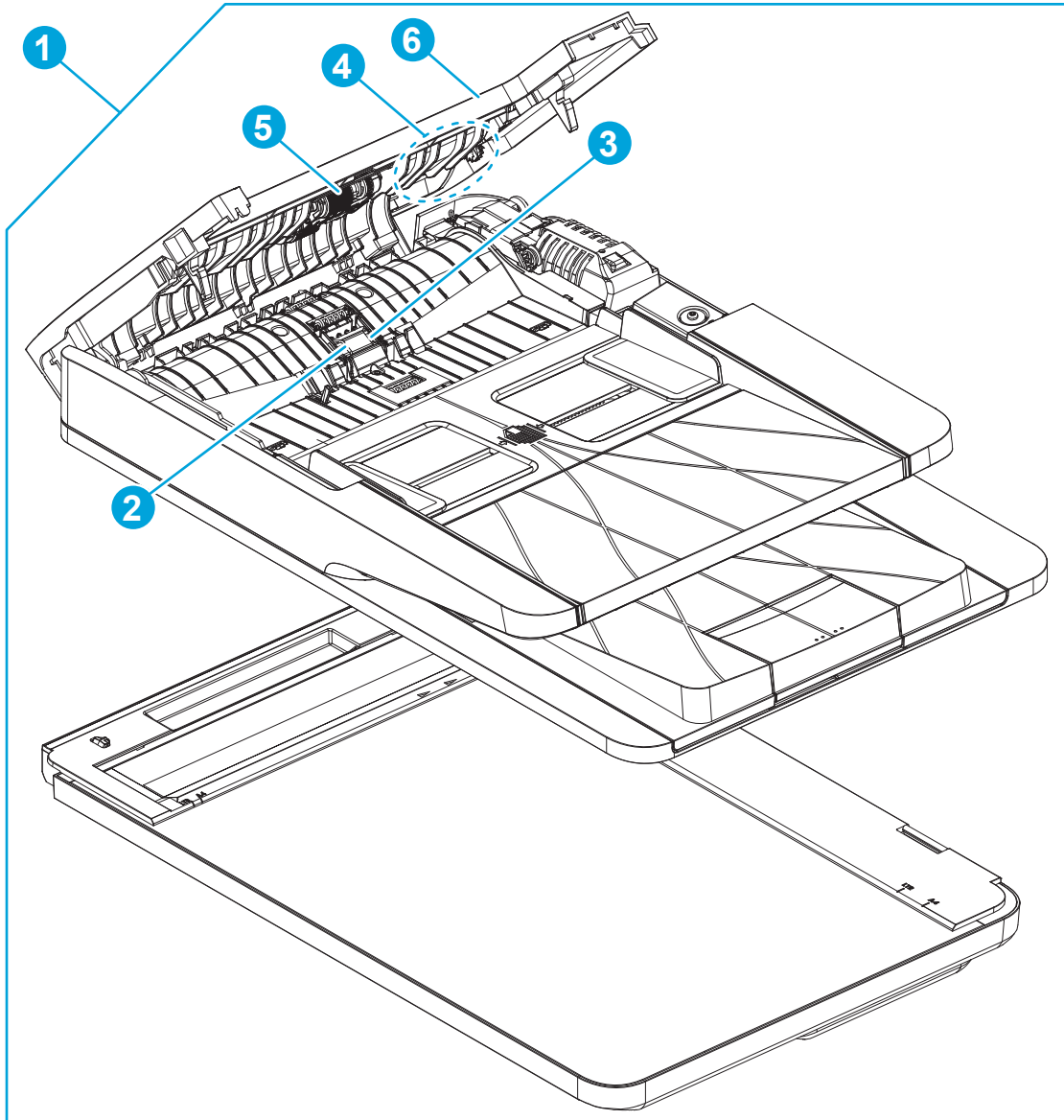
---

# Document feeder and image scanner

 **NOTE:** Parts listed in this section are for the M426 and M427 printers.

## Main assemblies

Figure 2-1 Main assemblies (document feeder and image scanner)



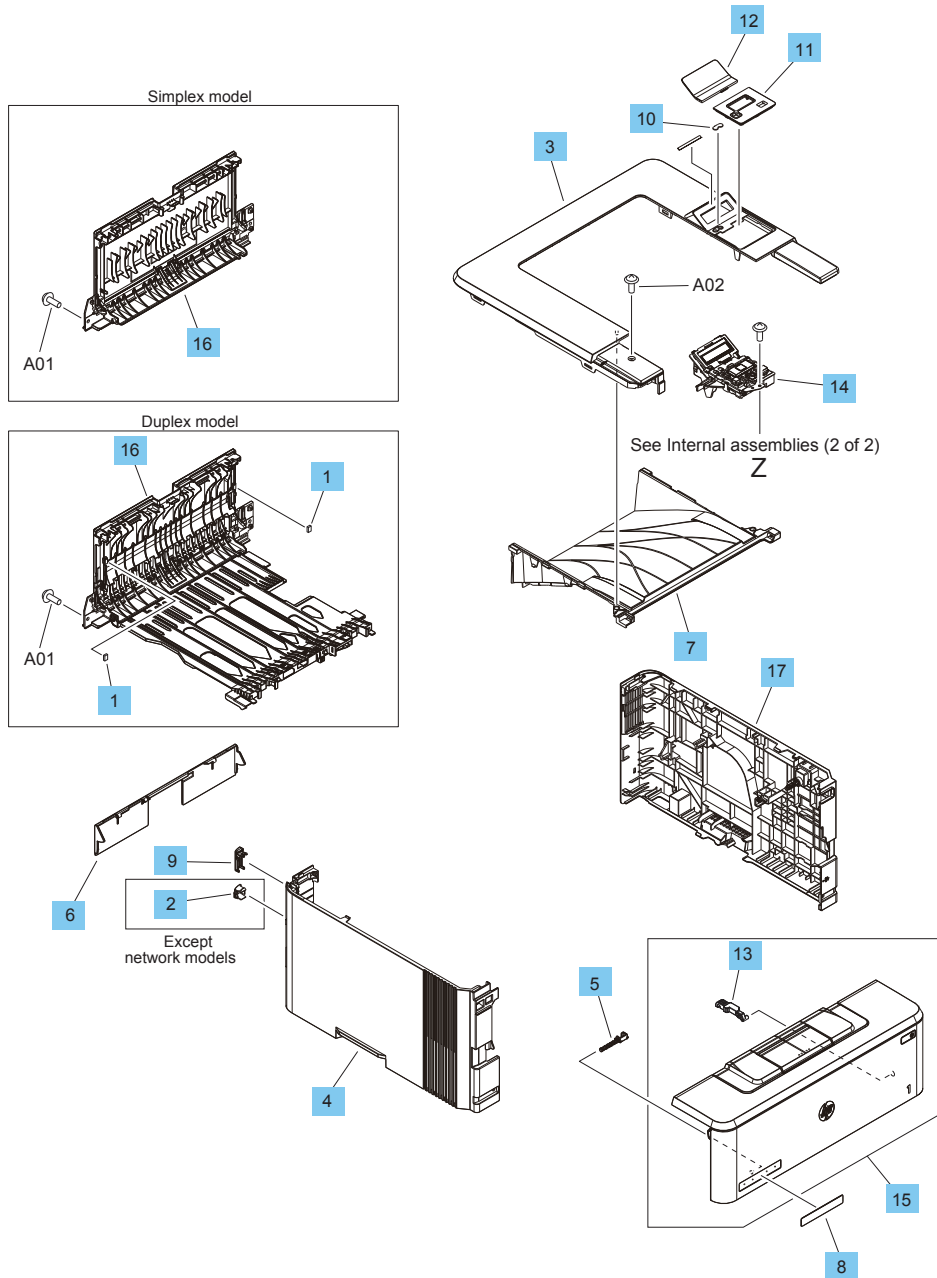
**Table 2-3 Main assemblies (document feeder and image scanner)**

<b>Ref</b>	<b>Description</b>	<b>Part number</b>	<b>Qty</b>
1	Document feeder and image scanner assembly (simplex models M426/M427)	C5F98-60109	1
1	Document feeder and image scanner assembly (duplex models M426/M427)	C5F98-60110	1
2	ADF separation pad	B3Q10-40080	1
3	Support, ADF separation pad	B3Q10-40079	1
Not shown	Spring, ADF separation pad (under the separation pad)	B3Q10-00019	1
4	Shaft, ADF pick extension	B3Q10-40081	1
5	ADF pick roller assembly	B3Q10-60105	1
6	Cover, ADF outer	B3Q10-40013	1
Not shown	Cover, ADF inner (under the out cover)	B3Q10-40012	1
Not shown	Ferrite ISA (M426fdn; M426fdw; M427fdn; M427fdw)	9170-2664	1
Not shown	Ferrite, ISA	9170-2437	1
Not shown	Ferrite, motor	9170-2659	1
Not shown	Cover, FFC	C5F98-40002	1
Not shown	Cover, core	C5F98-40003	1
Not shown	ISA lift	B3Q10-60128	1
Not shown	Slider pin, ISA lift	B3Q10-40041	1

# Covers, printer base

## Covers, M402 and M403

Figure 2-2 Covers, M402 and M403



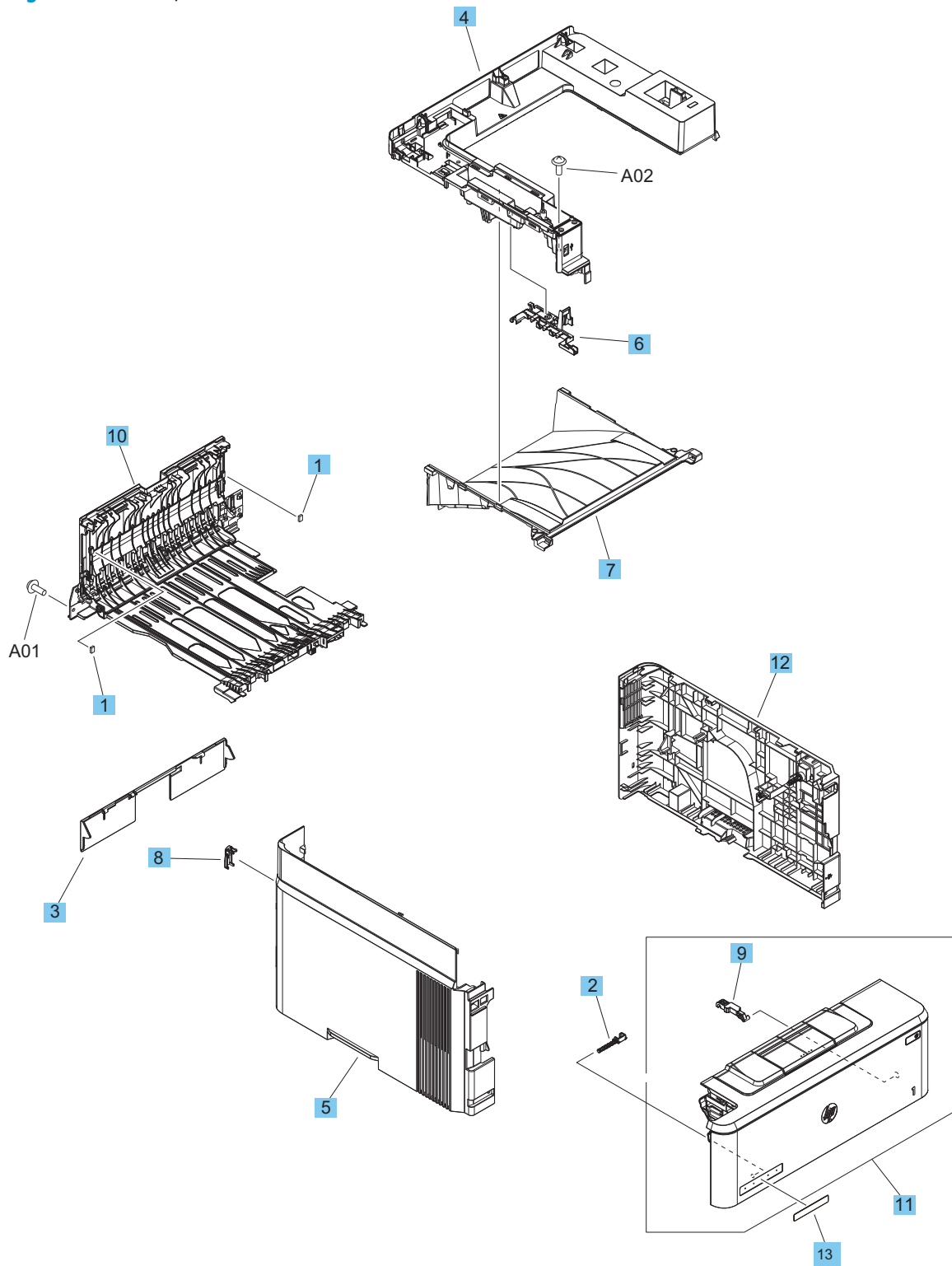


**Table 2-4 Covers, M402 and M403**

<b>Ref</b>	<b>Description</b>	<b>Part number</b>	<b>Qty</b>
1	Sheet, damper (duplex models only)	RC2-6075-000CN	2
2	Cover, network (non-network models M402/M403)	RC4-2907-000CN	1
3	Cover, top (M402/M403)	RC4-2956-000CN	1
4	Cover, left (M402/M403)	RL2-0673-000CN	1
5	Shaft, support	RC4-3002-000CN	1
6	Cover, cassette rear	RC4-3082-000CN	1
7	Tray, paper delivery	RC4-3231-000CN	1
8	Plate, name M402d	RC4-3288-000CN	1
8	Plate, name M402n	RC4-3270-000CN	1
8	Plate, name M403n	RC4-3267-000CN	1
8	Plate, name M403d	RC4-3266-000CN	1
8	Plate, name M402dn	RC4-3264-000CN	1
8	Plate, name M403dn	RC4-3268-000CN	1
8	Plate, name M402dw	RC4-3265-000CN	1
8	Plate, name M403dw	RC4-3269-000CN	1
9	Cover, rear USB (M402/M403)	RC4-3298-000CN	1
10	Guide, LED light	RC4-3311-000CN	1
11	Cover, operation (non-wireless models M402/M403)	RC4-3312-000CN	1
11	Cover, operation (wireless models M402/M403)	RC4-3322-000CN	1
12	Cover, indication	RL2-0675-000CN	1
13	Link, pressure release	RC4-4479-000CN	1
14	Control-panel assembly (non-wireless models M402/M403)	RM2-5391-000CN	1
14	Control-panel assembly (wireless models M402/M403)	RM2-5424-000CN	1
15	Cartridge door assembly (non-NFC models M402/M403)	RM2-5390-000CN	1
15	Cartridge door assembly (NFC models M402/M403)	RM2-5436-000CN	1
16	Door, rear assembly (simplex models M402/M403)	RM2-5430-000CN	1
16	Door, rear assembly (duplex models only)	RM2-5405-000CN	1
17	Cover, right assembly	RM2-5434-000CN	1
Not shown	HP logo jewel	7121-8686	1

## Covers, M426 and M427

Figure 2-3 Covers, M426 and M427



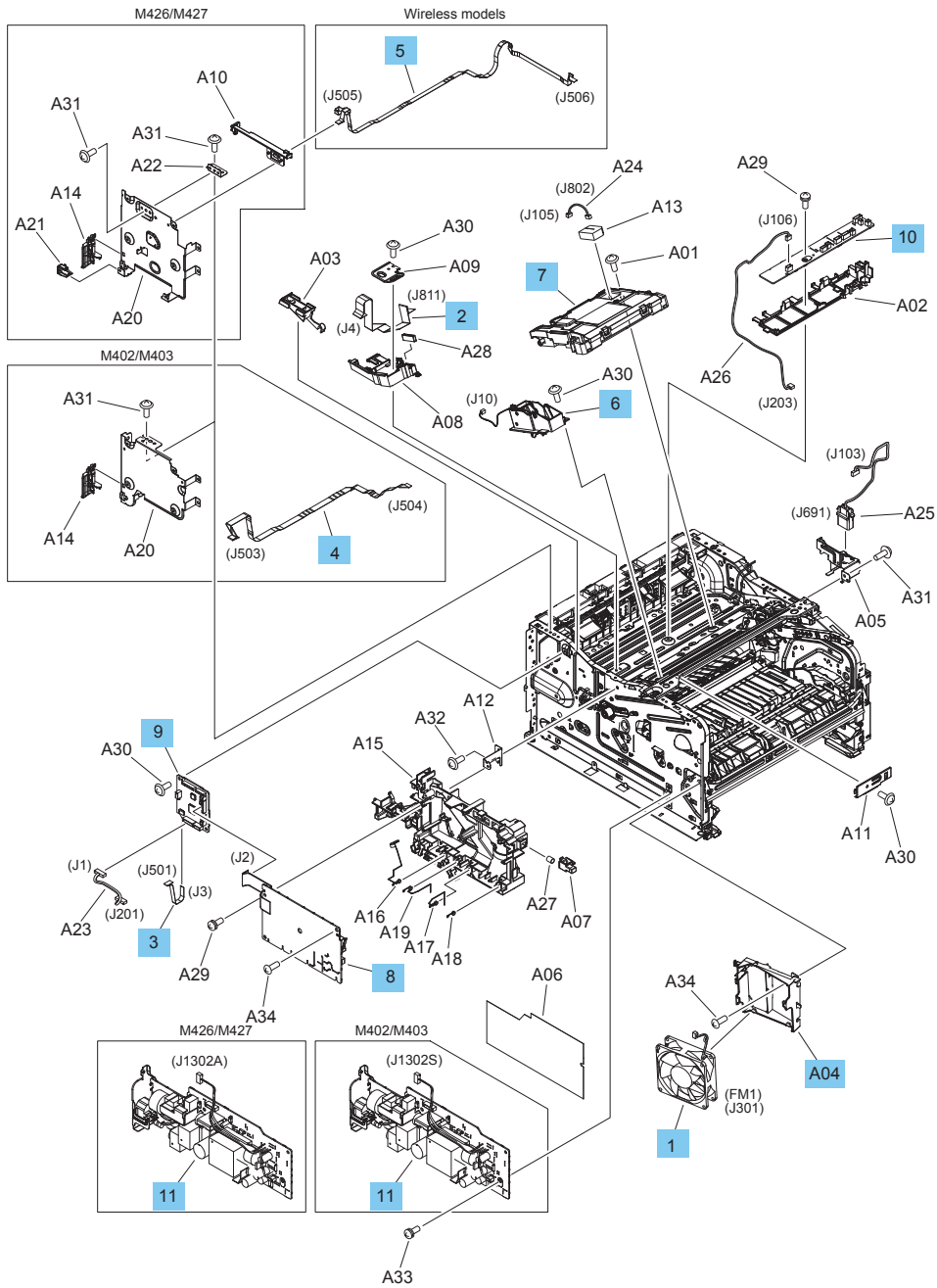
**Table 2-5 Covers, M426 and M427**

Ref	Description	Part number	Qty
1	Sheet, damper	RC2-6075-000CN	2
2	Shaft, support	RC4-3002-000CN	1
3	Cover, cassette rear	RC4-3082-000CN	1
4	Cover, top (M426/M427)	RC4-3207-000CN	1
5	Cover, left (M426/M427)	RL2-0674-000CN	1
6	Guide, cable	RC4-3217-000CN	1
7	Tray, paper delivery	RC4-3231-000CN	1
8	Cover, rear USB (M426 and M427)	RC4-3299-000CN	1
9	Link, pressure release	RC4-4479-000CN	1
10	Door, rear (duplex models only)	RM2-5405-000CN	1
11	Door, cartridge assembly (non-NFC models M426/M427)	RM2-5408-000CN	1
11	Door, cartridge assembly (NFC models M426/M427)	RM2-5435-000CN	1
12	Cover, right assembly	RM2-5434-000CN	1
13	Name plate M427dw	C5F97-40001	1
13	Name plate M427dn	C5F98-40004	1
13	Name plate M427fdw	C5F99-40002	1
13	Name plate M426dw	F6W13-40002	1
13	Name plate M426fdn	F6W14-40002	1
13	Name plate M426fdw	F6W15-40002	1
Not shown	Control panel (M426/M427)	B3Q10-60139	1
Not shown	Control panel mount cover	B3Q11-40002	1
Not shown	Control panel mount base	B3Q11-40001	1
Not shown	Control panel mount chassis assembly	B3Q10-60145	1
Not shown	Control panel 22-pin FFC	C5F98-60104	1
Not shown	Cover, fax port (M426fdn; M426fdw; 427fdn; M427fdw)	C5F99-40003	1
Not shown	HP logo jewel	7121-8686	1

# Internal components, printer base

## Internal components, printer base (1 of 3)

Figure 2-4 Internal components, printer base (1 of 5)

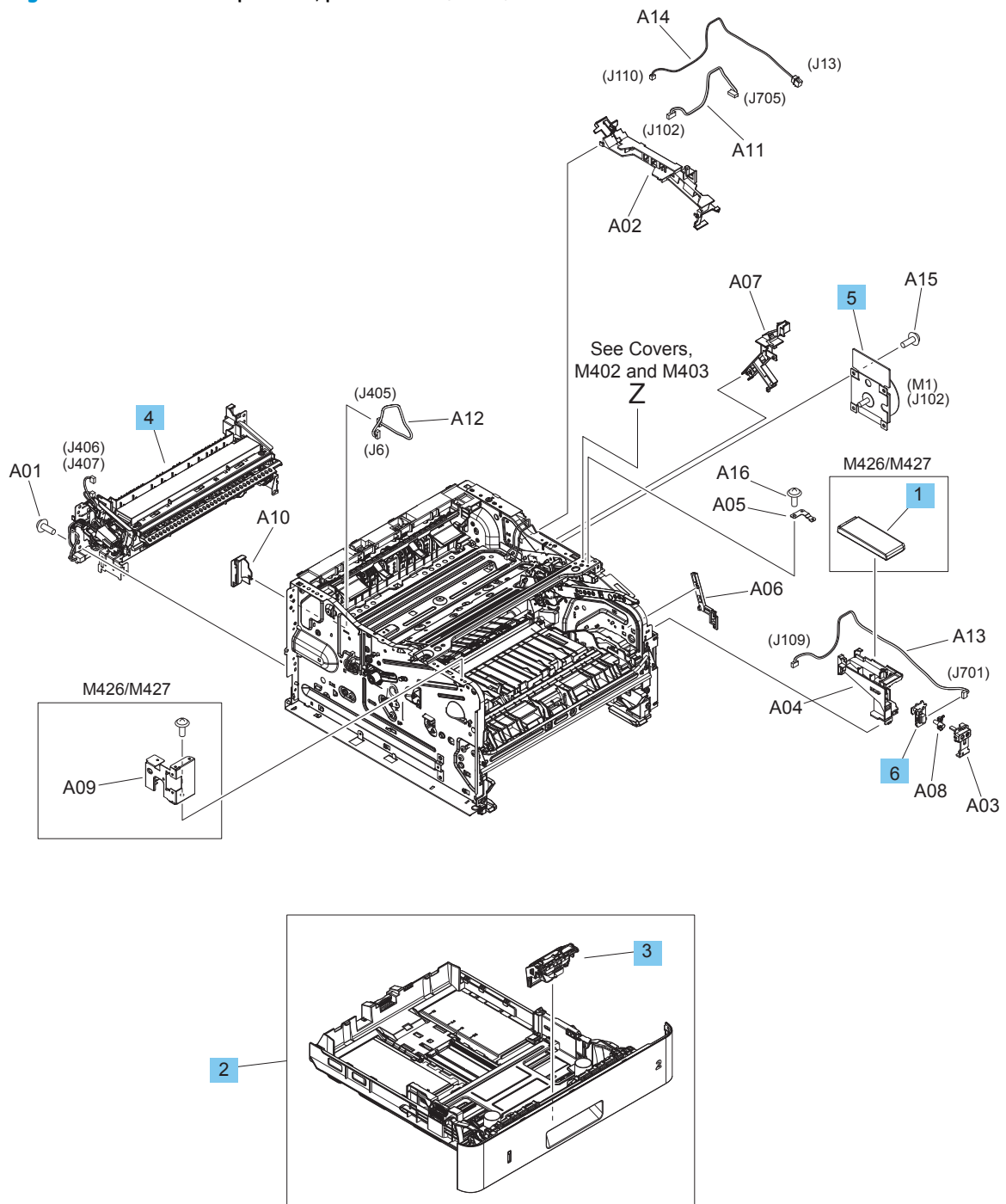


**Table 2-6 Internal components, printer base (1 of 3)**

Ref	Description	Part number	Qty
1	Fan, FM1	RK2-8068-000CN	1
2	Cable, laser-scanner FFC	RK2-6919-000CN	1
3	Cable, formatter FFC (M246/M247)	RK2-6931-000CN	1
3	Cable, formatter FFC (M402/M403)	RK2-6920-000CN	1
4	Cable, panel FFC (M402/M403)	RK2-6943-000CN	1
5	Cable, Near field communication (NFC) FFC (wireless models M402/M403)	RK2-6947-000CN	1
5	Cable, Near field communication (NFC) FFC (wireless models M426/M427)	RK2-6949-000CN	1
6	Cable, tag assembly	RM2-5426-000CN	1
7	Laser-scanner assembly	RM2-5528-000CN	1
8	High-voltage power supply (HVPS) PCA	RM2-7508-000CN	1
9	DC controller PCA	RM2-8680-000CN	1
10	Connecting PCA (duplex models)	RM2-7510-000CN	1
10	Connecting PCA (simplex models)	RM2-8510-000CN	1
11	Low-voltage power supply (LVPS) PCA (110–127 V M426/M427)	RM2-8518-000CN	1
11	Low-voltage power supply (LVPS) PCA (220–240 V M426/M427)	RM2-8519-000CN	1
11	Low-voltage power supply (LVPS) PCA (110–127 V M402/M403)	RM2-8517-000CN	1
11	Low-voltage power supply (LVPS) PCA (220–240 V M402/M403)	RM2-8516-000CN	1
A04	Duct, fan	RC4-2891-000CN	1
Not shown	Duplex release button	RC2-6075-000CN	1
Not shown	Pad, thermal transfer	5851-6550	1
Not shown	Formatter PCA (M426dw; M427dw)	C5F99-60001	1
Not shown	Formatter PCA (M426fdn; M426fdw; M427fdn; M427fdw)	C5F98-60001	1
Not shown	Formatter PCA (M402d; M403d)	C5F92-60001	1
Not shown	Formatter PCA (M402n; M402dn; M403n; M403dn)	C5F93-60001	1
Not shown	Formatter PCA (M402dw; M403dw)	C5F94-60001	1
Not shown	Fax PCA (US/AP; M426fdn; M426fdw; 427fdn; M427fdw)	CF206-60001	1
Not shown	Fax PCA (Euro; M426fdn; M426fdw; 427fdn; M427fdw)	CF207-60001	1
Not shown	Fax PCA (Brazil; M426fdn; M426fdw; 427fdn; M427fdw)	CF208-60001	1
Not shown	Spacer, hexagonal fax (M426fdn; M426fdw; 427fdn; M427fdw)	C5F98-20001	1
Not shown	Wireless module	0960-3293	1
Not shown	Wireless holder	B3Q10-40054	1

## Internal components, printer base (2 of 3)

Figure 2-5 Internal components, printer base (2 of 3)

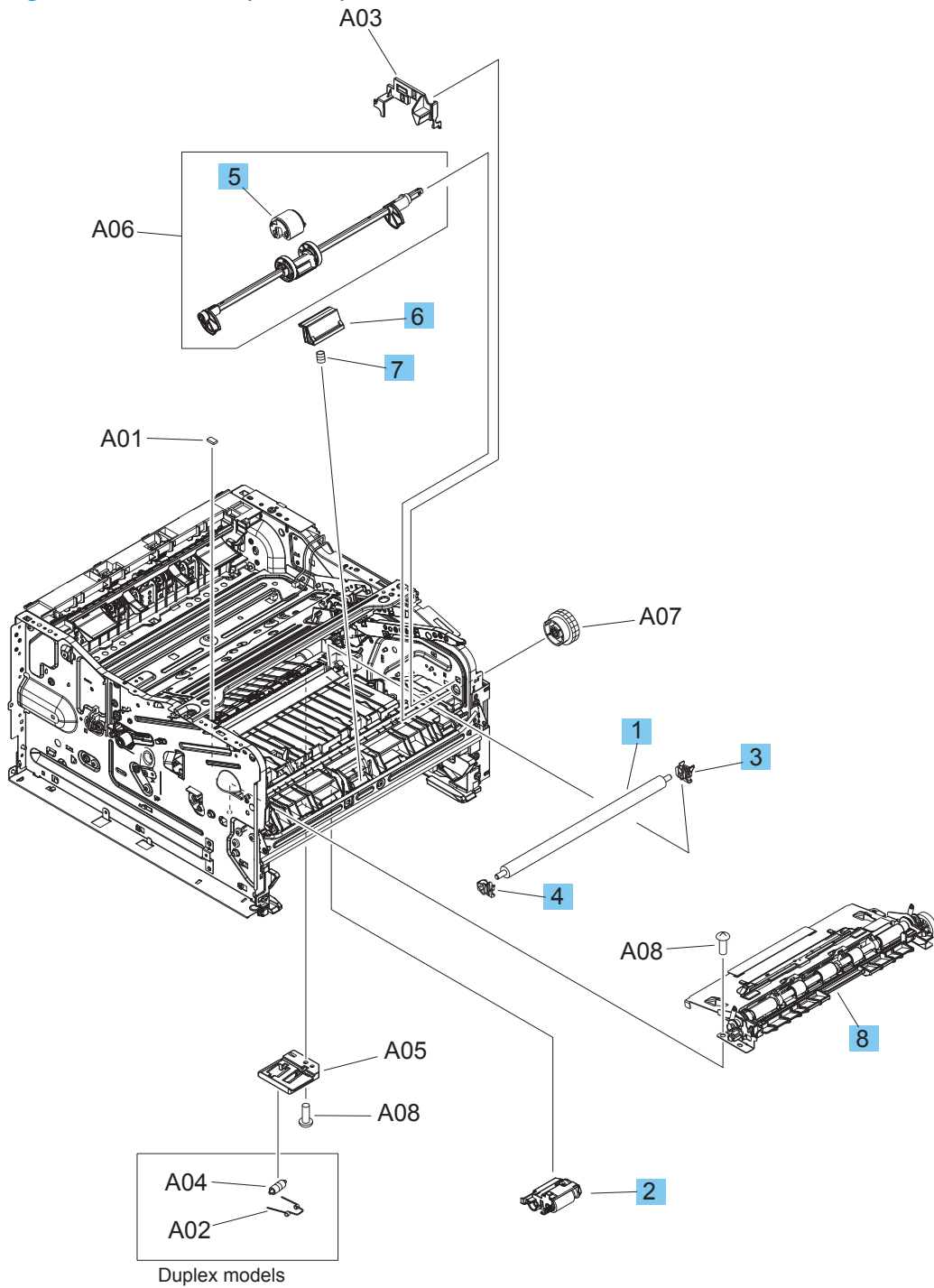


**Table 2-7 Internal components, printer base (2 of 3)**

<b>Ref</b>	<b>Description</b>	<b>Part number</b>	<b>Qty</b>
1	Cover, Near field communication (NFC) (M426/M427)	RC4-2961-000CN	1
2	Cassette (Tray 2) assembly	RM2-5392-000CN	1
3	Roller, separation assembly	RM2-5397-000CN	1
4	Fixing (fuser) assembly (110-127 V)	RM2-5399-000CN	1
4	Fixing (fuser) assembly (220-240 V)	RM2-5425-000CN	1
5	Main motor assembly	RM2-8684-000CN	1
6	Switch, power PCA	RM2-8506-000CN	1
Not shown	Ferrite, motor	9170-2659	1
Not shown	Walkup USB PCA (M426/M427)	CF368-60001	1
Not shown	Cable, walkup USB (M426/M427)	C5F98-60105	1
Not shown	NFC module	B4K93-60001	1

## Internal components, printer base (3 of 3)

Figure 2-6 Internal components, printer base (3 of 3)





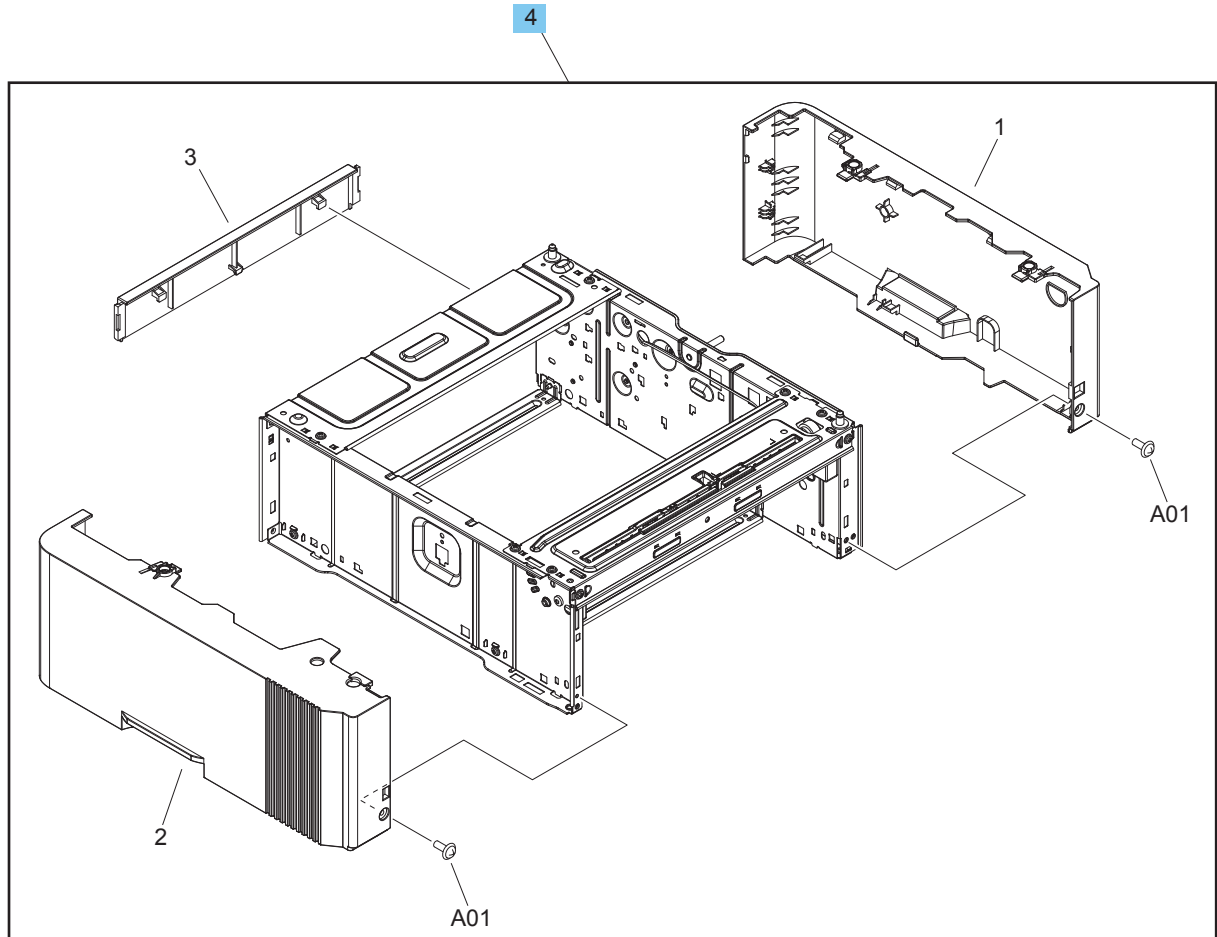
**Table 2-8 Internal components, printer base (3 of 3)**

<b>Ref</b>	<b>Description</b>	<b>Part number</b>	<b>Qty</b>
1	Roller, transfer	RM1-4023-000CN	1
2	Roller, paper pickup assembly	RM2-5452-000CN	1
3	Holder, transfer roller right	RC4-3133-000CN	1
4	Holder, transfer roller left	RC4-3134-000CN	1
5	Roller, multi-purpose (Tray 1)	RL2-0656-000CN	1
6	Pad, multi-purpose (Tray 1) separation	RL2-0657-000CN	1
7	Spring, compression	RU8-2935-000CN	1
8	Registration assembly	RM2-5671-000CN	1

# 550-sheet paper feeder

## Covers, 550-sheet paper feeder

Figure 2-7 Covers, 550-sheet paper feeder

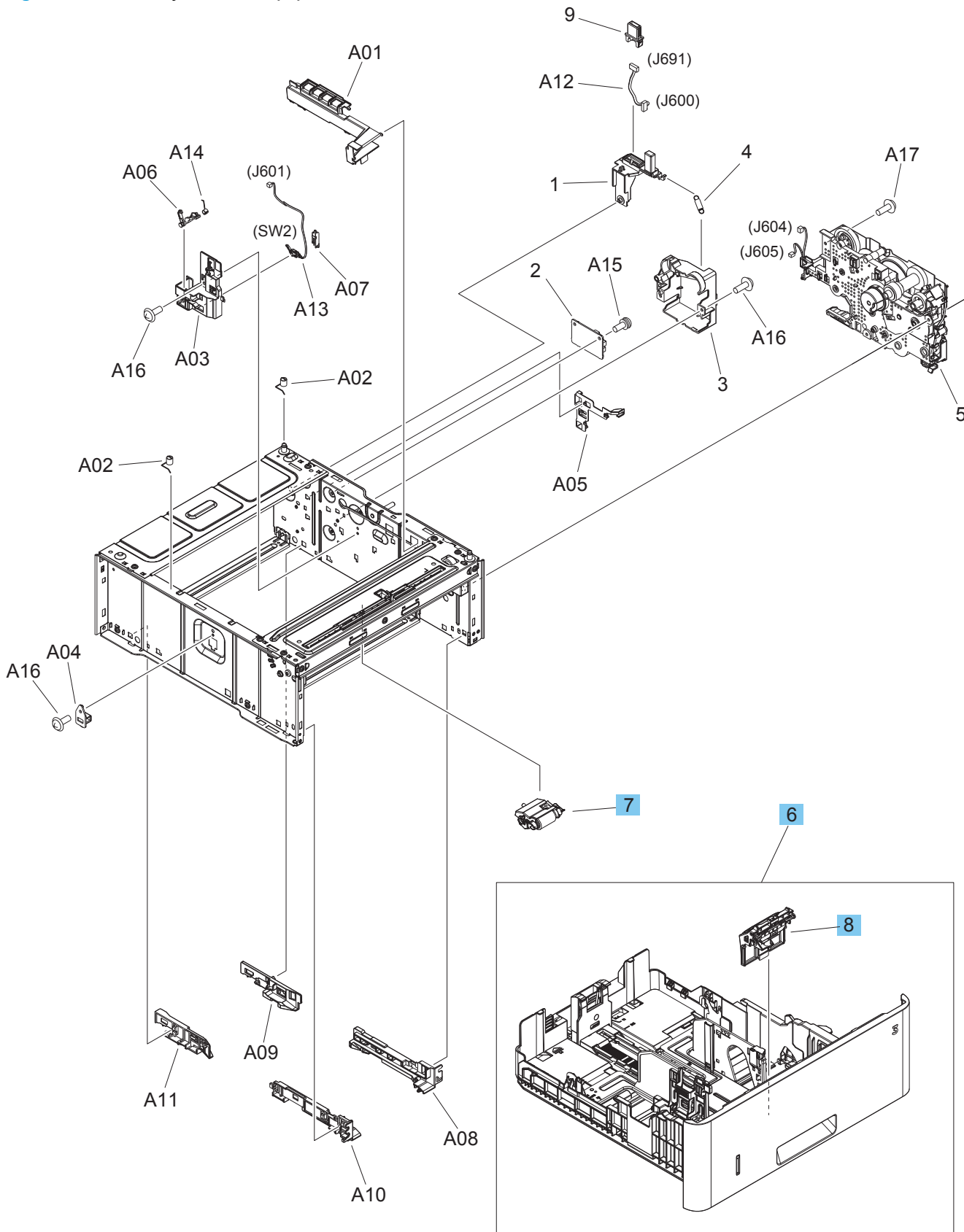


**Table 2-9 Covers, 550-sheet paper feeder**

<b>Ref</b>	<b>Description</b>	<b>Part number</b>	<b>Qty</b>
4	Paper feeder, 550-sheet assembly (whole unit)	C5F97-69001	1

# Main body, 550-sheet paper feeder

Figure 2-8 Main body, 550-sheet paper feeder



**Table 2-10 Main body, 550-sheet paper feeder**

<b>Ref</b>	<b>Description</b>	<b>Part number</b>	<b>Qty</b>
6	Cassette assembly (550-sheet feeder)	RM2-5413-000CN	1
7	Roller, paper pickup assembly (550-sheet feeder)	RM2-5741-000CN	1
8	Roller, separation assembly (550-sheet feeder)	RM2-5745-000CN	1

# Alphabetical parts list

**Table 2-11 Alphabetical parts list**

Description	Part number	Table and page
ADF pick roller assembly	B3Q10-60105	<a href="#">Main assemblies (document feeder and image scanner) on page 1209</a>
ADF separation pad	B3Q10-40080	<a href="#">Main assemblies (document feeder and image scanner) on page 1209</a>
Cable, formatter FFC (M246/M247)	RK2-6931-000CN	<a href="#">Internal components, printer base (1 of 3) on page 1215</a>
Cable, formatter FFC (M402/M403)	RK2-6920-000CN	<a href="#">Internal components, printer base (1 of 3) on page 1215</a>
Cable, laser-scanner FFC	RK2-6919-000CN	<a href="#">Internal components, printer base (1 of 3) on page 1215</a>
Cable, Near field communication (NFC) FFC (wireless models M402/M403)	RK2-6947-000CN	<a href="#">Internal components, printer base (1 of 3) on page 1215</a>
Cable, Near field communication (NFC) FFC (wireless models M426/M427)	RK2-6949-000CN	<a href="#">Internal components, printer base (1 of 3) on page 1215</a>
Cable, panel FFC (M402/M403)	RK2-6943-000CN	<a href="#">Internal components, printer base (1 of 3) on page 1215</a>
Cable, tag assembly	RM2-5426-000CN	<a href="#">Internal components, printer base (1 of 3) on page 1215</a>
Cable, walkup USB (M426/M427)	C5F98-60105	<a href="#">Internal components, printer base (2 of 3) on page 1217</a>
Cartridge door assembly (NFC models M402/M403)	RM2-5436-000CN	<a href="#">Covers, M402 and M403 on page 1211</a>
Cartridge door assembly (non-NFC models M402/M403)	RM2-5390-000CN	<a href="#">Covers, M402 and M403 on page 1211</a>
Cassette (Tray 2) assembly	RM2-5392-000CN	<a href="#">Internal components, printer base (2 of 3) on page 1217</a>
Cassette assembly (550-sheet feeder)	RM2-5413-000CN	<a href="#">Main body, 550-sheet paper feeder on page 1223</a>
Connecting PCA (duplex models)	RM2-7510-000CN	<a href="#">Internal components, printer base (1 of 3) on page 1215</a>
Connecting PCA (simplex models)	RM2-8510-000CN	<a href="#">Internal components, printer base (1 of 3) on page 1215</a>
Control panel (M426/M427)	B3Q10-60139	<a href="#">Covers, M426 and M427 on page 1213</a>
Control panel 22-pin FFC	C5F98-60104	<a href="#">Covers, M426 and M427 on page 1213</a>
Control panel mount base	B3Q11-40001	<a href="#">Covers, M426 and M427 on page 1213</a>
Control panel mount chassis assembly	B3Q10-60145	<a href="#">Covers, M426 and M427 on page 1213</a>

**Table 2-11 Alphabetical parts list (continued)**

<b>Description</b>	<b>Part number</b>	<b>Table and page</b>
Control panel mount cover	B3Q11-40002	<a href="#">Covers, M426 and M427 on page 1213</a>
Control-panel assembly (non-wireless models M402/M403)	RM2-5391-000CN	<a href="#">Covers, M402 and M403 on page 1211</a>
Control-panel assembly (wireless models M402/M403)	RM2-5424-000CN	<a href="#">Covers, M402 and M403 on page 1211</a>
Cover, ADF inner (under the out cover)	B3Q10-40012	<a href="#">Main assemblies (document feeder and image scanner) on page 1209</a>
Cover, ADF outer	B3Q10-40013	<a href="#">Main assemblies (document feeder and image scanner) on page 1209</a>
Cover, cassette rear	RC4-3082-000CN	<a href="#">Covers, M402 and M403 on page 1211</a>
Cover, cassette rear	RC4-3082-000CN	<a href="#">Covers, M426 and M427 on page 1213</a>
Cover, core	C5F98-40003	<a href="#">Main assemblies (document feeder and image scanner) on page 1209</a>
Cover, fax port (M426fdn; M426fdw; 427fdn; M427fdw)	C5F99-40003	<a href="#">Covers, M426 and M427 on page 1213</a>
Cover, FFC	C5F98-40002	<a href="#">Main assemblies (document feeder and image scanner) on page 1209</a>
Cover, indication	RL2-0675-000CN	<a href="#">Covers, M402 and M403 on page 1211</a>
Cover, left (M402/M403)	RL2-0673-000CN	<a href="#">Covers, M402 and M403 on page 1211</a>
Cover, left (M426/M427)	RL2-0674-000CN	<a href="#">Covers, M426 and M427 on page 1213</a>
Cover, Near field communication (NFC) (M426/M427)	RC4-2961-000CN	<a href="#">Internal components, printer base (2 of 3) on page 1217</a>
Cover, network (non-network models M402/M403)	RC4-2907-000CN	<a href="#">Covers, M402 and M403 on page 1211</a>
Cover, operation (non-wireless models M402/M403)	RC4-3312-000CN	<a href="#">Covers, M402 and M403 on page 1211</a>
Cover, operation (wireless models M402/M403)	RC4-3322-000CN	<a href="#">Covers, M402 and M403 on page 1211</a>
Cover, rear USB (M402/M403)	RC4-3298-000CN	<a href="#">Covers, M402 and M403 on page 1211</a>
Cover, rear USB (M426 and M427)	RC4-3299-000CN	<a href="#">Covers, M426 and M427 on page 1213</a>
Cover, right assembly	RM2-5434-000CN	<a href="#">Covers, M402 and M403 on page 1211</a>

**Table 2-11 Alphabetical parts list (continued)**

<b>Description</b>	<b>Part number</b>	<b>Table and page</b>
Cover, right assembly	RM2-5434-000CN	<a href="#">Covers, M426 and M427 on page 1213</a>
Cover, top (M402/M403)	RC4-2956-000CN	<a href="#">Covers, M402 and M403 on page 1211</a>
Cover, top (M426/M427)	RC4-3207-000CN	<a href="#">Covers, M426 and M427 on page 1213</a>
DC controller PCA	RM2-8680-000CN	<a href="#">Internal components, printer base (1 of 3) on page 1215</a>
Document feeder and image scanner assembly (duplex models M426/M427)	C5F98-60110	<a href="#">Main assemblies (document feeder and image scanner) on page 1209</a>
Document feeder and image scanner assembly (simplex models M426/M427)	C5F98-60109	<a href="#">Main assemblies (document feeder and image scanner) on page 1209</a>
Door, cartridge assembly (NFC models M426/M427)	RM2-5435-000CN	<a href="#">Covers, M426 and M427 on page 1213</a>
Door, cartridge assembly (non-NFC models M426/M427)	RM2-5408-000CN	<a href="#">Covers, M426 and M427 on page 1213</a>
Door, rear (duplex models only)	RM2-5405-000CN	<a href="#">Covers, M426 and M427 on page 1213</a>
Door, rear assembly (duplex models only)	RM2-5405-000CN	<a href="#">Covers, M402 and M403 on page 1211</a>
Door, rear assembly (simplex models M402/M403)	RM2-5430-000CN	<a href="#">Covers, M402 and M403 on page 1211</a>
Duct, fan	RC4-2891-000CN	<a href="#">Internal components, printer base (1 of 3) on page 1215</a>
Duplex release button	RC2-6075-000CN	<a href="#">Internal components, printer base (1 of 3) on page 1215</a>
Fan, FM1	RK2-8068-000CN	<a href="#">Internal components, printer base (1 of 3) on page 1215</a>
Fax PCA (Brazil; M426fdn; M426fdw; 427fdn; M427fdw)	CF208-60001	<a href="#">Internal components, printer base (1 of 3) on page 1215</a>
Fax PCA (Euro; M426fdn; M426fdw; 427fdn; M427fdw)	CF207-60001	<a href="#">Internal components, printer base (1 of 3) on page 1215</a>
Fax PCA (US/AP; M426fdn; M426fdw; 427fdn; M427fdw)	CF206-60001	<a href="#">Internal components, printer base (1 of 3) on page 1215</a>
Ferrite ISA (M426fdn; M426fdw; M427fdn; M427fdw)	9170-2664	<a href="#">Main assemblies (document feeder and image scanner) on page 1209</a>
Ferrite, ISA	9170-2437	<a href="#">Main assemblies (document feeder and image scanner) on page 1209</a>
Ferrite, motor	9170-2659	<a href="#">Main assemblies (document feeder and image scanner) on page 1209</a>



**Table 2-11 Alphabetical parts list (continued)**

<b>Description</b>	<b>Part number</b>	<b>Table and page</b>
Ferrite, motor	9170-2659	<a href="#">Internal components, printer base (2 of 3) on page 1217</a>
Fixing (fuser) assembly (110-127 V)	RM2-5399-000CN	<a href="#">Internal components, printer base (2 of 3) on page 1217</a>
Fixing (fuser) assembly (220-240 V)	RM2-5425-000CN	<a href="#">Internal components, printer base (2 of 3) on page 1217</a>
Formatter PCA (M402d; M403d)	C5F92-60001	<a href="#">Internal components, printer base (1 of 3) on page 1215</a>
Formatter PCA (M402dw; M403dw)	C5F94-60001	<a href="#">Internal components, printer base (1 of 3) on page 1215</a>
Formatter PCA (M402n; M402dn; M403n; M403dn)	C5F93-60001	<a href="#">Internal components, printer base (1 of 3) on page 1215</a>
Formatter PCA (M426dw; M427dw)	C5F99-60001	<a href="#">Internal components, printer base (1 of 3) on page 1215</a>
Formatter PCA (M426fdn; M426fdw; M427fdn; M427fdw)	C5F98-60001	<a href="#">Internal components, printer base (1 of 3) on page 1215</a>
Guide, cable	RC4-3217-000CN	<a href="#">Covers, M426 and M427 on page 1213</a>
Guide, LED light	RC4-3311-000CN	<a href="#">Covers, M402 and M403 on page 1211</a>
High-voltage power supply (HVPS) PCA	RM2-7508-000CN	<a href="#">Internal components, printer base (1 of 3) on page 1215</a>
Holder, transfer roller left	RC4-3134-000CN	<a href="#">Internal components, printer base (3 of 3) on page 1219</a>
Holder, transfer roller right	RC4-3133-000CN	<a href="#">Internal components, printer base (3 of 3) on page 1219</a>
HP logo jewel	7121-8686	<a href="#">Covers, M402 and M403 on page 1211</a>
HP logo jewel	7121-8686	<a href="#">Covers, M426 and M427 on page 1213</a>
ISA lift	B3Q10-60128	<a href="#">Main assemblies (document feeder and image scanner) on page 1209</a>
Laser-scanner assembly	RM2-5528-000CN	<a href="#">Internal components, printer base (1 of 3) on page 1215</a>
Link, pressure release	RC4-4479-000CN	<a href="#">Covers, M402 and M403 on page 1211</a>
Link, pressure release	RC4-4479-000CN	<a href="#">Covers, M426 and M427 on page 1213</a>
Low-voltage power supply (LVPS) PCA (110-127 V M402/M403)	RM2-8517-000CN	<a href="#">Internal components, printer base (1 of 3) on page 1215</a>
Low-voltage power supply (LVPS) PCA (110-127 V M426/M427)	RM2-8518-000CN	<a href="#">Internal components, printer base (1 of 3) on page 1215</a>

**Table 2-11 Alphabetical parts list (continued)**

<b>Description</b>	<b>Part number</b>	<b>Table and page</b>
Low-voltage power supply (LVPS) PCA (220–240 V M402/M403)	RM2-8516-000CN	<a href="#">Internal components, printer base (1 of 3) on page 1215</a>
Low-voltage power supply (LVPS) PCA (220–240 V M426/M427)	RM2-8519-000CN	<a href="#">Internal components, printer base (1 of 3) on page 1215</a>
Main motor assembly	RM2-8684-000CN	<a href="#">Internal components, printer base (2 of 3) on page 1217</a>
Name plate M426dw	F6W13-40002	<a href="#">Covers, M426 and M427 on page 1213</a>
Name plate M426fdn	F6W14-40002	<a href="#">Covers, M426 and M427 on page 1213</a>
Name plate M426fdw	F6W15-40002	<a href="#">Covers, M426 and M427 on page 1213</a>
Name plate M427dn	C5F98-40004	<a href="#">Covers, M426 and M427 on page 1213</a>
Name plate M427dw	C5F97-40001	<a href="#">Covers, M426 and M427 on page 1213</a>
Name plate M427fdw	C5F99-40002	<a href="#">Covers, M426 and M427 on page 1213</a>
NFC module	B4K93-60001	<a href="#">Internal components, printer base (2 of 3) on page 1217</a>
Pad, multi-purpose (Tray 1) separation	RL2-0657-000CN	<a href="#">Internal components, printer base (3 of 3) on page 1219</a>
Pad, thermal transfer	5851-6550	<a href="#">Internal components, printer base (1 of 3) on page 1215</a>
Paper feeder, 550-sheet assembly (whole unit)	C5F97-69001	<a href="#">Covers, 550-sheet paper feeder on page 1221</a>
Plate, name M402d	RC4-3288-000CN	<a href="#">Covers, M402 and M403 on page 1211</a>
Plate, name M402dn	RC4-3264-000CN	<a href="#">Covers, M402 and M403 on page 1211</a>
Plate, name M402dw	RC4-3265-000CN	<a href="#">Covers, M402 and M403 on page 1211</a>
Plate, name M402n	RC4-3270-000CN	<a href="#">Covers, M402 and M403 on page 1211</a>
Plate, name M403d	RC4-3266-000CN	<a href="#">Covers, M402 and M403 on page 1211</a>
Plate, name M403dn	RC4-3268-000CN	<a href="#">Covers, M402 and M403 on page 1211</a>
Plate, name M403dw	RC4-3269-000CN	<a href="#">Covers, M402 and M403 on page 1211</a>
Plate, name M403n	RC4-3267-000CN	<a href="#">Covers, M402 and M403 on page 1211</a>

**Table 2-11 Alphabetical parts list (continued)**

<b>Description</b>	<b>Part number</b>	<b>Table and page</b>
Registration assembly	RM2-5671-000CN	<a href="#">Internal components, printer base (3 of 3) on page 1219</a>
Roller, multi-purpose (Tray 1)	RL2-0656-000CN	<a href="#">Internal components, printer base (3 of 3) on page 1219</a>
Roller, paper pickup assembly	RM2-5452-000CN	<a href="#">Internal components, printer base (3 of 3) on page 1219</a>
Roller, paper pickup assembly (550-sheet feeder)	RM2-5741-000CN	<a href="#">Main body, 550-sheet paper feeder on page 1223</a>
Roller, separation assembly	RM2-5397-000CN	<a href="#">Internal components, printer base (2 of 3) on page 1217</a>
Roller, separation assembly (550-sheet feeder)	RM2-5745-000CN	<a href="#">Main body, 550-sheet paper feeder on page 1223</a>
Roller, transfer	RM1-4023-000CN	<a href="#">Internal components, printer base (3 of 3) on page 1219</a>
Shaft, ADF pick extension	B3Q10-40081	<a href="#">Main assemblies (document feeder and image scanner) on page 1209</a>
Shaft, support	RC4-3002-000CN	<a href="#">Covers, M402 and M403 on page 1211</a>
Shaft, support	RC4-3002-000CN	<a href="#">Covers, M426 and M427 on page 1213</a>
Sheet, damper	RC2-6075-000CN	<a href="#">Covers, M426 and M427 on page 1213</a>
Sheet, damper (duplex models only)	RC2-6075-000CN	<a href="#">Covers, M402 and M403 on page 1211</a>
Slider pin, ISA lift	B3Q10-40041	<a href="#">Main assemblies (document feeder and image scanner) on page 1209</a>
Spacer, hexagonal fax (M426fdn; M426fdw; 427fdn; M427fdw)	C5F98-20001	<a href="#">Internal components, printer base (1 of 3) on page 1215</a>
Spring, ADF separation pad (under the separation pad)	B3Q10-00019	<a href="#">Main assemblies (document feeder and image scanner) on page 1209</a>
Spring, compression	RU8-2935-000CN	<a href="#">Internal components, printer base (3 of 3) on page 1219</a>
Support, ADF separation pad	B3Q10-40079	<a href="#">Main assemblies (document feeder and image scanner) on page 1209</a>
Switch, power PCA	RM2-8506-000CN	<a href="#">Internal components, printer base (2 of 3) on page 1217</a>
Tray, paper delivery	RC4-3231-000CN	<a href="#">Covers, M402 and M403 on page 1211</a>
Tray, paper delivery	RC4-3231-000CN	<a href="#">Covers, M426 and M427 on page 1213</a>

**Table 2-11 Alphabetical parts list (continued)**

<b>Description</b>	<b>Part number</b>	<b>Table and page</b>
Walkup USB PCA (M426/M427)	CF368-60001	<a href="#">Internal components, printer base (2 of 3) on page 1217</a>
Wireless holder	B3Q10-40054	<a href="#">Internal components, printer base (1 of 3) on page 1215</a>
Wireless module	0960-3293	<a href="#">Internal components, printer base (1 of 3) on page 1215</a>

# Numerical parts list

**Table 2-12 Numerical parts list**

Part number	Description	Table and page
0960-3293	Wireless module	<a href="#">Internal components, printer base (1 of 3) on page 1215</a>
5851-6550	Pad, thermal transfer	<a href="#">Internal components, printer base (1 of 3) on page 1215</a>
7121-8686	HP logo jewel	<a href="#">Covers, M402 and M403 on page 1211</a>
7121-8686	HP logo jewel	<a href="#">Covers, M426 and M427 on page 1213</a>
9170-2437	Ferrite, ISA	<a href="#">Main assemblies (document feeder and image scanner) on page 1209</a>
9170-2659	Ferrite, motor	<a href="#">Main assemblies (document feeder and image scanner) on page 1209</a>
9170-2659	Ferrite, motor	<a href="#">Internal components, printer base (2 of 3) on page 1217</a>
9170-2664	Ferrite ISA (M426fdn; M426fdw; M427fdn; M427fdw)	<a href="#">Main assemblies (document feeder and image scanner) on page 1209</a>
B3Q10-00019	Spring, ADF separation pad (under the separation pad)	<a href="#">Main assemblies (document feeder and image scanner) on page 1209</a>
B3Q10-40012	Cover, ADF inner (under the out cover)	<a href="#">Main assemblies (document feeder and image scanner) on page 1209</a>
B3Q10-40013	Cover, ADF outer	<a href="#">Main assemblies (document feeder and image scanner) on page 1209</a>
B3Q10-40041	Slider pin, ISA lift	<a href="#">Main assemblies (document feeder and image scanner) on page 1209</a>
B3Q10-40054	Wireless holder	<a href="#">Internal components, printer base (1 of 3) on page 1215</a>
B3Q10-40079	Support, ADF separation pad	<a href="#">Main assemblies (document feeder and image scanner) on page 1209</a>
B3Q10-40080	ADF separation pad	<a href="#">Main assemblies (document feeder and image scanner) on page 1209</a>
B3Q10-40081	Shaft, ADF pick extension	<a href="#">Main assemblies (document feeder and image scanner) on page 1209</a>
B3Q10-60105	ADF pick roller assembly	<a href="#">Main assemblies (document feeder and image scanner) on page 1209</a>

**Table 2-12 Numerical parts list (continued)**

<b>Part number</b>	<b>Description</b>	<b>Table and page</b>
B3Q10-60128	ISA lift	<a href="#">Main assemblies (document feeder and image scanner) on page 1209</a>
B3Q10-60139	Control panel (M426/M427)	<a href="#">Covers, M426 and M427 on page 1213</a>
B3Q10-60145	Control panel mount chassis assembly	<a href="#">Covers, M426 and M427 on page 1213</a>
B3Q11-40001	Control panel mount base	<a href="#">Covers, M426 and M427 on page 1213</a>
B3Q11-40002	Control panel mount cover	<a href="#">Covers, M426 and M427 on page 1213</a>
B4K93-60001	NFC module	<a href="#">Internal components, printer base (2 of 3) on page 1217</a>
C5F92-60001	Formatter PCA (M402d; M403d)	<a href="#">Internal components, printer base (1 of 3) on page 1215</a>
C5F93-60001	Formatter PCA (M402n; M402dn; M403n; M403dn)	<a href="#">Internal components, printer base (1 of 3) on page 1215</a>
C5F94-60001	Formatter PCA (M402dw; M403dw)	<a href="#">Internal components, printer base (1 of 3) on page 1215</a>
C5F97-40001	Name plate M427dw	<a href="#">Covers, M426 and M427 on page 1213</a>
C5F97-69001	Paper feeder, 550-sheet assembly (whole unit)	<a href="#">Covers, 550-sheet paper feeder on page 1221</a>
C5F98-20001	Spacer, hexagonal fax (M426fdn; M426fdw; 427fdn; M427fdw)	<a href="#">Internal components, printer base (1 of 3) on page 1215</a>
C5F98-40002	Cover, FFC	<a href="#">Main assemblies (document feeder and image scanner) on page 1209</a>
C5F98-40003	Cover, core	<a href="#">Main assemblies (document feeder and image scanner) on page 1209</a>
C5F98-40004	Name plate M427dn	<a href="#">Covers, M426 and M427 on page 1213</a>
C5F98-60001	Formatter PCA (M426fdn; M426fdw; M427fdn; M427fdw)	<a href="#">Internal components, printer base (1 of 3) on page 1215</a>
C5F98-60104	Control panel 22-pin FFC	<a href="#">Covers, M426 and M427 on page 1213</a>
C5F98-60105	Cable, walkup USB (M426/M427)	<a href="#">Internal components, printer base (2 of 3) on page 1217</a>
C5F98-60109	Document feeder and image scanner assembly (simplex models M426/M427)	<a href="#">Main assemblies (document feeder and image scanner) on page 1209</a>
C5F98-60110	Document feeder and image scanner assembly (duplex models M426/M427)	<a href="#">Main assemblies (document feeder and image scanner) on page 1209</a>

**Table 2-12 Numerical parts list (continued)**

<b>Part number</b>	<b>Description</b>	<b>Table and page</b>
C5F99-40002	Name plate M427fdw	<a href="#">Covers, M426 and M427 on page 1213</a>
C5F99-40003	Cover, fax port (M426fdn; M426fdw; 427fdn; M427fdw)	<a href="#">Covers, M426 and M427 on page 1213</a>
C5F99-60001	Formatter PCA (M426dw; M427dw)	<a href="#">Internal components, printer base (1 of 3) on page 1215</a>
CF206-60001	Fax PCA (US/AP; M426fdn; M426fdw; 427fdn; M427fdw)	<a href="#">Internal components, printer base (1 of 3) on page 1215</a>
CF207-60001	Fax PCA (Euro; M426fdn; M426fdw; 427fdn; M427fdw)	<a href="#">Internal components, printer base (1 of 3) on page 1215</a>
CF208-60001	Fax PCA (Brazil; M426fdn; M426fdw; 427fdn; M427fdw)	<a href="#">Internal components, printer base (1 of 3) on page 1215</a>
CF368-60001	Walkup USB PCA (M426/M427)	<a href="#">Internal components, printer base (2 of 3) on page 1217</a>
F6W13-40002	Name plate M426dw	<a href="#">Covers, M426 and M427 on page 1213</a>
F6W14-40002	Name plate M426fdn	<a href="#">Covers, M426 and M427 on page 1213</a>
F6W15-40002	Name plate M426fdw	<a href="#">Covers, M426 and M427 on page 1213</a>
RC2-6075-000CN	Sheet, damper (duplex models only)	<a href="#">Covers, M402 and M403 on page 1211</a>
RC2-6075-000CN	Sheet, damper	<a href="#">Covers, M426 and M427 on page 1213</a>
RC2-6075-000CN	Duplex release button	<a href="#">Internal components, printer base (1 of 3) on page 1215</a>
RC4-2891-000CN	Duct, fan	<a href="#">Internal components, printer base (1 of 3) on page 1215</a>
RC4-2907-000CN	Cover, network (non-network models M402/M403)	<a href="#">Covers, M402 and M403 on page 1211</a>
RC4-2956-000CN	Cover, top (M402/M403)	<a href="#">Covers, M402 and M403 on page 1211</a>
RC4-2961-000CN	Cover, Near field communication (NFC) (M426/M427)	<a href="#">Internal components, printer base (2 of 3) on page 1217</a>
RC4-3002-000CN	Shaft, support	<a href="#">Covers, M402 and M403 on page 1211</a>
RC4-3002-000CN	Shaft, support	<a href="#">Covers, M426 and M427 on page 1213</a>
RC4-3082-000CN	Cover, cassette rear	<a href="#">Covers, M402 and M403 on page 1211</a>
RC4-3082-000CN	Cover, cassette rear	<a href="#">Covers, M426 and M427 on page 1213</a>

**Table 2-12 Numerical parts list (continued)**

<b>Part number</b>	<b>Description</b>	<b>Table and page</b>
RC4-3133-000CN	Holder, transfer roller right	<a href="#">Internal components, printer base (3 of 3) on page 1219</a>
RC4-3134-000CN	Holder, transfer roller left	<a href="#">Internal components, printer base (3 of 3) on page 1219</a>
RC4-3207-000CN	Cover, top (M426/M427)	<a href="#">Covers, M426 and M427 on page 1213</a>
RC4-3217-000CN	Guide, cable	<a href="#">Covers, M426 and M427 on page 1213</a>
RC4-3231-000CN	Tray, paper delivery	<a href="#">Covers, M402 and M403 on page 1211</a>
RC4-3231-000CN	Tray, paper delivery	<a href="#">Covers, M426 and M427 on page 1213</a>
RC4-3264-000CN	Plate, name M402dn	<a href="#">Covers, M402 and M403 on page 1211</a>
RC4-3265-000CN	Plate, name M402dw	<a href="#">Covers, M402 and M403 on page 1211</a>
RC4-3266-000CN	Plate, name M403d	<a href="#">Covers, M402 and M403 on page 1211</a>
RC4-3267-000CN	Plate, name M403n	<a href="#">Covers, M402 and M403 on page 1211</a>
RC4-3268-000CN	Plate, name M403dn	<a href="#">Covers, M402 and M403 on page 1211</a>
RC4-3269-000CN	Plate, name M403dw	<a href="#">Covers, M402 and M403 on page 1211</a>
RC4-3270-000CN	Plate, name M402n	<a href="#">Covers, M402 and M403 on page 1211</a>
RC4-3288-000CN	Plate, name M402d	<a href="#">Covers, M402 and M403 on page 1211</a>
RC4-3298-000CN	Cover, rear USB (M402/M403)	<a href="#">Covers, M402 and M403 on page 1211</a>
RC4-3299-000CN	Cover, rear USB (M426 and M427)	<a href="#">Covers, M426 and M427 on page 1213</a>
RC4-3311-000CN	Guide, LED light	<a href="#">Covers, M402 and M403 on page 1211</a>
RC4-3312-000CN	Cover, operation (non-wireless models M402/M403)	<a href="#">Covers, M402 and M403 on page 1211</a>
RC4-3322-000CN	Cover, operation (wireless models M402/M403)	<a href="#">Covers, M402 and M403 on page 1211</a>
RC4-4479-000CN	Link, pressure release	<a href="#">Covers, M402 and M403 on page 1211</a>
RC4-4479-000CN	Link, pressure release	<a href="#">Covers, M426 and M427 on page 1213</a>



**Table 2-12 Numerical parts list (continued)**

<b>Part number</b>	<b>Description</b>	<b>Table and page</b>
RK2-6919-000CN	Cable, laser-scanner FFC	<a href="#">Internal components, printer base (1 of 3) on page 1215</a>
RK2-6920-000CN	Cable, formatter FFC (M402/M403)	<a href="#">Internal components, printer base (1 of 3) on page 1215</a>
RK2-6931-000CN	Cable, formatter FFC (M246/M247)	<a href="#">Internal components, printer base (1 of 3) on page 1215</a>
RK2-6943-000CN	Cable, panel FFC (M402/M403)	<a href="#">Internal components, printer base (1 of 3) on page 1215</a>
RK2-6947-000CN	Cable, Near field communication (NFC) FFC (wireless models M402/M403)	<a href="#">Internal components, printer base (1 of 3) on page 1215</a>
RK2-6949-000CN	Cable, Near field communication (NFC) FFC (wireless models M426/M427)	<a href="#">Internal components, printer base (1 of 3) on page 1215</a>
RK2-8068-000CN	Fan, FM1	<a href="#">Internal components, printer base (1 of 3) on page 1215</a>
RL2-0656-000CN	Roller, multi-purpose (Tray 1)	<a href="#">Internal components, printer base (3 of 3) on page 1219</a>
RL2-0657-000CN	Pad, multi-purpose (Tray 1) separation	<a href="#">Internal components, printer base (3 of 3) on page 1219</a>
RL2-0673-000CN	Cover, left (M402/M403)	<a href="#">Covers, M402 and M403 on page 1211</a>
RL2-0674-000CN	Cover, left (M426/M427)	<a href="#">Covers, M426 and M427 on page 1213</a>
RL2-0675-000CN	Cover, indication	<a href="#">Covers, M402 and M403 on page 1211</a>
RM1-4023-000CN	Roller, transfer	<a href="#">Internal components, printer base (3 of 3) on page 1219</a>
RM2-5390-000CN	Cartridge door assembly (non-NFC models M402/M403)	<a href="#">Covers, M402 and M403 on page 1211</a>
RM2-5391-000CN	Control-panel assembly (non-wireless models M402/M403)	<a href="#">Covers, M402 and M403 on page 1211</a>
RM2-5392-000CN	Cassette (Tray 2) assembly	<a href="#">Internal components, printer base (2 of 3) on page 1217</a>
RM2-5397-000CN	Roller, separation assembly	<a href="#">Internal components, printer base (2 of 3) on page 1217</a>
RM2-5399-000CN	Fixing (fuser) assembly (110-127 V)	<a href="#">Internal components, printer base (2 of 3) on page 1217</a>
RM2-5405-000CN	Door, rear assembly (duplex models only)	<a href="#">Covers, M402 and M403 on page 1211</a>
RM2-5405-000CN	Door, rear (duplex models only)	<a href="#">Covers, M426 and M427 on page 1213</a>
RM2-5408-000CN	Door, cartridge assembly (non-NFC models M426/M427)	<a href="#">Covers, M426 and M427 on page 1213</a>

**Table 2-12 Numerical parts list (continued)**

<b>Part number</b>	<b>Description</b>	<b>Table and page</b>
RM2-5413-000CN	Cassette assembly (550-sheet feeder)	<a href="#">Main body, 550-sheet paper feeder on page 1223</a>
RM2-5424-000CN	Control-panel assembly (wireless models M402/M403)	<a href="#">Covers, M402 and M403 on page 1211</a>
RM2-5425-000CN	Fixing (fuser) assembly (220–240 V)	<a href="#">Internal components, printer base (2 of 3) on page 1217</a>
RM2-5426-000CN	Cable, tag assembly	<a href="#">Internal components, printer base (1 of 3) on page 1215</a>
RM2-5430-000CN	Door, rear assembly (simplex models M402/M403)	<a href="#">Covers, M402 and M403 on page 1211</a>
RM2-5434-000CN	Cover, right assembly	<a href="#">Covers, M402 and M403 on page 1211</a>
RM2-5434-000CN	Cover, right assembly	<a href="#">Covers, M426 and M427 on page 1213</a>
RM2-5435-000CN	Door, cartridge assembly (NFC models M426/M427)	<a href="#">Covers, M426 and M427 on page 1213</a>
RM2-5436-000CN	Cartridge door assembly (NFC models M402/M403)	<a href="#">Covers, M402 and M403 on page 1211</a>
RM2-5452-000CN	Roller, paper pickup assembly	<a href="#">Internal components, printer base (3 of 3) on page 1219</a>
RM2-5528-000CN	Laser-scanner assembly	<a href="#">Internal components, printer base (1 of 3) on page 1215</a>
RM2-5671-000CN	Registration assembly	<a href="#">Internal components, printer base (3 of 3) on page 1219</a>
RM2-5741-000CN	Roller, paper pickup assembly (550-sheet feeder)	<a href="#">Main body, 550-sheet paper feeder on page 1223</a>
RM2-5745-000CN	Roller, separation assembly (550-sheet feeder)	<a href="#">Main body, 550-sheet paper feeder on page 1223</a>
RM2-7508-000CN	High-voltage power supply (HVPS) PCA	<a href="#">Internal components, printer base (1 of 3) on page 1215</a>
RM2-7510-000CN	Connecting PCA (duplex models)	<a href="#">Internal components, printer base (1 of 3) on page 1215</a>
RM2-8506-000CN	Switch, power PCA	<a href="#">Internal components, printer base (2 of 3) on page 1217</a>
RM2-8510-000CN	Connecting PCA (simplex models)	<a href="#">Internal components, printer base (1 of 3) on page 1215</a>
RM2-8516-000CN	Low-voltage power supply (LVPS) PCA (220–240 V M402/M403)	<a href="#">Internal components, printer base (1 of 3) on page 1215</a>
RM2-8517-000CN	Low-voltage power supply (LVPS) PCA (110–127 V M402/M403)	<a href="#">Internal components, printer base (1 of 3) on page 1215</a>
RM2-8518-000CN	Low-voltage power supply (LVPS) PCA (110–127 V M426/M427)	<a href="#">Internal components, printer base (1 of 3) on page 1215</a>

**Table 2-12 Numerical parts list (continued)**

<b>Part number</b>	<b>Description</b>	<b>Table and page</b>
RM2-8519-000CN	Low-voltage power supply (LVPS) PCA (220–240 V M426/M427)	<a href="#">Internal components, printer base (1 of 3) on page 1215</a>
RM2-8680-000CN	DC controller PCA	<a href="#">Internal components, printer base (1 of 3) on page 1215</a>
RM2-8684-000CN	Main motor assembly	<a href="#">Internal components, printer base (2 of 3) on page 1217</a>
RU8-2935-000CN	Spring, compression	<a href="#">Internal components, printer base (3 of 3) on page 1219</a>



# Index

## Symbols/Numerics

- 2-line LCD operator and indication covers (M403/M402)
  - removing and replacing 232
- 2-line LCD operator and indication covers (M403/M402), removing and replacing 232
- 500-sheet feeder
  - parts lists and diagrams 1220
- 550-sheet paper feeder
  - removing and replacing 1181
- 550-sheet paper feeder, removing and replacing 1181

## A

- accessories
  - part numbers 1206
- after-service checklist 6

## C

- cable guide (M427/M426)
  - removing and replacing 172
- cable guide (M427/M426), removing and replacing 172
- cartridge-door assembly
  - removing and replacing 57
- cartridge-door assembly, removing and replacing 57
- cartridges
  - ordering 1205
  - part numbers 1205
- cassette rear cover
  - removing and replacing 114
- cassette rear cover, removing and replacing 114
- cautions iii
- checklists
  - preservice 6

- connecting PCA
  - removing and replacing 824
- connecting PCA, removing and replacing 824
- control panel (M427/M426)
  - removing and replacing 1134
- control panel 22-pin FFC (M427/M426)
  - removing and replacing 1134
- control panel and control panel 22-pin FFC (M427/M426), removing and replacing 1134
- control panel and control panel sub assemblies (M427/M426), removing and replacing 1134
- control panel FFC (M403/M402)
  - removing and replacing 656
- control panel FFC (M403/M402), removing and replacing 656
- control panel mount base (M427/M426)
  - removing and replacing 1134
- control panel mount base (M427/M426), removing and replacing 1134
- control panel mount chassis assembly (M427/M426)
  - removing and replacing 1134
- control panel mount chassis assembly (M427/M426), removing and replacing 1134
- control panel mount cover (M427/M426)
  - removing and replacing 1134
- control panel mount cover (M427/M426), removing and replacing 1134
- conventions, document iii

- cover NFC
  - removing and replacing 1033
- cover NFC, removing and replacing 1033
- covers, printer base
  - parts lists and diagrams 1210

## D

- damper sheets
  - removing and replacing 46
- damper sheets, removing and replacing 46
- DC controller
  - removing and replacing 724
- DC controller, removing and replacing 724
- document conventions iii
- document feeder
  - parts lists and diagrams 1208
- document feeder and image scanner
  - parts lists and diagrams 1208

## E

- electrostatic discharge (ESD) 4
- ESD electrostatic discharge (ESD) 4

## F

- fan (FM1)
  - removing and replacing 493
- fan (FM1), removing and replacing 493
- fan holder (FM1)
  - removing and replacing 507
- fan holder (FM1), removing and replacing 507
- fax PCA
  - removing and replacing 429
- FCC NFC
  - removing and replacing 609

- FCC NFC , removing and replacing 609
- FFC control panel (M403/M402)
  - removing and replacing 656
- FFC control panel (M403/M402), removing and replacing 656
- FFC laser scanner
  - removing and replacing 873
- FFC laser scanner, removing and replacing 873
- FFC, formatter
  - removing and replacing 678
- FFC, formatter, removing and replacing 678
- field-replaceable units (FRUs)
  - replacing 3
- flat-flexible cable, control panel (M403/M402)
  - removing and replacing 656
- flat-flexible cable, control panel (M403/M402), removing and replacing 656
- flat-flexible cable, formatter
  - removing and replacing 678
- flat-flexible cable, formatter, removing and replacing 678
- flat-flexible cable, laser scanner
  - removing and replacing 873
- flat-flexible cable, laser scanner, removing and replacing 873
- flat-flexible cable, near field communication
  - removing and replacing 609
- flat-flexible cable, removing and replacing 609
- formatter FFC
  - removing and replacing 678
- formatter FFC, removing and replacing 678
- formatter PCA
  - removing and replacing 474
- formatter PCA, removing and replacing 474
- FRUs (field-replaceable units)
  - replacing 3
- fuser
  - removing and replacing 325
- fuser, removing and replacing 325

- H**
- high-voltage power supply
  - removing and replacing 927
- high-voltage power supply, removing and replacing 927
- holder fan (FM1)
  - removing and replacing 507
- holder fan (FM1), removing and replacing 507
- HVPS
  - removing and replacing 927
- HVPS, removing and replacing 927
- I**
- I/O cover
  - removing and replacing 49
- I/O cover, removing and replacing 49
- image scanner
  - parts lists and diagrams 1208
- input/output cover
  - removing and replacing 49
- input/output cover, removing and replacing 49
- installation 5
  - screws 5
  - See also* replacing parts
- integrated scanner assembly (M427/M426)
  - removing and replacing 294
- integrated scanner assembly (M427/M426), removing and replacing 294
- internal components, printer
  - parts lists and diagrams 1214
- ISA
  - removing and replacing 294
- ISA (M427/M426), removing and replacing 294
- ISA lift assembly and slider pin
  - removing and replacing 316
- ISA lift assembly and slider pin (M427/M426)
  - removing and replacing 316
- ISA lift assembly and slider pin (M427/M426), removing and replacing 316

- L**
- laser scanner
  - warnings for servicing 3
- laser scanner assembly
  - removing and replacing 525
- laser scanner assembly, removing and replacing 525
- laser scanner FFC
  - removing and replacing 873
- laser scanner FFC, removing and replacing 873
- left cover
  - removing and replacing 73
- left cover, removing and replacing 73
- low-voltage power supply
  - removing and replacing 977
- low-voltage power supply, removing and replacing 977
- LVPS
  - removing and replacing 977
- LVPS, removing and replacing 977
- M**
- main motor (M1)
  - removing and replacing 402
- main motor (M1), removing and replacing 402
- maintenance kits
  - part numbers 1206
- multipurpose tray (Tray 1) roller
  - removing and replacing 8
- multipurpose tray (Tray 1) roller, removing and replacing 8
- N**
- near field communication PCA
  - removing and replacing 1070
- near field communication PCA cover
  - removing and replacing 1033
- near field communication PCA cover, removing and replacing 1033
- near field communication PCA, removing and replacing 1070
- NFC
  - removing and replacing 1070
- NFC FCC, removing and replacing 609
- NFC, removing and replacing 1070
- notes iii

**O**

optional Tray 3 paper pickup roller assembly (Tray 3), removing and replacing 27, 1190  
 ordering  
   toner cartridges and accessories 1205  
 output bin  
   removing and replacing 253  
 output bin, removing and replacing 253

**P**

paper delivery tray (output bin)  
   removing and replacing 253  
 paper delivery tray (output bin), removing and replacing 253  
 paper pickup roller assembly (Tray 2)  
   removing and replacing 20, 1168  
 paper pickup roller assembly (Tray 2), removing and replacing 20, 1168  
 paper pickup roller assembly (Tray 3)  
   removing and replacing 27, 1190  
 paper pickup roller assembly (Tray 3), removing and replacing 27, 1190  
 part numbers  
   accessories 1206  
   replacement parts 1206  
   staple cartridges 1206  
   supplies 1206  
   toner cartridge 1206  
   toner cartridges 1205  
 parts lists and diagrams 1203  
   500-sheet feeder 1220  
   covers, printer base 1210  
   document feeder and image scanner 1208  
   internal components, printer 1214  
   using 1207  
 PCA connecting  
   removing and replacing 824  
 PCA connecting, removing and replacing 824  
 PCA power switch  
   removing and replacing 414  
 PCA power switch, removing and replacing 414

post-service tests 6  
 power switch printed circuit assembly  
   removing and replacing 414  
 power switch printed circuit assembly, removing and replacing 414  
 preservice checklist 6  
 pressure-release link  
   removing and replacing 64  
 pressure-release link, removing and replacing 64  
 print quality  
   test 6

**R**

rear door assembly  
   removing and replacing 98  
 rear door assembly, removing and replacing 98  
 registration assembly  
   removing and replacing 347  
 registration assembly, removing and replacing 347  
 removal strategy  
   removing and replacing 3  
 removing and replacing  
   2-line LCD operator and indication covers (M403/M402) 232  
   550-sheet paper feeder 1181  
   cable guide (M427/M426) 172  
   cartridge-door assembly 57  
   cassette rear cover 114  
   connecting PCA 824  
   control panel and control panel sub assemblies (M427/M426) 1134  
   control panel FFC (M403/M402) 656  
   cover NFC 1033  
   damper sheets 46  
   DC controller 724  
   fan (FM1) 493  
   fan holder (FM1) 507  
   fax PCA 429  
   FFC control panel (M403/M402) 656  
   FFC laser scanner 873  
   FFC, formatter 678  
   flat-flexible cable, control panel (M403/M402) 656

flat-flexible cable, formatter 678  
 flat-flexible cable, laser scanner 873  
 flat-flexible cable, near field communication 609  
 formatter FFC 678  
 formatter PCA 474  
 fuser 325  
 high-voltage power supply 927  
 HVPS 927  
 I/O cover 49  
 input/output cover 49  
 integrated scanner assembly (M427/M426) 294  
 ISA (M427/M426) 294  
 ISA lift assembly and slider pin (M427/M426) 316  
 laser scanner assembly 525  
 laser scanner FFC 873  
 left cover 73  
 low-voltage power supply 977  
 LVPS 977  
 main motor (M1) 402  
 multipurpose tray (Tray 1) roller 8  
 near field communication PCA 1070  
 near field communication PCA cover 1033  
 NFC 1070  
 NFC FCC 609  
 output bin 253  
 paper delivery tray (output bin) 253  
 paper pickup roller assembly (Tray 2) 20, 1168  
 paper pickup roller assembly (Tray 3) 27, 1190  
 PCA connecting 824  
 PCA power switch 414  
 power switch printed circuit assembly 414  
 pressure-release link 64  
 rear door assembly 98  
 registration assembly 347  
 right cover 87  
 roller MP tray (Tray 1) 8  
 separation roller assembly (Tray 2) 34, 1175

- separation roller assembly (Tray 3) 39, 1197
- sheet-metal formatter bracket and formatter PCA 567
- support shaft 53
- tag-cable assembly (toner-cartridge memory) 776
- toner-cartridge memory (tag-cable assembly) 776
- top cover (M403/M402) 211
- top cover (M427/M426) 133
- Tray 1 roller 8
- Tray 2 13, 1165, 1166
- Tray 2 paper pickup roller assembly 20, 1168
- Tray 3 16, 1186
- walkup USB PCA 443
- wireless PCA 460
- removing parts
  - after-service checklist 6
  - checklists 6
  - tools, required 4
- replacement parts
  - part numbers 1206
- replacing
  - parts 3
- replacing parts
  - about 3
  - after-service checklist 6
  - screws 5
  - tools, required 4
- right cover
  - removing and replacing 87
- right cover, removing and replacing 87
- roller MP tray (Tray 1)
  - removing and replacing 8
- roller MP tray (Tray 1), removing and replacing 8

**S**

- screwdrivers, required 4
- screws
  - installing 5
  - replacing 4
  - types of 5
- separation roller assembly (Tray 2)
  - removing and replacing 34, 1175

- separation roller assembly (Tray 2), removing and replacing 34, 1175
- separation roller assembly (Tray 3)
  - removing and replacing 39, 1197
- separation roller assembly (Tray 3), removing and replacing 39, 1197
- service and support information v, 2, 1204
- service approach
  - removing and replacing 6
- sheet-metal formatter bracket and formatter PCA
  - removing and replacing 567
- sheet-metal formatter bracket and formatter PCA, removing and replacing 567
- staple cartridges
  - part numbers 1206
- static, precautions for 4
- supplies
  - part numbers 1206
- support shaft
  - removing and replacing 53
- support shaft, removing and replacing 53

**T**

- tag-cable assembly (toner-cartridge memory)
  - removing and replacing 776
- tag-cable assembly (toner-cartridge memory), removing and replacing 776
- tests
  - post-service 6
  - print-quality 6
- tips iii
- toner cartridge
  - part numbers 1206
- toner cartridges
  - ordering 1205
  - part numbers 1205
- toner-cartridge memory (tag-cable assembly)
  - removing and replacing 776
- toner-cartridge memory (tag-cable assembly), removing and replacing 776
- tools, required 4

- top cover (M403/M402)
  - removing and replacing 211
- top cover (M403/M402), removing and replacing 211
- top cover (M427/M426)
  - removing and replacing 133
- top cover (M427/M426), removing and replacing 133
- Tray 1 roller
  - removing and replacing 8
- Tray 1 roller, removing and replacing 8
- Tray 2
  - removing and replacing 13, 1165, 1166
- Tray 2 paper pickup roller assembly
  - removing and replacing 20, 1168
- Tray 2 paper pickup roller assembly, removing and replacing 20, 1168
- Tray 2, removing and replacing 13, 1165, 1166
- Tray 3
  - removing and replacing 16, 1186
- Tray 3, removing and replacing 16, 1186

**W**

- walkup USB PCA
  - removing and replacing 443
- warnings iii
- wireless PCA
  - removing and replacing 460