

# Friendly Robotics

## Operating & Safety Manual

### Robomow

**RL500 / RL550**

**RL800 / RL850**



[www.friendlyrobotics.com](http://www.friendlyrobotics.com)

DOC0012A

# EC Declaration of Conformity

1. **F. Robotics Acquisitions**, 1 Ha'yassur St., Hasharon Industrial Park, Kadima, Israel declares that the machines described in item 2 conforms with the directives listed in items 3 & 4.
2. Product: 24 Volt Battery operated automatic lawn mower, models RL500, RL550, RL800 and RL850\*.  
Serial number: see mark on the machine.
3. Tested by the British Standards Institute (BSI) to comply with The supply of Machine (Safety) Regulation 1992 Essential Health and Safety Requirements relating to the design and construction of machinery.

The following European standards were taken into consideration when testing the machine:  
EN 292: Parts 1 and 2:1991, Safety of Machinery - Basic concepts, general principles for design.

EN 294: 1992, Safety of Machinery - Safety distances to prevent danger zones being reached by the upper limbs.

EN 418:1992, Safety of Machinery - Emergency stop equipment, functional aspects - Principles for design.

EN 60204: Part 1:1997, Safety of Machinery - Electrical equipment of machines - general requirements.

EN 60335: Part 1:1994, Safety of household and similar electrical appliances.

In addition the following National standard and draft were taken into consideration when testing the machine:

BS 3456: Part 2: Section 2.42: 1997, Safety of household and similar electrical appliances - Section 2.42 Battery-operated lawnmowers.

PrEN 50338: 1999, Safety of household and similar electrical appliances –Particular requirements for pedestrian controlled battery powered electrical lawnmowers.

Noise level testing was conducted to the requirements of: 79/113/EEC and 88/181/EEC.

Results are published by BSI in report number 282/4077203 dated 14 July 2000.

Marylands Avenue, Hemel Hempstead, Hertfordshire HP2 4SQ, UK.

4. Also tested by Hermon Laboratories to comply with The Electromagnetic compatibility directive 89/336/EEC. Results are published By Hermon Laboratories in report number Frienmc\_EN.14123 dated 21 June 2000.  
Rakevet Industry Zone, Binyamina, 30550, Israel.
5. Measured sound power level: 85 db.
6. Guaranteed sound power level: 90 db.
7. Technical documentation kept by Mr. Dedy Gur, QA director.

I hereby declare that the above product conforms to the requirements as specified above.

\*The original RL500 was tested by BSI in 2000. All Friendly Robotics models currently sold were tested by F.Robotics Acquisitions Ltd.

Issued at  
Kadima, Israel

Shai Abramson – Senior VP R&D



# ● FriendlyRobotics



●  
© FriendlyRobotics, 2003-A Eur. All rights reserved. No part of this document may be photocopied, reproduced, electronically or otherwise or translated without the prior written consent of FriendlyRobotics.

Product, product specifications and this document are subject to change without notice. All other trademarks are the property of their respective owners.

CE approved

# FriendlyRobotics

## ***Welcome...***

To the world of robotic lawn mowing with the FriendlyRobotics Robomower. Thank you for purchasing our product. We know that you will enjoy the extra free time you will have while using Robomower to mow your lawn. When installed and used properly, Robomower will operate safely on your lawn and provide you with a quality of cut matched by few mowers of any kind. You will be impressed with your lawns' appearance and best of all Robomower did it for you.

## **IMPORTANT!**

The following pages contain important safety and operating instructions. Please read and follow all instructions in this manual. Carefully read and review all safety instructions, warnings and cautions contained in this manual. Failure to read and follow these instructions, warnings and cautionary statements may result in severe injury or death to persons and pets or damage to personal property.

### **A Basic How It Works**

A small wire, called the perimeter wire, is placed around the perimeter of the lawn and any other areas where you do not want the mower to enter. A small signal is generated from a device attached to the perimeter wire, called the Perimeter Switch. When turned on, this signal is carried through the perimeter wire, creating what we define as a *virtual wall*. The virtual wall is visible only to the Robomower, keeping the Robomower where you want it, on your lawn. The perimeter switch must be turned on to activate the perimeter wire before the Robomower will operate.

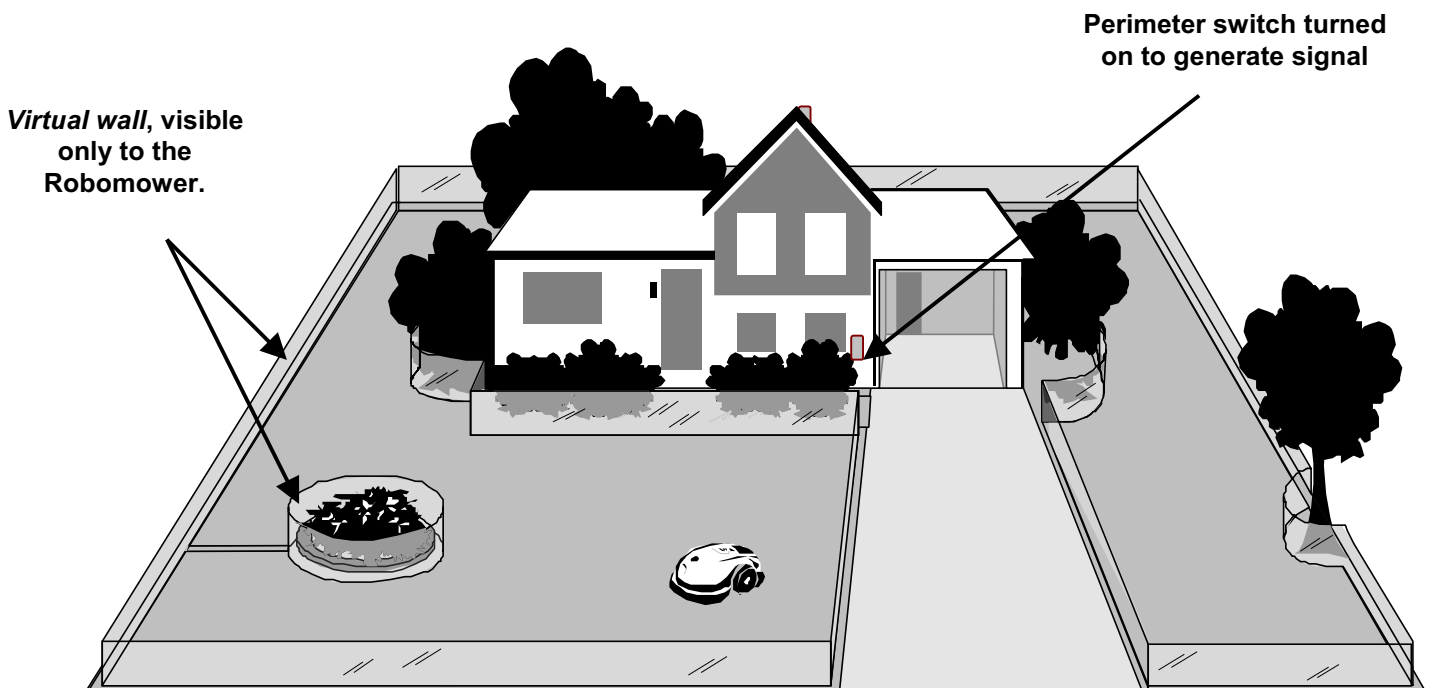

# **Safety Warnings & Precautions**

- 1. Read the owners/operating manual carefully and follow all safety and warning instructions.**
- 2. Keep bystanders, children and pets away from mower when in operation.**
- 3. Never allow anyone to ride or sit on mower.**
- 4. Never allow children or persons not familiar with the safe operation of the mower to operate the mower.**
- 5. Keep hands and feet away from the cutting blades and other moving parts.**
- 6. Never attempt to service or adjust the mower while it is in operation.**
- 7. Inspect and clear the mowing area of all debris before operating the mower.**
- 8. Never raise the mower or attempt to inspect the blades while the mower is operating.**
- 9. Always remove the power pack before lifting the mower or attempting any adjustments.**
- 10. When operating the mower in manual mode, maintain a safe distance from behind or around the mower and wear proper foot apparel.**
- 11. Do not operate the mower on slopes greater than 15 degrees or use it in manual operation on slopes where a firm footing is not possible.**
- 12. Do not operate the mower if any safety feature or device is damaged or inoperable.**
- 13. Do not attempt to disable or defeat any safety feature or device.**
- 14. Use heavy gloves when inspecting or servicing the blades.**
- 15. The charger is for indoor use only. Do not use in areas where moisture or water is likely.**
- 16. Wear eye protection and use gloves when installing the perimeter wire and driving the wire stakes/pegs.**

# Safety Warnings & Precautions

## Warning Decal Definitions

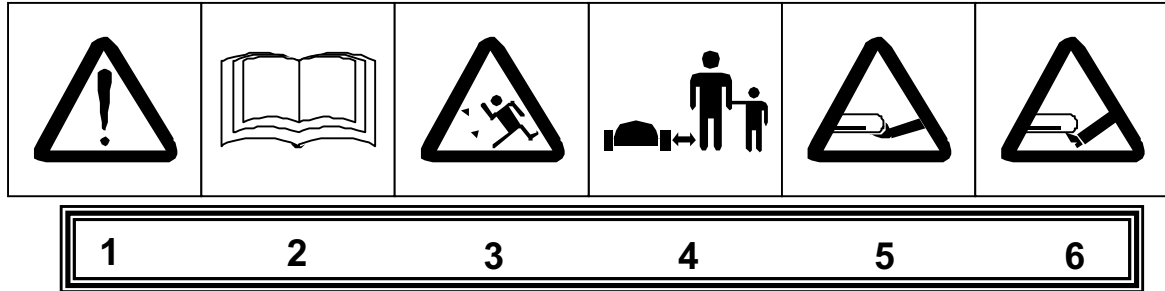

1. **WARNING**-this is a dangerous power tool. Use care when operating and follow all safety instructions and warnings.
2. Read the owner/operating manual carefully and follow all safety instructions.
3. Objects can be thrown from mower while operating, take caution.
4. Keep children, pets and bystanders away from mower.
5. Sharp rotating blades. Keep hands away and do not attempt to lift mower from this area.
6. Sharp rotating blades. Keep feet away.



**DANGER!** Sharp rotating blades. Keep hands and feet away.  
Serious injury can occur.



**CAUTION!** Remove battery/power pack before attempting to lift mower for any reason.

# Robomower RL500/RL550/RL800/RL850

## Safety Features

### 1. Child Guard / Safety Guard

This menu option offers a safety feature to help prevent children or others not familiar with the safe operation of the mower to operate it freely.

### 2. Lift Sensor

There is a sensor located on the front caster wheel of the mower. In the event the front of the mower is raised approximately 1-inch from its resting position on the ground during blade operation, the blades will stop rotating immediately (< 1 second).

### 3. Sensor Equipped Bumpers

The front and rear bumpers are equipped with contacts that will activate when the mower strikes a solid, fixed object when that object is at least 6-inches in vertical height from the supporting surface of the mower. When the bumper sensor is activated, the mower will stop movement in that direction and reverse itself away from the obstacle. In manual blade operation, bumper activation will stop the rotation of the blades immediately (<1 second).

### 4. Emergency Stop Switch

Located on the top outer surface of the manual controller, red in color. Pressing this button at any time during operation will stop all mower movement and stop the rotation of the blades immediately (<1 second).

### 5. Automatic Mode Recognition

The Robomower is designed so that it cannot be operated in the manual mode while the Manual Controller is in its' pocket and it cannot operate in the automatic mode while the Manual Controller is removed.

### 6. Two-Step Operator Presence Control

While in manual mode, it requires two independent finger actions in order to engage the mower blades. Once engaged, the mower blade button must remain depressed to continue blade operation. Once released, the two-step engagement process must be repeated.

### 7. Electronically Controlled Charging System

The Robomower is equipped with an on-board charge control system. This allows you to keep the charger connected at all times, even after the battery is fully charged. The control system will prevent an overcharge to the battery and keep it fully charged and maintained for the next use.

### 8. Sealed Power Pack

The power pack that operates the Robomower is completely sealed and will not leak any type of fluids, regardless of position. In addition, the power pack contains a one-time-use fuse in the event of a short-circuit or power malfunction.

### **9. Perimeter Switch and Perimeter Wire**

The Robomower cannot operate without a perimeter wire installed and activated through the Perimeter Switch. In the event the Perimeter Switch is turned off or otherwise fails to function, the Robomower will stop operating. Likewise, should a break in the perimeter wire occur the Robomower would again stop operation. A break in the perimeter wire prior to operation will prevent the Robomower from operating. The Robomower can only operate within the boundary of the perimeter wire.

### **10. Auto-Off Perimeter Switch**

The auto-off feature of the perimeter switch shuts down the perimeter switch operation after approximately 5 hours of continuous operation. This is typically 1 to 2 hours after which a fully charged Power Pack will need to be re-charged. This helps to prevent unauthorized persons from attempting to re-start the Robomower after it has completed its' operation.

### **11. Over-Current Monitoring Protection**

Each of the three blade motors and each of the two wheel drive motors are monitored continuously during operation for any situation that may cause these motors to over-heat. In the event this is detected, the Robomower will stop operation of at least that motor and possibly the mower itself and indicate that the motor is cooling down. While unusual, this may happen when the mower is put in grass that is severely overgrown; the underside of the mower is clogged from poor cleaning maintenance; the mower has encountered an obstacle that is unable to activate the bumper sensor preventing it from moving; or a problem landscape area has caused the mower to get stuck and is preventing it from moving.

## **WARNING!**



**This warning symbol will be found at several points throughout the pages of this owner/operator manual. It is intended to highlight an important safety, warning or cautionary message. Please pay particular attention to these areas and be sure you fully understand the message before proceeding.**



# What's in the Box

**Robomower**

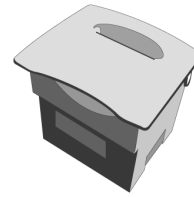
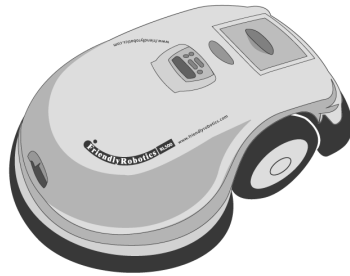

**Power Pack**



**Power Pack Fuse**  
(Must insert to operate)

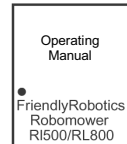

**Operating Manual**

**1. Standard Charger**

Used for recharging the Robomower power pack.



**2. RoboRuler**

Used for setting the distance of the perimeter wire from the lawn edge.

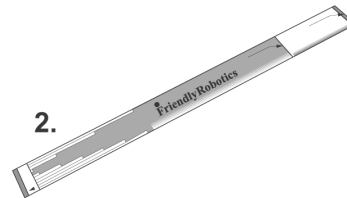

**3. Pegs**

Used for securing the perimeter wire to the ground around the lawn perimeter and around obstacles.

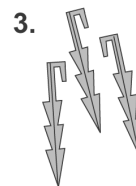

**4. Wire**

Used to create a virtual wall for your Robomower

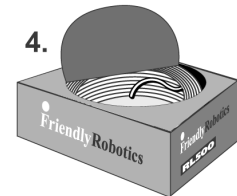

**5. Perimeter Switch & C-Cell Batteries**

Activates the perimeter wire, which defines the area in which the Robomower will operate.

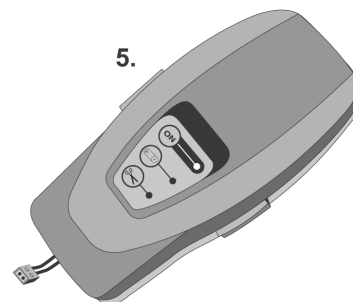

**6. Perimeter Switch Mounting Stake**

Used for supporting the perimeter switch in the lawn.

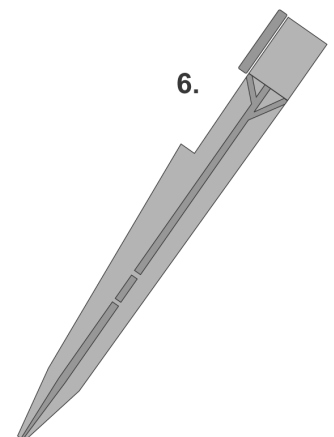

**7. Wire Connectors**

Used for splicing wires (as needed).

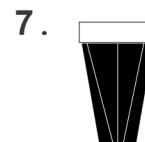

**8. Plot Connectors**

Used for connecting the completed screwdriver perimeter wire installation to the perimeter switch.

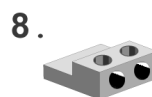

**NOTE:** Tools needed, but not included: hammerwire cutters, small flat-head screwdriver

# Table of Contents

<b>Welcome, Basic How It Work .....</b>	<b>2</b>
<i>The world of automatic mowing with the Robomower</i>	
<b>Safety Warnings and Precautions.....</b>	<b>3</b>
<i>Safely operating the Robomower</i>	
<b>What's In The Box.....</b>	<b>7</b>
<i>A list and descriptions of the items found in the Robomower box</i>	
<b>Chapter 1 – Perimeter Wire Setup.....</b>	<b>9</b>
<i>Setup of the perimeter wire in your lawn</i>	
<b>Chapter 2 – Preparing The Robomower.....</b>	<b>16</b>
<i>How to get the Robomower ready for the first use</i>	
<b>Chapter 3 – Automatic Operation.....</b>	<b>21</b>
<i>Operating the Robomower in automatic mowing (Robotic mowing)</i>	
<b>Chapter 4 – Power Pack and Power Management.....</b>	<b>23</b>
<i>Proper use and maintenance of the Power Pack and charging system</i>	
<b>Chapter 5 – Manual Operation.....</b>	<b>25</b>
<i>How to use the Robomower in manual mode</i>	
<b>Chapter 6 – Settings and Advanced Features.....</b>	<b>26</b>
<i>Settings and features for the customer to choose</i>	
<b>Chapter 7 – Messages and Troubleshooting.....</b>	<b>30</b>
<i>Understanding the text messages and troubleshooting</i>	
<b>Chapter 8 – Specifications.....</b>	<b>34</b>
<i>General product specifications</i>	
<b>Chapter 9 – Care and Maintenance.....</b>	<b>35</b>
<i>How to care and maintain your Robomower</i>	
<b>Chapter 10 – Accessories.....</b>	<b>37</b>
<i>Accessories available to enhance the mowing experience</i>	

# Chapter 1

## Perimeter Wire Setup

### 1.0 Where To Start

In order to determine the best location to begin the setup, it is best to first make some basic decisions based on your lawn. For each zone that is set up, allow for placement of one Perimeter Switch for that zone. Find a convenient spot outside the perimeter of each zone that is relatively easy for you to access. A spot sheltered from the elements is preferred

### 1.1 Using The RoboRuler

There are two basic measurements that are used on the RoboRuler. The shorter distance is used along perimeter edges where the area outside the immediate perimeter (about 12 inches/30 cm) is free of obstacles and is the same relative height as the perimeter edge. The longer distance is used along perimeter edges where the area outside the immediate perimeter has obstacles or differences in the height along the perimeter edge. See Figure 1.1.

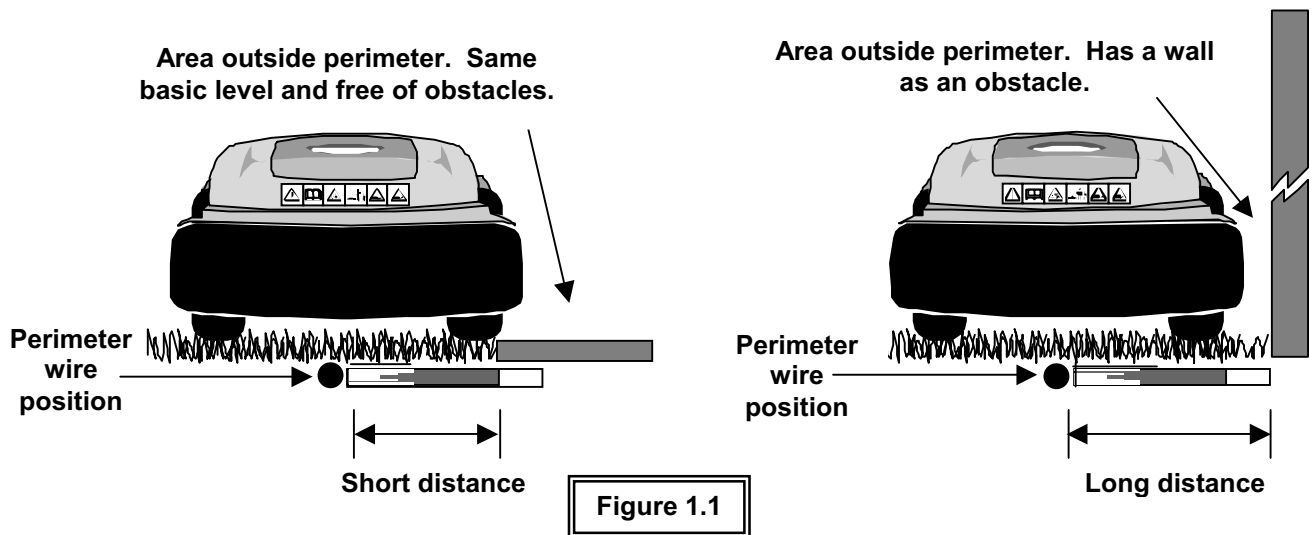

### 1.2 Starting The Perimeter Wire

Tear out the perforated center piece on the perimeter wire box. Puncture the plastic covering with your finger and feel around inside the center of the wire spool for the end of the wire. Pull the wire end out of the box. The box is designed as a dispenser for the wire so do not remove the wire spool from the box. After reviewing the illustrations and instructions in the following pages you will be ready to lay out the perimeter wire and start pegging it to the ground. Figure 1.2

Leave enough wire at the beginning, where the Perimeter Switch is going to be located. Use the RoboRuler to help guide you on placement of the wire along the perimeter. Use a minimum number of pegs at this point, as you will want to test the wire position at the end of the setup. See Section 2.5 for details on testing the setup.

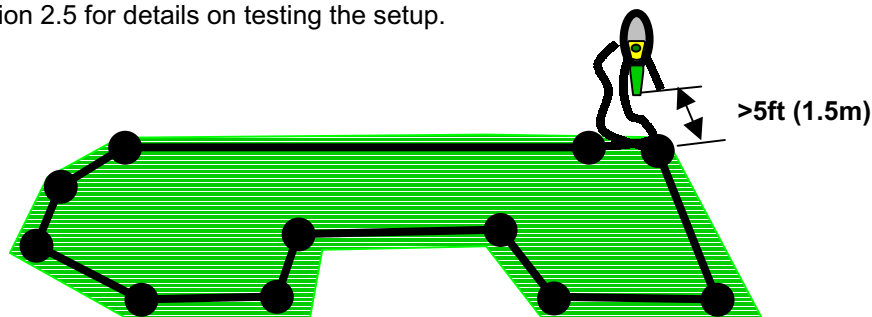

**WARNING!**



Damage to the eye is possible. Use proper eye protection and wear appropriate work gloves when hammering the pegs. Hard or dry ground may cause pegs to break when driving them in. In extreme cases, watering the lawn where the pegs will be driven can be beneficial.

### 1.3 Fastening The Wire To The Ground

Add pegs in to pull the perimeter wire down to the ground surface, below the grass tips Figure 1.3

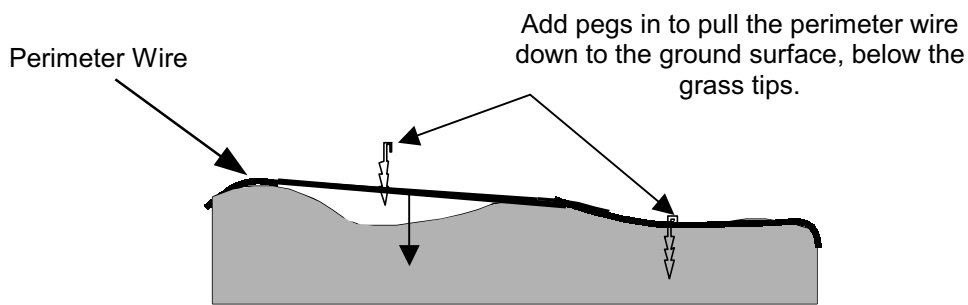

Figure 1.3

### 1.4 Corners & Sharp Turns

Care must be taken not to create a turn sharper than 90 degrees when setting up the perimeter wire. A turn sharper than 90 degrees can cause the Robomower to lose track of the perimeter wire. In situations where a corner may require a wire placement of less than a 90-degree angle, placement can be adjusted using several angles to avoid this. See Figure 1.4.

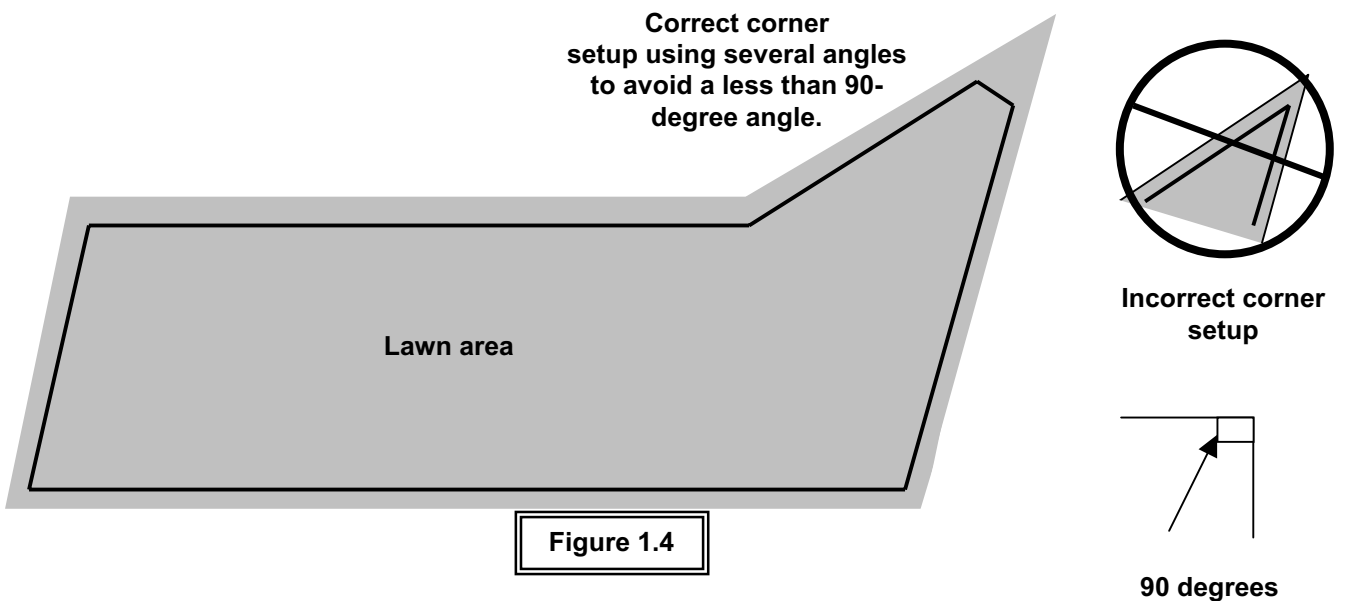

Figure 1.4

### 1.5 Narrow Areas And Narrow Passes

The minimum distance for an effective narrow pass is 5.5 feet (1.7 m) between perimeter wires. Figure 1.8.

### 1.6 Defining Obstacles-Perimeter Islands

Many obstacles can be left in the lawn without consideration to excluding them using the perimeter wire. The basic rule of thumb is that the obstacle must be at least 6 inches (15 cm) high from the ground and the obstacle must be relatively rigid. Good examples of these kinds of obstacles include many trees, phone poles, power poles and flag poles.

To create a perimeter island, take the wire from the perimeter section closest to the obstacle and peg the wire around the obstacle, returning back to the same spot of the perimeter. There are two keys to setting up the perimeter wire to exclude an obstacle; 1) the two wires going **to** and **from** the obstacle should be placed under the same peg (touching) and 2) follow the direction of set up as shown in Figure 1.6.

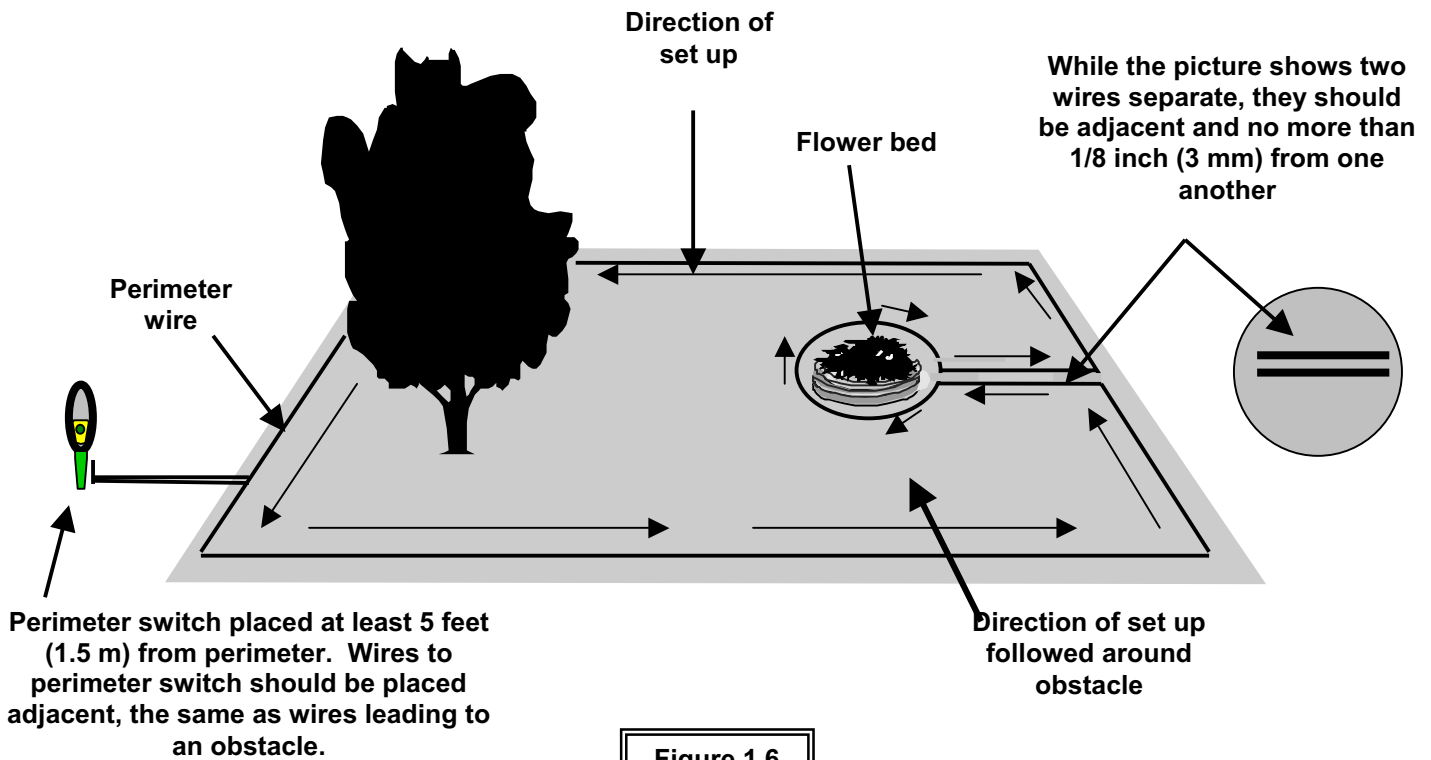

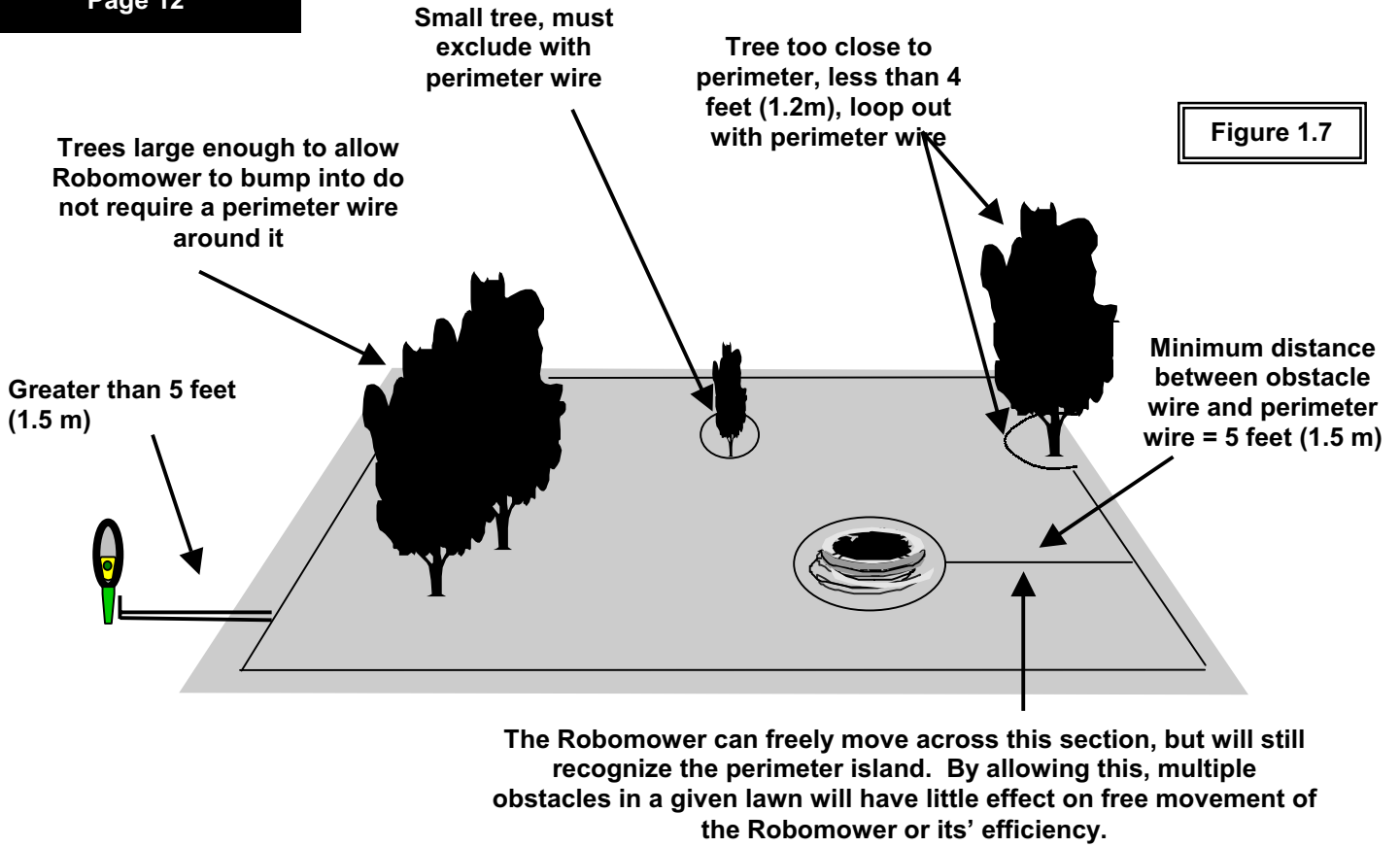

Figure 1.7

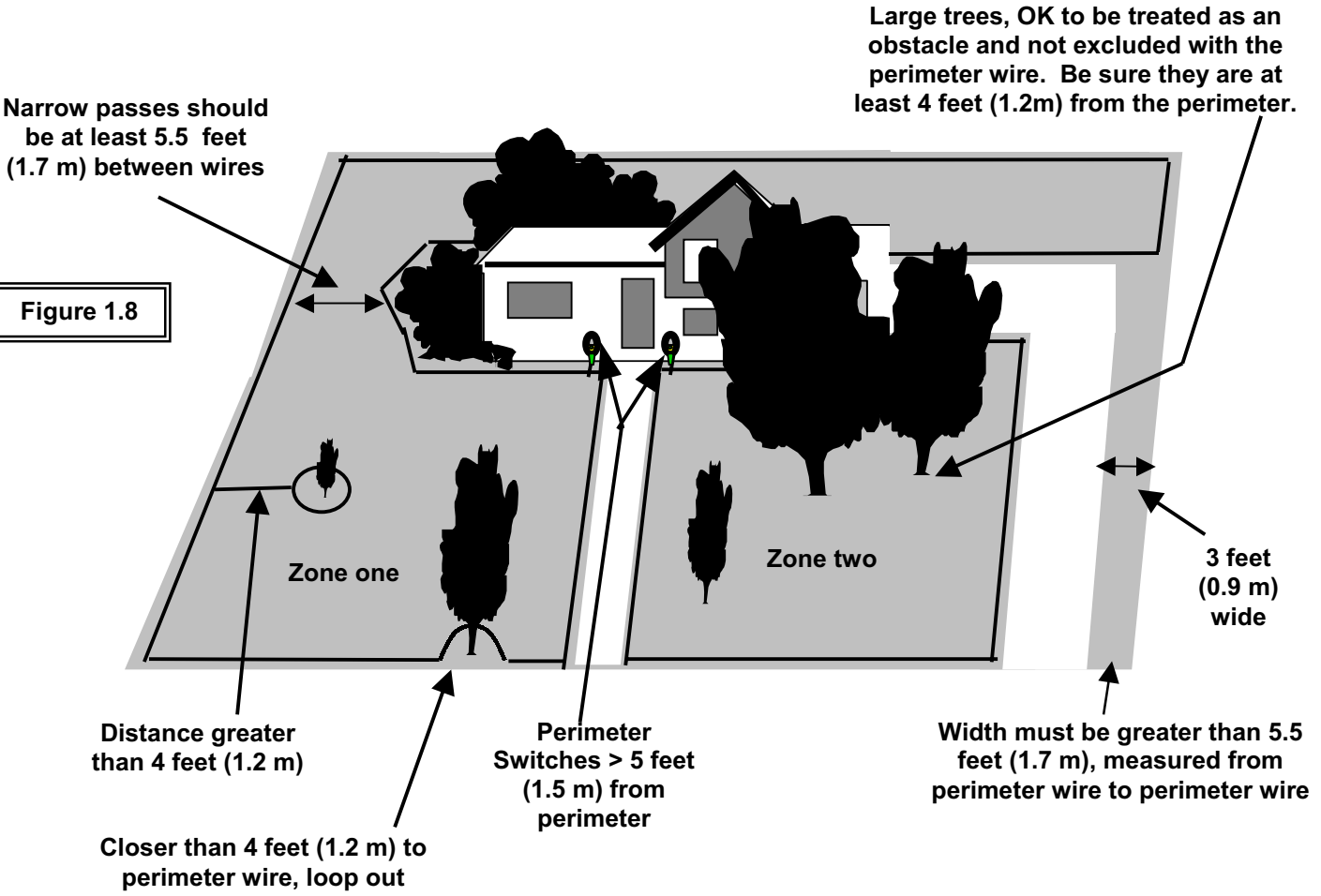

Figure 1.8

### 1.7 Multiple Zones/Areas

As mentioned earlier, your home may require more than one zone to be set up in order for the Robomower to work in all of your lawn effectively. Where grass areas are not contiguous, or are separated by fences or other objects, it is also recommended to make each of these a separate zone.

Perimeter switch can be moved between different zones or you can use one switch for each zone.

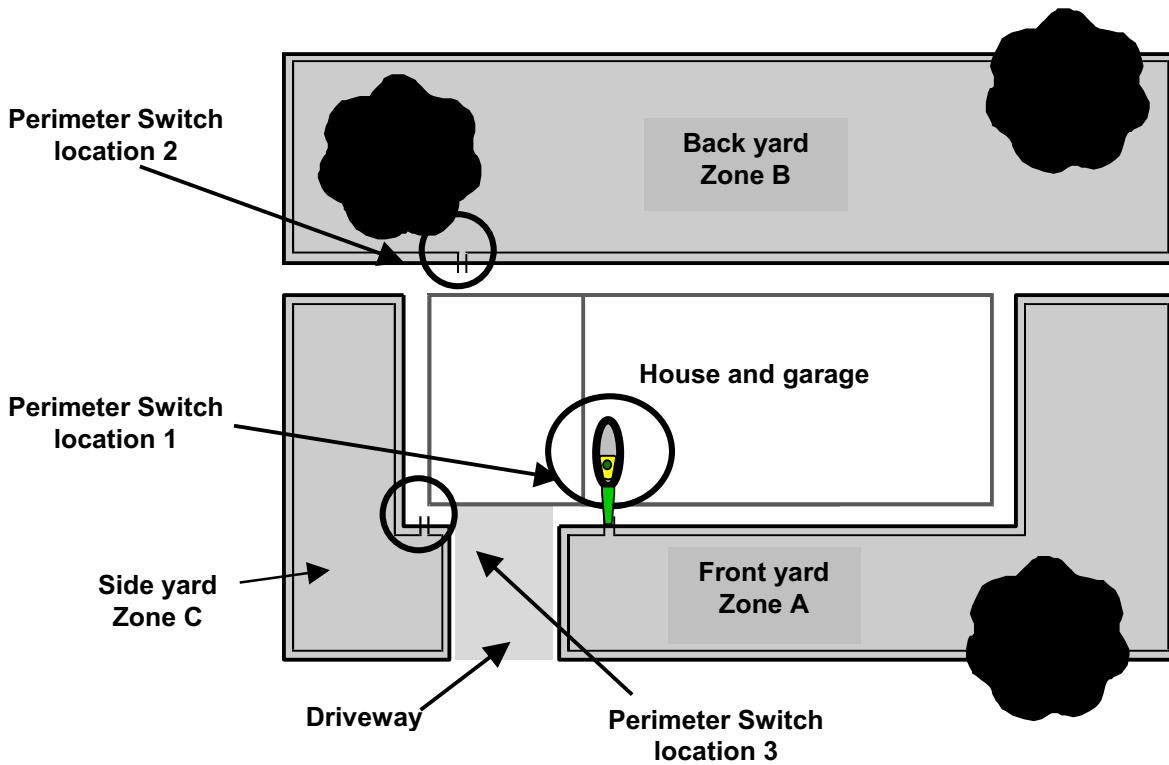



Figure 1.9

### 1.8 Slopes

The maximum slope limit is 15 degrees. If you are unsure as to whether a slope is too steep or not, attempt driving the Robomower manually up the slope. If the front of the mower does not lift from the ground, the slope is fine to include in the cutting area. If however it does lift, exclude this section from the cutting area.

<p><b>WARNING!</b></p> 	<p>Severe injury can occur. When attempting to mow sloped areas that are too steep for automatic operation of the Robomower, insure that you can maintain a safe and sure footing before attempting to mow. Cut across slopes for safety. Always wear appropriate closed toe shoes when operating the Robomower manually.</p>
--	---

### 1.9 Completing The Setup

Once the perimeter wire is completed and pegged to the ground, the last step to complete is attaching the Perimeter Switch to the perimeter wires and testing the setup. Figure 1.12

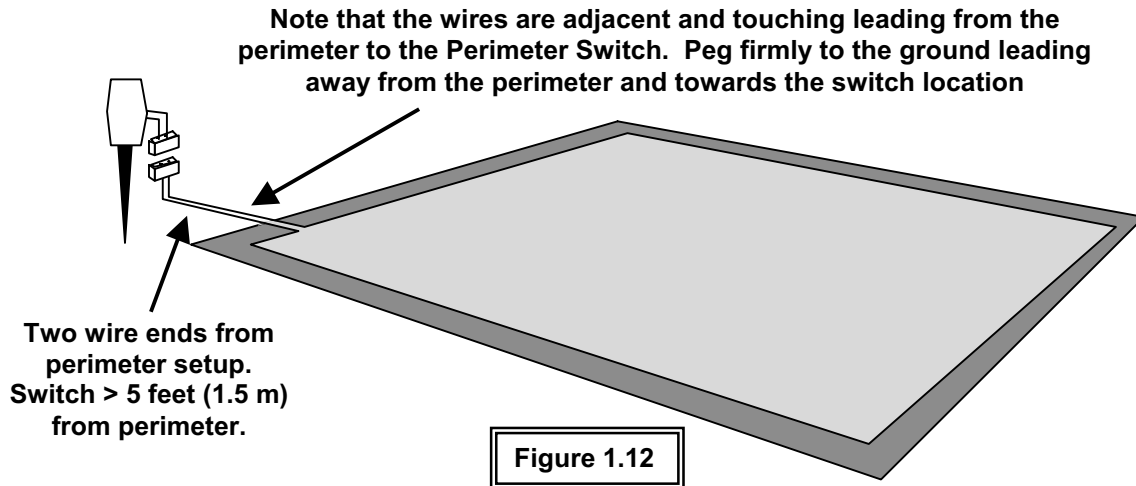

After installing the batteries, Figure 1.13, be sure the wire lead coming out of the Perimeter Switch is positioned at the small notch in the bottom of the housing before fully snapping the Perimeter Switch back together. Figure 1.14.

Squeeze at arrows to remove cover



**Figure 1.13**

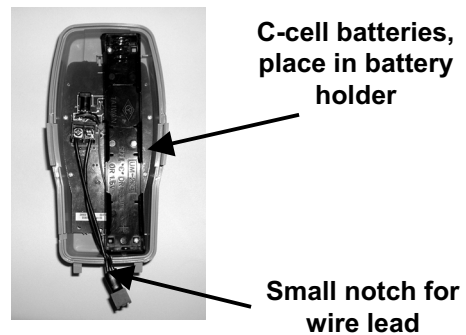

**Figure 1.14**

The lead coming from out of the Perimeter Switch has a female connector permanently attached. It is one part of a two-part connector. Figure 1.15 and 1.16. Plug the perimeter wire connector into the Perimeter Switch and press the 'ON' button.

Perimeter Switch connectors attached

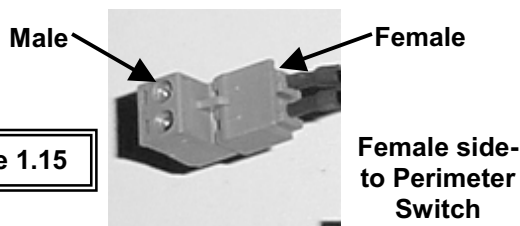

Perimeter Switch connectors unfastened





Insert the two perimeter wire ends into the male connector as shown in Figure 1.17. Using a small flat blade screwdriver, fasten the two screws tightly to hold the wire. Figure 1.17.

Strip back ¼ inch (6 mm) of insulation from each wire end and insert each perimeter wire end into hole of connector.

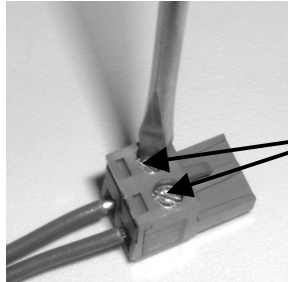

Using a small flat blade screwdriver, tighten these two screws to secure the perimeter wires into the connector

Figure 1.17

A small flashing green light next to the 'On' button indicates the system is on and functioning correctly. Figure 1.18. The Perimeter Switch also has an indicator for low batteries and for a disconnected/broken perimeter wire. Figure 1.18. The Perimeter Switch has an automatic shutoff feature, eliminating the need for you to turn it off after each use. It will shut itself off after 5 continuous hours of operation. Place the Perimeter Switch on the stake as shown in Figure 1.19 or mount on a fixed surface as shown in Figure 1.20.

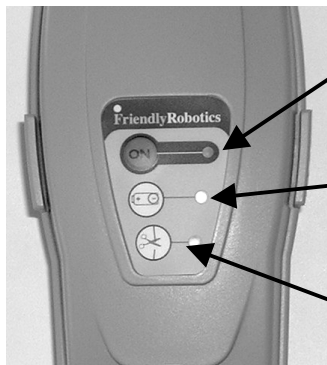

On button and indicator light  
Low battery indicator light  
Disconnected/broken wire indicator light

Figure 1.18

Mounting the Perimeter Switch using three mounting bosses on back cover

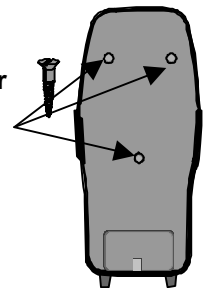
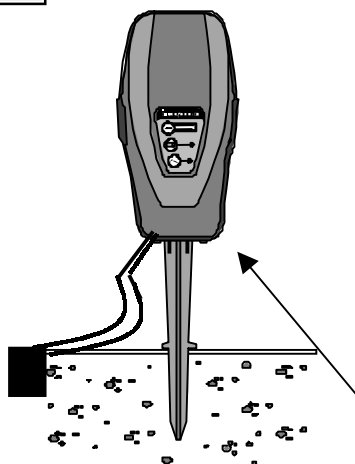
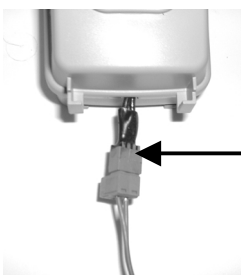

Figure 1.20



The Perimeter Switch MUST be mounted vertically in order to maintain its' water resistance



Perimeter Switch with mounting stake attached. Disconnect Perimeter Switch connector and move switch to new plot.

Figure 1.19

# Chapter 2

## Preparing The Robomower

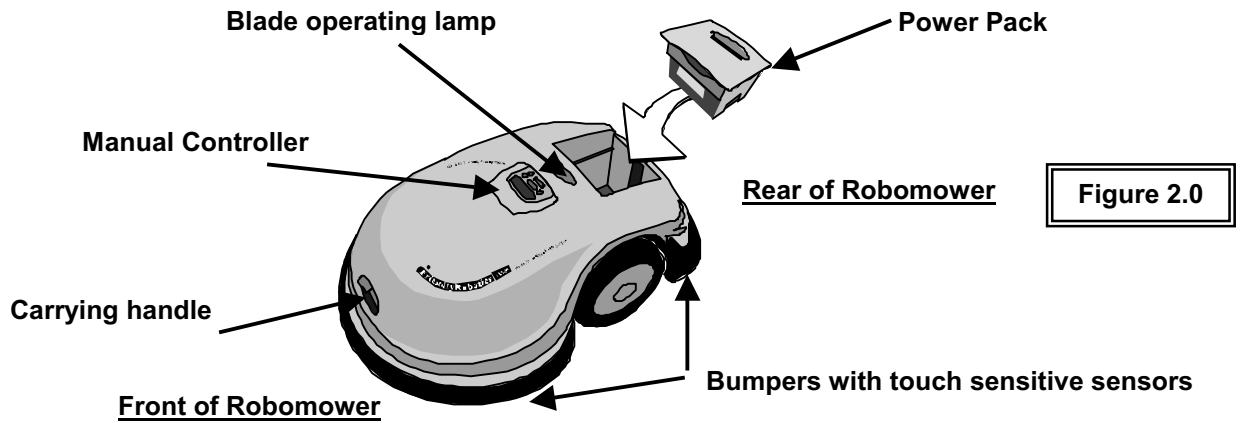

Figure 2.0

### A basic 'what is what' on the Robomower

#### 2.1 Inserting Power Pack Fuse

Carefully lower the Power Pack into the Robomower. After inserting the Power Pack back into the Robomower. See Chapter 4, [Power Pack Charging & Power Management](#) for more details on the Power Pack and charging.

Figure 2.1

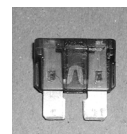
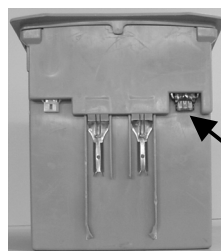

Insert the Power Pack fuse into the fuse holder. The fuse can be inserted in either direction

## 2.2 Using The Manual Controller

The Robomower is equipped with a Manual Controller. It allows you to manually drive and operate the mower. To get started on using the Manual Controller, study figure 2.2 to view the various operating controls and their functions. Refer to Chapter 5, [Manual Operation](#) for full details regarding use of the Manual Controller.

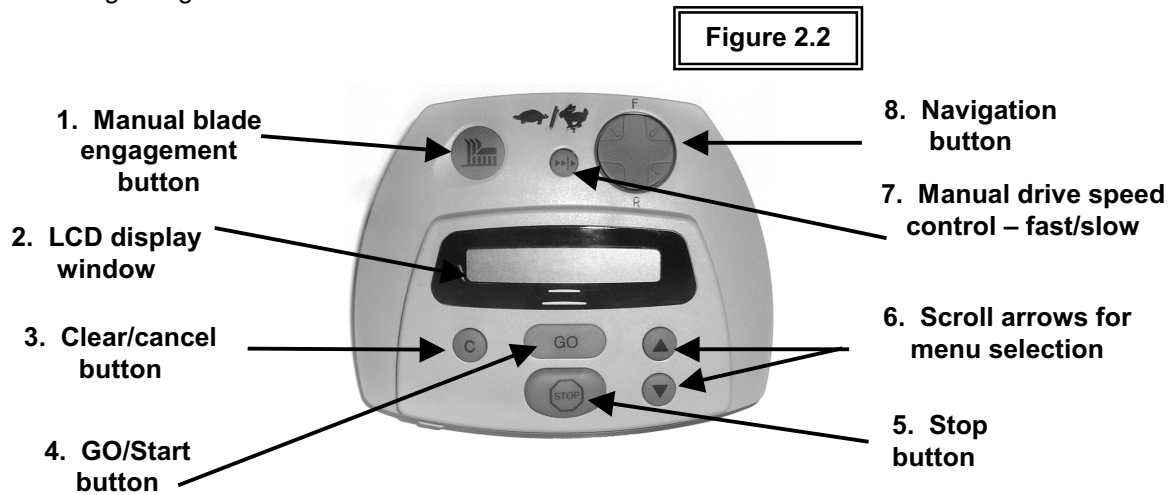

1. **Manual blade engagement button** – engagement of the blades in manual requires two distinct button operations in order to operate.
2. **LCD window display** – displays the text messages using a Liquid Crystal Display (LCD). Also shows current battery status.
3. **Clear/cancel button** – This button is used to cancel a selection shown in the LCD window when making user selections. It is also used as a means to reverse back out of the menu options that can be accessed in user options, returning you to the main screen.
4. **GO/Start button** – the main operating button for automatic operation. In addition it is used as a button for making or confirming selections made under user options in the LCD window.
5. **Stop button** – pressing this button will stop all operation of the blades and wheel motors when in the automatic operation mode. It can also be used to stop an operation in progress before it has commenced.
6. **Scroll for menu selection** – The arrow button, up and down, allows you to scroll through these different options.
7. **Manual drive speed control** – the manual drive function is equipped with two ground speeds, fast and slow. In order to change the ground speed, press the button once to move to the opposite speed of travel
8. **Navigation button** – pressing this button in the desired direction will allow manual driving of the mower. Use light pressure on the navigator pad, gently rolling it to the desired direction of travel for driving. The drive button is omni-directional in forward and reverse and constant pressure must be maintained for continued operation.

### 2.3 Setting The Cutting Height And Ground Clearance

Remove the Power Pack before making any adjustments. The Robomower has two basic adjustments, cutting height and ground clearance. The cutting height adjustment is located at the front wheel and is controlled by rotating the front wheel hub in or out, which effectively causes the front wheel to be raised or lowered. See Figure 2.6.

Rotate the front wheel hub in (lower) or out (higher) to adjust the cutting height. Each click represents about 1/4 inch (6 mm) in height of cut.



Figure 2.6

Rotate this direction for higher cut

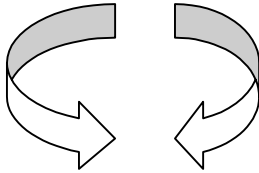

Rotate this direction for lower cut

#### WARNING!

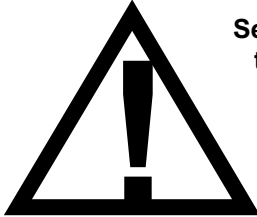

Severe injury is possible. Always remove the Power Pack when attempting to adjust the height of cut or otherwise lifting the mower off the ground. Never lift the mower or attempt to adjust the cutting height during operation. Blades are very sharp and severe cuts or lacerations are possible. When working around or near the blades always wear heavy gloves.

The ground height adjustment is located in the Power Pack compartment of the mower. See Figure 2.7. It has two positions, upper and lower. (*RL550 Europe has three; upper, lower and middle*) The lower position (closest to the bottom of the Power Pack compartment) provides the highest level of ground clearance while the upper position (farthest from the bottom of the Power Pack compartment) provides the least amount of ground clearance. See Figure 2.8.

Rear ground height adjustment is located in the Power Pack compartment.



Figure 2.7



To adjust ground clearance, pull out on tab as shown and slide tab up or down.

Figure 2.8

## 2.4 Set Country and Perform One Time Calibration

The one time calibration process is simple and the Robomower is designed to ask you to perform this step before it can ever be used in the automatic mode.

- Remove the Manual Controller
- Drive the Robomower to a flat and level section of the lawn, at least 4 feet (1.2 m) from the perimeter wire
- Insert the Manual Controller in the holder and pivot it down flush
- Turn on the Perimeter Switch
- Follow the calibration setup process as shown in Figure 2.10. (next page)

Note: If the calibration was not successful, the display will read '**Restart Elsewhere**'. Drive the Robomower to another flat and level surface within the lawn, at least 10-15 feet (3 – 4.5 M) from the first spot and repeat the calibration process as outlined above.

## 2.5 Testing Wire Position for Edge Mowing



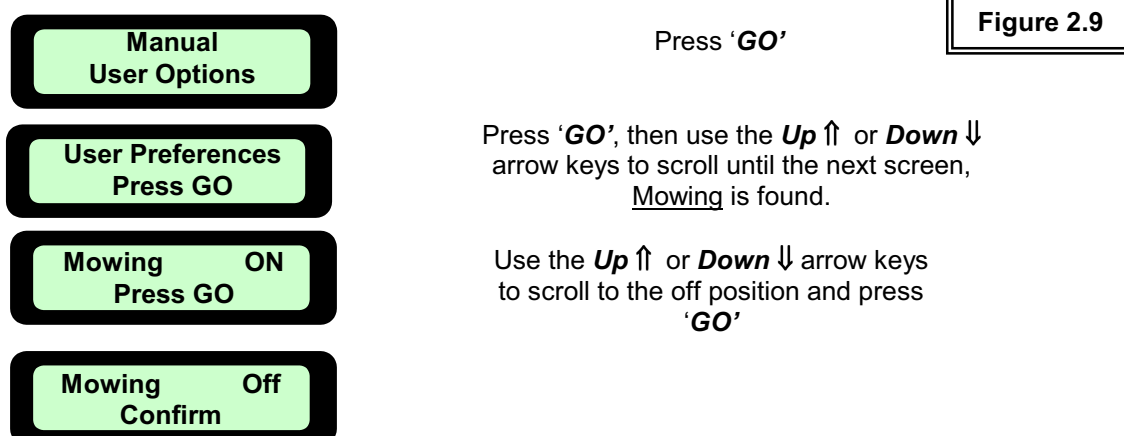





As mentioned in Chapter 1, it is best to test the position of the perimeter wire on edge mowing to determine if any small adjustments need to be made to the wire position before driving the rest of the wire pegs into place. Remove the Manual Controller from the holder and follow the steps in Figure 2.9 to turn off the mowing blades for this test. Repeat this process to turn the blades back on once you have completed this test.

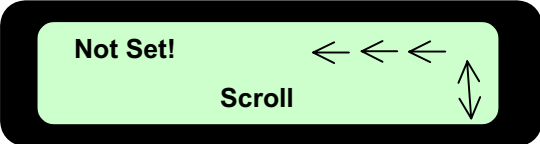

- Position the Robomower towards the perimeter wire.
- Insert the Manual Controller back into the holder and pivot down flush
- Confirm the Perimeter Switch is turned on
- Press the '**GO**' button once. The Robomower will drive to the perimeter wire and begin tracking for edge
- Walk along the mower while following the edge. Note places where the wire should be adjusted; the Robomower bumps into an object or wall along edge; the mower is not cutting far enough onto adjacent surfaces like the driveway; or areas where the mower may drop off into an adjacent area that is lower than the mowing surface.
- Slightly move the wire in these locations
- Once the test is completed and you are satisfied with the wire position, add in pegs along the wire where the wire is not pulled down to the ground level.

Calibration Setup Sequence

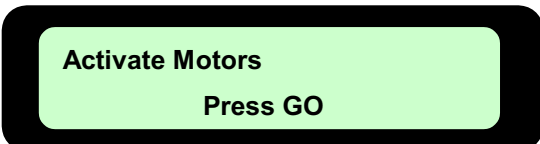
Figure 2.10

<u>LCD Display</u>	<u>Action Required</u>
	Press 'GO'
	Press 'GO'
	Scroll up or down to find your country
	Press 'GO' to confirm selection
	Press 'GO'
	Press 'GO'
	Press 'GO'. Process will begin and last 1-2 minutes.
	Press 'C' button
	Ready for mowing

# Chapter 3

## Automatic Operation

### 3.1 Activating The Perimeter Switch

The Robomower cannot operate unless the Perimeter Switch is turned on and the mower is on the inside of the active perimeter. Press the '**ON**' button to turn on the switch. You will hear one short beep when the switch is first pressed, indicating it is on. If one of the other indicators is on refer to [Chapter 7, Text Messages and Troubleshooting](#) for further help.

<p><b>WARNING!</b></p> 	<p>Serious injury or death can occur. This machine has sharp rotating blades. When operating in automatic mode, keep children, pets and bystanders away from mower. When operating automatically, do not leave unattended if children, pets or other persons will come in contact with the mower during operation. Never allow persons or pets to ride on this machine or block the path of travel.</p>
--	---

### 3.2 Positioning The Robomower On The Lawn

Remove the Manual Controller from its' holder and drive the Robomower into the lawn area to be cut. Position the Robomower at least 3 feet (1 m) from any straight length of perimeter wire, with the front of the mower pointing to the perimeter wire. Figure 3.1.

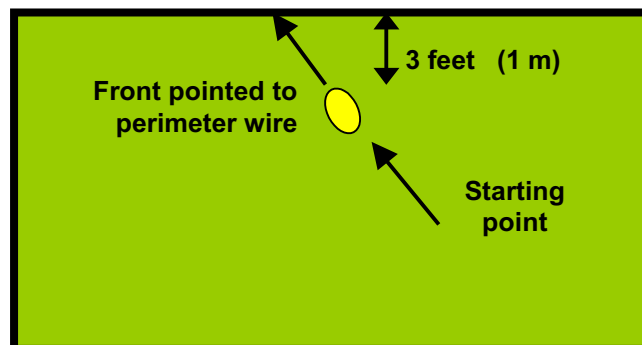

Figure 3.1

### 3.3 Edge Mowing

The first mowing chore for the Robomower is mowing the edge.

- Place the Manual Controller in the holder and pivot down flush
- Press the '**GO**' button once to start the automatic mowing sequence
- The Robomower will automatically follow the perimeter wire one to two passes around the perimeter and will automatically turn into the lawn to mow the inner area

### 3.4 Scanning (Mowing)

Keep in mind that the Robomower will not mow all the grass on its first pass, in fact it will leave uncut grass in between many of the legs it makes. This is expected and is entirely normal. These uncut areas will be cut on subsequent passes of the Robomower across the lawn. Just like a dishwasher, wait until the job is finished before you can appreciate the results. The Robomower will continue to run for the amount of time selected or for the default '**MAX**' time, which is generally 2.5 to 3.5 hours, depending on grass type and condition. (*RL550 Europe 2 hours*) See [Chapter 6, Operator Settings and Advanced Features](#) for more detail on setting operating time.

Note: There is an option to skip the edge mowing and to start scanning (mowing) the main area of the lawn. Simply press the '**GO**' button two times in sequence when starting the mower.

### 3.5 Mowing Complete

When the Robomower has operated the allotted time, it will simply stop in the lawn, waiting for you to drive it back home and plug it into the charger, ready for the next mowing session. The LCD will display a text message as seen in Figure 3.7 if the mowing time is set to the default time of '**MAX**' or the message as shown in Figure 3.8 if the mowing time has been selected to any time other than '**MAX**'.

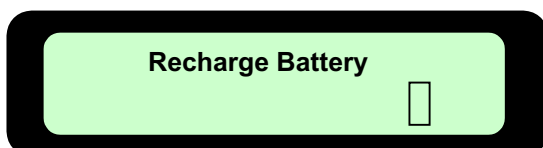

Figure 3.7

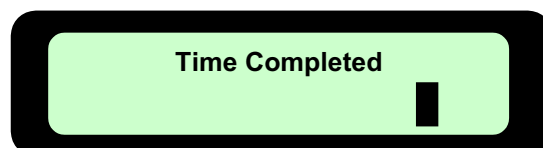

Figure 3.8

If the Robomower has completed its' mowing and it is more than 20 minutes before you arrive to move it, the LCD screen will be blank. The Robomower will shut itself down into a sleep mode after 20 minutes of inactivity at all times. This is an energy saving feature. Pressing the '**GO**' button or removing the Manual Controller from the holder will 'wake up' the Robomower and display the message that was on the LCD when it went into sleep mode. In this case, either the message in Figure 3.7 or 3.8.



# Chapter 4

## Power Pack Charging & Power Management

### 4.1 Charging

The standard charger (power supply) included with your Robomower will re-charge the Power Pack from the '**Recharge Battery**' level in approximately 24 hours, depending on conditions. Figure 4.1 There is a fast charger available as an accessory. See the accessories available for your Robomower in Chapter 10.

Connect the output lead of the charger, Figure 4.2, into the charging socket, located under the Manual Controller holder, Figure 4.3. Connect the other end of the charger to a regular household receptacle, 120 Volts AC and the charging process will begin (*European models utilize 230 volts mains power*). Lightly pivot the Manual Controller down, allowing it to rest gently on the charging cord. **DO NOT** attempt to force the Manual Controller all the way to the flush position. The Robomower charger is designed for indoor dry use only. Do not charge the Robomower where wet contact is likely. The LCD on the Manual Controller will display the text seen in Figure 4.4 and the battery icon will continually move from empty to full to show the charging. Once the battery is fully charged, the message will change to that as shown in Figure 4.5, reminding you to keep it connected to the charger until the next use.

Charging is such an important aspect for assuring good performance and Power Pack life that a special alert and power management system is incorporated into the mower to remind and alert you when the proper charging process is not occurring.

<p><b>WARNING!</b></p> 	<p><b>Shock hazard. Injury or electrocution can occur. The Robomower charger is designed for indoor use in dry locations only. Never use the charger or charge the Robomower in areas where extreme dampness or wet contact is likely. Never use a charger when the leads are damaged. Use only the recommended charger with your Robomower.</b></p>
--	--



Standard charger (power supply) 120 volt shown

Figure 4.1



Charger output lead

Figure 4.2



Standard charger connector socket

Figure 4.3

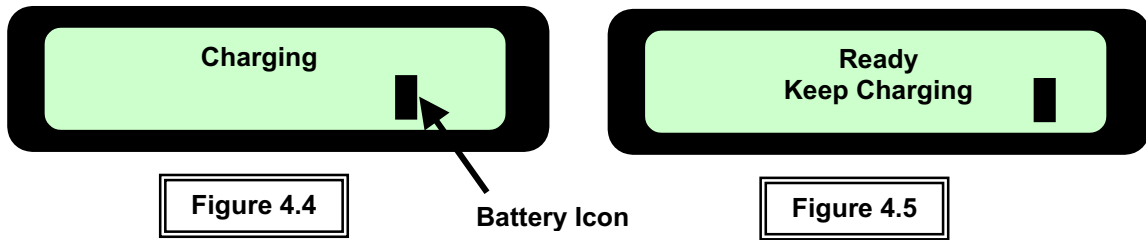

**The importance of proper charging and maintenance of the Robomower Power Pack cannot be stressed enough. Failure to follow the recommended charging procedures will result in poor performance of the Robomower and shorten the life of the Power Pack.**

### 4.3 Off-season storage

The Power Pack is best to stay connected to the charger at all times of non-use. The charging system is designed to operate continuously without a problem and will not damage the Power Pack. The only exception to this rule concerns extremely cold temperatures. If you store your Robomower in an area where the temperatures can reach  $-4\text{F}$  ( $-20\text{C}$ ) then follow these steps;

- 1) fully charge the Power Pack for each Robomower you own
- 2) store them in a dry area where the temperature will not fall below  $0\text{ degrees F}$  ( $-18\text{C}$ ).

**The Robomower should always  
be connected to the charger  
when not in operation**

# Chapter 5

## Manual Operation

### 5.1 Driving and Navigating

The Robomower is equipped with a Manual Controller that allows you to easily drive it. Using your thumb or index finger of your right hand, gently press the navigator button in the direction you want to drive. The button is omni-directional, allowing for slight turns as well as sharp turns, all the way to a complete circle.

#### WARNING!

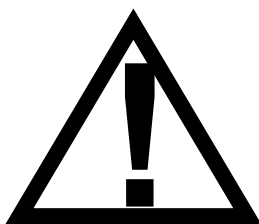

**Serious injury can occur. Always wear appropriate footwear when driving and using the Robomower in the manual mode. Keep a safe distance from the mower when operating it manually. Note that the reverse driving direction is from the point of view standing at the rear of the mower. Always look behind you when using the reverse direction drive. Do not operate the mower in areas not suitable for manual operation or on slopes where a sure footing is not possible. Cut across slopes for safety. Do not drive the mower with persons sitting on it and do not manually operate within 10 feet (3 m) of other persons or pets.**

### 5.2 Manual Mowing

You have the ability to manually activate the blades on the Robomower in order to trim small areas. After the blades are activated you may drive the mower using the navigator button and you may cut in any direction the navigator button will operate. The manual mowing operation on the Manual Controller is a two-step OPC (Operator Presence Control) type system for safe use. At any time the blades have been stopped, it will require the OPC activation process to be repeated. During manual mowing operation, activation to any bumper sensor will shut down the blades, requiring the blade activation process to be repeated.

#### Step 1



Using right thumb, press and hold 'C' button

#### Step 2



While holding the 'C' button, press the 'Mow' button with your left thumb. The blades will now start.

#### Step 3



Release the 'C' button. Maintain pressure on the 'Mow' button with your left thumb. Navigate and drive the mower using your right thumb on the 'Navigator' pad.

# Chapter 6

## Operator Settings and Advanced Features

### 6.1 User Options

Lifting the Manual Controller from its holder will change the text display on the LCD to the manual operating menu, as seen in Figure 6.1. Use the arrow keys to view options. Pressing 'GO' once will take you to the next screen, **User Preferences**. Figure 6.2. Press 'GO' to view the menu of user preferences, beginning with **Sound**, Figure 6.3. Using the 'Up ↑ Down ↓' arrow keys will allow you to scroll through these menu items. Pressing 'GO' will take you to these various preferences. Figure 6.4

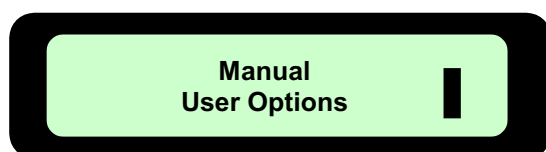

Figure 6.1



Figure 6.2



Figure 6.3

The 'GO' button is used as a means to select or confirm different menu options or settings. By pressing the 'GO' button, it will generally select or confirm what is shown on the second line of the LCD text message. There are several settings for which the operator can make changes to or features to enable/disable. Pressing the 'C' button at any time during the menu selection process will bring you back to the main menu. The following menu options are available to the user and may be changed as desired; (not all options are available on all models)

#### User Options

- 1) Child Guard
- 2) Safety Test
- 3) Service (not accessible to user)

#### User Preferences

- 1) Sound
- 2) Mowing
- 3) Language
- 4) Work Time
- 5) Learn Edge –(visible only when in Manual Controller holder and pivoted to the closed position) (RL800 US & RL850 Europe)
- 6) Set Default Edge
- 7) Wide Scan (RL800 US & RL850 Europe)
- 8) Anti-Theft (RL800 US & RL850 Europe)

Figure 6.4

## 6.2 Sound

Allows user to shut off non-safety related operating sounds.

## 6.3 Mowing

Allows user to turn blade operation off, preventing blade operation during automatic operation and manual mowing.

## 6.4 Language

Allows the user the option of viewing the LCD text in several different language versions.

## 6.5 Work Time

Allows the user the option of setting the operating time from the '**MAX**' default setting to times ranging from 20 minutes up to 2 hours. Figure 6.5 This option is available for up to 4 different zones, A, B, C or D. Having four different zones can allow you to set operating time for several different zones that are of varying sizes, not requiring the same operating time for mowing.

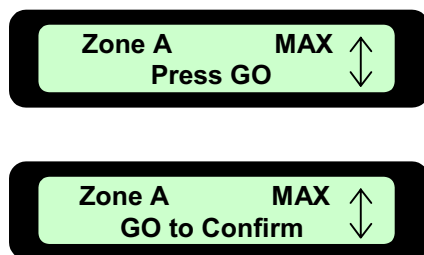

Scroll to select different zones.

Scroll to select different operating times. Times range from: None = (zero time) to 2 hours to '**MAX**'

Figure 6.5

## 6.6 Wide Scan

Wide scan provides the Robomower a secondary navigation technique which can prove to be beneficial in some lawns. Wide scan will increase the distance between subsequent legs of mowing after each movement off of the perimeter wire. If it appears that the Robomower is simply driving along the same path back and forth, activate wide scan.

## 6.7 Learn Edge

This menu option can only be seen when the Manual Controller is in the holder and flush with the mower top. '**Learn Edge**' gives you the ability to have the Robomower learn the distance around the perimeter during edge. Figure 6.6

- Position the Robomower to start edge mowing and place the Manual Controller in the holder
- Follow the steps described in Figure 6.6 to begin the process
- '**Learn Edge**' is specific to each zone, so be sure you have selected the correct zone where you want the edge learned

Figure 6.6

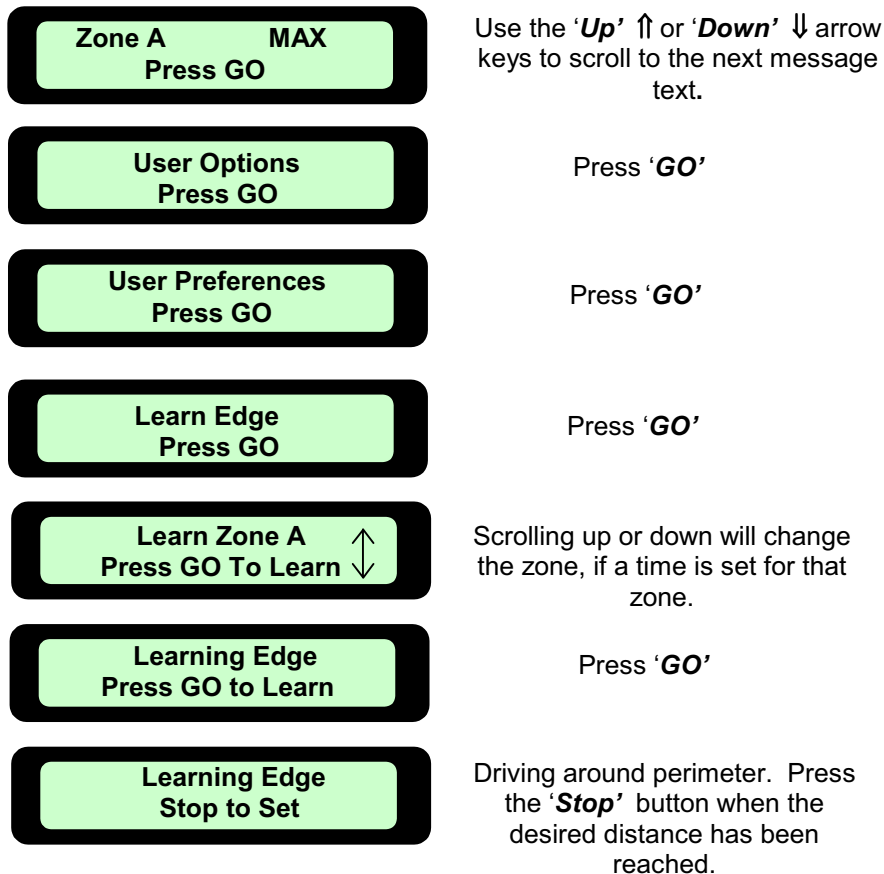

## 6.8 Set Default Edge

Selecting Default Edge restores the factory default edge distance to the specific zone selected.

## 6.9 Anti-Theft

The anti-theft system provides the user a disabling function that will prevent anyone from using or driving the Robomower unless they have the valid code to enter. You will be prompted to enter a four-digit code of your choice to use as your personal security code. Use the scroll arrows in order to change each digit position to a different number and then press '**GO**' to move to the next digit to select. You will find a place to record your personal security code in Chapter 8 of this manual. Be sure to record your code for future reference.

## 6.10 Child Guard

Child guard is a feature that when activated will help deter use by young children and other unauthorized people. It will prevent operation without a proper code, but it is a much simpler code and is intended as a means to prevent operation to those not familiar with or suitable for operating the mower. The key sequence to unlock the guard for operation is the same for all mowers, press the '**Up**' ↑ arrow key and then the '**C**' key to unlock the controls. One minute of inactivity will re-lock the keys.

### 6.11 Safety Tests

When selected, the safety test feature will allow you to test the primary safety devices on the Robomower; 1) front and rear bumpers, 2) lift sensor and 3) the Manual Controller buttons. Follow the prompts on the menus for testing. Never use the Robomower with a safety device or feature not properly operating. Never attempt to disable or bypass any safety device or system. See an authorized Friendly Robotics service facility for repair or information regarding any safety system or device.

# Chapter 7

## Text Messages and Troubleshooting

### 7.1 Messaging

The Robomower is equipped with a sophisticated monitoring system that will notify you in the form of a text message in the LCD panel when common operational faults occur. In addition, it will also communicate in text form several messages that are meant as a prompt to the user to perform a certain function or action. In the event the Robomower has not completed an anticipated operation and has stopped in the lawn, it will typically display a text message informing you of the reason it has stopped. If the LCD screen is blank, pressing the 'GO' button one time will wake the mower up and the last fault or message displayed prior to stopping will now be displayed.

While it is impossible to list every circumstance that will result in a message display, the most common reasons for a particular message are provided in the following chart. Following this chart, in Section 7.2, you will also find additional operational and fault issues that may not display a particular text message in the LCD panel. For issues that cannot be resolved through the use of these charts please contact your service provider.

Message Displayed	Probable Cause/Event	Corrective/User Action
<b><u>Check Mow Height</u></b>	Something is preventing a blade from rotating freely. Severe grass accumulation under the mowing deck; rope or similar object wrapped around mowing blade; object jammed under mower preventing blade from rotating.	<b><u>CAUTION</u></b> – Remove power pack before raising mower. Inspect blades for foreign material or debris. Clean out accumulated grass clippings using a wooden stick.
	Mowing motors have been working under a severe load. Attempting to remove more than normal growth of grass.	Raise height of blades or have grass cut to a more reasonable level.
<b><u>Check Power</u></b>	Power supply/charger is not plugged into the main power supply.	Confirm power supply is plugged into the main power receptacle.
	No power to receptacle or main power is shut off.	Check for power to this main receptacle by plugging in another appliance. Turn power on to the main receptacle.
<b><u>Keys Locked</u></b>	Child lock feature has been activated.	Press the <b>Up</b> ↑ arrow key and then press the 'C' button. Child lock can be deactivated under <b>User Preferences</b> .



Message Displayed

Probable Cause/Event

Corrective/User Action

<u>Restart Elsewhere</u>	Calibration failure from interference in the immediate area.	Move the Robomower 10-12 feet (3-4 m) from this spot and attempt calibration again.
<u>Start Elsewhere</u>	An unknown fault has occurred and operator help is required.	Manually drive the mower away from this particular area and restart operation.
<u>Theft Guard On</u> (RL800 & RL850 only)	The theft guard system is activated.	Enter the correct 4-digit code. ' <b>Theft Guard</b> ' can be deactivated under ' <b>User Preferences</b> '. Contact your service provider for assistance in a lost code situation.
<u>Move From Wire</u>	The Robomower is positioned too close or on top of the perimeter wire.	Move the Robomower approximately 6-10 feet (1.5 -3 m) away from the perimeter wire and start again.
<u>Drive Overload Cooling, Wait...</u>	The drive motors have been working under a severe load for too long of a time.	Wait until the message ' <b>Drive Overload – Press GO</b> ' is displayed
<u>Mowing Overload Cooling, Wait...</u>	The mowing motors have been working under a severe load for too long of a time.	Wait until the message ' <b>Mowing Overload – Press GO</b> ' is displayed
<u>No Wire Signal</u>	Perimeter Switch is not turned on or connected to the zone intended to mow.	Make sure the Perimeter Switch is connected to the correct zone and is turned on with the ' <b>ON</b> ' indicator flashing.
<p><u>Front Wheel Problem</u></p> <p>CAUTION – DO NOT attempt to disable this safety device in the event you are unable to isolate and correct the problem. Contact your service provider for repair before using.</p>	The front wheel has left the ground for more than 8-10 seconds	<b>CAUTION</b> – Remove Power Pack before raising mower.
		The Robomower has driven onto a raised obstacle, raising the front end. Remove or exclude this object from the mowing area.
		The Robomower is being used on a slope too steep for safe mowing. Exclude this from the mowing area.
		High grass is preventing the front wheel from fully riding on the ground. Raise the cutting height.
		The ground contains large holes or indentions where the front wheel can drop into when passing across. Fill these areas with dirt and level off.

7.2 Other Operational or Fault Problems

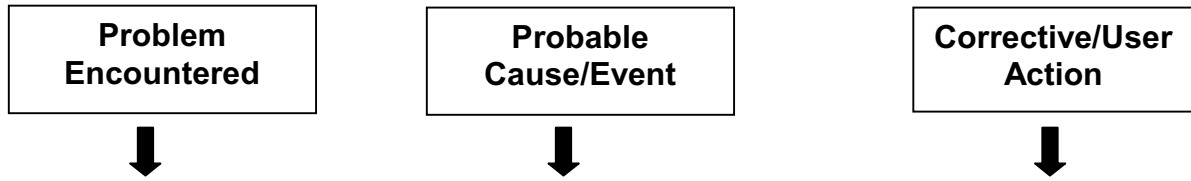

<b>'Cut wire'</b> indicator flashing on Perimeter Switch	Wire disconnected from switch	Confirm wire is plugged in and wire leads are firmly attached
	Perimeter wire cut	Walk along perimeter, including islands and obstacles excluded with the perimeter wire and look for obvious cuts or breaks in the wire. Repair with Robomower wire splice connectors.
	Poor connections	Check and repair all loose/poor or corroded connections
<b>'Replace Battery'</b> indicator flashing on Perimeter Switch	Weak batteries	Install fresh alkaline C-cell batteries
	Perimeter wire too long for one zone	A maximum perimeter wire length of 1000 feet (300 m) is recommended. Areas requiring longer lengths should be broken into separate zones. If the <b>'Cut Wire'</b> indicator flashes once when the Perimeter Switch is activated, this confirms a length too long for a single perimeter zone.
Perimeter Switch will not activate when turned on	Batteries are completely discharged.	Install fresh alkaline C-cell batteries
	Batteries installed with wrong polarity position.	Verify correct placement of batteries.
	Perimeter Switch not installed vertically and exposed to water/rain.	Water/moisture protection of the Perimeter Switch can only be insured when mounted vertically. Replace Perimeter Switch.
Robomower will not operate and nothing will display on the LCD screen.	Mower is in deep sleep.	If not connected to the charger at all times when not in use, the Robomower will conserve power by entering into a deep sleep mode. Lift Power Pack from mower and re-insert it after 10 seconds.
	Power Pack has been discharged from lack of charge maintenance.	It is required for the charger to remain connected to the Robomower when not in use. Failure to do so can cause permanent Power Pack damage. Contact your service provider.
Robomower drives but blades will not mow.	<b>'Mowing'</b> has been turned to off.	Change back on under <b>'User Preferences'</b>
The bumper does not activate when striking an obstacle.	The obstacle is less than 6 inches (15 cm) in height, is not rigid enough or is positioned at an angle relative to the ground preventing square contact with the outermost surface of the bumper.	Remove the obstacle or exclude it from the cutting area with the perimeter wire.

Problem Encountered	Probable Cause/Event	Corrective/User Action
---------------------	----------------------	------------------------

Short run time, operates less time than normal	Power Pack is not fully charged	Connect the charger to the mower and keep it connected until the <b>'Ready – Keep Charging'</b> message displays in the LCD screen.
	<b>'Work Time'</b> for that zone is set to stop at a pre-determined duration.	Work time can be changed under <b>'User Preferences'</b>
	Grass is extremely over grown or very wet. Dull blades.	Raise cutting height. Always mow the grass frequently enough to prevent over growth. Refrain from cutting wet grass. Replace blades.
	Power Pack is reaching a normal end of life state.	Replace Power Pack. Properly maintain Power Pack per instructions.
LCD display is in a foreign language.	The language setting was changed or not correctly set.	Remove the Manual Controller and follow the sequence listed; <ol style="list-style-type: none"> <li>1. Press <b>'C'</b> button</li> <li>2. Press <b>'GO'</b> button twice</li> <li>3. Press <b>'Down'</b> ↓ arrow key twice</li> <li>4. Press <b>'GO'</b> button once</li> <li>5. Using the arrow, scroll to the correct language</li> <li>6. Press <b>'GO'</b> to confirm this selection</li> </ol>
Large patches of uncut grass remain after Robomower has completed mowing.	Power Pack is not fully charged for operation.	Connect the charger to the mower and keep it connected until the <b>'Ready – Keep Charging'</b> message displays in the LCD screen.
	<b>'Work Time'</b> not sufficient for zone size.	Increase <b>'Work Time'</b> under <b>'User Preferences'</b> OR set <b>'Work Time'</b> to <b>'MAX'</b>
	Power Pack nearing natural end of life	Replace Power Pack and follow maintenance instructions in manual.
	Grass is extremely overgrown or very wet.	Raise cutting height. Always mow the grass frequently enough to prevent over growth. Refrain from cutting wet grass.
	Power Pack capacity is damaged from poor maintenance.	Replace Power Pack and follow maintenance instructions in manual.
Robomower does not complete the edge	Obstacle along path	Watch the full operation of edge and confirm no obstacles are present
	Peculiar geometry of perimeter	RL500 & RL550, start edge from the opposite side of the lawn. Contact your service provider if this does not correct the situation.
		On RL800 & RL850, perform <b>'Learn Edge'</b> function

# Chapter 8 Specifications

### Dimensions

35" L x 26" W x 12.5" H (89 x 66.5 x 31.5 cm)

### Weight

50 lb. (22.6 Kg) Unit & 28 lb. (12.6 Kg) Power Pack

### Power Pack

24 volt, sealed

### Normal Ground Speed

20" /sec. (.5 m/ sec)

### Cutting Width

21" (56 cm)

### Blade Motor RPM

5800 RPM

### Noise Level

< 90 db(A)

### Equivalent Mowing Power\*

5 HP gas walk mulching mower

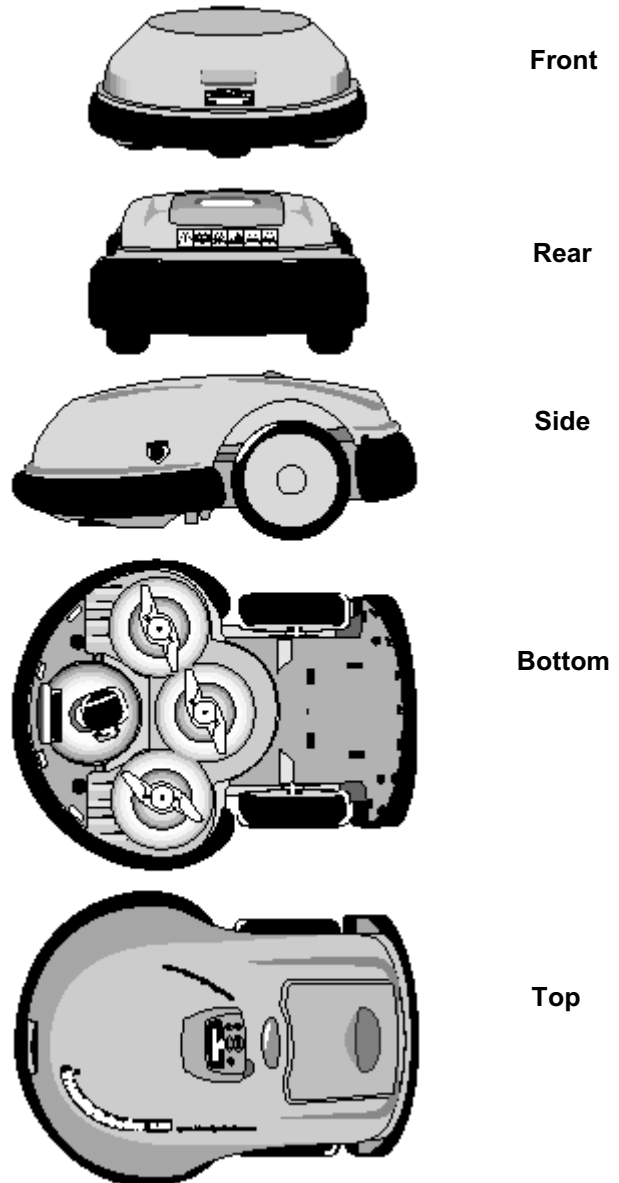

### Theft Guard Code

Fill in the four-digit code you have selected for the Theft Guard system as a safe record in the event you forget the code selected.

— — — —

\* Side by side comparison

# Chapter 9

## Care and Maintenance

### 9.1 Mowing Deck

The underside of the mowing deck needs to be inspected, and cleaned if necessary, between operations. The Robomower is a dedicated mulching mower and because of this can accumulate clippings under the mowing deck, particularly when mowing wet and damp grass. Figure 9.2

<p><b>WARNING!</b></p> 	<p><b>Serious injury can occur. Always remove Power Pack before lifting mower. Blades are very sharp and can cause severe cuts or lacerations. Always wear heavy work gloves when working in and around the blades. Never use a damaged or broken blade. Use only sharp blades.</b></p>
--	---

Most grass accumulation can be removed using a small wooden stick or similar object. Carefully scrape the collected grass debris from under the mowing deck. If necessary, remove the blades to gain better access to the mowing chambers in order to clean them. Do not place the mower upside down, damage to the Manual Controller can occur. Instead, lean the mower against another surface to gain access to the mowing deck area.

**NEVER** use a water hose or other type of liquid sprayer to clean the underside of the mower. Component damage can occur. Use only a damp or wet cloth to wipe the surface clean after scraping.

### 9.2 Blades

The cutting blades of the Robomower should be examined for damage between operations. Replace any damaged blade found. Only use sharp blades. Replace blades at least once per season, more often if they have been severely dulled. Machine sharpening is not recommended, as a good balance cannot be achieved after machine sharpening. See Figure 9.1.

### 9.3 Outer Housing

Use only a damp cloth and a dry brush to clean the outer surfaces of the Robomower. A light detergent can be used in a water solution, then soaking and wringing dry the cloth for cleaning. Never use harsh or abrasive cleaning solutions. Never spray with a garden hose or other type of liquid spray hose.

### 9.4 Power Pack

Always follow the maintenance and charging instructions found in Chapter 4 for the Power Pack.

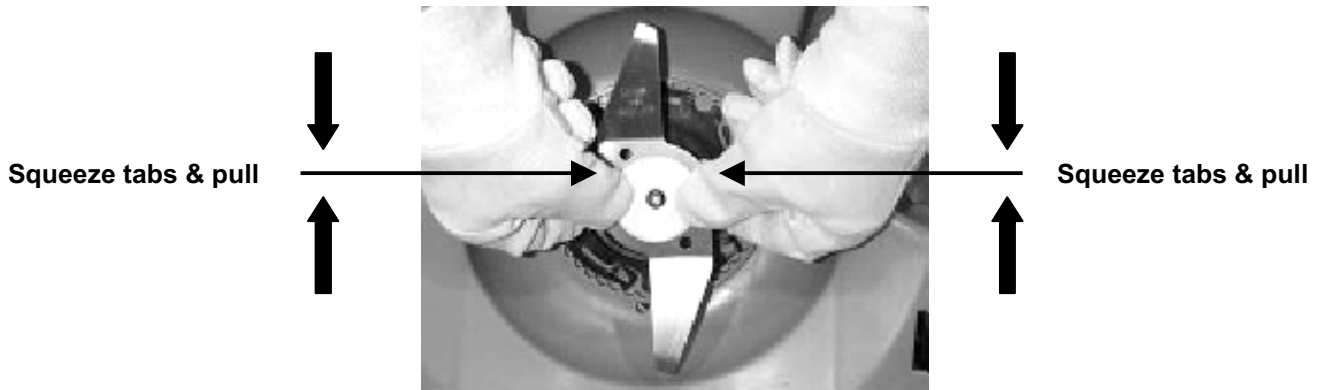
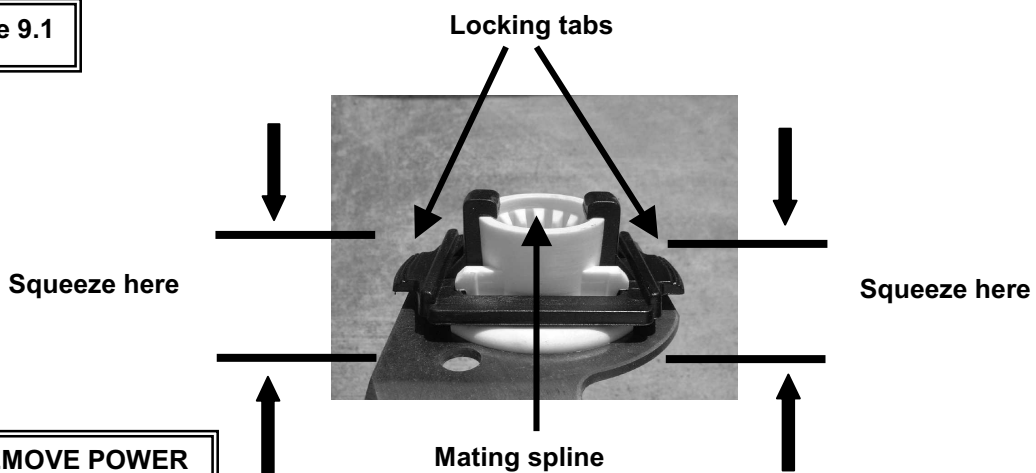

Figure 9.1



**ALWAYS REMOVE POWER  
PACK BEFORE SERVICING  
BLADES!**

To remove blades, squeeze locking tabs on each side of blade retainer, then pull blade assembly off, away from mower. When reinstalling the blade, line up the mating splines and push until a firm click is heard, indicating a proper seating of the blade onto the shaft.

Figure 9.2

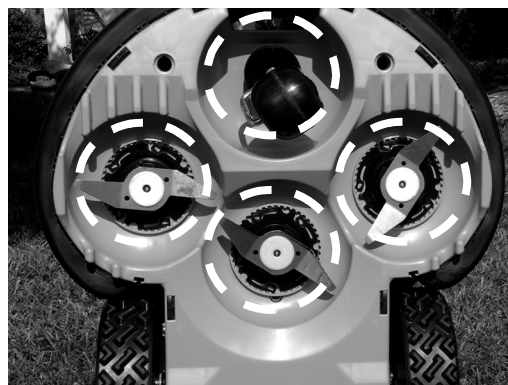

Using a wooden stick or similar object, clean accumulated grass from these areas of the mowing deck. Remove blades if necessary for better access.

# Chapter 10 Accessories



### Perimeter Switch

Convenience of having a switch for each zone and not moving one switch from zone to zone.



### Peg Pack (50)

For larger lawns and additional zones.



### Perimeter Wire

For larger lawns and additional zones.



### Power Pack

Convenience of increasing capacity with a second battery.



### Connector Kit

Includes two Perimeter Switch connectors for additional zones and three silicon filled wire nuts for repairing or splicing the perimeter wire.



### Fast Charger (External)

Recharges the primary or additional Power Pack outside of the mower in approximately 4 hours for fast service and use.



### Blade Set

Keep a spare blade set on hand. Sharp blades are important for safety and good cutting performance.

Accessories can be obtained through your local retailer or visit us on the web at:  
[www.friendlyrobotics.com](http://www.friendlyrobotics.com)



## Friendly Robotics RL Series Limited Warranty

Friendly Robotics warrants to the original purchaser that the RL series 'Product' is free from defects in materials and workmanship when used under normal residential\* purposes for a period of 24 months, 12 months for the batteries, beginning from the date of purchase. Product accessories, including replacement batteries, are warranted for a period of ninety days from the date of purchase. This warranty provides for the cost of parts and labor to repair covered defects when performed by an authorized Friendly Robotics service and warranty facility. A valid proof of purchase is required for warranty repairs. The limited warranty does not cover transportation costs of any kind. The owner bears all responsibility for transportation costs to an authorized Friendly Robotics service and warranty facility.

\*Normal residential purposes is defined as use of the product on the same lot as your primary home. Use at more than one location is considered commercial use, and this warranty would not apply.

### Items and Conditions Not Covered

This express warranty does not cover the following:

- Cost of regular maintenance service parts or procedures, such as blades or blade sharpening.
- Any product or part that has been altered, misused, abused or requires replacement or repair due to accidents or lack of proper maintenance.
- Normal wear and tear, including fading of paint or plastic parts.
- Cost of installation or reinstallation, removal of installation or any costs or damages associated with improper installation or use of product.
- Any product that has been opened, repaired, modified or altered by anyone other than a Friendly Robotics authorized repair facility.
- Repairs necessary due to improper battery care and/or improper charging process such as charging in wet conditions, electrical supply irregularities, or failure to properly prepare the mower or battery prior to any period of non-use.
- Repairs necessary due to water damage, other than incidental rain exposure, repairs due to lightning or other acts of God.

### Instructions for Obtaining Warranty Service

Should you feel your Friendly Robotics product contains a defect in materials or workmanship, contact the retailer who sold you the product.

### Owner Responsibilities

You must maintain and care for your Friendly Robotics product by following the maintenance and care procedures described in the owner/operator manual. Routine maintenance, whether performed by a service provider or by you, is at your expense.

### General Conditions

Repair by an authorized Friendly Robotics service and warranty repair facility is your sole remedy under this warranty. There is no other express or implied warranty. All implied warranties of merchantability and fitness for use are limited to the duration of this express warranty. Friendly Robotics is not liable for indirect, incidental or consequential damages in connection with the use of the Friendly Robotics Product covered by this warranty, including any cost or expense of providing substitute equipment or service during reasonable periods of malfunction or non-use pending completion of repairs under this warranty. Some states do not allow exclusions of incidental or consequential damages, or limitations on how long an implied warranty lasts, so the above exclusion and limitations may not apply to you. This warranty gives you specific legal rights, and you may also have other rights which vary from state to state.

**Always follow the safety instructions  
specified in the Operating Manual.**





●  
**FriendlyRobotics**

**allen**  
Powerful solutions for your growing needs

**Have a question?**  
**Please contact your local dealer**  
**Or call us at:**  
**01964 503817**