

SWISHER

**OWNER'S
MANUAL**

**MODEL NO.
RT10544
RT80044**



CAUTION:
Read and follow all
Safety Rules and
Instructions Before
Operating This
Equipment

Rev. 12.10.99

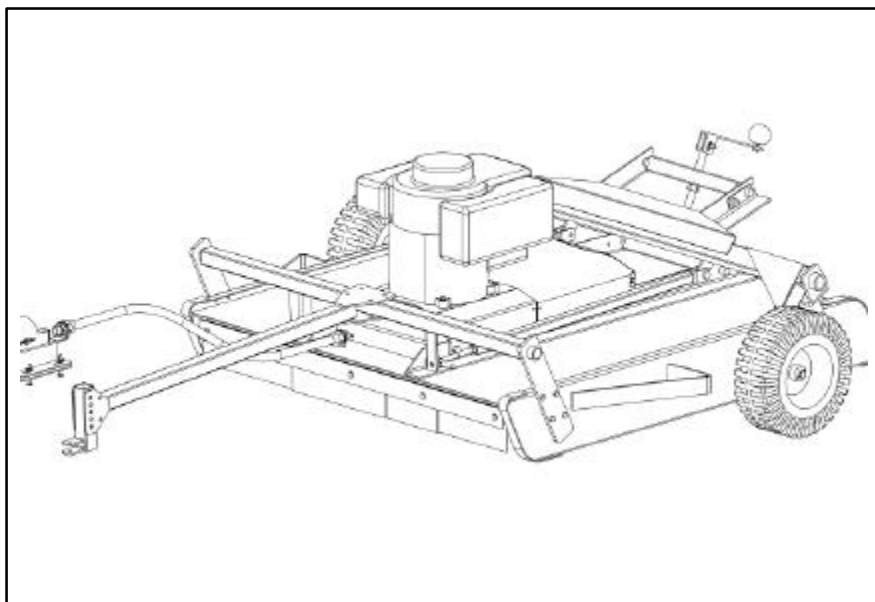

**44" RUGGED CUT
TRAILMOWER**

**Assembly
Operation
Service and Adjustment
Repair Parts**

SWISHER

1602 CORPORATE DRIVE, P.O. BOX 67, WARRENSBURG, MISSOURI 64093
PHONE (660) 747-8183 FAX (660) 747-8650

Manufacturing quality lawn care equipment since 1945

Made In The

U S A

LIMITED WARRANTY

The manufacturer's warranty to the original consumer purchaser is: This product is free from defects in materials and workmanship for a period of one (1) year from the date of purchase by the original consumer purchaser. We will repair or replace, at our discretion, parts found to be defective due to materials or workmanship. This warranty is subject to the following limitations and exclusions:

- 1) Engine Warranty All engines utilized on our products have a separate warranty extended to them by the individual engine manufacturer. Any engine service difficulty is the responsibility of the engine manufacturer and in no way is Swisher Mower Co., Inc. or its agents responsible for the engine warranty. The Briggs & Stratton Engine Service Hot-Line is 1-800-233-3723. The Tecumseh Engine Service Hot-Line is 1-800-558-5402.

- 2) Commercial Use The warranty period for any product used for commercial or rental is limited to ninety (90) days from the date of original purchase.

- 3) Limitations This warranty applies only to products which have been properly assembled, adjusted, and operated in accordance with the instructions contained within this manual. This warranty does not apply to any product of Swisher Mower Co., Inc., that has been subject to alteration, misuse, abuse, improper assembly or installation, shipping damage, or to normal wear of the product.

- 4) Exclusions Excluded from this warranty are normal wear, normal adjustments, and normal maintenance.

In the event you have a claim under this warranty, you must return the product to an authorized service dealer. All transportation charges, damage, or loss incurred during transportation of parts submitted for replacement or repair under this warranty shall be borne by the purchaser. Should you have any questions concerning this warranty, please contact us toll-free at 1-800-748-7108. The model number, serial number, date of purchase, and the name of the authorized Swisher dealer from whom you purchased the mower will be needed before any warranty claim can be processed.

THIS WARRANTY DOES NOT APPLY TO ANY INCIDENTAL OR CONSEQUENTIAL DAMAGES AND ANY IMPLIED WARRANTIES ARE LIMITED TO THE SAME TIME PERIODS STATED HEREIN FOR ALL EXPRESSED WARRANTIES. Some states do not allow the limitation of consequential damages or limitations on how long an implied warranty may last, so the above limitations or exclusions may not apply to you. This warranty gives you specific legal rights and you may have other rights, which vary from state-to-state. This is a limited warranty as defined by the Magnuson-Moss Act of 1975.

SAFETY RULES

Safe Operation Practices for Trailmowers

IMPORTANT: THIS CUTTING MACHINE IS CAPABLE OF AMPUTATING HANDS AND FEET, AND THROWING OBJECTS. FAILURE TO OBSERVE THE FOLLOWING SAFETY INSTRUCTIONS COULD RESULT IN SERIOUS INJURY OR DEATH.



Look for this symbol to point out important safety precautions. It means CAUTION!!! BECOME ALERT!!! YOUR SAFETY IS INVOLVED!!!



CAUTION:
ALWAYS DISCONNECT SPARK PLUG WIRE AND PLACE IT WHERE IT CANNOT CONTACT SPARK PLUG IN ORDER TO PREVENT ACCIDENTAL STARTING WHEN SETTING UP, TRANSPORTING, ADJUSTING OR MAKING REPAIRS.

I. GENERAL OPERATION

- Read, understand, and follow all instructions in the manual and on the machine before starting.
 - Read this operator's manual carefully. Become familiar with the controls and know how to operate your mower properly.
 - Only allow responsible adults who are familiar with the instructions to operate the machine.
 - Clear the area of objects such as rocks, toys, wire, etc. which could be picked up and thrown by the blade.
 - Be sure the area is clear of other people before mowing. Stop machine if anyone enters the area.
 - Never carry passengers.
 - Do not mow in reverse unless absolutely necessary. Always look down and behind before and while backing.
 - Be aware of the mower discharge direction and do not point it at anyone. Do not operate the mower without the guards in place.
 - Slow down before turning.
 - Never leave a running machine unattended. Always turn off blades, and stop engine.
 - Turn off blades when not mowing.
 - Mow only in daylight or good artificial light.
 - Do not operate the machine while under the influence of alcohol or drugs.
 - Watch for traffic when operating near or crossing roadways.
 - Use extra care when loading or unloading the machine into a trailer or truck.
 - Disengage power to mower and stop engine when transporting or not in use.
- Always wear safety glasses or eye shields when starting and while using your mower.
 - Exercise special care when mowing around fixed objects in order to prevent the blades from striking them. Never deliberately run tow vehicle or mower onto or over any foreign object.
 - Use mower only as the manufacturer intended and as described in the manual.
 - Do not operate mower if it has been dropped or damaged in any manner. Always have damage repaired before using your mower.
 - Dress properly. Do not operate mower when barefoot or wearing open sandals. Wear only solid shoes with good traction when mowing.
 - Always make cutting height adjustments before starting your mower. Never attempt to do this while the engine is running.
 - Keep your eyes and mind on your mower and the area being cut.
 - Do not let other interests distract you.
 - Do not put hands or feet near or under rotating parts. Keep clear of the discharge opening at all times.
 - Before cleaning, inspecting, or repairing your mower, stop the engine and make absolutely sure the blade and all moving parts have stopped. Then disconnect the spark plug wire and keep it away from the spark plug to prevent accidental starting.
 - Do not operate your mower if it vibrates abnormally. Excessive vibration is an indication of damage; stop the engine, safely check for the cause of vibration and repair as required.
 - Never operate your mower without proper guards, plates, or other safety devices in place.
 - Do not attempt to operate the tow vehicle when not in drivers seat.

II. SLOPE OPERATION

Slopes are a major factor related to loss-of-control and tip over accidents, which can result in severe injury or death. All slopes require extra caution. If you feel uneasy on it, do not mow it.

DO:

- Mow up and down slopes.
- Remove obstacles such as rocks, tree limbs, etc.
- Watch for holes, ruts, or bumps; uneven terrain could overturn the machine; tall grass can hide obstacles.
- Use slow speed. Choose a low gear so that you will not have to stop or shift while on the slope.
- Keep all movement on the slopes slow and gradual. Do not make sudden changes in speed or direction.

- Avoid starting or stopping on a slope. If tires lose traction, disengage the blades and proceed slowly straight down the slope.

DO NOT:

- Do not turn on slopes unless necessary, and then, turn slowly and gradually downhill, if possible.
- Do not mow near drop-offs, ditches, or embankments. The mower could suddenly turn over if a wheel is over the edge of a cliff or ditch, or if an edge caves in.
- Do not mow on wet grass. Reduced traction could cause sliding.

- Stop and inspect the equipment if you strike an object. Repair, if necessary, before restarting.
- Never make adjustments or repairs with the engine running.
- Mower blades are sharp and can cut. Wrap the blade(s) or wear gloves, and use extra caution when servicing them.

III. CHILDREN

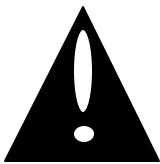

CAUTION:
 TRAGIC ACCIDENTS CAN OCCUR IF THE OPERATOR IS NOT ALERT TO THE PRESENCE OF CHILDREN. CHILDREN ARE OFTEN ATTRACTED TO THE MACHINE AND THE MOWING ACTIVITY. *NEVER ASSUME THAT CHILDREN WILL REMAIN WHERE YOU LAST SAW THEM.*

- Keep children out of the mowing area and under the watchful care of another responsible adult.
- Be alert and turn machine off if children enter the area.
- Before and when backing, look behind and down for small children.
- Never carry children. They may fall off and be seriously injured or interfere with safe machine operation.
- Never allow children to operate the machine.
- Use extra care when approaching blind corners, shrubs, trees, or other objects that may obscure vision.

IV. SERVICE

- Use extra care handling gasoline and other fuels. They are flammable and vapors are explosive.
 - Use only an approved container.
 - Never remove gas cap or add fuel with the engine running.
 - Allow engine to cool before refueling. Do not smoke while refueling.
 - Never refuel the machine indoors.
 - Never store the machine or fuel container inside where there is an open flame, like that of a water heater.
- Never run a machine inside a closed area.
- **Keep nuts and bolts, especially blade attachment nuts, tight and keep equipment in good condition.**
- Never tamper with safety devices. Check their proper operation regularly.
- Keep machine free of grass, leaves, or other debris build-up; clean oil or fuel spillage; allow machine to cool before storing.

SAFETY AND OPERATIONAL DECALS

Replace decal immediately if damaged. Order by part number from Swisher Mower and Machine Co. Inc.



D55-DANGER DECAL



D20-CAUTION DECAL

D30-WARNING DECAL



D28-OFF/ON DECAL



D10-ENGAGE DECAL



D99116-MED. SILVER LOGO DECAL



SAFETY AND OPERATIONAL DECALS

Replace decal immediately if damaged. Order by part number from Swisher Mower and Machine Co. Inc.



D82-44 RUGGED CUT DECAL

D29- DANGER DECAL



0-029

OPERATING YOUR NEW CUTTER



The operation of any mower can result in foreign objects being thrown into the eyes, which can result in severe eye damage. Always wear safety glasses or eye shields before starting your mower and while mowing. We recommend wide vision safety mask for over the spectacles or standard safety glasses.



CAUTION:

TRAGIC ACCIDENTS CAN OCCUR IF THE OPERATOR IS NOT ALERT TO THE PRESENCE OF CHILDREN. CHILDREN ARE OFTEN ATTRACTED TO THE MACHINE AND THE MOWING ACTIVITY. *NEVER ASSUME THAT CHILDREN WILL REMAIN WHERE YOU LAST SAW THEM.*

STOPPING

- Move blade clutch lever to disengaged (vertical) position.
- Turn key switch to OFF position.

TOW HITCH OFFSET FEATURE

This trail mower has been designed to run offset from the center of the tow vehicle in order to make the unit more flexible in a wide range of mowing situations.

- The adjustable tow hitch of this mower can be assembled from straight behind the tow vehicle to approximately 20" offset to either side

TOW HITCH OFFSET ASSEMBLY (refer to fig. 1)

- Install hitch tube (2) over the front torsion bar (1) on mower (Note: the hitch tube can be placed anywhere along the length of the torsion bar). Secure the hitch tube in place using four 3/8-16 x 2 1/2 bolts (4) and 3/8 -16 nyloc nuts (5).
- Install the "L" hitch (3) into the hitch tube, and loosely secure with two 5/16-18 x 2 12 bolts (6) and 5/16-18 nyloc nuts (7). The "L" hitch will be secured in place after the front to back adjustment has been determined (see next step).

FRONT TO BACK ADJUSTMENT

To obtain the best cutting results, the mower deck should be adjusted so that it is parallel to the ground. To check front to back adjustment, measure from the bottom edge of the deck to the ground at both the front and rear of the deck. This next series of instructions is best done with the mower and tow vehicle together.

- Install the hitch swivel (8) to the tow bar of the tow vehicle. (refer to fig. 1)
- Raise the hitch tube of the mower until the bottom of the deck is parallel to the ground. Note the position of the clevis on the "L" hitch in relation to the hitch swivel on the tow vehicle. The "L" hitch will have to be moved up or down to match this height.
- Set the mower back on the ground, remove the hardware, slide the "L" hitch into the predetermined position, and reinstall the nuts and bolts. The hardware can now be tightened.

ATTACHING CUTTER TO TOW VEHICLE

- Place cutter behind tow vehicle and back up to it for attaching.
- Slide tow bar of cutter over the tow vehicles hitch so that holes line up.
- Insert hitch pin until it extends through the bottom of the tow bar.
- Place safety latch over the end of the hitch pin.
- Secure control console to tow vehicle, making sure it can be reached from the operating position (see pre-assembly instructions. Use provided Velcro straps to secure control cable to cutter frame, hitch, and tractor.

Important: Make sure control cable is unrestrained through the turning range of the tow vehicle.

TRANSPORTING YOUR CUTTER

- Disengage the blade.
- Shut off cutter engine.
- Place cutter deck in the highest position.



CAUTION:

SHUT OFF MOWER ENGINE AND REMOVE SPARK PLUG WIRE FROM SPARK PLUG BEFORE MAKING ANY ADJUSTMENTS TO THE MOWER.

CUTTER HEIGHT ADJUSTMENT

The cutting height range of this unit is from approximately 2 1/2 to 6 inches. Heights are measured from the ground to the blade tip with the engine not running. Rotate height adjustment crank handle in a clockwise direction to raise the cutter and in a counter clockwise direction to lower.

BEFORE STARTING ENGINE

- Fill engine with oil (see engine manual for proper procedure and requirements).
- Add gasoline. Fill fuel tank using fresh clean unleaded gas.

ITEM NO.	QTY.	PART NO.	DESCRIPTION
1	1	4861	FRONT TORSION BAR
2	1	4866	HITCH
3	1	H 1	T _L HITCH
4	4	NB-221	3/8" - 16 X 2 1/2
5	4	NB-182	3/8" - 16 NYLOC NUT
6	2	NB-136	5/16" - 18 X 2 1/2
7	2	NB-181	5/16" - 18 NYLOC NUT
8	1	H10	SWIVEL HITCH
9	1	H11	SAFETY PIN
10	1	NB-145Z	5/8" - 11 X 1 1/2
11	1	NB-561	5/8" - 11 NYLOC NUT

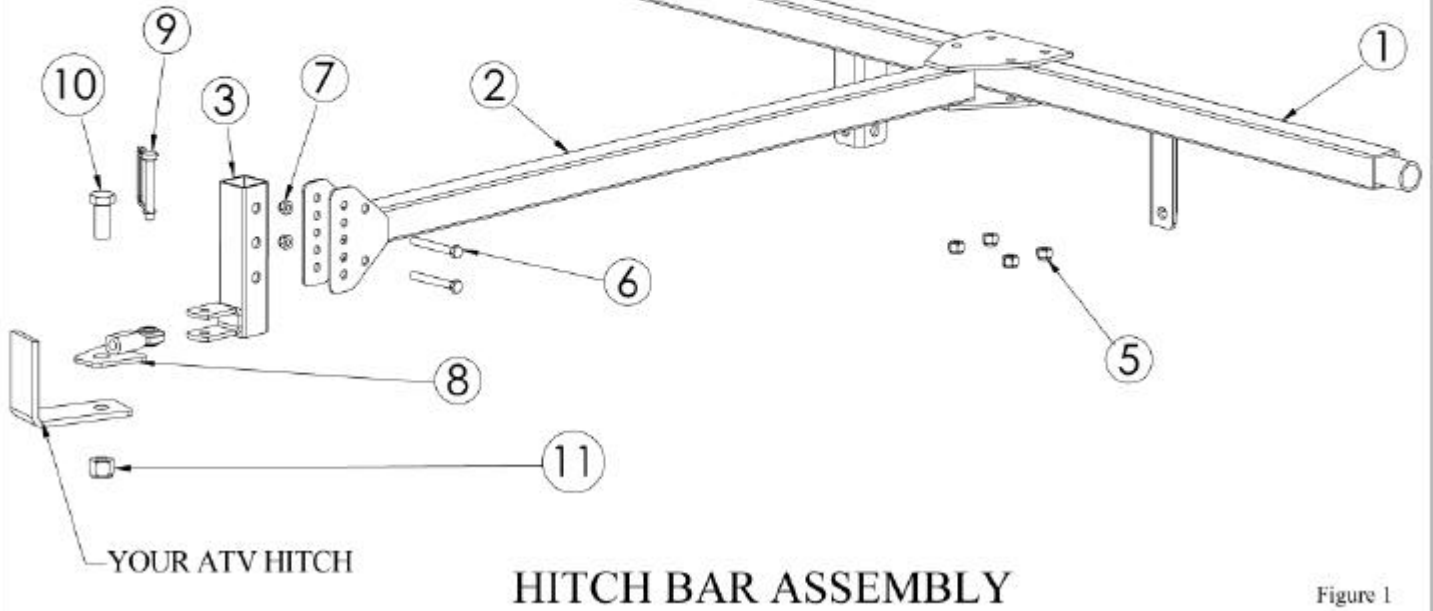

Figure 1

ENGINE PULLEY ASSEMBLY

ITEM NO.	QTY.	PART NO.	DESCRIPTION
1	1	Tecumseh Formula XL-C 8.9-10	10.5 RECOIL ENGINE
2	1	88105	ENGINE PULLEY
3	2	699	BELLY WASHER
4	1	NB-236	ENGINE BOLT
5	1	88105S	1.75" UPPER SPACER
6	1	88105SL	.415" LOWER SPACER
7	1	689K	KEYSTOCK
8	1	4867	BELT GUIDE
9	2	NB-556	.3125" FLAT WASHER
10	2	NB-253	.3125" - 18 X 1.25 FLANGE BOLT
11	4	NB-170	.3125" - 18 FLANGE NUT
12	2	NB-515	.3125" - 18 X 1.75 FLANGE BOLT

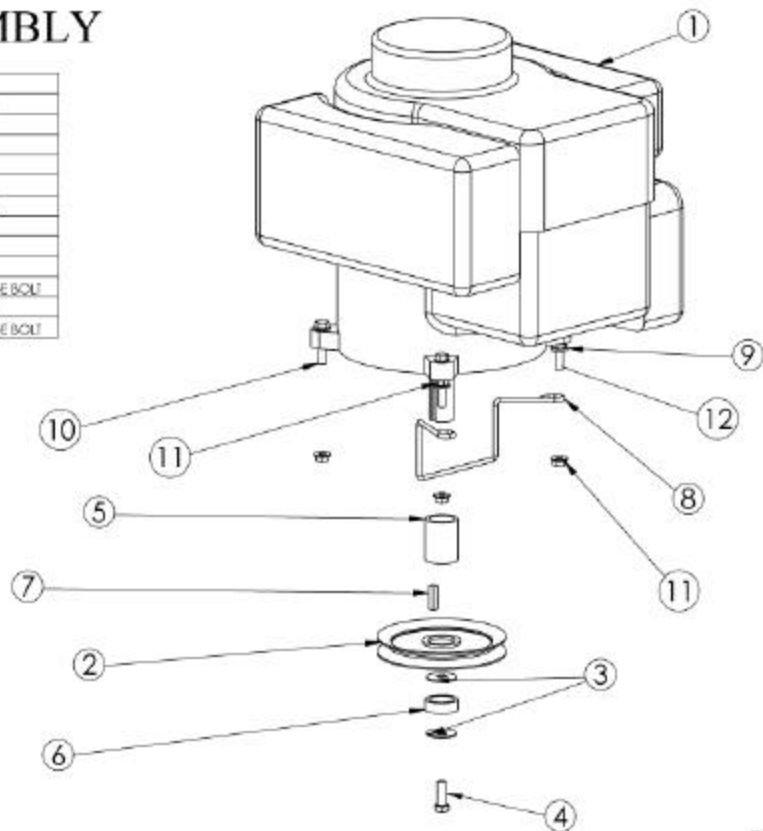

Figure 3



CAUTION:
FILL TO BOTTOM OF FUEL TANK FILLER
NECK. DO NOT OVERFILL. WIPE OFF
SPILLED OIL OR FUEL. DO NOT
STORE, SPILL, OR USE GASOLINE NEAR
OPEN FLAME.

TO START ENGINE



CAUTION:
KEEP THE BLADE CLUTCH LEVER IN
“DISENGAGED” POSITION WHEN
STARTING ENGINE.

- Make sure spark plug wire is properly connected.
- Place throttle control in “CHOKE” position if the engine is cold. A warm engine may not require choking to start.
- Grasp starter handle with one hand. Pull rope out slowly until engine reaches start of compression cycle (rope will pull slightly harder at this point).
- Pull rope with a rapid, continuous, full arm stroke. Keep a firm grip on starter handle and let rope rewind slowly. Do not let starter handle snap back against starter.
- When engine starts, move throttle control to the “RUN” position (full throttle).
- Allow engine to warm up for a few minutes before engaging blades.

Note: If at a high altitude (above 3000 feet) or in cold temperatures (below 32F), the carburetor fuel mixture may need to be adjusted for best performance (see Service and Adjustments section of the engine manual.)

BREAKING IN YOUR CUTTER



CAUTION:
CHECK AREA UNDER AND AROUND
MOWER FOR ANY OBJECTS THAT COULD
BE THROWN FROM UNDER MOWER.
MAKE SURE THAT MOWER DISCHARGE
AREA IS CLEAR.

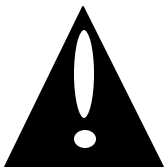

CAUTION:
TRAGIC ACCIDENTS CAN OCCUR IF
THE OPERATOR IS NOT ALERT TO
THE PRESENCE OF CHILDREN.
CHILDREN ARE OFTEN ATTRACTED
TO THE MACHINE AND THE MOWING
ACTIVITY. *NEVER ASSUME THAT
CHILDREN WILL REMAIN WHERE YOU
LAST SAW THEM.*

Break in your belts, pulleys, and engine before you actually begin mowing for the first time.

- Start engine, engage blade control to start blades rotating and allow blades to rotate for approximately five minutes to break in mower and engine.

STARTING TO CUT

Caution! Never operate cutter when not seated. Serious injury could occur.

- Starting the engine: To start the engine, be sure that the blade control lever is in the disengaged (vertical) position. Turn key switch to the start position.
- Engaging the blade: Move lever from the disengaged (vertical) position down to the engaged (horizontal) position.
- Disengaging the blade: Move the lever from the engaged (horizontal) position up to the disengaged (vertical) position.

Important: Make sure all bystanders are clear before engaging blade.

Important: Know the area you are about to cut. Tall grass can hide foreign objects and holes.

STOPPING

- Move blade clutch lever to disengaged (vertical) position.
- Turn key switch to OFF position.

SUGGESTED PRACTICES



CAUTION:
NEVER CARRY CHILDREN. THEY MAY
FALL OFF AND BE SERIOUSLY INJURED
OR INTERFERE WITH SAFE OPERATION.

- Mowing should be started with the tow vehicle in low gear and speed increased only as mowing conditions will safely permit. This speed should not exceed 3 1/2 mph.
- Better mowing results will be obtained in those areas with the least amount of growth. While your mower will cut through dense growth, you will experience a substantial increase in the horsepower required and some change in the finished appearance as compared to those areas with the least amount of growth.
- Mowing conditions will vary from place to place, including the types of grass and brush that are being mowed. When mowing tall grass and brush you may find that the pressure of the wheel tracks may cause certain grasses and brush to be pushed downward and will not be mowed properly. If this condition exists you may have to mow the area twice, the first mowing with the mower raised and the second mowing at the normal height that you have chosen. If it is practical, better results will be found if the second mowing is at a right angle in travel to the previous mowing.
- When mowing thick grass and brush you will find that the performance of the mower will be greatly improved if the

speed of travel is reduced. This allows the mower the time necessary to make its initial cut, and then the subsequent cuts that chop the materials into small pieces to be discharged properly. Failure to do this will result in a poor finished look and the possibility of stalling the engine.

- Do not mow grass when it is wet. Wet grass will accumulate under the mower deck and leave undesirable clumps. Allow grass to dry before mowing.

- Always operate mower engine at full throttle when mowing to assure the best mowing performance and proper discharge of material. Regulate ground speed by selecting a low enough gear to give the mower cutting performance as well as the quality of cut desired.
- When mowing extremely dense brush and saplings, do not attempt to mow over any area that the tow vehicle cannot maneuver through.

CUTTER MAINTENANCE

GENERAL RECOMMENDATIONS

The warranty on this cutter does not cover items that have been subjected to operator abuse or negligence. To receive full value from the warranty, operator must maintain unit as instructed in this manual.

Some adjustments will need to be made periodically to maintain your unit properly.

All adjustments in the service and adjustments section of this manual should be checked at least once each season.

BEFORE EACH SEASON

- Replace the spark plug.
- Clean or replace the air filter.
- Check blades and belts for wear.

A new spark plug and clean air filter assure proper air-fuel mixture and help your engine run better and last longer.

BEFORE EACH USE

- Check engine oil level. (Do this twice to insure an accurate reading.)
- Check condition of air filter and clean or replace if necessary.
- Check blade operation.
- Check for loose fasteners.

DAILY MAINTENANCE

Make sure all nuts and bolts are tight and cotter pins and retainer springs are secure. Keep blades sharp. Observe all safety precautions.

BLADE CARE AND SERVICE

For best results cutter blades must be kept sharp. The blades can be sharpened with a few strokes of a file or grinding wheel. Do Not attempt to sharpen while on the cutter.

Important: Replace blades that have been damaged or deeply nicked.

Important: Check blade and spindle hardware on a regular basis to make sure nuts are tight.

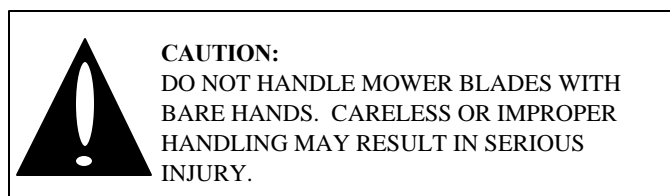

REPAIR PARTS

Your cutter has been produced with components designed for your unit. Although standard V-belts, bearings, blades, pulleys, etc. may look like parts used elsewhere, many are of a different construction and could, in some cases cause a malfunction in the operation of the machine.

ITEM NO.	QTY.	PART NO.	DESCRIPTION
1	1	4858	BLADE DRIVER HOUSING
2	1	NB-601	1" - 8 X 7 GR8 BOLT
3	1	NB-602	1" - 8 GR8 NUT
4	1	4846	10" PULLEY
5	2	4845	HOUSING BEARING
6	1	4859	STUMP JUMPER
7	2	4855	18" BLADE
8	1	4881	BEARING SPACER
9	2	NB-609	.75" - 10 NYLOC NUT
10	2	NB-611	.75" - 10 X 2.5 GR8 BOLT
11	4	NB-509	.50" - 13 X 2 GR5 BOLT
12	2	NB-146	.75" SAE WASHER
13	4	NB-281	.50" - 13 GR5 NUT
14	5	NB-614	1" MACH. RIM BUSHING

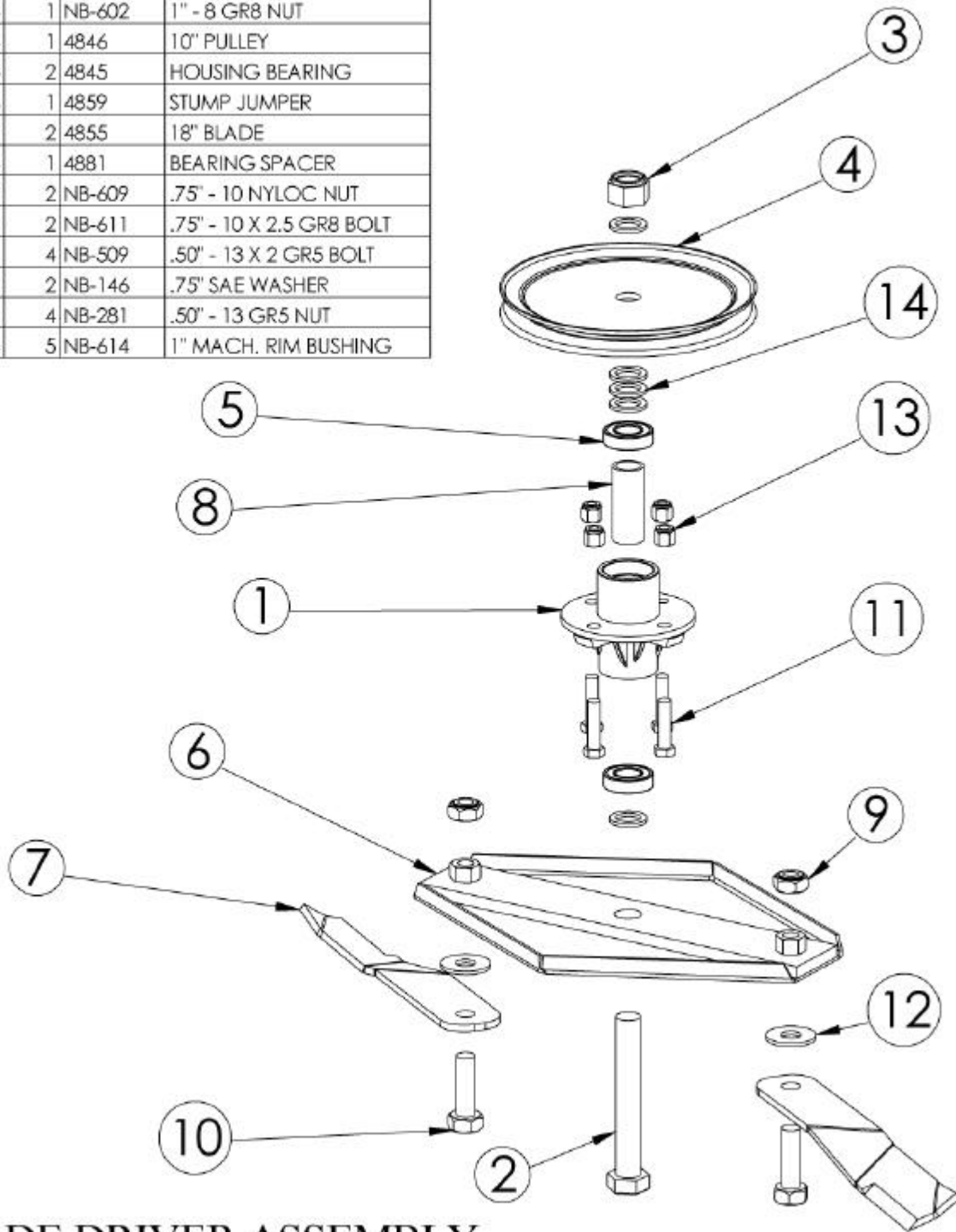

BLADE DRIVER ASSEMBLY

Figure 2

ENGAGE CONSOLE ASSEMBLY

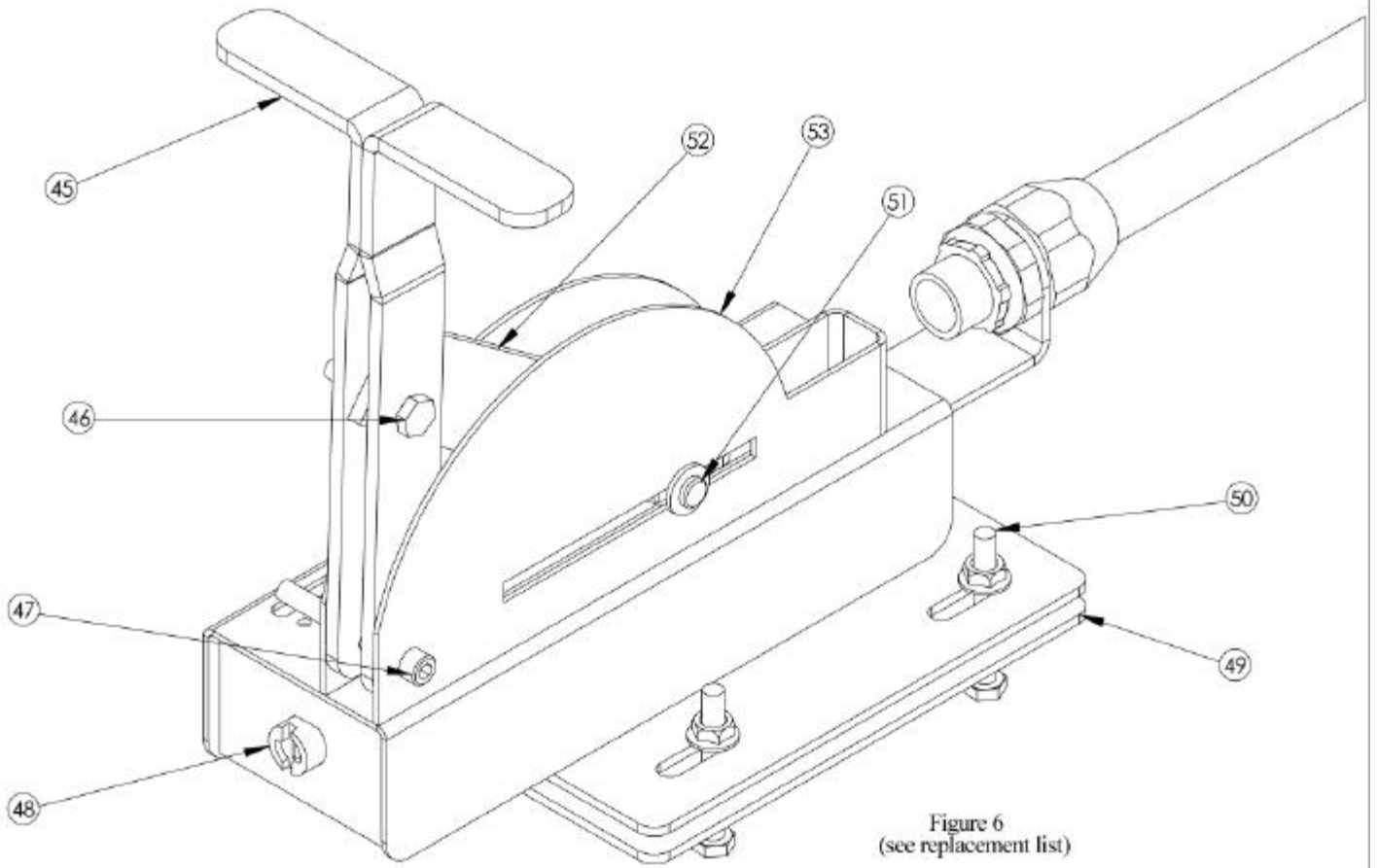

Figure 6
(see replacement list)

BLADE DRIVER PULLEY
4846

IDLER PULLEY
B527

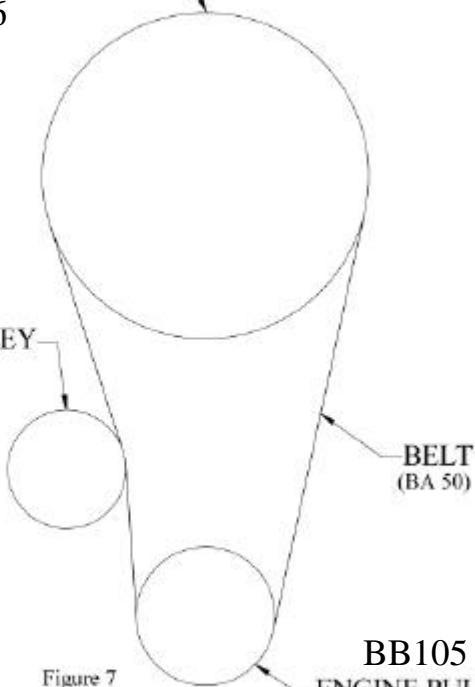
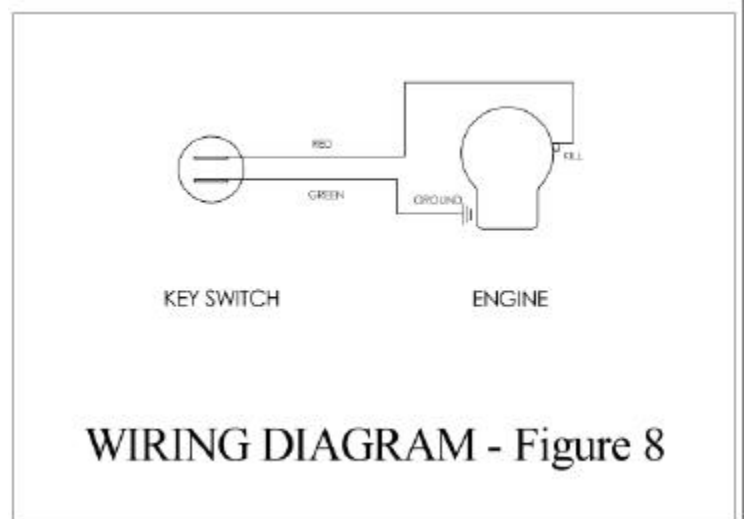

Figure 7

BB105
ENGINE PULLEY



WIRING DIAGRAM - Figure 8

ENGINE PULLEY CONFIGURATION

REPLACEMENT PARTS

ITEM #	PART #	DESCRIPTION	ITEM #	PART #	DESCRIPTION
1	4865	DECK WELDMENT	30	6681	IDLER ARM
2	NB-253	5/16-18 X 1 1/4 FLNGE BOLT	31	NB-588	1/2-13 X 2 1/2 BOLT
	NB-181	5/16-18 FLNGE NUT		NB-121	1/2-13 TWO-WAY LOC NUT
4	WHRT44TEC	WIR HRNES-TEC		NB-281	1/2-13 NYLOC NUT
4	WHRT44BS	WIR HRNES-BRIGGS&STRTON	32	NB-250	1/4-20 X 3/4 BOLT
5	NB-504	5/16-18 X 1 1/4 BOLT		NB-180	1/4-20 NYLOC NUT
	NB-181	5/16-18 FLNGE NUT	33	9023	CLEVIS U-CLIP
6	4853	RUBBER FLAP STRAP	34	4839	BELT ENGAGE ARM
7	4843	RUBBER FLAP	35	682S	IDLER SPRING
8	NB-617	1/2-13 X 1 1/2 BOLT	36	NB-102	1/4-20 X 1 BOLT
	NB-213	1/2-13 NUT		NB-139	1/4-20 NUT
	NB-281	1/2-13 NYLOC NUT		NB-180	1/4-20 NYLOC NUT
9	6745	LONG EYEBOLT	37	NB-501	5/16-18 X 1 FLNGE BOLT
10	NB-114	1/2-20 X 1/2 SELF-TAPPING BOLT		NB-181	5/16-18 NYLOC NUT
11	NB-238	3/8-24 X 1 ENG BOLT		NB-556	5/16 FLAT WASHER
	NB-216	3/8-24 TWO-WAY LOC NUT		B99S	SPACER
12	4836	MOTOR BASE	38	BT35	3 LINK CHAIN
13	NB-596	5/16-18 X 3/4 FLNGE BOLT	39	682S	IDLER SPRING
	NB-170	5/16-18 FLNGE NUT	40	NB-619	3/8-16 X 2 1/2 BOLT
14	4834	TIRE/WHEEL ASSEMBLY		NB-212	3/8-16 NUT
15	NB-195	13/16 X 1 1/4 X 1/8 WASHER		NB-280	3/8-16 TWO-WAY LOC NUT
16	4844	PULLEY COVER		NB-194	1/4 NYLON WASHER
17	NB-126	1/8 X 1 COTTER PIN	41	BP370S	BRAKE PAD CLIP
18	4864	HEIGHT ADJUSTMENT BAR	42	BP370	BRAKE PAD
19	4860	REAR TORSION BAR	43	BT297	BRAKE SPRING
20	NB-107	3/8-16 X 1 1/2 BOLT	44	B527	IDLER PULLEY
	NB-182	3/8-16 NYLOC NUT	45	4463	T HANDLE
	T2PB	3/8 PLASTIC BUSHING	46	NB-560	1/4-20 X 1 1/4 BOLT
21	NB-596	5/16-18 X 3/4 FLNGE BOLT		NB-180	1/4-20 NYLOC NUT
	NB-170	5/16-18 FLNGE NUT	47	NB-591	5/16-18 X 1 1/2 TORX BOLT
22	4850	TOP HEIGHT ADJUST SECTION		NB-181	5/16-18 NYLOC NUT
23	NB-618	3/8-16 X 1 1/4 BOLT	48	KSM	KEY SWITCH
	NB-280	3/8-16 TWO-WAY LOC NUT	49	4852	ENGAGE CONSOLE MOUNT PLATE
24	NB-104Z	1/4-20 X 1 1/2 BOLT	50	NB-141	1/4-20 X 2 1/2 BOLT
	NB-180	1/4-20 NYLOC NUT		NB-274	1/4 SAE WASHER
25	4857	BLACK PLASTIC KNOB		NB-608	1/4-20 WING NUT
26	4874	CRANK HANDLE	51	NB-597	3/32 X 3/4 COTTER PIN
27	4851	BOTTOM HEIGHT ADJUST SECTION		NB-274	1/4 SAE WASHER
	NB-252	5/16-18 X 1/2 FLNGE BOLT		NB-518	1/4 X 1 1/2 CLEVIS PIN
28	4837	AUXILARY PULLEY COVER	52	4461	T HANDLE LINK
29	NB-619	3/8-16 X 2 1/2 BOLT	53	4847	ENGAGE CONSOLE
	NB-212	3/8-16 NUT	54	4805	FRONT TORSION BRACKETS
	NB-182	3/8-16 NYLOC NUT	55	4809(L&R)	REAR TORSION BRACKETS
			NOT SHOWN	BR20CC	ENGAGE CABLE
			NOT SHOWN	BA50	BELT



OWNER'S MANUAL

MODEL NO.
RT10544
RT80044

44"ROUGH CUT TRAILMOWER

Each mower has its own model number. Each engine has its own model number. The model number for the mower will be found on the right hand side of the drive belt housing. The model number for the engine will be found on the top of the blower fan housing.

All mower parts listed herein may be ordered directly from Swisher Mower & Machine Co. Inc. or your nearest Swisher dealer.

All engine parts may be ordered from the nearest dealer of the engine supplied with your mower.

WHEN ORDERING PARTS, PLEASE HAVE THE FOLLOWING INFORMATION AVAILABLE:

- * PRODUCT - TRAILMOWER
- * SERIAL NUMBER - _____
- * MODEL NUMBER - _____
- * ENGINE MODEL NUMBER - _____
- TYPE - _____
- * PART NUMBER
- * PART DESCRIPTION

TELEPHONE - 1-800-222-8183

FAX - 1-660-747-8650

SWISHER MOWER & MACHINE CO. INC.
1602 CORPORATE DRIVE P.O. BOX 67
WARRENSBURG, MO 64093



SWISHER MOWER & MACHINE CO. INC.