



Service Manual

Lexmark™ C52x and C53x

5022-xxx

- ***Table of contents***
- ***Start diagnostics***
- ***Safety and notices***
- ***Trademarks***
- ***Index***

LEXMARK™

Lexmark and Lexmark with diamond design are trademarks of Lexmark International, Inc., registered in the United States and/or other countries.

Edition: March 30, 2007

The following paragraph does not apply to any country where such provisions are inconsistent with local law:

LEXMARK INTERNATIONAL, INC. PROVIDES THIS PUBLICATION "AS IS" WITHOUT WARRANTY OF ANY KIND, EITHER EXPRESS OR IMPLIED, INCLUDING, BUT NOT LIMITED TO, THE IMPLIED WARRANTIES OF MERCHANTABILITY OR FITNESS FOR A PARTICULAR PURPOSE. Some states do not allow disclaimer of express or implied warranties in certain transactions; therefore, this statement may not apply to you.

This publication could include technical inaccuracies or typographical errors. Changes are periodically made to the information herein; these changes will be incorporated in later editions. Improvements or changes in the products or the programs described may be made at any time.

Comments may be addressed to Lexmark International, Inc., Department D22A/032-2, 740 West New Circle Road, Lexington, Kentucky 40550, U.S.A or e-mail at ServiceInfoAndTraining@Lexmark.com. Lexmark may use or distribute any of the information you supply in any way it believes appropriate without incurring any obligation to you.

Lexmark, Lexmark with diamond design, MarkNet, and MarkVision are trademarks of Lexmark International, Inc., registered in the United States and/or other countries.

ImageQuick and PrintCryption are trademarks of Lexmark International, Inc.

PCL® is a registered trademark of the Hewlett-Packard Company. PCL is Hewlett-Packard Company's designation of a set of printer commands (language) and functions included in its printer products. This printer is intended to be compatible with the PCL language. This means the printer recognizes PCL commands used in various application programs, and that the printer emulates the functions corresponding to the commands.

All other trademarks are the property of their respective owners.

© 10/2/06 1:00 pm Lexmark International, Inc.

All rights reserved.

UNITED STATES GOVERNMENT RIGHTS

This software and any accompanying documentation provided under this agreement are commercial computer software and documentation developed exclusively at private expense.

P/N 12G9669

Table of contents

Laser notices	ix
Safety information	xv
Preface	xviii
Conventions	xviii
General information	1-1
Maintenance approach	1-1
Options and features	1-1
Specifications	1-2
Resolution	1-2
Data streams	1-2
Memory configuration	1-2
Performance factors	1-2
Power requirements	1-3
Electrical specifications	1-3
Environment	1-4
Acoustics	1-4
Dimensions	1-5
Media specifications	1-6
Paper and specialty media guidelines	1-6
Media guidelines	1-6
Unacceptable media	1-7
Selecting media	1-7
Selecting preprinted forms and letterhead	1-7
Using media	1-8
Using letterhead	1-8
Using transparencies	1-8
Using envelopes	1-8
Using labels	1-9
Using card stock	1-9
Storing media	1-10
Supported sizes	1-10
Media weight	1-11
Input and output capacities	1-12
Print area	1-12
Serial number and machine type	1-13
Tools required for service	1-13
Acronyms	1-14
Diagnostic information	2-1
Start	2-1
Paper jam messages (2xx.xx)	2-1
Operator panel and menus	2-2
Operator panel	2-2
Buttons and light description	2-2
Menus	2-4
Power-on self test (POST) sequence	2-5
Symptom tables	2-6
Printer symptom table	2-6
Print quality symptom table	2-6
Error codes and messages	2-7
User status and attendance messages	2-19

Service checks	2-27
110.xx—Mirror motor service check	2-27
111.xx, 112.xx, 113.xx, and 114.xx—Printhead error service check	2-27
120.01, 120.02, 120.08–120.10, 120.13–120.15—Fuser error service check	2-28
120.03—Fuser error service check	2-30
120.04–120.07—Fuser error service check	2-30
140.xx—Autocomp (tray 1) motor error service check	2-32
142.xx and 906.01–906.04—Motor (fuser) error service check	2-33
143.xx—Motor (EP drive assembly top cartridge) error service check	2-34
144.xx—Motor (EP drive assembly bottom cartridge) error service check	2-35
145.xx and 906.05–906.08—Motor (bump aligner) error service check	2-36
146.xx—Motor (duplex) error service check	2-36
147.xx, 149.xx—Motor (500-sheet/550-sheet option tray 2 motor) error service check	2-37
148.xx—MPF motor error service check	2-37
910.01—Transparency sensor error service check	2-38
920.01—POST (power on self test) error service check	2-38
920.02—POST (power on self test) error service check	2-38
920.03—POST (power on self test) error service check	2-38
920.04—POST (power on self test) error service check	2-39
920.05—POST (power on self test) error service check	2-39
920.06—POST (power on self test) error service check	2-40
920.07—POST (power on self test) error service check	2-40
920.08—POST (power on self test) error service check	2-40
920.09–12—POST (power on self test) error service check	2-41
920.13—POST (power on self test) error service check	2-43
920.14—POST (power on self test) error service check	2-44
920.15—POST (power on self test) error service check	2-45
920.16—POST (power on self test) error service check	2-45
920.17—POST (power on self test) error service check	2-46
920.18—POST (power on self test) error service check	2-46
920.19—POST (power on self test) error service check	2-46
925.01—Fan error service check	2-47
945.xx, 946.xx, 947.xx—Transfer roll error service check	2-48
950.00–950.29 EPROM mismatch failure	2-50
950.30–950.60 EPROM mismatch failure	2-50
Dead printer service check	2-51
Exit sensor service check	2-52
Input sensor service check	2-52
Operator panel service check	2-53
One or more operator panel buttons fail	2-53
Operator panel display blank, five <i>beeps</i> , and LED off	2-53
Operator panel display blank, five <i>beeps</i> , LED on	2-54
Operator panel display all diamonds, no <i>beeps</i>	2-54
Operator panel display all diamonds, five <i>beeps</i>	2-54
Print quality service check	2-55
Print quality—background	2-55
Print quality—blank page	2-56
Print quality—blurred or fuzzy print	2-59
Print quality—half-color page	2-59
Print quality—horizontal banding	2-59
Print quality—horizontal line	2-59
Print quality—insufficient fusing	2-59
Print quality—missing image at edge	2-59
Print quality—mottle (2–5mm speckles)	2-59
Print quality—narrow vertical line	2-59
Print quality—random marks	2-60
Print quality—residual image	2-60
Print quality—solid color page	2-61
Print quality—vertical banding	2-62

Diagnostic aids	3-1
Accessing service menus	3-1
Diagnostics menu	3-2
Diagnostics menu structure	3-2
Available tests	3-2
Registration	3-4
Skew	3-4
Print registration	3-5
Quick Test	3-6
Alignment	3-7
Motor tests	3-8
General motor tests	3-8
Mirror Motor Test	3-8
Motor Calibration	3-9
Servo Laser Test	3-9
Print Tests	3-9
Input source tests	3-9
Print quality test pages (Prt Quality Pgs)	3-10
Hardware Tests	3-11
Panel Test	3-11
Button Test	3-11
DRAM Test	3-11
CACHE Test	3-12
Duplex Tests	3-12
Quick Test (duplex)	3-12
Print Test (duplex)	3-13
Top Margin (duplex)	3-14
Motor Test (duplex)	3-14
Input Tray Tests	3-14
Base Sensor Test	3-15
Bin Full Test	3-15
Sensor Test	3-15
Printer Setup	3-16
Defaults	3-16
Page Counts	3-16
Serial Number	3-16
Engine Setting 1 through 4	3-16
Model Name	3-16
Configuration ID	3-16
EP Setup	3-17
EP Defaults	3-17
Fuser Temperature (Fuser Temp)	3-17
DC Charge Adjust, Dev Bias Adj, Transfer Adjust	3-17
Event Log	3-18
Display Log	3-18
Print Log	3-18
Clear Log	3-19
EXIT DIAGNOSTICS	3-19
Configuration menu (CONFIG MENU)	3-20
Available tests	3-20
Reset Fuser Cnt	3-21
Color Lock Out	3-21
Prt Quality Pgs	3-21
Color Trapping	3-21
Size Sensing	3-22
Panel Menus	3-22
PPDS Emulation	3-22
Download Emuls	3-22
Demo Mode	3-22

Factory Defaults	3-22
Energy Conserve	3-23
Event Log	3-23
Auto Align Adj	3-23
Auto Color Adj	3-23
Enforce Color Order	3-24
Color Alignment	3-24
Motor Calibration	3-24
Paper Prompts	3-24
Env Prompts	3-25
Jobs on Disk	3-25
Disk Encryption	3-25
Duplex Gloss	3-25
Font Sharpening	3-26
Exit Config Menu	3-26
Paper Jams	3-27
Error jam locations	3-27
Paper jams in the multipurpose feeder or manual feeder	3-28
Loading media in the multipurpose feeder or manual feeder	3-28
Clearing a paper jam in the multipurpose feeder	3-28
Clearing paper jams in the manual feeder	3-29
Theory of operation	3-30
Paper path	3-30
Main Components	3-32
Print media transport	3-33
Mechanical drive	3-37
Paper sensing	3-42
Electrophotographic (EP) process	3-44
Main components	3-44
Charging	3-46
Exposing	3-49
Developing	3-50
Transferring	3-51
Fusing	3-52
Cleaning	3-53
Electrical interlock	3-54
5 V interlock switch	3-54
24 V interlock switch	3-55
Repair information	4-1
Removal and cleaning precautions	4-1
Handling ESD-sensitive parts	4-1
Handling the photoconductor unit	4-2
Transportation/storage	4-2
Handling	4-2
Parts not to be touched	4-2
Adjustments	4-3
Printhead alignment	4-3
Overview	4-3
Printhead mechanical alignment	4-3
Skew (black)	4-6
Registration (black)	4-8
Alignment (cyan, yellow, and magenta)	4-10
Printer removal procedures	4-13
Precautions to take before maintenance work	4-13
Cover removals	4-14
Exit tray cover removal	4-15
Front access door cover assembly removal	4-16
Gearbox shield removal	4-19

Left cover removal	4-20
Operator panel outer bezel removal	4-21
Operator panel inner bezel removal—models C52x only	4-22
Operator panel assembly removal	4-23
Paper tray dust cover removal	4-24
Rear cover removal	4-25
Right cover removal	4-26
Top access cover assembly removal—model C52x only	4-28
Top access cover assembly removal—model C53x only	4-32
Bin full sensor removal—models C52x	4-37
Bin full sensor removal—models C53x	4-38
Bump aligner gear removal	4-39
Bump aligner motor removal	4-40
Bump aligner rollers and springs removal—models C53x	4-42
Contact springs removal	4-44
Deflector assembly removal—models C53x only	4-46
Electrophotographic (EP) drive assembly removal—model C52x only	4-48
Electrophotographic (EP) drive assembly removal—model C53x only	4-51
Front access door 5 V interlock switch removal	4-54
Front door assembly removal	4-55
Front door assembly front cable removal	4-59
Fuser removal	4-60
Fuser cable cover removal	4-61
High voltage power supply (HVPS) removal	4-62
Left bellcrank removal	4-64
Low voltage power supply (LVPS) removal	4-65
Multipurpose feeder (MPF) swing arm assembly removal—models C52x only	4-67
Paper pick mechanism assembly removal	4-68
Photoconductor unit removal	4-70
Pick roll rubber tires removal and replacement	4-71
Printer pad removal	4-73
Printhead removal, installation, and adjustment	4-74
Printhead removal	4-74
Printhead installation	4-77
Printhead alignment	4-81
Skew (black)	4-81
Registration (black)	4-84
Alignment (cyan, yellow, and magenta)	4-86
Right bellcrank removal	4-90
Smart chip card removal—models C52x only	4-91
System card removal	4-92
System card support shield removal	4-94
Toner level sensor removal	4-96
Top access door 24 V interlock switch removal	4-98
Top cover camshaft assembly removal	4-99
Transfer belt removal	4-103
Transfer contact assembly removal	4-104
Waste toner assembly removal	4-105
Locations and connectors	5-1
Locations	5-1
Covers	5-1
Front	5-2
Right	5-3
Rear	5-4
Left	5-5
Top	5-6
CRU and FRUs	5-7
Sensors	5-8

- Motors5-9
- Printer cards5-10
- Connectors5-11
 - System card (network)—models C52x5-11
 - System card (non-network)—models C52x5-12
 - Connector listing—models C52x5-13
 - System card (network)—models C53x5-18
 - Connector listing—models C53x5-19
- Preventive maintenance 6-1**
 - Scheduled maintenance6-1
- Parts catalog 7-1**
 - How to use this parts catalog7-1
 - Assembly 1: Covers 7-2
 - Assembly 2: Front 7-4
 - Assembly 3: Right 7-6
 - Assembly 4: Rear 7-8
 - Assembly 5: Left 7-10
 - Assembly 6: Top 7-12
 - Assembly 7: Customer replaceable units (CRUs) 7-14
 - Assembly 8: Contact springs 7-16
 - Assembly 9: Cable parts packet 7-18
 - Assembly 10: Miscellaneous 7-20
- IndexI-1**
- Part number indexI-7**

Laser notices

Laser notice

The printer is certified in the U.S. to conform to the requirements of DHHS 21 CFR Subchapter J for Class I (1) laser products, and elsewhere is certified as a Class I laser product conforming to the requirements of IEC 60825-1.

Class I laser products are not considered to be hazardous. The printer contains internally a Class IIIb (3b) laser that is nominally a 5 milliwatt gallium arsenide laser operating in the wavelength region of 770-795 nanometers. The laser system and printer are designed so there is never any human access to laser radiation above a Class I level during normal operation, user maintenance, or prescribed service condition.

Laser

Der Drucker erfüllt gemäß amtlicher Bestätigung der USA die Anforderungen der Bestimmung DHHS (Department of Health and Human Services) 21 CFR Teil J für Laserprodukte der Klasse I (1). In anderen Ländern gilt der Drucker als Laserprodukt der Klasse I, der die Anforderungen der IEC (International Electrotechnical Commission) 60825-1 gemäß amtlicher Bestätigung erfüllt.

Laserprodukte der Klasse I gelten als unschädlich. Im Inneren des Druckers befindet sich ein Laser der Klasse IIIb (3b), bei dem es sich um einen Galliumarsenlaser mit 5 Milliwatt handelt, der Wellen der Länge 770-795 Nanometer ausstrahlt. Das Lasersystem und der Drucker sind so konzipiert, daß im Normalbetrieb, bei der Wartung durch den Benutzer oder bei ordnungsgemäßer Wartung durch den Kundendienst Laserbestrahlung, die die Klasse I übersteigen würde, Menschen keinesfalls erreicht.

Avis relatif à l'utilisation de laser

Pour les Etats-Unis : cette imprimante est certifiée conforme aux provisions DHHS 21 CFR alinéa J concernant les produits laser de Classe I (1). Pour les autres pays : cette imprimante répond aux normes IEC 60825-1 relatives aux produits laser de Classe I.

Les produits laser de Classe I sont considérés comme des produits non dangereux. Cette imprimante est équipée d'un laser de Classe IIIb (3b) (arséniure de gallium d'une puissance nominale de 5 milliwatts) émettant sur des longueurs d'onde comprises entre 770 et 795 nanomètres. L'imprimante et son système laser sont conçus pour impossible, dans des conditions normales d'utilisation, d'entretien par l'utilisateur ou de révision, l'exposition à des rayonnements laser supérieurs à des rayonnements de Classe I.

Avvertenze sui prodotti laser

Questa stampante è certificata negli Stati Uniti per essere conforme ai requisiti del DHHS 21 CFR Sottocapitolo J per i prodotti laser di classe 1 ed è certificata negli altri Paesi come prodotto laser di classe 1 conforme ai requisiti della norma CEI 60825-1.

I prodotti laser di classe non sono considerati pericolosi. La stampante contiene al suo interno un laser di classe IIIb (3b) all'arseniuro di gallio della potenza di 5mW che opera sulla lunghezza d'onda compresa tra 770 e 795 nanometri. Il sistema laser e la stampante sono stati progettati in modo tale che le persone a contatto con la stampante, durante il normale funzionamento, le operazioni di servizio o quelle di assistenza tecnica, non ricevano radiazioni laser superiori al livello della classe 1.

Avisos sobre el láser

Se certifica que, en los EE.UU., esta impresora cumple los requisitos para los productos láser de Clase I (1) establecidos en el subcapítulo J de la norma CFR 21 del DHHS (Departamento de Sanidad y Servicios) y, en los demás países, reúne todas las condiciones expuestas en la norma IEC 60825-1 para productos láser de Clase I (1).

Los productos láser de Clase I no se consideran peligrosos. La impresora contiene en su interior un láser de Clase IIIb (3b) de arseniuro de galio de funcionamiento nominal a 5 milivatios en una longitud de onda de 770 a 795 nanómetros. El sistema láser y la impresora están diseñados de forma que ninguna persona pueda verse afectada por ningún tipo de radiación láser superior al nivel de la Clase I durante su uso normal, el mantenimiento realizado por el usuario o cualquier otra situación de servicio técnico.

Declaração sobre Laser

A impressora está certificada nos E.U.A. em conformidade com os requisitos da regulamentação DHHS 21 CFR Subcapítulo J para a Classe I (1) de produtos laser. Em outros locais, está certificada como um produto laser da Classe I, em conformidade com os requisitos da norma IEC 60825-1.

Os produtos laser da Classe I não são considerados perigosos. Internamente, a impressora contém um produto laser da Classe IIIb (3b), designado laser de arseneto de potássio, de 5 milliwatts, operando numa faixa de comprimento de onda entre 770 e 795 nanómetros. O sistema e a impressora laser foram concebidos de forma a nunca existir qualquer possibilidade de acesso humano a radiação laser superior a um nível de Classe I durante a operação normal, a manutenção feita pelo utilizador ou condições de assistência prescritas.

Laserinformatie

De printer voldoet aan de eisen die gesteld worden aan een laserprodukt van klasse I. Voor de Verenigde Staten zijn deze eisen vastgelegd in DHHS 21 CFR Subchapter J, voor andere landen in IEC 60825-1.

Laserprodukten van klasse I worden niet als ongevaarlijk aangemerkt. De printer is voorzien van een laser van klasse IIIb (3b), dat wil zeggen een gallium arsenide-laser van 5 milliwatt met een golflengte van 770-795 nanometer. Het lasergedeelte en de printer zijn zo ontworpen dat bij normaal gebruik, bij onderhoud of reparatie conform de voorschriften, nooit blootstelling mogelijk is aan laserstraling boven een niveau zoals voorgeschreven is voor klasse 1.

Lasermeddelelse

Printeren er godkendt som et Klasse I-laserprodukt, i overensstemmelse med kravene i IEC 60825-1.

Klasse I-laserprodukter betragtes ikke som farlige. Printeren indeholder internt en Klasse IIIB (3b)-laser, der nominelt er en 5 milliwatt galliumarsenid laser, som arbejder på bølgelængdeområdet 770-795 nanometer. Lasersystemet og printeren er udformet således, at mennesker aldrig udsættes for en laserstråling over Klasse I-niveau ved normal drift, brugervedligeholdelse eller obligatoriske servicebetingelser.

Huomautus laserlaitteesta

Tämä kirjoitin on Yhdysvalloissa luokan I (1) laserlaitteiden DHHS 21 CFR Subchapter J -määrityksen mukainen ja muualla luokan I laserlaitteiden IEC 60825-1 -määrityksen mukainen.

Luokan I laserlaitteiden ei katsota olevan vaarallisia käyttäjälle. Kirjoittimessa on sisäinen luokan IIIb (3b) 5 milliwatin galliumarsenidilaser, joka toimii aaltoalueella 770 - 795 nanometriä. Laserjärjestelmä ja kirjoitin on suunniteltu siten, että käyttäjä ei altistu luokan I määräyksiä voimakkaammalle säteilylle kirjoittimen normaalin toiminnan, käyttäjän tekemien huoltotoimien tai muiden huoltotoimien yhteydessä.

VARO! Avattaessa ja suojalukitus ohitettaessa olet alltiina näkymättömälle lasersäteilylle. Älä katso säteeseen.

WARNING! Osynlig laserstrålning när denna del är öppnad och spårren är urkopplad. Betrakta ej strålen.

Laser-notis

Denna skrivare är i USA certifierad att motsvara kraven i DHHS 21 CFR, underparagraf J för laserprodukter av Klass I (1). I andra länder uppfyller skrivaren kraven för laserprodukter av Klass I enligt kraven i IEC 60825-1.

Laserprodukter i Klass I anses ej hälsovådliga. Skrivaren har en inbyggd laser av Klass IIIb (3b) som består av en laserenhet av gallium-arsenid på 5 milliwatt som arbetar i våglängdsområdet 770-795 nanometer.

Lasersystemet och skrivaren är utformade så att det aldrig finns risk för att någon person utsätts för laserstrålning över Klass I-nivå vid normal användning, underhåll som utförs av användaren eller annan föreskriven serviceåtgärd.

Laser-melding

Skriveren er godkjent i USA etter kravene i DHHS 21 CFR, underkapittel J, for klasse I (1) laserprodukter, og er i andre land godkjent som et Klasse I-laserprodukt i samsvar med kravene i IEC 60825-1.

Klasse I-laserprodukter er ikke å betrakte som farlige. Skriveren inneholder internt en klasse IIIb (3b)-laser, som består av en gallium-arsenlaserenhet som avgir stråling i bølgelengdeområdet 770-795 nanometer.

Lasersystemet og skriveren er utformet slik at personer aldri utsettes for laserstråling ut over klasse I-nivå under vanlig bruk, vedlikehold som utføres av brukeren, eller foreskrevne serviceoperasjoner.

Avís sobre el Làser

Segons ha estat certificat als Estats Units, aquesta impressora compleix els requisits de DHHS 21 CFR, apartat J, pels productes làser de classe I (1), i segons ha estat certificat en altres llocs, és un producte làser de classe I que compleix els requisits d'IEC 60825-1.

Els productes làser de classe I no es consideren perillosos. Aquesta impressora conté un làser de classe IIIb (3b) d'arseniür de gal.li, nominalment de 5 mil.liwats, i funciona a la regió de longitud d'ona de 770-795 nanòmetres. El sistema làser i la impressora han sigut concebutos de manera que mai hi hagi exposició a la radiació làser per sobre d'un nivell de classe I durant una operació normal, durant les tasques de manteniment d'usuari ni durant els serveis que satisfacin les condicions prescrites.

Japanese Laser Notice

レーザーに関するお知らせ

このプリンターは、米国ではDHHS 21 CFRサブチャプターJのクラスI(1)の基準を満たしたレーザー製品であることが証明されています。また米国以外ではIEC 825の基準を満たしたクラスIのレーザー製品であることが証明されています。

クラスIのレーザー製品には危険性はないと考えられています。このプリンターはクラスIII b(3b)のレーザーを内蔵しています。このレーザーは、波長が770 ~ 795ナノメートルの範囲で、通常5ミリワットのガリウム砒化物を放射するレーザーです。このレーザーシステムとプリンターは、通常の操作、ユーザのメンテナンス、規定された修理においては、人体がクラスIのレベル以上のレーザー放射に晒されることのないよう設計されています。

注意：

本打印机被美国认证合乎 DHHS 21 CFR Subchapter I 对分类 I (1) 激光产品的标准，而在其他地区则被认证合乎 IEC 825 的标准。

分类 I 激光产品一般认为不具危险性，本打印机内部含有分类 IIIb (3b) 的激光，在操作过程中会产生 5 毫瓦含镓及砷的微量激光，其波长范围在 770-795 nm 之间。本激光系统及打印机的设计，在一般操作、使用者维护或规定内的维修情况下，不会使人体接触分类 I 以上等级的辐射。

Korean Laser Notice

본프린터는 1등급 레이저 제품들에 대한 DHHS 21 CFR Subchapter 3의 규정을 준수하고 있음을 미국에서 인증받았으며, 그외의 나라에서도 IEC 825 규정을 준수하는 1등급 레이저 제품으로서 인증을 받았습니다.

1등급 레이저 제품들은 안전한 것으로 간주됩니다. 본 프린터는 5 밀리와트 갈륨 아르세나이드 레이저로서 770-795 나노미터의 파장대에서 활동하는 Class III (3b) 레이저를 내부에 갖고 있습니다. 본 레이저 시스템과 프린터는 정상 작동 중이나 유지 보수 중 또는 규정된 서비스 상태에서 상기의 Class I 수준의 레이저 방출에 사람이 절대 접근할 수 없도록 설계되어 있습니다.

Safety information

- The safety of this product is based on testing and approvals of the original design and specific components. The manufacturer is not responsible for safety in the event of use of unauthorized replacement parts.
- The maintenance information for this product has been prepared for use by a professional service person and is not intended to be used by others.
- There may be an increased risk of electric shock and personal injury during disassembly and servicing of this product. Professional service personnel should understand this and take necessary precautions.
-  **CAUTION:** When you see this symbol, there is a danger from hazardous voltage in the area of the product where you are working. Unplug the product before you begin, or use caution if the product must receive power in order to perform the task.

Consignes de sécurité

- La sécurité de ce produit repose sur des tests et des agrégations portant sur sa conception d'origine et sur des composants particuliers. Le fabricant n'assume aucune responsabilité concernant la sécurité en cas d'utilisation de pièces de rechange non agréées.
- Les consignes d'entretien et de réparation de ce produit s'adressent uniquement à un personnel de maintenance qualifié.
- Le démontage et l'entretien de ce produit pouvant présenter certains risques électriques, le personnel d'entretien qualifié devra prendre toutes les précautions nécessaires.
-  **ATTENTION :** Ce symbole indique la présence d'une tension dangereuse dans la partie du produit sur laquelle vous travaillez. Débranchez le produit avant de commencer ou faites preuve de vigilance si l'exécution de la tâche exige que le produit reste sous tension.

Norme di sicurezza

- La sicurezza del prodotto si basa sui test e sull'approvazione del progetto originale e dei componenti specifici. Il produttore non è responsabile per la sicurezza in caso di sostituzione non autorizzata delle parti.
- Le informazioni riguardanti la manutenzione di questo prodotto sono indirizzate soltanto al personale di assistenza autorizzato.
- Durante lo smontaggio e la manutenzione di questo prodotto, il rischio di subire scosse elettriche e danni alla persona è più elevato. Il personale di assistenza autorizzato deve, quindi, adottare le precauzioni necessarie.
-  **ATTENZIONE:** Questo simbolo indica la presenza di tensione pericolosa nell'area del prodotto. Scollegare il prodotto prima di iniziare o usare cautela se il prodotto deve essere alimentato per eseguire l'intervento.

Sicherheitshinweise

- Die Sicherheit dieses Produkts basiert auf Tests und Zulassungen des ursprünglichen Modells und bestimmter Bauteile. Bei Verwendung nicht genehmigter Ersatzteile wird vom Hersteller keine Verantwortung oder Haftung für die Sicherheit übernommen.
- Die Wartungsinformationen für dieses Produkt sind ausschließlich für die Verwendung durch einen Wartungsfachmann bestimmt.
- Während des Auseinandernehmens und der Wartung des Geräts besteht ein zusätzliches Risiko eines elektrischen Schlags und körperlicher Verletzung. Das zuständige Fachpersonal sollte entsprechende Vorsichtsmaßnahmen treffen.
-  **ACHTUNG:** Dieses Symbol weist auf eine gefährliche elektrische Spannung hin, die in diesem Bereich des Produkts auftreten kann. Ziehen Sie vor den Arbeiten am Gerät den Netzstecker des Geräts, bzw. arbeiten Sie mit großer Vorsicht, wenn das Produkt für die Ausführung der Arbeiten an den Strom angeschlossen sein muß.

Pautas de Seguridad

- La seguridad de este producto se basa en pruebas y aprobaciones del diseño original y componentes específicos. El fabricante no es responsable de la seguridad en caso de uso de piezas de repuesto no autorizadas.
- La información sobre el mantenimiento de este producto está dirigida exclusivamente al personal cualificado de mantenimiento.
- Existe mayor riesgo de descarga eléctrica y de daños personales durante el desmontaje y la reparación de la máquina. El personal cualificado debe ser consciente de este peligro y tomar las precauciones necesarias.
-  **PRECAUCIÓN:** este símbolo indica que el voltaje de la parte del equipo con la que está trabajando es peligroso. Antes de empezar, desenchufe el equipo o tenga cuidado si, para trabajar con él, debe conectarlo.

Informações de Segurança

- A segurança deste produto baseia-se em testes e aprovações do modelo original e de componentes específicos. O fabricante não é responsável pela segurança, no caso de uso de peças de substituição não autorizadas.
- As informações de segurança relativas a este produto destinam-se a profissionais destes serviços e não devem ser utilizadas por outras pessoas.
- Risco de choques eléctricos e ferimentos graves durante a desmontagem e manutenção deste produto. Os profissionais destes serviços devem estar avisados deste facto e tomar os cuidados necessários.
-  **CUIDADO:** Quando vir este símbolo, existe a possível presença de uma potencial tensão perigosa na zona do produto em que está a trabalhar. Antes de começar, desligue o produto da tomada eléctrica ou seja cuidadoso caso o produto tenha de estar ligado à corrente eléctrica para realizar a tarefa necessária.

Informació de Seguretat

- La seguretat d'aquest producte es basa en l'avaluació i aprovació del disseny original i els components específics.
El fabricant no es fa responsable de les qüestions de seguretat si s'utilitzen peces de recanvi no autoritzades.
- La informació pel manteniment d'aquest producte està orientada exclusivament a professionals i no està destinada a ningú que no ho sigui.
- El risc de xoc elèctric i de danys personals pot augmentar durant el procés de desmuntatge i de servei d'aquest producte. El personal professional ha d'estar-ne assabentat i prendre les mesures convenients.
-  **PRECAUCIÓ:** aquest símbol indica que el voltatge de la part de l'equip amb la qual esteu treballant és perillós. Abans de començar, desendolleu l'equip o extremeu les precaucions si, per treballar amb l'equip, l'heu de connectar.

안전 사항

- 본 제품은 원래 설계 및 특정 구성품에 대한 테스트 결과로 안정성이 입증된 것입니다. 따라서 무허가 교체부품을 사용하는 경우에는 제조업체에서 안전에 대한 책임을 지지 않습니다.
- 본 제품에 관한 유지 보수 설명서는 전문 서비스 기술자용으로 작성된 것이므로, 비전문가는 사용할 수 없습니다.
- 본 제품을 해체하거나 정비할 경우, 전기적인 충격을 받거나 상처를 입을 위험이 커집니다. 전문 서비스 기술자는 이 사실을 숙지하고, 필요한 예방 조치를 취하도록 하십시오.
-  **주의:** 이 표시는 해당영역에서 고압전류가 흐른다는 위험 표시입니다. 시작전에 플러그를 뽑으시거나, 주의를 기울여 주시기 바랍니다.

安全信息

- 本产品的安全性以原来设计和特定产品的测试结果和认证为基础。万一使用未经许可的替换部件，制造商不对安全性负责。
- 本产品的维护信息仅供专业服务人员使用，并不打算让其他人使用。
- 本产品在拆卸、维修时，遭受电击或人员受伤的危险性会增高，专业服务人员对这点必须有所了解，并采取必要的预防措施。
-  **切记:** 当您看到此符号时，说明在您工作的产品区域有危险电压的存在。请在开始操作前拔掉产品的电源线，或者在产品必须使用电源来执行任务时，小心从事。

Preface

This manual contains maintenance procedures for service personnel. It is divided into the following chapters:

1. **General information** contains a general description of the printer and the maintenance approach used to repair it. Special tools and test equipment, as well as general environmental and safety instructions, are discussed.
2. **Diagnostic information** contains an error indicator table, symptom tables, and service checks used to isolate failing field replaceable units (FRUs).
3. **Diagnostic aids** contains tests and checks used to locate or repeat symptoms of printer problems.
4. **Repair information** provides instructions for making printer adjustments and removing and installing FRUs.
5. **Connector locations** uses illustrations to identify the connector locations and test points on the printer.
6. **Preventive maintenance** contains the lubrication specifications and recommendations to prevent problems.
7. **Parts catalog** contains illustrations and part numbers for individual FRUs.

Conventions

Note: A note provides additional information.

Warning: A warning identifies something that might damage the product hardware or software.

There are several types of caution statements:

	<p>CAUTION</p> <p>A caution identifies something that might cause a servicer harm.</p>
---	---

	<p>CAUTION</p> <p>This type of caution indicates there is a danger from hazardous voltage in the area of the product where you are working. Unplug the product before you begin, or use caution if the product must receive power in order to perform the task.</p>
---	--

	<p>CAUTION</p> <p>This type of caution indicates a hot surface.</p>
---	--

	<p>CAUTION</p> <p>This type of caution indicates a tipping hazard.</p>
---	---

1. General information

The Lexmark™ C52x and C53x color laser printers deliver superior text and brilliant graphics. The following models are available.

Model name	Configuration	Machine type
Lexmark C520n	Network	5022-010
Lexmark C522n	Network	5022-210
Lexmark C524	Non-network	5022-400
Lexmark C524n	Network	5022-410
Lexmark C524dn	Network	5022-430
Lexmark C530dn	Duplex, network	5022-130
Lexmark C532n	Network	5022-310
Lexmark C532dn	Duplex, network	5022-330
Lexmark C534n	Network	5022-510
Lexmark C534dn/dtn	Duplex, network (550-sheet tray)	5022-530

Maintenance approach

The diagnostic information in this manual leads you to the correct field replaceable unit (FRU) or part. Use the error code charts, symptom tables, and service checks to determine the symptom and repair the failure. You may find that the removals in the Repair information chapter will help you identify parts. After you complete the repair, perform tests as needed to verify the repair. Begin at **“Start” on page 2-1**.

Options and features

The following options or features are available. Some options are not available in every country. Contact your point of purchase for options available in your country.

- Memory options of 128MB, 256MB, and 512MB SDRAM
- Flash memory options of 32MB and 64MB
- Hard disk—40GB with adapter (models C524, C524n, and C524dn and models C534n, C534dn, and C534dtn)
- Media handling operations
 - 500-sheet optional tray assembly for models C522n, C524, C524n, and C524dn and 550-sheet optional tray assembly for models C532n, C532dn, C534n, and C534dn.
 - Duplex—not an option, available only on models C524dn, C524dtn, C530dn, C532dn, and C534dn/dtn (factory installed).
- Integrated network options
 - Token-Ring
 - Ethernet
 - External serial adapter
 - PRESCRIBE card assembly
 - Bar code card assembly
 - Parallel interface card
 - MarkNet™ Print Servers
 - Lexmark PrintCryption™ card
 - Lexmark Forms card (single-byte and Simplified Chinese) on models C534n, C534dn, and C534dtn

- Lexmark Bar Code Card is available on models C534n, C534dn, and C534dtn
- Lexmark ImageQuick™ Card is available for the models C534n, C534dn, and C534dtn
- DBCS font cards
 - Simplified Chinese
 - Traditional Chinese
 - Japanese
 - Korean

Specifications

Resolution

- 1200 x 1200 dpi
- 4800CQ

Data streams

- PostScript 3 emulation
- PCL 5c and 6 (XL) emulation
- PDF 1.5 emulation
- PPDS (if activated)

Memory configuration

Memory type	Models									
	C520n	C522n	C524	C524n	C524dn	C530dn	C532n	C532dn	C534n	C534dn/dtn
Standard DRAM (MB)	128	128	64	128	128	128	128	128	128	256
Optional memory (MB) (100 pin DDR SDRAM unbuffered DIMMs)	128, 256, and 512 MB available									
Maximum (MB)	640	640	576	640	640	640	640	640	640	768
Optional flash memory	32 and 64 MB available									

Performance factors

Performance speed depends on:

- Interface to the host (USB, serial, parallel, network)
- Host system and application
- Page complexity and content of the page
- Printer options installed or selected
- Available memory in the printer
- Media size and type
- Resolution

Power requirements

Average nominal power requirements for the base printer configuration (110 volt). Power levels are shown in watts (W). Maximum current is given in Amperes (A).

Printing states	Lexmark C524, C524n, C524dn, C524dtn	Lexmark C520n, C522n	Lexmark C534n, C534dn, C534dtn	Lexmark C530dn, C532n, C532dn
Idle—average power				
Power Saver on	<18 W	<16 W	<18 W	<17 W
Power Saver off	105 W	105 W	120 W	120 W
Printing—average power				
Basic printer	350 W	350 W	410 W	410 W
All options	375 W	350 W	410 W	410 W
Printing—maximum average current				
100 V	4.5 A	4.5 A	2.5 A	2.5 A
110 V	4.0 A	4.0 A	5.0 A	5.0 A
220 V	2.0 A	2.0 A	5.5 A	5.5 A

Electrical specifications

Low voltage model

- 110 to 127 V ac at 47 to 63 Hz nominal
- 99 to 137 V ac, extreme

High voltage model

- 220 to 240 V ac at 47 to 63 Hz nominal (not available in all countries)
- 198 to 259 V ac, extreme

100 V model

- 100 V ac at 47 to 63 Hz nominal
- 90 to 110 V ac, extreme

Notes:

- Using a 220 to 110 power converter with the 110 V printer is not recommended.
- Using an inverter (12 V dc to 120 V ac for example) to power the printer is not recommended.

Environment

Environment	Specifications
Operating	
Air Temperature—Product Operating	15.6 to 32.2° C (60 to 90.0° F)
Air Temperature—Product Power Off	10.0 to 40.0° C (50 to 104.0° F)
Air Relative Humidity	Relative Humidity 8 to 80%
Wet Bulb Temperature—Product Operating	22.8° C (73.0° F) Maximum
Web Bulb Temperature—Product Power Off	26.7° C (80.1° F) Maximum
Altitude	0 to 3048 meters (10,000 feet)
Atmospheric Pressure	74.6 kPa
Ambient Operating Environment [†]	15.6 to 32.2° C (60 to 90°F) and 8% to 80% RH
Shipping / Storage	
Cartridges	-40° C to +40° C (104° Fahrenheit)
Printer with Cartridges	-40° C to +40°C (104° Fahrenheit)
Printer without Cartridges	-40° C to +40°C (104° Fahrenheit)
Air Relative Humidity	Relative Humidity 8 to 80%
Altitude	10,300 meters (34,000 feet)
Web Bulb Temperature—Product Power Off	26.7° C (80.1° F) Maximum
[†] In some cases performance specifications (such as paper OCF, EP cartridge usage) are specified to be measured at an ambient condition.	

Acoustics

All measurements are made in accordance with ISO 7779 and conform with ISO 9296.

Printer	Operating mode	1-Meter Average Bystander Sound Pressure @4800 CQ	Declared Sound Power Level @4800 CQ
C520n, C522n, C524n	Printing	51 dBA	
	Idle	32 dBA	
C524dn, C524dtn	Printing	51 dBA	
	Duplex printing	52 dBA	
	Idle	32 dBA	
C532n, C534n	Mono printing	53 dBA	
	Color printing	51 dBA	6.6B
	Idle	31 dBA	4.6B
C530dn, C534dn, C534dtn	Mono printing	53 dBA	6.7B
	Color printing	51 dBA	6.6B
	Duplex printing	53 dBA	6.7B
	Idle	31 dBA	4.6B

Dimensions

Description	Models	Height	Width	Depth	Weight
Basic printer with no extensions	C520, C522n, C524, C524n, C524dn	19 in. (484 mm)	17.3 in. (440 mm)	16.1 in. (408 mm)	57.5 lb (26.1 kg)
	C532n, C534n	19 in. (484 mm)	17.3 in. (440 mm)	16.1 in. (408 mm)	57.0 lb (25.9 kg)
	C530dn, C532dn, C534dn	19 in. (484 mm)	17.3 in. (440 mm)	16.1 in. (408 mm)	58.8 lb (26.7 kg)
Printer with exit tray extended	C520, C522n, C524, C524n	19 in. (484 mm)	17.3 in. (440 mm)	20.2 in. (512 mm)	57.5 lb (26.1 kg)
	C532n, C534n	19 in. (484 mm)	17.3 in. (440 mm)	20.2 in. (512 mm)	57.0 lb (25.9 kg)
	C530dn, C524dn, C534dn	19 in. (484 mm)	17.3 in. (440 mm)	20.2 in. (512 mm)	58.8 lb (26.7 kg)
Printer, duplex unit, 500-sheet assembly	C524dtn	24 in. (610mm)	17.3 in. (440 mm)	22 in. (558 mm)	64.8 lb (29.4 kg)
Printer, duplex unit, 550-sheet assembly	C534dtn	24 in. (610mm)	17.3 in. (440 mm)	22 in. (558 mm)	64.0 lb (29.0 kg)
Optional 500-sheet assembly only	C52x models	5 in. (127 mm)	16.5 in. (420 mm)	20.4 in. (518 mm)	7.25 lb (3.29 kg)
Optional 550-sheet assembly only	C53x models	5 in.	16.5 in. (420 mm)	20.4 in.	7.0 lb (3.2 kg)
MPF configuration (printer with multipurpose feeder extended and exit tray extended)	C52x, C53x models	19 in. (484 mm)	17.3 in. (440 mm)	26.6 in. (676 mm)	57.5 lb (26.1 kg)
Primary tray configuration (printer with paper tray adjuster extended and output bin installed)	A4/letter size media	19 in. (484 mm)	17.3 in. (440 mm)	20.2 in. (512 mm)	—
	Legal size media	19 in. (484 mm)	17.3 in. (440 mm)	21.3 in. (540 mm)	—
Note: A buffer of 12 in. (304.8 mm) is needed on the back of the printer.					

Media specifications

Paper and specialty media guidelines

Media guidelines

Media characteristics

The following media characteristics affect print quality and reliability. Consider these characteristics when evaluating new media stock.

Weight

The printer can automatically feed media weights from 60 to 176 g/m² (16 to 47 lb bond) grain long. Media lighter than 60 g/m² (16 lb) might not be stiff enough to feed properly, causing jams. For best performance, use 90 g/m² (24 lb bond) grain long media. For media smaller than 182 x 257 mm (7.2 x 10.1 in.), we recommend 90 g/m² or heavier media.

Curl

Curl is the tendency for media to curl at its edges. Excessive curl can cause media feeding problems. Curl can occur after the media passes through the printer, where it is exposed to high temperatures. Storing media unwrapped in hot, humid, cold, or dry conditions, even in the trays, can contribute to media curling prior to printing and can cause feeding problems.

Smoothness

Media smoothness directly affects print quality. If media is too rough, toner cannot fuse to it properly. If media is too smooth, it can cause media feeding or print quality issues. Always use media between 100 and 300 Sheffield points; however, smoothness between 150 and 200 Sheffield points produces the best print quality.

Moisture content

The amount of moisture in media affects both print quality and the ability of the printer to feed the media correctly. Leave media in its original wrapper until it is time to use it. This limits the exposure of media to moisture changes that can degrade its performance.

Condition media before printing by storing it in its original wrapper in the same environment as the printer for 24 to 48 hours before printing. Extend the time several days if the storage or transportation environment is very different from the printer environment. Thick media may also require a longer conditioning period.

Grain direction

Grain refers to the alignment of the media fibers in a sheet of media. Grain is either grain long, running the length of the media, or grain short, running the width of the media. For 60 to 90 g/m² (16 to 24 lb bond) media, use grain long fibers.

Fiber content

Most high-quality xerographic media is made from 100% chemically treated pulped wood. This content provides the media with a high degree of stability resulting in fewer media feeding problems and better print quality. Media containing fibers such as cotton possesses characteristics that can negatively affect media handling.

Unacceptable media

The following media types are not recommended for use with the printer:

- Chemically treated media used to make copies without carbon paper, also known as carbonless papers, carbonless copy paper (CCP), or no carbon required (NCR) paper
- Preprinted media with chemicals that may contaminate the printer
- Preprinted media that can be affected by the temperature in the printer fuser
- Preprinted media that requires a registration (the precise print location on the page) greater than ± 2.3 mm (± 0.09 in.), such as optical character recognition (OCR) forms
In some cases, registration can be adjusted with a program to successfully print on these forms.
- Coated media (erasable bond), synthetic media, thermal media
- Rough-edged, rough, or heavily textured surface media, or curled media
- Recycled media containing more than 25% post-consumer waste that does not meet DIN19 309
- Media weighing less than 60 g/m^2 (16 lb)
- Multiple-part forms or documents

Selecting media

Using appropriate media prevents jams and helps ensure trouble-free printing.

To help avoid jams and poor print quality:

- Always use new, undamaged media.
- Before loading media, know the recommended print side of the media. This information is usually indicated on the media package.
- Do not use media that has been cut or trimmed by hand.
- Do not mix media sizes, types, or weights in the same source; mixing results in jams.
- Do not use coated media unless they are specifically designed for electrophotographic printing.

Selecting preprinted forms and letterhead

Use these guidelines when selecting preprinted forms and letterhead:

- Use grain long papers for best results for 60 to 90 g/m^2 weights.
- Use only forms and letterhead printed using an offset lithographic or engraved printing process.
- Avoid papers with rough or heavily textured surfaces.

Use papers printed with heat-resistant inks designed for use in xerographic copiers. The ink must be able to withstand temperatures up to 180°C (356°F) without melting or releasing hazardous emissions. Use inks that are not affected by the resin in toner. Inks that are oxidation-set or oil-based generally meet these requirements; latex inks might not. When in doubt, contact the paper supplier.

Preprinted papers such as letterhead must be able to withstand temperatures up to 180°C (356°F) without melting or releasing hazardous emissions.

Using media

Using letterhead

Check with the manufacturer or vendor to determine whether the chosen preprinted letterhead is acceptable for laser printers.

Page orientation is important when printing on letterhead. Use the following table for help when loading letterhead.

Process or paper source	Print side	Top of page
Tray 1	Letterhead faceup	Letterhead goes toward the front of the tray
Tray 2	Letterhead faceup	Letterhead goes toward the front of the tray
Duplex (two-sided) printing from trays 1 and 2	Letterhead facedown	Letterhead goes toward the rear of the tray
Multipurpose feeder	Letterhead facedown	Letterhead top edge enters first
Manual feeder	Letterhead facedown	Letterhead top edge enters first
Duplex (two-sided) printing from the multipurpose feeder	Letterhead faceup	Letterhead top edge enters last

Using transparencies

Print samples on the transparencies being considered for use before buying large quantities.

When printing on transparencies:

- From MarkVision™ Professional, the printer software, or the control panel, set the Paper Type to Transparency.
- Feed transparencies from the standard tray (Tray 1) or the multipurpose feeder.
- Use transparencies designed specifically for laser printers. Check with the manufacturer or vendor to ensure transparencies are able to withstand temperatures up to 180°C (356°F) without melting, discoloring, offsetting, or releasing hazardous emissions.
- Use transparencies that are 0.12–0.14 mm (4.8–5.4 mil) in thickness or 161–179 g/m² in weight.
- Print quality and durability depend on the transparencies used.
- To prevent print quality problems, avoid getting fingerprints on the transparencies.
- Before loading transparencies, fan the stack to prevent sheets from sticking together.
- We recommend Lexmark part number 12A8240 for letter-size and Lexmark part number 12A8241 for A4-size transparencies.

Using envelopes

- Print samples on the envelopes being considered for use before buying large quantities.

When printing on envelopes:

- From the control panel, set the Paper Source based on the source in use. From the control panel, the printer software, or MarkVision Professional, set the Paper Type to Envelope, and select the envelope size.
- Use envelopes designed specifically for laser printers. Check with the manufacturer or vendor to ensure the envelopes can withstand temperatures up to 180°C (356°F) without sealing, wrinkling, curling excessively, or releasing hazardous emissions.
- For the best performance, use envelopes made from 90 g/m² (24 lb bond) paper. Use up to 105 g/m² (28 lb bond) weight for envelopes as long as the cotton content is 25% or less. All-cotton envelopes must not exceed 90 g/m² (24 lb bond) weight.
- Use only new envelopes.

- To optimize performance and minimize jams, do not use envelopes that:
 - Have excessive curl or twist
 - Are stuck together or damaged in any way
 - Have windows, holes, perforations, cutouts, or embossing
 - Have metal clasps, string ties, or folding bars
 - Have an interlocking design
 - Have postage stamps attached
 - Have any exposed adhesive when the flap is in the sealed or closed position
 - Have bent corners
 - Have rough, cockle, or laid finishes
- Adjust the width guide to fit the width of the envelopes.

Note: A combination of high humidity (over 60%) and the high printing temperature may wrinkle or seal envelopes.

Using labels

Print samples on the labels being considered for use before buying large quantities. For detailed information on label printing, characteristics, and design, see the *Card Stock & Label Guide* available on the Lexmark Web site at www.lexmark.com/publications.

Note: Vinyl labels are not supported on this product. Use only paper labels.

When printing on labels:

- From the printer software, MarkVision Professional, or the control panel, set the Paper Type to Labels.
- Use only letter-, A4-, and legal-size label sheets.
- Use labels designed specifically for laser printers. Check with the manufacturer or vendor to verify that label adhesives, face sheet (printable stock), and topcoats can withstand temperatures up to 180°C (356°F) and pressure up to 30 psi without delaminating, oozing around the edges, or releasing hazardous fumes. Do not use vinyl labels.
- Do not use labels with slick backing material.
- Use full label sheets. Partial sheets may cause labels to peel off during printing, resulting in a jam. Partial sheets also contaminate the printer and the cartridge with adhesive, and could void the printer and cartridge warranties.
- Do not print within 1 mm (0.04 in) of the edge of the label, of the perforations, or between die-cuts of the label.
- Be sure adhesive backing does not reach to the sheet edge. Zone coating of the adhesive at least 1 mm (0.04 in) away from edges is recommended. Adhesive material contaminates the printer and could void the warranty.
- If zone coating of the adhesive is not possible, remove a 3 mm (0.125 in.) strip on the leading and driver edge, and use a non-oozing adhesive.
- Portrait orientation works best, especially when printing bar codes.
- Do not use labels with exposed adhesive.

Using card stock

Card stock is heavy, single-ply print media. Many of its variable characteristics, such as moisture content, thickness, and texture, can significantly impact print quality.

Print samples on the card stock being considered for use before buying large quantities.

When printing on card stock:

- From MarkVision Professional, the printer software, or the control panel:
 - Set the Paper Type to Card Stock.
 - Set the Paper Weight to Card Stock Weight.
 - Set the Card Stock Weight to Normal or Heavy.

- Be aware that preprinting, perforation, and creasing may significantly affect the print quality and cause jams or other paper handling problems.
- Check with the manufacturer or vendor to ensure the card stock can withstand temperatures up to 180°C (356°F) without releasing hazardous emissions.
- Do not use preprinted card stock manufactured with chemicals that may contaminate the printer. Preprinting introduces semi-liquid and volatile components into the printer.
- Use grain long card stock when possible.

Storing media

Use these media storage guidelines to help avoid jams and uneven print quality:

- For best results, store media where the temperature is 21°C (70°F) and the relative humidity is 40%.
- Store media in cartons when possible, on a pallet or shelf, rather than on the floor.
- Store individual packages of media on a flat surface.
- Do not store anything on top of individual media packages.

Supported sizes

The following tables provide information on standard and optional sources for both input and output trays and bins.

Media Sizes	250 Tray	MPF	Duplex	500 Tray	Manual Feed Slot
A4 210 x 297 mm	✓	✓	✓	✓	✓
A5 148 x 210 mm	✓	✓	✓	✓	✓
JIS B5 182 x 257 mm	✓	✓	✓	✓	✓
Statement ¹ 5.5 x 8.5 in.		✓	✓		✓
Letter 8.5 x 11 in.	✓	✓	✓	✓	✓
Folio ¹ 8.5 x 13 in.	✓	✓	✓	✓	✓
Legal 8.5 x 14 in.	✓	✓	✓	✓	✓
Executive 7.25 x 10.5 in.	✓	✓	✓	✓	✓
Universal ¹ (width)					
123.8 to 215.9 x 355.6 mm; 3.875 x 4.875 to 8.5 x 14 in.		✓			
152.4 to 215.9 x 355.6 mm; 3.875 x 6 to 8.5 x 14 in.		✓			✓
139.7 x 210 to 215.9 x 355.6 mm; 5.5 x 8.27 to 8.5 x 14 in.		✓	✓		✓
148 x 210 to 215.9 x 355.6 mm; 5.83 x 8.27 to 8.5 x 14 in.	✓	✓	✓	✓	✓
7 3/4 Envelope 3 7/8 x 7 1/2 in.		✓			✓
9 Envelope 3 7/8 x 8 7/8 in.		✓			✓
10 Envelope 4 1/8 x 9 1/2 in.		✓			✓
DL Envelope 110 x 220 mm		✓			✓
C5 Envelope 162 x 229 mm		✓			✓

Media Sizes (continued)	250 Tray	MPF	Duplex	500 Tray	Manual Feed Slot
B5 Envelope 176 x 250 mm		✓			✓
Other Envelope					
60.5 to 215.9 mm		✓			✓
97.4 to 215.9 mm					✓
¹ Lower feed reliability might be encountered when using non-standard media sizes.					

Media weight

Size	Type		Weight
Primary tray and 500-sheet optional tray			
Letter, Legal, A4	Xerographic and Bonds	Long Grain	16 to 47 lb (60 to 177 g/m ²)
		Short Grain	24 to 58 lb (90 to 218 g/m ²)
	Recycled	Long Grain	20 to 47lb (75 to 177 g/m ²)
		Short Grain	28 to 58 lb (105 to 218g/m ²)
	Card Stock (long and short)	Cover	50 lb/65 lb (135 g/m ² / 176 g/m ²)
		Index	67 lb/90 lb (120 g/m ² / 163 g/m ²)
		Tag	74 lb/100 lb (120 g/m ² / 163 g/m ²)
	Transparency	0.12 to 0.14 mm 4.8 to 5.4 mil	161 to 179 g/m ²
A5, B5, JIS-B5, Exec., Statement, Folio	Xerographic and Bonds	Long Grain	20 to 47 lb (75 to 177 g/m ²)
		Short Grain	24 to 58 lb (90 to 218 g/m ²)
Multipurpose feeder and manual feed slot			
Letter, Legal, A4	Xerographic and Bonds	Long Grain	20 to 47 lb (75 to 177 g/m ²)
		Short Grain	24 to 58 lb (90 to 218 g/m ²)
	Recycled	Long Grain	20 to 47 lb (75 to 177 g/m ²)
		Short Grain	28 to 58 lb (105 to 218 g/m ²)
	Card Stock (long/short)	Cover	50 lb/ 65 lb (135 g/m ² / 176 g/m ²)
		Index	67 lb/ 90 lb (120 g/m ² / 163 g/m ²)
		Tag	74 lb/ 100 lb (120 g/m ² /163 g/m ²)
	Labels (max)	Paper	35 lb (131 g/m ²)
Vinyl		Not Supported	
Letter, Legal, A4 (continued)	Transparency	Thickness: 0.12 to 0.13 mm	161 to 179 g/m ²

Media weight

Size	Type		Weight
A5, B5, JIS-B5, Exec., Statement, Folio	Xerographic and Bonds	Long Grain	20 to 47 lb (75 to 177 g/m ²)
		Short Grain	24 to 58 lb (90 to 218 g/m ²)
Envelope	Monarch, 7 ¼, #9, #10, DL, B5, C5, C6-C5, C6, B6		16 to 28 lb (60 to 105 g/m ²)
Duplex unit			
A5, B5, Executive, Statement, Folio, Letter, A4 and Legal	Xerographic and Bonds	Long Grain	20 to 32 lb (75 to 120 g/m ²)
		Short Grain	24 to 32 lb (90 to 120 g/m ²)
	Recycled	Long Grain	20 to 32 lb (75 to 120 g/m ²)
		Short Grain	28 to 32 lb (105 to 120 g/m ²)

Input and output capacities

The following table outlines the input and output source capacities by media type.

Source	Media	Maximum height	Approximate reference capacity
Input			
Standard 250-sheet tray ²	Plain paper ¹	54 mm	250 sheets (75 g/m ²)
Optional 500-sheet tray (C52x) or Optional 550-sheet tray (C53x) ²	Plain paper ¹	57.6 mm	500 sheets (80 g/m ²) 550 sheets (75 g/m ²)
Multipurpose feeder ²	Plain paper	10 mm	100 sheets (75 g/m ²)
	Envelopes		10 envelopes (75 g/m ²)
	Other		Various quantities
Manual feed slot	Any media	Single sheet	1 sheet
Output			
Standard 250-sheet output bin ^{1, 2}	Plain Paper	35 mm	250 sheets (75 g/m ²)
	Other		Various quantities
¹ 20 lb xerographic paper at ambient environment ² Capacity may vary and is subject to media specifications and printer operating environment. Note: Paper input is limited to below the input source indicator on the tray.			

Print area

The printable area is limited to within 4.2 mm (0.167 in.) of all edges of the media. Any information placed outside this specified printable area does not print.

Serial number and machine type

The serial number is located on the label on the rear of the right cover and on the service tag located on the inside right frame of the printer. The service tag also contains the configuration IDs, machine type, and model information.

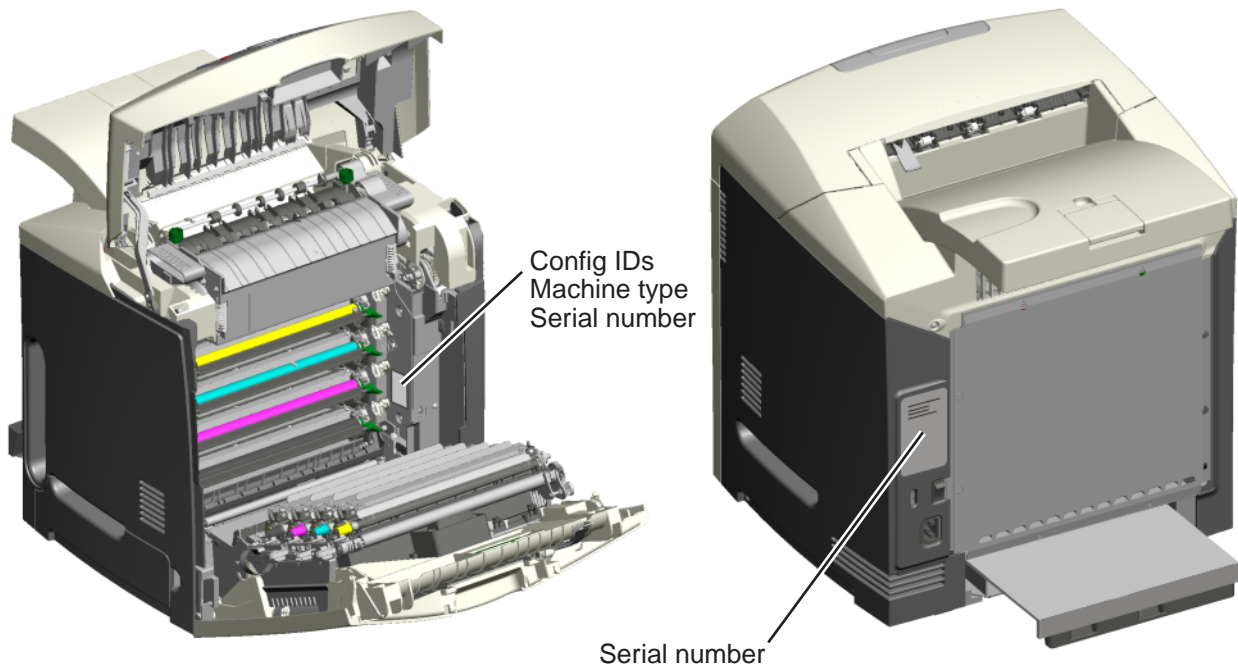

Tools required for service

- Flat-blade screwdriver
- #1 Phillips screwdriver, magnetic
- #2 Phillips screwdriver, magnetic
- #2 Phillips screwdriver, magnetic short-blade
- Needlenose pliers
- Diagonal side cutters
- Spring hook
- Feeler gauges
- Analog or digital multimeter
- Parallel wrap plug 1319128
- Twinax/serial debug cable 1381963
- Coax/serial debug cable 1381964

Acronyms

C	Cyan
CRU	Customer Replaceable Unit
DIMM	Dual Inline Memory Module
DRAM	Dynamic Random Access Memory
EP	ElectroPhotographic (process)
EPROM	Erasable Programmable Read-Only Memory
ESD	Electrostatic Discharge
FRU	Field Replaceable Unit
GB	Gigabyte
HVPS	High Voltage Power Supply
K	Black
LASER	Light Amplification by Stimulated Emission of Radiation
LCD	Liquid Crystal Display
LED	Light-Emitting Diode
LVPS	Low Voltage Power Supply
M	Magenta
MPF	Multipurpose Feeder
MS	Microswitch
NVRAM	Nonvolatile Random Access Memory
OPT	Optical Sensor
PC	Photoconductor
pel	Picture element
POR	Power-On Reset
POST	Power-On Self Test
PWM	Pulse Width Modulation
RIP	Raster Imaging Processor
SDRAM	Synchronous Dual Random Access Memory
SIMM	Single Inline Memory Module
SRAM	Static Random Access Memory
TAR	Toner Adder Roller
V ac	Volts alternating current
V dc	Volts direct current
Y	Yellow

2. Diagnostic information

Start

	<p>CAUTION</p> <p>Remove the power cord from the electrical outlet before you connect or disconnect any cable or electronic card or assembly for personal safety and to prevent damage to the printer. Use the handholds on the side of the printer. Make sure your fingers are not under the printer when you lift or set the printer down.</p>
---	---

Use the service error code, user status message, user error message, symptom table, service checks, and diagnostic aids in this chapter to determine the corrective action necessary to repair a malfunctioning printer. They will lead you to solutions or service checks, including use of various tests.

Symptom tables

If your printer completes the **“Power-on self test (POST) sequence” on page 2-5** without an error, and you have a symptom, go to **“Symptom tables” on page 2-6**. Locate your symptom, and take the appropriate action.

Service errors (1xx.xx/9xx.xx)

If a service error code appears while you are working on the printer, go to **“Service error codes and paper jam messages” on page 2-7**, and take the indicated action for that error.

Service error codes are indicated by a three-digit error code followed by a period and additional numbers in the format XXX.YY. In most cases, five digits are shown.

Paper jam messages (2xx.xx)

User attendance messages that indicate a paper jam these have been included with the service error codes since repeated instances may indicate an underlying service issue. Go to **“2xx paper jam messages” on page 2-8**.

User status and attendance messages

- User status messages provide the user with information on the current status of the printer.
- User attendance messages are indicated by a two-digit code that provides the user with information that explains a problem with a print cartridge, option, port, and so on. If a user error message displays, see **“User status and attendance messages” on page 2-19** or **“2xx paper jam messages” on page 2-8**.

Additional information

- **“Operator panel and menus” on page 2-2**
- **“Power-on self test (POST) sequence” on page 2-5**
- **“Theory of operation” on page 3-30**



Operator panel and menus



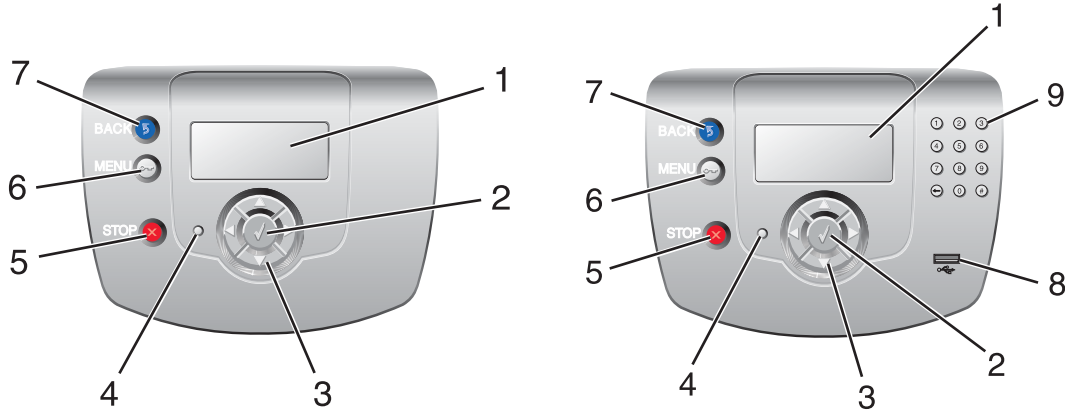

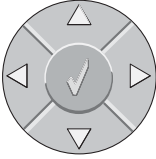

Operator panel

The operator panel consists of these items:



Buttons and light description

Button or light		Function
1	Display	The display shows messages and pictures that communicate the status of the printer.
2	 <p>Note: It has a check mark (✓) icon.</p>	<p>The  button functions as a select button. Press this button to:</p> <ul style="list-style-type: none"> • Open a menu and display the first item in the menu (called a menu item). • Open a menu item and display the default setting. • Save the displayed menu item as the new user default setting. The printer issues a <i>Saved</i> or <i>Submitted Selection</i> message and returns to the menu item. <p>Note: When a new setting is saved as the user default setting, it remains in effect until new settings are saved or until factory defaults are restored. Settings chosen from the software application can also change or override the user default settings selected from the operator panel.</p>
3	<p>Navigation arrow buttons</p> 	<p>▲, ▼—Press these buttons to scroll up or down through menus, menu items, or settings, called menu item values, or to scroll between screens and menu values. Each press moves one item in the list or a different setting for a menu item.</p> <p>◀, ▶—Press these buttons to scroll items that wrap off of the screen. For menu items with numeric values, such as Copies, press and hold this button to scroll through the values. Release the button when the needed number appears.</p>

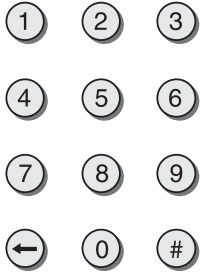
Button or light		Function										
4	Indicator light	<p>The two-toned light emitting diode called the indicator light on the operator panel gives information about the status of the printer using the colors red and green.</p> <table border="1"> <thead> <tr> <th>Indicator light status</th> <th>Indicates</th> </tr> </thead> <tbody> <tr> <td>Off</td> <td>Printer power is off.</td> </tr> <tr> <td>Blinking green</td> <td>Printer is warming up, processing data, or printing a job.</td> </tr> <tr> <td>Solid green</td> <td>Printer is on, but idle.</td> </tr> <tr> <td>Solid red</td> <td>Operator intervention is required.</td> </tr> </tbody> </table>	Indicator light status	Indicates	Off	Printer power is off.	Blinking green	Printer is warming up, processing data, or printing a job.	Solid green	Printer is on, but idle.	Solid red	Operator intervention is required.
Indicator light status	Indicates											
Off	Printer power is off.											
Blinking green	Printer is warming up, processing data, or printing a job.											
Solid green	Printer is on, but idle.											
Solid red	Operator intervention is required.											
5	Stop 	<p>Press  to stop or suspend all job activity. The  functions as a stop button.</p> <p>If printing, pressing  causes the Stop screen to appear on the display.</p>										
6	Menu 	Press to open the administration menus. These menus are only available when the printer is in the Ready state.										
7	Back 	<p>Press to return to the previous screen.</p> <p>Note: This button is only active if  appears on the top left of the screen.</p>										
8	USB direct port	Model C534 only: Insert a USB flash drive to send data to the printer.										
9	Numeric keypad 	Model C534 only: Consists of the numbers 0–9, a backspace button, and a pound (#) button.										

Menus

Note: Some menu items may not be available based on the printer model or the options installed.

Supplies Menu

Replace Supply
Cyan Cartridge
Magenta Cartridge
Yellow Cartridge
Black Cartridge
Cyan PC Unit
Magenta PC Unit
Yellow PC Unit
Black PC Unit
Waste Toner Box
Fuser
Transfer Belt

Security

Max Invalid PIN
Job Expiration

Paper Menu

Default Source
Paper Size/Type
Configure MP
Substitute Size
Paper Texture
Paper Weight
Paper Loading
Custom Types
Universal Setup

Network/Ports

TCP/IP
IPv6
Wireless
Standard Network
Network <x>
Standard USB
USB <x>
NetWare
AppleTalk
LexLink
USB Direct

Reports

Menu Settings Page
Device Statistics
Network Setup Page
Network <x> Setup Page
Wireless <x> Setup Page
Profiles List
NetWare Setup Page
Print Fonts
Print Demo

Help

Color Quality
Print Quality
Printing Guide
Supplies Guide
Media Guide
Print Defects
Menu Map
Information Guide
Connection Guide
Moving Guide

Settings

Setup Menu
Finishing Menu
Quality Menu
Utilities Menu
PDF Menu
PostScript Menu
PCL Emul Menu
HTML Menu
Image Menu

Power-on self test (POST) sequence

When you turn the printer on, it performs a Power-On Self Test. Check for correct POST functioning of the base printer by observing the following:

1. The LED turns on.
2. The main fan turns on.
3. The operator panel turns on.
4. A partial row of pixels appears.
5. The operator panel display clears.
6. Another row of pixels appears.
7. The operator panel display clears again.
8. The operator panel displays system information. For example:

*256MB	500Mhz
--------	--------

9. The fuser lamp turns on. The fuser takes longer to warm up from a cold start than a warm start.
10. The operator panel LED starts blinking.
11. A clock face appears on the display.
The following errors or messages may appear:
 - Close Door or Insert Cartridge display if the upper front cover is open or the print cartridge is missing.
 - Any cartridge errors, such as Defective Cartridge or Missing Cartridge.
12. Ready appears on the display.
13. The main drive motor turns on.
14. The EP drive assembly drives the developer shaft located in the toner cartridge.
15. The exit rollers turn.
16. The printer calibrates.

Symptom tables

Printer symptom table

Symptom	Action
Dead printer	Go to “Dead printer service check” on page 2-51.
Operator panel—one or more buttons do not work.	Go to “One or more operator panel buttons fail” on page 2-53.
Operator panel—display is blank. Printer sounds five beeps.	Go to “Operator panel display blank, five beeps, and LED off” on page 2-53.
Operator panel—display is blank.	Go to “Operator panel display blank, five beeps, and LED off” on page 2-53.
Operator panel continuously displays all diamonds and does not complete POST.	Go to “Operator panel display blank, five beeps, and LED off” on page 2-53.

Print quality symptom table

Symptom	Action
Background	Go to “Print quality—background” on page 2-55.
Blank page	Go to “Print quality—blank page” on page 2-56.
Blurred or fuzzy print	Go to “Print quality—blurred or fuzzy print” on page 2-59.
Half-color page	Go to “Print quality—half-color page” on page 2-59.
Horizontal banding	Go to “Print quality—horizontal banding” on page 2-59.
Horizontal line	Go to “Print quality—horizontal line” on page 2-59.
Insufficient fusing	Go to “Print quality—insufficient fusing” on page 2-59.
Missing image at edge	Go to “Print quality—missing image at edge” on page 2-59.
Mottle (2–5mm speckles)	Go to “Print quality—mottle (2–5mm speckles)” on page 2-59.
Narrow vertical line	Go to “Print quality—narrow vertical line” on page 2-59.
Random marks	Go to “Print quality—random marks” on page 2-60.
Residual image	Go to “Print quality—residual image” on page 2-60.
Solid color page	Go to “Print quality—solid color page” on page 2-61.
Vertical banding	Go to “Print quality—vertical banding” on page 2-62.

Error codes and messages

Service error codes and paper jam messages

Error code	Description	Action
1xx service error codes		
110.01–110.06 Mirror Motor	A mirror motor error has occurred.	POR the printer. If the error message persists, see “110.xx—Mirror motor service check” on page 2-27.
111.01–111.05 Printhead Error	An error has occurred in the cyan channel of the printhead.	POR the printer. If the error message persists, see “111.xx, 112.xx, 113.xx, and 114.xx—Printhead error service check” on page 2-27.
112.01–112.05 Printhead Error	An error has occurred in the magenta channel of the printhead.	POR the printer. If the error message persists, see “111.xx, 112.xx, 113.xx, and 114.xx—Printhead error service check” on page 2-27.
113.01–113.05 Printhead Error	An error has occurred in the yellow channel of the printhead.	POR the printer. If the error message persists, see “111.xx, 112.xx, 113.xx, and 114.xx—Printhead error service check” on page 2-27.
114.01–114.05 Printhead Error	An error has occurred in the black channel of the printhead.	POR the printer. If the error message persists, see “111.xx, 112.xx, 113.xx, and 114.xx—Printhead error service check” on page 2-27.
120.01–120.02 Fuser Error	An error has occurred in the fuser.	Remove and reseal the fuser. POR the printer. If the error message persists, see “120.01, 120.02, 120.08–120.10, 120.13–120.15—Fuser error service check” on page 2-28.
120.03 Fuser Error	An error has occurred in the fuser.	Remove and reseal the fuser. POR the printer. If the error message persists, see “120.03—Fuser error service check” on page 2-30.
120.04–120.07 Fuser Error	An error has occurred in the fuser.	Remove and reseal the fuser. POR the printer. Check the camshaft follower on the left side. If the error message persists, see “120.04–120.07—Fuser error service check” on page 2-30.
120.08–120.10, 120.13–120.15 Fuser Error	An error has occurred in the fuser.	Remove and reseal the fuser. POR the printer. If the error message persists, see “120.01, 120.02, 120.08–120.10, 120.13–120.15—Fuser error service check” on page 2-28.
140.03–140.08 Autocomp Motor Error	Tray 1 motor has failed.	POR the printer. If the error message persists, see “140.xx—Autocomp (tray 1) motor error service check” on page 2-32.
142.09–142.18, 142.20–142.25, 142.27 Motor Error	Fuser motor has failed.	POR the printer. If the error message persists, see “142.xx and 906.01–906.04—Motor (fuser) error service check” on page 2-33.
143.09–143.18, 143.20–143.25 Motor Error	EP Drive assembly cartridge 1 motor has failed.	POR the printer. If the error message persists, see “143.xx—Motor (EP drive assembly top cartridge) error service check” on page 2-34.
144.09–144.18, 144.20–144.25 Motor Error	EP Drive assembly cartridge 2 (bottom) motor has failed.	POR the printer. If the error message persists, see “144.xx—Motor (EP drive assembly bottom cartridge) error service check” on page 2-35.
145.09–145.18, 145.20–145.25 Motor Error	Bump aligner motor has failed.	POR the printer. If the error message persists, see “145.xx and 906.05–906.08—Motor (bump aligner) error service check” on page 2-36.

Service error codes and paper jam messages (continued)

Error code	Description	Action
146.01–146.08 Motor Error	Duplex motor has failed.	POR the printer. If the error message persists, see “146.xx—Motor (duplex) error service check” on page 2-36.
147.01–147.08 Motor Error	Tray 2 motor has failed.	POR the printer. If the error message persists, see “147.xx, 149.xx—Motor (500-sheet/550-sheet option tray 2 motor) error service check” on page 2-37.
148.01–148.08 Motor Error	MPF motor has failed.	POR the printer. If the error message persists, see “148.xx—MPF motor error service check” on page 2-37.
149.01–149.08 Motor Error	Tray 2 motor has failed.	POR the printer. If the error message persists, see “147.xx, 149.xx—Motor (500-sheet/550-sheet option tray 2 motor) error service check” on page 2-37.
2xx paper jam messages		
200.01	Input sensor is made when printer tries to print from an idle state. Possible causes: <ul style="list-style-type: none"> Paper jam leaving page over sensor Defective input sensor Faulty system card 	<ul style="list-style-type: none"> Check for anything in the paper path that might cause the paper to jam. If clearing a paper jam does not fix the problem, go to “Input sensor service check” on page 2-52.
200.11	Input sensor does not break. Possible causes: <ul style="list-style-type: none"> Incorrect media setting Incorrect paper loading Incorrect media restraint setting Paper tray failure Paper pick mechanism 	<ul style="list-style-type: none"> Ensure proper media is set for the type of paper used. Fan media, and stack flat in the tray or MPF. Properly set media restraints in the paper tray. Check the pick arm rolls (tires) and replace if worn. Replace the paper tray. Replace the paper pick mechanism. See “Paper pick mechanism assembly removal” on page 4-68.
200.16	Input sensor is made when printer powers up or covers are closed. Possible causes: <ul style="list-style-type: none"> Paper jam leaving page over sensor Defective input sensor Faulty system card 	<ul style="list-style-type: none"> Check for anything in the paper path that might cause the paper to jam. If clearing a paper jam does not fix the problem, go to “Input sensor service check” on page 2-52.
200.21	Bump aligner motor stalled. Possible causes: <ul style="list-style-type: none"> Faulty cable/connector 24 V interlock switch not working correctly Faulty bump align motor Faulty system card 	<ul style="list-style-type: none"> Check for anything in the paper path that might cause the paper to jam. If clearing a paper jam does not fix the problem, go to “145.xx and 906.05–906.08—Motor (bump aligner) error service check” on page 2-36.

Service error codes and paper jam messages (continued)

Error code	Description	Action
200.22	Pick (tray 1) motor stalled. Possible causes: <ul style="list-style-type: none"> • Faulty cable/connector • Faulty pick motor • Faulty system card 	<ul style="list-style-type: none"> • Check for anything in the paper path that might cause the paper to jam. • If clearing a paper jam does not fix the problem, go to “140.xx—Autocomp (tray 1) motor error service check” on page 2-32.
200.25	Input sensor is made when tray 1 is installed. Possible causes: <ul style="list-style-type: none"> • Improper placement of paper in tray 1 • Damaged input sensor flag or input sensor • Faulty system card 	<ul style="list-style-type: none"> • Fan media, and stack flat in the tray or MPF. • Properly set media restraints in the paper tray. • If clearing a paper jam does not fix the problem, go to “Input sensor service check” on page 2-52.
201.06	Paper is jammed between the input sensor and the exit sensor. Possible causes: <ul style="list-style-type: none"> • Damaged paper exit sensor or paper exit sensor flag • Damaged fuser autoconnect • Faulty fuser DC cable connection • Faulty fuser • Faulty system card 	<ul style="list-style-type: none"> • Check for anything in the paper path that might cause the paper to jam. • The fuser exit sensor may not be functioning properly. See “Exit sensor service check” on page 2-52.
201.07	Exit sensor is made early. Possible causes: <ul style="list-style-type: none"> • Damaged paper exit sensor or paper exit sensor flag • Damaged fuser autoconnect • Faulty fuser DC cable connection • Faulty fuser • Faulty system card 	<ul style="list-style-type: none"> • Check for anything in the paper path that might cause the paper to jam. • The fuser exit sensor may not be functioning properly. See “Exit sensor service check” on page 2-52.
201.08	Exit sensor is never made. Possible causes: <ul style="list-style-type: none"> • Improper loading of manual feed slot • Paper wrapped in fuser • Damaged paper exit sensor or paper exit sensor flag • Damaged fuser autoconnect • Faulty fuser DC cable connection • Faulty fuser • Faulty system card 	<ul style="list-style-type: none"> • Check for anything in the paper path that might cause the paper to jam. • Load paper in the manual feed slot. See “Paper jams in the multipurpose feeder or manual feeder” on page 3-28. • The fuser exit sensor may not be functioning properly. See “Exit sensor service check” on page 2-52.

Service error codes and paper jam messages (continued)

Error code	Description	Action
201.10	Input sensor flag broke early. Possible causes: <ul style="list-style-type: none"> Paper jam leaving page over sensor Defective input sensor Faulty system card 	<ul style="list-style-type: none"> Check for anything in the paper path that might cause the paper to jam. If clearing a paper jam does not fix the problem, go to “Input sensor service check” on page 2-52.
201.21	Cartridge motor 1 (top) or cartridge motor 2 (bottom) has stalled. Possible causes: <ul style="list-style-type: none"> Faulty cable/connector Faulty cartridge motor Faulty system card 	<ul style="list-style-type: none"> Check for anything in the paper path that might cause the paper to jam. If clearing a paper jam does not fix the problem, go to “143.xx—Motor (EP drive assembly top cartridge) error service check” on page 2-34 and then “144.xx—Motor (EP drive assembly bottom cartridge) error service check” on page 2-35 if necessary.
201.23	Special case. Possible cause: <ul style="list-style-type: none"> System card code failure 	<ul style="list-style-type: none"> POR the printer. Replace the system card if the error message persists. See “System card removal” on page 4-92. If replacing system card does not fix the problem, contact your next level of support.
201.24	A 201.08 jam occurred and was not cleared. Possible cause—Failure to open and close the top access door.	This error is generated as a protection for possible paper wrap in the fuser. Open the top access door, and check for a paper jam. Close the top access door. If the jam is cleared, and the error does not go away, go to “Exit sensor service check” on page 2-52.
202.02	Exit sensor is made when printer tries to print from an idle state. Possible causes: <ul style="list-style-type: none"> Damaged paper exit sensor or paper exit sensor flag Damaged fuser autoconnect Faulty fuser DC cable connection Faulty fuser Faulty system card 	<ul style="list-style-type: none"> Check for anything in the paper path that might cause the paper to jam. The fuser exit sensor may not be functioning properly. See “Exit sensor service check” on page 2-52.
202.12	Exit sensor broke early. Possible causes: <ul style="list-style-type: none"> Damaged paper exit sensor or paper exit sensor flag Faulty fuser Faulty system card 	The fuser exit sensor may not be functioning properly. See “Exit sensor service check” on page 2-52.
202.13	Exit sensor never broke. Possible causes: <ul style="list-style-type: none"> Damaged paper exit sensor or paper exit sensor flag Faulty fuser Faulty system card Faulty output bin flag 	<ul style="list-style-type: none"> Check output bin flag on fuser for proper operation. Ensure that paper is not hanging on the flag. The fuser exit sensor may not be functioning properly. See “Exit sensor service check” on page 2-52.

Service error codes and paper jam messages (continued)

Error code	Description	Action
202.17	Exit sensor is made when the printer powers up or covers are closed. Possible causes: <ul style="list-style-type: none"> • Damaged paper exit sensor or paper exit sensor flag • Damaged fuser autoconnect • Faulty fuser DC cable connection • Faulty fuser • Faulty system card 	<ul style="list-style-type: none"> • Check for anything in the paper path that might cause the paper to jam. • The fuser exit sensor may not be functioning properly. See “Exit sensor service check” on page 2-52.
202.21	Fuser motor stalled. Possible causes: <ul style="list-style-type: none"> • Faulty cable/connector • Faulty fuser motor • Faulty system card 	<ul style="list-style-type: none"> • Check for anything in the paper path that might cause the paper to jam. • If clearing a paper jam does not fix the problem, go to “142.xx and 906.01–906.04—Motor (fuser) error service check” on page 2-33.
203.09	During duplex printing retract, the exit sensor is never made. Possible causes: <ul style="list-style-type: none"> • Damaged paper exit sensor or paper exit sensor flag • Damaged fuser autoconnect • Faulty fuser DC cable connection • Faulty fuser • Faulty system card 	<ul style="list-style-type: none"> • Check for anything in the paper path that might cause the paper to jam. • The fuser exit sensor may not be functioning properly. See “Exit sensor service check” on page 2-52.
203.14	During duplex printing retract, the exit sensor broke early. Possible causes: <ul style="list-style-type: none"> • Damaged paper exit sensor or paper exit sensor flag • Faulty fuser • Faulty system card 	The fuser exit sensor may not be functioning properly. See “Exit sensor service check” on page 2-52.
203.15	During duplex printing, the exit sensor never broke. Possible causes: <ul style="list-style-type: none"> • Damaged paper exit sensor or paper exit sensor flag • Obstructed duplex • Faulty fuser • Faulty system card 	<ul style="list-style-type: none"> • Check the duplex paper path for damage that would obstruct the print. If damage is found, replace the duplex front door assembly. See “Front door assembly removal” on page 4-55. • The fuser exit sensor may not be functioning properly. See “Exit sensor service check” on page 2-52.
230.03	During duplex printing, the input sensor is never made. Possible causes: <ul style="list-style-type: none"> • Obstructed duplex path • Defective input sensor • Faulty system card • Faulty duplex drive 	<ul style="list-style-type: none"> • Check for anything in the duplex paper path that might cause the paper to jam. This includes the paper guides in tray 1. • If clearing the paper jam does not fix the problem and the paper is fan-folded, replace the front access assembly. See “Front door assembly removal” on page 4-55. • If clearing a paper jam does not fix the problem, go to “Input sensor service check” on page 2-52.

Service error codes and paper jam messages (continued)

Error code	Description	Action
230.04	<p>During duplex printing, the input sensor is made while the previous page is still in the aligner.</p> <p>Possible causes:</p> <ul style="list-style-type: none"> • Defective input sensor • Faulty system card 	<ul style="list-style-type: none"> • If clearing a paper jam does not fix the problem, go to “Input sensor service check” on page 2-52.
230.05	<p>During duplex printing, the input sensor is not made.</p> <p>Possible causes:</p> <ul style="list-style-type: none"> • Obstructed duplex path • Defective input sensor • Faulty system card • Faulty duplex drive 	<ul style="list-style-type: none"> • Check for anything in the duplex paper path that might cause the paper to jam. This includes the paper guides in tray 1. • If clearing the paper jam does not fix the problem and the paper is fan-folded, replace the front access assembly. See “Front door assembly removal” on page 4-55. • If clearing a paper jam does not fix the problem, go to “Input sensor service check” on page 2-52.
230.21	<p>Duplex motor stalled.</p> <p>Possible causes:</p> <ul style="list-style-type: none"> • Obstructed duplex path • Defective duplex motor • Faulty system card 	<ul style="list-style-type: none"> • Check for anything in the duplex paper path that might cause the paper to jam. This includes the paper guides in tray 1. • If clearing a paper jam does not fix the problem, go to “146.xx—Motor (duplex) error service check” on page 2-36.
241.03	<p>While feeding from tray 1, the input sensor does not break.</p> <p>Possible causes:</p> <ul style="list-style-type: none"> • Incorrect media setting • Incorrect paper loading • Incorrect media restraint setting • Paper tray failure • Paper pick mechanism failure 	<ul style="list-style-type: none"> • Ensure proper media is set for the type of paper used. • Fan media, and stack it flat in the tray or MPF. • Properly set media restraints in paper tray. • Check the pick arm rolls (tires) and replace if worn. • Replace the paper tray. • Replace the paper pick mechanism. See “Paper pick mechanism assembly removal” on page 4-68.
241.04	<p>While feeding from tray 1, the input sensor is made while the previous page is still in aligner.</p> <p>Possible causes:</p> <ul style="list-style-type: none"> • Incorrect media setting • Incorrect paper loading • Incorrect media restraint setting • Paper tray failure • Paper pick mechanism 	<ul style="list-style-type: none"> • Ensure the proper media is set for the type of paper used. • Fan media, and stack it flat in the tray or MPF. • Properly set media restraints in paper tray. • Check the pick arm rolls (tires) and replace if worn. • Replace the paper tray. • Replace the paper pick mechanism. See “Paper pick mechanism assembly removal” on page 4-68.

Service error codes and paper jam messages (continued)

Error code	Description	Action
241.05	While feeding from tray 1, the input sensor is never made. Possible causes: <ul style="list-style-type: none"> • Incorrect media setting • Incorrect paper loading • Incorrect media restraint setting • Paper tray failure • Paper pick mechanism failure • System card 	<ul style="list-style-type: none"> • Ensure proper media is set for the type of paper used. • Fan media, and stack it flat in the tray or MPF. • Properly set media restraints in paper tray. • Check the pick arm rolls (tires) and replace if worn. • Replace the paper tray. • If the previous actions do not fix the problem, go to “140.xx—Autocomp (tray 1) motor error service check” on page 2-32.
241.20	While feeding from tray 1, the transparency sensor is blocked. Possible causes: <ul style="list-style-type: none"> • Transparency sensor • Paper tray failure • Paper pick mechanism failure • System card 	<ul style="list-style-type: none"> • Replace the paper tray. • If the previous action does not fix the problem, go to “910.01—Transparency sensor error service check” on page 2-38.
241.21	Tray 1 motor stalled. Possible causes: <ul style="list-style-type: none"> • Incorrect paper loading • Paper pick mechanism failure • System card 	<ul style="list-style-type: none"> • Ensure proper media is set for the type of paper used. • Fan media, and stack it flat in the tray or MPF. • If the previous actions do not fix the problem, go to “148.xx—MPF motor error service check” on page 2-37.
242.03	While feeding from tray 2, the input sensor does not break. Possible causes: <ul style="list-style-type: none"> • Incorrect media setting • Incorrect paper loading • Incorrect media restraint setting • 500-sheet assembly failure • Paper pick mechanism 	<ul style="list-style-type: none"> • Ensure proper media is set for the type of paper used. • Fan media, and stack flat in 500-sheet tray (tray 2). • Properly set media restraints in tray 2. • Check the pick arm rolls (tires) and replace if worn. • Replace the 500-sheet assembly. • If the previous actions do not fix the problem, go to “140.xx—Autocomp (tray 1) motor error service check” on page 2-32.
242.04	While feeding from tray 2, the input sensor is made while the previous page is still in the aligner. Possible causes: <ul style="list-style-type: none"> • Incorrect media setting • Incorrect paper loading • Incorrect media restraint setting • 500-sheet assembly failure • Paper pick mechanism 	<ul style="list-style-type: none"> • Ensure proper media is set for the type of paper used. • Fan media, and stack it flat in the 500-sheet tray (tray 2). • Properly set media restraints in tray 2. • Check the pick arm rolls (tires) and replace if worn. • Replace the 500-sheet assembly. • If the previous actions do not fix the problem, go to “140.xx—Autocomp (tray 1) motor error service check” on page 2-32.

Service error codes and paper jam messages (continued)

Error code	Description	Action
242.05	While feeding from tray 2, the input sensor is not made.	<ul style="list-style-type: none"> • Ensure proper media is set for the type of paper used. • Fan media, and stack it flat in the 500-sheet tray (tray 2). • Properly set media restraints in tray 2. • Check the pick arm rolls (tires) and replace if worn. • If the previous actions do not fix the problem, go to “147.xx, 149.xx—Motor (500-sheet/550-sheet option tray 2 motor) error service check” on page 2-37.
242.21	The tray 2 autocomp or the redrive motor stalled.	<ul style="list-style-type: none"> • Fan media, and stack it flat in the 500-sheet tray (tray 2). • If the previous actions do not fix the problem, go to “147.xx, 149.xx—Motor (500-sheet/550-sheet option tray 2 motor) error service check” on page 2-37.
250.03	While feeding from the MPF, the input sensor did not break.	<ul style="list-style-type: none"> • Ensure proper media is set for the type of paper used. • Fan media, and stack it flat in the tray or MPF. • Properly set media restraints in the paper tray. • Check the pick arm rolls (tires) and replace if worn. • Replace the paper tray. • Replace the MPF swing arm assembly. See “Multipurpose feeder (MPF) swing arm assembly removal—models C52x only” on page 4-67. • If the previous actions do not fix the problem, replace the paper pick mechanism. See “Paper pick mechanism assembly removal” on page 4-68.
250.04	While feeding from the MPF, the input sensor is made while the previous page is still in the aligner.	<ul style="list-style-type: none"> • Ensure proper media is set for the type of paper used. • Fan media, and stack it flat in the tray or MPF. • Properly set media restraints in the paper tray. • Check the pick arm rolls (tires) and replace if worn. • Replace the paper tray. • Replace the MPF swing arm assembly. See “Multipurpose feeder (MPF) swing arm assembly removal—models C52x only” on page 4-67. • If the previous actions do not fix the problem, replace the paper pick mechanism. See “Paper pick mechanism assembly removal” on page 4-68.

Service error codes and paper jam messages (continued)

Error code	Description	Action
250.05	While feeding from the MPF, the input sensor is not made.	<ul style="list-style-type: none"> Ensure proper media is set for the type of paper used. Fan media, and stack it flat in the tray or MPF. Properly set media restraints in the paper tray. Check the pick arm rolls (tires) and replace if worn. Replace the paper tray. Models C52x only: Replace the MPF swing arm assembly. See “Multipurpose feeder (MPF) swing arm assembly removal—models C52x only” on page 4-67. If the previous actions do not fix the problem, replace the paper pick mechanism. See “Paper pick mechanism assembly removal” on page 4-68.
250.21	MPF motor stalled.	<ul style="list-style-type: none"> Ensure proper media is set for the type of paper used. Fan media, and stack it flat in the tray or MPF. Replace the MPF swing arm assembly. See “Multipurpose feeder (MPF) swing arm assembly removal—models C52x only” on page 4-67. If the previous actions do not fix the problem, go to “148.xx—MPF motor error service check” on page 2-37.
9xx service error messages		
900.00–900.99 Software Error	Unrecoverable RIP software errors.	POR the printer. If the error message persists, replace the system card. See “System card removal” on page 4-92.
902.01–902.99 Engine Software Error	Unrecoverable system software errors.	POR the printer. If the error message persists, replace the system card. See “System card removal” on page 4-92.
903.01–903.05 Engine Software Error	Unrecoverable system software errors.	POR the printer. If the error message persists, replace the system card. See “System card removal” on page 4-92.
904.01–904.04 Interface Violation by RIP	Unrecoverable system software errors.	POR the printer. If the error message persists, replace the system card. See “System card removal” on page 4-92.
905.xx Engine Software Error	Unrecoverable system software errors.	POR the printer. If the error message persists, replace the system card. See “System card removal” on page 4-92.
906.01–906.04 Fuser Motor Error	Fuser motor has failed.	POR the printer. If the error message persists, see “142.xx and 906.01–906.04—Motor (fuser) error service check” on page 2-33.
906.05–906.08 Bumper Motor error	Bump aligner motor has failed.	POR the printer. If the error message persists, see “145.xx and 906.05–906.08—Motor (bump aligner) error service check” on page 2-36.
907.xx Engine Software Error	Unrecoverable system software errors.	POR the printer. If the error message persists, replace the system card. See “System card removal” on page 4-92.

Service error codes and paper jam messages (continued)

Error code	Description	Action
908.00–908.99 Engine Software error	Unrecoverable system software errors.	POR the printer. If the error persists, replace the system card. See “System card removal” on page 4-92.
910.01 Transparency Sensor	Transparency sensor failed calibration.	See “910.01—Transparency sensor error service check” on page 2-38.
920.01 POST Error	Bump align motor not connected.	See “920.01—POST (power on self test) error service check” on page 2-38.
920.02 POST Error	Tray 1 motor not connected.	See “920.02—POST (power on self test) error service check” on page 2-38.
920.03 POST Error	Transfer belt not connected.	See “920.03—POST (power on self test) error service check” on page 2-38.
920.04 POST Error	Fuser motor not connected.	See “920.04—POST (power on self test) error service check” on page 2-39.
920.05 POST Error	Printhead motor not connected.	See “920.05—POST (power on self test) error service check” on page 2-39.
920.06 POST Error	Input sensor not connected.	See “920.06—POST (power on self test) error service check” on page 2-40.
920.07 POST Error	Narrow media sensor not connected.	See “920.07—POST (power on self test) error service check” on page 2-40.
920.08 POST Error	Exit sensor not connected.	See “920.08—POST (power on self test) error service check” on page 2-40.
920.09-12 POST Error	One toner sensor not connected.	See “920.09-12—POST (power on self test) error service check” on page 2-41.
920.13 POST Error	Cartridge motor 1 (top) not connected.	See “920.13—POST (power on self test) error service check” on page 2-43.
920.14 POST Error	Cartridge motor 2 (bottom) not connected.	See “920.14—POST (power on self test) error service check” on page 2-44.
920.15 POST Error	Bad transfer belt NVRAM data.	See “920.15—POST (power on self test) error service check” on page 2-45.
920.16 POST Error	Bad printhead NVRAM data.	See “920.16—POST (power on self test) error service check” on page 2-45.
920.17 POST Error	Output bin cable not connected.	See “920.17—POST (power on self test) error service check” on page 2-46.
920.18 POST Error	Tray 2 has failed.	See “920.18—POST (power on self test) error service check” on page 2-46.
920.19 POST Error	Stepper motor not connected.	See “920.19—POST (power on self test) error service check” on page 2-46.
925.01 Fan Error	Fan has stalled.	POR the printer. If the error message persists, see “925.01—Fan error service check” on page 2-47.
945.01 Transfer Roll	Yellow transfer roll has failed.	POR the printer. If the error message persists, see “945.xx, 946.xx, 947.xx—Transfer roll error service check” on page 2-48.
945.02 Transfer Roll	Cyan transfer roll has failed.	POR the printer. If the error message persists, see “945.xx, 946.xx, 947.xx—Transfer roll error service check” on page 2-48.

Service error codes and paper jam messages (continued)

Error code	Description	Action
945.03 Transfer Roll	Magenta transfer roll has failed.	POR the printer. If the error message persists, see “945.xx, 946.xx, 947.xx—Transfer roll error service check” on page 2-48.
945.04 Transfer Roll	Black transfer roll has failed.	POR the printer. If the error message persists, see “945.xx, 946.xx, 947.xx—Transfer roll error service check” on page 2-48.
946.01 Transfer Roll	Yellow transfer roll has failed.	POR the printer. If the error message persists, see “945.xx, 946.xx, 947.xx—Transfer roll error service check” on page 2-48.
946.02 Transfer Roll	Cyan transfer roll has failed.	POR the printer. If the error message persists, see “945.xx, 946.xx, 947.xx—Transfer roll error service check” on page 2-48.
946.03 Transfer Roll	Magenta transfer roll has failed.	POR the printer. If the error message persists, see “945.xx, 946.xx, 947.xx—Transfer roll error service check” on page 2-48.
946.04 Transfer Roll	Black transfer roll has failed.	POR the printer. If the error message persists, see “945.xx, 946.xx, 947.xx—Transfer roll error service check” on page 2-48.
947.01 Transfer Roll	Yellow transfer roll has failed.	POR the printer. If the error message persists, see “945.xx, 946.xx, 947.xx—Transfer roll error service check” on page 2-48.
947.02 Transfer Roll	Cyan transfer roll has failed.	POR the printer. If the error message persists, see “945.xx, 946.xx, 947.xx—Transfer roll error service check” on page 2-48.
947.03 Transfer Roll	Magenta transfer roll has failed.	POR the printer. If the error message persists, see “945.xx, 946.xx, 947.xx—Transfer roll error service check” on page 2-48.
947.04 Transfer Roll	Black transfer roll has failed.	POR the printer. If the error message persists, see “945.xx, 946.xx, 947.xx—Transfer roll error service check” on page 2-48.
950.00–950.29 NVRAM Mismatch	Mismatch between operator panel assembly NVRAM and system card NVRAM.	POR the printer. If the error message persists, see “950.00–950.29 EPROM mismatch failure” on page 2-50.
950.30–950.60 NVRAM Mismatch	Mismatch between system card NVRAM and smart chip card or printhead NVRAM.	POR the printer. If the error message persists, see “950.30–950.60 EPROM mismatch failure” on page 2-50.
951.01–951.99 NVRAM Failure	Smart chip card or printhead NVRAM failure.	POR the printer. <ul style="list-style-type: none"> • For C52x: if the error message persists, replace the smart chip card. See “Smart chip card removal—models C52x only” on page 4-91. • For C53x: if the error message persists, replace the printhead. See “Printhead removal, installation, and adjustment” on page 4-74.
952.01–952.99 NV Failure: <i>n</i>	CRC error has occurred. This is recoverable.	Perform a POR to clear the error.
953.01–953.99 NVRAM Failure	Operator panel assembly NVRAM.	POR the printer. Replace operator panel assembly if the error message persists. See “Operator panel assembly removal” on page 4-23.

Service error codes and paper jam messages (continued)

Error code	Description	Action
954.01–954.99 NVRAM Failure	System card NVRAM failure.	POR the printer. If the error message persists, replace the system card. See “System card removal” on page 4-92.
955.01–955.99 Code Failure	System card memory failure.	POR the printer. If the error message persists, replace the system card. See “System card removal” on page 4-92.
956.01–956.99 System card	Processor failure.	POR the printer. If the error message persists, replace the system card. See “System card removal” on page 4-92.
958.01–958.99 Memory Failure	Processor failure.	POR the printer. If the error message persists, replace the system card. See “System card removal” on page 4-92.
960.01–960.99 Memory Error	Memory failure.	RAM soldered on card is bad. Replace the system card. See “System card removal” on page 4-92.
961.01–961.99 Memory Failure	Memory failure.	POR the printer. If the error message persists, replace the system card. See “System card removal” on page 4-92.
990.xx Option Error	Tray 2 failure.	Replace 500-sheet assembly.

User status and attendance messages

User status and attendance messages

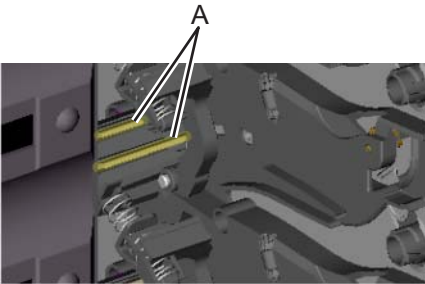
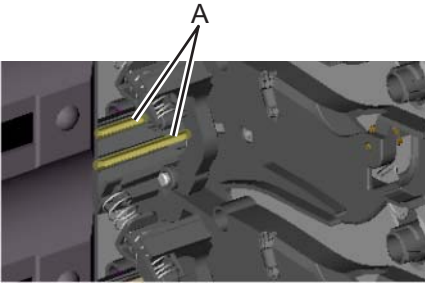
Error code	Action
3x through 8x attendance messages	
31 Defective or Missing <color> Cartridge	<ul style="list-style-type: none"> • Reseat the specified toner cartridge. • For models C52x: Inspect the smart chip card contacts (A) for damage, contamination or positioning error. If damaged, contact your next level of service.  <ul style="list-style-type: none"> • Inspect the toner cartridge contacts for damage/contamination. Replace the toner cartridge if defective. • Inspect the JSBTN1 cable connection. Properly connect the cable if not connected properly. Replace the cable if damaged. • For models C52x: Replace the smart chip card. See “Smart chip card removal—models C52x only” on page 4-91. • If the problem still exists, replace the system card. See “System card removal” on page 4-92.
32 Unsupported Cartridge	<ul style="list-style-type: none"> • Check to see if the toner cartridge is a supported cartridge. <p>Note: Once the cartridge shipped with the printer is exhausted, it must be replaced by a supply cartridge (refer to the <i>User's Guide</i> for part numbers.) If the specified toner cartridge is a supported cartridge, reseat the cartridge.</p> <ul style="list-style-type: none"> • For models C52x: Inspect the smart chip card contacts (A) for damage, contamination, or positioning error. If damaged, contact your next level of service.  <ul style="list-style-type: none"> • Inspect the toner cartridge contacts for damage or contamination. Replace the toner cartridge if defective. • Inspect JSBTN1 cable connection. Properly connect the cable if not connected properly. Replace the cable if damaged. • For models C52x: Replace the smart chip card. See “Smart chip card removal—models C52x only” on page 4-91. • If the problem still exists, replace the system card. See “System card removal” on page 4-92.

User status and attendance messages (continued)

Error code	Action
34 Short Paper	<ul style="list-style-type: none"> • Press ▼ until √Continue appears, and then press ⌂ to clear the message and continue printing. • The printer does not automatically reprint the page that prompted the message. • Check the tray length and width guides to ensure the media is properly fitted. • Make sure the print job is requesting the correct size of media. • Adjust the Paper Size setting for the media size being used. • If the MP Feeder Size is set to Universal, make sure the media is large enough for the formatted data. • Cancel the current job. Replace the paper pick mechanism. See “Paper pick mechanism assembly removal” on page 4-68. • If the problem still exists, replace the system card. See “System card removal” on page 4-92.
34 Incorrect Media	<ul style="list-style-type: none"> • Load the appropriate media in the selected source. • Press ▼ until √Continue appears, and then press ⌂ to clear the message and print the job using a different paper source. • POR the printer to recalibrate transparency sensor. • Ensure the transparency sensor is mounted correctly in the paper pick mechanism. If not, <i>snap</i> it into place. • Replace the paper pick mechanism. See “Paper pick mechanism assembly removal” on page 4-68. • If the problem still exists, replace the system card. See “System card removal” on page 4-92.
35 Insufficient memory to support Resource Save feature	<ul style="list-style-type: none"> • Press ▼ until √Continue appears, and then press ⌂ to disable Resource Save and continue printing. • To enable Resource Save after receiving this message: <ul style="list-style-type: none"> - Make sure the link buffers are set to Auto, then exit the menus to activate the link buffer changes. - When Ready is displayed, enable Resource Save. • Install additional memory. • If this does not fix the problem, replace the system card. See “System card removal” on page 4-92.
37 Insufficient memory to collate job	<ul style="list-style-type: none"> • Press ▼ until √Continue appears, and then press ⌂ to print the portion of the job already stored and begin collating the rest of the job. • Cancel the current job. • If this does not fix the problem, replace the system card. See “System card removal” on page 4-92.
37 Insufficient memory for Flash Memory Defragment operation	<ul style="list-style-type: none"> • Press ▼ until √Continue appears, and then press ⌂ to stop the defragment operation and continue printing. • Delete fonts, macros, and other data in printer memory. • Install additional printer memory. • If this does not fix the problem, replace the system. See “System card removal” on page 4-92.
37 Insufficient memory, some held jobs were deleted	<ul style="list-style-type: none"> • The printer deleted some held jobs in order to process current jobs. • Press ▼ until √Continue appears, and then press ⌂ to clear the message. • If this does not fix the problem, replace the system card. See “System card removal” on page 4-92.

User status and attendance messages (continued)

Error code	Action
37 Insufficient memory, some held jobs were lost	<ul style="list-style-type: none"> • The printer was unable to restore some or all of the confidential or held jobs on the hard disk. • Press ▼ until √Continue appears, and then press Ⓢ to clear the message. • If this message occurs again, replace the hard drive. • If this does not fix the problem, replace the system card. See “System card removal” on page 4-92.
38 Memory Full	<ul style="list-style-type: none"> • Press ▼ until √Continue appears, and then press Ⓢ to clear the message and continue printing. The job may not print correctly. • Cancel the current job. • Install additional printer memory. • If this does not fix the problem, replace the system card. See “System card removal” on page 4-92.
50 PPDS font error	<ul style="list-style-type: none"> • Press ▼ until √Continue appears, and then press Ⓢ to clear the message and continue printing. The job may not print correctly. • Cancel the current job. • If this does not fix the problem, replace the system card. See “System card removal” on page 4-92.
51 Defective flash detected	<ul style="list-style-type: none"> • Press ▼ until √Continue appears, and then press Ⓢ to clear the message and continue printing. • Install different flash memory before downloading any resources to flash. • If this does not fix the problem, replace the system card. See “System card removal” on page 4-92.
52 Not enough free space in flash memory for resources	<ul style="list-style-type: none"> • Press ▼ until √Continue appears, and then press Ⓢ to clear the message and continue printing. Downloaded fonts and macros not previously stored in flash memory are deleted. • Delete fonts, macros, and other data stored in flash memory. • Install a larger capacity flash memory card. • If this does not fix the problem, replace the system card. See “System card removal” on page 4-92.
53 Unformatted flash detected	<ul style="list-style-type: none"> • Press ▼ until √Continue appears, and then press Ⓢ to clear the message and continue printing. • Format the flash memory before storing any resources on it. If the error message remains, replace the flash memory. • If this does not fix the problem, replace the system card. See “System card removal” on page 4-92.
54 Serial option <x> error	<ul style="list-style-type: none"> • Make sure the serial link is set up correctly and the appropriate cable is in use. • Make sure the serial interface parameters (protocol, baud, parity, and data bits) are set correctly on the printer and host computer. • Press ▼ until √Continue appears, and then press Ⓢ to clear the message and continue printing. The job may not print correctly. • POR the printer. If this does not fix the problem, replace the PCI card.

User status and attendance messages (continued)

Error code	Action
54 Network <x> software error	<ul style="list-style-type: none"> • Press ▼ until √Continue appears, and then press ⏏ to clear the message and continue printing. The job may not print correctly. • Program new firmware for the network interface. • POR the printer. If this does not fix the problem, replace the PCI card.
55 Unsupported option in slot <x>	<ul style="list-style-type: none"> • Turn the printer off. • Unplug the power cord from the wall outlet. • Remove the unsupported option. • Connect the power cord to a properly grounded outlet. • Turn the printer on. • If this does not fix the problem, replace the system card. See “System card removal” on page 4-92.
56 Parallel port <x> disabled 56 Standard parallel port disabled	<ul style="list-style-type: none"> • Press ▼ until √Continue appears, and then press ⏏ to clear the message. The printer discards any data received through the parallel port. • Make sure the Parallel Buffer menu item is not set to Disabled. • If this does not fix the problem, replace the PCI card.
56 Serial port <x> disabled	<ul style="list-style-type: none"> • Press ▼ until √Continue appears, and then press ⏏ to clear the message. The printer discards any data received through the serial port. • Make sure the Serial Buffer menu item is not set to Disabled. • If this does not fix the problem, replace the PCI card.
56 Standard USB port disabled	<ul style="list-style-type: none"> • Press ▼ until √Continue appears, and then press ⏏ to clear the message. The printer discards any data received through the USB port. • Make sure the USB Buffer menu item is not set to Disabled. • If this does not fix the problem, replace the system card. See “System card removal” on page 4-92.
58 Too many flash options installed	<ul style="list-style-type: none"> • Turn off and unplug the printer. • Remove the excess flash memory. • Plug in the printer, and turn it on. • If this does not fix the problem, replace the system card. See “System card removal” on page 4-92.
58 Too many trays attached	<p>This printer does not support the 500-sheet assembly.</p> <ul style="list-style-type: none"> • Turn off and unplug the printer. • Remove the 500-sheet paper tray assembly. • Plug in the printer, and turn it on. • If this does not fix the problem, replace the system card. See “System card removal” on page 4-92.
61 Remove defective disk	<ul style="list-style-type: none"> • Press ▼ until √Continue appears, and then press ⏏ to clear the message and continue printing. • Install a different hard disk before performing any operations that require a hard disk. • If this does not fix the problem, replace the system card. See “System card removal” on page 4-92.

User status and attendance messages (continued)

Error code	Action
62 Disk full	<ul style="list-style-type: none"> • Press ▼ until ✓Continue appears, and then press Ⓞ to clear the message and continue processing. Any information not previously stored on the hard disk is deleted. • Delete fonts, macros, and other data stored on the hard disk. • Install a larger hard disk. • If this does not fix the problem, replace the system card. See “System card removal” on page 4-92.
63 Unformatted disk	<ul style="list-style-type: none"> • Press ▼ until ✓Continue appears, and then press Ⓞ to clear the message and continue printing. • Format the disk. • If the error message remains, replace the hard disk. • If this does not fix the problem, replace the system card. See “System card removal” on page 4-92.
64 Unsupported disk format	<ul style="list-style-type: none"> • Press ▼ until ✓Continue appears, and then press Ⓞ to clear the message and continue printing. • Format the disk. • If the error message remains, replace the hard disk. • If this does not fix the problem, replace the system card. See “System card removal” on page 4-92.
80 Fuser life warning	<ul style="list-style-type: none"> • Press ▼ until ✓Continue appears, and then press Ⓞ to clear the message and continue printing. • Order a replacement fuser. When print quality is reduced, install the new fuser using the instruction sheet that comes with the replacement fuser. • If this does not fix the problem, replace the system card. See “System card removal” on page 4-92.
80 Replace fuser	<ul style="list-style-type: none"> • Replace the fuser. • If this does not fix the problem, replace the system card. See “System card removal” on page 4-92.
82 Waste toner box nearly full	<ul style="list-style-type: none"> • Press ▼ until ✓Continue appears, and then press Ⓞ to clear the message and continue printing. • If printing continues, order a replacement waste toner box immediately. • If the problem persists, open the front access door and check the bump aligner shaft for binding. Clear the binding if possible. If not possible, contact your next level of service.
82 Replace waste toner box	<ul style="list-style-type: none"> • Replace the waste toner box using the instruction sheet that comes with the replacement waste toner box. • Ensure that there is no interference between the waste toner box and the printer. • If the problem persists, open the front access door and check the bump aligner shaft for binding. Clear the binding if possible. • If the problem persists, replace the system card. See “System card removal” on page 4-92. • If the problem persists, contact your next level of service.

User status and attendance messages (continued)

Error code	Action
82 Waste toner box missing	<ul style="list-style-type: none"> • Insert the waste toner box. • Inspect the top cover camshaft assembly for proper operation. When the top access cover is closed, the printer should mechanically interlock. • Check the JBUMP1 connection/cable connected to the system card for defects and proper connection. If the cable wiring or the cable connection is defective, replace the bump aligner motor. See “Bump aligner motor removal” on page 4-40. If the JBUMP1 connector is damaged on the system card, replace the system card. See “System card removal” on page 4-92. • Check the bump aligner shaft and the mechanical system for binds. • Replace the bump aligner motor. See “Bump aligner motor removal” on page 4-40. • If the problem persists, replace the system card. See “System card removal” on page 4-92.
83 Transfer belt missing	<ul style="list-style-type: none"> • Insert the transfer belt. • For models C52x: Check connector JTRANS1 for proper connection to the system card, the cable for pinch points, and the cable or connector for any other damage. If the connector is damaged on system card, replace the system card. See “System card removal” on page 4-92. • For models C53x: Check connector JTRANS2 for proper connection to the system card, the cable for pinch points, and the cable connector for any other damage. If the connector is damaged on the system card, replace the system card. See “System card removal” on page 4-92. • If the JTRANS1 cable (model C52x) or the JTRANS2 cable (model C53x) is damaged, replace the front door assembly. See “Front door assembly removal” on page 4-55. • Replace the transfer belt assembly. See “Transfer belt removal” on page 4-103. • If the problem persists, replace the system card. See “System card removal” on page 4-92.
83 Transfer belt life warning	<ul style="list-style-type: none"> • Press ▼ until ✓Continue appears, and then press ⏻ to clear the message and continue printing. • Order a replacement transfer belt. When print quality is reduced, install the new transfer belt using the instruction sheet that comes with the replacement transfer belt. • If the problem persists, replace the system card. See “System card removal” on page 4-92.
83 Replace transfer belt	<ul style="list-style-type: none"> • Replace the transfer belt using the instruction sheet that comes with the replacement transfer belt. See “Transfer belt removal” on page 4-103. • If the problem persists, replace the system card. See “System card removal” on page 4-92.
84 <color> PC Unit life warning	<ul style="list-style-type: none"> • Press ▼ until ✓Ignore appears, and then press ⏻ to clear the message and continue printing. • Order the specified photoconductor unit. When print quality is reduced, install the new specified photoconductor unit using the instruction sheet that comes with the replacement specified photoconductor unit. • If the problem persists, replace the system card. See “System card removal” on page 4-92.
84 Replace <color> PC Unit	<ul style="list-style-type: none"> • Replace the specified photoconductor unit using the instruction sheet that comes with the replacement specified photoconductor unit. • If the problem persists, replace the system card. See “System card removal” on page 4-92.

User status and attendance messages (continued)

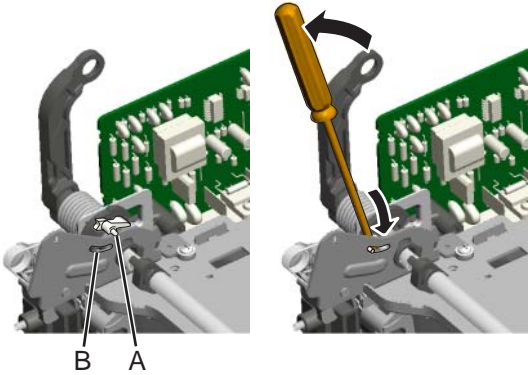
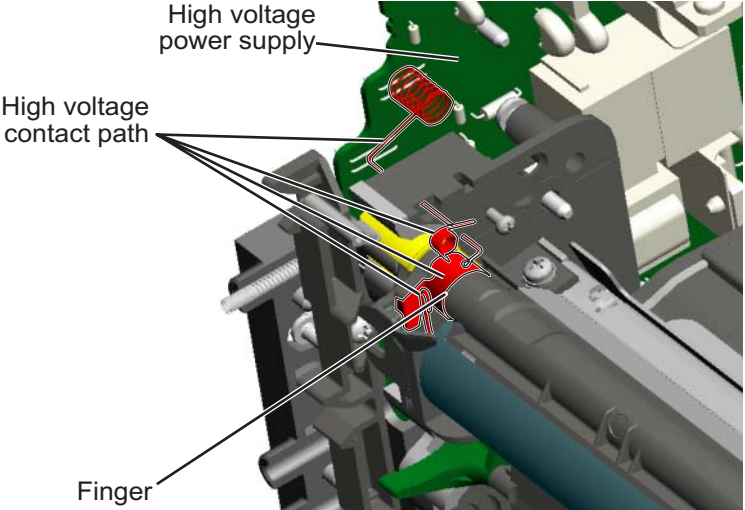
Error code	Action
84 <color> PC Unit missing	<ul style="list-style-type: none"> • Scroll down the operator panel to see if the printer is showing that all four of the PC units are missing. If so, check the HVPS cable between the system card and the HVPS. Ensure that the cable is not plugged in backwards on the HVPS. Disconnect and reconnect the cable to make sure there is good contact. • Insert or reinstall the specified photoconductor unit and see if problem clears. See “Photoconductor unit removal” on page 4-70. • Remove the top access cover assembly (see “Top access cover assembly removal—model C52x only” on page 4-28 or “Top access cover assembly removal—model C53x only” on page 4-32), and confirm that the camshaft follower (A) on the left side is not out of the groove (B). If the camshaft follower is out of the groove, raise the arm, use a screwdriver to ease the camshaft follower back into the groove. You need to press down to <i>snap</i> it into position.  <ul style="list-style-type: none"> • Check the high voltage contacts path, especially the “finger” on the specified photoconductor unit (printer is shown with components removed for clarity).  <ul style="list-style-type: none"> • If the contacts are good, replace the HVPS. See “High voltage power supply (HVPS) removal” on page 4-62. • If the problem persists, replace the system card. See “System card removal” on page 4-92.

User status and attendance messages (continued)

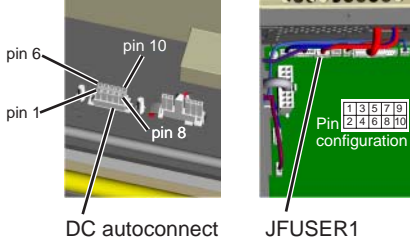
Error code	Action																
<p>87 Fuser missing</p>	<ul style="list-style-type: none"> • Install the fuser. Replace the fuser if the problem persists. • If the problem continues, turn the printer off and remove the rear cover. Check the JFUSER1 connector for proper connection to the system card, the cable for pinch points, and the cable or the connector for any other damage. If the connector is damaged on system card, replace the system card. See “System card removal” on page 4-92. If the fuser cable is damaged, replace the cable. • Check for the following continuity between the DC autoconnect and FUSER1. <div style="text-align: center;">  <p>DC autoconnect JFUSER1</p> <table border="1" data-bbox="743 777 1123 1054"> <thead> <tr> <th>DC autoconnect</th> <th>JFUSER1</th> </tr> </thead> <tbody> <tr> <td>Pin 3</td> <td>Pin 3</td> </tr> <tr> <td>Pin 4</td> <td>Pin 4</td> </tr> <tr> <td>Pin 6</td> <td>Pin 6</td> </tr> <tr> <td>Pin 7</td> <td>Pin 7</td> </tr> <tr> <td>Pin 8</td> <td>Pin 8</td> </tr> <tr> <td>Pin 9</td> <td>Pin 9</td> </tr> <tr> <td>Pin 10</td> <td>Pin 10</td> </tr> </tbody> </table> </div> • If continuity is not present, replace the fuser cable. If the problem persists after replacing cable, replace the system card. See “System card removal” on page 4-92. 	DC autoconnect	JFUSER1	Pin 3	Pin 3	Pin 4	Pin 4	Pin 6	Pin 6	Pin 7	Pin 7	Pin 8	Pin 8	Pin 9	Pin 9	Pin 10	Pin 10
DC autoconnect	JFUSER1																
Pin 3	Pin 3																
Pin 4	Pin 4																
Pin 6	Pin 6																
Pin 7	Pin 7																
Pin 8	Pin 8																
Pin 9	Pin 9																
Pin 10	Pin 10																
<p>88 <color> Cartridge low</p>	<ul style="list-style-type: none"> • Replace the specified toner cartridge. • Press ▼ until ✓Continue appears, and then press ⏻ to clear the message and continue printing. • If the message does not clear, replace the smart chip card. See “Smart chip card removal—models C52x only” on page 4-91. • If the problem persists, replace the system card. See “System card removal” on page 4-92. 																
<p>88 Replace <color> cartridge</p>	<ul style="list-style-type: none"> • Replace the specified toner cartridge. • Press ▼ until ✓Continue appears, and then press ⏻ to clear the message and continue printing. • If the message does not clear, replace the smart chip card. See “Smart chip card removal—models C52x only” on page 4-91. • If the problem persists, replace the system card. See “System card removal” on page 4-92. 																

Service checks

110.xx—Mirror motor service check



Step	Questions / actions	Yes	No
1	Turn the printer off, and remove the rear cover. Check the connector JMIRR1 for proper connection to the system card, the printhead cable for pinch points, and the cable or connector for any other damage. Is the cable damaged?	Replace the printhead. See “Printhead removal, installation, and adjustment” on page 4-74.	Go to step 2.
2	Replace the printhead. See “Printhead removal, installation, and adjustment” on page 4-74. Does the error clear?	Problem solved.	Replace the system card. See “System card removal” on page 4-92.

111.xx, 112.xx, 113.xx, and 114.xx—Printhead error service check

Step	Questions / actions	Yes	No
1	Is the front access door completely closed?	Go to step 2.	Properly close the door.
2	Turn the printer off, and remove the rear cover. Check the connector JINT1 (5 V interlock switch cable) for proper connection to the system card, the cable for pinch points, and the cable or connector for any other damage. Is the cable damaged?	Replace the front access door 5 V interlock switch. See “Front access door 5 V interlock switch removal” on page 4-54.	Go to step 3.
3	Turn the printer power on, and check for 5 V dc between JINT1 pin (red wire) and ground. Is voltage present?	Replace the front access door 5 V interlock switch. See “Front access door 5 V interlock switch removal” on page 4-54.	Go to step 4.
4	Replace the printhead. See “Printhead removal, installation, and adjustment” on page 4-74. Does the error clear?	Problem solved.	Replace the system card. See “System card removal” on page 4-92.

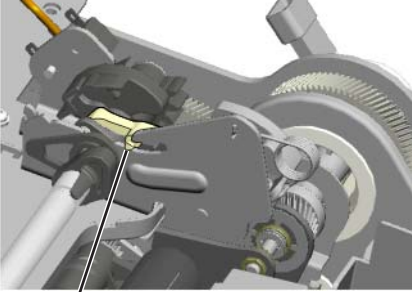
120.01, 120.02, 120.08–120.10, 120.13–120.15—Fuser error service check

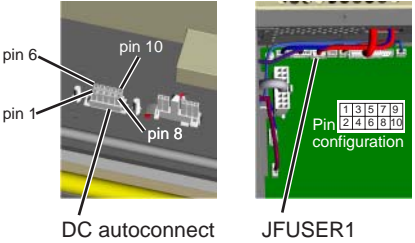
Step	Questions / actions	Yes	No
1	<p>Check the input voltage switch on the back of the low voltage power supply (LVPS). Is the voltage level (115/230) properly set?</p>	Go to step 2.	Set the switch for proper country voltage.
2	<p>Remove the fuser, and check the camshaft follower on the right side. If the camshaft follower (A) is above the crescent-shaped groove, it needs to be pressed down into the proper location.</p>  <p>Is the camshaft follower on the right side properly placed in the groove?</p>	Go to step 3.	Press the camshaft follower into the groove.
3	<p>Turn the printer off, and remove the rear cover. Check the connector JFUSER1 for proper connection to the system card, the cable for pinch points, and the cable or connector for any other damage. Is the cable damaged?</p>	Replace the fuser cable.	Go to step 4.
4	<p>Check the connector JLVPS1 for proper connection to the system card, the cable for pinch points, and the cable or connector for any other damage. Is the cable damaged?</p>	Replace the LVPS cable. See “Low voltage power supply (LVPS) removal” on page 4-65.	Go to step 5.
5	<p>Remove the fuser. See “Fuser removal” on page 4-60. Check the AC and DC autoconnects on both the fuser and the printer for damage. Are the connectors damaged?</p>	Replace the appropriate cable.	Go to step 6.

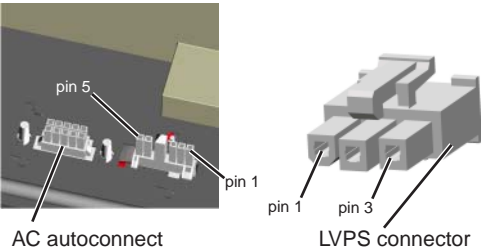

Step	Questions / actions	Yes	No								
<p>6</p>	<p>Check for the following continuity between the DC autoconnect and FUSER1.</p>  <table border="1" data-bbox="315 590 792 703"> <thead> <tr> <th>DC autoconnect</th> <th>JFUSER1</th> </tr> </thead> <tbody> <tr> <td>Pin 9</td> <td>Pin 9</td> </tr> <tr> <td>Pin 10</td> <td>Pin 10</td> </tr> </tbody> </table> <p>Is continuity present?</p>	DC autoconnect	JFUSER1	Pin 9	Pin 9	Pin 10	Pin 10	<p>Go to step 7.</p>	<p>Replace the DC fuser cable.</p>		
DC autoconnect	JFUSER1										
Pin 9	Pin 9										
Pin 10	Pin 10										
<p>7</p> 	<p>Check for continuity between the following pins of the AC autoconnect and the pins of the connector that connects to the LVPS.</p>  <table border="1" data-bbox="315 1136 792 1283"> <thead> <tr> <th>LVPS connector</th> <th>AC autoconnect</th> </tr> </thead> <tbody> <tr> <td>Pin 1</td> <td>Pin 5</td> </tr> <tr> <td>Pin 2</td> <td>Pin 4</td> </tr> <tr> <td>Pin 3</td> <td>Pin 1</td> </tr> </tbody> </table> <p>Is continuity present?</p>	LVPS connector	AC autoconnect	Pin 1	Pin 5	Pin 2	Pin 4	Pin 3	Pin 1	<p>Go to step 8.</p>	<p>Replace the AC fuser cable.</p>
LVPS connector	AC autoconnect										
Pin 1	Pin 5										
Pin 2	Pin 4										
Pin 3	Pin 1										
<p>8</p>	<p>Replace the fuser. See “Fuser removal” on page 4-60. Does the error clear?</p>	<p>Problem solved.</p>	<p>Replace the system card. See “System card removal” on page 4-92.</p>								

120.03—Fuser error service check

Step	Questions / actions	Yes	No
1	Check the input voltage switch on the back of the low voltage power supply (LVPS). Is the voltage level (115/230) properly set?	Go to step 2.	Set the switch for proper the country voltage.
2	Turn the printer off, and remove the rear cover. Check the connector JFUSER1 for proper connection to the system card, the cable for pinch points, and the cable or connector for any other damage. Is the cable damaged?	Replace the fuser cable.	Go to step 3.
3	Check the connector JLVPS1 for proper connection to the system card, the cable for pinch points, and the cable or connector for any other damage. Is the cable damaged?	Replace the LVPS. See “Low voltage power supply (LVPS) removal” on page 4-65.	Go to step 4.
4	Replace the fuser. See “Fuser removal” on page 4-60. Does the error clear?	Problem solved.	Replace the system card. See “System card removal” on page 4-92.

120.04–120.07—Fuser error service check

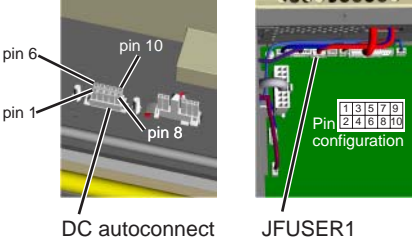

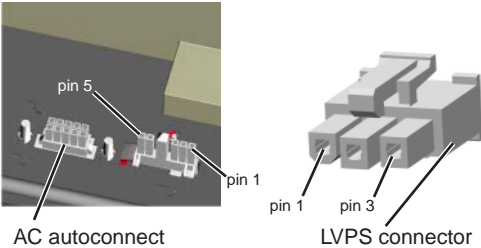
Step	Questions / actions	Yes	No
1	Check the input voltage switch on the back of the low voltage power supply (LVPS). Is the voltage level (115/230) properly set?	Go to step 2.	Set the switch for the proper country voltage.
 2	Turn the printer off, and remove the rear cover. Check the connector JFUSER1 for proper connection to the system card, the cable for pinch points, and the cable or connector for any other damage. Is the cable damaged?	Replace the fuser cable.	Go to step 3.
3	Remove the fuser. See “Fuser removal” on page 4-60. Check the AC and DC autoconnects on both the fuser and the printer for damage. Are the connectors damaged?	Go to step 4.	Replace the appropriate cable.

Step	Questions / actions	Yes	No								
4	<p>Check for the following continuity between DC autoconnect and JFUSER1.</p>  <table border="1" data-bbox="315 596 792 709"> <thead> <tr> <th>DC autoconnect</th> <th>JFUSER1</th> </tr> </thead> <tbody> <tr> <td>Pin 9</td> <td>Pin 9</td> </tr> <tr> <td>Pin 10</td> <td>Pin 10</td> </tr> </tbody> </table> <p>Is continuity present?</p>	DC autoconnect	JFUSER1	Pin 9	Pin 9	Pin 10	Pin 10	Go to step 5.	Replace the DC fuser cable.		
DC autoconnect	JFUSER1										
Pin 9	Pin 9										
Pin 10	Pin 10										
5	 <p>Check for continuity between the following pins of the AC autoconnect and the pins of the connector that connects to the LVPS.</p>  <table border="1" data-bbox="315 1136 792 1283"> <thead> <tr> <th>LVPS connector</th> <th>AC autoconnect</th> </tr> </thead> <tbody> <tr> <td>Pin 1</td> <td>Pin 5</td> </tr> <tr> <td>Pin 2</td> <td>Pin 4</td> </tr> <tr> <td>Pin 3</td> <td>Pin 1</td> </tr> </tbody> </table> <p>Is continuity present?</p>	LVPS connector	AC autoconnect	Pin 1	Pin 5	Pin 2	Pin 4	Pin 3	Pin 1	Go to step 6.	Replace the AC fuser cable.
LVPS connector	AC autoconnect										
Pin 1	Pin 5										
Pin 2	Pin 4										
Pin 3	Pin 1										
6	<p>Reinstall the fuser. See “Fuser removal” on page 4-60.</p> <p>Does the error clear?</p>	Problem solved.	Go to step 7.								
7	<p>Replace the fuser. See “Fuser removal” on page 4-60.</p> <p>Does the error clear?</p>	Problem solved.	Replace the system card. See “System card removal” on page 4-92.								

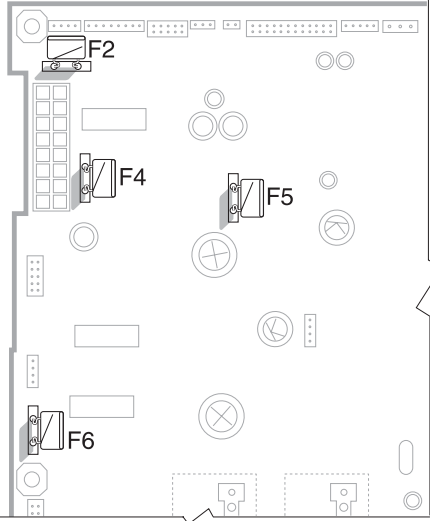
140.xx—Autocomp (tray 1) motor error service check

Step	Questions / actions	Yes	No
1	<p>Turn the printer off, and remove the rear cover. Check the connector JTRAY2 for proper connection to the system card, the cable for pinch points, and the cable or connector for any other damage. See “Connectors” on page 5-11 for the location of connectors.</p> <p>Is the cable damaged?</p>	<p>Replace the paper pick mechanism. See “Paper pick mechanism assembly removal” on page 4-68.</p>	<p>Go to step 2.</p>
2	<p>Measure the resistance across fuse F2 on the system card.</p>  <p>Is the fuse blown?</p>	<p>Replace the system card. See “System card removal” on page 4-92.</p>	<p>Go to step 3.</p>
3	<p>Replace the paper pick mechanism. See “Paper pick mechanism assembly removal” on page 4-68.</p> <p>Does the error clear?</p>	<p>Problem solved.</p>	<p>Replace the system card. See “System card removal” on page 4-92.</p>

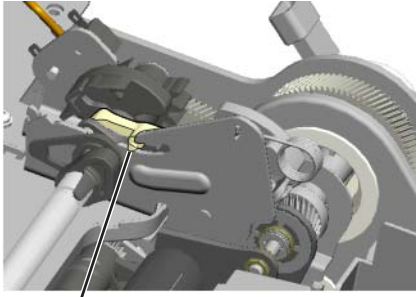
142.xx and 906.01–906.04—Motor (fuser) error service check

Step	Questions / actions	Yes	No
1	Is the top access door completely closed?	Go to step 2.	Close the top access door.
2	Turn the printer off, and remove the fuser.  A Is the right bellcrank (A) out of its slot?	Lift the top access door to its widest position, and put the right bellcrank (A) into its slot.	Go to step 3.
3	 Turn the printer off, and remove the rear cover. Check the connector JFUSER1 for the proper connection to the system card, the cable for pinch points, and the cable or connector for any other damage. Is the cable damaged?	Replace the fuser cable.	Go to step 4.
4	Turn the printer power on, and check for 24 V dc between JCVR1 pin 1 (red wire) and ground. Note: The ground lead of the voltmeter can be placed on the metal frame to obtain ground. Is voltage present?	Replace the top access door 24 V interlock switch. See “Top access door 24 V interlock switch removal” on page 4-98.	Go to step 5.
5	Replace the fuser. See “Fuser removal” on page 4-60. Does the error clear?	Problem solved.	Replace the system card. See “System card removal” on page 4-92.

143.xx—Motor (EP drive assembly top cartridge) error service check

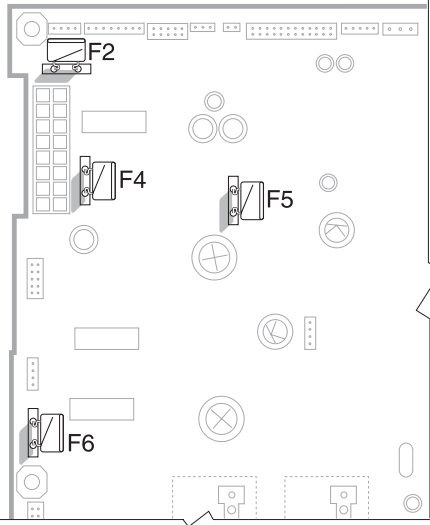
Step	Questions / actions	Yes	No
1	<p>Turn the printer off, and remove the rear cover. Check the connector JCART1 for proper connection to the system card, the cable for pinch points, and the cable or connector for any other damage.</p> <p>Is the cable damaged?</p>	Replace the JCART1 cable.	Go to step 2.
2	<p>Measure the resistance across fuse F4 and F5 on the system card.</p>  <p>Is either fuse blown?</p>	<p>Replace the system card. See “System card removal” on page 4-92.</p>	Go to step 3.
3	<p>Replace the EP drive assembly. See “Electrophotographic (EP) drive assembly removal—model C52x only” on page 4-48 or “Electrophotographic (EP) drive assembly removal—model C53x only” on page 4-51.</p> <p>Does the error clear?</p>	Problem solved.	<p>Replace the system card. See “System card removal” on page 4-92.</p>

144.xx—Motor (EP drive assembly bottom cartridge) error service check

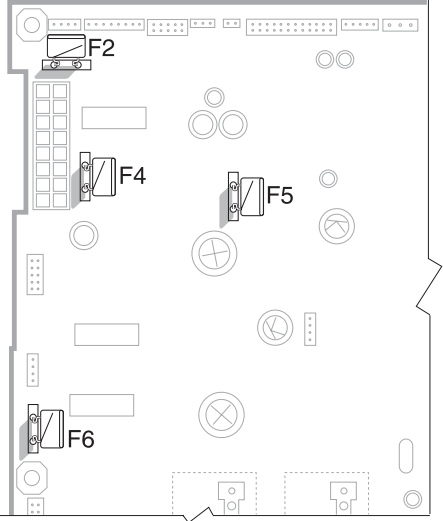
Step	Questions / actions	Yes	No
1	Turn the printer off, and remove the rear cover. Check the connector JCART2 for proper connection to the system card, the cable for pinch points, and the cable or connector for any other damage. Is the cable damaged?	Replace JCART2 cable.	Go to step 2.
2	Measure the resistance across fuse F5 and F6 on the system card.  Is either fuse blown?	Replace the system card. See “System card removal” on page 4-92.	Go to step 3.
3	Replace the EP drive assembly. See “Electrophotographic (EP) drive assembly removal—model C52x only” on page 4-48 or “Electrophotographic (EP) drive assembly removal—model C53x only” on page 4-51. Does the error clear?	Problem solved.	Replace the system card. See “System card removal” on page 4-92.

145.xx and 906.05–906.08—Motor (bump aligner) error service check

Step	Questions / actions	Yes	No
1	Is the top access door completely closed?	Go to step 2.	Close the top access door.
2	Open the top access door, and slowly close it. You should hear the top access door 24 V interlock switch closing when the door almost shuts. If you do not, check the switch for damage. Is the switch damaged?	Replace the top access door 24 V interlock switch. See “Top access door 24 V interlock switch removal” on page 4-98.	Go to step 3.
3	Close the top access door. Turn printer power on, and check for 24 V dc between JCVR1 pin 1 (red wire) and ground. Note: The ground lead of the voltmeter can be placed on the metal frame to obtain ground. Is voltage present?	Replace the top access door 24 V interlock switch. See “Top access door 24 V interlock switch removal” on page 4-98.	Go to step 4.
4	Replace the bump aligner motor. See “Bump aligner motor removal” on page 4-40. Does the error clear?	Problem solved.	Replace the system card. See “System card removal” on page 4-92.

146.xx—Motor (duplex) error service check

Step	Questions / actions	Yes	No
1	Is the top access door completely closed?	Go to step 2.	Close the top access door.
2	Turn the printer off, and remove the rear cover. Check the connector JDUPLEX1 for proper connection to the system card, the cable for pinch points, and the cable or connector for any other damage. Is the cable damaged?	Replace the duplex front door assembly. See “Front door assembly removal” on page 4-55.	Go to step 3.
3	Close the front access door. Turn the power on, and check for 24 V dc between JCVR1 pin 1 (red wire) and ground. Note: The ground lead of the voltmeter can be placed on the metal frame to obtain ground. Is voltage present?	Replace the top access door 24 V interlock switch. See “Top access door 24 V interlock switch removal” on page 4-98.	Go to step 4.
4	Replace the duplex front door assembly. See “Front door assembly removal” on page 4-55. Does the error clear?	Problem solved.	Replace the system card. See “System card removal” on page 4-92.

147.xx, 149.xx—Motor (500-sheet/550-sheet option tray 2 motor) error service check

Step	Questions / actions	Yes	No
1	Turn the printer off, and remove the rear cover. Check the connector JOPT1 for proper connection to the system card, the cable for pinch points, and the cable or connector for any other damage. Is the cable damaged?	Replace the option cable.	Go to step 2.
2	Replace the 500-sheet assembly or the 550-sheet assembly. Does the error clear?	Problem solved.	Replace the system card. See “System card removal” on page 4-92.

148.xx—MPF motor error service check

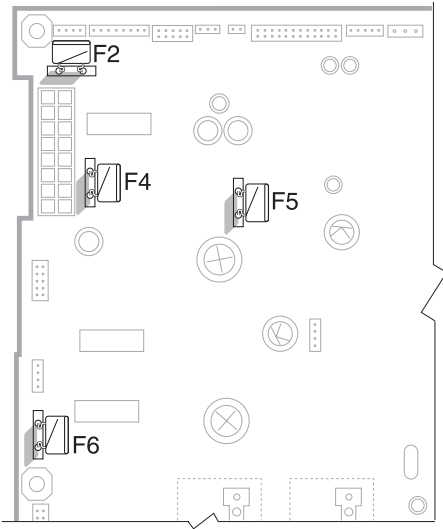
Step	Questions / actions	Yes	No
1	Turn the printer off, and remove the rear cover. Check the connector JTRAY2 for proper connection to the system card, the cable for pinch points, and the cable or connector for any other damage. Is the cable damaged?	Replace the paper pick mechanism. See “Paper pick mechanism assembly removal” on page 4-68.	Go to step 2.
2	Measure the resistance across fuse F2 on the system card.  Is the fuse blown?	Replace the system card. See “System card removal” on page 4-92.	Go to step 3.
3	Replace the paper pick mechanism. See “Paper pick mechanism assembly removal” on page 4-68. Does the error clear?	Problem solved.	Replace the system card. See “System card removal” on page 4-92.

910.01—Transparency sensor error service check

Step	Questions / actions	Yes	No
1	Turn the printer off, and remove the rear cover. Check the connector JTRAY1 for proper connection to the system card, the cable for pinch points, and the cable or connector for any other damage. Is the cable damaged?	Replace the paper pick mechanism. See “Paper pick mechanism assembly removal” on page 4-68.	Go to step 2.
2	Check the transparency sensor for correct mounting. Is the transparency sensor properly mounted in the paper pick mechanism?	Go to step 3.	Remove the paper pick mechanism, properly install the transparency sensor and reinstall paper pick mechanism. See “Paper pick mechanism assembly removal” on page 4-68.
3	Replace the paper pick mechanism. See “Paper pick mechanism assembly removal” on page 4-68. Does the error clear?	Problem solved.	Replace the system card. See “System card removal” on page 4-92.

920.01—POST (power on self test) error service check

Step	Questions / actions	Yes	No
1	Replace the bump aligner motor. See “Bump aligner motor removal” on page 4-40. Does the error clear?	Problem solved.	Replace the system card. See “System card removal” on page 4-92.

920.02—POST (power on self test) error service check

Step	Questions / actions	Yes	No
1	Replace the paper pick mechanism. See “Paper pick mechanism assembly removal” on page 4-68. Does the error clear?	Problem solved.	Replace the system card. See “System card removal” on page 4-92.

920.03—POST (power on self test) error service check

Step	Questions / actions	Yes	No
1	Turn the printer off, and remove the rear cover. Check the connector JTRANS2 (model C52x) or JTRANS1 (model C53x) for proper connection to the system card, the cable for pinch points, and the cable or connector for any other damage. Is the cable damaged?	Replace the damaged cable.	Go to step 2.
2	Replace the EP drive assembly. See “Electrophotographic (EP) drive assembly removal—model C52x only” on page 4-48. Does the error clear?	Problem solved.	Replace the system card. See “System card removal” on page 4-92.

920.04—POST (power on self test) error service check

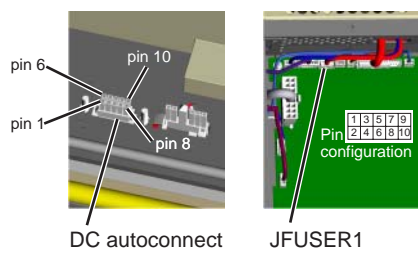
Step	Questions / actions	Yes	No										
1	Turn the printer off, and remove the rear cover. Check the connector JFUSER1 for proper connection to the system card, the cable for pinch points, and the cable or connector for any other damage. Is the cable damaged?	Replace the fuser cable.	Go to step 2.										
2	Remove the fuser. See “Fuser removal” on page 4-60 . Check the DC autoconnects on both the fuser and the printer for damage. Are the connectors damaged?	Replace the DC autoconnect cable.	Go to step 3.										
3	 <p>Check for the following continuity between the DC autoconnect and FUSER1.</p>  <table border="1" data-bbox="311 970 792 1159"> <thead> <tr> <th>DC autoconnect</th> <th>JFUSER1</th> </tr> </thead> <tbody> <tr> <td>Pin 3</td> <td>Pin 3</td> </tr> <tr> <td>Pin 8</td> <td>Pin 8</td> </tr> <tr> <td>Pin 9</td> <td>Pin 9</td> </tr> <tr> <td>Pin 10</td> <td>Pin 10</td> </tr> </tbody> </table> <p>Is continuity present?</p>	DC autoconnect	JFUSER1	Pin 3	Pin 3	Pin 8	Pin 8	Pin 9	Pin 9	Pin 10	Pin 10	Go to step 4.	Replace the DC fuser cable.
DC autoconnect	JFUSER1												
Pin 3	Pin 3												
Pin 8	Pin 8												
Pin 9	Pin 9												
Pin 10	Pin 10												
4	Replace the fuser. See “Fuser removal” on page 4-60 . Does the error clear?	Problem solved.	Replace the system card. See “System card removal” on page 4-92 .										

920.05—POST (power on self test) error service check

Step	Questions / actions	Yes	No
1	Replace the printhead card. See “Printhead removal, installation, and adjustment” on page 4-74 . Does the error clear?	Problem solved.	Replace the system card. See “System card removal” on page 4-92 .

920.06—POST (power on self test) error service check

Step	Questions / actions	Yes	No
1	Replace the paper pick mechanism. See “Paper pick mechanism assembly removal” on page 4-68. Does the error clear?	Problem solved.	Replace the system card. See “System card removal” on page 4-92.

920.07—POST (power on self test) error service check

Step	Questions / actions	Yes	No
1	Turn the printer off, and remove the rear cover. Check the connector JTRAY1 for proper connection to the system card, the cable for pinch points, and the cable or connector for any other damage. Is the cable damaged?	Replace the paper pick mechanism. See “Paper pick mechanism assembly removal” on page 4-68.	Go to step 2.
2	Check the transparency sensor for correct mounting. Is the transparency sensor properly mounted in the paper pick mechanism?	Go to step 3.	Remove the paper pick mechanism, properly install the transparency sensor, and reinstall the paper pick mechanism. See “Paper pick mechanism assembly removal” on page 4-68.
3	Replace the paper pick mechanism. See “Paper pick mechanism assembly removal” on page 4-68. Does the error clear?	Problem solved.	Replace the system card. See “System card removal” on page 4-92.

920.08—POST (power on self test) error service check

Step	Questions / actions	Yes	No
1	 Turn the printer off, and remove the rear cover. Check the connector JFUSER1 for proper connection to the system card, the cable for pinch points, and the cable or connector for any other damage. Is the cable damaged?	Replace the fuser cable.	Go to step 2.
2	Remove the fuser. See “Fuser removal” on page 4-60. Check the DC autoconnects on both the fuser and the printer for damage. Are the connectors damaged?	Replace the JFUSER1 cable.	Go to step 3.

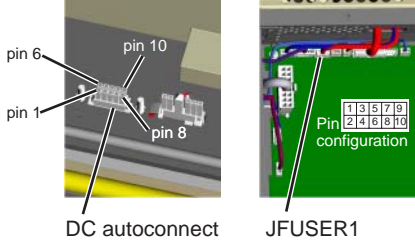
Step	Questions / actions	Yes	No								
3 	Check for the following continuity between the DC autoconnect and FUSER1.  <table border="1" data-bbox="313 617 792 766"> <thead> <tr> <th>DC autoconnect</th> <th>JFUSER1</th> </tr> </thead> <tbody> <tr> <td>Pin 6</td> <td>Pin 6</td> </tr> <tr> <td>Pin 7</td> <td>Pin 7</td> </tr> <tr> <td>Pin 8</td> <td>Pin 8</td> </tr> </tbody> </table> Is continuity present?	DC autoconnect	JFUSER1	Pin 6	Pin 6	Pin 7	Pin 7	Pin 8	Pin 8	Go to step 4.	Replace the DC fuser cable.
DC autoconnect	JFUSER1										
Pin 6	Pin 6										
Pin 7	Pin 7										
Pin 8	Pin 8										
4	Replace the fuser. See “Fuser removal” on page 4-60. Does the error clear?	Problem solved.	Replace the system card. See “System card removal” on page 4-92.								

920.09-12—POST (power on self test) error service check

Step	Questions / actions	Yes	No				
1	Turn the printer off, and remove the rear cover. Check the connector JHVPS1 for proper connection to the system card, the cable for pinch points, and the cable or connector for any other damage. Is the cable damaged?	Replace the top access cover assembly. See “Top access cover assembly removal—model C52x only” on page 4-28 or “Top access cover assembly removal—model C53x only” on page 4-32.	Go to step 2.				
2	Remove the left cover. See “Left cover removal” on page 4-20. Check all the toner level sensor cables connected to the rear of the HVPS for proper connection to HVPS, the cable for pinch points, and the cable or connector for any other damage. Are any of the cables damaged?	Replace the damaged sensor. See “Toner level sensor removal” on page 4-96.	Go to step 3.				
3	Disconnect JHVPS1 from the system card and the HVPS. Check for the following continuity. <table border="1" data-bbox="298 1593 802 1671"> <thead> <tr> <th>JHVPS1 cable HVPS end</th> <th>System card end</th> </tr> </thead> <tbody> <tr> <td>Pin 14</td> <td>Pin 14</td> </tr> </tbody> </table> Is continuity present?	JHVPS1 cable HVPS end	System card end	Pin 14	Pin 14	Go to step 4.	Replace the top access cover assembly. See “Top access cover assembly removal—model C52x only” on page 4-28 or “Top access cover assembly removal—model C53x only” on page 4-32.
JHVPS1 cable HVPS end	System card end						
Pin 14	Pin 14						

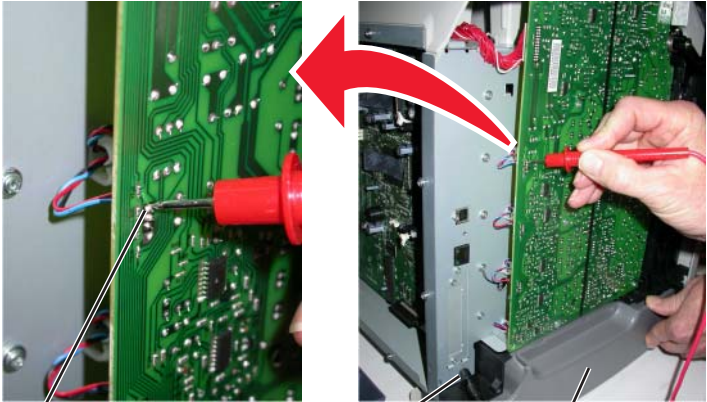
Step	Questions / actions	Yes	No
<p>4</p>	<p>Reconnect JHVPS1 cable to the system card and the HVPS. Do not reinstall the left cover, but make sure the front access door and the top cover assembly are closed, and that the waste toner assembly is reinstalled. Turn the printer on. Attach the negative end of the voltmeter to the ground, and check the voltage on pin 1 of each toner level sensor cable. You will need to check this on the back of the HVPS (see the illustration below).</p> <div style="text-align: center;">  </div> <p>Is there approximately 5 V dc on any of the pins?</p>	<p>Replace the toner level sensor that has 5 V dc on pin 1. See “Toner level sensor removal” on page 4-96.</p>	<p>Go to step 5.</p>
<p>5</p>	<p>Replace the HVPS. See “High voltage power supply (HVPS) removal” on page 4-62.</p> <p>Does the error clear?</p>	<p>Problem solved.</p>	<p>Replace the system card. See “System card removal” on page 4-92.</p>

920.13—POST (power on self test) error service check

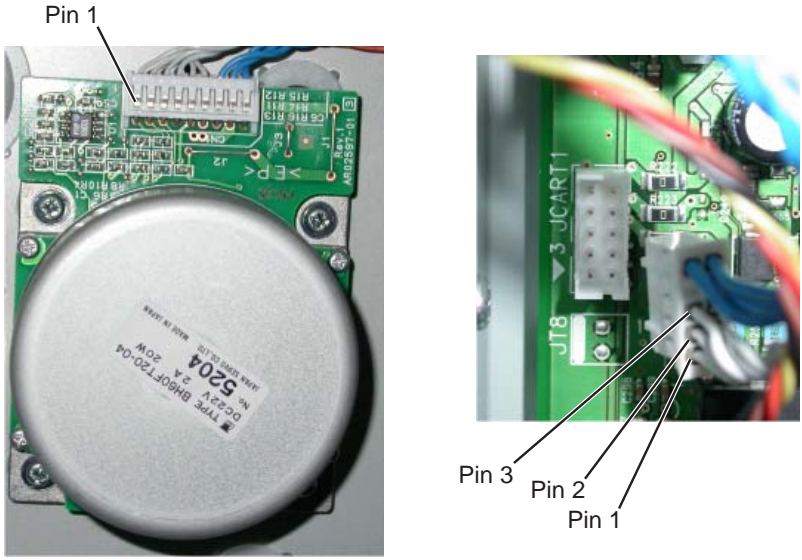
Step	Questions / actions	Yes	No								
1	Turn the printer off, and remove the rear cover. Check the connector JCART1 for proper connection to the system card, the cable for pinch points, and the cable or connector for any other damage. Is the cable damaged?	Replace the JCART1 cable. The cable parts packet contains one cartridge motor cable that works for either of the cartridge motors.	Go to step 2.								
2	Remove the right cover. Check for the following continuity between JCART1 and top cartridge connector.  <table border="1" data-bbox="313 1234 792 1402"> <thead> <tr> <th>JCART1</th> <th>To cartridge motor connector</th> </tr> </thead> <tbody> <tr> <td>Pin 1</td> <td>Pin 1</td> </tr> <tr> <td>Pin 2</td> <td>Pin 2</td> </tr> <tr> <td>Pin 3</td> <td>Pin 3</td> </tr> </tbody> </table> Is continuity present?	JCART1	To cartridge motor connector	Pin 1	Pin 1	Pin 2	Pin 2	Pin 3	Pin 3	Go to step 3.	Replace the JCART1 cable. The cable parts packet contains one cartridge motor cable that works for either of the cartridge motors.
JCART1	To cartridge motor connector										
Pin 1	Pin 1										
Pin 2	Pin 2										
Pin 3	Pin 3										
3	Replace the EP drive assembly. See “Electrophotographic (EP) drive assembly removal—model C52x only” on page 4-48 or “Electrophotographic (EP) drive assembly removal—model C53x only” on page 4-51. Does the error clear?	Problem solved.	Replace the system card. See “System card removal” on page 4-92.								

920.14—POST (power on self test) error service check

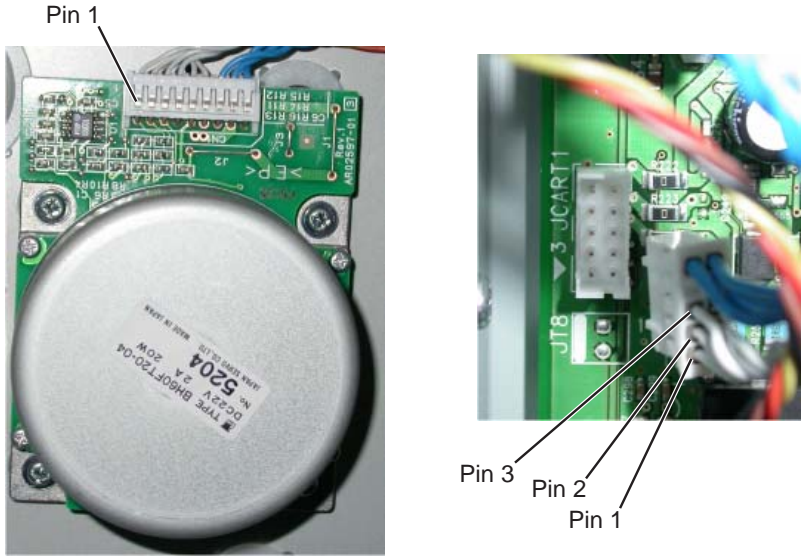
Step	Questions / actions	Yes	No								
1	Turn the printer off, and remove the rear cover. Check the connector JCART2 for proper connection to the system card, the cable for pinch points, and the cable or connector for any other damage. Is the cable damaged?	Replace the JCART2 cable. The cable parts packet contains one cartridge motor cable that works for either of the cartridge motors.	Go to step 2.								
2	Remove the right cover. Check for the following continuity between JCART2 and bottom cartridge connector.  <table border="1" data-bbox="266 1241 745 1415"> <thead> <tr> <th>JCART1</th> <th>Bottom cartridge motor connector</th> </tr> </thead> <tbody> <tr> <td>Pin 1</td> <td>Pin 1</td> </tr> <tr> <td>Pin 2</td> <td>Pin 2</td> </tr> <tr> <td>Pin 3</td> <td>Pin 3</td> </tr> </tbody> </table> Is continuity present?	JCART1	Bottom cartridge motor connector	Pin 1	Pin 1	Pin 2	Pin 2	Pin 3	Pin 3	Go to step 3.	Replace the JCART2 cable. The cable parts packet contains one cartridge motor cable that works for either of the cartridge motors.
JCART1	Bottom cartridge motor connector										
Pin 1	Pin 1										
Pin 2	Pin 2										
Pin 3	Pin 3										
3	Replace the EP drive assembly. See “Electrophotographic (EP) drive assembly removal—model C52x only” on page 4-48 or “Electrophotographic (EP) drive assembly removal—model C53x only” on page 4-51 . Does the error clear?	Problem solved.	Replace the system card. See “System card removal” on page 4-92 .								

920.15—POST (power on self test) error service check**Models C52x only**

Step	Questions / actions	Yes	No
1	Turn the printer off, and remove the rear cover. Check the connector JTRANS1 for proper connection to the system card, the cable for pinch points, and the cable or connector for any other damage. See “System card (network)—models C52x” on page 5-11 for the location of JTRANS1. Is the cable damaged?	Replace the front door assembly. See “Front door assembly removal” on page 4-55.	Go to step 2.
2	Replace the transfer belt assembly. See “Transfer belt removal” on page 4-103. Does the error clear?	Problem solved.	Replace the system card. See “System card removal” on page 4-92.

Models C53x only

Step	Questions / actions	Yes	No
1	Turn the printer off, and remove the rear cover. Check the connector JTRANS2 for proper connection to the system card, the cable for pinch points, and the cable or connector for any other damage. See “Connector listing—models C53x” on page 5-19 for the location of JTRANS2. Is the cable damaged?	Replace the front door assembly. See “Front door assembly removal” on page 4-55.	Go to step 2.
2	Replace the transfer belt assembly. See “Transfer belt removal” on page 4-103. Does the error clear?	Problem solved.	Replace the system card. See “System card removal” on page 4-92.

920.16—POST (power on self test) error service check

Step	Questions / actions	Yes	No
1	Turn the printer off, and remove the rear cover. Check the connector JPH1 (large printhead cable) for proper connection to the system card, the cable for pinch points, and the cable or connector for any other damage. Is the cable damaged?	Replace the printhead. See “Printhead removal, installation, and adjustment” on page 4-74.	Go to step 2.
2	Replace the system card. See “System card removal” on page 4-92. Does the error clear?	Problem solved.	Replace the printhead. See “Printhead removal, installation, and adjustment” on page 4-74.

920.17—POST (power on self test) error service check

Step	Questions / actions	Yes	No
1	Turn the printer off, and remove the rear cover. Check the connector JBIN1 for proper connection to the system card, the cable for pinch points, and the cable or connector for any other damage. Is the cable damaged?	Replace the top access cover assembly. See “Top access cover assembly removal—model C52x only” on page 4-28 or “Top access cover assembly removal—model C53x only” on page 4-32 .	Go to step 2.
2	Replace the top access cover assembly. “Top access cover assembly removal—model C52x only” on page 4-28 or “Top access cover assembly removal—model C53x only” on page 4-32 . Does the error clear?	Problem solved.	Replace the system card. See “System card removal” on page 4-92 .

920.18—POST (power on self test) error service check

Step	Questions / actions	Yes	No
1	Turn the printer off, and remove the rear cover. Check the connector JOPT1 for proper connection to the system card, the cable for pinch points, and the cable or connector for any other damage. Is the cable damaged?	Replace the option cable.	Go to step 2.
2	Replace the 500-sheet assembly (C52x models) or the 550-sheet assembly (C53x models). Does the error clear?	Problem solved.	Replace the system card. See “System card removal” on page 4-92 .

920.19—POST (power on self test) error service check**Models C52x only**

Step	Questions / actions	Yes	No
1	Replace the EP drive assembly. See “Electrophotographic (EP) drive assembly removal—model C52x only” on page 4-48 . Does the error clear?	Problem solved.	Replace the system card. See “System card removal” on page 4-92 .

Models C53x only

Step	Questions / actions	Yes	No
1	Turn the printer off, and remove the rear cover. Check the connector JTRANS1 for proper connection to the system card, the cable for pinch points, and the cable or connector for any other damage. See “Connector listing—models C53x” on page 5-19 for the location of the JTRANS1 connector. Is the cable damaged?	Replace the JTRANS1 cable.	Go to step 2.
2	Replace the EP drive assembly. See “Electrophotographic (EP) drive assembly removal—model C52x only” on page 4-48 or “Electrophotographic (EP) drive assembly removal—model C53x only” on page 4-51 . Does the error clear?	Problem solved.	Replace the system card. See “System card removal” on page 4-92 .

925.01—Fan error service check

Step	Questions / actions	Yes	No
1	Replace the top access cover assembly. See “Top access cover assembly removal—model C52x only” on page 4-28 or “Top access cover assembly removal—model C53x only” on page 4-32 . Does the error clear?	Problem solved.	Replace the system card. See “System card removal” on page 4-92 .

945.xx, 946.xx, 947.xx—Transfer roll error service check

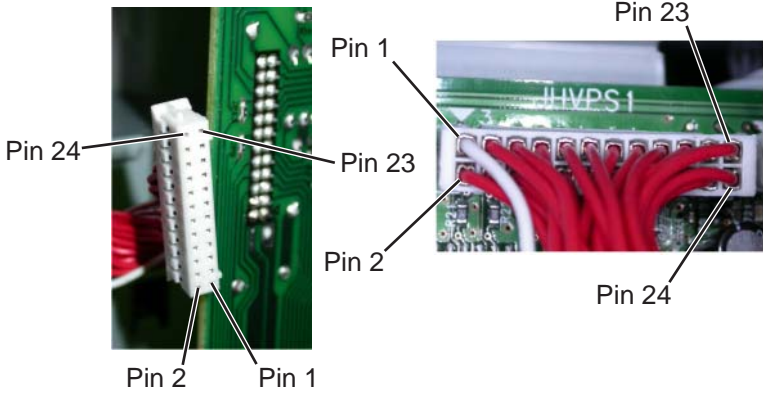
Step	Questions / actions	Yes	No																														
1	Turn the printer off, and remove the rear cover. Check the connector JHVPS1 for proper connection to the system card, the cable for pinch points, and the cable or connector for any other damage. Is the cable damaged?	Replace the top access cover assembly. See “Top access cover assembly removal—model C52x only” on page 4-28 or “Top access cover assembly removal—model C53x only” on page 4-32 .	Go to step 2.																														
2	Disconnect JHVPS1 from system card and HVPS. Check for the following continuity. <div style="text-align: center;">  </div> <table border="1" data-bbox="332 1060 1003 1438"> <thead> <tr> <th rowspan="2">Error code</th> <th rowspan="2">Color</th> <th colspan="2">JHVPS1 cable to:</th> </tr> <tr> <th>HVPS</th> <th>System card</th> </tr> </thead> <tbody> <tr> <td rowspan="2">945.01, 946.01, 957.01</td> <td rowspan="2">Yellow</td> <td>Pin 19</td> <td>Pin 19</td> </tr> <tr> <td>Pin 20</td> <td>Pin 20</td> </tr> <tr> <td rowspan="2">945.02, 946.02, 957.02</td> <td rowspan="2">Cyan</td> <td>Pin 15</td> <td>Pin 15</td> </tr> <tr> <td>Pin 16</td> <td>Pin 16</td> </tr> <tr> <td rowspan="2">945.03, 946.03, 957.03</td> <td rowspan="2">Magenta</td> <td>Pin 17</td> <td>Pin 17</td> </tr> <tr> <td>Pin 18</td> <td>Pin 18</td> </tr> <tr> <td rowspan="2">945.04, 946.04, 957.04</td> <td rowspan="2">Black</td> <td>Pin 23</td> <td>Pin 23</td> </tr> <tr> <td>Pin 24</td> <td>Pin 24</td> </tr> </tbody> </table> <p>Is continuity present?</p>	Error code	Color	JHVPS1 cable to:		HVPS	System card	945.01, 946.01, 957.01	Yellow	Pin 19	Pin 19	Pin 20	Pin 20	945.02, 946.02, 957.02	Cyan	Pin 15	Pin 15	Pin 16	Pin 16	945.03, 946.03, 957.03	Magenta	Pin 17	Pin 17	Pin 18	Pin 18	945.04, 946.04, 957.04	Black	Pin 23	Pin 23	Pin 24	Pin 24	Go to step 3.	Replace the top access cover assembly. See “Top access cover assembly removal—model C52x only” on page 4-28 or “Top access cover assembly removal—model C53x only” on page 4-32 .
Error code	Color			JHVPS1 cable to:																													
		HVPS	System card																														
945.01, 946.01, 957.01	Yellow	Pin 19	Pin 19																														
		Pin 20	Pin 20																														
945.02, 946.02, 957.02	Cyan	Pin 15	Pin 15																														
		Pin 16	Pin 16																														
945.03, 946.03, 957.03	Magenta	Pin 17	Pin 17																														
		Pin 18	Pin 18																														
945.04, 946.04, 957.04	Black	Pin 23	Pin 23																														
		Pin 24	Pin 24																														

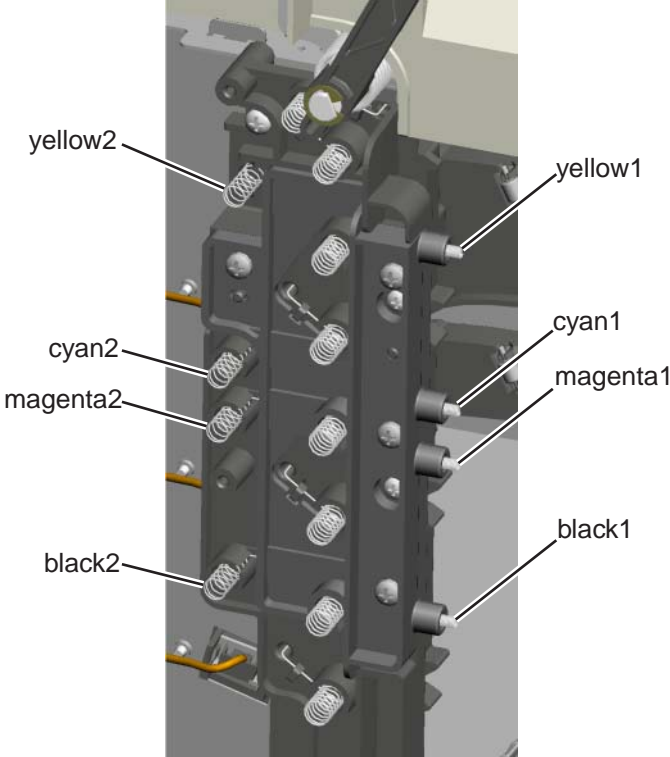
Step	Questions / actions	Yes	No
3	<p>Remove the HVPS. See “High voltage power supply (HVPS) removal” on page 4-62. Check for continuity between the contacts (yellow1 and yellow2, cyan1 and cyan2, magenta1 and magenta2, or black1 and black2) on the transfer contact assembly.</p>  <p>Is continuity present?</p>	Go to step 4.	Replace the transfer contact assembly. See “Transfer contact assembly removal” on page 4-104.
4	<p>Replace the HVPS. See “High voltage power supply (HVPS) removal” on page 4-62. Does the error clear?</p>	Problem solved.	Replace the system card. See “System card removal” on page 4-92.

950.00–950.29 EPROM mismatch failure

Warning: When replacing any one of the following components:

- Operator panel assembly
- System card
- Printhead assembly

Only replace one component at a time. Replace the required component, and perform a POR before replacing a second component listed above. If this procedure is not followed, the printer will be rendered inoperable.

Warning: Never install and remove components listed above as a method of troubleshooting components. Once a component has been installed in a printer, it cannot be used in another printer. It must be returned to the manufacturer.

This error code indicates a mismatch between the operator panel assembly and the system card.

Step	Questions / actions	Yes	No
1	Has the operator panel assembly been recently replaced?	Replace the operator panel assembly with a new, and not previously installed operator panel assembly. See “Operator panel assembly removal” on page 4-23.	Replace the system card with a new, and not previously installed system card. See “System card removal” on page 4-92.

950.30–950.60 EPROM mismatch failure

Warning: When replacing any one of the following components:

- Operator panel assembly
- System card
- Printhead assembly

Only replace one component at a time. Replace the required component, and perform a POR before replacing a second component listed above. If this procedure is not followed, the printer will be rendered inoperable.

Warning: Never install and remove components listed above as a method of troubleshooting components. Once a component has been installed in a printer, it cannot be used in another printer. It must be returned to the manufacturer.

This error code indicates a mismatch between the system card and the smart chip card.

Models C52x only

Step	Questions / actions	Yes	No
1	Has the smart chip card been recently replaced?	Replace the smart chip card with a new, and not previously installed smart chip card. See “Smart chip card removal—models C52x only” on page 4-91.	Replace the system card with a new, and not previously installed system card. See “System card removal” on page 4-92.

Models C53x only

Step	Questions / actions	Yes	No
1	Has the printhead been recently replaced?	Replace the printhead with a new, and not previously installed smart chip card. See “Printhead removal, installation, and adjustment” on page 4-74.	Replace the system card with a new, and not previously installed system card. See “System card removal” on page 4-92.

Dead printer service check

A dead printer is a condition where the display is blank, the LED on the operator panel is off, no fans turn, no motors turn, and the fuser lamp does not come on.

If a 500-sheet option assembly (C52x models) or a 550-sheet option assembly (C53x models) is installed, remove the option and check the base printer for correct operation. If the base printer operates correctly, replace the 500-sheet option assembly.

Warning: Observe all necessary ESD precautions when removing and handling the system card or any installed option cards or assemblies. See **“Handling ESD-sensitive parts” on page 4-1.**

	<p>CAUTION</p> <p>When you see this symbol, there is a danger from hazardous voltage in the area of the product where you are working. Unplug the product before you begin, or use caution if the product must receive power in order to perform the task.</p>
---	---

Remove any input and output paper handling options from the printer.

Step	Questions / actions	Yes	No
1	Check the AC line voltage. Is the line voltage correct?	Go to step 2.	Inform the customer.
2	Is the AC line cord damaged?	Replace the line cord.	Go to step 3.
3	Check the system card for +5 V dc between JLVPS1 pin 1 and ground. Is the voltage correct?	Replace the system card. See “System card removal” on page 4-92.	Go to step 4.
4	Is the JLVPS1 cable correctly installed at JLVPS1 on the system card?	Go to step 5.	Reseat the JLVPS1 cable.
5	Turn the printer off. Disconnect the JLVPS1 cable from the system card. Turn the printer on, and measure the voltage between the JLVPS1 cable pin 1 and the JLVPS1 pin 14 (black wire). Does this measure approximately +5 V dc?	Go to step 6.	Replace the LVPS. See “Low voltage power supply (LVPS) removal” on page 4-65.

Step	Questions / actions	Yes	No
6	<p>Turn the printer off. Connect the JLVPS1 cable to the system card. Remove one option/feature at a time, and turn the printer on to isolate the failing part.</p> <p>Warning: Observe all the ESD precautions (see “Handling ESD-sensitive parts” on page 4-1) and turn the printer off before any feature or option cards are removed or replaced.</p> <p>Is a failing part found?</p>	Replace the faulty part.	Contact your next level of support.

Exit sensor service check

Step	Questions / actions	Yes	No
1	<p>Verify the paper is loaded properly in the manual feed slot. See “Loading media in the multipurpose feeder or manual feeder” on page 3-28.</p> <p>Is the paper properly loaded in the manual feed slot?</p>	Go to step 2.	Load paper in the manual feed slot. See “Clearing paper jams in the manual feeder” on page 3-29 .
2	Is the exit sensor flag damaged?	Replace the fuser. See “Fuser removal” on page 4-60 .	Go to step 3.
3	Is the JFUSER1 properly connected to the system card?	Go to step 4.	Reseat the connector.
4	<p>Place a voltmeter between the JFUSER1 pin 7 and ground. Initially, the meter should indicate 5 V dc. Activate the exit sensor flag.</p> <p>Does the voltage drop to 0 V dc?</p>	Replace the system card. See “System card removal” on page 4-92 .	Replace the exit sensor.

Input sensor service check

Step	Questions / actions	Yes	No
1	Is the input sensor flag damaged?	Replace the paper pick mechanism. See “Paper pick mechanism assembly removal” on page 4-68 .	Go to step 2.
2	Is the JTRAY cable connector properly connected to the system card?	Go to step 3.	Reseat the connector.
3	<p>Place a voltmeter between JTRAY1 pin 2 and ground. Initially, the meter should indicate +5 V dc. Activate the input sensor flag.</p> <p>Does the voltage drop to 0 V dc?</p>	Replace the system card. See “System card removal” on page 4-92 .	Replace the paper pick mechanism. See “Paper pick mechanism assembly removal” on page 4-68 .

Operator panel service check

Warning: When replacing any one of the following components:

- Operator panel assembly
- System card
- Printhead assembly

Only replace one component at a time. Replace the required component, and perform a POR before replacing a second component listed above. If this procedure is not followed, the printer will be rendered inoperable.

Warning: Never install and remove components listed above as a method of troubleshooting components. Once a component has been installed in a printer, it cannot be used in another printer. It must be returned to the manufacturer.

One or more operator panel buttons fail

Step	Questions / actions	Yes	No
1	Run the Button Test. See “Button Test” on page 3-11 in Diagnostics mode. Did any of the buttons fail the test?	Replace the operator panel assembly. See “Operator panel assembly removal” on page 4-23 .	Go to step 2.
2	Disconnect the operator panel assembly cable from JOPP1 on the system card, and measure the voltage on pin 6 and ground. Does the voltage measure approximately +3.3 V dc?	Replace the operator panel assembly. See “Operator panel assembly removal” on page 4-23 . If this does not fix the problem, replace the top cover access assembly. See “Top access cover assembly removal—model C52x only” on page 4-28 or “Top access cover assembly removal—model C53x only” on page 4-32 .	Replace the system card. See “System card removal” on page 4-92 .

Operator panel display blank, five beeps, and LED off

Service tip: The printer has detected a problem with the system card, the operator panel assembly cable (part of the top cover access assembly), or the operator panel assembly if POST does not complete. The printer emits five beeps, and sticks in a continuous pattern until the printer is turned off.

Step	Questions / actions	Yes	No
1	Is the operator panel assembly cable properly installed at system card JOPP1 and at the operator panel assembly?	Go to step 2.	Reinstall the cable.
2	Measure the voltage between JOPP1 pin 2 and ground on the system card. Is the voltage approximately +5 V dc?	Go to step 3.	Replace the system card. See “System card removal” on page 4-92 .
3	Check continuity of the operator panel assembly cable. Is there continuity?	Replace the operator panel assembly. See “Operator panel assembly removal” on page 4-23 .	Replace the top cover access assembly. See “Top access cover assembly removal—model C52x only” on page 4-28 or “Top access cover assembly removal—model C53x only” on page 4-32 .

Operator panel display blank, five *beeps*, LED on

Service tip: The printer has detected a problem with the system card, the operator panel assembly cable (part of the top cover access assembly), or the operator panel assembly if POST does not complete. The printer emits five *beeps*, and sticks in a continuous pattern until the printer is turned off.

Step	Questions / actions	Yes	No
1	Check for ground between JOPP1 pin 4 and ground. Is the voltage approximately 0 V dc?	Replace the operator panel assembly. See “Operator panel assembly removal” on page 4-23.	Go to step 2.
2	Check the operator panel assembly cable. Is the cable damaged?	Replace the top cover access assembly. See “Top access cover assembly removal—model C52x only” on page 4-28 or “Top access cover assembly removal—model C53x only” on page 4-32.	Replace the system card. See “System card removal” on page 4-92.

Operator panel display all diamonds, no *beeps*

Step	Questions / actions	Yes	No
1	Check the operator panel assembly cable. Is the cable damaged?	Replace the top access cover assembly. See “Top access cover assembly removal—model C52x only” on page 4-28 or “Top access cover assembly removal—model C53x only” on page 4-32.	Go to step 2.
2	Measure the voltage between JOPP1 pin 2 and ground on the system card. Is the voltage approximately +5 V dc?	Replace the operator panel assembly. See “Operator panel assembly removal” on page 4-23.	Replace the system card. See “System card removal” on page 4-92.

Operator panel display all diamonds, five *beeps*

Step	Questions / actions	Yes	No
1	Check the operator panel assembly cable. Is the cable damaged?	Replace the top access cover assembly. See “Top access cover assembly removal—model C52x only” on page 4-28 or “Top access cover assembly removal—model C53x only” on page 4-32.	Go to step 2.
2	Measure the voltage between JOPP1 pin 2 and ground on the system card. Is the voltage approximately +5 V dc?	Replace the operator panel assembly. See “Operator panel assembly removal” on page 4-23.	Replace the system card. See “System card removal” on page 4-92.

Print quality service check

Note: This symptom may require replacement of one or more CRUs (Customer Replaceable Units) designated as supplies or maintenance items, which are the responsibility of the customer. With the customer's permission, you may need to install a developer (toner) cartridge or photoconductor unit.

Service tip: Before troubleshooting any print quality problems, do the following:

1. Print a menu settings page, and check the life status of all supplies. Any supplies that are low should be replaced.

Note: Be sure and keep the original menu page to restore the customer's custom settings if needed.
2. On the menu page, make sure the following is set to the default level:
 - Color Correction: Set to Auto.
 - Print Resolution: Set to 1200 dpi (print quality problems should be checked at different resolution settings).
 - Toner Darkness: Set to 4 (default).
 - Color Saver: Set to OFF.
 - RGB Brightness, RGB Contrast, RGB Saturation: Set to 0.
 - Color Balance: Select Reset Defaults to zero out all colors.
 - Check the paper type, texture and weight settings against what is loaded in the printer.

Once the printer has been restored to its default levels, do the following:

3. Inspect the transfer belt for damage. Replace if damaged.
4. Inspect the OPCs and toner cartridges for damage. Replace if damaged.
5. If paper other than 20lb plain letter/A4 paper is being used, load 20lb plain letter/A4 and print the Print Quality pages to see if the problem remains.
6. Use Tray 1 to test print quality problems.
7. Print the Print Quality Pages, and looked for variations in the print from what is expected.









An incorrect printer driver for the installed software can cause problems. Incorrect characters could print, and the copy may not fit the page correctly.

Measure all voltages from the connector to the printer ground.

Print quality—background

Service tip: Some background problems can be caused by rough papers, non-Lexmark toner cartridges or if the media texture is set to the rough setting.

Some slick or coated papers may also cause background problems. Some problems occur with printers that run a large amount of graphics in a humid environment.

Step	Questions / actions	Yes	No
1	<p>Read the current status of the photoconductor unit from the customer menus.</p> <p>To view the status of the photoconductor units:</p> <ol style="list-style-type: none"> 1. In Ready mode, press . 2. Select Reports, and press . 3. Select Device Statistics, and press . <p>Ask the customer if the photoconductor unit has been recently replaced. It is possible the photoconductor value was not reset and the photoconductor unit is past end of life. If the PC unit was recently replaced, reset the value. If the PC unit was not replaced, replace the PC unit.</p> <p>Has the photoconductor unit been recently replaced?</p>	<p>Reset the value. To reset this value:</p> <ol style="list-style-type: none"> 1. In Ready mode, press . 2. Select Supplies Menu, and press . 3. Select Replace Supply, and press . 4. Select the PC color unit you want to change, and press . 5. Select Yes, and press . <p>If this does not fix the problem, go to step 2.</p>	Go to step 2.

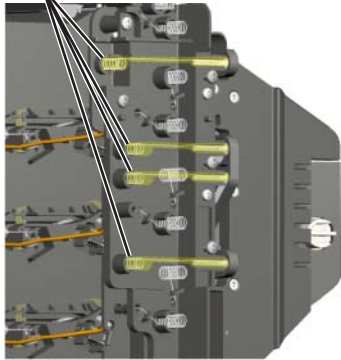
Step	Questions / actions	Yes	No
2	Replace the PC unit. See “Photoconductor unit removal” on page 4-70. Does this fix the problem?	Problem solved.	Go to step 3.
3	Check the high voltage contact from the HVPS to the transfer belt assembly. Transfer belt high voltage path (typical 4X)  Is a problem found?	Replace the spring or the transfer contact assembly. See “Transfer contact assembly removal” on page 4-104.	Go to step 4.
4	Reseat the JHVPS connector. Does this fix the problem?	Problem solved.	Go to step 5.
5	Replace the HVPS. See “High voltage power supply (HVPS) removal” on page 4-62. Does this fix the problem?	Problem solved.	Go to step 6.
6	Clean the printhead. Does this fix the problem?	Problem solved.	Replace the printhead. See “Printhead removal, installation, and adjustment” on page 4-74.

Print quality—blank page

Step	Questions / actions	Yes	No
1	Is all the packing material for the photoconductor unit in question removed?	Go to step 2.	Remove the packing material.
2	Replace the photoconductor unit for the color in question. Does this fix the problem?	Problem solved.	Go to step 3.
3			

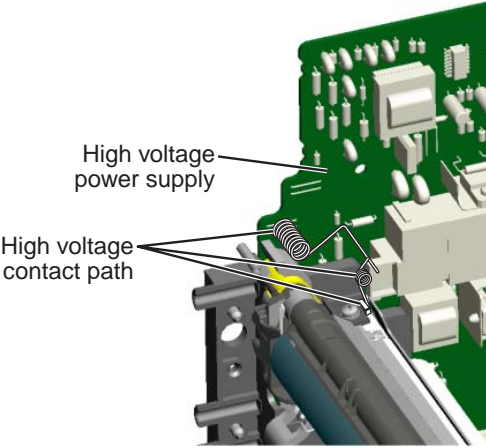
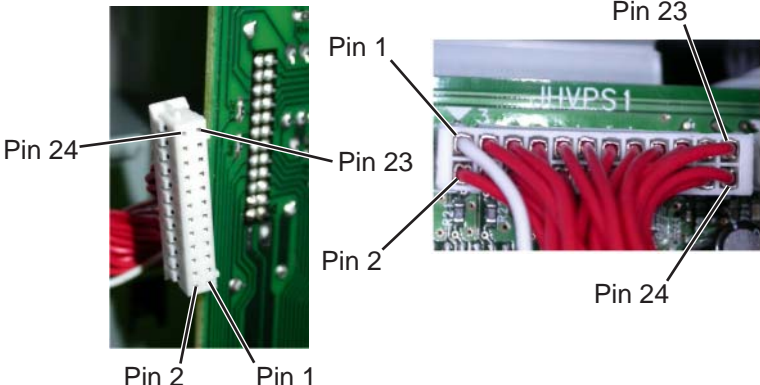
Step	Questions / actions	Yes	No
4	<p>Enter the Diagnostics mode (turn off the printer, press and hold ▼ and ►, turn on the printer, and release the buttons when the clock graphic displays), and run the appropriate cartridge drive motor test for the missing color. See “General motor tests” on page 3-8.</p> <p>Did the motor run?</p>	Go to step 5.	<p>Replace the EP drive assembly. See “Electrophotographic (EP) drive assembly removal—model C52x only” on page 4-48 or “Electrophotographic (EP) drive assembly removal—model C53x only” on page 4-51.</p>
5	<p>Check the high voltage contact from the HVPS to the photoconductor charge roll. Ensure the contact springs are properly mounted and that the charge roll contact spring is making good contact with the HVPS spring that runs through the left printer frame. See “Transfer contact assembly removal” on page 4-104 to view the proper mounting and for removal procedures.</p>  <p>Are the spring(s) defective?</p>	<p>Replace the transfer contact assembly. See “Transfer contact assembly removal” on page 4-104.</p>	Go to step 6.
6	<p>Turn off the printer and check the continuity of the HVPS cable.</p>  <p>Is there continuity?</p>	Go to step 7.	Replace the cable assembly.

Step	Questions / actions	Yes	No
7	Replace the HVPS. See “High voltage power supply (HVPS) removal” on page 4-62. Did this fix the problem?	Problem solved.	Go to step 8.
8	Replace the printhead. See “Printhead removal, installation, and adjustment” on page 4-74. Did this fix the problem?	Problem solved.	Replace the system card. See “System card removal” on page 4-92.

Print quality—blurred or fuzzy print

Blurred or fuzzy print is usually caused by a problem in the EP drive assembly or in the transfer belt assembly. Check the EP drive assembly and transfer belt assembly for correct operation.

Blurred print can also be caused by incorrect feeding from one of the input paper sources, paper trays, or duplex paper path.

Check the high voltage spring contacts to ensure they are not bent, corroded, or damaged. Replace as necessary.

Print quality—half-color page

A photoconductor unit is not properly seated. Reset the specific photoconductor unit.

Print quality—horizontal banding

Step	Questions / actions	Yes	No
1	Measure the distance between repeating bands. Is the distance between bands either 27 or 36mm?	Replace the print cartridge.	Replace the photoconductor unit. See “Photoconductor unit removal” on page 4-70.

Print quality—horizontal line

The photoconductor unit is defective. Replace the photoconductor unit.

Print quality—insufficient fusing

Step	Questions / actions	Yes	No
1	Is the fuser properly installed?	Go to step 2.	Install the fuser properly.
2	Replace the fuser. See “Fuser removal” on page 4-60. Does this fix the problem?	Problem solved.	Replace the LVPS. see “Low voltage power supply (LVPS) removal” on page 4-65.

Print quality—missing image at edge

Reseat the developer cartridge.

Print quality—mottle (2–5mm speckles)

Keep running prints through, and the problem normally clears up. If the problem persists, replace the developer cartridge.

Print quality—narrow vertical line

Step	Questions / actions	Yes	No
1	Replace the photoconductor unit. See “Photoconductor unit removal” on page 4-70.	Problem solved.	Replace the print cartridge.

Print quality—random marks

Service tip: The primary cause of random marks is due to loose material moving around inside the printer and attaching to the photoconductor unit, developer roll, or transfer belt.

Step	Questions / actions	Yes	No
1	Is there any loose or foreign material on the photoconductor unit?	Replace the photoconductor unit. See “Photoconductor unit removal” on page 4-70.	Go to step 2.
2	Is there any loose or foreign material on the cartridge roll?	Replace the print cartridge.	Go to step 3.
3	Is there any loose or foreign material on the transfer belt?	Replace the transfer belt. See “Transfer belt removal” on page 4-103.	Contact your next level of support.

Print quality—residual image

Service tip: Install a new print cartridge if available before doing this service check. Residual image can be caused by the photoconductor, cleaning blade, and other parts inside the print cartridge.

Step	Questions / actions	Yes	No
1	Is there any toner contamination on the fuser assembly?	Replace the fuser. See “Fuser removal” on page 4-60.	Contact your next level of support.

Print quality—solid color page

Service tip: A solid color page is generally caused by a problem in the high voltage system or an incorrect high voltage in the printing process resulting in toner development on the entire photoconductor drum.

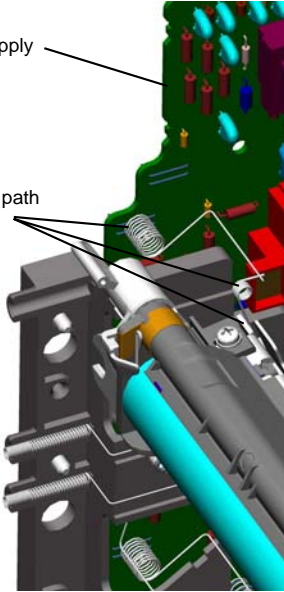
Step	Questions / actions	Yes	No
1	Replace the photoconductor unit for the color in question. Does this fix the problem?	Problem solved.	Go to step 2.
2	<p>Check the high voltage contact from the HVPS to the photoconductor charge roll. Ensure the contact springs are properly mounted and that the charge roll contact spring is making good contact with the HPVS spring that runs through the left printer frame. See “Transfer contact assembly removal” on page 4-104 to view the proper mounting and for removal procedures.</p>  <p>Note: Printer is shown with components removed for clarity</p> <p>Are the spring(s) defective?</p>	Replace the transfer contact assembly. See “Transfer contact assembly removal” on page 4-104 .	Go to step 3.

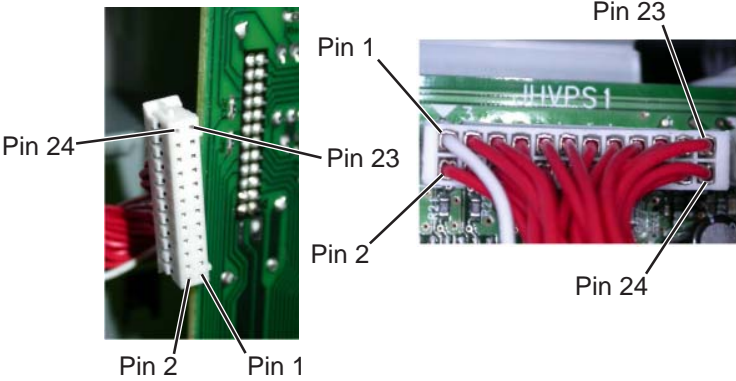
Step	Questions / actions	Yes	No
3	Turn the printer off, and check the continuity of the HVPS cable.  Is there continuity?	Go to step 4.	Replace the cable assembly.
4	Replace the HVPS. See “High voltage power supply (HVPS) removal” on page 4-62. Did this solve the problem?	Problem solved.	Replace the system card. See “System card removal” on page 4-92.

Print quality—vertical banding



Replace the developer cartridge.

3. Diagnostic aids

This chapter explains the tests and procedures to identify printer failures and verify repairs have corrected the problem.

Accessing service menus

There are different test menus that can be accessed during POR to identify problems with the printer.

Diagnostics menu	<ol style="list-style-type: none"> 1. Turn off the printer. 2. Press and hold ▼ and ►.  <ol style="list-style-type: none"> 3. Turn on the printer. 4. Release the buttons when the clock graphic displays. 	<p>The Diagnostics menu group contains the settings and operations used while manufacturing and servicing the printer.</p> <p>See “Diagnostics menu” on page 3-2 for more information.</p>
Configuration menu	<ol style="list-style-type: none"> 1. Turn off the printer. 2. Press and hold ↻ and ►.  <ol style="list-style-type: none"> 3. Turn on the printer. 4. Release the buttons when the clock graphic displays. 	<p>The Configuration menu group contains a set of menus, settings, and operations which are infrequently required by a user. Generally, the options made available in this menu group are used to configure a printer for operation.</p> <p>See “Configuration menu (CONFIG MENU)” on page 3-20 for more information.</p>

To run the printer diagnostic tests described in this chapter, you must put the printer in Diagnostics mode.

Diagnostics menu

Note: Tray 2 refers to the 500-sheet tray located in the 500-sheet option assembly.

Diagnostics menu structure

When the Diagnostics mode is entered, each Diagnostics main menu item displays on the operator panel. When a diagnostic test is selected from the main menu, a sub menu displays and each individual test displays in the order shown. Any options that are referred to in the menus are displayed when the option is installed.

Available tests

The tests display on the operator panel in the order shown:

Diagnostics mode tests

REGISTRATION	
Top Margin	See “Registration” on page 3-4.
Bottom Margin	
Left Margin	
Right Margin	
Skew	See “Skew” on page 3-4.
Quick Test	See “Quick Test” on page 3-6.
ALIGNMENT	
Cyan	See “Alignment” on page 3-7.
Yellow	
Magenta	
Factory Scanner	
Factory Manual	A summary page for all the color alignment settings. Can be used in place of alignment pages for each individual color.
MOTOR TESTS (order differs depending upon model)	
Align Motor Test	Tests the bump aligner motor. See “General motor tests” on page 3-8.
Fuser	Tests the fuser motor. See “General motor tests” on page 3-8.
Tray 1	Tests tray 1 motor located in the paper pick mechanism. See “General motor tests” on page 3-8.
Tray 2 (if installed)	Tests tray 2 motor located in the paper pick mechanism. See “General motor tests” on page 3-8.
Bottom Cartridge	Tests the bottom cartridge motor located on the EP drive assembly. See “General motor tests” on page 3-8.
Top Cartridge	Tests the top cartridge motor located on the EP drive assembly. See “General motor tests” on page 3-8.
Transfer	Tests the transfer belt assembly motor located on the EP drive assembly. See “General motor tests” on page 3-8.
Mirror Motor Test	Tests the mirror motor located in the printhead assembly. See “Mirror Motor Test” on page 3-8.
Motor Calibration	Synchronizes the bump aligner and fuser motor speeds with the transfer belt speed to ensure that output is printed correctly. See “Motor Calibration” on page 3-9.
Servo Laser Test	Tests servo laser located in the printhead. See “Servo Laser Test” on page 3-9.

Diagnostics mode tests (continued)

PRINT TESTS	
Tray 1	See “Input source tests” on page 3-9.
Tray 2 (if installed)	
Manual Feeder (if installed)	
MP Feeder	
Prt Quality Pgs	See “Print quality test pages (Prt Quality Pgs)” on page 3-10.
HARDWARE TESTS	
Panel Test	See “Panel Test” on page 3-11.
Button Test	See “Button Test” on page 3-11.
DRAM Test	See “DRAM Test” on page 3-11.
CACHE Test	See “CACHE Test” on page 3-12.
DUPLEX TESTS (if installed)	
Quick Test	See “Quick Test (duplex)” on page 3-12.
Print Test	See “Print Test (duplex)” on page 3-13.
Top Margin	See “Top Margin (duplex)” on page 3-14.
Motor Test	See “Motor Test (duplex)” on page 3-14.
INPUT TRAY TESTS (if Tray 2 is installed)	
Tray 2	See “Input Tray Tests” on page 3-14.
BASE SENSOR TEST	
Bin Full Test	See “Bin Full Test” on page 3-15.
Sensor Test	See “Sensor Test” on page 3-15.
PRINTER SETUP	
Defaults	See “Defaults” on page 3-16.
PAGE COUNTS	This menu contains three submenus: Prt Color Pg Count, Mono Pg Count, and Perm Page Count. See “Page Counts” on page 3-16.
Serial Number	See “Serial Number” on page 3-16.
Engine Setting 1 through 4	See “Engine Setting 1 through 4” on page 3-16.
Model Name	See “Model Name” on page 3-16.
Configuration ID	See “Configuration ID” on page 3-16.
EP SETUP	
EP Defaults	See “EP Defaults” on page 3-17.
Fuser Temp	See “Fuser Temperature (Fuser Temp)” on page 3-17.
DC Charge Adjust	See “DC Charge Adjust, Dev Bias Adj, Transfer Adjust” on page 3-17.
Dev Bias Adj	
Transfer Adjust	
EVENT LOG	
Display Log	See “Display Log” on page 3-18.
Print Log	See “Print Log” on page 3-18.
Clear Log	See “Clear Log” on page 3-19.
EXIT DIAGNOSTICS	
This selection exits Diagnostics mode, and Resetting the Printer displays. The printer performs a POR, and returns to normal mode.	

Registration

Note: If you need to perform alignment or registration, see **“Printhead alignment”** on page 4-3.

The following information is meant to explain the uses for the menu items.

Print registration makes sure the black printing is properly aligned on the page. This is one of the steps in aligning a new printhead. It is also the first step in aligning the duplex registration. See **“Quick Test (duplex)”** on page 3-12.

The settings available are:

- Top Margin
- Bottom Margin
- Left Margin
- Right Margin
- Skew
- Quick Test

Skew

One printhead houses the four color planes. The black plane is aligned to the printer, and the color planes are internally aligned to black. Adjust the skew mechanically by moving the printhead with a printhead adjustment screw. See **“Printhead mechanical alignment”** on page 4-3 for instructions on setting printhead alignment. Electronic alignment fine tunes the alignment of the color planes to the black plane once the printhead is installed. Skew adjustment must be performed before color alignment is attempted. The following illustration shows proper alignment versus skewed alignment.

Straight

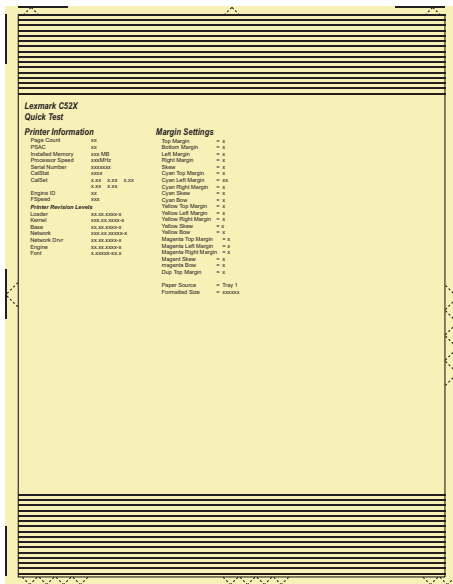

Skewed

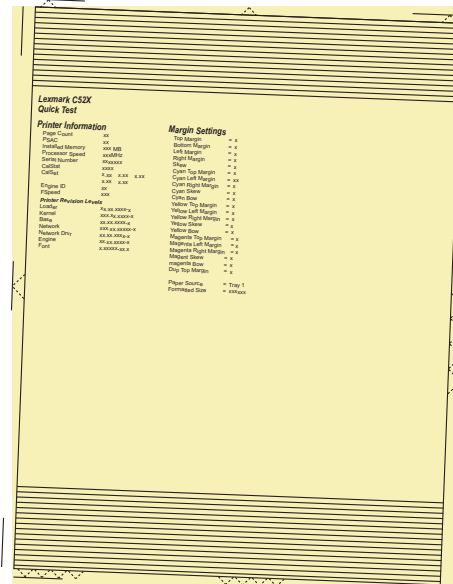

Print registration

To set print registration:

1. Select **REGISTRATION** from the DIAGNOSTICS menu.
2. Select Quick Test, and press **Select** (✓).

To print the Quick Test page:

- a. Press ▼ until the ✓ appears next to Quick Test.
- b. Press **Select** (✓).
The message Quick Test Printing... appears on the display.

Retain this page to determine the changes you need to make to the margin settings.

3. Use ▼ or ▲ to select the margin setting you need to change, and press **Select** (✓).
4. Use ◀ to decrease or ▶ to increase the offset values, and press **Select** (✓) to confirm the value.
The message Submitting selection displays, and the original REGISTRATION screen appears with the ✓ beside the previously selected margin setting.

The print registration range is:

Description	Value	Direction of change
Skew	Each increment corresponds to 1/1200 of an inch.	A positive value causes the right end of the scan line to move down the page. A negative value causes the right end of the scan line to move up the page. The left end stays fixed.
Top margin	-25 to +25 Each increment corresponds to 8 scans at a 600 dpi scan rate (0.0133 inches or 0.339 mm).	A positive change moves the image down the page and increases the top margin. A negative change moves the image up and decreases the top margin.
Bottom margin	-20 to +20 Each increment causes approximately 0.55 mm shift in the bottom margin.	A positive offset moves text up the page and widens the bottom margin, while a negative offset moves text down the page and narrows the bottom margin.
Left margin	-25 to +25 Each increment corresponds to 4 pels at 600 dpi (0.00666 in. or 0.1693 mm).	A positive change moves the image to the left, and a negative change moves the image to the right. No compression occurs.
Right margin	-10 to +10 Each increment corresponds to an approximate shift of 4 pels at 600 dpi.	A positive change moves the image to the right, and a negative change moves the image to the left.

5. Continue changing the settings by repeating steps 2 through 4.
6. Print another copy of the Quick Test to verify your changes.
7. To exit REGISTRATION, press **Back** (⊙).

Quick Test

The Quick Test contains the following information:

- Print registration settings
- Alignment diamonds at the left, right, top and bottom
- Horizontal lines to check for skew
- General printer information, including current page count, installed memory, serial number, and code level.

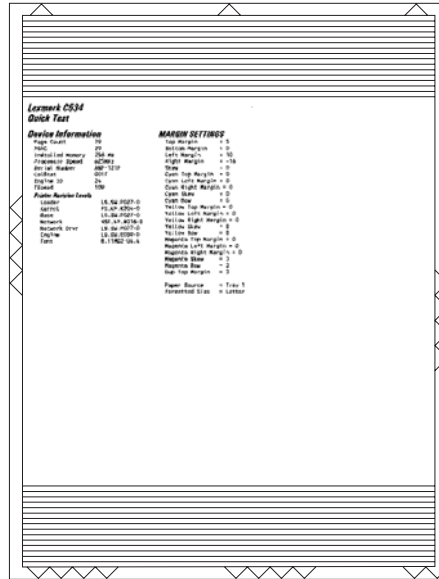

To print the Quick Test page:

Note: Print the Quick Test Page on letter or A4 paper.

1. Select **REGISTRATION** from **DIAGNOSTICS**.
2. Press ▼ until the ✓ appears next to **Quick Test**.

The message **Quick Test Printing...** appears on the display.

Once the Quick Test Page completes printing, the Registration screen displays again.

Alignment

Note: If you need to perform alignment or registration, see **“Printhead alignment” on page 4-3**.

The following information is meant to explain the uses for the menu items.

Alignment is part of the process of adjusting the printhead and the color planes to the black plane and to each other. Before you start, perform the black alignment (Registration). See **“Printhead alignment” on page 4-3**. If you are replacing a new printhead, see **“Printhead removal, installation, and adjustment” on page 4-74**.

To perform alignment:

1. Select **ALIGNMENT** from **DIAGNOSTICS**. Scroll until you reach the color that you desire to align. Go to each submenu, press **Select** (↵) and use the right and left arrow keys to zero out all settings. Press **Select** (↵) after you zero out each setting.
Note: It is important to zero out all settings to make the adjustment easier.
2. Scroll to Quick Test in the same color menu. Press **Select** (↵); two pages print.
3. On the pages, make sure all the Current Values are set to zero. If not, go back two steps and repeat.
4. Look at the coarse and fine adjustments on the top left of the page, and enter the best number for the top adjustment in the T space. Transfer this number over to the computation area for Z.
5. On the operator panel, use ▲ and ▼ to locate Top Margin. Press **Select** (↵), and then use ◀ or ▶ to enter the setting computed for T. Press **Select** (↵) to save.
6. Repeat this process for skew (Z). Add the T value and the current Z value to obtain the new skew (Z) value.
7. Reprint the Quick Test page, and observe the results. Make additional adjustments if necessary before proceeding on to Quick Test step two page.
8. Obtain left (L), right (R), and Bow (P) value using the same method as obtaining T from Quick Test Step 1. Reprint the Quick Test to ensure the settings are correct. Make additional adjustments as required.
9. Press **Back** (⏪) to return to ALIGNMENT.

See **“Printhead mechanical alignment” on page 4-3** for printout samples and additional information.

Motor tests

The motor tests are run primarily to locate noises in the printer.

General motor tests

In some instances, when you enter a particular test, you will be given the choice to run the motor in forward or reverse. Other times, there will only be the option to run the motor in forward direction.

Before you run any particular motor test, ensure you have configured the printer as directed in the following table:

Motor test	Setup requirements		Notes
	Top access cover	Front access door	
Align Motor Test	Closed	Closed	Select Forward or Reverse.
Fuser	Closed	Closed	Select Forward or Reverse.
Tray 1	Not applicable	Not applicable	Remove all paper from the input source tray to avoid paper jams while performing this test. Select Forward or Reverse.
Tray 2	Not applicable	Not applicable	
Bottom cartridge	Closed	Open	1. Close the top access cover and front access door. 2. Enter MOTOR TESTS. 3. Open the top access cover and front access door, activate the top right bellcrank by hand, close the top access cover. 4. Remove the toner cartridges if you plan to test for any length of time. 5. Run the desired motor tests. To finish: 1. Open the top access cover. 2. Deactivate the top right bellcrank 3. Close the top access cover and the front access door.
Top cartridge	Closed	Open	
Transfer	Closed	Open	

To run the motor tests:

1. Select **MOTOR TESTS** from DIAGNOSTICS.
2. Select the motor that you need to test, and press **Select** (✓).
3. Select the direction if a choice is offered (Forward or Reverse). Press **Select** (✓).
4. Press **Stop** (✗) to end the test.

Mirror Motor Test

1. Select **MOTOR TESTS** from DIAGNOSTICS.
2. Select **Mirror Motor Test**.
The panel displays *Mirror Motor Test*.
After the test completes, the panel displays either *Pass* or *Fail*.

To stop the test, press **Stop** (✗).

Motor Calibration

This test is run to match the fuser motor speed to the belt motor speed.

1. Select **MOTOR TESTS** from DIAGNOSTICS.
2. Select **Motor Calibration**.

The printer generates eight pages as part of this test.

To stop the test, press **Stop** (⊗).

Servo Laser Test

1. Select **MOTOR TESTS** from DIAGNOSTICS.
2. Select **Servo Laser Test**.

The panel displays Servo Laser Test. After the test completes, the panel displays either Pass or Fail.

To stop the test, press **Stop** (⊗).

Print Tests

Input source tests

The purpose of the diagnostic Print Tests is to verify that the printer can print on media from each of the installed input options. The contents of the Print Test Page varies depending on the media installed in the selected input source.



Check each Test Page from each source to assist in print quality and paper feed problems.

To run the Print Test Page:

1. Select **PRINT TESTS** from the DIAGNOSTICS.
2. Select the media source.
 - Tray 1
 - Tray 2 (if installed)
 - MP Feeder
3. Select **Single** or **Continuous**.

- If **Single** is selected, a single page is printed.
- If **Continuous** is selected, printing continues until **Stop** (⊗) is pressed to cancel the test.
If a source is selected that contains envelopes, an envelope test pattern is printed. If Continuous is selected, the test pattern is printed only on the first envelope.

Note: The Print Test Page always prints on one side of the paper, regardless of the duplex setting.

4. Press **Back** (⏪) to return to PRINT TESTS.

Print quality test pages (Prt Quality Pgs)

The print quality test consists of five pages. Pages one and two contain a mixture of graphics and text. The remainder of the pages only contain graphics. The test prints on the media in the default tray.

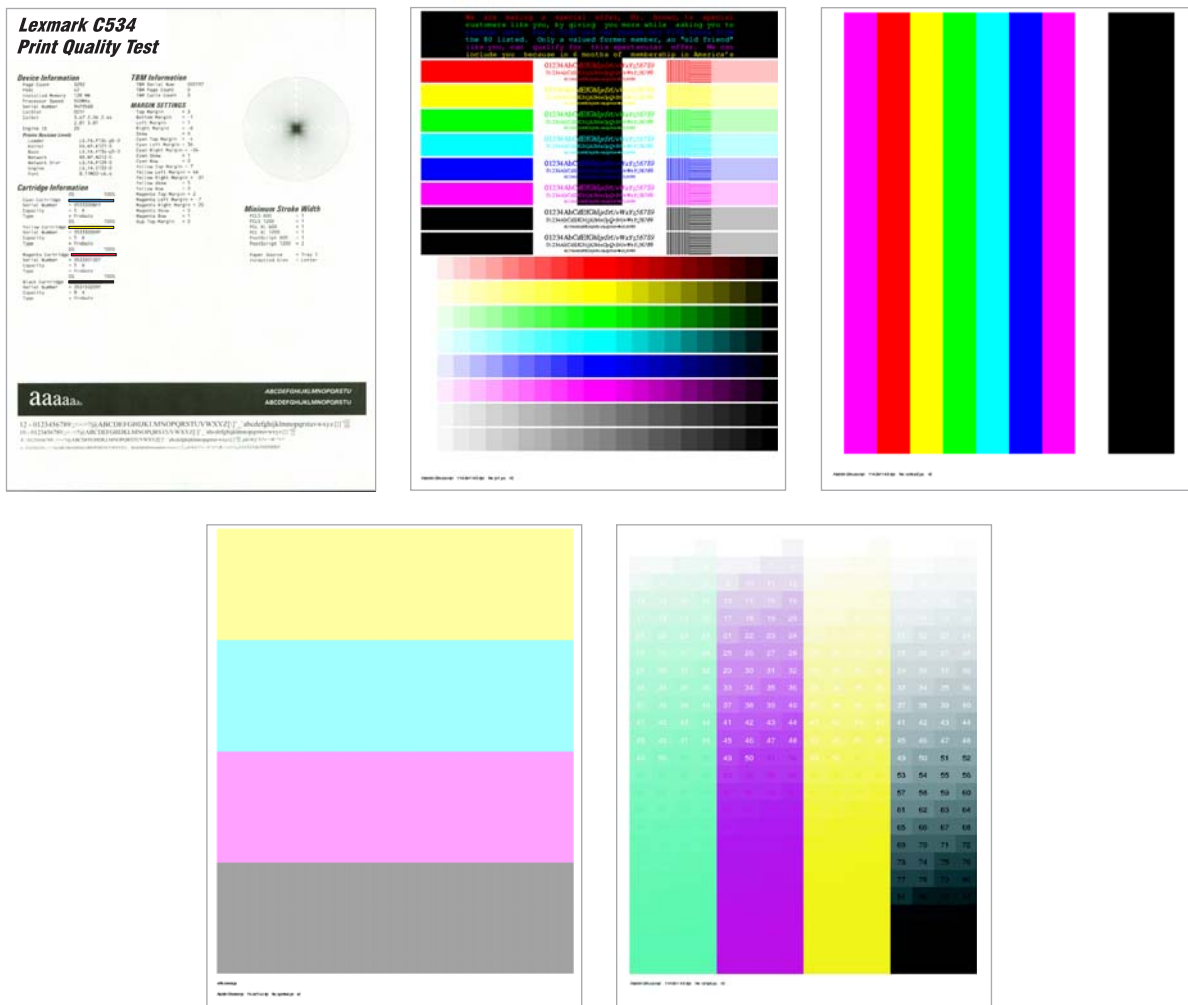

This test may be printed from either Configuration Menu or the Diagnostics mode. To run the print quality pages from the Diagnostics mode, select **PRINT TESTS** and **Print Quality Pgs** from the menu. Once the test is started, it cannot be canceled. When the test pages print, the printer returns to the original screen.

To run the Print Quality Test Pages, select **Prt Quality Pgs** from PRINT TESTS. The message **Printing Quality Test Pages** is displayed.

Hardware Tests

Panel Test

This test verifies the operator panel LCD function.

To run the Panel Test:

1. Select **HARDWARE TESTS** from **DIAGNOSTICS**.
2. Select **Panel Test**.
The Panel Test continually executes.
3. Press **Stop** (⊗) to cancel the test.

Button Test

This test verifies the operator panel button function.

To run the Button Test:

1. Select **Button Test** from **HARDWARE TESTS** in the **Diagnostics** mode.

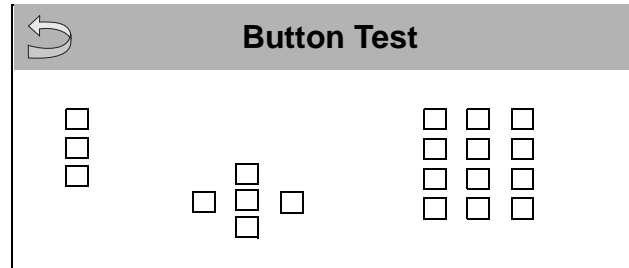

2. Press each button one at a time, and an X appears in the box that represents that button.
When you press **Back** (⏪) or **Stop** (⊗), the test ends.

Press **Back** (⏪) or **Stop** (⊗) to cancel the test.

DRAM Test

This test checks the validity of DRAM, both standard and optional. The test writes patterns of data to DRAM to verify that each bit in memory can be set and read correctly.

To run the DRAM Test:

Select **DRAM Test** from **HARDWARE TESTS** in **DIAGNOSTICS**. The power indicator *blinks* indicating the test is in progress.

Note: Turn off the printer to exit the test before the test is complete.

DRAM Test	128M
P: #####	F: #####

P:##### represents the number of times the memory test has passed and finished successfully. Initially, 000000 displays with the maximum pass count being 99,999.

F:##### represents the number of times the memory test has failed and finished with errors. Initially, 00000 displays with the maximum fail count being 99,999.

Once the maximum pass count or fail count is reached, the test is stopped, the power indicator turns on solid, and the final results appear. If the test fails, SDRAM Error appears for approximately three seconds and the failure count increases by 1.

CACHE Test

The CACHE Test is used to verify the processor CACHE is functioning properly.

1. Select **CACHE Test** from **HARDWARE TESTS** in **DIAGNOSTICS**.

The machine initiates a POR of the printer, and the following screen is displayed:



Upon completion of the POR, the following screen is displayed:

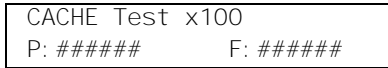

P:##### represents the number of times the CACHE test has passed, finished successfully.

Initially, 000000 is displayed. The maximum pass count is 999,999.

F:##### represents the number of times the CACHE test has failed, finished with errors.

Initially, 000000 is displayed. The maximum fall count is 999,999.

2. To exit the test, turn the printer off.

Duplex Tests

Quick Test (duplex)

Note: Before you set the duplex top margin, be sure to set the skew and alignment. See **“Printhead alignment” on page 4-3**.

This test prints a duplex version of the Quick Test that can be used to verify the correct placement of the top margin on the back side of a duplex page.

You can run one duplexed page (**Single**), or continue printing duplexed pages (**Continuous**) until **Stop** (⊗) is pressed. For information about changing the margin, see **“Top Margin (duplex)” on page 3-14**.

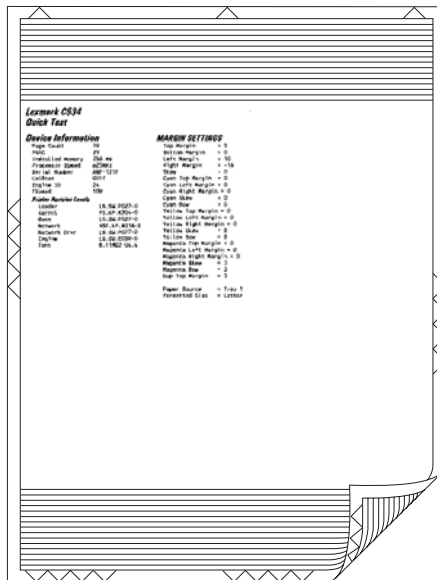

The paper you choose to print the page on should be either Letter or A4.

To run the Quick Test (duplex):

1. Select **Quick Test** from DUPLEX TESTS.
2. Select **Single** or **Continuous**.
 - The single Duplex Quick test cannot be canceled.
 - The printer attempts to print the Quick Test Page from the default paper source.
 - Check the Quick Test Page for the correct offset between the placement of the first scan line on the front and back side of a duplexed sheet.

The single test stops automatically when a single duplex sheet is printed, and the continuous test continues until you press **Stop** (⊗).

Print Test (duplex)

This test provides service personnel with a way to verify the function of the printer's duplex hardware. After the user selects this test, the device automatically executes a continuous print test that generates a duplexed, color output page. To stop the test, the user must press **Stop** (⊗). While this test executes, the power indicator light blinks green and the panel displays "DUPLEX TESTS Printing..."



The paper you choose to print the page on should be either Letter or A4.

To run the Print Test (duplex):

1. Select **Print Test** from DUPLEX TESTS. The printer executes a continuous print test that generates a duplexed, color output page.
2. To stop the test, press **Stop** (⊗).

Top Margin (duplex)

This setting controls the offset between the first scan line on the front of the duplex page and the first scan line on the back of the page. Therefore, be sure to set the top margin in REGISTRATION before setting the duplex top margin. See **“Registration” on page 3-4**.

To set the Top Margin (duplex):

1. Print the Quick Test (duplex):
 - a. Select **Quick Test** from DUPLEX TESTS.
 - b. Select **Single**.
 - c. Hold the page to the light to see whether the top margin of the back aligns with the top margin of the front.
2. Select **Top Margin** from DUPLEX TESTS.
3. Use ◀ or ▶ to select the margin setting you need to change.
 - Each increment shifts the duplex top margin by 1/100 of an inch.
 - The Top Margin (duplex) range is -20 to +20, and the default value is 0.
 - An increase moves the top margin down and widens the top margin. A decrease moves the top margin upward and narrows the top margin.
4. Press **Select** (⏴).
5. Print the Quick Test (duplex) again to verify the adjustment. Repeat if necessary.

Motor Test (duplex)

This test is used to determine whether or not the duplex unit paper feed drive system is working correctly.

1. Select **Motor Test** from DUPLEX TESTS. The duplex motor runs continuously until stopped.
The message `Motor Running` displays.
2. To stop the test, press **Back** (⏴) or **Stop** (⏹).

Input Tray Tests

If tray 2 is installed, the INPUT TRAY TESTS menu appears. This test is used to determine if the Tray 2 full sensor is sensing properly.

To run the Input tray test:

1. Select **INPUT TRAY TESTS** from the Diagnostics mode.
2. Select **Sensor Test**.
3. Select **Tray 2**.
`Tray2 full` displays.
4. Toggle the sensor to change the display and determine whether the sensor is operating properly.

Press **Back** (⏴) or **Stop** (⏹) to exit the test.

Base Sensor Test

Bin Full Test

This test is used to determine if the bin full sensor is operating correctly. This test is only applicable to network printers. To run the Bin Full Test:

1. Select **BASE SENSOR TEST** from DIAGNOSTICS.
2. Select **Bin Full Test**. The display shows **Bin Full** and the current state of this sensor, either **Closed** or **Open**. Move the bin full sensor flag (located on the fuser) up and down to toggle the sensor state.

Sensor Test

This test is used to determine if specific sensors are working correctly. If you need to know where a sensor is located, refer to **“Sensors” on page 5-8**. To run the Sensor Test:

1. Select **BASE SENSOR TEST** from DIAGNOSTICS.
2. Select **Sensor Test**. The display shows each one of the sensors, one line at a time, and the current state of the sensor. Use the down arrow to locate the sensor in question. Use the following table to toggle the sensor.

Sensor	Possible values	Sensor activation
Fuser Exit (paper exit)	Open/Closed	Open the top access cover. Activate the fuser exit flag. The sensor should change state.
Inner Door (front access door)	Open/Closed	Open the front access door. The sensor should change state.
Input	Open/Closed	Remove the paper tray 1. Activate the input sensor flag. The sensor should change state.
Narrow Media (transparency)	Open/Closed	Test the manual feed slot by pulling out the tray. The sensor should change state. Test the MFP tray by inserting a sheet of paper, and pushing up to sensor. The sensor should change state.
TPS	Open/Closed	Open the front access door. Slip a piece of paper between the TPS and the transfer belt. The sensor should change state.
Toner C	Open/Closed	Remove the cyan toner cartridge. Shine a flashlight on the toner level sensor. The sensor should change state.
Toner K	Open/Closed	Remove the black toner cartridge. Shine a flashlight on the toner level sensor. The sensor should change state.
Toner M	Open/Closed	Remove the magenta toner cartridge. Shine a flashlight on the toner level sensor. The sensor should change state.
Toner Y	Open/Closed	Remove the yellow toner cartridge. Shine a flashlight on the toner level sensor. The sensor should change state.
Top Door (top access cover assembly)	Open/Closed	Open the top access cover assembly. The sensor should change state.
Waste Toner	OK/Full	Remove the waste toner box before entering the sensor test. The actual test runs when the menu is entered. Replace the waste toner box, leave the menu, and re-enter the menu. The state should be OK.

Press **Back** (⏪) or **Stop** (⏹) to exit the test.

Printer Setup

Defaults

US/Non-US defaults changes whether the printer uses the US factory defaults or the non-US factory defaults. The settings affected include paper size, envelope size, PCL symbol set, code pages, and units of measure.

Warning: Changing this setting resets the printer to factory defaults, and data may be lost. It cannot be undone.

Page Counts

You can view, but not change any of the three counts displayed under PAGE COUNTS.

To view the Prt Color Pg Count, the Prt Mono Pg Count, or the Perm Page Count:

1. Select **PRINTER SETUP** from DIAGNOSTICS.
2. Select **PAGE COUNTS**.
3. Select the page count you wish to view:
 - Prt Color Pg Count
 - Prt Mono Pg Count
 - Perm Page Count

Press **Back** (⏪) to return to PRINTER SETUP.

Serial Number

The serial number can only be viewed and changed.

To view or change the serial number:

1. Select **Serial number** from PRINTER SETUP.
2. Press **Back** (⏪) to return to PRINTER SETUP.

Engine Setting 1 through 4

Warning: Do not change these settings unless requested to do so by your next level of support.

Model Name

The model name can only be viewed and cannot be changed.

Configuration ID

The two configuration IDs are used to communicate information about certain areas of the printer that cannot be determined using hardware sensors. The configuration IDs are originally set at the factory when the printer is manufactured. However, the servicer may need to reset Configuration ID 1 or Configuration ID 2 whenever the system board is replaced. The IDs consist of eight digits. The first seven digits in each ID are hexadecimal numbers, while the last digit is a checksum of the preceding seven digits. Each ID can contain a combination of the digits 0 through 9, and A through F.

Note: When the printer detects a Configuration ID that is not defined or invalid, the following occurs:

- The default standard model Configuration ID is used instead.
- Configuration ID is the only function available in DIAGNOSTICS.
- Unless the menu is in DIAGNOSTICS, Check Confi g ID displays.

To set the configuration ID:

1. Select **Printer Setup** from the Diagnostic mode.
2. Select **Configuration ID** from the Printer Setup menu.
Submi tti ng Sel ecti on displays, followed by the value for Configuration ID 1.
3. Enter the Configuration ID 1.
 - To select a digit or character to change, press ◀ or ▶ until the digit or character is underlined.
 - To change a digit or character, press ▲ to increase or ▼ to decrease the value.
 - When the last digit is changed, press **Select** (↵) to validate the Configuration ID 1.
If I nval i d ID appears, the entry is discarded, and the previous Configuration ID 1 is displayed on the screen.
If the process is successful, Submi tti ng Sel ecti on appears on the display, followed by the current value for Configuration ID 2.
4. Repeat the steps for entering the Configuration ID, and press **Select** (↵).
If the Configuration ID 2 is validated, Submi tti ng Sel ecti on appears, and a check (✓) appears next to **Printer Setup**.
5. Restart the printer.

EP Setup

EP Defaults

This setting is used to restore each printer setting listed in EP SETUP to its factory default value. Sometimes this is used to help correct print quality problems.

To restore EP Defaults:

1. Select **EP Defaults** from EP SETUP.
2. Select **Restore** to reset the values to the factory settings, and select **Do Not Restore** to exit without changing the settings.

Fuser Temperature (Fuser Temp)

This adjustment can be used to help solve some customer problems with paper curl on low grade papers and problems with letterheads on some types of media.

The fuser temperature can be adjusted to: Low, Normal, High. The default is Normal.

DC Charge Adjust, Dev Bias Adj, Transfer Adjust

Each of these three settings enables you to adjust the high voltage levels controlling the electrophotographic process. You will use these settings to compensate for unusual operating circumstances such as high humidity. The printer uses the value of these settings together with other settings to calculate printing speed and media selection.

Event Log

Display Log

The event log provides a history of printer errors. It contains the 12 most recent errors that have occurred on the printer. The most recent error displays in position 1, and the oldest error displays in position 12 (if 12 errors have occurred). If an error occurs after the log is full, the oldest error is discarded. Identical errors in consecutive positions in the log are entered, so there may be repetitions. All 2xx and 9xx error messages are stored in the event log.

To view the event log:

1. Select **EVENT LOG** from DIAGNOSTICS.
2. Select **Display Log**.

Up to three error codes display at a time. Press ▲ or ▼ to view additional error codes. Press ► to view additional details.

Press **Back** (⏪) to return to the EVENT LOG menu.

Print Log

Additional diagnostic information is available when you print the event log from DIAGNOSTICS rather than CONFIG MENU.

The Event Log printed from DIAGNOSTICS includes:

- Detailed printer information, including code versions
- Time and date stamps
- Page counts for most errors
- Additional debug information in some cases

Model and Serial number

Printer information

Panel display when error occurred

Page count

Earliest error code

```

Event Log (Page 1)
Lexmark C534 (sn:XXXXXXXXXX)

Device Information
Page Count 40
Installed Memory 256 MB
Processor Speed 425MHz
Strophe ID 24
CallList 11
CallList 0
3,7500 247074,0000 0,0000 0,0000
M 3,4000 9470,0000 0,0000 0,0000
K 4,9170 4070,0000 0,0000 21,5000
K 3,9170 43,0000 0,0000 4,7810
Mg-Mg U.S.M.P527-D
Lid-Mg U.S.M.P527-D
Armet U.S.M.P527-D
Base U.S.M.P527-D
Network HP JetDirect
Network Driver U.S.M.P527-D
Panel 3.0
Firm 0,1902-04,4

Event Log Information
992, 10 999M Mismatch 992, 10 999M Mismatch 108 and 0000-0386 no2netrrsopod.cpp:637, *
Error Message Error/System error
Mod 108
Process
Page Count 0
Page Count 0
Date and Time Thu Jan 01 00:00:04 1970 UTC
Op Time 4 secs 201 msec

Code Levels
Target Name Fri Jul 21 09:04:17 2006 mta-hd
0: Copyright U.S. JetDirect Fri Jul 21 09:04:52 2006 mta-hd
1: Copyright U.S. JetDirect Fri Jul 21 09:04:52 2006 mta-hd
2: Network HP JetDirect Fri Jul 21 09:04:52 2006 mta-hd
3: Base U.S. JetDirect Fri Jul 21 09:04:52 2006 mta-hd
4: Network HP JetDirect Fri Jul 21 10:57:20 2006 mta-hd
5: Network Driver U.S. JetDirect Fri Jul 21 09:04:52 2006 mta-hd
23: Security Filter 1.0 Fri Jul 21 09:04:18 2006 mta-hd
24: BootManagerData 1.0 Fri Jul 21 09:04:18 2006 mta-hd
25: MTA 1.0 Fri Jul 21 09:04:18 2006 mta-hd
26: MTA 1.0 Fri Jul 21 09:04:18 2006 mta-hd
27: MTA 1.0 Fri Jul 21 09:04:18 2006 mta-hd
28: MTA 1.0 Fri Jul 21 09:04:18 2006 mta-hd
29: MTA 1.0 Fri Jul 21 09:04:18 2006 mta-hd
30: MTA 1.0 Fri Jul 21 09:04:18 2006 mta-hd
31: Network MTA 1.0 Fri Jul 21 10:57:17 2006 mta-hd
    
```

The printed event log can be faxed to Lexmark or your next level of support for verification or diagnosis.

To print the event log:

1. Select **EVENT LOG** from **DIAGNOSTICS**.
2. Select **Print Log**.

Press **Back** (⏪) to return to **EVENT LOG**.

Clear Log

Use **Clear Log** to remove the current information in the Event Log. This affects both the viewed log and the printed log information.

1. Select **Clear Log** from the Event Log menu.
2. Select **YES** to clear the Event Log or **NO** to exit the Clear Log menu. If **YES** is selected, **Deleting EVENT LOG** displays on the screen.

Press **Back** (⏪) to return to **EVENT LOG**.

EXIT DIAGNOSTICS

Press **Select** (⏩) to exit **DIAGNOSTICS**. The printer performs a power-on reset and returns to normal mode.

Configuration menu (CONFIG MENU)

Available tests

The tests display on the operator panel in the order shown for models C53x. The order differs slightly in models C52x.

Configuration menu

Reset Fuser Cnt	See “Reset Fuser Cnt” on page 3-21.
Color Lock Out (For models C52x: Black Only Mode)	See “Color Lock Out” on page 3-21.
Prt Quality Pgs	See “Prt Quality Pgs” on page 3-21.
Color Trapping	See “Color Trapping” on page 3-21.
SIZE SENSING	See “Size Sensing” on page 3-22.
Panel Menus	See “Panel Menus” on page 3-22.
PPDS Emulation	See “PPDS Emulation” on page 3-22.
Download Emuls	See “Download Emuls” on page 3-22.
Demo Mode	See “Demo Mode” on page 3-22.
Factory Defaults	See “Factory Defaults” on page 3-22.
Energy Conserve	See “Energy Conserve” on page 3-23.
EVENT LOG	See “Event Log” on page 3-23.
Auto Align Adj	See “Auto Align Adj” on page 3-23.
Auto Color Adj	See “Auto Color Adj” on page 3-23.
Enforce Color Order	See “Enforce Color Order” on page 3-24.
Color Alignment	See “Color Alignment” on page 3-24.
Motor Calibration	See “Motor Calibration” on page 3-24.
Paper Prompts	See “Paper Prompts” on page 3-24.
Env Prompts	See “Env Prompts” on page 3-25.
Jobs on Disk (if hard disk is installed)	See “Jobs on Disk” on page 3-25.
Disk Encryption (if hard disk is installed)	See “Disk Encryption” on page 3-25.
Duplex Gloss	See “Duplex Gloss” on page 3-25.
Font Sharpening	See “Font Sharpening” on page 3-26.
Exit Config Menu	This selection exits Configuration Menu, and Resetting the Printer displays. The printer performs a POR and returns to normal mode.

Reset Fuser Cnt

Resets the fuser count value to zero. The Event Log records each time that a user executes the Reset Fuser Count operation. See **“Event Log” on page 3-23** for more information. This setting only appears if the Maintenance Warning and Intervention function is enabled in the printer Configuration ID.

To reset the fuser count:

1. Select **Reset Fuser Cnt** from the CONFIG MENU.
2. Press **Select** (↵).
3. Press **Select** (↵) to select Reset.
Resetting Fuser Count Value appears.
4. Select Motor Calibration. See **“Motor Calibration” on page 3-24**.

To cancel a reset, press **Back** (⏪).

Color Lock Out

Called Black Only Mode in C52x models.

Select On when printing for extended periods with only black toner. This saves the toner cartridges (cyan, magenta, and yellow) and photoconductor units from excessive wear. In addition to setting the values, the cyan, magenta, and yellow toner cartridges and their matching photoconductor units must be removed from the printer.

Select Off (default) when printing with color toner.

Note: Remove all the color supplies from the printer before selecting the On value from the operator panel. Install all the color supplies before selecting the Off value from the operator panel.

Prt Quality Pgs

To help isolate print quality problems, print the Print Quality Test Pages. The pages are formatted. The Printing Quality Test Pages message appears, then the pages print. The message remains on the operator panel until all the pages print.

Press **Select** (↵) to print the pages. The Print Quality Test Pages contain several pages. The first page which is printed in English text only contains a mixture of text and graphics. The information includes values of the Quality Menu settings in Settings and printer and toner cartridge configuration information. The remaining pages only contain graphics. For samples of the pages, see **“Print quality test pages (Prt Quality Pgs)” on page 3-10**.

Color Trapping

Uses an algorithm to compensate for mechanical mis-registration in the printer. When small black text or fine black lines are being printed, the printer checks to see if they are being printed on top of a colored background. If so, rather than remove the color from beneath the black content, the printer leaves the color around the edge of the text or line. The hole in the colored region is reduced in size which prevents the characteristic white gap that is caused by mis-registration.

This menu item applies to PCL 5 emulation, PCL XL, PDF, and PostScript.

Selections are Off and the values 1 through 5, with 2 as the default. Values 1 through 5 indicate the amount of color remaining beneath the black content. Each setting increments by 1/600 of an inch. The more inaccurate the registration setting, the higher the setting needs to be adjusted. Selecting Off disables color trapping.

Size Sensing

Turns the automatic size sensing for print media input sources either to Auto or Off.

Selections include Tray 2 Sensing, if the tray is installed, Auto (default), and Off. This is a two-level menu that displays only those print media sources which support automatic size sensing.

Panel Menus

Lets the system support person enable or disable the operator panel menus. Selecting Enable (the default) prevents users from changing values for the printer. Disable allows users to changes the values.

This menu item only appears when the PJJ PASSWORD Environment variable is set to 0.

PPDS Emulation

Activates or deactivates the Personal Printer Data Stream (PPDS) emulation language. This menu item only appears if the PPDS interpreter is available.

Download Emuls

Lets the system support person turn the download emulator off. This menu item only appears if one download emulator is installed.

The only selection is Disable. An Enable value is unnecessary because the printer automatically re-enables all download emulators after two instances of a power-on reset for the printer. To re-enable these emulators, a user would perform another power-on reset after exiting the CONFIG MENU.

Demo Mode

Lets marketing personnel or merchandisers demonstrate the printer to potential customers by printing the demo page.

Selections include Deactivate (default) and Activate. Select Deactivate to turn Demo Mode off; or select Activate to turn Demo Mode on.

Factory Defaults

Sets the majority of printer values back to their factory default settings.

Warning: This selection cannot be reversed, so this operation should only be used as a last resort to fix any printer problem. When factory default settings are restored:

- All downloaded resources (fonts, macros, symbol sets) in the printer memory (RAM) are deleted.
- All menu settings return to the factory default setting *except*:
 - The Display Language setting in the “Setup” Menu.
 - All settings in the Parallel Menu, Serial Menu, Network Menu, Infrared Menu, LocalTalk Menu, and USB Menu.

Selections are Restore Base and Restore Network. The Restore Network value only appears on printer models that have integrated network support.

Restoring Factory Defaults appears on the operator panel while factory defaults are restored.

Energy Conserve

Affects the values that appear in the Power Saver menu item in the Setup Menu. This menu item only appears when the printer model does not support Automatic Power Saver or has deactivated Automatic Power Saver. The menu item only affects the values that are displayed in the Power Saver menu item.

Select Off (default) to cause Power Saver to only display Disabled. If Disabled is selected in Power Saver, the printer deactivates the Power Saver feature. Select On to cause Disabled to not appear on the operator panel for Power Saver.

Event Log

Lets the system support person print a limited set of the information contained in the Diagnostics mode version of the printed Event Log. For a sample of a printout, see **“Event Log” on page 3-18**. The limited Configuration log and the full Diagnostics log printed versions show the same operator panel messages when they print and follow the same layout guidelines.

To print the event log:

1. Select **EVENT LOG** from the Config Menu.
2. Select **Print Log**.
3. Press **Select** () to begin printing the log.

Auto Align Adj

Controls whether the printer executes the automatic alignment calibration after an initiating event occurs. Toner Patch Sensing (TPS) is a diagnostic mechanism that automatically adjusts the printer toner density and alignment settings.

When TPS executes, the printer generates toner patches on the transfer belt. It then uses these to calculate the appropriate amount of adjustment, if necessary.

When an event initiates a TPS operation, the printer performs a toner density calibration, an alignment calibration, or both of the calibrations.

Selections are On (default) and Off.

Auto Color Adj

Sets the suggested number of pages which the printer should print between consecutive calibrations.

Selections are Off and the values between 100 and 1000 in increments of 50. The default is 500 pages.

If the printer exceeds the set value while printing a job, it completes the current job and any other jobs received while printing the current job before it initiates a calibration. The printer does not cancel or suspend an active job in order to perform a calibration. If a user is in any of the menus, including the Configuration Menu and the Diagnostics mode, an automatic color adjust calibration does not occur.

Enforce Color Order

Lets the system support person set whether the color order of the cartridges inside the printer is enforced and if messages appear.

From top to bottom, as indicated by the color labels in the printer, the enforced toner cartridges order is yellow, cyan, magenta, and black.

When On is selected, the printer lets users place each toner cartridge in only its specified slot. For instance, the Magenta toner cartridge must be in the Magenta slot. If the user tries to place a cartridge in an incorrect slot, the printer message 31 Defective or Missing [color] Cartridge or 32 Unsupported [color] Cartridge appears where [color] stands for Cyan, Magenta, Yellow, or Black.

When Off is selected, the printer does not issue any message to let the user know that the cartridge is placed in the wrong slot inside the printer.

Color Alignment

Prints the Print Alignment Page and requires that the best line in each set of lines must be selected.

Press **Select** (↵) to begin printing.

Consulting the printed page, follow the instructions on the operator panel to choose the best appearing line numbered 0 through 20 for the following sets of lines. These includes Set A, Set B, and so forth through Set L. For each of the sets listed, the sub-value is 0–20 (10 is the default).

Motor Calibration

Allows for speed calibration after resetting the fuser maintenance counter.

To calibrate the motors:

Press **Select** (↵) to select **Motor Calibration** from the CONFIG MENU. Calibrating displays, and the printer prints several blank pages and then returns to the CONFIG MENU.

Paper Prompts

Controls the source the printer selects for a change paper source message. The printer displays the change paper source message based on the size of the paper requested and not by the paper type.

Selections include Auto, MP Feeder, and Manual Paper. MP Feeder is only available on some printer models.

Note: If the Configure MP setting is changed to Manual, a power-on reset is performed, and the value of the Paper Prompts menu item before the power-on reset was MP Feeder, then when the printer restarts, the printer automatically changes the Paper Prompts setting to Manual Paper.

Load Manual overrides that would result in a change paper message are disabled for Paper or Env prompts that are set to Manual, Manual Paper, or Manual Env.

Env Prompts

Controls the source the printer selects for a change envelope source message. The printer displays the change envelope message based on the size of the envelope requested and not by the envelope type.

Selections include Auto, MP Feeder, and Manual Env. MP Feeder is only available on some printer models.

Note: If the Configure MP setting is changed to Manual, and a power-on reset is performed, and the value of the Env Prompts menu item before the power-on reset was MP Feeder, then when the printer restarts, the printer automatically changes the Env Prompt setting to Manual Env.

Load Manual overrides that would result in a change paper message are disabled for Paper or Env prompts that are set to Manual, Manual Paper, or Manual Env.

Jobs on Disk

Lets the user select whether or not the printer deletes all buffered jobs on the hard disk. This menu item only appears if a hard disk is installed. It appears even if no buffered jobs exist on the hard disk.

Selections include Do Not Delete and Delete.

Disk Encryption

Controls whether the printer encrypts the information that it writes to the hard disk.

Warning: When the value for Disk Encryption, the printer completely formats the hard disk which means that all information on the disk is deleted.

Note: If an encrypted disk is removed from the printer and another disk is installed, the Disk Corrupted. Reformat? message appears. The newly installed disk must either be formatted or removed from the printer.

Selections include Disable (default) and Enable. When Disk Encryption is selected, Yes or No appears for you to confirm. Select either Yes or No, and press **Select** (✓) to continue. To cancel, select No.

The Disk Encryption menu item only appears when:

- A non-defective disk is installed in the printer.
- The values of bits 3-2 of digit 4 in the Configuration ID 2 are either 01 for Supported, or 10 for Supported with an internal network adapter (INA).

A graphic appears, showing:

- The message Encrypting Disk or Formatting Disk
- A percentage scale
- The message DO NOT POWER OFF

The process is complete when the percentage scale displays 100.

Duplex Gloss

Generates higher quality duplex copies than when using the normal duplex mode. The major difference between normal duplex and duplex gloss mode is the number of sheets in the duplex print media path. Normal duplex mode feeds two sheets simultaneously, while duplex gloss feeds only one sheet.

Selections include Off (default) and On.

Font Sharpening

Lets a user set a text point-size value below the setting of the high frequency screens used when printing font data. This menu item only affects the PostScript, PCL 5, PCL XL, and PDF emulators.

Settings are in the range of 0–150 (24 is the default). For example, if the value is set to 24, then all fonts sized 24 points or less use the high frequency screens. To increase value by 1, press ►; to decrease the value by 1, press ◀.

Exit Config Menu

Press **Select** to exit the CONFIG MENU. The printer performs a power-on reset and returns to normal mode.

Paper Jams

Error jam locations

The following illustration shows the location and error codes generated for specific paper jams and the corresponding locations of these jams.

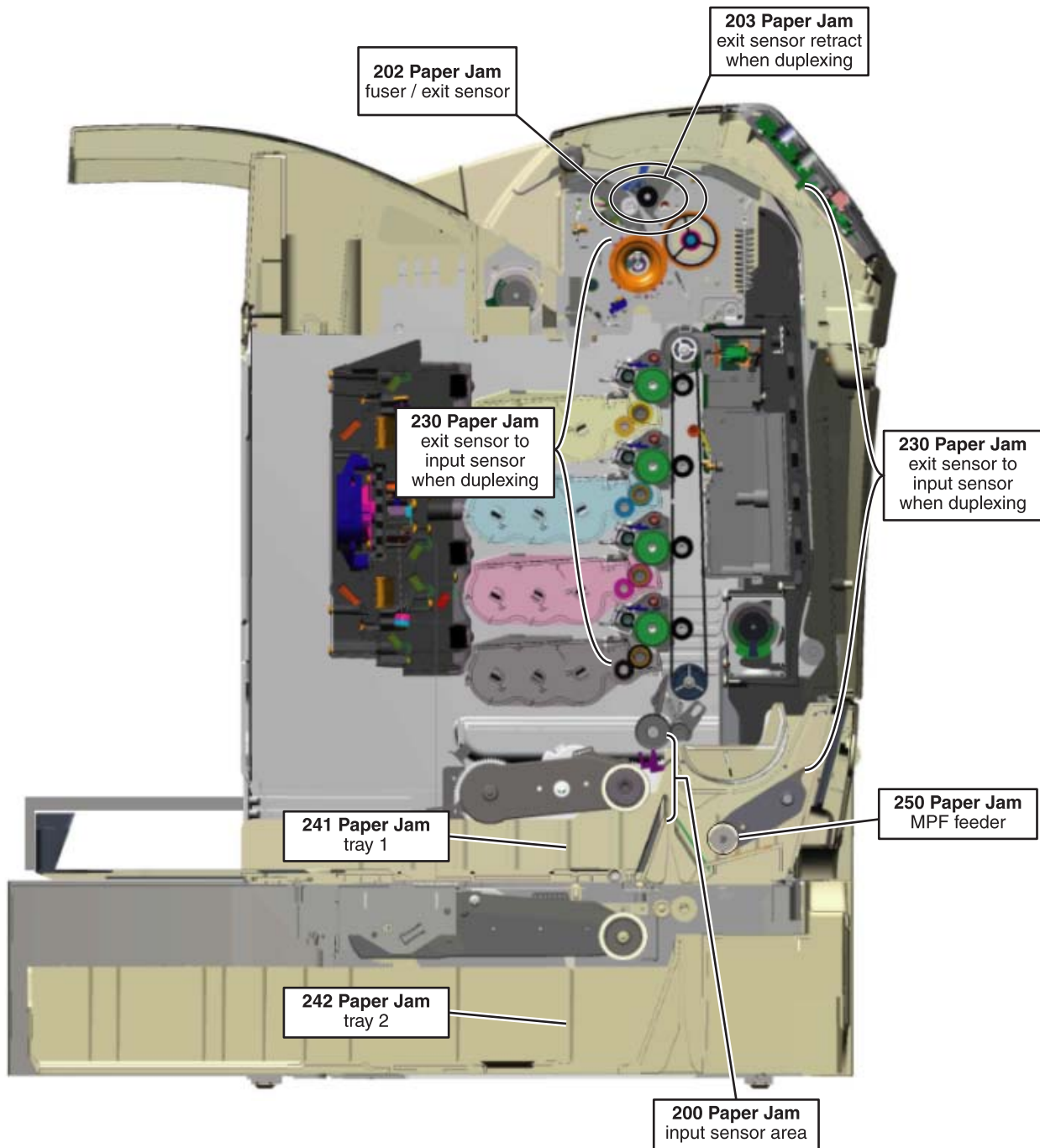

Paper jams in the multipurpose feeder or manual feeder

Note: The multipurpose feeder can also be used as a manual feeder.

Loading media in the multipurpose feeder or manual feeder

1. Use the marks above the slot to adjust the width guide for standard paper sizes. For odd sizes, once the paper is isolated, move the width guide until it lightly touches the sheet.
Warning: Do not force the width guide against the paper, or it could be damaged.

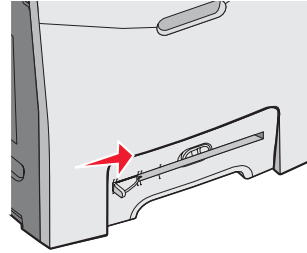
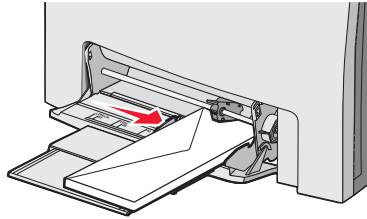

2. When Load manual feeder with <x> appears on the display, load a single sheet of paper flush with the right side of the slot, and then press **Select** (⏵).
Load an envelope with the flap side up.

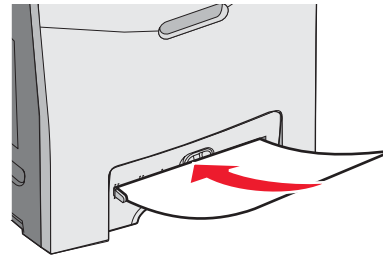
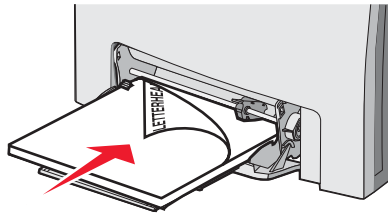

3. Push the paper in until it stops. The printer pulls it in farther.
Note: Maintain pressure on the paper or envelope until the printer takes the paper from your hand.

Clearing a paper jam in the multipurpose feeder

When paper jams in the multipurpose feeder, a 250.xx, 201.08, or 200.11 Paper Jam message appears.

1. Pull the paper down and out.
2. Open the top access cover, and close it.

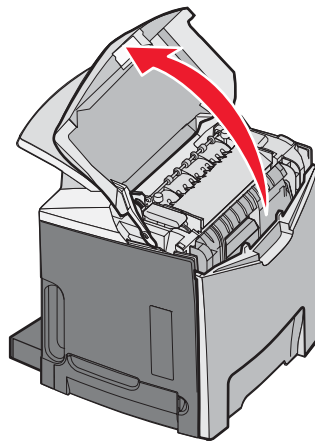
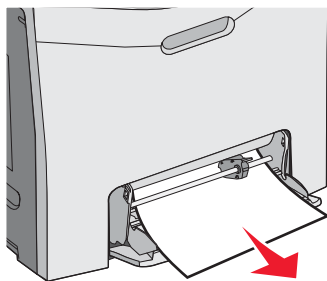

3. Load the paper, and push the paper in until it stops. The printer should pull it in farther.
Note: Maintain pressure on the paper or envelope until the printer takes the paper from your hand.

Clearing paper jams in the manual feeder

When paper is not placed far enough into the manual feeder, the display prompts you to insert paper.

If the paper is pushed far enough into the manual feeder for the printer to sense it, but not far enough to feed properly, 200.xx, 200.11, or 201.08 Paper Jam messages appear.

In either case, push the paper farther into the manual feeder.

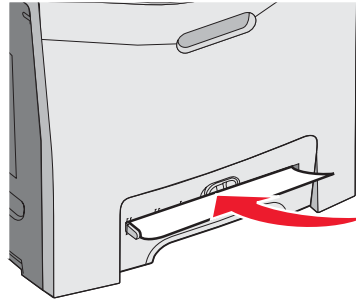

If the paper does not feed:

1. Remove the paper or envelope.
2. Open the top access cover, and close it.

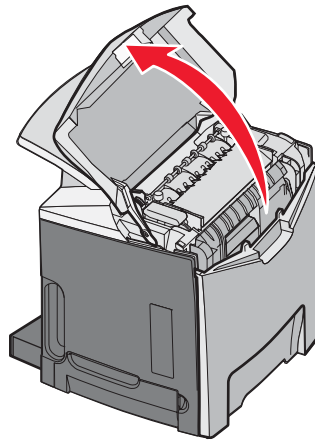

3. Load the paper, and push the paper in until it stops. The printer should pull it in farther.
Note: Maintain pressure on the paper or envelope until the printer takes the paper from your hand.

Theory of operation

Paper path

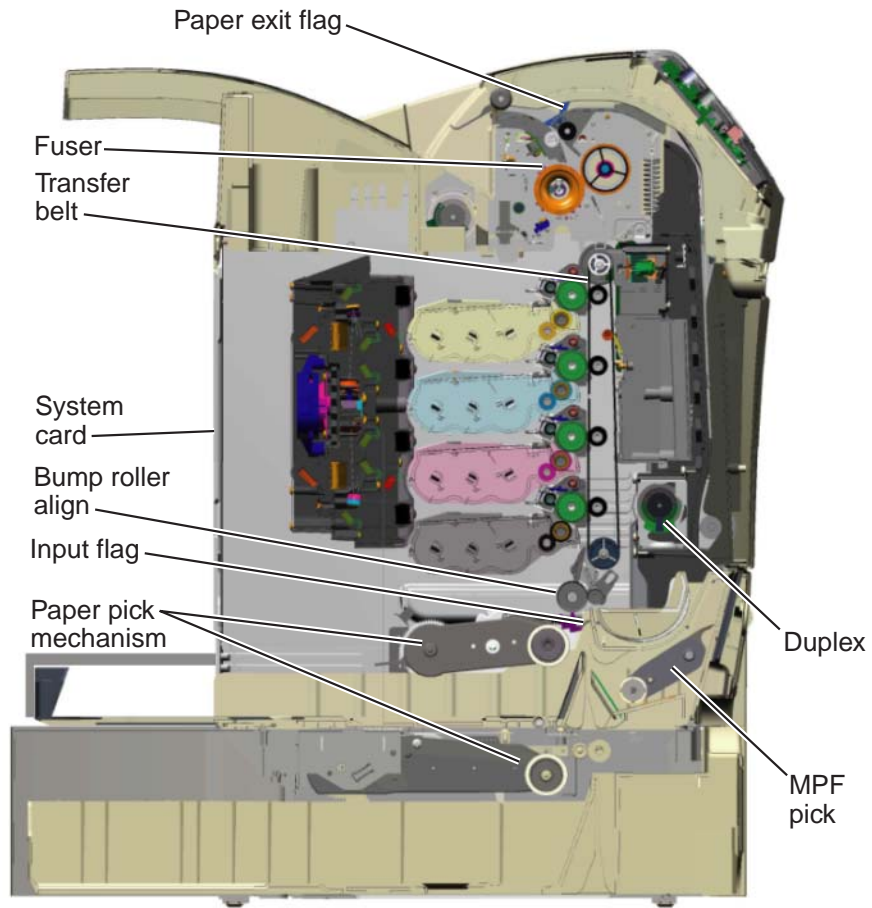

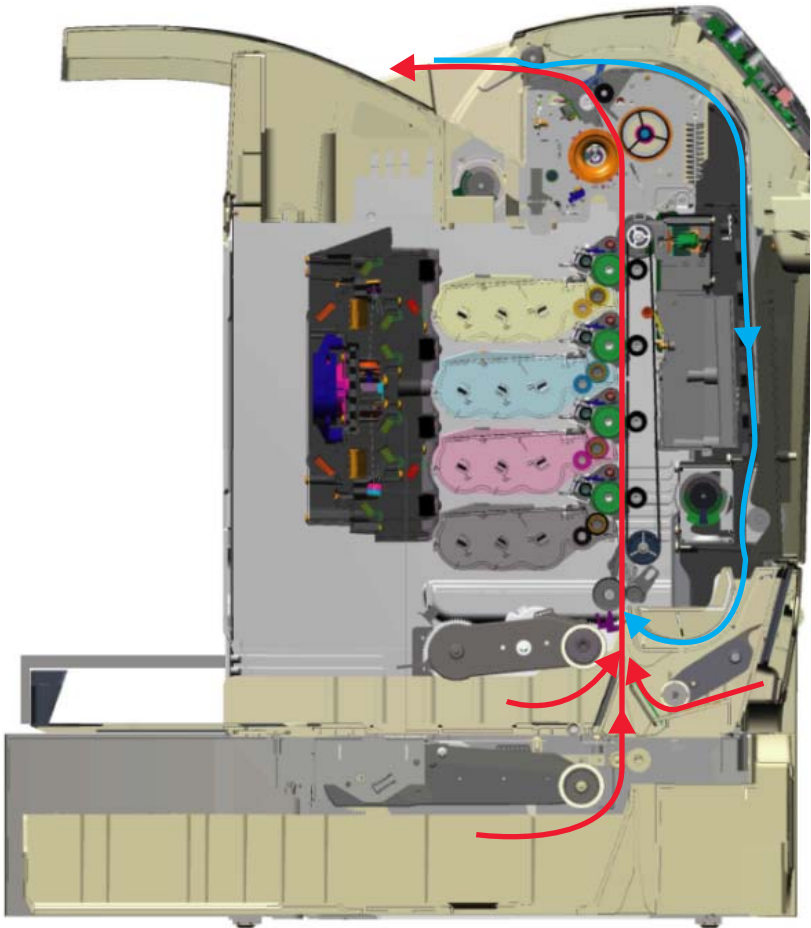

Main Components

System card

The system card provides the intelligence of the printer. Command and control signals originate in the system card that make print media travel possible. The system card controls the timing of the print media during the printing so the media arrives at certain positions in the print process at certain times.

Paper tray

Houses the print media.

Paper pick mechanism

Picks the print media from the paper tray. The paper pick mechanism contains the paper pick (input) sensor and the multifunction transparency sensor.

Bump aligner roll

The bump aligner roll advances the print media onto the transfer belt and corrects any media skew as it comes out of the paper trays or MPF.

Transfer belt

The transfer rolls (located inside the transfer belt unit) are an integral part of the electrophotographic process, and the transfer belt advances the print media through the printer.

Fuser

The fuser bonds toner to the print media and advances the print media through the last portion of the paper path. The paper exit sensor is also located in the fuser, and a flag is present on all fusers that activates the bin full sensors on network model printers.

Duplex

Duplex capability is present only on the C524dn or C524dtn model printers. The duplex function is built into the front access door and uses a two-pass method for rerouting the paper down and back through the paper path for a second time. To accomplish the two-pass method, the paper is fed partially out of the printer and is then reversed back into the printer.

Print media transport

The print media is picked from the input source and fed to the bump aligner roll. The media movement is detected by a sensor located in the paper pick mechanism. It does not matter where the media comes from (Tray 1, Tray 2, or the MPF); it will enter the electrophotographic process at the bump aligner drive. The bump aligner motor drives the bump aligner roll which feeds the paper to the transfer belt.

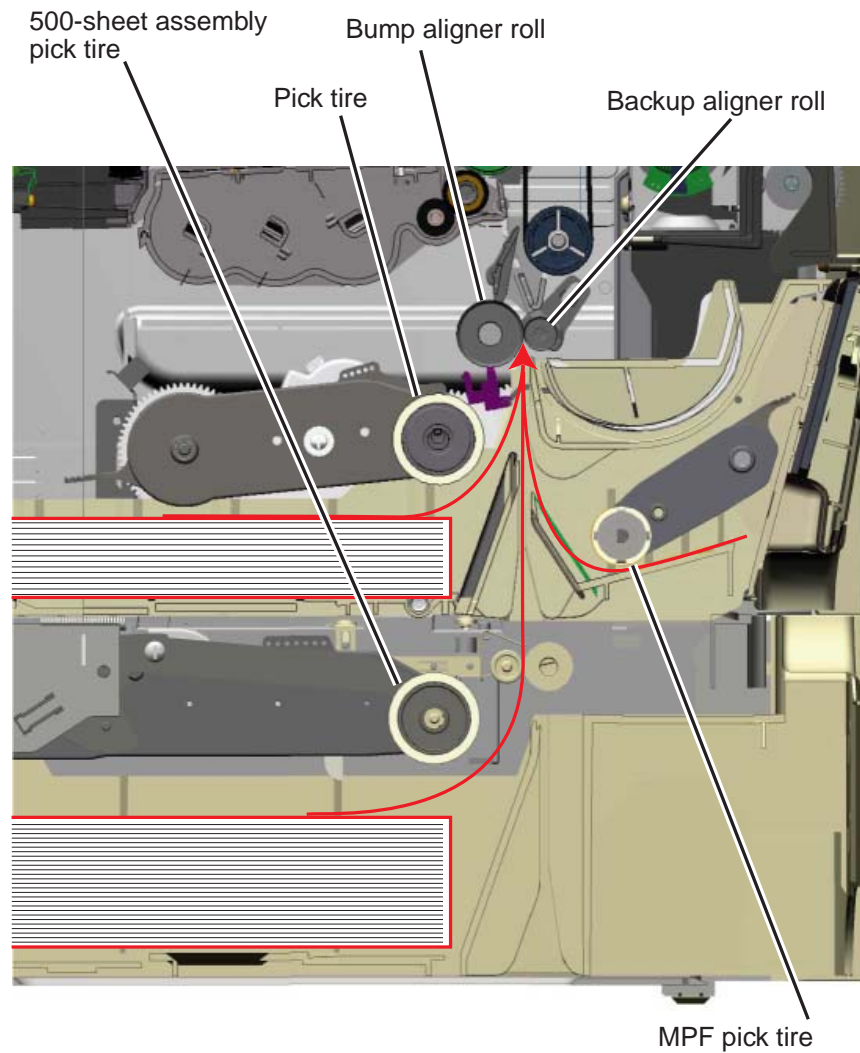

Once the paper is fed onto the transfer belt, the photoconductor drums in conjunction with the transfer belt pull the print media through the paper path.

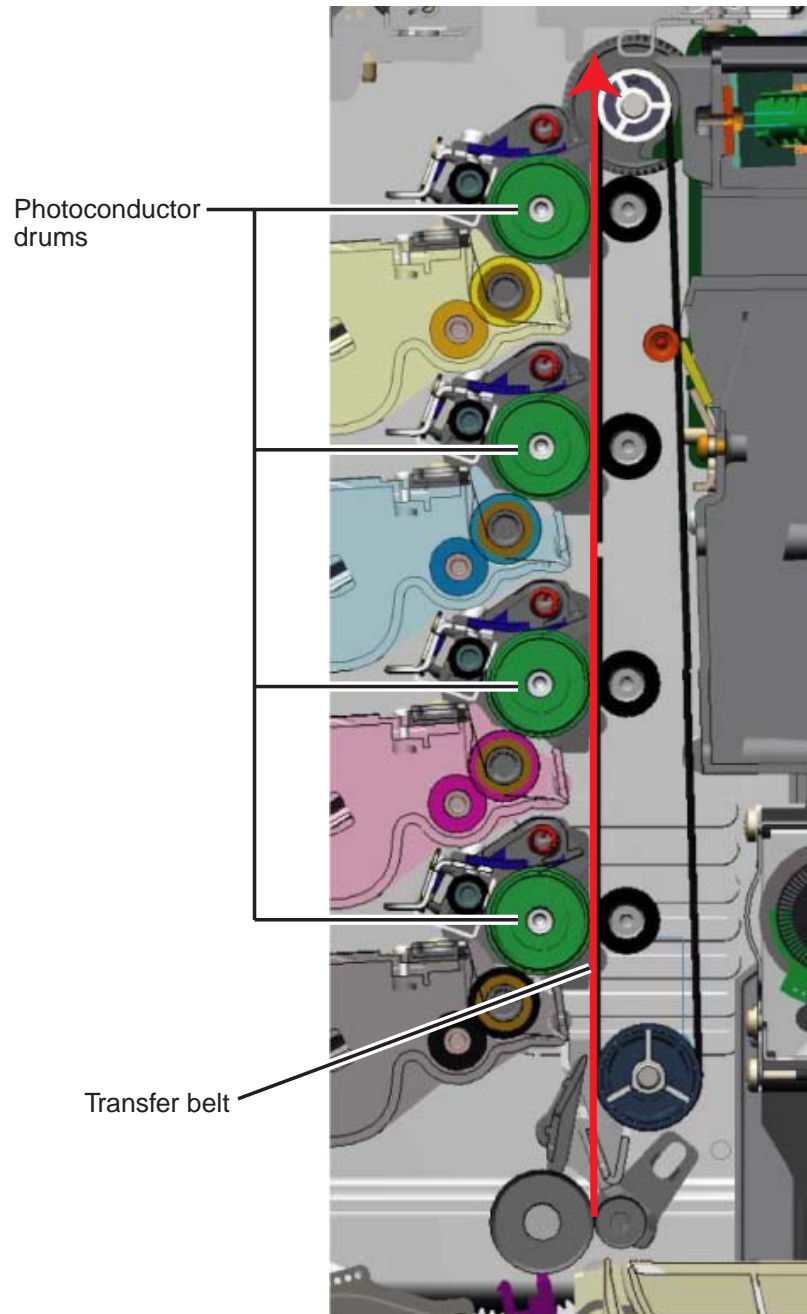

Once the print media exits the transfer belt, it enters the fuser where heat and pressure are applied to bond the toner permanently to the media. The fuser rollers continue to turn and pull the print media through the paper path until it reaches the exit drive roll. The exit drive roll pulls the print media from the fuser rollers and delivers it to the fuser output drive roll. Once the print media reaches the fuser output drive roll, the roller pushes the print media into the output bin.

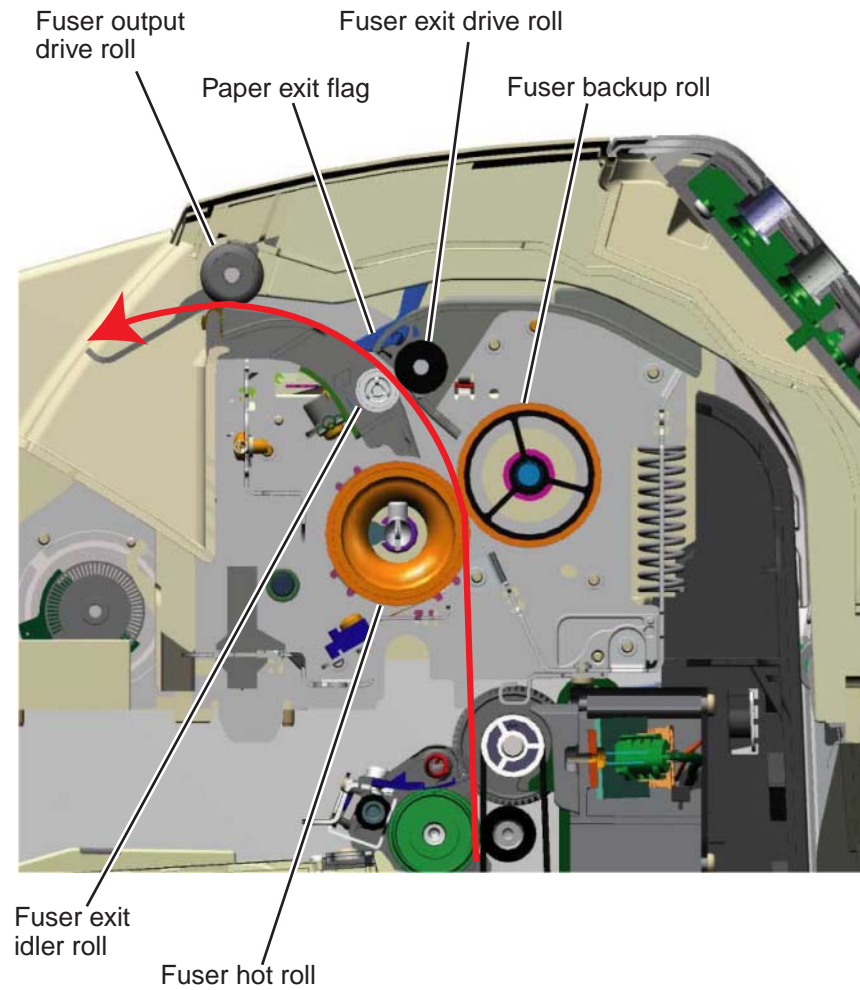

If the page is to be duplexed, the fuser output drive roll continues to pull the media until it clears the paper exit flag and then reverses the rotation of the roller in order to pull the media back into the printer duplex assembly. The media is then routed down through the duplex path until it reaches the bump aligner roll. Once in this position, it enters the EP path for the second time.

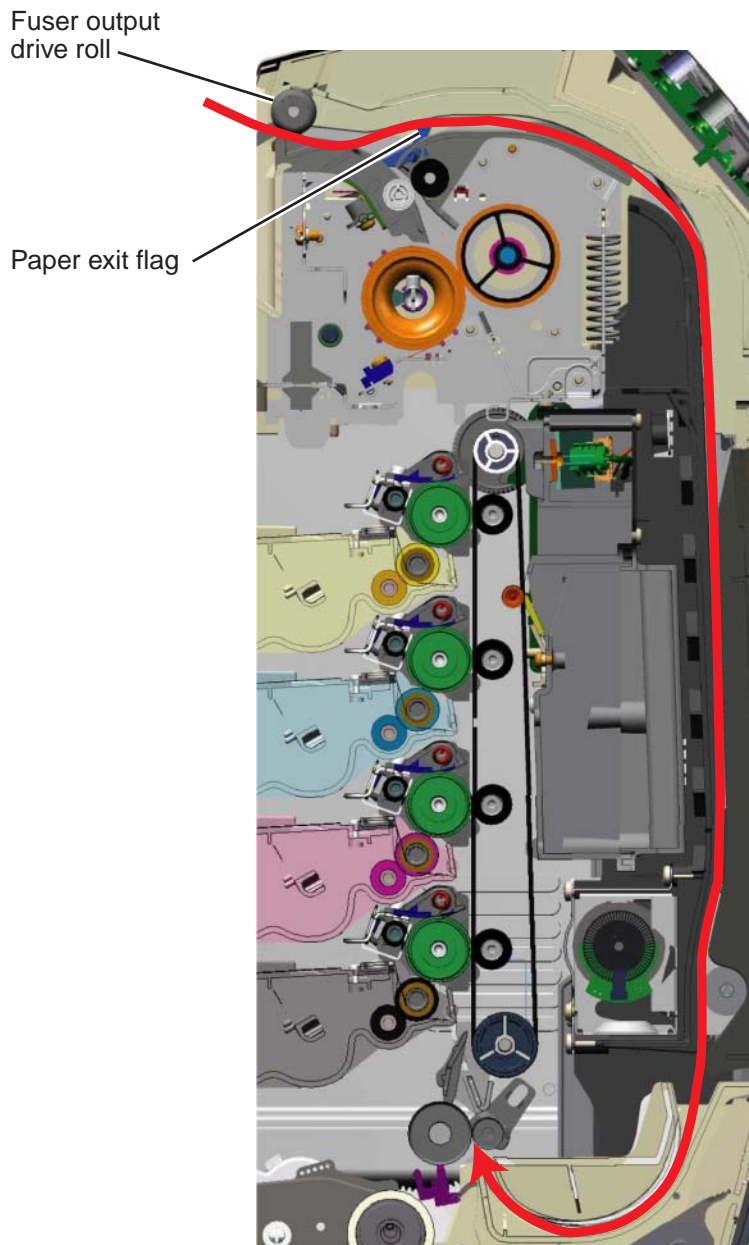

The paper exit flag serves two purposes. When it triggers the paper exit sensor, it serves as a one-way gate for the media when it is exiting the printer to the output bin and also serves as a one-way gate when the media is entering back into the printer for a duplex print. In other words, it diverts the print media's path, directing it to either the output bin or the duplex paper path.

Mechanical drive

In order for the print media to move through the paper path, there are several drive motors that supply the mechanical power to the rollers discussed previously. The drives for these components are illustrated and discussed in the following paragraphs.

Paper pick mechanism drive

When printing from Tray 1 or Tray 2, the paper pick motor drives the paper pick gears which causes the pick roller to turn. During an MPF print, the paper pick motor drives the swing arm assembly for the MPF and causes the MPF paper pick roller to turn.

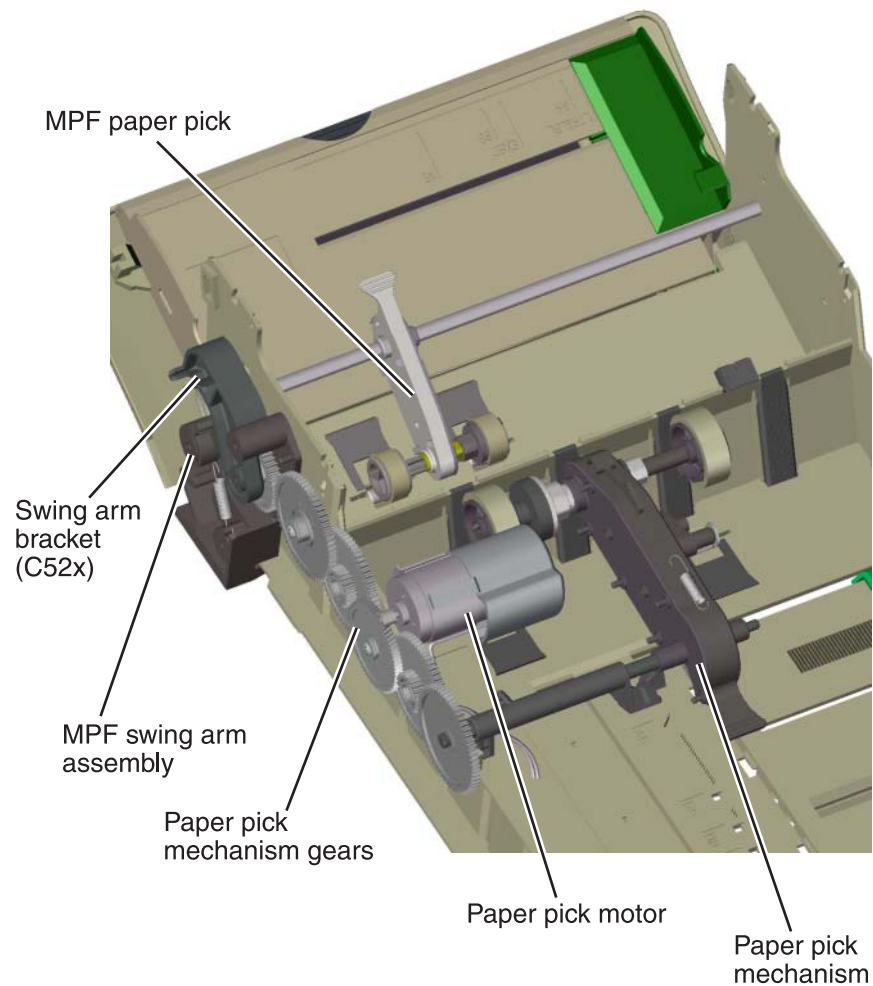

Paper tray and paper pick mechanism shown from rear with components removed for clarity

Bump aligner drive

The power to turn the bump aligner roll is supplied from the bump aligner motor. The motor drives a set of bump aligner gears which causes the bump aligner roll to turn.

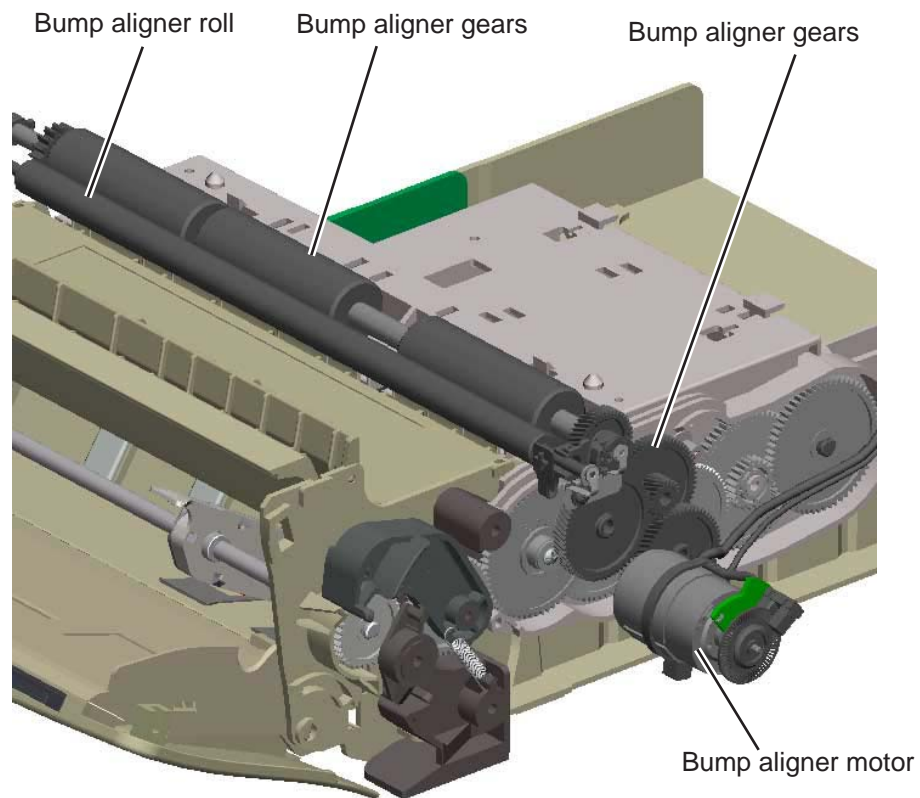

Note: If this motor is stalling or causing waste toner box full messages, the vertical auger mechanism might be causing the problem.

Photoconductor unit/toner cartridge drive

The photoconductor units (four) and toner cartridges (four) receive drive power from the EP drive assembly motors. The top cartridge motor 1 on the EP drive assembly provides drive to the top two photoconductor units and toner cartridges (yellow and cyan). Likewise, the bottom cartridge motor 2 drives the two bottom photoconductor units and toner cartridges. When the printer's top access door is open, the couplers for the toner cartridges and photoconductor units disengage.

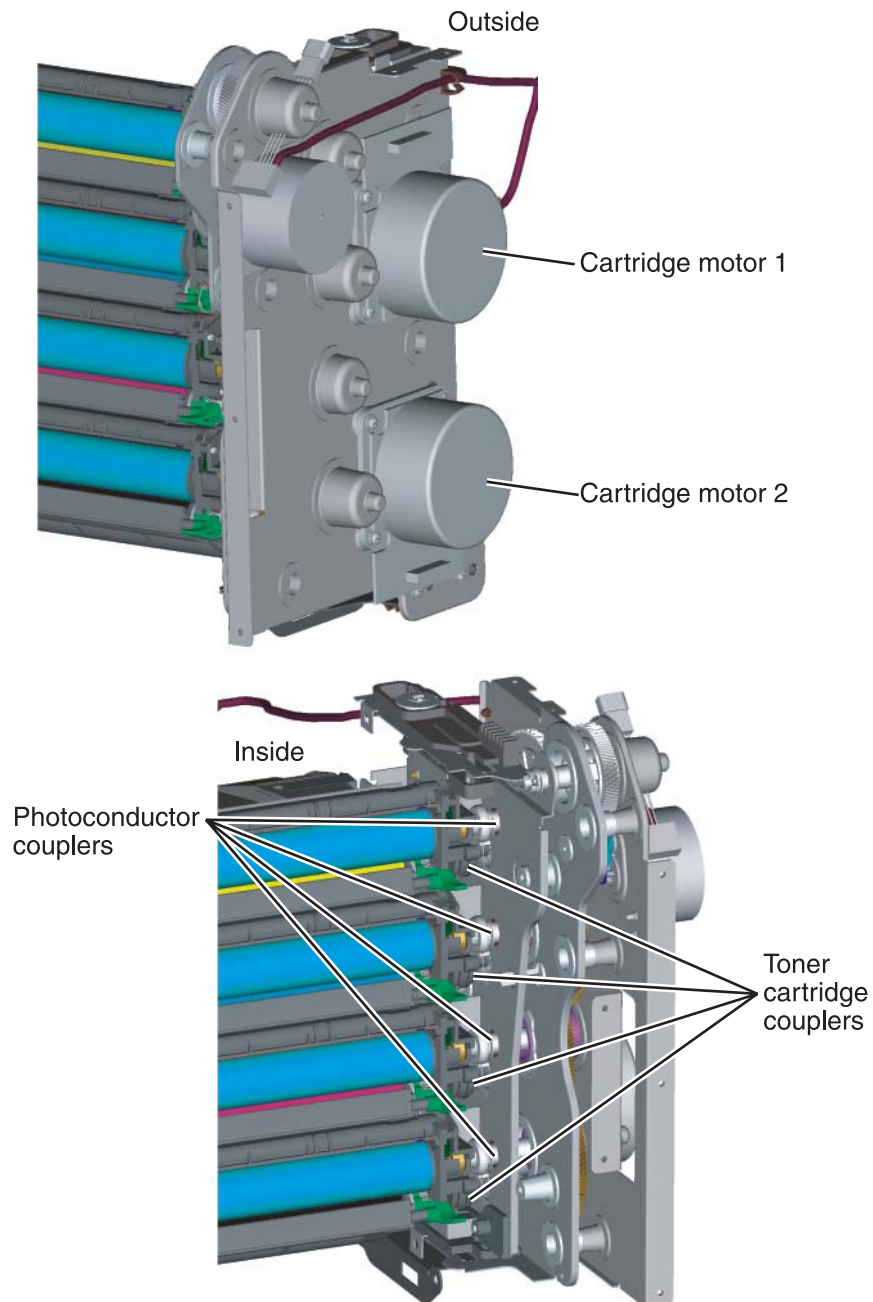

Transfer belt drive

The transfer belt unit receives drive from a motor located on the EP drive assembly. When the top access door is open, the coupler for the transfer belt disengages.

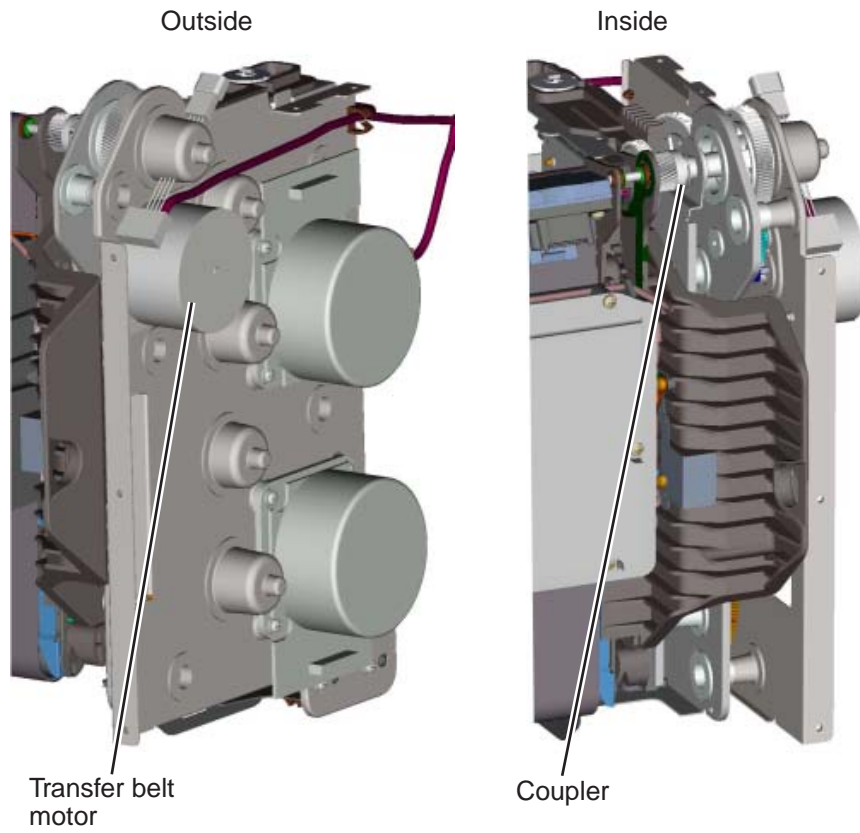

Fuser drive

The fuser drive (motor) is built into the fuser assembly and drives the fuser rollers to turn.

Duplex drive

The duplex motor is mounted on the front door assembly. Drive is provided to three drive shafts in the duplex unit by a belt that is driven by the motor. The drive shafts move the print media through the duplex unit during printing.

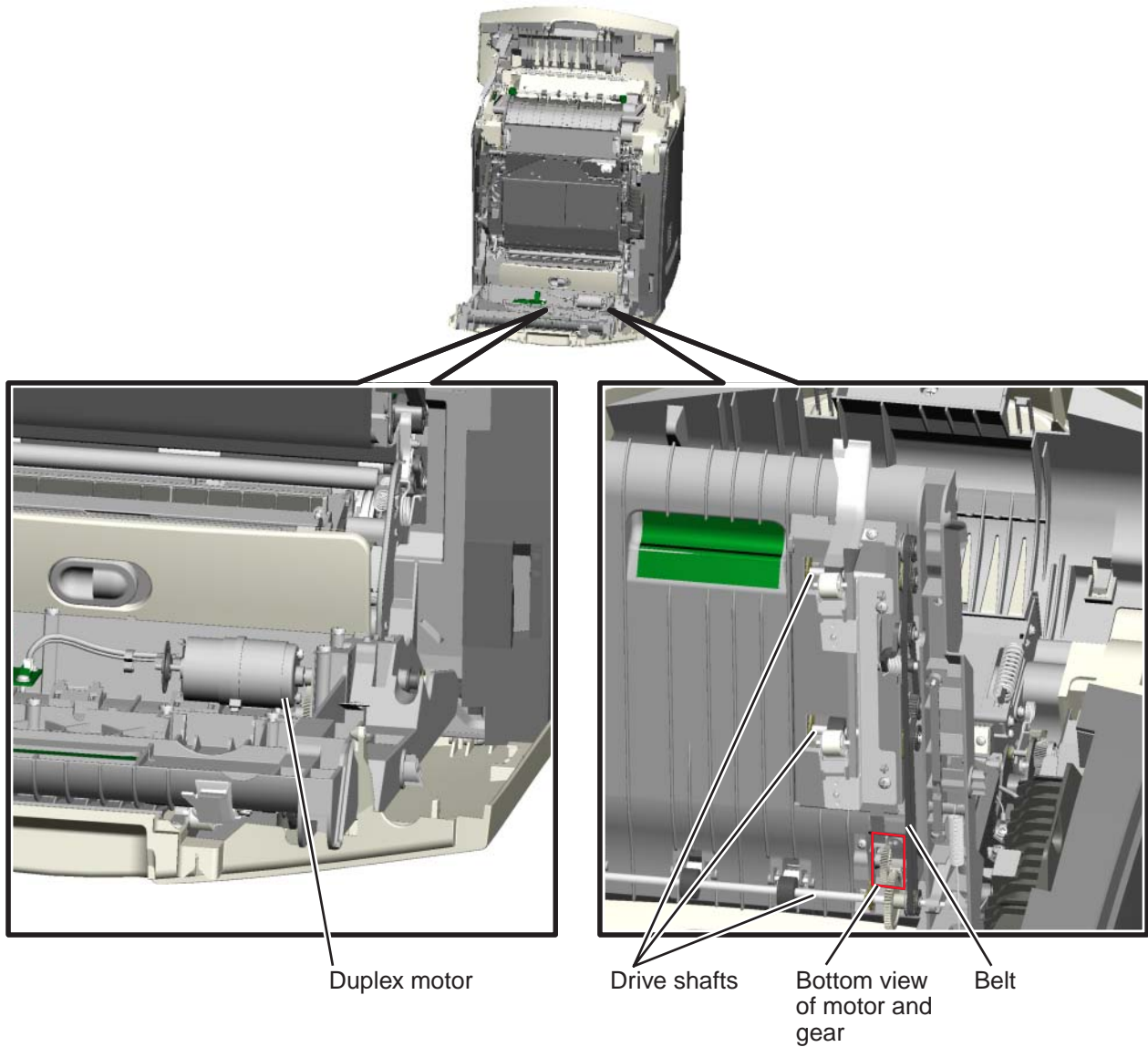

Paper sensing

Sensors are strategically placed in the printer to ensure that the print media is making it to specific points within a given time in the electrophotographic process. There are two paper flags: one at the bottom of the machine (paper pick) to detect input paper, including duplex second side, from all sources and one at the top (paper exit) to detect paper movement beyond the fuser. The flags are similar in design, in that a mechanical arm is moved by the media to interrupt an optical sensor; both are normally blocked when no media is present. There is also a multifunction transparency sensor that detects if: 1) tray 1 is present, 2) narrow media is being used, and 3) the media is a transparency. The sensor works for tray 1, tray 2 (500-sheet option), and the MPF.

Paper pick sensor

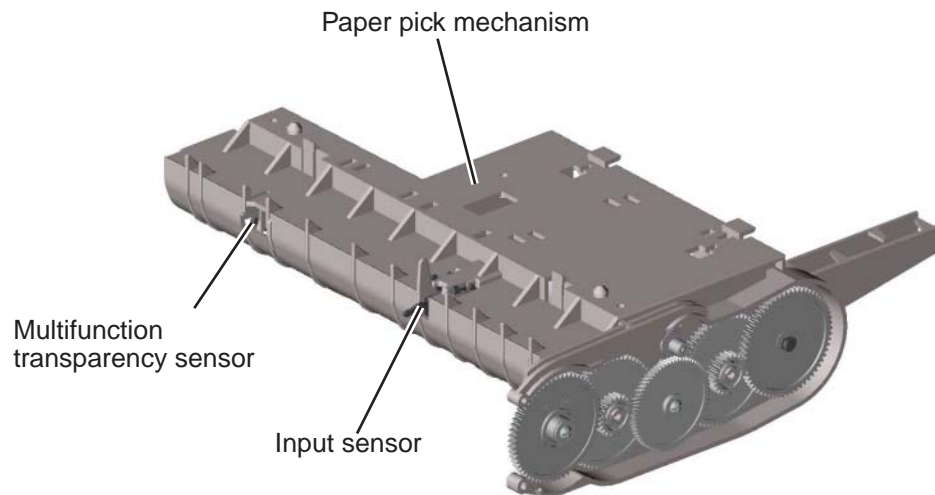

Paper exit/duplex entry sensor and bin full flag

The top sensor detects movement in two directions: as the paper exits the fuser and as it is retracted from the exit tray back into the duplex path. Each sheet must be driven past the fuser exit flag and allowed to fall before being turned around and starting the duplex path. If the print media activates the paper exit flag for too long, or the print media doesn't reach the paper exit flag within a given time, a paper jam error will be posted.

There is a similar paper flag (bin full) on the output of network machines. This sensor indicates when the output bin is full. The physical flag is located in the fuser on all machines; however, the electrical sensor is not present on the non-network models. The flag should move in and out of the sensor eye with every sheet until the bin is nearly full. Once in this state, the paper flag will break the sensor eye continuously.

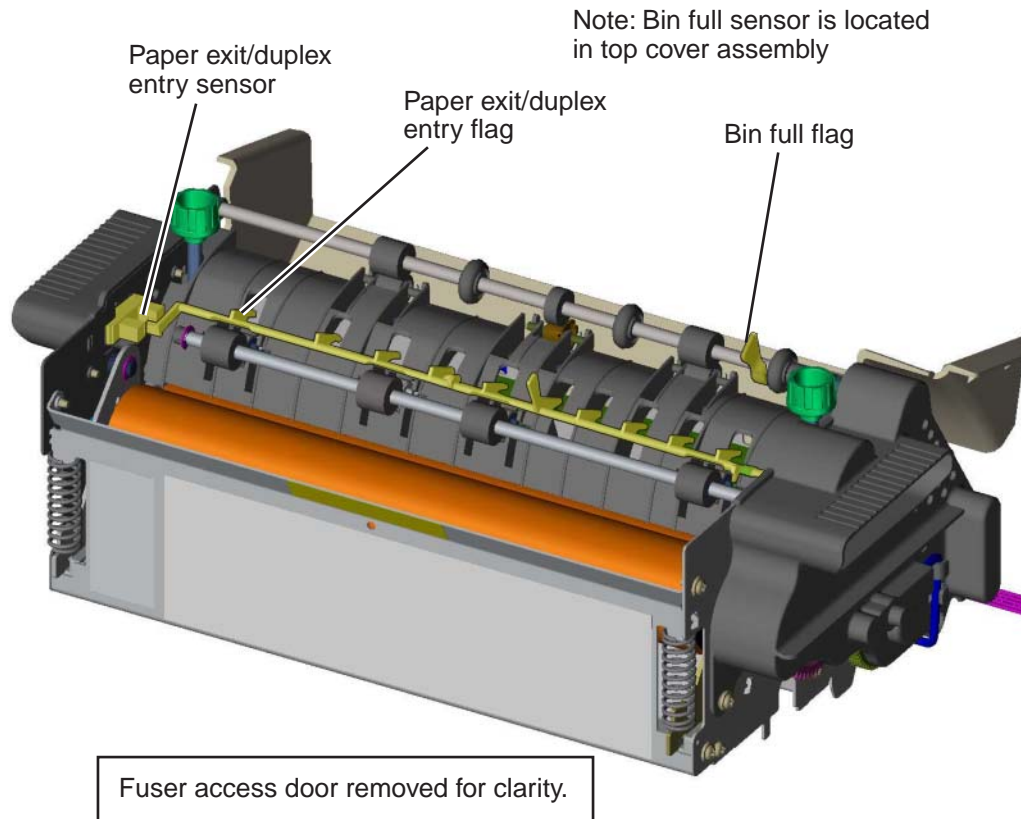

Electrophotographic (EP) process

Main components

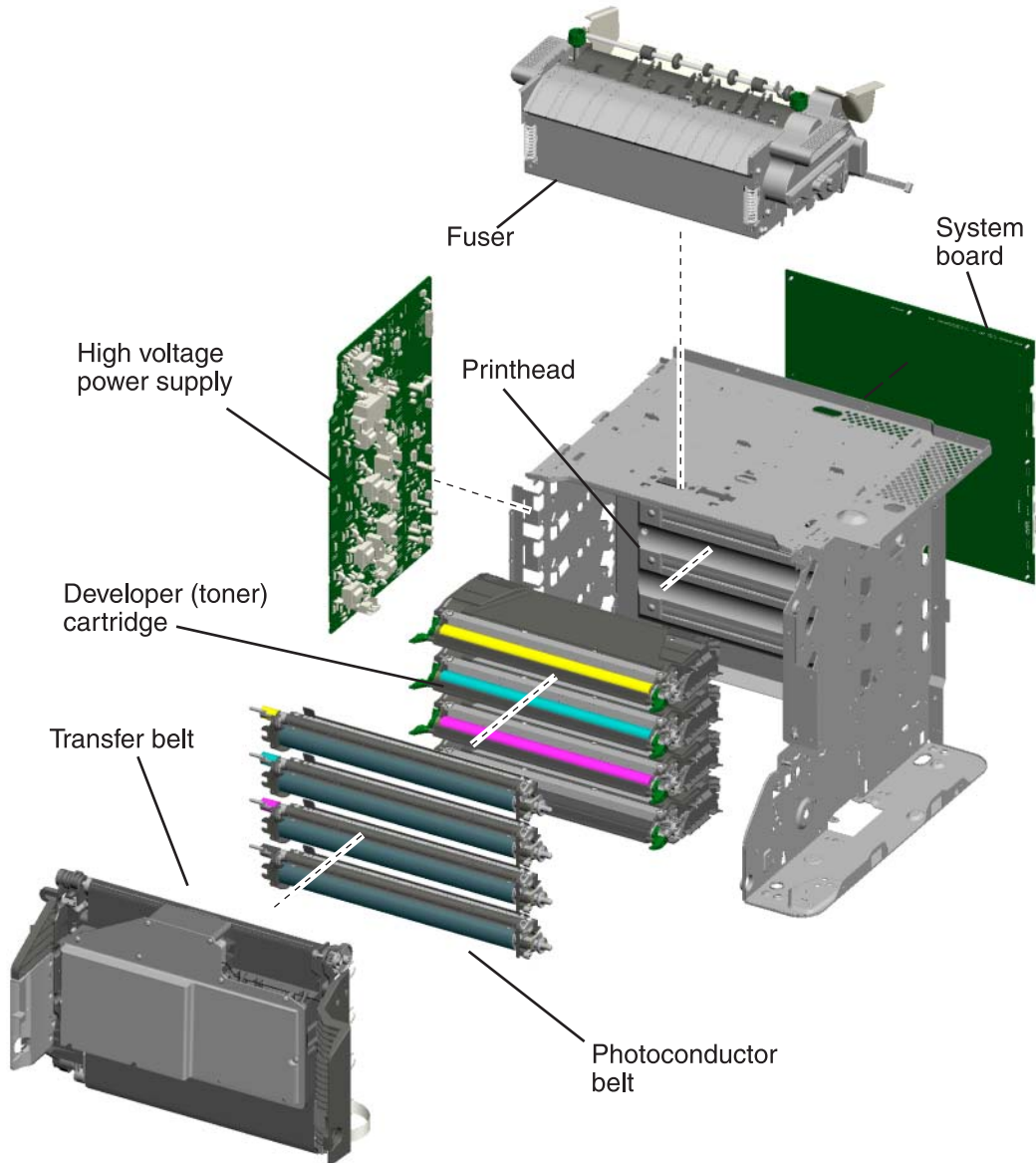

System card

The system card is the brain of the printer. During the print process, an image is sent from a computer to the system card. The raster image processor (RIP) portion of the system card converts the data into a raster image and feeds this data along with control information to the printhead.

High voltage power supply (HVPS)

Provides a high voltage charge to:

- The charge roll located in the photoconductor unit
- The photoconductor drum located in the photoconductor unit
- The toner adder roller (TAR) located in the toner cartridge
- The developer roll located in the toner cartridge
- The doctor blade located in the toner cartridge
- The four transfer rolls located in the transfer belt

Printhead assembly

The printhead receives control and image data from the system card (RIP). Through the use of a laser unit, the printhead irradiates the photoconductor drum with light and creates an invisible image called a latent or electrostatic image.

Photoconductor unit

The photoconductor unit consists primarily of a charge roll and the photoconductor drum. The charge roll charges the surface of the photoconductor drum to prepare it for the latent image “drawn” by the laser. Once the photoconductor drum has been written to by the laser, it is responsible for picking up toner from the cartridge developer roller and then transferring the image to the print media.

Toner cartridge

This unit consists primarily of the developer roll and the toner adder roll. The primary function of this unit is to supply charge toner to the photoconductor unit for transfer onto the print media. The toner adheres to the electrostatic image on the surface of the photoconductor drum which is then transferred to the print media.

Fuser

The fuser assembly uses heat and pressure to fuse the toner image onto the print media.

Charging

The primary component of the charging process is the high voltage power supply. The following provides information that covers the mechanical transfer of the high voltage through a set of springs to each subcomponent of the charging process.

Photoconductor unit (charge roll)

The following illustration shows the circuit path that allows high voltage current to flow from the HVPS to the charge roll contact on the photoconductor unit. It is essential that the contact springs are properly touching to provide a good flow. If not, print quality problems will occur.

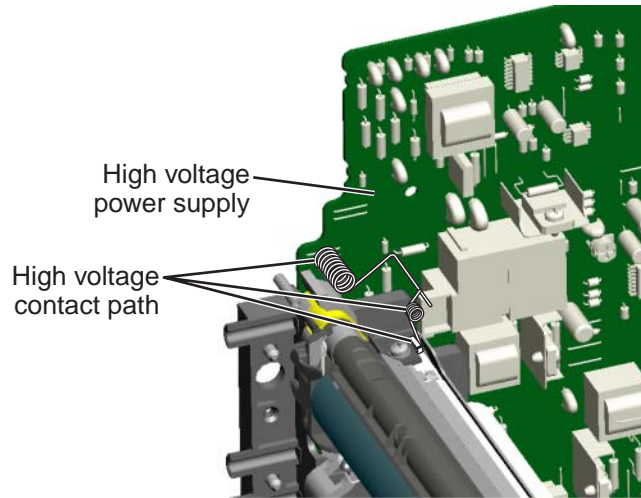

Photoconductor unit (photoconductor drum)

The following illustration shows the circuit path that allows high voltage current to flow from the HVPS to the photoconductor drum contact on the photoconductor unit. It is essential that the contact springs are properly touching to provide a good flow. If not, print quality problems will occur.

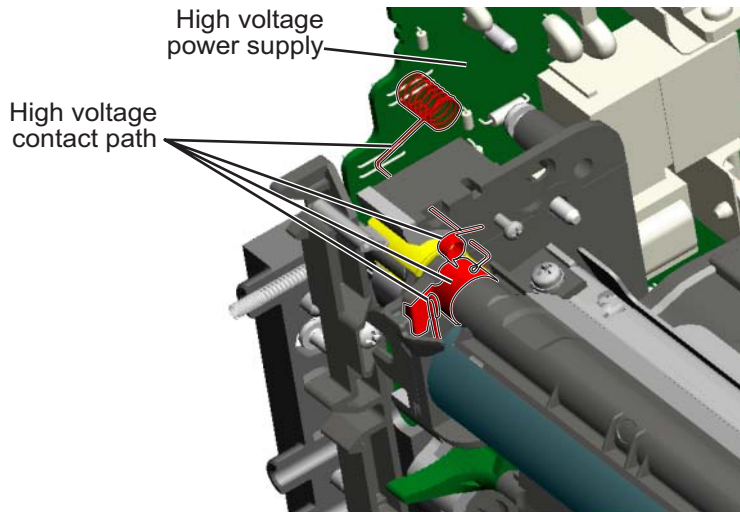

Toner cartridge

The following illustration shows the circuit path that allows high voltage current to flow from the HVPS to the toner cartridge. The toner cartridge contains three parts that are provided high voltage from the HVPS. These three parts are: the doctor blade, the developer roll, and the toner adder roll (TAR). It is essential that the contact springs are properly touching to provide a good flow. If not, print quality problems will occur.

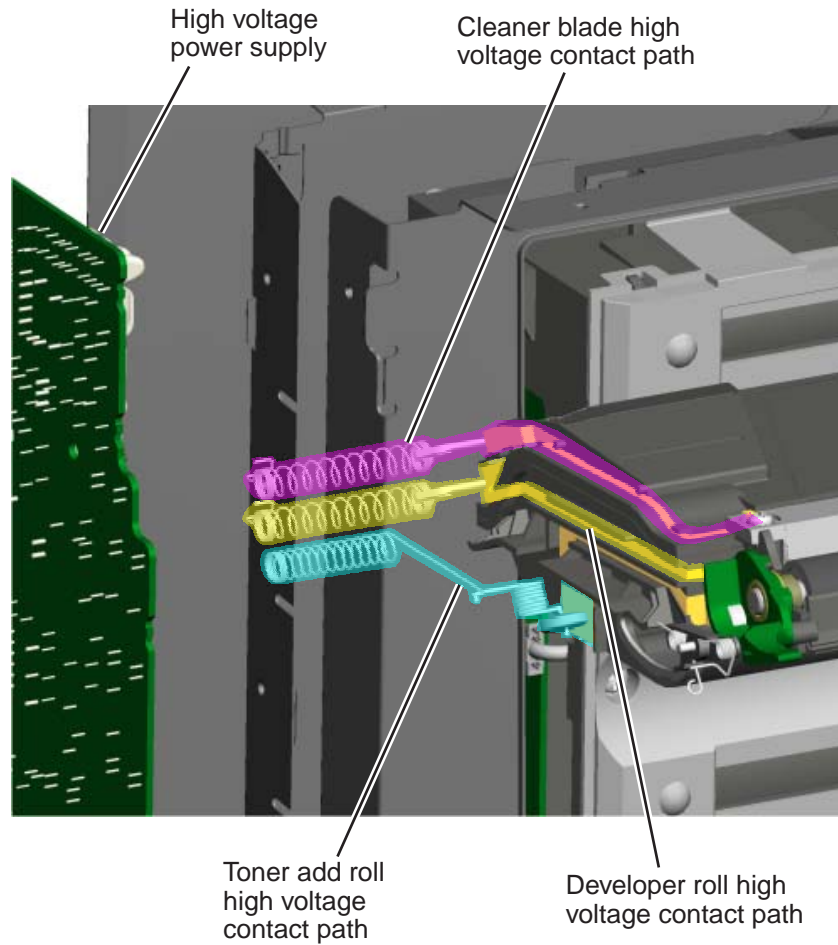

Transfer belt

The transfer belt houses four transfer rollers that provide image transfer from the photoconductor drum to the print media. The transfer belt receives its high voltage charge through spring contacts located on the transfer contact assembly as shown in the following illustration. For the sake of simplicity, only one of the roller's high voltage paths is shown. This path is typical for the other three rollers as well.

Transfer belt high voltage path

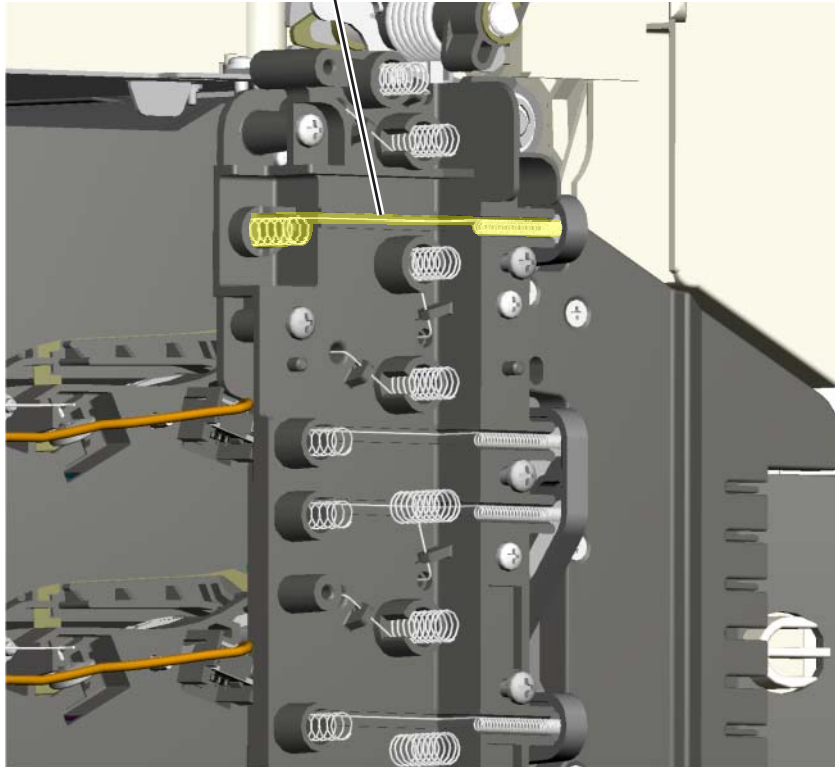

Exposing

The main components in the exposure process are the system card, the printhead and the photoconductor unit. The following illustration depicts a typical data path for a single color exposure.

Data is received from a computer into a port on the system card. The system card's RIP function converts this data into raster information which is fed to the printhead along with other control data. The data is converted by the printhead laser into light energy data that is directed to the light sensitive photoconductor unit.

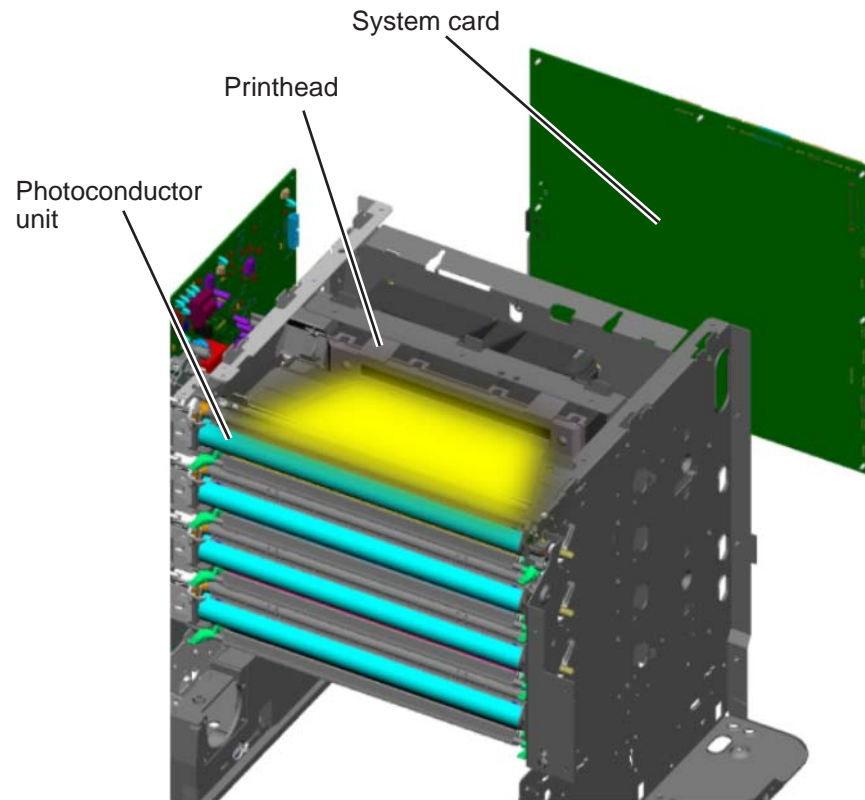

Developing

The two primary components of the developing process are the photoconductor unit and the toner cartridge. The toner cartridge contains a toner adder roll, developer roll and toner. Toner is advanced toward the toner adder roll by three paddle assemblies. The advanced toner clings to the electrically charged toner adder roll. The toner on the toner adder roll is then electrically attracted to the developer roll because of the difference in electrical charge between the toner adder roll and the developer roll. The toner uniformly coats the developer roll with help from the doctor blade and is introduced to the electrostatic image on the photoconductor drum. The toner then transfers to the photoconductor drum.

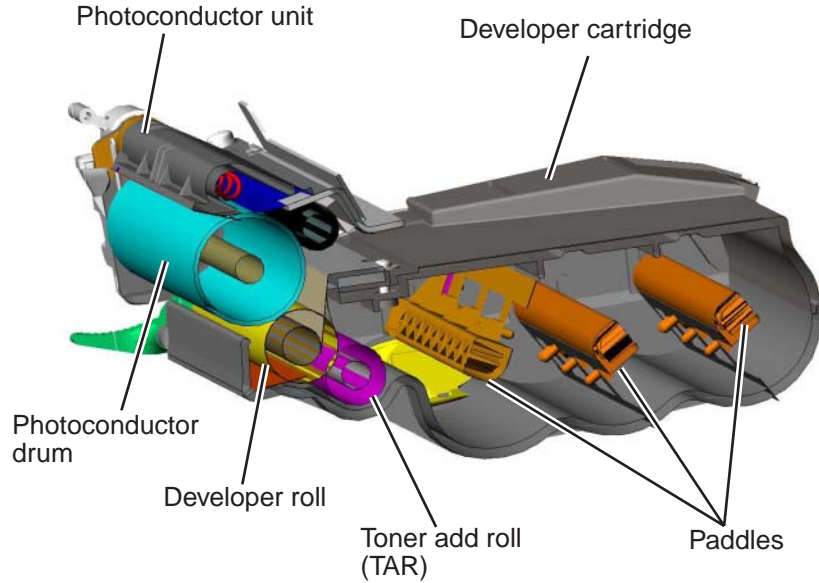

Transferring

After the toner is attracted to the photoconductor drum, the image is ready for transfer onto the print media. The print media is advanced in the paper path onto the transfer belt and is carried along the belt underneath each photoconductor unit. The charged transfer roll(s) located inside the transfer belt pulls the image from the photoconductor drum to the print media. This is a direct transfer method.

The main function of the transfer belt is to provide transport for the print media. Toner is not transferred directly to the belt during the print process.

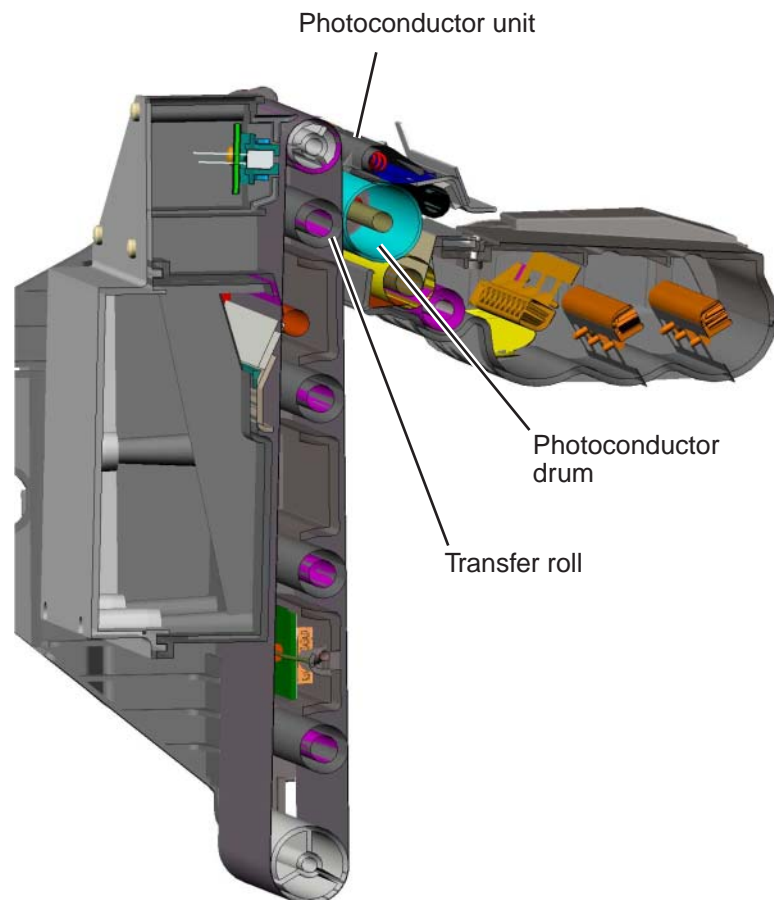

Fusing

After the image has been transferred onto the print media, it is ready for fusing. The print media is transported into the fuser where the hot roll and backup roll use a combination of high heat and pressure to melt and press the toner to the media.

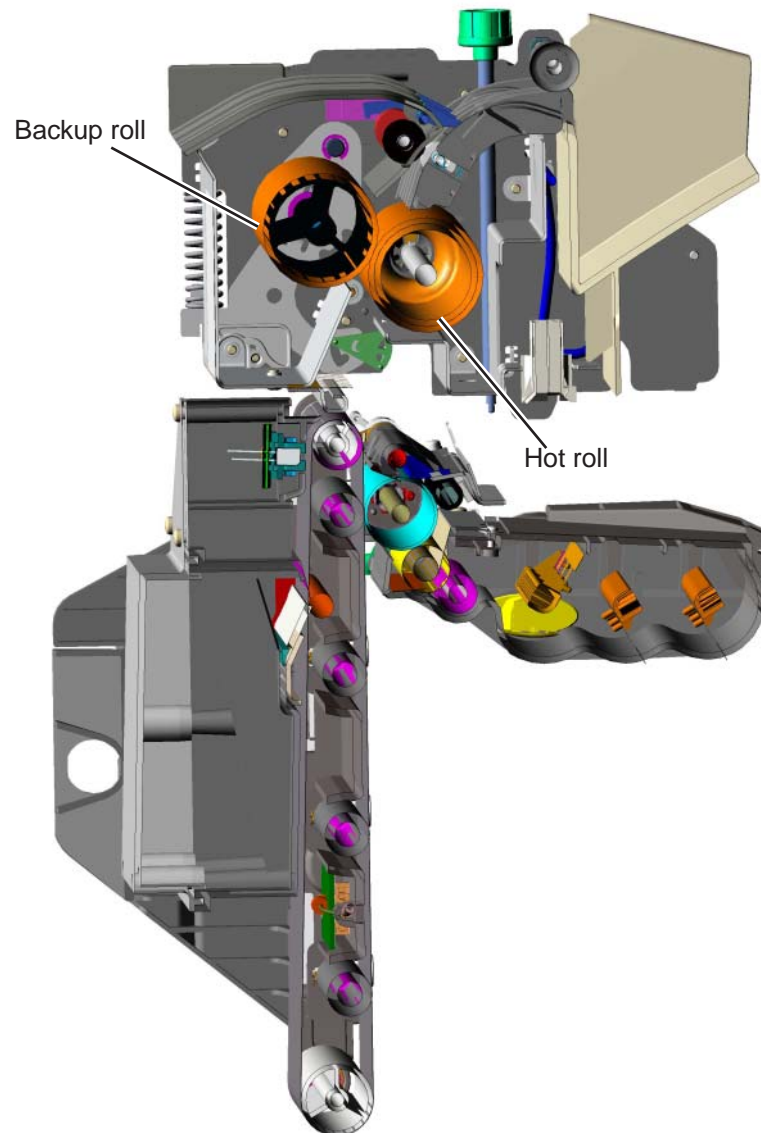

Cleaning

The transfer belt and photoconductor drum are cleaned at the end of the electrophotographic process cycle. The transfer belt surface is cleaned as it rotates past a cleaning blade and shaft located inside the transfer belt assembly. Any waste toner that is scraped off of the belt is collected in the waste toner container located next to the belt inside the transfer belt unit.

The photoconductor drum is cleaned by the cleaning blade.

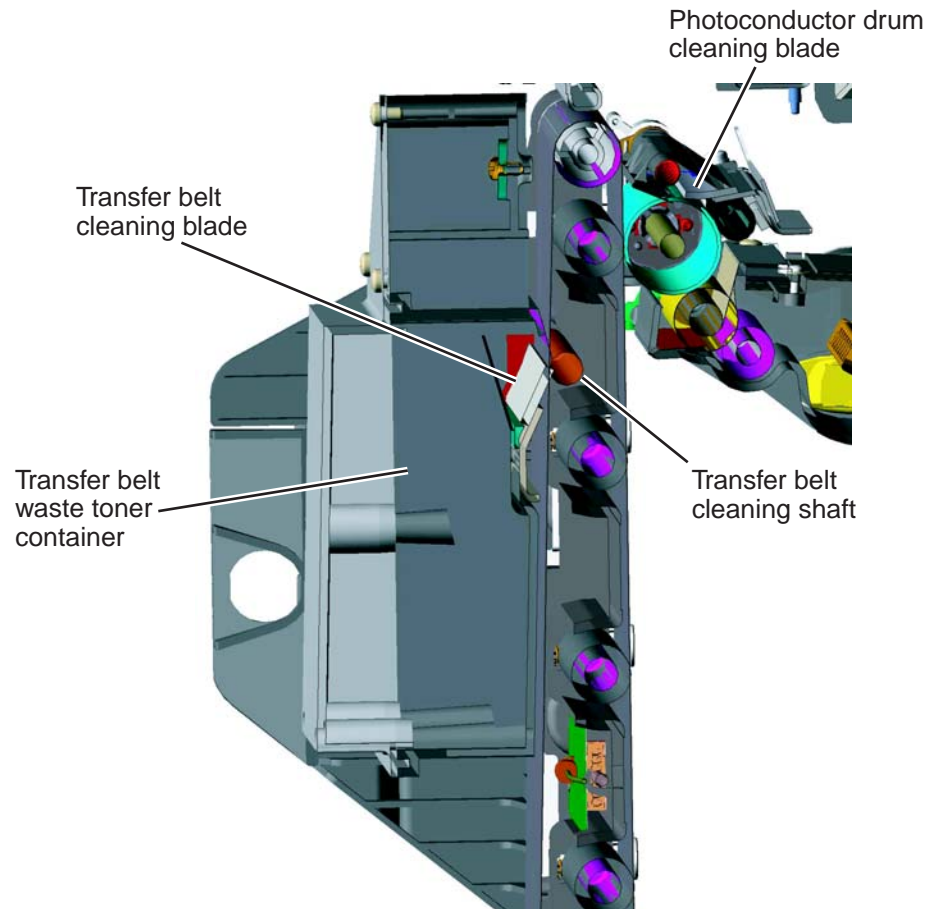

Electrical interlock

5 V interlock switch

An interlock switch triggered by the front access door disables the +5 V output to the printhead which turns off the laser.

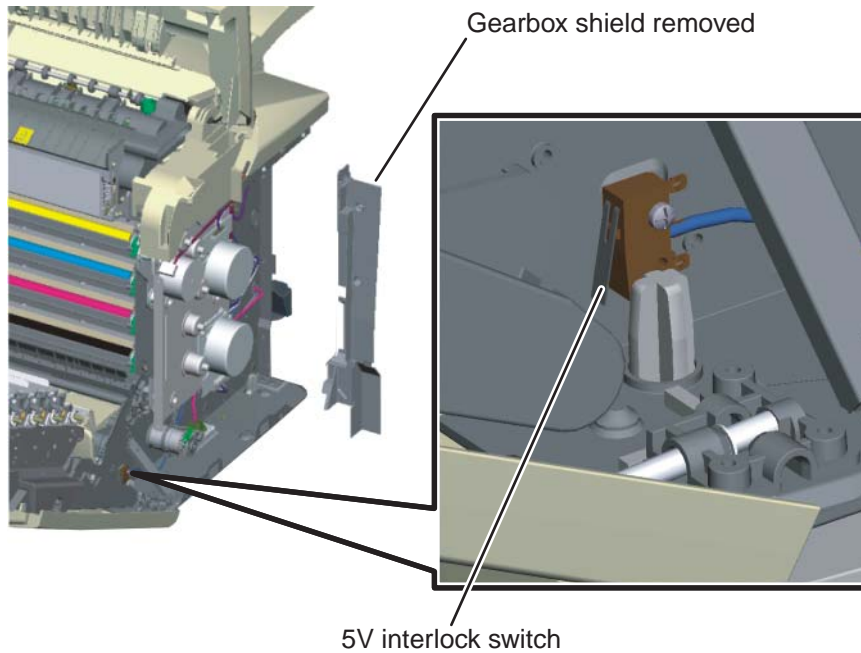

24 V interlock switch

The 24 V dc interlock switch is mounted to the right side of the top cover camshaft assembly. Opening the top door rotates the drive retraction lockout which opens the 24 V dc interlock switch. When the top door is closed with the front access door also closed, the drive retraction lockout trips the switch arm which closes the 24 V dc interlock switch.

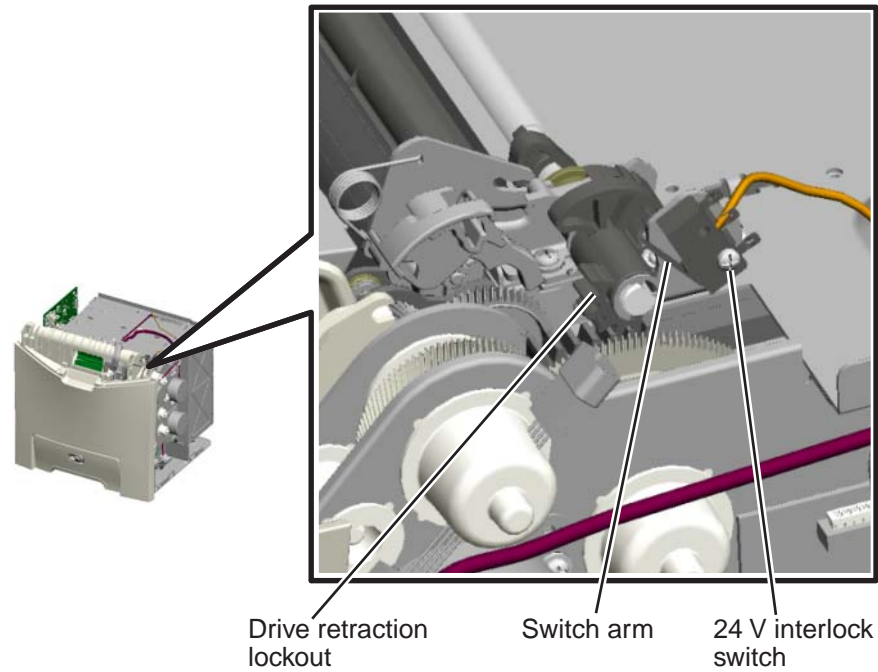

When the 24 V switch opens, the normally open side of the switch is activated which signals the system card to disable a +24 V power supply output, turning off all high voltage supplies, the bump/align motor, the duplex motor and the fuser motor for safety considerations.

4. Repair information

Removal and cleaning precautions



Observe the following precautions whenever you service the printer:

- Be sure to unplug the printer from the outlet before attempting to service the printer.
- To reassemble the printer, reverse the order of removal unless otherwise specified.
- Do not operate the printer anytime during removals. If it is absolutely necessary to run the printer with its covers removed, use care not to allow your clothing to be caught in revolving parts such as the gears, rollers and fan motor.
- Never touch the terminals of electrical parts or high-voltage parts such as the high-voltage power supply.
- After part replacement, ensure the wiring harness is not caught or damaged.
- Do not attempt to cut or extend the wiring harness.
- Confirm the wiring harness connector is connected properly.
- Be sure to handle the fuser carefully as it remains hot for a while after the printer stops running. Always unplug connectors by holding the connector housing.

Warning: Read the following before handling electronic parts.

Handling ESD-sensitive parts

Many electronic products use parts that are known to be sensitive to electrostatic discharge (ESD). To prevent damage to ESD-sensitive parts, follow the instructions below in addition to all the usual precautions, such as turning off power before removing electronic cards:

- Keep the ESD-sensitive part in its original shipping container (a special “ESD bag”) until you are ready to install the part in the printer.
- Make the fewest possible movements with your body to prevent an increase of static electricity from clothing fibers, carpets, and furniture.
- Put the ESD wrist strap on your wrist. Connect the wrist band to the system ground point. This discharges any static electricity in your body to the printer.
- Hold the ESD-sensitive part by its edge connector shroud (cover); do not touch its pins.
- If you need to put down the ESD-sensitive part for any reason, first put it into its special bag.
- Printer covers and metal tables are electrical grounds. They increase the risk of damage because they make a discharge path from your body through the ESD-sensitive part. (Large metal objects can be discharge paths without being grounded.)
- Prevent ESD-sensitive parts from being accidentally touched by other personnel. Install printer covers when you are not working on the printer, and do not put unprotected ESD-sensitive parts on a table.
- If possible, keep all ESD-sensitive parts in a grounded metal cabinet (case).
- Be extra careful in working with ESD-sensitive parts when cold-weather heating is used, because low humidity increases static electricity.

Handling the photoconductor unit

The following precautions must be observed when handling the photoconductor unit. The photoconductor unit is a supply item you will have to remove during some of the repair procedures:

Transportation/storage

Use the specified carton whenever moving or storing the photoconductor unit.

Handling

- The optical photoconductor roller in the photoconductor unit exhibits the greatest light fatigue after being exposed to strong light over an extended period of time. Never expose it to direct sunlight. Cover the photoconductor unit when you remove it from the printer.
- Use care not to contaminate the surface of the optical photoconductor roller with an oil-based solvent, fingerprints, and other foreign matter.
- Do not scratch the surface of the optical photoconductor roller.

Parts not to be touched

Any part where the mounting screws are used to meet a printer alignment set at the factory must not be removed, disassembled, or adjusted.

Adjustments

Printhead alignment

Overview

When aligning the printhead, it is important to keep in mind that the printhead mounting screws should be initially loose enough to just hold the printhead in the printer. This allows the pages to be printed that will be used to align the black plane to the printer frame and also allows skew adjustment with the printhead alignment screw. Once the black skew is adjusted, the mounting screws are fully tightened.

There is one printhead that houses the four color planes. The black plane is aligned to the printer, and the color planes are internally aligned to black. Electrical alignment is done to fine tune the alignment of the color planes to the black plane once the printhead is installed and skew is adjusted.

The first step in aligning the printhead is to loosen the printhead mounting screws, and to set the skew for black.

Note: If you need to replace the printhead, see **“Printhead removal, installation, and adjustment”** on **page 4-74**.

Printhead mechanical alignment

Skew (black)

1. Loosen the printhead mounting screws.
 - a. Turn off the printer.
 - b. Disconnect the power cord from the electrical outlet.
 - c. Remove the exit tray cover by lifting away from the printer.



- d. Disconnect the transfer belt cable (A).
- e. Press the two tabs (B) on either side of the transfer belt assembly, and lift out the transfer belt assembly.

Note: Leave the photoconductor units on the transport belt when removing.

Warning: To avoid damaging the photoconductor drum, hold the photoconductor units by their handle and place the photoconductor units on a clean surface. Never expose the photoconductor units to light for a prolonged period of time. See **“Handling the photoconductor unit” on page 4-2** for additional information.

C52x

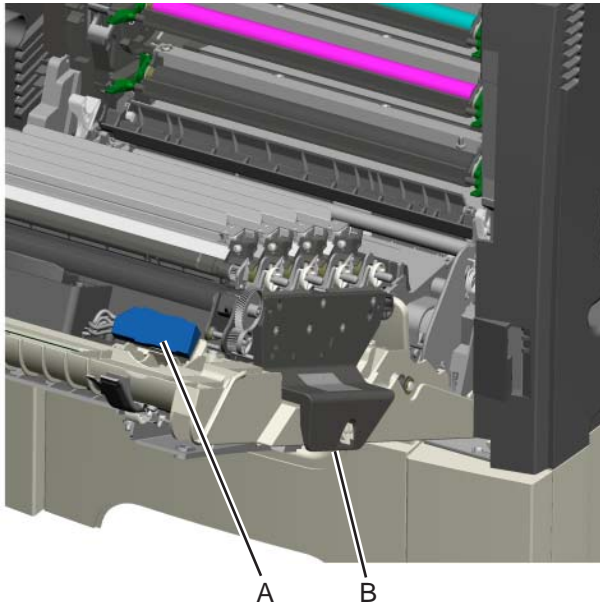

C53x

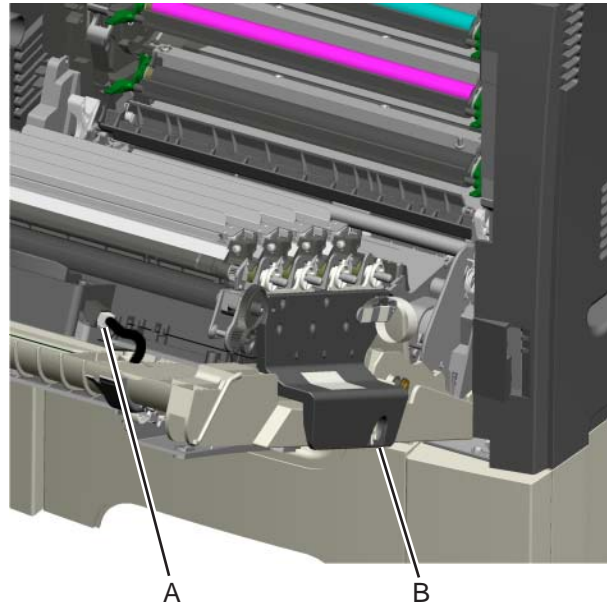

- f. Remove all of the toner cartridges.

- g.** Pull the locking tab (C) down on the left side of the cable cover (D), slide the cable to left, lower and remove.

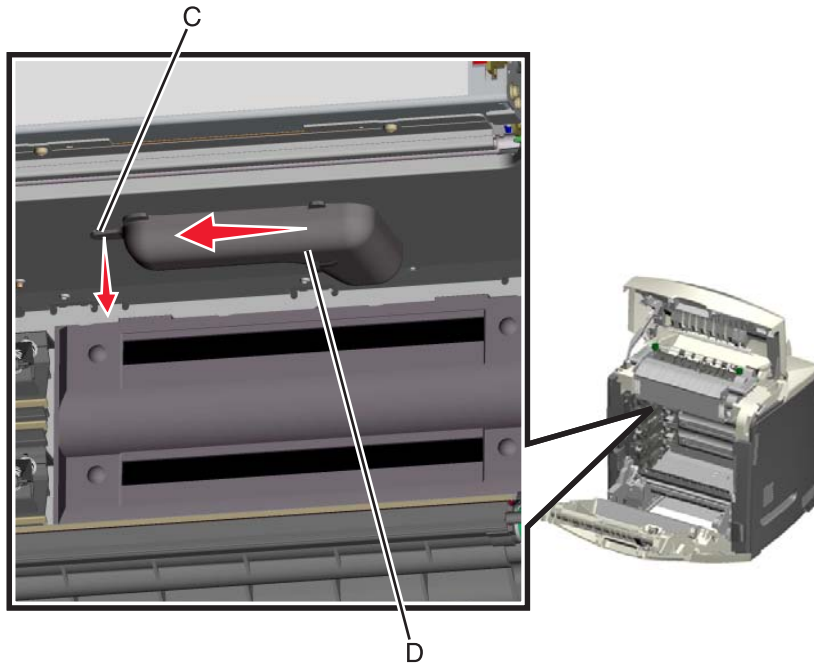

- h.** Loosen the printhead mounting screws (E) in the following order: top middle, lower left, and lower right.

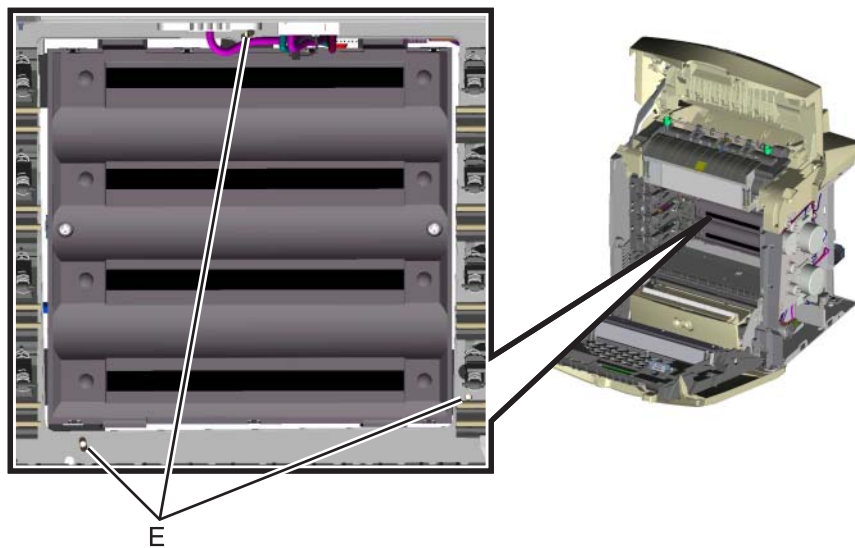

- 2.** Reinstall the transfer belt assembly and the photoconductor units.
- 3.** Connect the transfer belt cable.
- 4.** Replace the toner cartridges.

Skew (black)

1. Plug the electrical cord into the printer.
2. Plug the electrical cord into the outlet.
3. The first step in aligning the printhead is to set the skew for black.
 - a. Enter Diagnostic mode (turn off the printer, press and hold **▼** and **►**, turn on the printer, and release the buttons when the clock graphic displays).
 - b. Select **REGISTRATION**.
 - c. Select **Skew**.
 - d. Adjust this setting to zero, and press **Select** (**↵**).
 - e. Press **Back** (**⏪**).
 - f. Scroll down to **Quick Test**, and press **Select** (**↵**). A page similar to this one prints:

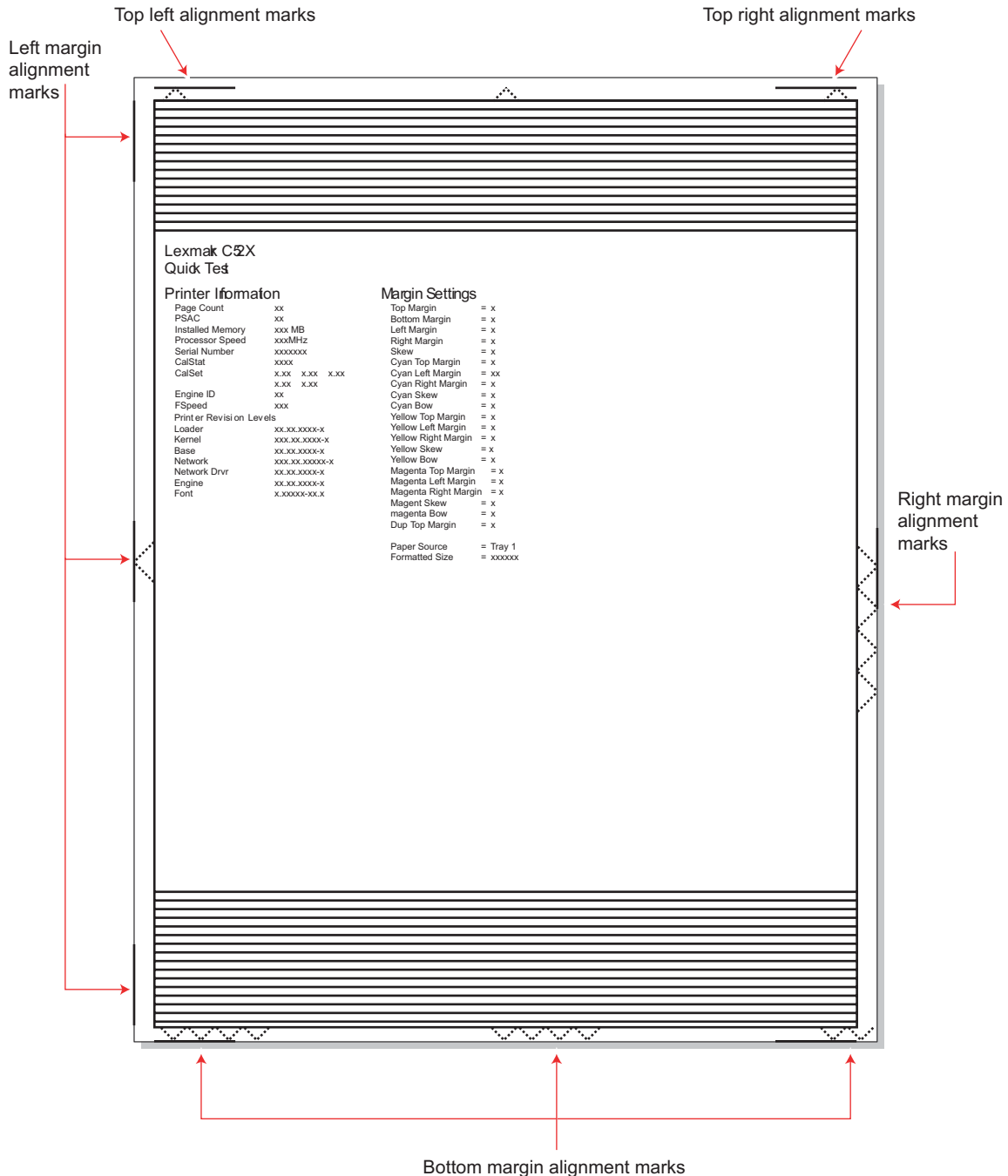

- g. Adjust the printhead alignment screw to adjust the skew and straighten the image on the paper.

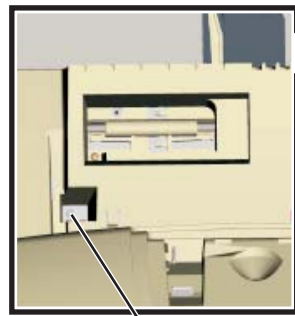

Printhead alignment screw



If the top right alignment marks are lower than the top left alignment marks, rotate the alignment screw counterclockwise a full revolution, and print the Quick Test page. Repeat adjusting the screw and printing the Quick Test until the top alignment marks are the same distance from the top of the media.

Note: One rotation of the printhead alignment screw equals approximately 0.5 millimeter movement of the top edge print alignment marks.

- h. When the top right and top left alignment marks are both showing and are even on the page, the skew is aligned.

Straight

Skewed

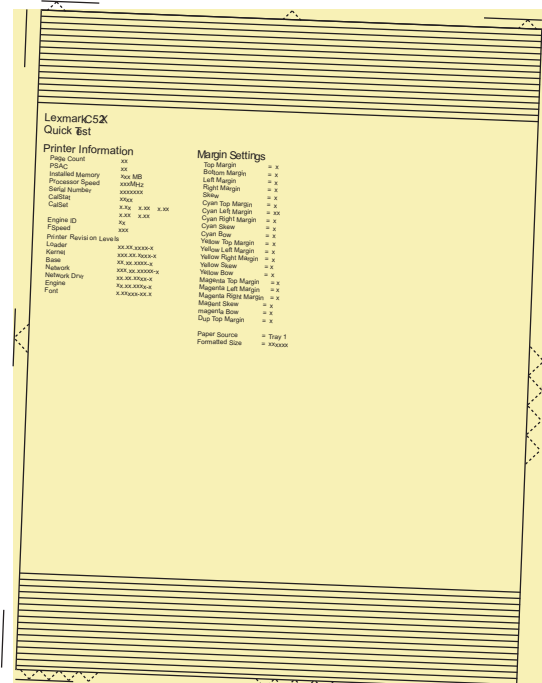
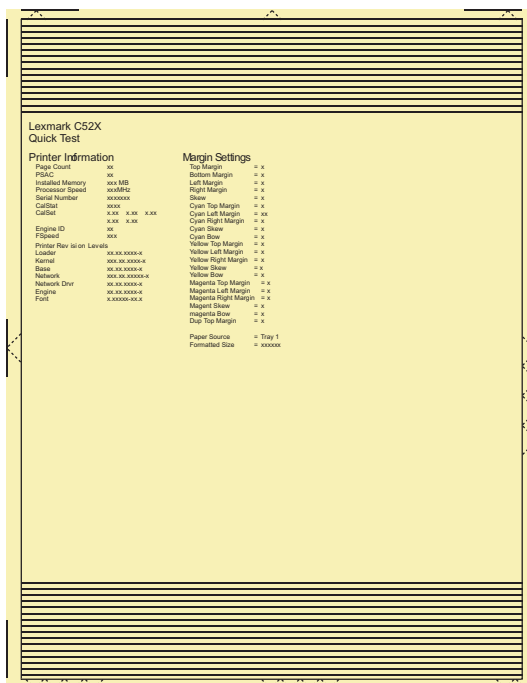

4. Tighten the printhead mounting screws.
 - a. Turn off the printer.
 - b. Disconnect the power cord from the electrical outlet.
 - c. Disconnect the transfer belt cable.
 - d. Press the two tabs on either side of the transfer belt assembly, and lift out the transfer belt assembly with the photoconductor units in place.
 - e. Remove all of the toner cartridges.
 - f. Tighten the printhead mounting screws in the following order: top middle, lower left, and lower right.

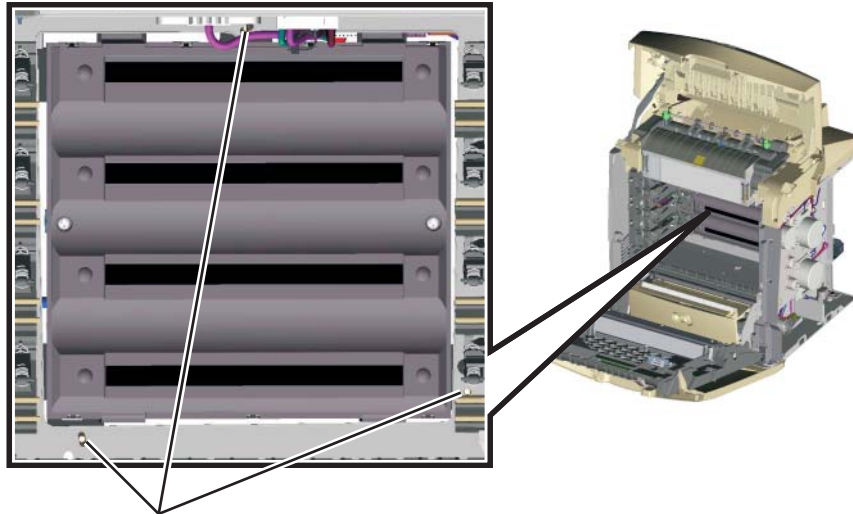

Printhead mounting screws

5. Replace the fuser cable cover.
6. Reinstall the transfer belt assembly and the photoconductor units.
7. Connect the transfer belt cable.
8. Reinstall the toner cartridges.
9. Reinstall the exit tray cover.

Registration (black)

Top Margin



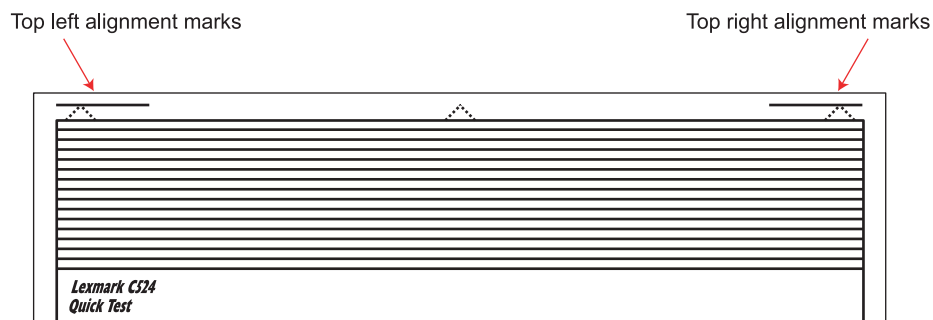

1. Reconnect the power cord to the electrical outlet, but do not turn on the printer yet.
2. Enter Diagnostic mode (press and hold **▼** and **▶**, turn on the printer, and release the buttons when the clock graphic displays).
3. Select **Quick Test** (REGISTRATION in the Diagnostics mode), or use the last Quick Test you used to adjust skew.



4. Select **Top Margin**, and press **Select** (⏏).
5. Adjust the values until both top alignment marks are on the top edge of the print.
 - Increasing the value (▶) moves the top alignment marks down on the page.
 - Decreasing the value (◀) moves the top alignment marks up on the page.

6. Press **Select** () to save the value.
7. Print the Quick Test page, and check the top alignment marks. Repeat adjustment of the top margin and printing of the Quick Test page until top margin is set.

Bottom Margin

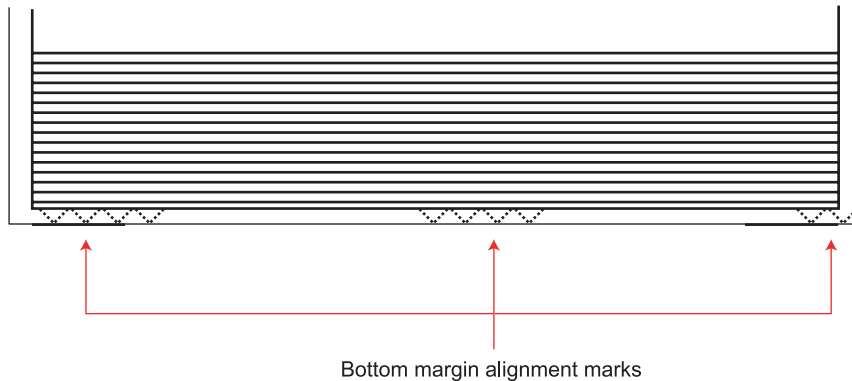

1. Select **Bottom Margin**, and press **Select** ().
2. Adjust the bottom margin until the points of the bottom margin alignment marks are visible and touching the edge of the paper.
 - Increasing the value () moves the bottom alignment marks up on the page.
 - Decreasing the value () moves the bottom alignment marks down on the page.
3. Press **Select** () to save the value.
4. Print the Quick Test page, and repeat this process until the bottom margin is adjusted.

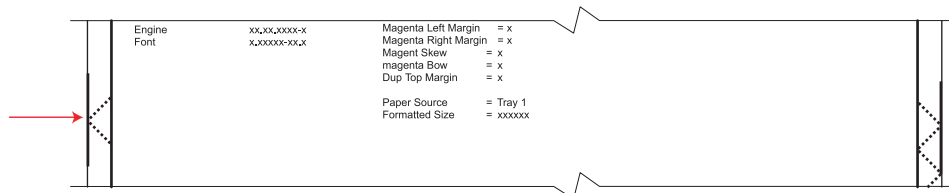

Left Margin

1. Select **Left Margin**, and press **Select** ().
2. Adjust the left margin until the points of the left alignment marks touch the edge of the page.



- Increasing the value () moves the left side alignment marks to the right.
 - Decreasing the value () moves the left side alignment marks to the left.
3. Press **Select** () to save the value.
 4. Print the Quick Test page, and check the left alignment marks each time until you are satisfied.

Right Margin

1. Select **Right Margin**, and press **Select** ().

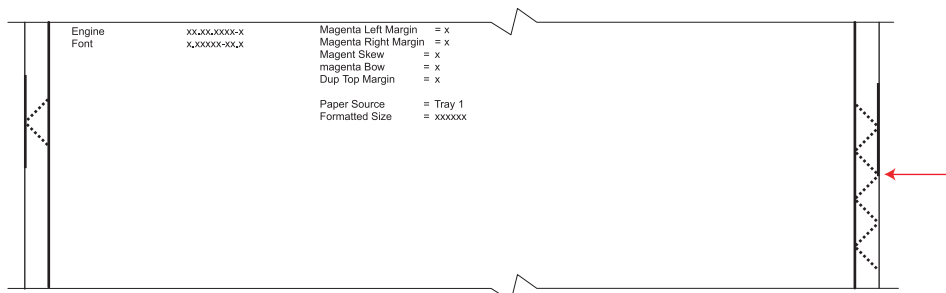

2. Adjust the right margin until the points of the left alignment marks touch the edge of the page.
 - Decreasing the value (◀) moves the right side alignment marks to the right.
 - Increasing the value (▶) moves the right side alignment marks to the left.
3. Press **Select** (⏎) to save the value.
4. Print the Quick Test page, and check the results. Repeat if necessary.
5. When the registration is complete, proceed to the color alignments.

Alignment (cyan, yellow, and magenta)

1. Press **Back** (⏪) on the operator panel until you reach the top menu, select **ALIGNMENT MENU**, and press **Select** (⏎).
 2. Select **Cyan**.
 3. Select **Top Margin**, and use ◀ or ▶ to select zero. Press **Select** (⏎) to save the setting.
 4. Select **Left Margin**, **Right Margin**, **Bottom Margin**, **Skew**, and **Bow**. In each menu, use ◀ or ▶ to select zero, and press **Select** (⏎) to save the value.
- It is important to set all the values to zero before starting.

5. Select **Quick Test** in the Cyan menu, and press **Select** (⏎).
- Two pages print. You may have to print these pages several times until you get T and Z aligned. Do not go to step 2 until T and Z are aligned. The first page is similar to the following:

Cyan Alignment Step 1

Top (T) Coarse Adjustment

Top (T) Fine Adjustment

Skew (Z) Coarse Adjustment

Skew (Z) Fine Adjustment

T

T = 0 + =

↑ ↑

Current New

Cyan Cyan

T value T value

Z

Z = 0 - + =

↑ ↑

Current New

Cyan Cyan

Z value Z value

STEP 1: Adjust the Top (T) margin and Skew (Z) then confirm before going to Step 2.

Press the up or down buttons until a check appears at the setting in need of adjustment.

Press Select. Then use the < and > buttons to enter the new value. Press Select to save.

NOTE: If the alignment values cannot be determined by using the fine adjustment scales, then use the coarse adjustment scales at the top of the page.

STEP 2: Go to the next page to adjust the Left (L) margin, Right (R) margin, and Bow (P).

STEP 3: Reprint these pages to confirm final settings.

Go To Step 2

6. Determine the line under Fine Adjustment that is closest. If the value is beyond the Fine Adjustment scale, use either of the Coarse Adjustment scales.

Top (T) Coarse Adjustment

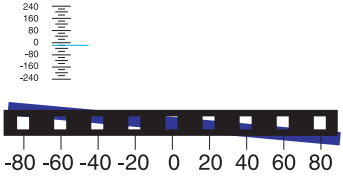

Top (T) Fine Adjustment

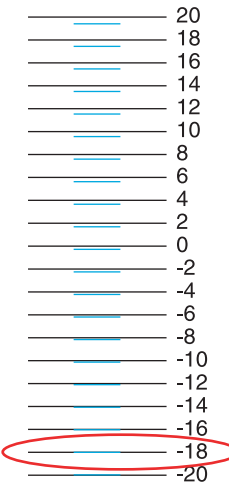

If the alignment is not close enough to use the fine adjustment, get close to the ideal value by using the coarse adjustment marks. Select the block that is most filled by the color on the left, or approximate if none of the blocks are completely filled, and enter it for the new value. Reprint the quick test page, and then use the fine adjustment.

First, locate the line of the color that you are aligning that lines up best with the scale line. In this example, it is -18. If none of the colored lines match up, use the coarse adjustment to get close, reprint this page and then use the fine adjustment.

7. Enter the number determined from the Fine Adjustment scale or the Coarse Adjustment scales on the part of the page for the "T" value. The current value is automatically entered on the sheet. At this point, it should be zero.

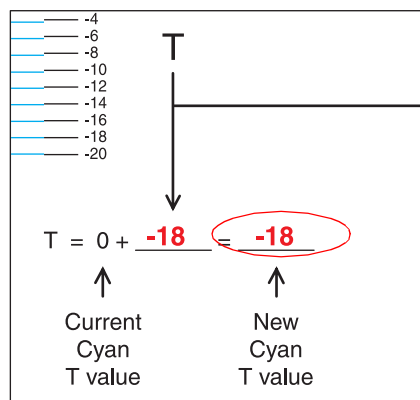

$$T = 0 + -18 = -18$$

Current Cyan T value New Cyan T value

8. Enter the "New Cyan T value" on the operator panel using ◀ or ▶, and press **Select** (⏏) to save the value.
9. Reprint the Quick Test, and evaluate whether you are at zero changes.

10. Repeat this process for skew (Z). Don't forget to add the T value and the current cyan Z value to obtain the new skew (Z) value.

An example is shown below:

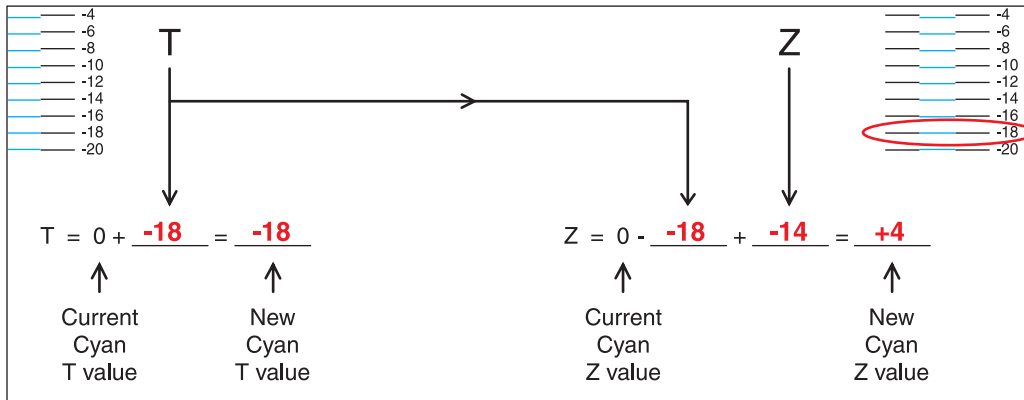

11. Continue to follow the directions on the bottom of the first page to find the Cyan Top Margin (T), the Skew (Z), and on the second page of the Quick Test page, the Left Margin (L), Right Margin (R), and Bow (P).

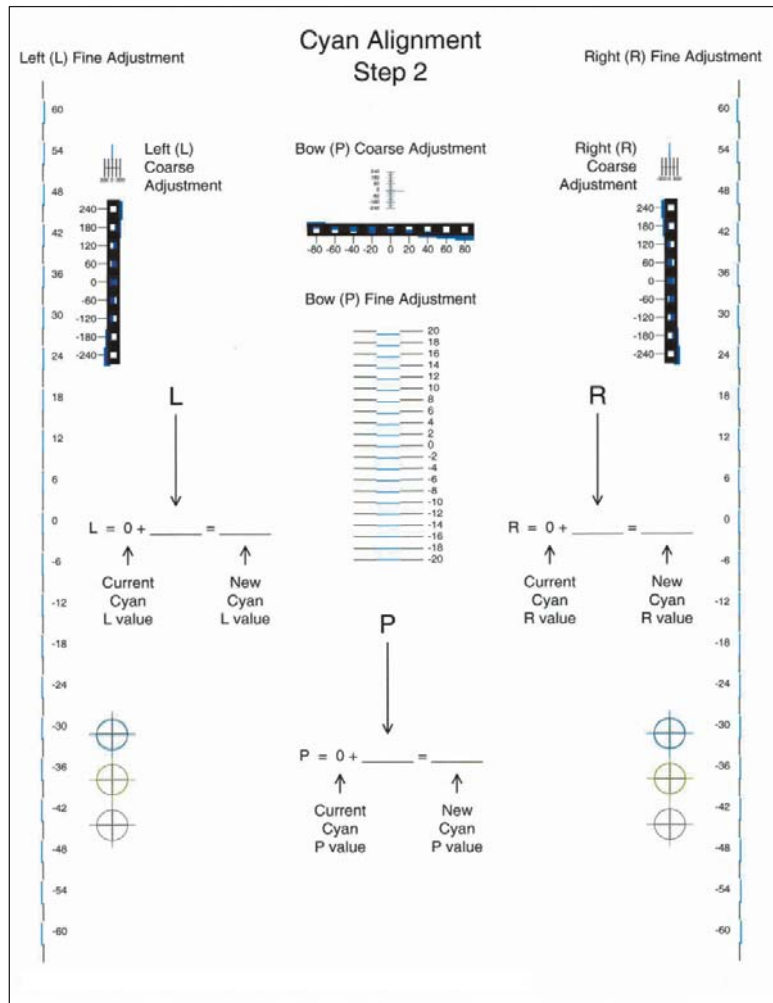

12. Repeat steps 2 through 11 for yellow and magenta.
Note: Start each color group by setting the Top Margin, Left Margin, Right Margin, Bottom Margin, Skew, and Bow to zero.

Printer removal procedures

Precautions to take before maintenance work

Do not implement any operation, removal, or modification and so on, which is not presented in this manual.



1. Turn the printer power off and unplug the power cable from the outlet prior to starting removals or checks.
2. Prior to starting any repairs, read and understand the warnings in this manual.
 - High temperature
 - High voltage
 - Laser radiation
3. Confirm the direction of all parts and screw lengths during removal/replacement.
4. Utilize the proper cleaning procedures/solvents during maintenance.
5. Confirm that all parts and covers are properly installed and assembled prior to starting the print test.

Cover removals

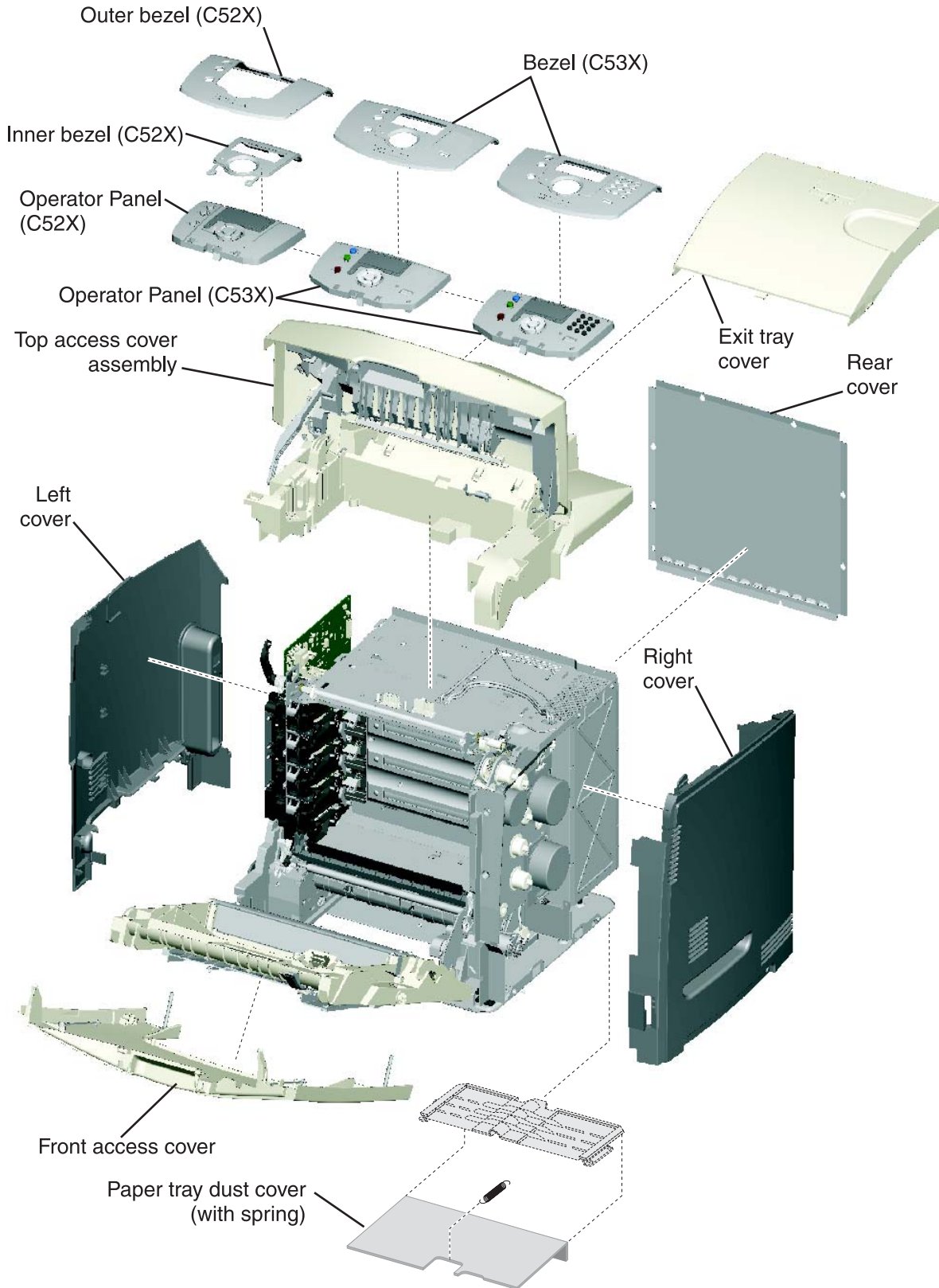

Exit tray cover removal

See “Exit tray cover, C52x” on page 7-3 for the part number.

Grasp the exit tray, and lift away from printer.



Front access door cover assembly removal

See Front access door cover assembly for the part number for the models you need on [page 7-3](#).

1. Remove the paper tray.
 2. Remove the right cover. See [“Right cover removal” on page 4-26](#).
 3. Disconnect the transfer belt cable (A).
 4. Press the two tabs (B) on either side of the transfer belt assembly, and lift out the transfer belt assembly.
- Note:** Leave the photoconductor units on the transport belt when removing.

Warning: To avoid damaging the photoconductor drum, hold the photoconductor units by their handle and place the photoconductor units on a clean surface. Never expose the photoconductor units to light for a prolonged period of time. See [“Handling the photoconductor unit” on page 4-2](#) for additional information.

Model C52x

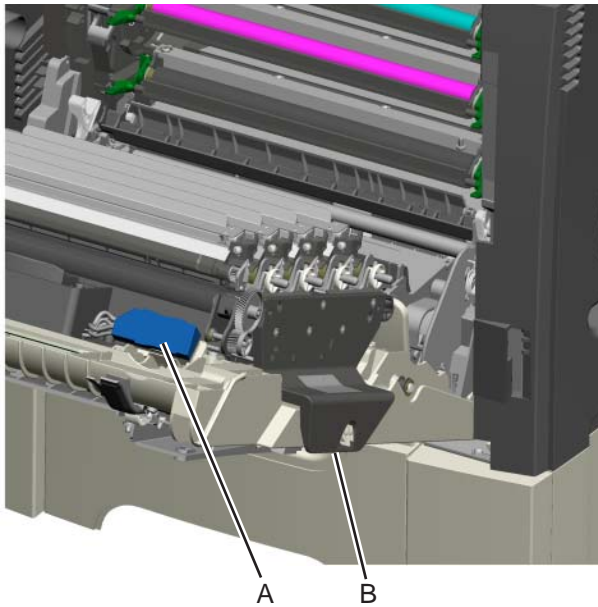

Model C53x

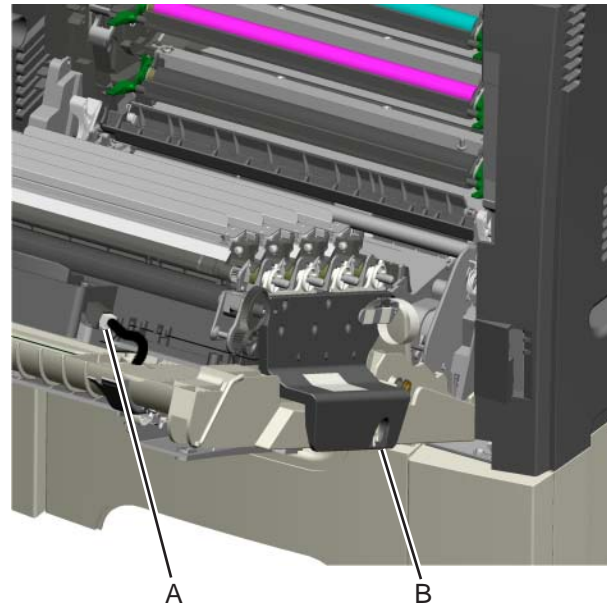

5. Looking down at the keyed end of the restraint (C), twist the end clockwise, slide the restraint upward through the slit (D), and slip the end of the restraint through the keyed hole (E). Repeat for the other side.

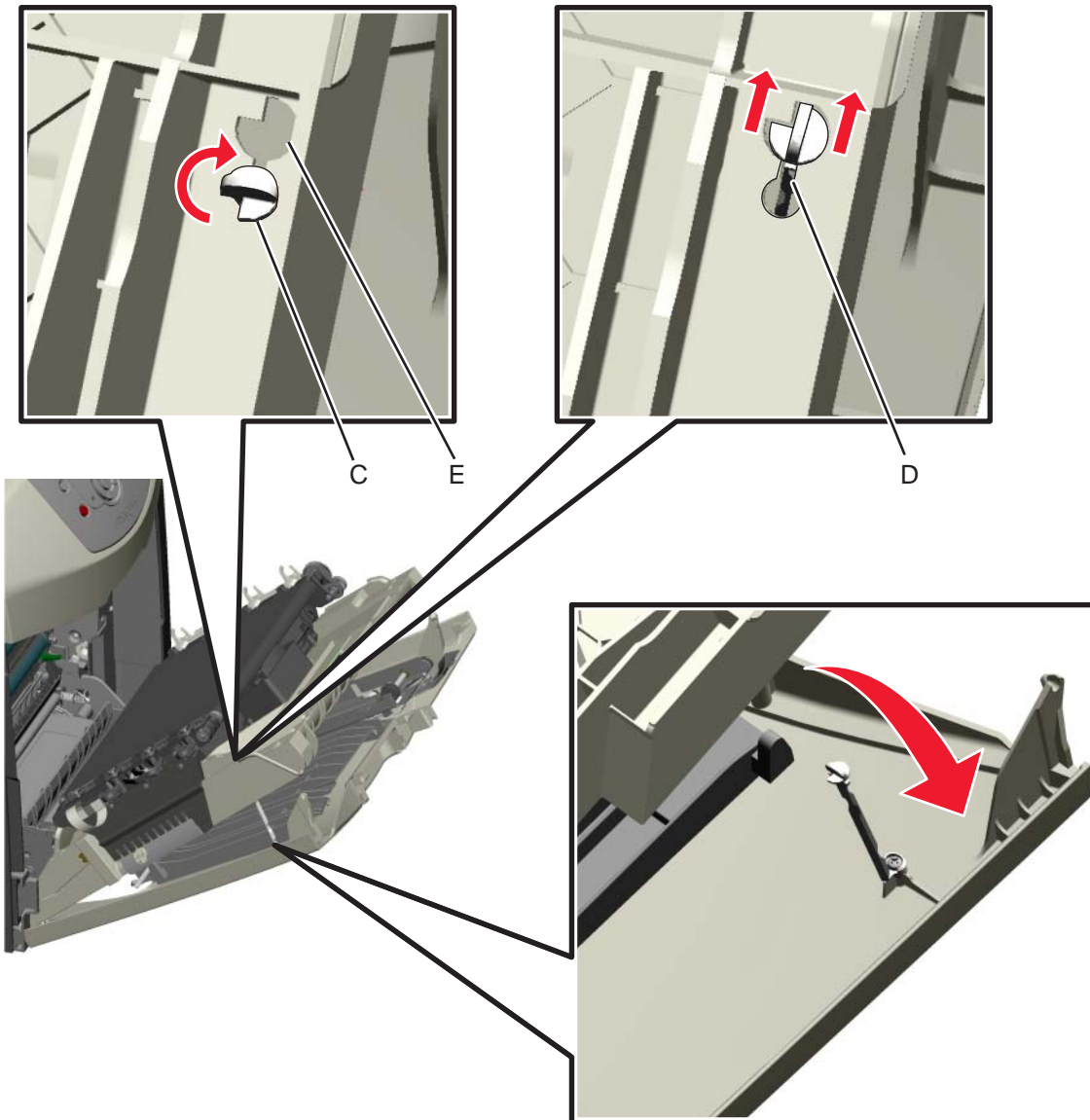

6. Close the front access door.

7. Remove the four screws (F) that attach the pivot pin to the front access door cover.

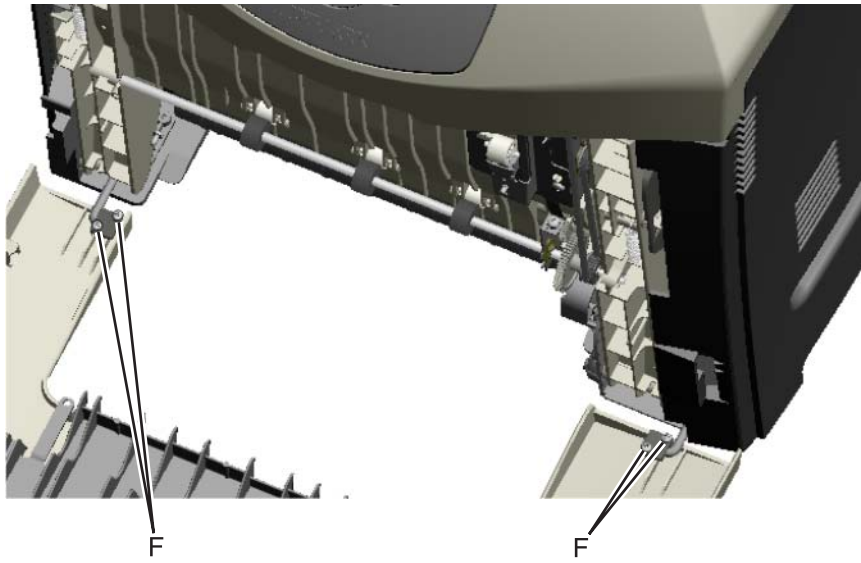

8. Remove the front access cover assembly.

Gearbox shield removal

Not a FRU.

1. Remove the paper tray.
 2. Remove the right cover. See **“Right cover removal” on page 4-26.**
 3. Remove the four screws (A).
 4. Remove the gearbox shield (B). There is a locking tab on the back of the gearbox shield.
- Warning:** When removing the gearbox shield, be careful not to damage the 5 V interlock switch arm.

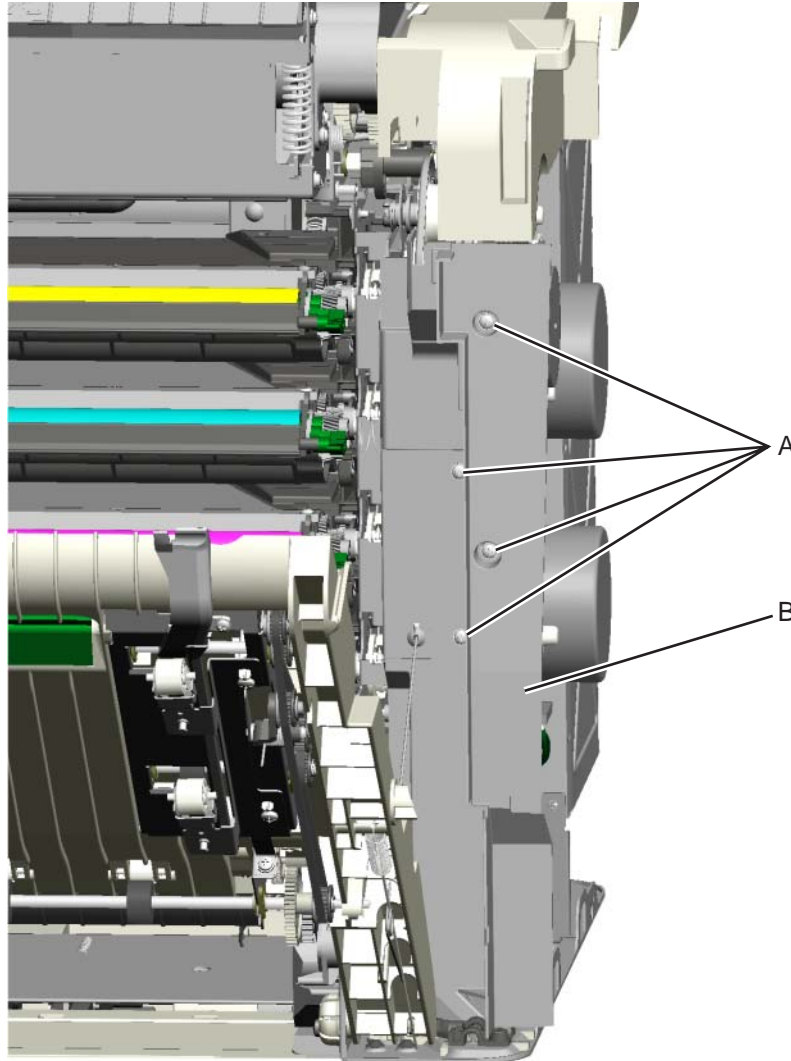

Left cover removal

See **“Left cover” on page 7-3** for the part number.

1. Place the printer on the table with the left side edge hanging over slightly.
2. Remove the waste toner assembly. See **“Waste toner assembly removal” on page 4-105**.
3. Open the top access door.
4. Open the front access door.
5. Remove the three screws (A).
6. Press the locking tab (B), slide the cover down, and lift the bottom out to remove the cover.
Warning: Be careful not to damage the two small locking tabs (C).

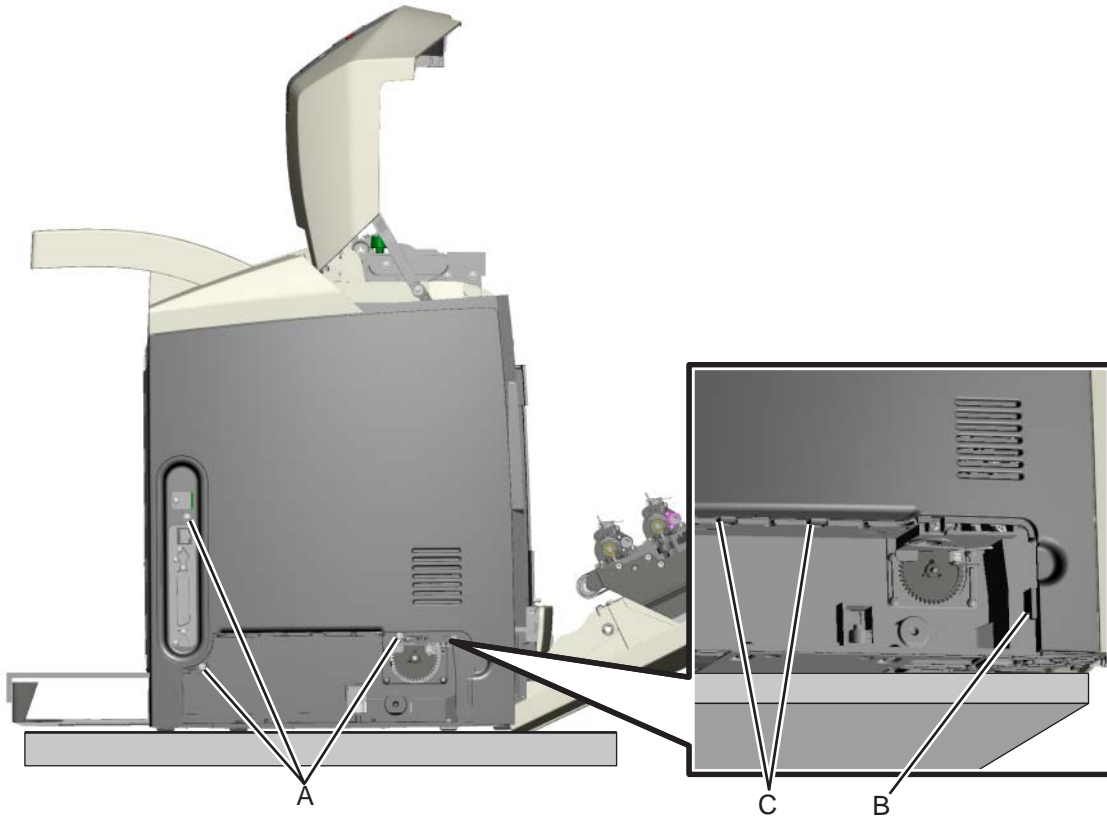

Operator panel outer bezel removal

See “**Outer bezel, C52x**” on page 7-3 for the part number for the C52x models. See the same page for the specific models for the bezels for the C53x models.

- Using a flathead screwdriver or similar tool, un*snap* the locking tabs (A) on the upper left and the upper right of the outer bezel.
Note: The top portion of the operator panel disengages with the outer bezel. Flex the top of outer bezel to disengage the operator panel.
- For models C52x:** Remove the outer bezel with the inner bezel (B) attached.
For models C53x: Remove the bezel. The bezel is one piece for this set of models.

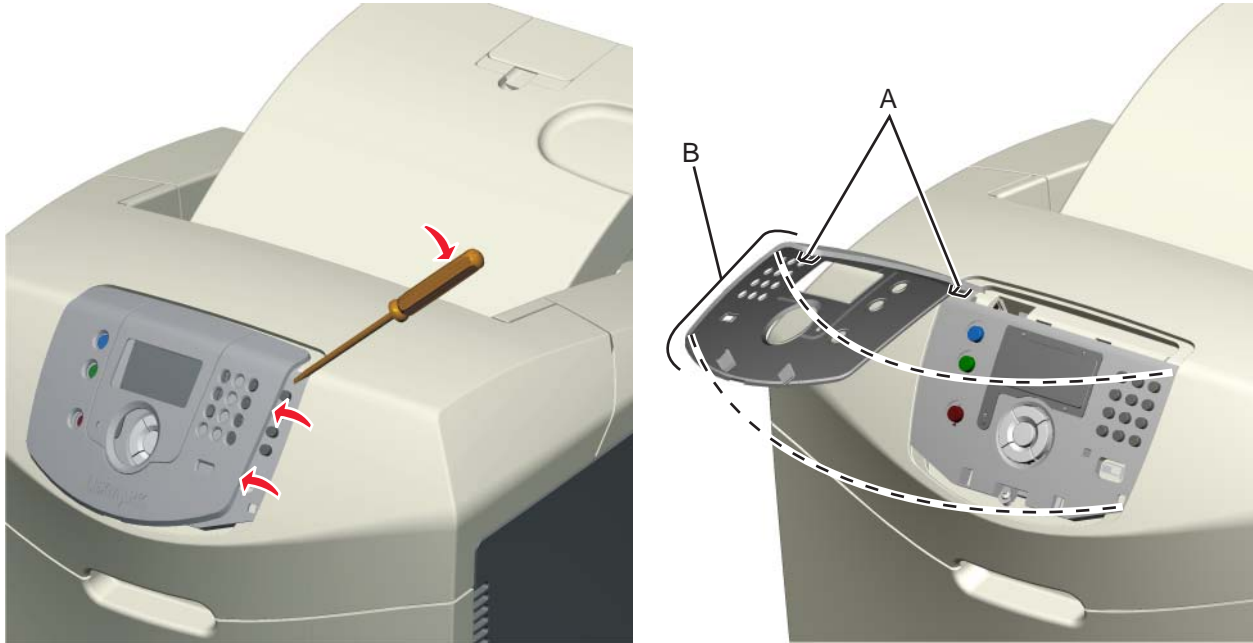

Installation note: When reinstalling or replacing the outer bezel, insert the bottom of the bezel first, ensuring that the outer bezel bottom portion fully seats.



Operator panel inner bezel removal—models C52x only

See the part number for the inner bezel for the model you need on [page 7-3](#).

1. Remove the outer bezel. See **“Operator panel outer bezel removal”** on [page 4-21](#).
2. Press the top of the inner bezel to release the inner bezel (A) from the outer bezel.
3. Gently twist to free the lower tabs (B).

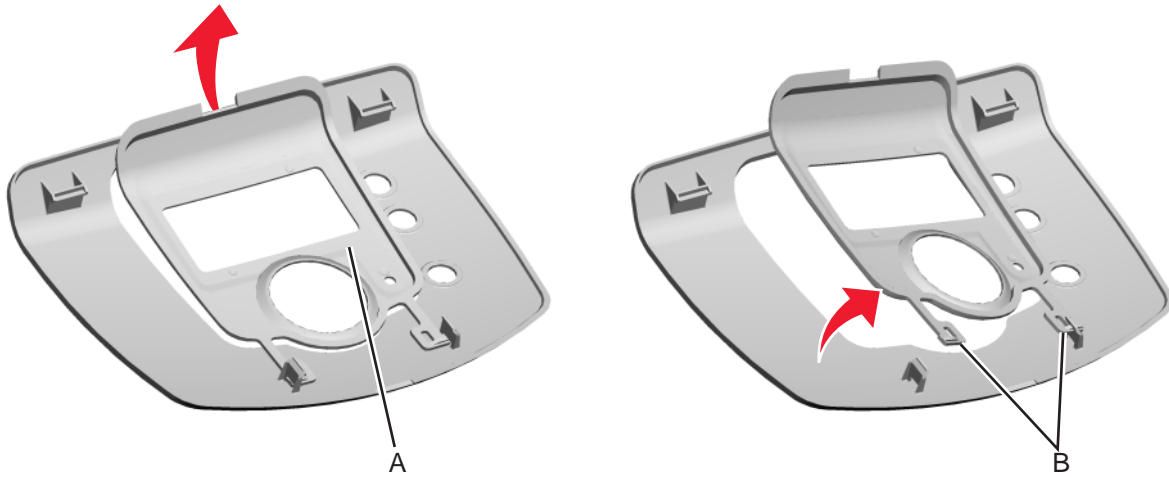

Operator panel assembly removal

See **“Operator panel assembly, C52x” on page 7-3** for the part number. See the same page for the individual part numbers for the C53x models.

Warning: When replacing any one of the following components:

- Operator panel assembly
- System card
- Smart chip card (C52x) or printhead assembly (C53x)

Only replace one component at a time. Replace the required component, and perform a POR before replacing a second component listed above. If this procedure is not followed, the printer will be rendered inoperable.

1. Remove the outer bezel. See **“Operator panel outer bezel removal” on page 4-21**.
2. Remove the screw (A).

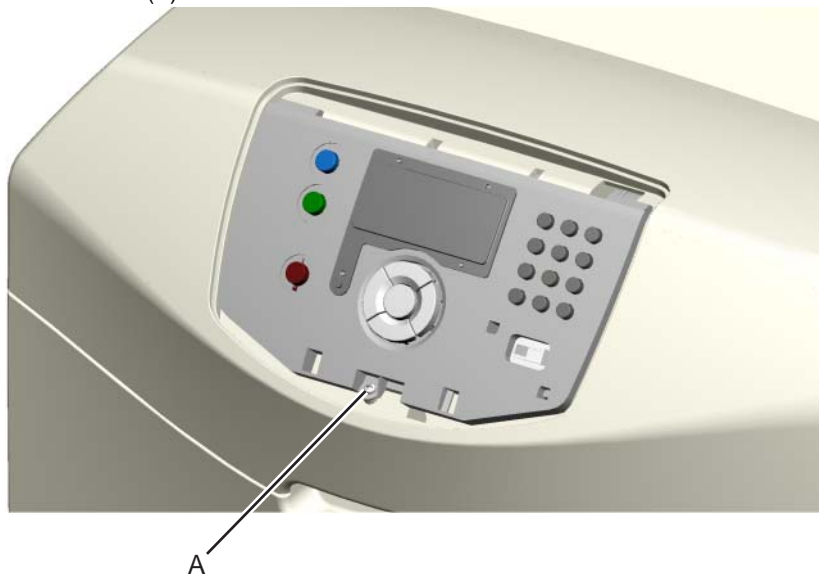

3. Disengage the upper locking tabs (B).
4. Disconnect the cables (C). **For model C534:** remove cables (C) and the USB cable (D).

Models C52x

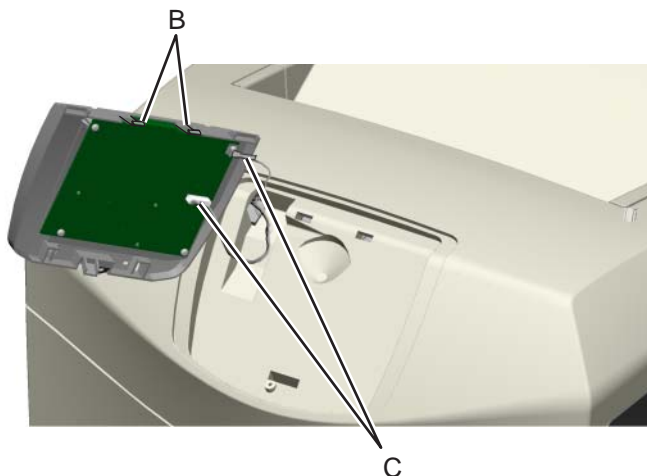

Models C53x (Model C534 shown)

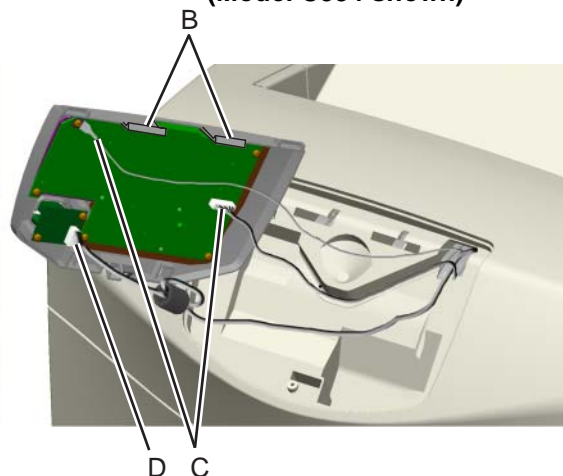

Paper tray dust cover removal

See **“Paper tray dust cover with dust cover spring, C53x” on page 7-3** for the part number.

1. Unplug the power cord from the printer.
2. Remove the exit tray. See **“Exit tray cover removal” on page 4-15**.
3. Remove the paper tray.
4. Place the printer on its back.
5. Remove the four screws (A). The upper right screw can be accessed through a hole in the frame (B).
6. Remove the paper tray dust cover assembly.

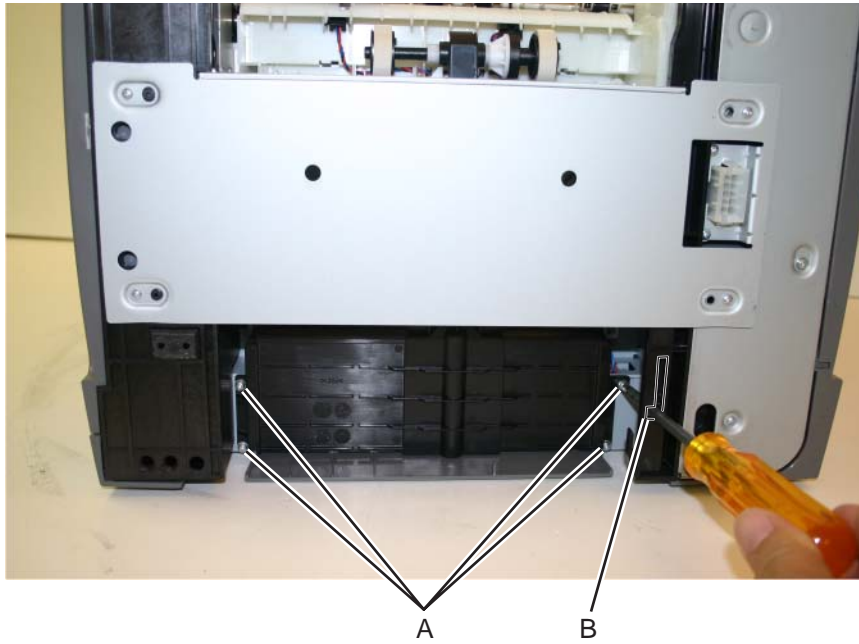

7. Lift the dust cover bracket (C), and disconnect the dust cover spring (D).

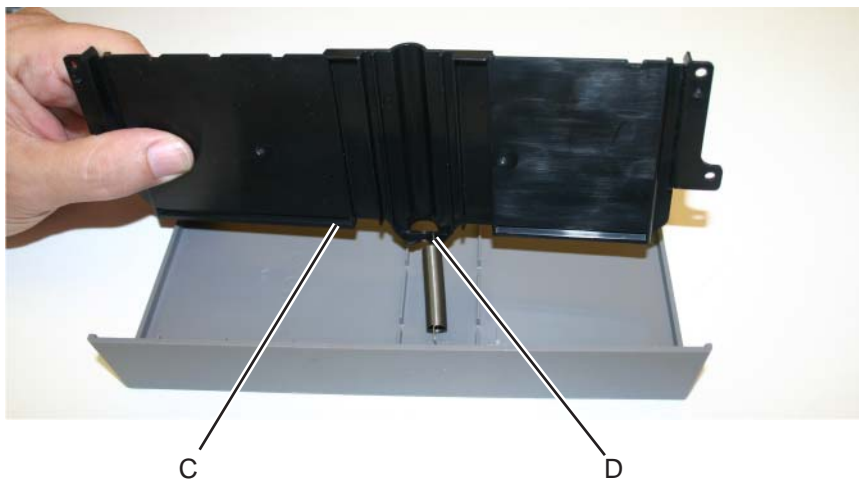

8. Set the dust cover bracket aside to reuse with the new FRU.

Rear cover removal

See **“Rear cover”** on page 7-3 for the part number.

1. **Loosen** the eight screws (A).
Note: Do not remove the screws.
2. Lift up on the rear cover, and slide to the right to remove from the back of the printer.

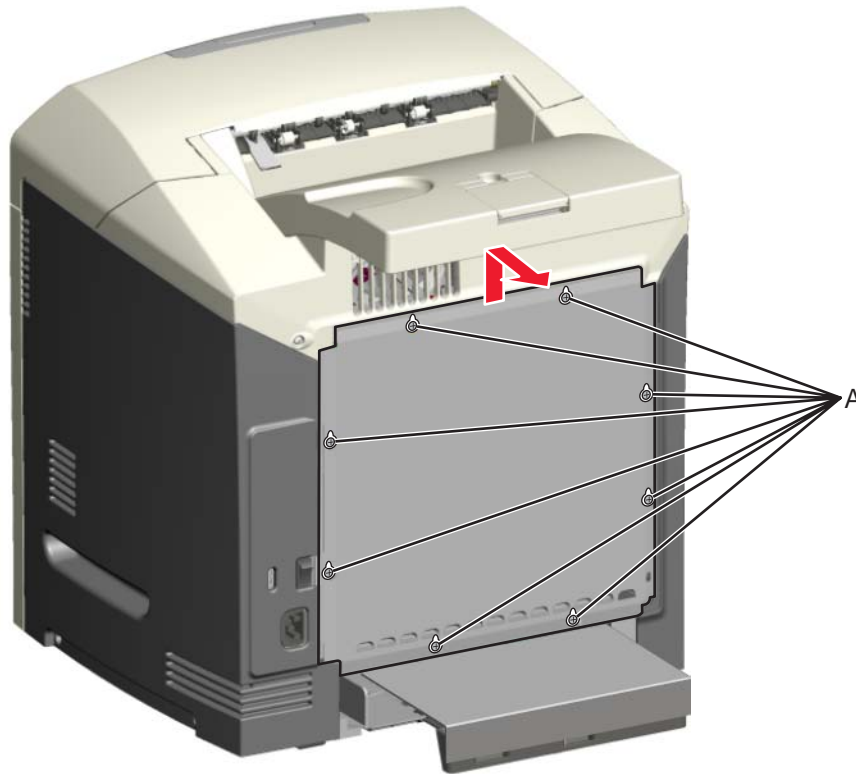

Right cover removal

See **“Right cover” on page 7-3** for the part number.

1. Make sure the power cord is removed.
2. Place the printer on the table with the right side edge hanging over slightly.
3. Open the top access door.
4. Open the front access door.
5. Remove the three screws (A).

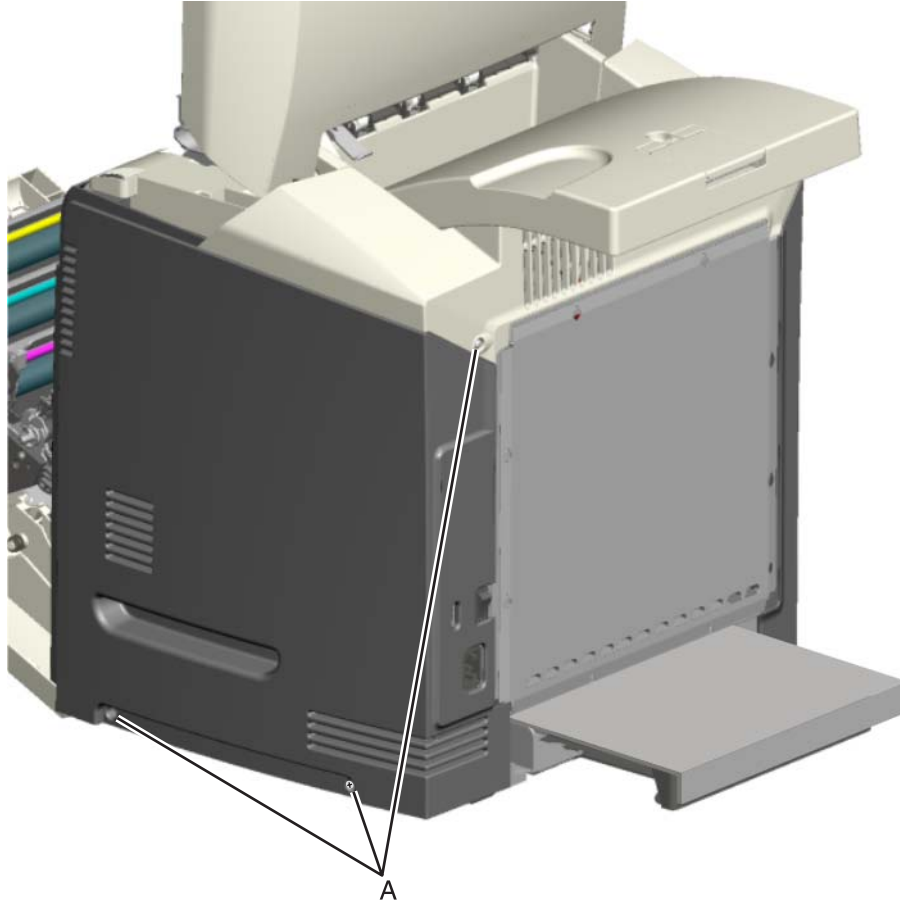

6. Lift the bottom of the cover out, and slide the right cover down to remove the cover.

Installation note: Be sure the tab (B) is fully engaged.

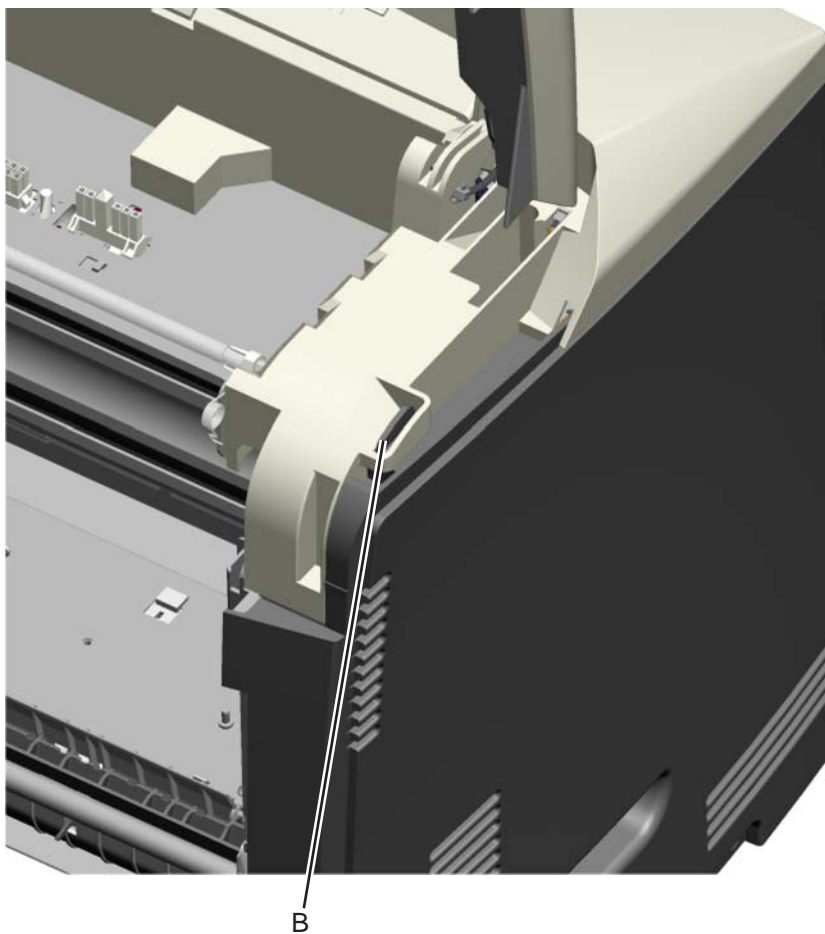

Top access cover assembly removal—model C52x only

See **“Top access cover assembly (network), C520n/C522n/C524n/C524dn”** on page 7-3 or **“Top access cover assembly (non-network), C524”** on page 7-3 for the part number.

1. Remove the rear cover. See **“Rear cover removal”** on page 4-25.
2. Remove the left cover. See **“Operator panel outer bezel removal”** on page 4-21.
3. Remove the fuser. See **“Fuser removal”** on page 4-60.
4. Remove the four screws (A) exposed after removing the fuser.

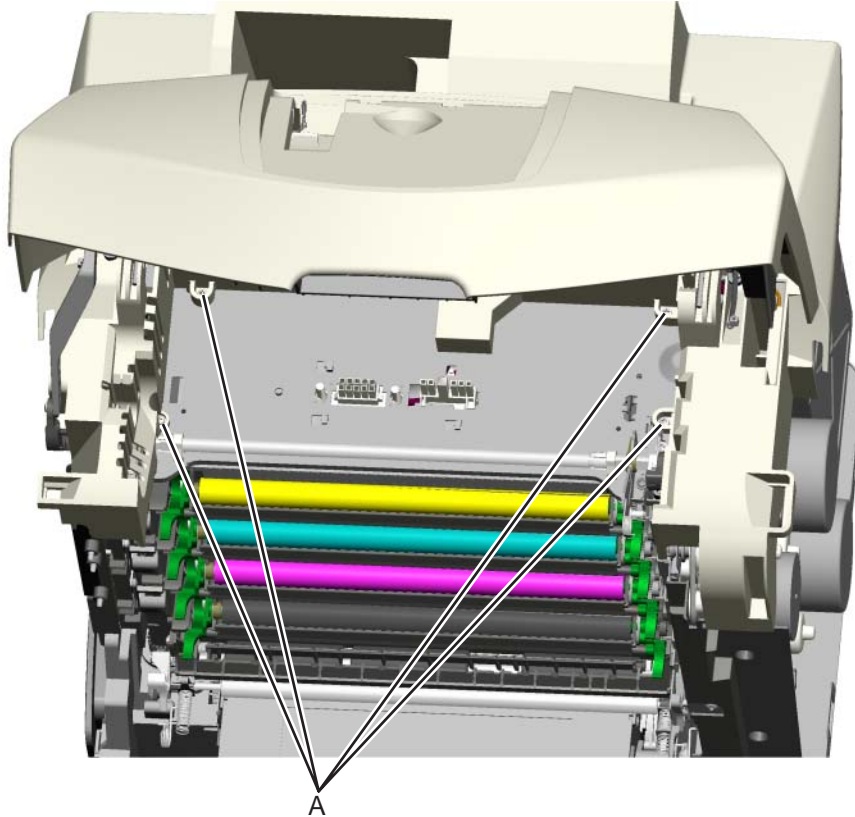

5. Remove the operator panel. See **“Operator panel assembly removal”** on page 4-23.
6. Remove the exit tray. See **“Exit tray cover removal”** on page 4-15.

7. Remove the screw (B) exposed after removing the exit tray.

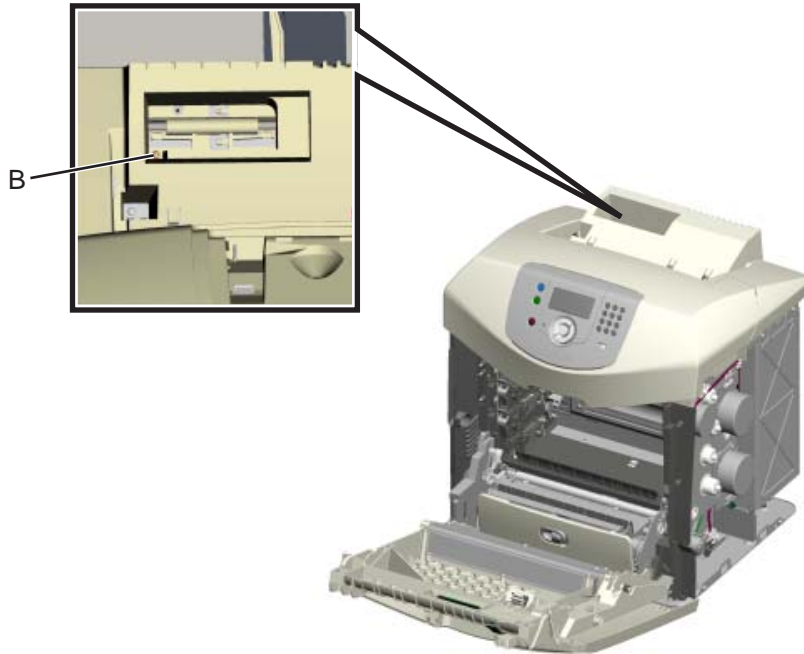

8. If the top access door is open, close it.
Warning: Ensure that the top access door is closed before removing the linkage screw. Failing to close the door leaves the linkage under a load, which may result in the linkage screw being catapulted away from the printer when removed.

9. Remove the linkage screw (C).

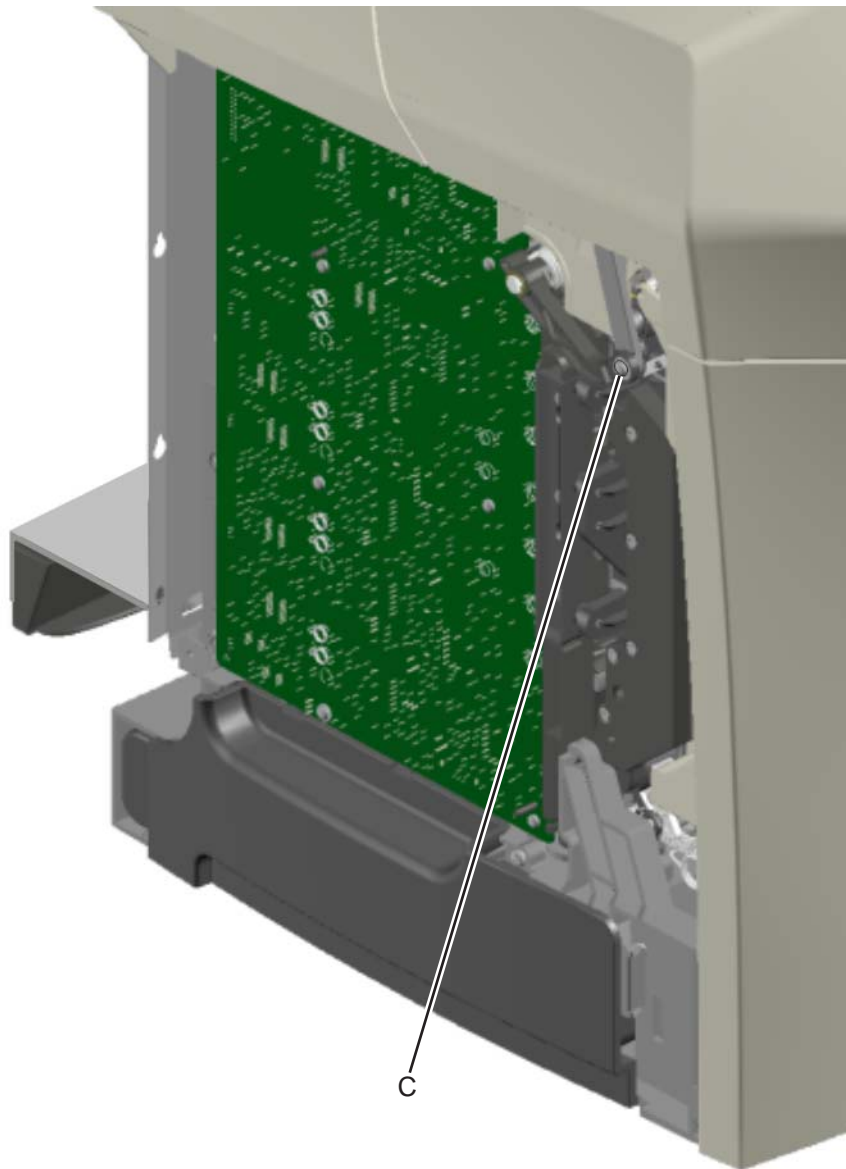

- 10.** Remove the screw (D) from the rear.

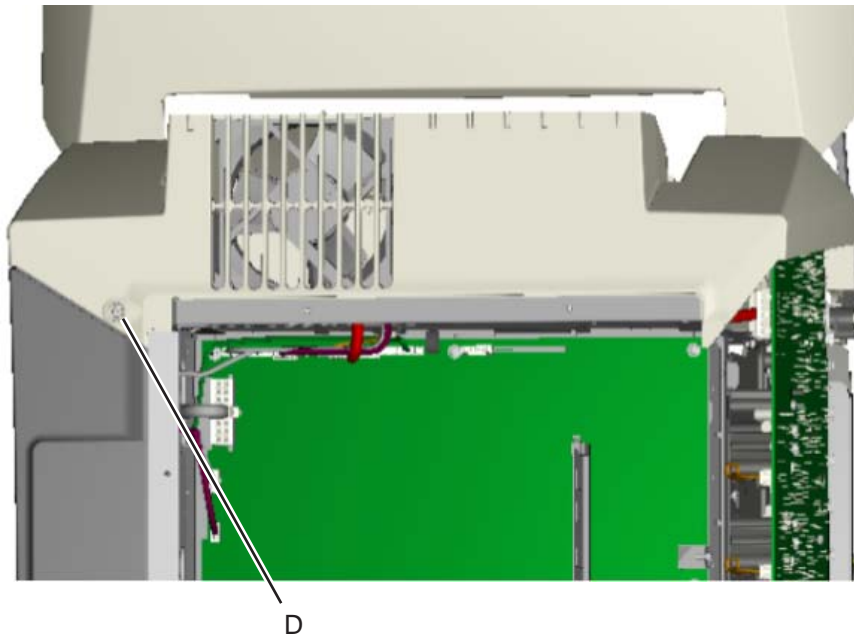

- 11.** Disconnect the cables for the fan at JFAN1 (E), the operator panel at JOPP1 (F), the high voltage power supply connector at JHVPS1 (G), and the bin full sensor at JBIN1(H) (for network printers only) from the system card.
- 12.** On the left side, unplug the connector (J) from CN1 on the high voltage power supply (HVPS).

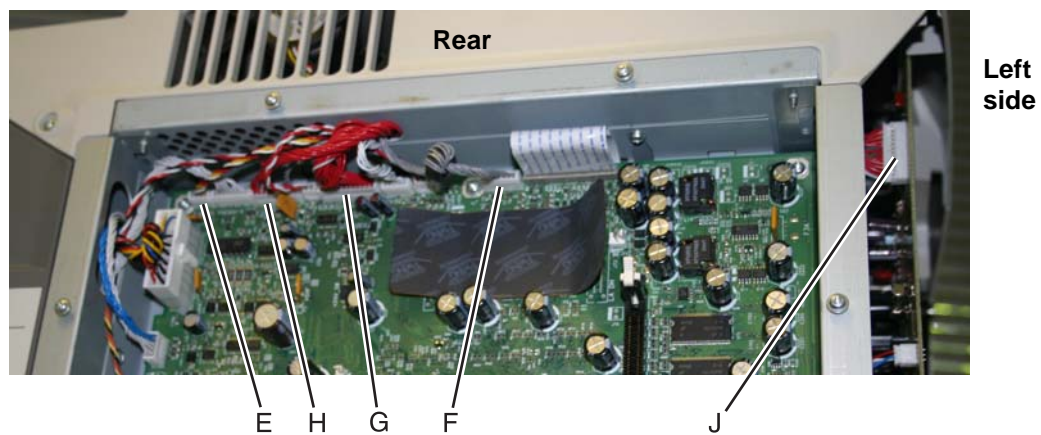

- 13.** Lift and remove the top access cover assembly.

Top access cover assembly removal—model C53x only

See **“Top access cover assembly (network), C532n/C534n”** on page 7-3 or **“Duplex top access assembly (network), C530dn/C532dn/C534dn”** on page 7-3 for the part number.

1. Remove the right cover. See **“Right cover removal”** on page 4-26.
2. Remove the left cover. See **“Operator panel outer bezel removal”** on page 4-21.
3. Remove the rear cover. See **“Rear cover removal”** on page 4-25.
4. Remove the fuser. See **“Fuser removal”** on page 4-60.
5. Remove the four screws (A) exposed after removing the fuser.

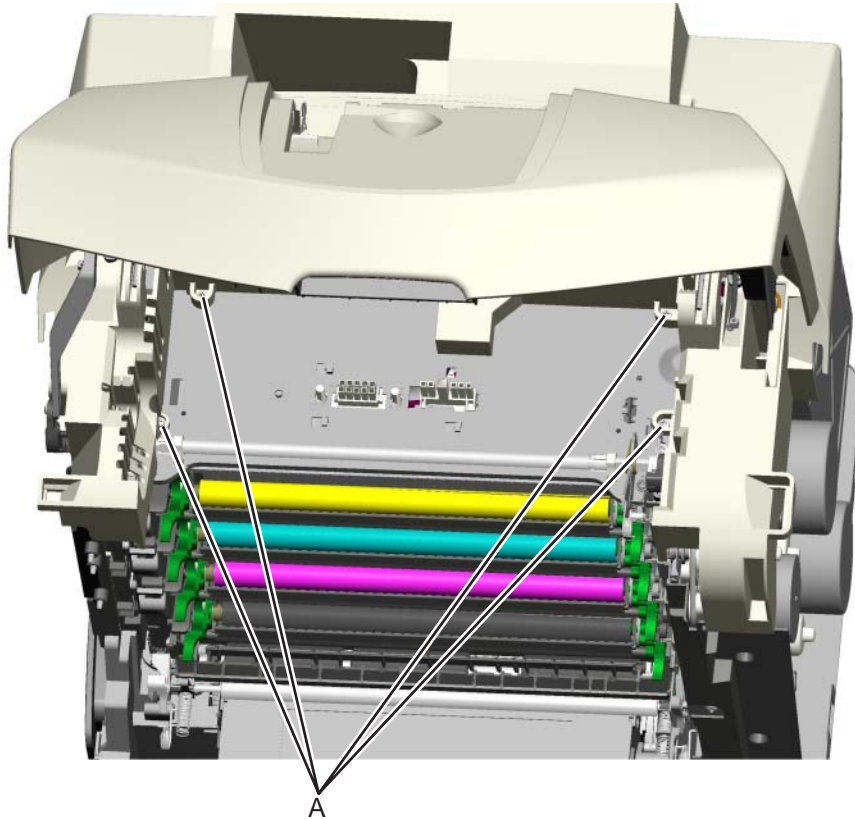

6. Remove the operator panel. See **“Operator panel assembly removal”** on page 4-23.
7. Remove the exit tray. See **“Exit tray cover removal”** on page 4-15.

8. Remove the screw (B) exposed after removing the exit tray.

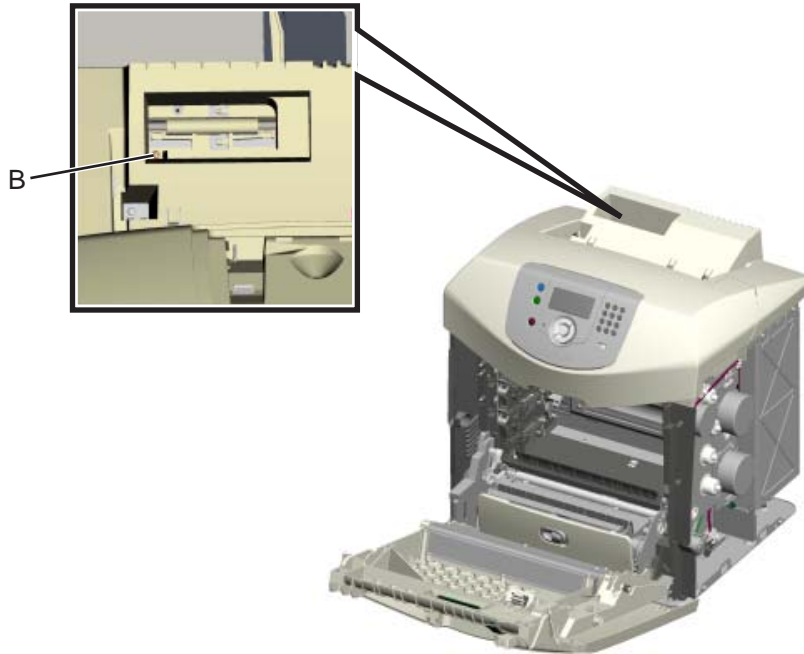

9. If the top access door is open, close it.
Warning: Ensure that top access door is closed before removing the linkage screw. Failing to close the door leaves the linkage under a load, which may result in the linkage screw being catapulted away from the printer when removed.

10. Remove the linkage screw (C).

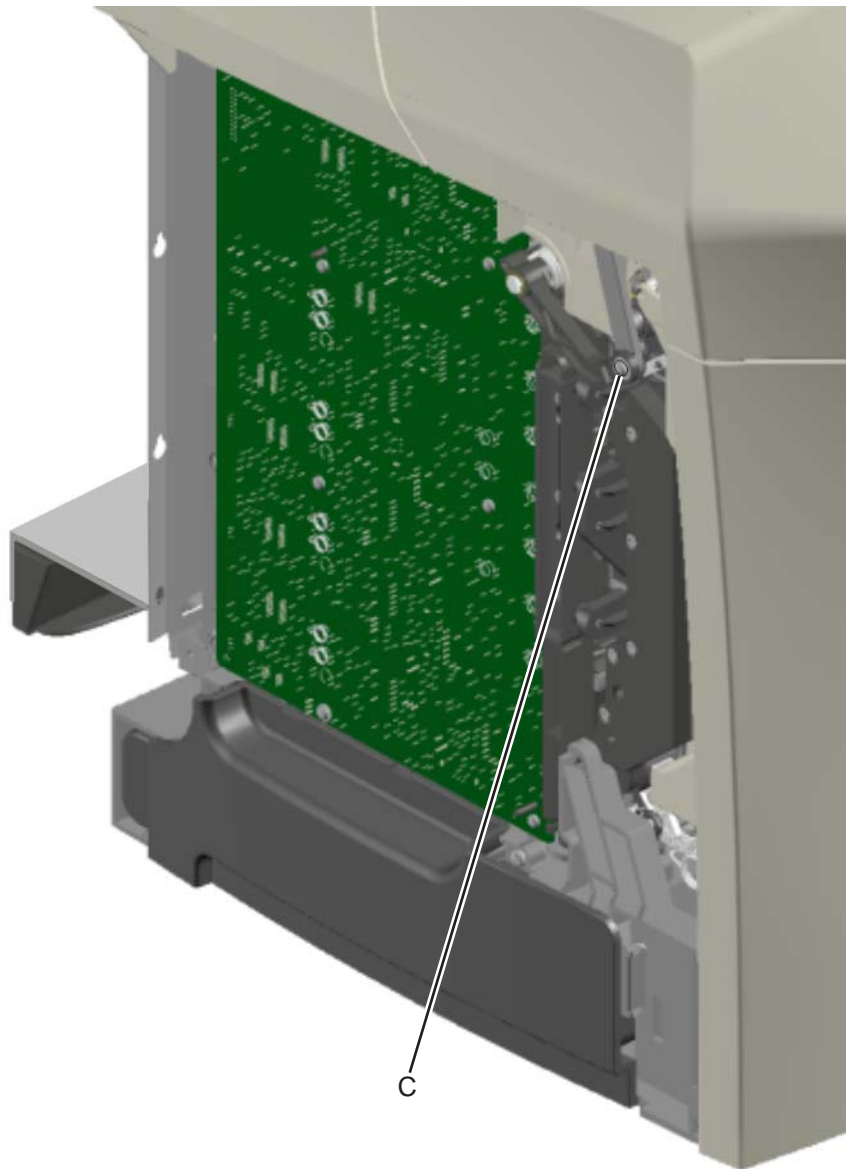

11. Disconnect the cables for the fan at JFAN1 (D), the operator panel at JOPP1 (E), the high voltage power supply connector at JHVPS1 (F), and the bin full sensor at JBIN1(G), and USB at J1 (H) (model C534 only) from the system card.

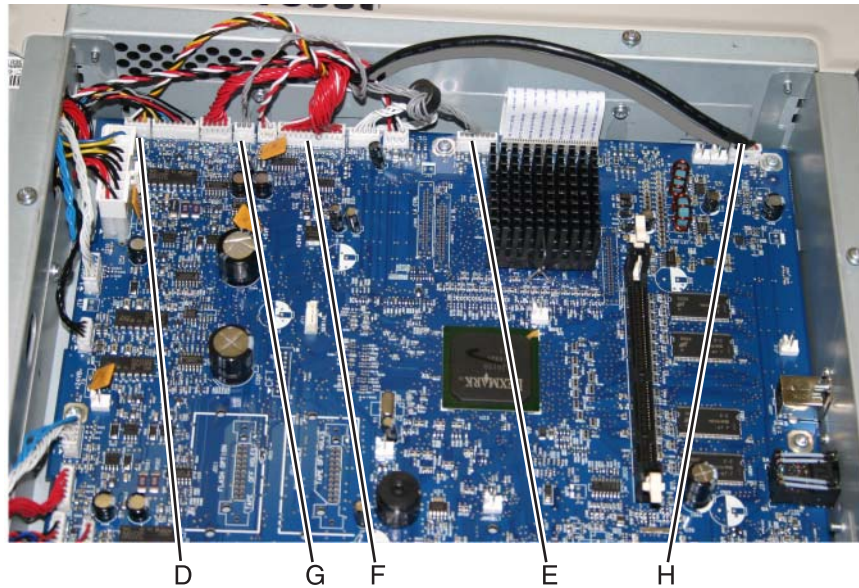

12. Unplug the connector (I) from CN1 on the high voltage power supply (HVPS).

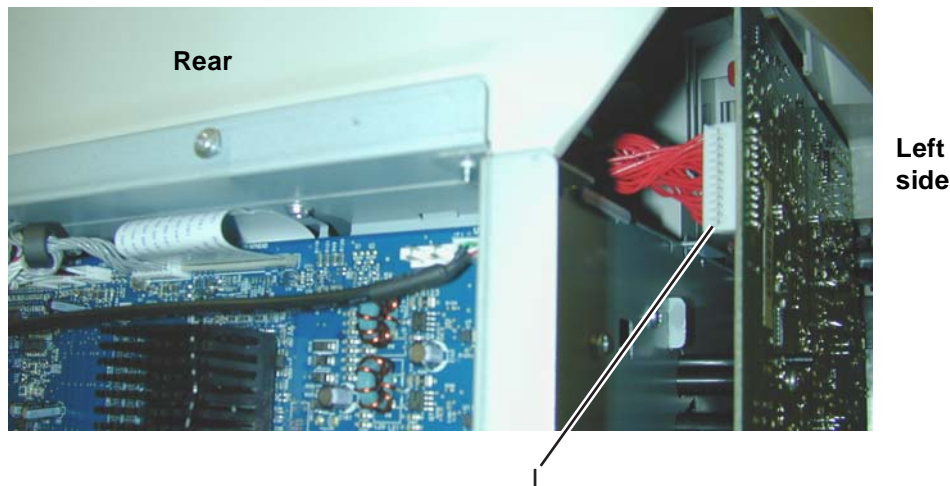

13. Disconnect the ground cable (J).

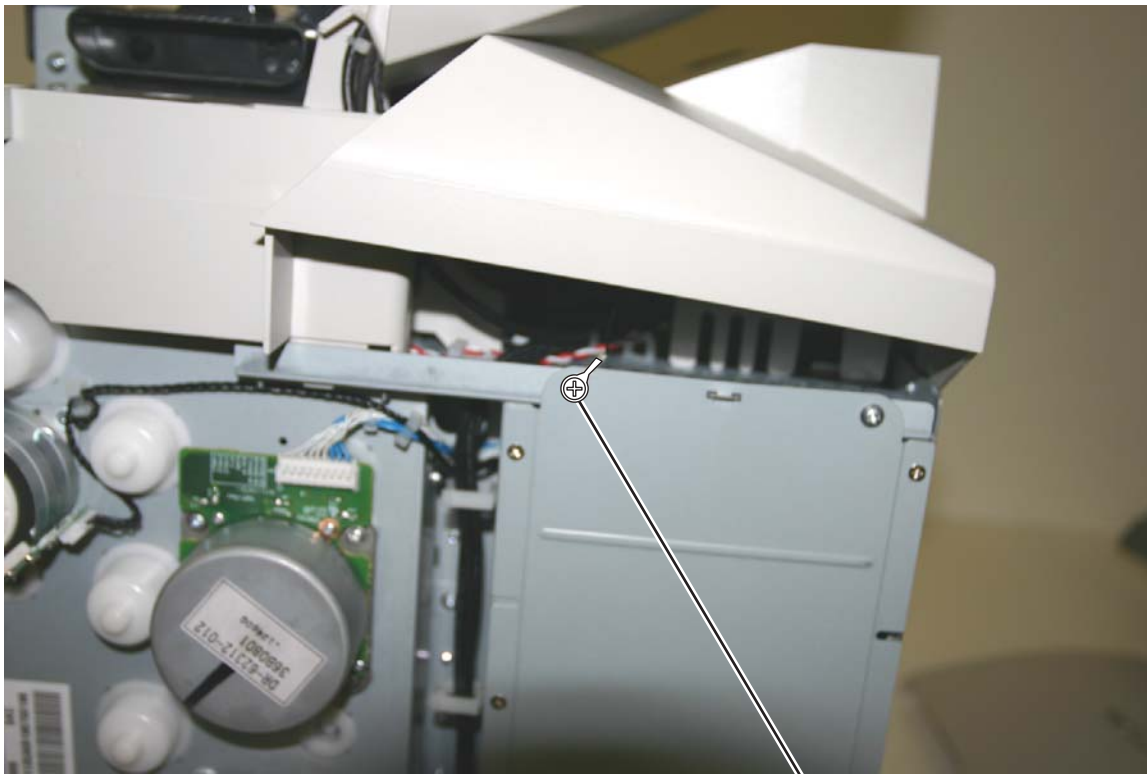

14. Lift and remove the top access cover assembly.

Bin full sensor removal—models C52x

See **“Bin full sensor with cable, C520n/C522n/C524n/C524dn”** on page 7-3 for the part number.

1. Open the top access door.
2. Remove the fuser. See **“Fuser removal”** on page 4-60.
3. Disconnect the spring (A).
4. Remove the seven screws (B) securing the inner access cover.

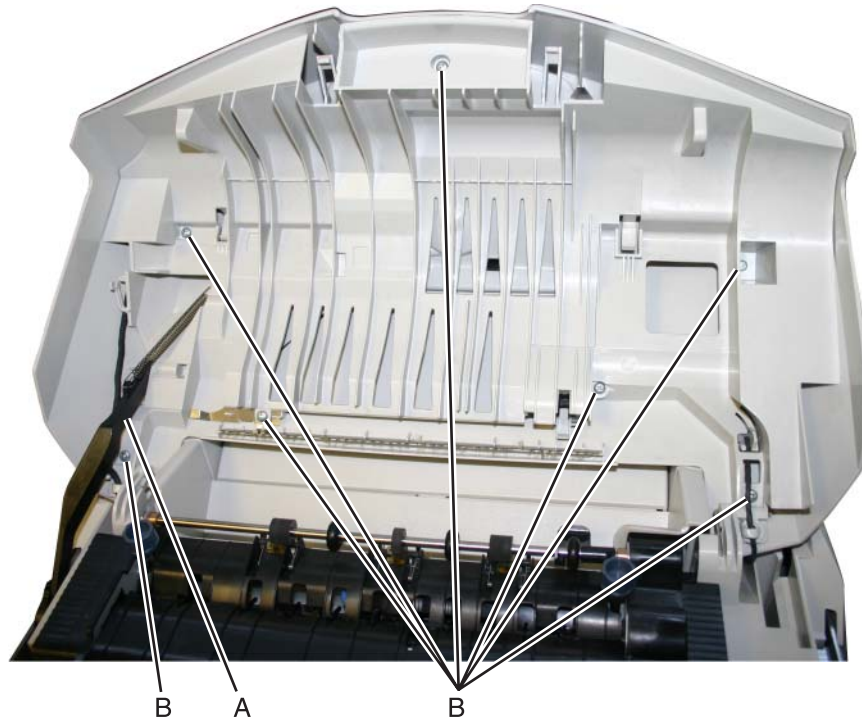

5. Remove the inner access cover.
6. Turn the access cover over, and press the back of the sensor to *snap* sensor (C) from the bracket.

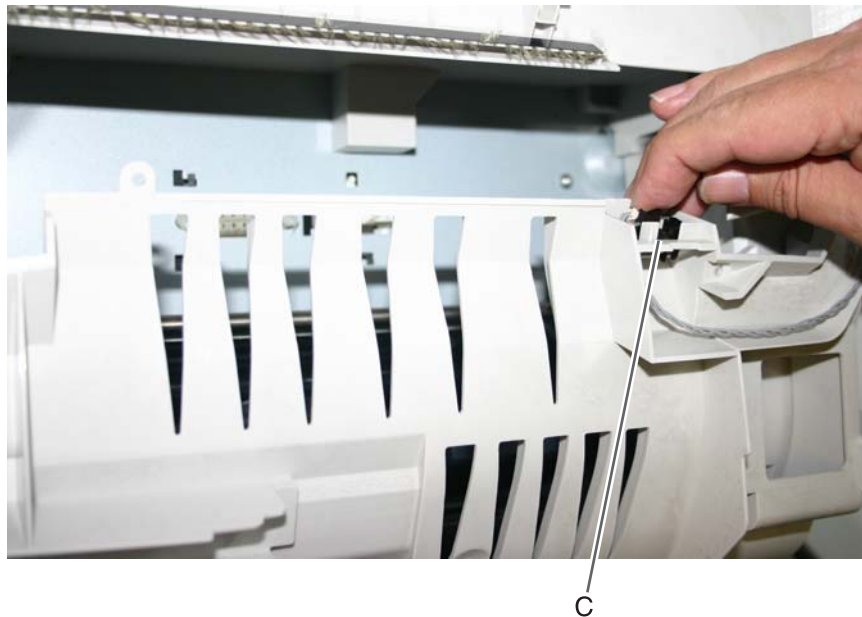

7. Remove the sensor and cable.

Bin full sensor removal—models C53x

See **“Bin full sensor with cable, C53x”** on page 7-3 for the part number.

1. Remove the top access cover assembly. See **“Top access cover assembly removal—model C53x only”** on page 4-32.
2. Remove the three screws (A) from the cable cover.

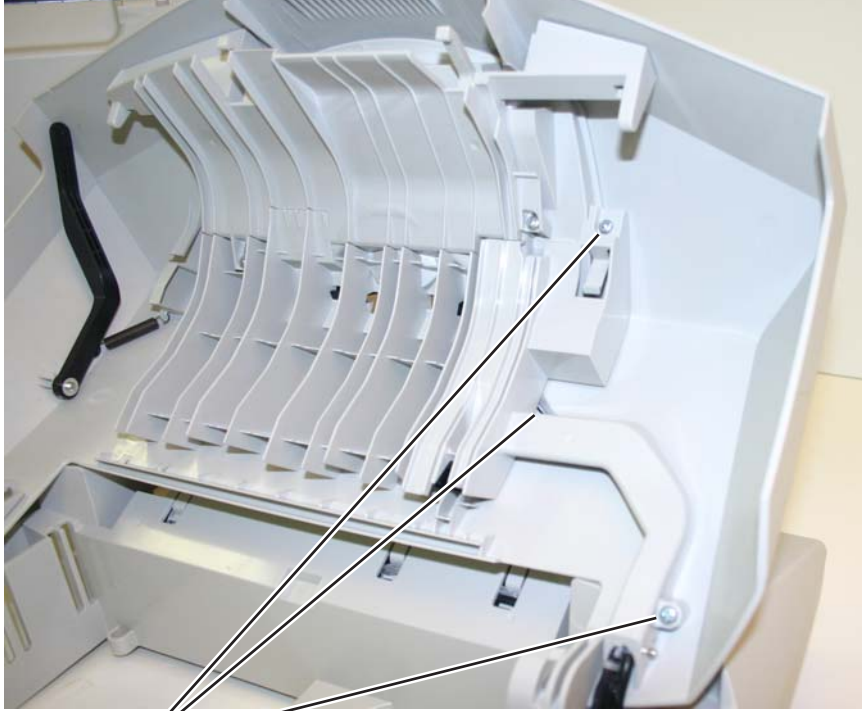

A

3. Turn the cable cover over, and press the side of the bin full sensor (B) to *snap* it loose from the cable cover.



B

4. Remove the bin full sensor and cable.

Bump aligner gear removal

See the Bump aligner gear kit on [page 7-5](#) for the part number.

1. Remove the paper pick mechanism assembly. See [“Paper pick mechanism assembly removal” on page 4-68.](#)
2. Close the front access door for better access to the gears.
3. Remove the three e-clips and washers (A).
4. Remove the gears.

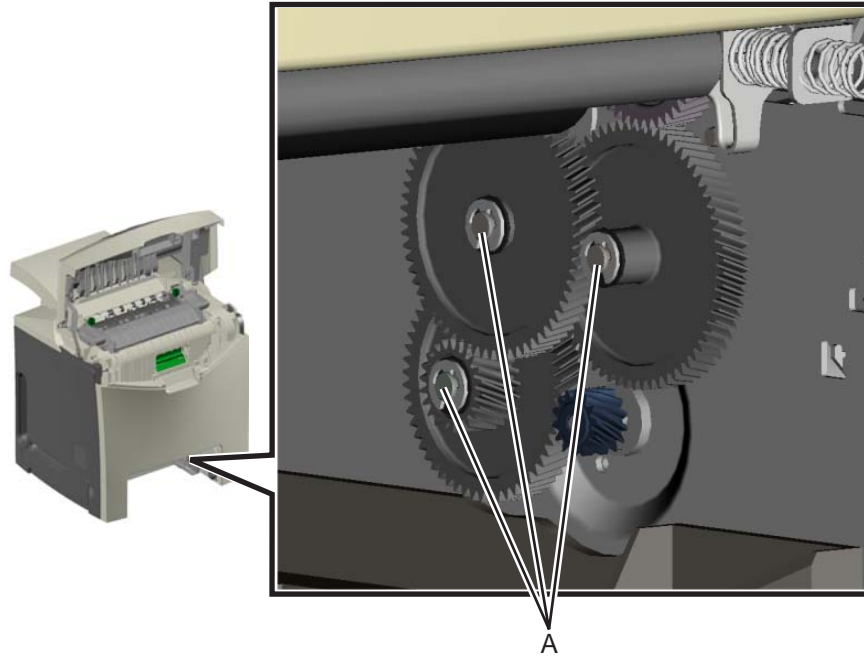

Installation notes:

- When reinstalling the gears, apply a light coat of the packaged grease.
- The following illustration shows proper orientation of the gears for installation. The two gears are reduction gears with the largest of the two (B) located in the middle, on the top.

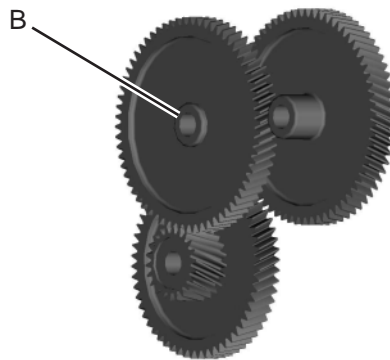

Bump aligner motor removal

See **“Bump aligner motor” on page 7-7** for the part number.

1. Remove the right side cover.
2. Remove the bump aligner gears. See **“Bump aligner gear removal” on page 4-39**.
3. Remove the two bump aligner motor mounting screws (A).

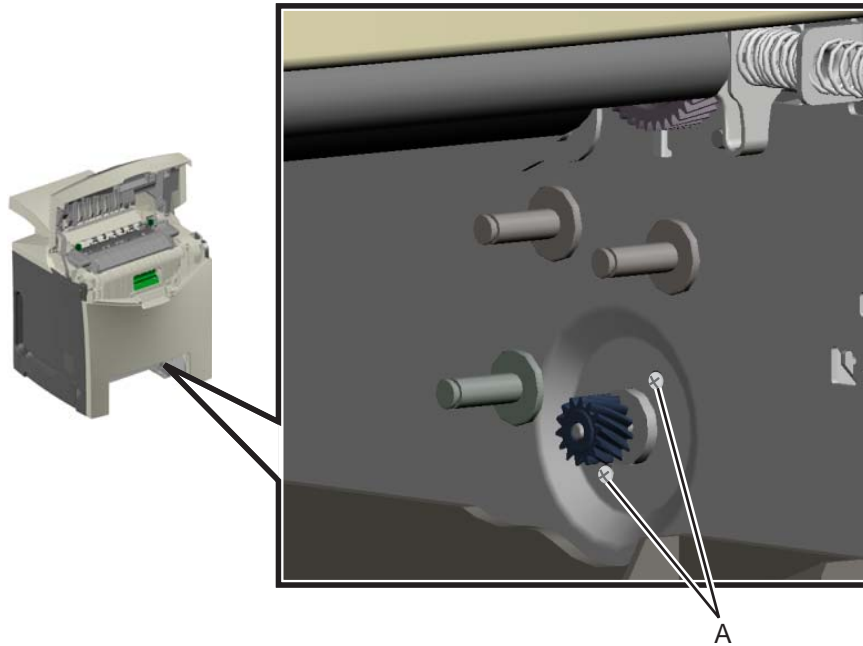

4. Disconnect the JBUMP1 connector (B) from the system card.

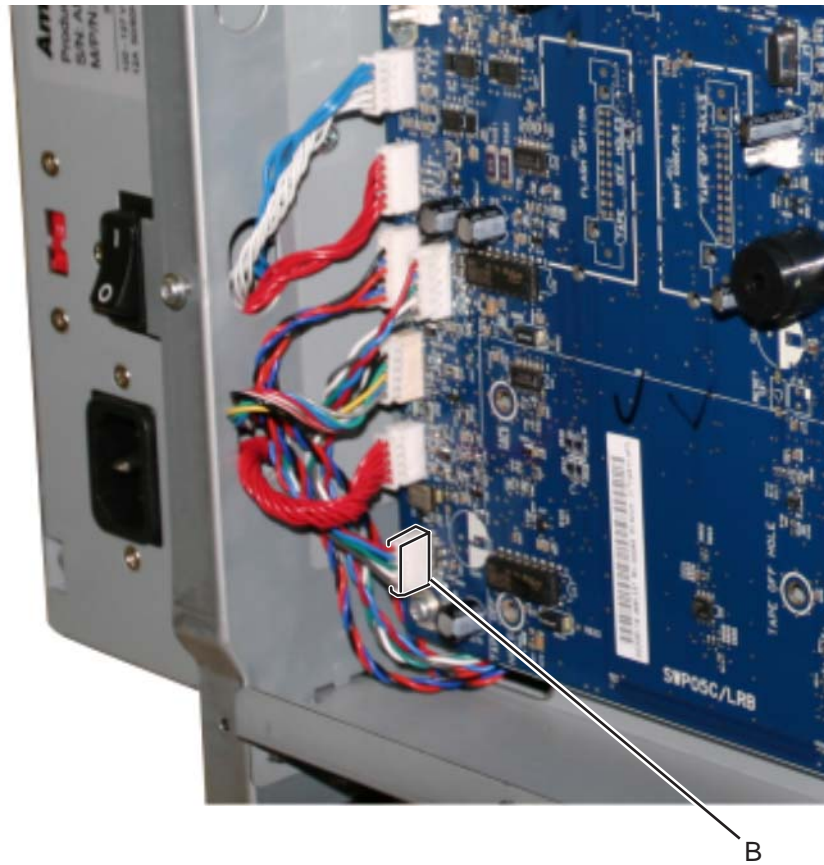

5. Remove the bump aligner motor from the printer.

Bump aligner rollers and springs removal—models C53x

See **“Deflector assembly, C53x”** on page 7-5 for the part number.

1. Remove the paper tray.
2. Push up and back to release the bump aligner spring.



3. Lower the bump aligner spring to remove it.

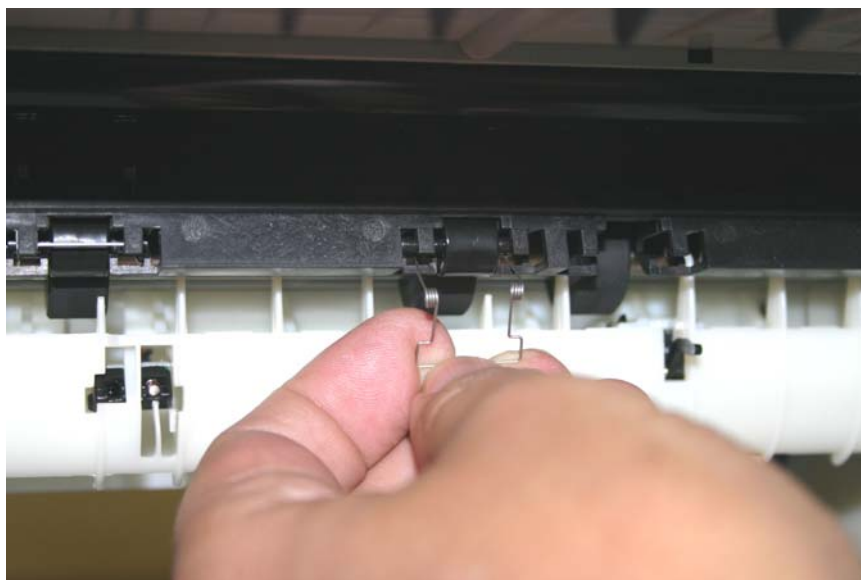

4. Remove the bump aligner roller.



Installation note: Make sure to support the bump aligner roller in the arms of the bump aligner spring.



Contact springs removal

See **“Contact springs”** on page 7-17 for the part number.

1. Remove all the toner cartridges.
2. Remove the screw (A) and the spring cap (B) of the appropriate contact spring.

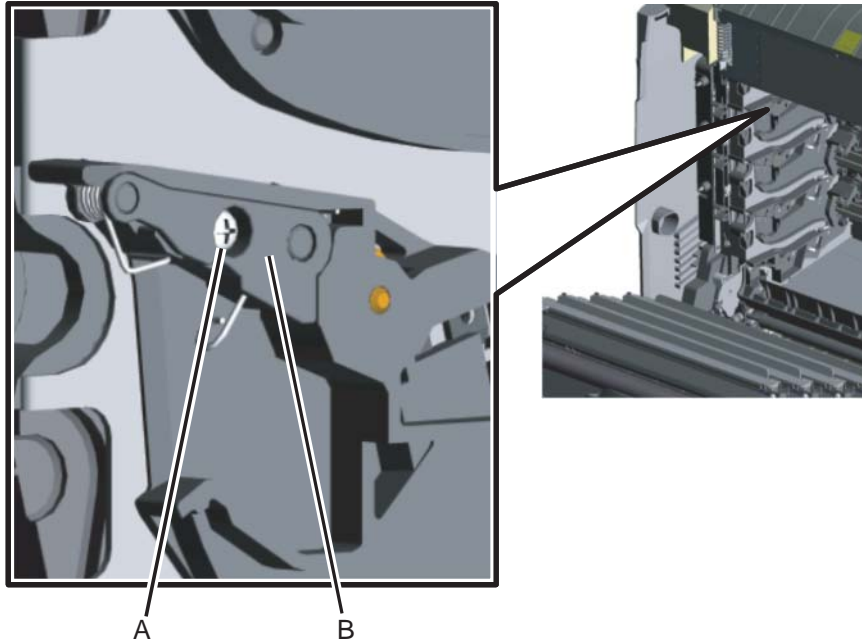

3. Press the lower half (C, D) of the springs and remove the springs.

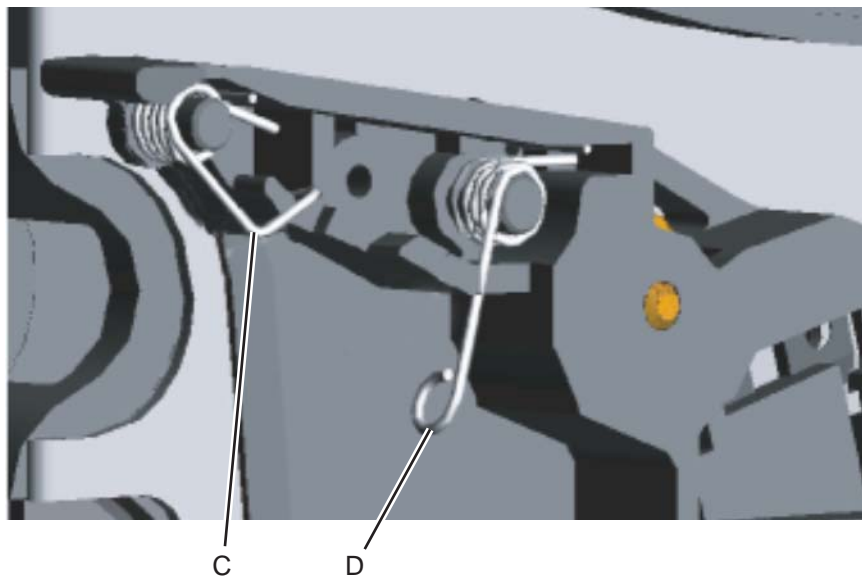

Installation notes: When installing, make sure the top half (E) of the spring is under the straight spring (F). This is typical for both types of springs. Also make sure the bottom half (D,G) of both springs are compressed and locked by the appropriate locking tabs (H, I).

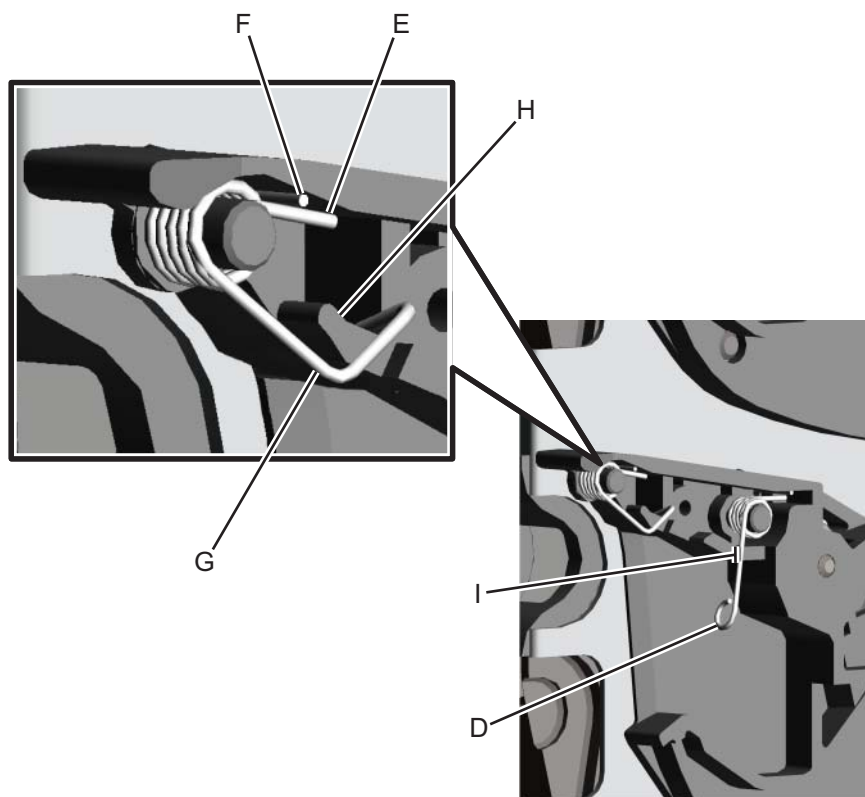

Deflector assembly removal—models C53x only

See “**Deflector assembly, C53x**” on page 7-5 for the part number.

1. Remove the right cover. See “**Right cover removal**” on page 4-26.
2. Remove the screw (A) securing the deflector assembly on the right side.

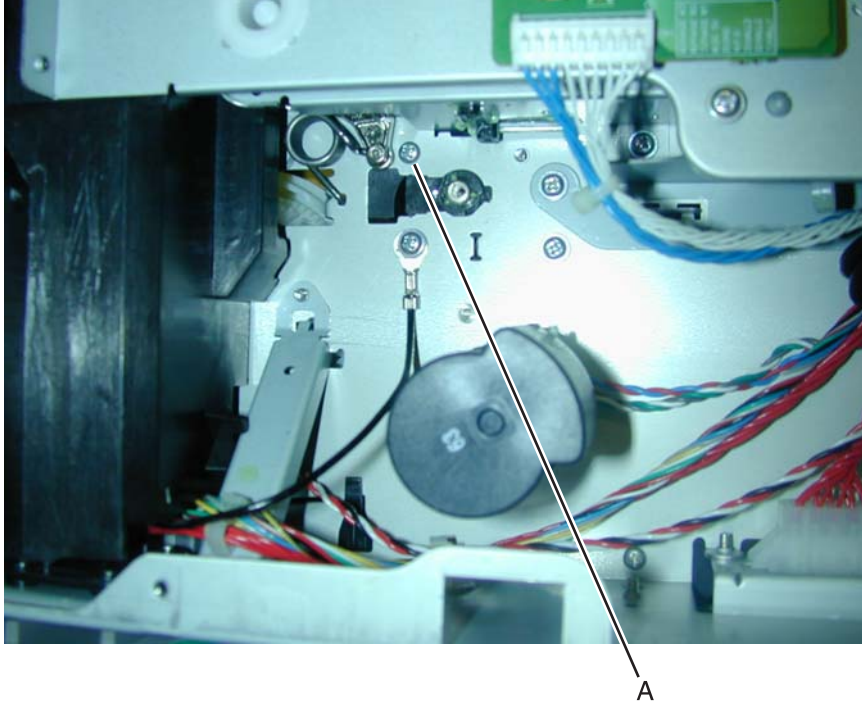

3. Place a flathead screwdriver between the deflector assembly and the right side frame, and lever the deflector away from the frame.

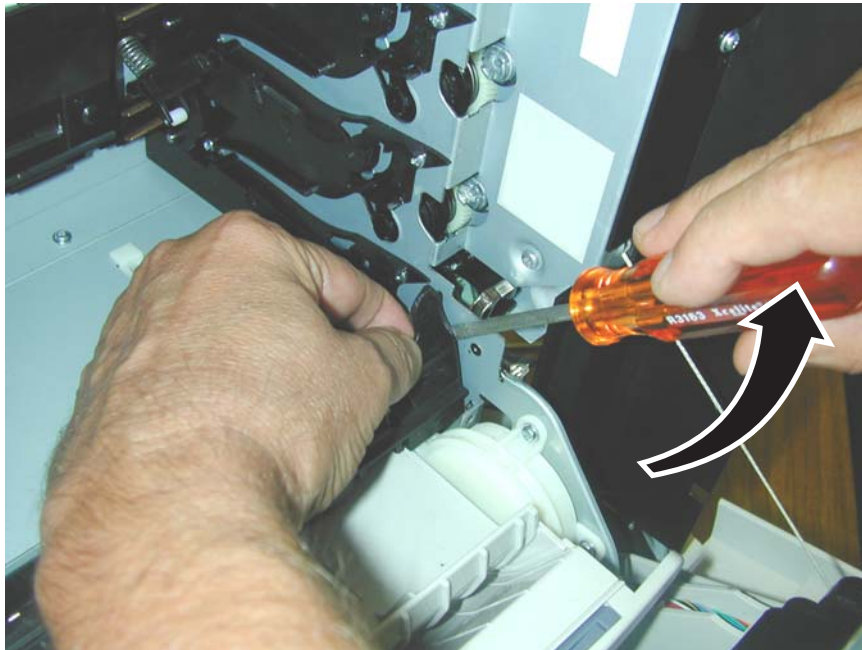

4. Pivot the deflector out, and remove.

Installation notes:

1. Align the two studs (A) to the two alignment holes (B) in the left side frame.

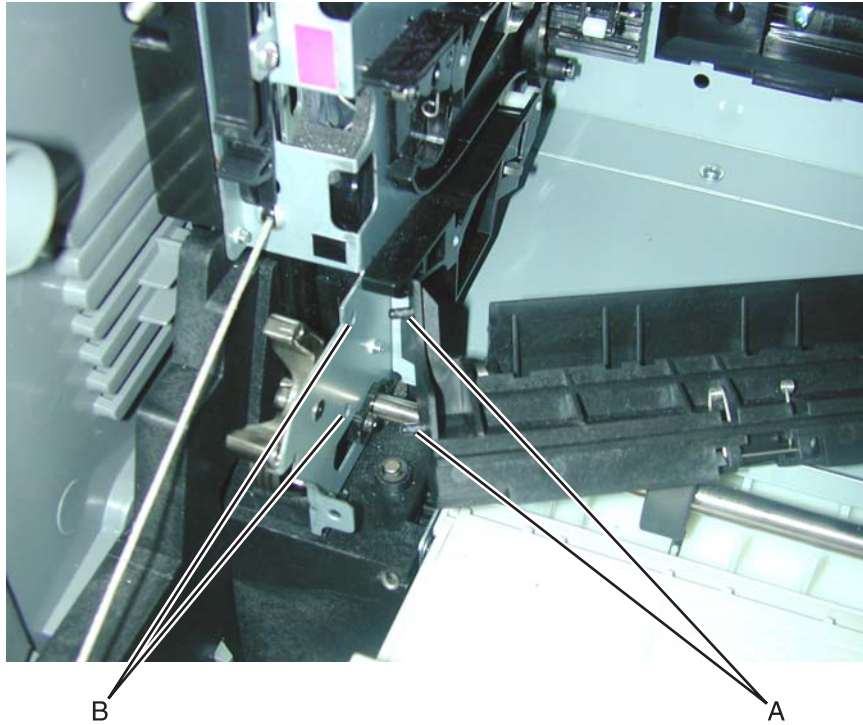

2. Align the stud (C) with the alignment hole (D) on the right frame.

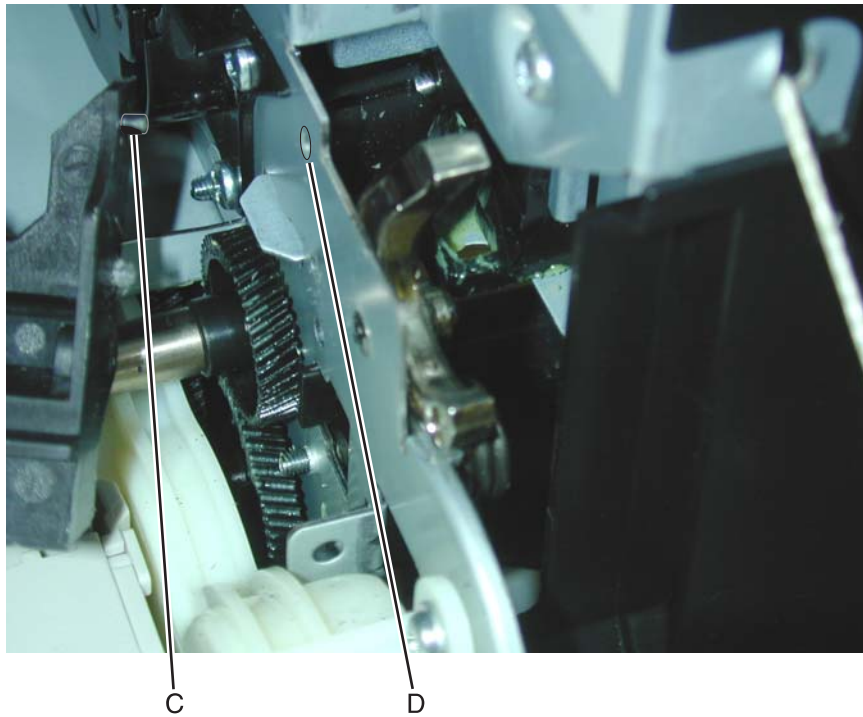

3. *Snap* into place.
4. Replace the screw on the right side.

Electrophotographic (EP) drive assembly removal—model C52x only

See “EP drive assembly, C52x” on page 7-7 or “EP drive assembly, C53x” on page 7-7 for the part number.

1. Remove the low voltage power supply. See “Low voltage power supply (LVPS) removal” on page 4-65.
2. Open the top access door.
3. Open the front access door.
4. Remove all the toner cartridges.
5. Disconnect the JTRANS2 connector (A) from the system card.

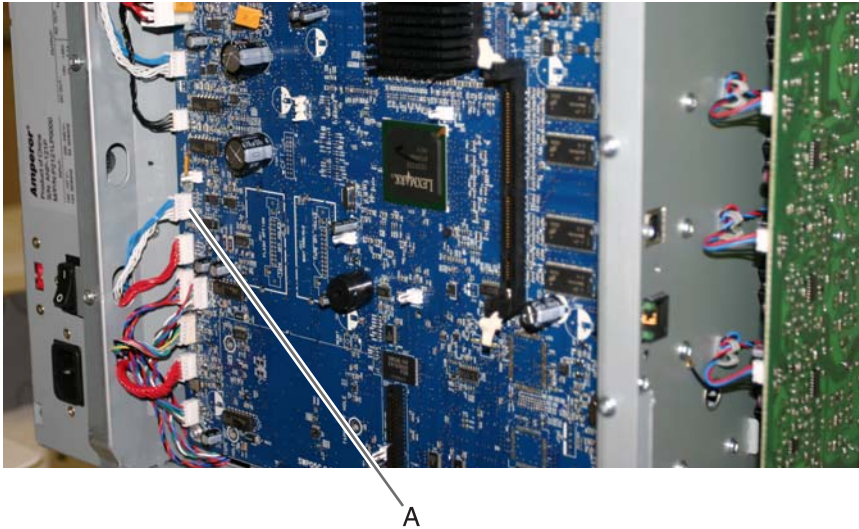

6. Disconnect JCART1 (B) and JCART2 (C) connectors from the drive assembly.

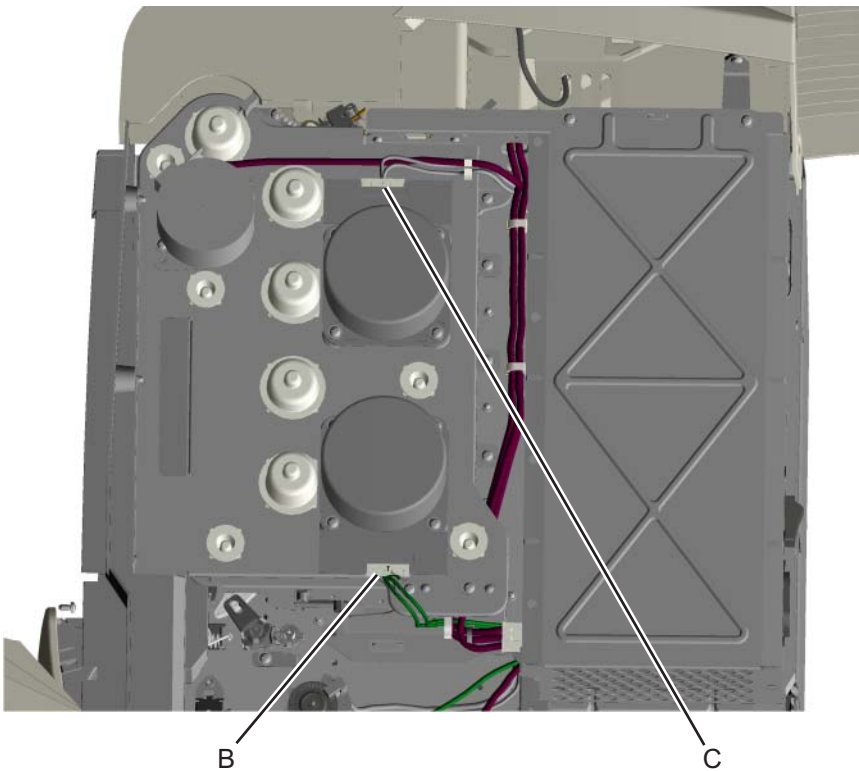

7. Remove the six inner screws (D).

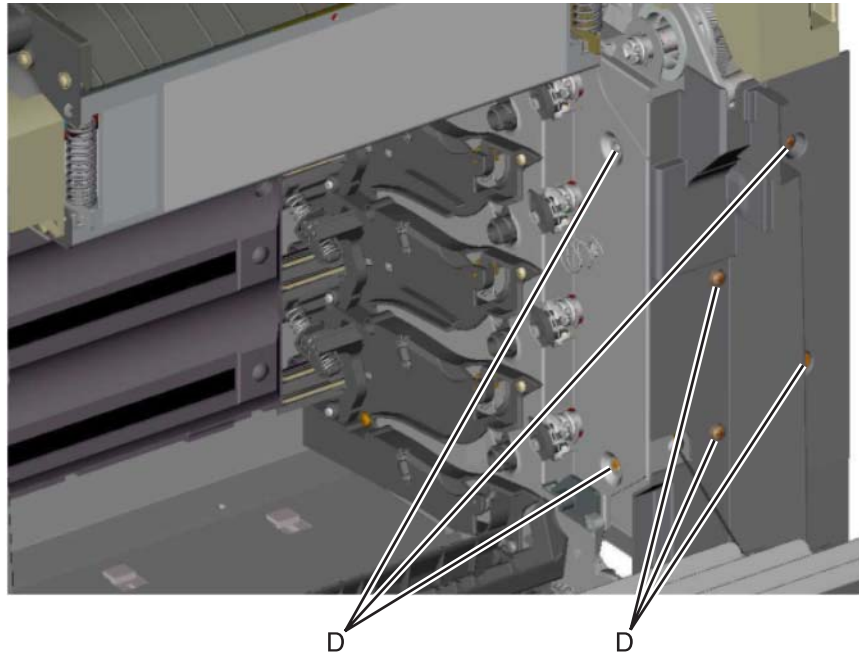

8. Remove the nine outer screws (E).
Note: Access the top two screws through the top cover.

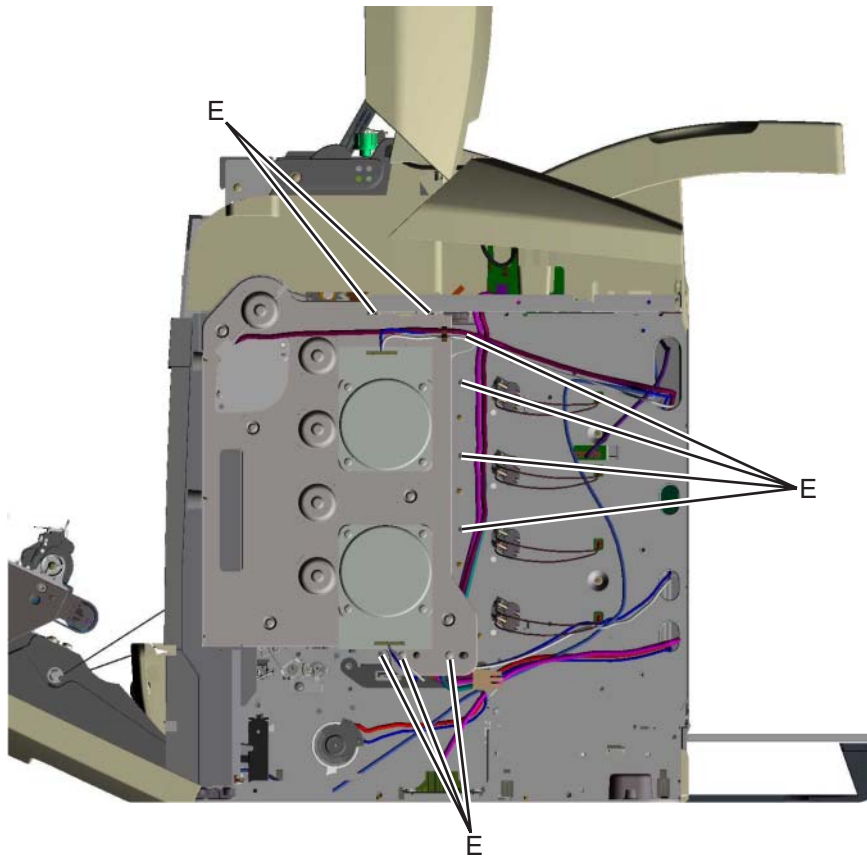

9. Remove the EP drive assembly from the printer.

Installation note: Ensure that the top access door is open and EP drive is retracted when installing the new EP drive assembly.

Note: When retracted, the upper (F) and lower retraction plates (G) will be fully forward. If not, slide the upper retraction plate forward until the EP drive retracts and is disengaged from the developers.

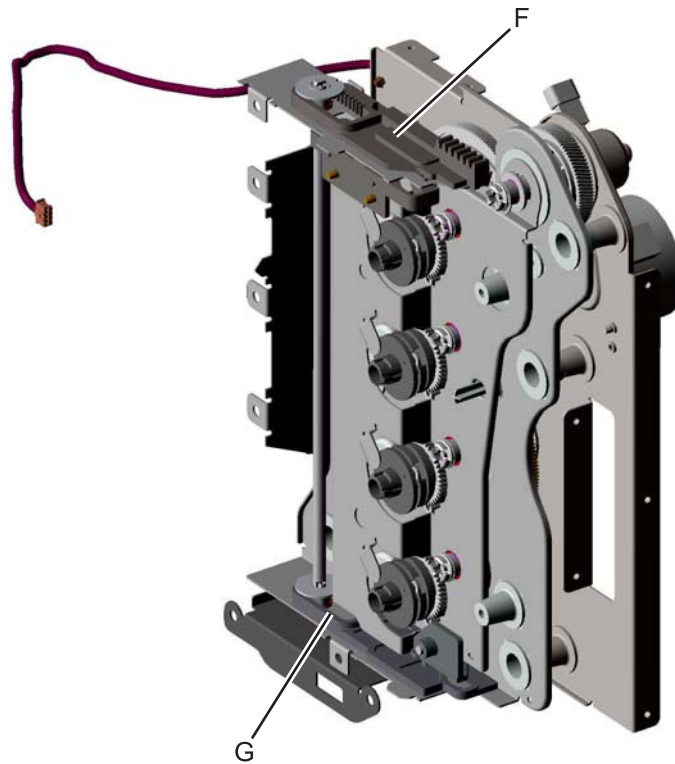

Electrophotographic (EP) drive assembly removal—model C53x only

See **“EP drive assembly, C53x” on page 7-7** for the part number.

1. Remove the right cover. See **“Right cover removal” on page 4-26**.
2. Open the top access door.
3. Open the front access door.
4. Remove all the toner cartridges.
5. Remove the six inner screws (A).

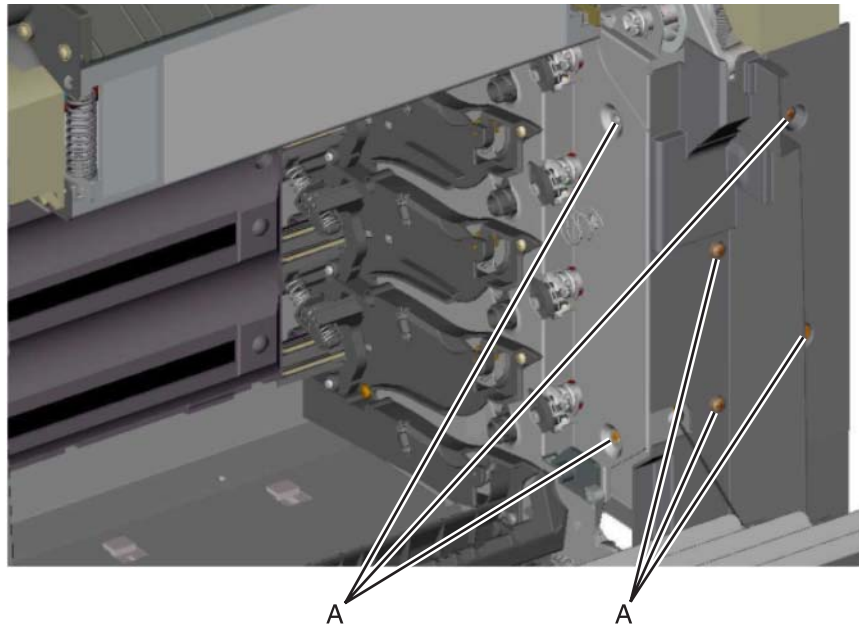

6. Disconnect JCART1 (B), JCART2 (C), and JTRANS2 (D) connectors from the drive assembly.

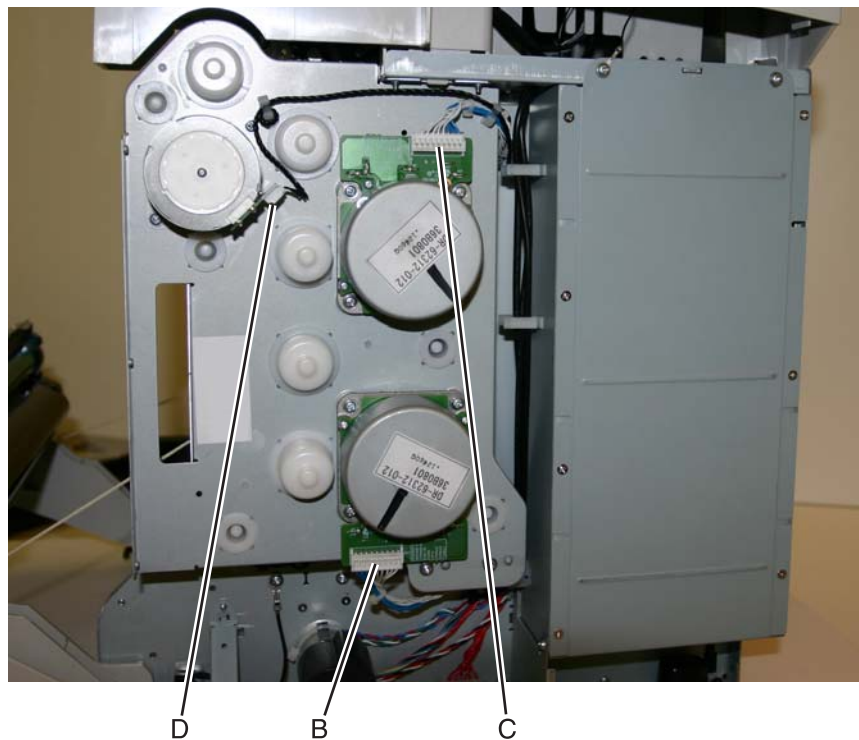

7. Remove the nine outer screws (E).
Note: Access the top two screws through the top cover.

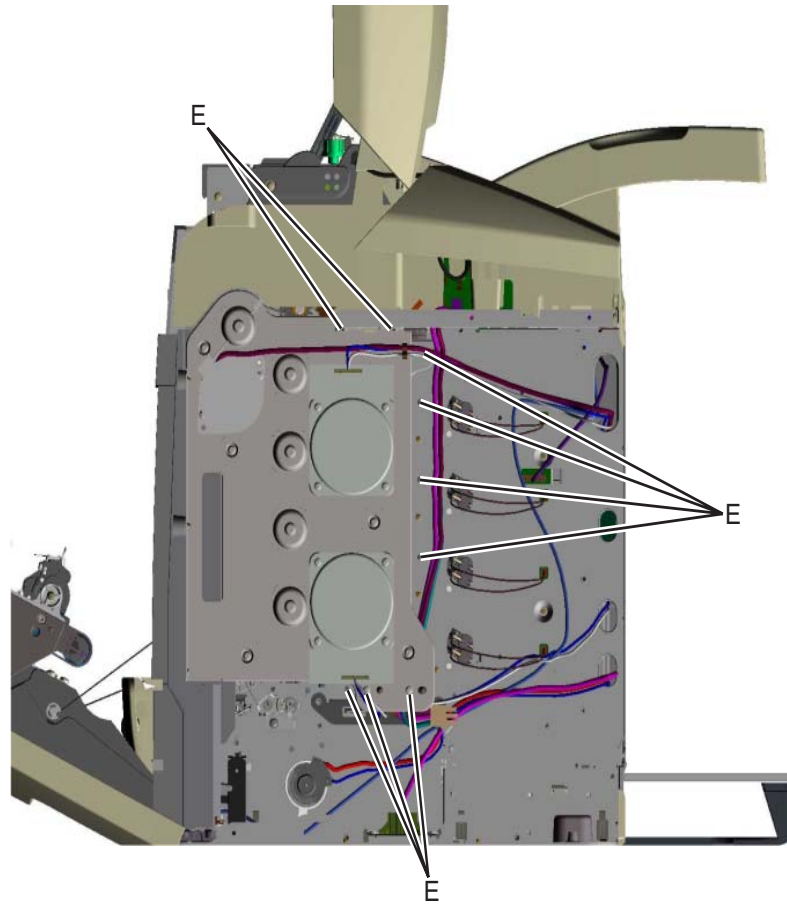

8. Remove the EP drive assembly from the printer.

Installation note: Ensure that the top access door is open and the EP drive is retracted when installing the new EP drive assembly.

Note: When retracted, upper (F) and lower retraction plates (G) will be fully forward. If not, slide the upper retraction plate forward until the EP drive retracts and is disengaged from the developers.

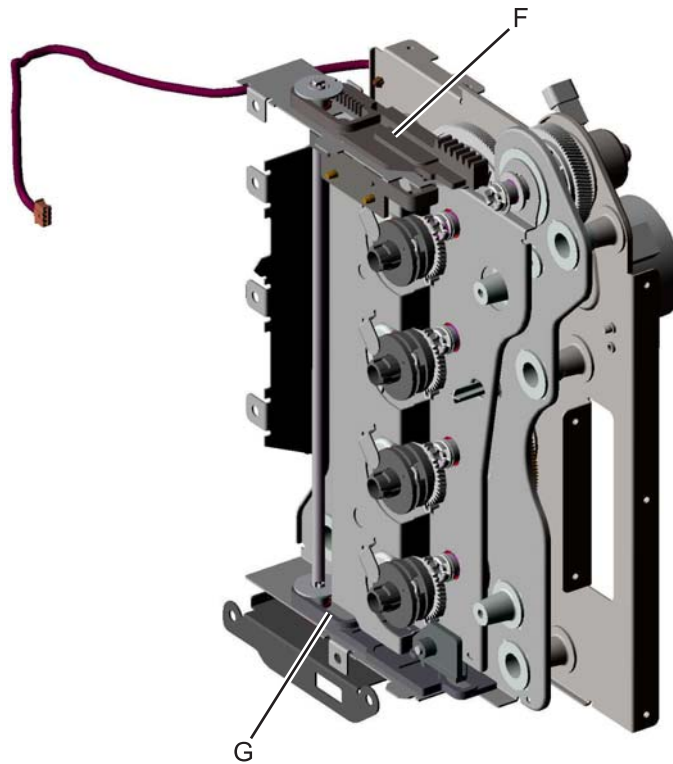

Front access door 5 V interlock switch removal

See **“Front door 5 V interlock switch”** on page 7-7 for the part number.

1. Remove the LVPS. See **“Low voltage power supply (LVPS) removal”** on page 4-65.
2. Disconnect the JINT1 connector (A) from the system card.

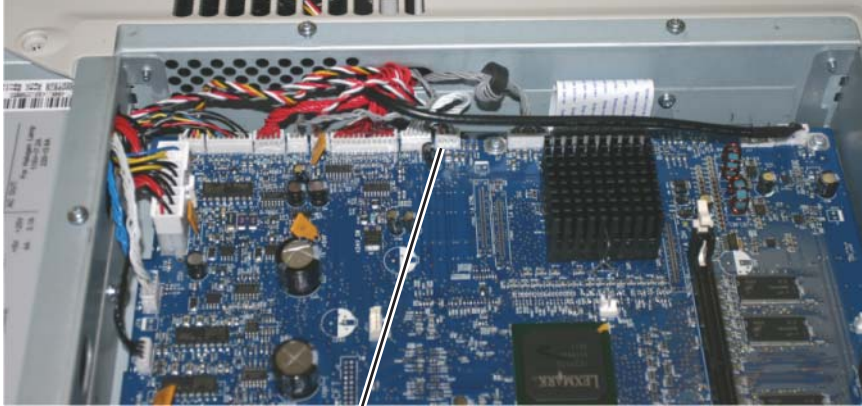

3. Open the top access door.
4. Remove the gearbox shield. See **“Gearbox shield removal”** on page 4-19.
5. Remove the interlock switch mounting screw (B) from the right side of the printer.

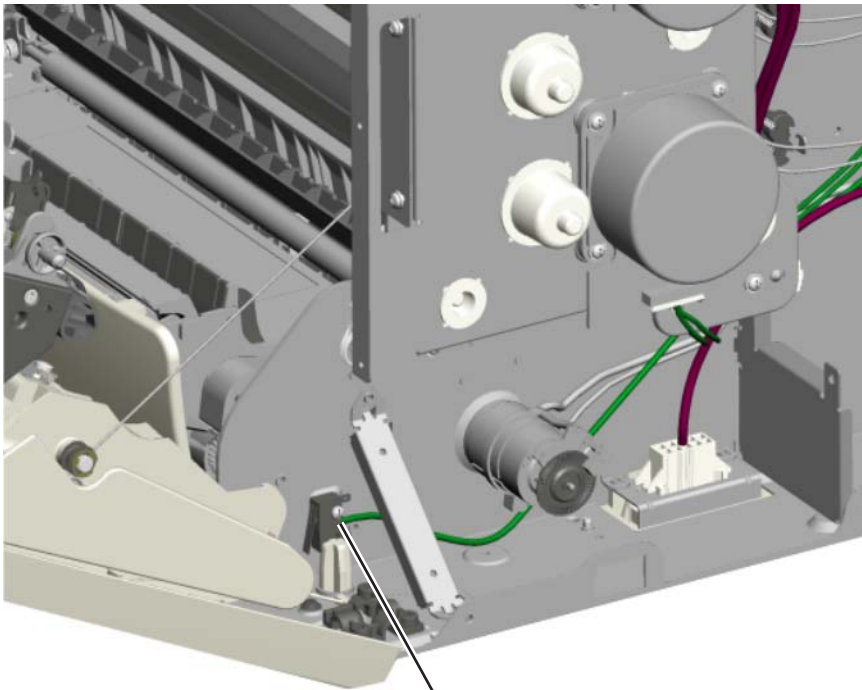

6. Remove the cable from cable guide, and remove the 5 V interlock switch.

Front door assembly removal

See the part number for the Front door assembly for the specific model you need on [page 7-5](#).

1. Remove the front access cover assembly. See [“Front access door cover assembly removal” on page 4-16](#).
2. Remove the rear cover. See [“Rear cover removal” on page 4-25](#).
3. **For C52x only:** Disconnect the JTRANS1 cable (A) from the system card.
For C53x only: Disconnect the JTRANS2 cable (A) from the system card.
Note: If you have a duplex model, also disconnect the JDUPLX1 cable (B) from the system card.

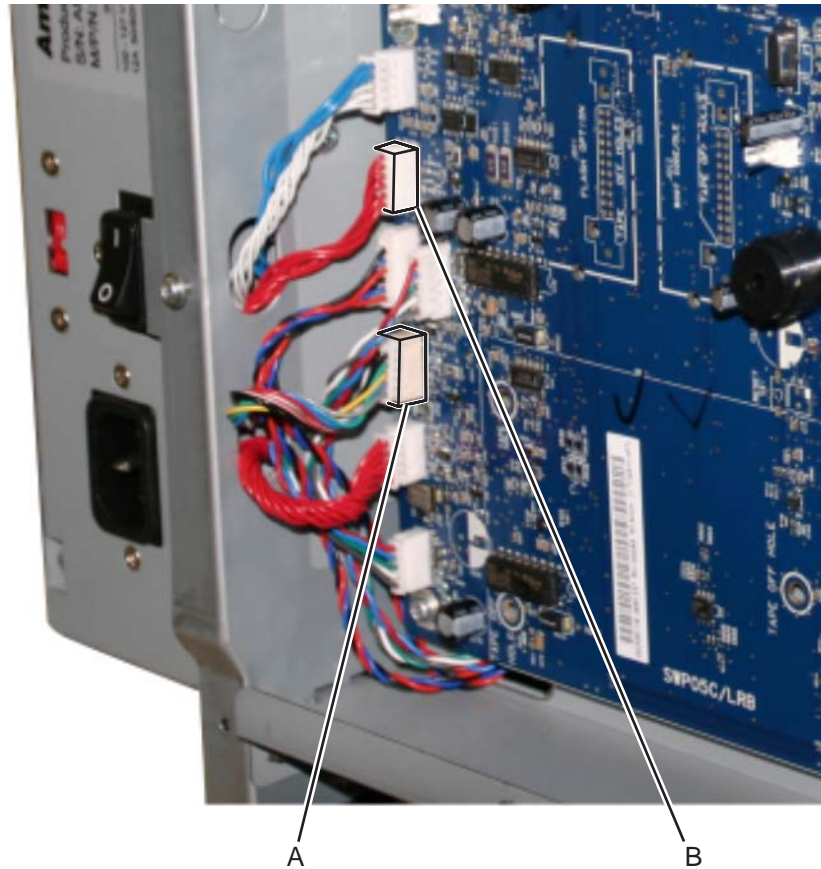

4. **Models C52x only:** Disconnect the cable (C) from the right side of the frame. Be careful not to lose the grounding clip (D).

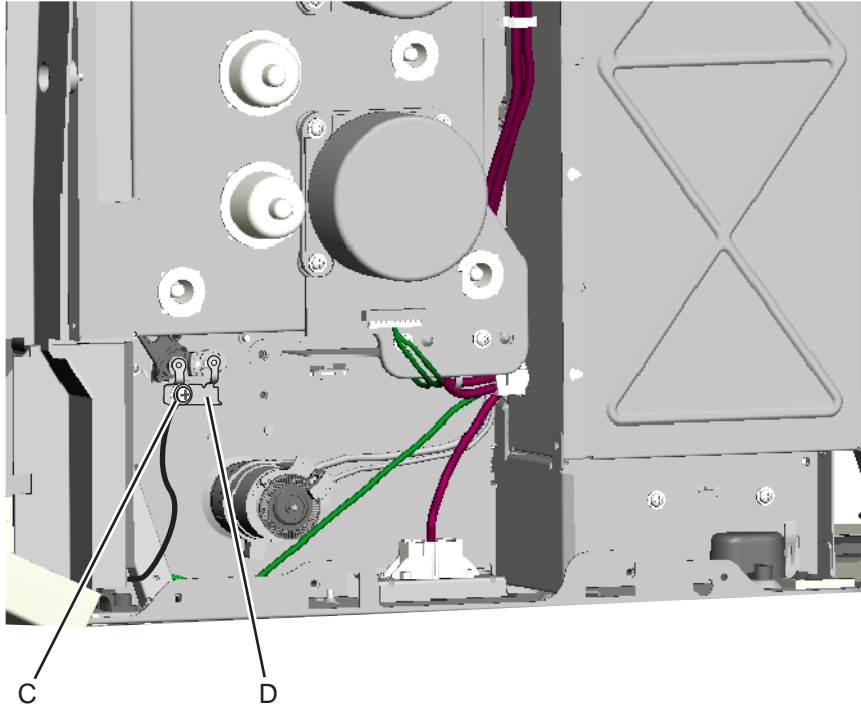

5. Remove the gearbox shield. See **“Gearbox shield removal”** on page 4-19.
6. Close the front door assembly.
7. Release the left and right front door assembly cable restraint springs (E) from the front door assembly.

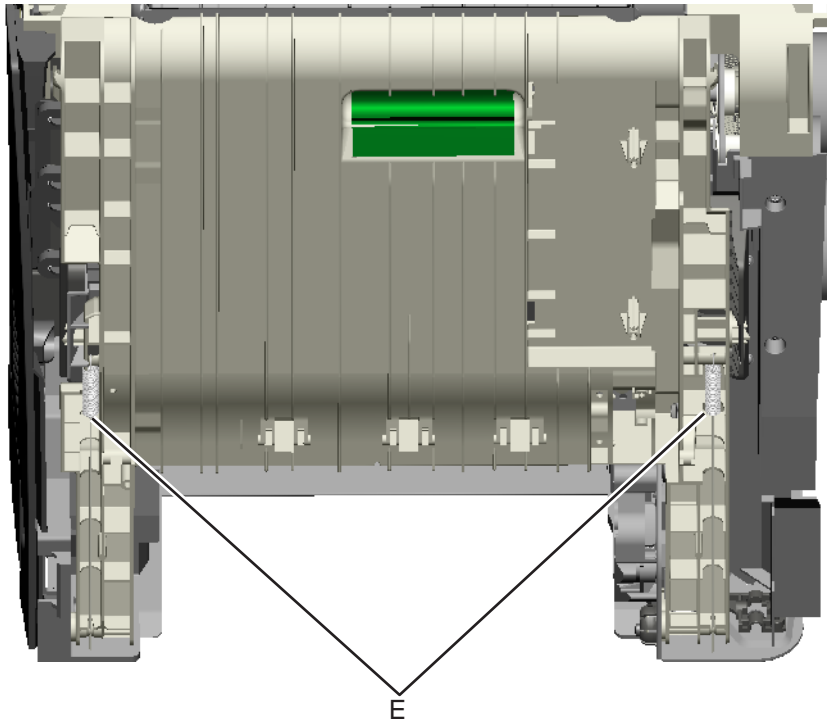

8. Open the front door assembly.

9. Unwrap and remove the cable from the left and right pulleys (F).

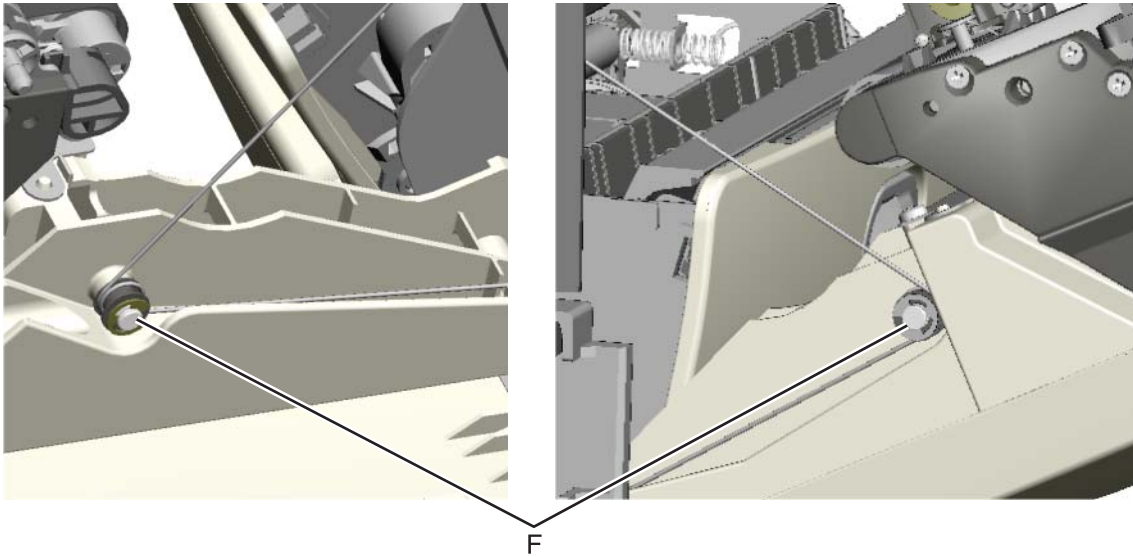

10. Remove the mounting screw (G) and the cap (H).

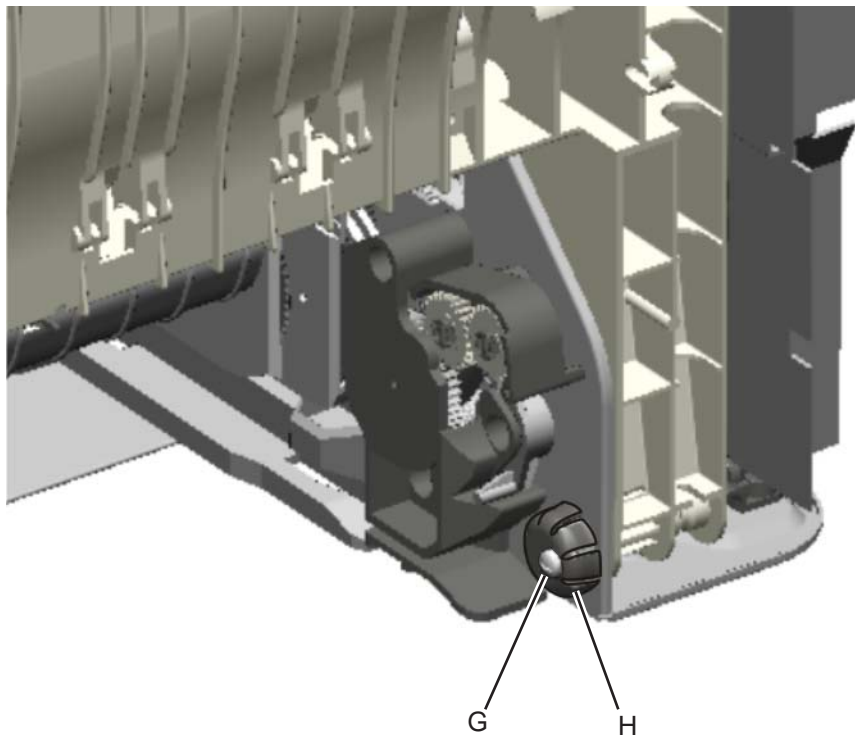

11. Open the front door assembly, slide it to the right, and remove. You need to press firmly to slide the front door assembly to the right.

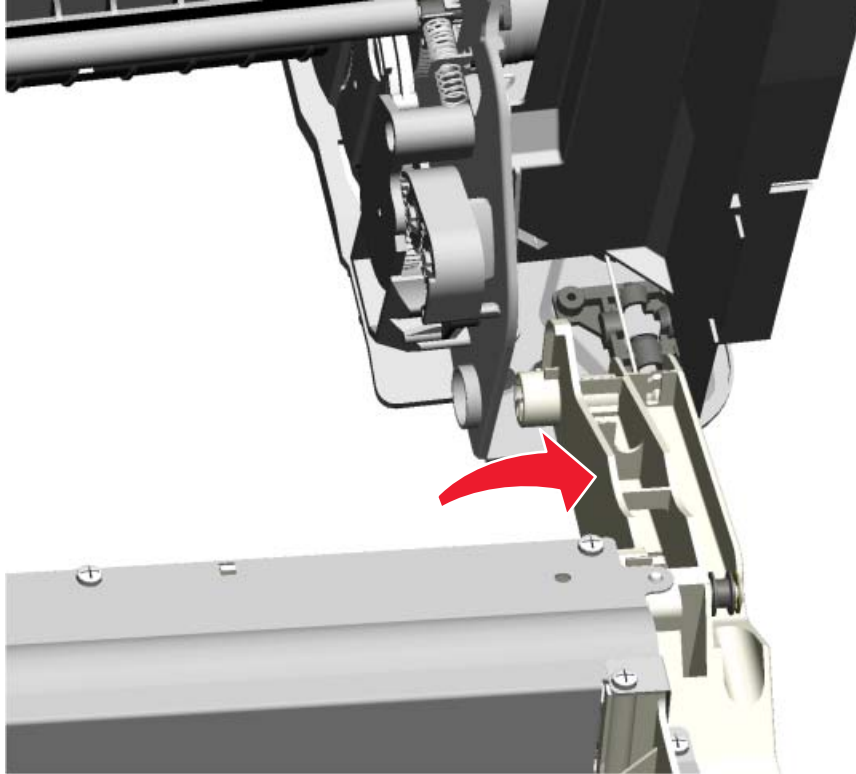

Installation note: See **“Front door assembly front cable removal”** on page 4-59 for proper installation of the cable restraints.

Front door assembly front cable removal

See the part number for the Front door parts packet for the model you need on [page 7-5](#).

Removal procedures are for either the left or the right front door assembly restraint cables.

Right restraint cable

1. Remove the front access cover assembly. See [“Front access door cover assembly removal” on page 4-16](#).
2. Release the cable spring (A) from the front door assembly.
3. Remove the gearbox/switch shield (B). See [“Gearbox shield removal” on page 4-19](#).
4. Remove the end of the cable (C) from the frame.

Left restraint cable

1. Remove the front access cover assembly. See [“Front access door cover assembly removal” on page 4-16](#).
2. Close the top access door.
3. Release the cable spring (D) from the front door assembly.
Note: In order to access the springs, make sure the top access cover is closed.
4. Remove the end of the cable (E) from the frame.

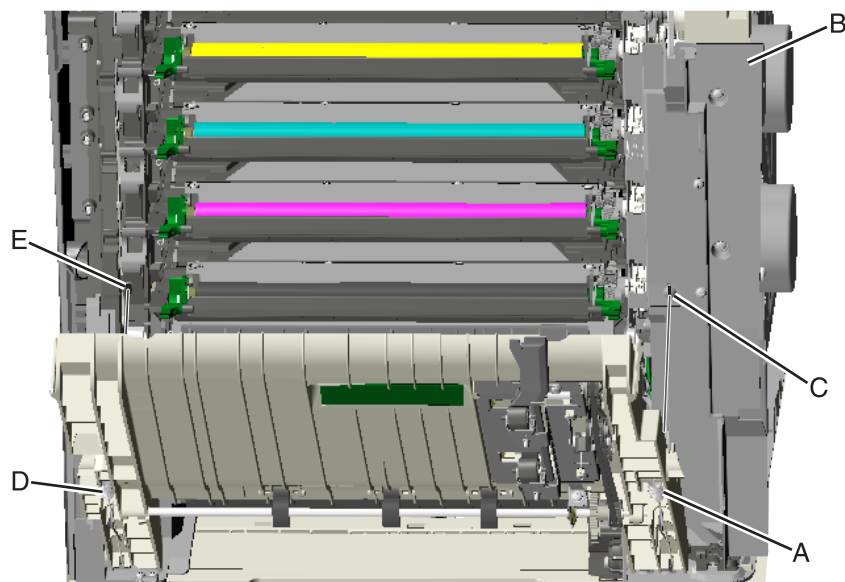

Installation note: The shortest cable installs on the right side of the printer.

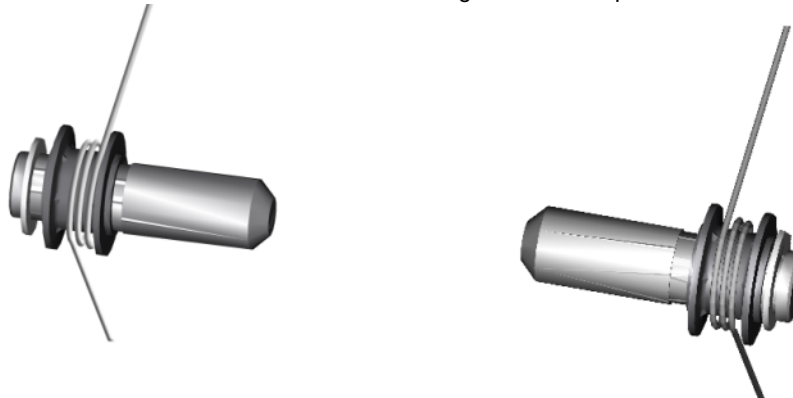

Fuser removal

See **“Fuser assembly, 115 V, C53x (also can be used in C52x)”** on page 7-15, **“Fuser assembly, 230 V, C53x (also can be used in C52x)”** on page 7-15, or **“Fuser assembly, 100 V, C53x (also can be used in C52x)”** on page 7-15 for the part number.

	<p>CAUTION</p> <p>The fuser can be extremely hot. Use care when handling to avoid burns.</p>
---	---

1. Turn off the printer.
2. Open the top access door.
3. Rotate the fuser thumbscrews (A) counterclockwise until loosened.
4. Grasp the handles (B), lift the fuser straight up and away from the printer.

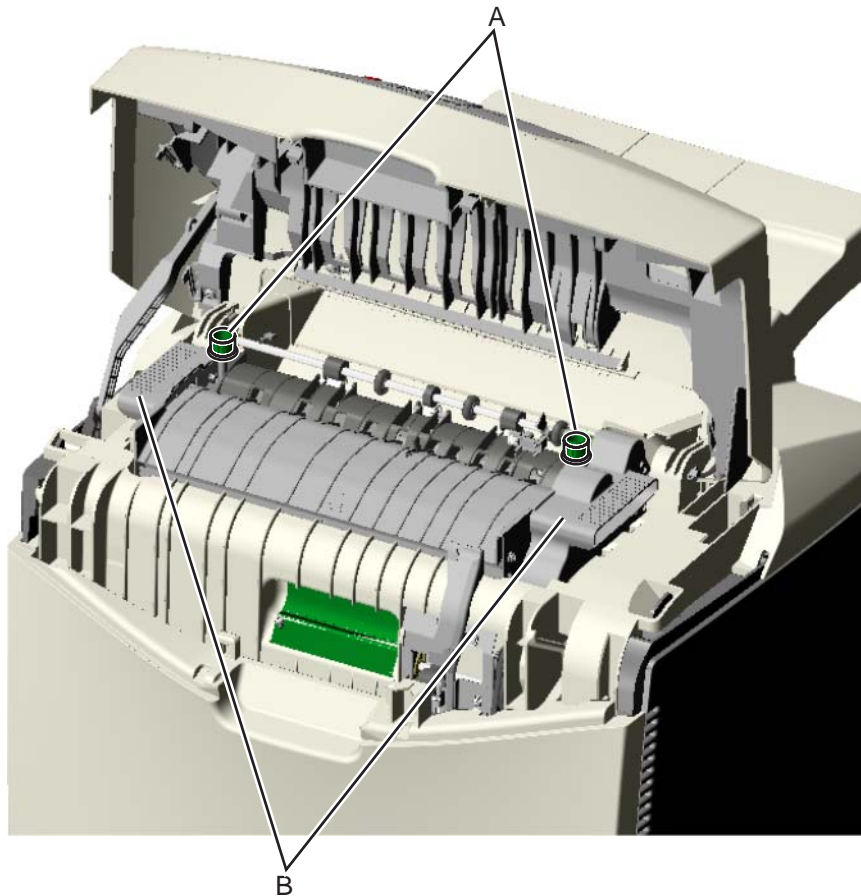

Installation note: If you install a new fuser, be sure to reset the fuser counter in the Configuration Menu. To reset the counter:

1. Enter the Configuration Menu. (Turn off the printer, press and hold **Select** (⏏) and **▶**, turn on the printer, and release the buttons when the clock graphic displays.)
2. Press **Select** (⏏) for the Reset value.
Resetting Fuser Count Value appears.
3. Press **Select** (⏏) to select **Motor Calibration** from the CONFIG MENU. Calibrating displays, and the printer prints several blank pages and then returns to the CONFIG MENU.
4. Select **Exit Config Menu**.

See **“Page Counts”** on page 3-16.

Fuser cable cover removal

See “Fuser cable cover, included in parts packet (P/N 40X1430), C52x” on page 7-5 or “Fuser cable cover, included in parts packet (P/N 40X3598), C53x” on page 7-5 for the part number.

1. Open the top access door.
2. Open the front access door.
3. Remove the yellow and cyan toner cartridges.
4. Pull the locking tab (A) down on the left side of the cable cover (B), slide the cable to left, lower and remove.

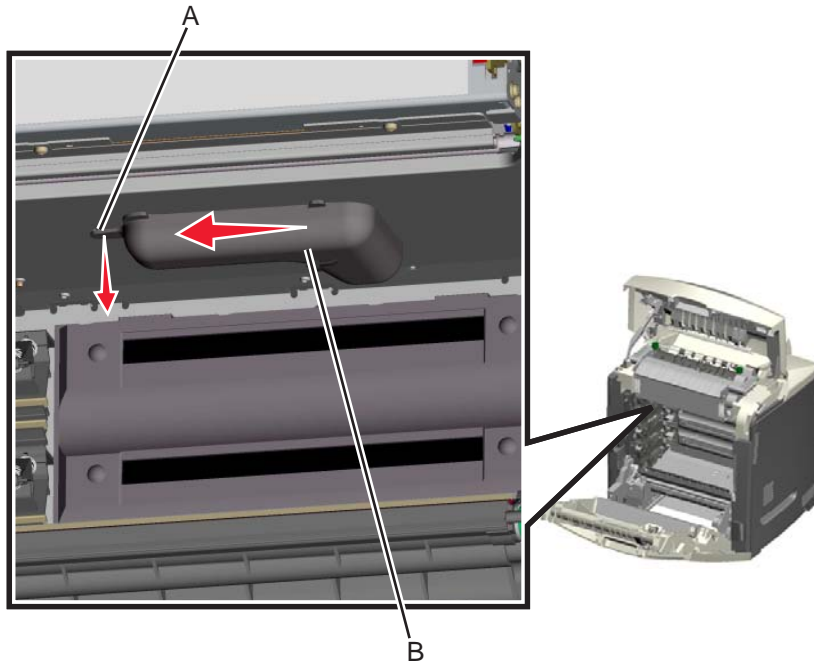

High voltage power supply (HVPS) removal

See **“High voltage power supply, C52x” on page 7-11** or **“High voltage power supply, C53x” on page 7-11** for the part number.

1. Remove the left cover. See **“Operator panel outer bezel removal” on page 4-21**.
2. Remove the six mounting screws (A).

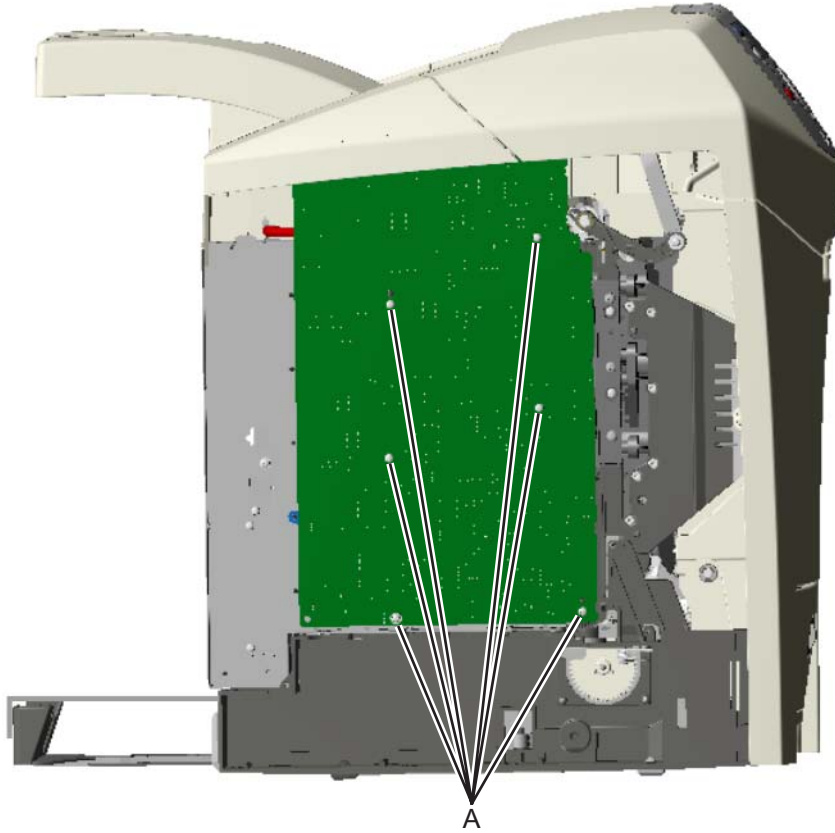

3. Release the locking tab (B) from the front, lower corner of the HVPS.

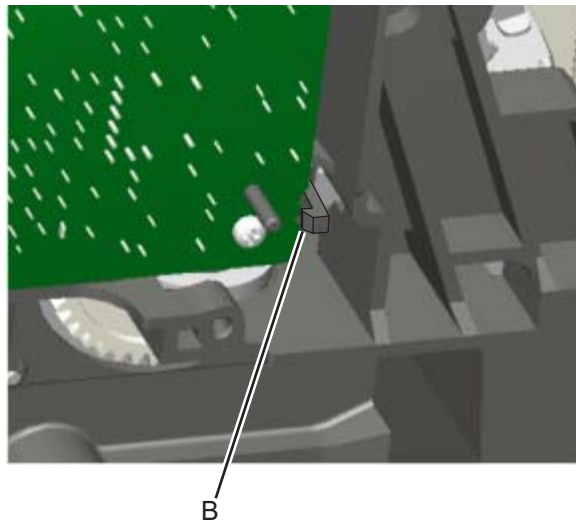

4. Disconnect the five connectors (C) from the HVPS.

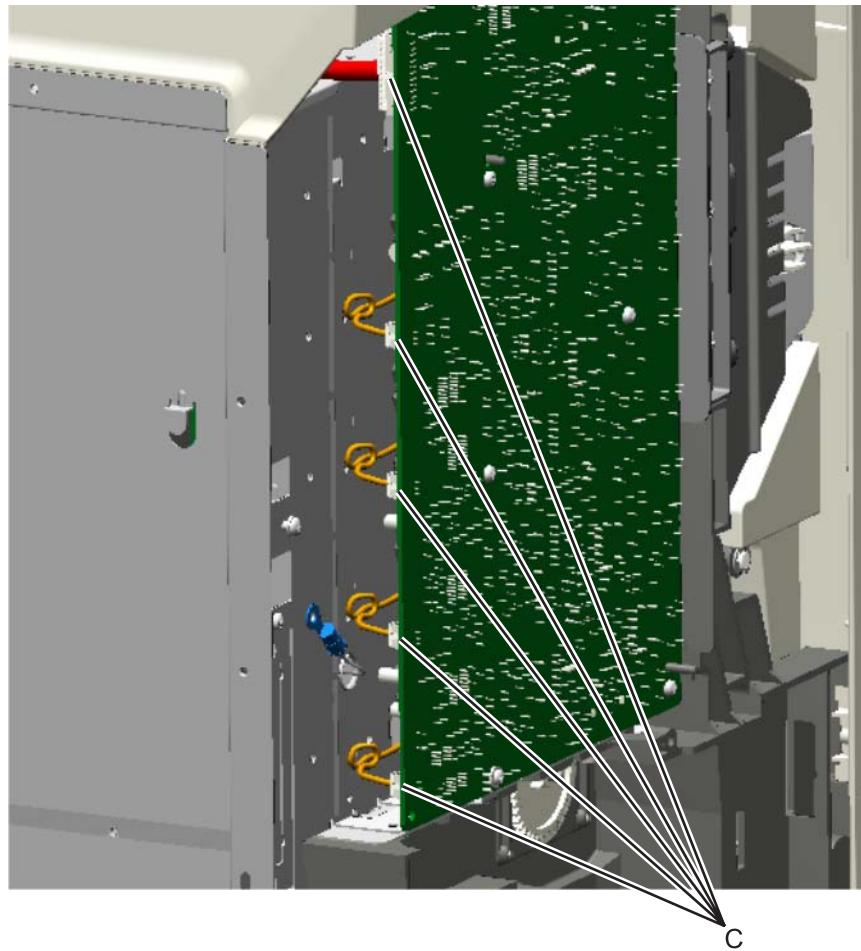

Installation notes: Be sure to replace the spring when replacing the HVPS. See the illustration for proper orientation.

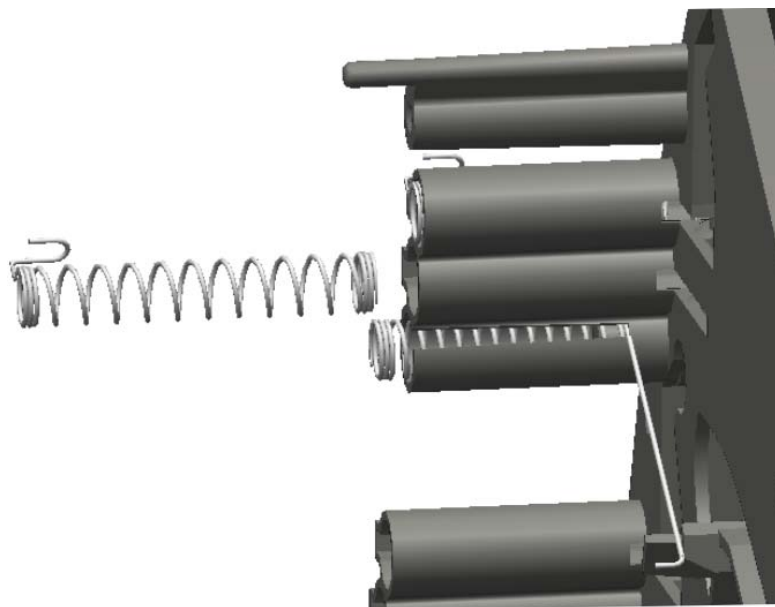

Left bellcrank removal

See **“Left bellcrank assembly” on page 7-5** for the part number.

- 1.** Remove the left cover. See **“Left cover removal” on page 4-20**.
- 2.** Remove the C-clip (A).

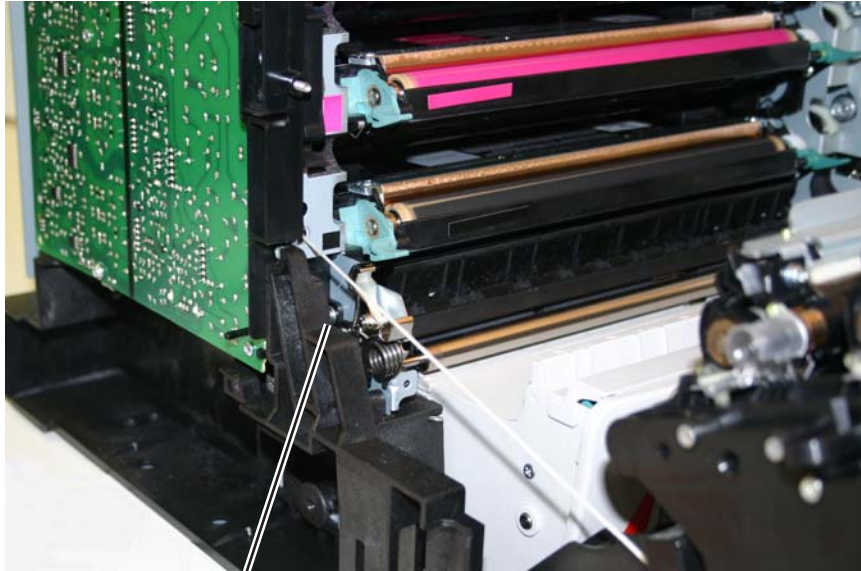

- 3.** Remove the left bellcrank.

Low voltage power supply (LVPS) removal

See “**Low voltage power supply, 115/230 V**” on page 7-7 for the part number.



1. Remove the right side cover. See “**Right cover removal**” on page 4-26.
2. Remove the rear cover. See “**Rear cover removal**” on page 4-25.
3. Unplug the JLVP1 connector (A) from the system card.

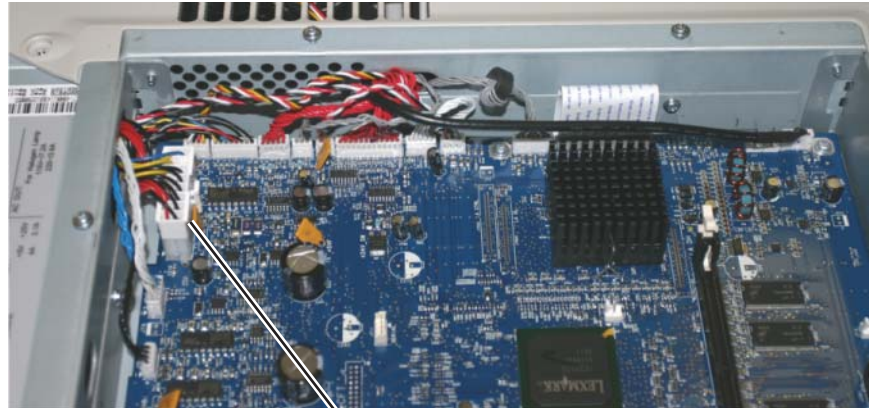

A

4. Remove the five LVPS mounting screws (B).
5. Disconnect the cable from the LVPS (C).

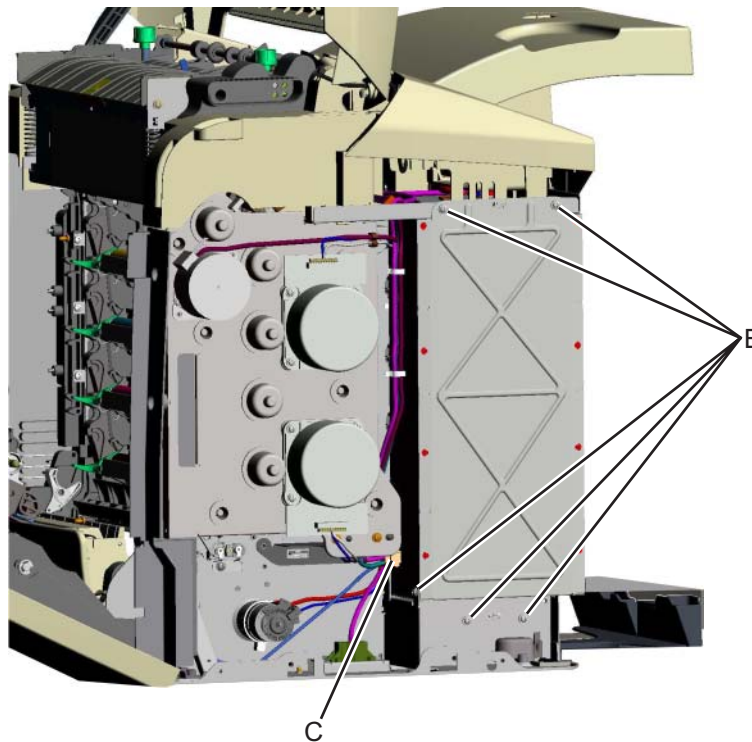

6. Remove the cable from the cable guide, and remove the LVPS.

Installation note: When installing the new LVPS, make sure the voltage switch (D) is set for the proper value (115 V or 230 V), depending on the country.

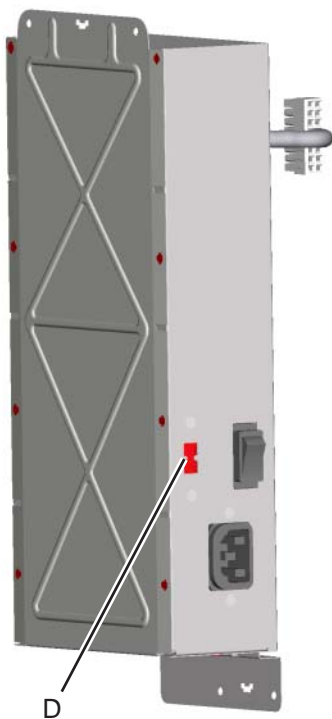

Multipurpose feeder (MPF) swing arm assembly removal—models C52x only

See **“MPF swing arm assembly, C52x”** on page 7-5 for the part number.

1. Open the top access door.
2. Open the front access door.
3. Remove the three mounting screws (A).

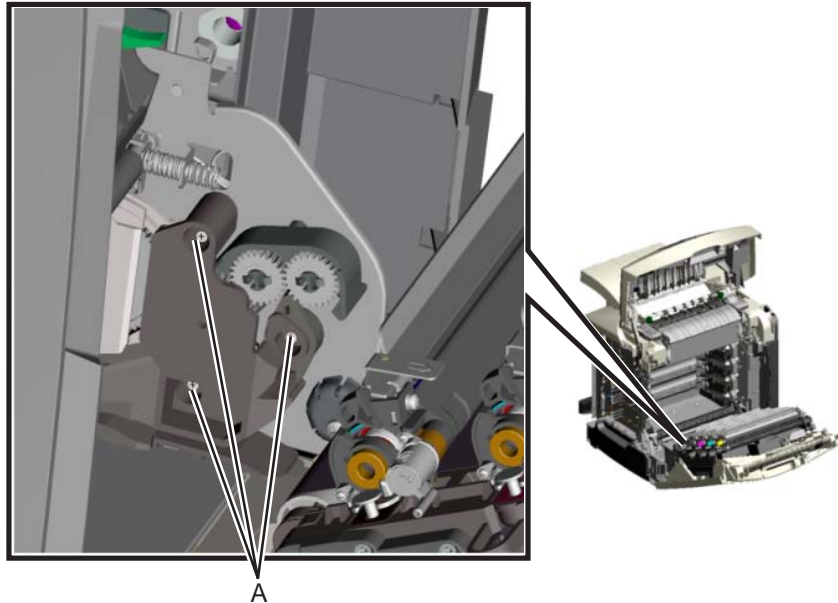

4. Remove the swing arm assembly from the frame.

Installation note: Refer to the following illustration if the swing arm crank comes loose from the swing arm assembly. Make sure the end of the spring (B) is under the retaining tab (C) on the swing arm crank after installation.

Note: Spring end (B) is shown disengaged from swing arm crank.

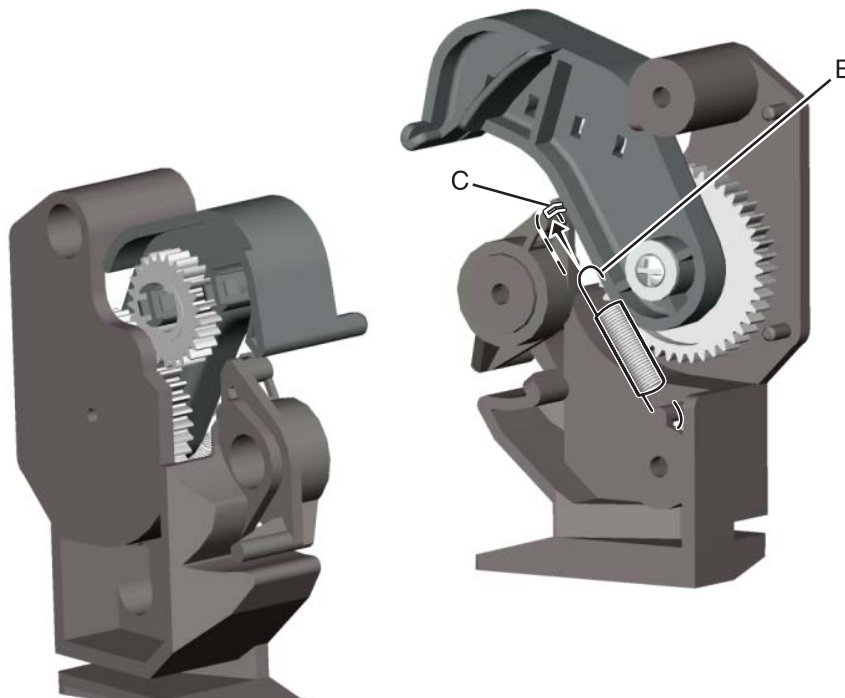

Paper pick mechanism assembly removal

See “**Paper pick mechanism assembly, C52x**” on page 7-5 or “**Paper pick mechanism assembly, C53x**” on page 7-5 for the part number.

1. Remove the rear cover. See “**Rear cover removal**” on page 4-25.
2. Disconnect the JTRAY1 (A) and JTRAY2 (B) connectors from the system card.

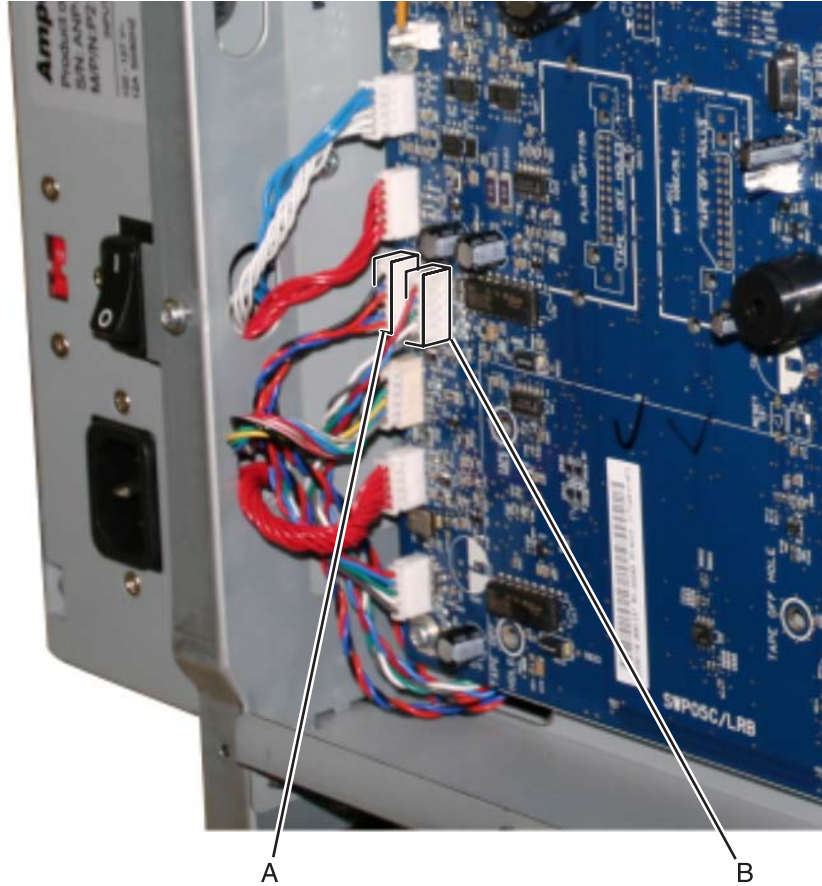

3. Remove all toner cartridges.
4. **For models C52x only:** If installed, remove the MPF swing arm assembly. See “**Multipurpose feeder (MPF) swing arm assembly removal—models C52x only**” on page 4-67.

5. Remove the three mounting screws (C).
6. Release the front locking tabs (D).
7. Slide the paper pick mechanism forward until the rear locking tabs (E) release.

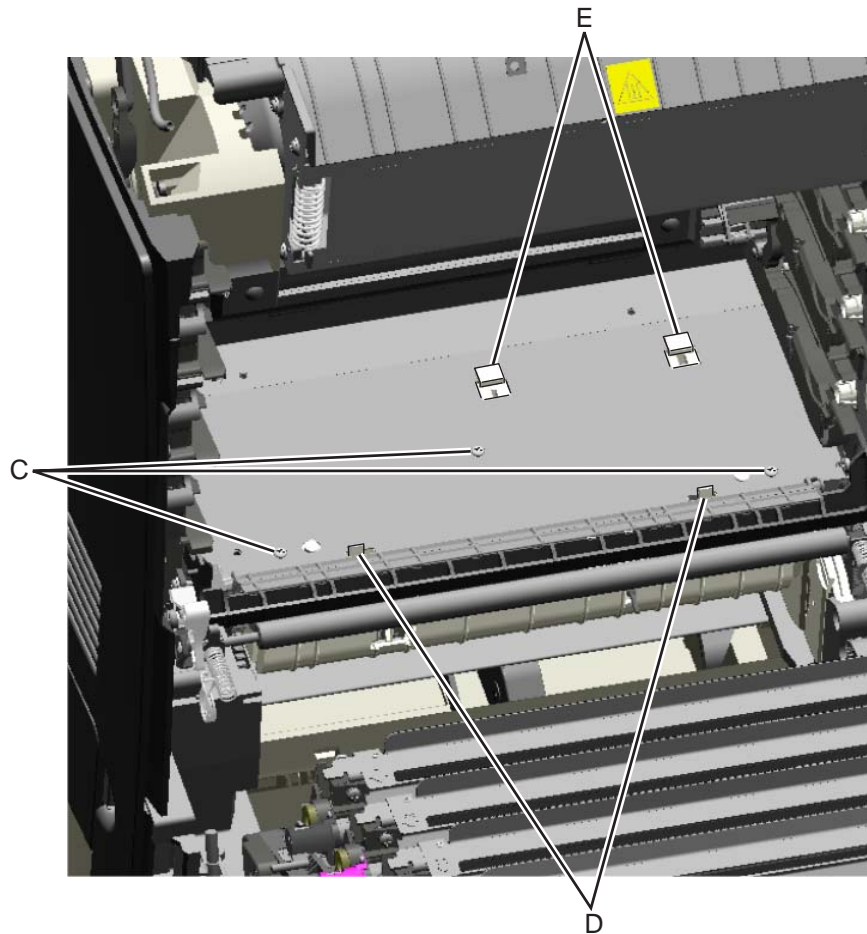

8. Lower the paper pick mechanism, and remove through the front of the printer.
Note: Make sure the JTRAY1 and JTRAY2 connectors do not bind when passing through the frame access hole.







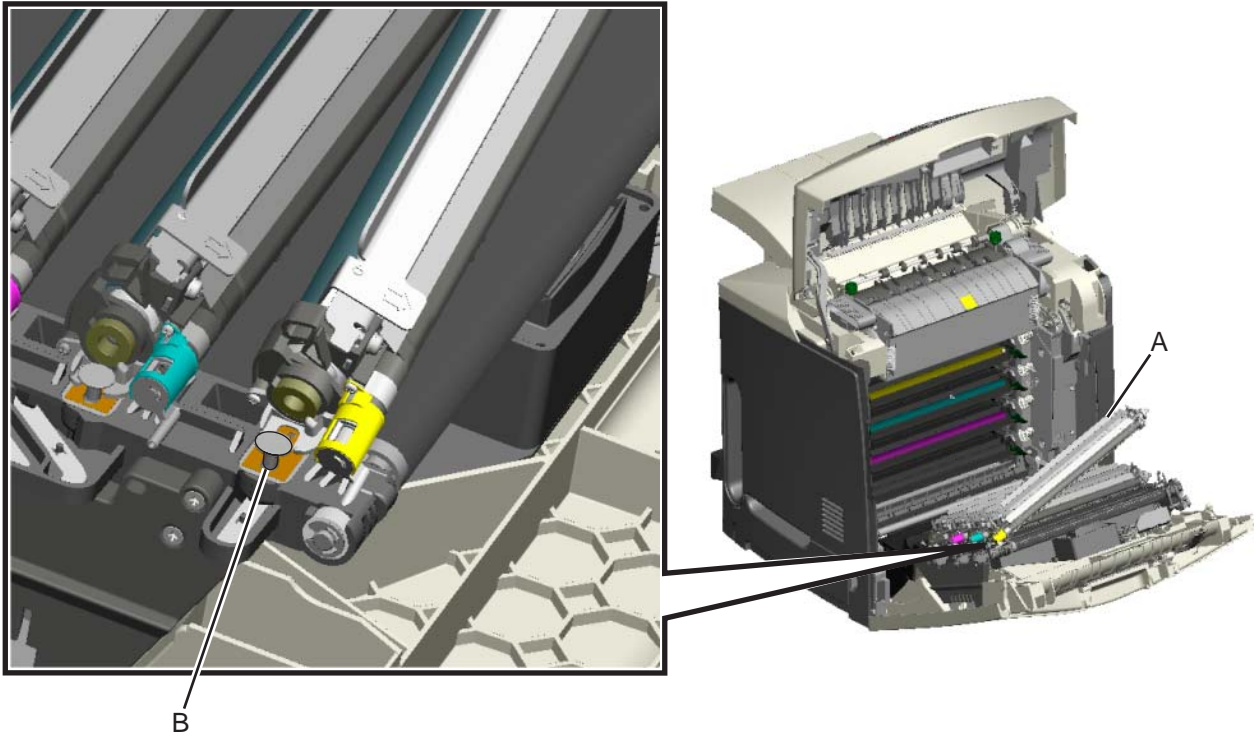

Photoconductor unit removal

Warning: To avoid damaging the photoconductor drum, hold the photoconductor units by their handle and place the photoconductor units on a clean surface. See **“Handling the photoconductor unit”** on page 4-2 for additional information.

1. Open the top access door.
2. Open the front access door.
3. Lift the right end handle (A) of the photoconductor unit, releasing from the mount.
4. Lift the unit up and away from the left side of printer, ensuring the left end of the photoconductor is released from the holding pin (B).



Installation note: If a new photoconductor unit is installed, reset the life count value in the printer memory.

- If a message appears on the operator panel:
 1. When 84 <col or> PC Uni t Li fe Warni ng or 84 Repl ace <col or> PC Uni t appears, select **Supply Replaced**, and then press .
 - Repl ace Suppl y displays.
 2. Select **Cyan PC Unit**, **Magenta PC Unit**, **Yellow PC Unit**, or **Black PC Unit** based on the photoconductor unit that was just replaced, and then press .
 - <col or> PC Uni t Repl aced displays.
 3. Select **Yes**, and then press  to clear the message.
- If no message appears:
 1. Press **Menu** (.
 2. Select **Supplies Menu**, and press .
 3. Press  to select **Replace Supply**.
 4. Select **Cyan PC Unit**, **Magenta PC Unit**, **Yellow PC Unit**, or **Black PC Unit** based on the photoconductor unit that was just replaced, and then press .
 - <col or> PC Uni t Repl aced displays.
 - Press  to select **Yes**.

Pick roll rubber tires removal and replacement

See “Pick arm roll” on page 7-15 for the part number.

The autocompensator pick roll tires are located in the base printer. There are also tires in all input options. If you have additional input options, and you are having problems with media picking, replace these tires also. Always replace the pick tires in pairs. The tires come in a package of two.



Warning: Remove only the rubber tires and not the pick tire assembly to avoid losing small parts.

1. Remove the paper tray.
2. Pull the autocompensator pick arm (A) down.

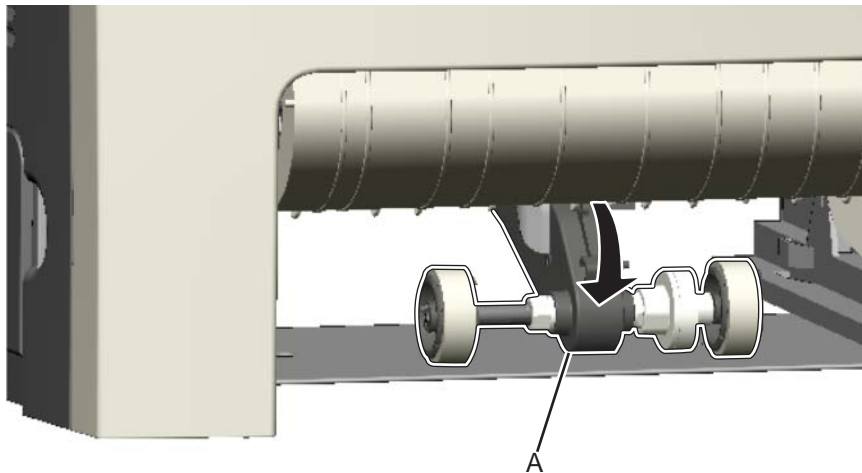

3. Remove the rubber tire (B) from the pick roll assembly (C). Repeat for the other pick roll assembly.

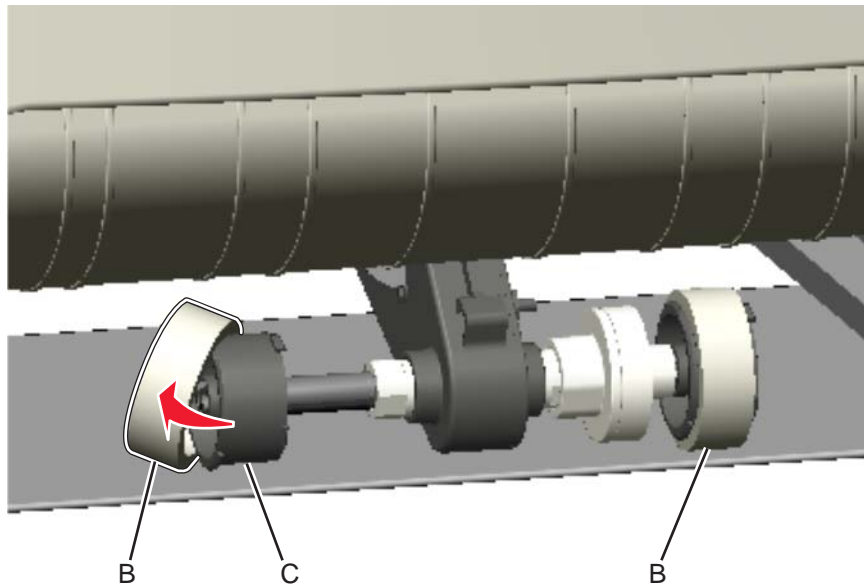

Installation notes: Install the new rubber tires with the surface texture (D) turning in the direction as shown.

Note: Feel the rubber surface to verify it turns properly in the direction shown.

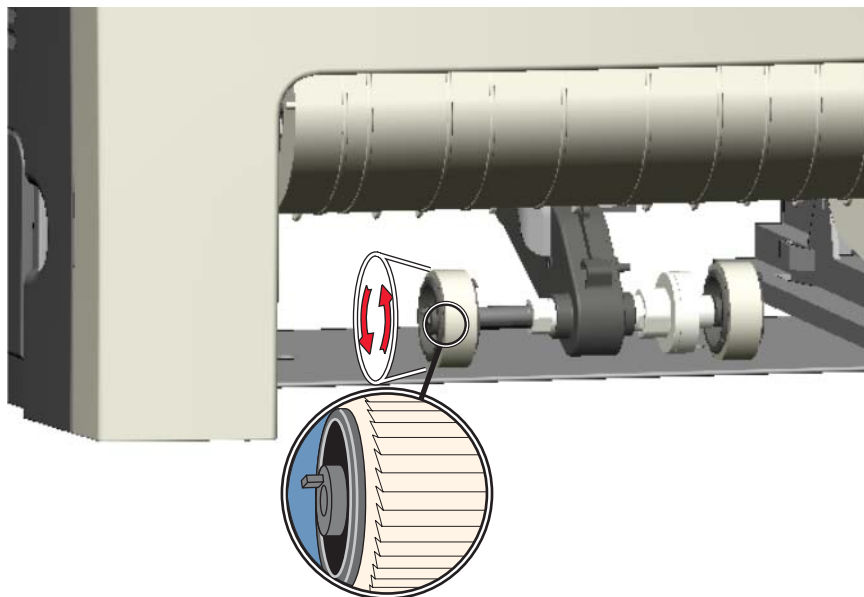

Printer pad removal

See “**Printer pad, included in parts packet, screws (P/N 40X1431)**” on page 7-5 for the part number.

1. Slide the corner of the printer containing the damaged pad over the corner of the table.
2. Pull the pad (A) from the bottom of the printer.

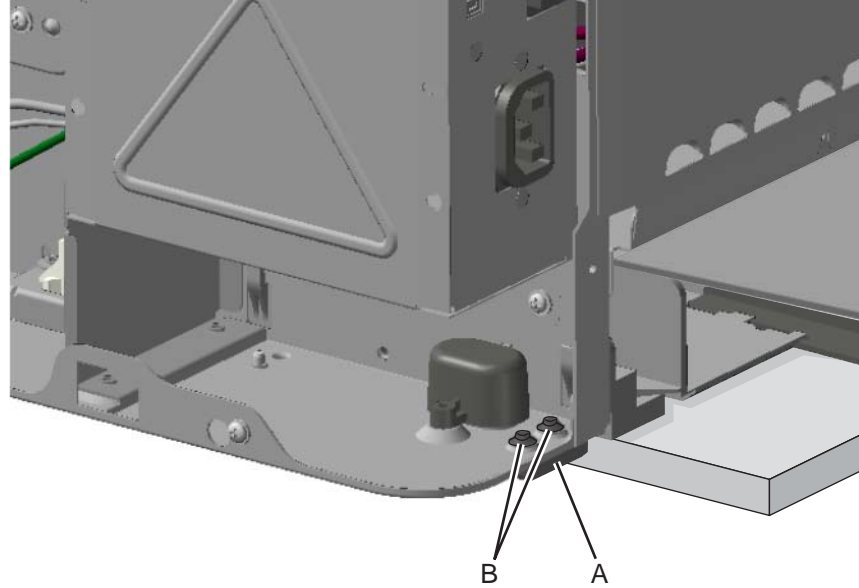

Installation Note: When installing the new pad, remove the appropriate side cover that corresponds to the damaged pad. It is necessary to remove the corresponding side cover to see if the pad fully seats in the installation holes (B).

Printhead removal, installation, and adjustment

See **“Printhead assembly, C52x” on page 7-9** or **“Printhead assembly, C53x” on page 7-9** for the part number.

Warning: When replacing any one of the following components:

- Operator panel assembly
- System card
- Smart chip card (C52x) or printhead assembly (C53x)

Only replace one component at a time. Replace the required component, and perform a POR before replacing a second component listed above. If this procedure is not followed, the printer will be rendered inoperable.

Printhead removal

1. Power the printer off.
2. Disconnect the power cord from the electrical outlet and from the printer.
3. Remove the exit tray cover by lifting away from the printer.



4. Open the top access door.
5. Open the front access door.
6. Remove all of the toner cartridges.

7. Disconnect the transfer belt cable (A).
8. Press the two tabs (B) on either side of the transfer belt assembly, and lift out the transfer belt assembly.

Note: Leave the photoconductor units on the transport belt when removing.

Warning: To avoid damaging the photoconductor drum, hold the photoconductor units by their handle and place the photoconductor units on a clean surface. Never expose the photoconductor units to light for a prolonged period of time. See **"Handling the photoconductor unit"** on page 4-2 for additional information.

C52x

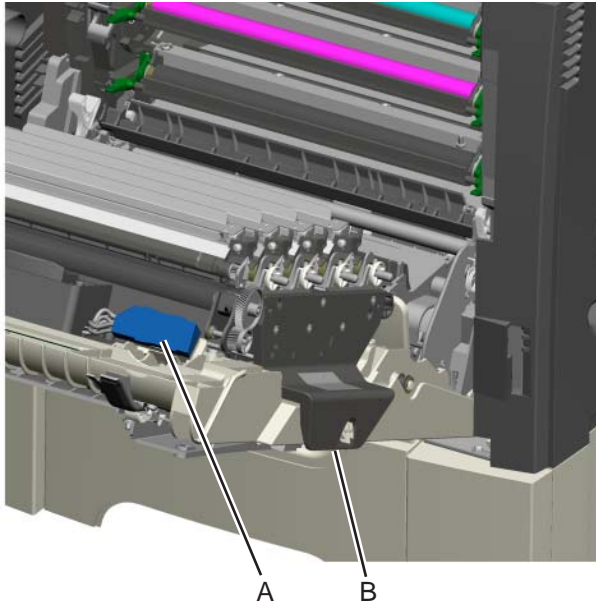

C53x

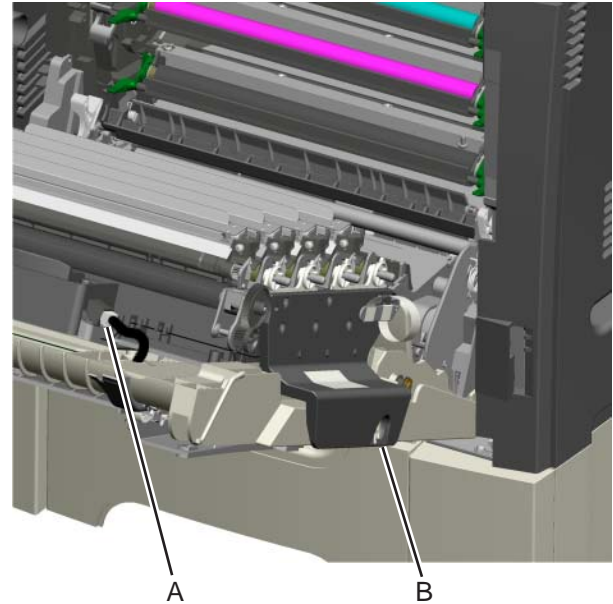

9. Remove the system card support shield. See **"System card support shield removal"** on page 4-94.
10. Pull the locking tab (C) down on the left side of the cable cover (D), slide the cable to left, lower and remove.

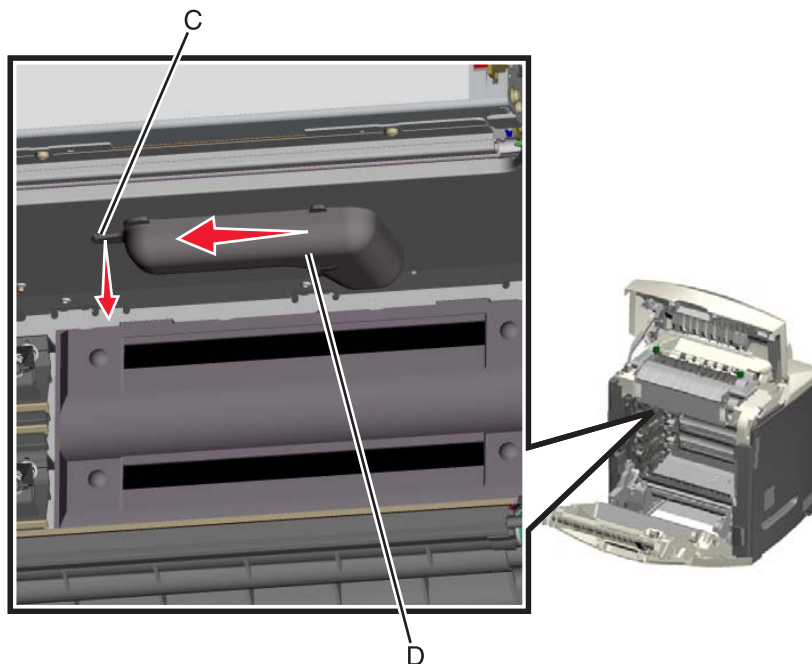

11. Remove the printhead.

- a. Remove the three mounting screws (E) from the front of the printhead.

Warning: Secure the printhead when removing the printhead alignment screw. Failure to do this allows the printhead to fall out of the printer, potentially damaging the printhead.

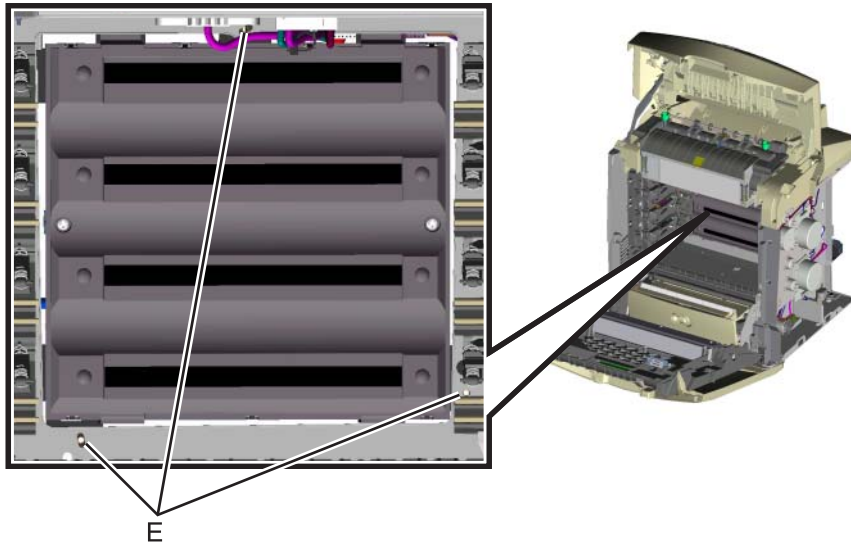

- b. Close the top access cover and remove the printhead alignment screw (F), and remove the printhead.

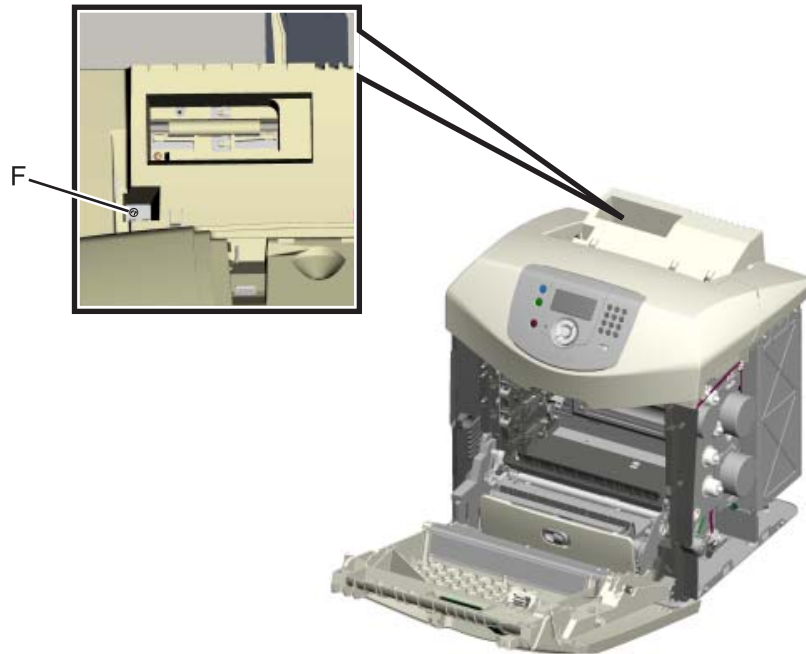

Printhead installation

Warning:

- When reinstalling the printhead, it is important to keep in mind that the printhead mounting screws should be **initially tightened just enough to hold the printhead in the printer**. The printer parts are installed with the printhead mounting screws loose so you can print the pages that will be used to align the black plane to the printer frame. This also allows the black skew adjustment with the printhead alignment screw.
 - Once the black skew is aligned, the mounting screws will be fully tightened, and the next steps of alignment can be completed.
1. When installing the printhead, do a rough alignment by visually centering the hole in the frame with the slot on the bottom of the printhead and adjusting the alignment screw on top of the printer.

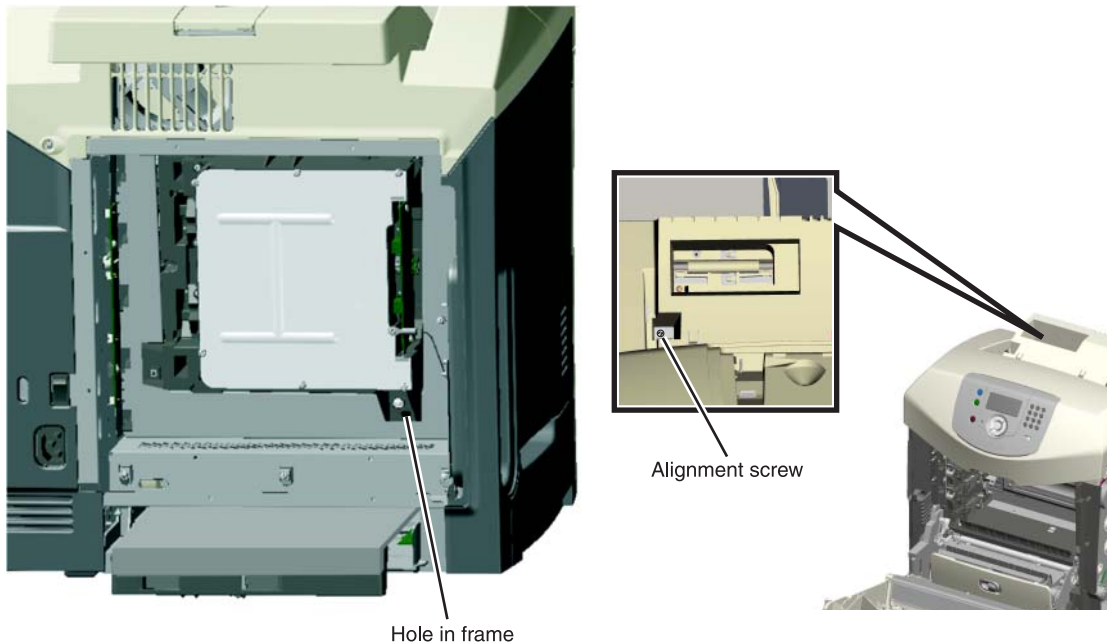

Warning: Do not fully tighten the printhead mounting screws until black skew has been adjusted.

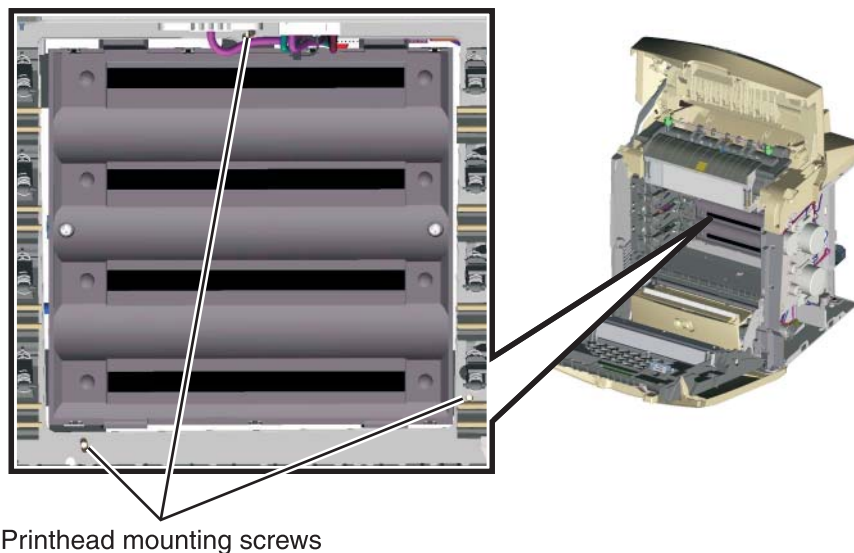

2. Replace the system support shield.
 - a. Replace the four mounting screws to the top and bottom of the support shield.
 - b. **For network printers**—Replace the two screws attaching the parallel connector support plate.
For non-network printers—Replace the two INA mounting plate screws and the INA mounting plate.
 - c. Route the cables through the access holes on the right side of the printer.
 - d. Replace the four screws from the inner right side of the support shield.
 - e. Replace the five mounting screws to the outer left side of the printer.
 - f. Reattach the printhead ground cable to the second screw from the bottom.
3. Replace the system card.
 - a. Replace the eight screws (A) in the system card.

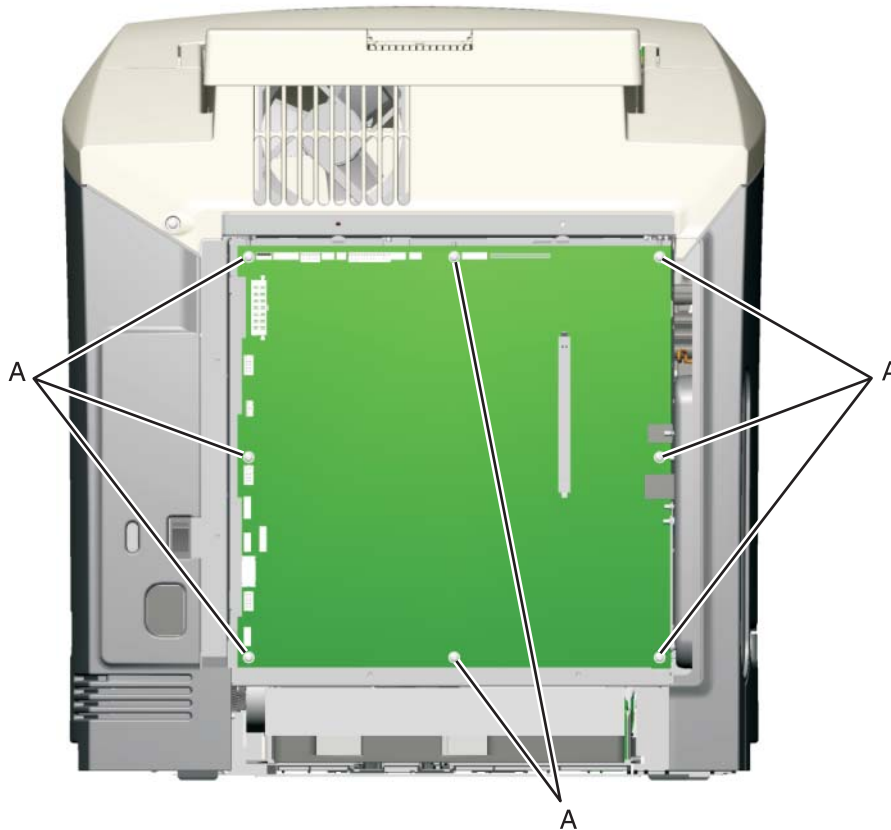

- b. Replace the screw in the USB connector.
 - c. **For models C52x only:** If a non-network system card is installed, also replace the two screws in the parallel connector.

- d. Reconnect all the connectors to the system card.

Warning: Be careful reconnecting the printhead ribbon cable (B). It can be damaged and should be handled carefully.



B

4. Replace the LVPS.

a. Install the LVPS, and make sure the cable is in the cable guides (C).

b. Reconnect the cable (D) to the LVPS.

c. Replace the five LVPS mounting screws (E).

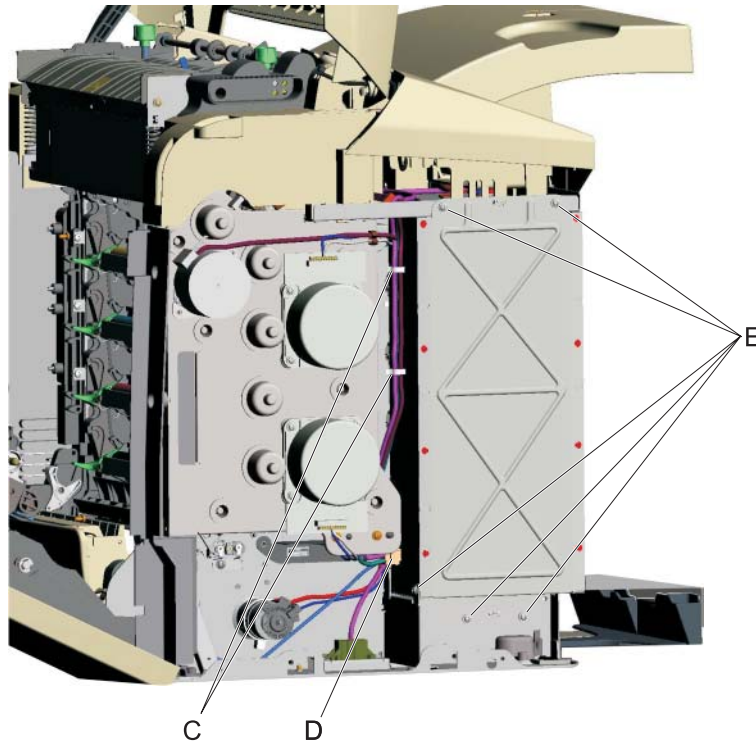

- d. Reconnect the JLVPS1 connector (F) from the system card.

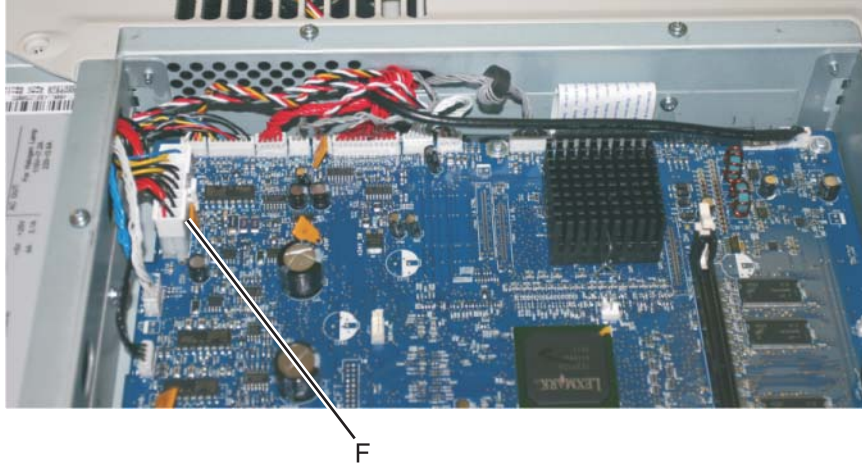

- 5. Replace the right cover.
 - a. Place the printer on the table with the right side edge hanging over slightly.
 - b. Slide the right cover up until it locks into position.
Note: Be sure the tab (G) is fully engaged.

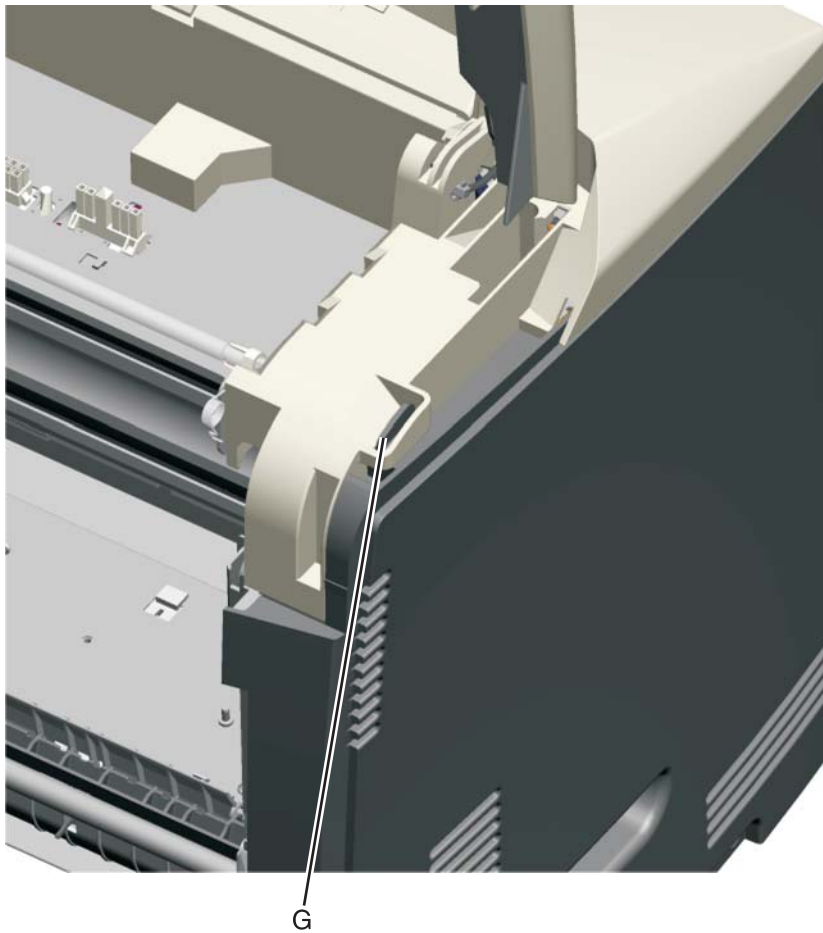

- 6. Replace the three screws.

7. Replace the left cover.
 - a. Place the printer on the table with the left side edge hanging over slightly.
 - b. Slide the cover up until it locks into position.

Warning: Be careful not to damage the two small locking tabs.
 - c. Replace the three screws.
8. Reinstall the transfer belt assembly with the photoconductor units still attached.
9. Reconnect the transfer belt cable.
10. Replace the toner cartridges.
11. Close the front access door.
12. Close the top access door.

Printhead alignment

Note: The printhead mounting screws should be initially tightened **just enough to hold the printhead in the printer**.

There is one printhead that houses the four color planes. The black plane is aligned to the printer, and the color planes are internally aligned to black. Electrical alignment is done to fine tune the alignment of the color planes to the black plane after the printhead is installed and black skew is adjusted using the alignment screw.

Skew (black)

1. Plug the electrical cord into the printer.
2. Plug the electrical cord into the outlet.
3. The first step in aligning the printhead is to set the skew for black.
 - a. Enter Diagnostic mode (turn off the printer, press and hold ▼ and ►, turn on the printer, and release the buttons when the clock graphic displays).
 - b. Select **REGISTRATION**.
 - c. Select **Skew**.
 - d. Adjust this setting to zero, and press **Select** (↵).
 - e. Press **Back** (⏪).

f. Scroll down to **Quick Test**, and press **Select** (✓). A page similar to this one prints:

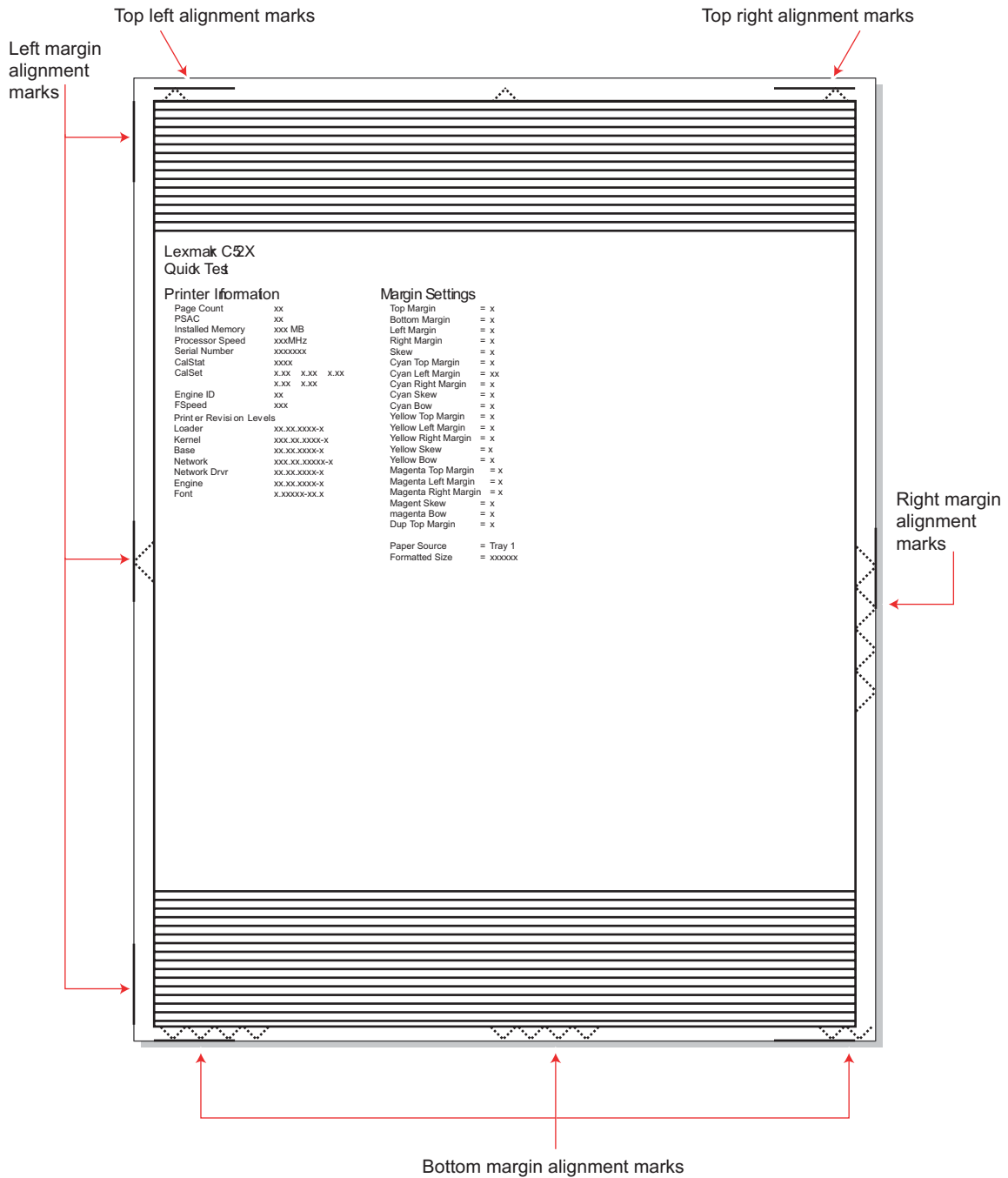

- g. Adjust the printhead alignment screw to adjust the skew and straighten the image on the paper.

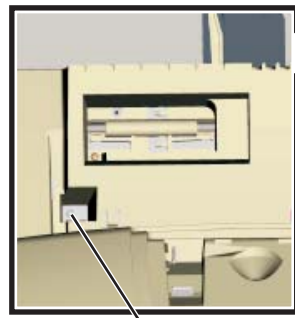

Printhead alignment screw



If the top right alignment marks are lower than the top left alignment marks, rotate the alignment screw counterclockwise a full revolution, and print the Quick Test page. Repeat adjusting the screw and printing the Quick Test until the top alignment marks are the same distance from the top of the media.

Note: One rotation of the printhead alignment screw equals approximately 0.5 millimeter movement of the top edge print alignment marks.

- h. When the top right and top left alignment marks are both showing and are even on the page, the skew is aligned.

Straight

Skewed

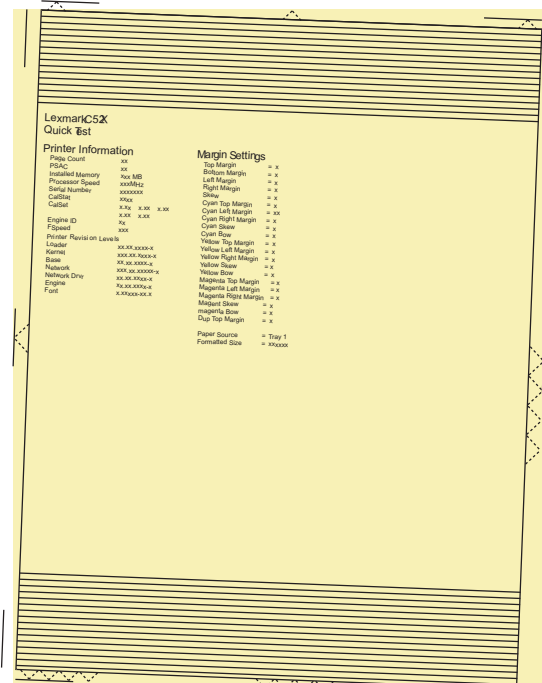
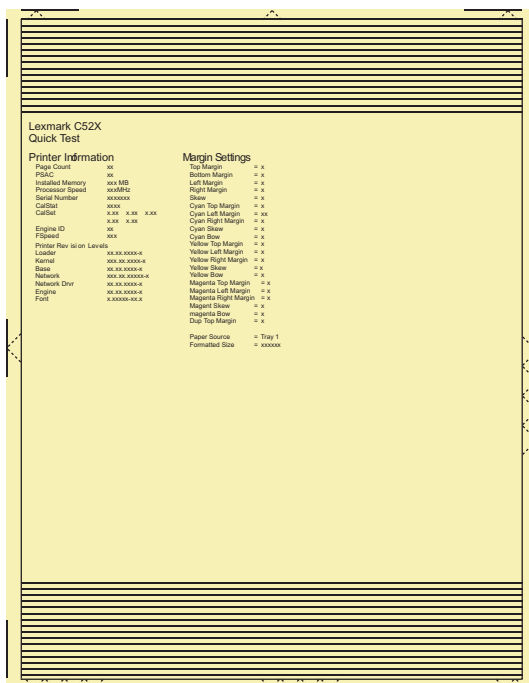

4. Tighten the printhead mounting screws.
 - a. Turn off the printer.
 - b. Disconnect the power cord from the electrical outlet.
 - c. Disconnect the transfer belt cable.
 - d. Press the two tabs on either side of the transfer belt assembly, and lift out the transfer belt assembly with the photoconductor units in place.
 - e. Remove all of the toner cartridges.
 - f. Tighten the printhead mounting screws in the following order: top middle, lower left, and lower right.

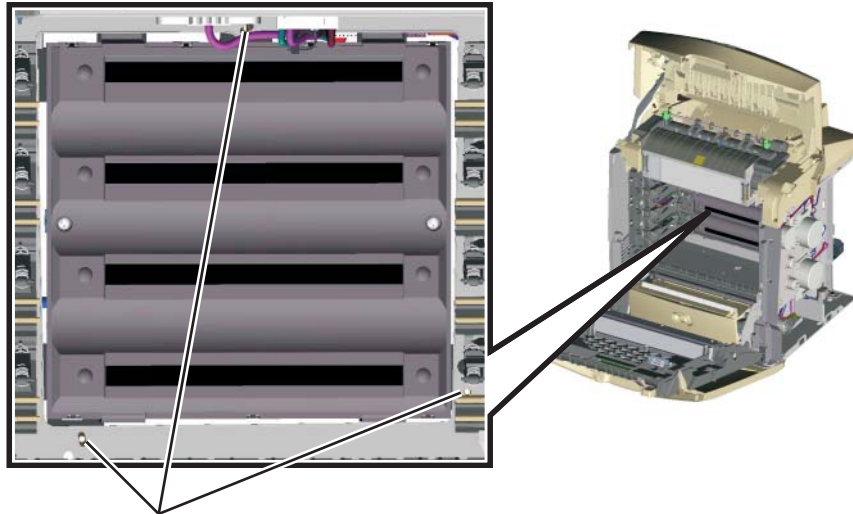

Printhead mounting screws

5. Replace the fuser cable cover.
6. Reinstall the transfer belt assembly and the photoconductor units.
7. Connect the transfer belt cable.
8. Replace the toner cartridges.
9. Replace the exit tray.

Registration (black)

Top Margin



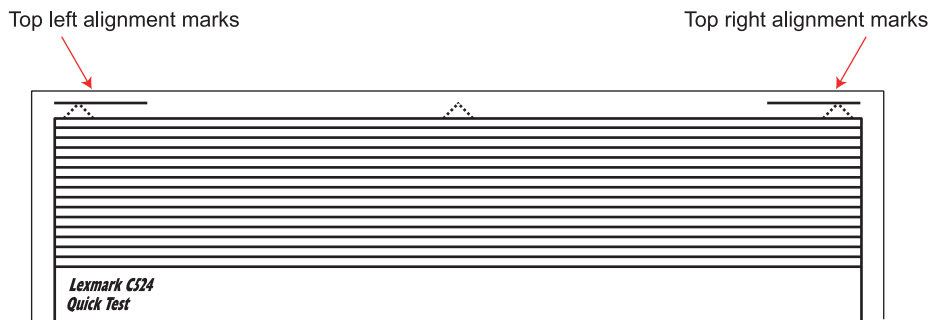

1. Reconnect the power cord to the electrical outlet, but do not turn on the printer yet.
2. Enter Diagnostic mode (press and hold ▼ and ►, turn on the printer, and release the buttons when the clock graphic displays).
3. Select **Quick Test** (REGISTRATION in the Diagnostics mode), or use the last Quick Test you used to adjust skew.



4. Select **Top Margin**, and press **Select** (✓).
5. Adjust the values until both top alignment marks are on the top edge of the print.
 - Increasing the value (►) moves the top alignment marks down on the page.
 - Decreasing the value (◄) moves the top alignment marks up on the page.

6. Press **Select** () to save the value.
7. Print the Quick Test page, and check the top alignment marks. Repeat adjustment of the top margin and printing of the Quick Test page until top margin is set.

Bottom Margin

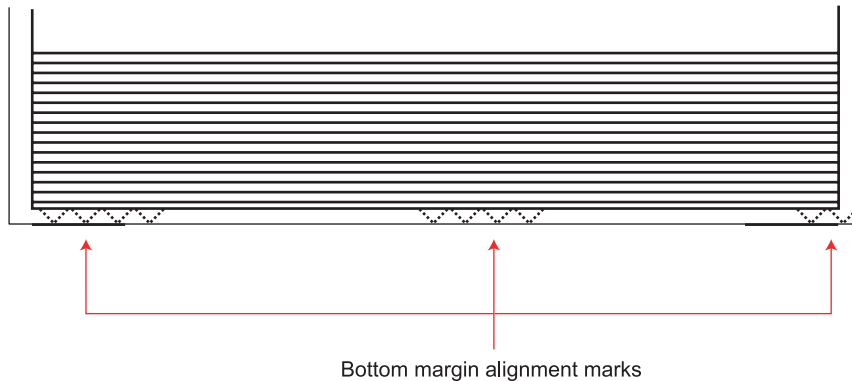

1. Select **Bottom Margin**, and press **Select** ().
2. Adjust the bottom margin until the points of the bottom margin alignment marks are visible and touching the edge of the paper.
 - Increasing the value () moves the bottom alignment marks up on the page.
 - Decreasing the value () moves the bottom alignment marks down on the page.
3. Press **Select** () to save the value.
4. Print the Quick Test page, and repeat this process until the bottom margin is adjusted.

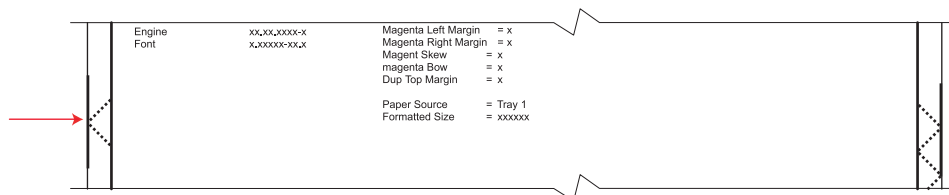

Left Margin

1. Select **Left Margin**, and press **Select** ().
2. Adjust the left margin until the points of the left alignment marks touch the edge of the page.





- Increasing the value () moves the left side alignment marks to the right.
 - Decreasing the value () moves the left side alignment marks to the left.
3. Press **Select** () to save the value.
 4. Print the Quick Test page, and check the left alignment marks each time until you are satisfied.



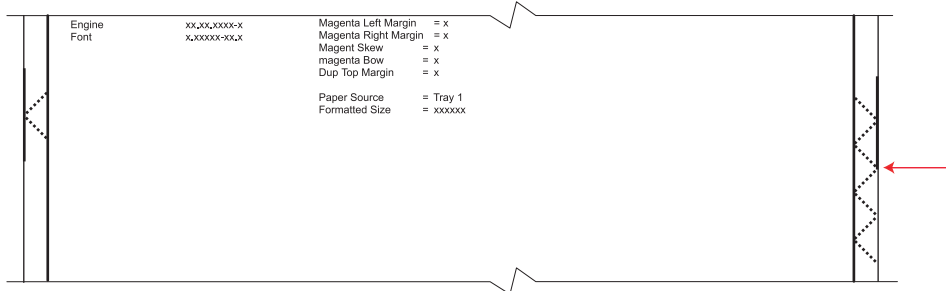





Right Margin

1. Select **Right Margin**, and press **Select** ().



2. Adjust the right margin until the points of the left alignment marks touch the edge of the page.
 - Decreasing the value () moves the right side alignment marks to the right.
 - Increasing the value () moves the right side alignment marks to the left.
3. Press **Select** () to save the value.
4. Print the Quick Test page, and check the results. Repeat if necessary.
5. When the registration is complete, proceed to the color alignments.

Alignment (cyan, yellow, and magenta)

1. Press **Back** () on the operator panel until you reach the top menu, select **ALIGNMENT MENU**, and press **Select** ().
2. Select **Cyan**.
3. Select **Top Margin**, and use  or  to select zero. Press **Select** () to save the setting.
4. Select **Left Margin**, **Right Margin**, **Bottom Margin**, **Skew**, and **Bow**. In each menu, use  or  to select zero, and press **Select** () to save the value.

It is important to set all the values to zero before starting.

5. Select **Quick Test** in the Cyan menu, and press **Select** ().
 Two pages print. You may have to print these pages several times until you get T and Z aligned. Do not go to step 2 until T and Z are aligned. The first page is similar to the following:

Cyan Alignment Step 1

Top (T) Coarse Adjustment

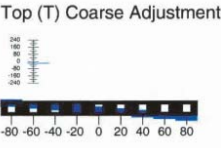

-80 -60 -40 -20 0 20 40 60 80

Skew (Z) Coarse Adjustment

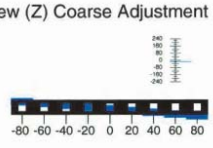

-80 -60 -40 -20 0 20 40 60 80

Top (T) Fine Adjustment

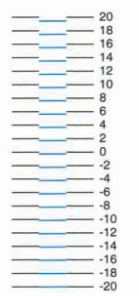

Skew (Z) Fine Adjustment

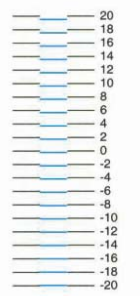

T

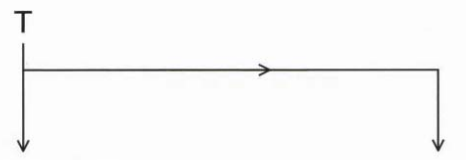

Z



$T = 0 + \text{Current Cyan T value} = \text{New Cyan T value}$

$Z = 0 - \text{Current Cyan Z value} + \text{New Cyan Z value}$

STEP 1: Adjust the Top (T) margin and Skew (Z) then confirm before going to Step 2.

Press the up or down buttons until a check appears at the setting in need of adjustment. Press Select. Then use the < and > buttons to enter the new value. Press Select to save.

NOTE: If the alignment values cannot be determined by using the fine adjustment scales, then use the coarse adjustment scales at the top of the page.

STEP 2: Go to the next page to adjust the Left (L) margin, Right (R) margin, and Bow (P).

STEP 3: Reprint these pages to confirm final settings.

Go To Step 2

- Determine the line under Fine Adjustment that is closest. If the value is beyond the Fine Adjustment scale, use either of the Coarse Adjustment scales.

Top (T) Coarse Adjustment

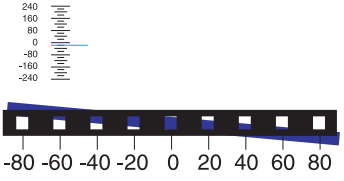

If the alignment is not close enough to use the fine adjustment, get close to the ideal value by using the coarse adjustment marks. Select the block that is most filled by the color on the left, or approximate if none of the blocks are completely filled, and enter it for the new value. Reprint the quick test page, and then use the fine adjustment.

Top (T) Fine Adjustment

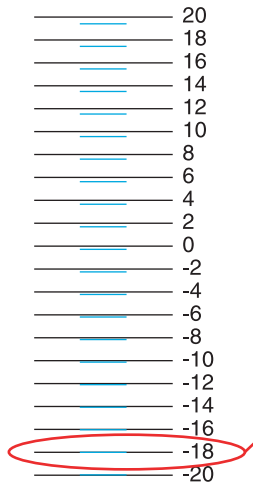

First, locate the line of the color that you are aligning that lines up best with the scale line. In this example, it is -18. If none of the colored lines match up, use the coarse adjustment to get close, reprint this page and then use the fine adjustment.

- Enter the number determined from the Fine Adjustment scale or the Coarse Adjustment scales on the part of the page for the "T" value. The current value is automatically entered on the sheet. At this point, it should be zero.

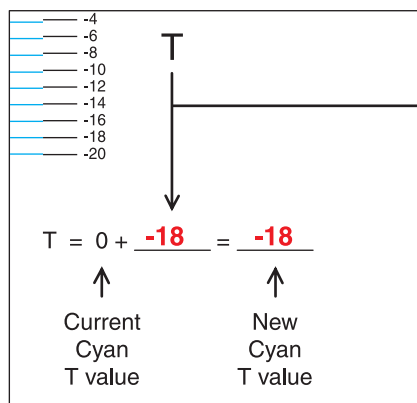

- Enter the "New Cyan T value" on the operator panel using ◀ or ▶, and press **Select** (Ⓢ) to save the value.
- Reprint the Quick Test, and evaluate whether you are at zero changes.

10. Repeat this process for skew (Z). Don't forget to add the T value and the current cyan Z value to obtain the new skew (Z) value.

An example is shown below:

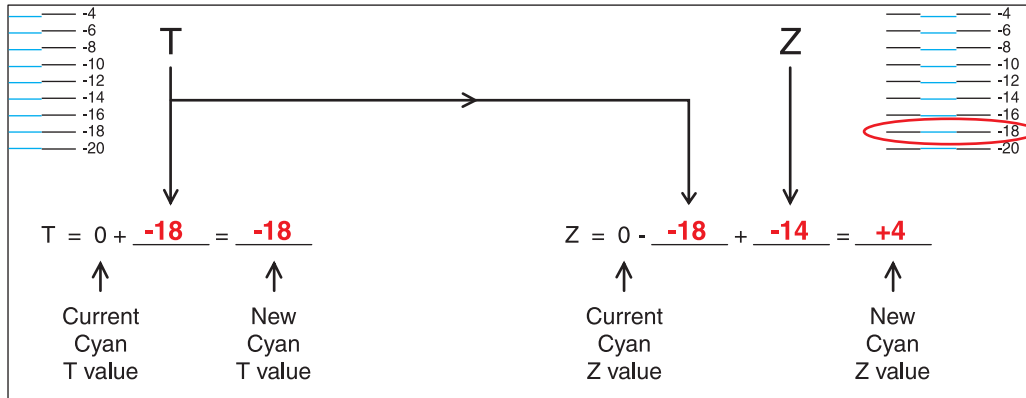

11. Continue to follow the directions on the bottom of the first page to find the Cyan Top Margin (T), the Skew (Z), and on the second page of the Quick Test page, the Left Margin (L), Right Margin (R), and Bow (P).

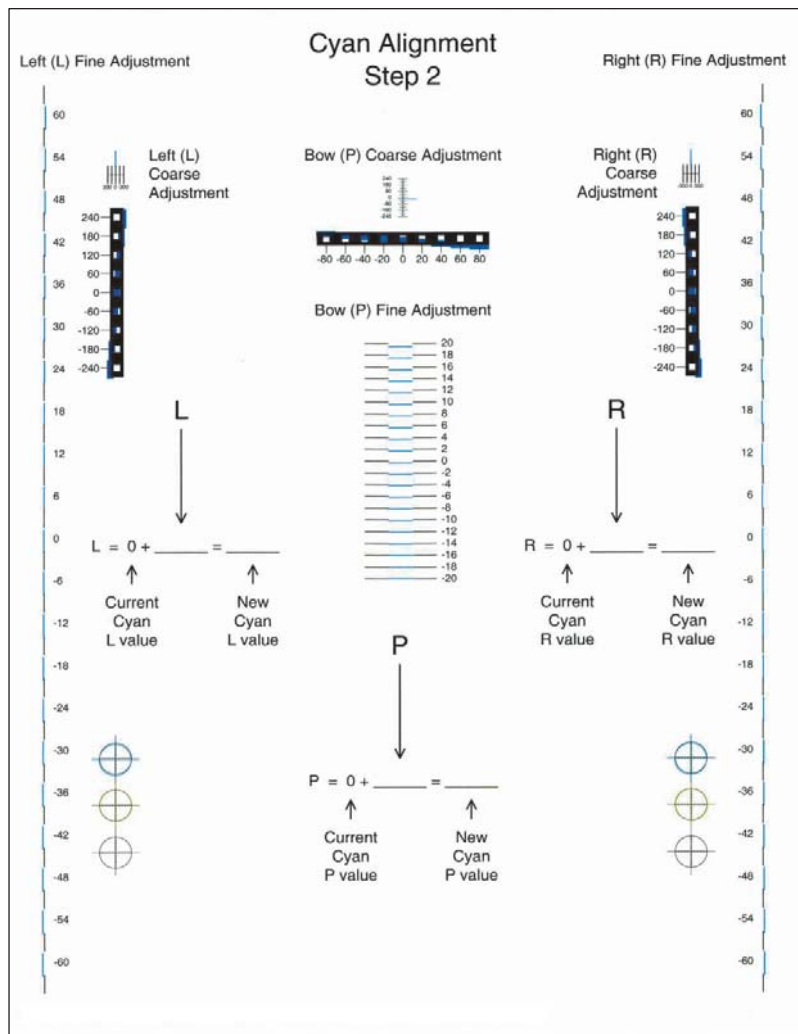

12. Repeat steps 2 through 11 for yellow and magenta.

Note: Start each color group by setting the Top Margin, Left Margin, Right Margin, Bottom Margin, Skew, and Bow to zero.

Right bellcrank removal

See **“Right bellcrank assembly” on page 7-5** for the part number.

1. Open the front access cover.
2. Remove the gearbox/switch shield. See **“Gearbox shield removal” on page 4-19**.
3. Remove the C-clip (A).

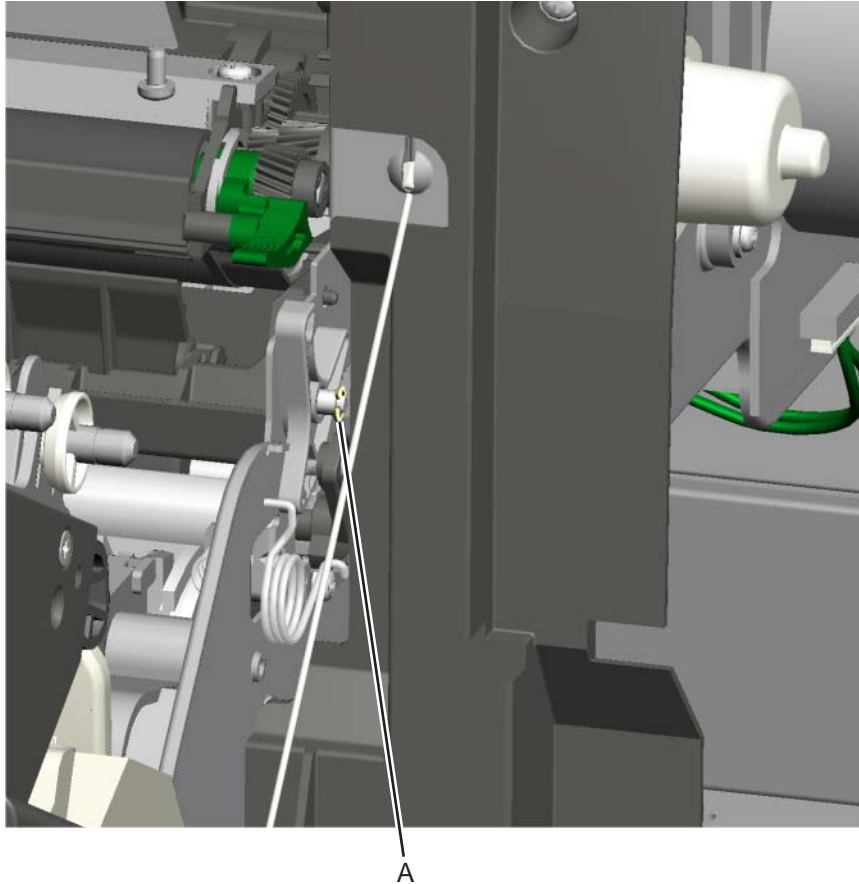

4. Remove the right bellcrank.

Smart chip card removal—models C52x only

See **“Smart chip card, C52x only”** on page 7-9 for the part number.

Warning: When replacing any one of the following components:

- Operator panel assembly
- System card
- Smart chip card (C52x) or printhead assembly (C53x)

Only replace one component at a time. Replace the required component, and perform a POR before replacing a second component listed above. If this procedure is not followed, the printer will be rendered inoperable.

1. Remove the system card support shield. See **“System card support shield removal”** on page 4-94.
2. From the outside right of the printer, disconnect the five connectors (A).
3. Remove the two mounting screws (B), and remove the smart chip card.

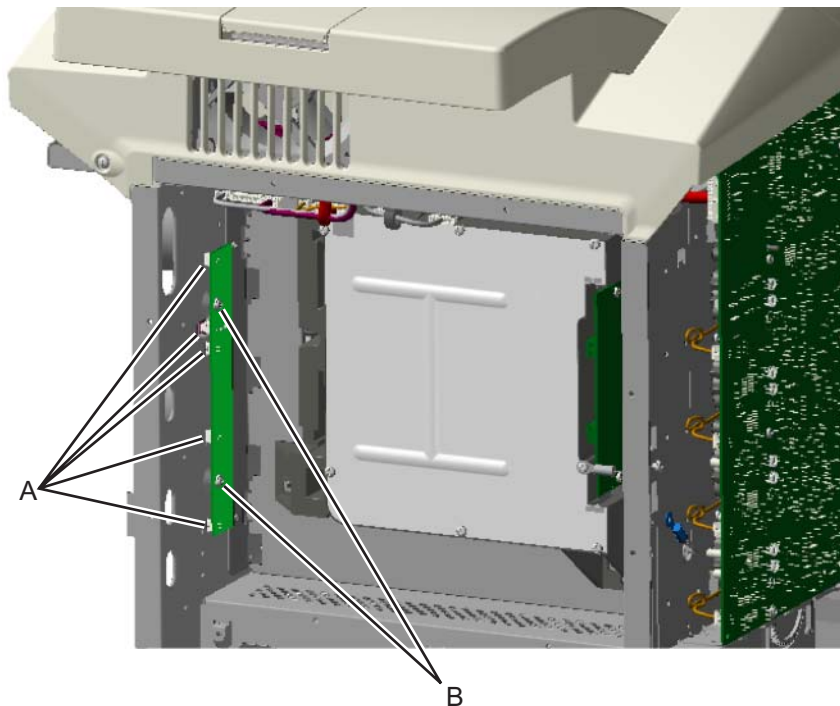

System card removal

See the system card part number for the model you need on [page 7-9](#).

Warning: When replacing any one of the following components:

- Operator panel assembly
- System card
- Smart chip card (C52x) or printhead assembly (C53x)

Only replace one component at a time. Replace the required component, and perform a POR before replacing a second component listed above. If this procedure is not followed, the printer will be rendered inoperable.

Warning: Be careful not to damage the printhead cable when removing the system card.

1. Remove the rear cover. See [“Rear cover removal” on page 4-25](#).
2. Disconnect all the connectors from the system card.

Warning: Do not use tools to remove the printhead ribbon cable (A). It can be damaged and should be removed gently by hand. When installing, carefully line up the cable, and press straight into the connector.

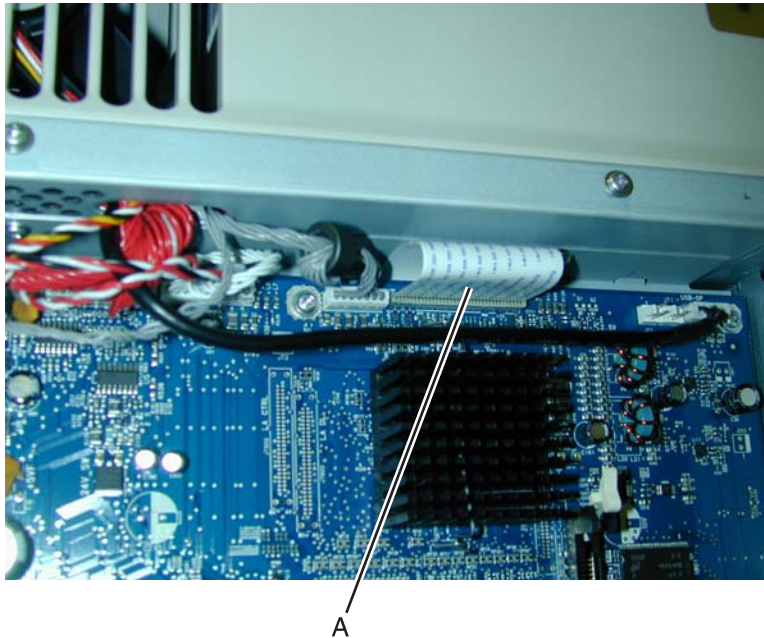

3. Remove the screw (B) from the USB connector.
4. Remove the two screws (C) from the parallel connector on non-network printers, or from the parallel connector shield on network printers.

Network system card

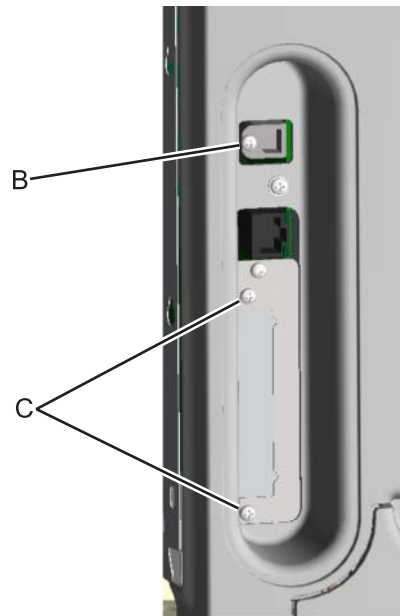

Non-network system card

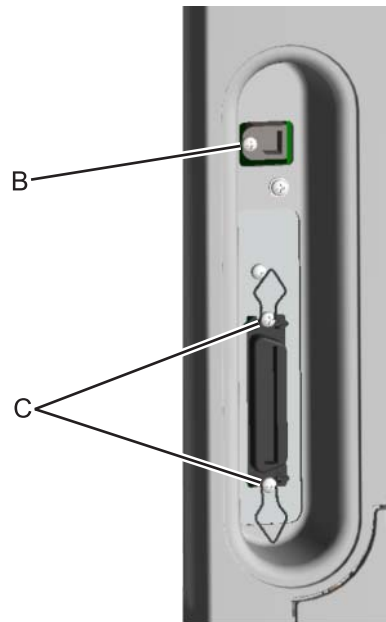

5. Remove the eight screws (D) from the system card.

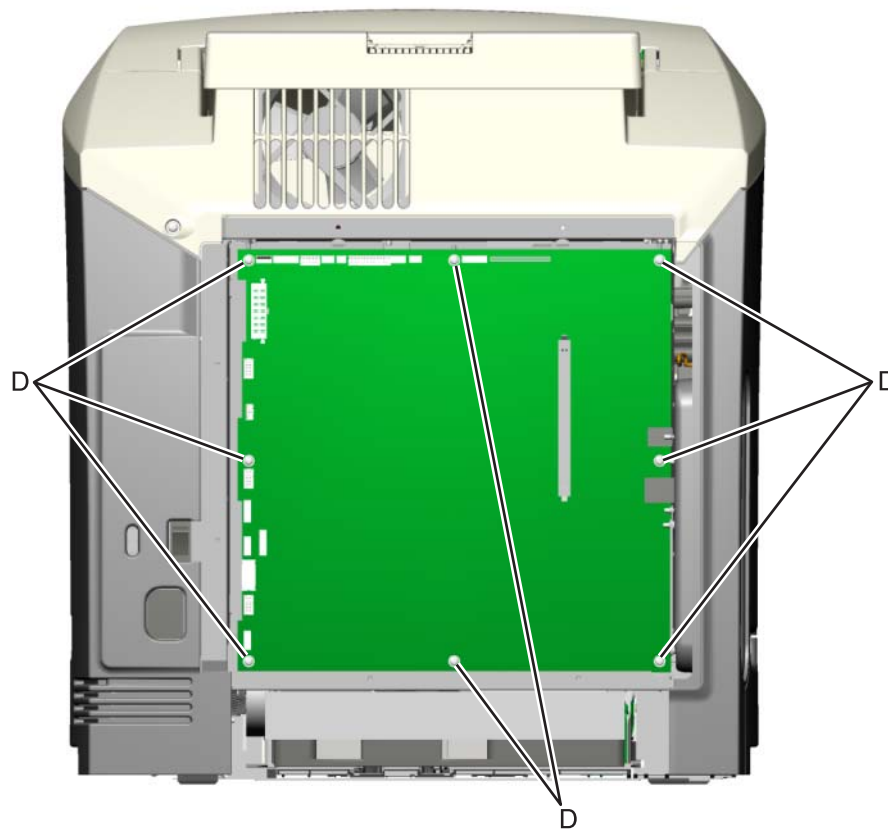

6. Remove the system card.

System card support shield removal

See **“System card support shield, C52x” on page 7-9** or **“System card support shield, C53x” on page 7-9** for the part number.

1. Remove the right cover. See **“Right cover removal” on page 4-26**.
2. Remove the left cover. See **“Left cover removal” on page 4-20**.
3. Remove the LVPS. See **“Low voltage power supply (LVPS) removal” on page 4-65**.
4. Remove the system card. See **“System card removal” on page 4-92**.
5. Remove the five mounting screws (A) from the outer left side of the printer.
Note: Make a note of the attachment of the printhead ground cable (B) to the second screw from the bottom for later installation.
6. Remove the four screws (C) from the inner right side of the support shield.
7. Pull the cables through the access holes on the right side of the printer.
8. **For network printers**—Remove the two screws (D) attaching the parallel connector support plate.
For non-network printers—Remove the INA mounting plate screw (E) and the INA mounting plate.

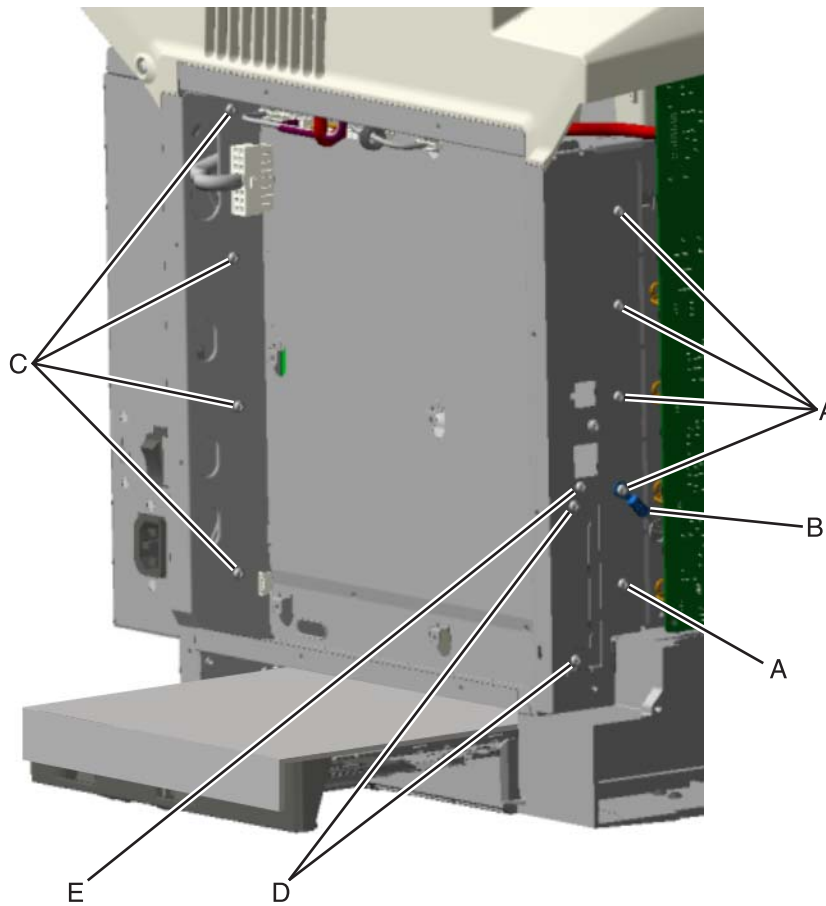

- Remove the four mounting screws (D) from the top and bottom of the support shield.
Note: Only the printhead cables come through the access holes in the system card support shield.

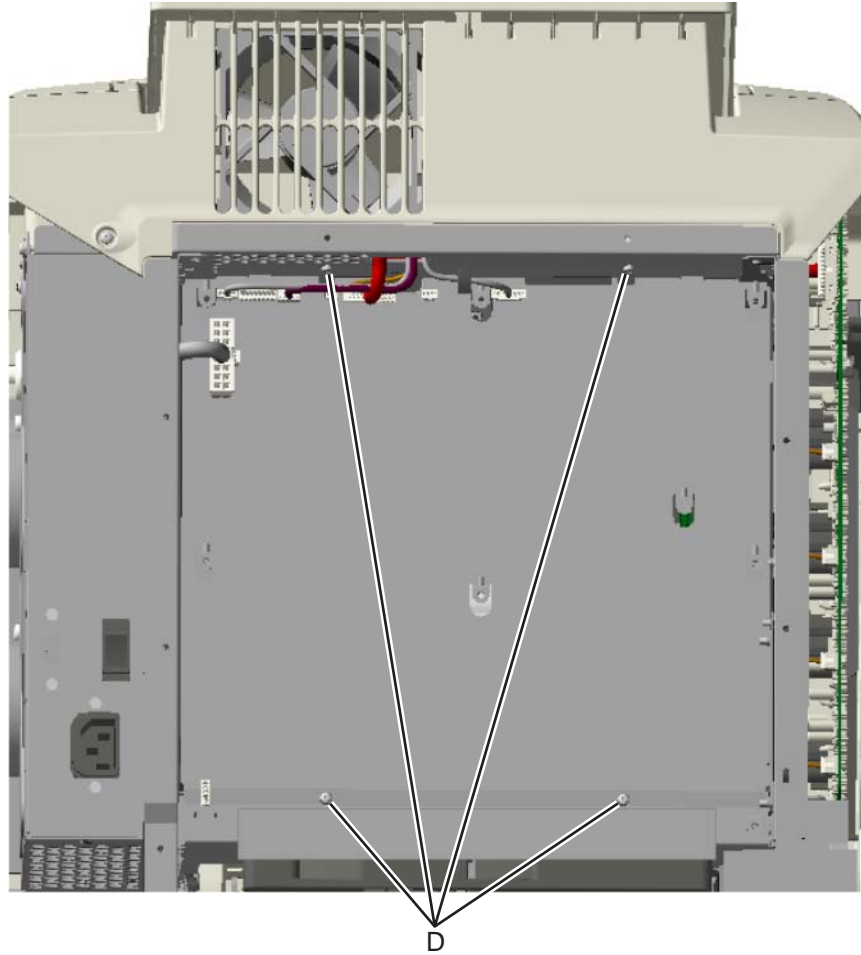

- Lower and remove the support shield. Be careful not to damage the cables that route through the top frame of the printer.

Toner level sensor removal

See **“Toner level sensor” on page 7-11** for the part number.

Note the locations of the toner sensors.

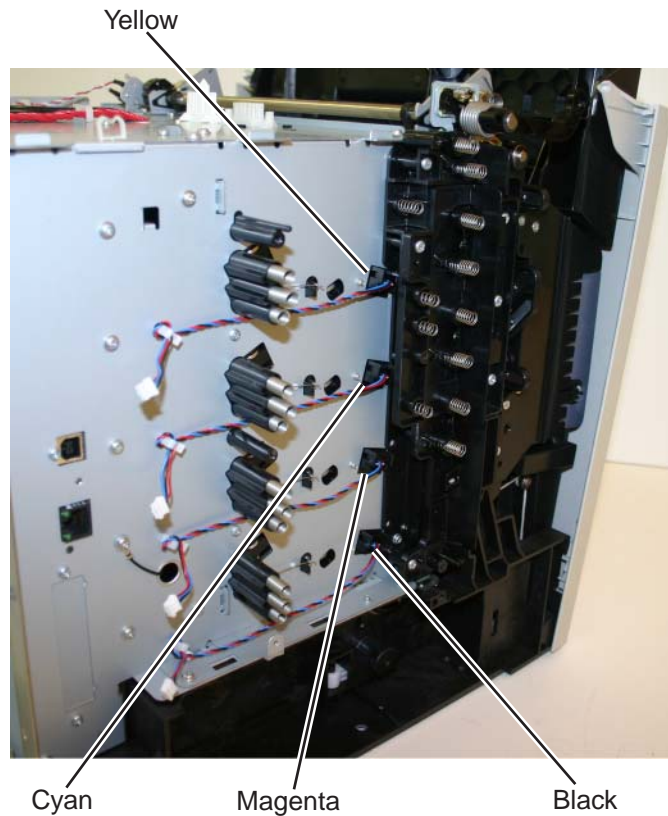

1. Remove the HVPS. See **“High voltage power supply (HVPS) removal” on page 4-62**.
 2. **For yellow and cyan only:** Remove the transfer contact assembly. See **“Transfer contact assembly removal” on page 4-104**.
- Note:** Do not remove the springs from the contact assembly as stated in the last step of the procedure.

3. For all colors: It is difficult to press both locking tabs at the same time. Using a spring hook, press the locking tab (A), and disengage the sensor on that side. Press the other locking tab (B), and remove the sensor.

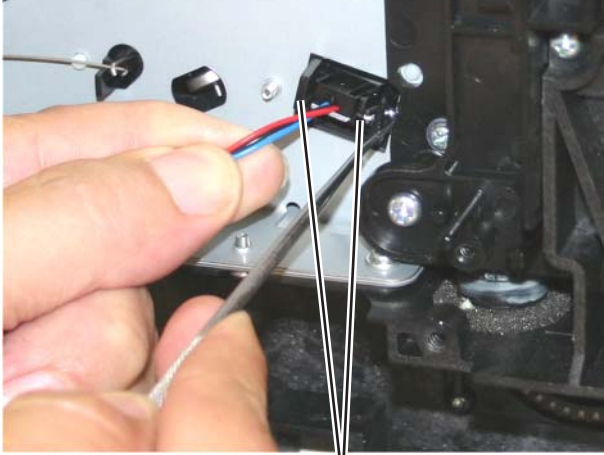

A

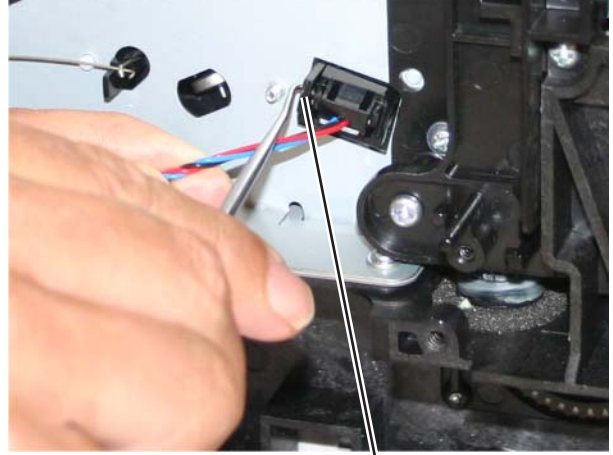

B

Top access door 24 V interlock switch removal

See **“Top access door 24 V interlock switch” on page 7-13** for the part number.

1. Remove the top access cover assembly. See **“Top access cover assembly removal—model C52x only” on page 4-28** or **“Top access cover assembly removal—model C53x only” on page 4-32**.
2. Disconnect the JCVR1 connector (A) from the system card.

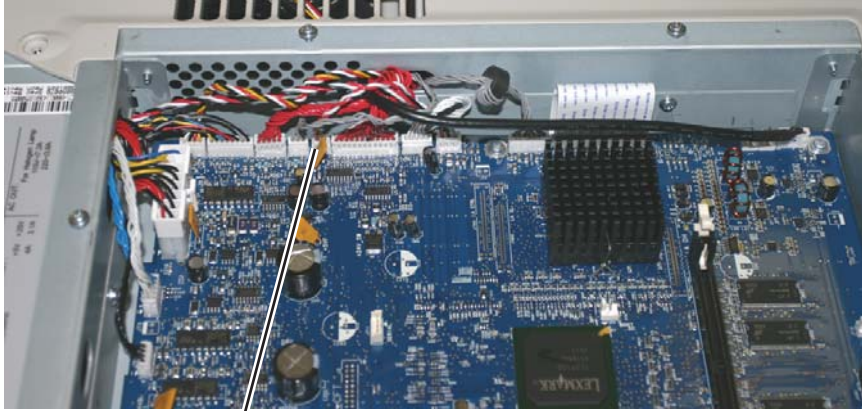

3. Remove the right cover. See **“Right cover removal” on page 4-26**.
4. Remove the mounting screw (B) and 24 V interlock switch (C).

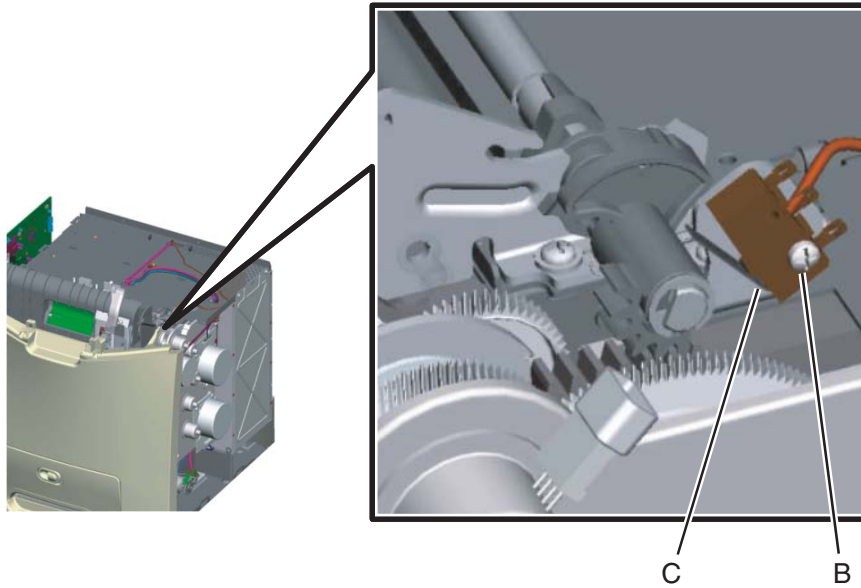

Top cover camshaft assembly removal

See **“Top cover camshaft assembly” on page 7-13** for the part number.

1. Remove the top access door 24 V interlock switch. See **“Top access door 24 V interlock switch removal” on page 4-98**.
2. Remove the left cover. See **“Left cover removal” on page 4-20**.
3. Rotate the lever arm (A) all the way up as if the top access door were open; hold the lever arm (A) in place, and rotate the camshafts (B) down to the closed position.
4. While still holding the lever arm (A) up, remove the left front mounting screw (C) and flip the right lock (D) back.
5. Continue to hold the lever arm (A) up, and remove the right front mounting screw (E); release the lever arm.
6. Remove the e-clip (F).
7. Slide the lever arm (A) and the spring (G) off the shaft.
Warning: When removing the right rear mounting screw, be careful not to damage or remove the spring that mounts over the screw.
8. Remove the rear mounting screws (H).
9. Remove the top cover camshaft assembly.

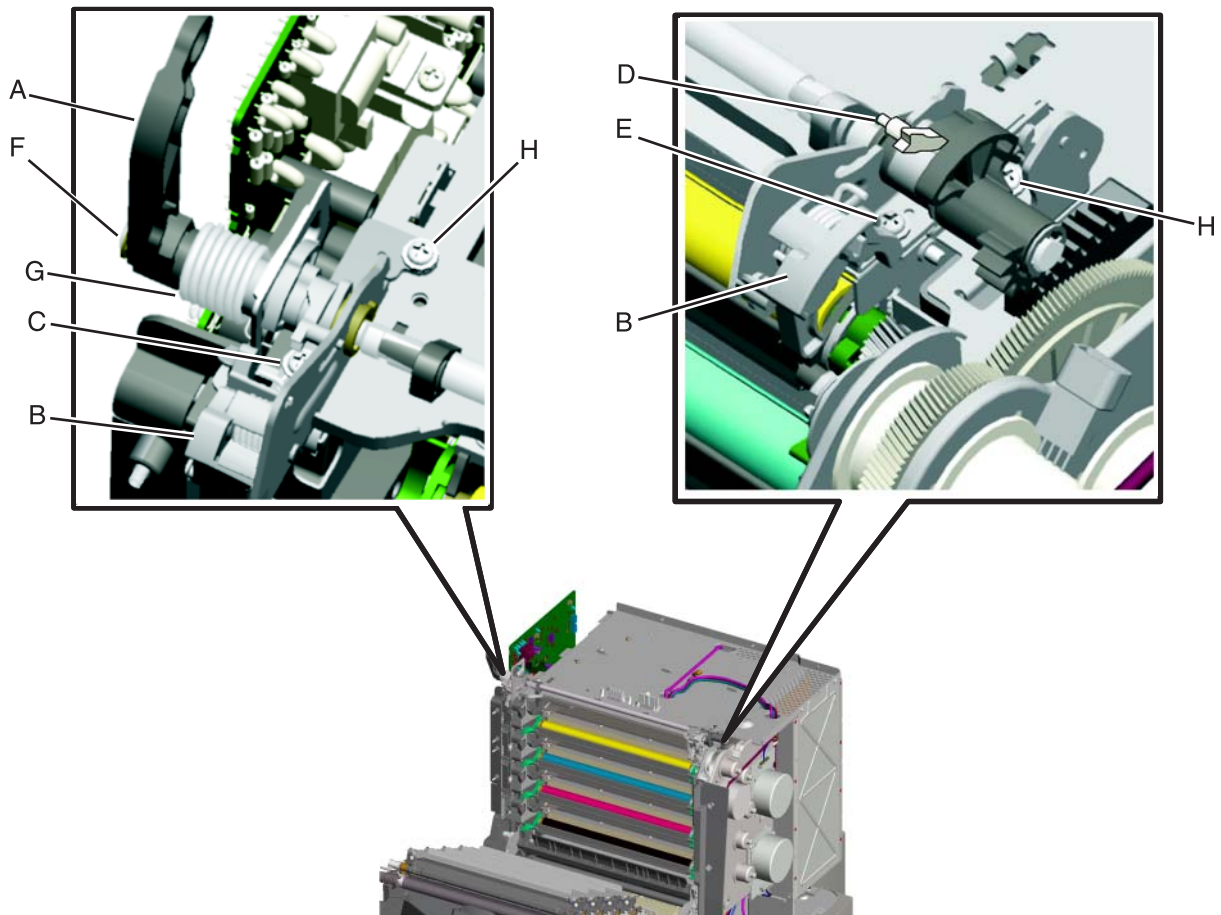

Installation notes:

Warning: Do not install the camshaft assembly by reversing the removal procedures. The camshaft assembly and EP drive assembly must be set to the closed and engaged positions respectively before the camshaft assembly is installed, or the printer will not work correctly.

1. Ensure the EP drive assembly is engaged by sliding the upper retraction plate (A) fully to the rear.

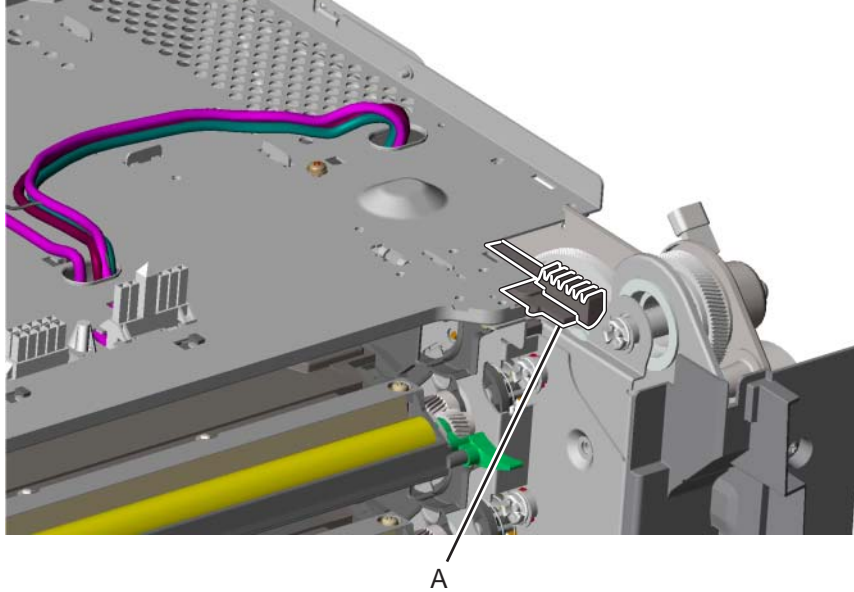

2. Remove the camshaft from the package, and place the left and right mounting brackets (B) on a flat surface.
3. Rotate the lever arm (C) all the way up as if the top access door were open; hold the lever arm (C) in place, and rotate the camshafts down (D) to the closed position.
4. Release the lever arm (C).
5. Remove the e-clip (E).
6. Slide the lever arm (C) and the spring (F) off the shaft.

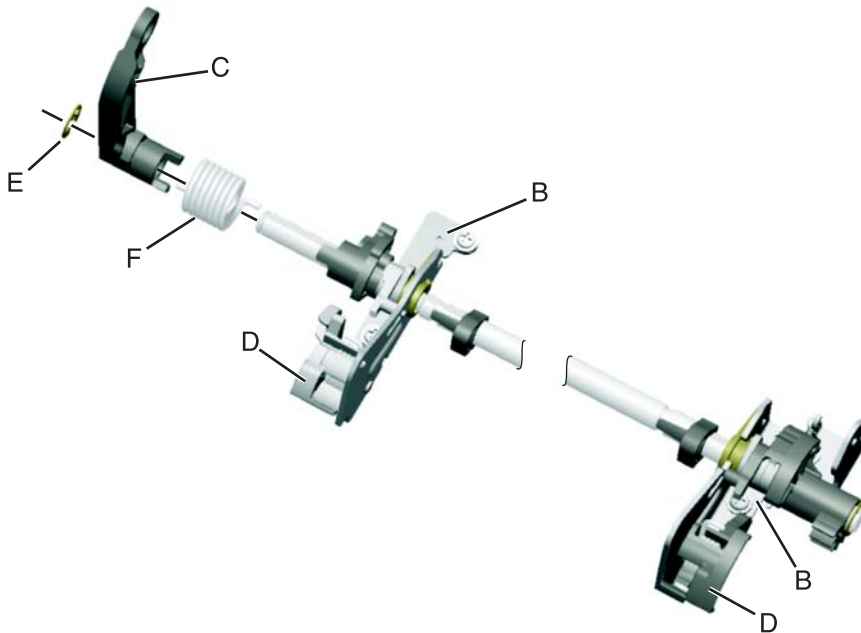

7. Place the left side of the camshaft assembly through the opening in the waste toner shutter (G). Make sure the cam (H) engages the waste toner shutter (G). Also make sure the drive pinion (I) engages the upper retraction plate (J).
8. Install the rear mounting screws (K).
9. Slide the spring (L) and the lever arm (M) onto the shaft.
10. Install the e-clip (N).

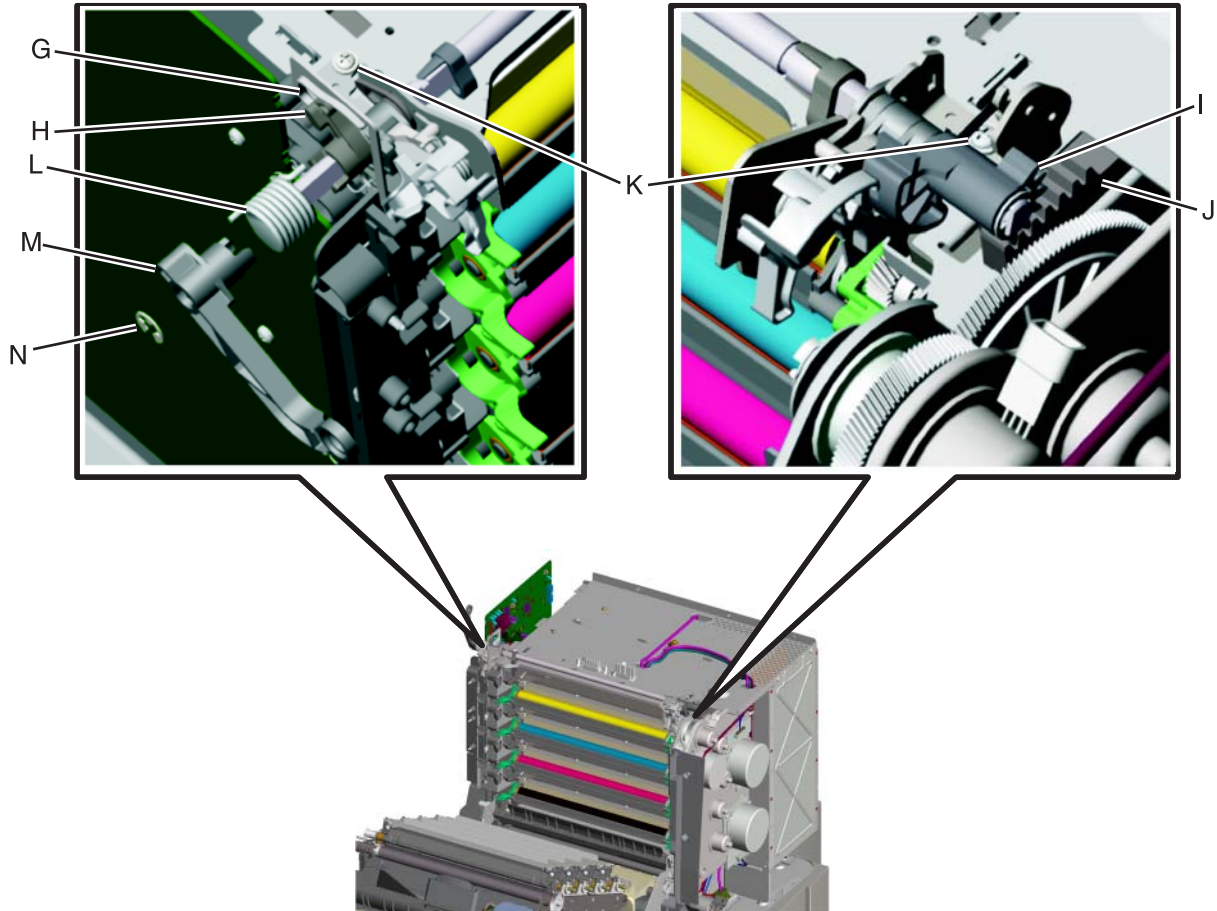

11. Rotate the lever arm (O) all the way up as if the top access door were open.
12. While still holding the lever arm (O) up, flip the right lock (P) up and install the front mounting screws (Q).
- Warning:** Failure to place the camshaft assembly in the open position prevents the front access door from closing and may cause damage to the door.
13. Continue to hold the lever arm (O) up. Flip the right lock (P) down, and rotate the camshafts (R) up. This is the open position.
14. Lower the lever arm (O), and make sure the left lock (S) and right lock (P) are positioned correctly in their respective channels (T).

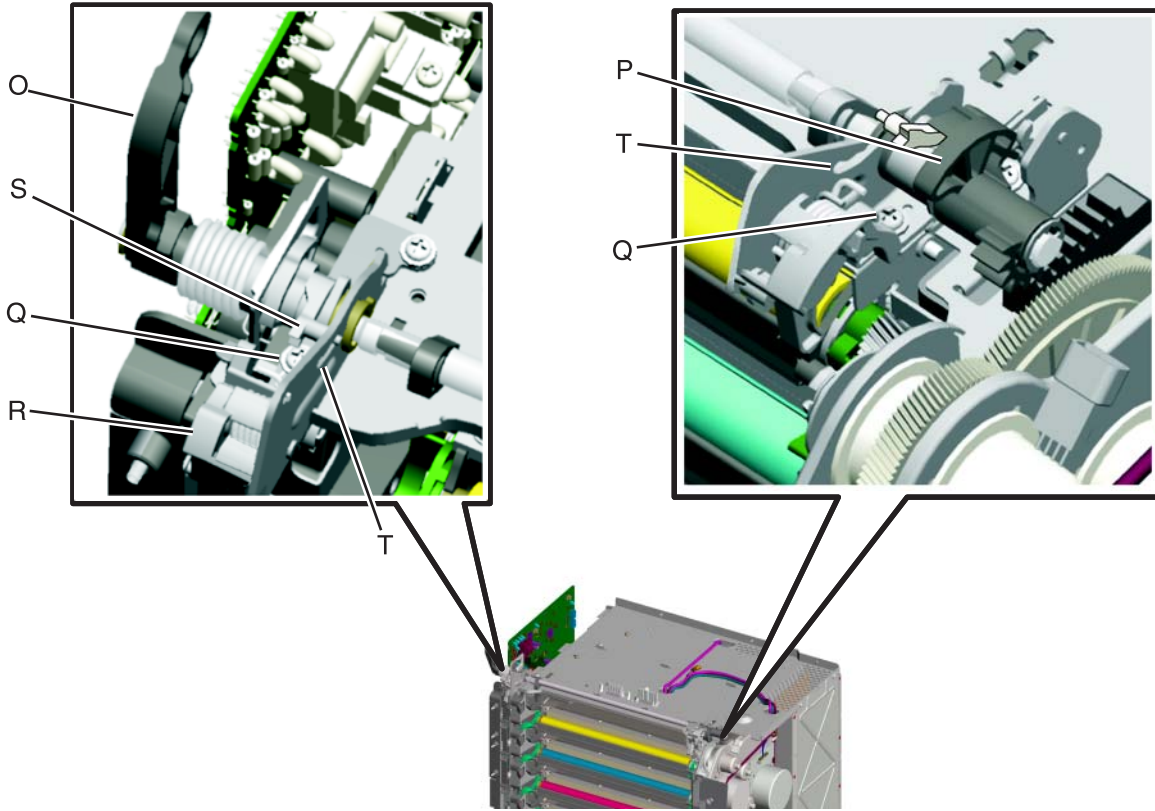

Note: If the left side of the camshaft assembly becomes disassembled, use the following illustration:

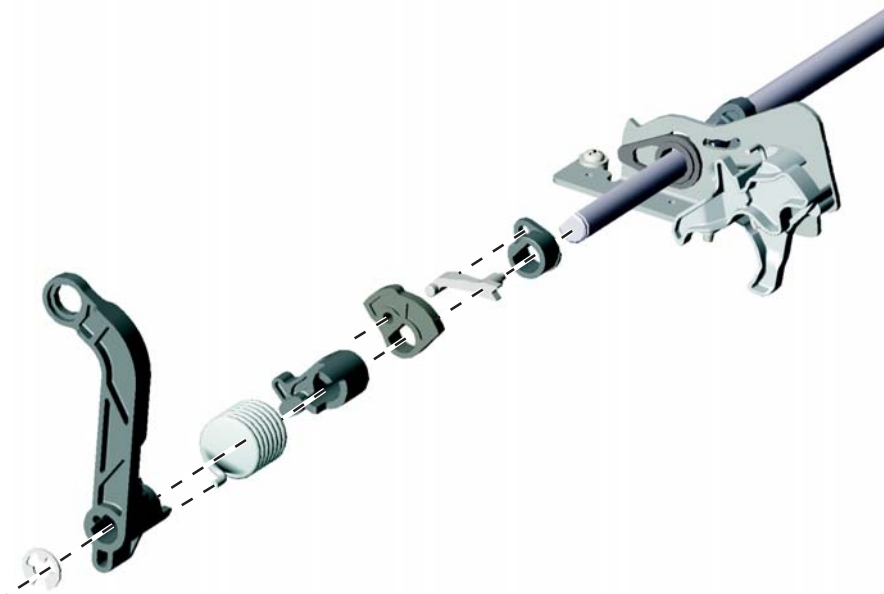

Transfer belt removal

See **“Transfer belt assembly, C52x”** on page 7-15 or **“Transfer belt assembly, C53x”** on page 7-15 for the part number.

1. Remove all photoconductor units. See **“Photoconductor unit removal”** on page 4-70.
Warning: To avoid damaging the photoconductor drum, hold the photoconductor units by their handle and place the photoconductor units on a clean surface. Never expose the photoconductor units to light for a prolonged period of time. See **“Handling the photoconductor unit”** on page 4-2 for additional information.
2. Disconnect the transfer belt cable (A).
3. Press the two tabs (B) on either side of the transfer belt assembly, and lift out the transfer belt assembly.

Model C52x

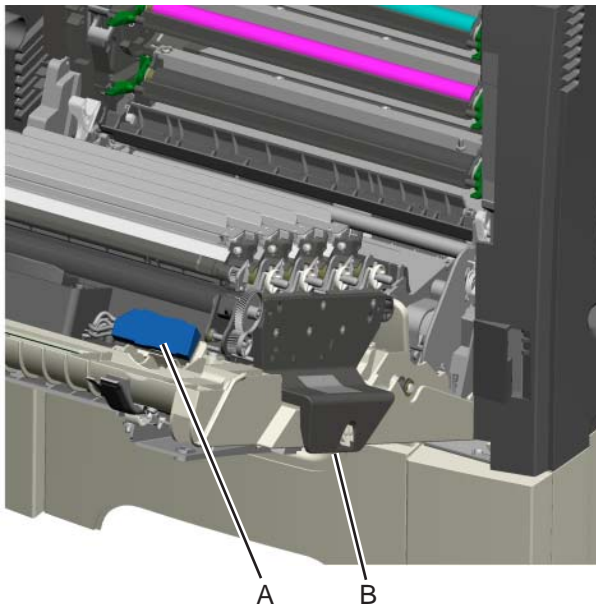

Model C53x

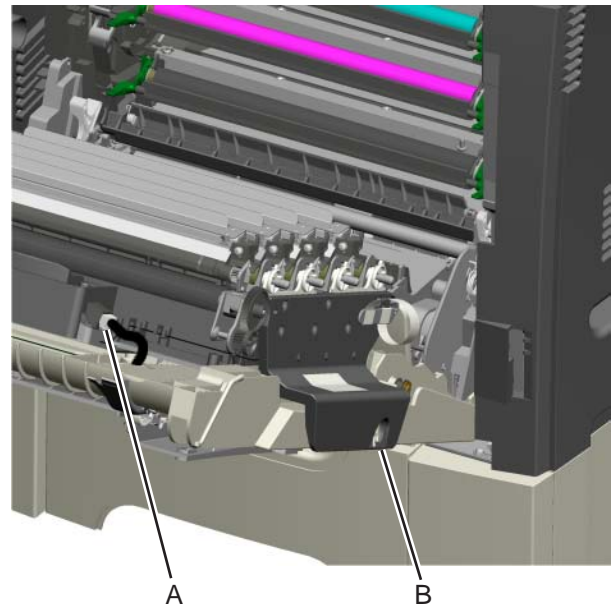

Installation notes: When you installed the new transfer belt and moved all the photoconductor units from the used one to the new one, the alignment of the toner cartridges and photoconductor units may have changed. For better color quality, perform the Color Alignment procedure in the Configuration Menu. See **“Color Alignment”** on page 3-24.

1. Enter the Configuration Menu. (Turn off the printer, press and hold **Select** (⏏) and **▶**, turn on the printer, and release the buttons when the clock graphic displays.)
2. Select **Color Alignment**. See **“Color Alignment”** on page 3-24.

Transfer contact assembly removal

See **“Transfer contact assembly”** on page 7-11 for the part number.

1. Remove the HVPS. See **“High voltage power supply (HVPS) removal”** on page 4-62.
2. Remove all the inside contact springs. See **“Contact springs removal”** on page 4-44.
3. Remove the four screws (A), and remove the transfer contact assembly.
4. Remove the eight springs (B) for reuse during installation.

Note: The top spring may fall away from the transfer contact assembly during removal.

Installation note: For ease of installation, put the transfer contact assembly on before installing the springs.

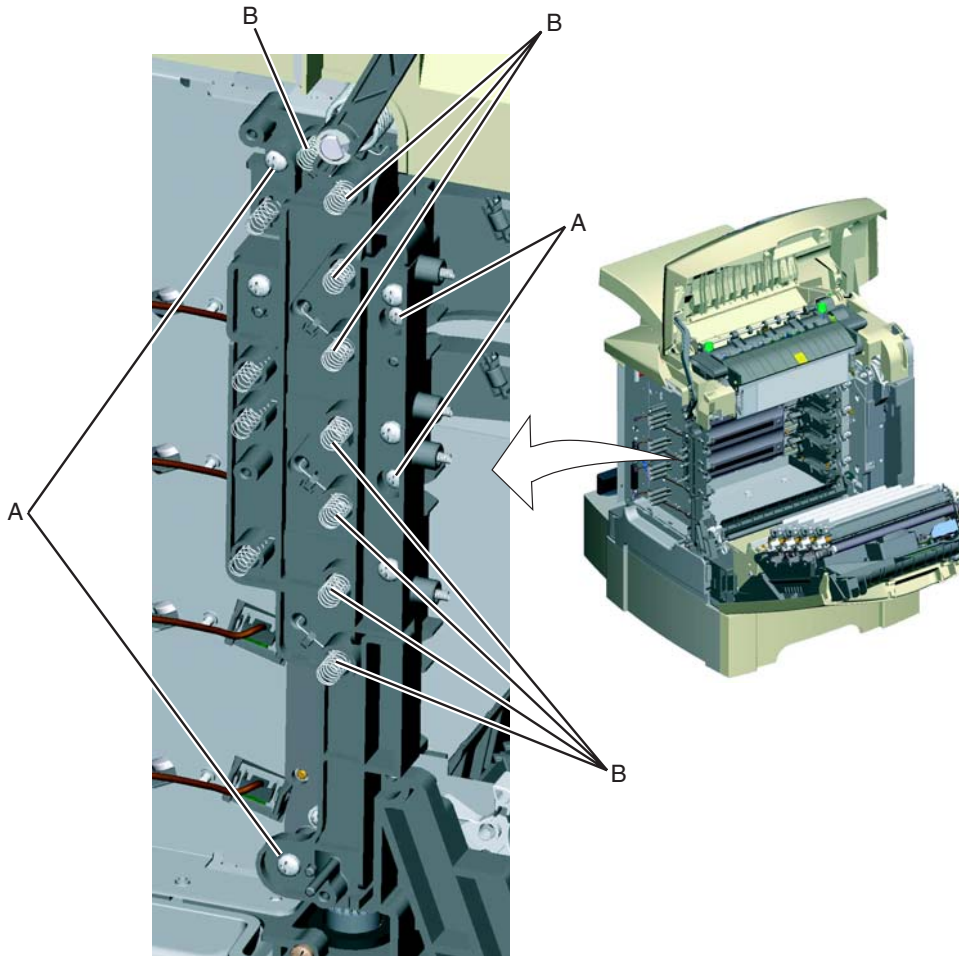

Waste toner assembly removal

Not a FRU.

1. Press the release latch (A).
2. Swing the front of the waste toner away from the printer and remove.



5. Locations and connectors

Locations

Covers

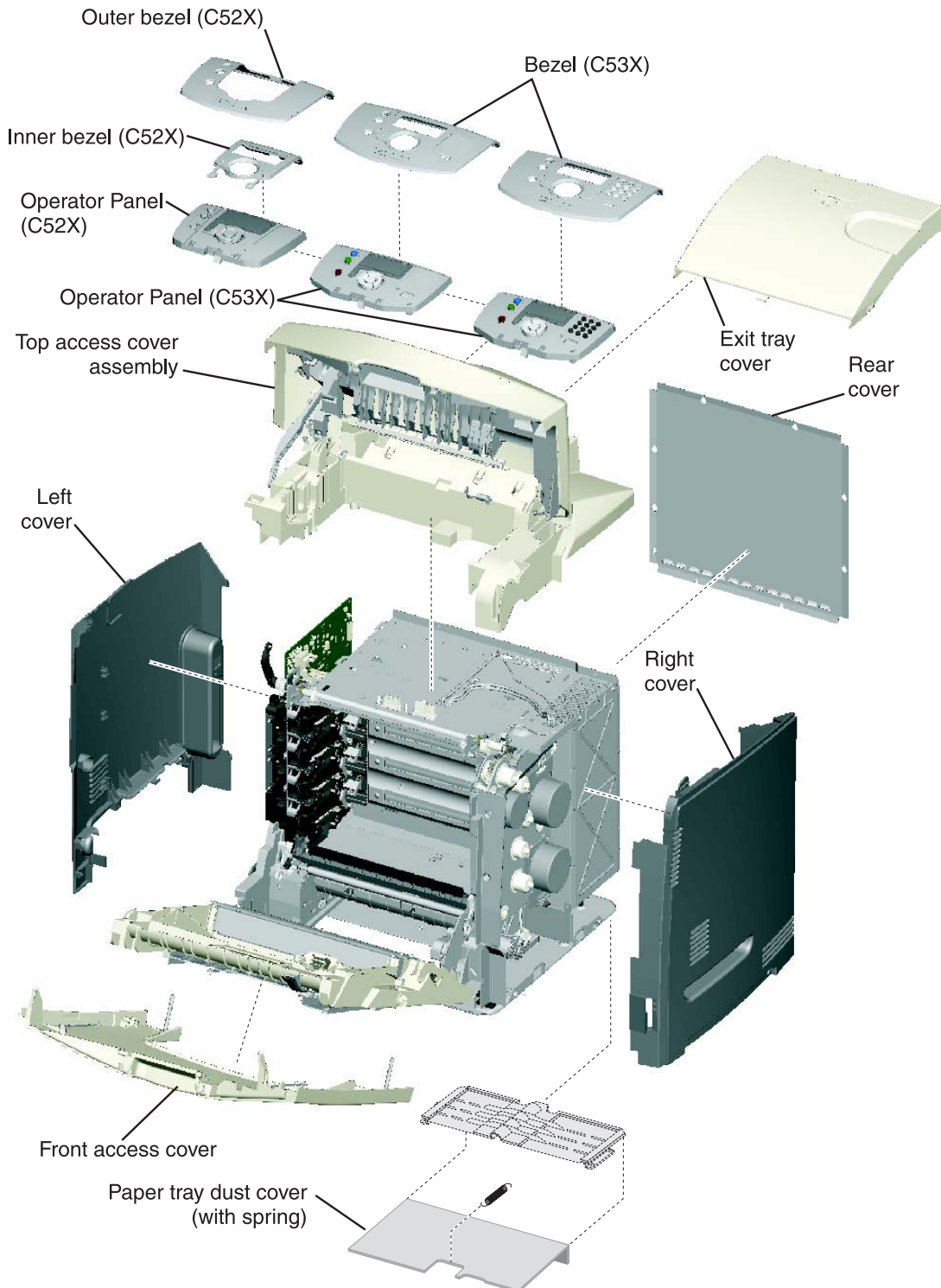

Front

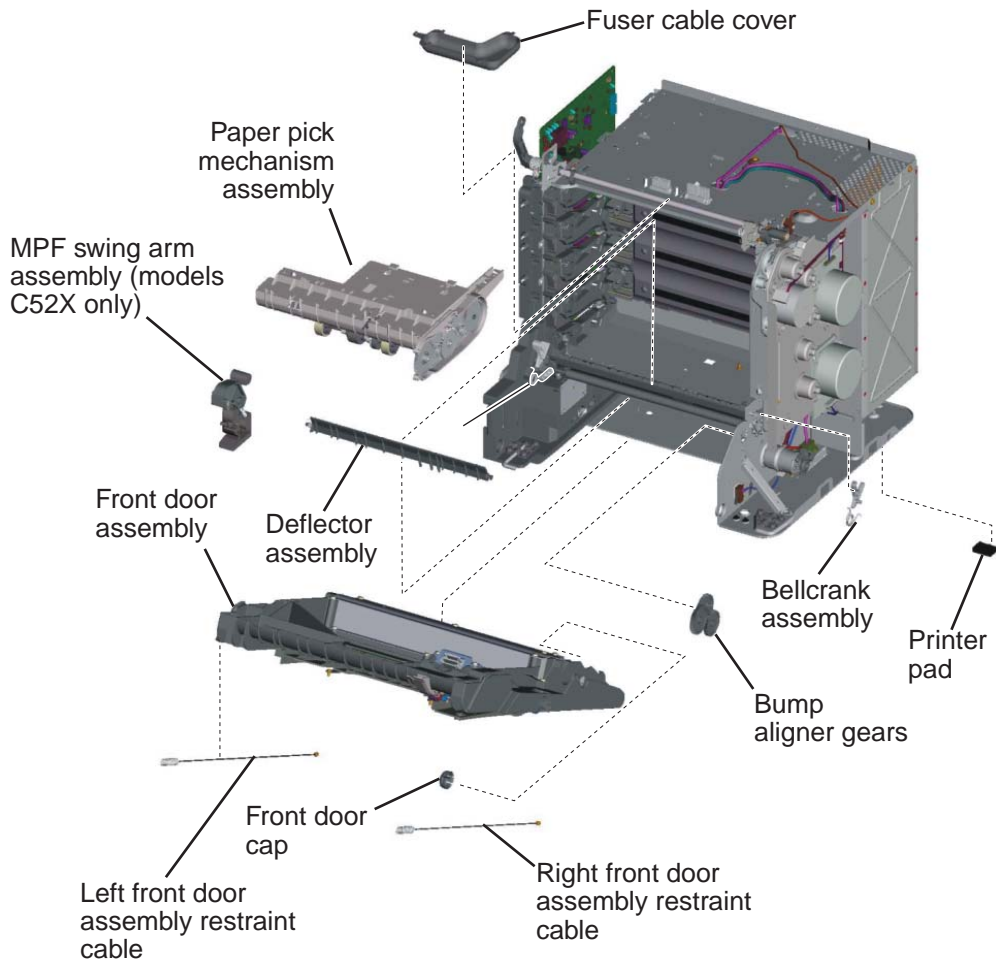

Right

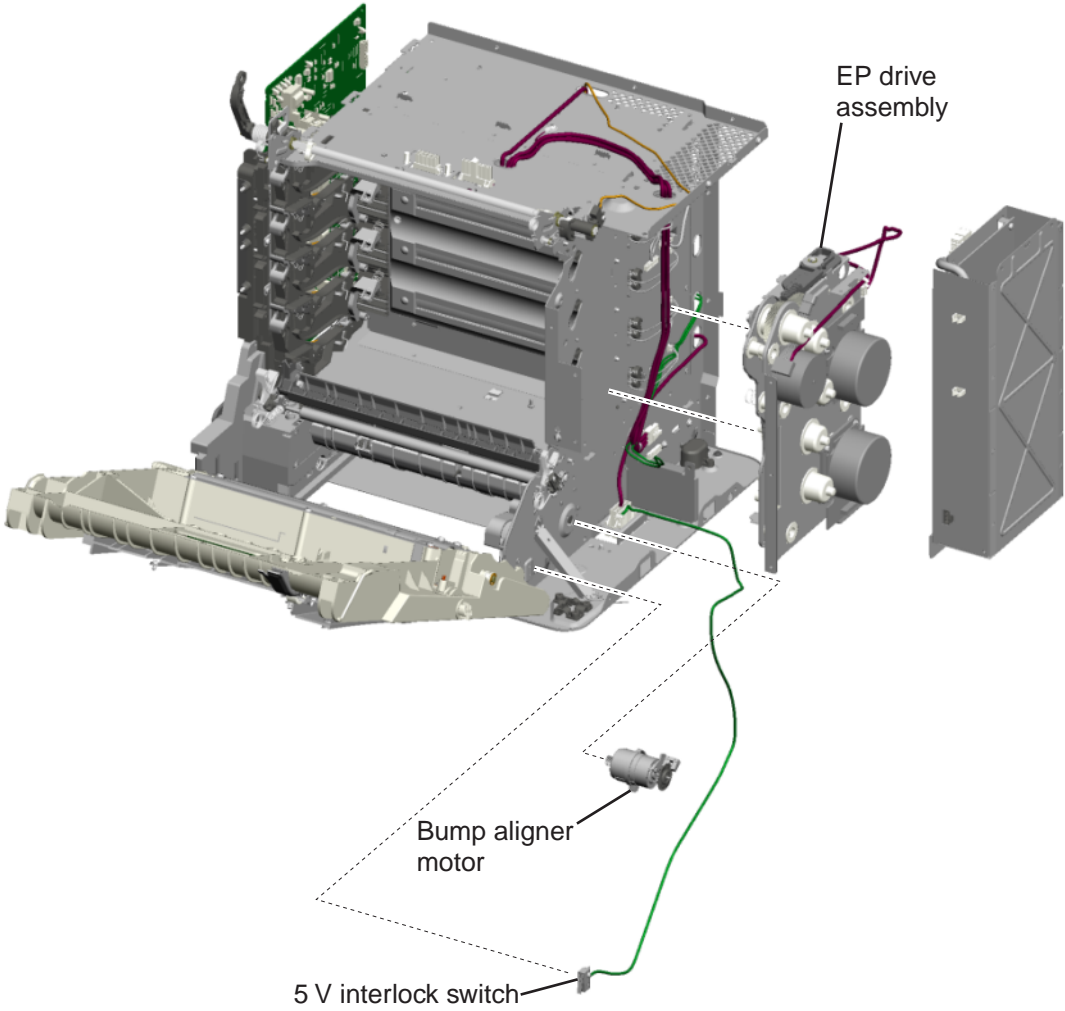

Rear

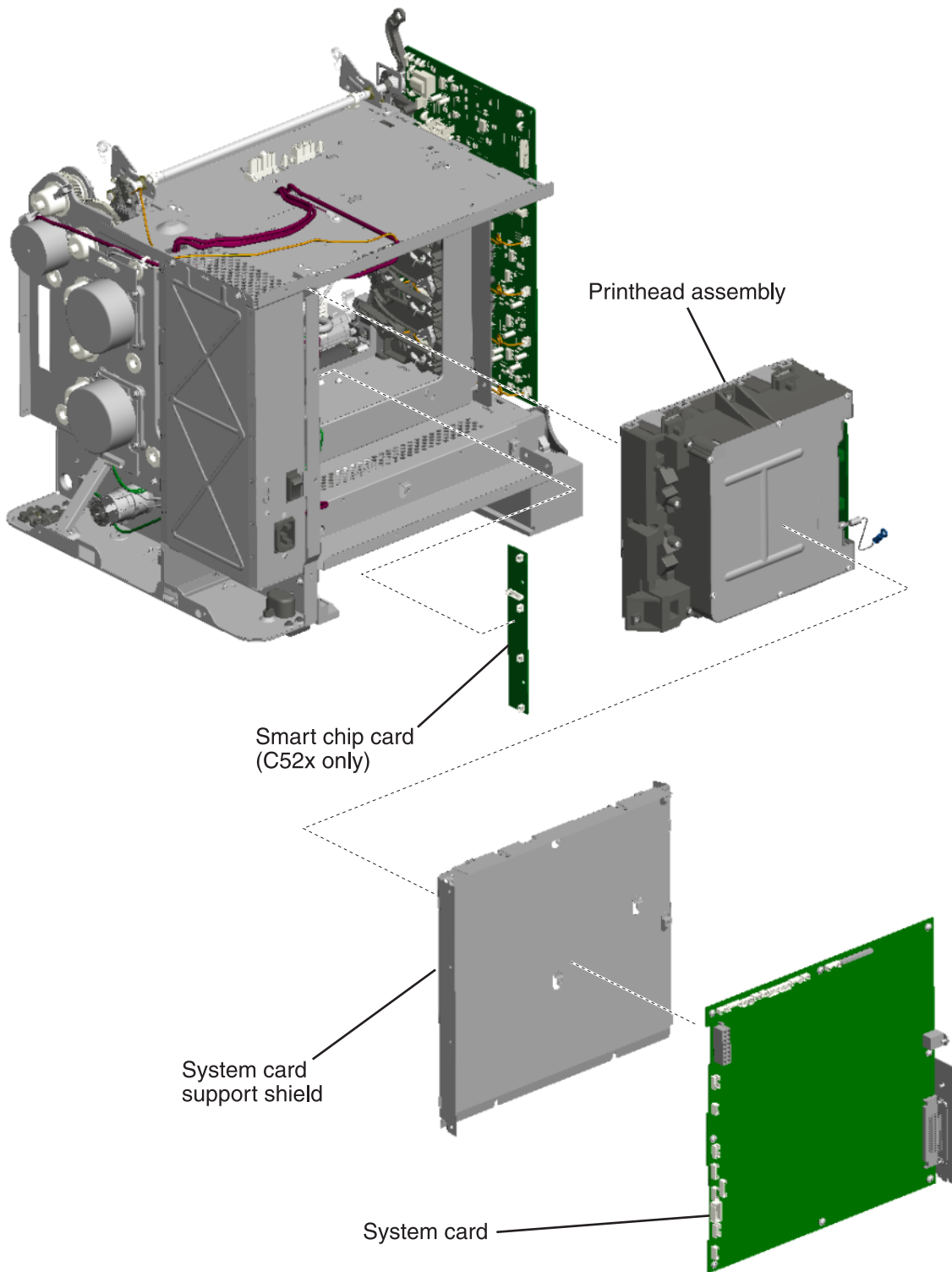

Left

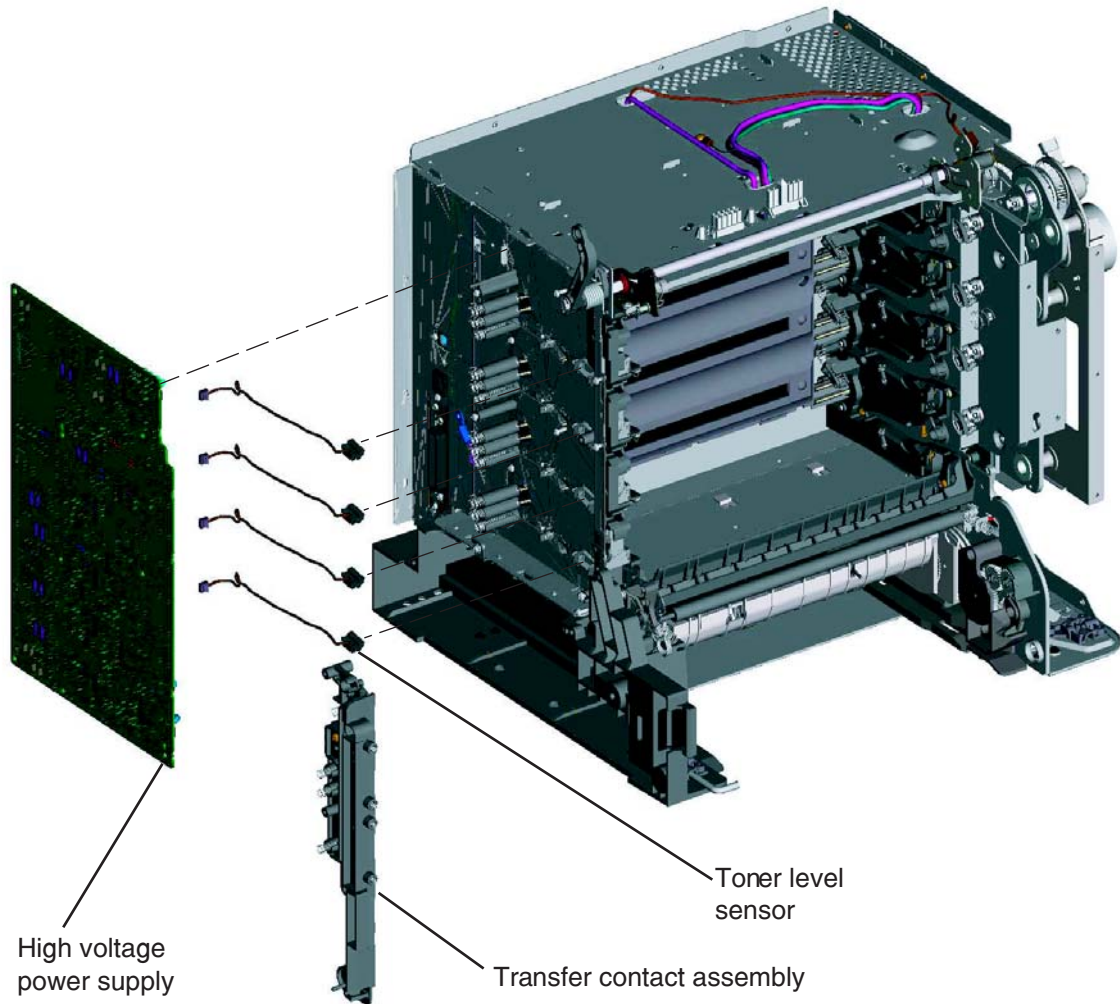

Top

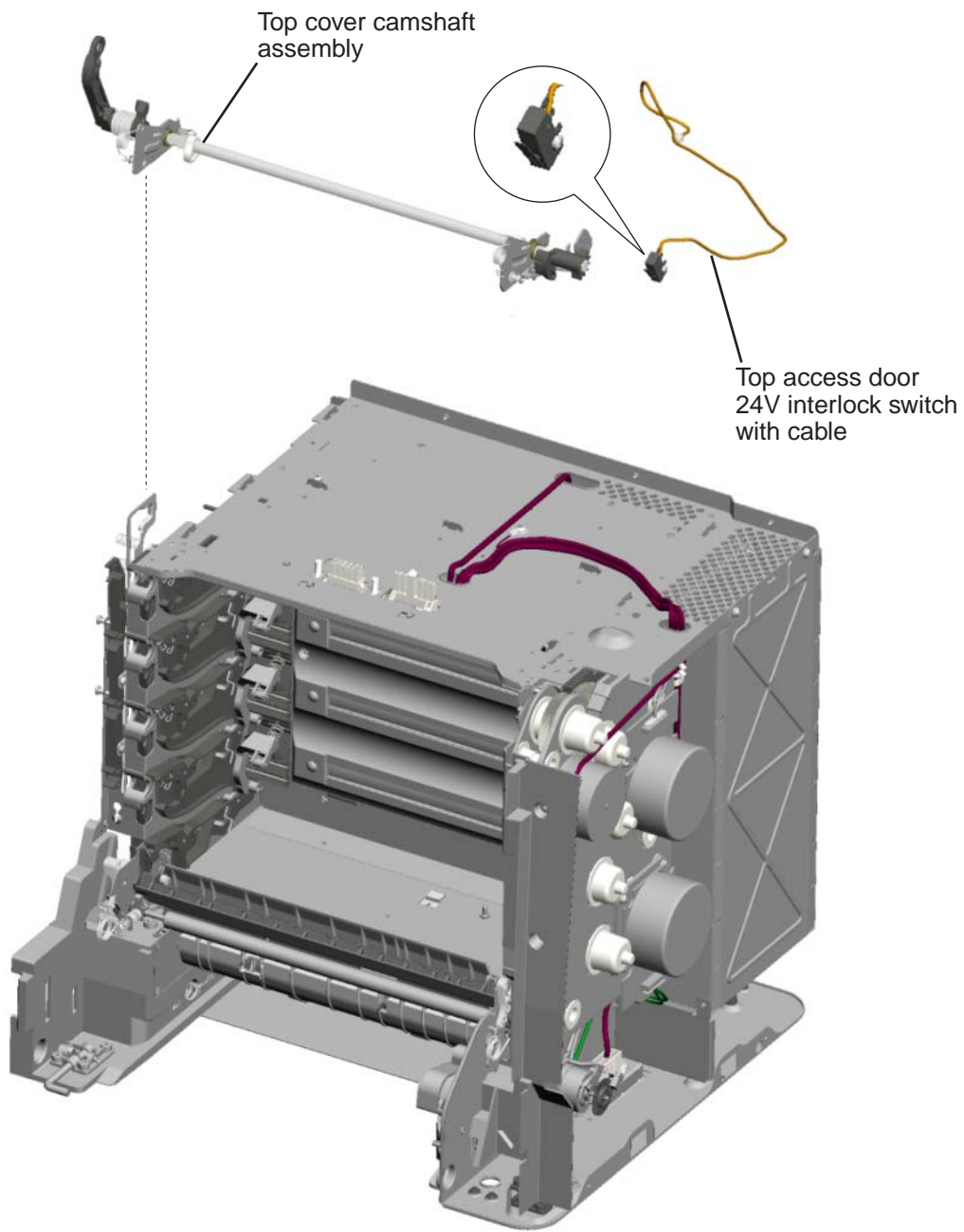

CRU and FRUs

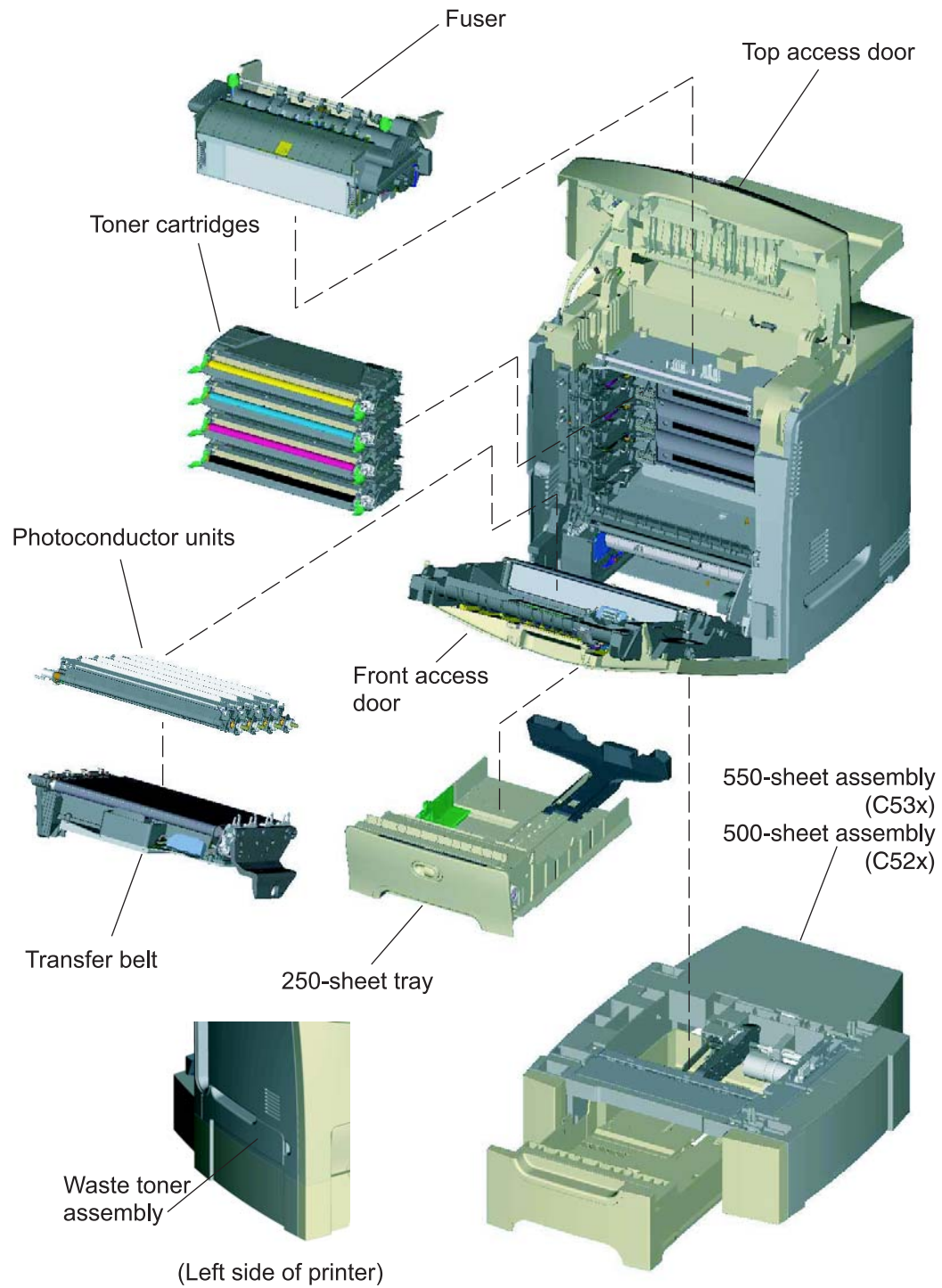

Sensors

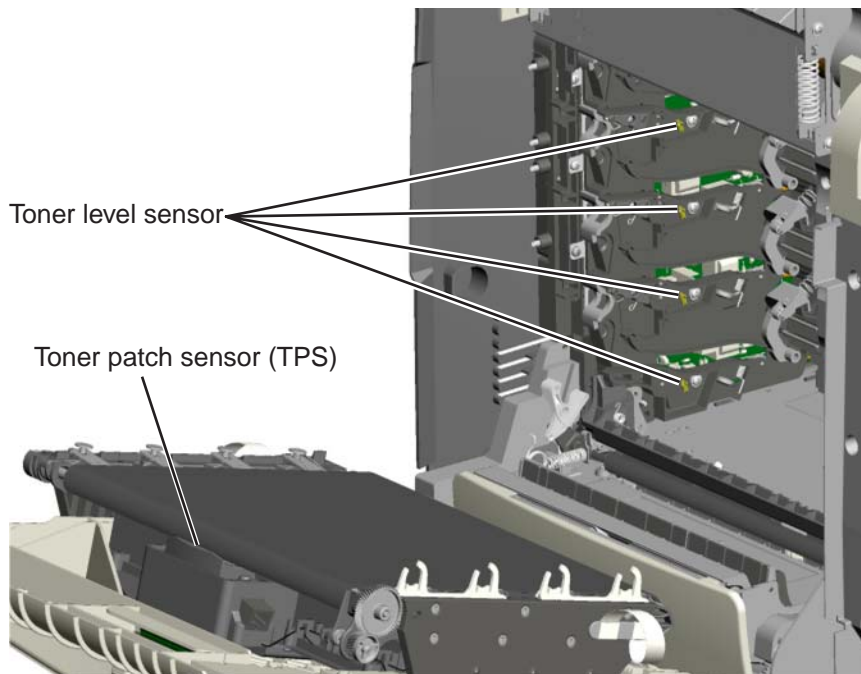
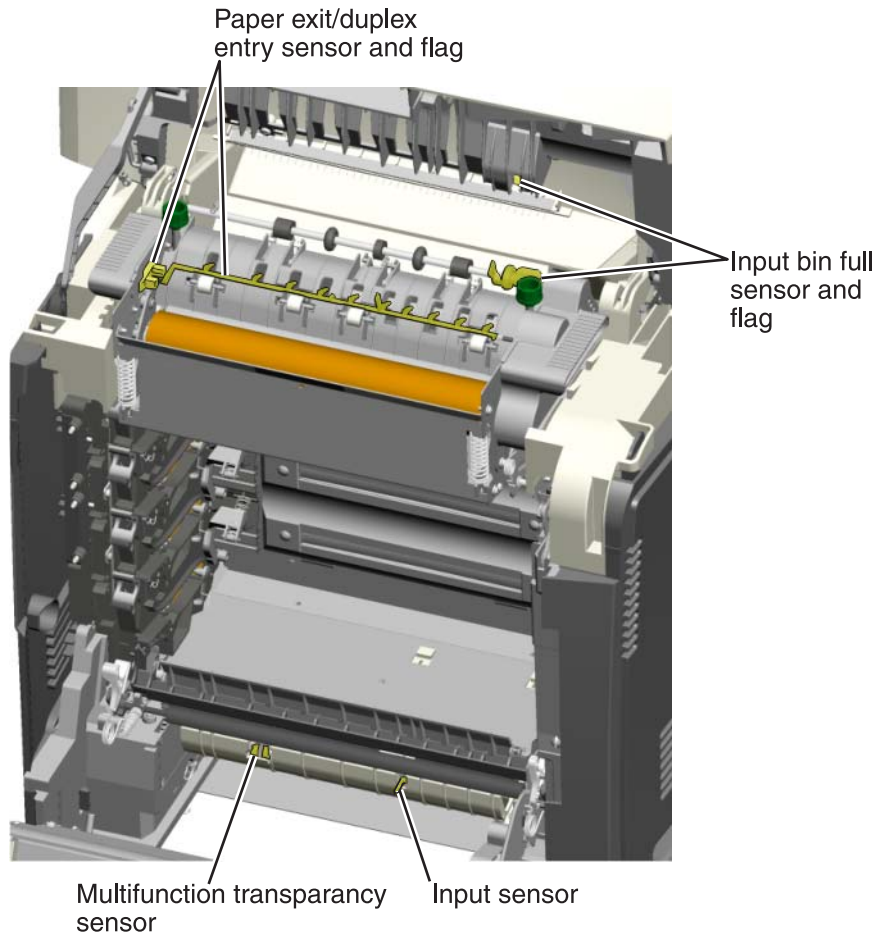

Motors

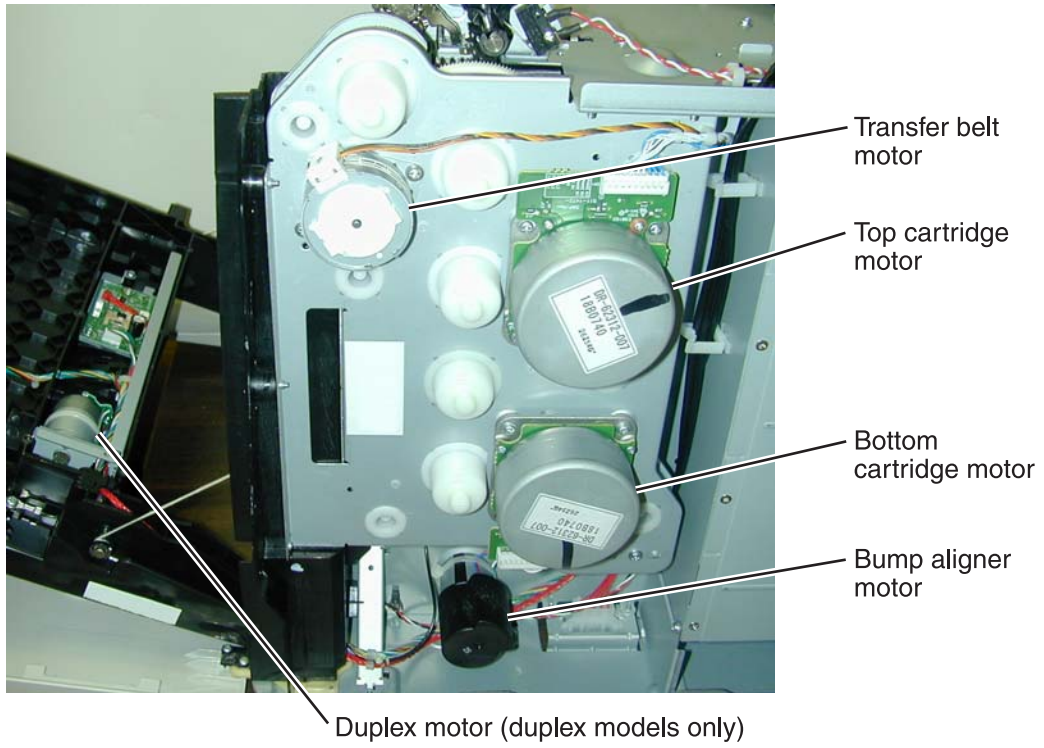

Printer cards

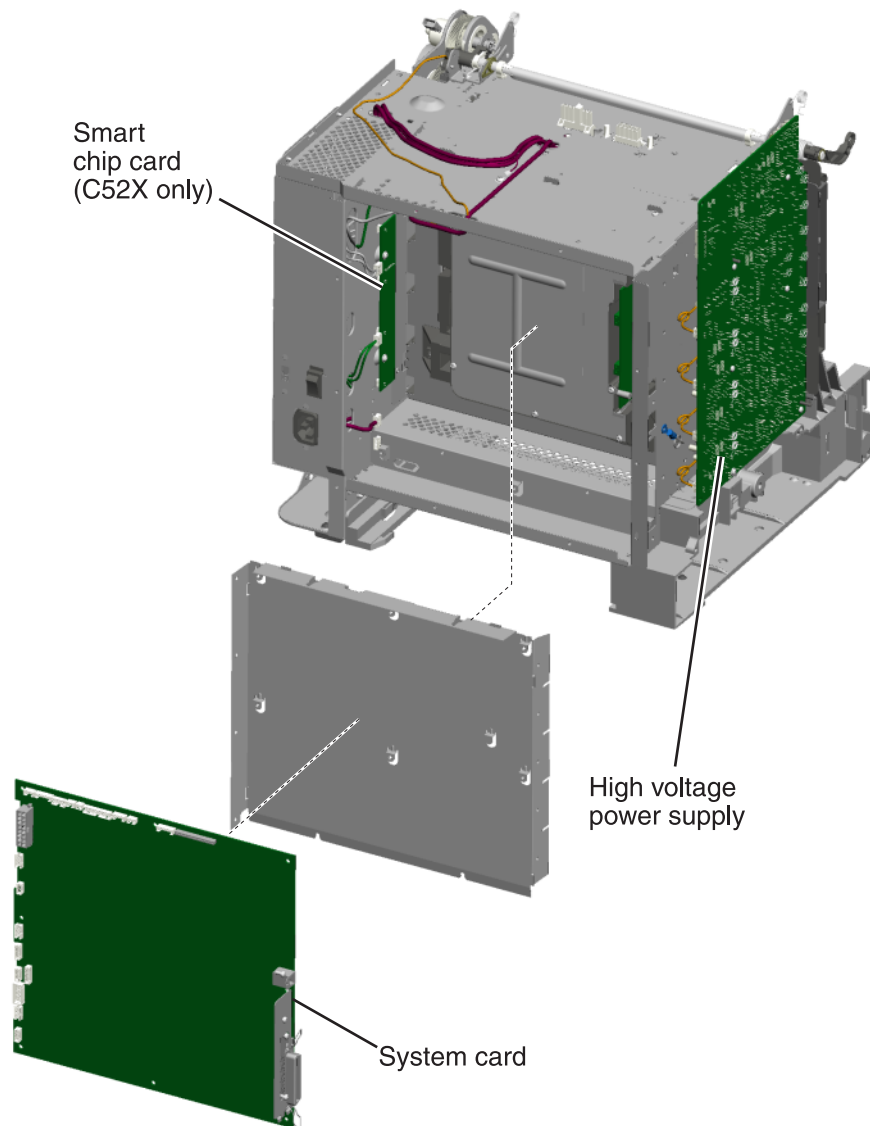

Connectors

System card (network)—models C52x

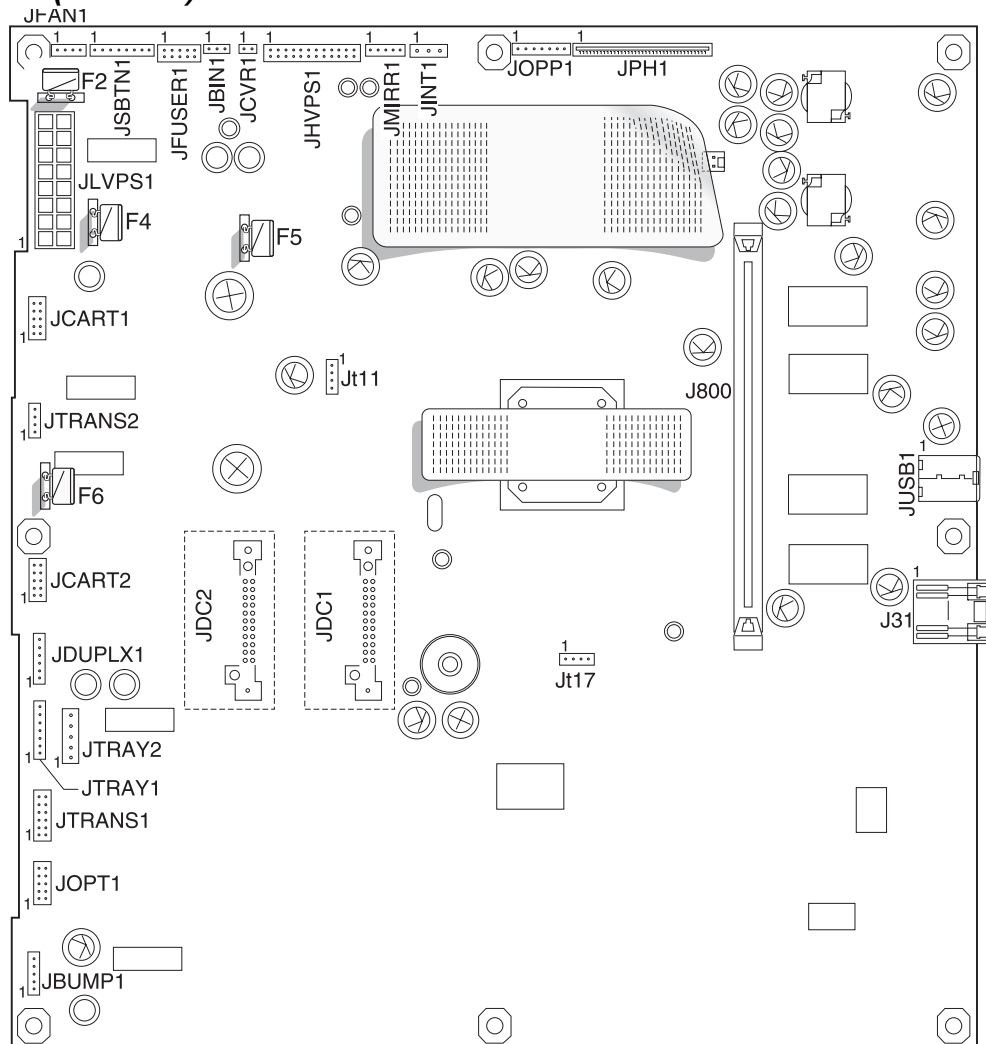

System card (non-network)—models C52x

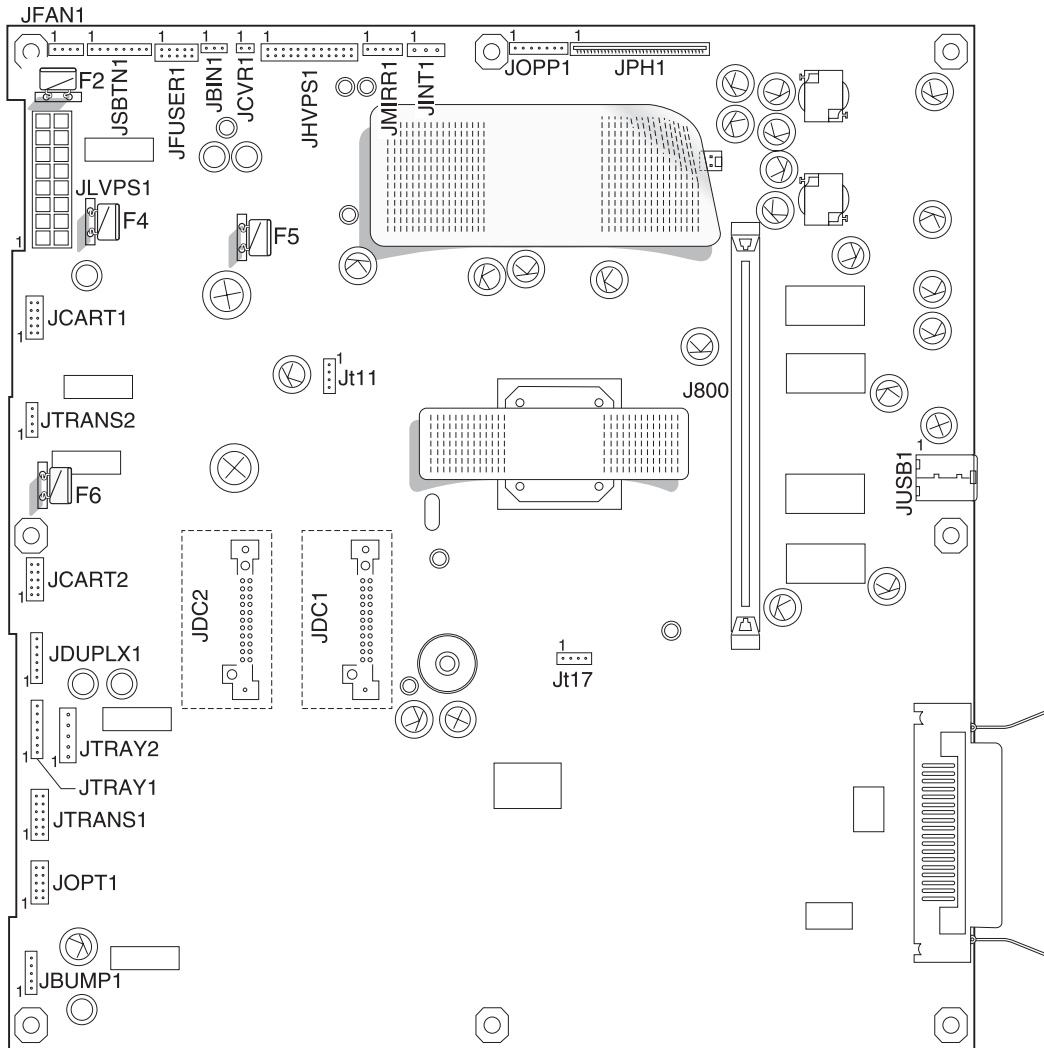

Connector listing—models C52x

(see “System card (network)—models C52x” on page 5-11 or “System card (non-network)—models C52x” on page 5-12)

Connector	Pin no.	Signal	Pin no.	Signal		
JBIN1	1	V_BF (+5 SW)				
	2	S_BIN_FB				
	3	Ground				
JBUMP1	1	VS_BUMP_LED				
	2	S_BUMP_ENC				
	3	Ground				
	4	V_BUMP_M-				
	5	V_BUMP_M+				
JCART1	1	V_JC1-1			2	V_JC1-2
	3	V_JC2-3			4	V_JC1-4
	5	Ground	6	+5V_SW		
	7	N/C	8	V_C2_U		
	9	V_C2_V	10	V_C2_W		
JCART2	1	CART2_HALL_V	2	V_JC2-2		
	3	CART2_HALL_W	4	V_JC2-4		
	5	Ground	6	_5V_SW		
	7	N/C	8	V_C2_U		
	9	V_C2_V	10	V_C2_W		
JCVR1	1	V_24V_CVR				
	2	COVER_OPEN_SNS				
JDUPLX1	1	VS_DUPLX (+5 V)				
	2	DUPLEX_PWM				
	3	DUPLEX_ENC				
	4	Ground				
	5	V_24VD				
	6	Ground				
JFAN1	1	FAN_FG				
	2	Ground				
	3	+24VC				
	4	FAN1_PWM				
JFUSER1	1	V_FUSER_M+	2	V_FUSER_M-		
	3	VS_FUSER_LED	4	S_FUSER_ENC		
	5	Ground	6	GND/BR_THERM		
	7	FUSER_EXIT_SNSD	8	VS_FUSER+5V		
	9	FUSER_HR_SNS	10	FUSER_HR_THM_RTN		

Connector listing—models C52x

(see “System card (network)—models C52x” on page 5-11 or “System card (non-network)—models C52x” on page 5-12) (continued)

Connector	Pin no.	Signal	Pin no.	Signal
JHVPS1	1	Ground	2	V_24VD
	3	C-DEVPWM	4	M-DEVPWM
	5	Y-DEVPWM	6	K-DEVPWM
	7	Ground	8	+5V_SW
	9	HV_EMPTY_C	10	HV_EMPTY_M
	11	HV_EMPTY_Y	12	HV_EMPTY_K
	13	HV_CHRG_PWM	14	TONER_CHK
	15	HV_XFER_PWM_C	16	XFER_SERV0_C
	17	HV_XFER_PWM_M	18	XFER_SERV0_M
	19	HV_XFER_PWM_Y	20	XFER_SERV0_Y
	21	CORE_CURR_SNSD	22	HVPS_ID
	23	HV_XFER_PWM_K	24	XFER_SERV0-K
JINT1	1	VS_JINT-1 (+5V_SW)		
	2	Ground		
	3	VS_INT (+5V_PH)		
JLVPS1	1	+5 V dc	2	+5 V dc
	3	+5 V dc	4	+5 V dc
	5	LVPS_ZERO_XING	6	+24 V dc
	7	+24 V dc	8	+24 V dc
	9	Ground	10	Ground
	11	Ground	12	Ground
	13	Ground	14	Ground
	15	LVPS_BRON	16	LVPS_HRON
JMIRR1	1	MM_REF		
	2	MM_LOCK		
	3	MM_START		
	4	Ground		
	5	+24 V dc		
JOPT1	1	VS_JOPT-1 (+5V_SW)	2	OPTION_PWM
	3	S_OPT_ENC	4	OPT_TYPE
	5	Ground	6	Ground
	7	+24VC	8	OPT_PSIZE
	9	OPT_PLEV	10	OPT_PCTL

Connector listing—models C52x

(see “System card (network)—models C52x” on page 5-11 or “System card (non-network)—models C52x” on page 5-12) (continued)

Connector	Pin no.	Signal	Pin no.	Signal
JOPP1	1	I2C_DATA5_OP		
	2	V_PANEL+5V		
	3	I2C_CLK_OP		
	4	Ground		
	5	I2CIRQ5_R		
	6	+3.3 V dc		
	7	Ground		
JPH1	1	Ground		
	2	D_VDO_M-		
	3	D_VDO_M+		
	4	Ground		
	5	D_VDO_C-		
	6	D_VDO_C+		
	7	Ground		
	8	PH_EMS1_SNS_R		
	9	VDO_BOOST1		
	10	VDO_LPOW1		
	11	VDO_LADJ01		
	12	VDO_HADJ01		
	13	PH_EMS0		
	14	VDO_BOOST0		
	15	VDO_LPOW0		
	16	VS_+5VPH_NVX_R		
	17	PH_EOS_THERM_SNS		
	18	+5V_PH		
	19	I2C_CLK_PH		
	20	I2C_DATA_PH		
	21	VDO_LENA		
	22	PH_EMS2_SNS_R		
	23	VDO_BOOST2		
	24	VDO_LPOW2		
	25	VDO_LADJ23		
	26	VDO_HYSNC1		
	27	PH_EMS3_SNS_R		
	28	VDO_BOOST3		
	29	VDO_LPOW3		
	30	Ground		

Connector listing—models C52x

(see “System card (network)—models C52x” on page 5-11 or “System card (non-network)—models C52x” on page 5-12) (continued)

Connector	Pin no.	Signal	Pin no.	Signal
JPH1 (continued)	31	D_VDO_K-		
	32	D_VDO_K+		
	33	Ground		
	34	D_VDO_Y-		
	35	D_VDO_Y+		
	36	Ground		
JSBTN1	1	S_SB_Y		
	2	S_SB_K		
	3	S_SB_M		
	4	S_SB_C		
	5	Ground		
	6	I2C_DATA_SB		
	7	I2C_CLK_SB		
	8	+3.3 V dc		
JTRANS1	1	VS_JTRANS-1 (+5V)	2	Ground
	3	I2C_CLK_SB	4	I2C_DATA_TB
	5	VS_JTRANS-5 (5V SW)	6	TRANS_BELT_SNS
	7	TRANS_THERM_SNS	8	VS_5V_TPS
	9	VS_JTRANS-9 (+3.3V)	10	TPS_SNS
	11	TPS_GAIN_ADJ	12	TPS_SNS_RTN
	13	TPS_THERM_SNS	14	N/C
JTRAN2	1	V_TRANS_PHA+		
	2	V_TRANS_PHA-		
	3	V_TRANS_PHB+		
	4	V_TRANS_PHB-		
JTRAY1	1	VS_TRAY_INPT_LED (+5V)		
	2	S_TRAY_INPUT		
	3	Ground		
	4	VS_TRAY+5V_NMT		
	5	TRAY_NMT (+3.3v)		
	6	Ground		
	7	N/C		

Connector listing—models C52x

(see “System card (network)—models C52x” on page 5-11 or “System card (non-network)—models C52x” on page 5-12) (continued)

Connector	Pin no.	Signal	Pin no.	Signal
JTRAY2	1	VS_TRAY_ENC_LED		
	2	S_TRAY_ENC		
	3	Ground		
	4	V_TRAY_PICK_M-		
	5	V_TRAY_PICK_M+		

System card (network)—models C53x

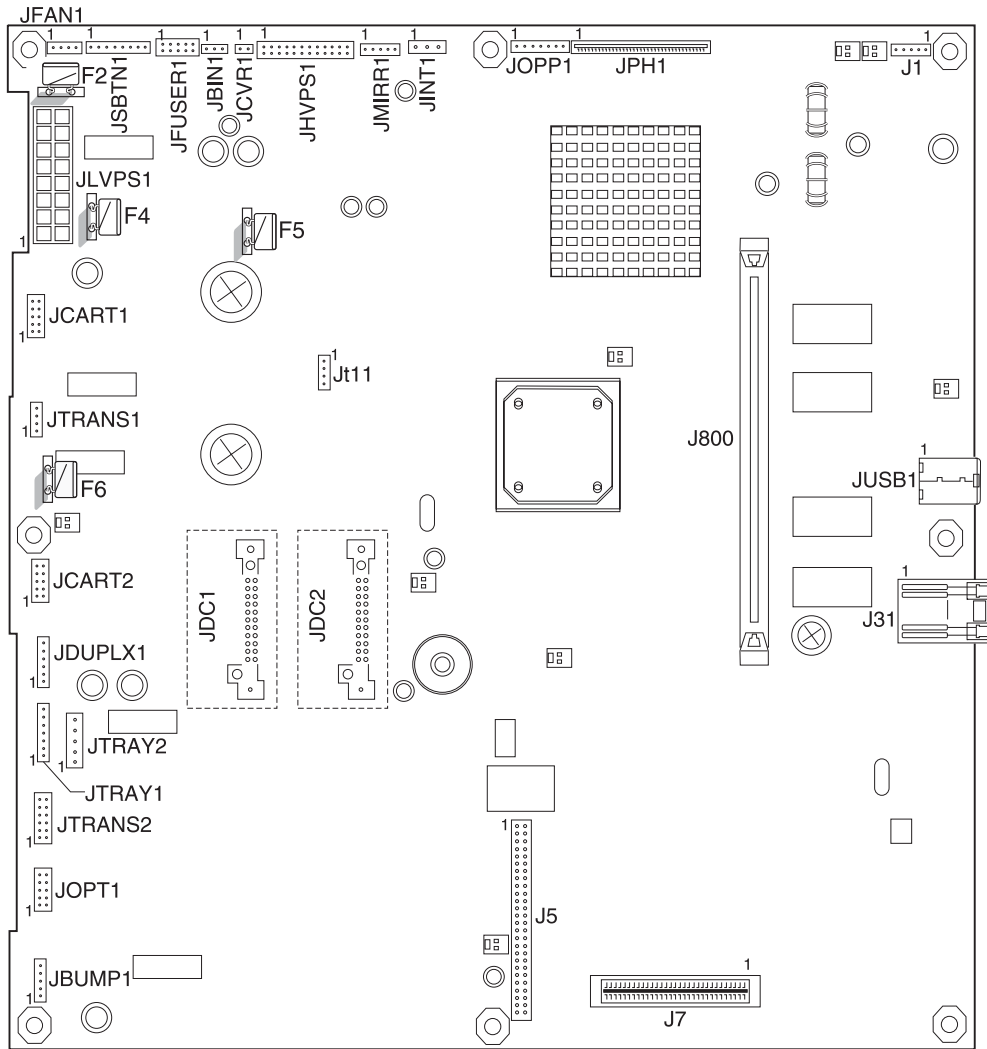

Connector listing—models C53x

(see “System card (network)—models C53x” on page 5-18)

Connector	Pin no.	Signal	Pin no.	Signal		
J1	1	V FHUSB_+5				
	2	JB_USB_RD-				
	3	JB_USB_RD+				
	4	Ground				
	5	Ground				
JBIN1	1	V_BF (+5 SW)				
	2	S_BIN_FB				
	3	Ground				
JBUMP1	1	VS_BUMP_LED				
	2	S_BUMP_ENC				
	3	Ground				
	4	V_BUMP_M-				
	5	V_BUMP_M+				
JCART1	1	CART1_HALL_U			2	CART1_HALL_V
	3	CART2_HALL_U			4	CART1_FG
	5	Ground	6	+5V_SW		
	7	N/C	8	V_CART1_WIND_U		
	9	V_CART1_WIND_V	10	V_CART1_WIND_W		
JCART2	1	CART2_HALL_U	2	CART2_HALL_V		
	3	CART2_HALL_W	4	CART2_FG		
	5	Ground	6	+5V_SW		
	7	N/C	8	V_CART2_WIND_U		
	9	V_CART2_WIND_V	10	V_CART2_WIND_W		
JCVR1	1	V_24V_CVR				
	2	COVER_OPEN_SNS				
JDUPLX1	1	VS_DUPLX (+5 V)				
	2	DUPLEX_PWM				
	3	DUPLEX_ENC				
	4	Ground				
	5	V_24VD				
	6	Ground				
JFAN1	1	FAN_FG				
	2	Ground				
	3	+24VC				
	4	FAN1_PWM				

Connector listing—models C53x

(see “System card (network)—models C53x” on page 5-18) (continued)

Connector	Pin no.	Signal	Pin no.	Signal
JFUSER1	1	V_FUSER_M+	2	V_FUSER_M-
	3	VS_FUSER_LED	4	S_FUSER_ENC
	5	Ground	6	GND/BR_THERM
	7	FUSER_EXIT_SNSD	8	VS_FUSER+5V
	9	FUSER_HR_SNS	10	FUSER_HR_THM_RTN
JHVPS1	1	Ground	2	V_24VD
	3	HV_EMPTY_C	4	HV_EMPTY_M
	5	HV_EMPTY_Y	6	HV_EMPTY_K
	7	Ground	8	+5V_SW
	9	TONER_C	10	TONER_M
	11	TONER_Y	12	TONER_K
	13	HV_CHRG_PWM	14	TONER_CHK
	15	HV_XFER_PWM_C	16	XFER_SERV0_C
	17	HV_XFER_PWM_M	18	XFER_SERV0_M
	19	HV_XFER_PWM_Y	20	XFER_SERV0_Y
	21	CORE_CURR_SNSD	22	HVPS_ID
	23	HV_XFER_PWM_K	24	XFER_SERV0-K
JINT1	1	VS_JINT-1 (+5V_SW)		
	2	Ground		
	3	VS_INT (+5V_PH)		
JLVPS1	1	+5 V dc	2	+5 V dc
	3	+5 V dc	4	+5 V dc
	5	LVPS_ZERO_XING	6	+24 V dc
	7	+24 V dc	8	+24 V dc
	9	Ground	10	Ground
	11	Ground	12	Ground
	13	Ground	14	Ground
	15	LVPS_BRON	16	LVPS_HRON
JMIRR1	1	MM_REF		
	2	MM_LOCK		
	3	MM_START		
	4	Ground		
	5	+24 V dc		
JOPT1	1	VS_JOPT-1 (+5V_SW)	2	SERIAL_TRANSMIT
	3	S_OPT_ENC	4	OPT_TYPE
	5	Ground	6	Ground
	7	+24VC	8	OPT_PSIZE
	9	OPT_PLEV	10	OPT_PCTL

Connector listing—models C53x

(see “System card (network)—models C53x” on page 5-18) (continued)

Connector	Pin no.	Signal	Pin no.	Signal
JOPP1	1	I2C_DATA5_OP		
	2	V_PANEL+5V		
	3	I2C_CLK_OP		
	4	Ground		
	5	I2CIRQ5_R		
	6	+3.3 V dc		
	7	Ground		
JPH1	1	Ground		
	2	D_VDO_C-		
	3	D_VDO_C+		
	4	Ground		
	5	D_VDO_Y-		
	6	D_VDO_Y+		
	7	Ground		
	8	PH_EMS1_SNS_R		
	9	VDO_BOOST1		
	10	VDO_LPOW1		
	11	VDO_LADJ01		
	12	VDO_HADJ01		
	13	PH_EMS0		
	14	VDO_BOOST0		
	15	VDO_LPOW0		
	16	VS_+5VPH_NVX_R		
	17	PH_EOS_THERM_SNS		
	18	+5V_PH		
	19	I2C_CLK_PH		
	20	I2C_DATA_PH		
	21	VDO_LENA		
	22	PH_EMS2_SNS_R		
	23	VDO_BOOST2		
	24	VDO_LPOW2		
	25	VDO_LADJ23		
	26	VDO_HYSNC1		
	27	PH_EMS3_SNS_R		
	28	VDO_BOOST3		
	29	VDO_LPOW3		
	30	Ground		

Connector listing—models C53x

(see “System card (network)—models C53x” on page 5-18) (continued)

Connector	Pin no.	Signal	Pin no.	Signal
JPH1 (continued)	31	D_VDO_K-		
	32	D_VDO_K+		
	33	Ground		
	34	D_VDO_M-		
	35	D_VDO_M+		
	36	Ground		
JSBTN1	1	S_SB_Y		
	2	S_SB_K		
	3	S_SB_M		
	4	S_SB_C		
	5	Ground		
	6	I2C_DATA_SB		
	7	I2C_CLK_SB		
	8	+3.3 V dc		
JTRANS1	1	V_TRANS_PHA+		
	2	V_TRANS_PHA-		
	3	V_TRANS_PHB+		
	4	V_TRANS_PHB-		
JTRANS2	1	VS_5V_TPS	2	V_JTRANS-9 (+3.3V)
	3	TPS_SNS	4	TPS_PWM1
	5	TPS_SNS_RTN	6	TPS_THERM_SNS
	7	Ground	8	I2C_CLK_TB
	9	I2_DATA_TB	10	V_TRANS-1 (+3.3V)
	11	Ground	12	N/C
JTRAY1	1	VS_TRAY_INPT_LED (+5V)		
	2	S_TRAY_INPUT		
	3	Ground		
	4	VS_TRAY+5V_NMT		
	5	TRAY_NMT (+3.3v)		
	6	Ground		
	7	N/C		
JTRAY2	1	VS_TRAY_ENC_LED		
	2	S_TRAY_ENC		
	3	Ground		
	4	V_TRAY_PICK_M-		
	5	V_TRAY_PICK_M+		

Wiring diagrams

Wiring diagrams are attached to the end of this document. Diagrams are designed for 11 x 17 in. or A3 paper. Print the individual wiring diagram pages separately on larger paper for best effect.

6. Preventive maintenance

Scheduled maintenance

The operator panel displays 80 Replace Fuser at 120K page count interval. The fuser assembly and the transfer roll should be changed at this interval to maintain the print quality and reliability of the printer. The following maintenance items are available for the customer:

Maintenance items

Description	Part number	
	Lexmark C52x models	Lexmark C53x models
Fuser assembly, 115 V	40X1400	40X3569*
Fuser assembly, 230 V	40X1402	40X3570*
Fuser assembly, 100 V	40X1403	40X3571*
Transfer belt assembly	40X1401	40X3572
* Also can be used in models C52x.		

7. Parts catalog

How to use this parts catalog

The following legend is used in the parts catalog:

Asm-Index	Part number	Units/mach	Units/FRU	Description
-----------	-------------	------------	-----------	-------------

- **Asm-index:** identifies the assembly and the item in the diagram. For example, 3-1 indicates Assembly 3 and the item number 1.
- **Part number:** identifies the unique number that identifies this FRU.
- **Units/mach:** refers to the number of units actually used in the base printer or product.
- **Units/FRU:** refers to the number of units packaged together and identified by the part number.
- **NS:** (Not shown) in the Asm-Index column indicates that the part is procurable but is not pictured in the illustration.

Model information used in the parts catalog.

Model name	Configuration	Machine type
Lexmark C520n	Network	5022-010
Lexmark C522n	Network	5022-210
Lexmark C524	Non-network	5022-400
Lexmark C524n	Network	5022-410
Lexmark C524dn	Network	5022-430
Lexmark C530dn	Duplex, network	5022-130
Lexmark C532n	Network	5022-310
Lexmark C532dn	Duplex, network	5022-330
Lexmark C534n	Network	5022-510
Lexmark C534dn/dtn	Duplex, network (550-sheet tray)	5022-530

Assembly 1: Covers

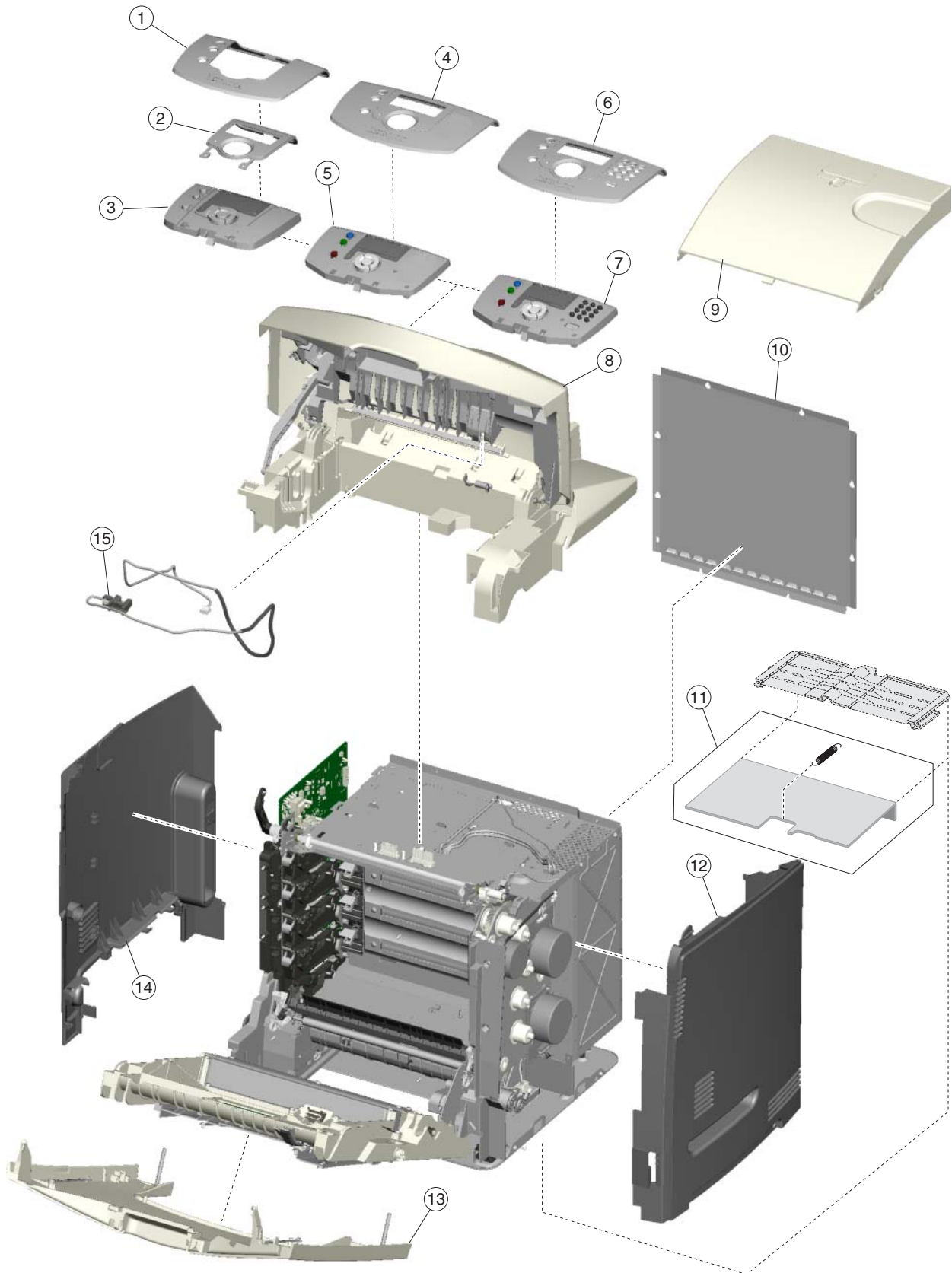

Assembly 1: Covers

Index	P/N	Units/ mach	Units/ FRU	Description
1-1	40X1415	1	1	Outer bezel, C52x
2	40X1448	1	1	Inner bezel, C524/C524n/C524dn
2	40X1449	1	1	Inner bezel, C522n
2	40X1450	1	1	Inner bezel, C520n
3	40X1414	1	1	Operator panel assembly, C52x
4	40X3608	1	1	Bezel, C530dn
4	40X3585	1	1	Bezel, C532n
4	40X3586	1	1	Bezel, C532dn
5	40X3582	1	1	Operator panel assembly, C530dn/C532n/C532dn
6	40X3587	1	1	Bezel, C534n
6	40X3588	1	1	Bezel, C534dn
7	40X3583	1	1	Operator panel assembly, C534n/C534dn
8	40X1451	1	1	Top access cover assembly (network), C520n/C522n/C524n/C524dn
8	40X1412	1	1	Top access cover assembly (non-network), C524
8	40X3604	1	1	Top access cover assembly (network), C532n/C534n
8	40X3605	1	1	Duplex top access assembly (network), C530dn/C532dn/C534dn
9	40X1422	1	1	Exit tray cover, C52x
9	40X3594	1	1	Exit tray cover, C53x
10	40X1427	1	1	Rear cover
11	40X3612	1		Paper tray dust cover with dust cover spring, C53x
12	40X1425	1	1	Right cover
13	40X1443	1	1	Front access door cover assembly (duplex), C524dn only
13	40X1413	1	1	Front access door cover assembly (non-duplex), C520n/C522n/C524/ C524n
13	40X3602	1	1	Front access door cover assembly (duplex), C530dn/C532dn/C534dn
13	40X3581	1	1	Front access door cover assembly (non-duplex), C532n/C534n
14	40X1426	1	1	Left cover
15	40X1440	1	1	Bin full sensor with cable, C520n/C522n/C524n/C524dn
15	40X3601	1	1	Bin full sensor with cable, C53x

Assembly 2: Front

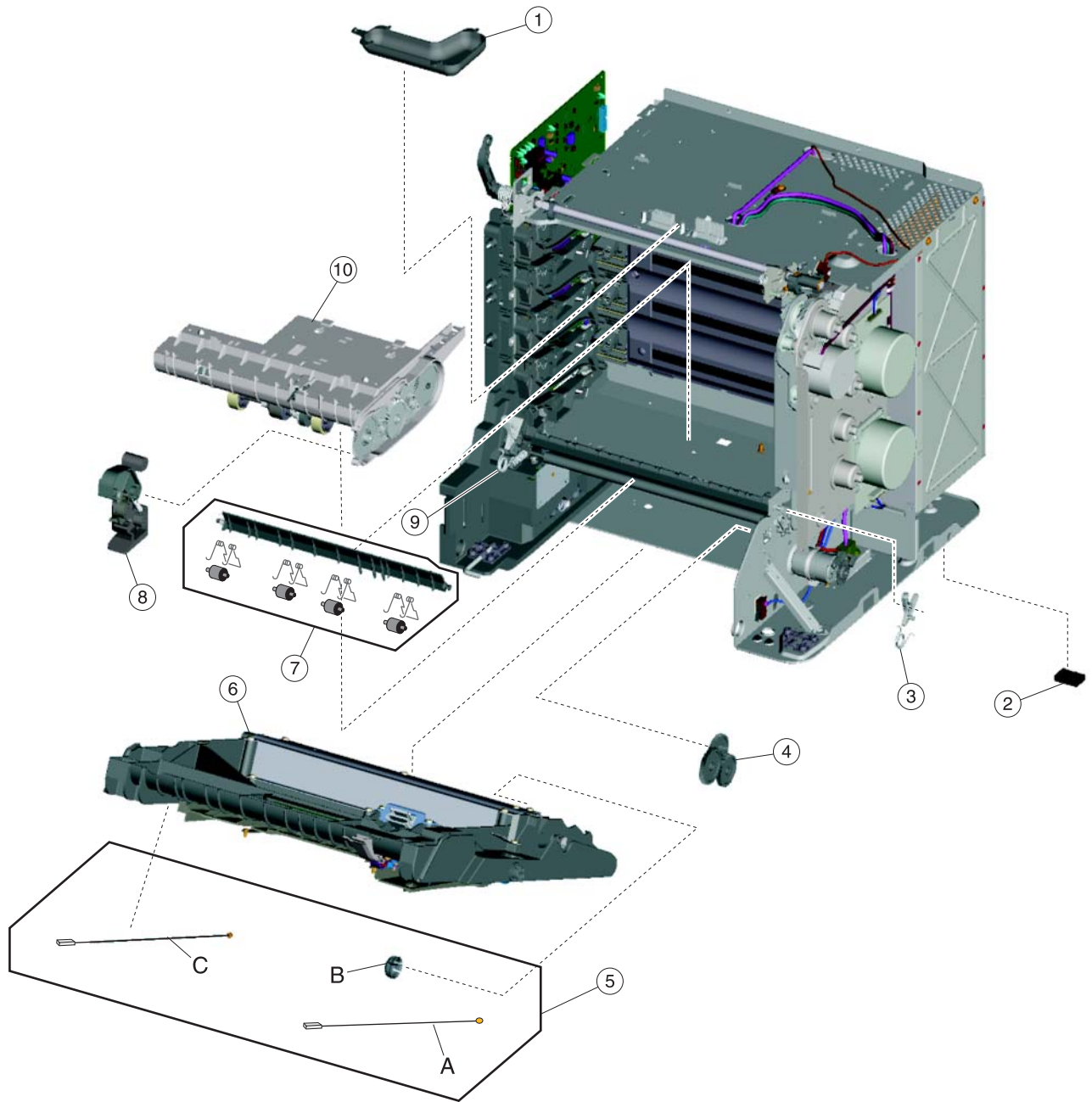

Assembly 2: Front

Index	P/N	Units/ mach	Units/ FRU	Description
2-1		1	1	Fuser cable cover, included in parts packet (P/N 40X1430), C52x
1		1	1	Fuser cable cover, included in parts packet (P/N 40X3598), C53x
2		4	1	Printer pad, included in parts packet, screws (P/N 40X1431)
3	40X1446	1	1	Right bellcrank assembly
4	40X1432	1	1	Bump aligner gear kit, including: <ul style="list-style-type: none"> • Align idler gear (1) • First reduction gear (1) • Second reduction gear (1) • Grease packet (1) • Washers (3)
5	40X1420	1	1	Front door parts packet, C52x, including <ul style="list-style-type: none"> • A—Right cable assembly (1) • B—Front door cap (1) • C—Left cable assembly (1)
5	40X3593	1	1	Front door parts packet, C53x, including <ul style="list-style-type: none"> • A—Right cable assembly (1) • B—Front door cap (1) • C—Left cable assembly (1)
6	40X1419	1	1	Duplex front door assembly, C524dn
6	40X1418	1	1	Front door assembly, C520n/C522n/C524n
6	40X3592	1	1	Duplex front door assembly, C530dn/C532dn/C534dn
6	40X3590	1	1	Front door assembly, C532n/C534n
7	40X3615	1	1	Deflector assembly, C53x
8	40X1435	1	1	MPF swing arm assembly, C52x
9	40X1447	1	1	Left bellcrank assembly
10	40X1405	1	1	Paper pick mechanism assembly, C52x
10	40X3573	1	1	Paper pick mechanism assembly, C53x

Assembly 3: Right

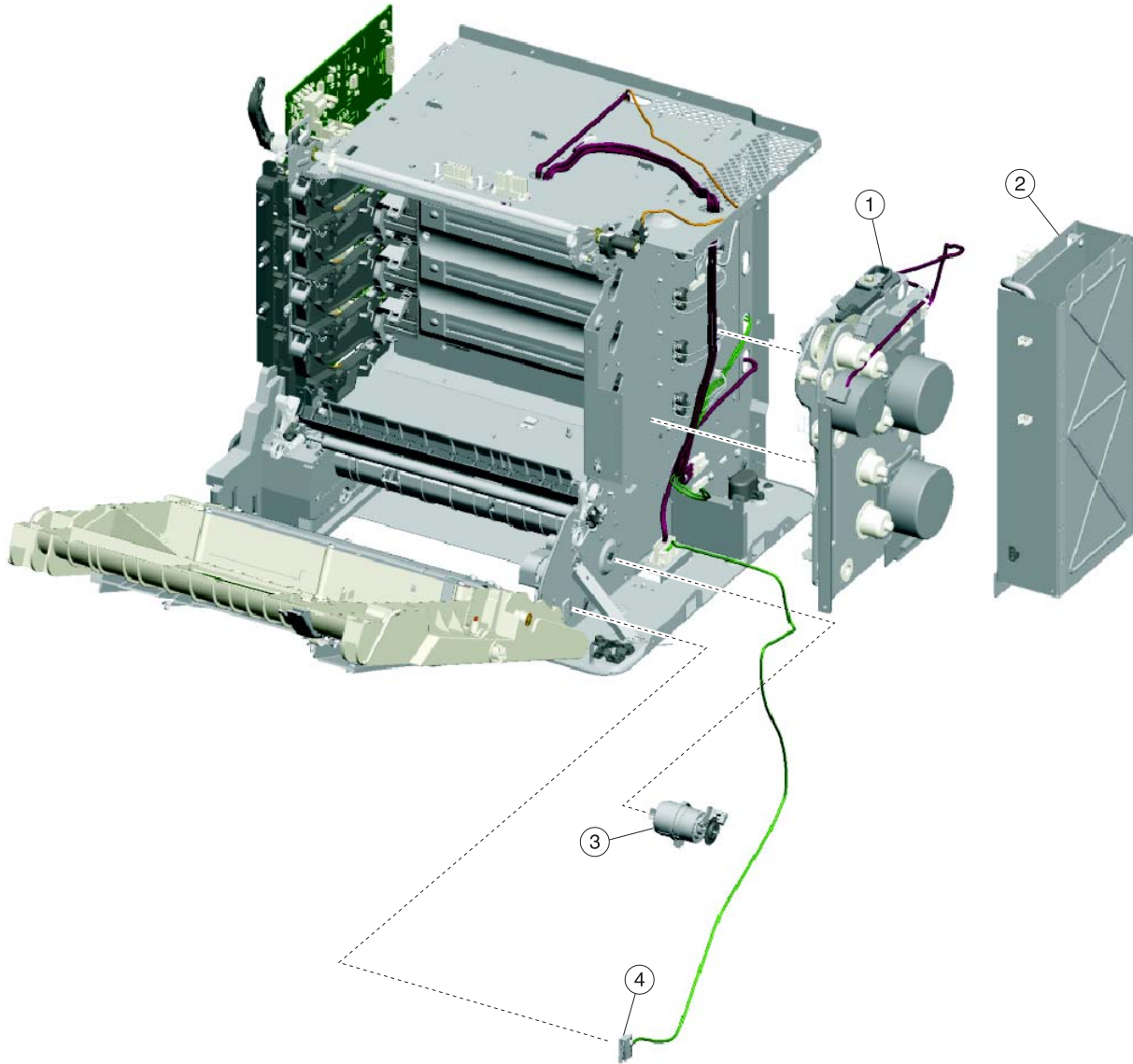

Assembly 3: Right

Index	P/N	Units/ mach	Units/ FRU	Description
3-1	40X1409	1	1	EP drive assembly, C52x
1	40X3578	1	1	EP drive assembly, C53x
2	40X3574	1	1	Low voltage power supply, 115/230 V
3	40X1433	1	1	Bump aligner motor
4	40X1436	1	1	Front door 5 V interlock switch
NS	40X1445	1	1	Ground contact plate, C52x only

Assembly 4: Rear

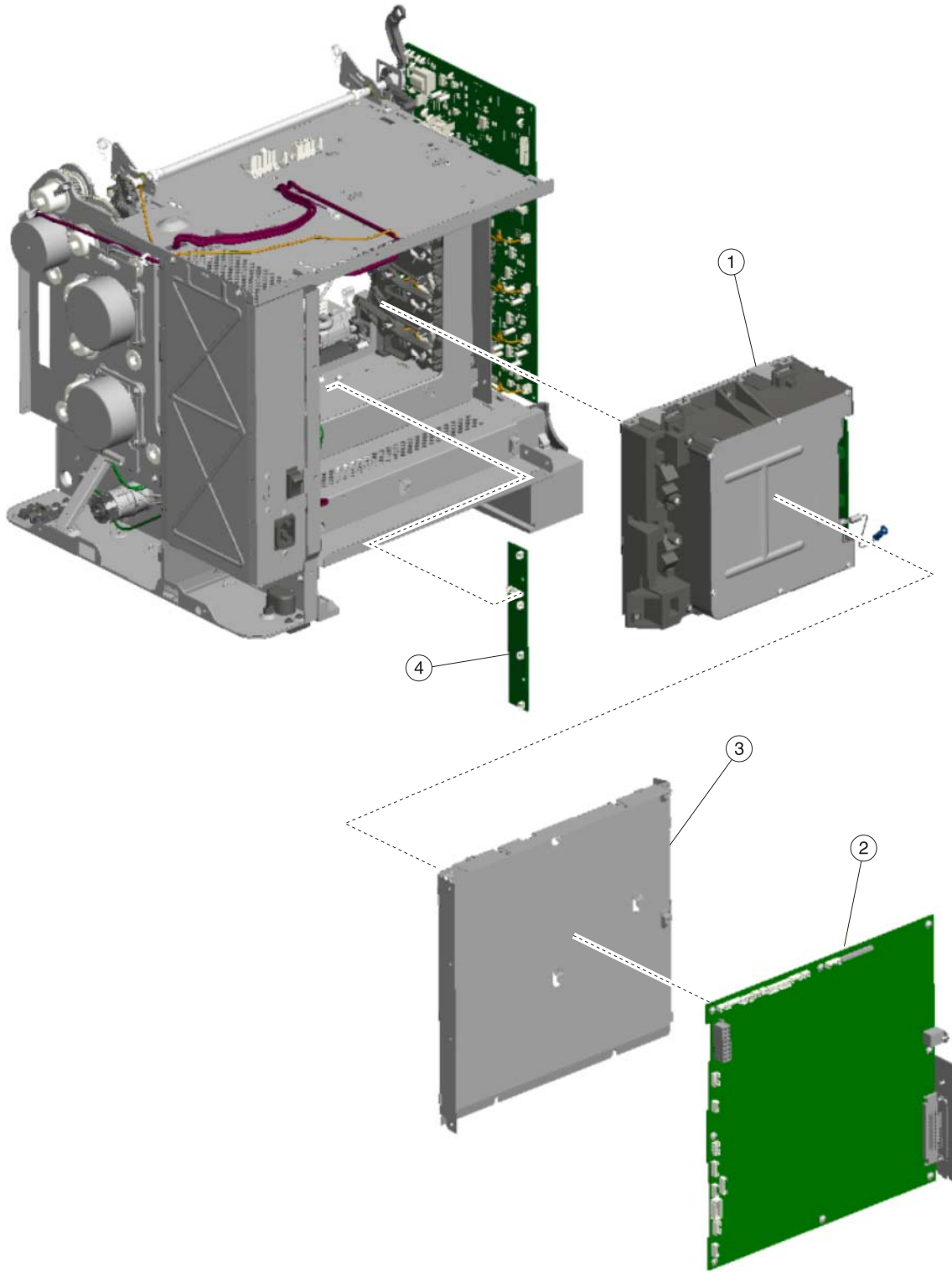

Assembly 4: Rear

Index	P/N	Units/ mach	Units/ FRU	Description
4-1	40X2167	1	1	Printhead assembly, C52x
1	40X2168	1	1	Printhead assembly, C53x
2	40X4218	1	1	System card (network), C524n/C524dn
2	40X4219	1	1	System card (network), C520n/C522n
2	40X4217	1	1	System card, C524
2	40X3616	1	1	System card (network), C530dn/C532n/C532dn
2	40X3617	1	1	System card (network), C534n
2	40X3618	1	1	System card (network), C534dn
3	40X1429	1	1	System card support shield, C52x
3	40X3597	1	1	System card support shield, C53x
4	40X1410	1	1	Smart chip card, C52x only

Assembly 5: Left

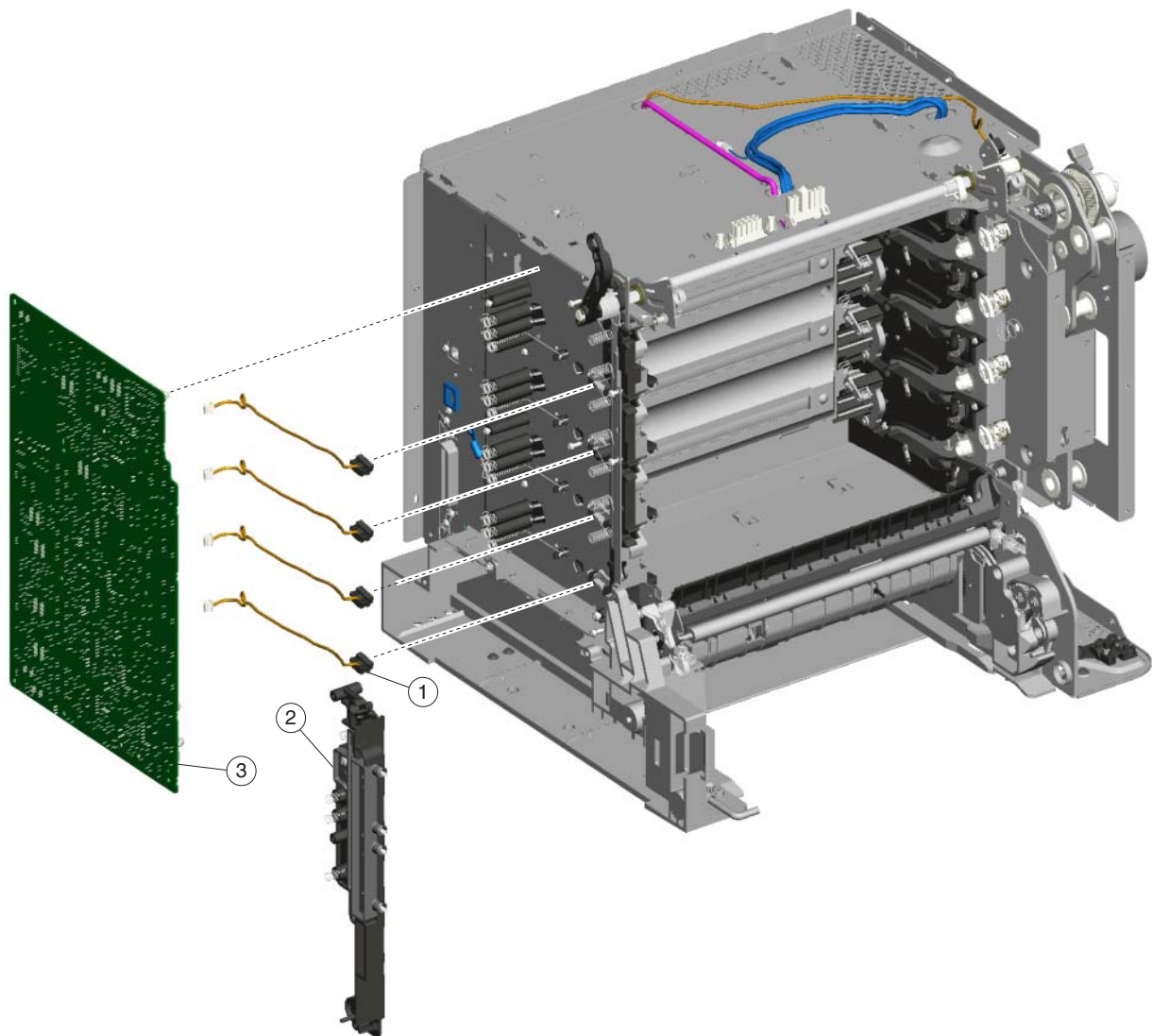

Assembly 5: Left

Index	P/N	Units/ mach	Units/ FRU	Description
5-1	40X1416	4	1	Toner level sensor
2	40X1428	1	1	Transfer contact assembly
3	40X1411	1	1	High voltage power supply, C52x
3	40X3579	1	1	High voltage power supply, C53x

Assembly 6: Top

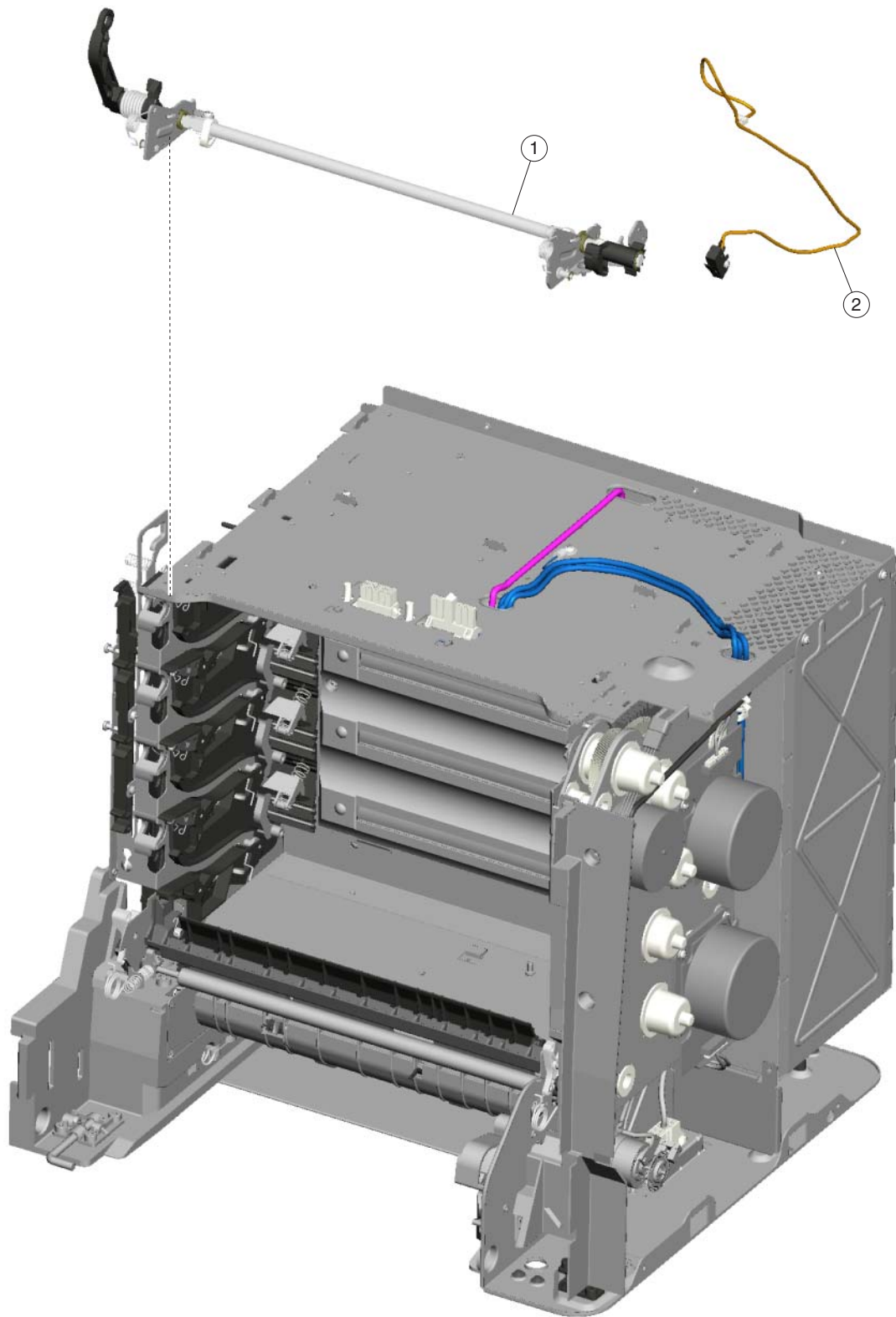

Assembly 6: Top

Index	P/N	Units/ mach	Units/ FRU	Description
6-1	40X3613	1	1	Top cover camshaft assembly
2	40X1437	1	1	Top access door 24 V interlock switch

Assembly 7: Customer replaceable units (CRUs)

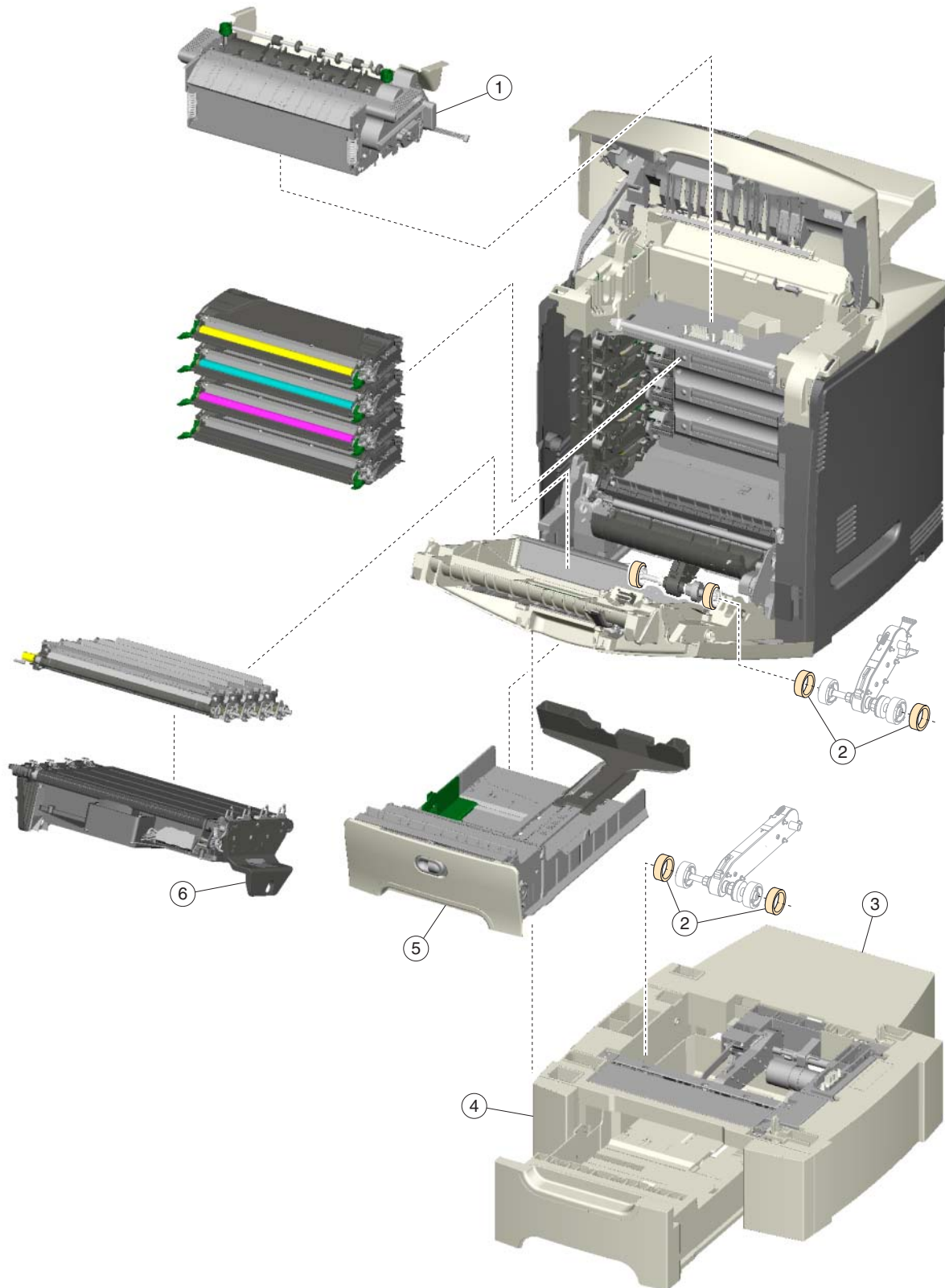

Assembly 7: CRUs

Index	P/N	Units/ mach	Units/ FRU	Description
7-1	40X1400	1	1	Fuser assembly, 115 V, C52x
1	40X1402	1	1	Fuser assembly, 230 V, C52x
1	40X1403	1	1	Fuser assembly, 100 V, C52x
1	40X3569	1	1	Fuser assembly, 115 V, C53x (also can be used in C52x)
1	40X3570	1	1	Fuser assembly, 230 V, C53x (also can be used in C52x)
1	40X3571	1	1	Fuser assembly, 100 V, C53x (also can be used in C52x)
2	40X3607	4	2	Pick arm roll
3	40X1439	1	1	Option tray assembly, 500-sheet option (includes tray), C522n/C524/ C524n/C524dn
3	40X3600	1	1	Option tray assembly, 550-sheet option (includes tray), C532n/C532dn/ C534n/C534dn
4	40X1423	1	1	Tray assembly, 500-sheet, C522n/C524/C524n/C524dn
4	40X3595	1	1	Tray assembly, 550-sheet, C532n/C532dn/C534n/C534dn
5	40X1404	1	1	MPF paper tray assembly, 250-sheet, C524/C524n/C524dn
5	40X1424	1	1	Paper tray assembly, single feeder, C520n/C522n
5	40X3599	1	1	MPF paper tray assembly, 250-sheet, C530dn/C532dn/C534dn
5	40X3596	1	1	Paper tray assembly, single feeder, C532n, C534n
6	40X1401	1	1	Transfer belt assembly, C52x
6	40X3572	1	1	Transfer belt assembly, C53x
NS	40X0297	1	1	Power cord—USA, Canada, Bolivia, Peru
NS	40X0288	1	1	Power cord—Argentina
NS	40X0296	1	1	Power cord—Australia, New Zealand
NS	40X0278	1	1	Power cord—Austria, Belgium, Catalan, Czechoslovakia, Finland, France, Germany, Greece, Hungary, Ireland, Italy, Netherlands, Norway, Paraguay, Poland, Portugal, Russia, Spain, Sweden, Turkey, United Kingdom
NS	40X0286	1	1	Power cord—Hong Kong, Ireland, United Kingdom
NS	40X3611	1	1	Power cord—Brazil
NS	40X0287	1	1	Power cord—Chile, Uruguay
NS	40X0282	1	1	Power cord—China
NS	40X0279	1	1	Power cord—Denmark, Finland, Norway, Sweden
NS	40X0275	1	1	Power cord—Israel
NS	40X3609	1	1	Power cord—Japan
NS	40X0280	1	1	Power cord—Korea
NS	40X0276	1	1	Power cord—South Africa
NS	40X0274	1	1	Power cord—Switzerland
NS	40X3610	1	1	Power cord—Taiwan

Assembly 8: Contact springs

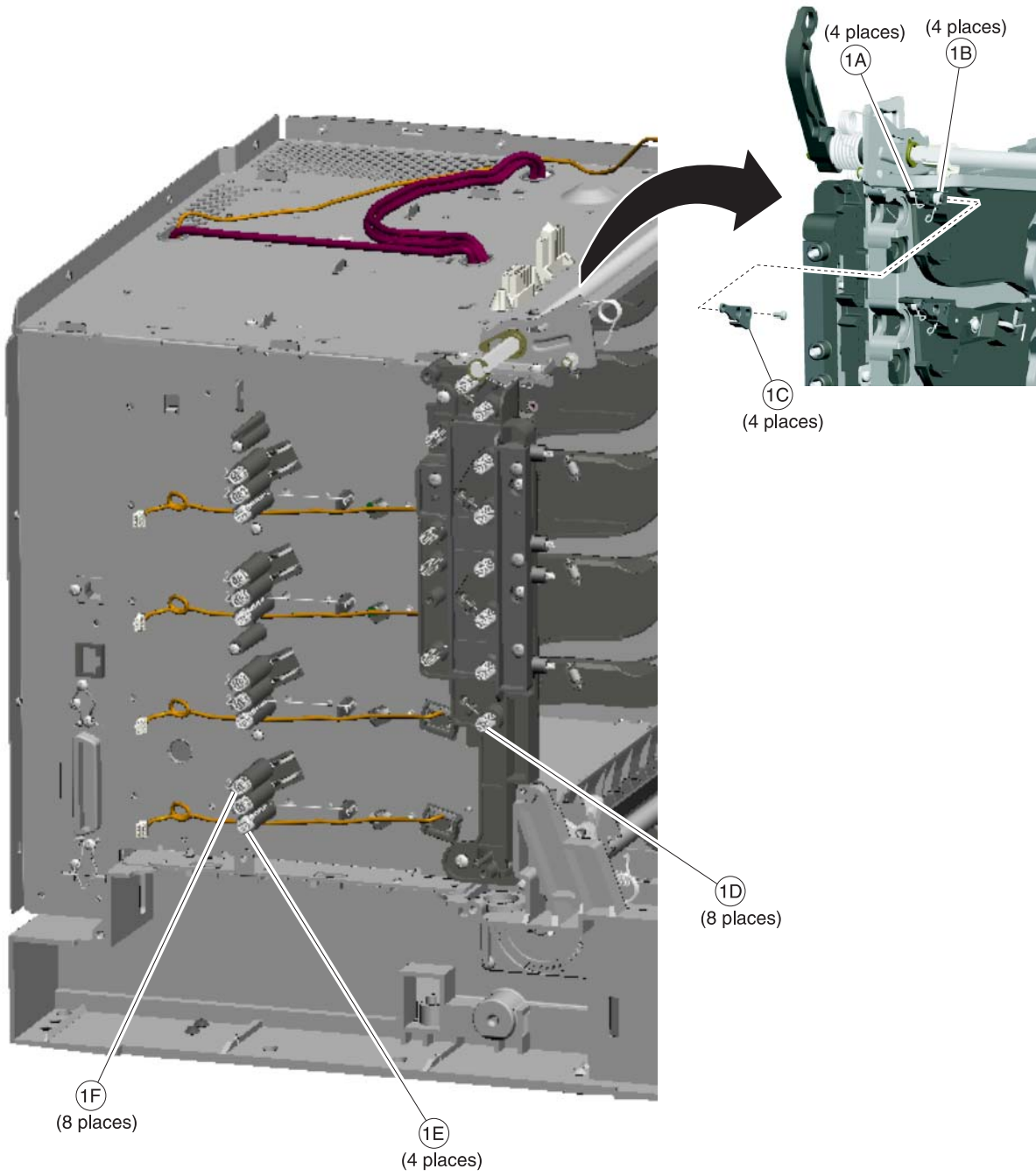

Assembly 8: Contact springs

Index	P/N	Units/ mach	Units/ FRU	Description
8-1	40X1434	1	1	Contact springs kit, including: <ul style="list-style-type: none">• A—Torsion PCD contact spring (4)• B—Torsion CR contact spring (4)• C—Contact spring cap (4)• D—Charge roll contact spring (8)• E—HVPS TAR contact spring (4)• F—HVPS doctor/developer contact spring (8)

Assembly 9: Cable parts packet

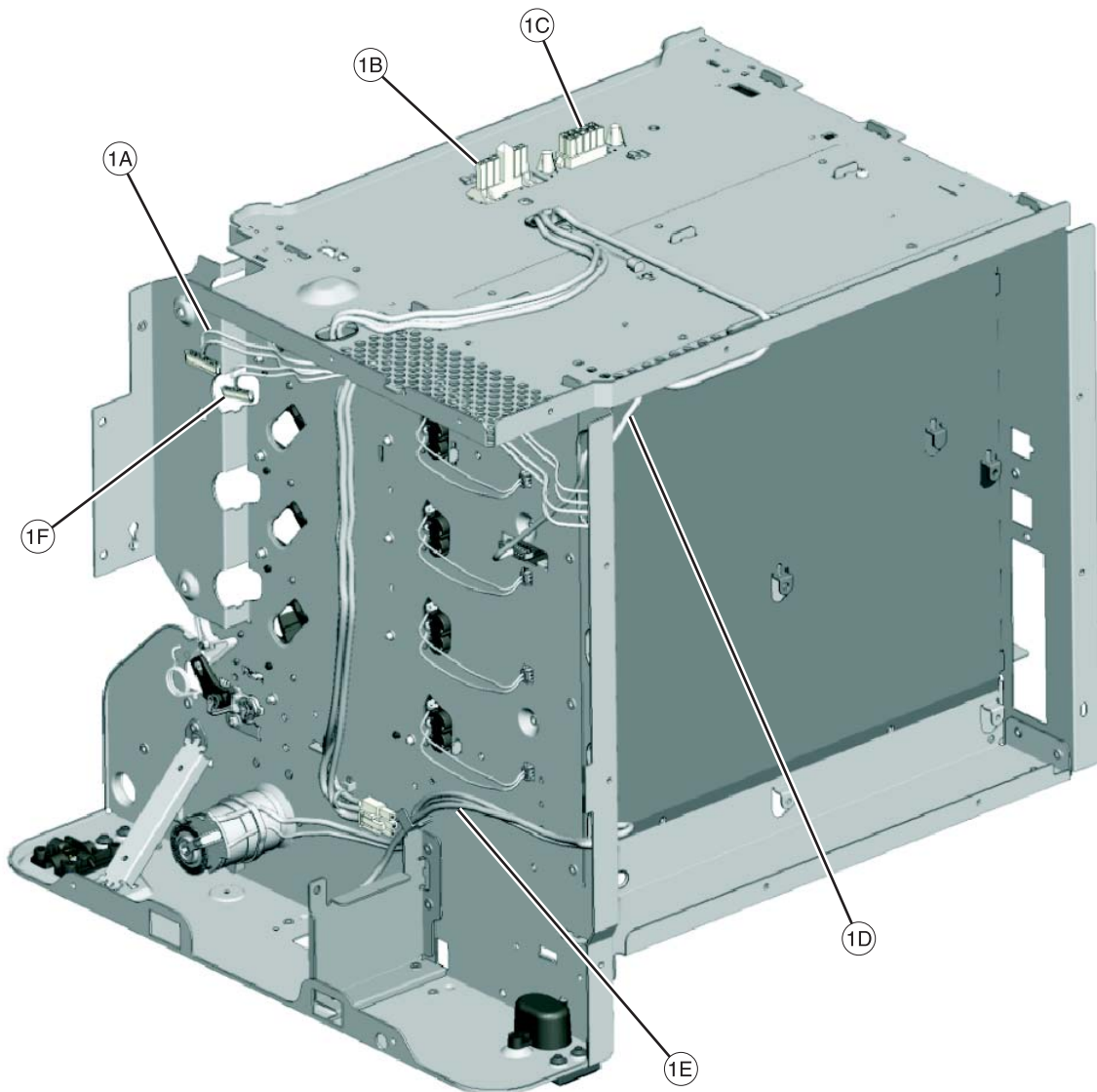

Assembly 9: Cable parts packet

Index	P/N	Units/ mach	Units/ FRU	Description
9-1	40X1430	1	1	Cables, C52x, including <ul style="list-style-type: none"> • A—Cartridge motor cable (1) • B—Fuser AC cable (1) • C—Fuser DC cable (1) • D—Smart chip cable (1) • E—Option cable (1) • Fuser cable cover (1) (see “Front” on page 7-4 for part identification and location) • Duplex cable (1)
2	40X3598	1	1	Cables, C53x, including <ul style="list-style-type: none"> • A—Cartridge motor cable (1) • B—Fuser AC cable (1) • C—Fuser DC cable (1) • E—Option cable (1) • F—Transport motor cable (1) • Fuser cable cover (1) (see “Front” on page 7-4 for part identification and location) • Duplex cable (1)

Assembly 10: Miscellaneous

Index	P/N	Units/ mach	Units/ FRU	Description
NS	40X1431	1	1	Parts packet, screw (contains one of each screw used in the printer, with the exception of the parts specifically called out.)
NS	40X1508	1	1	128 MB SDRAM, 100-pin
NS	40X1509	1	1	256 MB SDRAM, 100-pin
NS	40X1510	1	1	512 MB SDRAM, 100-pin
NS	40X1454	1	1	32 MB flash card
NS	40X1455	1	1	64 MB flash card
NS	40X1515	1	1	Korean font card
NS	40X1514	1	1	Traditional Chinese font card
NS	40X1513	1	1	Simplified Chinese font card
NS	40X1512	1	1	Japanese font card
NS	40X2664	1	1	Bar code card, C524/C524n/C524dn
NS	40X4653	1	1	Bar code card, C534n/C534dn
NS	40X4225	1	1	PrintCryption card, C524/C524n/C524dn
NS	40X4655	1	1	PrintCryption card, C534n/C534dn
NS	40X2663	1	1	Forms card, C524/C524n/C524dn
NS	40X4654	1	1	Forms card, C534n/C534dn
NS	40X1375	1	1	MarkNet N8000 fast ethernet print server, C524/C524dn
NS	40X1376	1	1	MarkNet N8020 gigabit ethernet print server, C524/C524dn/C534n/C534dn
NS	40X1377	1	1	MarkNet N8030 fiber ethernet print server, C524/C524dn/C534/C534dn
NS	40X1378	1	1	MarkNet N8050 802.11g wireless print server (US/Americas), C524/C524dn/C534n/C534dn
NS	40X1562	1	1	MarkNet N8050 802.11g wireless print server (rest of world), C524/C524n/C524dn/C534n/C534dn
NS	40X0291	1	1	Parallel 1284-B interface card adapter, C524/C524n/C524dn, C534n/C534dn
NS	40X0290	1	1	Serial interface card adapter, C524/C524n/C524dn./C534n/C534dn
NS	40X2610	1	1	40.0 GB hard disk assembly, C524n/C524dn/C534n/C534dn/C534dtn
NS	7377018	1	1	Printer relocation kit
NS	7377200	1	1	Options tray relocation kit

Index

Numerics

- 1xx service error codes **2-7-2-8**
- 24 V interlock switch
 - locations **5-6**
 - parts catalog **7-12**
 - removal **4-98**
 - theory **3-55**
- 2xx paper jam codes **2-8-2-15**
- 3x-8x attendance messages **2-19-2-26**
- 5 V interlock switch
 - locations **5-3**
 - parts catalog **7-6**
 - removal **4-54**
 - theory **3-54**
- 9xx service error codes **2-15-2-18**

A

- accessing service menus **3-1**
- acronyms **1-14**
- adjustments **4-3**
- Align Motor Test **3-8**
- alignment
 - diagnostics menu **3-7**
 - printhead **4-3**
- Auto Align Adj **3-23**
- Auto Color Adj **3-23**

B

- bellcrank
 - left bellcrank **4-64**
 - parts catalog **7-5**
 - right bellcrank **4-90**
- bezel
 - inner—C52x **4-22, 7-2**
 - outer—C52x **4-21, 7-2**
 - parts catalog **7-2**
 - removal **4-21**
- bin full sensor
 - Bin Full Test **3-15**
 - parts catalog **7-12**
 - removal—C52x **4-37**
 - removal—C53x **4-38**
- Bin Full Test **3-15**
- Black Only Mode **3-21**
- bump aligner gear
 - parts catalog **7-4**
 - removal **4-39**
- bump aligner motor
 - locations **5-3**
 - parts catalog **7-6**
 - removal **4-40**
- Button Test **3-11**
- buttons
 - description **2-2**
 - parts catalog (operator panel) **7-2**

C

- cables, parts catalog **7-18**
 - CACHE Test **3-12**
 - card stock **1-9**
 - Color Alignment **3-24**
 - Color Lock Out **3-21**
 - Color Trapping **3-21**
 - configuration ID **3-16**
 - configuration menu
 - accessing **3-1**
 - Auto Align Adj **3-23**
 - Auto Color Adj **3-23**
 - available tests **3-20**
 - Color Alignment **3-24**
 - Color Lock Out **3-21**
 - Color Trapping **3-21**
 - Demo Mode **3-22**
 - Disk Encryption **3-25**
 - Download Emuls **3-22**
 - Duplex Gloss **3-25**
 - Energy Conserve **3-23**
 - Enforce Color Order **3-24**
 - Env Prompts **3-25**
 - Event Log **3-23**
 - exit Config Menu **3-26**
 - Factory Defaults **3-22**
 - Font Sharpening **3-26**
 - Jobs on Disk **3-25**
 - Motor Calibration **3-24**
 - Panel Menus **3-22**
 - Paper Prompts **3-24**
 - PPDS Emulation **3-22**
 - Prt Quality Pages **3-21**
 - Reset Fuser Cnt **3-21**
 - Size Sensing **3-22**
 - connectors **5-11**
 - network system card **5-11**
 - parallel system card **5-12**
 - system card—models C52x (network) **5-11**
 - system card—models C52x (non-network) **5-12**
 - system card—models C53x (network) **5-18**
 - contact springs
 - parts catalog **7-16**
 - removal **4-44**
 - covers
 - identification **4-14**
 - locations **5-1**
 - parts catalog **7-2**
- ## D
- dead printer service check **2-51**
 - defaults **3-16**
 - EP Defaults **3-17**
 - factory defaults **3-22**

- deflector assembly
 - parts catalog **7-4**
 - removal **4-46**
- Demo Mode **3-22**
- diagnostic aids **3-1**
- diagnostics menu
 - accessing **3-1**
 - ALIGNMENT **3-7**
 - available tests **3-2**
 - Base Sensor Test
 - Bin Full Test **3-15**
 - Sensor Test **3-15**
 - Duplex Tests
 - Motor Test **3-14**
 - Print Test (duplex) **3-13**
 - Quick Test **3-12**
 - Top Margin **3-14**
 - Event Log
 - Clear Log **3-19**
 - Display Log **3-18**
 - Print Log **3-18**
 - exit diagnostics **3-19**
 - Hardware Tests
 - Button Test **3-11**
 - CACHE Test **3-12**
 - DRAM Test **3-11**
 - Panel Test **3-11**
 - Input Tray Tests **3-14**
 - Motor Tests
 - Align Motor Test **3-8**
 - Bottom cartridge **3-8**
 - Fuser **3-8**
 - Mirror Motor Test **3-8**
 - Motor Calibration **3-9**
 - Servo Laser Test **3-9**
 - Top cartridge **3-8**
 - Transfer **3-8**
 - Tray 1 **3-8**
 - Tray 2 **3-8**
 - Print Tests
 - input source tests **3-9**
 - Prt Quality Pgs **3-10**
 - Printer Setup
 - Configuration ID **3-16**
 - DC Charge Adjust **3-17**
 - Defaults **3-16**
 - Dev Bias Adj **3-17**
 - Engine Setting 1–4 **3-16**
 - EP Defaults **3-17**
 - Fuser Temp **3-17**
 - Model Name **3-16**
 - Page Counts **3-16**
 - Serial Number **3-16**
 - Transfer Adjust **3-17**
 - REGISTRATION **3-4**
 - Bottom Margin **3-5**
 - Left Margin **3-5**
 - Quick Test **3-6**
 - Right Margin **3-5**
 - Skew **3-4**
 - Top Margin **3-5**
 - dimensions **1-5**
 - Disk Encryption **3-25**
 - DRAM Test **3-11**
 - duplex
 - Motor Test **3-14**
 - Print Test **3-13**
 - Quick Test **3-12**
 - theory **3-41**
 - Top Margin **3-14**
 - Duplex Gloss **3-25**

E

 - electrical interlock **3-54**
 - 24 V interlock switch **3-55**
 - 5 V interlock switch **3-54**
 - electrophotographic (EP) drive assembly
 - locations **5-3**
 - parts catalog **7-6**
 - removal—C52x **4-48**
 - removal—C53x **4-51**
 - electrophotographic (EP) process **3-44**
 - charging **3-46**
 - cleaning **3-53**
 - developing **3-50**
 - exposing **3-49**
 - fusing **3-52**
 - main components **3-44**
 - transferring **3-51**
 - Energy Conserve **3-23**
 - Enforce Color Order **3-24**
 - engine setting **3-16**
 - Env Prompts **3-25**
 - envelopes **1-8**
 - error codes and messages
 - 1xx service error codes **2-7–2-8**
 - 9xx service error codes **2-15–2-18**
 - error codes and messages2xx paper jams **2-8–2-15**
 - error codes and messages3x–8x attendance messages **2-19–2-26**
 - ESD-sensitive parts **4-1**
 - event log
 - configuration menu **3-23**
 - diagnostics mode **3-18**
 - exit sensor
 - service check **2-52**

F

 - Factory Defaults **3-22**
 - Font Sharpening **3-26**
 - front door assembly
 - front cable removal **4-59**
 - parts catalog **7-4**
 - removal **4-55**
 - fuser
 - locations **5-7**
 - motor test **3-8**
 - parts catalog **7-14**

- removal **4-60**
 - Reset Fuser Cnt **3-21**
 - Fuser Motor Test **3-8**
- ## H
- high voltage power supply (HVPS)
 - locations **5-5**
 - parts catalog **7-10**
 - removal **4-62**
 - how to use this parts catalog **7-1**
- ## J
- jams
 - common messages (diagram) **3-27**
 - paper jam messages **2-8**
 - paper path **3-30**
 - Jobs on Disk **3-25**
- ## L
- labels **1-9**
 - locations
 - cards **5-10**
 - covers **5-1**
 - CRUs and FRUs **5-7**
 - front **5-2**
 - left **5-5**
 - machine type label **1-13**
 - motors **5-9**
 - printer cards **5-10**
 - rear **5-4**
 - right **5-3**
 - sensors **5-8**
 - serial number label **1-13**
 - top **5-6**
 - low voltage power supply (LVPS)
 - locations **5-3**
 - parts catalog **7-6**
 - removal **4-65**
- ## M
- machine type tag location **1-13**
 - maintenance approach **1-1**
 - mechanical drive
 - bump aligner drive **3-38**
 - duplex drive **3-41**
 - fuser drive **3-40**
 - paper pick mechanism drive **3-37**
 - photoconductor unit/toner cartridge drive **3-39**
 - transfer belt drive **3-40**
 - media
 - input and output capacities **1-12**
 - selecting
 - preprinted forms and letterhead **1-7**
 - storing **1-10**
 - supported media size **1-10**
 - supported media weight **1-11**
 - using
 - card stock **1-9**
 - envelopes **1-8**
 - labels **1-9**
 - letterhead **1-8**
 - transparencies **1-8**
 - media specifications
 - input and output capacities **1-12**
 - print area **1-12**
 - selecting media **1-6**
 - supported sizes **1-10**
 - using media **1-8**
 - weight **1-12**
 - memory **1-2**
 - menus
 - accessing service menus **3-1**
 - user menus **2-4**
 - Mirror Motor Test **3-8**
 - Model Name **3-16**
 - models **1-1, 7-1**
 - Motor Calibration **3-24**
 - Motor Calibration Test **3-9**
 - motors
 - locations **5-9**
 - MPF swing arm assembly—C52x
 - parts catalog **7-4**
 - removal **4-67**
- ## O
- operator panel
 - description **2-2**
 - indicator light **2-2**
 - locations **5-1**
 - parts catalog **7-2**
 - service check **2-53**
 - display all diamonds, 5 beeps **2-54**
 - display all diamonds, no beeps **2-54**
 - display blank, 5 beeps, LED off **2-53**
 - display blank, 5 beeps, LED on **2-54**
 - one or more buttons fail **2-53**
 - options and features
 - description **1-1**
 - parts catalog **7-20**
- ## P
- Panel Menus **3-22**
 - Panel Test **3-11**
 - paper
 - selecting
 - preprinted forms and letterhead **1-7**
 - storing **1-10**
 - supported media weight **1-10, 1-11**
 - using
 - card stock **1-9**
 - envelopes **1-8**
 - labels **1-9**
 - letterhead **1-8**
 - paper jams
 - error locations **3-27**
 - manual feeder **3-28**
 - multipurpose feeder **3-28**
 - paper path
 - diagram **3-30, 3-31**
 - main components **3-32**

- mechanical drive **3-37**
- paper sensing **3-42**
- print media transport **3-33**
- paper pick mechanism
 - parts catalog **7-4**
 - removal **4-68**
- Paper Prompts **3-24**
- paper sensing
 - paper exit/duplex entry sensor and bin full flag **3-43**
 - paper pick sensor **3-42**
- parts catalog
 - cable parts packet **7-18**
 - contact springs **7-16**
 - CRUs **7-14**
 - front **7-4**
 - left **7-10**
 - miscellaneous **7-20**
 - rear **7-8**
 - right **7-6**
 - top **7-12**
- Perm Page Count **3-16**
- photoconductor unit **4-2**
 - handling **4-2**
 - installation **4-70**
 - locations **5-7**
 - parts not to be touched **4-2**
 - removal **4-70**
 - transportation/storage **4-2**
- Pick roll tires, replacement **4-71**
- power cords **7-15**
- power-on self test (POST) sequence **2-5**
- PPDS Emulation **3-22**
- print area **1-12**
- print quality
 - background **2-55**
 - blank page **2-56**
 - blurred or fuzzy print **2-59**
 - half-color page **2-59**
 - horizontal banding **2-59**
 - horizontal line **2-59**
 - insufficient fusing **2-59**
 - missing image at edge **2-59**
 - mottle (2 - 5mm speckles) **2-59**
 - narrow vertical line **2-59**
 - random marks **2-60**
 - residual image **2-60**
 - solid color page **2-61**
 - vertical banding **2-62**
- printer pads
 - parts catalog **7-4**
 - removal **4-73**
- printhead
 - locations **5-4**
 - parts catalog **7-8**
 - removal **4-74**
- printhead alignment **4-3**
- Prt Color Pg Count **3-16**
- Prt Mono Pg Count **3-16**

- Prt Quality Pgs
 - configuration menu **3-21**
 - diagnostic menu **3-10**

Q

- Quick Test (duplex) **3-12**

R

- removal and cleaning precautions **4-1**
- removals
 - bin full sensor **4-38**
 - bin full sensor removal **4-37**
 - bump aligner gear **4-39**
 - bump aligner motor **4-40**
 - bump aligner rollers and springs—C53x **4-42**
 - contact springs **4-44**
 - covers
 - exit tray cover **4-15**
 - front access cover assembly **4-16**
 - gearbox shield **4-19**
 - left cover **4-20**
 - operator panel assembly **4-23**
 - operator panel inner bezel—C52x **4-22**
 - operator panel outer bezel **4-21**
 - rear cover **4-25**
 - right cover **4-26**
 - top access cover assembly—C52x **4-28**
 - top access cover assembly—C53x **4-32**
 - deflector assembly—C53x only **4-46**
 - electrophotographic (EP) process drive assembly—C52x **4-48**
 - electrophotographic (EP) process drive assembly—C53x **4-51**
 - front access door 5 V interlock switch **4-54**
 - front door assembly **4-55**
 - front door assembly restraint cable **4-59**
 - fuser **4-60**
 - fuser cable cover **4-61**
 - high voltage power supply (HVPS) **4-62**
 - left bellcrank **4-64**
 - low voltage power supply (LVPS) **4-65**
 - paper pick mechanism assembly **4-68**
 - paper tray dust cover **4-24**
 - photoconductor unit **4-70**
 - pick roll rubber tires **4-71**
 - precautions **4-13**
 - printer pad **4-73**
 - printhead **4-74**
 - right bellcrank **4-90**
 - smart chip card—C52x **4-91**
 - system card **4-92**
 - system card support shield **4-94**
 - toner level sensor **4-96**
 - top access door 24 V interlock switch **4-98**
 - top cover camshaft assembly **4-99**
 - transfer belt **4-103**
 - transfer contact assembly **4-104**
 - waste toner assembly **4-105**
- Reset Fuser Cnt **3-21**
- restraint cable, removal **4-59**

Ssafety information **xv**

sensors

bin full **7-12**exit sensor service check **2-52**input sensor service check **2-52**locations **5-8**theory **3-42**toner level **4-96, 7-10**

serial number

location **1-13**viewing **3-16**

service checks

110.xx—Mirror motor **2-27**111.xx–114.xx—Printhead error **2-27**120.01, 120.02, 120.08–120.10, 120.13–120.15—
Fuser error **2-28**120.03—Fuser error **2-30**120.04–120.07—Fuser error **2-30**140.xx—Autocomp motor error **2-32**142.xx—fuser motor error **2-33**143.xx—EP drive asm top cartridge motor **2-34**144.xx—EP drive asm bottom cartridge) motor error
2-35145.xx—bump aligner motor error **2-36**146.xx—duplex motor error **2-36**147.xx, 149.xx—500/550-sheet option motor error **2-37**147.xx/149.xx—500-sheet option motor error **2-37**148.xx—MPF motor error **2-37**906.01–906.04—fuser motor error **2-33**906.05–906.08—bump aligner motor error **2-36**910.01—transparency sensor error **2-38**920.01—POST error **2-38**920.02—POST error **2-38**920.03—POST error **2-38**920.04—POST error **2-39**920.05—POST error **2-39**920.06—POST error **2-40**920.07—POST error **2-40**920.08—POST error **2-40**920.09–920.12—POST error **2-41**920.13—POST error **2-43**920.14—POST error **2-44**920.15—POST error **2-45**920.16—POST error **2-45**920.17—POST error **2-46**920.18—POST error **2-46**920.19—POST error **2-46**925.01—fan error **2-47**945.xx, 946.xx, 947.xx—Transfer roll error **2-48**950.00–950.29 EPROM mismatch failure **2-50**950.30–950.60 EPROM mismatch failure **2-50**dead printer **2-51**exit sensor **2-52**input sensor **2-52**operator panel **2-53**print quality **2-55**service error codes **2-7**service tag location **1-13**Servo Laser Test **3-9**Size Sensing **3-22**skew **3-4, 4-3**

smart chip card—C52x

locations **5-4**parts catalog **7-8**removal **4-91**

specifications

acoustics **1-4**data streams **1-2**dimensions **1-5**electrical **1-3**environment **1-4**media **1-6**memory configuration **1-2**performance factors **1-2**power requirements **1-3**resolution **1-2**start **2-1**

symptoms

print quality **2-6**printer **2-6**

system card

connectors—C52x **5-11, 5-12**connectors—C53x **5-18**locations **5-4**parts catalog **7-8**removal **4-92**

system card support shield

parts catalog **7-8**removal **4-94****T**

test pages

print quality test pages **3-10, 3-21**Quick Test **3-6**quick test (duplex) **3-12**

theory

electrical interlock

24 V interlock switch **3-55**5 V interlock switch **3-54**

electrophotographic (EP) process

charging **3-46**cleaning **3-53**developing **3-50**exposing **3-49**fusing **3-52**main components **3-44**transferring **3-51**electrophotographic process (EP) **3-44**paper path **3-30**main components **3-32**mechanical drive **3-37**paper sensing **3-42**print media transport **3-33**toner cartridges, location **5-7**

toner level sensor

locations **5-5**parts catalog **7-10**removal **4-96**

Toner Patch Sensing (TPS) **3-23**

tools required **1-13**

top cover camshaft assembly

installation **4-100**

locations **5-6**

parts catalog **7-12**

removal **4-99**

transfer belt

locations **5-7**

parts catalog **7-14**

removal **4-103**

transfer contact assembly

locations **5-5**

parts catalog **7-10**

removal **4-104**

Transfer Motor Test **3-8**

transparencies

using **1-8**

W

waste toner assembly

locations **5-7**

removal **4-105**

Part number index

P/N	Description	Page
40X0274	Power cord—Switzerland	7-15
40X0275	Power cord—Israel	7-15
40X0276	Power cord—South Africa	7-15
40X0278	Power cord—Austria, Belgium, Catalan, Czechoslovakia, Finland, France, Germany, Greece, Hungary, Ireland, Italy, Netherlands, Norway, Paraguay, Poland, Portugal, Russia, Spain, Sweden, Turkey, United Kingdom	7-15
40X0279	Power cord—Denmark, Finland, Norway, Sweden	7-15
40X0280	Power cord—Korea	7-15
40X0282	Power cord—China	7-15
40X0286	Power cord—Hong Kong, Ireland, United Kingdom	7-15
40X0287	Power cord—Chile, Uruguay	7-15
40X0288	Power cord—Argentina	7-15
40X0290	Serial interface card adapter, C524/C524n/C524dn,/C534n/C534dn	7-20
40X0291	Parallel 1284-B interface card adapter, C524/C524n/C524dn, C534n/ C534dn	7-20
40X0296	Power cord—Australia, New Zealand	7-15
40X0297	Power cord—USA, Canada, Bolivia, Peru	7-15
40X1375	MarkNet N8000 fast ethernet print server, C524/C524dn	7-20
40X1376	MarkNet N8020 gigabit ethernet print server, C524/C524dn/C534n/C534dn	7-20
40X1377	MarkNet N8030 fiber ethernet print server, C524/C524dn/C534/C534dn	7-20
40X1378	MarkNet N8050 802.11g wireless print server (US/Americas), C524/C524dn/C534n/C534dn	7-20
40X1400	Fuser assembly, 115 V, C52x	6-1, 7-15
40X1401	Transfer belt assembly, C52x	6-1, 7-15
40X1402	Fuser assembly, 230 V, C52x	6-1, 7-15
40X1403	Fuser assembly, 100 V, C52x	6-1, 7-15
40X1404	MPF paper tray assembly, 250-sheet, C524/C524n/C524dn	7-15
40X1405	Paper pick mechanism assembly, C52x	7-5
40X1409	EP drive assembly, C52x	7-7
40X1410	Smart chip card, C52x only	7-9
40X1411	High voltage power supply, C52x	7-11
40X1412	Top access cover assembly (non-network), C524	7-3
40X1413	Front access door cover assembly (non-duplex), C520n/C522n/C524/ C524n	7-3
40X1414	Operator panel assembly, C52x	7-3
40X1415	Outer bezel	7-3
40X1416	Toner level sensor	7-11
40X1418	Front door assembly, C520n/C522n/C524n	7-5
40X1419	Duplex front door assembly, C524dn	7-5
40X1420	Front door parts packet, C52x	7-5
40X1422	Exit tray cover, C52x	7-3
40X1423	Tray assembly, 500-sheet, C522n/C524/C524n/C524dn	7-15
40X1424	Paper tray assembly, single feeder, C520n/C522n	7-15
40X1425	Right cover	7-3
40X1426	Left cover	7-3
40X1427	Rear cover	7-3
40X1428	Transfer contact assembly	7-11
40X1429	System card support shield, C52x	7-9
40X1430	Parts packet, C52x	7-5
40X1430	Parts packet, cables, C52x	7-19
40X1431	Parts packet, screws	7-5, 7-20
40X1432	Bump aligner gear kit	7-5
40X1433	Bump aligner motor	7-7
40X1434	Contact springs kit	7-17
40X1435	MPF swing arm assembly C52x	7-5

40X1436	Front door 5 V interlock switch	7-7
40X1437	Top access door 24 V interlock switch	7-13
40X1439	Option tray assembly, 500-sheet option (includes tray), C522n/C524/C524n/C524dn	7-15
40X1440	Bin full sensor with cable (network printers only)	7-3
40X1443	Front access door cover assembly (duplex), C524dn only	7-3
40X1445	Ground contact plate, C52x	7-7
40X1446	right bellcrank assembly	7-5
40X1447	Left bellcrank assembly	7-5
40X1448	Inner bezel, C524/C524n/C524dn	7-3
40X1449	Inner bezel, C522n	7-3
40X1450	Inner bezel, C520n	7-3
40X1451	Top access cover assembly, network	7-3
40X1454	32 MB flash card	7-20
40X1455	64 MB flash card	7-20
40X1508	128 MB SDRAM, 100-pin	7-20
40X1509	256 MB SDRAM, 100-pin	7-20
40X1510	512 MB SDRAM, 100-pin	7-20
40X1512	Japanese font card	7-20
40X1513	Simplified Chinese font card	7-20
40X1514	Traditional Chinese font card	7-20
40X1515	Korean font card	7-20
40X1562	MarkNet N8050 802.11g wireless print server (rest of world), C524/C524n/C524dn/C534n/C534dn	7-20
40X2167	Printhead assembly, C52x	7-9
40X2168	Printhead assembly, C53x	7-9
40X2610	40.0 GB hard disk assembly, C524n/C524dn/C534n/C534dn/C534dtn	7-20
40X2663	Forms card, C524/C524n/C524dn	7-20
40X2664	Bar code card, C524/C524n/C524dn	7-20
40X3569	Fuser assembly, 115 V, C53x	6-1, 7-15
40X3570	Fuser assembly, 230 V, C53x	6-1, 7-15
40X3571	Fuser assembly, 100 V, C53x	6-1, 7-15
40X3572	Transfer belt assembly, C53x	6-1, 7-15
40X3573	Paper pick mechanism assembly, C53x	7-5
40X3574	Low voltage power supply, 115/230 V	7-7
40X3578	EP drive assembly, C53x	7-7
40X3579	High voltage power supply, C53x	7-11
40X3581	Front access door cover assembly (non-duplex), C532n/C534n	7-3
40X3582	Operator panel assembly, C530dn/C532n/C532dn	7-3
40X3583	Operator panel assembly, C534n/C534dn	7-3
40X3585	Bezel, C532n	7-3
40X3586	Bezel, C532dn	7-3
40X3587	Bezel, C534n	7-3
40X3588	Bezel, C534dn	7-3
40X3590	Front door assembly, C532n/C534n	7-5
40X3592	Duplex front door assembly, C530dn/C532dn/C534dn	7-5
40X3593	Front door parts packet, C53x	7-5
40X3594	Exit tray cover, C53x	7-3
40X3595	Tray assembly, 550-sheet, C532n/C532dn/C534n/C534dn	7-15
40X3596	Paper tray assembly, single feeder, C532, C534n	7-15
40X3597	System card support shield, C53x	7-9
40X3598	Parts packet, C53x	7-5
40X3598	Parts packet, cables, C53x	7-19
40X3599	MPF paper tray assembly, 250-sheet, C530dn/C532dn/C534dn	7-15
40X3600	Option tray assembly, 550-sheet option (includes tray), C532n/C532dn/C534n/C534dn	7-15
40X3601	Bin full sensor with cable, C53x	7-3
40X3602	Front access door cover assembly (duplex), C530dn/C532dn/C534dn	7-3
40X3604	Top access cover assembly (network), C530dn/C532n/C534n	7-3
40X3605	Duplex top access assembly (network), C532dn/C534dn	7-3
40X3607	Pick arm roll	7-15
40X3608	Bezel, C530dn	7-3

40X3609	Power cord—Japan	7-15
40X3610	Power cord—Taiwan	7-15
40X3611	Power cord—Brazil	7-15
40X3612	Paper tray dust cover with spring, C53x	7-3
40X3613	Top cover camshaft assembly	7-13
40X3615	Deflector assembly, C53x	7-5
40X3616	System card (network), C530dn/C532n/C532dn	7-9
40X3617	System card (network), C534n	7-9
40X3618	System card (network), C534dn	7-9
40X4217	System card, C524	7-9
40X4218	System card (network), C524n/C524dn	7-9
40X4219	System card (network), C520n/C522n	7-9
40X4225	PrintCryption card, C524/C524n/C524dn	7-20
40X4653	Bar code card, C534n/C534dn	7-20
40X4654	Forms card, C534n/C534dn	7-20
40X4655	PrintCryption card, C534n/C534dn	7-20
7377018	Printer relocation kit	7-20
7377200	Options tray relocation kit	7-20

Lexmark C52X (5022) Wiring Diagram

24V Interlock switch for HVPS, fuser motor, and bump align motor.
Senses front door and top cover.

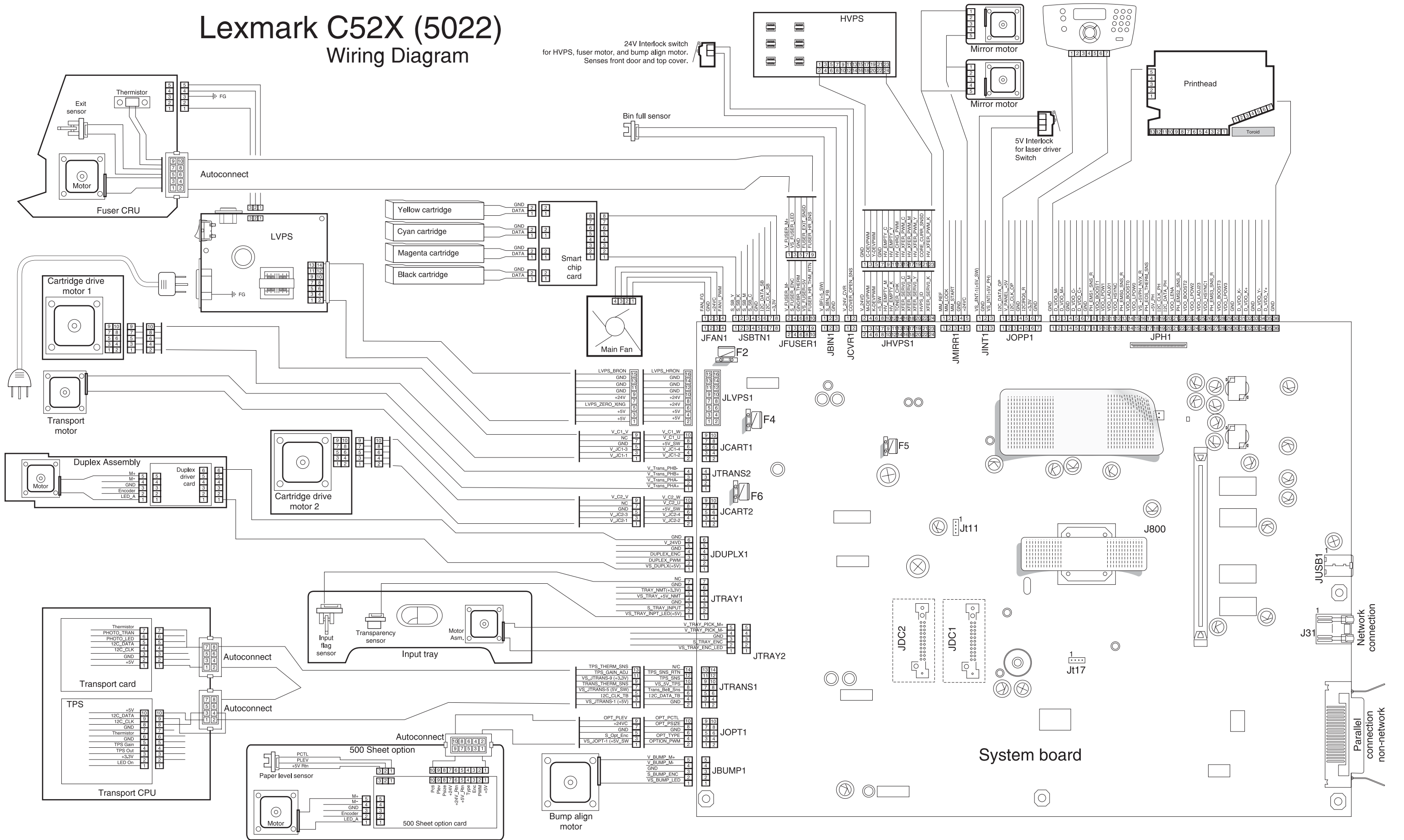

Lexmark C53X (5022) Wiring Diagram

24V Interlock switch for HVPS, fuser motor, and bump align motor. Senses front door and top cover.

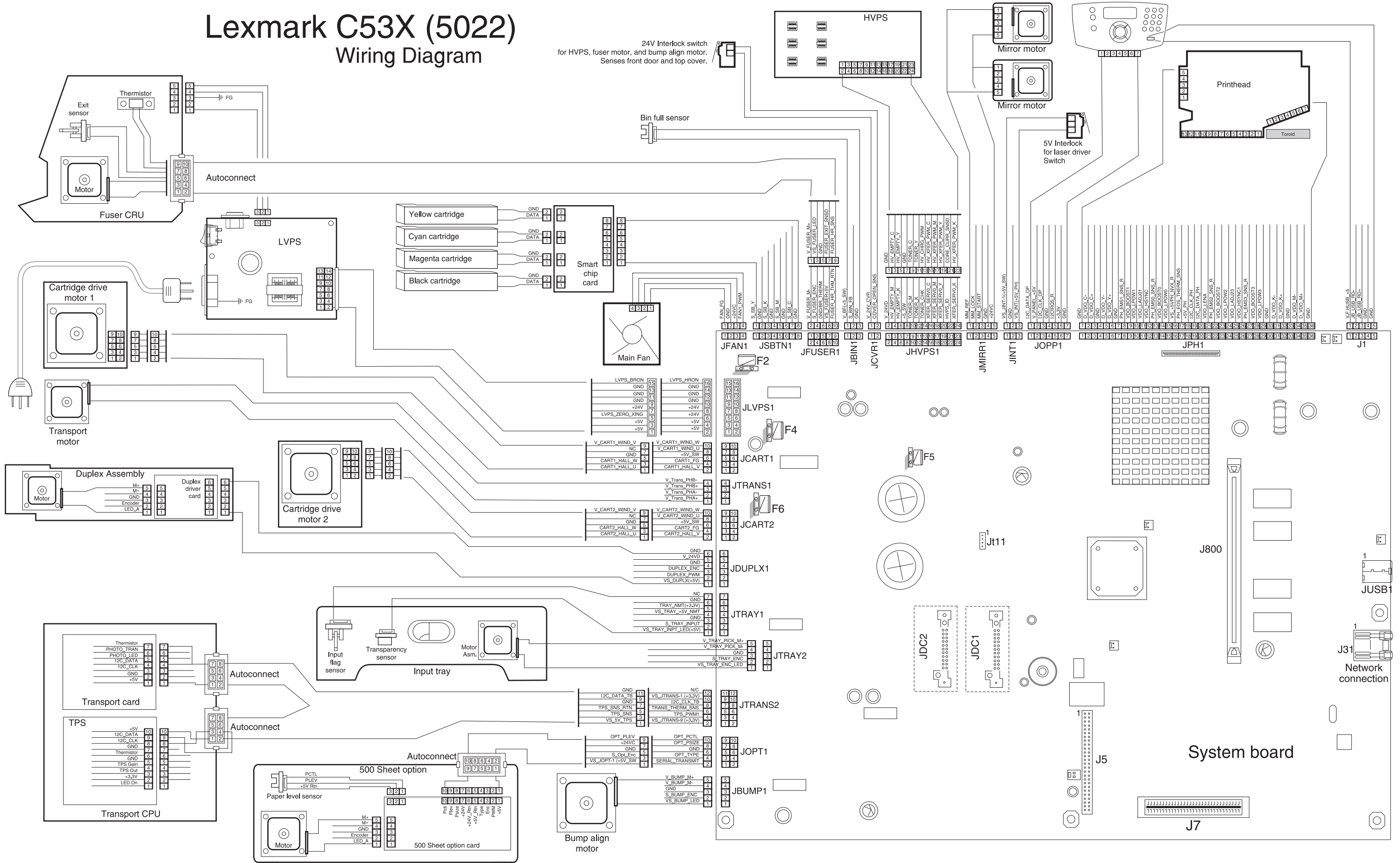

System board

Network connection

USB1

J800

J7

J5

JOPT1

JBUMP1

JTRANS2

JTRAY2

JTRAY1

JDUPLEX1

JCART2

JCART1

JLVPS1

JFUSER1

JHVP1

JBIN1

JCVR1

JMIRR1

JINT1

JOPP1

J1

