



Service Manual

Lexmark Forms Printer 2500 Series

25XX-100

25XX-110

- ***Table of contents***
- ***Start diagnostics***
- ***Safety and notices***
- ***Trademarks***
- ***Index***

LEXMARK[™]

Lexmark and Lexmark with diamond design are trademarks of Lexmark International, Inc., registered in the United States and/or other countries.

25XX-100, -110

Edition: September 17, 2007

The following paragraph does not apply to any country where such provisions are inconsistent with local law: LEXMARK INTERNATIONAL, INC. PROVIDES THIS PUBLICATION "AS IS" WITHOUT WARRANTY OF ANY KIND, EITHER EXPRESS OR IMPLIED, INCLUDING, BUT NOT LIMITED TO, THE IMPLIED WARRANTIES OF MERCHANTABILITY OR FITNESS FOR A PARTICULAR PURPOSE. Some states do not allow disclaimer of express or implied warranties in certain transactions; therefore, this statement may not apply to you.

This publication could include technical inaccuracies or typographical errors. Changes are periodically made to the information herein; these changes will be incorporated in later editions. Improvements or changes in the products or the programs described may be made at any time.

Comments may be addressed to Lexmark International, Inc., Department D22A/032-2, 740 West New Circle Road, Lexington, Kentucky 40550, U.S.A or e-mail at ServiceInfoAndTraining@Lexmark.com. Lexmark may use or distribute any of the information you supply in any way it believes appropriate without incurring any obligation to you.

Lexmark and Lexmark with diamond design are trademarks of Lexmark International, Inc., registered in the United States and/or other countries.

All other trademarks are the property of their respective owners.

© 2007 Lexmark International, Inc.

All rights reserved.

UNITED STATES GOVERNMENT RIGHTS

This software and any accompanying documentation provided under this agreement are commercial computer software and documentation developed exclusively at private expense.

Table of contents

Safety information	1-vii
Preface	1-xii
General information	1-1
Printer specifications	1-1
Printer speeds	1-2
Setup mode	1-2
Entering Setup mode	1-2
Exiting Setup mode	1-2
Setup menu options	1-3
Interface menu options	1-3
Setting the tear off position	1-4
Setting Top-of-form (continuous-pull mode)	1-5
Setting Top-of-form (cut forms, envelopes)	1-5
Printing a network setup page	1-6
Options	1-7
Diagnostic information	2-1
Start	2-1
Voltage, ground, and continuity readings	2-1
Error indication table	2-3
Symptom check table	2-6
Irrecoverable operator errors	2-13
Service checks	2-15
Abnormal noise service check	2-15
Auto Sheet Feeder (ASF) service check	2-16
Carrier service check	2-18
Intermittent problem service check	2-20
No print or abnormal print service check	2-23
Operator panel service check	2-23
Paper Present sensor service check	2-24
Paper feed service check	2-25
Paper Select sensor service check	2-28
POST service check	2-29
Power service check	2-30
Print speed service check	2-31
Printhead service check	2-32

- Pull Tractor sensor service check 2-34
- Top-of-forms service check 2-35
- Tractor 2 service check 2-36
- Network service check 2-40
- Diagnostic aids 3-1**
- Power-On Self Test (POST) 3-2
- Print test 3-3
- Hex Trace mode 3-4
- Printer default settings 3-5
 - U.S. defaults 3-5
 - World Trade defaults 3-5
- Clearing paper jams 3-6
 - Cut sheet jams 3-6
 - Continuous forms jams 3-6
- Web page at a glance 3-7
 - Device settings 3-7
 - Configuration page 3-8
 - Reports page 3-8
 - Flashing firmware 3-9
 - Importing and exporting INA settings 3-10
 - Resetting the INA to factory defaults 3-11
- Repair information 4-1**
- Handling ESD-sensitive parts 4-1
- Adjustments 4-2
 - Printhead-to-platen gap adjustment 4-2
 - Bidirectional print adjustment 4-4
 - Removal procedures 4-4
- Covers, removals 4-5
 - Covers, front removal 4-6
 - Covers, ribbon access removal 4-6
 - Covers, option removal 4-7
 - Covers, top removal 4-8
 - Covers, operator panel assembly removal 4-10
 - Covers, bottom removal 4-11
- Electronics removals 4-11
 - EPROM removal 4-11
 - Logic board removal 4-12
 - Network card removal 4-13
 - INA support frame removal 4-14
 - Power supply removal 4-16

Carrier removals	4-17
Carrier removal	4-17
Carrier, motor assembly removal	4-22
Paper handling removals	4-25
Paper Select lever removal	4-25
Paper feed motor removal	4-25
Forms Thickness lever removal	4-26
Print handling removals	4-27
Platen removal	4-27
Printhead removal	4-28
Printhead cables removal	4-28
Print unit removal	4-29
Ribbon drive rack gear removal	4-31
Gears removals	4-32
Left side gears removal	4-32
Right side gears, sub frame removal	4-35
Rollers removals	4-37
Roller, upper feed removal	4-37
Roller, lower pinch removal	4-39
Roller, lower feed removal	4-42
Sensor removals	4-44
Sensor, Pull Tractor removal	4-45
Sensor, Head Gap removal	4-45
Sensor, Top-of-form removal	4-45
Sensor, Paper Select removal	4-46
Sensor, Paper Present removal	4-46
Flags, Paper Present/Top-of-form removal	4-46
Sensor, Home Position sensor removal	4-47
Options removals	4-48
Auto Sheet Feeder gears removal	4-48
Auto Sheet Feeder pick-up roller removal	4-49
Locations and connectors	5-1
Signal connections	5-2
Power supply (9w & 24w)	5-2
Logic board– Parallel interface cable (9w & 24w)	5-5
Logic board– Serial board (9w & 24w)	5-7
Logic board– USB cable (9w & 24w)	5-9
Logic board– DC power (9w & 24w)	5-9
Logic board– Printhead (9w)	5-11
Logic board– Printhead (24w)	5-13

Logic board– Printhead (24w)	5-15
Logic board– Gap Set sensor (9w & 24w)	5-17
Logic board– Home Position sensor (9w & 24w)	5-17
Logic board– (9w & 24w)	5-17
Logic board– Paper Present sensor (9w & 24w)	5-17
Logic board– Paper Select sensor (9w & 24w).....	5-19
Logic board– Pull Tractor sensor (9w & 24w).....	5-19
Logic board– Top-of-form sensor (9w & 24w)	5-19
Logic board– Carrier motor (9w & 24w)	5-21
Logic board– Paper feed motor (9w & 24w)	5-21
Logic board– Operator panel (9w & 24w).....	5-23
Logic board– Dual tractor cable (9w & 24w)	5-25
Serial board– Serial cable (9w & 24w)	5-26
Tractor 2 cable connectors	5-27
Preventive maintenance	6-1
Lubrication	6-1
Lubrication points	6-2
Lubrication points (oil)	6-3
Lubrication points (grease)	6-4
Parts catalog	7-1
How to use this parts catalog	7-1
Assembly 1: Covers	7-2
Assembly 2: Carrier/paper feed (right side)	7-6
Assembly 3: Carrier/paper feed (left side)	7-10
Assembly 4: Electronics	7-14
Assembly 5: ASF– Roller/support	7-16
Assembly 6: ASF– Side frame/covers	7-18
Assembly 7: Tractor 2 option	7-20
Index	I-1
Part number index	I-5

Safety information

- The safety of this product is based on testing and approvals of the original design and specific components. The manufacturer is not responsible for safety in the event of use of unauthorized replacement parts.
- The maintenance information for this product has been prepared for use by a professional service person and is not intended to be used by others.
- There may be an increased risk of electric shock and personal injury during disassembly and servicing of this product. Professional service personnel should understand this and take necessary precautions.
-  **CAUTION:** When you see this symbol, there is a danger from hazardous voltage in the area of the product where you are working. Unplug the product before you begin, or use caution if the product must receive power in order to perform the task.

Consignes de sécurité

- La sécurité de ce produit repose sur des tests et des agréments portant sur sa conception d'origine et sur des composants particuliers. Le fabricant n'assume aucune responsabilité concernant la sécurité en cas d'utilisation de pièces de rechange non agréées.
- Les consignes d'entretien et de réparation de ce produit s'adressent uniquement à un personnel de maintenance qualifié.
- Le démontage et l'entretien de ce produit pouvant présenter certains risques électriques, le personnel d'entretien qualifié devra prendre toutes les précautions nécessaires.
-  **ATTENTION :** Ce symbole indique la présence d'une tension dangereuse dans la partie du produit sur laquelle vous travaillez. Débranchez le produit avant de commencer ou faites preuve de vigilance si l'exécution de la tâche exige que le produit reste sous tension.

Norme di sicurezza

- La sicurezza del prodotto si basa sui test e sull'approvazione del progetto originale e dei componenti specifici. Il produttore non è responsabile per la sicurezza in caso di sostituzione non autorizzata delle parti.
- Le informazioni riguardanti la manutenzione di questo prodotto sono indirizzate soltanto al personale di assistenza autorizzato.
- Durante lo smontaggio e la manutenzione di questo prodotto, il rischio di subire scosse elettriche e danni alla persona è più elevato. Il personale di assistenza autorizzato deve, quindi, adottare le precauzioni necessarie.



ATTENZIONE: Questo simbolo indica la presenza di tensione pericolosa nell'area del prodotto. Scollegare il prodotto prima di iniziare o usare cautela se il prodotto deve essere alimentato per eseguire l'intervento.

Sicherheitshinweise

- Die Sicherheit dieses Produkts basiert auf Tests und Zulassungen des ursprünglichen Modells und bestimmter Bauteile. Bei Verwendung nicht genehmigter Ersatzteile wird vom Hersteller keine Verantwortung oder Haftung für die Sicherheit übernommen.
- Die Wartungsinformationen für dieses Produkt sind ausschließlich für die Verwendung durch einen Wartungsfachmann bestimmt.
- Während des Auseinandernehmens und der Wartung des Geräts besteht ein zusätzliches Risiko eines elektrischen Schlags und körperlicher Verletzung. Das zuständige Fachpersonal sollte entsprechende Vorsichtsmaßnahmen treffen.



ACHTUNG: Dieses Symbol weist auf eine gefährliche elektrische Spannung hin, die in diesem Bereich des Produkts auftreten kann. Ziehen Sie vor den Arbeiten am Gerät den Netzstecker des Geräts, bzw. arbeiten Sie mit großer Vorsicht, wenn das Produkt für die Ausführung der Arbeiten an den Strom angeschlossen sein muß.

Pautas de Seguridad

- La seguridad de este producto se basa en pruebas y aprobaciones del diseño original y componentes específicos. El fabricante no es responsable de la seguridad en caso de uso de piezas de repuesto no autorizadas.
- La información sobre el mantenimiento de este producto está dirigida exclusivamente al personal cualificado de mantenimiento.
- Existe mayor riesgo de descarga eléctrica y de daños personales durante el desmontaje y la reparación de la máquina. El personal cualificado debe ser consciente de este peligro y tomar las precauciones necesarias.
-  **PRECAUCIÓN:** este símbolo indica que el voltaje de la parte del equipo con la que está trabajando es peligroso. Antes de empezar, desenchufe el equipo o tenga cuidado si, para trabajar con él, debe conectarlo.

Informações de Segurança

- A segurança deste produto baseia-se em testes e aprovações do modelo original e de componentes específicos. O fabricante não é responsável pela segurança, no caso de uso de peças de substituição não autorizadas.
- As informações de segurança relativas a este produto destinam-se a profissionais destes serviços e não devem ser utilizadas por outras pessoas.
- Risco de choques eléctricos e ferimentos graves durante a desmontagem e manutenção deste produto. Os profissionais destes serviços devem estar avisados deste facto e tomar os cuidados necessários.
-  **CUIDADO:** Quando vir este símbolo, existe a possível presença de uma potencial tensão perigosa na zona do produto em que está a trabalhar. Antes de começar, desligue o produto da tomada eléctrica ou seja cuidadoso caso o produto tenha de estar ligado à corrente eléctrica para realizar a tarefa necessária.

Informació de Seguretat

- La seguretat d'aquest producte es basa en l'avaluació i aprovació del disseny original i els components específics.
El fabricant no es fa responsable de les qüestions de seguretat si s'utilitzen peces de recanvi no autoritzades.
- La informació pel manteniment d'aquest producte està orientada exclusivament a professionals i no està destinada a ningú que no ho sigui.
- El risc de xoc elèctric i de danys personals pot augmentar durant el procés de desmuntatge i de servei d'aquest producte. El personal professional ha d'estar-ne assabentat i prendre les mesures convenients.
-  **PRECAUCIÓ:** aquest símbol indica que el voltatge de la part de l'equip amb la qual esteu treballant és perillós.
Abans de començar, desendolleu l'equip o extremeu les precaucions si, per treballar amb l'equip, l'heu de connectar.

안전 사항

- 본 제품은 원래 설계 및 특정 구성품에 대한 테스트 결과로 안정성이 입증된 것입니다. 따라서 무허가 교체부품을 사용하는 경우에는 제조업체에서 안전에 대한 책임을 지지 않습니다.
- 본 제품에 관한 유지 보수 설명서는 전문 서비스 기술자 용으로 작성된 것이므로, 비전문가는 사용할 수 없습니다.
- 본 제품을 해체하거나 정비할 경우, 전기적인 충격을 받거나 상처를 입을 위험이 커집니다. 전문 서비스 기술자는 이 사실을 숙지하고, 필요한 예방 조치를 취하도록 하십시오.
-  **주의:** 이 표시는 해당영역에서 고압전류가 흐른다는 위험 표시입니다. 시작전에 플러그를 뽑으시거나, 주의를 기울여 주시기 바랍니다.

安全信息

- 本产品的安全性以原来设计和特定产品的测试结果和认证为基础。万一使用未经许可的替换部件，制造商不对安全性负责。
- 本产品的维护信息仅供专业服务人员使用，并不打算让其他人使用。
- 本产品拆卸、维修时，遭受电击或人员受伤的危险性会增高，专业服务人员对这点必须有所了解，并采取必要的预防措施。
-  **切记：**当您看到此符号时，说明在您工作的产品区域有危险电压的存在。请在开始操作前拔掉产品的电源线，或者在产品必须使用电源来执行任务时，小心从事。

Preface

This manual contains maintenance procedures for service personnel. It is divided into the following chapters:

1. **General information** contains a general description of the printer and the maintenance approach used to repair it. Special tools and test equipment are listed, as well as general environmental and safety instructions.
2. **Diagnostic information** contains an error indicator table, symptom tables, and service checks used to isolate failing field replaceable units (FRUs).
3. **Diagnostic aids** contains tests and checks used to locate or repeat symptoms of printer problems.
4. **Repair information** provides instructions for making printer adjustments and removing and installing FRUs.
5. **Connector locations** uses illustrations to identify the connector locations and test points on the printer.
6. **Preventive maintenance** contains the lubrication specifications and recommendations to prevent problems.
7. **Parts catalog** contains illustrations and part numbers for individual FRUs.

Definitions

Note: A note provides additional information.

Warning: A warning identifies something that might damage the product hardware or software.

CAUTION: A caution identifies something that might cause a service harm.



CAUTION: When you see this symbol, there is a danger from hazardous voltage in the area of the product where you are working. Unplug the product before you begin, or use caution if the product must receive power in order to perform the task.

1. General information

Printer description

The Lexmark™ Forms Printer 25XX-100 and 25XX-110 are small, versatile tabletop printers suitable for use in the home or small business. They are especially well-suited for applications that use continuous or multi-part forms.

Printer specifications

- Printhead life: 300 million characters
- Standard ribbon life: 4 million characters
- High-yield ribbon life: 8 million characters
- Printer life: 5 years
- Power consumption: 38 watts-maximum/9 watts idle

Model	9-Wire	24-Wire	Short carriage	Long carriage
2580-XXX	X		X	
2581-XXX	X			X
2590-XXX		X	X	
2591-XXX		X		X

Printer speeds

	9-Wire		24-Wire	
	10 cpi	12 cpi	10 cpi	12 cpi
Fast draft	438 cps	510 cps	409 cps	465 cps
Draft	309 cps	304 cps	274 cps	328 cps
NLQ– Near Letter Quality	77.5 cps	77.5 cps	91.7 cps	109 cps

cpi = characters per inch

cps = characters per second

Setup mode

Entering Setup mode

1. Open the operator panel cover to access layer two.
2. Press **Setup** to put the printer in Setup mode and print the Main Menu.
3. Press **LineFeed** to print a list of all the available options.
4. Select any option from the Main Menu by pressing the corresponding button. A new menu prints each time you press a button, displaying new selections.
5. After making a selection, the printer prints a page with the changes shown.

Exiting Setup mode

1. Press **Set TOF** until the printer returns to the Main Menu, or press **Pitch** from any menu containing a **Return to Main Menu** selection.
2. Press **Set TOF** again to exit Setup mode. New settings are saved only when the printer exits Setup mode.

Note: If the printer runs out of paper while in Setup mode, load more paper into the tractor pins, and press **Setup** to continue.

Setup menu options

Menu	Function
Forms Macro options	Customize macros to print a variety of forms.
Data options	Define how information is processed.
Control options	Define how the printer performs basic tasks.
Emulation options	Determine how the printer interacts with software applications.
Interface options	Define how information is transferred from a computer to the printer.

Interface menu options

Menu	Function
Interface	<ul style="list-style-type: none"> • Automatically select the printer interface. • Use the parallel cable. • Use the USB cable. • Use the serial cable (only appears if optional serial adapter is installed).
Honor init	<ul style="list-style-type: none"> • Enable honors the init signal on the parallel port. • Disable ignores the init signal on the parallel port.
Data speed	<ul style="list-style-type: none"> • 300 bps • 600 bps • 1200 bps • 2400 bps • 4800 bps • 9600 bps • 19200 bps
Data bits	7, 8
Parity	No, Ignore, Odd, Even
Stop bits	1, 2
Protocol	<ul style="list-style-type: none"> • XON/XOFF • MultiXON/XOFF • DTR Pacing

Printer settings

Setting the tear off position

When Auto Tear Off is on, or set to One Second, it moves the top perforation of a continuous form to the tear off position, when all of the following are true:

- The printer has finished printing.
- The paper has advanced to the Top-of-form on the next page.
- No data, printer control codes, or escape codes have been sent to the printer after advancing to the Top-of-form.
- The print buffer has not received data for one second.

If you have already set Top-of-Form and now want to change the tear off bar position, follow these steps:

1. Press **Start/Stop** to take the printer offline.
2. Press and hold **Tear Off** until the printer beeps.
3. Open the operator panel cover to access layer two.
4. Press **Micro** ↑ or **Micro** ↓ to move the paper to the correct position on the tear off bar.
5. Close the operator panel cover. The printer beeps twice. The paper rolls backward, then goes to the new tear off position. The Ready light is on.

The paper remains at the current tear off position until you send another job to the printer. The paper moves from the tear off position to the Top-of-form and begins printing.

Setting Top-of-form (continuous-pull mode)

1. Turn the printer on. The Paper Out light blinks if no paper is loaded.
2. Move the Paper Select lever down to the continuous forms position.
3. Load continuous form paper on the pull tractor feed pins.
4. Open the operator panel cover to access layer two.
5. Press any paper movement button (**LineFeed**, **Micro**↑ , or **Micro**↓) to move the paper to the Top-of-form position.
6. Use the second sheet of continuous forms to set Top-of-form.
7. Press **Set TOF** to set and save Top-of-form.
8. Close the operator panel cover. Top-of-form is not saved if the printer is turned off, or if it runs out of paper when the printer is in Pull Tractor mode.
9. Press **Start/Stop** to set the printer online.

Setting Top-of-form (cut forms, envelopes)

Top-of-form can range from minus 1 to plus 22 inches from the top of cut sheet paper. To set and save Top-of-form:

1. Turn the printer on. The Paper Out light blinks if no paper is loaded. If the Paper Out light is off, tear off excess forms and press **Load/Unload**. If an individual form is loaded, press **FormFeed** to clear the paper path.
2. Move the paper select lever up to the cut forms position.
3. Load a cut sheet of paper or envelope through the manual feed door. The printer moves the paper or envelope to the current Top-of-form if Auto Cut Sheet is set to on. If not, press **FormFeed** when the Paper Out light goes off.
4. Open the operator panel cover to access layer two.
5. Press any paper movement button (**LineFeed**, **Micro**↑ , or **Micro**↓) to align the horizontal lines (located on the platen) with the Top-of-form you want.
6. Press **Set TOF** to set and save Top-of-form.
7. Close the operator panel cover.
8. Press **Start/Stop** to set the printer online.

Printing a network setup page

If the printer is attached to a network, print a network setup page to verify the network connection and find the printer address.

Note: This function is disabled if a USB cable is connected.

1. Make sure the printer is on and the paper is loaded.
2. With a paper clip or the tip of a pen, press the recessed button located just above the Network connection.
3. Check the first section on the network setup page, and confirm that the status is **Connected**. If the status is **Not Connected**, the LAN drop may not be active, or the network cable may be malfunctioning. See Networking service check.
4. Check the network setup page to find the IP Address and the Fully Qualified Domain Name. The Fully Qualified Domain Name is useful in situations where the Address changes. For instance, the Address changes if the printer is moved; however, the Fully Qualified Domain Name does not change.

Note: The network setup page also provides important network configuration information.

Options

The 25XX printers support the following options:

- Automatic Sheet Feeder (ASF)
- Internal serial interface (RS232)
- OKI emulation (9 wire only)
- Tractor 2 sheet feeder

Tools

The basic tools necessary to service the 25XX printers are:

- Basic CE tool kit
- #1 Phillips screwdriver
- #2 Phillips screwdriver
- Feeler gauges 0.33 mm (0.013 in.) and 0.37 mm (0.015 in.)
- Analog or digital volt-ohmmeter

Abbreviations

AFE	Analog front end
ASF	Automatic sheet feeder
CPU	Central processing unit
EPROM	Erasable Programmable Read-Only Memory
ESD	Electrostatic discharge
FRU	Field replaceable unit
HTTP	Hypertext transport protocol
HV	High voltage
LED	Light emitting diode
LV	Low voltage
MFP	Multifunction Printer
mm	Millimeter
NIC	Network interface card
NVRAM	Nonvolatile Random Access Memory
POST	Power-On Self Test
RAM	Random access memory
ROM	Read-only storage
TCP/IP	Transport control protocol/Internet protocol
USB	Universal Serial Bus
V ac	Volts alternating current
V dc	Volts direct current

2. Diagnostic information

Start

Make a quick visual check for defects (loose or broken parts, unplugged connectors, paper jams, and so on).

Voltage, ground, and continuity readings

Voltage readings

All DC voltages must be within +5% through -10% of the values to be considered correct. Unless stated otherwise, all connectors should be connected normally when a voltage measurement is performed.

When a “line voltage” measurement is to be performed, the voltage on United States and Canada printers should be between 100 V ac and 127 V ac. On World Trade printers, the voltage is according to each country’s specification.

Ground checks



To check for a correct ground, measure the voltage between the ground and a known good voltage source. The voltage measurement must be the same as the source voltage to consider that the ground is correct. Continuity measurements may be used to check grounds; however, be sure to measure to a known good ground using the lowest ohms scale and check for zero ohms.

Warning: Always unplug the power cord before doing any continuity measurement.

25XX-100, -110

Continuity readings

When measuring continuity, be sure no back circuits affect the measurement. If necessary, unplug connectors to remove any back circuits. Zero the ohm range on the lowest scale (X1). An open circuit will read infinity. A circuit with correct continuity will read zero ohms.

Error indication table

The following table describes the service check entries for the printer error indication codes.

When an error indication changes after you have entered a service check, you have an intermittent problem. If this occurs, leave the service check and go to **“Symptom check table” on page 2-6.**

LED	Status	Alarm	Action
Power Ready Tractor 2 Paper Out Panel Lock Font Lock	ON ON ON ON ON ON	None	POST RAM, ROM Controller Error Go to “POST service check” on page 2-29.
Power Ready Paper Out Panel Lock	ON Blinking Blinking Blinking	None	Switch Scan Test Error Go to “Operator panel service check” on page 2-23.
Power Ready Paper Out Font Lock	ON Blinking Blinking Blinking	None	NVRAM Read/Write Error Turn the printer off and then back on. If you get the same error during power-up, replace the logic board and readjust the bidirectional print adjustment. Go to “Bidirectional print adjustment” on page 4-4. If the printer completes POST successfully and eventually gets the same error, go to “Intermittent problem service check” on page 2-20.

LED	Status	Alarm	Action
Power Ready Paper Out Panel Lock Font Lock	ON Blinking Blinking Blinking Blinking	Beeps 10 times	Home Position Error Go to “Carrier service check” on page 2-18. Tractor 2 Home Position Error If Tractor 2 is installed, remove it to determine whether the problem is with the Carrier Home Position sensor or the Tractor 2 Home Position sensor. See the “Tractor 2 service check” on page 2-36.
		None	Home Position Error Without Alarm Go to “Power service check” on page 2-30.
Power Ready Tractor 2 Paper Out Font Lock	ON Blinking Blinking Blinking Blinking	None	Timer Error Turn the printer off and then back on. If you get the same error during power-up, replace the logic board and readjust the bidirectional print adjustment. Go to “Bidirectional print adjustment” on page 4-4.
Power Ready Tractor 2 Paper Out Font Lock	ON Blinking Blinking Blinking Blinking	None	Hardware Drive Error The printhead or the printhead cable(s) can cause this error. Go to “Printhead service check” on page 2-32. Turn the printer off and then back on. If you get the same error, replace the logic board and readjust the bidirectional print adjustment. Go to “Bidirectional print adjustment” on page 4-4. If the printer completes POST successfully and eventually gets the same error, go to “Intermittent problem service check” on page 2-20.

25XX-100, -110

LED	Status	Alarm	Action
			
All LEDs	OFF	None	Power Failure Check the continuity of the power cord and the voltage of the user's outlet. If they are correct, go to “Power service check” on page 2-30.
Power Tractor 2 Paper Out Panel Lock Font Lock	ON OFF OFF OFF OFF	None	Operator Panel Failure Go to “Operator panel service check” on page 2-23.
Any LED on and Power LED off		None	Go to “Operator panel service check” on page 2-23.
The Power LED blinks or changes intensity.		None	Go to “Power service check” on page 2-30.
Power Ready Font Lock	ON Blinking Blinking	None	Ethernet option not installed. Go to “Network service check” on page 2-40.

Symptom check table

1. Select the symptom that best describes the problem.
2. Perform the appropriate action before you go to the indicated service check.

Abnormal indications

Symptom	Action
<p>7 or more lights turn on but do not turn off.</p> <p>The Power light is on, but POST will not run.</p>	<p>Disconnect the interface cable from the printer and turn the printer off and then back on. If POST now runs correctly, the problem is in the computer or interface cable.</p> <p>Go to “POST service check” on page 2-29.</p>

Abnormal noise problems

Symptom	Action
<p>During POST, abnormal noise comes from the carrier.</p>	<p>Check the ribbon cartridge for binds or damage.</p> <p>Go to “Carrier service check” on page 2-18.</p>
<p>During idling, abnormal noise comes from the printer.</p> <p>Abnormal noise when feeding paper</p> <p>Abnormal noise during printing or POST</p>	<p>Go to “Abnormal noise service check” on page 2-15.</p>

Abnormal print operation problems

Symptom	Action
<p>Printer will not print, or become ready.</p> <p>Abnormal operation, incorrect characters, or incorrect line width</p> <p>Printer is ready but will not print from the computer correctly.</p> <p>Undefined or incorrect character(s)</p>	<p>Be sure the interface cable is connected properly.</p> <p>Go to “No print or abnormal print service check” on page 2-23.</p>
<p>Slow printing speed</p>	<p>Go to “Print speed service check” on page 2-31.</p>

Auto Sheet Feeder problems

Symptom	Action
<p>Auto Sheet Feeder does not feed paper.</p> <p>Auto Sheet Feeder double feeds.</p> <p>Auto Sheet Feeder has intermittent feed problems.</p>	<p>Be sure Sheet Feed is enabled in the Setup mode.</p> <p>Be sure the Paper Select lever is in the cut sheet position.</p> <p>Go to “Auto Sheet Feeder (ASF) service check” on page 2-16.</p>

Error indications

Symptom	Action
Ready and Paper Out lights blink.	Turn the printer off and then back on. Go to “Abnormal indications” on page 2-6.
Paper Out and Font lights blink.	Turn the printer off and then back on. Go to “Irrecoverable operator errors” on page 2-13.

Operator panel problems

Symptom	Action
The Start/Stop button does not function, but no error is indicated. Only the Power light turns on. One or more buttons do not function. One or more lights do not function.	Turn the printer off and then back on. Go to “Operator panel service check” on page 2-23.

Paper feed problems

Symptom	Action
<p>The Paper Out light is blinking when there is paper in the printer.</p>	<p>Go to “Paper Present sensor service check” on page 2-24.</p>
<p>The Paper Out light does not blink when there is no paper in the printer and the ASF is not installed.</p> <p>Print operation starts without paper.</p>	<p>Be sure the paper present sensor is not blocked.</p> <p>Go to “Paper Present sensor service check” on page 2-24.</p>
<p>The Load/Unload button does not function when the push tractor is installed.</p> <p>Form feed length is not correct.</p> <p>The Load/Unload button functions when cut sheets are being used.</p>	<p>Be sure the Paper Select lever is in the correct position.</p> <p>Go to “Paper Select sensor service check” on page 2-28.</p>
<p>Continuous forms feed, but cut sheets fail to load.</p>	<p>Be sure the Paper Select lever is in the cut sheet position.</p> <p>Verify that continuous forms have been parked using the Load/Unload button.</p> <p>Be sure Auto Cut Sheet is enabled in the Setup mode.</p> <p>Go to “Paper Select sensor service check” on page 2-28.</p>

Symptom	Action
<p>The Load/Unload button functions when the pull tractor is installed.</p> <p>The Paper Out light blinks, and the FormFeed button does not operate until paper is located at first print line.</p>	<p>Be sure the Paper Select lever is in the tractor position.</p> <p>Go to “Pull Tractor sensor service check” on page 2-34.</p>
<p>Lower feed roll shaft rotates, but paper does not feed.</p> <p>Pressing FormFeed does not feed paper.</p> <p>Abnormal noise created while printer is feeding.</p> <p>Paper jams, skews, or creases.</p> <p>Incorrect or no line spacing: wider, narrower, or overlapping lines.</p> <p>Push/Pull Tractor does not work.</p>	<p>Be sure the Paper Select lever is in the correct position.</p> <p>Go to “Paper feed service check” on page 2-25.</p>
<p>Incorrect Top-of-form positioning.</p>	<p>Go to “Top-of-forms service check” on page 2-35.</p>

Power problems

Symptom	Action 
<p>When the power switch is on, the Power light does not turn on or the printer does not start.</p> <p>The Power light blinks or changes intensity.</p>	<p>Check the continuity of the power cord and the voltage of the user's outlet.</p> <p>Go to “Power service check” on page 2-30.</p>

Print quality problems

Symptom	Action
<p>No print, but the carrier moves as if printing.</p>	<p>Adjust the Forms Thickness lever to a lower number.</p> <p>Be sure the printhead cables are not loose or damaged.</p> <p>Be sure the interface cable is connected properly.</p> <p>Check the ribbon cartridge for binds or damage.</p> <p>Go to “Print speed service check” on page 2-31.</p>
<p>Print density is light.</p>	<p>Turn the ribbon advance knob on the print cartridge from 1 to 2 to increase the darkness of print.</p> <p>If the ribbon has reached its end of life or is worn, replace the ribbon cartridge.</p> <p>Go to “Carrier service check” on page 2-18.</p>
<p>Uneven print density across the print line</p> <p>Specific dots missing</p> <p>Extra dots or lines printing</p>	<p>Turn the ribbon advance knob on the print cartridge from 1 to 2 to increase the darkness of print.</p> <p>Be sure the printhead cables are connected correctly to the printhead.</p> <p>Clean the printhead.</p> <p>Set the Forms Thickness lever to position 1, and run the print test.</p> <p>Go to “Carrier service check” on page 2-18.</p>
<p>Scattered ink smearing, blurred characters</p> <p>Fuzzy print</p>	<p>Clean the printhead nose.</p> <p>Clean the ribbon guide and shield.</p> <p>If the ribbon has reached its end of life or is worn, replace the ribbon cartridge.</p> <p>Go to “Carrier service check” on page 2-18.</p>
<p>Wavy vertical lines, uneven left margin, or character width is reduced</p>	<p>Clean and lubricate the carrier shaft.</p> <p>If the carrier drive belt is worn or broken, replace the carrier unit.</p> <p>Go to “Carrier service check” on page 2-18.</p>

Ribbon feed problems

Symptom	Action
Ribbon comes off, becomes loose or folded, or jams. Ribbon feeds correctly but is noisy.	Check the ribbon cartridge for binds or damage. Go to “Carrier service check” on page 2-18.

Unable to print on network

Symptom	Action
Unable to print on the network.	Go to “Network service check” on page 2-40.

Irrecoverable operator errors

Paper Out and Font lights blink. If this indication occurs, the problem may be with the Paper Present sensor or the Paper Select sensor. Check the following in the order listed, and if the printer does not work correctly, go to the indicated service check.

Paper Present sensor

Action	Check
Remove all paper from the printer. Turn the power on.	The Paper Out light blinks when paper is not loaded. The Paper Out light turns off when paper is loaded. Go to “Paper Present sensor service check” on page 2-24.

Paper Select sensor

Action	Check
<p>Turn the power off.</p> <p>Install the Push Tractor.</p> <p>Set the Paper Select lever to the tractor position, and load continuous forms.</p> <p>Turn the power on.</p>	<p>The Load/Unload button functions correctly.</p> <p>Go to “Paper Select sensor service check” on page 2-28.</p>
<p>Remove the continuous forms.</p> <p>Set the Paper Select lever to the cut sheet position, and insert a cut sheet.</p>	<p>When Auto Ready Cut Sheet is enabled, paper feeds automatically.</p> <p>When Auto Ready Cut Sheet is disabled, press FormFeed to load a cut sheet.</p> <p>Verify that the Load/Unload button does not function.</p> <p>Go to “Paper Select sensor service check” on page 2-28.</p>

Service checks

Abnormal noise service check

Check the entire printer for loose parts.

	FRU	Action
1	Ribbon cartridge	Remove and reinstall the ribbon cartridge.
2	Printhead	<p>Disconnect the printhead cable(s).</p> <p>Run the print test (do not fold or damage the cables during the test). Go to “Print test” on page 3-3.</p> <p>Replace the printhead if the noise is gone.</p>
3	Carrier motor ribbon drive mechanism	<p>Disconnect the carrier motor connector CN2 from the logic board. Turn the printer off and then back on.</p> <p>If the abnormal noise is gone, look for a problem with the carrier motor or ribbon drive mechanism. Go to “Carrier service check” on page 2-18.</p>
4	Paper feed mechanism	<p>Disconnect the paper feed motor CN1 from the logic board.</p> <p>Perform the Print Test. Go to “Print test” on page 3-3.</p> <p>If the abnormal noise is gone, look for the problem in the paper feed mechanism.</p>

Auto Sheet Feeder (ASF) service check

Note: Be sure the sheet feeder is enabled in the Setup mode. Go to **“Setup mode” on page 1-2.**

Auto Sheet Feeder principles of operation

The Auto Sheet Feeder (ASF) feeds into the cut sheet paper entry throat. To use the ASF:

- The Paper Select lever must be set to the cut sheet position.
- The Auto Sheet Feeder must be selected in the Setup Menu.

Continuous forms can be used with the ASF installed by moving the Paper Select lever to the continuous forms position and pressing **Start/Stop** to feed the continuous forms to the first print line.

The ASF contains no electrical parts. It is driven from the gear on the inside right side frame of the printer.

The combination lock mechanism is a clutch that causes the ASF pick rollers to feed only one sheet of paper at a time. When **Auto Sheet Feeder** is selected on the Setup Menu, the cut sheet paper drive reverses itself for a short distance during paper loading. This reversal engages the clutch and thus engages the paper picker rollers, which feed the top sheet from the cut sheet paper stack. The sheet is fed about 5 inches (125 mm), and the paper path briefly reverses again; this disengages the clutch and the picker rollers. The sheet is then fed to the print line by the upper and lower feed rollers of the ASF and the lower feed rollers of the printer. Although the ASF picker rollers continue to turn as the paper is fed, their drive is disengaged and they are actually turned by the paper.

	FRU	Action
1	Paper Select sensor	<p>With the Paper Select lever in the cut sheet position, do the following:</p> <ul style="list-style-type: none"> • Try to load a cut sheet with the Load/Unload button. (This button should not work.) • If paper loads, go to “Paper Select sensor service check” on page 2-28.
2	Paper feed	<p>If the paper does not feed, do the following:</p> <ul style="list-style-type: none"> • Remove the ASF. • Be sure the base printer feeds paper correctly. • If the base printer does not feed paper correctly, go to “Paper feed service check” on page 2-25.
3	Gear train	<p>Be sure the ASF drive gear on the inside right side frame of the printer rotates.</p> <p>Inspect the right side gear train for damage or debris.</p> <p>Remove the ASF right cover, and ensure that all the gears are in good condition.</p>
4	Combination lock mechanism	<p>Install the ASF, and press FormFeed.</p> <p>If the picker drive shaft does not rotate, replace the combination lock mechanism.</p>
5	Left and right hoppers	<p>If the ASF picker rollers rotate but a single sheet is not picked, inspect the springs and corner separators on the left and right hoppers.</p> <p>Be sure the Paper Load lever is in the correct position.</p>

Carrier service check

Note: The carrier service check includes the carrier drive, Home Position sensor, and ribbon feed.

	FRU	Action
1	Carrier	<p>Verify the carrier motor connector is connected to the logic board at CN2. If the carrier motor connector is connected properly, check the carrier belt and the ribbon cartridge for wear or damage. Check the belt and pulley engagement.</p> <p>Manually move the carrier the full length of the carriage to check for binds and to be sure the ribbon advances when the carriage moves in either direction.</p> <p>If the carrier binds, check the following:</p> <ul style="list-style-type: none"> • Correct printhead-to-platen gap. Go to “Printhead-to-platen gap adjustment” on page 4-2. • Clean and lubricated carrier shaft. • Idler pulley not binding. • Ribbon drive rack gear teeth not damaged. <p>If the carrier still binds: Remove the belt, and move the carrier again.</p> <ul style="list-style-type: none"> • If the bind is gone, replace the carrier motor. • If the bind remains, replace the carrier. <p>After replacing the logic board or any parts affecting the carrier, perform the bidirectional print adjustment. See “Bidirectional print adjustment” on page 4-4.</p>
2	Home Position sensor	<p>If the carrier moves manually without binding but the Home Position Error still occurs, verify that the logic board is receiving +40 V dc on pin CN12-1. Check that the 5 V dc Home Position sensor signal is reaching the logic board.</p> <p>Replace the sensor or the short flexible cable as necessary.</p>

	FRU	Action
3	Carrier motor	<p>If the Home Position sensor is okay, verify that the resistance of the carrier motor windings are approximately 2 ohms for all printers.</p> <p>Check the resistance at the following pin locations:</p> <p style="text-align: center;">CN2 - 1 and CN2 - 3 CN2 - 2 and CN2 -4</p>
4	Logic board	<p>If all parts appear okay but the Home Position Error still occurs, replace the logic board.</p> <p>After replacing the logic board or any parts affecting the carrier, perform the bidirectional print adjustment. See “Bidirectional print adjustment” on page 4-4.</p>

Intermittent problem service check

	FRU/Symptom	Action 
1	The printer sometimes fails before POST is complete.	<p>Check for the following:</p> <ol style="list-style-type: none"> 1. Loose connectors. Reconnect all connectors to the logic board. 2. Electrical noise or static discharge. Check the following: <ul style="list-style-type: none"> • Power supply ground • Printer frame ground • Printer interface cable is grounded and shielded. 3. Intermittently low voltages. <p>Check for ac and all dc voltages and short circuits on the logic board.</p> <ol style="list-style-type: none"> a. Check the user's outlet voltage, and ensure that it is within tolerance. b. Check the continuity of the power cord. c. Disconnect the power supply cable from connector CN12 on the logic board. Turn the printer power on, and check all dc output voltages at CN12-1, CN12-2, and CN12-6. <p>Verify the following output voltages:</p> <ul style="list-style-type: none"> CN12 - 1 (+40 V dc ±10%) CN12 - 2 (+40 V dc ±10%) CN12 - 3 (GND) CN12 - 4 (GND) CN12 - 5 (Signal GND) CN12 - 6 (+5 V dc ±5%) CN12 - 7 (Power Save Mode) <ul style="list-style-type: none"> • If the voltages are incorrect, replace the power supply. • If the failure remains, replace the logic board. <p>Note: When replacing the logic board, always reset the bidirectional print adjustment. See "Bidirectional print adjustment" on page 4-4.</p>

	FRU/Symptom	Action 
2	Printer power sometimes turns off.	<p>The cause of this problem may be that the power circuit is failing, or the wiring is intermittently open. Check the following in sequence:</p> <ol style="list-style-type: none"> 1. Check the user's outlet voltage, and be sure it is within tolerance. 2. Check the continuity of the power cord. 3. Disconnect the power supply cable from connector CN12 on the logic board. Turn the printer power on, and check all dc output voltages at CN12-1, CN12-2, and CN12-6. <p>Verify the following output voltages:</p> <ul style="list-style-type: none"> CN12 - 1 (+40 V dc \pm10%) CN12 - 2 (+40 V dc \pm10%) CN12 - 3 (GND) CN12 - 4 (GND) CN12 - 5 (Signal GND) CN12 - 6 (+5 V dc \pm5%) <ul style="list-style-type: none"> • If one of the voltages is 0, go to “Power service check” on page 2-30. • If the voltages are not 0 but are incorrect, replace the power supply unit.
3	Intermittent poor print quality	<ul style="list-style-type: none"> • Remove paper jams from the paper path. • Clean all feed roller surfaces. • Clean the ribbon shield and printhead. • Clean the platen surface. • Install the ribbon cartridge correctly. If the ribbon has reached its end of life, have the user replace the ribbon cartridge.

	FRU/Symptom	Action 
4	The previous suggestions have not corrected the problem.	<p>The following may cause undefined or intermittent failures:</p> <ul style="list-style-type: none"> • Loose connector pins that fail to contact. Check the following: <ul style="list-style-type: none"> — Reconnect the connectors of all FRUs and printer interface cables. — Check the continuity of the line cord. • Electrical noise. Check the following: <ul style="list-style-type: none"> — Power supply ground — Printer frame ground — Printer interface cable is grounded or shielded. • Undefined data in user applications. Check the baud rate at the controller. Check that the printer interface cable matches the printer.
5	Problem occurs only in specific user applications.	<p>Perform the Hex Trace Print (hexadecimal printing) by performing the following procedure, and check the data streams. Go to “Hex Trace mode” on page 3-4.</p> <ul style="list-style-type: none"> • Turn the printer off. • Press and hold Tractor, and turn the printer on. • Have the user print the failing job. • To stop printing, turn the power off. <p>If the failure still occurs, replace the logic board. Be sure to reset the bidirectional print adjustment. See “Bidirectional print adjustment” on page 4-4.</p>

No print or abnormal print service check

	FRU/Function	Action
1	Logic board	If the print test does not complete correctly, replace the logic board and reset the bidirectional print adjustment. See “Bidirectional print adjustment” on page 4-4.
2	Interface cable	Check the connection and continuity of the interface cable.
3	Emulation mode	Enter the Setup Menu, and be sure the printer is in the correct emulation mode for the computer, either IBM or Epson. Go to “Setup mode” on page 1-2.

Operator panel service check

If the operator panel is locked, only the Start/Stop, FormFeed, Tear Off, and Load/UnLoad buttons are active. 25XX printers have a Padlock LED to indicate that the operator panel is locked. To lock or unlock the operator panel, turn the printer off, and while holding the **Load/Unload** and **Tractor** buttons, turn the printer on.

	FRU	Action
1	Operator panel cable	Disconnect the operator panel cable from the operator panel and the logic board, and verify the continuity of the operator panel cable. Connect the operator panel to the logic board, and be sure +5 V dc is present at connectors CN13-1 and CN13-3. Replace the operator panel cable, or the power cable, as necessary.
2	Operator panel	If the problem remains, replace the operator panel.

Paper Present sensor service check

	FRU	Action
1	Paper Present sensor	<p>With no paper in the printer, the tractor in the push position, and the Paper Select lever set to continuous forms, press Load/Unload; the gear train should turn forward to load paper.</p> <p>Activate the Paper Present sensor with a screwdriver, and press Load/Unload again; the gear train should turn backward to park paper.</p> <p>Measure the voltage between CN5-2 (paper present signal) and CN5-3 (GND) on the logic board. There should be 0 V dc when there is paper in the printer, and +5 V dc when there is no paper in the printer.</p> <ul style="list-style-type: none"> • Be sure the Paper Present sensor and its actuator are properly installed and not damaged. • If the problem remains, replace the Paper Present sensor.
2	Logic board	<p>If the ASF is being used, it is normal for the Paper Out LED not to blink when there is no paper in the printer. Do the following:</p> <ul style="list-style-type: none"> • Enter the Setup Menu. • Be sure the ASF setting is off, unless the ASF is installed. • If the Paper Present sensor is good and the ASF setting is on, replace the logic board and reset the bidirectional print adjustment. Go to “Bidirectional print adjustment” on page 4-4.

Paper feed service check

Note: If paper creases or jams frequently, verify that the paper is neither too thick nor thin. If necessary, refer the user to the *User's Guide* for specifications of acceptable papers.

If the paper does not stop in the correct location, see “**Paper Present sensor service check**” on page 2-24 and the “**Top-of-forms service check**” on page 2-35.

	FRU/symptom	Action
1	Auto Sheet Feeder	<p>If the Auto Sheet Feeder is installed, remove it. Enter the Setup Menu, and reset ASF to off. Verify that the printer works correctly without the ASF installed.</p> <p>If the printer fails only with the Auto Sheet Feeder installed, go to “Auto Sheet Feeder (ASF) service check” on page 2-16.</p>
2	Gear train	<p>Remove all paper from the printer.</p> <p>Press FormFeed several times, and examine all rotating parts to find the problem.</p> <p>The feed rollers and pinch roller should all be clean and in good condition and should all rotate when pressing FormFeed.</p>
3	Paper Select lever	<p>Be sure the selector lever alternately engages and disengages the tractor gear and the ASF drive gear.</p> <p>Check the operation of the following parts as you move the Paper Select lever:</p> <ul style="list-style-type: none"> • The tractor gear engages correctly in the continuous forms position. • The tractor belts are in good condition and rotate correctly. • The pinch roller shafts move downward as the lever moves to the cut sheet position. • The paper separator moves upward as the lever moves to the cut sheet position.

	FRU/symptom	Action
4	Operator panel	<p>If paper does not move at all, verify that the Load/Unload button is working as follows:</p> <p>With the tractor in the push position, turn the power off and then back on, and then press Load/Unload. The carrier should move to the center of the platen. If it does not, go to “Operator panel service check” on page 2-23.</p>
5	Paper feed motor	<p>Disconnect the paper feed motor cable CN1 from the logic board. No pin should have continuity to ground. The resistance should be between 8 to 9 ohms, between CN10 - 1 and CN10 - 5, CN10 - 2 and CN10 - 5, CN10 - 3 and CN10 - 5, CN10 - 4 and CN10 - 5.</p>
6	Paper Select sensor	<p>Remove all paper from the printer, and place the tractor in the push position.</p> <p>Press FormFeed, and time how long the gear train rotates.</p> <ul style="list-style-type: none"> • With the Paper Select lever in the cut sheet position (sensor open), the gear train should rotate for less than 2 seconds. • With the lever in the continuous forms position (sensor closed), the gear train should rotate for more than 3 seconds. <p>If the printer does not do either of the above:</p> <ul style="list-style-type: none"> • Inspect the sensor to be sure it opens and closes by the paper separator. • Replace the sensor if the resistance does not change from zero to infinite as the Paper Select lever is moved.
7	Pull Tractor sensor	<p>If the pull tractor sensor fails to close, Load/Unload and Auto Tear Off do not work when using push tractors.</p> <p>The sensor fails to open. The Load/Unload button tries to park paper when using the pull tractors but, instead, the paper feeds all of the way out of the tractors and cannot be reloaded. See “Pull Tractor sensor service check” on page 2-34.</p>

25XX-100, -110

	FRU/symptom	Action
8	Logic board	If no other problem is found, replace the logic board and reset the “Bidirectional print adjustment” on page 4-4.

Paper Select sensor service check

If the form feed length is off by about 1 inch (25 mm), enter Setup mode and verify that the form length setting is correct. Go to **“Setup mode” on page 1-2.**

	FRU	Action
1	Paper Select sensor	<p>Remove all paper from the printer, and do the following:</p> <ul style="list-style-type: none"> • Place the tractor in the push position, and be sure the Auto Sheet Feed (ASF) is set to off in Setup mode. • Press FormFeed, and time how long the gear train rotates. <p>With the Paper Select lever in the cut sheet position (sensor open) the gear train should rotate for less than 2 seconds. With the lever in the continuous forms position (sensor closed), the gear train should rotate for more than 3 seconds. If the gear train does not rotate for more than 3 seconds:</p> <ul style="list-style-type: none"> • Inspect the sensor to be sure it opens and closes by the paper separator. • Replace the paper select sensor if the resistance does not change from zero to infinite as the Paper Select lever is moved from cut sheet to continuous forms. <p>If the Paper Select sensor is good, but the gear train does not run the right length of time:</p> <ul style="list-style-type: none"> • Set the head gap to position 1, and disconnect the short flexible cable from CN8 on the logic board. • Check the continuity between CN8-2 (paper select sensor) and GND while activating the Paper Select lever. <p>If the resistance is incorrect, replace the logic board and reset the bidirectional print adjustment. Go to “Bidirectional print adjustment” on page 4-4.</p>

	FRU	Action
2	Pull Tractor sensor	<p>A failed Pull Tractor sensor can cause the Load/Unload button to malfunction.</p> <p>With the tractor in the push position:</p> <ul style="list-style-type: none"> • Press Load/Unload several times while alternately holding down and releasing the left pull tractor actuator. The paper should not park or load when the pull tractor actuator is held down. • If the paper does park or load with the pull tractor actuator held down, go to “Pull Tractor sensor service check” on page 2-34.

POST service check

	FRU	Action
1	Cables	<p>A faulty interface cable can cause a POST error. Disconnect the interface cable from the printer, and turn the printer off and then back on.</p> <p>Check the connections of the power cable to the logic board.</p> <p>Check the condition and continuity of the operator panel cable.</p>
2	Code module	Turn the printer off and then back on. If you get the same error during power-up, verify that the code module on the logic board is correctly installed.
3	Logic board	Replace the logic board if necessary, and reset the bidirectional print adjustment. Go to “Bidirectional print adjustment” on page 4-4.

Power service check

	FRU	Action 
1	Power supply	<p>If the carrier does not move to the left after turning the printer off and then back on, be sure the line cord voltage to the power supply is correct and the power supply outputs are +40 V dc at CN12-1, +40 V dc at CN12-2 and +5 V dc at CN12-6.</p> <p>If the voltages are incorrect:</p> <ul style="list-style-type: none"> • Check the internal fuse before replacing the power supply. Generally if F1 is blown, it is due to a short-circuit in the printhead; replace the printhead and the fuse before turning the power on again. • Be sure the power supply cable from the power supply to the logic board is not damaged and is correctly installed.
2	Operator panel Operator panel cable	<p>If there is still a Power LED problem, check the operator panel cable continuity and replace the cable or the operator panel.</p>
3	Carrier motor	<p>Disconnect the carrier motor from logic board CN2, and turn the printer off and then back on. If the Power LED lights correctly only with the carrier motor disconnected, replace the carrier motor.</p>
4	Paper feed motor	<p>Disconnect the paper feed motor from logic board CN1, and turn the printer off and then back on. If the Power LED lights correctly only with the paper feed motor disconnected, replace the paper feed motor.</p>
5	Printhead Printhead cables	<p>Disconnect the printhead cable from the logic board, and turn the printer on. If the Power LED lights correctly only with the printhead cables disconnected from the logic board, there is a short-circuit in the printhead or printhead cables.</p> <p>Disconnect the printhead cable from the logic board, and be sure none of the leads on the cable are shorted to ground.</p>

	FRU	Action 
6	Logic board	If no problem is found with the other components, but the power problem still remains, replace the logic board and reset the bidirectional print adjustment. Go to “Bidirectional print adjustment” on page 4-4.

Print speed service check

The speed of the 25XX printers varies with the font, forms thickness setting, and printhead temperature. Graphics output may print slowly due to data throughput limitations. Thermal sensing is built into the printhead on 25XX printers and protects the printhead from overheating.

	FRU	Action
1	Head Gap sensor	<p>Check the function of the Head Gap sensor by turning the printer on while pressing the Macro button. Open the operator panel to the second level and do the following:</p> <ul style="list-style-type: none"> • With the Forms Thickness lever at 1, Macro LED 1 lights. • With the Forms Thickness lever at 2 and 3, Macro LED 2 lights. • With the Forms Thickness lever at 4 through 7, Macro LED 3 lights. <p>Disconnect the Head Gap sensor from connector CN4 on the logic board. Place the Forms Thickness lever in position 1 and verify continuity at the following pin locations:</p> <p style="text-align: center;">CN4 - 1 and CN4 - 2 CN4 - 2 and CN4 - 3</p> <p>Place the Forms Thickness lever in positions 2 and 3 and verify continuity at the following pin location:</p> <p style="text-align: center;">CN4 - 1 and CN4 - 2</p> <p>Verify that there is no continuity at Forms Thickness lever positions 4 through 7.</p>

Printhead service check

	FRU	Action
1	Printhead cables Printhead	<p>If the printout contains missing or extra dots or lines, do the following:</p> <ul style="list-style-type: none"> • Check the continuity and connection of the printhead cables and the short flexible cable. • Be sure the voltages to the logic board are correct. <p>If dots are missing:</p> <ul style="list-style-type: none"> • Perform the print test to determine which wire is not firing. • Remove the printhead, and verify that no pins on the printhead are broken or missing. If pin(s) are missing, replace the printhead. • Check the printhead resistance according to “Printhead impedance tables” on page 2-33. Be sure no pins have continuity to the printhead housing. <p>If the printout does not contain missing or extra dots or lines, be sure the printhead is securely installed in the carrier and perform the “Printhead-to-platen gap adjustment” on page 4-2.</p>
2	Carrier shaft Carrier unit Platen assembly Printhead nose Ribbon guide	Check and replace worn or damaged parts.

25XX-100, -110

Printhead impedance tables

2580, 2590 - approximately 5 ohms

Dot	Connector
1	CN400-13 & CN400-4
2	CN400-9 & CN400-6
3	CN400-15 & CN400-18
4	CN400-1 & CN400-7
5	CN400-17 & CN400-20
6	CN400-5 & CN400-2
7	CN400-19 & CN400-16
8	CN400-8 & CN400-3
9	CN400-10 & CN400- 14

2581, 2591 - approximately 8 to 16 ohms

Dot	Connector	Dot	Connector
1	CN300-1 & CN301-9	13	CN300-1 & CN300-9
2	CN300-1 & CN301-11	14	CN300-1 & CN300-11
3	CN300-1 & CN301-7	15	CN300-1 & CN300-2
4	CN300-1 & CN301-13	16	CN300-1 & CN300-16
5	CN300-1 & CN301-5	17	CN300-1 & CN301-4
6	CN300-1 & CN301-15	18	CN300-1 & CN300-14
7	CN300-1 & CN301-3	19	CN300-1 & CN301-6
8	CN300-1 & CN301-17	20	CN300-1 & CN300-12
9	CN300-1 & CN301-1	21	CN300-1 & CN300-4
10	CN300-1 & CN301-18	22	CN300-1 & CN300-10
11	CN300-1 & CN301-2	23	CN300-1 & CN300-6
12	CN300-1 & CN301-16	24	CN300-1 & CN300-8

Pull Tractor sensor service check

The Pull Tractor sensor detects the tractor in the pull position and disables the load/unload and auto tear-off functions. A failed sensor may prevent load/unload from functioning, with the tractor in the push position.

	FRU	Action
1	Pull Tractor sensor	<p>With the tractor in the push position, press Load/Unload several times while alternately holding down and releasing the left pull tractor actuator. The paper should load and unload when the actuator is not held down, and should not load or unload when the pull tractor actuator is held down.</p> <p>If the paper does not move correctly, disconnect CN3 from the logic board. There should be continuity from CN3-1 and CN3-2 when the left pull tractor actuator is pressed, and infinite resistance when the actuator is not pressed. Replace the sensor if necessary.</p> <p>If the sensor is good but the paper still does not move correctly, replace the logic board and reset the bidirectional print adjustment. Go to “Bidirectional print adjustment” on page 4-4.</p>

Top-of-forms service check

	FRU	Action
1	Top-of-form sensor	Check that the Top-of-form sensor and its flag are properly installed and are not damaged.
2	Logic board	<p>Remove the paper and set the Paper Select lever to the cut sheet position, and turn the printer on.</p> <p>Measure the voltage between logic board connector CN6-2 (TOF signal) and CN6-1 (GND). You should receive the following voltage readings:</p> <ul style="list-style-type: none"> • When there is paper in the printer, the voltage should be 0 V dc. • When there is no paper in the printer, the voltage should be 5 V dc. <p>Replace the Top-of-form sensor if the voltage is incorrect.</p> <p>Replace the logic board if the voltage is correct, and reset the bidirectional print adjustment. Go to “Bidirectional print adjustment” on page 4-4.</p>

Tractor 2 service check

The Tractor 2 in-place sensor opens during installation when its actuator touches the printer cover.

The Tractor 2 Home sensor detects the position of the slider:

- When Tractor 2 is selected, the motor-driven Tractor 2 slider pushes the printer sub slider cam lever to engage the printer gear train, which drives the Tractor 2 tractors.
- When the Tractor 2 is deselected, the motor retracts the slider, disengages the Tractor 2 gear drive, and reengages the printer tractors.

10 beeps and blinking Ready, Paper, Font and Pitch LEDs

Tractor 2 Home sensor never made after turning the printer off and then on, or made at the wrong time.

(The same error indication is used for carrier home failure.)

	FRU	Action
1	Tractor 2 Home sensor	Remove the Tractor 2, and turn the printer off and then back on again to determine if the fault is in the printer or Tractor 2. If the gear teeth chatter just before the beeps, replace the Home sensor.

	FRU	Action
2	Logic board	<p>Remove Tractor 2 from the printer, but leave the cable connected. Be sure the slider (the black plastic piece just above the right cover) moves after turning the printer off and then back on.</p> <p>If the slider does not move after turning the printer off and then back on:</p> <ul style="list-style-type: none"> • Be sure the slider and gear train are properly connected and move freely with the power off. • Be sure the Tractor 2 board is receiving: +40 V dc on CN1-1 and +5 V dc on CN1-5. <p>If the slider does move, check the cable connection and the voltages at logic board CN10-1. The upper right pin at CN10 is pin 1 (+40 V dc) and the pin just beneath it is pin 5 (+5 V dc).</p> <p>If these voltages are not present, replace the logic board.</p>
3	Tractor 2 motor board/cable assembly	<p>Check the resistances of the Tractor 2 motor windings at CN5 on the Tractor 2 board. There should be 101 ± 5 ohms between pins:</p> <p style="text-align: center;">CN5 -1 and CN5 - 4 CN5 -1 and CN5 - 6 CN5 -2 and CN5 - 3 CN5 -2 and CN5 - 5</p> <p>If the motor is good, replace the board/cable assembly.</p> <p>For information on the Tractor 2 cable connectors, see “Tractor 2 cable connectors” on page 5-27.</p>

3 beeps and Tractor 2 LED blinks 3 times

Tractor 2 is selected from the operator panel, but the printer does not detect Tractor 2 or detects that the Tractor 2 mechanism is not installed.

	FRU	Action
1	Tractor 2 board/cable assembly	<p>Check the Tractor 2 in-place sensor or the cable connection.</p> <p>The in-place sensor actuator extends through the Tractor 2 cover and rests on the printer cover when Tractor 2 is installed.</p> <p>Remove the Tractor 2 cover, and be sure the in-place sensor opens when the Tractor 2 is installed. The voltage at Tractor 2 CN1-13 should be +5 V dc with the sensor open and 0 when it is closed.</p> <p>Replace the Tractor 2 board/cable assembly if the sensor signal is wrong.</p> <p>For information on the Tractor 2 cable connectors, see “Tractor 2 cable connectors” on page 5-27.</p>
2	Logic board	<p>Check the cable connection from Tractor 2 to the printer.</p> <p>If possible, try the Tractor 2 with another printer to determine if the problem is the Tractor 2 board/cable assembly or the printer logic board.</p>

Tractor 2 paper feed problems

	FRU	Action
1	Tractor 2	<p>Be sure the gear on the printer that drives Tractor 2 turns freely when the lever is not pressed, but remains still when the lever is pressed.</p> <p>Remove the Tractor 2 unit from the printer, and remove all paper. With the Paper Select lever in the continuous forms position, press FormFeed; the tractors should rotate. Press the sub slider cam lever below the ASF/Tractor 2 drive gear, and press FormFeed again; the tractors should not rotate, but the drive gear should.</p> <p>Check the condition of the pin feed belts. With the printer off, make sure that the slider does not bind.</p> <p>Verify that:</p> <ul style="list-style-type: none"> • When the slider is to the rear, the white gear drives the tractors. • When the slider is to the front, the gear and tractors are not connected.
2	Tractor 2 cover	<p>Remove the Tractor 2 cover, and reinstall the Tractor 2 unit in the printer (if necessary, remove the printer covers also). Note that the small idler gear just below the slider is held in place by the cover. When the cover is removed, it tends to move off the stud. Also note that when operating the Tractor 2 with the printer cover removed, the Tractor 2 in-place sensor must be held open.</p> <p>Turn the printer on, and look for mechanical problems.</p> <p>For information on the Tractor 2 cable connectors, go to “Tractor 2 cable connectors” on page 5-27.</p>

Network service check

Step	Questions/actions	Yes	No
1	Is the printer online (Ready)?	Go to step 2	Put the printer online.
2	Check all of the network connections. Are all the network connections connected properly?	Go to step 3.	Properly connect all of the connections.
3	Are the indicator lights on the network card illuminated?	Go to step 4.	Go to step 9.
4	Open the printer's Web page in a web browser using the printer driver IP address. Does the web page open?	Go to step 13.	Go to step 5.
5	Print a network configuration page. See “Printing a network setup page” on page 1-6. Are the first two segments of the IP address 169.254.XXX.XXX?	Go to step 6.	Go to step 7.
6	Restart the printer. Is the problem still there?	Go to step 7.	Problem solved.
7	Reset the INA to factory defaults. See “Resetting the INA to factory defaults” on page 3-11. Did this fix the problem?	Problem solved.	Go to step 8.

Step	Questions/actions	Yes	No
8	Replace the LAN card. Did this fix the problem?	Problem solved.	Replace the main board.
9	Check the cable connected to CN15 on the main board. Is the cable connected properly?	Go to step 10.	Properly connect the cables.
10	Perform a continuity check on the USB cable connecting the LAN card and the main board. Is there continuity?	Go to step 12.	Go to step 11.
11	Replace the LAN USB cable. Did the problem go away?	Problem solved.	Go to step 12.
12	Check pin 1 on CN15 of the main board for +5V DC, and pin 4 for ground. Are the readings correct?	Replace LAN card.	Replace main board.
13	Perform a print test. See “Print test” on page 3-3. Did the job print?	Go to step 6.	Go to START. See “Print test” on page 3-3.

3. Diagnostic aids

The printer contains self tests to help find and solve problems. The printer does not need to be connected to a computer or terminal to run these tests.

Types of self tests are:

- Power-on self test (POST)
- Print test
- Hex Trace mode (a computer or terminal is necessary)

The following are special machine modes that run when the printer is turned off and then back on:

Turn printer on while pressing	Result
LineFeed	Prints print test with sample fonts.
Tractor	Sets printer in Hex Trace mode.
Load/Unload and Tractor	Disables/enables Operator Panel Lockout mode.
Tearoff and Tractor with the printhead at the left limit	Resets the printer to the World Trade defaults.
Tearoff and Load/Unload with the printhead at the left limit	Resets the printer to the U. S. defaults.

Power-On Self Test (POST)

The following tests are automatically performed when the printer is turned on.

- LEDs Test– Checks operation of LEDs on the operator panel. The LEDs turn on and off after the printer is turned on, and then all LEDs turn on for a few seconds.
- RAM Test– Checks that the CPU can write/read the RAM.
- Font ROM/Microcode Sum Test– Checks that the ROM data is correct.
- Timer/Interrupt Controller Test– Checks that this function works.
- NVRAM Test– Checks that the NVRAM data is correct.
- Switch Scan Test– Checks the buttons on operator panel.
- Carrier Initialization– Carrier moves to the left to activate the Home Position sensor, and then moves to the first print position.
- Feed Initialization– Form feed motor rotates forward and then backward.

If any errors occur during the POST tests, a combination of blinking LEDs indicates which test failed. See **“Start” on page 2-1**.

Print test

The Print test helps you test and troubleshoot the printer. To start the Print test:

1. Paper must be at the print position; the test does not print if paper is parked.
2. Press and hold **Line Feed**, and turn the printer on.
3. Release **Line Feed** when the printing starts.
4. To interrupt the printer test:
 - a. Press **Start/Stop**. The test stops after a complete line of characters prints.
 - b. Press **Start/Stop** to continue the test sample.
5. To stop the printer test, turn the printer off.

If the Print test fails, go to **“Start” on page 2-1**.

Note: The short horizontal lines at the top of the sample are a test of each printhead wire numbered in sequence, from top to bottom.

Hex Trace mode

The Hex Trace mode helps the user test and troubleshoot programs. Use the Hex Trace procedure to get a hexadecimal printout of the data stream sent to the printer. All data, including both control and character data, print in hexadecimal instead of ASCII.

To activate Hex Trace mode:

1. Press and hold **Tractor**, and then turn the printer on.
2. After a few seconds, release **Tractor**, and the lights go out.
3. Start your application program. Be sure the printout is similar to the hex trace sample shown. Two hexadecimal digits, followed by a space, are printed for each byte of data sent to the printer.
4. The printer continues to print in hexadecimal until you turn the printer off.

Hex trace mode sample

```

20 20 20 30 20 20 40 20 20 20 20 A0 20 20 B0 20 20 C0 20
20 00 20 20 E0 20 20 F0 00 20 61 20 20 71 20 20 81 20 20
91 20 20 A1 20 20 B1 20 20 C2 20 20 32 20 20 42 20 20 52
20 20 62 20 20 72 20 20 82 20 20 02 20 20 E2 20 20 F2 00 0A
0A 23 20 20 33 20 20 43 20 20 93 20 20 A3 20 20 B3 20 20 C3
20 20 03 20 20 E3 20 20 F3 20 20 64 20 20 74 20 20 84 20
20 94 20 20 A4 20 20 B4 20 20 0A 25 20 20 35 20 20 45 20 20
55 20 20 65 20 20 75 20 20 20 20 05 20 20 E5 20 20 F5 00
0A 0A 26 20 20 36 20 20 46 20 20 96 20 20 A6 20 20 B6 20 20
C6 20 20 D6 20 20 E6 20 20 57 20 20 67 20 20 77 20 20 87
20 20 97 20 20 A7 20 20 B7 20 20 0A 28 20 20 38 20 20 48 20
20 58 20 20 68 20 20 78 20 20 20 20 08 20 20 E8 20 20 F8
0D 0A 0A 29 20 20 39 20 20 49 20 20 99 20 20 A9 20 20 B9 20
20 C9 20 20 D9 20 20 E9 20 20 0A 20 20 6A 20 20 7A 20 20
8A 20 20 9A 20 20 AA 20 20 BA 20 20 0A 28 20 20 38 20 20 48
20 20 58 20 20 68 20 20 78 20 20 0B 20 20 DB 20 20 EB 20 20
FB 0D 0A 0A 2C 20 20 3C 20 20 0D 20 20 9C 20 20 AC 20 20 BC
20 20 CC 20 20 DC 20 20 EC 20 20 0D 5D 20 20 6D 20 20 7D 20
20 8D 20 20 9D 20 20 AD 20 20 0D 0A 0A 2E 20 20 3E 20 20
4E 20 20 5E 20 20 6E 20 20 7E 20 20 CE 20 20 DE 20 20 EE 20
20 FE 0D 0A 0A 2F 20 20 3F 20 20 8F 20 20 9F 20 20 AF 20 20
8F 20 20 CF 20 20 DF 20 20 EF
    
```

Printer default settings

U.S. defaults

To initialize or reset the printer to the U.S. factory defaults:
(Code page 437, Character Set 1, form length 11 inch)

1. Make sure paper and the ribbon cartridge are installed.
2. Turn the printer off.
3. Open the ribbon access cover.
4. Move the printhead toward the operator panel side of the printer until it stops.
5. Close the ribbon access cover.
6. Press and hold **Tear Off** and **Load/Unload** while you turn the printer on.
7. Continue holding these buttons until the carrier moves. The operator panel lights blink several times. Once the carrier moves, your settings have been reset to factory defaults.

World Trade defaults

To initialize or reset the printer to the World Trade defaults:
(Code page 858, Character Set 2, form length 12 inch)

1. Make sure paper and the ribbon cartridge are installed.
2. Turn the printer off.
3. Open the ribbon access cover.
4. Move the printhead toward the operator panel side of the printer until it stops.
5. Close the ribbon access cover.
6. Press and hold **Tear Off** and **Tractor** while you turn the printer on.
7. Continue holding these buttons until the carrier moves. The operator panel lights blink several times. Once the carrier moves, your settings have been reset to factory defaults.

Clearing paper jams

Cut sheet jams

To clear cut form paper jams:

1. Turn the printer off.
2. Set the Forms Thickness lever to position 7.
3. Push the Paper Select lever down to the continuous forms position.
4. Gently pull out the sheet of paper from the front of the printer.
5. Remove the ribbon access cover to clear any torn pieces of paper.
6. Set the Paper Select lever to the cut forms position.
7. Set the Forms Thickness lever to the proper setting for the type of paper you are using. Refer to the 25XX *User's Guide*.

Continuous forms jams

1. Turn the printer off.
2. Detach any continuous forms already printed.
3. Set the forms thickness lever to position 7.
4. Tear the continuous forms off at the perforation line before the forms enter the printer.
5. If you are using the tractor in the push position, open the front cover. (Skip this step if you are using the optional Tractor 2 Feeder.)
6. Open the left and right tractor doors.
7. Lift the paper from the tractor pins.
8. Carefully pull out the paper.
9. Remove the ribbon access cover to clear any torn paper.
10. Remove any torn perforation strips or bits of paper from the paper path.

Web page at a glance

The 2500 series internal web server enables a user or service technician to view and adjust the device settings. The web page can be accessed by opening a web browser and pointing it to the IP address of the networked printer.

The Device Status, Configuration and Reports pages are the commonly used pages to view printer settings and make adjustments to the settings.

Device settings

The Device Status Page presents an at-a-glance summary of essential information about the status of the device.

Device Status - Refresh	
Device Status:	Ready
Device Type:	Dot matrix
Serial Number:	8A-R0031
Lifetime Character Count:	35791
Lifetime Page Count:	27
Firmware Version:	VER.EVT1
Network Firmware Version:	LCU.053007 13:33

Configuration page

This page displays numerous links that enable users to access and (with proper permissions) to change various device settings.

Changing a configuration setting:

1. From the Configuration page, click the appropriate link to access the desired device setting.
2. Make the desired changes to the selected setting.
3. To save the changes as the new device faults, click **Submit**. Or, to cancel any changes and restore all fields on the form to their original values, click **Reset**.

Note: Changes to network settings of the device should only be performed by the network administrator.

Reports page

The Reports page contains the following links:

- **Print server setup**
The Print Server Setup page lists important print server information (for example, hardware addresses, firmware revision level, protocol settings, and so on.)
- **Network setup**
Network protocol settings are displayed. Adjustments can also be made to settings here.
- **Device information**
General device information is displayed here.



Flashing firmware

If the device is attached to the network, the firmware can be re-flashed, or upgraded from the web page.

To reflash the firmware, perform the following steps:

1. Open the Configuration page of the web server.
2. Click the **Update firmware** link.
3. Click the **Browse** button.
4. A standard Windows file browse dialog will open. Search for the desired flash file.
5. When the file is found, click **Submit**.

Importing and exporting INA settings

If the INA needs to be replaced, the internal settings can be downloaded to a file.

To export the INA settings, perform the following tasks:

1. Click the **Export settings** link from the Configuration page. The following page will display:



2. In the file save dialog, click **Save**.

To import the INA settings, perform the following tasks:

1. Click the import settings link from the Configuration page. The following page will display:

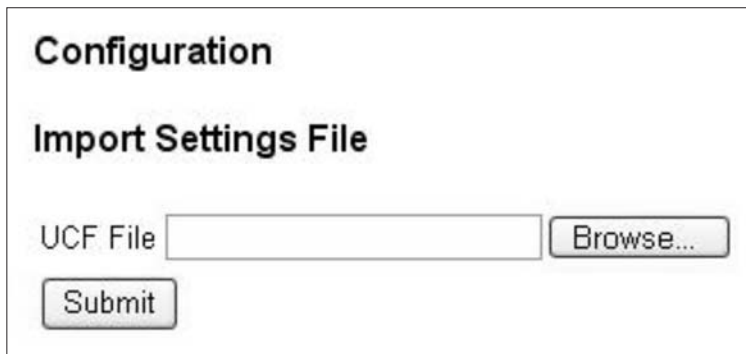

The screenshot shows a web interface with the following elements:

- Configuration** (Section Header)
- Import Settings File** (Section Header)
- UCF File (Text input field)
- (Browse button)
- (Submit button)

2. Click the **Browse** button, and search for the file to import.
3. When the file is found, click **Submit**.

Resetting the INA to factory defaults

1. Insert a pen or pencil into the small hole above the network port to restart the printer.
2. Keep the button depressed for 10–45 seconds while the printer restarts.

25XX-100, -110

4. Repair information

This chapter contains adjustments and removal procedures. Whenever parts are replaced, make sure that all adjustments are correct by running diagnostics procedures and checking adjustments as needed.

Handling ESD-sensitive parts

Many electronic products use parts that are known to be sensitive to electrostatic discharge (ESD). To prevent damage to ESD-sensitive parts, follow the instructions below, in addition to all the usual precautions, such as turning off power before removing logic boards:

- Keep the ESD-sensitive part in its original shipping container (a special “ESD bag”) until you are ready to install the part into the printer.
- Make as few movements as possible with your body to prevent an increase of static electricity from clothing fibers, carpets, and furniture.
- Put the ESD wrist strap on your wrist. Connect the wrist band to the system ground point. This discharges any static electricity in your body to the printer.
- Hold the ESD-sensitive part by its edge connector shroud (cover); do not touch its pins. If you are removing a pluggable module, use the correct tool.
- Do not place the ESD-sensitive part on the printer cover or on a metal table; if you need to put down the ESD-sensitive part for any reason, first put it into its special bag.
- Printer covers and metal tables are electrical grounds. They increase the risk of damage because they make a discharge path from your body through the ESD-sensitive part. (Large metal objects can be discharge paths without being grounded.)

- Prevent ESD-sensitive parts from being accidentally touched by other personnel. Install printer covers when not working on the printer, and do not put unprotected ESD-sensitive parts on a table.
- Keep all ESD-sensitive parts in a grounded metal cabinet (case).
- Low humidity increases static electricity during cold weather.

Adjustments



CAUTION: Be sure to unplug the power cord whenever you are working on the printer with one of the covers removed.

Printhead-to-platen gap adjustment

Perform the printhead-to-platen gap adjustment after replacing the carrier, platen, lower pinch roller, ribbon drive rack gear, left side frame, right side frame, paper separator, lower feed roller, or paper guide.

1. Turn the printer off and remove all covers, with the exception of the bottom cover. Go to **“Covers, removals” on page 4-5**.
2. Remove the ribbon cartridge and paper.
3. Remove the thread sealer from the Gap Adjust bushings on both the left and right side of the printer.
4. Set the Forms Thickness lever to position 1 by pushing it toward the back of the printer as far as it will go.
5. Move the printhead to the left edge of the rubber on the platen.
6. Shift the left Gap Adjust bushing clockwise as far as it will go.
7. Shift the right Gap Adjust bushing counterclockwise as far as it will go.

Note: At this time, the nose of the printhead should be touching the platen.

8. Using a feeler gauge (1), slowly adjust the left Gap Adjust bushing (2) counterclockwise, until a gap of 0.33–0.37 mm exists between the printhead (3) and the platen.

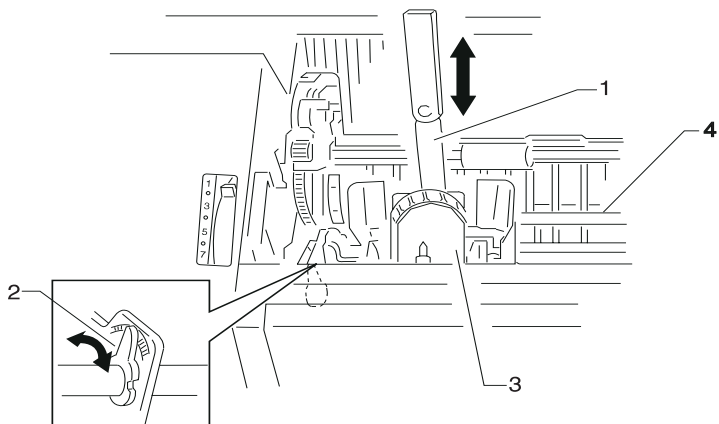

9. Move the printhead to the right edge of the rubber on the platen and using a feeler gauge (1), slowly adjust the right gap adjust bushing (2) clockwise, until a gap of 0.33–0.37 mm exists between the printhead (3) and the platen.

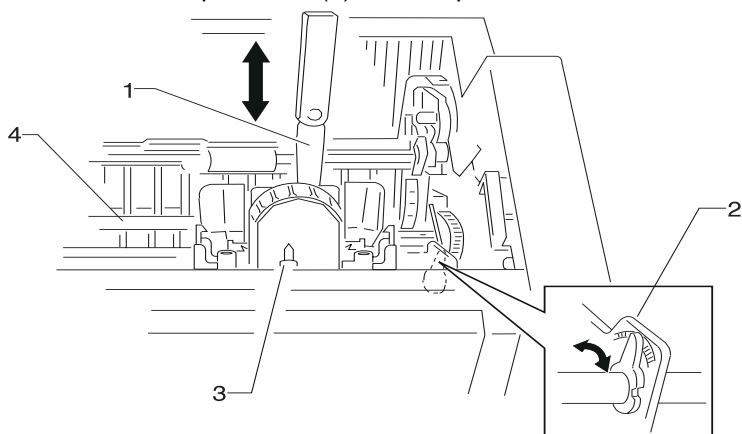

10. After adjusting both left and right Gap Adjust bushings, push the printhead to the center of the platen and verify that a gap of 0.33–0.37 mm exists between the printhead and the platen.

Note: For maximum print quality, adjust the head gap on both the left and right sides of the printer to within +/- 0.01mm. If the gap value exceeds the specified range, return to step 4 and readjust both left and right Gap Adjust bushings.

11. After confirming that the head gap is within the specified range for all printhead positions (left, right and center), apply the thread sealer to both bushings.

Bidirectional print adjustment

After replacing any mechanical part which affects the operation of the logic board or the carrier, perform the following procedure to adjust the bidirectional print. This adjustment cannot be completed if the printer runs out of paper, so be sure to use continuous forms.

1. Through the Setup Menu, be sure the default macro is set to disabled.
2. Turn the printer off.
3. Open the operator panel cover to access layer two.
4. Press and hold the **Pitch** key while turning the printer on.
 - The draft alignment bars print.
 - The current value is the number printed below the bars.
5. To set draft, select the best alignment from the alignment bars in rows 01–11.
6. Press **Micro**↑ or **Micro**↓ to select the best alignment by number, or keep the current value. After selecting, the printer prints a single row showing the current alignment setting.
7. Press **Set TOF** to save the selection.
 - The printer automatically prints the alignment bars for NLQ.
 - The current value is the number printed below the bars.
8. To set NLQ, select the best alignment from the alignment bars in rows 01–11. The current value is the number printed below the bar.
9. Press **Micro**↑ or **Micro**↓ to select the best alignment by number, or keep the current value. After selecting, the printer prints a single row showing the current alignment setting.
10. Press **Set TOF** to save the selection.
11. Close the operator panel cover. The printer returns to Ready.

Removal procedures



CAUTION: Be sure to unplug the power cord whenever you are working on the printer with one of the covers removed.

Covers, removals

Note: See **“Covers”** on page 7-3 for the description of each part.

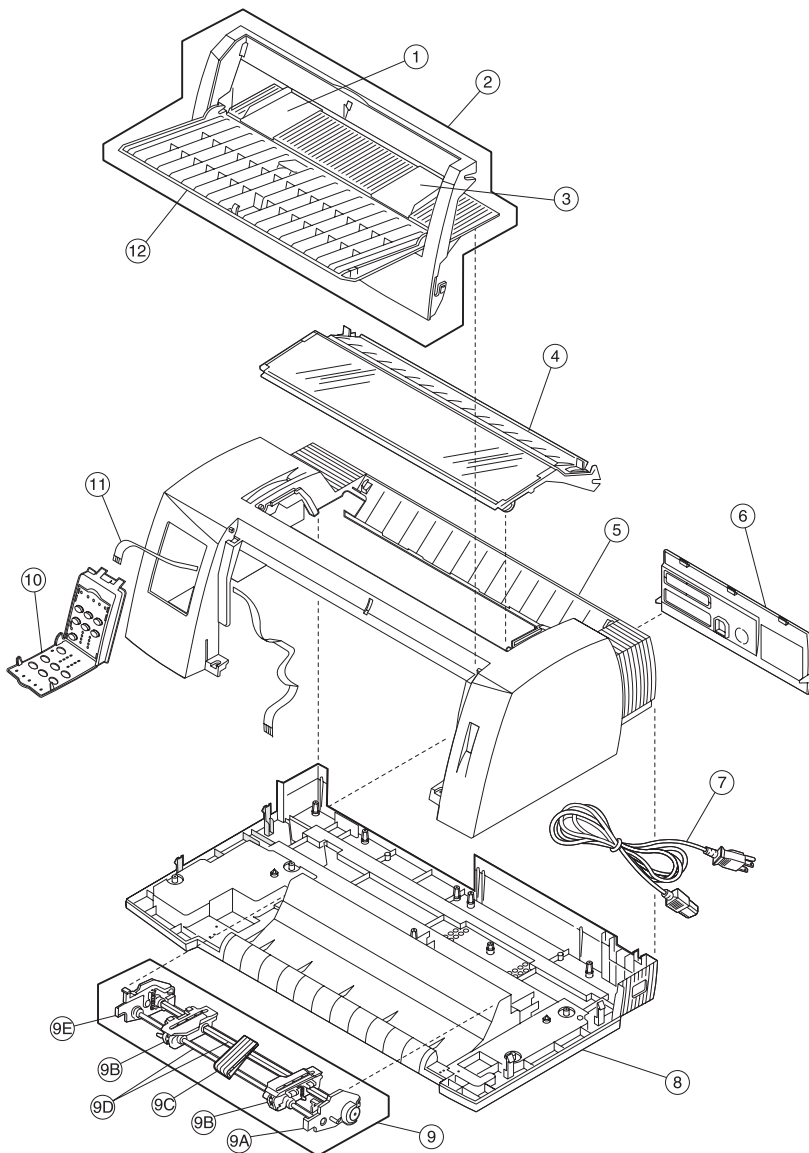

Covers, front removal

1. Rotate the front cover out and up about three inches from the bottom of the printer.
2. Push the front cover up and out of the printer.

Covers, ribbon access removal

1. Pull the gray spring-loaded ribbon access cover release latches (A), located on either side of the ribbon access cover, up toward the front of the printer.

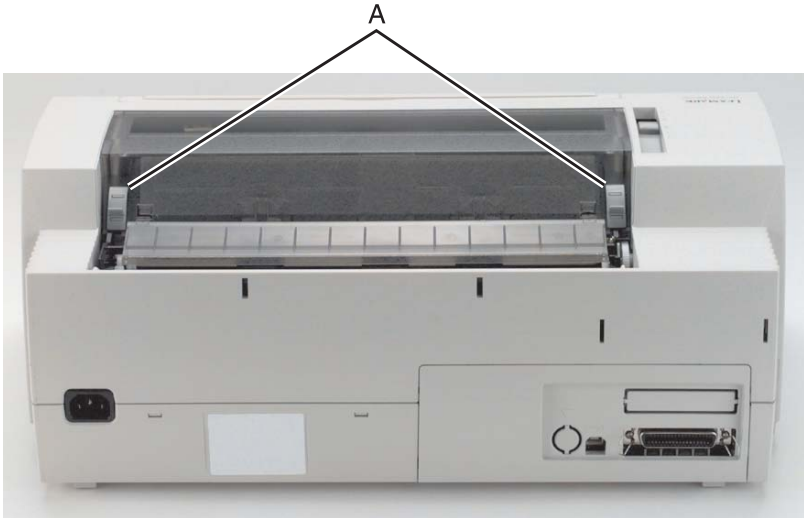

2. Lift the ribbon access cover up and out of the printer.

Note: When replacing the ribbon access cover, be sure to hook the front hinge points on either side of the ribbon access cover first, and then lower the cover into place. Be sure that both gray spring-loaded ribbon access cover latches snap and lock.

Covers, option removal

1. From the bottom, pull the option cover (A) outward and up, removing it from the printer.

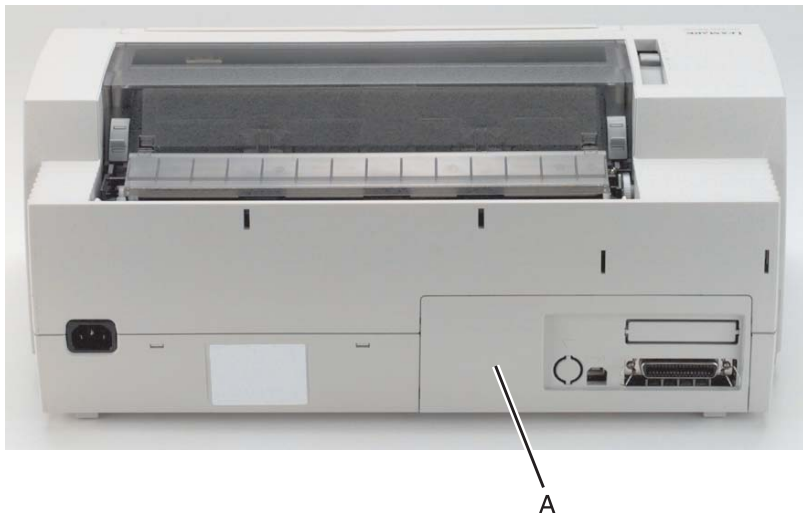

Covers, top removal



1. Turn the printer off and disconnect the power cord at the printer.
2. Remove the tractor assembly, if it is installed in the pull tractor position, by pressing the locking levers and pulling the tractor assembly out of the printer.
3. Remove the ribbon access cover. Go to **“Covers, ribbon access removal” on page 4-6.**
4. Remove the front cover. Go to **“Covers, front removal” on page 4-6.**
5. Remove the option cover. Go to **“Covers, option removal” on page 4-7.**

Note: With the option cover removed, you can see the operator panel cable attached to the logic board.

6. Disconnect the operator panel cable from the logic board.
7. Remove the two screws (A) from each side of the front cover area.

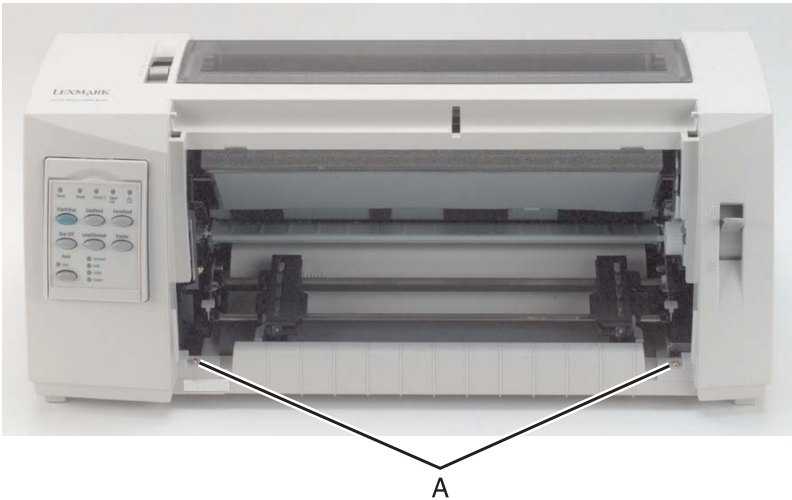

25XX-100, -110

8. Turn the printer upside down.
9. Insert a flat-blade screwdriver into each of the four holes (B) in the bottom cover, releasing the top cover from the bottom cover.

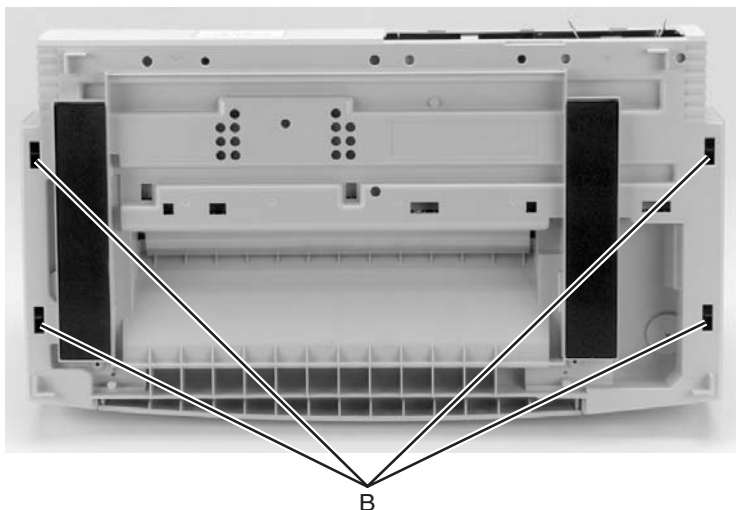

10. Turn the printer right side up, and insert a flat-blade screwdriver into each of the two holes (C) in the back of the top cover.

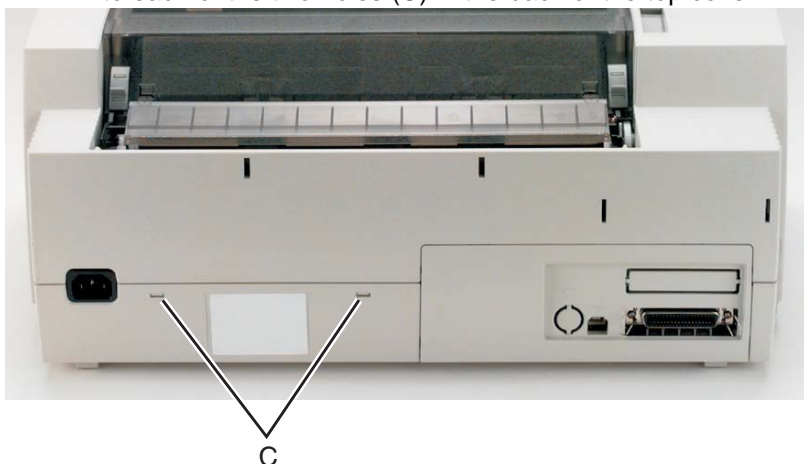

11. Lift the top cover up and over the print unit assembly.

Note: When replacing the top cover, be sure the operator panel cable is correctly aligned and inserted securely into the logic board. Damage to the operator panel cable may cause failure of other electrical components in the printer.

Covers, operator panel assembly removal

1. Remove the top cover. Go to **“Covers, top removal” on page 4-8.**
2. Disconnect the operator panel cable from the operator panel card on the inside of the top cover.
3. Push down on the two latches (A) at the top of the operator panel on the inside of the top cover, as shown.

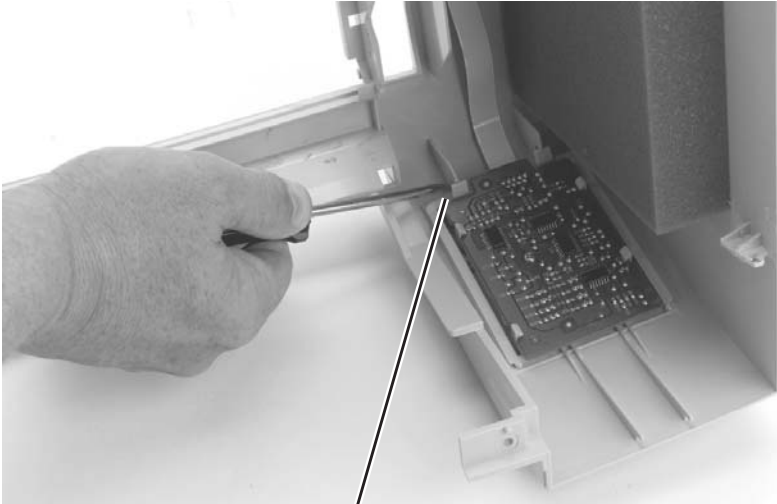

A

4. While holding the latches down, push the operator panel out of the top cover, toward the bottom of the cover.

Note: During replacement, be sure the operator panel cable is correctly inserted into both the operator panel card and the logic board.

Covers, bottom removal

1. Remove the top cover. Go to **“Covers, top removal” on page 4-8.**
2. Remove the logic board. Go to **“Logic board removal” on page 4-12.**
3. Remove the power supply unit. Go to **“Power supply removal” on page 4-16.**
4. Remove the print unit. Go to **“Print unit removal” on page 4-29.**

Electronics removals

EPROM removal

1. Remove the options cover (A) by pulling it outward and then up and out of the printer.

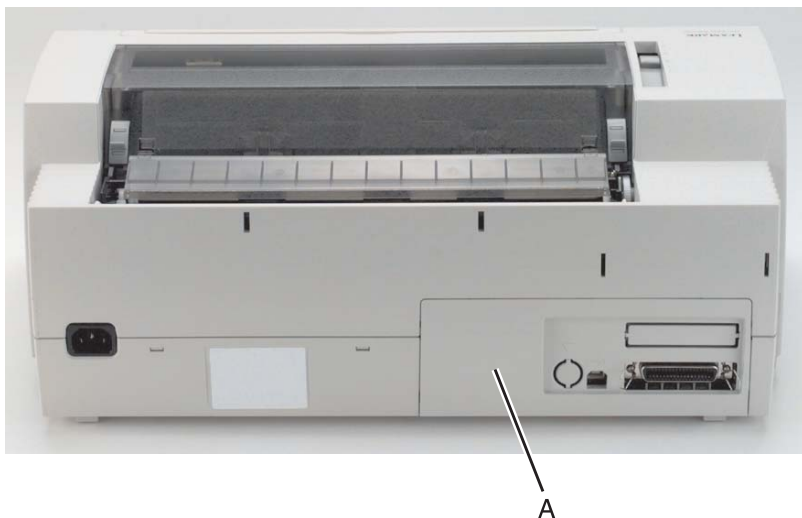

2. Remove the EPROM module.

Note: When replacing the EPROM module, be sure the notch on the module is toward the front of the printer.

Logic board removal

1. Remove the INA support frame. Go to **“INA support frame removal” on page 4-14.**
2. Disconnect all cables connected to the logic board. Go to **“Logic board (9w & 24w)” on page 5-3** for connector location details.

Note: Do not twist the flexible cable when disconnecting the printhead cable(s).

3. Remove the screw (A) securing the logic board to the bottom cover. Take care not to lose the ground clip, which must be replaced between the ground plate and the board.
4. Remove the ground clip screw (B) from the bottom cover.
5. Remove the logic board.

Note: Be sure to perform the bidirectional print adjustment after installing the logic board. Go to **“Bidirectional print adjustment” on page 4-4.**

Network card removal

1. Remove the top cover. Go to **“Covers, top removal”** on **page 4-8**.
2. Disconnect the USB cable (A) from the network card.
3. Remove the three screws (B) that secure the network card to the INA support frame.

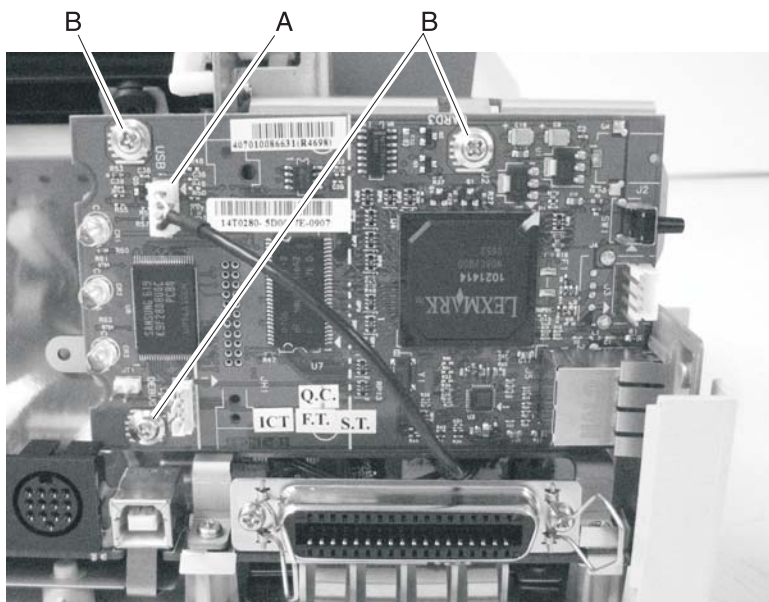

4. Slide the network card to the left, and remove it from the printer.

INA support frame removal

1. Remove the network card. Go to **“Network card removal” on page 4-13.**
2. Remove the screw (A) that secures the INA support frame to the paper feed mechanism.

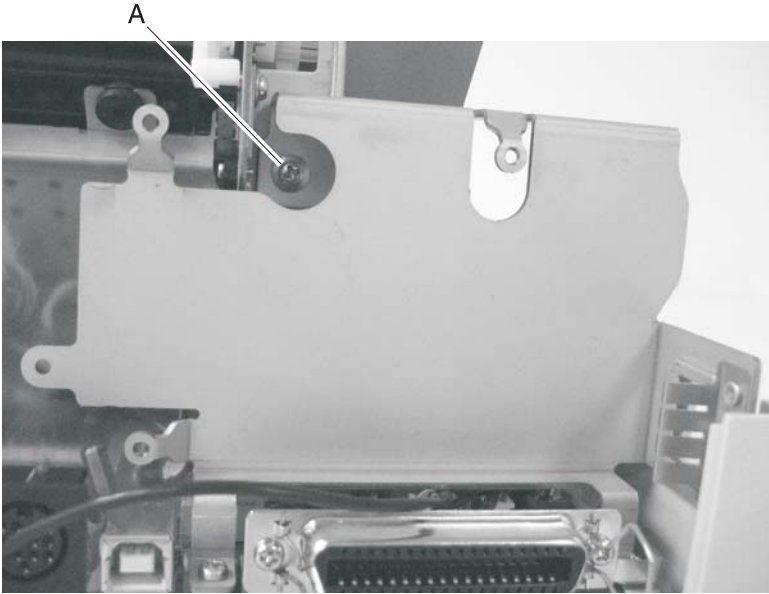

Note: To avoid printer alignment issues, make sure that the screw is not too tight when reinstalling the INA support frame.

25XX-100, -110

3. Remove the two screws (B) and the ground clips that secure the INA support frame to the bottom cover.

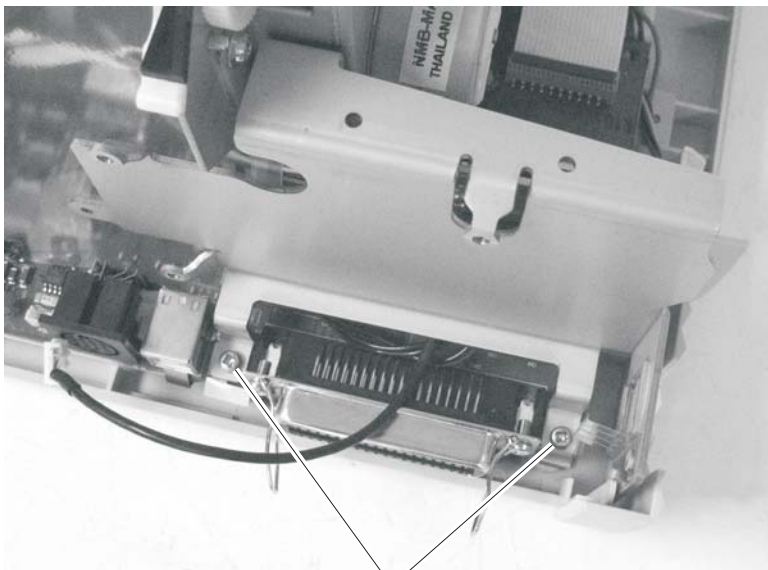

B

Note: The ground clips need to be used when reinstalling the INA support frame.

4. Remove the INA support frame from the printer.

Power supply removal



CAUTION: The power supply may be hot.

1. Turn off the printer, and disconnect the power cord at both ends.
2. Remove the top cover. Go to **“Covers, top removal” on page 4-8.**
3. Remove the print unit. Go to **“Print unit removal” on page 4-29.**

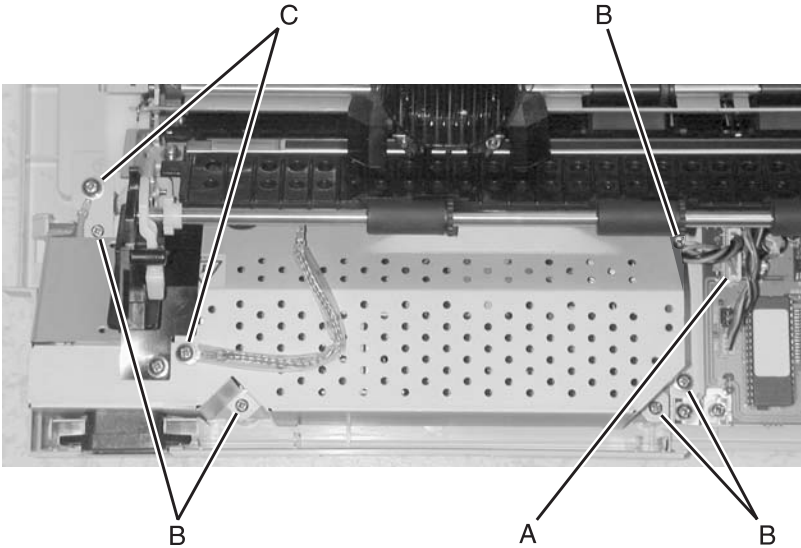

4. Disconnect the power supply cable (A).
5. Remove the five screws (B) securing the power supply to the bottom cover. Take care not to lose the ground clips, which must be replaced between the ground plate and the board.
6. Remove the two ground wire screws (C).
7. Remove the power supply.

Carrier removals

Carrier removal

1. Remove the top cover. Go to **“Covers, top removal” on page 4-8.**
2. Remove the printhead from the carrier. Go to **“Printhead removal” on page 4-28.**
3. Loosen the carrier belt:
 1. Loosen the tension screw (A).
 2. Remove tension from the belt by pulling up on the belt.
 3. Tighten the tension screw. Loosening the screw tightens the belt.



A

25XX-100, -110

4. Remove the retaining wire (B) from the left side of the carrier shaft.



25XX-100, -110

5. Remove the screw (C) from the forms thickness lever, and then remove the lever.

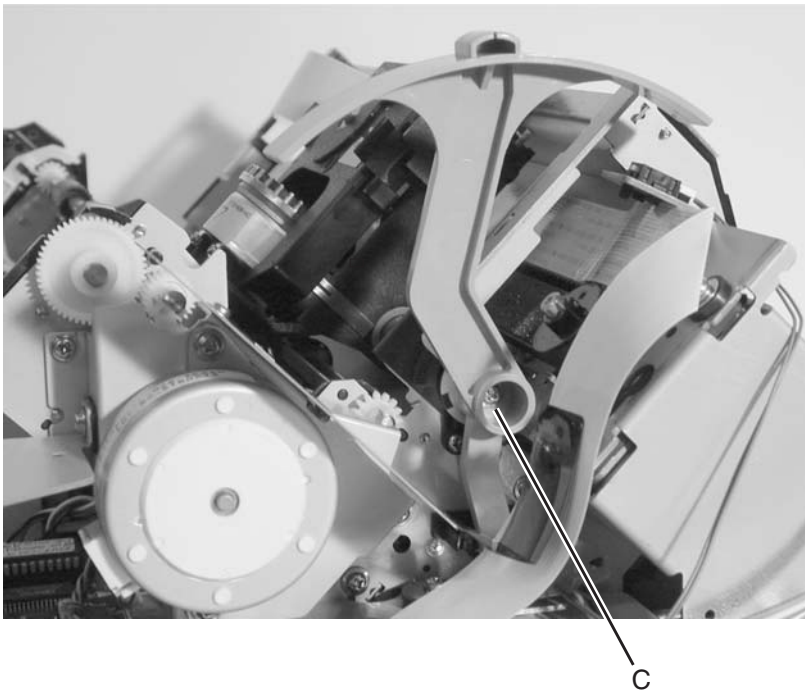

25XX-100, -110

6. Remove the lower carrier motor mount screw (D).
7. Remove the two screws (E) from the carrier shaft bushing bracket on the left end of the carrier shaft, and then remove the bracket.



E

D

8. Remove the E-clip from the right side of the carrier shaft.

25XX-100, -110

9. Push the carrier shaft (F) from the right side so it goes out of the left side of the printer.

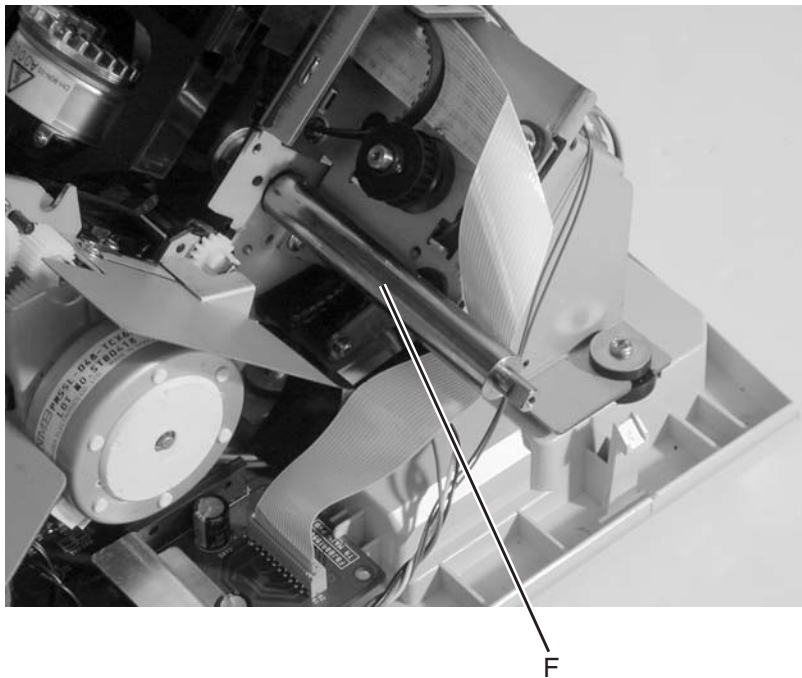

10. Remove the carrier from the printer.

Note: Following replacement, perform the printhead-to-platen gap adjustment. Go to **“Printhead-to-platen gap adjustment” on page 4-2.**

Carrier, motor assembly removal

1. Remove the top cover. Go to **“Covers, top removal” on page 4-8.**
2. Loosen the carrier belt:
 1. Loosen the tension screw (A).
 2. Remove tension from the carrier belt by pulling up on the belt.
 3. Tighten the tension screw. (Loosening the screw tightens the belt.)



3. Slip the belt off the carrier motor pulley.

25XX-100, -110

4. Remove the screw (B) from the forms thickness lever, and then remove the lever.

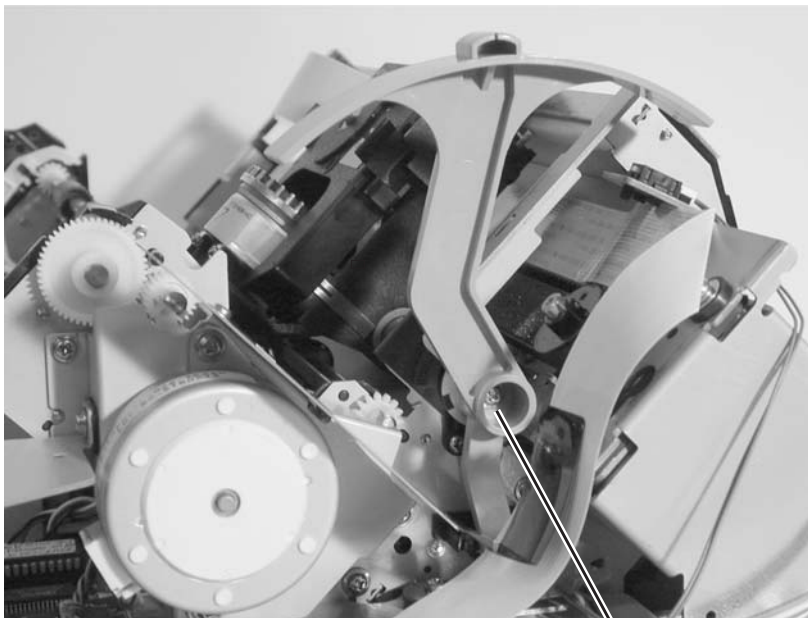

B

25XX-100, -110

5. Remove the screw (C) securing the carrier motor bracket to the bottom cover.

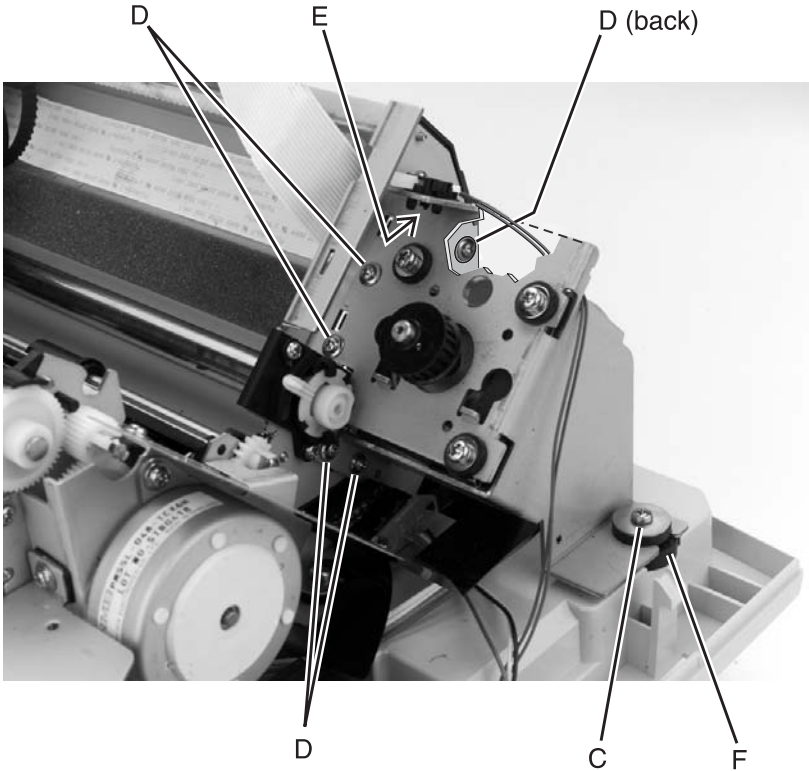

6. Disconnect the printhead cable from the logic board, and move it back and out of the way, as shown.
7. Remove the five screws (D) securing the carrier motor bracket to the print unit.
8. Remove the Home Position sensor (E) from the top of the carrier motor bracket by pinching the clips underneath the bracket.
9. Remove the carrier motor bracket from the print unit by pulling up and out on the rubber grommet (F) between the motor bracket and the bottom cover.
10. Disconnect the carrier motor cable from the logic board.
11. Remove the carrier motor from the motor bracket.

Paper handling removals

Paper Select lever removal

1. Remove the top cover. Go to **“Covers, top removal” on page 4-8.**
2. Release the latch, and remove the Paper Select lever from the right side frame.

Paper feed motor removal

1. Remove the top cover. Go to **“Covers, top removal” on page 4-8.**
2. Remove the two screws (A) from the paper feed motor bracket.

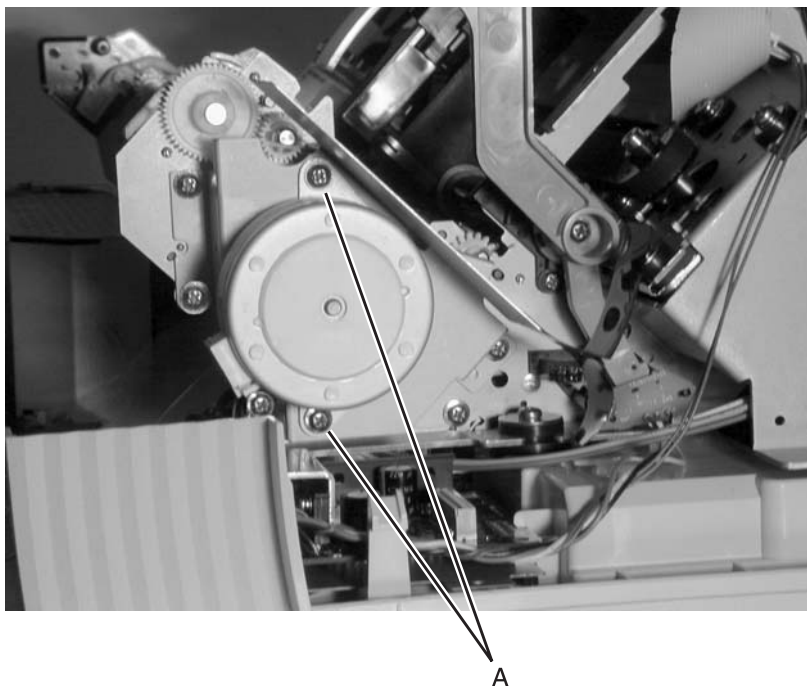

3. Remove the motor.
4. Disconnect the paper feed motor cable from the logic board.

Forms Thickness lever removal

1. Remove the top cover. Go to **“Covers, top removal” on page 4-8.**
2. Remove the screw (A) from the lever, and then remove the Forms Thickness lever.

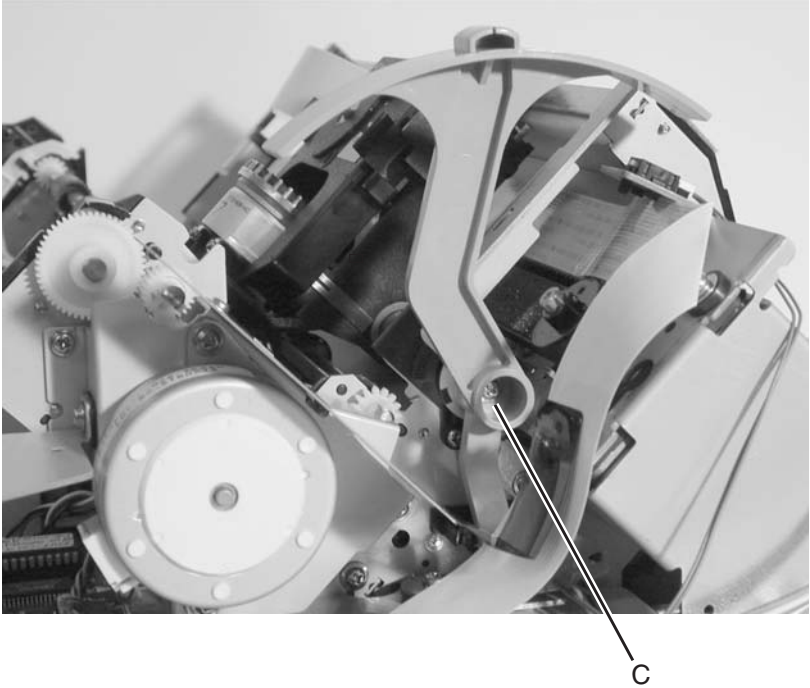

Print handling removals

Platen removal

1. Remove the top cover. Go to **“Covers, top removal” on page 4-8.**
2. Remove the two platen screws (A) from each end of the platen.

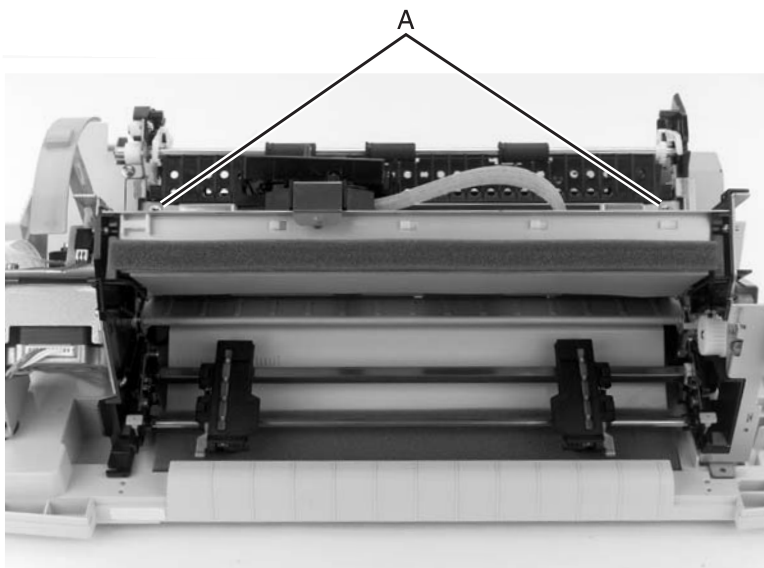

3. Remove the platen from the paper tray.
4. Perform the printhead-to-platen gap adjustment. Go to **“Printhead-to-platen gap adjustment” on page 4-2.**

Printhead removal



1. Turn the printer off.
2. Disconnect the power cord at the printer, and allow the printhead to cool for 15 minutes before you handle it.
3. Set the Forms Thickness lever to position 7.
4. Remove the ribbon access cover. Go to **“Covers, ribbon access removal” on page 4-6.**
5. Remove the ribbon cartridge.
6. Squeeze the printhead latches together while pulling the printhead up and out of the printer.
7. Disconnect the printhead cable(s) from the printhead.

Reassembly Note: Be sure the printhead cables are correctly aligned and secured. Be sure to perform the printhead-to-platen gap adjustment. Go to **“Printhead-to-platen gap adjustment” on page 4-2.**

Printhead cables removal

Warning: Be careful not to damage the printhead cable(s) as they are secured with double-sided adhesive tape.

1. Remove the top cover. Go to **“Covers, top removal” on page 4-8.**
2. Remove the printhead. Go to **“Printhead removal” on page 4-28.**
3. Release the printhead cables from the flexible cable holders.
4. Disconnect the printhead cables from the logic board.

Note: Be sure the printhead cables are correctly aligned and secured. They must be flat with no twists.

Print unit removal

1. Remove the top cover. Go to **“Covers, top removal”** on **page 4-8**.
2. Disconnect all cables from the logic board, except the power supply cable.
3. Remove the screw from the Forms Thickness lever, and then remove the lever.
4. Remove the two grommet-anchored screws (A) from the left side of the print unit.

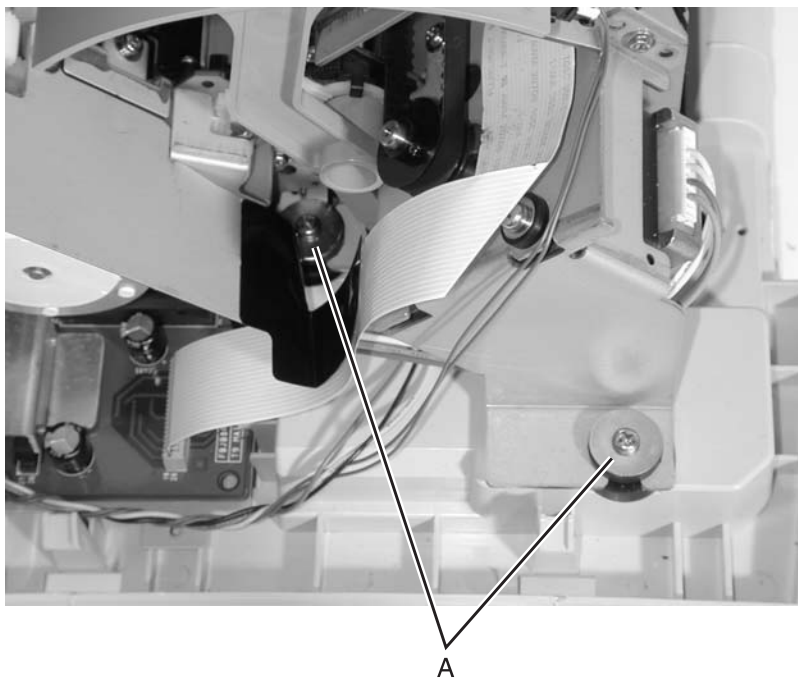

25XX-100, -110

5. Remove the two grommet-anchored screws (B) from the right side of the print unit.

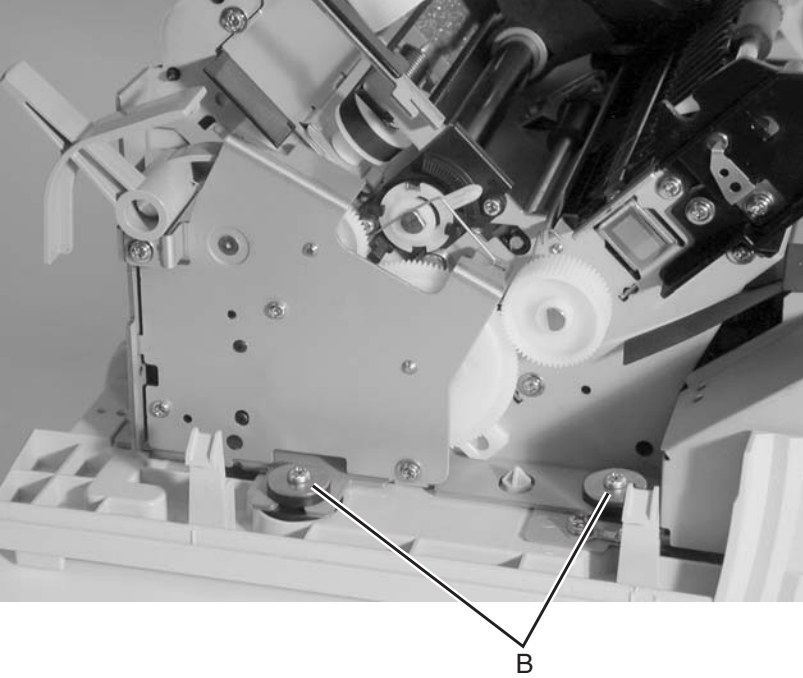

6. Remove the print unit from the bottom cover by pulling up forcefully on both sides of the print unit.

Ribbon drive rack gear removal

1. Remove the top cover. Go to **“Covers, top removal”** on **page 4-8**.
2. Remove the carrier. Go to **“Carrier removal”** on **page 4-17**.
3. Unsnap the white plastic end stop (A) from the top left side of the print unit.



A

4. Unlatch the left side of the rack from the top of the print unit.
5. Slide the rack to the right and out of the print unit.

Gears removals

Left side gears removal

1. Remove the top cover. Go to **“Covers, top removal”** on **page 4-8**.
2. Remove the three screws (A) from the serial interface card bracket.

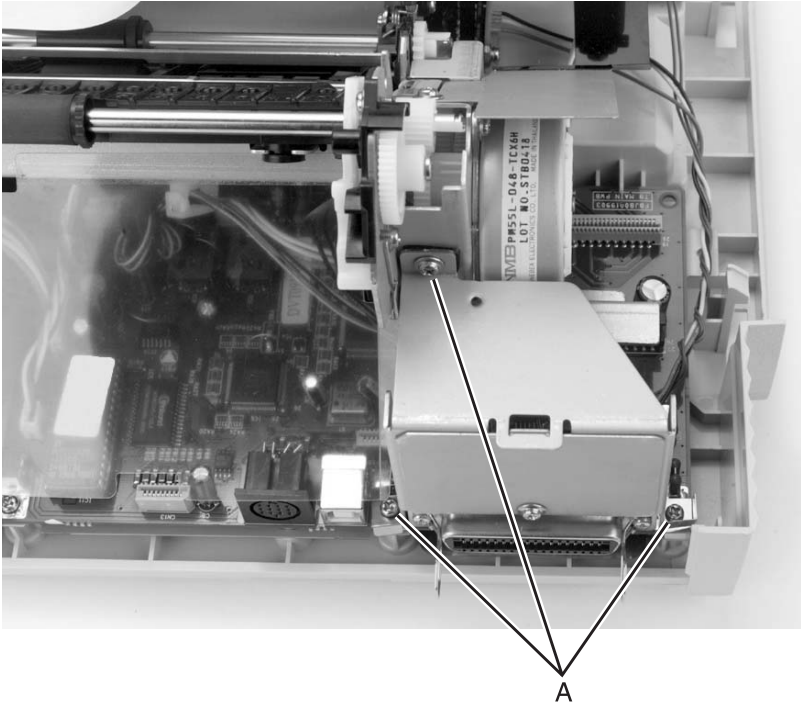

25XX-100, -110

3. Remove the four screws (B) from the paper feed motor bracket assembly.

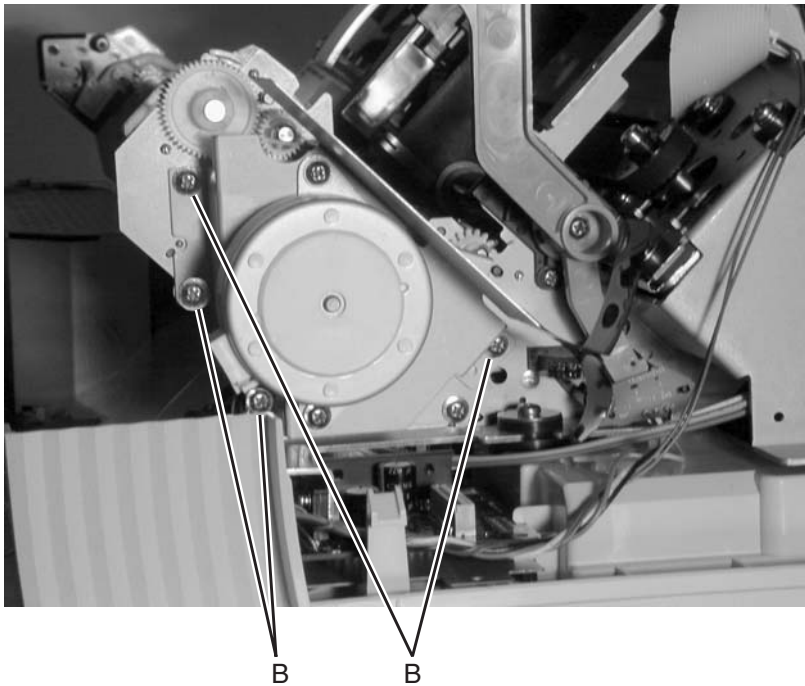

25XX-100, -110

4. Remove the paper feed motor bracket assembly, exposing the gears as shown.

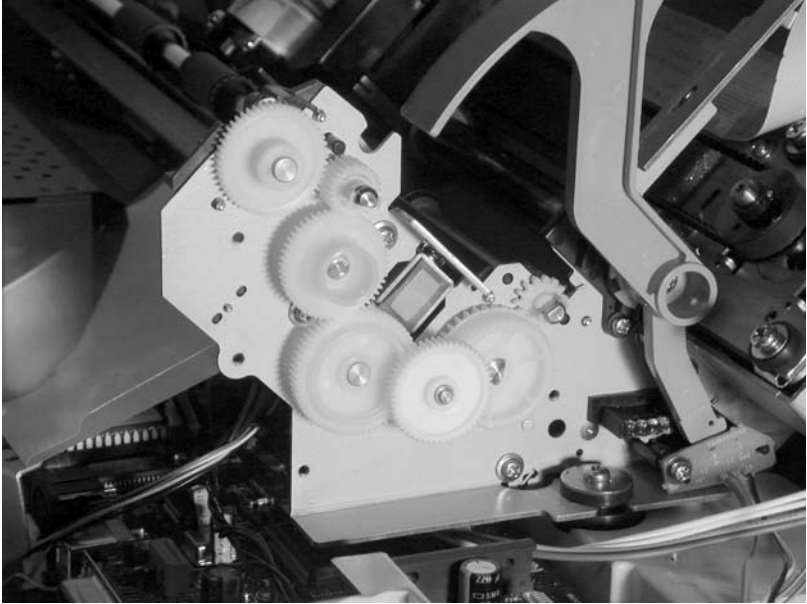

Right side gears, sub frame removal

1. Remove the top cover. Go to **“Covers, top removal”** on **page 4-8**.
2. Unhook the wire retainer (A) from the carrier shaft.

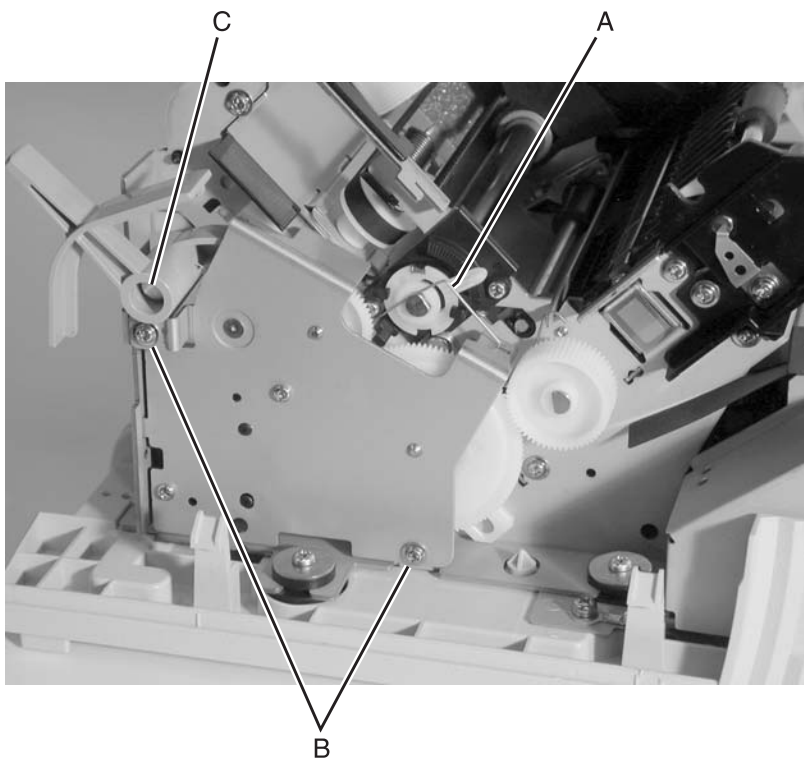

3. Remove the two screws and washers (B) from the sub frame.
4. Remove the Paper Select lever (C).

25XX-100, -110

5. Remove the sub frame, exposing the right side gears (D) as shown.

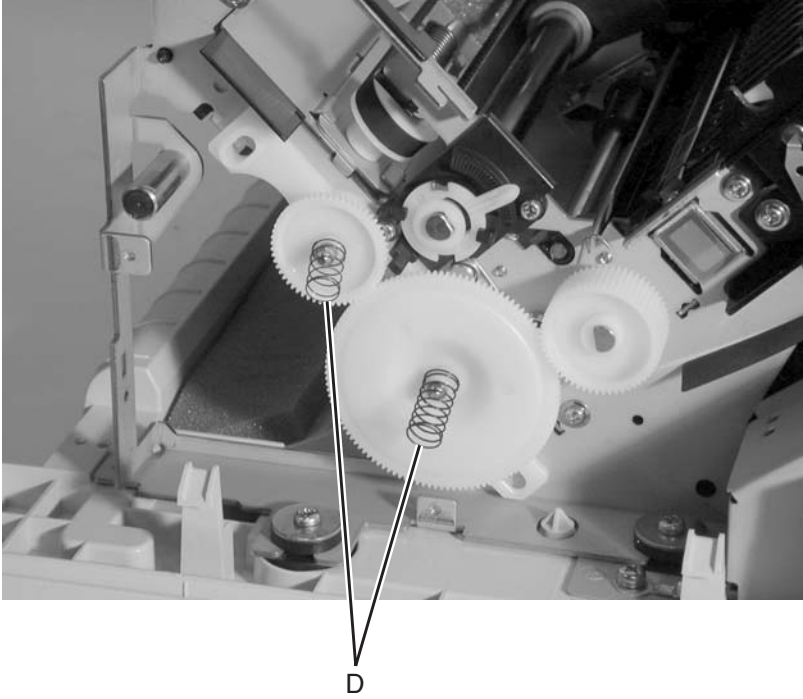

Rollers removals

Roller, upper feed removal

1. Remove the top cover. Go to **“Covers, top removal”** on **page 4-8**.
2. Remove the screw from the print cable shield, and then remove the shield.
3. Remove the gear from the left end of the upper feed roller, as shown.

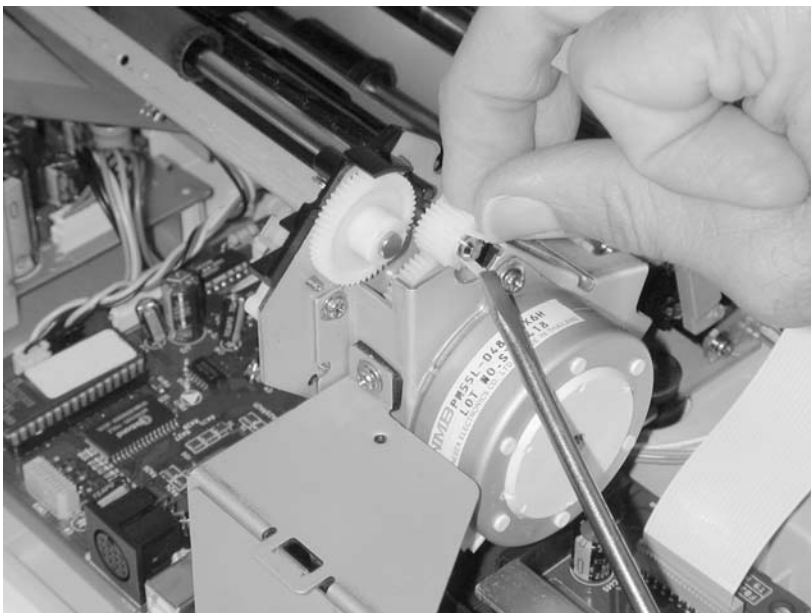

25XX-100, -110

4. Remove the two screws (A) from the right upper feed roller bracket. One screw also retains the upper feed roller ground clip.

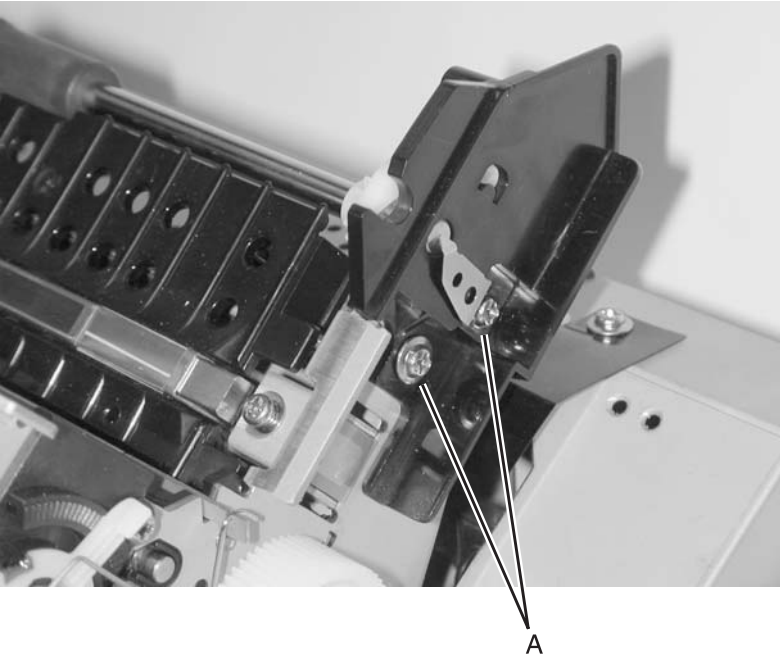

5. Pull the upper feed roller from the left bracket and then out of the printer.
6. Be sure to perform the Printhead-to-platen gap adjustment. Go to **“Printhead-to-platen gap adjustment” on page 4-2.**

Roller, lower pinch removal

1. Remove the top cover. Go to **“Covers, top removal”** on **page 4-8**.
2. Slide the carrier to the far left of the printer.
3. Remove the four screws (A) from the paper feed motor bracket.

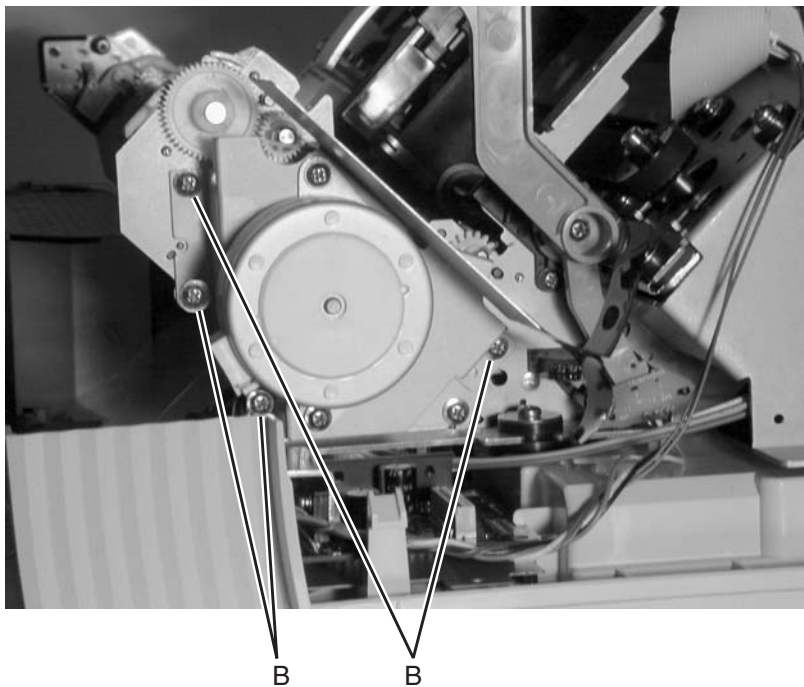

4. Remove the screw from the top of the serial interface card bracket.
5. Disconnect the paper feed motor cable from the logic board, and then remove the paper feed motor and bracket from the printer.
6. Slide the carrier to the left side of the printer.

25XX-100, -110

7. Unhook the spring clip (B) from the right end of the lower pinch roller shaft, and then push it off the gray slotted spring block (C) toward the back of the printer, as shown.

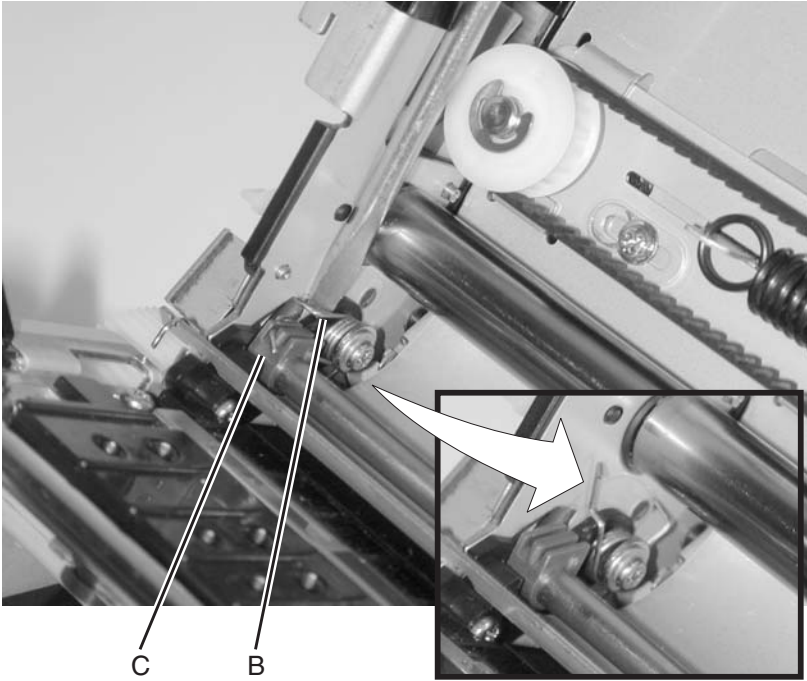

8. Slide the carrier to the right side of the printer.

25XX-100, -110

9. Unhook the spring clip (D) from the left end of the lower pinch roller shaft, and then push it off the gray slotted spring block (B) toward the back of the printer, as shown.

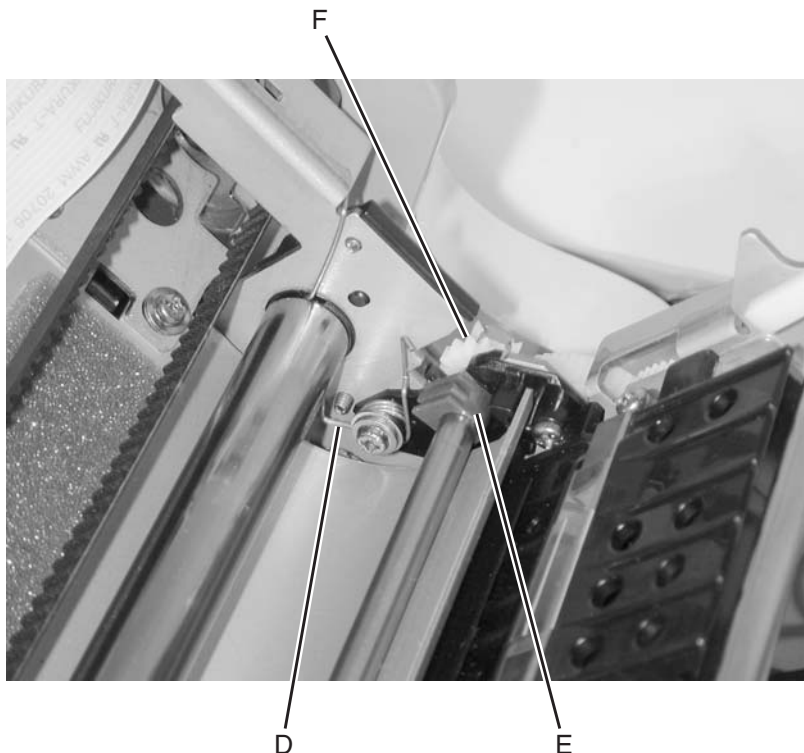

10. Slide the carrier to the center of the printer.
11. Slide the gray slotted spring blocks (E), on each end, toward the center of the roller shaft, taking care that the blocks remain with the shaft during removal.
12. Slide the carrier to the right side of the printer.
13. While holding the lower pinch roller shaft by the gear (F), move the shaft to the left approximately one-half inch. Lift the shaft up and to the back of the printer, and then carefully remove the lower pinch roller and shaft.
14. Perform the printhead-to-platen gap adjustment. Go to **“Printhead-to-platen gap adjustment” on page 4-2.**

Roller, lower feed removal

1. Remove the top cover. Go to **“Covers, top removal” on page 4-8.**
2. Remove the print unit. Go to **“Print unit removal” on page 4-29.**
3. Remove the carrier. Go to **“Carrier removal” on page 4-17.**
4. Remove the two screws securing the black bracket to the inside of the right side frame.
5. Remove the right side sub frame and the right side gears. Go to **“Right side gears, sub frame removal” on page 4-35.**
6. Remove the left side gears. Go to **“Left side gears removal” on page 4-32.**
7. Remove the gears and C-clip from both ends of the lower feed roller.
8. Remove the upper feed roller. Go to **“Roller, upper feed removal” on page 4-37.**

25XX-100, -110

9. Remove the two screws (A) securing the platen to the side frames.

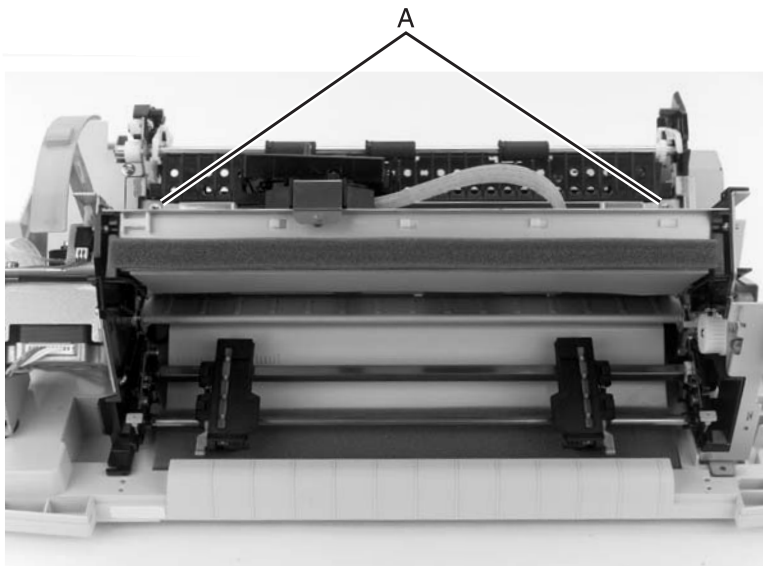

10. Remove the carrier motor bracket. Go to **“Carrier, motor assembly removal” on page 4-22.**
11. Remove the five screws securing the left side frame, and then remove the frame.
12. Remove the four screws from the right side frame, and then remove the bottom frame assembly.
13. Remove the five screws from the frame support plate, and then remove the lower feed roller.
14. Be sure to perform the printhead-to-platen gap adjustment. Go to **“Printhead-to-platen gap adjustment” on page 4-2.**

Sensor removals

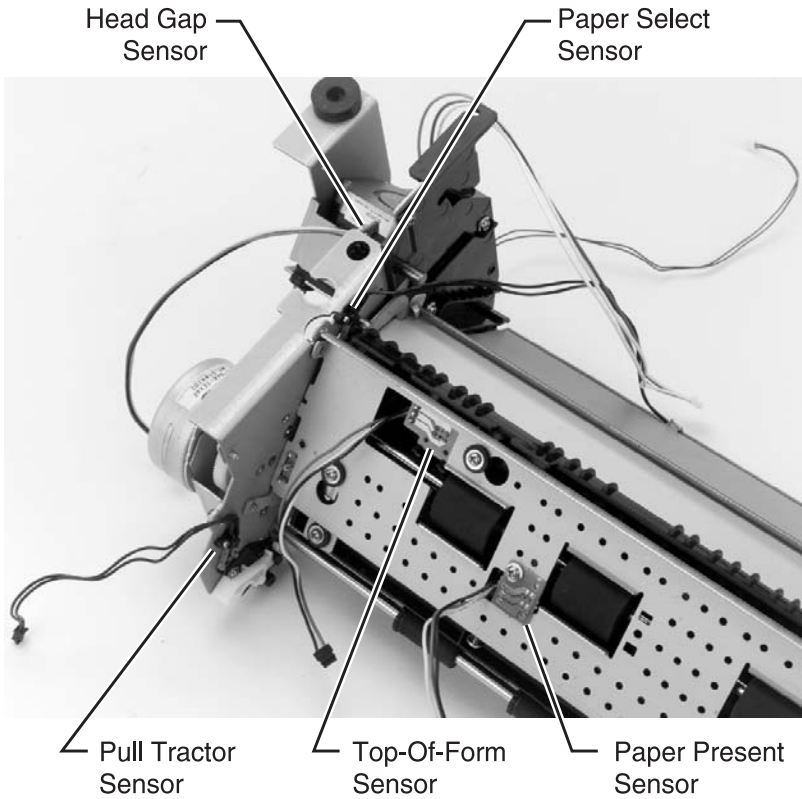

Sensor, Pull Tractor removal

1. Remove the top cover. Go to **“Covers, top removal” on page 4-8.**
2. Remove the small screw securing the Pull Tractor sensor to the inside of the left frame. Go to **“Sensor removals” on page 4-44.**
3. Disconnect the pull tractor sensor from the logic board.

Sensor, Head Gap removal

1. Remove the top cover. Go to **“Covers, top removal” on page 4-8.**
2. Remove the screw from the Forms Thickness lever, and then remove the lever.
3. Remove the screw from the Head Gap sensor, and then remove the sensor.
4. Disconnect the Head Gap sensor cable from the logic board. Go to **“Sensor removals” on page 4-44.**

Sensor, Top-of-form removal

1. Remove the top cover. Go to **“Covers, top removal” on page 4-8.**
2. Remove the print unit. Go to **“Print unit removal” on page 4-29.**
3. Turn the print unit upside down.
4. Unsnap the Top-of-form sensor from the platen. Go to **“Sensor removals” on page 4-44.**

Sensor, Paper Select removal

1. Remove the top cover. Go to **“Covers, top removal” on page 4-8.**
2. Remove the print unit. Go to **“Print unit removal” on page 4-29.**
3. Turn the print unit upside down.
4. Remove the four small screws securing the Paper Select sensor to the left side frame. Go to **“Sensor removals” on page 4-44.**

Sensor, Paper Present removal

1. Remove the top cover. Go to **“Covers, top removal” on page 4-8.**
2. Remove the print unit. Go to **“Print unit removal” on page 4-29.**
3. Turn the print unit upside down.
4. Remove the small screw securing the Paper Present sensor to the bottom frame. Go to **“Sensor removals” on page 4-44.**

Flags, Paper Present/Top-of-form removal

1. Remove the lower feed roller. Go to **“Roller, lower feed removal” on page 4-42.**
2. Remove the Paper Present flag or the Top-of-form flag from the paper guide. Go to **“Sensor removals” on page 4-44.**

Sensor, Home Position sensor removal

1. Remove the top cover. Go to **“Covers, top removal”** on **page 4-8**.
2. Disconnect the Home Position sensor cable from the logic board.
3. Unsnap the Home Position sensor (A) from the frame.

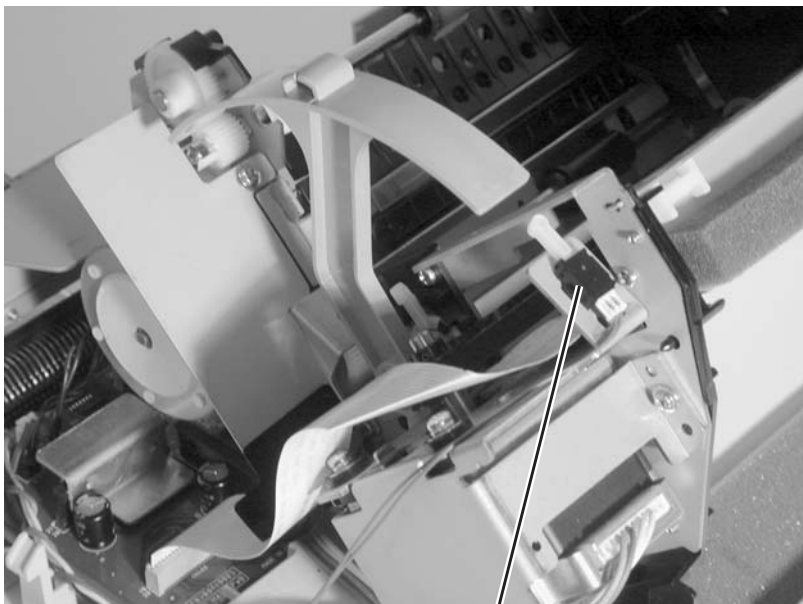

A

Options removals

Auto Sheet Feeder gears removal

1. Remove the right cover.
2. Release the joint gear latch (A) and remove the joint gear.

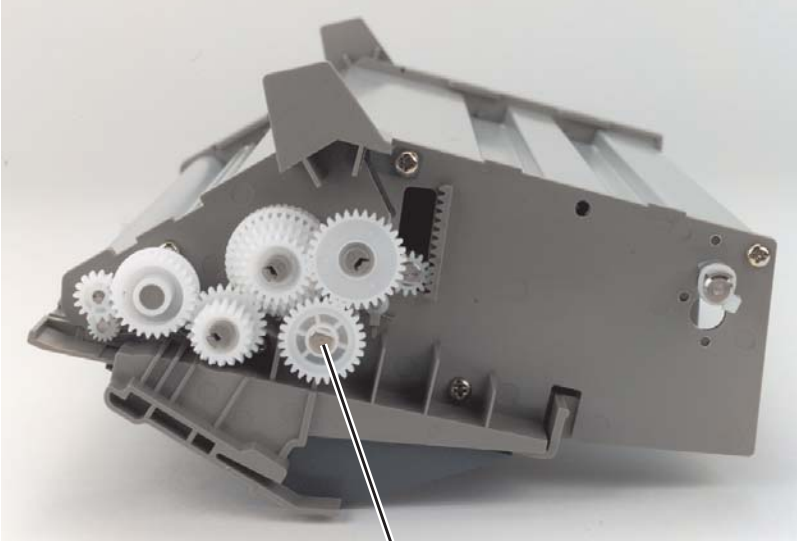

A

3. Release the idler gear latch, and remove the idler gear.
4. Release the pick-up gear latch, and remove the pick-up gear.
5. Release the combination lock mechanism latch.
6. Remove the tension plate on the locker cam, and remove the cam.
7. Release the lift gear latch, and remove the gear.

Auto Sheet Feeder pick-up roller removal

1. Remove the covers and the cut sheet support.
2. Release the joint gear latch (A), and remove the joint gear, idler gear, and pick-up gear.

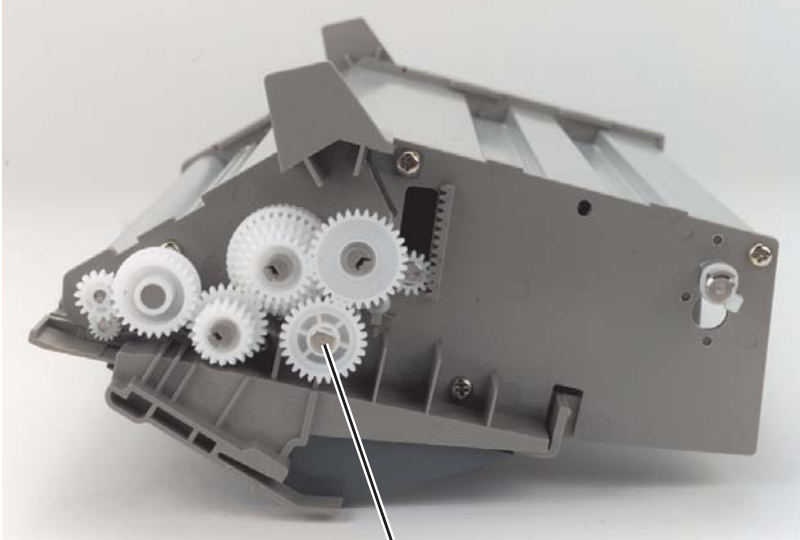

A

3. Remove the left and right roller bushings.
4. Move the pick-up rollers to the ends of the shaft, and then remove them.

25XX-100, -110

5. Locations and connectors

This chapter identifies the locations of specific parts of the printer.

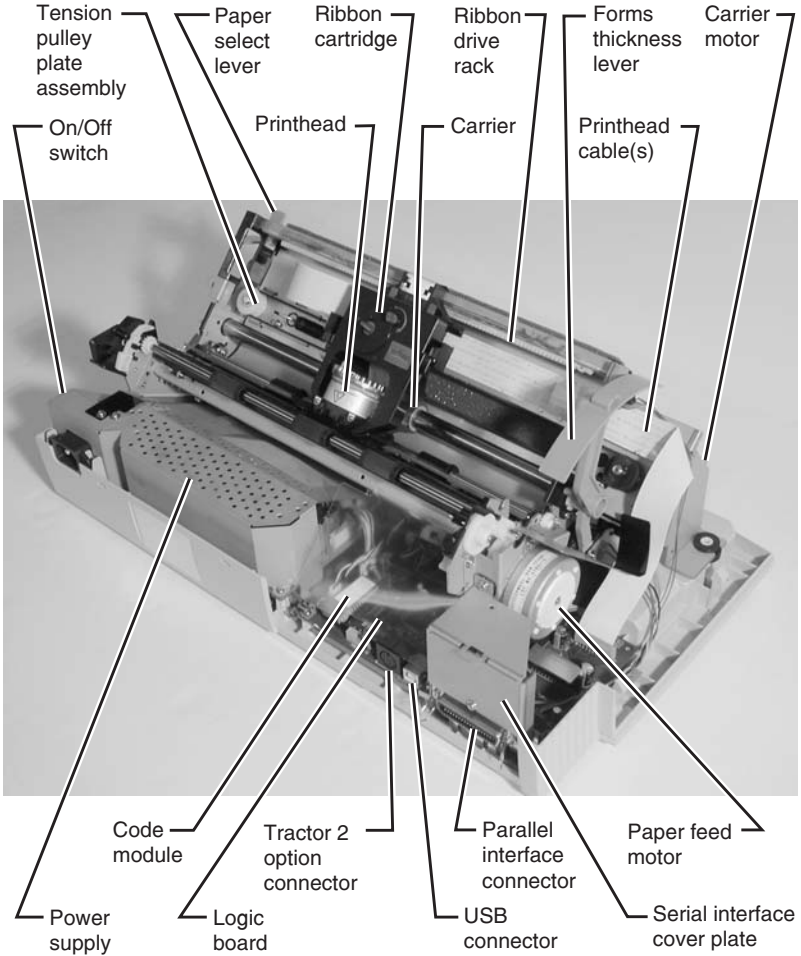

Signal connections

Power supply (9w & 24w)

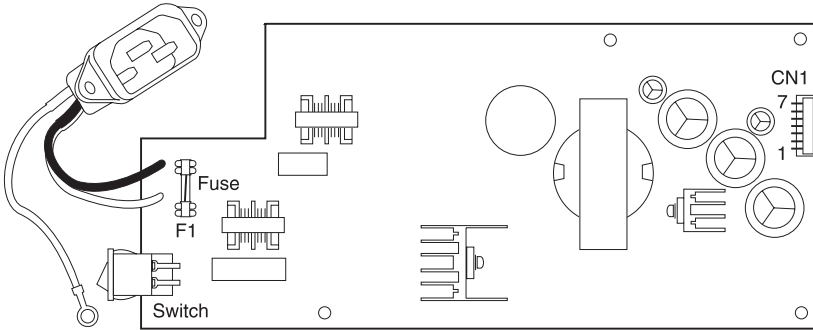

Connector	Pin #	Signal
CN1	1	+40 V dc
	2	+40 V dc
	3	Power Gnd
	4	Power Gnd
	5	Signal Gnd
	6	+5 V dc
	7	Power Save Mode
Connector	Signal	
F1	Fuse	

25XX-100, -110

Logic board (9w & 24w)

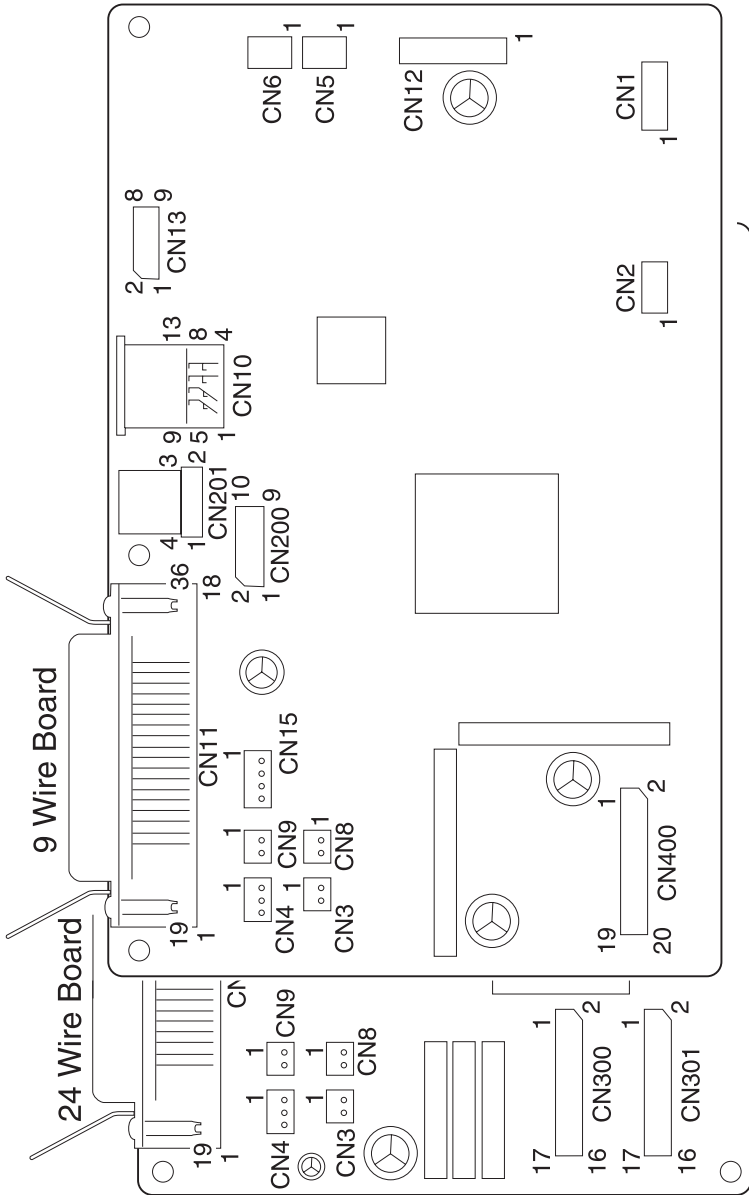

25XX-100, -110

Connector	Signal
F1	Fuse

Connector	Pin #	Signal
CN1	1	+40 V dc
	2	+40 V dc
	3	Power Gnd
	4	Power Gnd
	5	Signal Gnd
	6	+5 V dc
	7	Power Save Mode

Connector	Signal
F1	Fuse

Logic board– Parallel interface cable (9w & 24w)

Connector	Pin #	Signal	Pin #	Signal
CN11	1	-Strobe	19	Signal Gnd
	2	Data 0	20	Signal Gnd
	3	Data 1	21	Signal Gnd
	4	Data 2	22	Signal Gnd
	5	Data 3	23	Signal Gnd
	6	Data 4	24	Signal Gnd
	7	Data 5	25	Signal Gnd
	8	Data 6	26	Signal Gnd
	9	Data 7	27	Signal Gnd
	10	-Acknlg	28	Signal Gnd
	11	Busy	29	Signal Gnd
	12	PE	30	Signal Gnd
	13	Select	31	-INIT
	14	-AUTFED	32	-ERROR
	15	NC	33	Signal Gnd
	16	Signal Gnd	34	NC
	17	Chassis Gnd	35	+5 V dc
	18	+5 V dc	36	-SELIN

Logic board (9w & 24w)

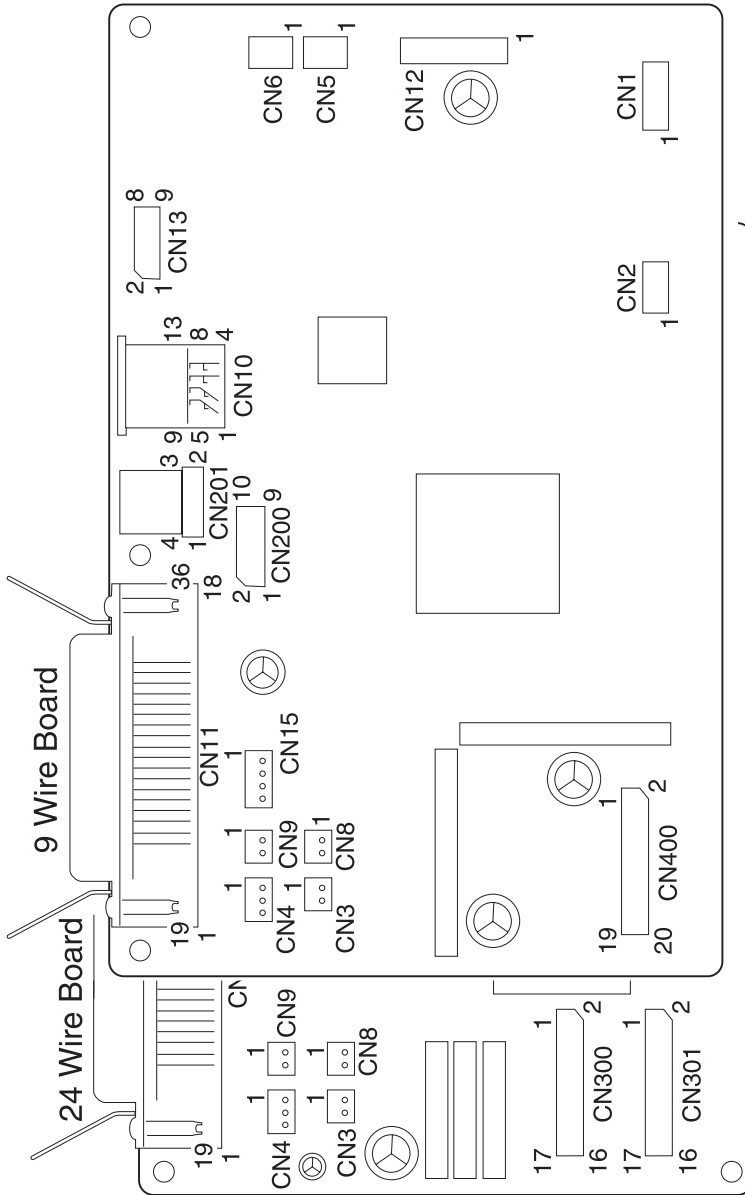

Logic board– Serial board (9w & 24w)

Connector	Pin #	Signal
CN200	1	+5 V dc
	2	+5 V dc
	3	-CTS
	4	DTS
	5	RXD
	6	RTS
	7	DSR
	8	TXD
	9	Signal Gnd
	10	SBSET

Connector	Pin #	Signal
CN1	10	+5 V dc
	9	+5 V dc
	8	-CTS
	7	DTS
	6	RXD
	5	RTS
	4	DSR
	3	TXD
	2	Signal Gnd
	1	SBSET

Logic board (9w & 24w)

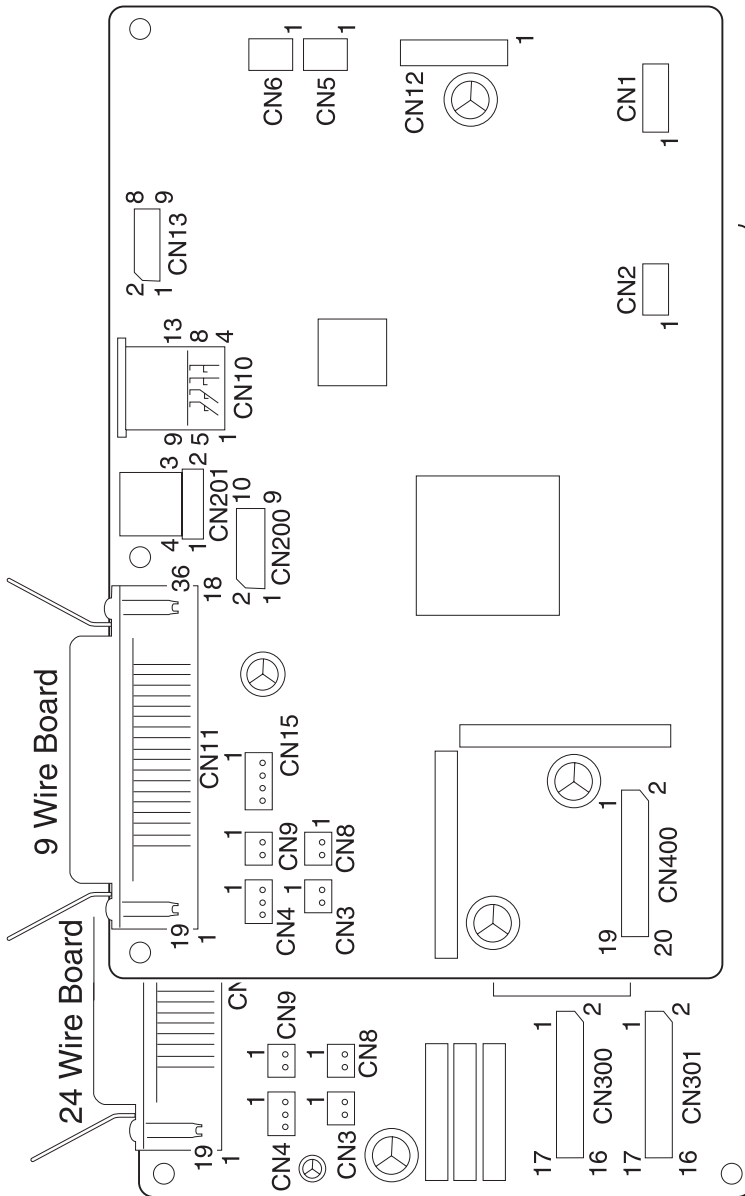

Logic board– USB cable (9w & 24w)

Connector	Pin #	Signal
CN201	1	+5 V dc
	2	DMNS
	3	DPLS
	4	Signal Gnd

Logic board– DC power (9w & 24w)

Connector	Pin #	Signal
CN12	1	+40 V dc
	2	+40 V dc
	3	Power Gnd
	4	Power Gnd
	5	Signal Gnd
	6	+5 V dc
	7	Power Save Mode

Logic board (9w & 24w)

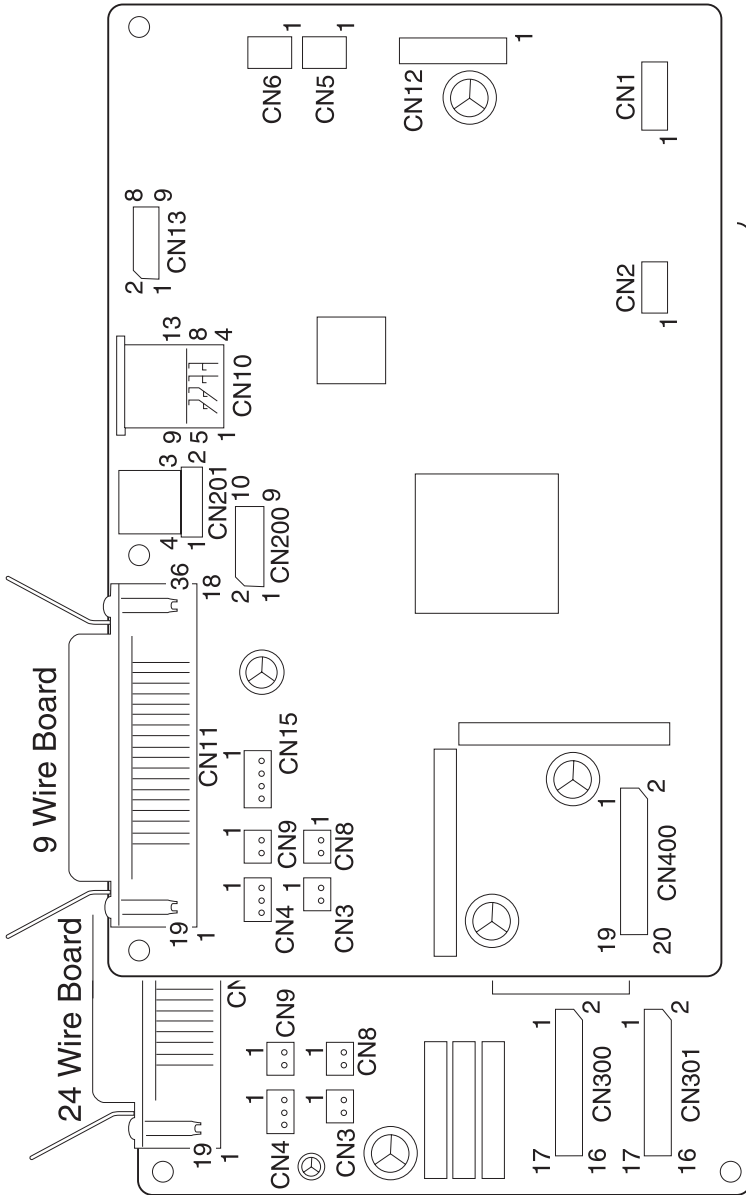

Logic board– Printhead (9w)

Connector	Pin #	Signal
CN400	1	H4
	2	H6C
	3	H8C
	4	H1C
	5	H6
	6	H2C
	7	H4C
	8	H8
	9	H2
	10	H9
	11	HDTHERMO
	12	+5 V dc
	13	H1
	14	H9C
	15	H3
	16	H7C
	17	H5
	18	H3C
	19	H7
	20	HSC

Logic board (9w & 24w)

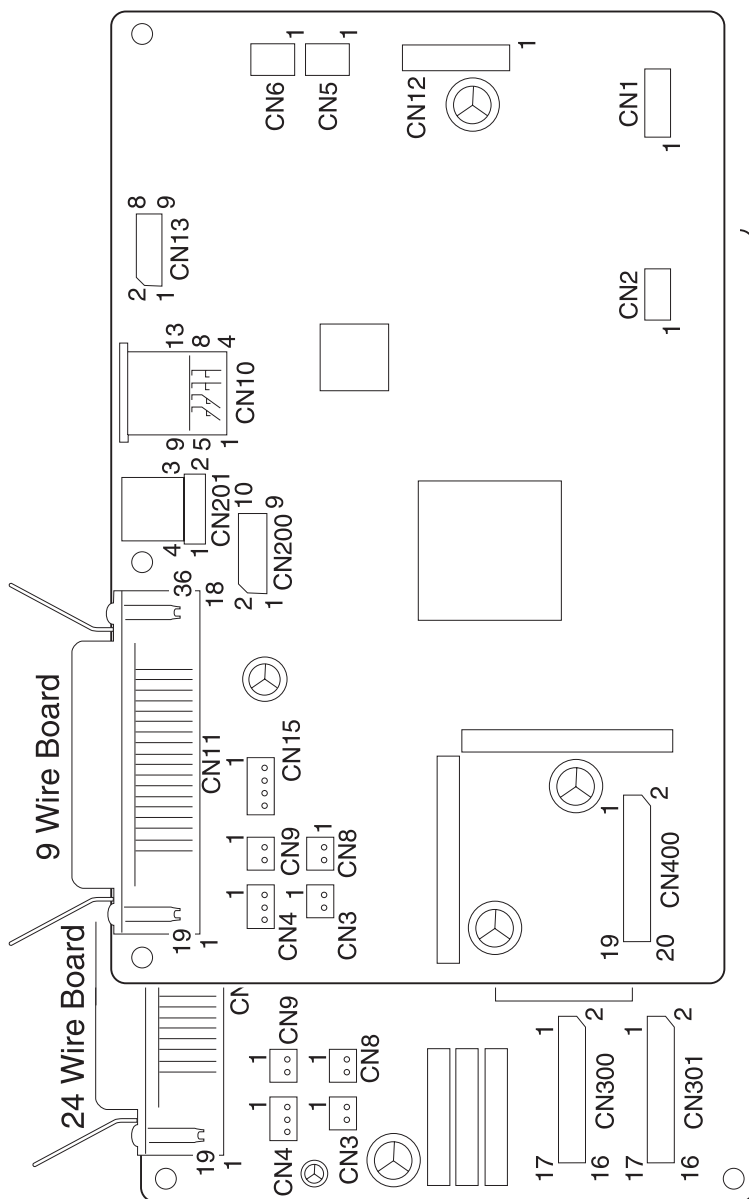

Logic board– Printhead (24w)

Connector	Pin #	Signal
CN300	1	+40 V dc
	2	R15
	3	+40 V dc
	4	R21
	5	+40 V dc
	6	R23
	7	+40 V dc
	8	L24
	9	R13
	10	L22
	11	L14
	12	L20
	13	+40 V dc
	14	L18
	15	+40 V dc
	16	L16
	17	+40 V dc

Logic board (9w & 24w)

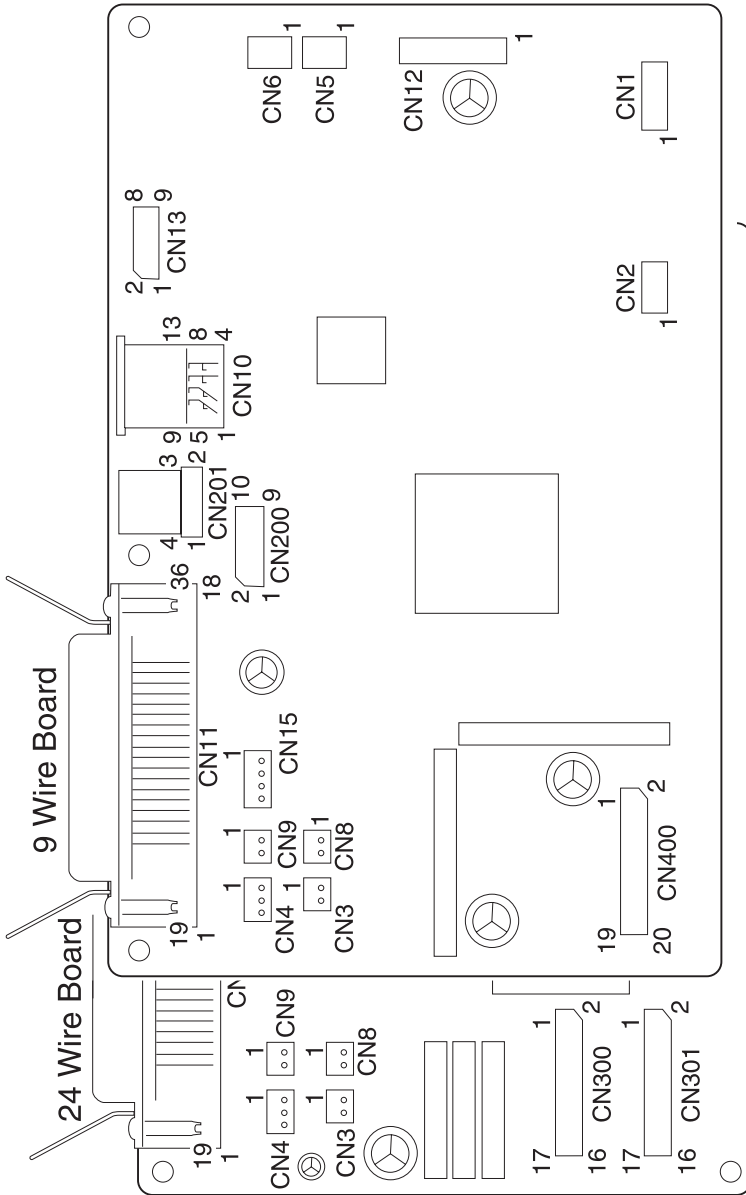

Logic board– Printhead (24w)

Connector	Pin #	Signal
CN301	1	R9
	2	R11
	3	R7
	4	R17
	5	R5
	6	R19
	7	R3
	8	HDTHERMO
	9	R1
	10	+5 V dc
	11	L2
	12	+40 V dc
	13	L4
	14	+40 V dc
	15	L6
	16	L12
	17	L8
	18	L10

Logic board (9w & 24w)

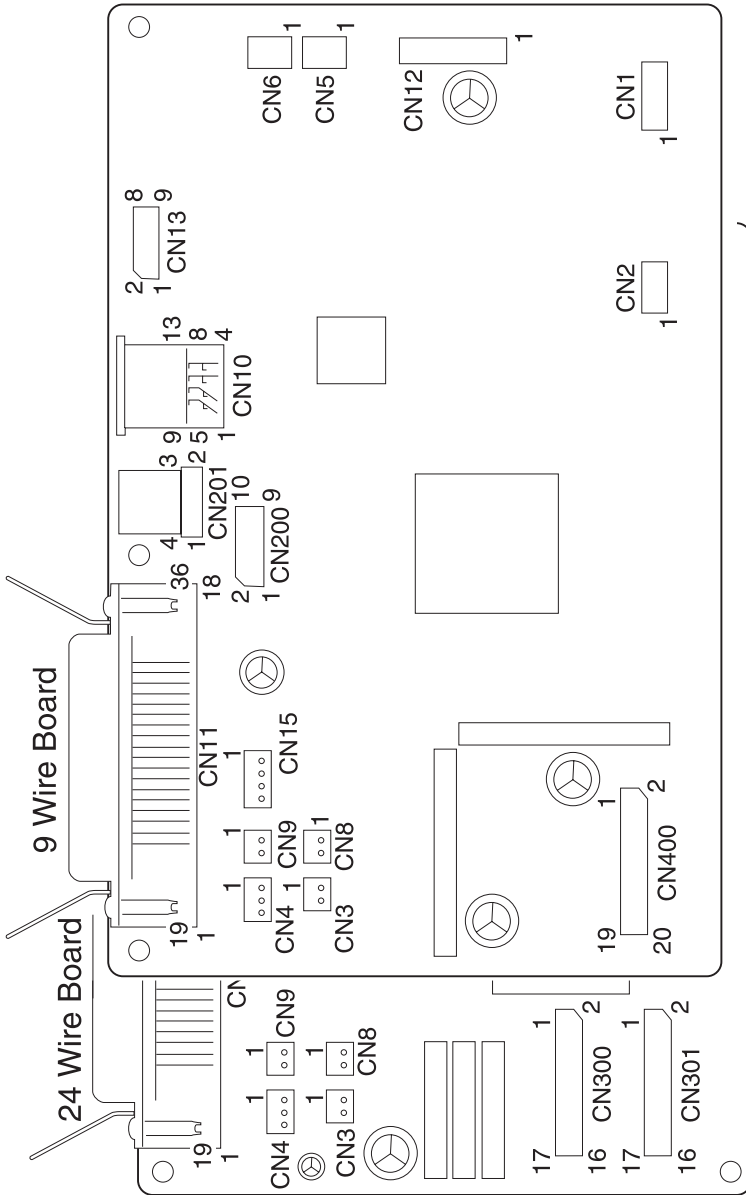

Logic board– Gap Set sensor (9w & 24w)

Connector	Pin #	Signal
CN4	1	GAP1
	2	Signal Gnd
	3	GAP2

Logic board– Home Position sensor (9w & 24w)

Connector	Pin #	Signal
CN9	1	HPSW
	2	Signal Gnd

Logic board– (9w & 24w)

Connector	Pin #	Signal
CN15	1	5V
	2	D-
	3	D+
	4	Signal Gnd

Logic board– Paper Present sensor (9w & 24w)

Connector	Pin #	Signal
CN5	1	PE1P
	2	PE1
	3	Signal Gnd

Logic board (9w & 24w)

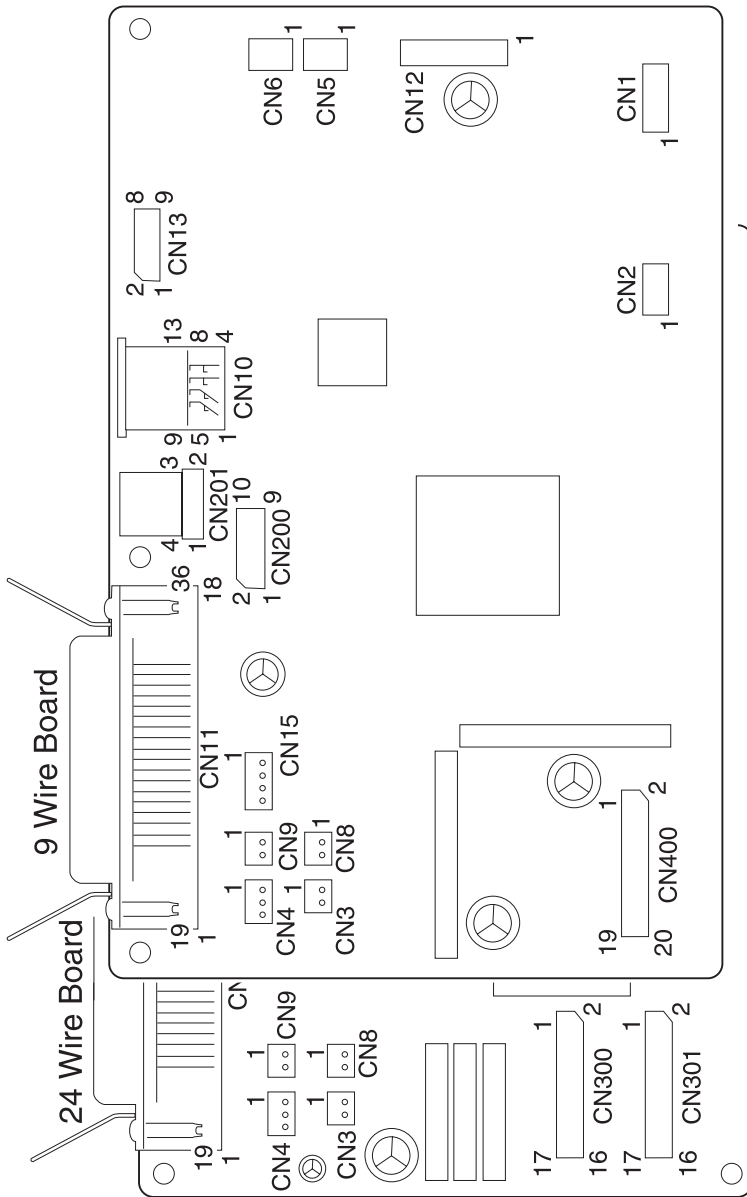

Logic board– Paper Select sensor (9w & 24w)

Connector	Pin #	Signal
CN8	1	TR/FR
	2	Signal Gnd

Logic board– Pull Tractor sensor (9w & 24w)

Connector	Pin #	Signal
CN3	1	PLTR
	2	Signal Gnd

Logic board– Top-of-form sensor (9w & 24w)

Connector	Pin #	Signal
CN6	1	Signal Gnd
	2	PE2P
	3	PE2

Logic board (9w & 24w)

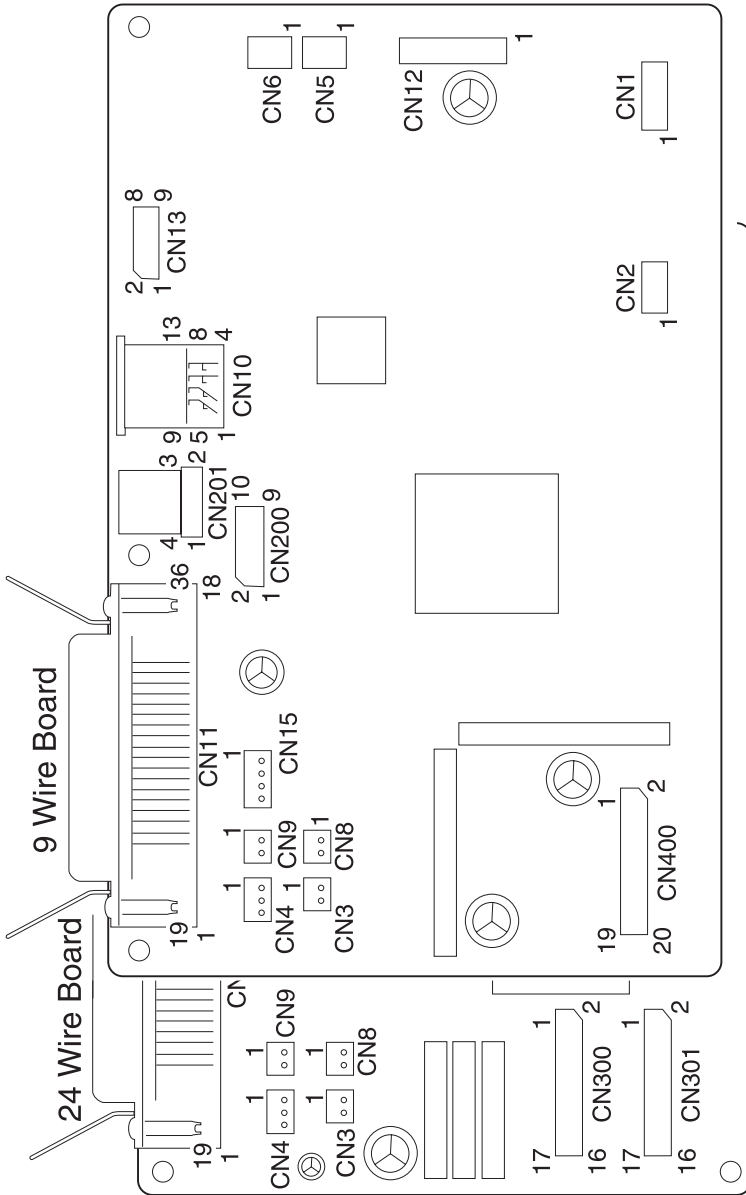

Logic board– Carrier motor (9w & 24w)

Connector	Pin #	Signal
CN2	1	CAD
	2	CAC
	3	CAB
	4	CAA

Logic board– Paper feed motor (9w & 24w)

Connector	Pin #	Signal
CN1	1	LFD
	2	LFC
	3	LFB
	4	LFA
	5	NC

Logic board (9w & 24w)

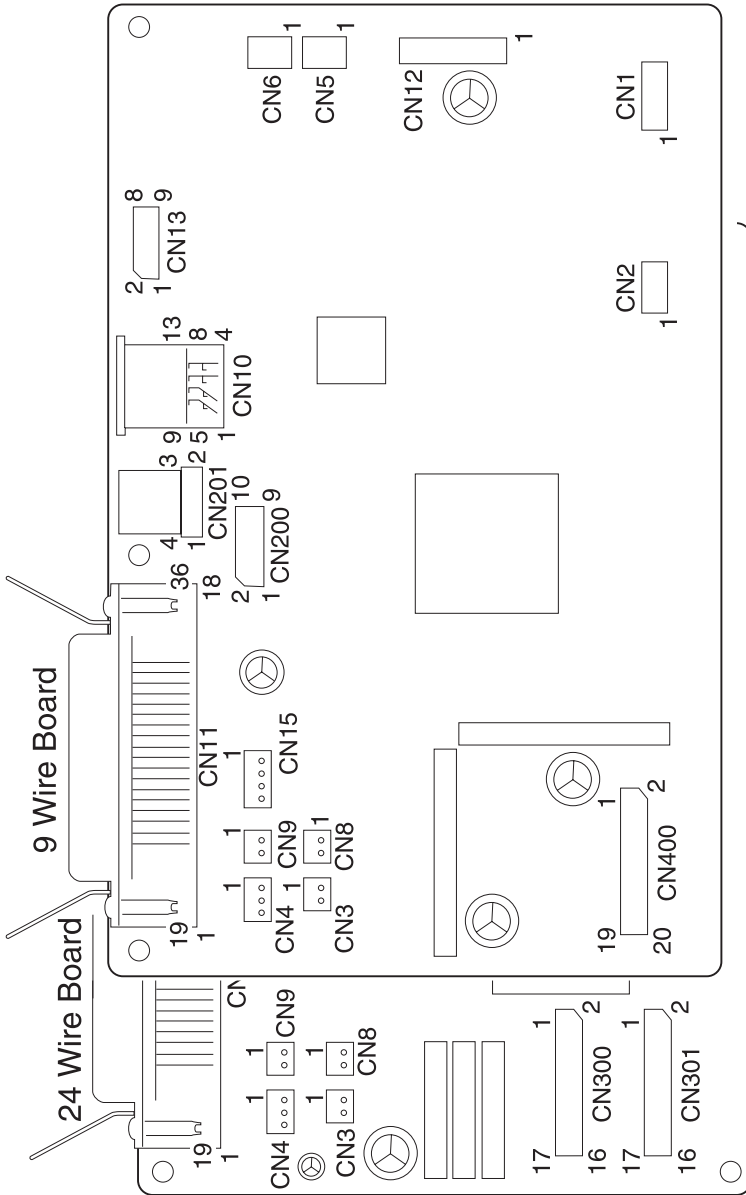

Logic board– Operator panel (9w & 24w)

Connector	Pin #	Signal
CN13 Logic board	1	+5 V dc
	2	SLATCH
	3	+5 V dc
	4	TXD
	5	Signal Gnd
	6	RXD
	7	Signal Gnd
	8	SCLK
	9	SG

Connector	Pin #	Signal
CN1 Operator panel	1	+5 V dc
	2	SLATCH
	3	+5 V dc
	4	TXD
	5	Signal Gnd
	6	RXD
	7	Signal Gnd
	8	SCLK
	9	SG

Logic board (9w & 24w)

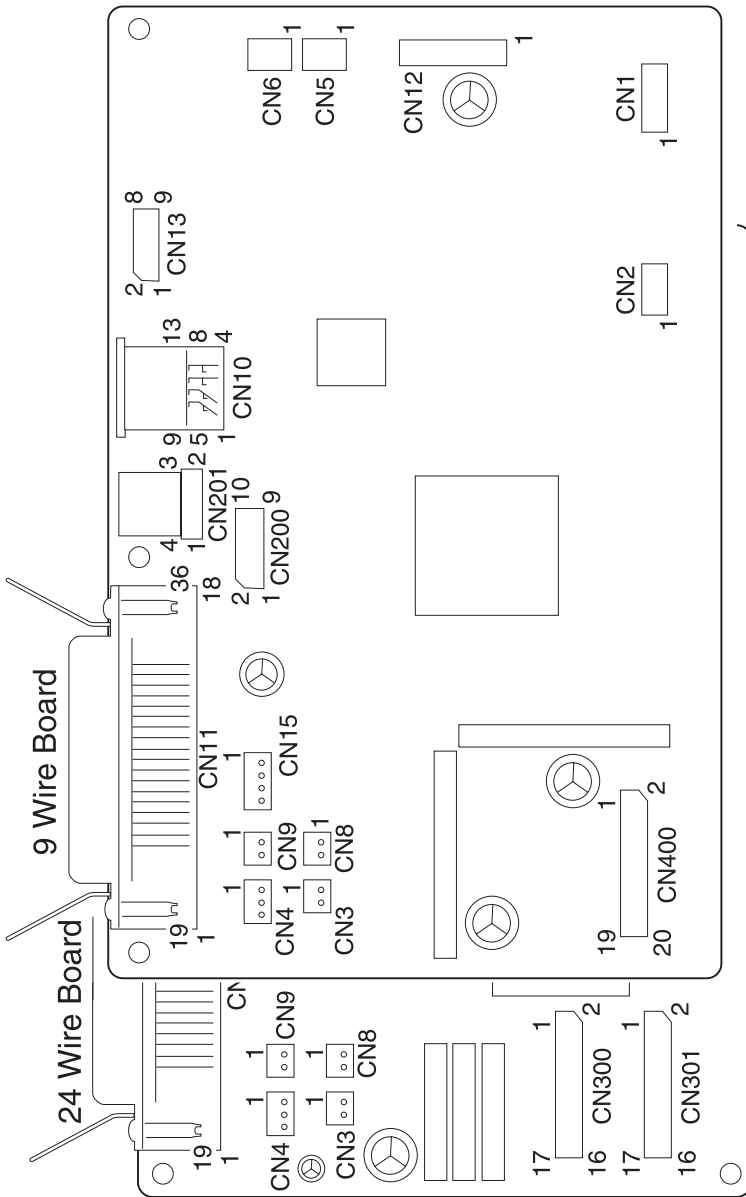

Logic board– Dual tractor cable (9w & 24w)

Connector	Pin #	Signal
CN10	1	+40 V dc
	2	+40 V dc
	3	Power Gnd
	4	Power Gnd
	5	+5 V dc
	6	COCOM
	7	D-SET
	8	Signal Gnd
	9	COA
	10	COB
	11	JAM
	12	D-H.P
	13	D-POS

Serial board– Serial cable (9w & 24w)

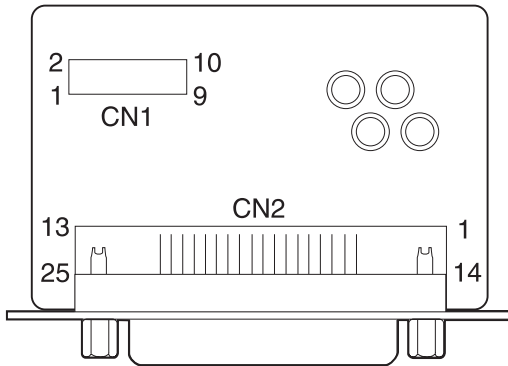

Connector	Pin #	Signal	Pin #	Signal
CN2	1	Chassis Gnd	13	NC
	2	TXD	14	NC
	3	RXD	15	NC
	4	RTS	16	NC
	5	-CTS	17	NC
	6	DSR	18	NC
	7	Signal Gnd	19	NC
	8	NC	20	DTR
	9	NC	21	NC
	10	NC	22	NC
	11	NC	23	NC
	12	NC	24	NC
			25	NC

Tractor 2 cable connectors

The Tractor 2 cable is soldered to the Tractor 2 board at CN1; there is no connector.

Connector	Mode
CN1-1	+26 V dc
CN1-2	+26 V dc
CN1-3	Frame GND
CN1-4	Not used.
CN1-5	+5 V dc
CN1-6	Motor common
CN1-7	D-Set (signal for Tractor 2 plugged in)
CN1-8	Signal GND
CN1-9	Motor phase A; 0 V dc except when Tractor 2 motor is on.
CN1-10	Motor phase B; +5 V dc when Tractor 2 not in use; 0 V dc when Tractor 2 is in use.
CN1-11	Not used.
CN1-12	Slider home sensor; +5 V dc when open, 0 V dc when closed.
CN1-13	Tractor 2 in-place sensor; +5 V dc when open, 0 V dc when closed.

25XX-100, -110

6. Preventive maintenance

This chapter describes procedures for preventive maintenance for the printer. Following these recommendations can help prevent problems and maintain optimum performance.

Lubrication

Warning: Petroleum-based lubricants can attack polycarbonate parts, causing premature failure. Use only mineral oil-based lubricants.

The following parts should be lubricated when replaced:

- Oil felt (carrier block)
- Tractor unit
- Side frame (left)
- Side frame (right)
- Pinch roller (lower)
- Pinch roller spring (left)
- Pinch roller spring (center)
- Pinch roller spring (right)
- Paper separator

Specified lubricants

- Oil– P/N 1280443
- Approved equivalents:
 - Mobil DTE27
 - Shell Tellus 100
 - Fuchs Renolin MR30
- Grease– P/N 6934659
- Approved equivalent: Mobil 28

Lubrication points

Oil

Lubricate the following contact positions:

- Oil felt (carrier block)
- Tractor shaft

Grease

Lubricate the following contact positions:

- Side frame (left) and gears
- Side frame (right) and ASF gears
- Pinch roller, pinch roller springs, and paper separator
- ASF side frames, gears, and combination lock mechanism
- ASF side frame (left) and upper feed roll shaft
- ASF pick-up roller shaft and roller bushings

Lubrication points (oil)

The oil felt (1) in the carrier block.

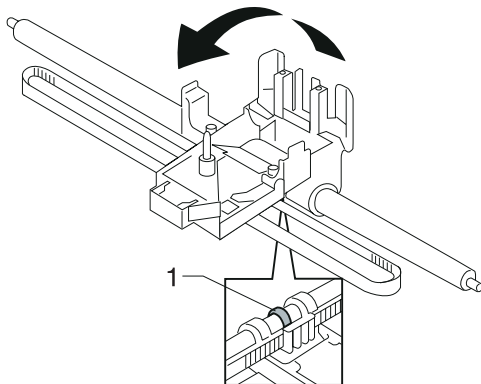

The tractor shaft (1).

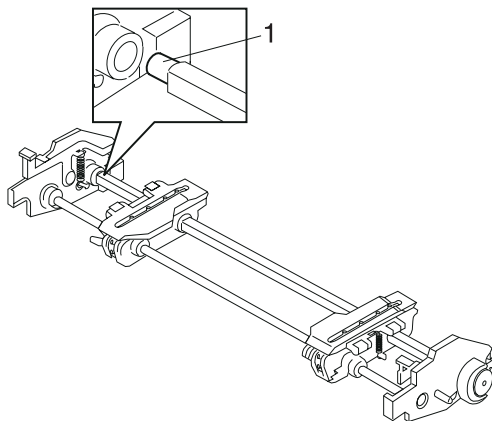

Lubrication points (grease)

Gear mounting studs on the right side frame (2).

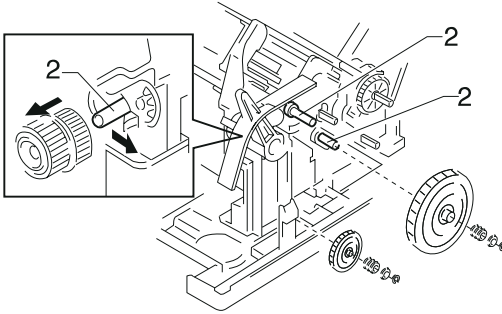

The lower pinch roller (2).

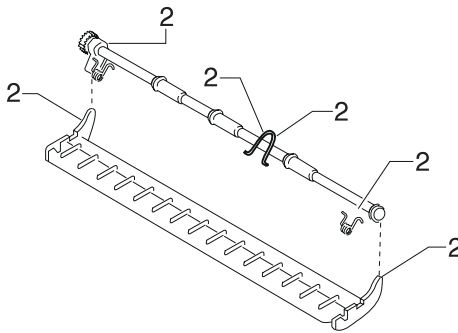

25XX-100, -110

Lubrication points (grease) cont.

Gear mounting studs on the left side frame (2)

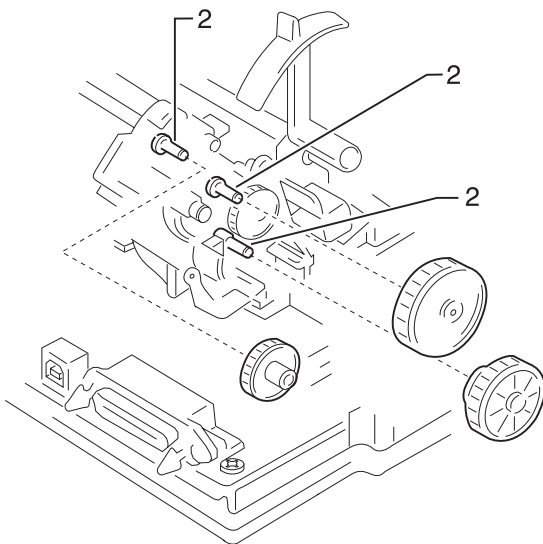

Lubrication points (grease) cont.

Gear mounting studs on the left ASF side frame (2)

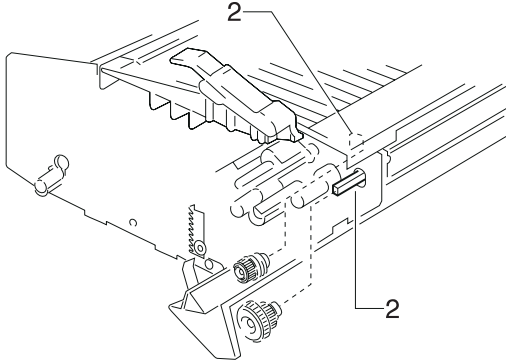

Gear mounting studs on the right ASF side frame (2)

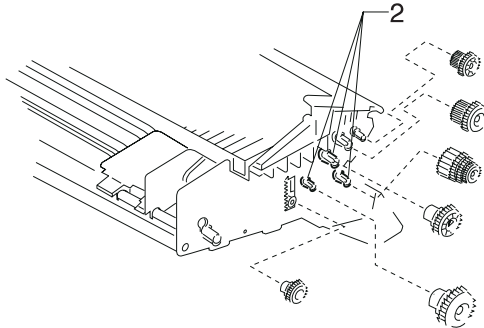

7. Parts catalog

How to use this parts catalog

Similar Assemblies: If two assemblies contain a majority of identical parts, they are shown on the same list. Common parts are shown by one index number. Parts peculiar to one or the other of the assemblies are listed separately and identified by description.

NS: (Not shown) in the Asm-Index column indicates that the part is procurable but is not pictured in the illustration.

Note: Graphic artwork depicting FRU assemblies is designed using the 2580-XXX (9-wire) model as reference. Some of the artwork may not be completely representative of all models. For example, the 24-wire models are not depicted with two printhead cables, and there is no artwork depicting the extended carriage models 2581 or 2591.

Assembly 1: Covers

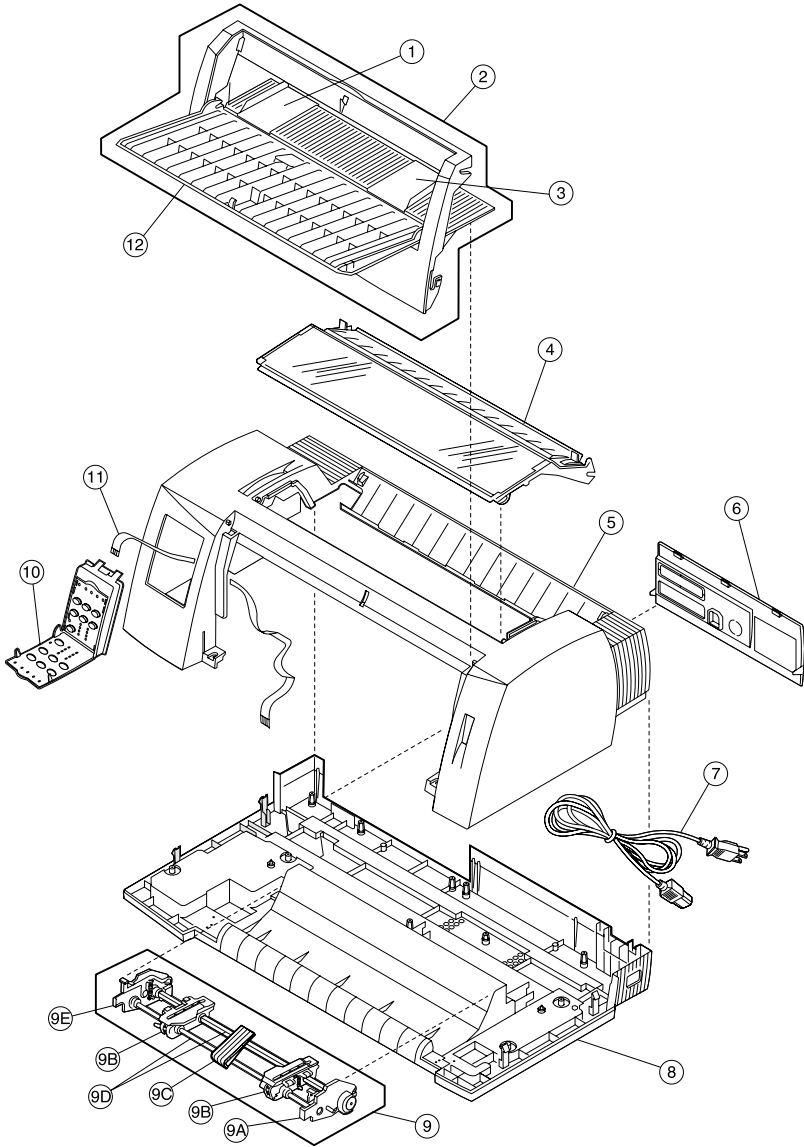

Assembly 1: Covers

Asm-Index	Part number	Description
1-1	40X2912	Guide, left paper
2	40X2992	Cover assembly, front unit (2580, 2590)
2	40X2993	Cover assembly, front unit (2581, 2591)
3	40X2913	Guide, right paper
4	40X3013	Ribbon access cover unit (2580)
4	40X3014	Ribbon access cover unit (2581)
4	40X3025	Ribbon access cover unit (2590)
4	40X3026	Ribbon access cover unit (2591)
5	40X4974	Cover, top (2580, 2590)
5	40X4975	Cover, top (2581, 2591)
6	40X2911	Cover, rear (2581, 2591)
7	40X0297	Power cord: U.S., AFE (LV), Canada, Central and South America, Mexico, Saudi Arabia (LV)
7	40X0271	Power cord: Malaysia, Singapore, United Kingdom
7	40X3141	Power cord: Austria, Belgium, Brazil, Germany, Greece, Finland, France, Indonesia, Luxembourg, Portugal, Norway, Saudi Arabia (HV), Spain, Sweden, Netherlands, Turkey
7	40X0294	Power cord: Denmark
7	40X0287	Power cord: Chile, Italy
7	40X0275	Power cord: Israel
7	40X0276	Power cord: South Africa
7	40X0274	Power cord: Switzerland
7	40X0296	Power cord: Australia, New Zealand
7	40X1766	Power cord: Peru

Assembly 1 (cont.): Covers

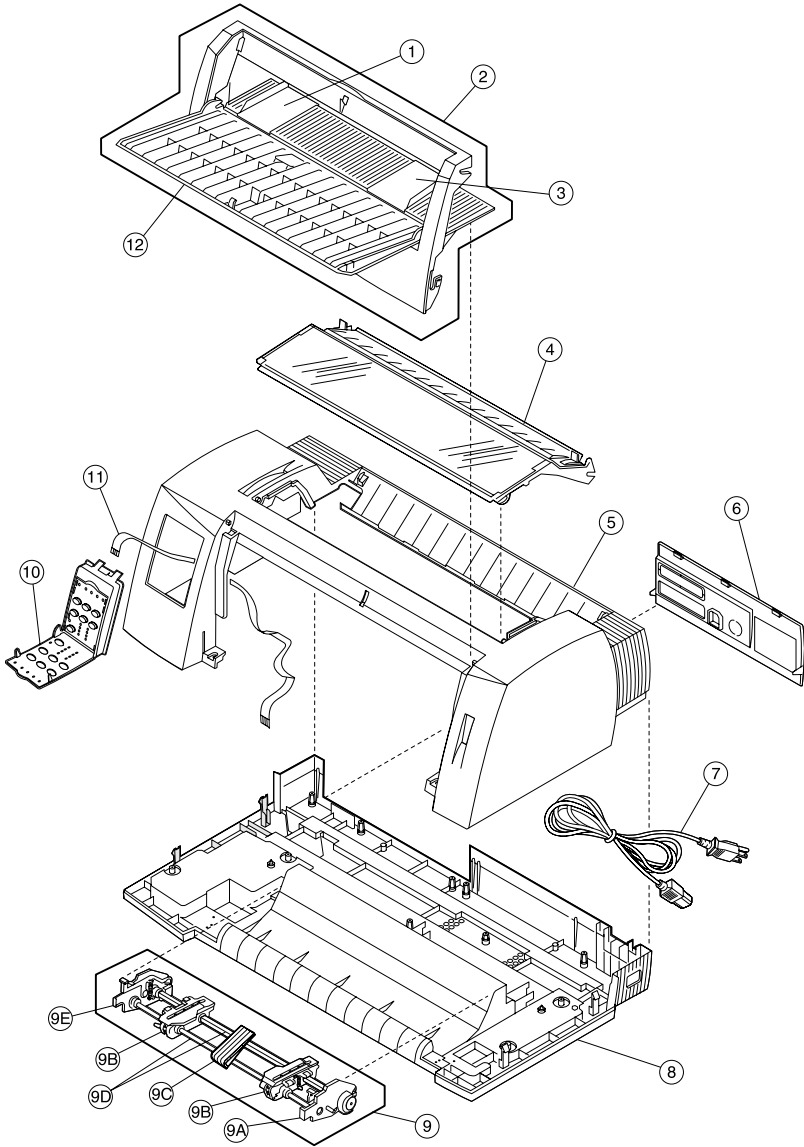

Assembly 1 (cont.): Covers

Asm-Index	Part number	Description
1-8	40X4972	Cover, bottom (2580, 2590)
8	40X4973	Cover, bottom (2581, 2591)
9	40X3002	Tractor unit (2580, 2590)
9	40X3003	Tractor unit (2581, 2591)
9A	40X2917	Frame, right side tractor
9B	40X2918	Tractors, left and right
9C	40X2905	Support, tractor paper
9D	40X3000	Shaft set, tractor (2580, 2590)
9D	40X3001	Shaft set, tractor (2581, 2591)
9E	40X2916	Frame, left side tractor
10	40X2962	Operator panel assembly (258X)
10	40X2963	Operator panel assembly (259X)
11	40X2914	Cable, operator panel
12	40X2994	Cover, front guide (2580, 2590)
12	40X2995	Cover, front guide (2581, 2591)
NS	40X2897	Cover, operator panel front with overlay packs
NS	40X2996	Overlay pack, operator panel (258X)
NS	40X2997	Overlay pack, operator panel (259X)
NS	40X2937	Stand, paper

Assembly 2: Carrier/paper feed (right side)

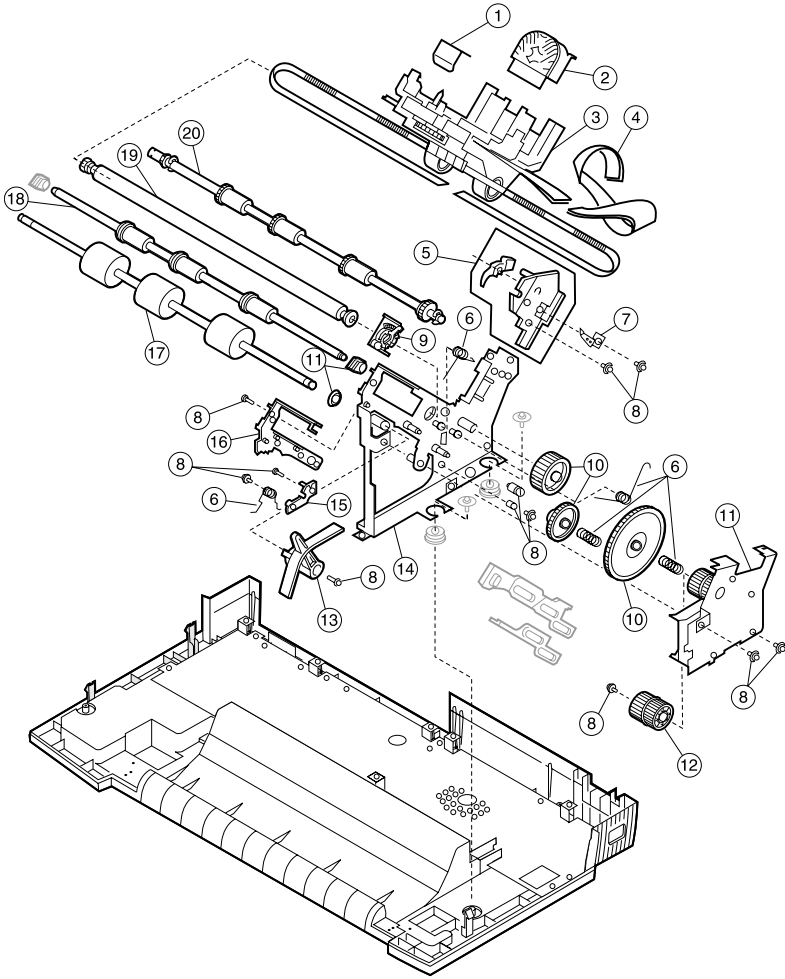

Assembly 2: Carrier/paper feed (right side)

Asm-Index	Part number	Description
2-1	40X2887	Carrier roller set
2	40X2998	Printhead assembly (80, 2581)
2	40X2999	Printhead assembly (2590, 2591)
3	40X2948	Carrier unit (2580)
3	40X2949	Carrier unit (2581)
3	40X2950	Carrier unit (2590)
3	40X2951	Carrier unit (2591)
4	40X2952	Cable, printhead (2580)
4	40X2953	Cable, printhead (2581)
4	40X2954	Cable, printhead (2590)
4	40X2955	Cable, printhead (2591)
5	40X2931	Kit, pull tractor actuator
6	40X2906	Springs, parts packet
7	40X2983	Kit, ESD ground (2590, 2591)
7	40X2982	Kit, ESD ground (2580, 2581)
8	40X2926	Screws, washers and clips, parts packet
9	40X2922	Kit, Head Gap adjustment
10	40X2910	Gears and bushings, parts packet (258X)
11	40X2980	Sub frame, right side
12	40X2956	Gear, idler (2580, 2581)
12	40X2957	Gear, idler (2590, 2591)
13	40X2907	Paper Select lever
14	40X2968	Frame, right side
15	40X3010	Holder, lower pinch roller shaft, right
16	40X2896	Guide, ASF/DTR, right
17	40X2971	Roller, lower feed (2581, 2591)
17	40X2981	Roller, lower feed (2580, 2590)
18	40X3019	Roller, lower pinch (2580, 2590)
18	40X3020	Roller, lower pinch (2581, 2591)
NS	40X3028	Narrow auto feeder assembly (2580, 2590)
NS	40X3029	Narrow dual tractor assembly (2580, 2590)
NS	40X3034	Wide auto feeder assembly (2581, 2591)
NS	40X3035	Wide dual tractor assembly (2581, 2591)

Assembly 2 (cont.): Carrier/paper feed (right side)

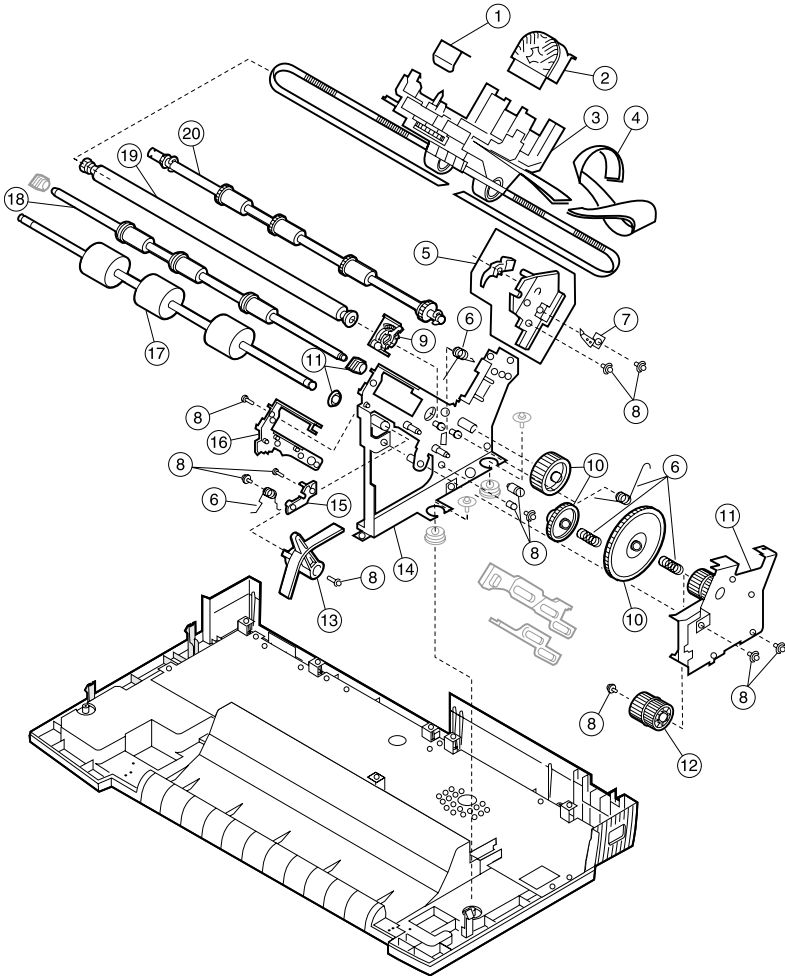

Assembly 2 (cont.): Carrier/paper feed (right side)

Asm-Index	Part number	Description
2-191	40X2988	Shaft, carrier (2580, 2590)
19	40X2989	Shaft, carrier (2581, 2591)
20	40X2978	Roller, upper feed (2580, 2590)
20	40X2979	Roller, upper feed (2581, 2591)

Assembly 3: Carrier/paper feed (left side)

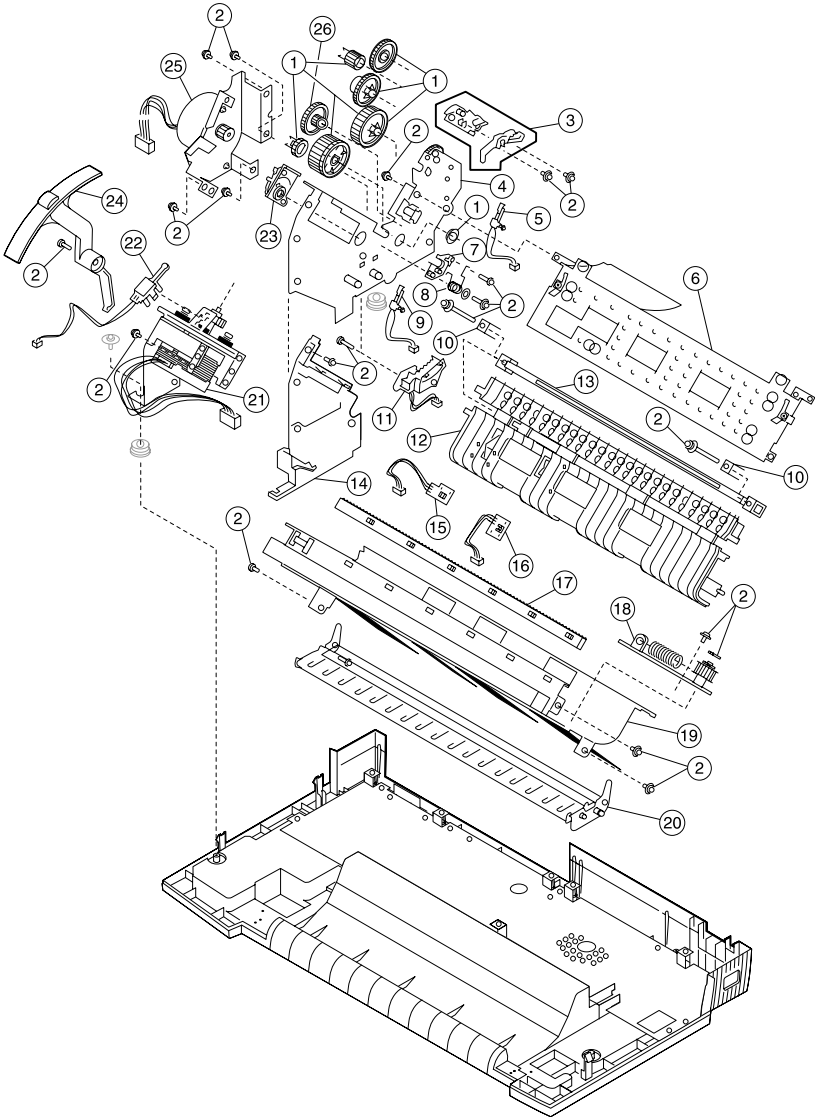

Assembly 3: Carrier/paper feed (left side)

Asm-Index	Part number	Description
3-1	40X2910	Gears and bushings, parts packet (258X)
2	40X2926	Screws, washers and clips, parts packet
3	40X2931	Kit, pull tractor actuator
4	40X2966	Frame, left side (2580, 2581)
4	40X2967	Frame, left side (2590, 2591)
5	40X2938	Sensor, Pull Tractor
6	40X3007	Plate, frame support (2580, 2590)
6	40X3008	Plate, frame support (2581, 2591)
7	40X2921	Holder, lower pinch roller shaft, left
8	40X2906	Springs, parts packet
9	40X2939	Sensor, Paper Select
10	40X2908	Holder, platen
11	40X2893	Sensor, Head Gap
12	40X2969	Guide, paper assembly (2580, 2590)
12	40X2970	Guide, paper assembly (2581, 2591)
13	40X2973	Platen (2580, 2590)
13	40X2974	Platen (2581, 2591)
14	40X2895	Guide, ASF/DTR, left
15	40X2919	Sensor, Top-of-form
16	40X2972	Sensor, Paper Present
17	40X2986	Gear, ribbon drive rack (2580, 2590)
17	40X2987	Gear, ribbon drive rack (2581, 2591)
18	40X2977	Plate, tension pulley assembly
19	40X3021	Plate, carrier assembly (2580, 2590)
19	40X3022	Plate, carrier assembly (2581, 2591)
20	40X2975	Separator, paper (2580, 2590)
20	40X2976	Separator, paper (2581, 2591)
21	40X2901	Motor, carrier (with BKT)
22	40X2920	Sensor, Home Position

Assembly 3 (cont.): Carrier/paper feed (left side)

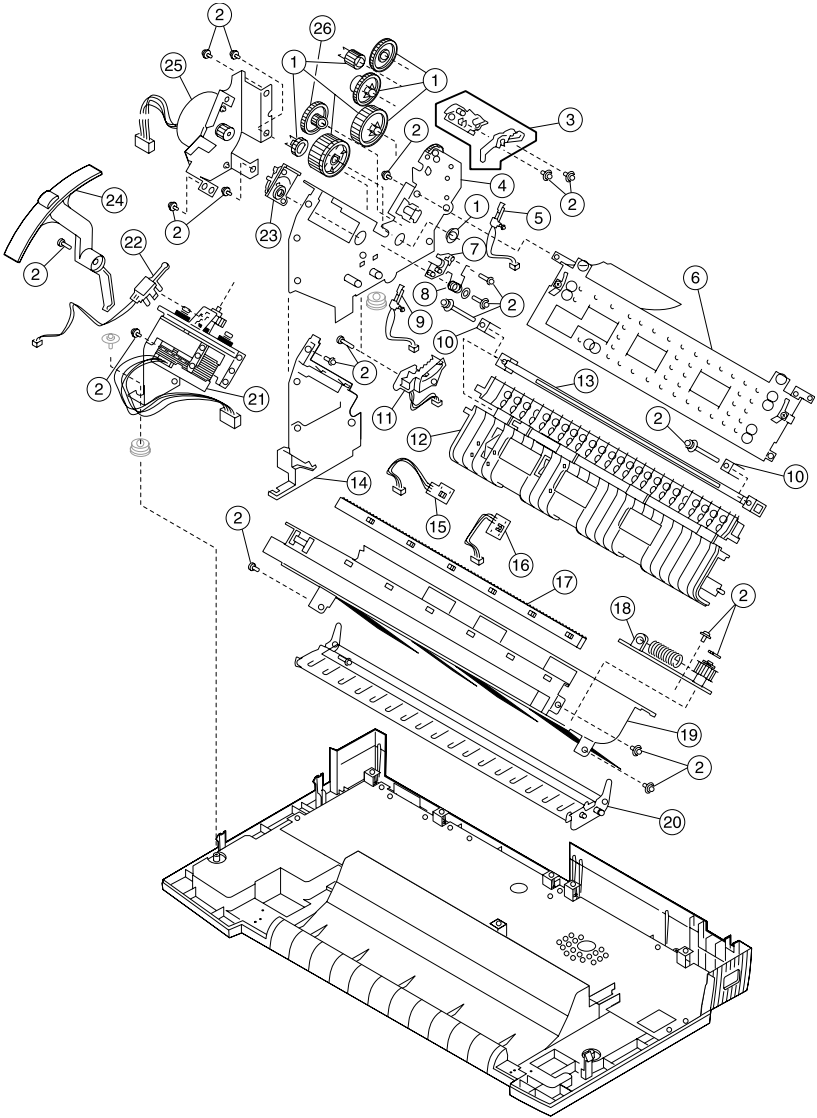

Assembly 3 (cont.): Carrier/paper feed (left side)

Asm-Index	Part number	Description
3-23	40X2922	Kit, Head Gap adjustment
24	40X2894	Lever, Forms Thickness
25	40X2902	Motor, paper feed (with BKT)
26	40X2956	Gear, idler (258X)
26	40X2957	Gear, idler (259X)

Assembly 4: Electronics

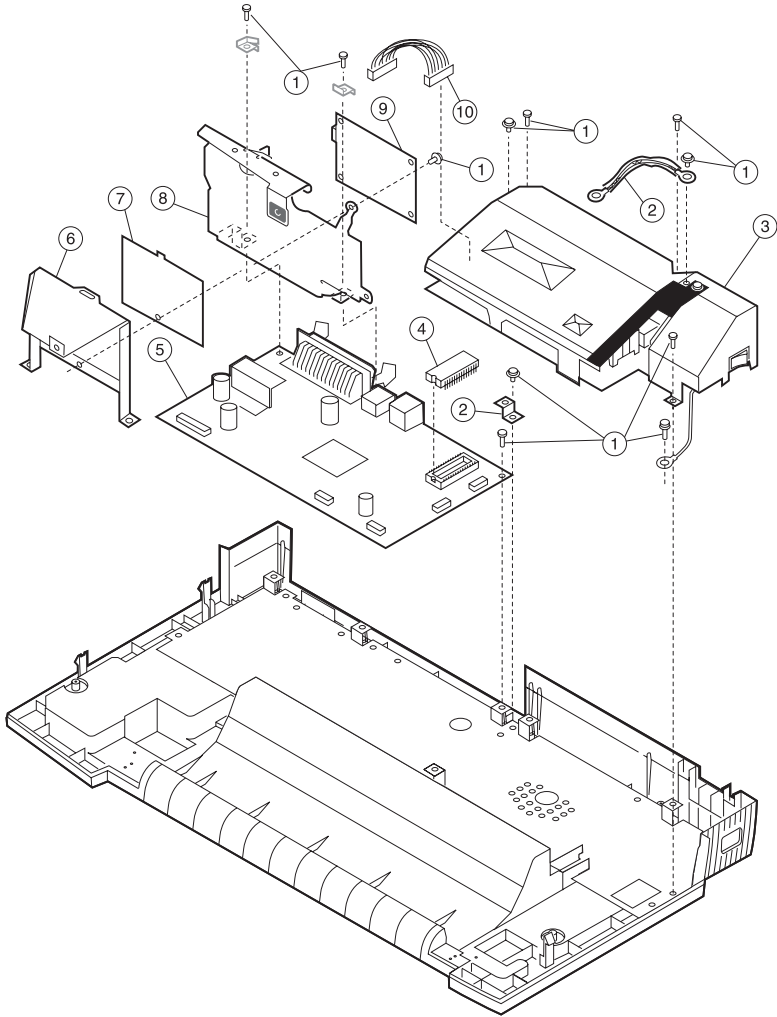

Assembly 4: Electronics

Asm-Index	Part number	Description
4-1	40X2926	Screws, washers and clips, parts packet
2	40X2983	Kit, ESD ground (2590, 2591)
2	40X2982	Kit, ESD ground (2580, 2581)
3	40X2886	Power supply unit, LV
3	40X2885	Power supply unit, HV
4	40X3030	Module, EPROM (258X)
4	40X2964	Module, EPROM (259X)
5	40X4960	Board, logic without EPROM (2580 LV)
5	40X4961	Board, logic without EPROM (2580 HV)
5	40X4962	Board, logic without EPROM (2581 LV)
5	40X4963	Board, logic without EPROM (2581 HV)
5	40X4964	Board, logic without EPROM (2590 LV)
5	40X4965	Board, logic without EPROM (2590 HV)
5	40X4966	Board, logic without EPROM (2591 LV)
5	40X4967	Board, logic without EPROM (2591 HV)
6	40X2903	Bracket, serial interface card
7	40X2915	Plate, serial interface card
8	40X4968	INA support frame
9	40X4791	LAN card (INA)
10	40X3015	Cable, power supply (2580, 2590)
10	40X3016	Cable, power supply (2581, 2591)
NS	40X4969	INA support plate
NS	40X4970	Earth LAN card
NS	40X5006	INA cable
NS	40X2909	Kit, fuse (LV)
NS	40X2930	Card, serial interface card with plate
NS	40X2934	Serial interface cable
NS	40X3032	Memory 259X no PNP EPROM

Assembly 5: ASF- Roller/support

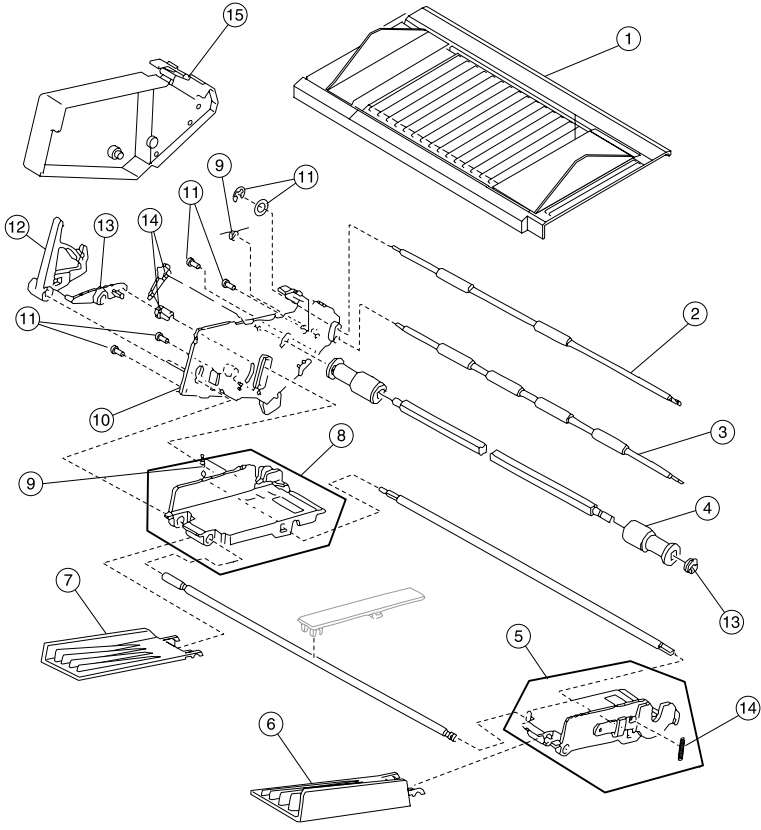

Assembly 5: ASF– Roller/support

Asm-Index	Part number	Description
5-1	40X2965	Support, ASF cut sheet with guides (2580, 2590)
1	40X3017	Support, ASF cut sheet with guides (2581, 2591)
2	40X2888	Roller, ASF upper feed (2580, 2590)
2	40X3023	Roller, ASF upper feed (2581, 2591)
3	40X2889	Roller, ASF lower feed (2580, 2590)
3	40X3024	Roller, ASF lower feed (2581, 2591)
4	40X2984	Roller, ASF pick-up left and right (2580, 2590)
4	40X2985	Roller, ASF pick-up left and right (2581, 2591)
5	40X3004	Hopper, ASF right (2581, 2591)
6	40X2927	Support, ASF paper right
7	40X2928	Support, ASF paper left
8	40X2929	Hopper, ASF left
9	40X2891	ASF springs, parts packet
10	40X2924	Frame, ASF side left
11	40X2892	ASF screws, parts packet
12	40X2932	Lever, ASF paper load
13	40X2933	Link, ASF paper load
14	40X3136	ASF gears and bushings, parts packet
15	40X2935	Cover, ASF left

Assembly 6: ASF- Side frame/covers

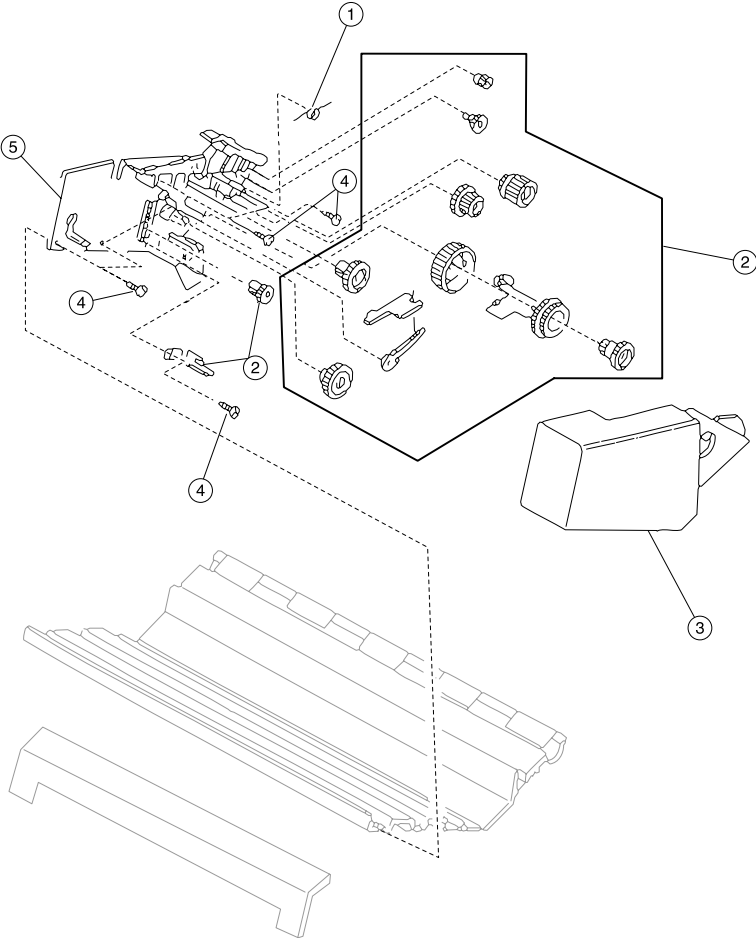

Assembly 6: ASF– Side frame/covers

Asm-Index	Part number	Description
6-1	40X2891	ASF Springs, parts packet
2	40X2890	ASF gears and bushings, parts packet
3	40X2936	Cover, ASF right
4	40X2892	ASF screws, parts packet
5	40X3011	Frame, ASF side right
NS	40X2937	Stand, paper

Assembly 7: Tractor 2 option

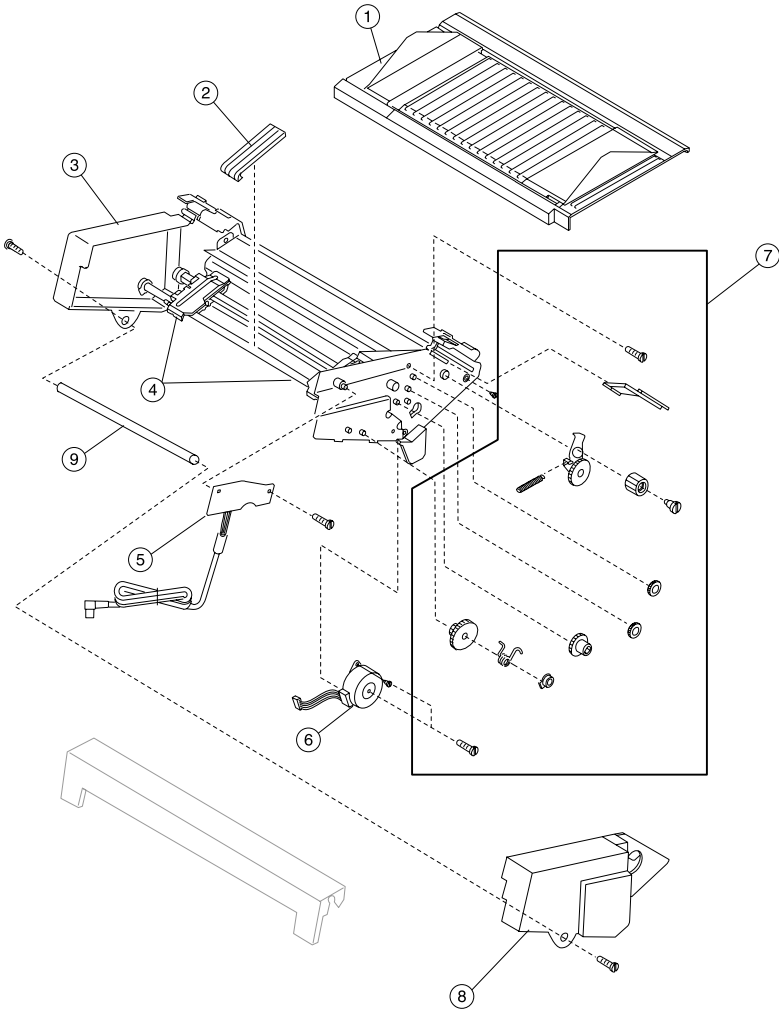

Assembly 7: Tractor 2 option

Asm-Index	Part number	Description
7-1	40X3018	Table, Tractor 2 paper with guides (2580, 2590)
2	40X2881	Guide, Tractor 2 paper
3	40X3009	Tractor and frame assembly, Tractor 2 (2580, 2590)
4	40X2918	Kit, tractors left and right
5	40X2960	Board assembly with cable and ferrite, Tractor 2 (2580, 2590)
5	40X2961	Board assembly with cable and ferrite, Tractor 2 (2581, 2591)
6	40X2880	Motor, Tractor 2
7	40X2882	Parts packet, Tractor 2
8	40X2923	Cover, Tractor 2, right
9	40X2958	Shaft, Tractor 2 support (2580, 2590)
9	40X2959	Shaft, Tractor 2 support (2581, 2591)

Index

A

- Abbreviations 1-8
- Adjustments 4-2
 - Bidirectional print 4-4
 - Printhead-to-platen gap 4-2
- ASF
 - Principles of operation 2-16

C

- Connections
 - Logic Board
 - Printhead (9w) 5-11
 - Logic board
 - Carrier motor 5-21
 - DC power 5-9
 - Gap Set sensor 5-17
 - Home Position sensor 5-17
 - Paper feed motor 5-21
 - Paper Present sensor 5-17
 - Parallel interface cable 5-5
 - Pull Tractor sensor 5-19
 - Serial board 5-7
 - Top-of-form sensor 5-19
 - Power supply 5-2
 - Serial board
 - Serial cable 5-26
 - Tractor 2 5-27

D

- Defaults
 - U.S. 3-5
 - World Trade 3-5
- Diagnostic aids 3-1

E

- Entering Setup mode 1-2
- Error codes 2-3
- Error indication table 2-3
- ESD-sensitive parts 4-1
- Exiting Setup mode 1-2

G

- General information 1-1

H

- Hex Trace mode 3-4

I

- Interface Menu options 1-3
- Irrecoverable operator errors
 - Paper Empty sensor 2-14
 - Paper Present sensor 2-13
 - Paper Select sensor 2-14

L

- Lubrication 6-1

M

- Menu
 - Interface Menu options 1-3
 - Setup Menu options 1-3

O

- Operator errors
 - Irrecoverable 2-13
- Options 1-7

P

- Paper jams
 - Clearing continuous forms 3-6
 - Clearing cut sheet 3-6
- Parts
 - ASF
 - Roller/support 7-16
 - Side Frame/covers 7-18
 - Carrier/paper feed left side 7-10, 7-12
 - Carrier/paper feed right side 7-6, 7-7, 7-8, 7-9
 - Covers 7-2
 - Electronics 7-14
 - Tractor 2 option 7-20

25XX-100, -110

Parts catalog

How to use 7-1

POST 3-2

Preventive maintenance

Lubrication 6-1

Lubrication points 6-2

Specified lubricants 6-1

Print test 3-3

Printer

Description 1-1

Options 1-7

Settings 1-4

Specifications 1-1

Speeds 1-2

Printer default settings 3-5

R

Removals 4-4

ASF

Gears 4-48

Pick-up roller 4-49

Carrier 4-17

Carrier motor assembly 4-22

Covers

Bottom 4-11

Front 4-6

Operator panel 4-10

Option 4-7

Ribbon access 4-6

Top 4-8

Covers illustration 4-5

Electronics

EPROM 4-11

Logic board 4-12

Power supply 4-16

Forms Thickness lever 4-26

Gears

Left side 4-32

Right side 4-35

Operator panel 4-10

Paper feed motor 4-25

Paper Select lever 4-25

Platen 4-27

Print unit 4-29

Printhead 4-28

Printhead cables 4-28

Ribbon drive rack gear 4-31

Right side sub frame 4-35

Rollers

Lower feed 4-42

Upper feed 4-37

Upper pinch 4-39

Sensors

Head Gap 4-45

Home Position 4-47

Paper Present 4-46

Paper Present flag 4-46

Paper Select 4-46

Pull Tractor 4-45

Top-of-form 4-45

Repair information 4-1

S

Safety information vii

Service checks 2-15

Abnormal noise 2-15

Abnormal print 2-23

Auto Sheet Feeder 2-16

Carrier 2-18

Intermittent problem 2-20

No print 2-23

Operator panel 2-23

Paper feed 2-25

Paper Present sensor 2-24

Paper Select sensor 2-28

POST 2-29

Power 2-30

Printhead 2-32

Printhead continuity tables 2-33

Pull Tractor sensor 2-34

Top-of-forms 2-35

Tractor 2 2-36

Settings

Tear off position 1-4

Top-of-form (continuous) 1-5

Top-of-form (cut forms) 1-5

Top-of-form (envelopes) 1-5

Setup Menu options 1-3

Setup mode 1-2

Entering 1-2

Exiting 1-2

Signal connections 5-2

25XX-100, -110

Specific printer parts 5-1

Specifications 1-1

Start 2-1

Symptom checks 2-6

Abnormal indications 2-6

Abnormal noise problems 2-6

ASF problems 2-7

Error indications 2-8

Operator panel problems 2-8

Paper feed problems 2-9

power problems 2-11

Print quality problems 2-12

T

Tools 1-7

V

Voltage, ground, and continuity 2-1

25XX-100, -110

Part number index

P/N	Description	Page
40X0271	Power cord– Malaysia, Singapore, United Kingdom	7-3
40X0274	Power cord– Switzerland	7-3
40X0275	Power cord– Israel	7-3
40X0276	Power cord– South Africa	7-3
40X0287	Power cord– Chile, Italy	7-3
40X0294	Power cord– Denmark	7-3
40X0296	Power cord– Australia, New Zealand	7-3
40X0297	Power cord– U.S., AFE (LV), Canada, Central and South America, Mexico, Saudi Arabia (LV)	7-3
40X1766	Power cord– Peru	7-3
40X2880	Motor, Tractor 2	7-21
40X2881	Guide, Tractor 2 paper	7-21
40X2882	Parts packet, Tractor 2	7-21
40X2885	Power supply unit, HV	7-15
40X2886	Power supply unit, LV	7-15
40X2887	Carrier roller set	7-7
40X2888	Roller, ASF upper feed (2580, 2590)	7-17
40X2889	Roller, ASF lower feed (2580, 2590)	7-17
40X2890	ASF gears and bushings, parts packet	7-19
40X2891	ASF springs, parts packet	7-17, 7-19
40X2892	ASF screws, parts packet	7-17, 7-19
40X2893	Sensor, head gap	7-11
40X2894	Lever, Forms Thickness	7-13
40X2895	Guide, ASF/DTR, left	7-11
40X2896	Guide, ASF/DTR, right	7-7
40X2897	Cover, operator panel front with overlay packs	7-5
40X2901	Motor, carrier (with BKT)	7-11
40X2902	Motor, paper feed (with BKT)	7-13
40X2903	Bracket, serial interface card	7-15
40X2905	Support, tractor paper	7-5
40X2906	Springs, parts packet	7-7, 7-11
40X2907	Paper Select lever	7-7
40X2908	Holder, platen	7-11
40X2909	Kit, fuse (LV)	7-15
40X2910	Gears and bushings, parts packet (258X)	7-7, 7-11
40X2911	Cover, rear (2581, 2591)	7-3
40X2912	Guide, left paper	7-3
40X2913	Guide, right paper	7-3
40X2914	Cable, operator panel	7-5
40X2915	Plate, serial interface card	7-15
40X2916	Frame, left side tractor	7-5

25XX-100, -110

40X2917	Frame, right side tractor	7-5
40X2918	Kit, tractors left and right	7-21
40X2918	Tractors, left and right	7-5
40X2919	Sensor, Top-of-form	7-11
40X2920	Sensor, home position	7-11
40X2921	Holder, lower pinch roller shaft, left	7-11
40X2922	Kit, Head Gap adjustment	7-7, 7-13
40X2923	Cover, Tractor 2, right	7-21
40X2924	Frame, ASF side left	7-17
40X2926	Screws, washers and clips, parts packet	7-7, 7-11, 7-15
40X2927	Support, ASF paper right	7-17
40X2928	Support, ASF paper left	7-17
40X2929	Hopper, ASF left	7-17
40X2930	Card, serial interface card with plate	7-15
40X2931	Kit, pull tractor actuator	7-7, 7-11
40X2932	Lever, ASF paper load	7-17
40X2933	Link, ASF paper load	7-17
40X2934	Serial interface cable	7-15
40X2935	Cover, ASF left	7-17
40X2936	Cover, ASF right	7-19
40X2937	Stand, paper	7-5, 7-19
40X2938	Sensor, Pull Tractor	7-11
40X2939	Sensor, Paper Select	7-11
40X2948	Carrier unit (2580)	7-7
40X2949	Carrier unit (2581)	7-7
40X2950	Carrier unit (2590)	7-7
40X2951	Carrier unit (2591)	7-7
40X2952	Cable, printhead (2580)	7-7
40X2953	Cable, printhead (2581)	7-7
40X2954	Cable, printhead (2590)	7-7
40X2955	Cable, printhead (2591)	7-7
40X2956	Gear, idler (2580, 2581)	7-7
40X2956	Gear, idler (258X)	7-13
40X2957	Gear, idler (2590, 2591)	7-7
40X2957	Gear, idler (259X)	7-13
40X2958	Shaft, Tractor 2 support (2580, 2590)	7-21
40X2959	Shaft, Tractor 2 support (2581, 2591)	7-21
40X2960	Board assembly with cable and ferrite, Tractor 2	7-21
40X2961	Board assembly with cable and ferrite, Tractor 2	7-21
40X2962	Operator panel assembly (258X)	7-5
40X2963	Operator panel assembly (259X)	7-5
40X2964	Module, EPROM (259X)	7-15
40X2965	Support, ASF cut sheet with guides (2580, 2590)	7-17
40X2966	Frame, left side (2580, 2581)	7-11
40X2967	Frame, left side (2590, 2591)	7-11
40X2968	Frame, right side	7-7
40X2969	Guide, paper assembly (2580, 2590)	7-11

40X2970	Guide, paper assembly (2581, 2591)	7-11
40X2971	Roller, lower feed (2481, 2491)	7-7
40X2972	Sensor, Paper Present	7-11
40X2973	Platen (2580, 2590)	7-11
40X2974	Platen (2581, 2591)	7-11
40X2975	Separator, paper (2580, 2590)	7-11
40X2976	Separator, paper (2581, 2591)	7-11
40X2977	Plate, tension pulley assembly	7-11
40X2978	Roller, upper feed (2580, 2590)	7-9
40X2979	Roller, upper feed (2581, 2591)	7-9
40X2980	Sub frame, right side	7-7
40X2981	Roller, lower feed (2580, 2590)	7-7
40X2982	Kit, ESD ground (2580, 2581)	7-7, 7-15
40X2983	Kit, ESD ground (2590, 2591)	7-7, 7-15
40X2984	Roller, ASF pick-up left and right (2580, 2590)	7-17
40X2985	Roller, ASF pick-up left and right (2581, 2591)	7-17
40X2986	Gear, ribbon drive rack (2580, 2590)	7-11
40X2987	Gear, ribbon drive rack (2581, 2591)	7-11
40X2988	Shaft, carrier (2580, 2590)	7-9
40X2989	Shaft, carrier (2581, 2591)	7-9
40X2992	Cover assembly, front unit (2580, 2590)	7-3
40X2993	Cover assembly, front unit (2581, 2591)	7-3
40X2994	Cover, front guide (2580, 2590)	7-5
40X2995	Cover, front guide (2581, 2591)	7-5
40X2996	Overlay pack, operator panel (258X)	7-5
40X2997	Overlay pack, operator panel (259X)	7-5
40X2998	Printhead assembly (2580, 2581)	7-7
40X2999	Printhead assembly (2590, 2591)	7-7
40X3000	Shaft set, tractor (2580, 2590)	7-5
40X3001	Shaft set, tractor (2581, 2591)	7-5
40X3002	Tractor unit (2580, 2590)	7-5
40X3003	Tractor unit (2581, 2591)	7-5
40X3004	Hopper, ASF right (2581, 2591)	7-17
40X3007	Plate, frame support (2580, 2590)	7-11
40X3008	Plate, frame support (2581, 2591)	7-11
40X3009	Tractor and frame assembly, Tractor 2 (2580, 2590)	7-21
40X3010	Holder, lower pinch roller shaft, right	7-7
40X3011	Frame, ASF side right	7-19
40X3013	Ribbon access cover unit (2580)	7-3
40X3014	Ribbon access cover unit (2581)	7-3
40X3015	Cable, power supply (2580, 2590)	7-15
40X3016	Cable, power supply (2581, 2591)	7-15
40X3017	Support, ASF cut sheet with guides (2581, 2591)	7-17
40X3018	Table, Tractor 2 paper with guides (2580, 2590)	7-21
40X3019	Roller, lower pinch (2580, 2590)	7-7
40X3020	Roller, lower pinch (2581, 2591)	7-7
40X3021	Plate, carrier assembly (2580, 2590)	7-11

25XX-100, -110

40X3022	Plate, carrier assembly (2581, 2591)	7-11
40X3023	Roller, ASF upper feed (2581, 2591)	7-17
40X3024	Roller, ASF lower feed (2581, 2591)	7-17
40X3025	Ribbon access cover unit (2590)	7-3
40X3026	Ribbon access cover unit (2591)	7-3
40X3028	Narrow auto feeder assembly (2580, 2590)	7-7
40X3029	Narrow dual tractor assembly (2580, 2590)	7-7
40X3030	Module, EPROM (258X)	7-15
40X3032	Memory 259X no PNP EPROM	7-15
40X3034	Wide auto feeder assembly (2581, 2591)	7-7
40X3035	Wide dual tractor assembly (2581, 2591)	7-7
40X3136	ASF gears and bushings, parts packet	7-17
40X3141	Power cord– Austria, Belgium, Brazil, Germany, Greece, Finland, France, Indonesia, Luxembourg, Portugal, Norway, Saudi Arabia (HV), Spain, Sweden, Netherlands, Turkey	7-3
40X4791	LAN card (INA)	7-15
40X4960	Board, logic without EPROM (2580 LV)	7-15
40X4961	Board, logic without EPROM (2580 HV)	7-15
40X4962	Board, logic without EPROM (2581 LV)	7-15
40X4963	Board, logic without EPROM (2581 HV)	7-15
40X4964	Board, logic without EPROM (2590 LV)	7-15
40X4965	Board, logic without EPROM (2590 HV)	7-15
40X4966	Board, logic without EPROM (2591 LV)	7-15
40X4967	Board, logic without EPROM (2591 HV)	7-15
40X4968	INA support frame	7-15
40X4969	INA support plate	7-15
40X4970	Earth LAN card	7-15
40X4972	Cover, bottom (2580, 2590)	7-5
40X4973	Cover, bottom (2581, 2591)	7-5
40X4974	Cover, top (2580, 2590)	7-3
40X4975	Cover, top (2581, 2591)	7-3
40X5006	INA cable	7-15