

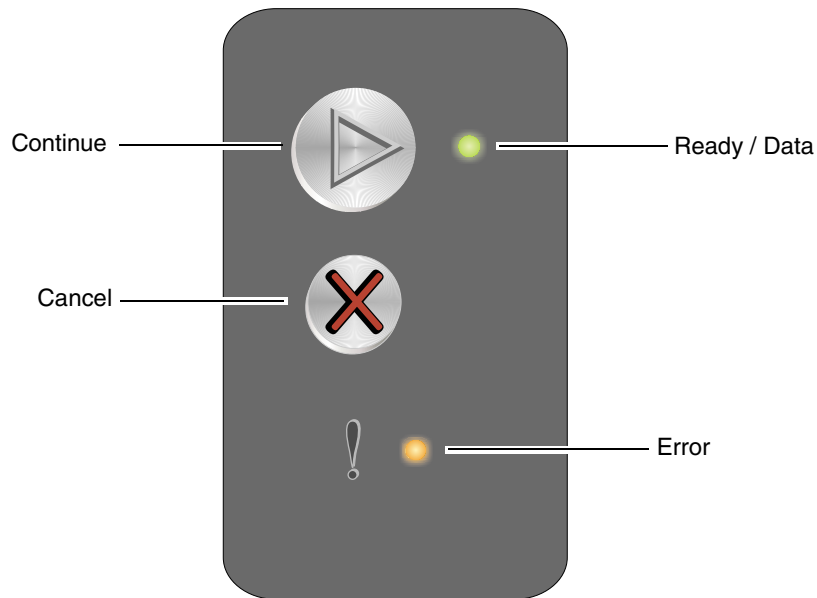





Quick Reference

Understanding the Operator Panel

The printer operator panel has two buttons and two lights. Lights indicate the status of the printer. Buttons are used to continue or cancel the current print job.

When the printer is turned on, both lights cycle as a self test is performed. Also, when the printer is reset, or when a printer setting is changed in the menus, both lights cycle.



- Press and release **Continue**  to resume printing.
- Press and release **Continue**  twice quickly to display the secondary light sequence.
- Press **Continue**  from the Ready state to print the menu settings page.
- Press and hold **Cancel**  to cancel the current job.
- Press and hold **Cancel**  until both lights come on to reset the printer.

Understanding the operator panel lights

The operator panel lights mean different things, depending on their sequence. Lights that are off, on, and/or blinking indicate printer conditions such as printer status, intervention, or service.

Use the light sequence table to find the message being indicated, then click the message for more information.

































Light sequence



















Ready / Data light on = 

Error light on = 

Ready / Data light blinking = 

Error light blinking = 

Primary light sequence		Secondary light sequence		Message
Ready / Data	Error	Ready / Data	Error	
				Ready / Power Saver
				Busy
				Waiting
				Cancel job / Reset printer
				Flushing buffer
				Invalid engine code (Ready / Data light blinks once)
				Not ready (Ready / Data light blinks once)
				Printing font list or menu settings page
				Programming engine code or system code
				Restoring factory defaults
				Cartridge region mismatch (Ready / Data light blinks four times)
				Change cartridge / Defective cartridge (Ready / Data light blinks three times)
				Open door (Ready / Data light blinks once)
				Complex page (Ready / Data light blinks three times)
				ENA connection lost (Ready / Data light blinks five times)
				Insufficient collation area (Ready / Data light blinks three times)
				Load media (Ready / Data light blinks once)
				Print side two of a duplex job (Ready / Data light blinks once)

Primary light sequence		Secondary light sequence		Message
Ready / Data	Error	Ready / Data	Error	
				Memory full (Ready / Data light blinks three times)
				Host interface disabled (Ready / Data light blinks five times)
				Jam in the printer paper path (Ready / Data light blinks ten times)
				Jam in Tray 1 / priority feeder (Ready / Data light blinks four times)
				Short paper (Ready / Data light blinks three times)
				Toner low (Ready / Data light blinks eight times)
				Replace long-life photoconductor kit (Ready / Data light blinks once)
				Service error (Ready / Data light blinks ten times)

Printing the menu settings and network setup page

To print the menu settings and network setup pages, press  from the Ready state. The printer automatically prints the menu settings and network setup pages.

A list of the printer settings and the current default values are printed on the menu settings page. The current default settings are marked with an asterisk. The network setup page confirms the network Status is “Connected” and lists the current network settings.

Restoring factory defaults

This function will return most of the settings back to their factory values. The display language and the settings in the Network and USB menus are not returned to the factory defaults.

To restore the printer to the original factory defaults, press and hold  for more than three seconds.

Note: Before restoring the factory defaults, make sure the host computer or network has stopped sending information to the printer.

Loading paper or other print media

Source	Sizes	Types	Capacity* (sheets)
Tray 1	A4, A5, JIS-B5, letter, legal, executive, folio, statement, universal†	Plain paper, bond paper, transparency, label	150 sheets 5 transparencies 5 labels
	3 x 5 inch, other	Card stock	5 cards
	7¼, 9, 10, DL, C5, B5, other	Envelope	5 envelopes
Priority feeder	A4, A5, JIS-B5, letter, legal, executive, folio, statement, universal†	Plain paper, bond paper, transparency, label	15 sheets 5 transparencies 5 labels
	A6	Plain paper, bond paper	30 sheets
	3 x 5 inch, other	Card stock	5 cards
	7¼, 9, 10, DL, C5, B5, other	Envelopes	3 envelopes

* Capacity for 20 lb print media, unless otherwise noted.

† Universal size ranges:

– **Tray 1:** 76–216 x 190–356 mm (3.0–8.5 x 7.5–14.0 in.) (includes 3 x 5 in. cards)

– **Priority feeder:** 76–216 x 190–356 mm (3.0–8.5 x 7.5–14.0 in.) (includes 3 x 5 in. cards)

To help prevent jams:

- Prepare print media for loading by flexing or fanning it back and forth. Straighten the edges on a level surface.



- Do not overload the paper trays.
- Never mix media types within a tray.

Loading Tray 1

- 1 Open the paper cover by lifting up until the cover *clicks* into a fully open position.

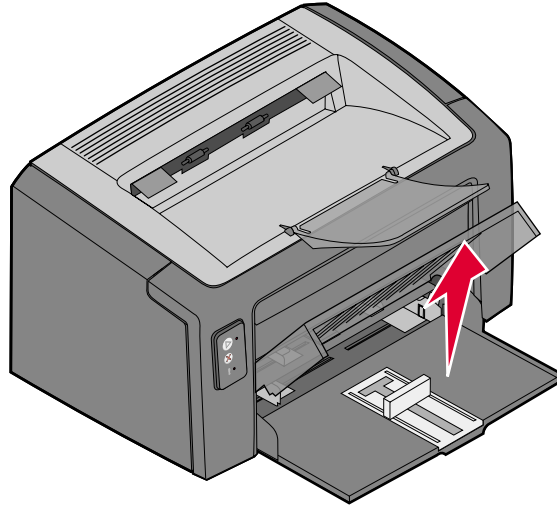

- 2 Adjust the slide and attached backstop to the length of the selected print media.

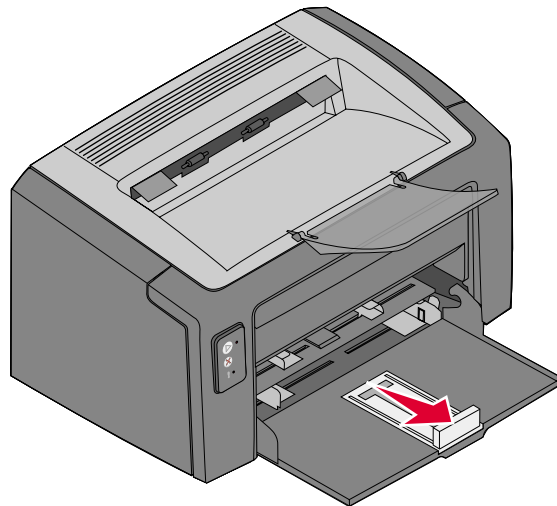

Note: To decrease width, push in on the left guide. To increase width, squeeze the tab attached to the right guide, and slide it to the right.

- 3 Place the prepared print media into the tray, and lightly adjust all guides against the loaded print media edges.

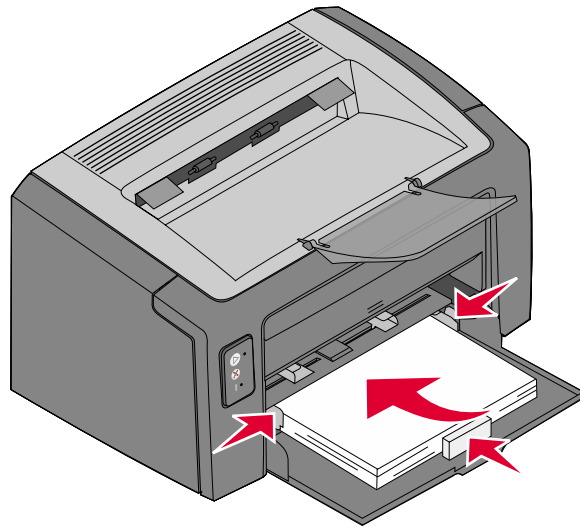

Note: Load letterhead paper with the design side facing up and the top edge of the sheet feeding into the printer first. Load envelopes with the flap side down and the return address first. The stamp area will feed through last.

- 4 Close the paper cover.

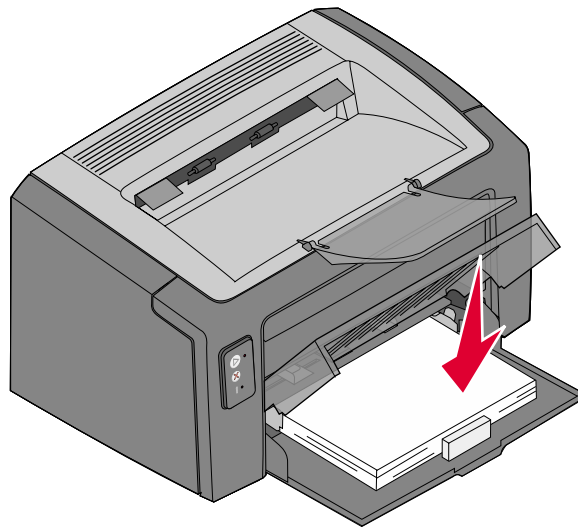

Loading print media into the priority feeder

The priority feeder can be used to make quick runs of print media types or sizes not currently loaded in Tray 1.

- 1** Adjust the guides to the width of the print media.
- 2** Place the selected print media, with the side to be printed faceup, at the center of the priority feeder. The print media rests on the Tray 1 paper cover.
- 3** Push the selected print media into the printer until the print media stops.

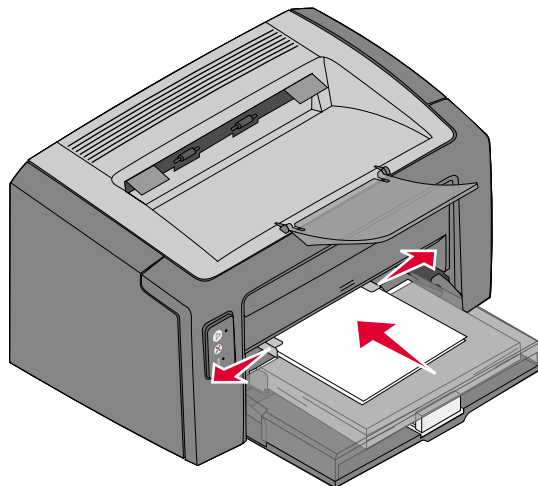



Note: Do not force print media into the feeder. Forcing print media causes jams.

Canceling a print job

A print job can be canceled from the operator panel or from the computer. The Cancel job light sequence appears on the operator panel when a job is canceled (see “Cancel Job/Reset printer” on page 30 of your *User’s Guide*).

From printer operator panel

Press and release  to cancel the current print job. Press and hold  for more than three seconds to reset the printer.

From a Windows computer

- 1 Click **Start** → **Settings** → **Printers**.
- 2 Double-click the printer being used to print the current job.
A list of print jobs appears.
- 3 Right-click the current document, and then click **Cancel**.

From a Macintosh computer

When a job is sent to print, the printer icon appears on the desktop.

- 1 Click **Applications**.
- 2 Click **Utilities**.
- 3 Double-click **Printer Setup Utility**.
A list of print jobs appears.
- 4 Double-click the printer name to see a list of print jobs.
- 5 Click the print job you wish to cancel.
- 6 From the tool bar, click **Delete**.

Clearing jams

When a jam occurs, the printer stops, and the Error light on the operator panel blinks. To determine the location of the jam, view the secondary light sequences. Prepare the printer for jam removal by opening the paper support and removing all printed pages from the output bin. Then, follow these steps to clear the entire paper path.

- 1 Open the rear door by sliding the door release button to the right.

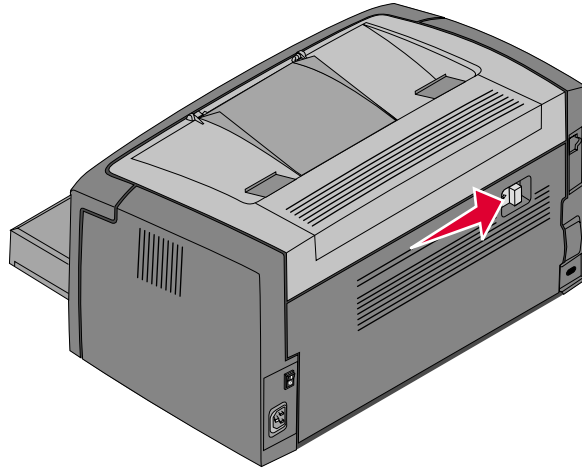

- 2 Remove any lodged print media from the paper path.

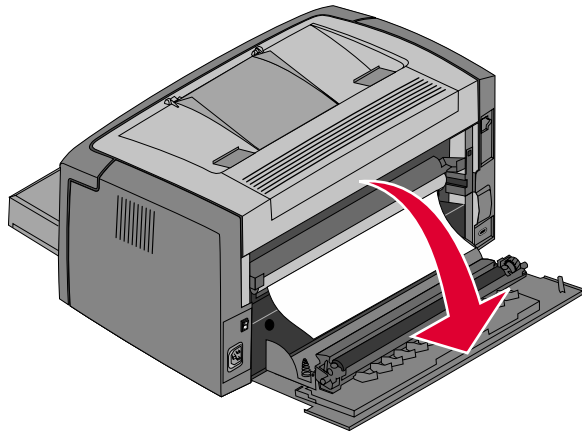

Warning: When the rear door is open, be careful not to touch the attached roller. Touching the roller can cause contamination and affect print quality. Do not leave the rear door open for an extended amount of time. Exposure to light will damage the blue drum of the long-life photoconductor kit and affect print quality.

- 3 Open the top door, and remove any lodged print media from the paper path.

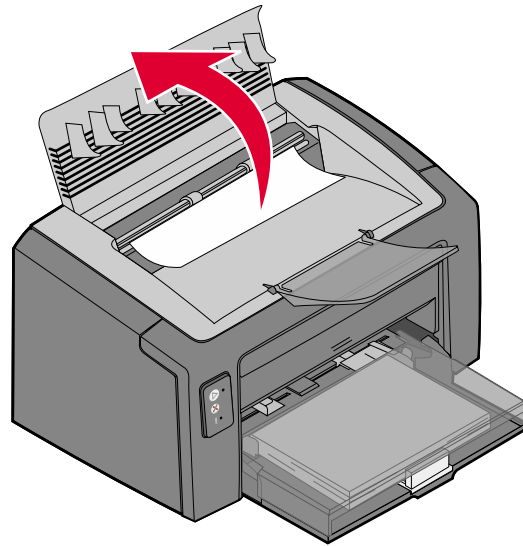

CAUTION: The fuser may be hot. To avoid personal injury, use caution when opening the top door to remove a jam from the fuser area.

- 4 Open the front door by sliding the release button to the left.

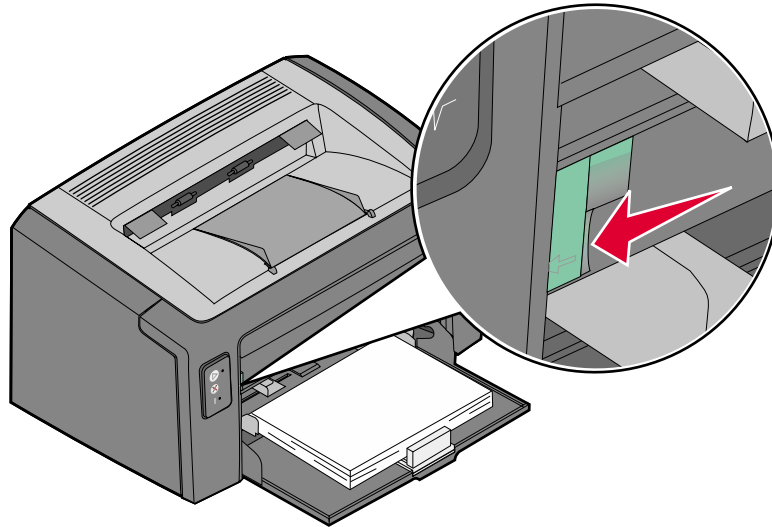

- 5 Pull the front door up until it *clicks* into an open position, and remove any lodged print media.

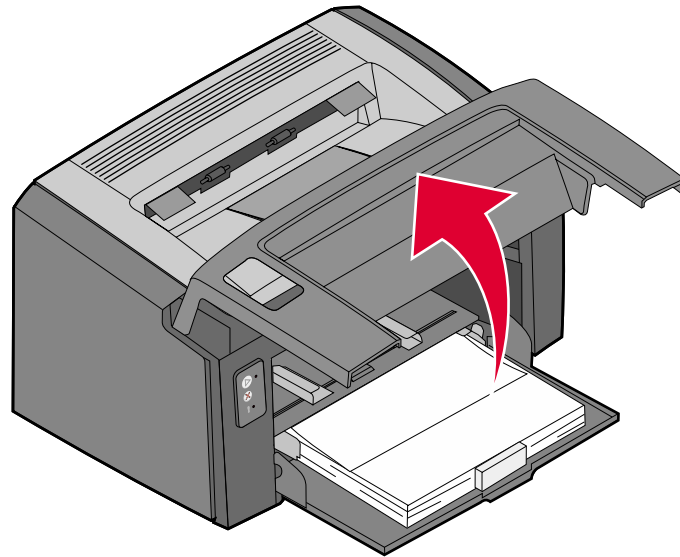

Note: It may be necessary to remove the toner cartridge and place it on a flat, clean surface to reach print media lodged behind it. Replace the toner cartridge when the print media has been located and removed.

- 6 Close the front door by pressing firmly in the center of the front door with your thumb until the door clicks shut.

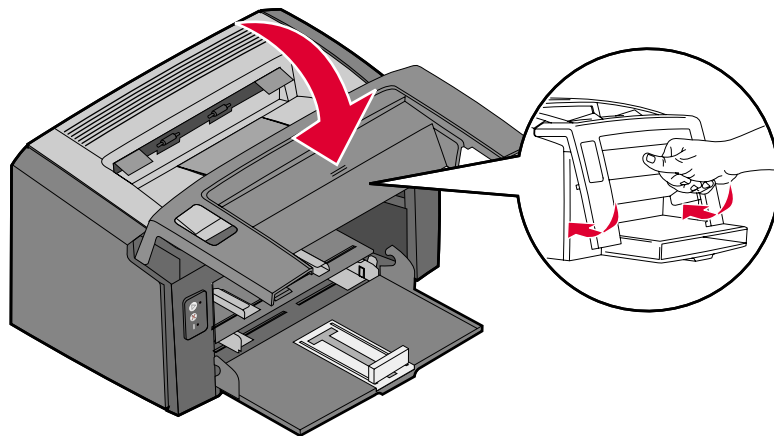

If you need more information

- Refer to the *Software and Documentation CD* that came with your printer for helpful information about using and maintaining your printer.
- Contact your administrator or Help desk if you have questions about network printing.