

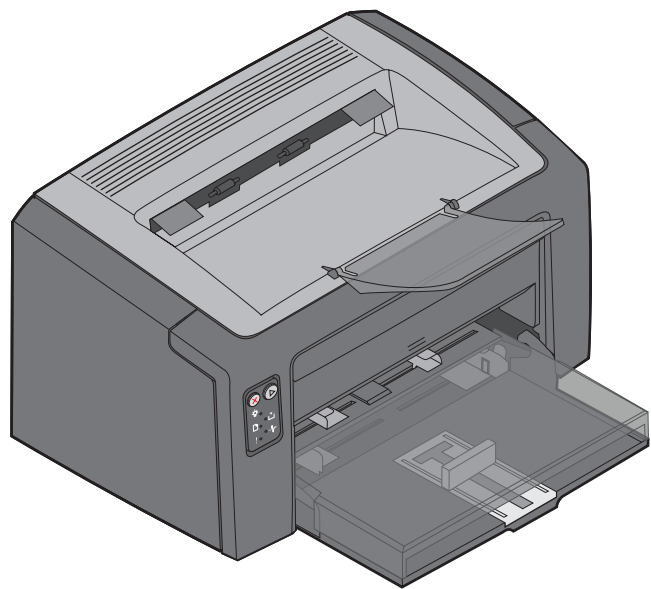

# E120, E120n

---

## User's Guide



**July 2005**

**[www.lexmark.com](http://www.lexmark.com)**

## Edition: July 2005

**The following paragraph does not apply to any country where such provisions are inconsistent with local law:** LEXMARK INTERNATIONAL, INC., PROVIDES THIS PUBLICATION "AS IS" WITHOUT WARRANTY OF ANY KIND, EITHER EXPRESS OR IMPLIED, INCLUDING, BUT NOT LIMITED TO, THE IMPLIED WARRANTIES OF MERCHANTABILITY OR FITNESS FOR A PARTICULAR PURPOSE. Some states do not allow disclaimer of express or implied warranties in certain transactions; therefore, this statement may not apply to you.

This publication could include technical inaccuracies or typographical errors. Changes are periodically made to the information herein; these changes will be incorporated in later editions. Improvements or changes in the products or the programs described may be made at any time.

Comments about this publication may be addressed to Lexmark International, Inc., Department F95/032-2, 740 West New Circle Road, Lexington, Kentucky 40550, U.S.A. In the United Kingdom and Eire, send to Lexmark International Ltd., Marketing and Services Department, Westhorpe House, Westhorpe, Marlow Bucks SL7 3RQ. Lexmark may use or distribute any of the information you supply in any way it believes appropriate without incurring any obligation to you. You can purchase additional copies of publications related to this product by calling 1-800-553-9727. In the United Kingdom and Eire, call +44 (0)8704 440 044. In other countries, contact your point of purchase.

References in this publication to products, programs, or services do not imply that the manufacturer intends to make these available in all countries in which it operates. Any reference to a product, program, or service is not intended to state or imply that only that product, program, or service may be used. Any functionally equivalent product, program, or service that does not infringe any existing intellectual property right may be used instead. Evaluation and verification of operation in conjunction with other products, programs, or services, except those expressly designated by the manufacturer, are the user's responsibility.

© 2005 Lexmark International, Inc.

All rights reserved.

### UNITED STATES GOVERNMENT RIGHTS

This software and any accompanying documentation provided under this agreement are commercial computer software and documentation developed exclusively at private expense.

## Trademarks

Lexmark and Lexmark with diamond design are trademarks of Lexmark International, Inc. Details relating to compatibility are included in the *Technical Reference*.

Other trademarks are the property of their respective owners.

## Safety information

- Connect the power cord to a properly grounded electrical outlet that is near the product and easily accessible.  
**CAUTION:** Do not set up this product or make any electrical or cabling connections, such as the power cord or telephone, during a lightning storm.
- Refer service or repairs, other than those described in the operating instructions, to a professional service person.
- This product is designed, tested, and approved to meet strict global safety standards with the use of specific Lexmark components. The safety features of some parts may not always be obvious. Lexmark is not responsible for the use of other replacement parts.  
**CAUTION:** Make sure that all external connections are properly installed in their marked plug-in ports, such as Ethernet and telephone system connections.
- Your product uses a laser.  
**CAUTION:** Use of controls or adjustments or performance of procedures other than those specified herein may result in hazardous radiation exposure.
- Your product uses a printing process that heats the print media, and the heat may cause the media to release emissions. You must understand the section in your operating instructions that discusses the guidelines for selecting print media to avoid the possibility of harmful emissions.

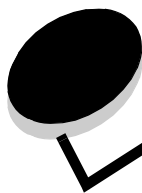

# Contents

---

<b>Chapter 1: Overview .....</b>	<b>5</b>
<b>Chapter 2: Using the operator panels .....</b>	<b>8</b>
Overview of the Lexmark E120 operator panel .....	9
Understanding the Lexmark E120 operator panel lights .....	10
Operator panel codes for the Lexmark E120 .....	12
Overview of the Lexmark E120n operator panel .....	25
Understanding the Lexmark E120n operator panel lights .....	26
Operator panel codes for the Lexmark E120n .....	28
Using the printer resident Web page .....	43
Printing the menu settings and network setup page .....	44
Restoring factory defaults .....	44
<b>Chapter 3: Print media tasks and tips .....</b>	<b>45</b>
Types of print media .....	46
Choosing appropriate print media .....	46
Paper .....	46
Preprinted forms and letterhead .....	47
Transparencies .....	47
Envelopes .....	47
Labels .....	47
Card stock .....	48
Storing print media .....	48
Loading print media into Tray 1 .....	48
Loading print media into the priority feeder .....	51
Preventing jams .....	52
Clearing jams .....	53
<b>Chapter 4: Printing tasks .....</b>	<b>58</b>
Printing from the priority feeder .....	59
From a Windows computer .....	59
From a Macintosh computer .....	60
Printing on both sides of the paper (manual duplex) .....	61
Printing multiple page images on one page (N-up printing) .....	62
From a Windows computer .....	62
From a Macintosh computer .....	63
Printing on letterhead .....	63
From a Windows computer .....	63
From a Macintosh computer .....	63
Canceling a print job .....	64
From printer operator panel .....	64
From a Windows computer .....	64
From a Macintosh computer .....	64

# Contents

---

<b>Chapter 5: Supplies information .....</b>	<b>65</b>
Supply items needed .....	66
Assessing supply needs .....	67
Changing the toner cartridge .....	68
Changing the long-life photoconductor kit .....	71
Lexmark Return Program .....	74
Refilled toner cartridge notice .....	74
Recycling Lexmark products .....	74
<b>Chapter 6: Troubleshooting .....</b>	<b>75</b>
General problems .....	76
Print quality problems .....	78
<b>Notices .....</b>	<b>82</b>
Licensing Notice .....	82
Conventions .....	82
Electronic emission notices .....	82
Noise emission levels .....	83
ENERGY STAR .....	83
Waste from Electrical and Electronic Equipment (WEEE) directive .....	83
Laser notice .....	84
Statement of Limited Warranty for Lexmark E120 and Lexmark E120n .....	84
<b>Index .....</b>	<b>86</b>

# 1

## Overview

---

The printer is available in two models: Lexmark E120 (base model) with 600 dpi (dots per inch) to 1200 IQ (image quality) resolution, 8 MB of standard memory, and a USB port; and Lexmark E120n (network model) with 600 dpi to 1200 IQ resolution, 16 MB of standard memory, a USB port, and an integrated Ethernet adapter.

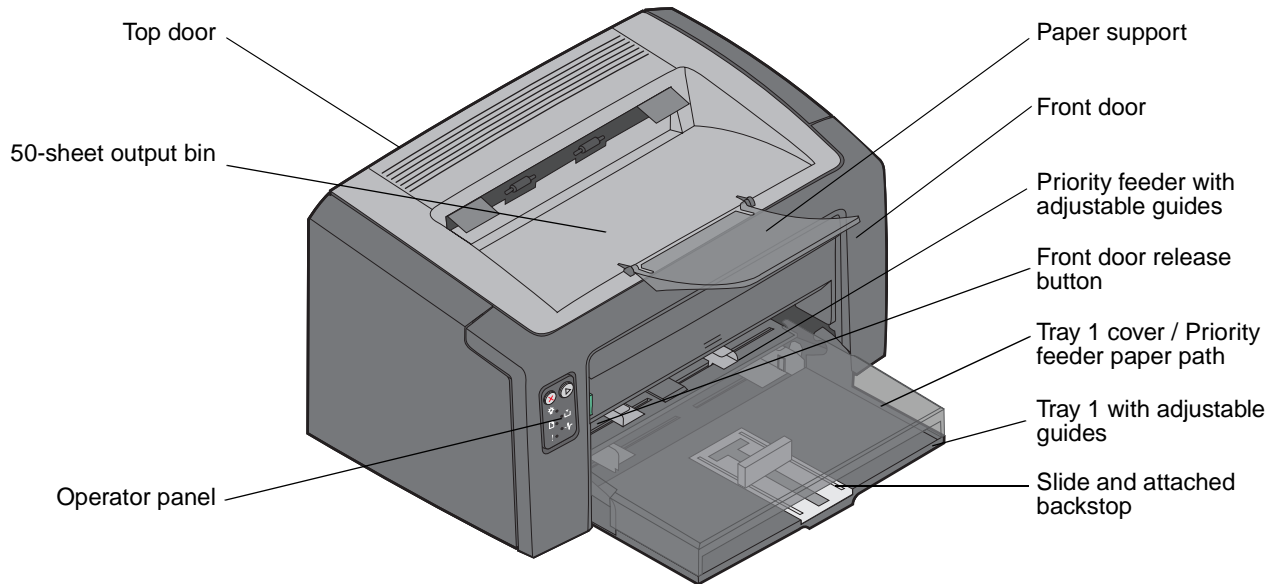

Both models have a 150-sheet paper tray (Tray 1), located in the front of the printer, and a multi-sheet priority feeder, located just above Tray 1. Print media will automatically pick from the priority tray until the supply is emptied, and then pick from Tray 1 to complete a print job.

Tray 1 has a dual-action slide with an adjustable guide built into the bottom of the tray. The white rectangular piece (slide) can be pulled out or pushed in to adjust to different print media sizes.

There is a paper support on top of the printer, which can be flipped out to assist with smooth paper stacking in the 50-sheet output bin.

The printer has three doors: a front door, a top door, and a rear door.

# Overview

---

The power button and the power cord port are located at the rear of the printer, on the left. The USB port and a cable lock access point can also be found at the rear of the printer, on the right. The network model (Lexmark E120n) has an Ethernet port located just below the USB port.

**Note:** All future references to the printer refer equally to both models.

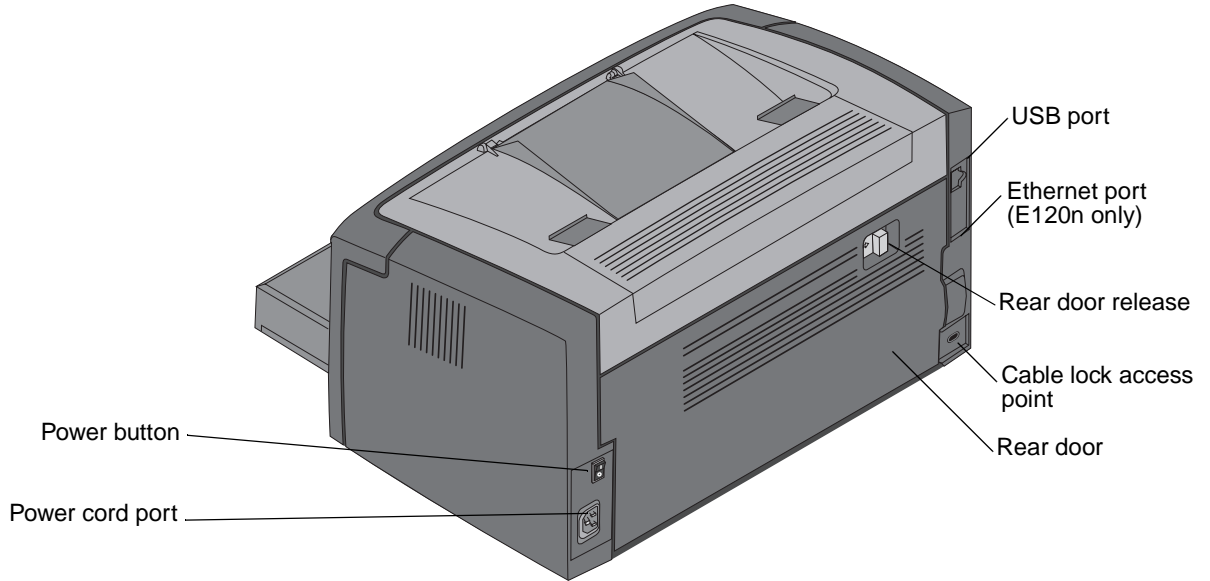

The base model (Lexmark E120) has two lights and two buttons.

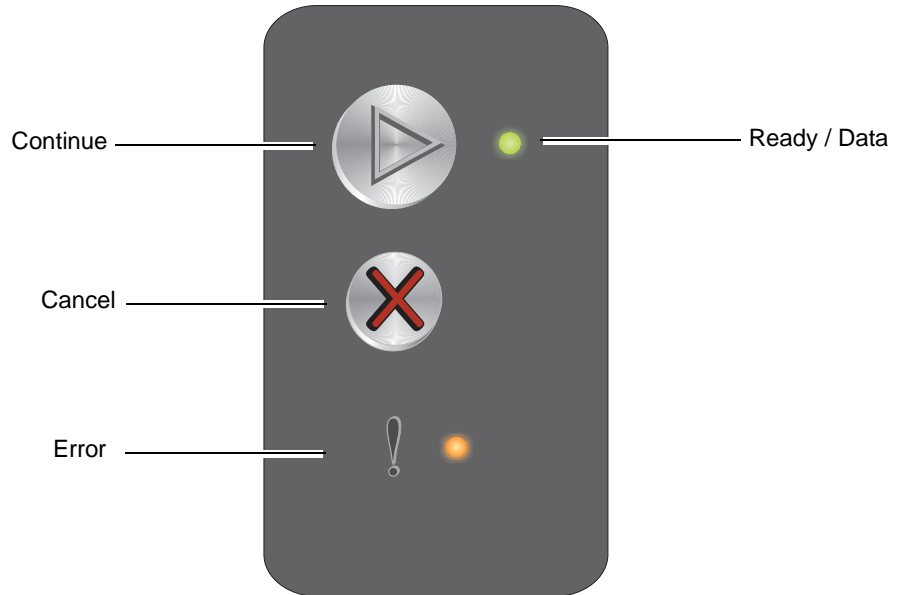





## Overview

---

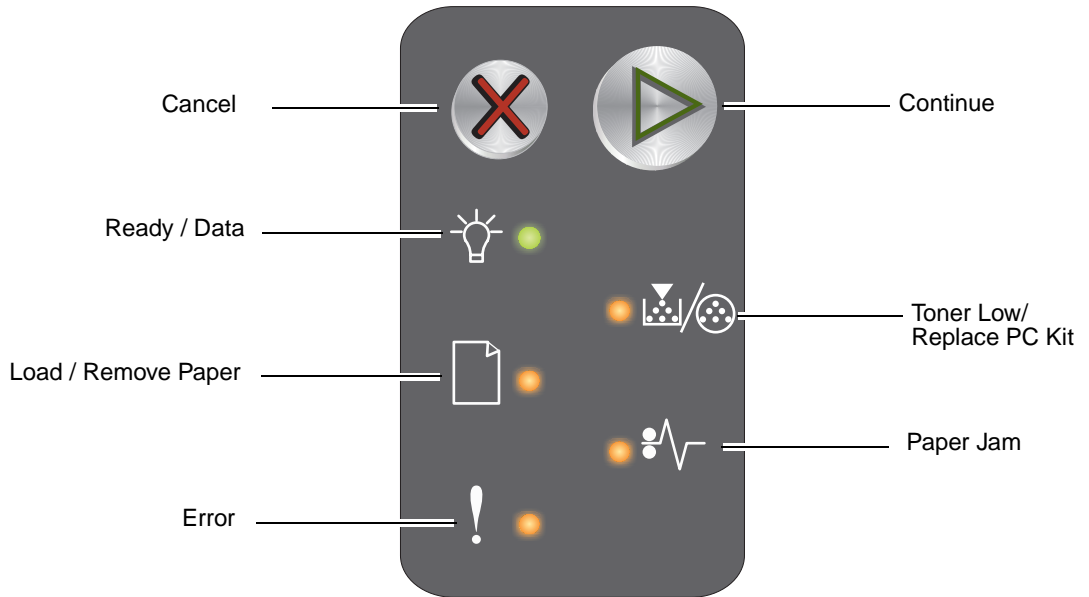
The network model (Lexmark E120n) has six lights and two buttons.

**Note:** The Continue button also functions as a light on the E120n model.



- Press and release **Continue**  to resume printing.
- Press the **Continue**  button from the Ready state to print menu and network setup pages.
- Press and release **Cancel**  to cancel the current job.
- Press and hold **Cancel**  until all lights come on to reset.

# 2

## Using the operator panels

---

Section	Page
Overview of the Lexmark E120 operator panel	9
Understanding the Lexmark E120 operator panel lights	10
Operator panel codes for the Lexmark E120	12
Overview of the Lexmark E120n operator panel	25
Understanding the Lexmark E120n operator panel lights	26
Operator panel codes for the Lexmark E120n	28
Using the printer resident Web page	43
Printing the menu settings and network setup page	44
Restoring factory defaults	44







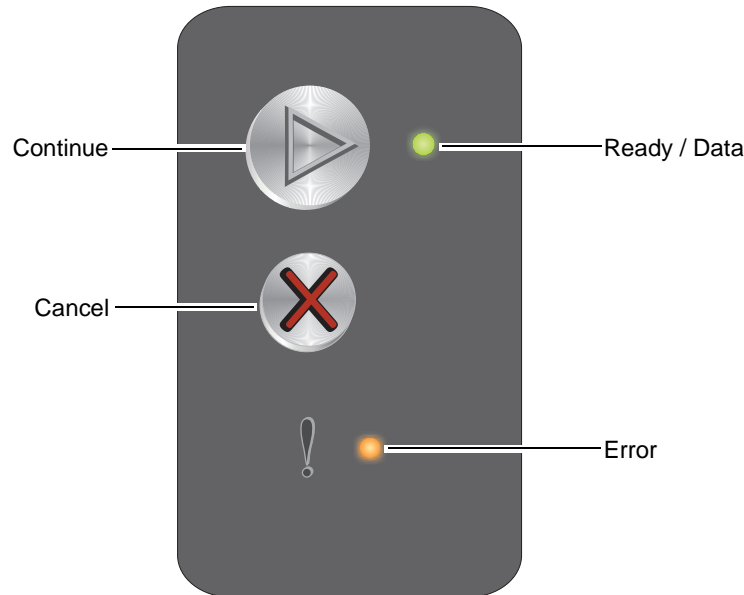

### ***Overview of the Lexmark E120 operator panel***

The printer operator panel has two buttons and two lights. Lights indicate the status of the printer. Buttons are used to continue or cancel the current print job.

When the printer is turned on, both lights cycle as a self test is performed. Also, when the printer is reset, or when a printer setting is changed in the menus, both lights cycle.

To learn more about the panel lights or to determine the status of the printer when lights are on, see **Understanding the Lexmark E120 operator panel lights**.



- Press and release **Continue**  to resume printing.
- Press and release **Continue**  twice quickly to display the secondary light sequence.
- Press **Continue**  from the Ready state to print the menu settings page.
- Press and release **Cancel**  to cancel current job.
- Press and hold **Cancel**  until all lights come on to reset.

## Using the operator panels





---

### Understanding the Lexmark E120 operator panel lights

Operator panel lights mean different things, depending on the sequence. Lights that are off, on, and/or blinking indicate printer conditions such as printer status, intervention, or service.

Use the light sequence table to find the message being indicated, then click the message for more information.























#### Light sequence

Ready / Data light On=		Error light On=	
Ready / Data light Blinking=		Error light Blinking=	

Primary light sequence		Secondary light sequence		Message
Ready / Data	Error	Ready / Data	Error	
				Ready / Power Saver
				Busy
				Waiting
				Cancel job / Reset printer
				Flushing buffer
				Invalid engine code (Ready / Data light blinks once)
				Not ready (Ready / Data light blinks once)
				Printing font list or menu settings page
				Programming engine code or system code
				Restoring factory defaults
				Cartridge region mismatch (Ready / Data light blinks four times)
				Missing cartridge / Defective cartridge detected (Ready / Data light blinks three times)
				Open door (Ready / Data light blinks once)
				Complex page (Ready / Data light blinks three times)
				ENA connection lost (Ready / Data light blinks five times)
				Insufficient collation area (Ready / Data light blinks three times)

## Using the operator panels

---

Primary light sequence		Secondary light sequence		Message
Ready / Data	Error	Ready / Data	Error	
				<b>Load media</b> (Ready / Data light blinks once)
				<b>Print side two of a duplex job</b> (Ready / Data light blinks once)
				<b>Memory full</b> (Ready / Data light blinks three times)
				<b>Host interface disabled</b> (Ready / Data light blinks five times)
				<b>Jam in the printer paper path</b> (Ready / Data light blinks ten times)
				<b>Jam in Tray 1 / priority feeder</b> (Ready / Data light blinks four times)
				<b>Short paper</b> (Ready / Data light blinks three times)
				<b>Toner low</b> (Ready / Data light blinks eight times)
				<b>Replace long-life photoconductor kit</b> (Ready / Data light blinks once)
				<b>Service error</b> (secondary Ready / Data light blinks ten times)

### ***Operator panel codes for the Lexmark E120***

Following are explanations of the primary and secondary light sequences, and what can be done to clear them.

#### **Primary Codes**

##### **Ready / Power Saver**

**Light sequence:**

Ready / Data—On

**Message:**

- Printer is ready to receive and process data.
- Printer is in Power Saver mode.

Printer is functioning properly.



**Note:** To change the Power Saver setting, use the Local Printer Setup Utility (see ***Software and Documentation CD***).

### Busy







**Light sequence:**

Ready / Data—Blinking

**Message:**

Printer is busy receiving and processing data or printing.

**Solution:**

- Busy:
  - Wait for message to clear.
  - Press and release  to cancel job.
  - Press and hold  to reset printer.
- Printing:
  - Wait for pages to print. The ready light blinks as pages print. The Ready light is on when printing stops.
  - Press and release  to cancel job.
  - Press and hold  to reset printer.
- Receiving/processing data:
  - Wait for message to clear.
  - Press and release  to stop processing.
  - Press and hold  to reset printer.



### Waiting



**Light sequence:**

Error—Blinking

**Message:**

Printer is waiting until a print timeout occurs, or until additional data is received.

**Solution:**

- Press  to print contents of the print buffer.
- Press and release  to cancel job.
- Press and hold  to reset printer.



## Cancel job / Reset printer

### Light sequence:

- Ready / Data—On
- Error—On

### Message:

- Current job is canceled.
- Printer is resetting to the user default settings. All active print jobs are canceled. A user default setting remains in effect until the user changes it or until the user restores the factory default settings.

### Solution:

Press and hold  to reset printer.



## Flushing buffer

### Light sequence:

- Ready / Data—On
- Error—On

### Message:

Printer is flushing a print job.

### Solution:

Wait for message to clear.

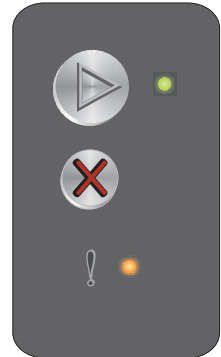

## Invalid engine code

### Light sequence:

Error—On

### Secondary light sequence:

Press  twice quickly to see the secondary light sequence.

Ready / Data—Blinks once

### Message:

The internal engine code has not been programmed, or the programmed code is not valid.

### Solution:

Download a valid engine code.



Primary light sequence



Secondary light sequence

## Not ready

### Light sequence:

Error—On

### Secondary light sequence:



Press  twice quickly to see the secondary light sequence.

Ready / Data—Blinks once

### Message:

Printer is not ready to receive or process data, or printer port is offline.

### Solution:

- Press  to return to Ready or Busy state.
- Press and release  to cancel job.
- Press and hold  to reset printer.



Primary light sequence



Secondary light sequence

## Printing font list or menu settings page

### Light sequence:

Ready / Data—Blinking

### Message:

The font list or menu settings page is being printed.

### Solution:

Wait for message to clear.



## Programming engine code or system code

### Light sequence:

- Ready / Data—On
- Error—On

### Message:

New code is being programmed into the engine or firmware.

### Solution:

Wait for message to clear. When printer has finished programming the code, it returns to ready.

**Note:** No button is active while this message is displayed.



### Restoring factory defaults

**Light sequence:**

- Ready / Data—On
- Error—On

**Message:**

Printer is resetting to the original factory default settings.

**Solution:**

Press and hold  to reset printer.



### Cartridge region mismatch

**Light sequence:**

Error—On

**Secondary light sequence:**

Press  twice quickly to see the secondary light sequence.

Ready / Data—Blinks four times

**Message:**

The toner cartridge being used is not programmed for the specific region.

**Solution:**

Remove the toner cartridge, and install a new toner cartridge that is programmed for the same region as your printer. See the back of the printer for a label with your printer region location. See **Ordering supplies on page 66** for a list of correct supplies and part numbers.



**Primary light sequence**



**Secondary light sequence**



### Missing cartridge / Defective cartridge detected

**Light sequence:**

Error—On

**Secondary light sequence:**

Press  twice quickly to see the secondary light sequence.

Ready / Data—Blinks three times

**Message:**

Either the toner cartridge is missing, the long-life photoconductor kit is missing, or a defective toner cartridge is detected.

**Solution:**

First, check to see if a toner cartridge is installed. If the toner cartridge is properly installed, check to see if a long-life photoconductor kit is installed. If the toner cartridge or the long-life photoconductor kit is missing, install the missing item. If both are properly installed, then remove the defective toner cartridge.



**Primary light sequence**



**Secondary light sequence**

### Open door

**Light sequence:**

Error—On

**Secondary light sequence:**

Press  twice quickly to see the secondary light sequence.

Ready / Data—Blinks once

**Message:**

Door is open.

**Solution:**

Close the open door.



**Primary light sequence**



**Secondary light sequence**

## Complex page

### Light sequence:

Error—On

### Secondary light sequence:

Press  twice quickly to see the secondary light sequence.

Ready / Data—Blinks three times

### Message:

The page may not print correctly because the print information on the page is too complex (that is, too large for printer memory).

### Solution:

Turn printer off and back on to try printing the page again. If not successful:

- Press  to clear message and continue processing the job (some print data may be lost).

To avoid this error in the future:

- Reduce complexity of the page by reducing the amount of text or graphics.
- Set **Page Protect** to On in the Local Printer Setup Utility (see **Software and Documentation CD**).



Primary light sequence



Secondary light sequence

## ENA connection lost

### Light sequence:

Error—On

### Secondary light sequence:

Press  twice quickly to see the secondary light sequence.

Ready / Data—Blinks five times

### Message:

During power-on cycle, the printer detected the connection to the external network adapter was lost.

**Note:** This error is only detected during the power-on cycle.

### Solution:

- Press  to clear message.
- Re-establish connection with the external network adapter.



Primary light sequence



Secondary light sequence

### Insufficient collation area

**Light sequence:**

Error—On

**Secondary light sequence:**

Press  twice quickly to see the secondary light sequence.

Ready / Data—Blinks three times

**Message:**

Printer memory does not have the free space necessary to collate print job. May occur due to one of the errors listed below:

- Printer memory is full.
- A page is too complex to print.
- Memory is insufficient to save what is in the print buffer.

**Solution:**

Turn printer off and back on to try printing the page again. If not successful:

- Press  to clear message and continue processing the job (some print data may be lost).

To avoid this error in the future:

- Reduce complexity of the page by reducing the amount of text or graphics.
- Set **Page Protect** to On in the Local Printer Setup Utility (see **Software and Documentation CD**).



### Load media

**Light sequence:**

Error—Blinking

**Secondary light sequence:**



Press  twice quickly to see the secondary light sequence.

Ready / Data—Blinks once

**Message:**

Printer is out of media, or media did not feed properly.

**Solution:**

- Load media into Tray 1 or priority feeder and press  to resume.
- Ensure media is loaded correctly in Tray 1 or priority feeder.
- Press  to cancel print job.

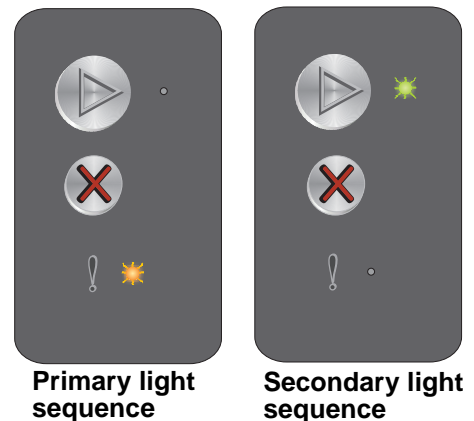

### Print side two of a duplex job

**Light sequence:**

Error—Blinking

**Secondary light sequence:**



Press  twice quickly to see the secondary light sequence.

Ready / Data—Blinks once

**Message:**

Print the other side of current duplex print job.

**Solution:**

- Insert print job into priority feeder using instructions in the driver pop-up menu to orient pages correctly, then press  to resume printing.
- Press  to cancel print job.
- Press and hold  to reset printer.



**Primary light sequence**



**Secondary light sequence**

### Memory full

**Light sequence:**

Error—Blinking

**Secondary light sequence:**



Press  twice quickly to see the secondary light sequence.

Ready / Data—Blinks three times

**Message:**

Printer is processing data, but the memory used to store pages is full.

**Solution:**

- Press  to clear message and continue printing job (may not print correctly).
- Press and release  to cancel print job.
- Press and hold  to reset printer.
- To avoid this error in the future: Simplify the print job. Reduce complexity of the page by reducing the amount of text or graphics and deleting unnecessary fonts or macros.



**Primary light sequence**



**Secondary light sequence**

## Host interface disabled

### Light sequence:

Error—Blinking

### Secondary light sequence:

Press  twice quickly to see the secondary light sequence.

Ready / Data—Blinks five times

### Message:

Printer USB or network port disabled.

### Solution:

- Press  to clear message. Printer discards all jobs previously sent.
- Enable the USB port by selecting a value other than Disabled for the USB Buffer item in the Local Printer Setup Utility (see **Software and Documentation CD**).



Primary light sequence



Secondary light sequence

## Jam in the printer paper path

**Note:** All jams show the same primary code. To determine the jam location, view the secondary light sequence.

### Light sequence:

Error—Blinking

### Secondary light sequence:

Press  twice quickly to see the secondary light sequence.

- Ready / Data—Blinks ten times
- Error—On

### Message:

A jam has occurred at the input sensor, at the exit sensor, or between the input and exit sensors.

### Solution:

See **Clearing jams on page 53** for instructions.



Primary light sequence



Secondary light sequence

### Jam in Tray 1 / priority feeder

**Note:** All jams show the same primary code. To determine the jam location, view the secondary light sequence.

**Light sequence:**

Error—Blinking

**Secondary light sequence:**

Press  twice quickly to see the secondary light sequence.

- Ready / Data—Blinks four times
- Error—On

**Message:**

A jam has occurred in Tray 1 / priority feeder.

**Solution:**

See **Clearing jams on page 53** for more information.



**Primary light sequence**



**Secondary light sequence**

### Short paper

**Light sequence:**

Error—Blinking

**Secondary light sequence:**



Press  twice quickly to see the secondary light sequence.

Ready / Data—Blinks three times

**Message:**

Paper length is too short to print the formatted data. This occurs when the printer does not know the loaded media size or when there is a problem feeding the media.

**Solution:**

- Make sure the loaded print media is large enough and paper size is set correctly in the Local Printer Setup Utility paper size menu (see **Software and Documentation CD**).
- Press  to clear message and continue the job.
- Press  to cancel print job.

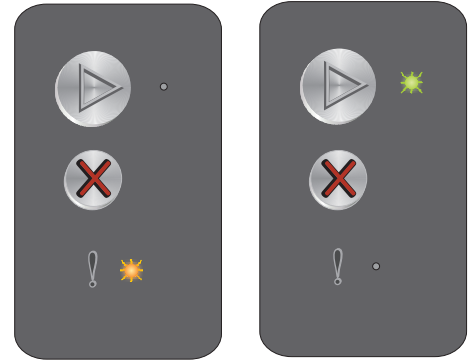

**Primary light sequence**

**Secondary light sequence**

### Toner low

**Light sequence:**

Error—Blinking

**Secondary light sequence:**

Press  twice quickly to see the secondary light sequence.

Ready / Data—Blinks eight times

**Message:**

Printer is ready to receive and process data. In addition, toner in the toner cartridge is getting low.

**Solution:**

- Press  to clear message and continue processing job.
- Remove the toner cartridge. Gently shake the toner cartridge from side to side and front to back several times to redistribute the toner, and reinsert it. Repeat this procedure multiple times. If the print remains faded, replace the toner cartridge. See **Changing the toner cartridge on page 68** for help.

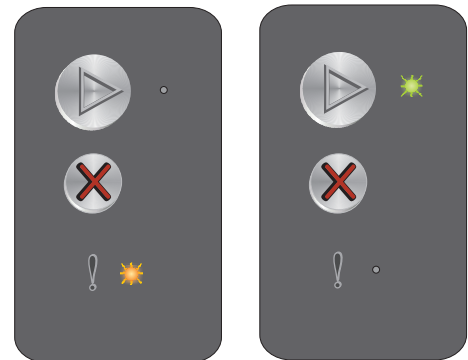

**Primary light sequence**

**Secondary light sequence**

### Replace long-life photoconductor kit

**Light sequence:**

Error—Blinking

**Secondary light sequence:**

Press  twice quickly to see the secondary light sequence.

Ready / Data—Blinks once

**Message:**

Long-life photoconductor kit should be replaced soon.

**Solution:**

- Press  to clear the message and continue processing the job.
- Replace the long-life photoconductor kit. See **Changing the long-life photoconductor kit on page 71** for help.



**Primary light sequence**



**Secondary light sequence**

### Service error

**Light sequence:**

- Ready / Data—Blinking
- Error—Blinking

**Secondary light sequence:**

Press  twice quickly to see the secondary light sequence.

- Ready / Data—Blinks ten times

**Message:**

Printer has a service error, and printing has stopped.

**Solution:**

Turn printer off and back on. If lights are still blinking, contact customer support. See the Lexmark web site at [www.lexmark.com](http://www.lexmark.com) for the phone number in your area.



**Primary light sequence**



**Secondary light sequence**







### Overview of the Lexmark E120n operator panel

The printer operator panel has two buttons and six lights (Continue button is both a light and button). Lights indicate the status of the printer. Buttons are used to continue or cancel the current print job.

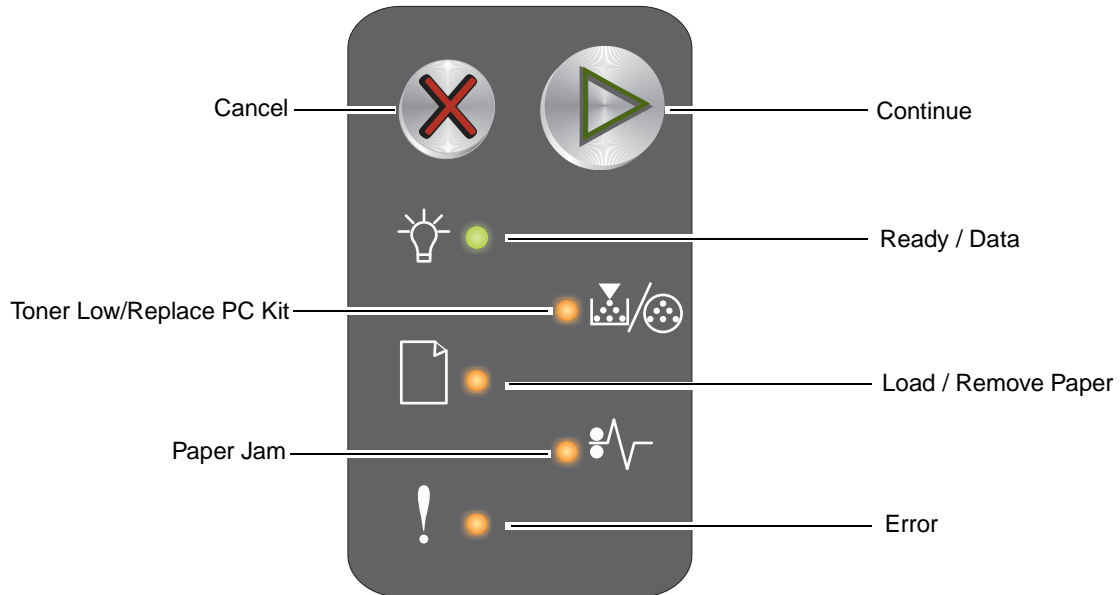
When the printer is turned on, all lights cycle as a self test is performed. Also, when the printer is reset, or when a printer setting is changed in the menus, all lights cycle.

To learn more about the panel lights or to determine the status of the printer when lights are on, see **Understanding the Lexmark E120n operator panel lights**.



- Press and release **Continue**  to resume printing.
- Press and release **Continue**  twice quickly to display the secondary light sequence.
- Press and release **Cancel**  to cancel current job.
- Press and hold **Cancel**  until all of the lights come on to reset.







## Using the operator panels































### Understanding the Lexmark E120n operator panel lights

The operator panel lights mean different things, depending on their sequence. Lights that are off, on, and/or blinking indicate printer conditions such as printer status, intervention, or service.

Use the light sequence table to find the message being indicated, then click the message for more information.

#### Light sequence

Continue On =       Ready / Data On=       Other panel lights On=   
 Continue Blinking =       Ready / Data Blinking=       Ready / Data Blinking= 

Primary light sequence						Secondary light sequence						Message
Continue	Ready / Data	Toner Low/Replace PC Kit	Load / Remove Paper	Paper Jam	Error	Continue	Ready / Data	Toner Low/Replace PC Kit	Load / Remove Paper	Paper Jam	Error	
												
												Ready / Power Saver
												Busy
												Resolution reduced
												Waiting
												Cancel job / Reset printer
												Flushing buffer
												Invalid engine code
												Not ready
												Printing font list or menu settings page
												Programming engine code or system code
												Restoring factory defaults
												Cartridge region mismatch

## Using the operator panels

Primary light sequence						Secondary light sequence						Message
Continue	Ready / Data	Toner Low/Replace PC Kit	Load / Remove Paper	Paper Jam	Error	Continue	Ready / Data	Toner Low/Replace PC Kit	Load / Remove Paper	Paper Jam	Error	
												Missing cartridge / Defective cartridge detected
												Open door
												Complex page
												ENA connection lost
												Insufficient collation area
												Load media
												Print side two of a duplex job
												Memory full
												Network interface errors
												Host interface disabled
												Jam at the input sensor
												Jam between the input and exit sensors
												Jam at printer exit sensor
												Jam in Tray 1 / priority feeder
												Resource save off
												Short paper
												Toner low
												Long-life photoconductor kit life warning
												Replace long-life photoconductor kit

## Using the operator panels

Primary light sequence						Secondary light sequence							
Continue	Ready / Data	Toner Low/Replace PC Kit	Load / Remove Paper	Paper Jam	Error	Continue	Ready / Data	Toner Low/Replace PC Kit	Load / Remove Paper	Paper Jam	Error		
													Message
													Unsupported toner cartridge
												Service error	

### Operator panel codes for the Lexmark E120n

Following are explanations of the primary and secondary light sequences, and what can be done to clear them.

#### Primary Codes

##### Ready / Power Saver

**Light sequence:**

Ready / Data—On

**Message:**

- Printer is ready to receive and process data.
- Printer is in Power Saver mode.

Printer is functioning properly.

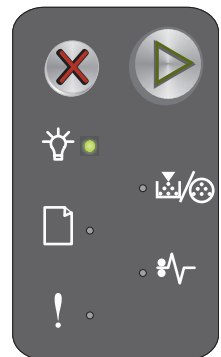

**Note:** To change the Power Saver setting, use the Local Printer Setup Utility (see **Software and Documentation CD**).

### Busy







#### Light sequence:

Ready / Data—Blinking

#### Message:

Printer is busy receiving and processing data or printing.

#### Solution:

- Busy:
  - Wait for message to clear.
  - Press and release  to cancel job.
  - Press and hold  to reset printer.
- Printing:
  - Wait for pages to print. The ready light blinks as the pages print. The Ready light is on when printing stops.
  - Press and release  to cancel job.
  - Press and hold  to reset printer.
- Receiving/processing data:
  - Wait for message to clear.
  - Press and release  to stop processing.
  - Press and hold  to reset printer.

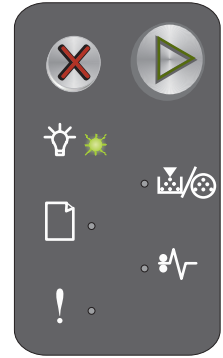

### Resolution reduced



#### Light sequence:

- Ready / Data—Blinking
- Error—Blinking

#### Message:

Printer is processing data or printing pages, but the resolution of a page in current job is reduced from 600 dots per inch (dpi) to 300 dpi to prevent a memory full error.

#### Solution:

- Wait until the operator panel returns to Ready to print new job.
- Press and release  to cancel job.
- Press and hold  to reset printer.



## Waiting



### Light sequence:

- Continue—On
- Ready / Data—On

### Message:

The printer is waiting until a print timeout occurs, or until additional data is received.

### Solution:

- Press  to print contents of the print buffer.
- Press and release  to cancel job.
- Press and hold  to reset printer.

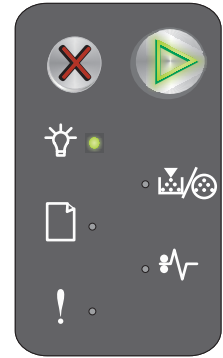

## Cancel job / Reset printer

### Light sequence:

- Continue—On
- Ready / Data—On
- Toner Low/Replace PC Kit—On
- Load / Remove Paper—On
- Paper Jam—On
- Error—On

### Message:

- Current job is canceled.
- Printer is resetting to the user default settings. All active print jobs are canceled. A user default setting remains in effect until the user changes it or until the user restores the factory default settings.

### Solution:

Press and hold  to reset printer.

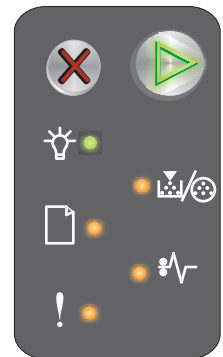

## Flushing buffer

### Light sequence:

- Ready / Data—Blinking
- Error—Blinking

### Message:

Printer is flushing a print job.

### Solution:

Wait for message to clear.



## Invalid engine code

### Light sequence:

- Ready / Data—On
- Error—On

### Secondary light sequence:

Press  twice quickly to see the secondary light sequence.

- Ready / Data—On
- Load / Remove Paper—On
- Error—On

### Message:

The internal engine code has not been programmed, or the programmed code is not valid.

### Solution:

Download valid engine code.



Primary light sequence

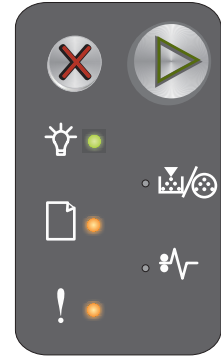

Secondary light sequence

## Not ready



### Light sequence:

- Continue—On
- Ready / Data—On
- Error—On

### Message:

Printer is not ready to receive or process data, or the printer port is offline.

### Solution:

- Press  to return to Ready or Busy state.
- Press and release  to cancel job.
- Press and hold  to reset printer.

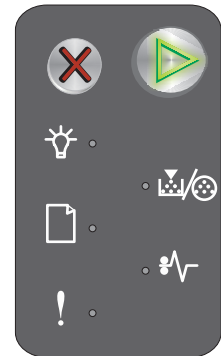

## Printing font list or menu settings page

### Light sequence:

Ready / Data—Blinking

### Message:

The font list or menu setting page is being printed.

### Solution:

Wait for message to clear.

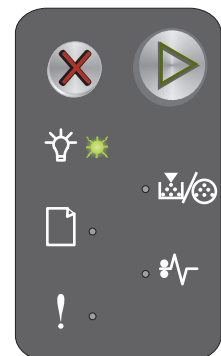

### Programming engine code or system code

**Light sequence:**

- Ready / Data—On
- Error—On

**Message:**

New code is being programmed into the engine or firmware.

**Solution:**

Wait for message to clear. When printer has finished programming the code, it returns to ready.

**Note:** No buttons are active while this message is displayed.

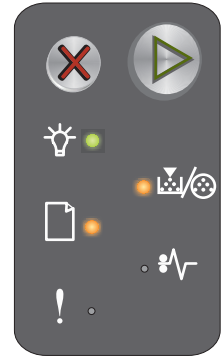

### Restoring factory defaults

**Light sequence:**

- Continue—On
- Ready / Data—On
- Toner Low/Replace PC Kit—On
- Load / Remove Paper—On
- Paper Jam—On
- Error—On

**Message:**

Printer is resetting to the original factory default settings.

**Solution:**

Wait for message to clear.



### Cartridge region mismatch

**Light sequence:**

- Toner Low/Replace PC Kit—Blinking
- Error—Blinking

**Message:**

The toner cartridge being used is not programmed for the specific region.

**Solution:**

Remove the toner cartridge, and install a new toner cartridge that is programmed for the same region as your printer. See the back of the printer for a label with your printer region location. See **Ordering supplies on page 66** for a list of correct supplies and part numbers.





### Change cartridge

**Light sequence:**

- Toner Low/Replace PC Kit—On
- Error—Blinking

**Message:**

Printer has detected a refilled Return Program toner cartridge has been installed.

**Solution:**

Remove current toner cartridge, and install a new toner cartridge.

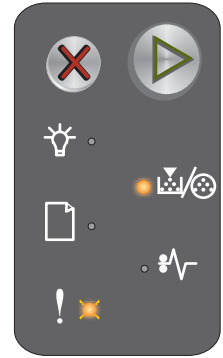

### Open door

**Light sequence:**

Error—On

**Message:**

Door is open.

**Solution:**

Close the open door.

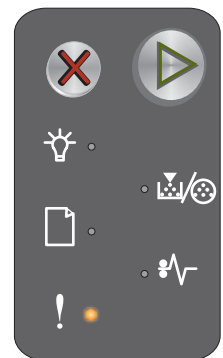

### Complex page

#### Light sequence:

- Continue—On
- Error—On

#### Secondary light sequence:

Press  twice quickly to see the secondary light sequence.

- Continue—On
- Ready / Data—On
- Error—On



Primary light sequence

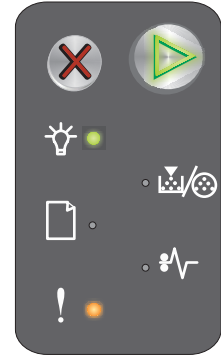

Secondary light sequence

#### Message:

The page may not print correctly because the print information on the page is too complex (that is, too large for the printer memory).

#### Solution:

- Press  to clear message and continue processing the job (some print data may be lost).
- To avoid this error in the future:
  - Reduce complexity of the page by reducing the amount of text or graphics.
  - Set **Page Protect** to On in the Local Printer Setup Utility (see **Software and Documentation CD**).

### Missing cartridge / Defective cartridge detected

#### Light sequence:

- Toner Low/Replace PC Kit—Blinking
- Error—On

#### Secondary light sequence:

Press  twice quickly to see the secondary light sequence.

- Toner Low/Replace PC Kit—On
- Error—On
- Paper Jam—Blinking



Primary light sequence



Secondary light sequence

#### Message:

Either the toner cartridge is missing, the long-life photoconductor kit is missing, or a defective toner cartridge is detected.

#### Solution:

First, check to see if a toner cartridge is installed. If the toner cartridge is properly installed, check to see if a long-life photoconductor kit is installed. If both are properly installed, then remove the defective toner cartridge. If the toner cartridge or the long-life photoconductor kit is missing, install the missing item.

### ENA connection lost

#### Light sequence:

- Continue—On
- Error—On

#### Secondary light sequence:

Press  twice quickly to see the secondary light sequence.

- Continue—On
- Paper Jam—Blinking
- Error—On



**Primary light sequence**

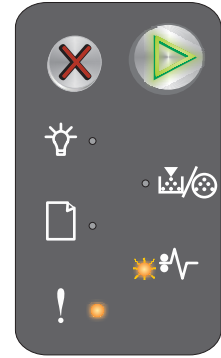

**Secondary light sequence**

#### Message:

During power-on cycle, the printer detected the connection to the external network adapter was lost.

**Note:** This error is only detected during power-on cycle.

#### Solution:

- Press  to clear message.
- Re-establish connection with the external network adapter.

### Insufficient collation area

#### Light sequence:

- Continue—On
- Error—On

#### Secondary light sequence:

Press  twice quickly to see the secondary light sequence.

- Continue—On
- Toner Low/Replace PC Kit—On
- Error—On



Primary light sequence

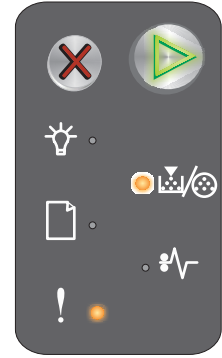

Secondary light sequence

#### Message:

Printer memory does not have the free space necessary to collate print job. May occur due to one of the errors listed below:

- Printer memory is full.
- A page is too complex to print.
- Memory is insufficient to save what is in the print buffer.

#### Solution:

Turn printer off and back on to try printing the page again. If not successful:

- Press  to clear message and continue processing the job (some print data may be lost).

To avoid this error in the future:

- Reduce complexity of the page by reducing the amount of text or graphics.
- Set **Page Protect** to On in the Local Printer Setup Utility (see **Software and Documentation CD**).

### Load media



#### Light sequence:

- Continue—On
- Load / Remove Paper—On

#### Message:

Printer is out of media, or media did not feed properly.

#### Solution:

- Load media into Tray 1 or priority feeder, and press  to resume.
- Ensure media is loaded correctly in Tray 1 or priority feeder.
- Press  to cancel print job.

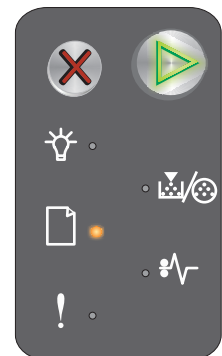

### Print side two of a duplex job



#### Light sequence:

- Continue—Blinking
- Load / Remove Paper—On

#### Message:

Print the other side of current duplex print job.

#### Solution:

- Insert print job into priority feeder using instructions in the driver pop-up menu to orient pages correctly, then press  to resume printing.
- Press  to cancel print job.
- Press and hold  to reset printer.

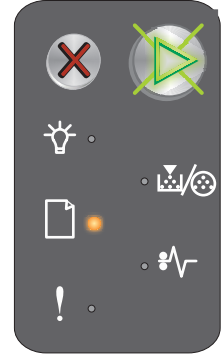

### Memory full

#### Light sequence:

- Continue—On
- Error—On

#### Secondary light sequence:



Press  twice quickly to see the secondary light sequence.

- Continue—On
- Ready / Data—On
- Toner Low/Replace PC Kit—On
- Error—On

#### Message:

Printer is processing data, but the memory used to store pages is full.

#### Solution:

- Press  to clear message and continue printing job (may not print correctly).
- Press and release  to cancel print job.
- Press and hold  to reset printer (may need to send the print job again).
- To avoid this error in the future: Simplify print job. Reduce complexity of the page by reducing the amount of text or graphics and deleting unnecessary fonts or macros.



**Primary light sequence**

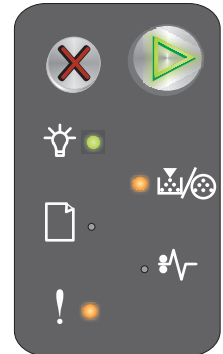

**Secondary light sequence**

## Network interface errors

### Light sequence:

- Continue—On
- Error—On

### Secondary light sequence:



Press  twice quickly to see the secondary light sequence.

- Continue—On
- Paper Jam—On
- Error—On

### Message:

Printer cannot establish communication with the network.

### Solution:

- Press  to clear message and continue printing. (may not print correctly).
- Press and hold  to reset printer (may need to send the job again).



Primary light sequence

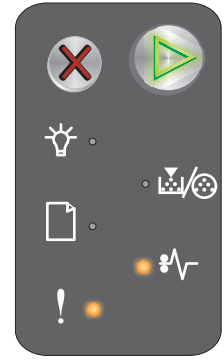

Secondary light sequence

## Host interface disabled

### Light sequence:

- Continue—On
- Error—On

### Secondary light sequence:

Press  twice quickly to see the secondary light sequence.

- Continue—On
- Load / Remove Paper—Blinking
- Paper Jam—Blinking
- Error—On

### Message:

Printer USB or network port has been disabled.

### Solution:

- Press  to clear message. The printer discards all jobs previously sent.
- Enable the network port by selecting a value other than Disabled for the Network Buffer item in the Local Printer Setup Utility (see **Software and Documentation CD**).



Primary light sequence

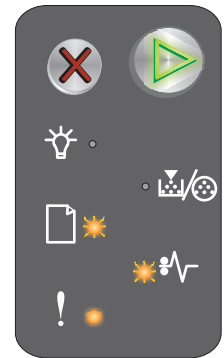

Secondary light sequence

## Jam at the input sensor

**Note:** All jams show the same primary code. To determine the jam location, view the secondary light sequence.

### Light sequence:

- Continue—On
- Paper Jam—On

### Secondary light sequence:

Press  twice quickly to see the secondary light sequence.

- Continue—On
- Ready / Data—On
- Paper Jam—On

### Message:

A jam has occurred at the input sensor; it can be after the paper leaves the tray and enters the printer or in the priority feeder.

### Solution:

See **Clearing jams on page 53** for more information.

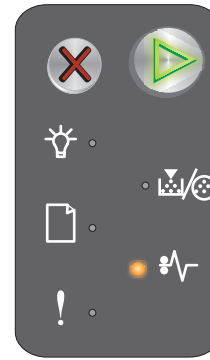

Primary light sequence

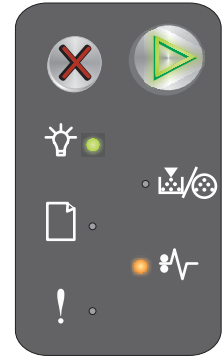

Secondary light sequence

## Jam between the input and exit sensors

**Note:** All jams show the same primary code. To determine the jam location, view the secondary light sequence.

### Light sequence:

- Continue—On
- Paper Jam—On

### Secondary light sequence:

Press  twice quickly to see the secondary light sequence.

- Continue—On
- Toner Low/Replace PC Kit—On
- Paper Jam—On

### Message:

A jam has occurred and paper is between the printer input and exit sensors.

### Solution:

See **Clearing jams on page 53** for more information.

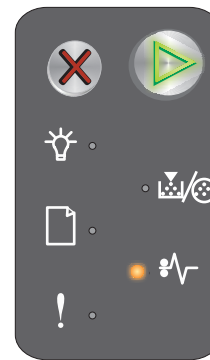

Primary light sequence

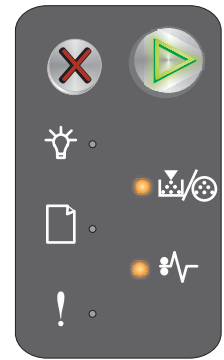

Secondary light sequence

### Jam at printer exit sensor

**Note:** All jams show the same primary code. To determine the jam location, view the secondary light sequence.

#### Light sequence:

- Continue—On
- Paper Jam—On

#### Secondary light sequence:

Press  twice quickly to see the secondary light sequence.

- Continue—On
- Load / Remove Paper—On
- Paper Jam—On

#### Message:

A jam has occurred at the printer exit sensor.

#### Solution:

See **Clearing jams on page 53** for more information.

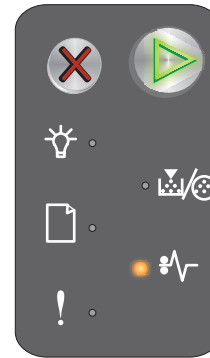

Primary light sequence

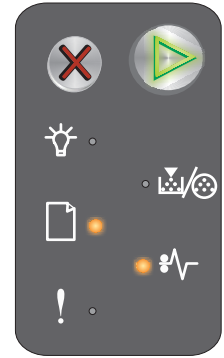

Secondary light sequence

### Jam in Tray 1 / priority feeder

**Note:** All jams show the same primary code. To determine the jam location, view the secondary light sequence.

#### Light sequence:

- Continue—On
- Paper Jam—On

#### Secondary light sequence:

Press  twice quickly to see the secondary light sequence.

- Continue—On
- Toner Low/Replace PC Kit—On
- Load / Remove Paper—On
- Paper Jam—On

#### Message:

A jam has occurred in Tray 1 / priority feeder.

#### Solution:

See **Clearing jams on page 53** for more information.



Primary light sequence

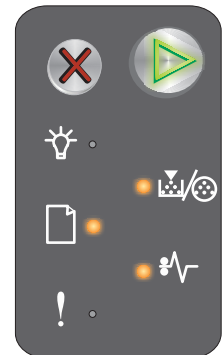

Secondary light sequence



### Resource save off

#### Light sequence:

- Continue—On
- Error—On

#### Secondary light sequence:

Press  twice quickly to see the secondary light sequence.

- Continue—On
- Ready / Data—Blinking
- Error—On



Primary light sequence

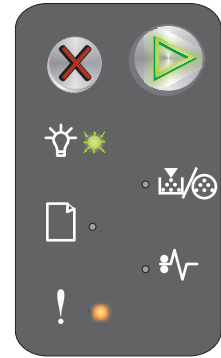

Secondary light sequence

#### Message:

Too much memory has been allocated to the print buffer.

#### Solution:

- Press  to clear message and continue printing.
- Change the print buffer to a lesser amount, or set the print buffer to **Auto** (see **Using the printer resident Web page on page 43**).

### Short paper

#### Light sequence:

- Continue—On
- Error—On

#### Secondary light sequence:

Press  twice quickly to see the secondary light sequence.

- Continue—On
- Ready / Data—On
- Load / Remove Paper—On
- Error—On



Primary light sequence

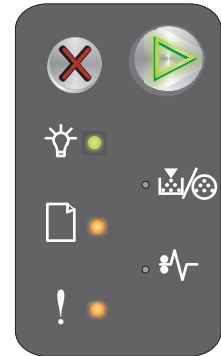



Secondary light sequence

#### Message:

Paper length is too short to print the formatted data. This occurs when the printer does not know the loaded media size or when there is a problem feeding the media.

#### Solution:

- Make sure the loaded print media is large enough and paper size is set correctly in the Local Printer Setup Utility paper size menu (see **Software and Documentation CD**).
- Press  to clear message and continue the job.
- Press  to cancel print job.

### Toner low

#### Light sequence:

- Continue—On
- Toner Low/Replace PC Kit—On

#### Message:

The printer is ready to receive and process data. In addition, the toner in the toner cartridge is getting low.

#### Solution:

- Press  to clear message and continue processing job.
- Remove the toner cartridge. Gently shake the toner cartridge from side to side and front to back several times to redistribute the toner, and reinsert it. Repeat this procedure multiple times. If the print remains faded, replace the toner cartridge. See **Changing the toner cartridge on page 68** for help.

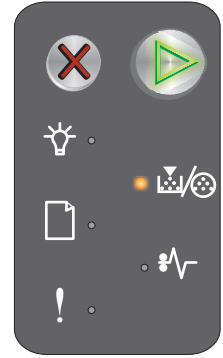

### Long-life photoconductor kit life warning

#### Light sequence:

- Continue—On
- Toner Low/Replace PC Kit—Blinks once

#### Message:

The long-life photoconductor kit is almost full and should be replaced soon.

**Note:** The Toner Alarm must be turned on from the web page for this message to appear (see **Using the printer resident Web page on page 43**).

#### Solution:

- Press  to clear the message and continue processing the job.
- Replace the long-life photoconductor kit. See **Changing the long-life photoconductor kit on page 71** for help.



### Replace long-life photoconductor kit

#### Light sequence:

- Continue—On
- Toner Low/Replace PC Kit—Blinking

#### Message:

The long-life photoconductor kit should be replaced soon.

#### Solution:

- Press  to clear the message and continue processing the job.
- Replace the long-life photoconductor kit. See **Changing the long-life photoconductor kit on page 71** for help.



### Unsupported toner cartridge

#### Light sequence:

- Toner Low/Replace PC Kit—On
- Error—On

#### Message:

The printer detects an unsupported toner cartridge.

#### Solution:

Remove the toner cartridge, and install a new one (see **Changing the toner cartridge on page 68**).



### Service error

#### Light sequence:

- Continue—Blinking
- Ready / Data—Blinking
- Toner Low/Replace PC Kit—Blinking
- Load / Remove Paper—Blinking
- Paper Jam—Blinking
- Error—Blinking

#### Message:

The printer has a service error, and printing has stopped.

#### Solution:

Turn the printer off and back on. If the lights are still blinking, contact customer support. See the Lexmark web site at [www.lexmark.com](http://www.lexmark.com) for a phone number in your area.

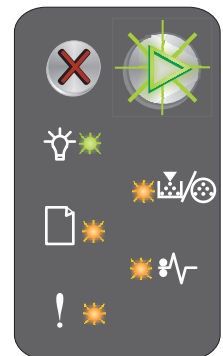

### Using the printer resident Web page

The Lexmark E120n (network model), has a resident Web page, which can be accessed from the browser. To access the resident Web page, type the printer's IP address in the URL address field of the browser (for example, <http://192.168.236.24>). If you do not know the IP address of your printer, it can be found on the network setup page. See **Printing the menu settings and network setup page**.

Some resident Web page features include a real-time status window of the printer and details of the printer's configuration, such as current memory and engine code levels. If you have administrative rights, you can also change printer settings.

### ***Printing the menu settings and network setup page***

To print the menu settings and network setup pages, press the **Continue** button from the Ready state. The printer automatically prints the menu settings and network setup page.

A list of the printer settings and the current default values are printed on the menu settings page. The current default settings are marked with an asterisk. The network setup page confirms the network Status is "Connected" and lists the current network settings.

### ***Restoring factory defaults***

This function will return most of the settings back to their factory values. The display language and the settings in the Network and USB menus are not returned to the factory defaults.

To restore the printer to the original factory defaults, press and hold the **Cancel** button for more than three seconds.

**Note:** Before restoring the factory defaults, make sure the host computer or network has stopped sending information to the printer.

**3**

## Print media tasks and tips

---

Section	Page
Types of print media	46
Choosing appropriate print media	46
Storing print media	48
Loading print media into Tray 1	48
Loading print media into the priority feeder	51
Preventing jams	52
Clearing jams	53

### Types of print media

Receive optimal use from the printer by properly loading trays. Never mix media types within a tray.

Source	Sizes	Types	Weight	Capacity* (sheets)
Tray 1	A4, A5, JIS-B5, letter, legal, executive, folio, statement, universal†	Plain paper, bond paper, transparency, label	60–105 g/m <sup>2</sup> (16–28 lb)	<ul style="list-style-type: none"> <li>• 150 sheets</li> <li>• 5 transparencies</li> <li>• 5 labels</li> </ul>
	3 x 5 inch, other	Card stock	135–163 g/m <sup>2</sup> (36–43 lb) bond	5 cards
	7¾, 9, 10, DL, C5, B5, other	Envelope	105 g/m <sup>2</sup> (28 lb) max	5 envelopes
priority feeder	A4, A5, JIS-B5, letter, legal, executive, folio, statement, universal†	Plain paper, bond paper, transparency, label,	60–163 g/m <sup>2</sup> (16–43 lb)	<ul style="list-style-type: none"> <li>• 15 sheets</li> <li>• 5 transparencies</li> <li>• 5 labels</li> </ul>
	A6	Plain paper, bond paper	60–163 g/m <sup>2</sup> (16–43 lb)	30 sheets
	3 x 5 inch, other	Card stock	135–163 g/m <sup>2</sup> (36–43 lb) bond	5 cards
	7¾, 9, 10, DL, C5, B5, other	Envelopes	105 g/m <sup>2</sup> (28 lb) max	3 envelopes

\* Capacity for 20 lb print media, unless otherwise noted.

† Universal size ranges:

– Tray 1: 76–216 x 190–356 mm (3.0–8.5 x 7.5–14.0 in.) (includes 3 x 5 in. cards)

– priority feeder: 76–216 x 190–356 mm (3.0–8.5 x 7.5–14.0 in.) (includes 3 x 5 in. cards)

### Choosing appropriate print media

To reduce printing problems and receive the best print quality, try a sample of the media you are considering before buying large quantities.

Refer to the *Card Stock & Label Guide* available on our Lexmark Web site at [www.lexmark.com](http://www.lexmark.com) for more information about which print media provides optimum results.

#### Paper

- For the best print quality, use 20 lb (75 g/m<sup>2</sup>) xerographic, grain long paper.  
The printer can automatically feed paper weights from 16 to 28 lb bond (60 to 105 g/m<sup>2</sup>) grain long. Paper lighter than 16 lb (60 g/m<sup>2</sup>) might not be stiff enough to feed properly, causing jams.
- The laser printing process heats paper to high temperatures of 185°C (365°F). Use only paper able to withstand these temperatures without discoloring, bleeding, or releasing hazardous emissions. Check with the manufacturer or vendor to determine whether the paper you have chosen is acceptable for laser printers.

### ***Preprinted forms and letterhead***

- Use only forms and letterhead printed using an offset lithographic or engraved printing process.
- Choose forms and letterhead types that absorb ink, but do not bleed.
- Avoid rough or heavily textured surfaces.

Use media printed with heat-resistant inks designed for use in xerographic copiers. The ink must withstand temperatures of 185°C (365°F) without melting or releasing hazardous emissions. Use inks that are not affected by the resin in toner. Inks that are oxidation-set or oil-based should meet these requirements; latex inks might not. If you are in doubt, contact the supplier.

### ***Transparencies***

- Use transparencies designed specifically for laser printers. Transparencies must be able to withstand temperatures of 185°C (365°F) without melting, discoloring, offsetting, or releasing hazardous emissions.  
We recommend Lexmark laser printer transparencies: part number 70X7240 for letter size transparencies; part number 12A5010 for A4 size transparencies.
- To prevent print quality problems, avoid getting fingerprints on transparencies.

### ***Envelopes***

- Use envelopes made from 24 lb (90 g/m<sup>2</sup>) bond paper, or with a maximum weight of 28 lb (105 g/m<sup>2</sup>)
- Use envelopes that can withstand temperatures of 185°C (365°F) without:
  - sealing
  - excessive curling
  - wrinkling
  - releasing hazardous emissions
- Do not use envelopes that:
  - Have excessive curl
  - Are stuck together
  - Are damaged in any way
  - Contain windows, holes, perforations, cutouts, or embossments
  - Have metal clasps, string ties, or metal folding bars
  - Have postage stamps attached
  - Have exposed adhesive when the flap is in the sealed position
  - Are self-sealing

If uncertain about the envelopes being considered for use, check with the supplier.

- A combination of high humidity (over 60%) and high printing temperatures may seal envelopes.

### ***Labels***

- Use labels that can withstand temperatures of 185°C (365°F) without sealing, excessive curling, wrinkling, or releasing hazardous emissions. Label adhesives, face sheet (printable stock), and topcoats must also be able to withstand 25 pounds per square inch (psi) (172 kilopascals) pressure.
- Do not use labels with exposed adhesive.
- Do not print a large number of labels continuously.
- Do not use vinyl labels.

### Card stock

- Use card stock with a maximum weight of 43 lb (163 g/m<sup>2</sup>) bond and a minimum size of 76 x 127 mm (3 x 5 inch).
- Preprinting, perforation, and creasing can significantly affect print quality and cause media handling or jamming problems.
- Avoid using card stock that may release hazardous emissions when heated.
- Do not use preprinted card stock manufactured with chemicals that may contaminate the printer. Preprinting introduces semi-liquid and volatile components into the printer.

### Storing print media

Use the following guidelines to avoid print media feeding problems and uneven print quality.

- Store all print media in an environment where temperature is approximately 21°C (70°F) and relative humidity is 40%.
- Store cartons of paper on a pallet or shelf rather than directly on the floor surface.
- If storing individual packages of paper out of the original carton, make sure they rest on a flat surface so edges do not buckle, curl, or become damaged.
- Do not place anything on top of paper packages.
- Store transparencies and envelopes in their original boxes.

### Loading print media into Tray 1

The printer has two print media sources: Tray 1 and a multi-sheet priority feeder. Media in the priority feeder will be picked first. After the supply of media has been used up, media will be picked from Tray 1

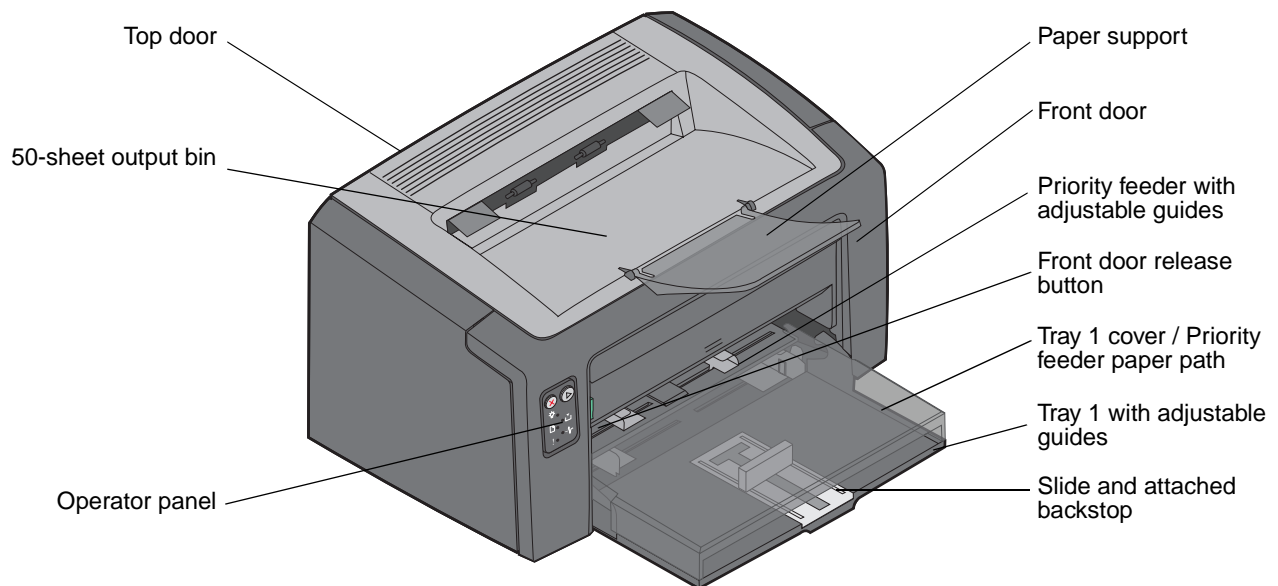



## Print media tasks and tips

---

Follow the steps below to load print media into Tray 1:

- 1 Open paper cover by lifting up until the cover *clicks* into a fully open state.

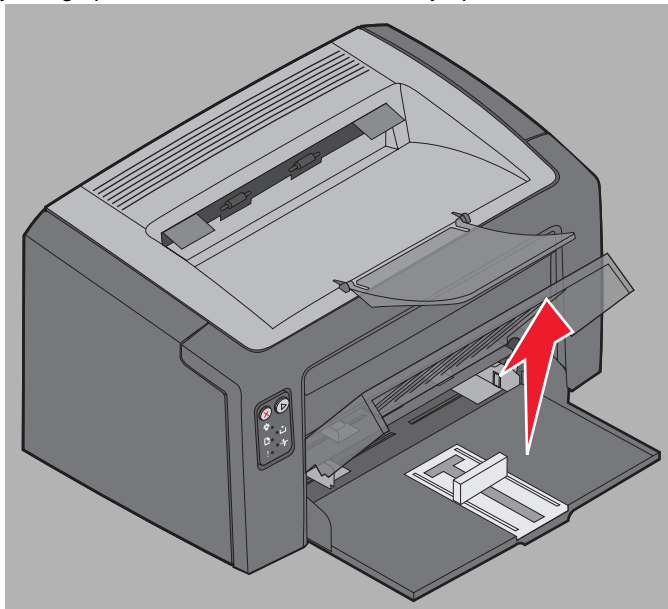

- 2 Adjust the slide and attached backstop to the length of the selected print media.

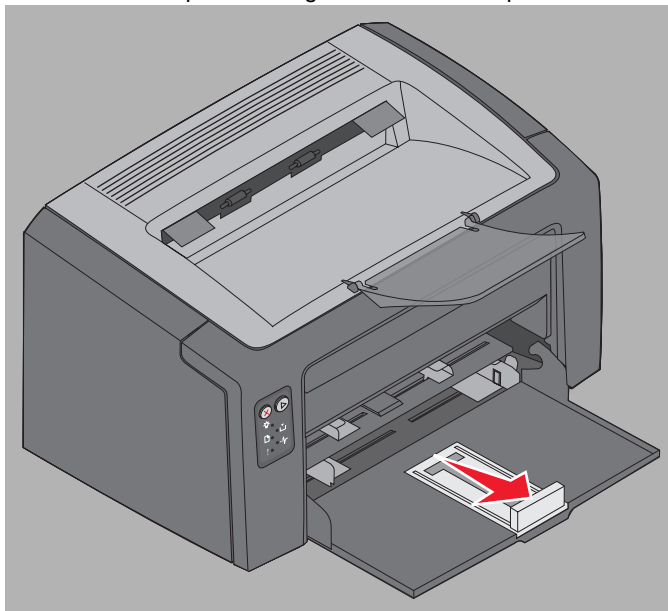

**Note:** The slide with attached backstop is a dual-action mechanism. The rectangular slide can be adjusted in and out to allow for the multiple sizes of print media the printer supports. The attached backstop can be adjusted in and out to fit the length of the multiple sizes of print media the printer supports.

**Note:** Tray 1 width can be adjusted by pushing in on the left guide. To increase the width, squeeze the tab attached to the right guide and slide to the right until the selected media width is matched.

## Print media tasks and tips

---

Prepare a stack of print media for loading by flexing or fanning it back and forth. Straighten the edges on a level surface.

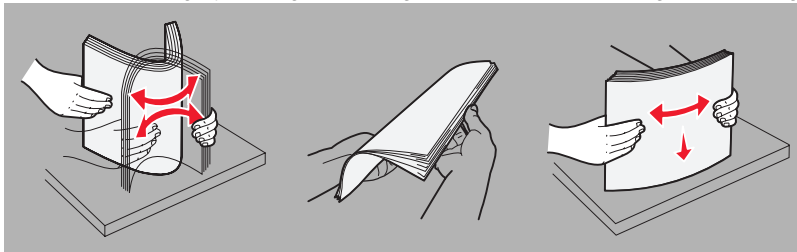

- 3 Place the prepared stack of print media into the tray and push the attached backstop lightly against the end of the loaded stack.

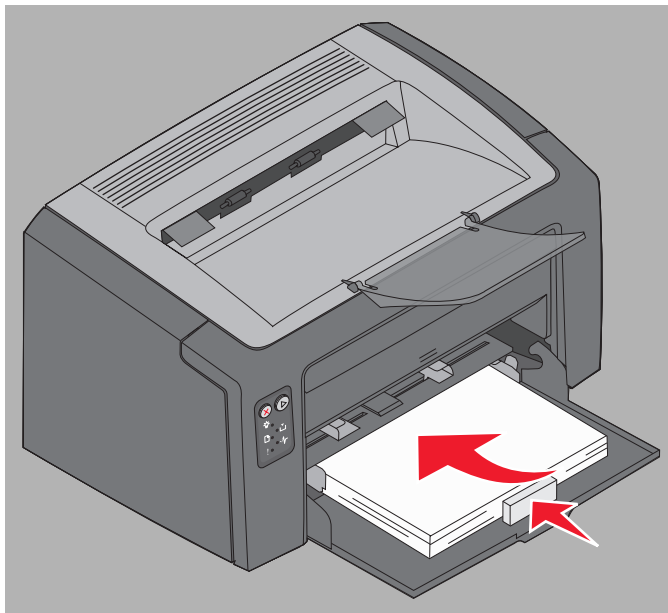

- 4 Push the guides lightly against the loaded stack of print media.

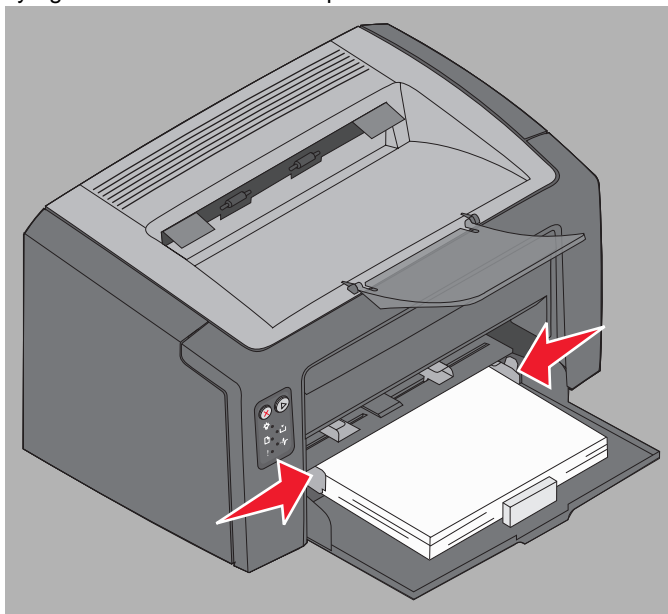

**Note:** Use care not to overfill. Placing more than 150 sheets into Tray 1 may cause jams.

- 5 Close the paper cover.

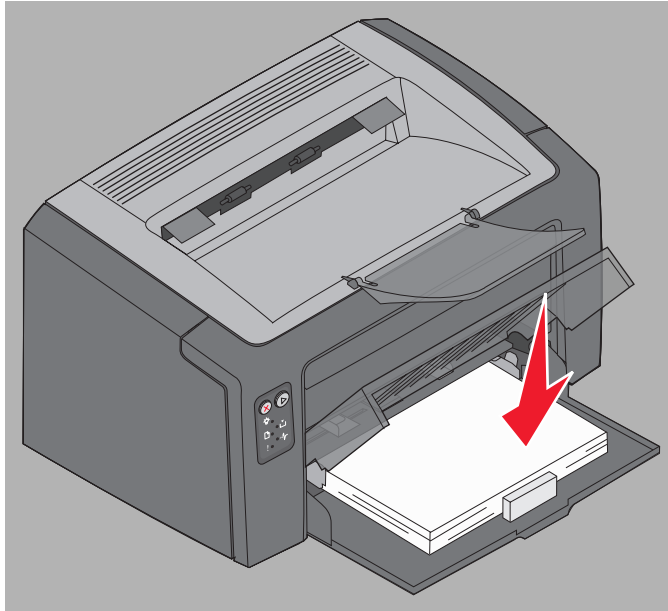

### ***Loading print media into the priority feeder***

The priority feeder is located at the front of the printer, just above Tray 1. Use the priority feeder to make quick runs of print media types or sizes that are not currently loaded in Tray 1.

For information on acceptable print media and quantity for use in the priority feeder, see **Types of print media on page 46**. Using only specified print media helps prevent jams and print quality problems.

- 1 Adjust the guides to the width of the print media.
- 2 Place selected print media, with side to be printed face up, at the center of the priority feeder, resting on the Tray 1 paper cover.
- 3 Push selected print media into the printer until the print media stops.

**Note:** Do not force print media into the feeder. Forcing media causes jams.

- Insert envelopes with flap side down and return address first. The stamp area will feed through last.
- Hold transparencies by the edges, and avoid touching the print side. Oil from fingers can affect print quality.
- Load letterhead face up, top of sheet first.

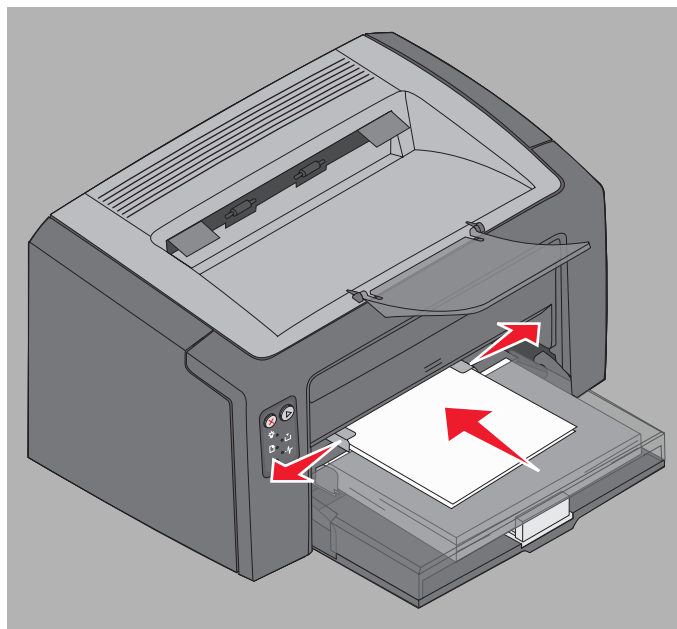

### ***Preventing jams***

Avoid most jams by correctly loading print media.

- Do not load wrinkled, creased, or damp print media.
- Never mix media types within a tray.
- Flex, fan, and straighten paper before loading.

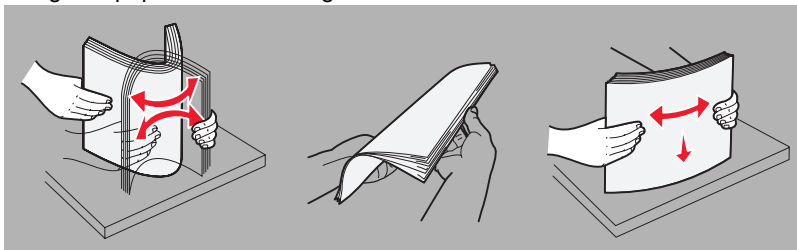

- Do not exceed maximum stack height.
- Make sure guides and backstop are positioned lightly against the loaded print media.
- Before loading transparencies, fan the stack to prevent sheets from sticking together.
- Do not use envelopes that:
  - Have excessive curl
  - Are stuck together
  - Are damaged in any way
  - Contain windows, holes, perforations, cutouts, or embossments
  - Have metal clasps, string ties, or metal folding bars
  - Have postage stamps attached
  - Have exposed adhesive when the flap is in the sealed position
  - Are self-sealing
- Use only recommended print media. See the *Card Stock & Label Guide* available on our Lexmark Web site at [www.lexmark.com](http://www.lexmark.com) for more information about which print media provides optimum results for your printing environment.
- See the *Card Stock & Label Guide* for detailed information prior to purchasing large quantities of customized print media.

### Clearing jams

When a jam occurs, the printer stops, and the Error light on the operator panel blinks. To determine the location of the jam, view the secondary light sequences (see **Operator panel codes for the Lexmark E120 on page 12** or **Operator panel codes for the Lexmark E120n on page 28**). Prepare the printer for jam removal by opening the paper support out and removing all printed pages from the output bin. Then, follow these steps to clear the entire paper path.

- 1 Open the rear door by sliding the door release button to the right.

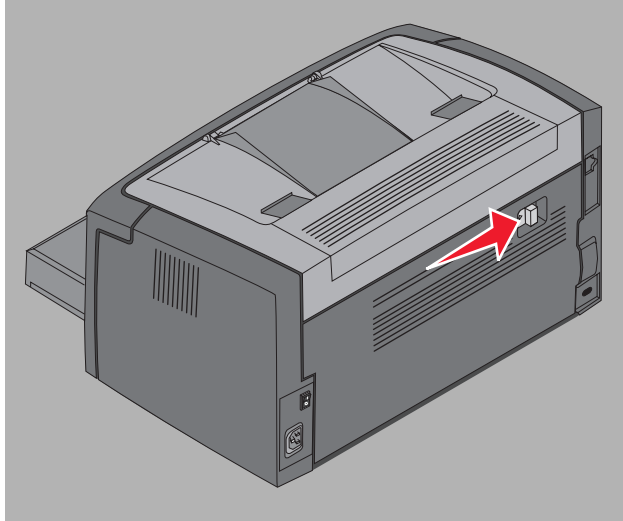

- 2 Remove any lodged print media from the paper path.

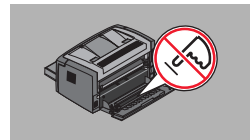
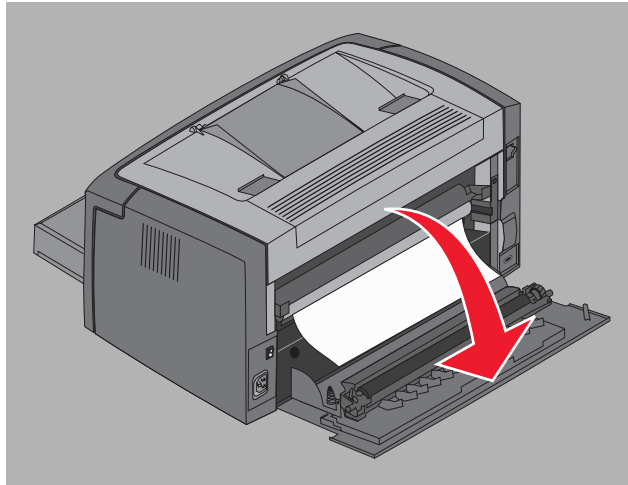

**Warning:** When rear door is open, be careful not to touch the attached roller. Touching the roller can cause contamination and affect print quality. Do not leave the rear door open for an extended amount of time. Exposure to light will damage the blue drum of the long-life photoconductor kit and affect print quality.

## Print media tasks and tips

---

- 3 Open the top door, and remove any lodged print media from the paper path.

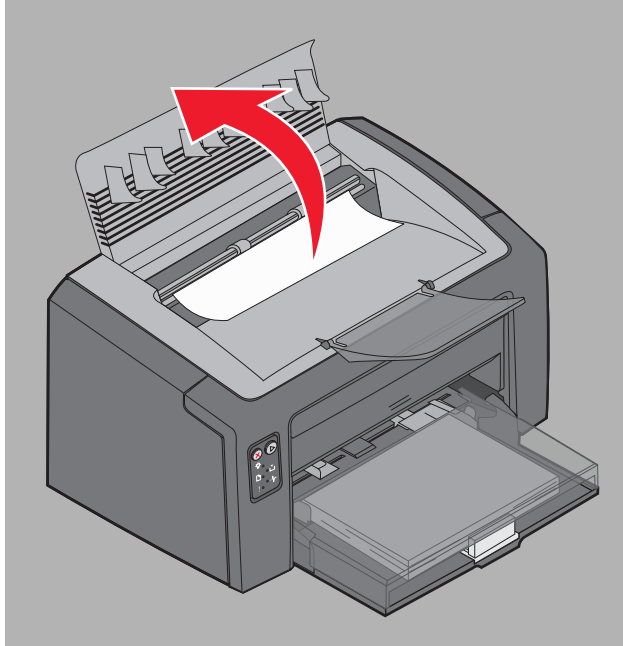

**CAUTION:** The fuser may be hot. To avoid personal injury, use caution when opening the top door to remove a jam from the fuser area.

- 4 Open the front door by sliding the release button to the left.

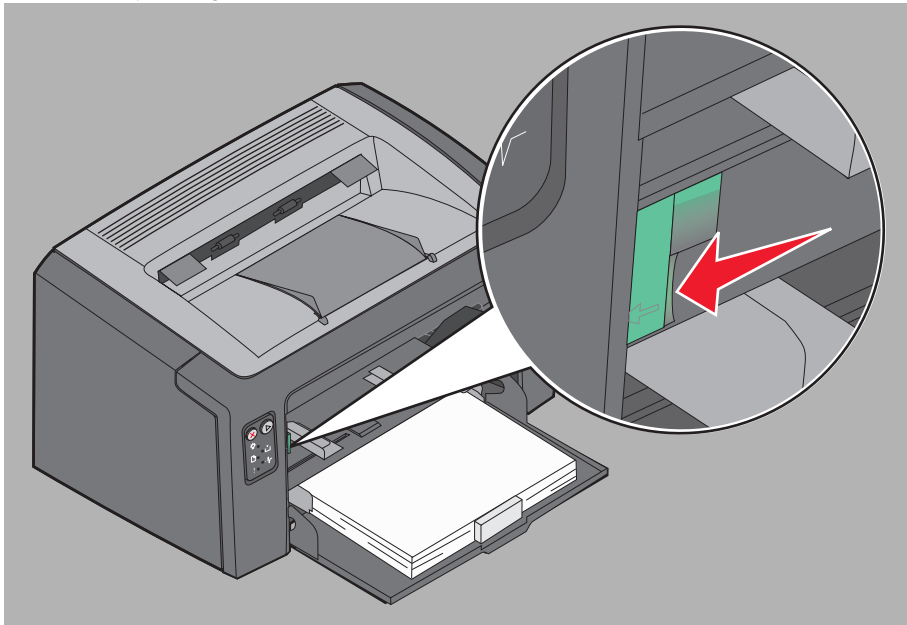

## Print media tasks and tips

---

- 5 Pull the front door up until it *clicks* into an open position, and remove any lodged print media.

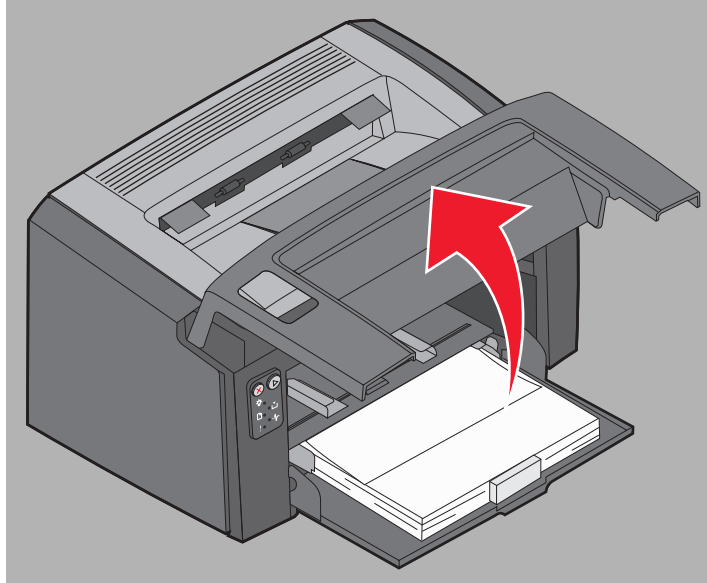

- 6 To remove print media behind the toner cartridge, it may be necessary to remove the toner cartridge by grasping the plastic handle and pulling straight out.

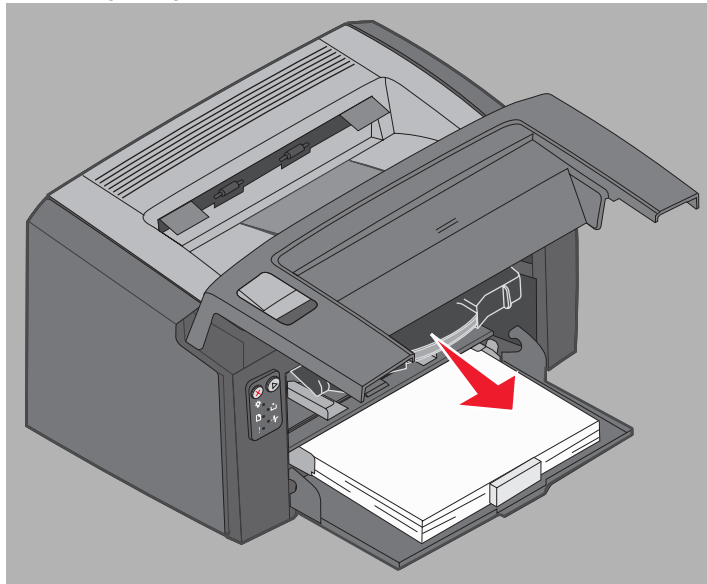

## Print media tasks and tips

---

- 7 Place the toner cartridge on a flat, clean surface.

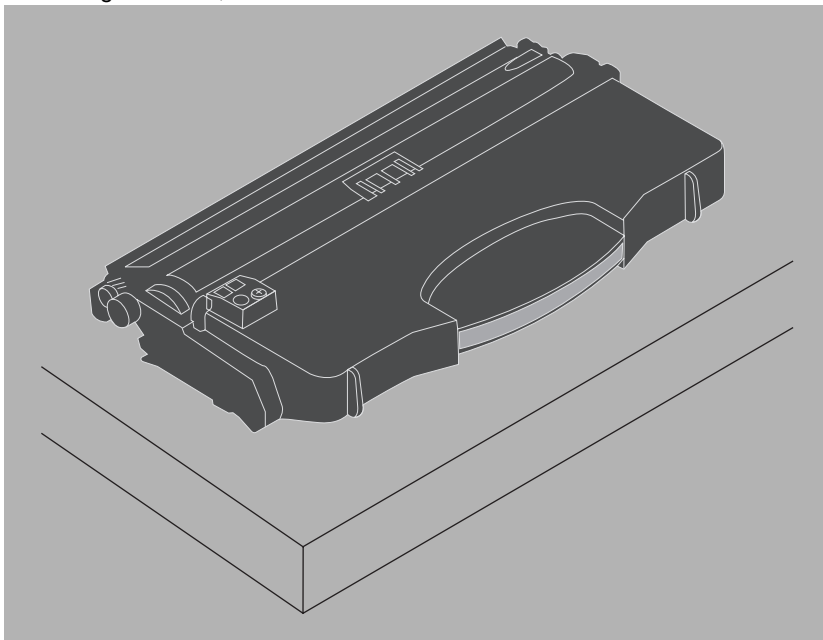

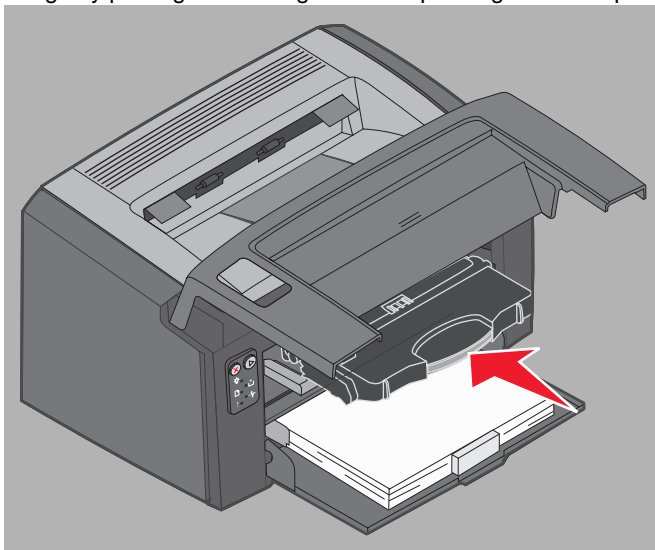

- 8 Replace the toner cartridge by placing it into the guides and pushing it into the printer.



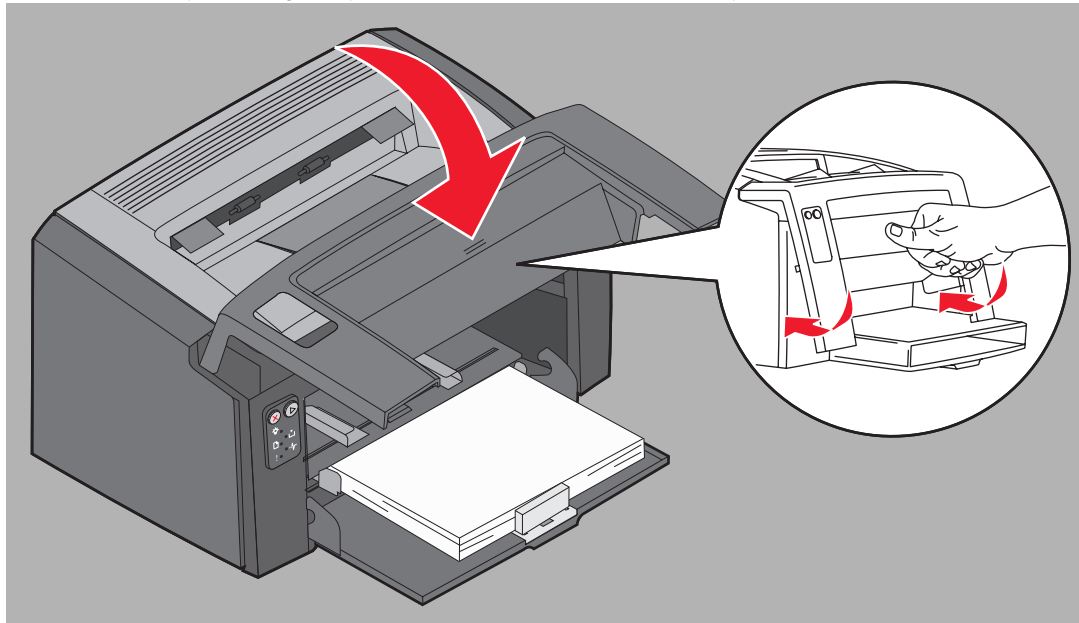

- 9 Close front door by pressing firmly in the center of the front door with your thumb until the door clicks shut.



- 10 Make sure all other doors are closed securely and press **Continue**  to resume printing.

**Note:** The page which caused the jam will reprint.

# 4

## Printing tasks

---

Section	Page
Printing from the priority feeder	59
Printing on both sides of the paper (manual duplex)	61
Printing multiple page images on one page (N-up printing)	62
Printing on letterhead	63
Canceling a print job	64

### ***Printing from the priority feeder***

The multiple-sheet priority feeder is located at the front of the printer just above Tray 1. It has an adjustable guide on each side, and uses the Tray 1 paper cover as a print media path. Use the priority feeder to make quick runs of print media types or sizes that are not currently loaded in Tray 1. Never mix media types within a tray. For information on acceptable print media and quantity for use in the priority feeder, see **Types of print media on page 46**.

If both the priority feeder and Tray 1 are loaded with print media, the printer will pick from the priority feeder until the print media is empty, then continue printing from Tray 1. To print to a specific print media type from the priority feeder, follow these instructions.

#### ***From a Windows computer***

- 1 Click **File** → **Print**.
- 2 Click **Preferences** (or **Options**, **Printer**, or **Setup**, depending on the application) to view the printer driver settings.
- 3 Click the **Paper** tab.
- 4 Select **Manual paper** or **Manual envelope** from the Paper tray drop-down list.
- 5 Select the appropriate Paper size and type.
- 6 Click **OK**.
- 7 Click **OK** on the Print window to send the job.

The printer displays the Load priority feeder light sequence on the operator panel; see **Load media on page 19 or page 36**.

- 8 Adjust the priority feeder guides to the width of the print media, and make sure the Tray 1 paper cover is in place.
- 9 Place selected print media with side to be printed facing up, at the center of the priority feeder. If you load more than one sheet, the stack should rest on the Tray 1 paper cover.
  - Hold transparencies by the edges, and avoid touching the print side. Oil from fingers can affect print quality.
  - Insert envelopes with the flap side down and return address first. The stamp area will feed through last.
  - Load letterhead face up, top of sheet first.

## Printing tasks

---

- 10 Hold both sides of the print media close to the priority feeder and push into the printer until the media stops.

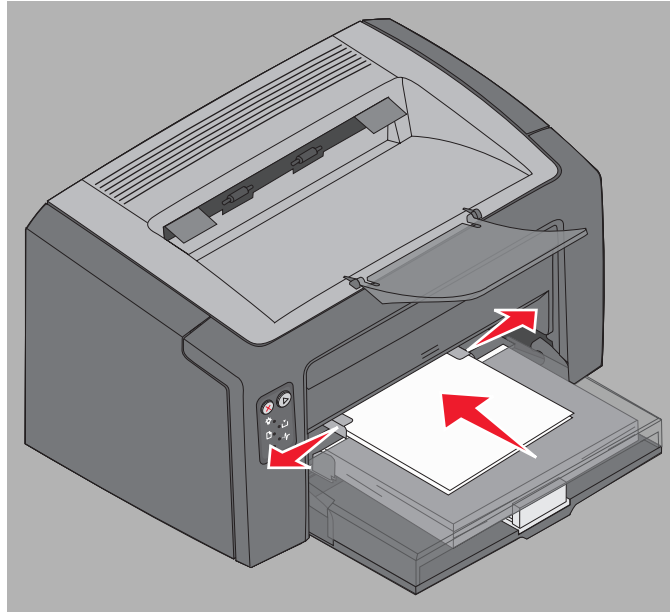

**Note:** Do not force the print media into feeder. Forcing media causes jams.

- 11 Press the flashing **Continue**  button to print the job.

### ***From a Macintosh computer***

- 1 Click **File** → **Page Setup**.
- 2 From the **Format for** pop-up, choose your Printer.
- 3 From the **Paper Size** pop-up, choose your paper size.
- 4 Click **OK**.
- 5 From the computer software application, select **File** → **Print**.
- 6 From the **Copies & Pages** pop-up, choose **Paper**.
- 7 From the **Paper Type** pop-up, choose your paper type.
- 8 From the **Paper** pop-up, choose **Paper Feed**.
- 9 Select **Manual Paper** or **Manual Envelope** as appropriate.
- 10 Adjust the priority feeder guides to the width of the print media, and make sure the Tray 1 paper cover is in place.
- 11 Place selected print media with side to be printed facing up, at the center of the priority feeder. If you load more than one sheet, the stack should rest on the Tray 1 paper cover.
  - Hold transparencies by the edges, and avoid touching the print side. Oil from fingers can affect print quality.
  - Insert envelopes with the flap side down and return address first. The stamp area will feed through last.
  - Load letterhead face up, top of sheet first.

Hold both sides of the print media close to the priority feeder and push into the printer until the media stops.

- 12 Press **Print**.

### ***Printing on both sides of the paper (manual duplex)***

Printing on both sides of the paper reduces total printing costs and is environmentally friendly.

Macintosh does not support manual duplex printing. Follow the directions below to print on both sides of the paper (manual duplex) from Windows.

Use Tray 1 to print the first side of a duplex job. Load the already-printed print media through either the priority feeder or Tray 1 to print the second side.

Choose how the job is duplexed: Long Edge or Short Edge.

- Long Edge means pages are bound along the long edge of the page (left edge for portrait, top edge for landscape).

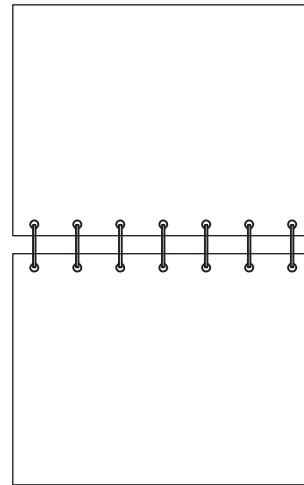
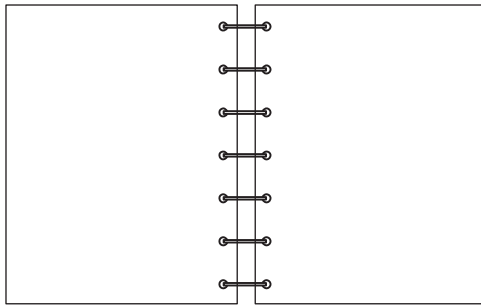

- Short Edge means pages are bound along the short edge of the page.

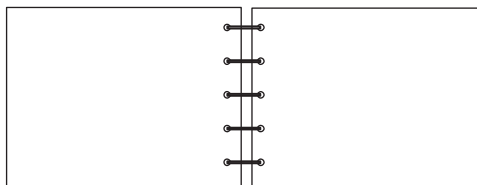
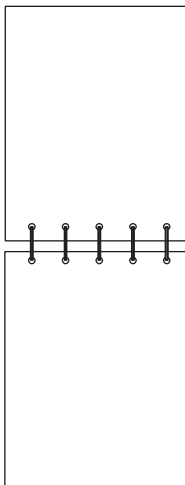

## Printing tasks

---

To manually duplex a print job from a Windows computer:

- 1 Click **File** → **Print**.
- 2 Click **Preferences** (or **Options**, **Printer**, or **Setup**, depending on the application) to view printer driver settings.
- 3 From the **Page Layout** tab, select **2-sided printing**.
- 4 Select either **Long Edge** or **Short Edge**.
- 5 Select **Manual 2-sided printing**.
- 6 Click the **Paper** tab.
- 7 Select appropriate **Input options** for the job.
- 8 Click **OK**.
- 9 Click **OK** on the Print window.

The printer prints every other page of the document first. Once the first side of a job prints, the Load Paper and Continue lights blink (see **Print side two of a duplex job on page 20 or 37**).

- 10 Load the printed page into Tray 1 or the priority feeder with the already-printed side down and the top of the page toward the front of the tray.

## ***Printing multiple page images on one page (N-up printing)***

The Multipage Printing (N-up) setting is used to print multiple page images on a single page. For example, 2-up means two page images are printed on one page, 4-up means four page images are printed on one page, and so on.

The printer uses the Multipage Order, Multipage View, and Multipage Border settings to determine the order and orientation of page images, and whether a border is printed around each page image. Follow the directions below to print multiple page images on one page.

### ***From a Windows computer***

- 1 From the computer software application, select **File** → **Print**.
- 2 Click **Preferences** (or **Options**, **Printer**, or **Setup**, depending on the application) to view printer driver settings.
- 3 From the Page Layout tab, select the number of images per sheet (from the Multipage printing section) and the orientation.

Positioning depends on the number of images and whether the images are portrait or landscape in orientation.

For example, if 4-Up multipage printing and portrait orientation are selected, the results differ depending on the Multipage Order value selected:

**Across**

1	2
3	4

**Down**

1	3
2	4

- 4 To print a visible border around each page image, select **Print page borders**.
- 5 Click **OK**.
- 6 Click **OK** on the Print window to send the job to print.

### ***From a Macintosh computer***

- 1 From the computer software application, select **File → Print**.
- 2 From the **Copies & Pages** pop-up, select **Layout**.
- 3 From the **Pages per Sheet** pop-up, choose the appropriate pages per sheet, layout direction, and border.
- 4 Click **Print** (if using the priority feeder, press the **Continue** button on the printer).

### ***Printing on letterhead***

To print on letterhead, make sure paper is loaded with the proper orientation.

- **Tray 1**—Load letterhead with the design side facing up and the top (logo) edge inserted first.
- **priority feeder**—Load letterhead with the design side facing up with the top (logo) edge inserted first.)

### ***From a Windows computer***

- 1 Click **File → Print**.
- 2 Click **Preferences** (or **Options**, **Printer**, or **Setup**, depending on the application) to view printer driver settings.
- 3 Click the **Paper** tab.
- 4 Select **Letterhead** from the Paper type drop-down list.
- 5 Select the appropriate paper size and tray.
- 6 Click **OK**.
- 7 Click **OK** on the Print window to send the job to print.
- 8 Click **OK**.

### ***From a Macintosh computer***

- 1 Click **File → Print**.
- 2 From the **Copies & Pages** pop-up, select **Paper**.
- 3 From the Paper type pop-up, select **Letterhead**.
- 4 Click **Print**.

### ***Canceling a print job***

A print job can be canceled from the operator panel or from the computer. The Cancel job light sequence appears on the operator panel when a job is canceled (see **Cancel job / Reset printer on page 14 or 30**).

#### ***From printer operator panel***

Press and release **Cancel** (⊗) to cancel the current print job. Press and hold the **Cancel** (⊗) button for more than three seconds to reset the printer.

#### ***From a Windows computer***

- 1 Click **Start** → **Settings** → **Printers**.
- 2 Double-click the printer being used to print the current job.  
A list of print jobs appears.
- 3 Right-click the current document, and click **Cancel**.

#### ***From a Macintosh computer***

When a job is sent to print, the printer icon appears on the desktop.

- 1 Click **Applications**.
- 2 Click **Utilities**
- 3 Double-click **Printer Setup Utility**.  
A list of print jobs appears.
- 4 Double-click the printer name for a list of print jobs.
- 5 Click on the print job you wish to cancel.
- 6 From the tool bar, click the **Delete** button.



**5****Supplies information**

---

<b>Section</b>	<b>Page</b>
<b>Supply items needed</b>	<b>66</b>
<b>Ordering supplies</b>	<b>66</b>
<b>Storing supplies</b>	<b>67</b>
<b>Conserving supplies</b>	<b>67</b>
<b>Assessing supply needs</b>	<b>67</b>
<b>Checking toner cartridge and long-life photoconductor kit levels</b>	<b>67</b>
<b>Changing the toner cartridge</b>	<b>68</b>
<b>Changing the long-life photoconductor kit</b>	<b>71</b>
<b>Lexmark Return Program</b>	<b>74</b>
<b>Recycling Lexmark products</b>	<b>74</b>

### Supply items needed

There are two supply items to replace: the long-life photoconductor kit and the toner cartridge. The long-life photoconductor kit typically lasts up to 25,000 pages (at approximately 5% coverage, on letter/A4 plain paper with intermittent printing, in an average Class B environment). How often the long-life photoconductor kit must be replaced depends on specific printing conditions. Factors such as temperature, humidity, media type, number of pages per job, page coverage and page size may affect the actual number of pages printed.

The toner cartridge must be replaced more frequently. How often the toner cartridge must be replaced depends on the average amount of toner coverage used on print jobs.

### Ordering supplies

Within the United States or Canada, order Lexmark supplies from an authorized Lexmark dealer. To locate a nearby dealer, call 1-800-539-6275. In other countries or regions, visit the Lexmark online store at [www.lexmark.com](http://www.lexmark.com) or contact the place where the printer was purchased. The following supplies are recyclable through the Lexmark Cartridge Collection Program. For information about the Lexmark recycle program, visit the online site at [www.lexmark.com/recycle](http://www.lexmark.com/recycle).

Part number	Description	Average cartridge yield
<b>For the USA and Canada</b>		
12026XW	Long-life Photoconductor Kit	up to 25,000 pages based on approximately 5% coverage
12015SA	Return Program Toner Cartridge <sup>2</sup>	2,000 standard pages <sup>1</sup>
12035SA	Toner Cartridge <sup>2</sup>	2,000 standard pages <sup>1</sup>
<b>For Europe, the Middle East, and Africa</b>		
12026XW	Long-life Photoconductor Kit	up to 25,000 pages based on approximately 5% coverage
12016SE	Return Program Toner Cartridge <sup>3</sup>	2,000 standard pages <sup>1</sup>
12036SE	Toner Cartridge <sup>3</sup>	2,000 standard pages <sup>1</sup>
<b>For the Asia Pacific Region</b>		
12026XW	Long-life Photoconductor Kit	up to 25,000 pages based on approximately 5% coverage
12017SR	Return Program Toner Cartridge <sup>4</sup>	2,000 standard pages <sup>1</sup>
12037SR	Toner Cartridge <sup>4</sup>	2,000 standard pages <sup>1</sup>
<b>For Latin America</b>		
12026XW	Long-life Photoconductor Kit	up to 25,000 pages based on approximately 5% coverage
12018SL	Return Program Toner Cartridge <sup>5</sup>	2,000 standard pages <sup>1</sup>
12038SL	Toner Cartridge <sup>5</sup>	2,000 standard pages <sup>1</sup>
<sup>1</sup> Declared yield value in accordance with ISO/IEC 19752. <sup>2</sup> Designed for use only in the USA and Canada. <sup>3</sup> Designed for use only in Europe, the Middle East, and Africa. <sup>4</sup> Designed for use only in the Asia Pacific Region. <sup>5</sup> Designed for use only in Latin America.		

### Storing supplies

Choose a cool, clean storage area for supplies. Store supplies right side up in the original packaging until needed.

Do not expose supplies to:

- Direct sunlight
- Temperatures above 35°C (95°F)
- High humidity (above 80%)
- Salty air
- Corrosive gases
- Heavy dust

### Conserving supplies

Lower total printing costs by following these suggestions:

- Conserve toner when printing drafts by changing the Toner Darkness setting in the printer driver. The settings range from 1 (very light) to 10 (very dark), with 8 being the default. Setting the Toner Darkness to 1 conserves the most toner (see **Software and Documentation CD** for specific instructions).
- Reduce print media consumption by printing on both sides.

## Assessing supply needs

The following sections describe ways to determine when supplies are needed.

### Checking toner cartridge and long-life photoconductor kit levels

Print a menu settings page to determine approximately how much toner is left in the toner cartridge and how much life is remaining on the long-life photoconductor kit. For help printing a menu settings page, see **Printing the menu settings and network setup page on page 44**.

The **Toner low** light sequence appears when the toner cartridge is nearing empty (see **Toner low on page 23** for the Lexmark E120, or see **Toner low on page 42** for the Lexmark E120n). Printing is still possible for a short time while the sequence is displayed, however print quality continues to degrade as the toner level decreases.

To ensure print quality, order a new long-life photoconductor kit shortly after the **Replace long-life photoconductor kit** light sequence appears (see **Replace long-life photoconductor kit on page 24** for the Lexmark E120, or see **Replace long-life photoconductor kit on page 43** for the Lexmark E120n). Replace the long-life photoconductor kit when streaks or background shadings appear on the left side or at the bottom of the printed page, or when ghost images appear at specific locations on the printed page, as shown.

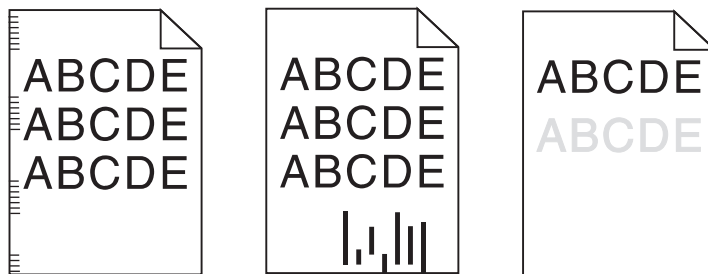

### Changing the toner cartridge

- 1 Remove all printed pages from the output bin.
- 2 Open the front cover by sliding the release button to the left and lifting the door until it *clicks* into an open position.

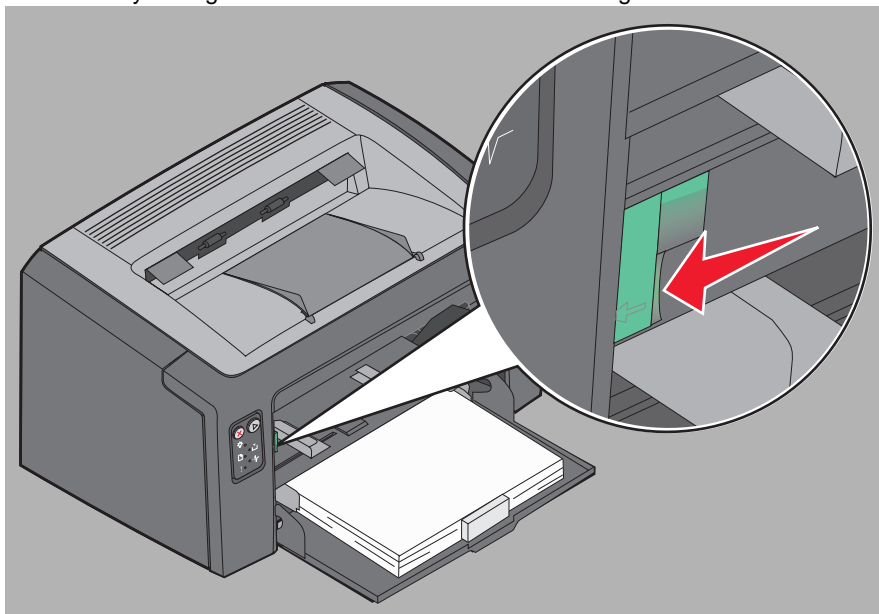

- 3 Remove the toner cartridge by grasping the handle and pulling out.

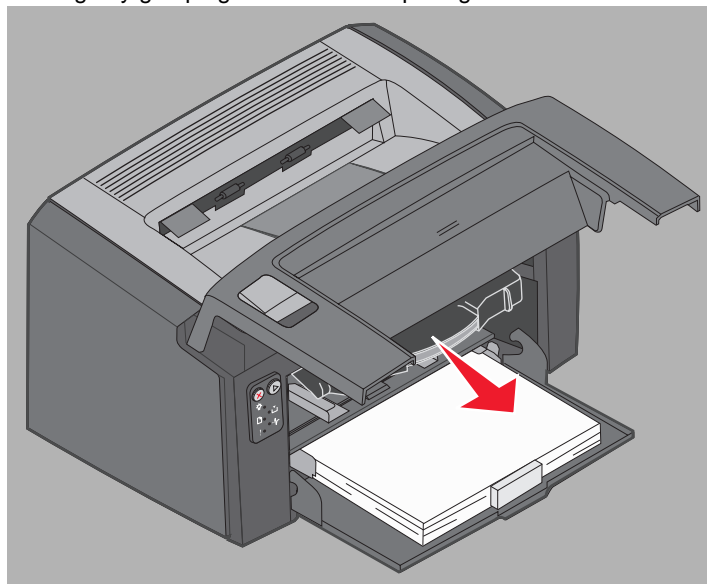

## Supplies information

---

- 4 Unpack the new toner cartridge.

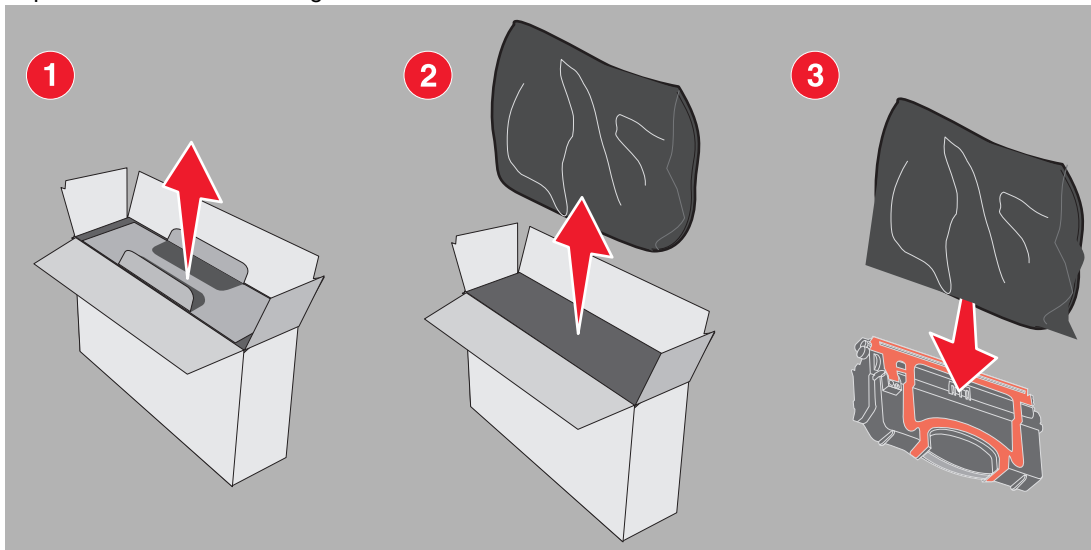

**Note:** Packing material from the new cartridge may be used to ship the old cartridge back to Lexmark for recycling. See **Lexmark Return Program on page 74** for more information.

- 5 Remove the red, plastic packing from the cartridge by grasping near the cartridge handle and pulling away from the cartridge.
- 6 Gently shake the toner cartridge from side to side and front to back to distribute toner.

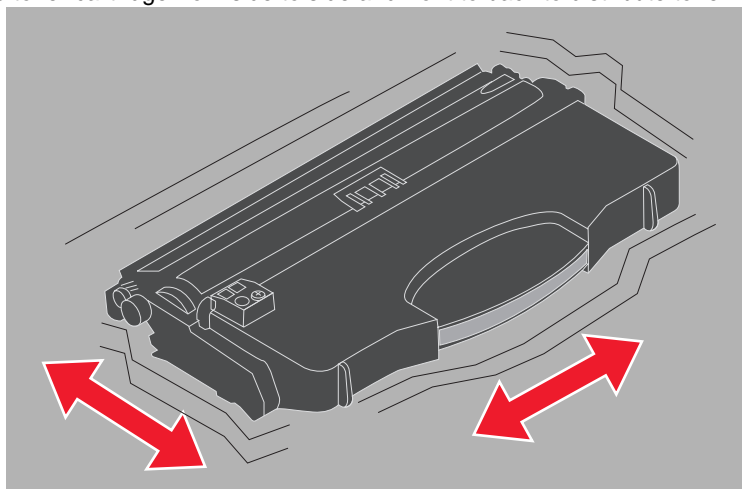

## Supplies information

---

- 7 Install the new toner cartridge by aligning the sides of the toner cartridge with the guides in the printer and pushing the toner cartridge in as far as it will go. The cartridge *stops* when correctly installed.

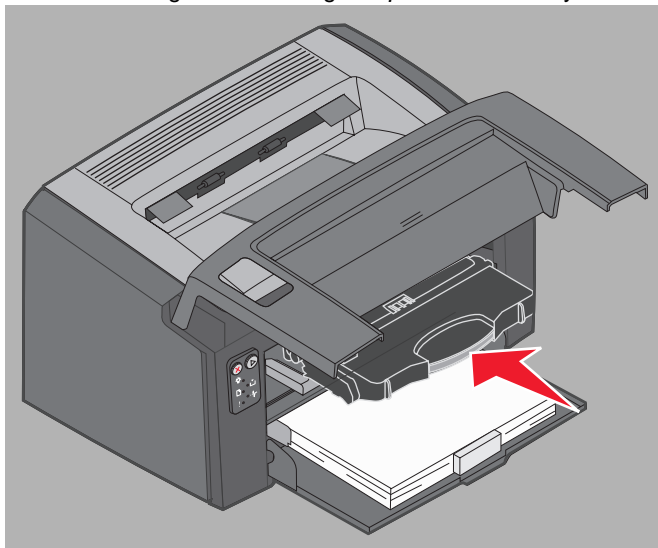

- 8 Close the front cover, and press **Continue**  to resume printing.

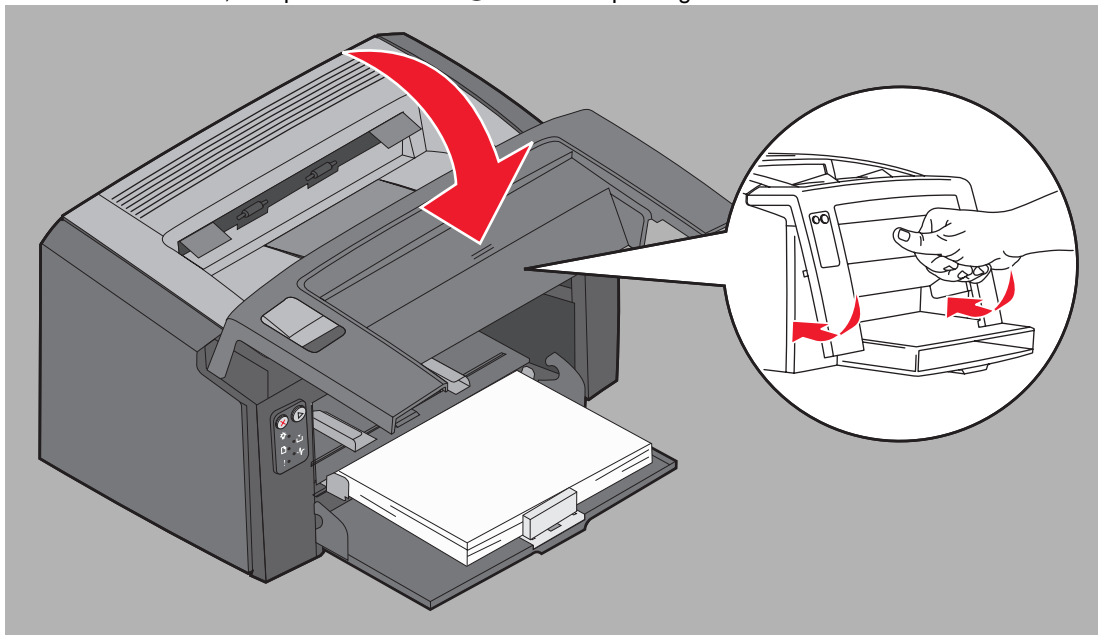

### Changing the long-life photoconductor kit

**Warning:** When replacing the long-life photoconductor kit, do not touch the blue drum. Touching the drum will contaminate the long-life photoconductor kit and affect print quality.

- 1 Open the rear cover by sliding the release button to the right.

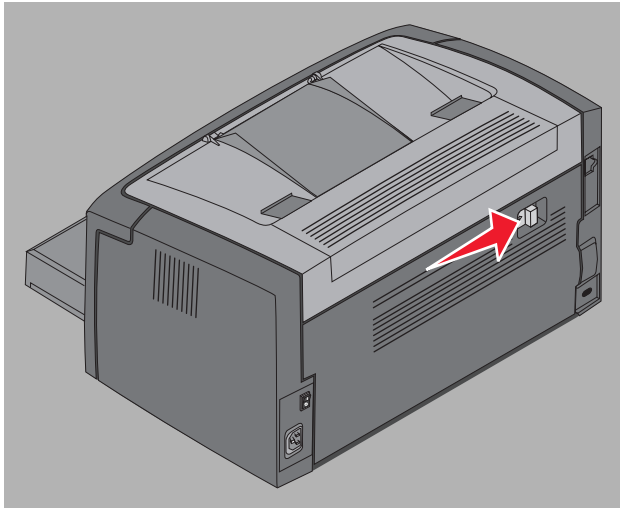

- 2 Remove the long-life photoconductor kit by pulling out on the extended tabs.

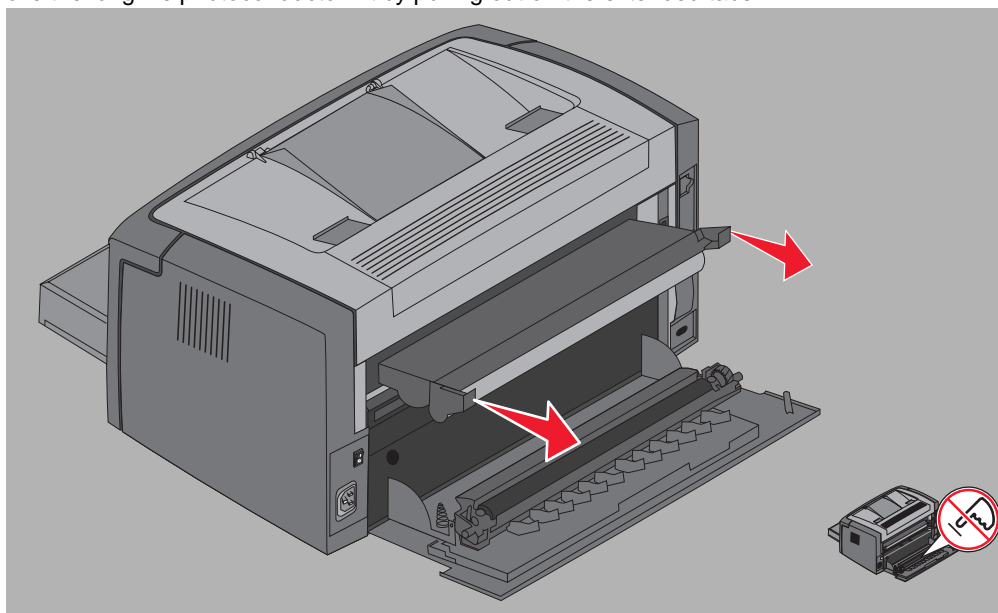

**Warning:** When rear door is open, be careful not to touch the attached roller. Touching the roller can cause contamination and affect print quality.

## Supplies information

---

- 3 Unpack the new long-life photoconductor kit, being careful not to touch the blue drum when removing the foam covering. Handle the long-life photoconductor kit by the tabs only.

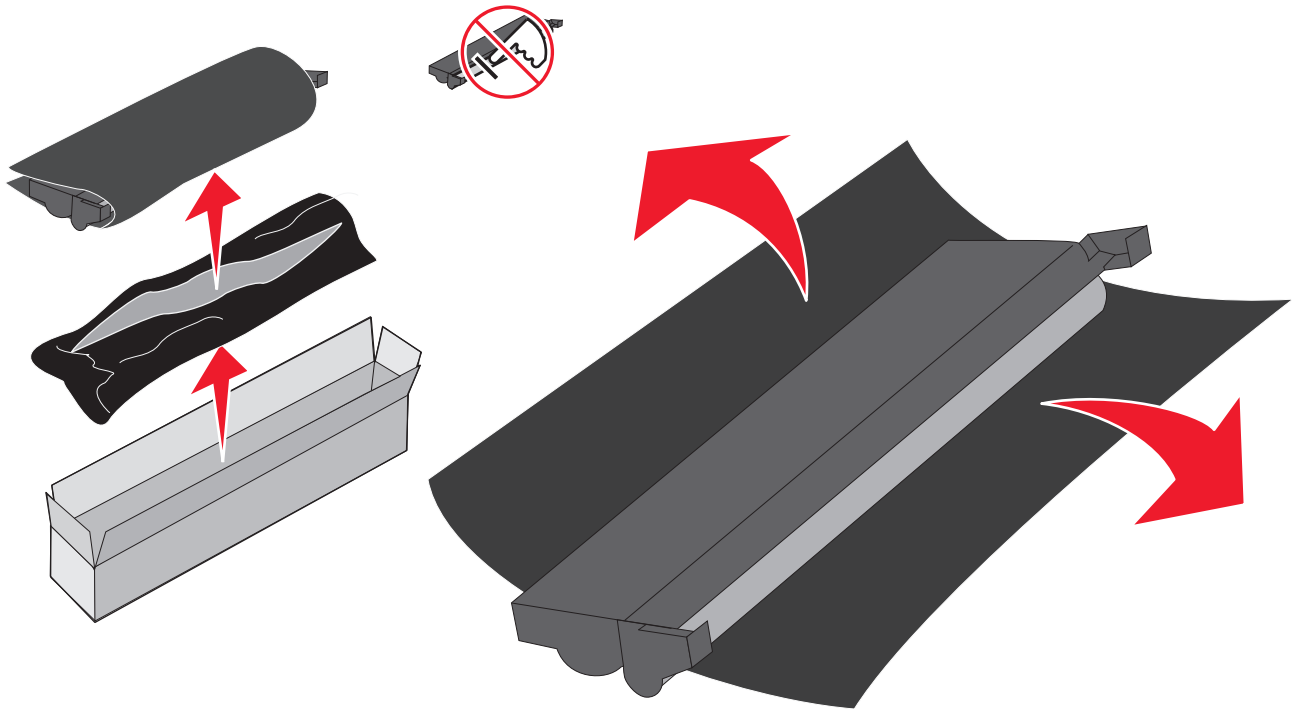

**Warning:** Touching the blue drum will cause contamination and affect print quality.

**Note:** For information about recycling the old long-life photoconductor kit, see **Recycling Lexmark products on page 74**

- 4 Carefully install the long-life photoconductor kit by inserting it into the guides marked with green arrows.

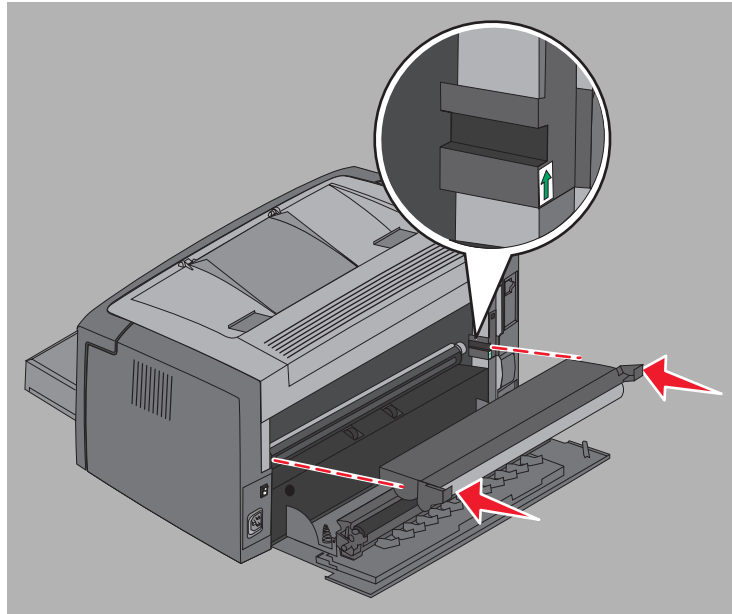



## Supplies information

---

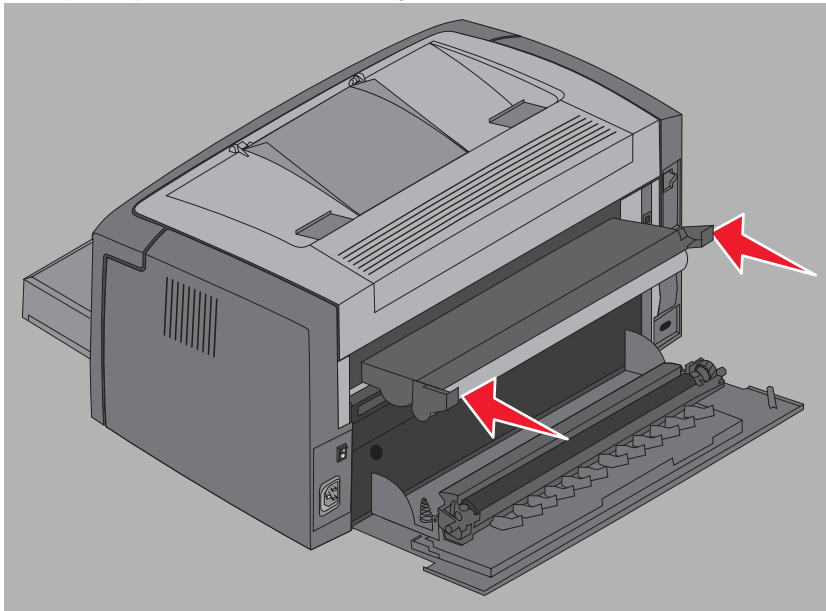

- 5 Push the tabs firmly with your thumbs until the long-life photoconductor kit *clicks* into place.

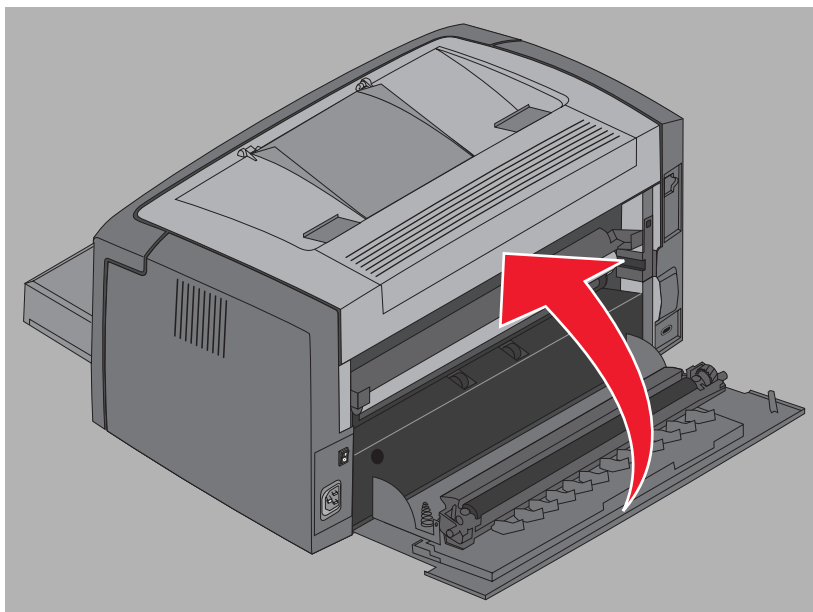

- 6 Close the rear door.



**Warning:** Do not leave the rear door open longer than necessary. Extended light exposure can damage the blue photoconductor drum and cause print quality problems.

- 7 Open the front cover and hold the **Cancel**  button until all lights begin to cycle to reset the long-life photoconductor kit counter and warning.
- 8 Close the front cover. The warning will be cleared and the counter will be reset to zero.
- 9 Press **Continue**  to resume printing.

### ***Lexmark Return Program***

The Lexmark Return Program is an environmental program in which Lexmark sells new toner cartridges at a special price with the agreement that the cartridge will be returned, at no cost, only to Lexmark for recycling.

Regular toner cartridges without this agreement are also available.

**Note:** Regular toner cartridges can also be returned, at no cost, to Lexmark using the Lexmark Cartridge Collection Program. To learn how to return a cartridge at no cost, visit the Lexmark web site at [www.lexmark.com/recycle](http://www.lexmark.com/recycle).

### ***Refilled toner cartridge notice***

Lexmark Return Program toner cartridges cannot be refilled. Lexmark does not recommend the use of third-party remanufactured cartridges. Lexmark cannot assure the excellent print quality and reliability of its toner cartridges after a toner cartridge has been refilled. A substantial reduction in long-life photoconductor kit life is also likely if refilled toner cartridges are used.

**Warning:** Toner cartridge leaks due to refilling can cause failure in several areas of a printer. Printer failures caused by third-party remanufactured toner cartridges are not covered by the Lexmark printer warranty, extended warranty, or service agreement.

### ***Recycling Lexmark products***

To return Lexmark products to Lexmark for recycling:

- 1 Visit our Web site:  
[www.lexmark.com/recycle](http://www.lexmark.com/recycle)
- 2 Follow the instructions on the computer screen.



## Troubleshooting

Section	Page
General problems	76
Print quality problems	78

### General problems

Problem	Solution / Answer
Lights begin blinking.	See <b>Understanding the Lexmark E120 operator panel lights on page 10.</b>
Characters missing when printing to envelopes	<p>Check printer driver settings to make sure Envelope has been selected from the Paper Type menu.</p> <p>If Envelope is selected, try selecting a rougher texture setting. Sometimes toner does not adhere well to smooth-textured envelopes. From the printer driver, select <b>Custom 6-Rough Env</b> from Paper Type menu.</p> <p>To change Custom 6 back to its default settings for Paper Type, Paper Texture, and Paper Weight, use Local Printer Setup Utility on the <b>Software and Documentation CD</b>. If you have installed printer drivers and utilities, skip to step 7.</p> <ol style="list-style-type: none"> <li>1 Insert the <b>Software and Documentation CD</b> into the computer.</li> <li>2 Click <b>Printer Software</b>.</li> <li>3 Click <b>Agree</b>.</li> <li>4 Select <b>Local Printer Install</b>, then click <b>Next</b>.</li> <li>5 Select the printer and port, and check Local Printer Setup Utility.</li> <li>6 Click <b>Finish</b>. The Utility will be installed on the computer under Program Files (unless a different directory is chosen).</li> <li>7 Open Local Printer Setup Utility.</li> <li>8 From the Paper Menu, scroll through the menu items for the Custom menu setting.</li> <li>9 Click <b>Custom</b>.</li> <li>10 Scroll down to Custom 6 Paper Type.</li> <li>11 Select <b>envelope</b> for Custom 6 paper type, <b>heavy</b> for Custom 6 paper weight, and <b>rough</b> for Custom 6 paper texture.</li> <li>12 From the tool bar, click <b>Actions</b>.</li> <li>13 Click <b>Apply</b> to save changes.</li> <li>14 Click <b>File</b> → <b>Exit</b> to close.</li> </ol> <p>Follow these instructions from a Macintosh:</p> <ol style="list-style-type: none"> <li>1 From <b>Applications</b>, click <b>Utilities</b>.</li> <li>2 Select Lexmark Utilities, and double-click <b>Printer Settings</b>.</li> <li>3 Click <b>Edit Printer List</b> (if the printer is not displayed in the pop-up).</li> <li>4 Choose <b>Edit Printer List</b>.</li> <li>5 Select appropriate printer from the list.</li> <li>6 Click <b>Add</b>.</li> <li>7 Click <b>Done</b>.</li> <li>8 Click <b>Edit Printer List</b> again and choose appropriate printer.</li> <li>9 Select <b>envelope</b> for Custom 6 paper type, <b>heavy</b> for Custom 6 paper weight, and <b>rough</b> for Custom 6 paper texture.</li> <li>10 Click <b>Quit Printer Settings</b>.</li> </ol>
Jam occurs	<ol style="list-style-type: none"> <li>1 Open the top door. Remove any paper caught in the fuser unit.</li> <li>2 Open the rear door by sliding the door release button to the right. Remove any paper caught in the paper path. Do not leave the rear door open for an extended length of time. Extended exposure to light can damage the blue photoconductor drum and cause print quality problems.</li> <li>3 Open the front door by sliding the door release button to the left. Pull door up until it <i>clicks</i> into an open position. Remove any paper caught in the paper path. Removal of the toner cartridge may be necessary to remove paper caught behind the toner cartridge. To remove the toner cartridge, grasp the handle and pull straight out.</li> <li>4 Place the toner cartridge on a flat, clean surface. Replace the toner cartridge by sliding along the guides into the printer.</li> <li>5 Close all the doors, and press the <b>Continue</b>  button to resume the print job.</li> </ol>

## Troubleshooting

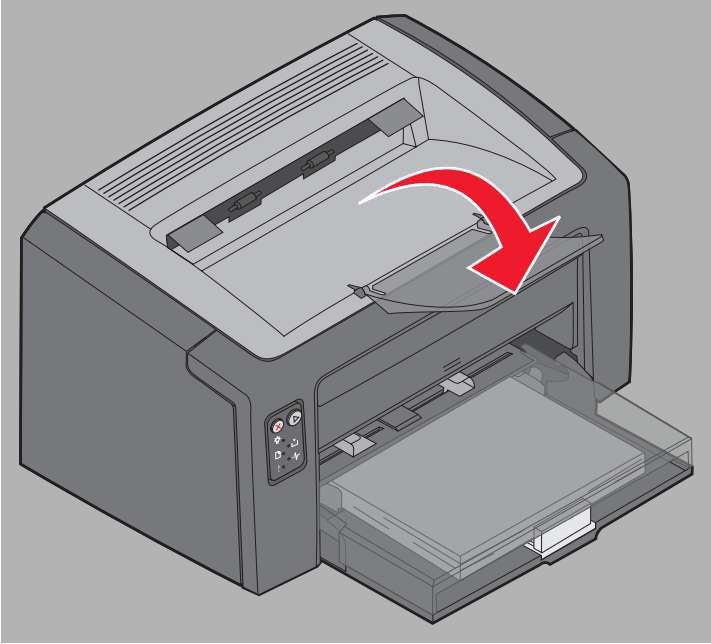
Problem	Solution / Answer
Toner low light sequence comes on	To extend toner cartridge life somewhat, remove the cartridge. Gently shake the toner cartridge from side to side and front to back several times to redistribute the toner, and reinsert it. Repeat this procedure multiple times. If the print remains faded, replace the toner cartridge. See <b>Changing the toner cartridge on page 68</b> for help.
Paper stacks poorly in output bin	<ol style="list-style-type: none"><li data-bbox="488 365 867 394">1 Turn the loaded paper stack over.</li><li data-bbox="488 396 935 426">2 Extend paper support on the output bin.</li></ol>  <p data-bbox="488 1068 1468 1115">3 If using legal size print media, contact technical support. Log onto <a href="http://www.lexmark.com">www.lexmark.com</a> for a technical support phone number in your area.</p>

## Print quality problems

To solve many print quality problems, replace supply or maintenance items that have reached the end of intended life. Use the following table for solutions.

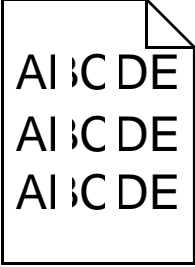
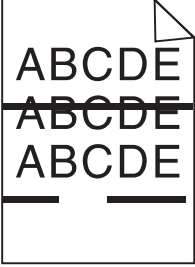
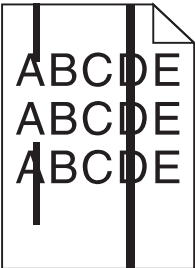
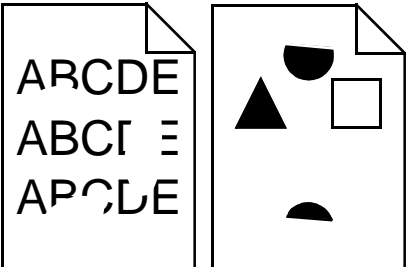
Symptom	Cause	Solution
<b>White lines</b> 	Either the toner cartridge or the fuser is defective.	Replace the toner cartridge or the fuser*, as needed.
<b>Streaked horizontal lines</b> 	If the lines are parallel to lines that are supposed to be there, see "Ghost Images" The toner cartridge or the fuser may be defective, empty, or worn.	Replace the toner cartridge or the fuser*, as needed.
<b>Streaked vertical lines</b> 	<ul style="list-style-type: none"> <li>The toner is smeared before fusing to the paper.</li> <li>The toner cartridge is defective.</li> </ul>	<ul style="list-style-type: none"> <li>If paper is stiff, try feeding from the priority feeder.</li> <li>Replace the toner cartridge.</li> </ul>
<b>Print irregularities</b> 	<ul style="list-style-type: none"> <li>The paper has absorbed moisture due to high humidity.</li> <li>The paper being used does not meet printer specifications.</li> <li>The fuser is worn or defective.</li> </ul>	<ul style="list-style-type: none"> <li>Load paper from a fresh package.</li> <li>Avoid textured paper with rough finishes.</li> <li>Make sure the printer driver paper type setting matches the type of paper being used.</li> <li>Replace the fuser†.</li> </ul>

\* To replace the fuser, call a service technician.

† This setting can be changed using the Local Printer Setup Utility (Windows), or through Printer Settings (Macintosh). See *Software and Documentation CD* for additional information.

## Troubleshooting

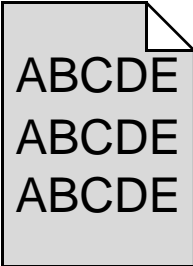
Symptom	Cause	Solution
<b>Light print</b>	<ul style="list-style-type: none"> <li>The Toner Darkness setting is too light.</li> <li>The paper being used does not meet printer specifications.</li> <li>The toner cartridge is low.</li> <li>The toner cartridge is defective.</li> </ul>	<ul style="list-style-type: none"> <li>Select a different Toner Darkness setting from the printer driver before sending the job to print.</li> <li>Load paper from a new package.</li> <li>Avoid textured paper with rough finishes.</li> <li>Make sure paper loaded in the tray is not damp.</li> <li>Replace the toner cartridge.</li> </ul>
<b>Dark print</b>	<ul style="list-style-type: none"> <li>The Toner Darkness setting is too dark.</li> <li>The toner cartridge is defective.</li> </ul>	<ul style="list-style-type: none"> <li>Select a different Toner Darkness setting from the printer driver before sending the job to print.</li> <li>Replace the toner cartridge.</li> </ul>
<b>Poor transparency print quality</b> (Print has inappropriate light or dark spots, toner is smeared, or horizontal or vertical light bands appear.)	<ul style="list-style-type: none"> <li>The transparencies being used do not meet printer specifications.</li> <li>The Form Type setting in the printer driver is set to a media other than transparency.</li> </ul>	<ul style="list-style-type: none"> <li>Use only transparencies recommended by the printer manufacturer (use care not to touch transparency surfaces with your fingers).</li> <li>Make sure the Form Type setting is set to transparency.</li> </ul>
<b>Toner specks</b>	<ul style="list-style-type: none"> <li>The toner cartridge is defective.</li> <li>The fuser is worn or defective.</li> <li>Toner is in the paper path.</li> <li>The long-life photoconductor kit is exhausted.</li> </ul>	<ul style="list-style-type: none"> <li>Replace the toner cartridge.</li> <li>Replace the fuser .</li> <li>Call for service.</li> <li>Replace the long-life photoconductor kit.</li> </ul>
<b>Toner rubs off paper easily when sheets are handled</b>	<ul style="list-style-type: none"> <li>The Paper Texture setting is wrong for the type of paper or specialty media being used.</li> <li>The Paper Weight setting is wrong for the type of paper or specialty media being used.</li> <li>The fuser is worn or defective.</li> </ul>	<ul style="list-style-type: none"> <li>Change the Paper Texture<sup>†</sup> from Normal to Smooth or Rough.</li> <li>Change the Paper Weight<sup>†</sup> from Plain to CardStock (or other appropriate weight).</li> <li>Replace the fuser .</li> </ul>
<b>Gray background</b> 	<ul style="list-style-type: none"> <li>The Toner Darkness setting is too dark or too light.</li> <li>The toner cartridge is defective.</li> <li>The long-life photoconductor kit is exhausted.</li> </ul>	<ul style="list-style-type: none"> <li>Select a different Toner Darkness setting from the printer driver before sending the job to print.</li> <li>First, remove and reset the toner cartridge. If problem persists, replace the toner cartridge.</li> <li>Replace the long-life photoconductor kit.</li> </ul>

\* To replace the fuser, call a service technician.

<sup>†</sup> This setting can be changed using the Local Printer Setup Utility (Windows), or through Printer Settings (Macintosh). See *Software and Documentation CD* for additional information.

## Troubleshooting

---

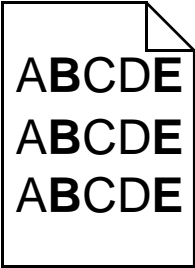
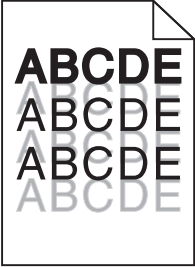
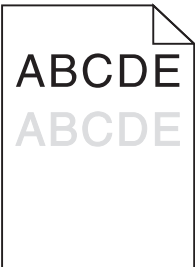
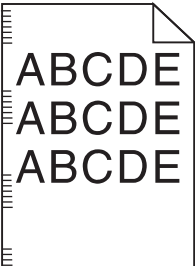
Symptom	Cause	Solution
<b>Uneven print density</b> 	The toner cartridge is defective.	First, remove and reset the toner cartridge. If problem persists, replace the toner cartridge.
<b>Ghost Images</b> 	The Form Type setting in the printer driver is incorrectly set.	Make sure the Form Type setting is correct for the paper or specialty media used.
<b>Specifically located ghost images</b> 	The long-life photoconductor kit is exhausted.	Replace the long-life photoconductor kit.
<b>Grouped streaks along the left side of the printed page</b> 	The long-life photoconductor kit is exhausted.	Replace the long-life photoconductor kit.

\* To replace the fuser, call a service technician.

† This setting can be changed using the Local Printer Setup Utility (Windows), or through Printer Settings (Macintosh). See *Software and Documentation CD* for additional information.

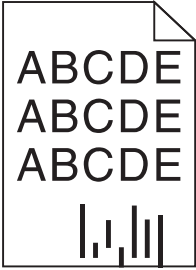
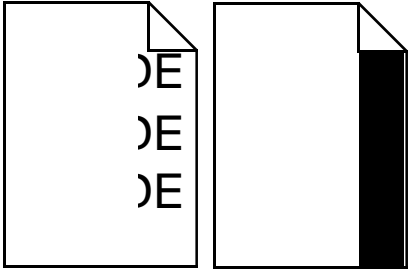

## Troubleshooting

Symptom	Cause	Solution
<b>Streaks at the bottom of the printed page.</b> 	The long-life photoconductor kit is exhausted.	Replace the long-life photoconductor kit.
<b>Uneven printing</b>  <p>(Print only appears on one side of the page.)</p>	The toner cartridge is not properly installed.	Remove and then reinsert the toner cartridge.
<b>Incorrect margins</b>	The Form Size setting in the printer driver is different from the paper size loaded in the tray. For example, A4 size paper is loaded into the tray, but the Form Size setting is not set to A4.	Change the Form Size setting to the appropriate size.
<b>Skewed print</b> (Print is inappropriately slanted.)	<ul style="list-style-type: none"> <li>The tray guide is not in the correct position.</li> <li>The priority feeder guides are not in correct position for the paper size loaded in the feeder.</li> </ul>	<ul style="list-style-type: none"> <li>Reposition the guide to fit lightly against the paper stack.</li> <li>Reposition the priority feeder guides to fit lightly against the print media.</li> </ul>
<b>Blank pages</b>	The toner cartridge is defective or empty.	First, remove and reset the toner cartridge. If problem persists, replace the toner cartridge.
<b>Solid black pages</b>	<ul style="list-style-type: none"> <li>The toner cartridge is defective.</li> <li>The printer requires service.</li> <li>The long-life photoconductor kit is defective.</li> </ul>	<ul style="list-style-type: none"> <li>First, remove and reset the toner cartridge. If problem persists, replace the toner cartridge.</li> <li>Call a service technician.</li> <li>Replace the long-life photoconductor kit.</li> </ul>
<b>Paper curls badly as it exits the bin</b>	The Paper Texture setting is wrong for the type of paper or specialty media being used.	Change the Paper Texture <sup>†</sup> from Rough to Normal or Smooth.

\* To replace the fuser, call a service technician.

<sup>†</sup> This setting can be changed using the Local Printer Setup Utility (Windows), or through Printer Settings (Macintosh). See *Software and Documentation* CD for additional information.

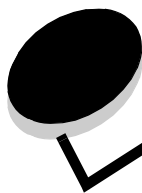

# Notices

---

## Licensing Notice

The printer resident software contains software developed and copyrighted by Lexmark.

In addition, the printer resident software may contain:

- Lexmark modified software licensed under the provisions of the GNU General Public License version 2 and/or the GNU Lesser General Public License version 2.1
- Software licensed under the BSD license
- Software licensed under other licenses

Click the title of the document you want to review:

- **BSD License and Warranty statements**
- **GNU General Public License**
- **Open Source License**

The Lexmark modified third-party software covered by these third-party licenses is free software; you can redistribute it and/or modify it under the terms of the licenses referenced above. These licenses do not provide you any rights to the Lexmark copyrighted software in this printer.

Since the third-party licensed software the Lexmark modifications are based on is supplied explicitly without warranty, use of the Lexmark modified version is similarly provided without warranty. See the warranty disclaimers in the referenced licenses for additional details.

To obtain source code files for the Lexmark modified GNU licensed software, launch the *Software and Documentation* CD that shipped with the printer, and click **Contact Lexmark**.

For source code that is required to be made available with the product, see the *Software and Documentation* CD.

## Conventions

**Note:** A *note* identifies something that could help you.

**CAUTION:** A *caution* identifies something that could cause you harm.

**Warning:** A *warning* identifies something that could damage your product hardware or software.

## Electronic emission notices

### Federal Communications Commission (FCC) compliance information statement

The Lexmark E120, Machine Type 4506-100 and Lexmark E120n, Machine Type 4506-110 have been tested and found to comply with the limits for a Class B digital device, pursuant to Part 15 of the FCC Rules. Operation is subject to the following two conditions: (1) devices may not cause harmful interference, and (2) devices must

accept any interference received, including interference that may cause undesired operation.

The FCC Class B limits are designed to provide reasonable protection against harmful interference in a residential installation. This equipment generates, uses, and can radiate radio frequency energy and, if not installed and used in accordance with the instructions, may cause harmful interference to radio communications. However, there is no guarantee that interference will not occur in a particular installation. If this equipment does cause harmful interference to radio or television reception, which can be determined by turning the equipment off and on, the user is encouraged to try to correct the interference by one or more of the following measures:

- Reorient or relocate the receiving antenna.
- Increase the separation between the equipment and receiver.
- Connect the equipment into an outlet on a circuit different from that to which the receiver is connected.
- Consult your point of purchase or service representative for additional suggestions.

The manufacturer is not responsible for any radio or television interference caused by using other than recommended cables or by unauthorized changes or modifications to this equipment. Unauthorized changes or modifications could void the user's authority to operate this equipment.

**Note:** To assure compliance with FCC regulations on electromagnetic interference for a Class B computing device, use a properly shielded and grounded cable such as Lexmark part number 12A2405 for USB attach. Use of a substitute cable not properly shielded and grounded may result in a violation of FCC regulations.

Any questions regarding this compliance information statement should be directed to:

Director of Lexmark Technology & Services  
Lexmark International, Inc.  
740 West New Circle Road  
Lexington, KY 40550  
(859) 232-3000

### Industry Canada compliance statement

This Class B digital apparatus meets all requirements of the Canadian Interference-Causing Equipment Regulations.

#### Avis de conformité aux normes de l'industrie du Canada

Cet appareil numérique de la classe B respecte toutes les exigences du Règlement sur le matériel brouilleur du Canada.

### European Community (EC) directives conformity

A declaration of conformity with the requirements of the directives has been signed by the Director of Manufacturing and Technical Support, Lexmark International, S.A., Boigny, France.

This product satisfies the Class B limits of EN 55022 and safety requirements of EN 60950.

### Japanese VCCI notice

If this symbol appears on your product, the accompanying statement is applicable.



この装置は、情報処理装置等電波障害自主規制協議会(VCCI)の基準に基づくクラスB情報技術装置です。この装置は、家庭環境で使用することを目的としていますが、この装置がラジオやテレビジョン受信機に近接して使用されると、受信障害を引き起こすことがあります。取扱説明書に従って正しい取り扱いをしてください。

### Korean MIC statement

If this symbol appears on your product, the accompanying statement is applicable.



이 기기는 가정용으로 전자파적합등록을 한 기기로서 주거지역에서는 물론 모든 지역에서 사용할 수 있습니다.

This equipment has undergone EMC registration as a household product. It can be used in any area, including a residential area.

### Noise emission levels

The following measurements were made in accordance with ISO 7779 and reported in conformance with ISO 9296.

1-meter average sound pressure, dBA	
Printing	49 - Machine types 4506-100, 4506-110
Idling	30

### ENERGY STAR



The EPA ENERGY STAR Office Equipment program is a partnership effort with office equipment manufacturers to promote the introduction of energy-efficient products and to reduce air pollution caused by power generation.

Companies participating in this program introduce products that power down when they are not being used. This feature will cut the energy used by up to 50 percent. Lexmark is proud to be a participant in this program.

As an ENERGY STAR Partner, Lexmark International, Inc. has determined that this product meets the ENERGY STAR guidelines for energy efficiency.

### Waste from Electrical and Electronic Equipment (WEEE) directive



The WEEE logo signifies specific recycling programs and procedures for electronic products in countries of the European Union. We encourage the recycling of our products. If you have further questions about recycling options, visit the Lexmark Web site at [www.lexmark.com](http://www.lexmark.com) for your local sales office phone number.

### Laser advisory label

A laser notice label may be affixed to this printer.

### LUOKAN 1 LASERLAITE

**VAROITUS!** Laitteen käyttäminen muulla kuin tässä käyttöohjeessa mainitulla tavalla saattaa altistaa käyttäjän turvallisuusluokan 1 ylittävälle näkymättömälle lasersäteilylle.

### KLASS 1 LASER APPARAT

**WARNING!** Om apparaten används på annat sätt än i denna bruksanvisning specificerats, kan användaren utsättas för osynlig laserstrålning, som överskrider gränsen för laserklass 1.

### **Laser notice**

The printer is certified in the U.S. to conform to the requirements of DHHS 21 CFR Subchapter J for Class I (1) laser products, and elsewhere is certified as a Class I laser product conforming to the requirements of IEC 60825-1.

Class I laser products are not considered to be hazardous. The printer contains internally a Class IIIb (3b) laser that is nominally a 5 milliwatt gallium arsenide laser operating in the wavelength region of 770-795 nanometers. The laser system and printer are designed so there is never any human access to laser radiation above a Class I level during normal operation, user maintenance, or prescribed service condition.

### **Statement of Limited Warranty for Lexmark E120 and Lexmark E120n**

#### **Lexmark International, Inc. Lexington, KY**

This limited warranty applies to the United States and Canada. For customers outside the U.S., refer to the country-specific warranty information that came with your product.

This limited warranty applies to this product only if it was originally purchased for your use, and not for resale, from Lexmark or a Lexmark Remarketer, referred to in this statement as "Remarketer."

#### **Limited warranty**

Lexmark warrants that this product:

- Is manufactured from new parts, or new and serviceable used parts, which perform like new parts
- Is, during normal use, free from defects in material and workmanship

If this product does not function as warranted during the warranty period, contact a Remarketer or Lexmark for repair or replacement (at Lexmark's option).

If this product is a feature or option, this statement applies only when that feature or option is used with the product for which it was intended. To obtain warranty service, you may be required to present the feature or option with the product.

If you transfer this product to another user, warranty service under the terms of this statement is available to that user for the remainder of the warranty period. You should transfer proof of original purchase and this statement to that user.

#### **Limited warranty service**

The warranty period starts on the date of original purchase as shown on the purchase receipt and ends 12 months later provided that the warranty period for any supplies and for any maintenance items included with the printer shall end earlier if it, or its original contents, are substantially used up, depleted, or consumed.

To obtain warranty service you may be required to present proof of original purchase. You may be required to deliver your product to the Remarketer or Lexmark, or ship it prepaid and suitably packaged to a Lexmark designated location. You are responsible

for loss of, or damage to, a product in transit to the Remarketer or the Lexmark designated location.

When warranty service involves the exchange of a product or part, the item replaced becomes the property of the Remarketer or Lexmark. The replacement may be a new or repaired item.

The replacement item assumes the remaining warranty period of the original product.

Replacement is not available to you if the product you present for exchange is defaced, altered, in need of a repair not included in warranty service, damaged beyond repair, or if the product is not free of all legal obligations, restrictions, liens, and encumbrances. Before you present this product for warranty service, remove all print cartridges, programs, data, and removable storage media (unless directed otherwise by Lexmark).

For further explanation of your warranty alternatives and the nearest Lexmark authorized servicer in your area contact Lexmark on the World Wide Web at <http://support.lexmark.com>.

Remote technical support is provided for this product throughout its warranty period. For products no longer covered by a Lexmark warranty, technical support may not be available or only be available for a fee.

#### **Extent of limited warranty**

Lexmark does not warrant uninterrupted or error-free operation of any product or the durability or longevity of prints produced by any product.

Warranty service does not include repair of failures caused by:

- Modification or unauthorized attachments
- Accidents, misuse, abuse or use inconsistent with Lexmark user's guides, manuals, instructions or guidance
- Unsuitable physical or operating environment
- Maintenance by anyone other than Lexmark or a Lexmark authorized servicer
- Operation of a product beyond the limit of its duty cycle
- Use of printing media outside of Lexmark specifications
- Refurbishment, repair, refilling or remanufacture by a third party of products, supplies or parts
- Products, supplies, parts, materials (such as toners and inks), software, or interfaces not furnished by Lexmark

**TO THE EXTENT PERMITTED BY APPLICABLE LAW, NEITHER LEXMARK NOR ITS THIRD PARTY SUPPLIERS OR REMARKETERS MAKE ANY OTHER WARRANTY OR CONDITION OF ANY KIND, WHETHER EXPRESS OR IMPLIED, WITH RESPECT TO THIS PRODUCT, AND SPECIFICALLY DISCLAIM THE IMPLIED WARRANTIES OR CONDITIONS OF MERCHANTABILITY, FITNESS FOR A PARTICULAR PURPOSE, AND SATISFACTORY QUALITY. ANY WARRANTIES THAT MAY NOT BE DISCLAIMED UNDER APPLICABLE LAW ARE LIMITED IN DURATION TO THE WARRANTY PERIOD. NO WARRANTIES, EXPRESS OR IMPLIED, WILL APPLY AFTER THIS PERIOD. ALL INFORMATION, SPECIFICATIONS, PRICES, AND SERVICES ARE SUBJECT TO CHANGE AT ANY TIME WITHOUT NOTICE.**

#### **Limitation of liability**

Your sole remedy under this limited warranty is set forth in this document. For any claim concerning performance or nonperformance of Lexmark or a Remarketer for this product under

this limited warranty, you may recover actual damages up to the limit set forth in the following paragraph.

Lexmark's liability for actual damages from any cause whatsoever will be limited to the amount you paid for the product that caused the damages. This limitation of liability will not apply to claims by you for bodily injury or damage to real property or tangible personal property for which Lexmark is legally liable. **IN NO EVENT WILL LEXMARK BE LIABLE FOR ANY LOST PROFITS, LOST SAVINGS, INCIDENTAL DAMAGE, OR OTHER ECONOMIC OR CONSEQUENTIAL DAMAGES.** This is true even if you advise Lexmark or a Remarketer of the possibility of such damages. Lexmark is not liable for any claim by you based on a third party claim.

This limitation of remedies also applies to claims against any Suppliers and Remarketers of Lexmark. Lexmark's and its Suppliers' and Remarketers' limitations of remedies are not cumulative. Such Suppliers and Remarketers are intended beneficiaries of this limitation.

### **Additional rights**

Some states do not allow limitations on how long an implied warranty lasts, or do not allow the exclusion or limitation of incidental or consequential damages, so the limitations or exclusions contained above may not apply to you.

This limited warranty gives you specific legal rights. You may also have other rights that vary from state to state.

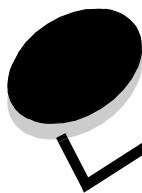

# Index

---

## B

busy 13, 29  
buttons 6, 7, 25, 32

## C

Cable lock 6  
canceling a print job  
    from a Windows computer 64  
    from printer operator panel 64  
card stock 48  
cartridge region mismatch 16, 32  
change cartridge 17, 33  
Choosing appropriate print media 46  
clear jams 53  
Complex page 18, 34

## D

defaults, restore 44  
defective cartridge 17, 34  
dual-action slide 5  
duplex 20, 37, 61

## E

E120 6  
E120n 6  
envelopes 47  
Error light 14, 15, 16, 17, 21, 22, 24, 30, 31, 32, 33, 39, 40, 43  
    See also operator panel, secondary error codes  
Ethernet 2, 5, 6

## F

Flushing buffer 14, 30  
fuser 54, 76, 78, 79

## G

general problems 76

## H

Host interface disabled 21, 38

## I

Invalid engine code 14, 31

## J

Jam  
    at printer exit sensor 40  
    at the input sensor 39  
    between the input and exit sensors 39  
    in the printer paper path 21  
    in Tray 1 / priority feeder 22  
jams  
    clearing 53  
    preventing 52

## L

labels 47  
letterhead 47, 63  
Lexmark Cartridge Collection Program 74  
Lexmark Return Program 74  
lights 10, 26  
loading  
    letterhead 63  
    priority feeder 51  
long-life photoconductor kit  
    changing 71  
    level 67  
    recycling 74  
    replacing 24, 43

## M

Macintosh 60, 61, 63, 64, 76, 78  
manual duplex  
    light sequence 20, 37  
    printing 61  
Memory full 20, 37  
menu settings page 44  
messages  
    See operator panel light sequences  
multiple page printing 62

## N

network model 5, 6, 44  
network settings page 44  
N-up printing 62

## O

Open door 33  
operator panel 13  
    base model 6  
    light sequences

- Busy 13, 29
- Canceling job 14, 30
- cartridge region mismatch 16, 32
- Close door 31
- Error 14, 15, 16, 17, 21, 22, 24, 30, 31, 32, 33, 39, 40, 43
- Load media 36
- Manual duplex 20, 37
- Not ready 15, 31
- Offline 15, 31
- Open door 15, 17, 33
- Print side two 20, 37
- Programming engine code 15, 32
- Programming system code 15, 32
- Ready/Power Saver 12, 28
- Resetting printer 14, 30
- Restoring factory defaults 14, 30
- Service error 24, 43
- Toner low 23, 24, 42, 43
- Unsupported toner cartridge 43
- Waiting 13, 30
- lights 10, 26
- network model 7

## P

- paper 46
  - choosing 46
  - loading 51
- Paper jam
  - at printer exit sensor 40
  - at the input sensor 39
  - between printer input and exit sensor 39
- power button 6
- preprinted forms 47
- print media 5
  - choosing 46
  - loading 46
  - sizes 46
  - storing 46
  - types 46
- print quality problems 76, 78
- printer models 5
- printer resident Web page 43
- printing
  - duplex 61
  - letterhead 63
  - menu settings 44
  - multi-page (N-up) 62
  - network settings 44
- Printing Font List or Menu Settings Page 15, 31
- priority feeder 51
- priority tray 5
- problems
  - print quality 78

## R

- recycling supplies 74
- resource save off 41
- restore factory defaults 44

## S

- safety information 2
- secondary error codes
  - Complex page 18, 34
  - Insufficient collation area 19, 36
  - Memory full 20, 37
  - Network interface errors 38
  - Short paper 23, 41
- service error lights 24, 43
- Short paper 23, 41
- standard memory
  - 16 MB 5
  - 8 MB 5
- supplies
  - assessing 67
  - conserving 67
  - ordering 66
  - recycling 74
  - storing 67

## T

- toner cartridge
  - changing 68
  - error 43
  - recycling 74
  - toner level 67
- Toner low 77
- Toner Low light 23, 24, 42, 43
- transparencies 46, 47, 51
- troubleshooting 75, 76
  - print quality 78

## U

- USB 5, 6, 21, 38, 44, 82

## W

- Waiting light 13, 30
- warranty 84, 85
- Windows 59, 61, 62, 63, 64, 78