

Quick Reference

Loading paper or other print media

Source	Sizes	Types	Capacity ¹ (sheets)
Tray 1 (250-sheet tray)	A4, A5, JIS B5, letter, legal, executive, folio, statement, Universal ²	Plain paper, paper labels, transparencies	250 paper; 50 labels; 50 transparencies
Tray 2* (550-sheet tray)	Universal ²	Plain paper, paper labels, transparencies	550 paper; 50 labels; 50 transparencies
Manual feeder	A4, A5, JIS B5, letter, legal, executive, folio, statement, Universal ²	Plain paper, paper labels, transparencies, card stock	1
	7¼, 9, 10, DL, C5, B5, other	Envelopes	

* Tray 2 not available on all models.
¹ Capacity for 20 lb print media, unless otherwise noted.
² Universal size ranges:
 – Tray 1: 89–216 x 210–356 mm (3.5–8.5 x 8.27–14.0 in.)
 – Tray 2: 148–216 x 210–356 mm (5.83–8.5 x 8.27–14.0 in.)
 – Manual feeder: 76–216 x 127–356 mm (3.0–8.5 x 5.0–14.0 in.) (includes 3 x 5 in. cards)

To help prevent jams:

- Flex all stacks of print media back and forth to loosen them, and then fan them before loading. Do not fold or crease the print media. Straighten the edges of the stack on a level surface.

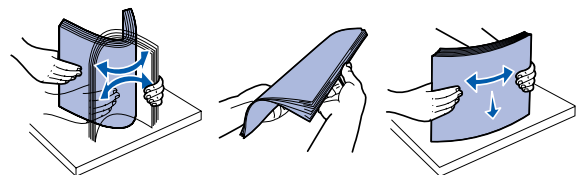

- Do not exceed the maximum stack height.
- Never mix media types within a tray.

Loading the 250-sheet or 550-sheet tray

- Remove the tray.
 - Note:** If you are going to load legal or folio size paper, you have to extend the length of the paper tray. See "Extending the tray for legal or folio size paper" for instructions.

- Prepare a stack of paper for loading by flexing or fanning it back and forth. Straighten the edges on a level surface.
- Load the paper in the tray with the print side facing down.

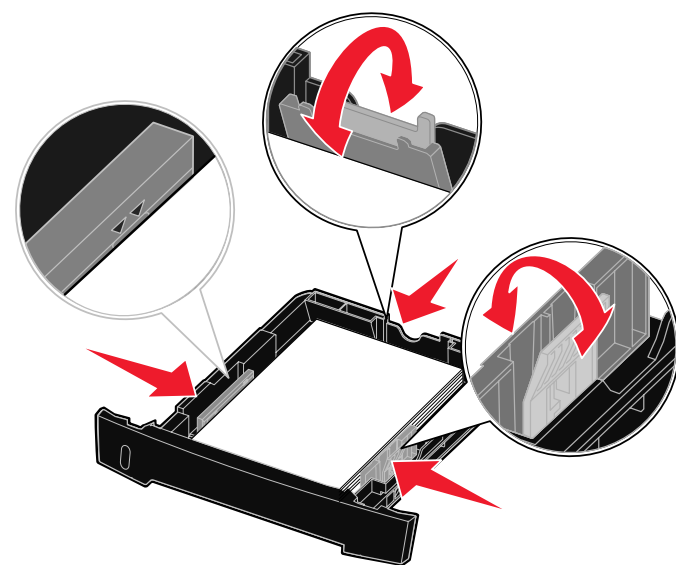

Note: Load letterhead paper with the design side facing down. The top edge of the sheet with the logo should be placed at the front of the tray.

Make sure the paper is below the maximum fill lines on the side guides. Overloading may cause jams.

- Slide the two side guides and the back guide until they fit snugly against the stack of paper.

- Insert the tray.

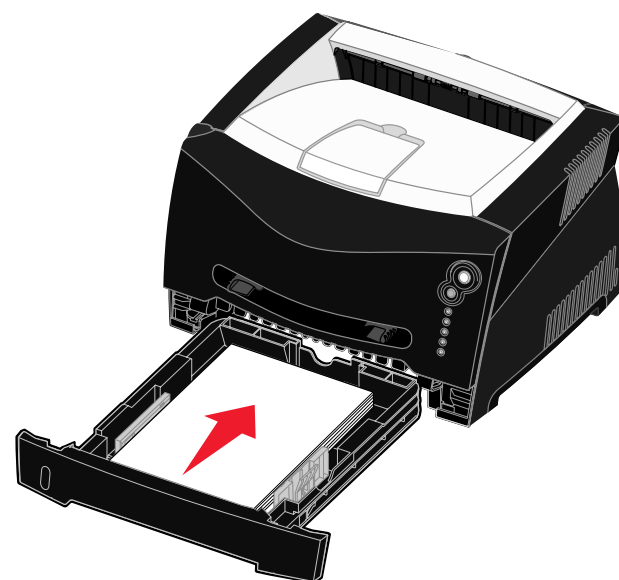

Extending the tray for legal or folio size paper

- Press down on the pressure point at the back of the tray.
- Expand the tray until the extender locks into place.

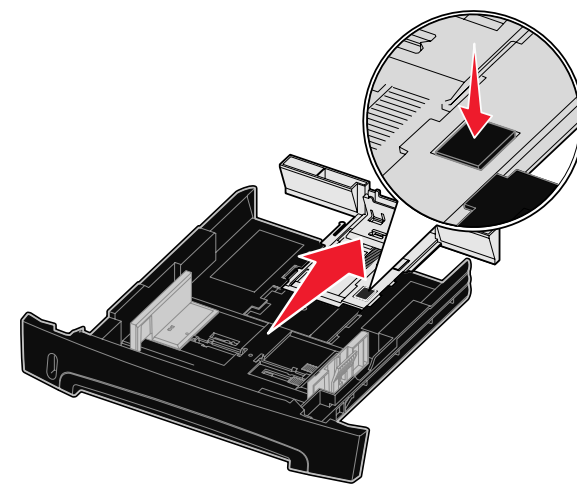

Using the manual feeder

The manual feeder can only feed one sheet of print media at a time.

- Send your print job to the printer (see to the *User's Reference* on the publications CD for help).

The printer Load Paper  light blinks when it is ready for the print media to be loaded.

- Place a sheet of the selected print media, print side facing up, at the center of the manual feeder, but only to the point where its leading edge can contact the paper guides.
- Adjust the paper guides to the print media width.
- Hold both sides of the print media close to the manual feeder and push it into the printer until it automatically engages.

There is a brief pause between the time the printer engages the print media and when it feeds into the printer.



Warning: Do not force the print media into the feeder. Forcing the media causes jams.

- Insert envelopes with the flap side face down and with the stamp area as shown.

- Hold transparencies by the edges, and avoid touching the print side. Oils from your fingers that are deposited on the transparency can affect print quality.
- Load letterhead face-up, with the top of the sheet first.

Using the rear exit

The single-sheet rear exit provides a straight-through paper path to help reduce curling and potential jams. This is especially useful for specialty media, such as transparencies, envelopes, labels, card stock, or index cards.

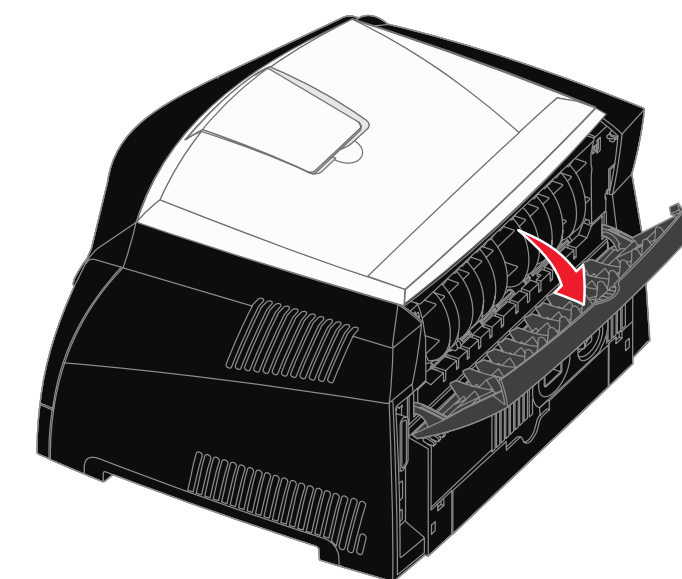

When the rear exit door is open, all print media comes out the rear exit. When closed, all media is sent to the output bin on top of the printer.

Printing on specialty media

Follow these instructions to print on media such as transparencies, card stock, labels, or envelopes. The type of print media you want to use determines which tray or feeder it should be fed from.

- Load the print media as specified for the tray you are using. See [Loading paper or other print media](#) for help.
- From the computer software application, set the paper type, size, and source according to the media you loaded.
 - From the computer software application, select **File** → **Print**.
 - Click **Properties** (or **Options, Printer, or Setup**, depending on the application) to view the printer driver settings.
 - Click the **Paper** tab.
 - Select your media type (transparencies, envelopes, and so on) from the **Form Type** list box.
 - Select the tray or feeder containing the specialty media from the **Form Source** list box.
 - Select the size of the specialty media from the **Form Size** list box.
 - Click **OK**, and then send your print job as usual.

Canceling a print job

Press and release **Cancel**  on the printer operator panel to cancel the job currently printing. The Cancel job light sequence is displayed on the operator panel while the job is being canceled.



Clearing paper jams

When a paper jam occurs, the printer stops and the operator panel

Paper Jam  and Continue  lights come on. Press and release

Continue  twice quickly to display the specific secondary error paper jam light sequence. See [Common operator panel light sequences](#) for more information.

We recommend that you clear the entire paper path when a paper jam occurs.

To clear a paper jam:

- 1 If you are feeding paper from a tray, remove the tray, and then remove any jams.
- 2 Open the front cover, and remove the print cartridge assembly.

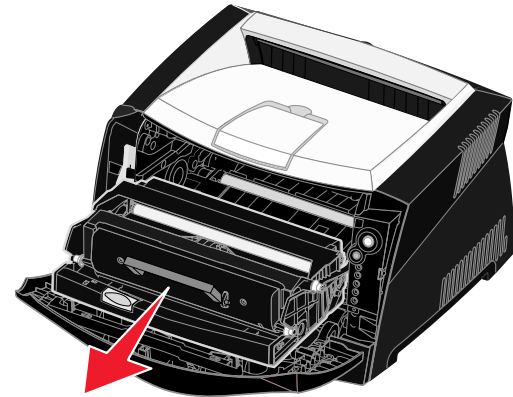

- 3 Remove any jams in the area behind the print cartridge assembly.

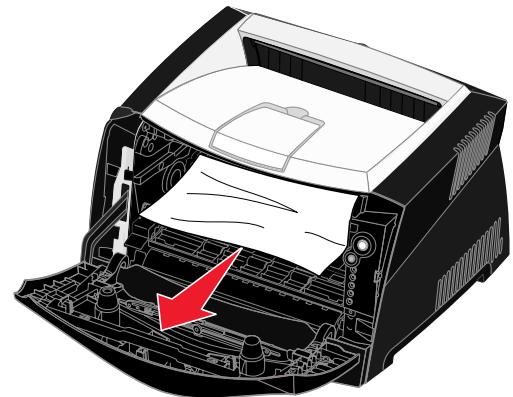

- 4 Lift the flap at the front of the printer, and remove any jams beneath the flap.

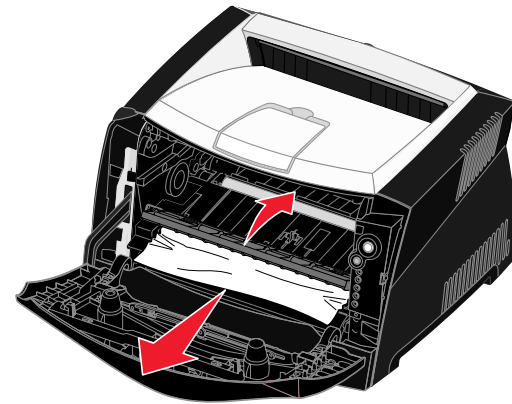

- 5 Open the rear exit, and remove any jams.

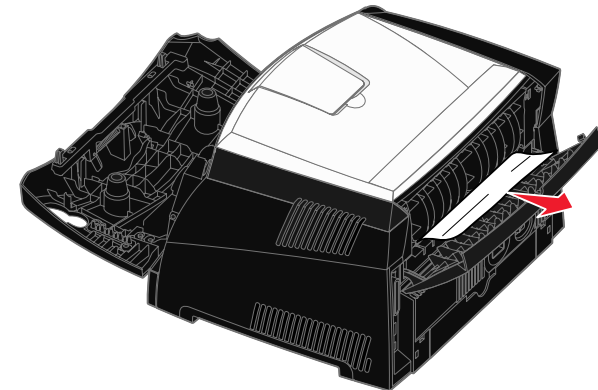

- 6 After you have cleared the jams, reinstall the print cartridge assembly, make sure all printer covers and trays are closed, and then press **Continue**  to resume printing.



If you need more information

- See the publications CD that came with your printer for helpful information about using and maintaining your printer.
- Contact your administrator or Help desk if you have questions about network printing.

Operator panel

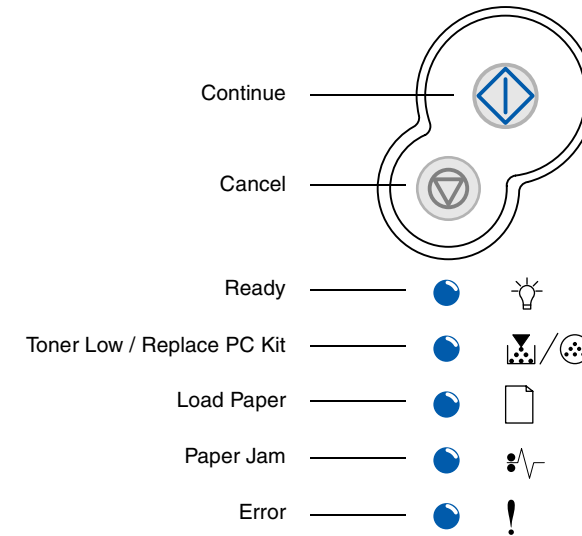
The operator panel has 5 lights and 2 buttons. The Continue button also has a light.



Press and release	To
 Continue	Resume printing.
 Continue twice quickly	Display a secondary error code.
 Cancel	Cancel the job currently printing.

Common operator panel light sequences







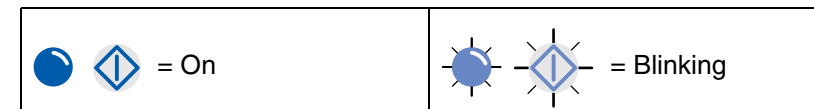

























































The operator panel lights mean different things, depending on their sequence. Lights that are off, on, and/or blinking indicate printer conditions such as printer status, intervention, or service.

The table on the right shows the most common light sequences. For more detailed information about the light sequences, see the publications CD.

Light legend



Common operator panel light sequences

Printer Condition	Ready / Power Saver	Busy	Waiting	Flushing / Resolution reduced	Not ready (printer is offline)	Close door	Load media	Load manual feeder	Print side two of a duplex job	Toner low	Photoconductor kit life warning	Replace photoconductor	Replace photoconductor kit (printer hard stop)	Unsupported print cartridge	Change cartridge invalid refill	Cartridge region mismatch	Cancel job / Reset printer	Service error	Printer error *	Paper jam printer error *	Paper jam secondary error codes*						
	Paper jam at the input sensor †	Paper jam in the manual feeder	Paper jam under the toner cartridge	Paper jam as a printed job exits the printer	Paper jam in Tray 1	Paper jam in Tray 2																					
 Continue																											
 Ready																											
 Toner Low / Replace PC Kit																											
 Load Paper																											
 Paper Jam																											
 Error																											

* When the Error (or Paper Jam) and Continue lights are both on, a secondary error has occurred. Press and release **Continue** twice quickly to display the secondary error code light sequence.

† Paper jams at the input sensor can be either after the paper leaves the tray and enters the printer or in the manual feeder.