

Quick Reference

Loading a tray

- 1 Remove the tray completely.

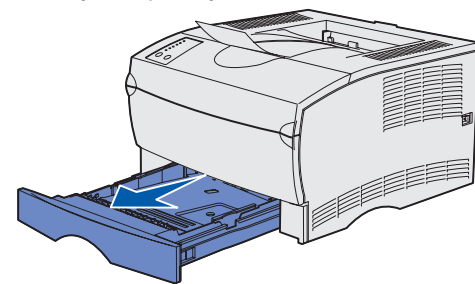

For the optional 500-sheet tray, open the cover.

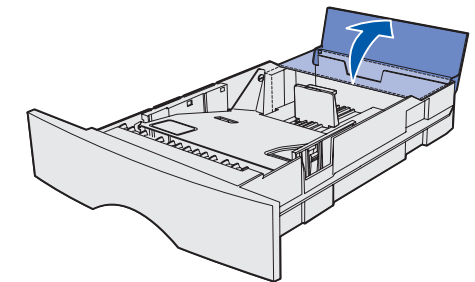

- 2 Press the metal plate down.

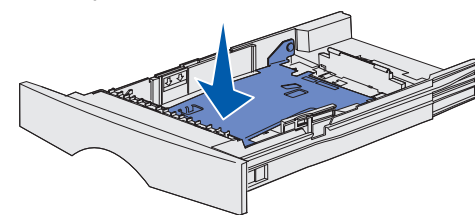

- 3 Squeeze the width guide tab and the width guide together, and then slide the guide all the way to the right.
- 4 Squeeze the length guide tab and the length guide together, and then slide the guide to its fully extended position.

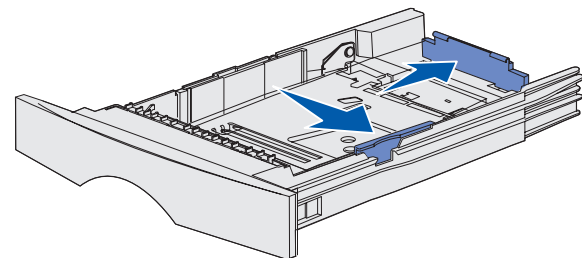

- 5 Flex the sheets back and forth to loosen them, and then fan them. Do not fold or crease the print media. Straighten the edges of the stack on a level surface.

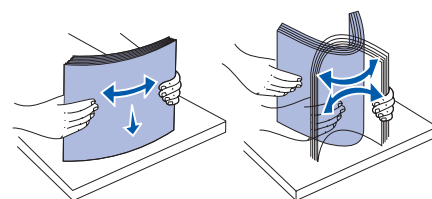

- 6 Place the print media against the left side of the tray and insert it under the metal stop, print side down, and facing the front of the tray. Do not bend or wrinkle the sheets.

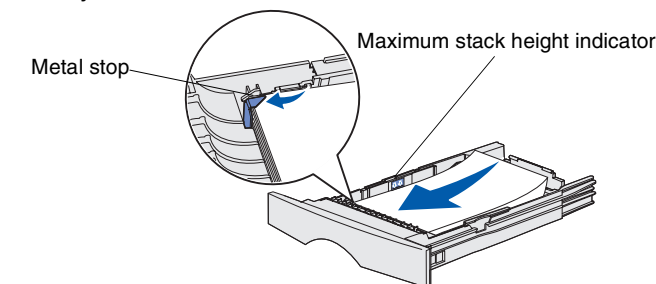

Note: Do not exceed the maximum stack height. Overfilling the tray may cause a jam.

- 7 Squeeze the width guide tab and the width guide together, and then slide the guide to the edge of the print media.
- 8 Squeeze the length guide tab and the length guide together, and then slide the guide to the edge of the print media.

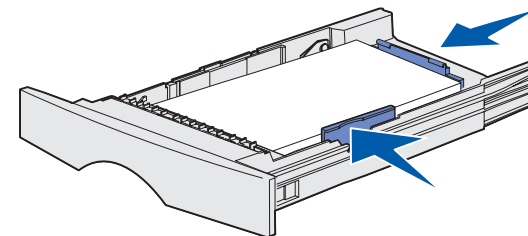

For the optional 500-sheet tray, close the cover.

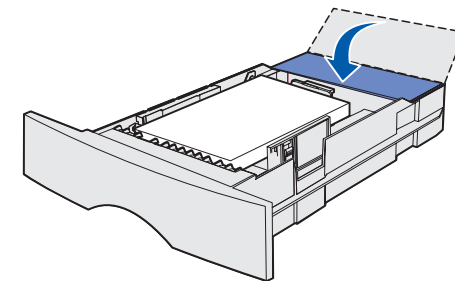

- 9 Reinstall the tray.

Loading the multipurpose feeder

The multipurpose feeder accepts plain paper, envelopes, transparencies, card stock, and labels.

- 1 Open the multipurpose feeder door, and then pull out the extension.

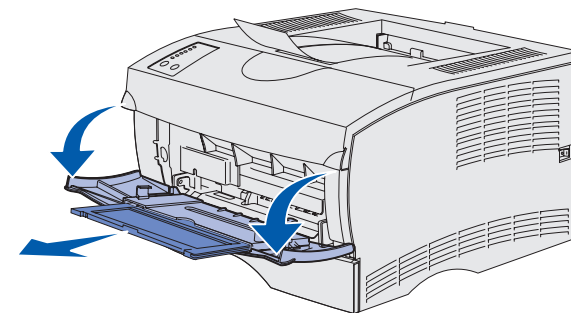

- 2 Unfold the extension.

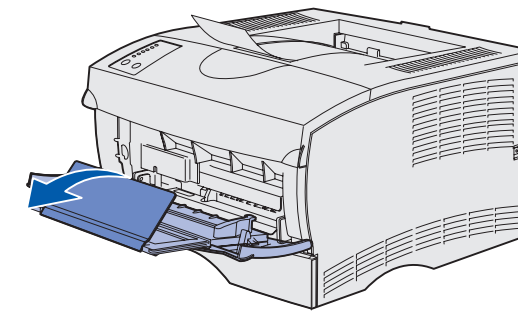

- 3 Slide the width guide all the way to the right.

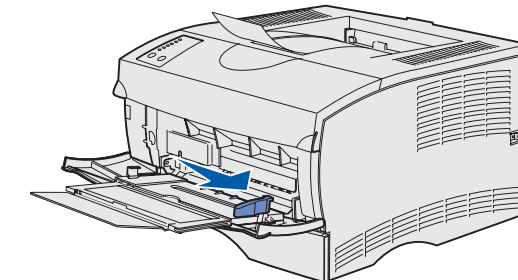

- 4 Place paper print side up, or envelopes flap side down, in the feeder. Push the print media forward without forcing it.

Note: Orient the print media correctly for the size, type, and print method you are using. Refer to the *Publications* CD for detailed information about orienting print media. Do not overfill the feeder.

- 5 Slide the width guide until it lightly touches the side of the stack.

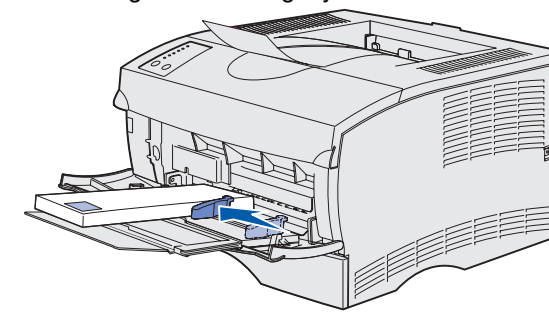

- 6 In your word processor, spreadsheet, browser, or other application, select File ► Print.
- 7 Click **Properties** (or **Options**, **Printer**, or **Setup** depending on the application) to view the printer driver settings.
- 8 Select **MP Feeder** from the Form Source list box.
- 9 Select your print media type (envelopes, transparencies, and so on) from the Media Type list box.
- 10 Click **OK**, and then send your print job as usual.

Canceling a print job

If the job you want to cancel is printing and the **Ready/Data** light is blinking, press **Cancel**. All the lights come on indicating the print job is canceled.

Printing a menu settings page

To print a menu settings page, press **Continue** while only the **Ready/Data** light is on.

Operator panel conditions

The operator panel can be used for more detailed functions than outlined here. Refer to the *Publications* CD for more information.

Light sequence	Printer status
Ready/Data on	The printer is ready to receive and process data.
Ready/Data blinks	The printer is busy receiving or processing data.
<ul style="list-style-type: none"> • Ready/Data on • Press Continue on 	The printer is waiting for additional data.
Error on	The printer top cover is open or the print cartridge is not installed.
<ul style="list-style-type: none"> • Error on • Press Continue on 	A secondary error has occurred. <ul style="list-style-type: none"> • Press Continue twice quickly to display the secondary error light sequence. • Refer to the <i>Publications</i> CD to resolve the problem.

Light sequence	Printer status
<ul style="list-style-type: none"> • Load/Remove Paper on • Press Continue on 	The printer is out of print media, or the print media is not loaded properly.
<ul style="list-style-type: none"> • Load/Remove Paper blinks • Press Continue on 	<ul style="list-style-type: none"> • The printer is prompting you to load a single sheet of media in the multipurpose feeder. • Press Continue to print the page.
<ul style="list-style-type: none"> • Paper Jam on • Press Continue on 	The printer detects a jam. <ul style="list-style-type: none"> • Press Continue twice quickly to display a jam light sequence. • See "Clearing jams" on this card or on the <i>Publications</i> CD.
<ul style="list-style-type: none"> • Ready/Data on • Toner Low on 	The printer is alerting you the toner is low. Removing the cartridge and shaking it may let you print more pages before replacing it.

Clearing jams

To clear the **Paper Jam** error light and resume printing, you must remove all jams and press **Continue**.

The following table may help you locate the jam based on the jam light sequence. However, you still have to check each possible jam area to find all the jams.

Jam light sequences

Light sequence	Meaning
<ul style="list-style-type: none"> • Ready/Data on • Paper Jam on • Press Continue on 	Input jam—see: <ul style="list-style-type: none"> • “Jams under the print cartridge or in the fuser” • “Jams in a tray”
<ul style="list-style-type: none"> • Toner Low on • Paper Jam on • Press Continue on 	Exit jam—see: <ul style="list-style-type: none"> • “Jams under the print cartridge or in the fuser” • “Jams behind the rear output bin door”
<ul style="list-style-type: none"> • Toner Low blinks • Paper Jam on • Press Continue on 	Duplex jam—see: <ul style="list-style-type: none"> • “Jams under the printer”
<ul style="list-style-type: none"> • Ready/Data blinks • Paper Jam on • Press Continue on 	Multipurpose feeder jam: <ul style="list-style-type: none"> • Remove any jams in the multipurpose feeder. • Make sure any print media in the multipurpose feeder is loaded correctly.

Jams under the print cartridge or in the fuser

- 1 Open the upper front door using the finger grips.

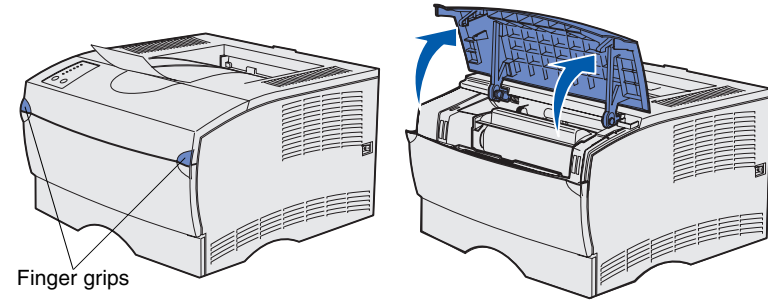

Finger grips

- 2 Remove the print cartridge.

CAUTION! The rear portion of the inside of the printer may be hot.

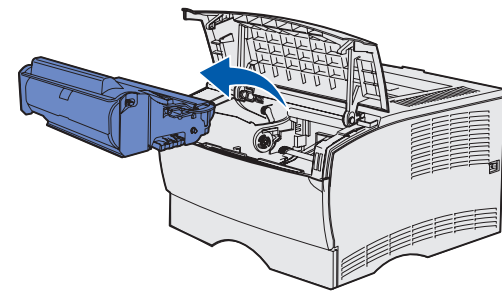

Warning! Do not touch the photoconductor drum on the bottom of the print cartridge.

- 3 Remove any jams.

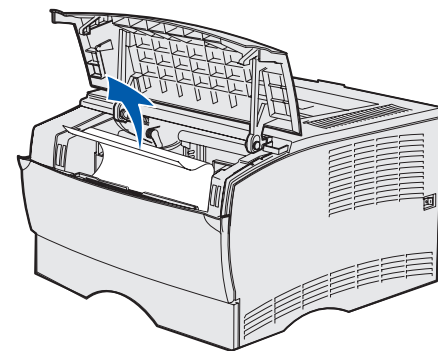

- 4 Reinstall the print cartridge.
- 5 Close the upper front door.

Jams behind the rear output bin door

- 1 Open the rear output bin door.

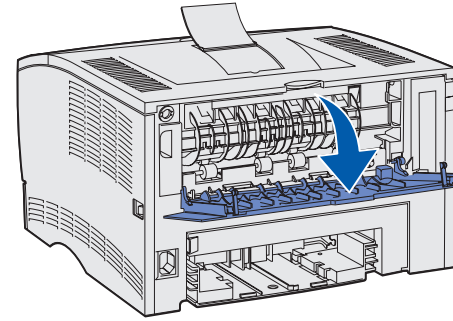

- 2 Remove any jams.

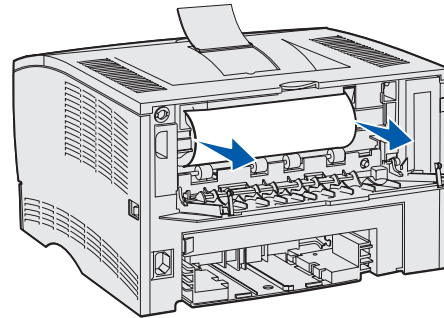

You may have to remove the print cartridge to clear a jam in this area.

- 3 Close the rear output bin door.

Jams in a tray

- 1 Gently open the tray until you can see the jam.
- 2 Remove any jams.

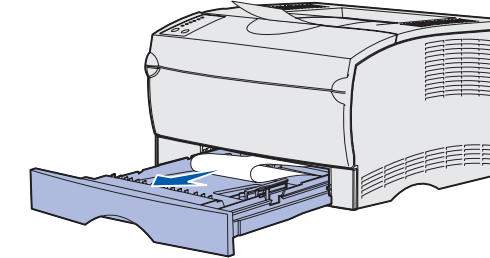

If you see any print media above the metal stop, completely remove the tray. Press down on the print media to lock the metal plate below it into place. Reposition the print media under the metal stop.

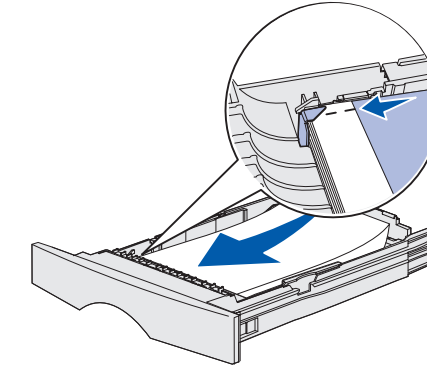

- 3 Reinstall the tray.

Jams under the printer

Print media can jam under the printer and above tray 1 when the duplex function is in use. To clear this type of jam:

- 1 Completely remove tray 1.
- 2 Press down the green lever on the left under the printer.

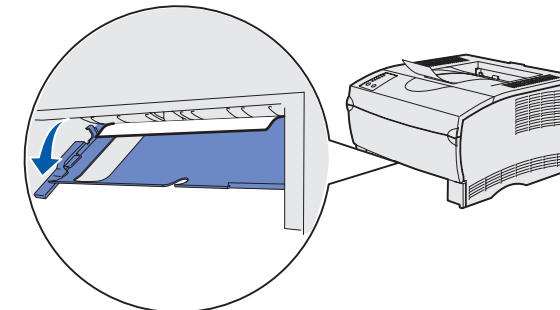

- 3 Remove any jams.
- 4 Grasp the tab on the rear door and pull the door open.

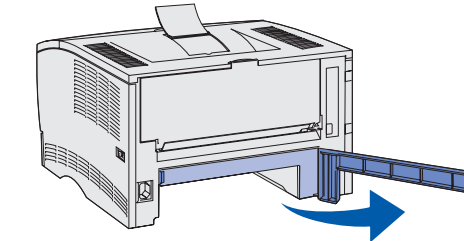

- 5 Press down the green lever on the right under the printer.

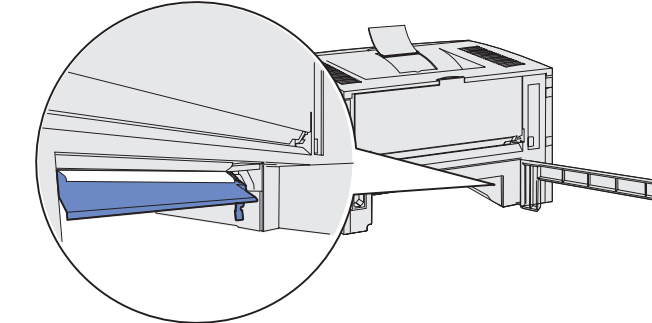

- 6 Remove any jams.
- 7 Close the rear door, and then reinstall the tray.

Jams in the standard output bin or multipurpose feeder

Remove any jams from these areas.

If you need more information

- Refer to the *Setup Guide* or the *Publications CD* for information about using and maintaining your printer.
- Contact your administrator or Help desk if you have questions about network printing.