

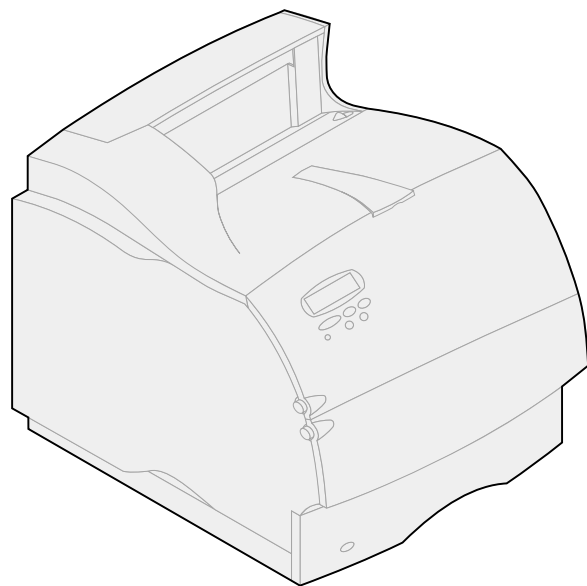

Lexmark T620 and T622

User's Reference



January 2001

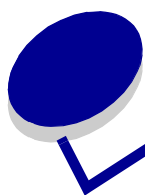

Table of Contents

Chapter 1: Printer overview	9
Chapter 2: Using the operator panel	10
Understanding the operator panel	10
Using the operator panel buttons	11
Using the operator panel to change printer settings	12
Printing the menu settings page	13
Menus Disabled	13
Chapter 3: Disabling operator panel menus	14
Chapter 4: Using the Print and Hold function	15
Printing and deleting held jobs	15
Accessing held jobs from the operator panel	16
Recognizing when format errors occur	16
Repeat Print	17
Reserve Print	17
Verify Print	17
Confidential jobs	17
Chapter 5: Canceling a print job	19
Chapter 6: Printing folio and statement size paper	20
Chapter 7: Choosing print material	21
Paper characteristics	21
Recommended paper	22
Unacceptable paper	23
Choosing preprinted forms and letterhead	23
Choosing prepunched paper	24
Choosing paper	24

Choosing envelopes	25
Choosing labels	25
Choosing card stock	26
Choosing transparencies	27
Chapter 8: Storing paper	28
Chapter 9: Print material specifications	29
Chapter 10: Loading print material	36
Chapter 11: Loading a paper tray	37
Chapter 12: Loading the multipurpose feeder	40
Capacity	40
Paper dimensions	40
Trouble-free printing	40
Closing the multipurpose feeder	48
Chapter 13: Loading the envelope feeder	49
Chapter 14: Loading the 2000-sheet drawer	53
Chapter 15: Tray linking	54
Chapter 16: Tips for avoiding paper jams	55
Chapter 17: Replacing the print cartridge	56
Chapter 18: Replacing the charge roll	57
Chapter 19: Replacing the transfer roll	58
Chapter 20: Replacing the fuser assembly	59
Chapter 21: Replacing the staple cartridge	60
Chapter 22: Resetting the maintenance counter	61
Chapter 23: Ordering supplies	63

Chapter 24: Storing supplies	66
Chapter 25: Checking an unresponsive printer	67
Chapter 26: Clearing paper jams	68
200 and 201 Paper Jam	
Remove Cartridge	70
202 Paper Jam	
Open Rear Door	71
230 Paper Jam	
Check Duplex	74
24x Paper Jam	
Check Tray x	77
250 Paper Jam	
Check MP Feeder	82
260 Paper Jam	
Check Env Feeder	83
27x Paper Jam	
Check Bin x	85
28x Paper Jam	89
Chapter 27: Clearing staple jams	91
Chapter 28: Solving display problems	94
Chapter 29: Solving print problems	95
Chapter 30: Solving print quality problems	97
Chapter 31: Solving option problems	100
Chapter 32: Solving network printing problems	102
Chapter 33: Resolving other problems and questions	103
Chapter 34: Understanding printer messages	104
Chapter 35: Using printer menus	136
Chapter 36: Finishing Menu	137

Chapter 37: Infrared Menu	143
Chapter 38: Job Menu	147
Chapter 39: LocalTalk Menu	150
Chapter 40: Network Menu	154
Chapter 41: Paper Menu	158
Chapter 42: PCL Emul Menu	166
Chapter 43: Parallel Menu	171
Chapter 44: PostScript Menu	176
Chapter 45: Quality Menu	177
Chapter 46: Serial Menu	179
Chapter 47: Setup Menu	185
Chapter 48: Utilities Menu	191
Chapter 49: USB Menu	195
Chapter 50: Removings options	198
Removing an output option	199
Removing the envelope feeder	201
Removing a paper tray or duplex unit	202
Removing printer or flash memory	203
Removing an option card	204
Chapter 51: Disabling Power Saver	205
Chapter 52: Printer specifications	206
Dimensions	206
Duty cycle	206

Notices	207
Edition notice	208
Trademarks	208
Safety information	209
Cautions and warnings	209
Electronic emission notices	210
Energy Star	212
Laser notices	212
Index	215

1

Printer overview

The following illustrations show a Lexmark™ T620 and T622 standard network model configuration and a fully configured printer. If you have attached paper handling options to your printer, it may look more like the fully configured model. For information on other possible configurations, refer to the *Setup Guide*.

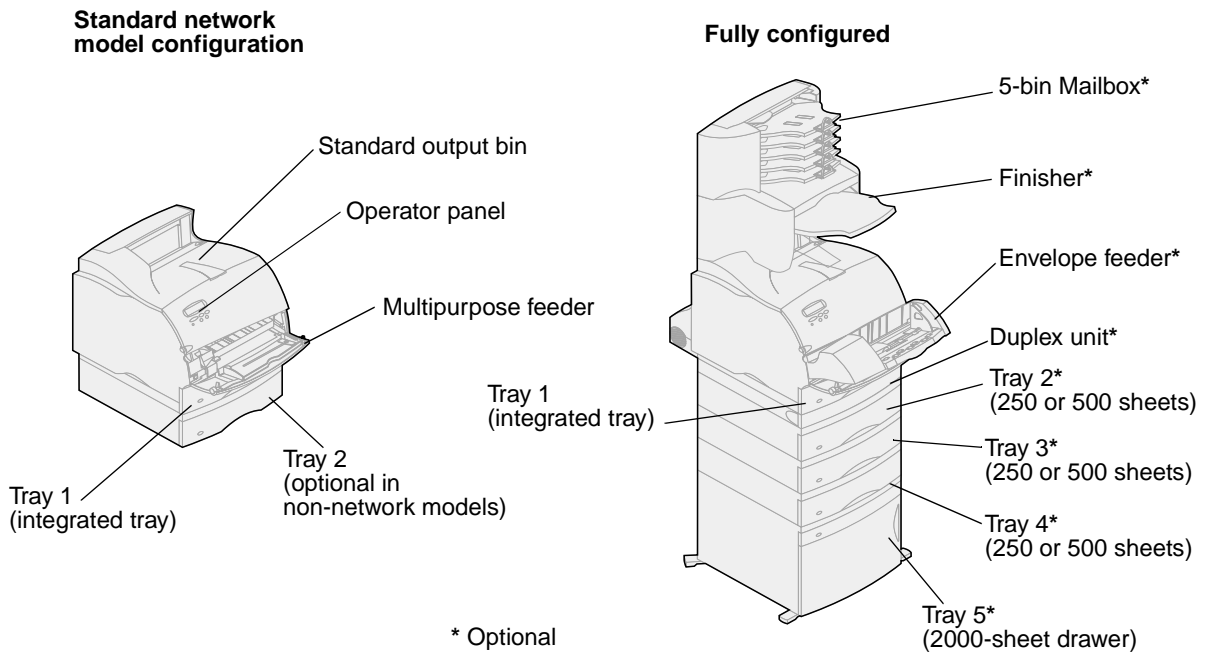

2 Using the operator panel

This section contains information about understanding the operator panel, changing printer settings, and understanding operator panel menus.

You can change most printer settings from your software application or printer driver. Settings you change from the application or printer driver apply only to the job you are preparing to send to the printer.

Changes made to printer settings from a software application override changes made from the printer operator panel.

If you cannot change a setting from your application, use the printer operator panel or the remote operator panel available from MarkVision™. Changing a printer setting from the printer operator panel or from MarkVision makes that setting the user default.

Understanding the operator panel

The printer operator panel has a 2-line by 16-character liquid crystal display (LCD), five buttons, and one indicator light.

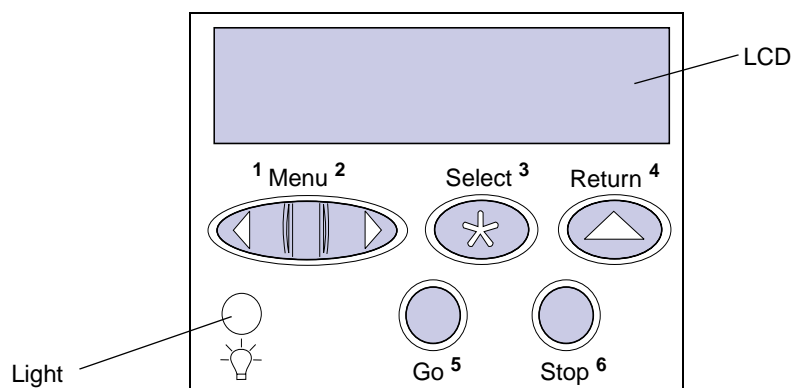

Indicator light

The indicator light gives information about the status of your printer. If the light is:

- Off, the printer is off
- On, the printer is on, but idle
- Blinking, the printer is on and is busy

Using the operator panel buttons

Use the five operator panel buttons to open a menu, scroll through a list of values, change printer settings, and respond to printer messages.

The numbers 1 through 6 appear beside the operator panel buttons; these numbers are used to enter personal identification numbers (PIN) for *Print and Hold* jobs. For more information, see [Using the Print and Hold function](#).

The following information describes the functions of each button.

Note: Buttons act upon the information displayed on the second line of the operator panel.

Go	<p>Press the Go button to:</p> <ul style="list-style-type: none"> • Return to the Ready state if the printer is in an offline situation (the Ready message does not display on the operator panel). • Exit printer menus and return to the Ready state. • Clear operator panel error messages. <p>If you've changed printer settings from the operator panel menus, press Go before sending a job to print. The printer must display Ready for jobs to print.</p>
Menu	<p>Each end of the button has a function. Press Menu:</p> <ul style="list-style-type: none"> • When Ready is displayed, to take the printer offline (out of the Ready state) and scroll through the menus. • When Busy is displayed, to take the printer to the Job Menu. • When the printer is offline, press Menu> to scroll through the menus. <ul style="list-style-type: none"> – Press <Menu to go to the previous item in the menus. <p>For menu items with numeric values, such as Copies, press and hold Menu to scroll through the values. Release the button when the number you want is displayed.</p>
Select	<p>Press Select to:</p> <ul style="list-style-type: none"> • Select the menu displayed on the second line of the operator panel. Depending on the type of menu, this action: <ul style="list-style-type: none"> – Opens the menu and displays the first item in the menu. – Opens the menu item and displays the default setting. • Save the displayed menu item as the default setting. The printer displays the saved message and returns to the menu item. • Clear certain messages from the operator panel.
Return	<p>Press Return to return to the previous menu level or menu item.</p>
Stop	<p>Press Stop at the Ready, Busy, or Waiting message to temporarily stop all activity and take the printer offline. The operator panel status message changes to Not Ready.</p> <p>Press Go to return the printer to the Ready, Busy, Or Waiting State.</p>

Using the operator panel to change printer settings

From the operator panel, you can select menu items and associated values to print your jobs successfully. You can also use the panel to alter the setup and operating environment of the printer. See [Using printer menus](#) for an explanation of all the menu items.

You can modify printer settings by:

- Selecting a setting from a list of values
- Changing an On/Off setting
- Changing a numerical setting

To select a new value as a setting:

- 1** From a **Ready** status message, press **Menu**. The menu names appear.
- 2** Continue to press and release **Menu** until you see the menu you need.
- 3** Press **Select** to select the menu or menu item displayed on the second line of the display.
 - If the selection is a menu, the menu is opened and the first printer setting in the menu appears.
 - If the selection is a menu item, the default setting for the menu item appears. (The current user default setting has an asterisk [*] beside it.)

Each menu item has a list of values for the menu item. A value can be:

- A phrase or word to describe a setting
 - A numerical value that can be changed
 - An On or Off setting
- 4** Press **Menu** to move to the value you need.
 - 5** Press **Select** to select the value on the second line of the operator panel. An asterisk appears beside the value to indicate that it is now the user default setting. The new setting appears for one second, clears, displays the word **saved**, and then displays the previous list of menu items.
 - 6** Press **Return** to go back to previous menus. Make additional menu selections to set new default settings. Press **Go** if this is the last printer setting to change.

User default settings remain in effect until you save new settings or restore the factory defaults. Settings you choose from your software application can also change or override the user default settings you select from the operator panel.

Printing the menu settings page

Complete the following steps to print a list of the current user default settings and installed printer options:

- 1 Make sure the printer power is on and the **Ready** status message appears.
- 2 Press **Menu** until you see Utilities Menu, and then press **Select**.
- 3 Press **Menu** until you see Print Menus, and then press **Select**.

The message **Printing Menu Settings** appears and remains until the page prints. The printer returns to **Ready** when the page or pages finish printing.

If a message appears, see [Understanding printer messages](#) for more information.

The [diagram](#) in [Using printer menus](#) shows the menu items in each menu.

An asterisk (*) next to a value indicates the factory default setting. Factory defaults may differ for different countries.

Factory defaults are the function settings in effect the first time you turn your printer on. These remain in effect until you change them. Factory defaults are restored if you select the Restore value for the Factory Defaults menu item in the Utilities Menu. See [Utilities Menu](#) for more information.

When you select a new setting from the operator panel, the asterisk moves next to the selected setting to identify it as the current user default.

User defaults are the settings you select for different printer functions and store in printer memory. Once stored, these settings remain active until new ones are stored or the factory defaults are restored.

Note: Settings you choose from your software application may override the settings you select from the operator panel.

Menus Disabled

If your printer is configured as a network printer available to a number of users, **Menus Disabled** may appear when you press **Menu** from the **Ready** state. Disabling the menus prevents users from using the operator panel to inadvertently change a printer default that has been set by the person managing the printer. You can still use Print and Hold features, clear messages, and select items from the Job Menu when printing a job, but you cannot change other printer settings. You can, however, use your printer driver to override printer defaults and select settings for individual print jobs.



Disabling operator panel menus

To disable the operator panel menus so that changes cannot be made to the printer default settings:

- 1 Turn the printer off.

Note: Disabling the operator panel menus does not prevent access to the Job Menu or to Print and Hold functionality.

- 2 Press and hold **Select** and **Return** and turn the printer on.

- 3 Release the buttons when you see **Performing Self Test**.

Config Menu appears on the first line of the display.

- 4 Press **Menu** until you see **Panel Menus**, and then press **Select**.

Disable appears on the second line of the display.

- 5 Press **Select**.

Locking Menus appears briefly.

- 6 Press **Menu** until you see Exit Config Menus, and then press **Select**.

The menus are disabled. If you press **Menu**, the message **Menus Disabled** appears.

To enable the menus:

- 1 Repeat steps 1 through 4.
- 2 Press **Menu** until you see Enable.
- 3 Continue with steps 5 and 6.



Using the Print and Hold function

When sending a job to the printer, you can specify in the driver that you want the printer to hold the job in memory. When you are ready to print the job, you must go to the printer and use the operator panel menus to identify which *held* job you want to print.

Note: *Print and Hold* functions require a minimum of 16MB available printer memory. We recommend a minimum of 32MB available printer memory and a hard disk.

To learn more about this function, click a topic:

- **Printing and deleting held jobs**
- **Accessing held jobs from the operator panel**
- **Recognizing when format errors occur**
- **Repeating print jobs at a later time**
- **Verifying print jobs**
- **Printing confidential jobs**
- **Reserving print jobs**

Printing and deleting held jobs

Once held jobs are stored in printer memory, you can use the printer operator panel to specify what you want to do with one or more of the jobs. You can select either Confidential Job or Held Jobs (Repeat Print, Reserve Print, and Verify Print jobs) from the **Job Menu**. If you select Confidential Job, you must enter the personal identification number (PIN) you specified in the driver when you sent the job. See **Confidential jobs** for more information.

From either the Confidential Job or the Held Jobs menu items, you have five choices:

- Print All Jobs
- Print A Job
- Delete All Jobs
- Delete A Job
- Print Copies

Accessing held jobs from the operator panel

- 1** To access held jobs from the operator panel:
 - If the printer is Busy, press **Menu** and the Job Menu appears.
 - If the printer is Ready, continue to step 2.
- 2** Press **Menu** until you see Held Jobs or Confidential Job on the operator panel display, depending on the type of job you want to access.
- 3** Press **Select**.

User Name appears on the first line of the operator panel. The second line displays the names of users currently associated with Print and Hold jobs.
- 4** Press **Menu** until you see your user name.

Note: If you are looking for a Confidential Job, you are prompted to enter your PIN. See **Confidential jobs** for more information.
- 5** Press **Select**.
- 6** Press **Menu** until the action you want to take is on the second line of the operator panel (Print A Job, Delete A Job, and so on).
- 7** Press **Select**.
 - If you are looking for a particular job, press Menu to scroll through the list of available jobs, and press Select when the correct job is displayed. An asterisk (*) appears next to the job name indicating you have chosen to print or delete that job.
 - If you are prompted to enter the number of copies you want to print, use the Menu button to increase or decrease the number on the display, and then press Select.
- 8** Press **Go** to print or delete specific jobs you have marked.

The printer briefly shows messages indicating what Print and Hold functions it is performing.

Recognizing when format errors occur

If the ⚡ symbol appears on the display, it indicates that the printer had trouble formatting one or more of the held jobs. These formatting problems are most commonly the result of insufficient printer memory or invalid data that might cause the printer to flush the job.

When a ⚡ symbol appears next to a held job, you can:

- Print the job. Be aware, however, that only part of the job may print.
- Delete the job. You may want to free up additional printer memory by scrolling through the list of held jobs and deleting others you have sent to the printer.

If formatting errors are a recurring problem with held jobs, your printer may require more memory.

Repeat Print

If you send a Repeat Print job, the printer prints all requested copies of the job *and* stores the job in memory so you can print additional copies later. You can print additional copies as long as the job remains stored in memory.

Note: Repeat Print jobs are automatically deleted from printer memory when the printer requires extra memory to process additional held jobs.

Reserve Print

If you send a Reserve Print job, the printer does not print the job immediately, but stores the job in memory so you can print the job later. The job is held in memory until you delete it from the Held Jobs menu. Reserve Print jobs may be deleted if the printer requires extra memory to process additional held jobs.

See **Printing and deleting held jobs** for information.

Verify Print

If you send a Verify Print job, the printer prints one copy and holds the remaining copies you requested from the driver in printer memory. Use Verify Print to examine the first copy to see if it is satisfactory before printing the remaining copies.

See **Printing and deleting held jobs** if you need help printing the additional copies stored in memory.

Note: Once all copies are printed, the Verify Print job is deleted from printer memory.

Confidential jobs

When you send a job to the printer, you can enter a personal identification number (PIN) from the driver. The PIN must be four digits using the numbers 1–6. The job is then held in printer memory until you enter the same four-digit PIN from the printer operator panel and choose to print or delete the job. This ensures that the job does not print until you are there to retrieve it, and no one else using the printer can print the job.

When you select Confidential Job from the Job Menu and then select your user name, the following prompt is displayed:

Enter PIN:
= _____

Use the buttons on the operator panel to enter the four-digit PIN associated with your confidential job. The numbers next to the button names identify which button to press for each digit (1–6). As you enter the PIN, asterisks are displayed on the operator panel to ensure confidentiality.

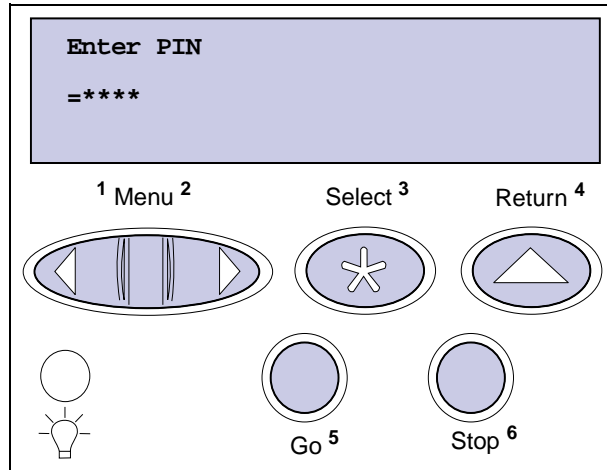

If you enter an invalid PIN, the message **No Jobs Found. Retry?** appears. Press **Go** to reenter the PIN, or press **Stop** to exit the Confidential Job menu.

When you enter a valid PIN, you have access to all print jobs matching the user name and PIN you entered. The print jobs matching the PIN you entered appear on the display when you enter the Print A Job, Delete A Job, and Print Copies menu items. You can then choose to print or delete jobs matching the PIN you entered. (See [Printing and deleting held jobs](#) for more information.) After printing the job, the printer deletes the confidential job from memory.



Canceling a print job

To cancel a print job:

- 1 Press **Menu**. Job Menu appears on the first line of the display and Cancel Job appears on the second line.

Note: Job Menu is the only available menu item when the printer is in the Busy state.

- 2 Press **Select**.

Canceling Job briefly appears in the display. The printer finishes printing any page already being printed, and then stops. The printer returns to the Ready state.



Printing folio and statement size paper

Folio and statement sizes are not available in the Paper Size menu until Size Sensing is turned off. To turn off Size Sensing:

- 1 Press and hold the **Select** and **Return** buttons while you turn the printer on.
- 2 Release the buttons when **Performing Self Test** appears on the display.
The printer performs its power-on sequence, and then Config Menu appears on the first line of the display.
- 3 Press **Menu** until you see Size Sensing, and then press **Select**.
Tray 1 Sensing appears on the second line of the display.
- 4 Press **Menu** to select the input option that will hold the folio or statement size paper, and then press **Select**.
The first line of the display shows the selected input option and the second line shows the current setting.
- 5 Press **Menu** to change the setting to Off, and then press **Select**.
SAVED appears briefly on the display, and then is replaced by Config Menu on the first line and Size Sensing on the second line.
- 6 Press **Menu** until you see Exit Config Menu, and then press **Select**.
- 7 Activating Menu Changes appears briefly, followed by Performing Self Test. The printer returns to the Ready state.



Choosing print material

The print quality and feed reliability of your printer and options can vary with the type and size of print material you use. This section provides guidelines for each type of print material. For information on card stock and labels, refer to the *Card Stock & Label Guide* located on Lexmark's Web site at www.lexmark.com.

Always print samples on the print material you are considering before buying large quantities.

Click a topic for more information:

- **Paper characteristics**
- **Recommended paper**
- **Unacceptable paper**
- **Choosing preprinted forms and letterhead**
- **Choosing prepunched paper**
- **Choosing paper**
- **Choosing envelopes**
- **Choosing labels**
- **Choosing card stock**
- **Choosing transparencies**

Paper characteristics

The following paper characteristics affect print quality and reliability. We recommend that you keep these guidelines in mind when evaluating new paper stock.

For detailed information, refer to the *Card Stock & Label Guide* located on the Lexmark Web site at www.lexmark.com.

Weight

The printer can automatically feed paper weights from 60 to 176 g/m² (16 to 47 lb bond) grain long. Paper lighter than 60 g/m² (16 lb) might not be stiff enough to feed properly, causing paper jams. For best performance, use 75 g/m² (20 lb bond) grain long paper. To use paper narrower than 182 x 257 mm (7.2 x 10.1 in.), we recommend that the weight be greater than or equal to 90 g/m² (24 lb bond).

Curl

Curl is the tendency of paper to curve at its edges. Excessive curl can cause paper feeding problems. Curl usually occurs after the paper passes through the printer, where it is exposed to high temperatures. Storing paper unwrapped in humid conditions, even in the paper tray, can contribute to paper curling.

Smoothness

The degree of smoothness of paper directly affects print quality. If the paper is too rough, the toner does not fuse to the paper properly, resulting in poor print quality. If the paper is too smooth, it can cause paper feeding problems. Smoothness needs to be between 100 and 300 Sheffield points; however, smoothness between 100 and 175 Sheffield points produces the best print quality.

Moisture content

The amount of moisture in the paper affects both print quality and the ability of the printer to feed the paper properly. Leave the paper in its original wrapper until you are ready to use it. This limits the exposure of the paper to moisture changes that can degrade its performance.

Grain direction

Grain refers to the alignment of the paper fibers in a sheet of paper. Grain is either *grain long*, running the length of the paper, or *grain short*, running the width of the paper.

For 60 to 176 g/m² (16 to 47 lb bond) paper, grain long fibers are recommended. For papers heavier than 176 g/m² (47 lb bond), grain short is preferred. For the multipurpose feeder, 60 to 135 g/m² (16 to 36 lb bond) paper, grain long fibers are recommended. For the multipurpose feeder, papers heavier than 135 g/m² (36 lb bond), grain short is preferred.

Fiber content

Most high-quality xerographic paper is made from 100% chemically pulped wood. This content provides the paper with a high degree of stability resulting in fewer paper feeding problems and better print quality. Paper containing fibers such as cotton possess characteristics that can result in degraded paper handling.

Recommended paper

To ensure the best print quality and feed reliability, use 75 g/m² (20 lb) xerographic paper. Business papers designed for general business use may also provide acceptable print quality.

Always print several samples before buying large quantities of any type of paper. When choosing any papers, consider the weight, fiber content, and color of the paper.

The laser printing process heats paper to high temperatures of 225°C (437°F) for Magnetic Ink Character Recognition (MICR) applications, and 205°C (401°F) for non-MICR applications. Use only papers that are able to withstand these temperatures without discoloring, bleeding, or releasing hazardous emissions. Check with the manufacturer or vendor to determine whether the paper you've chosen is acceptable for laser printers.

Unacceptable paper

The following papers are not recommended for use with the printer:

- Chemically treated papers used to make copies without carbon paper, also known as carbonless papers, carbonless copy paper (CCP), or no carbon required (NCR) paper
- Coated papers (erasable bond)
- Multiple-part forms or documents
- Preprinted papers that require a *registration* (the precise print location on the page) greater than ± 0.09 in., such as optical character recognition (OCR) forms

In some cases, you can adjust registration with your software application to successfully print on these forms.

- Preprinted papers with chemicals that may contaminate the printer
- Preprinted papers that can be affected by the temperature in the printer fuser
- Rough-edged or curled papers
- Synthetic papers
- Thermal papers
- Less than 60 g/m² (16 lb) recycled paper
- Recycled papers containing more than 25% post-consumer waste that do not meet DIN 19 309

Choosing preprinted forms and letterhead

Use the following guidelines when selecting preprinted forms and letterhead paper for the printer:

- Use grain long papers for best results.
- Use only forms and letterhead printed using an offset lithographic or engraved printing process.
- Choose papers that absorb ink, but do not bleed.
- Avoid papers with rough or heavily textured surfaces.

Use papers printed with heat-resistant inks designed for use in xerographic copiers. The ink must withstand temperatures of 225°C (437°F) without melting or releasing hazardous emissions. Use inks that are not affected by the resin in the toner. Inks that are oxidation-set or oil-based should meet these requirements. Latex inks might not meet these requirements. If you are in doubt, contact your paper supplier.

Choosing prepunched paper

Prepunched paper brands can differ in the number and placement of holes and in manufacturing techniques.

Use the following guidelines when selecting and using prepunched paper:

- Test paper from several manufacturers before ordering and using large quantities of pre-punched paper.
- Paper should be punched at the paper manufacturer and not drilled into paper already packaged in a ream. Drilled paper can cause paper jams when multiple sheets feed through the printer.
- Prepunched paper can include more paper dust than standard paper. Your printer may require more frequent cleaning and your feed reliability may not be as good as that of standard paper.
- Weight guidelines for prepunched paper are the same as for nonpunched paper.

Choosing paper

Proper paper loading helps prevent paper jams and ensure trouble-free printing.

To help avoid paper jams or poor print quality:

- *Always* use new, undamaged paper.
- Before loading paper, know the recommended print side of the paper you're using. This information is usually indicated on the paper package.
- *Do not* use paper that you have cut or trimmed yourself.
- *Do not* mix paper sizes, weights, or types in the same paper source; mixing results in paper jams.
- *Do not* use coated papers.
- *Do not* forget to change the Paper Size setting when you use a source that does not support auto size sensing.
- *Do not* remove paper trays while a job is printing or **Busy** is displayed on the operator panel.
- Make sure the Paper Type, Paper Texture, and Paper Weight settings are correct. (See **Paper Menu** for detailed information about these settings.)
- Make sure the paper is properly loaded in the paper source.
- Flex paper back and forth. Do not fold or crease the paper. Straighten the edges on a level surface.

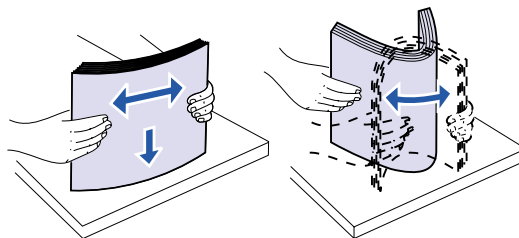

Choosing envelopes

When printing on envelopes:

- To achieve the best possible print quality, use only high-quality envelopes that are designed for use in laser printers.
- Use only new, undamaged envelopes.
- Load only one size of envelope at a time in the envelope feeder.
- Make sure the glue is not exposed.
- A combination of high humidity (over 60%) and the high printing temperatures may seal the envelopes.
- Be sure to select Env Feeder or MP Feeder as the paper source in the **Paper Menu** and set the correct envelope size.

The laser printing process heats envelopes to a temperature of 205°C (401°F). Use only envelopes that are able to withstand these temperatures without sealing, excessive curling, wrinkling, or releasing hazardous emissions. If you have any doubts about the envelopes you are considering using, check with the envelope supplier.

For best performance, use envelopes made from 75 g/m² (20 lb bond) paper. You can use up to 105 g/m² (28 lb bond) weight for the multipurpose feeder or 105 g/m² (28 lb bond) weight for the envelope feeder as long as the cotton content is 25% or less. Envelopes with 100% cotton content must not exceed 90 g/m² (24 lb bond) weight.

To minimize jams, do *not* use envelopes that:

- Have excessive curl or twist
- Are stuck together or damaged in any way
- Contain windows, holes, perforations, cutouts, or embossing
- Use metal clasps, string ties, or metal folding bars
- Have an interlocking design
- Have postage stamps attached
- Have any exposed adhesive when the flap is in the sealed or closed position
- Have nicked edges or bent corners
- Have rough, cockle, or laid finishes

Choosing labels

The printer can print on many labels designed for use with laser printers. These labels are supplied in letter size and A4 size sheets.

When printing on labels:

- Be sure to select Labels in the Paper Type menu item in the Paper Menu. (See **Paper Type** for detailed information about these settings.)
- *Do not* load labels together with paper or transparencies in the same paper tray; mixing print materials can cause feeding problems.

- *Do not* load partial sheets with areas exposed by missing labels; this can cause labels to peel off during printing, jam, and contaminate your printer and your print cartridge with adhesive. It can also void your printer and cartridge warranties.
- Avoid using labels that may release hazardous emissions when heated.

Note: Labels are one of the most difficult print materials for laser printers. The T620 and T622 printers require a special fuser cleaner for label applications in order to optimize feed reliability. See **Ordering supplies** for information on obtaining a label fuser cleaner.

After continuously printing approximately 10,000 page sides of labels (or each time you replace the print cartridge), complete the following steps to maintain printer feeding reliability:

- 1 Print five sheets of paper.
- 2 Wait approximately five seconds.
- 3 Print five more sheets of paper.

For detailed information on label printing, characteristics, and design, refer to the *Card Stock & Label Guide*, available on Lexmark Web site at www.lexmark.com.

Choosing card stock

Card stock is single-ply and has a large array of properties. The orientation of paper fibers, moisture content, thickness, and texture can all affect printing on card stock. See **Paper specifications** for information on the preferred weight for the grain direction of print materials.

When printing on card stock:

- Be sure to select Card Stock in the Paper Type menu item in the Paper Menu. (See **Paper Type** for detailed information about these settings.)
- Be aware that preprinting, perforation, and creasing can significantly affect the print quality and cause paper handling or jamming problems.
- Avoid using card stock that may release hazardous emissions when heated.

After printing approximately 10,000 page sides of card stock (or each time you replace the print cartridge), complete the following steps to maintain printer feeding reliability:

- 1 Print five sheets of paper.
- 2 Wait approximately five seconds.
- 3 Print five more sheets of paper.

For more information, refer to the *Card Stock & Label Guide*, available on the Lexmark Web site at www.lexmark.com.

Choosing transparencies

The printer can print directly on transparencies designed for use in laser printers. Print quality and durability depend on the transparency used. Always print samples on the transparencies you are considering before buying large quantities.

The Paper Type setting should be set to Transparency to help prevent jams. (See **Paper Type** for detailed information about this setting.) Check with the manufacturer or vendor to determine whether your transparencies are compatible with laser printers that heat transparencies to 212°C (414°F). Use only transparencies that are able to withstand these temperatures without melting, discoloring, offsetting, or releasing hazardous emissions. For detailed information, refer to the *Card Stock & Label Guide*, which is available on the Lexmark Web site at www.lexmark.com.

Transparencies can be fed automatically from the multipurpose feeder and all standard and optional trays, except the 2000-sheet drawer, for all printer models. See **Print material specifications** for information about transparency compatibility with output options.

Be careful when you handle transparencies. Fingerprints on the surface of the transparency cause poor print quality.



Storing paper

Properly storing the paper you buy helps ensure trouble-free printing. Use the following guidelines:

- For best results, store paper in an environment where the temperature is approximately 21°C (70°F) and the relative humidity is 40%.
- Store cartons of paper on a pallet or shelf, rather than directly on the floor.
- If you store individual packages of paper out of the original carton, make sure they rest on a flat surface so the edges do not buckle or curl.
- *Do not* place anything on top of the paper packages.

9

Print material specifications

The following tables provide information on standard and optional paper sources, as well as output options, for your printer model, including the paper sizes you can select from the Paper Size menu and supported weights.

Note: If you use a paper size not listed, select the next larger size.

For information on card stock and labels, refer to the *Card Stock & Label Guide* located on the drivers CD.

Paper size	Dimensions	T622	T620	250-sheet drawer	250 UAT	500-sheet drawer	400 UAT	Multipurpose tray	2000-sheet drawer	Envelope feeder	Duplex unit	Standard output bin	Output expander	5-bin mailbox	High-capacity output stacker	Finisher
A4	210 x 297 mm (8.27 x 11.7 in.)	✓	✓	✓		✓		✓	✓		✓	✓	✓	✓	✓	See separate Finisher output support table.
A5	148 x 210 mm (5.83 x 8.27 in.)	✓	✓	✓		✓		✓	✓		✓	✓	✓		✓	
JIS B5	182 x 257 mm (7.17 x 10.1 in.)	✓	✓	✓		✓		✓	✓		✓	✓	✓	✓	✓	
Letter	215.9 x 279.4 mm (8.5 x 11 in.)	✓	✓	✓		✓		✓	✓		✓	✓	✓	✓	✓	
Legal	215.9 x 355.6 mm (8.5 x 14 in.)	✓	✓	✓		✓		✓	✓		✓	✓	✓	✓	✓	See separate Finisher output support table.
Executive	184.2 x 266.7 mm (7.25 x 10.5 in.)	✓	✓	✓		✓		✓	✓		✓	✓	✓	✓	✓	
Folio ²	216 x 330 mm (8.5 x 13 in.)	✓	✓	✓		✓		✓			✓	✓	✓	✓	✓	
Statement ²	139.7 x 215.9 mm (5.5 x 8.5 in.)	✓	✓	✓		✓		✓			✓	✓		✓	✓	

¹ This size setting formats the page for 215.9 x 355.6 mm (8.5 x 14 in.) unless the size is specified by the software application.

² This size does not appear in the Paper Size menu until Tray Size Sensing is turned off. See **Printing folio and statement size paper** for more information.

Paper size	Dimensions	T622	T620	250-sheet drawer	250 UAT	500-sheet drawer	400 UAT	Multipurpose tray	2000-sheet drawer	Envelope feeder	Duplex unit	Standard output bin	Output expander	5-bin mailbox	High-capacity output stacker	Finisher	
Universal¹	139.7 x 210 mm to 215.9 x 355.6 mm (5.5 x 8.27 in. to 8.5 x 14 in.)	✓	✓	✓	✓	✓	✓	✓				✓	✓		✓	See separate Finisher output support table.	
	69.85 x 127 mm to 229 x 355.6 mm (2.75 x 5 in. to 9.01 x 14 in.)	✓	✓					✓				✓					
	148 x 182 mm to 215.9 x 355.6 mm (5.83 x 7.17 in. to 8.5 x 14 in.)	✓	✓	✓	✓	✓	✓	✓			✓	✓	✓		✓		
7 ¼ Envelope	98.4 x 190.5 mm (3.875 x 7.5 in.)	✓	✓					✓		✓		✓	✓		✓	See separate Finisher output support table.	
9 Envelope	98.4 x 225.4 mm (3.875 x 8.9 in.)	✓	✓					✓		✓		✓	✓		✓		
10 Envelope	104.8 x 241.3 mm (4.12 x 9.5 in.)	✓	✓					✓		✓		✓	✓		✓		
DL Envelope	110 x 220 mm (4.33 x 8.66 in.)	✓	✓					✓		✓		✓	✓		✓		
C5 Envelope	162 x 229 mm (6.38 x 9.01 in.)	✓	✓					✓		✓		✓	✓		✓	See separate Finisher output support table.	
B5 Envelope	176 x 250 mm (6.93 x 9.84 in.)	✓	✓					✓		✓		✓	✓		✓		
Other Envelope¹	98.4 x 162 mm to 176 x 250 mm (3.87 x 6.38 in. to 6.93 x 9.84 in.)	✓	✓					✓		✓		✓	✓		✓		

¹ This size setting formats the page for 215.9 x 355.6 mm (8.5 x 14 in.) unless the size is specified by the software application.

² This size does not appear in the Paper Size menu until Tray Size Sensing is turned off. See **Printing folio and statement size paper** for more information.

Print material	T622	T620	250-sheet drawer	500-sheet drawer	Multipurpose tray	2000-sheet drawer	Envelope feeder	Duplex unit	Standard output bin	Output expander	5-bin mailbox	High-capacity output stacker	Finisher
Paper	✓	✓	✓	✓	✓	✓		✓	✓	✓	✓	✓	See separate Finisher output support table
Card stock	✓	✓	✓	✓	✓			✓	✓	✓		✓	
Transparencies	✓	✓	✓	✓	✓				✓	✓		✓	
Vinyl labels*		✓	✓	✓	✓				✓	✓		✓	
Paper labels*	✓	✓	✓	✓	✓				✓	✓		✓	
Polyester labels*	✓	✓	✓	✓	✓				✓	✓		✓	
Dual-web labels*	✓	✓	✓	✓	✓				✓	✓		✓	

* Printing label applications on the T620 and T622 printers require a special label fuser cleaner which prevents duplexing. The label fuser cleaner is included with a special label cartridge for label applications. See **Ordering supplies** for more information on obtaining a label fuser cleaner.

Print material	Type	Print material weight		
		Integrated tray and optional 500-sheet drawer	Multipurpose feeder and optional 250-sheet drawer	Envelope feeder
Paper	Xerographic or business paper	60 to 176 g/m ² grain long (16 to 47 lb bond)	60 to 135 g/m ² grain long (16 to 36 lb bond)	Not recommended
Card stock—maximum (grain long) ¹	Index Bristol	163 g/m ² (90 lb)	120 g/m ² (67 lb)	Not recommended
	Tag	163 g/m ² (100 lb)	120 g/m ² (74 lb)	Not recommended
	Cover	176 g/m ² (65 lb)	135 g/m ² (50 lb)	Not recommended

¹ Grain short is preferred for papers over 176 g/m².
² Printing label applications on your printer requires a special label fuser cleaner which prevents duplexing.
³ Information on whether your vinyl label converter has passed Lexmark's criteria is available at Lexmark's Web site (www.lexmark.com); search for "converter list." You can also check Lexmark's Automated FAX system (LEXFAX™).
⁴ 28 lb bond envelopes are limited to 25% cotton content.
⁵ Includes envelopes fed from the multipurpose tray only.

Print material	Type	Print material weight		
		Integrated tray and optional 500-sheet drawer	Multipurpose feeder and optional 250-sheet drawer	Envelope feeder
Card stock—maximum (grain short)¹	Index Bristol	199 g/m ² (110 lb)	163 g/m ² (90 lb)	Not recommended
	Tag	203 g/m ² (125 lb)	163 g/m ² (100 lb)	Not recommended
	Cover	216 g/m ² (80 lb)	176 g/m ² (65 lb)	Not recommended
Transparencies	Laser printer	138 to 146 g/m ² (37 to 39 lb bond)	138 to 146 g/m ² (37 to 39 lb bond)	Not recommended
Labels—maximum²	Paper	180 g/m ² (48 lb bond)	163 g/m ² (43 lb bond)	Not recommended
	Dual-web paper	180 g/m ² (48 lb bond)	163 g/m ² (43 lb bond)	Not recommended
	Polyester	220 g/m ² (59 lb bond)	220 g/m ² (59 lb bond)	Not recommended
	Vinyl ³	300 g/m ² (92 lb liner)	260 g/m ² (78 lb liner)	Not recommended
Integrated forms	Pressure-sensitive area (must enter the printer first)	140 to 175 g/m ²	140 to 175 g/m ²	Not recommended
	Paper base (grain long)	75 to 135 g/m ² (20 to 36 lb bond)	75 to 135 g/m ² (20 to 36 lb bond)	Not recommended
Envelopes 100% cotton content maximum weight—24 lb	Sulfite, wood-free or up to 100% cotton bonds	Not recommended	60 to 105 g/m ² (16 to 28 lb bond) ^{4, 5}	60 to 105 g/m ² (16 to 28 lb bond) ⁴

¹ Grain short is preferred for papers over 176 g/m².

² Printing label applications on your printer requires a special label fuser cleaner which prevents duplexing.

³ Information on whether your vinyl label converter has passed Lexmark's criteria is available at Lexmark's Web site (www.lexmark.com); search for "converter list." You can also check Lexmark's Automated FAX system (LEXFAX™).

⁴ 28 lb bond envelopes are limited to 25% cotton content.

⁵ Includes envelopes fed from the multipurpose tray only.

Print material weight—output options						
Print material	Type	5-bin mailbox	Output expander	High-capacity output stacker	Finisher	
Paper (grain long)	Xerographic or business paper	60 to 90 g/m ² (16 to 24 lb bond)	60 to 176 g/m ² (16 to 47 lb bond)	60 to 176 g/m ² (16 to 47 lb bond)	See separate Finisher media weight table	
Card stock—maximum (grain long)	Index Bristol	Not recommended	163 g/m ² (90 lb)	163 g/m ² (90 lb)		
	Tag	Not recommended	163 g/m ² (100 lb)	163 g/m ² (100 lb)		
	Cover	Not recommended	176 g/m ² (65 lb)	176 g/m ² (65 lb)		
Card stock—maximum (grain short)	Index Bristol	Not recommended	199 g/m ² (110 lb)	199 g/m ² (110 lb)		
	Tag	Not recommended	203 g/m ² (125 lb)	203 g/m ² (125 lb)		
	Cover	Not recommended	216 g/m ² (80 lb)	216 g/m ² (80 lb)		
Labels—maximum	Paper	Not recommended	180 g/m ² (48 lb bond)	180 g/m ² (48 lb bond)		See separate Finisher media weight table
	Dual-web paper	Not recommended	180 g/m ² (48 lb bond)	180 g/m ² (48 lb bond)		
	Polyester	Not recommended	220 g/m ² (59 lb bond)	220 g/m ² (59 lb bond)		
	Vinyl	Not recommended	300 g/m ² (92 lb liner)	300 g/m ² (92 lb liner)		
Integrated forms		Not recommended	175 g/m ²	175 g/m ²		
Envelopes	Sulfite, wood-free or up to 100% cotton bond	Not recommended	60 to 105 g/m ² (16 to 28 lb bond)	60 to 105 g/m ² (16 to 28 lb bond)	Not recommended	

Paper size	Dimensions	Finisher output support		
		Standard ¹	Offset	Stapled
A4	210 x 297 mm (8.27 x 11.7 in.)	✓	✓	✓
A5	148 x 210 mm (5.83 x 8.27 in.)			
JIS B5	182 x 257 mm (7.17 x 10.1 in.)	✓		
Letter	215.9 x 279.4 mm (8.5 x 11 in.)	✓	✓	✓
Legal	215.9 x 355.6 mm (8.5 x 14 in.)	✓	✓	✓
Executive	184.2 x 266.7 mm (7.25 x 10.5 in.)	✓		
Folio²	216 x 330 mm (8.5 x 13 in.)	✓	✓	✓
Statement²	139.7 x 215.9 mm (5.5 x 8.5 in.)			

¹ Paper passes to the output tray without being stapled or offset.

² This size does not appear in the Paper Size menu until Tray Size Sensing is turned off. See **Printing folio and statement size paper** for more information.

Print material	Type	Finisher media weight		
		Standard ¹	Offset	Stapled
Paper	Xerographic or business paper	60 to 176 g/m ² (16 to 47 lb bond)	60 to 90 g/m ² (16 to 24 lb bond)	60 to 90 g/m ² (16 to 24 lb bond)
Card stock— maximum (grain long)	Index Bristol	163 g/m ² (90 lb bond)	Not recommended	Not recommended
	Tag	163 g/m ² (100 lb bond)	Not recommended	Not recommended
	Cover	Not recommended	Not recommended	Not recommended
Card stock— maximum (grain short)	Index Bristol	199 g/m ² (110 lb bond)	Not recommended	Not recommended
	Tag	203 g/m ² (125 lb bond)	Not recommended	Not recommended
	Cover	176 g/m ² (65 lb bond)	Not recommended	Not recommended
Transparencies	Laser printer	138 to 146 g/m ² (37 to 39 lb bond)	138 to 146 g/m ² (37 to 39 lb bond)	Not recommended
Labels		Not recommended	Not recommended	Not recommended
Integrated forms		Not recommended	Not recommended	Not recommended

¹ Paper passes to the output tray without being stapled or jogged.



10 Loading print material

This section provides information about loading the various input options. Proper paper loading helps prevent paper jams and ensure trouble-free printing.

Before loading paper, you need to know the recommended print side of the paper you're using. This information is usually indicated on the paper package.

Click below for information on loading a particular option:

- [Loading a paper tray](#)
- [Loading the multipurpose feeder](#)
- [Loading the envelope feeder](#)
- [Loading the 2000-sheet drawer](#)

11

Loading a paper tray

Complete these instructions to load print materials into any of the standard or optional trays.

- 1 Remove the paper tray.
- 2 Pull the width guide tab and slide the width guide to the far right side of the tray.
- 3 Squeeze the length guide lever and slide the length guide to the correct position for the size paper you are loading.

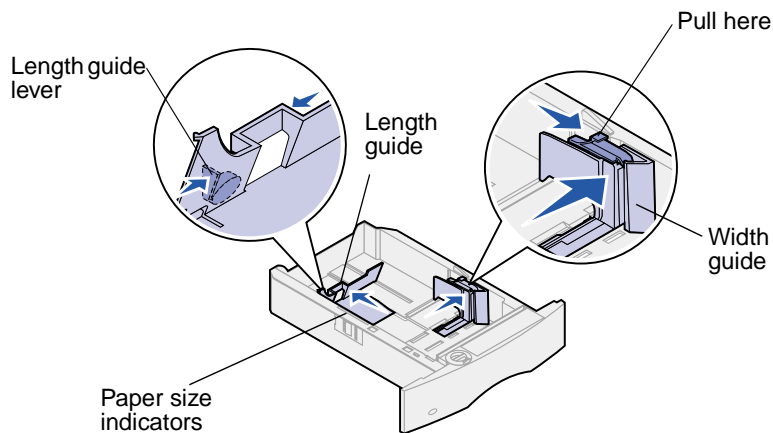

- 4 Place the paper into the paper tray with the recommended print side face down for single-sided printing and face up for double-sided printing. Do not fill paper above the paper capacity mark.
- 5 Pull the width guide tab and slide the width guide to the left until it lightly rests against the edge of the paper stack.

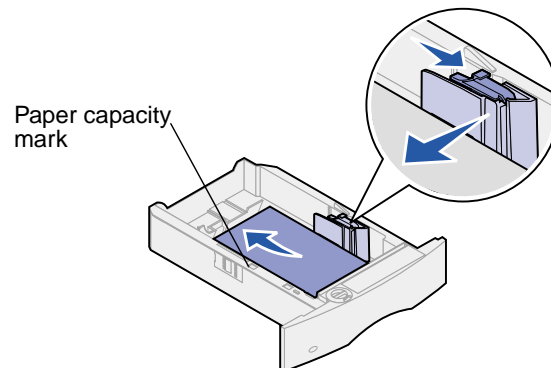

- 6 Adjust the knob to show the size of the paper currently loaded.

Note: This setting serves as a visual reminder only; it has no effect on the operation of the printer.

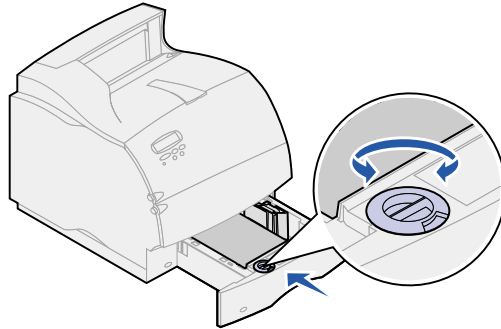

- 7 Reinstall the tray.

Loading letterhead

Letterhead must be loaded differently depending on what options you have installed on your printer.

Without a finisher installed

For *simplex* (single-sided) printing on letterhead, place the printed side *face down* as shown.

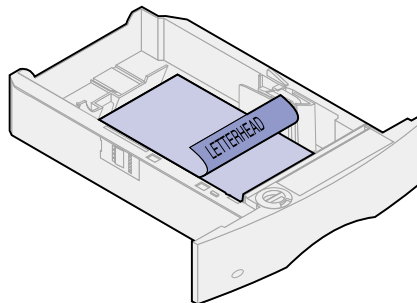

For *duplex* printing on letterhead, place the printed side *face up* as shown.

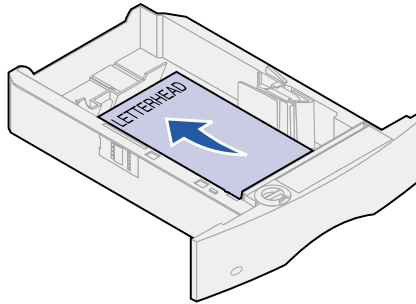

Note: The Paper Loading menu item lets you print simplex (single-sided) jobs on letterhead (or other preprinted media) that has been *loaded specifically for duplex printing*. See **Paper Loading** for more information.

With a finisher installed

For *simplex* (single-sided) printing on letterhead, place the printed side *face down* as shown.

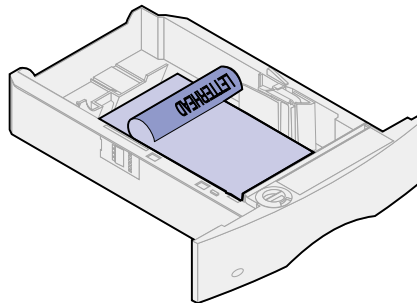

For *duplex* printing on letterhead, place the printed side *face up* as shown.

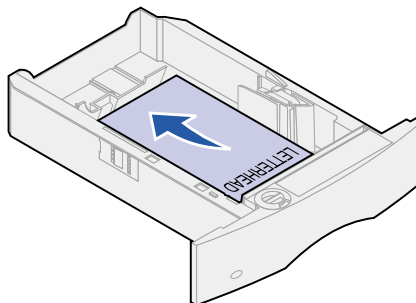

Note: The Paper Loading menu item lets you print simplex (single-sided) jobs on letterhead (or other preprinted media) that has been *loaded specifically for duplex printing*. See **Paper Loading** for more information.

12

Loading the multipurpose feeder

The multipurpose feeder can hold several sizes and types of paper, such as transparencies, postcards, note cards, and envelopes. It is useful for single page printing on letterhead, colored paper, or other special paper.

Keep in mind the following capacities, paper dimensions, and operating tips when loading the multipurpose feeder.

Capacity

The maximum stack height is 10 mm (0.4 in.). The multipurpose feeder can hold approximately:

- 100 sheets of 75 g/m² (20 lb) paper
- 10 envelopes
- 75 transparencies

Paper dimensions

The multipurpose feeder accepts paper within the following dimensions:

- Width—69.85 mm (2.75 in.) to 229 mm (9.01 in.)
- Length—127 mm (5 in.) to 355.6 mm (14 in.)

Trouble-free printing

- Load only one size of paper or envelopes at a time in the multipurpose feeder.
- To achieve the best possible print quality, use only high-quality print media that is designed for use in laser printers. For more guidelines on paper, see **Choosing print material**.
- To prevent paper jams, do not add or remove paper when there is still paper in the multipurpose feeder. This applies to other types of print materials, too.
- Never add print materials to the multipurpose feeder while the printer is printing from the multipurpose feeder. Doing so may cause a paper jam.
- Print material should be loaded with the recommended print side up and the top of the print material going into the multipurpose feeder first.

- *Do not* place objects on the multipurpose feeder. Also, avoid pressing down or applying excessive force on it.
- *Do not* remove any paper tray while a job is printing from the multipurpose feeder or **Busy** is displayed on the operator panel. Doing so may cause a paper jam.

Note: The multipurpose feeder may be used with the optional envelope feeder installed.

The icons on the multipurpose feeder show you how to load the multipurpose feeder with paper, how to turn an envelope for printing, and how to load letterhead paper for simplex and duplex printing. If a finisher is installed, it will affect how letterhead documents are loaded for duplexing. See [Loading letterhead](#) for detailed instructions on loading documents printed on letterhead.

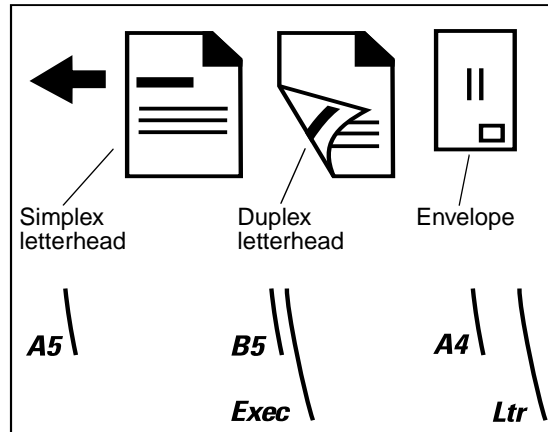

Note: The Paper Loading menu item in the Paper Menu lets you print simplex (single-sided) jobs on letterhead (or other preprinted media) that has been *loaded specifically for duplex printing*. For more information, see [Paper Loading](#).

To load the multipurpose feeder:

- 1 Push the lower release latch. The multipurpose feeder door drops open.

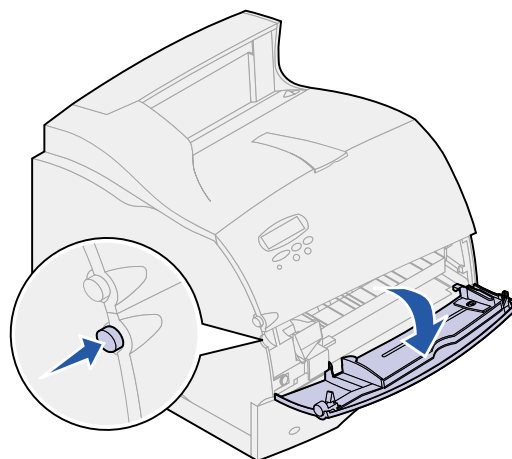

- 2** Locate the metal bar in the recessed area on the multipurpose feeder. Pull the bar out far enough to accommodate the paper you will be using.

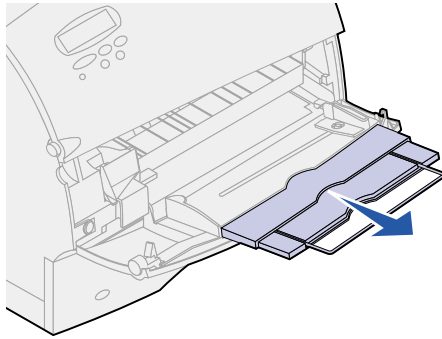

- 3** Slide the paper width guide to the far right.

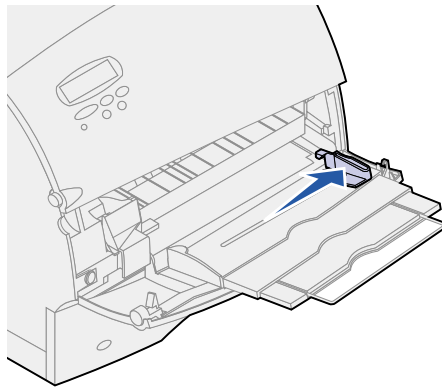

- 4** Prepare the print material for loading.

- Flex paper or fan envelopes back and forth. Do not fold or crease the paper. Straighten the edges on a level surface.

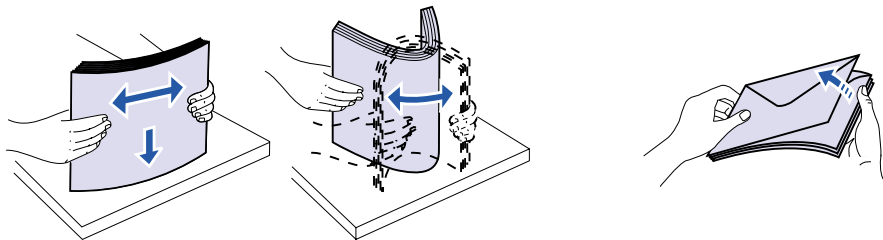

- Hold transparencies by the edges and avoid touching the print side. Fan the stack of transparencies to prevent jams. Be careful not to scratch or leave fingerprints on the transparencies.

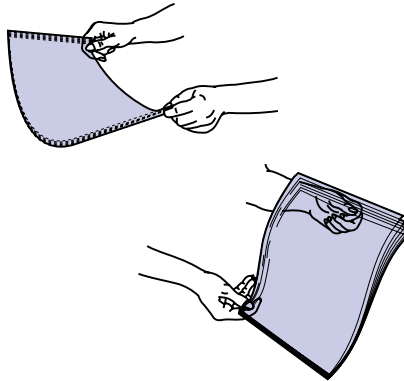

- 5** Use the stack height limiter as a guide for stack height when loading print materials.

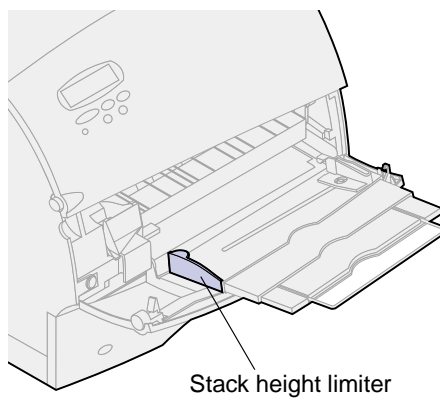

- 6** Load one type of print material in the multipurpose feeder. *Do not* mix types. Click a topic for loading instructions:
- **Loading paper and transparencies**
 - **Loading envelopes**
 - **Loading letterhead**

Loading paper and transparencies

- a Load paper with the left edge of the stack against the stack height limiter and with the recommended print side face up.

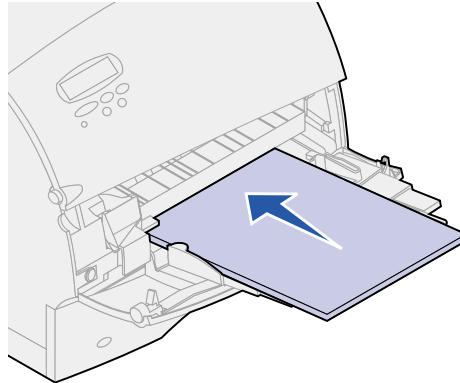

- b Continue with **step 7**.

Loading envelopes

- a Load envelopes flap side down with the stamp area and flap on the left. The end of the envelope with the stamp area enters the multipurpose feeder first.

WARNING: Never use envelopes with stamps, clasps, snaps, windows, coated linings, or self-stick adhesives. These envelopes may severely damage the printer.

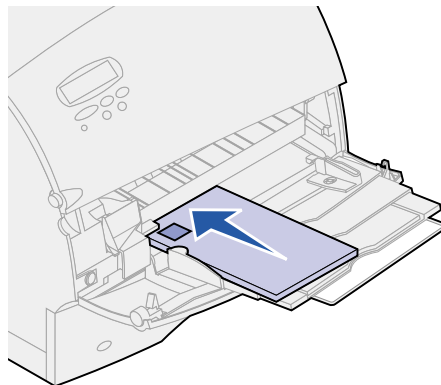

Note: If envelopes jam while printing, try reducing the number of envelopes in the multipurpose feeder.

- b Continue with **step 7**.

Loading letterhead

Load letterhead according to the options installed on the printer. Click the topic that describes your printer configuration.

- **Neither a duplex unit nor a finisher attached**
- **A duplex unit, but no finisher attached**
- **A finisher, but no duplex unit attached**
- **Both a duplex unit and a finisher attached**

Neither a duplex unit nor a finisher attached

- a Load letterhead paper for *single-sided* printing with the logo face up as shown.

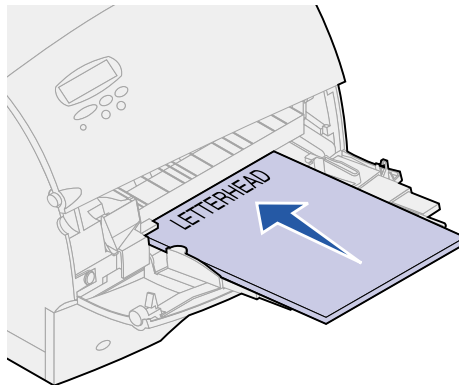

- b Continue with **step 7**.

A duplex unit, but no finisher attached

- a Load letterhead paper for *duplex* printing with the logo face down as shown.

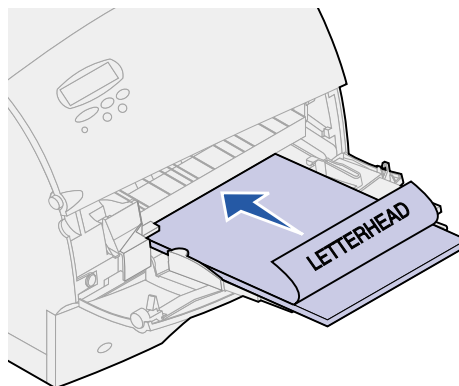

- b** Continue with **step 7**.

Note: The Paper Loading menu item in the Paper Menu lets you print simplex (single-sided) jobs on letterhead (or other preprinted media) that has been *loaded specifically for duplex printing*. For more information, see **Paper Loading**.

A finisher, but no duplex unit attached

- a** Load letterhead paper for *single-sided* printing with the logo face up as shown.

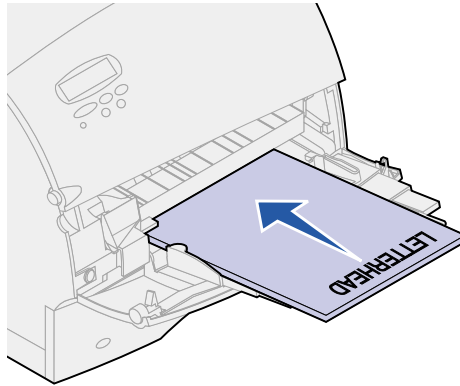

- b** Continue with **step 7**.

Both a duplex unit and a finisher attached

- a** Load letterhead paper for *duplex* printing with the logo face down as shown.

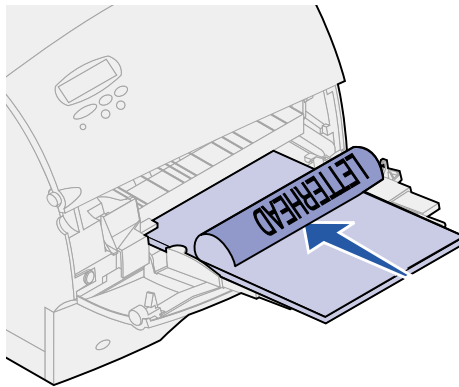

- b** Continue with **step 7**.

Note: The Paper Loading menu item in the Paper Menu lets you print simplex (single-sided) jobs on letterhead (or other preprinted media) that has been *loaded specifically for duplex printing*. For more information, see **Paper Loading**.

- 7 Gently slide the print material into the multipurpose feeder as far as it will go. Forcing the print material may cause it to buckle.

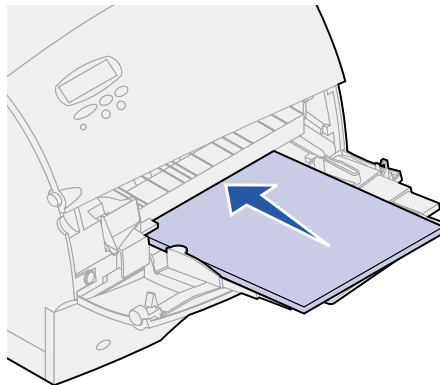

- 8 Slide the paper width guide to the left until it lightly touches the stack of print material. *Do not* bend the print material.

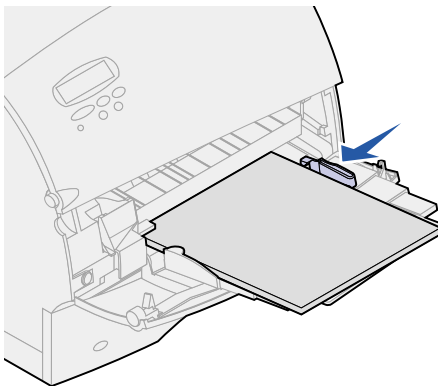

- 9 Select the paper source, size, and type from your software application and select paper size and type from the printer operator panel.
- a Make sure the Paper Size and Paper Type for the multipurpose feeder (MP Feeder Size and MP Feeder Type) are set to the correct value for the print material you are loading. (See **Paper Size** and **Paper Type** for detailed information about these settings.)
 - b Press **Go** to return to Ready.

Note: Software settings may override operator panel settings.

Closing the multipurpose feeder

- 1** Remove print material from the multipurpose feeder.

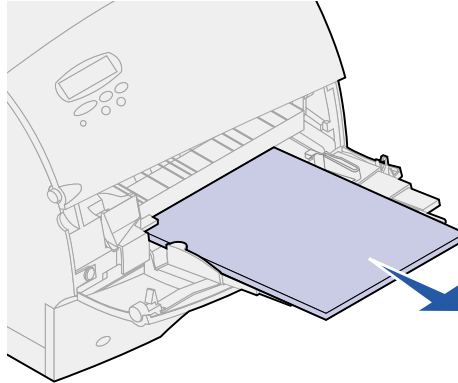

- 2** Push the metal bar straight back to collapse the multipurpose feeder to its short-length position.
- 3** Close the multipurpose feeder door.

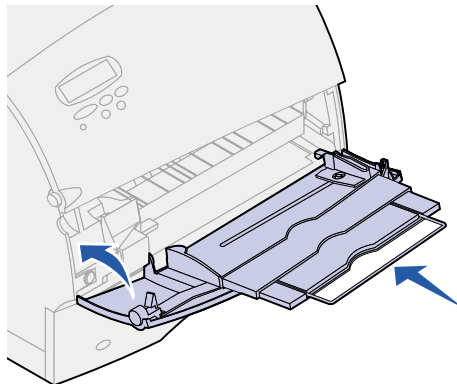

13

Loading the envelope feeder

- 1 Gently adjust the envelope support for the size you are loading:
 - Fully closed (pushed in toward the printer) for short envelopes
 - Extended to the middle position for medium-length envelopes
 - Fully open (extended to its full length) for long envelopes

WARNING: *Do not* place objects on the envelope feeder. Avoid pressing down on it or applying excessive force.

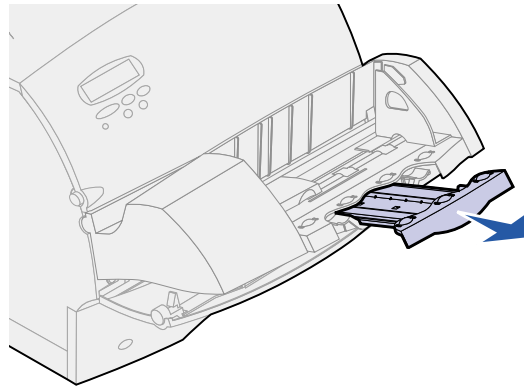

- 2 Lift the envelope weight back toward the printer. It stays in place.

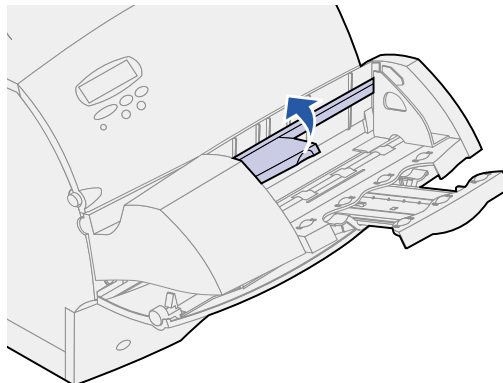

- 3 Slide the envelope edge guide to the far right.

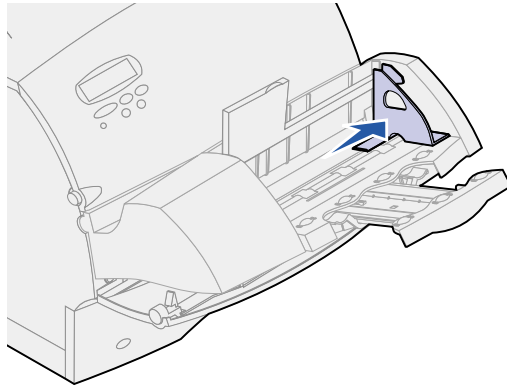

- 4 Flex a stack of envelopes back and forth and then straighten the edges on a level surface. Press down the corners to flatten them.

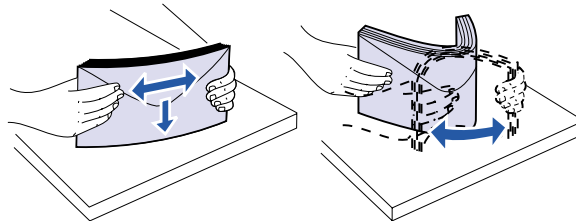

Fan the envelopes. This prevents the edges of the envelopes from sticking together and helps them feed properly.

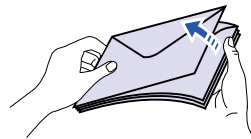

Note: When you load envelopes, do not exceed the maximum stack height of 64.7 mm (2.55 in.). The envelope feeder holds a maximum of 85 envelopes (75 g/m², 20 lb bond).

- 5 Load the stack of envelopes flap side down with the stamp area and the flap on the left. The end of the envelopes with the stamp area enters the envelope feeder first. Let the envelopes at the bottom of the stack slide into the envelope feeder slightly more than the ones at the top of the stack.

WARNING: Never use envelopes with stamps, clasps, snaps, windows, coated linings, or self-stick adhesives. These envelopes may severely damage the printer. See **Choosing envelopes** for more information.

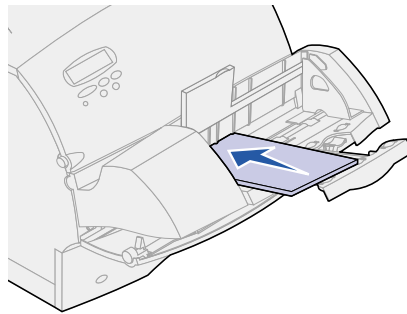

Note: Do not try to load more envelopes by forcing them under the envelope feeder weight. This results in jams.

- 6 Slide the envelope edge guide to the left until it lightly touches the stack. Make sure the envelopes do not buckle.

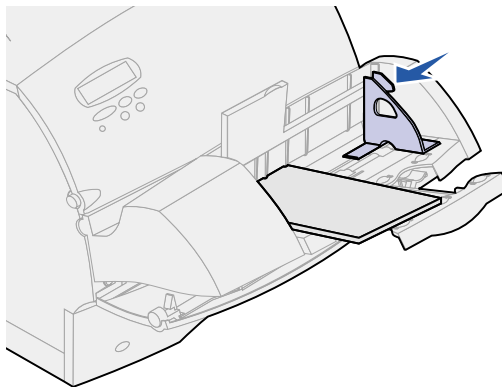

- 7 Lower the envelope weight to the stack.

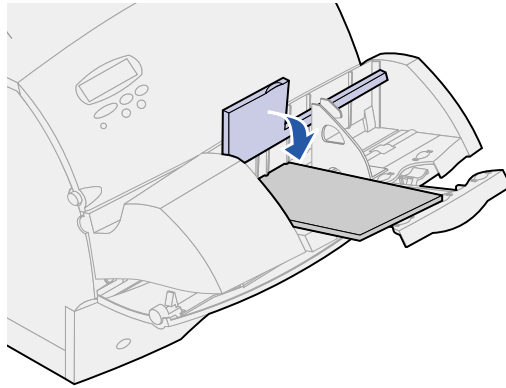

- 8** Select the paper source, size, and type from your software application.
- 9** Select the paper size and type from printer operator panel:
 - a** Make sure the Paper Size for the envelope feeder (Env Feeder Size) is set to the correct envelope size you are loading. (See **Paper Size** for detailed information about this setting.)
 - b** Press **Go** to return to Ready.

Note: Software settings may override operator panel settings.

If envelopes jam, see **Clearing paper jams**.



14 Loading the 2000-sheet drawer

For information on loading the optional 2000-sheet drawer, refer to the *2000-Sheet Drawer User's Guide* on the *Lexmark PRODUCT Publications* CD that came with your printer.

15

Tray linking

Tray linking enables the automatic linking feature for trays when you use the same size and type of print material in multiple paper sources (trays).

For example, let's say you have loaded two optional trays with the same size print material and both are set to the same paper type. When one tray becomes empty, the printer automatically selects print material from the other tray since the printer sees the trays as linked.

If you use different print material in the trays, each source with a different print material must have the Paper Type set to a unique value to disable the automatic linking feature. If all the trays do not have the same paper type when they are linked, you could mistakenly print a job on the wrong paper type.

16

Tips for avoiding paper jams

By carefully selecting print materials and loading them properly, you should be able to avoid most paper jams. If jams do occur, follow the steps outlined in [Clearing paper jams](#). If jams occur frequently, make sure you follow these tips to avoid jams:

- See [Loading print material](#) to load paper properly. Make sure the adjustable guides are positioned correctly.
- *Do not* overload the paper trays. Make sure the paper is under the paper capacity mark on the inside of the paper tray.
- *Do not* remove paper trays while print jobs are in process.
- Flex, fan, and straighten the paper before loading it.
- Fan stacks of labels or transparencies before loading them into trays or the multipurpose feeder. If jams do occur using the multipurpose feeder, try feeding one sheet at a time.
- *Do not* load wrinkled, creased, damp, or curled paper.
- *Do not* mix paper types or paper sizes in one tray.
- Use only recommended print materials. See [Recommended paper](#).
- Make sure the recommended print side is face down for simplex printing when loading all trays.
- Keep print materials stored in an acceptable environment. See [Moisture content](#).

17

Replacing the print cartridge

Order a new print cartridge when the **Toner Low** message first appears so you will have it when the current one no longer prints satisfactorily. See **Ordering supplies** for information on ordering print cartridges.

Note: Lexmark does not recommend that you use print cartridges from a third party. Print quality and printer reliability cannot be guaranteed if you do. For best results, use Lexmark supplies.

Complete the following steps to replace the print cartridge. Refer to the documentation that comes with the print cartridge for detailed installation information.

- 1 Turn the printer off and unplug the printer power cord.
- 2 Open the front doors and remove the used print cartridge.

WARNING: Never touch the photoconductor drum on the underside of the print cartridge. Use the handhold on the cartridge to avoid touching this area.

- 3 Clean the printer.
- 4 Install the new print cartridge and close the front door.
- 5 Replace the fuser cleaner if you are printing special label applications.
- 6 Plug the printer power cord into a properly grounded electrical outlet and turn the printer on.
- 7 Follow the instructions on the new print cartridge box to return the used print cartridge to Lexmark for recycling.

When you return a used print cartridge, you contribute to a worldwide recycling effort at no cost to you.



Note: The print cartridge warranty is voided by unauthorized refilling.

18

Replacing the charge roll

Order a new charge roll kit when toner fog or background shading appears on printed pages. See **Ordering supplies** for information on ordering a charge roll.

Complete the following steps to replace the charge roll. Refer to the documentation that comes with the charge roll for detailed installation information.

- 1 Turn the printer off and unplug the printer power cord.
- 2 Open the front doors and remove the print cartridge.
- 3 Remove the old charge roll.
- 4 Install the new charge roll.
- 5 Reinstall the print cartridge and close the front doors.
- 6 Plug the printer power cord into a properly grounded electrical outlet.
- 7 **Reset the maintenance counter.**

19

Replacing the transfer roll

Order a new transfer roll when light print, toner fog, or background shading appears on printed pages. See **Ordering supplies** for information on ordering a transfer roll.

Complete the following steps to replace the transfer roll. Refer to the documentation that comes with the transfer roll for detailed installation information.

- 1 Turn the printer off and unplug the printer power cord.
- 2 Open the front doors and remove the print cartridge.
- 3 Remove the old transfer roll.
- 4 Install the new transfer roll.
- 5 Reinstall the print cartridge and close the front doors.
- 6 Plug the printer power cord into a properly grounded electrical outlet.
- 7 **Reset the maintenance counter.**

20

Replacing the fuser assembly

Order a new fuser assembly when toner fog or background shading appears on printed pages. See **Ordering supplies** for information on ordering a fuser assembly.

Complete the following steps to replace the fuser assembly. Refer to the documentation that comes with the fuser assembly for detailed installation information.

CAUTION: The fuser assembly is hot! Turn the printer off and wait twenty minutes before changing the fuser assembly.

- 1 Turn the printer off, unplug the printer power cord, and wait twenty minutes.
- 2 Remove the top cover and all installed output options. If a duplex unit is installed, remove it.
- 3 Remove the fuser cover.
- 4 Lift up and remove the fuser cleaner.
- 5 Open the rear access door and remove the redrive.
- 6 Remove the old fuser assembly.

Note: For best results, use Lexmark supplies with the printer. If you are in the U.S. or Canada, call 1-800-438-2468 for information about Lexmark Authorized Supplies Dealers in your area. In other countries, contact the place where you bought your printer.

- 7 Install the new fuser assembly and replace the redrive.
- 8 Close the rear access door and replace the fuser cover.
- 9 If you have a duplex unit, reinstall it. Reinstall all output options and the printer top cover.
- 10 Plug the printer power cord into a properly grounded electrical outlet.
- 11 **Reset the maintenance counter.**

21

Replacing the staple cartridge

When **Staples Low** or **Staples Empty** appears on the operator panel display, complete the steps to insert a new staple cartridge in the finisher. Refer to the illustrations inside the stapler access door for more information. For information about ordering staple cartridges, see [Ordering supplies](#).

Note: If Staple Alarm is set to Single, the printer stops printing and displays the **Load staples** message. Install a new staple cartridge or press **Go** to clear the message and continue printing. If Staple Alarm is set to Continuous, the printer displays the **Load Staples** message and continues printing.

- 1 Open the stapler access door and remove the staple cartridge holder by pulling on the colored tab.

Note: A partial sheet of staples will remain in the staple cartridge holder when this message appears. Do not remove this sheet. Install a new staple cartridge to properly feed the partial sheet of staples.

- 2 Remove the empty staple cartridge.
- 3 Install the new staple cartridge.
- 4 Reinstall the staple cartridge holder and close the stapler access door.

Priming Stapler appears on the display. Priming occurs automatically without creating any output, and ensures the stapler is functioning properly.



Resetting the maintenance counter

After replacing all the items in the **maintenance kit**, reset the maintenance counter:

- 1 Press and hold the **Select** and **Return** buttons while you turn the printer on.
- 2 Release the buttons when **Performing Self Test** appears on the display.

The printer performs its power-on sequence, and then **Config Menu** appears on the first line of the display.

- 3 Press **Menu** until you see **Reset Maint Cnt** and then press **Select**.

Reset appears on the second line of the display.

- 4 Press **Select**.

Resetting Maint Cnt Value appears briefly on the display, and then is replaced by **Config Menu** on the top line and **Reset Maint Cnt** on the second line.

- 5 Press **Menu** until you see **Exit Config Menu**, and then press **Select**.

Activating Menu Changes appears briefly, followed by **Performing Self Test**. The printer returns to the Ready state.



Ordering supplies

For best results, use Lexmark supplies with the printer. If you are in the U.S. or Canada, call 1-800-438-2468 for information about Lexmark Authorized Supplies Dealers in your area, or visit the Lexmark Web site at www.lexmark.com. In other countries, contact the place where you bought your printer.

Maintenance kit

80 Scheduled Maintenance appears on the display after 300,000 pages have printed to let you know it is time to replace printer maintenance items. Order a maintenance kit when **80 Scheduled Maintenance** first appears on the display. The maintenance kit contains all the items necessary to replace the fuser assembly, the charge roll, and the transfer roll. See the following table for the maintenance kit part number for your specific printer.

Description	Part number
Maintenance kit for T622(n) 220 V, 875 W	99A2410
Maintenance kit for T622(n) 115 V, 875 W	99A2411
Maintenance kit for T620(n) 220 V, 875 W	11K2407
Maintenance kit for T620(n) 115 V, 875 W	11K2408

For finisher maintenance information, refer to the StapleSmart Reference that came with your finisher.

Print cartridges

Order a new print cartridge when **Toner Low** first appears on the display so you will have it when the current one no longer prints satisfactorily.

Three Prebate™ print cartridges and two regular priced print cartridges are specifically designed for your printer:

Prebate print cartridge part number ¹	Average yield	Print coverage (approximate)
12A6860	10,000 pages	5%
12A6865	30,000 pages	
12A6869 (Label Cartridge; shipped with a Label Fuser Cleaner ²)	30,000 pages	
¹ Sold at a special price with the understanding that you return your empty cartridges only to Lexmark. For regular priced cartridges without these terms, order part number 12A6760 (10,000 pages) or 12A6765 (30,000 pages).		
² Label fuser cleaners are not recommended for duplex printing.		

Label fuser cleaner

A special label fuser cleaner should be used for label applications to optimize feeding reliability. They are included in the print cartridge box when you order part number 12A6869. You also may order this item separately using part number 99A0725.

Label fuser cleaners are not recommended for duplex printing.

Charge roll

Order part number 99A1017.

Transfer roll

Order part number 99A1015.

Staples

Staple cartridges hold 3,000 staples. Use part number 11K3188 to order a pack of three staple cartridges.

Fuser assembly

Order a fuser assembly when **80 Scheduled Maintenance** first appears on the display. See the following table for the fuser assembly part number for your specific printer.

Description	Part number
Fuser assembly for T622(n) 115 V, 875 W	99A2405
Fuser assembly for T622(n) 220 V, 875 W	99A2404
Fuser assembly for T620(n) 115 V, 875 W	99A2402
Fuser assembly for T620(n) 220 V, 875 W	99A2401

24 Storing supplies

Store supplies in their original packaging until you are ready to install them.

Do not store supplies in:

- Temperatures greater than 43°C (110°F)
- An environment with extreme changes in humidity or temperature
- Direct sunlight
- Dusty places
- A car for a long period of time
- An environment where corrosive gases are present
- An environment with salty air

25

Checking an unresponsive printer

When you have a problem, first make sure that:

- The printer power cord is plugged into the printer and a properly grounded electrical outlet.
- The printer power switch is on.
- The electrical outlet is not turned off by any switch or breaker.
- Other electrical equipment plugged into the outlet is working.
- You try turning the printer off, then wait for about 10 seconds, and turn the printer on. This often fixes the problem.
- Your printer driver settings are correct.

Note: If an error message appears, see [Understanding printer messages](#).

26

Clearing paper jams

By carefully selecting print materials and loading them properly, you should be able to avoid most paper jams. (See the suggestions in **Tips for avoiding paper jams.**) If paper jams do occur, follow the steps outlined in this section.

To resolve the paper jam messages, *you must clear all paper from the paper path.* Press **Go** to resume printing. The printer prints a new copy of the page that jammed if Jam Recovery is set to On or Auto; however, the Auto setting does not guarantee the page will print.

Identifying paper jam areas

See the diagram on page 68 for the path the paper travels through the printer and options, and areas where jams may occur. The path varies depending on the paper source and output bin.

Note: If a jam occurs in the multipurpose feeder, you receive a **250 Paper Jam** message. The **260 Paper Jam** is shown here for a jam in the optional envelope feeder. Both types of jams occur in the same way.

201 Paper Jam
200 Paper Jam
260 Paper Jam
250 Paper Jam
230 Paper Jam
24x Paper Jam

Note: 24x Paper Jam may occur in any of the paper trays, including the 2000-sheet drawer. **x** indicates the tray where the jam is located. Jams can occur between two or three trays, on the incline surface of a tray, or between a tray, the duplex unit, and the printer integrated tray.

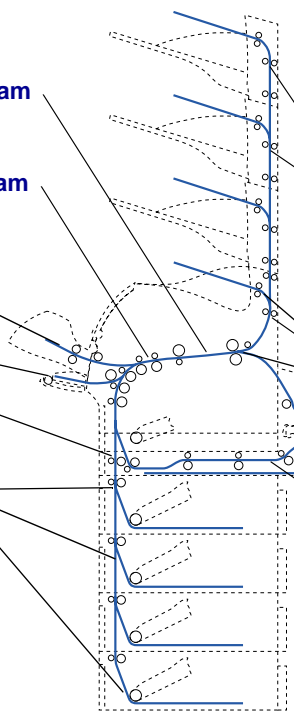

Note: 27x Paper Jam may occur in the output expander (shown in illustration), 5-bin mailbox, or high-capacity output stacker. **x** indicates the output option. Jam areas shown may occur in any output option.

Note: 28x Paper Jam occurs in the finisher option only.

202 Paper Jam

230 Paper Jam

Accessing paper jam areas

You open doors and covers, remove paper trays, and remove options to access paper jam areas. If your printer has a multipurpose feeder, it is visible when the lower front door is opened. The illustration shows the location of paper sources and possible paper jam areas.

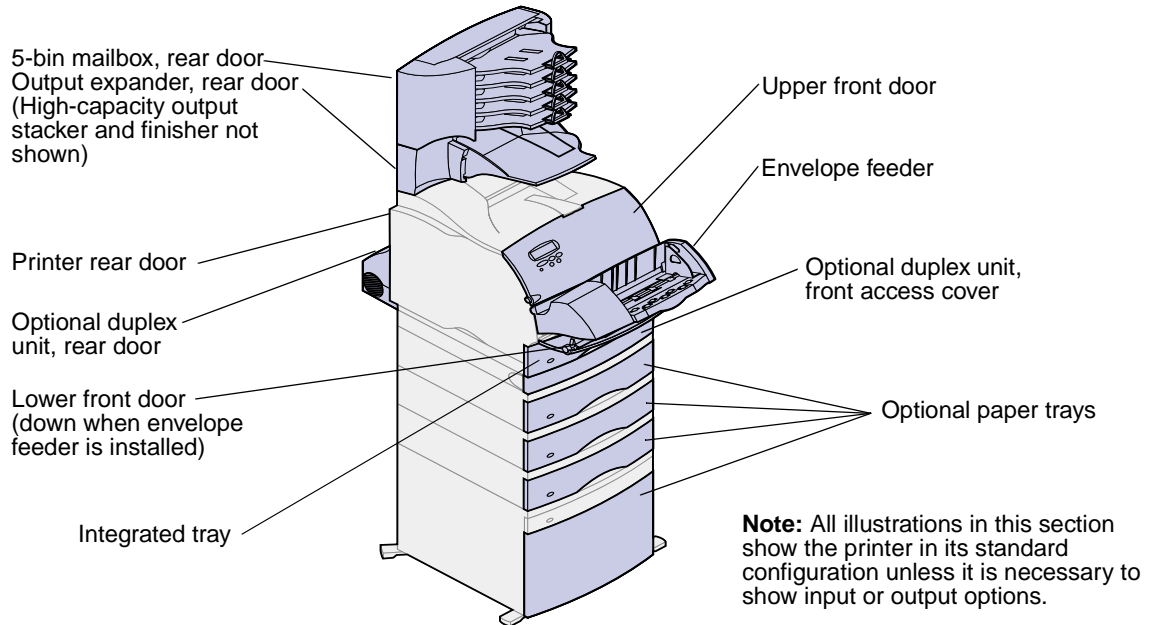

200 and 201 Paper Jam Remove Cartridge

A **200 Paper Jam** message indicates the paper is jammed in the area under the print cartridge. This requires removing the print cartridge from the printer. A **201 Paper Jam** message indicates the jam is farther inside the printer.

Note: To resolve the message, you must clear all paper from the paper path.

- 1 Push the release latch and open the printer upper and lower front doors.

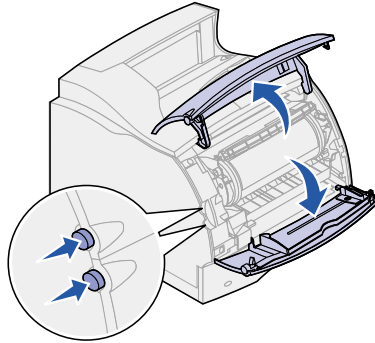

CAUTION: The rear portion of the inside of the printer is hot.

- 2 While grasping the print cartridge by the hand grip, pull the print cartridge up toward the upper front door, and then pull it straight out toward you.

WARNING: Never touch the photoconductor drum on the underside of the print cartridge. Use the handhold on the cartridge to avoid touching this area.

Lay the print cartridge aside.

Note: Do not leave the print cartridge exposed to light for extended periods.

- 3 Gently push the feed roller release lever toward the back of the printer.

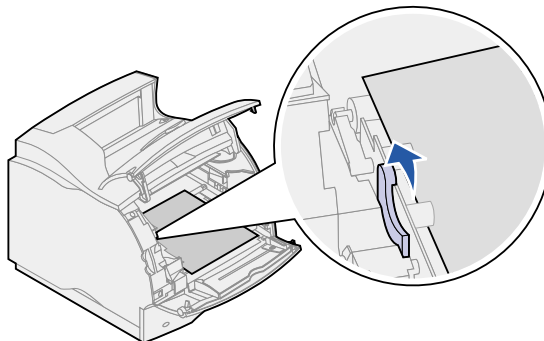

- 4 Pull the paper up and toward you.

Note: The paper may be covered with unfused toner, which can stain garments and skin.

If the paper does not move immediately when you pull, stop pulling. You need to access the paper from the rear door. See [Between the envelope feeder and the printer](#) for more information.

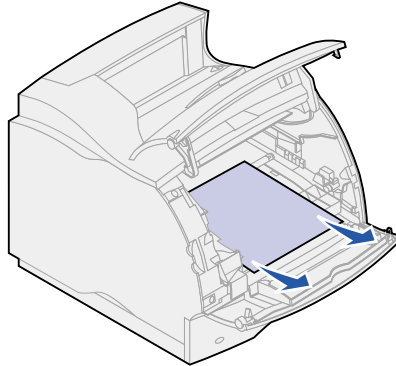

- 5 Reinstall the print cartridge.
- 6 Close the upper and lower front doors.

202 Paper Jam

Open Rear Door

Jams that cause a 202 **Paper Jam** message require opening the printer rear door.

Note: To resolve the message, you must clear all paper from the paper path.

For instructions on clearing the jam, click the area where the jam occurred:

- **Before reaching the standard output bin**
- **While exiting to the standard output bin**

Before reaching the standard output bin

- 1** Open the rear door.

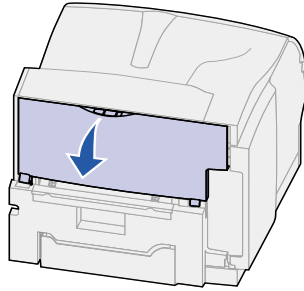

- 2** Remove the paper based on what part is visible.
 - If the middle section of paper is visible, grasp it on both sides and gently pull it straight out.

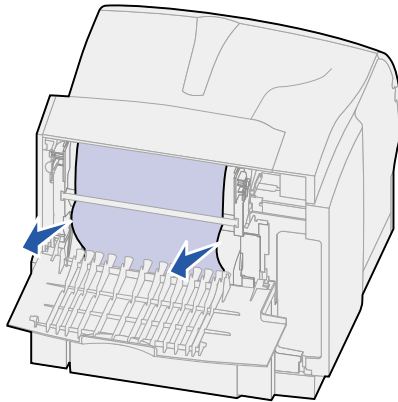

- If paper is still in the fuser area, open the upper front door and remove the paper.
- If the end of the paper is visible, pull the paper straight out.

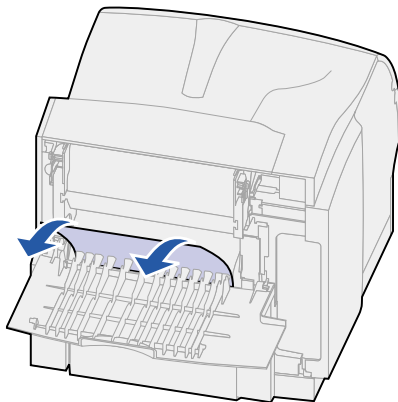

If the paper does not move immediately when you pull, stop pulling. Remove the print cartridge, and then pull the paper out.

- 3** Close the rear door.

While exiting to the standard output bin

Pull the paper straight out.

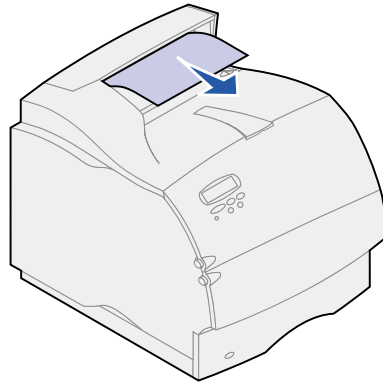

If the paper does not move immediately when you pull, stop pulling. Open the upper front door and pull the paper out.

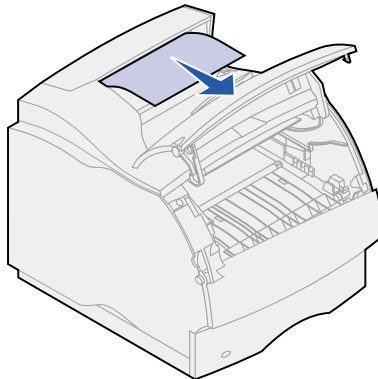

230 Paper Jam Check Duplex

Jams that cause a 230 **Paper Jam** message require opening the duplex front access cover.

Note: To resolve the message, you must clear all paper from the paper path.

- 1 Open the duplex rear door.

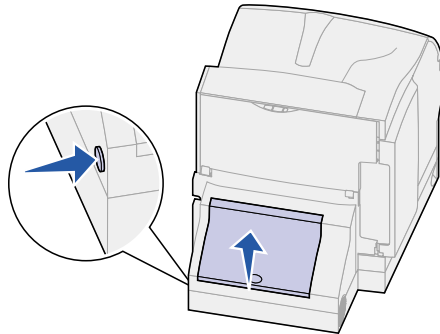

- 2 Look under the duplex rear door for the edge of the paper to determine how the paper is jammed:
 - If a short piece is visible inside the duplex unit next to the inner wall, grasp it and pull it out. If you cannot grasp it, see [step 6](#).
 - If only a short piece of paper is visible toward the rear of the printer, do not pull it out; it may be easier to access from inside the printer. See [200 and 201 Paper Jam Remove Cartridge](#) for instructions.
 - If most of the paper is visible, continue with the following.
- 3 Pull the paper up and out toward you if the paper is in this position:

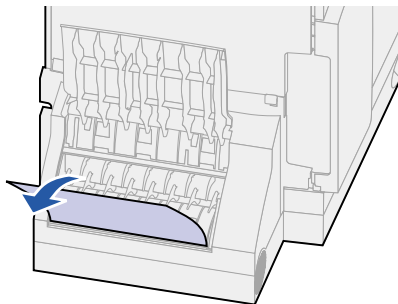

- 4** Pull down and out if the paper is in this position:

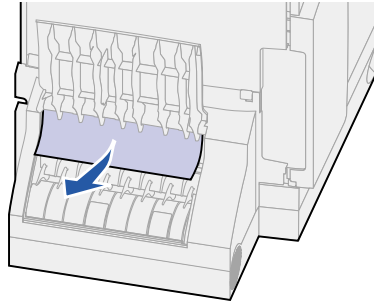

- 5** Close the duplex rear door. Make sure it *snaps* into place.

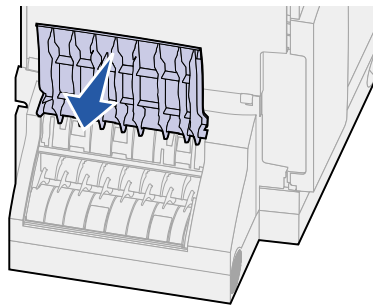

- 6** Locate the recessed areas on each side of the duplex front access cover.

- 7** Slowly pull the duplex front access cover straight out.

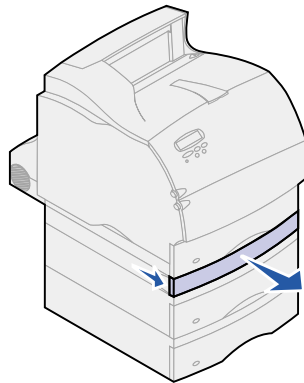

- 8** If the edge of the paper is visible, pull the paper straight up and out.

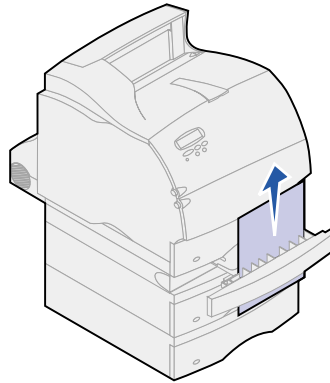

If the paper is not visible, continue with **step 9**. Otherwise, close the duplex front access cover.

- 9** Slide out the integrated tray.
- 10** Remove any sheets of paper lying in the duplex front access cover.
Interior view of duplex unit

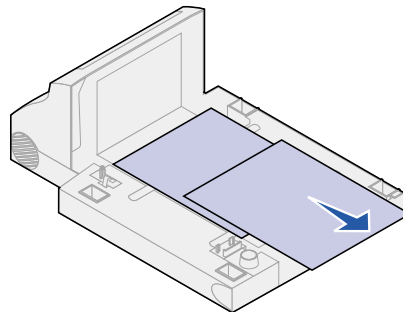

- 11** Slide the duplex front access cover back into the duplex unit. Make sure it *snaps* into place.
- 12** Slide the integrated tray back into the printer.

24x Paper Jam

Check Tray x

Jams in four areas result in a **24x Paper Jam** message, where **x** represents the tray number where the jam has occurred.

Note: To resolve the message, you must clear all paper from the paper path.

For instructions on clearing the jam, click the area where the jam occurred:

- **On the incline surface of a tray or between two trays**
- **Between three trays**
(This may happen if you are using legal-size paper in the trays or if you have an optional 250-sheet drawer installed with other optional drawers.)
- **Between a tray, the duplex unit, and the integrated tray**
- **Between the envelope feeder and the printer**
- **In the 2000-sheet drawer**

On the incline surface of a tray or between two trays

- 1 Pull the paper tray halfway out of the support unit.
- 2 Remove the paper based on how it is jammed:
 - If the paper is lying on the incline or wall surface at the front of the tray, pull the paper straight out.



- If the paper is in the pass-through area between two trays, pull the paper straight up and out.

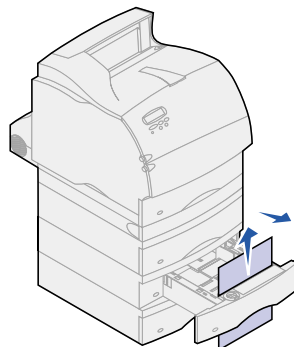

- If you do not see either end of the print material, see **Between three trays** to remove the jam.
- 3 Slide the paper tray back into the support unit.

Between three trays

This type of jam may occur if you are using legal-size paper in the trays or if you have a 250-sheet drawer installed with other optional drawers.

- 1 Pull the paper tray out of the support unit. If only a short piece of the paper is visible, do not pull down to remove the paper.

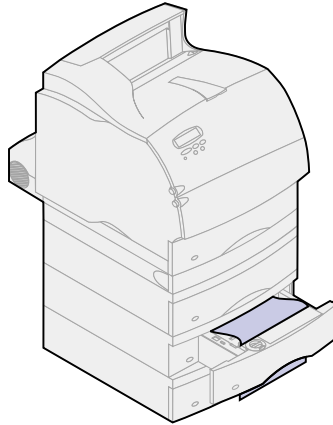

- 2 Gently slide the paper tray back into the support unit.
- 3 Pull the paper tray out of the support unit that is above the tray you just closed.
- 4 Pull the paper either up or down. If it does not pull easily one way, try the other way.

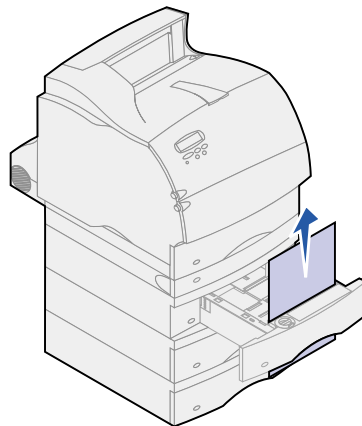

- 5 Slide the paper tray back into the support unit.

Note: With this type of jam, there may be another jam under the print cartridge. Remove the print cartridge and any jammed paper, and then reinstall the print cartridge.

Between a tray, the duplex unit, and the integrated tray

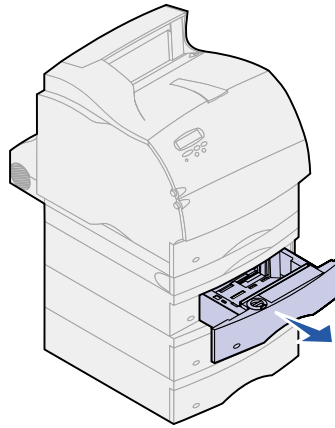

- 1** Pull the paper tray out of the support unit. If only a short piece of the paper is visible, do not pull down to remove the paper.
- 2** Slowly pull the duplex front access cover straight out from the duplex unit.

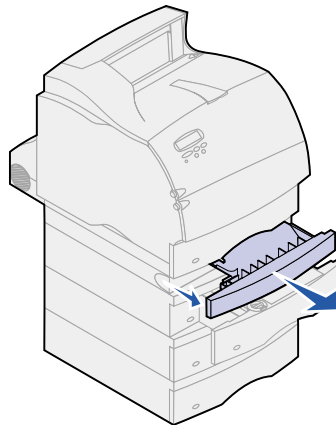

- 3 Pull the integrated tray out of the printer.

If you see the edge of the paper in the integrated tray:

- a Pull the paper down and out.

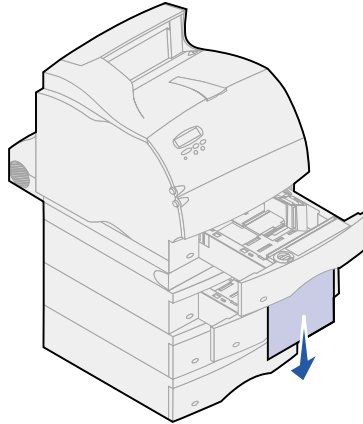

- b Slide the tray all the way into the printer.
- c Slide the duplex front access cover back into the duplex unit. Make sure it *snaps* into place.

If you do *not* see the edge of the paper in the integrated tray:

- a Push the tray back into the printer.
- b Open the printer upper and lower front doors.
- c Remove the print cartridge.

WARNING: Never touch the photoconductor drum on the underside of the print cartridge. Use the handhold on the cartridge to avoid touching this area.

You should see the leading edge of the paper now.

Note: The paper may be covered with unfused toner, which can stain garments and skin.

- d Gently push the feed roller release lever toward the back of the printer.

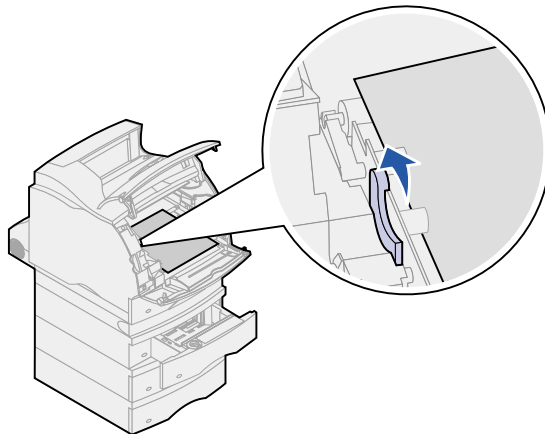

- e Pull the paper out.

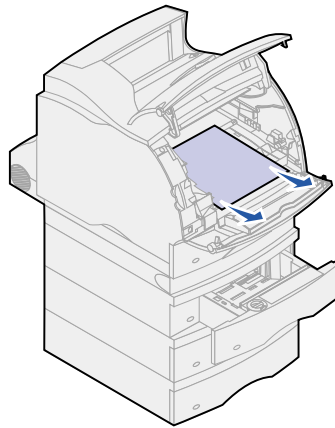

- f Reinstall the print cartridge.
Align the slides on the print cartridge with the slots on the print cartridge cradle. Use the colored arrows inside the printer for placement. Guide the print cartridge down as it *snaps* into place.

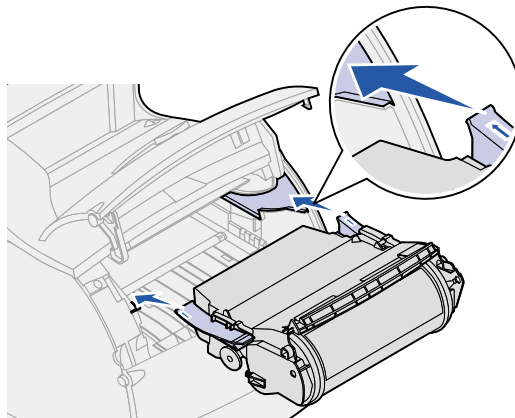

- g Close the printer upper and lower front doors.
- h Slide the paper tray all the way into the printer.

In the 2000-sheet drawer

- 1 Open the loading door.
- 2 Press the elevator down button.
- 3 Remove the paper jam. Clear all paper from the paper path of the drawer and printer.

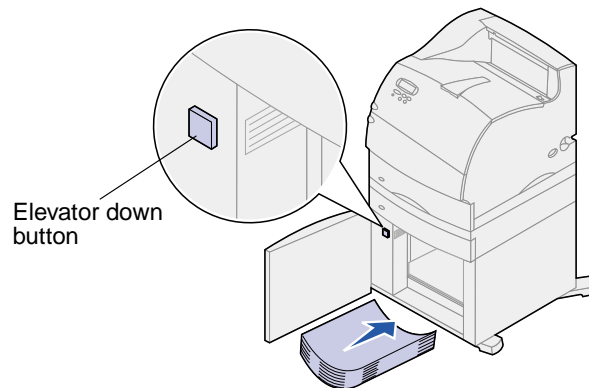

- 4 Make sure the stack of paper is neat and aligned; otherwise, another paper jam may occur.
- 5 Close the door.
- 6 Allow a few seconds for the elevator to reach the top.
- 7 Press **Go** to resume printing.

250 Paper Jam Check MP Feeder

Slowly pull the jammed print material straight out of the multipurpose feeder.

Note: To resolve the message, you must clear all paper from the paper path.

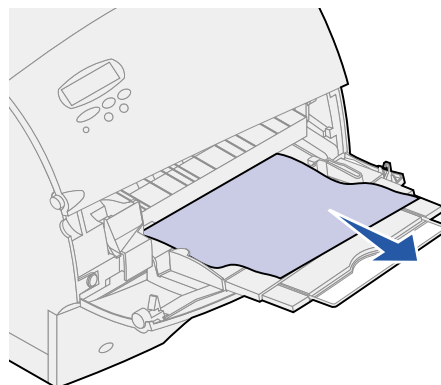

260 Paper Jam

Check Env Feeder

Envelope jams may occur in two areas.

Note: To resolve the message, you must clear all paper from the paper path.

For instructions on clearing the jam, click the area where the jam occurred:

- **At entry into the envelope feeder**
- **Between the envelope feeder and the printer**

At entry into the envelope feeder

Since the envelope feeder feeds envelopes from the bottom of the stack, the envelope on the bottom is jammed.

- 1 Lift the envelope weight.
- 2 Flip the envelope weight back toward the printer.
- 3 Remove the stack of envelopes from the envelope feeder.
- 4 Slowly pull the jammed envelope straight out toward you.

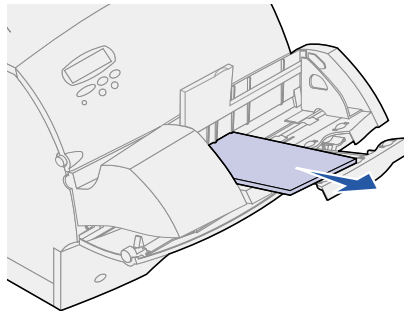

- 5 Replace the stack of envelopes in the envelope feeder.
- 6 Adjust the envelope edge guide.
- 7 Lower the envelope weight to the stack.

Note: If envelope jams continue to occur, repeat these steps and feed a single envelope between steps 4 and 5. This may correct the problem.

Between the envelope feeder and the printer

- 1** Lift the envelope weight.
- 2** Flip the envelope weight back toward the printer.
- 3** Remove the stack of envelopes from the envelope feeder.
- 4** Push the envelope support to the closed position.

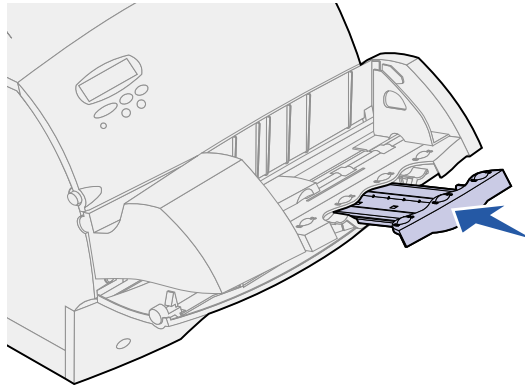

- 5** Open the printer upper front door.
- 6** Pull the envelope feeder up slightly and straight out of the printer. Set it aside.

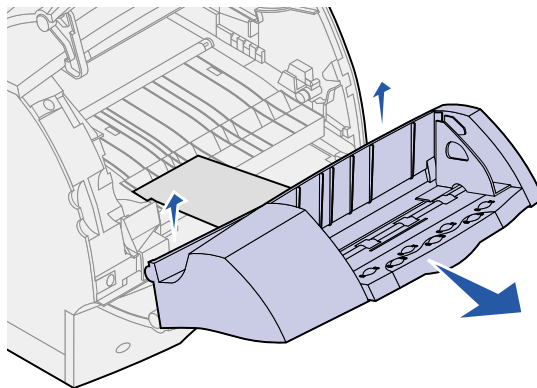

- 7 Pull the envelope straight out of the printer.

Note: You may have to remove the print cartridge to get the envelope out. See [reinstall the print cartridge](#) for instructions.

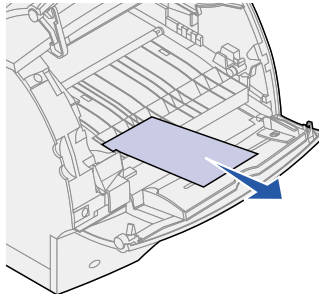

- 8 Reinstall the envelope feeder. Make sure it *snaps* into place.
- 9 Close the printer upper front door.
- 10 Replace the stack of envelopes in the envelope feeder.
- 11 Adjust the envelope edge guide.
- 12 Lower the envelope weight to the stack.

27x Paper Jam

Check Bin x

Jams in two areas result in a **27x Paper Jam** message, where **x** represents the bin number where the jam has occurred.

Note: To resolve the message, you must clear all paper from the paper path.

Paper jams in output options (output expander, high-capacity output stacker, or 5-bin mailbox) may be:

- **In an output option bin**
- **Between output options**

In an output option bin

Paper jams as it exits to an output option bin and:

- **A long portion of the paper is visible**
- **A short portion of the paper is visible**

A long portion of the paper is visible

- 1 Pull the paper straight out. If the paper does not give immediately when you pull, stop pulling. Continue with the next step.

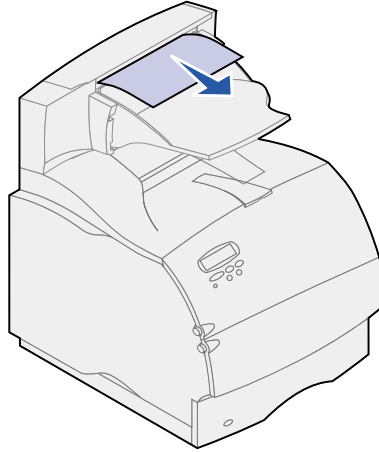

- 2 Push the output option rear door latches in toward the center. The rear door opens and drops down.

Note: Open *both* rear doors if the jam occurs in a high-capacity output stacker.

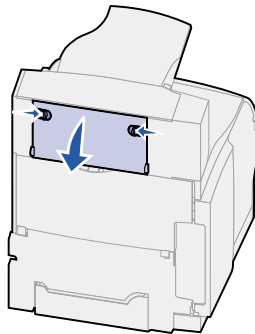

- 3 Loosen the paper if it is caught in the feeder rollers, and then pull the paper straight out.
- 4 Close all output option rear doors.

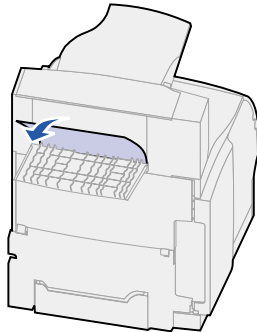

A short portion of the paper is visible

Try to pull the paper from the front of the bin. If you are not successful, complete the following steps.

- 1 Push the output option rear door latches in toward the center. The rear door opens and drops down.
- 2 Repeat for the output option installed above the option where the jammed has occurred.

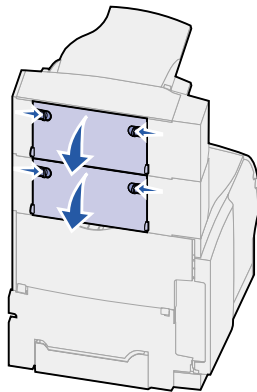

Note: Open *both* rear doors if the jam occurs in a high-capacity output stacker.

- 3 Pull the paper straight out from the output option.

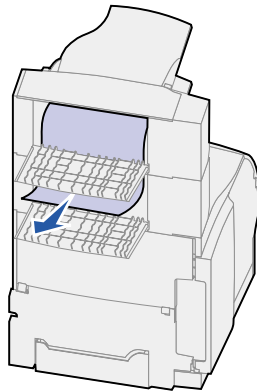

- 4 Close all output option rear doors. Make sure all rear door latches are closed.

Between output options

- 1 Push the output option rear door latches in toward the center. The rear door opens and drops down.
- 2 Repeat for the output option installed above the option where the jam has occurred.

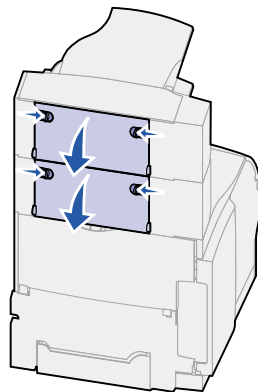

Note: If the jam occurs in a high-capacity output stacker, it may be necessary to open *both* of its rear doors.

- 3 Pull the paper straight out from the output option.

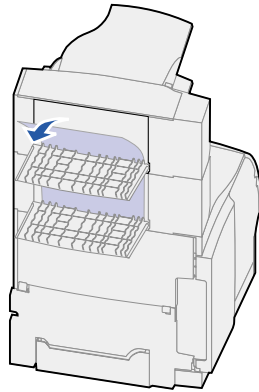

- 4 Close all output option rear doors. Make sure all rear door latches are closed.

28x Paper Jam

Jams in the optional finisher may result in a **28x Paper Jam** message, where **x** represents specific jam areas. The second line of the operator panel indicates the jam area.

Possible **28x Paper Jam** messages include:

- **280 Paper Jam Check Finisher**
- **281 Paper Jam Check Finisher**

Note: See **Clearing staple jams** for information about **28x Staple Jam** messages.

280 Paper Jam Check Finisher

- 1 Push the finisher rear door latches in toward the center. The rear door opens and drops down.

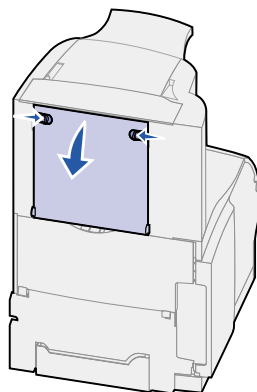

- 2 Pull the paper straight out from the finisher.

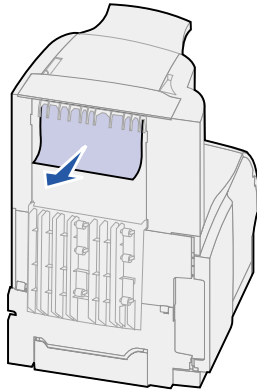

- 3 Close the rear door. Make sure the latches are closed.

281 Paper Jam Check Finisher

- 1 Lift the front edge of the finisher output bin cover until it locks into vertical position.

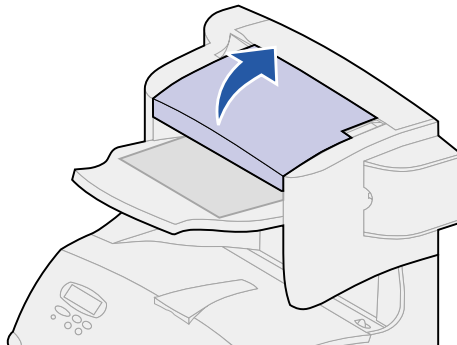

- 2 Remove the stack of paper.

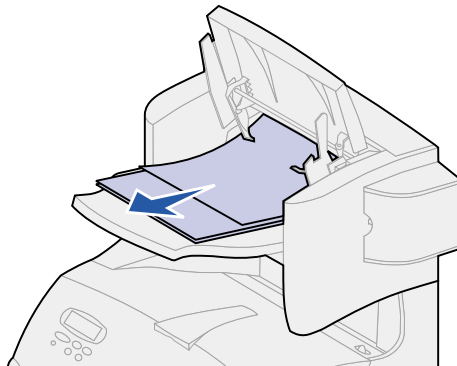

- 3 Close the finisher output bin cover.

27

Clearing staple jams

Jams in the optional finisher may result in a **28x Staple Jam** message, where **x** represents specific jam areas. The second line of the operator panel indicates the jam area.

Possible **28x Staple Jam** messages include:

- **282 Staple Jam Check Stapler**
- **283 Staple Jam Check Stapler**

Note: See **Clearing paper jams** for information about **28x Paper Jam** messages.

282 Staple Jam Check Stapler

- 1 Lift the front edge of the finisher output bin cover until it locks into vertical position.

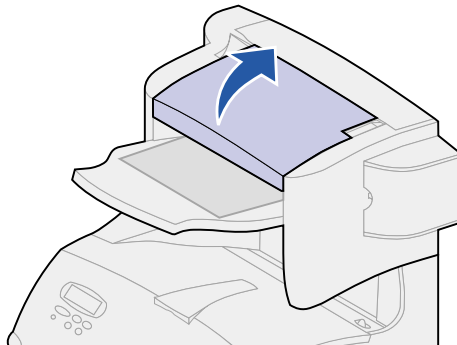

- 2 Remove the stack of paper.

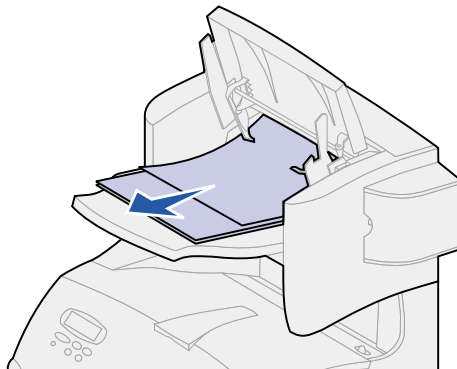

- 3 Continue with step 1 on page 92.

283 Staple Jam **Check Stapler**

- 1 Press the latch to open the stapler access door.

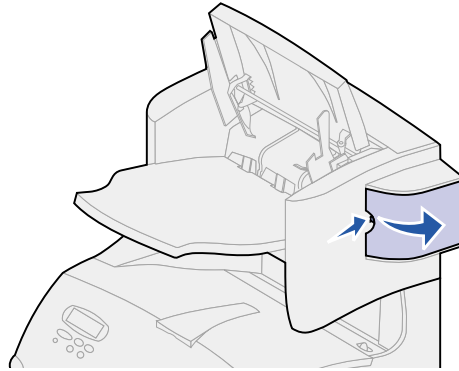

- 2 Firmly pull the colored tab to remove the staple cartridge holder from the stapler.

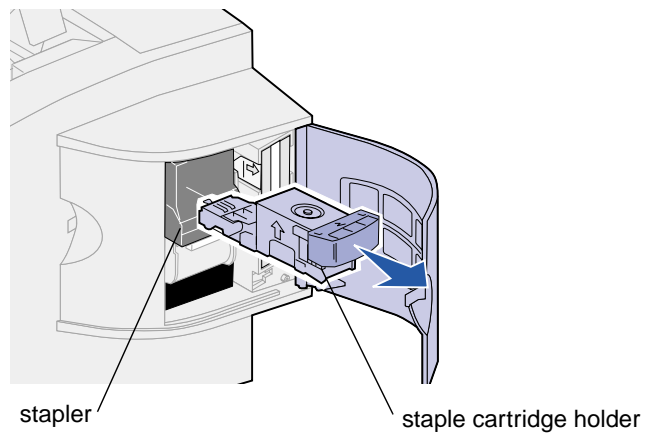

- 3 Turn the cartridge holder as shown in the illustration in step 4.

- 4 Use the metal tab to lift the staple guard, and then pull out the sheet of staples.
Discard the entire sheet.

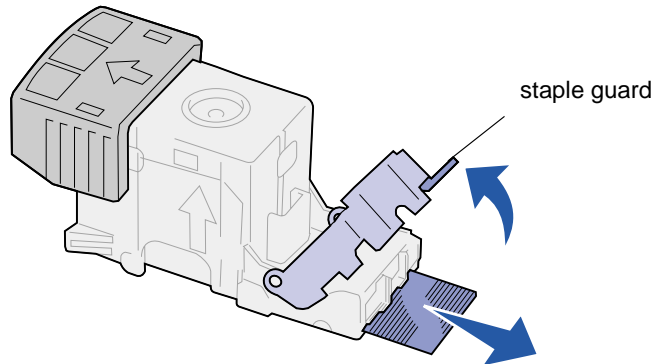

- 5 Remove any loose staples attached to the inside of the staple guard.
6 Look through the clear covering on the bottom of the cartridge holder to make sure no staples are jammed in the entry throat.
7 Press down on the staple guard until it *snaps* securely into place.

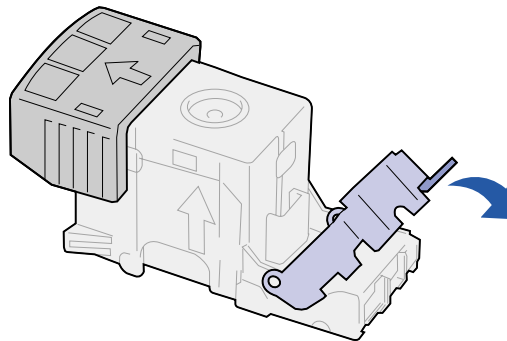

- 8 Push the cartridge holder firmly into the stapler until the cartridge holder *clicks* into place.

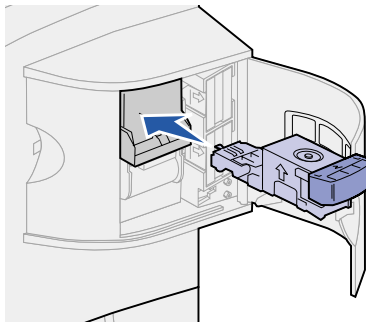

- 9 Close the stapler access door.
Priming Stapler appears on the operator panel display. Priming occurs automatically to ensure the stapler is functioning properly.
10 Close the finisher output bin cover.



Solving display problems

If the suggested corrective action does not fix the problem, call your service representative.

Problem	Action
Operator panel displays only diamonds or is blank.	<ul style="list-style-type: none">• Turn the printer off, wait about 10 seconds, and turn the printer on.• Performing Self Test appears on the operator panel. When the test is completed, Ready is displayed. <p>If the messages do not appear, turn the printer off and call the Lexmark Customer Support Center.</p>
Menu settings changed from the operator panel have no effect.	<p>Settings in the software application, the printer driver, or the printer utilities are overriding the settings made from the operator panel.</p> <ul style="list-style-type: none">• Change the menu settings from the printer driver, the printer utilities, or the software application instead of the operator panel.• Disable the settings in the printer driver, the printer utilities, or the software application so you can change settings from the operator panel.



Solving print problems

If the suggested corrective action does not fix the problem, call your service representative.

Problem	Action
Job did not print or incorrect characters printed.	Make sure Ready appears on the operator panel before you send a job to print. Press Go to return to Ready .
	Make sure there is print material loaded in the printer. Press Go to return to Ready .
	Verify that the printer is using the correct printer language.
	Verify that you are using the correct printer driver.
	Make sure the parallel, serial, ethernet, or USB cable is firmly plugged in at the back of the printer. Make sure you are using the correct cable. Use IEEE 1284-compliant parallel cable. We recommend Lexmark part number 1329605 (10 ft) or 1427498 (20 ft). If you use RS-232 Serial, verify that a null modem cable is used.
	If the printer is connected through a switch box, try a direct connection.
	Verify that the correct paper size is selected through the operator panel, in the printer driver, or in the software application.
	Make sure PCL SmartSwitch and PS SmartSwitch are set to On.
Job did not print or incorrect characters printed (continued).	If you are using a print spooler, verify that the spooler is not stalled.
	If you print across a network or on a Macintosh computer, see Network printing problems .
	Check the printer interface from the Setup Menu. Determine which host interface you are using. Print a menu settings page to verify that the current interface settings are correct. See Printing the menu settings page . If you are using a serial interface: <ul style="list-style-type: none"> • Make sure Honor DSR is set to Off. • Check the protocol, baud, parity, and data bit settings. The settings on the printer and on the host computer should match.
Printer is connected to the USB port, but will not print.	Make sure you are using Windows 98, Windows 2000, Windows Me, or another USB-capable operating system supported by Lexmark.
Print material misfeeds or multiple feeds occur.	Make sure the print material you are using meets the specifications for your printer. See Print material specifications for more details.
	Flex print material before loading it in any of the paper sources.
	Make sure the print material is loaded correctly.

Problem	Action
Print material misfeeds or multiple feeds occur (continued).	Make sure the paper width and length guides on the paper sources are adjusted correctly.
	Do not overfill the paper sources.
	Do not force print material into the multipurpose feeder when you load it; otherwise, it may skew or buckle.
	Remove any curled print material from paper sources.
	Load the recommended print side correctly for the type of print material you are using. See Loading print material for more information.
	Load less print material in the paper sources.
	Turn the print material over or around and try printing again to see if feeding improves.
	Do not mix print material types.
	Do not mix reams of print material.
	Remove the top and bottom sheets of a ream before loading the print material.
Load a paper source only when it is empty.	
Envelope misfeeds or multiple feeds occur.	Remove the stack of envelopes from the envelope feeder. Load one envelope, feed it through the printer, and then reload the stack of envelopes in the envelope feeder.
Page breaks in unexpected places.	Check the Print Timeout setting in the Setup Menu. Increase the setting.
Job prints from the wrong paper source or on the wrong print material.	Check the Paper Type setting in the Paper Menu from the printer operator panel and in the printer driver.
Paper does not stack neatly in any output bin.	<ul style="list-style-type: none"> • Turn the paper stack over in the tray or multipurpose feeder. • Make sure you are using a paper size compatible with your output options. See Print material specifications.
Printer does not duplex pages.	<ul style="list-style-type: none"> • Make sure Duplex is selected in both the Finishing Menu and in the printer driver. • Make sure you have enough printer memory installed.

30

Solving print quality problems

If the suggested corrective action does not fix the problem, call your service representative.

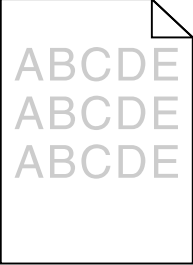
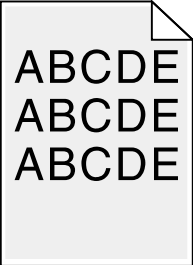
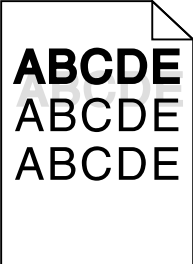
Problem	Action
<p>Print is too light.</p> 	<ul style="list-style-type: none"> • The toner may be low. To utilize the remaining toner, remove the cartridge by gripping the handles with both hands. With the cartridge arrows pointing downward, shake the print cartridge back and forth. Reinstall the cartridge and then press Go. • Change the Toner Darkness setting in the Quality Menu. • If you are printing on an uneven print surface, change the Paper Weight and Paper Texture settings in the Paper Menu. See Paper Type. • Verify that the correct print material is being used.
<p>Toner smears or print comes off the page.</p> 	<ul style="list-style-type: none"> • If you are printing on an uneven print surface, change the Paper Weight and Paper Texture settings in the Paper Menu. See Paper Type. • Verify that the print material is within the printer specifications. See Print material specifications for more details. • If the problem continues, call the Lexmark Customer Support Center.
<p>Toner appears on the back of the printed page.</p> 	<p>Toner is on the transfer roll. To help prevent this, do not load print material that is smaller than the page size of the job to be printed.</p> <p>Open and close the printer upper front door to run the printer setup cycle and clean the transfer roll.</p>

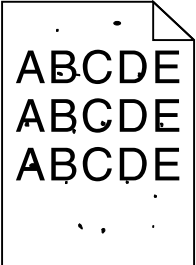
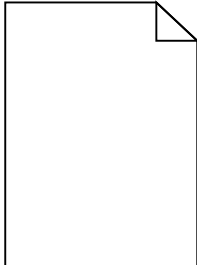
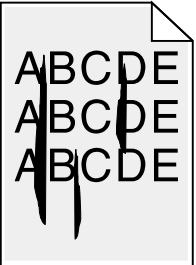
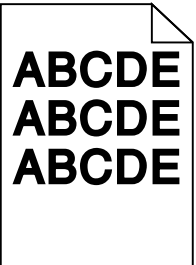
Problem	Action
<p>Toner fog or background shading appears on the page.</p> 	<ul style="list-style-type: none"> • Check the print cartridge to make sure it is installed correctly. • Change the print cartridge. See Replacing the print cartridge for more details. • If the problem continues, change the charge roll. See Replacing the charge roll for more details.
<p>Entire page is white.</p> 	<ul style="list-style-type: none"> • Make sure the packaging material is removed from the print cartridge. • Check the print cartridge to be sure it is installed correctly. • The toner may be low. To utilize the remaining toner, remove the cartridge by gripping the handles with both hands. With the cartridge arrows pointing downward, shake the print cartridge back and forth. Reinstall the cartridge and then press Go.
<p>Streaks appear on the page.</p> 	<ul style="list-style-type: none"> • The toner may be low. To utilize the remaining toner, remove the cartridge by gripping the handles with both hands. With the cartridge arrows pointing downward, shake the print cartridge back and forth. Reinstall the cartridge and then press Go. • If you are using preprinted forms, make sure the ink can withstand temperatures of 212°C (414°F).
<p>Printing is too dark.</p> 	<p>Change the Toner Darkness setting in the Quality Menu.</p> <p>Note: Macintosh computer users should make sure the lines per inch (lpi) setting is not set too high in the software application.</p>

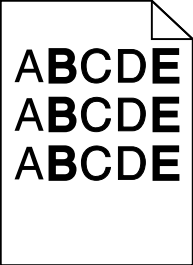
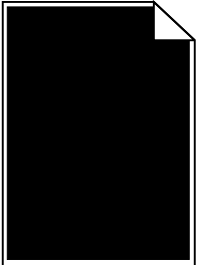
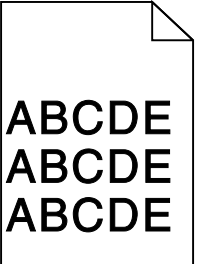
Problem	Action
<p>Characters have jagged or uneven edges.</p> 	<ul style="list-style-type: none"> • Change the Print Resolution setting in the Quality Menu to 600 dpi or 1200 dpi. • Turn PQET in the Quality Menu to On. • If you are using downloaded fonts, verify that the fonts are supported by the printer, the host computer, and the software application.
<p>Part or all of the page is printed in black.</p> 	<ul style="list-style-type: none"> • Check the print cartridge to see if it is installed correctly. • If the charge roll has been replaced, verify that it is installed correctly.
<p>The job prints, but the top and side margins are incorrect.</p> 	<ul style="list-style-type: none"> • Make sure the Paper Size setting in the Paper Menu is correct. • Make sure the margins are set correctly in your software application. ▲

31

Solving option problems

If an option does not operate correctly after it is installed or if it quits working:

- Make sure the paper handling option is marked with a colored triangle, indicating it is compatible with your printer.
- Turn the printer off, wait for about 10 seconds, and turn the printer on. If this does not fix the problem, unplug the printer, and check the connection between the option and printer.
- Print the menu settings page and check to see if the option is listed in the Installed Options list. If the option is not listed, reinstall it.
- Make sure the option is selected in the software application you are using.

For Macintosh computer users: Make sure the printer is set up in Chooser.

The following table lists printer options and suggested corrective actions for related problems. If the suggested corrective action does not fix the problem, call your service representative.

Option	Action
5-bin mailbox	Make sure the connection between each 5-bin mailbox or the connection between the 5-bin mailbox and the printer is secure. If the 5-bin mailbox is listed on the menu settings page, but print material jams when it exits the printer and enters the mailbox, it may not be properly installed. Reinstall each 5-bin mailbox.
Drawers	<ul style="list-style-type: none"> • Make sure the connection between drawers (250-sheet drawer, 500-sheet drawer, or 2000-sheet drawer), or the connection between a drawer and a duplex unit or the printer, is secure. • Make sure the print material is loaded correctly. See Loading print material for more details.
Duplex unit	<ul style="list-style-type: none"> • Make sure the connection between the duplex unit and the printer is secure. If the duplex unit is listed on the menu settings page, but print material jams when it enters or exits the duplex unit, the printer and duplex unit may not be properly aligned. • Make sure the duplex front access cover is securely installed.
Envelope feeder	<ul style="list-style-type: none"> • Make sure the connection between the envelope feeder and the printer is secure. • Make sure the Paper Size setting is correct in both the Paper Menu and in the software application. • Make sure the envelopes are loaded correctly. See Loading the envelope feeder for more details.
Finisher	<ul style="list-style-type: none"> • Make sure the connection between the finisher and the printer is secure. If the finisher is listed on the menu settings page, but print material jams when it exits the printer and enters the finisher, it may not be properly installed. Reinstall the finisher. • Make sure you are using a paper size compatible with your output options. See Print material specifications.
Flash memory	Make sure flash memory is securely connected to the printer system board.
Hard disk with adapter	Make sure the hard disk is securely connected to the hard disk adapter card. Also make sure the hard disk adapter card is securely connected to the printer system board.

Option	Action
High-capacity output expander	Make sure the connection between the output stacker and the printer is secure. If the high-capacity output stacker is listed on the menu settings page, but print material jams when it exits the printer and enters the output stacker, it may not be properly installed. Reinstall the high-capacity output stacker.
Infrared adapter	<p>If infrared communication stops or does not occur, make sure:</p> <ul style="list-style-type: none"> • The distance between the two infrared ports is 1 m (39 in.) or less. If communication does not occur between ports, move the ports closer together. • Both ports are stable. • The computer and the printer are on a level surface. • The angle of communication between the two infrared ports is within 15 degrees of either side of an imaginary line drawn between the two infrared ports. • No bright light, such as direct sunshine, is interfering with communication. • No objects are placed between the two infrared ports.
Internal print server	<ul style="list-style-type: none"> • Make sure the internal print server (also called an internal network adapter or INA) is securely connected to the printer system board. • Make sure you are using the correct cable, that it is securely connected, and that the network software is correctly set up. <p>Refer to the drivers CD for more details.</p>
Output expander	Make sure the connection between each output expander or the connection between the output expander and the printer is secure. If the output expander is listed on the menu settings page, but print material jams when it exits the printer and enters the output expander, it may not be properly installed. Reinstall each output expander.
Printer memory	Check to make sure printer memory is securely connected to the printer system board.
Tri-Port Adapter	<p>Make sure the Tri-Port Adapter is securely connected to the printer system board.</p> <p>For Macintosh computer users, make sure the host computer is set to LocalTalk.</p> <p>If you are using a phone wire connection, use a terminator plug.</p>
USB/Parallel interface	<ul style="list-style-type: none"> • Make sure the USB/parallel interface card is securely connected to the printer system board. <p>Make sure you are using the correct cable and that it is securely connected.</p>



Solving network printing problems

If a job did not print or incorrect characters printed, verify that the Lexmark internal print server or external print server is set up properly and the network cable is connected.

Note: Refer to the drivers CD for more details.

For Novell users:

- Make sure the netware.drv file is dated October 24, 1994, or later.
- Make sure the NT (no tabs) flag is included in the capture statement.

For Macintosh users:

- The printer may need an optional internal print server to allow Macintosh connection.
- Verify that the printer is set up correctly in Chooser.



Resolving other problems and questions

Problem	Action
I need to get updated printer drivers or utilities.	<ul style="list-style-type: none">• Refer to the drivers CD that came with your printer. It contains printer drivers and utilities.• Visit the Lexmark Web site, www.lexmark.com, for the most current printer drivers or utilities.
I need to attach a serial cable to the printer.	If your printer is configured with a serial port, or you have installed an optional interface card, refer to the <i>Setup Guide</i> .
I can't find the printer escape codes.	Refer to the <i>Technical Reference</i> available on the Lexmark Web site at www.lexmark.com .

34

Understanding printer messages

The printer operator panel displays messages describing the current state of the printer and indicates possible printer problems you must resolve. This topic provides a list of all printer messages, explains what they mean, and tells you how to clear the messages.

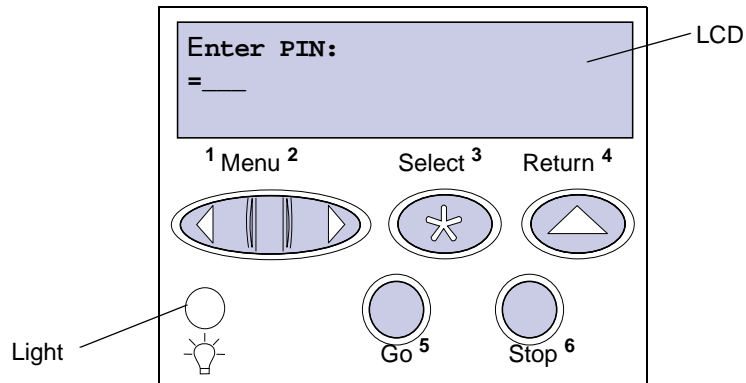

Click a letter or number at the bottom of the page to locate information about a message beginning with that character.

Activating Menu Changes

What this message means:

The printer is activating changes made to the printer settings.

What you can do:

Wait for the message to clear.

Bin <x> Full

What this message means:

The specified bin is full.

What you can do:

Remove the stack of paper from the bin to clear the message. If you assigned the bin a name, the bin name is displayed instead of the bin number.

Busy

What this message means:

The printer is busy receiving, processing, or printing data.

What you can do:

- Wait for the message to clear.
- Press **Menu** to open the Job Menu and cancel the current job.

See also:

[Cancel Job](#)

Canceling Job

What this message means:

The printer is processing a request to cancel the current print job.

What you can do:

Wait for the message to clear.

Change Tray <x>

What this message means:

The printer is requesting different paper than what is loaded in the specified tray or defined by the Paper Size or Paper Type settings for that tray.

What you can do:

- Load paper of the requested size and type in the tray specified on the display. The printer automatically clears the message and continues printing the job.
- Press **Select** to clear the message and continue printing on the paper currently loaded in the tray.
- Press **Menu** to open the Job Menu and cancel the current job.

Check <device> Connection

What this message means:

The specified device is either not fully connected to the printer or is experiencing a hardware failure.

What you can do:

- Reestablish communication by removing the specified device and reattaching it to the printer.
- Press **Go** to clear the message and continue printing.
- If a hardware failure occurs, turn the printer off and back on. If the error recurs, turn the printer off, remove the specified device, and call for service.

Clear Job from Finisher

What this message means:

The printer detects a paper jam, and you must remove the stack of paper in the finisher as well as clear the jam.

Note: Clear Job from Finisher alternates with the 2xx Paper Jam or the 28x Staple Jam message.

What you can do:

Clear paper from the entire paper path. Press **Go** to clear the message and continue printing.

Clearing Job Accounting Stat

What this message means:

The printer is deleting all job statistics stored on the hard disk.

What you can do:

Wait for the message to clear.

Close Door or Insert Cartridge

What this message means:

The upper front door is open or the print cartridge is not installed.

What you can do:

- Close the upper front door.
- Install the print cartridge.

Defragmenting

What this message means:

The printer is defragmenting the flash memory to reclaim storage space occupied by deleted resources.

What you can do:

Wait for the message to clear. No button actions are possible while this message is displayed.

WARNING: Do not turn the printer off while this message is displayed.

Delete All Jobs. Go/Stop?

What this message means:

The printer is requesting confirmation to delete all held jobs.

What you can do:

- Press **Go** to continue. The printer deletes all held jobs.

- Press **Stop** to cancel the operation.

Deleting Jobs

What this message means:

The printer is deleting one or more held jobs.

What you can do:

Wait for the message to clear.

Disabling Menus

What this message means:

The printer is responding to a request to disable the menus.

What you can do:

Wait for the message to clear.

Note: While the menus are disabled, you cannot change the printer settings from the operator panel.

See also:

[Disabling operator panel menus](#)

Disk Corrupted. Reformat?

What this message means:

The printer has attempted a disk recovery process and cannot repair the disk. The disk cannot be used unless it is reformatted.

What you can do:

- Press **Go**. All disk data will be lost when the disk is reformatted.
- Press **Stop** to clear the message without reformatting the disk. **Disk Recovery** may be displayed again and the printer will attempt to recover the disk.

See also:

[Disk Recovery x/5 yyy%](#)

Disk Recovery

x/5 yyy%

What this message means:

The printer is attempting to recover the hard disk after finding errors on it. The disk recovery takes place in five phases. The second line on the operator panel shows the percent complete of the current phase.

Note: Errors can occur if the printer is powered off while writing to the disk.

What you can do:

- Wait for the message to clear. No button actions are possible while this message is displayed.
- To avoid this error in the future, do not turn off the printer unless **Ready** is displayed on the operator panel.

Enabling Menus

What this message means:

The printer is responding to a request to make the menus available to all users.

What you can do:

Wait for the message to clear and then press **Menu** to view the menus from the operator panel.

See also:

[Disabling operator panel menus](#)

Energy Conserve

SAVED

What this message means:

Someone has changed the Energy Conserve setting in the Config Menu. This setting determines the values available for the Power Saver menu item.

What you can do:

- Wait for the message to clear.
- Open the Power Saver menu item in the Setup Menu to verify the current default setting or select a new setting.

See also:

[Power Saver](#); [Disabling Power Saver](#); *Technical Reference*

Enter PIN:

=____

What this message means:

The printer is waiting for you to enter your four-digit personal identification number (PIN).

What you can do:

Use the operator panel buttons to enter the PIN you identified in the driver when you sent the confidential job to the printer.

See also:

[Confidential jobs](#)

Flushing Buffer**What this message means:**

The printer is flushing corrupted print data and discarding the current print job.

What you can do:

Wait for the message to clear.

Formatting Disk

YYY%

What this message means:

The printer is formatting the hard disk. Since formatting the disk may take longer in some cases, the second line may show the percent complete.

What you can do:

Wait for the message to clear.

WARNING: Do not turn the printer off while this message is displayed.

Formatting Flash**What this message means:**

The printer is formatting the flash memory.

What you can do:

Wait for the message to clear.

WARNING: Do not turn the printer off while this message is displayed.

Held Jobs may be lost.

What this message means:

The printer memory is too full to continue processing print jobs.

What you can do:

- Press **Go** to clear the message and continue printing. The printer frees memory by deleting the oldest held job and continues deleting held jobs until there is enough printer memory to process the job.
- To avoid this error in the future:
 - Delete fonts, macros, and other data stored in printer memory.
 - Install more printer memory.

Note: The messages 37 **Insufficient Memory** and **Held Jobs may be lost** alternate on the display.

Infrared <x>

What this message means:

An infrared interface is the active communication link.

Insert Staple Cartridge

What this message means:

The stapler is either not installed or not installed correctly.

What you can do:

- Correctly install the staple cartridge holder to clear the message.
- Press **Go** to clear the message and continue printing without stapling.

Note: If you choose to ignore the message, the printer handles the job as if the staple cartridge holder were installed but out of staples. If the **Load Staples** message appears, press **Go** again to ignore the message and print the job without stapling it.

See also:

Setup Guide

Insert Tray <x>

What this message means:

The specified tray is either missing or not fully inserted.

What you can do:

Insert the specified tray completely.

**Install <device>
or Cancel Job**

What this message means:

The printer is requesting that a specified device be installed so it can print a job.

What you can do:

- Turn the printer off, install the specified device, and restart the printer.
- Press **Menu** to open the Job Menu and cancel the current job.

See also:

Setup Guide

**Invalid
Network <x> Code**

**Invalid Standard
Network Code**

What this message means:

The code in an internal print server is not valid. The printer cannot receive and process jobs until valid code is programmed into the internal print server.

What you can do:

Download valid code to the printer internal print server. No button actions are possible while this message is displayed.

Note: You can download network code while this message is displayed.

See also:

Technical Reference

Leave Job in Finisher

What this message means:

The printer detects a paper jam while printing a job that must be stapled.

Note: `Leave Job in Finisher` alternates with the `2xx Paper Jam` message.

What you can do:

Clear paper from the entire paper path, but leave the job waiting to be stapled in the finisher. Press **Go** to clear the message and continue printing.

See also:

[Clearing paper jams](#)

Load Manual

What this message means:

A request for a manual feed job has been sent to the printer. The printer is ready for insertion of a single sheet into the manual feed slot.

What you can do:

- Load a sheet of the paper specified on the second line of the display in the multipurpose feeder.
- Press **Select** or **Go** to ignore the manual feed request and print on paper already installed in one of the input sources. If the printer finds a tray that has paper of the correct type and size, it feeds paper from that tray. If the printer cannot find a tray with the correct paper type and size, it prints on whatever paper is installed in the default input source.
- Press **Menu** to open the Job Menu and cancel the current job.

See also:

[Loading the multipurpose feeder](#)

Load Staples

What this message means:

The printer is trying to staple a print job, but the stapler is empty.

What you can do:

- Install a new staple cartridge in the stapler.

- Press **Go** to clear the message and continue printing without stapling.
- Press **Menu** to open the Job Menu and cancel the current job.

See also:

[Replacing the staple cartridge](#)

Load Tray <x>

What this message means:

The printer is trying to feed paper from a source it detects is empty.

What you can do:

- Load paper of the size and type requested on the second line of the display in the specified tray. The printer automatically clears the message and continues printing the job.
 - Press **Menu** to open the Job Menu and cancel the current job.
-

LocalTalk <x>

What this message means:

A LocalTalk interface is the active communication link.

Maintenance

What this message means:

The printer requires replacement of routine maintenance items to maintain top performance and to avoid print quality and paper feed problems.

What you can do:

Replace the maintenance items and reset the printer maintenance counter (if necessary).

Menus Disabled

What this message means:

The printer menus are disabled. You cannot change the printer settings from the operator panel.

What you can do:

You can still open the Job Menu to cancel a job that is printing or to select a confidential job or a held job that you want to print. If you need access to the printer menus, contact your network administrator.

**Network Card
Busy****What this message means:**

An internal print server (also called an internal network adapter or INA) is being reset.

What you can do:

Wait for the message to clear.

Network <x>**What this message means:**

A network interface is the active communication link.

Network <x>, <y>**What this message means:**

A network interface is the active communication link, where <x> represents the active communication link and <y> represents the channel.

**No Jobs Found.
Retry?****What this message means:**

The four-digit personal identification number (PIN) you entered is not associated with any confidential print job.

What you can do:

- Press **Go** to enter another PIN.
- Press **Stop** to clear the PIN entry prompt.

Not Ready

What this message means:

The printer is not ready to receive or process data. Someone pressed **Stop** to take the printer offline.

What you can do:

Press **Go** to make the printer ready to receive jobs.

Overflow Bin Full

What this message means:

The printer designated overflow bin is full.

What you can do:

Remove the stack of paper from the bin to clear the message.

Parallel <x>

What this message means:

A parallel interface is the active communication link.

Performing Self Test

What this message means:

The printer is running the series of start-up tests it performs after it is turned on.

What you can do:

Wait for the message to clear.

Power Saver

What this message means:

The printer is ready to receive and process data. It is reducing its electricity consumption while idle. If the printer remains inactive for the period of time specified in the Power Saver menu item (factory default settings are 30 minutes on the T620 and 60 minutes on the T622), the **Power Saver** message replaces the **Ready** message.

What you can do:

- Send a job to print.
- Press **Go** to quickly warm the printer to normal operating temperature and display the **Ready** message.

Note: This message does not appear on the T620 printer.

See also:

[Power Saver](#) (Setup Menu)

**Priming Failed.
Retry?****What this message means:**

The printer failed to prepare the stapler to staple print jobs.

What you can do:

- Press **Go** to try priming the stapler again.
- Make sure staples are loaded and there is no jam in the stapler.
- Make sure paper is loaded in the tray specified in the Staple Prime Source menu item.
- Press **Return** or **Stop** to cancel priming.

Priming Stapler**What this message means:**

The printer is preparing the stapler to staple print jobs. The printer tests the stapler several times before returning to the Ready state.

What you can do:

Wait for the message to clear.

**Print Jobs on
Disk. Go/Stop?****What this message means:**

Jobs that were spooled to the hard disk before the printer was last turned off have not yet printed.

What you can do:

- Press **Go** to print the jobs.
- Press **Return** or **Stop** to delete the jobs from the hard disk without printing them.

Printing Directory List

What this message means:

The printer is processing or printing a directory of all files stored in flash memory or on a hard disk.

What you can do:

Wait for the message to clear.

Printing Font List

What this message means:

The printer is processing or printing a list of all available fonts for the specified printer language.

What you can do:

Wait for the message to clear.

Printing Job Accounting Stat

What this message means:

The printer is processing or printing all job accounting statistics stored on the hard disk.

What you can do:

Wait for the message to clear.

Printing Menu Settings

What this message means:

The printer is processing or printing the menu settings page.

What you can do:

Wait for the message to clear.

Prog Engine Code**What this message means:**

The printer is programming new code into the flash memory.

What you can do:

Wait for the message to clear.

WARNING: Do not turn the printer off while this message is displayed.

Prog System Code**What this message means:**

The printer is programming new system code.

What you can do:

Wait for the message to clear and the printer to reset.

WARNING: Do not turn the printer off while this message is displayed.

Program Flash**What this message means:**

The printer is storing resources, such as fonts or macros, in flash memory.

What you can do:

Wait for the message to clear.

WARNING: Do not turn the printer off while this message is displayed.

Programming Disk**What this message means:**

The printer is storing resources, such as fonts or macros, on the hard disk.

What you can do:

Wait for the message to clear.

WARNING: Do not turn the printer off while this message is displayed.

**Queuing and
Deleting Jobs****What this message means:**

The printer is deleting one or more held jobs and sending one or more jobs to print.

What you can do:

Wait for the message to clear.

Queuing Jobs**What this message means:**

The printer is sending one or more held jobs to print.

What you can do:

Wait for the message to clear.

Ready**What this message means:**

The printer is ready to receive and process print jobs.

What you can do:

Send a job to print.

Ready Hex**What this message means:**

The printer is in Hex Trace mode and is ready to receive and process print jobs.

What you can do:

- Send a job to print. All data sent to the printer is printed in hexadecimal and character representation. Control strings are printed, not executed.

- Turn the printer off and then on to exit Hex Trace mode and return to Ready status.
- Reset the printer.

Reattach <device>

What this message means:

The specified device is either not fully connected to the printer or is experiencing a hardware failure.

What you can do:

- Reestablish communication by removing the specified device and reattaching it to the printer.
- Press **Go** to clear the message and continue printing without using the device.
- If a hardware failure occurs, turn the printer off and back on. If the error recurs, turn the printer off, remove the specified device, and call for service.

Remove Paper <specified bin>

What this message means:

The specified output bin, or bins, is full.

What you can do:

Remove the stack of paper from the specified bin(s) to clear the message.

Res Reduced

What this message means:

The printer is reducing the resolution of a page in the current job from 600 dots per inch (dpi) to 300 dpi to prevent a **38 Memory Full** error. **Res Reduced** remains on the display while the job prints.

What you can do:

Press **Menu** to open the Job Menu and cancel the current job.

Resetting Active Bin

What this message means:

The printer is resetting to the active bin in a linked set of bins.

What you can do:

Wait for the message to clear.

Resetting the Printer

What this message means:

The printer is resetting to the current default settings. Any active print jobs are canceled.

What you can do:

Wait for the message to clear.

Resetting Maint Cnt Value

What this message means:

The printer is resetting the counter that tracks wear on the fuser.

What you can do:

Wait for the message to clear.

Restore Held Jobs. Go/Stop?

What this message means:

The printer detects Print and Hold jobs stored on the hard disk during a power-on cycle or a printer reset.

What you can do:

- Press **Go**. All Print and Hold jobs on the hard disk are restored to printer memory.
- Press **Return** or **Stop**. No Print and Hold jobs are restored to printer memory. The printer returns to the Ready state.

Restoring Factory Defaults

What this message means:

The printer is restoring the factory default printer settings. When factory default settings are restored:

- All downloaded resources (fonts, macros, symbol sets) in the printer memory are deleted.
- All menu settings return to the factory default setting *except*:
 - The Display Language setting in the Setup Menu.
 - All settings in the Parallel Menu, Serial Menu, Network Menu, Infrared Menu, LocalTalk Menu, USB Menu, and Fax Menu.

What you can do:

Wait for the message to clear.

Restoring Held Jobs

What this message means:

The printer is restoring held jobs from the hard disk.

What you can do:

Wait for the message to clear. No button actions are possible while this message is displayed.

Serial <x>

What this message means:

A serial interface is the active communication link.

Staples Empty

What this message means:

The stapler is out of staples, or the stapler is not installed.

What you can do:

If necessary, install a new staple cartridge. Reinsert the stapler to clear the message.

Note: A partial sheet of staples will remain in the staple cartridge holder when this message appears. Do not remove this sheet. Install a new staple cartridge to properly feed the partial sheet of staples.

See also:

[Replacing the staple cartridge](#)

Staples Low

What this message means:

The stapler has only a few staples remaining.

What you can do:

Install a new staple cartridge to clear the message.

Note: A partial sheet of staples will remain in the staple cartridge holder when this message appears. Do not remove this sheet. Install a new staple cartridge to properly feed the partial sheet of staples.

See also:

[Replacing the staple cartridge](#)

Std Bin Full

What this message means:

The standard output bin is full.

What you can do:

Remove the stack of paper in the bin to clear the message.

Toner Low

What this message means:

The print cartridge is low on toner.

What you can do:

- To utilize the remaining toner, remove the cartridge by gripping the handles with both hands. With the cartridge arrows pointing downward, shake the print cartridge back and forth. Reinstall the cartridge and then press **Go**.
- Press **Go** to clear the message and continue printing. You may notice reduced print quality.
- Replace the print cartridge.

See also:

[Replacing the print cartridge](#)

Tray <x> Empty

What this message means:

The specified tray is out of paper.

What you can do:

Load paper in the tray to clear the message.

Tray <x> Low

What this message means:

The specified tray is low on paper.

What you can do:

Add paper to the tray to clear the message.

Tray <x> Missing

What this message means:

The specified tray is either missing or not fully inserted into the printer.

What you can do:

Insert the tray completely into the printer.

USB <x>

What this message means:

The printer is processing data through the specified USB port.

Waiting

What this message means:

The printer has received a page of data to print but is waiting for an End of Job command, a Form Feed command, or additional data.

What you can do:

- Press **Go** to print the contents of the buffer.
- Press **Menu** to open the Job Menu and cancel the current job.

2<xx> Paper Jam**What this message means:**

The printer detects a paper jam. Although the location of the paper jam appears on the second line of the display, you must clear paper from the entire paper path.

What you can do:

Clear the paper path.

See also:

[Clearing paper jams](#)

**31 Defective
Print Cartridge****What this message means:**

A defective print cartridge is installed.

What you can do:

Remove the print cartridge and install a new one.

**32 Unsupported
Print Cartridge****What this message means:**

An unsupported print cartridge is installed.

What you can do:

Remove the print cartridge and install a supported one.

See also:

[Replacing the print cartridge](#)

34 Short Paper

What this message means:

The printer has determined that the length of the paper in the source specified on the second line of the display is too short to print the formatted data. For auto-size sensing trays, this error occurs if the paper guides are not in the correct position.

What you can do:

- Press **Go** to clear the message and continue printing. The printer does not automatically reprint the page that prompted the message.
- Make sure the Paper Size setting in the Paper Menu is correct for the size paper you are using. If MP Feeder Size is set to Universal, make sure your paper is large enough for the formatted data.
- Press **Menu** to open the Job Menu and cancel the current job.

35 Res Save Off Deficient Memory

What this message means:

The printer lacks the memory needed to enable Resource Save. This message usually indicates too much memory is allocated for one or more of the printer link buffers.

What you can do:

- Press **Go** to disable Resource Save and continue printing.
- To enable Resource Save after you get this message:
 - Make sure the link buffers are set to Auto, and exit the menus to activate the link buffer changes.
 - When **Ready** is displayed, enable Resource Save from the Setup Menu.
- Install additional memory.

37 Insufficient Collation Area

What this message means:

The printer memory (or hard disk, if installed) does not have the free space necessary to collate the print job.

What you can do:

- Press **Go** to print the portion of the job already stored and begin collating the rest of the job.

- Press **Menu** to open the Job Menu and cancel the current job.

37 Insufficient Defrag Memory

What this message means:

The printer cannot defragment flash memory, because the printer memory used to store undeleted flash resources is full.

What you can do:

- Delete fonts, macros, and other data in printer memory.
- Install additional printer memory.

37 Insufficient Memory

What this message means:

The printer memory is full and cannot continue processing current print jobs.

What you can do:

- Press **Go** to clear the message and continue the current print job. The printer frees memory by deleting the oldest held job and continues deleting held jobs until there is enough printer memory to process the job.
- To avoid this error in the future:
 - Delete fonts, macros, and other data in printer memory.
 - Install additional printer memory.

Note: The messages **37 Insufficient Memory** and **Held Jobs may be lost** alternate on the display.

38 Memory Full

What this message means:

The printer is processing data, but the memory used to store pages is full.

What you can do:

- Press **Go** to clear the message and continue printing the job. The job may not print correctly.
- Press **Menu** to open the Job Menu and cancel the current job.
- To avoid this error in the future:

- Simplify the print job by reducing the amount of text or graphics on a page and deleting unnecessary downloaded fonts or macros.
- Install additional printer memory.

39 Complex Page

What this message means:

The page may not print correctly because the print information on the page is too complex.

What you can do:

- Press **Go** to clear the message and continue printing the job. The job may not print correctly.
- Press **Menu** to open the Job Menu and cancel the current job.
- To avoid this error in the future:
 - Reduce the complexity of the page by reducing the amount of text or graphics on the page and deleting unnecessary downloaded fonts or macros.
 - Set Page Protect to On in the Setup Menu.
 - Install additional printer memory.

51 Defective Flash

What this message means:

The printer detects defective flash memory.

What you can do:

Press **Go** to clear the message and continue printing. You must install different flash memory before you can download any resources to flash.

52 Flash Full

What this message means:

There is not enough free space in the flash memory to store the data you are trying to download.

What you can do:

- Press **Go** to clear the message and continue printing. Downloaded fonts and macros not previously stored in flash memory are deleted.
- Delete fonts, macros, and other data stored on the flash memory.
- Install flash memory with more storage capacity.

53 Unformatted Flash

What this message means:

The printer detects unformatted flash memory.

What you can do:

- Press **Go** to clear the message and continue printing. You must format the flash memory before you can store any resources on it.
- If the error message remains, the flash memory may be defective and require replacing.

54 Serial Option <x> Error

54 Standard Serial Error

What this message means:

The printer has detected a serial interface error on a serial port.

What you can do:

- Make sure the serial link is set up correctly and you are using the appropriate cable.
- Press **Go** to clear the message and continue printing. The job may not print correctly.
- Press **Menu** to open the Job Menu and reset the printer.

54 Network <x> Software Error

54 Std Network Software Error

What these messages mean:

The printer cannot establish communications with an installed network port.

What you can do:

- Press **Go** to clear the message and continue printing. The job may not print correctly.
- Program new firmware for the network interface by way of the USB or parallel port.
- Press **Menu** to open the Job Menu and reset the printer.

54 Std Par ENA Connection Lost

54 Par <x> ENA Connection Lost

What this message means:

The printer has lost the connection to an external print server (also called an external network adapter or ENA).

What you can do:

- Make sure the cable connecting the ENA and the printer is securely attached. Turn the printer off and then on to reset the printer.
- Press **Go** to clear the message. The printer erases any reference to the ENA and then resets.

54 Parallel Error

**54 Parallel
Option <x> Error****What this message means:**

The printer has detected a protocol error on a parallel interface.

What you can do:

- Press **Go** to clear the message and continue printing. The job may not print correctly.
- Make sure the cable connecting the printer and the computer is securely attached and that the cable is not defective.
- Reset the printer.

**55 Insufficient
Fax Buffer****What this message means:**

The buffer used to process data is too full to receive an incoming fax. This has broken the connection between the printer and the sending fax machine. The printer will not accept additional fax data until sufficient fax buffer space is made available.

What you can do:

- Press **Go** to clear the message and print any fax data stored in the fax buffer. The job may not print correctly.
- Increase the size of the Fax Buffer in the Fax Menu.

**56 Serial
Port <x> Disabled**

56 Standard Serial Disabled**What this message means:**

Data has been sent to the printer through a serial port, but the serial port is disabled.

What you can do:

- Press **Go** to clear the message. The printer discards any data received through the serial port.
- Make sure the Serial Buffer menu item in the Serial Menu is not set to Disabled.

**56 Parallel
Port <x> Disabled**

**56 Std Parallel
Port Disabled**

What this message means:

Data has been sent to the printer through a parallel port, but the parallel port is disabled.

What you can do:

- Press **Go** to clear the message. The printer discards any data received through the parallel port.
- Make sure the Parallel Buffer menu item in the Parallel Menu is not set to Disabled.

**58 Too Many
Bins Attached**

What this message means:

- Too many output bins are installed on the printer.
- An unsupported configuration of output bins is installed on the printer.

What you can do:

Turn off and unplug the printer. Remove or reconfigure the output bins. Plug in the printer and turn it on.

**58 Too Many
Disks Installed**

What this message means:

Too many hard disks are installed on the printer. The printer only supports one hard disk at a time.

What you can do:

Turn off and unplug the printer. Remove the excess hard disks from the printer. Plug in the printer and turn it on.

58 Too Many Flash Options

What this message means:

Too many flash memory options are installed on the printer.

What you can do:

Turn off and unplug the printer. Remove the excess flash memory. Plug in the printer and turn it on.

58 Too Many Trays Attached

What this message means:

Too many drawers with matching trays are installed on the printer.

What you can do:

Turn off and unplug the printer. Remove the additional drawers. Plug in the printer and turn it on.

59 Incompatible <device>

What this message means:

The printer detects that an incompatible device is installed.

What you can do:

Remove the specified device.

61 Defective Disk

What this message means:

The printer detects a defective hard disk.

What you can do:

- Press **Go** to clear the message and continue printing.
- Install a different hard disk before you perform any operations that require one.

62 Disk Full

What this message means:

There is not enough memory on the hard disk to store the data sent to the printer.

What you can do:

- Press **Go** to clear the message and continue processing. Any information not previously stored on the hard disk is deleted.
- Delete fonts, macros, and other data stored on the hard disk.

63 Unformatted Disk

What this message means:

The printer detects an unformatted hard disk.

What you can do:

- Press **Go** to clear the message and continue printing.
- Format the disk before performing any disk operations. To format the disk, select Format Disk from the Utilities Menu.
- If the error message remains, the hard disk may be defective and require replacing. Install a new hard disk and format it.

70–79 <message>

What these messages mean:

Messages labeled 70–79 identify problems related to the internal print server.

What you can do:

Refer to the drivers CD for more information. Click **View Documentation**, and then click **MarkNet™ Print Servers**.

80 Scheduled Maintenance

What this message means:

The printer requires replacement of routine maintenance items to maintain top performance and avoid print quality and paper feed problems.

What you can do:

Replace the maintenance items and reset the printer maintenance counter, if necessary.

**81 Engine Code
CRC Failure****What this message means:**

Microcode in the engine flash code module has failed a system check.

What you can do:

Press **Go** to clear the message and discard the code. Retransmit the microcode data from the host computer.

88 Toner Low**What this message means:**

The print cartridge is low on toner.

What you can do:

- To utilize the remaining toner, remove the cartridge by gripping the handles with both hands. With the cartridge arrows pointing downward, shake the print cartridge back and forth. Reinstall the cartridge and then press **Go**.
- Press **Go** to clear the message and continue printing. You may notice reduced print quality.
- Replace the print cartridge.

See also:

[Replacing the print cartridge](#)

900–999 Service <message>**What these messages mean:**

Messages labeled 900–999 relate to printer problems that may require printer service.

What you can do:

Turn the printer off and check all cable connections. Turn the printer back on. If the service message recurs, call for service and report the message number and description of the problem.



Using printer menus

Select a menu from the following list for more information. Or, click a letter in the index at the bottom of the page to find a specific menu item that starts with that letter.

[Click here](#) for a one-page overview of all the menus and their menu items.

- **Finishing Menu**
- **Infrared Menu**
- **Job Menu**
- **LocalTalk Menu**
- **Network Menu**
- **Paper Menu**
- **Parallel Menu**
- **PCL Emul Menu**
- **PostScript Menu**
- **Quality Menu**
- **Serial Menu**
- **Setup Menu**
- **USB Menu**
- **Utilities Menu**

Select a menu or menu item for more details.

Finishing Menu Duplex Duplex Bind Copies Blank Pages Collation Separator Sheets Separator Source Multipage Print Multipage Order Multipage View Multipage Border Staple Job Staple Prime Src Offset Pages	Job Menu Confidential Job Held Jobs Cancel Job Reset Printer Print Buffer Prime Stapler Reset Active Bin	Paper Menu Paper Source Paper Size Paper Type Custom Types Universal Setup Output Bin Configure Bins Overflow Bin Assign Type/Bin Substitute Size Configure MP Envelope Enhance Paper Texture Paper Weight Paper Loading	PCL Emul Menu Font Source Font Name Point Size Pitch Symbol Set Orientation Lines per Page A4 Width Tray Renumber Auto CR after LF Auto LF after CR	PostScript Menu Print PS Error Font Priority	USB Menu PCL SmartSwitch PS SmartSwitch NPA Mode USB Buffer Job Buffering MAC Binary PS
Infrared Menu Infrared Port PCL SmartSwitch PS SmartSwitch NPA Mode Infrared Buffer Job Buffering Window Size Transmit Delay Max Baud Rate	LocalTalk Menu LocalTalk Port PCL SmartSwitch PS SmartSwitch NPA Mode LocalTalk Buffer Job Buffering NPA Hosts LocalTalk Name LocalTalk Addr LocalTalk Zone	Parallel Menu PCL SmartSwitch PS SmartSwitch NPA Mode Parallel Buffer Job Buffering Advanced Status Protocol Honor Init Parallel Mode 1 Parallel Mode 2	Setup Menu Printer Language Power Saver Resource Save Download Target Print Timeout Wait Timeout Auto Continue Jam Recovery Page Protect Display Language Alarm Control Toner Alarm Staple Alarm Job Accounting	Quality Menu Print Resolution Toner Darkness PQET PictureGrade	Utilities Menu Print Menus Print Net <x> Setup Print Fonts Print Directory Factory Defaults Format Flash Defragment Flash Format Disk Job Acct Stat Hex Trace
	Network Menu PCL SmartSwitch PS SmartSwitch NPA Mode Network Buffer Job Buffering Network <x> Setup MAC Binary PS		Serial Menu PCL SmartSwitch PS SmartSwitch NPA Mode Serial Buffer Job Buffering RS-232/RS-422 RS-422 Polarity Serial Protocol Robust XON Baud Data Bits Parity Honor DSR		



Finishing Menu

Use the Finishing Menu to define how the printer delivers the printed output.

Select a menu item for more details:

- **Blank Pages**
- **Collation**
- **Copies**
- **Duplex**
- **Duplex Bind**
- **Multipage Border**
- **Multipage Order**
- **Multipage Print**
- **Multipage View**
- **Offset Pages**
- **Separator Sheets**
- **Separator Source**
- **Staple Job**
- **Staple Prime Src**

Note: Values marked by an asterisk are the factory default settings.

Blank Pages

Purpose:

To specify whether to include application-generated blank pages as part of your printed output.

Values:

Do Not Print*	Does not print application-generated blank pages as part of your job.
Print	Prints application-generated blank pages as part of your job.

Collation

Purpose:

To keep the pages of a print job stacked in sequence, particularly when printing multiple copies of the job.

Values:

- Off*** Prints each page of a job the number of times specified by the Copies menu item. For example, if you set Copies to 2 and send three pages to print, the printer prints page 1, page 1, page 2, page 2, page 3, page 3.
- On** Prints entire job the number of times specified by the Copies menu item. For example, if you set Copies to 2 and send three pages to print, the printer prints page 1, page 2, page 3, page 1, page 2, page 3.

Copies

Purpose:

To set the number of copies you want for the printer default value. (Set the number of copies required for a specific job from the printer driver. Values selected from the printer driver always override values selected from the operator panel.)

Values:

1...999 (1*)

See also:

[Collation](#)

Duplex

Purpose:

To set duplexing as the default for all print jobs. (Select Duplex from the printer driver to duplex only specific jobs.)

Values:

- Off*** Prints on one side of the paper.
- On** Prints on both sides of the paper.

See also:

[Duplex Bind](#)

Duplex Bind

Purpose:

To define the way duplexed pages would be bound, and how the printing on the back of the sheet (even-numbered pages) is oriented in relation to the printing on the front (odd-numbered pages).

Values:

Long Edge*	Assumes binding along the long end of the page (left edge for portrait orientation and top edge for landscape orientation).
Short Edge	Assumes binding along the short edge of the page (top edge for portrait orientation and left edge for landscape orientation).

See also:

[Duplex](#)

Multipage Border

Purpose:

To print a border around each page image when using Multipage Print.

Values:

None*	Does not print a border around each page image.
Solid	Prints a solid line border around each page image.

See also:

[Multipage Print](#)

Multipage Order

Purpose:

To determine the positioning of multiple page images when using Multipage Print. The positioning depends on the number of images and whether the images are portrait or landscape in orientation.

Values:

Horizontal*
Vertical
Rev Horizontal
Rev Vertical

See also:

[Multipage Print](#)

Multipage Print

Purpose:

To print multiple page images on one side of a sheet of paper. Also called *N-Up* or *Paper Saver*.

Values:

Off*	Prints 1 page image per side.	6 Up	Prints 6 page images per side.
2 Up	Prints 2 page images per side.	9 Up	Prints 9 page images per side.
3 Up	Prints 3 page images per side.	12 Up	Prints 12 page images per side.
4 Up	Prints 4 page images per side.	16 Up	Prints 16 page images per side.

See also:

[Multipage Border](#); [Multipage Order](#); [Multipage View](#)

Multipage View

Purpose:

To determine the orientation of a multipage sheet.

Values:

Auto*	Lets the printer choose between portrait and landscape orientation.
Long Edge	Sets the long edge of the paper as the top of the page (landscape).
Short Edge	Sets the short edge of the paper as the top of the page (portrait).

See also:

[Multipage Print](#)

Offset Pages

Purpose:

To offset the output of each print job or each copy of a print job, making it easier to separate the documents stacked in the output bin.

Values:

None*	Stacks all sheets directly on top of each other.
Between Copies	Offsets each copy of a print job.
Between Jobs	Offsets each print job.

Note: Offset Pages is displayed only when a finisher is installed.

Separator Sheets

Purpose:

To insert blank separator sheets between jobs, between multiple copies of a job, or between each page of a job.

Values:

None*	Does not insert separator sheets.
Between Copies	Inserts a blank sheet between each copy of a job. If Collation is Off, a blank page is inserted between each set of printed pages (all page 1's, all page 2's, and so on). If Collation is On, a blank page is inserted between each collated copy of the job.
Between Jobs	Inserts a blank sheet between jobs.
Between Pages	Inserts a blank sheet between each page of a job. This is useful if you are printing transparencies or want to insert blank pages in a document for notes.

See also:

[Separator Source](#); [Collation](#)

Separator Source

Purpose:

To specify the paper source that holds separator sheets.

Values:

Tray <x> (Tray 1*)	Selects separator sheets from the specified tray.
MP Feeder	Selects separator sheets from the multipurpose feeder. (You must also set Configure MP to Cassette.)
Env Feeder	Inserts envelopes as separator sheets.

See also:

[Separator Sheets](#); [Configure MP](#)

Staple Job

Purpose:

To set stapling as the default for all print jobs. (Select stapling from the printer driver if you want to staple only specific jobs.)

Values:

- | | |
|-------------|--|
| Off* | Does not staple print jobs. |
| On | Staples each multi-page print job sent to the printer. |

Note: Staple Job is displayed only when a finisher is installed.

Staple Prime Src

Purpose:

To specify the paper source you want the printer to use when the Prime Stapler is selected from the Job Menu.

Values:

- | | |
|---------------------------------|--|
| Tray <x> (Tray 1*) | Selects paper from the specified tray. |
| MP Feeder | Selects paper from the multipurpose feeder. |
| Manual Pap | Selects a sheet of paper inserted in the manual feed slot. |

Note: Staple Prime Source is displayed only when a finisher is installed.

See also:

[Prime Stapler](#)



Infrared Menu

Use the Infrared Menu to change printer settings affecting jobs sent to the printer through an infrared port.

Select a menu item for more details:

- **Infrared Buffer**
- **Infrared Port**
- **Job Buffering**
- **Max Baud Rate**
- **NPA Mode**
- **PCL SmartSwitch**
- **PS SmartSwitch**
- **Transmit Delay**
- **Window Size**

Note: Values marked by an asterisk are the factory default settings.

Infrared Buffer

Purpose:

To configure the size of the infrared input buffer.

Values:

Disabled	Disables job buffering. Any jobs already buffered on the disk are printed before normal processing of incoming jobs resumes.
Auto*	Printer automatically calculates the Infrared Buffer size (recommended setting).
5K to maximum size allowed	User specifies the Infrared Buffer size. The maximum size setting depends on the amount of memory in your printer, the size of the other link buffers, and whether Resource Save is set to On or Off. To maximize the range for the Infrared Buffer size, disable or reduce the size of the parallel, serial, network, LocalTalk, and USB buffers.

Note: Changing the Infrared Buffer menu item automatically resets the printer.

See also:

[Resource Save](#)

Infrared Port

Purpose:

To activate the infrared port.

Values:

Disabled*	Disables the infrared port and all other menu items in the Infrared Menu.
IR Option <x>	Activates the specified infrared port.

Job Buffering

Purpose:

To temporarily store jobs on the printer hard disk before printing.

Values:

Off*	Does not buffer print jobs to the hard disk.
On	Buffers print jobs to the hard disk.
Auto	Buffers print jobs only if the printer is busy processing data from another input port.

Note: Changing the Job Buffering menu item automatically resets the printer.

Max Baud Rate

Purpose:

To specify the rate at which data can be received through the infrared port.

Values:

2400	115200
9600	576000
19200	1152000*
38400	4000000
57600	

The maximum baud possible for both the printer and the infrared adapter is automatically set during a power on reset. However, if your printer is situated in a bright or highly reflective environment, you may experience intermittent communication problems. If you do, select a lower baud for the infrared connection.

NPA Mode

Purpose:

To specify whether the printer performs the special processing required for bidirectional communication, following the conventions defined in the Network Printing Alliance (NPA) Protocol.

Values:

- On** Printer performs NPA processing. If data is not in NPA format, it is rejected as bad data.
- Off** Printer does not perform NPA processing.
- Auto*** Printer examines the data to determine the format and then processes it appropriately.

Note: Changing this menu item automatically resets the printer.

PCL SmartSwitch

Purpose:

To configure the printer so it automatically switches to PCL emulation when a print job received through the infrared port requires it, regardless of the default printer language.

Values:

- On*** Printer examines the data on the infrared interface and selects PCL emulation if the data indicates that is the required printer language.
- Off** Printer does not examine the incoming data. The printer uses PostScript emulation to process the job if PS SmartSwitch is On, or uses the default printer language specified in the Setup Menu if PS SmartSwitch is Off.

See also:

[PS SmartSwitch](#); [Printer Language](#)

PS SmartSwitch

Purpose:

To configure the printer so it automatically switches to PostScript emulation when a print job received through the infrared port requires it, regardless of the default printer language.

Values:

- On*** Printer examines data on the infrared interface and selects PostScript emulation if the data indicates that is the required printer language.
- Off** Printer does not examine the incoming data. The printer uses PCL emulation to process the job if PCL SmartSwitch is On, or uses the default printer language specified in the Setup Menu if PCL SmartSwitch is Off.

See also:

[PCL SmartSwitch](#); [Printer Language](#)

Transmit Delay

Purpose:

To define the amount of time, in seconds, the printer must wait before transmitting meaningful infrared data to the host computer, as well as the amount of time the printer requests that the host computer wait before transmitting infrared data.

Values:

- | | |
|---------------|---|
| Auto* | Printer sets the Transmit Delay value during a power-on reset to maximize link performance (recommended). |
| None | No delay is imposed by the printer. However, not all host computers can communicate without some transmission delays. |
| 1...15 | User selects a Transmit Delay value between 1 and 15 seconds. If you have trouble printing using the infrared port, selecting a high Transmit Delay value, such as 15, may resolve the problem. |

Window Size

Purpose:

To specify the maximum number of infrared frames the printer can receive before sending an acknowledgment to the host computer.

Values:

- | | |
|--------------|--|
| Auto* | Printer sets the Window Size value during a power on reset to maximize link performance (recommended). |
| 1 | User sets the Window Size to one frame (1). If you have trouble printing using the infrared port, changing the Window Size menu item to 1 may resolve the problem. ▲ |



Job Menu

The Job Menu is only available when the printer is busy processing or printing a job, when a printer message is displayed, or when the printer is in Hex Trace mode. Press **Menu** to open the Job Menu.

Select a menu item for more details:

- **Cancel Job**
- **Confidential Job**
- **Held Jobs**
- **Print Buffer**
- **Prime Stapler**
- **Reset Active Bin**
- **Reset Printer**

Cancel Job

Purpose:

To cancel the current print job.

Note: Cancel Job is only displayed if the printer is processing a job or has a job in printer memory.

Confidential Job

Purpose:

To print confidential jobs stored in printer memory. (When the confidential job prints, it is automatically deleted from printer memory.)

First select the user name associated with your confidential job.

Then enter the Personal Identification Number (PIN) associated with your Confidential Job:

Enter PIN	Use the operator panel buttons to enter the PIN associated with your confidential job.
------------------	--

Then select a value:

Print All Jobs	Prints all jobs associated with your user name and PIN.
Print A Job	Prints the specified confidential job. Press Menu to scroll through the list of confidential jobs associated with your user name and PIN. Press Select to print a specific job.
Delete All Jobs	Deletes all jobs associated with your user name and PIN.
Delete A Job	Deletes the specified confidential job. Press Menu to scroll through the list of confidential jobs associated with your user name and PIN. Press Select to delete a specific job.
Copies	Determines the number of copies printed for each confidential job. Press Menu to scroll through the list of confidential jobs associated with your user name and PIN. Press Select to specify the job you want to print. Press Menu to increase or decrease the number of copies, then press Select .

See also: [Confidential jobs](#)

Held Jobs

Purpose:

To print Reserve Print, Repeat Print, or Verify Print jobs stored in printer memory.

First, select the user name associated with your confidential job.

Values:

Print All Jobs	Prints all held jobs associated with your user name.
Print A Job	Prints the specified held job. Press Menu to scroll through the list of held jobs. Press Select to print the specific job.
Delete All Jobs	Deletes all held jobs associated with your user name.
Delete A Job	Deletes the designated held job. Press Menu to scroll through the list of held jobs. Press Select to delete the job.
Copies	Determines the number of copies for each held job. Press Menu to scroll through the list of held jobs. Press Select to specify the job you want to print. Press Menu to increase or decrease the number of copies, and then press Select .

Print Buffer

Purpose:

To print any data stored in the print buffer.

Note: Print Buffer is only available when you enter the Job Menu while **Waiting** is displayed. The Waiting state occurs if an incomplete job is sent to the printer or an ASCII job, such as a print screen command, is printing.

Prime Stapler

Purpose:

To prepare the stapler for proper functioning after a staple cartridge is replaced or a staple jam is cleared. **Priming stapler** is displayed, and the printer tests the stapler several times before returning to the Ready state.

Note: Prime Stapler is only displayed if a finisher is installed.

Reset Active Bin

Purpose:

To define the active bin as the start bin (the first bin to receive printed output) in a set of linked bins.

Reset Printer

Purpose:

To reset the printer to the user default value for each menu item, delete all downloaded resources (fonts, macros, and symbol sets) stored in printer memory (RAM), and delete all data in the interface link buffer.

Note: Before selecting Reset Printer, exit the software application you are using.



LocalTalk Menu

Use the LocalTalk Menu to change printer settings affecting jobs sent to the printer through a LocalTalk port.

Select a menu item for more details:

- **Job Buffering**
- **LocalTalk Addr**
- **LocalTalk Buffer**
- **LocalTalk Name**
- **LocalTalk Port**
- **LocalTalk Zone**
- **NPA Hosts**
- **NPA Mode**
- **PCL SmartSwitch**
- **PS SmartSwitch**

Note: Values marked by an asterisk are the factory default settings.

Job Buffering

Purpose:

To temporarily store jobs on the printer hard disk before printing.

Values:

- | | |
|-------------|---|
| Off* | Does not buffer the print job to the hard disk. |
| On | Buffers print jobs to the hard disk. |
| Auto | Buffers print jobs only if the printer is busy processing data from another input port. |

Note: Changing the Job Buffering menu item automatically resets the printer.

LocalTalk Addr

Purpose:

To identify the LocalTalk Node number assigned to the printer. This menu item cannot be modified through the operator panel.

LocalTalk Buffer

Purpose:

To configure the size of the LocalTalk input buffer.

Values:

Disabled	Disables job buffering. Any jobs already buffered on the disk are printed before normal processing of incoming jobs resumes.
Auto*	Printer automatically calculates LocalTalk Buffer size (recommended).
6K to maximum size allowed	User specifies the LocalTalk Buffer size. The maximum size depends on the amount of memory in your printer, the size of the other link buffers, and whether Resource Save is set to On or Off. To maximize the range for the LocalTalk Buffer size, disable or reduce the size of the parallel, serial, network, infrared, and USB buffers.

Note: Changing the LocalTalk Buffer menu item automatically resets the printer.

See also:

[Resource Save](#)

LocalTalk Name

Purpose:

To identify the printer model name stored in printer memory. This menu item cannot be modified through the operator panel.

LocalTalk Port

Purpose:

To activate the LocalTalk port.

Values:

Disabled*	Disables the LocalTalk port and all other menu items in the LocalTalk Menu.
LTalk Option <x>	Activates the specified LocalTalk port.

LocalTalk Zone

Purpose:

To identify the LocalTalk Zone provided by the LocalTalk network. This menu item cannot be modified through the operator panel.

NPA Hosts

Purpose:

To specify the maximum number of NPA host computers that can register for NPA alerts.

Values:

1...10 (2*)

Note: Changing this menu item automatically resets the printer.

NPA Mode

Purpose:

To specify whether the printer performs the special processing required for bidirectional communication, following the conventions defined in the Network Printing Alliance (NPA) Protocol.

Values:

- On** Printer performs NPA processing. If data is not in NPA format, it is rejected as bad data.
- Off** Printer does not perform NPA processing.
- Auto*** Printer examines the data to determine the format and then processes it appropriately.

Note: Changing this menu item automatically resets the printer.

PCL SmartSwitch

Purpose:

To configure the printer so it automatically switches to PCL emulation when a print job received through the LocalTalk port requires it, regardless of the default printer language.

Values:

- On*** Printer examines data on the LocalTalk interface and selects PCL emulation if the data indicates that is the required printer language.
- Off** Printer does not examine the incoming data. The printer uses PostScript emulation to process the job if PS SmartSwitch is On, or uses the default printer language specified in the Setup Menu if PS SmartSwitch is Off.

See also:

[PS SmartSwitch](#); [Printer Language](#)

PS SmartSwitch

Purpose:

To configure the printer so it automatically switches to PostScript emulation when a print job received through the LocalTalk port requires it, regardless of the default printer language.

Values:

- On*** Printer examines data on the LocalTalk interface and selects PostScript emulation if the data indicates that is the required printer language.
- Off** Printer does not examine the incoming data. The printer uses PCL emulation to process the job if PCL SmartSwitch is On, or uses the default printer language specified in the Setup Menu if PCL SmartSwitch is Off.

See also:

[PCL SmartSwitch](#); [Printer Language](#)



Network Menu

Use the Network Menu to change printer settings affecting jobs sent to the printer through a network port (either Standard Network or Network Opt <x>).

Select a menu item for more details:

- **Job Buffering**
- **MAC Binary PS**
- **Network Buffer**
- **Network <x> Setup**
- **NPA Mode**
- **PCL SmartSwitch**
- **PS SmartSwitch**

Note: Values marked by an asterisk are the factory default settings.

Job Buffering

Purpose:

To temporarily store jobs on the printer hard disk before printing.

Values:

- | | |
|-------------|---|
| Off* | Does not buffer jobs to the hard disk. |
| On | Buffers print jobs to the hard disk. |
| Auto | Buffers print jobs only if the printer is busy processing data from another input port. |

Note: Changing the Job Buffering menu item automatically resets the printer.

MAC Binary PS

Purpose:

To configure the printer to process Macintosh binary PostScript print jobs.

Values:

- | | |
|-------|---|
| On | Printer processes raw binary PostScript print jobs from computers using the Macintosh operating system.
Note: This setting often causes Windows print jobs to fail. |
| Off | Printer filters PostScript print jobs using standard protocol. |
| Auto* | Printer processes print jobs from computers using either Windows or Macintosh operating systems. |

Network Buffer

Purpose:

To configure the size of the network input buffer.

Values:

- | | |
|----------------------------|---|
| Auto* | Printer automatically calculates the Network Buffer size (recommended setting). |
| 3K to maximum size allowed | User specifies the Network Buffer size. The maximum size depends on the amount of memory in your printer, the size of the other link buffers, and whether Resource Save is set to On or Off. To maximize the range for the Network Buffer size, disable or reduce the size of the parallel, serial, infrared, LocalTalk, and USB buffers. |

Note: Changing the Network Buffer menu item automatically resets the printer.

See also:

[Resource Save](#)

Network <x> Setup

Purpose:

To configure an internal print server.

Values:

Values for this menu item are supplied by the specific print server. Select the menu item to see the available values.

Note: Refer to the documentation on the drivers CD for more information.

NPA Mode

Purpose:

To specify whether the printer performs the special processing required for bidirectional communication, following the conventions defined in the Network Printing Alliance (NPA) Protocol.

Values:

- On** Printer performs NPA processing. If data is not in NPA format, it is rejected as bad data.
- Off** Printer does not perform NPA processing.
- Auto*** Printer examines the data to determine the format and then processes it appropriately.

Note: Changing this menu item automatically resets the printer.

PCL SmartSwitch

Purpose:

To configure the printer so it automatically switches to PCL emulation when a print job received through the network port requires it, regardless of the default printer language.

Values:

- On*** Printer examines data on the network interface and selects PCL emulation if the data indicates that is the required printer language.
- Off** Printer does not examine the incoming data. The printer uses PostScript emulation to process the job if PS SmartSwitch is On, or uses the default printer language specified in the Setup Menu if PS SmartSwitch is Off.

See also:

[PS SmartSwitch](#); [Printer Language](#)

PS SmartSwitch

Purpose:

To configure the printer so it automatically switches to PostScript emulation when a print job received through the network port requires it, regardless of the default printer language.

Values:

- On*** Printer examines data on the network interface connection and selects PostScript emulation if the data indicates that is the required printer language.
- Off** Printer does not examine the incoming data. The printer uses PCL emulation to process the job if PCL SmartSwitch is On, or uses the default printer language specified in the Setup Menu if PCL SmartSwitch is Off.

See also:

[PCL SmartSwitch](#); [Printer Language](#)



Paper Menu

Use the Paper Menu to define the paper loaded in each paper tray and the default paper source and output bin.

Select a menu item for more details:

- **Assign Type/Bin**
- **Configure Bins**
- **Configure MP**
- **Custom Types**
- **Envelope Enhance**
- **Output Bin**
- **Overflow Bin**
- **Paper Loading**
- **Paper Size**
- **Paper Source**
- **Paper Texture**
- **Paper Type**
- **Paper Weight**
- **Substitute Size**
- **Universal Setup**

Note: Values marked by an asterisk are the factory default settings.

Assign Type/Bin

Purpose:

To send print jobs to a specific output bin based on the requested paper type.

Values (for Standard Bin* and Bin <x>):

Plain Paper Bin	Envelope Bin
Card Stock Bin	Letterhead Bin
Transparency Bin	Preprinted Bin
Labels Bin	Colored Bin
Bond Bin	Custom <x> Bin (where <x> represents 1 through 6)

Note: If a user-defined name is available, it is displayed instead of Custom <x> Bin. The name is truncated to 14 characters. If two or more bins share the same name, the name only appears once in the Assign Type/Bin value list.

Configure Bins

Purpose:

To determine which output bin(s) the printer uses for a particular job.

Values:

Mailbox*	Sends print jobs to the output bin designated for that user.
Link	Links all bins together as though they were one large bin. When one linked bin is full, the printer starts filling the next linked bin, and continues with each additional linked bin.
Mail Overflow	Sends print jobs to the output bin designated for that user until it is full, and then sends jobs to the designated overflow bin.
Link Optional	Links all optional output bins as though they were one large bin, while leaving the standard bin individually addressable.
Type Assignment	Sends each job to the output bin specified for that paper type.

Configure MP

Purpose:

To determine when the printer selects paper loaded in the multipurpose feeder.

Values:

Cassette*	Printer treats the multipurpose feeder like any other paper tray. If a print job requests a paper size or type that is only loaded in the multipurpose feeder, the printer pulls paper from the multipurpose feeder for the job.
Manual	Printer treats the multipurpose feeder like a manual feed tray, and displays Load Manual when you need to insert a single sheet of paper in the feeder.
First	Printer pulls paper from the multipurpose feeder until it is empty, regardless of the paper source or paper size requested for the job.

Custom Types

Purpose:

To specify the kind of paper associated with each of the Custom Types available in the Paper Type menu item.

Values (for Custom Type <x>, where <x> represents 1 through 6):

Paper*	Cotton Paper
Card Stock	Labels
Transparency	Envelope

Note: If a user-defined name is available, it is displayed instead of Custom Type <x>. The user-defined name is truncated to 14 characters. If two or more custom types share the same name, the name only appears once in the Custom Types value list.

Envelope Enhance

Purpose:

To ensure high quality printed envelopes and minimize envelope wrinkling.

Values:

- Off** Prints envelopes as any other printed material.
- On*** Modifies the printing process to prevent wrinkling as envelopes move through the fuser.

If Envelope Enhance is On, you may hear a tapping sound as the envelopes print. We recommend you leave Envelope Enhance set to On unless the tapping sound is too loud for your work area. To eliminate this sound, select Off. Print a few envelopes. If the quality of print is acceptable, leave Envelope Enhance set to Off. If envelopes crease or wrinkle, select On.

Output Bin

Purpose:

To specify the default bin for printed material.

Values:

- Standard Bin***
- Bin <x>**

Note: If a user-defined name is available, it is displayed instead of Bin <x>. The name is truncated to 14 characters. If two or more bins share the same name, the name only appears once in the Output Bin value list.

Overflow Bin

Purpose:

To designate an output bin as the overflow bin. If Configure Bins is set to Mail Overflow and a specific output bin is full, the printer automatically diverts printed material to the overflow bin.

Values:

Standard Bin*

Bin <x>

Note: If a user-defined bin is available, it is displayed instead of Bin <x>. The name is truncated to 14 characters. If two or more bins share the same name, the name only appears once in the Overflow Bin value list.

Paper Loading

Purpose:

To properly handle preprinted paper loaded in a tray, whether the job is a duplexed job or a single-sided job.

Values:

First select a paper type:

Card Stock Load	Colored Loading	Ltrhead Loading	Bond Loading
Labels Loading	Custom <x> Loading	Preprint Loading	

Then select a value:

Duplex	Notifies the printer that the specified paper type is loaded properly for duplex printing. If the printer receives a single-sided job using that paper type, the printer inserts blank pages as necessary to print the job properly on preprinted forms. This setting may slow single-sided printing.
Off*	Printer assumes preprinted material is loaded for single-sided printing. Duplexed jobs may not print properly.

Note: If a user-defined name is available, it is displayed instead of Custom <x> Loading. The name is truncated to 14 characters.

See also:

[Loading print material](#)

Paper Size

Purpose:

To identify the default paper size for each paper source. For trays with automatic size sensing, only the value detected by the hardware is displayed.

Values:

First select a paper source:

Tray <x> Size	Env Feeder Size	MP Feeder Size
Manual Pap Size	Manual Env Size	

*Then select a value (*denotes a country-specific factory default value):*

Letter*	A3	B4	10 Envelope*	Folio
Legal	A4*	B5	DL Envelope*	Statement
Executive	A5	11x17	C5 Envelope	
			7 3/4 Envelope	

Universal Select Universal when you load paper that doesn't match any of the other available sizes. The printer automatically formats the page for the maximum possible size. You can then set the actual page size from your application software.

Paper Source

Purpose:

To identify the default paper source.

Values:

- Tray <x> (Tray 1*)
- MP Feeder
- Env Feeder
- Manual Paper
- Manual Env

If you loaded the same size and type of paper in two paper sources (and the Paper Size and Paper Type menu items are correctly set), the trays are automatically linked. When one paper source is empty, paper automatically feeds from the next linked source.

Paper Texture

Purpose:

To identify the texture of the paper loaded in a specific source and to ensure that characters print clearly.

Values:

First select a paper type:

Plain Texture	Preprint Texture	Labels Texture	Ltrhead Texture
Card Stock Text	Colored Texture	Bond Texture	
Trnsprncy Text	Custom <x> Texture	Envelope Texture	

Then select a value:

Smooth
Normal*
Rough

Note: The default for Bond Texture is Rough instead of Normal. If a user-defined name is available for a custom Type, then the name is displayed instead of Custom <x> Texture. The name is truncated to 14 characters.

Use Paper Texture in connection with the Paper Type and Paper Weight menu items. You may need to change those menu items to optimize print quality for your specific paper.

See also:

[Paper Type](#); [Paper Weight](#)

Paper Type

Purpose:

To identify the type of paper installed in each paper source.

Values:

First select a paper source:

Tray <x> Type	Env Feeder Type	MP Feeder Type
Manual Pap Type	Manual Env Type	

Then select a value:

Plain Paper	Labels	Preprinted	Envelope
Card Stock	Bond	Colored Paper	Preprinted
Transparency	Letterhead	Custom Type <x>	Colored Paper

The Paper Type default for each envelope source is Envelope. The Paper Type default for each paper tray is as follows:

Tray 1–Plain Paper

Tray 2–Custom Type 2

Tray 3–Custom Type 3

Tray 4–Custom Type 4

Tray 5–Custom Type 5

MP feeder–Custom Type 6

Manual Pap Type–Plain Paper

Note: If a user-defined name is available, it is displayed instead of Custom Type <x>. The user-defined name is truncated to 14 characters. If two or more custom types share the same name, the name only appears once in the Paper Type value list.

Use this menu item to:

- Optimize print quality for the specified paper.
- Select paper sources through your software application by selecting type and size.
- Automatically link paper sources. Any sources containing the same type and size of paper are automatically linked by the printer, if you have set the Paper Size and the Paper Type to the correct values.

See also:

[Custom Types](#)

Paper Weight

Purpose:

To identify the relative weight of the paper loaded in a specific source and ensure that the toner adheres properly to the printed page.

Values:

First select a paper type:

Plain Weight

Cardstock Weight

Trnsprncy Weight

Preprint Weight

Color Weight

Custom <x> Weight

Bond Weight

Envelope Weight

Labels Weight

Ltrhead Weight

Then select a value:

Light

Normal*

Heavy

Note: If a user-defined name is available, it is displayed instead of Custom <x> Weight. The name is truncated to 14 characters.

Substitute Size

Purpose:

To have the printer substitute the specified paper size if the requested size is not loaded.

Values:

Off	Printer prompts the user to load the requested paper size.
Letter/A4	Prints A4 size jobs on letter size paper if only letter size paper is loaded, and prints letter size jobs on A4 size paper if only A4 size paper is loaded.
Statement/A5	Prints A5 size jobs on statement size paper if only statement size paper is loaded, and prints statement size jobs on A5 paper if only A5 paper is loaded.
All Listed*	Substitutes both Letter/A4 and Statement/A5.

Universal Setup

Purpose:

To determine the default size when the Paper Size setting for a tray or feeder is Universal.

Values:

First select a unit of measure (denotes a country-specific factory default value):*

- Inches***
- Millimeters***

Then select the values:

Portrait Width	3.00–14.17 in. (8.50 in.*)	76–360 mm (216 mm*)
Portrait Height	3.00–14.17 in. (14.17 in.*)	76–360 mm (360 mm*)
Feed Direction	Short Edge* Long Edge	

See also:

[Print material specifications](#)



PCL Emul Menu

Use the PCL Emul Menu to change printer settings that only affect jobs using the PCL emulation printer language.

Select a menu item for more details:

- **A4 Width**
- **Auto CR after LF**
- **Auto LF after CR**
- **Font Name**
- **Font Source**
- **Lines per Page**
- **Orientation**
- **Pitch**
- **Point Size**
- **Symbol Set**
- **Tray Renumber**

Note: Values marked by an asterisk are the factory default settings.

A4 Width

Purpose:

To select the width of the logical page for A4 size paper.

Values:

- | | |
|----------------|--|
| 198 mm* | Makes the logical page compatible with the Hewlett-Packard LaserJet 5 Printer. |
| 203 mm | Makes the logical page wide enough to print eighty 10-pitch characters. |

Auto CR after LF

Purpose:

To specify whether the printer automatically performs a carriage return after a line feed control command.

Values:

- Off*** Printer does not perform a carriage return after a line feed control command.
- On** Printer performs a carriage return after a line feed control command.

Auto LF after CR

Purpose:

To specify whether the printer automatically performs a line feed after a carriage return control command.

Values:

- Off*** Printer does not perform a line feed after a carriage return control command.
- On** Printer performs a line feed after a carriage return control command.

Font Name

Purpose:

To choose a specific font from the specified font source.

Values:

R0 Courier 10*

The font name and font ID for all fonts in the selected font source are displayed. The font source abbreviation is R for resident, F for flash, K for disk, and D for download.

See also:

[Font Source](#)

Font Source

Purpose:

To determine the set of fonts displayed in the Font Name menu item.

Values:

Resident*	Displays all fonts resident in printer RAM when the printer ships from the factory.
Download	Displays all fonts downloaded to printer RAM.
Flash	Displays all fonts stored in flash memory.
Disk	Displays all fonts stored on the printer hard disk.
All	Displays all fonts available to the printer from all sources.

See also:

[Font Name](#)

Lines per Page

Purpose:

To determine the number of lines that print on each page.

Values:

- 1...255
- 60* (country-specific)
- 64* (country-specific)

The printer sets the amount of space between each line (vertical line spacing) based on the Lines per Page, Paper Size, and Orientation menu items. Select the correct Paper Size and Orientation before changing Lines per Page.

See also:

[Orientation](#); [Paper Size](#)

Orientation

Purpose:

To determine how text and graphics are oriented on the page.

Values:

Portrait*	Prints text and graphics parallel to the short edge of the paper.
Landscape	Prints text and graphics parallel to the long edge of the paper.

Pitch

Purpose:

To specify the font pitch for scalable monospaced fonts.

Values:

0.08...100 (in increments of 0.01 cpi)

10*

Pitch refers to the number of fixed-space characters in a horizontal inch of type. You can select a pitch from 0.08 to 100 characters per inch (cpi) in increments of 0.01 cpi. For nonscalable monospaced fonts, the pitch is displayed, but cannot be changed.

Note: Pitch is only displayed for fixed, or monospaced, fonts.

Point Size

Purpose:

To change the point size for scalable typographic fonts.

Values:

1...1008 (in increments of 0.25 points)

12*

Point size refers to the height of the characters in the font. One point equals approximately 1/72 of an inch. You can select point sizes from 1 to 1008 in increments of 0.25 points.

Note: Point Size is only displayed for typographic fonts.

Symbol Set

Purpose:

To choose a symbol set for a specified font name.

Values:

10U PC-8* (country-specific)

12U PC-850* (country-specific)

A symbol set is a set of alphabetic and numeric characters, punctuation, and special symbols used when printing with a selected font. Symbol sets support the different requirements for languages or specific applications, such as math symbols for scientific text. Only the symbol sets supported for the selected font name are displayed.

See also:

[Font Name](#)

Tray Renumber

Purpose:

To configure your printer to work with printer drivers or applications that use different source assignments for the paper trays.

First select a paper source:

Assign Tray <x>

Assign Env Feeder

Assign Man Env

Assign MP Feeder

Assign Man Paper

Then select a value:

Off*

Printer uses factory default paper source assignments.

0...199

Select a numeric value to assign a custom value to a paper source.

None

Paper source ignores the Select Paper Feed command.

View Factory Def

Displays the factory default value assigned to the specified paper source.

Restore Defaults

Select Yes to return all tray assignments to factory default values.

Note: Refer to the *Technical Reference* for more information about assigning source numbers.



Parallel Menu

Use the Parallel Menu to change printer settings affecting jobs sent to the printer through a parallel port (either Std Parallel or Parallel Opt <x>).

Select a menu item for more details:

- **Advanced Status**
- **Honor Init**
- **Job Buffering**
- **NPA Mode**
- **Parallel Buffer**
- **Parallel Mode 1**
- **Parallel Mode 2**
- **PCL SmartSwitch**
- **PS SmartSwitch**
- **Protocol**

Note: Values marked by an asterisk are the factory default settings.

Advanced Status

Purpose:

To enable bidirectional communication through the parallel port.

Values:

- Off** Disables parallel port negotiation.
- On*** Enables bidirectional communication through the parallel interface.

Honor Init

Purpose:

To determine whether the printer honors hardware initialization requests from the computer. The computer requests initialization by activating the INIT signal on the parallel interface. Many personal computers activate the INIT signal each time the computer is turned on and off.

Values:

- Off*** Printer does not honor hardware initialization requests from the computer.
- On** Printer honors hardware initialization requests from the computer.

Job Buffering

Purpose:

To temporarily store jobs on the printer hard disk before printing.

Values:

- Off*** Does not buffer print jobs to the hard disk.
- On** Buffers print jobs to the hard disk.
- Auto** Buffers print jobs only if the printer is busy processing data from another input port.

Note: Changing the Job Buffering menu item automatically resets the printer.

NPA Mode

Purpose:

To specify whether the printer performs the special processing required for bidirectional communication, following the conventions defined in the Network Printing Alliance (NPA) Protocol.

Values:

- On** Printer performs NPA processing. If data is not in NPA format, it is rejected as bad data.
- Off** Printer does not perform NPA processing.
- Auto*** Printer examines data and determines the format and then processes it appropriately.

Note: Changing this menu item automatically resets the printer.

Parallel Buffer

Purpose:

To configure the size of the parallel input buffer.

Values:

Disabled	Disables job buffering. Any jobs already buffered on the disk are printed before normal processing of incoming jobs resumes.
Auto*	Printer automatically calculates the Parallel Buffer size (recommended setting).
3K to maximum size allowed	User specifies the Parallel Buffer size. The maximum size depends on the amount of memory in your printer, the size of the other link buffers, and whether Resource Save is set to On or Off. To maximize the range for the Parallel Buffer size, disable or reduce the size of the serial, infrared, LocalTalk, and USB buffers.

Note: Changing the Parallel Buffer menu item automatically resets the printer.

See also:

[Resource Save](#)

Parallel Mode 1

Purpose:

To control the pull-up resistors on the parallel port signals. This menu item is useful for personal computers that have open collector outputs on the parallel port signals.

Values:

On	Disables the resistors.
Off*	Enables the resistors.

Parallel Mode 2

Purpose:

To determine whether the parallel port data is sampled on the leading or trailing edge of strobe.

Values:

On*	Samples parallel port data on the leading edge of strobe.
Off	Samples parallel port data on the trailing edge of strobe.

PCL SmartSwitch

Purpose:

To configure the printer so it automatically switches to PCL emulation when a print job received through the parallel port requires it, regardless of the default printer language.

Values:

- On*** Printer examines data on the parallel interface and selects PCL emulation if the data indicates that is the required printer language.
- Off** Printer does not examine the incoming data. The printer uses PostScript emulation to process the job if PS SmartSwitch is On, or uses the default printer language specified in the Setup Menu if PS SmartSwitch is Off.

See also:

[Printer Language; PS SmartSwitch](#)

PS SmartSwitch

Purpose:

To configure the printer so it automatically switches to PostScript emulation when a print job received through the parallel port requires it, regardless of the default printer language.

Values:

- On*** Printer examines data on the parallel interface and selects PostScript emulation if the data indicates that is the required printer language.
- Off** Printer does not examine the incoming data. The printer uses PCL emulation to process the job if PCL SmartSwitch is On, or uses the default printer language specified in the Setup Menu if PCL SmartSwitch is Off.

See also:

[PCL SmartSwitch; Printer Language](#)

Protocol

Purpose:

To specify the parallel interface protocol.

Values:

- Standard** May resolve some parallel interface problems.
- Fastbytes*** Provides compatibility with most existing parallel interface implementations (recommended setting).

See also:

Technical Reference ▲



PostScript Menu

Use the PostScript Menu to change printer settings that only affect jobs using the PostScript emulation printer language.

Select a menu item for more details:

- **Font Priority**
- **Print PS Error**

Note: Values marked by an asterisk are the factory default settings.

Font Priority

Purpose:

To establish the font search order.

Values:

Resident*	Printer searches printer memory for the requested font before searching flash memory or hard disk.
Flash/Disk	Printer searches the hard disk and flash memory for the requested font before searching printer memory.

Note: Font Priority is only displayed when a formatted flash or hard disk is installed, is neither defective nor Read/Write or Write protected, and Job Buffer Size is not set to 100%.

Print PS Error

Purpose:

To print a page defining the PostScript emulation error when an error occurs.

Values:

Off*	Discards the print job without printing an error message.
On	Prints an error message before it discards the job.



Quality Menu

Use the Quality Menu to change printer settings affecting the quality of printed characters and images. Select a menu item for more details:

- **PictureGrade™**
- **PQET**
- **Print Resolution**
- **Toner Darkness**

Note: Values marked by an asterisk are the factory default settings.

PictureGrade

Purpose:

To improve the quality of grayscale printing at 300 and 600 dots per inch (dpi) in PostScript emulation.

Values:

- On*** Uses modified screening parameters to improve print quality of graphics.
- Off** Uses standard screening parameters.

PQET

Purpose:

To improve the quality of text and make characters appear smoother when Print Resolution is set to 300 dots per inch (dpi).

Values:

- Off** Does not alter quality of text characters printed at 300 dpi.
- On*** Smooths characters with jagged or uneven edges.

Print Resolution

Purpose:

To define the number of dots printed per inch (dpi). The higher the value, the sharper the clarity of printed characters and graphics.

Values:

300 dpi	Offers a lower resolution printing option when memory is at a premium.
600 dpi*	Produces high quality output for print jobs that are mostly text.
1200 Image Q	Uses line screening for print jobs that contain bitmapped images, such as scanned photos.
1200 dpi	Produces highest quality output for jobs where print speed is not important and memory is abundant.

Toner Darkness

Purpose:

To lighten or darken text images, or conserve toner.

Values:

1	6
2	7
3	8*
4	9
5	10

Select a lower value for finer line width, higher definition in graphics, and lighter grayscale images. Select a higher value for bolder line widths or darker grayscale images. Select 10 for very bold text. Select a value less than 8 to conserve toner.

On the operator panel display, a vertical bar (|) indicates the factory default value. An arrow symbol (V) indicates a user default value.



Serial Menu

Use the Serial Menu to change printer settings affecting jobs sent to the printer through a serial port (either Standard Serial or Serial Opt <x>).

Select a menu item for more details:

- **Baud**
- **Data Bits**
- **Honor DSR**
- **Job Buffering**
- **NPA Mode**
- **Parity**
- **PCL SmartSwitch**
- **PS SmartSwitch**
- **Robust XON**
- **RS-232/RS-422**
- **RS-422 Polarity**
- **Serial Buffer**
- **Serial Protocol**

Note: Values marked with an asterisk are the factory default settings.

Baud

Purpose:

To specify the rate at which data can be received through the serial port.

Values:

1200	57600
2400	115200
4800	138200
9600*	172800
19200	230400
38400	345600

See also:

Technical Reference

Data Bits

Purpose:

To specify the number of data bits that are sent in each transmission frame.

Values:

7

8*

See also:

Technical Reference

Honor DSR

Purpose:

To determine whether the printer uses the Data Set Ready (DSR) signal. DSR is one of the handshaking signals for most serial interface cables.

Values:

Off* All data received by the serial port is treated as valid data.

On Only data received while the DSR signal is high is treated as valid.

The serial interface uses DSR to distinguish data sent by the computer from data created by electrical noise in the serial cable. This electrical noise can cause stray characters to print. Select On to prevent stray characters from printing.

Note: Honor DSR can be used only by ports configured for RS-232.

Job Buffering

Purpose:

To temporarily store jobs on the printer hard disk before printing.

Values:

Off* Does not buffer print jobs to the hard disk.

On Buffers print jobs to the hard disk.

Auto Buffers print jobs only if the printer is busy processing data from another input port.

Note: Changing the Job Buffering menu item automatically resets the printer.

NPA Mode

Purpose:

To specify whether the printer performs the special processing required for bidirectional communication, following the conventions defined in the Network Printing Alliance (NPA) Protocol.

Values:

- On** Printer performs NPA processing. If data is not in NPA format, it is rejected as bad data.
- Off** Printer does not perform NPA processing.
- Auto*** Printer examines the data to determine the format and then processes it appropriately.

Note: Changing this menu item automatically resets the printer.

Parity

Purpose:

To select the parity for serial input and output data frames.

Values:

- Even**
- Odd**
- None***
- Ignore**

See also:

Technical Reference

PCL SmartSwitch

Purpose:

To configure the printer so it automatically switches to PCL emulation when a print job received through the serial port requires it, regardless of the default printer language.

Values:

- On*** Printer examines data on the serial interface and selects PCL emulation if the data indicates that is the required printer language.
- Off** Printer does not examine the incoming data. The printer uses PostScript emulation to process the job if PS SmartSwitch is On, or uses the default printer language specified in the Setup Menu if PS SmartSwitch is Off.

See also:

[PS SmartSwitch](#); [Printer Language](#)

PS SmartSwitch

Purpose:

To configure the printer so it automatically switches to PostScript emulation when a print job received through the serial port requires it, regardless of the default printer language.

Values:

- On*** Printer examines data on the serial interface and selects PostScript emulation if the data indicates that is the required printer language.
- Off** Printer does not examine the incoming data. The printer uses PCL emulation to process the job if PCL SmartSwitch is On, or uses the default printer language specified in the Setup Menu if PCL SmartSwitch is Off.

See also:

[PCL SmartSwitch](#); [Printer Language](#)

Robust XON

Purpose:

To determine whether the printer communicates availability to the computer.

Values:

- Off*** Printer waits to receive data from the computer.
- On** Printer sends a continuous stream of XONs to the host computer to indicate that the serial port is ready to receive more data.

This menu item only applies to the serial port if Serial Protocol is set to XON/XOFF.

RS-232/RS-422

Purpose:

To specify the type of serial communication.

Values:

- RS-232***
- RS-422**

Note: Selecting RS-422 automatically sets Serial Protocol to XON/XOFF.

RS-422 Polarity

Purpose:

To establish the behavior of the positive and negative signals when using RS-422 serial communication.

Values:

Normal*	Uses default definition of one and zero.
Reverse	Reverses the definition of one and zero, thereby allowing a positive connection to a host computer negative terminal without changing the physical cable.

Serial Buffer

Purpose:

To configure the size of the serial input buffer.

Values:

Disabled	Disables job buffering. Any jobs already buffered on the disk are printed before normal processing of incoming jobs resumes.
Auto*	Printer automatically calculates the Serial Buffer size (recommended setting).
3K to maximum size allowed	User specifies the Serial Buffer size. The maximum size depends on the amount of memory in your printer, the size of the other link buffers, and whether Resource Save is set to On or Off. To maximize the range for the Serial Buffer size, disable or reduce the size of the parallel, infrared, LocalTalk, and USB buffers.

Note: Changing the Serial Buffer menu item automatically resets the printer.

See also:

[Resource Save](#)

Serial Protocol

Purpose:

To select the hardware and software handshaking values for the serial interface.

Values:

DTR*	Hardware handshaking.
DTR/DSR	Hardware handshaking.
XON/XOFF	Software handshaking.
XON/XOFF/DTR	Combined hardware and software handshaking.
XON/XOFF/DTRDSR	Combined hardware and software handshaking.

See also:

Technical Reference



Setup Menu

Use the Setup Menu to configure a variety of printer features.

Select a menu item for more details:

- **Alarm Control**
- **Auto Continue**
- **Display Language**
- **Download Target**
- **Jam Recovery**
- **Job Accounting**
- **Page Protect**
- **Power Saver**
- **Print Timeout**
- **Printer Language**
- **Resource Save**
- **Staple Alarm**
- **Toner Alarm**
- **Wait Timeout**

Note: Values marked by an asterisk are the factory default settings.

Alarm Control

Purpose:

To establish whether the printer sounds an alarm when the printer requires operator intervention.

Values:

Off	Printer does not sound an alarm.
Single*	Printer sounds three quick beeps.
Continuous	Printer repeats three beeps every 10 seconds.

Auto Continue

Purpose:

To define the amount of time (in seconds) the printer waits after displaying an operator intervention error message before it resumes printing.

Values:

Disabled*	Printer does not resume printing until someone clears the error message.
5...255	Printer waits the specified amount of time, and then automatically resumes printing. This timeout value also applies if the menus are displayed (and the printer is offline) for the specified period of time.

Display Language

Purpose:

To determine the language of the text on the operator panel display.

Values:

English	Norsk	Russian
Français	Nederlands	Polski
Deutsch	Svenska	Hungarian
Italiano	Português	Turkish
Español	Suomi	Czech
Dansk	Japanese	

Note: All values may not be available.

Download Target

Purpose:

To specify the storage location for downloaded resources.

Values:

RAM*	All downloaded resources are automatically stored in printer memory (RAM).
Flash	All downloaded resources are automatically stored in flash memory.
Disk	All downloaded resources are automatically stored on the hard disk.

Storing downloaded resources in flash memory or on a hard disk is permanent storage rather than the temporary storage that RAM provides. The resources remain in the flash memory or on the hard disk even when the printer is turned off. Use MarkVision to download resources to the printer.

Jam Recovery

Purpose:

To establish whether the printer reprints jammed pages.

Values:

- On** Printer reprints jammed pages.
- Off** Printer does not reprint jammed pages.
- Auto*** Printer reprints a jammed page unless the memory required to hold the page is needed for other printer tasks.

Job Accounting

Purpose:

To store statistical information about your most recent print jobs on the hard disk. The statistics include whether the job printed with or without errors, the print time, the job size (in bytes), the requested paper size and paper type, the total number of printed pages, and the number of copies requested.

Values:

- Off*** Printer does not store job statistics on disk.
- On** Printer stores job statistics for the most recent print jobs.

Note: Job Accounting is only displayed when a hard disk is installed, is neither defective nor Read/Write or Write protected.

See also:

[Job Acct Stat](#)

Page Protect

Purpose:

To successfully print a page that may otherwise generate **Complex Page** errors.

Values:

- Off*** Prints a partial page of data if memory is insufficient to process the entire page.
- On** Ensures that an entire page is processed before it prints.

If, after selecting On, you still cannot print the page, you may also have to reduce the size and number of fonts on the page, or increase the installed printer memory.

For most print jobs, you do not need to select On. When On is selected, printing may be slower.

Power Saver

Purpose:

To specify the amount of time (in minutes) the printer waits after a job is printed before it goes into a reduced power state.

Values:

Disabled	Disables Power Saver; the fuser remains warm and ready to print at all times.
1...240	Specifies the amount of time after a print job before the printer goes into Power Saver mode. (Your printer may not support the entire range of values.)

The factory default Power Saver setting depends on your printer model. Print the menu settings page to determine the current Power Saver setting. When the printer is in Power Saver mode, it is still ready to receive print jobs.

Select 1 to put the printer in Power Saver mode one minute after it finishes a print job. This uses much less energy, but requires more warm-up time for the printer. Select 1 if your printer shares an electrical circuit with room lighting and you notice lights flickering.

Select a high value if your printer is in constant use. Under most circumstances, this keeps the printer ready to print with minimum warm-up time. Select a value between 1 and 240 minutes if you want a balance between energy consumption and a shorter warm-up period.

If the Disabled value is not available from the Power Saver menu item, see [Disabling Power Saver](#) for more information.

Print Timeout

Purpose:

To specify the amount of time (in seconds) the printer waits before printing the last page of a print job that does not end with a command to print the page. The print timeout counter does not start until `waiting` is displayed.

Values:

Disabled	The printer does not print the last page of a print job until one of the following occurs: <ul style="list-style-type: none">• The printer receives enough information to fill the page.• The printer receives a Form Feed command.• You select Print Buffer from the Job Menu.
1...225 (90*)	The printer prints the last page after the specified time.

See also:

[Print Buffer](#)

Printer Language

Purpose:

To establish the default printer language used to communicate data from the computer to the printer.

Values:

PCL Emulation*	PCL emulation, compatible with Hewlett-Packard printers.
PS Emulation	PostScript emulation, compatible with Adobe PostScript language.

Note: Setting a printer language as the default does not prevent a software application from sending print jobs that use the other language.

Resource Save

Purpose:

To determine what the printer does with downloaded resources, such as fonts and macros stored in RAM, if the printer receives a job that requires more memory than is available.

Values:

Off*	Printer retains downloaded resources only until memory is needed. It then deletes those resources associated with the inactive printer language.
On	Printer retains all downloaded resources for all printer languages during language changes and printer resets. If the printer runs out of memory, 38 Memory Full is displayed.

Staple Alarm

Purpose:

To specify how the printer responds when it is out of staples.

Values:

Off*	Staples Empty is displayed until someone loads staples.
Single	Printer stops printing, displays Staples Empty , and sounds three quick beeps.
Continuous	Printer stops printing, displays Staples Empty , and repeats three beeps every 10 seconds until the staple cartridge is replaced.

Toner Alarm

Purpose:

To specify how the printer responds when it is out of toner.

Values:

Off*	An error message is displayed until someone replaces the print cartridge. If an Auto Continue value is selected from the Setup Menu, the printer resumes printing after the specified timeout value.
Single	Printer stops printing, displays an error message, and sounds three quick beeps.
Continuous	Printer stops printing, displays an error message, and repeats three beeps every 10 seconds until the print cartridge is replaced.

See also:

[Auto Continue](#)

Wait Timeout

Purpose:

To specify the amount of time (in seconds) the printer waits to receive additional bytes of data from the computer. When this timeout expires, the print job is canceled.

Values:

Disabled	Disables Wait Timeout.
15...65535 (40*)	Specifies the amount of time the printer waits for additional data before it cancels the job.

Note: Wait Timeout is only available when you use PostScript emulation. This menu item has no effect on PCL emulation print jobs.



Utilities Menu

Use the Utilities Menu to print a variety of listings relating to available printer resources, printer settings, and print jobs. Other menu items let you set up printer hardware and troubleshoot printer problems.

Select a menu item for more details:

- Defragment Flash
- Factory Defaults
- Format Disk
- Format Flash
- Hex Trace
- Job Acct Stat
- Print Directory
- Print Fonts
- Print Menus
- Print Net <x> Setup

Defragment Flash

Purpose:

To retrieve storage area lost when resources are deleted from flash memory.

Values:

- | | |
|------------|--|
| Yes | Printer transfers all resources stored in flash memory to printer memory and then reformats the flash memory option. When the format operation is complete, the resources are loaded back into flash memory. |
| No | Printer cancels the request to defragment the flash memory. |

WARNING: Do not turn off the printer while the flash is defragmenting.

Factory Defaults

Purpose:

To return your printer settings to the factory default values.

Values:

- | | |
|-----------------------|---|
| Restore | <ul style="list-style-type: none">• All menu items are returned to the factory default values except:<ul style="list-style-type: none">– Display Language.– All settings in the Parallel Menu, Serial Menu, Network Menu, Infrared Menu, LocalTalk Menu, and USB Menu.• All downloaded resources (fonts, macros, and symbol sets) in printer memory (RAM) are deleted. (Resources residing in flash memory or on the hard disk are unaffected.) |
| Do Not Restore | User-defined settings remain. |

Format Disk

Purpose:

To format the printer hard disk.

Values:

- | | |
|------------|--|
| Yes | Deletes any data stored on the hard disk and prepares the device to receive new resources. |
| No | Cancels the request to format the hard disk and leaves current resources stored on the disk. |

WARNING: Do not turn off the printer while the hard disk is formatting.

Format Flash

Purpose:

To format the flash memory.

Values:

- | | |
|------------|---|
| Yes | Deletes any data stored in flash memory and prepares the flash memory to receive new resources. |
| No | Cancels the request to format the flash memory and leaves current resources stored in flash memory. |

WARNING: Do not turn off the printer while the flash is formatting.

Hex Trace

Purpose:

To help isolate the source of a print job problem. With Hex Trace selected, all data sent to the printer is printed in hexadecimal and character representation. Control codes are not executed.

To exit Hex Trace, turn the printer off or reset the printer from the Job Menu.

Job Acct Stat

Purpose:

To print a listing of all job statistics stored on the hard disk, or to clear all statistics on the disk.

Values:

Print	Prints all statistics available for the most recent print jobs.
Clear	Deletes all accumulated job statistics from the hard disk.

See also:

[Job Accounting](#)

Print Directory

Purpose:

To print a list of all the resources stored in flash memory or on the hard disk.

Note: Print Directory is available only when either a nondefective flash or disk is installed and formatted, and Job Buffer Size is not set to 100%.

See also:

Technical Reference

Print Fonts

Purpose:

To print a sample of all the fonts available for the selected printer language.

Values:

PCL Fonts	Prints a sample of all printer fonts available for PCL emulation.
PS Fonts	Prints a sample of all printer fonts available for PostScript emulation.

Print Menus

Purpose:

To print a listing of the current user default values, the installed options, the amount of installed printer memory, and the status of printer supplies.

Print Net <x> Setup

Purpose:

To print information relating to the internal print server and the network settings defined by the Network <x> Setup menu item in the Network Menu.

See also:

[Network <x> Setup](#)

49 USB Menu

Use the USB Menu to change printer settings affecting a Universal Serial Bus (USB) port (USB Option <x> or Standard USB).

Select a menu item for more details:

- **Job Buffering**
- **MAC Binary PS**
- **NPA Mode**
- **PCL SmartSwitch**
- **PS SmartSwitch**
- **USB Buffer**

Note: Values marked by an asterisk are the factory default settings.

Job Buffering

Purpose:

To temporarily store jobs on the printer hard disk before printing.

Values:

- | | |
|-------------|---|
| Off* | Does not buffer print jobs to the hard disk. |
| On | Buffers print jobs to the hard disk. |
| Auto | Buffers print jobs only if the printer is busy processing data from another input port. |

Note: Changing the Job Buffering menu item automatically resets the printer.

MAC Binary PS

Purpose:

To configure the printer to process Macintosh binary PostScript print jobs.

Values:

- On** Printer processes raw binary PostScript print jobs from computers using the Macintosh operating system.
Note: This setting often causes Windows print jobs to fail.
- Off** Printer filters PostScript print jobs using standard protocol.
- Auto*** Printer accepts print jobs from computers using either Windows or Macintosh operating systems.

NPA Mode

Purpose:

To specify whether the printer performs the special processing required for bidirectional communication, following the conventions defined in the Network Printing Alliance (NPA) Protocol.

Values:

- On** Printer performs NPA processing. If data is not in NPA format, it is rejected as bad data.
- Off** Printer does not perform NPA processing.
- Auto*** Printer examines the data to determine the format and then processes it appropriately.

Note: Changing this menu item automatically resets the printer.

PCL SmartSwitch

Purpose:

To configure the printer so it automatically switches to PCL emulation when a print job received through the USB port requires it, regardless of the default printer language.

Values:

- On*** Printer examines the data on the USB interface and selects PCL emulation if the data indicates that is the required printer language.
- Off** Printer does not examine the incoming data. The printer uses PostScript emulation to process the job if PS SmartSwitch is On, or uses the default printer language specified in the Setup Menu if PS SmartSwitch is Off.

See also:

[PS SmartSwitch](#); [Printer Language](#)

PS SmartSwitch

Purpose:

To configure the printer so it automatically switches to PostScript emulation when a print job received through the USB port requires it, regardless of the default printer language.

Values:

- | | |
|------------|---|
| On* | Printer examines data on the USB interface and selects PostScript emulation if the data indicates that is the required printer language. |
| Off | Printer does not examine the incoming data. The printer uses PCL emulation to process the job if PCL SmartSwitch is On, or uses the default printer language specified in the Setup Menu if PCL SmartSwitch is Off. |

See also:

[PCL SmartSwitch; Printer Language](#)

USB Buffer

Purpose:

To configure the size of the USB input buffer.

Values:

- | | |
|-----------------------------------|---|
| Disabled | Job buffering is disabled. Any jobs already buffered on the disk are printed before normal processing of incoming jobs resumes. |
| Auto* | Printer automatically calculates the USB Buffer size (recommended setting). |
| 3K to maximum size allowed | User specifies the USB Buffer size. The maximum size depends on the amount of memory in your printer, the size of the other link buffers, and whether Resource Save is set to On or Off. To maximize the range for the USB Buffer size, disable or reduce the size of the parallel, serial, network, infrared, and LocalTalk buffers. |

Note: Changing the USB Buffer menu item automatically resets the printer.

See also:

[Resource Save](#)



Removing options

Keep the following guidelines in mind when removing any options:

- Make sure the printer power is off and the power cord and any cables are unplugged *before* removing any options.
- Remove all print material from any option before removing it from the printer.
- To remove any input option, you must first remove the printer and any options installed above it.
- Remove all options individually; never attempt to remove two or more options at once.

For more information, click a topic:

- **Removing an output option**
- **Removing printer or flash memory**
- **Removing the envelope feeder**
- **Removing an option card**
- **Removing a paper tray or duplex unit**

Removing an output option

Follow these instructions to remove a finisher, 5-bin mailbox, high-capacity output stacker, or output expander. The following steps explain how to remove an output expander as an example.

- 1 If you are removing the topmost output option and do not plan to return it to that position, remove the top cover.

If you are removing a finisher, skip to **step 4**.

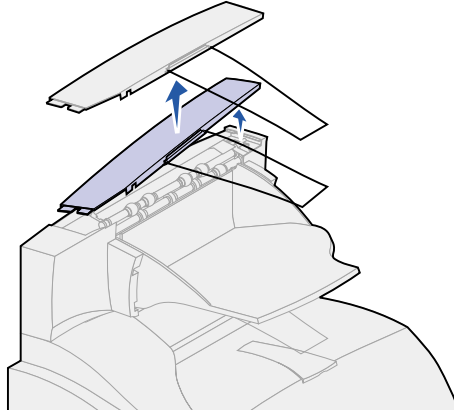

You must attach the top cover to the printer or topmost output option when you finish removing output options. In addition, it may be necessary to remove the paper bail from the top cover, depending on the type of output option to which it is attached. Refer to the *Setup Guide* for more information.

- 2 Detach the output expander tray.

If you are removing a 5-bin mailbox or high-capacity output stacker, skip to **step 3**.

- a Lift the edge of the tray so the lower tabs come out of the slots on the output expander.

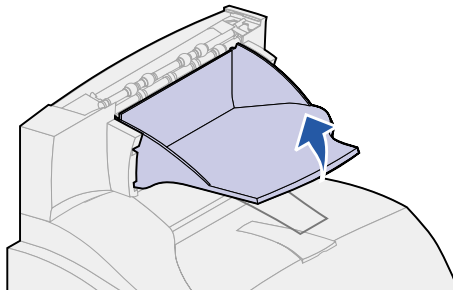

- b Pull the tray straight out toward you to remove the upper tabs from the output expander slots.

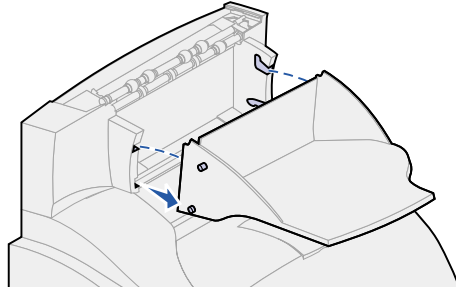

- 3 The output option may have a wire paper bail attached. If so, remove the tips of the paper bail from the ends of the plastic bracket on the bottom of the output option.

Refer to the *Setup Guide* when you are ready to reattach the paper bail to an output option.

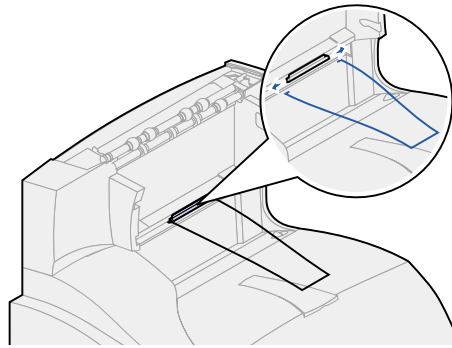

- 4 Carefully lift the option straight up until it is completely disconnected from the option below it or from the printer. Set it aside.

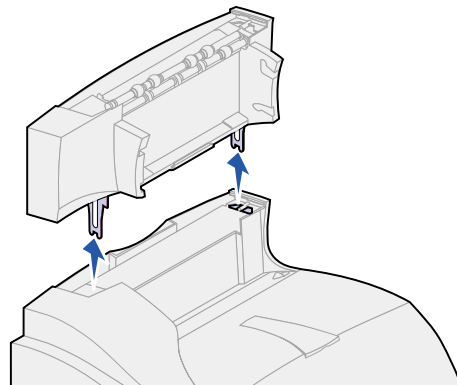

WARNING: The edges of the mounting brackets could damage tabletops or fabrics.

- 5 Refer to the *Setup Guide* when you are ready to reattach options.

Removing the envelope feeder

- 1 Remove envelopes from the envelope feeder.

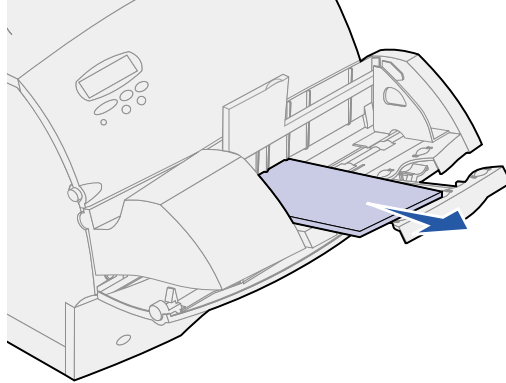

- 2 Push the envelope support to the closed position.

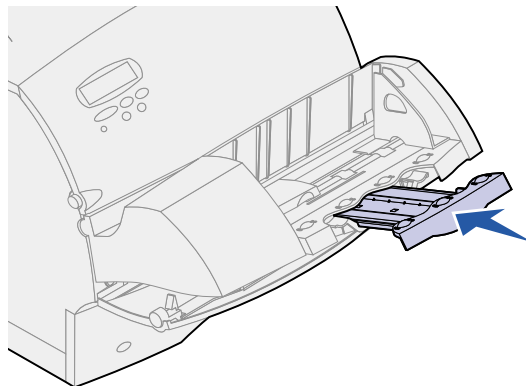

- 3 Open the printer upper front door.

- 4 Pull the envelope feeder up slightly and straight out of the printer. Set it aside.

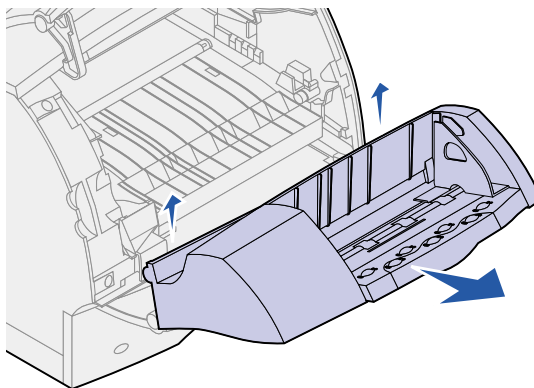

- 5 Close both front doors.
- 6 Refer to the *Setup Guide* when you are ready to reattach options.

Removing a paper tray or duplex unit

- 1 Ask someone to help you lift the printer by the handholds and set it aside.

CAUTION: Make sure your fingers are not under the printer when you set it down.

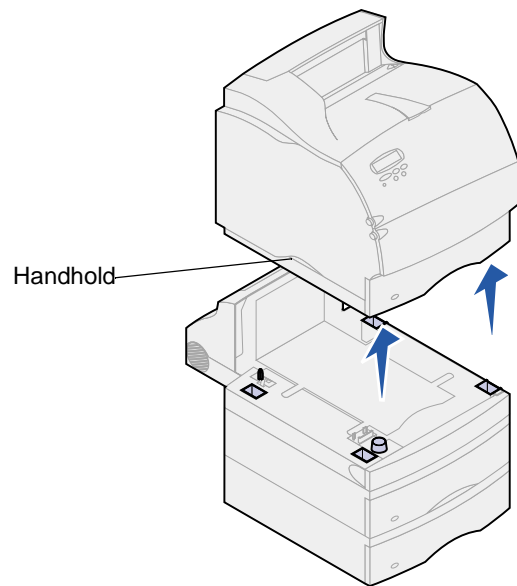

- Carefully lift the option straight up until it is completely disconnected from the option below it. Set it aside.

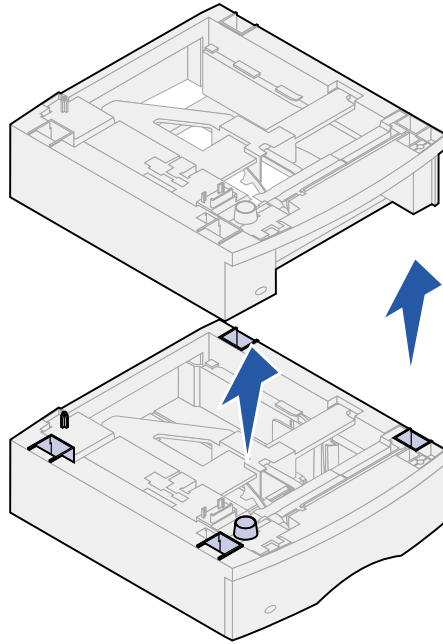

- Refer to the *Setup Guide* when you are ready to reattach options.

Removing printer or flash memory

If necessary, refer to the *Setup Guide* for instructions on accessing the printer system board.

- Locate the memory option you want to remove.

WARNING: Electronic components are easily damaged by static electricity. Touch something metal on the printer before you touch the memory option.

- Push out on the latches at each end of the connector.

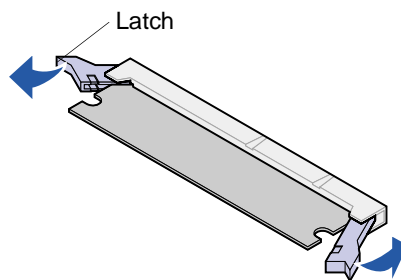

- 3 Pull the memory option out of the connector.

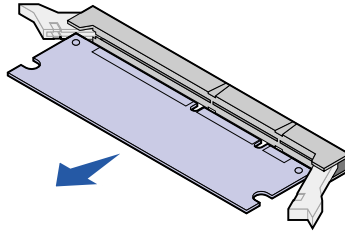

- 4 Place the memory option in its original packaging. If you did not save the packaging, wrap it in paper and store it in a box.
- 5 If you need to install a replacement memory option or other option on the system board, refer to the *Setup Guide*.
- 6 Refer to the *Setup Guide* for instructions on closing the printer system board.

Removing an option card

If necessary, refer to the *Setup Guide* for instructions on accessing the printer system board.

WARNING: Electronic components are easily damaged by static electricity. Touch something metal on the printer before you touch the card.

- 1 Locate the option you want to remove.
- 2 Loosen and remove the two screws over and under the slot. Gently pull the card out of the connector on the system board.

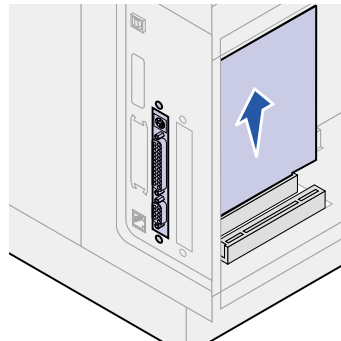
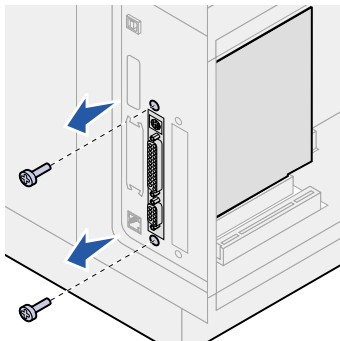

- 3 Place the option card in its original packaging. If you did not save the packaging, wrap the card in paper and store it in a box.
- 4 If you need to install another option on the system board, refer to the *Setup Guide*.
- 5 Refer to the *Setup Guide* for instructions on closing the printer system board.

51

Disabling Power Saver

If you always want your printer ready to print without delays, you may want to disable **Power Saver** in the **Setup Menu**. If the Disabled value is not available, first change the Energy Conserve setting to Off in the Config Menu:

- 1 Turn the printer off.
- 2 Press and hold the **Select** and **Return** buttons, and then turn the printer on.
- 3 Release the buttons when **Performing Self Test** appears on the display.

When the printer self test is done, Config Menu is displayed.

- 4 Press **Menu** until you see Energy Conserve, and then press **Select**.
- 5 Press **Menu** until you see Off, and then press **Select**.

Energy Conserve SAVED briefly appears, and then Config Menu is displayed.

- 6 Press **Menu** until you see Exit Config Menu, and then press **Select**.

Activating Menu Changes briefly appears, followed by **Performing Self Test**. The printer then displays the **Ready** message.

Now you can select the Disabled value from the Power Saver menu item.

Note: You can also disable Power Saver by issuing a Printer Job Language (PJL) command. For more information, refer to the *Technical Reference* available on Lexmark's Web site at www.lexmark.com.



Printer specifications

Dimensions

Dimension	T620 and T622
Height	404 mm (15.9 in.)
with drawer ¹	538 mm (21.2 in.)
Width	418 mm (16.5 in.)
Depth	513 mm (20.2 in.)
Weight ²	20.4 kg (45 lb)
with drawer ³	23.6 kg (52 lb) ³
¹ Includes printer and optional 500-sheet drawer. ² Includes print cartridge. ³ Includes printer and optional 500-sheet drawer.	

Duty cycle

Maximum duty cycle	
T620 and T622 T622(n)	T620 and T622 T620(n)
Up to 200,000 pages per month	Up to 130,000 pages per month

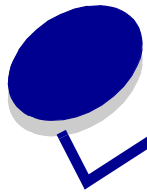

Notices

- **Edition notice**
- **Trademarks**
- **Safety information**
- **Cautions and warnings**
- **Electronic emission notices**
- **Energy Star**
- **Laser notices**

Edition notice

January 2001

The following paragraph does not apply to any country where such provisions are inconsistent with local law: LEXMARK INTERNATIONAL, INC., PROVIDES THIS PUBLICATION "AS IS" WITHOUT WARRANTY OF ANY KIND, EITHER EXPRESS OR IMPLIED, INCLUDING, BUT NOT LIMITED TO, THE IMPLIED WARRANTIES OF MERCHANTABILITY OR FITNESS FOR A PARTICULAR PURPOSE. Some states do not allow disclaimer of express or implied warranties in certain transactions; therefore, this statement may not apply to you.

This publication could include technical inaccuracies or typographical errors. Changes are periodically made to the information herein; these changes will be incorporated in later editions. Improvements or changes in the products or the programs described may be made at any time.

Comments about this publication may be addressed to Lexmark International, Inc., Department F95/032-2, 740 West New Circle Road, Lexington, Kentucky 40550, U.S.A. In the United Kingdom and Eire, send to Lexmark International Ltd., Marketing and Services Department, Westhorpe House, Westhorpe, Marlow Bucks SL7 3RQ. Lexmark may use or distribute any of the information you supply in any way it believes appropriate without incurring any obligation to you. You can purchase additional copies of publications related to this product by calling 1-800-553-9727. In the United Kingdom and Eire, call 0628-481500. In other countries, contact your point of purchase.

References in this publication to products, programs, or services do not imply that the manufacturer intends to make these available in all countries in which it operates. Any reference to a product, program, or service is not intended to state or imply that only that product, program, or service may be used. Any functionally equivalent product, program, or service that does not infringe any existing intellectual property right may be used instead. Evaluation and verification of operation in conjunction with other products, programs, or services, except those expressly designated by the manufacturer, are the user's responsibility.

Trademarks

Lexmark and Lexmark with diamond design, MarkNet, MarkVision, and *Prebate* are trademarks of Lexmark International, Inc., registered in the United States and/or other countries.

PictureGrade is a trademark of Lexmark International, Inc. LEXFAX and Operation ReSource are service marks of Lexmark International, Inc.

PCL[®] is a registered trademark of the Hewlett-Packard Company. PCL is Hewlett-Packard Company's designation of a set of printer commands (language) and functions included in its printer products. This printer is intended to be compatible with the PCL language. This means the printer recognizes PCL commands used in various application programs, and that the printer emulates the functions corresponding to the commands.

PostScript[®] is a registered trademark of Adobe Systems[®] Incorporated. PostScript 3 is Adobe Systems' designation of a set of printer commands (language) and functions included in its software products. This printer is intended to be compatible with the PostScript 3 language. This means the printer recognizes PostScript 3 commands used in various application programs, and that the printer emulates the functions corresponding to the commands.

Details relating to compatibility are included in the *Technical Reference*.

The following terms are trademarks or registered trademarks of these companies:

Helvetica	Linotype-Hell AG and/or its subsidiaries
ITC Avant Garde	International Typeface Corporation
Times New Roman	The Monotype Corporation plc
Zapf Chancery	International Typeface Corporation

Other trademarks are the property of their respective owners.

© Copyright 2001 Lexmark International, Inc.
All rights reserved.

UNITED STATES GOVERNMENT RESTRICTED RIGHTS

This software and documentation are provided with RESTRICTED RIGHTS. Use, duplication or disclosure by the Government is subject to restrictions as set forth in subparagraph (c)(1)(ii) of the Rights in Technical Data and Computer Software clause at DFARS 252.227-7013 and in applicable FAR provisions: Lexmark International, Inc., Lexington, KY 40550.

Safety information

- If your product is NOT marked with this symbol , it MUST be connected to an electrical outlet that is properly grounded.
- The power cord must be connected to an electrical outlet that is near the product and easily accessible.
- Refer service or repairs, other than those described in the operating instructions, to a professional service person.
- This product is designed, tested and approved to meet strict global safety standards with the use of specific Lexmark components. The safety features of some parts may not always be obvious. Lexmark is not responsible for the use of other replacement parts.
- Your product uses a laser, exercise

CAUTION: Use of controls or adjustments or performance of procedures other than those specified herein may result in hazardous radiation exposure.

- Your product uses a printing process that heats the print media, and the heat may cause the media to release emissions. You must understand the section in your operating instructions that discusses the guidelines for selecting print media to avoid the possibility of harmful emissions.

Cautions and warnings

CAUTION: A caution identifies something that might cause you harm.

WARNING: A warning identifies something that might damage your printer hardware or software.

Electronic emission notices

With a network cable installed

Federal Communications Commission (FCC) Compliance Information Statement

The T620 and T622 has been tested and found to comply with the limits for a Class A digital device, pursuant to Part 15 of the FCC Rules. Operation is subject to the following two conditions: (1) this device may not cause harmful interference, and (2) this device must accept any interference received, including interference that may cause undesired operation.

The FCC Class A limits are designed to provide reasonable protection against harmful interference when the equipment is operated in a commercial environment. This equipment generates, uses, and can radiate radio frequency energy and, if not installed and used in accordance with the instruction manual, may cause harmful interference to radio communications. Operation of this equipment in a residential area is likely to cause harmful interference, in which case the user will be required to correct the interference at his own expense.

The manufacturer is not responsible for any radio or television interference caused by using other than recommended cables or by unauthorized changes or modifications to this equipment. Unauthorized changes or modifications could void the user's authority to operate this equipment.

Note: To assure compliance with FCC regulations on electromagnetic interference for a Class A computing device, use a properly shielded and grounded cable such as Lexmark part number 1329605. Use of a substitute cable not properly shielded and grounded may result in a violation of FCC regulations.

Industry Canada Compliance Statement

This Class A digital apparatus meets all requirements of the Canadian Interference-Causing Equipment Regulations.

Avis de conformité aux normes d'Industrie Canada

Cet appareil numérique de la classe A respecte toutes les exigences du Règlement sur le matériel brouilleur du Canada.

European Community (EC) Directives Conformity

This product is in conformity with the protection requirements of EC Council directives 89/336/EEC and 73/23/EEC on the approximation and harmonization of the laws of the Member States relating to electromagnetic compatibility and safety of electrical equipment designed for use within certain voltage limits.

A declaration of conformity with the requirements of the Directive has been signed by the Director of Manufacturing and Technical Support, Lexmark International, S.A., Boigny, France.

This product satisfies the Class A limits of EN 55022 and safety requirements of EN 60950.

WARNING: When a print server is installed, this is a Class A product. In a domestic environment, this product may cause radio interference, in which case, the user may be required to take adequate measures.

Without a network cable installed

Federal Communications Commission (FCC) Compliance Information Statement

The T620 and T622 has been tested and found to comply with the limits for a Class B digital device, pursuant to Part 15 of the FCC Rules. Operation is subject to the following two conditions: (1) this device may not cause harmful interference, and (2) this device must accept any interference received, including interference that may cause undesired operation.

The FCC Class B limits are designed to provide reasonable protection against harmful interference in a residential installation. This equipment generates, uses and can radiate radio frequency energy and, if not installed and used in accordance with the instructions, may cause harmful interference to radio communications. However, there is no guarantee that interference will not occur in a particular installation. If this equipment does cause harmful interference to radio or television reception, which can be determined by turning the equipment off and on, the user is encouraged to try to correct the interference by one or more of the following measures:

- Reorient or relocate the receiving antenna.
- Increase the separation between the equipment and receiver.
- Connect the equipment into an outlet on a circuit different from that to which the receiver is connected.
- Consult your point of purchase or service representative for additional suggestions.

The manufacturer is not responsible for any radio or television interference caused by using other than recommended cables or by unauthorized changes or modifications to this equipment. Unauthorized changes or modifications could void the user's authority to operate this equipment.

Note: To assure compliance with FCC regulations on electromagnetic interference for a Class B computing device, use a properly shielded and grounded cable such as Lexmark part number 1329605. Use of a substitute cable not properly shielded and grounded may result in a violation of FCC regulations.

Industry Canada Compliance Statement

This Class B digital apparatus meets all requirements of the Canadian Interference-Causing Equipment Regulations.

Avis de conformité aux normes d'Industrie Canada

Cet appareil numérique de la classe B respecte toutes les exigences du Règlement sur le matériel brouilleur du Canada.

European Community (EC) Directives conformity

This product is in conformity with the protection requirements of EC Council directives 89/336/EEC and 73/23/EEC on the approximation and harmonization of the laws of the Member States relating to electromagnetic compatibility and safety of electrical equipment designed for use within certain voltage limits.

A declaration of conformity with the requirements of the Directive has been signed by the Director of Manufacturing and Technical Support, Lexmark International, S.A., Boigny, France.

This product satisfies the Class B limits of EN 55022 and safety requirements of EN 60950.

The United Kingdom Telecommunications Act 1984

This apparatus is approved under the approval number NS/G/1234/J/100003 for the indirect connections to the public telecommunications systems in the United Kingdom.

Energy Star



The EPA ENERGY STAR Computers program is a partnership effort with computer manufacturers to promote the introduction of energy-efficient products and to reduce air pollution caused by power generation.

Companies participating in this program introduce personal computers, printers, monitors, or fax machines that power down when they are not being used. This feature will cut the energy used by up to 50 percent. Lexmark is proud to be a participant in this program.

As an Energy Star Partner, Lexmark International, Inc. has determined that this product meets the Energy Star guidelines for energy efficiency.

Laser notices

Laser advisory label

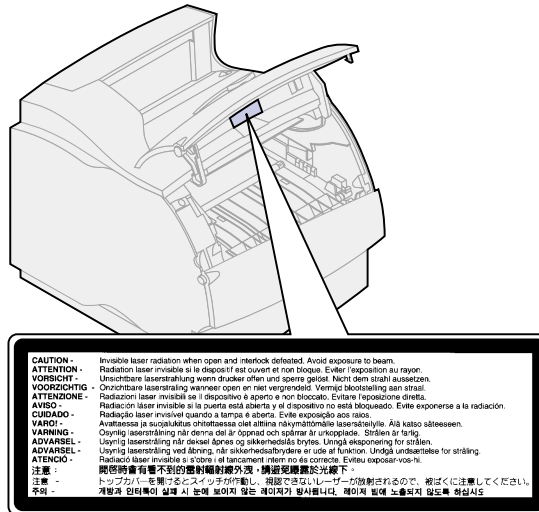

Laser notice

The printer is certified in the U.S. to conform to the requirements of DHHS 21 CFR Subchapter J for Class I (1) laser products, and elsewhere is certified as a Class I laser product conforming to the requirements of IEC 825.

Class I laser products are not considered to be hazardous. The printer contains internally a Class IIIb (3b) laser that is nominally a 5 milliwatt gallium arsenide laser operating in the wavelength region of 770-795 nanometers. The laser system and printer are designed so there is never any human access to laser radiation above a Class I level during normal operation, user maintenance, or prescribed service condition.

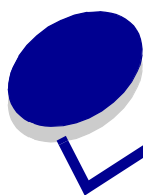

Index

A

- A4 Width (PCL Emul Menu) 166
- Advanced Status (Parallel Menu) 171
- Alarm Control (Setup Menu) 185
- alarms
 - error messages 186
 - setting 185
 - stapler 189
 - toner 190
- Assign Type/Bin (Paper Menu) 158
- Auto Continue (Setup Menu) 186
- Auto CR after LF (PCL Emul Menu) 167
- Auto LF after CR (PCL Emul Menu) 167
- avoiding paper jams 55

B

- Baud (Serial Menu) 179
- bins
 - assigning 158
 - configuring 159
 - output 160
 - overflow 160
 - resetting active 149
- Blank Pages (Finishing Menu) 137
- buffer sizes, adjusting
 - infrared 143
 - LocalTalk 151
 - network 155
 - parallel 173
 - serial 183
 - USB 197

C

- Cancel Job (Job Menu) 147
- canceling a print job 19
- card stock
 - guidelines 26
 - loading 37
- charge roll
 - ordering 64
 - replacing 57

- clearing paper jams 68
- Collation (Finishing Menu) 138
- collation, enabling 138
- complex page errors 187
- Confidential Job (Job Menu) 148
- Configure Bins (Paper Menu) 159
- Configure MP (Paper Menu) 159
- Copies (Finishing Menu) 138
- copies, specifying number 138
- Custom Types (Paper Menu) 159

D

- Data Bits (Serial Menu) 180
- Defragment Flash (Utilities Menu) 191
- disabling operator panel menus 14
- disk
 - See hard disk
- Display Language (Setup Menu) 186
- Download Target (Setup Menu) 186
- downloaded resources
 - printing 193
 - Resource Save 189
 - storing 186
- duplex
 - binding 139
 - enabling 138
- Duplex (Finishing Menu) 138
- Duplex Bind (Finishing Menu) 139

E

- Envelope Enhance (Paper Menu) 160
- envelope feeder
 - setting paper source, size, type 52
- envelopes
 - choosing 25
 - clearing jams 83
 - loading
 - envelope feeder 49
 - multipurpose feeder 44

F

- Factory Defaults (Utilities Menu) 192
- factory defaults, restoring 192
- fill line 37
- Finishing Menu 137
 - Blank Pages 137
 - Collation 138
 - Copies 138
 - Duplex 138
 - Duplex Bind 139
 - Multipage Border 139
 - Multipage Order 139
 - Multipage Print 140
 - Multipage View 140
 - Offset Pages 140
 - Separator Sheets 141
 - Separator Source 141
 - Staple Job 142
 - Staple Prime Src 142
- flash memory
 - defragmenting 191
 - formatting 192
 - printing downloaded resources 193
 - removing 203
 - setting as download target 186
- folio size 20
- Font Name (PCL Emul Menu) 167
- Font Priority (PostScript Menu) 176
- Font Source (PCL Emul Menu) 168
- fonts
 - choosing in PCL emulation 167
 - printing samples 193
 - priority 176
 - symbol sets supported 170
- Format Disk (Utilities Menu) 192
- Format Flash (Utilities Menu) 192
- fuser
 - ordering 65
 - replacing 59

G

- guidelines

- card stock 26
 - envelopes 25
 - labels 25
 - paper
 - recommended 22
 - storing 28
 - unacceptable 23
- H**
- hard disk
 - formatting 192
 - printing downloaded resources 193
 - setting as download target 186
 - Held jobs 15
 - Held Jobs (Job Menu) 148
 - Hex Trace (Utilities Menu) 193
 - hole-punched paper 24
 - Honor DSR (Serial Menu) 180
 - Honor Init (Parallel Menu) 172
- I**
- indicator light 10
 - Infrared Buffer (Infrared Menu) 143
 - Infrared Menu 143
 - Infrared Buffer 143
 - Infrared Port 144
 - Job Buffering 144
 - Max Baud Rate 144
 - NPA Mode 145
 - PCL SmartSwitch 145
 - PS SmartSwitch 145
 - Transmit Delay 146
 - Window Size 146
 - infrared port
 - activating 144
 - adjusting transmission speeds 144
 - configuring
 - buffer size 143
 - NPA Mode 145
 - PCL SmartSwitch 145
 - PS SmartSwitch 145
 - transmit delay 146
 - window size 146
 - Infrared Port (Infrared Menu) 144
 - integrated forms 32, 35
 - integrated tray 9
 - interfaces
 - infrared 143
 - LocalTalk 150
 - network 154
 - parallel 171
 - serial 179
 - USB 195
- J**
- Jam Recovery (Setup Menu) 187
 - jams
 - avoiding 55
 - clearing paper 68
 - See paper jams
 - job
 - canceling 147
 - confidential 148
 - held 148
 - statistics 187
 - Job Accounting (Setup Menu) 187
 - Job Acct Stat (Utilities Menu) 193
 - Job Buffering (Infrared Menu) 144
 - Job Buffering (LocalTalk Menu) 150
 - Job Buffering (Network Menu) 154
 - Job Buffering (Parallel Menu) 172
 - Job Buffering (Serial Menu) 180
 - Job Buffering (USB Menu) 195
 - Job Menu 147
 - Cancel Job 147
 - Confidential Job 148
 - Held Jobs 148
 - Prime Stapler 149
 - Print Buffer 149
 - Reset Active Bin 149
 - Reset Printer 149
- L**
- label fuser cleaner 64
 - labels
 - guidelines 25
 - printer maintenance 26
 - laser notices 212
 - letterhead 23
 - choosing 23
 - loading
 - multipurpose feeder 45
 - paper tray 38
 - Lines per Page (PCL Emul Menu) 168
 - linking trays 54
 - loading print material
 - card stock 37
 - envelopes
 - envelope feeder 49
 - multipurpose feeder 44
 - letterhead
 - multipurpose feeder 45
 - paper tray 38
 - paper
 - 2000-sheet drawer 53
 - multipurpose feeder 44
 - multipurpose tray 40
 - paper tray 37
 - transparencies
 - multipurpose feeder 44
 - paper tray 37
 - LocalTalk Addr (LocalTalk Menu) 150
 - LocalTalk Buffer (LocalTalk Menu) 151
 - LocalTalk Menu 150
 - Job Buffering 150
 - LocalTalk Addr 150
 - LocalTalk Buffer 151
 - LocalTalk Name 151
 - LocalTalk Port 151
 - LocalTalk Zone 151
 - NPA Hosts 152
 - NPA Mode 152
 - PCL SmartSwitch 152
 - PS SmartSwitch 153
 - LocalTalk Name (LocalTalk Menu) 151
 - LocalTalk port
 - activating 151
 - configuring
 - buffer size 151
 - NPA hosts 152
 - NPA mode 152
 - PCL SmartSwitch 152
 - PS SmartSwitch 153
 - LocalTalk Port (LocalTalk Menu) 151
 - LocalTalk Zone (LocalTalk Menu) 151
- M**
- MAC Binary PS (Network Menu) 155
 - MAC Binary PS (USB Menu) 195
 - maintenance
 - charge roll 57
 - fuser 59
 - print cartridge 56
 - staple cartridge 60
 - transfer roll 58
 - maintenance counter 61
 - Max Baud Rate (Infrared Menu) 144
 - maximum stack height 43
 - memory
 - 38 Memory Full 128
 - Defragmenting 107
 - Print and Hold function 15
 - removing 203
 - menus
 - language 186
 - main list of 136
 - messages
 - 2<xx> Paper Jam 126
 - 31 Defective Print Cartridge 126

- 32 Unsupported Print Cartridge 126
- 34 Short Paper 127
- 35 Res Save Off Deficient Memory 127
- 37 Insufficient Collation Area 127
- 37 Insufficient Defrag Memory 128
- 37 Insufficient Memory 128
- 38 Memory Full 128
- 39 Complex Page 129
- 51 Defective Flash 129
- 52 Flash Full 129
- 53 Unformatted Flash 130
- 54 Network <x> Software Error 130
- 54 Par <x> ENA Connection Lost 130
- 54 Parallel Error 131
- 54 Parallel Option <x> Error 131
- 54 Serial Option <x> Error 130
- 54 Standard Serial Error 130
- 54 Std Network Software Error 130
- 54 Std Par ENA Connection Lost 130
- 56 Parallel Port <x> Disabled 132
- 56 Serial Port <x> Disabled 131
- 56 Standard Serial Disabled 131
- 56 Std Parallel Port Disabled 132
- 58 Too Many Bins Attached 132
- 58 Too Many Disks Installed 132
- 58 Too Many Flash Options 133
- 58 Too Many Trays Attached 133
- 59 Incompatible <device> 133
- 61 Defective Disk 133
- 62 Disk Full 134
- 63 Unformatted Disk 134
- 70–79 messages 134
- 80 Scheduled Maintenance 134
- 81 Engine Code CRC Failure 135
- 88 Toner Low 135
- 900–999 Service 135
- Activating Menu Changes 105
- Bin <x> Full 105
- Busy 105
- Canceling Job 105
- Change Tray <x> 106
- Check <device> Connection 106
- Clear [Staple] Job from Finisher 106
- Clearing Job Accounting Stat 107
- Close Door or Insert Cartridge 107
- Defragmenting 107
- Delete All Jobs 107
- Deleting Jobs 108
- Disabling Menus 108
- Disk Corrupted 108
- Disk Recovery 109
- Enabling Menus 109
- Energy Conserve SAVED 109
- Flushing Buffer 110
- Formatting Disk 110
- Formatting Flash 110
- Held Jobs may be lost 111
- Infrared 111
- Insert Stapler 111
- Insert Tray <x> 112
- Install <device> or Cancel Job 112
- Insufficient Fax Buffer 131
- Invalid Network <x> Code 112
- Invalid Standard Network Code 112
- Leave Job in Finisher 113
- Load Manual 113
- Load Staples 113
- Load Tray <x> 114
- LocalTalk <x> 114
- Maintenance 114
- Menus Disabled 114
- Network <x> 115
- Network <x>,<y> 115
- Network Card Busy 115
- No Jobs Found. Retry? 115
- Not Ready 116
- Overflow Bin Full 116
- Parallel <x> 116
- Performing Self Test 116
- Power Saver 116
- Priming Failed, Retry 117
- Priming Stapler 117
- Print Jobs on Disk 117
- Printing Directory List 118
- Printing Font List 118
- Printing Job Accounting Stat 118
- Printing Menu Settings 118
- Prog Engine Code 119
- Prog System Code 119
- Program Flash 119
- Programming Disk 119
- Queuing and Deleting Jobs 120
- Queuing Jobs 120
- Ready 120
- Ready Hex 120
- Reattach <device> 121
- Remove Paper <specified bin> 121
- Res Reduced 121
- Resetting Active Bin 122
- Resetting Maint Cnt Value 122
- Resetting the Printer 122
- Restore Held Jobs 122
- Restoring Factory Defaults 123
- Restoring Held Jobs 123
- Serial <x> 123
- Staples Empty 123
- Staples Low 124
- Std Bin Full 124
- Toner Low 124
- Tray <x> Empty 125
- Tray <x> Low 125
- Tray <x> Missing 125
- USB <x> 125
- Waiting 125
- Multipage Border (Finishing Menu) 139
- Multipage Order (Finishing Menu) 139
- multipage print
 - border settings 139
 - configuring 140
 - order settings 139
 - view settings 140
- Multipage Print (Finishing Menu) 140
- Multipage View (Finishing Menu) 140
- multipurpose feeder, configuring 159
- multipurpose tray
 - closing 48
 - guidelines 40
 - icons 41
 - print material
 - envelopes 42
 - loading 43
 - paper 42
 - transparencies 43

N

- Network <x> Setup (Network Menu) 155
- Network Buffer (Network Menu) 155
- Network Menu 154
 - Job Buffering 154
 - MAC Binary PS 155
 - Network <x> Setup 155
 - Network Buffer 155
 - NPA Mode 156

- PCL SmartSwitch 156
- PS SmartSwitch 156
- network port, configuring
 - buffer size 155
 - NPA mode 156
 - PCL SmartSwitch 156
 - PS SmartSwitch 156
- NPA Hosts
 - (LocalTalk Menu) 152
- NPA Mode
 - (Infrared Menu) 145
 - (Network Menu) 156
 - (Parallel Menu) 172
 - (Serial Menu) 181
 - (USB Menu) 196
- NPA mode, setting
 - infrared port 145
 - LocalTalk port 152
 - See also NPA hosts 152
 - network port 156
 - parallel port 172
 - serial port 181
 - USB port 196
- N-Up printing
 - See Multipage Print 140

O

- Offset Pages (Finishing Menu) 140
- operator panel
 - disabling 14
 - LCD 10
 - light 10
 - using 11
- ordering supplies 63
- Orientation (PCL Emul Menu) 169
- Output Bin (Paper Menu) 160
- Overflow Bin (Paper Menu) 160

P

- Page Protect (Setup Menu) 187
- paper
 - avoiding jams 55
 - clearing jams 68
 - letterhead 23
 - preprinted forms 23
 - pre-punched 24
 - recommended types 22
 - storing 28
 - unsatisfactory types 23
- paper capacity mark 37
- paper guidelines
 - recommended papers 22
- paper jams
 - 200 Paper Jam Remove
 - Cartridge 70
 - 201 Paper Jam Remove

- Cartridge 70
- 202 Paper Jam Open Rear Door 71
- 230 Paper Jam Check Duplex 74
- 24x Paper Jams Check Tray x 77
- 250 Paper Jam Check MP Feeder 82
- 260 Paper Jam Check Env Feeder 83
- 27x Paper Jam Check Bin x 85
- reprinting jammed pages 187
- paper length guide 37
- Paper Loading (Paper Menu) 161
- Paper Menu 158
 - Assign Type/Bin 158
 - Configure Bins 159
 - Configure MP 159
 - Custom Types 159
 - Envelope Enhance 160
 - Output Bin 160
 - Overflow Bin 160
 - Paper Loading 161
 - Paper Size 162
 - Paper Source 162
 - Paper Texture 163
 - Paper Type 163
 - Paper Weight 164
 - Substitute Size 165
 - Universal Setup 165
- Paper Size (Paper Menu) 162
- paper size window 38
- Paper Source (Paper Menu) 162
- Paper Texture (Paper Menu) 163
- paper tray
 - length guide 37
 - width guide 37
- Paper Type (Paper Menu) 163
- Paper Weight (Paper Menu) 164
- paper width guide 37
- paper, specifying
 - custom type 159
 - if requested size not loaded 165
 - preprinted forms 161
 - size 162
 - source 162
 - texture 163
 - type 163
 - weight 164
- Parallel Buffer (Parallel Menu) 173
- Parallel Menu 171
 - Advanced Status 171
 - Honor Init 172
 - Job Buffering 172
 - NPA Mode 172
 - Parallel Buffer 173
 - Parallel Mode 1 173

- Parallel Mode 2 173
- PCL SmartSwitch 174
- Protocol 174
- PS SmartSwitch 174
- Parallel Mode 1 (Parallel Menu) 173
- Parallel Mode 2 (Parallel Menu) 173
- parallel port
 - configuring
 - bidirectional communication 171
 - buffer size 173
 - data sampling 173
 - hardware initialization 172
 - NPA mode 172
 - PCL SmartSwitch 174
 - protocol 174
 - PS SmartSwitch 174
 - enabling resistors 173
- Parity (Serial Menu) 181
- PCL Emul Menu 166
 - A4 Width 166
 - Auto CR after LF 167
 - Auto LF after CR 167
 - Font Name 167
 - Font Source 168
 - Lines per Page 168
 - Orientation 169
 - Pitch 169
 - Point Size 169
 - Symbol Set 170
 - Tray Renumber 170
- PCL emulation
 - A4 width 166
 - automatic carriage return 167
 - automatic line feed 167
 - font name 167
 - font sample print 193
 - font source 168
 - lines per page 168
 - orientation 169
 - pitch 169
 - point size 169
 - symbol set 170
 - tray renumber 170
- PCL SmartSwitch
 - (Infrared Menu) 145
 - (LocalTalk Menu) 152
 - (Network Menu) 156
 - (Parallel Menu) 174
 - (Serial Menu) 181
 - (USB Menu) 196
- PCL SmartSwitch, setting
 - See also Printer Language
 - infrared port 145
 - LocalTalk port 152
 - network port 156
 - parallel port 174

- serial port 181
- USB port 196
- PictureGrade (Quality Menu) 177
- Pitch (PCL Emul Menu) 169
- Point Size (PCL Emul Menu) 169
- ports
 - infrared 143
 - LocalTalk 150
 - network 154
 - parallel 171
 - serial 179
 - USB 195
- PostScript emulation
 - font priority 176
 - font sample print 193
 - printing PS errors 176
- PostScript Menu 176
 - Font Priority 176
 - Print PS Error 176
- Power Saver
 - configuring 188
 - disabling 205
- Power Saver (Setup Menu) 188
- PQET (Quality Menu) 177
- preprinted forms 23
- pre-punched paper 24
- Prime Stapler (Job Menu) 149
- Print and Hold function
 - see held jobs 15
- Print Buffer (Job Menu) 149
- print cartridge
 - ordering 63
 - replacing 56
- Print Directory (Utilities Menu) 193
- Print Fonts (Utilities Menu) 193
- print material specifications
 - characteristics 21
 - sizes 29
 - types 31
 - weight 31
- Print Menus (Utilities Menu) 194
- Print Net<x> Setup (Utilities Menu) 194
- print options
 - offset pages 140
 - print buffer 149
 - printing on envelopes 160
 - separator sheets 141
 - See also separator source 141
- Print PS Error (PostScript Menu) 176
- print quality, adjusting
 - character smoothing 177
 - PictureGrade 177
 - print resolution 178
 - toner darkness 178
- Print Resolution (Quality Menu) 178

- print statistics
 - job accounting 187
 - printing job statistics 193
- print timeout
 - configuring 188
- Print Timeout (Setup Menu) 188
- printer
 - model with paper handling
 - options 9
 - resetting 149
- Printer Language (Setup Menu) 189
- printer messages
 - Enter PIN 17
 - No Jobs Found. Retry? 18
- printer testing
 - Hex Trace mode 193
 - print defaults 194
 - print hardware statistics 194
- printing
 - folio 20
 - statement 20
- problem solving
 - paper jams 68
 - printer settings 10
 - unresponsive printer 67
- Protocol (Parallel Menu) 174
- PS emulation
 - See PostScript emulation
- PS SmartSwitch
 - (Infrared Menu) 145
 - (LocalTalk Menu) 153
 - (Network Menu) 156
 - (Parallel Menu) 174
 - (Serial Menu) 182
 - (USB Menu) 197
- PS SmartSwitch, setting
 - See also printer language 189
- infrared port 145
- LocalTalk port 153
- network port 156
- parallel port 174
- serial port 182
- USB port 197

Q

- quality
 - See print quality, adjusting 177
- Quality Menu 177
 - PictureGrade 177
 - PQET 177
 - Print Resolution 178
 - Toner Darkness 178

R

- recommended papers 22
- removing options 198

- replacing
 - charge roll 57
 - fuser 59
 - print cartridge 56
 - staple cartridge 60
 - transfer roll 58
- Reset Active Bin (Job Menu) 149
- Reset Printer (Job Menu) 149
- resetting printer 149
- resetting the maintenance counter 61
- Resource Save (Setup Menu) 189
- Robust XON (Serial Menu) 182
- RS-232/RS-422 (Serial Menu) 182
- RS-422 Polarity (Serial Menu) 183

S

- safety information 209
- Separator Sheets (Finishing Menu) 141
- Separator Source (Finishing Menu) 141
- Serial Buffer (Serial Menu) 183
- Serial Menu 179
 - Baud 179
 - Data Bits 180
 - Honor DSR 180
 - Job Buffering 180
 - NPA Mode 181
 - Parity 181
 - PCL SmartSwitch 181
 - PS SmartSwitch 182
 - Robust XON 182
 - RS-232/RS-422 182
 - RS-422 Polarity 183
 - Serial Buffer 183
 - Serial Protocol 184
- serial port
 - adjusting
 - transmission speeds 180
 - adjusting transmission speeds 179
 - configuring
 - buffer size 183
 - NPA mode 181
 - parity 181
 - PCL SmartSwitch 181
 - polarity 183
 - protocol 184
 - PS SmartSwitch 182
 - robust XON 182
 - enabling
 - DSR (Data Set Ready) signals 180
- Serial Protocol (Serial Menu) 184
- Setup Menu 185
 - Alarm Control 185
 - Auto Continue 186

- Display Language 186
- Download Target 186
- Jam Recovery 187
- Job Accounting 187
- Page Protect 187
- Power Saver 188
- Print Timeout 188
- Printer Language 189
- Resource Save 189
- Staple Alarm 189
- Toner Alarm 190
- Wait Timeout 190
- Size Sensing 20
- Staple Alarm (Setup Menu) 189
- staple and offset unit
 - alarm 189
 - enabling 142
 - priming 93
 - replacing staples 60
- staple cartridge, replacing 60
- Staple Job (Finishing Menu) 142
- Staple Prime Src (Finishing Menu) 142
- stapler
 - alarm 189
 - enabling 142
 - priming 93, 149
- staples 64
 - ordering 64
- StapleSmart
 - alarm 189
 - enabling 142
 - priming 93
 - replacing staples 60
- statement size 20
- statistics
 - printing 193
 - storing 187
- storing
 - paper 28
 - supplies 66
- Substitute Size (Paper Menu) 165
- supplies 64
 - charge roll 64
 - fuser assembly 65
 - label fuser cleaner 64
 - maintenance kit 63
 - ordering 63
 - print cartridges 63
 - storing 66
 - transfer roll 64
- Symbol Set (PCL Emul Menu) 170
- print 188
- wait 190
- Toner Alarm (Setup Menu) 190
- Toner Darkness (Quality Menu) 178
- transfer roll
 - ordering 64
 - replacing 58
- Transmit Delay (Infrared Menu) 146
- transparencies
 - loading
 - multipurpose feeder 44
 - paper tray 37
- tray linking 54
- Tray Renumber (PCL Emul Menu) 170
- troubleshooting
 - paper jams 68
 - printer settings 10
 - unresponsive printer 67

U

- Universal Setup (Paper Menu) 165
- unsatisfactory papers 23
- USB Buffer (USB Menu) 197
- USB Menu 195
 - Job Buffering 195
 - MAC Binary PS 195
 - NPA Mode 196
 - PCL SmartSwitch 196
 - PS SmartSwitch 197
 - USB Buffer 197
- USB port, configuring
 - buffer size 197
 - NPA mode 196
 - PCL SmartSwitch 196
 - PS SmartSwitch 197
- Utilities Menu 191
 - Defragment Flash 191
 - Factory Defaults 192
 - Format Disk 192
 - Format Flash 192
 - Hex Trace 193
 - Job Acct Stat 193
 - Print Directory 193
 - Print Fonts 193
 - Print Menus 194
 - Print Net <x> Setup 194

W

- Wait Timeout (Setup Menu) 190
- wait timeout, configuring 190
- width guide 37
- Window Size (Infrared Menu) 146

T

- test printing
 - Hex Trace mode 193
 - menus page 194
- timeout



Lexmark and Lexmark with diamond design are trademarks of Lexmark International, Inc., registered in the United States and/or other countries.

© 2001 Lexmark International, Inc.

740 West New Circle Road
Lexington, Kentucky 40550